

MAY 26, 1977

SPECIAL REPORT: NEW TECHNOLOGIES ENHANCE ACTIVE FILTERS/119

The EIA: must diversity mean weakness?/75

Plugging the analog world into microcomputer boards/106

FOUR DOLLARS A MCGRAW-HILL PUBLICATION

Electronics®

SILICON ON SAPPHIRE
unwrapped and ready



t.rupshur

97232
MAY 26 1977
MATT NEILL
2516 NE CLACKAMAS
PORTLAND OR

“When the heat’s on, I need hands-on performance without an armful of paper.”

Problem: The more completely you can define the effects of variables, the less you’re leaving to chance.

In hundreds of programs and models you’re faced with the challenge of pinpointing how each variable influences the end result ... as rapidly but as economically as possible. Trouble is, one set of answers leads to another set of questions. You need constant accessibility to processing power, without the pounds of printout that can bog you down for days.

Solution: Tektronix’ desktop Graphic System comes straight to the point.

The 4051 speaks a graphically beefed-up BASIC ... supported by software packages like statistics, that lets you explore analyses of variable and linear and nonlinear regression techniques with unequalled simplicity and interactivity. You command up to 32K of problem-solving power, with 300K bytes of built-in mag tape storage and optional on-line capability.

Graphic results are results you can use ... immediately. You can explore more options, keep closer to the experiment. You can communicate concepts more quickly, save them more compactly.

Take the heat off.

Personal 4051 Graphics can save you money like it saves you time. To see what it can do for you, talk to your Tektronix Sales Engineer, or write:

Circle 900 on reader service card



Standard 4051 features include twenty user definable functions and internal cartridge data storage. Plus, you can choose from a full line of Tektronix interfaces and peripherals to meet your specific needs.

Tektronix, Inc.
Information Display Group
P.O. Box 500
Beaverton, OR 97077
Tektronix Datatek N.V.
P.O. Box 159
Badhoevedorp, The Netherlands

Get the picture. Get total results.

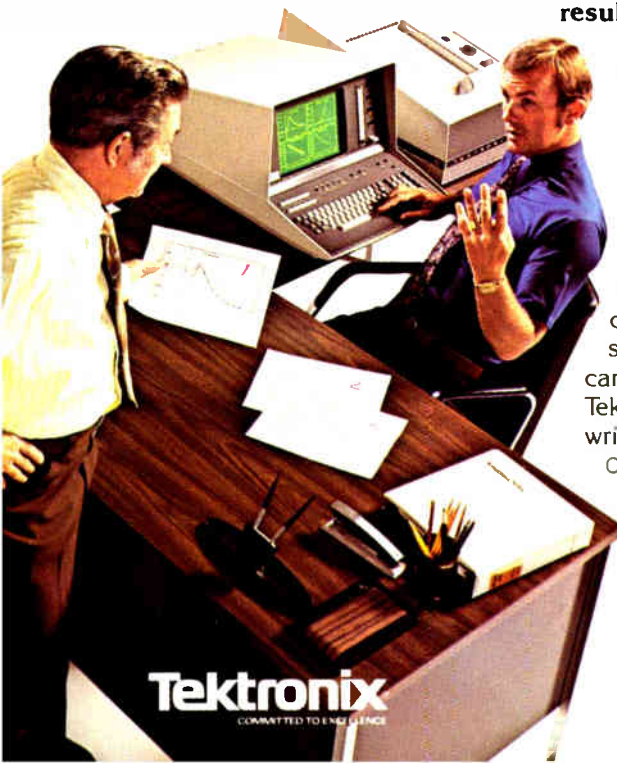

Tektronix
COMMITTED TO EXCELLENCE

World Radio History

Copyright © 1977, Tektronix, Inc. All rights reserved.

The snap action switch

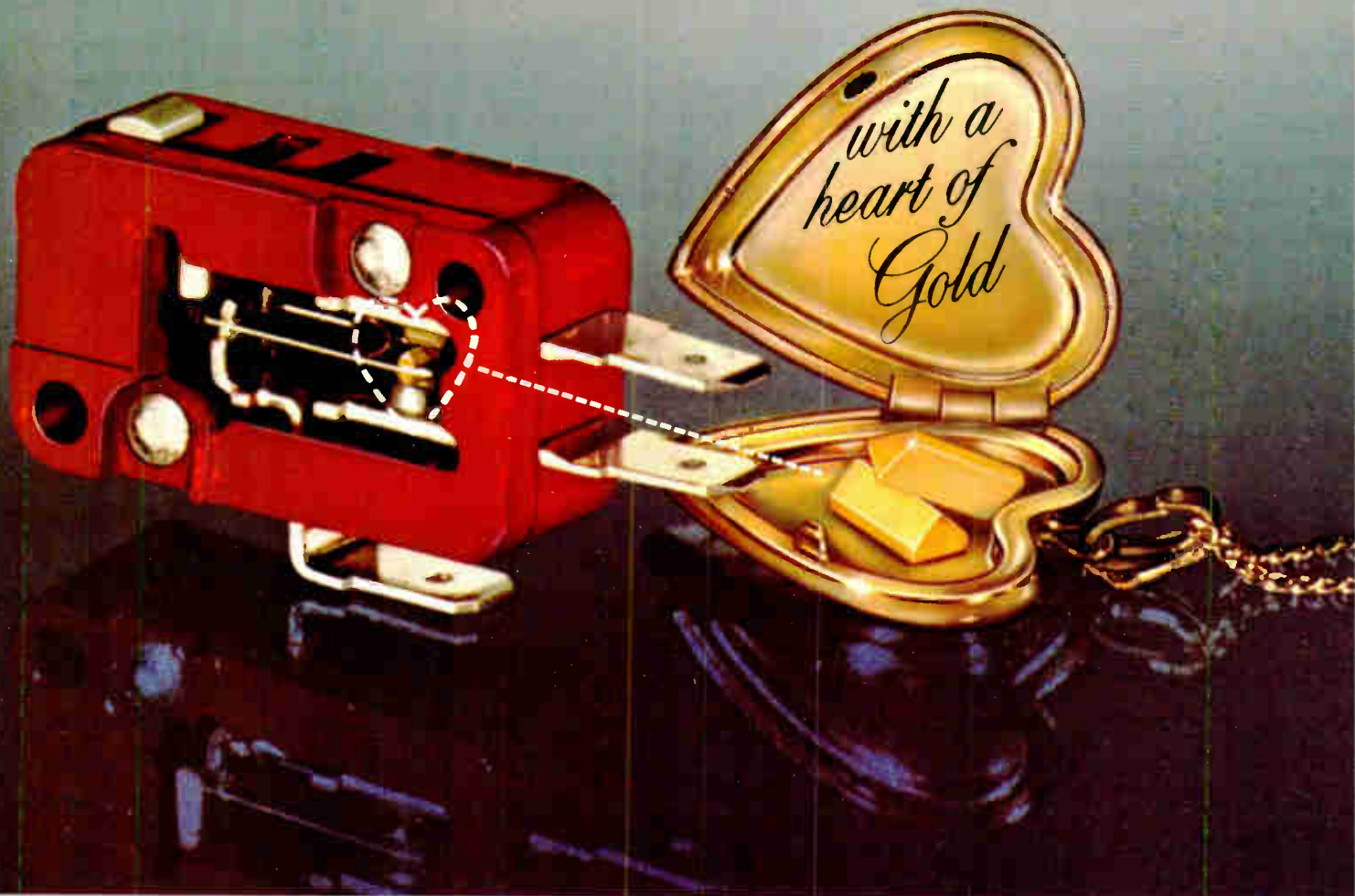

...for **POSITIVE** switching in low energy circuits

Now your 4 to 100 milliampere, 4 to 30 volt circuits can have the same high reliability you've learned to love in Cherry snap action switches. Because, our "heart of gold" snap action switches have the same long life coil spring mechanism, the same large overtravel as all of our snap action switches.

They also have gold crosspoint contacts. A configuration with knife-edge contact area so small (9 millionths of a square inch) ... with contact force so great (about 5,000 psi) ... and gold alloy so pure and film-free ... you are absolutely assured of positive contact every time. For 50 million operations and beyond.

Cherry Gold Crosspoint Contact Switches are available in virtually every snap action design in

Cherry's big catalog. And you *know* what a wide variety of switch types, sizes and mounts *that* is. Choose any switch design from a basic open or general purpose to a panel mount pushbutton, low torque, miniature, subminiature or subminiature module. Chances are 99 to 1 that the switch you have chosen is available with gold crosspoint contacts. Which will make designing low energy circuits a whole lot easier ... and a whole lot *better*. (No love letters, please.)

For free test sample and complete catalog, just TWX 910-235-1572 ... or PHONE 312-689-7700.

CHERRY 

Cherry switches now available locally from distributors.

CHERRY ELECTRICAL PRODUCTS CORP., 3608 Sunset Avenue, Waukegan, IL 60085

World Radio History



Circle 1 on reader service card



UBIQUITOUS

The Ballantine 3028A; at home in Bryce Cañon, on shipboard, or in your maintenance shop and laboratory. In one fine instrument Ballantine has combined features otherwise found only in a number of lesser multimeters. It is another new Ballantine with full performance and top quality.

DISPLAY: 3-1/2 large LED
FUNCTIONS: AC, DC Volts
 AC, DC Amps
 Ω low power
 Ω high power
 Display Test
 Battery Check
RANGES: 32
ACCURACY: To $\pm 0.05\%$ ± 1 digit
FREQUENCY: 15 Hz to 110 kHz
 rms responding
MODEL 3028A: \$279

Fully EMI shielded
 No fuses; circuit breaker protected
 AC RMS response for accuracy with
 distorted inputs
 One year calibration interval
 Safety compliant
 Uses only standard parts
Optional: battery pack, analog meter,
 20 amp range, 40 kV dc and
 700 MHz detector probes,
 full complement of accessories

Ballantine

41 Electronics Review

CONSUMER: Japanese show liquid-crystal television screen, 41
High-end calculators programmed with plug-in ROMs, 42
MILITARY: Services order high-speed facsimile, 42
SOLID STATE: GE speeds process of doping semiconductors, 44
TI plans big effort in very-large-scale integration, 46
SPACE: NASA astronomy satellite to search for X rays, 48
INSTRUMENTS: Box lens boosts CRT design at Tektronix, 50
COMPANIES: Optel emerging and doing well, 52
NEWS BRIEFS: 52

63 Electronics International

WEST GERMANY: Siemens aims IR-beam chips at U.S. market, 65
NETHERLANDS: Semiconductor laser simplifies video player, 65
JAPAN: Optical ROM uses lasers to write on spinning disk, 66
AROUND THE WORLD: 66

75 Probing the News

TRADE ORGANIZATIONS: Can the EIA handle diversity? 75
ELECTRONICS ABROAD: Civil-aviation picture cloudy, 78
CONSUMER ELECTRONICS: For TV games, a rerun, 83
ELECTRONICS ABROAD: Norway tries togetherness, 88

99 Technical Articles

SOLID STATE: Improved C-MOS on sapphire enters commercial use, 99
MICROPROCESSORS: Analog I/O hybrids simplify interfaces, 106
DESIGNER'S CASEBOOK: Intelligent multiplexer aids processor, 112
ICs slash component count in Costas loop demodulator, 113
INSTRUMENTS: Measuring average power in nonlinear devices, 116
SPECIAL REPORT: Active filters ride crest of new technology, 119
ENGINEER'S NOTEBOOK: Thermometer uses single quad op amp, 126
Low-cost oscillators build accurate capacitance meter, 127
Offsetting op amp forms low-threshold detector, 129

132 New Products

IN THE SPOTLIGHT: Chip peripherals outsmart CPUs, 132
Low-level analog plug-in for LSI-11 withstands 250 V, 136
DATA HANDLING: More flesh on the Naked Mini, 139
SEMICONDUCTORS: Decoder/driver eases LCD design, 144
MICROWAVES: Field-effect transistor generates 1 W at 8 GHz, 151
INSTRUMENTS: Counter/timer spans 1 gigahertz, 156
MATERIALS: 164

Departments

Publisher's letter, 4
Readers' comments, 6
News update, 8
Editorial, 10
People, 14
Meetings, 30
Electronics newsletter, 35
Washington newsletter, 59
Washington commentary, 60
International newsletter, 63
Engineer's newsletter, 130
New literature, 167

Services

Reprints available, 162
Employment opportunities, 172
Reader service card, 183

Highlights

Cover: C-MOS on sapphire hits the big time, 99

Now in production is a high-performance 16-bit microcomputer chip set that has complementary-metal-oxide-semiconductor circuits built on sapphire substrates. Making this possible are processing advances that solve the oxide-step and breakdown-voltage problems and sharply reduce leakage currents.

Cover illustrated by Thomas Upshaw.

Cloudy days for Europe's aircraft industry, 78

The Concorde may start landing in New York, but that will not affect the sales doldrums for Europe's civil-aircraft makers. Present orders and future prospects are better in the military field, but uncertainty prevails.

Analog I/O adjusts to microprocessors, 106

Thanks to hybrid technology, packaged analog input/output systems are now not much bigger than packaged integrated circuits. The newest plug-in units are compatible with many microprocessors.

Active filters up frequency, drop cost & size, 119

Advancing technology has brought a whole new look to active filters. This special report focuses on three major developments: better-performing operational amplifiers, improved thick-film hybrid resistors, and computerized design and production aids.

In the next issue . . .

Japan's plans for storming the data-processing market: a special report . . . a preview of the National Computer Conference . . . another example of microprocessors in action.

"How do I pick the right test instrument?"

ASK US!

... or look in our book

Our 1977 rental catalog has detailed specs. on more than 800 instruments, grouped by product type for fast price/performance evaluation.

So, look in our book or ask over the phone.

Call Continental Rentals

Div. Continental Leasing Co., Inc.
175 Middlesex Turnpike, Bedford, MA 01730
(617) 275-0850

FOR IMMEDIATE RESPONSE CALL:
N.E. (617) 275-0850; L.I. (516) 752-1622;
NY, NJ (201) 654-6900; Gtr. Phila. (609) 234-5100;
Wash., D.C. area (301) 948-4310;
Mid West (312) 439-4700;
So. Central (214) 690-1706;
Costa Mesa, CA (714) 540-6566;
L.A., CA (213) 477-7521;
Santa Clara, CA (408) 735-8300.

Circle 8 on reader service card

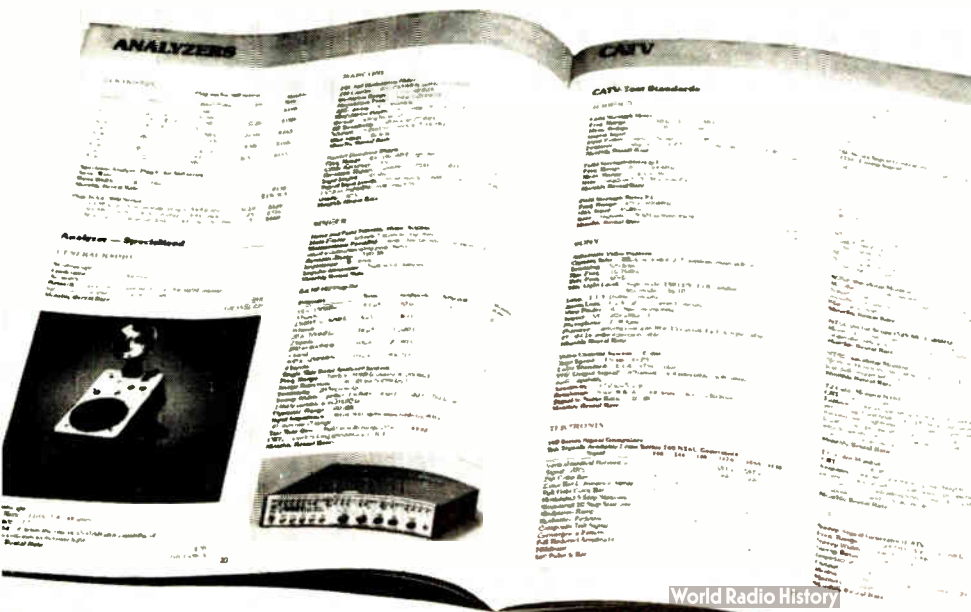

News update

■ The Auto-Lab division of Spectra-Physics Inc. in Mountain View, Calif., dominates the single-channel gas chromatograph business. Now the company claims to have doubled its share of the multichannel chromatograph market against Hewlett-Packard, Varian, Columbia Scientific, and others with its model SP4000 data system [*Electronics*, May 13, 1976, p. 26]. Arthur Leung, product manager, says he expects to sell \$5.5 million worth of the systems this year, with unit sales hitting 200 at an average selling price ranging up to \$18,000 per copy at \$3,600 to \$6,000 per channel.

Companies in the chemical industry have been the main customers for the 4000, says Leung, and many have used it as a dedicated analyzer by interfacing it with a minicomputer for a management-information system. "The design philosophy caught on a lot better than we anticipated," he says. The 4000 uses a hierarchical, or distributed, network of Intel 8080 microprocessors to control up to 16 channels.

■ A system intended to prevent collisions on the ground at busy airports, as well as allowing more takeoffs and landings per runway, is in jeopardy because of a shortage of Federal Aviation Administration funds. Portions of the trilateration position-fixing radar beacon system, which will share an airport's air-traffic-control surveillance radar, have been installed at Boston's Logan International Airport [*Electronics*, May 13, 1976, p. 34]. Testing is to begin this summer, but a later version has been pushed substantially beyond the hoped-for operational date of 1979.

John O'Grady, chief of the airport systems branch at the Transportation Systems Center in Cambridge, Mass., says funds for a follow-on system will not be requested until the fiscal 1981, 1982, and 1983 budgets, which would push the system's operational availability well into the mid-1980s. Funding between the Logan tests and follow-on system development "is pretty undefined," he says.

This semiconductor plant ain't exactly two guys in a garage.

It takes a lot of research, development, design, and production know-how to turn out a good line of semiconductor devices . . . it also takes a lot of sophisticated equipment . . . plus a lot of specially-educated and skillfully-trained people mutually striving for product excellence.

At Sprague Electric's Semiconductor Division, we have accumulated over fifteen years of intensive experience in the manufacture of *innovative* semiconductor devices . . . devices making special contributions to technology . . . devices manufactured under the most exacting QAR program . . . devices that assure total customer satisfaction.

We have built the kind of operation it takes to produce semiconductors compatible with today's as well as tomorrow's requirements.

We proudly invite customers and prospects to tour our plant, the nation's finest semiconductor facility of its type. Here you will see the magnitude of effort that goes into properly designed and manufactured devices. You'll be pleasantly surprised!

Write or call George Tully or Bob Milewski to arrange a visit. You can reach them at the Semiconductor Division, Sprague Electric Co., 115 Northeast Cutoff, Worcester, Mass. 01606. Tel. 617/853-5000.

FOR FAST INFORMATION, CALL YOUR NEAREST SPRAGUE SALES OFFICE:

ALABAMA, Sprague Electric Co. 205 883-0520 • ARIZONA, Sprague Electric Co. 602 279-5435 • CALIFORNIA, Sprague Electric Co. 213 649-2600 Wm. J. Purdy Co. 415 347-7701 KCE Corp. 714 278-7640 • COLORADO, Wm. J. Purdy Co. 303 777-1411 • CONNECTICUT, Sprague Electric Co. 203 261-2551 • DIST. OF COLUMBIA, Sprague Electric Co. (Govt. sales only) 202 244-6006 • FLORIDA, Sprague Electric Co. 305 831-3636 • ILLINOIS, Sprague Electric Co. 312 678-2262 • INDIANA, Sprague Electric Co. 317 253-4247 • MASSACHUSETTS, Sprague Electric Co. 617 899-9100 Sprague Electric Co. 413 664-4411 • MICHIGAN, Sprague Electric Co. 517 787-3934 • MINNESOTA, HMR Inc. 612 920-8200 • MISSOURI, Sprague Electric Co. 314 781-2420 • NEW JERSEY, Sprague Electric Co. 201 696-8200 Sprague Electric Co. 609 795-2299 Trinkle Sales Inc. 609 795-4200 • NEW MEXICO, Wm. J. Purdy Co. 505 266-7959 NEW YORK, Sprague Electric Co. 516 549-4141 Wm. Rutt Inc. 914 698-8600 Sprague Electric Co. 315 437-7311 Mar-Tom Associates 315 437-2843 • NORTH CAROLINA, Electronic Marketing Associates 919 722-5151 • OHIO, Electronic Salesmasters Inc. 800 362-2616 Sprague Electric Co. 513 278-0781 • PENNSYLVANIA, Sprague Electric Co. 215 447-5252 Trinkle Sales Inc. 215 922-2080 • TEXAS, Sprague Electric Co. 214 235-1256 • VERMONT, Ray Perron & Co. Inc. 617 762-8111 • VIRGINIA, Sprague Electric Co. 703 463-9161 • WASHINGTON, Sprague Electric Co. 206 632-7761 • CANADA (Ontario), Sprague Electric of Canada Ltd. 416 766-6123 • CANADA (Quebec), Sprague Electric of Canada Ltd. 514 683-9220

4SS-6139RI



**. . . and you thought we
only make great capacitors.**

Circle 9 on reader service card



Ramifications of executive search: at the IEEE . . .

By appointing an acting general manager, the Institute of Electrical and Electronics Engineers has wisely reduced the deadline pressure on finding a new general manager and given its search committee more time. Even though it may have been embarrassing for the IEEE to admit that the right candidate has not yet been found, in the long run extending the search timetable should pay off.

In addition, it is encouraging to note that the institute has hired an executive recruiting expert to help. As *Electronics* suggested some months ago, an outside searcher can be of vital assistance in broadening the field of candidates and in maintaining a politically important buffer between candidates and the IEEE during the evaluation process.

Now that the search committee has more time to do a careful job, it is worth considering a couple of more points regarding the qualifications of the new general manager.

. . . and at the EIA

While the Electronic Industries Association is searching for a new president, perhaps it should be looking for a new structure, too. Unlike most presidential posts in industry, the EIA president has distinctly limited authority, largely as a result of the diverse interests of EIA's several divisions. The departure of V.J. Aducci, who is moving over to head another trade organization, serves once more to raise questions among some of the member companies and staff about the EIA's structure and effectiveness.

One recurrent proposal surely deserves renewed investigation. It is the question whether EIA should become the Electronic Industries Federation, recognizing the autonomy of its divisions and permitting them to function as separate associations under a single umbrella. After serving as EIA's president from 1964 to 1966, TRW's Harper Q. North advocated a federation. One of his reasons was that it would persuade

It is not enough for the general manager to be an engineer. The IEEE needs a manager who can communicate with the members. This point is vitally important because whoever is chosen to be general manager must be ready to open up communications with all members, even though the pressing needs of administration make looking outward difficult.

Because IEEE presidents and boards come and go, the general manager has to represent continuity in service to members. As the expectations of members have changed, the general manager, as well as the leadership, has tended to be put in a position of reacting rather than innovating. Therefore, any candidate for this position ought to make his own demands on the institute, demands that give him leeway to act, not react, within the guidelines of IEEE policy, but without having to depend on the changing views of a changing board of directors and president.

smaller organizations to affiliate with EIA. North also favored the creation of a smaller, more effective board of governors, believing that such a board would attract more top-level representation from member companies. Then Motorola's Robert Galvin concluded his second term as EIA president in 1968 by recommending that the association review its structure and services.

This year's chairman, John Messerschmitt, says that these concerns are reviewed regularly by EIA's Strategic Planning Committee. Nevertheless, they now seem to warrant a higher priority than they have been receiving. After all, EIA's own 50-year history, put out in 1974, concluded: "Further reorganizations of EIA are inevitable. Whether EIA becomes a full federation or merely operates like one is only a matter of degree. The electronic industries themselves, as the use of the plural name implies, no longer have either completely common markets or objectives."

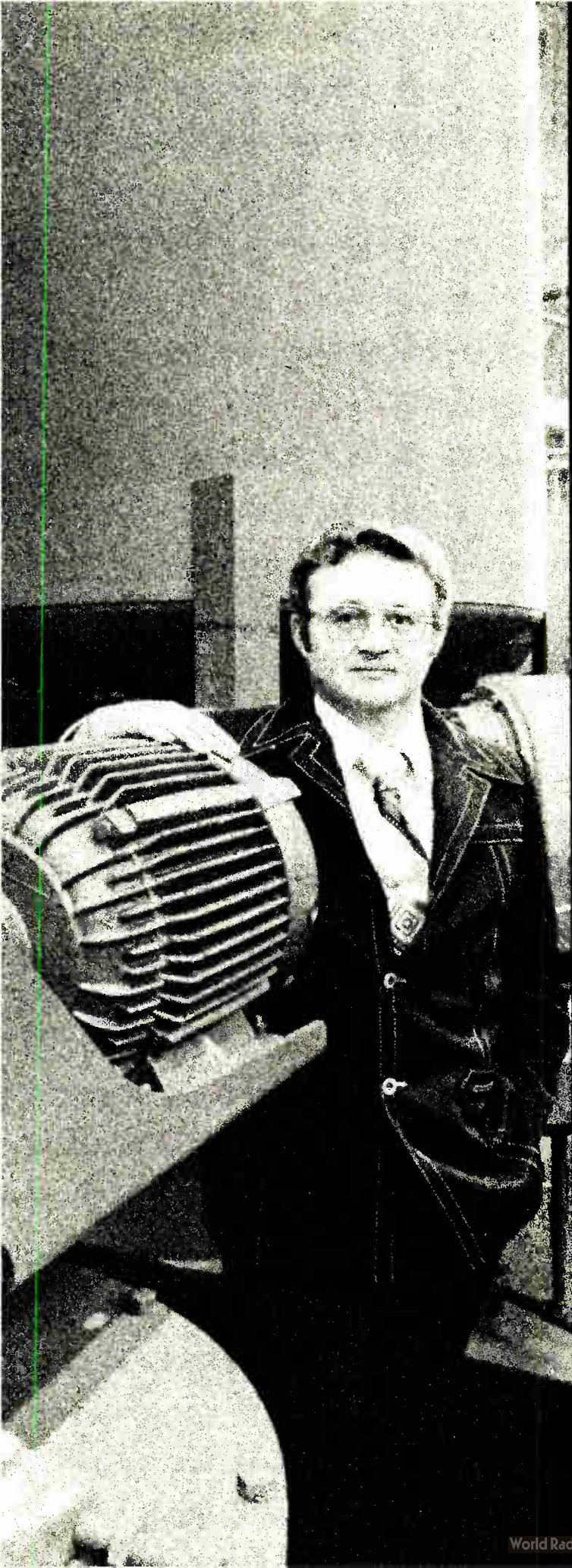

"Kodak helped us set up a reprographics program that could save us more than \$100,000 a year."

**Dennis Thurgood,
Document Control Manager,
EIMCO PMD Division,
Envirotech Corporation,
Salt Lake City.**

"EIMCO PMD is a leading manufacturer of pollution control equipment. Since much of this equipment has custom engineered features, we generate more than 2,000 drawings a month.

"We started working with Kodak back in 1973, expanding our microfilm capabilities. Most recently, we set up a reprographics center with a Kodak Startech processor. Doing the photoreproduction work internally has resulted in substantial dollar savings.

"Also, we have increased the individual drafter's capacity. Before, he was doing a basic pencil-to-paper operation. Now he comes to us and says, 'I need to get from here to here, can you help me?' And we can. Scissors drafting, opaquing, second originals via blowbacks from microfilm are all part of our capabilities. Making the drafter more efficient is probably the major justification for the installation.

"And it's certainly paying its way. We figure we'll save more than \$100,000 a year for the next five years. We've reduced cost by doing photoreproduction work internally; saved drafting time through reprographic techniques; and we've gotten our files under control with microfilm."

Reprographics can help you, too.

Send for more details about EIMCO'S use of reprographic techniques, plus a complete listing of Kodak products and other applications. Write: Eastman Kodak Company, Graphics Markets Division, Dept. R04803, Rochester, N.Y. 14650.

**VERSATILITY IN
REPROGRAPHICS**



64-bit RAMs without aspirin.

Advanced Micro Devices, Inc. • 901 Thompson Place, Sunnyvale, California 94086 • Telephone (408) 732-2400 •
Distributed nationally by Hamilton/Avnet, Cramer and Schweber Electronics and regionally by Arrow, Bell,
Century Electronics, Future Electronics and RAE Electronics.

Advanced Micro Devices announces brand new, trouble-free 64-bit RAM's. Am27S02A/3A, the world's fastest. Am27LS02/03, the world's best low-power, high-speed combination. And Am29700/01, the world's only non-inverting 64-bit RAM.

They're a whole new 64-bit RAM family. Rebuilt from top to bottom. No re-hash of eight-year-old designs. Internally compensated ECL circuitry. Optimum speed/power performance.

Modern LSI process techniques: Two-layer metalization. Ion-implantation. Three-micron EPI. Washed emitters. It's today's TTL RAM technology — designed to run extremely well over military specs. And even better over commercial.

They're cooler and faster.

Cooler and faster than the part has ever been. They're designed with a

temperature-compensated regulator system built in for stable performance over supply and temperature variations.

A transparent option is also available at no extra cost. It'll allow you to see the complement of the data in during the write cycle without lowering the part's overall speed.

Everything but the glitch.

The output circuitry is pre-conditioned so that true data is present at the outputs when the write cycle is completed. There's no "write/recovery glitch."

We don't take data sheets lightly.

Our new 64-bit RAM's will meet every single spec on those data sheets. And we mean every one.

Here's what you do: Send us your name on your letterhead and the part number you're interested in. We send you two free parts. You throw away the aspirin.

The specs.	THEIR LOW POWER COM'L/MIL	OUR LOW-POWER 27LS02* & 27LS03 COM'L/MIL	THEIR HIGH-SPEED COM'L/MIL	OUR HIGH-SPEED 27S02A* & 27S03A COM'L/MIL
MAX ADDRESS ACCESS tAA	80ns/100ns	55ns/65ns	35ns/50ns	25ns/30ns
MAX CHIP SELECT ACCESS tpZH/L (CS)	60ns/80ns	30ns/35ns	17ns/25ns	15ns/20ns
MIN WRITE PULSE WIDTH tpw (WE)	80ns/100ns	45ns/55ns	25ns/25ns	20ns/25ns
MAX WRITE RECOVERY tpZH/L (WE)	80ns/100ns	30ns/35ns	35ns/40ns	20/ns25ns
MAX POWER SUPPLY CURRENT	25mA/25mA	35mA/38mA	110mA/110mA	100mA/105mA

NOTES: COM'L = 0°C to 75°C V_{cc} = 5v ± 5%
MIL = -55°C to 125°C V_{cc} = 5v ± 10%

*open collector output

Advanced Micro Devices

Bipolar LSI. N-channel, silicon gate MOS. Low-power Schottky. Multiple technologies. One product: excellence.



Circle 252 on reader service card



OPTRON OPTICALLY COUPLED ISOLATORS

NEW JAN 4N22A SERIES
OFFERS
HIGHEST RELIABILITY

You can't buy a more reliable optically coupled isolator than one of OPTRON's new JAN 4N22A series. The popular JAN 4N22A, 4N23A and 4N24A all feature fully qualified JANTX and JANTXV ratings.

These new OPTRON isolators consist of a high efficiency, solution grown gallium arsenide LED and a silicon N-P-N phototransistor in a hermetically sealed 6-pin TO-5 package. Minimum input-to-output isolation voltage for the series is 1000 volts and minimum current transfer ratios range from 25% for the 4N22A to 100% for the 4N24A.

New "A" version OPTRON isolators are a significant improvement over the older 4N22 series since the case is isolated from the sensor and LED to eliminate the need for an insulating spacer in many applications.

OPTRON also offers a new JEDEC registered series of high reliability isolators in a 4-pin TO-18 package. The 3N243 series includes three devices with the same reliability and similar characteristics as the JAN 4N22A TO-5 series, yet in a smaller package.



3N243

In addition, OPTRON's complete line of optically coupled isolators includes other immediately available standard devices in high-rel metal cans and low cost DIP and other plastic configurations for almost every application.

Detailed technical information on optically coupled isolators and other OPTRON optoelectronic products... chips, discrete components, limit switches, reflective transducers, and interrupter assemblies... is available from your nearest OPTRON sales representative or the factory direct.



OPTRON, INC.

1201 Tappan Circle
Carrollton, Texas 75006, U.S.A.
TWX-910-860-5958
214/242-6571

People

More impact in U.S.

is goal of EMI's Lawson

Mention computerized X-ray brain and body scanners, and most technically oriented people will think of EMI Ltd., the billion-dollar British-based multinational that is the largest and most successful scanner manufacturer. But there is an EMI subsidiary that J. Thomas Lawson hopes will soon be getting equivalent recognition, especially in the U. S.

Lawson is the newly named president of EMI Technology Inc., Danbury, Conn. He is responsible for a collection of companies producing and marketing products like special vacuum tubes and electronic test and nuclear instrumentation to the tune of \$15 million a year.

Nonmedical. The 54-year-old Lawson is out "to develop EMI Technology's position in the U. S. electronics industry in areas outside of medical electronics as rapidly as possible." This could mean internal development as well as acquisition of companies "both inside and outside our present expertise," according to the former IBM and General Telephone and Electronics executive.

Right now, he is most interested in security—particularly in exploiting an English technique for secure coding of magnetic materials on cards used for cash and credit transactions and identification. "We see this [magnetic encoding] as a major growth area," he says. To help it gain a foothold, EMI recently acquired Malco Plastics Inc., a maker of credit and identification cards.

Marriage. Lawson is not interested in credit cards *per se* but in marrying them to the proprietary secure-magnetics technology. To broaden the product base in the security-system field, he wants to add several peripherals, including readers and printers tied together by computer.

He is also considering bringing to the U. S. a line of electronic fire and intrusion alarm equipment now made by EMI in Europe. He also finds the possibilities of voice-recognition systems intriguing. EMI holds



New. Secure magnetics is one area for Lawson to exploit at EMI Technology.

a significant interest in Threshold Technology Inc. of Delran, N.J., the firm that has pioneered commercial applications of this technology. "The next step would be voice verification systems, and that could be a very nice tie-in with the security business," he says.

Lawson's expertise extends into other areas of data handling and communications. Before joining GT & E in 1970 as president of its Ultronic Systems Corp., a maker of information terminals for brokerage houses, he spent 23 years at IBM, where he is credited with developing the System 3 business computer.

EMI already modifies and sells in Europe modems made by an American manufacturer, Rixon Inc. "It makes sense to expand our efforts in the data communications field because it is an area with growth potential," Lawson says.

Lear Siegler's Falco pushes
into intelligent terminals

For an executive who admits he is being "forced into the intelligent-terminal market," Lee Falco Jr. appears quite unworried. Until last year, in fact, he was content to turn out only "dumb" terminals at his EID Data Products group at Lear Siegler Inc., Anaheim, Calif., doing

Need a 2-digit BCD DAC?

Our DAC-20 is the world's first monolithic 2-digit BCD-coded DAC. Gives you very high speed performance (85nsec settling, typ.) with very low power consumption (37mW), terrific nonlinearity ($\pm 1/4$ LSB Max. over temp.)—all for very low cost.

It's simple to use. Provides a universal logic interface for TTL, CMOS, ECL, or any other logic. Full noise immunity is provided by high swing adjustable threshold logic inputs. And dual complementary current outputs with $-10V$ to $+18V$ compliance give you a voltage output with only a resistive termination. No speed-limiting output op amp needed.

Just ask . . . Applications for our DAC-20 series range from audio attenuators and analog meters to modems and micro-processors. We'll be glad to send you a data sheet full of these and other application ideas

using the DAC-20 in such things as reference amplifiers, logic threshold controls, and multiplying circuits with bipolar or pulsed references. Just circle the reader service number for a copy. And if you would like a free sample DAC-20, write us on your letterhead and tell us what application you're thinking about. We'll be glad to help you get going. Write DAC-20 at the address below.

Thank you.



Precision Monolithics, Inc.,
1500 Space Park Drive,
Santa Clara, CA 95050
(408) 246-9222. TWX 910-338-0528.

Circle 15 on reader service card



You finally have a choice:

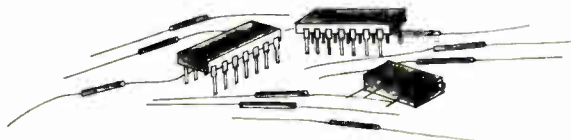

Make

Buy

4 1/2 Digit Programmable Systems/Lab DMM \$795.00



Model 3400, the world's most accurate systems/lab 4 1/2 digit DMM is completely programmable in function, range and even autorange. Remote triggering allows up to 12 conversions/sec. BCD interface standard and IEEE STANDARD 488 BUS interface optional.

Full 100% overranging (20,000 counts), basic DCV accuracy of $\pm 0.007\%$ of reading ± 1 L.S.D. for six months, measures from 10 microvolts to 1,000 VDC (ACV from 10 microvolts to 750V RMS), resistance from 10 milliohms to 20 Megohms; AC/DC and DC/DC voltage ratio.

Model 3400R with True RMS . . . \$895.00



For complete information or a demonstration, contact your local Data Precision representative or Data Precision Corporation, Audubon Road, Wakefield, MA. 01880 (617) 246-1600. TELEX (0650) 949341.

Circle 185 for demonstration
Circle 186 for additional information

People

so at a good profit and the rate of 2,000 monthly.

What changed his mind? As the group's vice president and general manager, he says, "If I don't broaden my product base, profitability and volume both will soon be under pressure." Volume users are demanding a processing capability in their cathode-ray-tube terminals, he explains. So, in what was "a quantum leap for us, we set out nine months ago to come up with a smart terminal, but the simplest one yet." The 39-year-old Falco believes the new ADM-4 will fill the bill. A prototype will be shown at the National Computer Conference in Dallas next month.

"For stand-alone uses, it's a mini-computer really," he says, built around a three-board 16-bit Fairchild 9400 Macrologic microprocessor system with 8 to 32 kilobytes of memory. This capacity allows all kinds of ways of manipulating data, including editing, storing in memory, transmitting, and printing it out. But the energetic Falco, who calls himself a "merchant, not a salesman," is most enthusiastic about the system's appearance. "I like pretty things," he observes, "and this is beautiful."

Constructed of an injection-molded plastic rather than metal, the 60-pound terminal snaps together without screws or bolts, Falco brags. Along with plug-in circuit modules, this design makes the terminal easier than any other terminal to assemble and maintain, he asserts. The price will be between \$2,400 and \$2,800, "but will settle down later."

Potential to come. Falco thinks the terminal market has only begun to realize its potential, despite already wide application by industrial users. "It's the home market that's not tapped. I can see one in every home not too far in the future," he says. Back in 1972 Falco was the one who persuaded Lear Siegler to jump into the terminal business. "Despite a lot of people telling me there was no room, I saw no one dominating it." His division recently delivered its 30,000th terminal, and he predicts 50,000 by December.

MAGNETIC SHIELDING FOR ANY CONFIGURATION

Ad-Vance reduces your shield costs because it already owns tooling for most standard shields. Or, our Magnetic Shielding Specialists will custom fabricate shields to your exact specifications.

- Magnetic Shields for 332 Types of Photomultiplier Tubes.
- AD-MU Sheet Stock.
- AD-MU Tape Data Protectors assure full fidelity of valuable tapes.
- Unequaled engineering & design service.
- In-house quality control.
- Fast delivery, competitive pricing.



Ask For NEW 48-PAGE Time-Saving Reference Data/Catalog on Magnetic Shielding Techniques & Problem Solving



Typical Custom Fabricated Shields For Components & Systems

AD-VANCE MAGNETICS, INC.

226 E. SEVENTH ST., ROCHESTER, IND. 46975
(219) 223-3158 TWX 810 290 0294

The Magnetic Shielding Specialists

hp MEASUREMENT COMPUTATION **NEWS**

product advances from Hewlett-Packard

MAY 1977

in this issue

New memory offers lightning fast retrieval

An HP first—6-pin optocouplers

New 22 GHz spectrum analyzer



The new 5004A Signature Analyzer displays a hexadecimal signature unique to a data node in one of HP's new products designed for troubleshooting using the signature analysis technique. This technique allows building economical component-level servicing into new products.

Signature analyzer simplifies microprocessor system servicing

Few, indeed, are the electronic product areas untouched by the microprocessor revolution. But despite the benefits of microprocessors, the question arises, "How will the products be serviced?" Swapping defective modules for good ones creates inventory and handling costs. HP now offers a timely, more economical alternative—**signature analysis**, for servicing down to the component level. It even eliminates the need to design the product as a modularized one, in some cases.

(continued on third page)

Trace serial data with parallel-mode logic analyzer

A new serial-to-parallel converter now makes it possible to use the measurement capabilities of HP's 1600A and 1607A Logic State Analyzers for the serial data domain. This accessory, the 10254A, accepts data in serial form and formats it into a parallel word for presentation as one line on the logic state analyzer's tabular display. Just as with parallel data, the logic state analyzer can be set to capture and display the data sequence beginning with a particular word, or data leading up to the word, or data at some point downstream from the word, enabling the user to find the part of the program where malfunctions occur.

If both the 1600A and 1607A are being used at the same time, with the 10254A converter, both serial and parallel data can be displayed in two tables on the 1600A display.

For more details, check B on the HP Reply Card.



The 10254A serial-to-parallel converter (lower unit) interfaces the HP 1600A logic state analyzer (upper unit) to serial data streams so serial data flow occurring at a node or on a bus can be presented as a table of binary words on the logic analyzer's display.

Cache speed memories at semiconductor prices

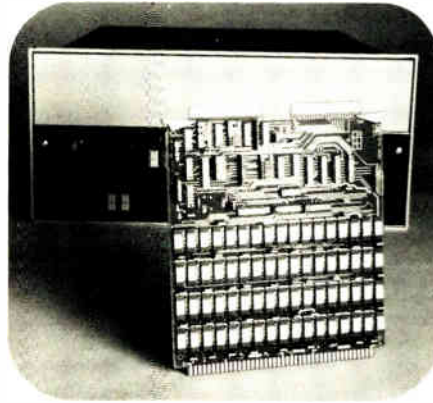

The addition of high-speed semiconductor memory options to the 21MX-E Series computer results in up to 30% overall system performance increase over previous memory modules.

In the time it takes light to travel 100 meters, an HP 21MX E-series computer with new high-speed memory can retrieve information and be ready for another access!

A major contribution to this speed is the new N-Channel MOS/RAM memory. New 4K RAMs cycle in 320ns.

The new structure of the HP 2102E controller has almost eliminated its time overhead. Cycle time of the system then is 350ns, almost equivalent to that of the chips.

To ensure reliability, all memory parts and boards undergo vigorous burn-in and proprietary diagnostic tests to discover and correct faults that would not have otherwise been detected.

The new HP 12741A memory modules meet stringent environmental specifications, .i.e., 0-55°C, up to 95% humidity, plus tough shock and vibration tests.

Available in 32-kbyte modules, the new 350ns memory may be ordered with 21MX E-Series computers, all HP 1000 Systems and 2126A DisComputers. Because HP offers full asynchronous interface with memory, field retrofit is possible; a change of controller is necessary.

With a memory cycle time at 350ns, the new memory exceeds that of many cache memory schemes, without the usual associated high cost.

Check D on the HP Reply Card for further information.

HP 7920—the disc that doesn't keep your CPU waiting

The new 50 megabyte (formatted) HP 7920 disc has some of the fastest access times in the minicomputer industry. Seek times—track to track—are 5 ms, averaging 25 ms, worst case is only 45 ms.

Designed with a light carriage/rail system for lower mass, and a linear voice coil motor with high force inputs, higher accelerations are possible and therefore greater speed.

Speed in stopping and accurately positioning the head is equally important. High-speed feedback circuitry, deriving a signal directly from the surface of the disc, allows optimization of over-shoot and settling times.

Reliability is also designed into the discs. The Error Correction Code hardware and algorithm are together capable of correcting one single-burst data error per sector, if the error is of length ≤ 32 bits. For burst errors of > 48 bits, 99.999% are detected.

A dual filtration system of the HP 7920 contributes to reliability by removing 99% of particles 0.3 microns or larger. Also, in the event of a black-out or circuit break, an emergency head retract prevents head crashes.

For further information, check O on the HP Reply Card.



The addition of the high-speed HP 7920 disc to a 256k byte HP 3000 Series II computer results in a 20% improvement in system response time in interactive sessions and a 30% improvement in throughput.

Enhance swept measurements with digital storage and normalization

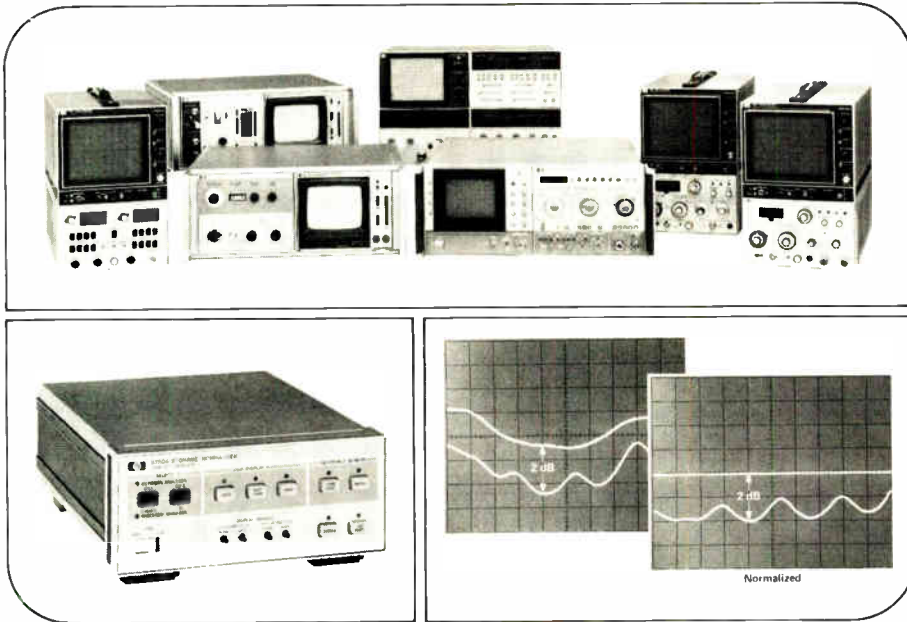

HP network and spectrum analyzers (top) gain additional accuracy, measurement speed and operational simplicity when the HP 8750A storage-normalizer (lower left) is used with them. In the example shown, test system frequency response variations are easily removed through normalization.

Here are some advantages the new HP 8750A Storage-Normalizer, a versatile accessory instrument for HP network and spectrum analyzers, can bring to swept measurement applications:

Remove frequency response errors—calibrate the test system's response and store it in the 8750A's memory. Then, subtract it from the measured data for increased display accuracy (i.e., a "normalized" measurement).
Flicker-free slow sweep measurements—response of narrowband devices requiring very slow sweeps is displayed fully and brightly because measurement data are displayed from memory at a fast rate with continuous memory refresh.

Direct comparison measurements—instead of having to scale deviations between two traces, the deviation itself can be displayed in a single, calibrated trace.

The 8750A is directly compatible with current model HP network analyzers and several HP spectrum analyzers, (existing models can be retrofitted). Even instruments not directly compatible, such as HP 140 series spectrum analyzers, can be used by adding a simple low-frequency oscilloscope for the digitally stored and/or normalized display.

The 8750A can "freeze" CRT displays for simplified photography. X-Y recordings are also easily made because plots all made at an automatic 30 second rate, independent of actual test system sweep speed.

Performance details, applications ideas, and instrument compatibility information are all in the 8750A data sheet. For your copy, check R on the HP Reply Card.

Understanding and measuring phase noise in the frequency domain

Hewlett-Packard's new Application Note 207 describes the theory and practice of making phase noise measurements from 5 Hz to 13 MHz from the carrier. Emphasis is placed on the correction factors required for making noise power spectral density measurements with wave and spectrum analyzers. Examples are given for both manual and automatic measurements.

For your free copy, check S on the HP Reply Card.

Troubleshoot complex microprocessor-based circuits

(continued from first page)

Signature analysis is based on the time-honored technique of signal tracing. HP's Model 5004A Signature Analyzer converts lengthy bit streams in the product into short, four-digit hexadecimal "signatures" when its requirements are designed into a product. By tracing signatures—good and bad—through the circuits, the faulty component can be isolated rapidly.

Here are some benefits:

- Increases product's value to user by lowering cost of ownership.
- Lowers warranty costs.
- Lowers material costs since product needs not be modularized for servicing purposes.

We've made a major commitment to this time and money-saving technique ourselves: the majority of HP's new microprocessor-based products are being designed for service using signature analysis, and several of them are already on the market.

Look into the 5004A signature analyzer's cost savings now. Check H on the HP Reply Card.

New triple output power supplies for use in microprocessor systems



New power supplies include the 6236B and 6237B (above) for operating microprocessor systems during the product design stage, and (shown below) the 62312D OEM modular supply for equipment component use.

Triple output supplies give you operating voltages for most microprocessor systems in one convenient package. HP offers two new triple output laboratory supplies for your system development work, and a new triple output OEM modular power supply for use in end-product equipment.

Models 6236B and 6237B, designed for lab use, offer fully metered, adjustable wide-range outputs with convenient operating controls. The 6236B main output is 0 to +6V at up to 2.5A, while the 6237B is 0 to +18V, at 1.0A. Both have adjustable plus and minus outputs of 0 to 20V at 0.5A.

When operated in the fixed tracking mode, the dual outputs match within 1% as a single voltage control sets both. Switching to the variable tracking mode allows the negative output to be separately set lower than the positive one, yielding three different output voltages. All three outputs are fixed current limit protected.

The new HP 62312D triple output OEM modular Supply is specifically designed as a complete component unit for powering microprocessor systems in end products. All outputs are independently adjustable and isolated from each other and the chassis, providing a wide selection of voltages and

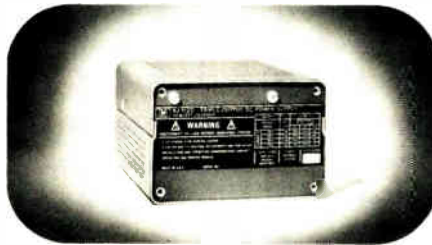

polarities from one basic model for a variety of systems. The main output is rated at 4.75V to 5.25V at 3A, while the other two each range from 4.75V at 0.38A to 12.6V at 0.6A at up to 40°C. The supply may be operated up to a 70°C ambient with current derating. It also features remote programming terminals to control the main 5V output for margin testing.

Protection features include an internal AC fuse, fixed foldback current limit and standard over-voltage protection on the main 5V output (optional on the other two outputs).

For more information on triple output laboratory supplies, check M on the HP Reply Card.

For information on the OEM Modular supplies, check L on the card.

Higher power, wider coverage with new microwave sweeper plug-in

At least 10 milliwatts of leveled output power over the frequency range from 2 to 18.6 GHz is what you get with the new HP 86290B RF plug-in for the HP 8620C Sweep Oscillator. You also get excellent frequency accuracy (± 20 MHz at 18.6 GHz) and linearity (0.05%), low harmonic and spurious content, and internal leveling to ± 0.9 dB over the full 2 to 18.6 GHz.

The 86290B/8620C Sweeper is directly compatible with the HP 8755 Frequency Response Test Set and HP 8410 Microwave Network Analyzer for wideband scalar and vector network measurements. And, when the 8620C mainframe is equipped with optional HP-IB frequency programming capability, the unit can be configured for many versatile applications, including a 2-18.6 GHz frequency synthesizer.

For details, check Q on the HP Reply Card.

Portable battery-operated calculator delivers a printed record

The HP-91 scientific printing calculator provides you with a full range of scientific and arithmetic functions—complete with a printed record—all in one compact calculator. And because the HP-91 prints and operates on AC or its own built-in batteries, you can use it anywhere—in the office or the remotest field locations.

For more information, check A on the HP Reply Card.



Thermal printing system can print—with labels—statistical summations, contents of the operational stack, or the contents of all sixteen addressable memories.

Two compact quartz oscillators rival performance of lab units

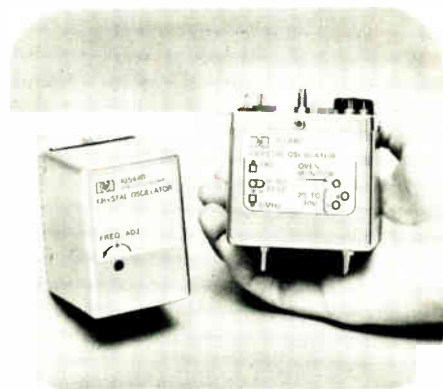

HP's new oscillators are particularly useful in communication and navigation systems and instruments such as counters, synthesizers and analyzers.

Two new 10 MHz compact component oscillators offer outstanding frequency stability, spectral purity and aging rate as well as ruggedness and fast warm-up at moderate prices.

They were designed to meet the high performance standards and time base requirements of several new HP instruments.

Key specifications include:

Aging rate: <math>< 5</math> parts in Phase noise: >150 dB for > 1 kHz offset

Warm-up:

Temperature co-efficient:

Short term stability	Averaging time
<math>1 10^{-8}<="" \times="" math><="" td=""> <td><math>10^{-4}< math>="" sec.<="" td=""> </math>10^{-4}<></td></math>1>	<math>10^{-4}< math>="" sec.<="" td=""> </math>10^{-4}<>
<math>1 10^{-9}<="" \times="" math><="" td=""> <td><math>10^{-3}< math>="" sec.<="" td=""> </math>10^{-3}<></td></math>1>	<math>10^{-3}< math>="" sec.<="" td=""> </math>10^{-3}<>
<math>1 10^{-10}<="" \times="" math><="" td=""> <td><math>10^{-2}< math>="" sec.<="" td=""> </math>10^{-2}<></td></math>1>	<math>10^{-2}< math>="" sec.<="" td=""> </math>10^{-2}<>
<math>1 10^{-11}<="" \times="" math><="" td=""> <td><math>10^{-1}< <math>10^1<="" math>="" sec.<="" td="" to=""> </math>10^{-1}<></td></math>1>	<math>10^{-1}< <math>10^1<="" math>="" sec.<="" td="" to=""> </math>10^{-1}<>

Size: 72x52x62 mm

Magnetic and gravitational field performance are also specified.

The two models are 10544B and C. The main difference is the connectors: Model B has a printed circuit connector board; C has filter feed-thru terminals for power connections and a snap-on RF connector for the 10 MHz output. Model C also has provision for shock mounting.

Check C on the HP Reply Card.

New Coaxial and Waveguide Catalog and Microwave Measurement Handbook

The new 1977-78 edition of the popular **MICROWAVE CATALOG** is now ready for RF and Microwave engineers. Intended for design engineers, production test personnel, quality assurance and metrology labs, the catalog contains 84 pages of product descriptions on over 300 microwave measurement accessories. Product sections include attenuators, detectors, couplers, filters, power sensors and many more.

Over 20 pages are devoted to a **MICROWAVE MEASUREMENT HANDBOOK SECTION**, summarizing common scalar measurement techniques of attenuation, impedance, power, frequency, and noise figure in coaxial and waveguide systems. Measurement tables offer comparison of accuracy vs cost for common measurements; equipment selection tables list model numbers needed for specific measurements by band, and important characteristics of products are described.

For your free copy, check U on the HP Reply Card.



Fast, on-line capacitor testing in inspection and manufacturing



With front-panel thumbwheel switches, high and low limits can be set for fast testing of capacitors.

For high-speed GO/NO GO measurements on the production line or during inspection, two new C meters check capacitors to 0.1% accuracy.

Both the 1 MHz Model 4272A and the 1 kHz Model 4273A are capable of 8 measurements per second.

With the 4272A, capacitors from 10 pF to 1000 pF full scale are measured to 0.001 pF resolution. Using the 4273A, capacitors from 100 pF to 10 μF full scale are measured to a resolution of 0.01 pF.

Go/no-go indications on the front panel are also available at reed relay and TTL outputs on the rear panel. A digital output for digital printers is also available for hard copy.

For more information, check F on the HP Reply Card.

of Hertz and Gigahertz

...part 3 in a series

The super performance counter

When your needs exceed the capabilities of the best of universal counters, consider a super performance unit such as HP's 5345A. It has a range of dc to 500 MHz, 20 mV sensitivity, sub-nanosecond gating throughout, and also gives you:

- reciprocal counting for greatest resolution per given gate time.
- time resolution of 2 ns for single shot events and 1 ps for repetitive events via time interval averaging. HP's unique jittered clock ensures accurate averaging for all input repetition rates.
- external gate times down to 20 ns. This, plus the 5345's high accuracy for brief gates, permits frequency profiling within a burst or characterizing rapidly swept cw signals.
- frequency averaging for greatly increased pulsed RF resolution.
- superb measurements to 4 GHz with the 5354A Auto Frequency Converter. It acquires in <2 ms, tolerates up to 500 MHz p-p deviation, measures RF pulses down to 250 ns. (100 ns manually). With frequency averaging, short microwave pulses can be measured about 100 times more precisely than with any conventional counter.
- HP Interface Bus option for easier, more economical systems design.

For the 20-page data sheet, check I on the HP Reply Card.



The HP 5345A super performance counter can accurately measure short RF pulses or rapidly swept signals.

No need for add-on options with NEW full capability X-Y recorder

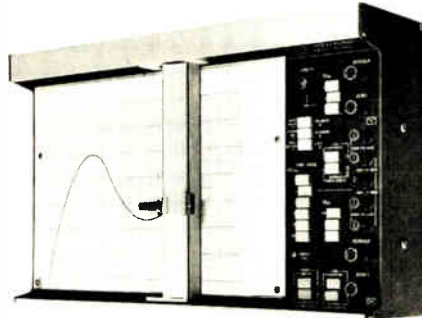

The 7015B lab X-Y recorder is a low cost, open instrument that features maximum electrical and mechanical flexibility to fit many and varied applications.

A new low-cost FULL CAPABILITY X-Y recorder, the HP 7015B, offers full capability recording without the need for costly add-on options or external equipment. The single, all inclusive price provides these four full capability features:

Internal Time Base can be slowed to ¼ hour sweep and has automatic pen control and remote triggering for sweep start and reset.

Matched Input Filters eliminate or reduce the always present signal noise. (Noise of less than 0.1% of full scale can start degrading the trace!)

Remote Pen Lift can mean the difference—during a quick plot—between an acceptable graph and one that must be redrawn by hand.

TTL Level Remote Control provides an easy interface with external equipment or systems.

Attention OEMs

To bring recording quality to your systems, consider HP recorders. We support worldwide what we sell.

The 7015B also offers top-of-the-line quality in its disposable pen writing system and continuous duty servo motors for operator convenience and low cost of ownership. It has sensitivities from 5mV/cm or 10mV/in on charts up to A4 or 8½ × 11".

For more information, check N on the HP Reply Card.

New microwave coaxial switch has 50 dB isolation at 26.5 GHz

A dc to 26.5 GHz coaxial microwave switch is now available. The HP 33311C is a SPDT switch which features all-matched ports by using internally switched 50Ω loads to terminate the unused secondary port and improve the isolation. Isolation is >85 dB at 18 GHz, >50 dB at 26.5 GHz.

Excellent repeatability results from use of "edge-line" design which switches only the center conductor. After 1,000,000 switchings, repeatability is typically 0.03 dB. APC-3.5 connectors allow operation to 26.5 GHz and are fully SMA compatible. SWR is <1.5 to 16 GHz, <2.3 to 26.5 GHz. Insertion loss at 16 GHz is <0.8 dB, <1.4 dB at 26.5 GHz. The switch will handle 1W average and 100W peak.

The 33311C is electrically switched and self-latching. Coils draw 3W at 24 VDC and automatically disconnect after the 30 ms switching time.

The small size (5.5 × 7 × 1.5 cm) and environmentally rugged construction makes the 33311C ideal for designing into microwave systems.

For more technical data, check E on the HP Reply Card.

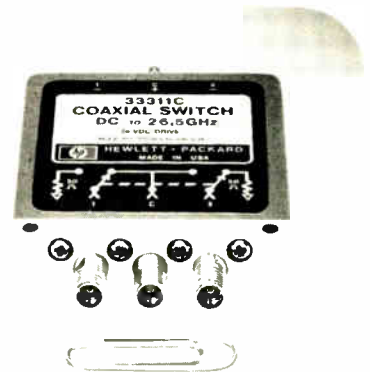

Internally switched 50Ω loads in this SPDT switch provide all-matched ports to 26.5 GHz.

MEASUREMENT & COMPUTATION NEWS

New HP-IB brochure cites more than 58 interfaceable products

The recent development of a standardized interface enables engineers to create flexible, cost-effective systems quickly and easily.

The Hewlett-Packard Interface Bus (HP-IB) is our implementation of IEEE standard 488, and it is also in accord with the main IEC document approved by member nations during 1976. With the bus, you can link instruments to perform automatic measuring and test-

ing. Under management of a computing controller, an HP-IB system virtually runs itself.

Now, a new 12-page brochure is available, covering:

- Evolution and benefits of the standard interface
- How HP-IB operates
- Typical applications
- A list of more than 58 HP-IB products currently available for "do-it-yourself" systems
- Selecting a computing controller
- Preassembled HP-IB systems

For a copy of this informative and helpful brochure, check T on the HP Reply Card.

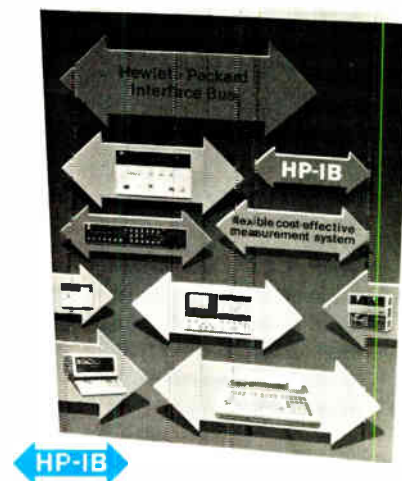

HP-IB

HEWLETT-PACKARD COMPONENT NEWS

Simplified optical design and higher channel density with new high radiant intensity emitter

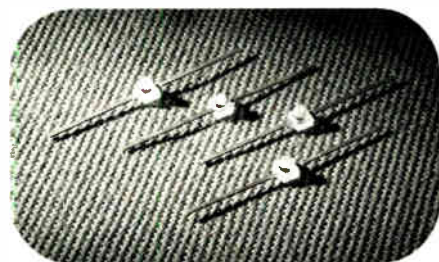

The clear optical port and offset wire bond also allow the HEMT-6000 to function as a photodiode. The typical responsivity is 0.35 amps/watt centered at 700 nanometers.

Designed for maximum efficiency at 700 nm wavelength, this visible, near-IR source is low cost and easy to align. The HEMT-6000 uses a GaAsP chip designed for optimum trade-off between speed and quantum efficiency. Axial radiant intensity is typically 250 microwatts/steradian. Bandwidth is dc to 5 MHz.

Applications for the HEMT-6000 include bar code readers, optical mark sensors, optical scanners, safety interlocks, tape sensing systems and fiber optic drivers.

For details, check J on the HP Reply Card.

New 6-pin optical couplers available for first time

Two photodarlington devices are announced from Hewlett-Packard. These Models 4N45 and 4N46 optocouplers feature low input current with high gain. Current transfer ratio (CTR) is typically 1000%.

The 4N46 has a 20V minimum output voltage rating and a 350% minimum CTR at an input current of only 0.5mA making it ideal for use in low input current applications such as MOS, CMOS and low power logic interfacing. The 4N45 has a 250% minimum CTR at 1.0mA input current and a 7V minimum output voltage rating.

Applications include uses as telephone ring detectors, digital logic ground isolation, low input current line receivers, line voltage status indicators or logic to reed relay interface.

For additional details, check G on the HP Reply Card.

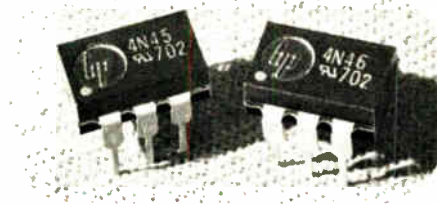

The 4N45/46 optocouplers contain a GaAsP light emitting diode optically coupled to a high gain photodetector IC.

HP microwave transistors now registered with EIA



2N6617 has been assigned by the Electronic Industries Association to Hewlett-Packard's HXTR-6101 low noise transistor. Specified at 3.0 dB noise figure at 4 GHz with 8 dB minimum associated gain, it is packaged in a 1.8 mm (0.070 in) diameter hermetic metal/ceramic package.

2N6618 has been assigned to the recently introduced HP HXTR-6103. Noise figure is 2.2 dB maximum at 2 GHz with 11 dB minimum associated gain. The 2N6618 is supplied in a 2.5 mm x 2.5 mm (0.1 in x 0.1 in) hermetic metal/ceramic package.

These transistors are intended for use in radar, EW and communications systems in the 1 to 6 GHz range.

For additional details, check K on the HP Reply Card.

Measure to 22 GHz with new easy-to-use spectrum analyzer

HP's new microwave spectrum analyzer, model 8565A, combines wideband performance (10 MHz to 22 GHz frequency coverage) with greatly simplified operation and unambiguous displays. The analyzer features absolute amplitude calibration, automatic preselection from 1.7 to 22 GHz, and flat frequency response for meaningful comparisons of multiple signals. In addition, the 8565A offers wide ranges of frequency spans (from broad spectra to close-in analysis), resolution bandwidths (from 1 kHz to a wide 3 MHz), and amplitude scale factors that provide from coarse to fine resolution.

Even with this breadth of performance capabilities, operation of the 8565A is remarkably straightforward. Most measurements are a simple 3-knob sequence. With a wide span selected, pick out the signal of interest with the TUNING control. Then zoom in on it with the FREQUENCY SPAN/DIV control. As you narrow the span, the resolution bandwidth, sweep time and video filtering are all automatically set to keep the display calibrated. Then set the signal amplitude to full deflection with the REFERENCE LEVEL control, which then indicates the signal's power level.

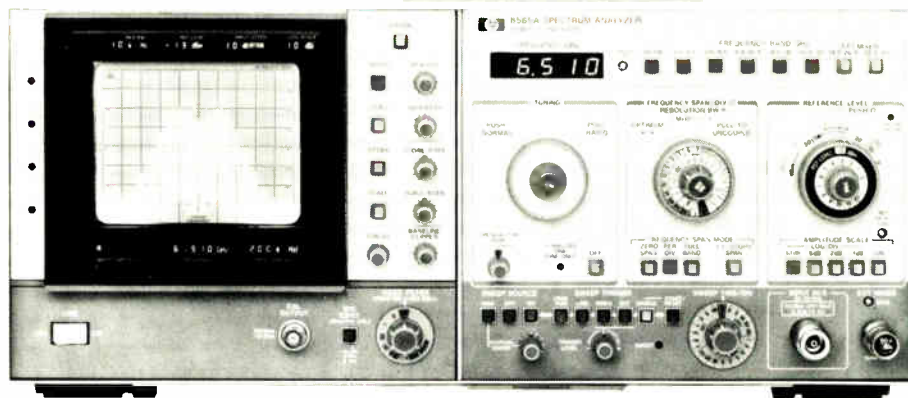

Wide range, spurious-free displays plus simple operation and digital display of control settings all contribute to the HP 8565A Spectrum Analyzer's usefulness in microwave applications.

To add to the operator's convenience and confidence, the value of each pertinent parameter—even the ones automatically established—is digitally displayed on readouts in the CRT bezel assembly. These data are captured when using a scope camera.

The 8565A Analyzer can measure to 40 GHz using the HP 11517A Waveguide Mixer. And the analyzer can be used with the HP 8444A Opt 058 Tracking Generator to make >90 dB swept response measurements in

the 10 to 1300 MHz range. A useful complement to the 8565A is the new HP 8750A Storage Normalizer (described elsewhere in this issue). The 8750A can digitally store a reference signal which can then be compared to a later input signal.

For more information about this versatile microwave instrument, check P on the HP Reply Card.

East-4 Choke Cherry Road, Rockville, MD 20850.
Ph. (301) 948-6370.

South-P.O. Box 10505, Atlanta, GA 30348.
Ph. (404) 434-4000.

Midwest-5201 Tollview Dr., Rolling Meadows, IL 60008.
Ph. (312) 255-9800.

West-3939 Lankershim Blvd., North Hollywood, CA 91604.
Ph. (213) 877-1282.

Europe-7, rue du Bois-du-lan, P.O. Box, CH-1217, Meyrin-2, Geneva, Switzerland. Ph. (022) 41 54 00.

Japan-Yokogawa-Hewlett-Packard Ltd., Ohashi Bldg., 1-59-1 Yoyogi, Shibuya-ku, Tokyo 151. Ph. 03-370-2281/92.

HEWLETT  PACKARD

 **MEASUREMENT news**
COMPUTATION
product advances from Hewlett-Packard

May/June 1977

New product information from
HEWLETT-PACKARD

Editor: Iona M. Smith

Editorial Offices:

1507 Page Mill Road
Palo Alto, California, 94304 U.S.A.

Your Problem Solvers!



Special Pots from Spectrol

For more than 20 years, designers with application problems have turned to Spectrol for special pot solutions. They have come to us for • cermet, conductive plastic, and wirewound pots • linears and non-linears • special torque devices • concentric shafts • spring returns • linear motions • pot/switch combinations • element sectors • 1000°F pots • Moon pots and Mars pots.

So for help with your tough applications, come to Spectrol. Let us design a "Problem Solver" for you.

Spectrol

SPECTROL ELECTRONICS GROUP

UNITED STATES Spectrol Electronics Corporation 17070 E. Gale Avenue, City of Industry, Calif. 91745, U.S.A. • (213) 964-6565 • TWX (910) 584-1314

UNITED KINGDOM Spectrol Reliance Ltd. Drakes Way, Swindon, Wiltshire, England • Swindon 21351 • TELEX: 44692

ITALY SP Elettronica SpA Via Carlo Piscane 7, 20016 Pero (Milan) Italy • 35 30 241 • TELEX: 36091

World Radio History

Circle 27 on reader service card



**Some Delevan designs
are very special...**

THEY'RE NOT MADE YET

Applications for inductive devices are virtually unlimited and not even Delevan's broad line of *standard* designs can fit every requirement. That's where Delevan's Application-Engineering capability comes in! No matter how unusual or highly-specialized your application may be... Delevan can provide a custom-engineered design to meet the most demanding specifications, the most unique applications.

At Delevan, the design of inductive devices is far more than an art... it is a highly-sophisticated science. State-of-the-art techniques in winding and molding, the instant availability of computerized data, and utilization of new materials and procedures... combined with the proven expertise of Delevan engineers... equals unmatched capabilities. If you have the application, Delevan can provide the design.

Delevan
Division



AMERICAN
PRECISION
INDUSTRIES INC.

270 QUAKER RD / EAST AURORA, N.Y. 14052
TELEPHONE 716/652-3600 TELFX 091-293

OTHER DIVISIONS OF AMERICAN PRECISION INDUSTRIES INC.
BASCO • DUSTEK

Meetings

11th Annual Consumer Electronics Show, Electronic Industries Association, McCormick Place, Chicago, June 5-8.

Chicago Spring Conference on Consumer Electronics, IEEE, Marriott Hotel, Chicago, June 6-7.

National Association for Remotely Piloted Vehicles Symposium, NARPV (Dayton, Ohio), Hyatt Regency Hotel, Washington, D. C., June 6-8.

1977 Intermag—International Magnetics Conference, IEEE, Los Angeles Hilton, Los Angeles, June 6-9.

International Conference on Communications, IEEE, O'Hare Inn, Chicago, June 12-15.

National Computer Conference, IEEE *et al.*, Dallas Convention Center, Dallas, June 13-16.

1977 Power Electronics Specialists Conference, IEEE, Rickey's Hyatt House, Palo Alto, Calif., June 14-16.

14th Design Automation Conference, IEEE and ACM, International Hotel, New Orleans, June 20-22.

1977 International IEEE/AP-S Symposium, USNC/URSI Meeting and URSI International Electromagnetic Symposium, IEEE and URSI, Stanford University, Palo Alto, June 20-24.

31st Annual Afcea Convention, Armed Forces Communications and Electronics Association (Falls Church, Va.), Sheraton Park Hotel, Washington, D. C., June 21-23.

1977 International Microwave Symposium, IEEE, Sheraton Harbor Island Hotel, San Diego, June 21-23.

Symposium on Machine Processing of Remotely Sensed Data, IEEE, Purdue University, West Lafayette, Ind., June 21-23.

World Electrotechnical Congress, IEEE *et al.*, Moscow, USSR, June 21-25.

TWIST'N'FLAT

PLANAR CABLE

BREAKTHROUGH!
MASS TERMINATION WITH
TWISTED PAIR CABLE!
LOW CROSSTALK AND
LOW INSTALLED COST!

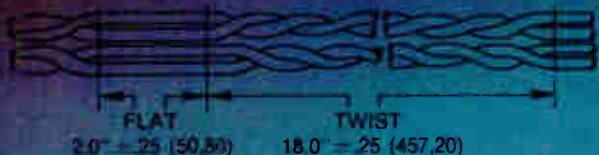

Standard cables have 18" twists, 2" flats
 Custom twist lengths (10" to 100" or more) available
 size range to 64 conductors (32 pairs), 28, 26 and 24 gauge.

Used with Spectra-Strip 802 Series IDC mass termination connectors, Twist'N'Flat planar cable provides 50% — 70% reduction in total installed cost with reliable terminations. Available with or without external strain relief.

Now, with the termination costs of twisted pair flat cables greatly solved, why not purge crosstalk from your entire system?? Standardize on Twist'N'Flat. It's available today from local distributor stocks.



Attn: Marketing Services
 Spectra-Strip
 P.O. Box 415
 Garden Grove, CA 92642

WANT SOME REALLY USEFUL AND UNIQUE INFORMATION?

Send for Spectra-Strip's NEW DESIGN GUIDE and CATALOG. 86 pages of useful technical and ordering material on Twist'N'Flat, 802 Series Connectors, Flexible Etched Circuits, and the widest range of planar interconnect systems and products available today.

Gentlemen: Send me your free 86 page Planar Interconnect Systems Catalog and Design Guide

Do you want a Spectra-Strip representative to call? Yes No

Do you specify or buy planar cable or connector products? Yes No

SPECTRA-STRIP

an **Eltra** company

Types _____

Name _____

Title _____ Phone No. _____

Company _____

Address _____

City/World Radio History _____ State _____ Zip _____

A new direction in microprocessor design aids.

Introducing a software development system that supports a variety of microprocessors: first the 8080 and 6800, then the Z-80*, with a wide selection to follow. Assembler software for two microprocessors is provided from those available at the time of purchase, and software for each additional microprocessor may be purchased as an option with a minimum of added expense.

This feature alone means that you can *change* direction without having to make a major investment in a new design aid. Choose a component on the basis of its suitability for a particular project, then, if it seems desirable, switch to another for the next project.

* Available late summer 1977.

It also means that you don't have to relearn your software development system each time you use a different microprocessor chip. And that can save valuable time.

The 8002 offers several other time-saving features to ease the task of program creation: a text editor that simplifies software entry and revisions, an assembler with macro capability, and dynamic trace for software debugging.

Since microprocessor-based program creation and prototype design typically go hand in hand, the 8002 also offers three progressive option levels for program emulation and debugging, prototype emulation and debugging, and real-time prototype analysis.

The 8002 Program Emulation and Debugging System, which adds an emulator processor and software for a selected microprocessor, enables the developmental software to be run, tested, changed, traced, and debugged on the desired microprocessor. The

THE TEKTRONIX 8002 MICROPROCESSOR LAB



emulator microprocessor is identical to the microprocessor in the designer's prototype; if the software is to be executed on an 8080 in the prototype, for example, an 8080 microprocessor chip is used in the emulator processor.

The 8002 Interactive Prototype Emulation and Debugging System adds a Prototype Control Probe for a selected microprocessor. With the probe inserted into the prototype, developmental software and hardware may be tested, traced, and debugged together.

The 8002 Real-Time Prototype Analyzer System adds real-time trace and an 8-channel Analyzer Probe. At this level bus transactions and events external to the microprocessor may both be monitored.

One final advantage: the Tektronix name. Tektronix has always been responsive to the instrumentation needs of the design engineer . . . and the 8002 Microprocessor Lab is no exception. Its ability to deal with a

number of different microprocessors, its many convenience features for software development, and its capabilities for software/hardware debugging, make it a unique design tool.

As a leading electronics instrument company, Tektronix offers you a full line of options and peripherals, from the three 8002 option levels . . . to PROM programming facilities for the 1702 or the 2704/2708 MOS PROMs . . . to a line printer and choice of system terminals.

Backed by years of experience, Tektronix also offers you a rare commodity in the field of microprocessor development tools: local Field Engineers and local service. A nation-wide network of Field Offices and Service Centers is ready to help you realize the full benefits of the 8002.

For more information or a demonstration of this new software development tool, write Tektronix, Inc., P.O. Box 500, Beaverton, Oregon 97077.

For availability outside the U.S., please contact the nearest Tektronix Field Office, Distributor, or Representative.

The 8002... with multiple microprocessor support.



Tektronix[®]
COMMITTED TO EXCELLENCE

For Technical Data circle 32 on reader service card
For Demonstration circle 33 on reader service card

World Radio History

A resistor for all reasons

Here's a way to cut the daylights out of your fixed resistor inventory. Standardize on our Type CC cermet. It's sized like a ¼-watt but you get performance that ranges from ⅛-watt at 125°C to ½-watt at 70°C (250 volt max.) Tolerance is 1% over the complete resistance range of 10 ohms to 22.1 megs or 0.5% from 10 ohms to 499K. TCR is as low as ± 50 ppm/°C. The one resistor for all reasons: industrial, RN55C, RN55D and RLR07 needs to 1% and 2% tolerance. We have what you need: our distributors have it when your need is now. Ask for Publication EC33.

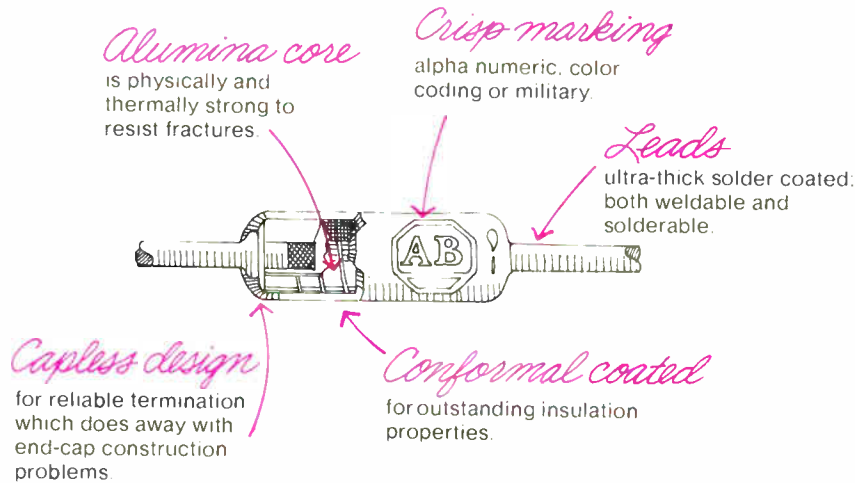

Quality in the best tradition.



ALLEN-BRADLEY
Milwaukee, Wisconsin 53204

Air Force ready to seek proposals for automatic tests

Look for the Air Force to request proposals from industry in about a month to develop a modular automatic test equipment "mate" system, which the service expects will save it over \$100 million a year by the mid 1980s. The mate system would consist of **interchangeable hardware and software modules for checkout of electronic equipment** on all types of aircraft and at all maintenance levels—organizational, field, and depot. If the concept proves feasible and cost-effective, Air Force spokesmen conservatively estimate the program's value at \$500 million.

Initial contracts are expected to be awarded early next year to at least two bidders that will build feasibility development models. The project is being handled by the Air Force's Aeronautical Systems division at Wright-Patterson Air Force Base.

TRW may quit monitoring/control field as unprofitable

TRW Inc. is weighing a departure from the computer-based supervisory controls business. The firm's Controls division reported a loss last year because of **cost overruns in contracts having a high engineering content** and continues in the red. If new management at the Houston operation "can't turn it into a viable business with a reasonable profit level," says Ruben F. Mettler, president and chief operating officer, "then we'll do one of two things. We'll either stop taking new orders and finish out on what we've got, or sell the business to someone else who wants it."

While Mettler has not set a date by which the producer of electric utility monitoring and control systems must turn profitable, he says, it could be as much as a year before the division's fate is sealed. "We think we'll roughly break even in 1977. We're in a wait-and-see-and-scrutinize mode," he adds, "and working the problem very hard."

AMD adding parts to 2900 family as it eyes 8748

Advanced Micro Devices Inc. is busily filling out its 4-bit microprocessor family, the industry standard bipolar 2900. It will soon introduce the first in a series of main program controls, Am 2930 through 2934. This will be followed in late summer by the Am 2910 microprogram control unit, with a 12-bit CPU slice, the Am 2903, due by late in the year.

In MOS, the Sunnyvale, Calif., firm plans not only to make and market an alternate to Intel Corp.'s 8948 single-chip microcomputer [*Electronics*, March 17, p. 17], but president Jerry Sanders says that AMD **intends to second-source Intel's 8748**, a version with an 8,192-bit programmable read-only memory that's erasable by ultraviolet light. Says Sanders, "We are avidly following the nonvolatile read/write memory technology and are developing a 16-k, 5-volt erasable-PROM technology that is required to make the 8748. We have every intention of making it."

Phillips testing part of 140-Mb/s optical link

Researchers at Philips Gloeilampenfabrieken in the Netherlands are currently testing the first part of an optical communications system that will ultimately consist of a 10-mile-long cable containing six glass fibers, each with a transmission capacity of 140 megabits per second. **The experimental system is scheduled for completion next year.** In similar experiments, GTE Laboratories in the U.S. is working with a 100-MB/s system, Britain's Standard Telephones and Cables has a 140-MB/s trial scheduled, and Nippon Telephone and Telegraph is working on an 800-Mb/s link.

In Philips's current tests, in which signal transmissions are over a 3.5-

mile-long single-fiber cable, the researchers are using a semiconductor laser light source that is “about the size of a grain of sand” and is thus comparable to the fiber’s diameter. The experimental lasers used in the tests are built up of mixed-crystal layers of aluminum-gallium-arsenide on a gallium-arsenide substrate and have an average life of about 20,000 hours. The Dutch company expects that it will “soon” be possible to achieve a life of 100,000 hours—a life it considers the minimum for an optical communication system.

Sanders develops YLF laser that operates at 0.85 μm

A solid-state laser that operates at a wavelength of 0.85 micrometer could find its way into a wide variety of commercial and military applications that now use ruby, neodymium-doped YAG, or gallium-arsenide lasers as the illuminator or light source. The lithium-yttrium-fluoride laser, developed by the Defense Systems division of Sanders Associates Inc., Nashua, N.H., is doped with erbium and **requires less power and is faster than other solid-state lasers.** For example, Sanders engineers say, the unit can operate at 10 to 30 hertz, some 900 times faster than pulsed ruby lasers, and while a system incorporating a ruby laser illuminator might require 200 joules of power, the unit would need only 10 joules.

The laser has been successfully tested as a flashbulb in long-range photography and could also be used in commercial holography systems. Military applications include surveillance and target acquisition. The 0.85- μm wavelength was chosen to match it well with silicon and infrared film detectors, but other dopants have been used to make the YLF material a good illuminator for systems operating at from 0.48 to 2.9 μm .

Japan gets first video disk set

Japan’s first video disk player has been put on sale by the General Corp. at a retail price of \$540. **It is based on the AEG-Telefunken TED unit** made under license to the German firm, but operates at the NTSC standards used in Japan rather than at the European PAL standards.

The player is designed for horizontal loading of the disk, with a selection button that can order repeat, rapid advance, and rapid reverse while the picture is being viewed. Two channels of audio are provided on separate subcarriers. Several Japanese companies are making disks for the player.

Addenda

Jeffrey C. Kalb is moving from National Semiconductor, where he was responsible for design, development, and manufacture of MOS and bipolar memories, **to become general manager of the Semiconductor division of Data General Corp. . . . Radio Shack will throw the retailing muscle of its 6,000 stores into the home-computer market. It plans to introduce a machine of its own design and construction reportedly built around a Zilog Z-80 microprocessor chip.** It will sell for about \$800 and includes a cathode-ray tube, 4,000 bytes of memory, a typewriter-style keyboard, and a cassette interface. The first batch is to be made next month. . . . Japan’s Toko Inc. and Mostek Corp. have agreed to make Toko a second source **for Mostek memory products** and other selected MOS LSI circuits. . . . The first crop irrigation system in the U.S. powered by solar photovoltaic cells will go into operation this summer in Nebraska. Designed by the MIT Lincoln Laboratory, the system will generate 25,000 watts peak power to drive a 10-hp pump.



Introducing the hungry ECLIPSE.

Data General's new ECLIPSE S/130 computer has a bigger appetite for work than any other mid-range mini. And enough speed and versatility to wolf down any kind of data you have to dish out.

The hungry ECLIPSE computer is built around the same powerful architecture as our super high-speed ECLIPSE S/230. Added to that is a host of special features that make the hungry ECLIPSE unique. Like our fast micro-coded floating point and efficient character string instruction sets. And our second-generation WCS general-purpose user microprogramming ability that results in unmatched throughput in demanding applications. To top it off it also includes AOS, our amazing new heuristic multi-programming advanced operating system, and of course the full range of Data General's economi-

cal big-computer peripherals, software and worldwide support.

Now, you don't have to skimp along with an undernourished mini that's too limited for your work. Or splurge on one that's too fat just to get the performance you need. Just order an ECLIPSE S/130 computer. It will make your work load a lot leaner. Want more food for thought? Send for our brochure.

- Send your S/130 brochure.
 Send your S/130 brochure and have your sales representative call.

Mail to: Data General, Westboro, MA 01581

Name _____

Title _____

Company _____

Address _____ Tel. _____

City _____ State _____ Zip _____

ECLIPSE is a registered trademark of Data General Corporation.
 © Data General Corporation, 1977

Data General
 It's smart business.

Circle 37 on reader service card

Data General, Westboro, MA 01581, (617) 366-8911. Data General (Canada) Ltd., Ontario.
 Data General Europe, 15 Rue Le Sueur, Paris 75116, France. Data General Australia, Melbourne (03) 82-1361.

World Radio History



GI introduces Stereomega. A new life style in Hi-Fi Tuning.

Digital tuning is rapidly becoming the "in thing". On television sets. Auto radios. Personal communications equipment. And now, Hi-Fi stereo.

General Instrument Microelectronics introduces Stereomega, the economical approach to phase-locked tuning in cost-competitive Hi-Fidelity equipment.

Stereomega offers your stereo line these "life style" advantages. Precise phase-locked loop tuning. Remote control. Push button control with preprogramming of up to ten favorite AM and FM stations. Search and scan modes to permit your customers to select across the dial. And easy-to-read digital display of station frequency.

That's not all. Through the use of the exclusive General Instrument EAROM, Stereomega remembers stored program information when the power is off.

After sound quality and reliability, convenience and special features are frequently cited by consumers as their reasons for selection of a particular Hi-Fi brand. Stereomega

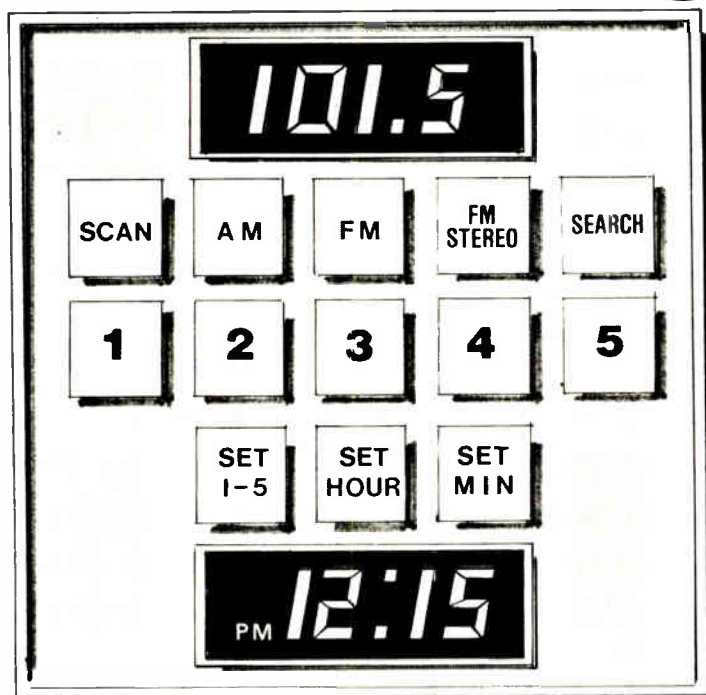

gives your product the convenience and special features to make it stand out in the crowd. No more guessing about station selection on a hard-to-read rotary or slide rule dial. With Stereomega, frequency is clearly indicated digitally. And, through the use of the EAROM memory, the set owner can return to the same optimum tuning point every time.

In addition to all these features, the Stereomega

system offers optional remote control and digital clock to further differentiate your Hi-Fidelity system from your competitors. No matter how you look at it, Stereomega is a microelectronics package your equipment can afford...and your customers can't afford to be without.

Just as GI's Omega and Economega microprocessor-controlled tuning circuits bring a new life style to TV viewers, so will Stereomega change the life style of Hi-Fi buffs.

If you'd like to make your products more competitive, write or call. General Instrument Microelectronics, 600 West John Street, Hicksville, New York 11802. Tel: (516) 733-3107.

We help you compete.

**GENERAL INSTRUMENT CORPORATION
MICROELECTRONICS**



7 trimmers handle 95% of your applications.

Single-turn

With these industry standard cermet trimmers, you're assured design versatility, high quality, and fast delivery.

Just decide what you need regarding: (1) single- or multiturn; (2) sealed or not; (3) size; (4) resistance; (5) pin spacing; and (6) price.

Then call your local Beckman Helipot distributor for *free* evaluation samples. To get his number, or immediate technical literature, call (714) 871-4848, ext. 1776. See how fast and easily you can solve trimmer problems.

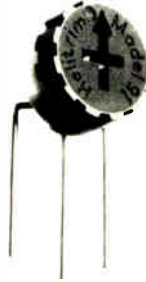

Model 91

- High quality — low price
- Unique brush contact
- Excellent setability
- Protective dust cover
- Top or side adjust
- Standoffs prevent rotor binding, permits board washing
- Small 3/8" dia. size



Model 72

- 3/8" square
- Sealed for board washing
- Available in flame-retardant SEO housing
- Top or side adjust
- Brush contact
- Excellent setability
- 2 ohms of end resistance



Model 82

- 1/4" dia. by 0.150" max. height
- Sealed for board washing
- Flame-retardant SEO materials
- 82P — top adjust; 82PA — side adjust
- Brush contact for excellent setability
- Resistance range: 10 Ω to 1 meg Ω

Multiturn

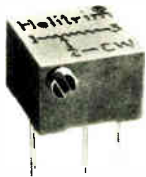

Model 64

- Miniature, sealed
- 22 turns of adjustment
- 0.25 watt at 85°C
- Resistance range: 10 Ω to 1 meg Ω
- 1/4" square for tight P.C. board packaging
- Unique brush contact
- Adjustability — voltage ratio within 0.01%

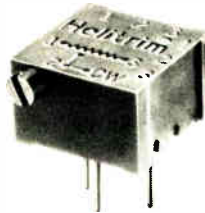

Model 68

- Low-cost
- Sealed for board washing
- 18 turns for adjustment accuracy
- 3/8" square housing
- Brush contact
- 3 pin styles for efficient packaging
- Broad resistance range: 10 Ω to 2 meg Ω
- Operates with 1/2 watt at 25°C

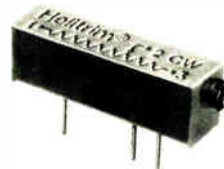

Model 89

- Our lowest cost multiturn
- Sealed for board washing
- 3/4" rectangular, 0.250" high
- 15 turns for accurate adjustment
- 7 pin styles for mounting versatility
- Panel mount available
- Resistance range: 10 Ω to 2 meg Ω

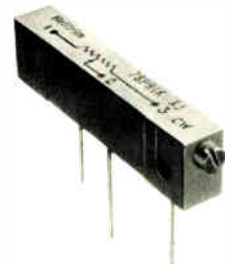

Model 78

- Military performance, industrial price
- 1 1/4" rectangular, 0.195" wide
- Sealed
- 3 terminal styles: flex leads, P.C. pins, solder lugs
- Power rating: 0.75 watt at 70°C
- 22 turns of adjustment
- Resistance range: 10 Ω to 2 meg Ω

BECKMAN®

HELIPOT DIVISION

Japanese show off liquid-crystal television screen

Flat panel from Hitachi could find its way into portable TV about the size of a hand-held calculator in two to three years

An experimental black-and-white television screen made of liquid crystals is displaying off-the-air broadcasts in Tokyo. Engineers from Hitachi Ltd., which built the 6-inch-diagonal screen, say the goal is to market in two or three years a pocket-size TV roughly the size of a hand-held calculator.

Hitachi concedes that its present design requires more work. For example, although it has an adequate number of 16 contrast steps, the contrast ratio of between 10:1 and 20:1 still needs improvement. So does the liquid-crystal response time of 200 milliseconds. It is not fast enough to keep up with fast-moving scenes. However, the screen seems free of light or dark lines from driver or display defects.

The screen is a thin layer of twisted nematic liquid crystal between two 3-millimeter-thick glass plates with transparent electrodes. The display is 120 mm wide by 90 mm high. Its case is 195 mm high by 245 mm wide and only 40 mm thick.

Polarizing filters are on both sides of the panel. Behind the rear filter is a light source to ensure that the display can be viewed even with low ambient illumination. The light could be replaced by a mirror in well-lighted rooms or outdoors. The display itself, driven by low-power complementary-metal-oxide-semiconductor integrated circuits con-

sumes only about 10 milliwatts. The remainder of the TV, including audio output, draws about 5 w, but this could be reduced, Hitachi says.

The panel has 8,938 elements—82 vertically by 109 horizontally. They display every third horizontal line in each transmitted field, sufficient resolution for a TV screen this small. As in other displays of this type there is slight vertical jitter because the same picture elements are used for both vertical and horizontal fields, but it is not apparent.

The panel is driven with balanced 15-volt unipolar pulses, having a dc, or average, value of zero in a

method first described by Hitachi engineers last October. Operation between half-select and full-select levels gives fast response with low crosstalk. In the television display, half-select is still black and full-select is maximum white. But the width of the pulse between these two levels is modulated to give 16 levels of white in accordance with the video signal at each picture element. Gamma-correction circuitry makes the steps appear equal.

U.S. effort. In the U.S., Hughes Aircraft Co., working with the Air Force, demonstrated a smaller liquid-crystal TV display more than a



LCD. Display area of liquid-crystal TV screen from Hitachi is 120 mm wide, 90 mm high. It is 4(1) mm thick. Picture elements are selected by matrix-addressing technique.

year ago [*Electronics*, Feb. 19, 1976, p. 29]. At present, Hughes has a 1.75-inch-square display with an array of 175 by 175 picture elements. By butting four of these together, it expects to have an array with 350 by 350 elements by the spring of 1978.

The major difference between the Hughes and Hitachi displays is that Hughes builds its liquid-crystal elements on a silicon wafer that serves as the backplate and in which one transistor is integrated to drive each picture element. This assures higher

maximum brightness and, thus, higher contrast ratio. Maximum voltage is not limited by half-select voltage, which must be below threshold voltage. Hitachi's system appears to be simpler because it uses a conventional glass and liquid-crystal sandwich, plus a matrix addressing scheme. Like Hughes' panel, Hitachi's has an inherent continuous gray scale—but the analog-to-digital converter and memory circuits in the prototype quantize brightness to 4 bits, or 16 levels of gray. □

TI programs high-end calculators with plug-in read-only memories

A new wrinkle to storing programs in Texas Instruments' programmable calculators boosts the number of program steps that can be handled by a factor of 20. In a new top-of-the-line model for business and scientific applications, called the TI Programmable 59, plug-in program libraries are stored in cube-like plastic-cased semiconductor read-only memories that contain 40,000 bits. The 59 uses the ROM plug-ins in conjunction with the same type of narrow, 3-inch-long magnetic program strips that slide into the side of TI's SR 52 and SR 56 calculators,

More storage. Programmable 59 professional calculator provides up to 5,000 program steps; older unit has 240.



which the company is phasing out.

The TI 59 will be available in June for \$300 list, about \$50 more than the SR 52. Also coming is a smaller-capacity TI Programmable 58 which, at \$125, is \$30 more than the SR 56.

Partitioning. Both the new models have a partitioning feature borrowed from computer design. The TI 59, for example, can be partitioned with up to 960 program steps or up to 100 memory registers; every change of 10 memory registers affects 80 program steps. With the ROM plug-in and its single p-channel metal-oxide-semiconductor chip containing 5,000 by 8 bits, the calculator provides up to 5,000 program steps; the older SR 52 with its magnetic strip allowed only 240 steps. The TI 58 operates without the magnetic strips and can be partitioned with up to 480 program steps or up to 60 memory registers.

The advantage of this partitioning is that the calculator can be tailored to suit the problem, points out TI's Peter Bonfield, manager of professional calculators at the U. S. Calculator Products division in Dallas. For example, short problems with many numbers need more memory than program steps, while complex problems with few variables need more program steps than memory.

Programs in the plug-in ROMs— they come in a plastic housing;

measuring about 5/8 by 3/4 by 1/4 inch—can be addressed from the calculator's keyboard or inserted as subroutines in other programs developed by the user. This is much more convenient than with the older calculators, which may require a user to run through several magnetic strips. Contents of the modules cannot be altered, although to develop a new program, the user may record up to 960 steps of it on a pair of those magnetic strips.

The TI 59 is sold with a master library program cube that helps solve problems involving such things as matrix inversion and simultaneous equations. Other program libraries available from TI cover such areas as statistics, real estate and investment, marine navigation, and surveying.

For hard copy, the calculator can be mated with a \$200 thermal printer-plotter. The printer also operates a "program prompting" feature that takes the operator through each step of a program via printed-out instructions.

Competition. Compared with its main competitor in the market for the high-end calculator with software—Hewlett-Packard Co.'s \$450 HP 67 and \$750 HP 67 printer version—TI has gone way ahead in numbers of program steps and memory registers, and price. Also, the TI 59 has six levels of subroutines, compared to two levels in the HP 67. Both TI machines use the algebraic operation system, rather than reverse Polish notation. □

Military

High-speed facsimile handles gray scale

Higher-speed facsimile machines appeal to the U. S. military as much as they do to private companies envisioning the coming of electronic mail. But the armed forces want even more spectacular performance. They are funding preproduction models of a digital facsimile machine that can send and receive data covering a 8 1/2-by-11-inch page in 15

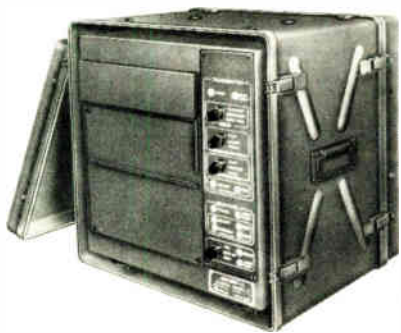

Fast picture. Facsimile machine from Litton's Datalog division will weigh in at under 75 lbs, transmit photos as well as text.

seconds using a rate of 16,000 bits per second. Unlike the commercial high-speed digital facsimiles, the under-75-pound units can transmit up to 32 shades of gray, though it will be specified at 16.

The latest commercial unit, introduced recently by 3M Co. [*Electronics*, April 28, p. 34], transmits a similar page size in 20 s at 9,600 b/s. But the 3M machine is a floor console weighing 325 lbs with no ability to discriminate gray scale. "There's nothing in the commercial market that comes close to [our] machines," says William D. Beebe, acquisition manager at the Naval Electronics Systems Command in Washington, D. C.

New contract. Navelex is the developing agency for the Tri-Services Tactical Communications Command (Tri-Tac), which wants the digital facsimile machines, the first ever for tactical applications. It recently awarded a \$7.6 million full-scale development contract to Litton Industries Inc.'s Datalog division in Melville, N. Y. [*Electronics*, April 14, p. 36]. The pact calls for delivery around July, 1979, of test hardware that uses a helium-neon laser as the light-source for both scanning and recording.

The machines can transmit over voice-grade phone circuits and high-frequency radio and could operate on Tri-Tac's upcoming 32,000 b/s tactical digital-communications network.

The performance of the Datalog machines will enable the services to

replace their older 3-to-6-minute, 250-lb. analog units, now used only for weather chart transmissions. But the big change will come in replacing teletypewriters. "The transmission speed of digital fax will enable one fax device to replace many of today's TTY machines," says George Constantinou, an engineer in the Army Electronics Command's Communications Laboratory at Fort Monmouth, N. J.

One machine at 16 kb/s transmission "would replace 10 teletypewriters transmitting at 60 words per minute and 19 teletypewriters preparing tape messages at 30 w/min," he says. According to Datalog president David Spencer, the equipment uses a proprietary data-compression algorithm that provides improvements in transmission time of 7 to 1 for typical text documents and 3 to 1 for photos.

The biggest user of the machines is expected to be the Army, which is reconfiguring its procedures for records traffic. "With the digital ma-

chines," Constantinou says, "we can eliminate skilled operators for transmitting the messages and preparing punchpaper tapes, as well as eliminate human error and people." Of greater importance, he adds, "we need much less time to send messages, and they're easier to encrypt automatically." The Navy will use the machines initially for transmitting weather charts, while the Air Force will use them for photos and the Marines for both record traffic and maps.

The Navy's Beebe looks for applications to grow swiftly "once we get the first systems out into the field. Then everybody will be coming up with requirements." The Datalog machines, he adds, "will become as popular as the Xerox [copying] machine." Beebe won't confirm it, but the initial production order could be for about 1,000 units, at a cost of about \$13,000 each. "We'll need at least several thousand throughout the military," Beebe says. "But we won't be able to nail down the total

Laser, photographic paper combine

Validation tests of new tactical digital facsimile equipment, now in full-scale development at Litton's Datalog division, have shown that the combination of laser beam and electrophotographic paper can produce more than 16 shades of gray, according to Army and Navy spokesmen. Paper fed into the equipment is illuminated by a focused laser beam scanned by a galvanometer. The diffuse light reflected from the copy is detected and converted to an analog electrical signal which is then digitized and processed by data-compression logic.

Compressed data is then transmitted over digital communications lines. Upon arrival at the receiver, it is expanded by the receiver's decompression logic and converted back to an analog electrical signal. The signal is then used to modulate the light intensity of a recording laser beam. The modulated beam serially exposes electrostatically-charged photosensitive paper, which is then toned, heat-fixed and cut to produce a hard-copy facsimile of the original document.

The laser scanner was chosen over solid-state scanners (both charge-coupled-device and metal-oxide-semiconductor) because the latter are but 1,728-element units providing a 200-line-per-inch resolution across an 8 1/2-x-11-in. page. "That's pushing at the limit of that technology for the resolution we require in our equipment," says Datalog president David Spencer. With the laser, he adds, "we can easily get 2,000-lines-per-inch resolution, and we're operating well within that technology's limits."

Electrostatic image-forming was chosen for the recording technology as an alternative to dry silver paper recording, Spencer notes. One reason, he says, is that the electrophotographic paper "is quite inexpensive, with a cost that's close to bond paper." But perhaps more importantly, the dry silver paper failed to meet the high-temperature storage requirements needed in a tactical environment.

number until the early 1980s when people have seen what the machine can do and have determined their requirements."

In the interim, Datalog is developing the first two models in what is expected to become a family of tactical digital facsimile equipment, designated AN/UXC-4. One model, the Tactical Record Traffic Facsimile, is a half-duplex transceiver for documents up to 9 inches wide and

of any length. It provides nominally black-and-white copy (2 to 4 shades) with resolutions of either 96 or 144 lines per in.

The second unit, the Tactical Facsimile, or Tacfax, is a full-duplex transceiver with resolutions of 96 or 192 l/in. explains Spencer. Again using a proprietary Datalog technique, Tacfax will provide as many as 16 shades of gray on relatively cheap electrophotographic paper. □

Solid state

General Electric process speeds doping of power semiconductors

General Electric Co. has discovered a much faster technique for adding doping impurities to silicon wafers. Since the approach also promises to reduce fabrication temperatures and increase process yields, the development could turn into one of the most significant advances in the production of semiconductor components.

Power semiconductors are the first to benefit. GE already has "several devices in the field as 'specials' on test with one of our customers," says Lyman Johnson, manager of the properties branch in the Metallurgy Laboratory at the GE Research and Development Center in Schenectady, N.Y. These are power modules consisting of pairs of silicon controlled rectifiers that had been delineated during manufacture by isolation grids made by what GE calls its thermomigration process.

"Right now there are plans for a couple of new products by the end of 1977 or early 1978," says John Hey, manager of GE's power components operation at the Semiconductor Products Group in Auburn, N. Y. "Under consideration are power modules in bridge or doubler configurations and discrete thyristors and diodes." According to Hey, the company is committing considerable resources to the product development.

Invented by Thomas R. Anthony and Harvey E. Cline, the process begins with aluminum being vapor-

deposited through masks on one side of a silicon wafer and the other side then being heated with a radiant heater. The temperature gradient then forces a liquid alloy of silicon and aluminum to migrate through the silicon to the hot side. "If you start with n-doped silicon, the result is a pn junction that goes vertically through the wafer," Johnson explains. "It's good for things like an isolation grid or other buried structures."

Only minutes. The isolation process takes about 10 minutes, a thousandfold improvement over doping in conventional diffusion furnaces, he says. It is carried out in air at atmospheric pressure, with migration occurring at anywhere from 900°C to 1,200°C. "We're doing it in a simple piece of equipment, with a heat source at one side of the silicon," he says. "The critical part is controlling the temperature gradient through the thin wafer." The "cold" side is cooler because it is further from the heat source, and its temperature depends on the normal heat transfer coefficient of the silicon.

At present, the process has been running at 1,100°C, about 100°C less than the temperature normally used. In addition, thicker and hence stronger wafers can be used because the dopant will penetrate much more deeply than the 2 to 3 mils of the conventional approach. "We've even done it several inches deep, through

a silicon ingot," Johnson says.

GE has migrated gold, gallium, tin, and other materials. But apparently none of them is as useful as aluminum.

Applied to present devices, the process offers exceptional advantages, says Johnson. Because the wafer is processed so quickly and at a lower temperature, quality improves and yield goes up. "It also gives a higher breakdown voltage, over 1,200 volts in about a 60-ampere device," he adds. "Usually, we get maybe 10% of our devices at this voltage. Now we get more."

The technique may also lead to cheaper packaging, he says. The narrow junctions on the surface of the wafer could be passivated with a glass film, so that the entire unit could be put in plastic packages without hermetic sealing. Before finally adapting its new process to commercial devices, GE first needs to learn more about its reliability, Johnson says.

The technique may even prove

New wafers. Doping technique that General Electric's Thomas R. Anthony helped develop was used to delineate hexagonal boundaries of silicon controlled rectifiers.



We're the industry's Hi-Rel leader, the pace-setting innovators.

Our position as industry leaders in the Hi-Rel area is due to our unceasing dedication and innovation in synchro conversion technology whether in meeting the precision demands for ruggedness in MIL spec requirements or the high-level needs of designers for tough, enduring industrial applications.

Never content with synchro conversion "as is", we were the first to modularize bulky rack-size equipment, the first to introduce thick-film hybrid synchro converters and the first to apply both thick-and thin-film technology to this, our major area of activity . . . synchro conversion.

The result is the broadest line of high-quality S/D and D/S products available anywhere. Products that use MIL-grade components throughout . . . products that achieve MTBF ratings in the hundreds of thousands of hours.

From our offerings, you can select whatever you need from single-channel, single-speed modules to the most sophisticated multiplexing converters ever developed. These are complemented with a full array of test instrumentation, building blocks, amplifiers, translators and every other

device in high-performance synchro conversion all the way through to complete systems.

If you're into data conversion, you are entitled to a free copy of our SYNCHRO CONVERSION HANDBOOK. This is the most complete, authoritative work on the subject that was ever compiled. Its 96 pages are filled with drawings, tables, illustrations and references that will be invaluable to you in your work. If you don't own a copy of this invaluable reference manual, get yours today. Just drop us a line on your company letterhead!



ILC DATA DEVICE CORPORATION

A wholly owned subsidiary of ILC Industries, Inc.

ILC DOVER is the sole designer and manufacturer of the Apollo 13, 14 and Shuttle



Airport International Plaza/Bohemia Long Island, NY 11716

(516) 567-5600 TWX 510-228 7324

West Coast: 7337 Greenbush Ave., N. Hollywood, CA 91605 • (213) 982-6454

Interested engineers, write or call Harry Lewis or request data sheets.

DDC - world's leader in synchro conversion



Circle 45 on reader service card

World Radio History

revolutionary. "We think its long-range impact will be to let us make new devices never made before," Johnson predicts. "They won't just be planar, for now the designer can

think in all three dimensions. In principle, signal and digital circuits could some time in the future be integrated with power devices on the same semiconductor chip." □

Very-large-scale integration at TI is industry's most ambitious effort

Texas Instruments Inc., the world's leading supplier of semiconductors, has embarked on its most extensive development program in its 30-year history. Costing millions of dollars annually, the program's three-year goals are a hundredfold improvement in computing power over what is possible with digital circuit technology today.

The program's milestones are the most ambitious in the industry: a 16-bit microcomputer with 4 kilobytes of memory on a single chip and a 65,536-bit random-access memory by 1979-80; a 32-bit computer chip with 4 to 8 kilobytes of memory and a 262,144-bit RAM by 1982-83. Also on the agenda are million-bit bubble memories and half-million-bit charge-coupled-device memories.

Goals such as these put TI in a technological competition with the Japanese, whose government-sponsored very-large-scale-integration

program involving five major electronics companies is aiming at megabit memories, 50,000-gate integrated circuits, and powerful new small- and middle-level computers by 1981. Such memory and logic components and micro- and minicomputer systems are just the territory that TI has staked out for itself as natural areas for development.

The company's VLSI program in Dallas, under the direction of H. Dean Toombs, vice president of technology, and Turner Hasty, manager of semiconductor R&D, includes all phases of semiconductor manufacturing: materials, processing, circuit design, wafer production, and IC package assembly.

For wafer fabrication, major emphasis is on obtaining fine-line patterns and reducing defect densities. For fine patterns, TI is developing its own vector-scan electron-beam system for projecting circuit

patterns directly on a wafer. It is also using the technique of manufacturing LSI masks with electron beams and then using photolithograph projection to fabricate the wafers. Slower and with less resolution than scanning on the wafer, this process has been used by TI for 4,096-bit and 16,384-bit RAMs for about two years.

Company planners are betting on electron-beam vector-scan projection, together with dry plasma etching and computer-controlled processing, for getting the 2-micrometer circuit dimensions and 500-angstrom junction depths needed for production VLSI wafers in 1980. The company already has several vector-scan projection machines working around the clock in prototype areas.

These systems, which scan first one complete circuit pattern before stepping to the next, can fabricate full wafers in 15 minutes. Most important, they appear to be within reach of achieving the throughput of 6 minutes per 4-inch-diameter wafer required for high-volume production. At the same time, a defect-reduction program is aimed at reducing wafer defects by factors of three to six over today's best levels and allowing TI to manufacture increasingly larger digital chips—130,000 to 140,000 square mils.

D-MOS and 1^2L . As for denser device structures, over the next few years TI may move from standard n-channel, silicon-gate metal-oxide semiconductors with depletion loads to fully implanted double-diffused MOS with micrometer-length channels. These double-diffused transistors shrink the size of a digital element (gate or bit) by two to three times and reduce power dissipation by about the same factor. Such improvements are essential for building the big 100,000-element chips that TI plans for 1980.

The firm is also moving swiftly into bipolar VLSI production. Using dry etching and oxide isolation, it has developed a walled-emitter inte-

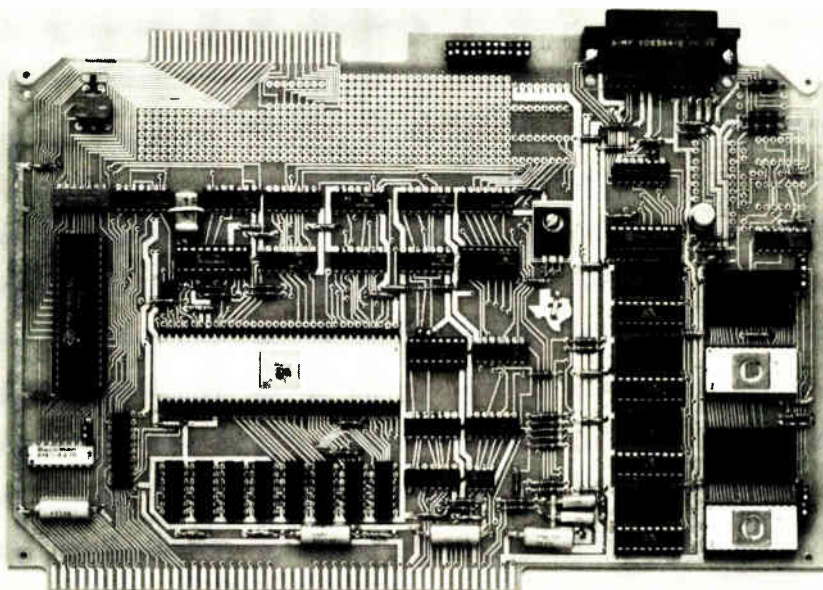

Shrinking. With VLSI, processing capability of recently introduced 16-bit TMS990/100M microcomputer will fit on a single chip.

SORENSEN IS THE SOURCE.

FOR MODULAR SWITCHING POWER SUPPLIES.

Check our standard features:

- 10 models, 1.8V to 56V with power levels ranging up to 225 watts.
- 115 / 220 Vac input by external barrier strip change.
- 50 / 60-Hz operation with no derating.
- Logic shutdown for system applications.
- Extra long hold-up time.
- Low ripple & noise through use of double-stage filtering.
- Wide-range output voltage adjustment.
- Built-in adjustable overvoltage protection.
- Superior line and load regulation.
- Internal adjustable current limiting.
- UL component recognition.
- High power-to-weight ratio.
- 20-kHz switching.
- Size (in.): 3.313. 5.125. 9.500.
- Immediate delivery.
- Made in U.S.A. of quality components.
- Five-year warranty, backed by worldwide service organization.

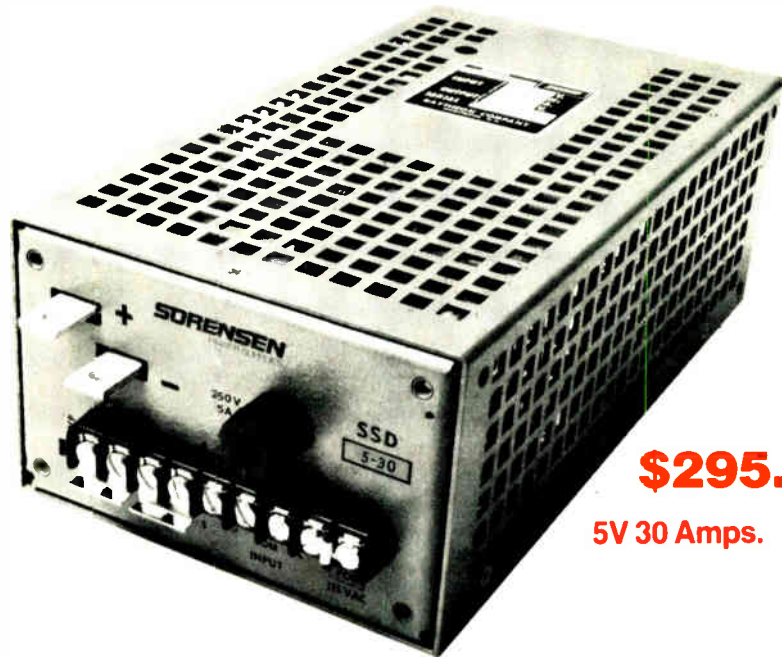

\$295.
5V 30 Amps.

Check our specifications:

AC Input Power: 98 Vac-132 Vac, 187 Vac-250 Vac.

Frequency: 47-63 Hz single phase. 360-440 Hz (double rms Ripple spec.) *No derating.* Voltage selectable by a single link on the front panel.

Voltage Regulation: Line: 0.03% over full AC input range.

Load: 0.03% for zero to full load.

Voltage Ripple: Typical 2m V rms, 20mV pk-pk (20Hz to 20 MHz).

Max. 5mV rms, 50mV pk-pk (20Hz to 20MHz).

Temperature Coefficient: 0.01% max. per °C.

Stability: 0.05% max. for 24 hours after warm-up.

Transient Response Time: Output voltage returns to within 1% in less than 1.2 ms following a step-load change from either 50% to 100% or 100% to 50% of full load.

Overshoot: No overshoot at turn-on, turn-off or power failure.

Hold-Up Time: Full regulated voltage holds up for 40ms after removal of power at full load, and nominal input and output voltages (80ms for half load).

Overvoltage Protection: Built-in adjustable overvoltage protection standard on all models

Efficiency: Up to 78%.

Remote Sensing: Voltage drops can be compensated for up to the max. specified terminal voltage.

Paralleling: May be directly paralleled without derating.

Soft-Start: In-rush current is limited by soft start circuit.

Model No.	Nominal Voltage	Output Voltage Range (Vdc)		Output Current				Price
		min.	max.	@40°C	@50°C	@60°C	@71°C	
SSD2-30	2	1.8	3.0	30.0	27.0	22.5	15.0	\$295
SSD5-30	5	4.7	6.5	30.0	27.0	22.5	15.0	295
SSD9-20	9	6.5	9.5	20.0	18.0	15.0	10.0	295
SSD12-15	12	9.5	13.0	15.0	13.5	11.2	7.5	295
SSD15-12	15	13.0	17.0	12.0	10.8	9.0	6.0	295
SSD18-10.5	18	16.0	21.0	10.5	9.4	7.8	5.2	295
SSD24-8.5	24	20.0	26.0	8.5	7.6	6.3	4.2	295
SSD28-7	28	25.0	33.0	7.0	6.3	5.2	3.5	295
SSD36-5	36	32.0	43.0	5.0	4.5	3.7	2.5	295
SSD48-4	48	42.0	56.0	4.0	3.6	3.0	2.0	295

For OEM discounts call:

Sorensen, (603) 668-4500.

**676 Island Pond Road,
Manchester, NH 03103.**

Circle 47 on reader service card

SORENSEN
POWER SUPPLIES

A Raytheon Company

Electronics review

grated-injection-logic process that is denser and uses less power than its present processes. The 1^2L process is capable of 5-nanosecond propagation delays at 1-milliwatt power dissipation in 4-k and 16-k static RAMs and 16- and 32-bit micropro-

cessors. The firm's present 1^2L production runs at twice the power dissipation at half the speed.

A major cost-reduction program is underway to make 1^2L processing as cheap as MOS processing, while retaining bipolar performance. □

TRW Systems Inc., Redondo Beach, Calif.

The experiment, directed by Herbert Friedman, chief of NRL's Space Science division, is expected to uncover several thousand X-ray sources—quasars, black holes, and the like—that the earth's atmospheric shield prevents ground-based systems from detecting. Moreover, Laxray will pinpoint these sources within one tenth of a degree even though some may be as far away as several billion light years, Friedman says.

The instrument will track X rays between 1,500 and 20,000 electronvolts. It has seven proportional counter modules—an array of six on one side of the spacecraft and the seventh on the opposite side to act as a "rear-view mirror." Four modules in the array, each with a viewing area of more than 5 square feet, will aim at the same point in space, while the remaining two will be slightly offset in a scheme for locating sources.

Each counter module is 6 inches deep, contains three detector layers of gas, a blend of xenon and methane, and is covered by a Mylar window 0.1 mil thick. As the spacecraft surveys the universe, completing one end-over-end rotation every 30 minutes, photons will penetrate the thin Mylar and enter the gas counter. Depending on its energy, each photon will pass through one or more of the three gas layers. The unit will count it and measure the X-ray pulse amplitude, as well as its spectrum and flux. Low-energy background X rays will be absorbed in the first layer of gas.

Two assemblies in the Laxray package will keep track of the detectors' survey. Thus, when the first six-month survey is complete, scientists may go back to a specific source of

NRL's Laxray. The largest experimental instrument ever placed in orbit will be the Naval Research Laboratory's large X-ray survey experiment, scheduled for a June 30 launch aboard NASA's High Energy Astronomy Observatory. Shown are four X-ray detector modules containing a xenon-methane gas and covered by 0.1-mil Mylar.

Space

NASA astronomy satellite to search space for X-rays with half-ton detector

Earthbound astronomers, frustrated by the planet's atmosphere, look forward to enhancing their understanding of one of the most intriguing mysteries of the universe—the origin and workings of space X rays—following the June 30 launch of the largest space instrument ever put into orbit. It is the half-ton, large-area X-ray survey experiment known as Laxray, developed by the Naval Research Laboratory over the past three years at a total cost of

approximately \$7 million.

Laxray will be flown on the first of three High-Energy Astronomy Observatory spacecraft to be placed in low earth orbit by the National Aeronautics and Space Administration from Cape Canaveral. Subsequent launches are set for 1978 and 1979. The \$237 million observatory program—exclusive of launch costs—is managed by Marshall Space Flight Center, Huntsville, Ala. Prime spacecraft contractor is

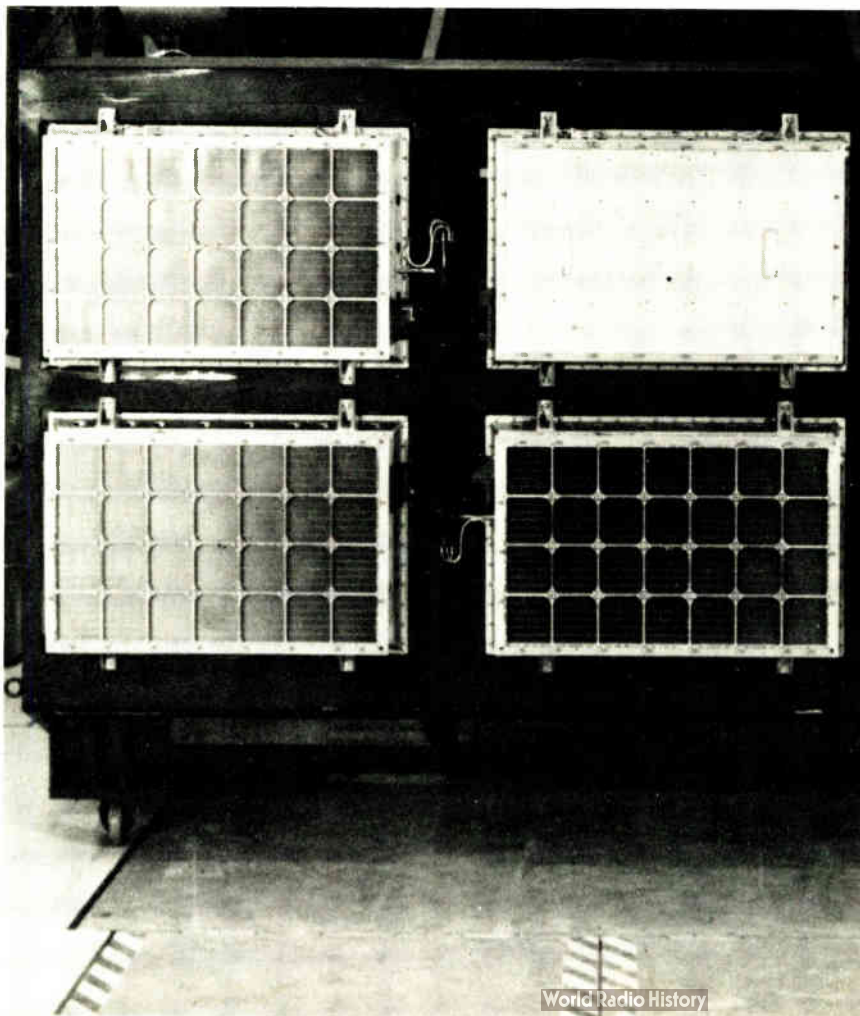

Now you can actually reduce system cost by using our hybrid microcircuit modules.

If you're designing circuits that have to be both cost-effective and high in reliability, it will probably pay you to talk with us.

We've developed a system for condensing circuit requirements into the most efficient hybrid packages possible. And we can help you reduce size and weight as well as manufacturing costs.

Here's how we do it: We design the hybrid circuits, develop the prototypes, manufacture custom components, then assemble, test, and guarantee the total hybrid package. We make both thick film and thin film hybrids. We use hermetically-sealed metal and ceramic packages. And we make custom MOS devices and bipolar chips right here in-house.

We produce hybrid modules in volume quantities at competitive prices, as well as small quantities for product development.

Result: Now you can work with the one company best equipped and experienced to handle your job from concept through production.

We must be doing a lot of things right, because we're one of the leading producers of custom hybrid circuits.

So when it comes to hybrids, call on Hughes. Especially if quality is as important as price. Write for additional information: 500 Superior Avenue, Newport Beach, CA 92663, Att'n. Hybrid Dept. Or call (714) 548-0671, ext. 204.

HUGHES
HUGHES AIRCRAFT COMPANY
MICROELECTRONIC
PRODUCTS DIVISION

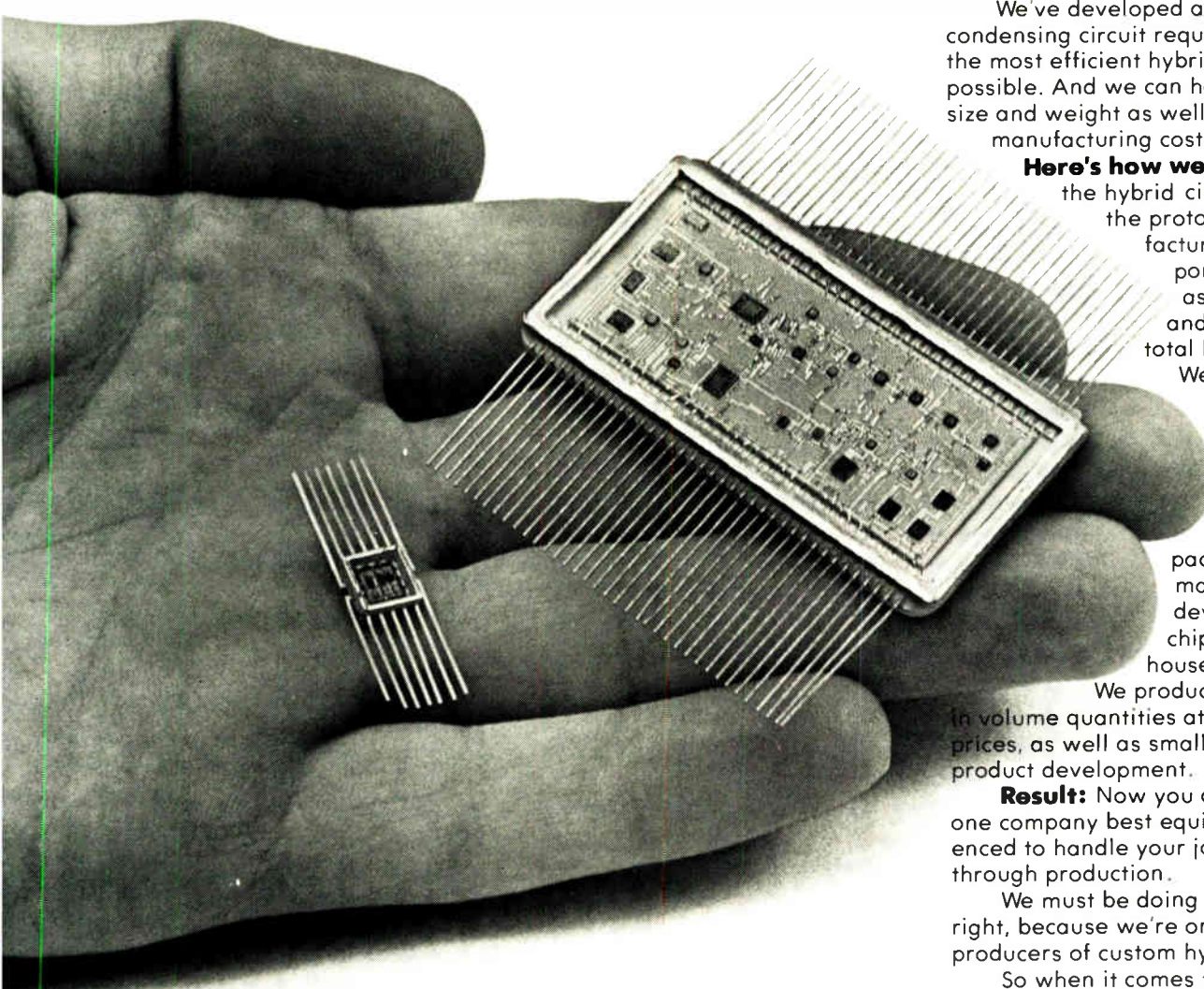
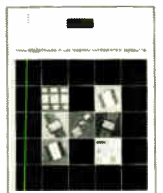

interest and study it in more detail. The observatory should last 12 to 15 months before its attitude-control propellants are exhausted and it begins tumbling out of control.

Data collected by Laxray will be recorded on a 220-min. tape, with data dumps to a ground station at a rate of 2.1 kilobits per second. A higher rate of 128 kb/s is available on ground command when specific sources are examined in real time.

Other experiments on the first observatory spacecraft also concern X rays. One joint project of NASA's Goddard Space Flight Center and the California Institute of Technology will determine the effect of discrete sources, such as radio and visible light rays, on measurement of the emission and absorption of

diffuse X rays in the 0.2 to 60 kilo-electronvolt range. Another project will determine the position, spectrum, time variation, intensity and other properties of hard X rays and gamma rays in the range of 10 keV to 10 million eV, an experiment undertaken by the University of California, San Diego, and Massachusetts Institute of Technology.

Should Laxray measure up to expectations, Friedman hopes that NASA will adopt his lab's proposal to use the experiment aboard the Space Shuttle. He says a second generation Laxray would, among other things, expand the depth of each counter module from 6 to 20 in. and extend the system's capability to measure X-ray sources to 60 keV from the present limit of 20 keV. □

the standard one-piece and relatively long deflection plate.

Tektronix engineers have replaced the dome-mesh and quadrupole-lens schemes with a simple, four-electrode, box-shaped lens measuring 2.5 by 4.2 by 1 inch. Each of the four lens elements is shaped in alternating convergent and divergent geometries. Each also has a biasing voltage of 2,500, 3,000, or 4,200 volts (see drawing) placed on it to correct for such tube alignment defects as distortion, vertical line bowing, and variations in horizontal sensitivity.

The dimensions and operating voltages of the lens are such that, when incorporated into a conventional electrostatic deflection CRT, it magnifies the scan 4.5 times vertically and 4 times horizontally to produce an 8-by-10-centimeter display. Focusing is done with the conventional focus ring and astigmatism controls of 150-to-200-MHz tubes, but bandwidth is about three to four times better, about 500 MHz.

Better beam. With deflection sensitivities and scan size equalized, a CRT using a box-shaped lens for scan magnification shows better beam current and trace width characteristics than one using a dome mesh. With a phosphor-screen voltage of 24 kilovolts, a 3-v-per-division vertical deflection, a 7-v-per-division horizontal deflection, and a beam current of 60 microamperes, the box lens produces a trace width of only 20 to 22 mils, while a mesh lens produces one 30% larger.

There are two reasons for this

Instruments

'Box' lens design being tried by Tektronix in experimental CRTs

Look for the relatively staid world of oscilloscope cathode-ray-tube design to be upset if a new technique for deflecting and focusing an electron beam makes it from the laboratory to production. Engineers at Tektronix Inc. in Beaverton, Ore., have built prototypes of a CRT using a new box-shaped expansion lens that promises to outperform the two most popular focusing devices now in use, the dome-shaped mesh and the electrostatic quadrupole.

According to research design engineer Conrad J. Odenthal, the new technique promises better beam-spot characteristics and linearity, higher deflection sensitivity and bandwidth, and lower distortion at much lower cost, primarily, he says, because of simplified construction.

Background. The movement of a CRT's electron beam is controlled by amplifier-driven deflection plates. But the impedance of the beam deflection plates, which precede the dome mesh or quadrupoles, is inversely proportional to the signal frequency, so that the amplifier that drives them must function over a

wide range of loads. As a result, amplifiers for large-bandwidth oscilloscopes (above 300 MHz) are very difficult to design.

For these reasons, conventional plate systems are not viable beyond 150 megahertz for dome-mesh tubes or 250 to 300 MHz for quadrupole-lens tubes, which have shorter deflection plates and therefore less plate-to-plate capacitance. For frequencies higher than these, transmission-line systems are used which substitute a series of short plates for

In focus. Box-shaped, four-electrode lens is being tried out by Tektronix in research CRTs. Bias voltages on electrodes are there to correct for defects in tube alignment.

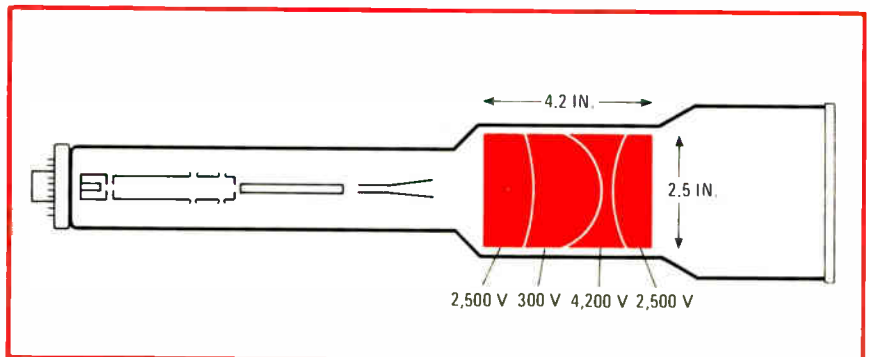

Electronics review

improvement, Odenthal says. The beam intercept and spot defocus caused by the mesh are eliminated, and the box lens is operated at a higher magnification ratio, 4.5 times vs 2.5 times for the dome mesh.

To top things off, the technique appears capable of shortening the CRT by 60%. Also, because it does away with hard-to-manufacture meshes and expensive multi-plate deflection schemes, tube costs would be reduced, particularly at higher bandwidths. However, the company has not announced plans to use the approach in any products. □

Companies

Optel comeback based on displays

Its innovative founder is gone, its gross sales have been clipped sharply, and five years of losses totalled almost \$20 million. But Optel Inc., the company that in 1971 was the first to announce an electronic watch with a liquid-crystal display, is still in business and, according to its president Jerry Heller, is to emerge next month from the protection of Chapter XI of the Federal Bankruptcy Act.

The 39-year-old Heller, who took the reins of the Princeton, N. J., company in February 1976, says the key to recovery was simple—he got Optel out of the watch business and back to what he regards as its basic expertise: display technology. “Our strength is in the chemical end of the electronics business,” he says.

European trip. Within days of joining Optel, Heller was off to Switzerland and Germany to terminate contracts with case and parts suppliers, beginning the process of reducing the company's level of watch production. It was some of these contracts, at prices that proved too high to yield a reasonable profit, that contributed to Optel's undoing. Also playing a role were the problems to be expected when any new technology is introduced into a product. In the process of pulling things

News briefs

Japan agrees to limit color TV exports to U.S. to 1.75 million a year

The proposed White House trade agreement with Japan will limit to 1.75 million the number of Japanese color TV receivers that may enter the U.S. annually for the three years beginning in July. The figure “is not the 1.3 million quota we wanted,” concedes one AFL-CIO official in Washington, “but it's a better compromise than we expected” to be offered. The 1.75 million level—62.5% of Japan's 1976 shipments to the U.S.—will include 1.56 million complete receivers plus 190,000 unassembled sets. Total U.S. color TV imports from all countries last year were a record near-3.3 million sets, setting in motion a variety of petitions for relief by U.S. manufacturers and organized labor before the International Trade Commission and in the courts [*Electronics*, April 28, p. 90].

Prime offers time-sharing system

Prime Computer Inc., the Framingham, Mass., minicomputer manufacturer, has unveiled a time-sharing system built around the firm's Prime 500 central processor. The system can accommodate up to 63 users simultaneously, a capability usually associated with much larger mainframe systems. There are five levels of software packages available with the system, all of which support the Primos V operating system. The packages are not available without the Prime 500 processor, and they range from a computational time-sharing package to an interactive data-processing package that includes Cobol and RPG II. A system that would accommodate the full 63 computational and graphics users sells for \$570,000, substantially less than a comparable System 2050 from Digital Equipment Corp.

ECD Corp. wins personal-computer contract

ECD Corp., the Cambridge, Mass., manufacturer of the MicroMind II personal computer [*Electronics*, Feb. 17, p. 38], has won a nice prize in the microcomputer sweepstakes. Avakian Systems Corp., Glastonbury, Conn., has ordered 1,000 of the machines to use as the basic building block in systems it is developing for use in public schools. The contract is worth \$1.3 million to ECD, a company less than two and a half years old, and deliveries will begin in June. MicroMind II is a fully packaged microcomputer built with the 6512A microprocessor from MOS Technology, it includes analog input/output, vector interrupt, memory mapping and 16,000 bytes of memory.

TI's LCD watches glow with tritium

As expected, Texas Instruments has introduced a line of liquid-crystal display watches but, something of a surprise, the 15 new mens' models all feature constant backlights made of tritium/phosphorus low-level-radiation tubes. The prices range from \$25.95 to \$48.95. TI's line will have both one- and two-tube tritium ampules: phosphorus-coated tubes of Pyrex glass with the radiation material sealed inside to excite the coating and create a glow in the dark. TI has at the same time introduced 45 LED watches.

Data General introduces small-business system

Last week, minicomputer maker Data General Corp. of Southboro, Mass., introduced its CS/40, which is the first small-business system to use interactive Cobol language. The three models in the series are expected to compete with such other machines as IBM's System 32 and 34, the Burroughs 1700, and Digital Equipment Corp.'s small-business systems. Cobol is important because it is probably the primary language used in business data processing and till now has been available only on more expensive machines. The least expensive offering in the Data General series is the C1 with one data entry and display station and various other peripherals for \$33,415. The top-of-the-line C5 can accommodate up to nine data entry and display terminals and sells for \$82,100. All three models use the Data General Nova 3 processor.



“Hey buddy... wanna buy a connector?”

Lots of people will sell you a connector. But a complete interconnection system, with complex or unusual requirements? That's something else. And that's when you should look to Fabri-Tek's National Connector Division. We're one of the few companies that can handle an interconnector system job from start to finish. Design to your specifications, tool up, manufacture, assemble, and service. And nobody beats us when it comes to quality. That's why we've been doing business successfully with many demanding customers in the computer, communications, and defense industries for 20 years.

Whatever shape, size, or material your interconnection system requires — call us. We can be a **real** buddy.

FABRI-TEK INC.
NATIONAL CONNECTOR DIVISION

9210 Science Ctr. Drive • Minneapolis, MN 55428
 (612) 533-3533

Circle 260 Fabri Pak™ back-panel systems Circle 263 Plate connectors
 Circle 261 Flat cable connector systems Circle 264 Teletone connectors
 Circle 262 Molded connectors

World Radio History

TELL ME MORE!

Fabri-Pak™ back-panel systems Molded connectors Plate connectors
 Flat cable connector systems Commercial Telephone connectors
 Military Send literature Have salesman call

Name and Title _____
 Company _____
 Address _____
 City, State, Zip _____
 Telephone _____

We're first on the Buss* (488)

... with programmable D.C. currents and voltages!

Our 501J meets the IEEE 488/1975* interface specs to let your computer, μ p's or programmable calculator call up voltages from $0.1\mu\text{V}$ to 200Vdc or current from 10nA to 100mAdc at speeds to 50μ seconds with accuracy to $\pm 0.005\%$.

Put these NBS traceable values to work checking A/D converters and other voltage or current sensitive function modules — Prices from \$1595. Contact Bob Ross at (617) 268-9696.

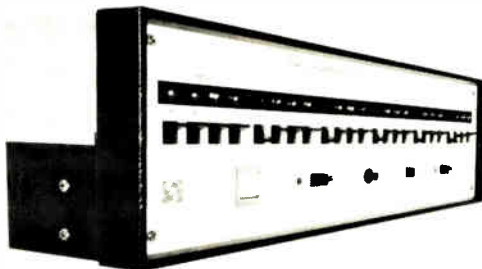

Circa 1982

Electronic Development Corp.

11 Hamlin Street, Boston, Mass. 02127
(617) 268-9696

together, Heller put the company into Chapter XI in June 1976.

Things now are a lot slimmer. From its peak year of 1975 when it took in \$11.9 million, Optel will finish 1977 with anywhere from \$4 to \$5 million—but it is already turning a small profit, says Heller. Its peak employment of 500 has been cut to 120 people. Its debt has been paid off partly in stock, and a remaining \$1 million owed to Chemical Bank and a subsidiary of Mitsubishi International is to be paid off in about eight years.

Sales of its liquid-crystal displays to watch and calculator manufacturers are doing well, according to Heller. "Even though a lot of the watch display business is captive, we'll get our share," he says. But perhaps most important for the company's future, it is concentrating on research and development, just as its founder, Zoltan Kiss, did. For example, it is working on radioactive tritium sources that allow the displays to be seen in the dark, as well as on solar power panels. Heller is also eyeing the electronic-clock market, the automobile industry, portable instruments, and hand-held electronic games.

(Zoltan Kiss, Optel's founder, is still in the liquid-crystal business at Chronar Corp., which he started in Princeton, about a year ago. The company produces custom-designed, low-volume watch modules using LCDs and is working on watches and calculators driven by solar-powered batteries. Chronar did about \$1.5 million in sales its first year and was "nicely profitable," Kiss says.

New displays. Optel is also working on three new types of displays. One uses a pleochroic dye with liquid crystals to orient the dye molecules to a transparent state so that white numerals are formed on a colored background. Another is the electrochromic display, which uses electric current to produce a chemical reaction, changing a colorless liquid to a dark state in the shape of numerals. The third is a fluorescent-backed LCD on which Optel is working as is Siemens in West Germany. □

AT YOUR COMMAND



AIRBORNE RADAR

IAI's combat-proven technologies enable us to offer a wide range of electronic products that help put you in command in the air, on land and on the sea.

S-8600 MILITARY COMPUTER SYSTEM—a high reliability state of the art system designed for use in the field, whether on land, sea or in the air. The S-8600 has a field-proven comprehensive software suite, and is completely modular so that it can be tailored to the user's specific needs. Principal elements include the general purpose digital computer, the unique fixed-head disk storage unit, the CRT terminal, a military line printer and a paper tape reader.

EL/M 2001B AIRBORNE RADAR—a range only radar for single-seat tactical aircraft operating in air-to-air and air-to-ground modes. It rejects heavy ground clutter and remains clutter-free even in very low level air combat. It is readily adapted to a wide variety of combat aircraft as either original equipment or for retrofit.

MABRA AUDIBLE BOMB RELEASE ALTIMETER—a simple to use barometric system which significantly increases bombing accuracy by letting the pilot concentrate on target tracking while receiving audible altitude information to release. MABRA fits most standard instrument panels and consumes minimal power.

ELECTRONIC FENCE SECURITY SYSTEM—converts any wire or chain link fence into a localizing intrusion detector. Activated by pressure or circuit interruption, this low-cost system is fail-safe and false alarm resistant.

AND MORE: Air, sea, and ground surveillance radars, UHF transceivers, computer communications control systems and peripherals, medical electronics and automatic test equipment. We also offer total capability to design and manufacture components and systems to your specifications.

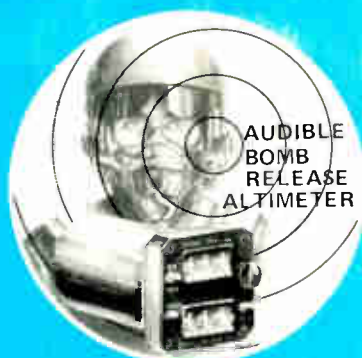

AUDIBLE BOMB RELEASE ALTIMETER



ELECTRONIC FENCE

See us at
Le Bourget
2.6-12.6

Electronics from IAI

Israel Aircraft Industries Ltd.

□ BEN GURION INTERNATIONAL AIRPORT, Telephone: 973111
Telex: ISRAVIA 031102, 031114, Cable: ISRAELAVIA

□ NEW YORK, COMMODORE AVIATION, INC., 505 Park Ave 10022, Telephone: 486-5900

□ BRUSSELS, 50 Ave des Arts, Telephone: 513 1455



The Electronics Book Series offers you:

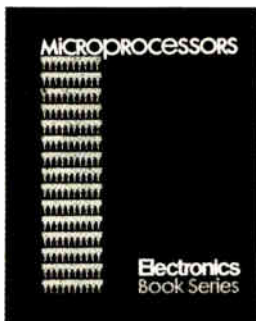

1

MICROPROCESSORS

This book cuts through the confusion, presenting the design and application potential of this exciting technology in a manner that will appeal to the design engineer who needs to know how to use microprocessors as well as the system analyst who must assess the tradeoffs between microprocessors and other techniques to accomplish his system goals.



2

APPLYING MICROPROCESSORS

This new book completes the engineer's transition from the old methods of electronic design to the new world of microprocessor engineering. The book contains the up-to-date and ready-to-use information that every designer needs to know about the new technology.

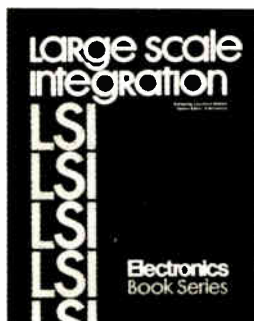

3

LARGE SCALE INTEGRATION

"Large Scale Integration" deals with the entire range of design applications main memory systems, peripheral memories, memory controllers, on-line industrial controllers, data acquisition boards, communication systems, calculators, watches, etc.

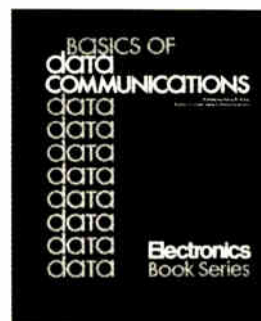

4

BASICS OF DATA COMMUNICATIONS

Chances are you are going to be a part of the data communications market. There's no better place to start than getting a copy of "Basics of Data Communications"—a 316-page compilation of essential articles which have appeared in Data Communications magazine.

Use form below to order your copy. Prices on 10 copies or more, available upon request.

Electronics Book Series

P.O. Box 669, Hightstown, N.J. 08520



- 1 Send me _____ copies of "Microprocessors" at \$8.95 per copy.
- 2 Send me _____ copies of "Applying Microprocessors" at \$9.95 per copy.
- 3 Send me _____ copies of "LSI" at \$9.95 per copy.
- 4 Send me _____ copies of "Basics of Data Communications" at \$12.50 per copy.

Full payment must accompany my order.

I must be fully satisfied or you will refund full payment if the books are returned after ten-day trial examination.

Name _____ Title _____

Company _____

Address _____

City _____ Country _____

Signature _____

Defense units agree on stiffer rules for counterfeit semis

Stiffer Pentagon regulations to guard against counterfeit semiconductors will include Government inspection at both the manufacturer and distributor levels, plus certificates of compliance by both producers and distributors that semiconductor shipments meet the specifications of the order. The extent of source inspection remains to be worked out. However, the Defense Logistic Agency, headed by Army Lt. Gen. W. W. Vaughan, and the Defense Electronics Supply Center will brief manufacturers and distributor members of the Electronic Industries Association June 21 at the logistic agency's headquarters at Cameron Station, Va. Concurrent with the invocation of the new rules, the supply center, in Dayton, Ohio, **will begin inspecting samples of incoming semiconductor shipments**—a tactic it has failed to employ in the past. The lack of such inspections has been the subject of much industry criticism in view of the increasing problems of counterfeiting.

Compact sees holes in U.S.-Japan color-TV agreement

The coalition of U.S. color television makers and labor known as Compact says it is upset with the American-Japan agreement to limit Japanese color TV exports to the U.S. to 1.75 million a year for three years. (see p. 52). **But the objections were relatively mild**, viewing the agreement "unenthusiastically" and saying Compact was "disheartened." Central to its complaint is the fact that the 1.75 million level will permit imports to "rise almost 60%" from the prevailing level because of the 1976 "flood of imports" that hit almost 2.8 million compared to the 1975 recession level of 1.1 million. Compact is also upset that the agreement is not retroactive to January but begins in July, permitting accelerated inventory buildup before the start of the agreement.

Satcom performance matched against cables

Outages of communications satellites occur about 16 times more often than they do in international undersea cables—about 12 interruptions per circuit per year vs 0.77 for cables—**but cable outages last far longer**, according to a new study by the Commerce Department's Office of Telecommunications. The study covers service between 1970 and 1975. Cable circuit outages averaged 96 hours per circuit per year, 90% of which resulted from cut cables, compared to about five hours per circuit per year for satellites.

Ground-equipment malfunctions accounted for 77% of all satellite service outages, with failures in transmitters accounting for 17%, tracking for 16%, power for 12%, and antennas for 9%. Of the remaining 23%, the lion's share—18%—resulted from satellite antenna failures.

Telecommunications market to double by 1985, says ADL

The world telecommunications equipment market will more than double to \$58 billion in the decade ending in 1985—an 8% compound annual growth rate—according to a market-by-market forecast from Arthur D. Little Inc. The forecast will be detailed in a June 13–14 Washington forum on international telecommunications. The ADL projection predicts a 10.8% annual growth rate for the Middle East and other developing nations, 10% for European countries, and 6.5% for the more mature North American equipment market. However, North America's projected \$24.5 billion market **will still account for more than half the world total**. Alan B. Kamman, telecommunications sciences director at ADL's Cambridge, Mass., headquarters, directed the study.

America's NATO choices: share the market or lose it?

President Jimmy Carter made a favorable impression on his counterparts from Europe and Japan at the London economic summit conference earlier this month. But he achieved little else and certainly nothing of substance on such thorny issues of concern to electronics and other industries as trade and investment. The failure was not Carter's as much as it was a reflection of the inability of many European leaders to negotiate meaningfully because of their own narrow margins of support at home.

Nevertheless, Carter did much better in his subsequent appearance before the leaders of the 12-nation North Atlantic Treaty Organization. If any American suppliers of military electronics to NATO forces doubted the seriousness of the President's commitment to giving European manufacturers a greater share of the NATO procurement pie, Carter quickly erased their hopes. "We must make a major effort . . . to provide each of our countries an opportunity to develop, produce and sell competitive defense equipment," he declared.

A three-pronged effort

That effort, Carter told NATO's beaming European members, should have three parts. "First, the United States must be willing to promote a genuinely two-way transatlantic trade in defense equipment. My Administration's decision about the development, procurement, and production of defense equipment will be taken with careful attention to the interests of all members of the alliance.

"Second," said Carter, "I hope the allies continue to increase cooperation among themselves in defense production." Finally, the President came to the issue of hardware standardization, saying "we are eager to join with you in trying to identify new opportunities for joint development of new equipment and for licensing or direct purchase of equipment that has already been developed. Together we should look for ways to standardize our equipment and make sure it can be used by all allied forces."

Secretary of Defense Harold Brown elaborated on the standardization problem later in Washington before departing for the NATO meeting. Emphasizing the alliance's strategic and tactical communications problems, he noted that "NATO commanders who need an effective capability to communicate up and down the command chain in wartime still cannot always do so."

Harold Brown is a realist, of course, recognizing that NATO standardization is going to be

very difficult to achieve on any significant scale during his optimum term in office—eight years. But he is anxious to make the start and believes communications between forces deserves the highest priority. Interchangeable ammunition and parts are close behind.

The Carter program to share the NATO military equipment budget is already encountering resistance from American manufacturers and some of their supporters in Congress [*Electronics*, April 28, p. 58]. The reaction is natural, since no one likes the prospect of losing a share of the market. But every indication from the White House and the Pentagon is that they believe the future of NATO depends on sharing the economic wealth. And they are pushing the concept hard because they believe the only alternative is to let the alliance become even less effective than it is now—if that is possible—and thereby guarantee its collapse. "If this program fails," argues one NATO specialist in the Pentagon, "then NATO fails, too. It is that simple. Then, instead of having a smaller share of a big market, American contractors will be left with no NATO market at all." But what troubles such analysts most is the possibility of the effective collapse of European political structures supporting the alliance.

The "scariest" alternative

The instabilities of the existing democratic governments in Italy, the United Kingdom, and France—even though it is no longer an active NATO participant—trouble the U.S. deeply, particularly since Communist party support in Italy and France has increased markedly. Britain's socialists, too, are gaining political strength despite their previously demonstrated ability to accelerate their country's race to bankruptcy. The prospect of a Communist majority in the governments of either Italy or France "scares us to death," says the Pentagon's NATO man. "I'm not sure anyone here knows what we would do about that. For example, do we still share details of our European defense plans with them? Share such things as data on troop and weapons disposition, or communications equipment specs?"

So far it appears that the U. S. does not have these answers. President Carter and Harold Brown seem to hope that they can prevent the questions from ever coming up by giving those European economies a larger share of the NATO budget and so injecting new economic life into them. It seems a relatively small price to pay.

Ray Connolly



About that 'new' kid on the block...

Actually, he's not that new. He's been around for quite a while now. Other vendors keep announcing miniature cylindrical ceramic capacitor 'innovations', but Sprague Electric, the pioneer in layer-built ceramics, can state with pride that this type of capacitor was introduced by Sprague more than ten years ago.

Sprague Type 292C MONOLYTHIC® Capacitors are the industry's best-constructed axial-lead capacitors, thanks to MFT*, a closely-monitored material modification of electrode metal and ceramic reacted with glass. The result—less capacitance change with temperature change, improved stability with life, and improved impedance with frequency characteristic.

These low-cost miniature capacitors feature a dimensionally-precise molded construction and can be ordered taped and reeled for automatic insertion. They are available in body formulations to meet characteristics Z5U (general application), X7R (semi-stable), and C0G (NP0).

For complete technical data, write for Engineering Bulletin 6250B to: Technical Literature Service, Sprague Electric Co., 35 Marshall St., North Adams, Mass. 01247.



Illustrated approx.
4x actual size



MINIATURE MOLDED
AXIAL-LEAD
CERAMIC
CAPACITOR

* Modified Formulation Technology

THE BROAD-LINE PRODUCER OF ELECTRONIC PARTS



New cost saving devices for computer peripheral manufacturers.

STANDARD MICROSYSTEMS' FAMILY OF MOS/LSI DATA COMMUNICATIONS CIRCUITS.

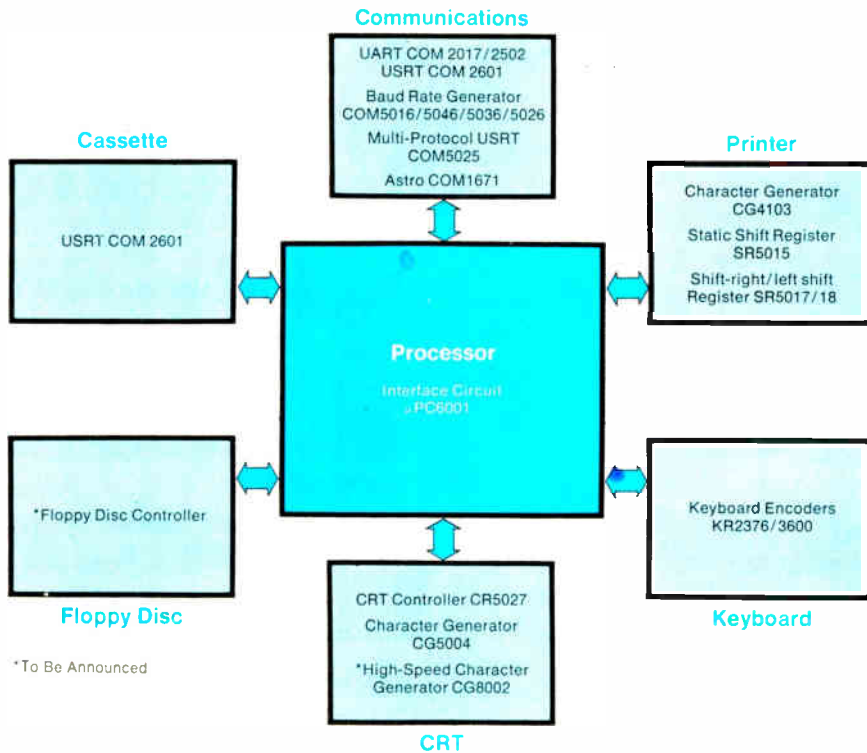

Now, with SMC's standard computer peripheral MOS/LSI circuits, most standard peripheral functions can be "plugged-in". Design is easier. Products are more reliable. Assembly is faster — and that keeps cost down. For details on our standard devices or for custom LSI requirements call today.



STANDARD MICROSYSTEMS CORPORATION

35 Marcus Boulevard, Hauppauge, N.Y. 11787
(516) 273-3100 TWX-510-227-8898

The largest manufacturer of data communication circuits

Component sales in West Germany to rise again

West Germany's electronic components production in 1977 is expected to be about 10% higher than last year's volume. That rise, says Alfred Prommer, chairman of the components section of Germany's electrical industry trade association, will bring production to a level above that of 1974, the year before the big components slump in Europe. Although this year's growth prospects are considered far from bad, they fall short of the increase last year, when the German components industry registered a 16% gain. **The main reason for the flatter rise this year is the slower growth of the entertainment equipment market**, Prommer says. There are, however, signs pointing to livelier sales to commercial equipment makers.

French government may aid component makers

Watch for new alignments in the French semiconductor industry. CII-Honeywell-Bull's talks with La Radiotechnique-Compélec on component supplies have now reached an advanced stage, according to industry sources, although nothing is signed yet. Then, too, faced with semiconductor supply problems for its time-division electronics exchanges, CGE is looking hard to find a solution. It is also thought that Fairchild and Thomson-CSF's Sescosem may come together in a move that would help Fairchild increase its so-far-lagging European sales—and also pull Sescosem out of its 30% losses on a \$62 million turnover. **The catalyst for all these moves may be a government aid package said to amount to \$20 million a year over four years.**

Britain's Muirhead eyes medical market with three new instruments

Muirhead Ltd., already successful in facsimile transmission gear and airborne control components, is entering the medical business with three new electronic instruments. The first is its small Mill Hill Infuser, which straps to a patient's arm so that injections can automatically be metered over a 24-hour period. A Motorola divider integrated circuit with quartz-crystal oscillator provides gated pulses to a driver motor connected to a syringe plunger. The second is an agglutination-rate analyzer, **complete with a small printer, that uses an Intel 8080 microprocessor to test for diseases in blood samples.** It does this by measuring the change in light transmission under controlled conditions in blood samples mixed with an appropriate antigen. The third, still under development, is a \$100,000 pulmonary function analyzer, which provides a computer printout of the efficiency of a patient's lungs in 10 seconds, thus obviating lengthy laboratory tests.

Matsushita will launch compatible video recorder

Next month's start of sales of VHS video tape recorders by Matsushita Electric Industrial Co. will mark a big step forward for the consumer-oriented system first introduced by the Victor Co. of Japan last September. **Matsushita initially will market 5,000 units a month at \$955, about \$36 more than those of its competitors.** For the extra outlay, consumers will get a built-in digital clock as standard equipment. Other features of Matsushita recorder are provision for remote control of pause and TV camera, reduction of operating power to 38 watts, and an improved dryer for removing condensation on the mechanism in damp weather.

Success.

I needed a quick turnaround and volume production to give my company a competitive edge. **Monochip[®]** proved to be the answer. We doubled our sales.



Failure.

I was afraid to try the **Monochip[®]**, thought it wasn't versatile enough and limited in application. I've missed my deadline and still don't have a solution.

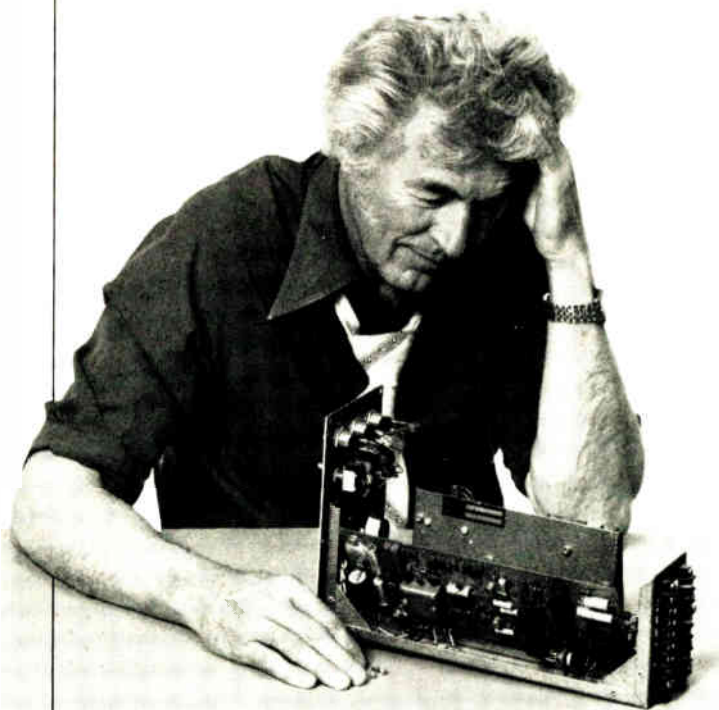

Monochip[®]

It will make a believer out of you!

interdesign

The real custom IC house
1255 Reamwood Avenue, Sunnyvale,
Ca. 94086, 408 734-8666

Siemens aims infrared-beam chips at U.S. consumer market

Banking on the American fondness of electric gadgetry, Siemens AG is about to launch on the U. S. market a set of integrated circuits designed for wireless remote control of various household items. With the German company's three ICs—a transmitter, a receiver, and a preamplifier circuit—designers, and even hobbyists, can put together an infrared transmission system for controlling everything from model trains to medical apparatus.

But it is in the consumer field that the company thinks most of its devices will be used. And that is why it chose the early June Chicago Spring Conference on Consumer Electronics to present the circuits in the U. S. Gernot Oswald, product and marketing manager for ICs at the Siemens Components division in Munich confides that about a dozen American firms are already lined up as potential customers for the circuit. In large quantities, the circuits will cost below \$5 apiece.

Commanding. The ICs are the key components in a system that can be designed to send as many as 60 command signals from a hand-held, battery-operated transmitting unit to a receiver on the equipment to be controlled. Initiated by push buttons, the signals are coded and modulated onto the infrared beam generated by the transmitter's light-emitting diodes. Pulse-code-modulated signals are used to provide high noise immunity.

At the receiver, which can be about the size of a cigarette pack, a photosensor picks up the IR beam and feeds its output via a preamplifier to a demodulator. The command signals are then checked, decoded, and sent to a serial interface as control signals.

The Siemens designers opted for IR light as the transmission medium because it provides several advantages over ultrasound, the other

medium often used for short-range transmission in confined areas. For one thing, infrared makes possible a higher information transmission speed because of its high propagation speed, says Maximilian Huber, product marketing manager for MOS entertainment circuits.

With IR beams there are no interference signals resulting from wall reflections, doppler effects, or intermodulation noise, Huber says. Among other advantages, he cites the IR beam's optical focusability to achieve highly directional transmission and its ability to penetrate glass. So the opening and closing of a

garage door can be triggered from inside a car.

The ICs that Siemens offers are the SAB3210 transmitter circuit, the SAB3209 receiver circuit and the TDA4050 preamplifier. The transmitter IC consumes less than 10 milliamperes. In the quiescent state, and external npn transistor disconnects the IC from the battery, thereby prolonging the latter's life. Assuming a 9-volt battery with a charge of about 200 milliampere-hours is used and considering that the transmitter operates for about half a second per command, the battery could power the transmission

Semiconductor laser simplifies optical video disk player

An optical readout system under development by Philips Gloeilampenfabrieken promises to considerably reduce the size and simplify the design of the Dutch company's future video disk players. The heart of the readout system is a semiconductor laser, which replaces the gas laser employed in the Philips disk players [*Electronics*, Sept. 11, 1972, p. 29] that are slated for market introduction soon.

With the new solid-state laser—a Philips-designed aluminum-gallium-arsenide double-heterojunction type—company researchers have been able to build an experimental

readout system measuring only 1 centimeter in diameter by 4 centimeters in length. The system weighs only 16 grams.

This light weight and compactness permit moving the system fast enough to allow tracking of the light spot—in contrast to the current player, in which tracking is done by moving separate components, such as mirrors. In radial, tangential, and vertical tracking, the readout system's position can be controlled in three mutually perpendicular directions by three electromechanical actuators.

By using optoelectronic feedback in the laser for reading out the high-frequency-modulated optical information on the disk, the number of optical components in the system is reduced to a minimum, Philips officials say. Intensive research work must still be carried out to determine the reliability and lifetime of the semiconductor laser, they caution. But the design simplification and reduction in size of the player should result in a lower final system price, they maintain.

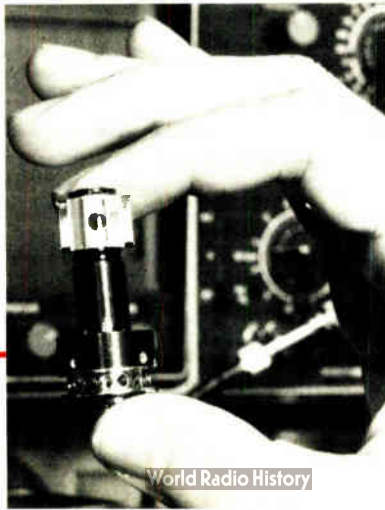

of some 250 commands per day for two years.

The receiver circuit, which accepts the signal coming from the preamplifier, consists of the actual receive section, which checks and decodes the incoming biphasic signals, and an evaluator section for evaluating the commands. A serial interface via which all received commands are read out is between these sections. □

Japan

Optical ROM uses spinning disk

Add to the ranks of advanced-technology memories an optical programmable read-only unit built around a spinning disk. Data can be written onto the ROM with one laser and immediately reproduced by another laser without requiring any intermediate processing. While the device is not reprogrammable, its developers at Hitachi Ltd.'s Central Research Laboratory, believe that its large capacity should offset that. Initially only part of total capacity would be used, with additions and updates to memory made over a long period of time.

In first applications, the memory will be used to record directly up to 50,000 color-television frames together with the address of each frame for random access in data retrieval systems. Included would be X rays for doctors, fingerprints for police, and signatures for banks—and also one-frame TV broadcasting. Further along, the disks will be used as computer memories with capacities of 10 billion bits—about 250 times that of a magnetic disk.

Access time for a desired track is 0.5 to 3.0 s, but Hitachi researchers believe they can improve this figure to about 0.1 s before the system hits the market in a year or two. This access time is orders of magnitude better than tape, the only available medium that has a comparable capacity.

The disk is made of polished window glass 300 millimeters in

Around the world

Watering system identifies plants

Powered by solar cells, a self-programming irrigation system for use in greenhouse or field monitors ambient light, evaporation rates, and soil conditions, computes how much water plants need and supplies them with the right amount. Dubbed Firmin, the French system comes in a package measuring only 12 by 12 by 20 centimeters and has three sections: a hemispheric dome that carries solar cells for power, an electronic block with calculating and memory circuits, and a motor block that is directly coupled to a valve that controls the water supply.

Some sensors are located right in the electronic block, but key inputs also come from probes placed in the soil at root depth and in the layer of mulch on the surface. Firmin takes measurements every few seconds of such key parameters as temperature, light, air humidity, rate of evaporation, and rainfall. The clever part of the system is what amounts to its recognition of the plants it must water. It can develop mathematical curves representing the changes in the potential evapotranspiration rate of the microclimate and of the real evapotranspiration rate of the plant. This information is then used to compute the actual plant water needs.

Portable instrument checks heart's output

The amount of blood a heart can pump is an important measure of its health, especially after delicate surgery. Now coming onto the market is an easy-to-use instrument that quickly gives a reading, in liters per minute, of a heart's output on a three-digit liquid-crystal display. In developing its CV600, Britain's Cardio Vascular Instruments Ltd. used a principle called thermal dilution. A clinician injects a known amount of fluid into the blood, and a thermistor detects the change of blood temperature after the solution has passed through the heart.

Because the rate of change of that temperature depends on the quantity of blood flowing through the heart, the CV600 calculates the cardiac output by integrating a time-temperature curve equation along with a few other factors. The unit also allows a diagnostician to select for display both the integrated dilution curve of the blood and injected fluid and their temperatures in degrees celsius. These are automatically monitored, and warning lights provide an alert to any drift outside preset limits. The outputs of the instrument can be fed into an oscilloscope, a recorder, or a hospital's central computer center for close monitoring in an intensive-care unit.

diameter by 10 mm thick. Data is recorded by burning elliptical nonreflective spots in a reflective film, consisting of a proprietary metal alloy several hundred angstrom-units thick deposited on the disk. The pitch between successive recording tracks is 2 micrometers, and track width is 0.8 μm . Spot size of the beam from the 30-milliwatt argon laser used for recording is 0.6 μm . Spot size of the beam from the 1-mw helium-neon or semiconductor laser used for reproduction is 1 μm .

Disk speed is 1,800 rpm, which allows recording of a single two-field TV frame during the 1/30 s it takes to make a single revolution. The signal is recorded as a frequency-modulated carrier that swings between 7 and 9.5 megahertz—about

the same frequency band used in broadcast-studio video-tape recorders. Frequency response is comparable to that of studio recorders, and the system achieves the signal-to-noise ratio in excess of 40 decibels that is required for quality pictures.

Hitachi researchers say that the power required to write on the disk's proprietary thin-film coating is only about 10% of that required to write on the photo-resist coatings used by others, and no post-recording processing is required. Once production begins, the price of disks can be reduced to about \$75, Hitachi researchers estimate. Cost of a complete system including retrieval hardware will come to about \$70,000, though, which limits it to professional installations. □



How to turn a computer into a disk jockey. The μ PD372 Floppy Disk Controller.

Now you can turn almost any micro or minicomputer into a genuine floppy disk jockey with the help of just one small chip.

Our μ PD372 Floppy Disk Controller. Or if your computer prefers playing tapes, we also have the μ PD371 Tape Cassette Controller.

Either one can take the place of from 50 to 60 TTL packages to save you space as well as money. The 372 is

completely compatible with IBM, Minifloppy,[™] and other formats and controls up to 4 floppy disk drives. The 371 controls up to 2 tape cassette drives. They come with complete documentation and—best of all—they're available now.

The μ PD372 and 371 are just part of our complete family of micro-processor products including 8080As, dynamic and static RAMs, ROMs,

Electrically Erasable PROMs, and 8212, 8214, 8216, 8224, 8228/38, 8251, 8255 and other support chips. All backed by full documentation, applications support, and software.

The μ PD372. The μ PD371.

And the hits just keep on comin'.

NEC Microcomputers, Inc.
Five Militia Drive, Lexington, MA.
02173. 617-862-6410

[™]TM Shugart Associates

NEC microcomputers, inc.

REPS: East—C&D Sales 301-296-4306, Contact Sales 617-273-1520, Harry Nash Assoc. 215-657-2213, Tech Mark 607-748-7473, 714-223-1252, 315-652-6229, Trionic Assoc. 516-466-2300, South-Perrott Assoc. 305-792-2211, 813-585-3327, 305-275-1132, Wolffs Sales Serv. Co. 919-781-0164, Midwest—Electronic Innovators 612-884-7471, W. Pat Fralia Co. 817-640-9101, 817-649-8981, 713-772-1572, K-MAR Eng. & Sales 816-763-5385, R. C. Nordstrom & Co. 313-559-7373, 616-429-8560, Technology Sales 312-438-3300, West—Mike Duffy Assoc. 303-934-7392, Electronic Component Marketing 714-524-9894, 213-649-5374, Spedden Assoc. 714-295-5122, Summit Sales 602-994-4587, Trident Assoc. 408-734-5900, Tri Tronix 206-232-4993, 505-265-8409, Canada—R.F.Q. Ltd. 416-626-1445, 514-626-8424.

DISTRIBUTORS: Century Electronics (Albuquerque, Salt Lake City, Wheatridge CO), Diplomat (Chicopee Falls MA, Clearwater FL, Elk Grove Village IL, Farmington MI, Minneapolis, Mt. Laurel NJ, Salt Lake City, St. Louis, Sunnyvale, Totowa NJ, Woodbury NY), Future Electronics (Montreal, Ottawa, Rexdale, Canada), Harvey Electronics (Fairfield NJ, Lexington MA, Norwalk CT, Woodbury NY), Intermark Electronics (San Diego, Santa Ana, Sunnyvale), Lionex (Burlington MA), G.S. Marshall (Sunnyvale), Micro Electronics (Phoenix), Resco (Raleigh), R-M Electronic (Kentwood MI, Madison Hgts MI), Semiconp (Newport Beach CA), Semiconductor Specialists (Burlington MA, Chicago, Dallas, Dayton, Farmington MI, Hazelwood MO, Indianapolis, Kansas City, Milwaukee, Minneapolis, Pittsburgh, St. Louis, Malton Canada), Sterling Electronics (Albuquerque, Dallas, Houston, New Orleans, Phoenix, San Diego, Seattle, Sun Valley CA, Watertown MA), Technico (Columbia MD, Roanoke VA), Zeus Components (Elmsford NY).

Here's what Mostek's 16K RAM

Technology: At 122×227 mils, the 4116 (with POLY II™ processing) has the smallest chip area in the industry—22%<Intel, 50%<TI.

Speed: Mostek's 4116P-2 is the industry's highest performer at 150 ns access and 375 ns cycle time. The 4116P-3 has 200 ns access and 375 cycle time.

System Speed: Schottky-TTL compatibility for truly high performance systems.

Power: Max power ratings are 462 mW active and 20 mW standby.

System Reliability: Mostek memories are recognized as the quality standard throughout the industry.

System Margins: Easy to use with ±10% tolerance on all power supplies (+12, ±5V). A Mostek exclusive.

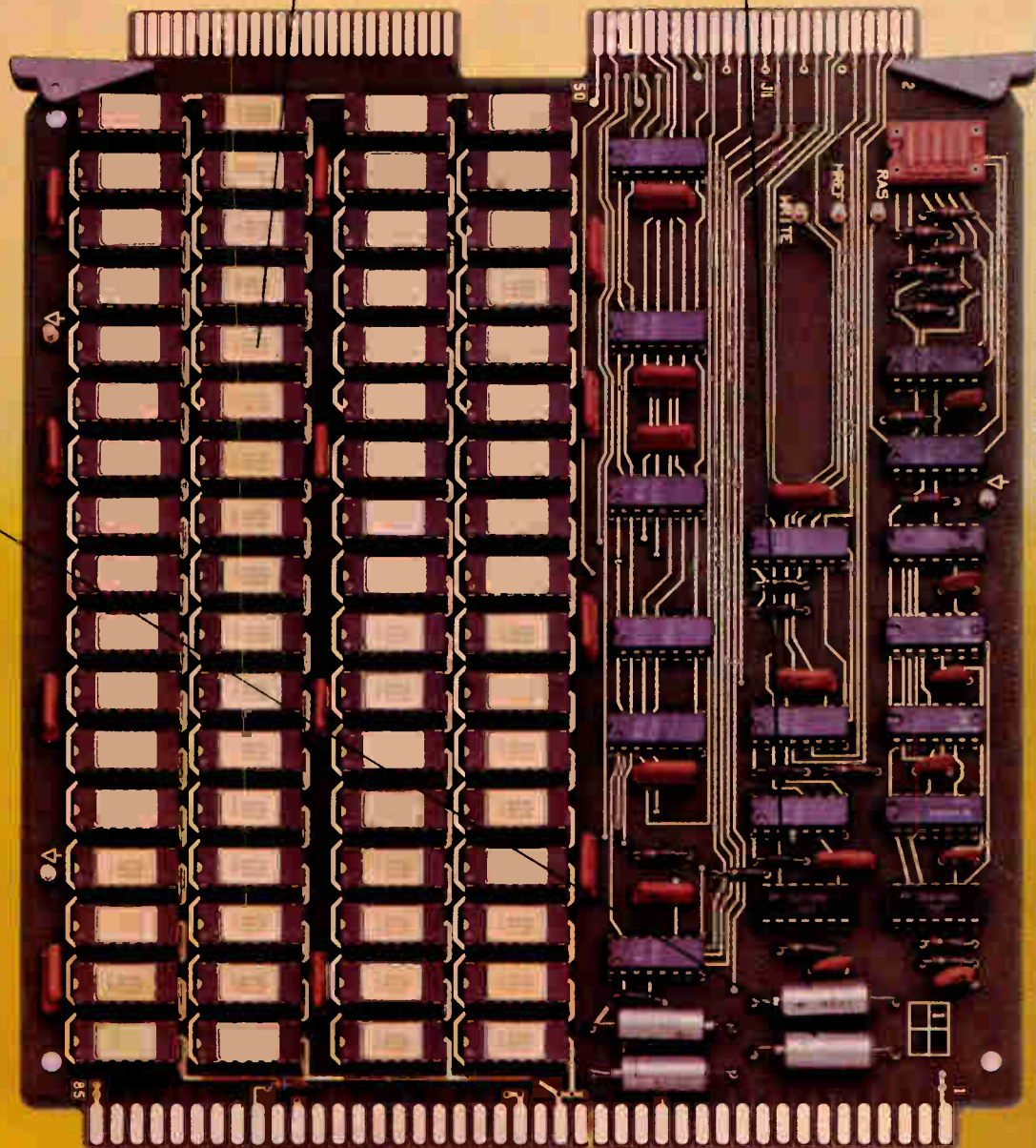

can do for your system.

Unlatched outputs for system flexibility.

The system implications of a product as advanced as the 16K RAM are significant. There are factors beyond the usual performance characteristics that will determine the efficiency and versatility of your system. Factors such as latched versus unlatched outputs. Mostek offers unlatched outputs for one reason—increased system flexibility.

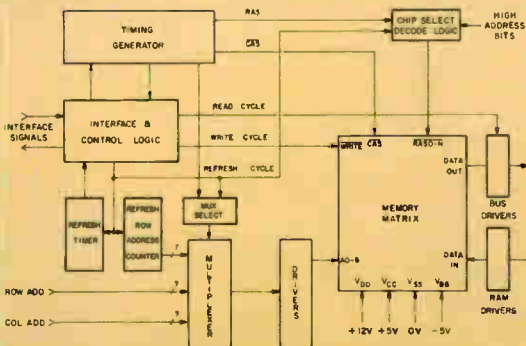

Common I/O operation. If all write operations are executed in the "early write" mode, then D_{IN} can be connected directly to D_{OUT} for a common I/O data bus.

Full control of D_{OUT} . Mostek's approach means that D_{OUT} remains valid throughout the entire cycle—until the Column Address Strobe (\overline{CAS}) is taken to the inactive state. Also, with unlatched outputs the $\overline{RAS}/\overline{CAS}$ clock timing relationship is much more flexible.

Two methods of chip select. Since D_{OUT} is not latched, \overline{CAS} is not required to turn off the outputs of unselected memory devices in a matrix. This means that both \overline{CAS} and \overline{RAS} can be decoded—allowing a two dimensional (X,Y) chip select array.

Extended page boundary. During page mode operation, Mostek's 4116 performs successive memory cycles at multiple column locations of the same row address. By decoding \overline{CAS} as a page cycle select signal, the page boundary can be extended beyond the 128 column locations in a single chip.

Greater multiplexing margins with Mostek's 4116.

Another system benefit realized from Mostek's 4116 is the wide timing window allowed for multiplexing. This means that your system can operate at its full performance rating. With no timing loss.

The maximum \overline{RAS} to \overline{CAS} delay available for Mostek's 4116 is a full 50 ns for the 4116P-3 and 40 ns for the 4116P-2.

Mostek's 16K RAM is on the board.

The 4116 is in volume production and on distributor's shelves now—ready to be designed into your memory system. In addition, alternate sources are lining up behind Mostek's 4116. Eleven of the manufacturers planning to build 16K RAMs are designing for pin compatibility as well as functional compatibility with Mostek.

Our data sheet discusses all of the system advantages of the 4116—including operating flexibility and the advantages of page mode. Write for one today.

MOSTEK

1215 West Crosby Road
Carrollton, Texas 75006
(214) 242-0444

In Europe, contact:
MOSTEK GmbH
Telephone: (0711) 70196

MOSTEK ASIA
Telex 8514 8MKA HX



ANNOUNCING THE WORLD'S BROADEST LINE OF FIBER OPTIC CABLE.

THE FUTURE IS NOW.

If you're working in a field that uses connectors like the ones shown here, you now can be working with fiber optics.

Because now there's Galite.[®]

The world's first line of optical communication cable that's broad enough to let you select exactly the right cable for your application. (Of course, your replacement optical connectors may look quite different from these old standards.)

So now you can bring the major advantages of optical communications to your product before it starts to look — and act — obsolete.

The world's broadest line of fiber optic cable begins with Galite 3000, which covers the biggest range of applications, and can be used up to 1100 feet. With its wide acceptance angle of light, it's the most efficient cable to couple, splice, and connect. And in most applications, it allows you to use proven, efficient, and durable LEDs, rather than the more fragile and temperature sensitive semiconductor lasers. But that's just the beginning.

We also offer, with varying light acceptance angles, Galite 1000, for use up to 150 feet. Galite 2000, for up to 250 feet. Galite 4000, for up to 3300 feet. Galite 5000, for beyond 3300 feet. And soon we'll be producing Galite 6000 and 7000 for even greater distances and wider bandwidths.

With this kind of choice, you can specify the exact characteristics for optimum performance in your application — strength, propagation efficiency, thermal compatibility, chemical resistance, weight — and cost.

What's behind this line of fiber optic cable nobody else can offer is a company with experience nobody else can match. We've pioneered in glass fiber optic products since 1959 and are now the world's largest manufacturer, with over 2 trillion feet shipped.

We also have the country's most integrated production facility where we do everything from formulating the glass to making complete systems including light sources, detectors, and connectors. So we can keep reliability up. And costs down.

Why not call, write, or circle the reader service number for our new information package, "Fiber Optics Now."

But don't put it off until tomorrow. Because tomorrow is already here.

Galileo Electro-Optics Corporation, Galileo Park, Sturbridge, Massachusetts 01518, 617-347-9191.

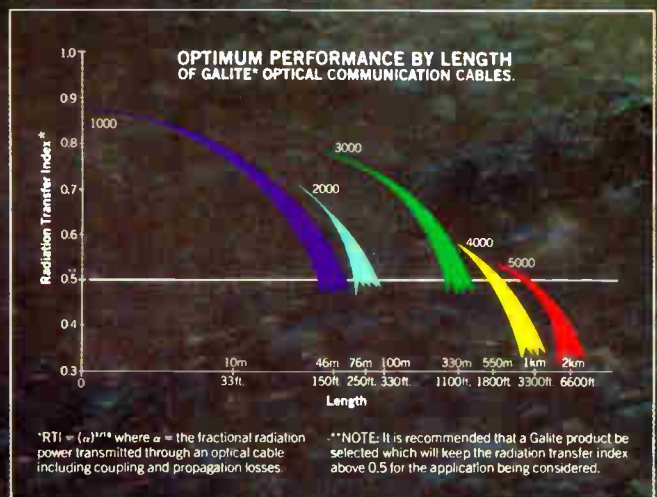

World Radio History



Galileo Electro-Optics Corp.

**THE FIRST COMPANY TO BRING FIBER OPTICS
OUT OF THE LAB AND INTO PRODUCTION.**

AMP research discovered Bonded Lubrication 5 years ago.

It's now today's better way to extend contact life without compromising performance.

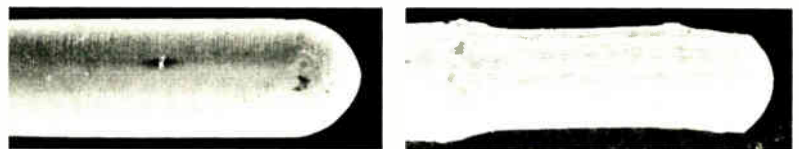
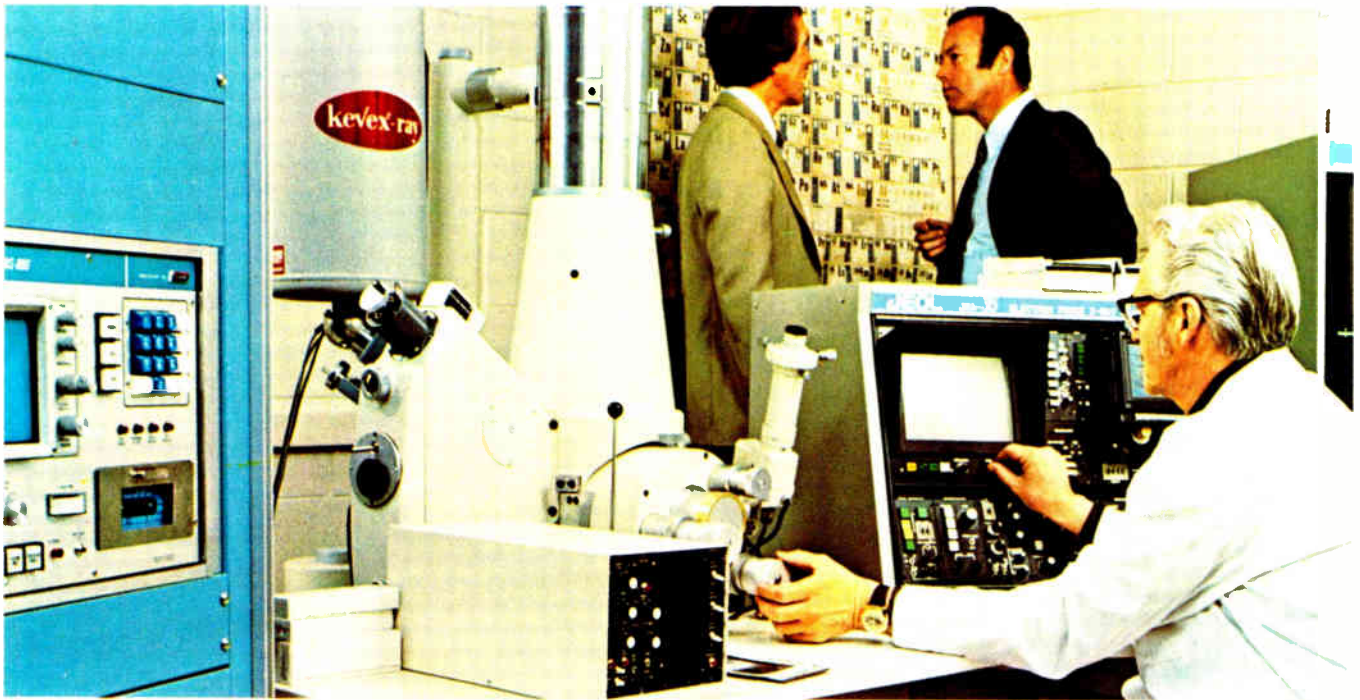

Through the electron microscope, the dramatic improvement AMP Bonded Lubrication makes in contact life and performance is clearly evident.

With the popular DUALATCH connectors, Bonded Lubrication has reduced plating thickness requirements and more than doubled the previously accepted cycle life of 10,000 insertions and withdrawals.

For example, look at the effect on the connector contact shown. Not only is wear to the plated surface greatly reduced by the permanent lubrication but it

Dramatic difference in wear between contacts utilizing the unique AMP Bonded Lubrication Process and ordinary contacts is shown by these electron images.

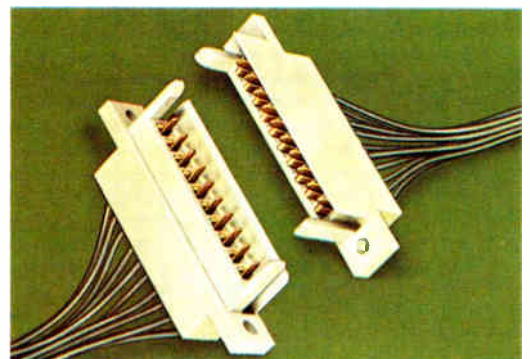

significantly lowers the insertion forces when mating high-pin count connectors. Now Bonded Lubrication can be applied to a variety of contact geometries without compromising electrical performance.

Or consider what AMP lubrication leadership has done for contacts used in our tin-plated products like surface mount ZIF connector and Bifurcated Leaf types. Their lubricated contact surfaces are protected from the detrimental effects of oxidation and fretting corrosion. Indeed, there are now applications where high performance tin-plating, with the correct contact design and Bonded Lubrication, can be used in place of noble metals.

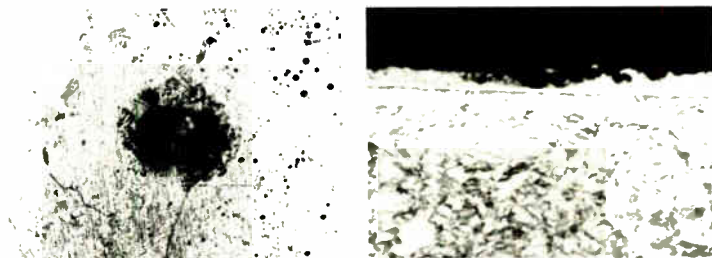
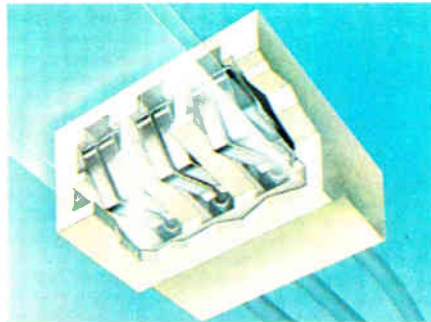

High Resolution scanning electron microscope at AMP's Materials Research Laboratories displays 3-dimensional pictures of surface oxidation and fretting corrosion on non-lubricated contacts.

AMP lubricated contacts are today's answer to extended contact life and performance, and together we can search out better ways to assist your designs.

For more information on the products mentioned, circle the reader service number. For more technical information on lubrication just call Customer Service at (717) 564-0100, extension 8400. Or write on your Company letterhead to AMP Incorporated, Harrisburg, PA 17105.

AMP has a better way.

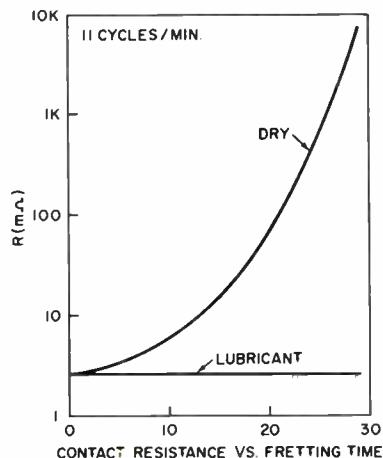

Flat, stable resistance of contacts with AMP lubrication compared to dry contacts.

AMP
INCORPORATED

1967
J259



1970
J283



1972
J273

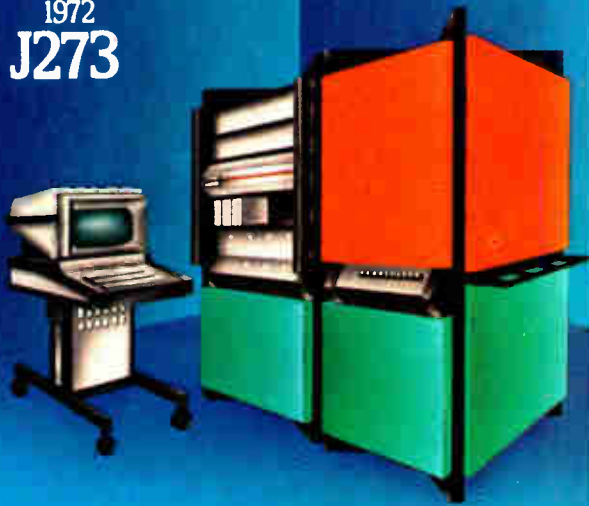

1975
J387



Is this the end of the line?

Wherever semiconductors are tested in high volume, one name says it all – Teradyne. Some of our systems have made history in their own right: the J259, which was industry's first computer-operated IC test system, the J283, the J273, the J325, the T317, the J387, to name a few. It all adds up to an installed base of almost a quarter of a billion dollars and a record of on-line experience no one else even approaches.

Today's Teradyne systems are capable of testing over 80% of all semiconductors being produced, including RAMs and ROMs to 65k, op amps, voltage regulators, chroma and stereo demodulators, TTL, CMOS, ECL, transistors, diodes, and just about every other semiconductor device produced in high volume.

We've won our dominant position at the end of the semiconductor production line and at the beginning of the electronics assembly line through hard work and understanding. What we start, we stay with, but you can see that every time you walk through your production-test or incoming-inspection area.

We've come to think of those places as our turf, and we intend to keep it that way.

TERADYNE

Semiconductor Test Division
Boston, Mass. – Chatsworth, Calif.

Is the EIA too diverse for its own good?

Some staff members see hunt for new president as opportunity to form loose federation as way around sometimes opposing views of members

by Ray Connolly, Senior Editor

In its 1976 annual report, the Electronic Industries Association says that its member companies concern themselves with "as yet nonexistent problems" while the EIA itself "acts in the present. . . . It provides a smooth, strong basis on which the industry builds."

Some members are amused by the suggestion that the problems they wrestle with do not yet exist and that the association is strong and smooth-running. In fact, there is feeling among some members and staff of the trade organization that quite the contrary is the case: that the EIA's very diversity is becoming less its strength than its most glaring weakness. Now that V. J. Adduci is leaving the presidency of the organization, some say that it would be a good time for chairman John C. Messerschmitt of North American Philips Corp. to supervise a reorganization.

But beyond the efforts of the Strategic Planning Committee, headed by Sidney Topol of Scientific-Atlanta, Messerschmitt sees no immediate reason to start a major restructuring. However, if the committee seeking a replacement for Adduci—it is headed by William J. Weisz of Motorola Inc.—should pick one of the seven staff vice presidents or its general counsel, it can expect to encounter more than one proposal to reshape the body—provided a staff vice president can be found who views ascent to the presidency as a promotion.

It is an open secret that some EIA vice presidents earn more and wield greater power within their divisions than the president's office. "The president's office is the poor boy of

this organization," Adduci concedes. The president can hire no one without a budget increase that the division members oppose.

The financially strongest unit is the Consumer Electronic division headed by senior staff vice president Jack Wayman, who says his group accounts for approximately 60% of the association's budget. Most of this is derived from shows, since the group has only 22 members. But the consumer group is now in the throes of an internal reorganization [*Electronics*, May 12, p. 49] in which it will get another staff vice president.

Wayman denies reports that the reorganization reflects any member dissatisfaction, insisting that the job has just become too big for one person. But he has less to say about concurrent reports that he is moving to take over staff responsibility for all EIA shows—notably the Personal Communications Show begun by Communications division staff vice president John Sodolski last year and built around the booming citizens' band radio business.

Held in Las Vegas, PC-76 was "a first-of-its kind, dramatically successful—attended by over 12,000 persons," Sodolski reports. The 1977 show was even bigger, and the fact that Wayman's consumer-electronics winter show next year is scheduled in Las Vegas one month before Sodolski's PC-78 is producing distinct internal tensions.

Standing apart from the consumer and communications units and the Industrial division (also headed by Sodolski), are two other heavyweight divisions—Government, whose staff vice president Jean Caffiaux coordinates the efforts of 33 defense and



Looking and going. EIA chairman John C. Messerschmitt, above, is seeking a new president for the trade organization to succeed V.J. Adduci, below.



Thin-Trim[®] capacitors



Tucked in the corner of this Pulsar Watch is a miniature capacitor which is used to trim the crystal. This Thin-Trim capacitor is one of our 9410 series, has an adjustment range of 7 to 45 pf., and is .200" x .200" x .050" thick. The Thin-Trim concept provides a variable device to replace fixed tuning techniques and cut-and-try methods of adjustment. Thin-Trim capacitors are available in a variety of lead configurations making them very easy to mount.

A smaller version of the 9410 is the 9402 series with a maximum capacitance value of 25 pf. These are perfect for applications in sub-miniature circuits such as ladies electronic wrist watches and phased array MIC's.

Johanson Manufacturing Corporation, Rockaway Valley Road., Boonton, N.J. 07005. Phone (201) 334-2676, TWX 710-987-8367.

MANUFACTURING CORPORATION
Circle 80 on reader service card

Probing the news

space electronics companies to keep on top of Federal rules and regulations, and Parts, headed by Tyler Nourse, who oversees service for 87 members.

The 133-member Distributor Products division is physically largest in the EIA, although its \$200-to-\$600 dues are lowest, since members receive fewer services from the association's engineering and marketing departments. Staff vice president for that division is Toby Mack, who also heads the 19-member Tube division.

Engineering. Where the EIA comes on strongest in the eyes of many members is in its Engineering department, where staff vice president Allen M. Wilson works with each division, multiple industry representatives, and other professional groups to develop, monitor, and update technical standards.

Wilson wears a second hat as staff vice president for the Solid State Products division, one of the association's problem areas ever since the defection of Texas Instruments Inc., some five years ago. With the subsequent rise in importance of new semiconductor producers—particularly in the integrated-circuit area—that did not join, the division was never able to recover. Messerschmitt and others still nurse hopes that the association can recoup and make the Solid State Products division truly representative of the industry by wooing makers back. But all visible evidence indicates that those hopes are no more than that.

When TI pulled out, the EIA's executive committee looked at the association's structure. The chairman, J. Frank Leach of Bunker Ramo Corp., said EIA's leadership "concluded unanimously—with representatives from all divisions and groups in the association participating—that we do have the best possible structure for flexible headquarters operations, to provide members with services in engineering, marketing data, legislative review, industrial relations, and international standards."

Hindsight is causing a number of members to seek reconsideration of that judgment. Several company



Showman. Staff vice president John Sodolski is responsible for successful PC-76 show. It drew 12,000 persons to Las Vegas.

representatives, who declined to talk for attribution, speak of restructuring the EIA into a federation of separate associations with the only common bond found in the engineering and marketing services departments. A number of staff members agree, but some do not, saying that would change only titles.

As for the presidency, reorganization proponents see it as a combination of two unappealing roles: First, an industry "front man" in Washington, occasionally testifying before the Congress but unable to deliver a strong EIA position on almost any given issue because of divisive divisional interests. For example, Parts members invariably favor tougher tariffs and quotas to limit imports, while the Consumer Electronics division—many of whose members import heavily from offshore facilities—refuses to take a position.

Second, the president must function as a general manager of sorts, monitoring such mundane affairs as distribution of office space and the overhead cost of operations.

More than one staff executive believes the president could best serve in a federation as a front man of a higher order—effectively "marketing" to outside organizations—investors groups, bankers, consumers, educators, anyone who will listen—the premise that the electronics industries are indeed several and do have multiple and diverse interests that can effectively address many problems facing society. □

Did you know that you can save \$1,005 by buying a Fluke 1953A Counter instead?

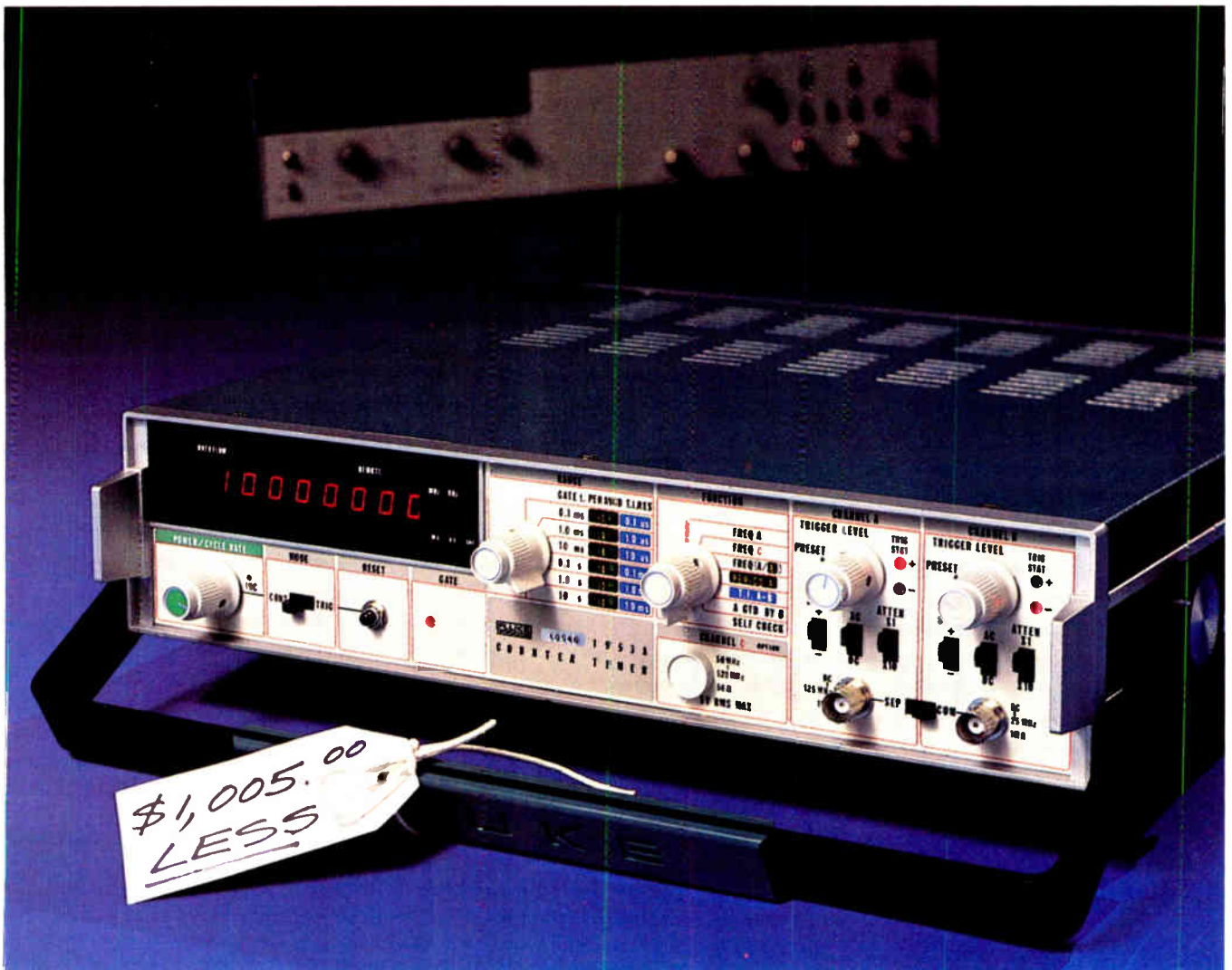

That's right.

Fluke's 1953A Universal Counter-Timer mainframe plus IEEE Programming option will cost you just \$1,595.* Instead of the \$2,600 or more you'd pay for comparable models.

And you won't get any less performance, either. In fact, you'll get extras.

Like "clean dropout." If the signal is too small, the 1953A will show zeros. Theirs can give you a wrong reading.

Our frequency range on Channel A is 125 MHz. Theirs is 100 MHz.

Our Z-axis time interval marker is standard. Theirs is optional.

Board access is better on the 1953A. We use one custom I.C. They use many.

Our input capacity on Channels A and B is 30 pF. Theirs is 40 pF. And our Channel B frequency response is 25 MHz. Theirs is 10 MHz.

The 1953A is half the weight, consumes one-fifth the power and makes no noise at all. On theirs you'll hear the fan and switching regulator.

Our switch and control "feel" is as good as theirs, and our front panel labeling is much less confusing.

Where the 1953A shows 9 digits all the time, theirs offers 9 digits only on

Channel C.

And, if you need the option of Parallel BCD, we have it. They don't.

So, if you're in the market for a programmable counter, consider the Fluke 1953A.

And consider how much you'll save.

For data out today, dial our toll-free hotline, 800-426-0361. John Fluke Mfg. Co., Inc., P.O. Box 43210, Mountlake Terrace, WA 98043. Fluke (Nederland) B.V., P.O. Box 5053, Tilburg, The Netherlands. Phone: (013) 673-973. Telex: 52237.

*U.S. price only

The 1953A. A programmable counter at a reasonable price.

FLUKE[®]

Circle 76 on Reader Service Card for literature

Circle 77 on Reader Service Card for demonstration

World Radio History

Electronics abroad

Forecast for Europe's aircraft makers: cloudy

by the European editors of Electronics



Like veteran airline pilots who can scan the jumble of instruments in a cockpit and spot at once a reading that signals trouble, Europe's avionics makers have spotted a worrisome indicator. Although exports of military aircraft are strong and some major domestic procurement is under way—notably the Tornado multirole combat aircraft and the F-16 fighter—production of civil aircraft has dwindled to downright disappointing levels.

What's more, there's a dearth of firm new projects on the drawing boards, either civil or military. "Right now, development is in the doldrums," laments Horst Schützendübel, chairman of the aircraft equipment committee of the German aerospace industry trade association.

So as they trek to Paris in early June for the biannual Le Bourget Salon International de L'Aéronautique et de L'Espace (the Paris air

show), many European avionics producers will be wondering how they can keep flying high after current aircraft projects wind down. More exports outside Europe should help. Perhaps there is better business in sight on the ground, as developing countries fit themselves out with air-traffic-control and navigation systems. "With few new planes on show this year, the emphasis is going to be on equipment," says an official of SPER, the French professional-electronics trade association.

France: new Mirage. French military aircraft producers face some five years more of counting heavily on exports before the next substantial domestic order comes along. The French air force plans to take deliveries on its new-generation interceptor, the Dassault-Breguet Mirage 2000, starting in 1983. The first prototype should fly next year. If it sells as well as current Mirages, then

Installation in Brazil. This radar is part of the air-traffic-control system supplied by Thomson-CSF of France for the Rio de Janeiro-São Paulo-Brasilia triangle.

it will bring a lift to French avionics producers since the avionics content in some orders has grown to 45%.

Exactly which ones will benefit still is not certain. Electronique Marcel Dassault and its traditional partner for interceptor/fighter radars—Thomson-CSF—have no serious competition for the doppler-pulse radar with 100-kilometer range under development for the Mirage 2000. And EMD will probably share orders for the plane's main and secondary computers with SAGEM, an important producer of telecommunications terminals as well as of avionics equipment. But the list of on-board electronics is not completed.

With the production lines for the supersonic transport Concorde nearly wound down at Société Nationale Industrielle Aérospatiale's plant in

Six important questions to ask of any DMM that claims to be designed for field service.



We give you a choice of 3½ or 4½ digits, manual or autorange.

At Fluke, we've been building DMMs for a long time. We're the leader.

And if there's one thing we've learned over the years, it's that what works for the bench doesn't always work for the field.

But a lot of companies don't understand that. They'd like you to believe their DMM is perfect for field service. Just because they've put it in a different case.

Here's how to tell the difference:

1) Is the size and shape designed for the field?

How do you carry your tools? We designed the 8030A/8040A DMMs into an ideal shape after we researched the requirements of field service work. It's sized to fit in a case. And it's rugged, to take the beating field instruments must survive.



If it doesn't fit here, it's not for field service.

2) Does it have true rms ac?

Make sure you get usable accuracy. You'll need true rms ac to eliminate errors when measuring distorted waveforms. (And if you don't understand the importance of true rms, write for our bulletin on True RMS Measurement.)

3) Does it give full performance?

Just because it's a field instrument, you shouldn't sacrifice

performance. Demand five measurement functions in 26 ranges. Top specs, like our 8040A basic dc accuracy of $\pm 0.05\%$ or our 8030A basic dc accuracy of $\pm 0.1\%$. And the specifications are guaranteed for one year. Important extras, like diode test for measurement of semiconductor junctions in-circuit, high voltage protection, and self test feature. And a complete line of accessories: various battery options, and probes for measurement of rf voltages, high current ac, high voltage dc and temperature.

4) Do you have a choice of manual or autorange?

We offer two versions: the 8030A 3½ digit and the 8040A 4½ digit with autoranging. Because we know not all field service applications are alike.

5) What is the price?

A field service DMM is a tool, and should carry a practical price. Our 3½ digit 8030A is \$250.* Our 4½ digit 8040A is \$440.* Check around and you'll see how practical that is.

6) Do you trust the company that builds it?

We became the leader in DMMs for one reason only. We build digital multimeters that people trust and continue to use, year after year. We've sold hundreds of thousands of DMMs.

And every bit of that experience has gone into the 8030A and 8040A DMMs.

For data out today, dial our toll-free hotline, 800-426-0361. John Fluke Mfg. Co., Inc., P.O. Box 43210, Mountlake Terrace, WA 98043. Fluke (Nederland) B.V., P.O. Box 5053, Tilburg, The Netherlands. Phone: (013) 673-973 Telex: 52237.

*U.S. price only.

The field service DMMs for field service people.



Circle 78 on Reader Service Card for literature

Circle 79 on Reader Service Card for demonstration

Probing the news

Toulouse, about the only realistic hope for additional business in civil transport remains the Franco-German A300 Airbus—which has fallen far short of sales expectations.

Airbus Industrie was hoping for sales of several hundred, but so far 37 have been ordered, with options on a further 23. Eastern Airlines might provide a boost for the project; the U. S. carrier has said it will need 50 Airbus-type planes over the next 10 years. Japan also is interested.

With aircraft production in a downdraft, French avionics firms have luckily been able to land some substantial business in air-traffic-control systems. The largest of them, Thomson-CSF, recently completed a \$70 million nationwide network in Brazil and has big ATC projects in the works in Colombia and Indonesia. According to reports from Peking, the firm has signed a whopping contract—something like its Brazilian deal—to build an ATC system in China.

Great Britain: mixed. Across the channel, British avionics makers can count on the multirole Tornado and advanced-warning version of the Nimrod, plus substantial export backlogs. Little wonder, then, that Jack Pateman, managing director of Marconi-Elliott Avionic Systems Ltd., has a tinge of optimism as he assesses his firm's prospects. "It doesn't look too bad," he says. "On the whole, we've been pretty successful in major programs."

Pateman, in fact, expects the next

several years will see some real growth. He lists the Tornado as a big plus and describes the Nimrod (Britain's Awacs) as an aircraft "with substantial production potential." Marconi-Elliott has a significant foothold in the tough U. S. market too—the head-up display contract for the General Dynamics F-16, the flight-stability system for the Boeing 747, and the fly-by-wire control for Boeing's entry in the short-takeoff-and-landing category, the YC-14. Even though the YC-14 may not turn out to be as big a seller as the F-16 and the 747, Pateman figures the experience gained will be immensely useful in future British programs: the still-to-be-decided follow-ons for the Jaguar and the Tornado.

At Smiths Industries, another major force in British avionics, the order books are brimming, but the optimism that Pateman radiates is missing. "We're suffering some of the effects of the backwash of the recession generally," says Ben Barden, managing director of Smiths' Flight Control and Instruments division. Because of the recession, Barden explains, many aircraft programs that his firm is relying on—the A300B Airbus, for example—"haven't sold in the quantities and in the time that everyone had hoped. We had hoped to see a better situation in the financial year beginning this August, but programs have not picked up. . . . We're more uncertain in looking to the future than before."

West Germany: uncertain. There is uncertainty, too, among German avionics producers, but mainly it is

over how to keep development teams together and busy. That's the plight of the industry, says Schützendübel, whose full-time job is director of marketing at Teldix GmbH, a joint venture of AEG-Telefunken and Robert Bosch. "It's either one or the other—development or production—that's doing well," he says. Right now the avionics gear for the British-German-Italian multirole combat aircraft Tornado and for other aircraft has moved from the drawing boards to the production lines.

The mainstay is the Tornado. The German air force has ordered 322 of them, enough to keep assembly lines busy until 1984 or 1985. "It's like the old days when the F-104 [Starfighter] was being produced," recalls Schützendübel.

But when the Tornados have subsided, the calm will be considerable. To be sure, some avionics development work may come from the all-weather antitank helicopter PAH2 that Messerschmitt-Boelkows-Blohm (better known as MBB) is likely to build. And there is some work in international space programs like the European communications satellite. But on the whole, the development teams are far from busy.

Benelux/Scandinavia: offsets. In Belgium, Holland, Denmark, and Norway, too, it is a matter of one or the other. Avionics producers that managed to cut themselves in for part of the roughly \$400 million in offset earmarked for electronics gear as part of the NATO four-country deal to buy 348 F-16s obviously should have plenty of business for the next few years [*Electronics*, Jan. 20, p. 79]. For the others, prospects are generally grim.

In neutral Sweden, the new coalition government has some national belt-tightening in mind. It still has to decide whether to risk asking the parliament to budget development funds for the B31A attack-trainer jet project that Saab-Scania has been pushing with backing from the air force. At the moment, the project, a follow-on to the Viggen jets now in production, is being rather heatedly debated by Swedes, many of whom feel Saab-Scania should put its designers to work on civil rather than military aircraft. □



Keeping an eye in the air. Console for Thomson-CSF's air-traffic-control system with operator at the controls. Thomson has had considerable success exporting ATC systems.

We say they're the industry standards. And the 118,723 people who've bought them will back us up.

The Fluke 8000A, 8600A and 8800A digital multimeters. Far and away the industry leaders, both in sales and performance.

They're why Fluke is #1 in multimeters. Worldwide.

8000A 3½ digit DMM. More people use the 8000A than any other DMM ever built. And there are good reasons. Specifications are guaranteed for 1 year for 5 measurement functions in 26 ranges. Input overload protection on all ranges. Basic accuracy is 0.1%. MTBF is 21,000 hours. And the 8000A comes in many versions: high current, low-ohms, with analog meter, or milliamperesecond. Base price \$299.*

8600A 4½ digit DMM. The 8600A is the prestige DMM in the portable class, featuring high accuracy and full auto-ranging.

Five ranges each of ac and dc volts to 1200V with 0.02% dc and 0.2% ac accuracy. Five ranges each of ac and dc current to 2A with 0.1% dc and 0.3% ac accuracy. Six ranges of resistance to 20 MΩ with 0.1% accuracy. AC bandwidth to 100 kHz. And demonstrated 10,000-hr MTBF. \$549.*

8800A 5½ digit DMM. The 8800A is a unique portable, laboratory standard digital multimeter. It has, for example, a dc accuracy of 0.005%. Full autoranging. And it's fully guarded. Zero stability is better than 10 μV for 90 days. Isolated 4 terminal ohms. A demonstrated MTBF of 10,000 hours. \$985.*

So now you have a rough idea of why the 8000A, 8600A and 8800A DMMs are the industry standards.

But to really find out how good they are, ask almost anyone nearby. He's probably using one of our DMMs right now.

And he'll be able to tell you why Fluke is #1 in DMMs. Worldwide.

For data out today, dial our toll-free hotline, 800-426-0361. John Fluke Mfg. Co., Inc., P.O. Box 43210, Mountlake Terrace, WA 98043. Fluke (Nederland) B.V., P.O. Box 5053, Tilburg, The Netherlands. Phone: (013) 673-973. Telex: 52237.

*U.S. price only.

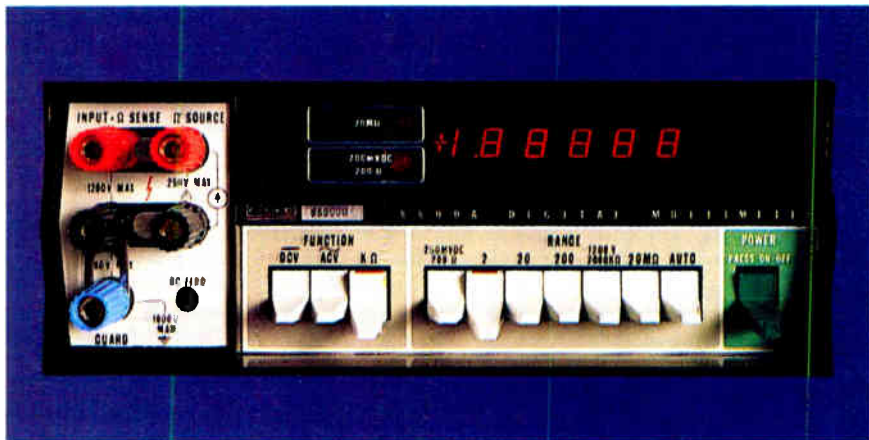

Fluke DMMs. Standards for the industry.



Circle 232 on Reader Service Card for literature

Circle 81 on Reader Service Card for demonstration

10 μ volt sensitivity, 10 nanoAmp sensitivity, and True RMS measurement in a 4 $\frac{1}{2}$ -digit portable DMM... \$345.*

The Model 248's exceptional sensitivity and accuracy is only the beginning. Data Precision has utilized proven circuit design techniques plus LSI/MOS chip economy and dependability to ensure outstanding reliability.

The result: a truly portable, high-performance, full-function instrument that provides sensitivity to 10 microvolts and 10 nanoAmps DC and AC, unsurpassed $\pm 0.05\%$ basic accuracy, and true RMS measurement for AC... with all specifications guaranteed for a full year.

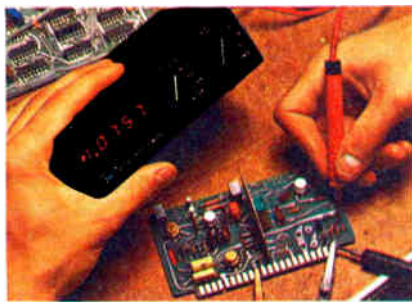

Measuring just 5 $\frac{1}{2}$ " x 1 $\frac{3}{4}$ " x 3 $\frac{1}{2}$ ", and weighing only 1.3 pounds, our 248 is the only rechargeable portable, 4 $\frac{1}{2}$ -digit DMM that brings you the advantage of True RMS voltage measurements. And with full 4 $\frac{1}{2}$ -digit resolution on all parameters, you'll have lab performance in the field or on the bench.

Exceptional Reliability

Model 248's sensitivity, accuracy, and portability place it in a class by itself, and its reliability is just as impressive. Its extremely low component count and optimal use of advanced chip technology and design makes Model 248 by far the most dependable True RMS 4 $\frac{1}{2}$ -digit portable

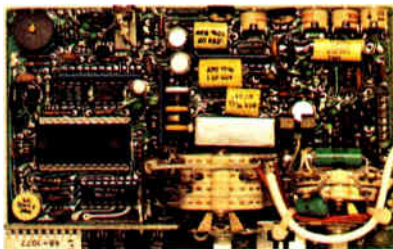

multimeter available (all the way down to 10 μ Volts). In fact, it's so reliable we guarantee its accuracy for a full year.

With only two controls — Function and Range — and the bright 0.33" LED display for easy reading in any light, you'll save time on every job. And Data Precision's overload protection



circuits make it forgiving of mistakes on all functions.

\$345.* Complete

Charger, NiCd battery, input leads and carrying case are supplied with the instrument. Model 248 is available throughout the world from Data Precision representatives, and service is available from any of our world-wide service centers.

Data Precision Corporation,
Audubon Road, Wakefield, MA.
01880, USA, (617) 246-1600.
TELEX (0650) 949341.



*price U.S.A.

Sensitivity.

DATA PRECISION[®]
...years ahead

For demonstration circle 82

For additional information circle 233

Consumer electronics

Programmable games look like a rerun

Last year's relatively simple versions were late because of a shortage of MOS chips, while the new ones await delayed shipments of microprocessors

by Gerald M. Walker, Consumer Electronics Editor

A raft of new programmable video games, some with functions that hint at use with the home computer of the future, will be demonstrated at the EIA Consumer Electronics Show in Chicago's McCormick Place next month. But for the most part, it looks as though the game makers will stage a summer rerun of last year's problems with the simpler ball and paddle games:

- A shortage of components (last year, the dedicated MOS chips weren't ready on time; this year, manufacturers are waiting for the microprocessors).
- A bottleneck at the Federal Communications Commission for type approval that is required to attach the programmables to TV receivers.

Even though there is considerable interest in the prototypes of programmable games, consumer electronics dealers focus on what they can sell. So those at the show will probably concentrate on the standard dedicated-chip models that already have the FCC's blessing. Right now only Fairchild Camera and Instrument Corp. of Mountain View, Calif., which made a hit with its programmable a year ago, and RCA Corp., which has been cautiously moving its Studio II programmable to the national market, have type approval, with Atari waiting at the Federal agency's starting gate.

Other firms are lining up despite the problems. The reason is the high stakes. For programmable video games not only are offering a way to separate the high end of the market from the toy makers, but they also offer a direct line up to the home computer—probably the next big consumer electronics product that

will create a run on the market. Virtually every one of the video game makers left with a shirt following the steep post-Christmas decline in sales is working on a programmable version, including Magnavox, APF Electronics, Coleco Industries Inc., Unisonic, and (from the ranks of the arcade game makers) Bally Manufacturing Corp. And there will be some newcomers to the market battle such as Microelectronics Inc.

But how many of these firms will be able to get their entries to market by this fall? That depends a great deal on how well the microprocessor firms are delivering. Once again the game makers say, the suppliers are

promising more than they can deliver.

So at least one programmable will show up with a customized microprocessor—source unrevealed—to beat the supply crunch. This \$150 game from APF will have three to four resident games plus six program cartridges covering ball and paddle, action, and strategy games. It will also have a keyboard that will serve primarily for inputs in the complex strategy games.

The company is caught in the regulatory bottleneck, however. Complains Howard Boilen, executive vice president, "It's the same FCC with the same number of personnel, and they just can't handle

Fun for the family. The new Bally Professional Arcade comes with two games plus a four-function printing calculator. Extra cartridges for the \$299 game cost \$20 apiece.



Designers Choice In Low-Cost 8-Bit A/Ds

3 New Series In Dual In-Line Packages

Provide choice of

- Input ranges
+10V, -10V, $\pm 5V$, $\pm 10V$
- Power supplies
 $\pm 12V$ or $\pm 15V$
- Conversion time
2.5 or 6 μsec max.
- Operating temperature
 -0° to 70°C
 -55° to $+125^\circ\text{C}$
- Mil-Std 883
processing

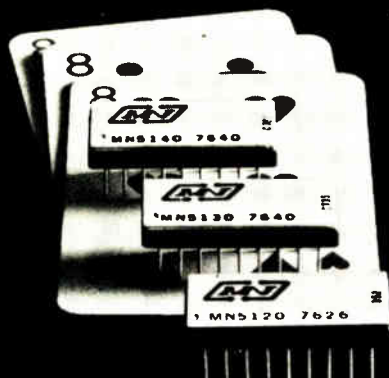

MN 5120 *\$49
($\pm 15V$ 6 μsec)

MN 5130 *\$59
($\pm 15V$ 2.5 μsec)

MN 5140 *\$59
($\pm 12V$ 2.5 μsec)

* (1 to 24 units)



Micro Networks Corporation
324 Clark Street, Worcester, MA 01601
(617) 852-5400 TWX 710-340-0064

Probing the news

the workload. There must be 48 different games in line, plus 1,000 citizens' band radios. It just took us 78 days to get type approval for a standard game with no failures. Imagine how much longer it will take with programmable games and with failures to go back and correct."

The preshow nominee for the highest priced programmable is the elaborate Bally Professional Arcade, priced at \$299. Using a custom chip from AMI, along with a microprocessor supplied by "a couple of sources," this game will be a home version of most of Bally's successful arcade games. This year the firm expects to have six cartridges with 12 games, plus two games resident in the console, and a four-function calculator capability. After the first six cartridges, Bally will introduce one per month thereafter with three games on each, according to Ross Scheer, director of marketing. Cartridges for the Arcade will retail at \$20 each.

Meanwhile, RCA, which has completed test marketing its Studio II, expects to be in national distribution next month. The set is designed to retail for \$150. It will introduce four new cartridges to add to the seven games on three cartridges already available, plus the five resident in the console—bowling, car racing, patterns, doodles, and a competitive math game. The cartridges will sell for \$15 to \$20. New programs will include professional tennis, squash, baseball, School House II (numbers games), and eventually blackjack played against the microprocessor—RCA's CDP 1802.

Earlier this year it appeared that the company was only lukewarm about the programmable-games business. But the firm is now seriously pursuing the market and plans to stay with it, a company spokesman confirms.

The programmable market is highly fragmented, even though it is barely off the ground. At the bottom are the quasi-programmable types in the \$80 range designed around very flexible dedicated chips, such as General Instrument's Gimini multi-



In the market. RCA has entered the field with Studio II. Five games are built into the \$150 set; cartridges cost \$15 to \$20.

game and tank-battle devices.

Next step up are the standard-microprocessor-based units in the \$150 category where most of the competition is bunching up. At the top are those that will probably contain customized processors, keyboards instead of joy-sticks, and programs leaning toward home computing.

As for the home computers, Commodore Business Machines showed a bare-bones version at the winter consumer show priced at \$495. Bally will probably have one in time for the next winter show using a Z-80 microprocessor. Other video games firms working on home computers are Atari, APF, Coleco, and Magnavox. These firms, however, expect the vertically integrated semiconductor makers to be in the competition, too.

An eye on computers. "Any game maker that is not aware of the home computer and is not getting ready to incorporate it in future planning, will be out of the business," remarks Joseph Searfoss, manager of consumer product merchandising for RCA Distribution and Special Products division, which handles the programmable game.

Meanwhile, if the programmable games makers clear the hurdles of microprocessor supply and FCC approval, their next challenge will be to break out of the toy market's business cycle of Christmas boom followed by bust that the ball and paddle models fell into last year. Otherwise, they may be facing another rerun next summer—no business after the Christmas rush of purchases. □

EDUARD RHEIN FOUNDATION

In agreement with the Advisory Council of the Eduard Rhein Foundation, the Board of Governors has laid down the Guidelines for the

Eduard Rhein Prize 1977

as set forth hereinafter,
Witnesseth.

1 The Eduard Rhein Prize shall be awarded each year for outstanding work in the field of further development of television technology serving consumers. The special field of endeavour for the Eduard Rhein Prize 1977 shall be as written hereinafter:

Scientific papers on the further development of improved picture quality (performance) of the overall system, particularly aimed at the „slimline design of telescreens“.

2 The Eduard Rhein Prize 1977 shall be endowed with DM 100,000.00.

3 Nominees for the Eduard Rhein Prize 1977 shall only be nominated by experts, as well as by organizations or institutions, active in research in the field of television technology. Papers may be submitted from all over the world.

The Eduard Rhein Prize shall only be awarded to individuals. Activity within the scope of employment with a firm or organization shall not be considered any objection to the awarding of the Eduard Rhein Prize. In the event that several persons have collaborated in producing the research paper, then the Prize shall be awarded to that person who exerted a determining influence on said paper. If the work has been equal in value, then a division of the Prize shall be possible.

4 The closing day for entries shall be September 15, 1977 (the date of the postmark shall be decisive).

The documents shall be sent to the
Board of Governors
of the Eduard Rhein Foundation
Klöpferstieg 3
2000 Hamburg 67
Federal Republic of Germany

Said documents may include the following:

Research report.
Internal laboratory report.
Papers submitted for publication.
Papers which have already been published.

5 The documents shall be in the German or English language.

The documents shall be submitted in triplicate, typewritten or printed by hand.

The documents shall, as a rule, not exceed 20 to 30 typewritten pages. Should the contents of the research paper demand a more comprehensive exposition, then the documents shall be preceded by a summary which shall not exceed 20 typewritten pages. In addition, each paper shall be accompanied by a summary of the significant research result; said summary shall not exceed one typewritten page in length.

A short curriculum vitae describing the nominee's scientific career shall be included with the documents.

6 Upon the recommendation of the Advisory Council of the Eduard Rhein Foundation, the Board of Governors of the Eduard Rhein Foundation shall decide as to the awarding of the Eduard Rhein Prize.

In the event no paper worthy of being awarded the Prize is submitted, then the Eduard Rhein Prize 1977 shall not be awarded.

There shall be no legal means of redress against the decisions of the Board of Governors.

7 All papers submitted shall be treated confidentially by the organs of the Eduard Rhein Foundation.

The Eduard Rhein Foundation shall not be obliged to return any papers submitted.

The guidelines can be obtained from the Eduard Rhein Stiftung,
Klöpferstieg 3, D-2000 Hamburg 57, Federal Republic of Germany.

Our fast

low pitch.

SC/MP II microprocessor

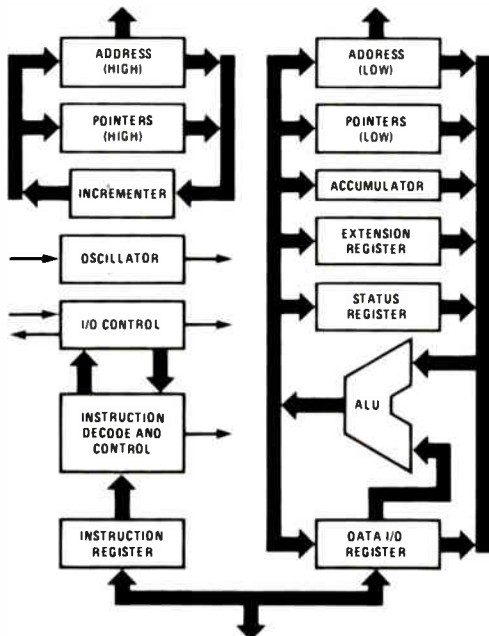

Introducing a new "fast and low" version of our SC/MP: SC/MP II.

Fast? *Twice* as fast.

And low as you can get.

In fact, the lowest-power n-channel MPU on the market. 225mW typical.

Another plus is that it now requires only a single + 5V power supply.

What doesn't change are the things that made SC/MP so almost-irresistible in the first place. Multiprocess-

ing capability built-in, easy expandability, low parts count, built-in serial I/O register, control flags and sense inputs, built-in delay timer instruction, the availability of good design tools, and a training program that teaches you how to use them.

It's available off your distributor's shelf. And of course, it's cheap. (Otherwise, why would we call it our Simple Cheap Micro-Processor?)

And that's our pitch.

National Semiconductor
2900 Semiconductor Drive
Santa Clara, CA 95051

E5-26

Please send details of your
 SC/MP II (ISP-8A/600D)
 SC/MP II Training Program

Name _____

Company _____

Address _____

City _____

State _____ Zip _____

National Semiconductor manufactures a full line of microprocessors, including the 8-bit INS 8080A, the single-chip 16-bit PACE, the bit-slice 16-bit IMP, the four-bit INS 4004, and low cost COPS microcontrollers.

See us at NCC
Booth 1565

National Semiconductor Microprocessors

Electronics abroad

Norwegian companies combine R&D

Three firms attack sagging exports and soaring production costs after the government is forced to come to Tandberg's aid

by Ottar Odland, McGraw-Hill World News

Picture the plight of electronics producers in a small nation like Norway. With markets at home severely constricted and served by other European companies as well as by giants in America and Japan, they cannot really compete internationally because they lack the capital to develop new products.

One route around the obstacle could be the one taken by three of the large electronics firms in Norway—Tandberg Radiofabrikk, Kongsberg Vapenfabrikk, and Elektrisk Bureau. The three had combined sales of \$334 million last year and account for half of all Norwegian electronics exports. In an effort to strengthen their presence in world markets, they will pool their research and development work in both product and production areas.

As a first step, Tandberg and Kongsberg have purchased many of the EB shares held by the large Swedish company, L M Ericsson. A complete merger of the three companies is an eventual possibility, though the move is not imminent.

The need for mutual help has been brought home forcefully in recent weeks by Tandberg's financial problems. The company, whose production is mainly consumer products such as tape recorders, radios, television sets, language laboratories, and speakers, struggled to a 1976 deficit of \$6 million. Government and bank loans have bailed it out and kept the R&D deal intact.

Such a combined research and planning operation faces two basic problems, says Finn Lied, Tandberg's chairman and Norway's for-

mer minister of industry. They are:

- A domestic market that is too small to support the industry, plus shrinking exports. The decrease in sales abroad was behind Tandberg's financial crunch. The company's inventory was glutted with \$8 million worth of unsold color television sets and other consumer products. Kongsberg, which specializes in military and industrial equipment, and Elektrisk Bureau, which makes communications gear, fear that they face the same problem of decreasing exports.

- Production costs in Norway have been rising steadily in recent years and are now second only to Sweden's, which leads Western Europe. The answer is to develop capital-intensive, specialized production with fewer and more carefully selected products and coordinated marketing efforts.

Modest start. So far, the tripartite alliance has one major advantage going for it: the companies sell different products in different markets. What is needed first is common to all three: research leading to production savings and development of production equipment.

There will be no organizational framework or central authority running a formal, centrally located research organization. Cooperation at this point is project oriented, with researchers at the three companies communicating about common problems and possible solutions.

One indirect result of the young alliance up to this point has been a sharp increase of state involvement in the Norwegian electronics industries. This was accomplished via the purchase of the Ericsson shares of EB

Drawing closer together

In Norway, electronics manufacturers must sell between 40% and 50% of their production on the export market to survive. This contrasts with other major industrial nations, where the electronics industries manage to sell around 75% of their output at home. Thus, the 40 or so Norwegian companies in electronics are looking increasingly to various combinations of common research, development, or marketing as a means of survival.

While the Kongsberg-Tandberg-Elektrisk Bureau attempt to cooperate on R&D of both products and production methods may be the most ambitious such undertaking, it is not the only one. Last October, three companies that make airport equipment put together a marketing department. They formed a new export firm, called Nerion A/V, to handle international sales. It will offer turnkey installations of instrument landing systems, radio transmitters and receivers, and communications control equipment made by Gustav A. Ring A/S, Nera A/S, and A/S Jotron Elektroñik. The U. S. Air Force, the British Home Office, and several international airports are already on the new firm's list of prospects.

Norwegian firms aren't averse to making agreements across international borders. For instance, A/S Norsk Dataelektronikk recently signed an agreement with LKB Produkter of Sweden, one of Europe's largest suppliers of laboratory instruments. The pact covers marketing and development of advanced data systems for hospital laboratories.

We're now an analog for Analog.

Analog Devices has named us the second source for these linear CMOS circuits:

The broadest selection of linear CMOS switches, multiplexers and converters used to be available from only one company—Analog Devices. Now you can get identical CMOS components from us.

We've become the second source for Analog Devices for a lot of good reasons. Like specs, functions and package options you can't find anywhere else. And CMOS—our brand of High-Density CMOS—which insures the lowest power dissipation available in linear ICs.

Multiplexers

- 7501 8 channels
- 7502 4 channels (differential)
- 7503 8 channels (inverted Enable)
- 7506 16 channels (DG506 replacement)
- 7507 8 channels (DG507 replacement)

So let's begin a dialogue about Analog today. Simply circle the R.S. number, and we'll send you more information about the circuits listed here. We'll also give you an opportunity to request detailed data sheets for the specific devices which interest you.

If your need is urgent, contact Linear Marketing at (408) 247-5350.



3100 Alfred Street, Santa Clara CA 95050

Switches

- 7510DI Quad SPST (protected)
- 7511DI Quad SPST (protected)
- 7512DI Dual SPDT (protected)
- 7513 Dual SPST (DG200 replacement)
- 7516 Quad SPST (CD4016A replacement)
- 7519 Quad SPDT (current steering)

If you've used Analog CMOS in the past, you'll find

it easy to order pin-for-pin replacements from us. Our numerical model numbers are identical, and our OEM prices are comparable. And of course, we offer the same reliability and product performance you've come to expect from Analog.

Check the tables for the linear CMOS you can get from us today. Soon, more unique circuits will join the roster. Whether you're a veteran user of linear CMOS, or just now contemplating its merits, you should know more about our responsive second-source capability.

Converters

Digital-to-Analog

- 7520 10-bit, Multiplying
- 7521 12-bit, Multiplying
- 7522 10-bit, Multiplying (buffered)

Analog-to-Digital

- 7550 13-bit (2's complement)
- 7570 10-bit (successive approximation)

The M-600 amp works harder at 2.5 ohms

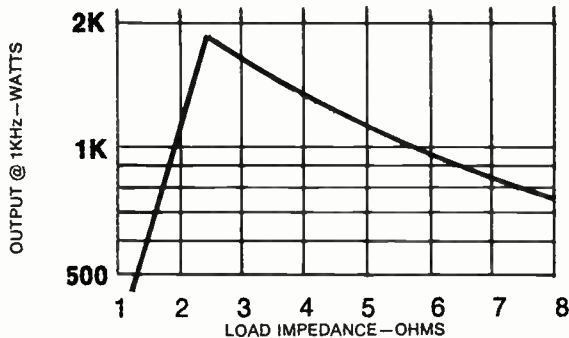

So each watt costs less

You get more watts per dollar from the Crown M-600 power amp if your circuit design lets it look at a 2.5Ω load.

The M-600 provides power from DC to 20KHz with complete protection against shorts, open circuits, mismatch, RF burnout and thermal overload. The M-600 will even drive a purely reactive load without overheating. Designed for continuous operation at full rated power, at any rated frequency.

One M-600 will cost you \$1,795. A copy of the spec sheet is free. Write today.

We'd also like to hear from you if you have any special amplification problems in the DC-20KHz range. We've already solved some tough, unique problems. We'd like to consider yours.



1718 W. Mishawaka Road, Elkhart, Indiana 46514
219 / 294-5571

Probing the news



Sees the problems. Finn Lied of Tandberg says production cost is too high.

when the Swedish company's interest was reduced to 25% from 43%. Of that 18%, Kongsberg picked up 5%, Tandberg 9%, and an aluminum company called Aardal OG Sundal Verk bought the other 4%. But Kongsberg is completely government-owned, while the aluminum firm is 75% owned by the government. And as far as Tandberg is concerned, it was only government financial intervention that saved it from bankruptcy.

Is the state considering taking over Tandberg? Observers consider such a prospect unlikely, but further efforts to save as many as possible of Tandberg's 2,000 jobs inside Norway undoubtedly will be made if necessary. That has been government policy since last year's crisis in shipping, shipbuilding, and other industries—a policy that is possible because the government anticipates considerable North Sea oil revenues in the future.

On the other hand, such government props also serve to choke off innovation in production cost-cutting by keeping outdated and low-productivity industries alive. For this reason, the Kongsberg-Tandberg-Elektrisk Bureau agreement must be viewed as a key effort to improve the chances for survival of the Norwegian electronics industries. □

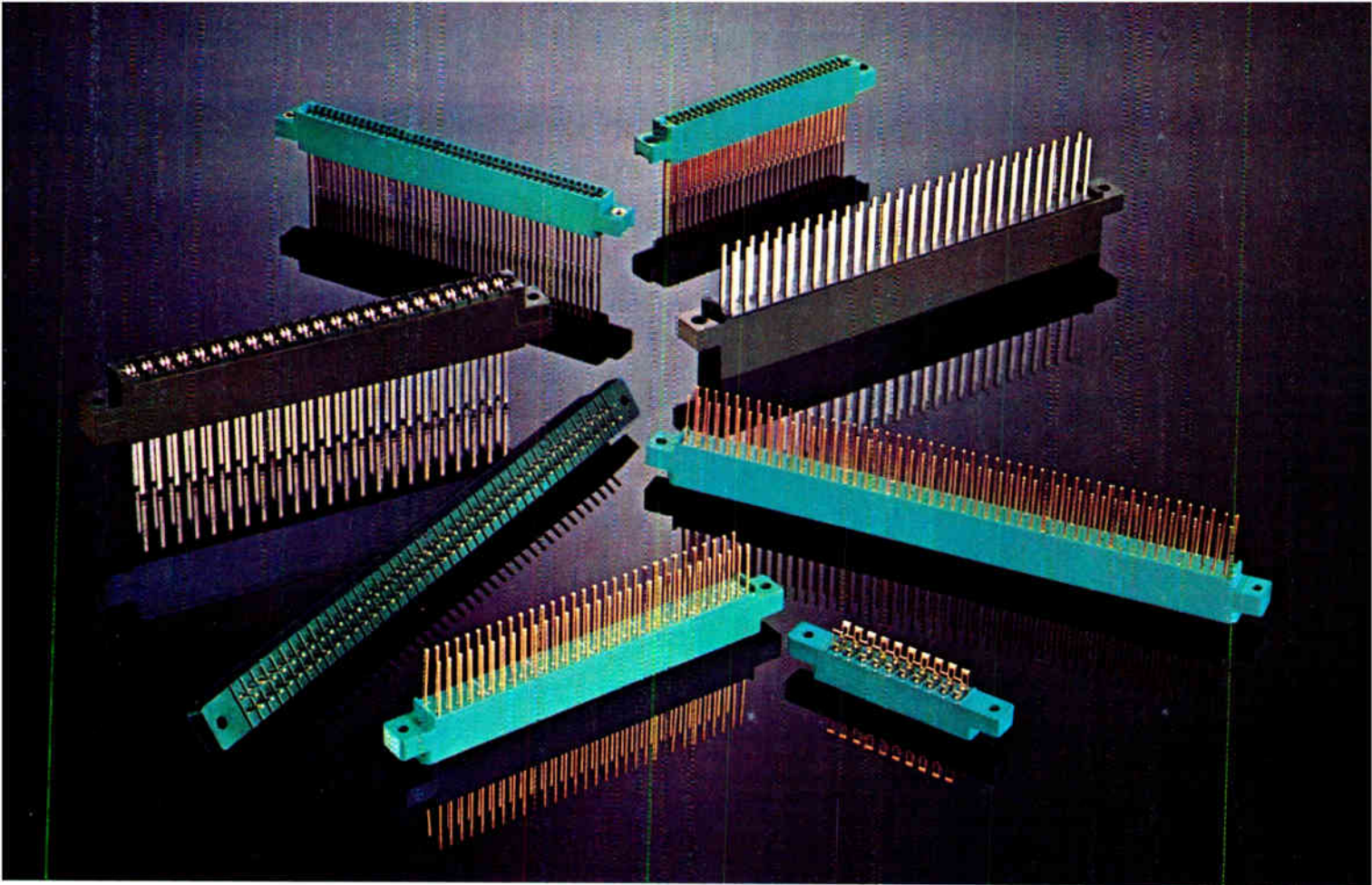

PC Connectors give our family the edge. We can give you the edge with fast delivery and wide variety in off-the-shelf PC connectors.

In .100, .125, .156 and .200 inch spacing you can take your choice for motherboard or automatic wiring applications.

You can also pick the contact you want —gold-dot or gold-plated. These include bifurcated bellows, cantilever beam and bifurcated cantilever beam designs.

Connector housings are available in glass-reinforced phenolic, diallyl phthalate and glass-reinforced polyester thermoplastic. A variety of mounting configurations are also readily available.

All have been designed to meet the applicable performance requirements of MIL-C-21097, and they're all available now.

So be sure to have a shipping date in mind when you contact GTE Sylvania, CPO, Box 29, Titusville, Pa. 16354 Phone 814-589-7071.

Remember, good connections run in our family.

GTE SYLVANIA

Circle 91 on reader service card 91



The newest source for power switching transistors is also the only source for some of them.

Introducing the Unitrode line of NPN silicon power switching transistors.

Second source products that match the offerings of RCA, Motorola, and TI.

Plus unique new products with characteristics nobody can match:

1. Half the fall times. To reduce switching power losses and simplify your circuitry.

2. Three times better $E_{S/b}$. A reverse bias second breakdown so good it virtually eliminates the possibility of catastrophic circuit failure.

And both our second source and unique products feature hard glass passivation and rugged clip lead connections to insure the utmost in reliability.

All this with dependable off-the-shelf delivery, in-depth applications assistance, and, of course, competitive pricing.

The new line of Industrial power switching transistors from Unitrode.

Your second source. And only source.

For data sheets, circle the reader service number, or contact Harv Hodsdon, Unitrode Corporation, 580 Pleasant St., Watertown, MA 02172. 617-926-0404.

Second Source:

Series	$V_{CE(SUS)}/I_C$	Pkge Style	Representative Pricing - 1000 Lot			
2N6544-45	400V/8A	TO-3	2N6545 - \$4.54			
2N6306-8	350V/8A	TO-3	2N6307 - \$2.55			
2N6510-14	350V/7A	TO-3	2N6512 - \$3.00			
2N3583-5* 2N4240	300V/2A	TO-66	2N3584 - \$1.19			
2N5038-9 2N6354 2N6496				120V/20A	TO-3	2N5038 - \$3.50
2N5427-30*	100V/7A	TO-66	2N5428 - \$3.82			
2N3878-9 2N5202 2N6500	90V/7A	TO-66	2N3879 - \$1.64			

*Plastic equivalents also available in TO 220 Package

Only Source:

Three times better $E_{S/b}$

Types	$V_{CE(SUS)}/I_C$	Pkge Style	Fall Time Max.	Pricing 1000 Lot
UMT1008	300V/8A	TO-3	0.4 μ s ⁽¹⁾	\$3.95
UMT1009	400V/8A	TO-3	0.4 μ s ⁽¹⁾	\$4.95
UMT1003	300V/3A	TO-66	0.4 μ s ⁽²⁾	\$1.60
UMT1004	400V/3A	TO-66	0.4 μ s ⁽²⁾	\$1.76

(1) $I_C = 5A, I_{ES} = I_{CS} = 1A$
 (2) $I_C = 2A, I_{ES} = I_{CS} = 0.4A$



Here's how Data General's microNOVA system stacks up against the competition.

microNOVA Processor:
Fully packaged 9-slot micro-computer. 16K words MOS memory, 2.4-microsecond arithmetic operations, hardware stack facility, multiply/divide, DMA capability. Includes RTC, PF/AR and APL. Supports up to 32K words RAM/PROM memory.

Dual-diskette subsystem:
Integral DMA controller, compact 630KB capacity.

Cabinet:
37 inches high, holds all rack mounted components.

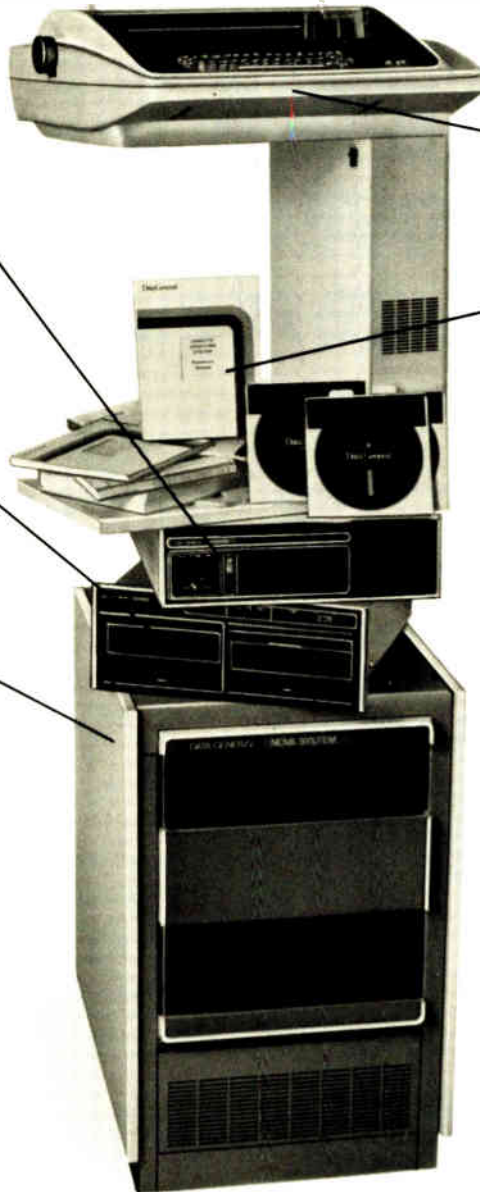

DASHER
terminal printer:
30 cps, 132-columns, typewriter keyboard, upper/lower case.

Systems Software:
Multitasking Disc Operating System, Real-Time Operating System, FORTRAN IV, Extended BASIC, Macro Assembler, Utilities.

\$10,970
List*

The facts speak for themselves. For \$10,970, Data General's new microNOVA gives you more system, software availability and support than any other comparable computer. And we deliver in 60 days.

Any way you look at it, it all stacks up in your favor. For more information and our brochure, call our toll free number, 800-225-9497, or, fill out and return the coupon.

*Additional software fees apply to first system only. Quantity and OEM discounts available.

Data General, Westboro, MA 01581
Sounds like smart business. Send me more information.

NAME _____
TITLE _____
COMPANY _____
ADDRESS _____ TEL. _____
CITY _____ STATE _____ ZIP _____
NOVA is a registered trademark of Data General Corporation.
DASHER is a trademark of Data General Corporation.

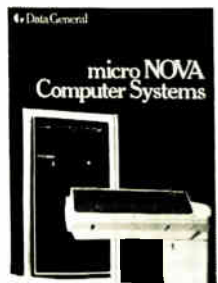

Data General
It's smart business.

Data General, Westboro, MA 01581, (617) 485-9100. Data General (Canada) Ltd., Ontario. Data General Europe, 15 Rue Le Sueur, Paris 75116 France. Data General Australia, Melbourne (03) 82-1361.

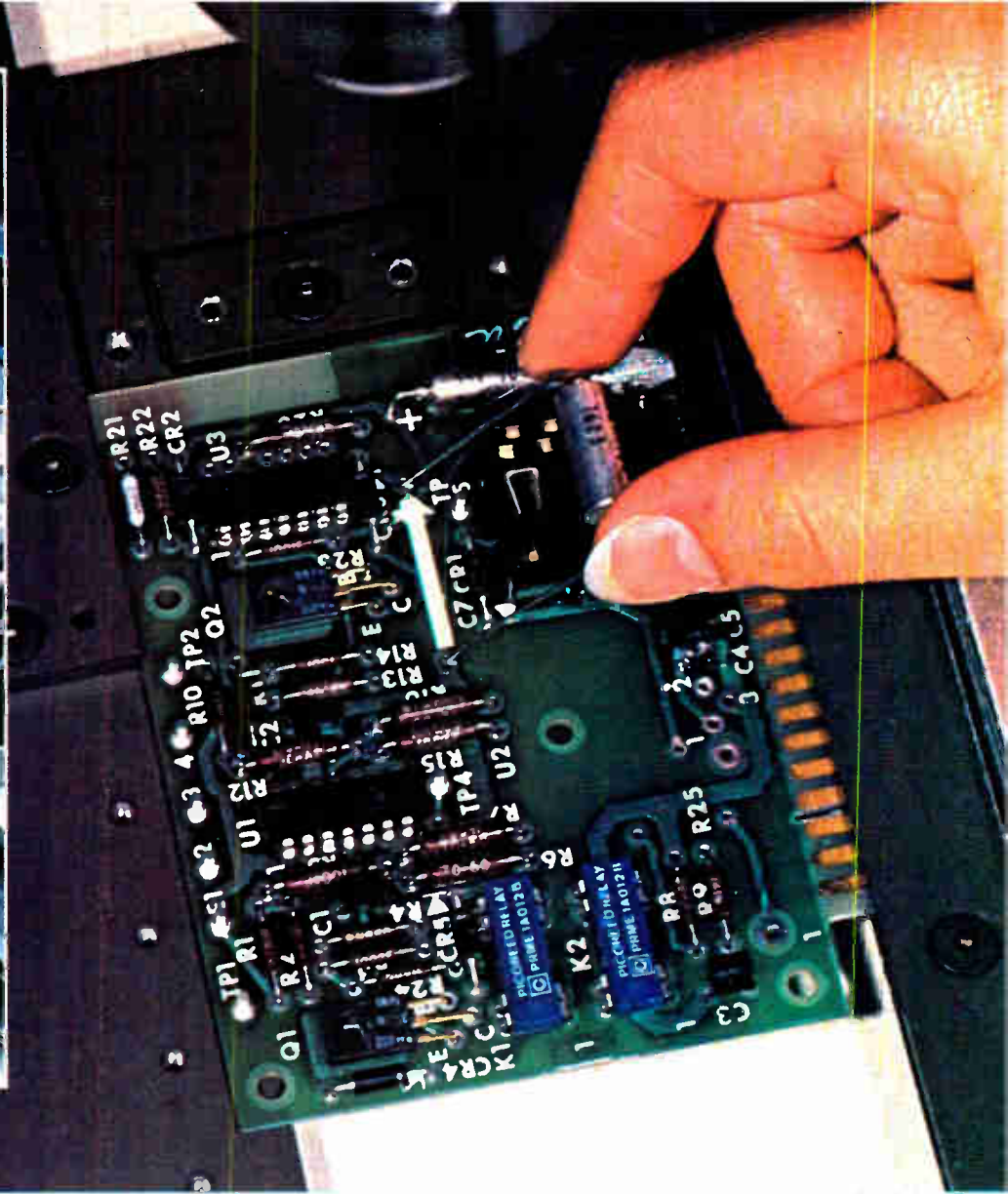

This easy-to-program hand assembly machine thinks for the operator and can cut and clinch leads.

Universal's Model 6232 automatically presents the right component to the operator, moves the PC board to the proper insertion position, and projects a brilliant light image that shows the exact location and orientation of the component. All the operator does is insert a component and hold it during the cut and clinch cycle. To make things even easier, operators can adjust the work table angle to suit their height and view of the boards. Quality of finished boards goes up. Touch-up and inspection time are reduced as much as 95%.

All functions except the actual insertion are controlled by Universal's Satellite Controller System. Programming can be accomplished by computer-aided design, off-line coordinate measuring, manual prep, or by the machine

itself, using an actual PC board. This provides easy programming, with on-line editing; and without film, drawings, or hole punching. Management data for monitoring machine and operator performance, and program storage are standard.

There are many other advantages. Write for descriptive literature on the world's most productive manual and automatic printed circuit board assembly systems.



Universal Instruments Corporation
Kirkwood Industrial Park
Box 825, Binghamton, New York 13902
Tel: 607/772/7522 TWX: 510/252/1990

The books you'll need, no matter what the energy crisis brings...

HANDBOOK OF COMPONENTS FOR ELECTRONICS

C. A. HARPER, Editor-in-Chief. 1,086 pp., 887 illus.

Here is the only reference to present detailed coverage of all types of components which are vital to today's electronic designer. Its contents range from advanced integrated and discrete semiconductor devices to high-frequency components, capacitors, resistors, relays, inductive devices, and more. Designed for working professionals, the Handbook puts component characteristics and performance data at your fingertips. With this one-stop source you no longer have to waste your time searching through countless loose data sheets, which describe products instead of giving you comparison data and guidelines for the best trade-off decisions.

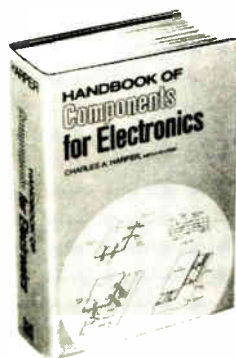

ELECTRONICS DESIGNERS' HANDBOOK

Second Edition

Revised and Edited by L. J. GIACOLETTO. 2,344 pp., 1,686 illus.

Totally rewritten and updated, this designers' classic gives you every assistance possible in making you aware of and helping you to understand the latest design techniques from the most simple to the most sophisticated. The sheer amount of practical information presented to you is, of course, a highly desirable feature. But the invaluable manner in which this information is pinpointed for you and the Editor's constant awareness of your need to know exactly the why as well as the how—and especially the how much these days—of every electronic project you're involved in, make the Handbook the most profitable piece of daily equipment you can own!

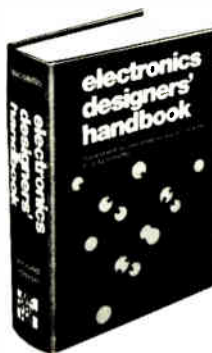

SHOCK AND VIBRATION HANDBOOK

Edited by C. M. HARRIS and C. E. CREDE. 2nd Ed., 1,322 pp., 1,025 illus.

Presents an up-to-date, unified, and definitive treatment of the subject of shock and vibration. Written by 54 distinguished authorities, this extensively revised Second Edition covers fundamentals, instrumentation and measurements, data analysis and testing, practical methods of control, equipment design and packaging, the effects of vibration on people, and solutions to engineering problems.

FUNCTION CIRCUITS

Design and Applications

By Y. J. WONG and W. E. OTT. 288 pp., illus.

To cut your design costs and to be sure you're choosing the optimum cost-effective circuit every time, use this Burr-Brown/McGraw-Hill best seller as you would a workside helper who is a top expert. A complete reference of the total array of today's analog function circuits, it gives you on-the-spot solutions to your problems involving the design and application of op amps, log-amplifiers, multipliers, dividers, rms, converters, and active filters!

MANAGEMENT OF ENGINEERING PROJECTS

By V. C. HAJEK. 2nd Ed., 250 pp., illus.

All major technical and administrative facets of an engineering project are covered in this highly practical work, which is written for contract administrators and staff personnel concerned with quality and control functions, as well as for project engineers and managers. The author presents professional guidelines for preparing a proposal, using a typical procurement to illustrate his technique. He takes the reader through the crucial area of cost estimating, and examines configuration management, a new administrative method used for tracking and keeping account of changes during the project life cycle.

LARGE SCALE INTEGRATION

Edited by L. ALTMAN. 208 pp., illus.

Covering a wide range of LSI applications, technology break-throughs, and problem-solving information, this volume contains the essential building blocks of an array of powerful new circuit tools. Fully and lavishly illustrated, it fills a long-felt need for a central depository of practical design information for equipment and system designers who want to apply LSI in solving day-to-day problems. A volume in the Electronics Book Series.

BASICS OF DATA COMMUNICATIONS

Edited by H. K. KARP. 303 pp., illus.

Focusing on the state of the art of today's networks, this book explains in detail the many considerations that have to be weighed in setting up a data communications system—from the selection of modems to the intricacies and impact of error control to centralized network diagnostics. Based on selected articles from *Data Communications*, it is a volume in the Electronics Book Series.

OPTOELECTRONICS APPLICATIONS MANUAL

By HEWLETT-PACKARD. 288 pp., illus., 8 1/2 x 11 format

One of the first books to be published on optoelectronics by a leading firm in the field. Hundreds of large clear illustrations are included with isometric illustrations showing good component arrangements, numerous circuit diagrams, specific optoelectronic devices, and clear mathematical development of major concepts. The book covers P-N junction electroluminescence, LED lamps, visual applications of LED lamps, LED arrays, communications and signalling applications, reliability of optoelectronic devices, and mechanical handling considerations for LED devices.

HANDBOOK OF OPERATIONAL AMPLIFIER CIRCUIT DESIGN

By D. F. STOUT. Edited by M. KAUFMAN. 434 pp., 223 illus.

Compact, concise, and highly concentrated, this unique "one-stop" designer's handbook contains an enormous amount of information and a rich collection of operational amplifier circuits, parameters, equations, tables, design steps, and practical examples. Leaving off all the frills, it is a safe bet that it will help you to solve any and every op amp circuit problem you're ever likely to run into!

POWER-TRANSISTOR AND TTL INTEGRATED-CIRCUIT APPLICATIONS

Edited by B. NORRIS, TEXAS INSTRUMENTS, INC. 256 pp., illus.

Written by engineering specialists in the Texas Instruments Application Laboratory, the chapters in this volume have a broad industrial focus. Practical and application-oriented, they are of interest to a wide spectrum of engineers using semiconductor devices. Also, the book's coverage of inverter and audio amplifier design will interest engineers who are not specializing in the field.

ENGINEERING MANUAL

A Practical Reference of Design Methods and Data in Building Systems, Chemical, Civil, Electrical, Mechanical, and Environmental Engineering and Energy Conversion

Edited by R. H. PERRY. 3rd Ed., 966 pp., 371 illus.

Provides the latest design methods and most needed data for solving a wide range of problems across the broad spectrum of the major engineering disciplines. Incorporating the most advanced techniques and newest changes in laws and codes, this Third Edition is a truly essential reference for every engineer and energy specialist.

McGraw-Hill Book Company
1221 Avenue of the Americas
New York, N.Y. 10020



SEND ME the book(s) checked for 15 days on approval. At the end of that time, I will remit for the book(s) I keep, plus local tax, postage, and handling, and return the unwanted books postpaid. (SAVE MONEY! Remit in full, plus local tax, with this order, and McGraw-Hill pays all regular postage and handling costs. Return books in 15 days for full refund if not completely satisfied).

Name _____

Street _____

City _____

State _____ Zip _____

This order good only in U.S. and is subject to acceptance by McGraw-Hill.

- | | |
|--|---------|
| <input type="checkbox"/> HANDBOOK OF COMPONENTS FOR ELECTRONICS (026682-4) | \$36.50 |
| <input type="checkbox"/> ELECTRONICS DESIGNERS' HANDBOOK (023149-4) | \$47.50 |
| <input type="checkbox"/> MANAGEMENT OF ENGINEERING PROJECTS (025534-2) | \$15.95 |
| <input type="checkbox"/> POWER-TRANSISTOR AND TTL INTEGRATED-CIRCUIT APPLICATIONS (063754-7) | \$16.50 |
| <input type="checkbox"/> OPTOELECTRONICS APPLICATIONS MANUAL (028605-1) | \$19.25 |
| <input type="checkbox"/> FUNCTION CIRCUITS (071570-X) | \$18.50 |
| <input type="checkbox"/> BASICS OF DATA COMMUNICATIONS (019159-X) | \$19.50 |
| <input type="checkbox"/> LARGE SCALE INTEGRATION (019187-5) | \$16.50 |
| <input type="checkbox"/> ENGINEERING MANUAL (049476-2) | \$19.75 |
| <input type="checkbox"/> HANDBOOK OF OPERATIONAL AMPLIFIER CIRCUIT DESIGN (061797-X) | \$24.50 |
| <input type="checkbox"/> SHOCK AND VIBRATION HANDBOOK (026799-5) | \$32.50 |

23A208-4018-3

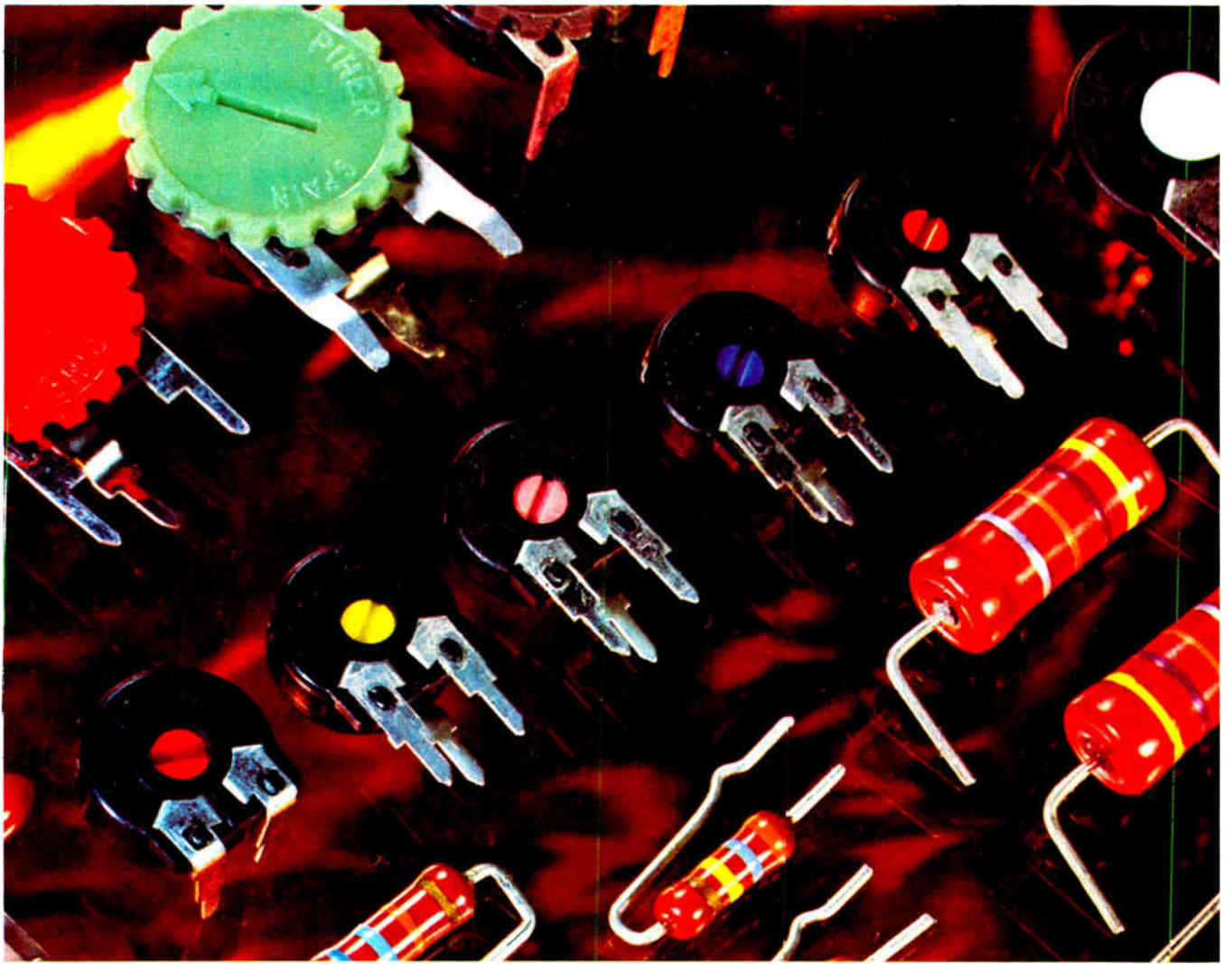

On reflection, you'll have to agree they're the finest passive components in the business.

If you need high quality carbon film resistors and potentiometers you don't have to look any further than the Piher International Corporation. Which means you never have to look far, for in the USA we're a coast-to-coast operation.

Our customer service facilities have been strengthened with a new headquarter and warehousing operation in Chicago – as have our East and West coast regional offices in New York and Los Angeles – and our whole operation is backed by 25 distributors and nationwide representatives.

Why the strengthening? Simply because of demand, and the fact that we appreciate the importance of the American market.

Piher International Corporation is the new name for a sales and marketing operation that has been set up to meet current demand – demand that will double Piher's turnover in the USA this year.

Find out more about Piher products. A lot of companies have – and they found it paid off.



Spain · Germany · Great Britain · France · USA · Italy · Austria · Holland

PIHER INTERNATIONAL CORPORATION, 505 WEST GULF ROAD, ARLINGTON HEIGHTS, CHICAGO, ILLINOIS 60005, U.S.A. TELEPHONE (312) 640 8300

The sweep signal generator world has a new leader to look up to. Model 2002 sweeps from 1 to 2500 MHz in four bands. Or it can sweep the entire range using the band stacking option. It has more flexibility than any broadband sweeper

we've made, along with +13 dBm output, ± 0.5 dB flatness, 0.005% marker accuracy, and $\pm 1\%$ display linearity. Look at the Model 2002 from any angle and you'll become a follower. Send us \$2700 and you'll become an

owner. Circle our reader service number for details. WAVETEK Indiana Incorporated, P.O. Box 190, Beech Grove, Indiana 46107. Telephone (317) 783-3221. TWX 810-341-3226.

WAVETEK®

The new 2002 will sweep you off your feet.



Circle 98 on reader service card

World Radio History

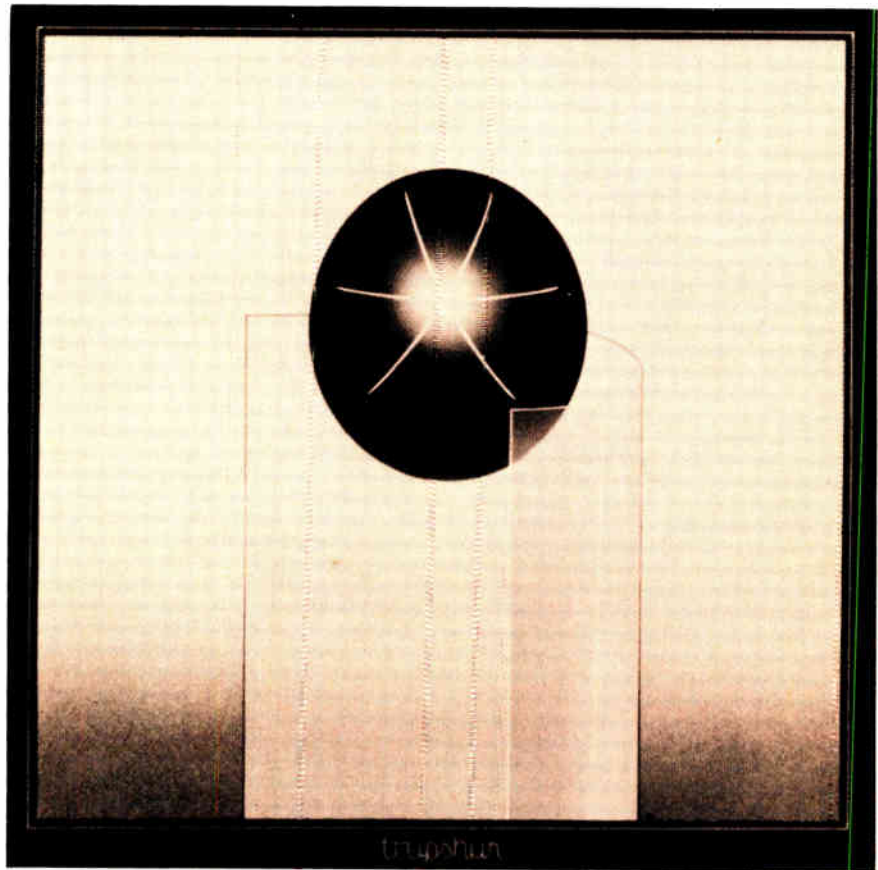

Process refinements bring C-MOS on sapphire into commercial use

First 16-bit microcomputer chip set attains speed of 125 nanoseconds, dissipates 100 milliwatts per chip

by Alan Capell, Daryl Knoblock, Larry Mather, and Larry Lopp,
Hewlett-Packard Co., Data Systems Division, Cupertino, Calif.

□ Complementary-MOS circuits built with the silicon-on-sapphire process are now a proven LSI technology, offering a combination of high speed, low power, and design flexibility unmatched by any other semiconductor process. Among the first group of Hewlett-Packard components to use it is a 16-bit microcomputer chip set that rivals bipolar designs in performance. Besides a central processor with an 8-megahertz maximum clock rate and read-only and random-access memories, the chip set includes the first single-chip interface to the IEEE-488 standard interface bus—a device that by itself can replace as many as 200 standard transistor-transistor-logic circuits.

To reach this point, several significant advances in processing had to be

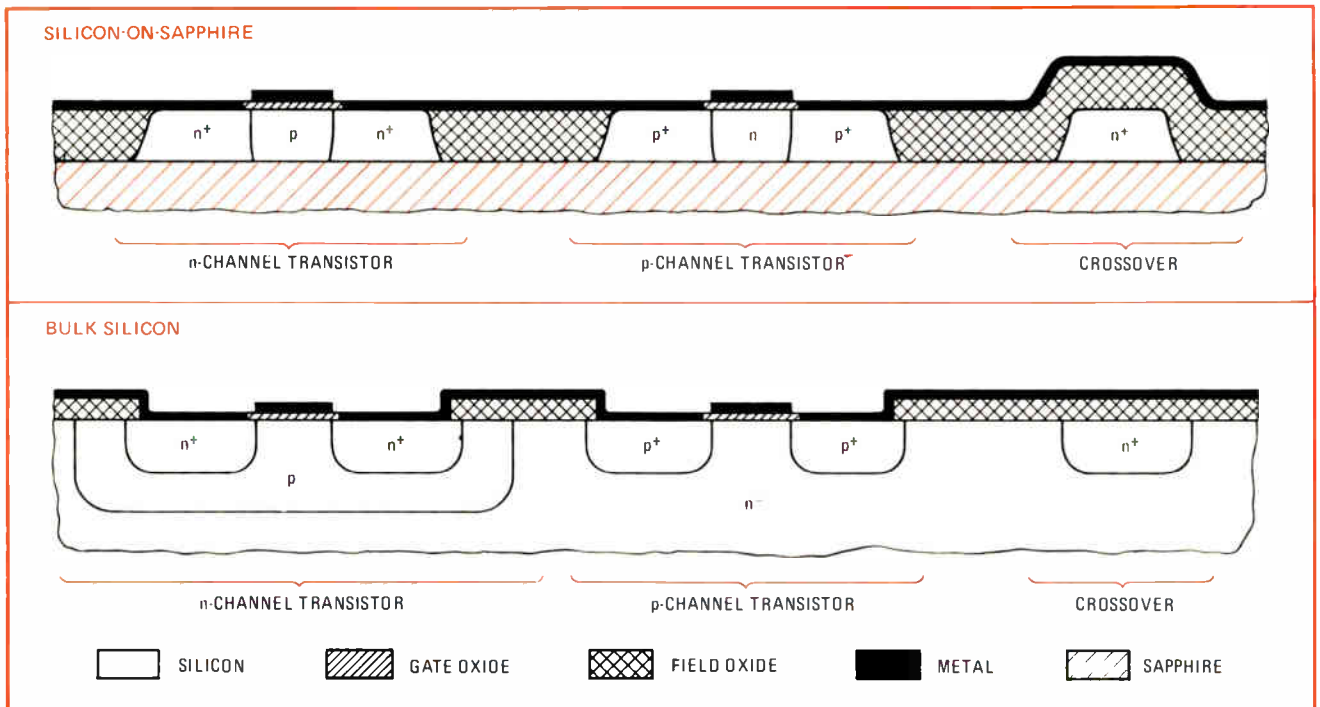

1. Silicon-on-sapphire vs bulk silicon. SOS devices, with vertical junctions, have less junction area and thus lower capacitance than devices built in bulk silicon. Capacitance between conductors and substrate is also significantly reduced by using SOS technology.

made. Although a complementary-metal-oxide-semiconductor-on-sapphire version of large-scale integration has long held the promise of high performance, previous silicon-on-sapphire circuits were plagued with high leakage currents, poor metal coverage of oxide steps, and low breakdown voltages for the oxide. Now with a new process called local-oxidation SOS (Losos), the oxide-step and breakdown voltage problems have been solved, while the leakage currents have been reduced by several orders of magnitude by careful attention to contamination and epitaxial-film growth rates and thicknesses.

Why C-MOS on sapphire?

Even with relatively low-resolution 6-micrometer design rules and a standard metal-gate process, the HP C-MOS-on-sapphire technology is currently producing chips longer than 6 millimeters (235 mils) on a side and typically packing 300 transistors into each square millimeter. Present yields correspond to a defect density of five defects per square centimeter (typical bulk MOS defect densities are closer to 10/cm²). Further improvements are likely as higher-resolution photolithography is introduced to the process.

The low power dissipation provided by C-MOS on sapphire primarily results from the use of the complementary static circuits, whereas the high speed comes from the very small parasitic capacitances associated with the devices and interconnections. The low capacitance also contributes to low ac power dissipation.

In the static C-MOS design, gates typically dissipate less than 0.1 microwatt of dc power, while typical chips dissipate about 100 milliwatts of ac power at speeds up to 8 MHz. The dc power dissipation is controlled by the leakage currents in the devices. Leakage currents typically are less than 10 nanoamperes for 6-by-6- μ m n-

channel transistors operating at 12 volts. This allows, for example, a 2,048-bit static RAM chip to dissipate less than 8 mw of standby power.

The major reduction in capacitance is due to the reduced junction area of the silicon-on-sapphire devices (Fig. 1). SOS devices have only the capacitance associated with the small area of the vertical junctions between the source- and drain-to-subchannel regions, whereas in bulk silicon, source and drain diffusions result in large-area junctions and thus associated large capacitances. The SOS dielectric isolation also virtually eliminates the capacitance between the conductors and the substrate, which can become significant in bulk-silicon circuits with complex interconnections and large conductor areas.

In previous SOS designs, the silicon islands were formed by anisotropically etching the field regions between devices completely down to the sapphire surface. The islands had well-defined, inward-sloping sides (Fig. 2a), but any subsequent thermal oxidation of the silicon produced an oxide with a negative, outward slope at the oxide-sapphire interface (Fig. 2b). All attempts to obtain reliable metal coverage over this type of step were unsatisfactory. The solution to the problem was a fundamental change in the process, avoiding oxide at the silicon-sapphire interface entirely.

Better processing

In the current process, the intended silicon island areas are defined by forming a pattern in a silicon-nitride film previously deposited on the silicon. After the silicon has been etched to about half its original thickness, the silicon areas not covered by silicon nitride are oxidized completely to the sapphire surface (Fig. 2c). This results in a planar structure that allows much more

The Losos process

Hewlett-Packard's high-performance complementary-MOS-on-sapphire circuits are being made with an eight-mask process sequence called Losos, for local oxidation of silicon-on-sapphire.

The substrate is made from a Union Carbide high-quality single-crystal sapphire (Al_2O_3) grown by the Czochralski method, cut on the $\langle 11\bar{0}2 \rangle$ plane, and then highly polished. The first process step at HP is the epitaxial growth on the sapphire of a film of single-crystal $\langle 100 \rangle$ -oriented silicon approximately 0.6 micrometer thick. This layer is doped n-type at the appropriate concentration to provide a 2-volt threshold for the p-channel enhancement-mode transistors.

After the surface of the silicon has been protected with a thin layer of thermally grown SiO_2 , a double-film structure of Si_3N_4 and SiO_2 is chemically vapor-deposited. The Si_3N_4 film will subsequently be used as a mask against both oxidation and diffusion in several steps in the process. The composite structure is shown in the accompanying figure (step 1).

Next, when silicon islands have been delineated as desired in photoresist, the pattern is transferred to the silicon by a series of chemical-etch processes. The sloped silicon profile is obtained with an anisotropic etchant. After etching the silicon film to approximately half its original thickness (step 2), the remaining silicon is thermally oxidized down to the sapphire interface (step 3). This field oxide provides excellent-quality interdevice dielectric isolation as well as a planar topology for subsequent deposition of oxide and metal layers.

The original Si_3N_4 layer is again selectively etched to form the gate pattern. A thick coating of photoresist is used as a mask to confine the boron ion implantation to the intended n-channel transistor areas only. The boron ions convert the entire area under the Si_3N_4 as well as the exposed silicon to p-type material with the appropriate concentration to provide a 2-V threshold (step 4).

After removal of the previous photoresist mask, the phosphorous source for the n⁺ diffusion is deposited onto the wafer in the form of a layer of phosphorus-doped oxide (PDO). In the areas where the p⁺ diffusion is desired, the PDO layer is removed with a masking and etching operation. The n⁺ and p⁺ regions are simultaneously doped in a single boron diffusion furnace (step 5).

Following the drive-in diffusion, the deposited oxide layers are removed and replaced with a new deposited oxide layer. An oversized gate pattern is etched into the new oxide layer to permit the subsequent removal of the remaining Si_3N_4 (step 6). With the Si_3N_4 and underlying SiO_2 layers removed, the gate oxide is grown. HCl is used to ensure low drift (step 7).

Contact openings are made to the silicon islands using the sixth masking and etching operation. After depositing a thin film of aluminum by evaporation, the conductor pattern is formed (step 8). Finally, after the Al-Si contacts are alloyed, a passivation layer is deposited and patterned to complete the process.

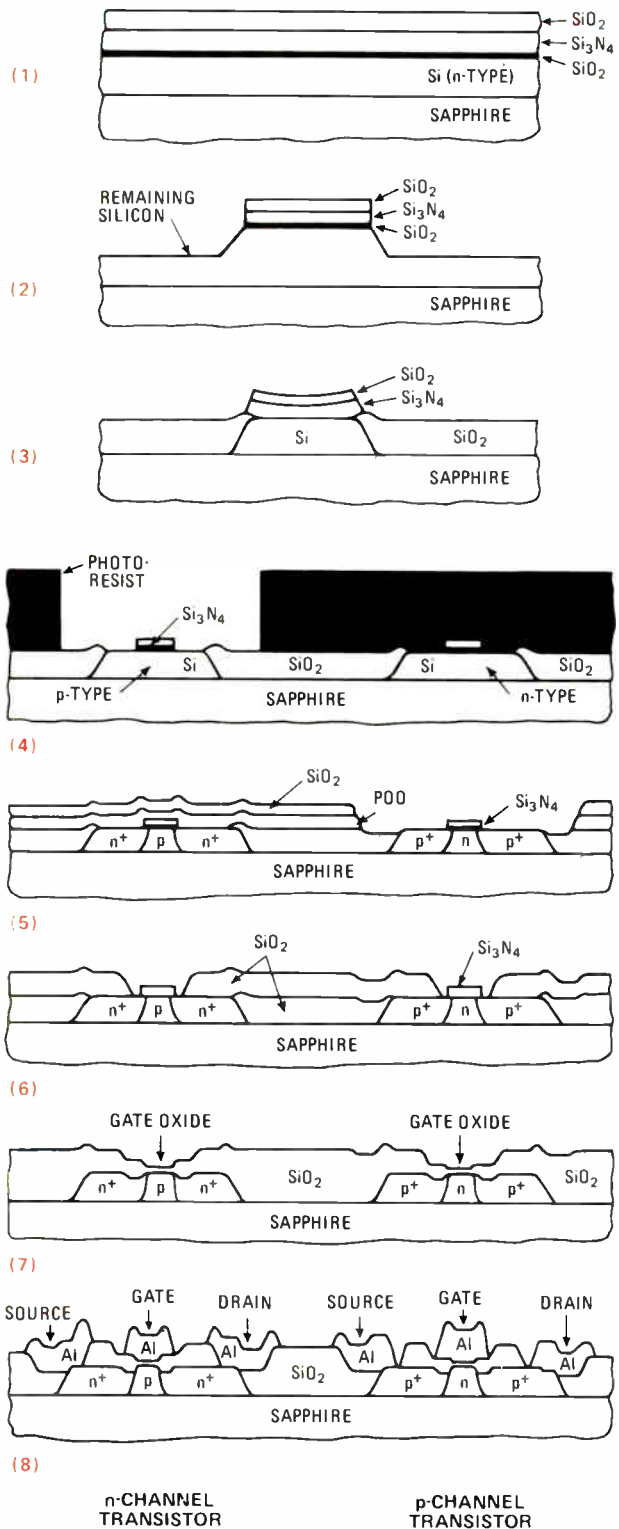

reliable deposition of metal, which in turn, when coupled with the very low current densities typical of C-MOS logic, results in interconnection patterns of high integrity and reliability (for details, see "The Losos process.")

The dielectric isolation feature of SOS also enhances

yield and reliability. Since there is no conducting layer in the field region (the region between devices), all shorts to the metal layer in the vertical direction are eliminated. This makes the process totally insensitive to defects in the field regions. Furthermore, dielectric isola-

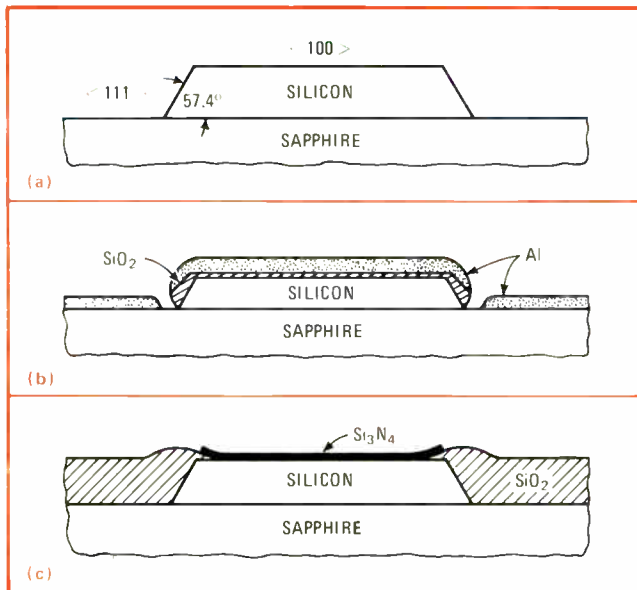

2. Improved SOS. In older SOS processes, silicon was etched down to the substrate (a), then oxidized, and an aluminum layer applied. But the aluminum covered the oxide step near the sapphire interface poorly. In new process (c), a planar surface eases metalization.

tion reduces the total pn junction area of each device to the point where junction failures are rarely observed. (In fact, a reliability analysis has revealed that there are no new failure modes peculiar to SOS among MOS technologies.) The result is a failure rate for RAM and ROM components that is well below 0.1% per thousand hours after burn-in at 125°C.

One of the major problems in the development was to understand the sources of leakage currents in the devices. Figure 3 gives a chronological record of decreases in leakage currents, each of which is directly associated with a known, controlled change in the process.

The most important process parameters affecting leakage were found to be contamination of the sapphire surface prior to epitaxial deposition, the rate of epitaxial film growth, and the final thickness. Thorough understanding of leakage, however, required the development of a battery of special test devices designed to monitor the various components of leakage current in the SOS transistor. These components include currents along the top surface, the two side walls, and the silicon-sapphire interface, and each had to be considered separately.

Fewer design problems

Many complications normally encountered while designing in other MOS technologies can be ignored in C-MOS-on-sapphire design. This is important because both the cost and the time of a design effort can increase significantly when an LSI circuit designer has to worry about process-related problems as well as the digital design of his circuit.

The following items highlight the freedom from process-related restrictions that is enjoyed by designers when they are working with SOS technology:

- Field inversion under metal lines in a bulk MOS process can create MOS transistors where none was expected.

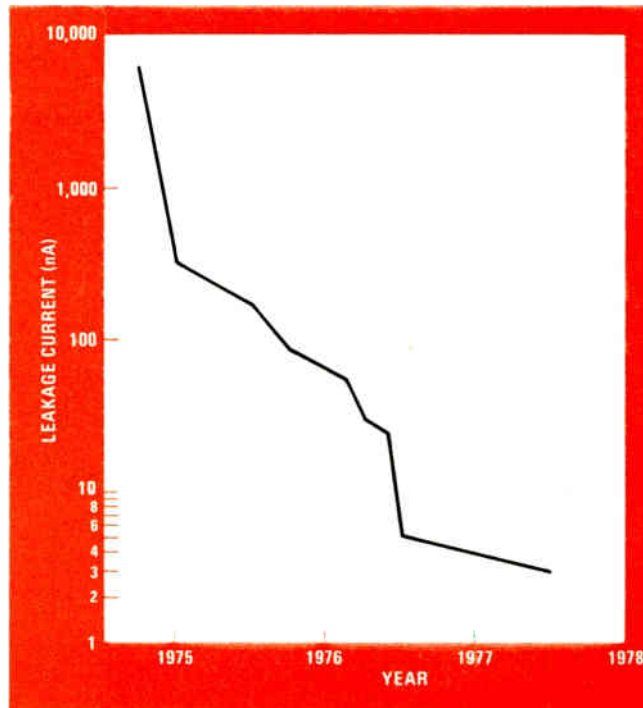

3. Less leakage. Record of progress in reducing leakage in n-channel SOS transistors shows a four-order-of-magnitude improvement over three years. Four sources of leakage were identified and reduced: upper surface, side walls, lower surface, and junction.

This phenomenon vanishes in SOS because the field region contains no semiconductor material.

- Isolation junctions are required in bulk C-MOS designs to electrically isolate transistors from signal lines and each other. SOS completely eliminates the need for these junctions because of the natural dielectric isolation.

Then, because static C-MOS is used:

- Transistor-ratio calculations normally performed in p- and n-channel MOS designs are eliminated by the push-pull effect of C-MOS structures.
- Circuit failure because of charge leakage during clock slowdown is a significant problem in dynamic MOS circuits, but is nonexistent in static C-MOS design, since leakage-sensitive charge-storage techniques are not used to save state information. Not only can a synchronous static-logic circuit be slowed down, but it also can be "frozen" to preserve its state at any time to facilitate debugging.
- Dynamic designs require that time limits be placed on external responses, since any input change that changes the circuit state must be synchronized with the clock. The clock period then becomes a lower bound on the time taken for the new state to be seen externally, and this period could be far too long in applications where the circuit is required to handshake quickly with external logic. Static design allows asynchronous logic circuits to be implemented, totally bypassing this problem.

Besides allowing functional logic gating, C-MOS-on-sapphire technology makes it possible to build transmission gates composed of n-channel and p-channel transistors in parallel (Fig. 4). When used as bidirectional switches, they allow greater speed in bus-driving applications than a single transistor and may be used in series

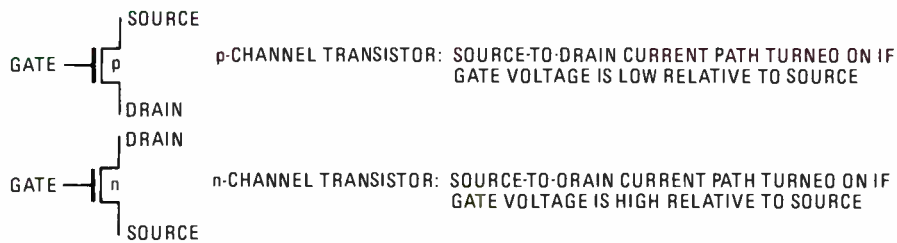

TWO-INPUT NAND GATE

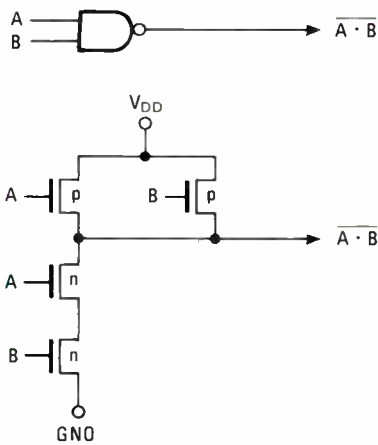

AND-NOR GATE WITH NAND TAP

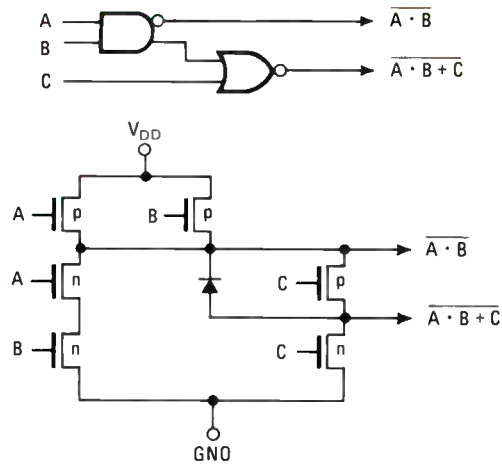

BIDIRECTIONAL SWITCH

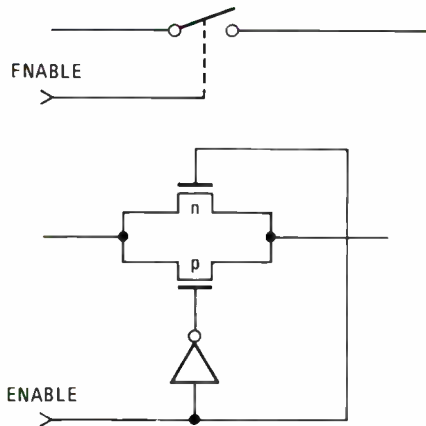

GATED D LATCH

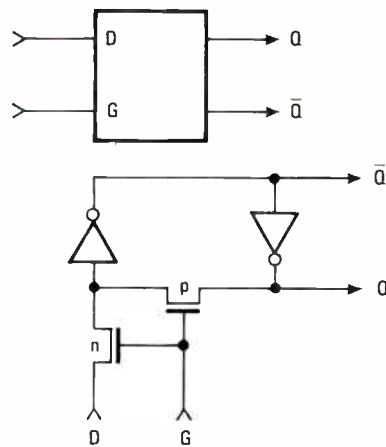

4. Complementary-MOS structures. In typical circuits built in C-MOS, note that bidirectional switch may be easily built with two transistors in parallel and that isolated diodes allow the addition of extra logic outputs from a gate, such as the NAND gate shown here.

strings without fear of threshold drops. Such gates present, at best, difficulties when built with bulk silicon technology.

The SOS process provides a special bonus by allowing the fabrication of electrically isolated diodes consisting of a single pn junction—an impossibility in bulk silicon. These diodes can be used to advantage in arrays to produce dense high-speed ROMs and can also be used to bring out intermediate outputs from large gates, thus reducing overall transistor count. (In one of the examples shown in Fig. 4, a single gate provides both a NAND

and an AND-NOR output with a single diode.)

A microcomputer chip set is one of the first applications for HP's SOS process (Fig. 5). Components in the set include a 16-bit CPU chip (MCC), a ROM, a RAM, and an interface chip (PHI) to couple the processor to the IEEE-488 standard interface bus. The chips communicate with one another over a parallel asynchronous bus that can run at any speed up to 4 MHz. The MCC can use this bus to directly address up to 65,536 16-bit memory locations and 2,048 external input/output registers used for peripheral control. Memories tied to the bus can run at

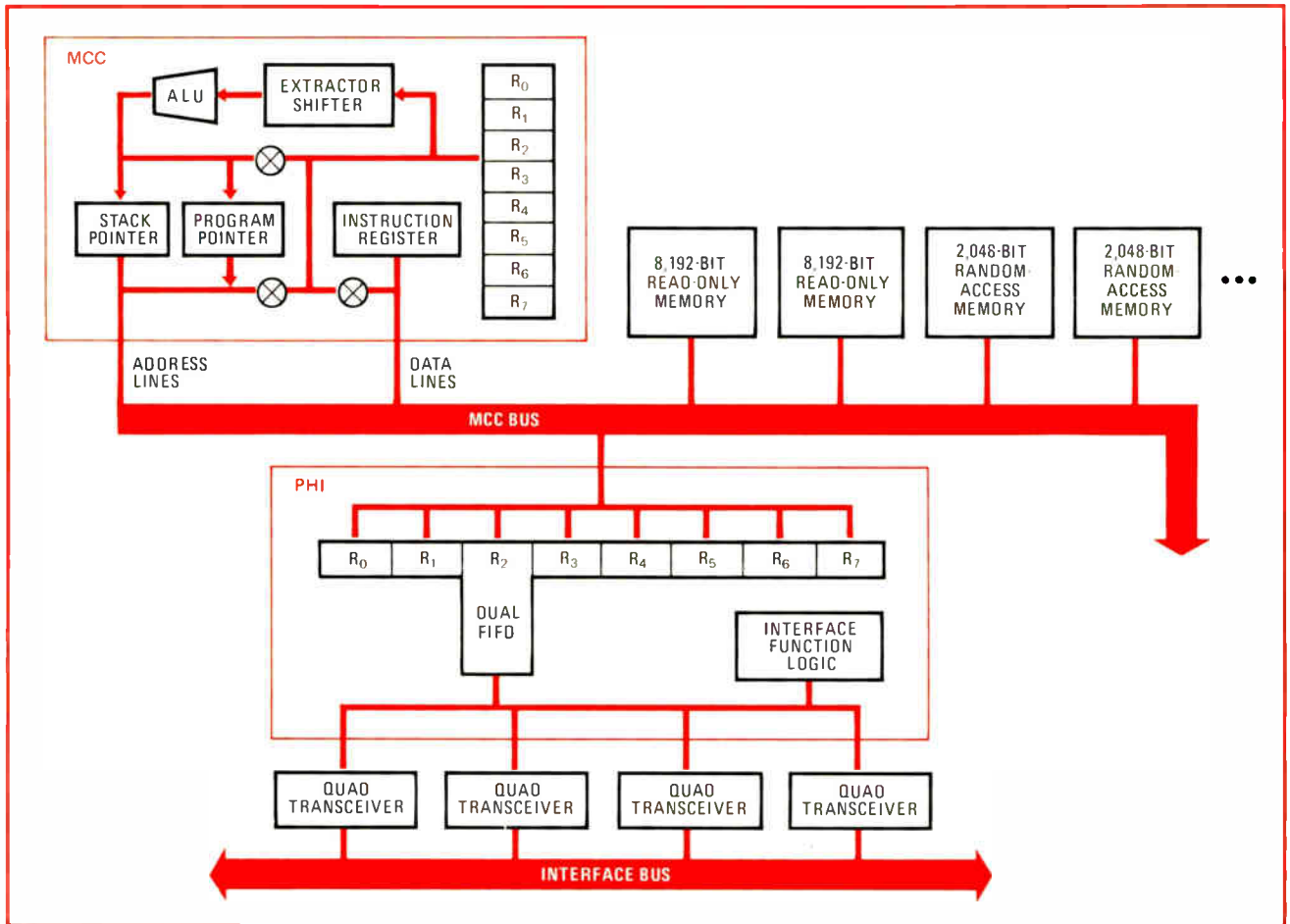

5. MCC system. Four types of chips built with the new C-MOS-on-sapphire process include a 16-bit central processing unit (MCC), an 8,192-bit read-only memory, a 2,048-bit random-access memory, and a new single-chip interface (PHI) to the IEEE standard interface bus.

any mixture of access and cycle times within the same product.

The MCC is the heart of the microcomputer chip set and is tailored for control applications, with an instruction repertoire covering 34 groups of instructions. These instructions take from 750 nanoseconds to 1.5 microseconds to execute (a full 16-bit register-to-register addition requires only 875 ns). While operating at its maximum clock rate of 8 MHz, the CPU chip typically dissipates only 350 mw drawn from a single 12-v power supply.

External registers

The bulk of its instructions operate directly on 16-bit registers, which can be selected either from the eight general-purpose registers within the MCC or from a "bank" of eight I/O registers external to the MCC. Because external-register interrogation is so important in control-oriented environments, the associated access time is optimized and approaches that of the internal registers.

Memory reference instructions can access directly or with indexing any of the 65,536 available memory locations. A system stack residing in external RAM is used by subroutine calls and interrupts for return address storage. Stack-oriented push and pop instructions are included to allow the programmer to use this stack.

Since the MCC was developed for control rather than processing applications, emphasis was placed on manipulation and interrogation of small clusters of bits as well as full 16-bit words. Word-oriented instructions such as ADD or AND can operate on extracted fields of 4, 8, or 16 bits from within a specified register, and bit-oriented instructions can operate on any selected bit of the register. Since all of these instructions can operate directly on an external I/O register, they can be very sophisticated in their manipulation of a peripheral device that the bits in that register control.

Built-in priority encoding is provided in the MCC, allowing it to make quick decisions based on the result of a previously executed instruction. After reading from the fault-indication register of a peripheral device, for example, the MCC could use this feature to branch immediately to a code sequence corresponding to the highest-priority fault detected.

Simplified debugging is stressed in the architecture of the MCC. In addition to allowing its clock input to stop so that the system state can be examined, the MCC also provides an "idle" mode during which all its internal registers (including the program pointer, stack pointer, and general-purpose registers) can be interrogated by external circuitry as if they were in two external register banks. Idle mode is entered either by external request or when an instruction from a special group is executed. In

6. PHI chip. The complex 8,000-transistor interface chip for the IEEE standard interface bus can replace up to 200 transistor-transistor-logic integrated circuits. (Apparent lack of focus is due to translucency of substrate, which allows backlighting effects.)

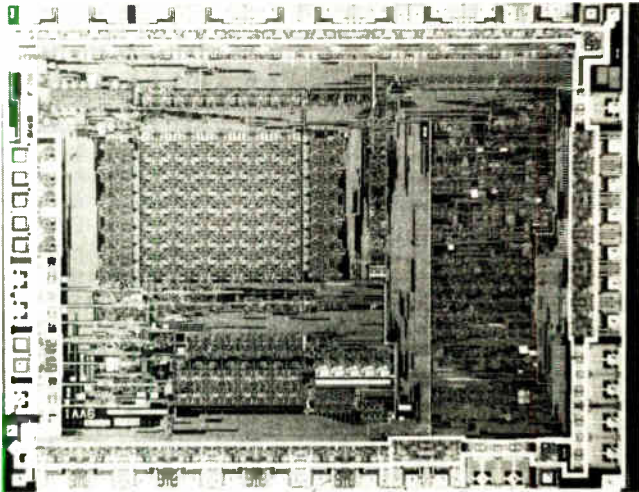

7. RAM chip. The 2,048-bit random-access memory has a six-transistor memory cell. Since it is a static RAM, it needs no refreshing and uses less than 50 microwatts during battery standby. Typical access times are 80 nanoseconds for 8 bits of parallel output.

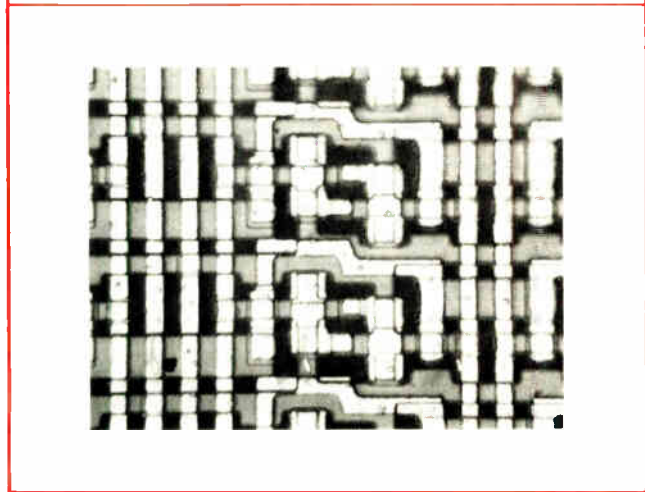
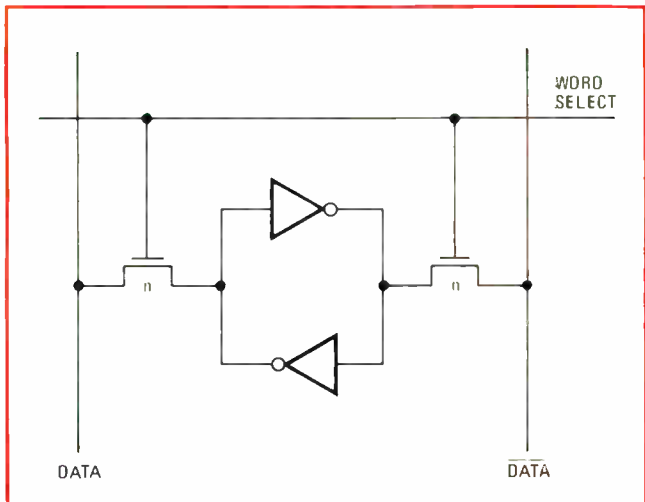

the latter case, external logic can decode and execute the instruction while the MCC is idle and then return control back to the MCC when execution is complete.

Hewlett-Packard, when participating in the development of the IEEE-488 instrument interface standard, began a strong commitment to make its new products compatible with this standard. However, to interface to the standard bus requires a significant amount of logic—up to 200 standard TTL integrated circuits if all features of the IEEE-488 are used. The PHI is a single-chip alternative, which provides a complete high-performance bus interface for both instruments and bus controllers and performs all the interface functions defined in IEEE-488. It ties directly into an MCC system, appearing to the MCC as a bank of eight external I/O registers.

The IEEE-488 interface chip

All data bytes that pass through the PHI chip are buffered in one of two first-in/first-out buffers—one for inbound data and one for outbound data. These buffers appear to the MCC as one of the eight registers in the PHI bank and improve performance by compensating for data transfer irregularities such as MCC interrupt response delays or temporary slowdown of the device at the other end of the bus. If the PHI is being used within a bus controller, the outbound FIFO also plays an important part in sequencing and synchronizing bus activities.

The PHI interfaces to the 16 IEEE-488 bus lines through four bipolar quad transceivers with which it communicates at standard low-power Schottky-TTL logic levels. Its interface to the MCC bus, however, can be configured to operate either at these logic levels or at the 12-v levels compatible with the MCC. To achieve 1-MHz data transfer rates over the bus, the PHI responds to standard handshakes in typically 50 ns. This performance, in an 8,000-transistor circuit (Fig. 6), requires the ability to perform large-scale integration of high-speed asynchronous circuits to a degree obtainable only with C-MOS on sapphire.

The two memories

Program and variable-storage capabilities are provided by an 8,192-bit ROM chip and a 2,048-bit RAM chip, which were both designed in C-MOS on sapphire for use in MCC systems. Both provide 8 bits of parallel output and are used in pairs to achieve the 16-bit word length of the MCC. Typical access times are 50 ns for the ROM and 80 ns for the RAM. Since the RAM is static, it requires no refreshing and consumes less than 50 μ W during battery standby operation (Fig. 7). Both the RAM and the ROM are contained in 24-pin dual in-line packages and operate from a single 12-v power supply.

C-MOS-on-sapphire technology has potential in several areas. Power dissipation seemingly sets no limit to chip complexity. Device density can easily be increased by an order of magnitude by the use of higher-resolution lithographic techniques—and, moreover, with no concern for parasitic devices, as each device can be considered as an independent element. Work is also continuing to reduce leakage currents further. Finally, the low sensitivity to defects will allow very complex, large-scale ICs to be fabricated with an economically acceptable yield. □

Analog I/O hybrids simplify microprocessor interfaces

Plug-in input/output units are shrinking the package of intelligent process-control and data-acquisition systems

by Paul Prazak and Andrij MROZOWSKI, *Burr-Brown Research Corp., Tucson, Ariz.*

□ Microprocessors simplify the design of process-control and data-acquisition systems, but the task of devising the interface with the analog world still can be difficult and time-consuming. One recent answer is the packaged analog input/output systems that have now evolved into miniature hybrid plug-in systems compatible with many different microprocessors.

Easy interfacing with a variety of processors is only the first of the specialized requirements for analog I/O systems. To work with as many different signal sources as possible, they should be capable of accepting single-ended or differential input signals across a wide voltage range. Since all microprocessors have memory reference instructions, the I/O systems should have address decoders to simplify software and to allow an almost unlimited number to be connected to a single microcomputer. They also should contain control logic capable of accepting memory read or write instructions and, if necessary, generating halt or interrupting signals. In addition, they should have three-state output buffers for direct connection to the microprocessor data bus.

Finding the memory

Since the MP20/21 and MP10/11 are memory-mapped, as opposed to accumulator input/output, devices, data access requires only memory-reference instructions. Memory-mapped units provide a choice of addressing modes, like index or relative, and permit using the pointer for a register stack to pop or push data.

In contrast, accumulator-I/O units must be treated as microprocessor peripherals, rather than as part of memory. For data access, then, the microprocessor must use special I/O instructions, and in most cases, only the accumulator is available as an I/O register. As a result, this approach usually requires longer execution times and more read-only-memory space than memory-mapped I/O.

An even worse situation arises with Motorola's 6800 microprocessor because it does not have I/O instructions. A memory-mapped unit may be connected directly to the 6800 bus, but a unit that is treated as a peripheral must be interfaced through a programmable interface adapter, which means higher costs and still longer execution times.

In the past two years, analog I/O systems that satisfy many of these requirements have become available as convenient plug-in components. Most of these component-like systems have been hand-sized modules, which require considerable real estate on a printed-circuit board, particularly in comparison to an integrated-circuit package such as a microprocessor.

With thick-film hybrid technology, though, complete analog I/O systems for microprocessors are now being made as plug-in components that require no external parts or adjustments and are not much larger than the microprocessor itself. They are the MP20/21, two self-contained 16-channel 8-bit analog input systems, and the MP10/11, a pair of complete two-channel analog output systems. All four of these recently developed devices are contained in IC-compatible hybrid packages.

From analog to digital

The MP20 and MP21 are designed to interface directly with a wide variety of the microprocessors available today—the MP20 with Intel's 8008, 8048, 8080A, and 8085, as well as Advanced Micro Devices' 9080, Zilog's Z-80, and National's SC/MP, and the MP21 with Motorola's 6800, MOS Technology's 650X, and Electronic Arrays' 9002. With a minimum of external parts, either model can interface with Fairchild's F8.

Laser trimming eliminates the need for external adjustments of system gain and offset errors over five different input signal ranges between 0 to 2.5 volts and ± 5 v, giving an absolute accuracy of better than $\pm 0.4\%$ (within ± 1 least significant bit). Total system nonlinearity is less than $\pm 0.2\%$, and throughput rate is faster than 35 microseconds per channel.

The MP20/21 fits into an 80-pin 2.1-by-1.7-by-0.2-inch quad in-line package with double rows of 20 pins on two sides. As shown in Fig. 1, each unit contains an input multiplexer that can accept as many as 16 single-ended or 8 differential analog signals, an instrumentation amplifier, a high-speed 8-bit analog-to-digital converter, three-state output buffers, and all necessary address decoding and control logic.

An important feature of the units is their ability to digitize low-level, as well as high-level, analog signals. The gain of the internal instrumentation amplifier may be programmed with a single external resistor, permitting input signal ranges to be as low as ± 10 millivolts.

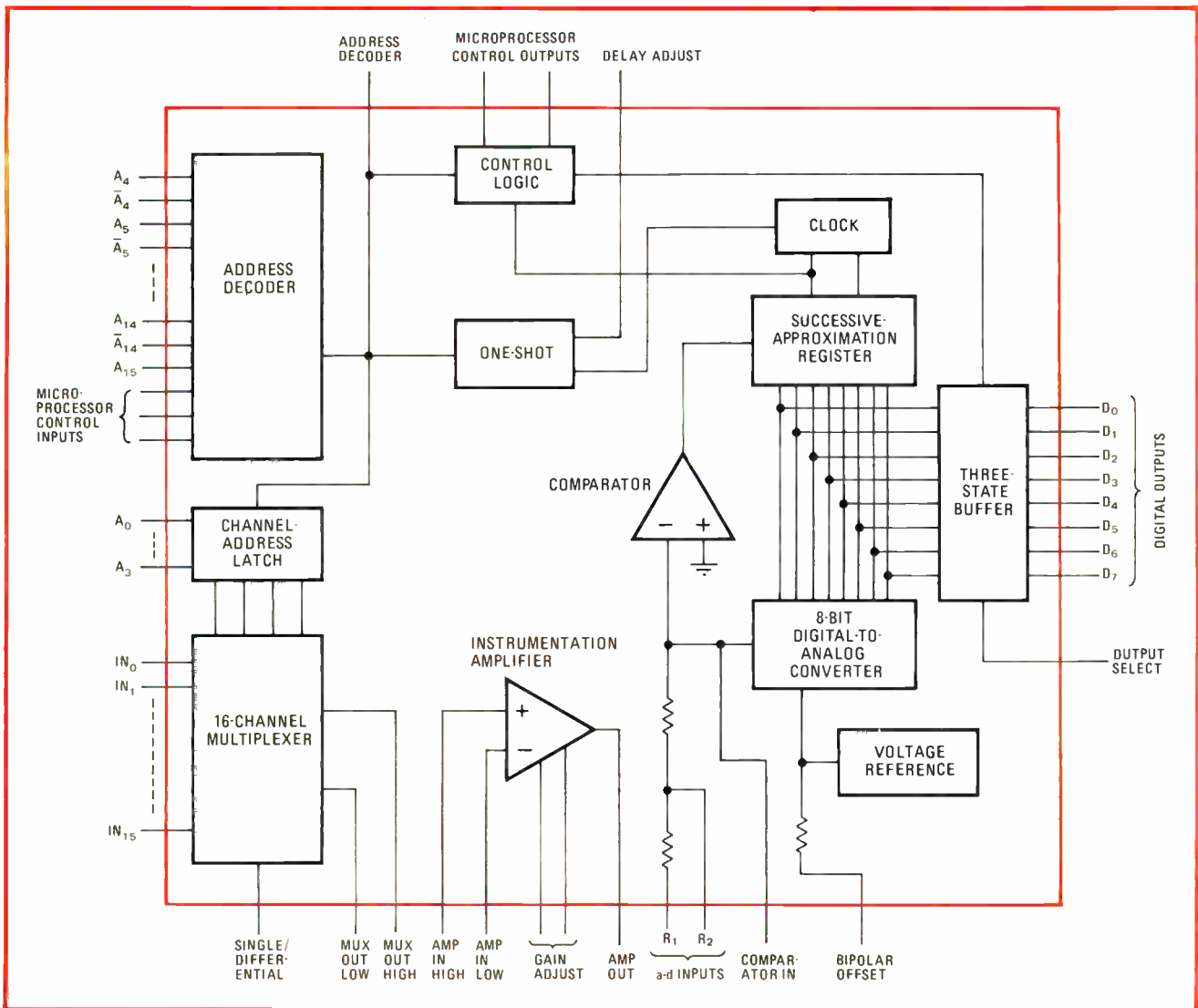

1. For analog inputs. This analog input system in an 80-pin hybrid package interfaces directly with a number of popular microprocessors. Besides channel-selection logic and output buffers, it contains an independent adjustable-gain instrumentation amplifier.

So the MP20/21 may be connected directly to low-level sensors like thermocouples and strain gauges with no need for additional signal amplification.

Since these are memory-mapped systems (see "Finding the memory"), microprocessors treat them as memory locations. The internal address decoder is a 16-bit part, with lines $A_{15,4}$ used by the processor to select the unit. The processor uses the remaining lines $A_{3,0}$ to select the channel to be digitized. Eleven address-select lines, $A_{14,4}$, are also brought out for hardwiring the unit for a specific address.

Choice of configurations

The multiplexer, instrumentation amplifier, and a-d converter are not connected to each other internally. This feature allows the user to hardwire the device for single-ended or differential input signals and to insert an external sample-and-hold circuit between the instrumentation amplifier and the converter. In what probably will be the most common configuration, the multiplexer output is connected to the instrumentation amplifier and

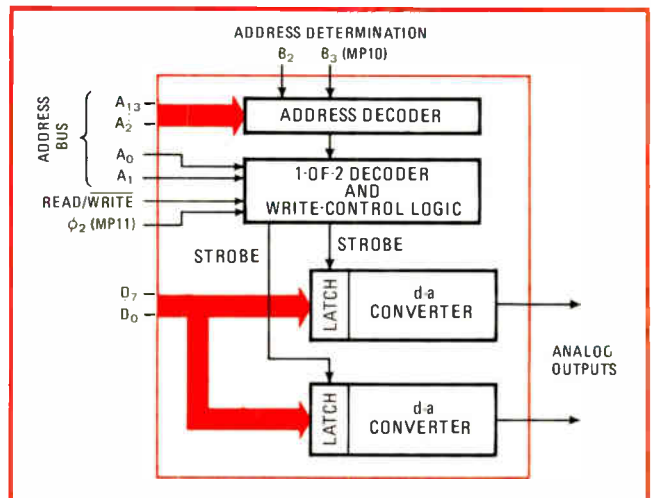

2. For analog outputs. Also able to interface directly with various microprocessor chips, this thick-film-hybrid analog output system is completely self-contained. Packaged in a 32-pin DIP, it provides two channels of output and includes all necessary decoder logic.

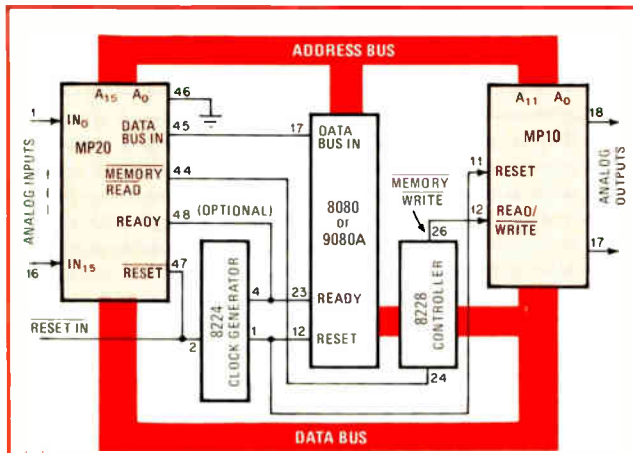

(a)

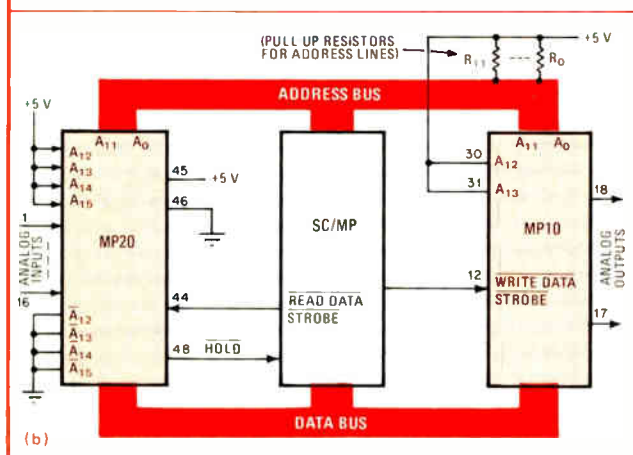

(b)

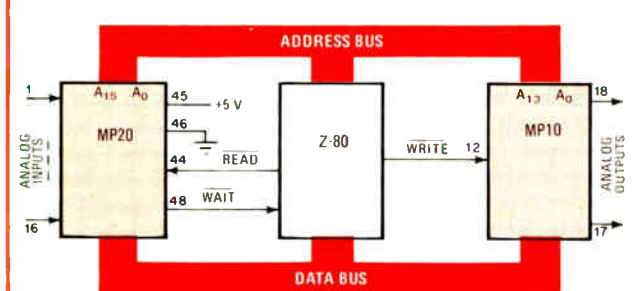

(c)

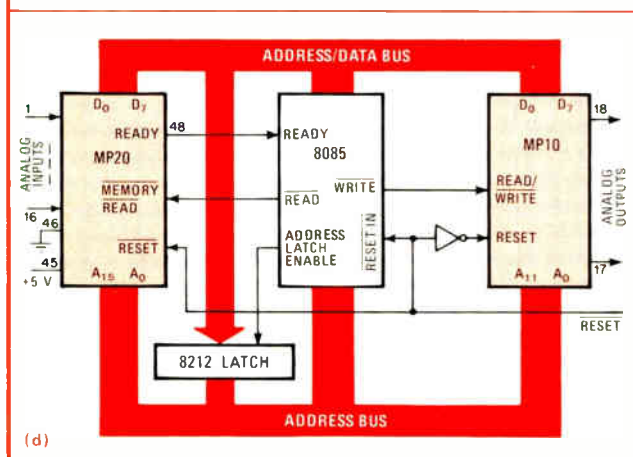

(d)

3. Easy hookup. Interfacing the MP20/10 analog I/O systems to a microprocessor is simple. With the 8080 or 9080 (a), a clock and controller are required. The units connect directly to the SC/MP (b) and to the Z-80 (c), but a latch is needed with the 8085 (d).

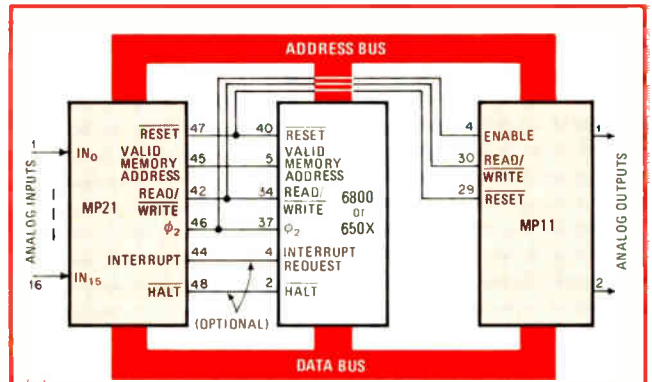

(a)

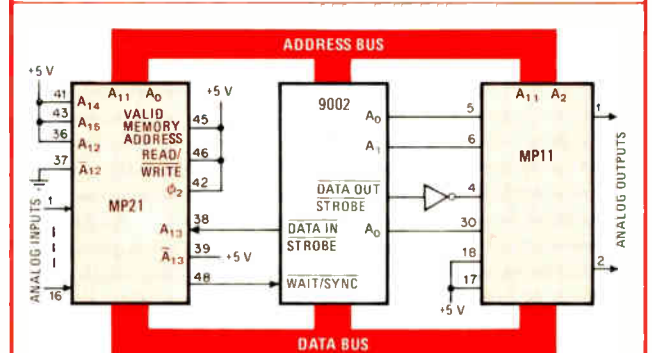

(b)

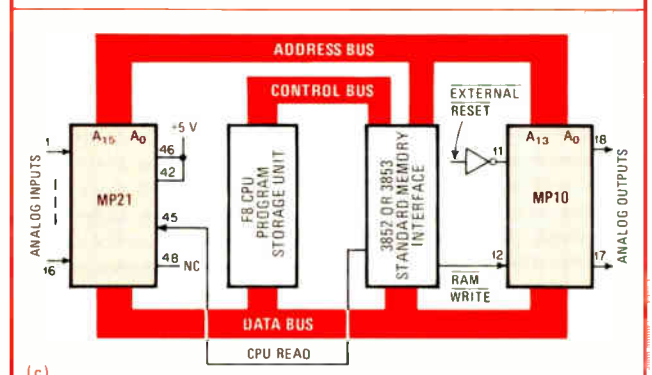

(c)

4. More hookups. The MP21/11 analog I/O systems are designed for interfacing directly to the 6800 or 650X (a) and the 9002 (b). The MP21/10 interfaces with the F8 (c), but this combination requires the addition of an external standard memory interface.

the amplifier's output to the converter's input.

In this configuration, the combination of a valid address and a read command initiates the conversion. Therefore, every time the MP20 receives a read command, the data from the previous conversion appears on output lines D_{7-0} , and a new conversion will begin. To facilitate interrupt operation with the MP21, a new conversion is initiated with every other read command. One of the control outputs from the MP20/21 may be used to stop the microprocessor, or software control may time it out.

When the unit receives a read command, the channel address (A_{0-3}) is strobed into a latch, and the one-shot triggers. This generates a 30- μ s delay pulse that allows the input signal to pass through both the multiplexer and the instrumentation amplifier, settling to within $\pm 0.02\%$ of its final value before the a-d conversion starts. (The

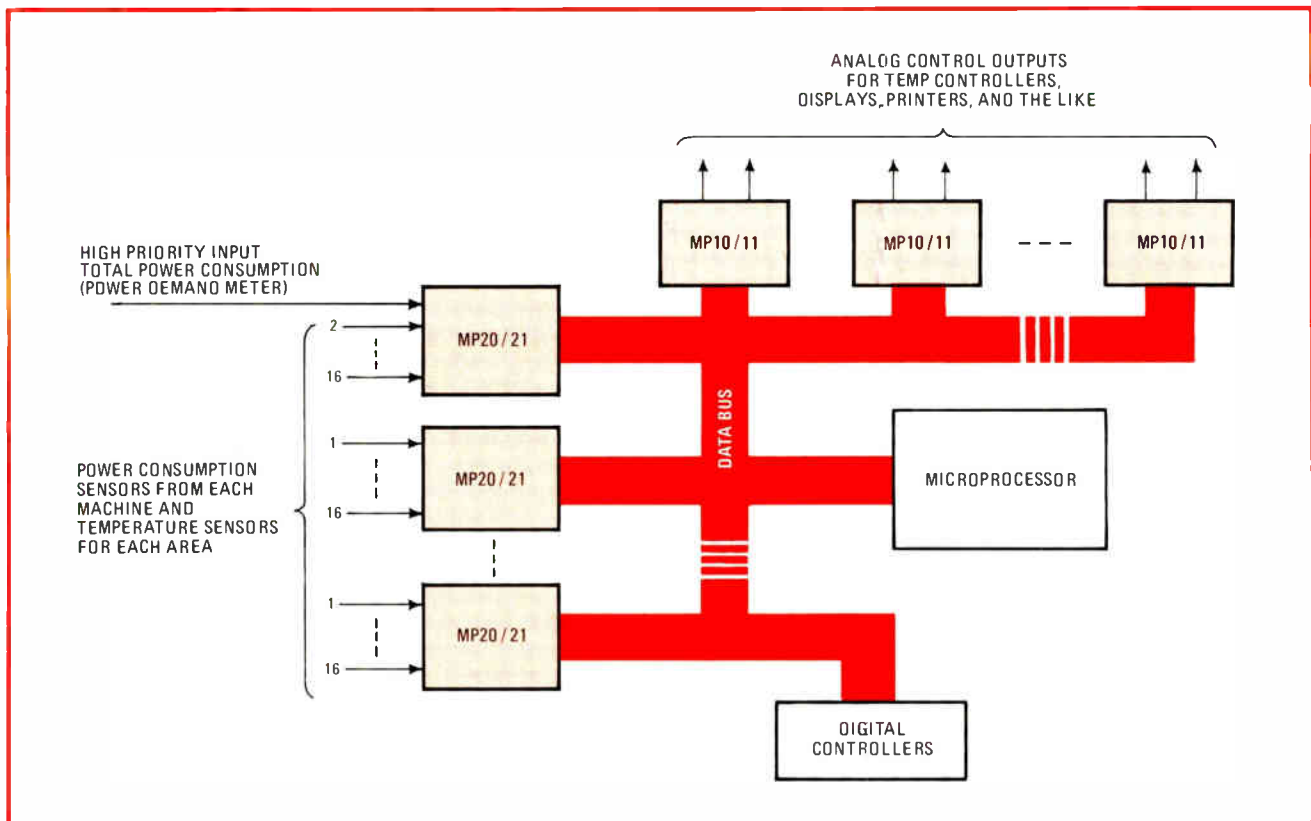

5. Controlling power. A microprocessor-based energy conservation system with analog I/O units could eliminate needless peaks in power demands for office buildings and industrial plants. Such a system would be simpler, more reliable, and cheaper than present approaches.

width of the delay pulse may be adjusted from 2 to 300 μ s with a single external resistor or capacitor.)

Initiating the conversion causes the ready line of the MP20 or the halt line of the MP21 to go low and remain low until the conversion is complete. Using this line to stop the microprocessor while the conversion is taking place prevents digital signals from affecting the accuracy of sensitive analog data, often noticeably improving overall system accuracy.

Not only does the design simplify the hardware interface with microprocessors down to pretty much a plug-in process, but it also simplifies the software interface. For example, with the MP20 and the 8080, a single software instruction, LHL D, brings in data from two analog input channels, storing it in the processor's H and L registers.

From digital to analog

Converting binary information to a bipolar analog voltage is the job of the MP10/11 analog output systems. As with the input systems, the two models interface directly with a majority of popular microprocessors—the MP10 with the 8008, 8048, 8080, 8085, and 9080 and the MP11 with the 6800, 650X, and 9002. Simply adding pull-up resistors permits the MP10 to interface with the SC/MP. It will operate with the F8 and Z-80 if a few timing restrictions are met.

The devices are complete two-channel analog output systems (Fig. 2) in a 32-pin triple-wide ceramic dual in-line package. Each one has three basic sections: analog output, control logic, and address decoder.

In the analog output, or d-a, section are two mono-

lithic 8-bit d-a converters, a quad operational amplifier, a precision voltage reference, and a thin-film resistor network. Again, laser trimming for gain and offset errors means that no external adjustments are required on either channel to obtain an absolute accuracy of $\pm 0.2\%$ typical ($\pm 0.4\%$ maximum) over a ± 10 -v output range. Moreover, the analog output remains linear to within $\pm 1/2$ LSB (or $\pm 0.2\%$). Monotonicity is guaranteed, and so is the full-scale settling time of either channel to within $\pm 1/2$ LSB if its final value is less than 25 μ s.

The heart of the control logic is a high-speed programmable interface device—Intel's 8255 in the MP10 and Motorola's 6820 in the MP11. As with any programmable peripheral, the MP10/11 must be initialized before attempting to send data out. The MP11 is initialized to use channels A and B of the 6820 as outputs, while the MP10 is initialized so that the 8255 is operating in the mode 0 with ports A and B programmed as outputs.

Each model contains a 14-bit address decoder, with the microprocessor using lines A_{13-2} to select the device, and lines A_1 and A_0 to select the output channel. With the number of package pins limited to 32, only A_2 and A_3 are user-defined on the MP10 and only A_2 on the MP11. However, these lines, along with the address-select lines, permit as many as four MP10 units or two MP11 units to be added to an analog control system without extra external address circuitry.

Operation of the MP10/11 is really quite simple. When the address appears on the address bus, data will appear on the data bus. The microprocessor then gener-

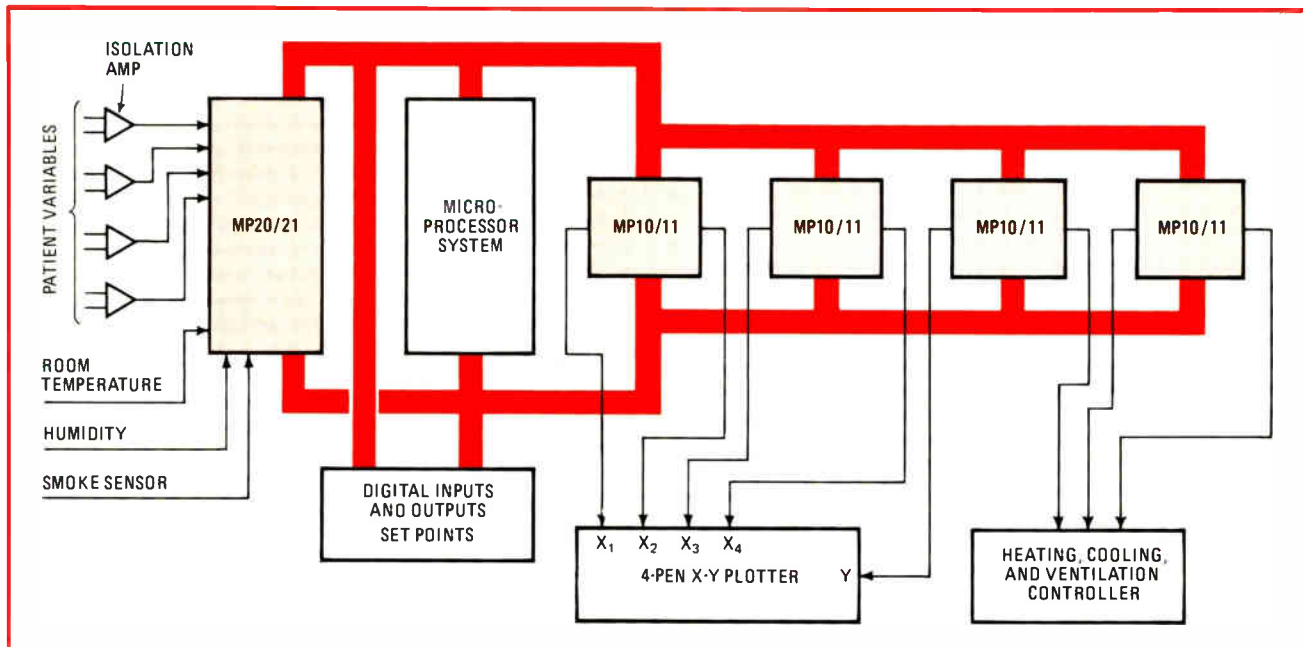

6. Biomedical. This patient-monitoring system could be made as a simple and low-cost portable unit. In addition to taking data on patient variables, it could monitor and control the immediate environment. The input isolation amplifiers protect against potentially lethal shocks.

ates a read/write pulse, and 25 μ s later, the analog voltage at the output selected by the processor will be stable. All the timing requirements that must be satisfied in order for these devices to be initialized and to operate correctly are completely compatible with their associated microprocessors.

Getting together with processors

A quartet of microprocessor hookups is shown in Fig. 3 for the MP20 input and the MP10 output systems. Besides memory read-write signals, these units require certain interface control signals—READY for the 8080 or 9080A (a), HOLD for the SC/MP (b) WAIT for the Z-80 (c). Such signals stop the microprocessor for a short time during the conversion cycle. If READY or an equivalent signal is not used, there must be a software delay or flag-polling routine to assure that no attempt is made to read data before the end of the conversion.

Figure 3d illustrates the control signals and external hardware needed to interface the MP20/10 to the Intel 8085 microprocessor. Since the 8085 has a time-multiplexed data bus, an Intel 8212 latch must be used to latch the lower 8 bits of the address when a full 65,536 bits of memory is used. They are latched during the high-to-low transition of the address-latch-enable signal. When there is a correct address present and READ goes low, the conversion begins and the READY line goes low, thus halting the microprocessor. When the READY line returns to high, data is read from the MP20. To send data to the MP10, the 8085 delivers the correct address and data, and the WRITE signal goes low.

The MP21 and the MP11 interface directly to the 6800 or 650X (Fig. 4a) and the 9002 (Fig. 4b) without any external hardware. To assure that the address is valid, the valid-memory-address line of the MP21 is used with the 6800. With the 650X, the VMA line should be connected to the high end (+5 v) of the supply.

Some external hardware is required to interface the MP21/10 to the F8 (Fig. 4c). Since this microprocessor is optimized for I/O operation, any device that appears as a memory to it must be interfaced through a unit called a standard memory interface, part number 3852 or 3853. But most data-processing systems have external read-only and random-access memories that require a 3852 or 3853, so the MP21/10 interface can hook into the same part.

One practical application of these new analog I/O systems is an energy conservation system (Fig. 5) that could save money, as well as energy, by eliminating unnecessary peaks in power demands. The analog input systems monitor the power consumed by air conditioning, heating, lights, and other equipment, while the analog output systems display and record this information, in addition to serving as proportional controllers for the equipment. Digital controllers handle the actual equipment turn-on and turn-off in accordance with a programmed shutdown sequence.

Putting analog I/O to work

The major advantage of such a system is its simplicity. Similar energy control systems without integrated devices generally require many more components, are more expensive, and quite often need periodic calibration. As well as being simpler and cheaper, a microprocessor system will be more reliable and easier to repair should a problem arise.

Another important application area is medical instrumentation. For instance, a patient-monitoring system (Fig. 6) may now be made as a simple, low-cost portable unit. The input devices take data on several patient variables, while the output units record these parameters. The isolation controllers at the front end of the system protect the patient against potentially lethal electrical shocks. □

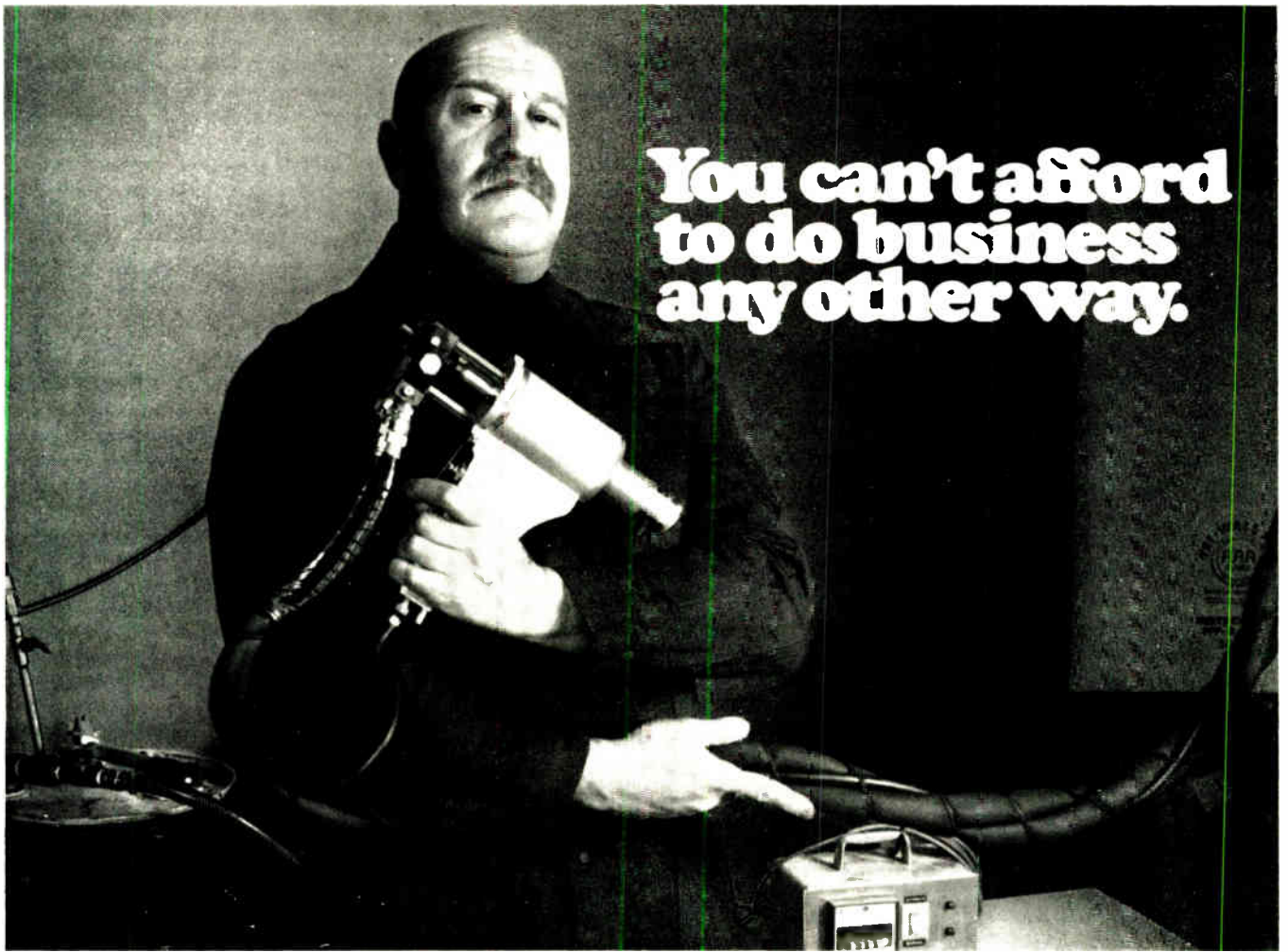

**You can't afford
to do business
any other way.**

Now that SolidiFoam is in, air pillows, corrugated inserts, excelsior and styrofoam are out.

Tri-Wall Containers, the innovator and leader in bulk packaging, proudly introduces SolidiFoam. A foam-in-place packaging system that is going to change the way America ships.

SolidiFoam Protects Against Damage in Transit. With SolidiFoam, your product will be completely encapsulated inside a protective, shock-absorbing cocoon of resilient, semi-flexible, light-colored urethane foam. It's the toughest protective packaging system you've ever had.

SolidiFoam Saves Space, Cuts Shipping and Labor Costs. Eliminate air pillows, corrugated inserts, excelsior, styrofoam and other bulky packaging materials. You produce SolidiFoam only as you need it. The foam is light, reducing tare weight. And less set-up time means lower labor costs. Economical 55 gallon drums give additional savings.

Consistent Foam Every Time. The SolidiFoam system has been engineered to insure the proper chemical mix, so you don't waste chemicals. Pressure and temperature are constantly monitored to produce urethane foam that won't be out of balance. A range of foam densities is available.

The SolidiFoam System is Easy to Use. Four switches control everything. A mechanical purge on the dispenser gun automatically cleans the chamber after each use. And learning to operate a system is uncomplicated so it can be quickly mastered. Tri-Wall will even train your operator on-site.

Tri-Wall Backs You Nationwide. The Tri-Wall network is your single source for equipment, chemicals and service. Conveniently located packaging specialists are there when you need them. And you can buy or lease.

Find out more about SolidiFoam by calling Bruce Geiger at (516) 364 2800 or send in the coupon below. We'll prove to you that SolidiFoam is the one foam-in-place system you can't afford to be without.

I want to know more about SolidiFoam, the one foam-in-place system you say I can't afford to be without. We ship these products: _____

- Send me a brochure and complete specifications.
 Call me to arrange an appointment.
 Telephone (area code) _____

Name _____

Company _____

Division _____

Job Title _____

Address _____

City _____

State _____

Zip Code _____



SolidiFoam. T.M.

From the Foam Packaging Division of
 Tri-Wall Containers.
 An Indian Head Company

E-526

100 Crossways Park West, Woodbury, N.Y. 11797

Intelligent multiplexer increases processor efficiency

by Edward Harriman
Boston, Mass.

The most efficient way to multiplex data into a computer is to initiate interrupts only when necessary. This circuit does just that. It polls the input lines and only in the event of an input change does it interrupt the processor, otherwise freeing it to attend to other tasks and therefore speeding overall system operation.

Shown in the figure, the circuit has worked successfully with the Motorola 6800 microprocessor. The hardware includes a 74150 1-of-16 multiplexer, a 74161 4-bit counter for encoding each line, and two 74165 8-bit shift registers for recording the previous state of each line. These elements, in conjunction with a standard compa-

rator and \overline{RS} flip-flop, control the actions of a 6820 peripheral interface adapter feeding the microprocessor.

To initialize the system, the microprocessor loads the 16-bit shift register (the two 74165 devices) by performing 16 read operations. The counter, which like most of the circuit is cycled by the system clock, selects each of the multiplexer's 16 input lines in turn. Assuming the system was initialized at line 0, on the 17th read operation the input of that line appears at the multiplexer's output and is fed to the comparator to be checked against the previous 0 line bit now stored in the last stage of the 16-bit shift register. If the comparator detects a difference in the two logic levels, it generates an interrupt to the processor through the peripheral interface adapter and also resets the flip-flop. This forces the scan-enable line low, disabling the counter.

Meanwhile, whether or not there has been a change from the previous state, the multiplexer's output is stored in the shift register. After 16 scans, the output of the last stage of the shift register is again compared to the present state of the input location 0. The loading and

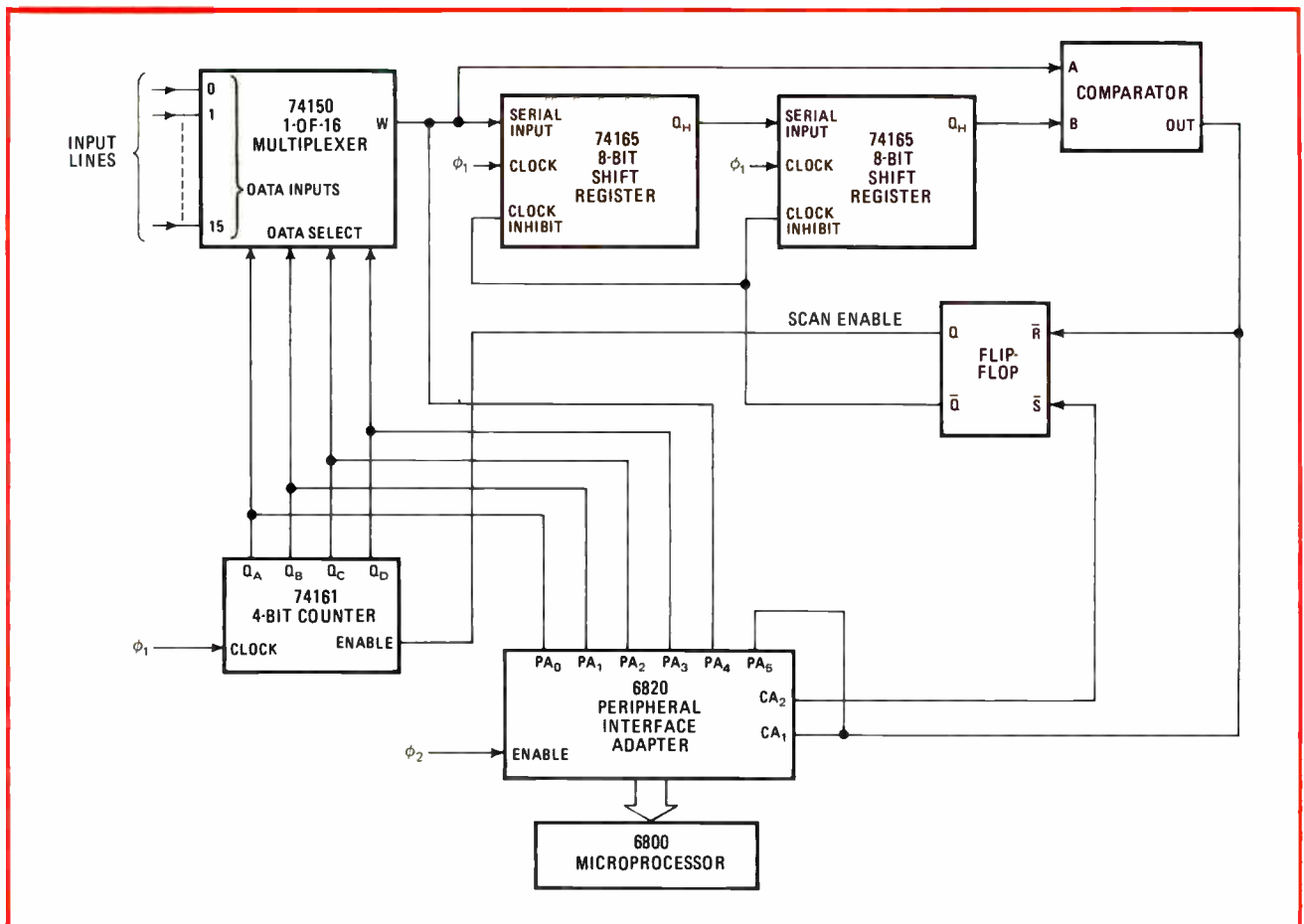

Smart controller. Sixteen lines are multiplexed to microprocessor, which performs input update only when notified of a state change on any line. The 6820 peripheral interface adapter is programmed to generate interrupt on negative transition of CA₁, which in turn generates negative-going CA₂ to advance counter by one. For eight input lines, an eight-input multiplexer and just one shift register would be used.

comparison operation takes place each scan for every input line.

If an interrupt is generated, the microprocessor, through prior programming, reads the location of change and the new data through the peripheral interface adapter. This operation also sets the flip-flop by generating a negative-going pulse from the control line CA₂. The pulse sends the flip-flop's Q output high for at least

one cycle, enabling the 4-bit counter to advance one count, regardless of the state of the comparator that initiated the halt. The microprogram is written to observe if this second scan encounters a change in the state of the next location—a more efficient procedure than releasing the microprocessor immediately. This is done by testing line CA₁, the interrupt-status control line, which is connected to the comparator output. □

ICs slash component count in Costas loop demodulator

by Carl Andren
E-Systems Inc., St. Petersburg, Fla.

Just three integrated circuits can build a Costas phase-locked loop that will detect differential phase-shift-keyed modulation. The Costas loop is named after its inventor, who first detected it with a PLL by regenerating the carrier in a double-sideband suppressed-carrier signal. The loop allows tracking of the desired frequency in a high-noise environment while ignoring carrier phase reversals caused by modulation.

The Costas loop (Fig. 1) has an input signal split into two channels. The in-phase channel (I) demodulates the data, and the quadrature channel (Q) tracks frequency and phase of the carrier.

The key to the loop's operation is the multiply-by- ± 1

function, which inverts the phase of Q's output signal upon detection of a carrier phase reversal. This inversion is reflected in the feedback signal and maintains lock in the voltage-controlled crystal oscillator. The I channel, which detects the phase change, determines if the Q-channel output is to be inverted or multiplied by unity.

In the demodulating circuit of Fig. 2, the two CA3089 frequency-modulated intermediate-frequency systems and the MC1558 operational amplifier take over the Costas loop functions. This circuit was optimized for a data rate of 9.6 kilobits per second in a system with an intermediate-frequency bandwidth of 40 kilohertz.

The CA3089s replace more than 70 devices usually needed for the Costas loop. A₁ fills the Q-circuit function, while A₂ is wired to serve as the I circuit. The high-gain limiting amplifiers of A₁ and the monolithic two-pole crystal-filter in conjunction with the IN5462 varactor make up the voltage-controlled crystal oscillator. The loop filter consists of the RC network that drives the varactor. The MC1558 (A₃) serves the multiplier function. Data filtering is accomplished by capacitive loading (4,700 picofarads) at the output of A₂ in

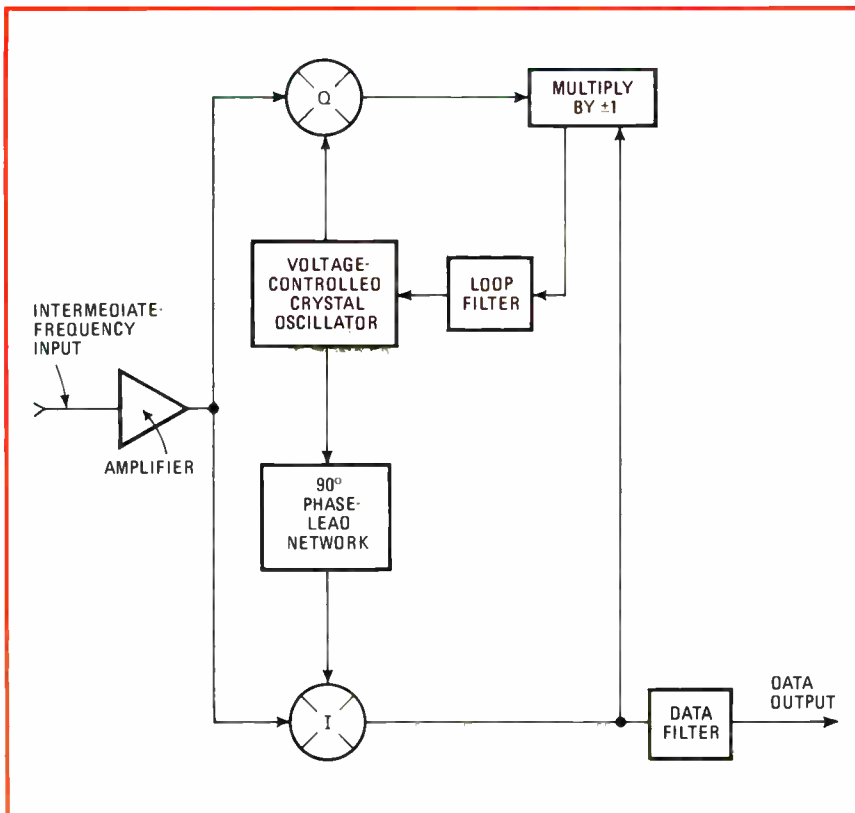

The Costas loop. An intermediate-frequency input signal is compared to the voltage-controlled crystal oscillator signal, and two quadrature signals are generated. The output from the Q (quadrature) channel is multiplied by ± 1 depending on phase detected by the I (in-phase) channel. The feedback loop facilitates tracking of the carrier frequency in high-noise environments and maintains locking despite phase reversals of the carrier caused by modulation.

MIL/NASA QUALIFIED RECTIFIERS

WE HELPED WRITE THE "BOOK"!

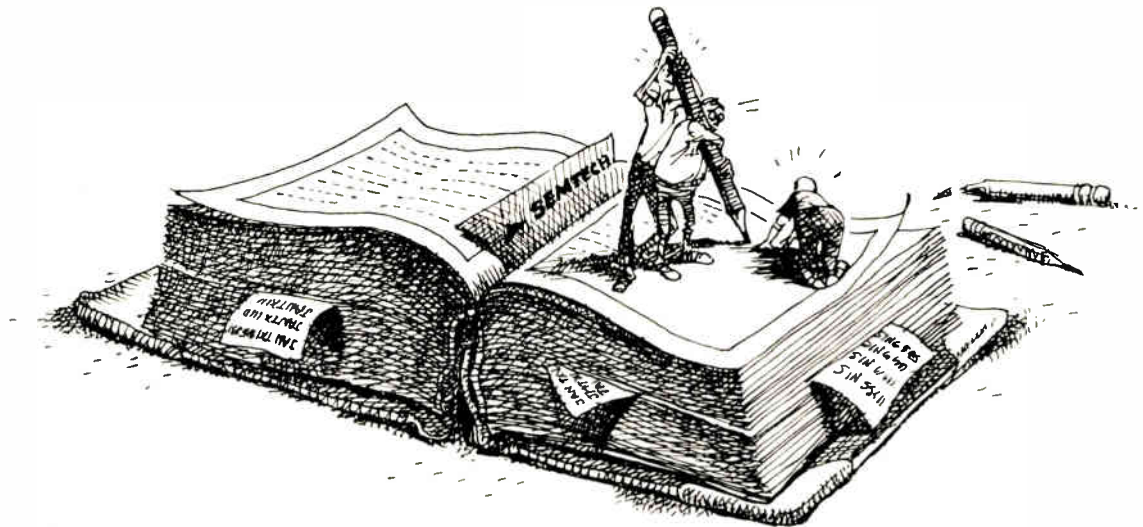

What's in a Number ?

For over a decade Military Specifications have been written around Semtech E.I.A. registered medium power rectifiers.

Many suppliers can provide parts with the same JAN, JANTX or JANTXV label. Although these devices may comply with the appropriate military specification, there can be significant differences in the design and manufacture that may affect the reliability; such as, different lead materials, pin materials, body materials, junction types and junction areas. Devices of one manufacturer are not necessarily the same as those of another, even though they are labeled with the same part number.

Semtech Corporation is one of the few manufacturers in the industry that has its own government approved Qualification Test Facilities equipped to perform tests that meet the requirements of Military and Space programs. A NASA approved Radiographic Inspection (X-Ray) facility rounds out the total capability of Semtech's environmental and test facilities.

We have earned the confidence of the Military establishment by supplying reliable devices to government specifications throughout our history.



Military Specifications

MIL-S-19500/2400

JAN, JANTX, JANTXV 1N645*·1
JAN, JANTX, JANTXV 1N647*·1
JAN, JANTX, JANTXV 1N649*·1

MIL-S-19500/279C (NAVY)

JAN, JANTX 1N3644*
JAN, JANTX 1N3645*
JAN, JANTX 1N3646*
JAN, JANTX 1N3647*

MIL-S-19500/286C

JAN, JANTX, JANTXV 1N4245
JAN, JANTX, JANTXV 1N4246
JAN, JANTX, JANTXV 1N4247
JAN, JANTX, JANTXV 1N4248
JAN, JANTX, JANTXV 1N4249

MIL-S-19500/359B

JAN, JANTX, JANTXV 1N4942
JAN, JANTX, JANTXV 1N4944
JAN, JANTX, JANTXV 1N4946
JAN, JANTX, JANTXV 1N4947
JAN, JANTX, JANTXV 1N4948

MIL-S-19500/411C

JAN, JANTX, JANTXV 1N5415
JAN, JANTX, JANTXV 1N5416
JAN, JANTX, JANTXV 1N5417
JAN, JANTX, JANTXV 1N5418
JAN, JANTX, JANTXV 1N5419

MIL-S-19500/420A

JAN, JANTX, JANTXV 1N5550
JAN, JANTX, JANTXV 1N5551
JAN, JANTX, JANTXV 1N5552
JAN, JANTX, JANTXV 1N5553
JAN, JANTX, JANTXV 1N5554

MIL-S-19500/427B

JAN, JANTX, JANTXV 1N5614
JAN, JANTX, JANTXV 1N5616
JAN, JANTX, JANTXV 1N5618
JAN, JANTX, JANTXV 1N5620
JAN, JANTX, JANTXV 1N5622

MIL-S-19500/429B

JAN, JANTX, JANTXV 1N5615
JAN, JANTX, JANTXV 1N5617
JAN, JANTX, JANTXV 1N5619
JAN, JANTX, JANTXV 1N5621
JAN, JANTX, JANTXV 1N5623

*Not E.I.A. registered by Semtech Corporation

MIL-S-19500/484(EL)

JAN, JANTX 1N5835
JAN, JANTX 1N5836

MIL-S-19500/503(EL)

JAN, JANTX, JANTXV 1N6073
JAN, JANTX, JANTXV 1N6074
JAN, JANTX, JANTXV 1N6075
JAN, JANTX, JANTXV 1N6076
JAN, JANTX, JANTXV 1N6077
JAN, JANTX, JANTXV 1N6078
JAN, JANTX, JANTXV 1N6079
JAN, JANTX, JANTXV 1N6080
JAN, JANTX, JANTXV 1N6081

NEW! Transient Voltage Suppressors

MIL-S-19500/516(EL)

JAN, JANTX, JANTXV 1N6102 thru 1N6137
JAN, JANTX, JANTXV 1N6102A thru 1N6137A
JAN, JANTX, JANTXV 1N6138 thru 1N6173
JAN, JANTX, JANTXV 1N6138A thru 1N6173A

NASA (MSFC) Approvals

85M01645 (NASA) S1N645S & S1N649S

85M03895 (NASA) S1N4245 1, S1N4247 1, S1N4249 1,
S1N4942 1, S1N4946 1 & S1N4948 1

85M03896 (NASA) S1N5199, S1N5201, S1N5417 1 &
S1N5419 1

RELIABILITY COSTS LESS !

1975 NATIONAL SBA SUBCONTRACTOR OF THE YEAR

 **SEMTECH**
CORPORATION

652 Mitchell Road, Newbury Park, California 91320
(805) 498-2111 • (213) 628-5392 • TWX: 910-336-1264
CHICAGO: (312) 352-3227 • DALLAS: (214) 234-6523
FLORIDA: (305) 644-5404 • MARYLAND: (301) 937-0070
NEW JERSEY: (201) 654-4884 • SAN FRANCISCO: (415) 494-0113
CANADIAN SALES: (416) 844-2121
EUROPEAN SALES: Bourns AG Zug, Switzerland (042) 232-242

conjunction with the device's output impedance.

At the input of A_2 , an i-f signal at 20 megahertz is amplified by the device's high-gain amplifiers, which provide three stages of amplification before presentation at the I-channel quadrature detector or mixer. A simple output buffer in this detector links it with the Q-channel quadrature detector in A_1 , thus driving the mixers in both devices with virtually no phase difference.

The I-channel mixer is a balanced transconductance amplifier, biased relative to pin 10 of A_2 . It is driven by the i-f input signal, as well as by the oscillator through a 90° phase-lead network. Its output drives two amplifiers in A_3 ; A_{3a} is in the feedback loop to the oscillator, and A_{3b} controls the multiply function through a transistor. The noninverting amp A_{3a} drives the op amp A_{3b} . The

gain is -1 when transistor Q_1 is on and $+1$ when the transistor is off.

The multiplier's action causes a feedback voltage that varies the oscillator's frequency through the varactor in the tank circuit of the oscillator, and phase lock is readily accomplished. The phase shift of the oscillator's amplifier network is about 360° at 20 MHz, and the crystal filter element has no phase shift at its center frequency—thus allowing smooth operation near the lock frequency. The loop filter is designed to provide the correct loop damping and gain coefficients needed for proper operation. □

Designer's casebook is a regular feature in *Electronics*. We invite readers to submit original and unpublished circuit ideas and solutions to design problems. Explain briefly but thoroughly the circuit's operating principle and purpose. We'll pay \$50 for each item published.

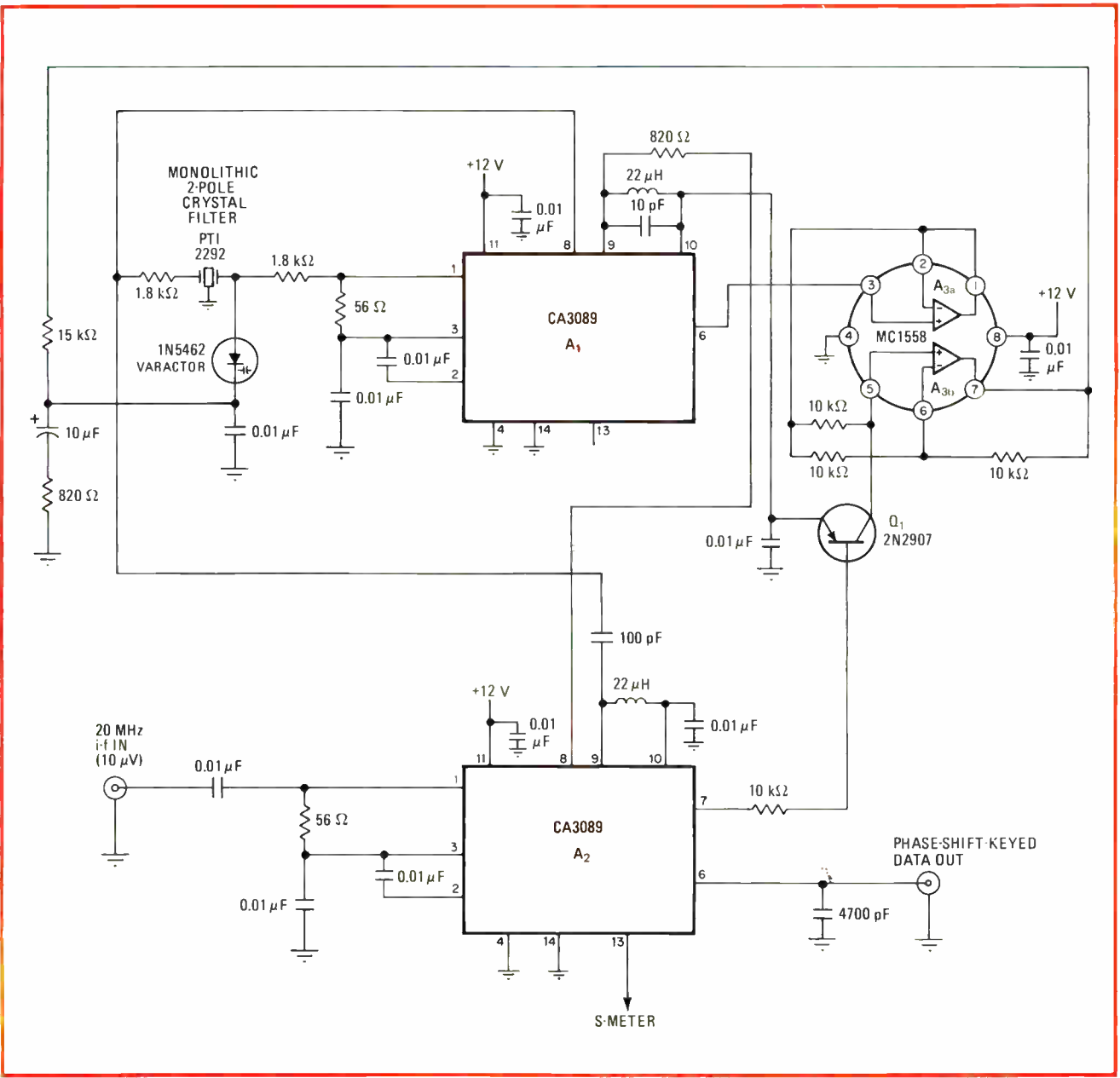

2. Differential-PSK demodulator. Two CA3089 phase-locked loops vastly reduce hardware needed for Costas loop demodulator. The circuit detects differential phase-shift-keyed signals with an i-f input of 20 megahertz. With proper attention to rf grounding and shielding, the detector can operate with signals as low as 10 microvolts. An S meter can be connected to pin 13 of A_2 for indicating signal strength.

Measuring average power in nonlinear devices

The knotty problem of determining semiconductor power dissipation requires a setup that takes instantaneous readings of voltage and current

by Warren Collier, Tektronix Inc., Beaverton, Ore.

□ Nonlinear devices, such as transistors, are the Achilles heel of true-root-mean-square voltmeters in power measurement setups. Although nonlinear devices are resistive in the sense they dissipate electrical energy as heat, their resistances cannot be used in the simple $P = E^2/R$ formula. In fact, they exhibit complex relationships between voltage and current that can only be handled by measuring their instantaneous values, multiplying the results, and then taking the average as the measure of power.

Figure 1 shows a circuit typical of semiconductor devices where the power must be measured—a transistor amplifier—and some of its waveforms. Voltage and current waveforms are measured directly, while power

waveforms are obtained by multiplication. Note that the V_{ce}^2 and I_e^2 waveforms are false representations of power, as may be seen by comparing them with the $V_{ce} I_e$ waveform.

It is not difficult to design an instrumentation system that determines power by the multiplication and averaging of voltage and current. There are four major aspects to consider with such systems: signal acquisition, multiplication, averaging, and calibration. For most of these, there is more than one choice of a device or instrument to do the work.

The process of acquiring the voltage signal is much the same as for display or processing by an oscilloscope or voltmeter. The choice of test leads or probes depends on

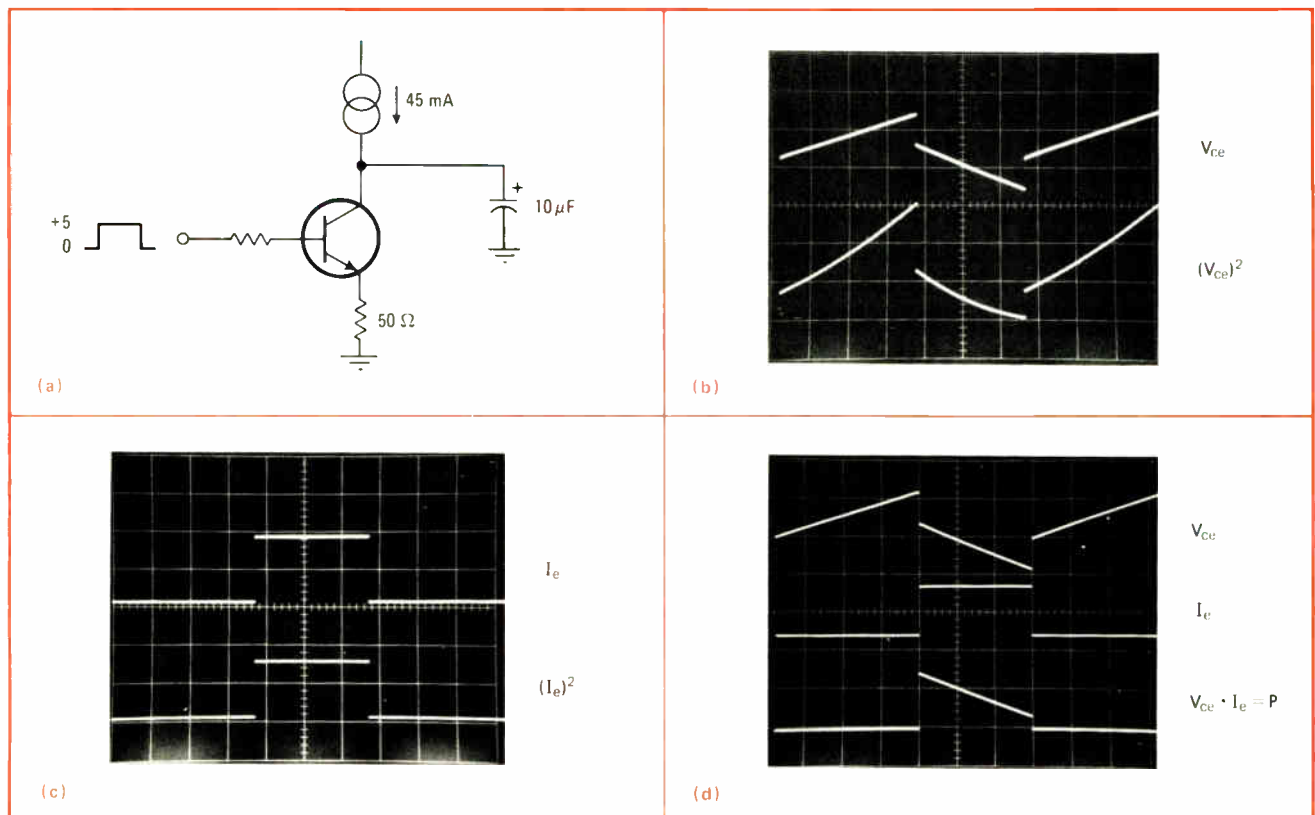

1. Nonlinear relationships. The waveforms of a typical transistor circuit (a) with nonlinear voltage-current characteristics show: collector-emitter voltage and its square (b), emitter current and its square (c), and product of voltage and current, the power (d).

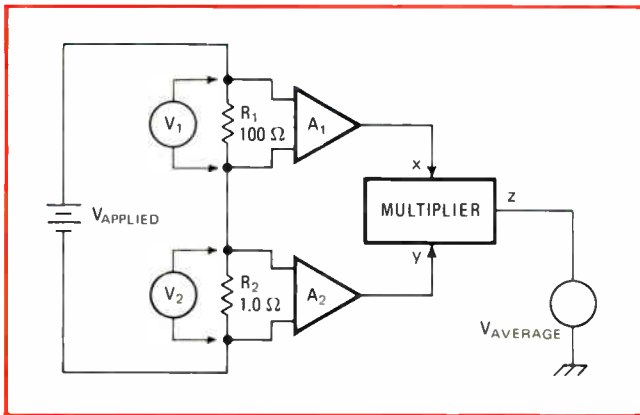

2. Acquire and multiply. Power dissipated in R_1 is measured by sensing its voltage and its current with R_2 . The two signals are multiplied in the analog multiplier to generate the power waveform, which then is averaged to develop a signal equivalent to power.

signal levels, impedance levels, signal bandwidth, and so on. It is imperative that the signal be acquired differentially unless the device under test has one terminal connected to ground.

The current signal may be acquired with a current probe or with a current-sampling resistor. If a current probe is used, it must pass both the ac and dc components of the signal, with bandwidth appropriate to the signal being measured.

Sampling current

There are three points that must be considered in using a current-sampling resistor:

- The value of the resistor must be small enough for its IR drop to have a negligible effect on the voltage across the device under test.
- If neither end of the resistor is at ground, its output voltage signal must be acquired differentially.
- For system calibration, the resistor must be stable and its value accurately known. Its reactance, voltage coefficient, and temperature coefficient should be negligible or at least accounted for in system accuracy.

The acquisition system has two channels: one for voltage and the other for current. The output signals from the acquisition system must reproduce both the ac and dc components of the input signal faithfully. The overall gain of the acquisition channels must bring the voltage signal to a level appropriate for the multiplier and must be accounted for in system calibration.

At the output of the acquisition channels, both signals are in the form of voltage signals. There must be no appreciable extra offset, common-mode signal, time delay, or phase shift between channels. Gain or loss of the channels will affect system calibration, but the signal level must be appropriate for multiplication.

The multiplier may be of the analog or digital variety, and the choice will affect the averaging and calibration functions. Analog multipliers are available as monolithic integrated circuits, functional modules, or self-contained instruments. The multiplier must be dc-coupled at both inputs and its bandwidth and accuracy appropriate to the application. The output of the multiplier is a power waveform, with the peak value representing peak power

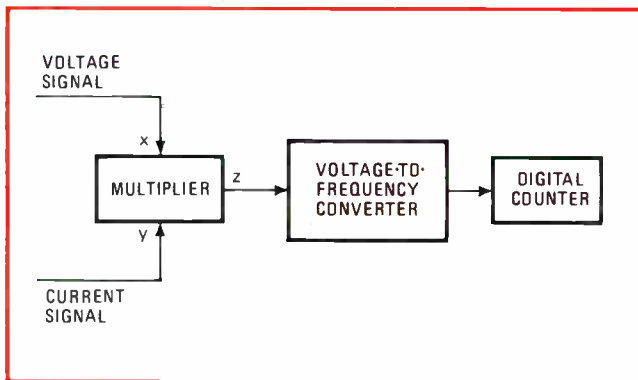

3. Counter averaging. The average output from the analog multiplier can be measured with a voltage-to-frequency converter that has its output measured by a frequency counter. The gate time of the counter determines the averaging time. A function generator with a voltage-controlled input may be used as the converter.

dissipation and the average value equal to average power. (If the device under test were a resistor, this average would be the value obtained using a true-rms meter and the $P = E^2/R$ formula.)

Once the basic instrumentation system is assembled, an averaging instrument must be plugged in. One choice is an average-responding voltmeter that may be used at the output of the multiplier. In addition to the usual requirements of accuracy and dynamic range, the meter's lower limit of frequency response must be considered. Low-frequency limitations will be exhibited as fluctuations in output indication that follow the low-frequency component of the power waveform. Low-frequency response, or averaging time, may be extended by use of a parallel filter capacitor at the expense of slower response to changes in average value.

Most dc analog meters will serve well as an output indicator. So will an integrating digital voltmeter used in the dc mode, with its integration time determining the low-frequency response. Average-responding dc meters

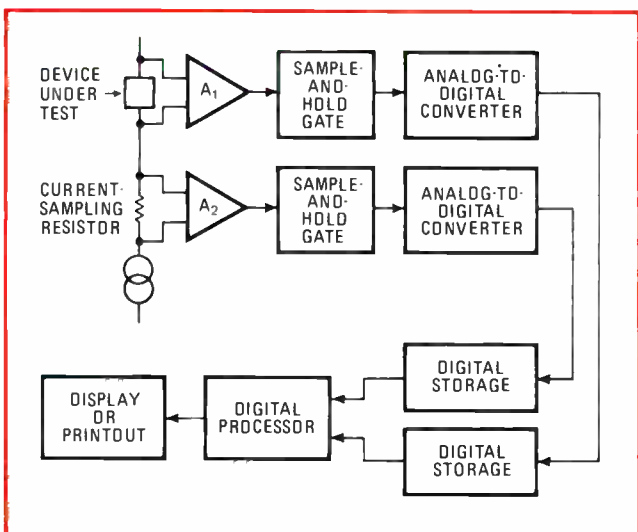

4. Digital measurement. Power can be measured with digital sample-and-hold gates and analog-to-digital converters, with the outputs multiplied digitally in a small processor. The entire system could be contained within a digital-processing oscilloscope.

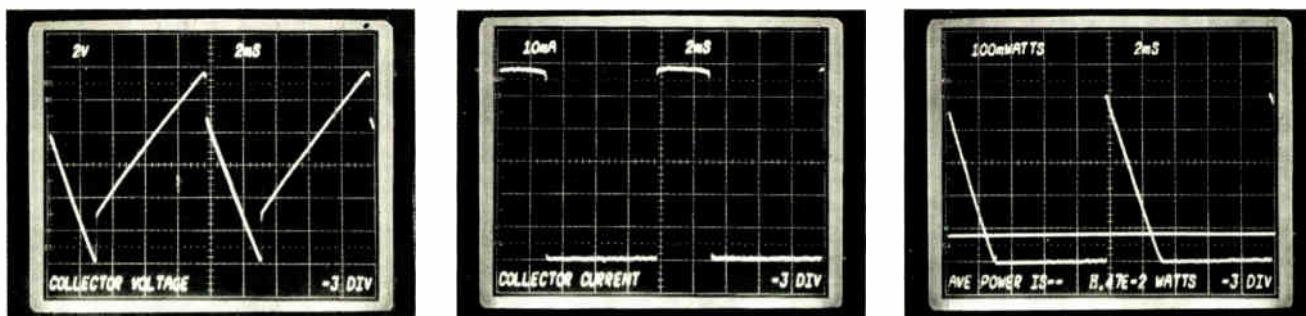

5. Scope power. A digital-processing oscilloscope can acquire waveforms of voltage (a) and current (b), digitize them, and store them, maintaining their time relationship. The instantaneous-power waveform then can be calculated and displayed.

have the advantages of simplicity and low cost. They are usually calibrated and typically have good high-frequency response. Digital types generally have better resolution and accuracy, but are difficult to read if the average value of the input is fluctuating.

System calibration

To determine the power represented by the output signal, the system must be calibrated. The calibration factor may be calculated if the characteristics of the various system blocks are well established. If their characteristics are uncertain, or if it is necessary to verify the calculations, calibration may be performed using known values of dc current and voltage.

In Fig. 2, R_1 takes the place of the device under test and is a 100-ohm resistance used only for calibration. The voltage across R_1 is acquired by the differential amplifier A_1 and input to the multiplier. R_2 is the current sampling resistor, and its voltage drop is acquired by the differential amplifier A_2 .

The voltage across R_1 is set to 20 volts, producing a 200-millivolt drop across R_2 . A_1 has an overall gain of 0.1, so that the input to terminal x of the multiplier is 2 v. A_2 has an overall gain of 10, so the input to terminal y of the multiplier is also 2 v. The multiplier has an input-output relationship specified as $V_z = V_x V_y / 10$ and its output is, therefore, 400 mv.

It may be seen that the input power to R_1 is 4 watts, and that this translates to a 400-mv output from the multiplier. The power in watts of R_1 , or of the device under test, is now equal to $10 V_z$. This relationship is valid as long as the gains of A_1 and A_2 and the value of R_2 are maintained. In addition, A_1 , A_2 , and the multiplier must be operating within the limits of their respective dynamic ranges.

If the voltage across R_1 is changed to any arbitrary waveform that can be handled by the amplifiers and the multiplier, the average voltage at the output of the multiplier will be equal to one tenth of the average, or equivalent dc, power (in watts) dissipated by R_1 . If R_1 is replaced by a semiconductor device, the calibration will still hold.

The current-sampling resistor of Fig. 2 may be replaced with a current probe, with or without an associated amplifier. Calibration procedures for the system are essentially unchanged, since the voltage output of the current probe is analogous to the output of A_2 . Depending on the current probe, A_2 may not be required.

It is important to evaluate the upper and lower frequency limits of the current probe relative to the waveforms that will be measured. For most applications, it is likely that the probe must have dc response plus a moderate ac bandwidth.

Another choice for averaging is a voltage-to-frequency converter and then a frequency counter (Fig. 3). This approach is actually quite similar to the use of an integrating DVM. The averaging time of the system is the gate time of the counter. This time needs to be long compared to the period of the waveform applied to the device under test in order to count enough cycles to take into account all voltage variations. Since it is relatively simple to extend the gate time of a counter to quite long intervals, this is a highly accurate approach for averaging over long periods of time.

However, such a subsystem must be separately calibrated. Its upper limit of frequency response may be constrained by slew-rate characteristics of the voltage-to-frequency converter, although it typically is much better than that of an average-responding meter.

Additional expense and complexity go against this choice for averaging in most applications. The greatest advantage is that averaging occurs over a selected interval. In fact, by using the counter in the totalize mode, power may be integrated over a set interval so that the system measures energy consumption during the interval rather than power or rate of energy consumption.

Digital processing

A digital technique may be used for multiplication and averaging (Fig. 4), while using the same technique for signal processing as in the analog setup. In this system, the current and voltage waveforms are digitized immediately following acquisition. The multiplication of the two waveforms is then performed by a processor such as a calculator or computer.

The processor also performs the averaging calculation. The average or equivalent dc power is displayed or printed out by any of several devices.

The entire instrumentation required, including signal acquisition, digitization, processing, and readout, may be combined in a digital-processing oscilloscope. This system has the additional advantage of providing an analog display of current, voltage, and power waveforms. Figure 5 illustrates the type of results obtained by using a digital-processing oscilloscope. It is a sophisticated but convenient method of gathering considerable data. □

Special report: active filters ride the crest of new technology

Bi-FET op amps boost their performance, improved thick-film inks cut their cost, and computers optimize their design

by Michael J. Riezenman, *New Products Editor*

□ Except possibly for amplifiers, filters are the most widely used analog circuits. Therefore, as with amplifiers, anything that improves their performance and reduces their cost and size gets a warm welcome from users.

Active filters, ever since they were first proposed in 1938,¹ have promised better performance than passive devices, at least at low frequencies. With the arrival of the monolithic operational amplifier and particularly the quad op amp, they began to look possible from a cost and size viewpoint as well. Lately, three developments have combined to make them look even more attractive:

- Operational amplifiers with input impedances on the order of 10^{12} ohms and gain-bandwidth products of approximately 5 to 10 megahertz have become available at low cost.
- New inks for the fabrication of thick-film hybrid circuits allow the routine production of resistors with temperature coefficients as low as 50 parts per million per degree Celsius.
- Reasonably priced minicomputers and programmable test equipment make automatic functional laser trimming of hybrid circuits possible at acceptable costs.

Op amps keep getting better and cheaper

Certainly the most important thing to happen to the active filter over the past year or two has been the introduction of the bi-FET op amp. Mixing bipolar and field-effect-transistor processes on one chip, devices of this kind have gain-bandwidth products some 5 to 10 times better than the standard 741 op amp, and they combine that asset with low noise, low power consumption, and low cost as well.

The performance of an active filter is limited principally by its op amp. As a rough rule of thumb, the gain-bandwidth product of the op amp must be about 10 times greater than the product of the Q and the center frequency of the filter. Thus any increase in the op amp's bandwidth translates directly into improved filter performance.

Just as important as a high gain-bandwidth product is a high slew rate. Slew rates are frequently expressed in terms of the op amp's full-power bandwidth. According to Don Jones of Harris Semiconductor, Melbourne, Fla., an active filter should be operated at no more than 20% to 25% of the op amp's full-power bandwidth to avoid

being slew-rate-limited. If that happens, the op amp becomes nonlinear and starts generating harmonics—frequently the very thing the filter was intended to eliminate. Of course, Jones points out, his 20% to 25% figure applies only when the op amp is delivering its full output—it is possible to increase the frequency by scaling down the output swing. A typical high-performance monolithic (i.e. bi-FET) op amp today has a gain-bandwidth product of 10 MHz, a full-power bandwidth of 100 kilohertz, and a price tag of about \$2 each in hundreds, although prices are dropping fast. National Semiconductor Corp., for example, recently cut the 100-piece price of its plastic-package LF 356N from \$2.10 to 75¢ each.

This price reduction is just as important as the bandwidth improvement, according to George Warren, senior design engineer at National Semiconductor's hybrid special products group. By making op amps cheap, and

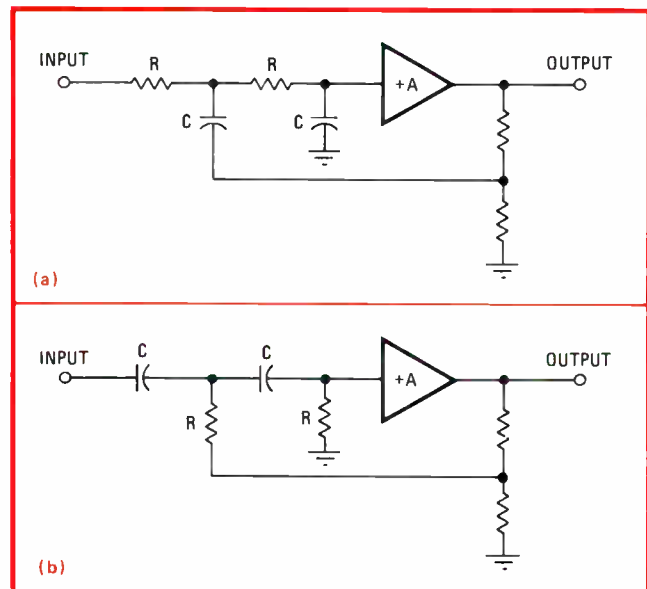

1. In the beginning. The earliest practical active filters, which were first described by Sallen and Key, were built around a single op amp. In the case of a Butterworth filter, the low-pass circuit (a) can be converted into a high-pass circuit (b) simply by interchanging its frequency-determining resistors and capacitors. A disadvantage of the Sallen and Key arrangement is that it is relatively sensitive to small changes in the values of its components.

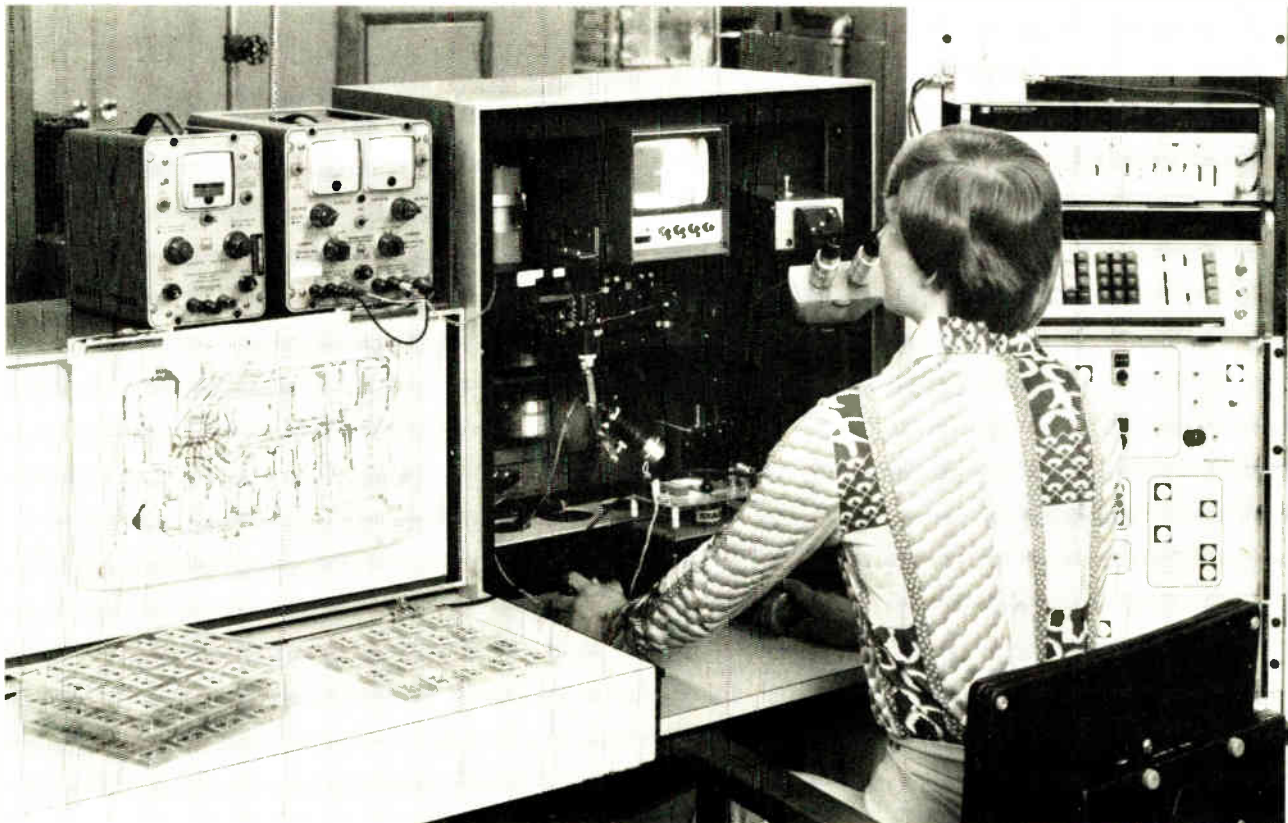

2. Automatic laser trimming. This computer-controlled dynamic laser trimmer at General Instrument Corp., Hicksville, N.Y., functionally adjusts hybrid active filters (see Fig. 6) for frequency, Q, phase, gain, and voltage while the circuits are under power.

particularly by making them available in quad form, op-amp manufacturers have enabled active-filter manufacturers (frequently one and the same) to switch from the somewhat touchy Sallen and Key active filter (Fig. 1) to the newer, more versatile, and less component-sensitive state-variable filter (Fig. 3).

The emergence of the state-variable filter

The Sallen and Key circuit is really an extensive catalog of circuits that was first described in 1955.² Although many variations have been described, a typical Sallen and Key circuit is a two-pole filter that contains one op amp, two resistors, and two capacitors. To realize a filter with more than two poles, all that is necessary is to cascade two-pole sections. As with other active filters, the various sections do not interact with each other because they are buffered by their op amps.

A major advantage of the Sallen and Key circuit is that it uses very few components—and in particular very few op amps. This becomes important in applications that require high-performance and therefore high-cost op amps.

For example, the line of instrument-type active filters from Rockland Systems Corp., West Nyack, N.Y., currently uses the Sallen and Key approach. President S. N. Thanos points out that his filters must exhibit very low dc offsets despite being switched over a wide range of frequencies. Therefore to minimize the effect of changing resistor values over a 1,000:1 range, the op amps should have low input-bias currents. This forces Thanos to buy FET-input hybrid op amps that cost him

\$10 each even in production quantities—though the picture will change as bi-FET op amps continue to improve in performance.

Instrument-type active filters are usually designed to provide a Butterworth response. The reason, Thanos explains, is that a Butterworth low-pass filter can be converted into a high-pass filter by simply interchanging its resistors and capacitors. The cutoff frequency and Q remain unchanged. This allows makers of instrument-type filters to offer units in which pushing a single button converts a high-pass filter into a low-pass device (Fig. 4). Since this type of instrument is usually configured as a two-channel filter, the user can easily form a band-pass or band-reject filter by interconnecting the two channels suitably (Fig. 5).

The state-variable configuration would do all this much more easily, and the advent of inexpensive high-quality op amps seems to be heralding its emergence. A typical state-variable active filter, such as the one shown in Fig. 3, uses three op amps per stage rather than the single op amp of the Sallen and Key design, and the individual amplifiers must be high-performance devices since their overall gain-bandwidth product is what limits the filter's performance.

The filter gets its name from the fact that it was first synthesized using state-variable techniques.³ It is really an analog-computer realization of a differential equation, for it combines integrators and summers to provide a specified transfer function. It has three advantages: independent adjustment of filter center frequency and Q; simultaneous low-pass, band-pass, and high-pass out-

Active and passive filters don't really compete

To view the active- and passive-filter technologies as battling for control of common terrain is true only to a very limited extent. Active and passive filters each have their positive and negative attributes, and the area in which it is difficult to choose between them is really very small.

Below approximately 100 hertz, active filters are clearly superior because of their smaller size and weight and lower cost. Above 100 kilohertz or so, active filters would require op amps with greater bandwidths than are now available, and, therefore, except for very simple applications, the advantage swings to passive filters. Between 100 Hz and 100 kHz is the range requiring thought.

Generally it turns out to be best to choose passive filters for critical applications and active filters for noncritical work. A critical application can be defined as one in which the theoretical limits of system performance are determined by the filter, or when the filter must meet some unusual specifications—wide temperature range, extremely low noise, very wide dynamic range, etc. One example might be a satellite communications system requiring filters that combine extreme complexity with ultrahigh stability. These filters are best synthesized as passive devices because passive devices offer considerably better performance with respect to stability, achievable sharpness, and phase response.

At first glance it might seem that the opposite should be true since active filters can be synthesized on the assumption of near-infinite Q and on a decoupled basis. Moreover, the singularities that determine the performance of an active filter can be placed accurately and individually. But often these advantages turn out to be the downfall of the active design. Decoupled designs requiring high Q suffer from extreme parameter sensitivity in, for example, sharp cutoff cases.

As a general rule, parameter sensitivity is dictated by the relative placement of the singularities of the transfer function with respect both to each other and to the $j\omega$ axis. Filters with singularities close to the $j\omega$ axis (high Q) and/or filters with poles near zeros exhibit high parameter sensitivity. For example, high-order elliptic filters have poles extremely close to the $j\omega$ axis at the band edge, and these same poles have zeros close by. The band edge of these filters therefore exhibits high parameter sensitivity: the composite transfer function results from the difference

between two large numbers. A small percentage change in either number will cause a large change in the response.

Group-delay equalizers are another case in which poles and zeros tend to be close to each other and to the $j\omega$ axis. As shown in the drawing, the characteristic all-pass response of the delay equalizer is the result of the algebraic cancelling of the pole response by the zero response. If either singularity moves with respect to the other, the all-pass response is lost.

Since passive networks are interactive, the relative placement of the singularities is reasonably well preserved even if one element shifts a modest amount. The validity of this viewpoint is borne out by the fact that active-filter designers have invented such circuits as the so-called "leapfrog" filter, which actually simulates the coupling equations of the equivalent passive-filter design. This type of active-filter design is obviously more difficult than the uncoupled design, and it also yields a larger and more costly filter.

For the large number of noncritical applications that one encounters, the active filter is usually the better choice. It is relatively easy to design, it can be made quite compact, and its inductorless design is amenable to a high degree of automation and integration. Finally, broadcast radios notwithstanding, active filters are much easier to tune over large bandwidths than are passive filters. **Ronald J. Juels**

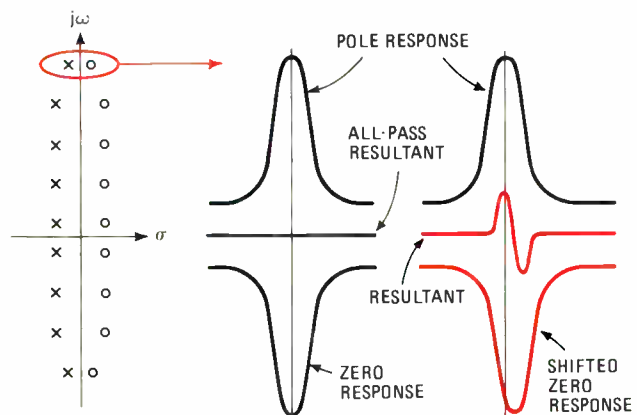

puts, and (especially important for high-Q filters) relative insensitivity to variations in component values.

This low component sensitivity results from the fact that, like any analog computer, the filter employs lots of stabilizing feedback. Filters that use just one op amp, on the other hand, are similar to balanced-bridge circuits because their response depends on the differences between pairs of numbers. For high-Q circuits, the numbers are large, and a slight change in one can materially affect the circuit response.

The resistive element

Fixed-frequency filters are also benefiting from the ability of state-variable active filters (and other multi-op-amp configurations) to tolerate moderate variations in their components. Here the catalyst is the development of good inks for stable thick-film resistors, which

allows the manufacture of communications-quality active filters in compact hybrid-circuit form at reasonable cost. Companies like Beckman Instruments Inc., General Instrument Corp., and National Semiconductor Corp. are producing this kind of active filter for large-scale use in telephone systems (Fig. 6).

Also of prime importance in this area, according to some manufacturers, is the fact that quad op amps reduce chip counts. But Mike English, National Semiconductor's engineering manager of hybrid special products, prefers to emphasize functional laser trimming, which he believes has done more for active filters than any other single development.

Accurate chip capacitors, he explains, are expensive, but in an active filter the important parameter is not a capacitance so much as an RC product, and, provided the capacitor is stable, the RC products can be adjusted

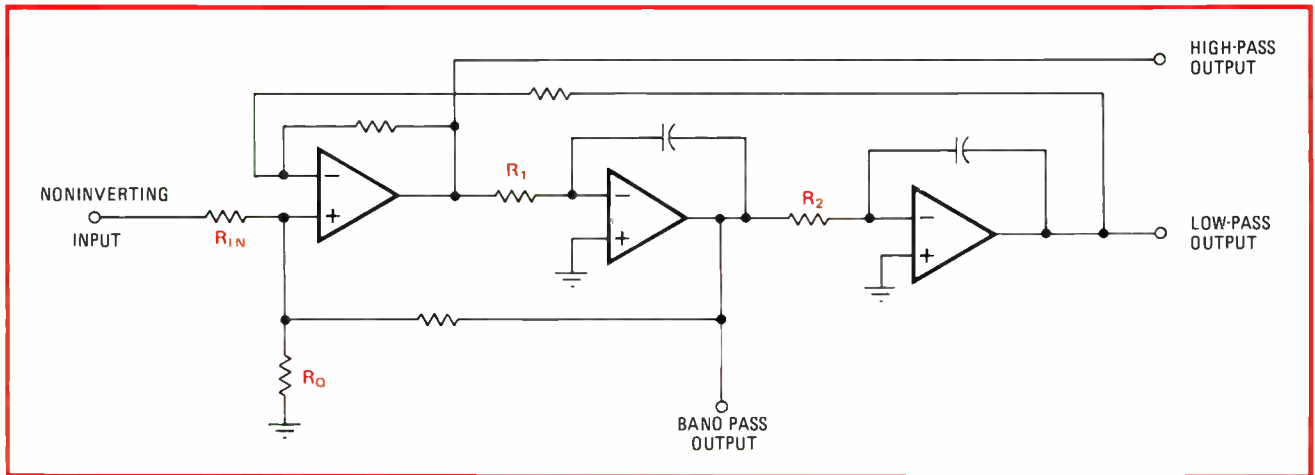

3. Versatile. The state-variable active filter provides high-pass, low-pass, and bandpass outputs simultaneously. Furthermore, it allows independent adjustment of its frequency (R_1 and R_2) and Q (R_{in} and R_Q). To make it even more attractive, it is relatively insensitive to small changes in the values of its components. On the negative side, this type of filter requires three high-quality op amps, making it economically unattractive until recently.

by laser-trimming the resistor. But when laser-trimming an active filter, most manufacturers do not trim to a predetermined RC product. Rather they trim functionally to bring the filter's amplitude and phase response into line. As might be guessed, this is a far from trivial task, and in fact it requires that a computer be used to control the laser trimmer.

Computers change the rules

Computers affect many other phases of filter design, and, as many filter-makers point out, have had a profound effect on the pricing and performance of all types of filters—both active and passive. For instance, as a look at the literature reveals, they enable the designer to make detailed sensitivity analyses to determine just how much effect a change in a component value will have on a filter's response. But, perhaps most importantly, according to Ronald J. Juels, executive vice president of Comstron-Seg, Freeport, N. Y., they allow the designers of both active and passive filters to make the filters fit their system requirements.

Juels, whose company makes both active and passive filters, maintains that the well-known Butterworth, Chebyshev, Bessel, Cauer, and similar filters are often used, not because they are best for a given job, but because they are described by transfer functions that are mathematically tractable. He goes as far as to state that from a systems viewpoint he knows of no application for which a Butterworth filter is really the best choice.

The point of his argument, and many people agree with it, is that today's filter designer can let a computer translate his amplitude and phase requirements into a pole-zero plot and even into component values. One of the characteristics of active filters is that each pole pair is determined independently of all the others. Thus the translation of a system requirement into a pole-zero plot is almost equivalent to designing an active filter. (With passive filters, of course, the singularities are all coupled,

so the design procedure is much more involved.)

Using a computer to design a filter is a fairly specialized activity and also a pretty expensive one, so it is usually done by companies that specialize in manufacturing filters. For the nonspecialist, if all he needs is something like a straightforward six-pole Butterworth filter, three choices have evolved: buying a custom filter from a specialist, designing his own active filter, or using a so-called universal active filter (UAF). (When he needs a truly high-performance filter with high Q , tight specifications on phase linearity, and so on, the nonspecialist is advised to go to an expert.)

Typically a UAF is a two-pole state-variable filter with the key frequency- and Q -determining resistors omitted. Most often, the filter is a hybrid circuit built on a ceramic substrate and housed in a dual in-line package. The op amps are usually part of a quad, so one amplifier is left over for other applications. The user can employ it as a summing amplifier to form a notch filter from the UAF's low-pass and high-pass outputs, for example.

Along with their hardware, manufacturers of universal active filters supply design manuals with equations, tables, and sample calculations that show the user how to determine his component values and hook up his filter. To build his six-pole Butterworth filter, the user therefore needs only three UAFs, a half-dozen metal-film resistors, and a few hours with the design manual.

How useful is the UAF?

A question that then arises is why use the UAF at all. If one is going to have to spend a few hours designing with the UAF, why not spend a few more hours and design the whole filter? The answer, according to Dennis Haynes of Burr-Brown Research Corp., Tucson, Ariz.,—a manufacturer of UAFs—is that the UAF gives convenience, small package size, and guaranteed performance. Since most of the filter has been designed already, he says, most of the noncreative paperwork also has been done already. The hybrid circuit is almost certainly smaller than anything anyone could build on a printed-circuit board. And, assuming that good-quality resistors are bought, the circuit has to work.

National's Mike English amplifies this last point by considering what would happen if one op amp in a filter were to go bad. If a designer uses a UAF, he says, it is

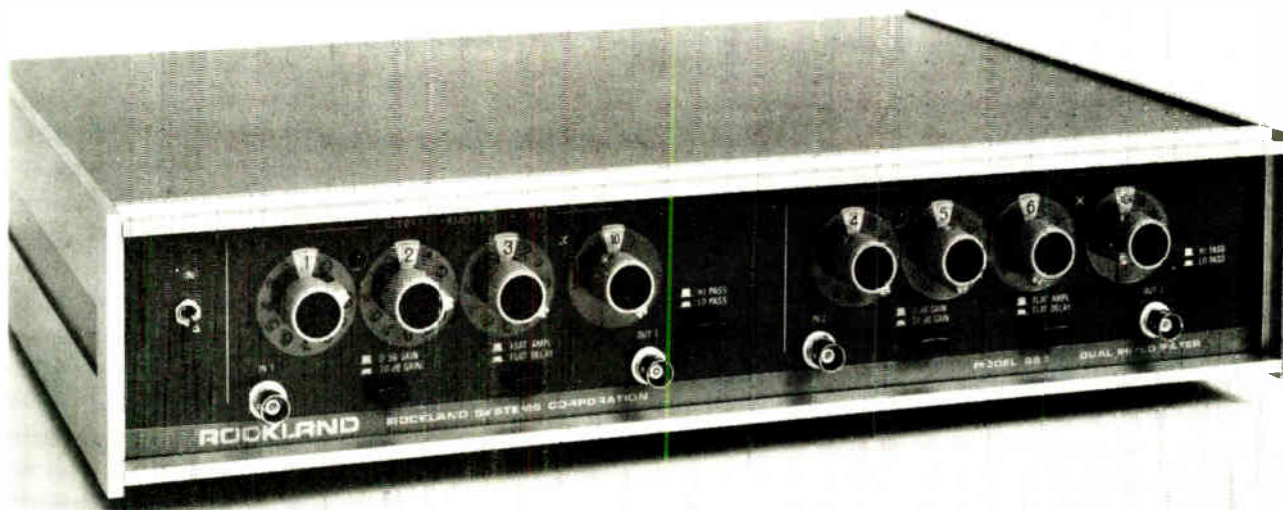

4. Instrumentation. Both of the channels in this two-channel active filter from Rockland Systems can be switched from low-pass to high-pass at the touch of a button. Similar instruments are made by Krohn-Hite, Ithaco, the Multimetrics division of Comstron-Seg, and A.P. Circuit Corp.

simple just to replace the whole package. The filter will work as before because the UAF manufacturer has taken steps to ensure a high degree of product uniformity. If, on the other hand, the designer builds his own filter, and if the filter response is critical, he may find that changing an op amp will affect the filter response.

As president of Frequency Devices Inc., Haverhill, Mass., which specializes in the manufacture of discrete-component active filters, Robert W. Steer Jr. thinks differently. He believes that UAFs require too much filter engineering on the part of the customer, and for most low-volume applications he recommends buying a custom filter. For certain nondemanding applications, though, his firm offers an almost-complete filter that the user can program over a 1,000:1 frequency range by adding a pair of equal-value 1% resistors.

When to buy

Steer and his marketing vice president, Steven M. Ruscio, believe that most users should not even consider making their own filters unless they need more than 25,000 units a year. Below that, Ruscio says, companies like Frequency Devices can do it more cheaply. Explaining how he can do that and still make a profit, Ruscio cites a factor mentioned by other filter makers—the ability to sort, select, and match components.

His company can buy large quantities of inexpensive op amps, he points out, and use the ones with especially low bias current for low-pass filters while reserving the units with especially wide bandwidths for high-pass filters. Haynes of Burr-Brown agrees that the filter manufacturer's handling of large volumes of components allows him to mix and match devices in a way that no

small-run user could hope to match. And it goes without saying that the purchase of an \$80,000 laser-trimming system is difficult to justify if it is only to build a couple of thousand filters.

If all of the preceding has failed to persuade you to leave filter making to the specialists (and it should be pointed out that many filter users—particularly modem makers—have not been persuaded), here are a few tips that various filter makers see fit to pass along.

Rolling your own

First, you have to decide whether to build an active filter or a passive one. If the filter is to be adjusted over a wide frequency range, it should probably be an active design. Then if it must operate above about 100 kHz, you will have to begin its design by designing your own amplifier. Likewise, if noise must be kept to the irreducible minimum, or if it is a low-pass device and you cannot tolerate any dc offset at all, you will have to choose a passive filter even if it means buying 50-pound chokes.

But ignoring these pathological examples, you'll generally make your decision on the basis of the factors discussed in "Active and passive filters don't really compete," p. 121.

One thing on which all filter makers seem to agree is that the only kind of resistor to use is the precision metal-film variety. Capacitors are a bit more controversial: the kinds to avoid are Mylar, high-K ceramic, and polypropylene, all of which are too much affected by temperature changes. NPO ceramics are definitely preferred for capacitances up to about 1,000 picofarads, but above that the devices get too big. Mica is also

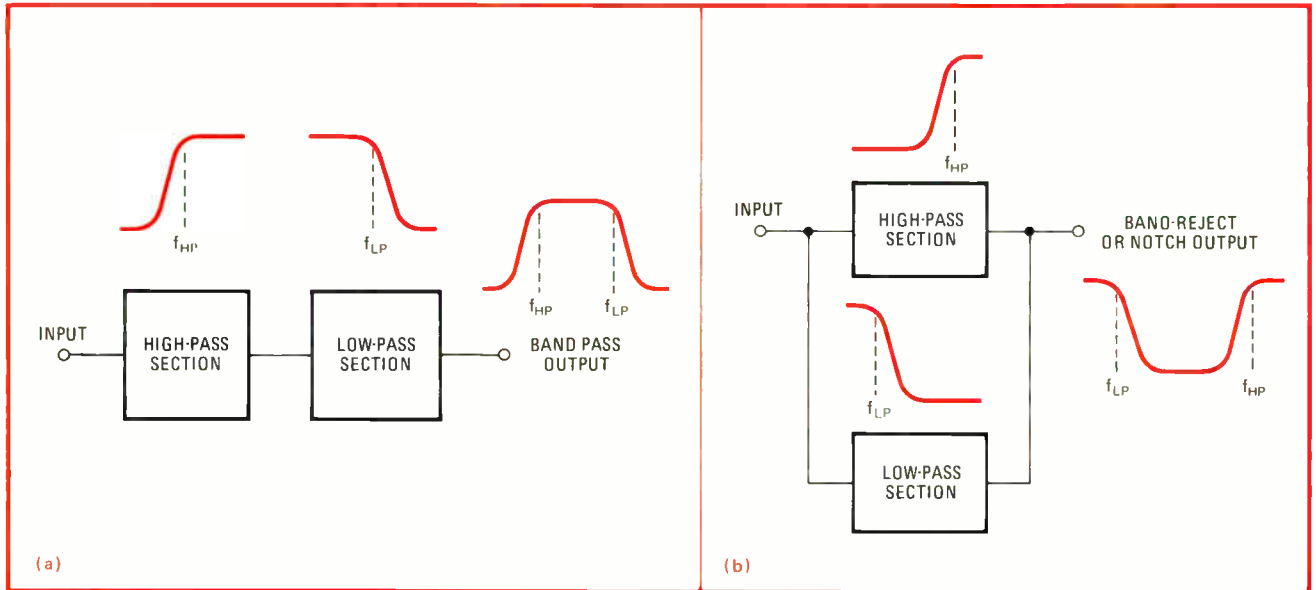

5. Interconnection. High-pass and low-pass filter sections can be cascaded to form bandpass (a) and band-reject (b) filters. In the case of a state-variable filter or of a two-channel instrument-type filter with both channels set to the same frequency, the band-reject output is actually a notch filter. The uncommitted op amp in a typical universal active filter is sometimes used to sum the outputs as in (b).

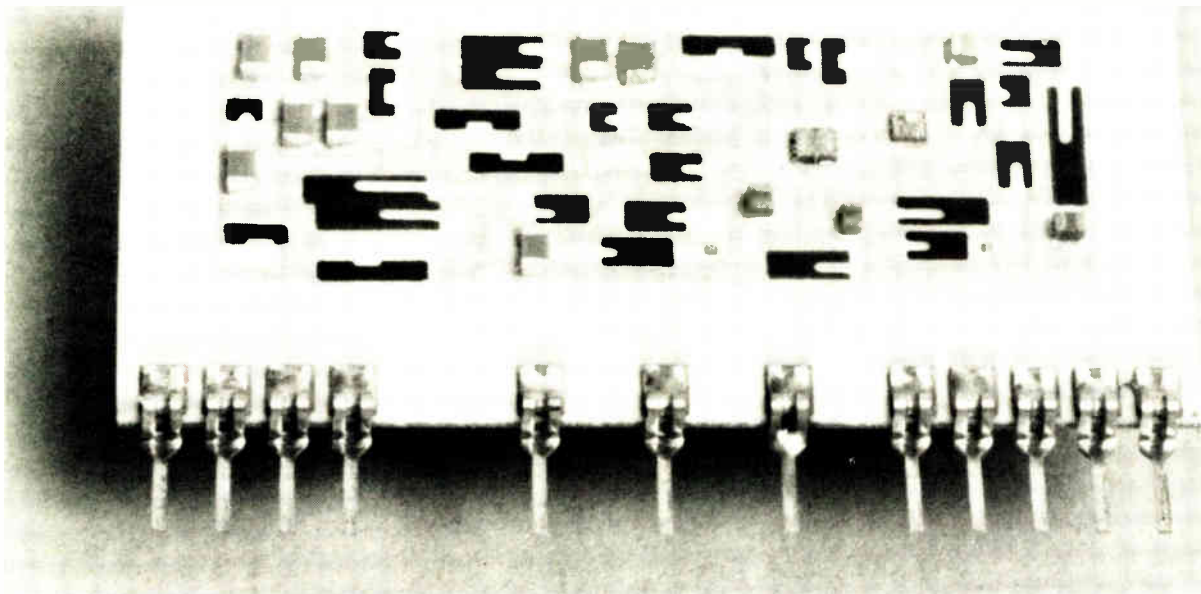

6. Hybrid. The dark areas on this ceramic substrate are laser-trimmed thick-film resistors. Stable to within 50 ppm/°C, they allow rapid functional trimming of large numbers of active filters. This filter is a General Instrument PCM D3 unit for use in PBX and PABX equipment.

recommended for small capacitances. For the larger capacitances, most makers suggest polycarbonate, but Andy Varenais of Krohn-Hite warns that these units are hygroscopic, changing up to 1% with humidity changes.

Of course, one way to get around using large capacitors is to use large resistors. That is now possible at low cost, thanks to the low bias current and high input resistance of bi-FET op amps.

One final word: remember that an active high-pass filter is really a bandpass filter with its upper frequency set by the op amp. So leave a little room up top. □

References

1. H. H. Scott, "A New Type of Selective Circuit and Some Applications," *Proc. IRE*, Feb. 1938, pp. 226–235.
2. R. P. Sallen and E. L. Key, "A Practical Method of Designing RC Active Filters," *IRE Trans. Circ. Theory*, March 1955, pp. 74–85.
3. William J. Kerwin, Lawrence P. Huelsman, and Robert W. Newcomb, "State-Variable Synthesis for Insensitive Integrated Circuit Transfer Functions," *IEEE, J. Solid-State Circ.*, Sept. 1967, pp. 87–92.

Note: An excellent reference book on active filters is "Active RC Filters: Theory and Application," L. P. Huelsman, ed., Dowden, Hutchinson & Ross, Stroudsburg, Pa. 1976. A compilation of 47 benchmark papers, with editorial comments and an introduction by the editor, it is distributed by the Halsted Press division of John Wiley & Sons.

Reprints of this article cost \$3.00 each. Write to Electronics Reprint Dept., P.O. Box 669, Hightstown, N.J. 08520. Copyright 1977, Electronics, a McGraw-Hill publication.

8-Bit high-speed monolithic A/D

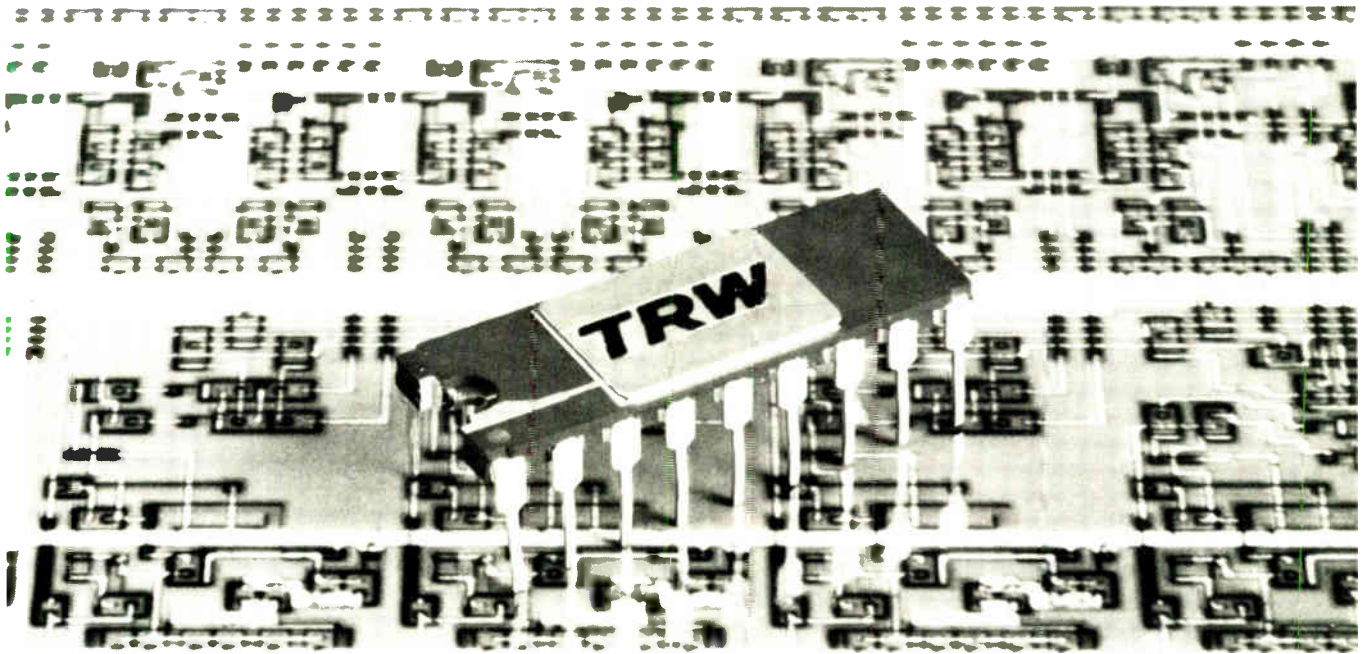

Priced under \$100

Off the shelf delivery:

TDC-1002J	1000 ns	\$75 in 100's
TDC-1001J	400 ns	\$175 in 100's

Two performance ranges—400 and 1000 ns conversion times: two price ranges for a wide variety of high-speed A/D applications.

Linearity is $\pm 1/2$ of LSB. Nine clock periods per conversion. All output bits are ready one clock period after the status signal indicates "ready to convert." There are no missing codes — ever!

TDC-1001J and TDC-1002J are supplied in an 18-pin ceramic DIP package designed to operate at a commercial temperature range of 0° to 70° C.

For more information and complete specifications, call (213) 535-1831, or use this coupon.

TRW LSI Products
E2/9085 • One Space Park
Redondo Beach, CA 90278

Please send data sheets on your 8-Bit A/D Converters.

NAME _____

COMPANY _____

DIV/DEPT _____

MAIL CODE _____

ADDRESS _____

CITY _____

STATE _____

ZIP _____

E

TRW LSI PRODUCTS

....from a company called TRW

Accurate thermometer uses single quad op amp

by Yishai Nezer
Haifa, Israel

For temperature ranges up to 150°C, a thermometer built around a single integrated circuit has not only greater linearity than a thermocouple but also far greater sensitivity—approximately 2 millivolts per degree Celsius. The sensor achieves this superior performance by exploiting the well-known voltage-to-temperature relationship of a semiconductor pn junction.

In the temperature-sensing scheme shown, the low-power LM324 quad operational amplifier and a diode probe are the central elements. The first two op amps, A₁ and A₂, have the job of keeping a constant current through the diode, to ensure that any voltage changes across the diode are a direct result of temperature changes at the probe. A₁ serves as a buffer for the input circuit divider resistors, producing an output of 4.5 volts that acts as a reference point for the other op amps and permits them to operate in their linear region. A₂, in conjunction with the LM113 reference diode, produces a constant 1.5-v output, which is practically independent

of variations in battery voltage or circuit temperature and thus supplies the diode probe with a constant current of about 0.5 milliampere.

The output voltage of this diode is buffered by op amp A₃, and changes in A₃'s output are reflected in the output of A₄, inserted to provide a separate point to adjust for device sensitivity and calibration.

A simple calibration procedure is necessary for proper operation. Once the range of temperatures to be measured has been determined, the zero-adjust potentiometer is set for zero output voltage at the low temperature extreme, and the sensitivity-adjust potentiometer is set for a convenient output (perhaps full-scale reading) at the upper temperature extreme. A 1-mA meter movement can be used at the output.

If a wide range of temperatures (0°–150°C) is to be measured, a diode-connected transistor (base and collector connected) is often preferable to a diode, because its properties better approximate an ideal pn junction. But in applications where the temperature variations are small, a glass-encapsulated diode is more convenient. The probe should be isolated when the circuit's power supply is not floating with respect to the tested environment.

Precision is better than 0.1°C, provided shunt conductances are minimized at the probe. Current drawn by the circuit is typically 4 mA. Power consumption can be conserved further by use of a switch. □

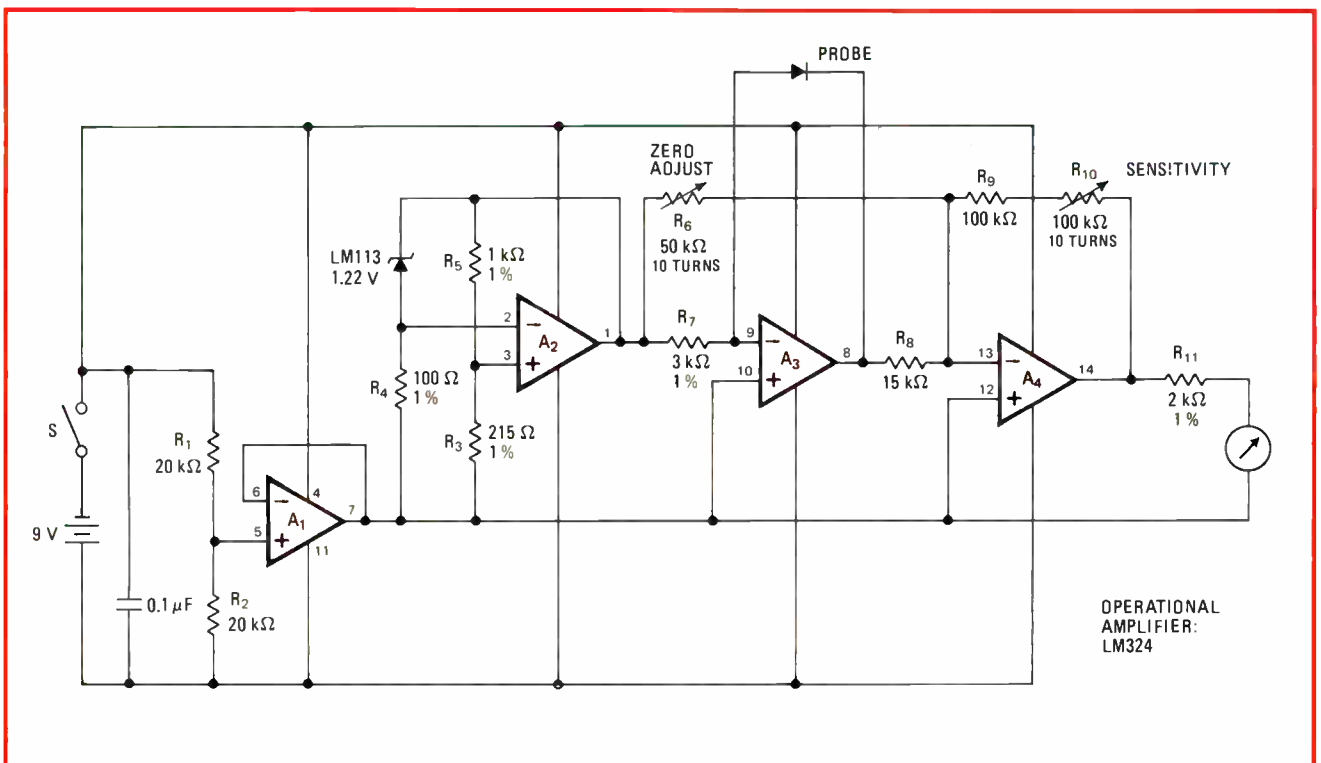

Precision thermometer. Accuracy is limited primarily by ammeter readability. Thermometer is sensitive enough for medical applications where temperature variations are small. LM113 can be replaced by two silicon diodes in series for less demanding applications.

Low-cost oscillators build accurate capacitance meter

by Willie H. Wang
Portland, Me.

An accurate digital capacitance meter can be constructed without an expensive, highly precise crystal oscillator. It uses a pair of 555 oscillators, deriving its accuracy from an arrangement that depends on the ratio of gating time to clock period rather than the precise frequency output of a master oscillator.

The two 555 timers operate as free-running oscillators.

one for gating and the other as the clock driving a typical digital counter, as shown in the figure. The key to the circuit's accuracy is in the counting scheme. Actually, the counter capacity is a full six digits; however, the two least significant digits are not displayed. Thus, any inaccuracies due to clock drift, trigger error, or +1 count bobble are eliminated.

A negative-going clear pulse from the output of the gating oscillator IC₂ through NAND gates G₃ and G₄ (wired as inverters) initializes all 93176 decade counters to zero at the beginning of each sampling interval. The output of clock oscillator IC₁, which has a period determined by the equation $t_1 = 0.69(R_1 + 2R_2)C$, is combined with IC₂ through G₁. Because the period of IC₂ is $t_2 = 0.69(R_3 + R_4)C_0$, where C₀ is the value of the capacitor under test, the number of pulses at the

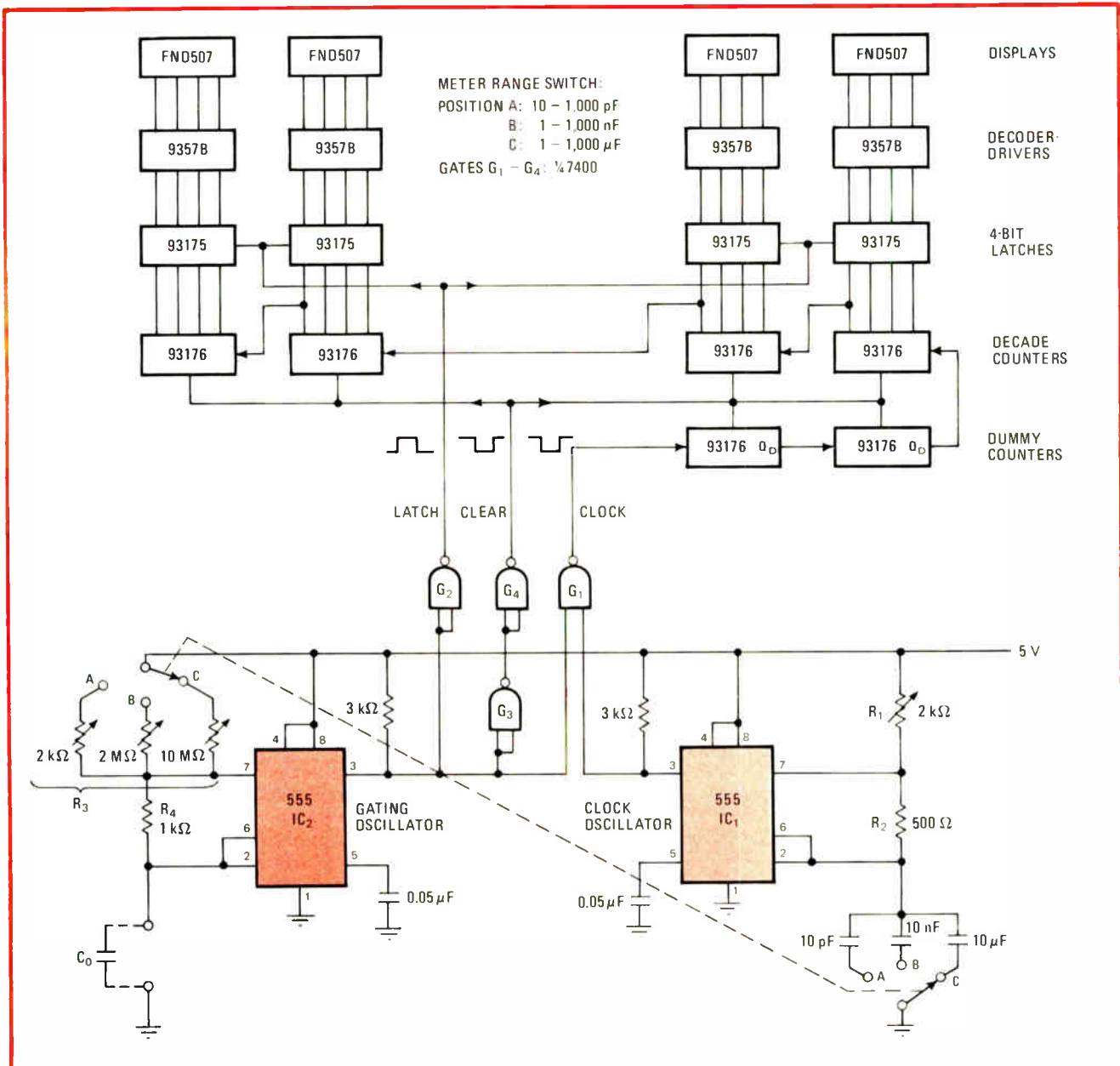

Digital-readout capacitance meter. Variable resistors in the timer networks should be accurately known and implemented with precision potentiometers where possible. Calibration must be performed for each meter range. Accuracy is greatest in the 1 - 1,000-nF range.

New Programmables from Texas Instruments

With plug-in Solid State Software™ ROM modules.
Up to 100 memories and 960 program steps.

The New Programmables

with Solid-State Software

Lectro-Media Ltd., the nation's leader in programmable calculators, introduces the new Texas Instruments line-up. Now available for the first time—plug-in Solid State Software—known in the electronics field as CROM (constant read-only memory).

The Super-Powerful Card Programmable

TI-59 — gives you up to 960 program steps or up to 100 memories to work with. Add the plug-in CROM and you have 5000 steps of subroutines at your disposal. The most powerful programmable on the market — at an incredibly low cost! You can allocate the 120 storage registers between program steps & memories based on your unique problem. You have the flexibility from the keyboard or from under program control.

AOSTM — T.I.'s algebraic operating system with 9 sets of parentheses lets you code problems the way you formulate them. Now you have an independent t register for testing, 10 more test registers, 72 labels, 6 levels of subroutines, indirect addressing, complete program editing. All this plus 175 functions and operations for science, engineering, finance and statistics.

Data & Program Storage — with the magnetic card capability of the TI-59, you may record the entire contents of the 120 storage registers, which you also have allocated between program & data, on 2 magnetic cards. Use this feature to store data for future analysis—no more aggravation with costly time-sharing or batch computer systems. Program protection feature acts like an object code for proprietary applications.

SR-52 Program Conversions

Your SR-52 programs may be transferred to the TI-58/59 with minor modifications (Magnetic cards not interchangeable).

TI Programmable 58 — The same powerful features as the TI-59 but no magnetic card I/O and only 60 storage registers. Easily affordable for students, sales personnel and production staff.

Is Programming the TI-58 / 59 Difficult?

With the aid of "Personal Programming" anyone with a logical mind can operate the new powerful hand-helds from T.I. This 260-page book is your complete guide to a whole new dimension in problem solving ease and power. Available immediately for \$12.95 (deductible from your TI-58 or TI-59 purchase price.)

Custom CROMs and Seminar Program

Lectro-Media Ltd., in conjunction with Texas Instruments, will provide seminars for your staff to demonstrate the productivity potential of the new T.I. programmables. Costly time-sharing programs can be eliminated through the development of custom-designed CROMs. Write on your company for details.

TI Programmable 57 (replaces SR-56)

Now with 50 efficient fully-merged program steps, the equivalent of up to 150 keystrokes; 10 labels now provided for ease of programming.

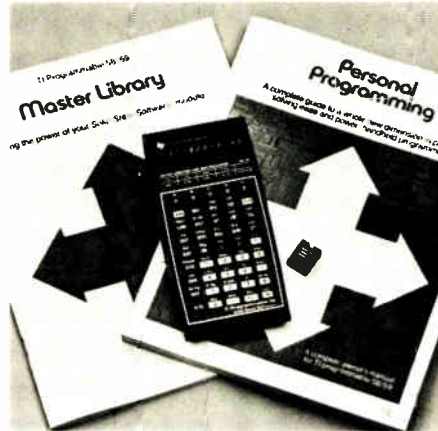

Plotting, Printing & Editing

With the alphanumeric PC100A printer.

The PC100A thermal printer turns your TI-58 or TI-59 into a quiet, high-speed printing calculator that prints, lists and traces your program at 60 characters a second. In the editing mode, the PC100A prints each memory location, the memory instruction coded and its alpha equivalent for ease of debugging. In the trace mode, the PC100A lists every calculation performed and the number generated.

Alphanumeric Prompting

```

1 7 8 9 A B C D E
2 - F G H I J K L
3 M N O P Q R S T
4 . U V W X Y Z +
5 * % ^ π e ( ) ,
6 ↑ ↓ / = ' × π
7 ? ? ÷ ∫ ∫ ∫ ∫
    
```

64 characters entered by 2-digit address code. Maximum 20 characters/line

Program Headings

```

#R WS XN: TESTS 3/22
    
```

Easy reference and identification. User prompting for non-technical staff use.

Data Labels

All program numerical labels may be printed on command to simplify program documentation for re-use

Data Plotting & Headings

Plot curves and histograms from keyboard or under program control.

Hewlett-Packard or Texas Instruments?

For a head-to-head complete comparison with the equivalent Hewlett-Packard models send \$2. and we'll let you decide if the extra \$150 to \$300 for HP is justified.

TI Programmable 59	\$299.95
with PC100A printer.	449.95
Blank Cards .40 per pack (TI59 only) .	14.95
TI Programmable 58	\$124.95
with PC100A printer.	274.95
Guide Book for TI-58/59	\$12.95
deductible from TI-58 or 59 purchase price	
Solid State Software Modules ea.	34.95
TI Programmable 57	\$79.95
120/240 Adapter/Charger	\$12.95
Thermal paper for PC100A...3 rolls	9.95

Solid-State Software™ Library Modules

Equivalent to a 25-card library in one small plug-in ROM memory module. The 5000 program-step module may be used in three ways:

- Standalone for conventional library programs with your data.
- As a base to call your specialized subroutines and functions entered from magnetic cards or keyboard.
- As a set of subroutines that your program can call. Perform chaining by calling subroutines both ways.

Library Modules Available:

all modules include diagnostic program and detailed instruction books

1. Master Library

(included free with TI58 or TI59)

25 programs including Matrix algebra, determinants, simultaneous equations, complex functions and arithmetic, polynomials, random number generator, combinations & permutations, compound int'st, annuities, checking acct management, and more

2. Applied Statistics

Random number generator, data entry programs, means & moments, histogram construction, theoretical histogram, data transforms, 2-way analysis of variance, rank sum, multiple linear regression, normal, binomial, chi-square, t & F distrib'tn and 3 more.

3. Real Estate/ Investment

Annuities, remaining balance/accumulated interest, compound interest; straight line, declining balance, sum-of-the-years digits, composite and excess depreciation; curve fit, optimal regression, internal rate of return, cash flow analysis, yearly amortization schedule, investment feasibility, annual property operating data, installment sale analysis.

4. Aviation

Flight Plan: with wind, verification, and long range; atmosphere, speed, temp., and altitude; predicting freezing level; lowest usable flight level; the wind triangle, dead reckoning, rhumbline navigation, and 13 more.

5. Marine Navigation

Coastal: time-speed-distance with current sailing, distance short of, beyond or to horizon; velocity, VMG and current vectors; course to steer and SMG; DMG, SMG, CMG from 2 pts. map initialization and 5 more. Celestial: time of sunrise/sunset/twilight, star iden.; sextant correction; sight reduction, noon sight fix and 3 more Ocean Sailing: great circle sailing; dead reckoning and rhumbline navigation.

Sailing & Tactics: Modified wind; CMG, SMG & time-to-lay-line; distance & bear'g to mark.

6. Surveying

Azimuth/bearing, inverse, field angle and circle traverse; closure; compass and transit rule balance; horiz. and vert. curve design; EDM slope reduction and 12 more

MAIL ORDERS TO:



Philadelphia's
Computer Store

LECTRO-MEDIA LTD.
P.O. BOX 1770 E.L.
PHILA., PA. 19105
(215) 925-4477

Showrooms:
NewMarket
America's Oldest Market
Front & Pine
(215) 925-9090

Lectro-Media Ltd. will match any advertised price. Simply clip ad and attach to order.

Shipping/Handling: \$3.50-1st unit, \$1 each add'l. PC100A: \$4 each. CAN/PR/HA/AK: add \$3 to order. Street Addresses only. PA.res. add 6% sales tax. Please, no CODs. Free Digital Thermometer with order.

CREDIT CARD ORDERS Only:

800-523-2906

Pa. & Canada: (215) 925-4477

output of G_1 per sampling interval is a linear function of C_o and is equal to $N = t_2/t_1$. This number, N , is ultimately shown on the 4-digit display.

The falling edge of the output of IC_2 's pin 3 announces the end of the gating period. At this time, the data contained in the counters is stored in the 93175 4-bit latches.

A clear pulse again resets the counters to initiate the next counting cycle. This pulse emanates from the same point as the latch signal, with a gate delay provided by G_4 in order to ensure that the data is transferred to the latches before the counters are cleared. The output of the latches is presented to the 9357B devices, which are binary-to-seven-segment decoder-drivers. The displays, which follow, are the Fairchild FND507.

By selecting the proper values of R_1 and C , a direct reading of C_o can be observed. For example, if R_1 is 1 kilohm, R_2 is 500 ohms, R_3 and R_4 are 1 megohm, and C is 10 nanofarads, N would equal 5,000 when a 50-nF

capacitor was measured. With its range switch in the 1-to-1000-nF position, the meter disregards the two least-significant digits. The accuracy factor in this case is determined by the R and C values in N and is obtained by isolating C_o from its constant term. In this circuit, $N = C_o(10^2)$, where 10^2 is defined as the accuracy factor.

This factor drops by a power of 10 when measuring large capacitors. The drop in accuracy occurs because resistor sum $(R_3 + R_4)$ must be reduced by a power of 10 to allow oscillation of IC_2 and to avoid the long gating time (23 minutes) that would be necessary to measure a capacitor of 1,000 microfarads or so.

There are potential difficulties when measuring small capacitors, also. The gating period must be increased in this case so that the display will operate correctly. This difficulty stems from the limiting frequency output (200 kilohertz) of the 555, and may be cured by increasing the values of R_3 and R_4 . □

Offsetting op amp forms low-threshold detector

by William D. Kraengel
Valley Stream, N.Y.

The offset-voltage option on many operational amplifiers can generate a low-voltage reference for millivolt-threshold comparator and detector circuits. As shown in the figure, offsetting the op amp slightly provides a reference voltage for the transducer amplifier circuit, which would otherwise require additional components to form a separate reference source.

The desired reference voltage for the proper triggering point in this circuit is determined by the equation:

$$V_{ref} = \frac{V_{utp}(R_2) + V_{ns}(R_1)}{(R_1 + R_2)} = \frac{V_{ltp}(R_2) - V_{ps}(R_1)}{(R_1 + R_2)}$$

where V_{utp} is the desired upper threshold (switching) point of the circuit, V_{ns} is the negative supply voltage, R_2 is the feedback resistor value, R_1 is the input resistance of the transducer, V_{ltp} is the lower switching point, and V_{ps} is the positive supply voltage. For example, if we desire a V_{utp} for 10 mv with a hysteresis of 4.5 mv (hysteresis = $V_{utp} - V_{ltp}$), V_{ref} would equal 7.3 mv at the inverting port of the op amp. Thus, triggering occurs when the noninverting port signal exceeds 7.3 mv.

However, if the inverting port were grounded, an additional -7.3 mv would be required at the noninverting port of the comparator for the switching action described above. This may be done by adjusting the 3-kilohm potentiometer between pins 5 and 6 of the op amp to offset the noninverting input by -7.3 mv.

The desired switching point can be verified by observing a constant 10 mv rms at the input of the op amp with an oscilloscope. The triggering points are clearly visible on the signal as the circuit switches.

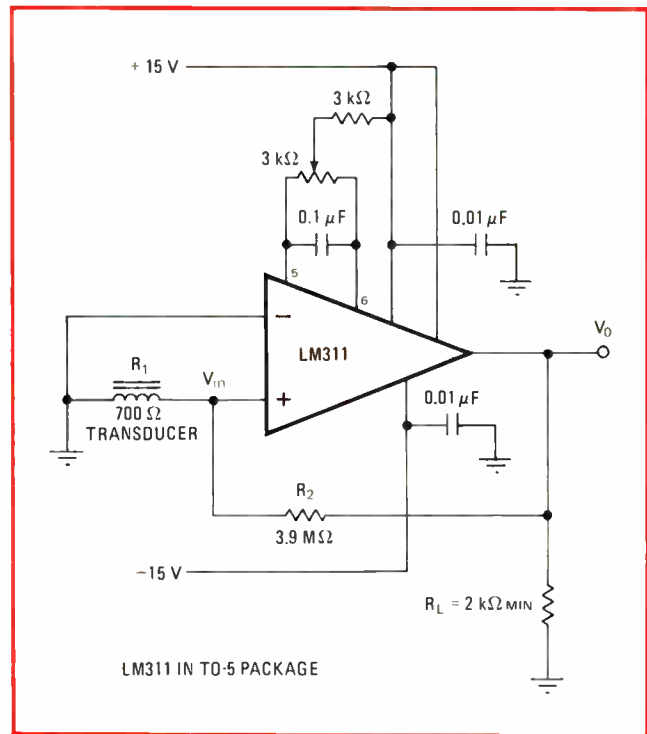

Saving components. Reference of 7.3 mV is developed by offset control for low-threshold trigger. If input bias and offset voltages are not excessive, op amp data sheet specifications will not be greatly affected. Current compensation is accomplished internally.

Another way to calibrate the circuit is to perform a static check. A -7.3 -mv source can be derived from a resistor voltage divider and connected to the inverting input of the op amp. The transducer is shorted and the output voltage of the op amp is brought to zero by adjusting the offset potentiometer. This procedure yields the approximate switching point. □

Engineer's notebook is a regular feature in *Electronics*. We invite readers to submit original design shortcuts, calculation aids, measurement and test techniques, and other ideas for saving engineering time or cost. We'll pay \$50 for each item published.

Red filter helps the color blind distinguish colors

Red-green color blindness, which affects about 8% of the male population, can be a serious handicap in electronics because so many components are color-coded, as is hook-up wire. "But while color defects cannot be cured, they can sometimes be surmounted," say Bernard Leikind of the University of Maryland in College Park and Karen Springer, an optometrist in Palo Alto, Calif. It seems that if you have trouble distinguishing reds and greens, you most likely can be helped **by looking through a dark-red-tinted filter with one eye and then observing an object with both eyes.** Colors will be more vivid and sometimes even lustrous or fluorescent. Reds remain unchanged to the eye with the filter, yet other colors, like browns and greens, appear darker in varying degrees.

The technique is most successful when one eye is fitted with the red-tinted contact lens developed by X-Chrom Corp., Boston, Mass., especially for correcting this type of color-vision problem. After a short period of adaptation, the person will become accustomed to the effects of the lens on colors and the possible changes in depth perception. Those unable to wear a tinted contact lens may benefit from holding a red filter over one eye or modifying a pair of flip-up/flip-down sunglasses. However, with these alternatives, there is no adaptation, and the red glass is cosmetically unappealing.

Laser light cures trapatt jitters

Have you considered trapatt oscillators for pulsed-radar applications, but rejected them because of their excessive frequency drift and start-up jitter? **Adding a laser diode to the oscillator structure may eliminate these drawbacks.** Richard Kiehl and Errol EerNisse of Sandia Laboratories, Albuquerque, N.M., have discovered that both drift and jitter can be reduced significantly if the trapatt's active device area is illuminated by a laser pulse during the rise of the applied bias pulse. In their work, they cut frequency drift from about 1.4%/microsecond to about 0.2%/μs and start-up jitter from about 75 nanoseconds to about 30 ns.

Custom LSI gets cheaper and faster

Custom large-scale integration is often the best solution to a tough design problem, but developmental costs can be prohibitively high and developmental time extremely long. Inaugurating a new program called React (for rapidly evaluate and apply custom technology), Micro Power Systems of Santa Clara, Calif., is **promising to deliver custom LSI for many applications within three to six months at costs of \$18,000 to \$38,000.** This is about half the time and expense required about two years ago, points out Dan Hauer, vice president of marketing. Rather than a library of gate arrays, cells, or mask-programmable chips, React employs a repertoire of optimized logic functions.

Moving up from small signal to power control

For those who want to learn about controlling power with solid-state electronics, Westinghouse Semiconductor has written a helpful "Introduction to Solid-State Power Electronics." The 144-page softbound book, which sells for \$6, teaches electronics designers about **the special considerations of controlling kilowatts instead of milliwatts** and acquaints power engineers with control in microseconds rather than cycles. For your copy, call (412) 925-7272 or write to the Semiconductor division, Westinghouse Electric Corp., Youngwood, Pa. 15697.

Lucinda Mattera

Trace quality. GOULD/Brush Recorders have it.

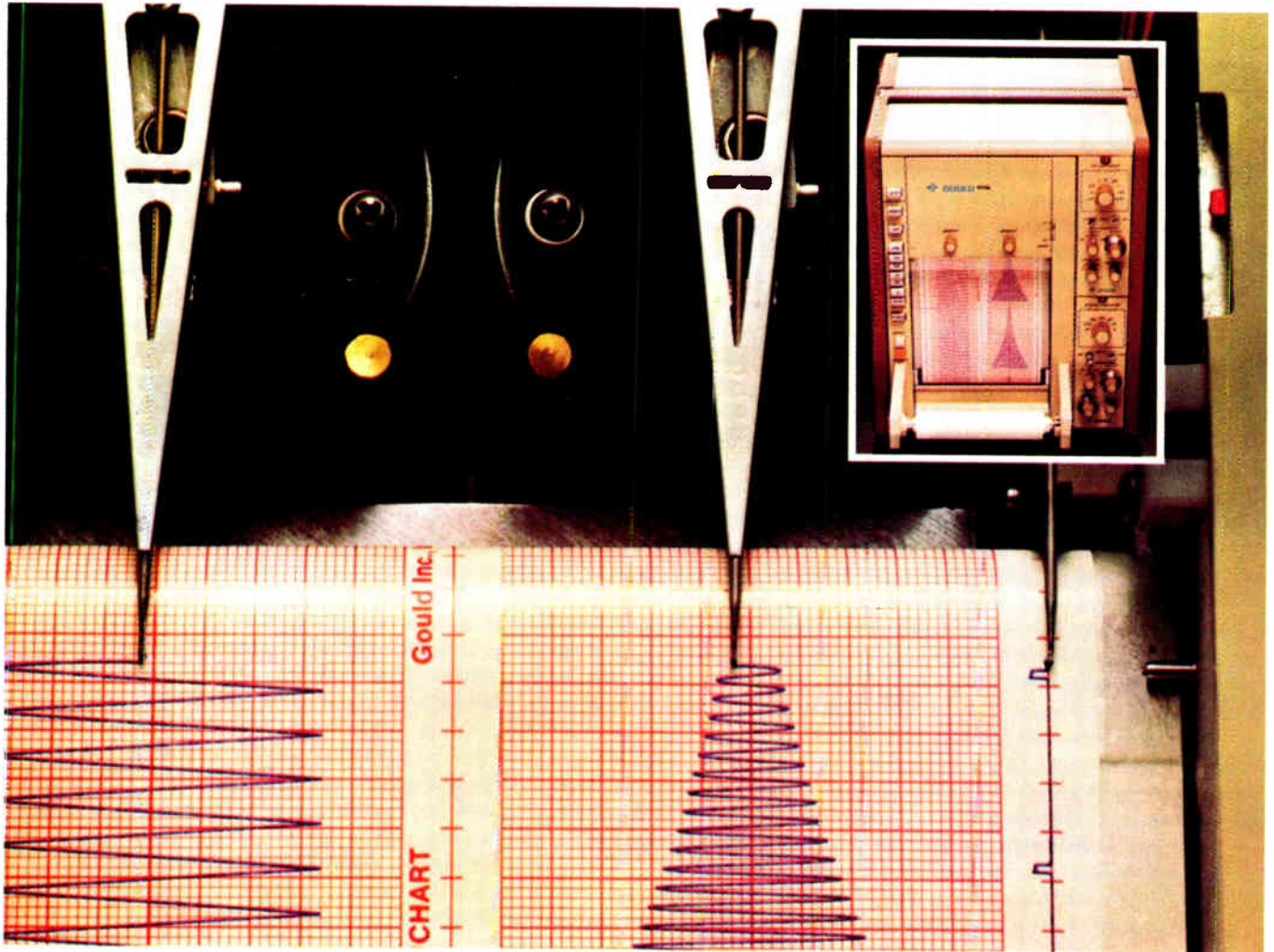

Regardless of pen velocity.

The exclusive GOULD pressurized fluid writing system assures you constant width traces regardless of pen velocity. The ink is injected into the paper and is wiped dry instantly by the high pen pressure seal. In combination

with GOULD low cost chart paper, your traces are permanent. They won't fade or deteriorate as do other writing methods.

An event that may only occur once demands the highest trace quality you can buy . . . GOULD.

For more information write Gould Inc., Instrument Systems Division, 3631 Perkins Ave., Cleveland, Ohio 44114. Or Gould Allco S.A., 57 rue St. Sauveur, 91160 Ballainvilliers, France.

For brochure, call Gould toll-free at (800) 325-6490, Ext. 77.
In Missouri: (800) 342-6600

 **GOULD**
The product development company

Chip peripherals outsmart CPUs

Intel's 827X series of dedicated devices is more complex than the most advanced of its n-MOS microprocessors

by Bernard Cole, San Francisco bureau manager

Over the next three to four months Intel Corp. will introduce a powerful new family of dedicated smart peripheral devices that in some ways are more sophisticated than the 8-bit microcomputers they are designed to support. To illustrate: Intel's most advanced n-channel metal-oxide-semiconductor central processor, the 8085, contains the equivalent of 6,500 to 7,000 transistors, but the chips in the 827X series may contain more than 22,000 devices.

First to be going into production is the 8279 keyboard/display controller. Soon to be available in sample quantities are the 8275 cathode-ray-tube controller, the 8273 synchronous-data-link controller, and the 8271 floppy-disk controller (diagram). All are 40-pin devices.

Typical of the series' sophistication is the 8271 floppy-disk controller, which contains the equivalent of more than 22,000 transistors. Architecturally, it is an impressive dual bit/byte processor. The front-end processor handles high-speed (250-nanosecond) data bit operations, and the back-end byte processor has 46 instructions with a minimum instruction execution time of 1.25 microseconds.

The 8271 interfaces one to four floppy disks to an 8-bit microcomputer and is fully compatible with the 8080 system bus. As an 8080 peripheral device, it accepts commands from the central processing unit, executes them, and feeds the result back to the 8080 CPU. Supporting a soft-

sectored format that is IBM 3740-compatible, the floppy-disk controller is a high-level unit that relieves the CPU of many of the control tasks associated with completing a floppy-disk interface.

The 8273 synchronous-data-link controller (SDLC), which has 22,000 transistors, and the 8275 CRT controller (15,000 devices) use a similar dual-processor architecture.

The 8273 is a single-chip device designed to support the SDLC protocol from IBM within the 8080 microcomputer system environment. Its internal supervisory instruction set is oriented to frame-level SDLC functions with a minimum of CPU overhead. (SDLC is a bit-oriented communications protocol, unlike IBM's earlier character- or code-oriented bi-synchronous protocol; it greatly reduces overall CPU software on the one hand and increases throughput on the other because of its ability to

go into a full-duplex mode.) In addition to full-duplex 56-kilobaud operation, the 8273 also features user-programmable modem control ports, programmable encode/decode, a digital phase-locked loop, and n-bit reception capability. It is also compatible with the 8080 system bus.

The 8275 interfaces CRT raster scan displays with the 8080 microcomputer system. Its primary function is to refresh the display by buffering the information from main memory and keeping track of the display's position on the screen. The chip provides the display-row buffering, raster timing, cursor timing, light-pen detection, and visual attribute decoding. It is programmable to fit a large number of display formats. The controller can be interfaced to standard-character-generator read-only memories for dot-matrix decoding. It is used with a direct-memory-access chip to provide the high-speed controlling function for a CRT.

The 8275 can generate a screen format size of from 1 to 80 characters per row, 1 to 64 rows per screen, and 1 to 16 horizontal lines per character row. The device has 7 character or code address bits, allowing for 6- or 7-bit ASCII capability. Or it can be used with 7-bit codes to generate up to 128 characters. It has six independent visual field attributes, 11 visual character attributes, four cursor-control modes, and a programmable direct-memory-access burst-mode capability.

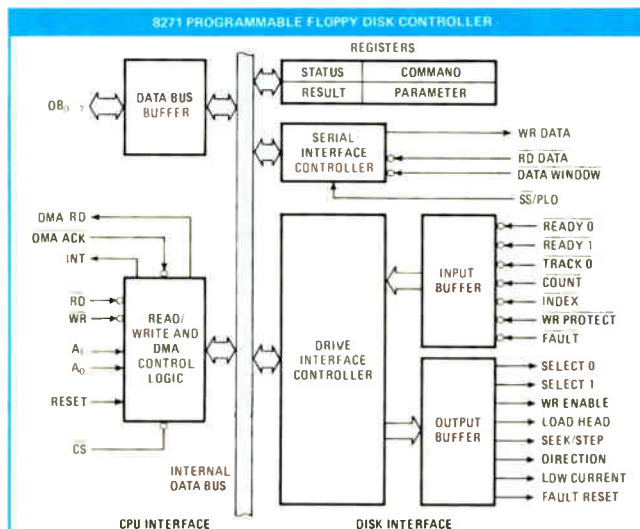

Internal bus. One of the peripheral devices being introduced by Intel Corp. is the 8271 floppy-disk controller with dual-processor design.

Accuracy. GOULD/Brush Recorders have it.

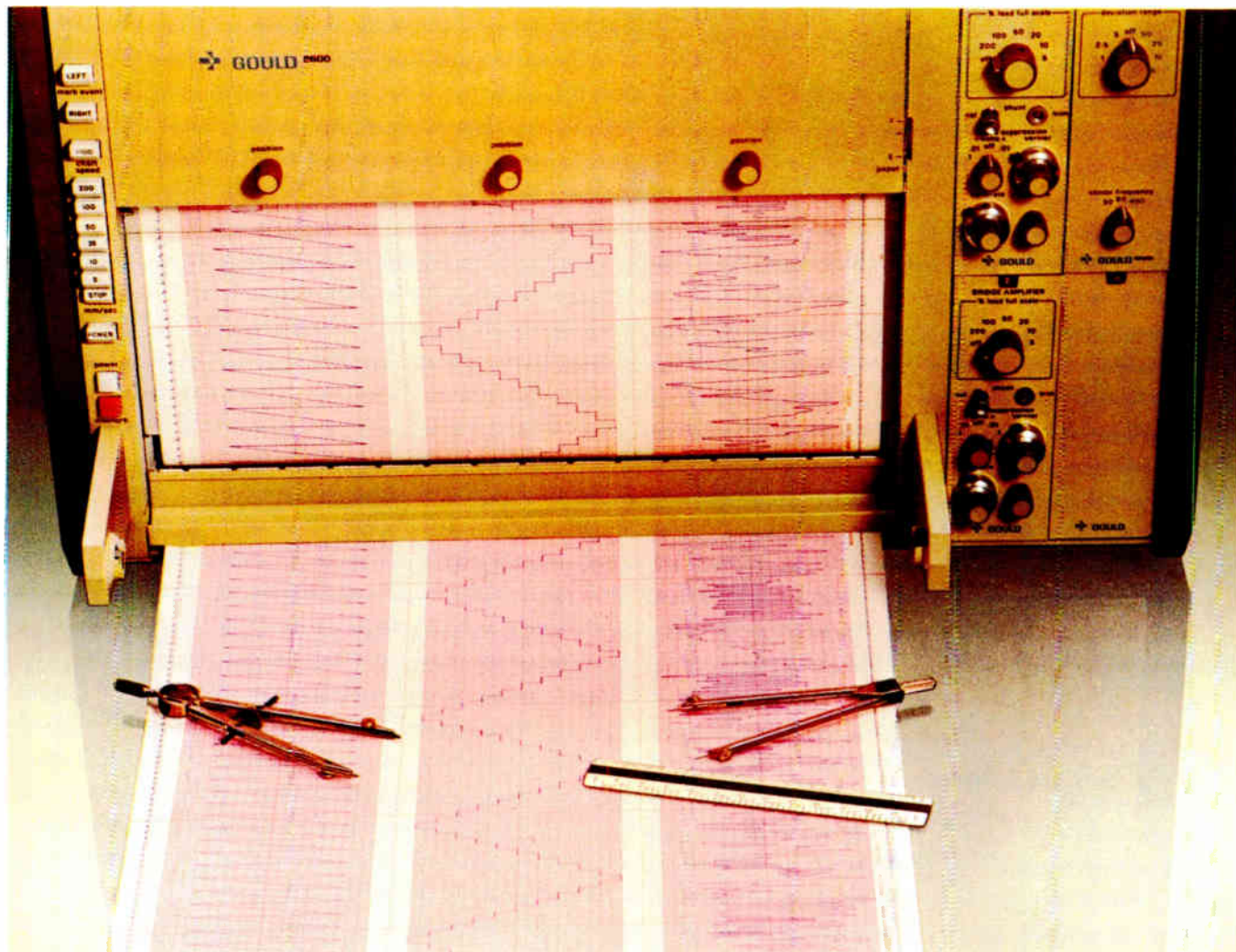

99.65% linearity.

Only GOULD Recorders offer you this exceptional accuracy because only GOULD Recorders give you a 100 gm/mm High Stiffness Pen Motor, a non contact METRISITE® position feedback

element having infinite resolution, and a unique servo drive system which anticipates changes in signal amplitude and velocity.

Accuracy is built into every GOULD direct writing recorder.

For more information on the best, write Gould Inc., 3631 Perkins Ave., Cleveland, Ohio 44114. Or Gould Allco S.A., 57 rue St. Sauveur, 91160 Ballainvilliers, France.

For brochure, call Gould toll-free at (800) 325-6400, Ext. 77.
In Missouri: (800) 342-6600

 **GOULD**
The product development company

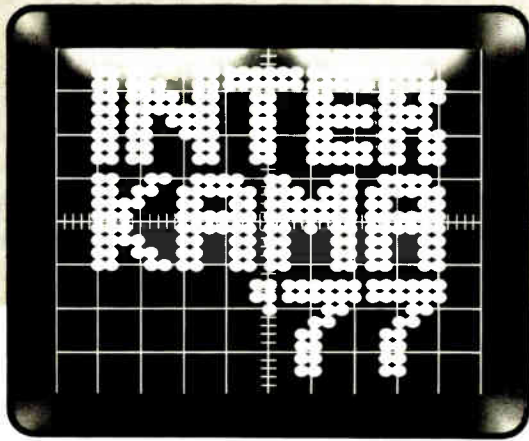

STILL MORE SYSTEMS ENGINEERING

For the past three years there has not been and for three years to come there will not be a better survey on instrumentation and automation (including control units and process computers) and on the technology of systems engineering than INTERKAMA '77. This is the world's largest trade fair for instrumentation and automation. 900 exhibitors from 25 nations. Almost 90 000 visitors from all over the world are expected.

At INTERKAMA '77 you will learn how systems engineering can save you money, simplify complicated technical processes and improve product quality as a controlling device.

WHAT DOES THE FAIR OFFER YOU?

- 1) Measuring instruments and installations
- 2) Devices for analytical and research work
- 3) Devices for testing and calibration
- 4) Devices and systems for the transmission of remote signals
- 5) Devices for the transmission of indicated values and other signals
- 6) Devices and systems for the performance of recording and control
- 7) Data processing units and systems for automation techniques
- 8) Setting devices, setting impetus
- 9) Auxiliaries and accessories
- 10) Switchboard galleries and control rooms
- 11) Automation: Planning, performance and service

**WORLD'S BIGGEST TRADE FAIR
FOR INSTRUMENTATION AND
AUTOMATION WITH CONGRESS**



DÜSSELDORF, OCTOBER 6 to 12, 1977
CONGRESS 5 AND 6 OCT. REPEATED 10 AND 11 OCT. 1977

REPLY COUPON FOR FURTHER INFORMATION

The Dusseldorf Trade Fair Company or its representatives will tell you all about INTERKAMA. Please simply return this coupon to: German-American Chamber of Commerce, 666 Fifth Ave. New York N.Y. 10019

Name: _____

Address: _____

Name of Company: _____

DÜSSELDORF TRADE FAIRS-BASIS FOR BUSINESS

New products

Least complex (6,000 to 7,000 transistors) and most general-purpose of the 827X series is the 8279 programmable keyboard/display interface chip, also designed for use on the 8080 system bus. The keyboard portion can provide a scanned interface to a 64-contact key matrix, which can be expanded to 128. The keyboard portion will also interface to any array of sensors or a strobed interface keyboard, such as the Hall-effect or ferrite variety. Keyboard entries are debounced and stored in an 8-character first-in/first-out on-chip memory. Key entries set the interrupt output line to the CPU.

The display portion of the chip provides a scanned interface for light-emitting-diode, incandescent, and other display technologies. Both numeric and alphanumeric segment displays may be used as well. The 8279 has a 16-by-8 random-access memory that can be organized into a dual 16-by-4 array. The RAM can be loaded or interrogated by the CPU. Other features include right or left entry formats, programmable clock as well as strobed input entry, and two-key or n-key rollover with contact debounce.

All four introductory parts in the 827X series are designed to operate with most of Intel's 8-bit microcomputers, including the 8080A, the 8085, the 8035, the 8048, and the 8748. The 8279 is designed to operate with the Intel 8008 as well.

Of note in the floppy-disk controller chip is a scan command that augments the standard read/write commands. With it, a user program can be designed to specify a data pattern and initiate a search for that pattern on the disk. The scan capability can be used without any intervention by the central processing unit.

All the parts require single +5-volt supplies and are built with the company's high-performance oxide-isolated n-channel MOS process, which borrows depletion loading and substrate biasing from its high-speed RAM designs. Pricing has not yet been set.

Intel Corp., 3065 Bowers Ave., Santa Clara, Calif. 95051 [338]

Versatility. GOULD/Brush Recorders have it.

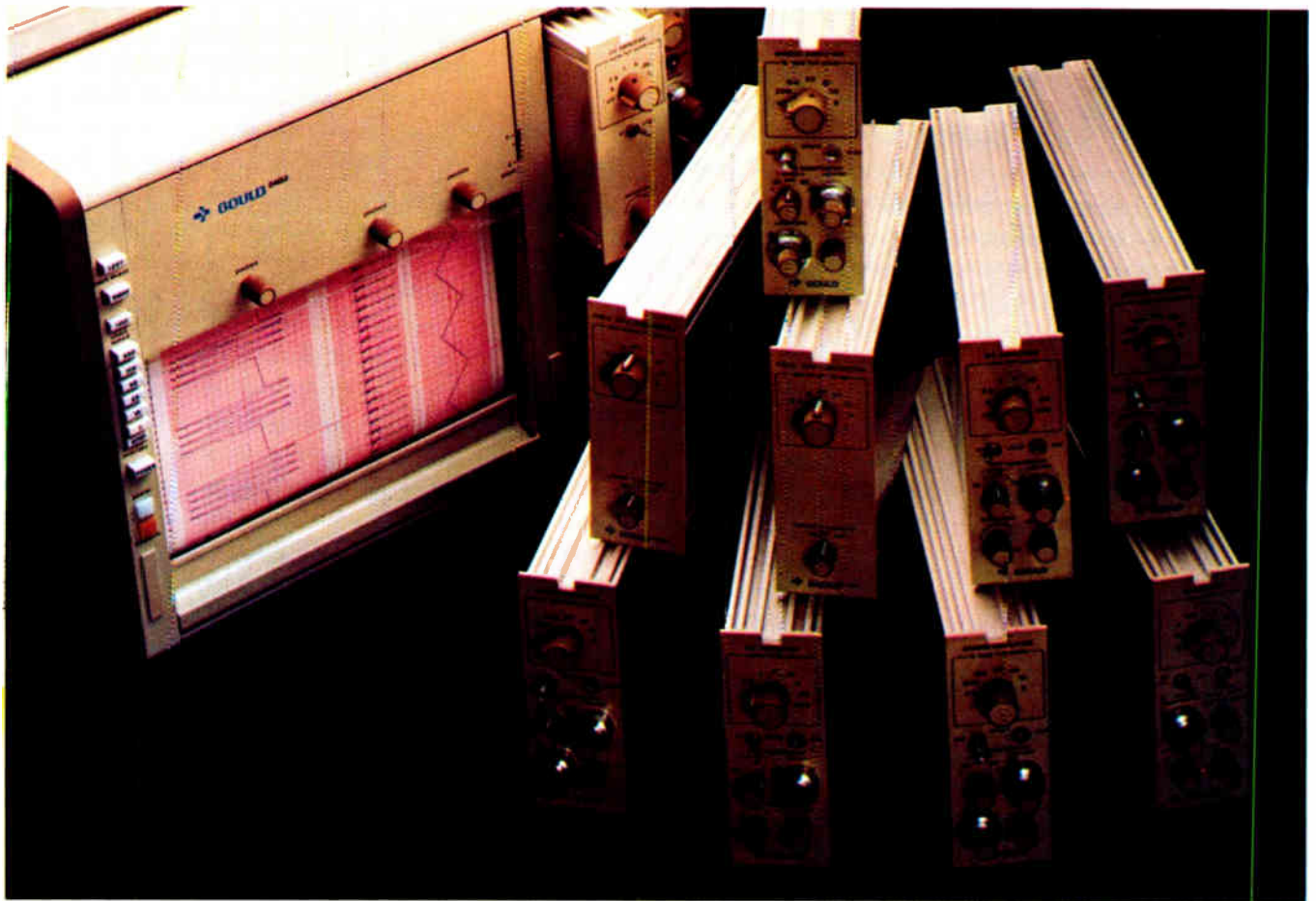

You can: amplify, convert, attenuate, suppress, reject, filter, expand, add, linearize, subtract, display, multiply, invert, square, divide, integrate, isolate, detect, alarm, control, demodulate . . .

Its modular design and interchangeable signal conditioners mean you get a recorder system "customized" to your needs with the ability to change input

parameters at will through the addition of appropriate plug-in conditioners. Let us tell you more. Write Gould Inc., Instrument Systems Division, 3631 Perkins

Ave., Cleveland, Ohio 44114. Or Gould Allco S.A., 57 rue St. Sauveur, 91160 Ballainvilliers, France.

For brochure, call Gould toll-free at (800) 325-6400, Ext. 77.
In Missouri: (800) 342-6600

 **GOULD**
The product development company

Plug-in for LSI-11 withstands 250 V

Data-acquisition board features 10-mV full-scale sensitivity and software-programmable gain on each of its 16 channels

by Michael J. Riezenman, New Products Editor

For the first time, a plug-in data-acquisition system for the Digital Equipment Corp. LSI-11 and PDP-11/03 microcomputers combines the capabilities to digitize low-level signals (10 millivolts full scale) and to provide different computer-controlled gains for each input channel with the capability to withstand common-mode voltages as high as 250 volts.

The 12-bit quad-size card is intended to work with slowly varying dc inputs such as are produced by strain gages and various other transducers—in particular, thermocouples. Indeed, one of the system options is an on-board cold-junction compensation circuit for use with thermocouples. This, along with the

programmable-gain capability, allows the system to handle a variety of thermocouple types simultaneously.

Developed by Adac Corp., the 1100RL is offered in both 8- and 16-channel versions. It has two-wire, floating, differential inputs that are band-limited by a two-pole, 1-hertz, low-pass filter. Input impedance is 2 kilohms in series with 80 microfarads, and input noise is 10 microvolts peak to peak. The common-mode rejection ratio is 300,000:1 at 60 hertz with a 1-kilohm source imbalance. Sampling time, per channel, is 5 milliseconds.

Key to the system's performance is its multi-reed "flying-capacitor" multiplexer. This subsystem, which

is designed for minimal thermal emfs, is capable of processing 16 differential inputs at rates up to 200 samples per second, even in the presence of a 250-v common-mode voltage. It feeds the software-programmable-gain analog-to-digital converter, which offers six sensitivities: 10, 20, 50, 100, 200, and 500 mv full scale.

The 1100RL can operate under computer control in two modes: program control or program interrupt. With the former, the computer orders the data-acquisition system to make a measurement and waits until the system signals that it has completed the task. Under program interrupt, the computer selects a channel, triggers a conversion, and goes about its business. When the conversion is complete, the data-acquisition system requests an interrupt to feed the data into the computer.

The 1100RL can be supplied with or without a dc-to-dc converter. With the converter it requires 5 v dc at 2 amperes and 12 v dc at 100 milliamperes. Both voltages must be regulated within $\pm 10\%$. Without the converter, it requires 5 v dc at 1.5 A, 12 v dc at 50 mA, and ± 15 v dc at ± 80 mA. The ± 15 -v supplies must be regulated to within $\pm 3\%$.

Pricing is one of the system's most attractive features. For single pieces, the 8-channel version sells for \$795, while the 16-channel unit goes for \$1,095. A cold-junction compensation circuit for 16 channels is priced at \$65. Delivery for all models takes from 30 to 45 days.

Adac Corp., 15 Cummings Park, Woburn, Mass. 01801. Phone A.L. Grant at (617) 935-6668 [339]

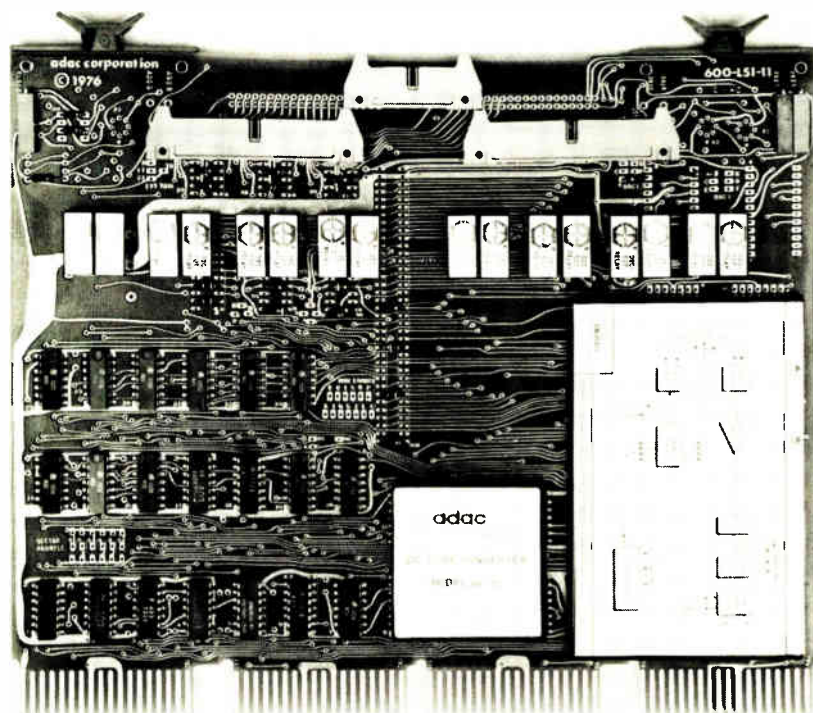

Reliability. GOULD/Brush Recorders have it.

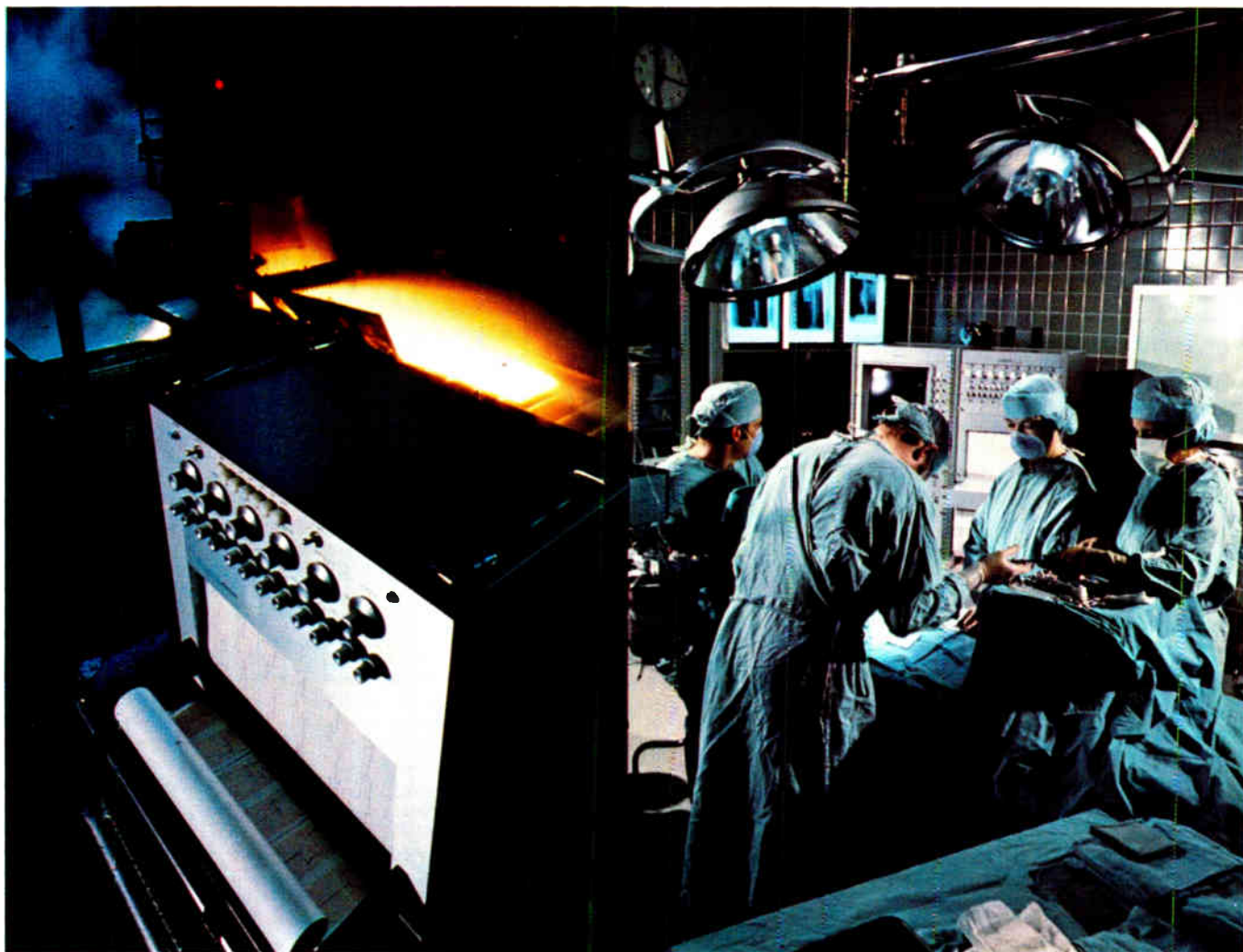

When you need it.

When there are no second chances, you need us — for a measurement you must have reliability. Gould gives it to you in every recorder. Rugged structural components and

proven design. Pressurized fluid writing for consistent trace quality. Very little maintenance required. It's what you'd expect from the leader.

Let us show you how we've

cut the element of risk. Write Gould Inc., Instrument Systems Division, 3631 Perkins Ave., Cleveland, Ohio 44114. Or Gould Allco S.A., 57 rue St. Sauveur, 91160 Ballainvilliers, France.

For brochure, call Gould toll-free at (800) 325-5400, Ext. 77.
In Missouri: (800) 342-6600

 **GOULD**
The product development company

The Mallory Capacitor Help-Force.

Everything to make buying easier for you.

The Help-Force is what we call our expanded product, sales and full-service organization. It's organized to make your job easier and free you from time-consuming details in getting the capacitors you need.

Now you can place your large or customized orders with our OEM direct sales force. Or get immediate off-the-shelf delivery through our authorized Mallory distributors.

Whichever way you choose, use our

headquarters services, too, to get the status of your production order at the same time; or on-the-phone price and delivery quotations. And if you have unusual applications, call our product managers. They can recommend the right capacitors to meet your needs.

The Mallory Help-Force can help you on a worldwide basis, too. We have distributors almost everywhere. So if you buy capacitors for overseas manufacturing, let us fill your needs either by direct shipment or through an authorized Mallory distributor.

Let the Mallory Help-Force take some of the weight off your shoulders. Call your local Mallory sales representative. Or Help-Force headquarters at (317) 856-3731. Mallory Capacitor Company, a division of P. R. Mallory & Co. Inc. Box 1284, Indianapolis, Indiana 46206.



MALLORY

New products

Data handling

More flesh on the Naked Mini

Family of low-price units
includes one model that
undercuts microcomputers

Deciding to beat microcomputers at their own game—pricing—Computer Automation has introduced a family of low-cost minicomputers with very high price/performance ratios. Furthermore, the three members of the family share a high degree of compatibility of both hardware and software. Each computer's instruction repertoire is a superset or a subset of those of the other two computers. Also, all memories, peripherals, and other hardware will work with all of the processors in the family.

One of the benefits of this family approach, says Robert T. Clark, the director of marketing/sales for the Naked Mini division, is that "if a customer wants to upgrade his hardware capability, he isn't constrained by the cost of rewriting application programs. If a program runs on any of the processors, it will run on them all."

The least expensive member of the family, aimed directly at the low-cost microcomputer market, is the Naked Mini 4/10. This 16-bit minicomputer has 89 standard instructions, 37 optional instructions, and a typical execution time of 4 microseconds. Equipped with 4,096 words of random-access memory and four input/output channels, it sells for \$645 in singles. A packaged version of the 4/10, including a chassis, an operator's console, and a power supply, has a one-piece price of \$995.

The midrange member of the family, designed to retain control of Computer Automation's traditional markets, is the Naked Mini 4/30. It is essentially a higher-performance, lower-price replacement for the pop-



ular LSI-2 series. The 4/30 has 106 standard instructions, including the 89 of the 4/10, 24 optional instructions, and a typical execution time of 2 μ s. A typical system price is \$2,995.

The top of the line is the 4/90. This is a 1- μ s machine with 119 standard instructions and 26 optional. It is intended for demanding multitasking applications such as industrial control and data communications. With 65,536 words of 550-nanosecond RAM, a chassis, an operator's console, and a power supply, a typical 4/90 configuration sells for \$9,950.

Features common to all members of the family include six levels of priority vectored interrupts, four program-selectable interrupt levels, a real-time clock, multiple general-purpose registers, stack registers and instructions, 65,536-word direct addressability, and word and byte operation. The computers all have a 30-

day delivery time and a 1-year warranty.

Computer Automation, 18651 Von Karman, Irvine, Calif. 92713. Phone (714) 833-8830

Low-cost memory plugs into 4051 graphic system

As the latest addition to its line of peripheral devices that operate with the Tektronix 4051 graphic system, Second Source Industries has developed the Max 2000, a low-cost 32-kilobyte workspace memory system.

According to sales manager Oliver Nalley, the plug-in Max 2000 will expand the memory in a 4051 system to 32 kilobytes for one price—\$2,500 in single quantities plus \$200 installation—anywhere in the United States, regardless of the 4051's current memory status—4, 16, or 24 kilobytes. Equipment exchange discounts up to \$200 are available for

If you don't see what you need...

ASK!

Our price/performance and availability make us the analog leader. Look to Jewell for Panel Meters, Aircraft Instruments, Meter Movements and Indicating Controllers. Phone today or circle the product family of interest!

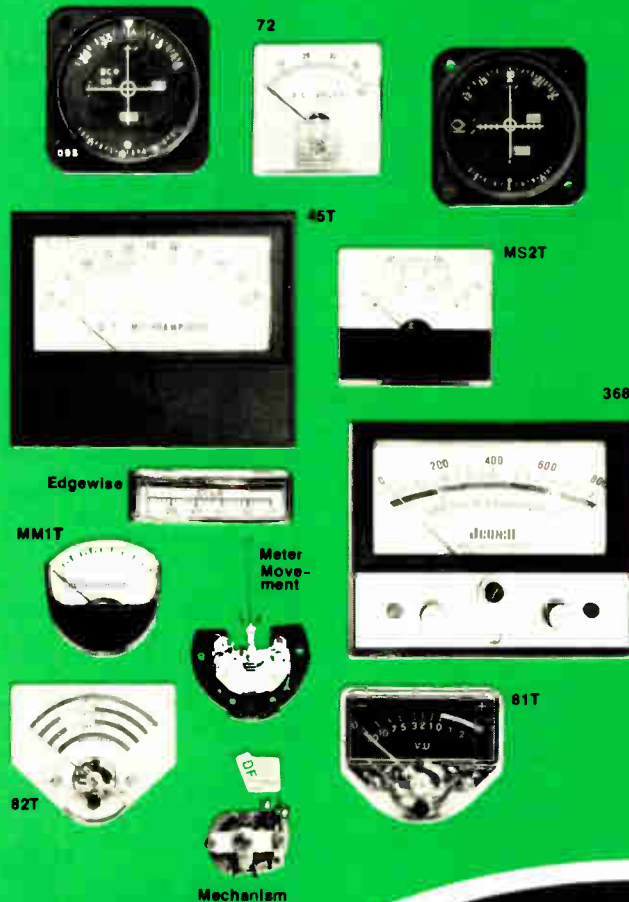

QUALITY IS THE SPECTRUM OF A JEWELL

Jewell



ELECTRICAL INSTRUMENTS, INC.

Grenier Field, Manchester, N.H. 03108
(603)669-6400 Telex 94-3435

Circle 142 on reader service card

World Radio History

New products

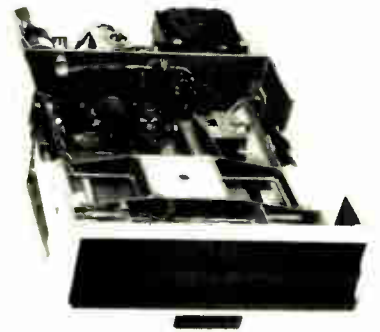

fer rate of 250 kilobits per second, a double-density transfer rate of 500 kb/s, and a small-quantity price of about \$750.

Shugart Associates, 415 Oakmead Parkway, Sunnyvale, Calif. 94086. Phone (408) 733-0100 [366]

RS-232-compatible keyboard offers selectable baud rates

A versatile table-top keyboard, the GCT-3071, provides ASCII RS-232-compatible outputs at selectable rates ranging from 110 bauds to 19.2 kilobauds. The unit also features an interactive array of 16 lighted push-button switches that provide 64

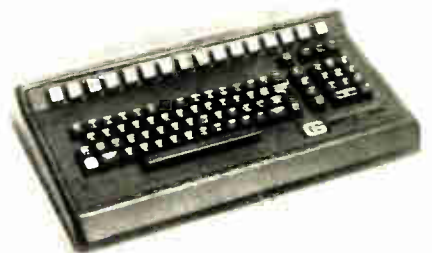

programming functions.

The 6.5-pound stand-alone device also provides a high-speed entry pad, automatic repeat on all keys, two-key rollover with N-key lockout, five cursor-control keys, and selectable parity (odd, even, or none). It has 128 ASCII characters. In singles, the GCT-3071 sells for \$1,500.

Genisco Computers, 17805-D Sky Park Circle Drive, Irvine, Calif. 92714. Phone William Huber at (714) 556-4916 [364]

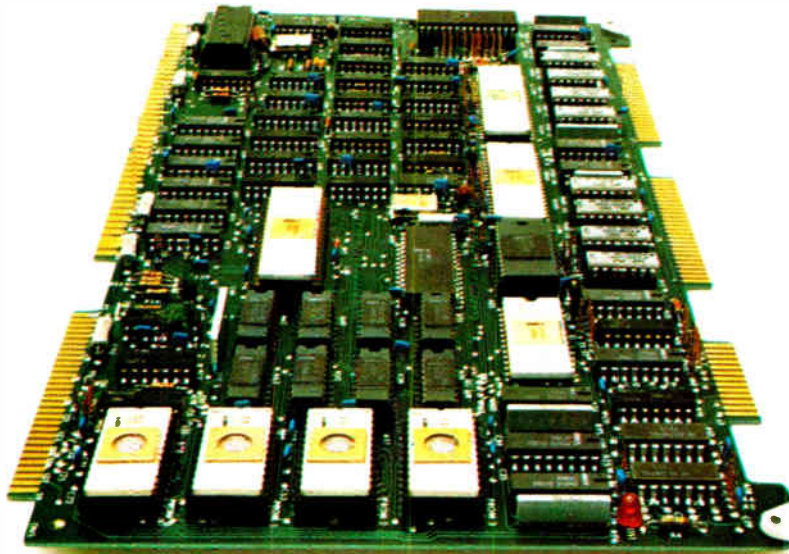

Intel delivers real time microcomputer multiprocessing. The new SBC 80/20 Single Board Computer.

SBC 80/20 delivers system throughput and design flexibility previously unobtainable on a Single Board Computer. Like our low cost industry standard SBC 80/10, the SBC 80/20 has everything you need—CPU, EPROM, RAM and programmable parallel and serial I/O—all on a single 6.75" x 12.0" board. And because the SBC 80/20 also has dual bus architecture, multiprocessor bus control, programmable eight level vectored interrupt and programmable timers, it is your best choice for real time multiprocessing and other high performance applications.

SBC 80/20 increases system throughput and improves system reliability by allowing tasks to be segmented in a true parallel processing

configuration. Operate up to sixteen SBC 80/20 systems simultaneously without tying up the system bus when using on-board memory and I/O. And when access is required to resources sharing the system bus, on-board multiprocessing logic provides the necessary bus priority control.

SBC 80/20 has eight levels of programmable vectored priority interrupt making it possible to immediately respond to critical I/O requirements. Priority assignments and priority algorithms are under program control and can be dynamically reconfigured as system requirements change.

SBC 80/20 has two programmable timers that increase throughput by relieving the CPU of timing and event counting operations. Each timer may

be programmed by system software to operate as a real time clock, interval timer, or event counter.

To protect data integrity, the SBC 80/20 includes an auxiliary memory power bus and all the logic necessary for implementation of a battery back-up system.

Ask for our new 24-page brochure describing the entire family of Intel® SBC 80 Single Board Computers, System 80 packaged systems and expansion boards. For your copy or for a demonstration contact your local Intel representative, use the reader service card or write: Intel Corporation, 3065 Bowers Avenue, Santa Clara, California, 95051.

intel delivers.

Semiconductors

Decoder/driver eases LCD design

40-pin device provides pure-ac drives for four 7-segment digits

A new large-scale-integrated circuit from Siliconix will make life much easier for instrumentation designers wishing to use liquid-crystal displays rather than light-emitting diodes for information readout. Designated the DF411, the complementary-metal-oxide-semiconductor device is a four-digit binary-coded-decimal decoder/driver that reduces component count by as much as two thirds and thus simplifies printed-circuit-board interfaces between the driver and both dual in-line and edge-connecting types of liquid-crystal displays.

According to Marvin Vander Kooi, Siliconix' manager of IC product marketing, more and more LCDs are appearing in instrumentation because of the appeal of their high daylight contrast and low power consumption—and despite the prob-

lem their ac drive requirement has always posed for designers.

Unlike LEDs, which are driven by steady or pulsed direct current, LCD displays require an ac potential between each "on" segment and the common backplane. This requirement is usually met by driving the backplane with a square wave obtained from six to eight decoder and driver chips.

The single DF411 chip, says Vander Kooi, contains all the circuitry needed to decode up to four digits of multiplexed BCD information and to create the ac-drive signals for the display. Measuring only 95 by 122 mils, the DF411 packs in an oscillator, a decoding read-only memory, four 7-bit latches, a divide-by-512 circuit, control logic, and switches needed to produce the ac-drive signals. Thanks to C-MOS construction, power consumption is about 1.5 milliwatts.

The on-board oscillator, the frequency of which is controlled by an external capacitor, develops the backplane square-wave signal. Segment drivers supply square waves of the same frequency as the backplane, either in or out of phase. (In this method of driving LCDs, the net dc voltage applied between segment and backplane is zero, a necessary

requirement for long display life.) The BCD input is decoded by the ROM into seven-segment data, which is then latched into the appropriate static latches via the digit strobe inputs and control logic.

Because all of these functions are incorporated into one 40-pin package, the number of packages is reduced from six to two in most instrumentation applications, says Vander Kooi, saving space and insertion costs. An added feature of the DF411 is its ability to reset the oscillator divide chain. With this feature and the addition of a small amount of external logic, two DF411 devices may be ganged together to drive up to eight LCD digits.

The DF411 is available in 100 and up quantities for \$6.48 each.

Siliconix Inc., 2201 Laurelwood Road, Santa Clara, Calif. 95054 [411]

Silicon power transistors switch in 250 nanoseconds

A series of six npn silicon power transistors keeps switching losses low by switching in only 250 nanoseconds. The units have collector-emitter sustaining voltages that range from 350 to 450 volts, while the continuous collector current rating is 10 amperes. Designated series 2N6582, the transistors are suited for off-line switching regulators, class D audio amplifiers, and similar high-frequency power switching applications. The devices sell for \$5.40 each in hundreds. Delivery is from stock.

TRW Power Semiconductors, 14520 Aviation Blvd., Lawndale, Calif. Phone (213) 679-4561 [416]

16-kilobit erasable PROM needs only a +5-volt supply

The 16,384-bit Intel 2716 is an ultraviolet-erasable programmable read-only memory that operates from a single 5-volt dc power supply. The floating-gate, avalanche-injection MOS (Famos) device is plug-

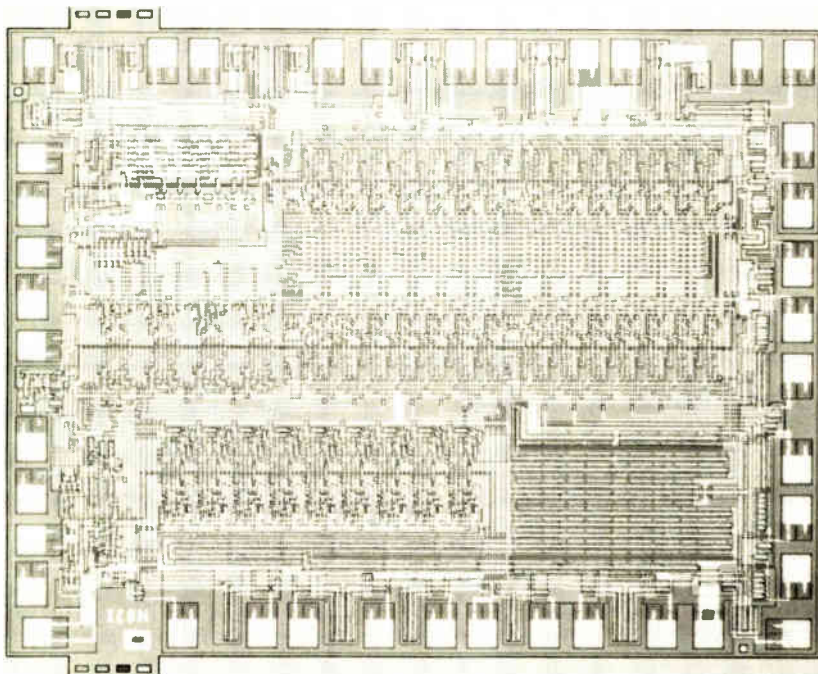

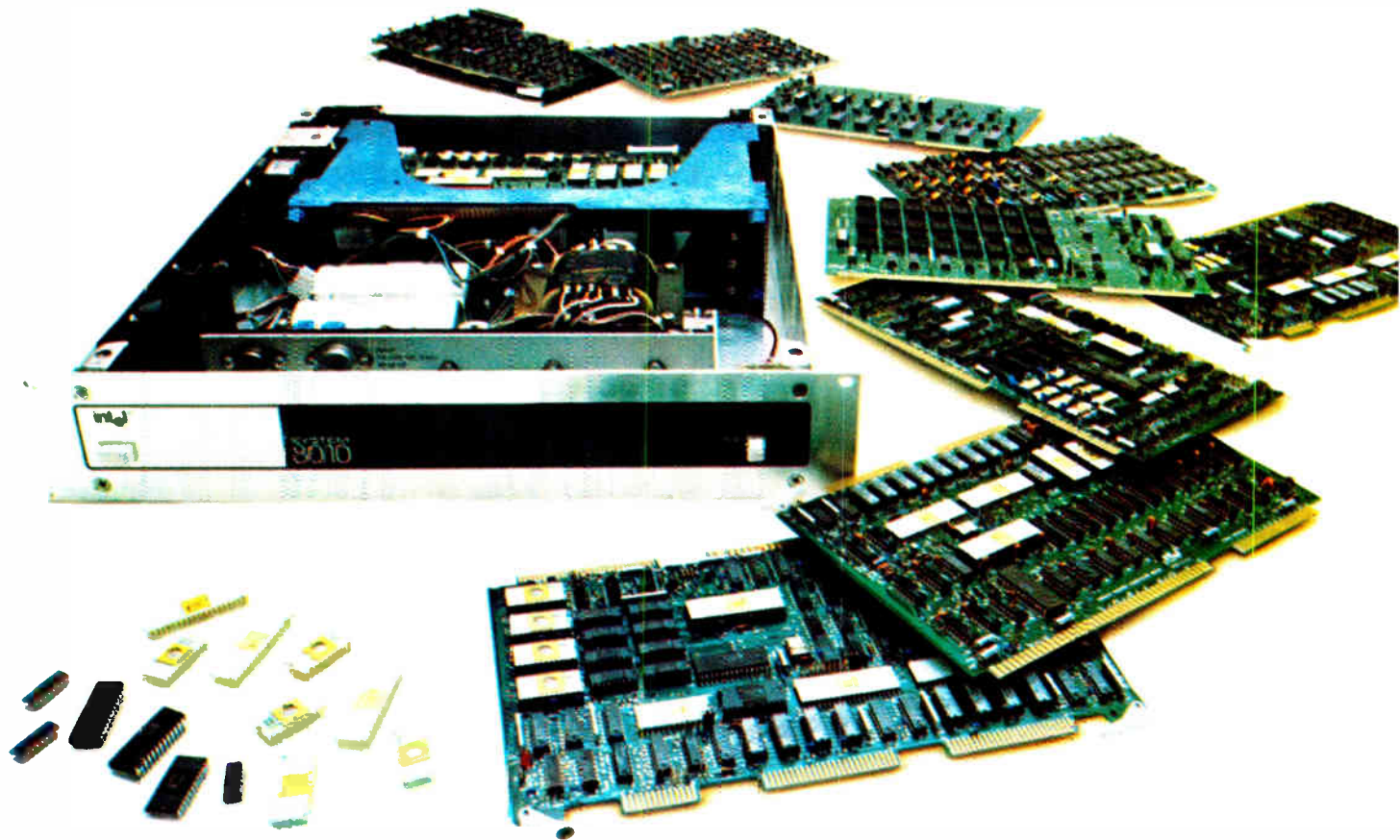

Intel delivers microcomputer systems that take the risk out of becoming successful.

Intel takes the risk out of becoming successful by providing economic, flexible and reliable microcomputer hardware and software solutions for your moderate and high volume requirements.

For most moderate volume microcomputer applications, it makes economic sense to buy an assembled and tested microcomputer system. That's why we offer two Single Board Computers (SBC 80/10, SBC 80/20) and two packaged systems (System 80/10, System 80/20). When you decide it's more economical to do the job "in-house," we'll make arrangements for you to use our bill of material, fab and assembly drawings, and artwork. And since we manufacture *all* the essential components — CPU, EPROMs, ROMs, RAMs, programmable I/O, and other LSI devices in volume, you can order the components from us and continue to take advantage of quantity discounts. *No penalty for success.*

Intel® microcomputer systems are flexible and easily configured to your specific needs. Expanding your system or reconfiguring the I/O is easy. All Intel microcomputer systems are supported by a complete line of I/O and memory expansion boards, diskette and DMA controllers, power supplies, card cages, and accessories. And since I/O, communications, timer and interrupt control functions are programmable, you can reconfigure the system to match your application by altering a few bytes of memory instead of redesigning system hardware.

And Intel delivers more than microcomputer systems that give you the cost/performance advantage. In addition we provide Intellec® Microcomputer Development System support to get you to market sooner. Intellec resident PL/M, the high level microcomputer language, can cut many months off your software development schedule. Intellec ISIS-II Diskette Operating Software, with

linkage and relocation capabilities, will save more programming time. Develop programs in small manageable modules — then link them together or link them with general purpose subroutines from a software library. Reduce system integration and checkout time with the Intellec resident ICE-80™ In-Circuit Emulator. Develop, symbolically debug and execute high level and assembly language programs directly on your System 80 or SBC 80 based prototype.

From hardware and software development all the way through production, Intel gives you the competitive advantage. For a copy of our new 24-page brochure or a demonstration contact your local Intel representative, use the reader service card, or write: Intel Corporation, 3065 Bowers Avenue, Santa Clara, California 95051.

intel delivers.

Circle 145 for technical information

World Radio History Circle 190 for a demonstration and technical information

WANT TO HOOK UP A CIRCUIT QUICK?

The PB-100 is only one of our family of solderless Proto-Board breadboarding units, designed to help you assemble, test and modify circuits as fast as you can push in or pull out a lead. *Preassembled* sockets with durable 5-point terminals provide low-resistance interconnections you can arrange and re-arrange at will.

Resistors, capacitors, transistors, DIP's, TO-5's, LED's etc. plug in without damage to leads. And jumper connections, where required, are lengths of #22 AWG solid wire. Models from 630 to 3060 tie-point (6 to 32 14-pin DIP) capacity available. For more information, see your CSC dealer, or write for our catalog and distributor list.



Proto-Board[®] 100, 760 solderless tie-points. Kit, \$19.95*

CONTINENTAL SPECIALTIES CORPORATION



EASY DOES IT

44 Kendall Street, Box 1942

New Haven, CT 06509 • 203-624-3103 TWX 710-465-1227

West Coast office Box 7809, San Francisco, CA

94119 • 415-421-8872 TWX 910-372-7992

© 1976 CSC

*Mfrs sugg list

Circle 148 on reader service card

New products

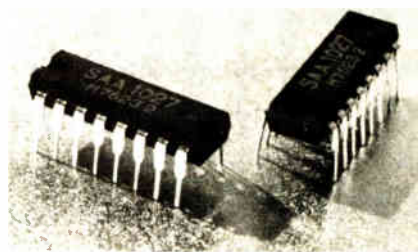

package, the driver is rated to deliver up to 350 milliamperes per phase. Its high noise immunity makes it suitable for use in electrically noisy environments. Although designed to work with the manufacturer's line of four-phase stepper motors, the driver can be adapted for use with other compatible stepper-motor systems. It sells for \$4.75 each in hundreds and has a delivery time of six weeks for large quantities. Prototypes are available from stock.

North American Philips Controls Corp., Cheshire, Conn. 06410. Phone (203) 272-0301 [415]

Panel-meter chip includes reference

All of the active circuitry needed to make a 2½-digit (200-count) panel meter, including a temperature-compensated reference, is contained in the ADD2500. The part uses a dual voltage-to-frequency conversion technique and requires only a few external passive components plus power supplies and a display to form a complete meter. Accurate to within 1%, the IC offers automatic polarity detection and indication, over-range indication, and externally settable conversion rate. Digit drivers and current-controlled segment drivers for LED displays are included on the chip. The unit requires supplies of +5 volts and -15 v. Housed in a rugged, 24-pin, Epoxy B dual in-line package, the ADD2500BCN sells for \$7.95 in hundreds and is available from stock. A ceramic-DIP version is also available.

National Semiconductor Corp., 2900 Semiconductor Drive, Santa Clara, Calif. 95051. Phone (408) 737-5000 [418]

Need a custom-tailored product?
SALOTA will solve your problem - in time.

The SALOTA special: We are fast and respond within hours. We are partners of many top-ranking West European companies. They know us. When it comes to chokes and transformers, they count on SALOTA. We produce special versions with regard to inductance, resonance frequency, load and shape upon request. Ask for our product information sheets or give us your specific requirements.

SALOTA

Phone West Germany: 0911-32177
Telex 622 466 hoco d
Raabstr. 24 · D 8500 Nurnberg/
West Germany

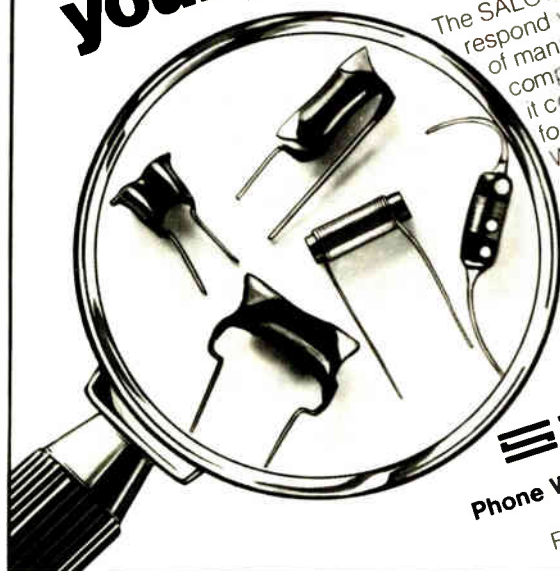

148 Circle 191 on reader service card

Electronics / May 26, 1977

Five new product lines for electronic motion control.

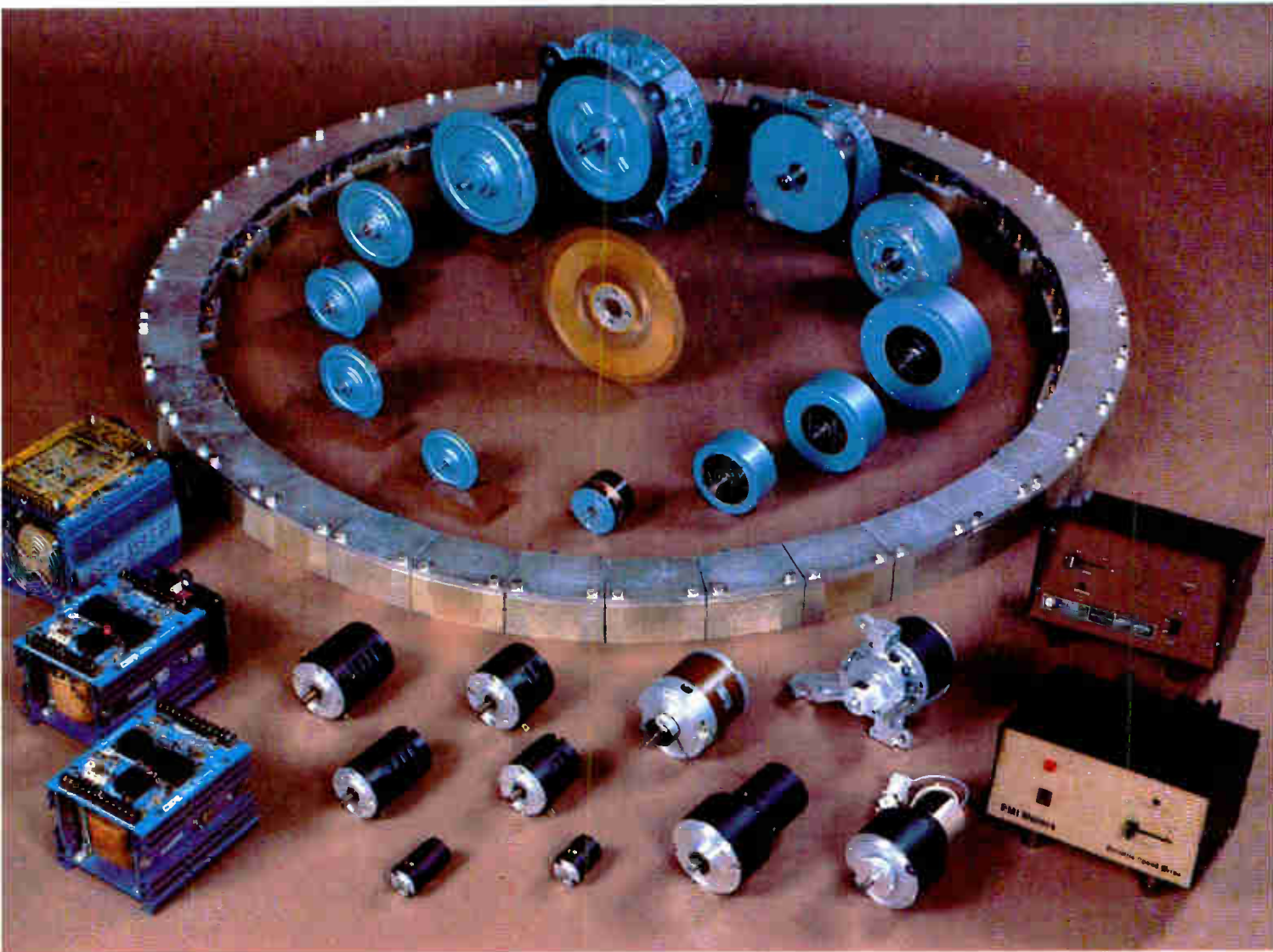

Over 15 years ago PMI created a new technology for motion control by introducing the printed circuit motor. An ironless armature with high pulse-torque capability and very low inertia allowed designers to replace conventional motors, brakes, clutches and hydraulics with an actuator that provided higher performance, greater reliability and lower cost.

Now PMI offers five new product lines for electronic motion control.

TorqueRing™ Motors.

Ring-shaped moving-coil dc motors with diameters from two to over ten feet. Peak torques of over 25,000 lb.-ft., negligible inductance, no cogging, and only 7" thick. Improved performance compared to torquers and

hydraulics for large rotating loads.

Super Minertia Motors.

Ironless cup-armature dc motors with inertias as low as 0.00018 oz.-in.-sec.², high pulse-torque capability and mechanical time constants below 1 millisecond.

Mini Minertia Motors.

Low-inertia dc motors providing excellent servo performance at low cost. Nine models 1.5" to 3.35" in diameter, mechanical time constants of 3 to 12 milliseconds and thermal time constants up to 27 minutes.

DC Servo Controllers.

Amplifiers designed to obtain maximum performance from PMI servo motors. Pulse width and frequency modulation, full power bandwidth to 1000

Hz, pulse currents from 10 to 75 amps.

Variable Speed Drives.

EMF sensing or tach feedback velocity controls matched for use with PMI pancake motors and gearmotors 100:1 speed range, infinite resolution, IC/power transistor design.

With industry's broadest line of dc servo motors, PMI can help you apply today's electronic motion-control technology. Write PMI Motors, 31 Sea Cliff Avenue, Glen Cove, N.Y. 11542. Phone: (516) 448-1234. A Division of Kollmorgen Corporation.

PMI Motors

Moving ahead in motion control.

Circle 149 on reader service card

TURNKEY 620 SYSTEMS FROM NEFF USING THE HP 9825 CALCULATOR.. the logical next step in data acquisition.

You're involved in a scientific, engineering, or industrial project that could use a high performance, low cost data acquisition system. But you know that system integration and software costs of most systems actually exceed the hardware. And your need is now, so you want a system that will take data immediately with minimum user training.

Our turnkey 620S was designed for you.

620S is a sophisticated data acquisition system with amplifier-per-channel or differential multiplexer analog signal processing and using the H.P. 9825 computing calculator for system control, data analysis and recording.

Neff systems are known for high performance and the 620S is no exception. Consider 0.1% accuracy with 50kHz channel scanning rate, fullscale input sensitivities from 5 millivolts to 10 volts, up to 256 channels or 2048 channels fully expanded, and 120dB rejection of common mode voltages up to 300 volts. Selectable data filters, simultaneous sample and hold and input signal conditioning are but a few of the many available features.

The Hewlett-Packard 9825 calculator provides the 620S computer performance with the operating convenience of a calculator. Programming is simple with HPL, an easy to learn, high level language designed for scientists and engineers. Standard features include a live-keyboard, alpha numeric printer and cassette recorder. Up to 24K memory is available. Plug-in peripherals include floppy disk, line printer, x-y plotter, and tape punch. It also attaches to H.P. Interface Buss.

A complete, integrated data acquisition system thats easy to use — thats our turnkey 620S.

Like to know more? Call us today at 213-357-2281 or write for our free brochure.

NEFF
INSTRUMENT CORPORATION

1088 E. Hamilton Rd., Duarte, Calif. 91010
Tel. (213) 357-2281 TWX 910-585-1833



New products

Microwaves

FET generates 1 W at 8 GHz

Line of field-effect devices, aimed at linear-amplifier use, has four models

Now there is another U.S. source for microwave field-effect transistors. Microwave Semiconductor Corp., Somerset, N. J., is announcing its first gallium-arsenide FETs, the MSC88000 series. The top-of-the-line model can generate 1 watt at 8 gigahertz with 7.5 decibels of gain. The new devices, says Ira Drukier, program manager, are primarily intended for use in linear amplifiers as replacements for 1- and 2-w traveling-wave tubes.

The series comprises four devices: the 88001 rated for 200 milliwatts typical at 8 GHz, the 88002 at 400 mw, the 88003 at 800 mw, and the 88004 at 1 w. The noise figure for the 88004 is typically 9.2 decibels at 8 GHz, dropping to 6.4 dB at 4 GHz. All the FETs are broadband devices, able to operate over the frequency range of 2 to 10 GHz.

Drukier attributes their power performance to their flip-chip configuration. The units are packaged, active face down, in the firm's proprietary Flipac enclosures, which are available in both flange-mounted and pill-style versions.

"The flip-chip configuration gives extremely low thermal resistance and permits us to make very short, solid connections to ground that have low inductance," explains Drukier. The benefits of this approach include minimal parasitics, improved gain and power performance, and long operating life.

The company even measures the thermal resistance of these FETs by employing infrared scanning at rated rf conditions. Maximum thermal resistance is 60°C/w for the 88001, 40°C/w for the 88002, and 25°C/w for the 88003 and the 88004. The company makes the ohmic contact by sintering gold-germanium/nickel on an n⁺ contact layer.

The firm says the data sheets for these new FETs, are thoroughly documented, including guaranteed electrical characteristics, absolute maximum ratings, S parameters, plots of operating characteristics, and typical circuit applications. Complete S-parameter data is also available from Compact Databank.

In lots of 100, price ranges from

\$125 each for the 88001 to \$575 each for the 88004. Delivery is within one week for small quantities. Microwave Semiconductor Corp., 100 School House Rd., Somerset, N. J. 08873. Phone: (201) 469-3311 [401]

Miniature attenuator covers dc to 2 GHz

The model 909 continuously variable attenuator is a miniature component small enough to be used for rf-level control in instruments with limited panel space. The attenuator, which spans the frequency range from dc to

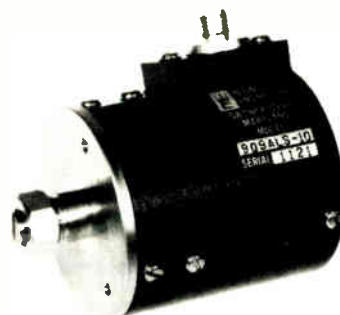

2 gigahertz, has a diameter of 1.62 inches and a length of 1.83 in. A built-in compensating line stretcher keeps incremental phase shift down to less than 1 degree per decibel per gigahertz.

The unit is offered in two ranges: 0 to 10 decibels and 0 to 20 dB. Both are rated at 1 watt average input power and have maximum input and output VSWRs of 1.25 up to 1 GHz and 1.35 to 2 GHz. Insertion loss at the minimum-attenuation setting is less than 0.5 dB to 1 GHz and less than 0.8 dB from 1 to 2 GHz. The model 909 sells for \$550.

Weinschel Engineering, Gaithersburg, Md. Phone (301) 948-3434 [403]

Coaxial switch has 50 dB of isolation at 26.5 GHz

A dc-to-26.5-gigahertz coaxial switch boasts more than 85 decibels of isolation at 18 GHz and more than

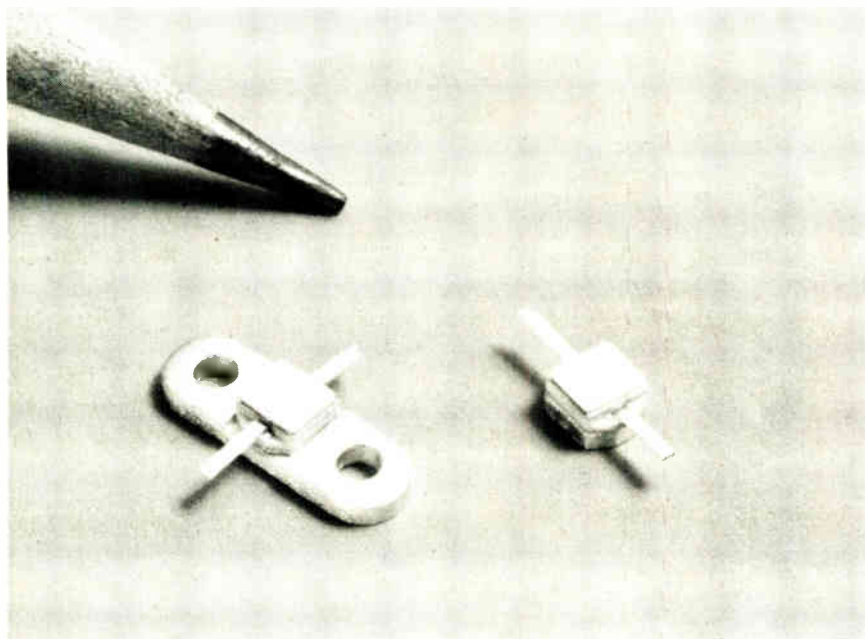

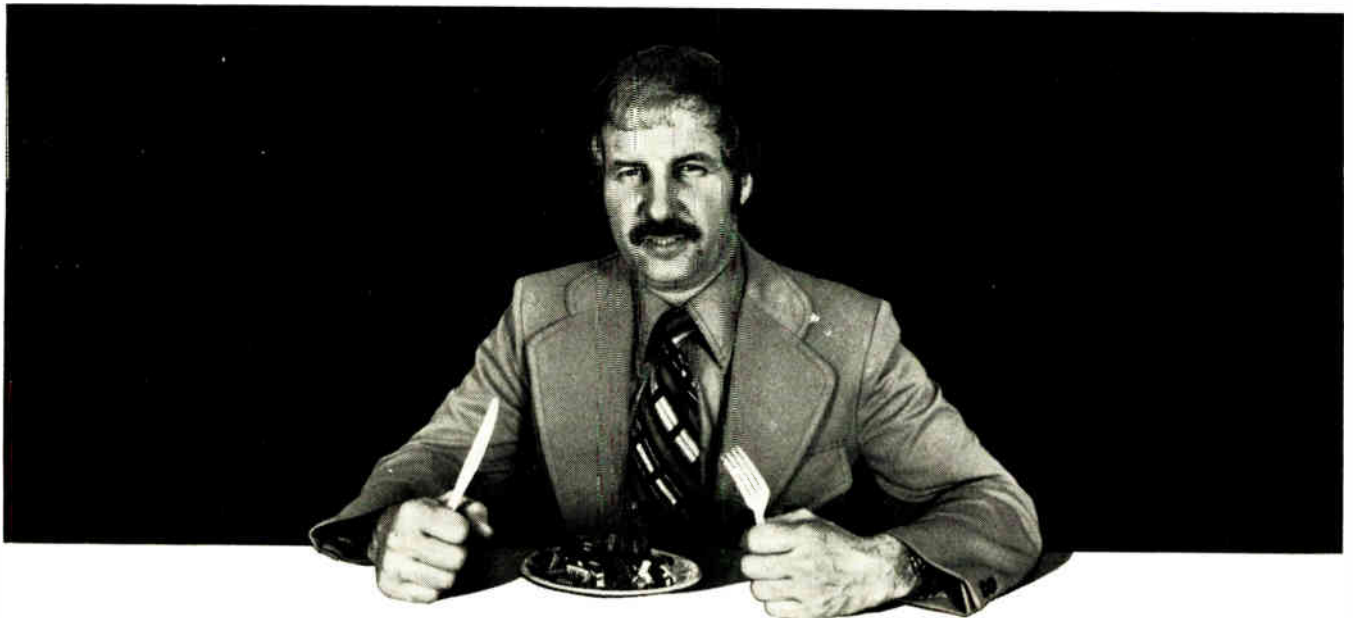

Your most difficult burn-in problems are my bread and butter

I'll design you the optimum facility for dynamic burn-in up to 200°C for your production quantities of IC's, RAMs, ROMs, Microprocessors or other components. How? With the new CRITERIA IV system plus the experience my company has in logging 10 billion device-hours in our Houston burn-in service. Interested? Want a full presentation with costs? Call me right now or mail the card today.



Reliability, Inc.

P. O. Box 37409/Houston, Texas 77036
713/666-3261/TWX: 910-881-1739

Circle 152 on reader service card

5 YEAR WARRANTY

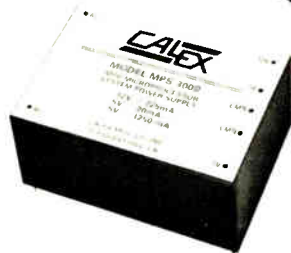

Designing a small 8080 system?

Look no further for your power supply needs!

The Calex MPS 3000 encapsulated modular unit supplies you with everything you need from +5 volts @ 1250mA to +12V @ 225mA and -5V @ 20mA for only \$95.00 in 1-9 quantities.

The MPS 3000 carries the Calex 5 year warranty and is available for delivery from stock. Call today for detailed information and quantity OEM pricing information.

CALEX
MFG. CO., INC.

3305 Vincent Road
Pleasant Hill, CA 94523
Tel: (415)932-3911
Telex: 338 506

152 Circle 193 on reader service card

THE μ P MEMORY...\$75*

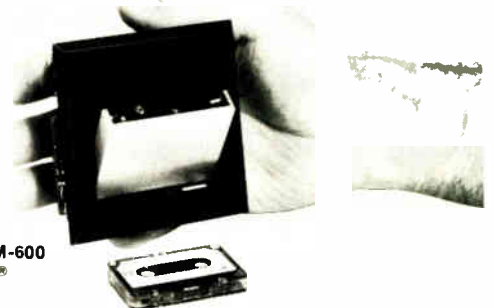

Model CM-600
Mini-Dek®

- For program loading, diagnostics, extended memory
- 1.6 megabits/200K Bytes, 2.4K Baud
- Includes all read/right and motion electronics
- Power 1Watt @ 5VDC, TTL I/O

BRAEMAR
COMPUTER
DEVICES, INC.

11950 TWELFTH AVENUE SOUTH
BURNSVILLE, MINNESOTA 55337, (612) 890-5135

*1K Qty.
Avail. N. Amer. only.

Circle 194 on reader service card

New products

50 dB at 26.5 GHz. Part of the unit's performance is attributable to its use of an internally switched 50-ohm load, which it uses to terminate the unused secondary port.

The model 33311C is electrically switched and self-latching. Its switching coils draw 3 watts at 24 v dc and automatically disconnect after the 30-ms switching time.

Rf power-handling capability is 1-w average, 100-w peak. The VSWR is less than 1.5 to 16 GHz and less than 2.3 to 26.5 GHz. Insertion loss is no more than 0.8 dB at 16 GHz and a maximum of 1.4 dB at 26.5 GHz. In small quantities, the 33311C sells for \$525; delivery time is four weeks.

Inquiries Manager, Hewlett-Packard Co., 1501 Page Mill Road, Palo Alto, Calif. 94304 [404]

Transistor has 2-dB noise figure, 13-dB gain at 2 GHz

The NE64580 is a bipolar microwave transistor with a noise figure that remains remarkably low over a wide range of collector currents. For example, at 2 gigahertz the minimum noise figure is 1.6 decibels at the optimum bias current of 7 milliamperes. Increasing the current to 20 mA only increases the noise figure to 2.0 dB. The associated gain increases from 12 dB to 13 dB. Made by Nippon Electric Co., the transistor is recommended for use from 500 megahertz to about 6 GHz. It sells for \$17 in chip form and \$54.50 in its packaged version for lots of 10 to 99 pieces.

California Eastern Laboratories Inc., 1 Edwards Court, Burlingame, Calif. 94010. Phone Jerry Arden at (415) 342-7744 [405]

Low-noise mixer/preamp spans 12 to 18 GHz

A new waveguide mixer/preamplifier offers a typical single-sideband noise figure of 5.7 decibels over the frequency range from 12 to 18 gigahertz. The WM12-18/15B has an rf VSWR of less than 2.0, minimum

isolation between the rf and local-oscillator (LO) inputs of 20 dB, and a typical LO injection level of 8 dBm. The 5.7-dB noise figure is obtained at an LO level of 10 dBm and an intermediate frequency of 60 megahertz. The WM12-18/15B sells for \$1,095 and has a delivery time of 60 days.

RHG Electronics Laboratory Inc., 161 E. Industry Court, Deer Park, N. Y. 11729. Phone (516) 242-1100 [406]

1-watt, 50-ohm attenuators work to 1.5 GHz, cost \$11

Series AT-52 coaxial attenuators are 1-watt 50-ohm devices made in 1-dB steps from 1 to 10 dB and in 2-dB steps from 10 to 20 dB. They are offered with MIL type BNC, TNC, N, and SMA connectors with silver or gold plating. Small-quantity prices range from \$11 to \$17 depending upon the connector type.

Elcom Systems Inc., 127F Brook Ave., Deer Park, N. Y. 11729. Phone (516) 667-5800 [407]

Parametric amplifiers cover 7.25 to 7.75 gigahertz

Series NC7 parametric amplifiers and Paraconverters include three low-noise uncooled units and two Paraconverters with noise temperatures from 80 kelvin to 120 K. Model NC7-101 is a two-stage paramp with a noise temperature as low as 100 K and a minimum gain of 26 decibels. The unit (see photograph) measures only 14.5 by 13 by 4 inches and includes its own power supply and (optional) GaAs FET post amplifier. Like other amplifiers in the series, the NC7-101 operates

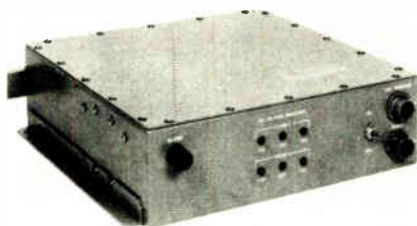

Our many, many, mini solids... fit your specs to a "T"



Select from 26 case sizes. These subminiatures give the stability and reliability of solid tantalum capacitors . . . in the smallest possible package size. Our method of encapsulation adds only mils to the component inside. Available in polar or non-polar styles, rectangular or cylindrical cases, radial or axial leads.

And the reliability is built in . . . so you get peak performance out of our mini solids (2 to 50 VDC; -55°C to +125°C; CAP range 0.001 μ F to 220 μ F).

For more information, call your local Tansitor rep . . . or contact . . .

Tansitor
ELECTRONICS
DIVISION OF AEROTRON, INC.

West Road, Bennington, Vermont 05201
Phone: (802) 442-5473
TWX: (710) 360-4782

Specialists in Tantalum Capacitors

**VECTRON CRYSTAL OSCILLATOR
OF THE MONTH**

**VHF LOW NOISE
MODEL CO-233FW**

Frequency: Any frequency in
5-500 MHz range

Level: +7dbm/60Ω (+13 db optional)

Stability: Std: ± 25 ppm over 0/+70°C
Opt: ± 3 ppm over 0/+50°C
 ± 50 ppm over -55/125°C

Phase Noise: -130db/Hz 5KHz from signal
(at 100MHz)

<p>CLOCK OSCILLATORS</p> <p>TTL: 1Hz to 100MHz CMOS: 1Hz to 10MHz ECL: 5 to 200MHz Stab: $\pm .01$ to $\pm .0003\%$</p>	<p>TCXOs</p> <p>0/+50°C: to $\pm 1 \times 10^{-7}$ -55/+85°C: to $\pm 1 \times 10^{-6}$ Aging: 1×10^{-4}/year Frequency: 60 Hz-140 MHz</p>
<p>VXOs</p> <p>Dev: $\pm .003$ to $\pm 1\%$ Lin: to $\pm 1\%$</p> <p>For both low distortion and phase lock applications</p>	<p>OVEN TYPE</p> <p>Aging: to 1×10^{-10}/day Freq: to 400 MHz Stab: to $\pm 2 \times 10^{-12}/^{\circ}\text{C}$</p>



VECTRON LABORATORIES, INC.

121 Water Street
Norwalk, CT 06854
Telephone: 203/853-4433

Circle 195 on reader service card

Send for your free product catalog and applications bulletin: "How to Specify Crystal Oscillators."



New products

over the military-satellite frequency range from 7.25 to 7.75 gigahertz.

The ultralow noise NC7-80 par-amp is a two-part system consisting of an antenna-mountable amplifier assembly and a control-and-monitor unit. It uses two identical, synchronously tuned paramp stages to obtain a typical noise temperature of 80 K and a minimum gain of 26 dB. Other units in the series include Paraconverters, which combine all of the front-end components into a single integrated design.

LNR Communications Inc., 180 Marcus Blvd., Hauppauge, N.Y. 11787. [409]

Wideband amplifier puts out 7 W, has 40-dB gain

The PRD 7855 linear power amplifier is a solid-state instrument that covers the frequency range from 450 to 1,000 megahertz. The unit has a gain of 40 decibels flat to within 1 dB. Maximum power output in its linear mode is 4 watts, but the amplifier has a saturated output of 7 w. Typical noise figure is 6.0 dB, and typical third-order-intercept point is 46 dBm. The PRD 7855 sells for \$2,100; delivery is from stock.

Harris Corp., PRD Electronics Division, 6801 Jericho Turnpike, Syosset, N.Y. 11791. Phone (516) 364-0400 [410]

High-gain, 3.3-GHz TWT has peak output of 120 kW

A grid-pulsed traveling-wave tube designed for use as a final output tube or as a driver for high-performance radar systems delivers a peak output of at least 120 kilowatts over the frequency range from 3.1 to 3.5 gigahertz. The VTS-5753A1 has a power gain of 47 dB. Its nonintercepting grid allows for low-voltage modulation, while its metal-ceramic construction and use of liquid cooling allow it to survive long service at high duty cycles.

Varian, Palo Alto Microwave Tube Division, 611 Hansen Way, Palo Alto, Calif. 94303. Phone (415) 493-4000 [408]



Talk to your computer for \$299.

SpeechLab™ lets you talk to and control any S-100 bus computer... Sol, Altair, IMSAI, etc. Use for computer input, research, vocal control and games. Price, \$299 assembled and tested. Complete hardware/software system, 275 page lab and 95 page hardware manuals.

Address Heuristics, Inc., 900 N. San Antonio Road, Los Altos, CA 94022. Phone (415) 948-2548.

Heuristics
INC.

Positively uniform.

Batch-after-batch consistency. That's the reason Kodak micro positive resist 809 offers you less waste, higher yields, and greater process reliability.

In addition, you get wide processing latitude, fast exposure, and high-quality results in contact, projection, and proximity printing.

And because the solids remain in solution, 809 resist needs no refiltering for at least twelve months.



For a free packet of information on Kodak micro positive resist 809, write Eastman Kodak Company, Dept. P04801, Rochester, N.Y. 14650.



Kodak micro positive resist 809

RESULTS COUNT



New products

Instruments

Counter/timer spans 1 GHz

Programming stored in read-only memory controls selectable-display unit

Logic circuitry controlled by a program stored in a read-only memory is the key to a 1-gigahertz universal counter/timer with automatic resolution control and autoranging in all 10 operating modes. Ballantine Laboratories' model 5500B-option 35 counter/timer covers frequencies from dc to 1 gigahertz with sensitivities at the high-frequency input of 15 millivolts root-mean-square from 110 megahertz to 512 MHz, but 25 mv rms over the broad range from 50 MHz to 1 GHz.

The unit's front-panel resolution control allows the user to set the number of digits to be displayed, from five to the full eight digits; the instrument then automatically selects the time base or gate width required. Ballantine says that this automatic feature holds not only for repetitive signals but also for single-shot time-interval measurements, a feature found only in instruments costing more than this unit's \$1,050. In the automatic mode, the instrument sequentially scans the gate widths until coincidence is sensed between pulses representing a decade output and the program that is

stored in the read-only memory.

The 10 operating modes are: totalize, frequency, period, positive pulse width, negative pulse width, period average, time interval, elapsed time, ratio, and check.

Input resistance is 50 ohms protected by a 100-milliamper fuse for signals above 5 v. The display uses 0.43-inch light-emitting diodes. The oven-stabilized crystal-controlled 10-MHz oscillator has an aging rate of less than 3 parts in 10^7 per month, while a clock that is stable to 3 parts in 10^9 is available as an option, as are binary-coded decimal outputs.

Ballantine Laboratories Inc., P. O. Box 97, Boonton, N.J. 07005. Phone (201) 335-0900 [351]

35-MHz generator produces both pulses and data words

The DG-7 digital signal generator is a 35-megahertz instrument that can function both as a pulse generator and as a generator of 16-bit serial data words. Its pulse-generator section provides both true and complementary outputs with pulse widths from 15 nanoseconds to 10 milliseconds. The amplitude can be varied from 300 millivolts to 5 volts, and the offset is adjustable over a ± 2 -v range when the generator is working into 50 ohms.

The word-generator section produces a 16-bit switch-programmable serial data word at the pulse-generator rate. Like the pulse generator, the word generator provides a pair of complementary outputs. It can oper-

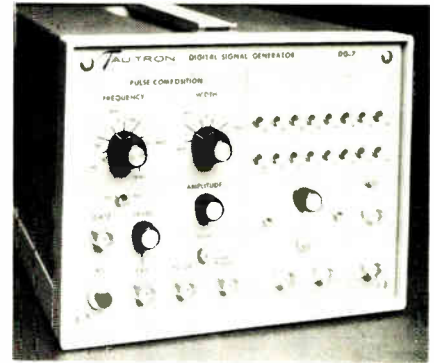

ate both continuously and in single bursts, and a switch allows the user to select either a nonreturn-to-zero or a return-to-zero format. The word-generator output amplitude and offset can be adjusted over the same range as those of the pulse generator.

The DG-7 sells for \$695 and has a delivery time of two to four weeks.

Tau-Tron Inc., 11 Esquire Road, North Billerica, Mass. 01862. Phone (617) 667-3874 [354]

Low-cost frequency counter covers 5 kHz to 40 MHz

Designed for use with citizens' band sets and other radios, the model FC-1 frequency counter is a \$169.95 instrument that covers the frequency range from 5 kilohertz to 40 megahertz. It has a sensitivity of 50 millivolts.

The portable unit can be powered by the ac line or by a 12-volt battery. It uses half-inch LED readouts for easy visibility and gives the user a switch-selectable choice of two resolutions: 100 hertz or 1 kilohertz.

Siltronix, 330 Via El Centro Ave., Oceanside, Calif. 92054. Phone (714) 757-8860 [356]

Inexpensive ohmmeter measures down to 0.01 ohm

The model RX-1 Lohmeter is a measurement accessory that can be connected to a digital or analog voltmeter to measure resistances down to 0.01 ohm. The unit has two linear ranges: 100 ohms and 10 ohms full



Versatility is written all over its face.

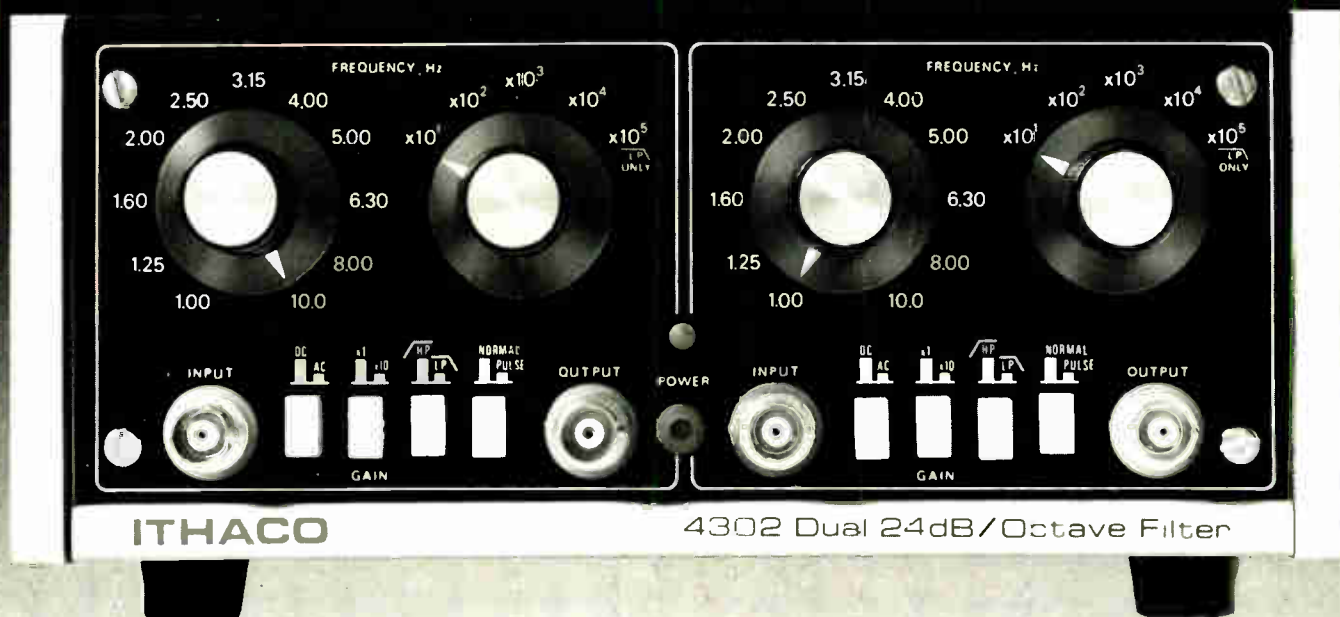

First thing you probably notice—it's a dual filter. Each of the 24db/octave filters can be used as high pass, or low pass, with selectable gain of 1 or 10.

Consider the possibilities.

Connect the dual channels in series for bandpass, 48db/octave high pass, and 48db/octave low pass, with selective gain of 1, 10, or 100. Butterworth and Bessel modes are available at

the push of a button. And you can select AC or DC coupling.

Versatility is not just skin deep.

Switch selectable frequency settings ensure repeatability of settings from 10Hz to 1MHz. And repeatability of settings, combined with only .005% distortion at 20 volts output, means you can predict results—without having to calibrate your tail off.

Look a little deeper and

you'll find 100db outband noise rejection, and a remarkably low 25 μ volts noise.

Ask for a demonstration.

Versatility like this should be seen to be believed. And wait till you see the price. \$655. Not bad for all that versatility.

Call or write John Hanson at Ithaco, Box 818, Ithaca, N.Y. 14850. Phone. (607) 272-7640.

ITHACO

SUPER MINIATURE

Neon Glow Lamps

Rated Voltage...AC 100V
Rated Current...AC 0.3mA
Total Flux...20mlm MIN.
Starting Voltage...AC 75V MAX
External Resistance...150K Ω



NL-8S

ULTRA-HIGH BRIGHTNESS

Neon Glow Lamps

Rated Voltage...AC 100V
Rated Current...AC 5mA
Total Flux...500 mlm MIN
Starting Voltage...AC 85V MAX
External Resistance...8.2K Ω



NE-2HU

CLEAR-GREEN

Fluorescent Glow Lamps

Rated Voltage...AC 100V
Rated Current...AC 1.5 mA
Total Flux...90 mlm MIN
Starting Voltage...AC 75V MAX
External Resistance...27K Ω

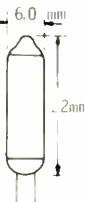

NL-21G

● MAIN PRODUCT

NEON GLOW LAMP, XENON FLASH LAMP,
RARE GAS, DISCHARGE LAMP.
MINIATURE : BLACK-LIGHT, UV-LIGHT,
FLUORESCENT COLOR-LIGHT.

ELEVAM ELECTRONIC TUBE CO., LTD.

NO. 17-8 CHUO 2-CHOME OTA-KU, TOKYO JAPAN
TELEPHONE : 03 (774) 1231 - 5

EXPORT DIVISION : JAPAN NANOTRONIX CO., LTD.
OTA-KU TOKYO, TELEPHONE. (03) 775-4811 TELEX 246-6583 JNANOX

Circle 158 on reader service card

New products

scale. It is priced at \$27.50.

Alpha Components Corp., 115 Eucalyptus Drive, El Segundo, Calif. 90245. Phone J. T. Cataldo at (213) 322-7780 [355]

Smart DMM both acquires data and processes it

Most measurements are a means, not an end—that is, after a person makes a measurement, he usually wants to do something with the information. For the majority of simple cases, in which the processing consists of converting the measurement from one unit into another, forming a ratio or product of two measured quantities, or solving a straightforward algebraic equation, the model ED6773 instrumentation processor should prove a boon.

The instrument, when outfitted with a variety of options, can measure ac and dc voltage, resistance, and frequency. It also can store 84 algebraic equations and 24 constants. It can measure and operate on two input variables at one time. Results are shown on an eight-digit LED display.

The basic ED6773 includes a single analog input for measuring dc voltage; it sells for \$2,200. Additional inputs for measuring ac voltage, resistance, and frequency, sell for \$250 to \$550 depending upon accuracy.

Electro Design Inc., 7364 Convoy Court, San Diego, Calif. 92111. Phone Cliff Griffin at (714) 227-2471 [357]

Calibrator offers improved accuracy

Designed to provide even better accuracy than the model 600, the model 610 meter calibrator is an ac/dc instrument with a maximum error of 0.002% of setting + 0.001% of range from 1 to 500 volts dc and 0.002% of setting + 0.0015% of range + 2 microvolts below 1 v. On ac, the voltage error is no more than 0.025% of setting + 0.0025% of range + 10 μ v from 400 hertz to 1

OEM DESIGNERS Get this FREE Design File

on our new
**modular switching
power supplies**

These compact, modular power supply switchers simplify design in 300-600 watt applications and keep costs down too. (They're priced at less than 90¢ per watt!) Benefits to the end user include **low EMI noise levels** (we are designed to meet VDE STD 0875) and **highly reliable operation** plus convenient maintenance and easy add-on capability up to 1200 watts in a single, 19 in. rack. Get specs, prices and feature details today from:

Jim Daly

phone (612) 830-5800
TWX 910 576 2978
or write: 7801
Computer Ave. So.
Minneapolis, MN 55435

**GD CONTROL DATA
CORPORATION**

What we put in makes ours better

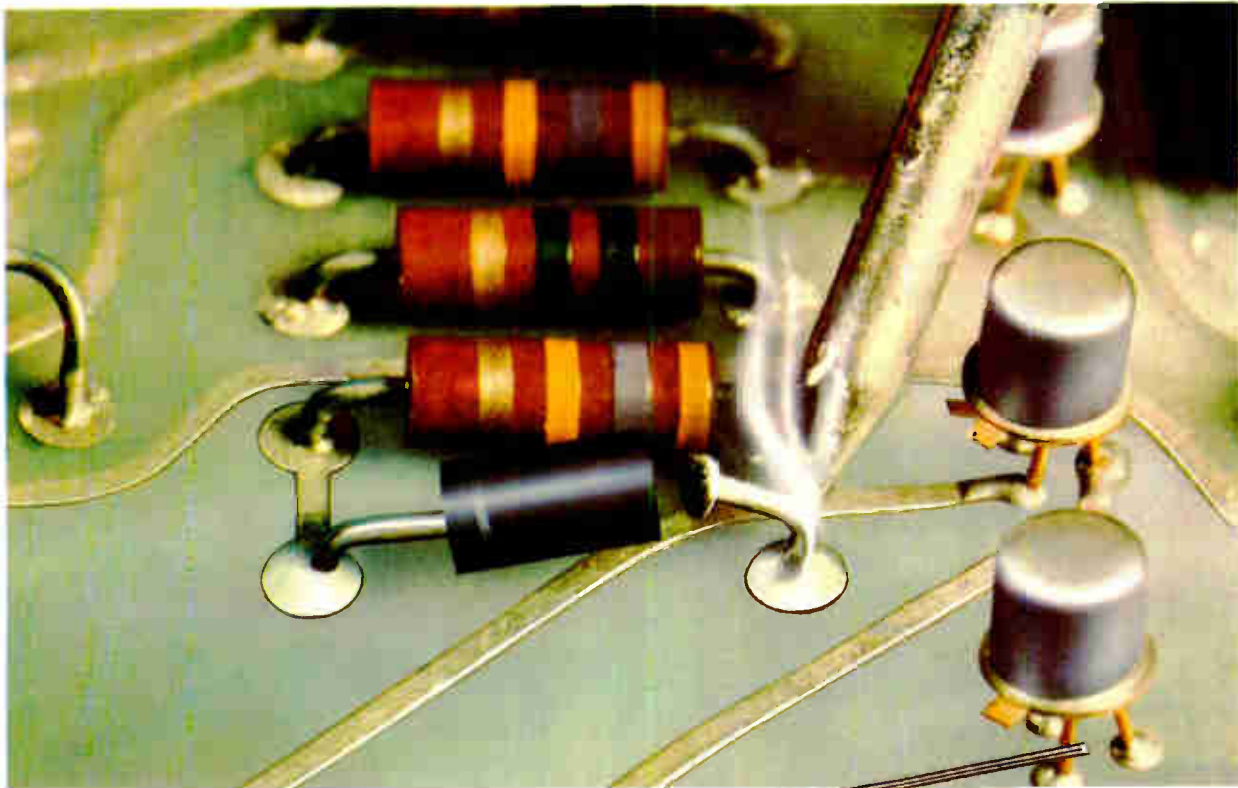

That's why this
can't happen with **SUPERECTIFIER**

Now you wouldn't normally solder this way, but neither would you be lucky enough to have a rectifier "open" so you could see it. On the other hand if you used SUPERECTIFIER that can't happen, because we braze (at greater than 600°C) at both the junction and the leads creating a metallurgical bond. No soft solders! No pressure contacts! No production failures caused by the stresses of automatic insertion or wave soldering. And no environmentally created intermittents. But we don't stop there.

Then we build in extra quality—exceeding military reliability and environmental

requirements by glass passivating the junction with our patented glass compound. Then and only then do we encapsulate with our UL listed, flame retardant epoxy to give you uniform size, clear marking and easy handling, both manually and with automatic insertion equipment. And finally, we put in our low, low price. So why pay more when you get it all in SUPERECTIFIER.

Call or write for our complete catalog today.

SUPERECTIFIER—
as good as if you designed it yourself.

GENERAL INSTRUMENT CORPORATION
DISCRETE SEMICONDUCTOR DIVISION
600 West John Street, Hicksville, New York 11802 (516) 733-3333



OEM PRICES REDUCED!

NOW AVAILABLE
FOR \$99 to \$140 EACH IN
OEM QUANTITIES. (100-1000)

MODEL DE/200 DISPLAY

EACH CHARACTER POSITION
DIRECTLY ADDRESSABLE

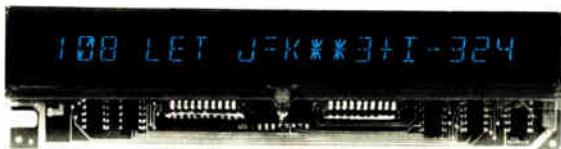

- Versatile Fluorescent Technology. Complete with interface, drive and refresh electronics.
- Readable up to 20 feet, even under high ambient light conditions.
- 20 alphanumeric character positions.
- Instantaneous display changes. No line shift.
- 14 segment, starburst character design, plus period and comma. All uniformly bright and sharp.

*For Readability. Striking Appearance,
and Cost-Effective Design*

DE DIGITAL ELECTRONICS CORPORATION
415 PETERSON STREET, OAKLAND, CALIFORNIA 94601 • (415) 532 2920

Circle 160 on reader service card

1977 Answer Book. It makes your job easier. \$25.

"What companies make the products I need? How do I contact them locally? How do I get their current catalogs fast?"

Ask The Answer Book. Over 4000 products, more than 5000 manufacturers with their local contacts and distributors, directory of trade names and catalogs, post-paid inquiry "bingo" cards for 5-second ordering of current catalogs.



Electronics Buyers' Guide

1221 Avenue of the Americas, N.Y., N.Y. 10020

Yes, send me a copy of The Answer Book.

I've enclosed \$25 (USA and Canada only,

elsewhere send \$35). Full money back guarantee if returned within 10 days.

Name _____

Company _____

Street _____

City _____

State _____

Zip _____



New products

kilohertz. Accuracy is reduced from 40 to 400 hertz and from 1 to 50 kilohertz.

Rotek Instrument Corp., 220 Grove St., Waltham, Mass. 02154 [358]

3½-digit multimeter

sells for \$99.95

A 3½-digit (2,000-count) digital multimeter with automatic zeroing, automatic polarity indication, and over-range indication costs only \$99.95. Called the model 2800, the meter has 22 ranges for measuring voltage, current, and resistance.



High- and low-power resistance ranges permit the measurement of in-circuit resistances with associated semiconductor junctions either turned on or off.

On its most sensitive ranges, the meter can resolve 1 millivolt, 1 microampere, and 0.1 ohm. Typical dc measurement uncertainty is 1%. Overload protection is a particularly important feature of the 2800. All ohms ranges can withstand voltages from -450 to +100 v dc or 300 v ac continuously. All ac and dc voltage ranges are protected up to ±1,000 v dc or 1,000 V rms. On dc voltage, the meter has an input resistance of 10 megohms. An optional probe, the PR-28, allows the measurement of dc voltages up to 40



FREON* (BLACO-TRON**) **A rose by any other name will clean as well.**



Why shouldn't BLACO-TRON precision cleaning solvents clean the same as FREON? They are completely interchangeable. DuPont calls their line of fluorinated solvents "FREON". We call ours "BLACO-TRON". So now you have a choice.

If they are equivalent, why should you try BLACO-TRON? Service. The service you get only from Baron-Blakeslee — for 45 years the accepted leader in advanced design precision

cleaning equipment and solvents

Chances are good that the machine you are now using to clean with FREON was developed by Baron-Blakeslee!

WRITE TODAY for complete "Precision Cleaning Solvents Guide". Contains full tech data on all BLACO-TRON fluorinated solvents.

BLACO-TRON®
FLUORINATED SOLVENTS—NOW THERE IS A CHOICE

... and now there's a FULL BOUQUET of BLACO-TRON 'roses'

Whatever type BLACO-TRON fluorinated solvent you need, you'll find it equivalent to the FREON solvent you may have been using:

FREON TF	BLACO-TRON TF
FREON TMC	BLACO-TRON TCM
FREON TE	BLACO-TRON TE
FREON TES	BLACO-TRON TES
FREON TMS	BLACO-TRON TMS Plus
FREON TA	BLACO-TRON TA
FREON T-E 35	BLACO-TRON T-E 35
FREON T-P 35	BLACO-TRON T-P 35
FREON T-WD 602	BLACO-TRON TWD



Baron-Blakeslee 1620 South Laramie Ave., Chicago, Ill. 60650—Offices in All Principal Cities. — (312) 656-7300

*FREON is DuPont's registered trademark for its fluorocarbon cleaning agents.

**BLACO-TRON is Baron-Blakeslee's registered trademark for its fluorocarbon cleaning agents.

Circle 161 on reader service card

ELECTRONICS ARTICLES AVAILABLE IN REPRINT FORM

No. of
copies
wanted

New reprints

- ___ R-703 Special report—memories 16 pp \$3.00
- ___ R-702 World market report 1977 24 pp \$4.00
- ___ R-616 Special issue—technology update \$4.00
- ___ R-614 Power supply choices for sophisticated designs 8 pp \$3.00
- ___ R-612 Fiber-optic communications special report 24 pp \$3.00
- ___ R-610 Special report on hybrid-circuit technology 19 pp \$3.00
- ___ R-606 Special issue—microprocessors \$4.00
- ___ R-526 How reliable are today's components 16 pp \$3.00

Charts

- ___ R-516 Electronic symbols \$2.00
- ___ R-213 Electromagnetic spectrum (updated 1976) \$3.00
- ___ R-326 Optical spectrum (6-page report and chart) \$3.00

Books

- ___ R-704 Thermal design in electronics \$5.00
- ___ R-701 Applying microprocessors—Electronics Book Series \$9.95
- ___ R-608 Basics of Data Communications—Electronics Book Series \$12.50
- ___ R-602 Large Scale Integration—Electronics Book Series \$9.95
- ___ R-520 Microprocessors—Electronics Book Series \$8.95
- ___ R-011 Computer-aided Design 135 pp \$4.00
- ___ R-032 Active Filters 88 pp \$4.00
- ___ R-031 Circuit Designer's Casebook 182 pp \$5.50 (outside U.S. \$12.00)

Other Reprints

- ___ R-600 World market report 1976 24 pp \$4.00
- ___ R-524 Special report on bipolar large-scale integration 12 pp \$3.00
- ___ R-522 Special report on power semiconductors 12 pp \$3.00
- ___ R-518 Special issue—productivity \$4.00
- ___ R-514 Eight ways to better radio receiver design 6 pp \$3.00
- ___ R-512 Design of circuits for dangerous environments 4 pp \$2.00
- ___ R-510 Bipolar integration advances with PL microprocessor 8 pp \$2.00
- ___ R-508 Designing microprocessors with standard logic 12 pp \$3.00
- ___ R-506 The case for component burn-in 7 pp \$2.00
- ___ R-434 Designing automated systems with the new standard interface 12 pp \$3.00
- ___ R-432 An update on communications satellites 8 pp \$2.00
- ___ R-430 Choosing the right bipolar transistor model for computer-aided design 20 pp \$3.00
- ___ R-428 Designing with low-cost lasers 6 pp \$2.00
- ___ R-424 Microprocessor applications 28 pp \$3.00
- ___ R-422 A microprogrammable minicomputer 8 pp \$2.00
- ___ R-420 Computerized text-editing and typesetting 8 pp \$2.00
- ___ R-418 Computer analyses of rf circuits 8 pp \$2.00
- ___ R-414 The ion-implanted n-channel process 6 pp \$2.00
- ___ R-412 Liquid cooling of power semiconductors 6 pp \$2.00

Payment must accompany your order

Make check or money order payable to Electronics Reprints. All orders are shipped prepaid by parcel post. Allow two to three weeks for delivery.

Cost of orders \$ _____
 Plus 10% handling charge \$ _____
 TOTAL AMOUNT ENCLOSED \$ _____

Mail your order to:
 Janice Austin
 ELECTRONICS REPRINTS
 P.O. Box 669
 Hightstown, N.J. 08520

SEND REPRINTS TO

Name _____

Company _____ Dept. _____

Street _____

City _____ State _____ Zip _____

New products

kilovolts. The meter is available through distributors.

B&K-Precision, Dynascan Corp., 6460 W. Cortland Ave., Chicago, Ill. 60635. Phone (312) 889-9087 [353]

Modulation meter covers 10 to 1,200 megahertz

The model 82AD fm/a-m modulation meter is an automatic instrument that covers the carrier-frequency range from 10 megahertz to 1.2 gigahertz. Among the features that make it extremely easy to use are automatic tuning, automatic leveling, and a four-digit light-emitting-diode display.

The meter makes fm deviation measurements at 10, 100, and 300-



kilohertz full-scale with a maximum error of 2% of reading. A-m full-scale ranges of 10% and 100% also provide readings that are accurate to within 2%. Options include an IEEE-488 bus interface, a rechargeable battery supply and an rf fuse. The 82AD sells for \$2,900.

Boonton Electronics Corp., Parsippany, N.J. Phone Wallace F. White at (201) 887-5110 [359]

Unit isolates faults on printed-circuit boards

A current-tracing meter, Microprober model 42, is intended to isolate defective integrated circuits on assembled printed-circuit boards. The sensitivity high of the current tracer, which spans a 10,000:1 range, permits equally effective fault isolation of TTL, DTL, C-MOS, and ECL circuits. It sells for \$94.50 and has a delivery time of 45 days.

Integral Electronics Corp., P.O. Box 286, Commack, N.Y. 11725. Phone Marcy Talbot at (516) 269-9207 [360]

How fast can you measure rise time, fall time and pulse width?



576967903

10

DANA, MODEL 9000
MICROPROCESSING TIMER/COUNTER

Your way.

(About 5 minutes.)

1. Connect signal to scope.
2. Adjust trace intensity.
3. Adjust focus.
4. Select VOLTS/DIV range.
5. Select TIME/DIV range.
6. Adjust vertical gain to fill screen for location of 10% & 90% points.
7. Locate 10% point.
8. Locate 90% point.
9. Determine horizontal displacement between 10% & 90% points.
10. Multiply displacement by horizontal scale factor.

That's RISE TIME. Only 9 more steps and you've got PULSE WIDTH and FALL TIME.

Our way.

(About 5 seconds.)

1. Connect signal.
 2. Push button for FUSE TIME.
 3. Push button for PULSE WIDTH.
 4. Push button for FALL TIME.
- The rest is automatic.

Your move.

Give us a call and we'll tell you how the Dana 9000 Microprocessing Timer/Counter can solve your measurement problem the easy way.

DANA

Others measure by us.

Dana Laboratories, Inc., 2401 Campus Drive, Irvine, CA 92715
Phone: 714/833-1234

Circle 162 for Product Demonstration
Circle 163 for Literature Only

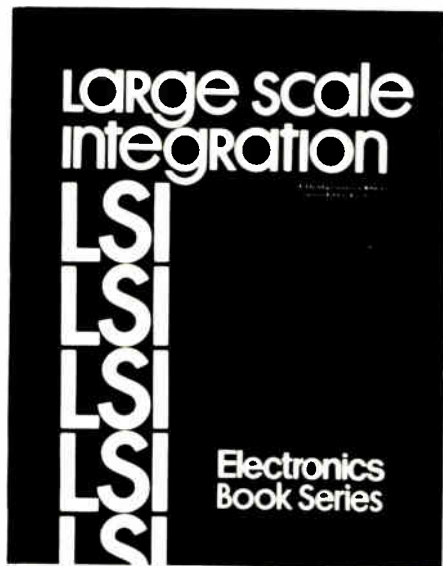

The Electronics Book Series offers you a handbook on the current and revolutionary impact of LSI on digital design. This 220-page book presents a unique opportunity for circuit designers, systems designers, and engineering managers and supervisors to bring their expertise into line with today's LSI design requirements.

Electronics Book Series
 PO Box 669, Hightstown, N.J. 08520

Send me _____ copies of "Large Scale Integration" at \$9.95 per copy.

I must be fully satisfied or you will refund full payment if the books are returned after ten day trial examination.

Payment enclosed Bill firm Bill me

Credit Cards Charge My Book To

American Express Master Charge
 Diners Club BankAmericard

Acct. No. _____

Date Card Expires _____

Interbank No. _____

1st No's. above name on Mastercharge only.

Name _____

Title _____

Company _____

Street _____

City _____

State _____ Zip _____

Signature _____

Electronics IS THE SOURCE FOR BOOKS.TOO



New products/materials

Ferrite loop cores for extremely-low frequency and very-low-frequency antennas are designed to help reduce the coil mass, and hence the size, of antennas used in underwater com-

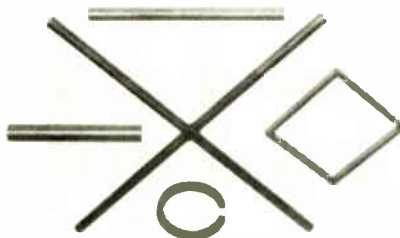

munications, mine communications, and such navigation systems as Loran and Omega. Among the available shapes are cross frames and cylindrical rods, both of which can be fabricated in any desired length and diameter. Tolerances in all dimensions can be held to within 1 mil.

Ceramic Magnetics Inc., 87 Fairfield Road, Fairfield, N. J. 07006. Phone (201) 227-4222 [476]

A low-loss impregnant and coating for use in a wide variety of radio-frequency and microwave applications combines a low dielectric constant with good moisture resistance and high insulation resistance. Based on polystyrene, the low-loss material can be used as a lacquer for rf coils and as a reinforcing medium for paper, fabric, and wood. It can be applied by brushing, spraying, or dipping. When a complete enclosing coat is needed, best results are obtained by dipping under vacuum at a temperature of about 250°F. Called Eccoseal High Q, the material sells for \$3.60 a pound in 8-lb lots.

Emerson and Cuming Inc., Canton, Mass. 02021. Phone (617) 828-3300 [477]

Thin multilayer laminates that meet the requirements of MIL-P-55617 are offered with core thicknesses from 2.5 to 31 mils and tolerances of 0.75 to 3 mils. Called the Hi-Tek series, these copper-clad laminates are offered with copper thicknesses

from 1 to 5 ounces. Thinner copper foils of 1/7, 1/4, and 1/2 oz are also available.

Lamination Technology Inc., 2720 S. Main St., Santa Ana, Calif. 92707. Phone (714) 556-1460 [478]

A fire-resistant compound for potting and encapsulating electronic components and assemblies, Thermasil is a silicone rubber with a thermal conductivity of 7 BTU/(hr)(ft²)(°F-in.). Available as both one- and two-part systems, it protects against corrosion and humidity over the temperature range from -50°C to 250°C. It sells for \$5 a pound in large quantities.

Transene Co., Inc., Route One, Rowley, Mass. 01969. Phone (617) 948-2501 or 2811 [479]

An epoxy staking compound specially formulated for high-vacuum applications cures overnight at room temperature or in a few hours at elevated temperatures. The two-part epoxy system mixes easily and completely to a smooth, thixotropic paste that will not flow, even on vertical surfaces. It is an electrical insulator with high resistivity and is also well suited for securing electronic components to printed-circuit boards.

Called Tra-Bond 2116, the material adheres very well to most metals, glass, ceramics, and rigid plastics.

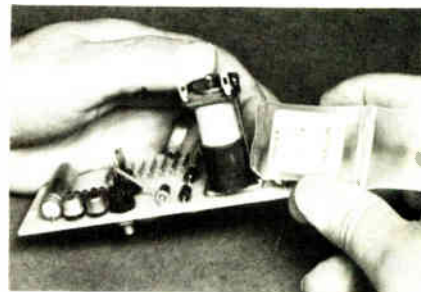

When fully cured, it combines high mechanical strength with superior resistance to a wide variety of organic and inorganic compounds. The compound is available from stock in a broad range of predisposed Bipax package sizes. These packages make the resin easy to mix, convenient to store, and safe to use.

Tra-Con Inc., Resin Systems Division, 55 North St., Medford, Mass. 02155 [395]

Datel has them . . . ADC-HX and ADC-HZ hybrid 12-bit A/D's and the DAC-HZ hybrid 12-bit D/A. The stock answer to your converter requirements.

Designed for performance and produced in quantity, these hybrids utilize quad current switches, laser-trimmed thin film resistor networks and a stable zener reference circuit. The A/D's also incorporate a monolithic S.A.R., precision comparator, buffer amplifier, and clock circuit.

Produced for economy, these popular industry standards are ready for immediate delivery. Just check the new, low prices. Datel's stock answers really make sense. Order yours today.

ADC-HZ12BGC

12 Bits Resolution
3 μ sec. Conv. Time
20 ppm/°C Gain Tempco
32 Pin Glass DIP
\$119* (1-24)
\$91.65* (100's)

ADC-HX12BGC

12 Bits Resolution
20 μ sec. Conv. Time
20 ppm/°C Gain Tempco
32 Pin Glass DIP
\$85* (1-24)
\$69.70* (100's)

DAC-HZ12BGC

12 Bits Resolution
3 μ sec. Settling Time
20 ppm/°C Gain Tempco
24 Pin Glass DIP
\$39 (1-24)
\$29.25 (100's)

ANOTHER STOCK PLUS . . .

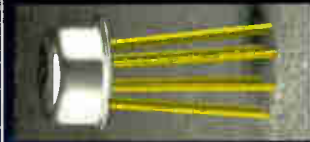

The ideal companion to ADC-HX and HZ converters is the new, low cost SHM-LM-2 monolithic sample-and-hold. Also available for off-the-shelf delivery.

- 6 μ sec. Acquisition Time
- 0.01% Accuracy
- 100 nsec. Aperture
- 200 μ V/msec. Droop

Requires only external capacitor
\$7.95* (1-9) **\$5.95*** (100's)

Hybrid A/D's-D/A's New Low Prices, Stock Delivery

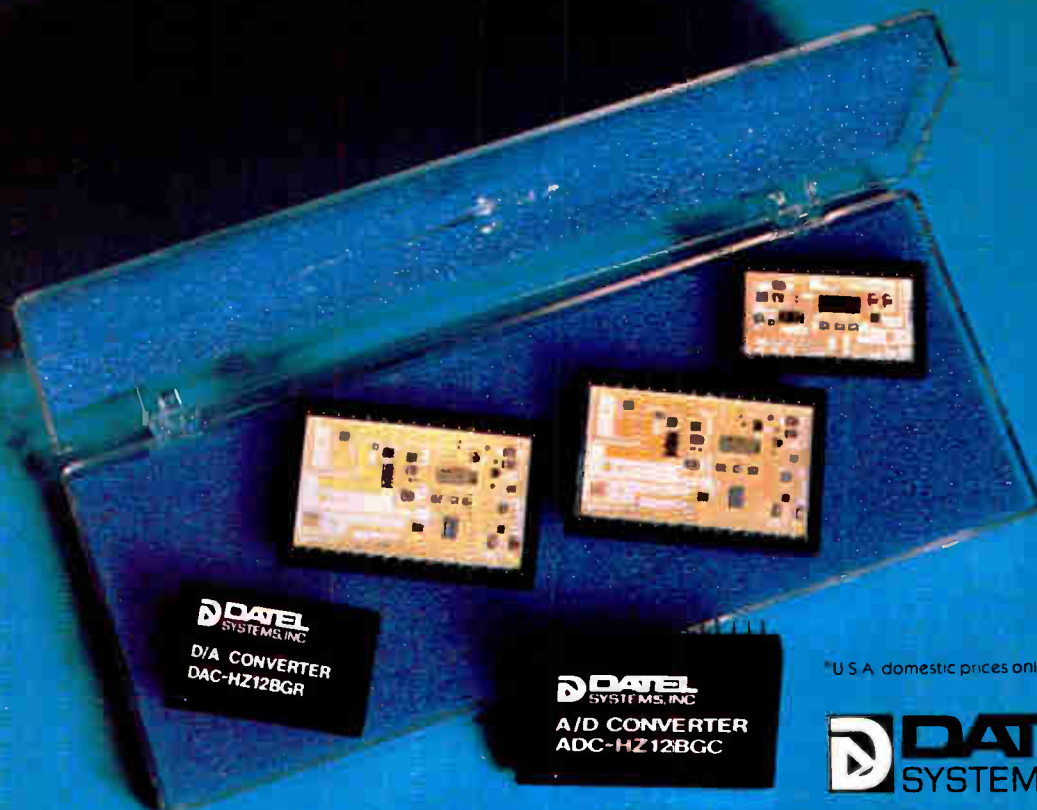

*U.S.A. domestic prices only

D **DATTEL**
SYSTEMS, INC.

1020 Turnpike St., Canton, MA 02021 • Tel. (617) 828-8000

Santa Ana, CA (714) 835-2751, (L.A. Exchange) (213) 933-7156 • Sunnyvale, CA (408) 733-2424 • Gaithersburg, MD (301) 840-9490

Circle 165 on reader service card



rare earths
rhône-poulenc

all grades
ranging
up to

99,9999% purity

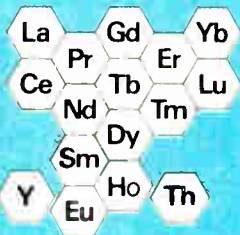

For further information, please send your name and address with the reference : [G.7.30](#)

For U.S.A.

rhodia inc

Chemicals Division - P.O. Box 125, Monmouth Junction, NEW JERSEY 08852 (USA), Tel. 201-846-7700, Telex 844527

For other countries

rhône-poulenc (CF/PSP) 21, rue J. Goujon, F-75 360 PARIS CEDEX 08, Tel. (1) 256-40 00, Telex 640 100 F

Circle 166 on reader service card

World Radio History



rhône-poulenc

New literature

Temperature control. A 25-page temperature-control handbook discusses the various systems parameters that must be considered in a wide range of applications, from heating a home to stabilizing the temperature of a quartz-crystal oscillator. It is offered by Multi-State Devices Ltd., 2255 Dandurand St., Montreal, Quebec H2G 1Z6, Canada. Circle reader service number 421.

Pulse measurements. Using a conventional oscilloscope to make timing measurements on pulses or on intervals between digital events typically introduces an uncertainty of about 3%. The Delta Time measurement package from Tektronix, which consists of the 7B80 and 7B85 plug-ins for 7000-series oscilloscopes, is claimed to reduce this uncertainty down to the range from 0.5% to 1.0%. The Delta Time approach is described in an application note that can be obtained from Tektronix Inc., P. O. Box 500, Beaverton, Ore. 97077 [422]

Cleaning vacuum components. Entitled "How to Make a Vacuum Cleaner," an eight-page booklet from Thermionics Laboratory Inc., P. O. Box 3711, Hayward, Calif. 94544, presents chemical cleaning procedures for certain types of ultra-high-vacuum components. Specific methods are detailed for ion-pump elements and for parts made of Kovar, Monel, and molybdenum. [423]

Exporting information. A compendium of information designed to help U. S. manufacturers, especially small ones, enter the international trade arena may be ordered from the Southern California District Export Council, U. S. Dept. of Commerce District Office, 11777 San Vicente Blvd., Los Angeles, Calif. 90049. The 80-page guide sells for a tax-deductible \$9.75 (\$5.25 to students). Checks should be made out to the Southern California District Export Council.

Designing for testability. One way to

beat the high cost of testing and fault isolation is to design your product so that it can be tested easily. Application Note AN 210-4, "Designing Digital Circuits for Testability," gives the designer some techniques for achieving this end. The techniques are applicable to large-scale-integrated circuits, printed-circuit boards, and complete digital systems. Copies of AN 210-4 are available from the Inquiries Manager, Hewlett-Packard Co., 1501 Page Mill Road, Palo Alto, Calif. 94304 [425]

One-chip microcomputer. The TMS1000 one-chip microcomputer is the subject of a 44-page data manual put out by Texas Instruments Inc., Inquiry Fulfillment, P. O. Box 1443, M/S 653 (Attn: TMS1000 Data Book), Houston, Texas 77001. The manual includes a technical description, product data, and applications information on the 4-bit, p-channel device. [426]

8080 information. The 8080A/9080A handbook is a 320-page compendium of information about the most popular 8-bit metal-oxide-semiconductor microprocessor. In addition to complete descriptions of the central processing unit and major support circuits, it includes detailed timing diagrams, memory and interface-circuit descriptions, and an applications section. For a copy, send \$7.95 to Advance Micro Devices' Library, P. O. Box 60668, Sunnyvale, Calif. 94086 [427]

Switches. An illustrated switch-selection guide covers Licon's line of switches: single- and double-break snap-action, lighted and nonlighted push-button, dual in-line push-button with light-emitting diodes, and industrial. The 36-page guide also includes lens-cap information. Copies are offered by Licon, a division of Illinois Tool Works Inc., 6615 W. Irving Park Road, Chicago, Ill. 60634 [428]

Image digitizing. A 37-page handbook covers the theory, operation,

μ P Power Supplies[®] Save Your Chips!

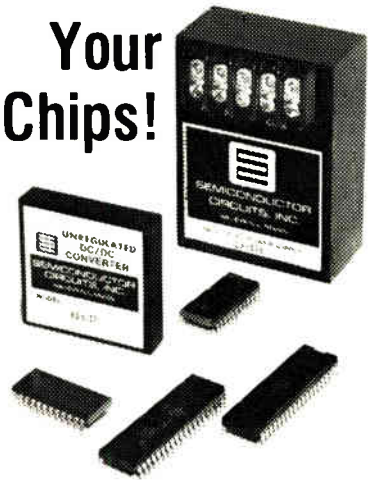

Choose ...

- ☐ **Output ratings** from a large selection of models
- ☐ **Input ratings** from among DG/DC converters and line operated supplies
- ☐ **Performance** you NEED at a sensible price
- ☐ **Low Unit Prices** from \$23.95 to \$99.95

Get The Facts Fast Call or write today for Free Catalog. We'll also include your copies of our new power supply journal,

WATTS UP at sci



**SEMICONDUCTOR
CIRCUITS, INC.**

POWER SOURCES
DIVISION

306 RIVER ST., HAVERHILL, MA 01830
Tel. (617) 373-9104, TWX. 710-347-0269

BUCKEYE

Buckeye knobs are in all types and sizes to enhance your instrumentation. Skirts and special markings are Buckeye specialties. Our catalog and samples of specific items will be sent upon request.

BEAUTY and the BEST!



the BUCKEYE stamping co.
555 Marion Rd., Columbus OH 43207
Phone 614/445-8433

Circle 168 on reader service card

Amazing AIRBRASIVE[®] "Wonder Tool"

It can cut or etch. Or strip and clean. Or drill and deflash. Amazing!

Try it. You'll wonder why you waited so long. You'll see why the versatile S.S. White Airbrasive tool is the low cost production tool for precision work on small electronic parts and components. It works on metals or glass, quartz or ceramics, the most delicate-to-handle semiconductor and crystalline materials. Airbrasive's stream of micro-abrasive particles gives you cool, shockless jet machining to the most critical tolerances. And at real savings in production time and labor costs. Wonder how much Airbrasive costs? Just \$825 for Model K—ideal for lab work, pilot runs, and similar light-duty, limited production. Model H, at \$1625, can deliver jet-machined production parts in high-volume to meet your most demanding production schedule.

Write for our illustrated brochure today. Or arrange for a demo and try the Airbrasive Wonder Tool on your parts. Write or call Jim McDonald, S.S. White Industrial Products, Pennwalt Corp., 151 Old New Brunswick Road, Piscataway, NJ 08854 (201) 752-8300.

*Trademark of Pennwalt Corporation

S.S. WHITE
PENWALT
EQUIPMENT • CHEMICALS
HEALTH PRODUCTS

The "Wonder Tool"
AIRBRASIVE



Precise and shockless enough to cut intricate patterns in an eggshell.

168 Circle 199 on reader service card

New literature

and specifications of the EyeCom Picture Digitizer and Display. For a copy, write to Spatial Data Systems Inc., Box 249, 508 South Fairview, Goleta, Calif. 93017 [429]

Breadboarding and test gear. A catalog of breadboarding equipment and test instrumentation features a line of sockets, boards, clips, logic probes, logic monitors, and other items to help the experimenter make and test solderless breadboards quickly. Copies may be obtained from Continental Specialties Corp., 44 Kendall St., P. O. Box 1942, New Haven, Conn. 06509 [430]

Batteries. A line of batteries for communications equipment and portable video-tape recorders and cameras is illustrated in a new catalog available from Alexander Manufacturing Co., Box 1645, Mason City, Iowa 50401. [431]

Making circuit-board screens. The direct/indirect process of making screens for printed-circuit boards combines the advantages of direct emulsion and indirect prepared films without the problems of either, according to a new publication from the originators of the direct/indirect system. For a copy, write to Chromaline Inc., 4832 Grand Ave., Duluth, Minn. 55807 [432]

High-purity materials. Approximately 500 high-purity compounds and elements are described in the new Spex HiPure Materials catalog. These inorganic chemicals range in purity from 99.9% to 99.99999% and are thus suitable for demanding optical and electronic applications. Virtually all the nonradioactive elements except the rare gases are represented—even the rare earths. Spex Industries Inc., 3880 Park Ave., Metuchen, N.J. 08840 [433]

Sound and vibration analysis. A short-form catalog from B&K Instruments Inc., 5111 West 164th St., Cleveland, Ohio 44142, covers the company's line of sound, vibration, and data-analysis instrumentation. [434]

International Rectifier "Function Fit" Power Transistors will enhance your circuit design and increase its reliability.

It's unlikely that you'll find a Power Transistor line with as many types as ours, or with functional characteristics that fit specific applications so well . . . to improve reliability.

For example, for **Switching Power Supplies**, our 2N6542-2N6547 and IR6002's will switch up to 600V $V_{CEX(sus)}$ with optimum t_f and E_s/b .

For **Display Terminal** horizontal and vertical deflection, you can get up to 900V V_{CBO} with a sharp breakdown (from hard-glass passivation) for added reliability . . . coupled with low $V_{CE(s)}$.

For **Automotive Ignition**, count on higher $V_{CEO(sus)}$ and higher inductive energy capability with the reliability you need. Clamped or unclamped performance in a TO-3 package, on a chip, or a chip on a Beryllia substrate.

For **High Current Applications** our BUX-20 not only switches 125V and 50A at 20KHz, but does it at commercial prices. Also try our 2N6274-2N6277.

For **Amplifiers**, try our high energy EPI base discretes and Darlington. You'll get the SOA you need plus better frequency response than you'll find in other companies' diffused types.

For **Motor Drives**, our rugged Darlington will provide the inductive energy, high $V_{CEO(sus)}$, and high gain needed for reliability in these tough applications.

Whatever your application, chances are good that we have a "Function Fit" Power Transistor that will give you extra-margin reliability without changing your circuit . . . or costs!

Contact your local IR Sales Office or Distributor for data or write to
 International Rectifier,
 233 Kansas Street,
 El Segundo, CA 90245
 (213) 322-3331, Telex 67-4464

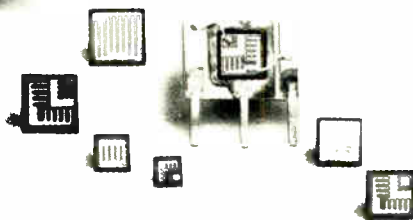
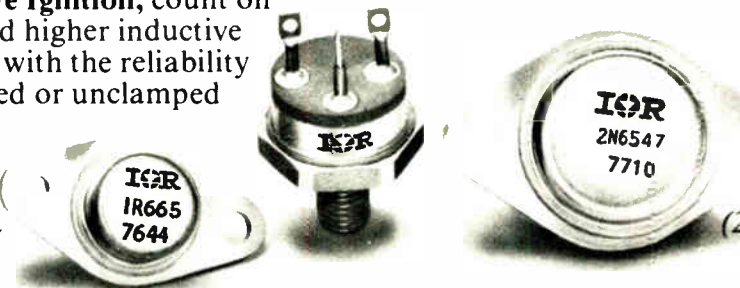

International Rectifier

... the innovative semiconductor people



Exhibition of Industrial Electronics and Electrical Engineering in the Halls of the Swiss Industries Fair

As the most significant event of its kind in this field, the Ineltec exhibition for 1977 will give a comprehensive survey of the market for industrial electronics and electrical engineering. More than 700 exhibitors from 14 countries will display reliable products

and innovations, processes and services offered by more than 1600 suppliers from 24 countries.
 September 6 and 7, 1977: Conferences on "Modular Systems and Applications in Control and Automation Technology".
 September 8, 1977: Symposium on international marketing and current marketing problems of the fields of industrial electronics and electrical engineering.
 Youth visitors day for students and apprentices on Saturday, September 10, 1977.

Literature, conference programs and catalogues:
 Secretariate Ineltec 77
 Postfach
 CH-4021 Basle-Switzerland
 Phone 061 26 20 20
 Telex 62685 fairs ch

**Basle/
 Switzerland
 Sept. 6
 to Sept. 10,
 1977**



Swissair official carrier

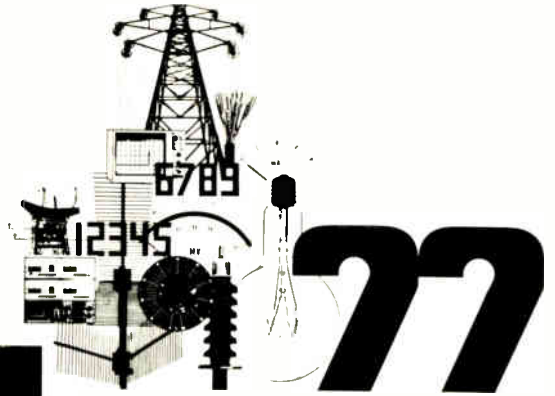

ineltec

Circle 170 on reader service card

COST-CUTTING WESTON BREAKTHROUGH!

3/8" MULTITURN CERMET TRIMMER

FOR ONLY **99¢**

(1,000-Pc. Price)

850-W



850-P

850-X

Same High Weston Quality At A Real Savings In Price!

Weston has done it with the new #850! We took this widely used square multiturn trimmer, and by radically improving manufacturing techniques have been able to trim the price without sacrificing quality, performance or uniformity. It can give you an important new competitive edge.

WRITE FOR SPECS AND DETAILED PRICE INFORMATION.

**SANGAMO WESTON
 Schlumberger**

WESTON COMPONENTS & CONTROLS
 A Division of Sangamo Weston, Inc.
 Archbald, Pa. 18403
 Tel. (717) 876-1500
 TWX 510 656-2902
 Telex 83-1873

170 Circle 200 on reader service card



ONE OF THE PURDY GROUP OF COMPANIES

**770 Airport Boulevard
 Burlingame, CA 94010
 (415) 347-8217 • TWX 910-374-2353**

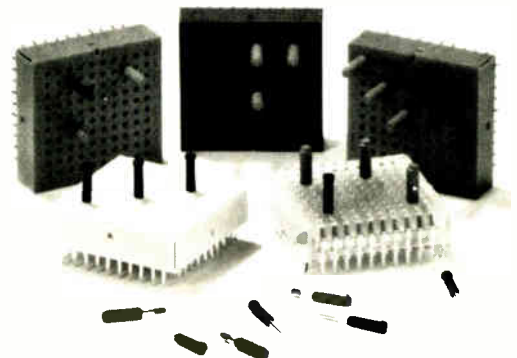

Circle 201 on reader service card

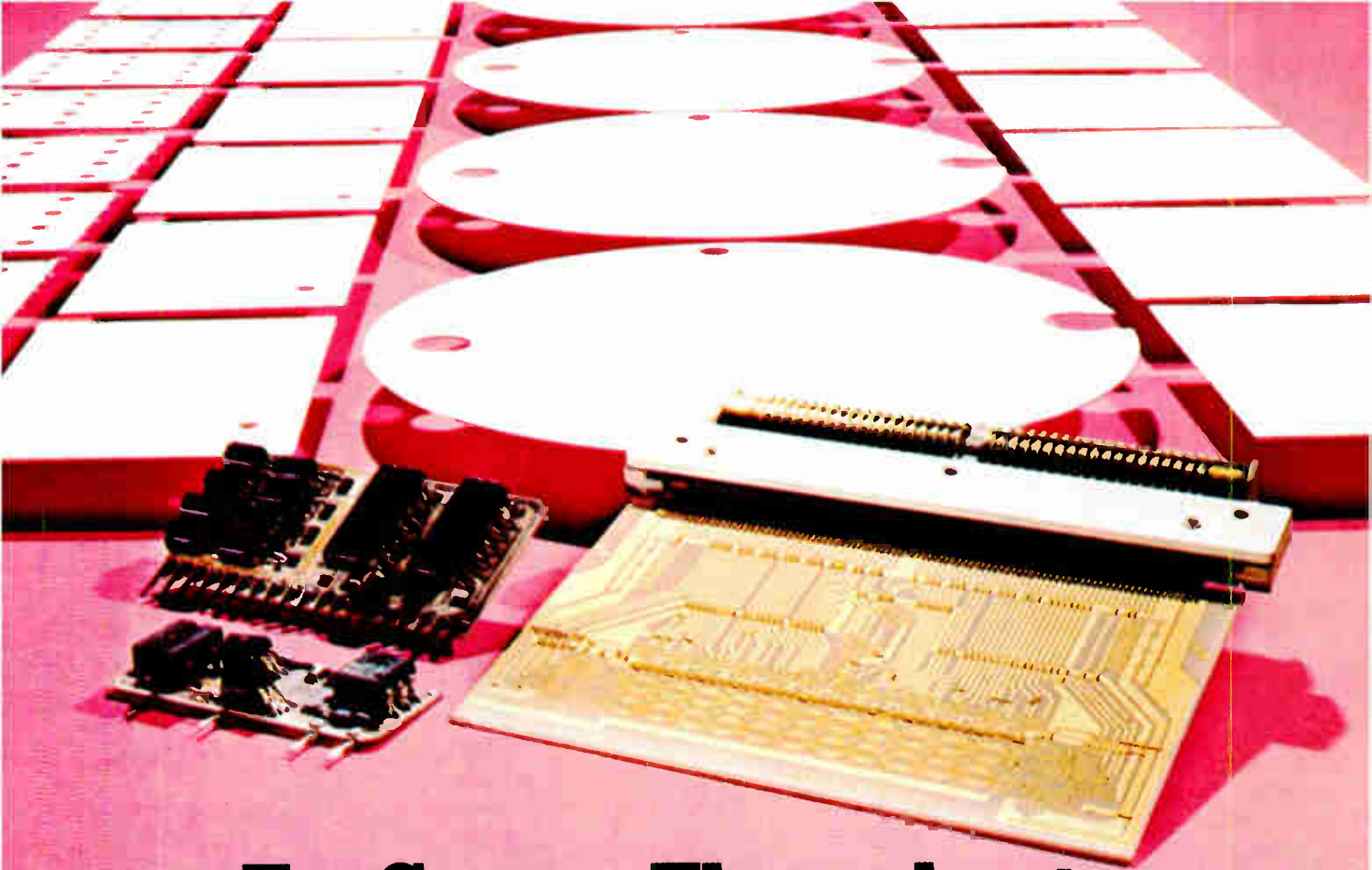

For Greater Throughput And Higher Yield, Start With a Dependable Base.

To guard your profits and your reputation, you need a dependable foundation for your thick- or thin-film circuits. On your production line and in service, Coors alumina ceramic substrates provide that measure of dependability.

Remarkable mechanical strength enables them to survive the rigors of high-speed, automated processing. Coors quality assurance program constantly monitors composition, dimension, and surface of substrates for greater yield. Our substrates' superior electrical, mechanical and chemical properties provide reliable operation in the field.

A choice of materials, backed with facilities for laser scoring, green scoring and metallizing, means Coors can match a substrate to your circuit specifications and finishing requirements. With tooling on hand for more than 1000 shapes, we can speed your designs and save you tooling charges.

The final elements of Coors dependability are a special substrate service group to give you personal follow-through on your substrate orders, and a new plant that will provide faster delivery in late summer, 1977.

For complete details on Coors substrates, write for our Electronic Ceramic Handbook, or call your local Coors representative.

For fast service, call Coors Substrate Hotline: (303) 279-8320.

Coors CERAMICS

Coors Porcelain Company

600 Ninth Street/Golden, Colorado 80401
(303) 279-6565/Telex 45-593

Circle 171 on reader service card

Classified section FOR ENGINEERING/TECHNICAL EMPLOYMENT OPPORTUNITIES

CLASSIFIED SALES REPRESENTATIVES

Atlanta ... Joe Lane	404/892-2868	Cleveland ... Mac Huestis	216/781-7000	Houston ... Mike Taylor	713/659-8381	Pittsburgh ... Dan Ferro	412/391-1314
Boston ... Holt Buchanan	617/262-1160	Dallas ... Mike Taylor	214/742-1747	Los Angeles ... Stan Kassir	213/487-1160	San Francisco ... M.E. Kenny	415/362-4600
Chicago ... Bill Higgins	312/751-3733	Denver ... Shirley Klotz	303/837-1010	New York ... Dave Hawksby	212/997-3594	Stamford ... Holt Buchanan	203/359-2860
		Detroit ... Mac Huestis	313/873-7410	Philadelphia ... Dan Ferro	215/568-6161	XEROX 400 TELECOPIER	212/997-6800

Engineers

Significant growth coupled with forecasted expansion and a solid commitment to new product development has created exciting professional opportunities for imaginative engineering talent with Gould's fast moving Ocean Systems Division. Immediate openings for:

Sr. Production Engineer (Mechanical)

The selected candidate will have at least a BSME and 10 years working experience. Also necessary is a familiarity with rotary equipment including engines, pumps, motors, and alternators/generators. In addition, exposure to fluid power equipment in the following areas is essential: valves, pumps, and servovalves. A final prerequisite is experience with military documents including weapon specifications as well as familiarity with government drawings in relation to dimensioning, tolerancing, and ANSI Y14.5.

Reliability Engineer

BSME or equivalent and 3 years experience in electro-mechanical component and system analysis plus a familiarity with government contracts are required. Exposure to MIL-Q-9858A and ANSI Y14.5 essential. Involves failure analysis at the component, sub-system and system level. In addition to identifying and writing-up failure analysis reports, candidates must display the ability to recommend corrective action.

If you're up to the large scale challenges and the exhilarating growth pace that have established Gould as an integrated technology company... you'll be rewarded with an exceptional salary, a full benefits package and highly-visible advancement opportunities. Submit letter or resume in confidence with earnings history and salary requirements, to:

GOULD OCEAN SYSTEMS DIVISION
18901 Euclid Avenue
Cleveland, Ohio 44117

An Equal Opportunity Employer, M/F/H.



We have been placing graduate ENGINEERS

in FEE-PAID positions THROUGHOUT THE U.S. since '59. Over 1,000 client companies. We are graduate engineers working full-time for you. Send resume & salary history today or request confidential application.

ATOMIC PERSONNEL, INC.
Suite L, 1518 Walnut St., Phila., Pa. 19102
An Employment Agency
For All Technical Fields

* SOFTWARE/FIRMWARE COMMUNICATIONS Design & Project Eng'rs. • BS, MS, Ph.D. • Nat'l Unadvertised Positions • \$16-30K • P'nB Consultants, Box 261 (M) Wayne, PA 19087
The Engineers Who Talk Your Language

Opportunities to Challenge Yourself and Your Ideas.

The Environmental Research Institute of Michigan (ERIM), serves as a catalytic agent among government agencies, universities and industries for the application of advanced technology and associated scientific methodology to society's problems.

Formerly Willow Run Laboratories of the University of Michigan, ERIM offers qualified candidates the opportunity to explore the areas of scientific research and development usually found only in the academic world, in the less constricted atmosphere of a private non-profit research organization. The independent environment of ERIM breeds challenges and complexities of opportunity which extend beyond specific job classifications.

Our expanding research and development program has created a number of new, permanent engineering staff positions. If you hold an advanced degree and have experience in the areas of Radar, Remote Sensing, Optics, Data Processing, or Energy Technologies and Applications, we want to hear from you.

The location of ERIM in Ann Arbor, Michigan, adjacent to the University of Michigan, offers cultural, academic, sports and entertainment opportunities of every kind. Salaries are competitive and fringe benefits are above average. All replies strictly confidential.

Send your detailed resume to:

ENVIRONMENTAL RESEARCH INSTITUTE OF MICHIGAN

P.O. Box 618, Ann Arbor, Michigan 48107
Attention: Personnel Administrator
An Equal Opportunity Employer

BUSINESS OPPORTUNITY

How To Earn Money As A Consultant
(including specimen contracts) \$17
Business Psychology Int'l 890/44
Nat. Press Bldg. Washington, DC 20045.

POSITIONS VACANT

Communications Engineer—Central
N.J. based employer seeking Communications/Digital Maintenance Management Engineering Personnel. MSEE with minimum 10 yrs. experience in position of Communications Engineer, Asst. Communications Engineer, or similar rank. Will be responsible for budgeting, construction, and maintenance of broad base Communication/Digital Systems which include microwave, cable plant, two-way radio, dial telephone, data transmission, and computer networks. Successful applicant should have demonstrated technical/managerial background. Excellent fringe benefits. Send resumes including salary requirements to P-4917. EQUAL OPPORTUNITY EMPLOYER. Electronics.

SERVICE SPECIALIST CHEMISTRY INSTRUMENTS

Senior professional position open for a well trained and experienced technician who can maintain, repair, improve NMR and Mass Spectrometers (& I.R./U.V. instruments), and effectively manage their operation/use. Send resume in confidence to: Assistant Personnel Director, Box 636,

UNIVERSITY OF ROCHESTER
260 CRITTENDEN BOULEVARD
ROCHESTER, NEW YORK 14642

An Equal Opportunity Employer
(M/F)

POSITIONS VACANT

Electrical Engineering Technology—Upper division E.C.P.D. accredited Bachelor of Technology Program seeks visiting professor to replace faculty member on a two year leave of absence. M.S. Degree in Electrical Engineering required with teaching and industrial experience desirable. Position available Fall 1977. 10 month contract. Send resume and references to Prof. J. Adams, Department of Electrical Engineering Technology, Rochester Institute of Technology, One Lomb Memorial Drive, Rochester, New York 14623. RIT is an Affirmative Action/Equal Opportunity Employer.

Electrical Engineering Technology faculty position—Assistant/Associate professor, depending upon qualifications, beginning in September 1977, hopefully to be filled by August 1. Applicants must have a Master's degree, preferably in the area of electrical/electronic engineering. P.E. or E.I.T. qualifications are highly desired. Three to five years of relevant work experience is necessary. Teaching experience is desired. Applicants should have competencies in electrical systems, digital logic, rotating machines, circuit design, energy converters and electrical distribution. Send resume and references to Dr. D. F. Hackett, Chairman, Technology Division, Georgia Southern College, Box 8044, Statesboro, GA 30458. Affirmative action/equal opportunity employer.

Field Technical/Service Supervisor Central N.J. based employer seeking personnel with BSEE or combination of relevant lesser education and strong field service experience. Knowledge and experience required in the areas of supervised digital control systems, computer managed data acquisition networks with both electro-mechanical and solid state terminal peripheral hardware. Responsible for direction and work activities of technical field service personnel. Intimate experience and familiarity with Digital Equipment Corp. mini-computers preferred. Excellent fringe benefits. Send resumes including salary requirements to P-4918 EQUAL OPPORTUNITY EMPLOYER, Electronics

Electrical Engineering Technology Tenure track position available. (Instructor, Asst. Professor, Assoc. Professor as credentials warrant). Emphasis on solid state digital circuitry—microprocessors. At least an earned M.S. degree in EE. Send resume & credentials to Dr. J.C. Warner, Dept. of Ind. & Tech., Northern Illinois University, DeKalb, IL 60115. An Equal Opportunity Employer.

Electronics Design Engineer Sacramento Peak Observatory is seeking a highly qualified Engineer with a broad range of experience in analog, signal processing, video, computer, digital and interfacing. Work will consist of the development of circuitry related to scientific instrumentation as well as supervising the maintenance of existing equipment. This hands-on position requires hardware familiarity with a wide range of electronic devices and equipment. Salary \$19,000 and above. Send resume and salary history to: Frank A. Hegwer, Sacramento Peak Observatory, Sunspot, New Mexico 88349. AN EQUAL OPPORTUNITY EMPLOYER.

Marketing Product Supervisor

The task is to plan and implement the total marketing program in the assigned product area. Activities will involve close relationships with Engineering and Sales groups during the planning, development, and introduction of products. Close customer interaction will be required to provide in-depth applications assistance.

Your industrial marketing experience will be necessary. Technical background should include broad experience in applications of general test equipment as well as computer interface standards such as GPIB. Software knowledge is necessary. Formal education might include BSEE/CS and MBA.

Salary is open. Benefits include educational support, insurance and profit sharing programs.

Please send detailed resume and salary history to: Bill Eppick, TEKTRONIX, INC., P.O. Box 500, E76, Beaverton, Oregon 97077.

An Equal Opportunity Employer M/F.



TEKTRONIX®
committed to
technical excellence

STILL LOOKING FOR YOUR DREAM JOB?



Then be sure to check out the employment opportunities contained in ELECTRONICS' Classified Section.

Or, why not consider placing a Position Wanted ad? The cost is low (only \$1.25 per line) and the results are often rewarding. For more information call or write:

ELECTRONICS Post Office Box 900
New York, N.Y. 10020 • Phone: 212/997-2556

PRINTER ENGINEERS

Computer Peripherals, Inc., the joint venture company of Control Data Corp., NCR Corp. and ICL Ltd. is involved in a major expansion program. We have immediate openings in the following areas:

MICROPROCESS ENGINEER

Candidate will have responsibility for hardware/software design and implementation of Microprocessor techniques to peripheral computer controller devices. Applicants for this position must demonstrate experience in:

- Design and implementation of microprocessor controllers
- TTL Logic Designs on peripheral equipment
- Intel 8080 Microprocessor family or equivalent

ELECTRICAL PROJECT ENGINEER

Experience will include knowledge of microprocessor technology, power supplies, power drive circuitry. Experience directing efforts of other engineers plus technicians is essential. Experience should include budgeting, scheduling of tasks and writing of proposals and specifications.

MECHANICAL PROJECT ENGINEER

Outstanding growth opportunities exist in creative line printer development group for imaginative and creative project leader. Experience should include vibration, stress, structural, dynamic and thermal analysis of electro-mechanical equipment. Responsibilities will also include product definition and generation of product specification. Supervisory experience with engineers and technicians essential.

For all engineering positions above, BS required, MS preferred, plus 2-5 years relevant experience.

We offer competitive salaries and benefits and outstanding growth potential. Please send resume and salary requirements to: Mr. Bob Brown.



COMPUTER PERIPHERALS, INC.

1480 N. Rochester Road, Box E-16
Rochester, Michigan 48063
1-313-651-8810

An Affirmative Action Employer M/F

Non-Impact Printer Specialists

Computer Peripherals, Inc., the joint venture company of Control Data Corp., NCR Corp. and ICL Ltd. is involved in a major expansion program.

Computer Peripherals, the nation's leading band-printer manufacturer, is engaged in advanced development programs which are extending the state-of-the-art in non-impact printers. Our vigorous growth has created immediate opportunities in our Ink Jet and Electrophotographic programs for Program Managers, Project Engineers, and design and development specialists in a variety of disciplines. An advanced degree in engineering or physics or a Bachelor's degree with equivalent advanced experience is required, plus the creative ability to develop new directions in non-impact printer technology. Talk with us about growth and un-paralleled creative latitude. Your resume and salary requirement will be reviewed in confidence. Please write Mr. Bob Brown.



COMPUTER PERIPHERALS, INC.

1480 N. Rochester Road Box E-16
Rochester, Michigan 48063
1-313-651-8810

Affirmative Action Employer M/F

FREE Your dream job.

We hope you're happy in your current position, but there's always that ideal job you'd prefer if you knew about it.

That's why it makes sense to have your resume on file in the Electronics Manpower Register, a computerized data bank containing the qualifications of career-conscious ELECTRONICS readers just like yourself.

You'll benefit from nation-wide exposure to industry firms privileged to search the system, and since the computer never forgets, if you match up with their job requirements you'll be brought together in confidence.

To take advantage of this free service, mail your resume to the address below.

ELECTRONICS MANPOWER REGISTER
Post Office Box 900/New York, N.Y. 10020

LOCAL INTERVIEWS IN 1977:

Microprocessor Hardware & Software Engineers
Computer Design Engineers & Programmers
Radar & Communication Engineers
Mechanical Design & Packaging Engineers
Electro-Optics & Laser Systems Engineers
Components & Quality Engineers

Regional Consultants, Inc. is a nationwide technical search firm representing a broad base of clients serving the Electronics field.

We will be conducting interviews in all areas of the country where there are concentrations of technical talent. Our clients are willing to come to you. To meet with them and us, send your resume, including present salary and geographic preferences to:

Search Director

REGIONAL CONSULTANTS, INC.
213 W. 9th Street • Cincinnati, Ohio, 45202
(513) 579-1513

Our Clients are Equal Opportunity Employers

**MAKE YOUR
NEXT
MOVE A STEP
IN THE
RIGHT
DIRECTION**



The road to professional fulfillment can be a real jungle. We can help you find the right path. Our affiliation with

**National
Personnel
Associates®**

keeps us informed of opportunities in the ELECTRONICS industry from coast to coast as they occur. Together with over 175 associates, we offer our knowledge and expertise at no charge to you. Fees are company paid.

**BRENTWOOD PERSONNEL
ASSOCIATES**
1280 Route 46
Parsippany, New Jersey 07054
(201) 335-8700

WETERRINGS & AGNEW, INC.
425 Midtown Tower
Rochester, New York 14604
(716) 454-3888

PERSONNEL INC.
Jim Trexel
836 National Road
Wheeling, West Virginia
26003
(304) 233-3000

**ALFRED J. ALLEN
& ASSOCIATES, INC.**
999 N. Sepulveda Blvd.,
Suite 704
El Segundo, California 90245
(213) 776-6852

AVAILABILITY, INC.
Engineering Consultants
1300 N. Westshore Blvd.
Tampa, Florida 33607
(813) 872-2631

ANDERSON-TAYLOR
P.O. Box 21
Exton, Pennsylvania 19341
(215) 363-1600

BOEING **Engineers**

The Boeing Company in Seattle, Washington has immediate requirements for experienced engineers in a variety of important assignments on a wide range of products as follows:

ELECTRICAL/ELECTRONICS ENGINEERS for:

- Analog and Digital Circuits
- Antennas and Radomes
- Electronic Countermeasures
- Electrical Power Systems Design
- Electronic Packaging
- Electromagnetic Compatibility
- Flight Control Systems
- Guidance and Navigational Systems
- Ground Support Equipment
- Instrumentation Subsystems
- Micro Electronics
- Radar Systems Analysis

LOGISTIC SYSTEMS ENGINEERS for:

- Maintenance/Maintainability
- Spares
- Systems Safety
- Reliability
- Technical Publications

SOFTWARE & COMPUTING SYSTEMS ENGINEERS for:

- Computers and Displays—Design and Development
- Microprocessor Software/Firmware Design and Development
- Real-Time Operational Software Development
- Signal Processing Software Development
- Software/Computing Systems Design Analysis
- Software & Computer Testing and Evaluation
- Support Software Design and Development

SYSTEMS ENGINEERS for:

- Configuration Management
- Product Systems
- Systems Analysis
- System Configuration Development

TEST ENGINEERS for:

- Electrical/Electronic Parts
- Electrical/Electronic Testing
- Flight/Mission/Systems Testing
- Test Program Requirements and Planning
- Wiring and Connector Display

MANUFACTURING TEST ENGINEERS for:

- Analog and Digital Circuit Analysis
- Automatic Test Development
- Custom Hybrid Microcircuit Assembly and Test
- Photo-Voltaic Cell Process and Test Procedure Development
- Test Equipment and Component Design

Candidates must have U.S. citizenship and an appropriate BS degree or higher. Attractive salary, fringe benefits and moving allowances will be offered qualified candidates. And living is a pleasure in the unspoiled Northwest with its many recreational and sports activities and relaxed life-styles.

Look into these outstanding opportunities.

Send your detailed résumé now to The Boeing Company, P.O. Box 3707-LDU, Seattle, WA 98124.

An equal opportunity employer.

BOEING
Getting people together

MOS Process Manager

You will start up industry standard MOS, N Channel, CMOS, and PMOS processes in our Portland, Oregon manufacturing facility. Having set up these processes, you will be responsible for managing the sustaining operation and implementing new processes into the system.

Extensive experience in MOS process engineering and manufacturing is necessary. You should have experience managing process engineers in a research or production environment.

In support of our development and manufacturing of precision electronic instrumentation, Tektronix designs and produces custom in-house state-of-the-art MOS and bipolar linear and digital IC's. Located near Portland, Oregon we are within a two hour drive from the Cascade Mountains or Ocean Beaches. The close-by nature playgrounds and the City of Portland provide a variety of recreational and cultural interests.

Salary is open. Benefits include educational support, insurance and profit sharing programs.

Send your resume to: Roy Epperson, TEKTRONIX, INC., P.O. Box 500, E78, Beaverton, OR 97077.

An Equal Opportunity Employer M/F.

Tektronix
COMMITTED TO EXCELLENCE

POSITION WANTED

Engineering technician with 10 years hands-on experience in analog, digital, rf, prototype design or assembly and troubleshooting. Mark Worley 1710 Arizona Flint, MI 48506 (313) 785-2602.

Recent U.K. Ph.D., 26, Teaching and Engineering experience in Micro-waves hazards, components and systems; leaky waves, antennae, diversity and correlation, seeking a suitable position. Please write PW-4940, Electronics.

OVERSEAS JOBS GUIDE

Job Hunting Guide + Directory of 600 Firms. Details on job sources, resumes, taxes. US\$6.00 + 50¢ P&H (US & Canada). To foreign addresses—add \$1.50 P&H. Friar Books, Dept. EL, 8965 E Ardenale, San Gabriel, CA 91775.

WHERE DO YOU FIT?

In today's job market, that is. One way to see if you're in demand is to check the employment opportunities contained in ELECTRONICS' Classified Section.

Another way to get a reading on your value is to place a blind (box number) Position Wanted ad there. The cost is low (only \$1.25 per line) and the results are often rewarding.

For more information call or write:

ELECTRONICS

Post Office Box 900
New York, N.Y. 10020
Phone: 212/997-2556

90,000 engineers and managers for \$46.00

For only \$46.00 per inch your recruitment advertising in ELECTRONICS' Classified Section will reach 90,000 career-conscious engineers and managers as they're reading to combat job obsolescence, while they're thinking about their future and bettering themselves.

There's no charge for typesetting and free layout service is provided. For more information call or write:

ELECTRONICS Post Office Box 900
New York, N.Y. 10020 • Phone: 212/997-2556



**Would
you hire
an engineer
who
couldn't
understand
this
magazine?**

Of course not. **ELECTRONICS** is the technical publication for technical people. If they can't understand it, they can't receive it. That's why, when you're looking for qualified engineers, you should consider our Classified Section.

For only \$46.00 per inch your recruitment advertising will reach 90,000 pre-screened engineers and managers as they're reading to combat job obsolescence, while they're thinking about their future and bettering themselves.

There's no charge for typesetting and free layout service is provided.

For more information call or write:

ELECTRONICS

Post Office Box 900
New York, N.Y. 10020
Phone: 212/997-2556

ENGINEERS PROGRAMMERS

**Now is the time to join ATI
on the San Francisco Peninsula.**

Noted for excellence in the field of computer based electronics, Applied Technology offers an atmosphere of excitement, challenge and opportunity to individuals looking for career growth. Contact us immediately if you qualify:

ELECTROMAGNETIC ENGINEERING

Engineering Specialist

Position requires ability to formulate, describe and specify general aspects of a receiving subsystem (i.e., frequency ranges, sensitivity, signal-to-noise, dynamic range, effects of compression and input-output interfaces). Must be thoroughly knowledgeable in present state-of-the-art components and techniques, their limitations and applied useages. A strong background in solid state circuits is also required. Candidates must have at least 10 years' experience in receiver subsystems, with at least 2 years in MIL-E-5400 airborne ECM receiver design. MSEE or PhD desired.

Senior Engineer

Candidate will provide technical contributions in the general area of wide-frequency range ECM-related RF receivers. Must be thoroughly knowledgeable in present state-of-the-art components and techniques—their limitations and applied useages. General receiver techniques utilized will include broad band crystal video, TRF (Yig tuned), and superheterodyne. Special emphasis will be on large, dynamic range, high gained broad band RF amplifiers and mixers, and associated passive and active circuit components. Candidate should have at least 5 years' experience in receiver subsystems, with at least 2 years in MIL-E-5400 airborne ECM receiver design. Recent experience in digital processor control-led receivers will be highly desirable. Qualified candidates should have at least a BSEE.

MECHANICAL ENGINEERING

Engineering Specialists

Your experience in the areas of electronic packaging and designing of electronic hardware for aerospace applications will be utilized in the performance of mechanical design of electronic hardware and implementation into hardware practical solutions to high density (Watts per cubic inch) packaging problems. You may also be required to exercise technical supervision of other engineers and designers. Proven experience in high density packaging of electronic components for military aircraft application in accordance with MIL-E-5400 and a minimum of 5-7 years' design experience in the aerospace environment is desirable. BSME MSME and/or graduate study in thermo-analysis and computer technology highly desirable.

ADVANCED SYSTEMS SOFTWARE

Sr. Scientific Programmer

Our projects involve the programming of commercial micro and mini-computers and our own highly sophisticated family of avionics computers. Our needs are in applications programming and involve control processing, signal processing and interfacing with special purpose hardware. These software engineers will routinely use HP computer systems with disk base real time operating systems in developing programs for several types of avionics computers. You will perform hands-on computer operation during avionics systems integration. BS MS PhD in EE, Math, Physics or Computer Science plus 3-7 years' working knowledge of mini-computer assembly language required.

For consideration, please send resume with salary history and requirements to Professional Staffing, 645 Almanor Avenue, Sunnyvale, California 94086. We are an equal opportunity employer, m/f.

**Itek Applied
Technology**

A Division of Itek Corporation

Engineers and Physicists

Application Development Design Evaluation Analysis

Does the opportunity to apply your training and experience to creative engineering, advanced technology and problem solving interest you?

Would you like to work with leaders in your profession—with the support of well-equipped laboratories and prototype fabrication facilities?

If so, we in the Technology Support Division would like to discuss career opportunities with you.

Permanent positions are available in a variety of technical fields in our Components and Processes Laboratory, Developmental Products Laboratory and Advanced Technology Laboratory. Various types of academic backgrounds and levels of experience are needed in the following and in other related activities:

- Complex integrated circuits and microprocessors
- Advanced passive components
- Hybrid microelectronics
- Device physics and failure analysis
- Electronic packaging and interconnections
- High-voltage magnetics and corona
- Semiconductor device characterization
- Component part standards
- Microwave devices and assemblies
- Electronic power supplies
- Electromechanical devices and connectors
- Supplier evaluation and coordination
- Instrumentation and automated testing

Please mail your resume to us today. We promise you a prompt reply. Write Professional Employment, Hughes Aircraft Company, 11940 W. Jefferson Blvd., Culver City, CA 90230

HUGHES

HUGHES AIRCRAFT COMPANY
AEROSPACE GROUP

U.S. Citizenship Required
Equal Opportunity M. F. HC Employer

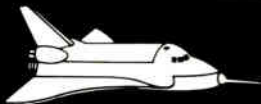

MOS/LSI TEST SYSTEMS ENGINEER

Project level responsibility to direct and coordinate all test program design, development and implementation for characterization, evaluation and production testing of MOS/LSI devices.

Prior experience must include direct work with test systems and significant involvement with circuits and logic in systems applications. A creative approach to I.C. testing along with an MSEE and knowledge of computer controlled test systems hardware will make you a preferred candidate.

If you are interested in this position, send us a resume or letter defining your particular qualifications and accomplishments. We want experience with digital circuits and logic design, the implementation of MOS circuitry into a system, test program writing and some prior project leader responsibility.

**T.F. Wade, Manager
Personnel Resources
Microelectronics Div.
NCR Corporation
8181 Byers Rd.
Miamisburg, OH 45342**

NCR

An Equal Opportunity Employer

Job-seekers... be the first to know with McGraw-Hill's Advance Job Listings

By having our weekly ADVANCE JOB LISTINGS sent to your home every Monday you can be the first to know about openings both in and out of your field. AJL will enable you to contact anxious recruitment managers BEFORE their ads appear in upcoming issues of 21 McGraw-Hill publications. To receive a free sample copy, plus information about our low subscription rates, fill out and return the coupon below.

ADVANCE JOB LISTINGS / P.O. BOX 900 / NY 10020

PLEASE SEND A SAMPLE COPY
OF ADVANCE JOB LISTINGS TO

NAME _____

ADDRESS _____

CITY _____

STATE/ZIP _____

Two unique reasons why Hughes can offer you a truly rewarding career in systems analysis

one Continuing responsibility throughout product development. The shaping of basic concepts is only the beginning of your contribution as a Hughes systems analysis engineer. It also includes systems and subsystems optimization, and responsibility for technical integrity of the system through prototype design and development, production design and testing, and operational phases. You monitor each stage of the program, evaluating all pertinent technical information and suggestions for refinement or possible modification. Your strong involvement from start to finish, and the responsibility you have for a successful outcome, provide the kind of incentives that inspire a man's best efforts.



two "Accent on enlightenment" among technical managers. From immediate supervision to the policy forming level, Hughes managers are aware, vigorous and technically oriented. A high percentage hold advanced degrees in science and engineering—an achievement encouraged and respected at

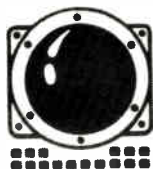

Hughes. Many present technical managers began their careers just a few years ago as Fellows in the Howard Hughes Masters

and Doctoral Fellowship programs. The resulting climate of rationality assures that your work and professional growth will be recognized and rewarded.



These policies have contributed measurably to the Hughes position of leadership in the aerospace systems industry. The company has grown rapidly from 2,000 employees in 1950 to over 35,000 in 1977. And this growth is continuing.

Hughes systems analysis is not limited to current programs. Much is directed toward the conception and development of advanced systems in electro-optics fire-control radar, lasers,



space sensors, and computer systems.

If you are a graduate of an accredited engineering university, are a U.S. citizen, and have acquired some applicable technical experience, we would like to acquaint you with some of our hundreds of openings.

For immediate consideration, please airmail your resume to:
Professional Employment
Hughes Aerospace Group
11940 W. Jefferson Blvd.
Culver City, California 90230



An equal opportunity M/F/HC/employer.

WE PROMISE YOU A REPLY WITHIN ONE WEEK

■ ADAC	6	‡ Eastman Kodak Company, Graphic Markets Div.	11,155	‡ Kollmorgen Corp., Photocircuits Division	149
Advanced Micro Devices	12-13	■ Electronic Development Corp.	54	■ Krohn-Hite Corp.	5
■ Ad-Vance Magnetics, Inc.	16	• Electronic Memories & Magnetics	40	Lectro Media, Ltd., Philadelphia Heritage Div.	128
• AEG Telefunken	11E	Electronic Navigation Industries	3rd cover	• Lemo SA	10E
■ Allen-Bradley	34	Elevam Electronic Tube Co., Ltd.	158	Mallory Capacitor Company	138
American Microsystems, Inc.	56-57	■ Entran Devices, Inc.	7	■ Matsuo Electric Co., Ltd.	142
■ Amp, Inc.	72-73	• Exar Integrated Systems, Inc.	53	• Mektron NV	17E
‡ Amperex Electronics, Div. No. Amer. Phillips	51	‡ Fabri-Tek, Inc.	53	■ Micro Networks	84
■ Ballantine Laboratories	2	• FEME	8E	‡ Micro Power Systems	89
‡ Baron Blakeslee	161	Figaro Engineering, Inc.	6	Mostek Corp.	68-69
• Bayer AG	23E	■ John Fluke Mfg. Co., Inc.	77,79,81	McGraw-Hill Book Co.	96
‡ Beckman Instruments, Helipot	40	‡ Galileo Electro-Optics Corporation	70-71	‡ National Connector	58
■ Bourns, Inc.	4th cover	■ General Instrument, Microelectronics	38-39	■ National Semiconductor Corp.	86-87
‡ Braemar Computer	152	■ General Instrument Corporation	159	‡ NEC Microcomputers	67
■ The Buckeye Stamping Co.	168	General Magnetics	182	Neff Corporation	150
• Burr Brown	149	■ Gould, Inc./Instrument Systems Div./T & M	131,133,135,137	• NEOHM SPA	13E
Calex Mfg., Inc.	152	■ GTE Sylvania/PMG Parts Division	91	Optron, Inc.	14
• Carlo Erba, S.P.A.	89	Heuristics	154	• Oscilloquartz	4E
■ Cherry Electrical Products	1	■ Hewlett-Packard, Electronic Products Group	17-26	■ Piher	97
• Communication Associates Inc.	11	■ Hipotronics, Inc.	140	• Philips Elcoma	64,2E,3E
Continental Rentals	8	■ Hughes Aircraft	49	• Philips TMI	18E-19E
■ Continental Specialties	148	■ ILC Data Device Corporation	45	■ Precision Monolithics, Inc.	15
■ Magnetic Components Group, Control Data Corp.	158	Ineltec	170	• Procond S.P.A.	14E
Coors Porcelain	171	Intel Memory Systems	28-29	Ramtek	146-147
• C.P. Clare International	15E	Intel—Microcomputer Components	143,145	Reliability, Inc.	152
Crown Industrial	90	Interdata, Inc.	141	Eduard Rhein	85
■ Dana Labs	163	‡ Interdesign	64	Rhone Poulenc—Chimie Fine	166
‡ Data General Corp.	37,94	International Rectifier Corp., Semi. Div.	169	• Riken Denki Co. Ltd.	16E
■ Data Precision	16,82	Interswitch	170	• Rohde & Schwarz	1E
■ Datel Systems, Inc.	165	Israel Aircraft Industries	55	Salota GmbH & Co. KG	148
■ Delevan Div., American Precision Ind.	30	■ Ithaco, Inc.	157	• Schlumberger Dept. Instruments	51
■ Digital Electronics Corporation	160	‡ Jewell Electrical Instruments	142	• S. E. Laboratories Ltd.	9E
Dusseldorfer Messgesellschaft mbH—NOWEA	134	■ Johanson Manufacturing Corp.	80	■ Semiconductor Circuits	167

• Sternice	24E
Semtech Corporation	114
• SGS ATEs	25E-30E
• Siemens AG Munich	62
Sorensen, Div. of Raytheon	47
Spectra-Strip	31
■ Spectrol Electronics	27
■ Sprague Electric	9.61
‡ Standard Microsystems	62
■ Tansitor Electronics	153
■ Tektronix	2nd cover 32-33
Teradyne, Inc.	74
• Thomson CSF Division D.T.E.	7E
• Trio Kenwood Corporation	71
• Triplett Corporation	58
Tri Wall Containers	111
■ TRW LSI Products	125
■ Unitrode Corp., Semiconductors	92,93
Universal Instruments	95
■ Vectron Laboratories, Inc.	154
• V/O Techmasheport	12E
■ Wavetek Indiana	98
Weston Pots Div., A Div. of Sangamo	170
S. S. White Industrial Products	168
• Yokogawa Electric Works	67

Classified and employment advertising

F. J. Eberle, Manager	212-997-2557
Atomic Personnel, Inc.	172
Boeing	175
Computer Peripherals, Inc.	174
Environmental Research Inst. of Mich.	172
Gould Oceans Systems	172
Hughes Aircraft	178, 179
Itek	177
NCR	178
National Personnel	175
P'n B Consultants	172
Regional Consultants	174
Tektronix	173, 176
University of Rochester	172

■ For more information of complete product line see advertisement in the latest Electronics Buyers Guide
 * Advertisers in Electronics International
 ‡ Advertisers in Electronics domestic edition

Advertising Sales Staff

Advertising sales manager: Paul W. Reiss
 1221 Avenue of the Americas, New York, N.Y. 10020
 [212] 997-4371
Atlanta, Ga. 30309: Glen N. Dougherty
 100 Colony Square, 1175 Peachtree St., N.E.
 [404] 892-2868
Boston, Mass. 02116: Frank Mitchell
 607 Boylston St.
 [617] 262-1160
Chicago, Ill. 60611
 645 North Michigan Avenue
 Robert W. Bartlett [312] 751-3739
 Robert M. Denmead [312] 751-3738
Cleveland, Ohio 44113: William J. Boyle
 [716] 586-5040
Dallas, Texas 75201: John J. Uphues
 2001 Bryant Tower, Suite 1070
 [214] 742-1747
Denver, Colo. 80203: Harry B. Doyle, Jr.
 123 Speer Blvd. #400
 [303] 837-1010
Detroit, Michigan 48202: Robert W. Bartlett
 1400 Fisher Bldg.
 [313] 873-7410
Houston, Texas 77002: John J. Uphues
 601 Jefferson Street, Dresser Tower
 [713] 659-8381
Los Angeles, Calif. 90010: Robert J. Rielly
 Bradley K. Jones, 3200 Wilshire Blvd., South Tower
 [213] 487-1160
Minneapolis, Minn. 55435: Robert M. Denmead
 4015 W. 65th St.
 [312] 751-3738
New York, N.Y. 10020
 1221 Avenue of the Americas
 Michael J. Stoller [212] 997-3616
 Matthew T. Reseska [212] 997-3617
Philadelphia, Pa. 19102: Matthew T. Reseska
 Three Parkway
 [212] 997-3617
Pittsburgh, Pa. 15222: Matthew T. Reseska
 4 Gateway Center
 [212] 997-3617
Rochester, N.Y. 14534: William J. Boyle
 1175 Pittsford-Victor Rd., Pittsford, N.Y.
 [716] 586-5040
San Francisco, Calif. 94111: Don Farris
 Robert J. Rielly, 425 Battery Street,
 [415] 362-4600
Paris: Alain Offergeld
 17 Rue-Georges Bizet, 75116 Paris, France
 Tel: 720-73-01
Geneva: Alain Offergeld
 1 rue du Temple, Geneva, Switzerland
 Tel: 32-35-63
United Kingdom & Scandinavia: Robert Ghey
 34 Dover Street, London W1
 Tel: 01-493-1451
Scandinavia: Andrew Karnig and Assoc.
 Kungsholmsgatan 10
 112 27 Stockholm, Sweden
 Tel: 08 51 68 70 Telex: 179 51
Milan: Luigi Rancati
 1 via Baracchini, Italy
 Phone 86-90-656
Brussels: Alain Offergeld
 23 Chaussee de Wavre
 Brussels 1040, Belgium
 Tel: 13-73-95
Frankfurt/Main: Fritz Krusebecker
 Liebigstrasse 27c, Germany
 Phone 72 01 81
Tokyo: Tatsumi Katagiri, McGraw-Hill
 Publications Overseas Corporation,
 Kasumigaseki Building 2-5, 3-chome,
 Kasumigaseki, Chiyoda-Ku, Tokyo, Japan
 [581] 9811

Business Department

Thomas M. Egan
 Production Manager [212] 997-3140
Gayla Black
 Production Manager [212] 997-2044
Carol Gallagher
 Production Manager International
 [212] 997-2045
Dorothy Carter
 Production Manager Domestic
 [212] 997-2908
Frances Vallone
 Reader Service Manager
 [212] 997-6057
Electronics Buyers' Guide
H.T. Howland, General Manager
 [212] 997-6642
Regina Hera, Directory Manager
 [212] 997-2544
Gayla Black, Production Manager
 [212] 997-2044
Frances Vallone, Reader Service Manager
 [212] 997-6057
Classified and Employment Advertising
Frank Eberle, Manager
 [212] 997-2557

ELECTRONICS REPRINTS

No. of
 copies
 wanted

New reprints

- ___ R-703 Special report—memories
16 pp \$3.00
- ___ R-702 World market report 1977 24 pp
\$4.00
- ___ R-616 Special issue—technology up-
date \$4.00
- ___ R-614 Power supply choices for so-
phisticated designs 8 pp \$3.00
- ___ R-612 Fiber-optic communications
special report 24 pp \$3.00
- ___ R-610 Special report on hybrid-circuit
technology 19 pp \$3.00
- ___ R-606 Special issue—microprocessors
\$4.00
- ___ R-526 How reliable are today's compo-
nents 16 pp \$3.00

Charts

- ___ R-516 Electronic symbols \$2.00
- ___ R-213 Electromagnetic spectrum (up-
dated 1976) \$3.00
- ___ R-326 Optical spectrum (6-page report
and chart) \$3.00

Books

- ___ R-704 Thermal design in electronics
\$5.00
- ___ R-701 Applying microprocessors—
Electronics Book Series \$9.95
- ___ R-608 Basics of Data Communica-
tions—Electronics Book Series
\$12.50
- ___ R-602 Large Scale Integration—Elec-
tronics Book Series \$9.95
- ___ R-520 Microprocessors—Electronics
Book Series \$8.95
- ___ R-011 Computer-aided Design 135 pp
\$4.00
- ___ R-032 Active Filters 88 pp \$4.00
- ___ R-031 Circuit Designer's Casebook 182
pp \$5.50 (outside U.S. \$12.00)

Payment must accompany your order

Make check or money order payable to Electronics Reprints. All orders are shipped prepaid by parcel post. Allow two to three weeks for delivery.

Mail your order to:

Janice Austin
 ELECTRONICS REPRINTS
 P.O. Box 669
 Hightstown, N.J. 08520

Back issues now available:

1960 to 1969, \$5.00 each
 1970 to 1973, \$3.00 each
 1974 to 1976, \$4.00 each

SOLID STATE 3 WIRE SYNCHRO TO LINEAR D.C. CONVERTER



RESPONSE CURVE

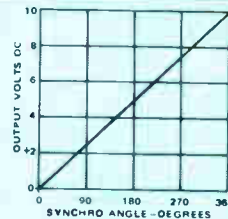
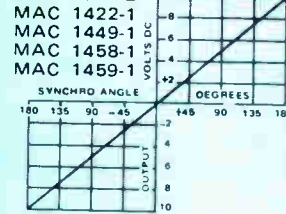

FEATURES:

- Develops a DC output voltage linearly proportional to a synchro angle over a $\pm 180^\circ$ range.
- Completely solid state with all of the inherent advantages over a mechanical system such as:
 - High reliability (since there are no moving parts)
 - Light weight—6 ozs.
 - Small size
 - All units hermetically sealed

- Wide temperature range operation
- Output short circuit protected
- Three wire inputs isolated from ground
- Package size may be altered at no extra cost
- Units can be altered to accept different line to line voltages or different operating frequencies at no extra cost
- Not affected by reference voltage or power supply variations.

UNIT	MAC 1422-1	MAC 1449-1	MAC 1458-1	MAC 1459-1	MAC 1460-1	MAC 1461-1
TRANSFER EQUATION	$\pm 1V/18^\circ$	$\pm 1V/18^\circ$	$\pm 1V/18^\circ$	$\pm 1V/18^\circ$	$+1V/36^\circ$	$+1V/36^\circ$
ACCURACY (+25°C)	½%	½%	½%	½%	½%	½%
ACCURACY (-25°C+85°C)	1%	1%	1%	1%	1%	1%
L - L SYNCHRO INPUT (VRMS)	11.8	90	11.8	90	11.8	90
FREQUENCY (Hz)	400	400	60	60	400	400
FULL SCALE OUTPUT	$\pm 10V$	$\pm 10V$	$\pm 10V$	$\pm 10V$	+10V	+10V
OUTPUT IMPEDANCE	$<1\Omega$	$<1\Omega$	$<1\Omega$	$<1\Omega$	$<1\Omega$	$<1\Omega$
L - L INPUT IMPEDANCE	$>10K$	$>30K$	$>2K$	$>10K$	$>10K$	$>30K$
REFERENCE VOLTAGE (VRMS)	26	115	26	115	26	115
OPERATING TEMP. °C	-25 - +85	-25 - +85	-25 - +85	-25 - +85	-25 - +85	-25 - +85
D.C. SUPPLY	$\pm 15V$	$\pm 15V$	$\pm 15V$	$\pm 15V$	$\pm 15V$	$\pm 15V$
D.C. SUPPLY CURRENT	$\pm 75MA$	$\pm 75MA$	$\pm 75MA$	$\pm 75MA$	$\pm 75MA$	$\pm 75MA$
BANDWIDTH	10Hz	10Hz	OPT.	OPT.	10Hz	10Hz
WEIGHT	6 oz.	6 oz.	6 oz.	8 oz.	6 oz.	6 oz.
SIZE	3.6x2.5x0.6	3.6x2.5x0.6	3.6x3.0x0.6	3.6x3.0x1.0	3.6x2.5x0.6	3.6x2.5x0.6

A.C. LINE REGULATION

A new method has been developed which allows us to provide a low distortion highly regulated AC waveform without using tuned circuits or solid state active filters of any kind.

The result is a frequency independent AC output regulated to 0.1% for line and load with greater than 20% line variations over a wide temperature range.

FEATURES:

- 0.1% total line and load regulation
- Independent of $\pm 20\%$ frequency fluctuation
- 1 watt output
- Extremely small size
- Isolation between input and output can be provided

Specifications: Model MLR 1476-1

AC Line Voltage: 26V $\pm 20\%$ @
400Hz $\pm 20\%$

Output: 26V $\pm 1\%$ for set point

Load: 0 to 40ma

Total Regulation: +0.1%

Distortion: 0.5% maximum rms

Temperature Range: $-55^\circ C$ to
 $+125^\circ C$

Size: 2.0" x 1.8" x 0.5"

Other units are available at different power and voltage levels as well as wider temperature ranges. Information will be furnished upon request.

SOLID-STATE SINE-COSINE SYNCHRO CONVERTER - NON VARIANT

This new encapsulated circuit converts a 3 wire synchro input to a pair of dc outputs proportional to the sine and cosine of the synchro angle independent of a-c line fluctuations.

- Complete solid state construction
- Operates over a wide temperature range
- Independent of reference line fluctuations
- Conversion accuracy—6 minutes
- Reference and synchro inputs isolated from ground

Specifications Model DMD 1508-2

Accuracy: Overall conversion accuracy 6 minutes. Absolute value of sine and cosine outputs accurate to $\pm 30MV$

Temperature Range: Operating $-40^\circ C$ to $+85^\circ C$, Storage $-55^\circ C$ to $+125^\circ C$

Synchro Input: 90V RMS $\pm 5\%$ LL 400Hz $\pm 5\%$

DC Power: $\pm 15V$ DC $\pm 10\%$ @ 50MA

Reference: 115VRMS $\pm 5\%$ 400Hz $\pm 5\%$

Output: 10V DC full scale output on either channel @ 5ma load

Temperature coefficient of accuracy: ± 15 seconds/ $^\circ C$ avg. on conversion accuracy ± 1 MV/ $^\circ C$ on absolute output voltages

Size: 2.0" x 1.5" x 2.5"

Units are available with wider temperature ranges and 11.8V LL, 26V reference synchro inputs. Information will be supplied upon request.

There is No Substitute for Reliability



GENERAL MAGNETICS • INC

211 Grove St., Bloomfield, New Jersey 07003 - Tel. (201) 743-2700

Circle 182 on reader service card

Electronics

Reader Service

For additional information on products advertised, new products or new literature, use these business reply cards.

Complete entire card. Please print or type.

Circle the number on the Reader Service postcard that corresponds to the number at the bottom of the advertisement, new product item, or new literature in which you are interested.

To aid the manufacturer in filling your request, please answer the three questions.

All inquiries from outside the U.S. that cannot reach Electronics before the expiration date noted on the Reader Service postcard must be mailed directly to the manufacturer. The manufacturer assumes all responsibilities for responding to inquiries.

Subscriptions & Renewals

Fill in the subscription card adjoining this card. Electronics will bill you at the address indicated on the card.

Electronics May 26, 1977 This reader service card expires August 26, 1977

NAME _____ TITLE _____

PHONE (_____) _____ COMPANY _____

STREET ADDRESS (Company or home check one) _____

CITY _____ STATE _____ ZIP _____

Was This Magazine Personally Addressed to You? Yes No

Industry classification (check one):

- | | | |
|--|--|--|
| <input type="checkbox"/> a Computer & Related Equipment | <input type="checkbox"/> e Test & Measuring Equipment | <input type="checkbox"/> j Independent R&D Organizations |
| <input type="checkbox"/> b Communications Equipment & Systems | <input type="checkbox"/> f Consumer Products | <input type="checkbox"/> k Government |
| <input type="checkbox"/> c Navigation, Guidance or Control Systems | <input type="checkbox"/> g Industrial Controls & Equipment | |
| <input type="checkbox"/> d Aerospace, Underseas Ground Support | <input type="checkbox"/> h Components & Subassemblies | |

Your design function (check each letter that applies):

- x I do electronic design or development engineering work.
 y I supervise electronic design or development engineering work.
 z I set standards for, or evaluate electronic components, systems and materials.

Your principal job responsibility (check one)

- + Management
 Engineering

Estimate number of employees (at this location): 1. under 20 2. 20-99 3. 100-999 4. over 1000

1 16 31 46	61 76 91 106	121 136 151 166	181 196 211 226	241 256 271 348	363 378 393 408	423 438 453 468	483 498 703 718
2 17 32 47	62 77 92 107	122 137 152 167	182 197 212 227	242 257 272 349	364 379 394 409	424 439 454 469	484 499 704 719
3 18 33 48	63 78 93 108	123 138 153 168	183 198 213 228	243 258 273 350	365 380 395 410	425 440 455 470	485 500 705 720
4 19 34 49	64 79 94 109	124 139 154 169	184 199 214 229	244 259 274 351	366 381 396 411	426 441 456 471	486 501 706 900
5 20 35 50	65 80 95 110	125 140 155 170	185 200 215 230	245 260 275 352	367 382 397 412	427 442 457 472	487 502 707 901
6 21 36 51	66 81 96 111	126 141 156 171	186 201 216 231	246 261 338 353	368 383 398 413	428 443 458 473	488 503 708 902
7 22 37 52	67 82 97 112	127 142 157 172	187 202 217 232	247 262 339 354	369 384 399 414	429 444 459 474	489 504 709 951
8 23 38 53	68 83 98 113	128 143 158 173	188 203 218 233	248 263 340 355	370 385 400 415	430 445 460 475	490 505 710 952
9 24 39 54	69 84 99 114	129 144 159 174	189 204 219 234	249 264 341 356	371 386 401 416	431 446 461 476	491 506 711 953
10 25 40 55	70 85 100 115	130 145 160 175	190 205 220 235	250 265 342 357	372 387 402 417	432 447 462 477	492 507 712 954
11 26 41 56	71 86 101 116	131 146 161 176	191 206 221 236	251 266 343 358	373 388 403 418	433 448 463 478	493 508 713 956
12 27 42 57	72 87 102 117	132 147 162 177	192 207 222 237	252 267 344 359	374 389 404 419	434 449 464 479	494 509 714 957
13 28 43 58	73 88 103 118	133 148 163 178	193 208 223 238	253 268 345 360	375 390 405 420	435 450 465 480	495 510 715 958
14 29 44 59	74 89 104 119	134 149 164 179	194 209 224 239	254 269 346 361	376 391 406 421	436 451 466 481	496 701 716 959
15 30 45 60	75 90 105 120	135 150 165 180	195 210 225 240	255 270 347 362	377 392 407 422	437 452 467 482	497 702 717 960

Electronics May 26, 1977 This reader service card expires August 26, 1977

NAME _____ TITLE _____

PHONE (_____) _____ COMPANY _____

STREET ADDRESS (Company or home check one) _____

CITY _____ STATE _____ ZIP _____

Was This Magazine Personally Addressed to You? Yes No

Industry classification (check one):

- | | | |
|--|--|--|
| <input type="checkbox"/> a Computer & Related Equipment | <input type="checkbox"/> e Test & Measuring Equipment | <input type="checkbox"/> j Independent R&D Organizations |
| <input type="checkbox"/> b Communications Equipment & Systems | <input type="checkbox"/> f Consumer Products | <input type="checkbox"/> k Government |
| <input type="checkbox"/> c Navigation, Guidance or Control Systems | <input type="checkbox"/> g Industrial Controls & Equipment | |
| <input type="checkbox"/> d Aerospace, Underseas Ground Support | <input type="checkbox"/> h Components & Subassemblies | |

Your design function (check each letter that applies):

- x I do electronic design or development engineering work.
 y I supervise electronic design or development engineering work.
 z I set standards for, or evaluate electronic components, systems and materials.

Your principal job responsibility (check one)

- + Management
 Engineering

Estimate number of employees (at this location): 1. under 20 2. 20-99 3. 100-999 4. over 1000

1 16 31 46	61 76 91 106	121 136 151 166	181 196 211 226	241 256 271 348	363 378 393 408	423 438 453 468	483 498 703 718
2 17 32 47	62 77 92 107	122 137 152 167	182 197 212 227	242 257 272 349	364 379 394 409	424 439 454 469	484 499 704 719
3 18 33 48	63 78 93 108	123 138 153 168	183 198 213 228	243 258 273 350	365 380 395 410	425 440 455 470	485 500 705 720
4 19 34 49	64 79 94 109	124 139 154 169	184 199 214 229	244 259 274 351	366 381 396 411	426 441 456 471	486 501 706 900
5 20 35 50	65 80 95 110	125 140 155 170	185 200 215 230	245 260 275 352	367 382 397 412	427 442 457 472	487 502 707 901
6 21 36 51	66 81 96 111	126 141 156 171	186 201 216 231	246 261 338 353	368 383 398 413	428 443 458 473	488 503 708 902
7 22 37 52	67 82 97 112	127 142 157 172	187 202 217 232	247 262 339 354	369 384 399 414	429 444 459 474	489 504 709 951
8 23 38 53	68 83 98 113	128 143 158 173	188 203 218 233	248 263 340 355	370 385 400 415	430 445 460 475	490 505 710 952
9 24 39 54	69 84 99 114	129 144 159 174	189 204 219 234	249 264 341 356	371 386 401 416	431 446 461 476	491 506 711 953
10 25 40 55	70 85 100 115	130 145 160 175	190 205 220 235	250 265 342 357	372 387 402 417	432 447 462 477	492 507 712 954
11 26 41 56	71 86 101 116	131 146 161 176	191 206 221 236	251 266 343 358	373 388 403 418	433 448 463 478	493 508 713 956
12 27 42 57	72 87 102 117	132 147 162 177	192 207 222 237	252 267 344 359	374 389 404 419	434 449 464 479	494 509 714 957
13 28 43 58	73 88 103 118	133 148 163 178	193 208 223 238	253 268 345 360	375 390 405 420	435 450 465 480	495 510 715 958
14 29 44 59	74 89 104 119	134 149 164 179	194 209 224 239	254 269 346 361	376 391 406 421	436 451 466 481	496 701 716 959
15 30 45 60	75 90 105 120	135 150 165 180	195 210 225 240	255 270 347 362	377 392 407 422	437 452 467 482	497 702 717 960

Electronics Reader Service

If the cards below have already been used,
you may obtain the needed information
by writing directly to the manufacturer,
or by sending your name and address,
plus the Reader Service number and issue date,
to Electronics Reader Service Department,
P.O. Box No. 2530, Clinton, Iowa 52732.

Affix
Postage
Here

Electronics

P.O. Box No. 2530
Clinton, Iowa 52732

Affix
Postage
Here

Electronics

P.O. Box No. 2530
Clinton, Iowa 52732

Tomorrow ideas today.



Using solid-state technology to replace bulky tube-type equipment, ENI's broadband amplifiers are tomorrow ideas available today.

ENI's Class A power amplifiers already cover the frequency spectrum of 10 kHz to 1 GHz, with power outputs ranging from 300 milliwatts to over 4000 watts. And we're still climbing. Driven by any signal generator, frequency synthesizer or sweeper, ENI's compact portable amplifiers are completely broadband and untuned. Amplifying inputs of AM, FM, SSB, TV and pulse modulations with minimum distortion, these rugged units are

versatile power sources for general laboratory work, RFI/EMI testing, signal distribution, RF transmission, laser modulation, data transmission, NMR, ultrasonics and more.

Designed to be unconditionally stable and failsafe (impervious to severe load conditions including open or short circuit loads), ENI power amplifiers will deliver their rated power to any load, regardless of match.

For information write: ENI, 3000 Winton Rd. So., Rochester, New York 14623. Call 716-473-6900. TELEX 97-8283 ENI ROC.

ENI

World's Leader in Solid State Power Amplifiers

Circle 90 on reader service card

A New Dial Design...

... beautiful
from any angle.

Any way you look at it, there's beauty and reliability at a low cost in our new Model H-1400 turns-counting dial. From the smooth, high impact tapered plastic design . . . to the big, bold legible numbers . . . this dial will add to the aesthetics of any control panel. But, with beauty being only skin deep, we've put durable long-lasting metal inside where it counts — including the gears and set-screw thread insert. And, the price is just as attractive — only \$4.26* in production quantities!

Send today for complete technical data and discover a beautiful new angle in turns-counting dials — from Bourns, naturally! Direct or through your local distributor.

TRIMPOT PRODUCTS DIVISION, BOURNS, INC. 1200 Columbia Ave.,
Riverside, CA 92507 Phone: 714 781-5123. TWX: 910 332-1252

*Domestic U.S.A. price only, H1411, without brake.



International Marketing Offices: European Headquarters — Switzerland 042/23 22 42 • Belgium 02/218 2005 • France 01/2039633 • Germany 0711/24 29 35 • Italy 02/32 56 88 • Netherlands 70/87 44 00 • United Kingdom 01/572 6531 • Norway 2/71 18 72 • Sweden 764/20 110 • Japan 075/921 9111 • Australia 02/55-0411 03/95-9566 • Israel 77 71 15/6/7

For Immediate Application — Circle 120
or for Future Application — Circle 220