

- 114 Video-disk recorder uses photographic film
- 133 Choosing between gold- and tin-plated connector contacts
- 138 MAGIC: a computer program that analyzes and optimizes

# Electronics®



TAPPING  
SOLAR  
ENERGY

1420 WILLIAMS  
2626 CHURCHILL RD  
RALEIGH NC 27608

t. upohun

# Dialight sees a need:

(**Need:** The right switch for the right price.)

## See Dialight.

For the switch buyer, choice of function and esthetics, reliability, ease of mounting, and low cost are his prime concerns. He may need a pushbutton switch for panel, sub-panel or snap-in mounting. He may need a choice of bezels with or without barriers in black, gray, dark gray or white. He may need a legend that's positive, negative, or hidden until ener-



gized...one that's white when "off" and red, green, amber, blue or light yellow when "on"...or colored both "on" and "off." He may need a highly reliable switch proven in thousands of installations. Matching indicators with same front-of-panel appearance are also available. Obtainable from our world-wide distributor network.

The cap has a metal insert designed for proper heat dissipation. Cap is illuminated by a T-1 3/4 incandescent lamp in voltage range to 28V. Lamp can be easily replaced without special tools from front of panel.

More than 12 colors available in round, square, or rectangular shapes in six basic sizes - 1/2" to 1 1/2". Choice of engraved, hot stamped or replaceable film legends with positive or negative presentations.

Available with or without bezels. Bezel allows for simple snap in mounting. Without bezel, switch can be used for panel or sub-panel mounting.

Terminals are gold plated for oxidized free solderability, and come in choice of solder blade or pc terminations.

NOW LISTED IN UNDERWRITER'S  
RECOGNIZED COMPONENTS INDEX.



Bezels available in black, gray, dark gray or white and in round, square or rectangular shapes.

Fingertip grip simplifies insertion or replacement of pushbutton cap.

Stainless steel clips lock switch into panel on four sides. No tools or additional hardware required for installing. Panel mounting switches come with required hardware for panel or sub panel mounting.

Alternate, momentary, and snap action contacts with ratings to 5 amps. All switch contacts are gold plated for high reliability. Normally open, normally closed, and two-circuit (one N.O., and one N.C.). Totally enclosed within anodized aluminum housing. Low level and D.P.D.T. snap action, and contactless solid state switches also available.

## DIALIGHT

Dialight Corporation, A North American Philips Company • 60 Stewart Avenue, Brooklyn, N.Y. 11237 (212) 497-7600

# DIVA'S COMPUTROLLER, PDP 11, AND 3330 TYPE DISC DRIVE UNIT.

## AN INCREDIBLE MARRIAGE.

*An Episode in the True Chronicle of the DIVAS, Proudest Peripheral Family in the Computeworld.*

The computeworld stares in awe at the incredible wedding scene which has unfolded before them. The bride is minicomputer PDP 11, offspring of the illustrious maxi-computer clan, begat of Abacus. The bridegroom is DIVA COMPUTROLLER, scion of this proud, most respected peripheral family. Officiating at the ceremony is Duke DIVA Disc Drive, direct descendant of IBM compatible 3330 type disc drives.

Realizing the great impact this interfacing will have on the computeworld, our happy guests monitor the wedding with joyous solemnity.

"Mated;" Interdata 70 whirrs, "PDP 11 will have access to 100 million bytes of data on a single spindle or 200 million bytes on a dual spindle disc drive unit within an average access time of 32 msec."

"And with COMPUTROLLER providing a buffering sector, data will be transferable at the rate of 645,000 bytes/sec," marvels Nova II.

"And keep in mind," interrupts a breathless TI 980A, "that with COMPUTROLLER controlling eight drives, mini will have access to 1.6 billion 8-bit bytes of data!"

But, hush! Listen to Duke DIVA repeating those always-inspiring words: "With the data stored in me, and with provided interconnecting cables and distribution panel, I now pronounce you linked in holy matrimony."

Resounding cheers befitting the occasion arise from the crowd. "A toast! A toast! A toast!" they roar. As is the custom, the proud parents, mini processor and DIVA controller, propose the toast to the dazzling couple: "To the most splendid and significant union in all our memories."



Duke DIVA Disc Drive

Mini PDP 11

"Vive, DIVA! Vive, DIVA! Vive, DIVA!" Everyone unwinds.

But even as we listen to the clink of ceremonial glasses and the exuberant laughter, we sense an underlying sadness. Those unchosen minis — do they count for nothing now? Will they not be able to enter the world of high speed data storage/access and low cost/bit performance? And why — throughout this entire festivity — has COMPUTROLLER remained hidden under his purple robe? Is there more to

COMPUTROLLER than meets the eye? Be sure to join us for the next episode in the True Chronicle of the DIVAS when we will hear the horrendous accusation: "Bigamy! BIGAMIST!"

In the meantime, learn COMPUTROLLER'S inside story. Find out about the free implementation and training courses, the software packages, and warranties that go with each disc system. All you PDP 11 users call George Roessler at 201-544-9000 for cost and delivery information. Or write: DIVA, Inc. 607 Industrial Way West Eatontown, N.J. 07724 TWX 710-722-6645.

REGIONAL SALES OFFICES:  
CT: 203-526-3222  
CA: 415-349-3482  
Wash. DC: 703-370-5211.  
GSA CONTRACT NO. GSS-OOC-00159.





THE INDUSTRY'S BROADEST LINE OF

# COUNTER/DISPLAY CIRCUITS

**FOR COUNTERS,  
PANEL METERS  
AND OTHER  
INSTRUMENTATION**

## **AY-5-4007, A, D**

**4-DIGIT COUNTER/DISPLAY DRIVERS WITH  
FULLY SYNCHRONOUS UP/DOWN COUNTER**

**FEATURES**

High current 7-segment output drivers  
Internal oscillator  
TTL compatible  
Full four-digit counter/display driver  
Storage register

## **AY-5-4057**

**4-DIGIT COUNTER WITH  
STORAGE REGISTER AND MULTIPLEXER**

**FEATURES**

TTL compatible  
Storage register  
Multiplexed BCD output  
16-pin DIP

**FOR COUNTERS,  
PANEL METERS  
AND OTHER  
INSTRUMENTATION**

## **AY-5-3507**

**3½-DIGIT DVM CIRCUIT  
COMPLETE DIGITAL VOLTMETER LOGIC**

**FEATURES**

3½-decade display  
Direct 7-segment LED drive  
Automatic polarity detection  
Overrange indicator

**FOR DIGITAL  
VOLTMETERS**

For further information call 800-645-9247 toll free (In New York State call 516-733-3107) or write,  
General Instrument Corporation, Microelectronics, 600 West John Street, Hicksville, N.Y. 11802

# GPS GOT IT!

**GENERAL INSTRUMENT CORPORATION  
MICROELECTRONICS**





## 39 Electronics review

SOLID STATE: C-MOS on sapphire resists radiation, 39  
Low-power Schottky gets speed shot, 40  
INSTRUMENTS: Spectrum analyzer uses digital storage, 40  
COMMERCIAL ELECTRONICS: High-rise alarm thinks of everything, 42  
MEDICAL ELECTRONICS: Sound pictures used to aid the blind, 46  
COMPANIES: Motorola's MOS effort begins to pay off, 44  
INSTRUMENTS: Oscilloscope breaks writing speed record, 46  
NEWS BRIEFS: 46  
MILITARY ELECTRONICS: Monitoring system checks military net, 48  
COMPONENTS: Efficient, cheap IR detectors in the offing, 48  
INDEX OF ACTIVITY: 50  
COMPUTERS: Ship loading gets computer treatment, 52  
GOVERNMENT: Digital light meter checks OSHA specs, 54

## 62 Electronics International

JAPAN: Laserscope offers better look over, under sea, 62  
WEST GERMANY: Video recorder to debut in color, 63  
AROUND THE WORLD: 63

## 75 Probing the News

COMMUNICATIONS: AT&T thunders into digital market, 75  
AUTOMOTIVE ELECTRONICS: Enthusiasm restrained for air bags, 78  
GOVERNMENT ELECTRONICS: Military develops base security, 82  
Weather Service starts computer network, 84  
AIR TRAFFIC CONTROL: Future looks bright for DABS, 88

## 99 Technical Articles

R&D: Energy crisis spurs photovoltaic power development, 99  
CONSUMER ELECTRONICS: Video-disk system uses photo film, 114  
DESIGNER'S CASEBOOK: Two-amplifier integrator extends timing, 120  
Sure-fire ignition system safely limits engine rpm, 121  
FET-controlled op amp permits wide dynamic range, 122  
SOLID STATE: Current-steering chip upgrades d-a converter, 125  
PACKAGING & PRODUCTION: Plated tin vs gold for contacts, 133  
CIRCUIT DESIGN: Computer program optimizes linear circuits, 138  
ENGINEER'S NOTEBOOK: Evaluating  $e^x$  with constants, 142  
Chain operation for finding  $e^x$ , 142  
Counting keystrokes to get results, 143  
Evaluating logarithms by counting keystrokes, 142  
Another way to compute  $e^x$ , 144  
Computing sine and cosine with linear interpolation, 144  
Fast number conversion from any base to base 10, 146  
Calendar computations: past, present and future, 146  
Polynomial evaluation can be fast and accurate, 145

## 155 New Products

IN THE SPOTLIGHT: DIP inserter aims at low-volume users, 155  
COMMUNICATIONS: Speaker replaces bell in phone sets, 156  
INSTRUMENTS: Leak detector needs no tuning, 167  
SEMICONDUCTORS: Package boosts transistor yield, 177  
DATA HANDLING: Acquisition system samples 64 channels, 183  
PACKAGING & PRODUCTION: Laminator with rollers runs cooler, 193  
MATERIALS: 207

## Departments

Publisher's letter, 4  
Readers comment, 6  
40 years ago, 8  
People, 14  
Meetings, 30  
Electronics newsletter, 35  
Washington newsletter, 59  
Washington commentary, 60  
International newsletter, 65  
Engineers' newsletter, 148  
New literature, 212  
New books, 218

## Highlights

### The cover: What price voltage from the sun? 99

The electric power produced from sunlight by today's photovoltaic devices is astronomically expensive. But, as this Special Report shows, the energy crisis has persuaded the Japanese and U.S. governments, as well as some private firms, to fund a lot of research into improving the efficiency and lowering the costs of solar cells. Cover is by illustrator Tom Upshur.

### AT&T offers new digital service at low rate, 75

Dataphone Digital Service tariffs proposed to the FCC by Bell have competitors complaining that the data-under-voice system exploits the telephone network to the consumer's and their own disadvantage. AT&T offers arguments to the contrary.

### Video-desk system uses photographic film, 114

In a break with convention, a laser optical system has been developed that records an hour-long track of color video signals on a 12-inch disk coated with silver-halide emulsion. Recorder plus a playback unit could reach the consumer market by mid-1975.

### The best circuits are created by Magic, 138

Computer-aided design programs are becoming more powerful. One of the latest, called Magic, not only analyzes conventional and microwave linear circuits—it also adjusts component values to optimize circuit performance.

### And in the next issue . . .

Three-part article on microprocessors . . . component design with a programmable calculator . . . a CAD program for very large circuits.

EDITOR-IN-CHIEF: Kemp Anderson

EXECUTIVE EDITOR: Samuel Weber

MANAGING EDITORS: Lawrence Curran, *News*;  
Arthur Erikson, *International*

SENIOR EDITORS: John Johnsrud,  
H. Thomas Maguire, Laurence Altman  
Ray Connolly, Stephen E. Scrupski

ART DIRECTOR: Fred Sklenar

ASSOCIATE EDITORS: John N. Kessler,  
Howard Wolff, Gerald M. Walker

DEPARTMENT EDITORS

*Aerospace*: William F. Arnold  
*Circuit Design*: Lucinda Mattera  
*Communications & Microwave*:  
Stephen E. Scrupski

*Components*: Joel DuBow

*Computers*: Wallace B. Riley

*Consumer*: Gerald M. Walker

*Industrial*: Alfred Rosenblatt

*Instrumentation*: Michael J. Riezenman

*Military*: Ray Connolly

*New Products*: H. Thomas Maguire

*Packaging & Production*: Stephen E. Grossman

*Solid State*: Laurence Altman

*Special Issues*: Harry R. Karp

COPY EDITORS: Margaret Eastman,  
Everett C. Terry

ASSISTANT EDITOR: Marilyn Offenheiser

ART: Charles D. Ciatto, *Associate Director*  
Patricia Cybulski, *Assistant Director*

PRODUCTION EDITOR: Arthur C. Miller

EDITORIAL SECRETARIES: Janet Annunziata,  
Julie Gorgoglione, Penny Roberts

FIELD EDITORS

*Boston*: Gail Farrell

*Los Angeles*: Paul Franson (Mgr.)

*Midwest*: Larry Armstrong (Mgr.)

*New York*: Alfred Rosenblatt (Mgr.)

*San Francisco*: Judith Curtis

*Washington*: Ray Connolly (Mgr.),  
William F. Arnold

*Frankfurt*: John Gosch

*London*: Michael Payne

*Paris*: Arthur Erikson

*Tokyo*: Charles Cohen

McGRAW-HILL WORLD NEWS

*Director*: Ralph R. Schulz

*Bonn*: Robert Ingersoll;

*Brussels*: James Smith;

*London*: Marvin Petal;

*Milan*: Peter Hoffmann, Andrew Heath;

*Moscow*: Axel Krause;

*Paris*: Michael Johnson, Richard Shepherd;

*Stockholm*: Robert Skole;

*Tokyo*: Mike Mealey

PUBLISHER: Dan McMillan

Director of Marketing: Pierre J. Braudé

ADVERTISING SALES SERVICE MANAGER:  
Wallis Clarke

BUSINESS MANAGER: Stephen R. Weiss

CIRCULATION MANAGER: George F. Werner

MARKETING SERVICES MANAGER:  
Tomlinson Howland

RESEARCH MANAGER: Margery D. Sholes

The sun, which we indirectly tap for a good portion of our energy needs, is tantalizingly close to being a source of directly harnessable power. The sun has packed energy into growing plants—both in today's trees and the gas, oil, and coal that are legacies from bygone eras—into the water falling through hydroelectric turbines, and even into winds that pump water, grind grain, and could generate electricity.

There are schemes to make electricity from the solar-generated temperature differentials in the oceans and to convert wood, municipal wastes, and other material into gasoline. Yet the direct conversion of solar power to electricity on a large scale remains a technological frontier for electronics.

As Industrial Editor Al Rosenblatt points out in the report on photovoltaic power sources that begins on page 99, solar cells have proven out in more than a decade of satellite applications, but their costs are still two orders of magnitude too high for wide-spread terrestrial use.

It took the energy crisis to focus attention on this segment of the solar-power picture, but work already had been going on in several countries. Japan, for example, has plans to get a 1-megawatt solar cell electric-power station going by 1980.

There's a long way to go between now and then. Solar cells—be they the now-common silicon, the up-and-coming cadmium sulfide, or some yet-to-be-investigated material—have to compete with other forms of energy, especially atomic fission and fusion, for research funds. Then, too, at today's high costs, there's no mass market to bring down solar-cell prices.

But, as you'll see when you read

the article, there's a lot of work being done to move photovoltaic devices out of the electronics laboratories and onto the roofs of the world's factories and homes.

The Government goes on being one of the most important customers of the electronics industries. And the share it spends on electronic hardware to meet civilian needs is no longer as vastly outweighed by military spending as it was in the days of the Cold War.

In our Probing the News section this issue, you'll find three stories illustrating how electronic systems are helping the Government in doing all of its jobs, not just in building weapons systems.

The first story (see p. 82) deals with the Pentagon's efforts to design an electronic security system to protect its bases around the world. The project, incidentally, is drawing a lot of interest from companies that need the same kind of protection—banks, factories, and the like.

Then, on page 84, there's an article on the delivery later this month of a prototype weather forecasting office, the first step toward one of the largest computer networks ever assembled by the Government. Finally, on page 88, you'll find a status report on the FAA's air-traffic control efforts, with emphasis on a key element in the upgraded third-generation ATC program: the Discrete Address Beacon System. It would add host of automated features to existing systems—and require new ground and airborne hardware.



April 4, 1974 Volume 47, Number 7  
93,361 copies of this issue printed

Published every other Thursday by McGraw-Hill, Inc. Founder: James H. McGraw 1860-1948, Publication office 1221 Avenue of the Americas, N.Y., N.Y. 10020; second class postage paid at New York, N.Y. and additional mailing offices.

Executive, editorial, circulation and advertising addresses: Electronics, McGraw-Hill Building, 1221 Avenue of the Americas, New York, N.Y. 10020. Telephone (212) 997-1221. Teletype TWX N.Y. 710-581-5234. Cable address: MCGRAW HILL L.N.Y.

Subscriptions limited to persons with active, professional, functional responsibility in electronics technology. Publisher reserves the right to reject non-qualified requests. No subscriptions accepted without complete identification of subscriber name, title, or job function, company or organization, including product manufactured or services performed. Subscription rates: qualified subscribers in the United States and possessions, Canada, and Mexico \$9.00 one year, \$18.00 three years; all other countries \$25.00 per year, except Japan \$50.00 per year, Brazil \$40.00 per year, Australia and New Zealand \$60 per year, including air freight. Limited quota of subscriptions available at higher-than-basic rate for persons outside of field served, as follows: U.S. and possessions and Canada, \$25.00 one year; all other countries \$50.00. Single copies: United States and possessions and Canada, \$1.00; all other countries, \$1.75.

Officers of the McGraw-Hill Publications Company: John R. Emery, President; J. Elton Tuohig, Executive Vice President-Administration; Gene W. Simpson, Group Publisher-Vice President; Senior Vice Presidents: Ralph Blackburn, Circulation; Walter A. Stanbury, Editorial; John D. Hoglund, Controller; David G. Jensen, Manufacturing; Gordon L. Jones, Marketing; Jerome D. Luntz, Planning & Development.

Officers of the Corporation: Shelton Fisher, President; Wallace F. Traendly, Group President, McGraw-Hill Publications Company and McGraw-Hill Information Systems Company; Robert N. Landes, Senior Vice President and Secretary; Ralph J. Webb, Treasurer.

Title registered in U.S. Patent Office. Copyright © 1974 by McGraw-Hill, Inc. All rights reserved. The contents of this publication may not be reproduced either in whole or in part without the consent of copyright owner.

Subscribers: The publisher, upon written request to our New York office from any subscriber, agrees to refund that part of the subscription price applying to copies not yet mailed. Please send change of address notices or complaints to Fulfillment Manager; subscription orders to Circulation Manager, Electronics, at address below. Change of address notices should provide old as well as new address, including postal zip code number. If possible, attach address label from recent issue. Allow one month for change to become effective.

Postmaster: Please send form 3579 to Fulfillment Manager, Electronics, P.O. Box 430, Hightstown, N.J. 08520.

# 4 filters in 1

Model 3202 offers two independent low-pass or high-pass channels or single channel band-pass or band-reject from 20 Hz to 2 MHz.

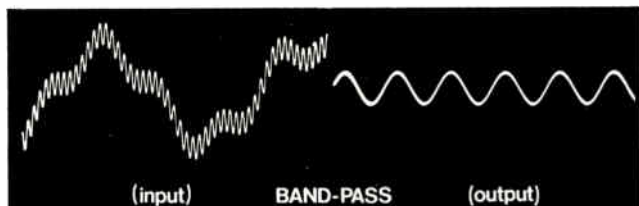
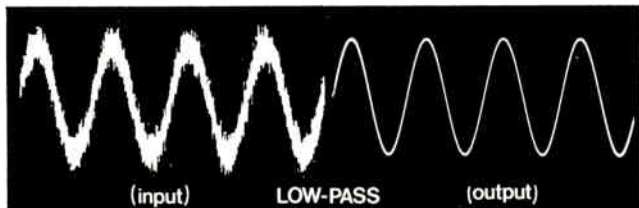

For only \$795, Model 3202 provides the flexibility essential for complex frequency or time domain measurements.

**FUNCTIONS:** Low-pass—direct coupled with low drift.  
High-pass—upper 3 dB at 10 MHz. Band-pass—continuously variable. Band-rejection—variable broad band or sharp null.

**TWO RESPONSE CHARACTERISTICS:** (1) Fourth-order Butterworth or (2) simple R-C (transient free).

**ZERO-dB INSERTION LOSS:** All-silicon amplifiers provide unity gain passband response. 24 dB per octave slopes per channel extend to at least 80 dB.

**90-dB DYNAMIC RANGE:** Low hum and noise (less than 100 microvolts) eliminate costly preamplifiers.

For fast action, call the Wavemakers at: (617) 491-3211  
TWX: 710-320-6583, Krohn-Hite Corporation,  
580 Massachusetts Ave., Cambridge, Mass. 02139, U.S.A.

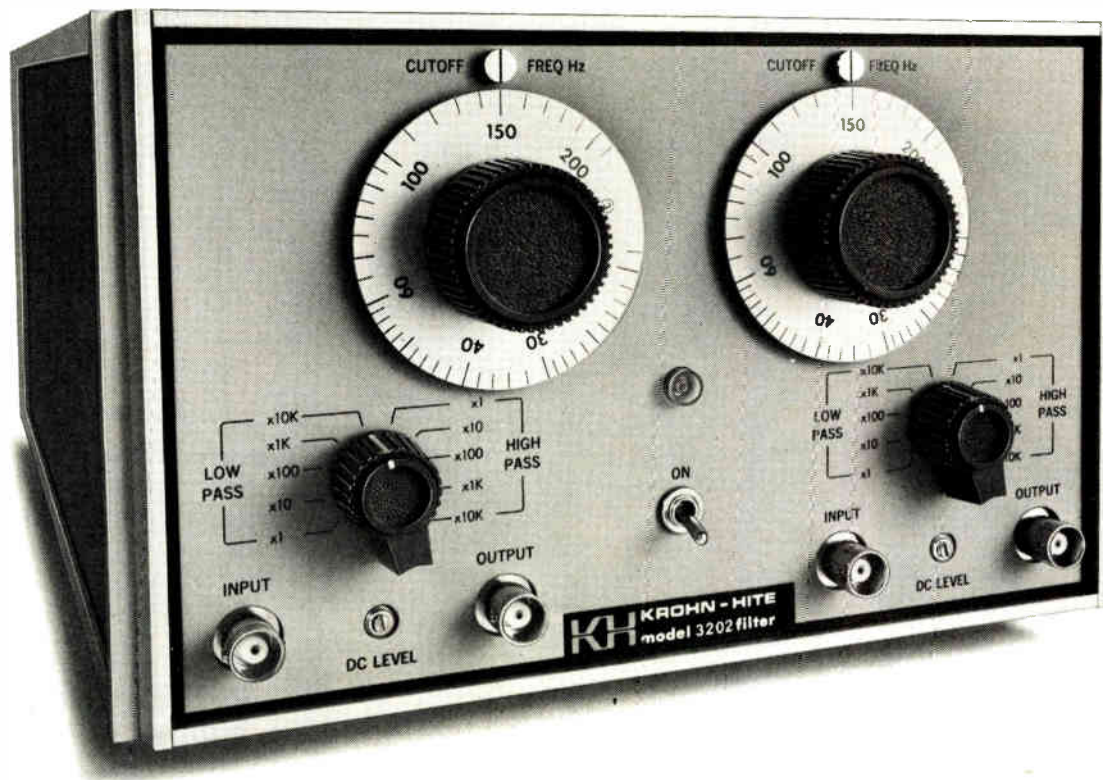

**KH KROHN-HITE CORPORATION**

SALES OFFICES: ALA., Huntsville (205) 534-9771; ARIZ., Scottsdale (602) 947-7841; CAL., Santa Clara (408) 243-2891, Inglewood (213) 674-6850; COLO., Denver (303) 934-5505; CONN., Glastonbury (203) 633-0777; FLA., Orlando (305) 894-4401; HAWAII, Honolulu (808) 941-1574; ILL., Des Plaines (312) 298-3600; INO., Indianapolis (317) 244-2456; MASS., Lexington (617) 861-8620; MICH., Detroit (313) 526-8800; MINN., Minneapolis (612) 884-4336; MO., St. Louis (314) 423-1234; N.C., Burlington (919) 227-3639; N.J., Haddonfield (609) 795-1700; N.M., Albuquerque (505) 299-7658; N.Y., E. Syracuse (315) 437-6666, Rochester (716) 328-2230, Vestal (607) 785-9947, Elmont (516) 488-2100; OHIO, Cleveland (216) 261-5440, Dayton (513) 426-5551; PA., Pittsburgh (412) 371-9449; TEX., Houston (713) 621-0040, Richardson (214) 231-2573; VA., Alexandria (703) 354-1222; WASH., Seattle (206) 624-9020; CANADA, Montreal, Quebec (514) 636-0525, Toronto, Ontario (416) 444-9111, Stittsville, Ontario (613) 836-4411, Vancouver, British Columbia (604) 688-2619.



# THERMISTORS

OBTAIN STATE-OF-THE-ART PERFORMANCE AT COSTS LOWER THAN YOUR PRESENT COMMERCIAL PRODUCT:

**BEADS  
PROBES  
FLAKES  
RODS  
ASSEMBLIES**

FAST RESPONSE ASSEMBLIES (TO 3ms)

HI-TEMP UNITS (TO 450°C)

SPECIAL CURVE MATCHES

0.05% TOLS. AND INTER-CHANGEABILITY

PRECISION CALIBRATIONS

DESIGNED TO MEET MIL-T-23648

**QUICK REACTION TO SPECIAL APPLICATIONS AND ASSEMBLIES!**



**THERMOMETRICS INC.**

15 JEAN PLACE  
EDISON, N.J. 08817  
(201) 548-2299

## Readers comment

### National's third quarter

**To the Editor:** In your Probing the news, "Recession? Not for U.S. electronic firms" [*Electronics*, March 21, p.65], some figures about National Semiconductor's sales and earnings were transposed.

At the time of the telephone interview, I said that we had not yet reported third-quarter earnings, but that nine-month sales from our 1973 fiscal year were \$66 million and that third-quarter sales a year ago were \$22 million. I did say that, in the first six months of fiscal 1974, our sales had equaled the previous year's figures and that that trend should continue.

As a point of record, we did not report third-quarter earnings until March 19, and they were \$52.6 million in sales, compared to \$22.8 million in the previous year, or earnings per share of 32 cents vs 7 cents a year ago. Nine-month, or 40-week, sales figures were \$153 million, compared to \$66.7 million or 92 cents a share vs 19 cents a share in 1972.

John F. Hughes  
Vice President, Finance  
National Semiconductor Corp.

### 'Plague' avoids F-15 avionics

**To the Editor:** Having been very close to the F-15 avionics program from the start of the concept formulation, I know of no cost-plagued problem for the F-15. Your report in the International Newsletter [*Electronics*, Feb. 7] is in error. It has been known for some time that the Navy F-14 has had its cost problems, but the Air Force F-15 is on schedule, within cost, and meeting performance. It is truly hard to understand why you claim F-15 avionics is cost-plagued.

Christo D. Pulos  
Lt. Col., USAF (Ret.)  
Woodland Hills, Calif.

■ *Electronics made no reference to problems of any kind with the avionics portion of the F-15 air-superiority fighter. In its newsletter examining the impact of Iran's latest order for 53 of the planes, the F-15 was identified as "price-plagued." And it is—largely because of problems in engine development and qualification that are unrelated to avionics, according*

*to the U. S. General Accounting Office and congressional committees on appropriations and armed services.*

### Matching microstrip networks

**To the Editor:** I would like to correct an error in the form in which equation 2 was presented in my article, "Microstrip matching networks can be designed fast with a Basic program" [*Electronics*, Dec. 6, 1973, p. 127]. The improper form causes an interrupt in program execution when complex impedances  $b + je$  are both pure real—i.e., where  $c = e = 0$

Equation 2 should be written in the form:

$$Z_o = \frac{[(cd+be)e + (d-b)(bd-ce) - (cd+be)c]/[d-b]^{1/2}}$$

In addition, statement 540 in the computer program should be changed to reflect the revised equation:

$$Y = \frac{((C*D+B*E)*E + (D-B)*B*D - C*E - C*(C*D+B*E))/(D-B)}$$

Finally, Eq. 4 should be rewritten so that the actual strip width,  $W$ , is given by:

$$W = W_{eff} - (t/\pi)[\ln(2h/t) + 1]$$

where  $t$  is the conductor thickness in inches.

James J. Lev  
Costa Mesa, Calif.

### Cutting that speed limit

**To the Editor:** I'd like to comment on R. W. Johnson's letter [*Electronics*, Feb. 7, p. 6] in regard to his negative comments on the 55-mile-an-hour speed limit.

My own experience and that of all drivers with whom I've discussed it is that the 55-mph limit has actually smoothed the flow of freeway traffic. I have no quarrel about the existence of backward-wave phenomena, but I get the feeling that when everyone drives at 55, entry and departure are easier, partly because there is less jockeying to get into and out of the fast lane.

Lawrence W. Johnson  
Los Altos Hills, Calif.

# Now it's dual JFETs for syncopated swings.

Before rock and roll ended dancing cheek to cheek, the rhythms of foxtrots, tangos and swing brought couples together on the dance floor. Teledyne has recaptured that old togetherness in a hundred types of monolithic dual JFETs.

Monolithic duals are intertwined on the same chip so they hug the same performance curves. The JFETs stay matched over a wide range of operating conditions and temperatures. One JFET of a differential amplifier can't rock while the other JFET goes rolling in a different direction.

With Teledyne's monolithic duals you can save up to 50% over two-chip duals. And if you need variety Teledyne has more duals than a jukebox has tunes. You can get the popular 2N3954 series or SU2365A series and many more low-noise, high-gain types from the 2N5561 family. Or general-purpose couples from the 2N5196 family. And duals with very low leakage and capacitance from the 2N5906 family.

How do offset drifts of a few microvolts, CMRRs around 100 dB and leakage currents down to a picoamp sound? Then swing on over to the nearest Teledyne rep or distributor. Or phone the factory. It still takes two to tango.



 **TELEDYNE  
SEMICONDUCTOR**

1300 Terra Bella Avenue Mountain View, California 94043  
(415) 968-9241 TWX: 910-379-6494 Telex: 34-8416



From the pages of *Electronics*, April, 1934

### Better fidelity—better business!

This question of high fidelity in radio-broadcast systems—from transmitter, through all channels to receivers—needs to be looked at first of all from the purely practical business viewpoint of increasing sales volume and restoring profits to radio manufacture.

Experience in allied fields has shown that as realism and fidelity improve, the industry proffering the improved service also prospers. The motion-picture industry in an example. Introduction of sound, extending the illusion of realism, resulted in doubling the box-office response. And successively new steps in quality improvement have been taken, raising the fidelity of reproduction. Audiences now demand this high fidelity in sound-track reproduction, and no theatre manager would willingly go back to the earlier quality limits—limits which unfortunately still restrain radio.

### The FCC:

*Its make-up as outlined under the Dill and Raytheon bills now before Congress*

The provisions of these bills are parallel on the following:

- Only four commissioners to be of same political party
- Chief engineer, general counsel, etc., to receive \$9,000
- Commissioners' salaries \$10,000 each, with assistant at \$4,000
- Communications Commission to render annual report to Congress
- Radio division to cover broadcasting, amateurs, and mobile services
- No commissioner shall be financially interested in radio or wire services
- Telephone division to cover voice communication other than broadcasting
- Commissioners' terms seven years; removable by President for misconduct only
- Telegraph division to cover record communication by radio, wire or cable
- Seven commissioners, appointed by President, confirmed by Senate

# ECCOL<sup>®</sup> A-C CAPACITORS



for  
today's  
ecology-conscious  
world

Equipment manufacturers using capacitors with polychlorinated biphenyl impregnant are finding that some nations have prohibited the import of products containing PCB because of its toxicity and non-degradability.

To meet industry needs for capacitors without pollutants, Sprague has designed a new series of capacitors utilizing a new non-toxic, bio-degradable impregnant that exhibits essentially identical electrical performance characteristics to those of PCB. Operating life and reliability are also equivalent. Even the size of ECCOL<sup>®</sup> Capacitors is similar to previous designs, except for a slight increase in case height.

Drawn-case ECCOL<sup>®</sup> Capacitors are available in a wide range of capacitance values from 1 to 55 $\mu$ F, with four voltage ratings from 330 to 660 VAC.

**For complete technical data, write for Engineering Bulletin 4550 to Technical Literature Service, Sprague Electric Co., 35 Marshall St., North Adams, Mass. 01247.**

45P-4107



THE BROAD-LINE PRODUCER OF ELECTRONIC PARTS



2,000X (original) unretouched photomicrographs of integrated circuit. Cropping only to accommodate space limitations.

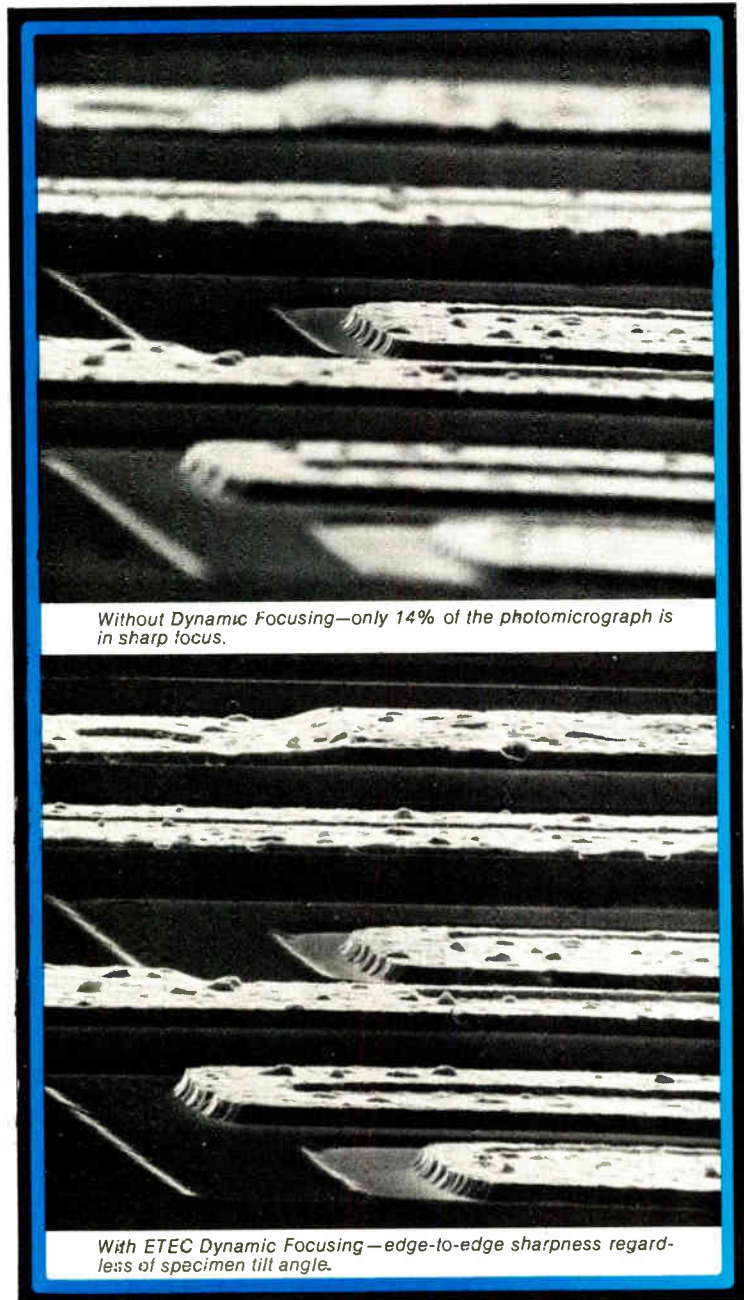

## Is your SEM a 14-Percenter?

Except for the ETEC Autoscan®, with exclusive Dynamic Focusing, **every** SEM is a 14-Percenter . . . gets only 14 percent of an exposure in sharp focus when you:

- Tilt a specimen at an 80° angle
- Set the magnification at 2,000X
- Set the working distance to 11mm
- Take the picture on a 1,000 line recording CRT

You must take **seven** exposures to equal the edge-to-edge sharpness you get with **one** photomicrograph taken on an ETEC Autoscan with Dynamic Focusing.

The split-frame photomicrographs above are proof. Both were taken by the most sophisticated SEM on the market

—the ETEC Autoscan. The photomicrograph on top was taken **without** ETEC's exclusive Dynamic Focusing system. The bottom photomicrograph was taken **with** Dynamic Focusing. Note the edge-to-edge sharpness.

Obsolescence-proof Autoscan offers still more. Now you can adapt the totally modular Autoscan to perform electron beam microfabrication of semiconductor devices and direct mask generation for experimental and production applications.



3392 Investment Blvd., Hayward, CA 94545

Telephone: (415) 783-9210

Distribution:

U. S. and territories,

Canada and Mexico—Etec Corp.

Other International Sales—Siemens, AG.

# The Am25S10.

(The S is for Simple.  
See also: Schottky, Speed,  
System Space Saving, Signal  
Processing, Shifting  
and Scaling.)

Now there's a faster, easier, more compact way to shift data. The Am25S10.

You can shift an N-bit word N places either up or down, logically, arithmetically or end around. The Am25S10 is a 4-bit shifter with three-state outputs for bus organized systems.

It has a data propagation delay of 6.5 nanoseconds.

If you want a fast reason why we're going to be the sixth largest maker of integrated circuits in the nation, try the Am25S10.

Sensational.

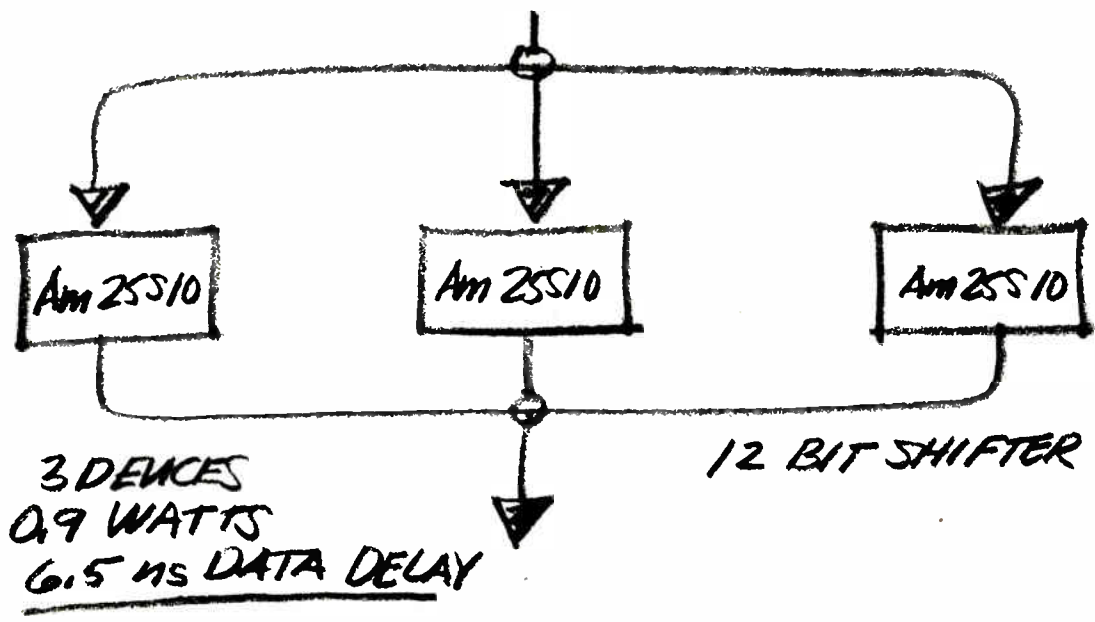
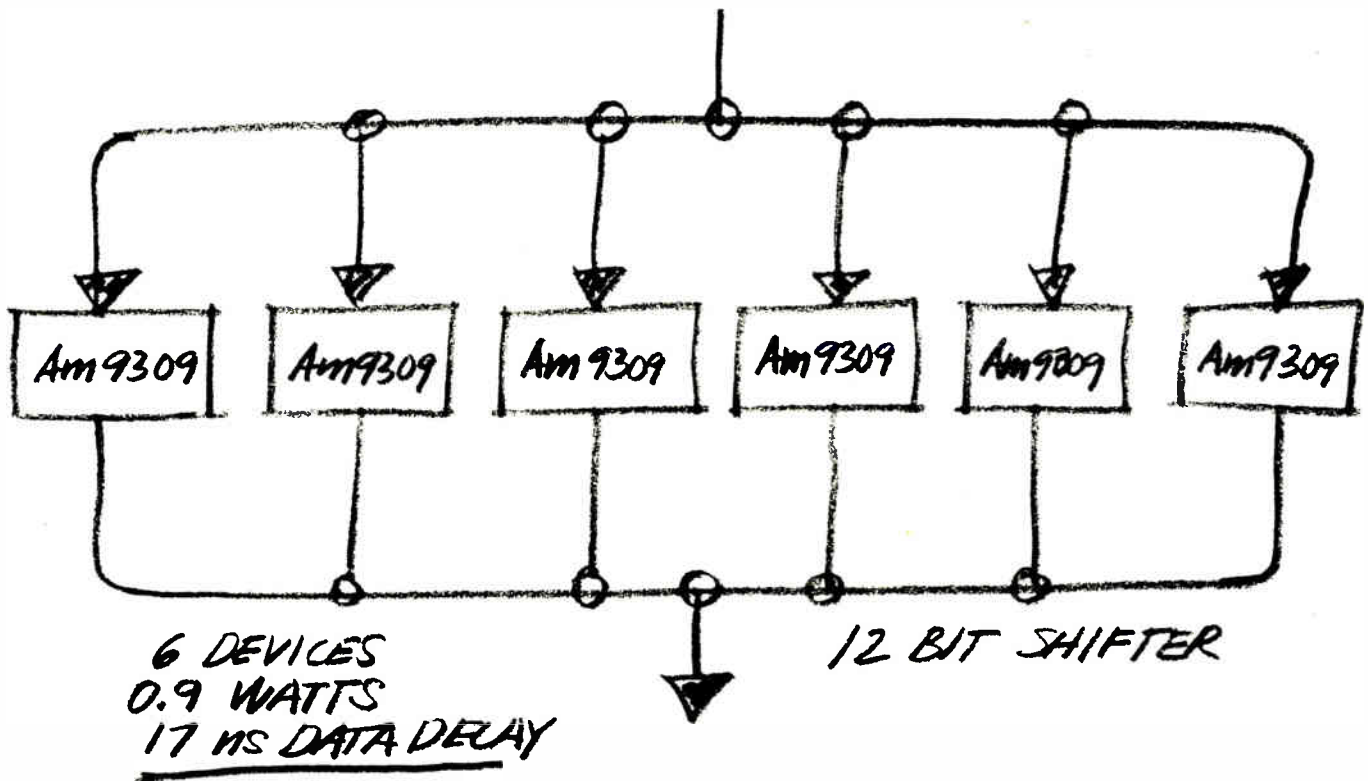

# Advanced Micro Devices

(We're going to be #6.)

Corporate offices are at 901 Thompson Place, Sunnyvale, California 94086. Telephone (408) 732-2400 / Southern California office: Beverly Hills (213) 278-9700 / Mid-America: Des Plaines, Illinois (312) 297-4115 / Edina, Minnesota (612) 835-4445 / Eastern United States: Roslyn Heights, New York (516) 484-4990 / Baltimore, Maryland (301) 744-8233 / Lexington, Massachusetts (617) 861-0606 / Britain: Advanced Micro Devices, Telephone Maidstone 52004 / West Germany: Advanced Micro Devices, Munich, Telephone (089) 53 95 88.  
Distributed nationally by Hamilton / Avnet and Cramer Electronics.



# IM6523

## New

# 256 bit CMOS RAM.

## Less than

# 0.002 $\mu$ W/bit

## standby.

### And it's so easy to use.

It's the Intersil IM6523 256 bit CMOS silicon gate RAM, a low, low power memory any designer will love working with.

It typically uses less than 2 nanowatts per bit standby and 20 microwatts per bit active power, and works from a single power supply. Supply voltage may be anything from 3 to 7 volts.



## Memories, memories everywhere

Use the IM6523 as medium speed buffer and main-frame memory in computers, calculators, point-of-sale systems, avionic systems and portable instrumentation... wherever low power consumption and simplicity of design are important.

Mount 48 of them on a board with a small battery and presto! You have a 1024 x 12 bit non-volatile memory plane with simple timing, 600nS access and 0.4 Watt power dissipation. Or use the battery-equipped memory planes for re-writable ROMs.

Send for product data and application details.

### Engineering opportunities.

Write or call John Waller, Intersil, Inc., 10900 North Tantau Ave., Cupertino, CA 95014. Phone (408) 257-5450.

# Intersil



### Intersil stocking

**distributors.** Elmar/Liberty Electronics. Schweber Electronics. Semiconductor Specialists. Weatherford.

### Intersil area sales offices.

Boston (617) 861-7380.  
Chicago (312) 371-1440.  
Los Angeles (213) 532-3544.  
Minneapolis (612) 925-1844.  
New York (201) 567-5585.  
San Diego (714) 278-6053.  
San Francisco Bay Area (home office) (408) 257-5450.  
Upstate New York (315) 463-3368.

**Representatives in all major cities.**

It's fully decoded and buffered, provides static asynchronous operation. Typical access time is 350 nanoseconds.

Packaging is in 16-pin DIPs. Price in ceramic DIPs at 100-999 quantities is \$25.60 for commercial (0° to +75°) version and \$46.00 for military (-55° to +125°C), immediately available from Intersil distributors.

# Intersil means memory

# ENI

## THE WORLD'S LEADER IN SOLID STATE POWER AMPLIFIERS

Covering the frequency spectrum of 10 kHz to 560 MHz, ENI offers a full line of solid state power amplifier models with outputs ranging from 300 milliwatts to more than 1000 watts. Capable of being driven by virtually any signal generator, frequency synthesizer or sweeper, ENI amplifiers are versatile and flexible sources of power for a wide variety of applications.

Completely broadband and untuned, these highly linear units will amplify inputs of AM, FM, SSB, TV and pulse modulations with minimum distortion. Although all power amplifiers will deliver their rated power output to a matched load, *only ENI power amplifiers will deliver their rated power to any load regardless of match.* ENI units are designed to internally absorb reflected power from a mismatched load.

Write to us for a copy of our *complete* catalog of amplifiers and power multicouplers.

### .3 WATT/MODEL 500L

- Flat 27 dB gain 2 MHz to 500 MHz
- 1.7MHz to 560MHz usable coverage
- Thin film construction
- 8dB noise figure
- Failsafe

### 40 WATT/MODEL 240L

- 20kHz to 10MHz coverage
- More than 40w linear power output
- Up to 150w CW & pulse output
- Works into any load impedance
- Metered output

### 20 WATT/MODEL 420L

- 150 kHz to 250MHz coverage
- 20 Watts power output
- Low noise figure
- 45dB  $\pm$  1.5dB gain
- Class A linearity

### 100 WATT/MODEL 3100L

- 250 kHz to 105MHz coverage
- More than 100w linear output
- Up to 180w CW & pulse
- Works into any load
- Unconditionally stable

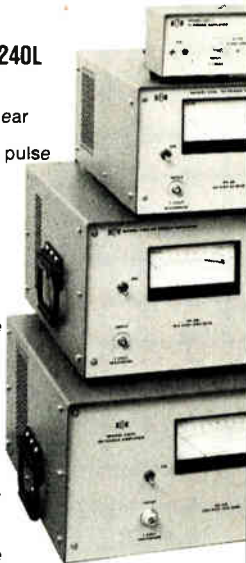

ENI, 3000 Winton Road South,  
Rochester, New York, 14623.  
Call 716-473-6900.  
Or TELEX 97-8283 ENI ROC.

## People

'Automation, yes' says  
Oak's Henderson

When the goal is to strip the labor cost from keyboard switches while keeping up quality and the question is whether to automate or to go offshore, D. Max Henderson, the new vice president of Oak Industries Inc.'s switch division, says firmly, "Automate." He should know—he's just left Taiwan where he helped run a large assembly operation.

One of his first moves at the Crystal Lake, Ill., firm has been to bring on stream a "no-hands" production assembly system for Oak's high-volume, low-profile keyboard switch, the model 415. "We automated for economies, of course," he points out, "but we couldn't assemble in a cheap labor area because reliability and repeatability are required. Automation gives us that, too."

The system will increase the firm's output of low-profile push-button switches by 300% within the year, he estimates. Designed by Oak and built by Evana Tool and Engineering Inc. of Evansville, Ind., the production module will crank out 2,000 units an hour under the supervision of a single operator who loads hoppers. In contrast, the firm's semiautomated line for the same product requires five operators for a 1,000/h yield. "Everything is tested before and after it's put together," says Henderson. "At the end of the line, it either falls in a good box or we throw it out. It's too expensive to rework."

The new switch has also opened eyes at Oak to styling and industrial design—something switch manufacturers traditionally aren't concerned with. "Since the switch is in the button, we have to supply the button," Henderson says. "Earlier, we made the switch, and someone else made the push button."

The current digital fad has a lot to do with switching concepts, Henderson says. "There's certainly a definite indication that the world is going to push buttons."

While improvements will certainly be made in low-profile switches for keyboards, they won't

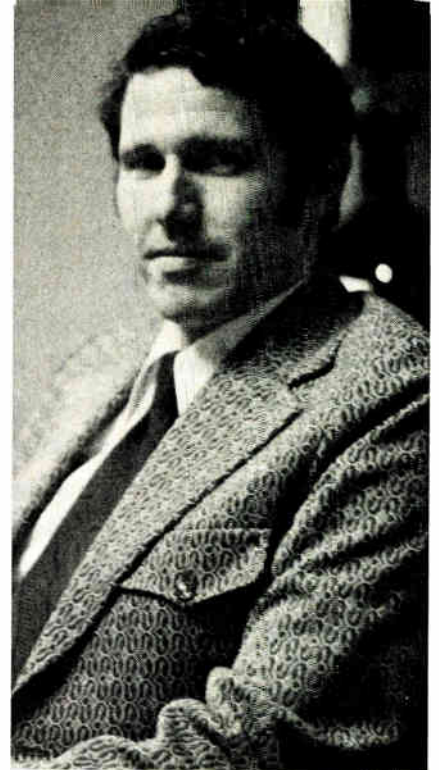

**No hands.** Automation is how to get high quality, low cost, says D. Max Henderson, Oak Industries' new vice president.

be getting smaller. "Sure, the devices are getting smaller," Henderson quips, "but your finger is staying the same size."

Henderson joined Motorola after receiving a BSEE 11 years ago from the University of Illinois. After a stint as a production engineer at the firm's Quincy, Ill., TV plant, he moved to Phoenix to become product manager for consumer ICs at Motorola's Semiconductor Products division.

## Callahan boosts Motorola's R&D

The new head of R&D at Motorola's Semiconductor Products division intends to erase the notion often circulated in industry circles that the company is not at the forefront of innovation in semiconductor technology. Michael J. Callahan, who took on the job last January, expects new developments in his area to result in significant changes, particularly in Motorola's manufacturing operation.

Callahan says that much of the work at the Phoenix, Ariz., division has been basic research into such topics as migration in thin metal



# interface- ability

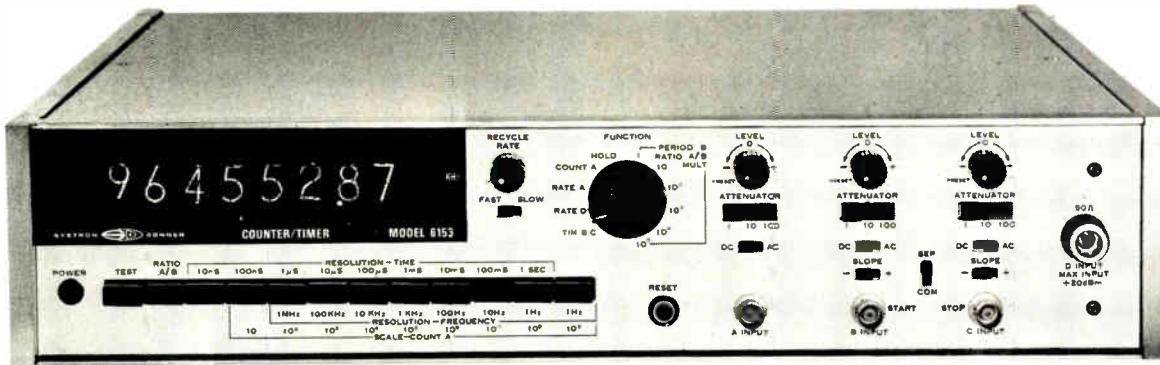
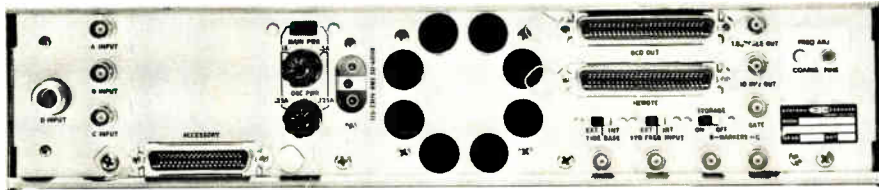

## Or why **systems people** buy more S-D counters

- 6 remote **programming** options
- 4 **BCD** outputs (low and high level)
- Special codes, formats, logic levels
- Universal counter/timer functions
- 50, 200, 512 MHz, 3 GHz

For details or a demo on series 6150 counters, call your Scientific Devices sales and service office (listed below). Or contact Concord Instruments Division, 10 Systron Drive, Concord, CA 94518. For immediate details call our Quick Reaction line (415) 682-6471 collect. In **Europe**: Systron-Donner GmbH, Munich, W. Germany; Systron-Donner Ltd., Leamington Spa, U.K.; Systron-Donner S.A. Paris (Le Port Marly) France. **Australia**: Systron-Donner Pty. Ltd., Melbourne.

SYSTRON  DONNER

Albuquerque, (505) 268-6729; Baltimore, (301) 788-6611; Boston, (617) 894-5637; Burlington, NC (919) 228-5279; Chicago, (312) 297-5240; Cleveland, (216) 261-2000; Denver, (303) 573-9466; Dayton, (513) 298-9904; Dallas, (214) 231-8106; Detroit, (313) 363-2282; Ft. Lauderdale, (305) 721-4260; Hamden CT (203) 248-9361; Huntsville, AL (205) 536-1969; Houston, (713) 623-4250; Indianapolis, (317) 783-2111; Kansas City, KS (913) 631-3818; Los Angeles, (213) 641-4800; Minneapolis, (612) 544-1616; New York City area (201) 871-3916; Norfolk, (703) 499-8133; Orlando, (305) 424-7932; Philadelphia, (215) 825-9515; Phoenix, (602) 834-1682; Rochester, NY (716) 334-2445; San Antonio, (512) 694-6251; San Diego, (714) 249-6642; San Francisco area (415) 964-4230; Seattle, (206) 454-0900; St. Louis, (314) 731-2332; Syracuse, (315) 457-7420; Washington, DC area (703) 451-6500.

When performance counts!

For a long time,  
Eastern Air Devices  
has meant  
the best  
fans and blowers  
you can get.  
That's still true  
today.

**HC EAD** Eastern Air Devices, Inc.  
Dover, N.H. 03820 • (603) 742-3330 • TWX: (510) 297-4454

Syn & Ind Motors • Gearmotors • Fans • Blowers

Circle 16 on reader service card

## People

films, but the charter of his present job is far broader.

The six laboratories he supervises include all the research at the division: materials research, electrical systems design, advanced product development, analytical labs, Micarl (the Motorola IC Applied Research Lab that performs IC work for other Motorola divisions), and advanced wafer systems. The last area holds much promise for increased productivity at the firm. "Up to now, semiconductor production lines have basically been giant laboratories," says Callahan. "We're trying to develop automated systems that turn these into true manufacturing lines."

**Smaller.** Among the parts of manufacturing that he is most interested in are crystal growing and photolithography. "IC patterns are getting smaller and smaller, and it's not clear that present exposure techniques will be satisfactory in the future. We're looking at electron-beam techniques, projection of patterns onto the wafer instead of using contact printing, and the use of soft X rays instead of light for exposing the wafers. All can offer better resolution, but none is fully developed yet."

Callahan expects these and other improvements to result in better yields, but much of his group's effort must go to deciding which of many problems to pursue most actively: "Part of the R&D job is to explore new ideas, and in some cases reject them. Most of us are used to working on gaining acceptance for new ideas, but we must learn the proper time to give up." In this, Callahan, and indeed all Motorola, is looking more and more to universities for help in basic research.

The firm is expanding its involvement with many university engineering schools, partly because of the drop in Government-funded work at companies like Motorola and partly to show students that Motorola is doing significant work. "We anticipate a shortage of talented new engineers in the future, and we want to make sure we get to them with our message," says the MIT graduate, who joined Motorola as an engineering trainee in 1962.



# MEASUREMENT COMPUTATION

innovations from Hewlett-Packard

# NEWS

APRIL, 1974

## in this issue

Lower prices for  
isolators and displays

Now, HP's dmm probe  
measures current

The most innovative  
counter of the year

## Another small miracle for engineers and scientists: the HP-65

The HP-65: a new programmable pocket-sized computer-calculator. It accepts pre-programmed magnetic cards or you can write your own programs on blank cards.

Two years ago, the HP-35 provided scientists and engineers with a revolutionary mathematical tool. Now, for the first time, Hewlett-Packard offers full programming capability in a pocket calculator. No other machine of its size and price lets you prepare and edit your own programs, then store them on magnetic cards for later use. The unique HP-65 lets you perform branching, logic comparisons, and conditional skips—sophisticated, efficient programming—over lunch, in the field, or in your home study.

The calculator has five master keys (A-E) for storing and recalling user pro-

*(continued on page 3)*





## Now, HP guarantees system specs at interface to unit-under-test

## Sampling modules extend HP 180 scopes to 18 GHz

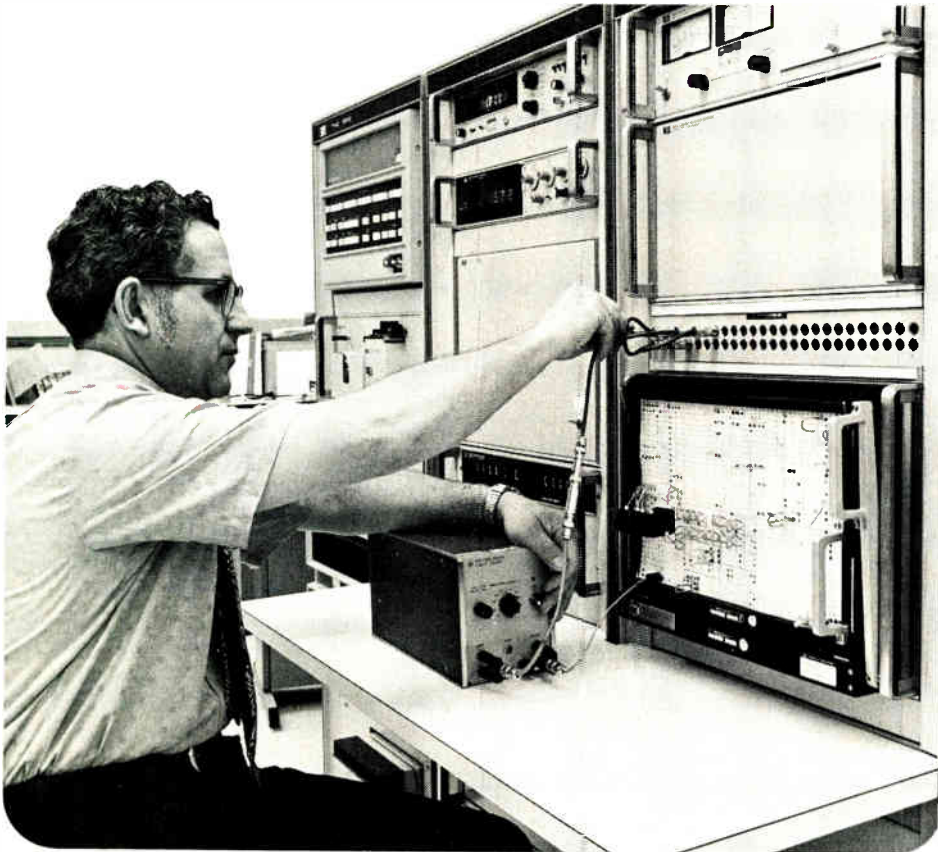

The 9510D automatic test system performs up to 400 complex tests in 4 or 5 minutes.

HP's new 9510D automatic test system is the first commercial test system *guaranteed* to meet specifications at the interface to the unit-under-test. Now you can match your requirements and pre-plan your testing facility with complete confidence; the 9510D performs each test with consistent repeatability to specified accuracy.

It's the only system with calibration initially traceable to the National Bureau of Standards. Standardization not only means reliability, but faster delivery and lower prices than custom-engineered systems.

The 9510D provides stimulus and measurement for voltage, resistance, frequency, distortion, phase, pulse digital and waveform analysis—plus RF stimulus and measurement of CW, AM and FM signals up to 500 MHz. It's designed to test electronic circuits and circuit functions, as well as sophisticated aircraft avionics, missile guidance and control, transceivers, TV receivers, satellites, navigation and communications equipment.

For specifications, check N on the HP Reply Card.

Dual-channel sampling modules for HP's 180 oscilloscopes offer qualitative and quantitative measurements of repetitive signals from dc to 18 GHz. The 1810A plug-in measures up to 1 GHz, while the 1811A module offers a choice of two sampling heads, 4 or 18 GHz. The remote sampling heads have feed-through design that allows measurements to be made using the system as a load, rather than an artificial termination in the system.

High-frequency applications include RF modulation testing, distortion and phase shift measurements up to 18 GHz. A sampling scope also displays the input vs. output of IF amplifiers to obtain gain and phase information. Fast sweep times are especially useful in nuclear laboratories for coincidence testing.

HP design improvements eliminate the need to trigger the sampling scope for modulation trapezoids. Now, you can make modulation trapezoid measurements on live transmission systems when triggering is impossible.

For details, check C on the HP Reply Card.

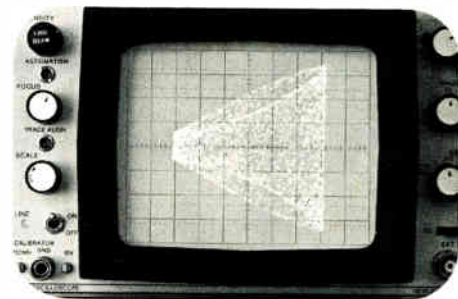

A non-triggered modulation trapezoid display of a 1 GHz carrier modulated with a 12 MHz sine wave.

## New measurement/control system can improve productivity

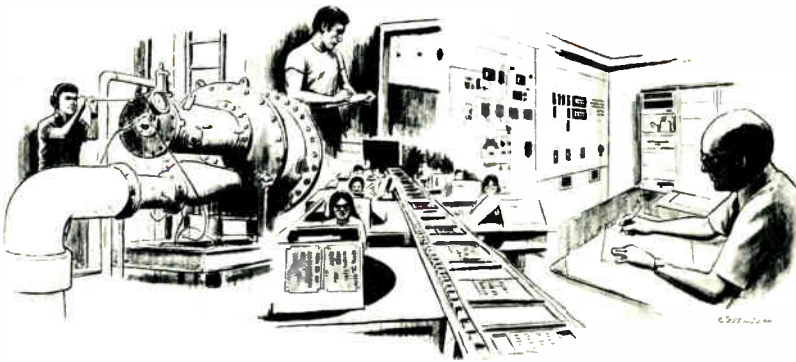

Applications for the 9610 system include: material handling, process control, information networks, and quality control.

HP's new 9610 industrial measurement and control system helps manufacturers in three important ways: it will ensure your materials are on hand, when needed, in the right quantity; it can control the manufacturing process itself; and when the job's done, the 9610 can check the quality of the finished products automatically. The system also integrates easily into a plantwide information network for management reports and data processing.

Start with a small system (12 digital I/O channels and 16 analog inputs) and expand up to 540 I/O channels and 336 analog inputs. This can be done on loca-

tion, with minimum down time. The high-speed analog subsystem has a 12-bit 45-kHz A/D converter with choice of high level and low level analog multiplexers.

Programming is done in simple HP BASIC or FORTRAN. Operating systems range from a low-cost interrupt-driven control system to a sophisticated disc-based real-time executive programmable in ALGOL and assembly language as well.

For more information, check O on the HP Reply Card.

## Spectrum analysis plug-in adds to 180 scopes

HP's economical 1500-MHz spectrum analyzer, the 8558B plug-in for 180 series oscilloscopes, has performance and operating features ideal for lab, production and field applications.

- **Three-knob operation**—For most measurements, just tune the frequency (shown on LED digital readout), select frequency span width, and set the calibrated amplitude level control. The analyzer itself takes care of sweep time and resolution (1 kHz to 3 MHz).

- **Accuracy**—The 8558B offers  $\pm 1$  dB frequency response and  $\pm 5$  MHz frequency accuracy plus  $> 70$  dB distortion-free dynamic range. This is comparable to what you'd find in analyzers costing up to twice the 8558's price.

- **Versatility**—Because the 8558B is part of the HP 180 scope family, you can combine its frequency-domain capabilities with the many time-domain plug-ins available.

For more information, check M on the HP Reply Card.

(continued from page 1)

grams of up to 100 steps. The HP-65 can be programmed either from the keyboard or by inserting a tiny, pre-recorded magnetic program card. Programs entered from the keyboard can be recorded on blank cards for future use. When you no longer need the program, erase the card and use it over again.

For your convenience, prerecorded programs are available from HP for statistical, mathematical, engineering, medical and surveying applications. Additional application pacs will be offered as they are developed. All HP-65 owners also receive a free one-year subscription to the HP-65 User's Library.

By itself, the HP-65 has 51 built-in functions: standard arithmetic operations plus logarithms, square and square root, exponential, factorial, reciprocal, and trigonometric functions. You can add and subtract in degrees, minutes and seconds format. You can choose

any of three trigonometric modes—degrees, radians and grads—and convert octal-based numbers to decimal-based integers or vice versa.

There are 9 addressable memory registers that can be used for data storage or register arithmetic. The 4-register operational stack stores intermediate answers and automatically retrieves them when needed in a calculation. Answers appear on the 10-digit LED display.

Rechargeable batteries operate the 11 oz. (3 hg) calculator for approximately 3 hours. Included with the HP-65 are hard and soft carrying cases, a recharger-adaptor, user's guides, and a standard application pac.

An impressive capability at a modest price.

For more information, check A on the HP Reply Card.

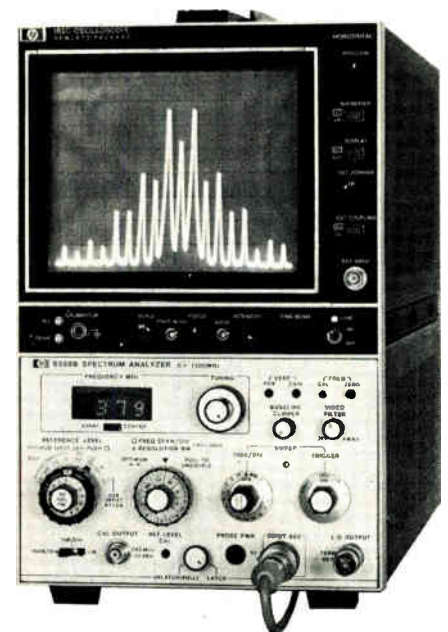

Accurate measurements are made easily with the economical 8558B spectrum analyzer (shown here in a 182C oscilloscope).



## New digital power sources for test systems

Designing a minicomputer or calculator-based test system? Then you'll need a programmable power source to generate stimulus, vary Vcc, or adjust bias potential—namely, HP's extensive line of digital voltage and current sources. More than simple D/A converters with extra power capability, the DVSs and DCSs satisfy all requirements for system use:

- Isolated digital inputs and outputs to eliminate ground loops.
- Flexible interface circuitry compatible with many programming sources.
- Internal storage of all digital input data to eliminate the need to refresh the supply.
- Programmable current or voltage limiting that protects supply and load.
- Feedback signals.
- External analog input to modulate the programmed output.

There are 5 digital voltage sources, programmable in 16-bit binary or 8421 BCD, covering an output range from  $\pm 10V$  to  $\pm 100V$  at currents up to 12.5A. Programming speed is 350  $\mu s$ . Two digital current sources are available: model 6140A, programmable in 16-bit binary or BCD; and 6145A, programmable in BCD only.

For digital power source specifications, check J on the HP Reply Card.



The 6145A digital current source has 200  $\mu s$  programming speed and 1  $\mu A$  (X1 range) or 10  $\mu A$  (X10 range) output accuracy.

## Microwave power meter has new accuracy

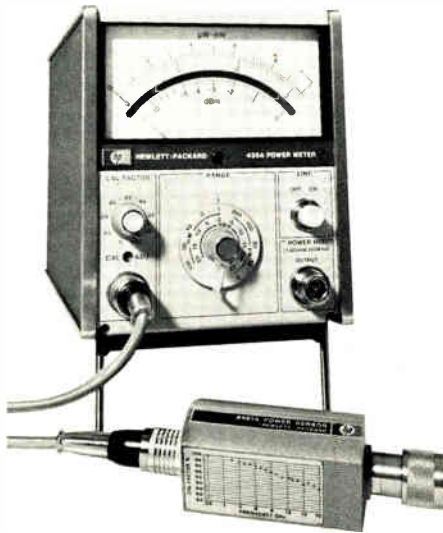

The 435A power meter's internal RF power reference provides added confidence in overall measurement accuracy.

HP's thermocouple power meter (435A meter/8481A sensor) covers wide ranges—10 MHz to 18 GHz in frequency and 0.3  $\mu W$  to 100 mW in power. It combines overall measurement accuracy with convenient operating features.

High accuracy results from the virtual elimination of mismatch uncertainties; the unique silicon-integrated thermocouple sensor has extremely low SWR ( $< 1.2$  at 30 MHz to 12.4 GHz,  $< 1.3$  from 12.4 GHz to 18 GHz). Overall system calibration can be verified anytime, anywhere, using the precise RF power reference that's built into the 435A meter.

Attractive optional features include an internal rechargeable battery pack and provision to operate the sensor up to 200 feet from the meter. The 435A/8481A accuracy can also work for you in field tests.

For more information, check F on the HP Reply Card.

## Now, prices reduced on IC troubleshooters

Now many IC troubleshooting instruments cost less, and the HP 10529A logic comparator has a new "no-cost" accessory. Price reductions affect the 10525E logic probe, 10528A logic clip, and the 5011T and 5015T kits.

The 10525E is the only logic probe with fast enough response for ECL logic. Even a 5 ns pulse causes the lamp in the probe tip to blink for 0.1 sec. The probe tip light indicates logic high, lows, open, and pulse trains.

The 10528A clips over 14 or 16-pin dual in-line DTL or TTL integrated circuits. The 16 LEDs on the clip indicate the instantaneous logic states of all the pins.

Always a low-cost way to buy IC troubleshooters, two HP kits are now even a better buy. The 5015T "mini" kit contains a logic probe, clip and pulser to stimulate your ICs in-circuit. The 5011T "maxi" kit contains the same three plus a logic comparator.

Along with each 10529A comparator, you now get a new plug-in reference board that has an IC socket and miniature switches rather than hard wiring the reference IC. You still get 10 of the old reference boards, too, for testing a specific type of IC frequently.

The new board can be ordered as a spare part (10529-60014).

For more on these lower prices, check Q on the HP Reply Card.



New plug-in reference board sets up quickly and economically for infrequently used ICs.



## Calculator-aided transformer design saves time and slashes costs



Simply input your specs (say, temperature rise, voltage and current requirements). The 9830 calculator automatically selects the fabrication parameters you need.

Designing power transformers involves using several charts, graphs and tables, plus your own intuitive feeling for each problem; selecting core material; calculating losses; determining temperature rise; and planning for the required regulation. Repeated guesstimates take time because they must be done carefully and accurately.

Now, there's a better way: add an HP 9830 programmable calculator and transformer design software to your staff. The 9830 is a powerful, computer-like calculator that is fast and easy to program in BASIC. At HP's Loveland facility, it's used for all new transformer design problems.

With the 9830 calculator and the HP-developed software, accurate trans-

former designing, quoting and specifying is performed with important reductions in time and cost. The software is user-tested: HP spent 5 years developing, using, then refining the programs.

The results? Designs that once took 4 hours (using manual techniques) now take only 15 minutes with calculator-aided design. Equally significant, only a third as many HP engineers are needed to do complex transformer designs. And turn-around time, from specification to prototype shipment, has decreased from an average 10 days to 3 days.

For more on calculator-aided design, check S on the HP Reply Card.

## New OEM disc system is fastest in its price range

Add a disc subsystem to the HP 2100A computer via a dual-channel DMA board, and you've got the HP 2123A, the fastest disc-based minicomputer system an OEM can buy.

The 2100A CPU provides 16K words of memory, memory parity, memory protect, hardware multiply/divide, and power fail/restart. The 5-megabyte disc has 30-ms access time, making the HP 2123A the fastest system available in its price range.

There's another HP exclusive: add a printed circuit board, Writable Control Store, to the 2123A system; and you have the only OEM disc system that is user-microprogrammable.

For more information, check D on the HP Reply Card.



The 2123A OEM disc-based system has a data transfer rate of over a million 16-bit words per second.

## New pulse generator works well with several logic families

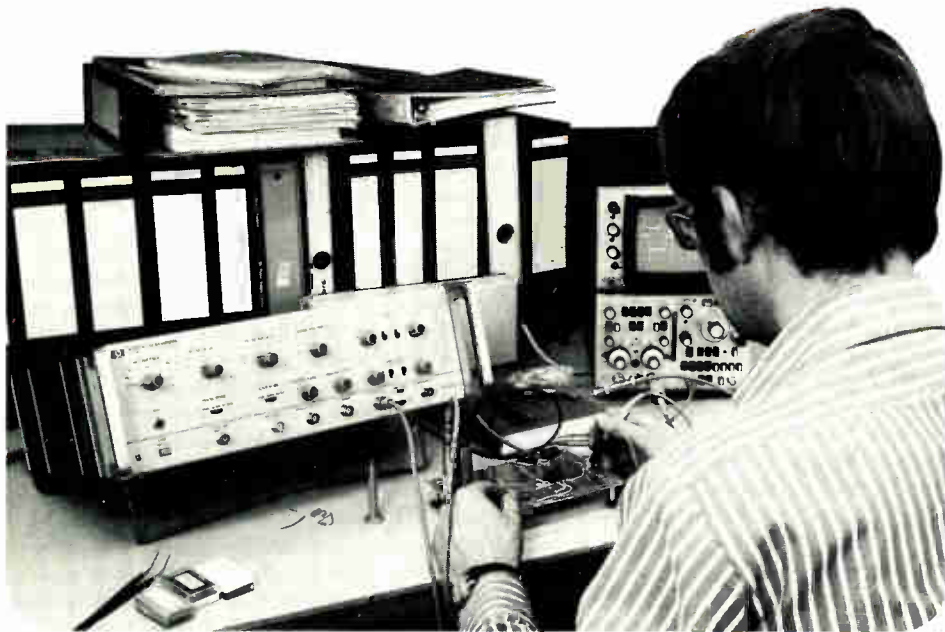

Now, test several different circuits over a full range with one easy-to-use pulse generator

Our new 20-MHz pulse generator has simultaneous +10V and -10V outputs, ample for HTL, DTL, RTL, discrete and analog circuits. The new 8005B also has a separate TTL-compatible output for testing TTL circuitry. Compared to its predecessor, the 8005A, the new generator has twice the pulse rate, twice the output, and three simultaneous outputs—all for the same price.

The normal/complement switch lets you change conveniently from posi-

tive to negative logic without readjusting offset. The 8005B has selectable output source impedance (50 $\Omega$  or current-source) and linear transition times from 10 ns to 2 sec. With a range from 0.3 Hz to 20 MHz, the pulse generator also features square-wave operation from 0.15 Hz to 10 MHz and a double-pulse mode to 10 MHz.

For the full story, check L on the HP Reply Card.

## Now, the dmm probe becomes a five-function bench instrument

Four months ago, HP introduced the 970A digital multimeter—a handheld probe that measures ac and dc voltages from .001V to 500V with automatic

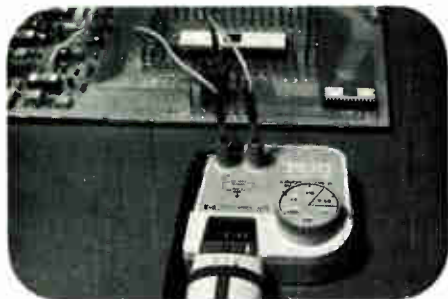

Equally handy in the field or in the lab, the 970A takes the trouble out of troubleshooting.

polarity, and resistance from .001 k $\Omega$  to 10,000 k $\Omega$ .

Now, you can convert the portable 970A into a five-function bench instrument. A new optional current shunt/bench cradle adds five ranges of ac/dc current measurement capability. Simply select a current range of 0.1 mA, 1 mA, 10 mA, 0.1 A, and 1 A. The cradle binding posts add terminal versatility: it accepts wrap-around, screw-down, clip-on or banana plug terminations. All readouts still appear on the dmm's 3 $\frac{1}{2}$  digit display.

For more on the probe and the new option, check P on the HP Reply Card.

## New measurement techniques with storage and variable persistence

High-speed signals, single-shot events, or low frequency signals are difficult, sometimes impossible, to see on a conventional oscilloscope. However, the HP 1703A portable 35-MHz storage scope captures these elusive signals with ease. Storage and variable persistence can solve many varied measurement problems.

At Four Phase Systems, a California computer company, a 1703A scope is used to detect a single-shot 100-ns command signal. The stored trace verifies that the pulse occurred at the proper time.

When IBM's instrumentation classes analyze the contact bounce of switches, they view these nonrepetitive signals with a storage scope. Capturing real-time waveforms lets the computer trainees examine this prevalent source of trouble. Thanks to fast writing speed, the 1703A displays these high-speed, single-shot signals clearly.

At the Utah Power and Light Company, the 1703A interrogates 40 remote stations sequentially. The signal from any one remote station is equivalent to measuring a low rep rate signal. Using a 1703A scope with delayed sweep, a technician isolates the desired signal, then adjusts the variable persistence to display both the master signal and the remote response. By comparing the two traces, he can determine the validity of the returned data.

For details and more information on storage applications, check B on the HP Reply Card.

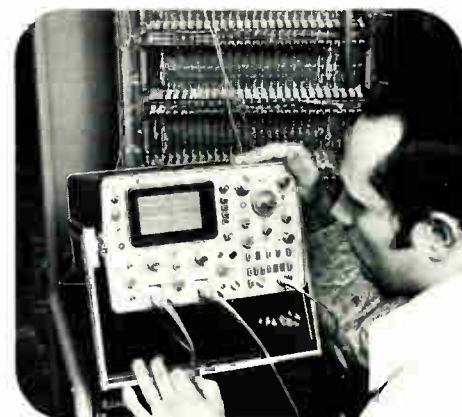

The portable 1703A scope on-site at Utah Power and Light Company.



## Now, use source cards for data entry

Save data preparation time with HP's new 7261A parallel card reader. Designed for use directly with a computer or smart terminal, this optical mark card reader accepts source documents for data entry. Thus, your initial functional set of cards—the ones you mark with ordinary pencil—can be input directly. The intermediate step of keypunching is eliminated, as well as the possibility and probability of keypunch errors.

No special marking pencils are

necessary; and yes, you can erase mistakes. You can even make notes; the card reader ignores areas used for handwritten messages. Yet, it will read marks, punched holes, and pre-printed data. Maximum feed rate is 300 cards per minute. An optional 500-card select hopper is available for operation under computer control.

For details, check K on the HP Reply Card.

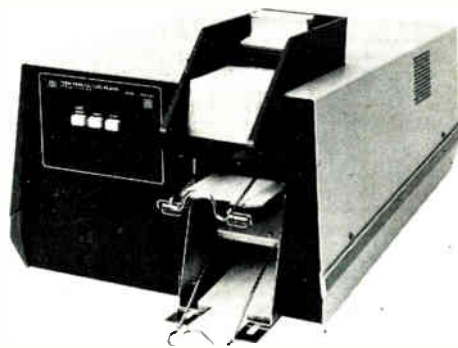

# HEWLETT-PACKARD COMPONENT NEWS

## New high-efficiency high-power IMPATTs

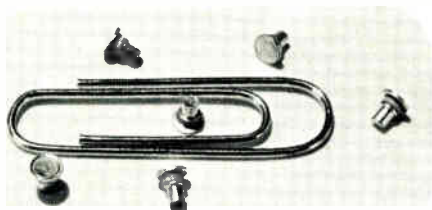

These developmental diodes have operating voltages from 100 to 143V, with operating current from 50 to 900 mA, depending upon frequency and power output.

Two new developmental silicon IMPATT diodes are now available for microwave radar and communications applications. The two pulsed units deliver peak powers of 12W at 10 GHz and 10W at 16.5 GHz. Designed for X-band and Ku-band, these double-drift diodes offer higher power and efficiency, lower junction capacitance, and lower FM noise than single-drift IMPATTs.

Two developmental CW IMPATTs, capable of 1.3 and 2.3W at 11.2 GHz, are also available for X-band oscillators and amplifiers in telecommunications applications.

For details, check R on the HP Reply Card.

## HP reduces prices of high-speed isolators

Now, you can save 22% to 40% on high-speed optically-coupled isolators. These devices combine an LED input optically-coupled with a P-N photo-diode driving a transistor. Isolation voltage is 2500V. Propagation time is only 225 ns, and bandwidth is 5 MHz. They can be direct-coupled to TTL loads at TTL speeds without additional buffers or triggers.

There are three isolators, designed for different applications. For general-purpose isolation, use the 5082-4350 with a typical dc current transfer ratio (CRT) of 11%. The 5082-4351 is a high gain device with CRT of 22% while the 5082-4352, with a CRT between 15% and 22%, is designed for critical gain control applications.

For prices and specs, check G on the HP Reply Card.

Maximum forward dc current is 20 mA; maximum forward peak current is 40 mA.

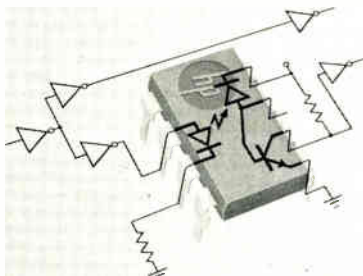

## New lower prices for hexadecimal display

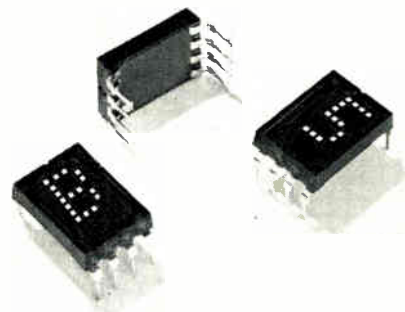

Display digits or letters with HP's low-cost hexadecimal indicators.

Now, you pay approximately 30% less for an LED display that converts binary logic to a base 16 numbering system and displays letter A-F, as well as digits 0-9. Used in computers and test instruments, this solid-state display is suitable wherever you need to show more than 10 states.

The 5082-7340 hexadecimal indicator has built-in decoder/driver and memory. The unique blanking control lets you turn off the display, and retain or change the data stored in the on-board memory. It's completely DTL and TTL compatible.

To learn more, check H on the HP Reply Card.



## New "super-counter" provides higher speed, greater resolution, and unique frequency averaging

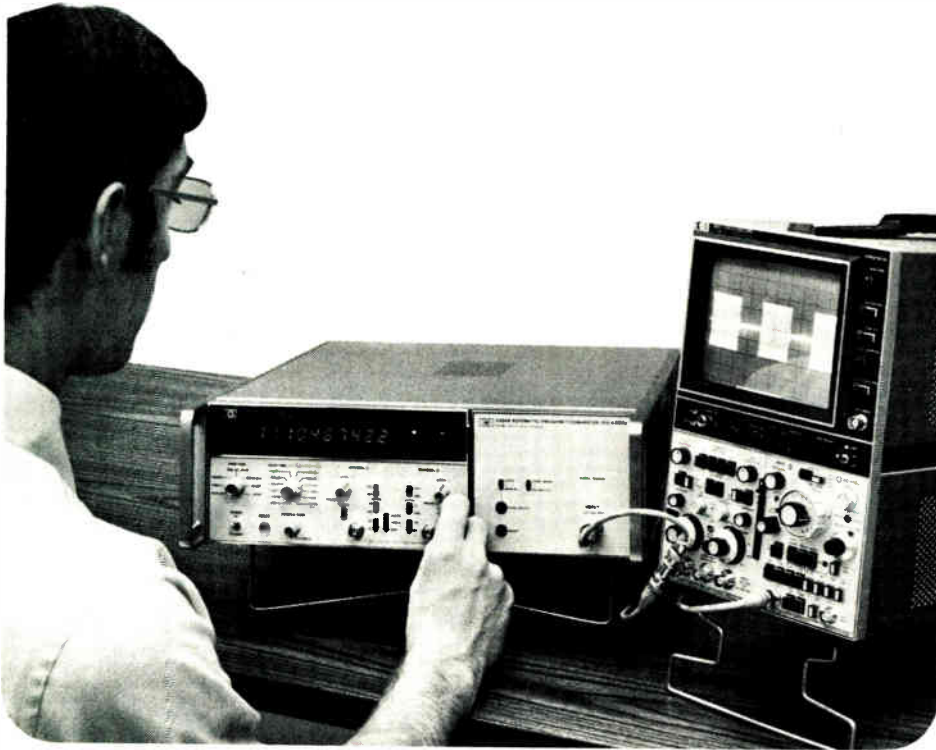

Pulsed RF and CW up to 4 GHz are measured automatically with a heterodyne converter plugged into the new counter.

Our new 5345A "super-counter" brings a quantum jump in measurement capabilities to general-purpose counters and opens new application areas.

This unique counter uses the period-measuring reciprocal-calculating technique for greater resolution in less time than conventional counters. For example, any frequency between 1 Hz and 500 MHz is displayed to 9 digits in just 1 second. Thus, for a desired resolution,

you can make hundreds more measurements in the same amount of time.

Unique input amplifiers not only give 10 mV sensitivity with switchable impedances but are also direct-coupled. Thus, the counter isn't limited to CW signals but handles non-symmetrical waveforms, random events, pulses, pulsed carriers, and time intervals.

New HP-developed sub-nanosecond digital logic ensures the counter's ac-

curacy to  $\pm 1$  clock pulse of the internal 500 MHz clock and allows gate times down to 50 ns.

Pulsed carriers can now be measured automatically, even for very narrow single-shot pulses. High-speed gating, the reciprocal technique, and a new technique known as "frequency averaging" maintain accuracy and resolution on pulses narrower than 100 ns. And plug-in modules extend automatic measurements to 4 and 18 GHz. (If you already have an HP 5245L counter, you can use the same plug-ins in the 5345A.)

Outstanding time interval capability gives resolution to 2 ns single-shot; improved time interval averaging extends into the picosecond region. External gating allows jitter to be easily characterized between any two pulses in a bit stream. Ratio measurement is more versatile than ever because you can ratio any two signals from dc to 500 MHz with full sensitivity.

System designers benefit, too, because the new counter interfaces easily with HP calculators and 2100 series computers.

*There's more. Check I on the HP Reply Card.*

**HEWLETT**  **PACKARD**

East-W 120 Century Road, Paramus, N.J. 07652,  
Ph. (201) 265-5000.

South-P.O. Box 2834, Atlanta, Ga. 30328,  
Ph. (404) 436-6181.

Midwest-5500 Howard Street, Skokie, Ill. 60076,  
Ph. (312) 677-0400.

West-3939 Lankershim Boulevard, North  
Hollywood, Calif. 91604, Ph. (213) 877-1282.

Europe-Post Office Box 85, CH-1217 Meyrin 2,  
Geneva, Switzerland, Ph. (022) 41 54 00.

Canada-6877 Gorway Drive, Mississauga,  
Ph. (416) 677-9478.

Japan-Yokogawa-Hewlett-Packard, 1-59-1,  
Yoyogi, 5hibuya-ku, Tokyo, 151.

CERAMIC  
AIR  
GLASS  
QUARTZ  
PLASTIC



## THE TRIMMER CAPACITOR YOU NEED APPEARS SOMEWHERE IN THIS SPOTLIGHT

**MORE THAN 1,000 VARIATIONS TO CHOOSE  
FROM . . . AND ERIE DELIVERS ON TIME**

When engineering and purchasing people need Trimmer Capacitors, most look to ERIE first. And for good reason. It's easy to find the trimmers they need. The price is right . . . the quality is typically ERIE . . . and they know ERIE delivers on time to meet production schedules.

ERIE Trimmer Capacitors range in size from the tiny new "Vari-Thin" 515 Ceramic Trimmer for quartz watches and other miniature circuits . . . up to a variety of larger sizes and assemblies. Whether you need ceramic, air, glass, quartz or plastic, we have the dielectric, capacitance range and mounting arrangement to meet your requirements. If you have the application . . . ERIE has the Trimmer Capacitor. In the spotlight above, can you find the Trimmer best suited to your current bread-board circuit?

Let ERIE serve as your one-stop source for quality Trimmer Capacitors.

**WRITE TODAY FOR OUR  
TRIMMER CAPACITOR  
CATALOG . . . 500  
OR CALL 814/453-5611**

**ERIE TECHNOLOGICAL PRODUCTS, INC.**  
Erie, Pennsylvania 16512

**ERIE**

Circle 27 on reader service card

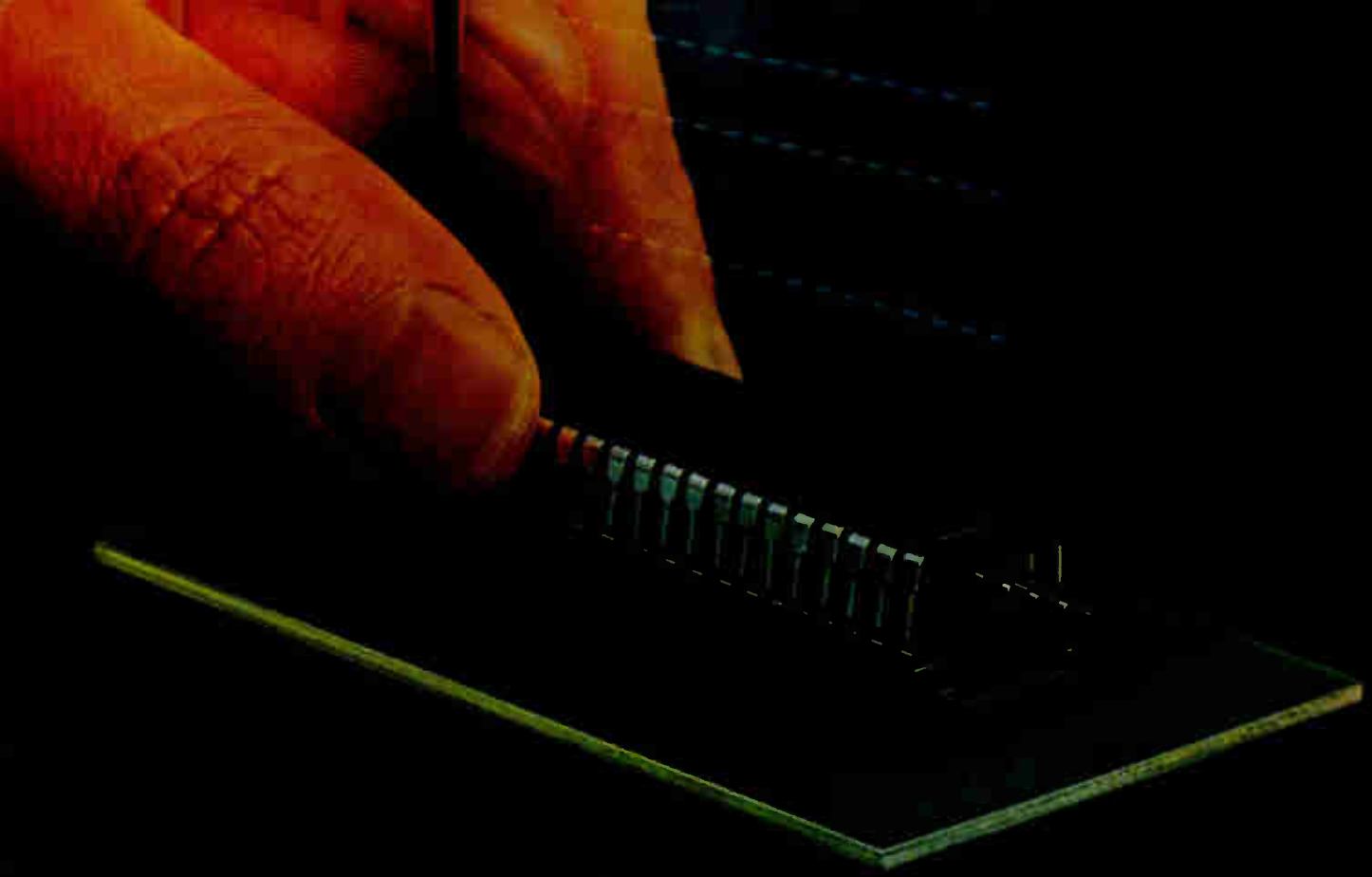

## Leadless connectors. By the lead.

They also give you low-cost, high-density packaging of MS and 3rd order substrates. They're pluggable, too.

Both AMP lines have stored-energy contacts. Just to assure you of electrically reliable, uniform connections. While the gold or tin plating gives you optimum solderability to pc boards.

You probably know of AMP's ability to give you a wide selection of leadless sizes. To satisfy virtually all your needs.

The same is true for our leaded connectors: 40-, 28- and 24-position, dual in-line configurations. Standard on .100 x .600" centers (others available). The low-profile housing provides an overall height of less than .250".

So when it comes to high-performance connectors, take our lead. Whether they're leaded or leadless. Call (717) 564-0101. Or write AMP Incorporated, Harrisburg, Pa. 17105.



# AMP

INCORPORATED

AMP is a trademark of AMP Incorporated





## If you don't go for our leaded connectors, try our leadless.

They also give you low-cost, high-density packaging of MSI and LSI substrates. They're pluggable, too.

Both AMP lines have stored-energy contacts. Just to assure you of electrically reliable, uniform connections. While the gold or tin plating gives you optimum solderability to pc boards.

You probably know of AMP's ability to give you a wide selection of leaded sizes. To satisfy virtually all your needs.

The same is true for our leadless connectors: 40-, 28- and 24-position, dual in-line configurations. Standard on .100 x .600" centers (others available). The low-profile housing provides an overall height of less than .250".

So when it comes to high-performance connectors, take our lead. Whether they're leadless or leaded. Call (717) 564-0101. Or write AMP Incorporated, Harrisburg, Pa. 17105.



# AMP

INCORPORATED

AMP is a trademark of AMP Incorporated

Circle 29 on reader service card

# YOUR SAKATA REPRESENTATIVE CAN DELIVER RESISTORS



Meet  
Jerry Snyder  
415/792-8323

## RESISTORS

carbon composition  
carbon film  
metal film  
wire wound

Faster (often out  
of stock), up to  
10% less cost

Jerry Snyder (pictured above) is the Sakata representative for California and Nevada. All of our representatives can give you faster delivery and better prices on a wide variety of top quality components. These include resistors (composition, carbon and metal film), capacitors, (ceramic disc, electrolytics), panel meters, lamps and tape heads. Write or phone for our price and delivery before you buy. Free catalog and engineering available. Delivery of many items from stock.

sakata international, inc.

312/593-3211

651 Bonnie Lane, Elk Grove Village, Illinois 60007  
resistors • capacitors • lamps • meters • tape heads

Save time, money  
with SAKATA

## Meetings

**Optical and Acoustical Micro-Electronics: IEEE, Commodore Hotel, New York, N.Y., April 16-18.**

**Carnahan Conference on Electronic Crime Countermeasures: IEEE, University of Kentucky, Lexington, April 17-19.**

**International Circuits and Systems Symposium: IEEE, Sir Francis Drake Hotel, San Francisco, Calif., April 21-24.**

**Communications Satellite Systems Conference: IEEE, International Hotel, Los Angeles, Calif., April 22-24.**

**Eurocon '74, IEEE, Amsterdam, The Netherlands, April 22-26**

**Hanover Fair, Hanover Fair Management, Hanover, Germany, April 25-May 3.**

**Electronic Components Conference, IEEE, EIA, Statler Hilton Hotel, Washington, D.C., May 13-15.**

**Pittsburgh Conference on Modeling and Simulation: ISA, University of Pittsburgh, Pa., April 24-26.**

**National Computer Conference, AFIPS/IEEE Computer Society, McCormick Place, Chicago, Ill., May 6-10.**

**International Instruments, Electronics, and Automation Exhibition, Olympia, London, England, May 13-17.**

**International Magnetism Conference (Intermag) '74, IEEE, Four Seasons Sheraton Hotel, Toronto, Canada, May 14-17.**

**Society for Information Display International Symposium, Town and Country Hotel, San Diego, Calif., May 21-23.**

**Semicon/West '74, SEMI, San Mateo Fairgrounds, San Mateo, Calif., May 21-23.**

**Power Electronics Specialists Conference, IEEE, Bell Labs., Murray Hill, New Jersey, June 10-12.**

## Your closest SIGNETICS distributor is...

### ARIZONA

Phoenix: Hamilton/Avnet Electronics (602) 275-7851  
Phoenix: Kierulff Electronics (602) 273-7331

### CALIFORNIA

Culver City: Hamilton Electro Sales (213) 870-7171  
El Segundo: Liberty Electronics (213) 322-8100  
Los Angeles: Kierulff Electronics (213) 685-9525  
Mountain View: Hamilton/Avnet Electronics (415) 961-7000  
Palo Alto: Kierulff Electronics (415) 968-6292  
San Diego: Cramer Electronics (714) 565-1881  
San Diego: Hamilton/Avnet Electronics (714) 279-2421  
San Diego: Kierulff Electronics (714) 278-2112  
Sunnyvale: Cramer Electronics (408) 739-3011

### CANADA

Downsview: Cesco Electronics (416) 661-0220  
Downsview: Cramer Electronics (416) 661-9222  
Montreal: Cesco Electronics (514) 735-5511  
Montreal: Hamilton/Avnet Electronics (514) 735-6393  
Ottawa: Cesco Electronics (613) 729-5118  
Ottawa: Hamilton/Avnet Electronics (613) 725-3071  
Quebec: Cesco Electronics (418) 524-3000  
Vancouver: Bowtek Electric Co. Ltd. (604) 736-7677

### COLORADO

Denver: Cramer Electronics (303) 758-2100  
Denver: Hamilton/Avnet Electronics (303) 534-1212

### CONNECTICUT

Hamden: Arrow Electronics (203) 248-3801  
Georgetown: Hamilton/Avnet Electronics (203) 762-0361  
North Haven: Cramer Electronics (203) 239-5641

### FLORIDA

Hollywood: Hamilton/Avnet Electronics (305) 925-5401  
Hollywood: Schweber Electronics (305) 927-0511  
Orlando: Hammond Electronics (305) 241-6601

### GEORGIA

Atlanta: Schweber Electronics (404) 449-9170  
Norcross: Hamilton/Avnet Electronics (404) 448-0800

### ILLINOIS

Elk Grove: Schweber Electronics (312) 593-2740  
Einhurst: Semiconductor Specialists (312) 279-1000  
Schiller Park: Hamilton/Avnet Electronics (312) 678-6310

### INDIANA

Indianapolis: Semiconductor Specialists (317) 243-8271

### KANSAS

Lenexa: Hamilton/Avnet Electronics (913) 888-8900

### MARYLAND

Hanover: Hamilton/Avnet Electronics (301) 796-5000  
Rockville: Pioneer Washington Electronics (301) 424-3300  
Rockville: Schweber Electronics (301) 881-2970

### MASSACHUSETTS

Burlington: Hamilton/Avnet Electronics (617) 273-2120  
Newton: Cramer Electronics (617) 959-7700  
Waltham: Schweber Electronics (617) 890-8484

### MICHIGAN

Detroit: Semiconductor Specialists, Inc. (313) 255-0300  
Livonia: Hamilton/Avnet Electronics (313) 522-4700  
Troy: Schweber Electronics (313) 583-9242

### MINNESOTA

Edina: Hamilton/Avnet Electronics (612) 941-3801  
Minneapolis: Semiconductor Specialists (612) 854-8844

### MISSOURI

Hazelwood: Hamilton/Avnet Electronics (314) 731-1144

### NEW MEXICO

Albuquerque: Hamilton/Avnet Electronics (505) 765-1500

### NEW YORK

Buffalo: Summit Distributors (716) 884-3450  
Farmingdale, L.I.: Arrow Electronics (516) 694-6800  
Rochester: Schweber Electronics (716) 328-4180  
Syracuse: Hamilton/Avnet Electronics (315) 437-2642  
Westbury: Hamilton/Avnet Electronics (516) 333-5800  
Westbury: Schweber Electronics (516) 334-7474

### NORTHERN NEW JERSEY

Cedar Grove: Hamilton/Avnet Electronics (201) 239-0800

### SADDLEBROOK: Arrow Electronics (201) 797-5800

### SOUTHERN NEW JERSEY AND PENNSYLVANIA

Cherry Hill, N.J.: Milgray-Delaware Valley (609) 424-1300  
Moorestown: Arrow/Angus Electronics (609) 235-1900  
Mt. Laurel, N.J.: Hamilton/Avnet Electronics (609) 234-2133

### CENTRAL NEW JERSEY AND PENNSYLVANIA

Somerset, N.J.: Schweber Electronics (201) 469-6008

### NORTH CAROLINA

Greensboro: Hammond Electronics (919) 275-6391

### OHIO

Beechwood: Schweber Electronics (216) 464-2970  
Dayton: Hamilton/Avnet Electronics (513) 433-0610  
Cleveland: Arrow Electronics (216) 464-2000  
Cleveland: Pioneer Standard Electronics (216) 587-3600  
Kettering: Arrow Electronics (513) 253-9176

### TEXAS

Dallas: Cramer Electronics (214) 350-1355  
Dallas: Hamilton/Avnet Electronics (214) 661-8661  
Houston: Component Specialties (713) 771-7237  
Houston: Hamilton/Avnet Electronics (713) 526-4661

### UTAH

Salt Lake City: Alta Electronics (801) 486-7227  
Salt Lake City: Hamilton/Avnet Electronics (801) 262-8451

### WASHINGTON

Bellevue: Hamilton/Avnet Electronics (206) 746-8750  
Seattle: Cramer Electronics (206) 762-5722

# JAN IC'S: NO WAIT. GREAT.

## We're organized to make life easy for JAN buyers and users.

Zing our distributors for Signetics JAN, and you'll be inundated with delivery vans—just about everything makable in 5400/54H, for instance. Demand really huge lots, and our special MILrel operation at the factory will trigger into action to amaze you with the best delivery in the industry. When your RFQ's and orders come in, they're snatched up by MILrel Marketing. RFQ's are immediately answered. Orders are immediately processed and shipped.

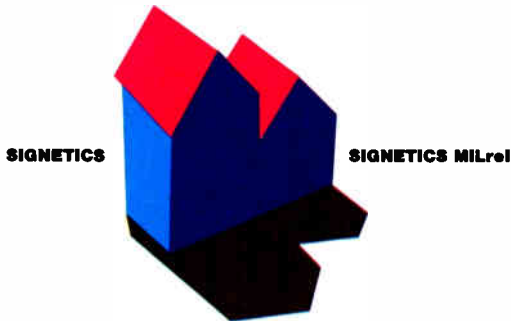

Where other suppliers jellybean JAN IC's among their commercial/industrial production, we give MILrel its own assembly and QA/QC organization within the factory. Your bonus is special attention to your order. And, when you call MILrel for a progress report, the person you talk to can finger the status right now. And keep his promises.

"Mill Run" Government source inspection lets MILrel build in quantity for stock and helps get more parts into your equipment sooner. This newest form of GSI provides in-process inspection rather than lot by lot inspection. Means we have continuous-run capability. Means you have better quality assurance, because only a dedicated production line with super-good procedures and control can be allowed Mill Run GSI. We got it, and we're the first to, in the IC business.

More firsts. First to offer the widest line in 5400/54H in the industry, so you'll have more freedom of choice. First to provide a definitive JAN IC reference (see coupon) that unscrambles the JAN/MIL/Hi-Rel mishmash of specs, certs, and terms. Get this book. It's invaluable.

Wrap it all up and it spells service in JAN IC's to you. Instant availability, wide product breadth, Mill Run GSI for faster production and deliveries, integral MILrel organization where you get the priority, first qualification on QPL slash sheets, and great product support.

Call your distributor now, for now-type needs. And send the coupon for the most definitive, helpful JAN IC handbook anywhere.



★ ★ ★ ★ ★ ★ ★ ★ ★ ★	
CLIP COUPON TO LETTERHEAD FOR FAST SERVICE	
Signetics MILrel P.O. Box 3004-10 Menlo Park, California 94025	
So JAN IC's are really big at MILrel? Okay, send me your JAN IC reference, including total product lists, and I'll see if it's as helpful as you say. My address you can get from the attached letterhead.	
Name	Title
Mail Stop	
<small>Signetics Corporation, a subsidiary of Corning Glass Works</small>	

**signetics milrel**



# More ideas from Amphenol's

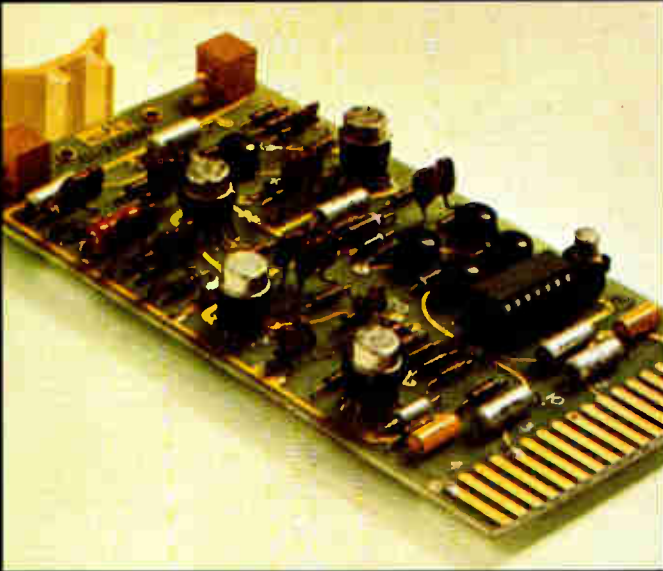

**level 1** Low-cost sockets for transistors in TO packages (above) allow easy replacement and service. ■ New IC sockets are end and side stackable for maximum single board density. Low profile design also allows maximum multi-board density.

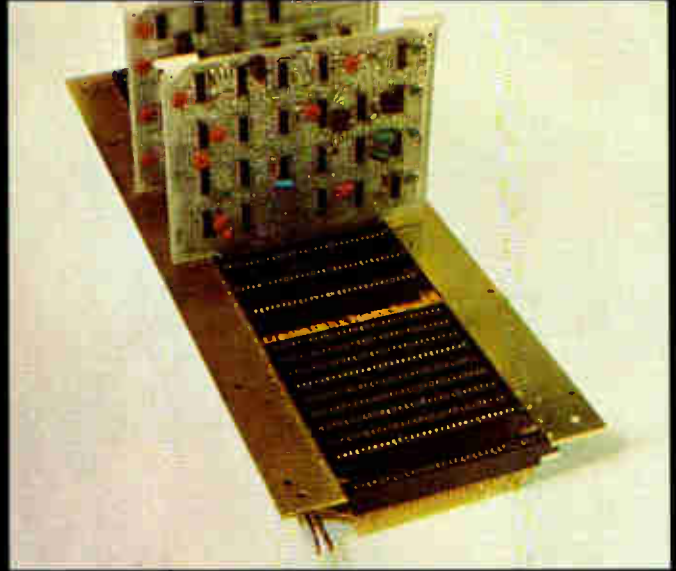

**level 2** Back panel edge board connectors with bifurcated contacts (above) can be wire wrapped or clip-terminated. ■ Bellows contact PC connectors (below) cut interconnection costs without sacrificing performance.

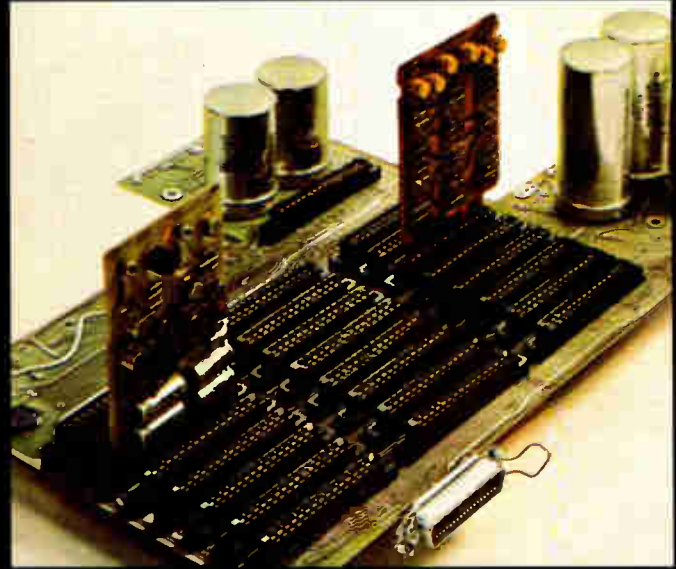
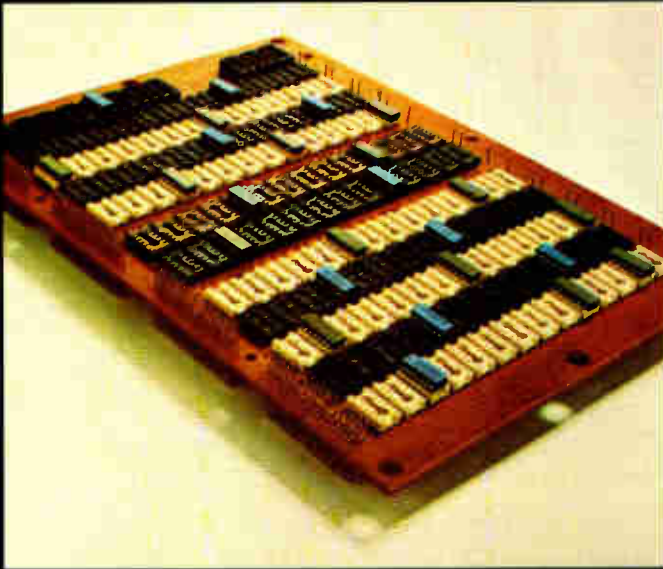

Above are seven new ideas from Amphenol Industrial Division's Spectrum of interconnection capability.

Amphenol's SPECTRUM offers you *all four* levels of interconnections from our unmatched breadth of product line:

**Level 1 . . . DEVICE TO BOARD OR CHASSIS.** We offer interconnections for components such as tubes, relays, transistors, IC packages, trimmers, resistors or capacitors to a PC board or chassis.

**Level 2 . . . BOARD TO MOTHERBOARD OR BACK PLANE.** We offer interconnections for PC boards or

other sub-circuit modules to a motherboard or to a back plane.

**Level 3 . . . MOTHERBOARD OR BACK PLANE WIRING.** We offer interconnections for levels to each other and to other sub-circuits with multi-layer circuit boards, wire wrapping, clip terminations, jumper techniques and dip-soldering.

**Level 4 . . . INPUT/OUTPUT CONNECTIONS.** We offer interconnections for power and signals to and from a system. This interface may be between sub-assemblies within the same enclosure or between individual units.

# Spectrum of interconnections.

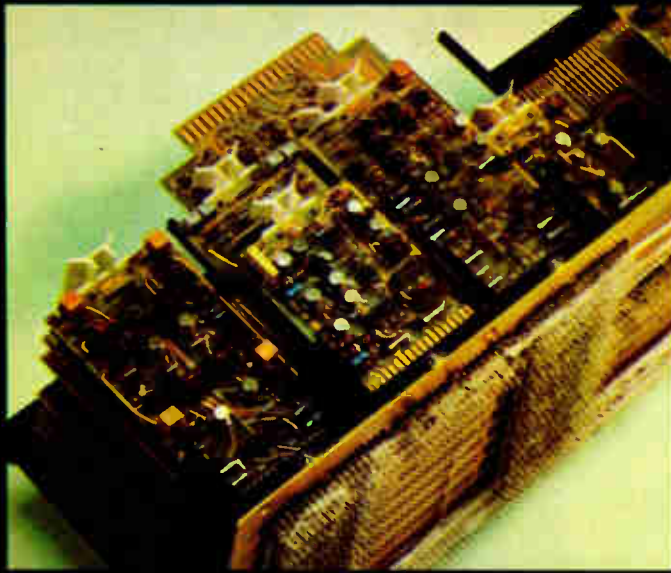

**level 3** Direct entry plate assembly offers modular packaging flexibility. Custom designed plates accommodate any size or style PC board with no tooling cost to you. Rectangular posts are true positioned for automatic wire-wrapping.

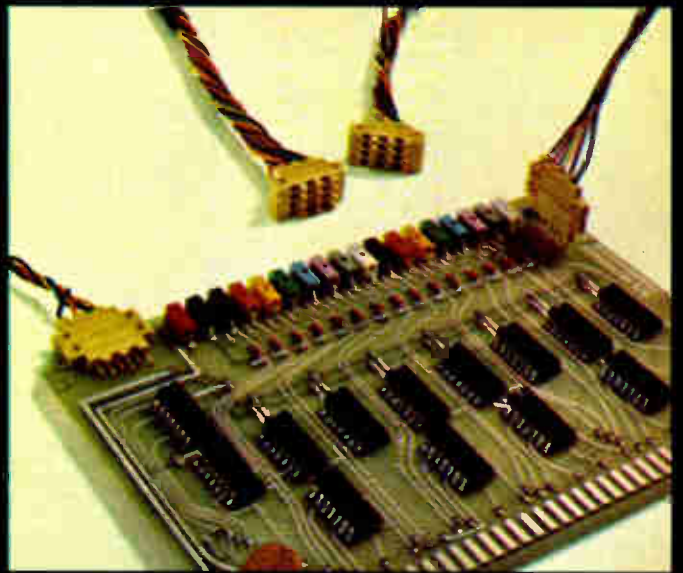

**level 4** Miniature contact (3 input, 3 output) hermaphroditic connectors can be snapped together to connect as many circuits as required. ■ Single finger-tip mounting of low cost connector saves assembly time. Available in UL Class SE-1 flammability rated material.

Write for our **Spectrum** brochure covering all levels of interconnections.

**Spectrum**  
OF INTERCONNECTION CAPABILITY

AMPHENOL  
INDUSTRIAL DIVISION

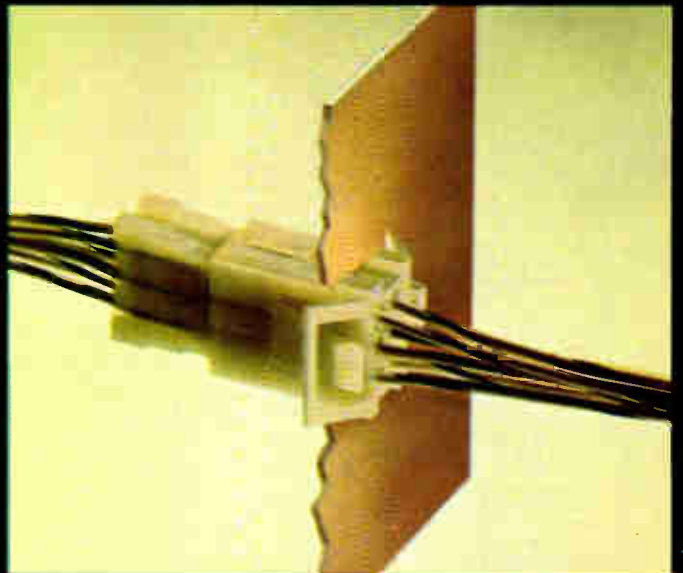

From the simple tube socket—to a myriad of electrical/electronic connectors—to complete and complex termination systems . . . SPECTRUM.

But SPECTRUM is far more than products. It is a depth of capability in engineering, manufacturing and quality control. Amphenol's SPECTRUM is a new height of service, availability and distribution backed by seven Amphenol interconnection-oriented divisions.

Amphenol can fulfill your total interconnection requirements because we are not limited to specifics such as one or two product lines, one or two levels.

Therefore we approach your interconnection needs with complete open-mindedness.

For more new ideas and specific information, write for your copy of "SPECTRUM." Amphenol Industrial Division, Bunker Ramo Corp., 1830 South 54th Ave., Chicago, Illinois 60650.

**BUNKER  
RAMO**

**AMPHENOL**

Circle 33 on reader service card



**Quality  
resistor networks  
now available  
off-the-shelf.**

**Pull ups or  
terminators,  
in popular  
values.**

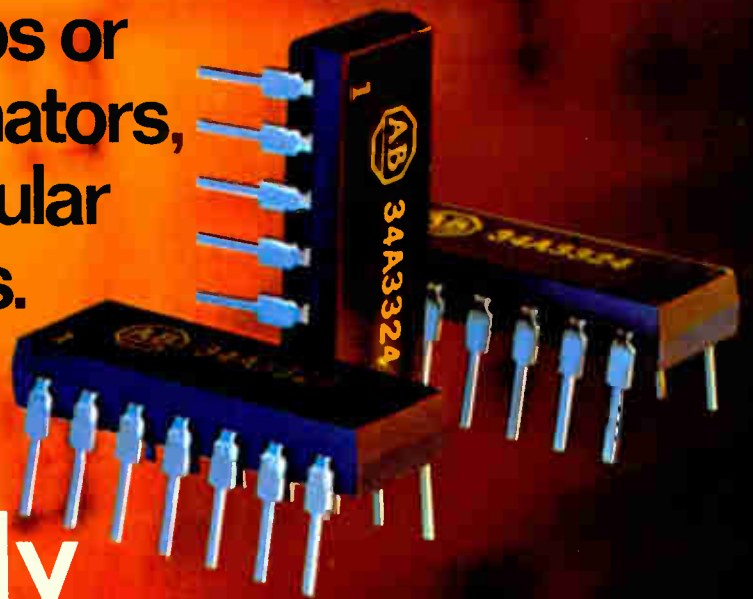

**If you're really  
serious about cost,  
be serious about quality.**

Now our most popular thick-film resistor networks are ready and waiting, in quantity, at your A-B electronics distributor. Pull-up networks and terminator networks with tolerances of  $\pm 2\%$  in popular values from 68 ohms to 22K ohms. All in compatible

14 lead .300 series DIP's. Or if you need something special we'll quickly custom design any circuit that'll fit into a 14 or 16 lead DIP. And we mean quickly. Overall specs include: absolute tolerances to  $\pm .5\%$ . Tracking  $\pm 50$  ppm/ $^{\circ}\text{C}$  (and lower). TCR to

$\pm 100$  ppm/ $^{\circ}\text{C}$ . Write for free technical publications 5850 and 5851. Allen-Bradley Electronics Division, 1201 S. Second St., Milwaukee, WI 53204. Export: Bloomfield, NJ 07003. Canada: Cambridge, Ontario. United Kingdom: Jarrow, Co. Durham NE32 3EN.



Actual Size



**ALLEN-BRADLEY**  
Milwaukee, Wisconsin 53204

Circle 34 on reader service card



## **Megabit memory to use CCDs**

Eyeing the replacement of rotating disk memories with charge-coupled devices, Bell-Northern Research of Ottawa, Canada, is putting together an experimental 1-megabit, 16-bit-word memory system **using 128 of its proprietary 8,192-bit CCD memory chips** [*Electronics*, June 21, 1973, p. 28]. The system, being readied for evaluation by the end of this month in the company's Electron Devices Laboratory, will interface with a PDP-11 computer and operate at data rates up to 1 megahertz. Each chip, measuring 178 by 168 mils, is divided into 32 recirculating serial memory tracks of 256 bits each. They'll be organized on boards containing 16 chips, or 131,072 bits that read out 2 bits at a time.

Compared with electromechanical memories, CCD systems promise long life and reliability because they have no moving parts. Moreover, in the Bell-Northern design, a latency time of 128 microseconds, the average time before actual transfer of data can begin, **is considerably faster than the 2.5 milliseconds required of conventional fixed-head disks**. And compared with other semiconductor memories, the CCD systems promise lower cost because they're simpler to fabricate.

## **Intersil develops 12-bit C-MOS microprocessor . . .**

Enter Intersil in the microprocessor derby. The company is in final mask layout of a **12-bit chip that it intends to sample by December and introduce next March. Using complementary-MOS technology**, Intersil joins RCA as the only semiconductor makers to take that route. Also, though most suppliers are offering 8-bit devices, Intersil is building a 12-bit processor so that it can take advantage of existing software from Digital Equipment Corp.'s ubiquitous PDP-8A

## **. . . as Rockwell plans to produce 8-bit p-MOS device**

At the same time, the Rockwell International Corp. Microelectronic Device division, which already has a 4-bit p-channel microprocessor, **will add an 8-bit p-channel family**. Consisting of a CPU, RAMs, ROMs, clock generator, direct-memory-access controller, and an assortment of general-purpose input/output devices, it will execute more than 90 microinstructions, each in 4 microseconds. Prototypes will be ready in July, with deliveries in late 1974, says Michel Ebertin, director of product planning.

## **Remote tester checks credit terminals**

National Data Corp. of Atlanta, in a move unique for a credit authorization service firm, **has developed its own test equipment** to remotely check both its point-of-credit terminals across the country and the communications links from those terminals to its data-processing center. The test system queries each terminal to establish proper performance and also diagnoses whether problems are National's or Bell Telephone's responsibilities.

The reason is to limit service calls to point-of-sale locations, particularly if the breakdown requires a telephone company repairman rather than a National representative. Moreover, when a repairman is making a service call, **the test system goes through a step-by-step repair procedure with him** by means of a remote computer.

## **CATV firm to install home printers**

TelePrompTer Corp., the country's largest cable TV operation, will in the next two months try out a new electronic printer as part of its ongoing development of two-way cable communications to homes. Built by Repco, Orlando, Fla., the device can handle up to 30 words per second printed on a 4-inch-wide paper roll and will be controlled through the TV receiver. **It will provide hard-copy receipts for purchases made by two-way cable and verify acceptance of other services,** such as pay-TV viewing. According to TelePrompTer, the printer would cost about \$150 in large quantities.

## **Rockwell buys wafer firm**

In a move to ease its dependence on outside silicon suppliers, Rockwell International Corp.'s Microelectronic Device division **has acquired silicon wafer maker Recticon Corp.,** Parkerford, Pa. Charles V. Kovac, the Rockwell division's vice president and general manager, hopes that Recticon eventually can supply 25% of the division's wafer needs as an addition to Rockwell's current list of suppliers, but not as a replacement. Harry Pappas continues as president of Recticon, with Kovac becoming board chairman. Recticon also will continue to supply wafers to such current customers as American Microsystems Inc. and Signetics Corp., even though AMI is a close Rockwell competitor.

## **Varian schedules fast processor**

Varian Data Machines will shortly announce a floating-point processor for its V-70 series of minicomputers. The \$5,000 option increases speed by a factor of 15 for 15 widely used Fortran and machine language arithmetic operations. The unit is connected to both CPU and memory, not just the data bus; Varian says that this, plus its instruction pipelining, gives added speeds as fast as 9 microseconds for a 32-bit double-precision operation. Varian claims this compares to speeds of 19 to 55  $\mu$ s for competitive models.

## **Remote job entry coming from General Automation**

General Automation is preparing to announce a remote job-entry system for the popular IBM 360 and 370 HASP (Houston automatic spooling operation) computer configuration for as little as \$27,000. This includes a General Automation 18/30 computer, card reader, line printer, teletypewriter, communications controller, and software.

Varian Data Machines has just announced a similar but larger system, including disk, for \$60,000. The two systems **give remote computer network capability at reasonable cost** with the option to expand to a free-standing computer system in the future.

## **Addenda**

The Food and Drug Administration wants to develop a portable, automated temperature calculator so that its field inspectors can better detect botulism in canned foods. The FDA is expected to choose a developer shortly to build a prototype of the concept, which, if successful, should "have a reasonably high demand within FDA and among manufacturers," says one official. . . . Look for the Microelectronic Products division of Rockwell International to come out with **its first electronic watch imminently. It will sell for about \$150,** and will combine a C-MOS counter-divider circuit with a quartz oscillator and liquid crystal display.

# Fast enough for the fastest transistors.

Unitrode ESP Power Rectifiers to 150V give you the switching speeds you need for today's high performance power supplies: reverse recovery times as low as 15ns and very fast forward recoveries with low overshoot voltages. Forward voltage drops are as low as 0.8V at 20A.

Unitrode's ESP Power Rectifiers make your power supplies more efficient. There's less power dissipation . . . even in the highest speed switching application. With fewer heat problems you can simplify heat sinking and increase package density and reliability.

In fact, only Unitrode Power Rectifiers have the *Efficiency, Speed and Power* you need to design high current, high frequency power supplies with low diode losses. That's why we call them ESP rectifiers.

Three discrete Series now available as 1N5802 through 1N5816. You can also order them as high efficiency assemblies, center tap rectifiers, bridges, or higher current modules. Send for our latest ESP literature. Or for faster action, call Fred Swymer collect at (617) 926-0404.

## Unitrode ESP Rectifiers.

Type	PIV	Maximum Average D.C. Output Current		Non-Repetitive Sinusoidal Surge (8.3ms)	Maximum Forward Voltage Drop	Leakage Current @ PIV 25° C	Maximum Reverse Recovery Time	Package
		V	A					
1N5802	50							
1N5803	75							
1N5804	100	2.5	35	0.875 @ 1	1	25	Axial leaded	
1N5805	125							
1N5806	150							
1N5807	50							
1N5808	75							
1N5809	100	6	125	0.875 @ 4	5	30	Axial leaded	
1N5810	125							
1N5811	150							
1N5812	50							
1N5813	75							
1N5814	100	20	250	0.900 @ 10	10	35	Stud-mount D04	
1N5815	125							
1N5816	150							

See Electronic Buyers' Guide Semiconductors Section for more complete product listing.

Circle 37 on reader service card

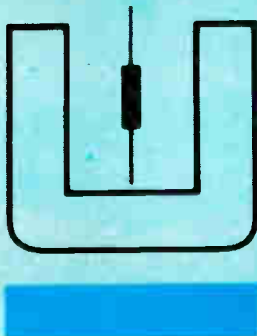

# UNITRODE

580 PLEASANT STREET, WATERTOWN, MA 02172



The Single Source For Reliable Protection For Every Type Of Electronic And Electrical Circuit And Device

# BUSS®

## SMALL DIMENSION FUSES AND FUSEHOLDERS

Include dual-element "slow-blowing" fuses, single-element "quick-acting" fuses and signal or visual indicating type fuses . . . in sizes from 1/500 amp. up . . . PLUS: a companion line of fuseholders.

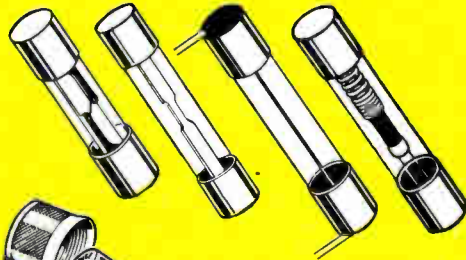

### BLOCKS FOR BUSS FUSES

All types available for every application. Single pole, multiple pole, small base, full base, molded base, laminated base, porcelain base for fuses from 1/4 x 5/8 inches up. Also signal fuse blocks and special blocks of all types.

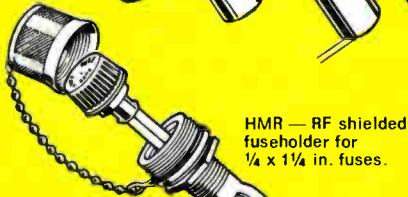

HMR — RF shielded fuseholder for 1/4 x 1 1/4 in. fuses.



HKP panel mounted fuseholder for 1/4 x 1 1/4 in. fuse.

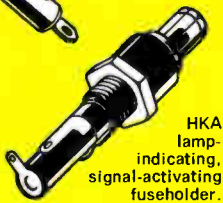

HKA lamp-indicating, signal-activating fuseholder.



**TRON® Rectifier Fuses For the Safe Protection of Solid State Devices**  
Provide extremely fast opening on overload and fault currents, with a high degree of restriction of let-thru current. Many types and sizes available. Ampere ratings from 1/2 to 1000 in voltages up to 1500.

**BUSS SNAP-LOCK FUSE-HOLDER** — Rear panel-mounted fuseholder for 1/4 x 1 1/4" fuses. Snaps into place. Specify HTA-00 for space-saver type, HLD-00 for visual-indicating type, HKP-00 for standard fuseholder, or HJM-00 for 1/4 x 1" fuses.



### THE COMPLETE LINE OF SIGNAL-INDICATING ALARM-ACTIVATING FUSES

For use on computers, microwave units, communication equipment, all electronic circuitry.



BUSS GBA 1/4 x 1 1/4 in. Visual-Indicating

BUSS GLD 1/4 x 1 1/4 in. Visual-Indicating, Alarm-Activating.



BUSS Grasshopper Fuse, Visual-Indicating, Alarm-Activating.



BUSS MIC 13/32 x 1 1/2 in. Visual-Indicating, Alarm-Activating.

BUSS MIN 13/32 x 1 1/2 in. Visual-Indicating.



BUSS ACH Aircraft Limiter, Visual-Indicating.



FNA FUSETRON® dual-element Fuse 13/32 x 1 1/2 in. slow-blowing, Visual-Indicating, Alarm-Activating. (Also useful for protection of small motors, solenoids, transformers in machine tool industry.)

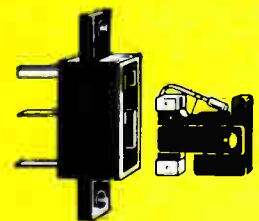

BUSS GMT and HLT holder, Visual-Indicating, Alarm-Activating.

**SUB-MINIATURE FUSE**—Ideal for space tight applications, light weight, vibration and shock resistant. For use as part of miniaturized integrated circuit, large multi-circuit electronic systems, computers, printed circuit boards, all electronic circuitry.

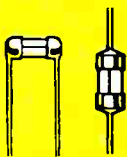

**TRON Sub-Miniature Pigtail Fuses** — Body size only .145 x .300 inches. Glass tube construction permits visual inspection of element. Hermetically sealed. Twenty-three ampere sizes from 1/100 thru 15.



**BUSS Sub-Miniature GMW Fuse and HWA Fuseholder.** Fuse size only .270 x .250 inches. Fuse has window for visual inspection of element. Fuse may be used with or without holder. 1/200 to 5 amp. Fuses and holders meet Military Specifications.

FOR MORE INFORMATION ON THE COMPLETE BUSS LINE, WRITE FOR BUSS FORM SFB.



BUSSMANN MANUFACTURING  
a McGraw-Edison Company Division  
St. Louis, Missouri 63107



## C-MOS on sapphire adds to its appeal with radiation resistance

Developed at Rockwell, hardened C-MOS devices compare favorably with dielectrically isolated TTL

C-MOS circuits on sapphire substrates have been in development at a number of semiconductor houses—and now it looks as if researchers at Rockwell International Corp.'s Electronics Research division have come up with major innovations that make such devices equal to or better than dielectrically isolated TTL devices in both resistance to radiation and conventional electrical characteristics.

The results should enhance the appeal of C-MOS, which is already attractive to military users because of its high device density and low power requirements. Rockwell officials caution, however, that radiation-resistant C-MOS on sapphire devices may still be 2½ to 5 years away from production, depending in part on whether a military program comes along to push them.

Rockwell has developed a number of radiation-resistant parts using both p-channel MOS and C-MOS; in C-MOS, they've developed a 4-bit adder, 8-bit digital multiplexer, and 256-bit RAM under military contracts, and with internal funds, a 4007S-type inverter and 4012S-type dual NAND gate.

**Rads.** The C-MOS-on-sapphire circuits fabricated so far compare very favorably with dielectrically isolated TTL and hardened p-MOS on sapphire. Neutron-dose tolerance is over  $5 \times 10^{15}$  rads for both types of sapphire circuits, compared to  $3 \times$

$10^{14}$  rads for dielectrically isolated TTL. Ionizing-dose tolerance is over  $10^7$  rads for all, ionizing-dose-rate tolerance is  $10^{10}$  rads for C-MOS on sapphire, three times higher than for p-MOS on sapphire and dielectrically isolated TTL. The C-MOS speed is 60 megahertz, compared with 20 MHz for p-MOS and 25 MHz for TTL. Power per logic gate is 0.2 milliwatts versus 0.5 mW for p-MOS and 10 mW for TTL, and density for both MOS types is much higher than for TTL. SOS is inferior to bulk silicon p-MOS in ionizing-dose radiation.

Generally, MOS parts are "extremely sensitive to total doses and transient ionizing radiation effects," says James E. Bell, director of engi-

neering sciences at the division. The Rockwell techniques that to a large measure overcome both problems are based on commercial C-MOS and SOS processes under high-priority development at the company's Microelectronics divisions. Yield and production problems with the hardened C-MOS-on-sapphire circuits remain to be solved, however, before the parts can find wide use. Other firms are also working on hardened MOS devices, notably Hughes, RCA, and Sperry.

**How to do it.** The solution chosen at Rockwell to minimize threshold shifts due to total ion dose is hardening the gate insulator in the MOS devices, minimizing charge buildup that leads to the shift. Very clean

**Bombarded.** Even when irradiated at  $10^6$  rads, the C-MOS devices developed by Rockwell still function adequately. The units were developed using commercial C-MOS and SOS

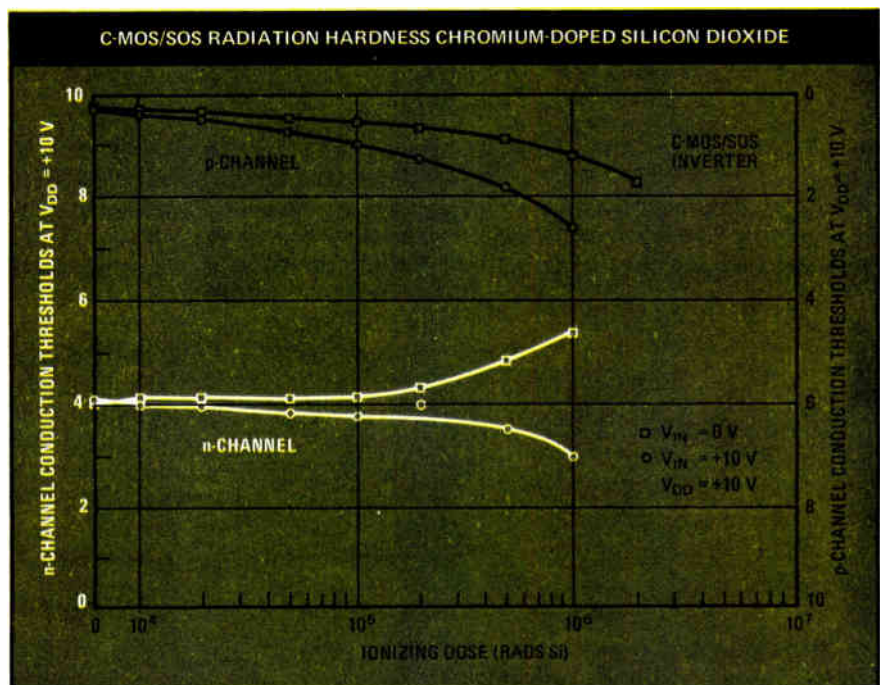



CURRENT RADIATION-HARDENED IC TECHNOLOGY				
Characteristics	Hardened dielectrically isolated TTL	Standard p-MOS	Hardened p-MOS/SOS	Hardened c-MOS/SOS
Neutron-dose tolerance	$3 \times 10^{14}$	$10^{13}$	$5 \times 10^{15}$	$5 \times 10^{15}$
Ionizing-dose tolerance	$> 10^7$	$10^4$	$> 10^7$	$> 10^7$
Ionizing-dose-rate tolerance	$3 \times 10^9$	$10^6$	$3 \times 10^9$	$10^{10}$
Speed	25 MHz	2.5 MHz	20 MHz	60 MHz
Power per logic gate	10 mW	0.5 mW	0.5 mW	0.2 mW
Logic gates per chip, TTL equivalent	100	800	500	500

oxide is required, because impurities store the charges, plus a hardening dosage of metal, usually chromium. This doping requires only an extra photomask and processing. Ion-implanted aluminum rather than chromium can also be used for doping, but requires separate steps for p- and n-channel transistors needed for C-MOS circuits; the chromium is applicable to both in one step. Also, ion-implanting induces radiation damage of its own.

Bell feels these gate-hardening techniques can solve the total-dose problem, with several orders of magnitude better radiation resistance, yet similar electrical characteristics. This approach is applicable to conventional MOS on bulk silicon as well as to MOS circuits with sapphire substrates.

The other problem, transient radiation, is best handled by dielectric isolation, as it is with bipolar circuits. Sapphire is the ideal material since thin silicon films can be grown heteroepitaxially on its surface, providing very small bulk for the generation of photo-currents that can disrupt circuits under radiation. This technique permits two to three orders of magnitude improvement in transient radiation resistance. Work is now in progress to overcome three

remaining yield problems that result from using the hardened oxide on sapphire: edge effects, back channels, and sapphire substrate photo-conductivity. □

## Low-power Schottky gets speed shot

Transient currents, which normally go to waste, provide the extra kick that makes Fairchild Semiconductor's version of low-power Schottky TTL twice as fast as anyone else's [*Electronics*, March 7, p.32]. Since the basic reason for using low-power Schottky TTL is to reduce power while maintaining high speed, the Fairchild devices, specified for an average delay of 5 nanoseconds, should become a major boon to military and industrial designers.

Signetics and Texas Instruments guarantee 20-ns maximum delay on a low-power Schottky NAND gate, for example, and quote typical delays of 10 ns. Their strategy is to retain compatibility with standard TTL speed while reducing power requirements. Typical gate delays refer to an average of observed data. "Max-

imum" is what the maker is willing to guarantee.

Transients in the Fairchild device, generated when the input square wave changes states, provide a pulse three times the value of the dc current to help turn on both the input and output transistors. Surprisingly, the extra speed derives from an increase in the size of the input Schottky diode, and hence, an increase in the capacitance of the device. An increase in capacitance acts to slow circuit operation. However, it increases the value of the transient current, which is defined as the change in the Q of the circuit, divided by the rise or fall time of the input signal.

Transient current =  $\Delta Q/\Delta t$ .  $\Delta Q$  is equal to the change in input voltage, 3 V, times the capacitance, which in the Fairchild design is 0.6 picofarad. Thus,  $\Delta Q$  is 1.8 picocoulombs. The fall time is 4 ns, and the transient current is 1.8 picocoulombs/4 ns, or 450 microamperes. The dc-current component is about 160  $\mu$ A.

Fairchild's Schottky design eliminates storage time at the input transistor by preventing it from saturating. The extra current is delivered to the base of the phase-splitting transistor; transferred to the collector, it becomes part of the base current to the output transistor and helps speed device operation.

**Size is critical.** The size of the input diode is critical to circuit performance says Fairchild's Raj S. Sengottaiyan, engineering supervisor, who headed the design effort. Increasing the size increases the capacitance and hence the numerator of the current equation above. But it also tends to decrease the voltage drop across the Schottky barrier, thus decreasing the numerator's value. Chip size and yield also become problems with large geometries. Fairchild simulated several designs on a computer to find the optimum size for the input diode.

Fairchild designed its low-power Schottky line to match TI specifications and is not trying to establish its line as an industry standard, a spokesman says. The extra speed is available, product manager Rick McCarthy points out, for those who



want it. The impact of the increased speed will come, he adds, not in the 54/74LS market, but over the entire TTL spectrum, except for standard Schottky TTL. Fast low-power Schottky can meet specifications of standard TTL, high-power (gold-doped) TTL, and low-power TTL, McCarthy claims. Now, of course, it has nothing like the depth of these lines. Fairchild's initial offering consists of a few gates and flip-flops, and the company only now is starting a program of medium-scale integration.

Moreover, processing for low-power Schottky is much trickier, and prices are therefore higher than they are for standard TTL. Fairchild drew on emitter-coupled-logic technology to make the necessary shallow diffusions. In addition, the shallow diffusions necessary to build low-power Schottky will keep prices lower than those of standard lines for some time. And like TI and Signetics, Fairchild is wooing space and defense markets first. □

## Instruments

### Spectrum analyzer uses digital storage

By superimposing the spectrum of a unit under test over that of a prototype unit, engineers using a new spectrum analyzer can actually compare the performance of components, such as filters, in real time. And, because the analyzer's CRT is scanned vertically, rather than in the conventional horizontal mode, the specific frequency of a spectral line can be precisely determined.

The spectrum analyzer, developed by England's Marconi Instruments Ltd., does not use an expensive storage tube. Instead, it depends on recirculating digital storage to retain a faintly defined display of a given spectrum. Thus, the spectrum of a prototype filter can be stored in the analyzer and subsequent production filters tested by simply seeing if the two spectrums match. Marconi claims that

wherever spectral comparison is required, the new instrument, which operates from 30 hertz to 110 megahertz, will save considerable time.

The display is a 512-line TV-type raster-scan tube 5 inches high by 4 in. wide. Because it scans vertically the signal amplitude at a given frequency is defined by the proportion of a line that is brightened. Using 512 lines gives fine visual resolution along the frequency axis. The amplitude axis is quantized into 256 levels. There's an eight-bit MOS memory for each line, and the storage number is read out to determine how much of a line is brightened.

**Frozen lines.** Freezing the display cuts off the memory from the signal input and recirculates the existing information for presentation. When two spectra have to be compared, as in the comparison of filter performance, only every other line is frozen. The other 256 continue to operate in real time.

Using a raster has other advantages. The spectrum appears as a solid white mass on a dark background, and there's no trace or spot that the operator has to follow with his eyes. What's more, the image doesn't fade on slow sweeps as it does when a storage tube is used. And Marconi has made the graticule electronic, with the scale expandable and contractable independently of the spectrum image. That kind of scale makes it possible to play tricks with frozen and real-time spectra as well as changing spectrum and graticule scales to make comparative measurements between spectra.

The main novelty of the instrument—labeled TF-2370—is in its display facilities, but Marconi engineers have built in other novel features. For instance, a nine-digit light-emitting-diode counter will give an instantaneous readout of center frequency—to 1-Hz resolution, using a scan width of 200 Hz and a 5-Hz filter, which is the finest measurement mode in which the analyzer will operate. Alternatively, it will give the frequency of any point on the spectrum selected by a movable electronic cursor-point line, or the difference between the

center frequency and the cursor-point frequency.

Further, digital logic is used to work out automatically the signal level that will give the best compromise between the conflicting effects of noise and intermodulation products. The level must be high to provide good dynamic range and freedom from noise, but if it's too high intermodulation will distort the spectrum. The unit also includes logic that automatically selects the fastest possible sweep speed for the sweep width and filter bandwidth selected.

Marconi men estimate that the world market for spectrum analyzers operating at frequencies under 1 gigahertz is \$40 million to \$50 million a year and going up. Most of the market now is for instruments

**Spectrum match?** Marconi's spectrum analyzer permits comparisons in real time.

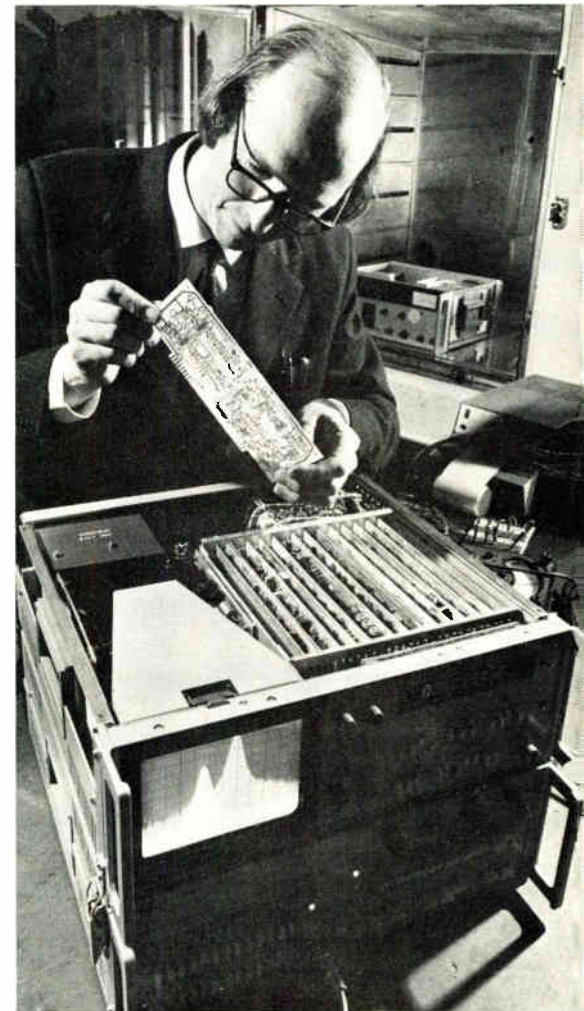

## Electronics review

operating below 100 MHz, they say.

Marconi engineers think that the display facilities in the instrument, and its price—about \$11,500 in Britain—will make it suitable for such production-line use as checking out communications transmitters against a specification. Higher-frequency versions are being developed, and eventually a microwave model will be offered. □

## Commercial electronics

### High-rise alarm thinks of everything

Residential security-alarm systems have finally become serious business for a score or more of electronics firms. And with the growth in the market has come inevitable specialization.

Late this month, for example, Westinghouse Security Systems Inc., Pittsburgh, will introduce the latest entry, an alarm system designed for entire high-rise apartment buildings. Built around a custom p-MOS LSI chip that does all the processing chores, the High-Rise Security System provides:

- Two-way voice communications between the central monitoring console and the dwelling unit.
- Alarm tones to distinguish fire and smoke from a break-in.

- A panel that identifies the specific dwelling in trouble.

- A light that tells the resident when the guard station is taking action.

- A private number code for arming or disarming each alarm.

- Automatic arming and disarming of the alarms.

Sensors are placed at windows and doors or cover strategic areas, inside or outside a home or apartment. The alarm can be tripped by infrared, ultrasonic, photoelectric, and heat sensors.

Using what design engineer W. Douglas Drumheller calls "random control logic," the LSI chip, mounted on the main pc board, contains a single programmable random-access memory to program a home-control unit. This control, together with a smaller board containing the communications circuits—essentially audio amplifiers for the alarms—is installed in the individual dwelling.

The alarm unit, which has a six-digit keyboard that arms the system via individual codes, contains circuitry and power supply to handle burglar, fire, emergency, alarm-test, and intercom functions. This, in effect, combines perimeter security with dwelling-unit security—the on-site alarms linked to a central panel at a manned guard station from which police, fire, or ambulance assistance is called.

**Tripping.** A two-way audio connection also allows the apartment

occupant to talk to the guard as soon as the burglar alarm is tripped. The idea is to provide human interruption in case of a false alarm caused by unintentional activation—a major nuisance in all home security systems.

Because it is hard-wired, the High-Rise Security System will be marketed to builders who can economically install the total package during construction. The system will cost from \$450 to \$600 per dwelling unit, plus about \$75 for each of the installations. □

## Medical electronics

### Sound pictures used to aid the blind

"Painting with sound" best describes the investigative technique developed by researchers at the Worcester Polytechnic Institute, Worcester, Mass., as an aid for the blind. The group decided on an auditory approach on the grounds that, next to the eye, the ear is the most sensitive and efficient information-gathering organ of the human body.

Their experimental system is based on the fact that high-frequency tones seem to originate from high positions while lower-frequency tones seem to come from lower positions, even though all the tones come from a fixed source. Also, sound sources are heard as coming from the left or right, because their intensity is different at each ear. Taken together, a sound "picture" might therefore be created by sounds of different pitches and intensities that would seem to come from a number of different locations.

The group started with a simple array of photocells, connected to an analog computer, which produced a scan of horizontal and vertical components. When a photocell with light falling on it was scanned, the subject heard a pleasant sine-wave audio tone through stereo earphones. The frequency from top to

**Deterrent.** Westinghouse High-Rise Security system's master control panel includes intercom and means for detecting and reporting fires and other emergencies.

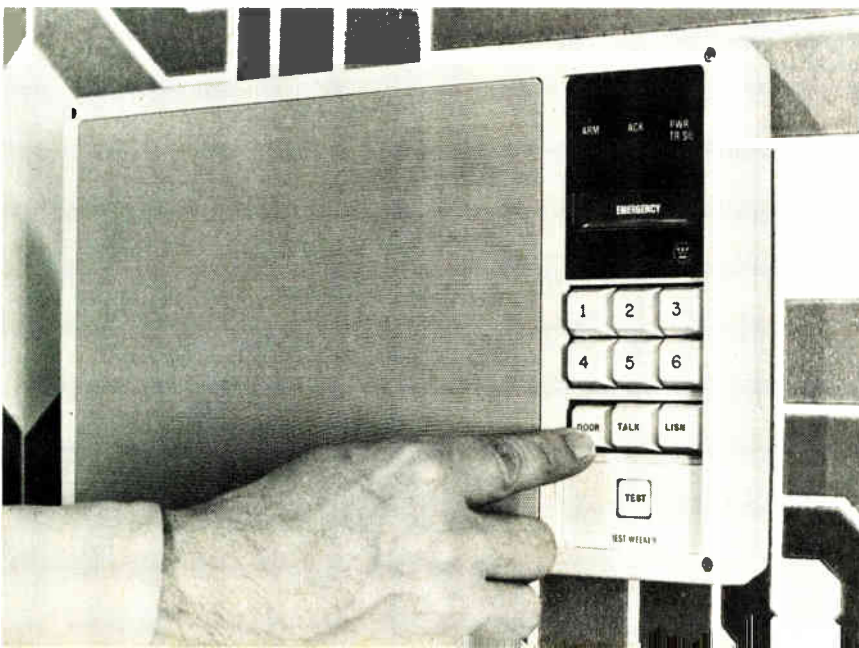



# Fingertip signal averaging...

## ...and a lot more

Any signal that can be displayed can be digitized, stored, and processed by the TEKTRONIX Digital Processing Oscilloscope.

A noisy signal . . .

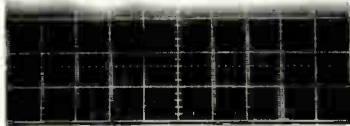
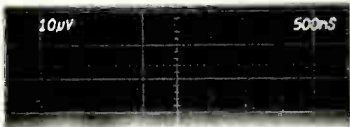

. . . is made useful by signal averaging with the DPO.

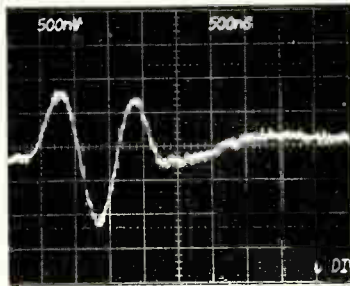

Over 30 TEKTRONIX 7000-Series oscilloscope plug-ins give the DPO unmatched acquisition flexibility. Signals from microvolts to kilovolts in amplitude, from picoseconds to seconds in duration, and from dc to 14 GHz are now available for computer analysis.

The range of possible measurements is almost unlimited. Program call buttons on the DPO give you fingertip access to waveform processing from simple multiplication, addition, and subtraction to integration, differentiation, Fourier transforms, and correlation.

Get all the details from your local Tektronix Digital Applications Engineer. For your copy of the "Digital Processing Oscilloscope" brochure, contact: Tektronix, Inc., P.O. Box 500A, Beaverton, OR 97005. Phone: (503) 644-0161. In Europe: Tektronix Ltd., Guernsey, C.I., U.K.

For a demonstration circle 42 on reader service card

Circle 43 on reader service card



**TEKTRONIX**

committed to technical excellence

MEASUREMENT  
SYSTEMS  
DIVISION



bottom of the scan varied from 7,000 to 200 hertz. When the scan was at the left edge, the amplitude was 40 decibels greater in the left earphone, in the center the amplitude to both ears was equal, and at the right edge it was 40 dB stronger in the right earphone.

**Edge detector.** Since that first version was developed three years ago, the system has been modified until now a blind subject has been able to identify such household objects as pliers and scissors. The present analog system scans objects with a Robot Research Model 80 TV camera coded to use edge detection, so a tone sounds only when a change from light to dark or dark to light is encountered. The camera feeds into a number of hard-wired circuits, which provide a tone to either of two headphones. A voltage-variable oscillator generates the tone, and the voltage in the TV oscillator determines the pitch.

Frequency is now restricted to between 200–5,000 Hz, since the ear is most sensitive at 2,000 Hz and older people lose the ability to hear high frequencies. This also allows the use of less expensive headphones. Two variable-gain amplifiers determine how much tone goes to each ear. A third circuit, a switch, shuts the tone off after the camera has passed an edge. The tone lasts about 4 microseconds.

The experimental system is housed in a 4-ft-high relay rack, but Richard G. Beschle, associate professor of life sciences, says the unit could eventually be shrunk to fit inside a handbag. "We could make it smaller, by using tiny TV camera tubes that are available," he says, "and as for the rest of the circuitry, all the technology is known to have miniaturized parts." The major hurdle to reaching this size is funding—Beschle estimates a prototype might cost \$200,000 although mass-

produced units could be made for perhaps less than \$1,000.

**Perception.** In the meantime, the group expects to work on giving depth and mobility perception. Previously, each scan lasted 8 seconds and contained 30 horizontal lines, but Beschle noted that in a few cases, the system was speeded up and subjects were still able to perceive objects. If high enough speeds can be attained, subjects might be able to perceive things growing larger or smaller as they move toward or away from them. And one team member has suggested that a sonar sensor feeding a high rate of information might give information on moving objects that would help the blind "perceive" them.

While resolution of the system may be increased, Beschle does not expect that it will become refined enough to enable the blind to read. Instead, he sees it as an aid to mobility. "I picture it as a system," he

## Motorola's 3-year MOS effort is beginning to pay off

For years, Motorola Semiconductor Products has appeared to miss out on MOS. Although the company said it was concentrating on c-MOS and n-channel MOS instead of the industry's standard, high-volume p-channel MOS, its actual production hasn't been high. Now, however, the long MOS incubation period appears to be paying off.

The Phoenix, Ariz., firm has already introduced about 80 separate circuits in the fast growing c-MOS family that most observers feel will be the last big conventional logic family, and the company is moving into high-volume production with a new 3-inch-wafer facility in Mesa, Ariz. Also, a new plant in Austin, Texas, is starting up in mid-year.

And the n-channel push has resulted in introductions and promised introductions of memory products that Motorola officials believe have or will become industry standards. The company has already announced an n-channel 4,096-bit random-access memory, developed in cooperation with American Micro

systems Inc. for true second-source availability. Motorola appeared to be late with its 4-kilobit RAM until early front runners—Micro International Ltd. and then Texas Instruments—floundered [*Electronics*, March 21, p. 70]. Recently, too, Motorola released details on its n-channel microprocessor set. As yet, these two products are in their early stages, although MOS marketing manager, Colin Crook says that Motorola is shipping 4-kilobit RAMs to more than 20 major customers.

Also in high volume at Motorola are some less dramatic but very popular products, namely the n-channel 1,024-bit 7001 RAM pioneered by Advanced Memory Systems, to be joined this spring by the slow, but easy-to-use static, 5-volt 1-kilobit 2102 RAM developed by Intel (Motorola's number will be MCM6602), and shortly after that, the MCM6610 RAM, similar in size and specifications but byte-rather than bit-oriented (128-by-8) for small-memory organizations. Motorola also claims to be a leading sup-

plier of n-MOS read-only memories, with numerous 8,192-bit ROMs in production, and 16-kilobit models to come.

The company expects its microprocessor set to find its way into many applications where random logic is now used, with special expectations for the explosive data-terminal and data-communications markets. Motorola's set appears to be the first complete 8-bit n-channel set announced in detail—Intel has an 8-bit processor chip—and this may help the company shed its "me-too" image. Also coming will be many n-channel data-communications parts such as modems and encoders, plus parts for electronic organs.

The brunt of the production problems that must be solved to turn promises into success will be handled by John A. Ekiss, now group operations manager, MOS. Jack Haenichen, who guided the MOS operation through its hectic three-year build-up, becomes director of university relations at Motorola. □

# The Fastest 1K RAM Runs Cooler than Bipolar

PRODUCT	ACCESS TIME	STANDBY POWER PER BIT	PRICE VOLUME QUANTITIES
AMS 7001	60 nsec (0°-70°)C	60 microwatts	≅ 1¢ per bit
Bi-Polar	45 nsec typical at 25°C	600 microwatts	> 1¢ per bit (aver.)
Other Fast 1K RAM's	80 nsec (0°-70°)C	100 microwatts	≅ 1¢ per bit

**The 7001, a 1024 x 1 Bit Static N-MOS RAM** The 7001 RAM is 20% faster over

the commercial temperature range than bipolar and other fast 1K MOS RAM's.

The AMS 7001 is easy to use since it is static, eliminating the need for refresh circuitry. It requires only one high level input clock, and all other inputs can be driven by TTL gates with a pull-up.

**30% Less System Power Consumption** The 60  $\mu$ W/Bit standby power dissipation of the 7001 is an order of magnitude lower than that of equivalent speed bipolar RAM's.

This results in a 30% power savings which has already been demonstrated in both memory cards and systems built with the AMS 7001.

**Deliveries** The 7001 has already received wide acceptance and is an industry standard.

There are over 200,000 7001's installed and operating to date. The 7001 is multiple sourced and distributors have it in stock.

(213) 986-3895 Los Angeles, Ca.  
(617) 828-2181 Boston, Ma.  
(408) 734-4330 Ext. 300 Sunnyvale, Ca.

Our name is our business. We build advanced memories—devices, subsystems and systems.

## Advanced Memory Systems®

**AMS** 1276 Hammerwood Avenue, Sunnyvale, CA 94086

Name: \_\_\_\_\_

Title: \_\_\_\_\_

Company: \_\_\_\_\_

Address: \_\_\_\_\_

City: \_\_\_\_\_ State: \_\_\_\_\_ Zip: \_\_\_\_\_

Phone: \_\_\_\_\_

Have salesman call

Send Data Sheet

says, "where a blind person could enter a room and see a table with three people around it, a doorway, and a few chairs." □

---

**Instruments**

---

## Oscilloscope breaks writing speed record

The state of the storage tube art has been advanced significantly by Tektronix' development of a portable instrument with a 3-decibel bandwidth of 100 megahertz and a stored writing speed of 1,350 centimeters per microsecond. These specs make it the fastest storage scope known—faster even than the company's 7633 laboratory plug-in scope, which has a maximum stored writing rate of 1,000 cm/μs.

The new instrument, model 466, has been carefully designed to be as similar as possible to Tektronix' model 465, a non-storage scope that is widely used in computer-servicing applications. Because of the similarities between the two instruments, an experienced serviceman can be trained to use the new scope very quickly—a far from trivial consideration in the digital-equipment servicing field.

The 466 has a vertical-deflection sensitivity of 5 millivolts per division and a maximum sweep speed—with 10× magnifier—of 5 nanoseconds per division. The top writing rate of 1,350 cm/μs is achieved at a reduced scan of 3.6 by 4.5 cm. Writing rates as high as 135 cm/μs, however, can be achieved with a large scan of 5.4 by 7.2 cm. The instrument is priced at \$3,850.

To further increase the usefulness of this and other oscilloscopes, Tektronix has also developed a four-bit word recognizer. Called the model 821, the word recognizer produces a trigger output when a switch-selectable preset word appears at its inputs. The \$200 device has an expander connector that allows up to four units to be hooked together to provide 16-bit word capability. In addition to recognizing TTL-level digital

## News briefs

### **FCC authority challenged**

The North Carolina Utilities Commission, AT&T, and the National Association of Regulatory Utility Commissioners have gone to court seeking to overturn a decision by the Federal Communications Commission that says the FCC has sole authority over all communications [*Electronics*, Feb. 21, p. 36]. The Federal Court will have to decide whether the FCC or the states have power to restrict private attachments to a telephone company's intrastate interconnections.

### **Philco-Ford wins \$20 million contract**

Philco-Ford's Western Development Laboratories won a \$20 million contract from Mitsubishi Electric Co. to build Japan's Engineering Test Satellites (ETS-2). The contract calls for development of a prototype and a flight model to test the country's N-rocket, which is designed to permit Japan to launch its own spacecraft. In February, WDL also won a \$30 million contract from Mitsubishi to build an experimental television satellite.

### **RCA advances solid-state TVs**

RCA corp. has advanced its changeover date for all-solid-state color-TV manufacture from 1975 to June, claiming the change will cut energy consumption compared with hybrid sets. The company is also eliminating the energy-consuming instant-on feature on all sets. Although all-solid-state color-TV sets are being manufactured at twice the rate they were last year in the total industry, RCA admits the move may cost the company some share of the market since the solid-state sets will be hiked in price from \$30 to \$80 over their hybrid counterparts.

### **Rockwell shifts executives**

With the recent reorganization of Rockwell International's Electronics Group, R. S. "Sam" Carlson is the man to watch for even broader responsibility, according to Rockwell insiders. Carlson remains president of the Microelectronics divisions, but also takes calculator maker Unicom Systems under his umbrella, giving him all commercial microelectronics and business equipment activities. Unicom formerly was directly under Donn Williams, Electronics Group president. D. A. Mitchell, the group's former vice president for business development, takes on line responsibilities as executive vice president for products, with Unicom Systems, the Microelectronic Products division and Sumlock Anita Ltd. under his guidance; Mitchell reports to Carlson.

T. L. Fox, formerly president of Unicom, becomes Electronics Group vice president for marketing under Williams. Charles V. Kovac remains vice president and general manager of the Microelectronic Device division.

### **IBM upgrades data module**

A data module for the IBM 3340 disk drive now has some fixed read-write heads, which sharply reduces the access time for part of the data kept in the module. The original modules for the 3340 had only movable heads, sealed with an access mechanism inside the cartridge containing the magnetic disks. This increased the reliability of data storage over the disk packs using heads as part of the drive [*Electronics*, March 29, 1973, p. 32].

### **Perkin-Elmer to acquire Interdata**

Instrument maker Perkin-Elmer Corp., Norwalk, Conn., has agreed in principle to acquire computer manufacturer Interdata Inc., Oceanport, N.J. Under the agreement, Perkin-Elmer will issue 0.8 of a share of its common stock for each share of Interdata common stock outstanding.

### **Autonetics wins Sperry contract**

The Autonetics division of Rockwell International has received \$20 million funding by Sperry Systems Management to design and produce four electrostatically supported gyro monitor systems for the Navy's Trident submarine program.



# SCIENCE / SCOPE

An automated telemetry and command station has been built by Hughes for Western Union Telegraph Company to provide telemetry processing spacecraft command and ranging for its Hughes-built Westar satellites. It will be in operation when the first of three Westars is launched this month. The station, first of its kind in the U.S. for domestic satellites, features a unique instant-readout display panel that shows the status of up to three satellites in orbit and requires only one engineer on duty at a time.

Microwave testing of a maritime satellite and its antenna system for the U.S. Navy is now under way in a new anechoic test chamber at Hughes. Several distinctive features enable the chamber to test the wide frequency range of the satellite's independent transponders in L-band, C-band, and UHF. The chamber's absorption materials vary from 26 to 48 inches in depth. It has seven antennas for measuring spacecraft systems and providing telemetry and command functions between spacecraft and systems test equipment. Three satellites are being built under contract with Comsat, the first scheduled for delivery next fall. They will provide communications for both the U.S. Navy and the maritime industry.

First of a new line of Hughes laser subsystems, aimed at the commercial market, is an ultra-ruggedized model providing high performance for such applications as construction alignment, pipe laying, surveying, and guidance systems for construction equipment. Similar design concepts, integrating laser components and optics, are under development for data processing and general systems markets.

Day and night cloud-cover pictures of the entire earth are now being beamed twice a day directly to nations around the world by the NOAA-3 satellite, new primary weather watcher of the National Oceanic and Atmospheric Administration's worldwide environmental satellite system. This is made possible by the scanning radiometer built by Santa Barbara Research Center, a Hughes subsidiary. The pictures can be received in real time by 550 simple, inexpensive APT (Automatic Picture Transmission) stations located in 80 countries. NOAA-3 is the 24th in the series of weather satellites launched since 1960.

Hughes Research Laboratories has openings for semiconductor scientists with experience in device technology and processing. Duties will be in area of compound semiconductor devices, exploiting advanced materials technologies presently under development at Hughes. U.S. citizenship required. Please write: Mr. A. J. Simone, Hughes Research Laboratories, 3011 S. Malibu Canyon Rd., Malibu, CA 90265. An equal opportunity M/F employer.

A new series of axial heat pipes for highly efficient thermal control has been introduced by Hughes. Typical applications: electronics, chemical and mechanical equipment, industrial processing, medical equipment. The heat pipes use copper as the envelope and wick material and distilled water as the sealed-in working fluid. They have a thermal transport capability between 35 and 6,000 watts maximum over a recommended operating temperature range of +50° to +150°C.

Creating a new world with electronics



words, the 821 has a drive mode in which it produces the preset word at a drive level sufficient to drive six TTL loads. □

---

**Military electronics**

---

## Military monitors monitoring system

This month, field tests will end on the automated technical control system (ATEC) built to monitor the performance of the U.S. government's far-flung defense communication system (DCS). Full-scale tests of ATEC will begin in Europe late this year.

ATEC, designed and developed by Honeywell Inc., Minneapolis, Minn., is undergoing tests at Croughton Royal Air Force Station, England. To automatically check the DCS—which uses virtually all types of communications media, including satellite, cable, and tropospheric scatter as well as digital baseband signals at many different frequencies—Honeywell combined a minicomputer with various terminals to anticipate and isolate failures.

The aim is to detect degradations in the performance of a communications link and avoid catastrophic failures at critical moments—and do all this automatically. With ATEC, Honeywell says that spare communications channels can be kept to a minimum, since systems performance data is always available and repairs can be made before failures occur.

Although the present system is being developed under the aegis of Rome Air Development Center, Rome, N.Y., Honeywell sees ultimate commercial applications, where private-line subscribers could reduce the costs of extra lines and also maintain records of service they have actually received from the communications carrier.

In service ATEC distributes various terminal units throughout the system. An in-service quality control subsystem, for example, automatic-



**One.** With Honeywell ATEC, one person can control as many as 120 performance monitors for the defense communication system.

ally monitors and analyzes circuits while they are in use at the rate of one circuit every 5 seconds. The minicomputer uses a fast Fourier transform to perform spectrum analysis. The in-service/out-of-service quality control subsystem injects a signal of known characteristics into an out-of-use circuit and evaluates the signal over a return loop, taking 15 seconds per circuit tested. A digital-distortion monitoring subsystem evaluates the performance of baseband data lines. A telemetry unit—the only one of the

four that does not include a minicomputer—monitors analog voltages and performs other equipment-related tests.

A signal operator, sitting at a control console that houses a cathode-ray-tube display and a keyboard, can check and control as many as 120 remote performance monitors spread over a wide geographical area. One of the console's features is a set of push buttons whose functions vary automatically as the operator places different labeling templates over them. □

---

**Components**

---

## French researcher finds key to efficient, cheap, IR detectors

In a small laboratory in the southern foothills of the French Alps, initial development has been completed on a new technique that could bring small infrared detectors to the mass markets.

Up to now, sophisticated high-performance devices of this kind have been the preserve of the military and of high-budget government research laboratories. But Alexis Argamakoff, who has been working almost unaided on his project for several years at his Applied Infrared Systems laboratory, thinks that his

latest device could break open a wide range of new applications.

If Argamakoff's claims hold good, and they have been checked out by the French Atomic Energy Agency as well as by the military, mass markets may not be so far away. He claims the detector can operate unprotected in temperatures ranging from  $-200^{\circ}\text{C}$  to  $+100^{\circ}\text{C}$ —far better than military specifications. In addition, sensitivity is higher than comparable detectors, giving 1-millivolt output per  $^{\circ}\text{C}$ .

Unlike Argamakoff's devices,

# MOSTEK's MK4008-9 1K dynamic RAM makes it easy to convert your 1 $\mu$ sec static system... and reduce costs by 50%.

It's a simple design conversion from a 2102-type static system to MOSTEK's MK 4008-9. And the savings are big. MOSTEK's 1K dynamic RAM is priced at only \$3.50 in quantities over one thousand.

The design conversion is easy since the MK 4008-9 is a functional, pin-for-pin replacement for the 2102. And the memory matrix is wired exactly the same, except for an

additional — 12V power supply for the MK 4008-9. There's no sacrifice in performance. The MK 4008-9 offers an improved access time of 800 nsec and an equivalent write cycle time of 1  $\mu$ sec. Refresh can be accomplished with the addition of only a few TTL packages.

The big benefit for your system is lower total cost. Even with the addition of refresh circuitry, the total cost of using

MOSTEK's MK 4008-9 will be at least 50% less than the comparable static circuit.

Find out how your system can benefit from this combination of performance and low cost. Call MOSTEK's Marketing Group at (214) 242-0444 for more information or write for MOSTEK's application report "Designing An Asynchronous Memory System Using the MOSTEK MK 4008-9," 1215 W. Crosby Road, Carrollton, Texas 75006.

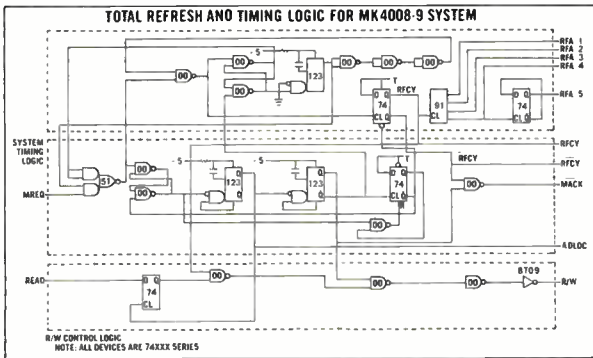

From Applications Note "Designing an Asynchronous Memory System."

**MOSTEK moves forward... in memories.**

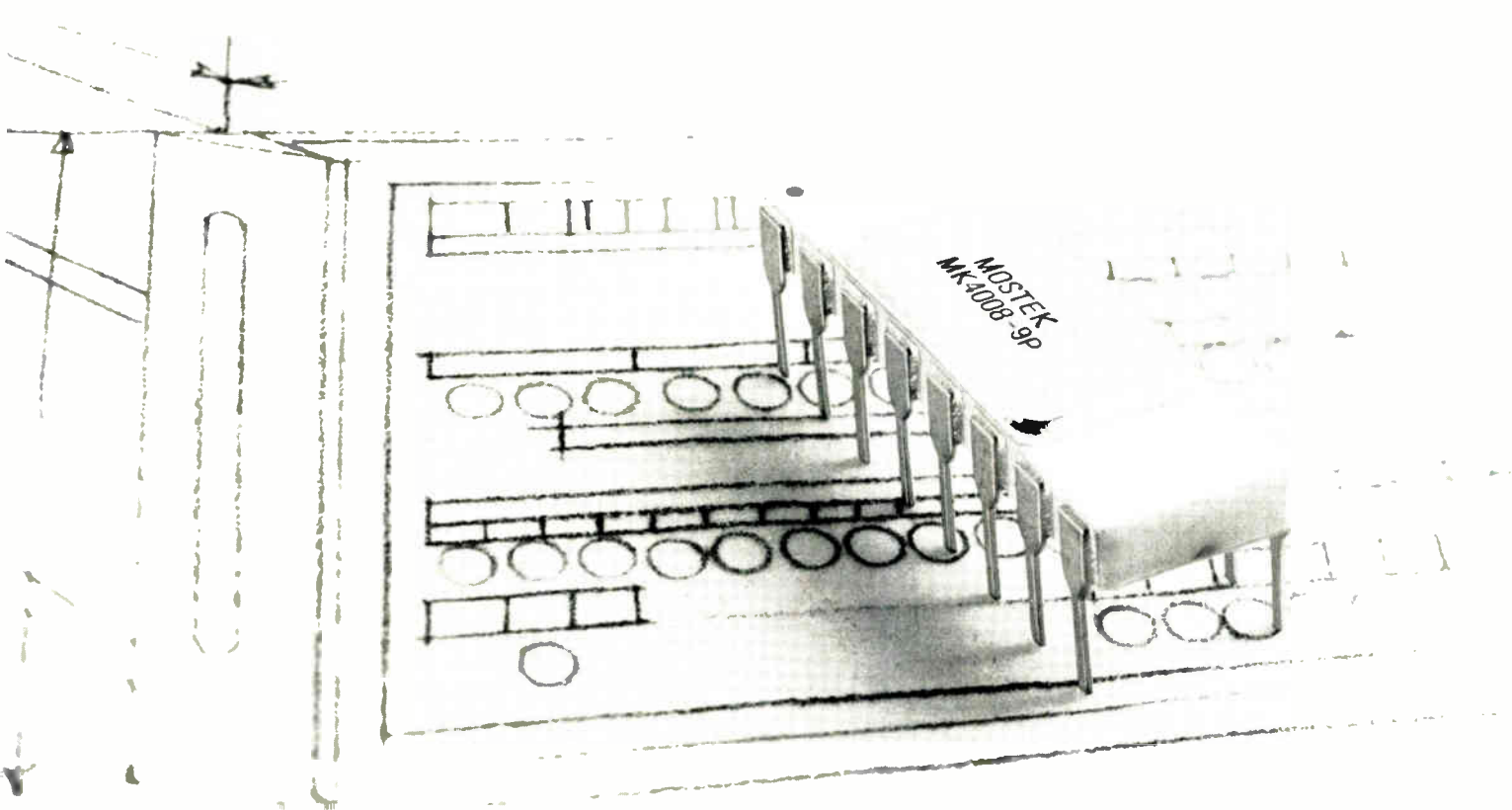



# HIGH PURITY ELEMENTS

We offer more than anyone else.

- Antimony
- Arsenic
- Bismuth
- Cadmium
- Copper
- Gold
- Indium
- Lead
- Selenium
- Silver
- Sulphur
- Tellurium
- Thallium
- Zinc

Asarco has the broadest selection of high purity elements in the business. All 99.999+ % pure. All ready for prompt delivery. For semiconductors, electronics, metallurgy, research, and other applications.

Our high-purity elements are also available in commercial quantities.

For more information on Asarco's array of high purity elements, write our By-Products Department at 120 Broadway, New York, N.Y. 10005.

75 Years of Progress in Metals  
**ASARCO**<sup>75</sup>  
 American Smelting and Refining Company

## Electronics review

most IR detectors are complicated and often sell for as much as \$40,000 each. But their performance has not measured up to French military needs as well as has Argamkoff's design. What's more, Argamkoff figures his device could be mass-produced for \$150 complete with display and could be as small as a pocket calculator.

The device is based on the Seebeck principle—that a voltage difference results from a temperature gradient across a material. It uses special metal alloys instead of pure

metals and takes the form of a three-dimensional triangular structure to obviate the problems of heat diffusion inherent in standard Seebeck detectors.

**Previous types.** Earlier IR detectors use either solid-state photodetectors or a type of thermal sensor. But the crystalline solid-state types must be immersed in liquid hydrogen or helium at 4°K to function efficiently in the spectral region between 7 and 20 micrometers—the window where absorption from particles of carbon dioxide and nitro-

## Electronics Index of Activity

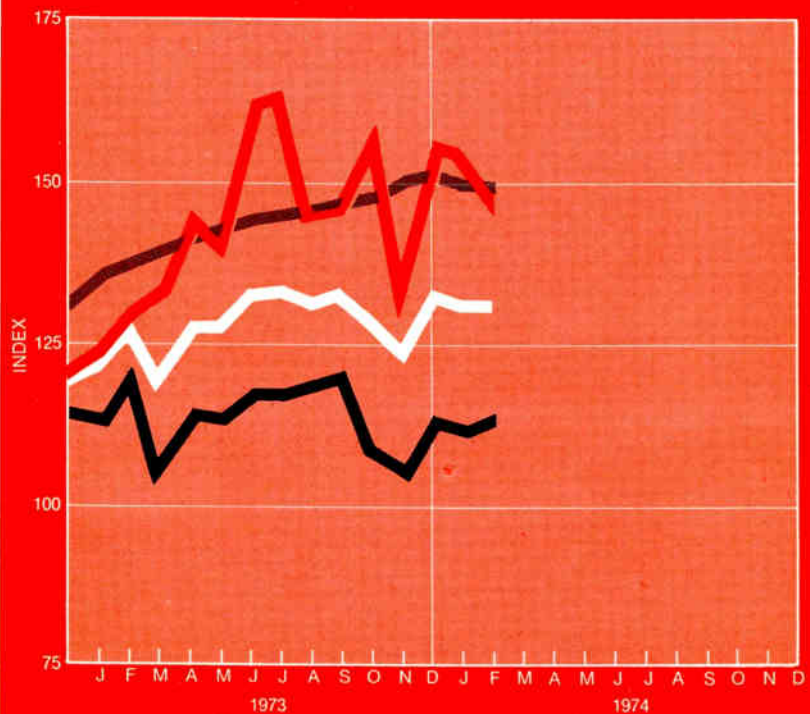

Segment of industry	Feb. '74	Jan. '74*	Feb. '73
Industrial-commercial electronics	148.4	155.6	130.9
Consumer electronics	114.9	112.9	111.8
Defense electronics	151.0	151.2	139.0
Total industry	131.6	131.7	123.2

The index fell 0.1% in February but remained 6.8% above last year's level. Defense was the strongest sector, rising 1.8% from January. The consumer and the industrial-commercial sectors declined; consumer electronics decreased 4.6%, and the industrial-commercial area edged downward 0.1%.

Indexes chart pace of production volume for total industry and each segment. The base period, equal to 100, is the average of 1965 monthly output for each of the three parts of the industry. Index numbers are expressed as a percentage of the base period. Data is seasonally adjusted. \*Revised.

# CONVERT 8 BITS IN 6 MICROSECONDS FOR \$25.....

*it's easy!*

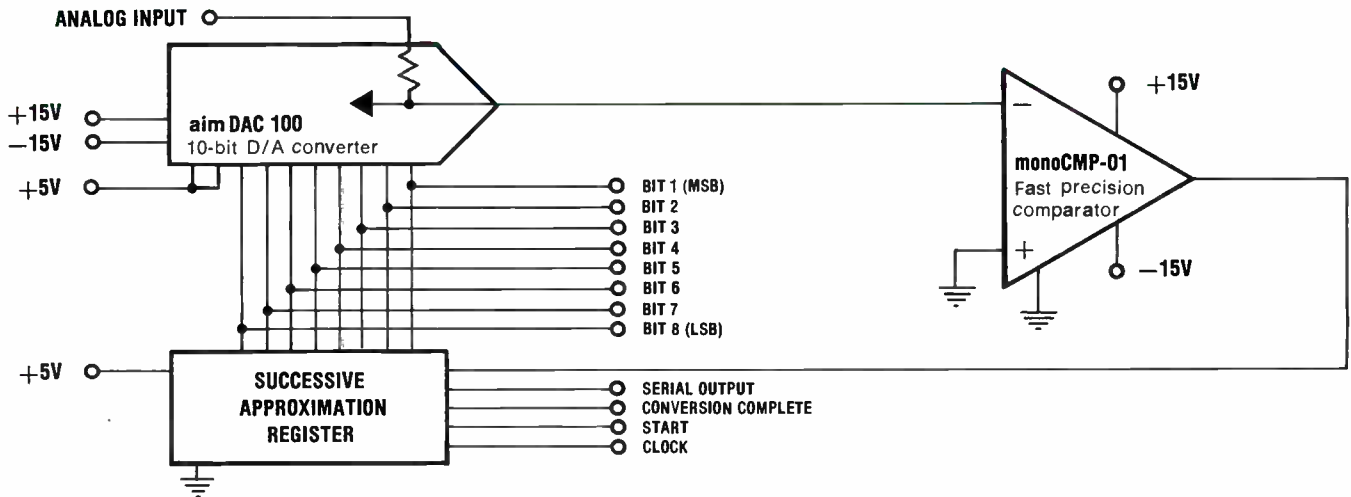

## THREE IC's BUILD A FAST A/D CONVERTER - FOR UNDER \$25!

It's easy with high performance analog components from Precision Monolithics—start with PMI's aimDAC100 Low Cost D/A Converter—with its internal precision reference voltage, 10-bit resolution, choice of linearities and high speed current output, it's ideal for all D/A and A/D applications. Next, add the PMI monoCMP-01 Precision Comparator with its fast 90ns response, low  $V_{os}$ , drift and superior stability—complete your converter with a

successive approximation logic chip and that's it! Sound easy? You bet—and 10-bit versions can be built for under \$40! Circuit construction and performance are fully detailed in our new Application Note: pre-drilled demonstration circuit cards are available free by contacting your local PMI rep or stocking distributor—call him today and find out how easy A/D conversion can be!

SPECIFICATIONS		PRICES
aimDAC 100 DDT1*	0.30% Linearity Max-0/70°C	\$ 9.95 @ 100 pcs.
aimDAC 100 CCT1*	0.20% Linearity Max-0/70°C	\$12.00 @ 100 pcs.
aimDAC 100 BCT1*	0.10% Linearity Max-0/70°C	\$17.00 @ 100 pcs.
aimDAC 100 ACT1*	0.05% Linearity Max-0/70°C	\$26.00 @ 100 pcs.
*Specify T1 for 0 to 10 Volt usage; T2 for 0 to 5 Volt usage.		
monoCMP-01CJ	Vos 2.8 mV Max	\$3.25 @ 100 pcs.
monoCMP-01EJ	Vos 0.8 mV Max	\$7.50 @ 100 pcs.

### PRECISION MONOLITHICS REPRESENTATIVES

Alabama .....	(205) 539-4411	Maryland .....	(301) 944-8262	North Carolina .....	(919) 725-5384
Arizona .....	(602) 992-9884	Massachusetts .....	(617) 890-0011	Ohio, North .....	(216) 461-8333
California, North .....	(415) 948-6533	Michigan .....	(313) 557-1934	Ohio, South .....	(513) 293-3145
California, Los Angeles .....	(213) 340-1745	Minnesota .....	(612) 646-7217	Pennsylvania, East .....	(215) 644-3477
California, South .....	(714) 830-3939	Missouri, St. Louis .....	(314) 731-5799	Texas .....	(214) 363-8591
Colorado .....	(303) 771-4920	Missouri, Kansas City .....	(816) 761-6543	Virginia .....	(703) 548-7818
Connecticut .....	(203) 634-0179	New Jersey, North .....	(516) 567-5900	Washington .....	(206) 624-9020
Florida, Ft. Lauderdale .....	(305) 776-4800	New Jersey, South .....	(609) 966-4070	Wisconsin .....	(414) 933-2733
Florida, Orlando .....	(305) 425-5505	New Mexico .....	(505) 265-5655	Canada, Toronto .....	(516) 864-2666
Illinois, North .....	(312) 774-3535	New York, New York City .....	(516) 567-5900	Canada, Vancouver .....	(714) 979-4894
Indiana .....	(513) 252-9981	New York, Upstate .....	(716) 464-8636		

### AUTHORIZED DISTRIBUTORS

NEW YORK METROPOLITAN AREA Harvey Radio, Woodbury, N.Y.: (516) 921-8700 • NEW ENGLAND AREA Gerber Electronics, Dedham, Mass.: (617) 329-2400 • UPSTATE NEW YORK Harvey Federal Electronics, Binghamton, N.Y.: (607) 748-8211 • NORTHEAST Newark Electronics, Woburn, Mass.: (617) 935-8350 • BALTIMORE-WASHINGTON Whitney Distributors, Baltimore, Md.: (301) 944-8080 • PHILADELPHIA Hallmark Electronics, Huntingdon Valley, Pa.: (215) 355-7300 • MICHIGAN RS Electronics, Detroit, Mich.: (313) 491-1000 • SOUTHWEST Kirkman Electronics, Winston-Salem, N.C.: (919) 724-0541 • EAST CENTRAL Pioneer/Cleveland, Cleveland, Ohio: (216) 587-3600 • Pioneer/Dayton, Dayton, Ohio: (513) 236-9900 • CENTRAL Hallmark Electronics, Elk Grove Village, Ill.: (312) 437-8800 • Minneapolis, Minn.: (612) 925-2944 • St. Louis, Mo.: (314) 521-3800 • TEXAS-OKLAHOMA Sterling Electronics, Houston, Texas: (713) 623-6600 • Dallas, Texas: (214) 357-9131 • SOUTHWEST Sterling Electronics, Albuquerque, N.M.: (505) 345-6601 • Phoenix, Ariz.: (602) 258-4531 • WEST Westates Electronics Corp., Chatsworth, Calif.: (213) 341-4411 • Sterling Electronics, San Carlos, Calif.: (415) 592-2353 • Intermark Electronics, Sunnyvale, Calif.: (408) 738-1111 • Denver, Colo.: (303) 936-8284 • Salt Lake City, Utah: (801) 359-0531 • San Diego, Calif.: (714) 279-5200 • Santa Ana, Calif.: (714) 540-1322 • Almac-Stroum, Seattle, Wash.: (206) 763-2300 • Portland, Ore.: (503) 292-3534.



1500 SPACE PARK DRIVE, SANTA CLARA, CALIFORNIA 95050  
TEL. (408) 246-9225 • TWX 910-338-0528 • CABLE MONO

# THE MODEL 250 HAS IT

15,000 Hr. MTBF  
1 Yr. Warranty  
Error Rate Better  
Than  $1 \times 10^{-7}$

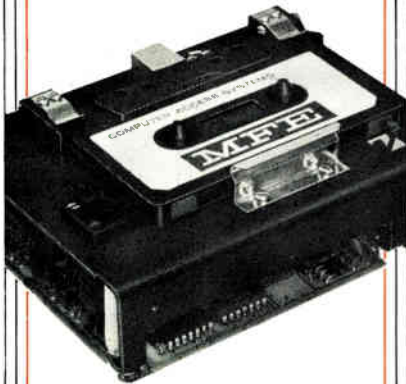

#### Digital Tape Transport With:

- Two moving parts
- Reel to reel
- Constant tape tension
- Constant tape speed
- $\pm 5$  VDC operation
- Guaranteed interchangeability
- Up to 800 BPI
- Up to 9600 Bits/Sec. transfer
- Read after write (standard)
- Full electronics
- Programmable tape speed
- A few \$525., a hundred \$325.

Call or write Brent Welling. For proof, call our customers. They have over 4,000 Model 250's.



COMPUTER ACCESS SYSTEMS

Keewaydin Drive  
Salem, New Hampshire 03079  
Tel: 603-893-1921  
TWX 710-366-1887  
TELEX 94-7477

## Electronics review

gen dioxide in the atmosphere is at its lowest.

To get around expensive cryogenic systems, some producers use a thermistor bolometer, the most common type of thermal IR detector. These devices operate by measuring the differential between a high-bias voltage and the small potential generated when IR radiation falls on an overlap area between two thin metallic films on a substrate. A light chopper pulses the IR radiation to distinguish the detected signal from the continuous bias voltage. Argamakoff, however, claims that noise generated by the bias voltage limits the minimum signal from the detectable amplifier.

**Alternative.** Some companies use Seebeck-effect detectors that obviate the need for a bias voltage by using the voltage generated by an IR radiation directed onto a weld between two thin films of pure antimony and bismuth. But Argamakoff explains that performance is again impaired—this time by heat diffusion into the substrate. Furthermore, the metals tend to degenerate because the crystalline structure of very thin films is different from that of thicker slices of the same metals.

Argamakoff solves both problems, he claims, by using a microscopic wedge of antimony and bismuth semiconductor alloys as the active element in his detector. Mounted with the welded "hot junction" up, only the ends of the 0.5-mm-thick alloy slices touch the substrate. Heat diffusion is thus cut two ways: by the reduced contact with the substrate, and by the low thermal conductivity of the alloys.

**Alloys.** The alloys are complex. Each pure metal is compounded with lead, tellurium and sulphur to produce the required semiconductive characteristics. The results are impressive. In ordinary metals, the response to infrared heat is  $100 \mu\text{V}$  per  $^{\circ}\text{C}$ . This jumps to  $1 \text{ mV}/^{\circ}\text{C}$  with the alloys.

Argamakoff has devised a thermocompression method for producing his 0.05-mm-thick slices, and he is betting that his knowhow is the only key to the process.

With his wedge structure, the

welded point is at the apex and thus presents a poor collecting area for trapping the IR beam. So Argamakoff uses small squares of blackened gold foil,  $0.15 \mu\text{m}$  thick, mounted across the apex to achieve an even better IR-beam focus.  $\square$

## Computers

### Ship loading gets computer treatment

Now that the oil embargo is lifted, a Swedish shipbuilder is promoting a system that makes sure oil tankers are loaded properly. Kockums Shipyard, of Malmoe, has delivered the first on-line version of its Loadmaster device—an analog computer that allows a ship's captain to calculate how his ship is to be loaded as it is being loaded.

The on-line system accepts analog or digital signals from tank gauges, and by means of a digital-analog converter, the signals are displayed on the display panel of the Loadmaster unit. These Loadmasters are located in the cargo control room of the ship.

The operator can have a constant indication of how the tanks are being loaded, with the information displayed on an indicator that shows the relative forces of each tank on the hull. Thus, if there is a mishap with a pump or valve, the operator can immediately see how much of the remaining forces can be shifted to other tanks. The operator also can determine how cargo might be distributed while certain pumps are out of order.

"You have tankers 350 meters long today, and the hull is made of 25-millimeter-thick steel plates," says Stig Berger, Loadmaster sales engineer. "If you were to build a 1:100 scale model of such a ship, it would be 3.5 meters long, and with hull plates the thickness of kitchen aluminum foil." With plates that thin, an evenly loaded ship is critically important.

Berger says that even though the standard Loadmaster will give an



### **±0.02% WATTMETER ACCURACY**

at 50 and 60 Hz plus 0.05% accuracy from 50 to 500 Hz even with distorted waveforms and low power factors. The YEW Model 2885 is the accepted standard in AC power measurements throughout the world.

Model 2885



### **TRUE RMS & 0.1% V-A-W ACCURACY**

over a wide frequency range, with distorted waveforms and with low power factors. For both laboratory and field application without extraordinary set-up requirements. The 2503 combines exceptional accuracy, a True RMS capability, and ease of operation all in one extraordinary instrument.

Model 2503

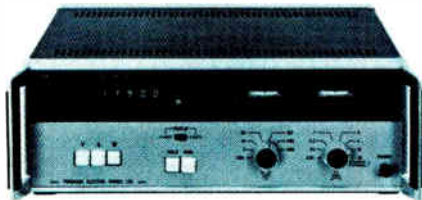

### **±0.5% PRECISION PORTABLES**

with rugged and precise tautband meter movements. Hundreds of models and ranges to choose from with accuracies traceable to N.B.S. Full one year replacement warranty, fast service and low cost (prices start at just \$95.00) combine to make these the world's best selling portables.

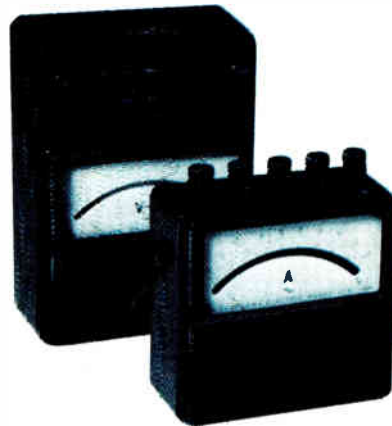

# PRECISION POWER

**... from YEW, the world's largest manufacturer of precision power and True RMS measuring instrumentation!**

YEW manufactures a complete line of precision power measuring instrumentation that meets the requirements of the most demanding instrumentation application. In fact, YEW's sophisticated APR-2 serves as a national standard in numerous countries of the world. YEW's precision portables are unexcelled in world-wide sales and have a reputation for being the most reliable and economical portable instrumentation available. Check some of our specs and we think you'll agree that YEW puts the "precision" in power instrumentation!

## **YEWTEC CORPORATION**

1995 Palmer Ave., Larchmont, N.Y. 10538  
Telephone: 914-834-3550



Yokogawa Electric



*60 Years of Measuring and Recording Instrumentation*

# Volts My Line?

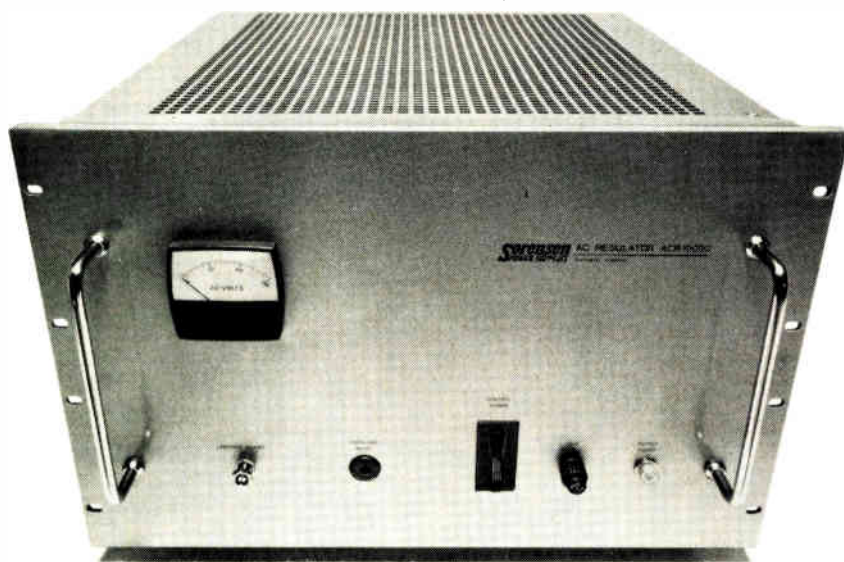

Holding that line voltage. AC voltage regulation is efficient with the Sorensen ACR Series all solid-state regulators. Problems and damage caused by erratic line voltage are eliminated . . . performance is maximized with ACR features that include MTBF > 25,000 hours . . . remote sensing and remote programming capabilities . . . electronic current limiting . . . adjustable output voltage . . . power outputs to 15kVA—depending on model. Eight models in series. Three-phase systems available. For complete data, contact the Marketing Manager at Sorensen Company, a Unit of Raytheon Company, Manchester, N.H. (603) 668-4500.

#### Representative Specifications—ACR

- Input Voltage: 95 to 130 Vac
- Total Regulation: 0.4% to 0.6%
- Efficiency: to 95%
- Price Range: \$380 to \$1775

**Sorensen**  
POWER SUPPLIES

## Electronics review

accurate pre-calculation of how to load—or unload—a tanker, accidents like pump failures or sticking valves can always occur. In such cases, the ship's captain must make new calculations. This, the Loadmaster On Line does automatically.

## Government electronics

### Digital light meter checks OSHA specs

The requirements of the Occupational Safety and Health Act are spawning a number of new instruments, which are being designed specifically to check whether the act's standards, defining such hazards as excessive sound level and inadequate lighting, are being met.

An inexpensive digital light meter has now been developed to help companies satisfy the act's demands. The Digaphot, from United Detector Technology Inc. of Santa Monica, Calif., is made to sell for under \$150. This unit has already been approved by the Food and Drug Administration, which administers OSHA requirements, according to Paul H. Wendland, president of UDT.

The Digaphot uses a comparison readout rather than the more expensive direct-digital display. A 10-turn, calibrated potentiometer is rotated until a low light goes out and a high light goes on, or vice versa. The only other controls are on-off and low-battery warning. The palm-size instrument uses a silicon planar photodiode, which provides excellent long-term stability, instead of the more commonly used cadmium sulfide cells, which drift with age. In addition to the photodiode itself, an optical diffuser and filters provide the proper response.

Unlike the light meters used by photographers, UDT's instrument uses a 3½-digit display instead of an analog meter. It reads directly in foot-candles from 0 to 1,000, with ±10% absolute accuracy and ±2% circular error area match. Its resolution is 0.5 foot-candle. □

**WANT A 16K BY 20  
650 NSEC. MEMORY  
ON A SINGLE CARD?**

**YOU  
JUST  
FOUND  
IT**

Not only do we have just the memory you're looking for, we have it in a thoroughly field-proven design. A design that has been accepted — even by our competitors — as the industry standard. Basically it is the same reliable 3 Wire, 3D design as our MICROMEMORY 3000. We doubled the capacity, but kept everything else the same.

It is the MICROMEMORY 3000DD. Consider its credentials. Cycle and access times of 650 nsec. and 300 nsec., respectively. Power requirements of  $\pm 15\text{VDC}$  and  $+5\text{VDC}$ . The complete system, including all necessary logic, drive and sense circuitry complete on one convenient plug-in circuit board. Standard configuration of 16K by 16, 18, or 20 bits, alterable to 32K by 8, 9, or 10. And it is interchangeable with the original MICROMEMORY 3000.

The MICROMEMORY 3000DD is also available as a pre-packaged, multi-card system, complete with power supply, self-test and interface cards, and various other features and options. And standard chassis are available to hold from one to 16 memory cards. Since both the original 8K MICROMEMORY 3000 and the new 16K MICROMEMORY 3000DD cards can be intermixed, this gives you new and greater growth flexibility from 8K to 256K.

Get complete information and technical details from your local EMM office, or call Commercial Memory Products Marketing Department at (213) 644-9881. Do it today.

**EMM ELECTRONIC  
MEMORIES**  
**COMMERCIAL MEMORY PRODUCTS**

A Division of Electronic Memories & Magnetics Corporation  
12621 Chadron Ave., Hawthorne, Calif. 90250  
Belgium 03/76.69.75; United Kingdom 01/751-1213; W. Germany 0811/74.30.40

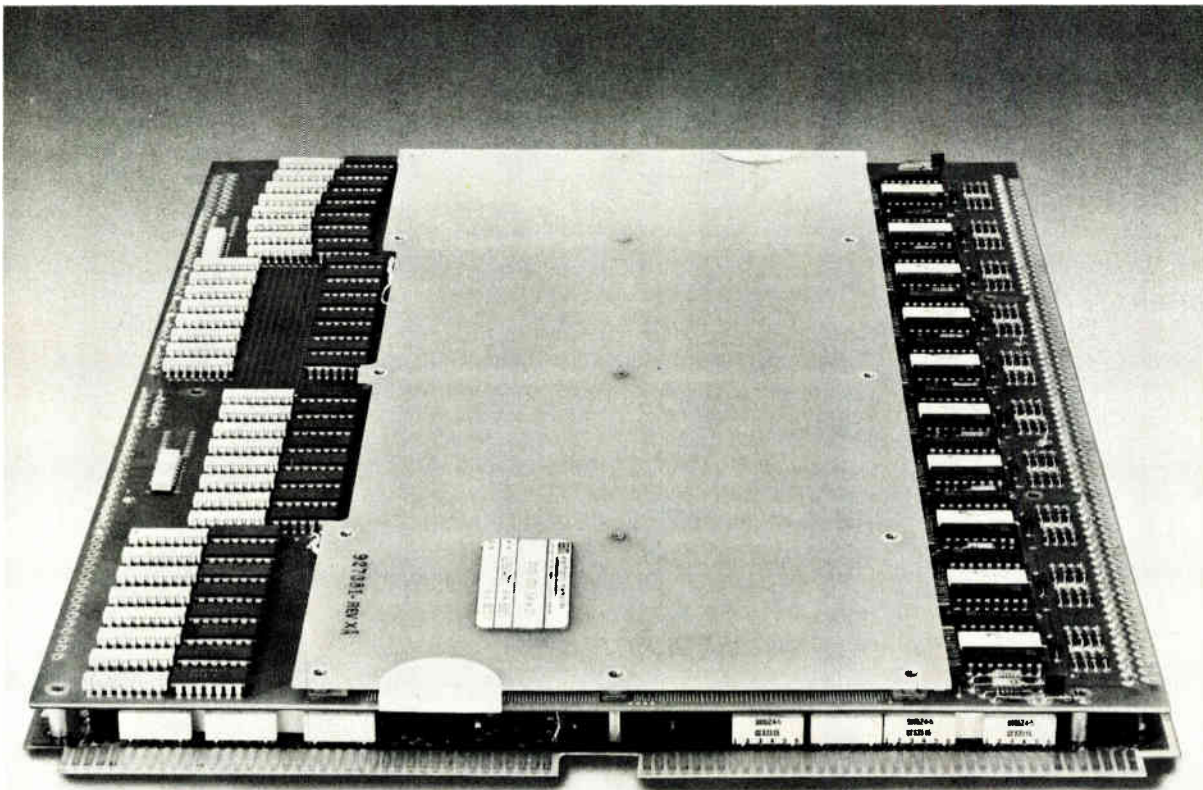



# 'rithmetic was never



# like this...

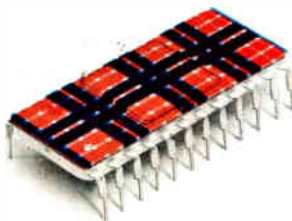

## Now CMOS Rings The Bell For Arithmetic Systems

The lessons of today focus attention on Motorola's McMOS\* MC14500 series. And we learn there's another new device designed to improve data handling in environmental controls, process controllers . . . or anywhere CMOS is used for arithmetic logic systems.

MC14580. The CMOS Four-Word by Four-Bit Multiport Register.

Let's briefly study a four-bit CMOS arithmetic processor where the MC14580, with its output latch capability, serves as a scratchpad memory to eliminate the need for storage registers on the inputs of the MC14581 ALU. It has one write and two read ports with independent addressing. All addressing, input (write) data, and output (read) data are stored on the positive transition of the clock, leaving storage registers required only for the input/output section of the processor.

Application of the MC14508 Dual 4-Bit Latch for storing input data further reduces the complexity of the processor by removing the data selector requirement on the ALU's B input. Data selection now is achieved by using the three-state capability of the MC14508 and MC14580. Expansion to larger m-by-n register files is also simplified by the three-state outputs of the Multiport Register.

Suppose we did have a larger design; a 16-bit processor with four MC14581s. As the CMOS version of the popular TTL Four-Bit ALU, the

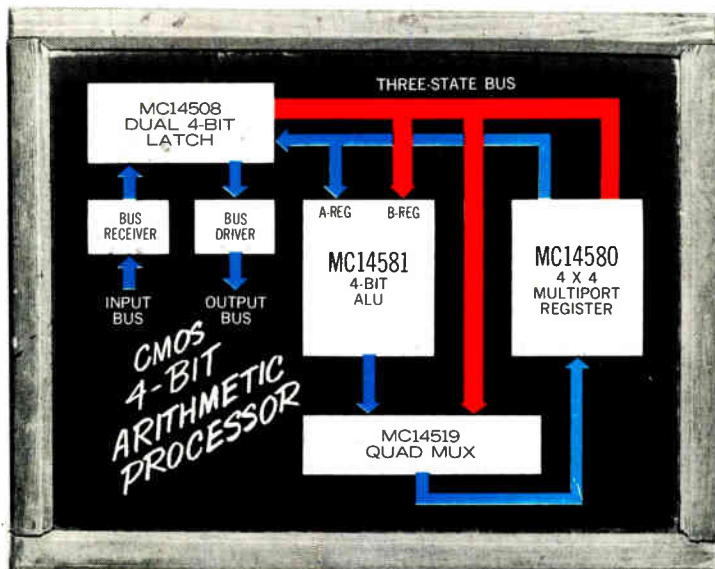

MC14581 performs 16 logical and 16 arithmetic operations. In the larger system, speed is maintained by adding the MC14582 Look-Ahead Carry Block for significant reduction of ripple-through delay.

A curriculum for further study of McMOS arithmetic devices should include the MC14527 BCD Rate Multiplier, the MC14554 Two-by-Two Flow Through Multiplier, and the MC14585 Magnitude Comparator. Optional courses cover the MC14008 Four-Bit Full Adder, MC14032 Triple Full Adder (positive), and MC14038 Triple Full Adder (negative).

Source materials for technical information on the McMOS MC14500 series arithmetic devices are available via the reader service card, or on request from Motorola Semiconductor Products Inc., P. O. Box 20912, Phoenix, Arizona 85036. Consult your Motorola salesman or franchised Motorola distributor for information on price and delivery.



## MOTOROLA McMOS

—MOS for contemporary systems

\*McMOS is a trademark of Motorola Inc.

## Another FIRST from DDC...

The smallest glitchless DAC is also the fastest! . . . 13 bit resolution, settling time 50 ns per bit . . . in the first hybrid glitchless DAC. From DDC, of course. DDC, the leader in data conversion, has done it again! This time with the first hybrid deglitched digital-to-analog converter. So you could have the benefits of high speed plus compact size for critical CRT displays and precise testing applications.

The new Model DDAC hybrid features a 13 bit monotonic output, with programmable output of  $\pm 2.5V$ ,  $\pm 5V$ , or  $\pm 10V$  and 300mA coax drive capability. Other features include internal or external reference, 150 mV•ns glitch, and short circuit protected output. It's available as a complete two channel P.C. card assembly, a set of 3 hybrid modules or individual DAC, deglitcher, and coax driver.

And it's from DDC. The data conversion people who have made a habit of being first.

For product or technical applications information, write or call Steve Muth or Jim Sheahan. They're engineers, so they talk your language.

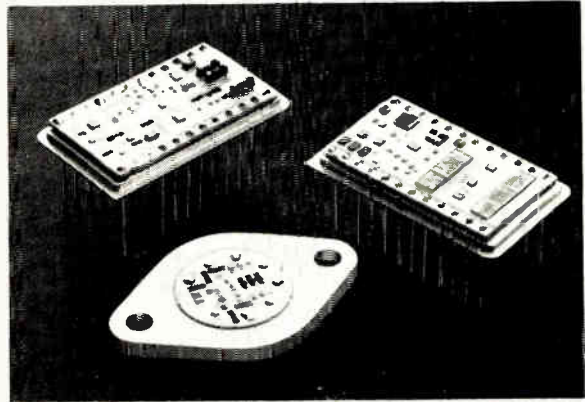

# DDC

## ILC DATA DEVICE CORPORATION

A Wholly Owned Subsidiary of ILC Industries, Inc.  
AIRPORT INTERNATIONAL PLAZA  
BOHEMIA, LONG ISLAND, N. Y. 11716 (516) 567-5600  
Shaping the future of data conversion.

### APPLICATION CENTERS

Long Beach, Calif.  
(213) 597-5744

Washington, D. C.  
(703) 536-2212

Europe  
(Tel. 62.01.59)

# Shaping the future of Display DACs

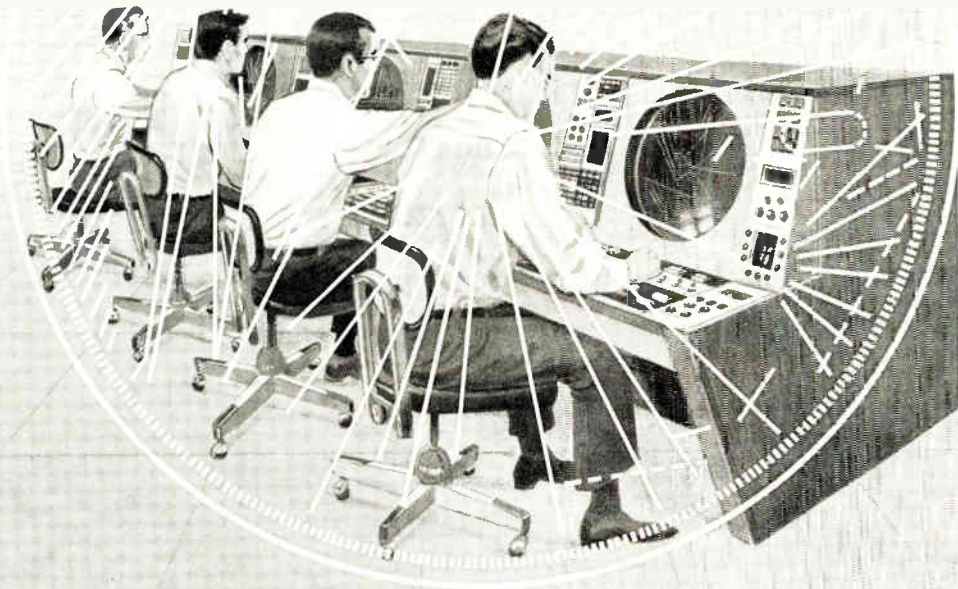



## **Congress seen approving long leases of computers by U.S.**

Outlook for congressional passage of a Senate bill **authorizing the General Services Administration to write multi-year leases for computers used in Government** is good, in the view of the Computer Lessors Association. The association, which is pushing the bill introduced by Sen. Charles Percy (R., Ill.), contends that multi-year hardware leasing would make its 10 member companies more competitive in the Government lease market with the computer industry's mainframe heavyweights like IBM. Moreover, **the General Accounting Office has estimated that annual rental costs for 636 computer systems might be cut "by as much as \$54 million under three-year leases and by as much as \$127 million under five-year leases."** The bill is now before the Senate subcommittee on Government operations.

## **RFPs due soon for automated car-test systems**

A Federal push for electronic automotive diagnostic inspection systems is expected to get under way soon when the National Highway Traffic Safety Administration issues the states with requests for proposals for demonstration sites. By law **the agency is empowered to give five to 10 states funding for automated or semiautomated systems that will test vehicles for compliance with mechanical safety and emission control standards.** The plan is to have the demonstrations "onboard and in operation by January 1975," says one official, with 90% of the cost being paid by the Government. **Although Congress has authorized a total of \$75 million for fiscal years 1973-75, the White House Office of Management and Budget has given the agency much less than that,** the official says. Currently, the agency is querying industry to see what off-the-shelf technology exists. Emission test equipment may be a problem.

## **EPA seeks hazardous-spill warning system**

The Environmental Protection Agency has asked qualified contractors to submit bids no later than May on **a prototype system for detecting the discharge of about 300 different pollutants in streams and rivers.** Goal of the program is a **marketable working design for use by Federal, state, and local pollution control agencies.** Winning contractor will be selected by June 30 and be given 24 months to construct and test the system and to produce fabrication specifications. Plans are also in hand for the development of more sophisticated, automated units that will identify particular acid, metal, and other contaminants. **Estimated costs of commercial versions are \$10,000 to \$15,000 for a simple system to several hundred thousand dollars for a sophisticated system.**

## **Addenda**

Sperry Rand Corp., Great Neck, N.Y., has pulled down a **\$35.4 million contract for design, development, and test of the prototype of the Trident submarine navigation subsystem.** . . . NASA's Lewis Research Center in Cleveland is looking into the feasibility of **automating the manufacture of silicon solar cells.** In June, provided the idea seems workable, the center will choose a contractor to set up a small experimental pilot line. . . . Within weeks the Bureau of Mines will select a contractor to **develop a prototype electronic sensor to warn of impending mine-roof cave-ins.** Mandated by Congress, the development calls for the contractor to build and test two types of the portable, battery-powered seismic detectors.

## Challenges facing the FCC's new chairman

Last month Richard E. Wiley told the Electronic Industries Association that, in the three working days that had passed since his elevation by the President to the chairmanship of the Federal Communications Commission, he had "appeared before two congressional committees—both without subpoena." As the successor to Dean Burch, Wiley will need that sense of humor in the months ahead.

In that period, the seven-man commission will come to grips with some of the most complex and difficult issues in its 40-year lifetime, as well as implement a number of other judgments made during the Burch régime. It will have to rule on how to allocate spectrum space in the 900-megahertz region. It will be called upon to resolve the continuing problem of the interconnection of special service carriers with the facilities of American Telephone & Telegraph Co. It will also enforce the commission's approval of services competitive with Bell.

The issue of competition is a particularly thorny one for the FCC now that AT&T has mounted a massive effort to combat it. Yet Wiley—who insists that his conservative views make him neither "an industry shill nor an advocate for any individual business entity *qua* entity"—appears to be standing firm in favoring competition for AT&T."

But Wiley does qualify his support for competition by special service carriers. First, he is convinced that they must offer "something new and different," rather than merely duplicate AT&T services and siphon off telephone company business. Second, he supports the view that AT&T can offer a competitive response to specialized carriers, provided it avoids cross subsidies and predatory pricing. And, finally, the new FCC chairman is determined that commission rulings offer special carriers no more than "a decent chance to get started and a full and fair chance to succeed." After that, he adds quickly, there must be "no protective umbrellas, no contrived allocations, no Governmentally inspired salvation" when AT&T drops the other shoe (see p. 75).

### The FCC's vacancies

Specialized carriers and their equipment suppliers can ask no more from chairman Wiley and his colleagues. But they should accept no less. The question still in the minds of some of Wiley's EIA audience is how effective he will be in getting his fellow commissioners to accept his views. As one EIA member points out, "The chairman is still just one voice out of seven when it comes to a vote."

Three of those seven votes are still unknown quantities because of vacancies on the commission. Confirmation of President Nixon's nomination of Detroit broadcast executive James H. Quello is still pending before the Senate and will not be acted upon before the remaining two appointments can be cleared as well. The name of a second nominee, Luther Holcomb, the vice chairman of the Equal Employment Opportunity Commission, was formally transmitted to Capitol Hill in mid-March, while a third is yet to come. Speculation on a variety of candidates for that job continues in Washington, but, like Holcomb, none of them has any particular meaning for the electronics industries. "It's disappointing," says one communications equipment industry official. "Right now, there is no one in sight that appears to have any knowledge whatsoever about the communications business and these problems."

### AT&T's counterattack

Meanwhile, AT&T board chairman John deButts has declared the company will continue to hang tough on the issues of interconnection and competition. "The contrived competition that is now being urged upon us," deButts told AT&T shareholders, "can have but one consequence—higher costs for poorer service." The company, he declared, will "oppose it with all the energies we can command." That opposition will not be limited to actions before the FCC: "Eventually it may fall to the Congress of the United States to determine once and for all where the public interest lies" in the development of domestic telecommunications.

The unfortunate aspect of all of this is that the long-simmering questions about competition and the related interconnect equipment market are coming to a boil at a time when the FCC is at its weakest in many years. Telecommunications equipment makers, whose future is being determined regularly by the FCC, are disturbed by the uncertainties about the makeup of the commission, as they should be. Chairman Wiley has outlined a reasonable set of goals, yet it is one that he cannot implement singlehandedly. And the apparent inability of the White House to come up with a single nominee for the commission with experience in telecommunications—or even an interest in the subject—is turning Wiley's difficult assignment into an impossible one. As Wiley himself mused when contemplating the departure of his predecessor, Dean Burch, to join the White House staff, "His timing is excellent."

—Ray Connolly



# **SPERRY™ Displays** are now **Beckman Displays**



There's a new name for one of the most popular lines of displays and readout accessories — Beckman. You can look for even faster service . . . even better design assistance . . . even more display ideas. Now, from Beckman, Information Displays Operations, P. O. Box 3579, Scottsdale, Arizona 85257, Phone (602) 947-8371.



**INSTRUMENTS, INC.**  
**INFORMATION DISPLAYS OPERATIONS**

## **There's more eye appeal in Beckman Displays!**

FOR THE NAME OF YOUR BECKMAN DISPLAYS DISTRIBUTOR OR SALES OFFICE

**CALL TOLL-FREE 800-645-9200**

(IN N.Y. STATE, CALL COLLECT, 516-294-0990)

Beckman Instruments, Inc., Information Displays Operations, P. O. Box 3579, Scottsdale, Arizona 85257. Telephone (602) 947-8371.



## Laserscope offers better look over and under sea

A **laserscope** being developed by Tokyo Shibaura Electric Co. promises to outdo radar and sonar by increasing the range for sensing objects over and under the sea at night and in foul weather. The instrument can provide three-dimensional images of objects for a few kilometers ahead of ships on hazy nights when vision is of little use. And even prototype underwater units provide about twice the range of eyesight and four times the range of television cameras.

**Overcoming limitations.** Other artificial aids all have their weaknesses. Powerful lights can be ineffective in piercing a fog, rainfall, or water because scattering of the beam both attenuates it and obscures desired reflections. Millimeter-wave radar has two disadvantages: the reflectivity of objects to radar waves can be quite different from their response to light, and the shapes of objects viewed on a radar screen can differ markedly from their normal shapes. Sea clutter and scatter from rain also interfere.

Under water, radar is useless. Sonar-type ultrasonic equipment is often used, but its wavelength is too long to reconstruct the shapes of objects. And at higher ultrasonic frequencies, where the wavelengths are short enough to give that information, attenuation reduces range to one or two meters.

The laserscope, on the other hand, transmits extremely high-energy pulses of extremely short duration. This makes it possible to gate the special image tube used to detect reflections and eliminate the interference encountered by other methods.

Thus the laserscope has potential for use in ship navigation within harbors and also can be used for surveillance of harbors. Although a strong laser beam is used, it is spread out and should not be a hazard to eyes at least 10 meters from

the transmitter, so personnel on ships being monitored are in no danger.

Under water, the laserscope's potential may be even greater because of the emerging areas of oceanography. The instrument can be used to monitor underwater robots, bulldozers, cable diggers, and other ocean-bottom surveillance gear.

In operation, gate-pulse switches on the image tube are operated as electronic shutters at the proper time to receive reflections from objects at a predetermined distance. A three-dimensional view is obtained by varying the delay of the gating pulse so that objects in the desired range can be observed. The duration of the shutter openings can be increased to view objects at different distances simultaneously.

**Pulses.** The laser is built around a neodymium-doped yttrium-aluminum-garnet rod; a Pockels-type Q switch is used to give nanosecond-order pulses at 60 pulses per second. Although the energy of each pulse is only about 0.02 joule, the short-duration pulses have a peak energy of about 3 megawatts.

The laser operates at 1,060 nanometers, in the infrared spectrum. The output frequency is doubled in a lithium-niobate frequency multiplier to give a 532-nm wavelength output, which is yellow-green. At this wavelength, attenuation through water is minimum.

Although the laser beam is pulsed in the same way as radar, the system does not emit a radar-like sharply focused beam. Instead, a lens directs the laser beam over the entire field to be viewed. And because the mechanism of beam formation is completely different, the laser beam emerging from the transmitting lens is divergent—beam angle is 0.1 to 0.5 radian. This makes it superficially similar to the beam of a well-focused searchlight.

The laser beam reflected from the

object being viewed is focused by another lens onto the photocathode of an image tube. The image tube is in many respects similar to that used to intensify the images produced by X rays, except that it has a switching grid near the photocathode. This grid, used as an electronic shutter, normally stops electrons emerging from the photocathode. The shutter is opened to view the return from a predetermined distance by a negative-gain high-voltage pulse with a width of 20 ns or longer. Two conventional image-intensifier tubes intensify the weak image. The image on the fluorescent screen of the final image tube is picked up by a closed-circuit TV system.

Since light travels at 0.3 meter per nanosecond in air, the transmitted pulse has a length of less than 3 meters. The short transmitted pulse and slightly longer minimum shutter opening thus provide an efficient means of viewing a region at a predetermined distance from the laserscope. The experimental unit has been able to clearly resolve small islands one or two kilometers away. Under water, it has sighted a 1.25-centimeter stripe on a target 10 meters away and a 2.5-cm stripe on a target 20 meters away. □

---

## West Germany

---

### Video recorder to debut in color

It's not too often that a lone engineer working in a small laboratory can challenge the work being turned out by teams at large companies, but a Nuernberg engineer appears to have done just that with a video-recording and playback system.

The engineer, Erich Rabe, first demonstrated an experimental system in West Berlin late last year

[*Electronics*, Sept. 13, 1973, p. 65]. Now, his MDR (for magnetic-disk recorder) appears to be further along than some video-disk systems developed earlier by bigger companies. By the end of this year, Rabe says, his system will be ready to go to market. And, a fully operable prototype color system will, in fact, be shown this month.

Rabe estimates that a disk player will cost about \$380 on the consumer market. The unrecorded disk, which has a capacity of 15 minutes worth of TV programs on each side, will sell for roughly \$5.70. Rabe is working on two versions simultaneously—one for the German-developed PAL color standard and the other for the French Secam. "An NTSC version will follow," he says.

With minimal production capacity of his own, Rabe is now negotiating with a number of as yet undisclosed electronics firms to produce and market the player unit. From West Berlin-based Wolfgang Bogen GmbH will come the system's most critical item, the magnetic head.

**Simplicity.** Prior to the MDR development, Rabe investigated such various other recording/playback methods as film-scanning and laser-recording. But finding them too complicated, he started looking into magnetic-disk pick-up principles.

Basically, the MDR system consists of a normal record player with high-fidelity characteristics, a video/audio signal processing unit, the magnetic disk, and the Bogen head for recording and playback. The disk, 12 inches in diameter, has two areas: an outer information-carrying, magnetic-layered zone extending over roughly half the radius of the disk's useful portion, and an inner zone with grooves for guiding the magnetic head over the information portion. The disk rotates at 156 revolutions per minute, a speed obtained by suitable step-up gearing of a 78-rpm player's drive system.

For guidance, the head is attached to an outrigger that has a sapphire needle riding in the grooves. With this type of forced tracking, any eccentricity or variations in peripheral speed of the disk do not lead to uneven rotation.

## Around the world

### Computerized system locates, controls buses

A growing problem in urban mass transit, particularly during rush hours, is how to prevent buses from jamming up at bus stops and keep them running at scheduled intervals. To solve this problem, bus operators in many cities around the world have turned to electronic monitoring systems that, using two-way radio and curb-mounted detector-receiver equipment, keep track of vehicle positions. Dispatchers at control centers then instruct drivers to go slower or faster so that jams do not start to build up.

As far as one electronic-equipment maker is concerned, existing systems are good, but far from ideal. What can be done to improve bus monitoring, Siemens AG believes, is to computerize the vehicle-control function. And that is just what the company is doing with a new system it is now readying for the market. "With a computer," says project leader Dietrich Bornewasser, "many more vehicles can be monitored." The Siemens system, which is good for buses and street cars alike, is designed to handle as many as 1,000 vehicles, and it can continuously spot the position of 700 of them in only one minute. Designated the LIO (for location identification organization), the Siemens system will be offered this summer.

### Engineer-musicians design tuner

For music lovers, nothing can be as boring as tuning up instruments before each performance. This is especially true for pop bands whose arrays of high-powered speakers make tuning by ear chancy exercises. However, two young Swedish electronics engineering students have done something about those delays for tuning. The two, who also play in pop bands, have developed a device that not only will speed up instrument tuning, but will actually enable the deaf to get jobs as piano tuners.

Johan Stark, 24, and Haakan Alsternaes, 23, who study at the Royal Stockholm Institute of Technology, have named their device Pitcher 3-E. It's used today by the Stadium Transistors, a pop band in which Stark plays saxophone. The next step, the inventors hope, is to interest companies in manufacturing and marketing the Pitcher 3-E. The instrument works on the principle that each tone has a specific frequency. The unit, in its initial design, has 10 tone-selector buttons. The sound of the corresponding note on the instrument is picked up by a directional microphone. The instrument's frequency is immediately displayed digitally in hertz on a light-emitting-diode display on the face of the Pitcher. Electronically amplified instruments, such as electric guitar, can be plugged directly into the Pitcher to register tone frequencies without using a microphone.

The information zone on the disk's outer edge is covered with extremely smooth and highly coercive magnetic layers, which, together with emulsion layers, are from 6 to 8 micrometers thick. The layer granularity is in the order of magnitude of the recorded data's wavelength, or less than 0.5  $\mu\text{m}$ .

These layer properties put stringent requirements on the head's gap and track width. The Bogen heads come with an effective gap width of about 0.3  $\mu\text{m}$ —smaller than half a light wavelength—and with a track width of about 50  $\mu\text{m}$ . That track width enables the disk to hold a maximum of  $1.57 \times 10^9$  bits on one side.

To keep the noise value as small as possible, the magnetic head is di-

rectly coupled to a low-noise preamplifier in the head's housing. The low-resistance output—1 volt peak-to-peak—allows feeding the video signal over a conventional cable installed in the player's pick-up arm. By using standard techniques, the video signal is frequency-modulated, and the color information is added by amplitude modulation. Sound is recorded by fm methods via the system's modulator.

Thanks to its high bandwidth, the MDR system is also suited for recording and playback of a multi-channel audio program with a maximum of eight hi-fi channels. In this application, the player rotates at  $33\frac{1}{3}$  revolutions per minute, permitting a one-hour program to be recorded or played back. □

# REI has one question for people who buy electronic test equipment.

## Why?

**When you need it fast . . . rent it.** Purchasing equipment usually involves long delivery lead times. When you rent your electronic equipment from REI it's a safe bet that you can get what you need within 36 hours of the time you call in your order, sometimes sooner. This fast service is possible because we maintain 9 Instant Inventory Centers throughout the U.S. and Canada, stocking millions of dollars worth of equipment.

**When you need it for only a short time . . . rent it.** Need equipment for a short-term project? Rent it from REI. When you don't need it any more, return it to us. It's the easy, low-cost way to use the equipment you need for just the time that you need it.

**When you care about what it costs . . . rent it.** Renting from REI can be less expensive than purchasing. There's no capital investment to adversely affect your company's cash flow. This means you'll get more mileage from your equipment budget. And, since you can treat your monthly payments as an expense in most situations, you'll also achieve tax advantages from renting.

All REI rental equipment is guaranteed to meet manufacturers' specifications and is operationally checked out prior to shipment. Routine maintenance is provided free of charge. Certification and calibration are available upon request. Our flexible arrangements include rental, rental-purchase and leasing packages to give you the use of equipment from one week to three years or more.

Get your free copy of our 1974 catalog that lists virtually every item in our rental inventory. Use reader service card, or write Rental Electronics, Inc., 99 Hartwell Ave., Lexington, MA 02173. For immediate information, call your local REI Instant Inventory Center listed below. Once you rent from REI, you may never buy electronic test equipment again.

## Rental Electronics, Inc.

A PEPSICO LEASING COMPANY

Burlington, MA (617) 273-2770 • Gaithersburg, MD (301) 948-0620 • Oakland, NJ (201) 337-3757 • Ft. Lauderdale, FL (305) 771-3500  
Des Plaines, IL (312) 827-6670 • Dallas, TX (214) 661-8082 • Mountain View, CA (415) 968-8845 • Anaheim, CA (714) 879-0561  
Rexdale, Ontario (PLC Leasing Ltd.) (416) 677-7513



**Think about renting.  
It's the smart way to go.**



## Europe's space agencies plan joint component specs

Sometime next fall 10 European space agencies will announce the first in a series of common specifications for high-reliability electronic components. **First products to get a stamp from the Space Components Coordination Committee will be resistors, condensers, discrete components, and integrated circuits.** Countries in the scheme are Belgium, Denmark, France, West Germany, Italy, the Netherlands, Spain, Switzerland, Sweden, and the United Kingdom.

The SCCC's aims are to coordinate development and production of components to avoid unnecessary multi-sourcing of supplies of the same component. At the same time, they hope that they will be able to order jointly from U.S. manufacturers, eliminating numerous small-volume orders for variations of the same product. But if the project works out as planned, **the European agencies will be able to whittle down their heavy 60% dependence on imports of U.S. products.**

## West German computer market looks bright

**Despite West Germany's economic slowdown, computer demand there figures to stay in high gear for a while.** That's the finding of market researchers at Diebold Deutschland GmbH who have analyzed the country's computer growth prospects for the next half decade. **Topping the performance list are minicomputers,** for which installations are expected to rise from 3,700 at the beginning of last year to 7,500 by 1975 and to 15,000 three years later—an average increase of 50%. A somewhat slower growth rate, but still impressive, is predicted for general-purpose computers for which corresponding figures are 9,400, 11,000, and 14,000. Also doing well are office computers, which will more than double in the coming half decade—from 45,000 in 1973 to 100,000 in 1978. **Total West German demand for EDP hardware amounted to roughly \$2.3 billion last year,** Diebold says, and overall expenditures for computer software, maintenance, service, and personnel costs to about \$4 billion.

## Britain's new budget holds little that is cheering

The first budget introduced by Britain's new Labor Government confirms the tendency to economic contraction that's been around in Britain since the beginning of the year. All-round increases in sales and income taxes, plus the effects of steep price increases in state-provided items like electricity, coal, and steel, are likely to have **an increasingly depressing effect on consumer discretionary spending for such things as color television.**

Already, in the first three months of this year color-TV sales and rentals have averaged only 120,000 sets a month against domestic production of 180,000 plus imports of 60,000, with exports negligible so far. Industry optimists point out that this roughly parallels last year's trends, and 1973 turned into a color-TV boom year after mid-summer. Pessimists reply that the boom was generated by a continuously expanding economy, while this year even the most rosy-spectacled don't expect any economic growth. **The next two or three months will tell: If stocks pass the half-million mark, with no upturn in sales, makers must cut back.** Already some importers of luxury sets are chopping orders.

In capital goods, the government has added a cut of another \$115 million in defense expenditure to the \$410 million cut ordered by the Conservative Government two months ago. **How both cuts will be ap-**

plied is not yet known, but they are more likely to be slow-ups rather than cancellations of projects. Nevertheless, expensive projects of limited application, such as the interceptor version for the RAF alone of the British-German-Italian multi-role combat aircraft, with its special Marconi-Elliott search radar, will be vulnerable. And the government is allocating no money for building Concorde beyond the 16 already authorized.

## Japan plans rocket improvement to up payloads

Japan's space agency is contemplating an improved version of its liquid-fuel N rocket—with sufficient thrust to lift a 350-kilogram satellite into stationary orbit. Final decision will be made in July or August, in time to request funds in fiscal 1975 budget. Fabrication of the first unit of the original N rocket should be completed in January or February next year. However, it is only designed to lift a satellite in the 130-kg class—and is much too small to orbit a practical satellite—which must weigh 300-kg or more.

Efforts will be made to expedite development of the improved version, because at present there is criticism of excessive reliance on U.S. help. In 1976, communications, broadcast, and weather satellites will be launched for Japan by the U.S. All three are designed for three-year life. By expediting development of an improved N rocket, it should be possible for Japan itself to launch replacement satellites.

## Watch IC runs on one 1.5-V battery

By using low-threshold complementary-MOS technology, coupled with ion-implantation methods, designers at Intermetall GmbH have developed an integrated circuit for quartz clocks with current drain is low enough to permit operating such timepieces with only 1.5-volt battery. Intermetall, a member of the ITT Semiconductor Group, is introducing its new IC at the current European Clock, Watch, and Jewelry Fair in Basel, Switzerland. The IC, designated SAJ 310, is designed to work with a 4.1948-megahertz quartz crystal. For clock operation, including frequency division down to 1 hertz, the IC can do without any peripheral components. This, Intermetall men say, is achieved by special circuit-design methods, details of which the firm does not yet want to disclose. A no-peripheral quartz clock IC should help the timepiece industries to streamline production and to reduce the prices of their products. Large-volume orders for the SAJ 310 have already been placed by several clock makers in Germany and elsewhere in Europe. A successor version is being developed for use in wrist watches.

## Study rates off-shore potential of Southeast Asia

Indonesia leads all other Southeast Asian off-shore-production countries in one important category—wages—according to a new study by Arthur D. Little Inc. The annual labor cost for a 1,000-person plant in Indonesia comes to \$505,000, based on a semiskilled-worker wage rate of \$28 a month. Thailand is close behind, with an equivalent plant costing \$561,000 and the comparable wage rate pegged at \$42 a month. The most expensive site is Hong Kong, where the same plant would cost \$1,815,000 and wages would be \$118. But, the study warns that wage rates do not give the whole story. Fringe benefits range from 6% to 30% of the basic wage, country-by-country productivity is far from even, availability and turnover of labor varies, local management skills may be in short supply, and investment incentives and laws are diverse.

# New Tool New Board New Method

**it's part of the TY-RAP® System**

**Now tie quicker than ever before...**

Our new high speed tool does it all . . . feeds a TY-RAP tie around bundle, cinches to a preset tension, locks securely and trims evenly . . . all in  $\frac{1}{10}$  of a second. There is no tool adjustment needed regardless of bundle diameter from  $\frac{1}{32}$ " to  $\frac{5}{8}$ ".

The off-the-board harnessing method allows the tool optimum use. This technique utilizes our new harness board and harnessing aids. The board is reusable and reversible. It's modular too . . . snaps together for larger work areas. It's constructed of polyethene foam sandwiched between two metal screens — nails are pushed in by hand. It's all part of the TY-RAP System to lower your costs of harness fabrication.

Write for new catalog, The Thomas & Betts Company, Elizabeth, New Jersey 07207 (201) 354-4321. In Canada, Thomas & Betts Ltd., P. Q.

**Sold Only Through Authorized T&B Distributors**

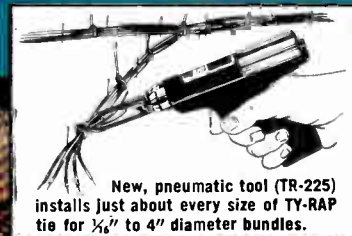

**THOMAS & BETTS**

Division of Thomas & Betts Corporation

517

Circle 67 on reader service card



# Reliability is staggered steps and a hunk of DAP.

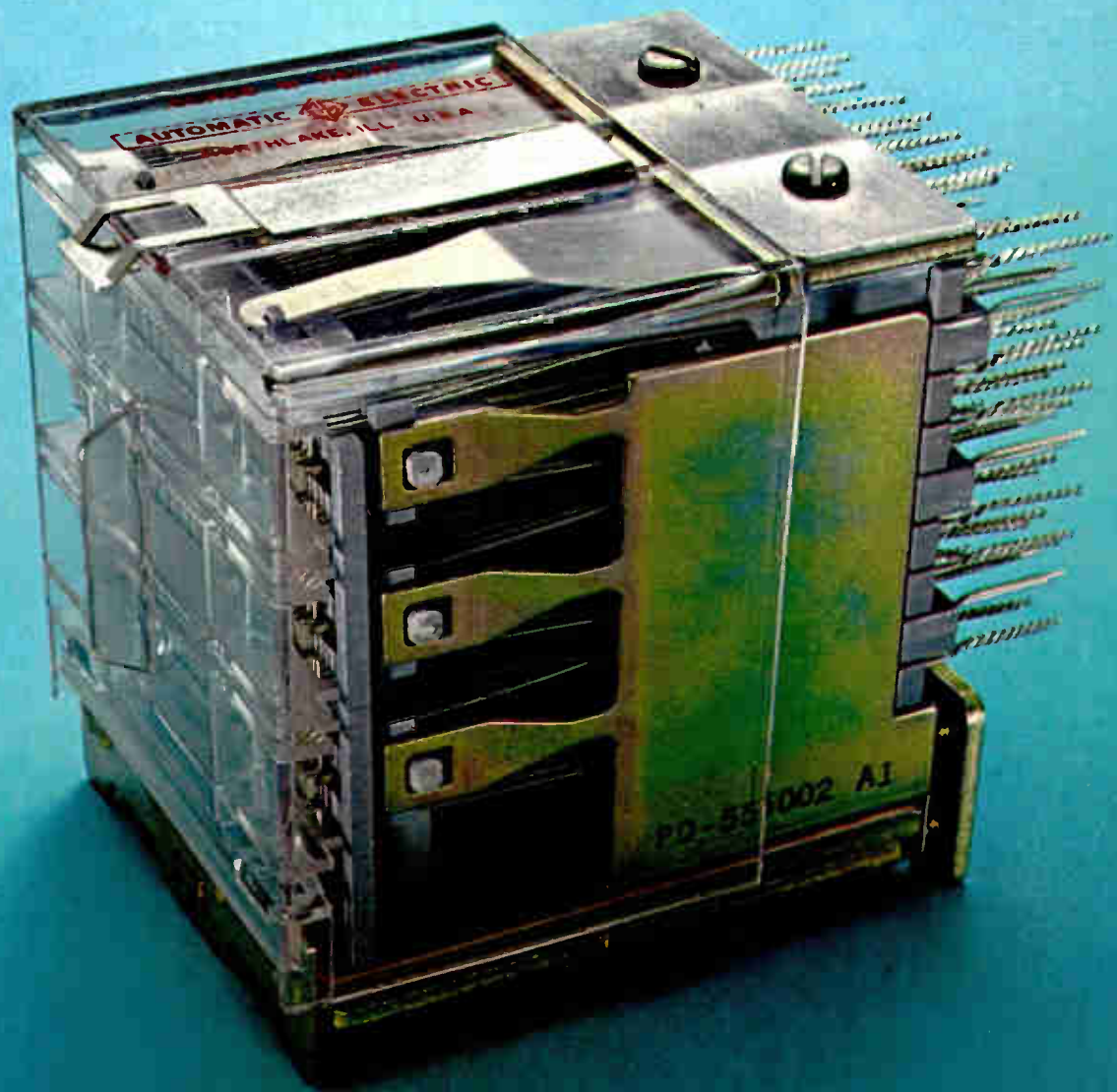

### Over a billion operations from 51 poles.

Our Class W wire-spring relay is different. In fact, there's nothing like it in the entire industry. Where else can you find a relay with 51 poles for transferring circuits and a mechanical life of more than a billion operations! That's about two and a half times the life of the best conventional relay around.

Another nice thing about our Class W is that it takes up a lot less space and costs less than using a bunch of other relays. That's because we build our Class W relay with one, two or three levels of contact assemblies, with 17 form C combinations per level. By the way, they're available with gold contacts for low-level switching.

### Making it tough on creepage.

All those staggered steps you see on the side were put in to raise the breakdown voltage between terminals. These molded steps add extra creepage distance between the terminals. This really counts for high voltage testing, or when using our Class W in unfavorable ambient conditions.

These steps, and all the molding compound used for insulating the contact springs, are made from

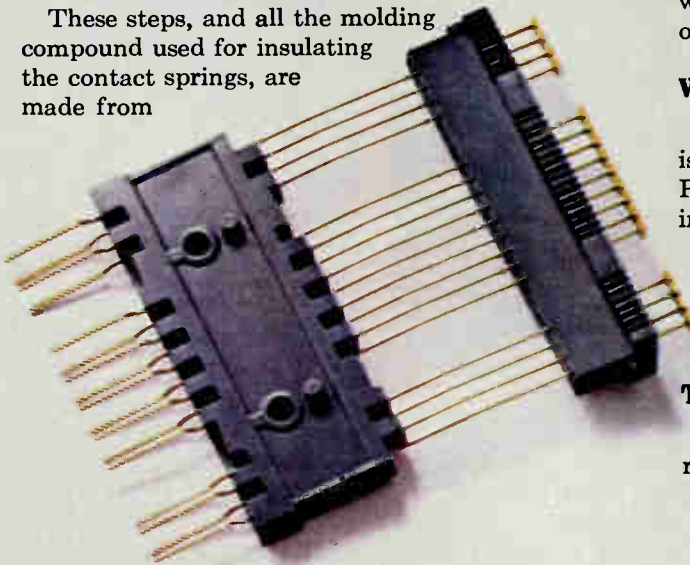

diallyl phthalate. (They call it DAP for short.) It has great insulating properties and it wears like iron. Even if the humidity is high, you have excellent protection.

### Redundancy—two springs are better than one.

Each of our long wire-spring contacts has an independent twin with the same function. One tiny particle of dust could prevent contact on other relays. Not with our Class W. You can be sure one of the twins will function. That's back-up reliability.

The twin contacts are twisted together at the terminal end. Then we give them a spanking (you might call it swedging) to provide solderless wrap.

### We're for independence.

Our springs are longer, because the longer the spring, the more independent they get. And the better contact they make. Don't forget, the wire-spring relay is the most reliable way to get a permissive make or break contact. You can rely on it.

The middle contact springs have to be stationary. To make sure they stay that way forever, we actually mold them between two thick pieces of DAP on both ends. Just try to move one.

### When we say flat, it's flat.

Each frame, banged out by a gigantic machine is extra thick and extra flat. Then they're planished. Planishing is another step we go through in forming the frame to add strength and stability by relieving surface strain.

We've made our spring-loaded pile-up clamp extra thick, too. Once it's tightened down, the whole pile-up is nice and tight, and stays tight.

### There's more.

We could tell you a lot more about our Class W relays. Like how the tough high-temp molded

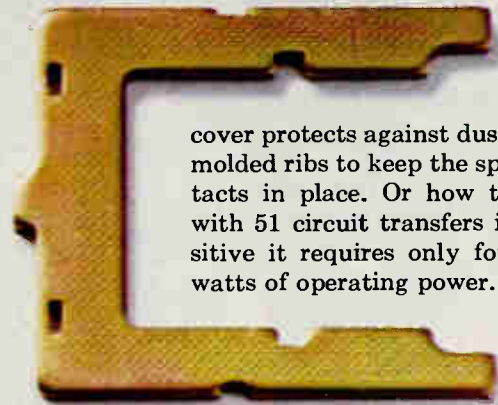

cover protects against dust and has molded ribs to keep the spring contacts in place. Or how this relay with 51 circuit transfers is so sensitive it requires only four to six watts of operating power.

But why don't you let us prove how much reliability we put into our Class W? We'll be waiting to hear from you. Government Industrial Sales Division, GTE Automatic Electric, Northlake, Illinois 60164.

**GTE AUTOMATIC ELECTRIC**

Circle 69 on reader service card

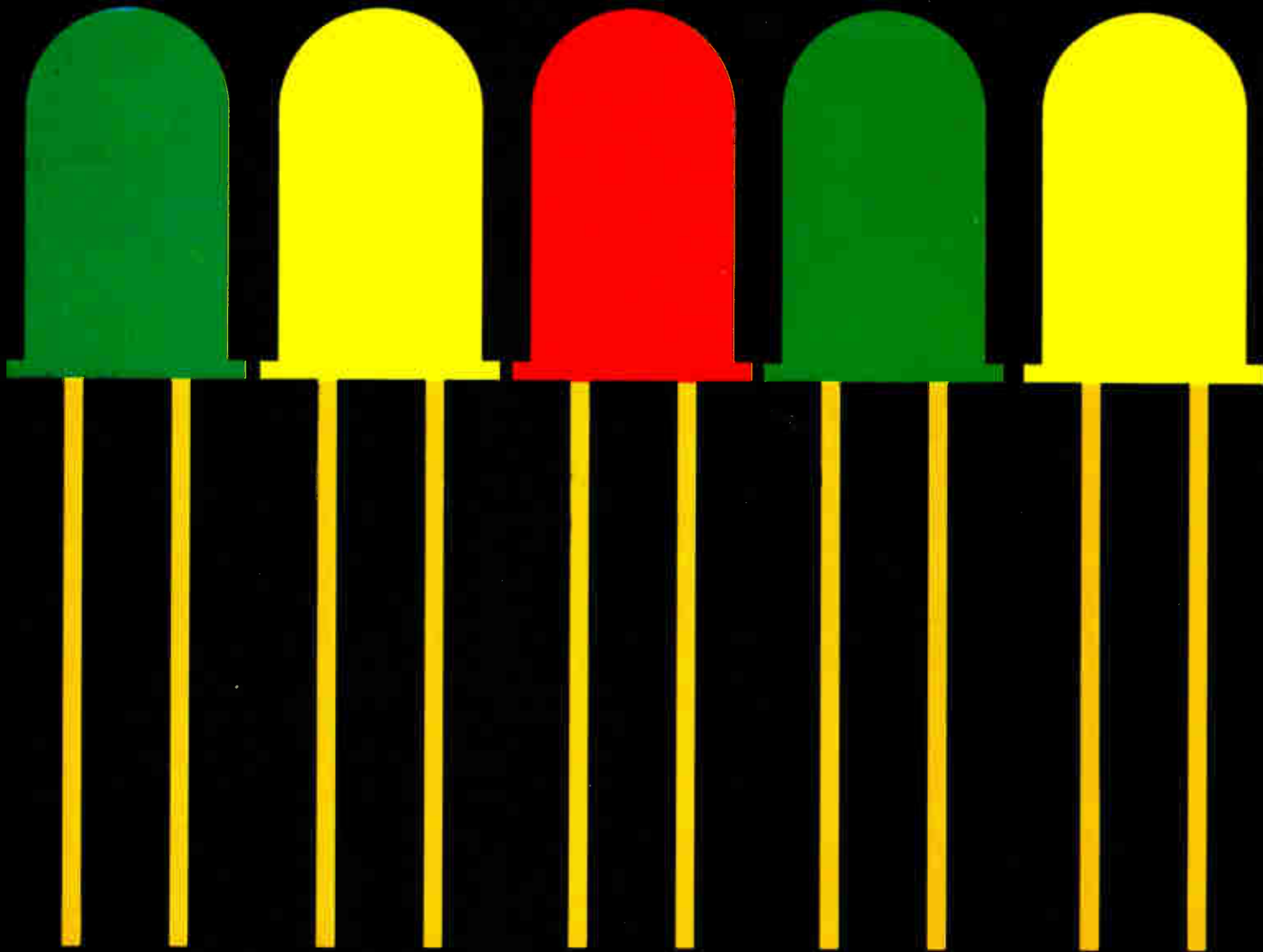

# INTRODUCING LEDs...

Motorola offers you more than a dozen red, green and yellow LEDs in 15 individual packages . . . engineered to meet 90% of your application needs.

Data sheet spec'd.  
*In production.*

We're also offering 25,000 discrete and integrated circuit devices. 1,050 linear integrated circuits. 7,100 power transistors. 6,400 rectifiers and diodes, etc. . . . enough to satisfy an overwhelming percentage of those

other design needs. Together, our LED standards make convenient, flexible component packages unmatched by most others and ready for most any design need.

Our established history of introducing hundreds of thousands of semiconductors for a corresponding number of applications and designs has made us experts in high-volume pro-



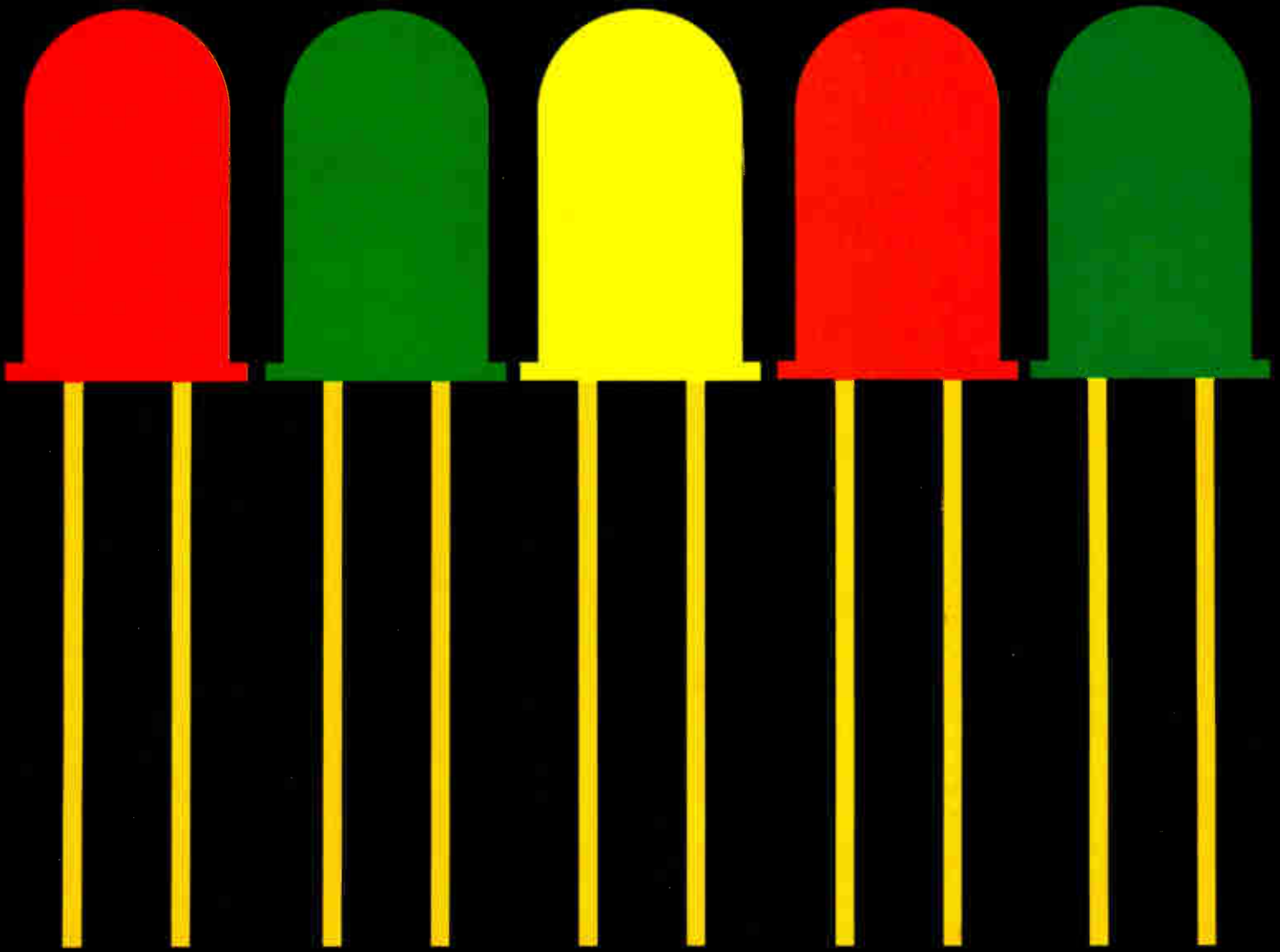

## plus all other semiconductors

duction of popular devices . . . including LEDs.

"Production House of the Industry" is what we're called. We'll be here long after specialty houses have dimmed their lights.

We can't wait to show you how easy it is to get all your LEDs (and the 25,000 other standards) from one supplier. A special literature package is waiting —

the new Optoelectronic Selector/Cross-Reference Guide and the Semiconductor Master Selector Guide.

Box 20912, Phoenix, AZ 85036

Contact your franchised Motorola distributor or factory representative for the right answers on LED delivery.

*Get it all together — right now...*

*obvious*  
**From Motorola, the <sup>^</sup>LED producer.**



# John Donohue's "blue line" turns out keyboard switches faster than you can say Oak.

John Donohue, Director of Manufacturing here at Oak, is mighty proud of his "blue line." He ought to be. It's the most sophisticated fully-automated keyboard switch assembly facility in the industry. It was designed with the customer in mind. We wanted to make sure we'd be able to meet his demands for huge quantities of our popular keyboard switches.

And popular they are. We build keyboard switches for everything from miniature calculators to data entry systems to point-of-sale terminals. You can buy them individually or in completely assembled custom keyboards.

If you need low-profile keyboard switches—we have 'em. Our Series 415 switches have a profile of less than  $\frac{1}{2}$  inch. And they're available in either single or double "human engineered" keycaps that dress up any product design.

Series 400 and 475 keyboard switches are built with self-cleaning gold cross-bar wiping contacts. You're assured of trouble-free operation through millions of cycles. And our variety of contact arrangements gives you true design versatility.

We also offer a full selection of lighted and unlighted pushbutton switches plus almost any other type of switch you can put your finger on. Let us know your needs.

Write Lou Roels at Oak for product literature, helpful keyboard design tips and free samples of our keyboard switches.

**DAK Industries Inc.**

SWITCH DIVISION / CRYSTAL LAKE, ILLINOIS 60014  
TELEPHONE: 815 • 459 • 5000 ■ TWX: 910 • 634 • 3353 ■ TELEX: 72 • 2447

**"Keep 'em coming, John"**

Circle 73 on reader service card



# Buying a function generator isn't a big deal.



## Using one everyday is!

Because there's not much difference in function generator prices, there is often a tendency to specify the "name" brand. But **handle-ability** can be an essential factor. When a basic signal-source goes into your lab, consider first the **day-to-day efficiency** of the instrument and its **effect on the real cost of ownership**.

For example, with sweep width a critical factor in testing network frequency response or developing a response plot, INTERSTATE's F34 allows you to precisely dial the controlled starting and end points. This, coupled with a Sweep Limit Indicator that won't let you dial an invalid output, puts it miles ahead of Wavetek's 134 for accuracy and ease-of-use.

This, and many other human engineering and price/performance differences that exist between the two function generators reflect INTERSTATE's continuing concern for the user, and are factually catalogued in our FREE specifier guide. Check the number below to receive it, or for more direct information, call John Norburg, (714) 772-2811.



"THE \$495 COMPARISON:  
INTERSTATE F34, WAVETEK 134 FUNCTION GENERATORS."



**IEC** INTERSTATE  
ELECTRONICS  
CORPORATION

Subsidiary of A-T-O Inc.

U.S. HEADQUARTERS: Dept. 7000, Box 3117, Anaheim, CA. 92803: OVERSEAS SALES OFFICES: AUSTRALIA, Parameters Pty., Ltd.; FINLAND, Havulinno Oy; FRANCE, Tekelec Airtronic, S.A.; ITALY, Tekelec Airtronic; ISRAEL, Radat International Company Ltd.; JAPAN, Asahi & Co., Ltd.; NETHERLANDS, Tekelec Airtronic, N.V.; NEW ZEALAND, David J. Reid, Ltd.; REPUBLIC OF CHINA, Bons International Co., Ltd.; SPAIN, Telco. S.L.; SWEDEN, M. Stenhardt AB.; SWITZERLAND, Traco Trading Co., Ltd.; UNITED KINGDOM, Euro Electronic Instruments, Ltd.; WEST GERMANY, Tekelec Airtronic GMBH. TWX U.S.A. 910-591-1197 TELEX U.S.A. 655443 & 655419

## AT&T thunders into digital market

Datran, MCI complain about predatory pricing as Bell files tariffs with the FCC for its new Dataphone Digital Service

by Stephen E. Scrupski, Communications & Microwave Editor

The specialized common carriers competing with AT&T once again are claiming predatory pricing by the big communications firm. The reason: the proposed rates that AT&T has filed with the FCC for its new Dataphone Digital Service are low.

The service, AT&T's first purely digital one, will in the main use existing facilities—four-wire lines from customer locations to a central office, digital transmission cables to microwave towers, and then microwave links to a distant city. Because it uses existing facilities, AT&T's investment for new equipment is modest, and the rates are therefore "attractive" if you're a user but "anti-competitive" if you're a competitor.

AT&T proposes to start the service on May 18, using equipment already in place, to provide links between five cities: New York, Boston, Washington, D.C., Philadelphia, and Chicago. The company wants to add 19 other cities by the end of the year and then expand the network to a total of 96 cities by 1976. It estimates that annual revenues would reach \$116 million by then.

Charges would vary according to distance and data speed. AT&T is offering users four speeds: 2.4, 4.8, 9.6, and 56 kilobits per second. On the long-distance intercity links, data will be multiplexed to travel at 1.544 megabits per second. A typical New York-Chicago user operating at 4.8 kilobits would pay \$667.20 per month, substantially less than the \$1,159 per month now paid by private-line users. The \$667.20 breaks down this way: a \$40 fixed charge for intercity digital channels, \$427.20 for distance-sensitive charges (712 airline miles at 60 cents

per mile), \$30 for two AT&T-supplied terminals on the customer's premises at either end of the link, and \$170 for the two digital access lines that take the data from the customer's location to the central office.

These are proposed interstate rates. Intrastate rates would have to be approved by the individual state's utility commission, and Bell operating companies are now performing cost studies in preparation for such filings.

Those figures do appear inviting to potential users. One of these is Telenet. A so-called value-added-network operator, Telenet leases lines from a common carrier and then, in turn, rents time to individual companies. Says a spokesman: "We are pleased that the tariff has finally been filed. Our general posture is to use the most cost-effective transmission facilities that are available in and among the cities that we

**Testing, 1-0-1.** A Bell Labs employee puts new Dataphone Digital Service equipment through its paces.

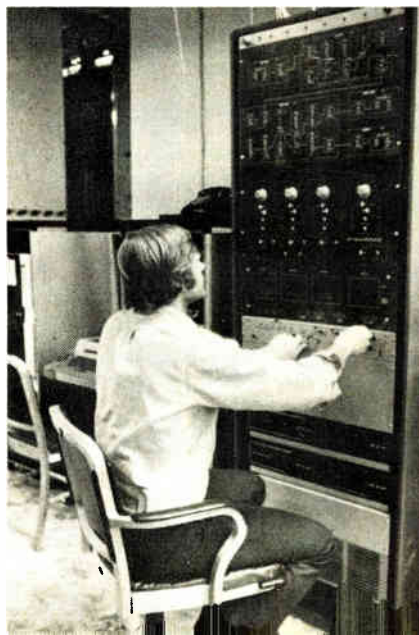

want to serve. And it turns out, as things now stand, that Bell's Digital Data Service filing, which we have been expecting for some time, is the most cost-effective 56-kilobit service available. We'll use it initially in our network among those cities where it's available."

The AT&T system will initially use the data-under-voice (DUV) technique to send digital signals over microwave links (see "DUV, DSU, and CSU," p. 76). AT&T essentially gets the microwave spectrum space for nothing. All the microwave towers are already in place, and only some terminal equipment is needed to merge the digital signals into an unused part of the microwave channels that is unsuitable for voice transmission.

According to Bell, only \$1.3 million was spent on setting up the system for the first five cities; for the 19 additional cities planned this year, the cost will be another \$2.5 million. Thus, for a 1974 investment of only \$3.8 million, in almost a single stroke, the company will be able to serve 24 cities located from coast to coast (from Los Angeles, San Francisco, and Portland in the west to Miami, Washington, and Boston in the east).

The next move is up to the FCC. It has set an April 12 deadline for pleadings, petitions, or comments on the two AT&T filings—one for permission to operate the system, the other for rates. The commission then will have about 40 days to decide the questions, acting first on the operational authority.

Complicating things for the FCC may be the fact that it is now three members short. On controversial issues, the four commissioners appear

to be delaying decisions until the remaining three members are appointed, and this feeling may extend to the AT&T filings if enough heat can be generated by AT&T's competitors—primarily MCI Communications of Washington, D.C., and Datan of Vienna, Va.

MCI, which has been battling AT&T in the courts, may not involve itself deeply in this issue. An MCI spokesman points out that "about 20% of our volume currently is data and the rest is voice, so the impact on us could only be maximally 20%." However, he notes that FCC approval of the proposed rates is a "large assumption" right now, and says there is a question of fairness. Data under voice is an efficiency added to the whole system, he points out, but its benefits are being passed on only to businessmen and not to all the ordinary telephone users.

Datran, which has no voice service, is presently operating a digital data link between Dallas and Houston, but is extending its system to Oklahoma City, Tulsa, Kansas City, and St. Louis and will be in Chicago by August. Datran is now getting ready to file its own rates with the FCC for the new interstate links. Its mileage rates for the intrastate Dallas-Houston link are in some cases higher than AT&T's: 75 cents a mile per month for 2.4- and 4.8-kilobit service (AT&T's are 40 and 60 cents a mile, respectively) and 90 cents a mile per month for 9.6 kilobits (the same as AT&T's). However, the company emphasizes that these are intrastate rates and could be quite different from the still unannounced interstate rates.

A Datran spokesman sums up his company's position thus: "We feel that what they're [AT&T] trying to do is stop us at the pass. The threshold issue as far as Datran is concerned is whether or not an environment is going to be created that will permit competition to exist." The FCC has enunciated a policy of encouraging competition, he points out, and he asks whether a competitive environment could exist if the AT&T rates are approved.

To quote from Datran's state-

## DUV, DSUs, and CSUs

The AT&T Dataphone Digital Service introduces three acronyms to digital data communications—DUV for data under voice, a method for transmitting digital data over microwave links; DSUs for data service units, terminal equipment to process digital signals for transmission on telephone lines; and CSUs for channel service units, simpler terminals that allow the customer's equipment to do some of the processing.

DUV transmits data in the part of the microwave channel that is close to the microwave carrier frequency. Voice channels are transmitted in bands starting 564 kilohertz away from the microwave carrier frequency because of the danger of interference from other microwave carrier frequencies. A single voice channel—about 4 kHz wide—could be wiped out by a strong carrier. However, data can be transmitted in the space close to the carrier because interference that would knock out a 4-kHz voice channel would only slightly degrade digital information, which is spread over a much broader frequency range.

Digital data is transmitted over the cables leading to the microwave tower at 1.544 megabits per second with a bipolar format expressed in three-level signals (positive, zero, and negative). If these bipolar pulses were applied directly to the 564-kHz band, their spectrum would not fit in the available space. The spectrum therefore is compressed to about 386 kHz by adding some amplitude modulation, converting the bipolar pulses to a seven-level scheme—three positive levels, a zero level, and three negative levels.

At the customer's end of the line, terminal equipment must be installed to process the data and prepare it for transmission on the telephone lines. AT&T is offering two types of units: a DSU, which interfaces to EIA standard RS232C format of data or to CCITT standard V35 at 56 kilobits per second, and the simpler CSU.

The CSU is considered part of the telephone system and thus has no charge, but the DSU will rent for \$15 a month for the three lower speeds, and \$20 per month for the 56-kilobit speed.

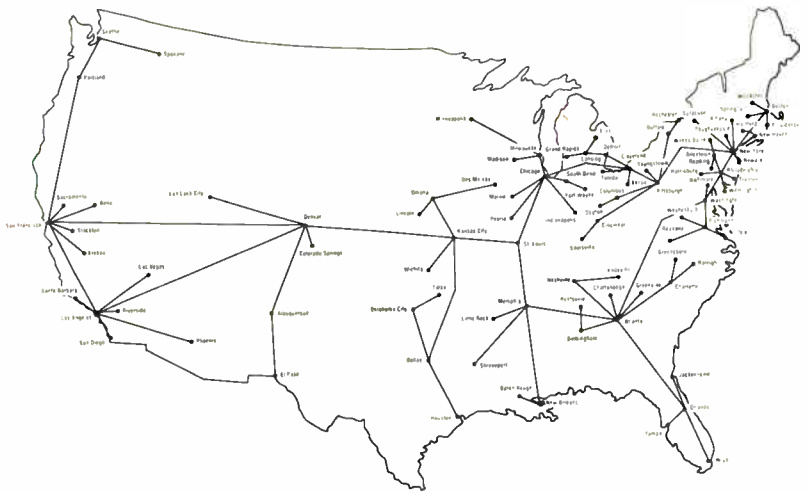

ment: "The Dataphone Digital Service announced by AT&T is a service offering similar to Datran's. There is, however, a significant difference. Datran has constructed a digital service for data only, while AT&T has modified its existing analog facility, designed and used for its monopoly voice service, to accommodate data. The potential for cross-subsidizing from AT&T's monopoly telephone services favoring its competitive Dataphone Digital Service becomes

obvious and merits our and the public's concern."

To this, AT&T retorts there is no question of "subsidy," since it is not taking dollars from some other service to make this new one look healthy. The company points to its desired 10.5% rate of return and says that, in addition to earning this rate, it will be able to make a substantial contribution to offset and help hold down the costs of regular telephone service. □



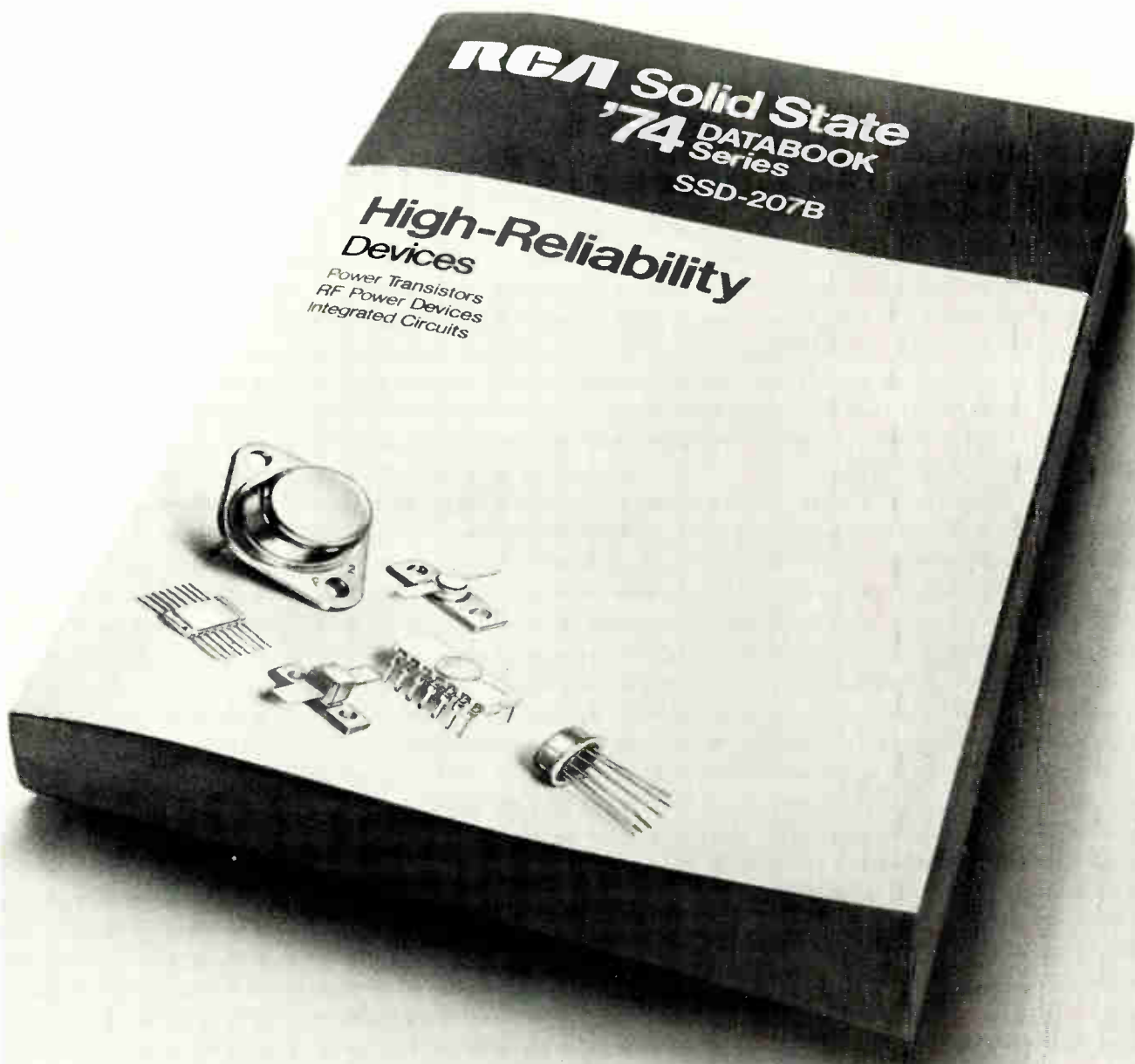

## It may not be sexy. But to an engineer, it's dynamite.

Finally, someone has put its family of High Rel products between the covers of a book.

That someone is RCA Solid State. The people who created an entire organization exclusively to tackle your IC High Rel problems. And this High Rel Data Book is a good place to start.

Almost 600 pages of problem-

solving facts including application notes, design features, operating considerations. Even a cross index to the other RCA Solid State Data Books.

To an engineer searching for High Rel digital CMOS building blocks; linear IC's for military or industrial applications; RF devices or power transistors, this is the

place to look. The first place.

So if you've always wanted to know about High Rel products, but didn't know where to go, you do now. Available from your RCA distributor, your nearest RCA sales office or direct from us (send \$2.00).

Write: RCA Solid State, Section 70D4, Box 3200, Somerville, N.J. 08876.

International: RCA, Sunbury-on-Thames, U.K., or Fuji Building, 7-4 Kasumigaseki, 3-Chome, Chiyoda-Ku, Tokyo, Japan.  
In Canada: RCA Limited, Ste. Anne de Bellevue 810, Canada.

**RCA** Solid State

Consumer electronics

## Auto makers prefer seat belts

Government requirement for passive-restraint (air-bag) systems in 1977s  
dismays Detroit and also poses new electronics cost problem

by Gerald M. Walker, Consumer editor

If U.S. auto manufacturers and their electronics systems suppliers had their way, the controversial requirement for air-cushion passive restraints in passenger cars would dwindle to an option, and the seat-belt/shoulder-harness ignition interlock system that was first installed on this year's models would be retained.

But on this issue the auto companies cannot have their way, a point brought painfully to their attention recently when the National Highway Traffic Safety Administration (NHTSA) put out the word that passive-restraint systems, like air cushions, will be mandatory in the front seats of all passenger cars manufactured on or after Sept. 1, 1976—that is, in all 1977 model cars. This announcement extended by a year the requirement contained in Federal Motor Vehicle Safety Standard No. 208, Occupant Crash Pro-

tection, one of the Government's best-read documents in the electronics industries. This regulation requires the 1977 model cars to provide passive protection in frontal, angular, and lateral crashes at 30-mph or greater. Regulations also stipulate that the cushions pass a roll test.

The car companies are not too happy with the regulation because they are genuinely satisfied with the seat-belt systems, which require front-seat passengers to buckle up in order to start the engine. While it's possible to "defeat" the interlock, auto firms are pointing to an estimated increase from 5% use to 60% as a sign that motorists would rather go along with the belts than tinker with the defeat mechanics.

In addition, Detroit is not certain as yet that the bags are effective, especially in accidents involving multiple collisions. Nor, they complain,

has Uncle Sam provided enough guidance on designs.

"The way has not even been cleared for agreement between Government and industry on an effective test device, sometimes called a 'dummy,' for monitoring the effectiveness of air bags. They have yet to issue the first performance standard for such a dummy," contends Roy Haeusler, chief engineer, automotive safety and security, for Chrysler Corp. "Once again, we're protesting that the Government hasn't even begun its job of testing, or even providing a feasible measuring device," he adds, "while they, in their political fashion, complain that we're not hopping to it and installing these things."

**Higher price.** Haeusler echoes the stand of others in the Big Three when he points out that it's unfair to force a consumer who faithfully uses lap and shoulder belts to pay \$225

**Cushioning the blow.** Passive-restraint systems like this General Motors air bag must be installed on 1977 autos. Auto makers say they'd rather make it optional, staying with the seat and shoulder belt and ignition interlock feature.



# An industry first.

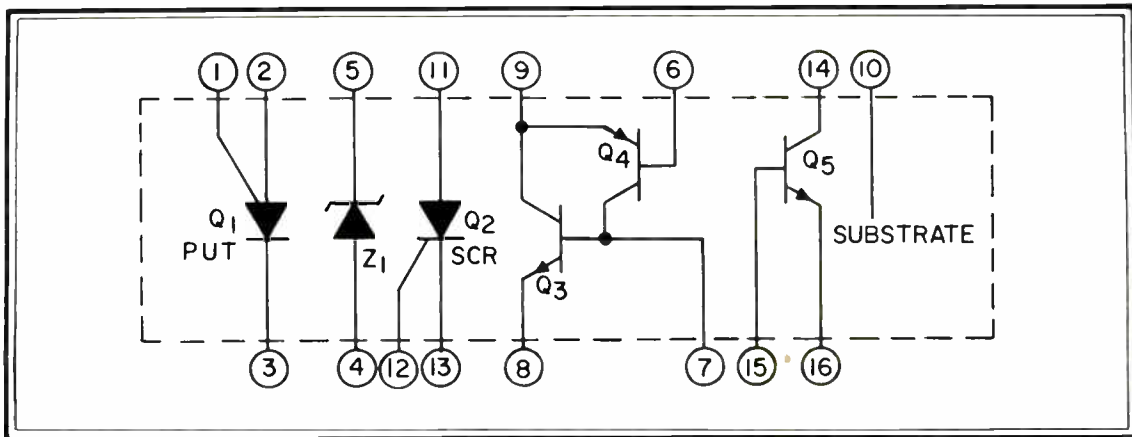

## RCA Solid State's CA3097E Thyristor/Transistor IC Array

There are so many ways to use it that we can't even begin to describe them to you.

We've put a programmable unijunction transistor (PUT), sensitive gate SCR, zener diode, p-n-p/n-p-n transistor pair and an n-p-n transistor ... all together in the 100 times improved plastic package system — RCA's new E-55 (16 lead DIP).

Check these characteristics and decide for yourself how to use the CA3097E in your system.

### Characteristics

- Programmable unijunction transistor (PUT)
  - peak-point current = 15 mA (typ) at  $R_G = 1\text{ M}$
  - $V_{AK} = \pm 30\text{ V}$
  - DC Anode Current = 150 mA
- Sensitive-gate silicon controlled rectifier (SCR)
  - 150 mA forward current (max.)
- Zener diode
  - $8\text{ V} \pm 10\%$
  - $Z_z = 15\ \Omega$  (typ.)

- DC Current 25 mA (max.)
- p-n-p/n-p-n transistor pair
  - $\beta \cong 8000$  (typ)
- @  $I_c = 10\text{ mA}$
- n-p-n transistor
  - $V_{CE0} = 30\text{ V}$  (min.)
  - $I_c = 100\text{ mA}$  (max.)
- Thermal and electrical component tracking with the design flexibility of discrete components
- Improved product reliability with the E-55 plastic packaging system, which demonstrates two orders of magnitude improvement in reliability over previous industry average.
- Operation over a temperature range of  $-55$  to  $+125^\circ\text{C}$ .

If the CA3097E can work for you, order now. It is available in quantity — at a price that will stop you in your tracks: \$1.35 (1K price).

Want to know more about the CA3097E? Write: RCA Solid State, Section 70D4, Box 3200, Somerville, New Jersey 08876. Or phone: (201) 722-3200, Ext. 3144.

**RCA Solid State**

products that make products pay off

International: RCA, Sunbury-on-Thames, U.K./RCA, Fuji Building, 7-4 Kasumigaseki, 3-Chome, Chiyoda-ku, Tokyo, Japan/RCA, 103 Nanking E. Road, Sect. 2, 2nd Floor, Taipei, Taiwan. In Canada: RCA Limited, Ste. Anne de Bellevue 810, Canada.



## Probing the news

or more for a passive system, compared to \$50 for belts. "We think it's the height of arrogance on the part of the Government, especially when the use of belts has increased from 5% to 60% by the Government's own statement. We have to assume that there will be a further climb in the use of belts, and steps could be taken to insure that use increases and at a very much lower price."

**Choice.** John C. Eckhold, director, automotive safety office, Ford Motor Co., in expressing his disappointment with the Government's announcement, comments, "We believe that the customer should decide if he wants the highly effective protection provided by the seat/shoulder-belt system in preference to a substantially more expensive system."

There's general agreement that, while no significant changes in the present seat-belt interlock systems will take place during this uncertain interim period, Detroit will most certainly insist on bringing down the costs of the interlock electronics. Because the first installations were hurried, cost considerations were soft-pedaled. But typically, auto engineers squeeze out what they consider excess cost in the second year of production. It's possible that some of the protection circuits now on the interlock pc board will be added to the logic IC chip used in the system. And there will doubtless be some derating of passive components. But none of these changes will be major, essentially because the interlocks appear reliable.

**Held back.** As for the air bag, the only auto maker with much high-way experience is General Motors Corp., which this year has been offering them as an option on its larger Oldsmobiles, Buicks, and Cadillacs. So far, the company has had orders for about 3,000 systems, though GM says it has spent \$60 million to develop the air bag and has geared up to supply 100,000 systems during the 1974 model year. Because of the energy crisis, which crimped sales of big cars badly through the first quarter, sales of the air bags will fall far short of expectation.

In addition to these autos, GM had added the air-cushion restraints to a test fleet of a thousand 1973-model Chevrolets leased mainly to its own executives. To date there have been only 12 deployments during a total fleet mileage of over 30 million miles. According to GM, there has been only one "inadvertent" deployment, and never has the system failed to go off when it should have, that is, past 30 mph.

Although GM is still waiting for more conclusive data on air-cushion systems, other indications are that the lap-and-shoulder-harness system may be just as effective. A GM study of 700 fatal accidents showed that 31% of the fatalities could have been prevented if lap and shoulder harnesses had been fastened in place. However, the air-cushion restraints alone would have prevented only 18% of the fatalities, while a combination of air-cushion restraints and lap belt, which is the way GM sells the system, would have prevented 20%. Accordingly, GM "does not now support narrowing consumer choices" and would like to continue offering the air-cushion restraint system as an option "for those who don't like the belts, interlocks, and buzzer system," a spokesman reports.

**Not enough.** This point may sound reasonable in Motown, but it doesn't carry much weight in Washington. Also, many will remember that the car companies griped about the seat-belt interlock just a year ago. James B. Gregory, administrator of the safety agency, says experience with lap and shoulder belts continues to support the agency's judgment that belt systems fall short of the best crash protection that can be achieved with today's technology. Pointing to the 60% usage of belts, or put another way, 40% failure to buckle up despite the elaborate electronic interlock, Gregory states that air-cushion restraint systems provide "excellent front and angular crash protection with reliability extremely close to 100%. We find, on the evidence available, that passive systems, which do not depend on the cooperation of the driving public, are practicable and will provide substantially greater levels of life and injury-saving protection than active belt systems," he states.

Thus, despite their misgivings, the auto firms are turning their electronics design and production crews on to air bags. Yet to be clarified is how well air bags will perform in rollover tests. If they are not effective, a combination bag and lap-belt system will be required, similar to what GM is now offering for \$225. The lap belt would have a buzzer and light warning, but not an interlock.

**Diagnostics.** "The present system," relates Frank E. Jaumot Jr., director of research and engineering at GM's Delco Electronics division and air-cushion supplier, "has a crash sensor in the passenger compartment, as well as a bumper impulse detector. Most of the electronics is in the diagnostics—a fairly complex chip and a couple of diodes 'look' at the whole system continually to see that everything is working." The GM system also includes a back-up power supply in case the battery cables come off under impact.

Jaumot believes that the auto industry won't use air bags across the board in coping with the passive restraint requirement. "I'll give you very high odds that the entire industry won't use air bags," he says. Luxury cars will probably have air cushions, but compacts could go with alternate restraint systems for models that do not have a middle-front-seat passenger to protect. The NHTSA has not been enthusiastic about passive belt systems of the kind that pop up at crash impact to restrain passengers, however.

One clear point in this otherwise murky passive-restraint issue is that radar sensors to trigger cushion inflation will not be on Detroit's spec sheets for quite some time, if at all, despite the great amount of research going into auto radar these days. Simple inertial devices or deformation sensors in the bumpers are much closer to automotive pocket-books today, though there may well be a future application of radar for either automatic braking or crash sensing as the price of microwave semiconductors comes down. Aside from the cost of radar, the performance problems associated with fail-safe target acquisition to fire a safety device makes the auto designers nervous. □

# LASER-TRIMMED PRICE

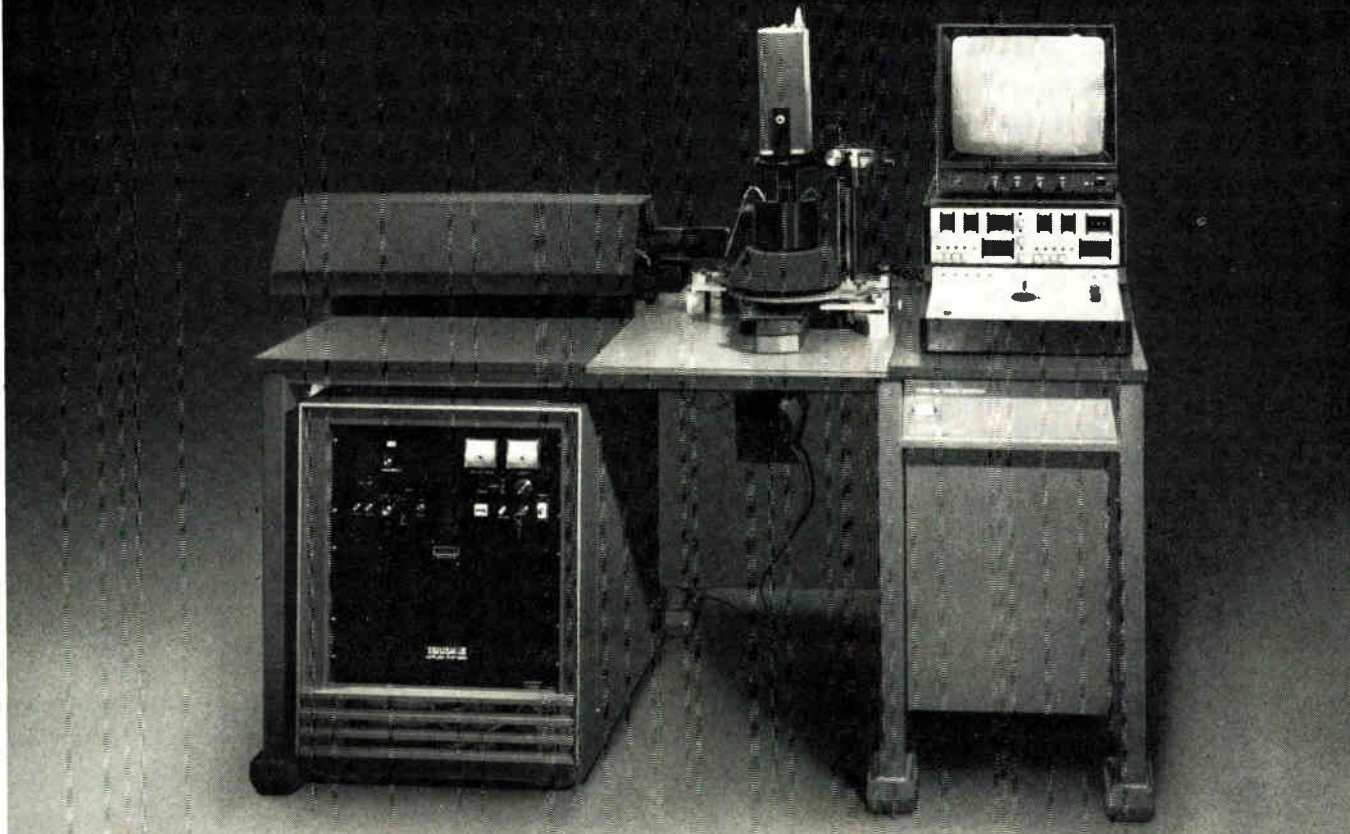

## TERADYNE ANNOUNCES A LASER TRIMMER YOU CAN PROGRAM AT A PRICE YOU CAN AFFORD

Introducing the Teradyne W233 Unitrimmer. The first programmable laser trimmer with a trimmed-down price.

The Unitrimmer is designed for people who trim only one or two resistors at a time, do development work or multiple trims in low-volume applications.

And it's from Teradyne—the company that makes the finest computer-controlled laser trimming system in the business—the W311.

The Unitrimmer lets you program two trims at a time by setting front panel digit switches. It can also be programmed electrically to interface with other systems. The trims can be on the same resistor, or one each on two resistors. Additional trims can be handled in multiple passes.

Length and direction, resistance or voltage, Q-switch rate, bite size, and trim speed are all programmable. A single joy-stick lets you position the start-trim point in seconds.

The laser, optics, beam positioner, and parts

handler are all identical to those on the W311. So you get galvanometer-controlled beam positioning for unmatched speed, resolution, and reliability; a clear view of work in process via TV monitor or microscope; your choice of in-line, rotary, or step-and-repeat feed. And if you ever want to upgrade to computer-controlled trimming, the Unitrimmer can be field-expanded into a W311.

Best of all, since the Unitrimmer doesn't need a computer, mag tape unit, software, etc., you can get one for less than half the price of a computer-controlled system.

The Teradyne W233 Unitrimmer. Programmable laser trimming.

At a trimmed-down price.

Write Teradyne:

183 Essex Street, Boston, Mass. 02111. In Europe:  
Teradyne Europe S.A.,  
11 bis, rue Roquépine,  
75 Paris 8<sup>e</sup>, France.

**TERADYNE**

CHICAGO (312) 298-8610 / DALLAS (214) 231-5384 / NEW ENGLAND (617) 458-1256 / NEW YORK (516) 364-9797 / SUNNYVALE (408) 732-8770  
LONDON (093-28) 61111 / PARIS 265 72 62 / ROME 59 47 62 / MUNICH (0811) 33 50 61 / TOKYO (03) 406-4021



Government electronics

# Military develops base security

Air Force supervises tri-service BISS program aimed at providing modular systems for external protection at installations around world

by Gail Farrell, Boston bureau

With little publicity, the Air Force Electronics Systems Division (ESD) is developing a tri-service sensor-based electronic security system for world-wide use. ESD is developing, designing, testing, and providing production specifications for a family of modular, fully compatible equipment known as base and installation security systems (BISS). The equipment can be configured into any type of system the user may require for external physical security. And the program is drawing interest from the private sector.

The origins of BISS go back to the Vietnam war, when the Air Force started developing security sensors for bases and trails. By 1967, a program office was created, and gradually the program, called SAFE, spread to other bases around the world. When in 1972 the Pentagon decided to go for tri-service security systems, it handed the job of external security to the Air Force. The

work is being done at ESD's headquarters at Hanscom Field, Bedford, Mass.

ESD's charter is to develop product specifications, send out RFPs for all three services, and plan procurement for the Air Force. While no system has yet reached the final procurement stage, some prototype systems have been developed, and a number of commercially available systems are being investigated. Eventually, all critical areas such as ammunition dumps, landing fields, and missile sites will be protected by external security systems.

BISS is divided into three basic categories of fixed, temporary, and mobile installations, as well as six technological areas. In each area, several alternatives are being pursued. Areas of primary interest are:

- Sensors, ranging from small, fence-mounted mercury switches to detect disturbances to radar or buried pressure/strain lines.

- Data communications, including hardware collection, rf, and power distribution, between sensors and monitoring posts and patrols.

- Monitor displays.

Three auxiliary technical areas include alarm-verification systems, such as low-light-level or infrared television to look into blind spots, entry-control systems to replace identification badges, and an automated response system that can be set off by either a sensor or a guard.

**Starting small.** ESD is developing systems in the order of priority, with small fixed security systems first on the list, followed by entry control. Mobile-sensor systems are receiving less emphasis, and it is expected that much of the work here will be applicable to temporary installations. The first phase is to be completed by Dec. 31, 1976, and the second phase, which would include refinements of systems already developed, is to be complete by the end of 1981, subject to Pentagon priorities.

Tri-service technology groups, one for each technical area, plus one for over-all requirements and one for test and evaluation, meet periodically to help develop priorities and requirements, while ESD coordinates efforts to make sure that what is developed is useful and satisfies all three services. There is also a working group of security police at Hanscom Field to advise on priorities and usefulness of systems. Since July 1972, when BISS was started, R&D costs have totaled about \$6 million, and Col. John L. Gilbert, BISS program director, expects the budget for fiscal 1975 to be another \$6 million.

Gilbert notes that, at the completion of BISS, "there will be more in-

**Check It out.** Air Force security police confer. Airman outside car has prototype four-channel, frequency-synthesized radio in his pocket. It was developed under aegis of ESD.





stallations than bases, so it is a pretty sizable buy system." And BISS eventually will replace the SAFE program, which has cost between \$10 million and \$15 million to deploy currently available equipment. Some systems used in SAFE will be spun off to BISS, such as Honeywell's parked-aircraft security system (PASS), mercury-switch fence-disturbance-detectors, and a laser fence, slightly modified to communicate with other BISS systems.

The mercury-switch fence-disturbance detector will be the smallest, simplest device in the BISS program. A commercially available device from Datacom Inc., it was adapted and simplified by ESD. So far, 15,000 sensors have been bought at \$8 to \$10 each, and eventually, 50,000 units will be bought by the Air Force alone.

**Laser fence.** A much larger system has come out of the Mitre Corp., working under contract to ESD—a laser fence that acts as an intrusion-detection unit. Harmless, low-energy beams from six pulsed gallium-arsenide laser diodes, housed in a laser-transmitter terminal, are pulsed and staggered to provide both temporal and spatial separation of the pulses.

When the fence is activated, an optical receiver begins searching for specified staggered signal patterns, using defined acquisition loops, and synchronizing with the laser transmitter in a phase-locked variable frequency loop. Once synchronized, the optical receiver looks for missing pulses in any of the six laser beams and accounts for any signals it should not be receiving.

When the number of missing pulses exceeds a predetermined threshold, an alarm is triggered to the local collector/display unit, a terminal that can communicate in a time-division-multiplexed mode under polling conditions with the optical terminal. A light panel on the collector display indicates normal, alarm, or degraded operating modes of five optical terminals and a 300-hertz tone sounds for an alarm.

Eventually, the unit could be combined with some sort of identification system via television to check out alarms. Cost of the system has not yet been determined because responses to RFPs have not yet

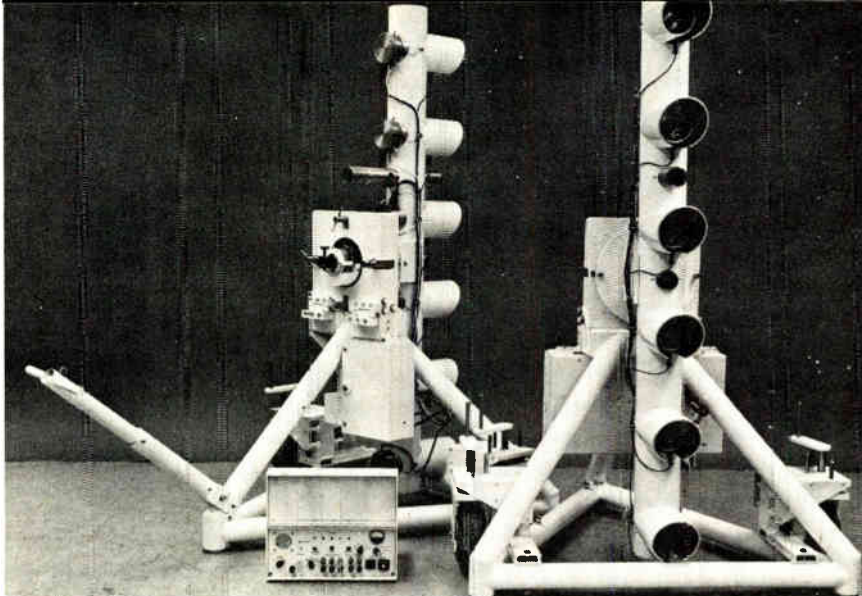

**Intruder detector.** Laser fence has six devices in vertical row. Their beams are picked up by optical receiver. Small instrument is local collector/display unit of the system.

been received. But Gilbert says that at least 40 systems with a minimum of four fence segments each will be ordered, and "there are an awful lot of applications coming in for it" from all three services.

ESD isn't doing all the research or major systems itself, however; Gilbert estimates that "at least half of our ideas come from industry." For example, ESD is investigating Ampex's TVID (for television identification system), which, with a "minor amount of militarization" is being developed into something called Caveat (for code and visual entry-authorization technique).

The system can store a maximum of 4,000 images in a video-disk unit. These are checked against the image, transmitted by a television camera at the entry station, of the person trying to gain admittance to a restricted area. Ampex has received a \$97,000 contract to install a system at a Strategic Air Command base, and tests of the system are now under way. The various services have expressed interest in at least 35 systems with up to four entry points per system.

Other identification systems using ineradicable characteristics—such as fingerprints, voiceprints, and handwriting—are also being considered. Texas Instruments, Philco-Ford, and Datawest have proposals in on a voice-print system that is nearly ready to go to contract, and responses on other systems are being evaluated. ESD hopes to have prototypes ready by fall.

Gilbert notes that industry has

also done a lot of work on low-light-level television, so ESD plans to buy off-the-shelf equipment and modify it as little as possible for the SAFE program. For the BISS program, however, ESD will probably undertake some development.

**Long list.** ESD's list of devices being investigated—sensors, communications gear, and the like—is a long one. It includes buried line-pressure sensors, magnetic intrusion-line sensors, transducers that use more than one phenomenon to produce an alarm. And in conjunction with the Law Enforcement Assistance Administration, ESD is developing a crystal-controlled frequency-synthesized radio.

Gilbert reports a lot of interest from the Government, banks, and industry in the work ESD is doing on BISS, and he believes that "most equipment developed will have applications for industry." ESD has been attending security conferences and publishing papers on problems and possible solutions for external physical security. At one international countermeasures conference, the British Home Office expressed an interest in security systems for jails.

External physical security is a new, rapidly expanding field, Gilbert says, and what has been developed so far is only "the tip of the iceberg. I see a lot of development in the future to improve existing technology, as well as introduce new technology. A lot of basic research is at a stage where we are not able to develop it yet." □

Government electronics

# Weather Service starts computer net

Delivery of prototype forecast office, built by E-Systems, marks start of \$40 million automation project to be finished by 1980-81

by Larry Armstrong, Midwest Bureau manager

When delivered later this month, a prototype weather-forecast office will mark the National Weather Service's first hardware step toward one of the largest computer networks ever built by the Federal Government. The \$40 million project goes under the general code word AFOS—for automation of field operations and services—and is a long-overdue attempt by the service to simultaneously decentralize and cut through the reams of paperwork that now flood its facilities.

A major impetus for the expensive system is time and motion studies showing that up to 40% of a forecaster's time is now spent getting ready to forecast—ripping off teletypewriter messages and paging through the 500-plus charts that the

National Meteorological Center generates and faxes daily.

"Our plans are to have it fully implemented by 1980-81," says Robert Johnson, National Weather Service program manager and the originator of the concept. "The funding outlook is very good—it's an economical system. The payoff period is about six years, and the operating cost is about \$6.5 million less per year than the present system," he says. The project has Office of Management and Budget support for fiscal 1975—the first big money year.

"Requests for proposals should hit the streets about next January, with the intent of awarding contracts in July for about 10 to 15 field stations," Johnson adds. "And we

expect 20 to 40 very serious bidders" on the stations, which will average about \$250,000 each.

But dollars for the electronics industries won't stop at his office, he indicates. One of the ground rules in the contract for the prototype system, awarded last June to E-Systems Inc. of Garland, Texas, was that the hardware and software package maintain the service by teletypewriter and facsimile to users of the low-budget National Oceanographic and Atmospheric Administration Weather Wire.

**Big spenders welcomed.** "But any user that wants to make a higher-level terminal investment can do so, and we encourage it," he says. "It's a lot easier for us to drive another computer than a Teletype." Among

**Silver lining.** Console for automatic network for Weather Service is put through a dry run. Prototype for project was built by E-Systems.





# Semiconductor technology is invading the memory market.

Here's the book to expand your applications knowledge in this explosive field.

Semiconductor memories are rapidly changing the traditional structure of the memory market. Faster access and cycle times. Simpler architecture. Reduced power dissipation. The increasing use of semiconductor devices as the main storage components of memory systems stands as one of the major innovations in contemporary computer technology.

The field of semiconductor memories is becoming enormously complex—and to the creative designer, increasingly confusing. "Semiconductor Memories Design and Application" helps to clarify the present state of the art by providing systems designers with the first fully integrated, comprehensive guide to the application of semiconductor storage elements in the construction of larger memory systems. Produced by the Texas Instruments Learning Center, this single volume systematically details the ideas and techniques which today's successful designer must master to build electronically competitive, cost-effective memory units.

Among subjects discussed are: Memory Functions and Economics • Reliability • Sequentially Accessed Storage Design and Application • Random Access Memory Design and Application—both Bipolar and MOS • Fixed Program Storage Design and Application.

"Semiconductor Memories Design and Appli-

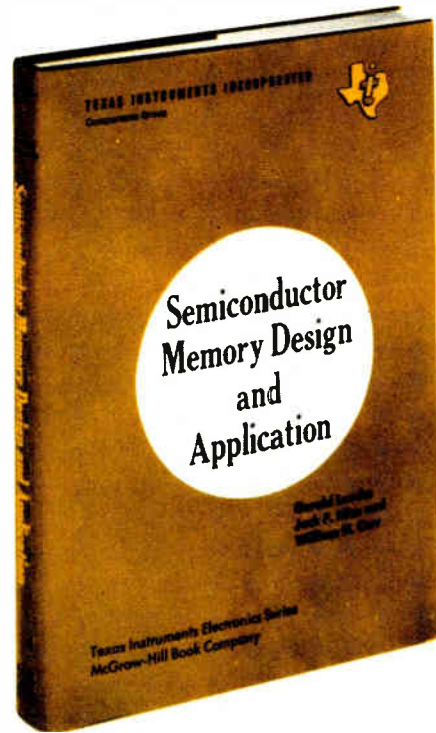

cation" has been organized to meet the needs of the practicing designer who is going to apply semiconductor storage elements and build larger memory systems. Both practical and up-to-date, it outlines the motivations shaping semiconductor memory technology and supplies the design and applications information necessary to make optimal circuit decisions.

Hard-bound. 321 pages. McGraw-Hill Book Company. Use accompanying coupon to order now.





**MOS, TTL design aids also available.**

If you want to update your knowledge of MOS/LSI, Texas Instruments' "MOS/LSI Design and Application" provides concise yet thorough information. From basic principles to practical system applications, this volume discusses device physics, economics and reliability for the entire spectrum of this vital technology.

And from the bipolar side, "Designing with TTL Integrated Circuits" covers design philosophy, economics, basic principles, device performance and practical applications in digital systems. Use coupon to order either volume.

To: Texas Instruments Learning Center, P. O. Box 3640, Dallas, Texas 75221

Please send:

- "Semiconductor Memories Design and Application." \$18.50
- "Designing with TTL Integrated Circuits." \$18.50
- "MOS/LSI Design and Application." \$18.50

Enclosed is check or money order for \$ \_\_\_\_\_

Please add state and local taxes where applicable.

Name \_\_\_\_\_ Company \_\_\_\_\_  
 Address \_\_\_\_\_  
 City \_\_\_\_\_  
 State \_\_\_\_\_ Zip \_\_\_\_\_

**TEXAS INSTRUMENTS**  
 INCORPORATED

95100



## Probing the news

those expected big spenders, Johnson lists other Government agencies, including the Federal Aviation Administration, Interior Department, and the Army Corps of Engineers; universities with meteorological programs; weather-dependent industry, such as construction and airlines; large private

meteorologists; and TV stations and cable-TV systems.

After shakedown of the model facility this summer at National Weather Service headquarters on the outskirts of Washington, D.C., the network will be implemented in two stages. The first is essentially a store-and-forward network that zig-zags over 11,000 miles around the U.S., linking 49 Weather Service forecast offices into a loop, and also

shooting out spurs to pick up offices in Alaska, Hawaii, and Puerto Rico. The massive net will also connect four regional centers and 14 river forecast centers, as well as the National Meteorological Center, National Hurricane Center, National Severe Storms Forecast Center, and National Climatic Center.

The second phase, under system study now, calls for the gradual automation of 200-plus smaller Weather Service offices, to give each forecast office its own mini-network of service offices sending and receiving data. The forecast offices are essentially identical, and all will use duplicates of the E-Systems prototype. "But there's a tremendous difference in the service offices, and we're trying to tailor a system for each individual station," Johnson remarks.

E-Systems has designed a modular data-handling, communications, and display system that will make customizing of the service office systems possible and simple. The prototype consists essentially of an unmanned supervisor's console and two forecaster's consoles going to national headquarters, with a spare supervisor's console being delivered to the National Meteorological Center in Suitland, Md. The service projects that a supervisor's console and from two to four forecaster's consoles will be required at each of the 53 nodes on the system's main network.

The supervisor's console consists of communication gear, a pair of digital clocks with battery backup for local and Greenwich mean times, two pre-formatted Linc tape systems for forecast office archiving, three Diablo 31 disk drives with storage for 7.3 million characters, and keyboard/printer, all grouped around a Data General Nova 840 with 64,000 words of storage expandable to 128,000.

**Quick forecasts.** The dedicated voice-grade telephone lines that the network will use will transmit data at 2,400 bits per second, and since each forecast generated by a forecast office is sent around the loop both ways, new forecasts are available to the entire circuit within 25 seconds. Each forecast office receives the message, checks it for errors, stores what it needs, and passes

## 8 CASES FOR SWITCHING TO NATIONAL<sup>®</sup> SCRs



16-1600 Amperes rms  
25-1700 Volts  
Power and Inverter SCRs  
Patented Regenerative Gate

*Call or write for full details*



**NATIONAL ELECTRONICS**

a varian division

geneva, illinois (312) 232-4300

it along—until one office receives it from both sides and issues a signal to terminate it. Total capacity is 414 million bits a day, compared to the 50 million to 60 million bits the service now moves daily on teletypewriter and facsimile equipment.

E-Systems chose voice-grade lines so that it would have the full U.S. telephone system as a backup—Weather Service communications are most vital when telephone lines might be down, during storms and floods, for example. "If a node has to withdraw from the system for some reason, it is bypassed using commercial lines," says Chris L. Lynes, an E-Systems engineer who worked on the system's hardware. "The neighboring node will store data for him while he's off the circuit; when he comes back on, he's automatically replenished," he says.

**Selection available.** Forecast offices pull off only the weather information categories that they are interested in or, in some cases, messages can be addressed to specific stations. Purging is both real-time and automatic. Typically, warning categories such as flash floods, severe weather, travelers' advisories, and fire weather are purged by time—24, 48, or 72 hours. Some 60 other less critical categories, including local, river, recreational, and aviation forecasts, are purged by the number of messages—the system keeps the last three, or five.

The real showcase of the system, though, is the forecaster's console. This has five CRTs—a 525-line display legend controller and monitor from Ann Arbor Terminal with E-Systems' own data-retrieval keyboard flanked by four Conrac RQA17s with self-adjusting sync from 525 to 1,029 lines. It's all driven by the supervisor's console and a Hughes Conograph 12, including a central processor, four 3,000-line-resolution scan converters, and data entry keyboard.

Tomorrow's forecaster will still have to cope with some paper: the high-resolution photos that the National Weather Service anticipates from the soon-to-be-launched Geostationary Operational Environmental Satellite program. But the system was designed with raster-scan video-input capability, in anticipation of the satellite. □

# SYSTRON-DONNER POWER SUPPLIES

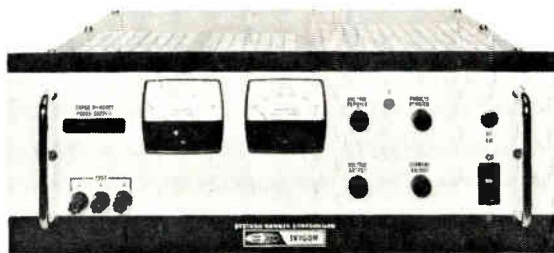

**SUPER  
MERCURY  
SERIES**

from  
**\$710**

**Up to 160VDC  
Up to 400 AMPS**

**Your "BEST VALUE" high power laboratory or systems supply with Constant-Voltage/Constant-Current and precision performance.**

- Choice of 17 models in ranges from 0 to 5VDC at 400 amps to 0 to 160VDC at 25 amps
- Remote programming of voltage and current
- 1mV RMS Ripple
- Overvoltage Protection standard on most models, optionally available on all others
- Automatic Load Share Paralleling with single knob control of up to 4 units
- Mode Indicator Light signals overload condition
- Built to strict QC Standard to guarantee dependable and reliable operation
- Five Year Warranty
- Three package sizes; 5¼", 7" and 8¾" standard full rack
- Precision regulation to 0.005%
- 0.015% Stability
- Adjustable Current Limiting in voltage mode, adjustable compliance voltage in current mode
- Master-Slave Tracking
- Remote Sensing
- Special modifications available to meet customer requirements

**Dollars per watt, watts per dollar or whatever measure you use ... your Best Value is a SYSTRON-DONNER SUPER-MERCURY POWER SUPPLY.**

**Write or call us or your local Scientific-Devices Sales Office for complete specifications and applications data.**

**TRYGON ELECTRONICS  
SUBSIDIARY**

**SYSTRON  DONNER  
CORPORATION**

1200 SHAMES DRIVE ■ WESTBURY, NEW YORK 11590 ■ PHONE (516) 997-6200

Air traffic control

# DABS is about to fly

FAA's proposed Discrete Address Beacon System spells big money for suppliers of required ground and aircraft equipment

by William F. Arnold, Aerospace Editor

The FAA's presentation on its proposed Discrete Address Beacon System (DABS) had two messages for the industry representatives jammed into the agency's auditorium that late March day. First, the planned "upgraded third generation" air-traffic-control system will mean lucrative business to electronics suppliers. Second, the agency at last seems to be managing a program from scratch successfully, without the delays and cost overruns that have plagued so much of its procurement. At least, that's how industry representatives judge the program so far. "There were so many people there because they smell big money," comments one.

And big money it should be, too, when the Federal Aviation Administration decides to implement the system. DABS, which will add many new, mostly automated features to the existing ATC system, will require new surveillance and communications equipment on the ground and brand-new transponders for the thousands of private and commercial aircraft in the air. The FAA won't say officially how big the program might be, but it is known that at least 60 new ground-based antenna-processor sites would be needed to augment the present ATC radar beacon sites. Aircraft transponders for DABS will cost 40% to 80% more than present models, which cost \$500 to \$5,000.

DABS would be a key part of the so-called upgraded third-generation ATC system (see "ATC system genealogy"). It would solve a major problem encountered by the automated third-generation system; namely, that the crowding of more and more beacon-equipped aircraft

into airport areas will cause interference and garble and necessitate speedier and more accurate ways to identify and track aircraft. DABS would accomplish this by sending out narrower interrogating beams than a radar. Once queried, a plane's DABS transponder would respond with a unique (discrete) digitally coded 24-bit reply giving its identity. Thereafter, the ground-based DABS station could query specific aircraft and discriminate among other planes in the area.

Industry gets its first crack at the DABS program this June when the FAA plans to issue requests for proposals for developmental models. The agency will buy three ground stations and about 20 transponders for testing at the National Airways Facilities Experimental Center, says David R. Israel, acting deputy administrator for research and engineering [*Electronics*, Feb. 21, p. 72]. The winning contractor, to be selected before the end of the year, will have 18 months to deliver the first ground station for a year's testing. This development phase will cost about \$20 million over three fiscal years, according to Spencer S. Hunn, head of systems research and development service.

But this development cycle means

that the FAA probably won't have to make a decision on procurement until 1978 or 1979 at the earliest. In fact, agency officials maintain that they won't decide to buy until after the testing is over and they're convinced the system works. "It's one of the first times we can start a system from scratch without inheriting someone else's mistakes," declares Kenneth A. Wise, DABS branch chief. "There's no urgency. We don't need it today," he says, adding that, if started, the program would take all of 20 years to implement, probably starting with the Chicago and New York regions followed by the West Coast.

**Nothing—unless.** On the other hand, if the agency decides not to implement DABS after spending some \$32 million in R&D, it would have nothing with which to handle future traffic except the present third-generation beacon system and some improvements.

Basically, DABS consists of two parts: the ground-based interrogating and receiving stations, and the replying airborne transponders. This up and down data line capability means that other ATC instructions, too, can be digitally transmitted between ground and pilots. DABS units will be designed to oper-

## ATC system genealogy

In FAA parlance, a first-generation air-traffic-control system is pre-World War 2, the second generation adds postwar radar beacon techniques, and the third is the automation of the radar system the agency is finishing installing. The billion-dollar third, composed of the Automated Radar Terminal System 3 and the en-route systems, provides such features as automatic tracking of beacon-equipped aircraft, presentation on a controller's scope of aircraft identity, altitude, and ground speed, and automatic updating and forwarding of flight plans.



# 20 amp high voltage fast switching power transistors less than \$10



SDT 12301-3

The price of our new series of fast switching 20 Amp, 200 Volt NPN Silicon Power Transistors are probably a lot less than what you've been paying. And though you'll pay less than \$10.00 per unit in quantity orders, you're getting the best!

Solitron's SDT 12301-3 Series features typical switching times of  $t_{(on)}=0.2 \mu$  sec,  $t_s=1.2 \mu$  sec and  $t_f=0.2 \mu$  sec. Other specifications include  $V_{CEO(sus)}$  from 200V to 350V;  $V_{CE(sat)}=0.6$  (max) and  $f_t=20$  MHz (min). Packaged in a TO-3 case, these transistors were designed for high voltage switching regulators and DC to DC converters.

If you're ready to order, call us direct on our toll-free line (800) 327-3243 for complete information. The SDT 12301-3 Series is available from stock and ready for delivery - at low prices!



1177 BLUE HERON BLVD. / RIVIERA BEACH, FLORIDA 33404  
(305) 848-4311 / TWX: (510) 952-7610

PLANTS IN: CALIFORNIA • FLORIDA • NEW YORK • ENGLAND • HONG KONG • MEXICO

# OUR ANGLE: The FIRST Digital Phase Angle Voltmeter



...This NEW DPAV provides complete analysis of complex AC waveforms at discrete frequencies and displays the results on a high readability 4½ digit display. Parameters measured are Total, Fundamental, In-Phase, and Quadrature voltage plus Phase Angle. Phase angle is displayed directly in degrees from 0° to 360° with a resolution of 0.1°.

The Model 220 operates phase-sensitively at a single factory-set frequency from 30 Hz to 32 KHz. The Model 225 has the capability of operating with two to four pre-specified frequencies. Both models have a total voltage measuring capability from 30 Hz to 100 KHz.

The DPAV can be used on the bench or in Automatic Test (ATE) applications. Remote programming, 10MΩ input isolation auto ranging, and BCD output options allow for complete hands-off operation necessary in automated test consoles. Priced from \$2950.00.

Let our sales engineering representative demonstrate our NEW angle to you. Call toll-free (800) 645-9200 for his name and address.



**NORTH ATLANTIC industries, inc.**

200 Terminal Drive, Plainview, New York 11803 • Phone (516) 681-8600  
California District Office: 13418 Wyandotte Street, N. Hollywood, CA 91605 • Phone (213) 982-0442

Circle 90 on reader service card

## Fight Them All

Heart Attack, Stroke  
High Blood Pressure  
Rheumatic Fever

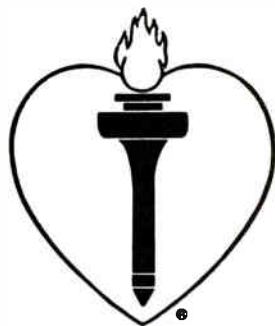

**Help your Heart... Help your Heart Fund**

## Probing the news

ate with existing radar-beacon equipment so that DABS interrogators will be capable of tracking conventional radar-beacon aircraft and DABS transponders capable of replying to present radar interrogations. For example, the DABS up- and down-link queries will use the present 1,030-megahertz up and 1,090-MHz down frequencies.

**Packed package.** Thus, the ground stations, called DABS sensors, will be sophisticated electronics packages of antennas, digitizers, hardwired digital processors, and correlators. These will perform the functions of surveillance processing, data-line processing, network management and reference monitoring and will communicate with other sensors and ATC centers. A DABS transponder would add a phase-shift-key processor, a mode decoder, parity decoder/encoder, and an up-link register to the present master control unit, receiver, video processor, mode decoder, reply generator, reply assembler, modulator, and transmitter.

The June request for proposals will call for over-all performance tests for the transponders. The level of detail for the sensors, however, will be akin to a functional design specification, according to Paul N. Drouilhet, program manager for MIT's Lincoln Laboratory, which performed systems engineering for DABS as part of the FAA's two-year, \$12 million first-phase effort. He says DABS will be grafted onto the present radar system as an upgrade on a one-for-one replacement basis when procurement of the system begins.

Despite the FAA's approach of "let's not buy it until we know it works," some see problems with the DABS development. The airlines, which would have to make a heavy investment, are lukewarm and have a wait-and-see attitude. "We're most anxious to see improvements to the beacon system," says Siegbert B. Poritzky, director of NAS systems engineering for the Air Transport Association, the airlines trade group. "Many of the things in the development of DABS are equally applicable to the beacon system." □

# GUARDIAN<sup>®</sup> SOLENOIDS

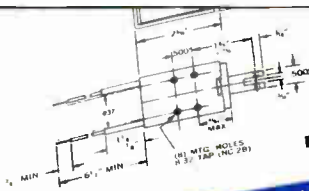

**DIMENSIONS**

## DATA AND SPECIFICATIONS

**Standard Voltages:**  
AC: 6, 12, 24, 120, 240  
DC: 6, 12, 24, 31.2, 240  
Voltage available from Distributor Stock are indicated in blue.  
Other voltages available on request.

**AC Operating Frequency:**  
60 Hz standard, 50 Hz available on request.

**Power Requirements:**  
DUTY CYCLE—25%  
with maximum on time of 171 VA  
**POWER DISSIPATION:**  
intermittent not recommended for 6 and 12V

**Insulating Materials:** Class A standard Other classes available on request.

Coil Finish: Electroplated acetate yarn standard. Also available: Varnish epoxy encapsulation and fungus resistant finishes.

**Coil Termination:** Leads per drawing standard. Also available: Solder lugs and quick connect terminals.

**Dielectric Strength:**  
Solenoid coil rated at 50V or less, 300 Vrms, 60 Hz  
Solenoids rated at 51V or more, 1500 Vrms, 60 Hz

**UL Recognition:** Recognized under the component program of Underwriters Laboratories Inc.

**Life Expectancy:** at 25°C: 5 x 10<sup>6</sup> cycles at 50% of full stroke shown on graph, nominal voltage and 110°C curve load value for low coil voltage.

**Plunger Weight:** 2 ounces (58 grams)  
**Total Weight:** 16 ounces (453 grams)

# Here's the proof Guardian's No.1 in SOLENOIDS

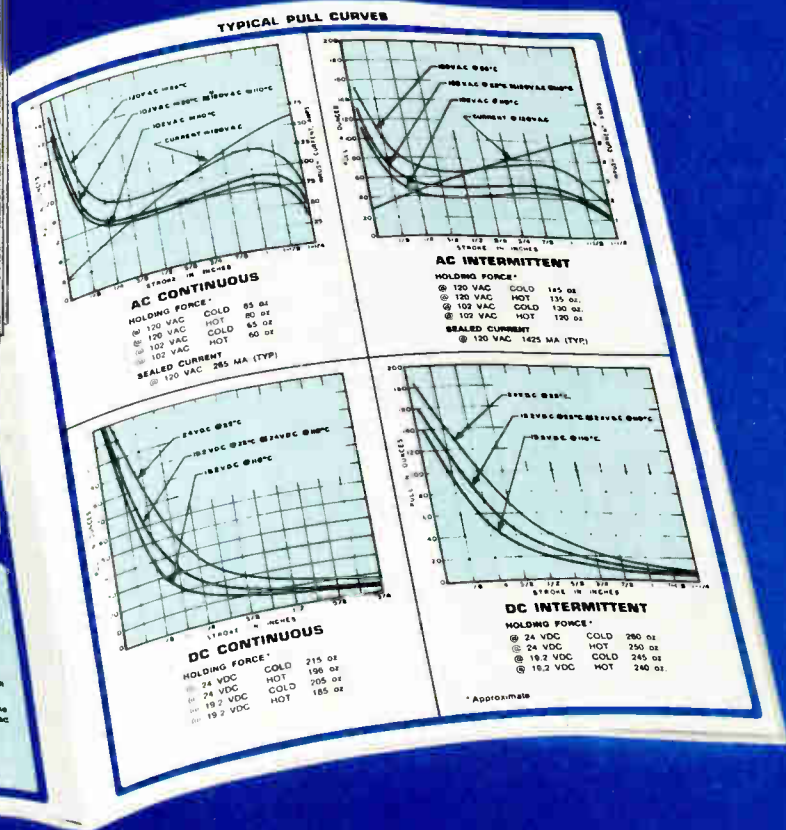

# CIRCLE NO. 250

on the readers service card  
to get your free copy of  
this new 72 page catalog.



FREE from your Guardian Angel.

# GUARDIAN<sup>®</sup>

GUARDIAN ELECTRIC MANUFACTURING CO. • 1566 West Carroll Ave., Chicago, Illinois 60607





## Test VOR/ILS the way the FAA does.

For aircraft safety, the FAA continues to establish ever stricter requirements for testing VOR and ILS receivers in the 108-118 MHz and 329-335 MHz ranges. To meet these demands, Singer introduces the Model 6106 Signal Generator, built for the FAA to their specifications as the primary standard for calibration of flight inspection equipment. Consider these features: Output frequency locked to a counter readout to achieve synthesizer-like stability of 1 ppm/24 hrs. Metered AM from DC to 50 kHz. Phase shift less than 0.01° at 30 Hz for precise VOR modu-

lation. Modulation frequency response less than 0.02 dB between 90 Hz and 150 Hz for accurate ILS modulation. Demodulated output signal providing modulation index values within  $\pm 0.3\%$  accuracy. Frequency range of 61 kHz to 1024 MHz to cover many other beacon, IF, navigation, and communication test requirements. With performance like this, the 6106 sets a new standard, the kind of standard today's VOR/ILS equipment testing demands. For the full 6106 story, write Singer

**SINGER**  
INSTRUMENTATION

Instrumentation, 3176 Porter Drive, Palo Alto, Calif., 94304. Tel.: (415) 493-3231.

# CUTLER-HAMMER'S BIG LINE OF COMMERCIAL MINIATURES.

Toggles. Pushbuttons. Rockers. Rotaries. Available in a vast array of operator styles, colors, and shapes. Including illuminated pushbuttons and rockers. Many featuring snap-in mounting. And all in stock for fast delivery!

Now the same great quality, service and availability you've come to expect from Cutler-Hammer is available in miniature size—at a competitive price!

Make your selection. Standard or watertight. Single or multiple pole. A wide range of decorator caps, buttons, bezels that extend application flexibility. And for their size, hefty electrical/mechanical ratings.

Before you place that next order, check with your source for commercial miniature switches—your nearest Cutler-Hammer Sales Office or Authorized Stocking Distributor.



**CUTLER-HAMMER**

SPECIALTY PRODUCTS DIVISION, Milwaukee, Wis. 53201



Switch  
to No. 1

More than just switches;  
prompt availability,  
field help, innovation,  
quality assurance, too.



# The "Above-Average" Sub-System by Celco



CELCO makes Precision CRT Displays for your "above-average" CRT requirements.

Need a CRT spot-size as small as 0.00065"? This standard CELCO 5" CRT display is being used for Satellite Photography. They needed the best they could get. You can get performance like that too with CELCO's DS5-065 Precision CRT Display.

A CELCO DS5-08 with 0.1% linearity, and spot size of 0.0008" is being used by another CELCO customer for Nuclear Photography Film Recording. Special features include programmable Raster Generators, and triple-layer and articulated shielding for ambient fields from earth's field and from dc to RF fields.

Fingerprint Scanning is the job of CELCO's DS5-10 Optical Character Recognition System for one of our customers. They needed that wide 2.5 MHz deflection bandwidth for high-speed scanning of vast amounts of data. And the DS5-10 has a settling time of

10 microseconds to 0.1% large signal, and 350 nanoseconds to 0.02% small signal settling time. Spot-size is 0.001".

One CELCO customer is using our 5" Color Display System for color separation and color photo scanning. One display does all that!

If your *needs* are "above-average" but your budget is *below-average*, CELCO also makes a 5" Precision CRT Display System especially for you that's ideal for your Low-Cost Film-Scan applications. Or if your display needs are larger, CELCO makes standard precision 7" and 9" CRT displays.

Our DS5-075 provides NASA with a 0.00075" spot-size for their Viking Orbiter and Viking Lander satellite photography. They needed 0.01% repeatability too. And they got it. From CELCO.

Two different customers with "above-average" display needs are using CELCO CRT Display Systems for Astronomy Research. One is an observa-

tory; they're keeping their eye on the Sun. The other is recording their Stellar Observations with a CELCO CRT Display System.

High-speed map making is the task of another CELCO customer using a CELCO precision display for topographical projects.

CELCO displays are helping a leading Oil Company in their oil explorations. While another CELCO display is being used in Eye Research.

Maps and satellites, eyeballs and oilwells. All "above-average" display requirements. If your needs are ABOVE-AVERAGE, you need a CELCO "above-average" Precision CRT Display System.

(Don't you think so too?)

Call CELCO for your "above-average" CRT Display System.

UPLAND CA 714-982-0215  
MAHWAH NJ 201-327-1123

(average is so . . . ho-hum to us.)

CONSTANTINE ENGINEERING LABORATORIES COMPANY  
1150 E. Eighth Street, Upland, CA 91786

70 Constantine Drive, Mahwah, NJ 07430





## Computer terminals for non-computer people.

Say you're the manager of a textile mill. Or a parts warehouse. Or a factory. Your people have to enter data — vat levels, crane positions, logged time, whatever — into a remote computer.

You've got a bit of a problem. Because no matter how good your forklift operators and production supervisors are, they're probably not computer experts.

We've got the solution. The RT01 and RT02 remote terminals.

They're simple to operate and extremely reliable, with few moving

parts and no fussy CRT displays. And the RT02 models will even prompt the inexperienced operator, spelling out on the display what information is needed next.

The RT01 has 16-key input and numeric I/O display. The RT02 has 16-key or 58-key input and an alpha-numeric I/O display.

They're both ASCII-compatible, so you can interface them to any computer that has a Teletype port. And they're both light enough to be portable.

The prices are down-to-earth, too.

From \$600 to \$1500, depending on the options you want.

The RT01 and RT02 from Digital. Remote terminals that people can get close to. Write, and we'll tell you more.

We're Digital Equipment Corporation, Logic Products Group, Maynard, Mass. 01754. (617) 897-5111, ext. 2785.

In Canada: P.O. Box 11500 Ottawa, Ontario, K2H 8K8. (613) 592-5111.

In Europe: 81 route de l'Aire, 1211 Geneva 26. Telephone: 42 79 50.

**We think terminals are so important, we give you a choice.**

**digital**

Circle 95 on reader service card

# Centralab perspectives

FOR USERS OF ELECTRONIC COMPONENTS



CENTRALAB

Electronics Division  
GLOBE-UNION INC.

5757 NORTH GREEN BAY AVENUE  
MILWAUKEE, WISCONSIN 53201

## Ceramic capacitors are now available with lead times as short as 6 weeks.

In the last year, Centralab increased production and established a new distribution center. That means they have larger inventories of quality ceramic disc capacitors to meet today's requirements.

In January 1973, when industry-wide lead times on capacitor deliveries were at an unprecedented high, Centralab took positive action. As a result, today they are able to assure the electronics buyer of 12 to 16 week delivery on any of their broad line of reliable disc capacitors. And some types in 6 weeks!

The first step in Centralab's Capacitor Service Program was a drastic one. In January 1973 they began refusing orders rather than accepting them for extended delivery. They then moved to bring to full production a new capacitor assembly plant in Juarez, Mexico. To provide dual sources for raw fired ceramic discs, they increased capacity at their plants in Milwaukee and Mexico City. At the same time, a new Service and Distribution Center was established in El Paso, Texas. Its 40,000 square feet provided for broadening capacitor inventories received from Centralab's five manufacturing locations.

Within six months most large OEM orders were on schedule, the backlog reduced and, with inventories of selected types available, orders were again accepted. Today, with inventories of all types and production facilities running at full capacity, Centralab offers capacitor buyers the only reasonable answer to meet their requirements. A buyer placing an order at the beginning of his 13 or 20 week planning cycle, for example, can be certain of on-time delivery of the types he needs.

Circle 96 on reader service card

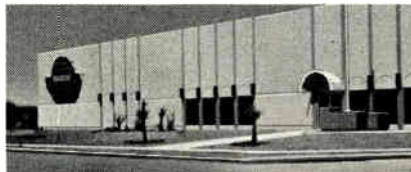

Located just across the border from Centralab's Distribution Center in El Paso, this Juarez, Mexico plant has helped shorten lead times on capacitor delivery.

Centralab's Distribution Center in El Paso is a key reason why today they can provide better service on capacitor orders. Its 10 man customer service staff is equipped to handle any capacitor delivery problem from order entry through special shipments. An application engineering staff is also on call to help with design problems. After reviewing a cus-



tomers' specifications, for example, they may even be able to recommend stock types which eliminate the need for special requirements. That could be important when delivery is critical.

Customer service is important — to the buyer and to Centralab. It requires more than fancy promises. It takes positive action. Centralab has done just that to help you meet your capacitor needs. For further information or assistance, call Bob Michaels at 915/779-3966 or write Centralab, Milwaukee.

Customer service is important — to the buyer and to Centralab. It requires more than fancy promises. It takes positive action. Centralab has done just that to help you meet your capacitor needs. For further information or assistance, call Bob Michaels at 915/779-3966 or write Centralab, Milwaukee.

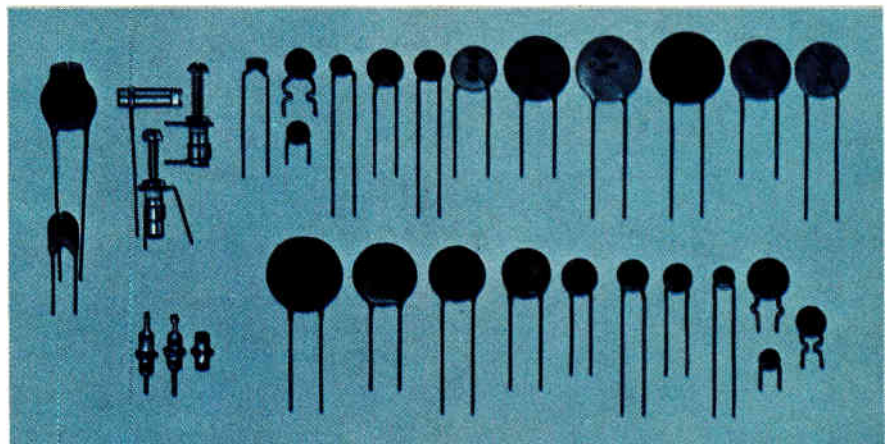

The extensive line of Centralab capacitors includes both disc and tubular types, with sizes and ratings designed for a variety of functions.



## Centralab perspective:

### Rotary Switches.

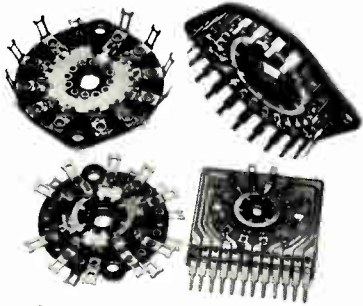

### Design them in for multi-circuit switching needs.

When your best circuit design requires switching an array of many circuits, the benefits of rotary switches makes them the logical choice. Centralab, with the most complete line, gives you benefits like this:

- Simultaneous switching of many circuits by varying the number of switching decks.
- Choice of index types — for 2 to 24 positions — 15° to 90° throw.
- Shorting and non-shorting contacts can be intermixed on the same section.
- Phenolic, ceramic, glass or diallyl phthalate insulation — to match your dielectric specifications.
- Optional electrostatic shielding.

Get the facts on total benefits. Write Centralab for Bulletin 1101SR.



Circle 105 on reader service card

## Centralab perspective:

### Trimmer resistors.



### Now, with new Snap-Tite® rigid PC mounts.

When you specify the new Snap-Tite rigid mount you can simplify both installation and assembly. Available on both Centralab Series S carbon and cermet trimmer resistors, it lets you snap them into a PC board. Easy. The mount locks the trimmer securely into the board prior to soldering.

Centralab gives you more of the things you want in trimmers. Ceramic bases for higher wattage in a smaller space. Smooth positive adjustment. A variety of choices in mountings, terminations and knobs. And multiple sections too!

Send for Bulletin 1549T so you'll have all the specs.



Circle 106 on reader service card

## Centralab perspective:

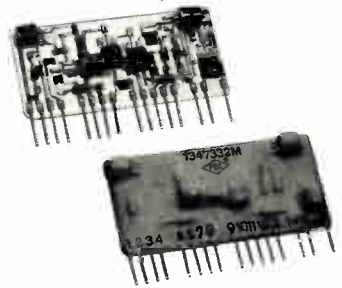

### Two thick film hybrid systems. PEC and MEC.

Centralab offers the flexibility to design and fabricate thick film modules to fit virtually any application and cost parameter.

Low-cost silver/carbon or  systems for consumer applications:

- Resistor Range..... 10 ohms to 10 megohms
- Resistor Tolerance... ±10% preferred minimum
- Ratio Matching..... ±5% minimum
- Capacitor Types..... Ceramic and tantalum
- Active Devices..... Diodes, transistors & IC's
- Operating Temp. Range.... -55° C to +85° C

Noble metal/cermet or MEC systems for commercial and industrial uses:

- Resistor Range..... 3 ohms to 3 megohms
- Resistor Tolerance..... ±.5% minimum
- Ratio Matching..... ±1% minimum
- Capacitor Types..... Ceramic and tantalum
- Active Devices..... Diodes, transistors & IC's
- Operating Temp. Range... -55° C to +150° C

For Bulletin 1429H write  
A.R. Wartchow, Manager,  
Electroceramic Marketing,  
Outside U.S.A. contact  
J.H. Meunier, Manager,  
International Sales.



Circle 97 on reader service card



**Centralab**  
perspectives



**CENTRALAB**  
Electronics Division  
GLOBE-UNION INC  
5757 NORTH GREEN BAY AVENUE  
MILWAUKEE, WISCONSIN 53201

# spice

**VARIETY IN PUSHBUTTON SWITCH SELECTION.** That's how Centralab can help put a little more spice in your work-a-day life. Because nobody else can give you all the up-to-date features and functions that let you design the way you want to. Start with the basic module . . . then select the options you want, and every functional and appearance specification suddenly becomes reality.

Maybe you'll select Centralab pushbutton switches\* because they require so little space. That's important when you also consider that up to 29 modules can be ganged on a single bracket with horizontal or ver-

\*Isostat licensed

tical mounting, rear or back-to-back coupling.

Or, you may want the flexibility that 5 different center-to-center spacings offer you. You can have 10, 12.5, 15, 17.5 or 20 mm in non-lighted switches. Lighted pushbutton switches are available in 15 or 20 mm. For interlock and lockout functions, Centralab is your clear choice. We not only offer you momentary, push-push and interlocking action switches, but four types of lockout as well.

You'll find some of the brightest benefits in our lighted pushbutton switches. First, we supply both white and black lamp

housings with a variety of filters and lenses for the precise control of light output over a wide range of ambient light conditions. And the snap-in lens permits relamping through a front panel. Our shock-mounted filament lamps are designed for low maintenance and long life.

The lamp circuit can be integral or separate from the pushbutton switch circuit. Where it's integral, lamp and switch circuits are in the same terminal plane and can be flow soldered simultaneously for easier installation and service.

If you're looking for the boundless variety that means true design flexibility, we've got your kind of pushbutton switch. We'd like you to know about our epoxy sealed terminals, selective pin cutting, wrap-around support bracket, dust-seal covers, line switch and 25 button styles in 18 colors. And how we can furnish legends for buttons, filters or lenses. We've put it all in a new 24 page catalog that includes complete specifications, dimensional drawings and ordering data. It's yours for the asking. Just circle the information service card or write Centralab for Catalog 1550P. Put some spice in your life.

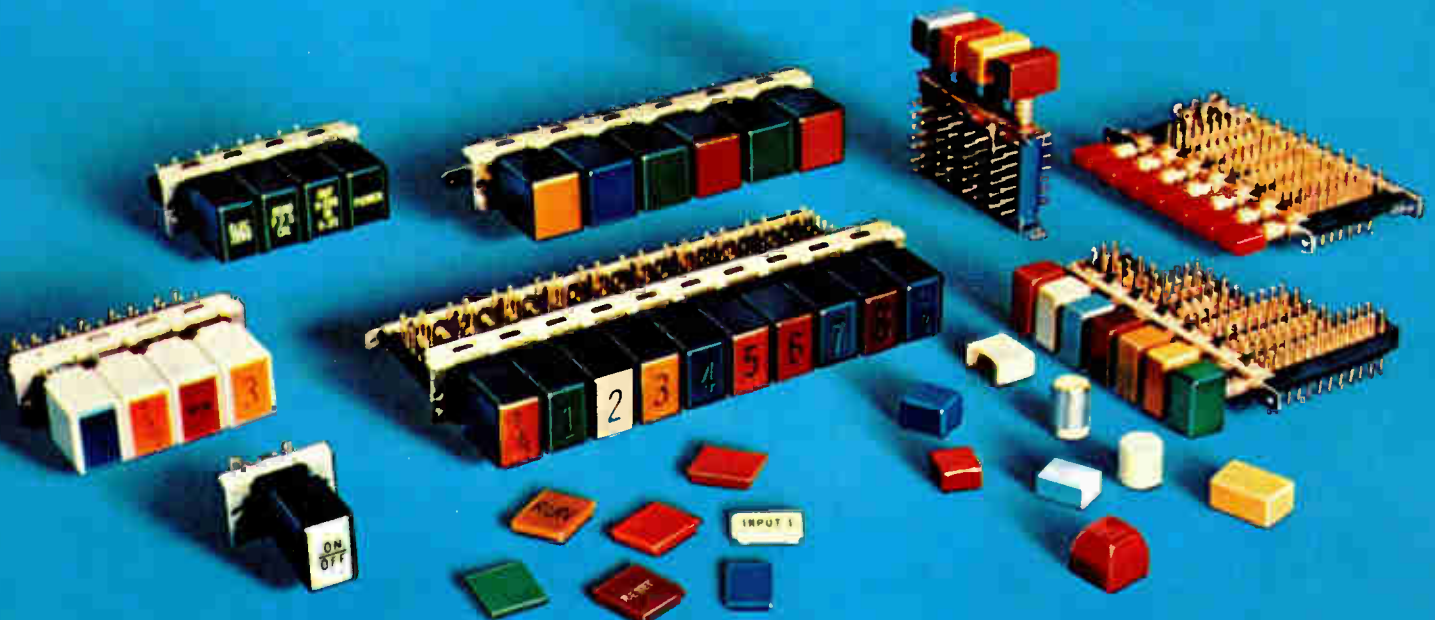

Circle 98 on reader service card



# Energy crisis spurs development of photovoltaic power sources

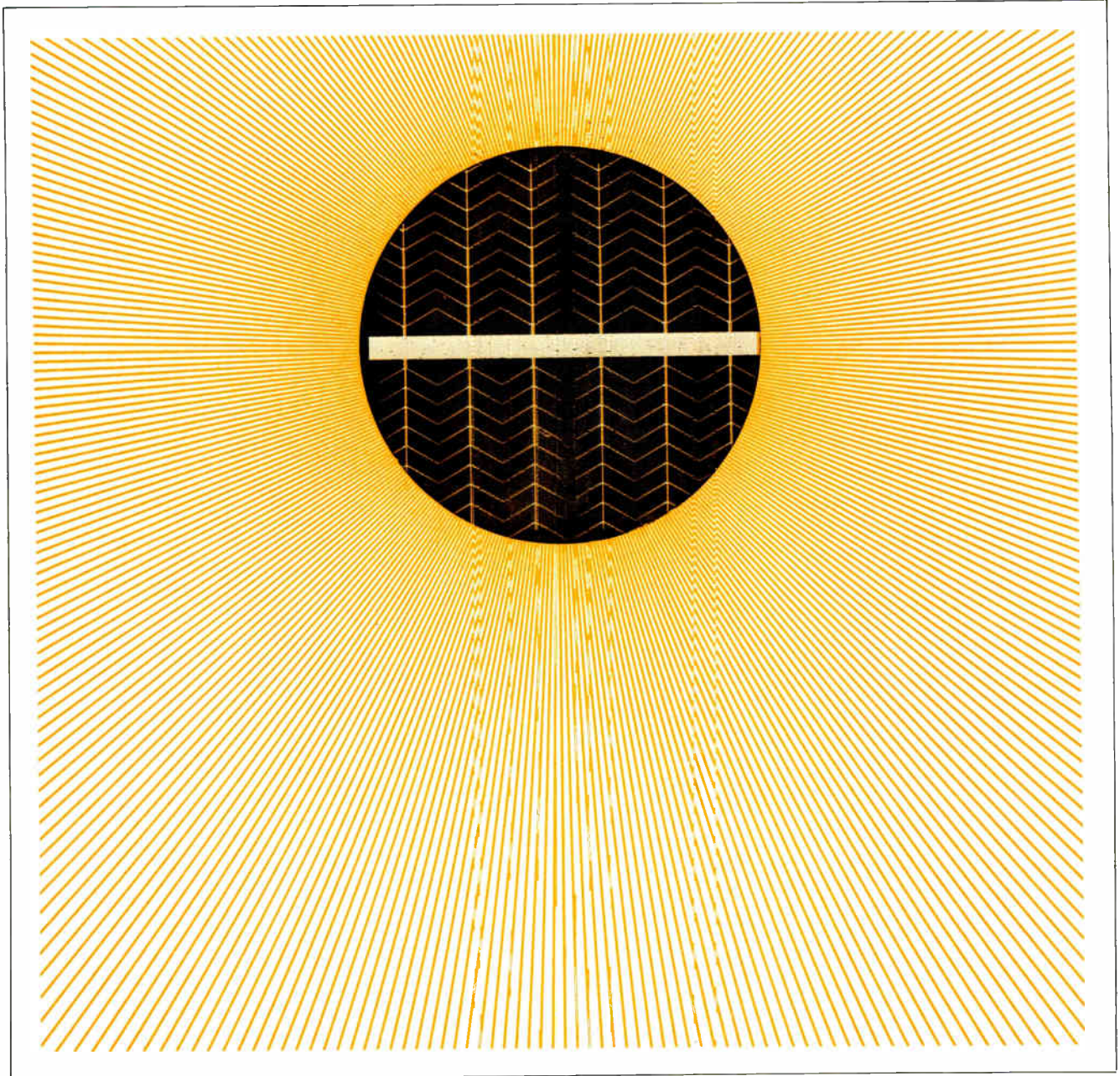

---

As Japan emphasizes solar-energy program, National Science Foundation supervises R&D in the U.S. for terrestrial applications of solar cells; universities join business in seeking economical electric-power systems

---

by Alfred I. Rosenblatt, *Industrial Editor*



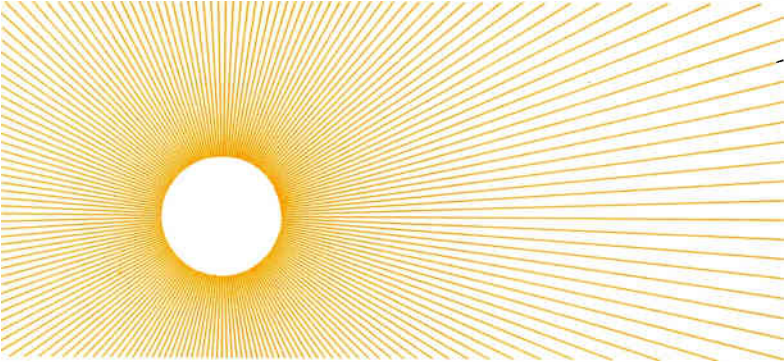

□ The photovoltaic conversion of light into electricity, used with such great success in solar-cell panels to provide power aboard spacecraft, is coming down to earth in a big way. Within the next few years, solar-cell power systems may be intercepting sunlight from the rooftops of buildings and providing a portion, if not all, of the occupants' energy requirements.

By the early 1980s, engineers may know whether or not it will be feasible to build solar-cell power stations instead of conventional central power plants. What's more, Japan is planning to operate a 1-megawatt solar-cell electric-power station by 1980.

In fact, H. Richard Blieden, manager of the photovoltaic program at the National Science Foundation, estimates that by 1990, U.S. industry each year will be turning out solar arrays that produce about 5,000 megawatts at peak output. This rate will be doubled by 1995 and redoubled again by the year 2000 to 20,000 MW, Blieden predicts. Altogether, the installed capacity by 2000 may well be somewhere between 1% and 2% of the nation's total electric-power needs.

In order to achieve these goals, efforts must be concentrated on reducing costs, which still are more than two orders of magnitude too high. The energy shortage has motivated the governments of the U. S. and Japan to increase funds and provide the impetus for developing solar-cell technology for terrestrial use. In Japan, the development is considered crucial because of the energy squeeze on that country resulting from the Arab oil boycott and the necessity to clear away some of the industrial smog that smothers citizens in the cities (see "In Japan, clean energy comes first," p. 104).

### U.S. industry seeks sun power

In the U.S., private industry is also trying to stir up interest. Last month, for example, a consulting and engineering firm, the Mitre Corp., decided to push ahead and invest its own money in a rooftop solar electric power system that will generate 1 kilowatt of peak power [*Electronics*, March 21, p. 25]. And the cause of solar power is being promoted and subsidized to some extent by large oil companies and public utilities, which may enhance their "clean-energy" image.

Development of photovoltaic power for terrestrial applications is being directed in the U.S. by the National Science Foundation. In April a year ago, the Office of the President designated NSF the lead Federal agency to

**1. The shape of things.** No longer merely adaptations of rectangular solar cells manufactured for space, a photovoltaic cell for terrestrial applications (p. 99) can have a shape all its own. This cell by Solarex Corp., sliced from a boule of single-crystal silicon, also shows off its current-collecting grid of conductors.

coordinate solar-energy research and technology (see "Photovoltaic lead goes to NSF," p. 101). Several colleges and universities, funded mostly by NSF, are working on both silicon and cadmium-sulfide solar cells, as well as other materials.

And NASA, particularly because of its experience in pioneering the use of solar cells to supply power for spacecraft, has an especially valuable base of talent in this field. The goals for both Federal agencies are quite similar—namely to reduce the cost of cells and arrays and to boost the efficiency of the cells. NASA, of course is further concerned with such things as the radiation resistance of cells, a factor that is of little importance for cells used in earth applications.

NSF is requesting some \$49 million for fiscal year 1975, a \$35.8 million increase from the appropriation of a year ago, to be applied to the broad area of solar-energy development. Of this, \$8 million is earmarked for research and development in photovoltaic cells.

### NSF shapes the program

The \$8 million requested by NSF for photovoltaic conversion projects may be considered modest by some standards in the electronics industry. But for NSF and photovoltaic development, it's a heady amount, representing, as officials are quick to point out, almost a four-fold increase over the \$2.25 million budgeted last year.

"That's a lot of money for this field," points out Paul Rappaport, a noted consultant on solar energy and director of the Process and Applied Materials Research Laboratory at the RCA Corp. laboratories in Princeton, N.J. "It's a very good start on the R&D end of things. The question is, however, whether it's going to be backed up with substantially more dollars when large systems and arrays are being contemplated."

NSF has fashioned a multiyear program for its photovoltaic projects. These are divided into two major areas—R&D involving solar devices and arrays, and application of the arrays—reports NSF's Blieden.

Associated with array development are four major milestones, Blieden says. First, by 1977, NSF hopes to have attained a level of solar-cell technology, based on refining present techniques, that could produce electric power at a cost of \$5 a watt at peak power.

Two years later, by 1979, the goal is to demonstrate the feasibility of dropping the cost by another factor of 10—to 50 cents a watt at peak power. This would involve such new techniques as fabricating cells in continuous ribbons instead of individually, Blieden points out.

The third milestone is targeted for 1981, when NSF hopes to start funding a pilot line for manufacturing arrays to cost 50 cents a watt peak power. By 1983-1985, the line should be turning out arrays in quantity. In 1986, work is to begin on a pilot line to manufacture arrays costing 30 cents a watt at peak power and even less, with production quantities to be turned out by 1990.

During the first few years, at least, R&D efforts will move along parallel paths, Blieden says. In the forefront will be the development of processing techniques for single-crystal silicon, with emphasis on automating the present batch process for making cells from wafers and then integrating them into finished arrays.

Simply refining conventional techniques alone would



be sufficient, says Blieden, to bring costs down to \$5 a watt at peak level. Moreover, he points out, these reduced-cost cells will make practical many small-scale "specialty" applications and promote an expansion of the solar-cell-array industry, producing the volume needed to reduce costs even further. Moreover, the cells developed in this phase of the program will be used to demonstrate the feasibility of applying solar-cell systems on a large scale for residences and other buildings.

Concurrently, NSF will also sponsor research into other candidate materials for solar arrays, including films made of such materials as polycrystalline silicon and cadmium sulfide. Gallium arsenide, and other III-V materials will be tried, as will metal oxides and organic compounds, new Schottky barrier devices, and photovoltaic materials with strong infrared sensitivity.

Arrays of stable, thin films of cadmium sulfide are

among the more promising possibilities for cheaper solar cells, costing less than \$1 a peak watt, according to Blieden. They are now made on a "hand-batch" basis in sizes of 3 by 3 inches, starting with the evaporation of the CdS on a thin conductive substrate and followed by a dip in copper-sulfide solution and baking. Material instability and short lifetimes have been the two most nagging problems. But, once these are solved, automation can be brought to the fabrication process, and Blieden feels the cost goal can be readily achieved.

Turning to applications of devices and arrays, Blieden predicts that by about 1985 costs will have been reduced to less than 50 cents a watt at peak power, and solar photovoltaic technology could be applied on a large scale. But, he cautions, providing array technology alone to potential users will not be enough. System-design data will also be vital. This will include such data

## Photovoltaic lead goes to NSF

The National Science Foundation, long noted for its efforts to direct research in the basic sciences, took on an applications-oriented mantle in 1971 with the inauguration of the Research Applied to National Needs (RANN) efforts. Its purpose is to focus U.S. scientific and technical resources on problems of national importance so as to shorten the lead time between the discoveries made by scientists and their applications toward meeting the nation's needs.

So far, three major problem areas have been identified under RANN, for which a budget of \$148.9 million, more than double the outlay of the year before, is being requested in fiscal year 1975. The three areas are energy, the environment, and productivity.

With the acceleration throughout Government of energy-related R&D in the face of the nation's fuel shortages and the Arab oil boycott, NSF is also stepping up its solar-energy expenditures. For fiscal 1975, the agency is asking for around \$49 million, a hefty \$35.8 million increase over the funds to be expended during fiscal 1974. Of this, photovoltaic-energy conversion is slated for \$8 million, up from the previous year's \$2.25 million.

The balance of the \$49 million is devoted to the development of solar-energy heating and cooling systems for homes and offices, the bioconversion of organic matter to fuel via photosynthesis, and harnessing both the energy of wind and of differences in the ocean's thermal currents.

The manager of the photovoltaic program at NSF is H. Richard Blieden, a 37-year-old physicist from the Midwest with experience in particle and nuclear physics. He's the author of more than 60 publications, and his major areas of expertise include energy research and technology, instrumentation, radiation detection, nuclear structure and particle physics, and on-line computer techniques.

The tall, dark-haired, Blieden, who, when he speaks, chooses his words carefully, works in the division of Advanced Energy Research and Technology. This group, plus NSF's Office of Public Technology,

is charged with shepherding the burgeoning photovoltaic technology.

Blieden received a doctorate in physics from Florida State University in 1962 and came to NSF only two years ago. Before that, he'd been on the staff of the State University of New York at Stony Brook, and from 1965 to 1969, he held an appointment at Brookhaven National Laboratory. Earlier, he traveled under several fellowships, including NSF post-doctoral fellowships at the European Organization for Nuclear Research in Geneva and at the Niels Bohr Institute in Copenhagen.

Blieden says he's excited about the prospects for applying photovoltaic devices terrestrially. "The country is fortunate to have so strong a group of people in the field," he says, referring to some 150 technical experts from industry, universities, and Government laboratories who attended an NSF-sponsored workshop on the status of photovoltaics held in Cherry Hill, N.J., last October. And besides, he chuckles, "crisis breeds progress," referring to a mock advertising slogan he had seen once.

He emphasizes that NSF, not having any laboratories of its own will have to "lean heavily" on the expertise in Government laboratories at other agencies throughout the country. In particular, he stresses that continued cooperation with NASA, which pioneered the application of solar cells in space, is crucial.

**H. Richard Blieden** is manager of the photovoltaic program at National Science Foundation, which is directing U.S. efforts.



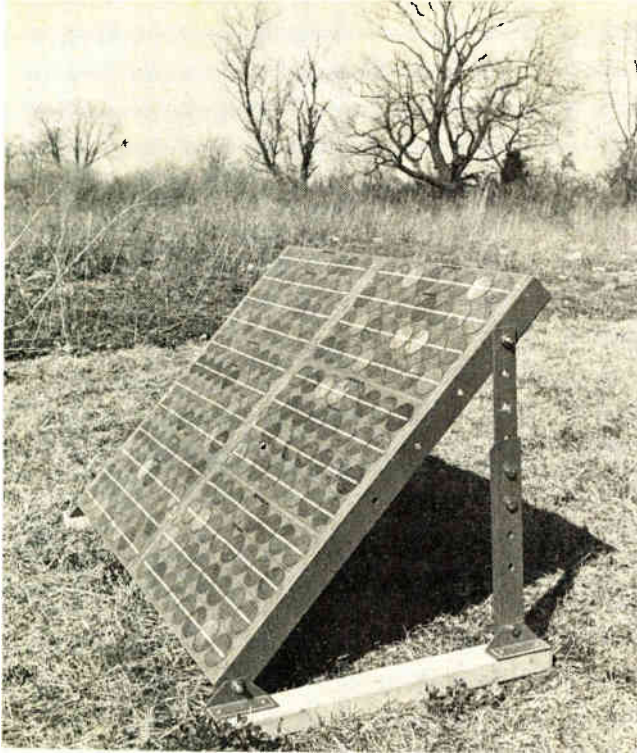

as that needed for scaling the systems up in size, ways to trade off between different kinds of systems, and devices for power storage, transfer, and control.

NSF has set forth another set of milestones for the applications area. To measure the sun's intensity and duration, insolation data-collection networks are to be established around the country by 1975 with the aid of the National Oceanic and Atmospheric Administration. Such information would help evaluate the economy and efficiency of photovoltaic converters at particular locations. In the same time-frame, materials characterization and analysis laboratories are also to be established in existing facilities.

During the following year, a terrestrial environmental test facility will begin operating to check out arrays and cells. And lifetime data will be taken under accelerated tests. Determinations will also be made of the maximum allowable costs of photovoltaic systems for on-site (on the roof of a residence, for example) and central-station applications in several U.S. locations.

By 1977, on-site system designs should be completed and tests begun on candidate cells and arrays. Two years later, according to the NSF plan, the first on-site systems will be installed. Attention will then turn to the design of a central-station system.

In the early 1980s, installations of test-bed central-power systems of 1 to 10 MW will be started. By 1985, 10-MW systems will be integrated into communities and large industrial plants. And by 1990, Blieden foresees the possibility of giant systems of 100-MW capacity being integrated into towns and power networks.

### NASA's role

Altogether, NASA has about \$1.5 million this year for solar-cell development, and about 40 people are working in the field at Jet Propulsion Laboratory, Pasadena, Calif., Lewis Research Center, Cleveland, Ohio, and Goddard Spacecraft Center, Greenbelt, Md.

Broadly speaking, NASA wants to reduce its space-array costs from \$270 per watt in 1972 to \$90 a watt by

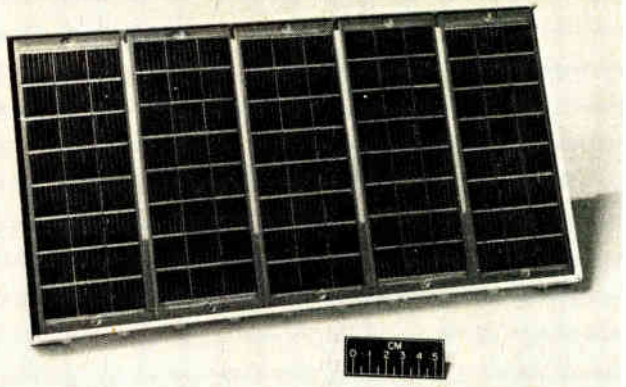

**2. Solar arrays.** Six 9¾-by-18-inch modules are put (left) into a 50-watt (at peak) array from Solarex Corp. NASA's Lewis Research Center is experimenting with encapsulating space-type solar cells between sheets of plastic for structural strength and easy handling.

1978. The figure of \$90 a watt holds if solar cell production stays constant, but it could drop to \$40 a watt if terrestrial applications catch on and production rates of solar cells go up, points out Ernst M. Cohn, manager of solar and chemical power at NASA headquarters in Washington. Power density is also being improved to 110 watts/kilogram from the present 66 w/kg.

Cohn also describes some specific target dates. These include having standards for a "violet" cell with 14% efficiency (based on a high-efficiency cell developed by the Communications Satellite Corp., Clarksburg, Md.) ready by fiscal 1975; pilot production of thin, 4-mil cells, and cells fabricated from silicon ribbon ready for evaluation by fiscal 1976; a new low-cost array technology ready by fiscal 1978, and cells with 18% efficiency by 1979.

He points out that between 1979 and 1990, NASA could save more than \$100 million if solar-array costs were decreased by only half.

The bulk of NASA's R&D effort in photovoltaic technology is being carried out at NASA's Lewis Research Center, Cleveland, which, according to Dan Bernatowicz, chief of the Solar branch, has undertaken two main programs. In one, Lewis engineers and physicists are striving to raise the efficiency of silicon solar cells "as far as we can." In the other program, the researchers are trying to develop methods for reducing the cost and labor needed to assemble individual cells into arrays.

Bernatowicz describes the efforts to raise efficiency as involved with research into the physics of the solar cell, in contrast with the "technology approach" used by Comsat Laboratories when its 13% efficiency "violet" cells were developed.

Lewis, on the other hand, hopes to use silicon that is more highly doped and has lower resistivity. Commonly, silicon cells used in space have resistivity of either 10 or 2 ohm-centimeters. The latter yields somewhat higher starting efficiency, but after perhaps a year or so in orbit, time and effects of radiation tend to negate the advantage. More highly doped silicon with resistivity down around 0.1 ohm-cm is now under consideration.

Theoretically, cell voltage should go up as resistivity goes down because the barrier height of the pn junction increases. But the voltage output in cells fabricated in the laboratory seems to peak at 600 mV and even goes



down. The explanation could be very complex, going beyond the simple diode theory of the junction and related to such things as the reverse leakage currents that flow through the junction, crystal impurities and imperfections, and the shape of the doping profile.

The other Lewis effort is aimed at reducing the labor and cost of assembling arrays. To this end, the center is using sheets of plastic—fluorinated ethylene propylene (FEP)—and creating a sandwich, with the solar cells as the “meat.” Under heat and pressure, and with a layer of Kapton added for strength, Lewis produces a laminate which resembles an identification badge, according to Bernatowicz. Besides supporting the cells, the FEP also serves to replace the 6-mil-thick cover glasses, costing about \$1 each, that are placed atop each cell as protection against the radiation encountered on space missions. Cost of the plastic is about \$1 per square foot.

Lewis has encapsulated 6-by-8-cell-array modules, and has applied two arrays as power sources for remote weather stations for the National Weather Service. One unit, for example, was built up from the smaller modules to measure 3.6 by 2.6 feet and produces about 60 w. It is currently being tested at a weather station on Mammoth Mountain, Calif. (Fig. 3). Moreover, the group at Lewis is considering developing solar-cell power systems to be used on buoys of NASA's Langley's Research Center and on walkie-talkies and remote mountain repeater stations for the Forest Service.

In addition to this work, Lewis has contracted with TRW Inc., Redondo Beach, Calif., to build even larger modules—20 by 20 in.—and to test and evaluate them. And some modules are scheduled to go up in a few months aboard the ATS-F satellite.

In the future, Bernatowicz sees the possibility of making modules using the “wraparound” contact technique recently developed by NASA. Presently, solar cells are interconnected electrically into arrays by zig-zagging contacts from the top of one cell (p-layer) to the bottom of the adjacent cell (n-layer). With the new technique, each cell is fabricated with a top contact that is wrapped around one edge of the cell to the back. The result is that cells can be interconnected solely through the back contacts, so that the zig-zagging is eliminated and the connection process could be readily automated.

Eventually, Bernatowicz sees the possibility of automating the entire array-making process by feeding together reels of plastic material and solar cells.

Still another important NASA project is going on at Jet Propulsion Laboratory, where thinner silicon cells are being developed. These extremely fragile cells are only 4 mils thick, compared with the 10-to-12-mil thickness of cells generally used for space applications. The advantage of the thinner cells is, of course, that because they use less silicon, their cost should be reduced.

#### **Mitre to test system**

Mitre Corp., a consultant to industry and Government on aspects of the energy crisis, is investing \$130,000 of its own money in its new system, the largest terrestrial photovoltaic-energy converter ever installed. It will be a test bed, not only for solar cells, but also for a new energy-storage concept, as well. Thus, Mitre is including an electrolysis unit that will use electric power

from the solar cells to hydrolize water into its constituents, hydrogen and oxygen.

These gases can be held in storage and, at night and when it is cloudy, fed into a fuel cell to generate electricity anew to make power available 24 hours a day. All of the components will be purchased off the shelf, says Richard S. Greeley, associate technical director of the Systems Development division in McLean, Va., where the new system will be installed. No new development is planned. An inverter is also to be included to boost the dc current from the solar cells and fuel cell to 110 v ac for application to a demonstration load.

The 1-kv peak output will be supplied by 20 individual panels that generate 50 w each. Seventeen of the panels will be supplied by Solarex Corp., Rockville, Md.; and the others come from three firms that are now developing and fabricating terrestrial solar-power systems—Solar Power Corp., Braintree, Mass., Centralab Semiconductor Products, El Monte, Calif.; and the Spectrolab division of Textron Inc., Sylmar, Calif.

The price of each panel will be \$24 to \$30 per peak watt, says Greeley. The 1-kw system may be only the beginning for Mitre; Greeley hopes to have a 1-MW system design ready in a year or two.

“At Mitre, we feel the photovoltaic area should be vigorously explored. The systems aspects are as important as the research on the cells themselves,” declares Greeley. “We're a little more bullish than a lot of others,” he continues, “but we hope they'll jump in, too, and help to stimulate the market. That's the only way to step up production and lower prices.”

#### **'Breeder' is advocated**

Joseph Lindmayer, president of Solarex, is also anxious to start demonstration projects at once to show the feasibility, as well as the desirability, of solar electric power. In testimony early this year before the energy subcommittee of the Senate Committee on Finance, he outlined a program to develop what he calls a solar breeder.

Lindmayer contends that at least one solar-cell manufacturer should be subsidized to produce solar cells that would be ear-marked for arrays to be placed atop its factory. Electricity generated by these arrays would be used to help manufacture additional cells—hence the name, breeder. Eventually, the plant could generate its own electric-power requirements and even go so far as to be removed from electric power lines. From then on, the output of the factory would be available for installation elsewhere.

Lindmayer estimates this could be accomplished, and a “sizable” half-megawatt system installed, in five years, at a cost ranging between \$10 million and \$15 million. In his own plant, Lindmayer is already trying to “solarize” parts of his manufacturing process. His first target is the system used to test completed cells.

But as ambitious as the NSF program may seem, there are those familiar with solar-cell technology who feel the agency is being too conservative, both in its initial goal of cells costing \$5 a watt and in not funding demonstration systems right away.

They point out that prices for solar panels and systems now being quoted by companies in the field are





not far away from the \$5 figure. Centralab Semiconductor, for example, says its complete units, with cells mounted in an array panel, and with storage batteries and power conditioning gear, are priced in the range of \$40 to \$70 per watt.

A company spokesman claims that \$5 to \$7 a watt appears feasible within four years "with simplified processing of cells and arrays, a larger assured market, and [maybe] some degree of sunlight concentration."

Solarex' Lindmayer is even more hopeful. The company could sell its complete system, he says, for only \$20 to \$30 per watt "in quantity." Solarex is already delivering a complete 40-W system to the Forest Service for powering a remote mountaintop transmitter for less than \$1,200, a rate of \$30 per watt.

This price is still, of course, far too high to be directly competitive with electric power generated by conventional fossil-fuel plants. Cost of such power ranges between \$300 and \$500 per kilowatt, and this is an average rate for 24-hour-a-day production. Solar-cell systems are generally rated at their peak capacity—the power they produce when the sun is bright and shining at its maximum. The figure for average power over a 24-hour day is obtained by dividing the peak power by a factor of five or six. Thus, to provide a kilowatt of av-

erage power, a solar-cell system must be large enough to produce at least 5 kw of peak power. Using the Solarex figures then, the present cost of solar power ranges between \$20,000 and \$30,000 per watt (peak) or \$100,000 to \$150,000 per watt (average).

Demonstration projects begun right now would help to create a market for solar cells, and, with increased production, costs would undoubtedly fall. RCA's Rappaport adds, "We would gain valuable experience in operating the system and learn about questions of reliability, cost and energy storage."

Moreover, an expanded market would help encourage newcomers to the field, Rappaport insists, because there are still relatively few companies with expertise for R&D in solar-cell-array technology. For example, none of the nation's present suppliers of semiconductor integrated circuits have any products on the market, and almost none is interested in the field.

### Companies tackle market

The payoff for R&D funds invested now could be enormous if solar cells will be capable of supplying only 1% or 2% of the nation's estimated 1,636 million kw electric-power budget by the year 2000.

If this power were to be obtained solely from im-

## In Japan, clean energy comes first

More solar-powered photovoltaic systems probably have been installed by the Japanese around their home islands than in any other nation. But even though the first system dates back to 1958—a 70-watt silicon solar-cell power supply by Nippon Electric Co. for a remote telemetering system owned by an electric utility—the cumulative total installed since then produces little more than an estimated 20 kilowatts.

However, this figure may begin climbing sharply within the next few years, as the Japanese progress with their Sunshine project, an extremely high-priority government program to develop clean energy sources. In national significance, the Japanese compare the project to the United States' Apollo program of the 1960s to land men on the moon. The Japanese project is scheduled to run until the year 2000, and its total cost will exceed an astronomical  $10^{12}$  yen, or anywhere from \$3.6 billion to \$7 billion. The name Sunshine was chosen with wry humor because it is hoped that use of clean energy will eliminate smog, and the Japanese islands will once again enjoy the sunshine—weather permitting, of course.

Since the Arab oil embargo, the Sunshine project has taken on new significance. Unlike government programs in the past to develop technology for industrial advancement, this effort is considered vital to Japan's very existence. Solar cells and other applications of solar energy are only one part of the technology to be developed. Other efforts are being made to develop geothermal power, gasification and liquefaction of coal, and use of hydrogen as a fuel and storage medium.

The Sunshine project started in fiscal year 1974, which for the Japanese began on April 1. Appropriations for the initial year are \$8.7 million, of which a large portion—\$3.1 million—is for solar-energy studies. These include developing methods for generating electric power from solar heat and solar light, for solar-energy heating

and cooling systems, and solar furnaces. There is no breakdown yet of how much will be spent for each purpose, although most of the money will be spent on preliminary studies. The first contracts will probably be awarded next month.

According to a tentative timetable, a 1-megawatt solar-cell electric-generation system should be completed by 1980. About midway through the project a 10-MW system will be started, and it is scheduled for completion by 1986. A 100-MW system is to be completed in 1991, and even larger plants are to start operating by 2000.

At present, Nippon Electric and Sharp Corp. are the only companies with much experience in fabricating silicon solar cells and systems for electric-energy applications. A Sharp spokesman estimates the total market for terrestrial systems this year, including domestic and export customers, is on the order of 3.5 kilowatts. Sharp will supply the bulk—roughly 75%—of this market, he claims, and Nippon Electric, the rest.

Most of the applications are for flashing navigation lights on buoys and lighthouses installed and operated by Japan's Maritime Safety Agency, and for powering telephone repeaters, telemetering systems, and communications equipment in remote islands and atop mountains. The largest installation is in the 250-W range, with the average between 30 and 40 W.

Prices of Sharp's units, for example, range from \$110 to \$175 per watt, including storage batteries and control and regulating circuitry. This is, of course, far too high by at least two orders of magnitude for generating electric power on a large scale.

As government funds become available for development of technology, and the range of economic applications increases, more companies are expected to participate. Likely candidates are such major semiconductor manufacturers as Hitachi Ltd., Toshiba (Tokyo Shibaura Electric Co. Ltd.), and Mitsubishi Electric Corp., manufacturers of hydro- and thermal-power stations.

Another candidate is Matsushita Electric Industrial Co.

ported oil, billions of dollars could be saved annually. And the way oil prices are rising, there is no way of telling how high this figure could go.

Commercially, a handful of companies are already pursuing the terrestrial solar-power market, which is quite small and highly specialized. And even Comsat, emboldened by its success in developing the violet cell, is soliciting funds from NSF to develop a terrestrial photovoltaic cell. The research group in the Comsat laboratories must seek outside funding because terrestrial solar cells aren't included in the charter that created Comsat, E. S. Rittner, director of Applied Sciences for the laboratories, points out.

Rittner stresses that his mission is primarily to improve space cells for his company's satellites, but he says his group has lots of ideas to further the silicon-based technology in both uses. He would like nothing better than to tackle the problem of designing a cell strictly for terrestrial purposes, which he says has not been done yet.

Of the firms already in the field, however, some have been at it since the late 1950s. Centralab, for example, was packaging a line of solar panels back in 1957, and Nippon Electric Co. installed its first system in 1958.

Centralab, incidentally, is one of two U.S. suppliers

of silicon solar cells for the American space program. The other space-cell supplier, in a market that reaches about \$5 million per year, is the Heliotek division of Textron Inc., Sylmar, Calif. Heliotek got into the solar-cell business in 1956, but began as a maker of the glass shields to protect the cells against radiation. The company soon decided that the shields it was making were of better quality than the cells they were protecting, so it started making the cells, as well. Cells built by Heliotek are fabricated into complete systems for both space and terrestrial uses by its sister division, Spectrolab, also in Sylmar.

Other companies in the field include Sharp Corp. in Japan, la Radiotechnique Compelec in France, and Stone-Chance division of Stone-Platt Industries Ltd., in England, which buys its silicon solar cells from the space-cell production line of the sole English cell maker Ferranti Ltd. However, Ferranti itself expects to have preproduction terrestrial arrays by next September.

New American companies have also moved into the field. One is Solarex Corp., formed by Lindmayer who used to be manager of the Solid State Physics Laboratory of Comsat [*Electronics*, May 22, 1972, p. 30].

Solarex is also expanding its operations through the acquisition of the solar-cell facilities and business of the

Its one major effort so far, sintered ceramic cells using cadmium sulfide, has not been successful. Reliability is poor. However, Matsushita has silicon capabilities too.

If silicon is applied successfully—and silicon cells are attracting the most interest at present—consumption of single-crystal silicon in Japan will jump appreciably. For example, one Japanese estimate is that a 10-MW generating station made with present technology would require 1,000 tons of silicon. This alone amounts to about the present annual worldwide market. And plants of many times this scale are being considered.

Solar-cell efficiency for the Japanese-made cells is about 10%, and manufacturers are casting covetous eyes at theoretical maximums in the range of 20% to 22%. However, the price-performance ratio is most important, and the Japanese will not insist on higher efficiency if it makes the cells too costly. About 16% appears to be the highest value yet achieved in Japan.

As in the United States, the Japanese will attack the entire sand-to-solar-cell process in their efforts to reduce costs. Especially important to them is reducing the electric power used when making single-crystal silicon.

Sharp is already considering the over-all purification process for the silicon and large-scale crystal growth. There may be hope in production of silicon dendrites or edge-defined film-fed ribbon growth to produce strips 2 to 2½ inches wide and 100 to 200 micrometers thick, a spokesman says. Loss of material would be reduced, and there would be great economies in such continuous processes. In addition, the need for slicing up the silicon into single-crystal wafers will be eliminated, saving more than half of the silicon now lost in slicing wafers out of ingots and etching them.

Sharp also says it will design solar-cell panels to follow the sun and further increase efficiency by concentrating sunlight up to 10 times. Company officials are looking for a reduction of several hundred to one in over-all cost per installed watt during the next eight years.

**Charles L. Cohen**

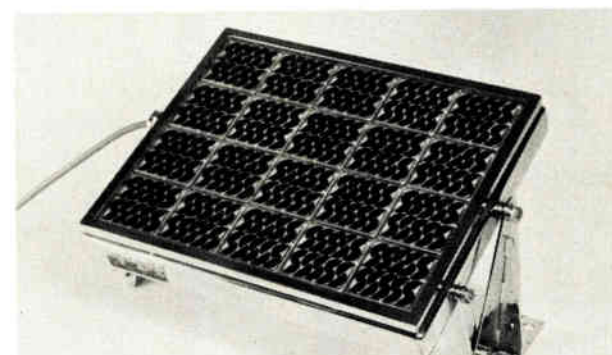

**Safe harbor.** With packing demands less critical than those of space, terrestrial arrays use all the silicon in a wafer. Cells from Sharp Corp. provide power for this Japanese lighthouse.



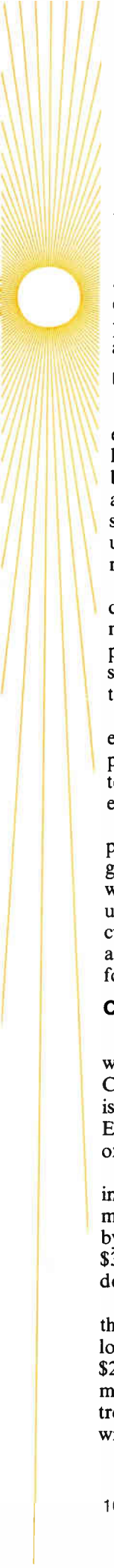

larger Centralab, until now an under-\$10-million-division of the \$240-million Globe-Union Inc., Milwaukee, the storage-battery manufacturer. Centralab's products included lines of photodiodes and zener-diode regulators. In terms of its other businesses, Globe-Union found the fledgling solar-cell marketplace too small to wait around for.

Other competitors include Solar Power Corp., Braintree, Mass., and Solar Energy Systems Inc., Newark, Del. Incidentally, both of these companies received either their technical impetus or funding from oil companies, which are apparently taking seriously their image of themselves as "total energy" companies.

### Utilities show interest

Even the electric-power utilities are showing an interest, not only in photovoltaic systems, but also in solar heating and cooling. For example, the solar energy R&D being conducted at the Institute of Energy Conversion at the University of Delaware, Newark, Del., is being supported partly by funds from a number of East Coast utilities, including Delmarva Power & Light Co., Wilmington.

"We're trying to find new sources of energy, and we can't neglect any new areas," says a Delmarva spokesman. "Solar power might help us meet the sort of peak power requirements that occur, for example, on hot summer days when everyone's air conditioning is turned on.

"To handle this now, we must have gas-turbine generators on standby that are used for only relatively short periods of time." Such generators range in size from tens to several hundreds of megawatts, and they're an extra investment utilities would like to avoid.

Rooftops of individual buildings equipped with solar-power converters for heating and cooling, as well as for generating electricity, could be the answer. Moreover, when electricity demand has been reduced at night, the utilities might also be able to feed power back to their customers for such things as charging storage batteries and dealing with the eutectic salts that might be used for thermal storage.

### Oil companies support R&D

Solar Power is fabricating arrays of silicon cells that were designed in the research laboratories of Exxon Corp., the world's largest oil company. Although there is no corporate relationship between the two companies, Exxon is probably supporting continuing development of the cells.

Solar Energy Systems, the only company concentrating on the development of the largely experimental cadmium-sulfide technology, is being assisted handsomely by Shell Oil Corp., Houston. Last October, Shell made \$3 million available to the company, which will also be developing solar-heating and cooling systems.

Applications for terrestrial solar-cell systems have run the gamut of requirements for remote, unattended, and long-life power sources. However, the market is small—\$2 million to \$3 million per year, estimates Jerry Ravin, marketing manager for remote power products at Spectrolab. Optimistically, he expects it to reach \$10 million within two or three years.

Some of the first uses for the arrays were for powering remote mountaintop radio transmitters for the U.S. Forest Service, and these applications, which are extremely cost-effective, continue. For example, the Solarex 40-w system for the Forest Service, priced at less than \$1,200, includes charge regulators and lead-acid batteries for storing power. The setup is considerably cheaper than the estimated cost of \$1,800 to \$7,000 for installing propane-powered thermoelectric generators. And experts estimate that the silicon-cell array will last between 10 and 15 years, if not longer, while the thermoelectric generator would require new propane gas tanks to be hauled in periodically.

"The big advantage of solar power," explains Spectrolab's Ravin, "is that the power supply becomes virtually maintenance-free. Once a year, you should check the water in the battery and maybe wipe off the panel, but that can be done when the equipment it powers receives its periodic maintenance check. We don't need power lines, gasoline, propane, or other expendables."

The Solarex Forest Service unit, made up of basic building-block modules measuring 9.75 by 18 inches, produces from 5 to 8 w of peak power, depending on how many cells the modules have, says Lindmayer. The company also has smaller modules, 3.5 by 13 in., which produce 1, 1.5 and 2 w. The 1.5-w unit, for example, sells for \$72.50 [*Electronics*, Feb. 21, p. 32].

### Isolated sites benefit

Radio-repeater stations are also good customers for the system. The state of California, for instance, is outfitting its 40-station radio-repeater network with systems from Centralab. Oregon and Nevada are also buying them. Navigational aids, such as flashing lights on lighthouses and buoys, are also getting solar-powered systems.

Overseas, Radiotechnique Compelec recently won an order from the French atomic-energy agency for a 120-w signalling beacon for the South Pacific. In South America, the company has installed a chain of TV-signal-booster stations using eight 12-w modules each. In Africa, RTC and the French national broadcasting authority are developing a plan to equip school television sets in Nigeria with solar-array power packs.

Another recent market has been developing for lights on offshore oil rigs. "There are hundreds of oil rigs in the Gulf of Mexico, and the Coast Guard requires that they be lighted—both because of the hazard they present and to assist in navigation," says Ravin, adding that Spectrolab has installed about 100 such systems. A typical Spectrolab panel for this application consists of a basic 12-v module sealed in a rugged, impact-resistant flat plastic tube. The cells are suspended in a clear, inert silicone compound, and the tube is sealed with epoxy. Output power is an average 6W/ft<sup>2</sup>, under conditions of bright sunlight having an intensity of 100 milliwatts/centimeter<sup>2</sup>.

The basic module contains 120 cells, covers an area of 37 by 3 in., and supplies 0.3 A. Panels can be fabricated with varying numbers of modules and will produce a maximum of 7.2 A. Other examples abound. Centralab says it has supplied a solar-power installation as the principal electric-power source in remote villages in In-



dia and to power the world's first highway call-box system in California. The company even used solar cells to power tiny radio transmitters attached to migrating wild animals, for remote snow and water gages, and fire alarms and seismographs. The last two systems get by with less than 0.33 w.

Spectrolab, for one, has been selling its power sources to private and commercial power and sailboats to keep their batteries fully charged and to supply power for navigation lights, communications, and other electronic systems.

But hovering above all these applications—literally and figuratively—is the 1968 proposal by Peter Glaser of Arthur D. Little Inc., Boston, to orbit a 10,000-MW solar-cell converter around the earth and transmit electric power down via microwave links. The idea stimulated a considerable amount of thought about solar-cell technology, but, at the moment, that idea is in a funding limbo.

### Studies are extensive

Perhaps the most far-reaching studies of solar-cell systems are headed by Martin Wolf of the National Center for Energy Management and Power at the University of Pennsylvania, Philadelphia. The goal: to develop low-cost processes for fabricating solar arrays made of silicon that would yield a 100-fold cost reduction in five years.

"We're looking at the total process from the raw sand to the finished array," declares Wolf, a physicist involved with R&D in photovoltaic solar cells since 1955. "We can't solve this by tackling one step in the production process at a time; we have to consider each step along the way as part of a single over-all process."

Wolf hopes to combine the heretofore separate processes of device fabrication and array assembly. Thus, at the input end of the process, Wolf, with the assistance of Dow Corning Corp., Midland, Mich., is considering simplification of the silicon-making techniques—reducing the mineral to silicon, purifying it, and then crys-

talizing the material into a new sheet form.

And at the output end, Wolf hopes to fabricate integrated solar arrays that contain a large number (possibly more than 200) series-connected cells within a common sheet of silicon.

Wolf has selected the number of 200 so that the electrical output of the array is either at the common 110-V utility-line voltage, or at a significant fraction of it. This would reduce to a minimum the relatively high costs of making external electrical connections. Instead, he aims to replace the external metal connections with the methods used in interconnecting integrated circuits.

To do this, Wolf hopes to fabricate silicon sheets roughly 0.1-mm thick and having an area of one square meter. This area may be increased, he conjectures, to approximately four feet square or even four by eight feet—large enough to form significant building blocks for an entire system, but not too large to cause undue handling problems.

The cells in the integrated array would extend essentially perpendicular to the cross section of the sheet and down its length, as shown in Fig. 4. Thus, in a one-meter-square array, each individual cell would have an area of about 50 cm<sup>2</sup>. Wolf also points out that the long, narrow geometry of the individual cells would reduce problems of series resistance and might lead to the elimination of the contact grid required on conventional cells.

He asserts that a 50-cm<sup>2</sup> cell should not be as difficult to build as it may sound, pointing out that silicon solar cells with up to 20 cm<sup>2</sup> have already been made for the space programs.

### Design aids assembly

A great advantage of the array geometry is that it permits the sheet to move past individual work stations for such operations as vacuum evaporation and sputtering through masks, printing, ion implantation, and electron-beam or radiant heating.

Rather than waiting for the sheet-fabricating pro-

**3. At work.** Arrays from Solar Power Corp. are being put to use aboard offshore oil rigs (below). NASA's plastic-encapsulated cells get snowy test at Mammoth Mountain, Calif. (right), while 3-W array from Centralab provides power for stream-gaging telemetry.

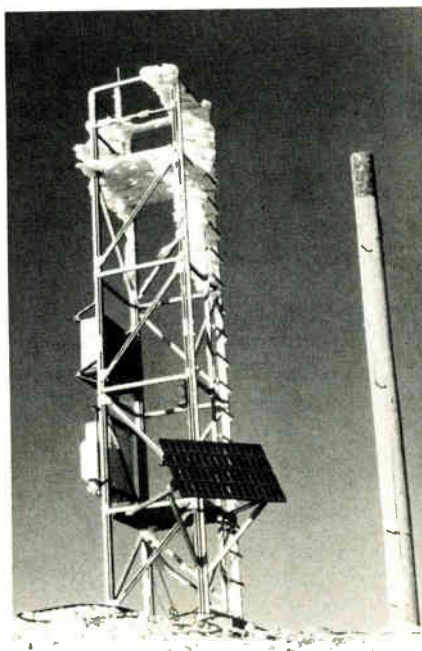

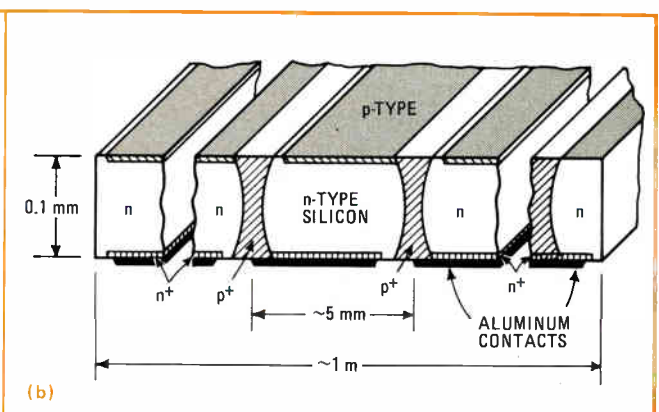
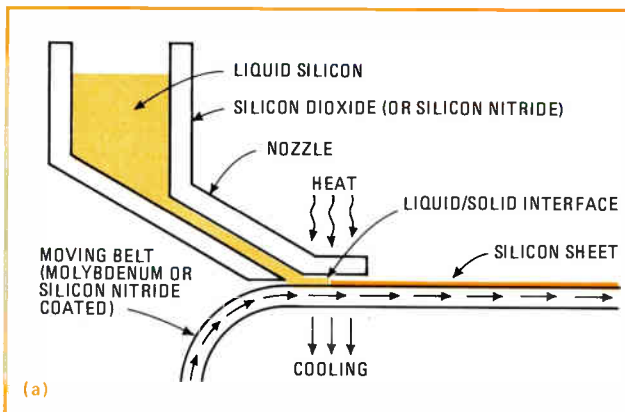

**4. Mass production.** The possibility of producing silicon in sheets at least a meter wide (left), is being considered by the University of Pennsylvania. Pn junctions could be diffused the length of the sheet, which could be processed sequentially at individual work stations.

cesses to be perfected, Wolf proposes to explore immediately the feasibility of the integrated array by using wafers cut from ordinary Czochralski-grown ingots. From common 3-in. ingots, single-crystal wafers measuring 5 by 10 cm and larger could be readily cut, lapped, and etched down to the 0.1 mm thickness.

At Dow Corning, where the program is just getting

underway, there's a great deal of optimism. "We've already come up with things that look very promising," says Lee Hunt, senior project chemist at the company's Solid-State Research Laboratories in Hemlock, Mich.

Pointing out that silicon for solar cells does not have to be as pure as silicon for the semiconductor industry, Hunt continues, "We're looking at various processes

## Making solar cells

Silicon solar cells are fabricated from single-crystal silicon, which is sliced into wafers 10 to 12 mils thick. In one type of cell, the wafer is first treated and doped with a minute quantity of boron to transform the raw silicon into a p-type semiconductor. Next, an n-type dopant, such as arsenic, phosphorus, or antimony, is diffused into the top of the wafer to a depth of about 1 mil. Because n-type silicon has a high free-electron density, current in this layer is a flow of electrons.

These diffusions create a pn-junction and a barrier region like that of a junction diode, but covering a much larger area.

When the cell's surface is exposed to light, the light photons are absorbed and create electron-hole pairs in the p-junction region. Current flow in p-type silicon is caused by a migration of holes, or positively charged sites, through the material. Any electrons in the p-region that are within a diffusion length of the junction will drift to the n-region.

Similarly, the holes in the n-region within a diffusion length of the junction will drift to the p-region. These carriers are free to move into an external circuit and deliver power to a load.

For silicon, the semiconductor bandgap that sets up the potential barrier is 1.1 electronvolts. Open-circuit voltage of present-day silicon cells is about 0.6 volt; short-circuit currents are around 0.38 milliamperes per square centimeter. Light effectively reduces the height of the junction barrier.

In complete systems, the cells are connected in various series-parallel combinations to produce the desired output voltage and current.

Most solar cells for space applications measure 2 centimeters square, but some newer units are as large as 2 by 6 cm. For terrestrial applications, the entire silicon wafer sliced from Czochralski-grown boules can be used, and the cells, since they don't have to be diced into rec-

tangles to provide high packing density, may be several inches in diameter, depending on the size of the boules.

Other steps are involved, of course, in the fabrication of a complete space cell. A metal contact layer must be added to the bottom of the silicon, as well as a grid of current-collecting contacts on the top, plus an anti-reflection coating, an ultraviolet filter, a radiation-resistant glass cover, and then another anti-reflection coating. Although the basic 2-by-2-cm doped silicon slice may cost only 40 cents, the additional processing may boost the cost of the complete cell to \$4, points out Luther W. Slifer Jr., head of the Solar Power Sources section at Goddard Spacecraft Center, Greenbelt, Md. Fortunately, because terrestrial cells can do without some of these accoutrements, they are inherently cheaper. For one thing, because space radiation is absorbed by the atmosphere before reaching the ground, glass cover slides can be omitted, as can one or both of the anti-reflection coatings.

Efficiency of the silicon cells, taken as the ratio of each cell's power output to the optical power striking the junction area, has increased slowly over the last decade. For space cells, it ranges between 10% and 12%, with the median of the bell-shaped production output curve at 11.3%, Slifer says. So-called violet cells for space use, developed by Communications Satellite Corp. and being brought into production at Centralab Semiconductor, have an efficiency of 13%, and Solarex says cells fabricated with its own design are yielding 15% efficiencies on the ground.

However, the theoretical efficiency of solar cells in space has been predicted at as high as 22%, according to a report prepared in 1972 for the National Academy of Sciences. Interestingly, a solar cell is some 3% more efficient on the ground than in space. This is because the spectral frequencies of light in space differ from those of light that has been filtered by the atmosphere and reached earth. In space, the cell is subjected to more blue-violet wavelengths; on earth, these wavelengths are filtered out by the atmosphere to a greater degree than



that have been used in the past for semiconductor-grade silicon, but which are not currently used because of purity problems." These older processes are applicable because it would be possible to tolerate contaminants such as boron, phosphorus, and aluminum in the solar-cell silicon; for other semiconductor devices, they'd have to be eliminated.

Dow Corning scientists envision a 10-year project: three years for experimental development, three years for a pilot plant scale-up phase, and a final three or four years for operating the pilot plant continuously.

Coming along well before sheet-growing techniques will likely be silicon-ribbon-growing methods such as Tyco Laboratories, Waltham, Mass., is developing. In addition, Westinghouse Research Laboratories is seeking funds to reactivate its dendritic growth methods in which silicon is made to grow in ribbon shapes along a preferred crystal orientation. This program was dropped about seven years ago.

### Silicon grows in ribbons

Tyco developed its process originally to grow sapphire for use in silicon-on-sapphire integrated circuitry. "We are growing single-crystal silicon and making solar

cells experimentally, and we're very happy with the results," declares senior vice president A.I. Mlavsky. So far, silicon ribbons 1 in. wide and 18 in. long have been produced.

In growing the long silicon ribbons, a seed crystal of the desired crystal orientation is dipped into a silicon melt through a capillary, and then pulled. If temperature conditions are right, a filament of silicon will solidify at the rate at which it is being pulled. With no constraints, the seed crystal will grow a rod-shaped filament, but other shapes can be grown by using different shapes and sizes of capillaries and adding a die through which the seed crystal is drawn, as shown in Fig. 5. Since the shape of the growing crystal is defined by the edge of a die, and growth takes place from a film of liquid between the die and the capillary, the process is called edge-defined, film-fed growth.

The ribbons have been grown with various thicknesses, down to as thin as 4 mils. "To optimize cost, you want the thinnest ribbon that doesn't compromise performance," Mlavsky notes. "Any silicon thicker than that is just a convenience to handling." With Tyco's process, silicon ribbon could be produced continuously from raw polycrystalline silicon, and the company ex-

the others. Thus, the spectrum of light reaching the ground has relatively more energy in the infrared region, where, happily, single-crystal silicon solar cells are more sensitive. The result is that, although a greater amount of light will strike the cell in space (140 milliwatts/cm<sup>2</sup> versus 100 milliwatts/cm<sup>2</sup>), more efficient conversion occurs on earth.

The fact that the optical spectrum energy in space is weighted in favor of the blue region was exploited by Joseph Lindmayer in his development of the violet cell when he was director of physics at Comsat. Because the violet cells are more sensitive than other cells to the blue spectral region, their efficiency reaches 13%. This was accomplished by introducing such things as more suitable contact materials and extremely shallow n-layer diffusions—down to 0.05 micrometer and less, instead of the usual 0.3 to 0.5  $\mu$ m. And because the thinner n-layer has a higher sheet resistance, a grid with more current-collecting fingers had to be added atop the cell.

Higher efficiency is one of the keys to the successful application of solar cells terrestrially. It means a cell of a given size will generate more electric power so that the system needs fewer cells and its cost is reduced. Another important objective, of course, is to lower the cost of the entire cell-making process.

Optimizing material properties is probably one of the most important ways to boost efficiency, and the National Academy of Science report cited a host of ways in which this could be done. The initial silicon crystal should be as nearly perfect as possible—free of point defects, defect clusters, dislocations, twins, stacking faults, and unwanted chemical impurities. Under these conditions, bulk lifetime would increase markedly so that more carriers would collect across the pn junction. Treating the surface properly would also decrease the surface recombination rate and increase efficiency.

Among the techniques for lowering production costs are some that seek to use less silicon. Since the active pn region is only a micrometer or so thick, it seems feasible to cut back on cell thickness. However, the cell must still

be strong enough to support the metal current-collecting contacts. Some cells that have been developed are only 4 mils thick.

Besides the work on thinner devices, Schottky-barrier-diode photovoltaic cells are being studied. In addition, researchers are experimenting with polycrystalline cells—cells that are merely thin films of silicon whose structure falls somewhere in the broad range between the completely amorphous and the completely uniform.

For the present, at least, when it comes to photovoltaic action, nature seems to abhor nonperiodicity. Polycrystalline-silicon cells can be made with efficiencies of only about 1%, but researchers are plugging away at understanding the mechanisms under which they operate.

Thus far, however, the thin-film solar cell offering the highest efficiency is fabricated from cadmium sulfide. This type of cell relies on light photons being absorbed in a heterojunction of cadmium sulfide and copper sulfide.

In the configuration being developed at the Institute of Energy Conversion, for example, cadmium sulfide (CdS) is vacuum-evaporated as a thin film on a metal-foil base electrode. Then a layer of copper sulfide (Cu<sub>2</sub>S) is electroplated onto the CdS (both films together are thinner than a human hair). A metal grid electrode is then placed on top of the first three.

Light photons passing through the metal grid activate a current flow in the CdS-Cu<sub>2</sub>S junction, which is then picked up through the two electrodes. Plastic material is laminated on the entire cell to encapsulate it. Efficiencies obtained with such cells have been about 5% or 6%, with some unusual cells ranging to 8%. A drawback, however, is that the cells, which are extremely sensitive to water vapor and oxygen, must be hermetically sealed to operate on the ground.

Researchers are working on many other materials, as well. Included are gallium arsenide, which offers the possibility better efficiencies (18% has been reported) and higher voltages than silicon, other compounds such as organic semiconductors, and other members of the cadmium-sulfide family, such as cadmium telluride.



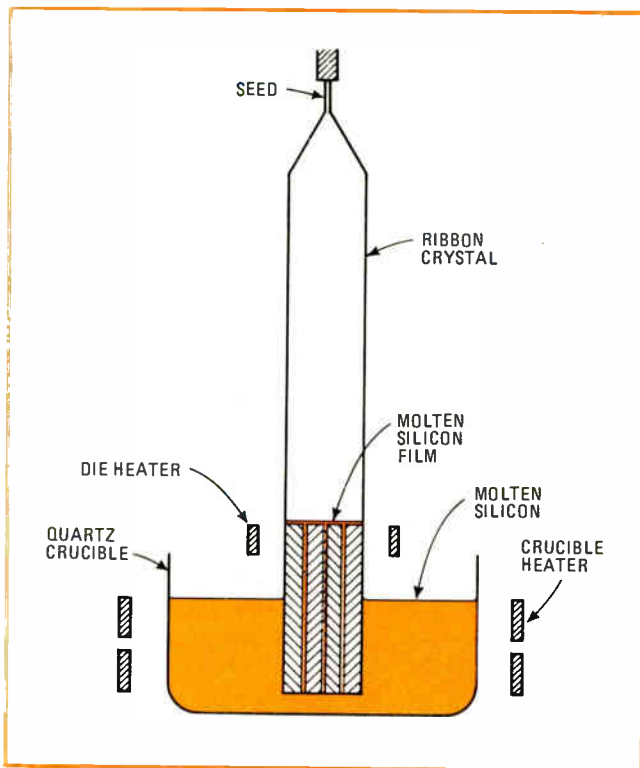

**5. Another way.** Ribbon-growing method at Tyco Laboratories entails pulling single-crystal silicon from melt through die. So far, inch-wide ribbons 18 inches long have been formed.

pects this could significantly lower the cost of solar cells.

Presently, Tyco is shooting for 10% efficiency in its solar cells. So far, researchers have not tried to grow ribbons wider than one inch. Though it might be difficult, this would be a straightforward engineering problem.

To produce adequate voltage, the ribbons will have to be connected in parallel-series to protect against failure of any one cell, so very wide ribbons would have to be cut up lengthwise. Mlavsky thinks ribbons will not need to be more than 2 to 3 in. wide.

Within two to three years, Mlavsky thinks Tyco will be making production quantities of silicon ribbon for specialized applications. But "in order to make an impact on the real necessities for energy production, it will take about five years," he says.

Theoretical work on silicon-ribbon growth is being done at Harvard University, Cambridge, Mass. Bruce Chalmers, of the university's division of Engineering and Applied Physics, says Mlavsky, is "deriving and refining the theory to guide us in our experimental approach to the process."

A well-understood theory helps guide Tyco in deciding what the limits of the process are, how to design equipment, and, in particular, how to design the dies through which the silicon ribbon is drawn. Unfortunately, these dies may be oxidized away because of the hot temperatures under which they operate.

### University develops CdS cells

Tackling the job of developing cadmium-sulfide solar cells is the Institute of Energy Conversion at the University of Delaware, Newark, Del. Directed by physicist Karl W. Böer, the Institute has adopted a multipronged

approach to applying solar energy, including the construction of Solar One, an experimental house for testing methods for converting sunlight into electricity and also using sunlight for heating and cooling.

The problem of making better cells is being approached along three lines, according to Böer. These involve understanding the basic photovoltaic mechanism of the cell, finding conditions under which the cells will survive for long periods, and perfecting production techniques to yield high-quality, reproducible devices.

Insofar as photovoltaics are concerned, Böer's institute is concentrating on solar cells made of a "sandwich" of cadmium sulfide and copper sulfide. Such cells rely on light-generated electrons and holes in the CdS-Cu<sub>2</sub>S heterojunction.

However, cadmium-sulfide cells have been plagued with problems, and NASA finally dropped them in favor of silicon for use on space satellites some three years ago. Most bothersome has been reaction of the cells to oxygen and water vapor, as well as sensitivity to the radiation in space. This has meant that the cadmium-sulfide cells degrade very rapidly—in months or at most a year—on earth. Still another problem had been the difficulty in making cells in any quantity with properties that are consistent and reproducible. "If we got 10 cells, their efficiencies would be scattered all over the place," recalls Böer.

The program has met with several successes, although Böer is quick to point out that everything is still quite experimental, and the bulk of the work lies ahead. But Böer is "very encouraged" that he will achieve "the goal of making CdS a means of converting solar energy to electric power on a practical and useful scale."

### Life potential is increased

For one thing, Böer has slowed cell degradation by sealing the cells hermetically and keeping the temperature below +50°C. Following tests since last July on some 1,000 cells series-connected in nine separate panels, Böer has extrapolated 20-year lifetimes, based on average solar exposure of five hours per day.

Although wary of extrapolating lifetimes "because an additional degradation mechanism could become dominant at any time, causing even more rapid degradation to occur," the results are encouraging. "Properly encapsulated, cadmium cells should have lifetimes that are acceptable," he concludes. And he doesn't rule out the possibility that special dopants may be found to prevent degradation by acting against the photochemical reaction in the presence of oxygen and water vapor.

Physicists at the institute have also been able to improve the basic cell-making process so that cells are made more reproducible. "We are now getting the efficiencies much closer together," says Böer. "Instead of being scattered all over the place, they're distributed within 10% to 15% of a mean."

Böer stresses that this aspect of the research is involved purely with reproducibility of the process, rather than with efficiency, per se. Each of the 30 or so individual process steps have been closely examined and adjusted, he says, and some have even been eliminated. However, because the actual number of cells involved is relatively small, and the work is experimental, he de-

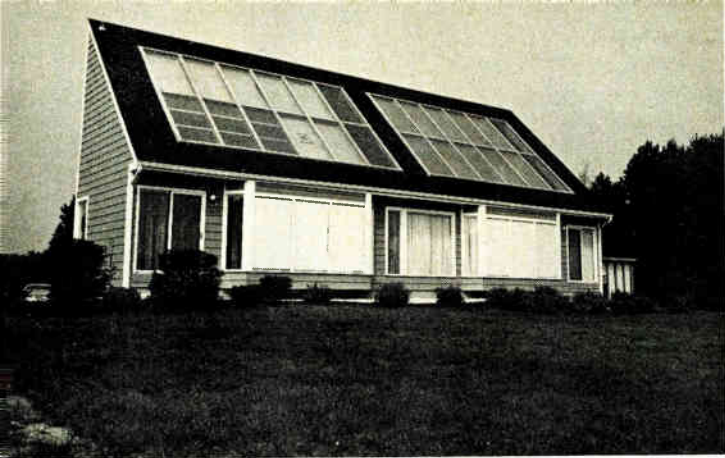

**6. Test house.** Under direction of Karl W. Böer (right), Institute of Energy Conversion has built Solar One, an experimental house for testing solar-heating and cooling methods and cadmium-sulfide solar cells (the darker panels at lower left on the roof).

clines to reveal more specific results.

Böer readily concedes that much still needs to be learned to bring the cadmium-sulfide cells to the level of performance of their silicon counterparts. Moreover, the CdS-Cu<sub>2</sub>S system—Böer says that chalcocite, or Cu<sub>2</sub>S, is the desirable molecule to be used with the CdS—is much more complicated. It involves three atoms “which do the music,” instead of one.

Presently, cells are about 15  $\mu\text{m}$  thick, but Böer believes they can be made thinner still—down to less than 1  $\mu\text{m}$ . The active region around the junction is only 0.1  $\mu\text{m}$  deep, he adds, but the big problem with making the devices thinner is to avoid pinholes, which can short out the cells. As for efficiency, Böer declines to give a hard and fast figure for the maximum that could be expected. Because the mechanisms in the device are far from understood, he says, it is uncertain how high the efficiency will go.

### French use CdS cells

The French Société Anonyme de Télécommunications (SAT), which probably has devoted more effort to CdS technology over the years than any other organization, reports laboratory measurements of its latest cells show efficiencies somewhat higher than 7%. Under what it calls operating conditions, this drops to an average of 5.5% to 6%.

However, these operating conditions apply to the space environment, where atmospheric difficulties plaguing Böer's cells are absent, although they're replaced, unfortunately, by problems of radiation.

SAT has thus far concentrated on applying its CdS-Cu<sub>2</sub>S devices in power supplies to fly aboard French spacecraft. Light-weight arrays are important because of the relatively small launch vehicles the French use.

So far, SAT has not yet successfully sealed its cells hermetically for long-life, ground-level applications. However, at ground level, the latest SAT cells could produce adequate power. Output in space is 350 mV, and short-circuit current ranges from 550 to 600 mA. Size of the cells can go up to 100 cm<sup>2</sup>, but it's normally 27 cm<sup>2</sup>.

In its latest cells, fabricated following experimentation with various doping levels and junction characteristics, SAT has licked many of the chronic instability problems of CdS cells, at least for space applications,

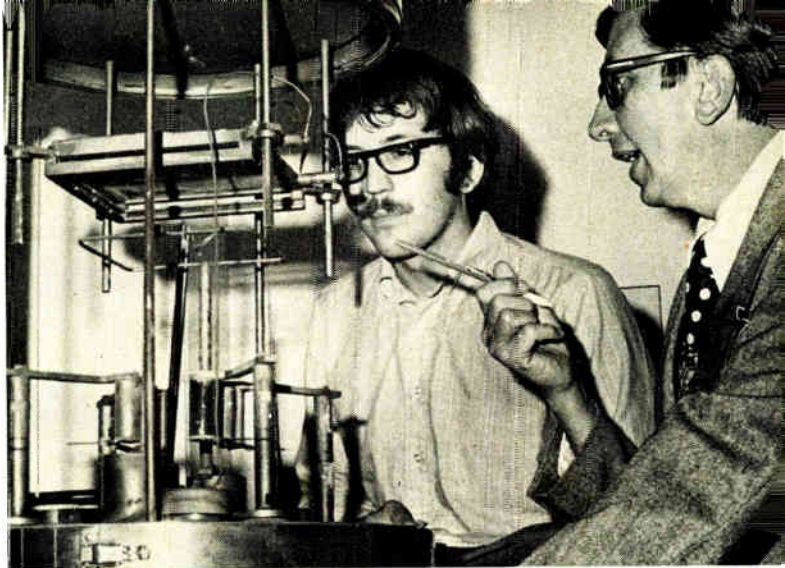

claims T. Nguyen Duy, member of the solar group at SAT. Together with France's national space agency, SAT is embarking on a 10,000-hour program to test the feasibility of using the cells aboard spacecraft. In addition, the company is studying the prospects for manufacturing the cells on a large scale, and “a major study” will soon be started to consider ground applications and the problem of sealing the cells hermetically.

### Stanford explores CdS

Also researching CdS thin films is Richard H. Bube, professor of materials science and electrical engineering at Stanford University, Palo Alto, Calif. In particular, he's looking at alternatives for the cuprous sulfide used to create the positive side of the junction with the cadmium sulfide. The aim is to find something that won't react as strongly as the cuprous sulfide with the atmosphere, nor diffuse as readily as copper atoms into the cadmium sulfide. Cadmium telluride is only one of the alternatives he's considering. Right now, the question for Bube is what kinds of materials “are useful under the circumstances, rather than which are cheapest.”

Another material being studied at Stanford is single-crystal gallium arsenide, which, theoretically, promises greater efficiency than silicon. One technique being researched by James F. Gibbons, professor of electrical engineering, places the right amount of impurities into the pn junction through ion implantation. The aims are to make the GaAs trap-free and to grow crystals as nearly perfect as possible.

Another researcher in thin films is Paul H. Fang at Boston College. He is growing polycrystalline films of silicon on thin sheets of steel for structural support and forming Schottky-barrier devices. And in still another project, senior scientist Wigbert Siekhaus at Lawrence Berkeley Laboratory at the University of California in Berkeley is trying to develop thin films of single-crystal silicon. This would combine the best of two worlds—solar-cell material would be held to a minimum, while the excellent photovoltaic characteristics of single-cell silicon would still be available.

Unfortunately, the objective is a long way in the future. Siekhaus says a more refined understanding of the basic crystallinity mechanism in silicon is required before the thin-film single crystals can be grown. □



- Independent control of pulse high and low levels
- Pulse amplitude to 5 volts
- Output window +5 V to -5 V
- Less than 1 ns risetime
- 250 MHz rep rate

The Tektronix PG 502 Pulse Generator is a high performance instrument ideal for designing, testing, or maintaining the logic circuitry in high-speed digital computers, and similar applications. It is a general purpose signal source with rise and fall times less than 1 ns. Both the pulse duration and period of the PG 502 output can be controlled and independent control of the pulse high and low levels is offered. The trigger circuit includes external trigger input, manual triggers, and pre-trigger output.

Tektronix offers a range of signal sources in addition to the PG 502.

FG 501 Function generator; 0.001 Hz to 1 MHz, five waveforms . . . . . \$ 325

FG 502 Function generator; 0.1 Hz to 11 MHz, 25 ns rise and fall, five waveforms . . . . \$ 425

PG 501 Pulse generator; 5 Hz to 50 MHz, 3.5 ns rise and fall . . . . . \$ 295

PG 502 Pulse generator; 250 MHz, 1 ns rise and fall, independently controllable logic 1 and 0 levels . . . . . \$ 995

PG 505 Pulse generator; 100 kHz, 80 V floating output, independently variable rise and fall times . . . . . \$ 265

RG 501 Ramp generator; 10 $\mu$ s to 10s ramp, with four scope type trigger controls . \$ 175

# Signal Sources: Another way to think of Tektronix



SG 502 RC oscillator; 5 Hz to 500 kHz, sine and square-waves, 0.1% distortion . . . \$ 295

SG 503 Sinewave oscillator; regulated, constant-amplitude variable from 250 kHz to 250 MHz . . . \$ 600

TG 501 Time-mark generator; 1 ns to 5s markers, measures timing errors with resolution within 0.1% over timing-error range of 7.5% . . . \$ 650

Signal sources are just one category of instruments in the Tektronix TM 500 Series. Presently, 24 general purpose modular test and measurement instruments are available including digital counters, digital multimeters, power supplies, signal processors, and CRT monitors. These inter-

changeable instruments plug into power units with single (\$115) or triple (\$150) compartments. In the triple compartment power unit, the modules can be interconnected via a common interface board and optional rear panel connectors. This results in increased intermodule capabilities and can actually produce a synergistic effect. The modularity feature also saves bench space. The TM 500 Series is based on the latest technology and proven principles developed in building oscilloscopes.

Send for a free brochure and spec sheets on signal sources, and Tektronix other TM 500 test and measurement instruments. They're all new ways to think of Tektronix!

Write: Tektronix, Inc.  
P.O. Box 500  
Beaverton, Oregon 97005  
In Europe write:  
Tektronix Ltd.  
P.O. Box 36  
St. Peter Port, Guernsey, C. I., U.K.



**TEKTRONIX®**  
committed to  
technical excellence

Digital Multimeter  
Price, \$395 to \$495

Pulse Generator  
Price, \$995

Counter  
Price, \$1,195

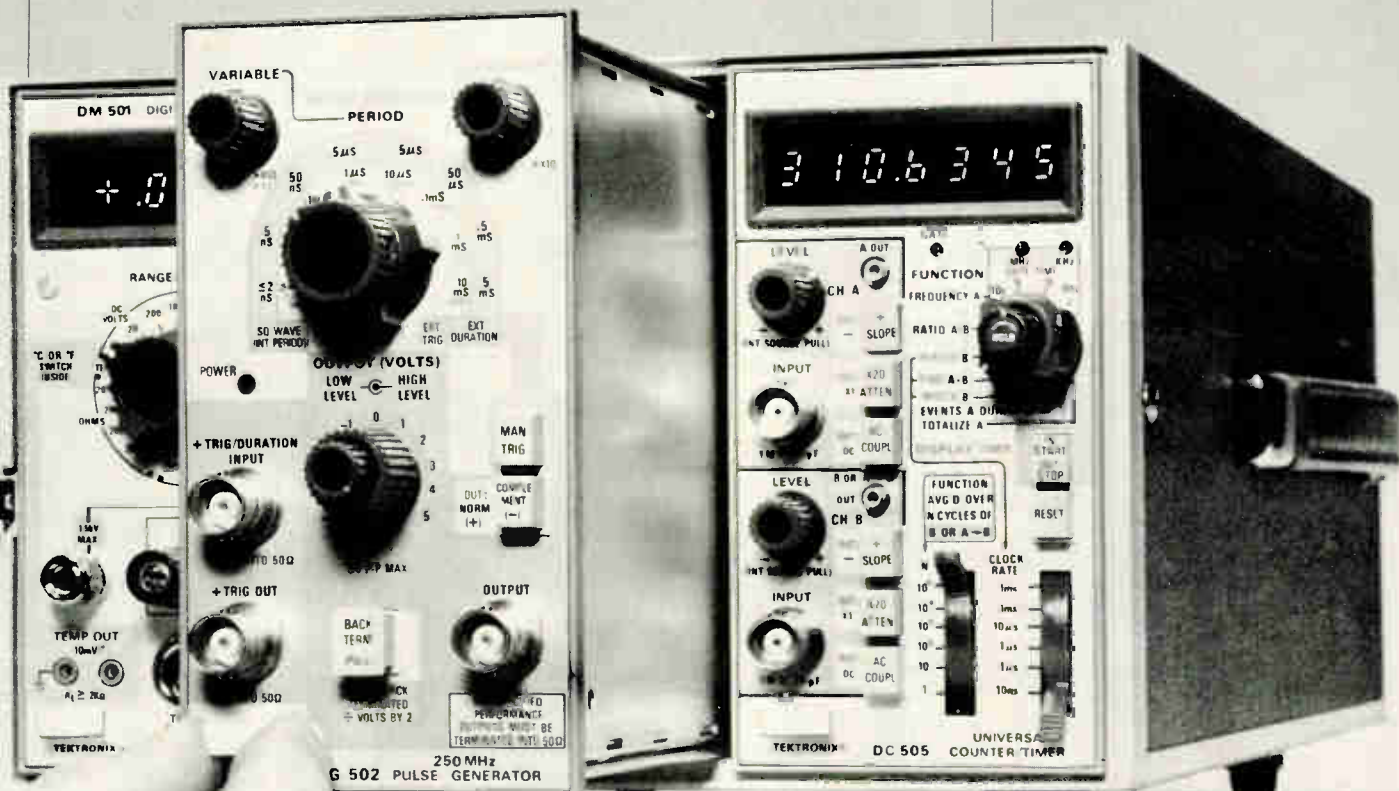

Circle 112 on reader service card

For a demonstration circle 113 on reader service card

# Home video-disk system creates a new image on photographic film

Fast, low-cost reproducibility of TV recordings and a simple playback unit are the major advantages of equipment involving a laser-based recorder and a video player designed around a low-intensity incandescent lamp

by Jonathan A. Jerome and Edward M. Kaczorowski, *i/o Metrics/Videonics, Sunnyvale, Calif.*



**1. Disk picture.** This TV picture is from the *i/o Metrics* video-disk system. The top is an unprocessed video signal and the bottom the video signal after clamping and a line-by-line AGC. Horizontal banding caused by encoding is not visible in normal viewing. The firm has negotiated with manufacturers to produce the system.

□ Development of practical video-disk recording and playback systems has progressed both in the U.S. and abroad, despite market uncertainties and, more recently, the threat of materials shortages. The reason for this dogged determination in the face of increasingly discouraging portents for short-term success is the belief that a huge consumer market for video-disk players will eventually emerge to complement the widespread use anticipated for video-tape recorders and players.

Now, for the consumer video-disk market, a laser optical system has been developed to record color video signals on a silver-halide emulsion, a departure from the traditional use of magnetic tapes and plastic disk materials. What's more, the playback unit requires only a miniature incandescent light bulb to reproduce color pictures of reasonable quality on a television screen (Fig. 1).

A prototype recording system (Fig. 2) has made it possible to record an hour of color video information at a constant linear rate on a single 12-inch photographic-film disk. Four times higher recording density has been achieved with the film than has been possible with other recording media, which typically have tracks less than 1 micrometer wide, spaced 2  $\mu\text{m}$  apart. And the cost of the film system is comparable with that of other disk systems. Commercial versions of laser-based film-recording equipment and simple TV-playback units could be introduced by the middle of 1975.

Technically, storage of video signals is but one segment of a much wider-ranging development of complete systems for data storage and retrieval. Viewed in this light, a video-playback system amounts to more than a player attached to a television receiver. Before any system is built, the designer must consider the storage media, the recording technique, and the playback equipment because all are interdependent. For disk systems aimed at eventual consumer sales, the overriding interest is low cost in all three aspects of the design, beginning with recording materials.

## Recordings excel

The main attractions of the film system are low-cost reproducibility and high resolution. Thus far, the resolution has been as high as 10,000 line pairs per millimeter, and even higher resolutions are expected in the future. This resolution corresponds to storage densities greater than  $10^{12}$  bits per square foot, and more than

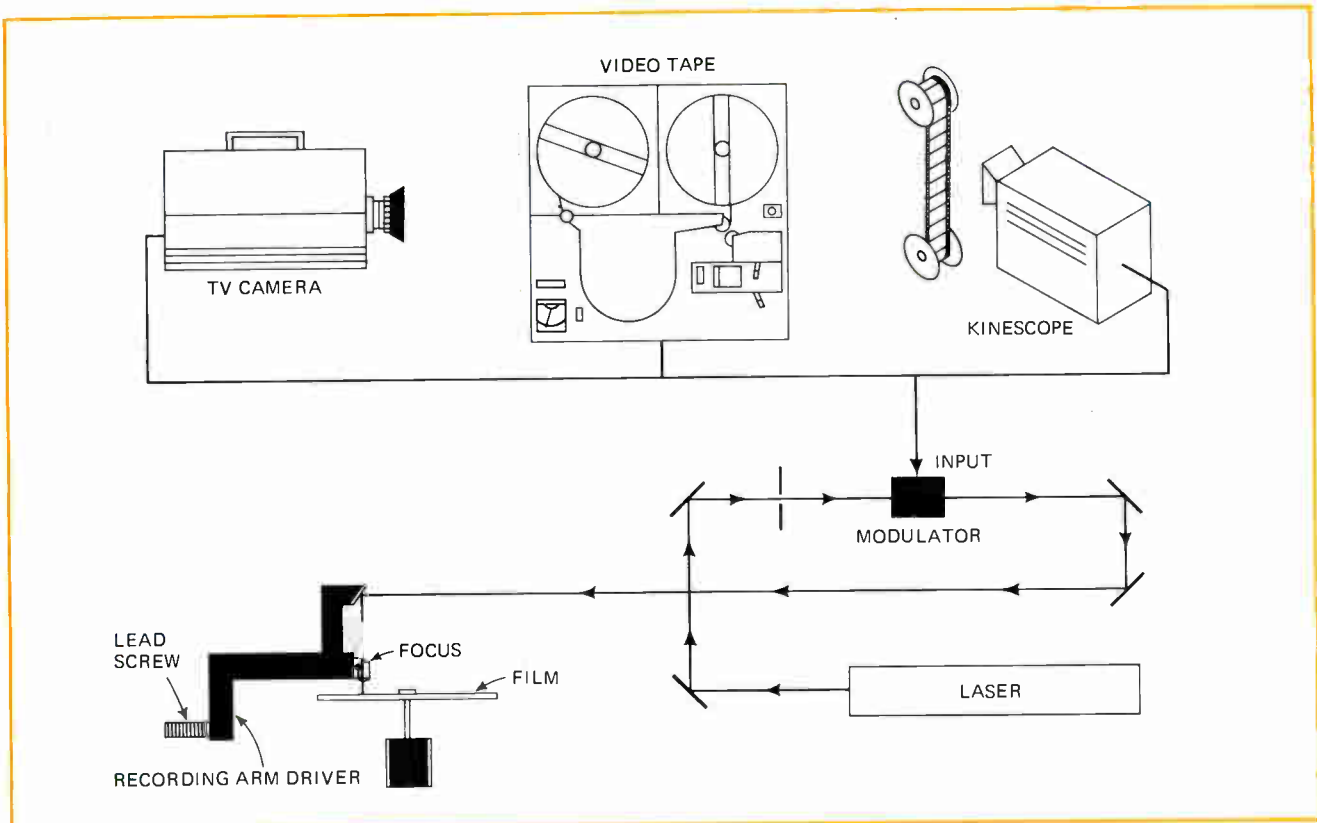

**2. Recording.** Any video medium, TV camera, tape, or kinescope, can be recorded on the film disk by using a helium-neon laser. The light beam, modulated with the video signal, is delivered to the turntable by mirrors aimed to pass through a focusing device.

**3. Real-time recorder.** Disk recording system could easily be designed into a relatively inexpensive real-time recording unit. The research model (b) now being used could be redesigned into a production version (a), priced between \$20,000 and \$30,000.

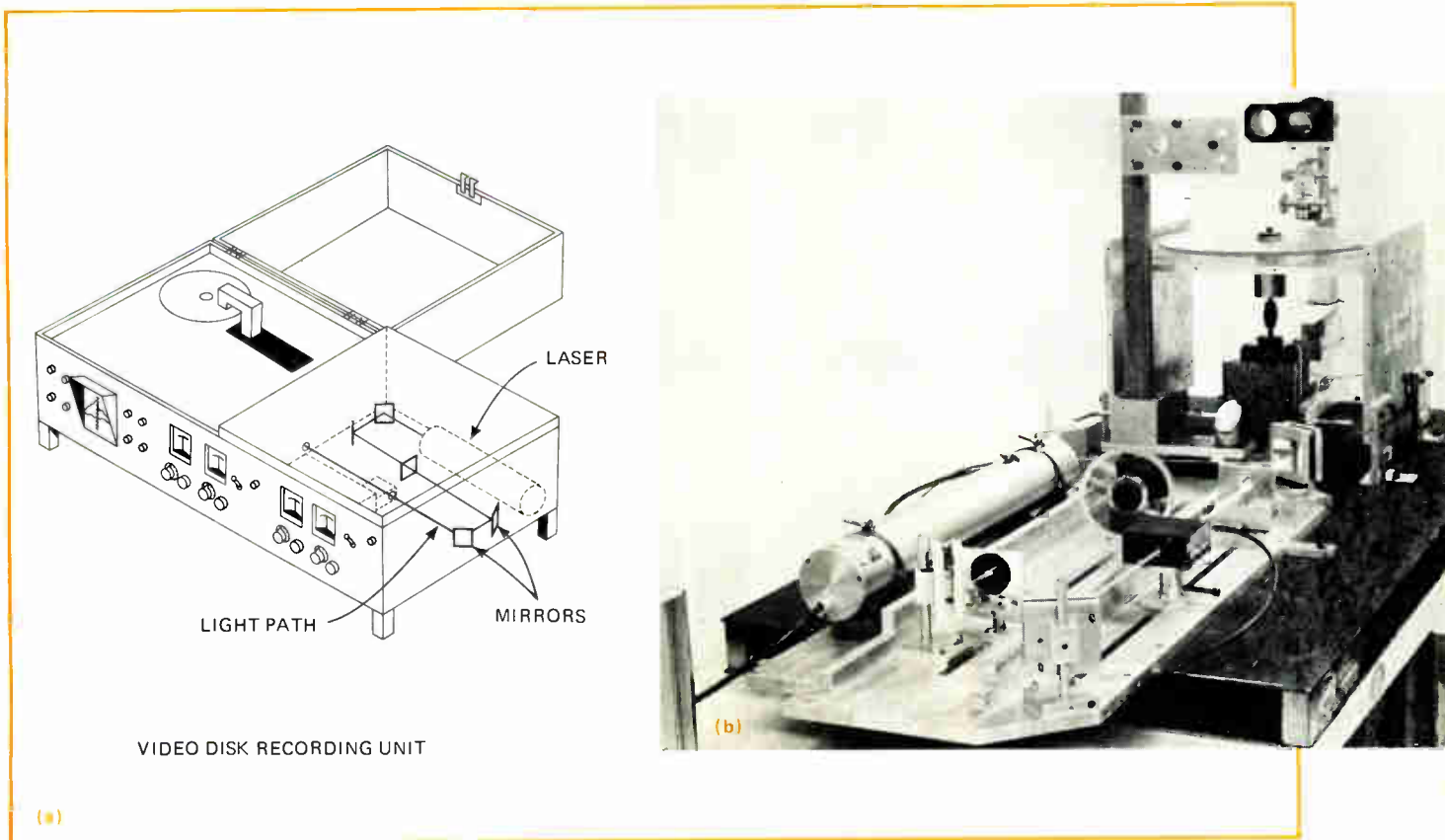



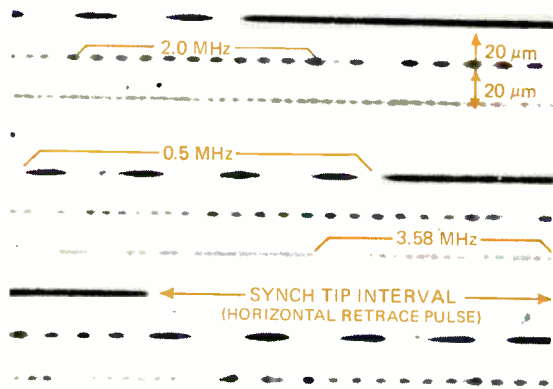

(a)

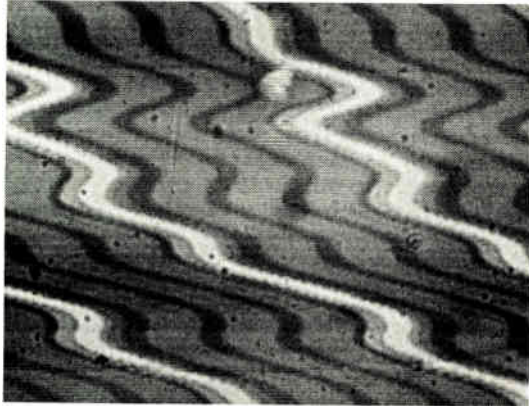

(b)



(c)

**4. Setting records.** Phase-contrast microphoto of the disk surface (a) shows the standard multiburst test video signal and the sync-tip interval (horizontal retrace pulse). At a lower magnification (b), it's possible to see the separate color bars and individual record tracks. One important advantage of the film disk (c) is that it can be handled without harming the recorded information.

$10^{11}$  bits/ft<sup>2</sup> are easily retrievable by optical means.

In addition, film can be used with equal ease for storing either digital or analog signals. The complete composite video signal can be recorded directly on film in analog form. Storing video signals on film has other advantages, including:

- When correctly processed, the film yields records of archival quality.
- Master records can be reproduced in large quantities by using straightforward and well understood contact-printing with limited degradation of the master.
- The optical display of information stored on the film is nondestructive because there is no sensor contact or friction to wear out the storage medium.

Numerous films have been tried by i/o Metrics researchers for recording video signals. Best results were achieved with commercial holographic-grade emulsions on Mylar bases. These films can be used to produce disks a standard 12 inches in diameter with emulsion gel approximately  $6 \mu\text{m}$  thick on a 4.5-mil base. When a protective coating is laminated over the top, thickness is doubled.

Holographic emulsions are typically slow and relatively stable. They can be developed by means of standard darkroom techniques with off-the-shelf photographic chemicals. The uncomplicated cycle of development and fixing requires only about 10 minutes. For mass production, many exposed films can be developed simultaneously. Fast, easy reproduction is of great importance for the low-price, high-volume consumer market.

#### Recording the video film disk

Although the i/o Metric Video disk system features an inexpensive playback unit for use in the consumer market, the simplicity of the recording portion of the system is equally important to the success of low-cost records (Fig. 3). In recording, the composite video signal is first encoded with the audio signal in the horizontal and vertical retrace interval.

The video signal may also be processed in real time to lower the bandpass and stability requirements with respect to its intrinsic color information. To promote simplicity in signal processing at the playback end, the video signal may be further modified to match the film and playback-device characteristics.

The modified video signal is next fed to an acousto-optical modulator that has a bandpass and signal resolution that's matched to the high frequency response of the film. At the modulator, the video signal is modulated on a low-power laser beam, and the laser beam is delivered to the film surface through a microscope-lens system.

The film is on a rotating turntable, and the microscope-lens system is mounted on a moving stage that is keyed to the turntable rotation rate. This arrangement allows the laser to write a spiral track as the stage moves inward. The particular film used for recording, together with the intended application, determines the choice of laser power, lens aperture, turntable rate, spiral pitch, and other parameters. For example, to record National Television Standards Committee (NTSC) video signals, the TV system used in the United States, Japan, and

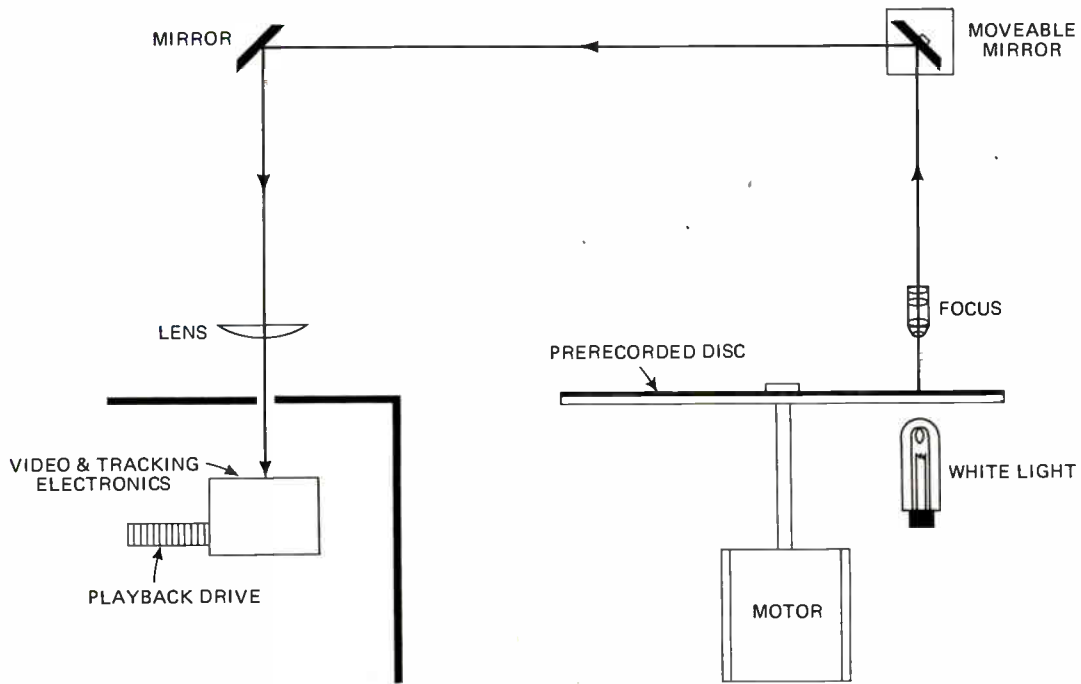

(a)

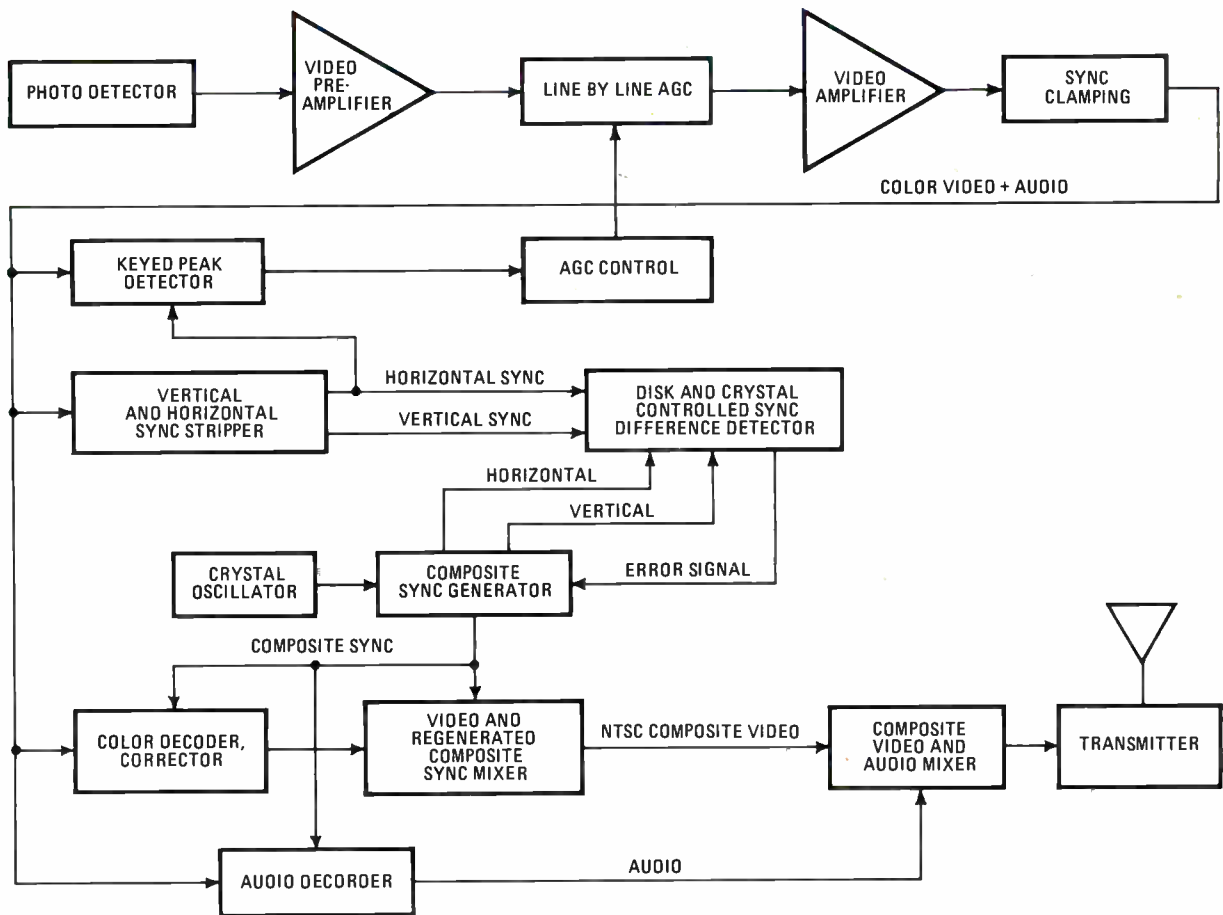

(b)

**5. Recorded message.** Using a white-light source and a carefully designed optics arrangement, the playback unit (a) can be built inexpensively. The electronics (b) is also simple and straightforward, but can be upgraded for improving picture quality.

elsewhere, a turntable rate of 1,800 revolutions per minute is the obvious choice. At 1,800 rpm, it's possible to use a laser with a total energy output of 3 milliwatts or less. The choice of the lens aperture is not critical in this application, and it can be chosen to yield a compromise between track width and depth of focus.

To reduce the mechanical requirements of the recording device, the depth of focus can be long enough to obtain good track definition with static focusing for an entire recording pass. The recording turntable has a large moment of inertia, and its short-term rotation rate can be limited to a deviation of less than 0.01%.

In general, the recording device has been engineered to tolerances so tight that production of the playback unit needs to be less critically controlled. Thus, the playback unit is required to deal only with instabilities induced in playback and nonlinearities that were in the signal before it was transmitted to the TV set.

Figure 3 shows the research model of the i/o Metrics recording unit and a simple drawing of the more compact model planned for production. An example of the recorded analog video signal enlarged for study (Fig. 4a) shows various frequencies in the standard video multiburst test signal, separated by 20  $\mu\text{m}$  for ease of interpretation.

Also indicated in this phase-contrast microphoto of the disk surface is the synchronizing-tip interval. This is the special pulse that signals horizontal retrace in scanning, which in the original video signal is at maximum signal strength, but is recorded at minimum film density on the disk.

A photo of lower magnification (Fig. 4b), shows the microscopic structure that can develop during the recording of an analog video signal. Here, the track spacing is 8  $\mu\text{m}$ , and individual tracks are barely resolvable. The recorded signal is a three-bar color-test pattern, and the light bands correspond to the sync tips mentioned above. Between each of the sync-tip bands are three wide dark bands that correspond to the test bars seen at maximum white level on a TV screen. The disk (Fig. 4c) is made of transparent film that can be rolled and handled without fear of harming the recorded information.

### The play's the thing

For the consumer market, the key element for success of a video-disk system is the playback device. Video information can be retrieved from a photographic film disk in a number of ways, depending on the quality of the picture desired. For example, by means of a laser readout and a carefully aligned, high-quality optical system, signals have been retrieved at a 10-megahertz rate at a disk-rotation rate of 1,800 rpm. A less sophisticated system, however, is essential for widespread consumer use.

To get a video picture comparable to the quality typical in home reception, i/o Metrics uses a white-light source, simple microscope lenses, and a p-i-n diode or photomultiplier light detector with a well-matched wideband amplifier. These elements are linked together in dual servomechanism loops, one for an automatic focusing device and one for an automatic track-following device.

The signal is presented to the detector (Fig. 5a) as a projected image at the disk surface. It is subsequently processed by the appropriate video electronics (Fig. 5b) to compensate for the effects of the inexpensive mechanical and optical components. These form the basis for the simple playback unit. As in the recording procedure, the playback unit must be able to track toward the disk's center.

A key element in this video-player's optical system is the microscope lens, which must be capable of transferring information recorded on the film to the video detectors with adequate modulation and phase-inversion. The modulation-transfer function (MTF) of a typical lens declines toward the center of the recorded disk because the disk spins at a constant rate, requiring signal elements to be recorded closer together in the center than at the edge. In addition, the MTF also declines as the lens moves out of optimum focus for any fixed radius, which explains why automatic focusing is essential to preserve signal quality. However, automatic focusing is not effective at frequencies much higher than 34 MHz.

### Lighting the picture

The least expensive light source available to provide illumination for the system is a simple miniature incandescent light bulb, while for higher intensities, a 25-w quartz halogen lamp has been used. By using an aspheric condenser arrangement in the playback system, irradiance levels exceeding 1  $\text{mW}/\text{cm}^2$  have been achieved by the detector.

As an alternative to direct illumination by the light bulb, fiber optics can be used, thereby simplifying the playback configuration. Typical operating levels achieved through this approach are compatible with home-TV reception, specifically, an observed frequency response of -3dB at 3 MHz, video signal-to-noise ratios exceeding 40 dB, and time stability at 3.58 MHz to 5° of 360° over one video line. These results were achieved with white-light illumination and with limited processing of the video signal as received from the disk.

The spiral track from the disk can be followed out automatically by a balanced split photodiode or a more sophisticated linear diode array. Excursions of the track being followed generate an error signal, which drives a rotating mirror element to compensate. Such a system corrects for the major errors in track motion that are inevitably caused by the loose mechanical tolerances of a simple playback device.

Anomalous motions are further reduced by the use of a passive astigmatic optical element in the path of the signal beam. One tracking system has a servo bandwidth capable of compensating for up to a 6-mil error in the centering of the video disk. Any residual video-signal modulation caused by track wander is removed by a fast-attack automatic-gain-control device on a line-by-line basis.

A related servo loop drives the microscope lens to maintain correct focusing. To compensate for any variation in the position of the disk surface, the servo drives a small magnetic coil that is the mounting for the lens system. In practice, these variations are found to be quite small because of the flattening effect of rotation. □



2 Hz to 200 kHz frequency range  
Sine, square, and triangle outputs  
Linear and logarithmic sweep  
Battery powered for maximum portability

# All of the above in the function generator below

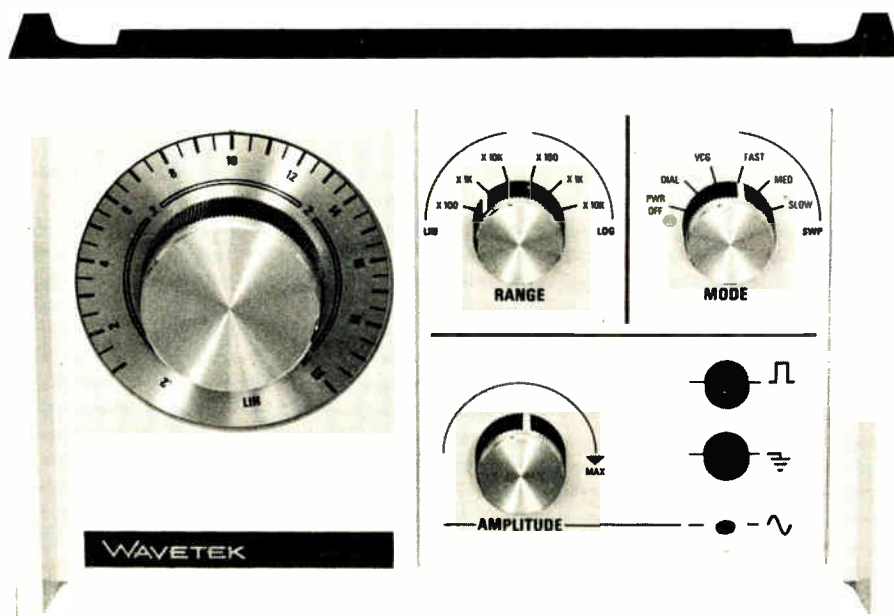

## for only \$149.95.

Well, Wavetek's gone and done it again—another function generator first. For less than 150 bucks, you can get a complete audio signal source with the capability of many generators costing several times as much. With our new Model 30, you can generate sine, square, and triangle waveforms over a frequency range of 2 Hz to 200 kHz. You can also sweep the frequency in either the linear or logarithmic mode. The battery-powered Model 30 operates

anywhere with complete line isolation. And for unlimited line operation, you can get an optional rechargeable power supply kit. At \$149.95, the Model 30 has performance and versatility that everyone can afford. So don't just sit there. Order one.

### WAVETEK®

P.O. Box 651, San Diego, California 92112  
Telephone (714) 279-2200, TWX 910-335-2007

## Two-amplifier integrator extends timing performance

by Nabil R. Bechai  
Leigh Controls Ltd., Ottawa, Ont., Canada

A simple integrator normally consists of a single operational amplifier and an RC network for setting up the desired time constant. Although uncomplicated, this approach can be troublesome if either a very small or a very large time constant is needed.

The integrator in the figure, however, makes it easy to obtain either short or long timing periods because the values of the timing components are scaled by a straight resistance ratio. The integrator's output voltage is given by:

$$V_{out} = -\frac{R_1}{RCR_2} \int V_{in} dt$$

and its time constant becomes  $(R_2/R_1)RC$ . The circuit provides very good linearity when precision resistors

having a tolerance of  $\pm 0.1\%$  are used for resistors  $R_1$  and  $R_2$ .

Although a second op amp is needed to build the integrator, the circuit offers some additional advantages. For example, it permits initial conditions to be established easily. One of the capacitor's leads goes to ground, and if one end of the switch is connected either to ground or to some dc voltage, the capacitor's initial condition can be set up as either zero or otherwise by simply closing the switch.

Furthermore, when the switch is activated, the integrator's output is not shorted, and the circuit's output op amp operates as a voltage-follower. In a conventional integrator, the initial-condition switch is generally placed across the capacitor, which is in the op amp's feedback loop. With the switch closed, then, the output of a conventional integrator is shorted to the op amp's inverting input.

The integration period of the two-amplifier circuit described here can be as short as 1 nanosecond or as long as 1,000 seconds. The bandwidth of the integrator depends on which op amps are used. For high-frequency operation, National's type LM318 op amp and RCA's type CA3100 op amp are recommended. □

**Broad timing range.** An extra op amp permits this integrator's time constant to be scaled by resistors  $R_1$  and  $R_2$  so that an exceptionally short or long timing period can be obtained easily. The time constant is  $(R_2/R_1)RC$ , rather than the usual  $RC$  alone. The desired initial condition for the capacitor is established by simply closing the switch, which can go to ground (for zero initial charge) or to some dc voltage.

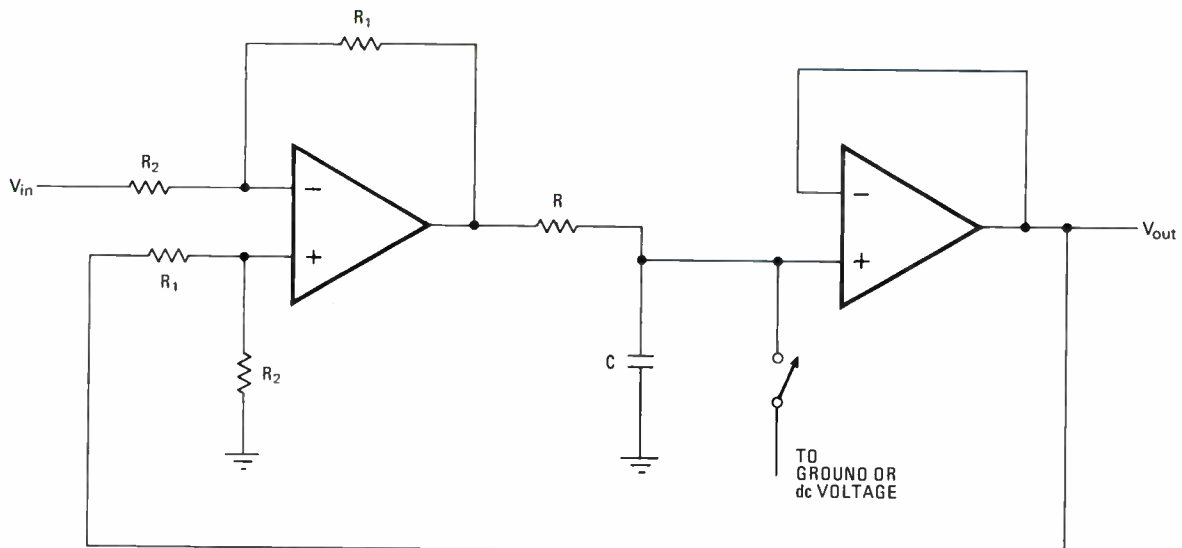

# Sure-fire ignition system safely limits engine rpm

by L.G. Smeins  
Ball Brothers Research Corp., Boulder, Colo.

For a capacitive-discharge automobile ignition system to work properly, the SCR in the circuit must receive an accurate and stable triggering signal. The circuit shown not only produces a reliable SCR trigger, but also filters point-bounce, limits rpm, and buffers the point opening.

The trigger pulses for the SCR are generated by a conventional unijunction-transistor trigger circuit that contains a UJT having a high intrinsic standoff ratio ( $\eta$ ). The values of resistors  $R_1$  and  $R_2$  are chosen to make  $R_2/(R_1 + R_2)$  less than  $\eta$ .

When the points close, the bipolar transistor turns off and the base-2 voltage ( $V_{B2}$ ) of the UJT becomes approximately  $12R_{BB}/(R_{BB} + 1 \text{ k}\Omega)$ , provided that resistor  $R_1$  is much greater than 1 kilohm. ( $R_{BB}$  is the interbase resistance of the UJT.) Capacitor  $C_1$  charges to a voltage that is slightly less than  $\eta V_{B2}$ .

When the points open, the bipolar transistor saturates, pulling  $V_{B2}$  to about 6 v and raising the capacitor's voltage to more than  $\eta V_{B2}$ . The UJT now goes into avalanche, producing a voltage pulse across resistor  $R_3$

that fires the SCR. The charging rate of capacitor  $C_1$  limits the SCR's firing repetition rate, thereby providing point-bounce filtering and rpm-limiting.

Suppose that an rpm limit of 6,000 is to be imposed on an eight-cylinder engine. For a type-2N4871 UJT,  $\eta = 0.75$  and  $R_{BB} = 6$  kilohms. Resistor  $R_1$  can be set equal to 21.4 kilohms, and resistor  $R_2$  to 50 kilohms, so that  $R_2/(R_1 + R_2) = 0.7$ , which is less than  $\eta$ . The firing voltage for the UJT is 4.55 v, and capacitor  $C_1$  must charge to this voltage 6,000 times per minute.

Two different charging rates occur because the target capacitor's voltage changes when the points close. If the point gap is adjusted properly, the ratio of the closed period to the open period is  $2/3$  to  $1/3$ . Since the total period is 2.5 milliseconds, the points remain open for 0.833 ms and closed for 1.67 ms. The value required for capacitor  $C_1$  can be found by computing capacitor voltage at the end of each of these periods. In this case, a value of 0.05 microfarad has been chosen for  $C_1$ .

The exact rpm setting needed for limiting can be obtained by adjusting the value of resistor  $R_4$  slightly. When the limiting speed is reached, the ignition fires every other plug, in this way avoiding the severe transient loads associated with circuits that shut down completely to limit rpm.

Although the circuit shown here is for a point-driven system, it can be adapted easily for a magnetic or optical pickup by removing resistor  $R_5$  and driving the bipolar transistor with a logic-level signal. □

**Improving gas mileage.** Efficient automobile combustion is provided by this capacitive-discharge electronic ignition, which features reliable SCR-triggering. The charging rate of capacitor  $C_1$ , because it determines how often the SCR is fired, provides rpm-limiting and point-bounce filtering. When the limiting speed is reached, only every other plug is fired to avoid the transient loading caused by a complete shutdown.

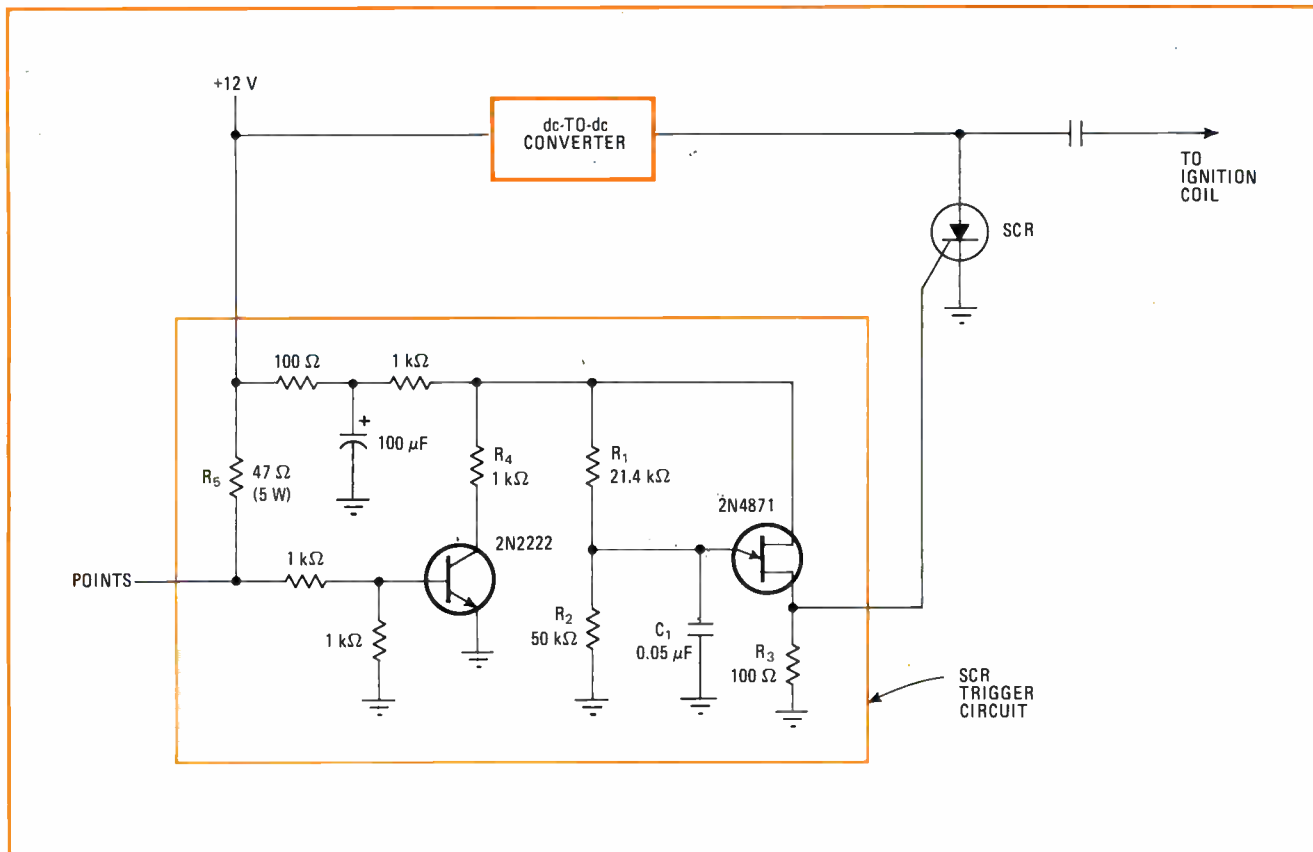



# FET-controlled op amp permits wide dynamic range

by Henry E. Santana  
Hewlett-Packard, Loveland Instrument Division, Loveland, Colo.

When a field-effect transistor is operated as a voltage-controlled resistor, it is usually limited to a relatively small dynamic signal-voltage range. This is due to the nonlinearity of its drain-source resistance over a wide range of drain-source voltage.

But a wide-range voltage-controlled amplifier can be realized if a pair of FETs is connected in the bridge configuration shown in the diagram. The inverting terminal of the operational amplifier is kept at virtual ground, permitting the range of each FET's drain-source voltage to remain small, regardless of how broad the actual signal-voltage range is. This also assures that the excursions of  $V_{DS}$  will remain well within the FET's pinch-off region.

**Wide-ranging.** Voltage-variable amplifier can operate over a broad range of input-signal voltages. The FETs, which function as voltage-controlled resistors, are wired in a bridge configuration. Their inherent resistance nonlinearity is avoided by limiting each FET's drain-source voltage range, no matter how large the signal voltage becomes. The op amp's inverting input is held at virtual ground.

The circuit's voltage-transfer function can be written as:

$$A_V = -(R_2/R_1) + N(R_1+R_2)/R_1 + NR_2r_{on}[1 - (V_{GS}/V_P)]$$

where  $r_{on}$  is the on-resistance of the right-hand FET,  $V_{GS}$  is the gate-source voltage, and  $V_P$  is the pinch-off voltage. Variable  $N$  represents a resistance ratio:

$$N = r_{on}/(r_{on} + R_1)$$

If  $N$  is very small, and  $r_{on}$  is much less than  $R_1$ , then:

$$A_V = -(R_2/R_1)(V_{GS}/V_P)$$

Although  $N$  must be small, it must, nevertheless, be greater than zero for the circuit to work. The control voltage for the circuit can range from 0 to  $V_P$ , and the peak ac input-signal voltage is determined by  $I_{DS}R_1$ .

Applications for this voltage-controlled amplifier include automatic gain control, true rms conversion, amplitude compression, and signal modulation. □

Designer's casebook is a regular feature in Electronics. We invite readers to submit original and unpublished circuit ideas and solutions to design problems. Explain briefly but thoroughly the circuit's operating principle and purpose. We'll pay \$50 for each item published.

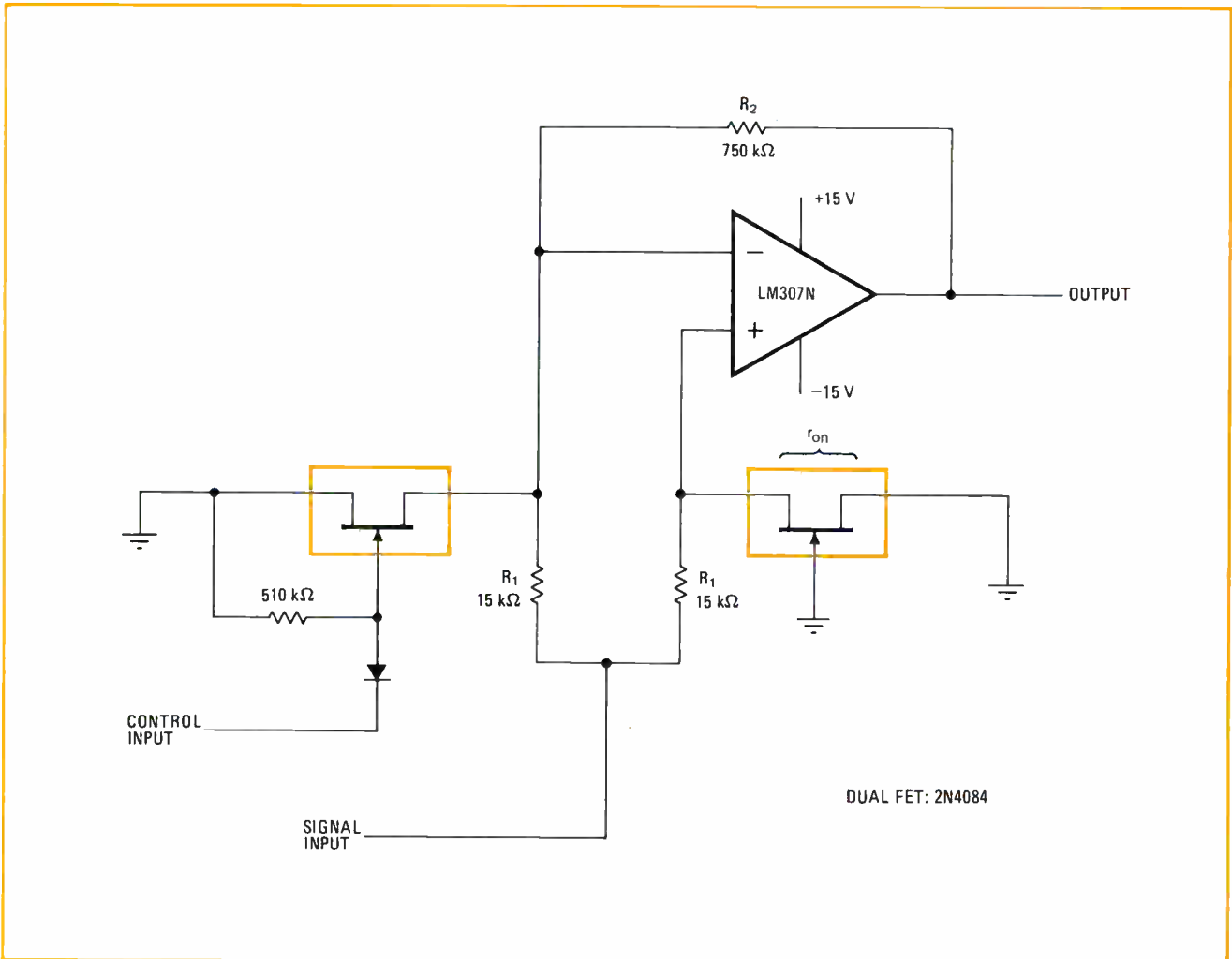

# 150 Microwatt Triple Op Amp

The L144 monolithic triple op amp draws only  $50\mu\text{A}$  of current per amplifier, from a  $\pm 1.5\text{ V}$  supply. What's more, it is

**AVAILABLE NOW FROM YOUR LOCAL DISTRIBUTOR!**

L144 features include:

- Monolithic triple op amp in DIP or Flatpac packages
- Wide power supply range— $\pm 1.5\text{ V}$  to  $\pm 15\text{ V}$
- Internal compensation
- Programmable power dissipation
- Programmable input bias current
- Single programming resistor
- 80 dB gain with  $20\text{ K}\Omega$  load
- Cost effective: \$1.63 per single op amp<sup>(1)</sup>

<sup>(1)</sup>L144CJ 100-piece price

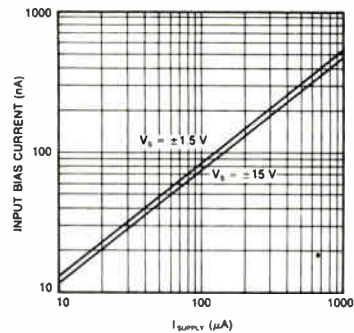

Applications examples:

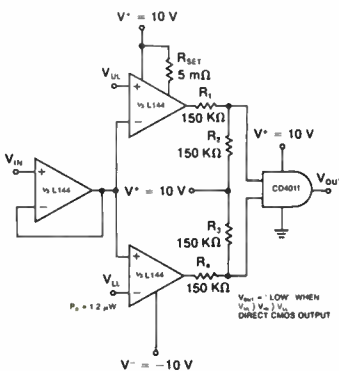

DOUBLE-ENDED LIMIT COMPARATOR

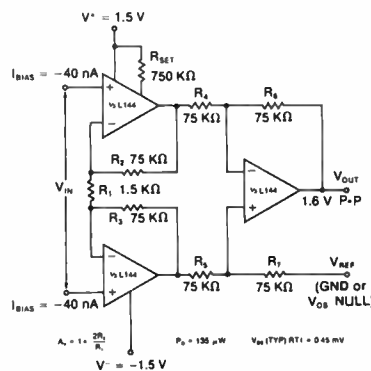

INSTRUMENTATION AMPLIFIER

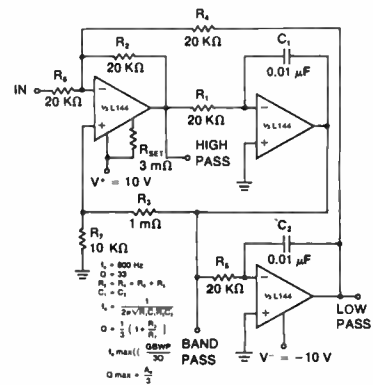

ACTIVE FILTER

The L144 is a practical industry-standard operational amplifier for use when low current drain, low voltage, low power, or very small physical size are controlling criteria. If your circuit requirements are unique—and whose aren't—our applications people are eager to help.

For complete information

**write for data**

IC Applications: (408) 246 8000, Ext. 120



**Siliconix incorporated**

2201 Laurelwood Road, Santa Clara, California 95054

# If your printed wiring can't stand the heat, switch to Norplex G-30.

Ordinary laminates just can't take the extreme temperatures generated by high density electronic systems.

But Norplex G-30 is no ordinary copper-clad laminate/prepreg material. It's a woven glass impregnated with polyimide resin, which assures you an outstanding combination of processing and operating characteristics.

For example, its exceptional heat resistance permits continuous operating temperatures in the 400°-500° F. range. G-30 gives you unexcelled dimen-

sional stability, flexural strength and processability. In multilayer applications, it also eliminates the smearing of resin during hole drilling, and minimizes cracking of plated-through holes.

Thus, Norplex G-30 performs with unequalled excellence in such demanding applications as aerospace electronics, computers, and com-

munications equipment.

Send coupon for our brochure on G-30 glass-polyimide, a new breakthrough in circuit technology. Or phone: 608/784-6070.

**Norplex® laminates**  
by **UOP**

Circle 124 on reader service card

© 1974 UOP

Norplex Division, UOP  
(Universal Oil Products Company)  
Norplex Drive,  
La Crosse, Wis. 54601  
Please send me your brochure on  
G-30 glass-polyimide.

Name \_\_\_\_\_  
Title \_\_\_\_\_  
Company \_\_\_\_\_  
Address \_\_\_\_\_  
City \_\_\_\_\_ State \_\_\_\_\_ Zip \_\_\_\_\_

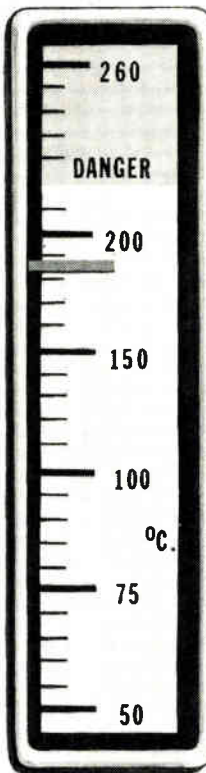
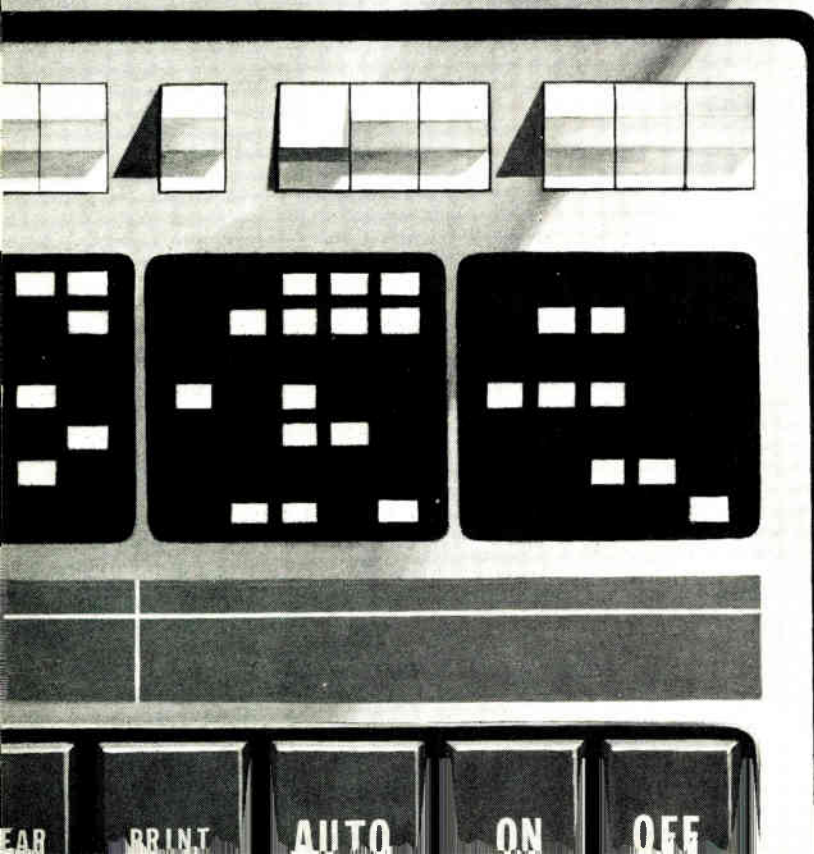



# Current-steering chip upgrades performance of d-a converter

Steered bit-switching currents produced by a dielectrically isolated monolithic IC provide increased speed and accuracy by avoiding thermal tails, the lag in time involved in stabilizing switching transistors

by Ed Maddox, Teledyne Philbrick, Dedham, Mass.

Improvements in the operation of precision digital-to-analog converters have been brought about primarily by improvements in the bit switches. These are binary weighted switchable current sources that sum their currents in a resistor to generate voltages that correspond to the digital inputs. There is one bit switch for each digital input to the converter, and each must switch a current on and off in response to a digital command at the input.

One of the major problems in obtaining high precision and speed in d-a converters has been the thermal settling time involved in turning the current-source transistors on and off. This and other problems have been solved by current steering. This technique is employed by Philbrick's monolithic pnp bit switch, which will soon be available to OEM users.

Current steering is a method by which the current-source transistors operate continuously while the current to the output is switched by an auxiliary transistor. Current steering is not new—it has been used in discrete-component circuits. But when such a circuit is built in monolithic integrated-circuit form, it produces

significant improvements in the converter's speed and thermal performance.

The new monolithic array of bit switches uses dielectrically isolated pnp transistors in the current-steering mode. The transistors are configured to avoid the effects of thermal gradients on the chip, while a low output capacitance permits better rise times than have been possible in the past. And, because the transistors are built in a monolithic circuit, it is economical to use current-sharing methods to equalize base-emitter voltages, thereby reducing errors.

This bit switch, in achieving its basic objective of switching bit currents without degrading the speed or accuracy of the d-a converter, also meets these desirable criteria over the entire temperature range:

- Provides TTL-compatible interfacing (on voltage is 2.0 V, and off voltage is 0.8 V).
- Responds quickly to digital commands.
- Is accurate enough for use in high-resolution d-a converters.

Accuracy can be separated into two factors—linearity and scale-factor accuracy. Linearity is the degree to which the ratios between the values of individual bits are set and maintained. Scale-factor accuracy is the degree to which the converter produces the desired output

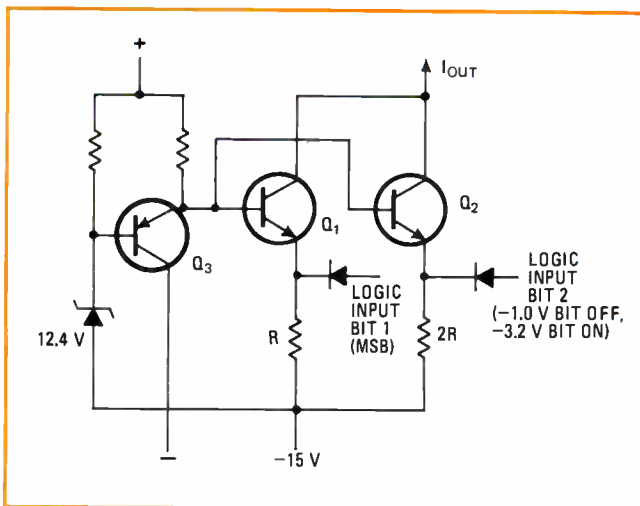

**1. Diode-npn switches.** Transistors  $Q_1$  and  $Q_2$  are switchable current sources whose currents are set by resistors  $R$  and  $2R$ .  $Q_3$  transfers 12.4-V zener drop to resistors  $R$  and  $2R$  to help set the individual currents: Output current  $I_{OUT}$  goes to a summing resistor. Unequal heating or cooling can cause imbalances in the base-emitter voltages of the transistors and also in the current gains, both of which affect accuracy. Logic inputs were not compatible with TTL levels.

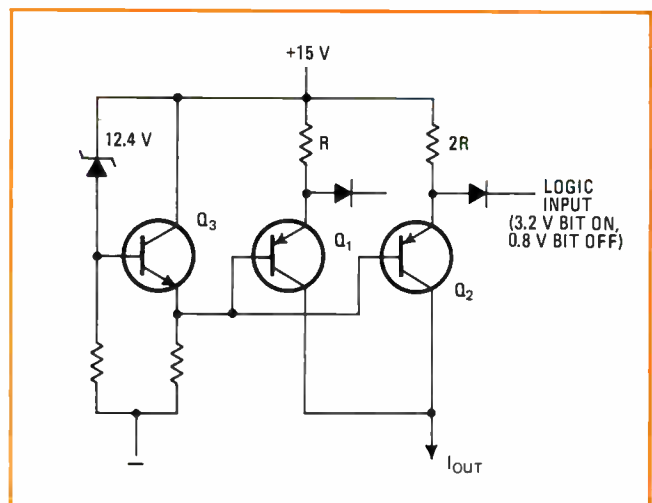

**2. Diode-pnp.** Nearly a mirror image of the circuit in Fig. 1, this circuit provides compatibility with TTL-logic inputs, but it still shows the same deficiencies in compensating for changes in transistor-current gains and base-emitter voltages.

magnitude. For example, a converter could have good linearity, but poor scale-factor accuracy; this condition may be acceptable in certain applications.

### Evolution of bit switches

Tracing the development of bit switches over the past five years or so sheds a great deal of light on improvements that have evolved. The characteristics of five major previous types of bit switches, as well as the new switch, are summarized in the table, p. 129.

■ *The discrete diode-npn switch* was one of the earliest forms of current-switching bit switches. It used discrete npn transistors to switch the current sources. In Fig. 1, transistor  $Q_1$  and resistor  $R$  form one current source, and  $Q_2$  and  $2R$  form another that has half the current value of the first. The 12.4-v reference zener sets  $Q_3$ 's base at about  $(-15 + 12.4 \text{ v})$ , or about  $-2.6 \text{ v}$ .

The base-emitter voltage ( $V_{BE}$ ) of  $Q_3$  approximately cancels the  $V_{BE}$  of  $Q_1$  and  $Q_2$ , and thus the voltages across  $R$  and  $2R$  are about equal to the voltage across the 12.4-v zener. A diode couples the logic signal to the transistor emitter and when the logic is at its high level ( $-1.0 \text{ v}$ ), the transistor is biased off, and no current is fed to the output. When the logic input is low ( $-3.2 \text{ v}$ ), the diode is biased off, the transistor turns on, and the resistor current is fed to the output.

This circuit's speed is affected by the coupling diode's recovery time and the finite time constant for a voltage change at the  $Q_1$  or  $Q_2$  emitter, which also reduces switching and settling speed. Any difference in switching speed from one transistor to another causes glitches in the converter output.

Thermal problems are substantial, too. A difference in the  $V_{BES}$  of  $Q_1$  and  $Q_2$  results in unequal voltages across  $R$  and  $2R$  and thus an error in the bit ratio, affecting linearity. Although this difference could be initially canceled by trimming the values of  $R$  and  $2R$ , unequal heating or cooling of  $Q_1$  and  $Q_2$  could cause subsequent differences in the  $V_{BES}$ , and that difference produces errors in bit ratio.

When the logic command turns on a transistor, there is a change in transistor dissipation, and the final bit

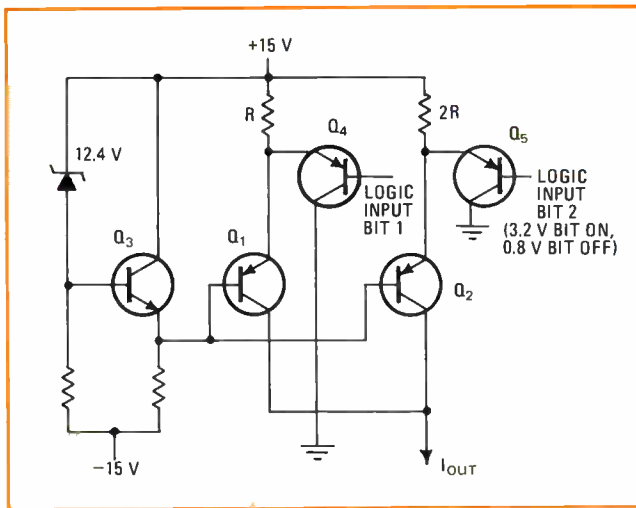

3. **Pnp-pnp.** Replacing diodes of Fig. 2 with transistors eliminates diode storage times and thus raises speed, but this change does not affect problems of changing current gain and base-emitter voltages.

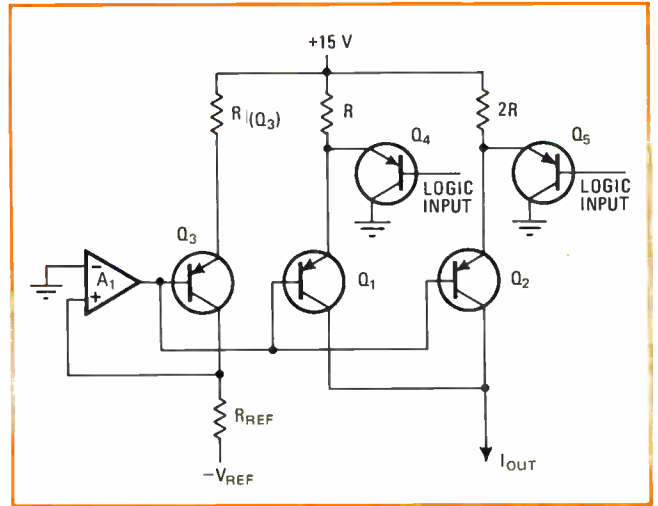

4. **Adding a reference servo.** Addition of an operational amplifier helps to compensate for changing current gain and base-emitter voltage. All bases are adjusted to maintain constant current through  $Q_3$ , and, if the transistors are matched, the currents through  $Q_1$  and  $Q_2$  are thus controlled by the operational amplifier.

value will not be reached until the transistor stabilizes thermally. The primary mechanism involved here is the variation of  $V_{BE}$  with temperature. A discrete-component assembly usually has long thermal time constants and poor thermal coupling between bit switches, producing a long final settling time, commonly referred to as a thermal tail.

The npn-diode circuit of Fig. 1 has no compensation for variations in  $\alpha$  (current gain) that result from temperature changes in  $Q_1$  and  $Q_2$ . The zener reference voltage, repeated across  $R$  and  $2R$ , establishes specific currents through  $R$  and  $2R$ , but these are transistor-emitter currents. Since  $\alpha$  is less than 1 (finite  $I_{BASE}$ ) and subject to change with transistor temperature, the  $Q_1$  and  $Q_2$  collector currents (which make up the output current  $I_{OUT}$ ) will change with operating temperature. If  $Q_1$  and  $Q_2$  change  $\alpha$  in a matched or tracking fashion, the ratio of bit values may not err, but the scale factor will show an error. The  $V_{BES}$  of  $Q_1$  and  $Q_2$  (npns) are essentially compensated by the opposite  $V_{BE}$  of  $Q_3$  (pnp). This is effective, but crude, since the pnp and npn devices never match well. Also, a current leakage through the coupling diode of a turned-on bit could produce significant error at elevated temperature, which usually limits resolution to less than 12 bits.

One final limitation of this circuit is its sensitivity to power-supply voltage variations. As the supply voltage shifts, the logic threshold likewise shifts.

■ *The diode-pnp circuit* of Fig. 2, a logical variation of the circuit of Fig. 1, is the basis for many converters. It produces a direct DTL/TTL-compatible logic input (with a slight bending of standards for TTL-logic high), deleting one shortcoming of Fig. 1. Otherwise its problems are very similar to the diode-npn circuit. And in this circuit, too, the logic threshold level is sensitive to power-supply variations.

■ *The pnp-pnp configuration* in Fig. 3 moves a step ahead by replacing the coupling diode with a transistor, thus removing the problem of diode-storage time and current leakage. The low level of input-logic currents

also improves matters, especially when adapting to other logic levels. The operating speed improves with the elimination of storage-time problems, but many shortcomings remain.

■ A reference servo (an operational amplifier) added to the pnp-pnp to compensate for variation in  $\alpha$  and  $V_{BE}$  was the next advance (Fig. 4). The equivalent job of  $Q_3$ —setting the voltage across the bit resistors—in previous circuits is handled here by  $Q_3$  in a quite different circuit arrangement.  $Q_3$  is connected as a current source similar to that in the  $Q_1$  circuit. This current source is sometimes referred to as a dummy bit.  $Q_3$  has in its collector path a resistor ( $R_{REF}$ ) to which a negative-polarity reference voltage is applied.

An operational amplifier,  $A_1$ , drives the transistor bases on a common-voltage bus and adjusts the base voltage so that the  $Q_3$  collector current maintains the  $A_1$  + input terminal at 0 V (the voltage  $V_{REF}$  is thus forced across the resistor  $R_{REF}$ ). If  $R_{Q3}$ —the reference dummy resistor—and  $R$  and  $2R$  are matched in ratio, and if  $Q_1$ ,  $Q_2$ , and  $Q_3$  are matched in  $\alpha$ , then variations in  $\alpha$  are cancelled by the action of the servo loop, consisting of  $A_1$  and  $Q_3$ . (If, for example,  $\alpha$  decreases, then so do  $I_C$  and the voltage across  $R_{REF}$ . The op amp then counteracts this change by reducing the base voltage and increasing  $I_C$ .) Since the loop regulates  $I_C$  for  $Q_3$ , a matched set of transistors will produce a stable value of  $I_C$  and thus  $I_{out}$  for  $Q_1$  and  $Q_2$ .

Conveniently, the circuit improvement for compensa-

tion also gives a more ideal compensation of  $V_{BE}$ , resulting in smaller scaling errors as the temperature changes. The improved compensation is the direct result of using a pnp  $V_{BE}$  to match and subtract out a similar pnp  $V_{BE}$ . The very best compensation will result when the compensating device ( $Q_3$ ) is operated at the same  $I_C$  as the compensated device ( $Q_1$  or  $Q_2$ ).

### Problems remain

Distinct progress in switching technology was indicated, but problems still remained. The discrete assemblies still had thermal problems associated with the gross distance and poor thermal coupling between devices. Speed was still limited by current-switching times, and the thermal settling tails still persisted. These were perhaps even more noticeable as the improvement in  $\alpha$  and  $V_{BE}$  compensation made it practical to obtain resolution from 12 to 14 bits, and the tail is thus larger relative to one least significant bit (LSB).

Attempts at higher-resolution designs also brought attention to an additional  $V_{BE}$  problem previously ignored here. To achieve ratio tracking, and thus linearity over a wide temperature range, the change in  $V_{BE}$  of the individual current-source transistors must track. A matched set of transistors would track, but only if all were operated at the same current.

As the weighting of bit currents for this class of converters is binary for a 4-bit section, each successive bit operates at one half the prior bit's current. Transistors,

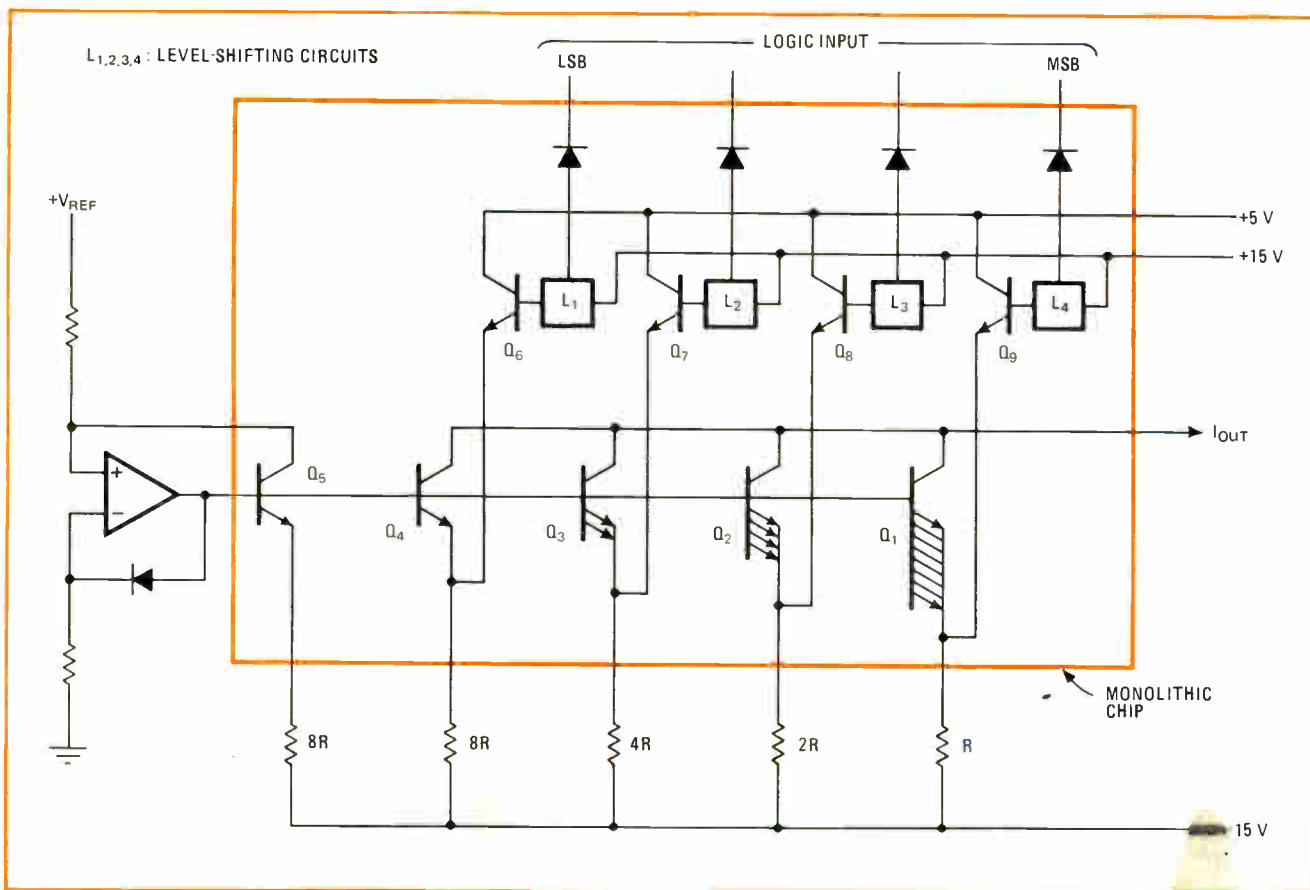

5. Monolithic npn. Paralleled transistors in the bit switches assure similar currents through each device and thus similar base-emitter voltages. However, use of npn transistors requires level-shifting circuits ( $L_{1-4}$ ) to work with TTL inputs. Also, switching is done directly on current-source transistors, which introduces thermal-stabilization problems (thermal tails), as in the discrete-component circuits.



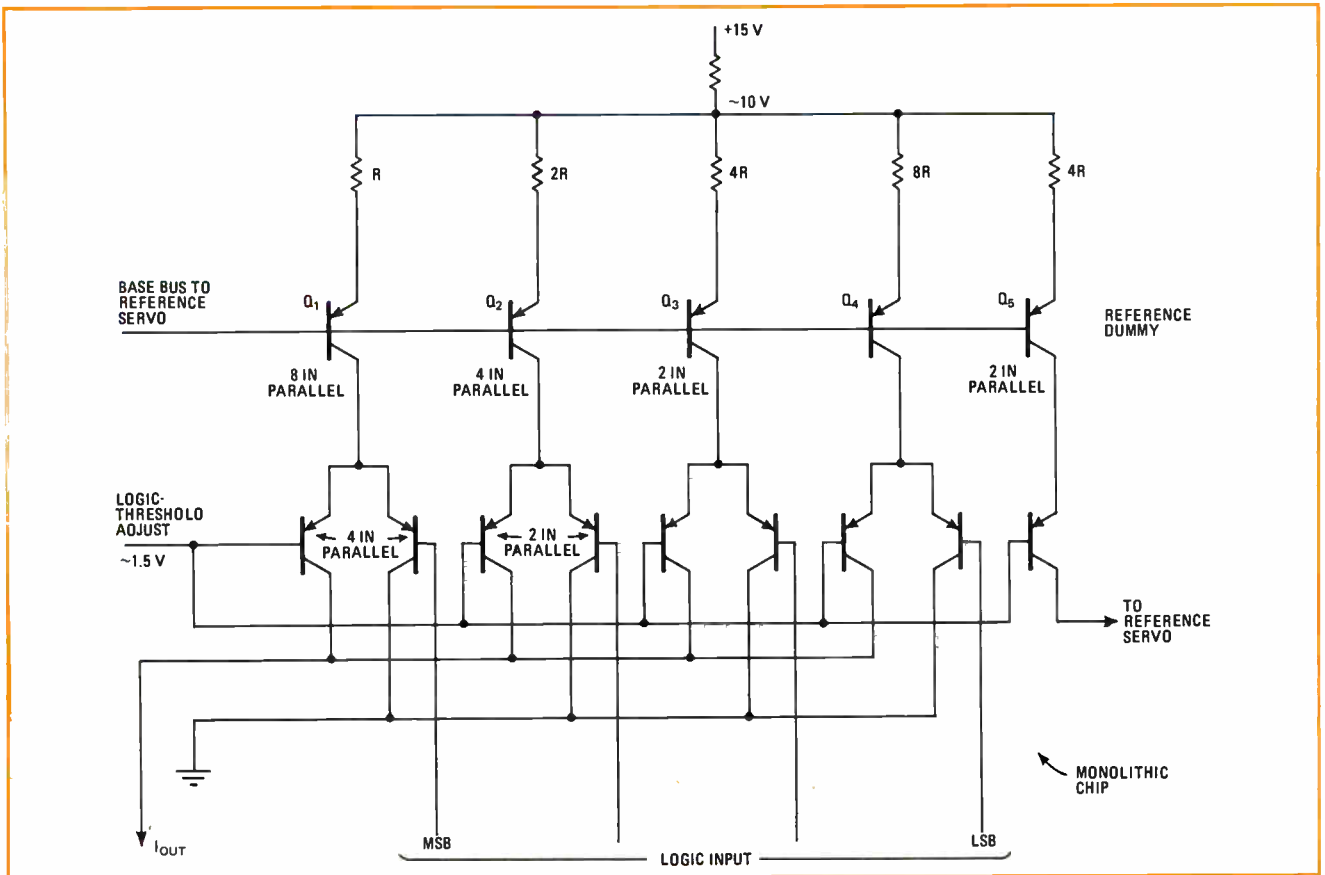

**6. Monolithic current-steering.** Current-source bit transistors  $Q_{1-4}$  operate continuously, while logic inputs switch currents from ground path to output line, thus avoiding thermal tails. Multiple transistors for each bit help assure base-emitter voltage-matching. A reference servo is also used in this circuit; it is not shown to minimize drawing complexity, but is similar to that in circuit of Fig. 5.

when initially matched at equal currents, will operate at a  $V_{BE}$  difference of approximately 18 millivolts with a 2:1 current relationship. This difference can be accommodated by changing resistor values, but this will only help at one temperature.

The differential change of  $V_{BE}$  with temperature for a transistor pair is approximately 3 microvolts per degree Celsius per millivolt of the  $V_{BE}$  difference. Thus an 18-mV initial differential produces a  $54\text{-}\mu\text{V}/^\circ\text{C}$  tracking error. This error must be considered in relating the voltage appearing across the current-setting resistors  $R$ ,  $2R$ , and so on, to the differential error in current ratios. Thus, to improve the performance in high-resolution converters beyond the ability of a Fig. 4 circuit, a solution to this  $V_{BE}$  tracking problem had to be found.

#### Monolithic current-sharing helps $V_{BE}$ match

The power of integration was then brought to bear on the problems of the bit switch. Figure 5 illustrates a monolithic npn-based bit switch having four switches with associated level shifters for the logic inputs. This circuit, an available, widely used, standard product, provides the dummy bit for use in a reference-servo circuit to compensate  $V_{BE}$  and  $\alpha$ .

The problem of differential  $V_{BE}$  caused by unequal bit currents is solved by paralleling appropriate numbers of transistors so that all transistors pass equal currents. The monolithic construction results in good matching of the initial values of  $V_{BE}$  and  $\alpha$ , as well as in

thermal coupling not attainable in discrete assemblies. This unit is built with npn transistors to achieve reasonable-quality devices with the standard linear integrated-circuit process.

However, this circuit suffers from other problems. A level-shifting circuit is required. The junction-isolated process produces junction leakage, which limits bit accuracy, especially at elevated temperatures. And bits are switched by turning the current-source transistors on and off, which results in speed problems due to the emitter-circuit time constant and settling problems due to the thermal tail associated with device-dissipation changes.

In this type of bit switch, the geometrical arrangement of the transistors is such that the eight transistors used for bit 1 are arranged in a line. Below, in the same line are the four transistors for bit 2, the two transistors for bit 3, and one transistor for bit 4.

This geometrical arrangement results in problems not evident from the schematic diagram. A thermal gradient across the chip—particularly along the line of transistors—will produce a significant error in  $V_{BE}$  matching, which degrades linearity. Such gradients can be generated by external heat sources or internally by heat sources within the chip.

The internal heat sources vary with time because they are dependent on the state of the digital commands. This causes another form of thermal tail, further limiting the high-speed performance of the switch. An addi-

tional problem resulting from the in-line arrangement of the transistors is the mismatches caused by processing diffusion gradients across the wafer. This will reduce the yield for devices usable at high resolution.

### Monolithic current steering does it

Philbrick's ultimate goal was to design high-performance d-a and a-d converters. The monolithic pnp quad switch is now being used in the military-grade 4050-series hybrid d-a converters and in display d-a converters. The quad switch (Fig. 6), a 4-bit switch with a dummy bit for the reference servo, is a dielectrically isolated pnp array that provides bit switching by current steering. Paralleled transistors in the current sources permit equal-current operation of the transistors. The use of pnp transistors provides a direct TTL-compatible logic input, thereby avoiding speed degradation and skew associated with logic-level shifting. Further, the logic threshold is programable, offering a flexibility not previously available.

Since, in current steering, the current sources operate continuously, any thermal-tail problems associated with turning current sources on and off are eliminated. The bit currents are turned off and on at the output by the logic-input level turning the logic-input transistor on and off. At logic high, this transistor is off, and the current from the bit-current source is fed through a pass transistor to the output. When the logic transistor is on (logic low), the pass transistor is biased off, and the current flows through the logic transistor to ground.

This current-steering technique aids the dynamic performance of the switch in two ways. First, by eliminating thermal tails through continuous operation of the current sources, the time required to settle to a very small error is reduced. Second, the current-setting resistors, seeing only dc currents, do not influence the settling time and thus need not be high-speed resistors—wirewounds could be used for this purpose.

The speed of the bit switch is especially enhanced by the low parasitic capacitances resulting from dielectric isolation and the low common-base output capacitance,  $C_{OB}$ , of the bit-switch transistors. The time constant at the steering transistors' emitter is very short because of the low output capacitance of the current-source transistor and the low stray capacitances that result from the absence of connections to external circuitry.

The total output capacitance, which limits the speed of any current-to-voltage conversion following the switch, is exceptionally low—approximately 5 picofarads total for all eight collectors connected to the output point. The low output capacitance also permits the greatest bandwidth to be realized from broadband operational amplifiers in high-accuracy converters and with resistive terminations provides better rise times than had been previously possible. An added benefit of dielectric isolation is the low device-to-device leakage.

The chip geometry, which contributes heavily to the performance, is shown in Fig. 7. Unlike the chip previously described, a special arrangement of the current-source transistors is used to counteract the effects of

PROPERTIES OF D-A CONVERTER BIT SWITCHES

Configuration	Current switching or steering	TTL compatibility	Resolution (bits)	Speed	Thermal tracking	Freedom from thermal tail	Compensation		Freedom from current leakage
							$\alpha$	$V_{BE}$	
Diode-npn (Fig. 1)	Switching	Level shifted	10 - 11	Slow	Fair	Poor	No	Crude	Poor
Diode-pnp (Fig. 2)	Switching	Direct	10 - 11	Slow	Fair	Poor	No	Crude	Poor
pnp-pnp (Fig. 3)	Switching	Direct	10 - 11	Medium	Fair	Poor	No	Crude	Good
pnp-pnp ref. servo (Fig. 4)	Primarily switching	Direct	12 - 14	Medium	Fair	Poor	Yes	Fair	Good
Monolithic npn (Fig. 5)	Switching	Level shifted	12 - 14	Medium	Good	Fair	Yes	Precise	Fair
Monolithic pnp (Fig. 7)	Steering	Direct	16	Fast	Excellent	Excellent	Yes	Precise	Good

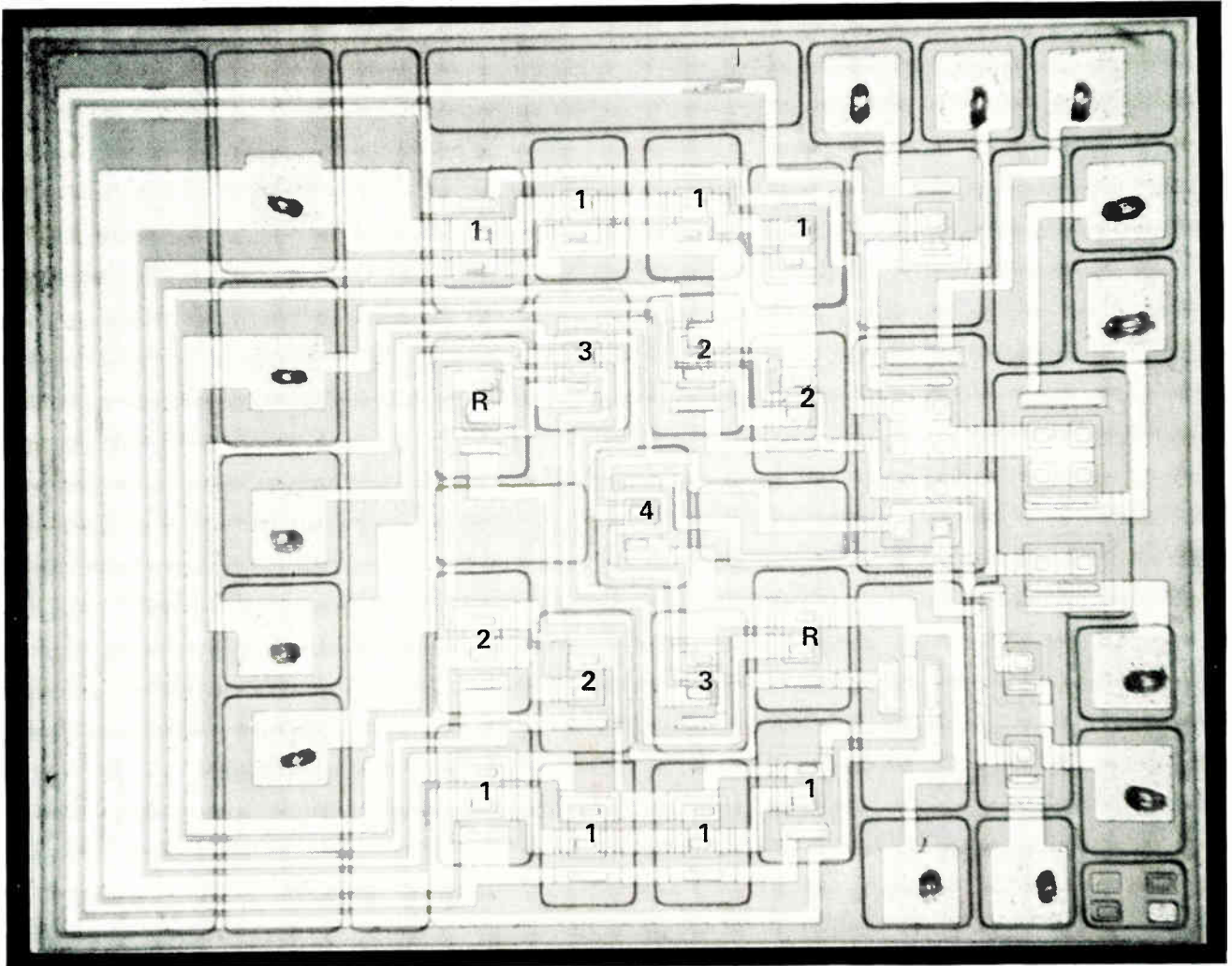

**7. Current-steering geometry.** Multiple-bit transistors are arranged symmetrically around geometric center so that gradients tend to average out—eight transistors for bit 1, for example, have same average temperature as four transistors for bit 2.

thermal gradients on transistor parameters.

The paralleled transistors used for each bit are arranged so that the geometric centers of all bits are coincident (the transistors are symmetrically arranged around the transistor for bit 4). This results in the elimination of thermal-gradient effects, whether internally or externally generated, since the average temperature for each group of bit transistors will be the same.

Thus, thermal tracking of the bits is substantially improved, and internally generated thermal tails are eliminated. The geometry of the chip results in thermal-tail values of less than 1 part per million of full scale for 3-mA full scale and 4 ppm of full scale for a full-scale output of 16 mA. Further, this geometry provides cancellation of diffusion gradients in any direction, resulting in excellent matching of  $\alpha$  and  $V_{BE}$ .

The performance of d-a converters constructed with current-steering bit switches can exceed in accuracy, over wide temperature ranges without sacrificing speed, converters that are constructed with previously available switches. A 0.3-mV  $V_{BE}$  match, in combination with a 1% match in  $\beta$ , which are characteristic of the chip, permits the construction of d-a converters having a  $\frac{1}{4}$ -LSB linearity and 14- to 16-bit resolution when used with suitably accurate and trimmed resistors.

The contribution of the switches to the temperature coefficient of differential nonlinearity is primarily the result of a temperature-coefficient error in the dc match, which is 1 ppm/ $^{\circ}$ C nominal. This value, when applied to converters, results in approximately 1 ppm/ $^{\circ}$ C worst-case and  $\frac{1}{4}$  ppm/ $^{\circ}$ C typical differential nonlinearity.

The  $V_{BE}$  match of  $2 \mu\text{V}/^{\circ}\text{C}$  maximum will contribute only 0.1 to 0.3 ppm/ $^{\circ}$ C error as differential nonlinearity (the  $V_{BE}$  match error will always be small, compared with the  $\alpha$ -related error for bit-resistor voltages of 3 V or greater, but is more significant for a smaller voltage, such as 1 V). Output-current leakage totals 10 pA nominal and doubles with each  $+10^{\circ}\text{C}$ . At  $125^{\circ}\text{C}$ , this is still only 1 ppm of full scale for a 10-mA full-scale converter.

The switching speed of a current-output d-a converter using the chip exceeds previous discrete or monolithic bit-switch designs, with 2- to 3-nanosecond rise time and typical settling times of 30 ns to within 0.1% and 60 ns to 0.01%. The low voltage and current errors permit the construction of micropower converters with full-scale output as low as  $40 \mu\text{A}$  and bit-resistor voltages as low as 1 V or 1.5 V. A low-voltage converter can be assembled to operate from a single +5-v dc supply with performance comparable to units powered from  $\pm 15$  V dc, but it will have a unipolar output current.  $\square$



# WHO MAKES THE MOST GLASS PRODUCTS FOR ELECTRONICS?

- CERDIP Sealing Materials . . . we sell the industry standard . . . including the lowest temperature sealing glasses on the market
- Substrates . . . you can choose standard sizes off the shelf, or order special glasses
- Diode Cases . . . we're the largest supplier in the world
- Infra-red Sealing Reed Switch Glass . . . we developed it to give you fast, efficient processing
- Glass Preforms . . . more than 1,200 shapes of IC frames, beads, and other preforms
- CRT Bulbs . . . more than 100 standard shapes, from 1" to 36", plus special shapes and sizes
- Quartz Crucibles . . . O.D. sizes up to 10"
- Chemically Machinable Glass Ceramics . . . for unique shapes and configurations
- Display Materials . . . cell sheets, back plates, mercury capsules and sealing frit, everything for flat panel displays

# CORNING MAKES IT!

We can do almost anything with glass for electronics.  
Got a problem? Write or call:



Electronic Materials Department

**CORNING**

CORNING GLASS WORKS

Corning, New York 14830

(607) 974-8866

# Some buying decisions are easy.



At least where interactive design and drawing systems are concerned. Among these tools for designing and preparing finished art for IC's, PC's and electrical schematics, one system has become the hands down favorite of the major U.S., European and Japanese manufacturers. The Calma Graphic Data Station. It didn't happen overnight. The Calma system earned its place over the past four years by outperforming other systems in the toughest kind of competition. By consistently achieving twice the thruput. By performing reliably when others failed. By supporting more work stations without loss of performance. By making it more economical to expand than other systems. Today, you don't have to take a chance on the untried. Calma has proved itself. Just ask around. The experience of others will make your buying decision easy. Write or call today for literature or a demonstration. Calma Company, Corporate Marketing Headquarters, 1930 Isaac Newton Square East, Reston, Virginia 20090. Phone (703) 471-1450.



**Calma**  
**Interactive Design and Drawing Systems.**

# Low-cost tin, as a plating for contacts, can sometimes be as good as gold

Contact force, wear requirements, circuit voltage and current—these are only some of the factors that a designer must trade off before he can safely pick tin- or gold-plated contacts for his system

by James H. Whitley, AMP Inc., Harrisburg, Pa.

□ An electroplater remarked recently that after all the work that goes into an electrical connector—the high-powered design engineering, followed by precision stamping and forming, high-speed assembly, and application tooling—the ultimate success of the product still depends on the last few micrometers of material which he puts on the contact surface.

Press an IC into its socket, or home a printed-circuit board into an edgeboard connector, or couple two cable connectors together—it is the contact surface that must complete the circuit and assure the uninhibited flow of electric current. This is no trivial matter; in a growing number of cases, system designers are learning that the over-all reliability of an electronic system depends as much on its interconnections as on any active solid-state device.

Generally, the most reliable contact material available is gold, which therefore has come into widespread use in multiple-circuit, separable connectors. But to come to grips with the question of whether costly gold can be eliminated in a particular application, we first must consider the reasons for its success as a contact material.

## The case for gold

Gold is a noble metal: it does not react with other substances. In particular, it does not react with the atmosphere to tarnish or form oxides on its surface. No other metal, not even platinum or rhodium, is so completely free of oxide films.

This is a very important asset because a mere microinch of oxide or sulfide film can raise contact resistance from 1 milliohm to thousands of ohms. Even films that are broken but not wholly removed during contact engagement can easily cause contact resistance to vary by factors of 10, 100, or 1,000. Any film present has to be removed, whether mechanically, electrically, chemically, or thermally, before adequate electrical contact can be established.

The gold plating on a contact must be pore-free and thick enough

to prevent the beryllium copper or other metal below it from diffusing through. To stop this diffusion, a barrier underplate, such as nickel, is often used. Furthermore, the gold plating itself must be free of impurities and/or alloying elements that might form films on an otherwise clean surface.

If the porosity and purity criteria are not met, the gold on the plated contact must be considered a non-noble metal, and problems like the one in Fig. 1 can develop. Here, the contact was given a porous gold plating and subjected to a nitric acid vapor. In just two hours, the vapor penetrated the gold surface, ate through the nickel underplate, and attacked the underlying copper. A gold plate that can withstand such a hostile environment without degradation is costly to apply because, over and above the basic cost of the metal itself, is the cost of processing it into an adequate plating solution.

However, the nobility of gold is neither needed nor desirable in all contact applications. For instance, it's of no value in arcing contacts where it erodes rapidly and tends to weld. The sliding wear characteristics of pure

**Gold or tin?** Platings measured in microinches are crucial to an effective electrical contact on connectors such as this 120-pin connector pair capable of carrying 7.5 amperes per pin. But choosing gold plate can boost connector cost by as much as 50%. A multiplicity of factors determine which plating, if any, is necessary.

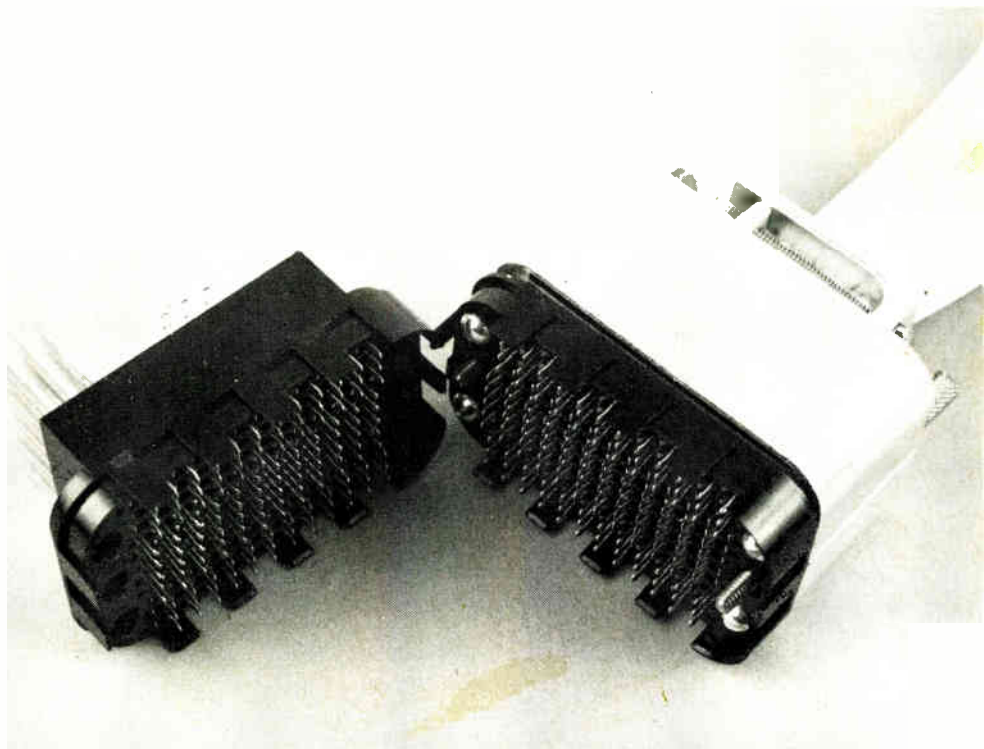



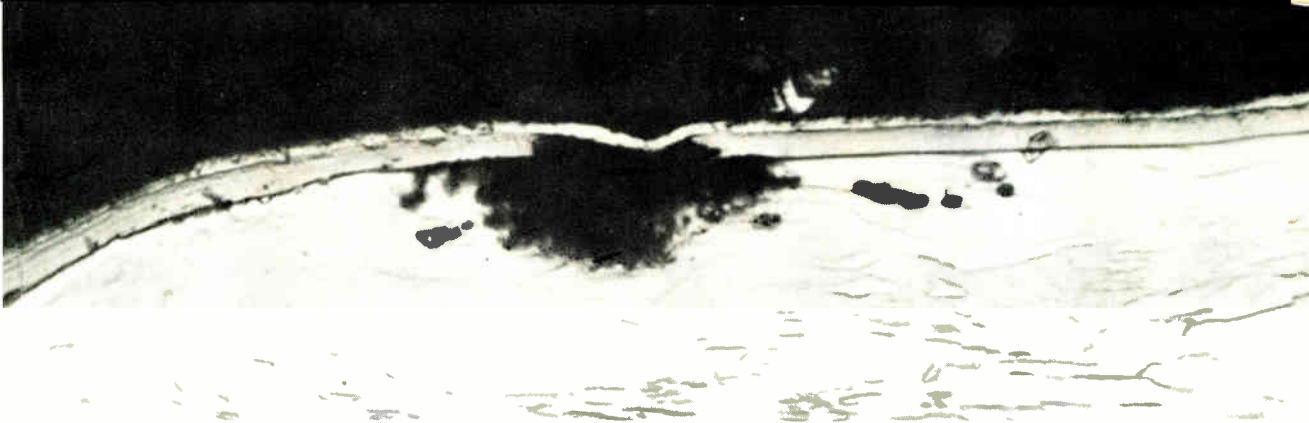

**1. Trouble.** If pores exist in gold plating, contaminants can destroy the contact face. This contact was attacked by a nitric acid vapor that in just two hours penetrated the 30 microinches of gold, attacked the nickel underplate, and ate into the copper beneath.

gold are not very favorable. It tends to stick, smear, and wear off in high-pressure, semipermanent connectors or in crimp connections, where it should not be used except in certain corrosive environments.

### Tin as an alternative

Tin alloys are popular alternatives because they are relatively inexpensive. However, both pure tin and its alloys form oxide films when exposed to air. In even a moderately severe environment a tin surface can become heavily coated with oxides or other insulating corrosion products. The black inclusions in Fig. 2 are the oxide that developed in a normal room atmosphere and that has actually been driven deep into the 200-micro-inch-thick tin plate by the lateral motion between the contact shown and an identical mate.

What makes tin useful for contacts is the relative ease with which any oxide film can be mechanically broken through so that a low-resistance metal-to-metal contact is established with the underlying tin base. However, certain minimum values of force, motion, and geometry are required to assure that this breakthrough occurs.

Thin films can also be punctured by the application of voltage across a contact pair. When a large enough voltage is assured, films can no longer threaten contact reliability. For instance, unplated brass contacts are acceptable in 110-volt appliance plugs and sockets even though films are present. On the other hand, in connectors that handle low-level signals in the millivolt region, film resistance at the interface is very critical.

### Some guidelines

The engineer faced with choosing gold- or tin-plated contacts will be helped by the bar graphs in Fig. 3 to approach the decision in a systematic way. Based on both theory and field experience, the graphs present two types of guidelines, related to the design of the connector and to the intended application. As disclosed in the figure, there are twilight areas and regions of overlap, so no single factor is likely to be decisive. Only a combination of factors can indicate which way the ultimate choice will go.

Contact force is important in the gold versus tin decision because it is vital to both surface cleaning and a low contact resistance. The normal contact force is measured along a perpendicular to the contact interface. Force is deliberately preferred to pressure because the actual interface area over which the force is applied is generally unknown and depends upon both the size and

the geometry of the contacts. The area also varies with the force applied and the amount of slide during the engagement.

When contact forces are below 30 grams, they are usually insufficient to break through oxide film, regardless of the geometry of the contact. Here, gold is mandatory (Fig. 3), except where the absolute level of contact resistance is unimportant—be it milliohms or kilohms—or where the applied voltage is high enough to puncture whatever films may be present.

In the twilight zone between 30 and 100 grams in Fig. 3—and many multiple-pin connectors and IC sockets are in this range—other considerations become more important. If a good sliding action occurs during engagements and the environment is mild or protective, tin plating could be satisfactory down to 30 grams force. Conversely if normal force engagement occurs on a smooth surface with almost no sliding action, in adverse environments, it may be necessary to use gold at 100 grams or higher.

Normally, however, a contact force of 100 grams will almost certainly break any contact film mechanically, so that a tin-plated interface can be selected with the assurance that contact resistance will be low.

When forces are a kilogram or more, and when there is some slide during engagement, plating a base metal is probably unnecessary. With such high forces, a soft metal plating would not survive very many insertions anyway. When plating is used in such cases, it is intended to inhibit corrosion, to enhance the cosmetics or, in high-current applications, to achieve the lowest possible contact resistance to prevent overheating.

### Insertion force

The human force available to engage and/or disengage the contacts usually sets a limit on the maximum number of contacts in a multiple-circuit connector. The engaging force, which is generally greater than the withdrawal force, is determined by the contact-system geometry, the normal contact force, and the friction coefficient. For instance, the insertion force is often minimized by the process of gentle lead-in tapers or ramps that deflect the contact springs during engagement. Figure 4 shows the geometry of a typical contact in a printed-circuit connector—note the curved entry ramps of the contacts. A further reduction can be accomplished by decreasing normal contact force by resorting to gold plating. For, if insertion forces fall below 100 grams per contact, wiping will be insufficient to re-

## New products

Components

# Potentiometer is a 10-mm cube

Tiny component is believed first of kind in U.S. with 'hard metric' dimensions

Measuring 10 millimeters on a side, a cube-shaped potentiometer introduced by Allen-Bradley's Electronics division is configured as a dual variable resistor or as a pot-and-switch combination. It's said to be

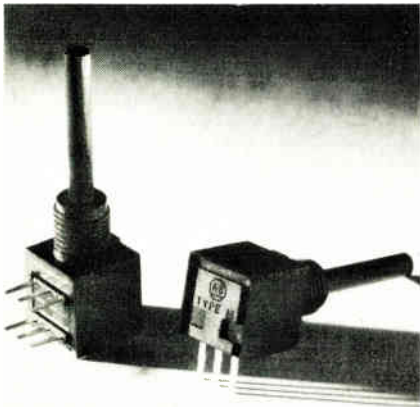

the smallest available to makers of portable electronic equipment.

Since its dimensions are metric, the Type M Mini-metric pot is aimed at new U.S. designs, says John Stanley, manager of variable-resistor sales at Allen-Bradley. "Manufacturers of instruments and medical electronics are both going heavily toward portable devices, and of course we'll also find applications in communications equipment, such as pagers and two-way radios," he adds.

Besides being the first "hard-metric" pot built in the U.S.—the case is a 10-millimeter cube with 7-mm bushing diameter and 3-mm shaft diameters—the device conforms to International Electrotechnical Commission resistance-value standards, ranging from 100 ohms to 1 megohm.

Case, bushing, and shaft of the Type M pot are built from a flame-retardant (SE-O) glass-filled polyester. When coupled with a plastic knob, the pot gives two levels of electrical isolation for protection of the user. For the resistive elements, Allen-Bradley designed a new conductive plastic system, integrally molded to the plastic substrate.

The device is rated at 0.1 watt on the panel section and 0.05 w at the rear section at a maximum working voltage of 90 volts rms or dc. Standard total resistance tolerance is  $\pm 20\%$ , while independent linearity is specified with a maximum deviation of 5%. Variation in contact resistance, or adjustability, is less than 2%, or 3 ohms, whichever is greater.

Resistive elements are available in three standard tapers—one linear and two audio—and switch sections can have a detent at either end of rotation, clockwise or counterclockwise.

Delivery time for Type M pots with one or two resistor sections, or with a resistor section and a rotary switch, is six to eight weeks. In quantities from 500 to 1,000, prices range from \$2 to \$2.50 each, depending on options. The pot will cost much less in large volumes.

Allen-Bradley Electronics Division, 1201 South Second St., Milwaukee, Wis. 53204 [341]

## 4-ampere solid-state relay occupies only 1 cubic inch

Requiring no external heat sinking, and able to switch loads from 0.1 ampere to 4 A, the Grayhill Power

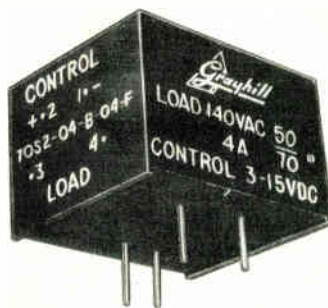

# Dynatrac<sup>®</sup> 3 lock-in analyzer can measure noisy signals up to 200 kHz.

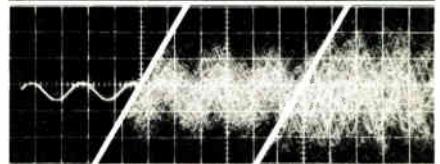

This unique new tool measures amplitude, phase, and frequency of signals obscured by noise, from picovolts to volts at frequencies from .1 Hz to 200 kHz and selectable bandwidths from .001 Hz to 100 Hz.

And, unlike conventional lock-in amplifiers, no phase adjustments are required.

There are many applications (with new ones turning up all the time) in which Dynatrac 3 picks up where the performance of vector voltmeters, phase meters, lock-in amplifiers, wave analyzers, transfer function analyzers, bridge balance null detectors, and noise meters leave off.

To get the complete Dynatrac 3 story (and to tell us about your measurement problems), contact Ithaco, Box 818-ElR, Ithaca, N.Y. 14850. Or call (607) 272-7640, TWX 510-255-9307.

**ITHACO**



## New products

Cube is a solid-state relay that measures 1.0 by 1.2 by 0.85 inches. Its control input is compatible with logic circuitry operating on 3 to 15 or 14 to 30 v dc, and its output can handle line voltages of 120 or 240 v ac. Optically isolated, and including zero-voltage turn-on as a standard feature, the unit has a dv/dt rating of 3,000 v per microsecond. It sells for \$12.60 each in hundreds. Prototype quantities are available from stock; production quantities require about four weeks.

Grayhill Inc., 561 Hillgrove Ave., La Grange, Ill. 60525. Fred Stevens (312) 354-1040 [344]

Ceramic trimmers are only 0.134 inch in diameter

Measuring only 0.134 inch (3.4 millimeters) in diameter, a line of ceramic trimmer capacitors from Panasonic consists of five general-purpose devices that are particularly well suited for use in small electronic watches. The five devices have capacitance ranges of 2.5 to 5 picofarads, 4 to 10 pF, 4.5 to 25 pF, and 5.5 to 35 pF. They meet the shock and vibration specifications of MIL-STD-202D. Nonstandard lead configurations and capacitance ranges are available on a custom basis.

Matsushita Electric Corp. of America, One Panasonic Way, Secaucus, N.J. 07094. Steve M. Fried (201) 348-7284 [343]

Modular potentiometer is factory-assembled

The model 80 series modular potentiometer is a building-block line of components assembled in the factory to a customer's specifications, so that they combine the versatility of modular construction with the reliability of factory assembly. The 1/2-inch-square building blocks have both cermet and conductive-plastic resistance elements, and both types may be combined in an assemblage of up to four sections. Power dissipation



## Will your next frequency counter have all these features?

- **Frequency Range:** 20 Hz to 512 MHz
- **Input Protection:** 45 Watts instantaneous, 2 Watt continuous
- **Metered Input:** Visual indication of high/low signal strength
- **Tone Measurement:** Example: measure 1020.001 Hz automatically in 1 sec.
- **Price:** All of the above standard features on Model 6252 for only \$895
- **Options:** Tailor your counter with two TCXO's or three oven oscillators, internal battery pack, external DC operation, carry case, etc.

### Meet the whole family:

5 MHz Frequency Counter	\$430
50 MHz Frequency Counter	\$595
50 MHz Universal Counter	\$695
180 MHz Frequency Counter	\$795
512 MHz Frequency Counter	\$895

For more details, contact Scientific Devices or Systron-Donner at 10 Systron Drive, Concord, California 94518. Phone (415) 676-5000.

**SYSTRON**  **DONNER**

Circle 136 on reader service card

## Need a current catalog?

Use your EBG to order the catalogs you need. Last year, 80,000 requests for catalogs were generated through the use of EBG Catalog Inquiry Cards. Put EBG to work for you—and your company.



**Electronics Buyers' Guide**

THE **ACTION** BOOK





**2. Attacked.** One problem that tin plating can develop is the fretting corrosion shown here. The black tin-oxide inclusions, shown magnified 750 times, were driven deep into the tin plate by relative motion between this surface and an identical mating contact.

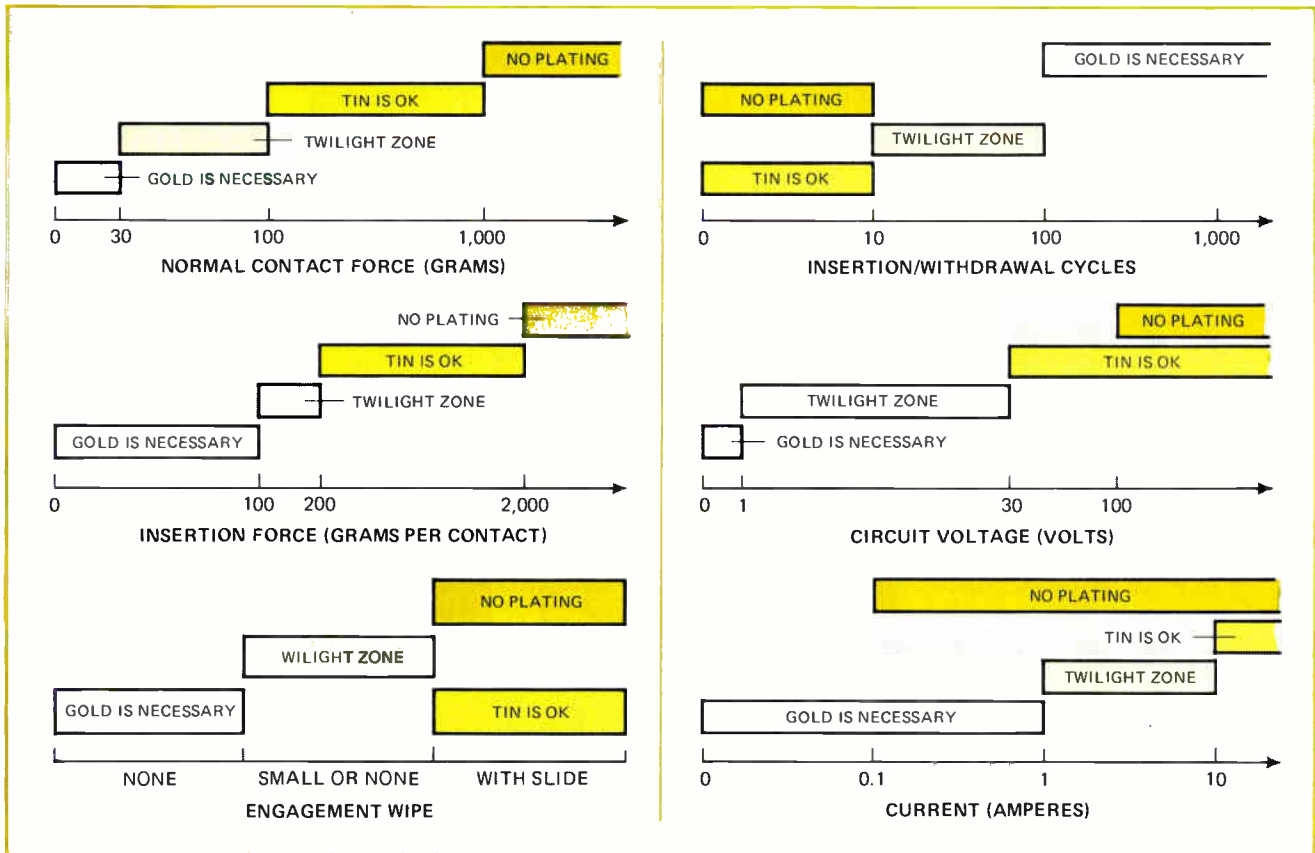

**3. Plate It?** These guidelines will help a designer to choose gold, tin, or no plate at all, for connector contacts. The recommendations relate the plating choice to both the design of the connector and the application for which the connector is intended.

move any oxide film. Also, in miniaturized connectors, when high normal forces might otherwise be feasible, the contact retainers, usually plastic, cannot withstand the high insertion forces.

Finally, the insertion force can be further lowered by thin boundary-layer lubrication, which can reduce the friction coefficient, typically 0.5 to 1.5 in gold and tin systems, to approximately 0.1 without significantly degrading contact resistance. Thus lubrication makes it possible to operate contacts with normal forces high enough to permit tin-plated contacts at 100 grams and above, while maintaining the low insertion forces normally associated with gold-plated connectors.

The zero-insertion-force (ZIF) connector, of course, does away with insertion and withdrawal forces altogether. It incorporates a mechanism that postpones a heavy normal force until engagement is completed.

Thus the severe wear problems associated with sliding under a high-normal force can be avoided. ZIF connectors have, in principle, enormous advantages. However, the expense of the added mechanical complexity in such a connector must be weighed against the savings obtainable by the use of non-noble platings. The insertion force values shown in Fig. 3 refer to good contact designs with or without lubrication, but they do not consider ZIF designs.

### Engagement wipe

The combination of low normal force and absence of sliding action, as in the case of the zero-insertion-force connector, requires a film-free gold surface. But non-noble metals can be used, as Fig. 3 indicates, when higher normal forces are combined with some sliding action to clean the surface. Sharp-point contact geom-

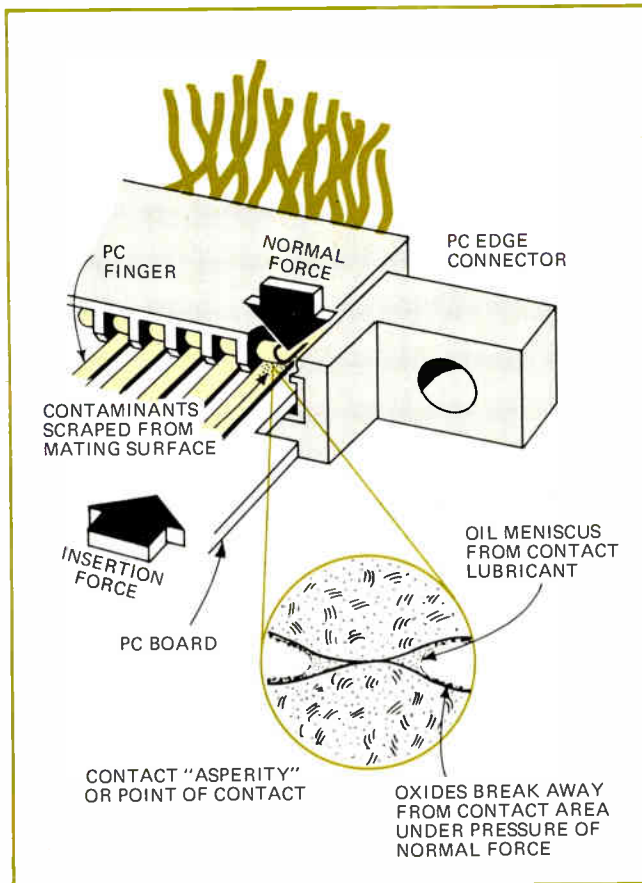

**4. The action.** Inserting a printed-circuit board into an edge connector causes the mating contacts to develop a normal force which depends on both the spring constant and the contact deflection when mated. Repeated insertions and withdrawals remove tiny particles from the surface of the pc-board fingers.

eries, though, are an exception to the rule that sliding is necessary with non-noble contacts, because sliding occurs on a microscopic scale, thereby breaking through surface contaminants. However, such factors as wear, contact heating, and plating penetration must be carefully considered with pointed contacts.

### Wear cycles

An application requiring many mating cycles—engagements and disengagements—often tips the decision against non-noble metals. Such metals require a large contact force and a disruptive sliding action that over repeated mating cycles are incompatible with low wear. However, it is possible to lower the wear rate by using light contract forces on special hard gold-alloy contacts.

The wear requirement should be reviewed carefully when this is the principal factor favoring the use of gold. The design engineer should avoid specifying more mating cycles than the connector could ever encounter, because it is a very expensive safety factor.

### Circuit voltage

Although there is general agreement that gold is the preferred material for "dry-circuit" contacts, there is little agreement as to just what constitutes a dry circuit. A dry circuit is one in which the voltage is too low to puncture insulating films on the contact pair inter-

rupting the circuit. Figure 3 offers some values for the circuit voltage boundaries based on theory, laboratory experiments and field experience.

Laboratory experiments disclose that about 1 to 2 volts will puncture the natural oxide films on many base metals, including tin, with the highest value at about 10 v. Therefore, if the applied voltage is less than 1 v, gold should be considered. If the voltage is 30 v or more, it is highly unlikely that any base-metal oxide could insulate the contact pair and so gold is not necessary—tin plate, or possibly no plating, will suffice.

It must be emphasized that these circuit voltage limitations assume that a film does cover the interface region and insulate the contact. However, if connector engagement wipe will clean the contact and prevent the film from forming anew, these voltage limitations don't apply. In these cases tin plating will prove satisfactory for circuits with voltages of less than 1 v.

In the twilight zone, between 1 and 30 v, films could insulate such voltages. The choice of base-metal contacts in this region therefore presupposes that a satisfactory mechanical cleaning action occurs upon engagement.

### Circuit current

The current flowing through a contact also affects the selection of a plating. When a film-covered contact suffers electrical breakdown from an applied voltage, the steady-state resistance of the breakdown path is determined by the current. If the current is small, the resistance may remain too high for satisfactory circuit performance, so that a film-free gold surface may become necessary.

On the other hand, if an operating current is of the order of amperes, a low interface resistance again becomes mandatory, even when film breakdown may not be the problem. Again gold is in order to assure a large area of clean metal with a low resistance. At still higher current levels, larger and stronger contact members are commonly used and these quite naturally will require high contact forces. So it is seldom necessary to consider gold plating when currents rise to 10 A or more.

### And finally . . .

Some factors which play a role in contact selection don't lend themselves to a simple graphical presentation. As an example, gold is immune to most environmental attack and should be used in corrosive environment. However, in many normal environments tin and its alloys are attacked very slowly, and will provide some protection for an underlying copper-based alloy.

There is no denying that gold delivers highest possible reliability. Moreover, in critical applications, where there is no chance to repair or remate a failed connection, gold always provides an added margin of safety.

However, the current demand for lower cost, plug-gable components, and the proliferation of low, millivolt signals is indeed a heavy burden for the engineer designing interconnections. By examining each application in accordance with these guidelines, the engineer can determine if low-cost tin and its alloys can provide a satisfactory and reliable enough contact interface. □

# If you test, handle, sort, or straighten leads on DIPs, there's a RAMSEY unit to fit your exact requirement... and your pocketbook.

For example, Ramsey's Model RH-905 I-C Handler, the top of the line. We've been saying no other I-C handler can do so much, so well, so fast, and we're prepared to prove it. It features 5 category sorts . . . it's software programmable, via convenient thumbwheel switches . . . convenient thumbscrew adjustments permit handling of a full range of package sizes and configurations . . . a unique photo detector system provides instant readout of the status of all input, output and test functions . . . it incorporates a built-in interface board . . . and its modular design permits easy interchange between mechanical and electronic sections to accommodate different package size configurations.

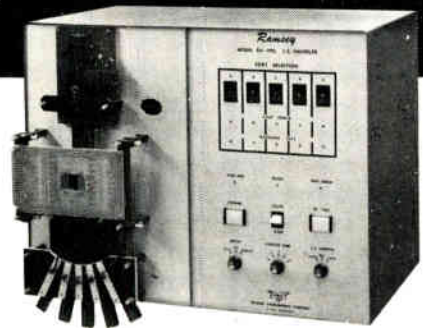

MODEL RH-905  
I-C HANDLER

The Model RH-903 I-C Handler retains many of the features of the RH-905 . . . but at a considerable saving in cost if you don't require the full capability of the higher priced unit. It features 3 category sorts, built-in interface board and the same photo detector system for instant status readout.

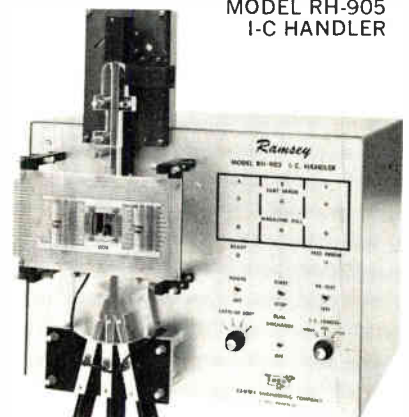

MODEL RH-903  
I-C HANDLER

Then there's the manually operated Model RH-202, a lot of I-C handler for the money. It provides an easy, inexpensive way for you to automate your I-C testing. The Model RH-202 is completely self-contained . . . requires no air or power. It accommodates a variety of package configurations, 6- through 18-pin, or 24- through 40-pin. Precious metal contacts are individually replaceable. It incorporates a performance board for bypassing and decoupling for device compensation.



MODEL RH-202  
I-C HANDLER

If people sitting at benches, using long-nose pliers to straighten DIP leads manually, sounds like a horse-and-buggy operation, take a look at Ramsey's RS-5618 Automatic Lead Straightener. It matches the continuous throughput of 17 to 20 persons straightening DIP packages manually. Operating continuously at speeds up to 5,000 devices/hour, it handles 6- through 18-pin DIP packages, straightening leads uniformly to any degree required for automatic or manual insertion into PC board hole locations.

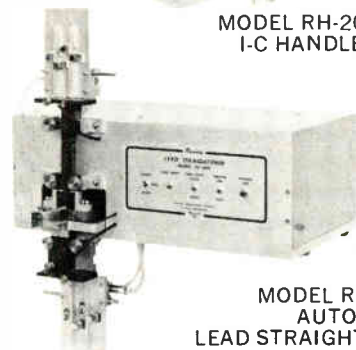

MODEL RS-5618  
AUTOMATIC  
LEAD STRAIGHTENER

For additional information, write or call  
Ramsey Engineering Co., Electromechanical Products.

**RAMSEY**   
**ENGINEERING COMPANY**  
**ELECTRO-MECHANICAL PRODUCTS**

1853 W. County Rd. C, St. Paul, Mn. 55113 • Phone: (612) 633-5150  
Cable: RAMCO      TWX: 910-563-3553      TELEX: 29-7001



# Magic: a computer program for optimizing linear circuits

Frequency-domain software package provides a complete arsenal of aids for circuit analysis and design, including optimization, sensitivity and stability analyses, and statistical and worst-case studies

by John D. Trudel, *Scientific System Technology Inc., Richardson, Texas*

□ Circuit-analysis computer programs are getting better all the time—becoming more powerful design tools that are both easier and more efficient to use. One of this new breed of programs is called Magic—for Modern Analytical Generator of Improved Circuits. Magic is intended for handling both conventional and microwave linear circuits in the frequency domain. Besides its analysis capabilities, the program can automatically adjust circuit elements to optimize circuit performance.

Magic is available on a dial-up-access basis through University Computing Co., Dallas, Texas; Chi Corp., Cleveland, Ohio; Information Systems Design Inc., Oakland, Calif.; and Sci Tek Inc., Wilmington, Del. It can also be obtained as a leased in-house package. The program is approximately two and a half years old, but it has been continually updated since its introduction [*Electronics*, Aug. 2, 1973, p. 118].

## Implementation is easy

Magic has a free-format structure and is engineering-oriented, as well as fully conversational. For example, an inductor is denoted by L, a transmission line by LINE, a transformer by XFMR. Commands are also straightforward—like OPTIMIZE VSWR, PRINT RIN XIN, and PLOT DBGAIN. Moreover all Magic input and output data is specified in engineering terms and is directly related to what can be measured in the laboratory.

The program is also realistic, being able to reflect the practical component considerations that must often be taken into account. For instance, an inductor can have a related Q factor and a dc resistance. Moreover, transmission lines and stripline can be specified by either electrical or physical length and impedance, in addition to having an associated loss.

Even though Magic is primarily structured for linear networks, it can be applied to the design of inherently nonlinear equipment, such as class B or class C amplifiers, because it can accept measured data inputs directly. In these cases, Magic optimizes linear subnetworks to match (or properly mismatch) the nonlinear devices. Oscillators and antenna-matching networks can be designed in a similar manner.

The major difficulty in computer-aided circuit design has always been device modeling. Very few companies have the resources to measure nonlinear device parameters, and converting to linear models can be tedious—although some programs now automate this step. Fur-

thermore, existing device libraries are not necessarily accurate.

Even if the engineer manages to obtain a hybrid-pi model of, say, a transistor, he may find that the model is only a poor approximation of what he needs, particularly if he is working at microwave frequencies. More complicated devices, such as integrated circuits and FETs, merely compound these problems. It is even possible to use up the capability of a program completely in modeling just one device.

Magic bypasses device modeling by working with the actual measured S, Y, or Z device parameters. The resulting device representation, therefore, will always be realistic. And it becomes no more difficult to characterize a monolithic filter or an entire integrated circuit than it is to characterize a single transistor. Small-signal parameters are easily measured, and several semiconductor vendors now publish typical S, Y, or Z parameters for their devices. Furthermore, Magic also offers a measured-data file that currently includes microwave transistors made by Hewlett-Packard Co., Palo Alto,

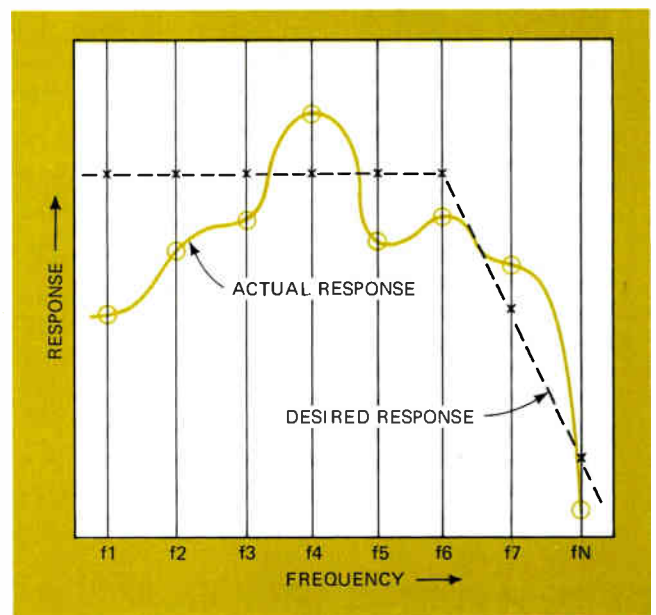

**1. The optimization process.** Magic optimizes a circuit design by minimizing a weighted error function that represents the difference between the desired response and the actual response. Optimization is done only at the frequencies specified by the user.

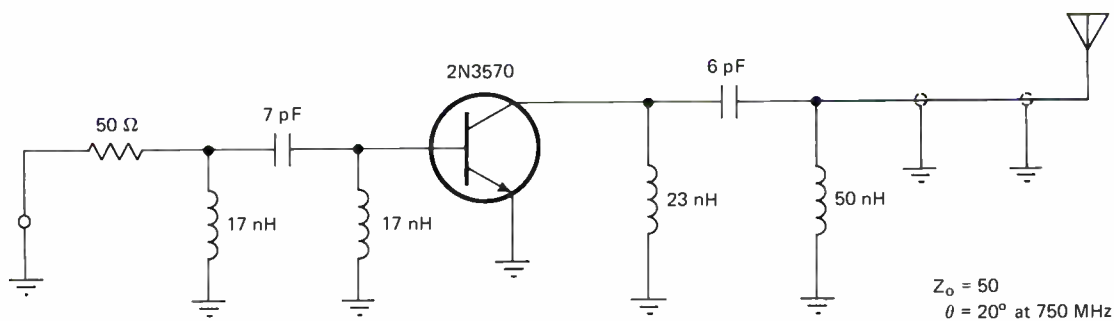

INDUCTOR Q: QL = 50  
CAPACITOR Q: QC = 150

```

10UNITS MHZ NHY PF
20ELEMENTS
30GV L 17. 50.
40SV C 7. 150.
50GV L 17. 50.
60S SCAT1
70GV L 23. 50.
80SV C 6. 150.
90GV L 50. 50.
100SV LINED 50. 20. 750.
110RESPONSE
120500. -10.5 8.
130625. -9.5 5.
140750. -10.5 9.
150SCAT1
160.385, -55., .045, 90., 2.7, 78., .890, -26.5

```

```

170.33, -57., .062, 91., 2.3, 70., .869, -28.
180.277, -59., .078, 93., 1.92, 64., .848, -31.
190ENR 50.
200LOADZ
21056 20.
22047. 10.
23045. -5.
240OPTIMIZE DBTOT
250SECONDS 200.
260RUN
270PRINT VSWR RIN XIN
280PRINT ROUT XOUT PHASE
290PRINT SMAT
300END
END OF FILE
>

```

**2. Starting point.** The uhf amplifier is to be optimized for maximum power gain. In the Magic input data, circuit elements are listed from left to right. For inductors and capacitors, their values, as well as their Q factors, are given. S-parameters are used to characterize the transistor.

Calif. and CTC Corp., headquartered in San Carlos, Calif.

Magic allows the design engineer to optimize, characterize, and analyze his circuit. Additionally, the program can do both sensitivity and stability analyses, and statistical (Monte Carlo) or worst-case studies.

### A complete design tool

One of the program's key features is its ability to optimize large-scale circuits economically. The engineer simply specifies a preliminary design, as well as the response curves he wishes his circuit to exhibit. Magic then automatically finds the set of circuit-element values that yield an optimum fit to these curves.

In a single run, for example, Magic can optimize circuit gain and find the absolute worst-case gain for arbitrary bounds on circuit elements. It can then do a statistical analysis with arbitrarily toleranced components to determine 66% (one sigma) confidence limits and 99% (three sigma) confidence limits for any desired circuit response at each frequency of interest.

A sensitivity analysis can also be run to determine the percentage change in a circuit response due to a given percentage change in each circuit element. Such an analysis isolates the actual impact of small changes in each circuit element so that the designer can find the components he wishes to tune for production.

Magic can display the S, Y, or Z matrix parameters of the over-all circuit at each frequency of interest and dis-

play or plot any measurable circuit response, as well as draw Smith charts. It can also supply all measurable circuit responses in a single computer run. The program will even do a stability analysis to determine what passive terminations, if any, may cause oscillation, find the circuit-stability factor, and compute the maximum available gain and the circuit conditions that produce this gain.

### How optimization is done

All optimization schemes operate by mathematically reducing an error function, which is simply an artificial figure of merit that represents a measure of circuit performance. The smaller the value of the error function becomes, the closer the circuit is to the design goals.

The success of any optimization process depends on how quickly a minimum value of the error function can be found and how well the error function represents the design goals. Although Magic is computationally efficient, the designer must understand the error-function concept to get good results.

Figure 1 illustrates how the error function used by Magic works. In this case, it is a simple weighted power summation of the difference between the desired response and the analyzed response over all frequencies of interest:

$$\text{error function} = \sum (\text{desired} - \text{actual})^P (\text{weight})$$

The default value for exponent P (P-2) gives a least-

OPTIMIZE TIME LIMIT EXCEEDED  
 RAISE SECONDS LIMIT TO MAKE FURTHER IMPROVEMENT

OPTIMIZATION REQUESTED

INITIAL LEAST SQUARE ERROR = 264.6  
 FINAL LEAST SQUARE ERROR = 23.79

IMPROVEMENT OF  
 ROUGHLY A FACTOR  
 OF 11 IN THE ERROR  
 FUNCTION

OPTIMIZED CIRCUIT  
 ELEMENTS

INITIAL VARIABLES	FINAL VARIABLES	% CHANGE
17.00	23.51	38.32
7.000	4.725	-32.49
17.00	12.51	-26.43
23.00	14.63	-36.39
6.000	2.977	-50.39
50.00	49.70	-.6044
50.00	27.52	-44.97
20.00	11.67	-41.67

AVERAGE PERCENTAGE  
 CHANGE ABOUT 33%

OPTIMIZED GAIN

FREQ	WEIGHT	AIM	INITIAL DBTOT	FINAL DBTOT	ERROR
500.000	8.0	-10.50	-8.7255	-9.7822	.718
625.000	5.0	-9.500	-7.2710	-10.788	-1.29
750.000	9.0	-10.50	-5.6173	-9.3757	1.12

FREQUENCY	VSWR	RIN	XIN
500.000	1.182	42.92	-3.196
625.000	1.357	56.19	15.03
750.000	1.212	60.56	-8.745

FREQUENCY	ROUT	XOUT	PHASE
500.000	8.300	-46.55	-26.53
625.000	13.90	.3027	-118.6
750.000	36.21	46.88	-176.4

PRINT DETECTED ( SMAT )

DISPLAY OF OVER-ALL  
 S-PARAMETERS

CIRCUIT MATRIX (MAGNITUDE-ANGLE)

\* INDICATES POSSIBLE INSTABILITY FOR SOME PASSIVE TERMINATIONS  
 (DO STABILITY ANALYSIS FOR DETAILS)

-----  
 ELEM(1,1)      ELEM(1,2)      ELEM(2,1)      ELEM(2,2)  
 -----  
 F = 500.000      K FACTOR = 1.3693  
 .1089+00-.1574+03 .4486-01-.2243+02 .2692+01-.3443+02 .8377-00-.9325+02

F = 625.000      K FACTOR = 1.1991  
 .1798-00 .6285+02 .9227-01-.9294+02 .3423+01-.1139+03 .5650-00 .1792+03

F = 750.000      K FACTOR = 1.2207  
 .1002+00 .9427+01 .1180+00-.1434+03 .2905+01-.1724+03 .4980-00 .7785+02

SINCE \* DID NOT APPEAR, CIRCUIT IS  
 STABLE FOR ALL PASSIVE TERMINATIONS  
 S MATRIX IS NORMALIZED TO 50 OHMS

**3. Optimization run.** In a single computer run, Magic adjusts circuit-element values to achieve the desired amplifier performance. The optimized circuit produces a nominal gain of 10 decibels, which remains flat to within ±0.75 dB from 500 to 750 megahertz. The printout of the over-all S-parameters shows the amplifier to be stable. A second optimization run would further improve circuit performance.



squares fit, and high powers of P yield Chebyshev minimum/maximum-type approximations.

The success or failure of an optimization run depends on many different decisions made by the designer. These include the choice of the frequencies considered, the responses optimized, the aims, the weights, the order of P, and which circuit elements are varied. Another factor is whether or not constrained optimization (letting elements vary only over a specified range) is used. And, of course, a good deal depends on the initial circuit chosen for optimization.

To aid in selecting the initial circuit, a sensitivity analysis could be done to determine those elements that affect circuit performance most. Once an initial circuit is chosen, a reasonable procedure is to start with a single-response unconstrained optimization and make several short optimization runs while adjusting aims, weights, and frequencies. The program automatically stores the results of the previous run, allowing the user to continue his optimization without interruption.

Magic runs until an optimum solution is reached or until the time limit specified by the user is reached. The PLOT command can be invoked here to get a fast look at circuit performance over the entire operating-frequency band. When the designer is satisfied that his wishes for optimization have been accurately transmitted to Magic, he may raise the time limit and run his problem to completion.

Since Magic is a cascade-oriented program, it cannot handle general circuit topologies completely. Nor can Magic easily accommodate circuits having a high level of nodal interconnections, such as integrated circuits. It is meant for cascade-based circuits with junctions, stripline, branching, and feedback loops.

Although Magic theoretically does not limit network size, practical considerations currently restrict the program to 100 branches in a single run. (A branch can be quite general and may contain up to five circuit elements.) Up to 50 circuit elements may be varied simultaneously for optimization, and larger networks can be handled by multiple runs. And with tabled input data, networks of infinite size may be handled by using repeated runs.

### A Magic example

A uhf amplifier will be designed with a type 2N3570 transistor that is biased at a collector-emitter voltage of 10 v and a collector current of 4 milliamperes. The design goal is to maximize power gain, as well as to achieve a low input VSWR and a gain flatness of  $\pm 1.0$  decibel from 500 to 750 megahertz. The amplifier is to drive an antenna through a short length of stripline.

Figure 2 shows the proposed amplifier circuit, as well as the input data for Magic. The measured antenna-terminal impedance is put directly into Magic (under the LOAD Z listing), as are the S-parameters for a typical type 2N3570 transistor (under the SCAT1 listing). Both the element value and Q factor are noted for each inductor and capacitor ( $Q_L = 50$  and  $Q_C = 150$ ). Circuit elements are listed from left to right, from the generator end to the load end.

Connection codes appear after the statement number for each element listing. These codes are used to con-

nect the circuit branches, instead of using node numbers. G is for a shunt (grounded) element; S for a series element; GV for a variable shunt element; SV for a variable series element; GVC for a constrained variable shunt element; and SVC for a constrained variable series element. (FB is a special code that is not shown here and that is used for feedback loops.)

Every Magic input listing contains certain key words whose meanings are predefined. For example, UNITS signifies that the units of frequency, inductance, and capacitance are to be defined. ELEMENTS notes that statements describing each circuit element are to be listed. Each branch in the circuit requires a separate statement. RESPONSE indicates that the frequencies of interest, the desired goals at each frequency, and the weight associated with each frequency are to be described. Separate statements must be made for each frequency.

Three different descriptions can be used to define the generator. GENR indicates that the generator exhibits a constant resistance at all frequencies. After the GENR statement, the one value of resistance that applies is noted. GENRX means that the generator impedance is to be described with both a real part and an imaginary part. A separate statement containing the real part and the imaginary part is needed for each frequency, and these frequencies must be the same as those used to define the aims. GENZ says that the generator impedance is going to be described with a magnitude and a phase. Again, a separate statement is needed for each frequency, and the frequencies must be identical to the frequencies used for the aims.

Three other key words—LOADR, LOADRX, and LOADZ—have the same meanings as GENR, GENRX, and GENZ, respectively, but refer to the load end of the circuit. Other key words include OPTIMIZE, which points out the responses that are to be optimized, and SECONDS, which spells out the maximum number of seconds the user wishes Magic to iterate the optimization. (A listing of zero seconds produces an analysis-only run.)

In the amplifier example, a previous ANALYSIS ONLY run (not shown here) indicated that a power gain of about 10 dB can be obtained. The series of Magic outputs given in Fig. 3 illustrates how the program can operate, even from a bad starting point. In this optimization run, all of the circuit elements are varied, and only three frequencies are considered—500, 625, and 750 MHz.

How poor the starting point is can be assessed by the high initial error-function value and the large percentage changes in the adjusted element values. In fact, Magic used the full time allowed (200 seconds) for optimization and could still make further improvements, if desired. The final optimized amplifier circuit has a low input VSWR and provides a nominal power gain of 10 dB, which is flat to within  $\pm 0.75$  dB from 500 to 750 MHz. The circuit will also be unconditionally stable, as predicted by the display of its over-all S-parameters.

If better circuit performance is desired, it would be a good choice to use this optimized circuit as the starting point for another optimization run, one employing more frequency points and a higher-order error function. □

## Calculator algorithms

While you're saving up for that more expensive electronic slide rule, try updating your four-function electronic calculator. In this Engineer's notebook, you'll find a collection of algorithms that extend the computing power of your pocket calculator considerably. Although calculator algorithms are frequently not really brand new, don't forget that a new look at an old equation can save you many keystrokes or even a trip to

your library shelf for those time-consuming lookup tables.

Electronics is still interested in publishing that super time-saving calculator algorithm you've been keeping up your sleeve. We're willing to pay you for it—provided that it's original, useful and does not require a special calculator.

—Lucinda Mattera, Circuit Design Editor

## Evaluating $e^x$ with constants

by Steve Larson  
Maynard L. Larson Co., Yankton, S.D.

This straightforward procedure for computing  $e^x$  produces answers that are accurate to six or more decimal places. No paper is necessary—just a common pocket calculator having a constant register.

The method, in effect, constructs the product of  $e^A \times (e^{0.1})^B \times (e^{0.01})^C \times (e^{0.001})^D \times \dots$ , where A, B, C, D, . . . are the digits of  $x$ —for example, the value of  $e^{A.BCD}$ . In practice, however, negative powers of  $e$  are used because of the way in which the calculator's constant register is loaded.

Four constants will usually be needed for a computation, and they should be memorized or written down, say, on the back of the calculator. These values of  $e$  are:  $e^{-1} = 0.3678794$ ,  $e^{-0.1} = 0.9048374$ ,  $e^{-0.01} = 0.9900498$ , and  $e^{-0.001} = 0.9990005$ . Moreover, "free" significant digits are easily obtained for very small values of  $x$  since  $e^x = 1 + x$  (e.g.,  $e^{0.000306} = 1.000306$ ).

As a sample problem, let's evaluate  $e^{2.513306}$ . For this function, A = 2, B = 5, C = 1, and D = 3:

$$e^{2.513306} = e^2(e^{0.1})^5(e^{0.01})^1(e^{0.001})^3e^{0.000306}$$

The key strokes are:

- Enter 1.000306, which is equivalent to  $e^{0.000306}$
- Press the divide key.

- Enter 0.9990005, which is  $e^{-0.001}$ .
- Press and hold the constant key.
- Press the add/equal key two times (one time less than the exponent of  $e^{0.001}$ ).
- Release the constant key.
- Press the add/equal key. The display now contains  $e^{0.003306}$ .
- Press the divide key.
- Enter 0.9900498, which is  $e^{-0.01}$ .
- Press the add/equal key. The constant key is not used because division occurs only once. The display now contains  $e^{0.013306}$ .
- Press the divide key.
- Enter 0.9048374, which is  $e^{-0.1}$ .
- Press and hold the constant key.
- Press the add/equal key four times.
- Release the constant key.
- Press the add/equal key. The display contains  $e^{0.513306}$ .
- Press the divide key.
- Enter 0.3678794, which is  $e^{-1}$ .
- Press and hold the constant key.
- Press the add/equal key once.
- Release the constant key.
- Press the add/equal key to get the final answer.

The display register now contains the value of  $e^{2.513306}$ :

$$e^{2.513306} = 12.345677$$

The technique is fast, too—the total keying time for this example will be about half a minute.

The same procedure can be used even if  $x$  is negative—simply compute  $e^{-x}$  first and then find the reciprocal of the result.

## Calculator algorithms

### Chain operation for finding $e^x$

by Russell E. Price  
Hughes Aircraft Co., Space and Communications Group, El Segundo, Calif.

It is possible to evaluate the exponential function to an accuracy of within 0.002% with the ordinary four-function calculator. And since the procedure is a chain operation, there's no need to write down any intermediate computations.

For values of  $x$  between 0 and 10, the equation is:

$$e^x = \frac{(\dots(((x \div N + 1)x \div (N - 1) + 1)x \div (N - 2) + 1)\dots \times \div (1) + 1}$$

where N is the number of iterations required to achieve a specific accuracy for a given value of x. The graph shows how many iterations are needed to evaluate  $e^x$  to accuracies of within 0.05%, 0.01%, and 0.002%. For instance, to find the value of  $e^5$  (where  $x = 5$ ) to an accuracy of within 0.01%, you will need 15 iterations. The procedure is both fast and simple—you only need to remember the value of x and to be able to count N keystrokes.

For large values of x, you can even make do with fewer iterations than indicated on the graph without sacrificing accuracy. Suppose, for example, you want to find  $e^{9.3}$  to within 0.05% accuracy. First find  $e^{0.93}$  to within 0.005% accuracy and then multiply the result by itself 10 times (raise the result to the 10th power):

$$e^{9.3 \pm 0.05\%} = (e^{0.93 \pm 0.005\%})^{10}$$

Instead of 22 iterations, you need only seven. □

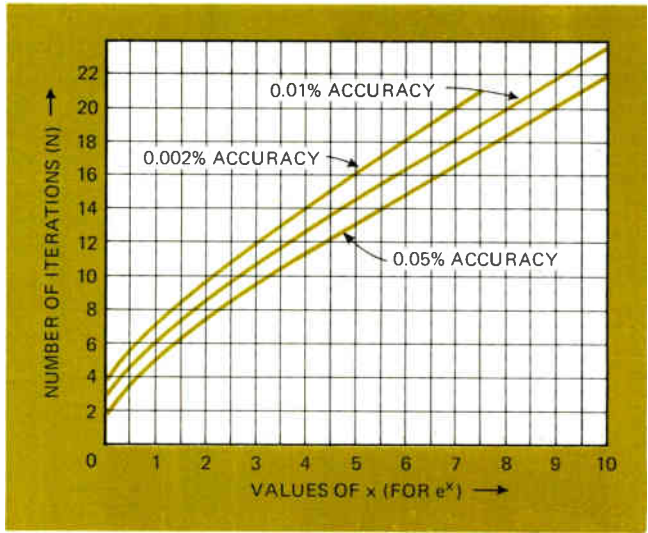

## Calculator algorithms

### Counting keystrokes to get results

by Frank Alexander  
FMC Corp., Chemical Group, Marcus Hook, Pa.

If you're fond of counting keystrokes, here are three ideas that will put your counting to good use—for evaluating the exponential function, or for finding decibel equivalents or even music notes. The trick is to find a convenient integer power of the quantity you wish to evaluate.

For the exponential function, if you choose  $e^{0.1}$  as this basic quantity, you can evaluate  $e^x$  to seven significant figures.

- Enter 1.1051709 (which is  $e^{0.1}$ ) as a constant.
  - Raise this constant to the power needed to obtain x.
- To evaluate  $e^{2.3}$ , for instance, raise 1.1051709 to the 23rd power:

$$e^{2.3} = (e^{0.1})^{23}$$

With this procedure, three-digit values of x can be found by using  $e^{0.01} = 1.0100502$  as your constant but, naturally, many more keystrokes must be counted.

The same sort of technique—counting the number of keystrokes—can be used to convert from decibels to a

voltage gain by remembering that  $10^{1/20} = 1.1220185$ .

- Enter 1.122085 as a constant.
- Multiply it by itself as many times as there are decibels to be converted.

A quantity of 12 dB, for example, requires raising the constant to the 12th power:

$$(10^{1/20})^{12} = 3.9810729$$

Of course, other fractional ratios of powers of 10 can be treated in the same way.

Undoubtedly, Johann Sebastian Bach had the four-function pocket calculator in mind when he proposed that music notes be separated by the 12th root of 2. In this case, the constant becomes:

$$2^{1/12} = 1.0594632$$

Each time this constant is raised to the next integer power, the music frequency is increased by one note. In the tempered chromatic scale (ASA 1936), for instance, part of the note progression will be computed as:

- A<sub>3</sub> = 220.00000 hertz
- A#<sub>3</sub> = 233.08190 Hz
- B<sub>3</sub> = 246.94169 Hz
- C<sub>4</sub> = 261.62563 Hz
- C#<sub>4</sub> = 277.18272 Hz

through to:

$$A_4 = 440.00045 \text{ Hz}$$

(This last number for note A<sub>4</sub> includes a round-off error of 0.00045.) □

## Calculator algorithms

### Evaluating logarithms by counting keystrokes

by Louis R. Baerst  
Rockwell International, Autonetics Division, Anaheim, Calif.

Counting keystrokes can also be applied to evaluating logarithms and antilogarithms. To do this, though, your calculator should have a constant register.

For example, to determine the value of a base-10 logarithm ( $\log_{10}N$ ), choose a convenient power of 10—say,  $10^{0.01} = 1.0233 = k$ . Enter k in the constant register and multiply it by itself m times, until you see number N in the display register. The number of keystrokes



(m) divided by 100 is the value of log N.

The same procedure can be used for any positive base or number, either by modifying the initial k value or by dividing or multiplying by the appropriate factor. The accuracy of the procedure for base-10 logarithms can be doubled by letting  $k = 1.01158 = 10^{0.005}$  and then dividing m keystrokes by a factor of 200.

To find an antilogarithm, the method is reversed. First multiply the mantissa of the log by 100 (or whatever factor you are using) to get the value of m. Then raise k to the mth power to obtain the result.

A similar technique can be employed to raise a number to a fractional power without using logarithms. Suppose you want to find the value of  $1.75^{2.3}$ . First determine m by multiplying constant k by itself until number N is displayed. If  $k = 10^{0.005} = 1.01158$ , then  $m = 49$  ( $1.01158^{49} = 1.758$ ). Next multiply m by the exponent ( $49 \times 2.3 = 112$ ), and then raise k to this power to obtain the final result ( $1.01158^{112} = 3.631$ ). The answer, therefore, is  $1.75^{2.3} = 3.631$ .

Remember that the number of keystrokes can be reduced by making use of appropriate factors. □

## Calculator algorithms

### Another way to compute $e^x$

by James C. Frauenthal  
Harvard University, Cambridge, Mass.

Are you satisfied with the methods already suggested in these columns for evaluating  $e^x$ ? If not, then try this one. It is fast, easy to remember, does not make use of any pre-computed constants, and does not require any numbers to be reentered or written down. You can even estimate the size of the error to be expected.

The algorithm, although not strictly convergent, does work:

$$e^x = \lim [1 + (x/m)]^m \\ \text{as } (x/m) \text{ approaches } 0 \\ \text{and } m \text{ approaches infinity}$$

where m is an arbitrary number that you choose. Therefore, to evaluate  $e^x$  for any arbitrary value of x, you raise the quantity of  $[1 + (x/m)]$  to the mth power. If

you are using a pocket calculator, it is convenient to make m an integer power of 2 (like 2, 4, 8, 16, . . .).

Moreover, the value chosen for m determines the size of the error in the final answer. To see this, you can expand both  $e^x$  and  $[1 + (x/m)]$  in their respective power series and take the difference between the two:

$$e^x - [1 + (x/m)]^m \\ \text{approximately equals } (x^2/2m) + \dots$$

Clearly then, if the quantity of  $(x^2/2m)$  is chosen to be small, the higher-order terms in the series on the right-hand side of this equation can be neglected. And the absolute error can be regarded as being on the order of  $(x^2/2m)$ .

To use the algorithm, first choose m so that the quantity of  $(x^2/2m)$  is tolerably small. Then the keying sequence becomes:

- Enter the value of x.
- Divide x by m.
- Add 1 to the quotient of  $(x/m)$ .
- Raise the factor of  $[1 + (x/m)]$  to the mth power.

It should be noted that if m is chosen sufficiently large, the accuracy of the final answer can exceed eight significant digits. □

## Calculator algorithms

### Computing sine and cosine with linear interpolation

by H.W. Crowley  
Analog Devices, Inc., Norwood, Mass.

Simple linear interpolation is a good way to approximate both sine and cosine trigonometric functions to an accuracy of within better than 5%. It's not necessary to learn any new constants—you can make use of the ones that you never really forget:

$$\begin{aligned} \sin 30^\circ &= 0.500 \\ \sin 45^\circ &= 0.707 \\ \sin 60^\circ &= 0.866 \\ \sin 90^\circ &= 1.00 \end{aligned}$$

Conveniently, angles remain in degrees, rather than having to be converted into radians. To find the cosine

of an angle, it is a simple matter to first determine the sine of an equivalent angle, making use of the identity:

$$\cos \theta = \sin(90^\circ - \theta)$$

The procedure is straightforward. For angles between  $0^\circ$  and  $30^\circ$ :

- Multiply the angle by 0.0166, which is  $0.500/30^\circ$ .

For angles between  $30^\circ$  and  $45^\circ$ :

- Subtract  $30^\circ$  from the angle.
- Multiply this number by 0.0138, which is  $(0.707 - 0.500)/(45^\circ - 30^\circ)$ .
- Add 0.500.

For angles between  $45^\circ$  and  $60^\circ$ :

- Subtract  $45^\circ$  from the angle.
- Multiply this number by 0.0106, which is  $(0.866 - 0.707)/(60^\circ - 45^\circ)$ .
- Add 0.707.

For angles between  $60^\circ$  and  $90^\circ$ :

- Subtract  $60^\circ$  from the angle.

■ Multiply this number by 0.00447, which is  $(1.0 - 0.866)/(90^\circ - 60^\circ)$ .

■ Add 0.866.

As an example, evaluate  $\sin 49^\circ$ . Since  $\sin 45^\circ = 0.707$  and the increment per degree is 0.0106, the interpolation is:

$$\begin{aligned} \sin 49^\circ &= \sin 45^\circ + 4^\circ(0.0106) \\ \sin 49^\circ &= 0.707 + 0.0424 = 0.7494 \end{aligned}$$

which is accurate to within 0.7% of the exact value (0.7547) of  $\sin 49^\circ$ .

There is another sine approximation that is a bit slower than the linear-interpolation approach, but is far more accurate. It is valid for angles of less than  $90^\circ$  and

provides an accuracy to within better than 0.01%. Let:

$$x = \theta(\text{in degrees})/90^\circ$$

Then:

$$\sin \theta = ax + bx^3 + cx^5$$

where:

$$\begin{aligned} a &= 1.5706268 \\ b &= -0.6432292 \\ c &= 0.0727102 \end{aligned}$$

If you memorize the constants, even this method can be quite fast. □

**BIBLIOGRAPHY**

"Approximations for Digital Computers," C. Hastings, Princeton University Press, 1955.

## Calculator algorithms

### Polynomial evaluations can be fast and accurate

by David Rowland

Electro Scientific Industries Inc., Portland, Ore.

Both trigonometric and logarithmic functions can be approximated accurately by evaluating polynomials with the four-function calculator. Very few keystrokes are required to find any one function, and each procedure is relatively easy to remember. The table shows the simple keying sequences needed for the sine, tangent, arcsine, and arctangent functions, as well as those for common and natural logarithms and the exponential function.

The worst relative error these approximations produce is about  $\pm 0.0005$ , which means that the answer is accurate to at least three significant digits. The relative error is the difference between the exact function value and the approximated function value divided by the exact function value:

$$\text{relative error} = (\text{exact} - \text{approximated})/\text{exact}$$

The relative errors for the approximations given here are:  $\pm 0.00015$  for the sine,  $\pm 0.0005$  for the tangent,  $\pm 0.0005$  for the arcsine,  $\pm 0.00022$  for the arctangent,  $\pm 0.0005$  for the base-10 logarithm,  $\pm 0.00003$  for the base-e logarithm, and  $\pm 0.00025$  for the exponential.

To get the most out of these approximations, you should keep a couple of basic equivalents in mind. For example, the cosine can be computed from:

$$\cos(x) = \sin(90^\circ - x)$$

Similarly, the tangent of an angle lying between  $45^\circ$  and  $90^\circ$  can be found by making use of:

$$\tan(x) = 1/\tan(90^\circ - x)$$

This relationship is also useful for evaluating the arc-tangent when  $x$  is greater than 1.

Solving for the arcsine can become troublesome, because as this function's argument approaches 1.0, its slope becomes infinite, and no polynomial can track an infinite slope. You can extend the range of the approximation given in the table by using the double-angle formulas, or you can compute  $\cos(x)$  as:

$$\cos(x) = [1 - \sin(x)^2]^{1/2}$$

and then divide the result into the known value of  $\sin(x)$ . This permits the approximation for the arc-tangent to be used for the evaluation.

Unfortunately, there doesn't seem to be an easy way to compute the value of  $10^x$ . One possible approximation for  $10^x$  is:

$$\begin{aligned} (1 + 1.1499196x + 0.6774323x^2 \\ + 0.2080030x^3 + 0.1268089x^4)^2 \end{aligned}$$

which does not reduce to a convenient format. □

**BIBLIOGRAPHY**

"Approximations for Digital Computers," C. Hastings, Princeton University Press, 1955.

**CALCULATOR KEYING SEQUENCES**

sin (x) $-90^\circ \leq x \leq 90^\circ$	tan (x) $-45^\circ \leq x \leq 45^\circ$	arcsin (x) $-0.7 \leq x \leq 0.7$	arctan (x) $-1 < x < 1$	$\log_{10} (x)$ $10^{-1/2} \leq x \leq 10^{1/2}$	$\log_e (x)$ $e^{-1/2} \leq x \leq e^{1/2}$	$e^x$ $0 < x < 1$
Enter 0.01x X 0.5924 Square - 1.257 Square + 0.1645 X 0.01x	Enter 0.01x X 1.324 Square + 0.4686 Square + 1.5275 X 0.01x	Enter x X 1.671 Square + 1.561 Square + 54.89 X x	Enter x Square + 1.897 Take reciprocal X 67.44 + 21.73 X x	$z = (x-1)/(x+1)$ Enter z Square X 0.36415 + 0.86304 X z	$z = (x-1)/(x+1)$ Enter z Square X 0.70225 + 1.99938 X z	Enter 8.469 - x Take reciprocal X x X 2.122 + 1 Square twice

# Fast number conversion from any base to base-10

by Robert P. Harris  
McDonnell Douglas Aircraft Co., St. Louis, Mo.

Changing numbers from a base- $q$  (any base) system to a base-10 system need not be a long and tedious process. Moreover, if you are converting whole numbers, it's even possible to do the computation mentally.

The generalized polynomial for converting from any number to any base  $q$  is:

$$a_nq^n + a_{n-1}q^{n-1} + \dots + a_1q + a_0q^0 + a_{-1}q^{-1} + a_{-2}q^{-2} + \dots + a_{-m}q^{-m}$$

Solving this polynomial can be a relatively lengthy process. Here's a simpler way to do the number conversion for whole numbers:

- Multiply the most significant digit by the base  $q$ .
- Add the next most significant digit.
- Multiply the result by the base  $q$ .
- Add the next most significant digit.
- Multiply the result by the base  $q$ .
- Continue through to the addition of the least significant digit.

Suppose the octal number  $2,450_8$  is to be converted to a decimal number. The sequence of mathematical operations will be:

- $2 \times 8 = 16$
- $16 + 4 = 20$
- $20 \times 8 = 160$
- $160 + 5 = 165$
- $165 \times 8 = 1,320$
- $1,320 + 0 = 1,320_{10}$

This procedure is the inverse of the well-known technique for changing from a base-10 number to a base- $q$  number. To make the conversion, you divide the base-10 number by the new base  $q$  and collect the remainders of each step of the division. □

## Calculator algorithms

### Calendar computations: past, present, and future

by R. Wilson Rowland  
Vitro Labs, Silver Spring, Md.

Once you master this technique, you will be able to name the day of the week for any given calendar date, besides being able to determine the number of days occurring between two given dates.

The technique is to compute the day number of a specific date by considering day 1 as Sunday, Dec. 29, in 1596 (and day 2 as Monday, Dec. 30, in 1596, etc.). The year of 1596 is used here for convenience—and it is close to 1582, the year in which our current calendar system was introduced.

When you divide this day number by 7, you will get a whole number and a fraction; this result represents the number of weeks since day 1. The fraction indicates what the day of the week is— $1/7$  is Sunday,  $2/7$  is Monday, . . . , and  $0/7$  is Saturday. If the day numbers are

found for two different dates, the difference between these two numbers will yield the number of days between the two dates.

Correction terms, which are given in the tables, are used to account for the nonstandard lengths of months and centuries. When you read the month-correction table, be sure to remember that 1700, 1800, and 1900 were not leap years. (MC indicates a month correction, and CC indicates a century correction.)

Three equations are needed for a computation. A given date is expressed in terms of a YEAR, a MONTH, and a DAY. Using these numbers, first find:

$$\text{day of year} = (\text{MONTH} - 1) \times 30 + \text{MC} + \text{DAY}$$

Next, compute:

$$\text{day number} = [(\text{YEAR} - 1597) \times 365.25]_{\text{truncated}} + \text{CC} + \text{day of year}$$

To perform the truncation called for in this equation, simply subtract whatever fraction, if any, results from the multiplication by 365.25. And finally, find:

$$(\text{day number})/7 = \text{whole weeks} + (\text{day of week})/7$$

As an exercise, you can determine that the first Independence Day—July 4, 1776—occurred on a Thursday. Your computations should be: day of year = 186 and day number =  $65,567 = 9,366 + (5/7)$ . For accurate answers, your calculator must have eight digits. □

Engineer's Notebook is a regular feature in Electronics. We invite readers to submit original design shortcuts, calculation aids, measurement and test techniques, and other ideas for saving engineering time or cost. We'll pay \$50 for each item published.

CENTURY CORRECTION

Year	1597-1700	1701-1800	1801-1900	1901-2100
Correction	3	2	1	0

MONTH CORRECTION

Month	January	February	March	April	May	June	July	August	September	October	November	December
Leap year correction	0	1	0	1	1	2	2	3	4	4	5	5
Other year correction	0	1	-1	0	0	1	1	2	3	3	4	4





# Carborundum works on the frontiers of high temperature materials technology. And exciting plastics happen.

## Like Ekkcel™

Ekkcel's exciting performance is a direct outgrowth of the Carborundum high temperature technology. An aromatic copolyester, Ekkcel has long-term thermal stability and strength at temperatures in excess of 550°F. Plus extremely low moisture absorption, excellent friction and wear properties, outstanding dielectric characteristics, and superior flammability resistance - Ekkcel satisfies Underwriters Laboratory specification VE-0. All of which are excellent reasons why designers like Ekkcel.

## What about moldability?

Ekkcel can be processed in standard injection molding equipment. And it runs like a dream for fast cycle times and minimal rejects. So processors like Ekkcel, too.

## Go tell Tracy . . .

If you have an application requiring performance at high temperatures, tell us about it. Write or call: Tracy O'Rourke, General Manager, Engineered Plastics Group, The Carborundum Company, P. O. Box 337, Niagara Falls, New York 14302. (716) 278-2441.

Carborundum Ekkcel. It lives up to its name.

**CARBORUNDUM**



## **Build your own low-cost precision voltage reference**

Buying a good enough voltage reference for precision comparator applications is expensive. But Donn Soderquist, a marketing applications engineer at Precision Monolithics Inc. of Santa Clara, Calif., points out that **an instrumentation op amp and a potentiometer are the only parts needed for a good reference—and you may already have them in the lab.**

**Hookup is simple.** Wire the op amp as a unity-gain buffer, and place the potentiometer across the amplifier's offset-nulling terminals, with the wiper going to the positive supply voltage. The only other amplifier connections are the usual ones to the positive and negative supply voltages. Then use the potentiometer to adjust the amplifier's output to the desired voltage level.

But, cautions Soderquist, **for the circuit to work well, the op amp must have low long-term drift as well as low offset drift, good power-supply rejection, and freedom from chopper and popcorn noise.** The op amp should also provide high gain around a zero output voltage (to keep the circuit's output impedance low) and negligible thermal-induced drift (to achieve stable circuit performance under varying load conditions).

## **LED sidelights to remember**

Display designers are finding that comparing LEDs by reading data sheets can be tricky. For example, **the oft-quoted luminous intensity specification (typically in millicandela or microcandela) is almost always an on-axis specification,** so high numbers in this department only refer to forward light. **But it's often important that the display be easily visible from the side, so be sure to also examine the viewing-angle spec, or better yet, a graph showing the angular distribution of luminous intensity.** Like gain and bandwidth, viewing-angle and axial luminous intensity can each be increased at the expense of the other. So if one of these parameters seems too good to be true, check the other.

## **Feed your engineering social conscience**

It's just a year since the IEEE formed its Committee on Social Implications of Technology (CSIT), and already membership has swelled to 5,000. **If you're an IEEE member, you can join free,** and you'll receive a copy of the group's newsletter, which raises **issues such as the impact of a national data bank on personal freedoms, engineering ethics,** and the like. In addition, the committee has organized about half a dozen **working groups.** To get on the mailing list, contact IEEE headquarters, 345 E. 47th St., N.Y., N.Y. 10017.

## **Sense about measuring diode sensitivity**

**It's a slow business, using an oscilloscope to measure a detector diode's tangential sensitivity—**by definition, the power needed to make the bottom level of a detected pulse fall just above (be tangent to) the top level of the noise displayed on either side of it on the CRT. As it happens, however, **this scope measurement corresponds to a signal-to-noise ratio of about 8 decibels—**a figure that works well for most practical systems, even though dependent on many system factors. And of course, **using an RMS voltmeter to measure a diode's S/N ratio is quick, easy,** and lends itself to use in automated test systems. Hewlett-Packard describes the procedure in its application note 956-1, available without charge from the Inquiries Manager, 1501 Page Mill Road, Palo Alto, Calif.

# again

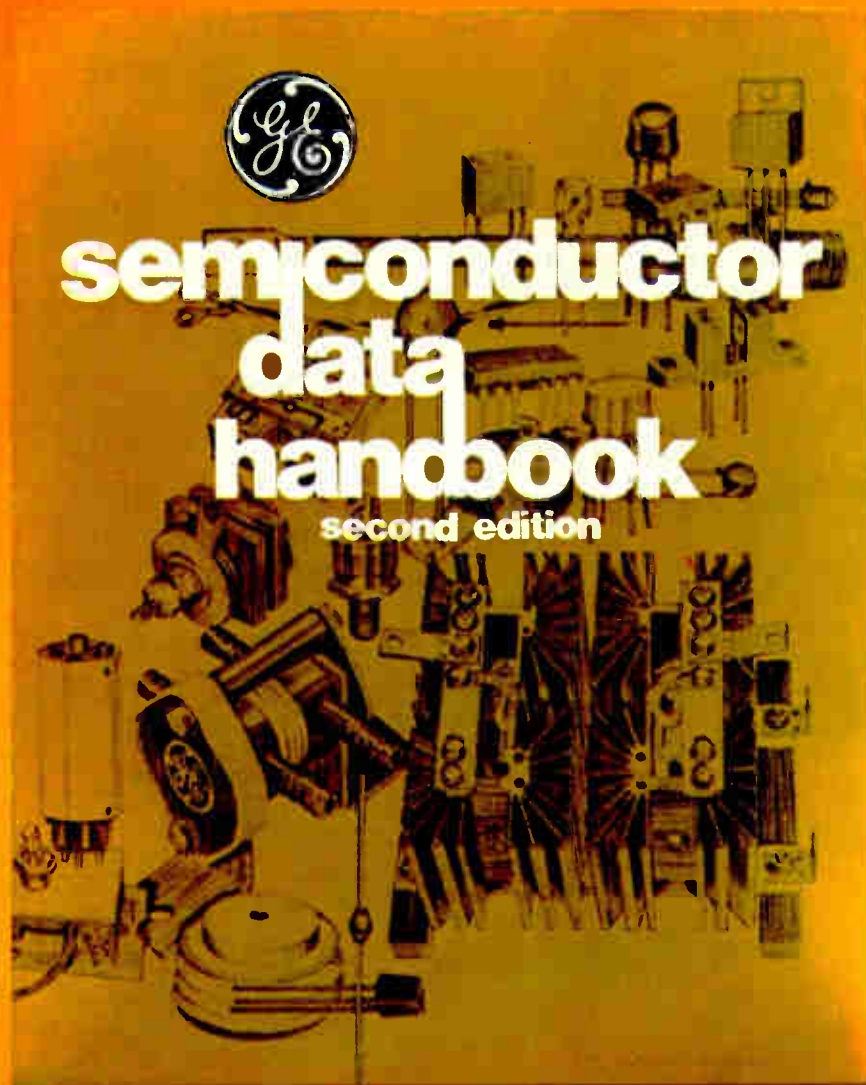

New 1484 page 2nd edition Semiconductor Data Handbook from General Electric...leading supplier of transistors unijunctions, diodes, rectifiers, varistors, SCRs and triacs.

To get your copy, contact any authorized GE distributor, GE Electronic Components Sales Office, or send \$4.95 plus tax to GE Semiconductor, Electronics Park, 7-49, Syracuse, N.Y. 13201.



Do you face  
a make or buy  
decision on  
power supplies?

# BUY LAMBDA'S LZ SERIES MOUNTABLE POWER SUPPLY.

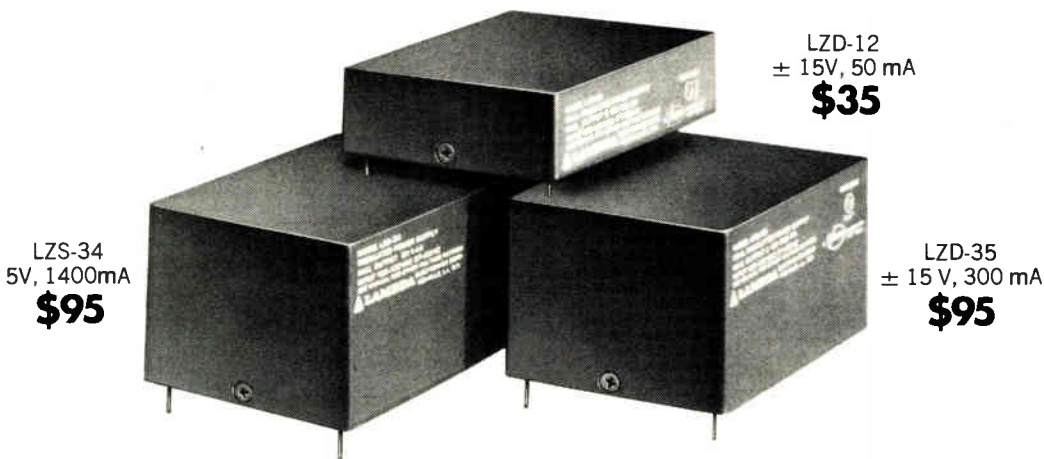

LZS-34  
5V, 1400mA  
**\$95**

LZD-12  
± 15V, 50 mA  
**\$35**

LZD-35  
± 15 V, 300 mA  
**\$95**

## LZ-10 SERIES SINGLE OUTPUT

2 1/2" x 3 1/2" x 7/8"

MODEL	VOLTAGE <sup>(1)</sup> VDC	CURRENT mA	PRICE <sup>(2)</sup>
LZS-10	3	317	\$35
LZS-10	4	384	35
LZS-10	5	450	35
LZS-11	10	225	35
LZS-11	12	195	35
LZS-11	15	150	35

## LZ-20 SERIES DUAL TRACKING OUTPUT

2 1/2" x 3 1/2" x 1 1/4"

MODEL	VOLTAGE <sup>(1)</sup> VDC	CURRENT mA	PRICE <sup>(2)</sup>
LZD-21	± 3	217	\$55
LZD-21	± 4	258	55
LZD-21	± 5	300	55
LZD-22	±10	61	40
LZD-23	±10	114	55
LZD-22	±12	73	40
LZD-23	±12	129	55
LZD-22	±15	90	40
LZD-23	±15	150	55

## LZ-10 SERIES DUAL TRACKING OUTPUT

2 1/2" x 3 1/2" x 7/8"

MODEL	VOLTAGE <sup>(1)</sup> VDC	CURRENT mA	PRICE <sup>(2)</sup>
LZD-12	±15V	50	\$35

## LZ-20 SERIES SINGLE OUTPUT

2 1/2" x 3 1/2" x 1 1/4"

MODEL	VOLTAGE <sup>(1)</sup> VDC	CURRENT mA	PRICE <sup>(2)</sup>
LZS-20	10	247	\$55
LZS-20	12	268	55
LZS-20	15	300	55
*LZD-22	24	73	40
*LZD-23	24	129	55
*LZD-22	28	84	40
*LZD-23	28	143	55

## LZ-30 SERIES SINGLE OUTPUT

2 1/2" x 3 1/2" x 1 1/4"

MODEL	VOLTAGE <sup>(1)</sup> VDC	CURRENT mA	PRICE <sup>(2)</sup>
LZS-30	3	633	\$65
LZS-30	4	767	65
LZS-30	5	900	65
LZS-33	10	293	65
LZS-33	12	336	65
LZS-33	15	400	65
LZS-34	3	950	95
LZS-34	4	1180	95
LZS-34	5	1400	95
*LZD-32	24	186	65
*LZD-32	28	208	65
*LZD-35	24	240	95
*LZD-35	28	280	95

\*Single output ratings for dual output models connected in series

\*Single output ratings for dual output models connected in series

# ...PRINTED-CIRCUIT BOARD

## LZ-30 SERIES DUAL TRACKING OUTPUT

MODEL	2½" x 3½" x 1⅞"		PRICE <sup>(2)</sup>
	VOLTAGE <sup>(1)</sup> VDC	CURRENT mA	
LZD-31	± 3	333	\$65
LZD-31	± 4	417	65
LZD-31	± 5	500	65
LZD-32	±10	163	65
LZD-32	±12	186	65
LZD-32	±15	220	65
LZD-35	±10	200	95
LZD-35	±12	240	95
LZD-35	±15	300	95

## LZ-30 SERIES TRIPLE OUTPUT

MODEL	2½" x 3½" x 1⅞"		PRICE <sup>(2)</sup>
	VOLTAGE <sup>(1)</sup> VDC	CURRENT mA	
LZT-36	5	500	\$70
	±15	50	

NOTES: (1) LZ models are adjustable between the following limits: LZS-10 2.5 to 6V LZS-11 8 to 15V LZS-20 8 to 15V LZS-30 2.5 to 6V LZS-33 8 to 15V LZS-34 2.5 to 6V LZD-12 ± 14.5 to ± 15.5V LZD-21 ± 2.5 to ± 6V LZD-22 ± 8 to ± 15V LZD-23 ± 8 to ± 15V LZD-31 ± 2.5 to ± 6V LZD-32 ± 8 to ± 15V LZD-35 ± 8 to ± 15V LZT-36 2.5V-6V for + 5V output only, ± 14.5 to ± 15.5 for ± 15V output only. Contact factory for current ratings at voltage settings not indicated in the tables. (2) All prices and specifications are subject to change without notice.

## SPECIFICATIONS FOR LZ SERIES

### Regulation

0.15%—line or load; models LZS-10, LZS-30, LZS-34, LZD-21 and LZD-31 have load regulation of 0.15% + 5mV; model LZD-12 has line or load regulation of 0.25%; LZT-36 line regulation 0.15% (+5V) 0.25% (±15V); load regulation 0.15% + 10mV (+5V), 0.25% (±15V).

### Ripple and noise

1.5mV RMS, 5mV, pk-pk

### Temperature coefficient

0.03%/°C

### Overshoot

no overshoot on turn-on, turn-off, or power failure

### Tracking accuracy

2% absolute voltage difference for dual output models only and only for the ±15V output in LZT-36; 0.2% change for all conditions of line, load and temperature

### Ambient operating temperature range

continuous duty from 0°C to + 50°C

### Wide AC input voltage range

105 to 132 Vac, 57-63 Hz

Storage temperature range  
-25°C to +85°C

Overload protection  
fixed automatic electronic current limiting circuit

Input & output connections  
printed circuit solder pins on lower surface of unit. For model LZT-36 the ± 15V outputs are independent from the 5V output.

Controls  
screwdriver voltage adjustment over entire voltage range.

Mounting  
tapped holes on lower surface

Physical data  
Size see tables  
Weight LZ-10 series 10 oz. net 18 oz. ship.  
LZ-20 series 17 oz. net 25 oz. ship.  
LZ-30 series 24 oz. net 32 oz. ship.

60-day guarantee  
60-day guarantee includes labor as well as parts

## LZ SERIES NOW AVAILABLE IN NEW TRIPLE OUTPUT MODEL



MODEL	VOLTAGE <sup>(1)</sup> VDC	CURRENT mA	PRICE <sup>(2)</sup>
LZT-36	5V	500	\$70
	±15V	50	

**1 DAY DELIVERY  
60 DAY GUARANTEE**

**LAMBDA**  
ELECTRONICS CORP  
A *Veco* Company

MELVILLE, NEW YORK 11746 515 Broad Hollow Road Tel. 516-694-4200 ARLINGTON HEIGHTS, ILL. 60005 2420 East Oakton St., Unit Q Tel. 312-593-2550 NORTH HOLLYWOOD, CALIF. 91605 7316 Varna Ave. Tel. 213-875-2744 MONTREAL, QUEBEC 100C Hymus Blvd., Pointe Claire, Quebec 730 Tel. 514-697-6520 HIGH WYCOMBE, BUCKS, ENG. Abbey Barn Road, Wycombe Marsh Tel. High Wycombe 36386/7/8 ORSAY, FRANCE 91 Gometz le Chatel. ACHERN-FAUTENBACH, W. GERMANY 1m. Holzbosch 14 Tel. 078-41-5527

Circle 151 on reader service card

# Some of the little things we've done to keep you competitive.

Take a look. Every IC, most of them firsts in linear circuit development, is specially designed using FET, bipolar and CMOS technology to keep you — and us — one step ahead of everyone else.

Because it's our job to know what you need. Then to reach ahead — and deliver — beyond the expected. And at a practical price.

In proven quantities of hundreds. Or thousands. Whenever you need them.

So you meet your cost/performance goals and production deadlines. And we meet with your approval.

Because we're Analog Devices, the people who design, make and sell more analog devices than anyone else.

Analog Devices, Inc., Norwood, Massachusetts 02062.

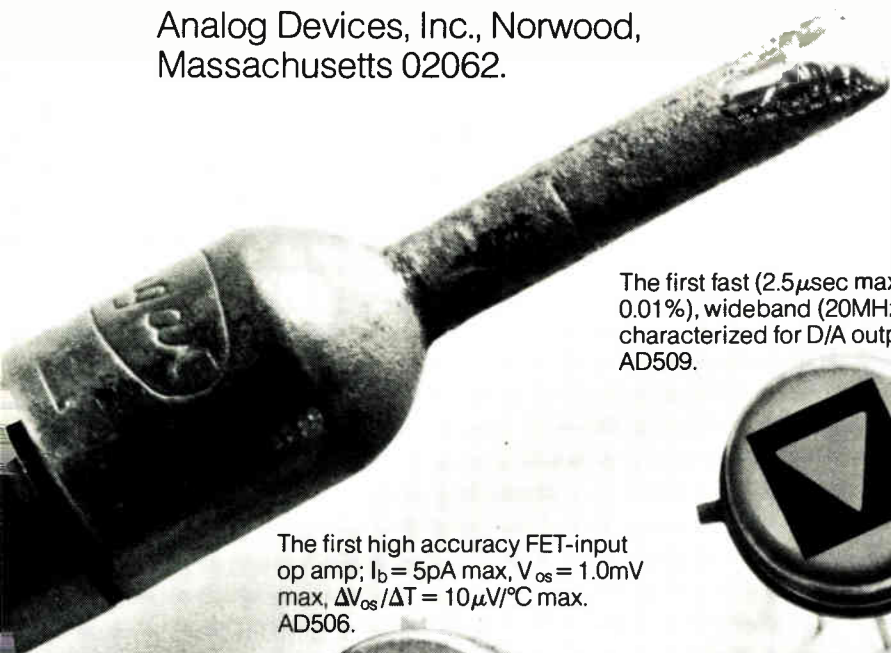

The first fast ( $2.5\mu\text{sec}$  max to 0.01%), wideband (20MHz) op amp characterized for D/A outputs. AD509.



The first totally self-contained and internally trimmed monolithic multiplier,  $V_o = (V_{x1} - V_{x2})(V_{y1} - V_{y2})/10$ . AD532.

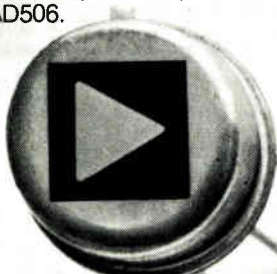

The first high accuracy FET-input op amp;  $I_b = 5\text{pA}$  max,  $V_{os} = 1.0\text{mV}$  max,  $\Delta V_{os}/\Delta T = 10\mu\text{V}/^\circ\text{C}$  max. AD506.

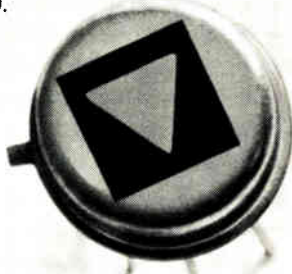

The first low drift ( $0.5\mu\text{V}/^\circ\text{C}$  max), low noise ( $0.6\mu\text{Vp-p}$  max) op amp with single-capacitor compensation and reasonable slewing rate. AD504.



The first monolithic instrumentation amplifier with high CMR and input impedance at gains from 1 to 1000. A true closed loop gain block. AD520.

**Call 617-329-4700**

**for everything you need to know about high performance linear integrated circuits**



The first analog CMOS switches and multiplexers that are not only CMOS logic compatible, but DTL, TTL logic compatible as well. And only 30  $\mu$ W standby power dissipation.

A new kind of dual monolithic transistor, with the lowest gate leakage ever: 0.1pA. AD830



The first monolithic quad voltage switches capable of 12-bit conversion. Especially for multiplying D/A's. AD555.

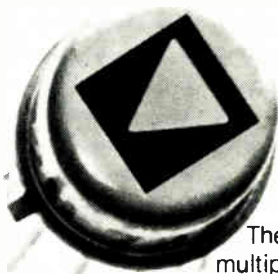

The first monolithic multiplier/divider with reference multiplying element and output op amp;  $V_o = V_x V_y / 10$ . AD530.

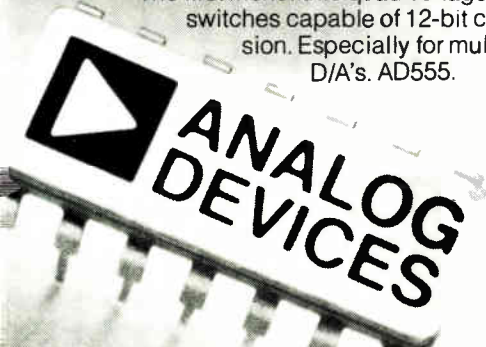
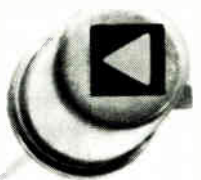

A super beta dual monolithic transistor, featuring 2000 beta at a breakdown voltage of 20V. AD815.

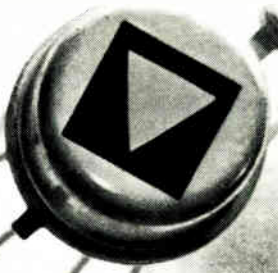

The highest accuracy 741 available ( $I_b = 50$ nA max,  $V_{os} = 0.5$ mV max,  $\Delta V_{os} / \Delta T = 5.0 \mu$ V/ $^{\circ}$ C max). AD741L.



The first monolithic quad switches capable of 16-bit conversion using proportioned emitters. AD550

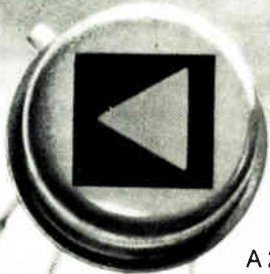

A 25V/ $\mu$ sec amplifier with 15nA max  $I_b$  and 15 $\mu$ V/ $^{\circ}$ C max  $\Delta V_{os} / \Delta T$ . AD507.



The first complete monolithic three-variable ( $V_o = [V_{x1} - V_{x2}] [V_y] / V_z$ ) multiplier/divider. Perfect for rms-to-dc, AGC, vector summation. AD531.

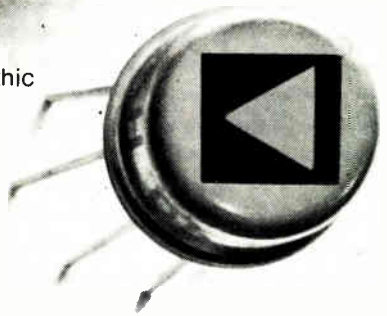

The lowest cost (\$1.95), trouble-free (60 $^{\circ}$  of phase margin), wideband (10MHz) op amp. AD518.

The lowest bias current (0.25pA max) J-FET input IC op amp. For electrometer applications. AD523.

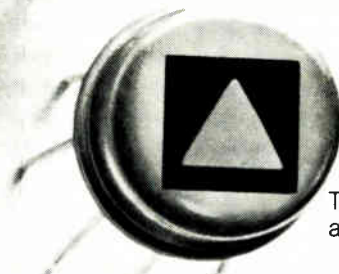

The first high performance FET op amp in a TO-99 package. AD503.

# We have a keyboard to fit every need and every budget.

At MICRO SWITCH, we have the world's most complete line of solid-state keyboards. Which means unmatched design flexibility for you.

Our application engineers will custom tailor a keyboard to your exact specifications. Whether from our time-proven SW series or our new low-profile SD series.

Choose from keys offering over 8,000 legends, 30 colors, and 60 shapes, including standard, sculptured or re-legendable keys.

Or create new keys to fit your needs. Even lighted and two-level keys are available.

MICRO SWITCH keyboards are available with features like MOS, TTL and DTL encoding, and with two-key or N-key rollover. Your choice of arrays include standard touch typing and point-of-sale.

Working with MICRO SWITCH, you draw on our extensive solid-state experience. We've been designing reliable keyboards for hundreds of

applications since 1968 and are presently producing over 1,000 units a week. Each offering a 1% AQL and two-year warranty. This means we can supply you quickly at lower unit prices.

So whatever your needs, and whatever your budget, we'd like to supply a keyboard to fit. Contact a MICRO SWITCH Branch Office for complete information.



**MICRO SWITCH**

FREEPORT, ILLINOIS 61032

A DIVISION OF HONEYWELL



# DIP inserter aims at low-volume users

Semiautomatic machine can handle 3,600 dual in-line packages an hour; technique is aimed at manufacturers of calculators and minicomputers

by Gail Farrell, Boston bureau editor

For years, the machinery division of the USM Corp. has sold high-volume component-insertion systems into such mass production markets as television and automobiles. But with its model VDIP-A/P10 inserter for dual in-line packages, the Beverly, Mass. firm hopes to appeal to companies with lower-volume production, like calculator and minicomputer manufacturers. USM claims that, for about half the price of a computer-controlled system, the semiautomatic unit can insert up to 3,600 components per hour.

A circular turret holds up to 40 sticks, typically containing 25 DIPs each, which are loaded in the order in which they are to be inserted. The DIPs can have 14, 16, or 18 leads and can range in length from 0.685 to 1 inch, with a width of  $0.250 \pm 0.030$  in. and thickness of  $0.150 \pm 0.025$  in. The machine is cycled once to dispense the first component into the "form-feed" mechanism in the inserting unit, the turret turns to the next stick, and the machine is cycled again to transfer the first component onto the mandrel, ready for insertion, and dispense a second component into the form-feed mechanism. Thereafter the machine will insert one component, dispense another, and rotate the turret one position.

A pneumatically operated table holds boards measuring up to 17 by 17 in. under the inserter. Actual insertion area can be up to 16 by 16 in. The operator guides insertion by moving a needle attached to the pneumatic table over a template and by then punching the needle down where a component is to be inserted. Insertion-head accuracy is within  $\pm 0.002$  in.

In the automatic mode, the oper-

ator simply punches the "ready" button and hits the template, as a result of which the machine dispenses one component, inserts another and rotates the turret. However, the first two DIPs must be started in the manual mode, in which each portion of the insertion cycle is individually controlled.

In the manual mode, hitting the "escape" switch meters out one DIP, hitting the "gate" switch drops it to the form-feed mechanism, and the leads are straightened when the "form" switch is thrown. Throwing the "gate" switch again brings the DIP to the insertion mandrel. At this point the machine returns to automatic and will only continue in manual if the "transfer/pusher" switch is thrown. Still in manual, the

"finger/hold down" switch traps the DIP in fingers, which insert it when the "insert" switch is thrown. The leads are cut and made fast by throwing the "cut/clinch" switch. A light next to each switch lets the operator know what stage of insertion the machine has reached.

Keyboard electronics, which includes TTL board, driver board, switch filter, and power supply, are housed near the template and control all functions and timing.

USM claims that over-all reliability of the unit is above 98%. Price of the VDIP-A/P10 varies according to the amount of tooling needed, but it is estimated that average price will be between \$15,000 and \$20,000.

USM Corp., Machinery Division, Balch St., Beverly, Mass. 01915 [338]

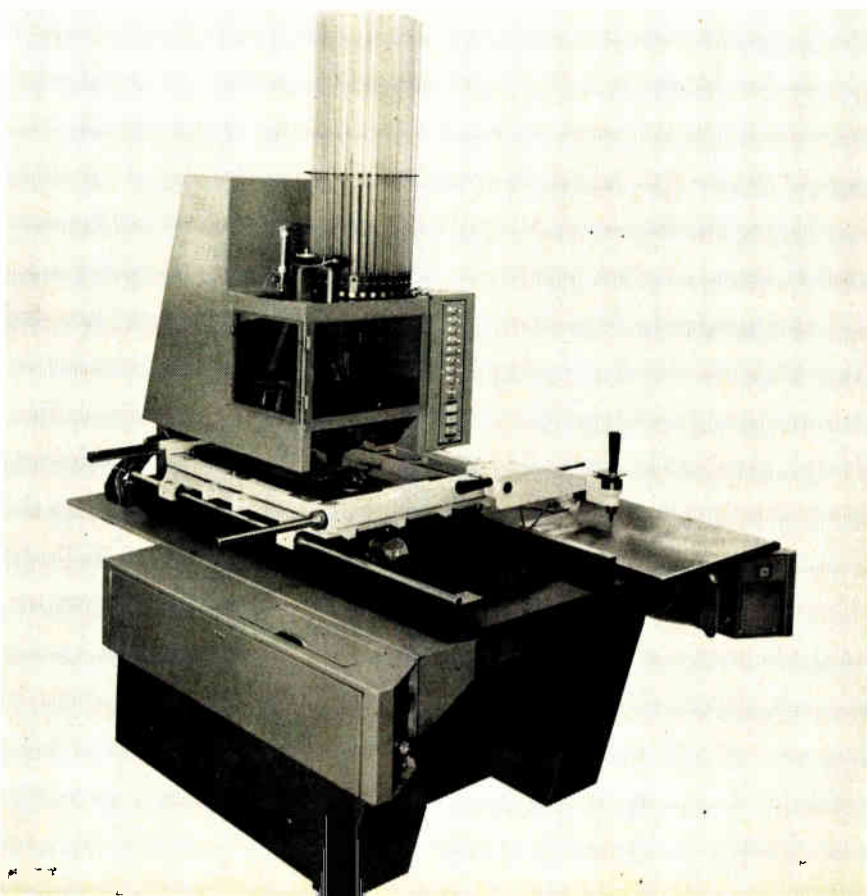



Communications

## Speaker replaces bell in phones

---

Circuit for PABX systems reduces voltage needs, adds user flexibility

---

A lot of new technology—like complementary MOS circuits and time-division switching—has been applied to electronic private automatic branch exchanges (PABXs). But a component that has resisted improvements is one of the simplest in a telephone system—the bell in the telephone set.

The bell requires a 20-hertz signal of about 90 volts rms, a voltage that is not very compatible with the low voltages normally used in integrated-circuit systems. Now, Mitel Canada Ltd. has developed a circuit that reduces the voltage requirements and eliminates buffer high-voltage relays in PABXs, while adding flexibility to telephone systems.

Called the Mitel telephone signaling system, the unit is a small circuit board holding a loudspeaker and amplifying and control circuitry. The board replaces the bell in the telephone without modification to the set itself. Not only will it produce a pleasant “ringing” sound when driven with a low voltage but it also can be used to convey any other audio message to the user, since the speaker can be accessed with the receiver still on the hook and the sound emanates from the base of the telephone. If the receiver is off hook, the announcement overrides the conversation and sounds in the listener's ear.

This feature, says Mitel, will be useful in hotels or motels, where emergency announcements can be made to all rooms simultaneously, or where “message waiting” signals can take the form of an audio announcement rather than the familiar red light on the set (which normally requires about 50 v, also incompatible with integrated-circuit

voltage levels). When programmed from the PABX control unit, announcements could be made to selected rooms.

The circuit, which is connected to the same two wires as the bell, is mounted on a board measuring about 4 by 2.75 inches. The speaker is about 2 in. in diameter. The circuitry is turned on by a pilot tone of about 1 v rms, after which the message can be transmitted to the speaker. Mitel says the circuit can be built for about the same cost as the bell mechanism. The company also offers a central control circuit and an agc pre-amplifier for installation in the PABX.

Mitel Canada Ltd., 39 Leacock Way, Kanata, Ont., Canada [401]

---

## Two instruments team up to test data links, terminals

A pair of portable instruments, intended for checking a wide variety of data and telegraph terminals and links, are being introduced to the U.S. by W&G Instruments, a company primarily engaged in marketing the German-made Wandel and Golterman instruments to the telecommunications field. The instruments, a Telegraph and Data Message Generator (TDMG) and a Telegraph and Data Signal Analyzer (TDSA), are made by an English company, Trend Communications Ltd.

The TDMG generates test messages and patterns at various speeds with known distortion, while the TDSA measures the results, for both start-stop and synchronous data. Together, the units can check speed errors, signal distortion, element error rate, parity error rate, and character error rate.

TDMG combines the capabilities of three instruments in one package, since it can introduce variable amounts of speed, distortion, and amplitude. Bit rates of the unit vary from 37.5 to 9,600 bits per second with 21 discrete settings, and each setting can be varied in frequency by  $\pm 20\%$ . As for distortion, the instrument can introduce cali-

brated amounts of bias distortion (a shift in the average mark-space ratio) and start-element distortion (a variation in the width of the start pulse, which produces a timing displacement of the remaining character elements). Finally, the unit also allows control of output-pulse amplitudes from 10 volts to 110 v.

The TDSA has a built-in cathode-ray-tube display for monitoring input waveforms and for use in measurements. The instrument's main feature is that it can separate speed variations from other distortions. The user can offset speed variations with a front-panel control, watching the CRT display, and then note the amount by which he has changed speed, namely, the speed error. He then can perform other measurements for distortion. For error rates, the instrument has two counters: one for errors and the other for total blocks of data received.

The TDMG is priced at \$2,075, with an optional program matrix to allow programmed message sequences, the price is \$2,565. The basic TDSA is priced at \$2,310; with an error-counter option, the price is \$2,950.

W&G Instruments, 119 Naylor Ave., Livingston, N.J. 07039 [402]

---

## Multiplexer channels signals from 16 lines to computer

A multiplexer that enables signals from up to 16 communications lines to be channeled through the H-P-2100 computer's input/output system operates at from 57 to 2,400 bauds per channel. Designated the model 12920A, the asynchronous unit can interface with other asynchronous devices that are hardwired locally or connected remotely through a 103-type data set. The



now...  
**RESISTOR  
NETWORKS**  
from  
**BOURNS**

The Leader in resistive component technology now brings you a line of thoroughly tested and qualified DIP and SIP Resistor Networks . . . that live-up to their specifications, stand-up to your applications. BOURNS® Resistor Networks are available off-the-shelf in a selection of standard configurations to replace the most popular Allen-Bradley, Beckman, Dale, Sprague, CTS, Centralab, and Mepco part numbers.



**CONSIDER WHY BOURNS IS BETTER:**

• Proven thick-film production expertise • Proprietary resistor ink system provides  $\pm 100\text{ppm}/^\circ\text{C}$  tempco through all resistances . . . from  $33\Omega$  to  $220\text{K}\Omega$  • Better power handling characteristics • Design qualified and life tested to meet or exceed tough Mil-Standards. Inquiries for special values, schematics and specifications invited.

Your local Bourns representative has complete specs, cross-reference data and order forms at the ready. Call him today . . . or the factory direct.



BOURNS, INC., TRIMPOT PRODUCTS DIVISION  
1200 COLUMBIA AVENUE  
RIVERSIDE, CALIF. 92507

Circle 157 on reader service card

BOURNS

TRIMPOT®  
PRODUCTS

ADJUSTMENT POTENTIOMETERS  
PRECISION POTENTIOMETERS  
CONTROLS/VARIABLE RESISTORS  
RESISTOR NETWORKS



TRIMPOT®  
PRODUCTS

TRIMPOT PRODUCTS



**We've measured:**

**Auto  
crashes**

**Aircraft  
stresses**

**Biomedical  
parameters**

**Jet engine  
distortions**

**Ship  
signatures**

**Turbine  
vibration**

for:

Boeing, Dornier,  
FIAT, General Electric,  
Grumman,  
Hawker-Siddeley,  
Hughes, Liberty Mutual,  
Lockeed, Martin,  
McDonnell-Douglas,  
New York University,  
Republic,  
Rockwell International,  
SUD Aviation,  
SAAB, United Aircraft,  
Westinghouse,  
the US Government,  
and many more!

**What  
can we measure  
for you?**

*Telemetry/Communications  
Products & Systems*



**DATA-CONTROL SYSTEMS, INC.**  
Commerce Drive, P.O. Box 584  
Danbury, Ct. 06810 ■ (203) 743-9241

## New products

basic 12920A consists of three interface cards, a connector panel and cables and is installed into existing I/O slots of the 2100 central processing unit. Price is \$2,200.

Hewlett-Packard Co., 1501 Page Mill Rd., Palo Alto, Calif. 94304 [376]

### Switching system handles EIA duplex channels

Called the Dyna-Switch, an interfacing and data-channel switching system provides push-button operation for entire EIA RS-232 duplex data channels between on-line and standby equipment. Applications are in computer ports, modems, terminals, and data-communications

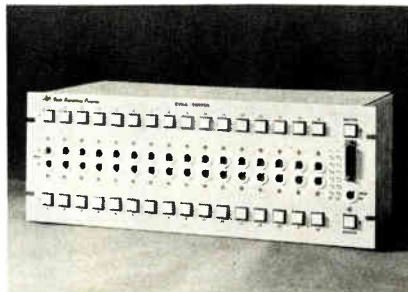

channels, which may be switched individually or in groups, without the use of patchcords. For monitoring, jacks are provided to permit entry to on-line equipment circuits without circuit interruption. Standby or inoperative circuits are also accessible for testing and fault isolation.

Cooke Engineering Co., 900 Slaters Lane, Alexandria, Va. 22314 [375]

### Modem provides rates to 40,000 bits/second

Variable data-transmission speeds from 0 to 40,000 bauds are possible with a modem designed for local terminal/computer communications and telecommunications applications. The modem converts digital data to rf signals, which may be transmitted up to one mile away over a single coaxial line. For complex system applications, a mother board is offered that can support up

to eight of the modems. The mother board has a built-in multiplexer that either operates automatically or may be preset for specific sequential operations. In addition, clock signals can be transmitted to any device on the line, enabling the modem to be used for telemetry.

Teleplex Co., 327 Connecticut Ave., Norwalk, Conn. 06854 [373]

### Booster amplifier tests land-mobile equipment

A booster amplifier covering the 800-to-960-megahertz land-mobile communications band provides 20 watts of continuous-wave output power over the full frequency range. The model 1410 is intended to test equipment either in the laboratory or on the production line. It is designed for use primarily with the Hughes model 1401H 1-watt linear amplifier, although others can be used. When used with the 1401H, total gain exceeds 43 dB over the 800-960-MHz range. Price is \$2,995, and the model 1401H driver amplifier is priced at \$1,495.

Hughes Electron Dynamics Division, 3100 W. Lomita Blvd., Torrance, Calif. 90009 [377]

### Communications receiver tunes from 2 to 30 MHz

A general-purpose communications receiver, the model 1230, is continuously tunable over the range from 2 to 30 megahertz. Digital automatic frequency control is refer-



enced to a proportionally controlled master oscillator for a stability of  $\pm 1$  hertz at any frequency. Direct digital readout to the nearest hertz and tracked preselection are features of



# 3-in-1 logic tester

logic probe  
logic clip  
IC tester

Logic misbehaving? Forget old-fashioned scope-and-probe, hunt-and-peck methods. The Fluke Trendar TESTCLIP™ finds and displays logic defects. It pinpoints faults ten times faster: component faults... solder faults... board defects. **3-in-1:** A logic probe, logic clip

and IC tester are combined in one pocket-size unit. TESTCLIP finds the culprit where loops or multiple faults defy the most sophisticated test systems. The reference IC plugs in the side and TESTCLIP does the rest. Your test technicians can now turn out more product... Service can fix boards on site... R & D can cut prototype checkout time. **The result:** inventory is saved, productivity zooms, and customers admire your fast, reliable field service. All for only \$395. Your Fluke representative has TESTCLIP in stock for immediate delivery and will show you the secret of FAULTRACK,® the universal troubleshooting method. Ask him.

## \$395

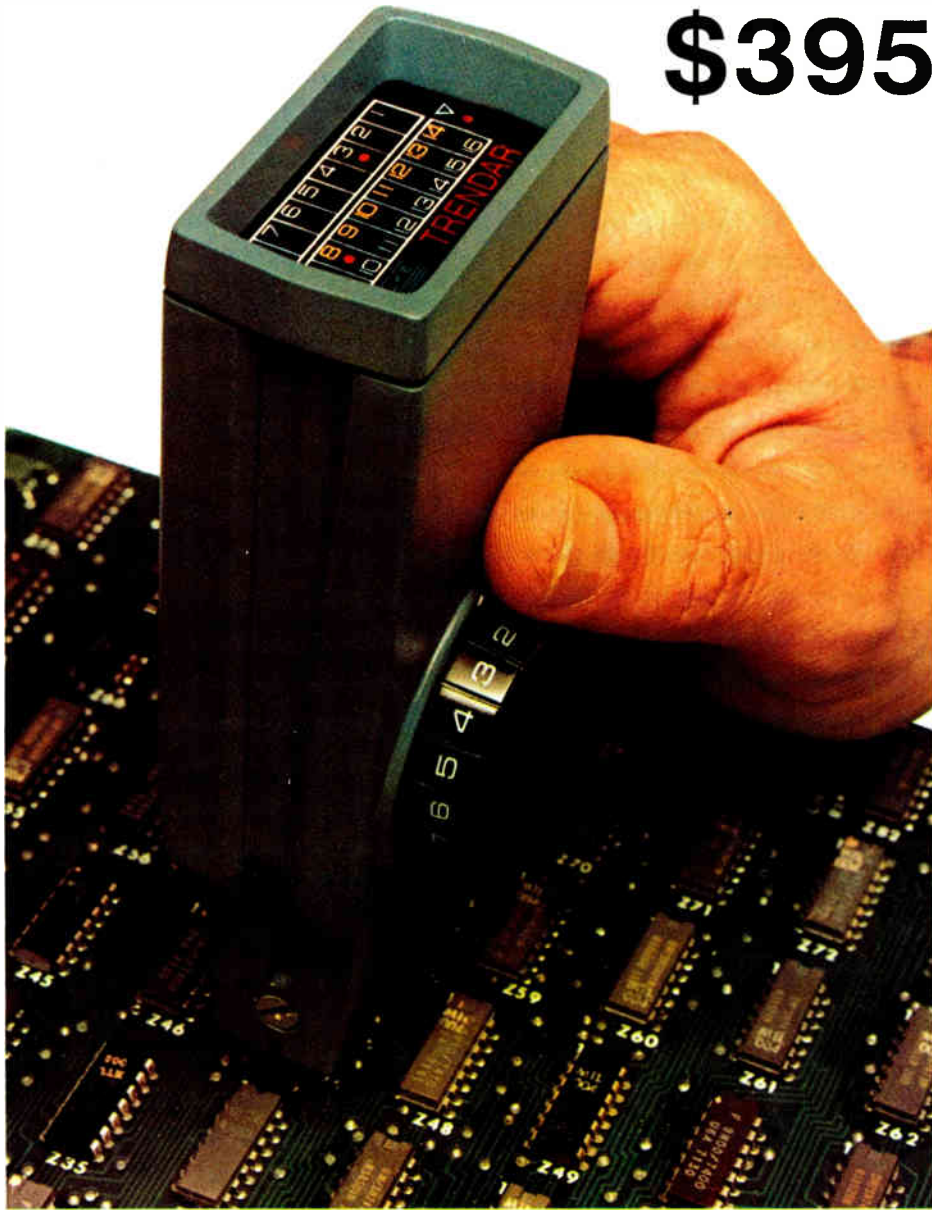

## Sales and Service

### U.S. AND CANADA

Albuquerque, NM (505) 299-7658  
Cleveland, OH (216) 267-0445  
Dayton, OH (513) 434-7500  
Denver, CO (303) 934-5505  
Des Plaines, IL (312) 298-3600  
Detroit, MI (313) 892-2500  
Glastonbury, CT (203) 633-0777  
Glendale, CA (213) 245-9404  
Greensboro, NC (919) 273-1918  
Houston, TX (713) 621-0040  
Huntsville, AL (205) 881-6220  
Indianapolis, IN (317) 244-2456  
Kensington, MD (301) 881-5300  
King of Prussia, PA (215) 265-1600  
Lexington, MA (617) 861-8620  
Minneapolis, MN (612) 884-4336  
Orlando, FL (305) 896-4881  
Pittsburgh, PA (412) 892-2953  
Pleasantville, NY (914) 769-1811  
Richardson, TX (214) 231-2573  
Rochester, NY (716) 266-1400  
San Diego, CA (714) 565-2555  
Santa Clara, CA (408) 244-1505  
San Juan, PR (305) 896-4881  
Scottsdale, AZ (602) 947-7841  
St. Louis, MO (314) 423-1234  
Seattle, WA (206) 624-9020  
Vancouver, WA (503) 283-3287  
Union, NJ (201) 687-8737  
Calgary, Alta (403) 261-0780  
Montreal, Que (514) 670-1212  
Ottawa, Ont (613) 829-9651  
Toronto, Ont (416) 678-1500  
Vancouver, BC (604) 253-7136

### INTERNATIONAL

Athens, Marios Dalleggio Rep. 710-669  
Auckland, David J. Reid, (N.Z.) Ltd.  
Bangkok, G. Simon Radio, Ltd. 30991-3  
Bogota, Marones Ltda 36 47 31  
Bombay, Hindltron Services Pvt. Ltd. 365344  
Brookvale, (Australia)  
Eimeasco Instruments Pty. Ltd. 939-7944  
Brussels, C. N. Rood S.A. 352135  
Buenos Aires, Coasin S.A. 523185  
Caracas, Coasin C.A. 72 23 11  
Copenhagen, Tage Olsen A/S 294800  
Helsinki, OY Findip AB 717799  
Hong Kong, Gilman & Co., Ltd. 227011  
Johannesburg, Elairco, (Pty.) Ltd. 20272  
Karachi, Pak International Operations  
Kota Kinabalu, O'Connor's (Pte) Ltd.  
Lagos, Deemtee Electrotechnics, Ltd.  
Lima, Importaciones Y Rep Elect 272078  
Lisbon, Equip. De Laboratorio Ltda 976551  
Madrid, Atalo Ingenieros S.A. 2153543  
Mexico, Mexitek, S.A. 5-36-09-10  
Milano, Sistel SpA 248-52-33  
Montevideo, Coasin Uruguay S.A.  
Munich, Fey Elektronische Messgeraete 184041  
Oslo, Morgenstjerne & Co. A/S 372940  
Paris.  
(Suresnes) M. B. Electronique, S.A. 7723108  
Quito, Proteco Coasin CIA, Ltda 526-759  
Rijswijk, C. N. Rood B. V. 996360  
Rio de Janeiro, Ambriex, S.A. 264-7406  
Rome, Sistel SpA 500-1860  
Santiago, Coasin Chile Ltd. 396713  
Sao Paulo, Ambriex, S.A. 52-7806  
Selangor, O'Connor's (Pte) Ltd.  
Seoul, Asia Science & Co. 24-1431  
Singapore, O'Connor's (Pte) Ltd. 637944  
Taipei, Heighen Trading Co. Ltd. 518324  
Tehran, Berkeh Company Ltd. 628294  
Tel Aviv, R. D. T. Electronics Engrg. Ltd. 456181  
Tilburg, Fluke (Nederland) B.V. 013-673973  
Tokyo, Toyo Trading Co. Ltd. (03) 279-0771  
Vallingby, Telinstrument AB 380370  
Vienna, Kontron GmbH & Co. KG 420202  
Watford, U.K., Fluke International Corp. 33066  
Zurich, Kontron Electronic AG 628282  
Caribbean, West Indies Sales Co.  
(San Juan) (809) 723-3743  
Peoples Rep. of China,  
May Lee Industries (N.Y.) (212) 532-9200  
U.S.S.R., Codevintec Pacific, Inc.  
(L.A.) (213) 348-1719

**FLUKE** TRENDAR

® subsidiary of John Fluke Mfg. Co., Inc.

500 Clyde Avenue, Mountain View, California 94043 • 415 / 965-0350 TWX 910-379-6573  
Europe, Fluke (Nederland) B.V., P. O. Box 5053, Tilburg, Netherlands, Tel. 013-673973. Telex 52273.  
U.K., Fluke International Corp., Garnett Close, Watford, WD2 4TT, Tel. Watford (0923) 33066, Telex 934583

# USING ACTIVE FILTERS OR PASSIVE FILTERS ?

**Are size, shape or weight considerations important? Special mechanical configurations offered—Hermetically sealed or encapsulations for pcb installations**

**Low, high, band pass and reject designs—Butterworth, Chebishev, Bessel or elliptic response characteristics—wide range of source and load impedances**

**Low frequency actives, stable toroidal LC's, RC twin-T's**

**No EXTERNAL components required**

**Unbiased recommendations on active or passive filter selections for maximum economy**



**instruments, incorporated**

**PHONE AREA 512/892-0752 • P.O. Box 698 AUSTIN TEXAS 78767**

Circle 160 on reader service card

Years ago we made a decision to let the other guys knock out all of the simple printed circuit boards they could make. We wanted the tough jobs.

Multilayer and two-sided PCs. Complex drilling, printing and plating.

And we wanted to do them better than anybody in the business.

Since then, we've been doing

more of the hard work than anyone. And delivering it on time. With precision and economy.

We built a reputation on hard work. We're not about to take things easy now.

If you've got a tough job, call us at (213) 722-6810 collect. Or write Data Products Division, 6201 East Randolph Street, Los Angeles, California 90040.

**We built a reputation on hard work.**

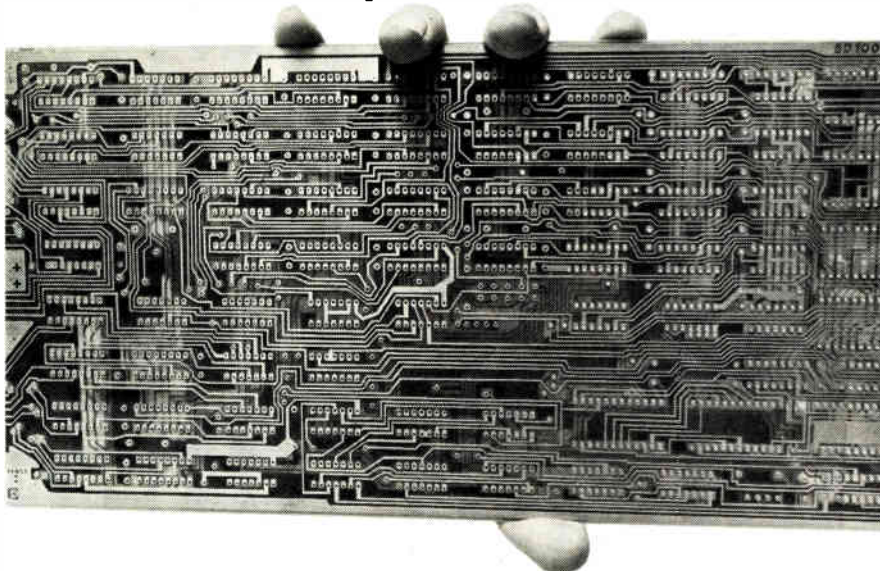

**Lockheed Electronics—First In Complex PCs**  
15 YEARS OF LEADERSHIP IN ELECTRONICS. 1959-1974.

160 Circle 108 on reader service card

## New products

the unit, in addition to phase-locked detectors on a-m and fm. Price is \$4,475.

Raytheon Co., Electromagnetic Systems Division, Box 1542, Goleta, Calif. 93017 [378]

**Baseband translator permits insertion of 1 to 12 channels**

A supervisory baseband translator for microwave multiplex permits insertion of one to 12 order-wire or special-service channels into any 48-kilohertz slot in the baseband, between 60 kHz and 2,540 kHz. The basic translator provides one 300-Hz to 12-kHz channel consisting of a group translator, the baseband translator, and a carrier generator. The unit can also accommodate high-frequency input and output levels in the range of from -23 to -3 dBm at 135 and 75 ohms.

Karkar Electronics Inc., 245 11th St., San Francisco, Calif. 94103 [374]

**Channel simulator generates phase jitter, distortion**

A telephone-channel simulator, for communications channel users and modem designers, is designated the model FA-1564A. It is designed to generate impairments such as phase jitter and hits, harmonic distortion, frequency translation, and broad-



band and impulse noise. The unit adds calibrated impairments to a data signal over the range from 300 to 3,000 hertz. Phase jitter can be added at a rate from 0° to 45°, selectable by setting a front-panel digital control and analog vernier. Price is \$1,980.

SEG Electronics, 120-30 Jamaica Ave., Richmond Hill, N.Y. 11418 [379]

**Electronics/April 4, 1974**



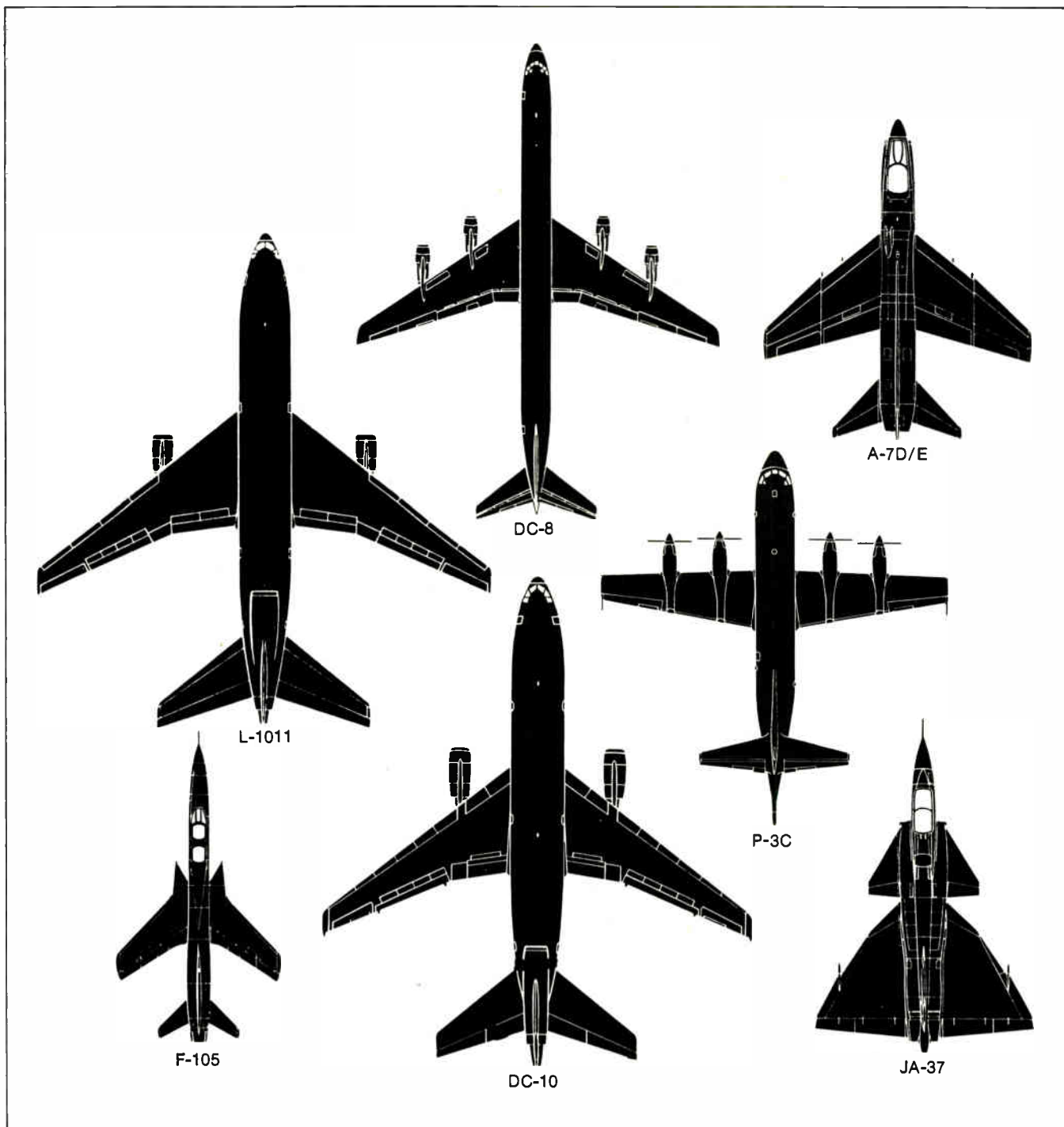

## Over 3000 Second Generation Inertial Systems for the World's Finest Aircraft.

More than 3000 Kearfott inertial systems have logged over 1.5 million hours in the most diverse and demanding airborne applications.

In addition to superior navigational performance, the demonstrated reliability of these systems in the military environment has exceeded 1200 hours MTBF while in the commercial world the MTBF has been better than 2000 hours.

Kearfott systems are basically

better because they are designed that way.

- Simple, reliable inertial sensors are used with over 20,000 hours MTBF
  - Dual two-axis non-floated gyroscopes permit 100% performance monitoring
  - Built-in self-test and self-alignment capability
- Coupled with our second generation design is our experience

which now spans two decades of inertial system engineering and production.

For more details, please write to The Singer Company, Kearfott Division, 1150 McBride Avenue, Little Falls, N.J. 07424.

**SINGER**  
AEROSPACE & MARINE SYSTEMS



# Only the Gould 6000 gives you 128 floating and integrating inputs, real time monitoring, 200 points/sec. and a 3M computer grade tape cartridge in a Data Acquisition System.

The Gould 6000 is an analog to digital data logger-reader that's the best way we know of to monitor and record low frequency data. It scans up to 128 input channels, converts the data to digital form, displays the data for real-time monitoring and stores the results on 3M 1/4" computer grade magnetic tape.

## High performance, high or low scanning speed.

Our full-floating integrating front end minimizes signal noise and eliminates sampling errors inherent with other data collecting systems. Each analog input is fully floating with respect to the chassis ground and continuously integrated during the entire scanning period.

The Gould 6000's 128 inputs may be all analog or up to 48 digital

and 80 analog. There are four full scale programmable gain sensitivity ranges:  $\pm 10\text{mV}$ ,  $\pm 100\text{mV}$ ,  $\pm 1\text{V}$  and  $\pm 10\text{V}$ .

To select the scanning rate, push one of the six buttons on the front. The rate can be varied from 200 points per second to 1 scan every ten minutes. In an external record mode, a scan can be triggered by an external clock or an event.

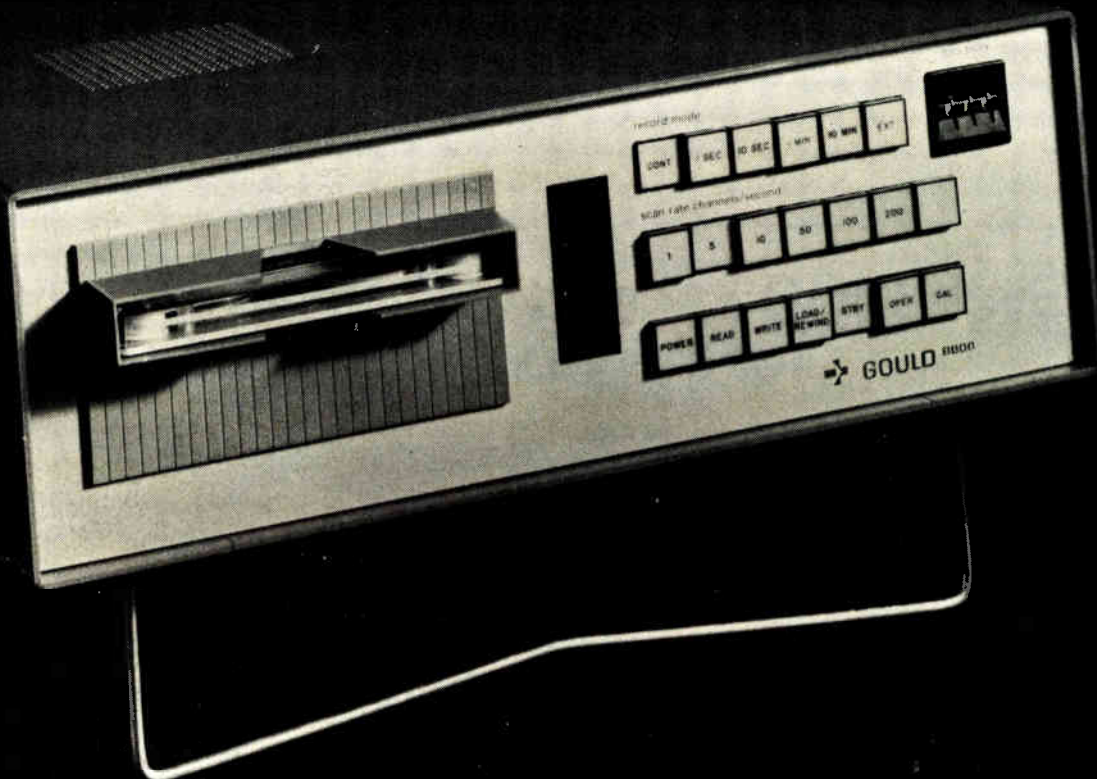

## significant advance in tape handling.

The 1/4" computer grade magnetic tape in a front loading reel-to-reel cartridge represents a significant improvement in tape handling. The 3M cartridge has 8 times the storage capacity of a cassette while eliminating tape handling problems frequently associated with large, expensive 1/2" reel-to-reel transports.

In addition, the cartridge combines plug-in convenience, foolproof operation with a single

motor drive, a built-in File Protect, 4-track read-write capability.

## A typical writing error rate approaching one part in 100 million.

The Gould 6000's typical error rate which approaches 1 part per 10<sup>8</sup> translates to only one writing error for every 12 tape cartridges used.

## Connect up to 128 inputs to the Gould 6000 and you won't miss a thing.

The Gould 6000 can be used about anywhere to monitor just about anything. It's being used for pollution monitoring, chemical processing and refining, weather and seismic recording, product testing, and applied research in various fields.

The Gould 6000's light-weight (under 36 pounds), easy to use controls and rugged construction make it a natural for portable, as well as on-site data acquisition jobs

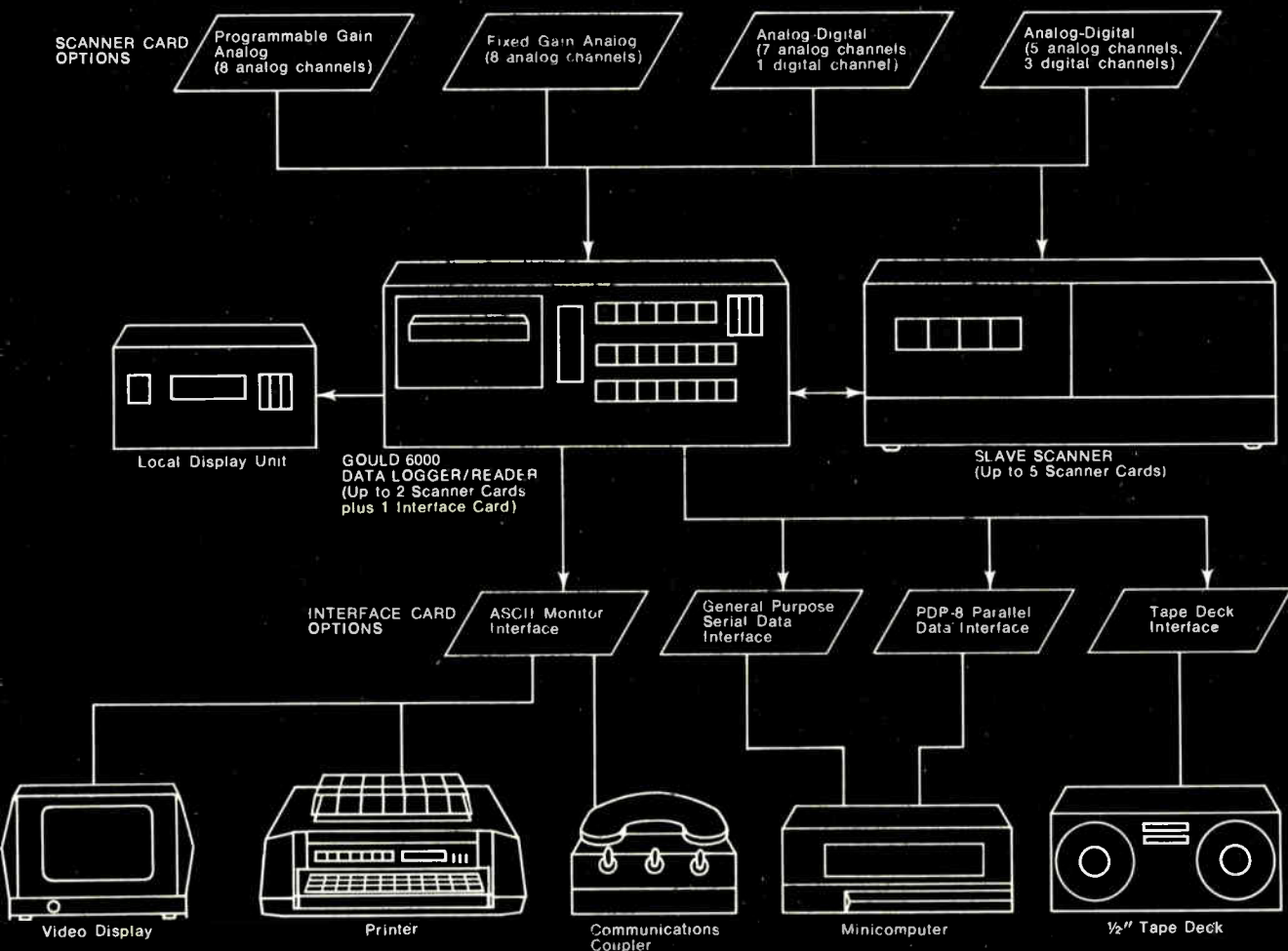

### The complete data acquisition system.

The Gould 6000 is truly an operational definition of what a high performance data logger-reader should be. If your research requires an instrument of this quality, contact your nearest Gould

Sales Engineer or Representative. Or write us for detailed performance information and specifications. Gould Inc., Instrument Systems Division, 3631 Perkins Avenue, Cleveland, Ohio 44114 or Kouterveldstraat Z/N, B 1920, Diegem, Belgium.

 **GOULD**

Circle 163 on reader service card

# BIG SHOW. SMALL DOUGH.

The EPC Model 2200 is the first truly fine quality, lightweight, low cost XYZ recorder ever made.

When matched with a spectrum analyzer, the Model 2200 prints spectral data on continuous, dry-paper hard copy over a 19.2" display. A hard copy history-plot of spectral data not only permits data comparison, but reveals spectrum lines buried as much as 6 db below the noise level. And the 19.2" display presents in excess of 3,000 data points with each sweep. Information that is subtle and transient on a scope

becomes clear and permanent on an XYZ recorder.

The Model 2200 interfaces with either digital or analog equipment, and is completely tape compatible. It sweeps at speeds between 1/10 second and 8 seconds.

While a new design, the EPC Model 2200 is a direct result of our versatile Model 4600 and our sophisticated Model 4100. It shows the same design elegance, and the same operating reliability.

Please write for our free literature.

## The new EPC Model 2200 XYZ recorder for spectrum analysis.



Please write  
for  
complete  
specifications.

# EPC

EPC LABS, INC.  
Box 97  
123 Brimbal Avenue  
Beverly, Massachusetts 01915  
(617) 927-2523



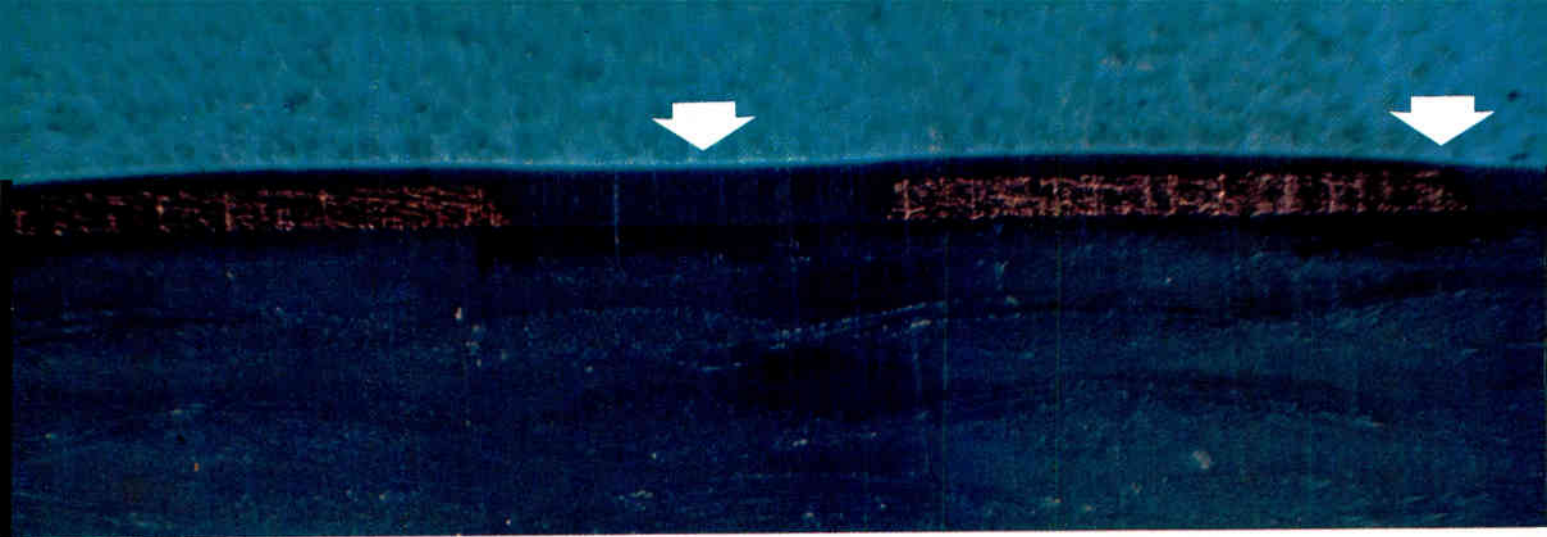

## When spray or dip coatings fail...

## Parylene works.

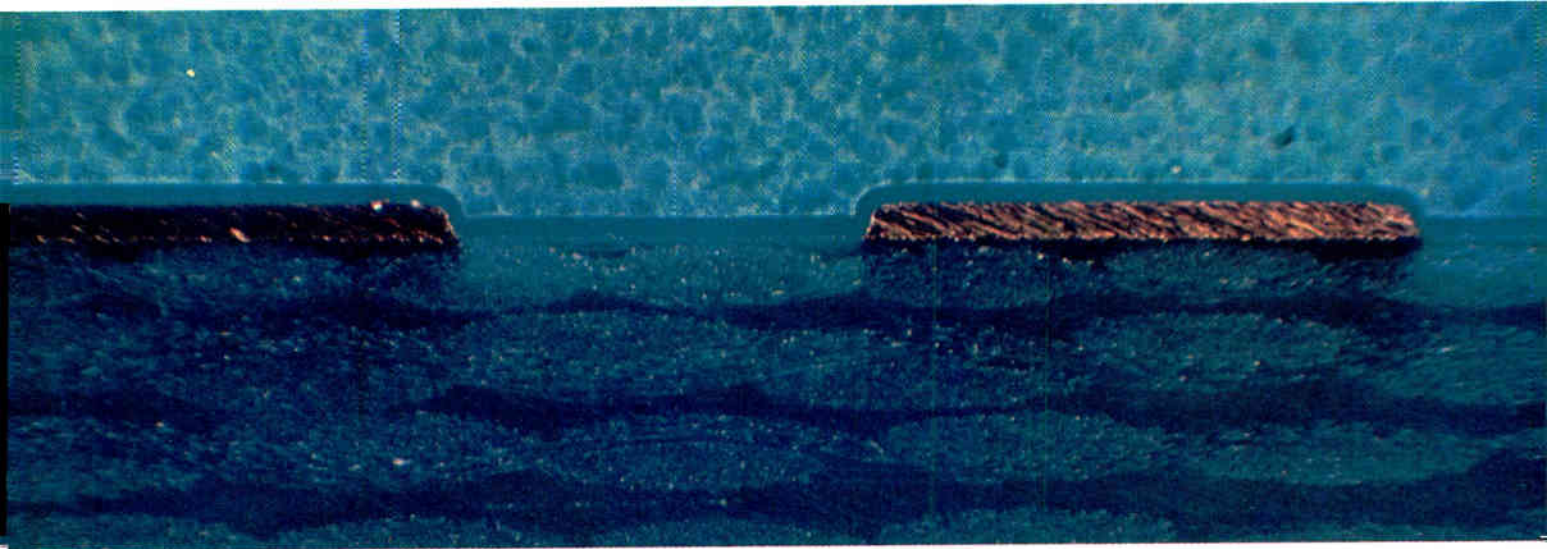

You are looking at magnified cross-sectional views of copper conductors on a circuit board . . . and why parylene protection brings the highest reliability to electronic circuitry.

The spray-applied urethane coating (top photo) bridges the channel between conductors, and offers scant protection at the edges. Urethane, silicone, epoxy . . . liquid coatings are uneven, and can produce potential failure points.

Parylene forms a thin and even coating, whatever the configuration, however complicated or delicate or densely populated. Without bridging. Without pinholes, voids, bubbles. We call it a conformal coating. From conformality comes reliability.

Parylene conformal coatings can be applied in precisely controlled thicknesses from 0.002 to 3 mils. *In one step.*

Parylene is applied at *room temperature*. No heat, no melting, no cure. No coating shrinkage. In other words, no discomfort for delicate components.

Parylene provides better barrier protection than urethanes, silicones or epoxies. It is extremely resistant to chemical attack,

exceptionally low in trace metal contamination, and compatible with all electronic solvents. Dielectrics are excellent .

Parylene has qualified under the stringent requirements of MIL-I-46058C; it does so with a 0.6 mil coating—parylene excels in the micro-electronic virtue of thinness.

Parylene conformal coatings have shown excellent cost effectiveness in many applications. On delicate, sophisticated and complex circuitry, in hybrid circuits and components, they may be the most cost effective answer for long term reliability.

Union Carbide invented the parylene system. The method is gas phase deposition, which is the only route to the reliability of conformal protection. Various patents apply; commercial use of the patented technology is licensed.

You can get complete information on parylene by writing for our 16-page brochure: Union Carbide Corp., 270 Park Ave., Dept. RB36, New York, N.Y. 10017. Further investigation will no doubt indicate a trial run, which we can perform at reasonable cost. If you would like to discuss that or any other related matters, please call Bill Loeb at (212) 551-6071 .



# Color your IC systems Cambion.

You can let your imagination soar, and still keep your most advanced IC packaging concepts practical. With Cambion's growing line of digital products, state of the art design ideas become a reality. And we can meet your needs with repeatable Quality, no matter how great the Quantity. Our variety of components is so extensive you won't have to think "specials".

Just take a look at our new Catalog 119. It features advanced new Cambi-Cards™, card files, drawers, universal panels with and without premounted socket strips and power planes, specific logic function cards, general purpose and discrete component cards, plus strip connectors, cable assem-

blies, integrated socket strips, component socket adapters, cable cards and card extenders.

We also offer a complete NC wrapping service to speed economical production of your IC system designs.

Develop your system ideas to their fullest potential *without component restriction*. Get your own copy of the new Cambion Catalog. It has 22 more pages than its predecessor showing more new products to keep ahead of your design needs. And they all have the Cambion Double "QQ" approach: the Quality stands up as the Quantity goes on. Order your copy today. Cambridge Thermionic Corporation, 445EM Concord Avenue, Cambridge, Mass. 02138. Phone (617) 491-5400. In Los Angeles, 8703 La Tijera Blvd. 90045. Phone (213) 776-0472.

Standardize on

## **CAMBION™**

... the Guaranteed Digital Products

Circle 166 on reader service card





## New products

### Instruments

## Leak detector needs no tuning

Compact instrument finds leaks as small as  $10^{-8}$  cc/s and as large as  $10^{-2}$  cc/s

A new gas-leak detector, the model 2310 Bantam from Varian, offers sensitivity of an order previously provided only by mass spectrometric instruments. Unlike the mass spectrometric units, however, the

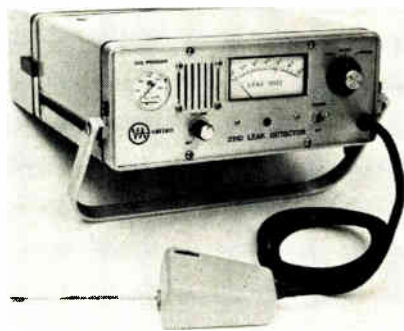

Bantam requires no tuning, calibration, or peaking when used in its search mode. Further, the new detector spans a six-decade range—from  $10^{-8}$  cc/s to  $10^{-2}$  cc/s—without any switching or other adjustment.

In addition to being highly sensitive and easy to use, the Bantam is fast. Its total response time—from the entrance of tracer gas into its probe to the indication of a leak—is less than 1 second. Recovery time is also very short: it takes less than 3 seconds to clear the instrument of gas after a 100% overload so that it can again operate at full sensitivity.

The model 2310 operates on the principle of electron capture. Virtually any electronegative gas—such as Freon, oxygen, or sulfur hexafluoride—can be used as a tracer. The piece being tested for leaks is pressurized with the tracer gas and is then probed by the leak detector. Any gas leaking out of the test piece is drawn into the Bantam by a small pump and sampled by a sensing cell. A small, safe radioactive source

in the cell sets up a measurable current of electrons. Any tracer gas that gets into the cell captures some of these electrons and thus changes the cell current, indicating a leak.

Obviously, devices which are normally pressurized with an electronegative gas can be checked for leaks without the use of a tracer. This makes the Bantam suitable for checking power transformers, circuit breakers, cables, and waveguides which are often pressurized with  $SF_6$ . Besides the checking of gas-insulated electrical and electronic equipment, the Bantam is expected to find applications in the production and/or maintenance of air conditioning and refrigeration systems, aerosol cans, fire extinguishers, chemical reaction vessels, and other devices that are pressurized during manufacture or operation.

For pressurizing devices in the field, the Bantam carries its own gas supply, sufficient for 24 hours of continuous operation. The unit comes in two models: the ac-operated 2310, which sells for \$3,900; and the portable, battery-operated model 2320, which carries a \$4,400 price tag. Delivery takes six to eight weeks.

Varian Vacuum Division, NRC Operation, 121 Hartwell Avenue, Lexington, Mass. 92173 [351]

### Portable oscilloscope covers dc to 5 megahertz

A portable oscilloscope, designed for on-site checks and servicing of electronic instruments, weighs only 4 pounds and can be hung around the neck. Measuring 3.5 by 5 by 7.75 inches, the unit has a 1.5-in. screen that can be enlarged to 2.25 in. with a snap-on magnifier. Moreover, it is powered by either an ac line or a battery pack that permits up to five hours of continuous service before a recharge is necessary. Frequency range covered is from dc to 5 mega-

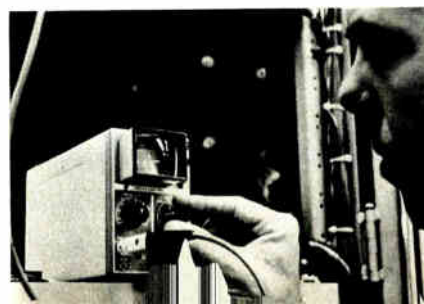

## Pro-Log Eliminates Hard Wired Logic

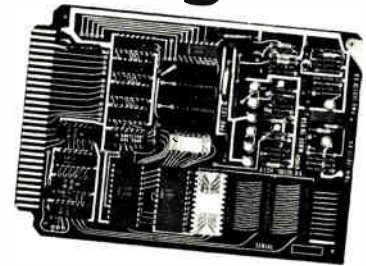

Our 4-bit microprocessor system can replace a rack full of your TTL chips. You'll save design time and production costs. No big redesign jobs for options or changes because the logic is stored in reprogrammable ROMs. Our programmed logic systems are available now, off the shelf.

Our PLS-401 microprocessor system costs less than \$400 in a quantity of one, with substantial OEM discounts. Plus we've got all the support you need: Design manuals, 2-day intensive design course, ROM Programmers, System Testors, special interface cards and support hardware to make your system go together smoothly.

## and Mini Computers

Our MPS-800 microprocessor systems are modular production systems with mini-computer features such as: Expandable RAM, DMA, and 8 level priority interrupt. From under \$950 in a quantity of one with RAM. We have special interface cards and support hardware.

## Micro Processor Systems from Pro-Log



852 Airport Road  
Monterey, Calif. 93940  
(408) 372-4593

Circle 167 on reader service card



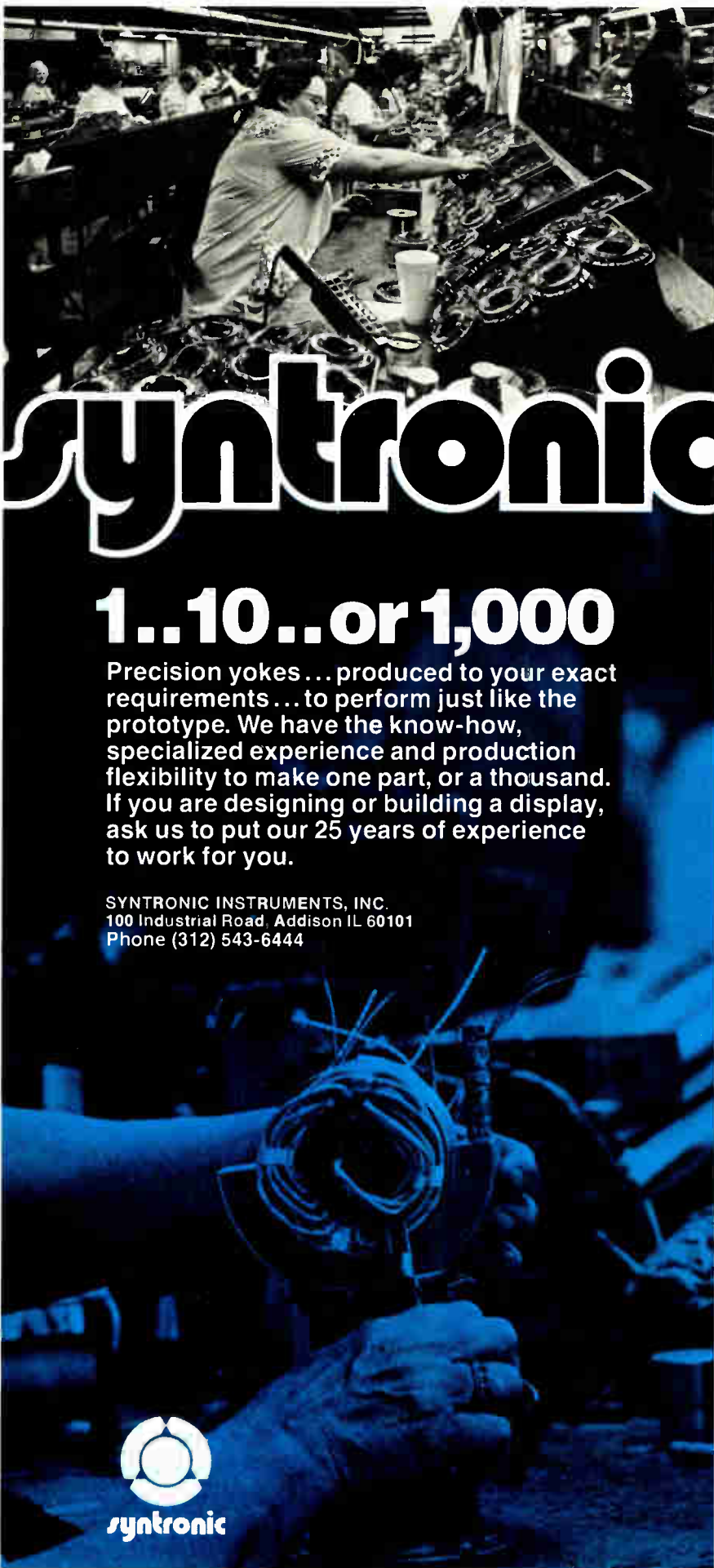

# syntronic

## 1..10..or 1,000

Precision yokes... produced to your exact requirements... to perform just like the prototype. We have the know-how, specialized experience and production flexibility to make one part, or a thousand. If you are designing or building a display, ask us to put our 25 years of experience to work for you.

SYNTRONIC INSTRUMENTS, INC.  
100 Industrial Road, Addison IL 60101  
Phone (312) 543-6444



## New products

hertz. Price starts at \$595.

Telonic Industries Inc., 21282 Laguna Canyon Rd., Box 277, Laguna Beach, Calif. 92652 [355]

Function synthesizer  
is programmable

The model GF 106 function synthesizer is a programmable unit that the company claims combines the advantages of a low-frequency synthesizer, digital function generator and digital phase generator. Sawtooth, triangle, square, and sinusoidal waveforms are obtained by coding the amplitude as a function of time in 600 time steps for signals



in the range from 0.001 hertz to 10 kilohertz and 40 time steps up to 100 kHz. Crystal-controlled frequency stability is  $10^{-6}$ /degree, resolution is  $10^{-5}$  of range, and signal linearity varies less than 0.5%. Price is \$995.

Schneider Electronics Inc., 3 Hazel St., Peabody, Mass. 01960 [353]

Isolation amplifier  
measures low noise

An isolation amplifier, model 207, measures low noise and offers high isolation for measurements requiring other than ground reference. The unit also offers a high common-mode rejection, which can be used to reduce the effect of ground loops



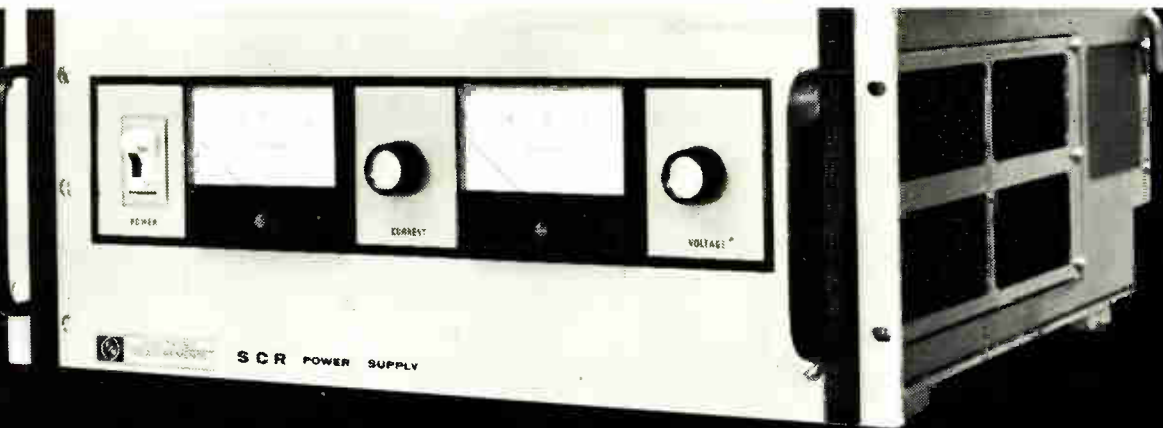

# POWER SUPPLIES

Electronic Measurements has designed and built many power supplies to solve a wide range of applications. Design reliability has been field proven since 1968. We have a wealth of application experience, and the flexibility to help solve your power supply problems. Call us.

The table shows the 0.1%-regulation SCR models and 1%-regulation EM models, but Electronic Measurements has a full line, bench-type and modular, with single and multiple outputs, from 5V to 500V and from 2.5A to 650A.

And there's more: remote sensing and programming, automatic E/I crossover, stability within 0.05%, full overload protection, rugged construction that's easy to service, and a five-year guarantee.

In Power Supplies, the best is Engineer Power, from Electronic Measurements. For a short-form catalog, use the Reader Service card, or contact Electronic Measurements.

Rating	Price	
	EM	SCR
6V-600A	\$1,900	\$2,200
7.5V-300A	1,200	1,400
10V-250A	1,200	1,400
10V-500A	1,900	2,200
20V-125A	1,100	1,300
20V-250A	1,500	1,800
20V-500A	2,300	2,700
30V-100A	1,100	1,300
30V-200A	1,500	1,800
40V-60A	1,100	1,300

Rating	Price	
	EM	SCR
40V-125A	\$1,400	\$1,700
40V-250A	2,100	2,500
50V-200A	2,300	2,700
80V-30A	1,100	1,300
80V-60A	1,400	1,700
100-100A	2,300	2,700
120V-20A	1,100	1,300
120V-40A	1,400	1,700

Rating	Price	
	EM	SCR
160V-15A	\$1,100	\$1,300
160V-30A	1,400	1,700
160V-60A	2,100	2,500
250V-10A	1,100	1,300
250V-20A	1,500	1,800
250V-40A	2,300	2,700
500V-5A	1,400	1,600
500V-10A	1,900	2,200

19" Rack, 20" depth. Voltage and current adjustable over wide range.

See EEM Vol. 1, Pages 673, 674, 675 for additional product information.



## ELECTRONIC MEASUREMENTS INC.

405 Essex Road, Neptune, N. J. 07753  
 Phone: (New Jersey) 201 - 922-9300 • (Toll-Free) 800 - 631-4298  
*Specialists in Power Conversion Equipment*

FROM SINGLE UNITS...  
to  
COMPLETE SYSTEMS

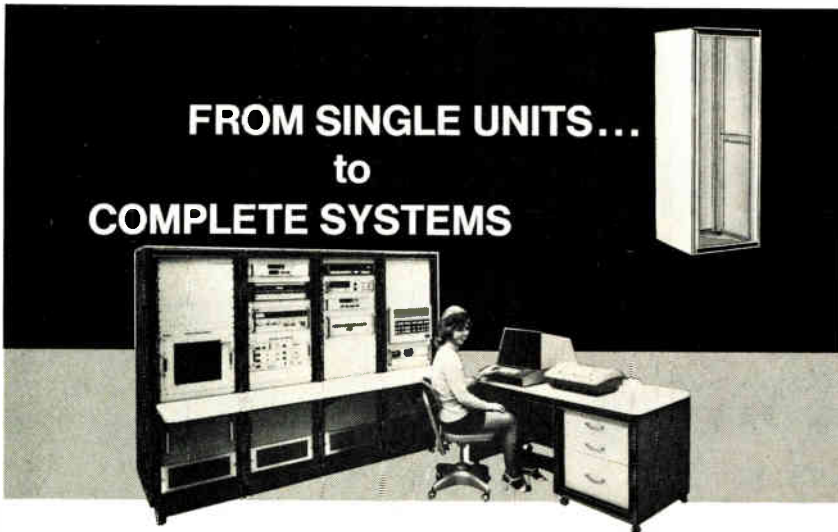

Specify VENT-RAK CABINETS

Your systems call for functional packaging. Vent-Rak cabinets provide an enclosure that affords protection, easy access and modern styling. In a compact package. Choose from a complete line of Vent-Rak standard cabinets in almost any size you might need. You can use them as free-standing individual units or multi-bay installations. You can even specify matching desk-style units. Your system will look like a system should look . . . sleek, efficient, reliable.

Vent-Rak cabinets are suitable for military, commercial and O.E.M. applications. Heliarc welded steel frames assure rugged construction. A wide range of optional features permits design flexibility. All units shown above are low-cost, rugged 6000 Series Cabinets . . . one of the six different series we offer. Specify a basic Vent-Rak Cabinet or a custom modification to meet your specific requirements. Write for full details.



DIVISION OF  
**GENERAL DEVICES COMPANY, INC.**

525 S. Webster Avenue, Indianapolis, Indiana 46219 • 317/359-5407 Telex 27-2169

Circle 234 on reader service card

Try it first. Send for a free sample.

# Tempilabel<sup>o</sup>



**Temperature Indicating Labels**

The center spot on a Tempilabel<sup>o</sup> turns black when the surface to which it is affixed reaches the specified temperature (from 100° to 600°F).

Tempilabels<sup>o</sup> are available with single spots, or with multiple spots for monitoring safe operating temperatures. They provide permanent temperature records, and are thus useful in designing components and selecting materials.

If you are not now using Tempilabels<sup>o</sup>, fill in the coupon. We'll be glad to send you a sample that you can try in your own plant or laboratory.

**Tempilabel<sup>o</sup>**

Division, Big Three Industries, Inc.  
Hamilton Blvd., South Plainfield, N.J. 07080  
Phone: 201 • 757-8300 • Telex: 138662

Send sample of Tempilabel<sup>o</sup>.  
For use at ° temperature.

Name \_\_\_\_\_

Title \_\_\_\_\_

Company \_\_\_\_\_

Street \_\_\_\_\_ City \_\_\_\_\_

State \_\_\_\_\_ Zip \_\_\_\_\_

**Can you spot  
your limitations?**

170 Circle 235 on reader service card

**New products**

of electromagnetic interference—important to medical applications, for example. Price is \$390.

Quan-Tech division, Scientific Atlanta Inc., 43 S. Jefferson Rd., Whippany, N.J. 07981 [354]

Miniature servo recorder offers 100-mV sensitivity

A solid-state miniature servo recorder provides a sensitivity of 100 millivolts full scale and a 0.5-second response speed full scale with an error of  $\pm 0.5\%$  of span. The recorder is available as an eight-speed unit with an input range from 0 to 10, 50, 100, or 500 millivolts, or



1 volt. Single range to 1 millivolt, single-speed thermocouple and thermistor ranges are optional. In addition, full-scale zero can be adjusted with a screwdriver, and the leads connect to the front or back. Price is \$349 or \$484, depending on the range.

Esterline Angus, Box 24000, Indianapolis, Ind. 46224 [356]

Thermocouple indicator has 1° repeatability

A digital thermocouple indicator with 1° repeatability over the temperature range from 0 to 1,370°C is called the model DS-530-T3. The unit has automatic zero-correction circuitry and digital linearization



# "We subjected the Augat plug-in socket panel to an accelerated-life test in order to induce contact failure."

## "We failed."

Dave Fillio  
Principal Engineer, Component & Materials Engineering  
Honeywell Information Systems

"We needed an interconnection system for controllers on the H716 mini-computer that could help us meet four basic requirements:

"High density to get as much as possible into a small package and still meet the increasing customer demand for a broad range of peripherals, each requiring a separate controller.

"The capability of automatically wiring, with a minimum of two-levels.

"Flexibility to permit anticipated design changes and still allow us to meet a very tight schedule.

"And finally, all these features had to be available in a standard product.

"The most logical approach seemed to be printed wiring boards. But to accommodate all our controllers could have required as many as eight boards. And we couldn't afford the room. Also, when recycling changes are taken into consideration, the design cycle of printed wiring boards becomes too long and, consequently, too costly.

"Multi-layering offered a minimum of flexibility, and it, too, was rejected.

"The only practical solution was the plug-in socket panel. And of all the vendors, Augat was the only manufacturer that could provide a completely uniform, broad range of standardized products, the lowest possible profile and maximum reliability.

"The reliability tests we

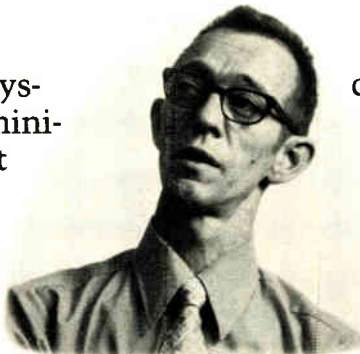

Dave Fillio

conducted on the Augat machined sockets included environmental exposures, accelerated-life, vibration, thermal shock, and durability. All tests with the Augat system were positive.

"From a field service standpoint, a key consideration with increasingly complex and flexible systems like the H716 is keeping them on the air at all times. Because of the reliability of the Augat interconnection system, we've had no reports of machine down-time associated with the Augat product since the introduction of the H716 eight months ago."

More and more companies like Honeywell are realizing that Augat socket-panels are an economical, reliable and totally flexible solution to interconnection problems, including development, production and field service requirements.

Augat's precision-machined tapered entry contact has made Augat the reliability standard for the industry. As the world's leading manufacturer of socket panels and other IC interconnection products, Augat is ready to help you solve your interconnection problems.

Call or write today for a free brochure and complete product information. Augat, Inc., 33 Perry Avenue, Attleboro, Massachusetts 02703. Represented and distributed internationally.



The H716

# AUGAT

Circle 171 on reader service card

# The Real Time Spectrum Analyzer you've needed...

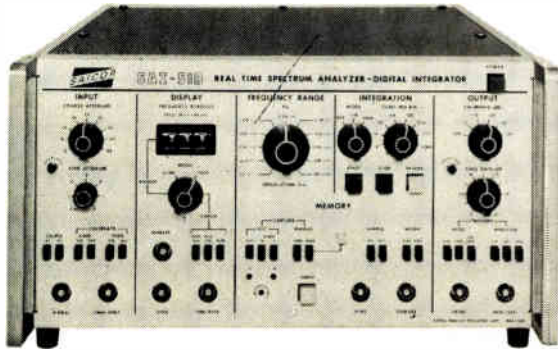

**is now within your budget!**

If you've been "making do" with sound level meters, tracking filters, wave analyzers or other limited frequency analysis techniques — we've got exciting news for you.

For only \$5000 you can now buy all the advantages of real time narrow band spectrum analysis with our 200-line Saicor 51B Real Time Analyzer/Digital Integrator... and get built-in spectrum averaging and linear, peak hold and exponential averaging modes. A superior frequency analysis technique for thousands of dollars less than ever before. Can you afford not to find out more? Call for a demonstration or write today for our free "25 Ideas" brochure.



## Honeywell

Signal Analysis Operation/Test Instruments Division  
595 Old Willlets Path/Hauppauge, New York 11787/(516) 234-5700

Circle 172 on reader service card

## Bridge Rectifiers



**IBR**  
SILICON  
CONTROLLED  
AVALANCHE  
INTEGRATED  
BRIDGE  
RECTIFIERS



Stud Mount



TO-3 outline  
mounting flange



Press-fit

- 10A and 25A ( $I_o$ ) single phase full-wave bridges
- 15A & 36A ( $I_o$ ), 3 $\phi$  full-wave bridges
- 100V, 200V, 400V, 600V ( $V_{RRM}$ )
- 250V, 450V, 650V minimum avalanche voltages ( $V_{BR}$ ) permit lower ( $V_{RRM}$ ) safety factors in design considerations
- Fast recovery series, 200 nsec. ( $t_{rr}$ )
- Low junction-to-case thermal resistance ( $R_{\theta JC}$ ) 1°C/W or less allows operation at full rated load to 100°C,  $T_c$

**\$2<sup>50</sup> ea.**

(10A, 200V, TO-3 mounting  
1000 qty.).



Design us in; we'll stay there

**VARO SEMICONDUCTOR, INC.**

P.O. BOX 676, 1000 N. SHILOH, GARLAND, TEX. 75040, 214/272-4551, TWX 910-860-5178

Distributed by:

**ALLIED ELECTRONICS**, Chicago, Ill. 312/421-2400. **THE ALTAIR CO.**, Houston, Tex. 713/462-3029, Richardson, Tex. 214/231-5166. **BELL INDUSTRIES**, Menlo Park, Cal. 415/323-9431; Skokie, Ill. 312/282-5400; Bellevue, Wash. 206/747-1515. **BLUFF CITY DIST. CO.**, Memphis, Tenn. 901/725-9500. **CRAMER ELECTRONICS**, Nationwide; Newton, Mass. 617/969-7700; **ELECTRONIC PARTS CO.**, Denver, Colo. 303/744-1992. **MILGRAY ELECTRONICS**, Freeport, N. Y. 516/546-6000; Hyattsville, Md., 301/864-1111; Cherry Hill, N. J., 609/424-1300. **WESTATES ELECTRONICS**, Chatsworth, Calif. 213/341-4411.

In Canada:

**ELECTRO SONIC**, Toronto, Ont. 416/924-9301. **R.A.E. IND. ELECTRONICS**, Vancouver, B. C. 604/687-2621. **PRELCO ELECTRONICS, LTD.**, Montreal, Quebec 514/389-8051. **WESTERN RADIO SUPPLY**, Hamilton, Ont. 416/528-0151.

172 Circle 236 on reader service card

## New products



that together eliminate the need to compensate the preamplifier and linearizer drift by periodic manual zeroing. Maximum zero drift is less than 1 microvolt over a six-month period, without additional adjustment. Price is \$299.

Doric Scientific Corp., 3883 Ruffin Rd., San Diego, Calif. 92123 [357]

## Fast Fourier transform unit plugs into any Nova

Consisting of one card that plugs into any Data General Corp. Nova minicomputer, the model 306 MFFT fast-Fourier-transform unit provides forward and inverse transforms, spectral magnitude, Hanning weighting, and complex multiply.

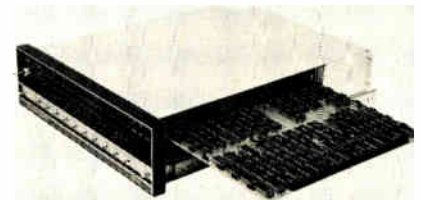

When used with a Nova 800, a 1,024 real-sample-time series can be transformed and the magnitude of the spectrum formed in 139 milliseconds. Time-domain signal-processing functions can be calculated at a rate of 2.8 microseconds per multiply-accumulate. Price is \$6,000.

Elsytec Inc., 212 Michael Dr., Syosset, N.Y. 11791 [358]

## Panel meter provides 20 readings per second

Providing up to 20 readings per second, a digital panel meter called the model 2000AS monitors outputs



# The \$100,000 control sub-assembly!

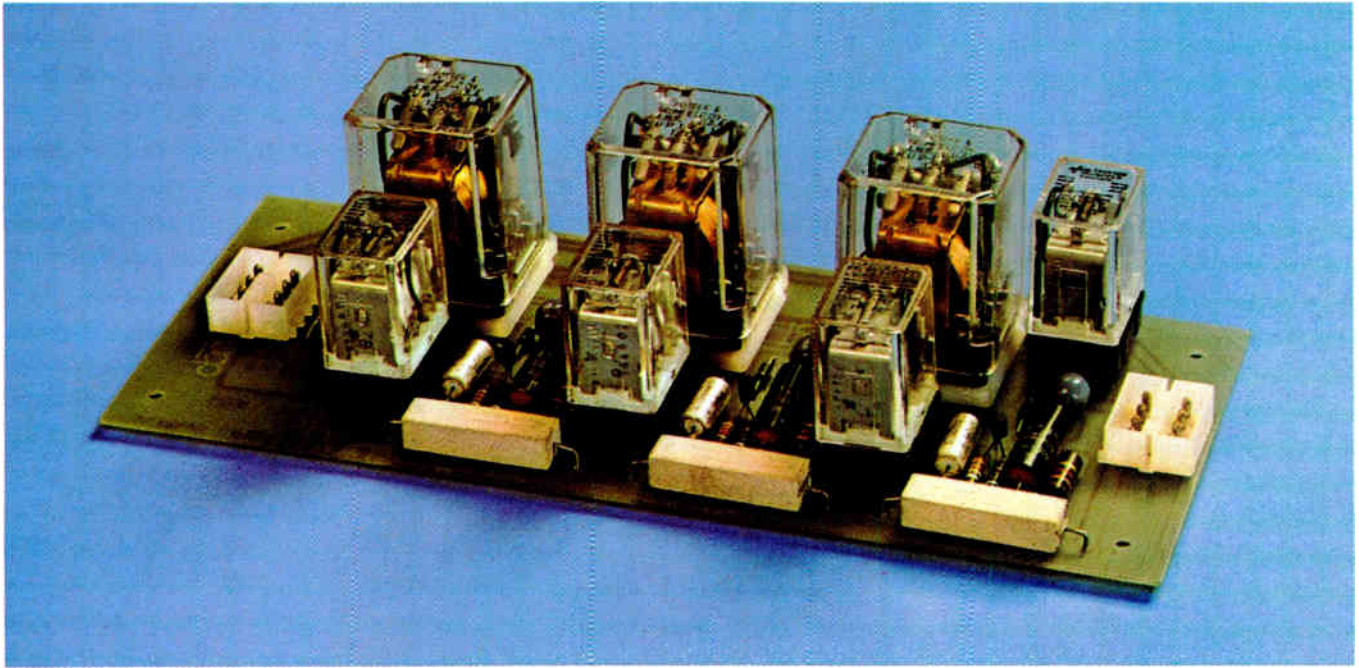

## A case for conducting your own "make or buy" analysis.

Initially, there may be no question about producing the control assemblies for your products in-house.

However, a careful "make or buy" analysis could save your company thousands of dollars.



Personnel—training, supervision, FICA, Workmen's Compensation, and many other contingent expenses—can contribute substantially to the cost of each unit you produce.



Special test equipment, jigs, fixtures, and machinery can represent a sizable capital investment. The extra costs of procuring, warehousing and controlling an extra inventory of parts and materials should be a part of your cost analysis. Floor space, too, is a very important consideration. When all costs are included, you could have \$100,000 invested before you produce that first assembly.

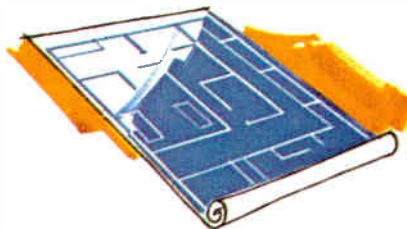

At Potter & Brumfield, we make thousands of control assemblies every month. We have the necessary people, equipment and test gear to produce your assemblies right and on time.

Also, we normally purchase the components we do not manufacture at maximum quantity discounts. Right there, the opportunities for savings are obvious.



Make a realistic analysis of all costs associated with your control assembly. Then, call us for a quotation. We think we can save you money. Perhaps lots of it.

Today, get in touch with your local P&B representative or call Potter & Brumfield Division of AMF Incorporated, Princeton, Indiana 47670. 812 385 5251.





# LOOK TO US FOR TOTAL CAPABILITY

## EMI FILTERS

### Pi Filters

Bushing sizes from .156 hex. to .500 hex.  
Rated 50 Vdc to 2500 Vdc

### L Section Filters

Available in these outside diameters .250, .312, .375 & .690  
Rated from 10 to 25 amps and from 50 Vdc to 240 Vac

### L, Pi, T Section Styles

.375, .410, .690 max. o.d.  
Ratings range from 50 Vdc to 150 Vdc 125 Vac to 240 Vac 10 amps to 25 amps

Multi-section Filters  
6 section, 12 section and many custom styles. U. L. types also available.

### L Filter

Solder Mount  
Rated 500 Vdc

### Pi Filters

Solder Mount  
Rated 250 Vdc to 500 Vdc

—EMC CONSULTING—  
APPROVED TESTING  
FACILITIES TO MEET:

MIL-STD-461 HEW 90-602  
MIL-I-6181 FCC PARTS 15 & 18

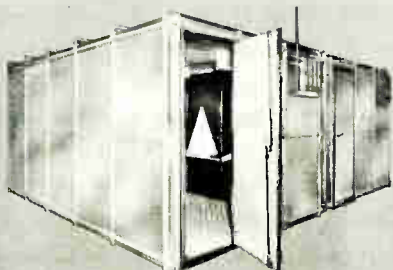

## SPECTRUM CONTROL INC.

152 EAST MAIN ST. • FAIRVIEW, PENNSYLVANIA 16415  
specialists in electromagnetic compatibility

SPECTRUM CONTROL, INC. has purchased the ALLEN BRADLEY COMPANY'S entire line of filters and capacitors, as well as their technology and patent rights. This acquisition now gives SPECTRUM CONTROL the broadest line of EMI/RFI filters and feed-thru capacitors in the electronics industry. We also hold more QPL listings to MIL-F-15733 than any other filter manufacturer. So whenever you need total capability, look to SPECTRUM CONTROL.

## FEED-THRU CAPACITORS

The most complete ranges of sizes, cap. values, and ratings, for your selection. MIL-C-11015 types.

## CERAMIC TRIMMERS

A full line of variable capacitors available in .218, .375 & .500 dia. MIL-C-81 types.

## MULTI-LAYER FEED-THRU CAPACITORS

These unique components are available in a wide range of capacitance values to 1 MFD.

Multi-layer feed-thru capacitors and miniature feed-thru filters designed for filtered connector pins.

## CERAMIC CHIP CAPACITORS

Available in sizes from .080 x .050 x .050 to .375 x .285 x .090 and the following dielectric characteristics: COG, X7R, X7S and X7U.



## New products

from process transmitters, signal conditioners, and transducers. Readings may be scaled as desired for direct readout, and one or two



optional fixed nonfunctional zeros at the right of the Sperry planar display are available for scale and weight-meter applications. Full-scale ranges from 400 millivolts to 400 volts are provided, with resolutions to 10 microvolts per digit. Delivery is from stock.

Newport Laboratories Inc., 630 E. Young St., Santa Ana, Calif. 92705 [359]

## Digital impedance meter

offers accuracy within 0.25%

A digital impedance meter with an accuracy within 0.25% measures inductance, capacitance, resistance and conductance. Four-terminal shielded connections and an external guard-signal help eliminate the effects of lead resistance, leakage or shunt impedances, and stray fields. In addition, the display has overload blanking to prevent false readings. Other features include external bias input for polarizing electrolytic capacitors or measuring diode capacitance. Price is \$990.

Electro Scientific Industries Inc., 13900 N.W. Science Park Dr., Portland, Ore. 97229 [360]

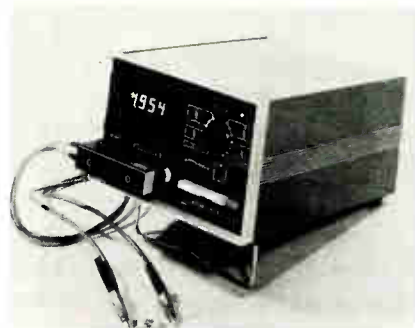

Digesting the extraordinary capabilities of Ramtek's new color graphic display systems is a little like turning a nine-year-old loose in a candy factory.

There's almost too much to swallow.

So let's take it one morsel at a time.

To begin with, Ramtek series Color Graphic Display Systems totally obsolete conventional process control display methods. You've seen, or are now working with, the archaic bank of meters, the slow tedious strip charts and the space taking plot boards.

All those techniques are now "out of it" with the introduction of Ramtek's solid state Color Graphics System. Our basic system begins with black and white alphanumeric display. Flicker-free color graphics and animated displays are created by using a non interlaced repeat field at 60 frames/sec, thus making a real time reporting system a reality.

Perhaps the most important features of our new systems are their flexibility and expandability. Our graphic systems feature multiple channel input and varying mixtures of resolution. The system is totally adaptable to the specific and changing needs of the user.

There's lots more to be said about our systems. Contact us for a demonstration of the potential savings in cost and time between a Ramtek Color Graphic Display and any combination of conventional display techniques.

Or, for some rather startling information about our new systems, contact: Ramtek Corporation, 292 Commercial Street, Sunnyvale, California 94086. Telephone: (408) 735-8400.

RAMTEK CORPORATION  
THE GRAPHIC DISPLAY COMPANY



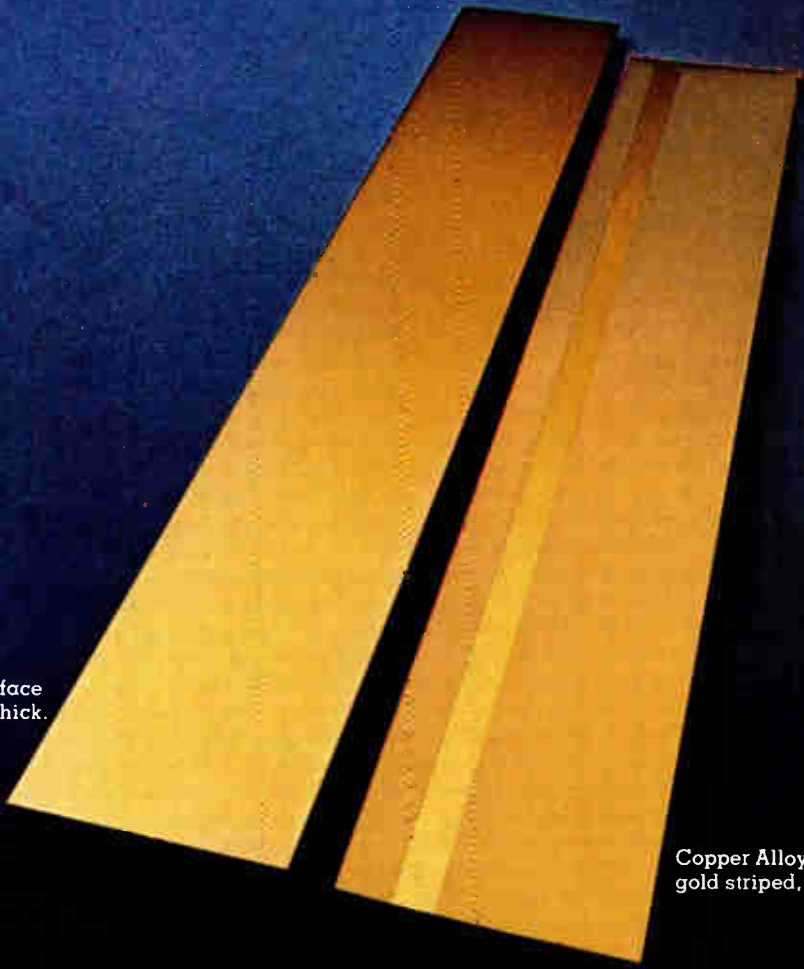

Phosphor Bronze, 100% of surface gold plated, 30 micro inches thick.

Copper Alloy 725, 3% of surface gold striped, 100 micro inches thick.

## Cut gold plating 90% on contact springs with CA-725.

CA-725 is the copper-base spring alloy that is rapidly becoming the standard of the electronics industry. Bare CA-725 has outstanding wrap-resistance stability. It's easy to solder and has good corrosion resistance without gold plating. Some gold is still used for resistance stability in critical circuits. But can be concentrated only where you need it... at the contact points.

That means proven cost reductions: Actual experience has confirmed CA-725's ability to cut gold plating by 90%. This substantially reduces the cost of the finished part even with increased gold thickness at the contact points. One main frame-connector user reports bare CA-725 connector springs with heavier gold at the contact points outlasted former springs by 10 times in wear tests.

Stay ahead of your competition: Copper Alloy 725 is rapidly gaining acceptance with the

largest electronic component users. You should know more about it. It is available from your regular brass and copper suppliers. Gold-striped material is available from composite metal producers. Call them today. Or write to Dept. 7173, The International Nickel Company, Inc., One New York Plaza, New York, N.Y. 10004.

The amount of gold you save depends on your design. Here is our calculation for an average-size connector spring:

Design	Spring Alloy	Gold Plating Thickness Micro Inches At Contact	Overall	Relative Amount of Gold Required
Overall plating	CA-510 (Phosphor Bronze)	30	30	10
Stripe	CA-725	100	Bare	1

# INCO

THE INTERNATIONAL NICKEL COMPANY INC. ONE NEW YORK PLAZA, NEW YORK, N.Y. 10004



Semiconductors

## Package boosts transistor yield

Technique for power devices eliminates voids between chips and housing

It costs Communications Transistor Corp., a Varian affiliate that makes rf and microwave transistors, more to make packages for its chips than to buy them. Nevertheless, last fall CTC installed its own packaging facility, in which packages are fabricated as tenderly as the chips themselves and from which a new package has now emerged. In it, the company is introducing several rf power devices.

"The higher assembly yield more than makes up for the extra manufacturing cost for the package," explains CTC president Tom Ciochetti. Rf power chips are packaged by bonding them to a gold pad on a ceramic substrate. CTC found that, no matter how it prepared the dice or performed the bonding operation, voids occurred between chip and bonding pad. Heat was then generated in the voids and power had to be derated.

The voids, CTC found, were caused by gases and other contaminants trapped to the metal film that came out of solution during the bonding process, when 400°C is applied to the bond for 30 seconds. To eliminate these voids, CTC decided it had to control the way the substrate was plated.

In its electroplating process, CTC uses ionized water, with constantly monitored resistivity of 18 megohms. To control contaminants, the same strict controls used in wafer fabrication are applied to making packages. As a result, CTC can now bond very large chips without voids. Its new package accommodates chips up to 50 by 220 mils.

To reduce costs, CTC has adapted a package structure that it has used successfully on nonmicrowave pack-

ages for three years. The new package consists of a metal flange to which is bonded a metalized (gold on moly-manganese) beryllium-oxide wafer. BeO has a high thermal conductivity but is an electrical insulator. A silicon-gold eutectic bond attaches the transistor chip to a metalized pad in the center of the upper surface of the BeO wafer. This pad is electrically isolated by a gap from the rest of the metalization covering the BeO wafer. It's the purity of the plating on the wafer that determines whether voids occur during transistor bonding.

Because the package is so large, CTC has been able to put an entire LC matching network inside, a step which increases the bandwidth of the device. Bandwidth depends on how the impedance of the chip, typically under 1 ohm, is matched to the impedance of the system, typically 50 ohms. Putting the matching network inside the package doubles effective bandwidth.

CTC mounts the capacitor on a 20-by-200-mil island next to the 50-by-220-mil island used for chip mounting. Inductance is a function of the size of the lead wires; the wires between die and lead frame must be of the same size, or inductance will vary from device to device. CTC uses a digitally programed bonder in which X and Y stepping motors control wire size and placement automatically.

Package size also affects bandwidth—the larger the distance across the package, the greater the inductance between the chip and the transmission line it is connected to. The CTC package measures 225 mils across, the same as the standard small low-parasitic, microwave package made by Microwave Semiconductor Corp. CTC has boosted power ratings by stretching its package laterally.

Into this new package, CTC is putting:

- The CD 2155, matched for 600–1,100 megahertz, minimum power output 38 watts at 28 volts.
- The CD 2146, matched for 1–2 gigahertz, minimum power 20 w at 28 v.
- The L-25-28, matched for L band,

# Liquid Rivets, Bolts, Nails, Staples, Etc.

One drop goes a long way in fastening almost anything to almost anything.

Metals, for instance. And plastics. And ceramics. And rubber.

Eastman 910® adhesive bonds fast, too. Almost instantaneously. With only contact pressure.

Tensile strength? Up to 5,000 psi at room temperature.

New Eastman 910 MHT and THT grades hold when the heat is on. Even over 400°F.

For further data and technical literature, write: Eastman Chemical Products, Inc., Kingsport, Tennessee 37662.



# MASTER-MITE™

## NEW HEAT GUN FROM MASTER



Now bring a new dimension to heat shrinking as well as countless other industrial applications. Easier to handle... only two pounds with nozzle... perfectly balanced.

Three easily interchangeable color-coded nozzles to speed specific jobs. Silver (standard)... used for most shrinkables (475°F.). Blue nozzle for Mylar\* (500°F.)... and Black for Teflon\* (800°F.) both optional equipment. Nozzles can be changed in seconds.

For information on our exciting 1974 Rio de Janeiro Incentive Travel Program, write now for our special brochure.

Draws only 5.4 amps. High impact housing withstands hard knocks of shop use. For information on the new Master-Mite Heat Gun or the full line of Master Heat tools, contact your distributor or write:

\*Reg. Trade Name of DuPont

**MASTER**

appliance corporation

Racine, Wisconsin 53403  
Phone 414/633-7791

Circle 178 on reader service card

## MICROTEMP Time Delay MultiProtector

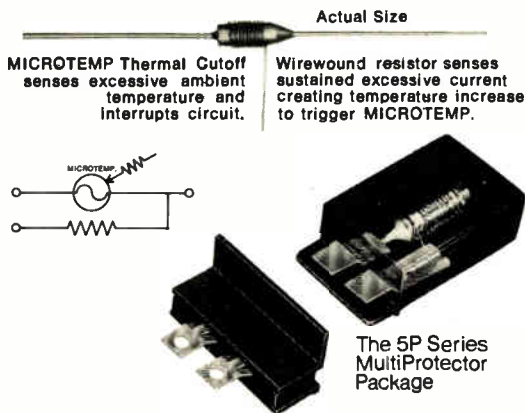

MICROTEMP Thermal Cutoff senses excessive ambient temperature and interrupts circuit.

Wirewound resistor senses sustained excessive current creating temperature increase to trigger MICROTEMP.

The wide selection of MICROTEMP temperature ratings and resistor values provide an infinite selection of time delay factors. Small overload surges are ignored by the MultiProtector. Available in convenient terminations or packages for installation ease, MICROTEMP Time Delay Multi-Protectors are custom designed to fulfill your specific current and/or thermal overload condition. For illustrated brochure and details regarding your application, call or write:



**MICRO DEVICES CORP.**

1881 Southtown Blvd., Dayton, Ohio 45439  
Ph. (513) 294-0581 Telex 28-8087

178 Circle 237 on reader service card

## New products

with 25 w minimum at 28 v.

■ The DM 100P, a pulsed transistor matched for 960-1,215 MHz, minimum power 100 w (10-microsecond pulse at 1% duty) at 43 v.

■ The CD 2147, matched for 960-1,215 MHz, 35 w at 28 v.

Communications Transistor Corp., 301 Industrial Way, San Carlos, Calif. 94070 [411]

## Tuning diodes designed for uhf applications

The HA1217A line of tuning diodes offers a capacitance change from 5.5 to 1.5 picofarads for a bias-voltage change from 3 to 8 volts. Package capacitance is specified at 0.15 pF

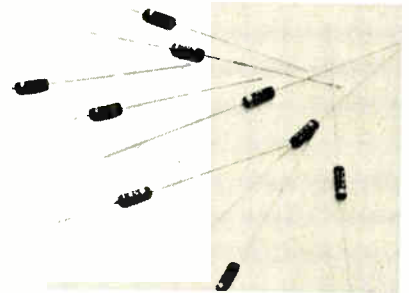

and inductance is rated at 2.5 nanohenries. The units are useful for applications in the uhf range. The hyperabrupt diodes also offer a Q of 400, measured at 50 MHz and 4 volts bias. Price is \$12 in 100-lots.

MSI Electronics Inc., 34-32 57th St., Woodside, N.Y. 11377 [415]

## Temperature transducer has -55° to +125°C range

A temperature-measurement and -control system, called the LX5600, is for use over the temperature range from -55° to +125°C. The transducer consists of a temperature sensor, stable voltage reference, and an operational amplifier fabricated on a single monolithic chip. The output is a voltage directly proportional to temperature in degrees Kelvin. With zero gain set around the internal op amp, the output is 10 millivolts per °K, but by adjusting the gain with external resistors, al-

# SIEMENS

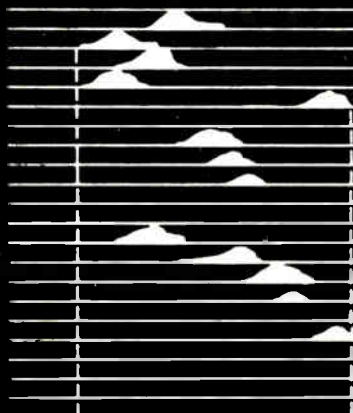

## Seizure of Nominal Value Deviations – considering previous events

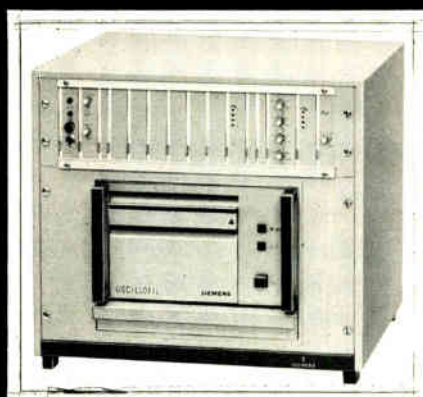
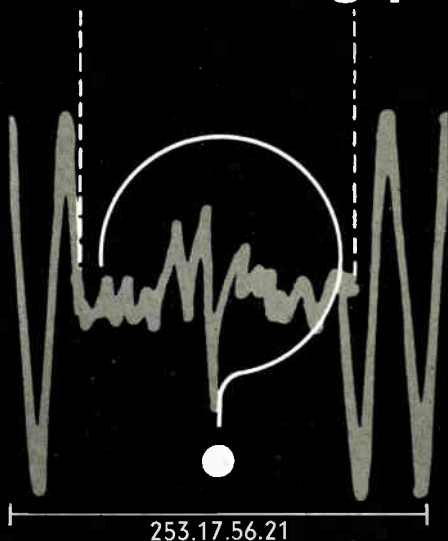

What caused the anomaly? Which variable quantities are effected? How long does the nominal value deviation last? What eliminated it eventually? – Questions, needing answers to make an exact fault analysis possible. OSCILLOSTORE® helps you to answer such questions. Because OSCILLOSTORE can monitor all continuous processes which can be represented through electrical signals up to 10 kHz. OSCILLOSTORE simultaneously registers, depending on task, up to 32 measurement values for milliseconds or minutes.

OSCILLOSTORE reacts as soon as the monitored measurement value exceeds its limits: A connected recording device is switched on to record the delayed measurement value – a few undisturbed periods, then the process of the entire disturbed measurement value and finally the recurrence of the nominal value.

Would you like to know more about OSCILLOSTORE? Where this modular system has been applied successfully in electrical power stations or processing systems?

Please write to:  
Siemens Aktiengesellschaft,  
ZVW 133,  
7500 Karlsruhe 21,  
Postfach 21 1080.

in USA to:  
Siemens Corporation,  
186 Wood Avenue South, Iselin,  
New Jersey 08830

in Canada to:  
Siemens Canada Limited,  
7300 Trans-Canada-Highway,  
Point Claire 730, Québec

## with the OSCILLOSTORE by Siemens

Circle 179 on reader service card



# FLICK.

The great American switch.

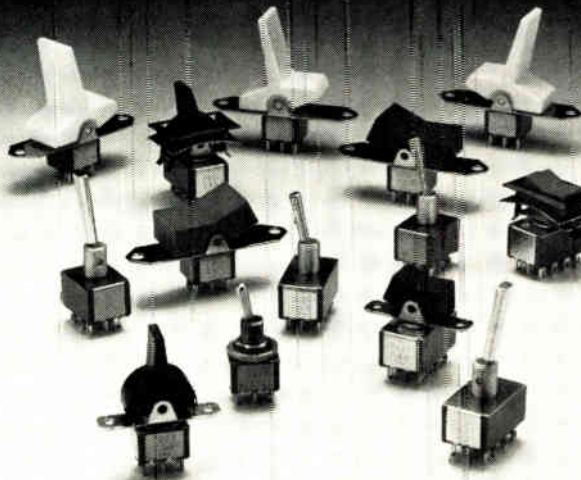

The most complete line of UL listed subminiature switches.

Subminiature toggles, rockers and paddle handles by C&K. The most complete line. All models and all options UL listed. Best quality. Best price. Best delivery to any place in the world. Now there's a *switch*. Get the catalog.

**C&K COMPONENTS, INC.**  
103 Morse Street, Watertown, Mass. 02172  
TEL: (617) 926-0800 - TWX: 710 327 0460  
The great American switch.

Engineering samples on request.

"See us at Nepon Southwest"

Circle 238 on reader service card

## Heath 15 MHz scope with triggered sweep...

just \$329.95\*  
in Kit form...

only \$475\*  
Factory  
Assembled &  
Calibrated



An excellent bench or design scope at low cost. DC-15 MHz vertical bandwidth with 24 ns risetime ...10 mV input sensitivity ...12 calibrated vertical attenuator positions up to 50 V/cm...1 megohm/40 pf Input: Z protected up to

600 VDC...22 calibrated time bases from 2 s/cm to 0.2  $\mu$ s/cm... x5 magnifier...normal or auto triggering...AC/DC coupling...ext. trigger input...built-in calibrator...6 x 10 cm screen... 120/240 VAC operation. Send for FREE catalog for complete details & specs.

Kit IO-104, 44 lbs. .... \$329.95\*  
Factory assembled & calibrated SO-106A, 40 lbs. .... \$475.00\*

Send for  
**FREE catalog**  
**NOW!**



HEATH	
Schlumberger	
Heath Company, Dept. 53-4 Benton Harbor, MI 49022	
<input type="checkbox"/> Please send latest Heathkit catalog.	
Name _____	
Address _____	
City _____	
State _____	Zip _____
*Mail order prices; FOB factory	
TE-304	

## New products

most any scale factor can be obtained. Price is \$13.35 in 100-lots. National Semiconductor Corp., 2900 Semiconductor Dr., Santa Clara, Calif. 95051

Three-state circuits are for bus design applications

A series of monolithic C-MOS three-state interface circuits is for use in common-bus design applications. The devices, designated HD-4800 series, have gating functions that allow information to pass through a system or be disconnected from the system. When information is discon-

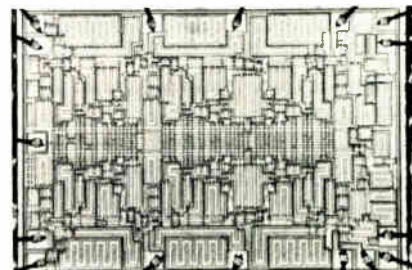

nected, the logic function is essentially removed from the bus, eliminating the load effects between that element and other active elements. Six new devices offer an array of circuits capable of adapting to any requirement; they are priced at \$6.15 or \$7.65 in 100-lots.

Harris Semiconductor, Box 883, Melbourne, Fla. 92301 [417]

IR-emitting diode chip built for hybrid circuits

The SG1007 is a gallium-arsenide infrared emitter in chip form. The chip measures 0.016 by 0.016 by 0.007 inch typically, and is intended for use in the fabrication of electro-optical hybrid circuits, especially in card readers, solid-state relays, and photo-coupled devices. Wavelength of peak radiant intensity is 940 nanometers. When the device is operated in continuous service, it provides a typical radiant flux of 2.3 mW at 100 mA.

RCA Electronic Components, 415 S. 5th St., Harrison, N.J. 07029 [418]

# GREATEST YIELD IN THE ELECTRICAL FIELD

**Allegheny Ludlum gives designers  
more for their money.**

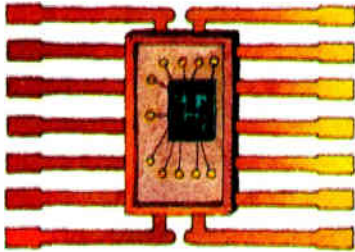

Critical demands for leadframes in semiconductors are more than semiffilled by Allegheny Ludlum. Our product range and consistently high quality fill numerous needs.



Wider strip? In widths up to 25 inches, our electrical alloy strip yields more good parts faster to cut costs. Sheet? Plate? Bar? Get the best... for laminations and shieldings. Motors. Transformers. Generators. Relays. Solenoids. Vibrators. Cores. Check our Sealmet alloys. Or Ohmaloy. Mumetal. Moly Permalloy, etc.: all products of strict A-L quality control... from computerized melting to final shipment... for consistently superior characteristics.



We can earn your seal of approval... with special steels for glass-to-metal seals: AL 42 and 4750. Sealmet 1 and 4. AL 430Ti. And others. All meet tightest tolerance requirements... for sealed-beam headlights, fluorescent lights, electronic tubes.

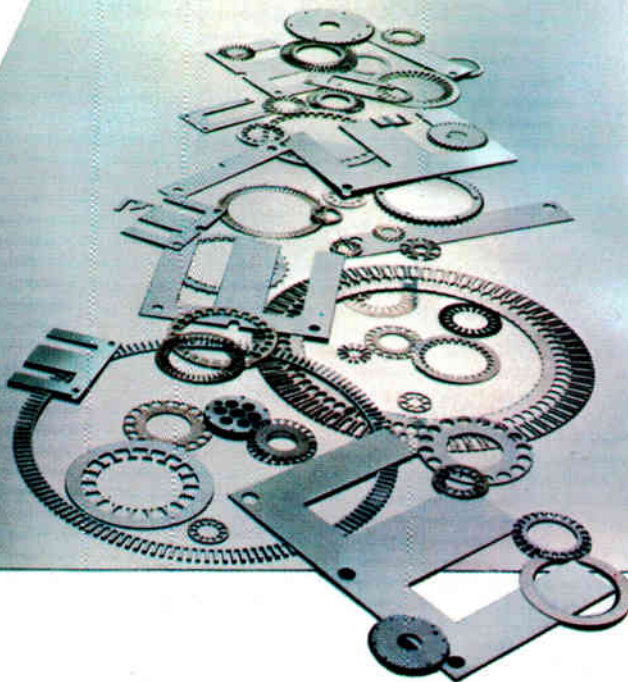

A pioneer in developing magnetic shielding materials, we stock Mumetal and Moly Permalloy for prompt delivery. Our Research Center, most elaborate in stainless and specialty alloys, helps solve special shielding problems.



For more on how America's leading producer of stainless and specialty alloys can help you in the electrical field, write: Allegheny Ludlum Steel, Dept. 432, Oliver Building, Pittsburgh, Pa. 15222.



**Allegheny Ludlum Steel**  
Division of Allegheny Ludlum Industries



# Cinch adds sum logic to I.C. logic board logistics



Some people stop half way. Sum people get it all together, like TRW/Cinch Connectors does with its new integrated circuit logic boards.

Working from the logic of a national distribution network to assure fast, off-the-shelf delivery on popular board configurations, Cinch assembled the features and flexibility that facilitate prototyping and short production runs:

1. Universal boards accommodating 14 to 40-lead plug-in IC's and high density DIP boards in 14 and 16-pin patterns (in 30-pattern multiples up to 180).
2. Socket terminals that accept varying sizes of DIP leads and round pins, with a choice of two and three-level wire wrap\* terminals for high wiring density and flexibility in circuit changes.
3. A full line of accessories—adapter plugs—input/output plugs, board interconnectors, and edge connectors.
4. FR-4 epoxy glass boards, 1/8 or 1/16 in., with power and ground planes on each side connected to each pattern.

For special requirements, our application engineers are available to assist in developing custom boards. These can be produced with minimum turn-around time at our extensive manufacturing facilities.

To sum up: design flexibility, distributor stocking, and custom board availability point to Cinch Connectors as your logical source for IC logic boards.

Available nationwide through these distributor networks

Pioneer-Standard Electronics  
Rampart Components  
RESCO Electronics  
Sterling Electronics  
Wilshire Electronics

Dial toll-free (800) 645-9201 for the name and phone of your nearest facility.

For additional information see listings in EEM Vol. 4 or contact your TRW/Cinch logic board distributor or TRW/Cinch Connectors, An Electronic Components Division of TRW Inc., 1501 Morse Ave., Elk Grove Village, Illinois 60007; (312) 439-8800. CC-7311

\*T.M. Gardner-Denver



## New products

Data handling

### System samples 64 channels

Data-acquisition setup for differential transducers offers 300-volt range

Because operational amplifiers and analog-to-digital converters operate in a common-mode range of 10 volts, data-acquisition systems are generally also limited to the same range. But some applications using differential transducers, as in the making of sheet materials like paper, require floating transducers of several hundred volts, common mode.

By using a flying-capacitor technique to disconnect the converter's analog inputs from the actual external signals at the time of conversion, Datel Systems is able to offer a common-mode range of  $\pm 300$  v in its model DAS-300CMV, a 64-differential-channel data-acquisition system. The input transducers have up to a  $\pm 10$ -v difference, but with respect to ground, there can be up to a 300-v difference.

In the flying-capacitor technique, each of the 64 mercury-wetted reed relays has a double-pole, double-throw switch. Each relay first samples the differential transducer input, puts it across a nonpolarized capacitor, and then transfers that voltage to an a-d converter. Each switch is digitally controlled by a channel selector.

The system operates in either of two modes. In the single-scan mode a single-channel switch pair is closed, the input is transferred to the converter and allowed to settle, the switch is opened in sequence, and the cycle is repeated. Each channel has a conversion rate of about 5 milliseconds.

In the multiscan mode all 64 pairs of reed switches are closed simultaneously, and a very fast solid-state FET analog multiplexer samples the 64 analog values held on the capaci-

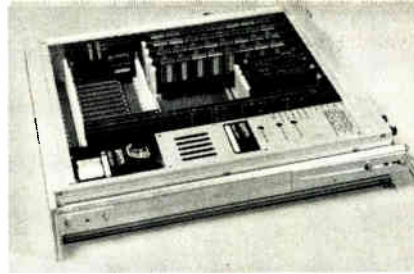

tors at a 50-kilohertz rate in about 1 ms. All 64 channels can be cycled every 5.5 ms, allowing for reed-switch signal-acquisition time, settling, and conversion. Both the controller and multiplexer are C-MOS devices, so power dissipation is low, about 70 watts from an ac line.

The DAS-300 accepts analog differential voltage inputs of 0 to +5 v and 0 to +10 v unipolar, or  $\pm 5$  v and  $\pm 10$  v bipolar. These inputs are converted into 8-, 10-, 12- or 14-bit binary words by the converter; there are small differences in settling time. Inputs can be sequentially or randomly addressed under external computer control in the single-scan mode, making possible different scanning speeds.

Common-mode rejection ratio from dc to 1 hertz is 100 decibels, with a 1-kilohm source imbalance. Linearity is within  $\pm 0.01\%$  of full scale. Temperature coefficient of zero (offset) is  $\pm 15$  ppm/ $^{\circ}\text{C}$  of full scale, and range (gain) temperature coefficient is  $\pm 13$  ppm/ $^{\circ}\text{C}$ . Over-all system accuracy is within  $\pm 2.5$  v,  $\pm 1/2$  least significant bit. Nominal input impedance is  $10^{10}$  ohms.

Power supplies of  $\pm 15$  v and  $\pm 5$  v are included in the DAS-300, which is powered by a conventional 115-v, 60-Hz ac line. The relays are energized by a separate internal 12-v supply to isolate the signal sections from relay transients.

The DAS-300CMV is priced at \$4,121 for a 64-channel, 8-bit system. Delivery time is four weeks.

Datel Systems Inc., 1020 Turnpike St., Canton, Mass. 02021 [361]

Digital printers operate  
at three lines per second

Containing the electronics on a printed circuit board, the model DM-300 series of digital printers offers the power supplies and print mechanisms as separate components. Printing speed is three lines per second for a maximum of 18

# Pistoncap™ TUBULAR TRIMMER Capacitors

NOW IN EXPANDED  
RANGE DESIGNS



Expanded capacitance range is featured in a new series of sealed PISTONCAP tubular trimmer capacitors.

Ten different capacitance range ratings are available in both panel mounting and printed circuit mounting styles. Capacitance ranges may be selected from 1 pF min. to 14 pF max. to 1 pF min. to 120 pF max.

A low-loss glass dielectric embedded electrode construction results in high stability under conditions of changing frequency, voltage, temperature, and other environmental parameters.

All of these new PISTONCAP capacitors feature a multi-lobe seal at the adjust end with a simplified long-life adjust mechanism. All meet or exceed MIL-C-14409C requirements.

For full technical information, ask the Sprague Electric district office or sales representative nearest you for Bulletin 203.

PISTONCAP trimmer capacitors are available for immediate delivery from stocking Sprague distributors.

SPRAGUE  
GOODMAN

Sprague-Goodman  
Electronics, Inc.

(An Affiliate of the Sprague Electric Company)

371 Willis Ave., Mineola, N.Y. 11501  
516/746-1385

# Brain Trust.

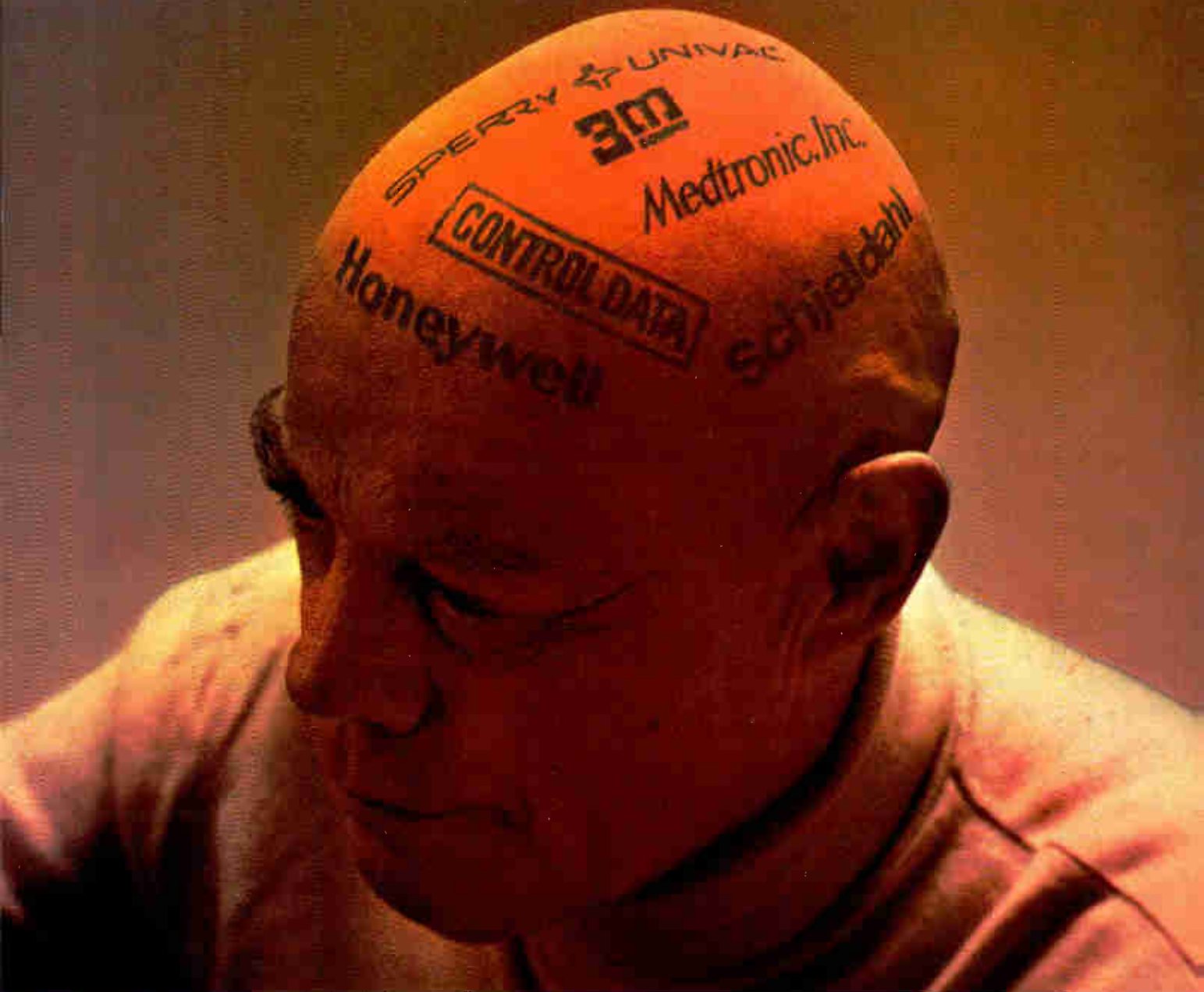

These leading "knowledge" firms have a bright idea for you. Minnesota.

By "knowledge," we mean the scientific-technical kind.

The kind behind the growth of 3M, Medtronic, Control Data, Schjeldahl, Honeywell, Sperry Univac and hun-

dreds of Minnesota companies who depend on the most current state of the art in many disciplines.

They'll tell you why it's so profitable to locate here.

More scientists in the labor force. More dollars invested in research. More em-

phasis on education.

Plus other resources that equate with a superior Quality of Life.

Write and we'll tell you more. Minnesota Department of Economic Development. 480 Cedar Street, St. Paul, Minnesota 55101. (612) 296-5021

## It's good to be in Minnesota.



## New products

columns. The print drum has 13 positions per column and can print 40 characters and numbers. Other print drums are available with a greater selection of characters. The OEM version is priced at \$340.

Keltron Corp., 225 Crescent St., Waltham, Mass. 02154 [365]

Communications terminal transmits at 19,200 bauds

The CT-6 communications terminal provides users who have data-rate requirements in excess of 9,600 bits per second a system comprised of a blexer and two modems. The system provides full-duplex data transmission at speeds up to 19,200 bits per second by combining the capacity of two independent voice-grade channels. The unit also offers automatic and semiautomatic fall-back



and fall-forward capabilities, which maintain a communications link despite line degradation and failures. Codex Corp., 15 Riverdale Ave., Newton, Mass. 02195 [366]

Tape-cassette system is for Nova computers

Designated Zipper, a tape-cassette system is designed to interface with Data General Corp. Nova mini-computers. The interface is contained on a standard-size board and connects directly to a low-priced entertainment-grade cassette recorder, which needs no modifications. Zip-

per is primarily a replacement for low-speed paper-tape input/output; it can load a 4,000-word Nova 1200 in less than 90 seconds. Price is \$500

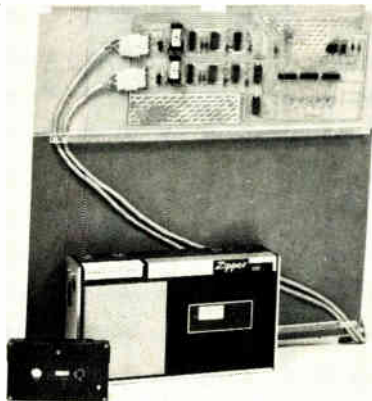

per is primarily a replacement for low-speed paper-tape input/output; it can load a 4,000-word Nova 1200 in less than 90 seconds. Price is \$500

for a complete system including cassette tape transport, interface and software drivers. Progressive Systems, 215 First St., Hockens, N.J. 07423 [367]

Disk/controller for PDP-11 stores 256,000 words

A plug-compatible disk/controller system for the Digital Equipment Corp. PDP-11 family of mini-computers is designated the model M-200D/11, and is a replacement for DEC's RS11/RF11 series. The basic model offers 256,000 words of storage, and it is expandable in 256,000-word increments to 2 million words by adding four disk drives. Capacities below 256,000 words are also available. Average access time is 12.5 milliseconds. Unit price of the M200D/11 is \$12,145 for up to four systems.

Okidata Corp., 111 Gaither Dr., Moorestown, N.J. 08057 [368]

Nonimpact printer handles 3,200 characters/second

The Videoprint 615 is a nonimpact printer that produces up to 6,000 lines a minute by using a cathode-ray tube and fiber optics. This enables the unit to print up to 3,200

**1**  
AMERICAN MADE  
**Tolerance**  
**SCHAUER**  
**1-Watt**  
**ZENERS**

**Immediate Shipment**  
**Low Prices**

ANY voltage from 2.0 to 16.0

Quantity	Price each
1-99	\$1.07
100-499	.97
500-999	.91
1000-4999	.86
5000 up	.82



All welded and brazed assembly

No fragile nail heads

Gold plated leads

Write for complete rating data and other tolerance prices.

**Buy the kit-**  
**Save a lot**

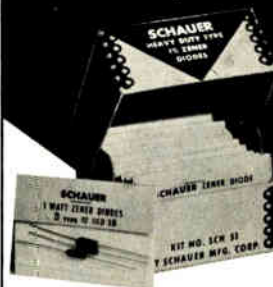

Kit contains a 51-piece assortment of SCHAUER 1% tolerance 1-watt zeners covering the voltage range of 2.7 to 16.0. Three diodes of each voltage packaged in reusable poly bags. Stored in a handy file box. Contact your distributor or order direct.

A \$54.57 value for  
**ONLY \$24.50**

Semiconductor Division  
**SCHAUER**  
Manufacturing Corp.

4514 Alpine Ave. Cincinnati, Ohio 45242  
Telephone: 513/791-3030



# ALCOSWITCH®

Now! Miniature PC Slide Switches with toggle switch reliability. Used for programming, test equipment, instrumentation. Low profile with choice of top or side lever. Rated 2 amps @ 230 VAC, 4 amps @ 115 VAC. Gold contacts available for dry circuits.

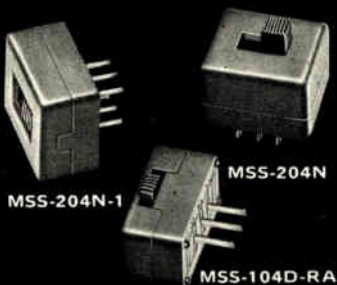

**ALCO** ELECTRONIC PRODUCTS, INC.  
1551 OSGOOD STREET, NORTH ANDOVER, MASS. 01845

Circle 103 on reader service card

# ALCOSWITCH®

New miniature right angle PC Toggle Switches. Plain or threaded bushing. Silver contacts & terminals. Used on computers, instrumentation, medical equipment. Rated 2 amps @ 230 VAC, 4 amps @ 115 VAC. Optional gold contacts available.



**ALCO** ELECTRONIC PRODUCTS, INC.  
1551 OSGOOD STREET, NORTH ANDOVER, MASS. 01845

Circle 186 on reader service card

## Easy Access At Newest Plant Site In Rochester, New York

The Outer Loop Industrial Park is right next to a freeway system that connects you with the New York State Thruway and the World. Expressways also lead you straight to the profitable Rochester market.

Neighboring companies know the benefits of this fine location on Rochester's west side. Some of them are Eastman Kodak, Bendix Corporation, 3M Company, General Motors, and Ragu Foods.

Railroad service is available on-site and an airport served by three major airlines is minutes away via the freeways. The Port of Rochester, a few miles to the north, has deep water accommodation for ocean-going vessels.

For more information, contact Robert J. Hall, Director of Area Development, Rochester Gas and Electric Corporation, 89 East Avenue, Rochester, New York 14649 or call (716) 546-2700, ext. 2466.

We know more about sites in our nine-county area than just about anyone else. Contact us for information on available facilities from 10,000 to 800,000 square feet.

**RGE** ROCHESTER GAS AND ELECTRIC  
89 EAST AVENUE ROCHESTER N.Y. 14649 • 546 2700

186 Circle 239 on reader service card

## New products

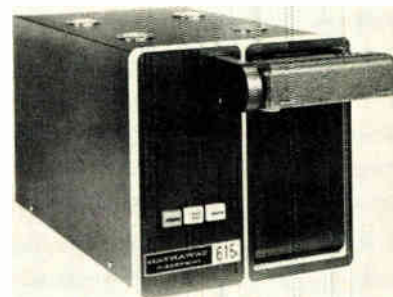

characters per second synchronously or asynchronously. The machine can link to computers, and the following logic levels or their complement are accepted: logic 1, +2.4 to +5 V and logic 0, 0.0 to +0.4 V.

Hathaway Industries, Tulsa, Okla. 74105 [369]

## Computer monitor offers real-time display

The Micro-Sum model 1020-D computer-monitor system provides a real-time display of 16 factors and 20 sensors. The system includes ½-inch magnetic-tape recorder and a report generator. The 1020-D monitors the frequency and duration of activity taking place within the host computer and records the data on the magnetic tape. Activity is measured in time intervals selected by the operator and ranges from 2 seconds to 72 minutes. Price is \$13,500, or \$460 per month for a lease of less than three years.

Tesdata Systems Corp., 7900 Westpark Dr., McLean, Va. 22101 [370]



Electronics/April 4, 1974

Reliability is buying 100 DPM's and having less than five fail in your plant — or in the field, installed in your instrument.

You're probably *not* getting reliability now and it's costing you \$5, \$10, up to \$25 *extra* for every DPM you buy — not only for the ones that fail, but the ones that don't too!

Consider the paperwork costs, the shipping costs, the downtime costs, and the cost of useless inventory; and you'll see we're right. Then add on customer frustration,

wasted time, mistakes on vital readings — and the cost will *really* mount up.

LFE has a complete line of the most reliable DPM's available today. Not according to "calculated MTBF" numbers, but actual experience. The initial cost is probably a little higher than less reliable units, but you pay less — and worry less — in the long run.

LFE Digital Panel Meters, Digital Control Meters, and Digital Temperature Indicators are available in models ranging from 2½

digits to 4¾ digits. For complete specifications and for applications assistance on LFE's Digital Panel Meters, Digital Temperature Indicators, and Digital Control Meters, call or write LFE Corporation, 1601 Trapelo Road, Waltham, Massachusetts 02154, telephone (617) 890-2000.



CORPORATION

Process Control Division

Circle 187 on reader service card

a new concept in  
digital panel meters...  
**RELIABILITY**



**INTERDATA  
ANNOUNCES  
THE INDUSTRY'S  
FIRST \$3200  
MINICOMPUTER  
TO CHALLENGE  
THE NOVA.**



# PDP-11 PERFORMANCE AT A NOVA 2 PRICE.

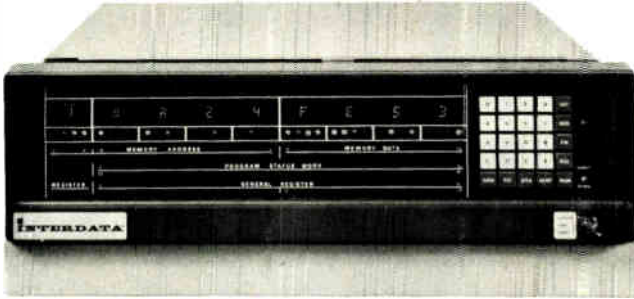

Minicomputer myths you can live without:

1. There is no such thing as a high-performance, low-cost minicomputer.
2. You have to choose between two extremes — pay a ton for a machine like the PDP-11 and save on software costs, or buy a cheapie like the Nova 2 and pay the price later.

All wrong.

Because now there's the Interdata 7/16 — an extremely flexible 16-bit OEM minicomputer that combines the best of both worlds.

It's easier to program than the PDP-11 because it has 16 hardware registers, up to 64K bytes of directly addressable main memory, 255 I/O interrupts with automatic vectoring to service routines and a comprehensive set of more than 100 instructions. That's a lot of muscle.

It's completely modular in design — plug-in options can be installed in the field to meet your specific application requirements.

Options like multiply/divide, programmers' console with hexadecimal display, power fail/auto restart, memory protect and a high-speed Arithmetic Logic Unit that includes floating point hardware. In fact, you can expand the low-cost 7/16 all the way up to the 32-bit Interdata 7/32.

Yet it costs as little as \$3200. Just like the machines that give you the barest minimum. And quantity discounts can reduce that low price by as much as 40%.

Performance	7/16	Nova 2/4	PDP-11/05
Data word length (bits)	4, 8, 16	16	1, 8, 16
Instruction word length (bits)	16, 32	16	16, 32, 48
General-purpose registers	16	4	8
Hardware index registers	15	2	8
Maximum memory available (K-bytes)	64	64	64
Directly addressable memory (K-bytes)	64	2	64
Automatic interrupt vectoring	Standard	Not available	Standard
Parity	Optional	Not available	Special order
Cycle time (usec.)	1.0 or 0.75	1.0 or 0.8	0.9
Available I/O slots	4	2	2

Price	7/16	Nova 2/4	PDP-11/05
8 KB processor	\$3,200	\$3,200	\$4,795
16 KB processor	3,700	3,700	6,495
32 KB processor	5,300	5,300	10,895
Multiply/Divide option	\$950	\$1,600	\$1,800
Floating Point option	\$4,900	\$4,000 plus \$1,000 for 2/10 configuration	Not available

Source: Data General Price List, Copyright 1973, and addendum dated 5/15/73. Nova 2/4 bulletin 012-000060, 1973. DEC OEM & Product Services Catalog, 1972. Auerbach Minicomputer Characteristic Digest, June, 1973. "How to use Nova Computers", 1973.

So you no longer have to make the painful choice between good performance and good price. Or between hardware economy and software efficiency. Now you have a minicomputer that gives you both.

The Interdata 7/16.

We put our muscle where their myth is.

**INTERDATA®**

2 Crescent Place, Oceanport, New Jersey 07757 (201) 229-4040.  
 Boston — (617) 890-0557. Washington — (703) 525-4806. Philadelphia — (215) 436-5579.  
 Orlando — (305) 851-6962. Chicago — (312) 437-5120. Detroit — (313) 356-5515.  
 Dayton — (513) 434-4193. Kansas City — (913) 384-1606. Houston — (713) 783-3060.  
 Dallas — (214) 238-9656. Denver — (303) 758-0474. Los Angeles — (213) 640-0451.  
 Phoenix — (602) 968-2477. San Diego — (714) 565-0602. San Francisco — (415) 969-1180.  
 Seattle — (206) 455-0680. Toronto — (416) 677-8990. Tokyo — (270) 7711.  
 Sydney — 439-8400. London — Uxbridge 52441. Munich — 0811-8543887.

# TTL, MOS, LEDs interface them all with

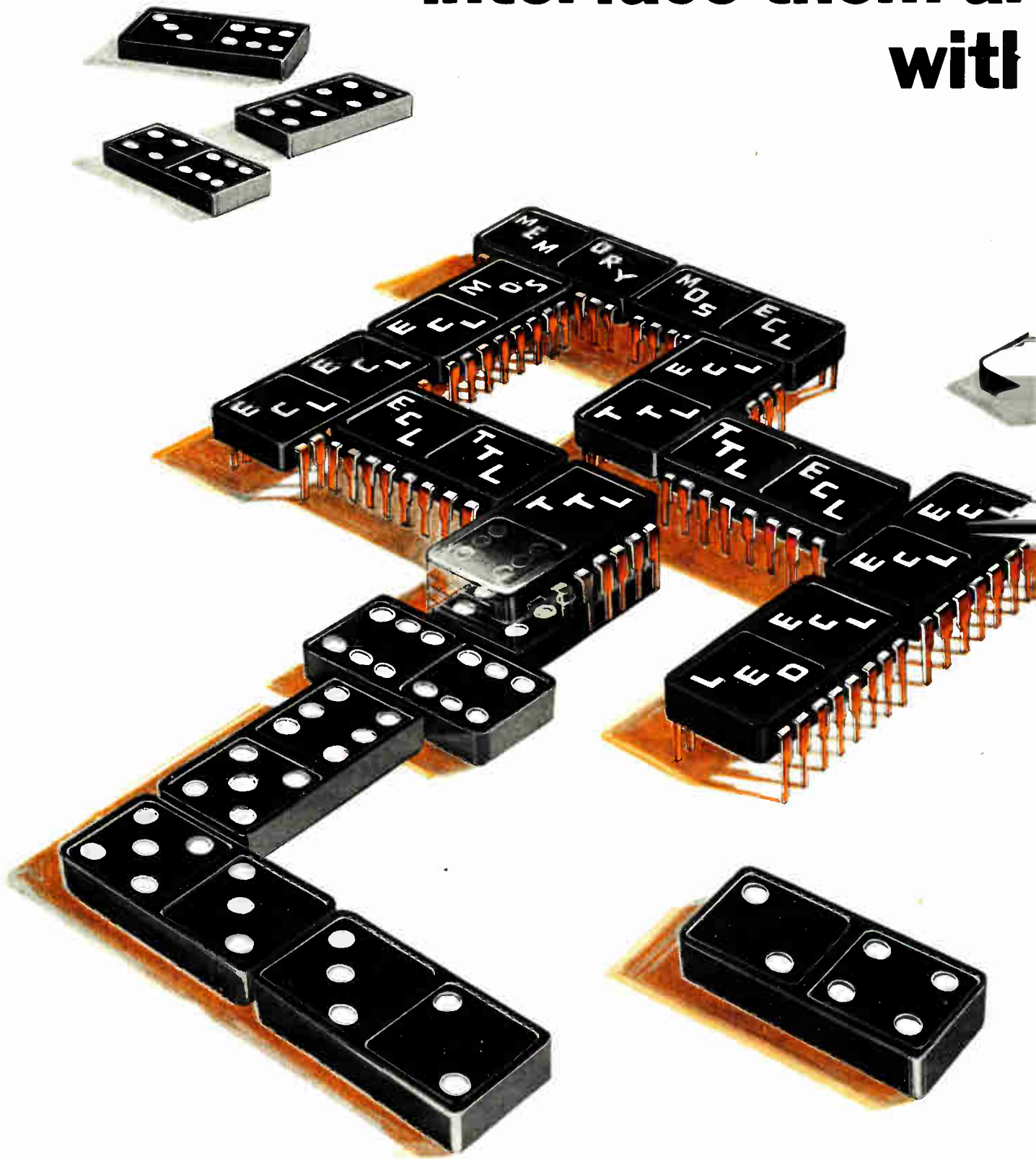

MECL and MECL 10,000  
are trademarks of Motorola Inc.



# MECL 10,000



Designing a system today is like a game of dominoes. To realize an optimized system may require the use of several logic families. The challenge is to translate and match different logic levels, maintain a minimum part count, and still operate at maximum speed.

MECL 10,000 offers a comprehensive selection of interfacing devices to meet the various input and output problems encountered. MECL translators, drivers, receivers, and comparators open up new methods for efficient coupling of non-compatible signals.

## Interfacing Made Easy!

We have a new design file covering system interfacing. It's loaded with interfacing techniques, line driving/receiving tips, bus line interfacing, operating from common power supplies, and latest methods of driving LED displays. For your copy, write to Motorola Semiconductor Products Inc., P.O. Box 20912, Phoenix, AZ 85036 and ask for MECL Design File No. 6.

**Face Up To  
System Interfacing  
with MECL 10,000!**

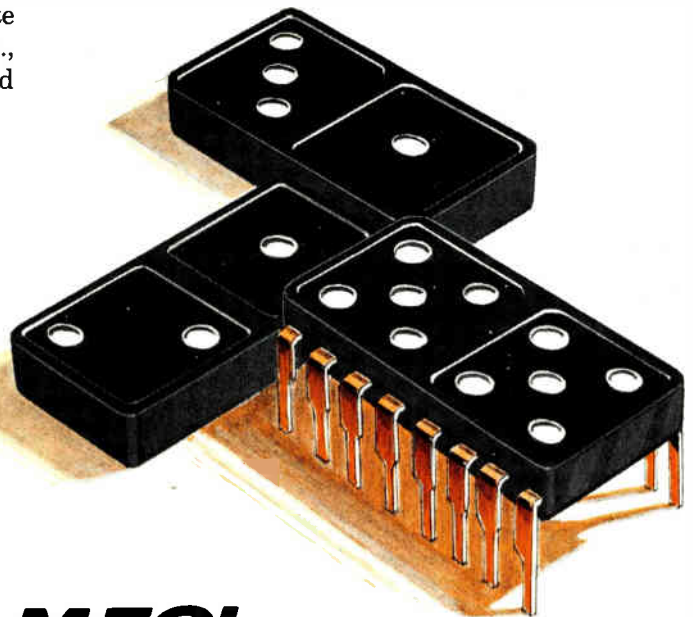

**MOTOROLA MECL**  
*... new logic capabilities for the 70's!*





**“Forget it.  
I’m not paying to have  
MOS circuits designed outside  
when we can do it ourselves.**

**“What we need  
is a company that can produce  
our circuits.”**

## **Now for the good news:**

We now have a separate Customer Tooling Department. It's set up to deal directly with companies that have their own design departments or work with engineering consultants. You provide us with the tooling; we provide you with high volume production and broad process capabilities. It's another first-rate service from the Number One MOS company. For complete information, including our new brochure, write to Bill Robson, American Microsystems Inc., 3800 Homestead Road, Santa Clara, CA 95051. Phone: (408) 246-0330. Or ask your distributor.

**AMI**  
AMERICAN MICROSYSTEMS, INC.

# Our Customer Tooling Service is for companies with designs of their own.

We've already worked with enough big firms to know that we've got what they need: an ability to produce large quantities of circuits in a wide variety of processes.

Now we're ready to work with you, starting at any stage you want. We can take the designs from your own engineering department and run them. We can act as an interface between you and an outside MOS design firm. Or we can work with you all the way from the concept through the finish.

## Which is the best process for you?

When you come to AMI, you get a complete choice. P-Channel, High Voltage, Metal Gate; P-Channel, Low Voltage, Metal Gate; P-Channel, Ion Implanted, Metal Gate; P-Channel, Silicon Gate; P-Channel, Ion Implanted, Silicon Gate; N-Channel, Silicon Gate; and Complimentary MOS.

Each process has its trade-offs in terms of cost, speed, power consumption, chip size, noise immunity, flexibility etc. So, between us, we can pick the one that will do the job for you most efficiently and economically.



## Read all about it in our new brochure.

We spell out how we work and exactly what we have to offer in this new Customer Tooling booklet. It tells you about such things as our Design Workshop, our standard interface procedures, product testing, work scheduling, and background on the company. In short, it sums up most things you might want to know about AMI's capabilities, experience and services.

Your local AMI distributor has copies on hand. Or contact us direct and we'll stick one in the mail. And you won't get stuck paying for more MOS services than you need.

### Call one of the following sales offices:

#### WESTERN AREA

California—Cupertino (408) 255-3170

Manhattan Beach (213) 379-2452

#### CENTRAL AREA

Illinois—Elk Grove Village (312) 437-6496

Michigan—Livonia (313) 478-9339

Minnesota—Minneapolis (612) 546-3354

Texas—Richardson (214) 231-5721

#### EASTERN AREA

Massachusetts—Norwood

(617) 762-0726

New York—Monsey

(914) 352-5333

# AMI

## New products

Packaging & production

# Laminator runs cooler

Unit for applying dry-film resists uses rollers instead of heat shoe

Thanks to heated rollers, a laminator for applying dry-film resists to printed-circuit boards runs 30°F cooler than earlier models. Temperature is lower because the rollers are more efficient than the heat shoe formerly used. The result is less fumes during lamination, with no adverse effect on resist adhesion, according to the Riston Products Division of DuPont Co., which developed the machine.

The hot-roll laminator, called the HRL-24, is designed to apply dry-film resists such as Du Pont's Riston. For imaging a pc board, dry-film resists have become a popular alternative to liquid resists because, in many applications, they reduce labor and rework costs and result in less scrap. The laminator removes the separator sheet from the photo-sensitive polymeric film and, with rollers heated to about 220°F, bond it to the pc laminate. Heat sensors in the working area of both laminating rollers are components of a control circuit that holds temperature to within ±8°F.

The new laminator is said to be easy to operate because controls and temperature indicators face the operator. Roller entrance and exit tables provide convenient, accurate board-feed and trimming after lamination. Edge guides ensure accurate board alignment and reduce resist waste.

A built-in exhaust hood funnels laminating fumes and odors away from the working area. The hood does not obstruct the operator's view of the boards being laminated and can be swung aside during threadup.

The HRL-24 can handle film in widths to 24 inches at speeds up to

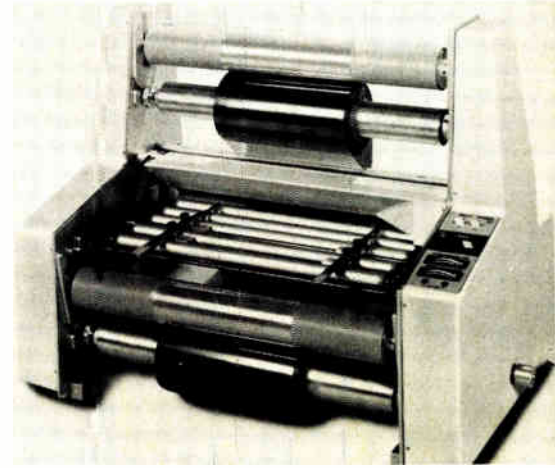

13 feet per minute. Normal working rate is 5 to 8 ft/min. By adding a 6-in. core adaptor, available as an option, 1,000-ft rolls of film can be accommodated.

Priced at \$3,950, the laminator is 32½ in. wide, 23½ in. long and 27¼ in. high. Delivery time is 10 weeks.

Du Pont Co., Photo Products Department, Riston Products Division, Wilmington, Del. 19898 [391]

## Light-spot targeting speeds rate of wire bonder

The search sequence is a big brake on the speed at which wire bonders can be operated. But a thermocompression bonder developed by Unitek Corp. uses a light-spot targeting system that does away with 50% of the stopping points in the conventional search sequence, enabling an operator to achieve rates as high as 3,000 bonds an hour.

Designated the model 8-161-01, the high-speed bonder has an all-electronic sequence control that re-

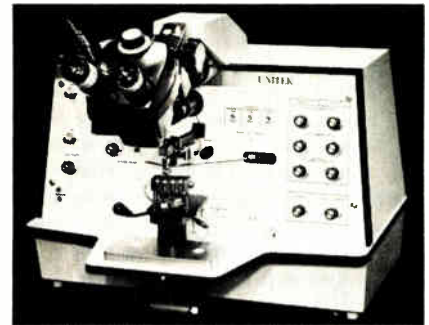



# GOOD

# BETTER

# BEST

Choosing the right cassette is easy ... if you have a choice. CONRAC gives you 3 excellent cassette series so you specify the right one for your application.

- D Series—standard polystyrene case—good low cost applications with standard requirements.
- F Series—Glass-metal filled plastic case. Premium performance, general purpose digital cassette built to ANSI/ECMA standards.
- CM Series—metal computer grade case. Total performance ANSI/ECMA. Tape density 800 bpi or 1600 FCI. Speeds read/write 50 IPS, search 300 IPS.

Write for descriptive literature.

**CONRAC** CRAMER DIVISION  
CORPORATION

Mill Rock Rd., Old Saybrook, Conn. 06475  
(203) 388-3574

## New products

places about 90% of the cams, levers and microswitches usually found in wire-bonding equipment. Such a design promises higher reliability because there are fewer mechanical parts which can wear. Bonding force is controlled electromechanically, doing away with the slower inertia-plagued sliding weight system—another limit on bonding rate.

In operation, the bonder securely holds the package down while a work-stage manipulator that improves operator efficiency moves the device to the exact site for the first bond. Positioning is guided by the precision light-spot targeting element that, in addition to speeding production and increasing accuracy, reduces eye fatigue for the operator. Selectable automatic search mode is retained when required in certain applications.

Independent controls for both the first and second bond enable adjustment of the bond sequence variables such as bond time, bonding force, and scrub amplitude. Adjustable controls are provided for control tip and package temperatures, package vacuum hold-down, and other critical parameters.

Devices that are to be bonded are mounted in a heater column on the work-stage manipulator. Heater columns are available for all current packaging styles and can be changed quickly.

Micrometer-type valves adjust the hydrogen-oxygen cut-off torch so that the flame will sweep through the bond wire and form a ball with an exact diameter as well as bonds without tails. The capillary holder accepts all commercially available tungsten carbide and ceramic as well as the pure tungsten capillaries marketed by Unitek.

The light-spot targeting element can be supplied with a selection of spot shapes, such as round and doughnut, as well as a variety of colors.

The bonder operates on 117 volts, 50/60 hertz. It weighs 70 pounds.

Delivery is expected in the second quarter of 1974 at a price of approximately \$3,000.

Unitek Corp., Equipment Division, 1820 Myrtle Ave., Monrovia, Calif. 91016 [392]

## DIP connectors added to flat-cable line

Designers who have been troubled by the limited availability of commercial-grade connectors for flat cable are finding now that the selection of such units is growing.

One manufacturer, Berg Electronics, is adding several versions to its Quickie connector line. These include 14- and 16-pin dual in-line plugs and a socket. The socket accommodates devices with leads on 200- or 300-mil centers. Both connectors employ a cable-piercing action to interconnect with 28 or 30 AWG flat, flexible, round-conductor cables that have conductors spaced 50 mils apart.

An assembly tool permits connec-

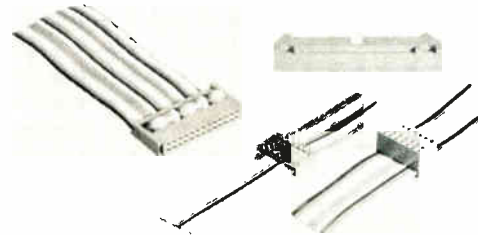

tion to the male and female connectors in about 10 seconds without any need for stripping. Berg has also introduced a shielded right-angle header, upper right in photo, which is compatible with other connectors in the Quickie line such as the earlier female connector shown at left in photo.

Berg Electronics, division of E.I. du Pont de Nemours & Co., New Cumberland, Pa. 17070 [371]

## Spot bonder operates without using flames

For soldering and repairing hybrid circuits, a flameless spot bonder, called the model HG720, uses hot gas for the bonding and replacing of semiconductor components on circuit substrates. The unit uses heated but low-temperature air or nitrogen



**If  
you  
think all card  
readers  
are alike...**



**take a look  
at  
CONRAC**

Take a good, long look before you specify... check and compare all the features offered by the CONRAC A-31 Series Magnetic Card Reader. Here are only a few: • Read or write on Standard Magnetic Cards • Industry Compatible Credit Cards— IATA, ABA, THRIFT, NTT • Card remains stationary and visible at all times—minimizing chances of card loss, damage or jamming • Card-in-place switch—insures proper insertion of card before operation • USA designed and made for OEM applications requiring rugged, long life • All this plus more and it's one of the lowest priced. <sup>500</sup>

*Write For Descriptive Literature.*

**CONRAC** CRAMER DIVISION  
CORPORATION

Mill Rock Road, Old Saybrook, Conn. 06475  
(203) 388-3574

Circle 240 on reader service card

**New products**

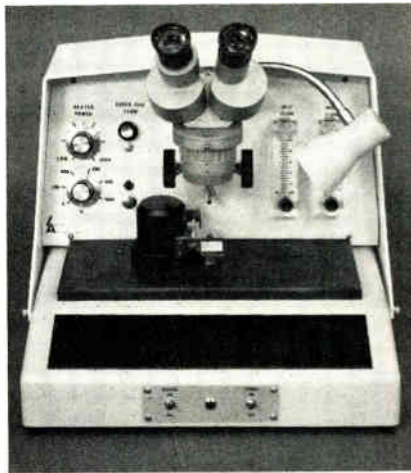

instead of the 5,000° hydrogen flames used in other spot bonders, eliminating water formation and leaching problems. With the HG720, an electrically heated, controlled stream of the hot gas is directed to the reverse side of the substrate, protecting the circuit side from solder-tip contamination, oxidation, and electrical transients. Price is \$1,300.

Laurier Associates Inc., 550 Newton Rd.,  
Littleton, Mass. 01460 [393]

Wire-wrapping tool is  
for telephone applications

Designed for telephone system use, the model EW-7D-48-P wire-wrapping tool is specifically configured to operate directly from the 48-volt dc power available in telephone switching frames. Equipped with a phone plug for insertion into the battery test block, the unit also comes in a version having clips for power lug terminals. The tool has a 9-foot cord, and it accepts bits and sleeves of any make for wire types 22 through 32 AWG.

O.K. Machine and Tool Corp., 3455 Conner  
St., Bronx, N.Y. 10475 [394]

Soldering-iron-tip cleaner  
needs no wiping or rubbing

Called Re-Tip, a soldering-iron-tip cleaner removes oxides and contaminants, leaving tips cleaned and

**We've made  
a  
great tape  
transport  
a lot better.**

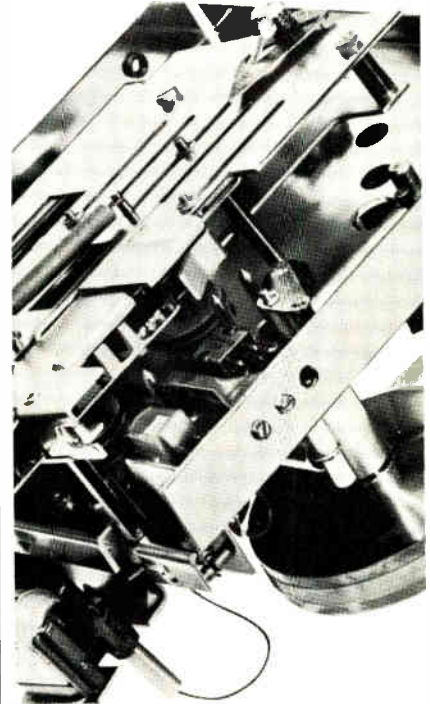

**take a look  
at  
CONRAC**

Now, there's no reason for you to "trade-off" when specifying an audio cassette tape transport...not if you specify the Conrac CAS-4. Here are only a few reasons why: • USA designed and manufactured • 3 motor design • No mechanical clutches or brake bands required • Designed for remote control • OEM priced. 501

*Write for descriptive brochure*

**CONRAC** CRAMER DIVISION  
CORPORATION

Mill Rock Road, Old Saybrook, Conn. 06475  
(203) 388-3574

Circle 195 on reader service card 195

Visual images are fleeting—so, for the record, . . . you need pictures. No telling when or how often they can prove invaluable.

# THE CHAMP

## ...PICTURE TAKER



For literature circle Reader Service Card No. 100  
For demonstration circle Reader Service Card No. 196

That's why so many of your peers are routinely snapping pictures while looking at specimens and samples with Bausch & Lomb's StereoZoom 7 visual-photographic system. The Champ's superb optical system which gives unbeatable visuals will put the images on film right while you're looking. And they will be available as often as you want to refresh your memory, make comparisons, prove points.

There's a choice of most camera formats with the new Integrated Cameras, Series II with optional exposure meter. They're integral, but do not interfere with the optical system and interchange to fit varying needs.

**Be ready. Write for our new Stereomicroscope catalog 31-15 and our free demonstration offer.**

**BAUSCH & LOMB**   
SCIENTIFIC OPTICAL  
PRODUCTS DIVISION

62304 Bausch Street, Rochester, N.Y. 14602

StereoZoom, Reg. T.M.  
Bausch & Lomb.

## New products

uniformly tinned by a quick insertion and withdrawal of the hot tip. No wiping or rubbing is required. The Re-Tip, the use of which elimi-



nates impurities at connections, allows irons to stay hot by absorbing a minimum amount of heat while working. No abrasives are used, and any shape of tip up to 1/4 inch in diameter can be handled. Re-Tip consists of a non-skid base and a replaceable cartridge.

Solder Removal Co., 1077 E. Edna Place,  
Box 1678, Covina, Calif. 91724 [395]

Probe-card station does  
assembly, maintenance

The model 200 probe-card station is designed for assembly, modification, or renewal of Rucker and Kolls type 310 and 410 probe cards. The company will supply a variety of new probes and edge sensors for replacement so that the user's probe cards are constantly updated. The



### Own your own holder to hold your own!

Hold your own copies of Electronics in specially designed slipcase holders. They'll keep your Electronics library neat and handy—a permanent information file, issue by issue.

Just complete the coupon and mail to Jesse Jones. He'll process your order upon receipt, postpaid.



**ELECTRONICS BOXER**  
Jesse Jones Box Corporation  
2250 E. Butler St., Philadelphia, Pa. 19137

Please send me:  boxes @ \$4.25 each;  3 boxes @ \$12.00;  6 boxes @ \$22.00.  
My check or money order is enclosed.

Name: \_\_\_\_\_

Address: \_\_\_\_\_

City: \_\_\_\_\_

State: \_\_\_\_\_

Zip: \_\_\_\_\_

# After accuracy, what do you want in a lab-type voltmeter?

The TRI 6567 is a laboratory type *precision* DC voltmeter. It employs a patented DSS method; whereby input signals can be measured *much* more accurately than by conventional methods. To wit, it's accurate to 0.004%, has a short-term stability of  $\pm 2$  ppm for 24 hours, it resolves to  $1\mu\text{V}$ . In addition, it offers automatic ranging, automatic zero compensation, BCD output, and is remote control capability equipped.

The TRI 6656 measures (in one unit) frequency, time interval, period, voltage, current, resistance and totalizes the events. With DCV to 1000V, it promises accuracy to 0.005%; with ACV to 300V, it is accurate to 0.3% on 40Hz to 50Hz, and 0.2% on 50Hz to 10KHz, and 0.3% on 10KHz to 20KHz.

Resistance is measured to 100M ohm with accuracy to 0.015% on the 10K, 100K and 1M ohm range, or 0.15% on the 10M ohm range, or 0.6% on the 100M ohm range. Frequency is measured to 50MHz with a time base stability of  $1 \times 10^{-5}$ /day. It too has a BCD output and is remote-control-capability equipped.

## More Accuracy

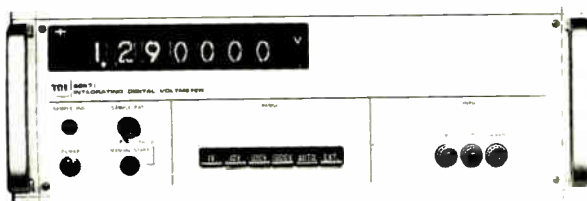

TRI 6567



TRI 6656



T.R.I. CORPORATION  
505 West Olive Avenue  
Sunnyvale, CA 94086  
(408) 733-9080



# Recent additions to SAMS bookshelf of technical knowledge

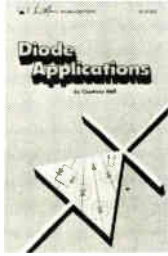

## DIODE APPLICATIONS

By Courtney Hall

Acquaints technicians and hobbyists with the control functions and properties of diodes in electronic circuits. Typical diode applications and circuits described include: power supplies, voltage doublers, waveform converters, zener diode circuits, logic elements, temperature compensating devices, regulators and signal detectors. Also discussed: LEDs, tunnel diodes, varactor diodes and semiconductor lasers. 96 pages, softbound.  
No. 21033 \$3.50

## INTRODUCTION TO BIOMEDICAL ELECTRONICS

By Edward J. Bukstein

Although written for electronics technicians, this book will also help medical personnel understand the electronic equipment they use daily. It describes the wide variety of complex patient-monitoring devices, centrifuges, electrocardiographs, and defibrillators used in hospitals today; provides detailed circuit descriptions of the systems; explains the purpose and application of each; covers safety, service and maintenance techniques; and familiarizes technicians with the medical terminology needed for communication with medical personnel. 208 pages, softbound.  
No. 21005 \$5.50

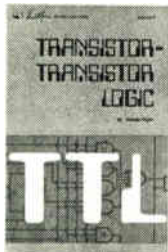
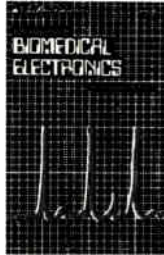

## TRANSISTOR-TRANSISTOR LOGIC

By George Flynn

An invaluable aid to understanding the function and circuit construction of logic devices. The book discusses the digital families of which TTL is a part, and covers the basic units—the gate, the various basic circuits, and the voltage and current requirements. Also covered are: flip-flops, decoders, multiplexers, shift registers, counters, TTL math, methods for determining information priority and storage, and how TTL, the dominant form of semiconductor logic, works with other types of circuits and logic families. 176 pages, softbound.  
No. 20967 \$5.50

## PRACTICAL SOLID-STATE CIRCUIT DESIGN

By Jerome E. Oleksy

This instructive book shows the technician or experimenter how to design the right circuits for any number of electronic applications. It presents many formulas and tables in explaining the designs of transistor amplifiers, FET and op amp circuits, audio power amplifiers, and regulator circuits. Problems are offered and solved to show how solutions are obtained. 192 pages, softbound.  
No. 21018 \$5.95

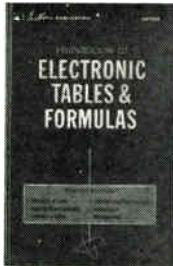
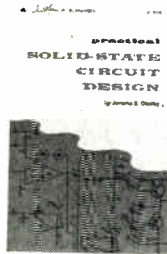

## HANDBOOK OF ELECTRONIC TABLES & FORMULAS 4th Edition

By Donald Herrington and Stanley Meacham

A time-saver for beginners, professionals, and technicians alike. It presents a complete and orderly collection of the formulas and laws, constants and standards, symbols and codes used in electronics. Included also are service and installation data, design data, mathematical tables and formulas, and a full-color foldout chart showing the latest FCC allocations for the entire frequency spectrum. 258 pages, hardbound.  
No. 20982 \$6.95

... and finally, invaluable assistance for all inventors—

## TECHNIQUES FOR PREPARING AND OBTAINING YOUR OWN PATENT

By Hrand M. Muncheryan

In spelling out what you must do to obtain a patent, this helpful book covers the types of patents available, interprets them, and gives instructions on how to file and follow through on patent applications. Here is an explanation of every necessary step from invention to final issuance of a patent. 96 pages, softbound.  
No. 20995 \$3.95



**HOWARD W. SAMS & CO., INC.**  
4300 West 62nd Street, Indianapolis, Indiana 46268

Order from your Electronics Parts Distributor, or mail to Howard W. Sams & Co., Inc.  
Send books checked at right, \$\_\_\_\_\_ enclosed. Please include sales tax where applicable. Canadian prices slightly higher.

Name \_\_\_\_\_

Address \_\_\_\_\_

City \_\_\_\_\_

State \_\_\_\_\_

Zip \_\_\_\_\_

- 21033
- 21005
- 20967
- 21018
- 20982
- 20995

E 044

## New products

model 200 locates probes—in respect to device pads—by a micrometer-adjusted positioner; the probes are then soldered in place on a probe-card pc board that is mounted in the machine's rotating stage. Also provided are an adjustable vacuum chuck and depth micrometer, allowing fabrication of probe cards to a standard height throughout a system.

Rucker & Kolls, 1335 Terra Bella Ave., Mountain View, Calif. 94042 [399]

Coax-cable trimmer handles  
750 to 1,250 cables an hour

A coaxial-cable trimming machine can strip jackets and dielectric without damaging the underlying shield and center conductor. Applications are in CATV, MATV, aircraft, and broadcasting. The unit handles 750



to 1,250 cables per hour, depending on the size of the cable. The trimming heads can be changed in less than 30 seconds to accommodate cable sizes, which can range up to 0.440 inch in outside diameter.

Utility Tool Corp., Town St., E. Haddam, Conn. 06423 [396]

Wafer abrader maintains  
consistent texturing

A wafer-abrading machine, designated the model SWAM 1120, is a variation of the company's basic model 1110 unit. The new version uses two S.S. White model H Air-brasive units to double the throughput of semiconductor slices while maintaining consistent oxide re-

Integrating man's creativity with a computer's speed and memory isn't easy. But Gerber has done it with an interactive system which can create and plot drawings as complex as the operator can imagine ... all at the touch of a button.

Think what this can mean in your department. Drafting drudgery eliminated. More accurate drawings, faster. More time for designers to think and create. Lead time drastically reduced to give you a competitive edge in bringing new products to the marketplace.

Translated into dollars, this means more profits from your engineering department profit center. More profits whether you make automobiles, aircraft, electronic equipment, machine tools. Or anything else that requires drafting.

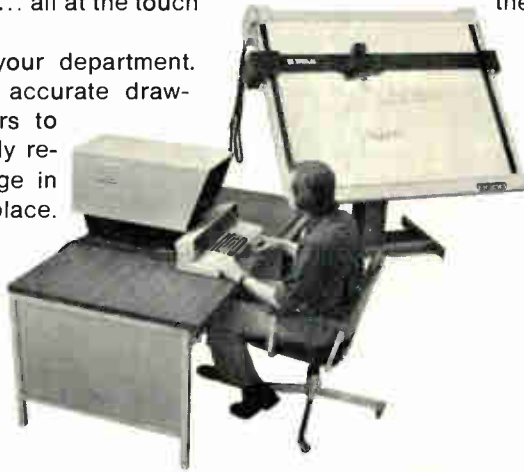

The Gerber interactive system is delivered complete and ready to go to work for you. And, of course, the entire system is designed, built and serviced by Gerber Scientific, the internationally recognized pioneering leader of the industry.

Find out how the Gerber Interactive Design System can produce for you.

A note or phone call will bring a prompt response.

The Gerber Scientific Instrument Company, Hartford, Connecticut 06101. (203) 644-1551.

 **GERBER  
SCIENTIFIC**

Circle 199 on reader service card

# Push Button Drawing.

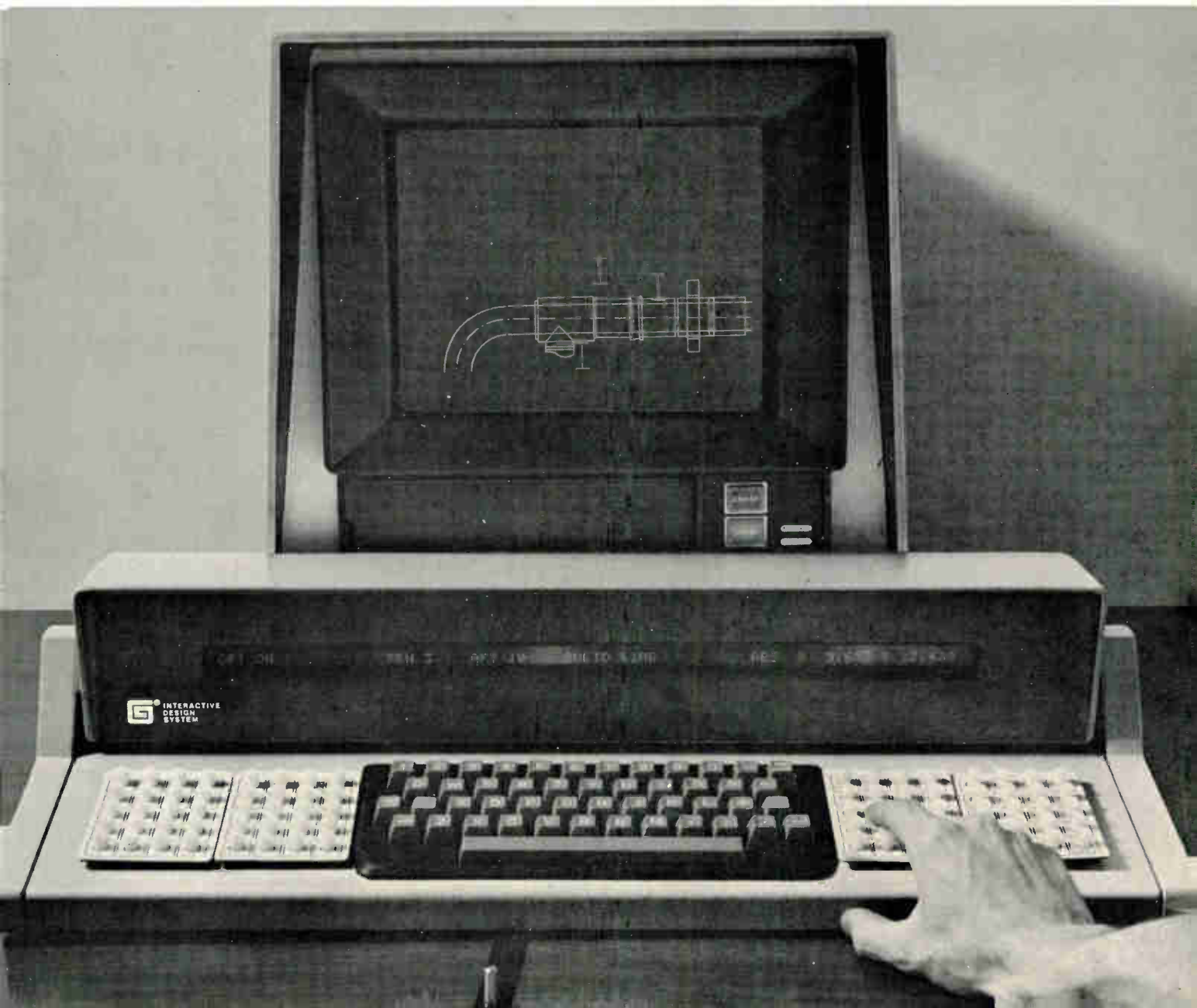



# international coil winding association

(Devoted Entirely To The Coil Winding Industry)

PRESENTS

## COIL WINDING CHICAGO '74

CONVENTION & EXHIBITION

21, 22, 23, SHERATON O'HARE HOTEL  
May, 1974 ROSEMONT, ILLINOIS, U.S.A.

Devoted exclusively to the coil winding industry this event is being held yet again to serve as a platform for presentation of specialized papers on new materials and techniques and a showcase for displaying the latest product developments.

### CONVENTION:

Papers will be presented by Internationally recognised authorities in various fields of coil winding.

### PRODUCT DISPLAY:

Covering the entire spectrum from coil winding machines to custom built coils.

### EUROPEAN AND HEAD OFFICE

Cleveland House  
344A Holdenhurst Road  
Bournemouth BH8 8BE  
Hampshire  
England  
Telephone: Bournemouth 38738  
Telex: 417123

### NORTH AMERICAN OFFICE

Suite 106  
3158 Des Plaines Avenue  
Des Plaines  
Illinois 60018  
U.S.A.  
Telephone: (312) 827-4060

Please send all details  We are interested in a booth of ..... sq.ft.

NAME ..... please complete in BLOCK LETTERS

POSITION .....

COMPANY .....

ADDRESS .....

PRODUCTS .....

CH

## New products

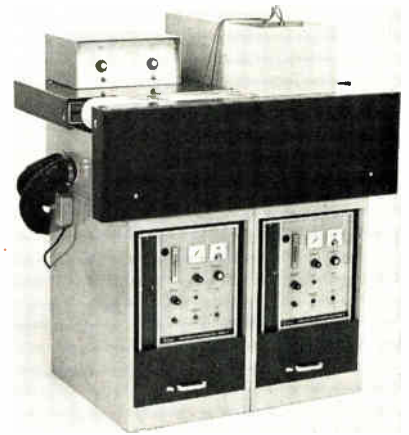

moval and texturing. The model 1120 also makes backlapping and gross material removal practical on silicon wafers.

Crystal Mark Inc., 613 Justin Ave., Glendale, Calif. 91201 [398]

## Mounting frames built for pluggable boards

A mounting system for certain pluggable electronic circuit boards is said to help reduce costs by eliminating the need for conventional mounting units. The mounting frames are for use with the NCS and NCP series of boards and are com-

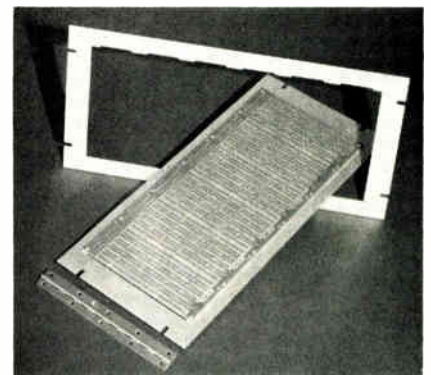

patible with standard 19- and 24-inch relay racks. The units are designated Swing Mount, and they can be used with boards, measuring 6.875 by 21.600 inches or 7.475 by 21.600 in. in increments of 2.7 in. The frames are hinge-mounted and can be bolted to the rack.

Garry Manufacturing Co., 1010 Jersey Ave., New Brunswick, N.J. 08901 [400]



# Proven Performance.

<b>Computer:</b>	General Automation SPC-12/20. Step and repeat, mirror image, automatic rewind. Handles variety of formats.
<b>Spindle feed rate:</b>	20-250 ipm. Accuracy to within 2% of setting. Stroke limit adjustable, 0.001-in. increments.
<b>Table travel speed:</b>	400 ipm each axis. Computer-driven, high-torque, high-speed, low-inertia servo motor gives instant acceleration.
<b>Drill hit rate:</b>	200/min. Quality holes on 1/4-in. movement with 3-high stacks and 0.002 chip load.
<b>Spindle motor speed:</b>	15,000-45,000 rpm electric motors; 15,000-60,000 rpm liquid-cooled, frequency-controlled motors; 30,000-80,000 rpm air-bearing frequency-controlled motors.

## The Excellon Mark III. Nobody's equalled it yet.

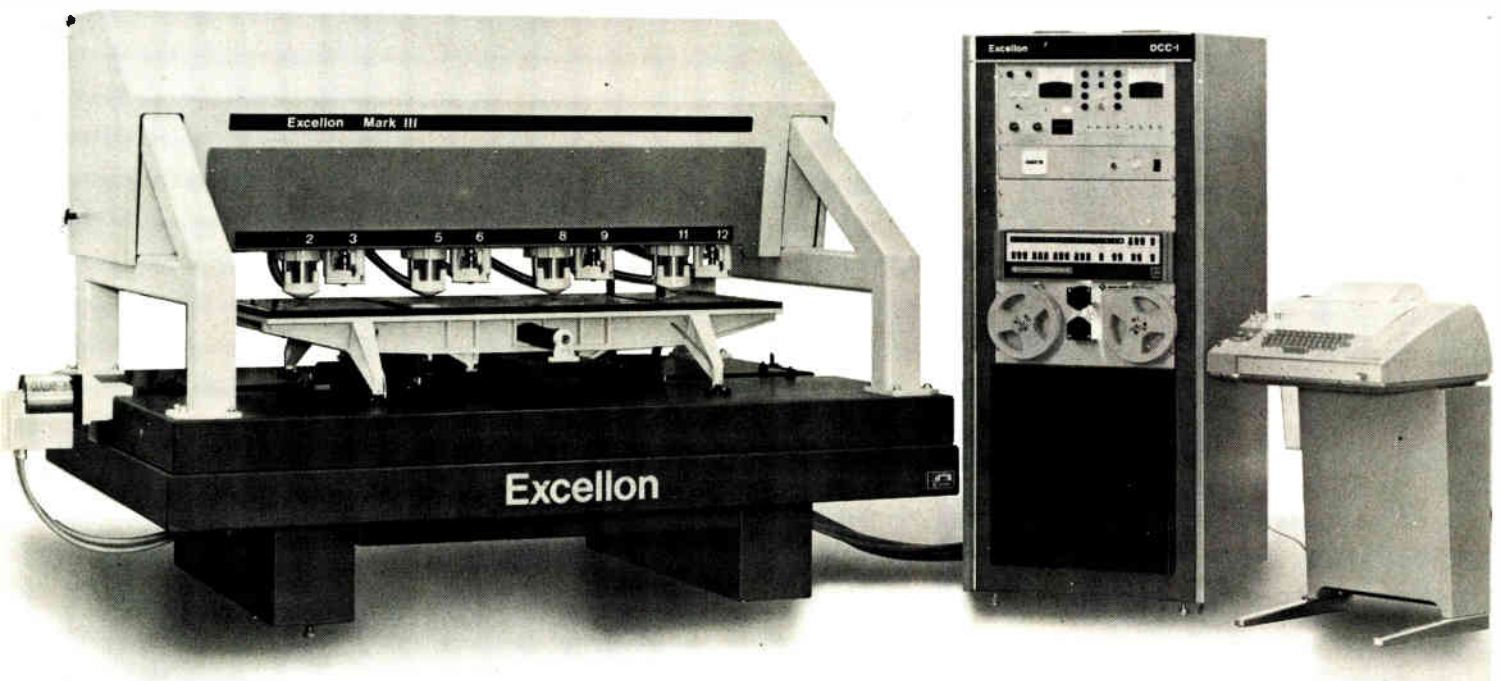

The Excellon Mark III is the most advanced p.c. drilling system in the industry today.

We've had more than our share of advances over the years. The fact is, when we added up the knowledge we've gained from our successes (and failures), we had all the makings of a major breakthrough.

The magnificent Mark III, for instance.

World-wide, the Excellon Mark III is giving unequalled performance with highest production rates possible . . . at the lowest hole costs possible, with high accuracy and clean, smear-free holes.

It has no competition because nobody's equalled it yet. Call or write Dick Hogan, Sales Manager. His number is (213) 325-8000.

### Excellon Automation

A Division of Excellon Industries  
23915 Garnier Street  
Torrance, California 90509  
Phone: (213) 325-8000

Telex: 67.45.62 Cable: Excellon Torrance



Excellon Sales and Service in ENGLAND • FRANCE  
SCANDINAVIA • W. GERMANY • HOLLAND • AUS-  
TRALIA • HONG KONG • TAIWAN • JAPAN

# The 2102 to get as it is to

The Intel 2102 n-channel RAM is the most popular 1024 bit static memory available today. It is *the* general purpose RAM with more second sources than any other semiconductor memory component.

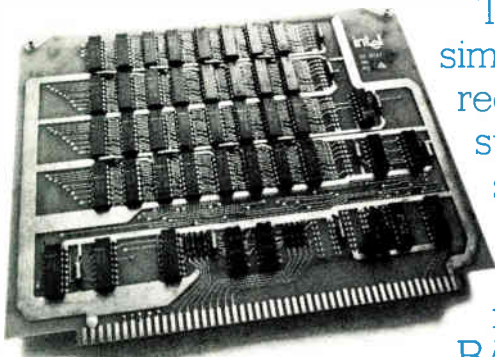

INTEL IN-26 MEMORY SYSTEM

The 2102 is extremely simple to use because it requires no peripheral supporting circuits, no special supplies, nor does it require the extra design effort needed by most RAMs to interface with TTL.

By using the 2102, you can achieve greater system economy because it does not require level shifters, MOS drivers, interface circuits, clocks, refresh and decode circuits, nor even pull-up resistors.

Every pin is TTL compatible, including the +5 volt  $V_{cc}$  supply and the three-state, OR-tie data output that simplifies memory expansion. To connect the 2102 to TTL, just add solder dots. In fact, the 2102 RAM performs exactly as if it were a TTL circuit.

The 2102 speed specs are efficient also. Guaranteed maximum access time is 1 microsecond, typical access time is 500 nanoseconds. Minimum read and write cycle time is also 1 microsecond.

The 2102 costs less per bit in quantity than penny candy. And when you

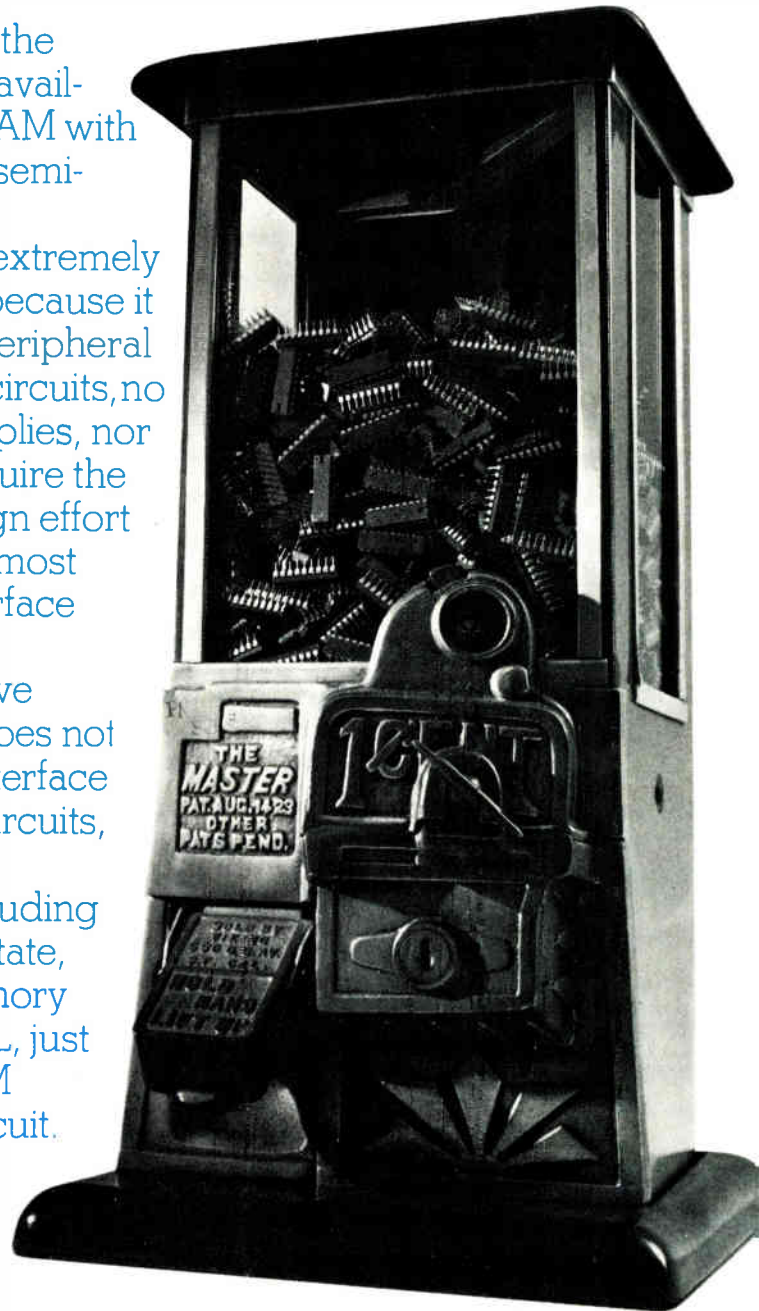



# RAM is as easy use.

## N-C HANNEL

subtract what you don't spend on design time, other parts, special supplies, boards and labor, the 2102 is easily the most economical static RAM for a wide range of applications.

What's more, the Intel 2102 is easy to get. We have been producing it in volume since early 1972 with the industry's most mature n-channel silicon gate technology. Today, we ship more 2102's than the combined outputs of the dozen or so announced second sources.

The Tektronix 31 Programmable Calculator uses the 2102 and millions of our 2102's are now being used in peripheral equipment, instrumentation and microcomputer

systems. It's a favorite with designers who want to simulate buffer, refresh and variable length registers with something more convenient and less costly than custom MOS registers.

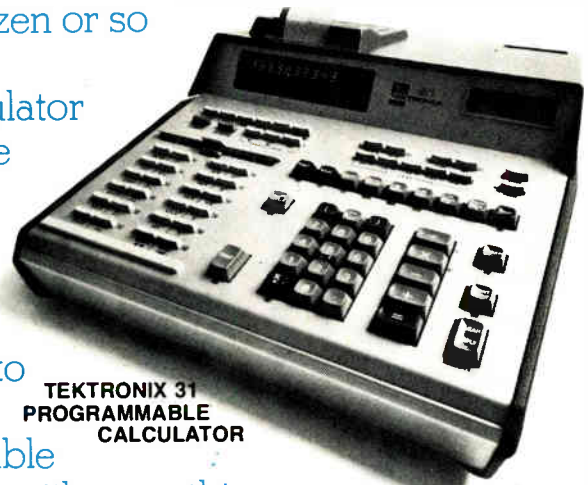

TEKTRONIX 31  
PROGRAMMABLE  
CALCULATOR

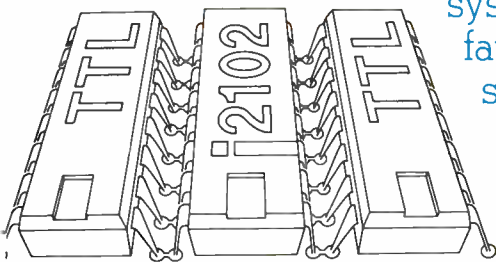

EVERY PIN IS TTL COMPATIBLE

The 2102 is only one of Intel's popular MOS RAMs available in volume and from distributor stock. Send for a full catalog of our products including RAMs, ROMs, PROMs, interface circuits and Microcomputers.

Write to: Intel Corporation, 3065 Bowers Avenue, Santa Clara, California 95051. (408) 246-7501.

## intel® delivers.



# New!

# Programmable Optimum

**Now you can design linears your way. Our new single and dual programmable op amps offer greater economy and design flexibility, let you set your own parameter specifications, and minimize power consumption at the same time.**

All it takes to tailor the characteristics of our new HA-2720/2730 is one external resistor. This provides a master bias setting which will establish the desired current-flow through the devices.

As a result, critical parameters such as bias currents, supply currents, bandwidth, slew rate, input noise, and others can be optimized to meet your particular needs. And because the devices have such a wide power supply range ( $\pm 1.2V$  to  $\pm 18V$ ) they can be used in an almost unlimited variety of linear designs.

A single programmable op amp, the HA-2720 is a direct replacement for many currently available op amps, yet it offers superior performance features over all of them. Among these are a wider range of programming, higher slew rate and bandwidth at low power levels, superior output current, and lower noise current. The HA-2730 is a dual monolithic version of the HA-2720 with identical performance features.

For the user these devices offer substantial benefits. First, they are highly reliable because

they are short-circuit protected and have internal compensation with classical frequency response. They also provide you with considerable economy because the wide range of programming possible allows you to standardize your op amp inventory and change parameters as needed. Finally, by modulating the set current terminal you can minimize systems components and obtain such applications as VCO's, Wien bridge oscillators, and waveform generators.

Among other applications are

low power instrumentation, portable battery operated instruments, active filters, and hearing aids. For details see your Harris distributor or representative.

## Features

- Wide range A.C. programming
  - Slew rate 0.06 to  $6V/\mu s$
  - Gain x
  - Bandwidth 5KHz to 10MHz
- Wide range D.C. programming
  - Power supply range  $\pm 1.2V$  to  $\pm 18V$
  - Supply current  $1\mu A$  to 1.5mA
  - Input bias current 0.4 to 50nA
  - Output current up to 15mA

Suitable for direct replacement of:

- Fairchild  $\mu A776$
- Soliton UC 4250
- National LM 4250
- Intersil ICL-8021

} HA-2720  
100-999 units

HA-2725  $0^{\circ}C$  to  $+75^{\circ}C$  \$ 3.30  
 HA-2720  $-55^{\circ}C$  to  $+125^{\circ}C$  \$ 8.80  
 Supplied TO-99  
 HA-2735  $0^{\circ}C$  to  $+75^{\circ}C$  \$ 7.15  
 HA-2730  $-55^{\circ}C$  to  $+125^{\circ}C$  \$16.50  
 Supplied TO-116

## Typical Biasing Circuits

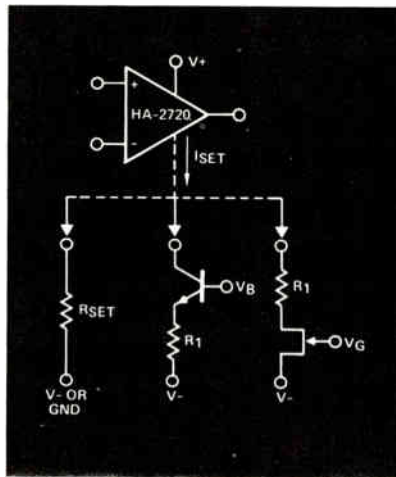

## HA-2720/30 Programming

	SLEW RATE	BANDWIDTH	INPUT VOLTAGE NOISE	INPUT CURRENT NOISE	OPTIMUM SOURCE RESISTANCE	BIAS CURRENT	POWER DISSIPATION	OPEN LOOP VOLTAGE GAIN	
ISET	↑	↑	↓	↑	↓	↑	↑	↑	↑ ↓ BELL-SHAPED ↓ DECREASE
POWER SUPPLY VOLTAGE	↑	↑	← → NO CHANGE			↑	↑	↑	← → NO CHANGE ↑ INCREASE

# Programmable Op Amps for Slew Rate Solutions

**HA-2720 Single Programmable Operational Amplifier**

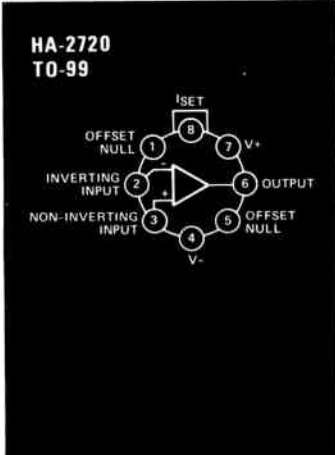

**Slew Rate vs. Supply Current**

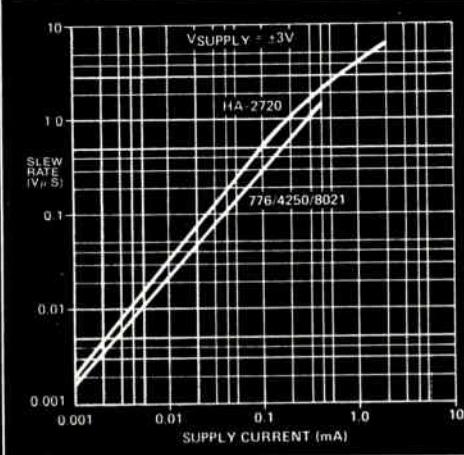

**Output Current vs. Supply Current**

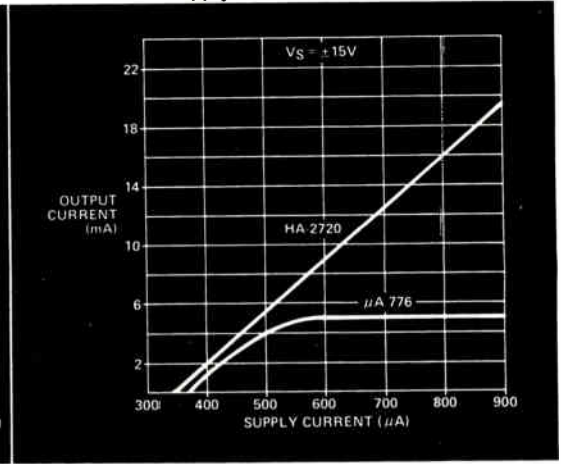

**HA-2730 Dual Programmable Operational Amplifier**

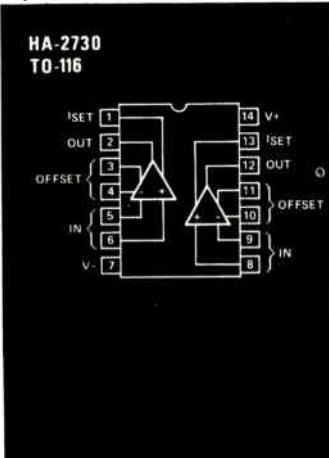

**Gain Bandwidth Product vs. Supply Current**

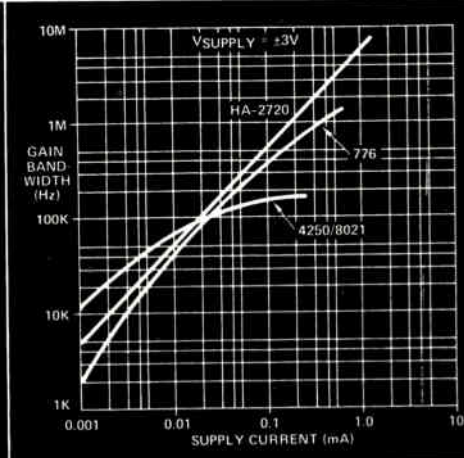

**Input Noise Current vs. Supply Current**

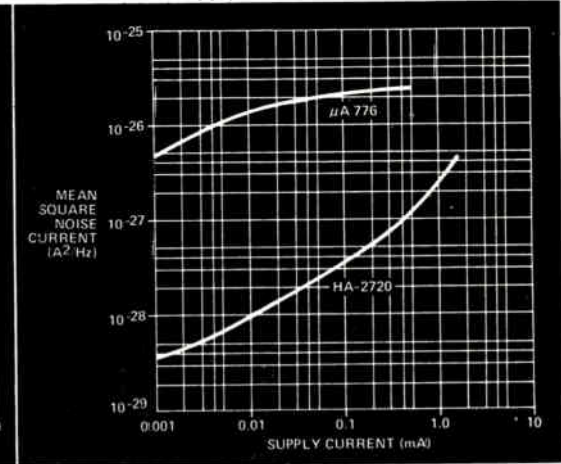

Above comparative data curves were experimentally derived or extrapolated from published data sheets where available.

# Harris



**HARRIS SEMICONDUCTOR**  
A DIVISION OF HARRIS-INTERTYPE CORPORATION

P.O. Box 883, Melbourne, Florida 32901  
(305) 727-5430

WHERE TO BUY THEM: ARIZONA: Phoenix—Hamilton, Liberty, Weatherford, Scottsdale—HAR (602) 946-3556 CALIFORNIA: Anaheim—Weatherford, El Segundo—Liberty, Glendale—Weatherford, Long Beach—HAR (213) 426-7687, Mountain View—Elmar, Palo Alto—Weatherford, HAR (415) 964-6443, Pomona—Weatherford, San Diego—Liberty, Weatherford COLORADO: Commerce City—Elmar, Denver—Hamilton, Englewood—Weatherford CONNECTICUT: Danbury—Schweber, Norwalk—R&D FLORIDA: Hollywood—Hamilton, Schweber, Melbourne—HAR (305) 727-5430 GEORGIA: Atlanta—Schweber, Norcross—Hamilton, ILLINOIS: Elk Grove Village—Schweber, Schaumburg—HAR (312) 894-8824, Schiller Park—Hamilton INDIANA: Indianapolis—Pioneer KANSAS: Lenexa—Hamilton MARYLAND: Baltimore—Hamilton, Rockville—Schweber MASSACHUSETTS: Burlington—Hamilton, Lexington—R&D, Wellesley—HAR (617) 237-5430 MICHIGAN: Livonia—Hamilton, Troy—Schweber MINNESOTA: Edina—Hamilton, Schweber, Minneapolis—HAR (612) 432-6111 MISSOURI: Hazelwood—Hamilton NEW JERSEY: Cedar Grove—Hamilton, Mt. Laurel—Hamilton, Somerset—Schweber NEW MEXICO: Albuquerque—Hamilton, Weatherford NEW YORK: East Syracuse—Hamilton, Melville—HAR (516) 249-4500, Syracuse—HAR (315) 463-3373, Rochester—Schweber, Westbury—Schweber, Woodbury—R&D NORTH CAROLINA: Raleigh—Schweber OHIO: Beachwood—Schweber, Cleveland—Pioneer, Dayton—Pioneer, HAR (513) 226-0636 PENNSYLVANIA: Wayne—HAR (215) 687-6680 TEXAS: Dallas—Hamilton, Weatherford, HAR (214) 231-9031, Houston—Hamilton, Weatherford UTAH: Salt Lake City—Hamilton WASHINGTON: Seattle—Liberty, Weatherford WASHINGTON, D.C.: HAR (202) 337-3170 CANADA: Mississauga, Ont.—Hamilton, Montreal, Que.—Hamilton, Ottawa, Ont.—Hamilton.

LEGEND FOR HARRIS SALES OFFICES & DISTRIBUTORS: Elmar Electronics (Elmar); Hamilton Avnet Electronics (Hamilton); Harris Semiconductor (HAR); Harvey/R&D Electronics (R&D); Liberty Electronics (Liberty); Pioneer Standard Electronics (Pioneer); Schweber Electronics (Schweber); R. V. Weatherford Co. (Weatherford)

# Look at That!

## Four Opto-Isolators in One Money Saving Package.

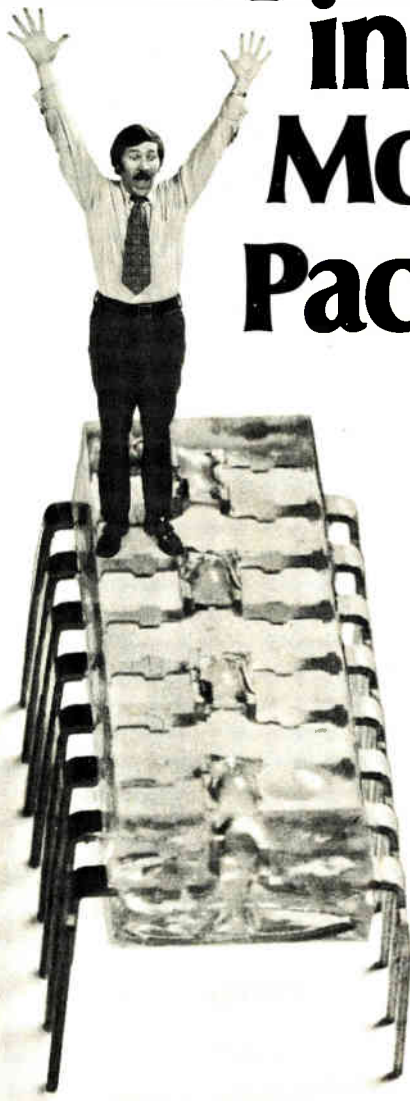

The Bright Guys do it again. By packaging four independent opto-isolator channels into one 16-pin DIP—the new ILQ-74 quad isolator—we've created the first family of perfectly compatible single, dual and quad opto-isolators.

And because the ILQ-74 has the same specs as the ILD-74 dual and IL-74 single opto-isolator, they mix and match ideally. You can absolutely minimize parts counts regardless of the number of channels per board.

The new ILQ-74 quad pares down the cost per

channel to 83¢ in 1K quantities and even more in higher volumes. In multi-channel designs, the quad replaces single and dual isolators, to save still more on parts handling, assembly labor and board area.

All three are compatible with TTL and lots of linear circuits. All three have a breakdown voltage of 1500V, typical transfer ratio of 35% and coupling capacitance of only 0.5pF. All three have passed UL safety tests.

Now's the time to replace outmoded transformers and relays with economical, efficient Litronix opto-isolators. Isolate high-voltage transients and eliminate both ground loop feed-through and common mode noise in long lines the solid-state way.

Only Litronix makes a compatible family of quad, dual and single opto-isolators. Call or write for complete data and application notes.



# litronix

Litronix, Inc. 19000 Homestead Road, Cupertino, California 95014  
(408) 257-7910 TWX: 910-338-0022  
European Headquarters: Litronix, Inc. Bevan House, Bancroft Court  
Hitchin, Hertfordshire SG5 1LW England Tel: 2676 Telex: 825-497



## New products/materials

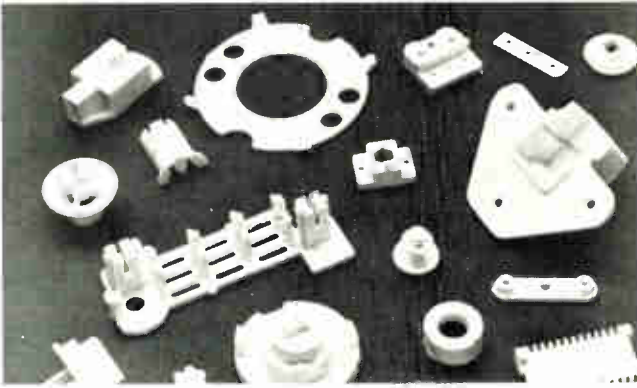

**Glass-reinforced polyester** for the fabrication of electronic parts is self-extinguishing. Applications are in circuit receptacles and circuit breakers, for example. Sizes range up to 5 by 3 by 1 $\frac{3}{8}$  inch in ivory or dyed colors. The material is said to surpass the characteristics of nylon, acetal and phenolic materials in certain applications.

Security Plastics Inc., 14427 N.W. 60th Ave., Miami Lakes, Fla. 33014 [478]

**A line of soft solder pastes** made of lead-tin materials are available in almost any combination of the two metals with any proportion of binder and fluxes added to meet specific applications. The solders can be used in automatic dispensing equipment or in automatic paste applicators.

Krohn Industries Inc., Powder & Powder Products Division, 221 Seventh Ave., Hawthorne, N.J. 07507 [479]

**A thick-film conductor** called Platinum+ offers a very high density and leach resistance that is said to be equivalent to or exceeding that of palladium-silver compositions. The reactive bonding material contains no glass contaminants and provides strong adhesion to ceramic substrates, plus the ability to wet quickly. Platinum+ requires more than 6,000 psi to pull it off the substrate, which fractures at this tension.

Electro Oxide Corp., 3896 Burns Rd., Palm Beach Gardens, Fla. 33403 [480]

**Two silicone resin adhesives** can bond to unetched polyethylene and polypropylene. Silgrip SR-574 is a pressure-sensitive adhesive with good peel strength, and Silgrip SR-573 is a heat-sealable grade that gives high lap shear. These materials bond to low-energy surfaces with no pretreatment necessary.

General Electric Co., Silicone Products Department, Waterford, N.Y. 12188 [342]

**Eccosorb LS** is a series of low-density flexible foam sheets characterized by high electrical loss. The material absorbs electromagnetic energy and may be used to line a cavity to reduce Q, to wrap around a radiating element to eliminate surface currents, or as a dissipative material in a waveguide. The semiconductive material is offered in five versions priced at from \$14.25 to \$22

Electronics/April 4, 1974

## Licon takes the "butterflies" out of pioneering.

By putting its double-break, double reliable Butterfly® switches to work in radar tracking stations around the world.

If you are doing some pioneering on your own, such as the initial design of equipment requiring lighted pushbutton switches, put the Licon team to work for you.

The same quality and reliability required to track the endless reaches of space are yours in every Licon® switch you specify.

Licon's lighted pushbutton switches are offered in a wide variety of switching configurations, button styles and current capabilities.

Your Licon representative or distributor has a switch solution for you.

 **LICON**

Division Illinois Tool Works Inc.  
6615 W. Irving Park Road  
Chicago, Illinois 60634  
Phone (312) 282-4040  
TWX 910-221-0275



# LICON

puts ideas to work  
in electronics

The Innovative Electronic Group of ITW...  
LICON • ELECTRO MATERIALS • PAKTRON

© ILLINOIS TOOL WORKS INC. 1974  
Circle 207 on reader service card

# GREAT CONNECTIONS!

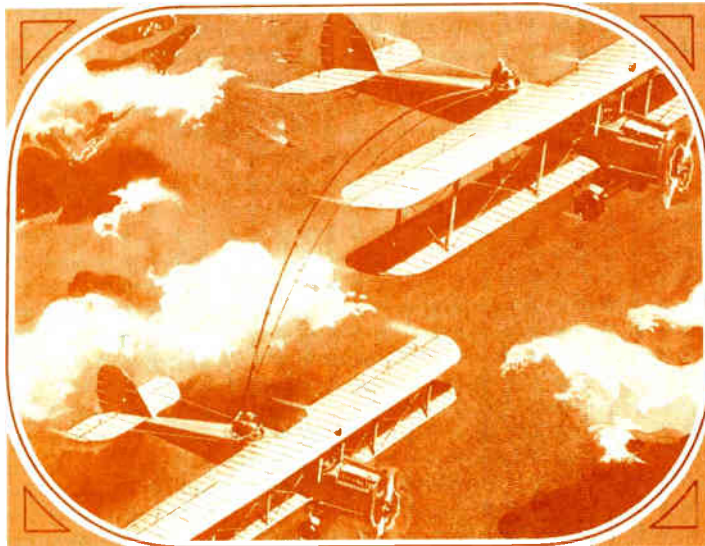

The first successful in-flight re-fueling connection recorded was accomplished by U.S. Army fliers, Captain L. H. Smith and Lt. J. P. Richter, flying a DeHavilland D.H. 4-B Biplane, June 27, 1923. On August 27 and 28, 1923, they set an endurance record of more than 37 hours, re-fueling 15 times.



## SPECTRA-STRIP made another great connection

Spectra-Strip connected with Hays Electronic Ignition Systems, Inc., and was awarded the manufacture of interconnecting systems for their Magna-Pulse Electronic Ignition Conversion Kits. The kits, used in the auto aftermarket, eliminate points and condensers, are compatible with all emission control devices, and improve gas mileage, power, acceleration and maintenance problems. Easy to install, the kits are available for most U.S. car and truck V-8 engines.



SPECTRA-STRIP flat ribbon cable, uniquely bonded or laminated, encompasses both round and flat conductors. It is available from 14 to 34 AWG, and in widths up to 100 conductors. They can be standard or custom color-coded to meet your special needs. SPECTRA-STRIP also has a total capability for creating and producing custom interconnecting harness assemblies to meet your particular design requirements.



**SPECTRA-STRIP CORPORATION**

7100 Lampson Ave., Garden Grove, CA 92642 (714) 892-3361  
385 Putnam Ave., Hamden, Conn. 06517 (203) 281-3200

Circle 208 on reader service card

## Own your own holder to hold your own!

Hold your own copies of Electronics in specially designed slipcase holders. They'll keep your Electronics library neat and handy—a permanent information file, issue by issue.

Just complete the coupon and mail to Jesse Jones. He'll process your order upon receipt, postpaid.



**ELECTRONICS BOXER**  
Jesse Jones Box Corporation  
2250 E. Butler St., Philadelphia, Pa. 19137

Please send me:  boxes @ \$4.25 each;  3 boxes @ \$12.00;  6 boxes @ \$22.00.  
My check or money order is enclosed.

Name: \_\_\_\_\_

Address: \_\_\_\_\_

City: \_\_\_\_\_ State: \_\_\_\_\_ Zip: \_\_\_\_\_

## New products/materials

per two-foot-square, depending on thickness and loss factor.

Emerson & Cuming Inc., Microwave Products Division, Canton, Mass. 02021 [343]

Processed green-emitting gallium-phosphide LED wafers can be finished to produce all kinds of lamps and display devices with conventional semiconductor-processing

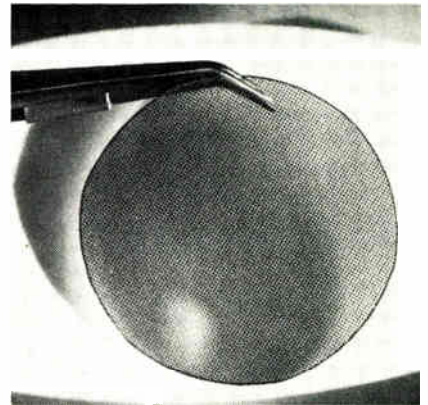

equipment. This will allow semiconductor manufacturers to supplement existing LED product lines. The wafers are made of monocrystalline GaP grown by the Czochralski method in high-pressure chambers using liquid encapsulation.

Xciton Corp., Shaker Park, 5 Hemlock St., Latham, N.Y. 12110[476]

Semiconductor-grade silicone resin coatings, called EJCO245, are designed for passivated or unpassivated device surfaces. The two-component system has a chemical purity achieved through the use of an atomic absorption analysis process. A wide variety of curing schedules is possible. The material is suitable for plastic power transistors, LEDs, hybrid ICs, and hermetic packages.

Silicone Products Dept., General Electric Co., Waterford, N.Y. 12188[477]

A glass polyimide laminate, which is said to have a greater heat resistance than glass-epoxy compounds in all three axes, is called G-30. The material's flexural and copper-peel strength improve with temperature increase. In multilayer applications, resin smearing is eliminated.

Norplex Division of UOP, 1300 Norplex Dr., LaCrosse, Wis. 54601 [478]



# 16Kx18 =

# more core in Fabri-Tek's reliable 600 Series

We have an addition to our 600 Series! It's the Model 686 Core Memory System with a basic module capacity of 16K x 18. Like all 600 Series models, the 686 combines off-the-shelf availability with reliable performance and minimum cost. Modular constructed, ferrite core memories permit operation of up to eight

core modules in a single enclosure.

Developed for a wide variety of data storage applications, the entire 600 Series is completely compatible with TTL logic. So, check the specifications, then specify the 600 Model that best fits your application.

**The 620 Core Memory System**

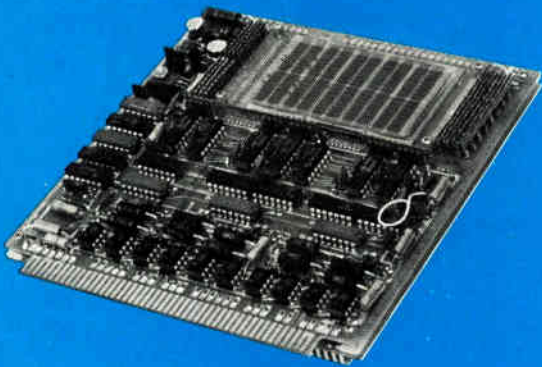

Capacity of 1,024 words by 10 bits on a single card. Planar 3-D, 4-wire configuration measures 6.0 x 6.4 inches. Expandable. Access time: 350 nanoseconds. Full cycle time: 1.0 usec.

**The 684 Core Memory System**

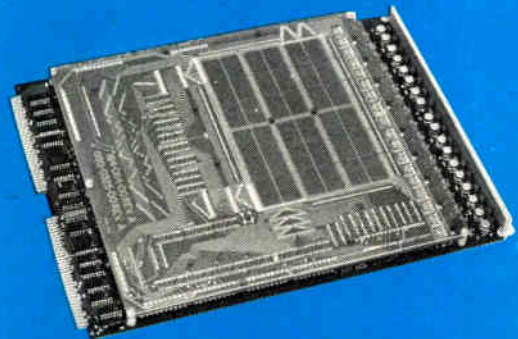

Basic module capacity of 8,192 words by 18 bits on a single card. Expandable to 32K, 64K or 128K by 9, 18 or 36 bits. Planar 3-D, 3-wire configuration measures 11.0 x 14.75 inches. Access time: 300 nanoseconds. Full cycle time: 650 nanoseconds. System options include: enclosures with printed circuit back panels, power supplies and test exerciser.

**The 686 Core Memory System**

**NEW**



Basic module capacity of 16,384 words by 18 bits on a single card. Expandable to 64K, 128K or 256K by 9, 18 or 36 bits. Planar 3-D, 3-wire configuration measures 11.0 x 19.0 inches. Access time: 350 nanoseconds. Full cycle time: 750 nanoseconds. System options include: enclosures with printed circuit back panels, power supplies and test exerciser.

**The 688 Core Memory System**

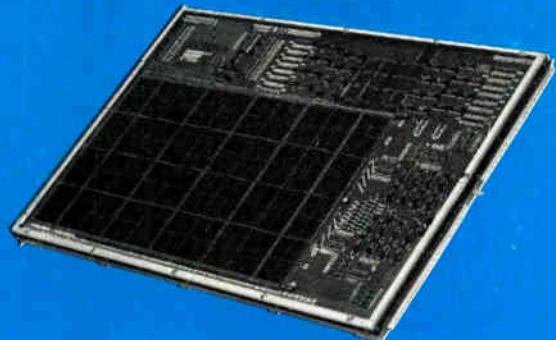

Basic module capacity of 32,768 words by 20 bits on a single card. Expandable to 64K, 128K, 256K or 512K by 10, 20 or 40 bits. Planar 3-D, 3-wire configuration measures 15 x 21.5 inches. Access time: 500 nanoseconds. Full cycle time: 1.2 microseconds. System options include: enclosures with printed circuit back panels, power supplies and test exerciser.

**FABRI-TEK INC.**  
**COMPUTER SYSTEMS**

5901 South County Road 18 • Minneapolis, MN 55436 • (612) 935-8811  
Leader in Memory Technology for Over a Decade

<b>SALES OFFICES IN:</b>	Chicago (312) 437-4116	Denver (303) 753-0631	New Jersey (201) 964-4770	Sunnyvale (408) 739-4780	Hong Kong K-331383	Tokyo (03) 432-6901
	Boston (617) 969-5077	Dallas (214) 661-3155	Long Beach (213) 420-2493	Phoenix (602) 266-4448	Toledo (419) 865-6693	Munich 089-755-8298
						United Kingdom 01-903 1923/5





We set the industry standard  
the day we started making computers.

When we were designing our first computer, we decided to put as big a subsystem as we could on each PC board.

Within three years, the accepted way to build small computers was the Data General way.

And when we were working on our second computer, we made it completely compatible with our first. So all our software and peripherals could run on both computers. And the interfacing would be just as easy.

And we held on to that idea. The nine computers we've made since then are fully compatible, too. For the same reasons.

In other words, we invented what's now known as a "family" of small computers.

We're at it again with our Nova 2. Only this time we're helping you get your products out into the marketplace faster.



We've given the Nova 2 the operating systems you'll need to develop your software and run your hardware. So you won't have to come up with your own.

We're offering low-cost 16K memory so your programmers can work in high-level languages. And write software faster.

We have the general purpose interfaces you'll need to make that job go faster.

And we have the support organization you can call anytime you need help.

Making computers easier for you to work with isn't exactly standard in the industry.

Someday it may be.

At Data General, that day is now.

# DataGeneral

The computer company you can understand.

◆ Data General Corporation Southboro, Massachusetts 01772, (617) 485-9100.  
Datagen of Canada Ltd., Hull, Quebec (819) 770-2030/Data General Europe, Paris, France 504-23-44.

Circle 211 on reader service card

DESIGN ENGINEERS:

# Custom's Capacitors have what you need

Do you deal with specifications like these in your work:

- capacitance over 40 pf up
- frequencies in MHz
- voltage over 1000 VDC

**Then reconstituted mica capacitors are what you need.**

Do you work with energy density of .05-.25 joules/in.<sup>3</sup>, at high voltage?

**Reconstituted mica capacitors will best fill your requirements.**

Looking for high voltage in small packages?

**You need reconstituted mica capacitors!**

Another of the many advantages of reconstituted mica capacitors is excellent performance under environmental extremes.

Custom can meet your needs better, because each process in our capacitor production begins and ends with quality control to avoid failure in the field. Let us show you how we can fill your requirements.

See our page in *Electronic Buyer's Guide and EEM* and write for FREE product sheets today.

P.S. Oil exploration personnel: Custom can help you with your logging tool problems.



**CUSTOM ELECTRONICS, Inc.**  
12 Browne St., Oneonta, N.Y. 13820  
PH: (607) 432-3880 TWX: 510-241-8292

## New literature

**Power supplies.** Kepco Inc., 131-38 Sanford Ave., Flushing, N.Y. 11352. A 32-page handbook is offered on ways to get the most out of programmable power supplies. Discussed are signal-processing capability, digital interface, control by digital logic, and gain. Circle 421 on reader service card.

**Lock-in amplifiers.** Brookdeal Electronics Ltd., Market St., Bracknell, Berks., England, has published a 16-page guide on lock-in amplifiers. Systems versus modular approaches are discussed, as well as applications. [422]

**Toggle switches.** General-purpose, industrial, and military toggle switches are described in a brochure from J-B-T Instruments, Inc., Box 1818, New Haven, Conn. 06508. [423]

**Temperature controls.** Single and dual setpoint solid-state temperature controls are described in bulletin 9456 from Love Controls Corp., 1714 S. Wolf Rd., Wheeling, Ill. 60090. On-off, proportioning, limit, and heat-cooling models are discussed. [424]

**Programmable controller.** Eagle Signal, 736 Federal St., Davenport, Iowa 52803, has published an eight-page brochure describing the initial steps in writing a control sequence of operations and selecting the best programmable controller to execute that sequence. [425]

**Connectors.** A connector-selection guide, listing the most popular connector configurations in standard and special versions, is available from ITT Cannon, 666 E. Dyer Rd., Box 929, Santa Ana, Calif. 92702. The six-page booklet includes environmental specifications and model differences. [426]

**Filters.** A four-page brochure from LectroMagnetics Inc., 6056 W. Jefferson Blvd., Los Angeles, Calif. 90016, describes a line of filters for radio-frequency-interference control in power-line, communications, and signal applications. [427]

**Power supplies.** Advance Power Inc., 1621 S. Sinclair St., Anaheim, Calif. 92806, has issued a catalog describing advances in the design of ac voltage regulators and dc power supplies. [428]

**Timing instrumentation.** Datatron Inc., 1562 Reynolds Ave., Santa Ana, Calif. 92707. A brochure provides information on the company's range of precision timing instrumentation, including time-code generators, translators, tape-search units, remote displays, and digital clocks. [429]

**Sapphire.** Bird Precision Jewels, 1 Spruce St., Waltham, Mass. 02154. Technical literature discusses why single-crystal sapphire substrates are playing an important role in microwave and other electronics technologies. [430]

**Power supplies.** Specifications on eight 500-watt general-purpose power supplies are available from Sorensen Co., 676 Island Pond Rd., Manchester, N.H. 03103 [431]

**Converters.** The system DAC-HR high-resolution digital-to-analog-converter module is described in a brochure from Datal Systems Inc., 1020 Turnpike St., Canton, Mass. 02021. The literature contains applications information, as well as specifications, input/output connections, and ordering information. [432]

**Function generators.** Cal Tek Engineering, 29 Pemberton Rd., Weyland, Mass. 01778, has issued an applications note describing the uses of the company's function generators. [433]

**Trimmer capacitor.** A bulletin on trimmer capacitors from Sakata International Inc., 651 Bonnie Lane, Elk Grove Village, Ill. 60007, describes rotary versions, giving dimensional information, specifications, and test values. [434]

**Limiter modules.** Alpha Industries Inc., 20 Sylvan Rd., Woburn, Mass. 01801. A four-page brochure describes the MO-1930 line of limiter



# Blowbacks. Another good reason for microfilm.

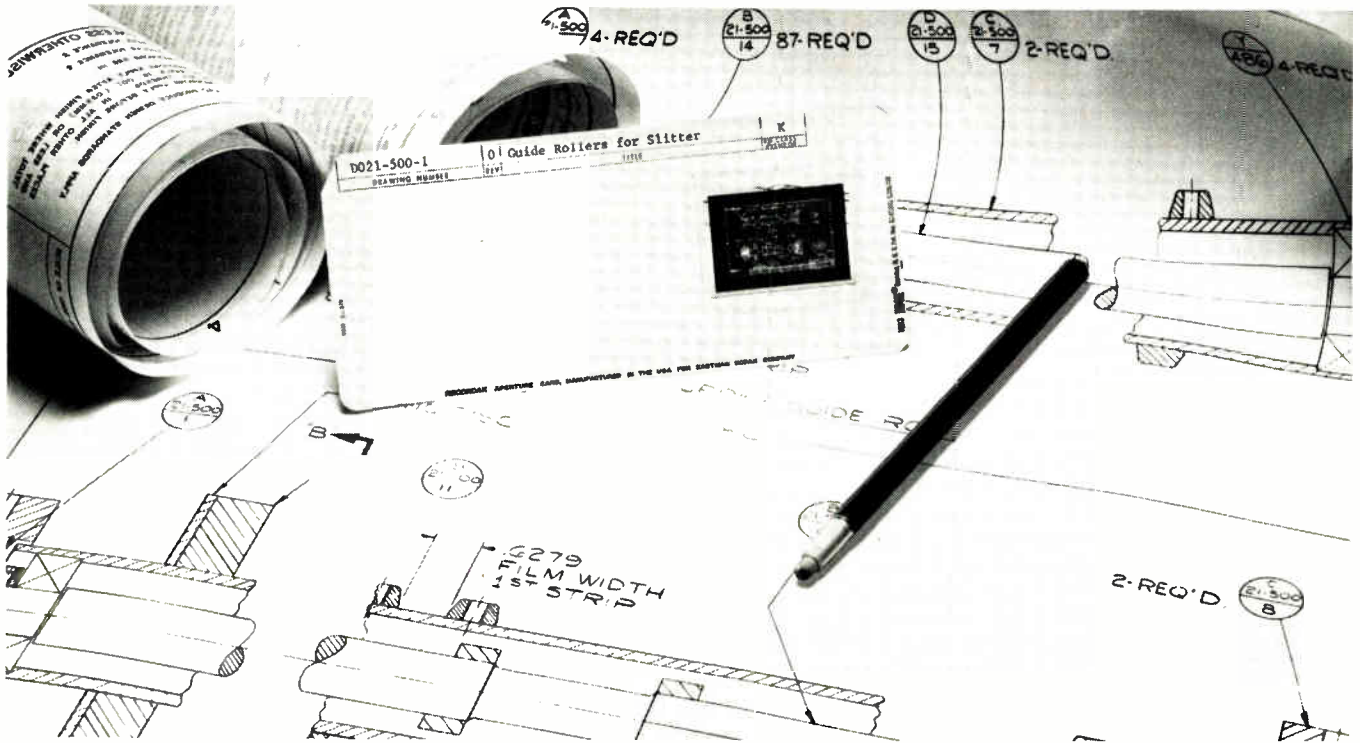

Put the flexibility of Kodak microfilm into your engineering program.

There are many advantages to microfilming your drawings. It saves space, it provides security, and it's one of the most efficient methods of filing and retrieving engineering data. And now, you can make high-quality enlargements directly from the sharp, crisp microfilm images that Kodak products have produced.

Blowing back onto Kodagraph films or papers from microfilm is a fast, easy way to make second originals. And you not only eliminate the need to use original drawings; you also save material because you can

produce the exact size reproductions you require.

You'll find that you save in other ways, too! Whether the job is revising drawings or restoring them, or even making distribution prints, blowbacks from Kodak microfilm can save you time and money.

Get the details.

Find out how Kodak microfilm and drawing reproduction products can benefit your department. Write for our booklet on Engineering Document Control or ask for a sales representative to call. Eastman Kodak Company, Business Systems Markets Division, Dept. DP751, Rochester, N.Y. 14650.

**Kodak products for engineering data systems.**



# Procond

Synthetic film  
capacitors  
Electrolytic capacitors  
Filters  
Push Buttons

Quadrangolo

PROCOND S.p.A.  
32013 Longarone (Belluno) Italy

telephone (0437) 76145/76355  
telex 44029

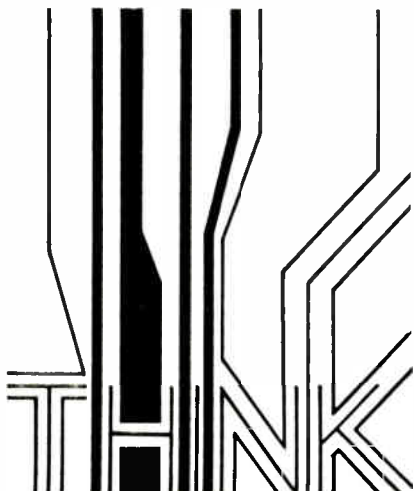

## New literature

modules for microwave applications. [435]

**Ceramic trimmer capacitors.** Brochure C-11000 from Sakata International Inc., 651 Bonnie Lane, Elk Grove Village, Ill. 60007, describes the company's line of instrument-grade ceramic trimmer capacitors, which are miniaturized for printed-circuit mounting. [436]

**Switches.** Ledex Inc., 123 Webster St., Dayton, Ohio 45401. A catalog providing applications information as well as specifications, describes the line of push-button switches and indicators offered by the company. [437]

**Dc power supplies.** Miniaturized epoxy-encapsulated modular dc power supplies are described in a brochure from Amphenol Component Marketing Service, 2875 S. 25th Ave., Broadview, Ill. 60153. Specifications, dimensional line drawings and prices are provided. [438]

**Lasers.** A 12-page catalog from Moletron Corp., 177 N. Wolfe Rd., Sunnyvale, Calif. 94086, provides information on dye lasers, super-radiant nitrogen lasers, CO and CO<sub>2</sub> lasers, dual-channel gated integrators, and pyroelectric detectors. [439]

**Screen printer.** A revised edition of bulletin 3130 describes the Accu-Coat model 3130 wide-area thick-film screen printer manufactured by Aremco Products Inc., Box 429, Ossining, N.Y. 10562 [440]

**Multimeter.** A.W. Sperry Instruments Inc., 245 Marcus Blvd., Hauppauge, N.Y. 11787. Bulletin SP-24 describes a line of volt-ohm-ammeters for use in servicing applications. [372]

**Laser trimmer.** Electro-Scientific Industries, 13900 N.W. Space Park Dr., Portland, Ore. 97229. The System 25 laser trimmer is described in a 12-page bulletin that also lists a number of options available with the unit. [341]

## The pollution problem. Maybe your engineers deserve a little help.

The engineers' will be the ones to find the technical solutions to pollution problems. There's no doubt about it.

But pollution is a people problem, too. And the engineers' technological approach to pollution isn't going to solve people problems.

Maybe this booklet can help. It lists some of the things all people can do to fight pollution. And with all the people supporting your engineers we'll have a better chance of winning the fight.

For a free copy or a list of bulk rates write to Keep America Beautiful, Inc., Box 1771, Radio City Station, New York, New York 10020.

### Keep America Beautiful

Advertising contributed for the public good



People start pollution.  
People can stop it.

# The AILTECH RF Power Source

Line  
means  
one  
thing —



# POWER

AILTECH RF Power Signal Sources provide more power at every frequency than any comparable instrument around. Power for susceptibility testing to Mil Std 461/462; power for pattern measurements and VSWR tests of antennas; power for the testing of RF Power Transistors and for RF wattmeter calibration; power for the researcher for NMR, plasma and related investigations.

Covering the complete 0.01 to 2500MHz range, there's Model 445 VHF-UHF Power Oscillator. Features include plug-in heads for eight frequency ranges, positive no-load protection, and power outputs to 50 watts with full AM and FM capability. The most versatile power source available,

with direct frequency readout, single dial control and monitoring of both forward and reflected power.

For broad frequency coverage, from 200MHz to 8000MHz, we offer Models 125 and 126. Model 125 has CW power available as high as 90 watts with continuous adjustment of power to 30dB below maximum. Model 126 covers all S- and C-bands from 2 to 8GHz in a single range.

For any application that requires power — stable, abundant power — there's an AILTECH Power Signal Source. Write today for the complete story or for a really powerful argument, ask for a demo.

PART OF THE GOLD LINE SERIES FROM

**AILTECH**   
A CUTLER-HAMMER COMPANY CONTROL

EAST COAST OPERATION • 815 BROADHOLLOW ROAD • FARMINGDALE, NEW YORK 11735 • TELEPHONE: (516) 595-6471 • TWX: 510-224-6558

WEST COAST OPERATION • 19535 EAST WALNUT DRIVE • CITY OF INDUSTRY, CA. 91748 • TELEPHONE: (213) 965-4911 • TWX: 910-584-1811

Crowthorne, Berks, England (Crowthorne 5777) • 92 Gennevilliers, Paris, France (733.72.20) • Munich, West Germany (0811) 5233023

OTHER SOLID GOLD PRODUCTS FROM AILTECH INCLUDE SPECTRUM ANALYZERS, NOISE MEASUREMENT EQUIPMENT, FUNCTION GENERATORS, OSCILLATORS AND TRANSDUCERS.

Circle 215 on reader service card



# it takes more

Than a neon lamp to solve a circuit problem like this . . .

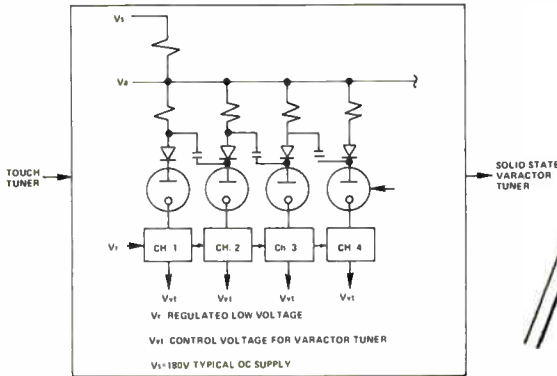

When the new varactor tuning systems for color TV sets were designed, components were required to perform two functions — illuminating the channel selector and transferring precise, regulated voltage to the solid state tuner. Reliable performance, long life and low cost were design objectives.

Design engineers evaluated and selected a circuit component similar to the Signalite A-221C. This dual function neon device effectively acts as a visual indicator and a sequential switch. The A-221C provides excellent light output and exhibits stable breakdown and maintaining voltages throughout its long life.

It takes application help from a group of gas discharge specialists . . .

. . . yours for the asking!



**SIGNALITE DIVISION  
GENERAL INSTRUMENT CORP.**

Contact us at 1933 Heck Ave.,  
Neptune, New Jersey 07753  
(201) 775-2490

Circle 216 on reader service card

CC1

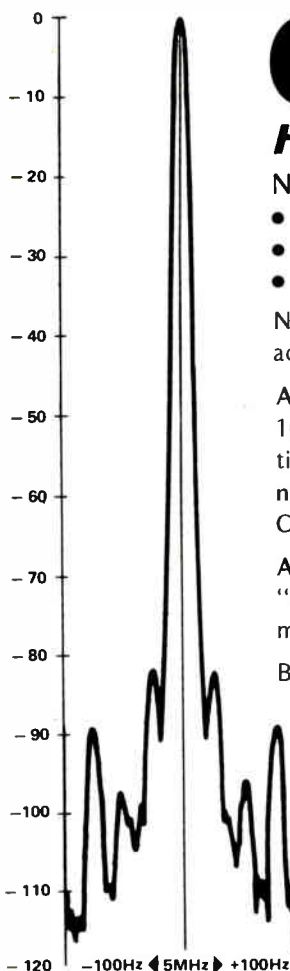

## OVER 120dB

*How's that for dynamic range in a spectrum analyzer?*

Not to mention . . .

- Center-Frequency Range 0 to 11MHz, plus 1 to 110MHz (with 100dB dynamic range).
- Dispersion Range,  $\pm 200\text{Hz}$  to  $\pm 10\text{kHz}$  (to  $\pm 100\text{kHz}$  on 110MHz band).
- Fixed Analysis Window, 10Hz
- Accuracy,  $\pm 5\text{Hz}$ !

NOW you can go after those elusive low-level modulations and perturbations, and get meaningful, accurate measurements, displayed on an X-Y recorder or storage scope, and on a panel dB meter.

AND that's with just a Model 6303 Plug-In Unit. Replace it with a Model 6300 and you've got a 10kHz to 110MHz Frequency Synthesizer, with 1Hz resolution (.01Hz optional), AM/FM modulation, Search, attenuation from +10 to -115dBm in -1dBm steps, 500  $\mu\text{sec}$  programming speed with no switching transients. Auxiliary-Function Plug-ins offer Sweeps and Markers, Phase/Frequency Comparison, Sine/Square Wave Modulation, and other functions.

All Series 6000 models are manually and remotely programmable. Adret "handshake interface" PC cards provide compatibility with virtually any minicomputer on the market today.

Bulletin 3545 gives full details Request your copy today.

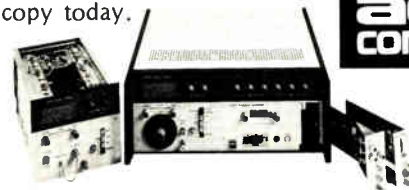

1887 Lititz Pike, Lancaster, Pennsylvania 17601; (717) 569-7059

216 Circle 102 on reader service card

Electronics/April 4, 1974

Careful there . . .  
you're likely  
to start  
something.



Just a  
"flutter" of pressure  
. . . and SNAP!

Less than 2 grams of force actuates this Cherry snap-action miniature switch. Outside, the external aluminum actuator is purposely  $2\frac{3}{8}$ " long to provide this unusually low operating force. Inside, an extra internal actuator further reduces operating force while maintaining solid contact mating pressure for reliable performance.

The "flutter force" switch is only one of Cherry's E22 series of unique miniatures. All are rated 3 amps, 125 VAC. All are also available in gold "crosspoint" configuration for low energy solid state circuits.

**A switch in your hand is worth two in the tree, so . . . SNAP UP A FREE SNAP-ACTION SAMPLE.**

Just TWX 910-235-1572 . . . or PHONE 312/689-7700 and ask Frank to give you facts on miniature switches . . . or circle appropriate reader service number.

**E22-75HX**  
5 grams LIGHT  
FORCE actuation  
Circle No. 168 for  
Free Sample



**E22-55HX**  
3.5 grams LIGHTER  
FORCE actuation  
Circle No. 169 for  
Free Sample

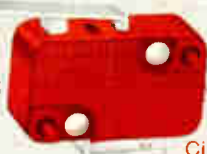

**E22-85HX**  
Less than 2 grams  
"FLUTTER  
FORCE" actuation  
Circle No. 170 for Free Sample



**CHERRY** 

CHERRY ELECTRICAL PRODUCTS CORP.  
3608 Sunset Avenue, Waukegan, Illinois 60085



Cherry affiliates worldwide • Hirose Cherry Precision Co., Ltd., Tokyo • G. W. Engineering Pty. Ltd., Sydney  
Cherry Electrical Products (U.K.) Ltd., St. Albans, Herts • Cherry Mikroschalter GmbH, Bayreuth, Germany

Announcing a reliable, nationwide source of precision

# Ceramics

Multilayer IC packages, Cerdips. Watch components (Case, CMOS packages, PCB). Microwave & power transistor packages. Sub-assemblies for digital readout displays. Substrates and hybrid IC subassemblies. Sliders. Magnetic tape heads. And more. An entire line of electronics and mechanical ceramic components is here.

Turning custom designs on these products into fast, efficient mass production has made Kyoto Ceramic

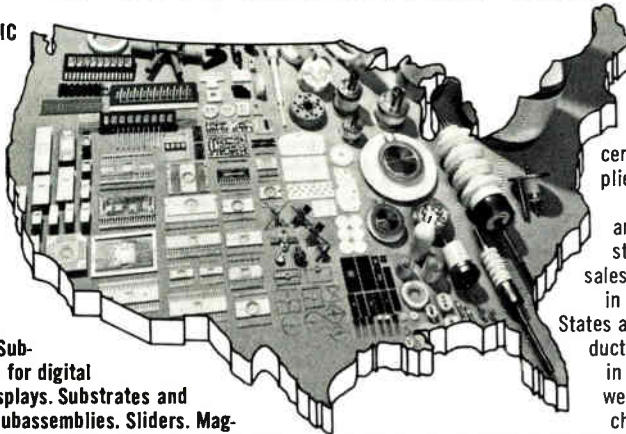

Co. Ltd. (our principal) the largest technical ceramics supplier in Japan. Now, with an expanded staff of field sales engineers in the United States and our production facility in San Diego, we are out to change a lot of ideas about performance in the ceramics business.

If you need precision ceramics, please contact our sales manager, Jim Uyeda, Jr. for further information. (408) 257-8000.

**Kyocera**

Kyocera International, Inc.

ADMINISTRATION & SALES: 10050 North Wolfe Road, Valco Park, Cupertino, California 95014, (408) 257-8000  
 EASTERN REGIONAL SALES OFFICE: 29 West Main Street, Somerville, New Jersey 08876, (201) 526-6448  
 PLANT: 5625 Kearny Villa Road, San Diego, California 92123.

Complete Supply Source of Electronics and Industrial Ceramics.

Circle 218 on reader service card

## New books

**Peripheral Devices**, Ivan Flores, Prentice-Hall, 1973, 499 pp., \$22.95.

In his preface, Prof. Flores claims no other book has been written entirely on the subject of computer-peripheral equipment. He may be correct. His book is well organized, comprehensive, thorough, and apparently accurate. Unfortunately, one must add that it is not well written. The book is recommended for reference, provided the user takes care to avoid its pitfalls, some of which are cited here.

Flores sails right into chapter 1—ostensibly an “introduction”—using unexplained jargon, apparently on the theory that the way to teach someone to swim is to throw him bodily into water over his head. This gets the book off to a bad start, and the situation is not helped by a spelling error on page 2, typographical errors here and there, and footnotes on pages 2 and 3 referring to six of the author’s previous books—no other books are referenced anywhere. All the other chapters also begin with the same jump-in-with-both-feet approach.

Early in the book, the concept of the OR gate is introduced with what Flores calls a “two-throw,” which is what anybody else would call a single-pole, double-throw, or SPDT switch. He implies in this context that the logic connection called variously a dot-OR, a wired-OR, or a solder-OR won’t work, which is ridiculous—the connection, of course, is widely used, subject to certain restrictions that the explicit OR-gate avoids.

The book, hardware-oriented, is limited to IBM equipment; the author assumes this is adequate because most installed equipment is either made by IBM or is built by independent manufacturers to be compatible with it. He starts with data and data organization, goes on in steadily ascending steps through devices, controllers, multiplexers, channels, and the channel interface—the standard interface used by IBM in its Systems 360 and 370 for all peripheral devices.

He does discuss software and includes sections on specific devices, including card equipment, printers,

CONNECTORS/  
P.C.

## JACKS & PINS

BERYLLIUM  
COPPER  
CAGES

**CONCORD ELECTRONICS CORPORATION**  
37 GREAT JONES STREET NEW YORK, N.Y. 10012 (212) 777-6571 • TWX 710-581-4930

and  
**TEFLON\***  
AND SOLDER  
**TERMINALS**

\*DUPONT T.M.

SEND FOR CATALOG

218 Circle 241 on reader service card

## BROADBAND

## AMPLIFIER

MODEL AM-108

- 5-300 MHz Frequency Range
- 28.5dB Gain @ 50 MHz
- +15dBm Min. 1dB Output Compression
- \$100/Stock Availability

**anzac**  
ELECTRONICS

39 Green Street, Waltham, Mass.  
(617) 899-1900 • TWX 710-324-6484

Circle 242 on reader service card



# Digitec introduces another product in the **HT SERIES** (a breakthrough in High Technology)

## a new, portable Digital Multimeter.

Digitec's new Model 2110, 3½ Digit Multimeter is the latest product in the new HT Series (High Technology). This new family is the realization of a long term R & D program producing digital instrumentation with the ultimate in reliability and performance. These demanding standards have been achieved by using field proven technology combined with proprietary design, state-

of-the-art components and advanced production techniques. The application of human engineering principles, enables simple and self evident use of the instrument. Our proudest achievement, the HT series instruments are housed in attractive, designer-styled, enclosures that protect and enhance the advanced technology they contain.



Model 2110 Digital Multimeter

**\$219.**

Features: DC ranges to 1000 volts with autopolarity, sensitivity 0.1mV / AC ranges to 500 volts, sensitivity 1mV / Ohms ranges to 20M $\Omega$ , sensitivity 0.1 $\Omega$  / Monsanto, easy-to-read, long life LED's / 115/230VAC, 50 to 400Hz line operation or self-contained batteries yielding 8 hrs. continuous operation / Built-in automatic battery charger / Batteries optional \$35.00 / Compact, lightweight and rugged / Ideal for bench or field operation / "Off-the-shelf" availability from your local Digitec Representative.

For demonstration only circle 101 on reader service card

For information only circle 219 on reader service card

UNITED SYSTEMS CORPORATION  
18 Woodley Road Dayton, Ohio 45403  
Ph (513) 254-6251 Twx (810) 459-1728  
a subsidiary of

**Monsanto**

**Digitec.**

# SEARCHLIGHT SECTION

- CLASSIFIED ADVERTISING
- BUSINESS OPPORTUNITIES
- USED OR SURPLUS EQUIPMENT

## AUTOTRACK MOUNT

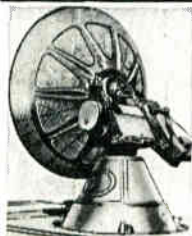

### AUTOTRACK SCR-584 RADARS

360 degree azimuth, 210 degree elevation sweep with better than 1 mil. accuracy. Missile velocity acceleration and slewing rates. Amplify and servo control. Will handle up to 20 ft. dish. Supplied complete with control chassis. ALSO in stock 10 cm. van mounted radar system. Conical scan PPI. 6 ft. dish. Ideal for S band telemetry, weather, balloon trk, missile trk, rocket trk, ECM range. Write for complete data. 600 pg. instr. bk. avail. at \$25 ea.

### 1 MEV LINEAR ACCELERATOR

Dual Mode, Ion or Electron, RF Drive, 300 KHZ at 45 KW. Includes control console, RF unit, accelerator, etc.

### MOD IV HIGH RESOLUTION TRACKER

Instrumentation radar, freq. 8.5-9.6 GHz, Pwr: 250 KW, 1 mil tracking accuracy, 6' Fresnel lens antenna with 4 horn monopulse feed. Tracking range 50 or 200 miles. Formerly used as range safety radar at Cape Kennedy.

### PULSE MODULATORS

245 KW LINE PULSER Output 16 KV at 16 amp., 25  $\mu$ s at 4000 PPS.  
 405 KW FLOATING DECK PULSER Output 20 KV at 20 amp., 1  $\mu$ s to 10 millisecc pulse.  
 500 KW LINE PULSER Output 22 KV at 28 amp., 4/1.75/2.25  $\mu$ s at 2500/550/300 PPS.  
 1 MW HARDTUBE MIT MODEL 9 Output 25 KV at 40 amp., 25-2  $\mu$ s at .002 D.C.  
 2.0 MW LINE PULSER Output 30 KV at 70 amp., 1/2  $\mu$ s at 600/300 PPS.  
 3 MW LINE PULSER Output 39 KV at 75 amp., 25/1  $\mu$ s at 500 PPS.  
 10 MW LINE PULSER Output 76 KV at 135 amp., 2.5  $\mu$ s at 350 PPS.  
 17 MW LINE PULSER Output 17 KV at 1000 amp., 2-5  $\mu$ s at 150-2x10 PPS.

### HV POWER SUPPLIES

6.3 KV @ 5 Amps; 20KV @ 1.3 Amps; 35KV @ 1.5 Amps; 28KV, 70MA; 12KV @ 800MA; 18KV @ 2.25 Amps; 17.5KV @ 1.8 Amps.

### RECON DRONE CONTROL RADARS

X Band systems autotrack and search complete with plotting boards. Fully mobile van mounted. Gives PPI, slant range, altitude data. Ground to air control links and beacons also in stock. AN/MPQ-29 & AN/LUPW-1

### RADAR DATA MICROWAVE LINK

Freq. 7.1-7.9 GHz, Pwr. 100 mw., 4 channels. Transmits video, pulse, synchro, and voice information. Mfr: Motorola.

### SPARE PARTS IN STOCK

Nike Ajax, Nike Hercules, M-33, MPS-19, TPS-ID, TPS-10D, FPS-6, SPS8, SCR-584, HIPAR

### RADAR & RF PKGS.

3ghz/40kw Pulse RF pkg  
 24ghz/40kw Pulse bomb toss system  
 16ghz/130kw Pulse B-58 search radar system  
**X BAND SEARCH 40 KW PULSE WEATHER RADAR**  
**X BAND AUTOTRACK 250KW PULSE M-33**  
 compl w / plot boards  
**X BAND BEACON 400 W PULSE AN/DPN-62**  
**X BAND AUTOTRACK 50KW PULSE B-47**  
 fire control complete  
**C BAND WEATHER RADAR 250 KW PULSE**  
**C BAND HEIGHT FINDER**  
 AN/FPS-26 5 megawatt output  
 AN/TPS-37, 1 megawatt output.  
**C BAND 1 MEGAWATT AUTOTRACK**  
 10ft dish mortar locator MPQ-21  
**C BAND 285KW PULSE Search AN / SPS-5**  
**S BAND AUTOTRACK 500 KW PULSE 10' DISH**  
**S BAND 1 MEGAWATT COHERENT AN / FPS-18**  
**S BAND 1 MEGAWATT PULSE NIKE ACQ.**  
**S BAND 5 MEGAWATT HEIGHT FINDER AN/FPS-6**  
**S BAND BEACON 1 KW PULSE**  
**L BAND 500KW PULSE AN / TPS-ID / E**  
**L BAND 5 to 20KW PULSE**  
 400mhz 1KW CW AN / FPS-23  
 225mhz 1 MEGAWATT PULSE AN/TPS 28  
 3-10mhz 100K W PULSE  
 CW 950-5ghz/150 WATTS  
 CW 1.5mhz-10.5ghz/5 WATTS  
 CW 7.4GHZ 2 KW  
**AN / GPG-1 SKYSWEEP TRACKER**  
 .1 cm. auto tracking radar system. Comp. pkg w / indicator sys. Full target acquisition & auto tracking. Input 115v 60 cy. new. In stock for immed. del. Entire sys. 6' x 3' x 10'. Ideal for infrared tracker, drone tracker, missile tracker. R & D

HUNDREDS MORE IN STOCK  
 LARGEST RADAR  
 INVENTORY  
 IN WORLD.  
 WRITE  
 FOR  
 CATALOG  
 ON YOUR  
 LETTERHEAD

## Radio-Research Instrument Co. INC.

3 Quincy St., Norwalk, Conn. 06850 • 203-853-2600

CIRCLE 951 ON READER SERVICE CARD

## IMMEDIATE DELIVERY

Minis & Peripherals  
**DEC—HIS—NOVA**  
**SEL—HP—MOHAWK**

CPU, Card, Printer, Tape, Disk  
**NEW • MOHAWK 4320 PRINTERS**

**PDP 11 PERIPHERALS**  
**CPU, MEMORY**

**PDP 8 CPU \$1500**

**\$750 Minis**

**TELETYPE 35 & 37**  
**DEC & HONEYWELL Modules**  
**617/261-1100**

Send for Free Report "Maintenance of Computers"

**AMERICAN USED COMPUTER CORP.**  
 P.O. Box 68, Kenmore Sta., Boston, MA 02215  
 member COMPUTER DEALERS ASSOCIATION

CIRCLE 952 ON READER SERVICE CARD

# Tall & Big MEN

Write Today for FREE  
 Shop-At-Home Catalog  
 of Guaranteed-To-Fit  
 Apparel & Footwear.

**KING-SIZE**

3134 King-Size Bldg.  
 Brockton, Mass.

CIRCLE 953 ON READER SERVICE CARD

## EMPLOYMENT OPPORTUNITIES

### POSITIONS VACANT

Positions Available-Electrical & Electronic Eng's. Over 1000 US client co's pay our fees for selected technical referrals. Est. 1959. Send resume with pres. sal. Atomic Personnel, Inc., Box L, 1518 Walnut St., Phila., Pa. 19102.

Assistant Professor of Electrical Engineering Technology, University of Cincinnati. Immediate appointment successful applicants MSEE, preferably industrial controls/computer experience, research and promotional interests. To teach associate and bachelor State-of-the-Art Programs at mature 145 year old institution. Reply to John C. Spille, Dean, Ohio College of Applied Science, 100 E. Central Parkway, Cincinnati, Ohio 45210. Equal Opportunity Affirmative Action Employer.

Q. Whom do I contact or call to re-new my classified ad or make corrections?

A. Write Electronics, Class. Adv. Dept., P.O. Box 900, NY, NY 10020 or call: (212) 997-6585 or 6586. Give full company name, size of ad, & date or dates it is scheduled to appear.

## free catalog

**POTTING APPLICATORS**  
 MANUAL OR AIR OPERATED  
 2 1/2cc 6cc 12cc 30cc  
 FOR POTTING, ENCAPSULATING ETC.

**PHILIP FISHMAN CO., INC.**  
 7 CAMERON ST. WELLESLEY, MASS 02181

## FREE CATALOG

### HARD-TO-FIND PRECISION TOOLS

Lists more than 2000 items—pliers, tweezers, wire strippers, vacuum systems, relay tools, optical equipment, tool kits and cases. Also includes ten pages of useful "Tool Tips" to aid in tool selection.

**JENSEN TOOLS**  
 4117 N. 44th Street, Phoenix, Ariz. 85018

CIRCLE 954 ON READER SERVICE CARD

## EMPLOYMENT SERVICES

Growth Positions, \$14-30,000. Fees Paid. Nationwide. Longberry of Pittsburgh. Suite 962-G, Two Gateway Center, Pittsburgh, Pa. 15222.

## New books

magnetic tapes, disks and drums, and the operator's console.

The book uses four typefaces, in addition to that of the running text, to bring out terms being defined, hardware units, software systems, and programming languages.

—Wallace B. Riley

### Recently published

**Ion Beams with Applications to Ion Implantation**, R.C. Wilson and G.R. Brewer, John Wiley & Sons, 500 pp., \$19.95.

**Injection Electroluminescent Devices**, C.H. Gooch, John Wiley & Sons, 198 pp., \$15.95.

**An Introduction to the Analysis and Processing of Signals**, Paul A. Lynn, John Wiley & Sons, 222 pp., \$11.50.

**Introducing Systems and Control**, David M. Auslander, Yasundo Takahashi, and Michael J. Rabins, McGraw-Hill Co., 389 pp., \$12.95.

**Vibration Analysis for Electronic Equipment**, D.S. Steinberg, John Wiley & Sons, 467 pp., \$24.95.

**Protective Relays: Their Theory and Practice**, A.R. Van C. Warrington, Chapman & Hall, 434 pp., \$17.50.

**Experimenting with Electronic Music**, Robert Brown and Mark Olsen, Tab Books, 180 pp., \$7.95.

**Network Analysis, Theory & Computer Methods**, Randall W. Jensen and Bruce O. Watkins, Prentice-Hall, 495 pp., \$18.95.

**Thermionic Energy Conversion Volume I: Processes and Devices**, G.N. Hatsopoulos and E.P. Gyftopoulos, The MIT Press, 265 pp., \$17.95.

**Hybrid Microelectronic Circuits—The Thick Film**, Richard A. Rikoski, John Wiley & Sons, 217 pp., \$13.50.

**Manual of Active Filter Design**, John L. Hilburn, David E. Johnson, McGraw-Hill Book Co., 189 pp., \$12.50.

**Tables of Physical and Chemical Constants**, G. W. C. Kaye and T. H. Laby, Longman, 386 pp., \$23.95.

**Laser Devices and Applications**, ed. I. Kaminow and A. Siegman, IEEE Press, 495 pp., \$14.95.

**Modeling and Simulation**, Vol. 4, ed. W.G. Voigt and M.H. Mickle, Instrument Society of America, 532 pp., \$25.00.

## NEW TALLY PHOTOREADER



### 250 cps; only \$275

Or \$375 with complete electronics. No need to sacrifice speed to get a low price now. The new Model 2050 delivers all the performance power you could want.

Features like adjustment-free operation. Nothing to tinker with... nothing that can get out of sync. A read head that lets you see the last character read. And reads tape with up to 60% transmissivity. Sure performance tape handling—no drag, slippage, or skew problems. DTL/TTL compatible.

Reliability tests showed no more than one read error in every 10 million characters.

For complete technical and quantity discount information, we invite your inquiry.

## TALLY®

Tally Corporation, 8301 So. 180th Street,  
Kent, Washington 98031. Phone: (206) 251-5500.

Circle 221 on reader service card

## ac, dc, volts, amps, ohms

### 25 ranges

### \$595 complete

### 5-day delivery



- New expanded AC response to 100 KHz
- New carrying case option
- New color-coded pushbuttons
- Optional battery pack with recharger (\$95) mounts internally
- 0.01% dc accuracy
- 1,000 megohm input impedance on 3 lowest ranges
- lab, field, or systems use.

For Model 7004A literature, contact your Scientific Devices office or Systron-Donner at 10 Systron Drive, Concord, CA 94518. For immediate details, call our Quick Reaction line (415) 682-6471 collect. **Europe:** Munich, W-Germany; Leamington Spa, U.K.; Systron-Donner S.A. Paris (Port Marly) France. In **Australia:** Systron-Donner Pty. Ltd. Melbourne.

**SYSTRON**  **DONNER**



# Omnigraphic™ Capable Recording

## X-Y CAPABILITY

Some 27 interchangeable modules plug into the basic chassis to give you the most capable X-Y recorder in the world or any place else.

- 30 in/sec speed (40 in/sec available)
- $\pm 0.2\%$  accuracy
- local/remote pen control
- electric pen lift
- high input resistance
- interchangeable amplifiers

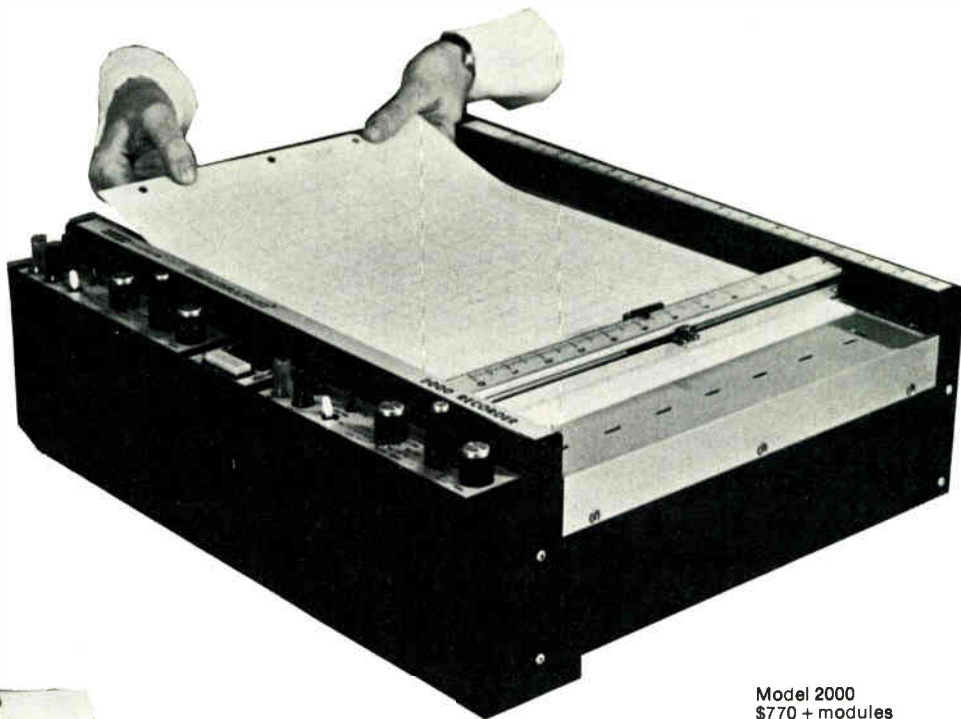

Model 2000  
\$770 + modules

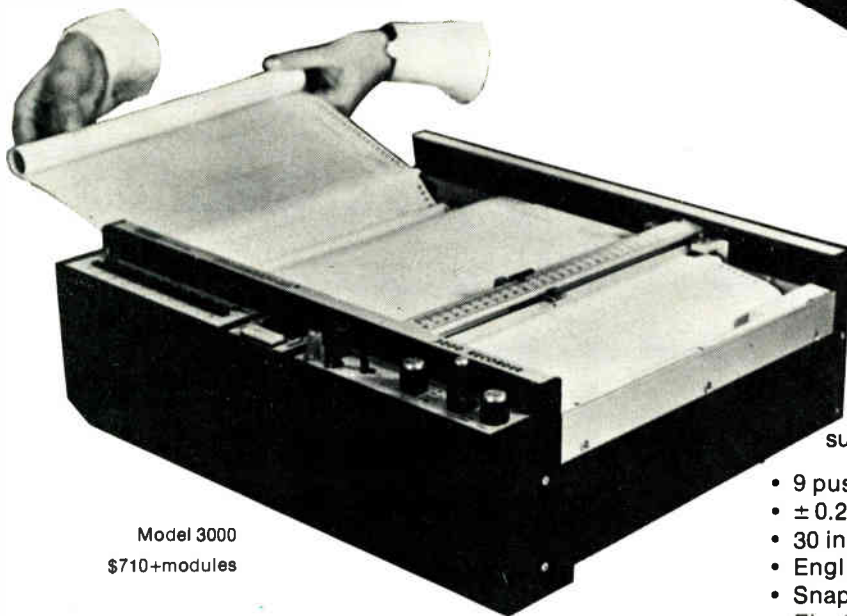

Model 3000  
\$710+modules

## STRIP CHART CAPABILITY

A truly capable strip chart recorder for such diverse functions as GC or spectrometry.

- 9 pushbutton speeds from 20 to 0.05 in/min
- $\pm 0.2\%$  accuracy
- 30 in/sec slewing speed (with 40 in/sec available)
- English/Metric scaling at the flick of a switch
- Snap-in disposable pen
- Electric pen lift

Plug-in modules include:

Type 0 Customizing  
Type 1 DC Coupler  
Type 2 Ranging  
Type 3 Switching  
Type 4 Switching  
/Time Base

Type 5 Precision Attenuator  
Type 6 Precision Attenuator  
/Time Base  
Type 7 Pre-Amp Attenuator  
Type 8 Pre-Amp Attenuator  
/Time Base

Type 9 Precision Ranging  
Type 10 High Sensitivity  
AC Converter  
Type 11 1 mv Full Scale  
Type 12 Precision Attenuator/Offset  
Type 13 Integrator  
Type 14 Log Converter  
Type 15 Two Channel

Type 16/17 Point Plotter  
Type 18 Thermo Couple  
Type 19 Strain Gauge  
Type 20 AC, DC Switching  
Type 50 Chart Drive  
Type 51 Chart Drive  
Type 52 Chart Drive  
Type 53 Chart Drive  
Type 100 Control  
Type 200 Control

**THE  
RECORDER  
COMPANY**

**houston  
instrument**

ONE HOUSTON SQUARE (at 8500 Cameron Road) AUSTIN, TEXAS 78753  
(512) 837-2820 TWX 910-874-2022 cable HOINCO

European Office Rochesterlaan 6, 8240 Gistel, Belgium  
Telephone 059-27445 Telex BAUSCH 19399

OEM DISCOUNT

Be sure to ask about our unique module trade-in plan.

# Electronics advertisers

April 4, 1974

<b>Adret Corporation</b> T.C. Gams & Associates, Inc.	216	<b>Coil Winding International Exhibitions, Ltd.</b> Colonsay Communications	196	<b>The Gerber Scientific Instrument Co.</b> Charles Palm & Co., Inc.	199
<b>Adret Electronique</b> Psycho Publicite	67	<b>Computer Components, Inc.</b>	18E	<b>Gould, Inc./Instrument Systems Div.</b> Carr Liggett Adv., Inc.	182-183
<b>Advanced Memory Systems, Inc.</b> Robert A. Schlötfeldt	45	<b>Concord Electronics Corp.</b> Sound Advertising	218	<b>Guardian Electric Mfg. Co.</b> Kolb/Tookey and Associates, Inc.	91
<b>Advanced Mikro Devices</b> Keys Donna Pearlstein	8E	<b>Coming Glass Works, Electronic Materials Dept.</b> Pierce Brown Associates, Inc.	131	<b>Harris Semiconductor</b> Tucker Wayne & Company	204-205
<b>Advanced Micro Devices</b> Keys Donna Pearlstein	10-11	<b>Cramer Division of Conrac</b> McCarthy, Scelba, DeBlasi	194-195	<b>Heath/Schlumberger Scientific Instruments</b> Advance Advertising Services	180
<b>AILTECH/Cutler-Hammer</b> R.L. Thompson Advertising	215	<b>C. Tennant Sons &amp; Co.</b> A.D. Adams Advertising Inc.	12E	<b>Hewlett-Packard</b> Corporate Marketing Communications	17-28
<b>Airpax Electronics, Inc.</b> Robert B. Walker & Associates, Inc.	225	<b>Custom Electronics, Inc.</b> Laux Advertising, Inc.	212	<b>Honeywell Test Instrument Division</b> Campbell Mithun, Inc.	172
<b>Alcatei</b>	13E	<b>Cutler Hammer, Inc.</b> Campbell-Mithun, Inc.	93	<b>Houston Instrument</b> Ray Cooley and Associates, Inc.	222
<b>Alco Electronic Products, Inc.</b> Marketronics Advertising	186	<b>Dale Electronics, Inc., A Sub. of the Lionel Corporation</b> Swanson, Sinkay, Ellis Inc. Advertising	4th Cov	<b>Hughes Aircraft Company</b> Foote, Cone & Belding	47
<b>Allegheny Ludlum Steel Corporation</b> VanSant, Dugdale and Company, Inc.	181	<b>Data Control Systems, Inc.</b> Ada & Images	158	<b>ILC Data Device Corporation</b> Marchin Weltman Advertising, Inc.	58
<b>Allen Bradley Company</b> Hoffman, York, Baker & Johnson, Inc.	34	<b>Data General Corporation</b> Scall, McCabe, Sloves, Inc.	210-211	<b>Industrie Bitossi s.a.s.</b> C.E.T.I.	9E
<b>American Microsystems Inc.</b> Wilton Coombs & Coinett Inc. Advertising	192-193	<b>Datal Systems, Inc.</b> John Dolan Advertising	3rd Cov	<b>Intel Corp.</b> Regis McKenna, Inc.	202-203
<b>American Smelting and Refining Company</b> Clyne Maxon, Inc.	50	<b>Diallight Corporation</b> Michel-Cather, Inc.	2nd Cov	<b>Interdata</b> Shaw Elliott, Inc.	188-189
<b>AMF/Potter &amp; Brumfield Division</b> Fuller & Smith & Ross, Inc.	173	<b>Digital Equipment Corporation</b> Schneider Parker, Inc.	95	<b>International Nickel Company</b> Ogilvy & Mathers, Inc.	176
<b>AMP Incorporated</b> Altkin-Hynett Co., Inc.	28-29	<b>Diva, Inc.</b> Halloff & Caine	1	<b>Interall, Inc.</b> Tycer-Fultz	12-13
<b>Amphenol Components Group</b> Bunker Remo Corp. Marsteller, Inc.	32-33	<b>Eastern Air Devices</b> Weston Associates, Inc.	16	<b>Interstate Electronics Corp.</b> Chris Art Studio Inc.	74
<b>Analog Devices, Inc.</b> Schneider Parker, Inc.	152-153	<b>Eastman Chemical Products, Inc., Industrial Chemicals</b> J. Walter Thompson Company	177	<b>Krohn-Hite Corp.</b> Impact Advertising, Inc.	5
<b>Anzac Electronics</b> Ken Puleo Advertising	218	<b>Eastman Kodak Company, Business Systems Markets Div.</b> J. Walter Thompson Co.	213	<b>Kyocera International, Inc.</b> Hall Lawrence Inc.	218
<b>Augat</b> Creamer, Trowbridge, Case & Basford, Inc.	171	<b>Electronic Measurements, Inc.</b> Hill Advertising Agency	169	<b>Kyodo Electronic Laboratories, Inc.</b> Sanko, Tsushinsha Ltd.	226
<b>Automatic Electric</b> Marsteller, Inc.	68-69	<b>Electronic Memories and Magnetics Corporation</b> S. Michelson Advertising	55	<b>Lambda Electronics Corp.</b> Michel Cather, Inc.	150-151
<b>Bausch &amp; Lomb, Inc.</b> Wolff Assoc., Inc.	196	<b>Electronic Navigation Industries</b> Hart Conway Co., Inc.	14	<b>LFE Corp., Process Control Division</b> LFE Advertising	187
<b>Beckman Instruments, Inc. (Information Displays Operations)</b> N.A. Winter Advertising Agency	61	<b>EPC Labs, Inc.</b> Superfine Productions	164	<b>LICON division, Illinois Tool Works Inc.</b> Post Keyes Gardner Inc.	207
<b>Bourns, Inc.</b> Marlborough Assoc., Inc.	157	<b>Erie Technological Products Co., Inc.</b> Altman Hall Associates Advertising	27	<b>Litronix, Inc.</b> Regis McKenna, Inc.	206
<b>Bussman Mfg. Division of McGraw-Edison Co.</b> Henderson Advertising Company	38	<b>ETEC Corp.</b> Allen & Dorward, Inc.	49	<b>Lockheed Electronics Co.</b> McCann-Erickson, Inc.	160
<b>Calma Company</b> William Cain, Inc., Advertising	132	<b>Excellon Industries</b> Graham & Sparkman Advertising etcetera	201	<b>LTT</b>	15E
<b>Cambridge Thermionic Corporation</b> Chirurg & Cairns, Inc.	166	<b>Fabri-Tek Inc.</b> Midland Associates, Inc. Marketing and Advertising Services	209	<b>Master Appliance</b> Hoffman, York, Baker & Johnson, Inc.	178
<b>The Carborundum Company</b> Stahlka/Faller, Inc.	147	<b>Fairchild Wiesbaden</b> Nord-Sud Werbung GmbH 7 Co. KG	5E	<b>MFE Corporation</b> Brightman Company, Inc.	52
<b>CELCO (Constantine Engineering Laboratory Co.)</b> Stano Advertising	94	<b>Fluke Trender</b> Lincoln Associates, Inc.	154	<b>Micro Devices</b> Advertising & Merchandising, Inc.	178
<b>Centralab Electronics Div., Globe-Union Inc.</b> Action Communicators	96-98	<b>General Devices Company</b> Market Communicators, Inc.	170	<b>Micro Switch Division of Honeywell</b> N.W. Ayer & Son, Inc.	154
<b>Cherry Electrical Products, Corp.</b> Kolb/Tookey and Assoc., Inc.	217	<b>General Electric Co., Semiconductor Products Department</b> Advertising & Sales Promotion Syracuse Operation	149	<b>Mostek Corporation</b> David W. Evans, Inc./Texas	9
<b>Cinch Connectors, Operation of TRW Electronic Components</b> Stral Advertising Company, Inc.	182	<b>General Instrument Europe S.P.A.</b> Studio Hedy	54	<b>Motorola Semiconductor Products, Inc.</b> E.B. Lane & Associates, Inc.	56-57, 70-71, 190-191
<b>Circuit-Stik, Inc.</b> Haaga Advertising	224	<b>General Instrument Corporation, Semiconductor Comp. Div.</b> Norman Allen Associates, Inc.	2	<b>National Electronics</b> Lea Advertising	86
<b>C &amp; K Components</b> Van Christo, Inc.	180			<b>Nippon Kogaku K.K.</b> K & L Advertising Agency	97
				<b>North Atlantic Industries, Inc.</b> NOAT Advertising Company	90

# FROM BREADBOARD TO FINAL PACKAGING HARDWARE...

ALL AVAILABLE FROM ONE SOURCE

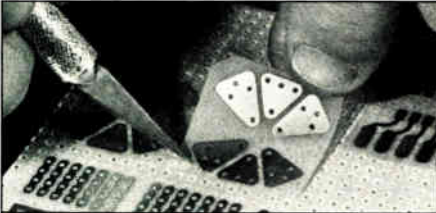

★ **ADHESIVE BACKED CIRCUIT SUB-ELEMENTS**  
(Over 200 Pre-Drilled component mounting patterns available "off-the-shelf.")

★ **EPOXY GLASS BOARD MATERIALS**

- 76 Standard "Off-the-Shelf" Boards.
- Including Unclad, Copper Clad, Cut & Peel Copper Clad, Pre-etched "X-Y" Pattern and Plated thru Hole Copper Clad.
- .100" Grid Hole Pattern or Undrilled.

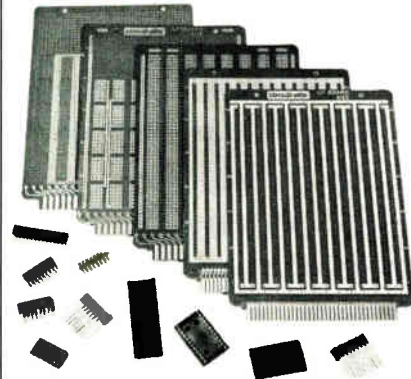

★ **GP CIRCUIT BOARDS and ACCESSORIES**

- Highest Quality — Choose from 74 "Off-the-Shelf" Boards.
- Sockets — Low & Standard Profile, P.C. and Wire Wrap.
- Highest Quality Gold Contacts.
- Adapter plugs • Connectors
- Card Pull Handles.

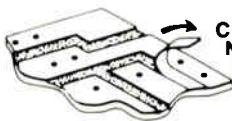

**CIRCUIT-STIK'S NEW CUT & PEEL BOARDS**

SEND FOR OUR NEW CATALOGS #502 & #801

**circut-stik**

P.O. BOX 3396 • Torrance, California 90510  
Phone (213) 530-5530

■ <b>Oak Switch</b> Marsteller, Inc.	72-73	<b>Tally Corporation</b> Bonfield Associates	221
■ <b>OK Machine &amp; Tool Corporation</b>	226	• <b>Technab Export Luras</b> Office Publicitaire de France	14E
• <b>Phillips Elcoma</b> Intermarco Nederland	2E	■ <b>Tektronix, Inc.</b> McCann Erickson, Inc.	43,112,113
• <b>Phillips N.V. Pit/T &amp; M Division</b> Broekies Communications Systems SA	64	• <b>Teledyne Relays</b> S. Michelson Advertising	147
‡ <b>Precision Monolithics, Inc.</b> Marlborough Associates, Inc.	51	<b>Teledyne Semiconductor</b> Regis McKenna, Inc.	7
<b>Procond S.p.A.</b> OUADRAGONO	214	<b>Tempil Ind. Div. of Big Three Ind.</b> Black-Russell-Morris	170
<b>Pro-Log Corporation</b> Kassler Noble Advertising	167	<b>Teradyne Inc.</b> Quinn & Johnson, Inc.	81
<b>Ramsey Engineering Co.</b> Midland Associates, Inc.	137	<b>Texas Instruments Incorporated, Learning Center</b> Tracey-Locke, Inc.	85
<b>RAMTEK, CORP.</b> McDonough Communications	175	■ <b>THERMOMETRICS, INC.</b> H. & M. Associates, Inc.	6
<b>RCA—Solid State Division</b> Marsteller, Inc.	77,79	‡ <b>Thomas &amp; Betts Company</b> McCarthy, Scelba, DeBiasi Advertising Agency, Inc.	67
• <b>RCA Electronic Components</b> Al Paul Lefton Company, Inc.	98	<b>Thomson CSF/Dumont</b> Ranieri, Saslaw, Mohr and Associates, Inc.	157
‡ <b>Rental Electronics, Inc.</b> Humphrey Browning MacDougall, Inc.	64	<b>T.R.I. Corporation</b> Kassler/Noble Advertising	197
<b>Rocheater Gas &amp; Electric Corp.—Ad Group</b> Hutchins/Darcy Inc.	186	■ <b>Trygon Electronic Subsidiary of Syston Donner Corporation</b> RAMA Advertising	87
• <b>Rohde &amp; Schwarz</b>	1E	■ <b>Union Carbide Corp.</b> J.J. Lane, Inc.	165
<b>Sakata International Inc.</b> David H. Stremmel & Co.	30	<b>United Systems Corp., A sub. of Monsanto Co.</b> Advertising & Merchandising, Inc.	219
<b>Howard W. Sams &amp; Co.</b> Aitkin-Kynett Co., Inc.	198	■ <b>Unitrode Corporation</b> Culver Advertising, Inc.	37
<b>Schauer Manufacturing Corp.</b> Nolan, Keelor & Stites	185	<b>Univeraal Oil Products, Norplex Division</b> Campbell Mithun, Inc.	124
• <b>Secossem</b>	53,62	<b>Varo Semiconductor, Inc.</b> Warren-Guild	172
<b>Siemens AG</b> Bazaine PublicitePeDg Linder Presse Union GmbH	179	<b>Wavetek San Diego</b> Chapman Michetti Advertising	119
<b>Signalite, Inc.</b> McCarthy, Scelba, DeBiasi Advertising Agency, Inc.	216	■ <b>White Instruments, Inc.</b> Wilson & Associates, The Art Studio, A Division of Graphic Studios	160
<b>Signalite Corp., Sub. of Corning Glass Works</b> Hall Butler Blatherwick, Inc.	30-31	‡ <b>Yewtec Corporation</b> Kenmarc Advertising, Inc.	53
<b>Siliconix</b> Robertson West, Inc.	123		
<b>Singer Company, Kearfott Div.</b> Gaynor & Ducas, Inc.	161		
<b>Singer Instrumentation—Alfred Div.</b> N.W. Ayer/Jorgensen/MacDonald, Inc.	92		
<b>Solltron Devices, Inc., Translater Division</b> Haselmire Pearson Advertising, Inc.	89		
■ <b>Sorensen Company, A Unit of Raytheon Company</b> Provandie Eastwood & Lombardi, Inc.	54		
<b>Spectra-Strip Corp.</b> Wilshire Newport, Inc.	208		
• <b>Spectrol Reliance Limited</b> J M R Advertising	6E-7E		
<b>Spectrum Control, Inc.</b> Egon Jackson Advertising	174		
<b>Sprague Electric Company</b> Harry P. Bridge Company	8		
<b>Sprague-Goodman Electronics, Inc.</b> Herbert Lindaur Associates	183		
<b>State of Minnesota</b> Church Ruhr & Assoc. Agency	184		
<b>Syntronic Instruments, Inc.</b> Moody & Harrison, Inc.	168		
<b>Syston Donner Concord Instruments</b> Fred Schott & Associates	221,15		

## Classified & Employment Advertising

F. J. Eberte, Manager 212-997-2557

<b>EQUIPMENT (Used or Surplus New) For Sale</b>	
<b>American Used Computer Corporation</b> .....	220
<b>Philip Fishman Co., Inc.</b> .....	220
<b>Jensen Tools</b> .....	220
<b>King Size Co.</b> .....	220
<b>Radio Research Instrument Co., Inc.</b> .....	220

■ For more information on complete product line see advertisement in the latest Electronics Buyer's Guide  
• Advertisers in Electronics International  
‡ Advertisers in Electronics domestic edition



### Advertising Sales Staff

**Pierre J. Braudé** New York [212] 997-3468  
London 01-493-1451  
Director of Marketing

**Atlanta, Ga. 30309:** Joseph Lane  
100 Colony Square, 1175 Peachtree St., N.E.  
[404] 692-2866

**Boston, Mass. 02116:** James R. Pierce  
607 Boylston St. (617) 262-1160

**Chicago, Ill. 60611:**  
845 North Michigan Avenue  
Robert W. Bartlett (312) 751-3739  
Paul L. Reiss (312) 751-3736

**Cleveland, Ohio 44113:** William J. Boyle  
[716] 566-5040

**Dallas, Texas 75201:** Charles G. Hubbard  
2001 Bryant Tower, Suite 1070  
[214] 742-1747

**Denver, Colo. 80202:** Harry B. Doyle, Jr.  
Tower Bldg., 1700 Broadway  
[303] 266-3663

**Detroit, Michigan 48202:** Robert W. Bartlett  
1400 Fisher Bldg.  
[313] 673-7410

**Houston, Texas 77002:** Charles G. Hubbard  
2270 Humble Bldg. [713] CA 4-6361

**Los Angeles, Calif. 90010:** Robert J. Rielly  
Bradley K. Jones, 3200 Wilshire Blvd., South Tower  
[213] 467-1160

**New York, N.Y. 10020**  
1221 Avenue of the Americas  
Warren H. Gardner [212] 997-3617  
Michael J. Stoller [212] 997-3616

**Philadelphia, Pa. 19102:** Warren H. Gardner  
Three Parkway,  
[215] 997-3617

**Pittsburgh, Pa. 15222:** Warren H. Gardner  
4 Gateway Center, [212] 997-3617

**Rochester, N.Y. 14634:** William J. Boyle  
9 Graylock Ridge, Pittsford, N.Y.  
[716] 566-5040

**San Francisco, Calif. 94111:** Don Farris  
Robert J. Rielly, 425 Battery Street,  
[415] 382-4600

**Paris:** Alain Offergeld  
17 Rue-Georges Bizet, 75 Paris 16, France  
Tel: 720-73-01

**Geneva:** Alain Offergeld  
1 rue du Temple, Geneva, Switzerland  
Tel: 32-35-63

**United Kingdom & Scandinavia:** Keith Mantle  
Tel: 01-493-1451, 34 Dover Street, London W1

**Milan:** Robert Saidei  
1 via Baracchini, Italy Phone 67-90-656

**Brussels:** Alain Offergeld  
23 Chaussée de Wavre  
Brussels 1040, Belgium  
Tel: 13-73-95

**Frankfurt/Main:** Fritz Krusebecker  
Liebigstrasse 27c, Germany  
Phone 72 01 61

**Tokyo:** Tatsumi Katagiri, McGraw-Hill  
Publications Overseas Corporation,  
Kasumigaseki Building 2-5, 3-chome,  
Kasumigaseki, Chiyoda-Ku, Tokyo, Japan  
[561] 8811

**Osaka:** Ryji Kobayashi, McGraw-Hill  
Publications Overseas Corporation, Kondo  
Bldg., 163, Umegae-cho Kita-ku, Japan [362] 6771

**Australia:** Warren E. Ball, IPO Box 5106,  
Tokyo, Japan

### Business Department

**Stephen R. Weiss, Manager**  
[212] 997-2044

**Thomas M. Egan,**  
Production Manager [212] 997-3140

**Carol Gallagher**  
Assistant Production Manager [212] 997-2045

**Dorothy Carter,** Contracts and Billing  
[212] 997-2906

**Frances Vallone,** Reader Service Manager  
[212] 997-6057

### Electronics Buyers' Guide

**George F. Werner,** Associate Publisher  
[212] 997-3139

**Regina Hers,** Directory Manager  
[212] 997-2544

NEW  
FROM  
AIRPAX



A  
PRECISION

CONTROL

TACHOMETER THE SERIES  
300

Compact, solid state, flexible and all new... designed to meet industrial control requirements... can monitor shaft RPM... provide start-up, over/underspeed protection, turbine overspeed alarm and control; sequential switching; conveyor protection and machine control. The 300 Tachometer will accept signals from any type sensor. It will operate from signals produced by magnetic or zero-velocity type pickups mounted in proximity to a rotating gear as well as many other signal sources. Set points are adjustable from 0-100% of full scale range. Other set point options available for special application requirements. Analog control outputs, verify features, selectable relay logic and other standardized options are available.

Write for bulletin 8511.

AIRPAX Controls Division P.O. Box 8488  
Fort Lauderdale, Florida 33310 Phone: 305/587-1100

AIRPAX™



Kyodo Electronic Laboratories Inc.

# Numerical Indication Tube Driver

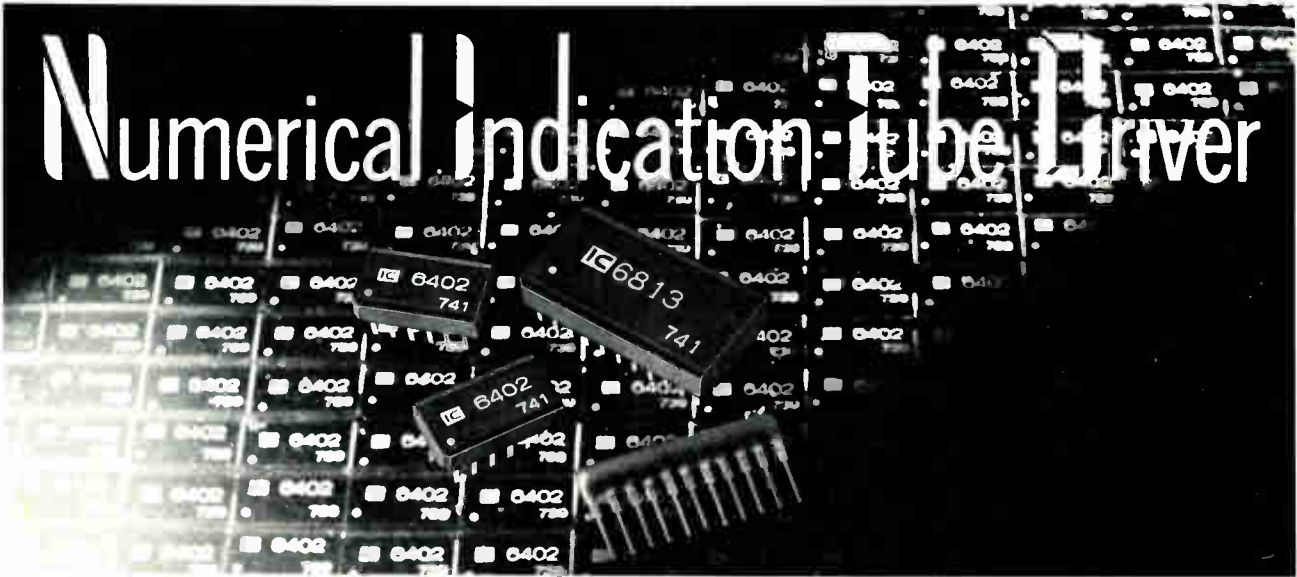

KB-6400 LED Segment Driver	KH-6288 Nixie Tube Segment Driver	KH-6814 Nixie Tube Digit Driver	KH-6298 Printer Driver
KB-6401 LED Digit Driver	KH-6800 Nixie Tube Digit Driver	KM-6608 Fluorescent Tube Driver	KH-6275 Printer Driver
KB-6402 LED Digit Driver	KH-6811 Nixie Tube Digit Driver	KM-6609 Fluorescent Tube Driver	KH-6269 Printer Driver
KH-6286 Nixie Tube Segment Driver	KH-6813 Nixie Tube Digit Driver	KH-6270 Printer Driver	KB-5404 Clock Generator Dual Phase

# Trademark of Burroughs corporation.



11-18, 2 Chome, Sonan, Sagami-hara-shi,  
Kanagawa-ken, Japan  
TEL: 0427-42-6731-6  
CABLE ADDRESS: KELIC MACHIDA  
TELEX: 2872-239 KELIC

Circle 226 on reader service card

**IN WIRE-STRIPPING  HAS THE LINE....**

**NEW**

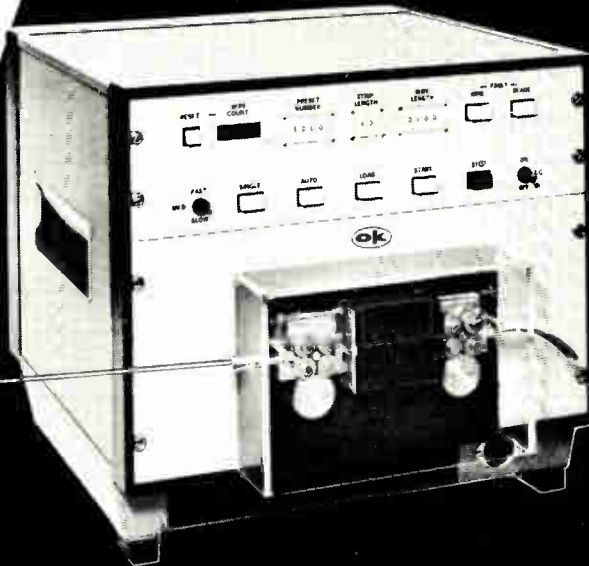

*Electronic*  
**WIRE  
STRIPPER**

**MODEL EWS - 6K**

- ★ CUT TO LENGTH
- ★ BOTH ENDS STRIPPED

**OK MACHINE AND TOOL CORPORATION**

3455 CONNER STREET, BRONX, NEW YORK, N.Y. 10475 U.S.A.

TELEX NO. 12-5091 TELEX NO. 232395

PHONE (212) 994-6600

226 Circle 244 on reader service card

Electronics/April 4, 1974

Integrating man's creativity with a computer's speed and memory isn't easy. But Gerber has done it with an interactive system which can create and plot drawings as complex as the operator can imagine ... all at the touch of a button.

Think what this can mean in your department. Drafting drudgery eliminated. More accurate drawings, faster. More time for designers to think and create. Lead time drastically reduced to give you a competitive edge in bringing new products to the marketplace.

Translated into dollars, this means more profits from your engineering department profit center. More profits whether you make automobiles, aircraft, electronic equipment, machine tools. Or anything else that requires drafting.

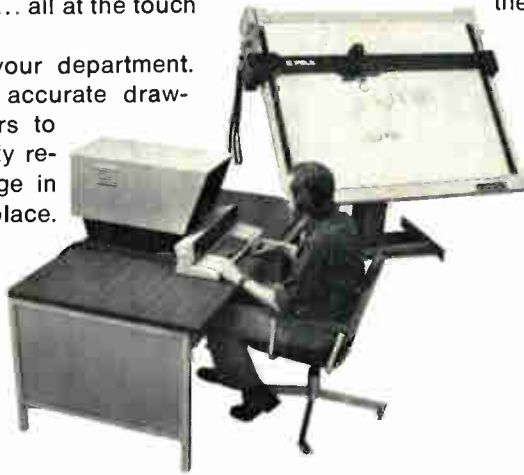

The Gerber interactive system is delivered complete and ready to go to work for you. And, of course, the entire system is designed, built and serviced by Gerber Scientific, the internationally recognized pioneering leader of the industry.

Find out how the Gerber Interactive Design System can produce for you.

A note or phone call will bring a prompt response.

The Gerber Scientific Instrument Company, Hartford, Connecticut 06101. (203) 644-1551.

**GERBER  
SCIENTIFIC**

Circle 152 on reader service card

# Push Button Drawing.







**TI**

## Greater stability in a dual one-shot.

TI's new 54/74221 puts two 54/74121's in a single package.

Few IC functions are as popular as the 54/74121. The industry's standard for high stability one-shots.

Now there's a new device that combines the high stability of the 54/74121 single one-shot with the pin-out of the 54/74123 dual one-shot—and outperforms them both. The 54/74221.

It's brand new. It's available in quantity. And it's from TI.

The 54/74221 features an output pulse programmable from 40 nanoseconds to 28 seconds. You can trigger it from either positive or negative going input transitions with complementary outputs available from each one-shot.

The 54/74221 has stable, jitter-

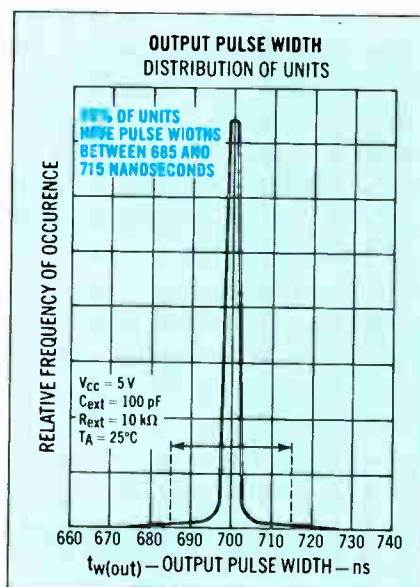

free operation even in high noise environments, thanks to the Schmitt-trigger input.

Plus. The 54/74221 has direct overriding clears to terminate output pulses upon command.

If you've been attracted to the performance of the single 54/74121, but disappointed by existing dual one-shots, then the 54/74221 may be just what you're looking for.

Order SN54/74221 from your local authorized TI distributor or directly from TI. For data sheets, specify by type number and write: Texas Instruments Incorporated, P. O. Box 5012, M/S 308, Dallas, Texas 75222.



**TEXAS INSTRUMENTS**  
INCORPORATED

# ERIE EMI Filters

WORLD'S BROADEST LINE OF MINIATURE CERAMIC FILTERS  
AND FILTER SYSTEMS

- FIRST-** in subminiature design capability
- FIRST-** in total in-house production capability
- FIRST-** in Quality and Volume Production
- FIRST-** to develop a complete line of subminiature EMI Filters

ERIE's stature as undisputed world leader in subminiature high performance Ceramic EMI Filters has been earned by our ability to apply 35 years of sophisticated ceramic and related technology to developing superior EMI Filters. Virtually all other presently known ceramic EMI filters are a copy of an Erie design. Yet, no firm has been able to equal Erie's combined in-house filter capability and proprietary ceramic technology.

Today these miniature filters "do their thing" in noise pollution control, eliminating extraneous noises and emissions from air waves.

There's an application for reliable Erie filters in your communications, aerospace, aircraft and industrial equipments. We'll be happy to help solve the problem.

Write for our new EMI Filter brochure  
ERIE TECHNOLOGICAL PRODUCTS  
Erie, Pennsylvania 16512



**ERIE** TECHNOLOGICAL PRODUCTS, INC. • Erie, Pennsylvania 16512

Circle 901 on reader service card

# GaAs lasers go commercial at new low prices!

RCA GaAs laser diodes have now reached a level of product maturity; many developmental types have been assigned commercial numbers; and they are priced lower than ever—as low as \$6.95 (at 1000-level) for type 40858.

RCA GaAs lasing devices are available as diodes, stacks, and arrays. They feature high peak and average power outputs at exceptionally low drive currents. They are also available in 800 to 900 nanometers in GaAIAs for improved match to image intensifiers. A wide range of custom designs can be provided to meet system needs.

You will find that RCA lasers offer design advantages in data-link communications, fuzing devices, intrusion alarms, ranging equipment, target designation equipment, night-vision systems, and many other infrared systems. Put the competitive advantages of RCA lasers to work in your application.

RCA also offers a line of matching P-I-N Photodetectors for use with laser systems.

For further information see your local RCA Representative or RCA Distributor. Or write: RCA, Commercial Engineering, Section 70 G-19 /US8, Harrison, N. J. 07029. International: RCA, Sunbury-on-Thames, U.K., or P.O. Box 112, Hong Kong.

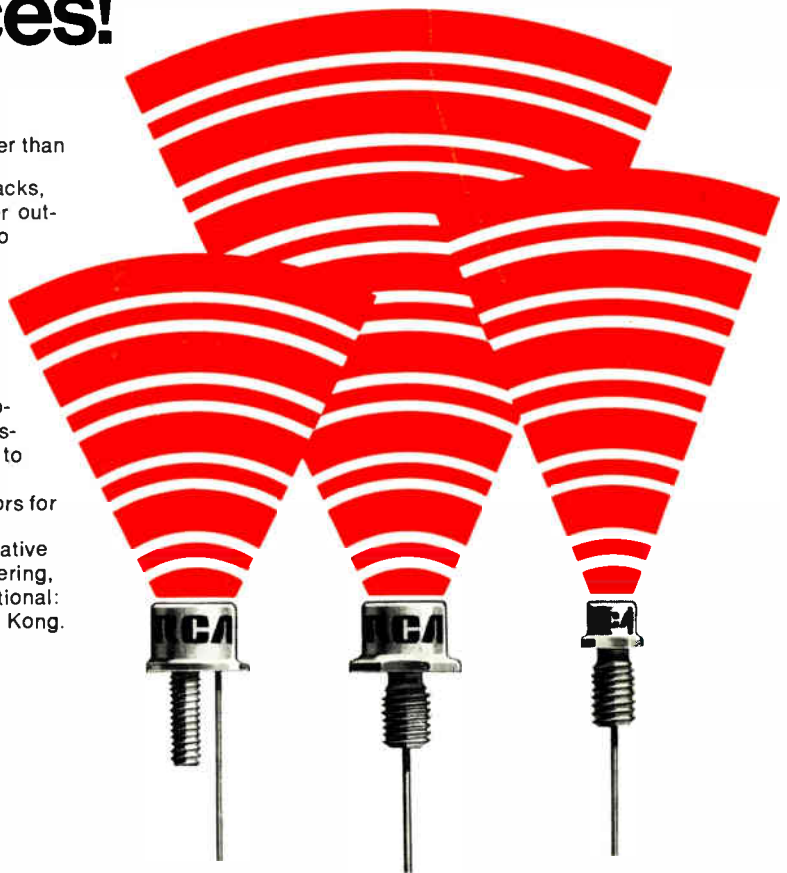

## RCA Solid State

### Single diode lasers

- efficiency—3%
- wavelength—905 nanometers
- pulse duration—0.2  $\mu$ s (max.)\*
- case polarity—negative (Reverse-polarity types available)

Type	Pkg	Power Output (W) (min.)	I <sub>FM</sub> (A)	Source Size (mils)	Duty Factor %
40855	OP-3	0.7	10	3x0.08	0.1
40856	OP-3	1.0	10	3x0.08	0.1
40857	OP-3	2.0	10	3x0.08	0.1
40858	OP-3	3.0	25	6x0.08	0.1
40859	OP-3	5.0	25	6x0.08	0.1
40860	OP-3	5.0	20	6x0.08	0.1
40861	OP-3	7.0	40	9x0.08	0.1
40862	OP-3	10.0	40	9x0.08	0.1
40863	OP-3	10.0	30	9x0.08	0.1
40864	OP-3	12.0	75	16x0.08	0.1
40865	OP-3	15.0	75	16x0.08	0.1
40866	OP-3	15.0	60	16x0.08	0.1
TA7864	OP-12	25.0	75	24x0.08	0.02
TA7763	OP-12	25.0	100	24x0.08	0.02
TA7705	OP-12	40.0	250	55x0.08	0.005
TA7787	OP-12	60.0	250	55x0.08	0.005

\*Except 0.1  $\mu$ s max for TA7705 and TA7787

### Laser arrays

- wavelength—905 nanometers
- series wired
- duty factor—0.02%
- pulse duration—0.2  $\mu$ s (max)
- case polarity—negative (Reverse-polarity types available)
- package—OP-4A

Type	No. of Diodes	Power Output (W) (min.)	I <sub>FM</sub> (A)	Source Size (mils)
TA7687	10	25	25	100x0.08
TA7687A	10	50	25	100x0.08
TA7688	15	35	25	150x0.08
TA7688A	15	75	25	150x0.08
TA7690	30	75	25	160x40
TA7690A	30	150	25	160x40
TA7692	60	150	25	160x60
TA7692A	60	300	25	160x60

### GaAIAs laser diodes and arrays

Type	Center Wavelength (nm)	Peak Power Output (W) (min.)	I <sub>FM</sub> (A)	Source Size (mils)	No. of Diodes	Pkg
TA7867	850 $\pm$ 50	3	25	6x0.08	1	OP-3
TA8127	850 $\pm$ 50	7	40	9x0.08	1	OP-3
TA8101	800 $\pm$ 20	85	40	150 x0.08	12	OP-4A
TA8105	850 $\pm$ 30	85	40	150 x0.08	12	OP-4A
TA8106	800 $\pm$ 20	170	40	160 x 40	24	OP-4A
TA8107	850 $\pm$ 30	170	40	160 x 40	24	OP-4A
TA8131	800 $\pm$ 20	300	40	160 x 60	48	OP-4A
TA8132	850 $\pm$ 30	300	40	160 x 60	48	OP-4A

### Stacked-diode lasers

- wavelengths—905 nanometers
- series wired
- package—OP-12
- pulse duration—0.2  $\mu$ s (max)
- case polarity—negative (Reverse-polarity types available)

Type	No. of Diodes	Power Output (W) (min.)	I <sub>FM</sub> (A)	Source Size	Duty Factor %
TA7764	3	25	40	9.5x9.5	0.02
TA7964	2	30	75	16x4	0.04
TA7765	2	50	100	24x4	0.02



# FREE!

## 1974 Condensed Catalog Data Conversion Products



A new 40-page short form catalog contains 17 new data conversion products from Datel Systems. The catalog has complete electrical and mechanical specifications on all of Datel Systems products with over six pages of applications information.

Modular products described in this catalog include: A/D converters, D/A converters,

sample and hold amplifiers, operational amplifiers, DC power supplies, DC to DC converters, digital panel meters, analog multiflexers, active filters, voltage to frequency converters, and a 16 channel data acquisition system. Systems products include a 256 channel data

acquisition and distribution system with minicomputer interfacing for digital signal processing and a low power data logging system for remote environmental applications.



1020 Turnpike Street, Canton, Mass. 02021  
• TEL. (617) 828-8000 • TELEX 924461  
• TWX 710-348-0135

DATELEK SYSTEMS GMBH  
8 Munchen 71, Becker-Gundahl-Strasse 1  
W. Germany • Telefon 089/ 784045

#### FIELD SALES REPRESENTATIVES

(201)944-1600, Fort Lee, N.J.  
(205)837-1601, Huntsville, Ala.  
(206)285-2525, Seattle, Wash.  
(213)476-2251, Los Angeles, Ca.  
(214)231-9489, Richardson, Texas  
(215)265-5211, King of Prussia, Pa.  
(216)486-0782, Cleveland, O.  
(303)427-5299, Westminster, Colo.  
(305)943-3076, Lighthouse Pt., Fla.  
(312)585-5485, Chicago, Ill.  
(313)564-6325, Berkley, Mich.

(314)426-3656, St. Louis, Mo.  
(315)622-2350, Liverpool, N.Y.  
(317)293-0696, Indianapolis, Ind.  
(319)377-6313, Marion, La.  
(412)243-1111, Pittsburg, Pa.  
(414)464-5555, Milwaukee, Wis.  
(415)941-4080, Los Altos Hills, N.C.  
(416)678-9241, Rexdale, Ont.  
(505)281-5602, Sandia Park, N.Mex.  
(513)294-2838, Dayton, O.  
(514)389-8051, Montreal, Quebec

(612)544-9393, Minneapolis, Minn.  
(613)237-6150, Ottawa, Ont.  
(616)327-8390, Portage, Mich.  
(703)522-6666, Arlington, Va.  
(713)777-4477, Houston, Texas  
(714)461-1033, San Diego, Ca.  
(801)571-0129, Draper, Utah  
(808)946-1533, Honolulu, Hawaii  
(913)831-4259, Overland Park, Ks.  
(918)622-0321, Tulsa, Oklahoma  
(919)722-1783, Winston-Salem, N.C.

INTERNATIONAL SALES OFFICES: AUSTRIA & E. EUROPE/BACHER-TELE: 83 63 96 0 • GERMANY/DATELEK-TELE: 089/78 40 45 • ISRAEL/MTI-TELE: 242943  
ITALY/3G-TELE: 544291 • JAPAN/FUSOH SHOJI-TELE: (580) 4015-7 or TAIYO SHGJI-TELE: (436) 3601-7 • NETHERLANDS/TECHMATION-TELE: 020-456955  
SWEDEN/SVENSK-TELE: 08-91 04 40 • SWITZERLAND/INTERTEST-TELE: 031/224481 • LATIN AMERICA/CONSOLIDATED-TELE: (213) 397-6231

Circle 901 on reader service card





**FILM RESISTOR  
DALE  
SUPERMARKET**

# Faster delivery on high value metal film resistors

Dale has expanded production...extended value ranges...and shortened delivery for HMF resistors in popular sizes. These precision metal film styles provide the higher value range associated with carbon composition styles plus the added assurance of excellent stability. They are much in demand for medical electronic and other precision instrumentation.

Style	Value Range (Ohms)	Tolerance
HMF-1/10	500K-5 Meg.	1%
HMF-1/8	1.01 Meg.-10 Meg.	1%
HMF-1/4	2.01 Meg.-15 Meg.	1%
HMF-1/2	2.5 Meg.-30 Meg.	1%

*Temperature Coefficient:  $0 \pm 100$  ppm/°C*

Other HMF styles from 1/20 to 1 watt are also available.

For complete price information and delivery, call Metal Film Sales Department at 402-371-0080.

**Write for FREE  
Film Resistor Reference Guide**



**DALE ELECTRONICS, INC.**

P. O. Box 74, Norfolk, Nebraska 68701

A subsidiary of The Lione Corporation. In Canada: Dale Electronics Canada Ltd.

Circle 902 on reader service card