

Japan moves in on computers 42

Solid state light sensor rivals photomultiplier 50

Automatic digital tuner for surveillance 60

Electronics®

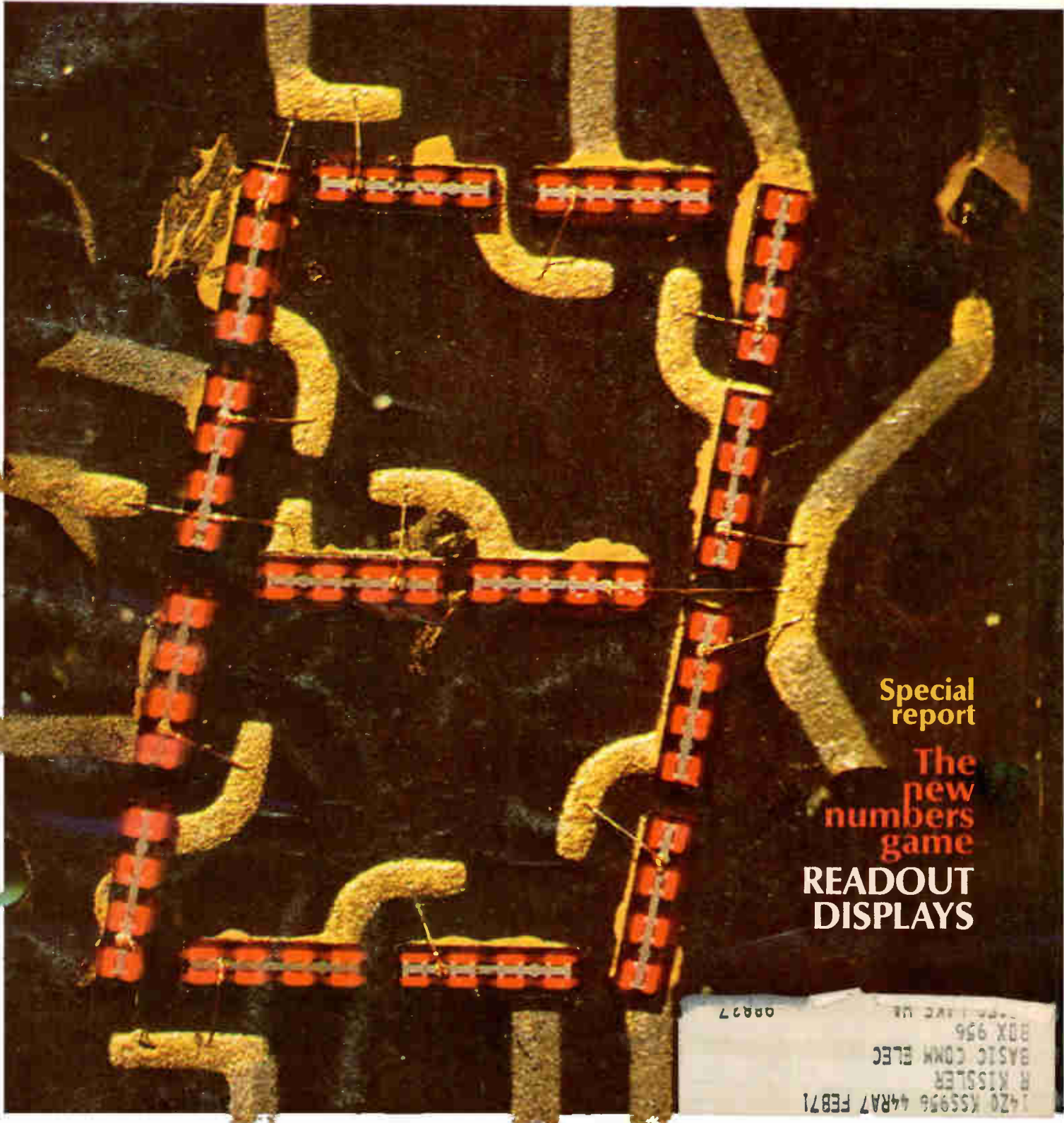

Special report

The new numbers game

READOUT DISPLAYS

1420 K55956 44RA7 FEB71
 R KISSLER
 BASIC COM ELEC
 BOX 956
 0827

MOS

is
IS THROWING A RAM!

or, announcing that our all-new
MCS 2050
is ready now!

MOS'S MCS 2050, a 256 BIT STATIC RANDOM ACCESS READ/WRITE MEMORY that's high in speed, low in power consumption! MCS 2050—a monolithic integrated circuit using P-channel MOS transistors and organized as 256 words by 1 bit per word . . . all wrapped up in a 16 pin dual-in-line package.

In every memory chip: 256 memory cells, complete address buffers and decoders, read/write control logic, sense amplifiers, chip select logic and complementary output buffers.

In each memory cell: a D.C. binary cell which permits non-destructive read-out of storage data.

In addition, all these beautiful features: static circuitry that eliminates clocks, input buffers that interface directly with TTL, DTL or MOS without additional external circuitry, input address buffers that are insensitive to input address skew (up to 200 nsec of input address skew will not cause inadvertent destruction of stored memory data), complete decoding accomplished internally, data and its complement are available outputs and expansion to larger memory systems possible through "OR" tying the outputs!

The MCS 2050 from MOS TECHNOLOGY—for guys who know that throwing in a RAM can mean getting a lot more out of a job!

*We've turned
a technology
into a company*

MOS

MOS TECHNOLOGY, INC.

VALLEY FORGE INDUSTRIAL PARK, VALLEY FORGE, PENNA. 19481 • 215-666-7950

*A Proud Affiliate
of Allen Bradley Co.*

MOS TECHNOLOGY, INC.

EASTERN REGION

Mr. William Whitehead, Sales Director, MOS Technology, Inc., 88 Sunnyside Blvd., Suite 307, Plainview, N. Y. 11803 • 516-822-4240 • REPRESENTATIVES—Michael Scott Co., Inc., 20 Walnut St., Wellesley Hills, Mass. 02181 • 617-235-0102 • Ossmann Component Sales Corp., 280 Metro Park, Rochester, N. Y. 14623 • 716-442-3290 • Bob Jackson, Mfr.'s Rep., P. O. Box 17484, Charlotte, N. C. 28211 • 704-366-6678 • Falk-Baker Associates, 383 Franklin Ave., Nutley, N. J. 07110 • 201-661-2430 • Currie Aerospace Associates, Inc., 2907 McCoy Rd., P. O. Box 13229, Orlando, Fla. 32809 • 305-855-0843 • C. H. Newson & Associates, Inc., 711 Bethlehem Pike, Philadelphia, Pa. 19118 • 215-248-3377.

CENTRAL REGION

Mr. Alan Mattal, Sales Director, MOS Technology, Inc., 10400 W. Higgins Rd., Suite 631, Rosemont, Ill. 60018 • 312-298-2035 • REPRESENTATIVES—Norvell Associates, 10210 Monroe Drive, P. O. Box 20279, Dallas, Texas 75220 • 214-357-6451 • Coombs Associates, Inc., 1001 East Touhy, Des Plaines, Ill. 60018 • 312-298-4830 • Irvin J. Arron, 1905 Third Avenue South, Minneapolis, Minn. 55404 • 612-336-6650 • 6659 • Harlan J. Weisler & Associates, Inc., 2050 Woodson Rd., St. Louis, Mo. 63114 • 314-428-3934 • R. C. Merchant & Co., Inc., 18411 W. McNichols St., Detroit, Mich. 48219 • 313-535-6000.

WESTERN REGION

Mr. Jack Turk, Sales Director, MOS Technology, Inc., 2172 Dupont Dr. (Patio Bldg.), Suite 221, Newport Beach, Calif. 92660 • 714-833-1600 • REPRESENTATIVES—Hunter Associates, 1208 Fox Plaza, San Francisco, Calif. 94102 • 415-626-8576 • J. A. Tudor & Associates, Inc., 2605 Western Ave., Seattle, Wash. 98121 • 206-682-7414 • Tward Engineering Associates, Inc., P. O. Box 15268, Arcadia Station, Phoenix, Ariz. 85018 • 602-955-3193

INTERNATIONAL

REPRESENTATIVES—ENGLAND (Wales, Scotland, Ireland): Impectron Limited, 23-31 King Street, London W3, England • 01-992-5388 • FRANCE: Bureau de Liaison 113 Rue de L'Universite, Paris (7e) France • Invalides 99-20 • GERMANY (The Netherlands): Elwest Establishment Vaduz, 9490 Vaduz, P. O. Box 34.722, Aeuilestrasse 772 Germany • (075) 2 34 34 • INDIA: Electronics Enterprises, 46 Karani Building, New Charni Road, Bombay 4, India • 375375 • ISRAEL: Eastronics, Ltd., 75 Haifa Road, P. O. Box 21029, Tel-Aviv, Israel • 38352 • ITALY: Special-Ind Corporation, Via D. Manin 33, Milano, Italy • 632-435 • JAPAN (Hong Kong, Korea, Taiwan): Takachiho Koheki Company Ltd., 7, 1-Chome Kohjimachi, Chiyoda-Ku, Tokyo 102 Japan • 263-3211 • SWEDEN (Denmark, Norway, Finland): Thure F. Forsberg AB, Forshagatan 58, P. O. Box 79, Farsta 1, Sweden • 647040 • SWITZERLAND: Ernst M. Egli, Ingenieur-Bureau AG, Witkonstrasse 52, Zurich, Switzerland (8032) • 52619.

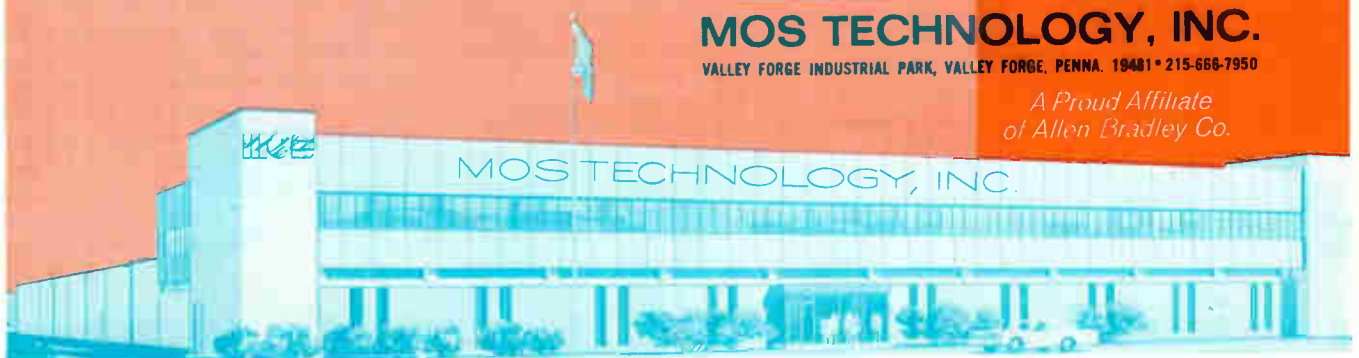

Circle 900 on reader service card

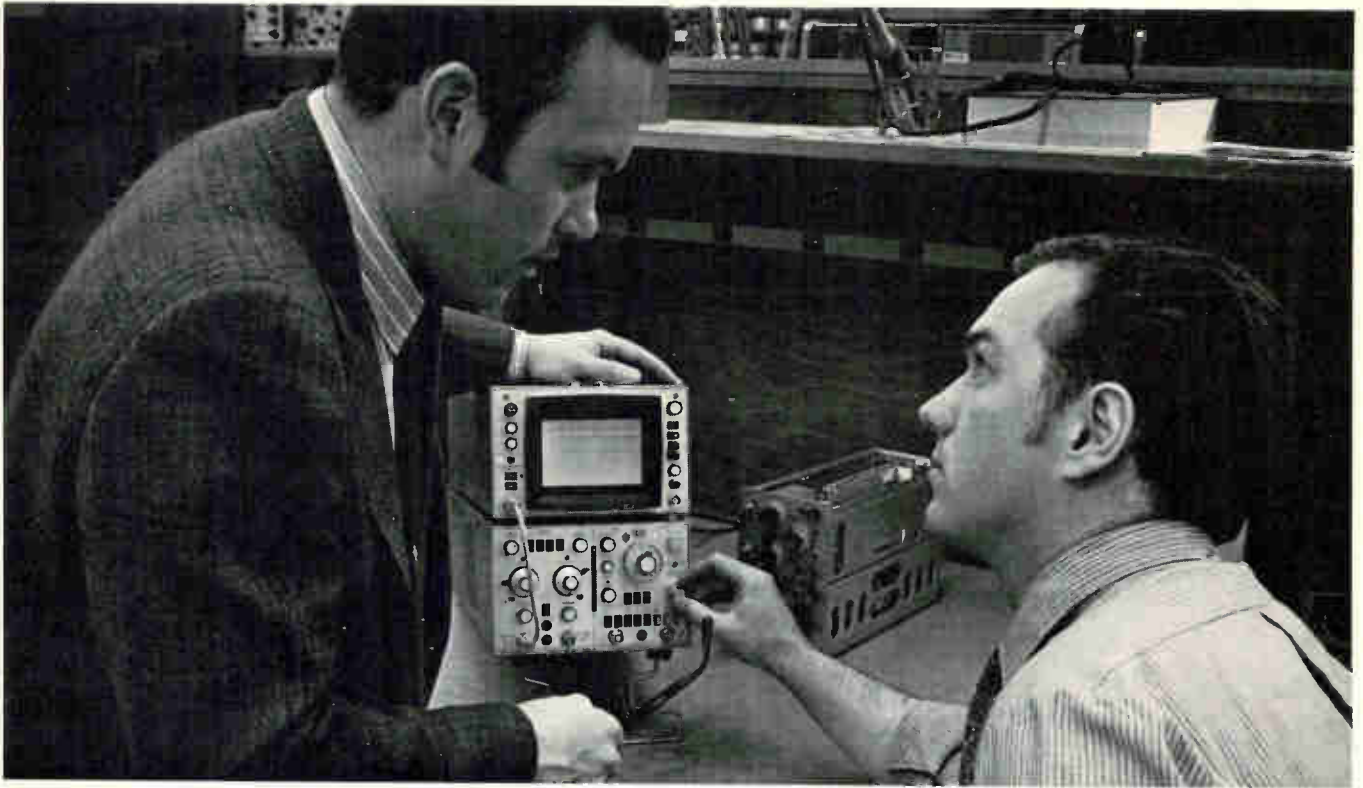

HP's 250 MHz 183: Still The Performance Champ! Ask For A Demo.

If you want to look at waveforms in high-speed logic circuits, or to photograph ultra-fast transients—there's still only one general purpose, lab oscilloscope that gives you a real-time window from DC to VHF. It is HP's 183, the 250 MHz 10 mV/div scope (to 600 MHz with direct access plug-in)—**now available for demos on your bench.**

HP pioneered in the development of the first useful, usable high-frequency scope to give you these features: 10 mV sensitivity, 1.5 ns rise time, 4 cm/ns writing speed, negligible distortion from input capacitance. **Balancing price and performance the 183A system is a bargain**—with delayed sweep, \$3900; without delayed sweep, \$3400 (available in either cabinet or 5¼" rack-height versions).

HP's technical leadership, covering a wide area of disciplines, made it all possible. An in-house IC capability produced monolithic transistor arrays for the vertical amplifier—

key factor in achieving good transient response with 250 MHz bandwidth and high-fidelity reproduction of waveforms.

HP's step-ahead CRT technology produced a unique CRT to display fast signals. The CRT uses two transmission lines for the vertical deflection system, to provide distributed deflection of the electron beam and to give the CRT a **cutoff frequency well beyond present IC technology.**

Since the 183A mainframe is not limited by hard-wired, internal amplifiers, you have freedom to take advantage of any existing HP 180 Series plug-ins, plus any HP high frequency innovations, as they become available—and higher bandwidth amplifiers are now in HP development labs.

Meanwhile, the HP 183 250 MHz Scope is a deliverable system, **capable of making your measurements, now.** And it's backed by almost two years of successful, in-the-field performance on customer workbenches.

The same step-ahead thinking

exemplified in the HP 250 MHz scope also exists in all HP scopes. To find out all about the most exciting new developments in the rapidly changing world of oscilloscopes, ask your HP field engineer to show you the whole HP 180 scope family, including sampling and storage. Or write, Hewlett-Packard, Palo Alto, California 94304. Europe: 1217 Meyrin-Geneva, Switzerland.

Scopes are
changing.
Are you?

081/13A

HEWLETT  PACKARD



Can your instrumentation recorder pass these tests?

The Spec Test: Check the specifications you were quoted before delivery. Are flutter and skew still within tolerance? Tape speeds still on target? How about signal-to-noise ratio and distortion? How hard would it be to bring everything up to spec again? Any new recorder should be able to pass a spec check. But if yours is over a year old and flunks, you're not getting what you paid for.

The Obsolescence Test: If your requirements change, can your recorder change with them? Can you easily increase the number of channels? Mix modes? Add accessories? How about

changing prices? If you've got doubts about the answers to any of these questions, maybe you should review your supplier's list.

The Manufacturer's Test: You can't always afford the test equipment — or the time — to check out every single item on your recorder system. Can you take the manufacturer's word on performance? How about replacement parts? How long will they be available for your model?

Make sure you get all the right answers the first time. You can, with HP's 3950, 3955 and



3960 instrumentation recorders. One of them will fit your needs. And not just the first year you have it, either. Prices begin at \$4300. Put us to the test and check out our analog recorders with your nearby HP field engineer. Or for further information write to Hewlett-Packard, Palo Alto, California 94304; Europe: 1217 Meyrin-Geneva, Switzerland.

42103

HEWLETT  PACKARD
MAGNETIC RECORDERS

21 Electronics Review

EMPLOYMENT: U.S. releases \$16 million to aid jobless professionals, 21
ADVANCED TECHNOLOGY: Area imager uses charge coupling, 21
MEDICAL ELECTRONICS: Solar cell key to patient safety scheme, 22
OCEANOGRAPHY: Data buoy contract opens doors for General Dynamics, 22
LASERS: One-mile hospital link moves color TV, 23
MANUFACTURING: Auger spectrometer wed to scanning scope, 23; Sperry looks beyond Mil standards, 24
AVIONICS: Luneberg lens system helps radar spot small planes, 25
COMMERCIAL ELECTRONICS: Prismatic fingerprint reader, 25
DISPLAYS: Plasma panel goes into commercial system, 26
PATENTS: Battle looms over silicon gate technique, 26
COMPUTERS: H-P microprograms instruction set on bipolar ROMs, 26
FOR THE RECORD: 28

41 Technical Articles

COMPUTERS: Japan is packing everything into large computer project, 42
SOLID STATE: Solid state combo senses light well enough to vie with tubes, 50
CIRCUIT DESIGN: Designer's casebook, 56
COMMUNICATIONS: Computerized frequency control keeps many receivers in tune, 60
SPECIAL REPORT: The right numeric readout: a critical choice for designers, 65

75 Probing the News

INTERNATIONAL: Europe's avionics: up in the air, 75
CONSUMER ELECTRONICS: Pipe organ goes digital, 79
COMMERCIAL ELECTRONICS: Bankers call for more EDP help, 83
COMPUTERS: Silicon disk memories beat drums, 85

91 New Products

IN THE SPOTLIGHT: Reactor deposits GaAsP films for light emitters, 91
DATA HANDLING: Digitizing and plotting combined on same drafting board, 95
INSTRUMENTS: IC tester offers choice of collector voltage, 97; High-input unity-gain amplifier, 98
MICROWAVE: Transistor delivers a half-watt at 4 gigahertz, 101
PACKAGING & PRODUCTION: Thermal tester for ICs, 105; Coax-contact assembler, 106; Component marker, 107
SEMICONDUCTORS: ROMs have 3-state outputs, 108; C/MOS shift register with on-chip control logic, 110
MATERIALS: 110

119 Electronics International

JAPAN: Thick film route to thin glow display tube, 119
FRANCE: Liquid crystal display is built on top of MOS drive, 120
GREAT BRITAIN: Dual-gate MOS transistors, 120; Tunable dye laser, 121; Yellow electroluminescence, 121
WEST GERMANY: Electroluminescence: wide-screen display, 122
THE NETHERLANDS: Modular test system for TV set alignment, 122

Departments

Publisher's letter, 4
Readers comment, 6
People, 8
40 years ago, 13
Meetings, 14
Electronics Newsletter, 17
Washington Newsletter, 31
New Literature, 112
International Newsletter, 117

EDITOR-IN-CHIEF: Kemp Anderson

EXECUTIVE EDITOR: Samuel Weber

MANAGING EDITORS: Robert Henkel, *News*;
Arthur Erikson, *International*

SENIOR EDITORS: John Johnsrud,
H. Thomas Maguire, Stephen E. Scrupski

ASSOCIATE EDITORS: William Bucci,
Richard Gundlach, Howard Wolff

DEPARTMENT EDITORS

Aerospace: Jim Hardcastle
Circuit Design: Lucinda Mattera
Communications & Microwave:
John N. Kessler

Computers: Wallace B. Riley
Consumer: Gerald M. Walker
Industrial: Alfred Rosenblatt
Instrumentation: Owen Doyle
Military: Ray Connolly
New Products: H. Thomas Maguire
Packaging & Production:
Stephen E. Scrupski
Solid State: Laurence Altman

COPY EDITORS: William S. Weiss,
Margaret Eastman

ART: Fred Sklenar, *Director*
Charles D. Ciatto, *Associate Director*

PRODUCTION EDITORS:
Susan Huriburt, Arthur C. Miller

EDITORIAL ASSISTANT: Marilyn Offenheiser

EDITORIAL SECRETARIES: Claire Goodlin,
Vickie Green, Bernice Pawlak

FIELD EDITORS

Boston: James Brinton (Mgr.), Gail Farrell
Dallas: Paul Franson (Mgr.)
Los Angeles: Lawrence Curran (Mgr.)
New York: Alfred Rosenblatt (Mgr.)
San Francisco: Stephen Wm. Fields (Mgr.),
Roberta Schwartz
Washington: Ray Connolly (Mgr.),
Jim Hardcastle, Larry Armstrong
Frankfurt: John Gosch
London: Michael Payne
Paris: Arthur Erikson
Tokyo: Charles Cohen

McGRAW-HILL WORLD NEWS

Director: Walter A. Stanbury; **Atlanta:** Stan Fisher; **Chicago:** Mike Sheldrick; **Cleveland:** Arthur Zimmerman; **Detroit:** James Wargo; **Houston:** Robert E. Lee; **Los Angeles:** Michael Murphy; **Gerald Parkinson;** **San Francisco:** Margaret Drossel; **Seattle:** Roy Bloomberg; **Washington:** James Canan, Herbert W. Cheshire, Seth Payne, Warren Burkett, William D. Hickman; **Bonn:** Robert F. Ingersoll; **Brussels:** James Smith; **London:** Marvin Petal; **Milan:** Peter Hoffmann; **Moscow:** Axel Krause; **Paris:** Stewart Toy; **Tokyo:** Mike Mealey

PUBLISHER: Dan McMillan

PLANNING & DEVELOPMENT MANAGER:
Donald Christiansen

ADVERTISING SALES MANAGER: Pierre Braudé

CIRCULATION MANAGER: George F. Werner

RESEARCH MANAGER: David Strassler

PROMOTION MANAGER: Tomlinson Howland

ADVERTISING SALES SERVICE MANAGER:
Wallis Clarke

Displays are a hot subject. Nearly every one of our news and technical sections has a story about some new development in this fast-growing sector of electronics. First, there's a big in-depth roundup (see p. 65) on just what's available to equipment designers today—be it LED, plasma, electroluminescent, or incandescent. We think you'll find this a valuable reference tool.

Our New Products section leads off with another display-based story (see p. 91), this one about the first commercial reactor for epitaxial deposition of gallium-arsenide-phosphide film. And the Electronics Review section has a piece on plasma panels for terminals (see p. 26). For sheer numbers, though, the Electronics International section takes some sort of prize, with four significant new approaches to displays from as many countries. Two of the new developments are based on electroluminescence—yellow, green, and blue elements from Great Britain, and a wide-screen display from West Germany. French researchers have built a liquid crystal display right on top of its MOS drive IC. And Japan's Sony has come up with a remarkable thick film, flat, multi-digit glow tube. It all adds up to some very illuminating reading.

Speaking of Japan, it may interest you to know that the nation that grabbed the transistor radio and made it its own is priming its computer industry with something of the same goal in mind. Its large-scale computer project (see article

on p. 42) is aimed at taking a giant step forward into advanced computers. Up to now five of the six major domestic computer makers in Japan have built their machines through licensing and knowhow agreements with U.S. makers. The knowledge and experience gained on the large-scale project is already beginning to change that. And the project is not only spinning off new ideas in computer architecture, but in displays, semiconductor technology, and other areas as well. This article is a must if you're concerned about Japanese competition.

Sometimes our editors find that reporting a story is educational in more ways than one. In getting the facts on the digital electronic organ (see *Probing the News*, p. 79), Los Angeles bureau manager Larry Curran had to jump some unfamiliar linguistic hurdles.

Not being a musician, he had to first master the special terms of the organist. Words such as "great" and "swell" that sound like slang adjectives have much different meanings to an organ buff. Great is used to describe the lower set of keys on an organ with two sets of keys, for example. And "diapason," which sounds like it belongs on a menu in an Italian restaurant, is a term used to describe the distinctive voice of an organ.



May 24, 1971 Volume 44, Number 11
91,672 copies of this issue printed

Published every other Monday by McGraw-Hill, Inc.
Founder: James H. McGraw 1860-1948. Publication office
330 West 42nd, N.Y., N.Y. 10036; second class postage
paid at New York, N.Y., and additional mailing offices.
Executive, editorial, circulation and advertising ad-
resses: Electronics, McGraw-Hill Building, 330 W. 42nd
Street, New York, N.Y. 10036. Telephone (212) 971-3333.
Teletype TWX N.Y. 710-581-4235. Cable address:
MCGRAW HILL N.Y.

Subscriptions limited to persons with active, profes-
sional, functional responsibility in electronics technol-
ogy. Publisher reserves the right to reject non-qualified
requests. No subscriptions accepted without complete
identification of subscriber name, title, or job function,
company or organization, including product manufac-
tured or services performed. Subscription rates: quali-
fied subscribers in the United States and possessions
and Canada, \$8.00 one year, \$12.00 two years, \$16.00
three years; all other countries \$25.00 one year. Lim-
ited quota of subscriptions available at higher-than-
basic rate for persons outside of field served, as fol-
lows: U.S. and possessions and Canada, \$25.00 one
year; all other countries \$50.00. Air freight service to
Japan \$60.00 one year, including prepaid postage. Single
copies: United States and possessions and Canada,
\$1.00; all other countries, \$1.75

Officers of the McGraw-Hill Publications Company:
John R. Emery, President; J. Elton Tuohis, Senior Vice
President—Services; Donald B. Gridley, Group Vice
President; Vice Presidents: Ralph Blackburn, Circula-
tion; John R. Callahan, Editorial; William P. Giglio,
Administration; David G. Jensen, Manufacturing; Jerome
D. Luntz, Planning & Development; Joseph C. Page,
Marketing; Robert M. Wilhelmy, Finance.

Officers of the Corporation: Shelton Fisher, President;
Joseph H. Allen, Group Vice President—Publications
and Business Services; John J. Cooke, Senior Vice Pres-
ident and Secretary; Ralph J. Webb, Treasurer.

Title © registered in U.S. Patent Office; © Copyright
1971 by McGraw-Hill, Inc. All rights reserved. The con-
tents of this publication may not be reproduced either in
whole or in part without the consent of copyright owner.

Subscribers: The publisher, upon written request to
our New York office from any subscriber, agrees to re-
fund that part of the subscription price applying to copies
not yet mailed. Please send change of address notices or
complaints to Fulfillment Manager; subscription orders
to Circulation Manager, Electronics at address below.
Change of address notices should provide old as well as
new address, including postal zip code number. If pos-
sible, attach address label from recent issue. Allow one
month for change to become effective.

Postmaster: Please send form 3579 to Fulfillment Man-
ager, Electronics, P.O. Box 430, Hightstown, N.J. 08520.

SOLID TANTALUM CAPACITORS



BOARDABLE & AFFORDABLE

RIGHT ON THE MONEY
FOR PRINTED WIRING BOARDS
IN INDUSTRIAL, COMMERCIAL,
AND ENTERTAINMENT
ELECTRONICS

Sprague Type 196D Dipped Solid-Electrolyte Tantalex® Capacitors cool the performance/budget argument. Newly broadened line—now available in all popular 10% decade values between 0.1 μF and 330 μF . Voltage range: 4 to 50 vdc. Hard insulating resin coating is highly resistant to moisture and mechanical damage. Straight or crimped, long or short leads. Operate to 125C with only $\frac{1}{3}$ voltage derating. Write for Engineering Bulletin 3545A.

Technical Literature Service
Sprague Electric Company
35 Marshall Street
North Adams, Mass. 01247



THE BROAD-LINE PRODUCER OF ELECTRONIC PARTS

Eight rays of hope for the incurably trigger-happy.

You know how it is with conventional dual-channel scopes. You re-position a trace and you have to re-adjust the trigger. A man can get trigger-happy.

Well, Dumont's 1050 scope series puts an end to all that. All eight models have trigger systems that bypass the positioning circuits. Result: No loss of trigger (in either channel, in any position), no trace flicker in dual trace, and no re-adjusting the trigger level after trace positioning.

Ask us about our 1050 Series. About the easy operation, about the tremendous sensitivity, about the excellent wide-band operation.

At prices that begin at \$1845, they should shed a little glow in the budget department too.

Write or call for details.

Dumont Oscilloscope Laboratories, Inc., 40 Fairfield Place, West Caldwell, New Jersey 07006, (201) 228-3665 / TWX (710) 734-4308.

DUMONT
OSCILLOSCOPE LABORATORIES INC.

Circle 6 on reader service card

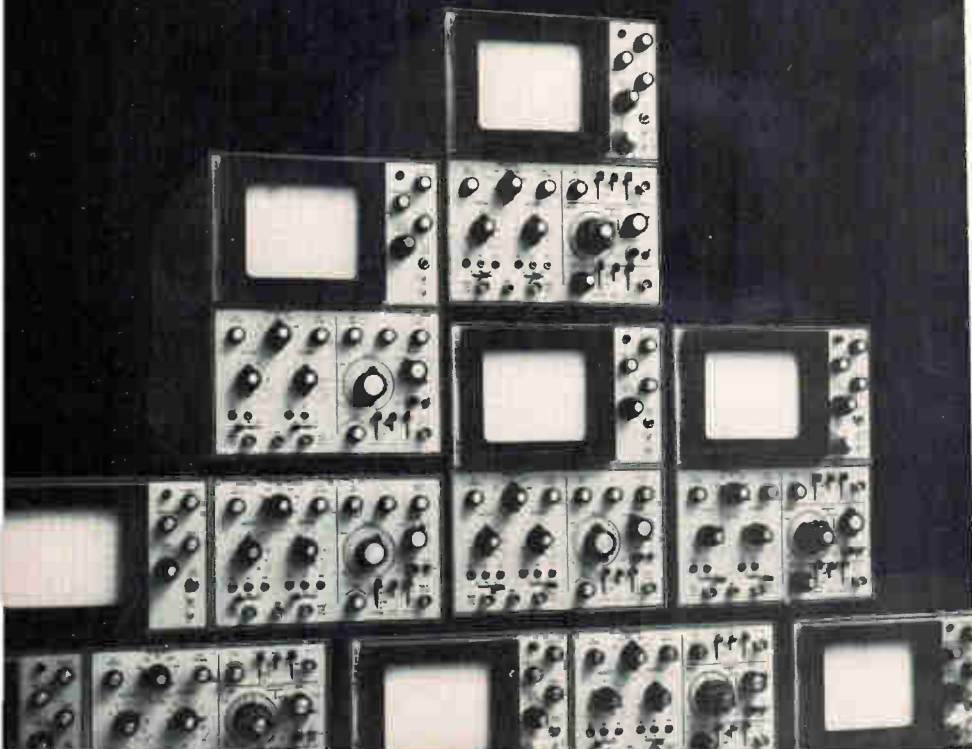

Readers comment

SGS and MOS

To the Editor: I was very much surprised to read in the International Newsletter of April 12 that I was quoted as saying I "would like SGS to concentrate on MOS circuits for the company's [Olivetti's] office calculators." I never made that statement, which was wrongly attributed to me, nor any statement that could be interpreted in that way. There is no change in the Olivetti attitude toward SGS as well as toward SGS products, strategies, and policies. SGS is more than ever determined to increase its total effort, both in standard and custom bipolar and MOS ICs, for all applications.

Roberto Olivetti
President
Ing. C. Olivetti & C., SpA
Ivrea, Italy

Low-cost recorders

To the Editor: Re the article on using low-cost recorders for instrumentation data [April 12, p. 35], I can see how arithmetical manipulation during differential pulse-width modulation can significantly reduce errors caused by transport wow. But I don't see how this relates to achieving 60- or 120-inches-per-second performance at $1\frac{7}{8}$ in./s. The only reason for gobbling up tape is to obtain large bandwidth, and there is no magic that I know of in DPWM that endows it with 32 to 64 times the bandwidth capabilities of other tape-encoding techniques.

Frederick A. Stone
CBS Records
Milford, Conn.

▪ Electronics erred in implying that a cassette deck could beat the bandwidth capabilities of a 120 in./s machine. Rather, the Setra deck is designed for applications such as industrial control bioengineering, and environmental recording where data rates are dc to 200 hertz. For those jobs, buyers often must go to expensive machines with broad-band capabilities just to obtain low-speed performance.

Room for improvement.

Until now, most rack and panel and I/O connectors came with contacts spaced at .150". Or wider.

Which meant that your dense forest of .100" center connections had to spread out whenever it came to an R/P connector.

Or your standard .125" center automatic-wire-wrapping grid had to lengthen stride to accommodate an I/O connector.

No more.

Our new crimp-and-insert mini-Varilok™ contact fits easily, with no sacrifice of electrical or mechanical integrity, into .100" or .125" center plugs and receptacles.

R/P connectors with mini-Varilok contacts on .100" centers (Series 8026) are less than half the size of their .150" counterparts. They're suitable either for the rigors of military service or the air-conditioned comfort of a computer room. And they have all the options you'll need: 33-contact connectors with plastic covers; 75- or 117-contact connectors with metal covers;

cable clamps; jackscrews; polarizing hardware.

For I/O applications you can use the same connectors, mating them with modular receptacles (Series 5540). The receptacles—a keyed connector-center module, contact modules, and polarizing hardware modules—have Varicon™ contacts, ready for wire-wrapping. Your choice of 33, 75, or 117 contacts on .100" centers. 55 or 79 contacts on .125" centers.

When you're ready, you'll find all these connectors, all ready, at your Elco distributor. In the meantime, to get your copy of our new 1971 R/P and I/O connector guide, write us at Elco, Willow Grove Division, Willow Grove, Pa. 19090. Elco, Huntingdon Division, Huntingdon, Pa. 16652. Elco, Pacific Division, 2200 Park Place, El Segundo, California 90245.



Improvements.



ELCO .100"/.125" square grid
input/output, rack & panel
and plate connectors

Send for your 1971 Design Handbook

Manufacturing in USA, Australia, Belgium, Canada, Denmark, England, France, Germany, Israel, and Japan. Sales offices throughout the world.

Circle 7 on reader service card

Our passive components can be obtained from a well-stocked industrial distributor right near you, for even faster delivery. Isn't it time you investigated our innovative people and products? Write Airco Speer Electronics, Bradford, Pennsylvania 16701.

We do.

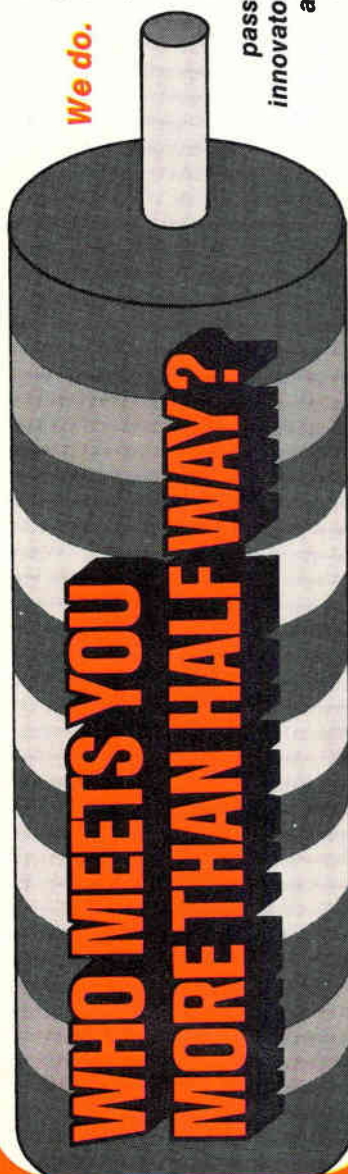

The
passive
innovators
at **AIRCO Speer Electronics**

People

When one man can evaluate a new market, design the products to fit it, and muster the clout to get it manufactured, he's probably the president of a small electronics company. Joel Naive fits the description, except that he had to step out of the presidency of Wavetek, San Diego, Calif., and become chairman of the board in order to get enough time to complete those tasks.

Wavetek's bread and butter has been signal-generating equipment, phase meters, and function gen-



Joel Naive: Back to the drawing board.

erators. From its founding in 1963 Naive, as president, was preoccupied with getting the firm off the ground. "However, I wanted the freedom to spend time where I'm most valuable to the company—in technology and marketing rather than business administration," the 42-year-old EE explains.

A professional manager with Harvard Business School credentials became president and Naive (rhymes with rave) returned to his first love—designing.

The result has been formation of a new subsidiary, Wavetek Data Communications, and entry into an entirely different market. Naive did most of the design and develop-

ment of a pushbutton audio response system for point-of-sale credit authorization, banking, and industrial data communications.

The shift for Naive was primarily from analog back to digital design, which had been his specialty after getting his MSEE from Stanford University. But he adds, "I had no formal training in logic design in the conventional meaning. So I had to brush up on NAND and NOR gates, TTL, computer technology, and the like."

Turning the company's engineer-president-turned-chairman loose to pursue new markets paid off in speed, too. It took just six months to move the audio response system from concept to prototype and another three months to produce and install the first units.

"How glad I am that we moved," says Fred Becker, president of tiny Becker Electronics in East Durham, N.Y. "Everytime I go back to the metropolitan area, I realize more and more I don't regret moving." The speaker company founded by his father in Valley Stream, N.Y., in the heart of Long Island's electronics complex, has relocated 150 miles to the Catskills.

Though Durham might be described as one of those places you can't get to from here, the advantages have been financial as well as psychic. Though near a resort area, the mountain locale is also among the most economically distressed spots in the nation. As a result, the Small Business Administration has helped finance Becker's \$600,000 plant, and labor has been plentiful. Now the company has shifted from its stance as a basic OEM supplier to one offering direct consumer sales in stereo speakers and radios. This required an expansion of the original plant.

As for the mental rewards, Becker sounds more like a local tourist agent. "The engineers like the country for the relaxed style of living," he boasts. "It's quiet up here away from the constant grind and panic of doing business in the metropolitan area. We have no trouble getting people up here."

National presents the Tri-State-of-the-art.

(A timely, information-filled discussion of the National Tri-State logic scene featuring systems design input by Jeff Kalb and systems applications data by Dale Mrazek with introductory notes by Floyd Kvamme.)*

*Tri-State is a Trademark of National Semiconductor Corporation



"The first DTL devices were designed with passive pull-up. Then, to improve speed, you went to an active pull-up which caused havoc with the bus OR'able system. So, the next step in evolution was to use an uncommitted collector output.

Tri-State logic, then, is the next step beyond that."

FLOYD KVAMME,
DIRECTOR OF MARKETING

To the designers of bus-organized data systems, Tri-State logic is good news. Tri-State logic devices give you all the speed, power and noise immunity of TTL plus the ability to interconnect outputs of similar devices to a common bus line.

Three States, Explained

Basically, a Tri-State IC is a logic element with three distinct output states: "0", "1" (normal TTL levels) and OFF which is a high impedance state that can neither sink nor source current at a definable logic level. (At most, it may require $40\mu\text{A}$ leakage current to be supplied to it from other devices connected to the same output line. But more on that later.)

The Advantages Of Tri-State Logic

There are a number of decided advantages. For one thing, Tri-State logic totally eliminates the need for a pullup resistor in a bus-organized system. Which means you save space and money. You also get more speed with no effective increase in cost. Noise susceptibility is improved by a factor of 10. And Tri-State logic is completely compatible with all existing 54/74 devices. (In fact, we've made a special effort to make conversion to Tri-State logic extremely easy.)

Tri-State Logic Is, At This Very Moment, Being Second-Sourced

Happily, other companies have jumped onto the Tri-State logic bandwagon. Which is

good news for you. And good news for us, since it's always nice to be followed.

Speaking of second-sourcing, it would be well to list our devices so you can see what all the others are copying.

Right now, we have eight Tri-State logic devices. All available off-the-shelf.

They are as follows:

- DM8093N... Tri-State Quad Buffer
- DM8230N... Bus Line Demultiplexer
- DM8831N... Party Line Driver
- DM8551N... Quad-D Flip Flop
- DM8094N... Tri-State Quad Buffer
- DM8214N... Dual 4-Line-to-1-Line Multiplexer
- DM8598N... 256-Bit Expandable ROM
- DM8599N... 64-Bit RAM

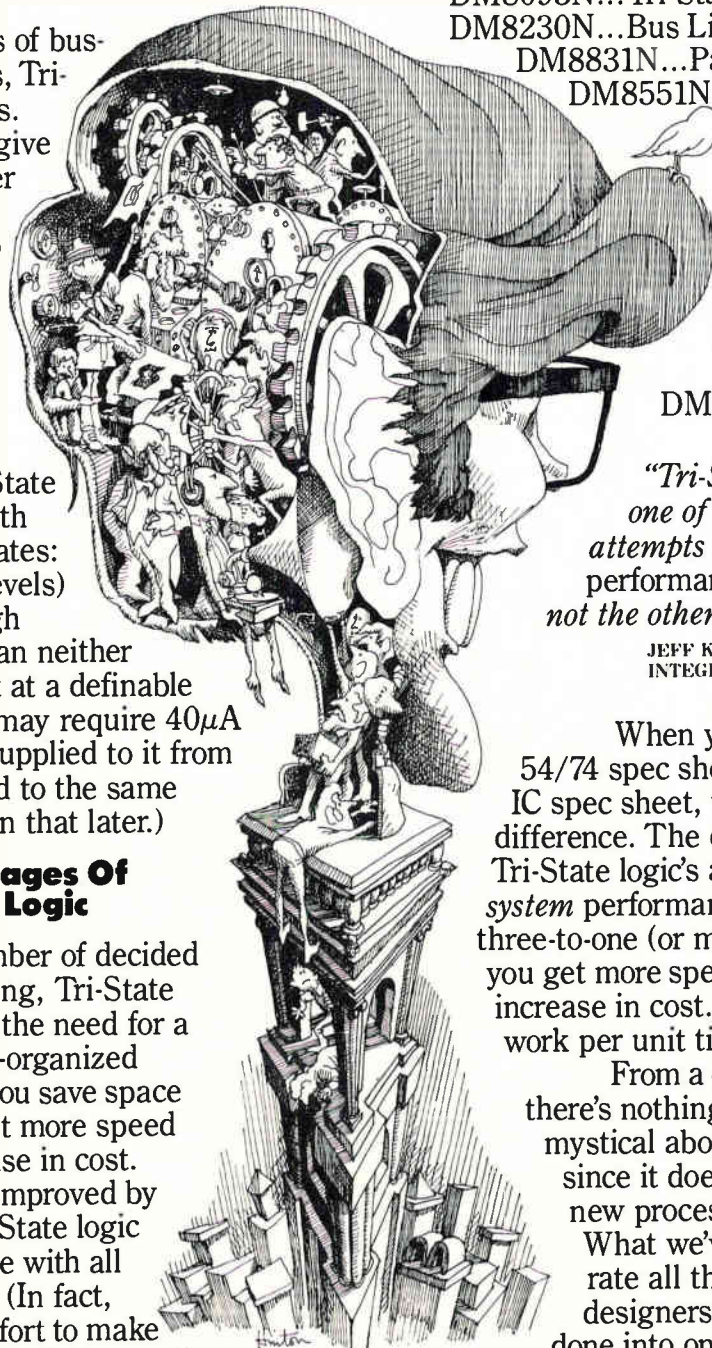

"Tri-State logic is really one of the very first attempts to relate systems performance to circuit design, not the other way around."

JEFF KALB, DIRECTOR OF DIGITAL INTEGRATED CIRCUITS

When you compare a 54/74 spec sheet to a Tri-State IC spec sheet, there's really little difference. The difference lies in Tri-State logic's ability to improve system performance by a ratio of three-to-one (or more). In the end, you get more speed with no effective increase in cost. You also get more work per unit time.

From a circuit standpoint, there's nothing spectacular or mystical about Tri-State logic since it doesn't require any new processing techniques.

What we've done is incorporate all the things that designers can do and have done into one overall systems oriented concept. A refinement of existing techniques specifically aimed at solving the problems of bus-organized data systems.

How It's Done

Actually, the concept of creating a

Tri-State TTL device is relatively simple. We've just provided a means of removing the drive current from the totem-pole output of the TTL device. The output then resembles two semiconductor junctions biased in the non-conducting or high impedance state. The only load they offer to the common bus line is the junction leakage which must be provided by the output of the device that's driving the bus line.

In addition, the inputs of many Tri-State circuits also disable and, in doing so, load the driver with only leakage current. In effect, this makes both output bussing and fan-out into other inputs virtually unlimited.

Thus, all Tri-State logic elements have been designed with a Darlington-connected power stage to provide a source current of at least 5.2mA in the logic "1" state (13 times the TTL norm of $400\mu\text{A}$!). The lower output transistor sinks the 16mA normally required for a fan-out of 10 in the "0" state.

Some Interesting Calculations

A source current of 5.2mA in the enabled "1" state means that at least 128 Tri-State outputs can be bus-connected. If one output drives while 127 other outputs on the same line are inhibited, the maximum leakage current to be sourced is $127 \times 40\mu\text{A} = 5.08\text{mA}$. Which means at least three TTL loads can be driven with the minimum of $120\mu\text{A}$ remaining.

Another Tri-State logic benefit is that lines longer than 10 feet can be driven reliably, while standard TTL can drive only 10 to 12 inches of line before noise immunity

becomes a problem. The higher power of the Tri-State IC output also improves "1" level noise immunity by a factor of 10.

Finally, one of the unique things about the Tri-State logic gating system is that it runs *in parallel* with the existing logic functions. It doesn't slow down the logic function itself while it's operating, it just provides a means of turning it off—in parallel. So, you're not adding any time to the system, you're really adding a control.

"One of the functions of Tri-State logic (as we were designing it) was to make any previously-designed MSI elements bus-structurable".

DALE MRAZEK, DIGITAL APPLICATIONS MANAGER

Reduced to its most basic and flexible form, a Tri-State IC output is a special kind of gate. And so, the most universal Tri-State devices we've designed to date are the DM8093 and DM8094 Quad Buffers. With these buffers, any other TTL-compatible device or MSI module can be given Tri-State input or output characteristics. Using Tri-State Buffers, many logic circuits can be saved. For example, in Fig. 1, they operate in pairs on a single control line to perform the two-wide multiplex function so commonly needed in logic design.

A comparison of this design with a standard design will show that an inverter and four 2-input NOR gates are saved in just this one subassembly. And, the subassembly can be expanded modularly.

More Nice Things You Can Do With Tri-State Logic

There are, obviously, many different

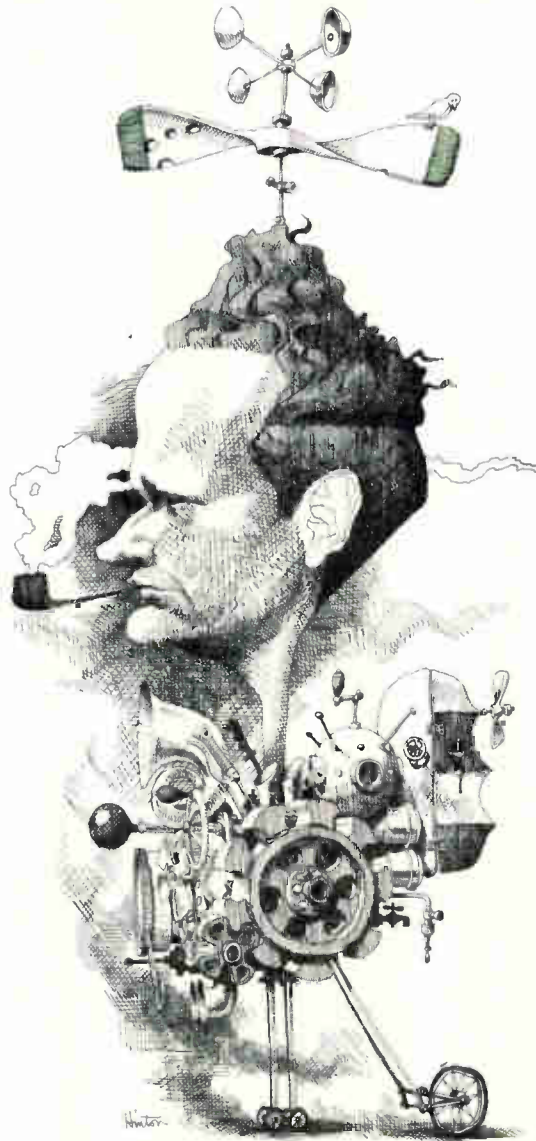

bus-structured systems applications using Tri-State devices. Some are relatively simple, others very complex. On this page we've diagrammed some typical applications. Each contains a Tri-State device or a series of Tri-State devices. All improve overall system performance substantially in addition to reducing the physical number of elements required.

of bus-organized systems, but improves overall system performance by a factor of three-to-one.

How To Get Your Very Own Tri-State Logic Seminar

Obviously, there's a lot more to talk about when it comes to Tri-State logic. So, we're prepared to offer you your very own Tri-State Logic Seminar. In your very own office. Conducted by one of our very own Field Applications Engineers who'll show up with an arm-load of Applications Notes and a headful of answers to just about any question you're likely to come up with.

Our Operators Are Standing By For Your Calls

To get the ball rolling on your very own Tri-State Logic Seminar, or simply get more information, call (408) 732-5000. Or write National Semiconductor Corporation, 2900 Semiconductor Drive, Santa Clara, Calif. 95051. TWX: (910) 339-9240. Cable: NATSEMICON.

Future Tri-State

Our eight Tri-State devices are just the beginning of a logic family which will continue to expand at a rapid rate.

And as we expand our line of devices, we are looking at each new function *not* from the standpoint of "Is this a nice function?"; but, rather, how does it fit into the system to make the system work better.

As a result, there are a variety of RAMs, ROMs, Low Power TTL devices and more systems-related MSI functions, on our drawingboards.

Very soon, too, we will offer Tri-State logic devices which feature common I/O, which will give even more performance in an already small package.

A Summary

Tri-State logic is an innovative new concept in logic design that combines the speed, power and noise immunity of TTL with the wire-OR'able flexibility required for real-life bus systems.

But even more importantly, Tri-State logic is a *systems-oriented* concept that not only simplifies the design and construction

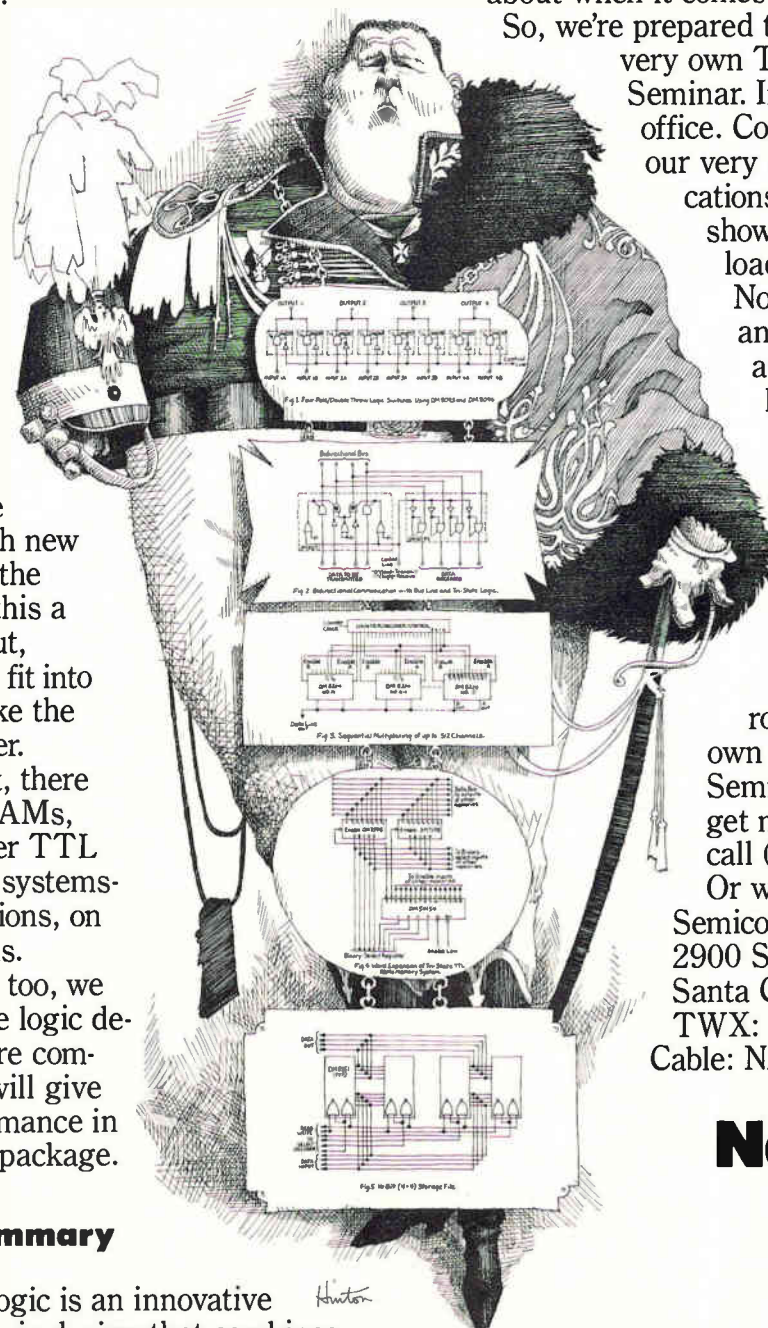

40 years ago

From the pages of *Electronics*, May 1931

Soviet Russia is now building a broadcasting station at Noghinsk, a suburb of Moscow, which will have a power of 500 kw, the largest in the world. The Soviet government also hopes to have eleven new 100,000-watt stations and twenty-eight 10,000-watt broadcasters in operation before the end of 1933. Amtorg, the official Russian trading agency in the United States, further reports that 47 stations are already built and operating, that about 2,746,000 receiving sets are in use, and that 14,000,000 will have been distributed by 1933.

Of the first 15 states and District of Columbia thus far reported, the number of families owning radio sets, according to the latest U.S. Census Bureau reports, was less than 33 per cent. Connecticut and the District of Columbia are well in the lead of the states so far reported, their percentage totals being 54.9 and 53.9 respectively.

A tiny automatic radio transmitter that is attached to free balloons and then tracked by radio direction-finding apparatus to trace air currents has been developed by Major W. Blair of the Army Signal Corps. Believed to be the smallest and lightest radio transmitting outfit ever built, the weight of the combined transmitter, antenna, and battery is only $17\frac{1}{4}$ ounces. It is said to be capable of sending on a frequency of 2,300 kilocycles (130.4 meters) up to 25 miles.

Activity in many directions indicates that the selenium cell is anything but "dead." In England it is being used to detect smoke in steamer holds, to turn on and off street lights, to control the flow of oil in oil-burning furnaces, and generally to perform all the multitudinous functions for which the phototube is being sold.

In this country selenium is being used in a large chain of sound-picture theaters, and a device is ready for the market which, by means of a selenium tube, regulates the amount of illumination.

the new Bausch & Lomb StereoZoom 7 Coaxial Illuminator
(Patented)

You're looking at a major advancement in microelectronics cost reduction and quality assurance

Now—speedily, surely—you can examine reflective micro-objects for the first time *as they really are*. Full-color definition. Without flare, glare, shadowy ambiguity. With image quality comparable to the best monobjective microscope . . . and in 3-D.

One-step visual quality control is now possible, for example, in assembling microelectronics. And quality assurance checking of multi-layer elements is swift and conclusive. Results: significant time and cost reductions.

New, unique, vertical illumination is the reason. The Bausch & Lomb StereoZoom 7 Coaxial Illuminator supplies uniform-intensity, full-aperture, on-axis illumination to both sides of the optical system. Better than ring lighting. Better than ordinary vertical and incident light systems.

But words can only hint. See it for yourself. Ask for Catalog 31-2368 and a demonstration of the Bausch & Lomb StereoZoom 7 Microscope with Coaxial Illumination . . . now.

BAUSCH & LOMB 
SCIENTIFIC INSTRUMENT DIVISION

99741 Bausch St., Rochester, N. Y. 14602

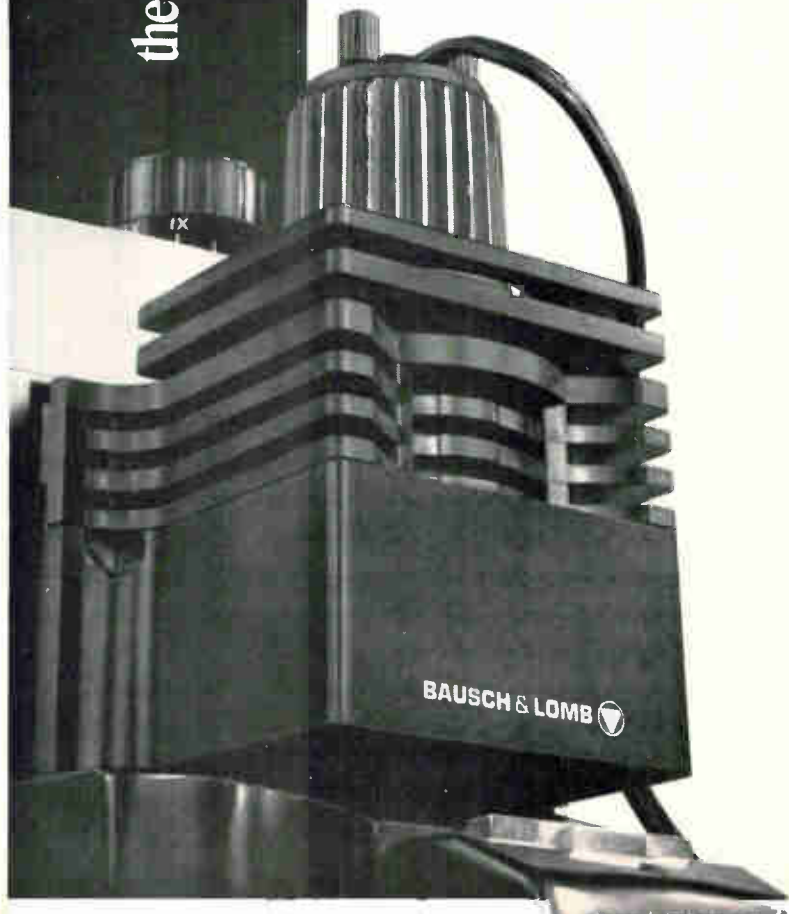

We make them pure and simple.

- ANTIMONY
- ARSENIC
- BISMUTH
- CADMIUM
- COPPER
- GOLD
- INDIUM
- LEAD
- SELENIUM
- SILVER
- SULFUR
- TELLURIUM
- THALLIUM
- ZINC

High purity elements readily available. Asarco offers the widest selection in the business. For semiconductors, electronics, metallurgy, and other applications. In research or production quantities.

New facilities are on-stream to meet the rising demand. Our purity capabilities meet ultra (or lesser) requirements.

For data sheets, or further information, on Asarco high purity elements, write our By-Products Department.



AMERICAN SMELTING AND REFINING COMPANY

120 BROADWAY, NEW YORK, N.Y. 10005

Meetings

Calendar

Electric & Electronic Measurement & Test Instrument Conference, IEEE; Skyline Hotel, Ottawa, Ont., Canada, June 1-3.

Conference on Laser Engineering & Applications, IEEE; Washington Hilton Hotel, Washington, June 1-4.

Symposium on Applications of Ferroelectrics, IEEE; IBM Research Center, Yorktown Heights, N. Y., and Holiday Inn, White Plains, N. Y., June 7-8.

Conference on Aerospace Antennas, IEE; London, June 8-10.

International Conference on Communications, IEEE; Queen Elizabeth Hotel, Montreal, June 14-16.

Cost Engineering Symposium, American Association of Cost Engineers; Hotel Bonaventure, Montreal, June 19-23.

Temperature, its Measurement and Control in Science and Industry, American Institute of Physics, Instrument Society of America, National Bureau of Standards; Washington, June 21-24.

Pollution Engineering & Equipment Exposition and Conference, McGraw-Hill Inc., Technical Industry Expositions, Inc.; Conrad Hilton Hotel, Chicago, June 22-24.

Design Automation Workshop, IEEE; Shelburne Hotel, Atlantic City, N.J., June 27-July 1.

Reliability and Maintainability Conference, American Society of Mechanical Engineers; Disneyland Hotel, Anaheim, Calif., June 27-30.

International Symposium on Electromagnetic Compatibility, IEEE; Bellevue Stratford Hotel, Philadelphia, July 13-15.

Power Engineering Society Summer Meeting and International Symposium on High Power Testing, IEEE; Portland Hilton Hotel, Oregon, July 18-23.

Conference on Nuclear & Space Radiation Effects, IEEE; New England Center for Continuing Education, Durham, N.H., July 20-23.

Intersociety Energy Conversion Engineering Conference, IEEE; Boston Hilton Hotel, Boston, Aug. 2-6.

European Microwave Conference, IEEE; Royal Institute of Technology, Stockholm, Sweden, Aug. 23-28.

From RCA, the world's leader in power devices...new power hybrid circuits for your needs

OP AMPS AND LINEAR AMPS HC-1000, TA7625A, and TA7926

Up to 7 A peak current

- Servos
- Tape drivers
- Stepper motors
- Linear motors
- Magnetic deflection
- HF amplifiers to 100 kHz



HIGH CURRENT POWER ARRAYS TA7631 and TA7632

IC levels to 300 amperes

- High power inverters
- Power supply regulators
- Variable-speed inductance motors
- Stepper motors

HIGH GAIN CURRENT AMPLIFIER PAIRS

TA8141

Dual 5 A Darlingtons

- Hammer drivers
- Solenoid drivers
- Stepper motors

SERIES REGULATORS

TA7955, TA7956, and TA7957

5, 8, and 12 volts

- 4 A current capability
- Integral crowbar trigger
- Booster capability to 12A

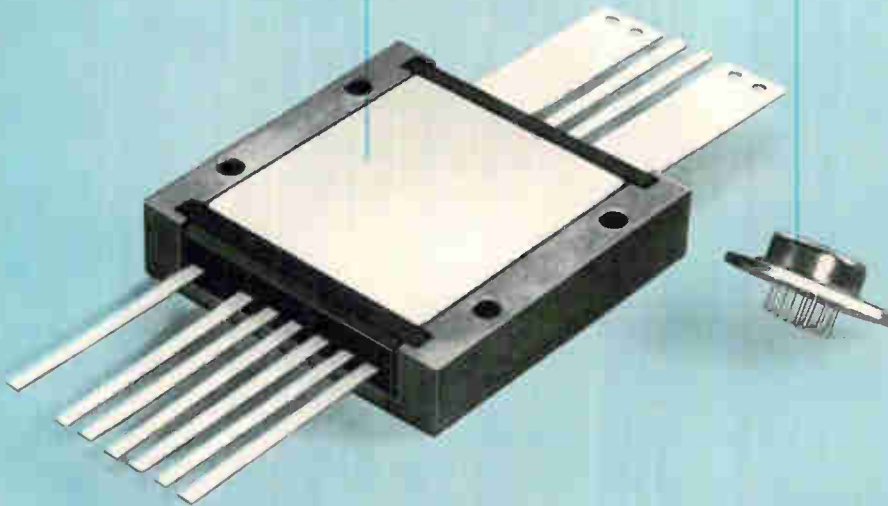

If your design requires power amplifiers, or power control circuits, or power supplies or something else you don't see here, call your local RCA Representative. For a copy of catalog 2L1149, along with product sheets detailing design concepts on various RCA power hybrid circuits, write: RCA, Commercial Engineering, Section 70E-24/UC3, Harrison, N.J. 07029. International: RCA, Sunbury-on-Thames, U.K., or P.O. Box 112, Hong Kong.

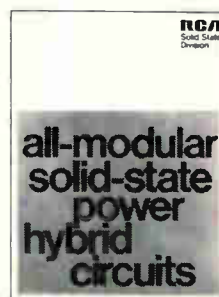

Everything's subminiature except their capacity.

Our subminiature switches may be tiny, but there's nothing small about their electrical capacity, long life expectancy, or application versatility.



Shown actual size.

Our SM series, for example, has a switching capability to 10 amps, bifurcated gold contacts for high reliability and a wide choice of integral or auxiliary actuators. Available are several terminal styles, including new flat quick-connects. To meet your other design needs, there's now a sealed version of the SM.

And if that's not enough, our smallest snap-action switch—the 1SX series—combines precision operation and long life in a 1 gram package. Plus it offers most of the features found in the SM.

For more information, call your MICRO SWITCH Branch Office or Authorized Distributor (Yellow Pages, "Switches, Electric"). Or write for Catalog 50.

MICRO SWITCH

FREEPORT, ILLINOIS 61032
A DIVISION OF HONEYWELL

MICRO SWITCH products are available worldwide through Honeywell International.

Electronics Newsletter

May 24, 1971

Bell to open digital link in 2 cities in '74

The first cities to get the Bell System's digital data service will be Washington and Boston, but they will have to wait until Jan. 1, 1974. By May of that year, an additional two or three cities—probably New York and Philadelphia—will be added. But the digital network serving 60 cities, announced by New York Telephone Co. president William M. Ellinghaus last August, won't be in service until 1976, according to latest estimates. Bell spokesmen refuse to confirm the details.

The system will use point-to-point transmission via short haul T1 and the recently announced T2 links, which have a capacity of 6.3 megabits per second. For transmission paths over 500 miles long, digital equipment will be installed at L4 coaxial cable and TD2 microwave stations. By adding repeaters and changing terminal equipment, any of the 10 TD2 broadband channels can be fitted out to carry 20 megabits per second.

Meanwhile, Datran of Falls Church, Va., is waiting for the FCC decision on its proposed 35-cities switched data network. "We are planning on offering services in 1974," says a company spokesman, "but we can't pinpoint that date until the FCC makes its decision on competition vs. monopoly and we get all the permits" for frequency approval and construction of microwave towers.

Multiplex system 'changes' door locks

Aiming at the market created by the hundreds of new hotels and motels built each year, the Telephonics division of Instrument Systems Corp. in Huntington, N.Y., is developing a door lock that can be changed electronically from a central console. ISC also has its eye on the retrofit potential—via the TV cable already installed in each room in most large hotels.

In the so-called Muxlock system, multiplex signals are sent over a common set of wires from a central console at, say, the hotel's registration desk to the lock. There, the signals set magnetically coded "tumblers." At the same time, the console modifies the room key to give it the magnetic code. The system will make it impossible for potential thieves to use duplicate keys; a new magnetically coded lock and key can be set up as soon as a guest checks out.

Phillips' firm plans CAD setup for circuits

Listen for the other shoe to drop soon at General Digital Corp., the Newport Beach, Calif., MOS/LSI firm founded and headed by Alvin B. Phillips. General Digital surprised observers by introducing an LSI tester as its first product [*Electronics*, March 15, p. 119], but activity in custom array design and sales shouldn't be far behind. Phillips says the firm is using its silicon gate process to produce test devices with thresholds at 1.8 volts in its newly completed 35,000-sq.-ft. manufacturing facility.

Further, the company is touting a low-cost computer-aided design system for circuits that cost more than \$200,000 to develop. It's built around a PDP-11 computer, an interactive CRT graphics terminal, and a mask pattern generator that sells for about \$40,000. Applicon Inc., Menlo Park, Calif., takes full system responsibility, including software. The system is operating in Menlo Park and should be completely installed at General Digital by mid-July.

Electronics Newsletter

Helium-neon laser produces 5 mW

The predicted low-cost, high-performance helium-neon laser with an internal mirror is ready for the market. Spectra-Physics of Mountain View, Calif., has developed such a plasma tube, which will sell for as little as \$165 and puts out as much as 5 milliwatts c-w (the most powerful comparable devices now available produce 1 and 2 mW).

The tube is also very stable—the internal mirror and the absence of an external resonator mean that it doesn't display any troublesome frequency jump. It can be used to scribe wafers, align machine tools, and record data, and will be available within 60 days.

Narisco to help N.Y.C. keep eye on landlords

New York City landlords will soon have to be more responsive to their residents' complaints or be denied permission to raise their rents. North American Rockwell Information Systems Co. (Narisco) has won a one-year, \$400,000 competitive contract from the city's Housing & Development Administration that makes two demands: first, create a data base on landlords and keep it current; second, update the owner/resident file and enter landlord violations.

The computerized system will match a landlord's request to raise rents against his file, permitting the housing administration to grant his request only if he has rectified any deficiencies in the dwelling.

Federal weather men seek to improve local forecasts . . .

Funds for an experimental network using sophisticated hardware to improve the speed and accuracy of short-term local weather forecasting will be sought by the National Oceanographic and Atmospheric Administration (NOAA) in the fiscal 1973 budget. The field test facility, which will comprise 16 remote automatic meteorological observing stations dubbed AMOS 3-70, and priced around \$50,000 apiece, will attempt to forecast short-term weather events within a six-hour period in a 100-mile range, none of which is now routinely observed by the National Weather Service. NOAA officials say the \$1 million budget request also will cover evaluation of other hardware such as radar digital data terminals, automated weather message composition equipment, and radar-satellite mosaic equipment that superimposes radar returns on area satellite photographs.

The NOAA effort represents the first step toward building the AMOS system into a dense national weather network.

. . . as SDM Corp. wins first award

In the first AMOS contract set for award in June, existing NOAA money will be used to begin upgrading earlier automated weather equipment, and replacing weather stations recently closed by the Federal Aviation Administration and Coast Guard, in about 100 locations across the country. Low bidder was SDM Corp., Woburn, Mass., which will build 16 stations, each a \$25,000 stripped-down version of the AMOS 3-70.

Addendum

As if in answer to IBM's recent introduction of the 3735 programable buffer terminal and 3270 terminal system, Digital Equipment Corp. announced at the Spring Joint Computer Conference its Decdatacenter—a CRT terminal with 30-character-per-second hard copy printout built around its PDP-11/20, 16-bit minicomputer. The terminal uses a type-writer/adding-machine type keyboard, instead of a Teletype keyboard.

Voltage Comparators.

(If we can handle a 30-volt differential, you can forget about us.)

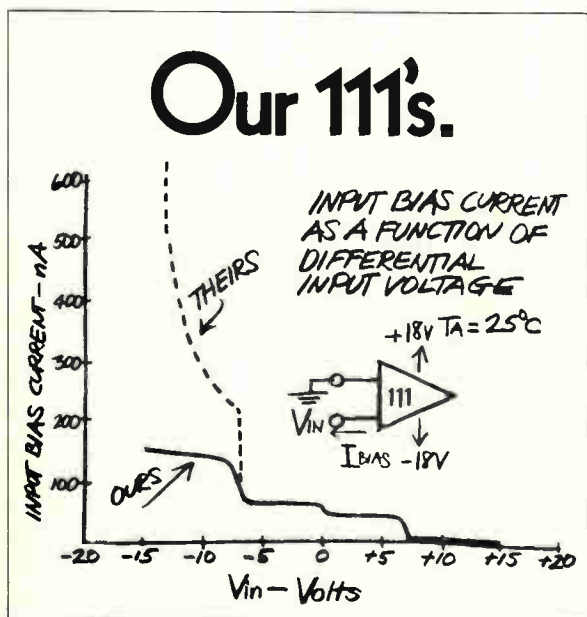

Are you thinking about your voltage comparators more than you want to?

Does a 7-volt input send your bias currents wandering above 300nA?

Then, talk to us.



We have a voltage comparator that still makes sense at 30 volts.

How many companies make a comparator like that?

One. Us.

We have them now; so does Hamilton/Avnet.

	111/211	311
Offset Voltage	0.7mV	2mV
Offset Current	4nA	6nA
Input Bias Current	60nA	100nA
Voltage Gain	200V/mV	200V/mV

Circle 306 on reader service card

So if you're thinking about voltage comparators more than you want to, think about us. Just once.

Advanced Micro Devices, Inc.

Telephone 800-538-7904 toll free, and ask for Shel Schumaker. In California, call 408-732-2400. In Los Angeles, call Steve Zelencik at 213-360-2102. In the eastern United States, call Steve Marks at 212-343-2220. 901 Thompson Place, Sunnyvale, California 94086/TWX 910-339-9280/TLX 346306

Designing computer memory systems?

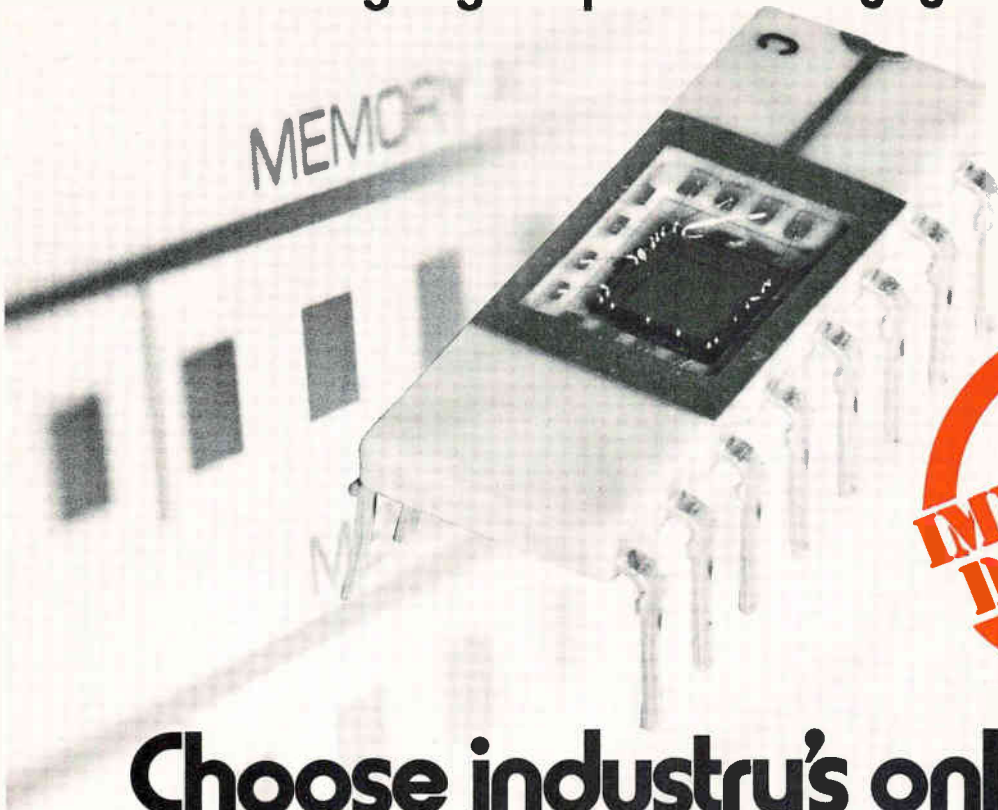

IMMEDIATE DELIVERY

Choose industry's only TTL compatible 1024-bit RAM

It's the most advanced semiconductor memory component available.

You can improve performance and reduce costs of memory systems for mini-computers and peripherals—mainframes too!—with MOSTEK's new MK 4006 P dynamic random access memory. This new design is made possible through MOSTEK's exclusive ion-implantation process...*enabling both depletion and enhancement mode devices to be incorporated on the same silicon chip.* In the MK 4006 P MOSTEK has combined process leadership with creative design to bring you a whole bag of new features.

- Consider a few:
- Full TTL compatible decoding on the chip
 - No precharging or clocks required
 - First 1024-bit RAM in a 16-pin package
 - Fast access time—300 ns typical

MOSTEK makes it easy for you to use MOS. All products are designed with the system designer's job in mind. Simple cycle timing; read, write, or read-modify-write. No need for interface circuitry like level shifters and clock drivers. (You don't even need pull-up resistors!) Result: you avoid noise problems and at the same time realize big savings in component costs and board space.

If you're ready to consider the advantages of solid state memories, make a smart move... to MOSTEK! Call Gordon Hoffman at (214) 242-1494, or your nearest Sprague Electric Company representative, for more reasons why.

MK 4006 P FUNCTIONAL DIAGRAM

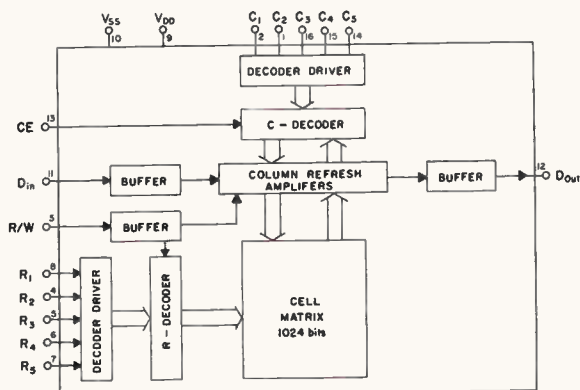

Applications literature available on request

An affiliate of Sprague Electric Company.
1400 Upfield Drive, Carrollton, Texas 75006
The Calculator-on-a-Chip Company

Government will give job-seeking EE up to \$4,000

Technical personnel in areas hard hit by defense-aerospace unemployment are eligible for Labor Department aid

The Labor Department has handed out the first awards to unemployed engineers — including EEs—scientists, and technicians in the 14 areas where defense-aerospace unemployment is concentrated—the first of its \$42 million Technology Mobilization and Reemployment Program. As part of the \$16 million in initial allocations, the awards are to be used for job searches, retraining, and relocation. As much as \$4,000 is available per eligible individual.

Since registration began in mid-April, more than 15,000 have signed up for the program, which will provide job-search grants of up to \$500 for interviews with companies that will not reimburse travel costs for the interview; up to 80% of the cost of relocation, as much as \$1,200, for persons who obtain jobs beyond normal commuting range; and up to \$2,000 for on-the-job training up to 20 weeks, or institutional training up to 26 weeks, for persons who find jobs dependent upon that training, and even more for both on-the-job and academic training.

To qualify for the Labor Department's assistance, a jobless professional must show that he was employed for at least 12 of the last 24 months and two of the last five years with companies in the

target areas whose products and services were at least 40% derived from defense or aerospace. If employed, he must show that his employment is stopgap work, paying considerably less than his previous job and not using his primary capabilities and experience in his profession.

Advanced technology

Charge-coupled imager now covers area

Following up quickly their charge-coupled imaging device [*Electronics*, March 29, p. 19], researchers at Bell Laboratories have put together a more sophisticated and useful version—an area imager. Though still far from commercial introduction, this 64-bit, 8-by-8 ar-

ray shows that CCD technology can be applied to camera-type imaging, and thrusts solid state concepts deeper into picture tube country.

The Bell Labs development should hearten those who, impressed by promised low cost and reliability, want to employ solid state in picture devices but have found the only such device commercially available so far—the silicon diode target tube—is largely lacking on both counts.

The CCD device, using standard metal-over-silicon CCD construction, has two sections: the 8-by-8 image section where the picture is focused and the light integrated, and an 8-by-8 storage section where the integrated image is stored and read out line by line, a bit at a time. The last line of this section (a 1-by-8 array) is the readout line. Transformation from image section

JOB AID GRANTS

AREA	NUMBER	ALLOCATION
Huntsville, Ala.	1,500	\$ 598,000
Los Angeles	10,000	2,993,000
Orange City, Calif.	2,400	1,196,000
San Diego, Calif.	700	837,000
San Jose, Calif.	1,300	837,000
Cape Kennedy, Fla.	3,100	598,000
Atlanta	2,500	957,000
Wichita, Kans.	700	957,000
Boston	2,200	1,196,000
St. Louis	800	1,196,000
Long Island, N.Y.	2,900	1,436,000
Philadelphia-Camden	2,500	1,436,000
Dallas-Ft. Worth	2,400	957,000
Seattle, Wash.	1,700	1,156,000

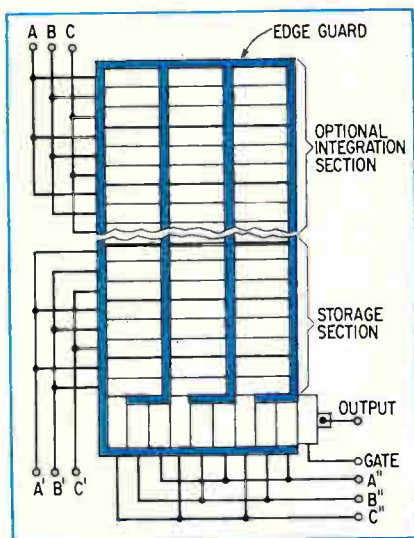

Glow. Area imager, of which only three vertical "lines" are shown, has three sections: imaging, where the charge is integrated; storage, where charge is then transferred and read out line by line; and linear readout, where final action occurs.

to storage section is done by parallel transfer—all lines at the same time, bit by bit. Thus, the overall scheme successfully achieves parallel-to-serial transformation of data, something never done before.

Before the CCD imagers can be called practical devices, Bell has to build more complex arrays, and this means smaller line geometry. Right now researchers are using 60-by-18-micron lines spaced 2 microns apart, well within current photolithographic limits. But narrower stripes at closer spacing may stretch production-line fabricating technology. Also, the smaller electrodes mean weaker transfer signals because the storage area under the electrodes will be smaller; techniques may have to be developed to handle these signals in commercial devices.

How far from the real system ballpark is the imager? Here are the numbers: character recognition can be accomplished with a 32-line system, Picturephone with 250 lines, and commercial TV with 525 lines. So a factor of 4 would get the line imager into the picture; significantly, density for at least Picturephone is within reach.

Oceanography

General Dynamics poised for data buoy splash

After more than 10 years of designing and developing ocean data buoys, General Dynamics Corp. appears to be on the verge of getting into the buoy business in a big way. A \$5.5 million contract awarded by the National Oceanic and Atmospheric Administration for six ocean platform systems may open the flood gates of considerable future business from the National Data Buoy Program, which eventually will require hundreds of platforms [*Electronics*, April 27, 1970, p. 46].

Under the contract, whose initial funding is \$3.3 million, the Electro Dynamic division in San Diego, Calif., will deliver six systems between January and April of 1972. The 40-foot-diameter, instrumented platforms will be anchored in the Gulf of Mexico in water about 12,000 feet deep and will provide telemetered meteorological and oceanographic data.

After an evaluation of these systems lasting about two years, NOAA's plans call for a preprototype phase to upgrade specific subsystems as required, then development and production of 35 prototype buoys to be placed off both coasts. This will be followed by an operational program that may involve 100 to 150 buoys and eventually hundreds. The operational program will start by 1978. General Dynamics will not necessarily get all the business, which will be awarded through competitive bidding.

In addition to the NOAA project, the company has just installed seven large operational navigation buoys for the Coast Guard; delivered a buoy to the British Lighthouse Service to replace a lightship; and has signed up a Japanese licensee, Matsushita Communication Industrial Co.

The British are evaluating the buoy, along with another unit from

Hawker-Siddeley. And the Japanese meteorological agency says it intends to deploy environmental data buoys, just the sort of business General Dynamics hopes to land through Matsushita.

The six ocean platform systems being built for NOAA will be steel structures, each 40 ft in diameter by 7.5 ft thick, with a superstructure extending about 33 ft above the water line in the center. Meteorological sensors on the superstructure will measure solar radiation, rainfall, dew point, wind speed and direction, and barometric pressure, and take dry-bulb temperature readings.

Oceanographic sensor packages will be attached to the mooring line at up to 13 levels, to a depth of 1,700 ft. They will gauge water temperature, pressure, electrical conductivity, and water current speed and direction. Hull-mounted oceanographic sensors also will check these parameters, as well as water sound velocity. Other hull-mounted equipment will measure buoy heave, pitch and roll attitude, and directional orientation.

An onboard data-processing system consisting of a basic minicomputer adapted to buoy needs will sample the sensors, format and store the data in digital form, and relay it via an onboard high-frequency communications system that will be periodically interrogated from shore. Power will come from diesel generators.

Medical electronics

Solar cell helps make patient monitoring safe

For medical electronics companies, an increasingly important question is how to isolate patients from potentially damaging leakage currents in monitoring probes. One possible answer is telemetry to isolate the patient from ac lines and other current sources by transmitting signals from body probes to a receiver built into measuring equipment. But this would require frequent battery checks and replacements, and in-

roduce the danger of a battery failure during a critical measurement.

Gilson Medical Electronics Inc. feels it has solved the problem by getting rid of the batteries. In its isolator, solar cells driven by an incandescent lamp power the transmitter. Although the Middleton, Wis., firm developed the scheme specifically for medical work, there's no reason it couldn't be adopted for other measuring applications where isolation is needed.

The signal being measured goes to a tiny transmitter where it frequency modulates a very-low-frequency carrier. The modulated signal is transmitted to the receiver, 0.75 inch away, where it's demodulated, amplified, and sent to the appropriate measuring instrument, such as an electrocardiograph. Power for the receiver comes from 115-volt ac lines.

In the same package as the receiver is an incandescent lamp imbedded in a piece of clear plastic. It acts as an optical bridge between transmitter and receiver. Ac line power turns on the lamp, whose light travels through the bridge to a bank of 12 solar cells in the transmitter. The output of this bank (approximately 6 volts at 2 milliamperes) runs the transmitter, including the vlf oscillator. In other words, ac line power drives the transmitter without introducing the danger of line leakage.

Besides transmitting light, the plastic bridge maintains the transmitter and receiver a fixed distance apart, and acts as a support for the receiver's antenna. This antenna is imbedded in the plastic, and is only 3/16 in. from the transmitter. The entire isolator-transmitter and receiver-can fit into a package that is as small as a 3-in. cube.

Company president Warren Gilson says that the isolator will be included in his firm's polygraph and electrocardiograph, and will be offered as a separate product (tentative price: \$450). The unit is undergoing clinical testing at the University of Wisconsin.

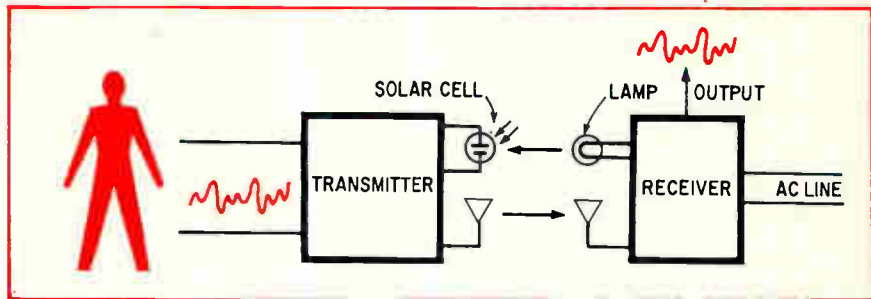

Tight loop. In this scheme to isolate patients from line leakage in monitoring probe, solar cells replace batteries as transmitter power source.

Lasers

Hospital link moves color TV

Neither rain, nor sleet, nor gloom of night will stay the transmission of color TV signals over a 1-mile laser link between Cleveland's Lakeside and Veteran's Administration Hospitals. While a number of laser communication systems are now being marketed and still more are under development [*Electronics*, Dec. 21, 1970, p. 91], the communications link in Cleveland is an example of how the once exotic laser is being used in a practical system.

According to the developer of the system, Dr. Yoh-Han Pao, head of the Division of Electrical Sciences and Applied Physics at Case Western Reserve University, the reason for high system reliability is the use of a helium-neon laser and an intensity-modulated fm scheme. While some optical communication systems now being marketed use inexpensive noncoherent light emitters, such as gallium arsenide diodes, the dispersion of such light makes them unreliable in poor weather, says Pao. Also, he points out that am signals are subject to phase shifts as they pass through the atmosphere, making for significant distortion at the receiving end.

Pao says that broadcast-quality color TV pictures are achieved with the CWRU system "99.999% of the time, regardless of weather conditions." The two-channel system

costs about \$10,000 and could span six miles. Pao says that he expects the cost to be "quite a bit lower than that in the very near future."

The system uses a subcarrier of 30 megahertz with 10-MHz modulation for the two TV channels which are multiplexed. The laser, which emits strong red light at 6,328 angstroms, has an output power of 5 to 15 milliwatts. The cutoff limit at the receiving end is less than 1 nanowatt, according to Pao.

A laser communication system developed by Lockheed Missiles & Space Co. last year is similar to the CWRU link, but that system operates at a frequency of 1 gigahertz and thus requires traveling wave amplifiers and sophisticated modulators at about double the cost of his setup, says Pao.

Manufacturing

Scan scope, spectrometer give failure answers

Auger spectrometers, with resolution of about half a millimeter in diameter, and scanning electron microscopes, which give resolutions as fine as 200 angstroms, make a powerful tool when combined and put under digital control. Scientists at North American Rockwell Corp.'s Science Center in Thousand Oaks, Calif., are using this happy marriage to pinpoint potential failures in semiconductor devices and to probe the critical surface phenomena that can cause faulty bonds, among other things.

In addition to the conventional

detectors that monitor the low-energy (0.50 electron-volt) secondary electron emissions from a specimen in a scanning electron microscope, the Science Center team incorporated a cylindrical velocity analyzer (Auger detector) in the instrument's ultrahigh-vacuum chamber. The analyzer can monitor all the electrons coming from a specimen being bombarded with the electron beam, and measure their velocities, which is critical for Auger spectroscopy.

Using a Digital Equipment Corp. PDP-8I computer, scientists can move the scanning electron microscope beam, turn it on and off, process the signals coming from the cylindrical velocity analyzer that give Auger information, and store or display the output of that detector as they wish.

One important offspring of this combination is a voltage map of a specimen. Early work with an MOS device produced one-dimensional voltage maps of metal electrodes separated by about 100 microns, demonstrating that fine resolution is possible using the combined technologies. The next step will be two-dimensional maps. To do this, the scanning electron microscope first will make a conventional topographical scan to pinpoint the region of interest on a circuit. Then the computer will drive the beam in a raster scan across that region, with the cylindrical velocity analyzer programmed to look for, say, carbon. That element has an energy of 270 eV without any potential applied, and may be only one atomic layer thick.

The scientists say they can pick out an energy range near that peak, and direct the computer to look at all points on the resulting curve to locate the carbon peaks, when voltage is applied to the MOS circuit, the carbon peak shifts in energy (but not spatially) proportional to the potential at the point. The energy of the Auger peak is independent of the electron-beam energy, but there's a linear relationship between the applied voltage and the shift in energy of the

carbon peak; it may rise to 280 eV, for example. The method could yield a quantitative measure of the potential of a circuit's area, with submicron spatial resolution, that could predict a failure at certain points where the voltage is too high.

Science Center staffers haven't yet made two-dimensional voltage maps of semiconductor devices. However, they're confident they can do it reliably because they've produced a two-dimensional digital surface chemistry analysis of a region in a metal sample—copper imbedded with 1-mil iron rods.

Sperry test looks beyond Mil standards

A pair of military standards has gone a long way toward weeding out bad devices before they get into systems. But at least one systems manufacturer, the Flight Systems division of Sperry Rand Corp., Phoenix, Ariz., has gone several steps further to insure that its device suppliers' processes remain under control consistently.

The standards are Mil-Std-883, which sets forth test methods, and Mil-M-38510, the specification that must be met by manufacturers to be accepted as suppliers to military equipment makers.

The Sperry division has come up with a modification and extension of specified test methods that helps characterize hermetically sealed devices and their manufacturers. Sperry says it's particularly helpful in determining how much of a safety factor the IC supplier has built into his parts in comparison with specified maximum ratings.

Eugene Thoennes, staff engineer for solid state technology, says Sperry engineers have found they can rely on one test—a high-stress thermal shock test, with repeated cycling until failure—to exercise the five major environmental failure mechanisms: faulty interconnect wire bonding, defective metalization, surface contamination, faulty package sealing, and improper die bonding.

The division, a manufacturer of high-reliability avionics equipment, formerly relied on thermal and mechanical shock tests, temperature and power cycling, and centrifuge checkouts for environmental characterization. But the high-stress thermal shock test induces enough mechanical fatigue by itself to help categorize a supplier's quality and monitor his process control. Coupled with the analysis performed after the devices fail, the test data allows Sperry to pinpoint suppliers' problems.

In the Sperry test, a batch of ICs is dunked in a dry-ice-and-alcohol bath at -65°C , held there for 90 seconds to allow the device temperature to stabilize, then transferred within 5 seconds to a silicone oil bath at $+250^{\circ}\text{C}$. These devices, which have been accepted as electrically good at incoming inspection, and which again have been checked electrically to all data sheet specifications before the thermal shock test, are held in the hot bath for 90 seconds, too, then pulled out and immersed back in the cold bath.

After 10 such cycles, the devices are removed and electrically tested once more, but this time not to full specs. For linear operational amplifiers, Thoennes says, Sperry may be primarily interested in input voltage offset, input current offset, and open loop gain; in digital gate-type ICs, the parameters of prime concern after such a stress test are threshold voltage and output voltage saturation.

After these checkouts, thermal shock cycling is resumed. After each 100 hours, the test lot is brought back to room temperature, and electrically tested—but again, not to the limits of all specifications.

Sperry repeats the thermal cycling until half the devices in the test batch have failed. The limited electrical tests are continued at room temperature every 100 hours. Thoennes reports that devices made by a supplier with good controls on his process usually pass 500 cycles. But once half the devices have failed, complete electrical tests are

performed on the remaining good devices, and a failure analysis is done on the dead ones. "The critical data we're looking for," Thoenes says, "is how the devices failed and when." Without failure analysis, he says, this would not be a good test.

Avionics

Luneberg lens called cure for small-plane invisibility

To an air traffic controller, a small aircraft means a dangerously low level of radar visibility. It's so low that the National Transport Safety Board has requested that the FAA solicit interest in passive reflectors to increase radar cross-sections in order to decrease the danger of mid-air collisions.

Working in-house, Emerson & Cuming Inc. of Canton, Mass., has adapted a bit of radar sophistication called the Luneberg lens to the job of identification and at a potential cost of only about \$200 to \$300 per aircraft.

The Luneberg lens is a sphere with a dielectric constant varying with distance from the sphere's center. Because dielectric materials refract radar waves in the same way that glass refracts light, it's been possible to use the lens approach to build very efficient passive beam-shaping elements for high-powered radar systems. The Navy's Typhon missile system, for example, was to have used Luneberg spheres to shape and help steer the beam of one of the most powerful shipboard radar systems ever considered.

Emerson & Cuming has turned the lens into a reflector by wrapping a reflective metal coating around one of its hemispheres. As it's bounced off the metal, the radar beam is tightly shaped and aimed when re-emitted, giving a strong return.

"It's more effective than a corner reflector," says E.J. Luoma, Emerson & Cuming's senior physicist. "While the corner reflector responds best to radar beams striking

it from only a 30° to 40° conical viewing angle, the Luneberg lens returns beams from a full hemisphere," he says. And while the corner reflector's return is about 6 decibels weaker than the incoming beam, the lens' return is weakened by only about 4 dB.

Initial flight tests used four 9-inch spheres faired, fore and aft, into the wheel covers of a two-seat Cessna 150. (The 150 probably is FAA radar's original invisible aircraft; pilots continually get requests from ground controllers for tight turns or course changes to help make their weak blip more visible on the screen.)

In tests near Boston's Logan Airport, the FAA's S-band radar was able to find lens-equipped 150s more than 50 miles away from the transmitter, a range at which 150s previously had been invisible. Luoma says detection range was sometimes doubled.

Later tests using a larger Cessna, a four-seater 172, compared the lenses with active transponders, and indicated that if the transponder's signal could be picked up, a weaker but usable signal also could be brought in from the lenses. These tests sometimes were conducted in severe rain with the same good results; Luoma claims that "as long as we were within line of sight of the radar, the lenses were about as effective as the transponder, except for the lack of an identification coding function."

He lists other pluses for the lens system: no wiring or power to fail, no possibility of human error (with a transponder a pilot can select the wrong code), and a weight penalty of only 10 pounds in a four-lens setup.

This month, Emerson & Cuming is scheduling tests of a belly-mounted model for retractable gear aircraft. Though it's only a single 18-inch diameter hemisphere backed by a metal ground plane, the unit is expected to do as good a job for retractables as a four-sphere system did for smaller planes. And this time, the weight penalty would be reduced to 4 pounds.

Commercial electronics

Prism print reader does it with digits

The Autonetics division of North American Rockwell Corp. may not have won a hardware follow-on for its feasibility study contract to develop a fingerprint reader [*Electronics*, March 30, 1970, p. 52], but the FBI didn't send the team home empty-handed. The agency told officials at the Anaheim, Calif., division that their work on a small, low-cost fingerprint reader could be a boon to municipal and state law enforcement agencies in need of a digital system compatible with the FBI's, but with fingerprint files much smaller than the FBI's 20-million-print book.

Autonetics went back to the drawing board, and is discussing its latest version—a direct fingerprint reader—with at least eight state and city policy departments. It looks like Tulsa, Okla., will be the first city to try the hardware, which already has been assembled and demonstrated.

The system developed for the FBI was far less mobile than the current version, and use a flying-spot scanner and six photomultiplier tubes to read a fingerprint on paper. The new unit uses an edge-lighted prism on which the suspect's finger is placed. His print features then are scanned by a vidicon tube that doesn't look for shades of gray, as did the earlier model. Rather, the distinctive ridges in a fingerprint whorl are digitally recorded as black data, and the valleys that don't come into contact with the prism are recorded as white features.

The vidicon looks through the prism at the print as it's made, and does a raster scan. The system records features with a signal value above a certain preset level as digital 1s, meaning these are ridges, or black features. Portions of the finger that make little or no contact with the prism registration block have a value below the

preset signal level, and are recorded as 0s, or white data. This technique results in a simplified print, but it's sufficient for positive identification.

Cedric F. O'Donnell, vice president and general manager for research and technology at Autonetics, points out that there may be more than 100 minutiae in a fingerprint, but that only nine to 12 are needed for a positive identification when a set of fresh prints is compared with prints on file.

While 50,000 bits of data may be required to store the original print in the police files, only three numbers of about 12 bits each are needed to get the X, Y, and theta information about a given ridge feature, or 300 12-bit numbers for the usual 100-minutiae print.

Ultimately, the digitized data is sent from a remote police station to central headquarters and compared with the digitized file there.

Autonetics doesn't have firm prices for the direct fingerprint reader, but O'Donnell believes a central police headquarters installation would cost well below \$1 million. Moreover, the remote system is quite simple, consisting of the block, vidicon, and simple logic. The data link already exists—it's the patrol car's transmitter.

Displays

Plasma panels appear in display terminals

Gas discharge panels, otherwise known as plasma display panels, are suddenly becoming a potent force in display technology. By the end of May, 10 operational display terminals built around them will be delivered to the University of Illinois by the Magnavox Corp. If they live up to expectations, Magnavox will build 250 more for the university. The terminals, which use new Owens-Illinois panels 10 inches square with a line density of 60 lines per inch, follow close on the heels of recent developments in plasma panels with color and with gray-scale capability [*Elec-*

tronics, March 15, p. 31; May 10, p. 35].

Each terminal can draw lines at over 600 inches per second, and can display up to 2,048 characters and write them at 180 per second, in any language including Chinese. It contains a slide projector that projects on the rear of the screen unchanging information like coordinate axes, against which computer-generated curves can be traced. The terminal can also transmit and receive data on voice-grade telephone circuits, permitting it to be used with a remote computer.

The big 10-inch panels represent an improvement on the basic plasma display units, 4 inches square and with 33 lines per inch, that Owens-Illinois has been marketing in small quantities for two years [*Electronics*, March 31, 1969, p. 133]. In addition to the higher-density lines, they use less electronic circuitry for driving the panels. They'll be manufactured in Owens-Illinois' new plant near Toledo, Ohio; the University of Illinois has a commitment for the first several hundred produced.

The university will use the Magnavox terminals in its Plato computer-assisted instruction project, for which the plasma panel was invented five years ago. Magnavox is making the first 10 terminals for about \$5,000 apiece, and hopes to get the cost down to about \$2,500 within two years—compared to \$8,000 or so for cathode-ray tube terminals with equivalent capacity, which Plato has had to use.

Magnavox will probably develop the new terminals into a line of commercially available units.

[See Special Report on displays, p. 65.]

Patents

GI to press silicon gate rights

Another semiconductor patent fight may be brewing—this time over who developed the silicon gate MOS structure and the self-aligned

gate manufacturing process. Taking the lead against patents owned by Hughes Aircraft and Western Electric is General Instrument Corp., Hicksville, N.Y., which purchased patents only last month from Philco-Ford. Altogether, GI acquired more than 200 patents, including a number for MOS devices.

Wasting no time, GI early this month requested the Patent Office in Washington to set up an interference with a patent (3,544,399) issued on Dec. 1, 1970 to Hans Dill of Hughes and dealing with self-aligned silicon gate devices. Also, GI expects an interference will be declared in an action initiated against a Western Electric self-aligned manufacturing process patent. In addition, GI has a patent for the silicon gate MOS structure issued on April 27, 1971 to Watkins and Selser for work performed at General Microelectronics Inc., Santa Clara, Calif. The company was acquired by Philco-Ford in 1966. This patent also "has claims which cover silicon gate devices as presently made," explains a GI spokesman.

GI also says it will press for licensing agreements based on other newly acquired patents, particularly those describing MOS logic circuits.

Computers

H-P 2100A compatible, but has bipolar ROM

When Hewlett-Packard computer designers sat down 18 months ago to design a new small computer, they split into two camps: one opted for new architecture, the other wanted to retain compatibility with existing H-P machines. But because improved performance from a new design didn't justify the higher price, the designers went the compatible route in the 2100A, introduced May 18 at the Spring Joint Computer Conference.

Still, it's innovative. The 16-bit word machine may well be the first minicomputer to have its complete instruction set microprogrammed in

Bell & Howell & The Kitchen Sink

Not long ago, I was sitting around having a few and swapping lies and business cards with an R&D type.

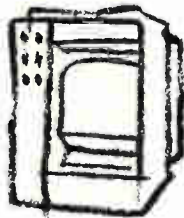

"Oh, Bell & Howell," he says. "The motion picture projector guys."

"We're also in data acquisition."

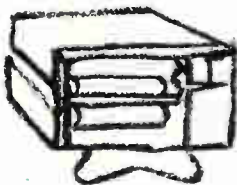

"Who isn't?" he chuckles. "What'd you do, come out with a new little oscillograph and figure you'd tear up the market?"

"So happens we have the most complete line of stuff in the business. Everything you need."

"Come on. Like what?"

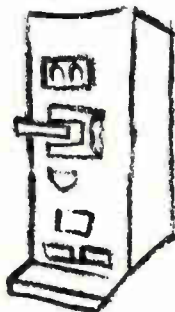

"Well, like our 5-130. A direct print out, 12 channel recorder with 10 transport speeds. Only weighs 33 pounds. Is real inexpensive. And it works off 12 volts DC."

He raises an eyebrow. "Not bad for openers. But you got anything that's real precise? Like we use in R&D?"

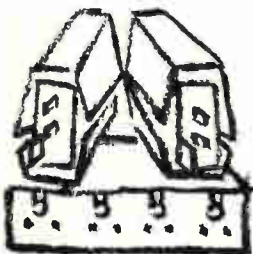

"Sure. A thing we call the 5-133. The great mother of all recorders. Does up to 52 channels. Has 12 speeds, 5 recording modes and'll meet MIL specs.

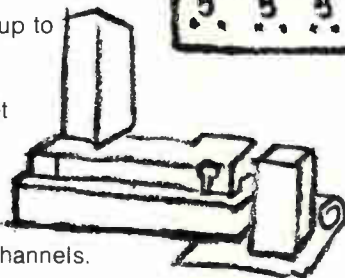

"Then we've got a 5-134 portable that works up to 18 channels. At writing speeds up to 125,000 ips. Very sharp output. And a not so fancy version of it, the 5-135, a 9 channel number they use for industrial and medical."

I can see I got him going, now. "What about system hook-up capability?"

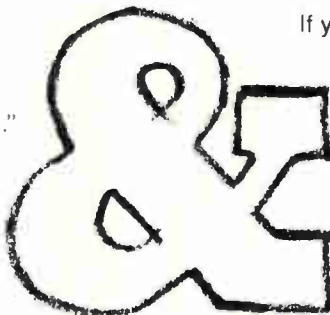

"We got it. We can sell you a stock DG 5000 data recording system. Or design custom. Everything's easy to update, too. You see with us, when you buy one of our oscillographs, you get more than just metal. You get all the support equipment you need. You even get help. Our guys are all over the U.S. The world. They can get to your problem in hours."

"What other support equipment?"

"Oh, bridge signal conditioners. Galvo drivers. Amplifiers. For instance, we've got a new low cost bridge power supply/amplifier that's got remote or internal calibration and filtering features just like the high priced babies.

"We've got paper processors, too. Even portable. Anybody can run 'em. They don't need an outside water circulating system either. Just plug it in. And we even supply the paper. High speed stuff. Reads in seconds. No chemicals."

"O.K., O.K., I'm impressed. You guys got everything but the kitch..."

"No, man. We've got everything. Period. Even the but."

"Send me the poop."

"Done. Let's have another. I'm buying."

If you'd like all the fine points on our oscillographs, data systems, amplifiers, signal conditioners, processors and paper, just write The Works. Bell & Howell Instruments Division. 360 Sierra Madre Villa, Pasadena, California 91109.

INSTRUMENTS DIVISION

 **BELL & HOWELL**

semiconductor read-only memories. Also, everything fits into a 12-inch-high package, including a new type of power supply and up to 32,768 words of memory.

Power supply problems though, nearly forced H-P to go to a 19-inch-high package and a standard power supply. The original silicon-controlled-rectifier design was causing heat-transfer problems, particularly after potting. However, H-P's laboratories speeded up development for a new transistor-switched power supply which not only requires fewer components and costs less, but requires half the power input of existing supplies. Patents have been applied for and the company expects to use the supply in its instrument line.

The read-only memories are 1,024 bit bipolar ROMs, six to a pack. One pack of 256 words (24 bits) contains the complete control and instruction set for the machine. The machine is capable of accepting three more packs, or 18,432 bits, for future expansion of the machine's "hardwired" instruction set.

H-P will undoubtedly produce customized instruction sets, but not right away. For now it plans to have a committee of H-P divisions that use computers come up with a way of using the ROMs for specialized instruction sets without interfering with the standard operation of the machine. Instruction sets that are "potentially promising" says Robert Bond, H-P Data Products Group planning manager, include such repetitive routines in communications as error correction, and many tasks in instrumentation systems such as interrupt processing routines.

While he maintains the company is not moving away from the OEM market, Robert Yeager, marketing manager for the Cupertino division, says the machine is not aimed at the OEM customer who needs a 2K controller or a stripped minicomputer. Its wired-in, extended arithmetic, its minimum memory of 4K words (980-nanosecond access), and memory protect circuits and automatic power-fail restart make it suitable for larger systems in

data acquisition, instrumentation, and automatic control.

The 2100A uses MSI and LSI TTL logic from Texas Instruments, plus H-P's own design in the folded-planar core memory. "The only reason we didn't use semiconductor RAMs was the cost," Bond says. "We'll sure use them when they get down to a half cent to one cent a bit." Though reports persist [*Electronics*, April 26, p. 17] that H-P will introduce a computer with a semiconductor mainframe memory by this fall, Bond sees RAM prices dropping to the 1- to 3-cent range no sooner than "within 24 months."

The 2100A is "reasonably asynchronous, so its could be redesigned with RAMs," Bond says. "We could buffer the input/output and make it fully asynchronous." The plan is to "keep the 2100A alive indefinitely by incorporating new technology when it is ready," he says. Base price of the 2100A is \$3,750 without memory; 4K of memory costs \$3,500.

For the record

Advice. Arthur D. Little Inc. is getting a chance to do unto itself what it's been doing for others all along. The Cambridge, Mass., firm, with a long history of defining and drafting solutions to customers' problems, is forming a new affiliate, ADL Systems Inc., to supply such EDP-related services as turnkey systems, proprietary software packages, "integrated systems," facilities management, and processing functions.

No sale. Corning Glass Works is taking its 904 interactive computer graphics display [*Electronics*, April 13, 1970, p. 45] off the market. The reason, says the company, is that demand was less than anticipated and was growing too slowly. The 904 utilized photochromic glass as a medium for short-range storage.

Sign of the times. The Western Electronic Show and Convention (Wescon) has been moved from San Francisco's Cow Palace to

Brooks Hall and Civic Auditorium in downtown San Francisco. Robert M. Ward, chairman of the Wescon board of directors and general manager of Perkin-Elmer Corp.'s Ultek division, tried to put the best light on the action in saying he is proud "that in a year of restraint for our industry, we are able to move positively to produce a better, more effective and more economical major show." But the fact is that the Cow Palace is too big for the anticipated 700 to 750 booths that will be occupied. It will be no small feat, however, to make the switch only three months before the Aug. 24-27 convention opens.

Into the Bay. In a move that gets it a foothold in the San Francisco Bay area, Tektronix Inc. of Beaverton, Ore., has purchased Cintra Inc. of Sunnyvale, Calif. Cintra, a subsidiary of Physics International, makes a line of scientific calculators [*Electronics*, Aug. 17, 1970, p. 126] and associated peripherals. Cintra couldn't buck the marketing and service organizations of Wang Laboratories and Hewlett-Packard.

Pay cuts. Due to a decline in new orders, Collins Radio Co. is reducing the salaries for administrative, professional, and management personnel by 1% to 14%. The action affects approximately a quarter of the employees on the Dallas payroll. Production employees are not affected; some recently received raises under union contracts.

Big chip. Honeywell Information Systems, Waltham, Mass., is funding a multicompany development of a 2,048-bit MOS random access memory chip. The reason: because of the very large demand anticipated for these chips the firm will require "a number of alternate sources," says a company spokesman. In the past, Honeywell had from two to four or more alternate sources for the scratchpads. Also, it wants chips with sufficiently similar performance and organization to be compatible with one another, despite manufacturing differences.

C-LINE PLASTIC SCRs



A simple case of putting 12 years of thyristor know-how in a simple case.

It's Elementary.

We offer plastic SCRs at competitive prices for those who don't require the optimum environmental protection of our hermetically sealed metal packages. In either case, there's the same Unitrode high quality inside. The kind you expect from a company that makes thyristors a major part of its effort . . . not just a sideline. Our expanding line of SCRs offers a wide range of choices for easy interchangeability in literally hundreds of applications, including lamp and relay driving, or as sensors in pulse generators, tuning circuits, motor controls and process controllers. We can build an even more convincing case for these IP100-IP104 series industrial SCRs when you request complete specs, pricing and samples. For fast action, call Sales Engineering collect at (617) 926-0404. Unitrode Corporation, 580 Pleasant St., Watertown, Mass. 02172



UNITRODE quality takes the worry out of paying less.

Unitrode Corporation, Inquiry Processing Dept. 6 C,
37 Newbury St., Boston, Mass. 02116

- Please send me two free samples of IP100 Series plastic SCRs in
 30V, 60V, 100V, 150V, 200V models.

NAME _____ TITLE _____

COMPANY _____

ADDRESS _____

CITY _____ STATE _____ ZIP _____

Eight for One ROM Sale

Introducing the world's first
8K bit bipolar read only memory.

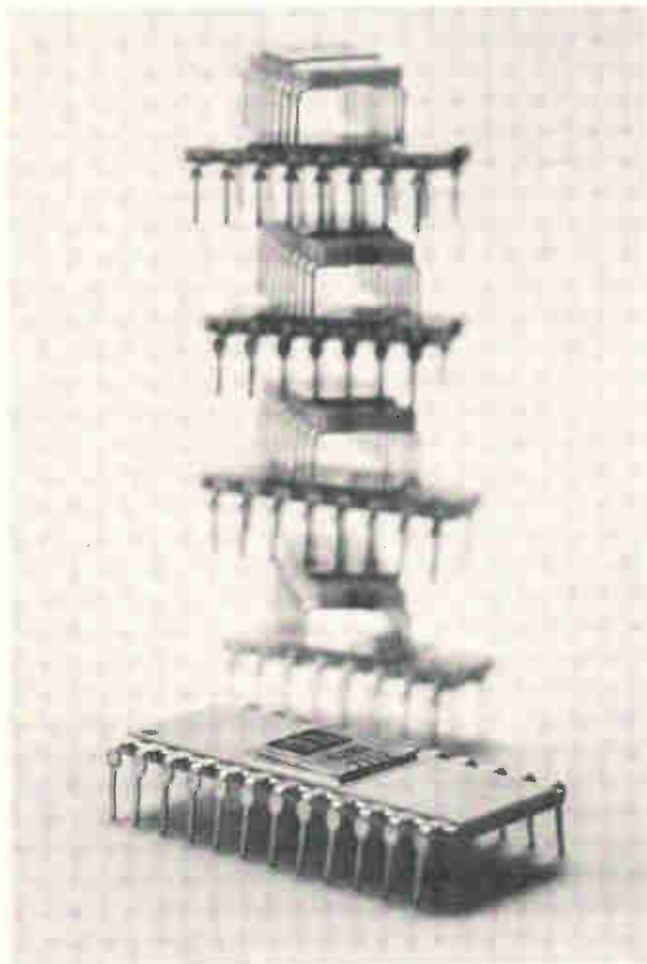

Sooner or later someone was bound to do good things with bipolar memories. We did it sooner. Think about it. That's a lot of memory on one little chip. Even MOS can't touch it. With our new MM6280 you can

replace eight 1K ROMs or 32, 256 Bit ROMs. Quite a savings when you consider one masking charge vs. eight, reduced P.C. card area, fewer interconnections, lower power requirement, lower insertion costs, and so on and so on.

On top of all that, it's got 100 nsec access time and nibbles only 60 microwatts per bit of power. It has four enable lines so you can go to 16K words without adding additional decoding. And no clocks are required because it is static.

What can you do with this big bipolar ROM? Plenty. You can use it to store the full 128 ASCII character set, row or column scan, put multiple trig functions in one package (including sine, co-sine, tangent and co-tangent); build a mighty powerful microprogrammed CPU or achieve high accuracy look-up tables.

A few detail specs:

1024 words by 8 bit
60 microwatts per bit
100 nsec access time
4 enable lines
160 microamps address input current
DTL/TTL compatible
Fantastic price: .7¢/bit in hundred quantity

Pick a winner, write, call, TWX or telex for full data. Do it quick!

Monolithic Memories



Monolithic Memories, Inc., 1165 East Arques Avenue, Sunnyvale, Ca 94086
(408) 739-3535 TWX: 910-339-9229 Telex 346 301

Washington Newsletter

May 24, 1971

Domsat filers see 18-30-GHz systems replacing 4-6 GHz

Domestic communications satellite competitors now see the approved 4-6 GHz frequencies as inadequate for future needs and useful only on first-generation satellites, pending development of 12-13-GHz and 18-30-GHz satellites. AT&T and Communications Satellite Corp., a leading team in the competition pending before the Federal Communications Commission, are independently forecasting such a move, despite the higher frequencies' well-known problem with the severe interference that local storms create in ground station reception. Observations by sources in both companies indicate the problem can be handled by increasing and diversifying the number of ground stations. **Moreover, they believe that the politics of frequency allocation are such that higher frequencies now unused are the only ones that will be available in future.**

International blessing for expansion of satellite frequencies upward is expected to come at the World Administrative Radio Conference, which convenes at Geneva in June. And AT&T suggests that 12-13-GHz systems, which could be developed in three years for about \$60 million, should be bypassed in favor of a six-year program to develop 18-30 GHz, which has "compensating bandwidth and multiple frequency reuse advantages" lacking at the lower band.

Comsat wants FCC to bar satellite competitors . . .

By urging the Federal Communications Commission to keep makers of satellites and related electronics, as well as firms with terrestrial communications interests, out of the domestic satellite competition because of "anti-competitive questions," Communications Satellite Corp. has both amused and angered industry sources. Comsat's request would eliminate Fairchild Industries, Hughes, Lockheed, and Microwave Communications of America, RCA, Western Tele-Communications, and Western Union from the domsat race. "With its plan to run a satellite system for AT&T and another for all comers," huffed a competitor's executive, "they've got to be kidding. Comsat's coming on as one of the biggest monopolies in town."

. . . but hints rate cut that could expand data terminal market

While Comsat's domestic satellite comments irked most manufacturers, an almost simultaneous suggestion—the hint of a cut in its international tariffs—is pleasing the terminal equipment makers, who see it as a spur to their sales. Comsat has been ordered to tell the FCC by early next month if it can reduce rates, now that the commission has ruled that carrier customers must use satellite circuits on a 5-to-1 ratio with cables. Comsat chairman Joseph McConnell's observation that the company is "interested in reducing our charges for satellite services consistent with appropriate returns" is being widely construed to mean charges will drop. Not incidentally, such a move would also appease the Pentagon, a major Comsat customer unhappy with its charges.

ABM computer gains from PEPE net

A new antiballistic missile computer concept (dubbed PEPE for parallel element processing ensemble) under way at Bell Laboratories has one large commercial computer running many small-scale processors. Goal of the PEPE program is have up to 16 small, Bell-developed computers

Washington Newsletter

tied into the net, although Army sources say their aim is "as many computers as you want." Industry sources report that Bell has successfully tested three of the small computers under control of an IBM 360/67 with a simulated missile attack problem. Economy and speed are reported advantages of using the small computers for sensor processing and the modified, larger, commercial machine for ABM command functions.

Army officials don't expect PEPE to be ready in time for first-generation Safeguard or Hard Site systems, although it could be incorporated later if the program pace is maintained.

Navy study questions future of bubble stores

Serious doubts about the potential of magnetic bubble memories for commercial as well as airborne computer systems have been raised by an in-house study made by the Navy Air Systems Command. The study, which will be outlined at an industry briefing on the Advanced Avionics Digital Computer in June, indicates that their projected costs are too high to make them competitive with ferroacoustic memories in mainframe applications [*Electronics*, July 6, 1970, p. 49].

Ronald S. Entner, AADC system manager, concedes that costs could be driven down by placing many storage loops on a common substrate and using a single sensor to detect bubbles. But this, he says, would preclude access time faster than 5 microseconds and the use of data blocks shorter than 500 bits.

Although Bell Labs hasn't pinned itself down, the company considers bubble technology to have its most immediate application to moderately large disk files—10 million to 100 million bits—in which it yields the most evident savings in space, power and costs [*Electronics*, April 26, p.21].

"Wired city" test proposed to FCC for 1973 start

To start the first full-scale test of "wired city" concepts in late 1973, twenty U.S. companies and Arthur D. Little, Inc., are working up proposals for the Federal Communications Commission. Covering an estimated 10,000-20,000 homes, the test system will require only 10 kilowatts to operate with a proposed bandwidth of more than 1 megahertz, says an ADL spokesman.

Approval of a test probably will be needed from the Justice Department and the Federal Trade Commission as well as the FCC because of the potential for antitrust and unfair competition charges. A second hurdle will be the location of the test site, since established cable television and local communications interests in a given area could raise enough opposition to stall the effort.

Search to test holographic aids for fingerprints

To assess the statistical effectiveness of holographic fingerprint systems, the Law Enforcement Assistance Administration's Project Search has awarded \$150,000 to the quasi-governmental California Crime Technological Research Foundation for the funding of up to four identical contracts from the 20 companies that now claim holographic capability. The foundation will provide a reference data base of 10,000 full print cards, and will duplicate the operational flow of prints with a test set of 500 cards. From an evaluation of the contractors' holographic aids and test demonstration programs, the Search staff will design and recommend a holographically assisted system.

When it comes to survivability...

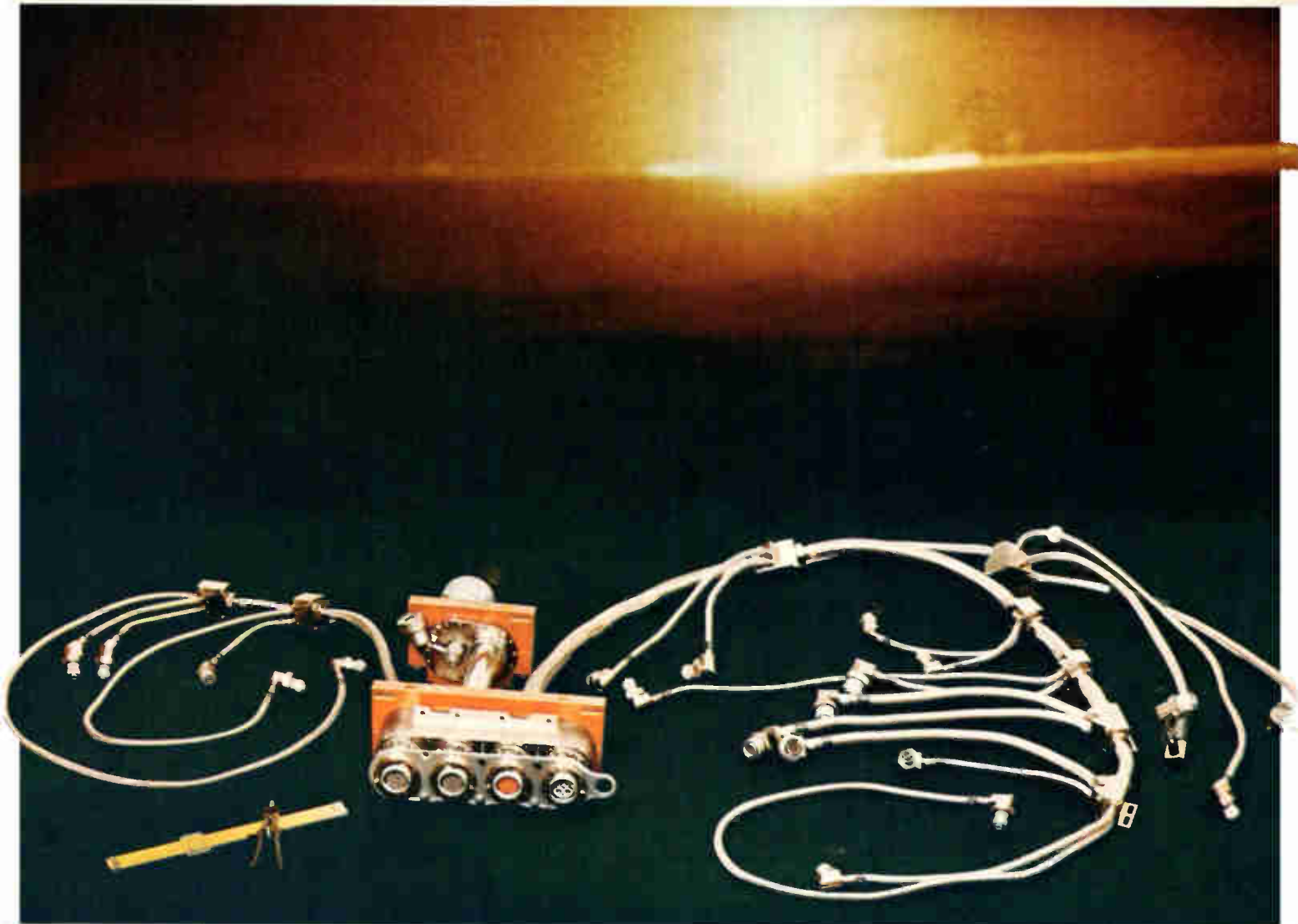

missilemen come to SAMS.

You're looking at Amphenol Space and Missile Systems Division's solution to three of the most critical problems of strategic missile design: EMC/RFI/EMP Shielding survival, Field Repairability and Weight.

Our shielding on this electrical interconnection system protects against interference by radiation and electromagnetic fields. The system is designed in segments. So field repairability is easy. Reproducibility, too. And segmented design permits efficient modification of systems for update. Finally, advanced materials and techniques reduce weight.

This system is a product of Amphenol SAMS Division — in every sense of the word. Because of our total in-house capability, we designed, developed and manufactured it here.

It's been the same story with other electrical interconnection systems since America's space and missile programs began. And the story will be repeated as even more sophisticated designs are required in the future.

In fact, we're working on those designs now.

We not only have the facilities and talent. We have a proven Program Management capability, which has traditionally helped us turn out the most advanced products in the field. All under one roof. All the time. Come to SAMS. You'll find out.

Write for information. Amphenol Space and Missile Systems, 9201 Independence Avenue, Chatsworth, California 91311. Or call (213) 341-0710, TWX 910-494-1211.

BUNKER
RAMO

AMPHENOL

New Triacs/MAC10/11
 Energize Economically In 500 V Plastic!

- Reliable, 8 A Thermopads*
- Symmetrical, 2 or 4 quadrant switching
- Lower-cost heat, light, speed control

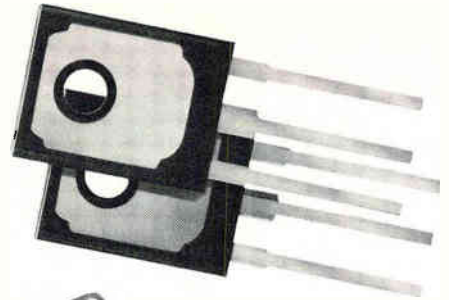

New Triacs/MAC35/36/37/38
 Control 6,000 Full-Wave Watts!

- Symmetrical gating and holding
- Big, 25 A, 500 V capability
- Quick, 1.0 μ sec turn-on



New SCR's/2N5164-71(R)
 Economize Medium-Current!

- Broad, 20 A, 600 V application
- Safe, 240 A surge protection
- Consumer-industrial cost

New SCR's/MCR3835/3935
 Step Up To 35 A Stepless Control!

- Brawny, 600 V energy-handling
- Practical, 10 mA gating/holding
- Low, 1.2 V "on" voltage

New Triacs/MAC1/6
 Pick 2 or 4 Mode
 Switching In 3 Cases!

- Hermetic, 8 A Elf* reliability
- Secure, 100 A surge capability
- Minimized, 1.0 V "on" voltage



Thyristor Power

Take your pick of the newest of the new in thyristor power control . . . from 6 SCR and Triac families that combine the latest performance with the best packaging!

Now more than 250 Motorola SCR's and Triacs give you the exact degree of step-

less, full or half-wave power control you want . . . from 25 to 800 volts in 17 different, optimized metal and plastic package designs.

Now more devices are available than ever from the volume-oriented thyristor supplier to win the "power vs. price" contest in your heat, light and speed controls, vending machines, automotive applications, tools, welders and power switching systems.

Now there are informative new data sheets on any of these six new types — waiting for your response — plus off-the-shelf evaluation units from your Motorola distributor and immediate production-lot quantities from the biggest discrete device warehouse you can find.

Now there's more in Motorola thyristor power.

Use it today!

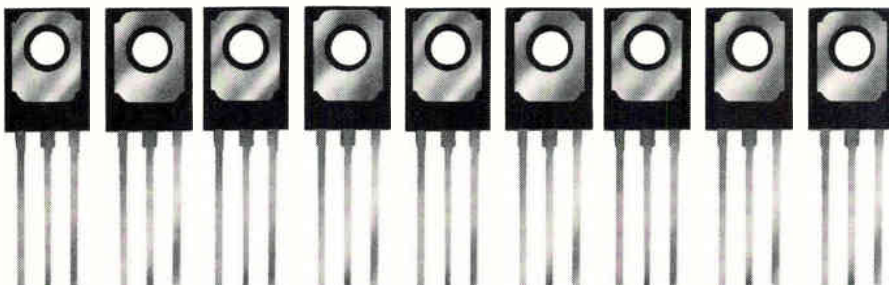

New Triacs/MAC77-1 to -8
 Close the 1,000 W Power-Gap!

- 4 A/600 V capability
- Symmetrical, 30 mA gating, holding
- 86¢ (100-up), 200 V price

— 300 ways to get control

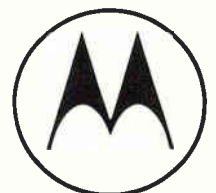

(R) Reverse Polarity
 *Trademark Motorola Inc.

Up-to-Date Technology

Overcome Environment With Hermetic Chips!

- Uncontaminated, sealed junctions
- Higher plastic blocking voltages
- Increased cost savings

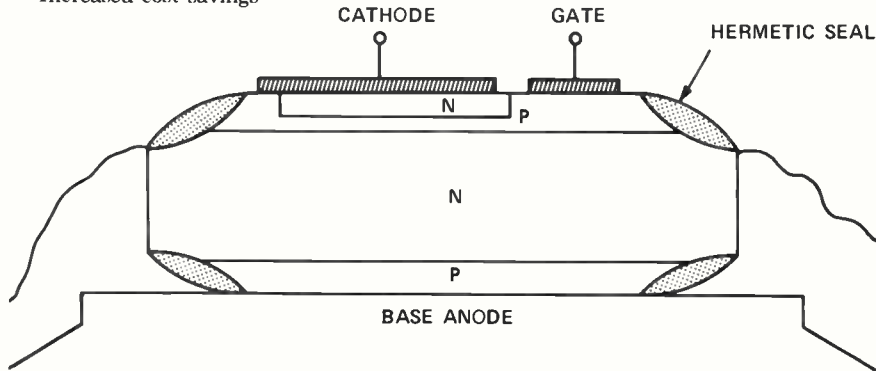

New Bilateral Switches

MBS4991-92/2N4993

Phase-Control Triacs . . . Fast!

- Nimble, 1.0 μ s turn-on
- Uniform characteristics both ways
- Moderate, 8 V switching voltage



New Signal SCR's /2N5060/MCR101/115

Choose Optimized θ_{JA} !

- Flexible, 85°, 110° or 125° C application
- Sensitive, 200 μ A triggering
- Low-as-30¢ prices (100-up)

New Programmable UJT's

2N6027-28

Do Your Own Thing In Plastic!

- Variable, R_{int} , τ , I_V and I_T
- Top, 15 V typical output voltage
- Negligible, 5 nA leakage

New Unilateral Switches /MUS4987, 88

Trigger Full Control In Half-Wave!

- Ideal, 8 V SCR controller
- Excellent, 0.02%/°C temperature coefficient
- Low, 1.5 V, "on" voltage

Trigger It On

The ideal SCR and Triac complement is a triggering or signal thyristor optimized to meet design and cost considerations.

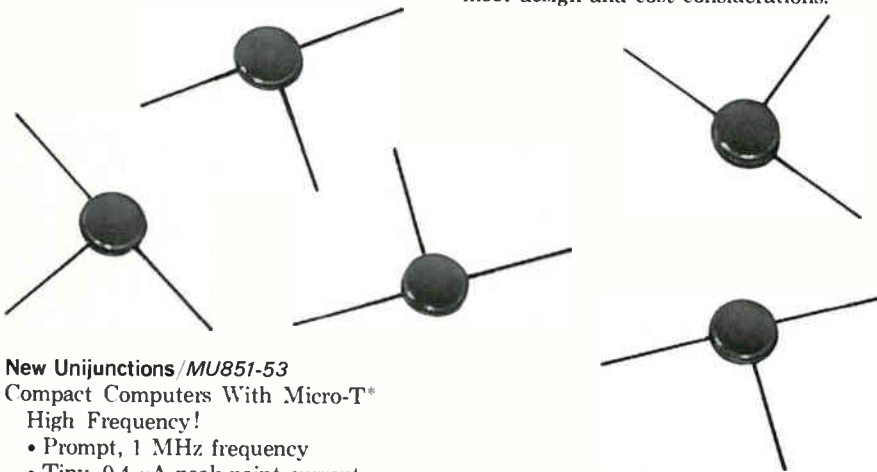

New Unijunctions /MU851-53

Compact Computers With Micro-T*

High Frequency!

- Prompt, 1 MHz frequency
- Tiny, 0.4 μ A peak point current
- Convenient, color-coding

And Motorola has the broadest line of signal thyristors!

New unilateral switches for SCR triggering, bilateral switches for Triac control, unijunctions for half-wave triggering with a timing function — there are now more than 3 dozen Motorola signal thyristor devices available that enable you to pick the right metal or plastic device for virtually any thyristor power control application . . . at prices low as 30¢, 100-up.

You can select new, low-current signal SCR's that have 3 operating temperature ranges, switches with T_V 's low as 0.02%/°C, and UJT's that are fixed or "programmable" and cased in popular Unibloc,* Micro-T* or TO-18 metal packages.

Motorola has the right triggering device for your next half or full-wave power control design.

Turn on with one today!

MOTOROLA THYRISTORS

Motorola Semiconductor Products Inc. • P O Box 20912 • Phoenix, Arizona 85036

electronic arrays silicone shift

Any bit length you need. Don't be embarrassed by an odd bit length problem (all our inquiries are held strictly confidential). You can select off-the-shelf registers from EA that will give you any bit length. By combining *any EA variable* length register, you can trim your final length to the number of bits you want. The EA variable length register allows you to select from 1 to 64 bits simply by varying the control line connection. And it's now in silicone DIP.

Best speed/power product. If you need the maximum number of bits with the best possible speed/power product, EA dynamic registers are the way to go. We have registers with speeds up to 3MHz and ones with power dissipation down to .12mW/bit. You can select from 20 different registers, in bit lengths from 1 to 512. And you have the option of the new, low cost, silicone DIP, ceramic DIP or TO package.

DC to 3MHz—no sweat. And that's in a static shift register and you just can't get that anywhere else. The EA1004, dual 100 bit static dissipates only 2mW/bit at 3MHz. It's a TI second source, but not a second best. We just introduced a new dual 80 bit static for card reader applications. It's available with single phase low level or two phase clocking operation. Eight static registers are available from dual 32 to dual 100.

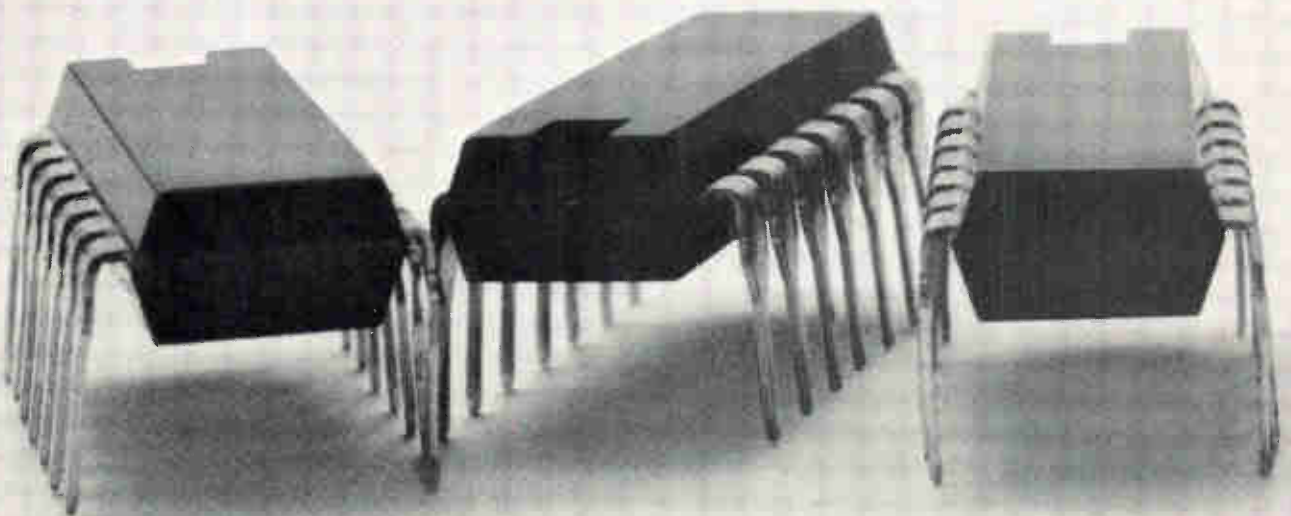

registers offer a little bit for everyone

Choice of clocks. EA is the only company in the world that has single phase dynamic registers. So you can reduce your clock driving to a single TTL circuit, if you only need 1MHz speed. But if you want more speed, use one of our two phase registers. The EA 1206, for example, is a two phase 512 bit register that operates up to 5MHz at .35 mW/bit. It's now in silicone DIP.

MOS at non-inflationary prices. EA silicone MOS registers are our contribution to help fight inflation. Call your local EA distributor or representative for prices on new low cost silicone MOS line.

Here's the new silicone MOS line.

Quad 32 bit dynamic, 2 phase	EA1200SD
Quad 32 bit dynamic, 1 phase	EA1201SD
1-64 bit variable dynamic, 2 phase	EA1202SD
1-64 bit variable dynamic, 1 phase	EA1203SD
512 bit recirculating dynamic, 2 phase	EA1206SD
Dual 256 bit dynamic, 2 phase	EA1210SD
512 bit dynamic, 2 phase	EA1212SD
Dual 100 bit static, 2 phase	EA1004SD
Dual 100 bit static, 1 phase	EA1005SD

More on the way.

They have undergone extensive processing and acceptance testing using Mil-Std-883 criteria. Write for a full list of EA shift registers and other MOS products.

electronic arrays, inc. 

501 Ellis Street, Mountain View, California 94040
Telephone (415) 964-4321, TWX: 910-339-6985

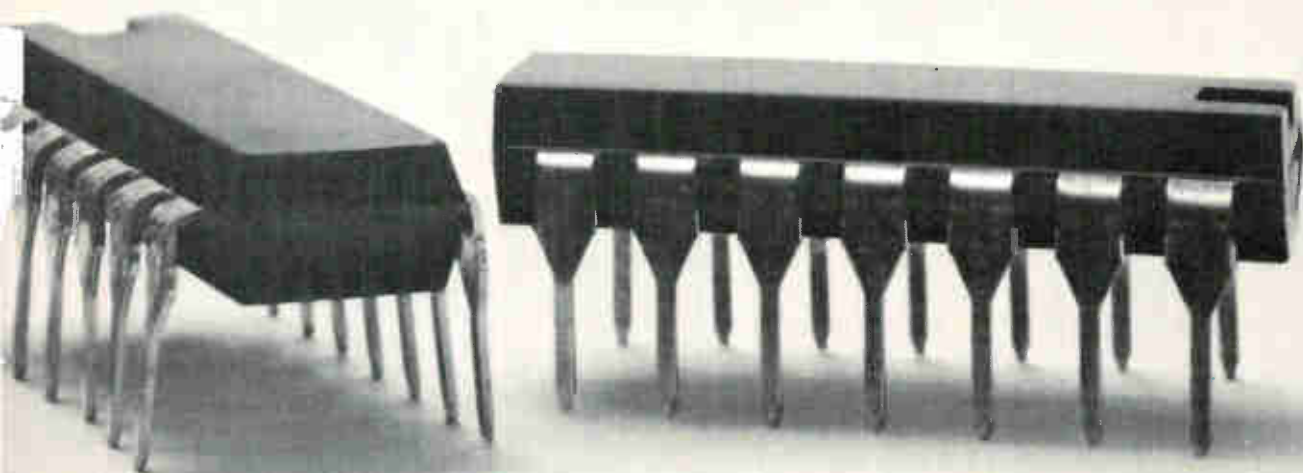

Stocking Distributors: Computer Components Corp., Cramer, Intermark, K-tronics/Wesco, Schweber Electronics

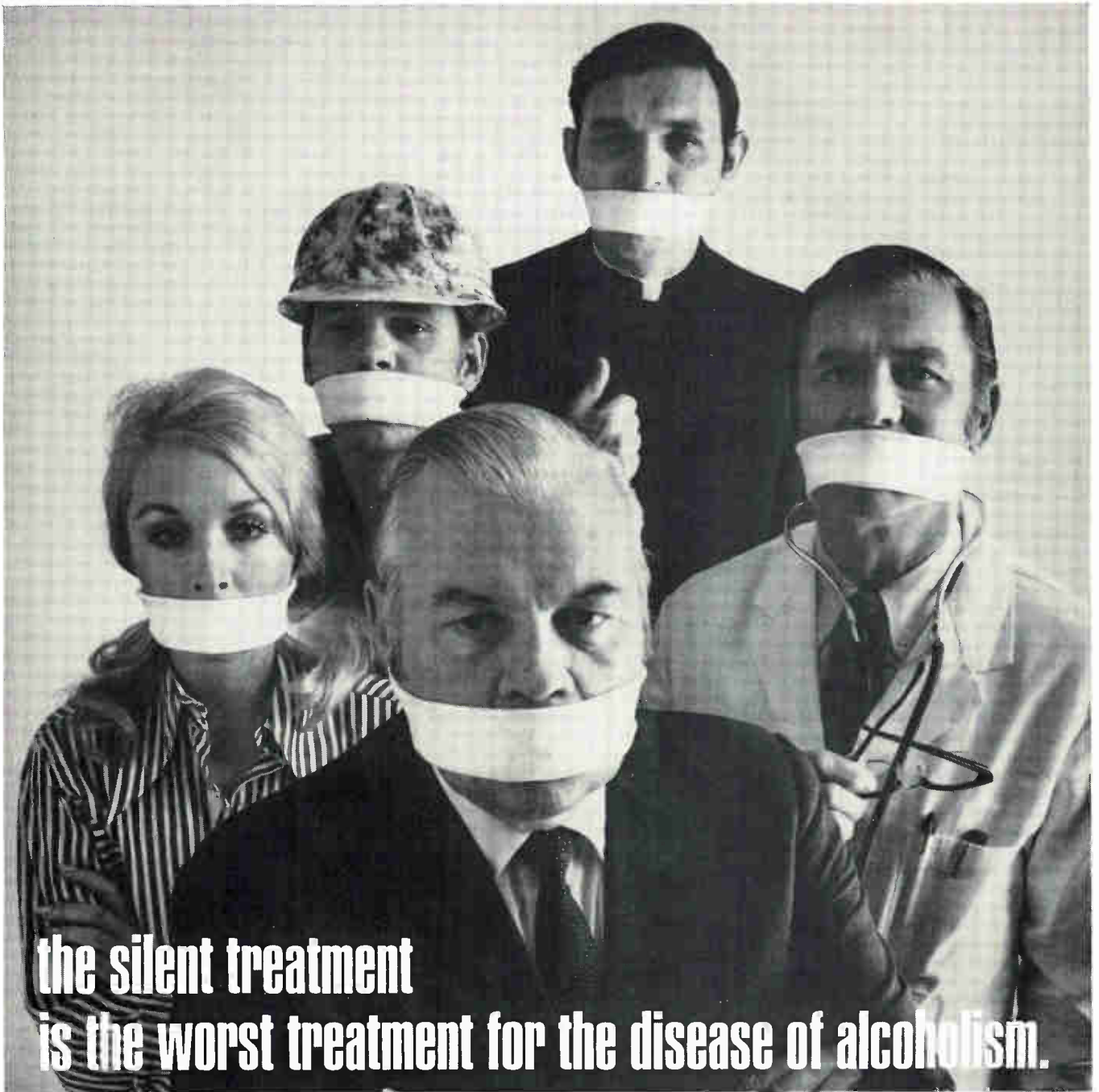

**the silent treatment
is the worst treatment for the disease of alcoholism.**

When one out of 20 employees in America—including executives—has alcoholism, it's time for some plain talk about alcoholism. The alcoholic's family, friends and employer may mean well, but the silent treatment is no way to treat a disease. And alcoholism is a disease from which recovery is possible, rather than a moral weakness for which the alcoholic should be pitied—or fired. It's a disease which ranks with heart disease, cancer and severe mental disorders as a public health menace.

The National Council on Alcoholism has pioneered in setting up joint union-management alcoholism programs. In these programs, industry is achieving *recovery rates averaging 60 to 70 percent*. Management profits by re-

taining its experienced employees and regaining lost productivity—estimated at six billion dollars. Unions profit by increasing health and welfare protection for members and keeping them in the active work force.

If you think alcoholism is affecting your business, **talk it over with the Director of Labor Management Services, National Council on Alcoholism, 2 Park Avenue, New York, N.Y. 10016.**

**National
Council
on
Alcoholism**  **INC.**

DESIGN

IDEAS

FROM
SYLVANIA

Look for the silicon lining.

Even though we've stopped making devices, GTE Sylvania still has a slice of the semiconductor business. We're continuing to make the stuff that diodes, transistors, IC's and MOS's are made of.

Silicon.

We've been working with the hyperpure material since its birth. And we'll produce any kind you need. P-type. N-type. With resistivities ranging from .008 to 100 ohm cm. Diameters to 3 inches. Sliced from 13 to 20 mils thick. Doped to your specs.

And polished by our special combination of mechanical and chemical steps so that you get a surface second to none in the industry.

Something to grow on.

(Your devices can't be any better than the silicon they start with. Our material is made for maximum yields.)

Now we supply you with the same top-notch material we always made for our own people when we were making devices.

Our cloud, maybe. But your silicon lining.

Our silicon people can be reached at 717-265-2121. Ask for Al Alexander. Or write to him at: GTE Sylvania, Chemical & Metallurgical Division, Towanda, Pa. 18848.



Single-crystal silicon by the slice.

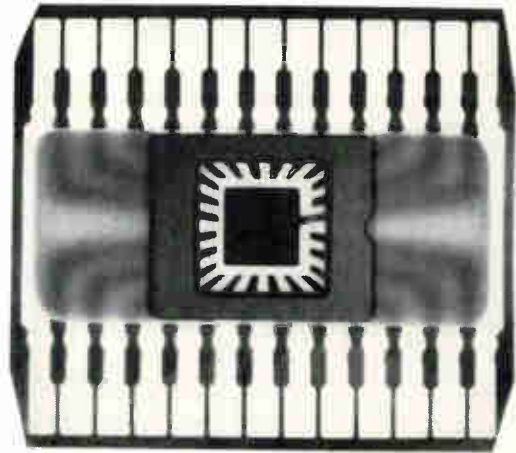

Getting it all together.

What a relief when you've finished the excruciating business of mass-producing IC and LSI chips. You're tempted to lean back, but there's one more step that's just as critical as making them: putting those micro-leads in contact with the macro world.

We've got the packages to help you do it.

Our one-piece lead frames bring strong metal fingers to the edge of the chips. (We manufactured more than 100 million lead frames last year.)

We embed the frames in molten ceramic and end up with a high-strength monolithic sandwich. (Our special glass-ceramic has the same coefficient of expansion as the metal, so they stick together like Siamese twins.)

We make all our own parts and assemble the packages ourselves. (Some manufacturers have to buy frames, lids and bases for assembly.)

We test our packages till they beg for mercy. We examine them for insulation, thermal shock resistance, hermeticity, internal shorts and strict conformity to blueprint.

We have a full line of packages with 14, 16, 24 and 28 leads, and we have different versions of each. We're in the midst of developing other variations to meet the foreseeable needs of MOS/LSI users.

Chances are we'll have what you need right off the bat.

Our prices are reasonable; you don't have to pay a bundle for a package.

Sound good?

Then let's get together and get them together:

Our packages. And your chips.

For more about IC packages, call Bill Williamson at 207-947-8386. Or write to him at: GTE Sylvania, Parts Division, Bangor, Maine 04401.

GTE SYLVANIA

We're always glad to talk to you about our electronic parts, processes and high-purity chemical products.



When space is at a premium turn to our stable $\frac{3}{8}$ " diameter cermet pots

Allen-Bradley Type SP. Tiny panel-mount pots for solving your severe space problems. These cermet pots give you exceptional stability in high-temperature or high-humidity environments. A lot of performance, in a small pot. Rugged, too. Handles 1 watt loads to 70°C.

Operational range -65° to +150°C. Rotational life 25,000 cycles with less than a 10% resistance change. Resistance range 50 ohms to 1 meg. For panel or PC board mounting. Leads fit standard 0.1 inch spacing. Immersion-proof, can be encapsulated. Plain or locking

bushings, all watertight. Several shaft and bushing options. Allen-Bradley SP. Available from your A-B electronics distributor, or write: Allen-Bradley, Electronics Division, Milwaukee, Wisconsin 53204. Export: Bloomfield, N. J. 07003. In Canada: Galt, Ontario.



Actual Size

NEW DIMENSION ELECTRONICS
ALLEN-BRADLEY 

Circle 40 on reader service card

Technical articles

The rising sun shines on Japan's large computer project: page 42

To improve Japan's competitive position in electronic data processing, the government is funding a large-scale, state-of-the-art computer. The project, nearing completion, integrates most of the newest electronic techniques, and already is paying handsome dividends, says author Charles Cohen, in the commercial sector. There, the nation's six computer companies are developing models around the advances embodied in the national project.

Solid state comes to light detection: page 50

The photomultiplier tube, once the undisputed king of low-light-level sensing jobs, is being challenged by an upstart solid state combination of silicon photodiodes and operational amplifiers; together they're capable of detecting infrared radiation levels as low as 10^{-13} watt/cm². The solid state duo features better linearity, stability, and frequency response than the tube, says author Paul H. Wendland, and should be ideal for star tracking and optical character recognition.

Keep your receiver in tune with computerized frequency control: page 60

Need fast acquisition, wide frequency coverage, and high accuracy in frequency monitoring applications? Try using a closed-loop computer-controlled system, recommends author Josef Osterweil. Thanks largely to a dynamic digital-to-analog converter, the system is able to correct frequencies for up to eight radio receivers, with sharp tuning accuracy. And time-shared digital circuitry helps keep its cost at a reasonable level.

Numeric readouts: the choice is yours, but choose right: page 65

The hot competition in display technology has given designers an abundance of devices to choose from. But since displays are taking electronics into new and competitive areas, cautions author Owen Doyle, this choice is critical, and the designer must be familiar with all of the advantages and tradeoffs involved in gas-discharge and incandescent tubes, light-emitting diodes, and liquid crystal readouts.

And in the next issue . . .

Special report: an in-depth look at the engineering career in the 1970s
. . . designing an active RC bandpass filter the easy way.

Japan is packing everything into large computer project

A government-funded program for bringing Japan's computer technology up to date integrates most of the newer electronic techniques; already the country's commercial machines are benefitting

by Charles Cohen, *Tokyo bureau manager*

□ Nearing completion in Japan, and paid for almost entirely by the government, is a national project to build a large, state-of-the-art computer. Intended to raise the level of Japanese computer technology and to reduce the country's dependence on foreign companies, it has already begun to pay off. The country's six domestic computer manufacturers have already begun to develop commercial models around technological advances that were first made in the primary machine.

Two major aims of the effort were to develop a means of making different kinds of software compatible with one another and to standardize the input-output interface.

Software compatibility is intended to reduce the percentage of the total cost of an individual installation that presently goes on software. This cost, and the cost of hardware development, is remarkably high in Japan, because of the peculiar statistics of computer production there. Although the value of computers produced by Japanese companies, as everywhere else, has risen rapidly from year to year, it is only about 2% of the world total. When this is divided among six companies, clearly only a small number of any given model is produced, and the entire cost of hardware and software development has to be borne by the purchasers of this small number.

A word to the wise . . .

Obviously, if Japan's national project succeeds, she will depend less on foreign firms to supply her computers, and those firms will lose a portion of their market. They would do well, therefore, to keep an eye on what the Japanese are doing, and to profit from it technologically if not monetarily.

For the most part, the Japanese appear only to have closed the technological gap between themselves and the West—they have not opened a reverse gap. However, the national project computer has a buffer memory, a multiprocessor configuration, and a virtual-address scheme, all in the same system. Each of these can be found in a U.S. computer, but no one U.S. computer contains them all. Combining them is difficult at best; so the Japanese success in this respect alone is enough to put the rest of the computer world on notice. —W.B.R.

To permit more users to share software costs, the national project includes a specification for a common language that should enable a user to run a program from any manufacturer or software house on any machine. It takes the form of an intermediate language, into which programs written in conventional source languages, such as Fortran, Cobol, or PL/1, are compiled and from which they are then recompiled into machine language for a specific make and model of computer. (Conventional source languages, of course, were originally conceived as similarly machine-independent, but in use have turned out to be considerably less so than had been hoped.)

The price of the double compilation is increased overhead from inefficient use of storage space, awkward sequences of machine-language instructions, and the simple-minded but minutely detailed process of compilation itself. However, though this overhead is 50% to 70% greater than that of a conventional Fortran compilation, it is still small compared with the order of magnitude difference in overhead between late and early versions of Fortran.

Standardizing the input-output interface will permit users to attach to their computers whatever peripheral equipment they consider best, whether or not it was made by the same firm as manufactured the computer. It will also simplify the connection of computers to existing data communication networks.

The standardized interface could be either that between the input-output device and its controller—the device interface—or that between the controller and the central processor—the channel interface. Most efforts toward standardization have been directed toward the channel interface. This standard has been submitted by Japan to the International Standardization Organization [*Electronics*, Oct. 26, 1970, p. 115].

The crux of Japan's entire national project is a large-scale computer configured as a multiprocessor with time-sharing capability (Fig. 1). It can have up to four central processors, each of which comprises a basic processing unit and an input-output processor. The latter performs all input-output functions and is made of TTL integrated circuits. All other processing functions are carried out in the basic processor, which is made of current-mode logic in hybrid packages.

The basic processor's speed is enhanced by its use of advance control, a technique which enables it to

separate each instruction into several parts and execute different parts of several instructions simultaneously. A typical separation might be fetching the instruction from memory, interpreting it, computing the address of its operand, fetching the operand from memory, and finally executing the indicated operations. The computer is divided into several independent parts corresponding to the instruction parts. For example, it might be made up of an instruction fetcher, an instruction decoder, an address calculator, an operand fetcher, and a simple arithmetic and logic unit.

As Fig. 2 shows, computation begins when the instruction fetcher calls for the first instruction in a program. As soon as it arrives, it is transferred to the instruction decoder, and the fetcher calls for the second instruction. When the first instruction has been decoded, the address calculation begins; the decoder starts to work on the second instruction, and the fetcher calls for instruction number three. The sequence continues until eventually all five sections of the machine are working on five different instructions simultaneously.

This method of advance control is called pipeline processing. In actual practice it can become quite complex since the exact pipeline connections are not always the same but differ according to the particularly instruction being processed. Nor can the various parts of the machine be guaranteed always to finish

their parts of an instruction at the same instant.

Nevertheless, to refer back to the example, once the system has been in operation for a while, the time it appears to take to process an instruction is one-fifth the time it actually takes. In the national project the minimum apparent time is 50 nanoseconds, which is the time required for addition after all the fetching and decoding is finished. The average apparent time for a typical mixture of instructions is over 100 ns. When the pipeline is disrupted or a reference to main memory is necessary instead of to the buffer (see below), this average can grow to 250 ns.

As Fig. 3 shows, the actual basic processor consists of 10 elements connected to five buses, plus a large number of specialized data and control lines, not shown in the diagram.

The input-output processor transfers data both ways between the basic processor and the controllers for specific input or output devices and performs various types of diagnostic routine. It consists of several channels and a common control section. The channels may be either multiplexors, selectors, or high-speed selectors.

The multiplexer channel can simultaneously control many low-speed units such as printers, card readers, and the like. The selector channel is for faster units such as magnetic disk files; it controls only one such unit at any given time, but transfers data to or

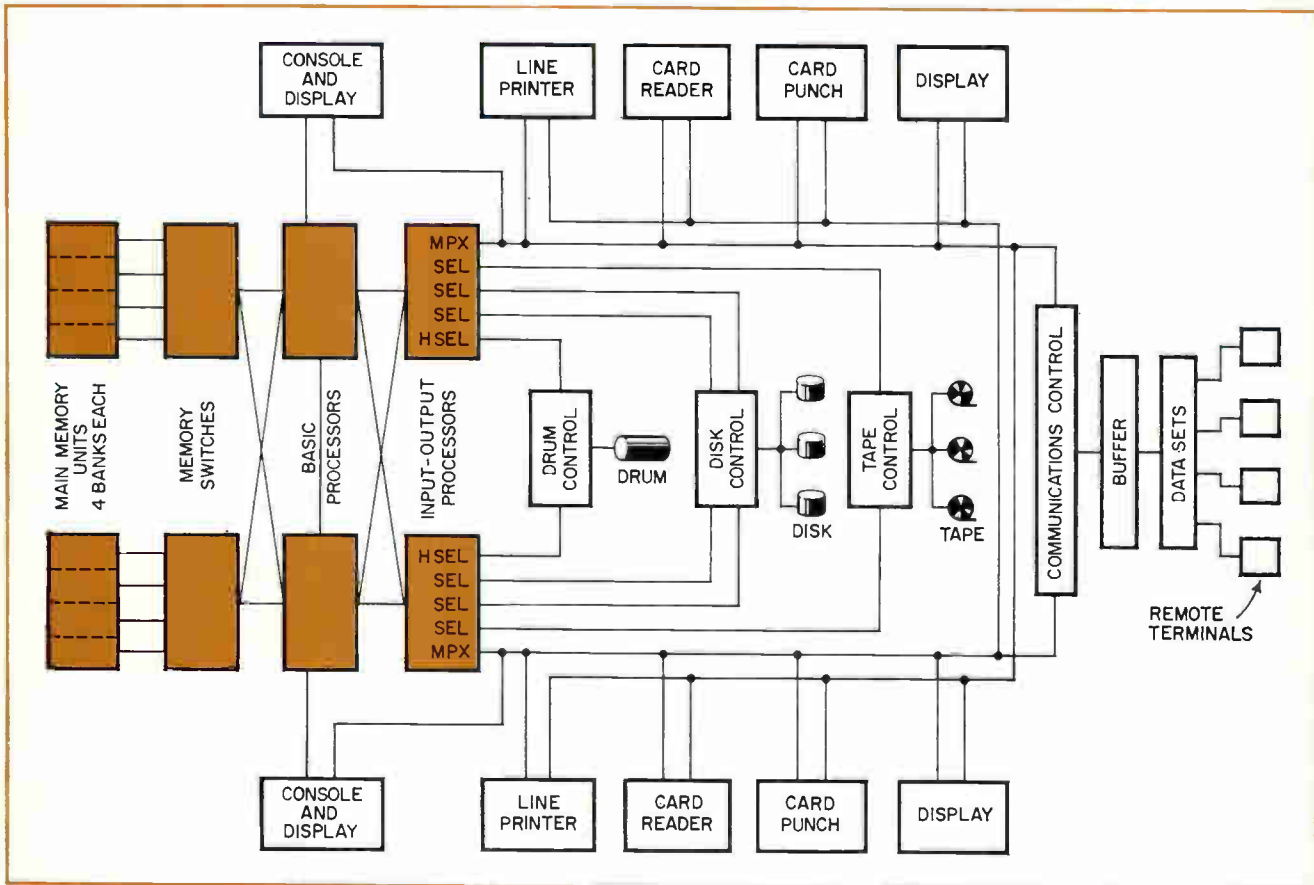

1. Time-sharing multiprocessor. One version of Japan's large-scale computer has two processors and two sets of input-output equipment; but the system can be expanded to include as many as four processors and eight memory units, totaling 8,388,608 bytes.

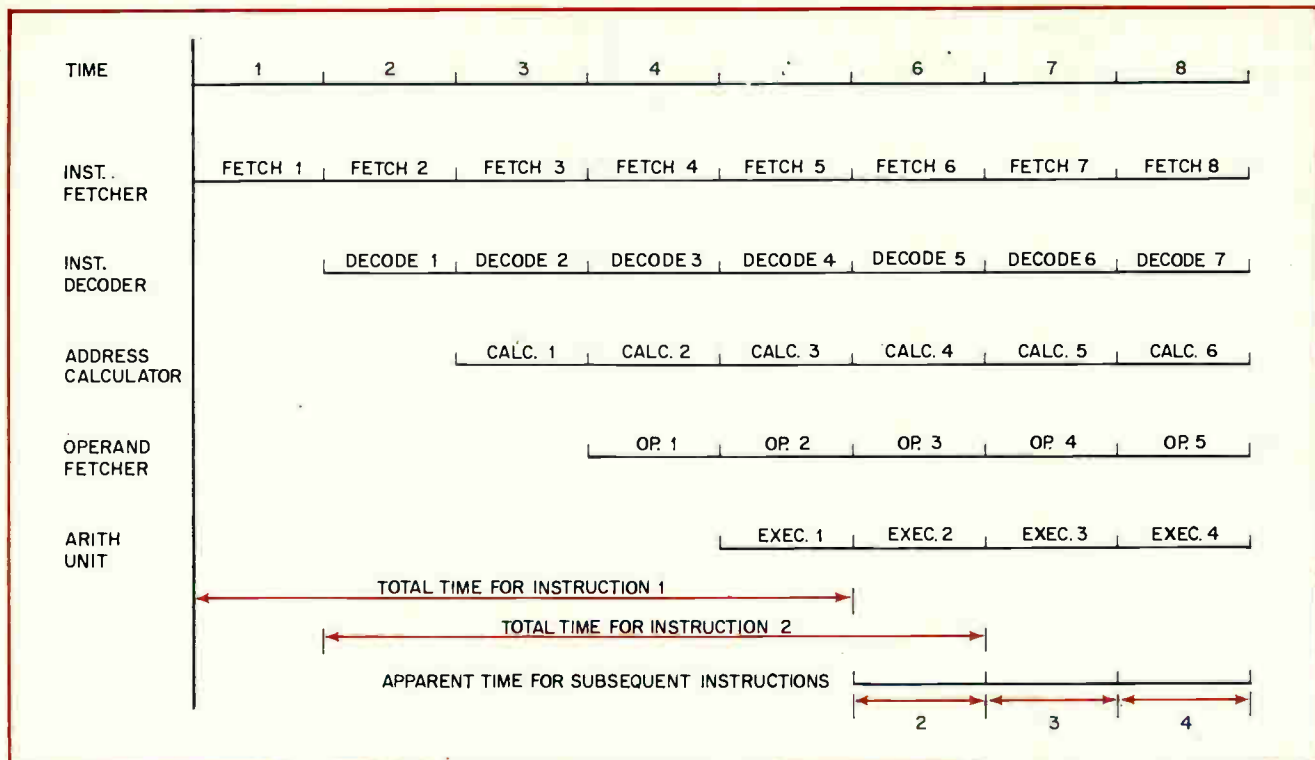

2. Pipeline. National project computer divides each instruction into several parts and executes different parts of consecutive instructions concurrently. By this means it enhances its performance considerably.

from it at a maximum rate of a million bytes per second. The high-speed selector is for the very fastest devices, usually magnetic drums, and has a maximum transfer rate of four million bytes per second.

The common control, which renders the input-output processor independent of the basic processor, contains a microprogram that switches data paths between the basic processor and the various channels, checks the operation of the channels, and diagnoses malfunctions when they occur. If one channel fails, the microprogram can diagnose the cause while maintaining normal operation on other channels.

The main memory is a million-byte core memory unit comprising four banks of 262,000 bytes each (capacities are powers of two, rounded off). Hitachi makes the memory units using 16-mil cores of lithium manganese ferrite developed within the company. Up to eight of these million-byte units can be included in a single computer system. Each unit has a 600-ns cycle time—the interval between two successive read operations—but actual access time is about 800 ns; the increment is created by intervening connections.

In addition to the main memory, each basic processor has an internal buffer memory through which all data and instructions pass between itself and the main memory. Either a woven-wire design or a metal oxide semiconductor design can be used as the buffer; at the start of the project much experience had already been accumulated with woven wires, but the rapid development of semiconductor memories was correctly foreseen and provided for.

The wire version of the buffer has a capacity of 32,768 bytes of eight bits each and a cycle time of

125 ns, while the MOS version's capacity is 16,384 bytes and its cycle time is 100 ns. Both versions are divided into two banks capable of independent operation. The versions are organized into blocks of 64 bytes and sectors of 16 or 32 blocks, with 16 sectors per buffer. During a single cycle each bank of the buffer receives eight bytes from the memory, or transmits one to eight bytes to the basic processor. The wire memory compensates in part for its lower speed by not being compelled to call on the main memory as often. The two may not perform equally at the system level, but it is not obvious which will be better.

A similar buffer is used in the input-output processor, but its capacity is only about 4,000 bytes and its cycle time is about 500 ns—considerably slower than the buffer in the basic processor and not much faster than the main memory.

When the basic processor requests a byte of data from the main memory, a full block of 64 bytes is transferred automatically into its buffer, eight at a time, in four buffer cycles per bank, by two banks simultaneously. They come from the main memory at 100- or 125-ns intervals, following an initial pause for 800 ns for the first bank to get itself cranked up and to get addresses and data through the cables and switches between the processor and the memory. Thus in just over one and one-half main-memory cycles, 64 bytes are transferred into the buffer, the first byte—the one called for in the beginning—has been processed, and the computer is ready for another.

This use of the buffer would not make sense were not the second and several subsequent requests almost certainly for data somewhere in that 64-byte block, so

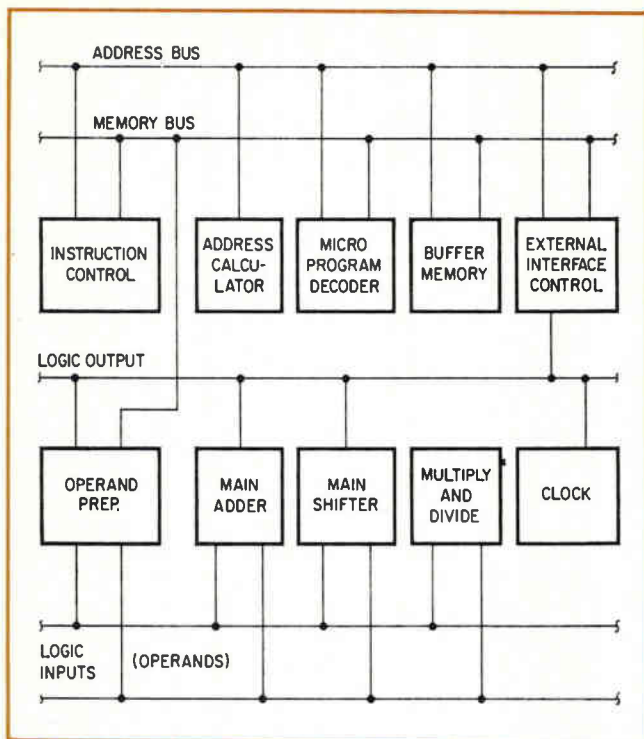

3. Subdivision. These 10 elements and five buses are the principal components of the Japanese computer, which uses them to implement pipeline control.

that the lengthy delay while the main memory turns over and the block is transferred should occur only rarely. Furthermore, after several 64-byte blocks have been transferred, references to main memory will occur even more rarely. The probability that requests for data will occur according to this pattern is 95% or more in most applications, with the result that the entire main memory appears to be capable of operating with the speed of the buffer.

Hardware interlocks insure that new data replacing old goes directly to the main memory as well as to the buffer, so that when different processors are using the same part of the memory, the second processor is protected from the risk of working with stale data.

This mechanism will be recognized as similar to that first implemented commercially by IBM in the System 360 model 85 in 1968. Similar buffers have also been used by IBM in subsequently introduced computers, and are being studied by other manufacturers.

To permit the various basic processors to gain access to different main memory units, switches are interposed between the processors and the memories. There is one switch for each memory unit, providing all four basic processors in the system with access to all four banks within that unit. Furthermore, each basic processor can be connected to as many as four switches, and therefore to up to four memory units. If a very large system requires a basic processor to have access to five or more memory units, additional memory switches can be connected in series to a single interface at the processor—at the cost, of course, of additional delay through the extra switching unit.

The transfer rate designed into the switches, allow-

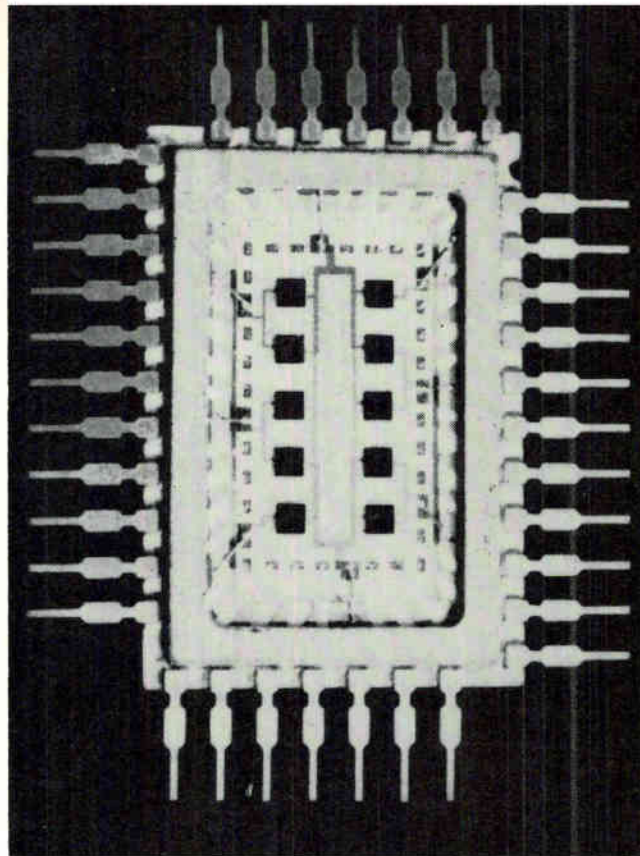

4. Hybrid. Like the other 15 arrays used in the national computer project, this one is made from five basic monolithic ICs.

ing for a safety factor to prevent overloading, is 50 million bytes per second, passing through in groups of eight. At this rate the transfer time through the switch must be 8 divided by 50 million, or 160 ns. Peak rate can rise to 100 million bytes per second.

Also in the national project computer are a memory protection scheme and error correction circuits. Although they control the main memory operation, they are actually in the memory switch. The memory protection prevents faulty programs from erasing valuable data in the memory by means of a four-bit key accompanying the address whenever a store operation is attempted. If the address key doesn't match the key in storage, the operation is blocked. Error correction uses the parity bit that goes with every byte; when transferred in groups of eight bytes, the parity bits are redefined to correct single-bit errors and detect double-bit errors anywhere in the eight bytes.

In accordance with design specifications of the national project, the computer can execute a simple addition of two numbers in 50 nanoseconds, exclusive of fetching and decoding operations, as described previously. In general, simple operations such as addition require about 10 logic gates to be connected in cascade, so that each gate must have a delay time of no more than 5 ns. Of this delay, about one-third, or 1.5 ns, is in the individual logic circuits.

But in fact, the intrinsic delay per gate is only about 1.2 ns. These gates are emitter-coupled integrated circuits bonded face down on a ceramic substrate with two layers of wiring. On the IC chips themselves, the gate delay is actually less than 1 ns.

Sixteen different kinds of hybrid arrays are used in

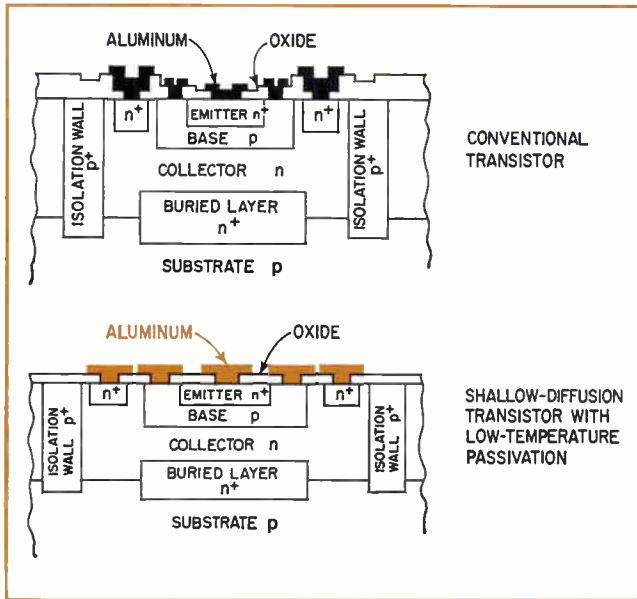

5. Shallow for speed. 2.5-micron epitaxial layer with low-temperature passivation is thin enough to keep capacitance low and therefore speed high.

the national computer project—all made of five different kinds of monolithic ICs mounted in rectangular 36-pin packages (Fig. 4). In addition, the five ICs are used individually in 16-pin dual in-line packages, along with interfacing circuits that match the ECL in the basic processor to the TTL in the input-output processor. Hitachi makes all the ICs, except those for the semiconductor memory and the sense amplifiers for the wire buffer memory, made by Nippon Electric Co.

Hybrid integrated circuits were chosen because, at the time the project was begun, the technology showed no promise of being able to produce monolithic ICs of sufficient size with the necessary characteristics—notably the cutoff frequency of the transistors—within the expected time span of the project. Furthermore, even if they could have been produced, there would have had to be many more than the five types used in the hybrid approach; and changes in the partitioning of logic among chips would have been difficult and time-consuming, whereas with the hybrid approach the chips need only be juggled around in the package.

Using the hybrid approach, a 36-pin package was chosen that can hold a maximum of 10 chips having 30 to 40 gates each and dissipating about 200 milliwatts, or a total of 2 watts for the entire package.

The circuit's high speed is enhanced by an epitaxial layer only 2.5 microns thick, and by shallow junctions such as a base junction only 0.8 micron below the chip surface. Similarly, the distance between the emitter-base junction and the base-collector junction is only 0.17μ , while the emitter itself is only 8μ across, and its metalization window is 4μ wide (Fig. 5).

These dimensions are made possible by Hitachi's low-temperature passivation process [*Electronics*, Aug. 5, 1968, p. 269], in which the oxide layer that forms on the surface of the IC during diffusion is removed and replaced by another oxide coating at low temperature. The high-temperature oxide layer has an irregular

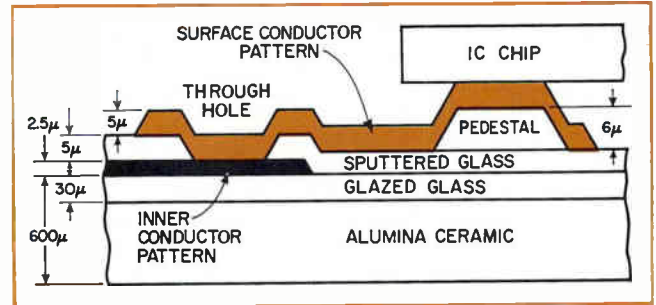

6. Substrate. Successive layers of glass and metal on alumina ceramic make up the substrate on which the monolithic chips are mounted in the hybrid package.

surface on which it is difficult to deposit narrow metalization patterns. But the low-temperature oxide layer has a planar surface, in which small windows can readily be opened and on which it is relatively easy to deposit narrow metalization patterns.

The ceramic substrates on which the chips are mounted measure 0.39 by 0.79 inch and consist of a slab of alumina 570μ thick plus a $30\text{-}\mu$ -thick layer of silicon glass. On this smooth surface is deposited the first conductor pattern of etched aluminum, 2.5μ thick, followed by a $4.5\text{-}\mu$ sputtered layer of insulating glass. In this layer approximately 200 holes are opened to interconnect the wiring patterns above and beneath it, and on the surface of the layer pedestals of aluminum are fabricated, about 6μ high and shaped like truncated pyramids. A second layer of aluminum, this time 5μ thick, is deposited on the glass and connects with the bottom aluminum layer through the holes; the pedestals form bumps to which the integrated circuit chips can be bonded. Finally this upper layer is etched to form a second conductor pattern (Fig. 6).

This completed substrate, slightly over 600μ or 0.6 mm thick, is glued to a 1.5-mm-thick ceramic base with silver epoxy adhesive; this base has a 4-mm-high rim. The IC chips are placed face down on the bumps, one bonding pad per bump, and ultrasonically bonded; and the package cover is attached to the rim.

Because the chips are standard in every way, they can also be conventionally wire-bonded in individual packages. No special fabrication processes are applied to the chips intended for the hybrid arrays.

Both hybrid LSI circuits and individual ICs are mounted on six-layer printed-circuit boards which use 50-ohm striplines as signal lines. These boards in turn are mounted on eight-layer backboards through which the smaller boards are interconnected.

Work on an even faster series of ICs, with propagation times of 500 picoseconds, was begun during the project but temporarily shelved because it could not be completed in time for use in the prototype. Hitachi has now resumed work on this faster series, and hopes to make a commercial line out of it.

The semiconductor version of the buffer memory is made of MOS chips, each containing 16 words of nine bits each. Each basic cell is a static flip-flop, as shown in Fig. 7, where Q_1 and Q_2 form the flip-flop itself, Q_3 and Q_4 are switches for write-in and read-out, and Q_5 and Q_6 are resistances. The chip measures 140

by 119 mils and is mounted in a 40-lead package.

Access time at the chip level of these circuits is 5 ns for read-out and 15 ns for write-in. For the entire time that an address signal is applied to an MOS cell, a dc readout signal appears at its output terminals. Thus the read-out is nondestructive, and data taken out need not be rewritten. Because the cells are static, no internal clocking is necessary; an address applied at the input ripples through and brings the output to the terminals in the shortest possible time.

The memory's peripheral circuits are made with nonsaturating bipolar ICs. Individual dual in-line packages contain four word drivers, or three digit drivers, or three sense amplifiers. The word and digit drivers must generate larger voltage swings than are ordinarily required of bipolar circuits, and must feed these voltages into a relatively large capacitance. This accounts for the long write time of 15 ns.

Sixty-four memory chips form a subunit of 1,024 bytes, organized as 128 words of 72 bits each. The word drivers are addressed by an 8-by-16 matrix driven by three-bit and four-bit subaddresses, and then subaddresses are fed in parallel to all eight subunits in the basic, 8,192-byte unit of the buffer. Consequently the same 72-bit word is addressed in all subunits at once. A third subaddress of three bits selects one of the eight subunits by enabling one set of 72 digit drivers and one set of 72 sense amplifiers. By this means 72 bits, corresponding to eight 9-bit bytes, are transferred in or out of one subunit at a time, to or from one of 16 corresponding locations in each of eight chips.

The 64 packages forming a subunit of the buffer are on two identical boards, each 13.4 by 9.1 inches, and each having five layers of wiring to interconnect the chips. Sixteen of these boards make up a basic unit of the buffer memory; each basic processor contains two of these units. The basic unit measures 16.5 by 18.0 by 11.8 inches.

At the unit level the reading cycle and the writing cycle are each less than 60 ns. Following any write cycle, however, a 30-ns wait is required before a new

read cycle can be initiated, because a proper level must be restored to the digit lines. These lines have a time constant of about 10⁷ ns, so that they do not return to a reasonably close approximation to the proper level for 30 ns, or three time constants. Awkward as this waiting time may seem, it is still within the specified cycle time of 100 ns.

The optical character reader included in the national project is based on a spatial network technique for processing topological information, as opposed to the digital electronic computer techniques required for processing logical information. The technique produces a chain of transformations of a pattern while retaining the pattern's topological properties, and involves electrical networks that have analog and parallel properties as distinguished from purely digital properties. It is based on theoretical work done since 1960 at the Electrotechnical Laboratory by Taizo Iijima; the hardware prototype was built at Toshiba's Central Research Laboratory.

The national project's optical character reader is called Aspet, an acronym for analog spatial processor that also manages to recognize the Electrotechnical Laboratory (e) and Toshiba (t). A prototype, Aspet/70, was completed last year (Fig. 8); an improved model with a modified optoelectronic front end and an automatic paper feed, called Aspet/71, is just complete.

This model is capable of reading the 26 capital letters of the roman alphabet, 10 numerals, and eight other symbols, all in the ISO-B font. Its circuits are capable of processing 2,000 characters per second, faster than the paper-feed mechanism can provide them. These specifications represent a cutback for budgetary reasons from the original plans, which called for the reading of 26 capital and 26 lower-case letters, 46 Japanese katakana characters, 10 numerals, and up to 20 miscellaneous symbols, in a variety of fonts.

The optical character reader is composed of an optoelectronic conversion unit, a preprocessor, and a recognition unit (Fig. 9). The first two units use digital circuits, and convert the incoming data into multiple analog signals at the output. The recognition unit

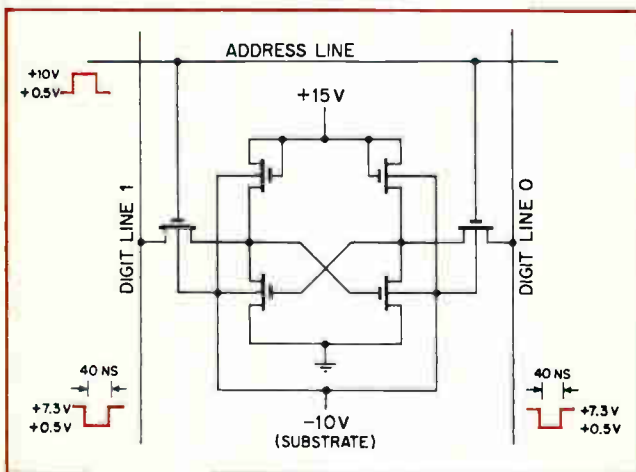

7. Static flip-flop. Semiconductor version of the buffer memory is made of MOS chips each containing 144 circuits like this one.

Who's who in the national project

The national project started officially on April 1, 1966, and its completion is planned for March 31, 1972. The Agency of Industrial Science and Technology, a part of the Ministry of International Trade and Industry, has jurisdiction over the project. The Electrotechnical Laboratory, which is part of the Agency of Industrial Science and Technology, is responsible for the project's technical aspects. Actual research and development is shared by the Electrotechnical Laboratory with the six native computer manufacturers in Japan: Hitachi Ltd., Nippon Electric Co., Fujitsu Ltd., Tokyo Shibaura Electric Co. Ltd. (Toshiba), Oki Electric Industry Co., and Mitsubishi Electric Corp. Hitachi is the principal hardware contractor, and the Nippon Software Company, a joint venture of Fujitsu, Hitachi, and Nippon Electric, was established specifically to develop software for the project. Component manufacturer Toko Inc. and Tokyo, Kyoto, Osaka, and Tohoku Universities have also participated in the effort.

compares these multiple signals with fixed patterns by a method called multiple similarity: the pattern providing the highest output is identified as the character being read at that moment. This process requires a large number of operational amplifiers, and wouldn't be economical without the availability of linear ICs for these amplifiers.

In the optoelectronic conversion unit a flying-spot scanner converts the printed characters into electrical signals and quantizes these into binary, zero-one, black-white signals. Quantization also removes most of the noise from the signal.

At the input of the preprocessor is a two-dimensional shift register, a 39-by-27 matrix of flip-flops. The array stores an entire character and is capable of shifting it up, down, or sideways to center it properly for the next stage of the recognition process. This shifting is controlled by circuits that sense the edges of the

character. No size normalization is necessary because the characters are all in a standard font.

Next the signal is summed, partly to remove more noise and partly to reduce the number of inputs to the recognition unit to a practicable minimum. For summing, the 39-by-27 matrix is divided into 117 submatrixes of nine flip-flops each, in a 3-by-3 array. The 40 submatrixes around the outside of the main matrix are ignored, because after centering all or almost all of them are off; this leaves 77 submatrixes in an 11-by-7 array, or 693 flip-flops in a 33-by-21 array. One submatrix of nine flip-flops, plus the three nearest flip-flops in each of the submatrixes above, below, and on each side, makes a group of 21 flip-flops. From each group, 21 resistors and one operational amplifier add up the number of flip-flops in the group that are on. The values of the resistors are such that the summation is gaussian—in other words, the center flip-flop in the group contributes most to the summation, those at the perimeter of the group contribute least.

At this point the stroke widths of the characters are normalized, using the summations from the operational amplifiers. If the summations are not zero but less than the voltage reference, the flip-flops that are on, corresponding to black areas in the character being read, transfer their states to adjacent "off" flip-flops, and the new summations again are compared with the reference. If necessary, the process is repeated once more. This is equivalent to blurring the character being read (Fig. 10); it improves the accuracy of reading mutilated characters. Such blurring is diametri-

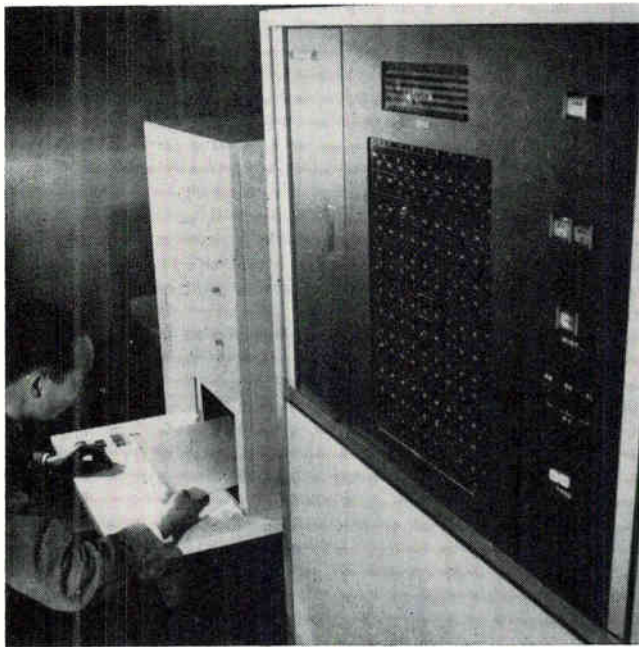

8. *Aspet/70*. Prototype optical character reader includes a two-dimensional shift register whose contents appear on the large display at right in the photo.

9. Optical character reader. Conversion unit and preprocessor are digital subsystems generating data for the recognition unit, which is largely analog. The system's operation is based on a spatial network technique announced in 1965.

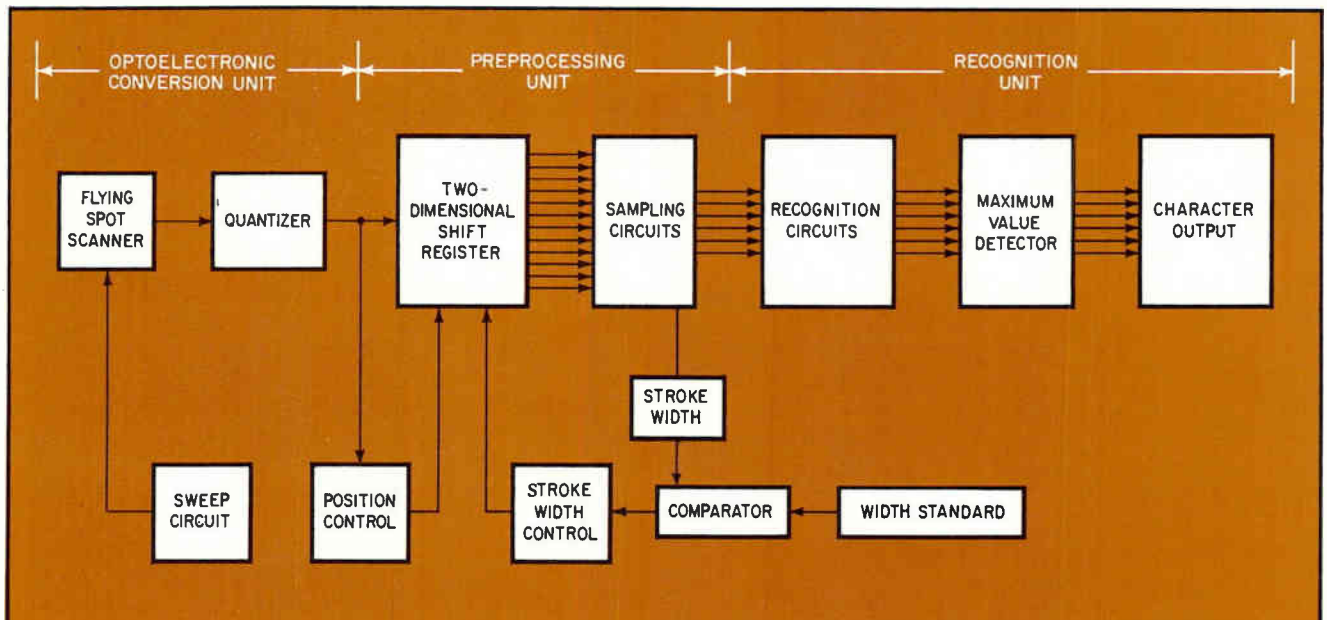

cally opposed to the aim of most other optical character readers, which is to sharpen characters.

Following the blurring or broadening operation, the character is identified. A particular subset of the 77 summations, corresponding to a recognizable character, is fed through weighting resistors to an operational amplifier with a squaring characteristic. Three subsets corresponding to variations of one character drive three of these amplifiers, whose outputs then pass to another amplifier that has a square-root characteristic. The result is the root-mean-square value of the three patterns for that character. This rms computation compensates for irregularities such as improper printing of the original character, which would result in its being improperly centered. Since the reader can recognize any of 44 characters, 44 rms values are being computed all at once. One of these values is considerably larger than any of the others; and it identifies the character.

The graphic display system that was developed as part of the national computer project comprises one display console, with a screen and a keyboard, and a controller that is capable of running four consoles (Fig. 11). The computer communicates with the controller itself through a set of 18 input-output instructions, and with the display console through the controller with 22 more instructions. The display generates vectors from points in a grid of 1,024 by 1,024. The two coordinates in this grid are addressed by 10 bits each, while another 4 bits denote control information for the display.

10. **Stroke width normalization.** To simplify recognition process, narrow strokes in the character are broadened or blurred, as shown here in two representations of the character in the shift register.

11. **Graphic display system.** Control unit, at left, can run up to four consoles like the one diagramed at right below. Vectors and alphanumeric characters are traced on a grid of 1,024 by 1,024 points.

Vectors of any length are traced out at a constant speed, to maintain a constant brightness. The data specifying the pattern to be traced out is stored in a buffer memory, in which the displayed material is refreshed 40 times per second without interfering with the computer. If the entire display cannot be traced out in 1/40 second, the refreshing is slower.

Firmware wired into the display causes a line to be drawn as solid, dashed, dotted, or as alternate long and short dashes. Other firmware controls three levels of brightness in the display and can cause any specified part of the display to blink four times per second. The display also contains a hardware character generator that can create 54 different characters on the screen.

The graphic display system was developed by Mitsubishi, and is for the most part only a small improvement on a design completed by Mitsubishi in 1967. It included an alphanumeric keyboard, program function keys, and a light pen. □

Acknowledgment

The editors of Electronics wish to acknowledge the use of information provided by Katsuhiko Noda, of the Electrotechnical Laboratory, Japanese Ministry of International Trade and Industry, in the preparation of this article.

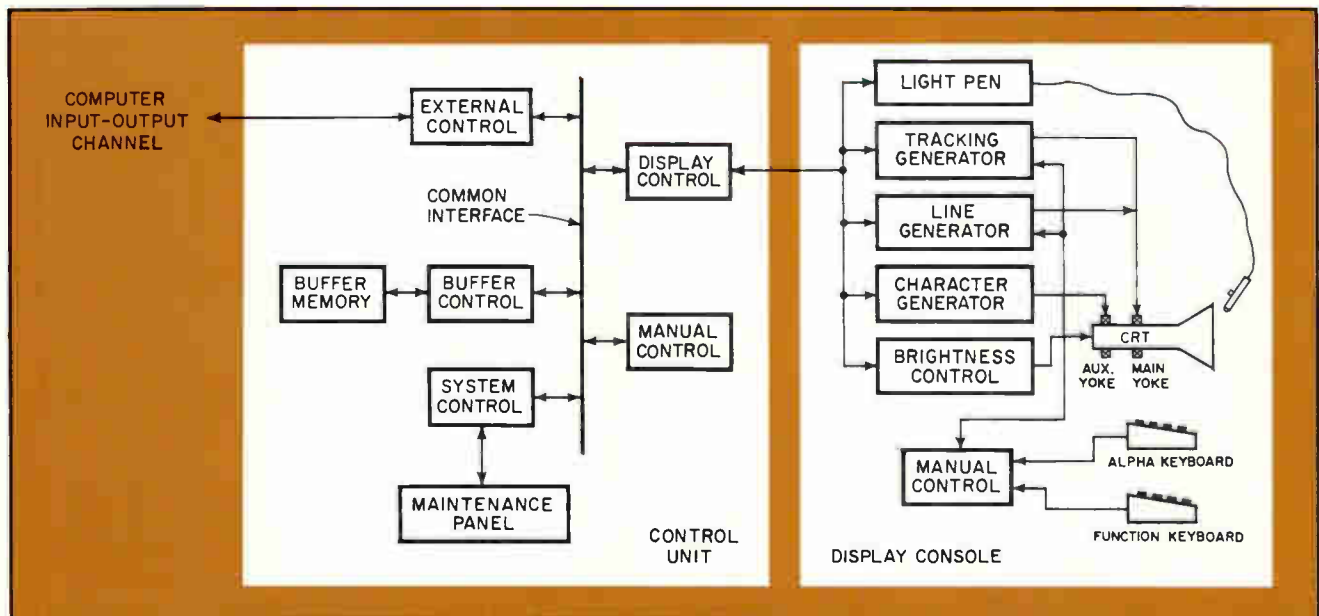
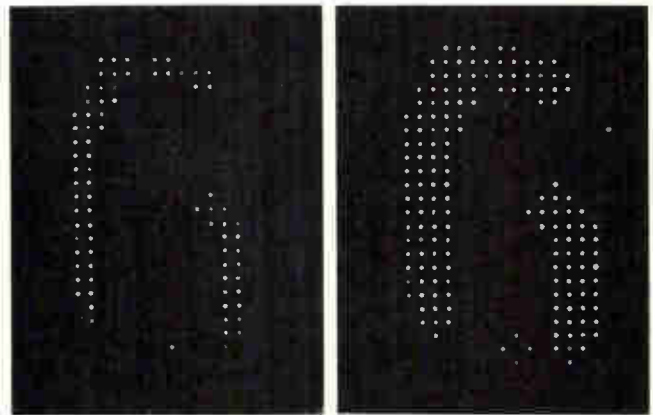

Solid state combo senses light well enough to vie with tubes

Advantages that the silicon photodiode/op amp has over photomultipliers include better linearity, stability and frequency response; the pair is ideal for star tracking and for optical character recognition

by Paul H. Wendland, *United Detector Technology Inc., Santa Monica, Calif.*

□ The photomultiplier's monopoly in low-light-level sensing systems is being challenged by an all-solid-state combination. The sensitivity of silicon photodiodes has been steadily increasing, op amp performance has also been upgraded, and the two elements when paired are now capable of detecting light levels as low as 10^{-13} watt per square centimeter of infrared radiation or 10^{-7} foot-candle of visible radiation. The combination is therefore ideal for many applications not previously open to photodiodes alone, among them optical character recognition systems, commercial photometric and radiometric instruments, and earth resources scanning systems.

Although the photomultiplier is more sensitive than a photodiode, since it can detect individual photons, the photodiode/op amp combination has the competitive advantage in just about every other device specification. Photodiode/op amps have two to three times greater linearity—1% maximum deviation from absolute linearity of output current over nine decades of input light intensity. They are more stable, showing only a 0.5% maximum deviation in responsivity over six months compared to 1 to 2% for multipliers. Their light tolerances are higher, and they avoid overloading and saturation. They have a wide range of spectral response (2,000 to 11,000 angstroms in one detector), better shock and vibration tolerance levels, smaller power supply requirements (± 15 volts for an op amp as against 1,000 V for a photomultiplier), superior packaging capability, and easier geometrical control (for high density arrays).

Figure 1 is an example of a commercially available silicon photodiode/op amp combination. Effective utilization of the low-noise characteristics of the photodiodes depends upon proper selection and coupling to available low-noise op amps. The coupling scheme shown in Fig. 2 has several advantages: the output of the photodiode is a constant current, and therefore the op amp functions as a simple current-to-voltage converter. For an op amp with open loop gain A and impedance R_f , the impedance presented to the photodiode by the op amp is $R_i = R_f/A$, which is typically less than 10 ohms. This optimizes response time because photodiode capacitance is shorted out, and it also optimizes signal linearity, because the load line on the I-V curves is vertical and falls in the linear or photoconductive region of the curves (see load lines

1 and 2 in Fig. 3). However, when an unbiased photodiode is coupled to an amplifier that does not present a low load impedance, the load line falls in the non-linear or photovoltaic portion of the I-V curve, as shown in load line 3.

Design parameters for typical photodiode/op amp combinations also are as shown in Fig. 2. The signal current out of the photodiode is linearly related to the input light intensity; thus:

$$i_s = RI_L \quad (1)$$

where i_s = signal current in amperes or microamperes, R = responsivity of the photodiode in amperes per watt, and I_L = input light intensity in watts or microwatts. The voltage out of the op amp is the product of the current in the feedback loop and the feedback resistance. If the open loop gain $A \gg 1$, the feedback current and input signal current are equal, and the op amp output voltage is

$$e_o = i_s R_f \quad (2)$$

Combined with Eq. (1),

$$e_o = RR_f I_L \quad (3)$$

Table 1 lists typical values of op amp voltage outputs for various light levels striking the photodiode. It is clear that as the light intensity is reduced, the

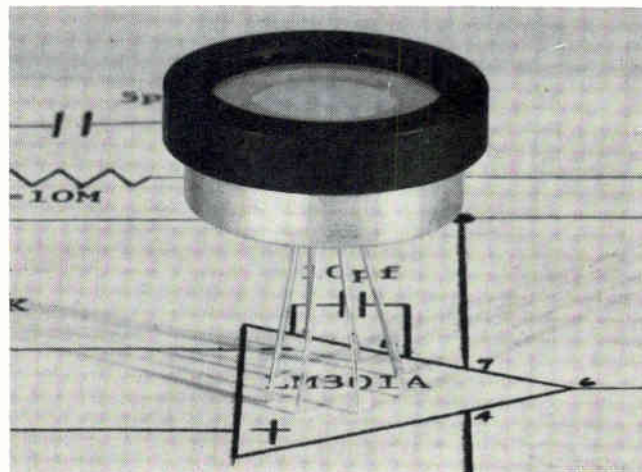

1. Tough competitor. This photodiode/op amp combination is ousting the photomultiplier in many areas. Large photodiode areas and low noise of op amp make unit capable of detecting 10^{-12} watt/cm² of radiation at wavelengths from 2,000 to 11,000 Å.

feedback resistance must be increased to preserve output voltage. From this is derived a great advantage of photodiode/op amps: by switching different feedback resistances from 100 ohms to 100 megohms, light levels from 10^{-11} W to 10^{-3} W can be registered on a simple millivolts meter.

Eq. (3) shows that, for any given light intensity, the op amp output voltage is related only to the feedback resistance value and responsivity of the photodiode. Consequently, if a feedback resistor with low temperature coefficient is chosen, temperature compensation is required only for the variation of photodiode responsivity with temperature. Typical variation is $\pm 0.05\%/^{\circ}\text{C}$ when the photodiode is in the unbiased mode (V_b in Fig. 2 is zero). The responsivity will first increase, then decrease, then increase again as temperature is raised, so that its variation between 0 and 125°F never exceeds 4%.

When the coupling scheme of Fig. 2 is used for very-low-light sensing applications, one factor that must be taken into account is the voltage developed at the output when there is no light on the input. This output offset voltage originates from: the input offset voltage of the op amp (e_i), which is reflected directly to the output; the input bias current of the op amp (i_b), which flows through the feedback resistor; and any dark current (i_d) generated by the photodiode when a bias voltage is applied to it. The expression for the total output offset voltage is:

$$e_{oo} = e_i + R_f(i_d + i_b)$$

For low-light-level dc applications, where large feedback resistors must be employed, input bias current and photodiode dark current must be kept as small as possible, to hold offset voltage down. Field effect transistor op amps are therefore preferred here, as well as low-leakage PIN photodiodes. A typical arrangement is shown in Fig. 4.

Although the output offset voltage can be minimized, the temperature variation of e_i , i_d , and i_b still remains a concern. The photodiode dark current i_d

doubles with every 10°C rise in temperature; for this reason, in many applications the photodiode is unbiased ($V_b = 0$ in Figs. 2 and 3), so that $i_d = 0$. Also, chopper-stabilized op amps can be used when temperature variation of e_i and i_b presents a problem. For high-speed ac light sensing applications, the op amp can be ac-coupled to the next stage, so that temperature drift of dc output offset is not a problem; here the photodiode is often voltage-biased to reduce capacitance and increase response time.

The frequency response of the circuit of Fig. 2 to sinusoidally varying or pulsed light sources is determined principally by the feedback resistance and capacitance of the op amp. Capacitance values between input and output of FET op amps typically range from 1 to 10 picofarads. A 1-megohm feedback resistance and 5-pF feedback capacitance would yield a 3-decibel frequency response of 60 kilohertz. Reducing the RC product with a smaller feedback resistance increases the frequency response correspondingly. The upper limit of frequency response is fixed by the slewing rate of the op amp. A typical upper limit for low-noise FET op amps is 1 MHz.

One of the key advantages of the circuit in Fig. 2 is that the photodiode looks into a virtual short circuit, and any charge on it is pulled immediately into the op amp. For this reason, photodiode capacitance,

Table 1: Solid state sensor performance at various input light levels

Input conditions	Photodiode responsivity	Op amp feedback resistance	Resultant output voltage
1 μW radiation at 6,328 \AA	.25 A/W	1 k 10 k 100 k	.25 mv 2.5 mv 25 mv
1 nW radiation at 3,000 \AA	.05 A/W	10 M	.5 mv
100 foot candles (approx. room illum.)	.2 μA ft candle	10 k	.2 v

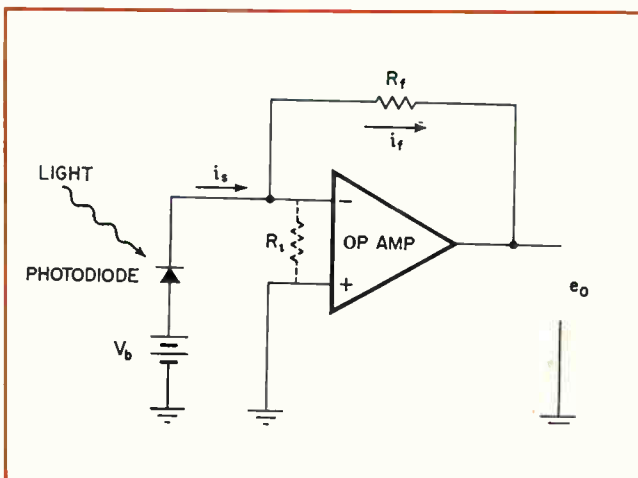

2. **Happy couple.** In this scheme of a typical coupling of photodiode and op amp, the output of the photodiode is a constant current, i_s , enabling the op amp to function as a current-to-voltage converter. The op amp's low impedance minimizes capacitance and optimizes response time.

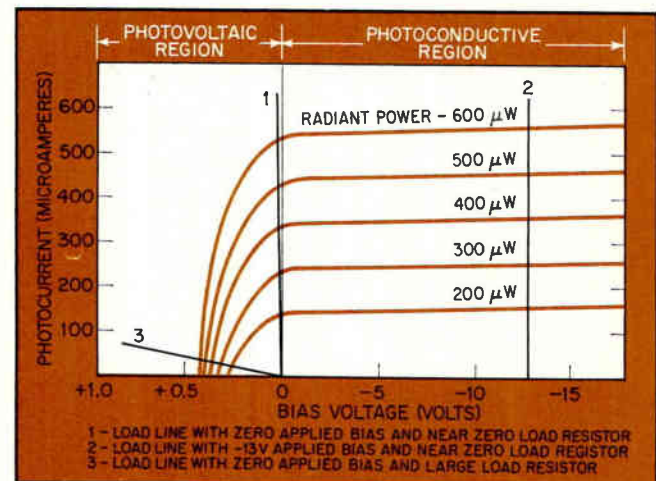

3. **Vertical.** In these I-V curves of silicon photodiodes, vertical load lines 1 and 2 for devices with minimum capacitance fall into linear region of the curves. Unbiased photodiodes with significant load produce load line 3 which fall into nonlinear zone, resulting in longer response times.

Table 2: How photodiode/op amp parameters shape up

	Parameter	Symbol	Desired	UDT-500 photodiode (typical)
Photodiode section	Responsivity	R	Large for maximum signal	0.4 A/w (8,500 Å)
	Dark current	i_d	Small, for low noise	10^{-7} A (-5v)
	Capacitance	C_d	Small, for low noise	150 pF (-5v)
	Area	A	Large	1 cm ² (0.44 in. dia)
	Photovoltaic source impedance	R_s	Large, for low noise	1.5 megohm
	Spectral response width	$\Delta\lambda$	Wide as possible	2,000 Å-12,000 Å (uv)
	Noise equivalent power	NEP	Small, for low light detection	10^{-12} w
Op amp section	Input offset voltage	e_i	Small, for low dc adjust	5 mv, adjustable to zero
	Input bias current	i_b	Small	5 pA
	Input offset current	i_o	Small	.5 pA
	Noise (rms)	e_{on}	Small	7 μV (4-10 Hz)
	Output resistance	R_o	Small	75 ohms
	Slew rate		Large	6 v/μs
	Unity gain bandwidth	GB	Large	1 MHz
	Supply current		Small	3 mA
	Supply voltage		Small	± 12 to ± 20
	Cost		Small	\$90 (1-9)/\$65 (101-up)

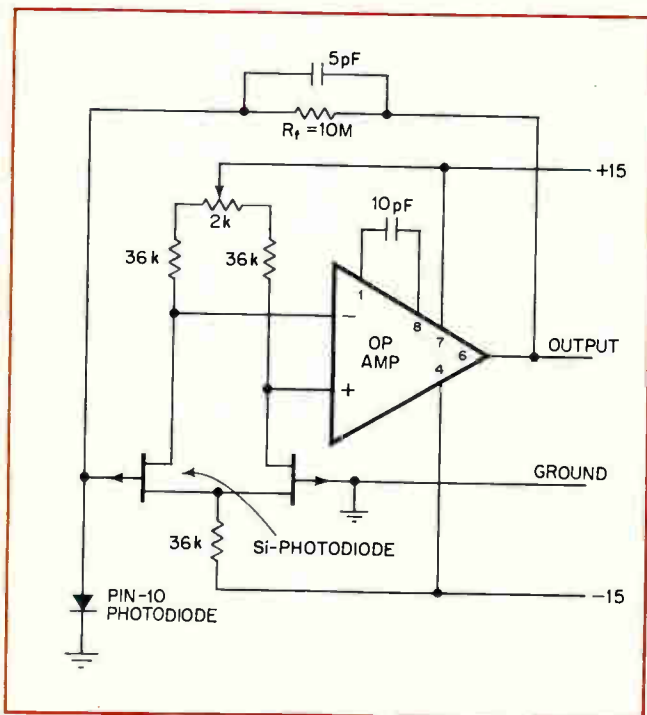

4. Error offset. FET op amp's low input bias current combined with low photodiode dark current minimizes detector's overall offset voltage and noise.

which can run as high as 1,000 pF in the unbiased condition, is not a direct factor in determining frequency response.

However, photodiode capacitance does have one subtle and important effect on the noise spectrum. At the frequency where the capacitive impedance of the photodiode is less than the feedback impedance, the amplifier input noise voltage is multiplied by the ratio of the latter impedance to the former. Beyond this frequency the noise spectral density can increase at a rate of 6 dB per octave, depending on the relative values of the op amp input noise, photodiode noise, and feedback resistor noise involved.

The effect of detector capacitance on noise can be minimized by choosing an op amp with as small a capacitance as possible or, when active detector areas of one square centimeter or greater are required, by using a PIN-type silicon photodiode rather than a p-n type. It should be emphasized that this capacitance-noise interaction has no effect on signal output as a function of frequency.

Table 2 lists representative characteristics of a photodiode/op amp combination typified by the UDT-500 system. Large area (1 cm² and greater), low-capacitance, high-performance PIN silicon photodiodes are available at unit prices at \$39 to \$120 in small quantities, and drop below \$25 in quantities of 1,000. In addition, suitable high-performance op amps

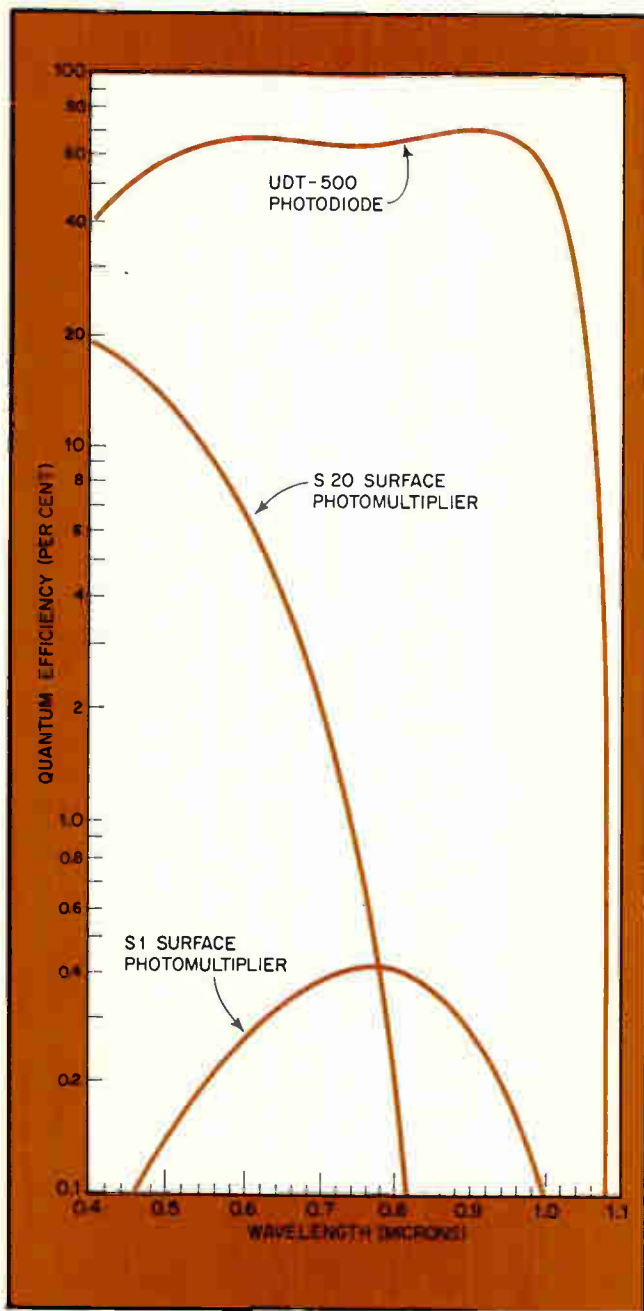

5. Flat out. Photodiode/op amp spectral response (quantum efficiency) is flat over several octaves, while photomultiplier surfaces (S1 and S20) have narrower range.

—FET op amps, chopper-stabilized op amps, and varactor bridge op amps—range in price from \$25 to \$125 in small quantities and from \$10 to \$60 in 100-lot quantities.

It's instructive to compare a photodiode/op amp combination with a typical phototube. Table 3 demonstrates that on all key design factors—spectral range, stability, linearity—the former has a clear advantage. In more detail, Fig. 5 compares the spectral responses of S1 and S20 photomultiplier surfaces and a solid-state sensor, and shows that a single photodiode/op amp combination covers the spectral range of both photomultiplier surfaces with a quantum efficiency higher than that of either of them.

A limit to noise

Clearly, if very low levels of light are to be detected, noise must be minimized. Noise at the output of the photodiode/op amp combination arises from shot or thermal noise from the photodiode (i_{dn}), voltage noise from the op amp (e_{on}), current noise from the op amp (i_{on}), and thermal noise from the feedback resistor, (i_{rn}). The combination of these four factors is the total output noise voltage, which is given by:

$$e_{nt} = [e_{on}^2 + (i_{dn}^2 + i_{on}^2 + i_{rn}^2)R_f^2]^{1/2} \quad (1)$$

where for a voltage-biased (photoconductive) photodiode $i_{dn} = (2e_i d B)^{1/2}$ and for an unbiased (photovoltaic) photodiode $i_{dn} = (4KT B/R_s)^{1/2}$. B = bandwidth in cycles per second, and R_s = unbiased equivalent impedance of the photodiode.

The values of e_{on} and i_{on} can be obtained from manufacturers' data sheets. But since in today's devices these terms are small in relation to photodiode and feedback resistor noise, (1) reduces to

$$e_{nt} = [(i_{dn}^2 + i_{rn}^2)R_f^2]^{1/2} \quad (2)$$

From (2) and from the signal output voltage of $e_o = RR_f I_L$, the signal-to-noise voltage ratio works out at $S/N = RI_L / (i_{dn}^2 + i_{rn}^2)^{1/2}$. If the photodiode is unbiased, and R_f is chosen to be larger than R_s , $i_{dn} \gg i_{rn}$ and the signal-to-noise ratio reduces to

$$S/N = RI_L (4KT B/R_s)^{-1/2} \quad (3)$$

The minimum detectable light level is that which produces a signal voltage equal to the noise voltage. This level is called the noise equivalent power, NEP , and is obtained from (3) by setting $S/N = 1$, and solving for I_L :

$$\begin{aligned} NEP &= (I_L \text{ when } S/N = 1), \text{ or} \\ &= R^{-1} (4KT B/R_s)^{1/2} \\ &= 1.28 \times 10^{-10} R^{-1} (B/R_s)^{1/2} \end{aligned}$$

The factors that determine the noise equivalent power in this limiting situation are responsivity (R), and unbiased photodiode source resistance (R_s). For low-light-level sensing, the photodiode must have high responsivity, low dark current, and high zero bias resistance. As an example of what can be obtained with presently available equipment, a photodiode with a responsivity of 0.5 ampere/watt and source impedance of 5 megohms, coupled to an op amp with feedback resistance greater than 10 megohms, would have a noise equivalent power in unit bandwidth ($B = 1$) of only 1.1×10^{-13} watt.

Applications of the combination are growing rapidly. There are several low-light-level systems now operating in which silicon photodiode/op amps are outperforming photomultiplier tubes. Photometer/radiometer instruments, which are used as a transfer standard between a standard and an unknown light source, have for a long time depended on photomultiplier tubes as their basic sensors. But these tubes do not have the long-term stability necessary to maintain an absolute calibration over a period of months or years. The photodiode/op amp, however, permits a radiometer to hold a calibration to within 1% for years, independently of ambients, high light levels, or voltage overloads. Figure 6 is a photograph of

Table 3: Comparison of solid state and photomultiplier characteristics

Characteristic	Photodiode/op amp	Photomultiplier
Spectral range	2,000 Å to 11,000 Å in one detector	2,000 Å to 10,000 Å in several different units
Stability	Unaffected by time, light, or temperature extremes	Variable with time, light, and temperature extremes
Response time	Less than 5-ns response in the detector, 50-ns to 1-µs in the op amp	Less than 5-ns rise and decay; but up to several microsecond delay in dynode transit
Minimum detectable light level	10^{-13} w in 1 cm ² $5 \cdot 10^{-16}$ w in 20 mil dia	Will count single photons
Power supply	± 6 v to ± 20 v and insensitive to power supply fluctuations	600-3,000 v and output sensitive to voltage fluctuations
Cost	\$30—\$150	\$15—\$250
Power supply cost	\$15—\$35	\$75—\$200
Geometry variation	Can be made in single continuous strips up to 10 in. in length, or as small as 2 mils in diameter, or on curved surfaces	Glass envelope restricts very large areas and small precision arrays

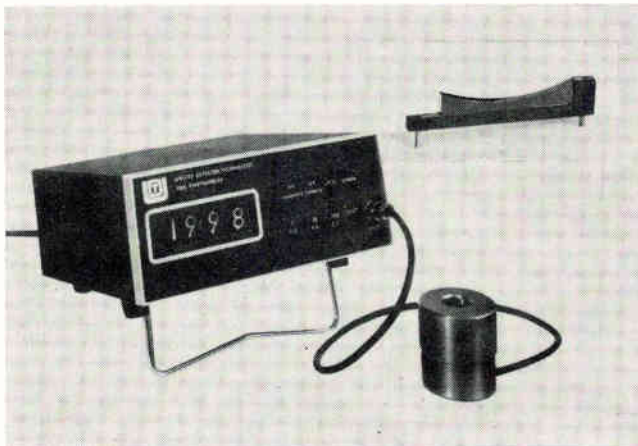

6. Long term. Commercial photometer/radiometer with solid state sensor achieves long-term stability and wide light-level range. The insert, a 2½-inch-long curved silicon photodiode for star tracker, achieves detection level of 10^{-13} watt.

one instrument that's suitable for calibration uses.

The spectral region between 8,000 Å and 11,000 Å is particularly suitable for silicon photodiodes. The quantum efficiency for silicon in this region is greater than 75%, while that of photomultipliers is less than 10%. Because of this spectral range, two earth resources scanning satellites now being built use silicon

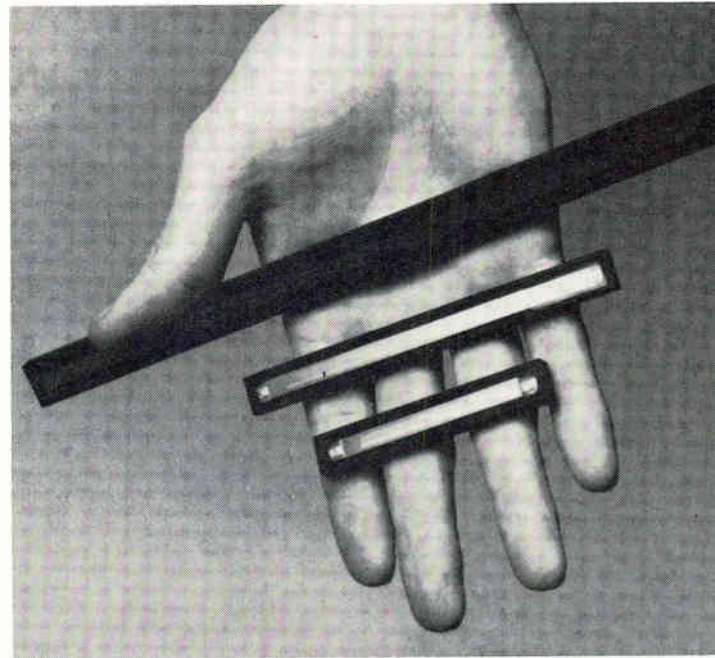

7. Reader. These quarter-inch-wide single-element Schottky barrier photodiodes, 2, 4, and 9 inches long, are used in high-speed laser scanning and OCR applications. Uniformity of response over the 9-inch span is 10%. Leakage is less than 10 microamps at 50 volts reverse bias.

photodiode/op amps capable of detecting 10^{-14} W, well within the necessary operating margins for using the incident light available from the earth.

Star trackers previously used photomultiplier tubes because of the low-light-level detection requirement, but one designed for the Grand Tour of the outer planets has been built with solid state sensors. Minimum detectible light levels of 10^{-13} W are achieved. Silicon is particularly advantageous here because of its size, weight, stability, and power characteristics. The insert of Fig. 6 shows a star tracker silicon sensor in which the active junction is located on a precision-curved surface, with a radius of curvature of 4 inches.

Many designers of optical character recognition systems have also made the switch to silicon photodiode/op amps. The 9-inch long silicon photodiode strip shown in Fig. 7 has found a unique application as a page reader. A laser beam is moved across a page so that the spot travels just below the strip photodiode, which is placed above and across the width of the page. The reflected light from the page is recorded by the photodiode, and the information transferred to a computer or remote location for identification or reproduction. □

Bibliography

- Richard Fisher, "PIN Diode Detectors for Astronomical Photometry," *Applied Optics*, Vol. 7, No. 6, June 1968.
- P.G. Witherell and M.E. Faulhaber, "The Silicon Solar Cell as a Photometric Detector," *Applied Optics*, Vol. 9, No. 1, Jan. 1970.
- P.H. Wendland, "Silicon Photodiodes Revisited," *Electro-Optical Systems Design*, p. 48, Aug. 1970.
- R.W. Engstrom and R.L. Rodgers, "Camera Tubes for Night Vision," *Optical Spectra*, p. 28, Feb. 1971.

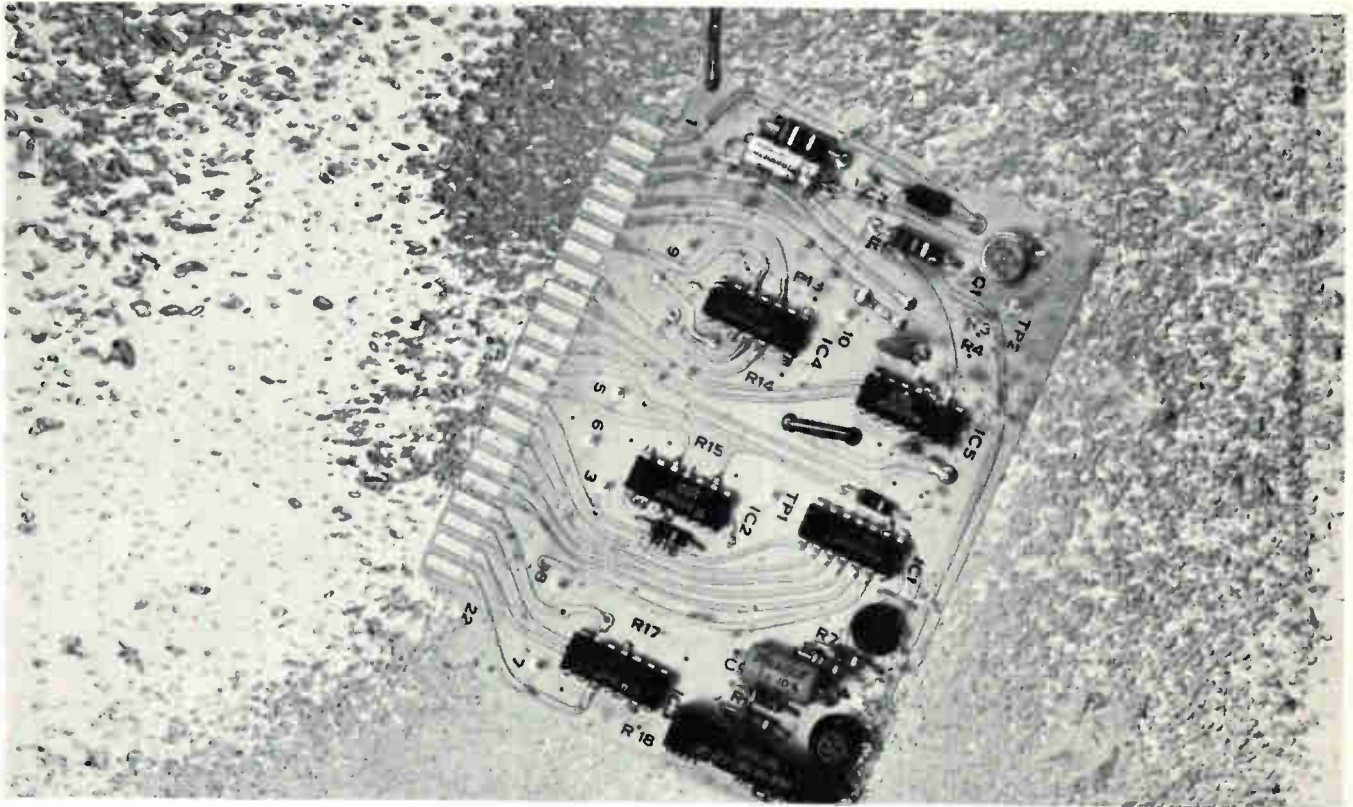

Clean the entire package residue-free with compatible FREON and save.

You can lower cleaning cost per board with FREON cleaning agents because they're compatible with most materials of construction, including polycarbonates. You can clean completely assembled boards without damage to substrate, components or markings. Remove all rosin-based flux and other contaminants at the same time. Get clean, dry, residue-free boards.

Flux Removal. A typical cleaning cycle for cleaning p.c. boards in a four-stage vapor defluxer is (1) gross removal of flux and contaminants in boiling FREON (below 118°F), (2) liquid rinse in FREON, (3) spray rinse, (4) final vapor rinse in vapors of freshly distilled FREON.

Low Solvent Replacement Cost. FREON cleaning agents are constantly

recovered and purified for reuse. In a properly designed and operated defluxer, solvent losses are minimal.

Purity. FREON cleaning agents are electronic grade materials and chemically stable. No stabilizers or inhibitors are needed.

Safety. FREON cleaning agents have a low order of toxicity. They are non-flammable and nonexplosive and do not require any special safety equipment.

See what a difference a properly designed FREON cleaning system can make in your cleaning costs. Write for more information about FREON and cleaning and defluxing systems. Du Pont Company, Room 22443C, Wilmington, Del. 19898.



FREON is Du Pont's registered trademark for its fluorocarbon cleaning agents.

Designer's casebook

Flip-flop pair synchronizes pulses and floats clocks

by Lee E. Baker

University of Wisconsin, Madison, Wisc.

Two J-K flip-flops can do the work of a digital one-shot—and more. They can synchronize random events with clocks, change a square-wave signal generator into a pulse generator, and with a frequency divider modulate clock frequencies. Unlike a one-shot, pulse lengths and separations are widely and easily varied.

In the basic pulse separator's standby state, the two flip-flops are latched so the Q_1 output is low. When a reset pulse is applied, both flip-flops are unlatched. A trigger pulse to FF_1 causes Q_1 to go high (logic 1) and relatches FF_2 . The action resembles a monostable multivibrator's, but the on time varies with the trigger period, the off time with the reset pulse period.

This action results from the J_1 and K_1 inputs to FF_1 changing state with FF_2 while the J_2 and K_2 inputs are grounded. During standby, \bar{Q}_2 and J_1 are 0 and Q_2 and K_1 are 1. Therefore Q_1 remains low regardless of the trigger pulses (a J-K flip-flop's Q output is forced to 0 by a trigger if J is 0 and K is 1).

A reset pulse on the R_2 input changes FF_2 's state

and resets J_1 and K_1 . This allows FF_1 to change state on the next trigger-pulse trailing edge (the $\mu L923$ triggers on a trailing edge). Because J_1 is 1 and K_1 is 0, Q_1 goes high immediately. The drop of \bar{Q}_1 is seen by FF_2 as a trigger trailing edge, and FF_2 changes state, reverting to the standby condition.

Consequently, Q_1 returns to 0 with the following trailing edge. FF_2 cannot be triggered again, nor can FF_1 , because \bar{Q}_1 rises to 1 and stays there. The pulse output on Q_1 closely coincides with the trigger-pulse period, synchronizing the trailing edges. The trailing edge can therefore be used to change counter states or for other control functions.

Reset pulses must be noise-free and shorter than the trigger period if double triggering is not to occur and FF_1 is not to be locked in the on state. A circuit like the "noiseless" pushbutton shown will shape and clean up switch inputs. It normally operates from dc to 75 kilohertz, but can be extended to at least 1 megahertz by changing the RC timing network on the $\mu L914$ dual RTL gate.

The timing diagram shows what happens when reset pulses occur randomly. But if reset is periodic, the pulse-separator output will be periodic and the timing of the output pulse train will depend on the trigger and reset periods.

This circuit was developed through a research grant from the National Air Pollution Control Administration, Consumer Protection Environmental Health Service, Public Health Service.

More than a one-shot. Two flip-flops operating as a pulse separator (A) align reset pulses with a trigger pulse train. FF_1 cannot change state until FF_2 is reset and changes the state of J_1 and K_1 . Then FF_2 triggers and causes FF_1 to return to the standby state. Applications include "noiseless" pushbutton control (B).

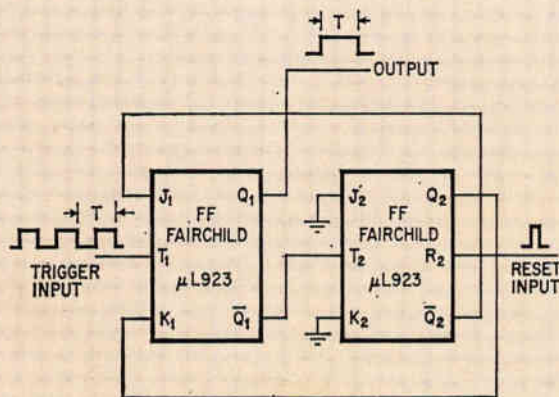

(A) PULSE SEPARATOR

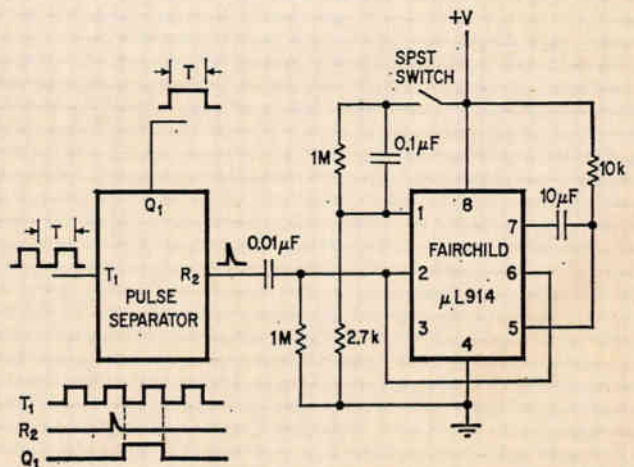

(B) "NOISELESS" PUSHBUTTON

Bootstrap boosts gain of low-noise rf preamp

by R.J. Turner

Radio Corporation of America, Moorestown, N.J.

An easy way to improve the gain of a low-noise rf preamplifier while increasing bandwidth is to put a bootstrapped transistor between the input and output stages. The input stage can be operated at a higher load-resistance level, producing better gain and bandwidth due to the lower input capacitance of the output buffer.

The preamplifier shown has a gain of 20 decibels and a first stage designed for a bandwidth of 380 megahertz. Without the bootstrap connection between Q_3 's emitter and Q_2 's collector, the cutoff frequency is only 150 MHz, but with the the cutoff jumps to 275 MHz. The physical capacitance of Q_2 's base is mostly C_{cb} . It is typically 0.5 picofarads but is reduced to an effective capacitance of less than 0.1 pF by the bootstrap action of C_1 .

This method is useful in vhf receivers that need a low-noise, high-gain preamp to overcome losses when low-level signals are mixed or gated. The design will detect 5-microvolt signals, doesn't hang up on strong signals, and recovers in less than 50 nanoseconds from a 40-dB overload.

As usual, the gain-bandwidth tradeoffs are

$$\text{gain} \approx \beta R_L$$

$$\text{bandwidth} = 1/(2 \pi R_L C)$$

Here, beta is Q_1 's high-frequency current transfer ratio, R_L its collector load, and C is Q_2 's collector-base capacitance. The bootstrap divides C by $(1/1 - A_v)$. A_v is the voltage gain between Q_2 's base and collector via Q_3 's emitter. Typically, this gain is over 0.95.

Some compromises are needed if larger values of R_L are wanted at the input stage. Collector current has to be high enough to give good gain, but low enough to reduce shot noise.

Also, it's desirable to have a high impedance looking into the base of Q_1 , in order that a physical resistive termination may be used to provide a low input VSWR. (For this case R_1 equals 390 ohms.) The effective resistance appearing at Q_1 's base should be 100 ohms for the optimum noise figure. But in practice, when a compromise must be made between noise figure and VSWR, and with Q_1 's emitter biased at 2.25 milliamperes, this resistance is 130 ohms.

A toroidal, wideband transformer, T_1 , transforms a 50-ohm input to an impedance of 200 ohms at the base of Q_1 . Resistor R_1 and inductor L_1 are selected to optimize the input VSWR. R_1 is typically 390 ohms and L_1 0.33 microhenries.

The net result is a first-stage gain of 20 dB, a noise figure of 4.5 dB and a VSWR of less than 1.2 from 130 to 170 MHz.

Q_1 has enough feedback (emitter degeneration) to provide a first-stage bandwidth of 380 MHz. However, the shunt-peak networks on the collectors of Q_1 and Q_3 are tuned to 150 and 300 MHz, respectively, to keep the response flat within ± 0.5 dB from 90 to 250 MHz. The corresponding 0.1-dB points are 100 and 200 MHz. Finally, the Q_2 - Q_3 state isolates the input stage from a normal 50-ohm output load.

Low C, low noise. Low noise, large bandwidth, and low input VSWR are achieved by optimally loading input stage Q_1 . Q_2 's collector is bootstrapped from Q_3 's emitter. This lowers the capacitance seen by Q_1 and allows gain or bandwidth to be increased.

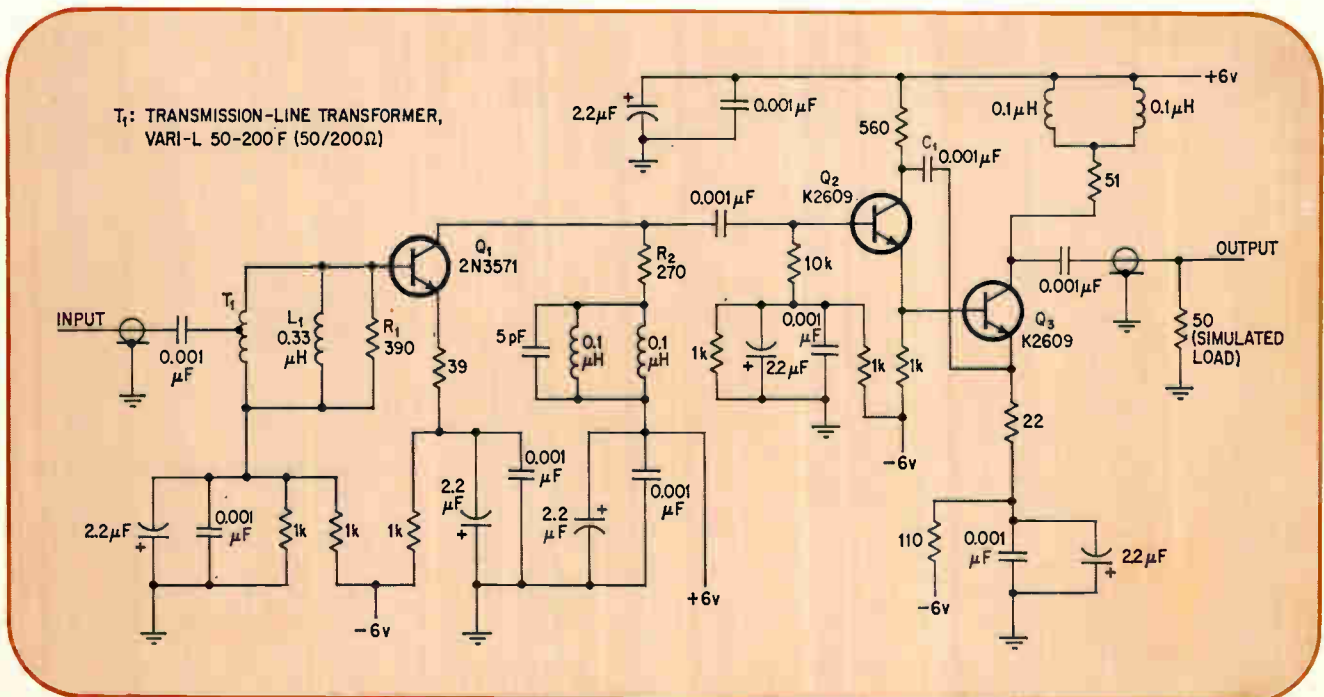

High-voltage pulser spares battery supply

by W.J. Orr

National Research Council of Canada, Ottawa

A high-voltage one-shot will make its batteries last, thanks to a big capacitor and a small output duty cycle that enable it to time and generate pulses with large peak values while draining very little current. Pulse delays are variable between 0.5 and 20 microseconds.

The circuit is much more convenient to use in laser and plasma physics experimentation than line-powered pulsers and coaxial-cable delay lines. It can't upset instrument synchronization with line transients, and delay adjustment is easy.

Transistors Q₁ through Q₄ form a monostable multivibrator timed by R₁ and C₁. The multivibrator is triggered within 50 nanoseconds by dropping the input level to -3 volts. Zener diode D₁ is selected for the negative trigger level desired; a pulse-inverting transformer can be used for positive triggers. After Q₁ turns on, a 15-V step pulse is generated.

The pulse level is maintained by electrolytic capacitor C₂ until the current charging C₁ through R₁ drops enough to bring Q₂ out of saturation. On time is approximately $R_1 C_1 \ln(0.4h_{FE})$, where h_{FE} is Q₂'s dc current gain. For this circuit, on time is 400 μs.

The voltage step across zener diode D₂ charges C₃

through R₂. When the current through R₃ reaches the peak-point current of tunnel diode D₃, the diode switches to its higher-voltage state. This saturates Q₅, releasing the charge stored in C₄ and triggering thyristor D₄. Thus, C₅ is discharged, generating the output pulse. The pulse has a rise time of 30 ns and peaks at more than 300 V when transformer T₁ is used. D₄ can switch 30 amperes in 30 ns.

C₃'s charging slope (and therefore the time D₃ and Q₅ delay the pulse output from the trigger input) is adjusted by varying R₂. Delay time is

$$t_d \approx \frac{R_2 R_3}{R_2 + R_3} C_3 \ln \left[\frac{1}{1 - (R_2 + R_3) I_p / V_{zener}} \right]$$

where V_{zener} is 15 V and I_p is 1 milliamperes for D₃.

The batteries mainly supply bias currents to their circuit stages during the pulse times; they recharge C₂, C₄, and C₅ during recovery times. C₂ gives up only a fraction of its energy in charging C₁ and C₃, so the recharging current from battery B₁ is low. C₄ is small and C₅ can be trickle-charged through a large resistor, R₄, keeping output pulse duty cycle (and therefore average dissipation) low.

On standby, the current drain is a mere 2 microamperes, due mostly to leakage of C₂ and Q₅. Timing jitter is within ±0.01 μs; temperature stability is excellent. A drop of 5 V in B₁ changes the delay only 0.05 μs at the 20-μs delay setting.

Designer's casebook is a regular feature in Electronics. Readers are invited to submit novel circuit ideas and solutions to design problems. Descriptions should be brief. We'll pay \$50 for each item published.

Delay generator. An input pulse triggers a sequence of charge transfers that delay and generate a high-voltage pulse output. C₁ pulls energy from C₂ to time the one-shot's basic period while C₃ charges through R₂ to set the pulse delay time. Then C₄ switches the thyristor to discharge C₅, which has been storing output pulse energy.

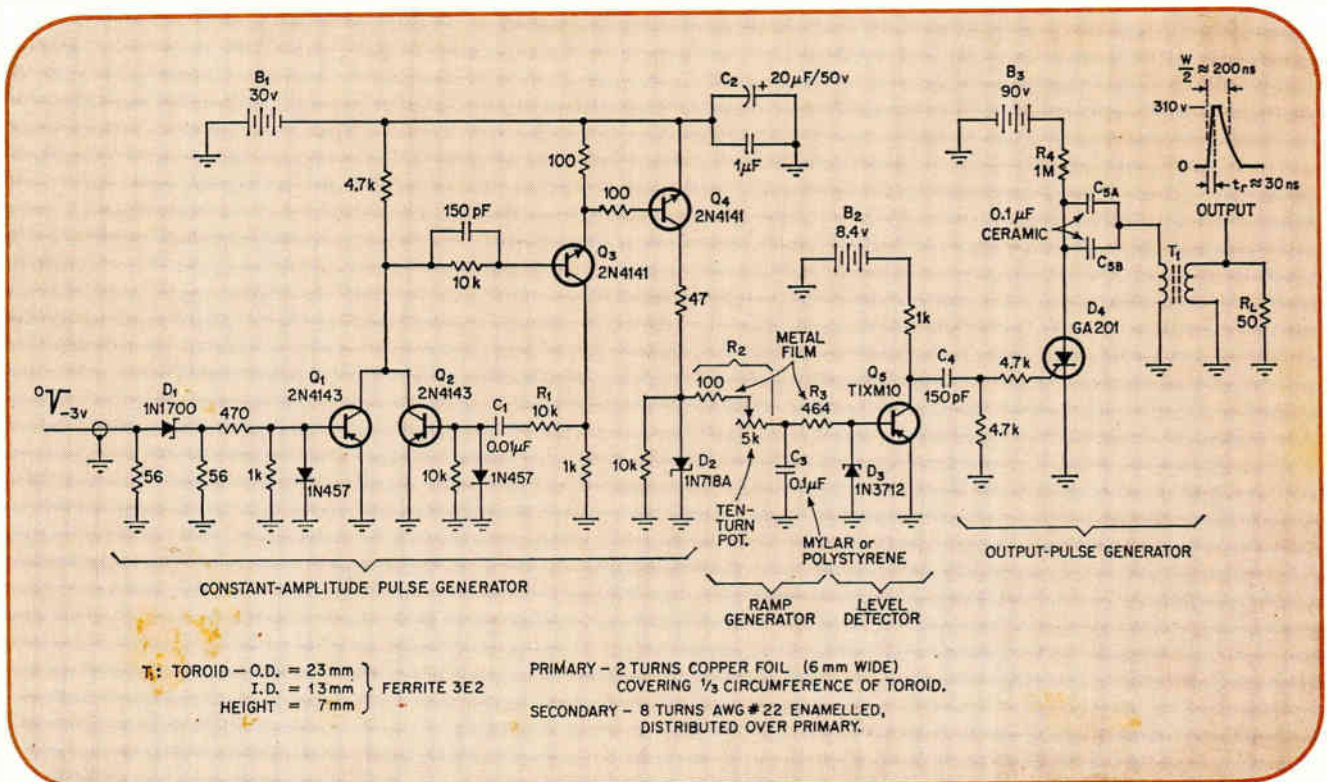

truly remarkable

25-MHz BANDWIDTH

DELAYING SWEEP

3% ACCURACY

10-mV SENSITIVITY

DUAL TRACE &

SIGNAL DELAY LINE

ALL FOR ONLY

\$975

The new Telequipment D67 Oscilloscope offers the performance you have always desired at a price that is several hundred dollars lower than any other comparable model.

In addition to its impressive array of specifications, the D67 has other features not usually found in low-priced scopes: regulated power supplies, FET inputs to keep vertical trace drift to a minimum, fully solid-state design to improve reliability, transistors in sockets to make servicing easier and faster.

Bright displays are obtained by using 10-kV high voltage on the rectangular 5-inch CRT which has a big 8 x 10 cm display area.

A wide range of sweep rates from 2 s/cm to 0.2 μ s/cm (40 ns with X5 magnifier), delayed sweep, 3% accuracy and 14-ns risetime, make the D67 ideal for high

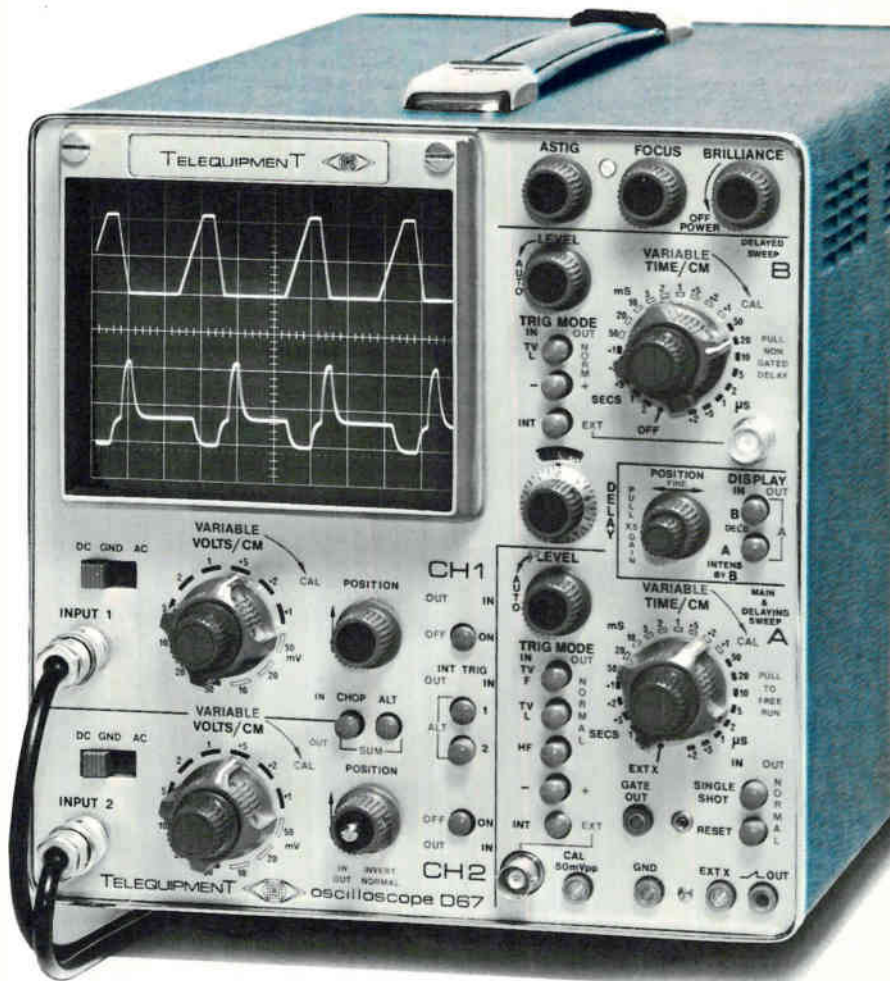

resolution analysis of pulse sequences. And if some of the pulses are jittery, that won't be a problem because the delayed sweep can be triggered. Those who have a need to view television signals will be pleased with the D67's ability to trigger at TV field and line rates. This feature allows viewing a selected line in a field.

Even if portability is not a prime consideration, you are certain to like the D67's lightweight—it weighs only 25 lbs.

Telequipment Oscilloscopes are marketed and supported in the U.S. through the Tektronix network of 57 Field Offices and 30 Service Centers. The instruments are warranted against defective parts and workmanship for one year. For more information call your nearby Tektronix field engineer or write: P. O. Box 500, Beaverton, Oregon 97005.

Telequipment Oscilloscope prices start as low as \$245.

U.S. Sales Prices FOB Beaverton, Oregon

TELEEQUIPMENT



..... a subsidiary of **TEKTRONIX®**

Computerized frequency control keeps many receivers in tune

Automatic system computes correct frequencies for up to eight radio receivers, tunes them with 2-kHz accuracy; time-shared digital circuitry keeps system cost down

by Josef Osterweil, Watkins-Johnson Co., CEI division, Rockville, Md.



Programed surveillance. Heart of the CAFC system is represented by rack-mounted equipment at left, shown hooked up to a panoramic receiver—one of eight that can be controlled automatically. Tape punch and reader at top is used as input/output device, primarily for entering and updating programs in the PDP-11 computer below it. Control unit completes the rack assembly. Operator is seated at teleprinter which enters instructions to computer and prints out system status.

□ Frequency monitoring in applications like surveillance or rfi analysis requires fast acquisition time, wide frequency coverage, accuracy, and extremely good stability. All four of these characteristics are present in a recently developed, computer-controlled, automatic system, which is capable of simultaneously controlling the tuned frequencies of up to eight radio receivers operating in one or more bands from hf to uhf (2-1,000 megahertz).

Called CAFC (for computed automatic frequency control), the system uses a closed-loop technique to achieve digital frequency acquisition and stabilization of voltage-tuned receivers. Time sharing of its digital control circuitry also provides considerable cost-savings over systems based on frequency synthesizer control methods.

Basically, CAFC computes the difference between the desired frequency for a receiver and its actual tuned frequency, and then translates this difference information, including its sign, into a voltage step. This voltage step is applied to the receiver local oscillator, tuning it to the desired frequency. A simplified block diagram is shown in Fig. 1.

At the heart of the system is a dynamic digital-to-analog converter, consisting of an integrator that's driven by pulsed current sources and controlled by the computed-difference information. The integrator's output voltage is the control voltage for the receiver. Current pulses at the integrator's input produce proportional voltage changes at the integrator output, and these in turn produce proportional changes in the receiver local oscillator frequency. The remainder of the CAFC system consists of digital circuitry necessary to produce current pulses of the right magnitudes.

The desired-frequency information is stored in binary form within the control unit. Binary information representing the actual tuned frequency of the controlled receiver is obtained from a binary counter. By serially subtracting these two binary numbers, the frequency difference information is obtained that is used to control the duration, amplitude, and polarity of the current pulses applied to the integrator.

This entire process is repeated periodically, and the repetition rate determines the frequency acquisition time. Limiting factors on the repetition rate are the counting interval required to determine the

receiver's tuned frequency to the required resolution, and the number of receivers being controlled.

This technique lends itself to time sharing, since only a small portion of the system—the integrator—is tied to the receiver continuously. The remainder of the system can be time-shared between many receivers—just how many depends only on the acquisition time requirements for a given frequency resolution, and on the quality of the integrators (integrator drift rate dictates a minimum frequency update repetition rate).

An important advantage of the CAFC system is that the time-shared binary frequency counter is the only rf handling device, and hence the only device that may require modification as the frequency range of the system is changed. The rest of the system consists of logic and dc control circuits which would not require modification. With existing frequency counting techniques, the system can be used into the gigahertz region. In addition, the receivers under the control of the system do not have to be operated in the same band, but several operating on different bands can be controlled simultaneously.

The CAFC system is implemented with a Watkins-Johnson DCU-8 digital control unit, eight W-J 205 voltage-tuned receivers, and a PDP-11 minicomputer (Fig. 1). Besides driving the digital control unit, the minicomputer controls many receiver functions, such as signal strength, average fm output, intermediate-frequency bandwidth, and automatic gain control.

Figure 2 is a detailed diagram of the control unit. Two operating modes are provided: regular, and priority. Each interlaces the execution of counting and information-processing events.

In the regular mode, the unit processes the error information for the receiver (n) at the same time as it is determining the actual frequency information for the receiver (n + 1), thus halving the required

operating cycle time. The receiver for counting is selected by commutator state code A, the receiver for processing by commutator code B. Code B lags code A by one cycle.

In the priority mode, one receiver is given priority and processed every other cycle, alternately with the other receivers being dealt with in numerical order. The priority receiver is selected by applying the relevant binary code to the priority-receiver address lines.

Figure 3 illustrates the sequence of events in the 512-microsecond control cycle. They are timed by three 20-bit clock pulse burst sources derived from a highly stable crystal source. Data flow in the control unit is serial, with the least significant bit first. Clock A controls both the subtraction process and the comparison process necessary for arriving at the error sign. Clock B controls the absolute-error computation, the serial-to-parallel conversion of the absolute error, and the comparison of the absolute error to two predetermined programmable frequency tolerances, ϵ and δ . The memory clock generates a pulse burst every 64 μ s, enabling new desired-frequency information to be rapidly entered into the memory.

Both ϵ and δ are four-bit binary numbers. Tolerance ϵ is determined for each operating band of the associated receiver. In the process of correcting voltage generation, the absolute error, Δf , is compared to ϵ to determine whether a fine or "superfine" correction current should be used. (The "superfine" current is employed to prevent the statistical counter error of ± 1 count from causing incidental fm in the receivers.) Tolerance δ is programmable and is used in certain applications to reduce the frequency acquisition time. The comparator provides an output whenever the tuned frequency is within the tolerance limits and the receiver output data is deemed usable.

The complete operating cycle for the control unit

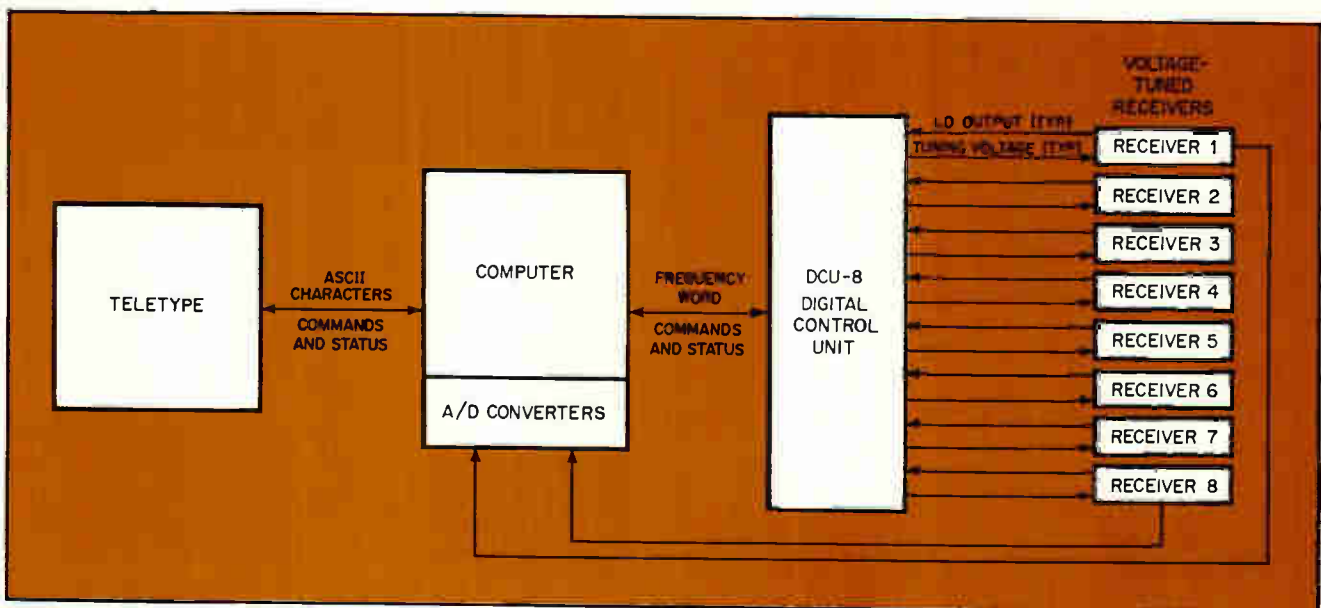

1. Digital receiver control. Input frequency commands go to computer which drives digital control unit. In sequence, desired frequency for each receiver is compared with actual tuned frequency and corrected to within 2 kHz.

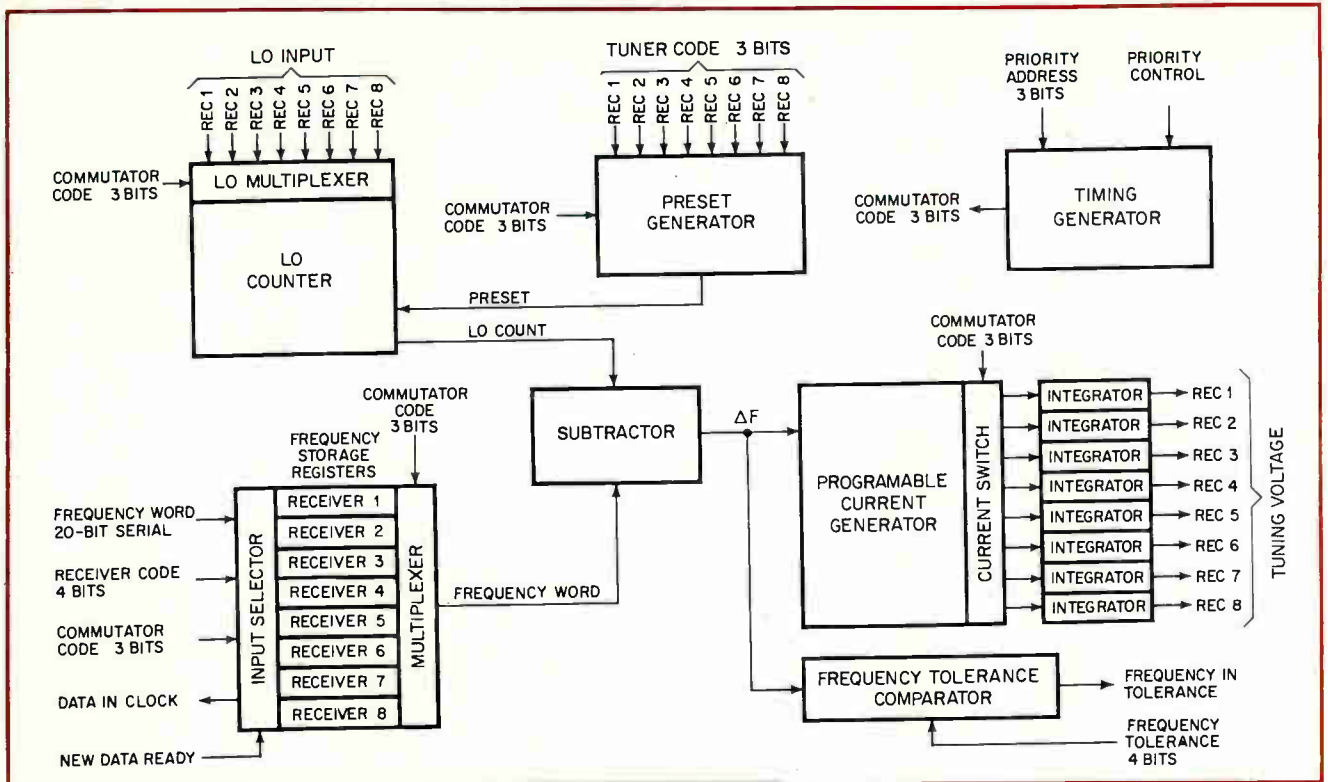

2. Digital controller. Desired frequencies for receivers are stored in frequency storage registers and released to subtractor by 3-bit commutator code. Actual local oscillator frequencies of receivers are counted and then placed in subtractor. Preset generator sets counter prior to start of LO frequency count. Subtractor calculates difference frequency, Δf , feeding it to programable current generator which drives integrators that develop frequency tuning voltage. Frequency tolerance comparator determines the amount of correction necessary, while timing generator develops address codes.

takes 512 μ s, of which 500 μ s goes to determining the selected receiver's actual frequency (counter gate) and the remaining 12 μ s is used to generate three pulses in the following sequence:

- A "commutate" pulse, which shifts the A and B state codes to the next position.
- A "transfer" pulse, which transfers the counter information to the parallel-to-serial converter.
- A "preset" pulse, which sets the counter preset for the next receiver count.

At the end of clock B's processing burst, ϵ and δ data for the next cycle are entered into the appropriate registers. Next, a "correction" pulse strobe starts the width-programable pulse generators by transferring the Δf parallel information to these generators. They in turn activate the input signal current to an integrator, which thereupon produces the corrected tuning voltage for its associated receiver.

For data entry in the control unit the format selected is a 20-bit binary word presented in serial form, with the least significant bit first. Since the frequency resolution of the system is 2 kilohertz, the input frequency word represents the desired frequency in 2-kHz units, i.e.

$$\text{frequency word} = \text{binary} \left(\frac{f \text{ desired (kHz)}}{2 \text{ kHz}} \right)$$

This word is presented in buffered form to the FREQ

WORD input, accompanied by a four-bit address indicating the memory location (Receiver Number) and by a positive-going pulse edge to the NEW DATA input. Upon receipt of the "new data ready" signal, the sync logic circuit starts the first available complete train of 20 pulses from the memory clock. These pulses will be delayed 64 μ s or less and then appear at the "data in clock" output, where they are applied to the buffer shift registers to synchronize the buffered frequency-word input with the memory cycle. (In frequency-word terms the memory is organized in a random access, read-write format, where both the read and write functions are independent, but within the frequency word itself it is organized in a serial-access format.)

The "actual" frequency now has to be obtained in the same word form as the desired frequency. For anything up to 321.4 MHz, the actual-frequency counter is a direct 20-bit binary counter preceded by a broadband amplifier and driven by an rf multiplexer that's controlled by commutator state code A. Above 321.4 MHz, a frequency-translating extender pushes the upper frequency limit of the system to 1 GHz.

To compensate for the difference between the actual tuned frequency of the receiver and the frequency counted, the counter is preset before it starts to count the input signal. The preset generator consists of a preset matrix controlled by

the receiver tuner code and commutator state code A inputs, plus circuitry to develop a four-bit ϵ tolerance for each tuning band. Tuner code inputs are preassigned for each frequency band and each tuner. Changing receiver tuners or receiver location in the system automatically changes the tuner code input to the preset generator, and therefore the preset output. The preset output is multiplexed by the code A input.

After 500- μ s gated counting is completed, the information is applied to a parallel-to-serial converter when a "transfer" command occurs. This information is now in the same format as the input frequency word, i.e.

$$\text{binary} \left(\frac{f \text{ tuned (kHz)}}{2 \text{ kHz}} \right)$$

The error word or difference between the desired and actual frequency is derived by a serial subtractor during 20 pulses of the clock A pulse burst. By the end of that burst, a 20-bit parallel-to-serial converter acting as an accumulator has stored the error word. A comparator, also controlled by clock A, stores the sign of the error. When the error is positive, its format is straight binary. When it is negative, its

format is 2's complement in the accumulator. The error word is clocked out of the accumulator by the clock B burst and applied to a 20-bit serial-to-parallel converter.

For further processing, sign-magnitude format is required. Therefore, the error word is transferred directly when positive and complemented when negative. While being transferred to the serial-to-parallel converter by the clock B burst, the absolute error word $|\Delta f|$ is compared both to the frequency tolerance binary number δ and to the binary word ϵ developed in the preset generator. Next, it is applied to the coarse- and fine-width programable pulse generators, which are then triggered by a correction strobe pulse.

The fine-current-width programable pulse generator has eight-bit resolution, i.e., generates current pulses programable in a 1-to-256 width ratio. The narrowest pulse width is 800 ns, the longest 204.8 μ s. The coarse-current-width programable pulse generator has nine-bit resolution and generates pulses from 0.8 μ s to 409.6 μ s long. Since the difference in weight between the fine- and the coarse-current-width programable generators is $2^8 = 256$, the coarse cur-

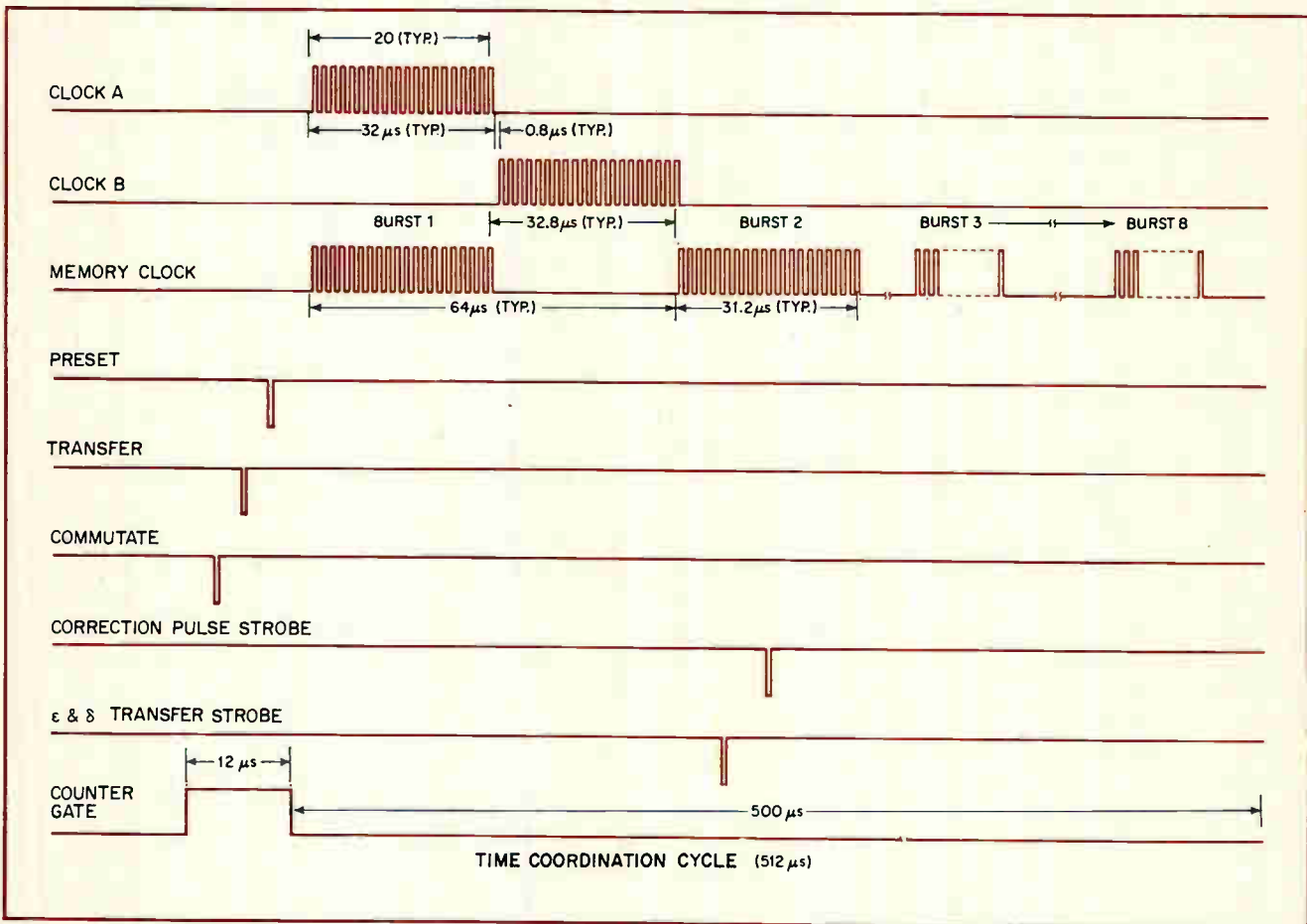

3. **Timing pulses.** Control unit timing is accomplished by 20-bit clock bursts derived from 5-MHz crystal oscillator. Complete operating cycle takes 512 μ s, where 12 μ s is allotted to preset, transfer, and commutate pulses, and 500 μ s is used to determine selected receiver's actual frequency. Clock A controls subtraction process and process of arriving at error sign. Clock B controls frequency error computation and programable frequency tolerances. Memory bursts, generated at same time as clock A, enable rapid entry of new desired frequency information to proper memory location.

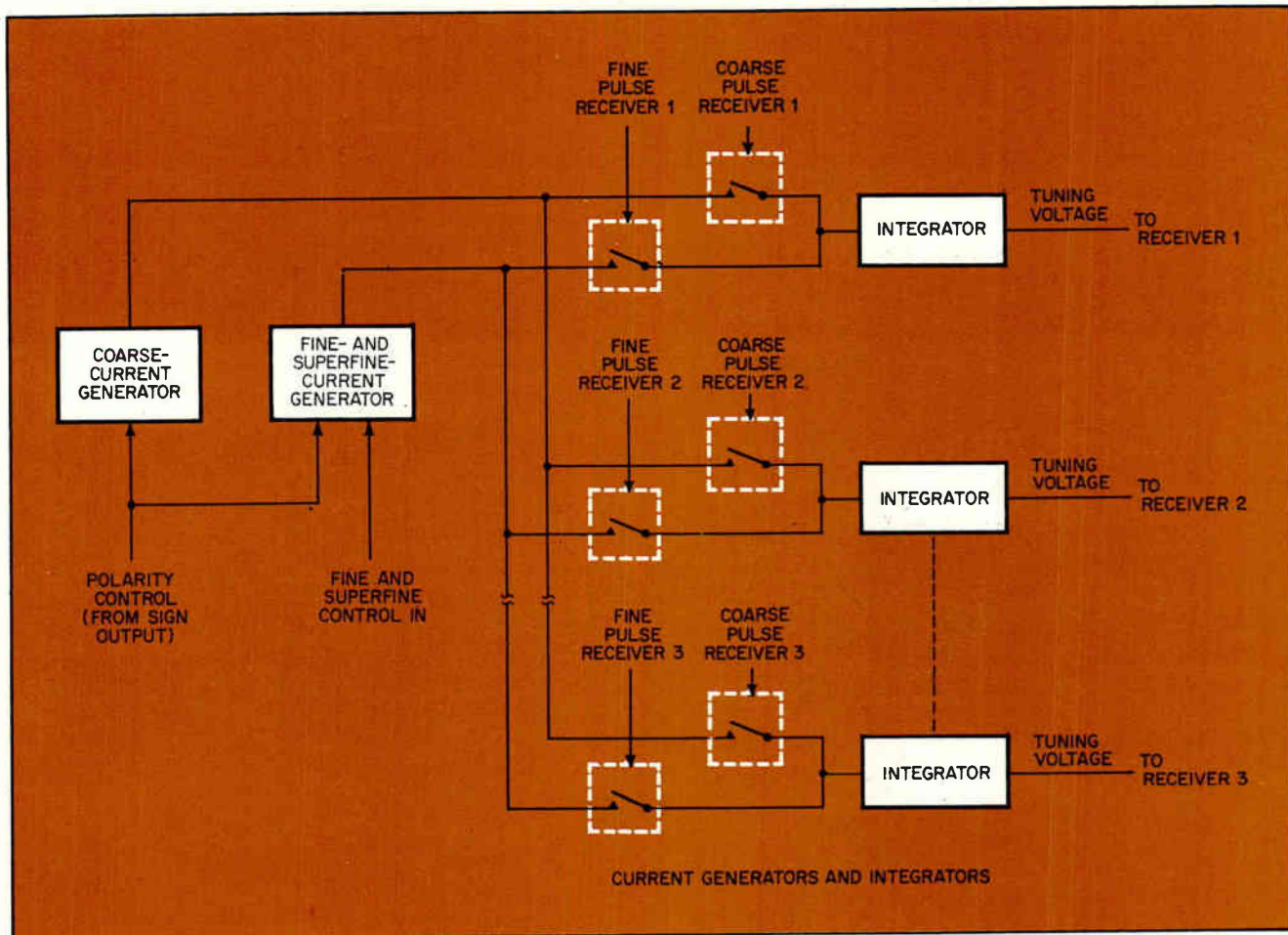

4. Fine and superfine. Current pulses from programmable generators are applied to fine- and coarse-current switches at integrator inputs. Result is step voltage output with amplitude proportional to duration and magnitude of current pulse at integrator input. Step voltage applies correction to voltage-tuned receivers in accordance with commutator state code B.

rent is 256 times greater than the fine current.

These current pulses are directed by commutator state code B to the fine- and coarse-current switches at the input of the integrator for the appropriate receiver (Fig. 4). Both coarse and fine currents may be applied to the integrator simultaneously. The error word sign stored earlier determines their polarity. The result at the output of the integrator is a voltage step whose amplitude is determined by the duration and magnitude of the current pulse from the switch at the integrator input.

When the error is zero, both switches remain open, and no voltage change should occur at the output of the integrator. Because of leakage currents in the switches and integrators, however, some drift must be expected. This drift is one of the limiting factors on the "refresh rate" and consequently on the number of receivers that the system may control.

Instead of a fine correction current, the "superfine" correction current may be applied. It's needed because the counter's least significant digit is subject to a statistical ambiguity of ± 1 count. When frequency acquisition has occurred, there will be a random error of ± 1 count—or of ± 2 kHz in the DCU-8. If an immediate response by the correction mechanism were permitted, a random incidental ± 2 kHz fre-

quency modulation would therefore be produced.

To prevent this occurrence, the "superfine" correction technique compares the absolute value of Δf to ϵ , which represents a safe margin of the random error and is different for different frequency bands. When $|\Delta f| \leq \epsilon$, the "superfine" mode achieves a fractional correction by allowing only a small portion of the normal fine correction current to flow. This "superfine" mode correction must be capable of overcoming all combined drifts for the worst-case conditions of environment and aging, and yet be small enough to maintain low incidental fm.

In a similar manner, $|\Delta f|$ is compared to δ . Frequency tolerance δ is generated by an external source and is a four-bit word, expandable to any desired length. When using the system for wide-band applications, the value of δ , which represents on-frequency tolerance, allows an increase in acquisition speed. When $|\Delta f| \leq \delta$, "on frequency" is registered for that particular receiver, and when $|\Delta f| > \delta$, "off frequency" is registered. This provides a simple positive method of recognizing frequency acquisition, and is particularly valuable when the system is poorly calibrated and requires an indeterminate number of operating cycles for frequency acquisition. □

SPECIAL REPORT

The right numeric readout: a critical choice for designers



Display technology is taking electronics into competitive new areas; with tubes, LEDs, and liquid crystals to select from, the correct decision is a must

by Owen Doyle, *Instrumentation editor*

□ An embarrassment of riches greets the designer trying to choose a numeric display. And making the right decision now is critical, because digital readouts, coupled with LSI technology, are taking electronics into vast new markets where competition will be keen and cost all-important. Hand-held calculators, electronic watches, dashboards, cash registers, grocery scales, and even gasoline pumps are just a few of the applications that are opening up for electronic numeric and alphanumeric displays.

Predicting trends about displays seemed a cut-and-dried affair just a couple of years ago. Prices of LED readouts were supposed to fall gradually, easing gas discharge and fluorescent tubes out of most applications in an orderly transition. But two factors—the emergence of new types of displays, particularly liquid crystals, and uncertainty about whether LED readouts will ever be price competitive—have created a new ballgame. However, it's reasonably certain that:

■ Liquid crystal numeric readouts will be available

from a number of manufacturers before the end of this year.

- The price of LED displays will continue to drop through the next 12 months, but won't reach the \$1-to-\$2-per-digit level of numerical display tubes bought in very large quantities.

- The seven-segment hybrid display will remain the most common type of LED readout. The reasons: monolithic seven-segment units use up much more material, which remains costly; and dot matrixes, with alphanumeric capability, are too expensive to drive.

- Red will remain the dominant color of LED readouts. Green-emitting diodes suitable for numeric displays are still in the prototype stage.

- LED displays won't get much taller than the present 0.6-inch maximum during the next year. The reasons: small characters are less expensive to make; products that use displays, such as digital voltmeters and calculators, are getting smaller; and with the advent of LED displays, people are getting used to looking at 1/8-in. and 1/4-in. characters.

- Numeric displays tubes—gas-discharge, fluorescent, and luminescent—will continue to command a large portion of the display market over the next year simply because of their low prices. However it's unlikely that prices will fall much below present levels.

It's easy to see why LED displays are often called the logical successor to gas-discharge tubes. The solid state readouts are compact, rugged, TTL-compatible and give a crisp, bright character. Besides, LED displays use relatively little power—a 1/4-in.-high, seven-segment character typically draws around 100 milliwatts per segment and operates at less than 5 volts dc.

Barely four years old as commercial products, LED readouts during that time have dropped in price from \$60 per digit to the point where it's now possible to buy an 1/8-in.-high, seven-segment numeric display (Monsanto's MAN 3A) in 1,000-unit lots for \$3.95 per digit. Ian McCrea, optoelectronics marketing manager at Texas Instruments Inc., predicts that by 1972 the industry-wide average price for a 1/4-in.-high numeric will be \$4.95, dropping to \$3.40 in 1973 (in 1,000-unit lots).

All LED display makers agree that price is the key to promoting high-volume usage. However they feel that LED displays won't actually have to beat the price—around \$2—of gas-discharge and other readout tubes to compete successfully. Their reasoning is that at a certain price level designers will be willing to spend some extra money for the advantages of LED readouts. Peter Polgar, optoelectronics product manager at Motorola Semiconductor Products Inc. puts it somewhere between \$2 and \$3 per digit in large quantities.

When LEDs are designed into equipment, it's likely they will be multiplexed: instead of each character having its own decoder/driver, a single decoder/driver will apply periodic current pulses to each character in turn in a complete display. Given the prices of decoder/drivers, multiplexing circuitry, transistors, and resistors, it's generally economical to multiplex a display with eight or more digits. But with the

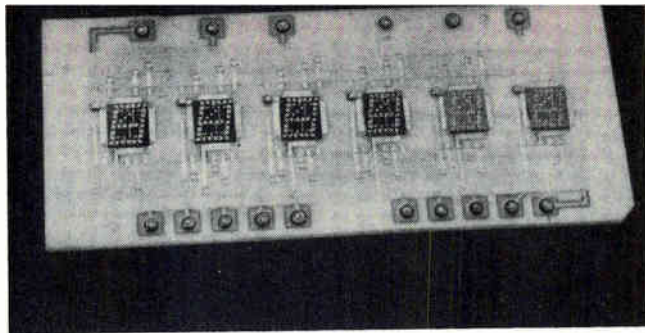

1. **All in one.** Display makers are beginning to offer complete modules—readouts, decoder/drivers, and timing circuits—on one card. Above is Fairchild's new FND 21, which has six numerics and a multiplexer.

2. **Weighing in.** Big potential market for displays lies in consumer products, such as electronic scale shown below. Display (in this case a fluorescent type) shows total weight and price of commodity placed on scale.



prices of multiplexers falling, the probability is that it soon will be more economical to strobe as few as five digits. In fact, it may be feasible to multiplex as few as three digits if much of the drive circuitry can be put on custom ICs. For example the 3 1/2-digit display in a new Hewlett-Packard Co. voltmeter [*Electronics*, April 26, p. 38] is multiplexed.

There's another benefit to multiplexing. A pulsed LED appears brighter to the eye than a continuously driven one when both are receiving the same average current. Thus, it's more efficient to multiplex an LED readout.

Still another advantage is that multiplexing reduces the number of leads needed to connect the display to the rest of the circuitry. This is particularly important in equipment like digital voltmeters and calculators where the trend is to put most of the circuitry on one or two LSI chips. Of course, low pin count is a major goal in designing any LSI circuit.

Since pulsed LEDs require peak current pulses up to 1 ampere, it won't be possible to drive multiplexed displays directly from MOS circuits. Therefore, all the multiplexing and timing circuits will probably be contained on one of the MOS/LSI chips, and be connected to the display via bipolar buffers.



3. Liquid crystals in place. Convinced that lifetime limitations and other problems can be solved, several major firms already are thinking of applications for their liquid crystal readouts. At left is multimeter put together at Texas Instruments. At right is calculator fitted with liquid crystal display made by France's Thomson-CSF.

Despite being small, rugged, and TTL-compatible, LED displays aren't necessarily suited to all types of portable equipment. They drain a relatively large amount of current, and thus cut down on battery life in an instrument that is supposed to run for a long period of time on the same battery. In most applications batteries live only eight to 12 hours with an LED display that operates continuously.

The chances of any sudden substantial current reduction seem slim. The current level needed for a given brightness is tied to efficiency, which is a function of the quality of the GaAsP material. And material improvements are won slowly and painfully. Even improvements in material won't necessarily result in lower current needs. Display makers are giving top priority to getting prices down. Therefore, as material efficiency improves, display makers are likely to maintain current specifications and try to cut costs by reducing the amount of material per diode.

On the other hand, manufacturers are confident that they can get the price of LED displays down as volume picks up and the cost of GaAsP drops. "LEDs are really in the embryonic stages in pricing and design," says Clarence Bruce, director of marketing at Monsanto Electronic Products and Controls division, which makes Monsanto's LED displays.

One possible stumbling block is that LED display makers are virtually dependent on a single supplier—Monsanto Electronic Materials—for their GaAsP. The division maintains it can fill large-volume orders, but buyers always like to have a second source so that any production problems at the major supplier would not result in long delivery time.

To protect themselves, some displays manufacturers are developing an in-house material capability. Motorola and Hewlett-Packard Associates already are growing GaAs and expect to be producing GaAsP this year. Fairchild has a limited capability "to handle overflow orders," says Robert Zettler, general manager for optoelectronics. None of these companies plans to become self-sufficient; they just want second, and third, sources. "Even when we get in-house capability," says Motorola's Polgar, "we'll still buy from Monsanto. The only question is in what proportion."

The demand for alphanumeric displays is small

right now, possibly because cost of both the displays themselves and decoder/drivers are much higher than those for numeric-only units. HPA, for example, charges \$20 in 1,000-unit lots for one alphanumeric—a 5 x 7 dot matrix called the 5082-7100. A typical drive circuit—such as the recently announced character generator from Motorola [*Electronics*, May 10, p. 145] sells for \$14.60 in 1,000-unit lots. For seven-segment characters, decoder/drivers typically cost \$3.

Still, there's some action taking place in alphanumeric. For example, Derek Mash of Standard Telecommunication Laboratories Ltd. in the United Kingdom says that his firm, an ITT subsidiary, this year will market five- or six-letter modules comprising 7 x 5 matrices of GaAsP diodes with driver circuitry. Mash estimates that the cost of the drive circuitry will be 10 times that for a numbers-only readout. The company is bringing it out, says Mash, to encourage applications, without any expectations of fast, large-volume sales. Others planning to introduce alphanumeric this year include both Motorola and TI, with 5 x 7 dot matrices, and Bowmar Canada Ltd. of Ottawa, with a 16-segment character.

Compared to U.S. efforts, LED work is lagging in Europe and Japan. One of the few foreign firms ready with a product is France's La RadioTechnique-Complec (RTC), which will market a 3-millimeter high (0.118-in.) seven-segment display this summer. Price will be high; \$8.20 each in 1,000-unit lots. In the fall, RTC will unveil a 0.28-in.-high seven-segment unit. For alphanumeric work, the French firm, which is part of the Philips network, will introduce both a 13-segment display and a 5 x 7 matrix. All RTC products will be made from GaAsP LEDs. Other large firms, such as Germany's Siemens AG and France's Thomson-CSF, also are working on LED readouts but are at least a year away from introducing products.

In Japan, Nippon Electric is marketing an LED display, while several other companies, including Hitachi Ltd., Toshiba, and Mitsubishi have announced prototypes or say they are working on them.

Some Japanese calculator makers also are developing LED readouts. This has ominous overtones for U.S. LED display makers, who are counting on sales to calculator firms. Both Sharp Corp. and Sanyo

Which material to use?

By far the most popular material for light-emitting diode displays is gallium arsenide phosphide. The only company not using GaAsP in a commercial product is Opcoa Inc. of Edison, N.J., whose seven-segment display is made from gallium phosphide devices. But this doesn't mean GaP doesn't have other supporters. Bell Laboratories, which is developing displays that may eventually be used on telephones and data terminals, is committed to GaP.

GaAsP represents an older better-known technology since several companies—HP, Monsanto, and Texas Instruments, to name three—have spent a lot of money over the last several years on the material. In addition, since GaAsP diode junctions are formed by vapor-phase deposition of impurities into the wafers, making GaAsP diodes parallels IC fabrication in many ways. By contrast, GaP crystals represent a young technology involving the use of a high-temperature, high-pressure chamber. Moreover, forming efficient junctions in GaP involves the relatively new technique of liquid phase deposition.

Another plus for GaAsP diodes is that their brightness increases with current, limited only by their burnout point. GaP diodes, on the other hand, saturate before burnout. A GaP display, such as the Opcoa's unit, is bright enough for most applications, but its brightness can't be adjusted up to the levels possible with GaAsP displays. A more important consideration with GaP diodes is that saturation limits the number of digits

GaP at Bell. Searching for high-efficiency solid state readout, Bell Labs is concentrating on gallium phosphide technology. Latest development is fabrication of beam-lead LEDs.

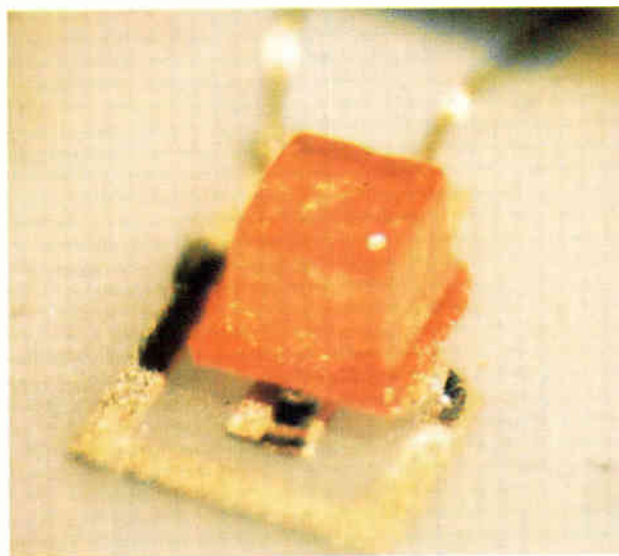

that can be multiplexed. Richard Ahrons, vice president for engineering at Opcoa, reports that up to eight of his company's seven-segment numerics can be displayed together by multiplexing. With GaAsP numerics the figure is between 15 and 20.

Another disadvantage of GaP diodes is their transparency—they emit light in all directions. Therefore care must be taken to isolate each diode optically from others in a display. With GaAsP diodes, the light only comes out of the top of diode.

GaP does have one important advantage. It's two to three times more efficient as a light emitter than GaAsP (where efficiency is defined as the ratio of input to visible light output). Therefore it's possible to make GaP displays with less material than GaAsP displays require, or use the same amount of material and get more light for less power. This gives a clue to Bell Labs' interest in GaP. Some thought is being given not only to putting numerical displays onto telephones, but also to driving the displays with power coming over the telephone lines, which would favor the display with the lowest possible power requirement.

For the next year or two, it seems likely that GaAsP will remain the primary material for solid state readouts, simply because all the major manufacturers have invested equipment in the technology and are more familiar with it. The higher efficiency of red-emitting GaP over this time span will continue to be negated by the higher cost of the material.

GaP crystal. First step in making GaP diodes is pulling a GaP crystal, such as this "wine bottle" made at Motorola. Ingot is then sliced into wafers, and junctions are made by liquid-phase epitaxial process.



Electric Co. Ltd. say they're working on their own displays, while Canon says it's studying the possibility of an in-house capability.

Red will continue to be the color of LED displays for the next year. Green numerics have been built in laboratories—Bell Labs has one and so does RCA,

and Monsanto plans to offer one this year. But green displays initially will cost much more than red ones.

It seems almost certain that when green numerics come, they'll be made from GaP. (In red-emitting GaP diodes, the p region is doped with zinc; in green-emitting diodes, the dopant is nitrogen.) The

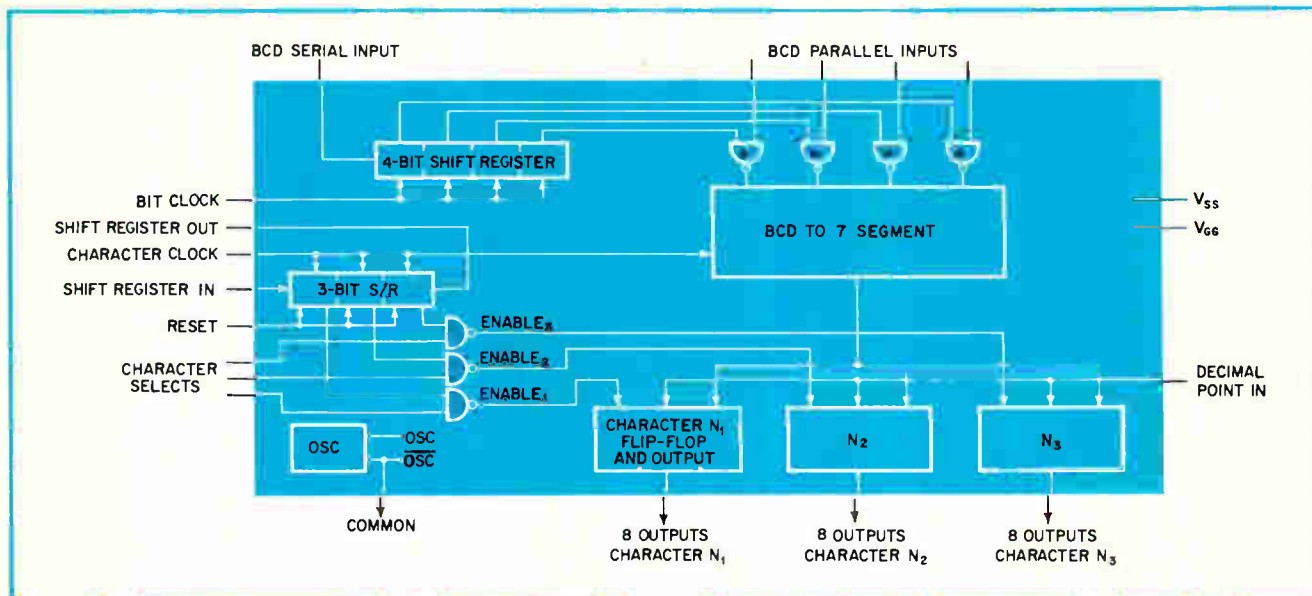

4. Crystal drive. American Micro-Systems Inc. gets credit for developing first off-the-shelf decoder/driver for liquid crystal display, specifically, Optel's three-digit readout. Basic circuit is BCD-to-seven-segment converter.

green-emitting diodes that GE, Monsanto, and Ferranti Ltd. [*Electronics*, April 26, p. 99] produce are all made of this material. But there are two problems to be solved before inexpensive displays can be built. Efficiencies have to be higher—they're still limited to 0.2%, while red GaP diodes show 7% in the laboratory and 2% on the production line. Second, even when efficiency is boosted, the processing control will have to be much tighter than with any red-emitting diode. The eye is not particularly sensitive to slight differences in brightness and wavelength in the red region of the spectrum. But response peaks at the green wavelengths. Thus green-emitting diodes essentially must be identical for display purposes.

Strongly feeling the challenge of LEDs is John Pittman, product marketing manager for Burroughs Electronics Components division, which makes Nixie tubes. However, Pittman professes to be unimpressed by LED displays; he says they've been oversold by both their makers and the technical press. "We like to believe that LEDs are a little bit like tunnel diodes or some of those other great and wonderful things that never made it," he says.

LED display makers, too, reach for the tunnel-diode analogy for their own up-and-coming competitors—liquid crystals. Little more than a lab curiosity two years ago, liquid crystal displays now loom as potentially the most important of all display technologies [*Electronics*, July 6, 1970, p. 64]. Publicly, executives at LED display companies profess to be unworried by the new competitors, but privately most will admit to a touch of concern—or more. "They've got us scared to death" says one manager.

The excitement of liquid crystal displays centers about their promise of microwatt power dissipation, "shamefully low costs" (to quote an executive at one company investing in liquid crystals), and the capability of being read in high ambient light.

The compounds used for displays—a class of liquid

crystal called nematic—are clear organic liquids that become opaque when exposed to an electric field. Displays are made by putting a thin layer of liquid crystal between two plates of glass, one of which is completely coated with a conductive film and the other coated in a pattern, such as the seven segments of a numeric readout. Electric fields can then be applied selectively to form characters. Since the glass/liquid crystal/glass sandwich has very high resistance, power dissipation is extremely low—in the microwatt region. And since the display operates by reflecting, and not generating, light, the brighter the ambient light is, the better the visibility of the readout.

Liquid crystal material is inexpensive and fabrication uncomplicated because the change in reflectivity is a bulk, and not a junction, phenomenon. As a result, liquid crystal displays are inherently inexpensive.

However, there are problems. One is temperature: liquid crystal material tried to date must be kept above 0°C and below 70°C. Another is the long response time of the material: it requires about 200 milliseconds to go from the opaque to the clear state, and the eye can see this slow turn-off. Moreover, operating lifetime is limited—10,000 hours when run with an ac field.

All of these problems relate to the electrochemical properties of the liquid crystal material. Researchers feel that the solution largely amounts to coming up with the right compound. But even if the ideal material doesn't turn up, there are ways around the problems with today's compounds. Some type of heating circuit—such as a wire defroster—could be built into the display to control temperature. A turn-off field, while increasing power consumption by a factor of approximately four, could cut the decay time of the material to a level undetectable to the eye. And if their low cost potential is realized, liquid crystal displays could be replaced much as are light bulbs.

Commercial numerical displays using liquid crystals already are available from Optel Inc. of Princeton,

How bright is bright?

A highly subjective aspect of display device performance complicates the process of comparing alternatives strictly on the basis of manufacturers' specifications. For example, it seems logical that brightness is one parameter that would be meaningful to designers, and also easy to measure. Unfortunately, it isn't. Brightness—or luminance—usually expressed in foot-lamberts, is measured right at the surface of the light source and thus bears little or no relationship to how the display will look when viewed from a distance. The situation is further complicated by the fact that measurement techniques vary among manufacturers: there are no standards for the required instrumentation or its calibration.

Even if a display does have a high brightness, it may not necessarily fill the observer's ideas of contrast, and over-all aesthetic appeal. Furthermore, two types of displays with the same brightness may not be equally visible in high ambient light.

The brightness spec does give display users a rough idea of efficiency. The brightness is usually specified

for a given current and voltage. Thus it's possible to compute a display's ft-L/input power.

Richard Ahrons, vice president for engineering at Opcoa Inc., feels that luminous intensity (millicandelas), as well as luminance, should be specified. Intensity, says Ahrons, gives a better idea of how much of the light from a display a viewer actually will see. Opcoa measures intensity by placing a photometer (with a one-inch diameter sensor) one foot from the display, measuring the response in ft-L, and converting it into a millicandela reading.

The chances of standard techniques being adopted soon are remote. Joseph Puchilowski, a Fort Monmouth physicist and chairman of an IEEE task force on standards for solid state display devices, reports that his group is submitting proposed standards for terms and definitions, and measurement techniques relating to the physical, optical, and thermal properties of single LEDs. Faced with review by several committees, these standards are at least a year away from release. As for standards on LED alphanumeric displays, Puchilowski says: "It's going to be at least a year before we even start on those."

N.J. Texas Instruments, Display Tek of Dallas, and France's Thomson CSF are all expected to offer products this year. And RCA is far along in development and could put out a display any time it chooses.

Among the companies investigating the possibility of building liquid crystal readouts are Burroughs, Sperry, Siemens, Intersil, Varadyne, Marconi, and several LED display makers. And just about any other company could get into the business on short notice because start-up costs are very low—between \$25,000 and \$50,000. And these other companies don't even have to be electronics firms. For example, a maker of gasoline pumps recently has been shopping for a drive circuit to go with its developmental liquid crystal display.

The first liquid crystal display on the market came from Optel. It's a seven-segment readout containing three digits each 0.45-in. high, and draws 40 microwatts per segment at 20 V. Price is \$5 a digit on a 1,000-module order. Decoder/drivers for the display are being built by American Micro-systems Inc. Scheduled for introduction later this year is an eight-digit display aimed at calculators; it will sell for \$1.25 per digit for 1,000 modules. By the end of 1972, Optel vice president Edward Kornstein says, prices will be under \$1 per digit plus 50 cents for the drive circuitry.

Robert Dugan, marketing manager for time systems/portable electronics at Intersil Inc. says that his firm is on the verge of building a pilot production facility for liquid crystal displays. Intersil, says Dugan, wants a big share of the developing market for electronic wristwatches. His company makes the microwatt watch circuitry, but couldn't find a compatible display, and so began developing its own liquid crystal readouts. The main effort has been directed toward finding a liquid crystal material that can be multiplexed (without multiplexing, pin requirements for the watch's LSI circuits get out of hand). Dugan says

Intersil scientists think they have liquid crystal material that can be multiplexed, and if they're right, Intersil will put forth a big effort.

Thomson-CSF launched a major effort in liquid crystals two years ago, and expects to go to market with a 16-segment display in about six months. Price will be \$10 per digit, and the company expects it to fall quickly to the \$5 level. The company has also developed dot-matrix displays using liquid crystals but will hold them unless a demand emerges. Price would be on the order of \$50 per digit.

Potential customers include the French firm Peugeot, which is interested in the displays for production-line test equipment, and a German automaker who wants a liquid crystal speedometer. Thomson-CSF also hopes to attract calculator makers—and in a hurry. The company has designed a decoder/driver to interface present calculator circuitry with its display so that calculator makers won't have to go into another round of design to accommodate liquid crystals.

TI's effort in liquid crystal goes back about 18 months. The company expects to be supplying prototype panels by year's end. Siemens AG also has developed a prototype liquid crystal display.

Displaytek Corp. expects to have commercial products available in three to six months, says company president Ed Ruggiero, with prices at the \$1-a-digit level within a year. The company already has prototypes of ¼-in.-high characters, and expects to offer custom arrays of 8 to 12 digits.

In Japan, both Sharp and Canon are considering liquid crystal readouts for their calculators, while Busicom expects to market such a calculator.

While liquid crystals and LEDs contend for the future markets, the Nixie, and similar gas-discharge tubes, remain today's most popular digital readout component. They're inexpensive; a tube with ½-in.-high characters typically sells for approximately \$3.95 in 1,000-unit lots, with that figure falling under \$2.00

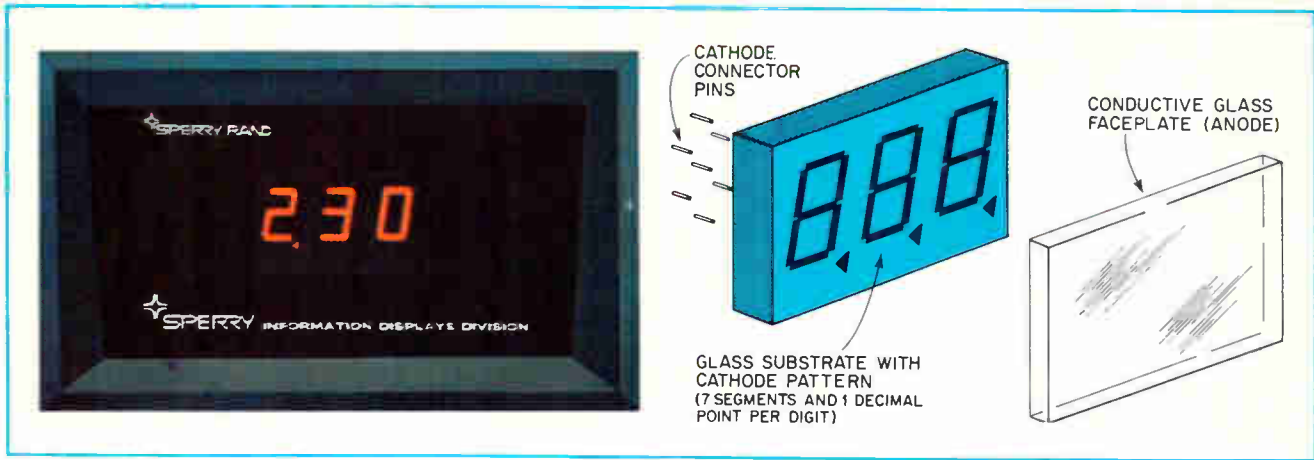

5. Flat tube. Family resemblance may not show, but Sperry's new digital readout is first cousin to gas-discharge tube. Characters are formed by applying high voltage—170 V—across anode and cathodes, ionizing gas between them.

for very high-volume orders. (LED displays—the MAN 3A in particular—now sell for about the same price as Nixies in 1,000-unit lots. But LED makers are still far from being able to match Burrough's prices and delivery times for orders of 10,000 digits and up.) The decoder/drivers for the tubes are readily available, with prices in the \$1 to \$2 range, depending on quantity. But with other display components available—particularly ones that don't need the 175 V demanded by a Nixie—the latter's sales have leveled off. Product marketing manager Pittman says that there's still room to trim Nixie prices, but he rules out any big price cuts.

These days Burroughs is putting most of its engineering effort into SelfScan—a dot matrix in which characters are formed by glow discharge at the dots [*Electronics*, March 2, 1970, p. 121]. However, this so-called plasma display is designed primarily for multiline readouts, such as those found at computer terminals and for alphanumeric work.

To fill the gap between the Nixie and the SelfScan, as well as to penetrate the calculator market, Burroughs recently introduced the Panaplex. It's a single tube containing 8, 12, or 16 0.4-in.-high digits. Like a Nixie, Panaplex is a cold-cathode gas-discharge tube and hence a high-voltage display. But unlike a Nixie, the Panaplex digit is formed by a planar arrangement of 9 segments, each a cathode, with a single screen anode in front of each digit. Since the unit is designed for strobed operation only, the complete package (16-character model) has only 28 pins.

The big advantage of Panaplex tubes, from Burroughs' point of view, is that they involve a lot less hand labor in assembly than an equivalent number of Nixies. As a result, the cost per digit can be a lot lower. For a 16-digit display in 1,000-unit lots, the Panaplex is priced at \$1.50 per digit, says Pittman; in a "few years" the price will be under \$1.

Panaplex is Burroughs' answer to the charge that cold-cathode gas-discharge display technology begins and ends with the Nixie. Another company with its own answer is Sperry Information Displays division, formed by Sperry less than a year ago. The division's first product is its SP-730 series—a seven-segment

display available in two-digit and three-digit packages [*Electronics*, April 12, p. 124]. Unlike Panaplex, the Sperry display doesn't have a screen in front of the digits. By a patented process, Sperry converts the glass front-plate into the unit's anode. Character height is 0.33 in., and, with a red filter in front of it, the display resembles an LED readout. Price in 1,000-module lots is \$2.52 per digit.

The Sperry display, like other gas-discharge types, requires a high voltage—170 V. Decoder/drivers will be available September for \$1.55 in 1,000-unit lots.

Sperry is after the same markets as every other display maker—calculators, small instruments, etc. Sales manager Larry Pond is particularly optimistic about the future for electronic displays in automobiles. Compactness will be important, he says, because Government-imposed safety requirements—such as the proposed air bag—will result in automakers leaving a lot less room for wiring a dashboard.

Sony Corp. too has a new type of gas-discharge display. Like Sperry's, it's a segmented readout; but the Japanese unit has both cathodes and anodes on the same surface (see *Electronics International*).

Before the introduction of LED displays, the most prominent challengers to gas-discharge readouts came from incandescent tubes—like RCA's Numitron—and fluorescent tubes—like Tung-Sol's Digivac. Generally lower priced than gas-discharge tubes (typically \$2.50 in 1,000-unit lots), both types are seven-segment readouts. The incandescents are low-voltage, high-current (typically 4.5 V dc and 24 mA per segment for a 0.6-in. character units) while the fluorescents are higher-voltage, low-current (typically 25 V dc and 300 μ A per segment for a 0.6-in. character display). Neither type of readout has the ruggedness of a solid state or other type of planar display.

But at their low prices, both types will continue to command a sizable market segment, particularly in applications where cost is the major consideration.

Sigmatron of Santa Barbara, Calif. awards itself the prize for the lowest-priced electronic display. Sigmatron makes a seven-segment electroluminescent readout, and its first off-the-shelf product—a six-digit package with a 0.4-in. character height—is scheduled

AVAILABLE NUMERICAL READOUTS						
Type and typical character height (in.)	Representative manufacturers	Price/digit (in 1,000-digit lots)	Voltage (V)	Current for figure "8" (mA)	Decoder/driver cost (1,000-unit lots)	Number of digits that can be multiplexed
Fluorescent 0.5	GE, Tung Sol	\$2.50	25	3.85	\$4 to \$6	16
Gas-discharge (planar) 0.4	Burroughs (Panaplex)	\$2.00	180	25 peak	not available as off-the-shelf IC	16
0.33	Sperry	\$2.52 (per digit for 1,000 3-digit modules)	200	1.4	\$1.55	16
Gas-discharge (tube) 0.5	Amperex, Burroughs, National Electronics, Raytheon	\$3.95	170	3.0	\$1 to \$2	16
Incandescent 0.4	Pinlites, RCA, Readouts Inc., IEE, Inc., Master Specialties, Oppenheimer	\$2.95	3.5 to 5	184	< \$5	5
LEDs 1/8-in. character (GaAsP)	Fairchild, Monsanto, Motorola, TI, Bowmar	\$3.95 to \$6.00	1.6	175	\$2 to \$5	15-20
1/4-in. character (GaAsP)	Bowmar, Litronix, H-P, Monsanto, TI, Dialight	\$7.50	4	210	\$2 to \$5	15-20
(GaP) 0.3	Opcoa	\$7.30	2	105	\$2 to \$5	8
Onboard decoder/driver and memory 0.3	H-P, TI (later this year)	\$10	5.5	75	\$0	can't be multiplexed
Liquid crystal 0.45	Optel	\$5 (per digit for 1,000 3-digit modules)	15 to 60 ac	0.014	\$15 (available in July from AMI)	can't be multiplexed
Thin-film electroluminescent 0.4	Sigmatron	\$1.50	150 ac	10	not available as off-the-shelf IC	16

to be available this summer. Company president Martin Reder says price will be \$1.50 per digit.

The company faces some skepticism because of the track record of electroluminescent readouts. During the 1950s, many large firms tried to make them, but none could solve the problem of short life for the light-emitting phosphors involved. Sigmatron builds its displays by evaporating a thin film of the electroluminescent material on a dielectric substrate. No extended life test data is available, however, although Reder claims that the thin film displays have been operated for over 10,000 hours.

The Sigmatron unit is a high-voltage ac device. Drive requirements vary with frequency—which can range from 2 to 20 kilohertz—but typically the display

requires drive voltages of 150 v peak-to-peak.

Sigmatron's claim to produce the lowest-priced display probably won't go unchallenged for long. Looking at the recent history of displays, it's almost certain that a new technology or price cut soon will put the lowest-price-per-digit crown on some other manufacturer's head. Thus, the designer selecting a display should look not only at what's around now, but also anticipate the new displays, the price changes in the older ones, and the improvements that are sure to occur in driving techniques. □

Reprints of this report will be available for \$2 a copy. Prices for quantity order on request. Address all orders to Electronics Reprint Department, P.O. Box 669, Hightstown, N.J. 08520. Contributing to this article were Charles Cohen in Tokyo, Paul Franson in Dallas, John Gosch in Frankfurt, Michael Payne in London, and Stewart Toy, McGraw-Hill World News in Paris.

The fishes that tended to forget.

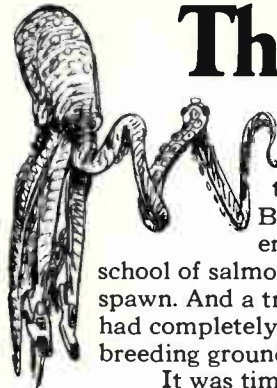

WHICH IS BAD because the whole structure of the fish world seems to be based on remembering.

But lately there had been some embarrassing slip-ups. A whole school of salmon swam downstream last year to spawn. And a troop of male yellowbelly sunfish had completely lost their way to the traditional breeding ground.

It was time to activate the plan proposed by a young mackerel named Max, which he called the *Wondrous Elemental Thinking & Traffic Encoding Reservoir* — or WETTER for short. WETTER's magic function was to hold all the information needed by all the fishes and answer any and all questions with nanosecond speed.

To build this great machine, the fishes elected a committee. The committee quickly decided that the major problem would be getting the huge supply of kelp that was needed for the machine's giant memory. Not just ordinary kelp. But teeny chips of kelp processed under very special conditions and housed in modules of tiny seashell.

Well. The prospect of building and selling these little kelp-shells quickly became one of the most exciting and most talked about prospects in the fish economy. Betting ran high on the octopus product — Mostly Octopus Shell or MOS — which was already announced as being in high volume production. The octopi promised to deliver a kelp-shell of low cost, high performance and great reliability.

When the committee met to make its final selection, the octopi were ready. They wheeled in a huge load of their little kelp-shells and dumped them before the committee. Then they stood on top of the heap waving all of their arms. A whole group of octopi waving all of their arms is quite a thing to behold.

"Here they are," yelled the octopi. "Fully decoded and ready to go. They make up into an operating memory system with 300 nanoseconds access time and 600 nanoseconds cycle time. You can use them in memory systems from 50,000 bits to 10 million bits."

And what about cost? "So low you won't believe it," chorused the octopi.

The committee members' gills moved fast with gleeful anticipation. But then a puffed-up

sea bass raised his fins to ask a question.

"Exactly how do we use your kelp-shells to build our memory system for WETTER?" he asked. "I understand there are a multitude of problems in putting these things together. And solving all those problems could cost us a lot of money. Not to speak of time."

There was stunned silence. The octopi dropped all of their arms. And the chief octopus confronted the puffed-up sea bass with his best imitation of a fishy stare.

"We'll be glad to give you some advice on that subject," he intoned haughtily. "But, frankly old man, solving the system problems will have to be your job. After all, we're busy turning these things out. We're already in high volume production, you know. As a matter of fact, we should be getting back to our plant right now."

And the octopi marched out of the grotto.

Then out from under a rock crawled a young lobster. Clutched in one of his claws was a card-like object that had several kelp-shells affixed to it. They looked different from the Mostly Octopus Shells.

"I suppose," said the sea bass, "that you have another problem to dump in our laps."

"Not exactly," said the lobster. "What I have here is a kelp card system. It holds up to 9216 bits of memory and includes the memory address register, decoder, sense amplifiers, write amplifiers and output buffers. Power consumption is low and system cycle time is less than 200 nanoseconds.

And this one card system is capable of infinite expansion. We now have fully debugged cards in quantity production. I think you'll find they meet your needs. And they'll allow you to concentrate on all the other problems in building Max's machine."

The committee burst into spontaneous applause.

"But what inspired you to take this novel approach," asked the sea bass?

The lobster blushed. All lobsters are naturally shy.

"Well, what you wanted was a function. A system to relate to your system. So before I rushed out to go into high volume production, I spent some time studying the mackerel's plans and understanding what he was really trying to do."

"We're certainly glad you remembered," bubbled the sea bass. "We almost ended up with a lot of arm waving, when what we really need is to get WETTER."

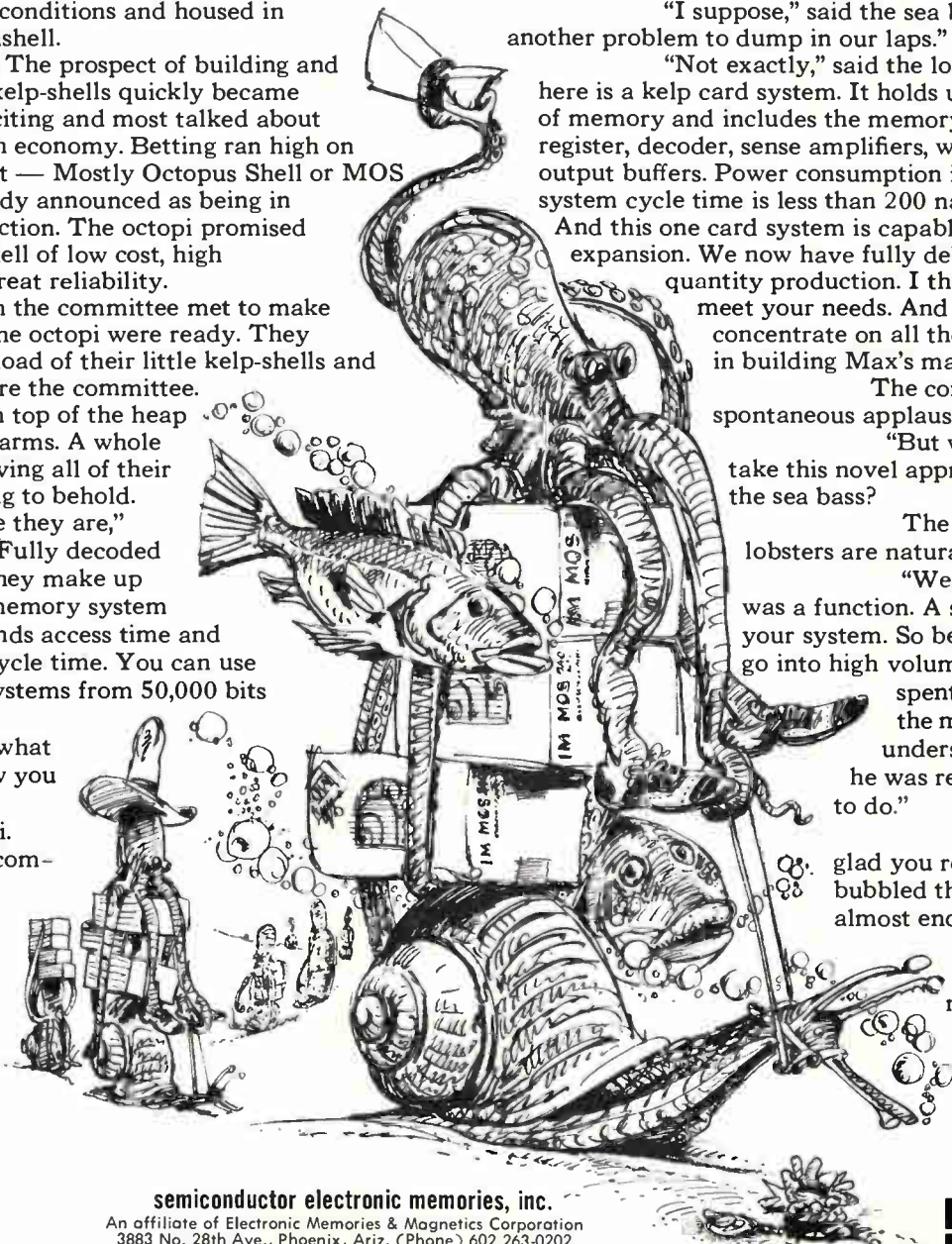

semiconductor electronic memories, inc.

An affiliate of Electronic Memories & Magnetics Corporation
3883 No. 28th Ave., Phoenix, Ariz. (Phone) 602 263-0202

SEMI

Circle 73 on reader service card

SEE WHAT YOU ARE COUNTING

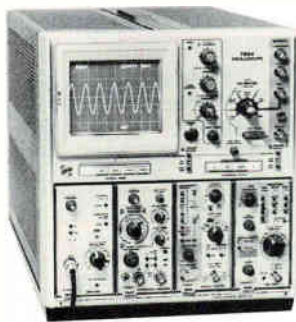
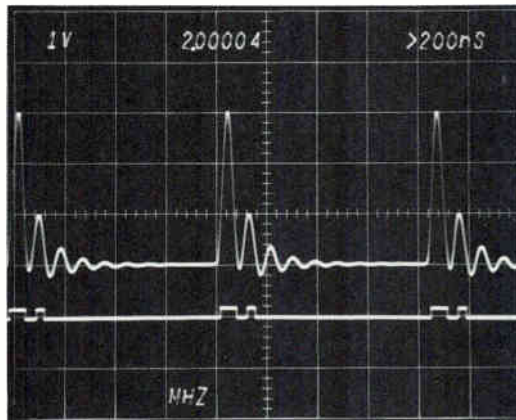
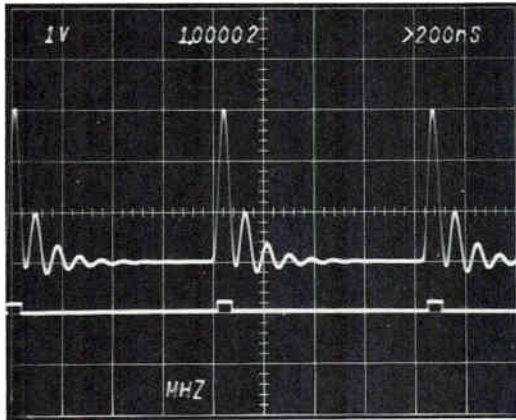

You are assured that the signal being counted is the right one when you use a 7D14 Digital Counter in a 7000-Series Oscilloscope.

The top waveforms in the above photos are identical, yet the indicated frequency changes from 1 MHz to 2 MHz when the position of the counter's trigger level control is changed. Which is the correct frequency? The unique "trigger indicator" feature of the 7D14 answers this important question.

By placing the oscilloscope's vertical in the CHOP mode, the shaped signal from the counter's Schmitt trigger circuit (lower trace in both photos) is displayed directly on the CRT. The top photo shows that the highest amplitude signal is triggering the counter. In the bottom photo the level control is set to a point where it also triggers on a lower level signal so there are two outputs from the Schmitt trigger and, therefore, twice the frequency is indicated. Ambiguous readings are no longer a problem when you can see what you are counting.

Having a digital counter that is a plug-in for an oscilloscope allows you to make other measurements that were previously impossible. The use of 7000-Series amplifier plug-ins as signal conditioners and the delayed sweep for gated burst measurements are just two examples. The 7D14 also is no ordinary digital counter. In addition to being an oscilloscope plug-in, it counts up to 500 MHz . . . without prescaling.

Price of the 7D14 Digital Counter is \$1400. For a demonstration or more information, contact your nearby Tektronix field engineer or write: Tektronix, Inc., P.O. Box 500, Beaverton, Oregon 97005.

U.S. Sales Prices FOB Beaverton, Oregon

Tektronix lease and rental programs are available in the U.S.

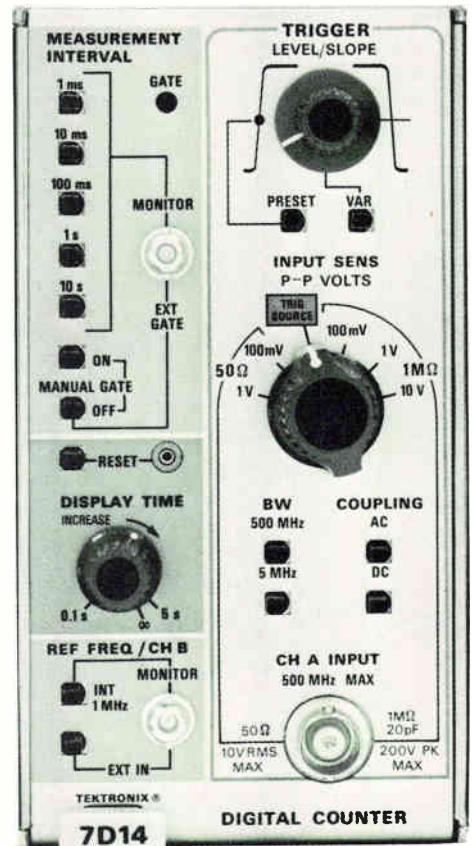

500 MHz DIRECT



TEKTRONIX®

committed to
technical excellence

Europe's avionics: up in the air

British and Continental companies pin hopes on two projects—
MRCA and A-300 Airbus; U.S. makers may grab a piece of the action

Everybody who's anybody in world aviation figures to be on hand May 27 when the biannual aerospace-industry jamboree gets underway at Paris' Le Bourget airport. For the average show-goer, a pair of prototype supersonic transports—the Anglo-French Concorde and the Soviet Tupolev 144—should provoke the most neck-craning as they take to the air. But for Western Europe's avionics makers, the planes to watch are two that have yet to fly.

Long plagued by too much capacity and too few planes to outfit, the avionics makers now see a lift in sight from two multinational projects. One is the Franco-German-Dutch A-300 Airbus, a short-haul transport that's scheduled to make its first test flight in late summer next year. The other is the German-British-Italian multirole combat aircraft, the MRCA/Panavia 200. A variable geometry, twin-engine plane designed for Mach-2 performance at high altitudes, the MRCA is slated to fly the first time during the second half of 1973.

Neither plane, actually, will do much for the state of the art in avionics. To be sure, the Airbus has an unusual bit of hardware in its vertical reference and heading system. But otherwise it's outfitted fairly conventionally. As for the MRCA, it will be heavily larded with avionics and very likely will turn out to be the first European plane ever with all-digital avionics. But cost is a kingpin consideration and the consortium charged with its development, the Munich-based Panavia Aircraft GmbH is plumping for off-the-shelf avionics wherever possible. It is striving to hold the price tag on the aircraft to about \$4 million per plane, based

on May 1970 prices, with the avionics package running somewhere between \$800,000 and \$1 million. If the MRCA sells as well as Panavia hopes, close to \$1 billion of avionics business will be generated.

Having managed to hammer out a trilateral agreement for the airframe and the engines, Panavia is striving to arrive at a uniform avionics package. But it seems almost certain that there'll be at least two versions of MRCA avionics: Britain's and Germany's. Nothing has been officially settled yet, but it's hard to see how these two countries can get together on specifications for ground-mapping and terrain-following radars. There's a hassle, too, over instrument landing systems and tactical navigation gear (Tacan). Even the communications transceivers are in dispute, though they really aren't a major stumbling block. If two versions are developed, the Italians are likely to take the West Germany mapping/terrain package.

The squabble over common specifications in large measure stems from opposing procurement philosophies of the Britons and the Ger-

mans. The UK traditionally has been an innovator in avionics and understandably wants to carry forward the research and development it has been doing in recent years. So they'd like a heavy portion of development money in the 42.5% share of MRCA avionics coming to them.

The Germans, by contrast, see little evil in tried-and-true hardware designed in the U.S. What's more, the Germans are committed to heavy buying of U.S. military hardware under the arrangement that partly compensates for the cost of keeping American troops in Europe. U.S.-built equipment, then, is a convenience for the Germans as they pick up their 42.5% share (Italy has the remaining 15%).

The conflicting attitudes of the Germans and the British are underscored in the radar hassle. Britain wants an X-band terrain-following radar and K_u-band ground-mapping equipment. Not surprisingly, Britain's Ferranti Ltd. and Elliott Radar Systems Ltd. have developed these two pieces of hardware. And though K_u-gear has better resolution, West Germany wants K_u-band

Digital fighter. MRCA plane, shown in mockup, will be stuffed with avionics.

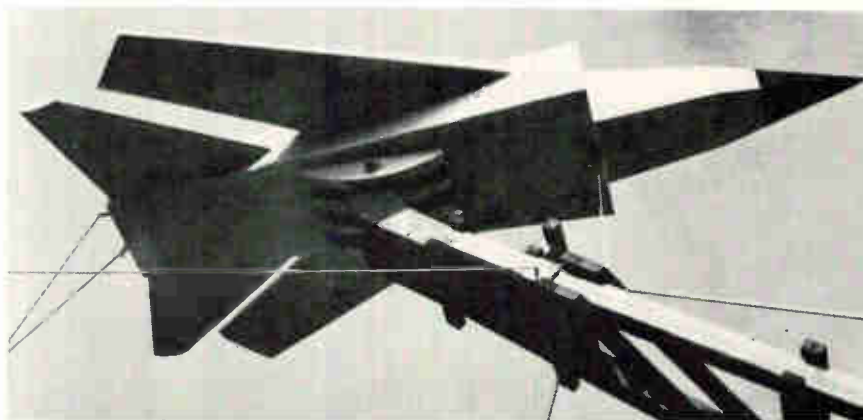

Probing the news

hardware for both mapping and terrain following, hardware that is available in the U.S. and has already flown hundreds of hours.

Although the squabble over specs continues, Panavia has called for proposals on some 50 avionics subsystems for the MRCA, ranging from automatic direction finders and communications gear to more complex equipment, such as low-level television, autopilots, and inertial navigation systems. The contracts will be farmed out to British, German, and Italian companies following the 42.5%/42.5%/15% formula, but U.S., French, and other "outsider" companies can nonetheless make a pitch for some of the business to cost-conscious Panavia. However, when outsider gear is selected, arrangements will have to be made for heavy local participation.

U.S. companies already have proposals in for the terrain-following/mapping equipment, among them: Texas Instruments, General Electric, and North American Rockwell Microelectronics Co. Should a U.S. K_a -band version be chosen, any equipment redevelopment required would be handled by the respective American firm with European engineer's present. Actual production, however, would be carried out in Europe by various consortia working under license agreements similar to those that existed for

Checkup. Engineers test resistance and impedance of MRCA antennas.



avionics production for NATO's F-104 Starfighter. The firms going together in these consortia are West Germany's Siemens AG and AEG-Telefunken, the UK's Elliott and Ferranti, and Italy's CGE-FIAR and Selenia.

Although the Germans will settle for lower radar resolution, they want higher precision for the Tacan than do the British. Thus both Hoffmann Electronics Corp., El Monte, Calif. and West Germany's Standard Elektrik Lorenz (SEL) are offering micro-Tacan gear. The SEL-designed version incorporates sector-Tacan (Setac) capabilities for both azimuth and elevation. Setac is a mobile landing system which provides very precise information on azimuth, elevation and distance. If the British opt for less sophisticated Tacan, SEL could wind up as the sole producer of Tacan for German versions of the MRCA.

British companies, too, are counting on sophistication—to win the central digital computer contract. Though Panavia still hasn't made the award, the front runners seem to be Elliott Flight Automation and Ferranti. Elliott also has proposed a head-up display and again the main competition will be home grown—Smiths Industries Ltd. Ferranti hopes to get further into the act with proposals for a digital inertial navigator, low-light TV, a target-seeking system that spots reflections from targets illuminated by a ground-operated helium-neon laser, and a moving-map display. Despite Panavia's penchant for off-the-shelf avionics, at least one UK firm is proposing hardware with light-emitting-diode readouts.

Off-the-shelf is also the avionics guideline at Toulouse, France, where Airbus Industrie SA is now assembling the first prototype for the A-300 Airbus. Company officials hope to sell some 600 planes by 1985. Each plane will sell for about \$1.2 million with something like \$360,000 worth of avionics slated for each craft.

The hardware is mostly conventional, but there are a few noteworthy items. Topping the list is an ingenious vertical reference and heading system developed by France's SAGEM. The company's

engineers believe theirs is the first system available that meets the 1969 ARINC 569 norm, which specifies the replacement of highly fragile classical gyroscope systems with higher precision hardware that is also easier to maintain.

SAGEM's new MGC-10 is a hybrid of standard gyroscopes and costly inertial platforms. The system uses three light-weight gyroscopes suspended from tiny gimbals placed in a cube-shaped platform that floats in a dense, neutral liquid so that little force is exerted on the gimbals. A cylindrical outer case surrounds the entire shock-proof system. The result is an inertial platform that is servo-controlled by gyroscopes, each of which senses rotation in one of three perpendicular axes. This system has a drift rating of only 0.02° per hours, 10 times better than classical gyroscope systems and almost as good as inertial platforms, which produce drift of 0.01°.

The electronics of the servo-mechanism are standard, but the SAGEM unit has a unique automatic starter based on integrated logic circuits that control the starting sequence—turning on the gyroscopes for 30 seconds before starting other devices.

By the end of this year, SAGEM expects to have built a prototype computer that can be hooked to the MGC-10, turning it into a pure inertial system for customers needing extra precision and compensation for aircraft acceleration—which throws the simpler system slowly out of whack. The MGC-10 will sell for \$22,000 and the computerized version, to be called the MGC-30, will cost \$55,000.

This spring, SAGEM signed an agreement that names Litton Industries as the U.S. distributor and gives it the right to manufacture the unit. But a Litton spokesman says the company has no plans to manufacture the MGC-10.

The Airbus will have an automatic pilot developed by France's SFENA, with subassemblies supplied by Germany's Bodenseewerk Geratetechnik GmbH and Britain's Smiths Industries. □

Reporting for this article were John Gosch, Frankfurt; Michael Payne, London; and Stewart Toy, McGraw-Hill World News, Paris. Arthur Erikson, Paris, wrote the story.

The first application of the "ADAPT" G. P. Computer concept has been the air inlet control system for the Navy's F-14. It meets all the requirements of MIL-E-5400, Class 2 and is in quantity production.

Some of its obvious advantages are the direct result of MOS/LSI technology. Models in the "ADAPT" series weigh as little as 8 pounds, measure 4¼" x 7" x 8", and run on 20 watts of MIL-STD-704 power. At low cost. With high reliability. No cooling is required.

Even more remarkable is the flexibility of the "ADAPT" series, achieved through

- microprogramming
- bus orientation
- the "bit-slice" building block concept.

Garrett has a new family of minimum weight, highly flexible MOS/LSI general purpose computers — the "ADAPT" series.

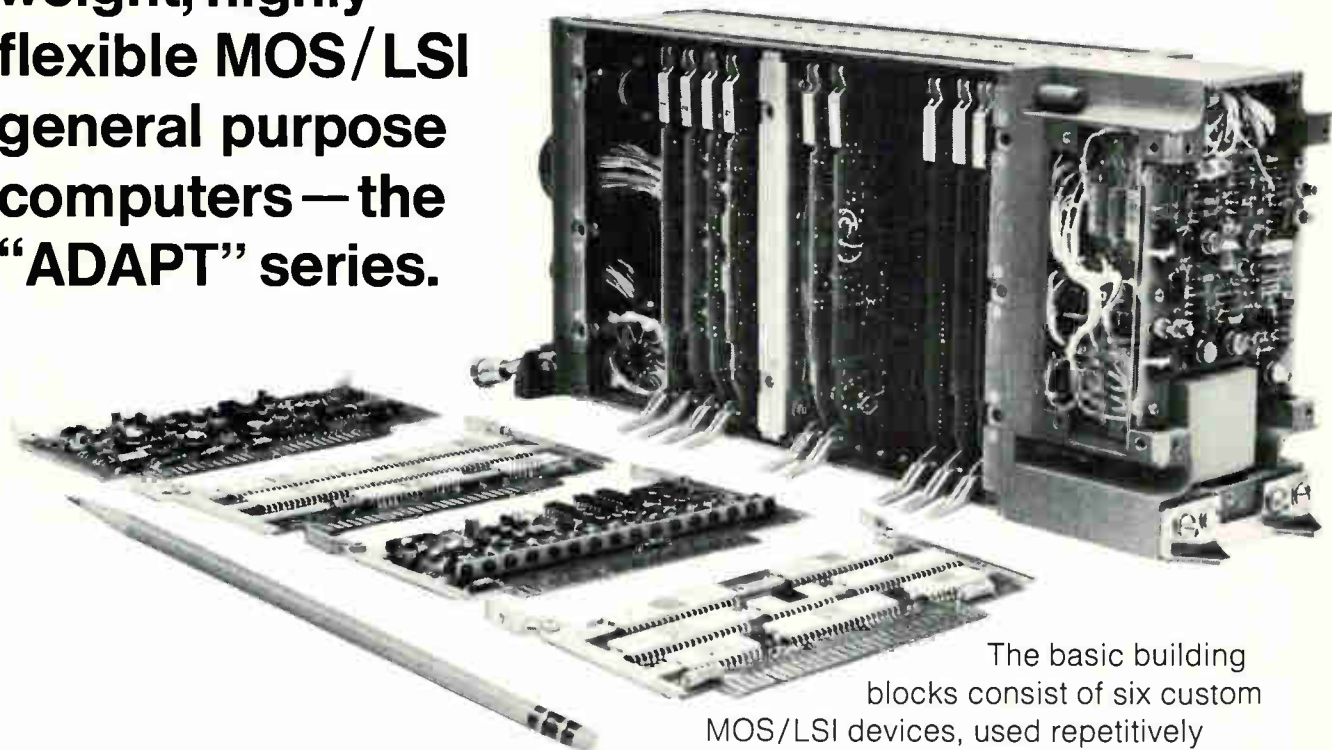

The basic building blocks consist of six custom MOS/LSI devices, used repetitively to tailor a task-oriented processor for your application with a minimum of non-recurring cost. Garrett has a family of MOS/LSI general purpose computers; and you can learn more about them with a phone call or letter.

Contact: Sales Manager, Garrett AiResearch Electronic Systems, 2525 West 190th Street, Torrance, California 90509



AiResearch Manufacturing Co.
one of The Signal Companies 

Centralab Ultra-Kaps semiconductor type capacitors are an economical approach to miniaturization. As low as 2½¢ each on quantity orders.

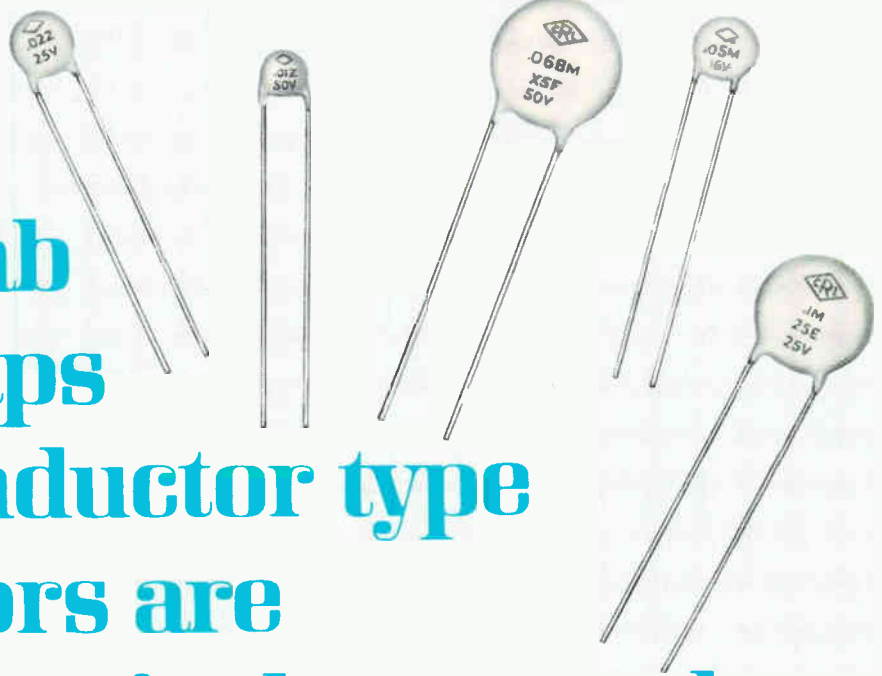

Ultra-Kaps® replace mylar and "Hi-K" ceramic capacitors and you still save space and money. Their reliability has been field tested and proven on millions of circuits. To obtain samples for independent evaluation, write, on your letterhead, to Capacitor Sales Manager, Centralab.

RANGE CHART

Maximum Diameter	16 volt		25 volt		50 volt	
	Max. Cap. MFD	Min. I.R. Megohms	Max. Cap. MFD	Min. I.R. Megohms	Max. Cap. MFD	Min. I.R. Megohms
.290	.02	5.0	.015	65.0	.01	1000
.390	.033	3.0	.022	45.0	.015	1000
.405	.05	2.0	.033	30.0	—	—
.485	—	—	.05	20.0	.022	1000
.515	.068	1.5	—	—	.033	1000
.590	0.1	1.0	.068	15.0	.047	1000
.690	0.15	0.65	0.1	10.0	.05	1000
.760	—	—	—	—	.068	1000
.820	0.2	0.5	0.15	6.5	—	—
.920	0.3	0.33	0.2	5.0	0.1	1000

Thickness: .156 inches maximum
 Temperature Characteristics: 16 and 25 volt: X5R, Y5F, Z5E
 50 volt: X5F, Y5F, Z5F



CENTRALAB

Electronics Division
GLOBE-UNION INC.

5757 NORTH GREEN BAY AVENUE
MILWAUKEE, WISCONSIN 53201

CENTRALAB PRODUCTS ARE MARKETED THROUGH
CENTRALAB INDUSTRIAL DISTRIBUTORS AND INTERNATIONALLY
THROUGH GLOBE-UNION INC., INTERNATIONAL DIVISION.

Consumer electronics

Pipe organ goes digital

Computer control of synthesized waveforms stored in MOS/LSI memories gives church-organ sound at a moderate price

by Lawrence Curran, Los Angeles bureau manager

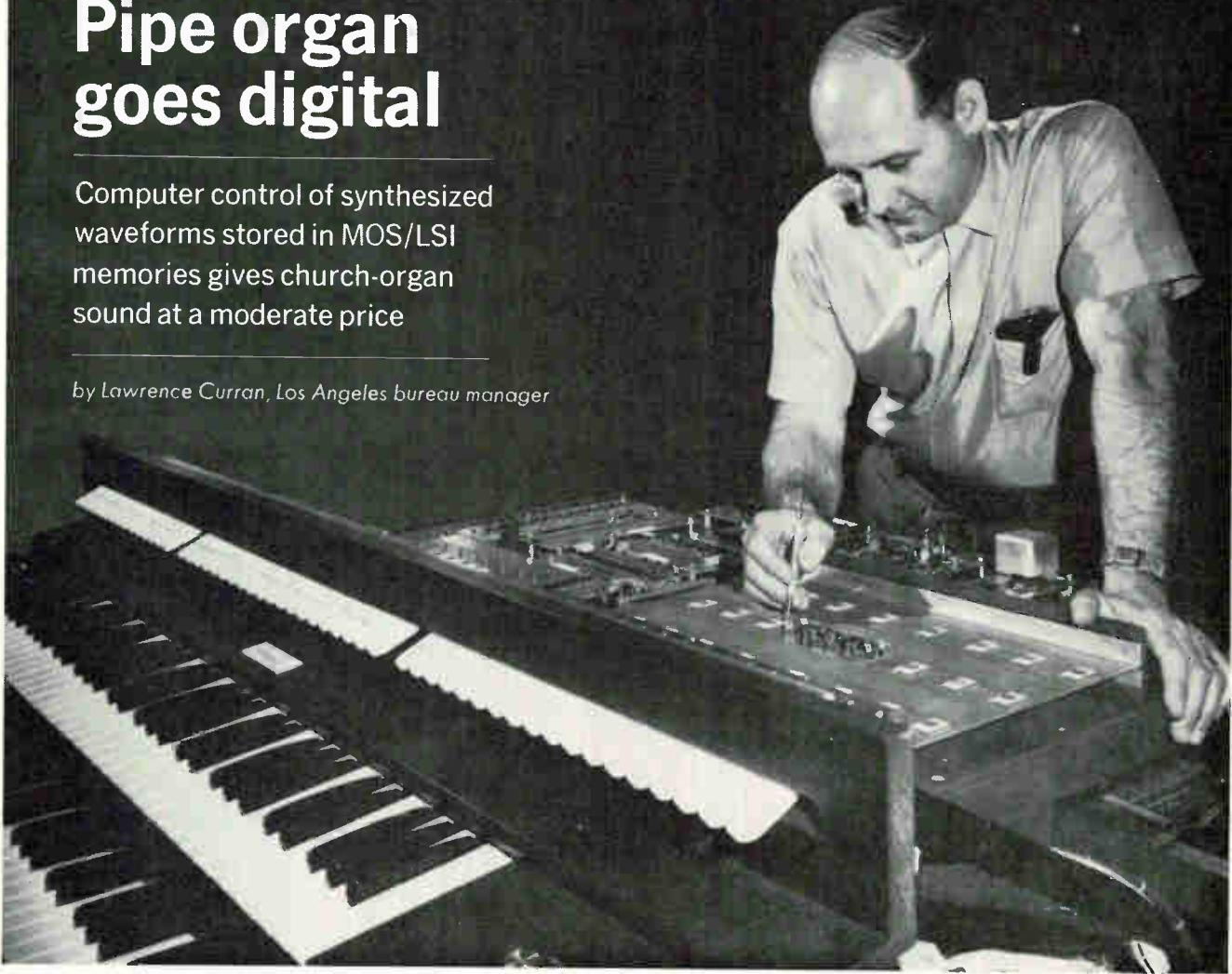

Cost cutter. Digital computer controls synthesis of waveforms in Allen/NRMEC electronic organ, keeping price down.

It took three years and a digital computer, but now there's an electronic organ that's hard to distinguish from a church pipe organ. And it took the combined efforts of an organ maker—Allen Organ Co.—and an MOS/LSI maker—North American Rockwell Microelectronics Co. (NRMEC)—to “faithfully reproduce the sounds of a pipe organ.”

Perhaps even more significant, the development makes it possible to build such an organ in the medium-price range—\$10,000 to \$20,000—according to Ralph Deutsch, program manager at NRMEC who conceived of the project. He also developed the computer programs for converting analog tape recording

of pipe organs into a digital format that is stored in the computer's memory.

“Churches worry about price, and the organist worries about sound,” comments Deutsch, himself an organist. He feels the Allen/NRMEC digital organ will satisfy both. “Pipe organists who have played it like it,” he reports.

Besides duplicating many pipe organ sounds more closely than existing electronic organs, the developers claim that the computer represents the first completely digital electronic system that produces musical sounds. Electronic church organs, including those made by Allen, Macungie, Pa., a pioneer in the field, have up to now been an-

alog instruments. One of the most bothersome—and costly—drawbacks in the analog approach is that separate oscillators are required for each note or frequency produced. The minimum complement is 164 oscillators, and they are difficult to tune. For example, even though Allen does this tuning with relatively expensive toroid coils, Deutsch says that the fastest he and his son, also an accomplished organist, have tuned a 210-oscillator organ was two hours.

Moreover, using hundreds of oscillators to generate the analog organ's frequencies still doesn't produce music. “You still have only a sine wave,” Deutsch says. To get other “voices,” analog networks

OUR ANGLE: Modular D/S and S/D Converters



Do Low Cost
Repairable
Circuit Cards
Make Sense
from Your Angle?

IN

A

North Atlantic's new 701 D/S and 711 S/D Converters offer unmatched advantages for the digital/analog interface at low-low cost . . . typically \$1000.

Open-card construction is easily and economically maintained. Adaptable to systems needs, interchangeable converter cards are compatible with your automatic test, simulation or digital control systems.

Compared to 19" panel designs, these units provide a choice of accuracy, frequency, resolution, and systems customization without the extra bulk and expense of unnecessary power supplies and other panel controls. They are ideal for multi-channel applications where a converter is assigned to a specific function.

These new converters are available to meet a wide range of systems needs. The 701 D/S has selectable accuracies of 9 or 12 bits with resolution of 8 through 14 bits, transformer output isolation and short circuit protection, operation at 60 Hz or 400 Hz with 1VA or 10VA output. The 711 S/D has 0.05° accuracy, 13 bit resolution with input transformer isolation, and continuously tracks 400 Hz synchro data to 1000°/second.

Don't these converters make sense from any angle? Talk it over with your North Atlantic sales engineering representative today.

NORTH ATLANTIC
industries, inc.

200 TERMINAL DRIVE, PLAINVIEW, NEW YORK 11803
cable: noatlantic / twx: 510-221-1879 / phone: (516) 681-8600

Probing the news

have to be provided to shape the sine waves.

By contrast, the digital organ synthesizes all waveforms from a single 4-megahertz frequency standard. The four-phase MOS/LSI logic and memory circuits used in the standard and the synthesizing operation provide such stability that there's no need for tuning the organ.

Glen Griffith, program engineer for the MOS prototype at NRMEC in Anaheim, explains that basically the system stores a normalized digital representation of a complex periodic waveform and provides a mechanism for repetitiously reading the waveform from memory at a rate corresponding to a musical frequency. Waveshapes representing all pipe-organ tones are selected, digitized, and stored in the organ computer's read-only memory.

When an organist actuates a set of stops, the points of each corresponding wave stored in memory are summed and deposited in a random-access, read-write buffer memory. The organ's frequency

synthesizer also has a memory that contains the ratio of the frequency of each note to the computer clock frequency.

When the organist depresses a key, the appropriate ratio is deposited in an addition register. At each 1-MHz computer clock pulse, that ratio is added to itself, and the integer part of the addition register addresses the buffer memory. Thus, while the buffer memory is addressed at the computer clock rate, the address itself changes at a rate equal to the number of sample points in the waveshape multiplied by the audio frequency.

The normalized waveshape essentially is altered so it corresponds to the note played on the organ keyboard. Finally, the beginning and end of the waveshape are modified to produce the characteristic attack and decay of an organ tone. Then the tone is put through a digital-to-analog converter and a conventional audio amplifier, and is actually reproduced by two speakers.

The keyboards and stops are time-multiplexed to provide substantial savings in console cabling and interconnection within the MOS chips. Emphasizing the im-

Father and son

The idea for the digital organ was conceived more than four years ago when Ralph Deutsch's son, Les, then 12, decided he wanted to take organ lessons. Deutsch's home organ wasn't adequate for the practice Les needed. But when Ralph decided to look for a new electronic organ, he "was horrified at the high cost and poor quality" of available instruments. "They didn't sound like organs, but boy, were they expensive," Deutsch recalls.

"Then, while driving along on the freeway, I got a flash insight to try to make a low-cost, high-quality digital organ." Thirty minutes more of thinking through the concept in bed that night solidified the idea. Then mathematician-musician Deutsch and his son went to a few churches in the Los Angeles area to tape-record pipe organ tones for Ralph's early research studies. This led to development of a demonstrator that could be linked to a commercial electronic organ to produce sound digitally.

Allen Organ Co.'s president, Jerome Markowitz, was the first to see the digital organ's potential, but even after the engineering model was developed, it took some convincing to make the then-Autonetics division of North American Rockwell continue to fund the development. Deutsch points out that though it was a big risk, the project has turned out to be a sound business decision.

Deutsch describes Les, now 16, and a special organ student at UCLA, as an organ "snob." Les was nagging his father for a pipe organ until last January, when he got a chance to play the digital computer version. He now concedes that the digital organ is better than many pipe organs, Deutsch says.



Wide Band, Precision CURRENT MONITOR

With a Pearson current monitor and an oscilloscope, you can measure pulse or ac currents from milliamperes to kiloamperes, in any conductor or beam of charged particles, at any voltage level up to a million volts, at frequencies up to 35 MHz or down to 1 Hz.

The monitor is physically isolated from the circuit. It is a current transformer capable of highly precise measurement of pulse amplitude and waveshape. The one shown above, for example, offers pulse-amplitude accuracy of +1%, -0% (typical of all Pearson current monitors), 10 nanosecond rise time, and droop of only 0.5% per millisecond. Three db bandwidth is 1 Hz to 35 MHz.

Whether you wish to measure current in a conductor, a klystron, or a particle accelerator, it's likely that one of our off-the-shelf models (ranging from 1/2" to 10 3/4" ID) will do the job. Contact us and we will send you engineering data.

PEARSON ELECTRONICS INC

4007 Transport St., Palo Alto, California 94303
Telephone (415) 326-7285

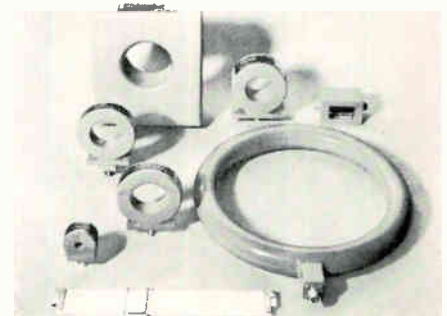

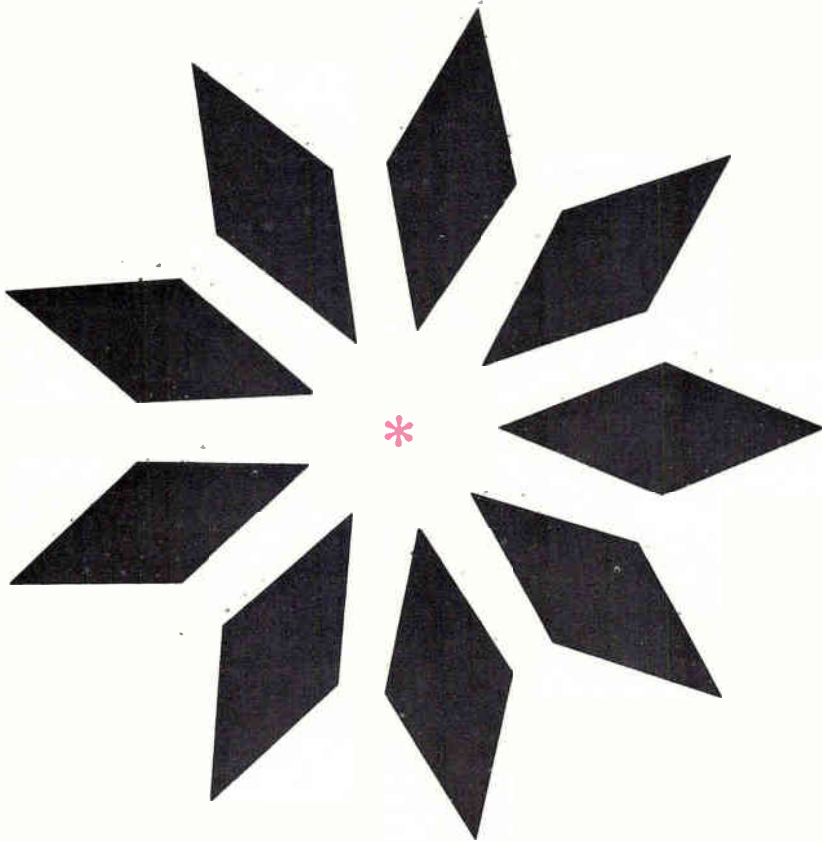

Complete HF Receive Antenna capability in a 50 meter circle

How Hermes did away with vast rhombic or log-periodic antenna farms shoed away by a shrewd array ...

Take 1 meter diameter loops 4 meters apart and get an omni directional broad-band receiving array.

covers 2 - 32 MHz

optimum beam characteristics for both long and short range communications.

Rosette configuration of linear arrays gives a number of overlapping high gain beams all available simultaneously.

* Using less than one hundredth of the real estate.

Aperiodic Loop Systems are shrewd enough for restricted space, quick set up, roof mountable, or just below ground level.

Governments and military agencies use them.

Give up the antenna farm. ASK US

Hermes Electronics Limited

Suite 315

2020 F Street N. W.

WASHINGTON

D.C., 20006

Telephone 202 296-2978

TWX 710-882-1106

portance of multiplexing, Deutsch says, "The first thing that strikes you when you look at the back of this organ and a conventional electronic organ is the lack of cabling."

The organ's computer, consisting of 22 MOS/LSI chips, is mounted on a circuit board 17.75 inches long, 11.5 in.-wide and 1-in. thick. Optional is an alterable random-access memory that provides for storing additional waveforms that give the organ four more voices. These digital waveforms are read into memory using punched cards and a card reader built into the console.

Converting the usual analog procedures of an electronic organ to a digital format was complex enough, but the really tricky part of the operation was digitizing the actual tones produced by a pipe organ to give the most natural sounds.

To give Allen Organ a variety of sounds to choose from, NRMEC first recorded the pipe organ sounds on analog tape and put them through a 12-bit a-d converter. The resulting digital tape went through a computer program that generated a harmonic analysis of the waveform. Then the computer drove a plotter to print the harmonic analysis of a given wave-shape in decibels. This was then compared to the printout of the harmonic analysis of a synthetic waveform.

The digital content of the synthetic waveform was encoded onto punched cards. These were fed into a special voicing device that NRMEC engineers built to be played like an organ so that Allen Organ's musical authorities, including Jerome Markowitz, president, could listen to the tones to see how closely they approach genuine pipe organ sounds.

NRMEC provided Markowitz with five punched cards per tone, each representing a different volume. From these, Markowitz chose what he considered the proper loudness to duplicate the pipe organ's sound for the same tone.

Deutsch reports, "We're now almost fully automated from the decibel input point to what goes into the ROM masks. The programs exist to do this fully automatically," he says. □

Commercial electronics

Bankers call for more EDP help

Committee urges electronics systems for authorization, point-of-sale, interbank transactions; some companies move even before standards are set

by Jim Hardcastle, Washington bureau

Conservative by nature, most bankers instinctively would rather invest in high-grade securities than in expensive electronics systems. But as businessmen with an obligation to protect profits, they're listening carefully to a report by their trade group that urges implementation of a multibillion-dollar electronic payments system to dam the flood of paper threatening to swamp banks.

The stakes are high, because "to remain static with the present payments system and rely too heavily on the check processing method of funds transfer would be a costly mistake" for the banking industry, says the American Bankers Association's monetary and payments system planning committee. Wrapping up a two-and-a-half-year study of the nation's payments and money-transfer systems, the committee recommends an all-electronic system that ultimately would make the bank credit card the successor to cash and checks [*Electronics*, May 10, p. 57]. The group also is plumping for a paperless approach to transferring money between banks.

The system as envisioned in the report could develop into a huge market for computer, communications, and terminal companies. But the electronics firms, familiar with the banks' slow progress in implementing systems and their propensity for retaining close control over any innovations affecting banking, are proceeding cautiously.

Meanwhile, the committee predicts that the computer-based credit authorization networks the major card plans are building to reduce their enormous losses to fraud

and bad debt—\$115 million in 1970—soon will be interfaced to ease the load on the merchant. The logical next step would be to expand the networks to capture point-of-sale data for the merchant's computer, while inputting charge account debits into the card plan's computer. Ultimately, the whole system could be used as an electronic funds transfer system.

Both authorization and transaction networks require merchant terminals, and these represent the largest market for electronics companies. Dale Reistad, a former director of automation for the ABA and now president of Payment Systems Inc., New York, predicts that terminals will be needed at eight to 10 million locations and says their total value could be \$10 billion. But the ABA committee report offers a word of caution for the 60 or more firms marketing card authorization terminals: "The glue that will hold all of the various systems together will be the vigorous pursuit of standards."

Bankers eliminated many product offerings from the bank card market when they proposed a dual-intensity, magnetic-stripe encoding

standard, points out Edward Piehl, an ABA standards aide [*Electronics*, March 29, p. 46]. "There were 22 different encoding technologies recommended, and there are at least 10 more around that I know of," he says. This summer, Piehl continues, more terminals may be knocked out of the running when the bankers complete their specification for credit card authorization terminals.

The standard will require that terminals be able to read a magnetic-stripe code and accept a manually inputted amount, Piehl says. For security, it may also require a merchant identification feature. Since "banks have to look to the future and the conversion from a credit card to a transaction card," Piehl says the standard also will require that terminals be modularly expandable.

Despite the uncertain status of the banker's standards, however, several manufacturing giants are introducing new equipment that they hope will give them a leg up in the terminal market. Perhaps the most ambitious product—a magnetic-stripe credit authorization terminal—is being shown by Burroughs

Authorizer. Burroughs credit authorization terminal is intended for retail outlets.



Best Buy

in 1% Tolerance
1-Watt Zeners
SCHAUER
Immediate Shipment



No fragile nail heads
All welded and brazed assembly
Gold plated leads

Low Prices

ANY voltage from 2.0 to 18.0

Quantity	Price each
1-99	\$1.07
100-499	.97
500-999	.91
1000-4999	.86
5000 up	.82

Write for complete rating data and other tolerance prices.

Buy The Kit!

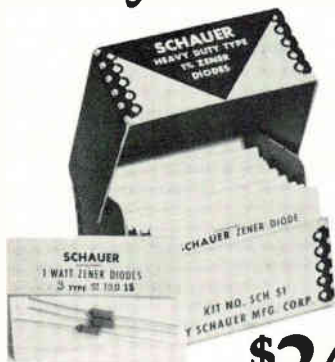

A
\$54.57
value
for
only

\$24⁵⁰

Kit contains a 51-piece assortment of SCHAUER 1% 1-watt zeners covering the voltage range of 2.7 to 16.0. Three diodes of each voltage in reusable poly bags. Stored in a handy file box. Contact your distributor or order direct.

Semiconductor Division

SCHAUER

Manufacturing Corp.

4514 Alpine Ave. Cincinnati, Ohio 45242

Telephone: 513/791-3030

Corp., Detroit, whose equipment is used widely by banks.

The unit—the TU-300—is designed for use in volume retail outlets, which handle 80% of the credit card transactions. The unit automatically reads the card once it is inserted, dials the proper credit authorization center, and transmits the account number, merchant identification code and transaction amount to the center. If the approval is pulsed back, the terminal prints the captured data on the credit card slip, along with a computer-generated code that proves the transaction was authorized.

On a referred transaction, a lighted panel instructs the operator to lift the phone from the acoustic coupler and talk to the credit center. If credit is denied, the machine automatically ejects the card and sales invoice. The unit will be leased for \$40 a month.

IBM takes another approach. Its model 2730 magnetic-strip terminal is an austere machine with a low purchase price—\$515 [*Electronics*, March 15, p. 34]. In essence, the unit is a magnetic card reader with a Touch-Tone pad for entering the amount of the transaction. To enter an authorization query, the user slips the buyer's card into the terminal next to another magnetic card encoded with the merchant's identification number. He then slides the reading heads to a start position, dials the authorization center, and enters the card data into the center's computer by releasing the head. The transaction amount is entered by tapping the numbers on Touch-Tone keys. Response is via voice answerback.

To make use of IBM's low terminal costs, however, the data center would have to invest heavily in

EDP. ASCII-coded credit card and FSK-coded Touch-Tone data must be translated into a common digital format by a model 2968-9 control unit that sells for \$44,000 in its simplest four-line configuration. On top of this must be added the cost of IBM voice answerback units. For example, a 32-word vocabulary unit that handles four telephone lines sells for \$59,000.

Meanwhile, American Telephone and Telegraph Co. is making a determined pitch for its punched-card-reading Touch-Tone telephone [*Electronics*, Feb. 1, p. 21]. Armed with a reader that leases for \$3.50 a month and a new \$3-a-month automatic dialing service AT&T reportedly has convinced the New England Bankcard Association to give its system a field trial.

Punched credit cards will never be used, though, in transactions where an interchange is needed between credit centers because the cards don't meet banking standards, says Gerald Lowrie, staff director of the ABA's committee. He concedes, however, that the punched cards could be used within a bank charge card plan. Howard J. Deinel, AT&T marketing manager for the service, points out that the punched-hole configurations do not interfere with magnetic-stripe encoding.

Other manufacturers, however, are waiting for the dust to clear before they enter the terminal market. Victor Casebolt, a vice president of Honeywell Information Systems, Minneapolis, says his firm has an active interest in credit terminals. But he notes that "our direction will be dictated by standards and market acceptance—two key areas that have to be more clearly established." □

Paper and profits

Elimination of paper is the main goal of the American Bankers Association's recommendations for implementing an electronic payments system. But even if paperless payment systems start up, a study conducted for the group by Arthur D. Little Inc. says, check volume will still grow from the 21.5 billion checks reached in 1970 to more than 43 billion by 1980. The banking industry is capable of handling this volume—but only at a tremendous cost.

Thus, if banks maintain their dependence on the check, "rising labor costs will continually expand the relative costs of banking operations," the ABA committee's report says.

Computers

Silicon disk memories beat drums

Low-power, solid state analog of motor-spun disk and drum memories costs twice as much per bit, but it offers 100-fold speed gain

by Stephen Wm. Fields, San Francisco bureau manager

Far faster now than they were 10 years ago, rotating disk and drum memories still haven't kept up with the rapidly increasing speeds of central processors and in fact are falling farther behind. Most systems people say the electromechanical technology has run out of wind. But a solid state analog, the silicon disk, is moving along fast, and some feel it offers the most economical way to fill the "memory gap" between present cpu and low-cost peripheral speeds.

In a silicon disk memory system, MOS shift registers are connected together electrically and are clocked to read in, recirculate, and read out stored data, thus simulating disk rotation. Unlike normal shift registers, the silicon disk shift register chip contains all of the circuitry for controlling these recirculating functions. And so, with a minimum of external decoding circuitry, the silicon disk can connect directly to an input-output channel; no software changes are necessary. Silicon disks have another advantage: they are designed for low power consumption. And they "idle" at a slow rate, consuming less than 1 watt in a million-bit system, for example.

First announced a year ago by Advanced Memory Systems, Sunnyvale, Calif., these special shift registers are also being made by National Semiconductor Corp., Santa Clara, Calif., and Signetics Corp., Sunnyvale, Calif. The latter two sell the registers and also offer design help to prospective silicon disk users. Advanced Memory Systems only sells complete systems.

"In systems storing several million bits, magnetic disks cost about

a half a cent per bit or less, while disks built with these new shift registers will cost about a penny per bit," admits Dale Mrazek, manager of digital systems applications at National Semiconductor. But the silicon disk is up to 100 times faster than a typical low-cost electromechanical system and "speed is still an important factor in computer economics—the silicon disk can help a computer do twice as much work by minimizing data transfer delays," he points out.

"Hardware, software, and overhead can make a \$20,000 computer worth \$50,000 to its owner. Consequently, any peripheral that helps the computer do 20 to 50% more work is worth from \$10,000 to \$25,000," he reasons. And \$25,000 is the price range of a 1-2.5-million bit silicon disk system. For example, AMS has a 32,000-word-by-32-bit system—1 million bits—that sells for \$17,826.

Silicon disks aren't limited to large computer applications, however. According to George Rigg, manager of memory systems applications at Signetics "the minimakers are looking at silicon disks as well . . . It's more attractive to the minimaker if he can include a disk system within the same package as the computer—the lower power requirements and the high density of a silicon disk system will allow him to do this." AMS says it has two such customers for its silicon disk systems.

National, Signetics, and AMS are all after large computer users, as well as minicomputer makers and users. Signetics has a 1,024-bit shift register with internal recirculate, chip select, and output gating—the model 2512—available now for silicon disks, and Rigg says that a dual 512 is in the lab. Although both store the same number of bits, the dual configuration offers a faster

Circulation. Silicon disk memory systems like AMS Mini Semiconductor Storage unit shown below simulate rotation of magnetic disks and drums.

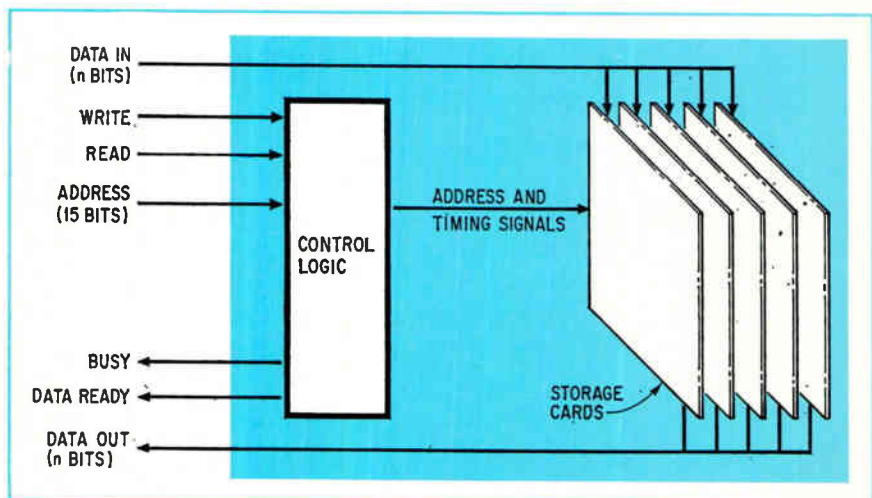

HICKOK Digital Measuring System



3 1/2 DIGIT MAIN FRAMES FROM \$385



This all-solid-state precision measurement system offers unlimited expansion capability through plug-in additions, resulting in a specialized instrument for each type of measurement. New plug-ins now broaden the measurement capability of this field-proven unit.

Scaling controls make possible resolution of up to seven digits on the three-digit display by utilizing the overrange capability of many of the plug-ins, thus providing high resolution and accuracy with minimum investment. Companion devices such as the 4900 Digital Printer and 1050 Digital Set-Point Controller further extend the utility of the 3 1/2 Digit 3202 System.

- | | |
|--|--------------|
| DC VOLTMETER PLUG-IN DP 100 | \$150 |
| 00.1 mV to 1500. volts
± 0.1% rdg ± 1 digit | |
| DC MICROVOLTMETER PLUG-IN DP 110 | \$475 |
| 0.001 mV to 1300. volts
± 0.05% rdg ± 1 digit
4-digit resolution | |
| AC VOLTMETER PLUG-IN DP 130 | \$395 |
| 0.01 mV to 1000. volts
± 0.1% rdg ± 1 digit
22 Hz to 1.0 MHz | |
| EVENT COUNTER/SLAVE PLUG-IN DP 140 | \$100 |
| Up to 1,000,000 counts/sec
Cascade with second DMS to
obtain 6-digit display | |
| 1 MHz COUNTER PLUG-IN DP 150A | \$255 |
| 0.1 Hz to 1 MHz
± 0.0005% rdg ± 1 digit
7-digit resolution | |
| 100 MHz COUNTER PLUG-IN DP 160 | \$395 |
| 00.1 Hz to 100.0 MHz
± 0.0005% rdg ± 1 digit
7-digit resolution | |
| OHMMETER PLUG-IN DP 170 | \$305 |
| 0.001 ohm to 1000. megohms
± 0.1% rdg ± 1 digit
Microamp test current | |
| CAPACITY METER PLUG-IN DP 200 | \$305 |
| 0.001 picofarad to 10.00 millifd
± 0.1% rdg ± 1 digit
Low DC test voltage | |
| TIME INTERVAL METER PLUG-IN DP 210 | \$295 |
| 0.01 ms to 1,999. seconds
± 0.0005% rdg ± 1 digit
Period or time interval | |
| DC CURRENT METER ADAPTER D 310 | \$100 |
| .0001 microamp to 13.00 amps
± 0.15% rdg ± 1 digit | |

HICKOK

INSTRUMENTATION &
CONTROLS DIVISION
10514 Dupont Ave.
Cleveland, Ohio 44108
Phone 216-541-8060

Probing the news

access time. For example, Rigg says that the 1,024-bit unit operating at 2 megahertz yields a maximum access time of 512 microseconds with the typical time being 256 microseconds. But the dual 512 will offer a maximum access time of 256 microseconds and a typical time of 128 microseconds.

National presently has a dual 256-bit shift register, the MM5012, that includes gating for data-input and data-output steering, and three levels of decoding logic. It also has tri-state outputs that allow many registers to time-share a data bus. Maximum access time is 128 microseconds. And Mrazek says that a quad 256 is in the works.

AMS has developed two types of silicon disk memory systems, which it calls Semiconductor Storage Units (SSU). The larger storage units are 1- to 8-million-byte systems aimed at IBM drum replacement and connect directly to an IBM data channel. The smaller systems are called SSU/M and are intended to be used with minicomputers and smaller systems. The controller for the SSU/M is not included in the package since the unit is an OEM item—the mini manufacturer will provide this. The SSU/M stores 32,000 words of 8, 16, 32, or 64 bits each.

One of the primary causes of failure in a semiconductor system is heat or chip power level. To reduce this, the three companies have all designed their systems so that they operate on a two-speed cycle. Data is circulated around the shift register loops at low speed until it is needed.

AMS has had a unit out on field trial with a major insurance company since last October. The primary purpose of the trial was to test out the IBM interface—it worked. And now AMS plans to ship its first system by the end of this summer. One of the first customers will be Bell Laboratories in Naperville, Ill. Bell, which will use the SSU with an IBM 360/67, has asked for two special instructions—read page and write page. These two commands will allow 4,096 bytes of data, or one page, to be transferred in one shot. □

This new IEC 10 MHz Function Generator has a couple of things going for it!

(like sweep & phase lock)

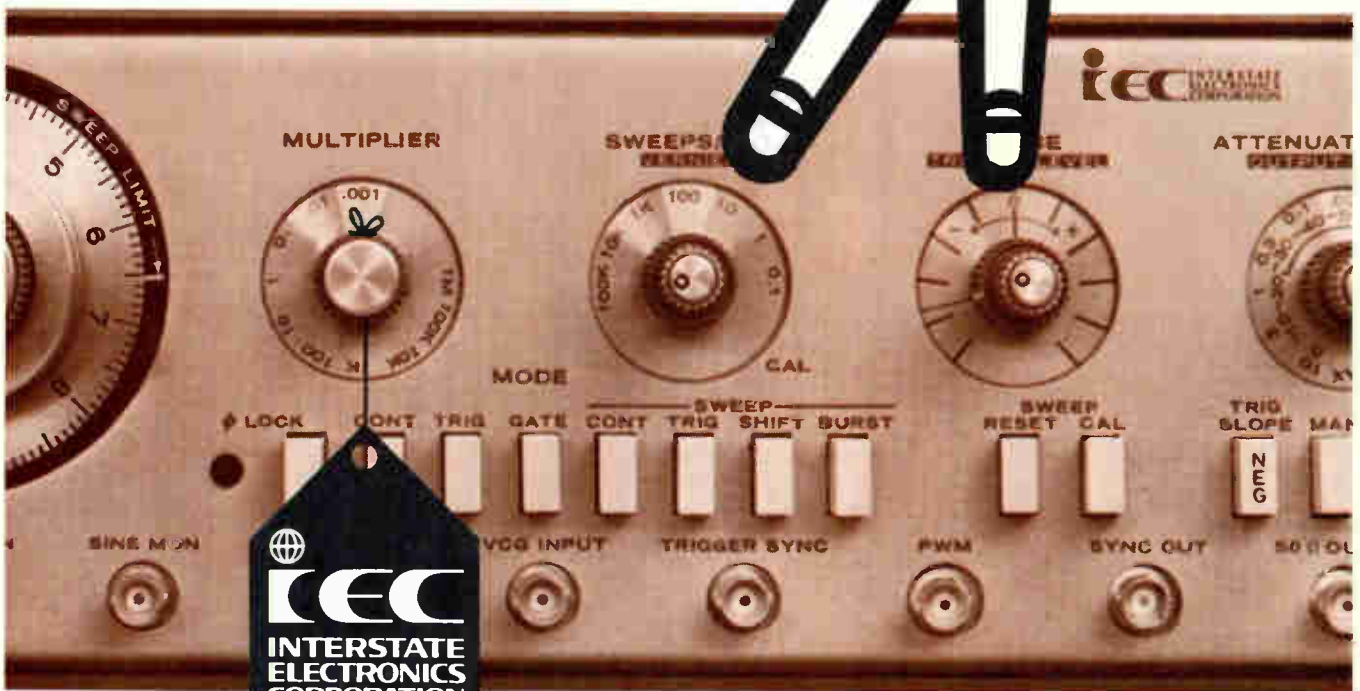
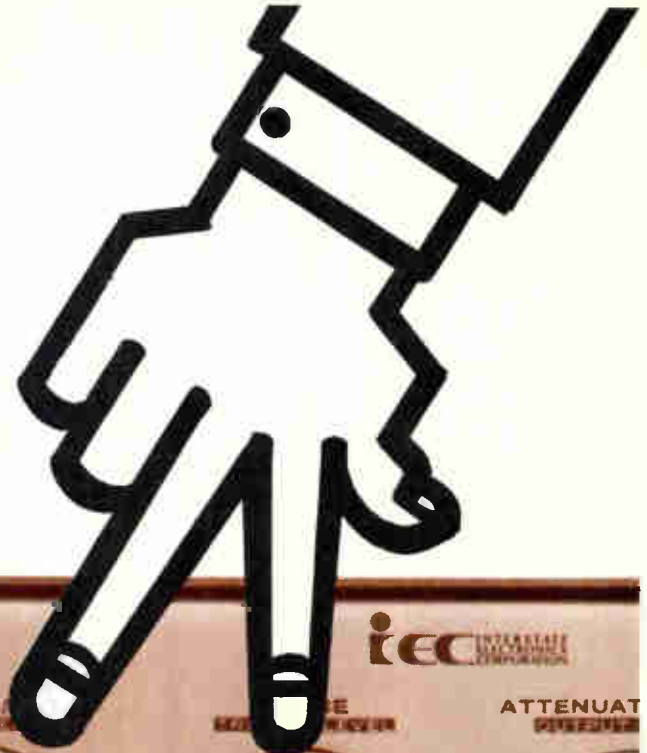

**INTERSTATE
ELECTRONICS
CORPORATION**

A Subsidiary Of A-T-O Inc.

Dept. 7000, Box 3117
Anaheim, Calif. 92803
(714) 772-2811,
TWX 714-776-0280
Telex Nos.
655443, 655419

And that's not all. Sweep and phase-lock are just two of the numerous features that distinguish this new IEC 0.0005 Hz to 10 MHz all-purpose test instrument. For example, trigger/gate, and calibrated output attenuation. The F55. The Great One. Top of the Series 50 line that includes four other brand new function generators. What do they have in common besides superb performance? 10 MHz capability, fixed and variable offset, variable width pulses as well as fixed width pulses and ramps, simpler man/machine interface and much, much easier maintainability. That's what. Plus the special features of each model, such as the sweep and phase-lock blend of the F55.

Depending on requirements, there's a particular Series 50 model that's exactly right for your needs. And priced accordingly, from \$595 up. Like a look? Call, TWX, write or wire our John Norburg at Interstate today. Ask for a demonstration. Get a new IEC Function Generator going. For you.



Announcing new
Sperry display devices!
At \$2.30* per digit--

it's a whole new ball game

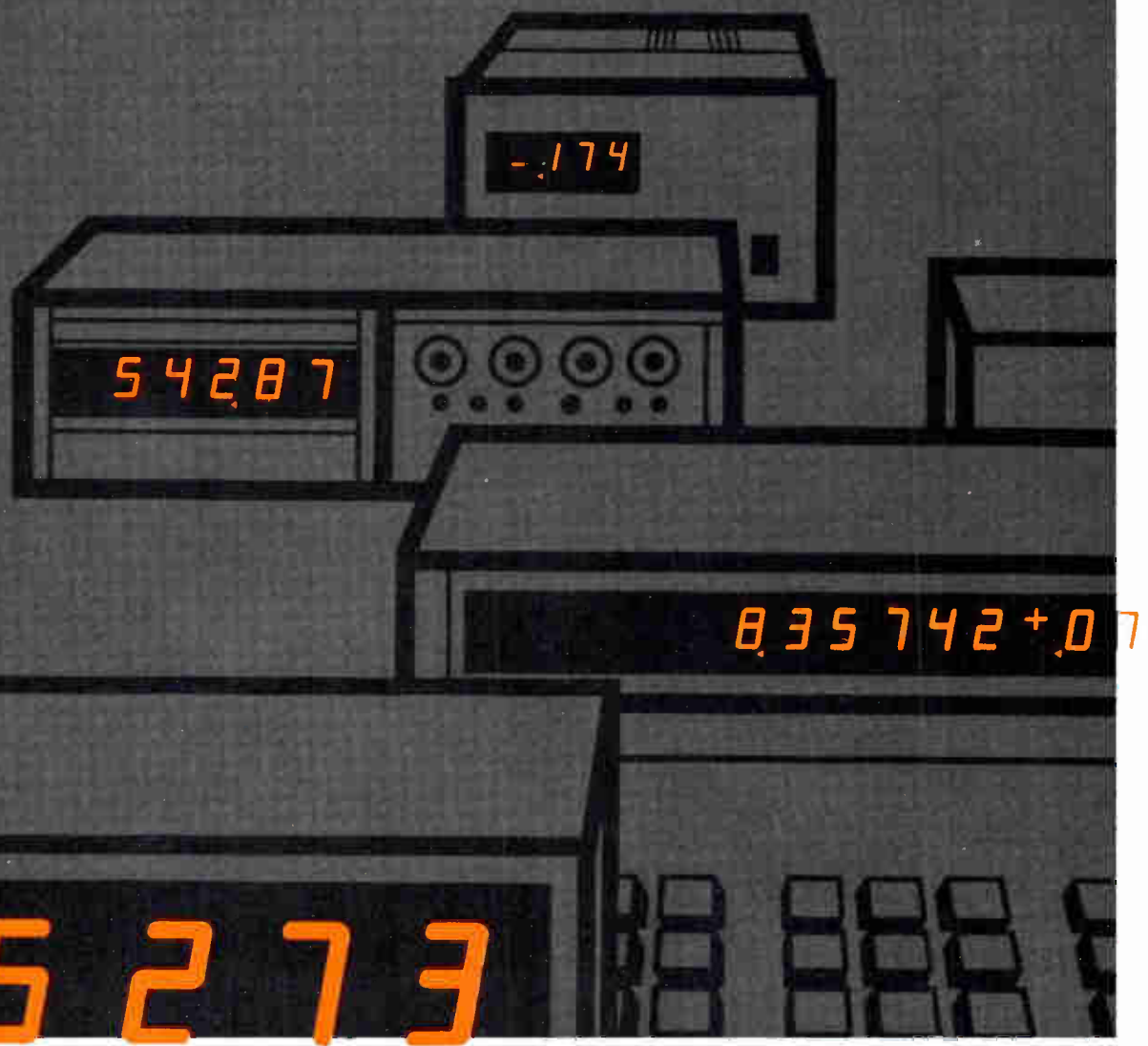

value — the result of design and fabrication breakthroughs. New Sperry seven-segment display devices† offer significant advantages over others on the market. High visibility and outstanding performance at a remarkably low cost make them especially suitable for use in calculators and other business machines, test and measurement instruments, process control equipment and many consumer products. Take a look at these major Sperry advantages.

Greater clarity and brightness — Sperry displays are bright, crisp, and very easy to read. The pleasing orange glow provides excellent character definition and gives the segmented figures the appearance of continuous script. They're highly readable under all lighting conditions — not overpowering in soft light, yet clearly legible in direct sunlight.

Preferred character size and spacing — Offering a character height of 0.33" with 0.375" centerline spacing, Sperry displays have the appearance of printed figures.

The uniform spacing is retained. The reduced size permits engineers to save critical housing space without loss of readability.

Wider viewing angle — Advanced planar design permits Sperry displays to be read accurately within a 150° viewing angle. Characters are housed on a flat plane so all figures are displayed equally bright and clear regardless of combination.

Reduced current requirements — Sperry devices rank among the lowest. Typical current drain is only 200 μ A per segment or 1.4 mA for a figure 8. Power dissipation is just 200 mW. Displays operate on 170 volts DC so they can be used in existing equipment without redesigning the power supply.

Multiplex capability — A single decoder/driver may be used to multiplex several decades without impairing the appearance of the display. In standard applications, a decoder/driver can be used for each digit.

The cold cathode, gas discharge principle utilized in the new Sperry display device has proven reliable in thousands of applications including a number of cockpit instruments aboard the Boeing 747. Sperry displays have a useful life expectancy in excess of 100,000 hours.

A full line of accessories is available, including connectors, decoder/drivers, and multiplex boards for horizontally stacking and multiplexing.

For complete technical information on new Sperry display devices, use this publication's reader service card or phone or write:

Sperry Information Displays Division
P.O. Box 3579, Scottsdale, Arizona 85221
Telephone (602) 947-8371

SPERRY
INFORMATION DISPLAYS

n display devices!



The Sperry SP-733 (3-digit model), actual size. Also available are 2 and 1½ (a † device with a figure 1 and a full 7-segment character) digit models.

*Price is based on 5,000 quantity.

†Patents Pending



Circle 89 on reader service card

TRW capacitors pin down most any set of specs

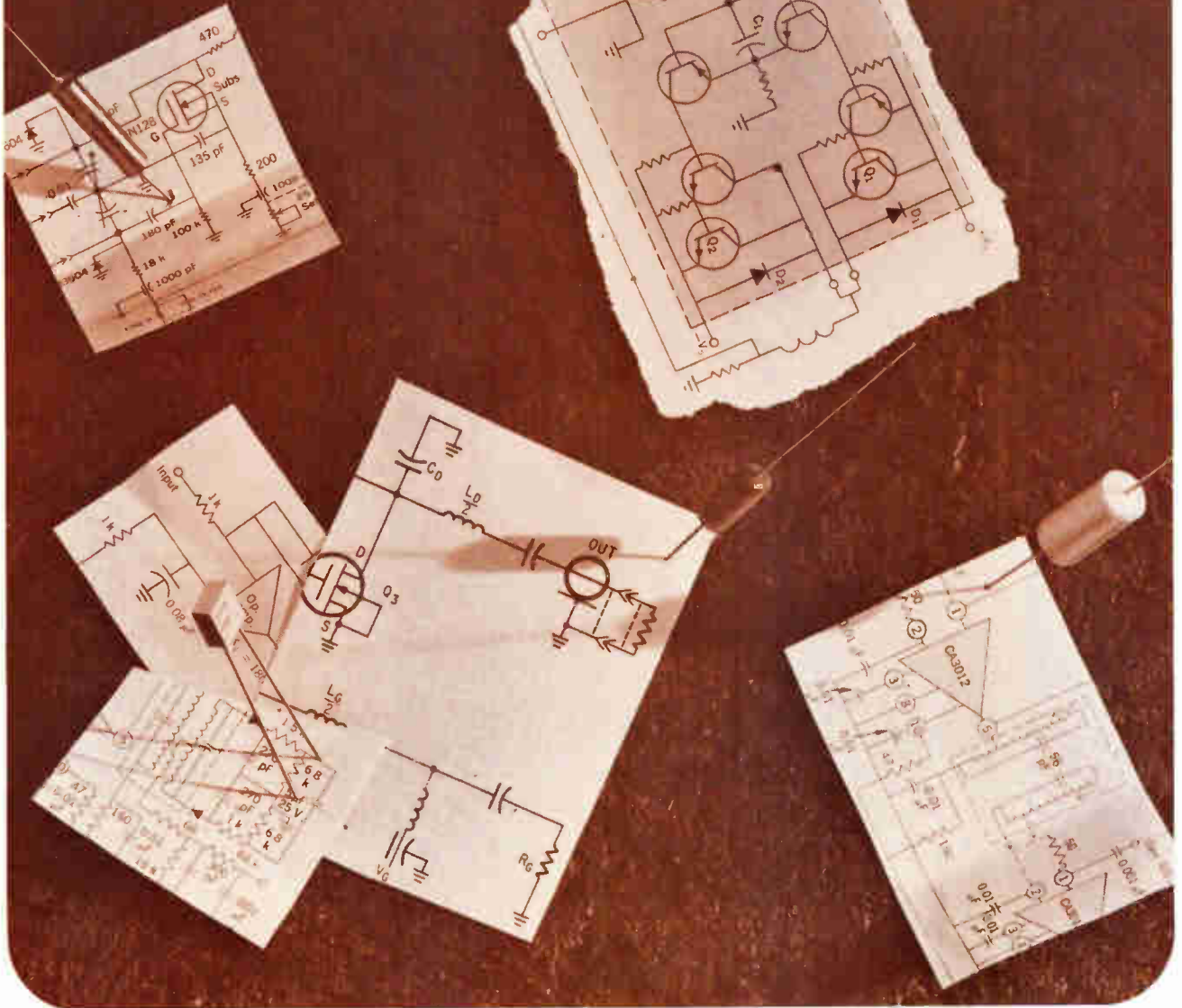

TRW makes capacitors in all shapes and sizes, in standard values from .001 mfd to 10.0 mfd.

For dielectrics, choose from tantalum, Mylar,™ metallized Mylar, polystyrene, polycarbonate, metallized polycarbonate or combinations. Other dielectrics including H-film are available on a special order.

TRW capacitors are available with axial or radial leads, in hermetically sealed metal, tape wrap, epoxy

dip, molded or preformed cases.

We combine technological and volume production capabilities to hold the highest performance and reliability standards throughout your longest production runs.

When you need capacitors for any purpose, check with your TRW distributor or write TRW Capacitor

Div., Box 1000, Ogallala, Nebraska 69153. Phone (308) 284-3611. TWX 910-620-0321.

TRW®

Reactor deposits GaAsP films for light emitters

by Stephen E. Scrupski, Packaging and Production editor

Commercial three-zone unit for epitaxial process offers automatic timing and temperature control

Although most pundits predict bright futures for light-emitting diodes, there are relatively few producers of the devices, primarily because of the difficulties in setting up the production facilities—which are far greater than those of producing devices in silicon. But the technology should spread around a little more now with the introduction of the first commercially available epitaxial reactor for gallium-arsenide-phosphide films on gallium arsenide substrates. The reactor was developed by Applied Materials Technology Inc.

It is a three-zone, radio-frequency-heated system enclosed in a single 5½-by-20-inch bell jar. It will handle seven 1¼-by-2-inch elliptical wafers. Reactants are introduced through a hollow, rotating substrate holder pedestal.

The reactor has several features that allow both it and the personnel that operate it to function efficiently. Up to five runs can be made without cleaning it. Automatic time sequencing, and programmed automatic flow and temperature control provide films of precise gradient, composition, and dopant level. The system also is designed to be leak-proof, and it uses interlocks to protect against erroneous operation and unsafe operating conditions.

With the reactor, film thickness uniformity is guaranteed at $\pm 20\%$, carrier concentration is better than $\pm 20\%$, phosphorus concentration is better than $\pm 0.5\%$, and deposition cycle time is 2½ to 5 hours for film thicknesses of 50 to 150 microns.

In operation, HCl/H₂ is introduced into the reactor through an inlet tube and passes upward to the gallium source chamber, which is maintained at 900°C. The reaction there forms GaCl, which exits

peripherally from the chamber and flows downward. PH₃/AsH₃ dopant enters through a concentric tube around the HCl inlet and mixes with the downflowing GaCl/H₂ immediately below the Ga source at a temperature of 925°C. The combined gases continue downward to enter a region of reducing temperature gradient located in a rotating carousel. Mounted to this carousel are wafer carriers on which the LED substrates are placed. It's in this area that the deposition finally oc-

Controlled reactance. Electronic flow sensing in epitaxial reactor helps assure precision films, guards against erroneous and unsafe operation.



Miniature switches from Raytheon?

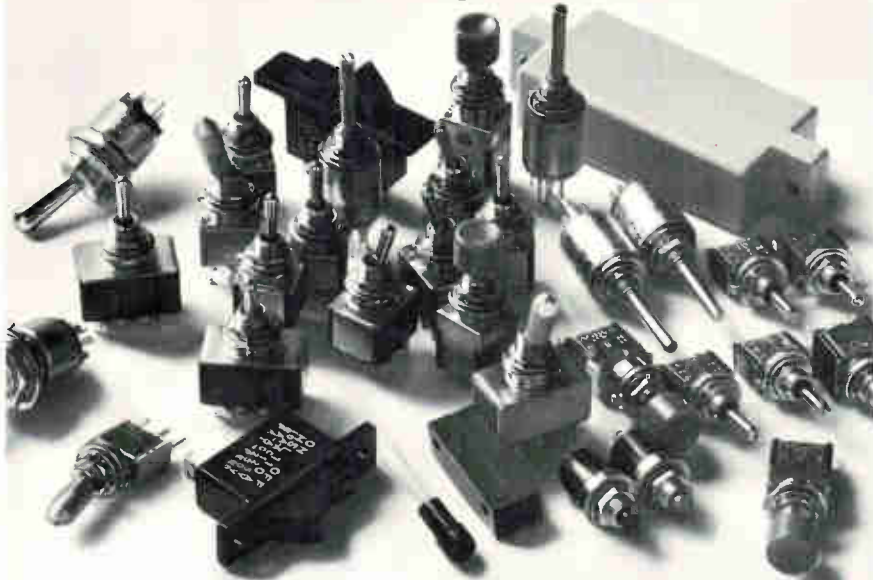

Now that's a switch.

When Raytheon creates a brand new line of miniature panel switches and lights, you can be sure of high quality. But there's more. Our new Rayswitch line includes all the popular rotary, toggle, push-button, proximity and rocker type designs.

There's a Raytheon switch perfect for your panel, whether the application is anything from advanced test equipment to computer peripherals. So next application, switch to Rayswitch. Just call your Raytheon representative. For a copy of our catalogue, write Raytheon Company, Distributor Products Operation, Fourth Avenue, Burlington, Mass. 01803.

RAYTHEON

Circle 92 on reader service card

FIGHT THEM ALL...

Heart Attack
Stroke
High Blood Pressure
Rheumatic Fever



GIVE ...SO MORE WILL LIVE HEART FUND

New products

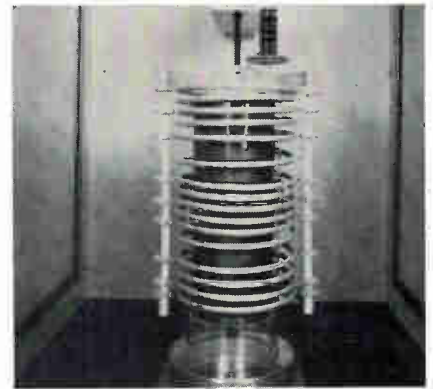

Film maker. Rf coil heats reactor that can handle seven wafers.

Control of the temperature gradients and rotation of the carousel insure control of wafer-to-wafer and within-wafer uniformity.

A curtain flow of hydrogen is set up between the carbon susceptor cylinder—which is heated by rf energy—and the bell jar to reduce the deposition of reactants in unwanted areas. There also is a continuous flow of nitrogen in the reactor chamber when the system is open to the atmosphere.

Temperature is monitored with quartz-encased thermocouples located in each of the three principal zones—the gallium monochloride generator, the GaCl- PH_3 - AsH_3 mixing zone, and the deposition zone.

The automatic flow control system uses electronic flow sensing, with digital readout and program-actuated pneumatic valves, to assure that flow repeatability will be within $\pm 0.15\%$ of the set point over 80% of the operating range. All monitored and programmable functions are displayed on the front control panel. The time sequence programmer displays the position of a process in the total sequence and the total elapsed time in any given sequence.

The reactor requires floor space about 70 inches wide by 48 in. deep by 97 in. high, 120 volts ac at 50 amps, and water at 1 gallon per minute at 40 psi.

Price of the basic system is \$69,000. Delivery time is 12 weeks.

Applied Materials Technology Inc., 2999 San Ysidro Way, Santa Clara, Calif. 95051 [338]

Signetics announces 19 silicon gate MOS circuits. In silicone packs.

8 Pin Silicone DIP — "V" Package

2503V	Dual 512 Dynamic Register	(10 MHz)
2504V	1024 Dynamic Register	(10 MHz)
2506V	Dual 100 Dynamic Register	(5 MHz)
2507V	Dual 100 Dynamic Register	(5 MHz)
2517V	Dual 100 Dynamic Register	(5 MHz)
2521V	Dual 128 Static Register w/Logic	(3 MHz)
2522V	Dual 132 Static Register w/Logic	(3 MHz)
2524V	512 Dynamic Register w/Logic	(5 MHz)
2525V	1024 Dynamic Register w/Logic	(5 MHz)

14 Pin Silicone DIP — "A" Package

2509A	Dual 50 Static Register w/Logic	(3 MHz)
2510A	Dual 100 Static Register w/Logic	(3 MHz)
2511A	Dual 200 Static Register w/Logic	(3 MHz)

16 Pin Silicone DIP — "B" Package

2501B	256 Static Random Access Memory (750ns AT)	
2502B	Quad 256 Dynamic Register	(10 MHz)
2518B	Hex 32 Static Register w/Logic	(2 MHz)
2519B	Hex 40 Static Register w/Logic	(2 MHz)

24 Pin Silicone DIP — "NX" Package

2513NX	64x8x5 Static Row Output Character Generator (ASCII, Katakana Fonts)	(450ns AT)
2514NX	512x5 Static Read-Only-Memory	(450ns AT)
2516NX	64x6x8 Static Column Output Character Generator (ASCII Font)	(450ns AT)

These new silicon gate circuits, added to those we recently introduced, represent a solid Signetics commitment to silicon gate as the most useful technology in MOS. We intend to stand by this commitment.

Note that all of these circuits fill existing system needs.

To summarize: we now have nineteen silicon gate MOS circuits available in silicone packs; we don't intend to be all things to all people; and we introduce new products because you need them, not because they turn us on.



Signetics — MOS 811 East Arques Avenue
Sunnyvale, California 94086 • (408) 739-7700
A subsidiary of Corning Glass Works.

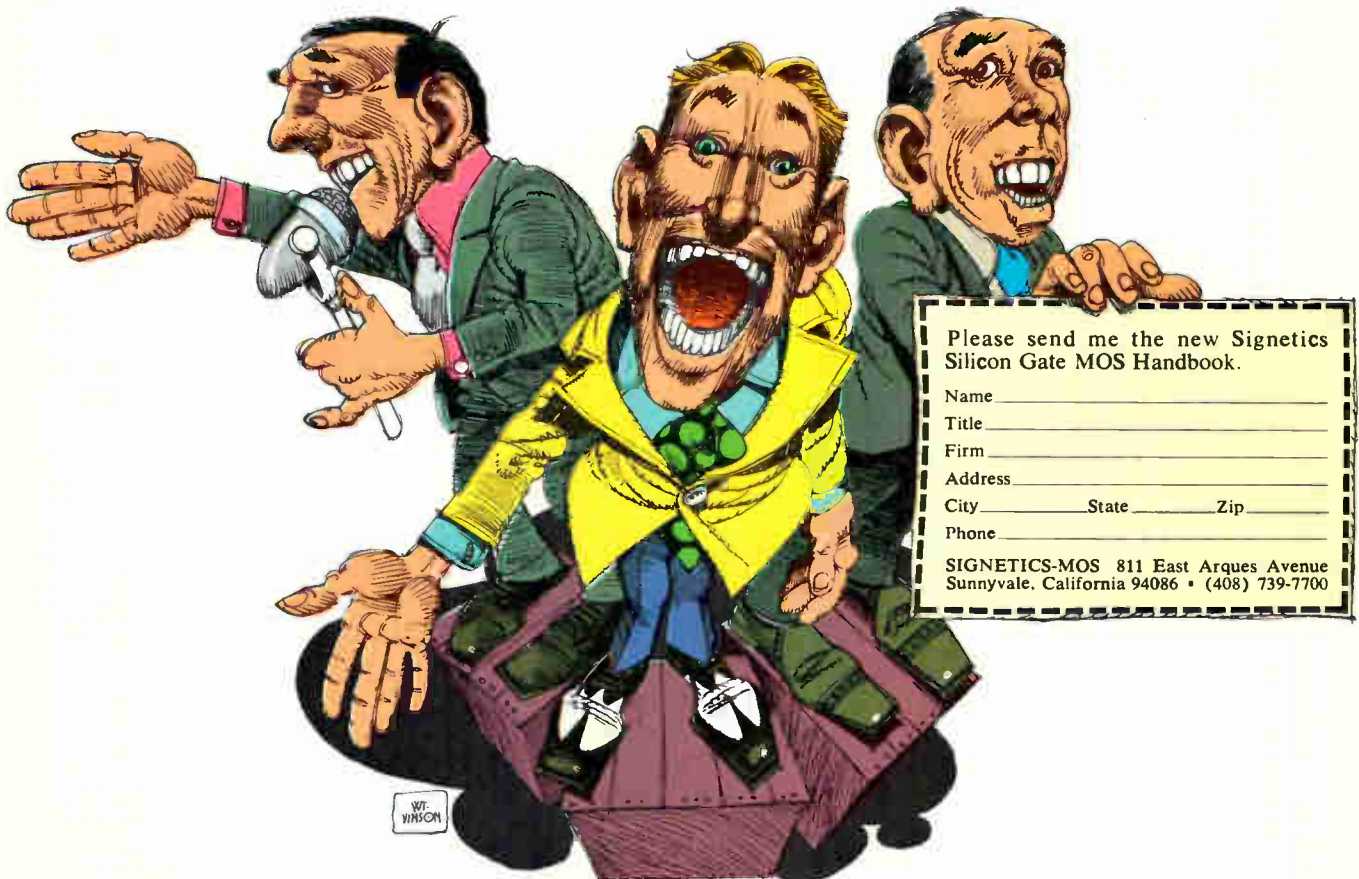

Please send me the new Signetics
Silicon Gate MOS Handbook.

Name _____
Title _____
Firm _____
Address _____
City _____ State _____ Zip _____
Phone _____

SIGNETICS-MOS 811 East Arques Avenue
Sunnyvale, California 94086 • (408) 739-7700

We asked 37 LSI/MOS experts to put in their 2¢ worth.

Announcing the 74¢ high speed tester.

Before designing our LSI/MOS tester, we asked 37 top semi-conductor experts to put in their two-cents worth.

Then we took their advice.

Figuratively speaking, this adds up to 74¢ of very good advice.

It also adds up to Spectrum One. The best MOS/Bi-Polar test system in the world.

Spectrum One is here. It's now. It's sensibly priced.

Thanks to 37 contributing experts. And our fine, experienced Xintel design team.

Spectrum One performs parametric and functional tests on P-Channel MOS, N-Channel MOS, Complimentary MOS, and Bi-Polar Devices.

Spectrum One has a 5 MHz functional test frequency with 10 nano-second dynamic test resolution. It also performs parallel parametric tests up to 10 KHz.

Spectrum One has a RAM test pattern memory of up to 1024 bits per pin. It can handle devices with up to 64 pins, using all solid state switching.

Spectrum One is computer-controlled with easy-to-use DOS (Disc Operating System) software, featuring multiple station operation.

Spectrum One is the product of a lot of valuable two-cents worth of advice.

Spectrum One has too many exciting features to cover here.

So send for your Spectrum One brochure. It's full of facts, figures, specs and diagrams. We'll also include a comparison chart of all the LSI-MOS testers available.

You'll get more than your 2¢ worth.



Xintel
Corporation

20931 Nordhoff Street, Chatsworth, California 91311 Telephone (213) 882-8811.

Circle 94 on reader service card

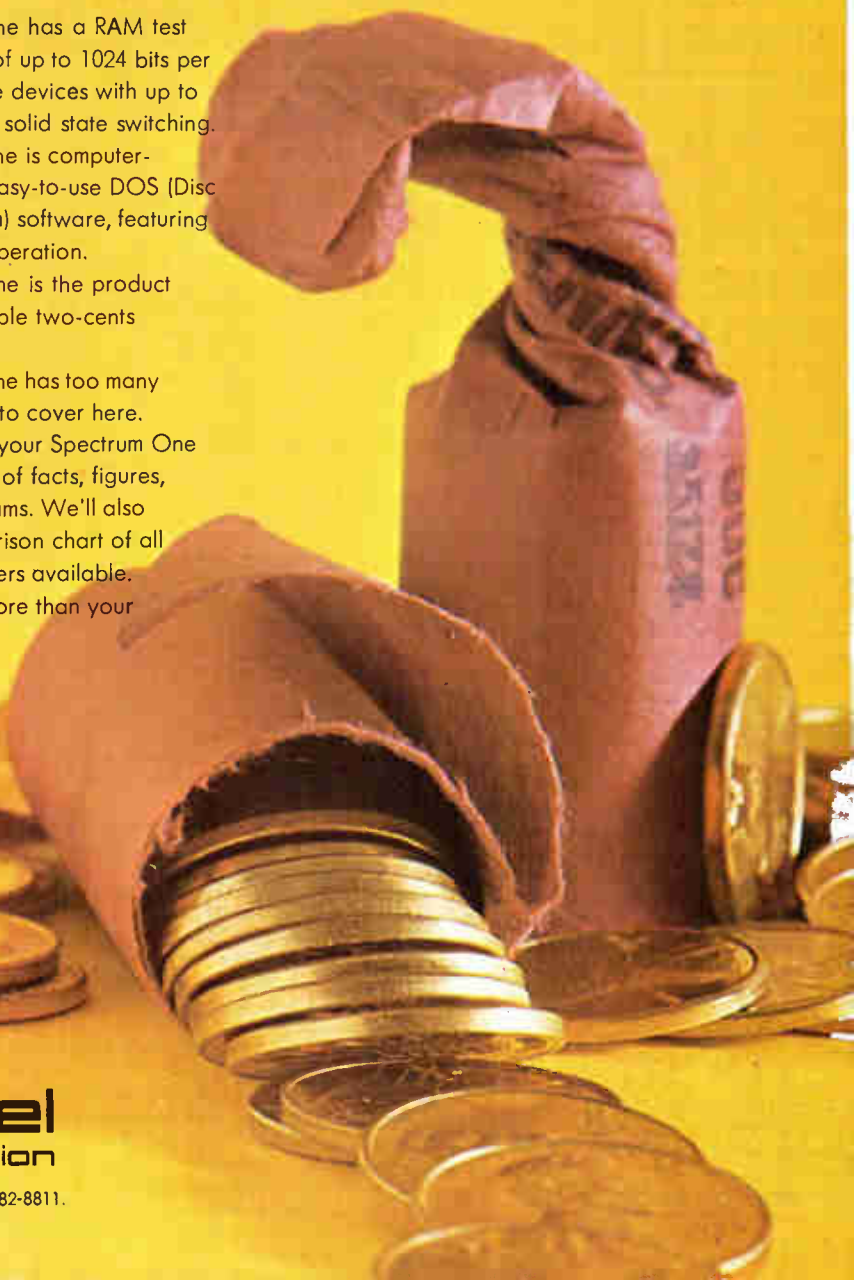

New products

Data handling

Digitizer plots, too

Cursor-pen position-sensing grid permits both operations on 42-by-60-in. drafting board

Eighteen months ago, Bendix's Computer Graphics operation announced a new type of system for digitizing graphical data. Last

week, at the Spring Joint Computer Conference, it closed the loop by introducing a plotter that translates digital data back into a draftsman's mechanical drawings, charts, or graphs.

The Datagrid Digitizer-Plotter actually can perform both functions, digitizing and plotting, on a board measuring 42 by 60 inches and at a cost estimated by the company as 25% less than that of a similar plotter alone. A clue to the lower cost is that the new unit does its job without the expensive precision rails, lead screws, encoders, or optical gratings of conventional plotter systems. "With these items, all you know is the position of the

stepper motors driving the plotting pen, not of the pen itself," says Vern Kamm, product director for Bendix Computer Graphics.

Instead, the new machine is designed around the Datagrid principle of position determination, first used in the company's original digitizer. This technique relies on a grid of conducting wires placed under the drafting board. Position of a digitizing cursor, or of a plotting pen, is sensed through magnetic coupling between the grid wires and a small magnetic coil placed in the mechanism moving over the plotting board. By processing the signals picked up on the grid wires, the center of the coil,

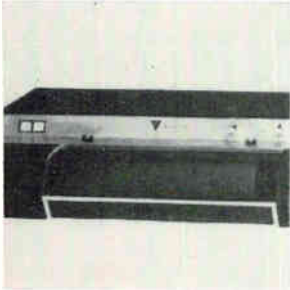

Graphic conversion terminal model GC-3 digitizes documents up to 11 in. x 17 in. at resolutions up to 200 optical lines per in. It is part of a hardware system including buffered digital magnetic tape recorder and visual monitor. System operates for off-line data preparation. Visicon Inc., State College, Pa. [341]

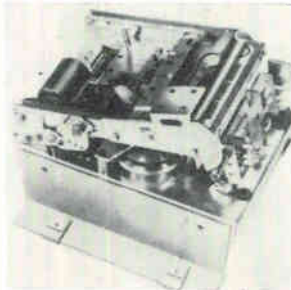

Digital cassette deck CAS-20 offers electrically adjustable speeds, single direction read-write from 1.5 to 15 in./s with dual direction search from 40 to 400 in./s. Device has three 10,000-hour-rated life brushless dc motors, file-protect sensor. Quantity price is \$96. Auricord Div.-Scovill, 35-41 29th St., Long Island City, N.Y. [342]



Variable time division multiplexer is for use in data communication networks. It is hard wired and does not require programming. Features include computer port contention - cross - mapping, universal line adapter, local or remote control, and flexibility. On Line Computer Corp., 370 Ludlow St., Stamford, Conn. [343]



Analog monitor 12101M1 continuously monitors and records magnitude of all three phases of voltage and frequency, including high speed transients of 2 ms duration or longer, and gives audible and visual alarms at the time of occurrence. Airoyal Manufacturing Co., 19 Gloria Lane, Fairfield, N.J. [344]

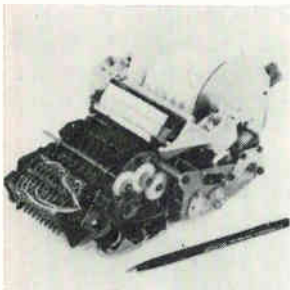

Digital printer 4501 consists of solenoid unit, timing, printing units. Options include ribbon mechanism or cassette, paper feed device, and motor. Printer operates at 3.5 lines/s with a maximum capacity of 20 columns, 12 or 17 characters per column. An OCR font is available. Facit-Ohdner Inc., Secaucus, N.J. [345]



High-speed terminal for corporate communications network has two buffers providing 50,000-character storage for send-receive, with speeds up to 2,400 b/s without interrupting data entry. Data entry devices can be Teletype or CRT with 2,000-character display. Wiltek Inc., 59 Danbury Rd., Wilton, Conn. [346]

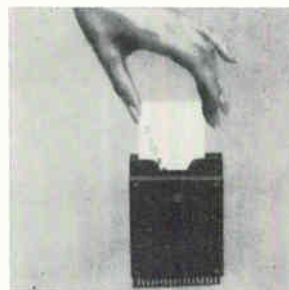

Reader for Hollerith-coded cards, badges is available in horizontal (CU 100HC) or vertical (CU 100VC) configurations. Models operate on low-level light source. Incandescent lamps, arranged in x-y matrix, drive TTL or DTL circuits. Price is \$75. Matsushita Electric Corp., 200 Park Ave., New York, N.Y. [347]



Optical scanners called Op-Scan 12 and 17 read documents from 2 x 4 in. to 8½ x 11 in. at throughput speed of about 300 documents/hr. Units accept handwritten block-printed numerics. Price for model 12 is \$3,500 or \$125/mo. rental; for 17, \$5,000 or \$195/mo. Optical Scanning Corp., Newton, Pa. [348]

Some day these tests may save your life...

because DCS VCO's and FM Demodulators are on the job today!

Whether your application is gathering test data from advanced automotive safety testing systems or from any transducer input . . . GOM-5 Series Voltage Controlled Oscillators will faithfully FM-encode your data for recording and future analysis. DCS FM Demodulators will reduce the recorded data to original format for accurate analysis and evaluation.

GOM-5 Series VCO's feature highest input sensitivities available. Our GFD-15 Demodulators interface with your computer or stand alone as the finest unit available.

**Circle Reader Service Number
for Free Application Data**

Data Control Systems, Inc.
Commerce Drive
Danbury, Conn. 06810
Tel: (203) 743-9241
TWX: 710-456-0376



DATA CONTROL SYSTEMS, INC

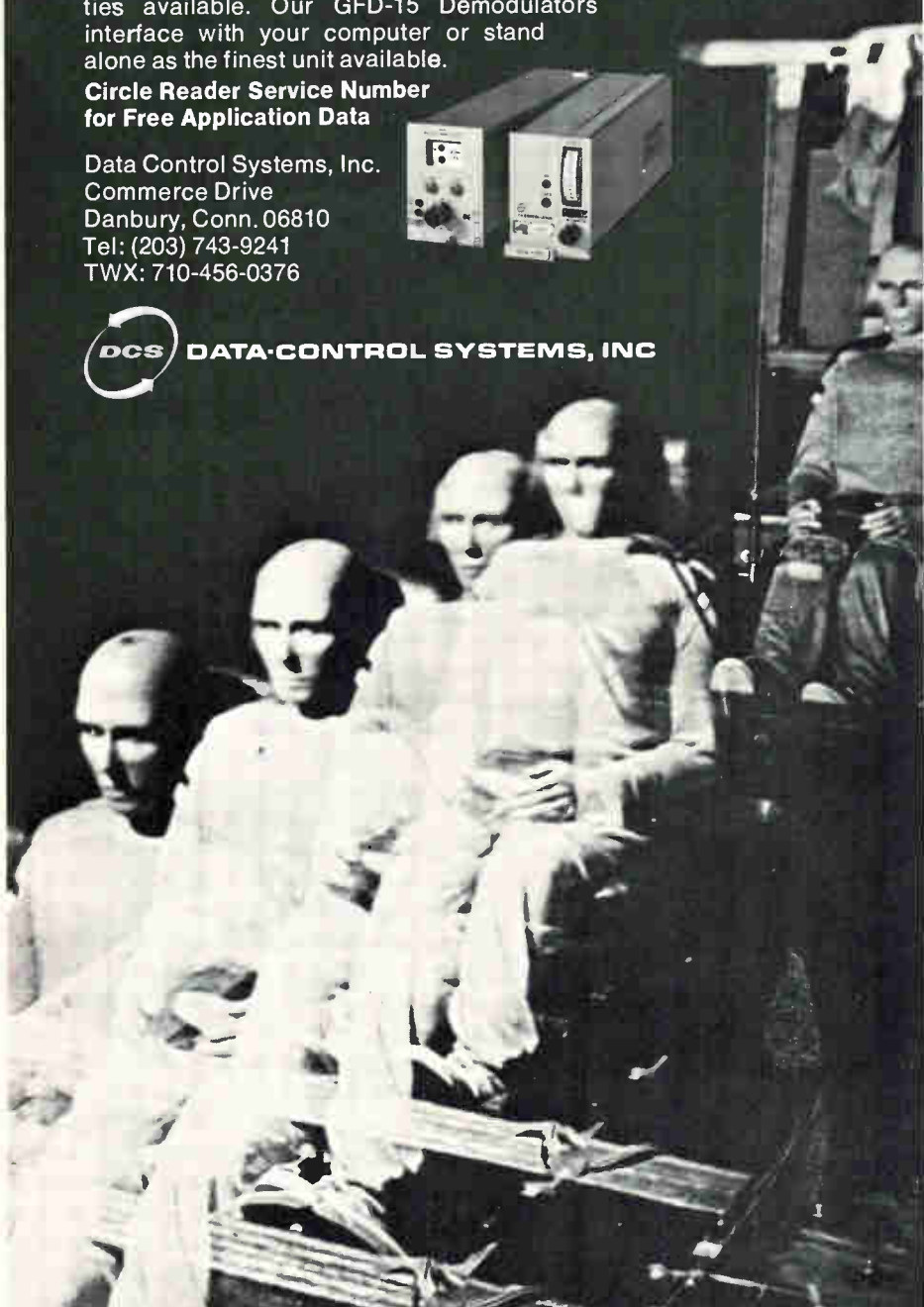

New products

through which the plotting or digitizing point is placed, can be determined precisely.

Plotting resolution of the Bendix machine is 0.001 inch in both X and Y directions, and position is repeatable to within 0.002 in. from any direction, says Burris Dennis, marketing manager. Position accuracy to 0.005 in. is obtainable anywhere on the plotting surface. In addition, the plotting pen mounted on a set of orthogonal rails can move at speeds ranging up to 20 inches per second. For digitizing, Bendix supplies a hand-held cursor.

With its new unit, Dennis says, Bendix is gunning for the estimated \$30 million market served by the \$100,000-class of plotters manufactured by companies like California Computer Products Inc. and Gerber Scientific Instrument Co.

Two basic plotter-only configurations will be marketed. For \$41,000, Bendix will supply a plotter plus an optical paper tape reader, control electronics, and a special hard-wired controller for linear and circular interpolation. The second, deluxe, configuration uses the same plotting mechanism and interpolation hardware but also contains a programable minicomputer that accepts information from either 7- or 9-channel IBM-compatible magnetic tape. Plotting is controlled by the minicomputer, which also generates symbols and characters and can interpret a variety of information formats. Dennis points out that this format interpretation feature means a user is unlikely to have to change his present drafting procedures: format changes can be handled automatically with the minicomputer.

Bendix prices this more complex configuration at \$65,000, including a model 33 Teletype for communicating with the computer. For less than \$10,000 more, Bendix says it will also supply the electronics to enable the plotter to digitize as well. Delivery time is four months, but the company hopes to speed this up by the end of the year.

Bendix Computer Graphics, 23850 Freeway Park Drive, Farmington, Michigan 48024 [349]

New products

Instruments

IC tester offers choice

Collector supply-voltage levels can be selected; RAM checkout is built in

The number of available benchtop IC testers is growing almost as fast as the number of ICs. But most have major drawbacks, says Lee

Ritchey, designer of a new tester made by Alma Corp. "Most use a nominal collector supply voltage to test the devices, but the IC makers don't spec the ICs that way," he says. So in Alma's model 380 bipolar IC tester, specific V_{cc} levels can be selected for different tests. Also, says Ritchey, "some testers force a current into a pin and measure a voltage to determine operation. But we do it the way the device manufacturer specs it—we force a voltage and measure a current."

"Another problem with existing benchtop testers," says Ritchey, "is that they have only one data pattern for testing all devices; and

since some ICs, like R-S flip-flops and counters, have forbidden states, you run into trouble." For example, in an R-S flip-flop, the set and reset inputs can't both be an "L" at the same time. And for testing shift registers, output blanking is needed so that there is no output until the input data has shifted along the complete length of the register. "We interrupt the strobe for the first 128 clock cycles for testing a 128-bit shift register so we don't get garbage out—we wait for known data," says the designer.

There is a special board for testing RAMs: it provides a pattern that exercises every cell. In fact, says Ritchey, "we can test any bipolar

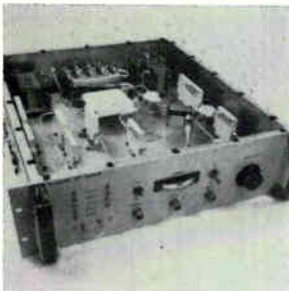

Programable microwave simulator sets for radar, altimeter, and missile checkout come with simulator drawer, power supply, and anechoic test chambers. Computer-controlled ro-1020 models use stripline components, can be tailored to application. Price is \$20,000-\$40,000. Raytheon Co., Oxnard, Calif. [361]



Sampling scope 1810A looks and works like a real-time unit. Sweeps trigger with less than 0.03-ns jitter on 100 mv pulses, and useful triggering can be obtained with 5-mv signals. Unit is plug-in for H-P 180 series. Price is \$1,650. Hewlett-Packard Co., 1601 California Ave., Palo Alto, Calif. [362]



Data channel analyzer 7024 tests synchronous and asynchronous systems on an end-to-end basis. Data, line measurements may be made simultaneously, enabling operator to relate errors to line events. System is for common-carrier two-wire channels. Northeast Electronics Corp., Concord, N.H. [363]



Rotary-table ic probe station s-10 can be fully integrated into production line. Carriers convey circuits under microscope, or transport assembly may be removed and replaced fully loaded, eliminating damage from handling. Olson Industrial Corp., 3910 S. Kalamath St., Englewood, Colo. [364]



Packaged counters PC-1 and -2 are counter/controllers for applications requiring counting up to 100 khz. The PC-2 can have three to six plug-in decade modules, gives output pulse at zero and the decode count. The PC-1 provides timed output at decode count only. Square D Co., Dept. SA, Milwaukee, Wis. [365]

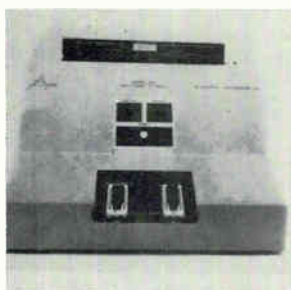

Functional tester model 824 handles ICs with up to 24 leads. Displaying pass-fail conditions, it exercises all combinations of true and false logic levels. Suitable for incoming inspection and production testing, it can check 400 devices per hour. Microdyne Instruments, 225 Crescent St., Waltham, Mass. 02154 [366]

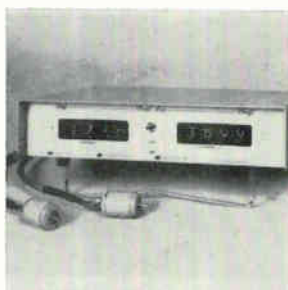

Shaft-to-digital converters provide direct readout of physical quantities, convert two-shaft inputs from 0 to 360° into four-character BCD information. Devices provide displays with equivalent resolution of 0.1°, accuracy of $\pm 0.1^\circ$. Price starts at \$495. Computer Conversions Corp., 6 Dunton Ct., East Northport, N.Y. [367]

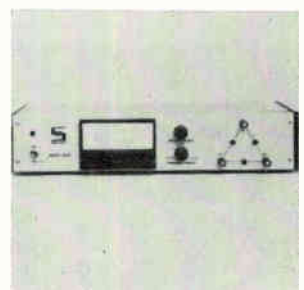

Frequency changer model 6400 tests airborne electronic equipment. Portable unit accepts inputs from 45 to 450 Hz and can be varied from 45- to 450-Hz outputs with 250 va, single- or three-phase. Voltage is adjustable from 100 to 130 v ac. Price is \$995. Shane Industries Inc., 608 Vaqueros Ave., Sunnyvale, Calif. [368]

DETECTIVE FOR HIRE

FACT (Flexible Automatic Circuit Tester), Hughes' random access test system can analyze the wiring integrity of any circuit. And FACT is for hire.

Through Hughes' lease/rental program, FACT's services can be contracted for a specific time period: short run production testing, peak loading, prototype assembly checkout—any schedule where time is short, but product reliability requirements are long.

Contact:

L. W. Risner
FACT Systems
Hughes Aircraft Company
P. O. Box 92904
Los Angeles, California 90009
(213) 670-9040



New products



Adaptable. Tester design permits user to select desired V_{cc} level.

device up to a 16-pin package."

Other features of the 380 include Kelvin contacts for precision measurements—accuracy is 0.1%—and diagnostics that allow failure mode recognition: "You know what pin failed, what was the failure mode and under what conditions the device failed," says Ritchey. An optional digital voltmeter provides direct readout. Test voltage range is ± 10 volts "and so we can also test ECL devices." These, he notes, require negative voltages and other testers only provide +2 to +8 V.

The basic 380 sells for \$5,000. Options include the DVM (\$350), a logic state display (\$300), and a handler interface (\$250).

Alma Corp., 570 Del Rey Ave., Sunnyvale, Calif. 94086 [369]

Unity-gain amplifier has 10^{12} -ohm input

Engineers are always taking general-purpose hardware and using it for biomedical applications. At Bioelectric Instruments, technical director Ernest Amatniek turned the process around in developing the company's Uni-amp.

A unity-gain amplifier in a TO-5 can built for neurophysiological experimentation, the device has all the properties—high input impedance, low offset levels, speed—needed for handling the signals encountered in this type of research. Amatniek feels those same properties will make the amplifier attractive for more conventional applications, as in electrometers, fast-pulse instrumentation, and analog-to-digital and d-a converters.

The Uni-amp is a hybrid circuit,

made with one field effect device and four other transistors. Input resistance is 10^{12} ohms, while input capacitance is less than 0.1 picofarad. Input offset current is 1.0 picoampere maximum, adjustable to within 0.1 pA, and offset voltage is 20 millivolts maximum, adjustable to 0 V. The output impedance is 30 ohms.

As for rise time, it's 30 nanoseconds when the amplifier is driven by a 100-mV signal from a 1 kilohm source, and outputs settle to within 0.1% of final value within 200 ns.

Besides these features, the Uni-amp has wide dynamic range—from 10 microvolts up to the supply voltage minus 1 V. Maximum supply voltage is ± 25 V. Linearity over this range is 0.01% of the maximum output. Input noise is 10 μ V peak-to-peak from 30 hertz to 30 kilohertz.

Amatniek says that the Uni-amp may replace either a voltage follower or an operational amplifier in most applications. "It's much closer to unity gain [than a voltage follower]," he says, "which turns out to be very important when you run such things as differentiators, integrators, bootstrap devices, and so on. We have a gain of 0.999 instead of the 0.99 you normally get in an emitter follower."

Circuits that could be built with the Uni-amp replacing an op amp include current generators, logarithmic converters, and anti-logarithmic converters.

Price for the unit is \$115.

Bioelectric Instruments, 155 Marine St., Farmingdale, N.Y. 11735 [370]

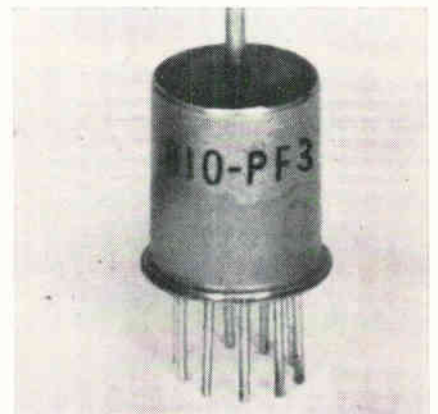



Maintaining a strong worldwide position in semiconductor marketing requires a large, widely dispersed sales force. At ITT, 713 sales personnel work out of 169 offices in 22 countries. That kind of coverage gives us a profitable fifth position in semiconductor sales.

Our staff is a balanced combination of factory men, manufacturers' representatives and distributor sales people. They are knowledgeable and aggressively helpful about a full line of bipolar and MOS integrated circuits, transistors, diodes and rectifiers. Whether you need hi-rel, MIL-STD-883 devices, or components for industrial and consumer products, the ITT man can get them for you. On time. In any quantity. He shares something with all the people back at our factories... he's committed.

ITT'S COMMITMENT TO CONTINUITY

713 SALESMEN BASED IN 22 NATIONS: WORLDWIDE COVERAGE FOR WORLDWIDE RESULTS

ITT
SEMICONDUCTORS WORLDWIDE

ITT Semiconductors is a division of International Telephone and Telegraph Corporation, 3301 Electronics Way, West Palm Beach, Florida 33407. Phone 305/842-2411. Factories in West Palm Beach, Florida • Lawrence, Massachusetts • Footscray, England • Colmar, France • Freiburg, Germany • Cascais, Portugal • Sydney, Australia.

New generation business machines benefit from General Electric's full-line motor capability

Electronic technology has put office equipment into a new generation. Information handling systems, drive-in banking equipment, copy machines and many others all have advanced to the 70's with a new look that will continue to change our way of business life.

General Electric motor technology has grown with these new developments.

High performance computer drives, tape drives, keypunch drives, cooling motors . . . all for your new generation of machines. And as your new equipment is born, you can depend on General Electric motors to drive it.

General Electric Company, General Purpose Motor Department,
Fort Wayne, Indiana.

720-01

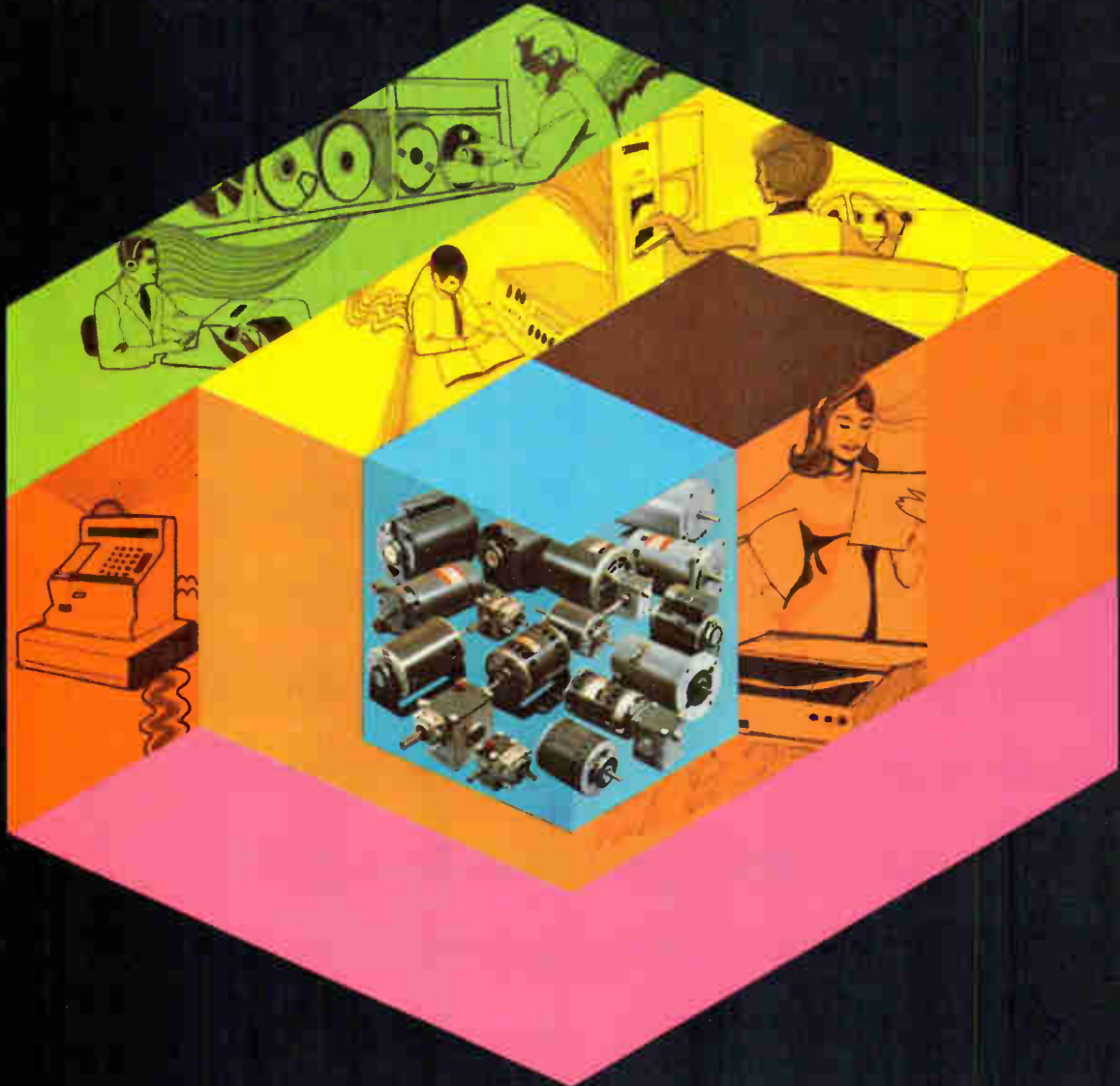

GENERAL  ELECTRIC

New products

Microwave

1/2-W transistor runs at 4 GHz

Chip's star geometry provides uniform distribution of current to prevent burnout

The power/frequency race among U.S. manufacturers of solid state sources moves takes a new turn with development of a 4-gigahertz

transistor by Hewlett-Packard Co. The previous high for commercially available units was 3 GHz [*Electronics*, May 26, 1969, p. 84]. The new device delivers a half-watt, and its chip has a star geometry instead of the common interdigitated design. The star pattern, according to Douglas C. Spreng, marketing manager, distributes the current evenly throughout the chip, preventing hot spots.

Designated the H-P 11, the transistor is offered in both common-base and common-emitter configurations.

In narrow-band amplifiers and oscillators, the common-base configuration yields the highest gain

at rated power. For example, at 1 GHz, power out is 1.25 W and gain is 11 decibels; at 2 GHz, it's 1 W with 8.5-dB gain; and at 4 GHz, the figures are 0.5 W and 5 dB.

Although in the common-emitter configuration the transistor has lower gain (3 dB at 2 GHz for 1-W output), the advantage of simpler matching "more than offsets the lower achievable gain. The real part of the input and output impedance is closer to 50 ohms, and the imaginary part remains relatively constant over a wide range of frequencies," says Spreng.

One application for a broad-band device with an improved gain/bandwidth product is in



Traveling wave tube amplifier package SSD-5410 is a 50-lb, integrally cooled unit. System puts out 100 w cw from 7.0 to 8.0 GHz with minimum gain of 35 db and is designed for primary power input of 115 v, three phase, 400 Hz. Price is \$15,000. Sperry Electronic Tube Div., Waldo Rd., Gainesville, Fla. [401]



Rf power transistors series SRF and SRD deliver up to 10 w at 1 GHz from a 28-v source. They are built for military, industrial applications in 600 MHz to 1.2 GHz region. Features include 6 db power gain at 1 GHz, 40% efficiency, and broad-band capability. Solitron Devices Inc., Blue Heron Blvd., Riviera Beach, Fla. [402]

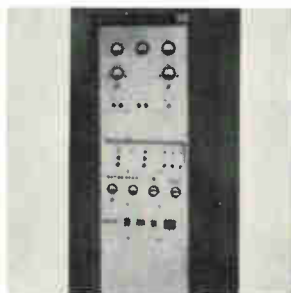

Triode RF-762 produces 5 kw average power at vhf with PEP rating of 10 kw. Unit automatically tunes and loads from 146 to 156 MHz, has full power output with 250 w of drive. Included are power supply, air cooling, full metering, and protection. RF Communications Inc., University Ave., Rochester, N.Y. [403]



SPDT switch model M870 is microwave IC control device operating from 200 MHz to 18 GHz with minimum isolation of 55 db. Insertion loss is less than 1.2 db through 124 GHz and less than 1.6 db to 18 GHz. Unit can be switched (10 to 90%) within 50 ns. General Microwave Corp., 155 Marine St., Farmingdale, N.Y. [404]



Microwave transmitters using pulsed LSA diodes produce peak powers of 250 w in c band, 100 w in x band, and 50 w in ku band. Duty cycle is .001 max, pulse width is selectable from 50 to 400 ns, pulse rise time and jitter are 10 ns max. Prices start at \$3,000. Microlab/FXR, 10 Microlab Rd., Livingston, N.J. [405]



Broadband microwave absorbers type FC have wide range of applications, are weatherproof, resilient and lightweight. They may be shaped, cut, or preformed without degrading electrical performance. Material comes in 24- by 24-in. sheets, and mounts with commercial adhesive. McMillan Radiation Labs, Ipswich, Mass. [406]



Subminiature p-i-n attenuator/modulator 750 and matched driver 751 permit control of rf signals over 45 db range from 0.2 to 18 GHz. Combination can also be used in closed-leveling-loop rf control systems for calibration purposes. Combined price is \$1,275. Weinschel Engineering, Gaithersburg, Md. [407]



Solid state sources, series LS-11, feature Gunn or Impatt diode stabilized by high-Q cavity, provide output from 10 to 500 mw in 8 to 18 GHz range. Sources offer 2% single-knob mechanical tuning, low fm noise. Litton Industries, Electron Tube Div., 960 Industrial Rd., San Carlos, Calif. [408]

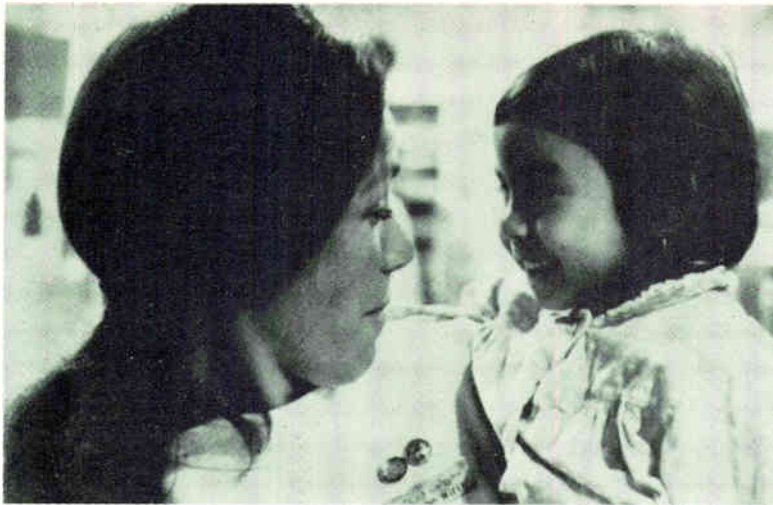

Priceless Cargo

The medical training and knowledge that is HOPE is indeed a priceless cargo. It is delivered daily aboard the hospital ship S.S. HOPE or through important medical shore programs on four continents.

Help us deliver HOPE to those who have none.

Your contribution is tax deductible

PROJECT HOPE

Dept. A, Washington, D.C. 20007

New products

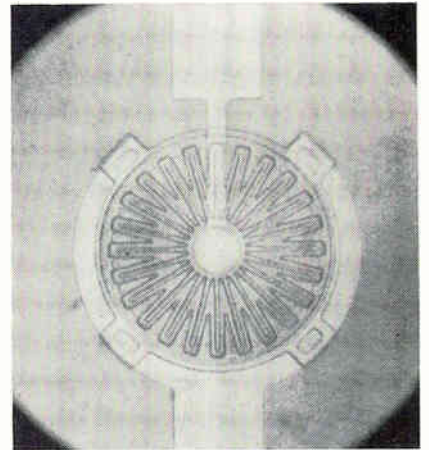

cable television systems. Spreng says that, with the transistors presently available, the maximum frequency of oscillation is 2.3 GHz, "But with our device in the common-emitter configuration, we get an F_{max} of 6 GHz." He adds that H-P is using the device in a hybrid CATV amplifier that the company builds. This amplifier, Spreng says, is flat from 1 hertz to 1.3 GHz and has a gain of 20 dB and a 16-dBm power output. "The transistor, however, is entirely suitable for higher-power output or for bandwidths extending as high as 4 GHz."

In the common-base mode, Spreng says, the high output and gain "will open up new designs in the 4-GHz communications band." The high output power from the common-emitter configuration allows linear operation over a wide frequency range, he points out.

The H-P 11 comes in a variety of packages. For those who can handle chips, the unit will be offered in packs of five at \$175 (\$35 per chip) as model number 35830A. A 200-mil (H-Pac 200) stripline package is available in common-emitter form as model 35831E and in common-base configuration as model 35831B. These are \$40 each in quantity 1-9. The same package is offered with a stud for best heat-sinking, as 35832E for common emitter and 35832B for common base. Price is \$45 each in quantity 1-9. Small-quantity delivery is from stock on all types.

Hewlett-Packard Co., Inquiries Manager, 1601 California Ave., Palo Alto, Calif. 94304 [409]



Make and repair your own patchcord stacking plugs in seconds. Any color, any length for 40% less cost.

These new kits contain everything you need to custom assemble and/or replace damaged molded stacking patchcord plugs: 60 metal banana or .080 standard tip metal plugs, 60 housings, 10 in each of the six standard colors. An assembly tool and fixture for fast, easy assembly. Use with standard 0.144" wire (not included in kit). To assemble, simply feed stripped end of wire through cross-hole metal contact. Insert contact and wire into housing. Place in fixture and snap contact into place.

Convenience and flexibility, plus savings of at least 40% over molded stacking patchcord plugs.

E. F. Johnson Company, Waseca, Minnesota 56093

Please send me complete information on your new stacking patchcord kits.



Name _____ Firm _____
 Address _____
 City _____ State _____ Zip _____

E. F. JOHNSON COMPANY

*up,
down,
around,
back & forth*

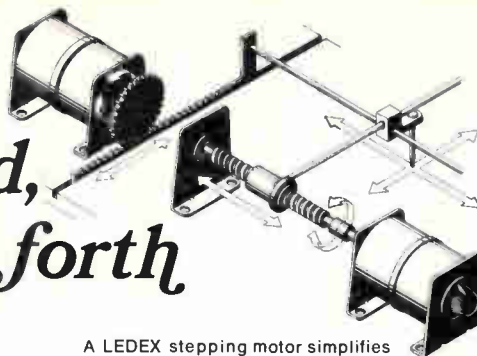

A LEDEX stepping motor simplifies bidirectional positioning

The next time you have a load to move in precise increments . . . consider a Ledex stepping motor

A Ledex stepping motor gives you a simple and economical way to drive a load in precise rotary increments. Its $\pm 1^\circ$ indexing accuracy assures you of repeatability.

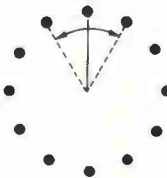

With a bidirectional model, a pulse to one coil gives cw step, to the other, ccw. Standard shelf models move in increments of 10, 15, 20, 30, or 36 degrees.

When your load is rotary, couple directly to the shaft. If it's linear, you can use combinations of lead screws, gear trains, drive belts, or pulleys. Step up or step down, to whatever incremental motion you need.

To drive, all you need is a simple square wave pulse. No expensive logic circuitry. New Ledex Series 50/12S model goes even one better. It has built-in pulsing circuitry, so it self-steps as you apply voltage.

And if it's torque you're after, our 36-position (10°) model, for example, gives you up to 246 ounce-inches. Of course, you can always step this up, or down.

The next time you have a load to move . . . up, down, around, back and forth . . . talk to our positioning technology people.



the total technology people

LEDEX INC.
123 Webster Street
Dayton, Ohio 45401
(513) 224-9891

POSITIONING rotary solenoids for fast, direct action with strokes to 95° and torque to 117 lb-in; life over 100 million actuations. Push & pull solenoids for short, medium and long strokes; built for speed, durability. Stepping motors, for precise incremental power positioning.

Circle No. 271

SWITCHING Manual rotary switches, featuring Starmate detent for positive indexing. Stepping switches for dependable remote multi-pole switching, programming, checkout. Packaged switches—solid state and electromechanical black box solutions to complex switching and timing problems.

Circle No. 272

MICROELECTRONICS Power drivers, pulsers, time interval controls, level adapters/shifters, voltage regulators—standard and custom circuits to blend microelectronic miniaturization and power with the higher current and voltage levels needed to drive electro-mechanical products.

Circle No. 273

*new things
keep
happening
at Ledex*

*. . . like the
sandwich stepper*

Here's a 1P12T stepping switch, prewired and ready to start switching for you as fast as you can snap it into a standard PC card edge connector. It's only half an inch thick and weighs all of two ounces.



mini specs: has zero reset circuit
steps at 60 steps per second
carry current, 2 amperes
make/break (res.), 500 ma @ 28 vdc
120 ma @ 120 vac

Another right-now solution from our switching technology people, you can get a 28 or 100 vdc model off the shelf for only \$17.50. In 1,000 lots, about \$7.25 each. Write for full size spec. sheet. Better yet, would you like a personal demonstration?

Circle No. 274

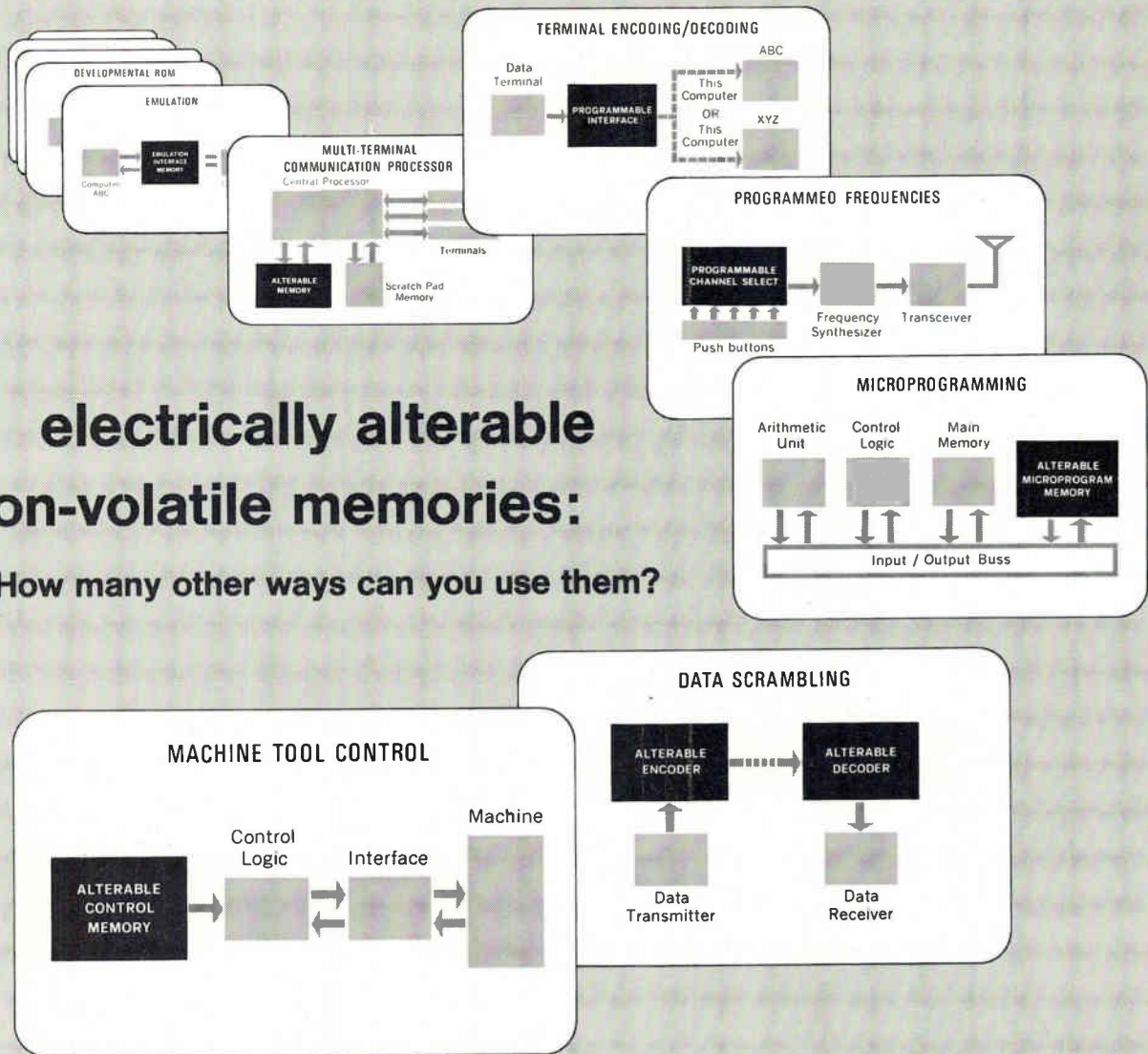

electrically alterable non-volatile memories:

How many other ways can you use them?

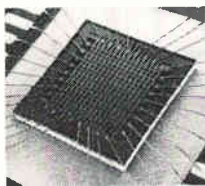

Up until now you've had to settle for non-volatility *or* electrical alterability in a semiconductor memory system. One or the other; not both together.

Today, we're glad to say, you can have your cake and eat it too. Because the

best of both have now been combined in a single device: our new 256-bit Read-Mostly Memories (RMM).

Key to their unique characteristics is the use of amorphous and silicon semiconductors integrated in a 16x16 matrix on a monolithic chip, with a diode-isolated Ovonic Memory Switch (OMS) at each cross-point. What makes them alterable and non-volatile, too, is the fact that the OMSs are, in essence, bistable resistors. They can be reversibly switched between their high resistance (300k Ω) and low resistance (500 Ω) states by the application of controlled current-time pulses. And they're also capable of remaining in either state indefinitely, even when power is removed.

Add to these exclusive features non-destructive readout plus read speeds of 150 nsec access and 200 nsec cycle time (including decoding delay) and you've got yourself a versatile memory element that's readily adaptable to a host of applications beyond those diagrammed above.

Availability? Off-the-shelf! At prices ranging from \$120 each in quantities of 1 to 9, \$75 each from 10 to 99, and \$60 each for 100 or more. Application engineering assistance is available upon request without obligation. Write or call for complete information today.



Energy Conversion Devices, Inc.

1675 WEST MAPLE ROAD • TROY, MICHIGAN 48084 • 313/549-7300

New products

Packaging and production

Thermal tester checks ICs

Scanning infrared camera attached to microscope has 1-mil resolution

Infrared sensing has long held promise for testing semiconductor devices. Being a noncontact instrument, an IR scanner neither dam-

ages nor alters the devices under test. But by itself a scanner does not have the spatial resolution needed for inspection of integrated circuits. Sweden's AGA has widened the usefulness of the technique by combining a basic scanner (the company's 680 Thermovision camera) with a microscope attachment. The system has a spatial resolution of 1 mil, and so can isolate faults in ICs as well as discrete devices.

The camera scans an area 65 by 65 mils, at a frame rate of 16 per second, to produce a real-time thermogram that is displayed on an oscilloscope specially modified by AGA engineers. Because of its high frame rate, the scanning sys-

tem displays transient as well as steady state thermal conditions. For example, it enables the circuit designer to study the thermal response of a circuit to a single input pulse.

AGA expects the first major application to be in research laboratories for materials studies. But the company predicts that the system will find widespread use in design labs and in production lines for testing high-power (over 100 milliwatts) ICs and power transistors.

The major tests will include: detection and identification of hot spots on prototype circuits; investigation of faulty bonding; observation of destructive testing; analysis

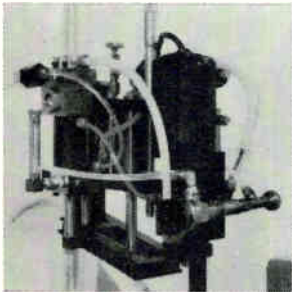

Mixing and dispensing system 415 is for use with highly filled, abrasive epoxy, other multi-component resins for potting and encapsulation. Portable system meters about 1/2-25 grams per shot of materials at up to 30 shots/min. Price is from \$3,500 to \$4,500. Fluidyne Instrumentation, 470 27th St., Oakland, Calif. [421]



Digitizing/drilling machine SNC400DIG allows pc boards with undimensioned artwork or errors caused by screening process to be drilled at high rates. System includes numerical tape control, magnified viewer, teletypewriter, positioning control, and X-Y digital readout. Price is \$24,700. Superior Electric Co., Bristol, Conn. [422]

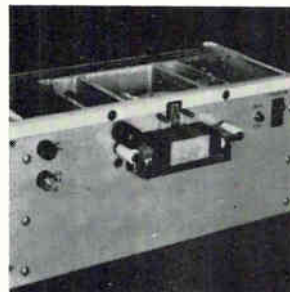

Paper tape programmer for multiple circuit controls is applicable to metal plating systems, batching, mixing controls, and process controls in finishing operation. Unit has unidirectional photoelectric punched tape reader. Price is \$1,875 for one, \$1,490 each for 100. Datascan Inc., Clifton, N.J. [423]



Crimping tool H28 for insulated and noninsulated solderless terminals handles butt and parallel splices in wire slices from #10 to #26 gauge, and large and small pigtails. Tool operates on 85-100 psi shop air. Hollingsworth Solderless Terminal Co., Nutt & French Creek Rds., Phoenixville, Pa. [424]

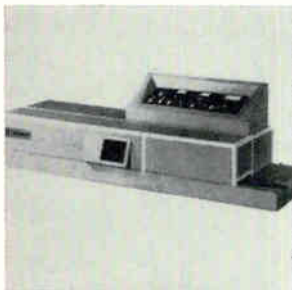

Solder fusion oven TS21 is a conveyor system with speeds of 3-5 feet/min. Unit uses infrared heat for uniform tin-lead plating to printed circuit boards. System also spots defects in board preparation and replaces need for hot oil. Glo-Quartz Ovens Inc., E. Walnut St., Pasadena, Calif. [425]

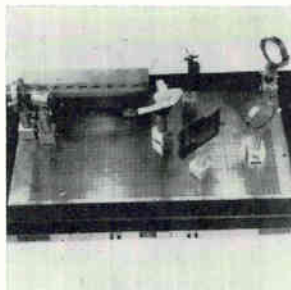

Small, flexible system for producing holograms uses controllable beam ratios, simplified component layout. Bench has air suspension design with air control valves on front of support frame. All components have magnetic bases with on-off controls. Gaertner Scientific Corp., 1201 Wrightwood Ave., Chicago, Ill. [426]

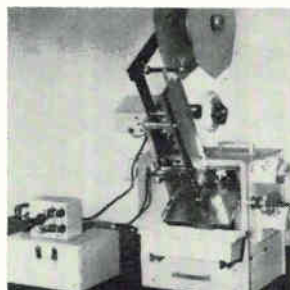

Axial component feeder automatically feeds body-taped components to Leadmaster lead-forming machine. Unit is designed for easy field installation and has own drive system so that feed rate is locked in to lead former. Price is \$595. Heller Industries Inc., 18 Microlab Rd., Livingston, N.J. 07039 [427]

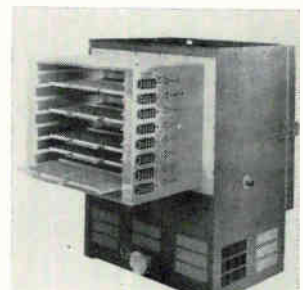

Life-test system model 1025 is for small-quantity testing. Unit features forward- or reverse-bias dc testing of 1600 components with two leads or 800 with three leads, and separate, removable load trays. Price is under \$5,000. Micro Instrument Co., 12901 Crenshaw Blvd., Hawthorne, Calif. [428]

New products

of failure modes; the determination of thermal characteristics for semiconductor devices; verification of thermal characteristics calculated from electrical characteristics; inspection of internal lead wires and welds; complete thermal mapping of ICs; and assistance in the solution of heat sinking problems.

In studying failure modes by thermal mapping, the microscope-camera setup detects scratches on device surfaces, aluminum absorption or migration, aluminum-silicon monoxide reaction, and metalization defects.

Checkout time is fast. AGA estimates that it takes 3 minutes to inspect a 50-by-20 array of monolithic transistors.

Since the instrumentation accurately measures the level of heat being radiated from points on the circuit surface, the system is capable not only of detecting flaws but also classifying circuits, according to the level of thermal energy

that the circuits give out.

Besides a collimating lens, the camera has two eight-sided lenses that rotate horizontally and vertically, and which cause the microscope in effect to scan the surface of the device and produce a 140-line frame each 1/16 of a second.

The lenses reflect the thermal radiation onto an indium-antimonide detector. The resulting electrical signal is amplified and sent to the display where it modulates—TV style—the intensity of the electron beam. The deflection circuits in the display are synchronized with the motion of the rotating lenses.

With the microscope attached, the camera has a resolution of 1°C. Temperature range is variable between -20°C and +2,000°C, and filters are available that allow temperature differences to show on the monitor as differences in color.

System price is \$27,000.

AGA Corp., 550 Country Ave., Secaucus, N.J. 07094 [429]

Coax-contact assembler slashes installation time

It usually takes three minutes to assemble a three- or five-piece coaxial contact and solder it onto the end of a cable. A machine and a one-piece contact from Burndy Corp. cut the time to about 20 seconds.

The new machine has three holes in its front panel. To operate it, the girl first puts the stripped coaxial cable into a hole that crimps the inner contact assembly to the inner conductor when she steps on the foot pedal. She then inserts the combination in the second hole and uses the foot pedal, and the machine crimps the outer ferrule to the braid. Then the piece is inserted in the third hole, where it is heated with an induction coil to reflow the solder on the contact and complete the connection. For twisted pair, there is a fourth hole

MDS 2000 Tape Drives. Digitized, deskewed, buffered. Complete from head to casters. 7 and 9 track operator switchable (NRZI). 7 or 9 track read/right (NRZI). 1600 bpi read/right or read only. Speeds to 75 ips. Call us collect (215) 265-0160.



MDS Mohawk Data Sciences Corp.
King of Prussia, Pa.

MDS Paper Tape Readers. Adjustable for 5, 6, 7, 8 level. Speeds to 60 cps. For numerical control, data input, machine tools, communications, EDP. Single unit prices for 30 cps start at \$200. (Complete). Call collect (215) 265-0160.



MDS Mohawk Data Sciences Corp.
King of Prussia, Pa.



The machine will not be sold. In common with most special machines for connectors, it will be installed in the customer's plant for use with the purchased connectors.

Burndy Corp., Norwalk, Conn. 06852 [430]

Axial-lead-component marker handles 40,000 units an hour

Manufacturers frequently imprint their customer's stock numbers on components. But since the device makers must wait for the order to arrive before they do the printing, slow printing means slow shipping. Thanks to an axial-lead component printer offered by Markem Corp., up to 40,000 resistors, capacitors, or diodes can be imprinted in an hour. In the new model U-1205, which is more than twice as fast as previous units, the printing legend is carried on an etched aluminum plate. This

lasts longer and withstands corrosive environments better than the previously used rubber plates. In addition, the aluminum unit can be changed in just a few seconds, instead of several minutes.

The parts are manually or automatically fed into a trough that directs them into a channel, from which a pair of slotted wheels picks them up by the leads, one at a time. The wheels carry the parts to the printing station, where an offset process is used to put the legend on. The parts then are transferred to a conveyor unit which moves them to the next station. The system handles components with leads up to 4 inches long, body lengths up to 1 in., and diameters up to 3/8 in.

Overall size of the 145-pound machine is 11 1/4 by 12 by 50 1/2 in., including the 30-in. conveyor. Price of the U-205 is \$6,100. It can be leased for \$300 per month.

Markem Corp., 150 Congress St., Keene, N.H. 03431 [431]

which is used as the first step. It strips the wire before insertion in the other three holes.

The contacts are in the Burndy Trim Trio line of connectors, available in either round or rectangular form. The contact's outer ferrule is marked with a heat-sensitive paint that changes color during soldering, indicating if sufficient heat and time were used for a reliable connection.

**MDS 2010.
Acoustic Coupler.
Simplex, half-duplex,
full duplex.
Speeds to 500 baud.
No frequency drift.
No external noise.
No better coupler.
Call us collect.
(215) 265-0160.**



MDS Mohawk Data Sciences Corp.
King of Prussia, Pa.

**MDS Paper Tape
Punches.
Accept coded data
serially by character,
parallel by bit. Switches
for error checking.
Electromagnetic
backspace. Call us
collect. (215) 265-0160.**



MDS Mohawk Data Sciences Corp.
King of Prussia, Pa.

Semiconductors

ROMs have 3-state outputs

Design permits OR tie-in without external resistors or additional access time

In most microprogramming applications, more than one read-only memory is required. So when engineers at National Semiconductor

Corp. developed a new 4,096-bit ROM, they designed it with tri-state outputs. According to Dilip Bapat, MOS design engineer at National, "in order to tie normal ROMs together in a system you need an external resistor, but with the tri-state-output configuration, you can do it directly."

The ROM, model MM5232, is a p-channel enhancement mode MOS IC that employs low-threshold technology to achieve bipolar compatibility. The tri-state outputs provide wired-OR capability without loading common data lines or increasing system access time. Bapat says that with regular ROMs, "for each resistor that is added to OR the outputs

together, you lose 50 nanoseconds or so per tie-in in access time. Thus, if each memory has an access time of 800 nanoseconds and you tie three of them together in a system, the system access time would be 950 nanoseconds."

The ROM is organized as either 512 words by eight bits or 1,024 words by four bits, depending on how the mode control input is set. Two program chip-enable inputs allow up to four memories to be controlled without any external logic. And a separate output supply lead is provided to reduce internal power dissipation in the output stages. Bapat points out that since the memory is static, no clocks are

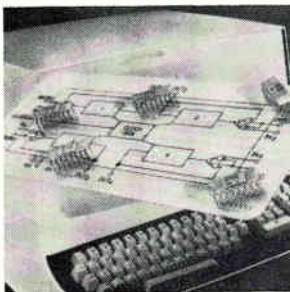

Dynamic shift register MK-1007P, made by ion implantation, is TTL/DTL compatible at all inputs and outputs. Unit is for in-line memories of CRT displays and buffer memories of card readers. Clock frequency range is 10 kHz to 2.5 MHz. Price is \$13.50 in 100-lots. Mostek Corp., 1400 Upfield Dr., Carrollton, Texas. [436]

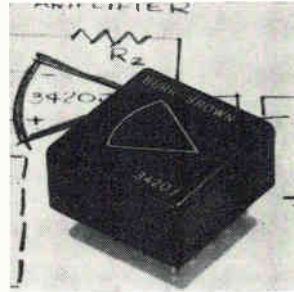

FET op amp 3420L has low drift of $\pm 1 \mu\text{V}/^\circ\text{C}$ max, low noise, high gain, high common mode rejection. Unit is designed for buffer amplifier applications in instruments and data systems. FET input eliminates source loading. Prices range from \$36 to \$84. Burr-Brown Research Corp., Airport Industrial Park, Tucson, Ariz. [437]

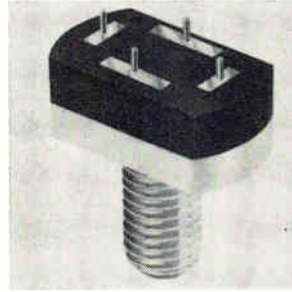

Linear power transistor 2N-6093 for hf single-sideband equipment delivers 75 w PEP at 30 MHz, with intermodulation distortion below -30 dB, 13 dB gain, and 40% efficiency. It operates at 28 v, and design includes emitter ballast resistors. Price is \$55 each for 1,000. RCA Solid State Div., Somerville, N.J. 08876 [438]

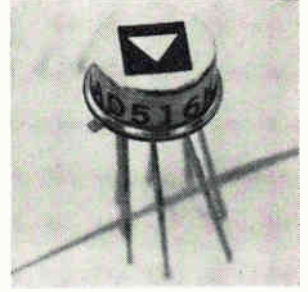

Integrated-circuit op amp series AD516 in TO-99 can, uses FET input circuitry for $10^{11}\text{-}\Omega$ input resistance, 5 pA maximum bias current. Laser adjustment of bias circuit resistors brings initial offset voltage to less than 1 mv. Prices range from \$32 to \$45. Analog Devices Inc., 221 5th St., Cambridge, Mass. [439]



Hybrid ICs DH0034/34c handle voltage level translations among peripherals, data transmission systems and memory devices on two channels at a time. Typical propagation delays are 15 ns to a 0 and 35 ns to a 1. Prices are \$11.20 to \$26. National Semiconductor Corp., Semiconductor Dr., Santa Clara, Calif. [440]

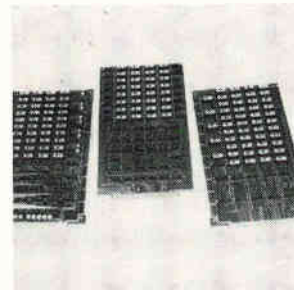

Memory systems are designed for mix of high speed, standard speed and read-only units in one card rack. Called Compatibles, units are a programmable ROM, a bipolar read-write, and an MOS read-write memory. They may be purchased separately or in combination. Quadri Corp., 2950 W. Fairmont, Phoenix, Ariz. [441]

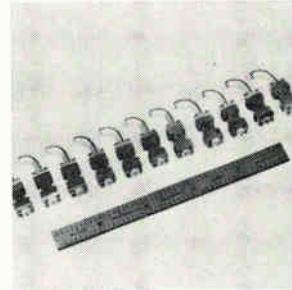

Microminiature detectors weigh less than 3 grams, operate between 8 and 10 GHz with -54 dBm tangential sensitivity. They use field-replaceable back diodes, have maximum VSWR of 1.50, and are designed for phased array applications. Engelmann Microwave Co., Skyline Dr., Montville, N.J. 07045 [442]

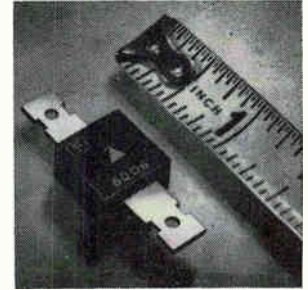

Silicon diode rectifiers series 60D are rated at 12 A, come in seven peak inverse voltage ratings from 50 to 1,000 v. Corresponding rms ratings are from 35 to 700 v. Price is 40 to 60 cents each, depending on rating, for 10,000-lots. Sarkes Tarzian Inc., 415 N. College Ave., Bloomington, Ind. 47401 [443]

THE GREAT DAC DEAL

Tear out this ad and show it to some of the boys in your lab. It's an offer you can't pass up.

OUR OFFER: We'll send you your choice of any of our standard data conversion modules absolutely free — for a 30-day evaluation. Check your DAC's performance and compare competitive prices. In that way you'll learn some eye-opening facts about the new Philbrick and its ever-growing capabilities. Then, 30 days after you've plugged our D/A or A/D converter in your system we'll contact you. When we learn you like it, we'll apply the cost of your evaluation unit against your initial order — at the same discount price you earn through quantity purchases. If it doesn't perform to spec, return it. No questions asked... no hassle. One outstanding thing you'll discover when you plug in a Philbrick DAC is that it was "human engineered." Pins and bits are in sequential order. You get DIP pin compatibility. Features include $\leq \pm 0.002\%/\% \Delta V_s$ power supply rejection ratio, unequalled temperature stability and buffered input to reduce sink current. Eight standard models with 8 to 14 bit resolution. Custom D/A and A/D's? You bet! We can produce hundreds of customer specified DAC's usually within four weeks on OEM quantity orders. And Philbrick DAC's are low-priced, too. From our general purpose DAC's to the highly sophisticated deglitched models like a 14-bit binary $\pm 1/2$ LSB, deglitched output of < 10 mV p-p and < 200 nsec update rate. You get the best price/performance ratio. Philbrick power modules insure optimum performance and guarantee dependability. To help select your free trial evaluation module, send for our data packet containing all the details on Philbrick Data Conversion Modules. Contact your local field engineer or write Teledyne Philbrick, Allied Drive at Route 128, Dedham, Mass. 02026. TWX: (710) 348-6726. TELEX: 92-4438. Cable: TELEPHIL.

*PHILBRICK 4022 AND 4023
GENERAL PURPOSE 10-BIT
BINARY DAC'S. MAXIMUM
LINEARITY $\pm 1/2$ LSB. BOTH
EXHIBIT LOW DRIFT (LESS THAN
40 ppm/0°C). THE 4022 CURRENT
OUTPUT IS 0 TO +2 mA. THE 4023
VOLTAGE OUTPUT IS ZERO TO -10V
BOTH CAN BE USED UNIPOLAR
OR BIPOLAR BY EXTERNAL
CONNECTIONS. PRICES ARE
\$27 AND \$29 IN SINGLE UNITS.*

*PHILBRICK 4103, 4104 AND 4105
HIGH PERFORMANCE 12-10-8-BIT
A/D CONVERTERS. IDEAL FOR
HIGH SPEED CONVERSION OF (30 μ sec.
LINEARITY OF $\pm 1/2$ LSB. BOTH
SERIAL AND PARALLEL OUTPUT
AVAILABLE. ALL EXHIBIT LOW
DRIFT (LESS THAN 20 ppm/0°C).
LOW PROFILE PACKAGING.
PRICE: \$ 275 FOR
12-BITS IN
SINGLES*

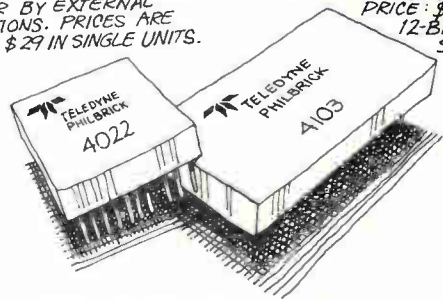

**FOR ROUND-THE-CLOCK
TOLL-FREE READY DATA
DIAL 800-225-7883**

TELEDYNE PHILBRICK
DATA CONVERSION

Sanken® Packs

50 Watts into A Hybrid Audio Amplifier!



SI-1050A (50W)

OUTSTANDING FEATURES :

- * Single-ended push-pull circuit
- * Largest output power, 25W and 50W
- * No external component required
- * Harmonic distortion 0.5% max. at full power level

	SI-1020A	SI-1050A
Power supply voltage	48V	62V
Max. continuous output power (distortion < 0.5%)	25W	50W
Voltage gain	30dB typ.	
Frequency range (output 1W)	20Hz~100kHz	
Input impedance	70kΩ typ.	
Output impedance	0.2Ω typ.	
S/N ratio	90dB typ.	
Idling current	30mA typ.	

10W and 20W types also available

SANKEN ELECTRIC CO., LTD

1-22-8, Nishi-Ikebukuro, Toshima-ku, Tokyo
Cable: SANKELE TOKYO
Phone: 986-6151
Telex: 0272-2323 SANKELE TOK

U. S. Agent:

AIRPAX ELECTRONICS Inc.

P.O. Box 8488, Fort Lauderdale, Florida 33310
Phone: 305-587-1100
Twx: 510-955-9866
Telex: 051-4448

New products

required with the MM 5232.

Another unusual feature is a bootstrapping technique applied to the ROM's addressing circuitry to keep access time constant, independent of address location. Bapat says that in most ROMs, the access time can vary depending on the content of the memory. "It depends on how many bits are on a given address line, and in an 800-nanosecond memory, it can go as high as 950 nanoseconds." The bootstrapping technique eliminates this variation. Bapat says the bootstrapping, though well known, is not usually applied to ROMs: "It has a voltage-doubler effect or positive feedback which increases the turn-on time of the gate of a transistor," says Bapat. "And so you get a faster turn-on time and hence a more uniform delay throughout the chip."

Applications for the ROM include character generators for displays, random logic synthesis, microprogramming, and table-lookup functions. Bapat says that, especially in display systems, "you need high-speed ROMs and you have to know what the access time will be. With the 5232, the time is 750 nanoseconds and it is constant."

Pricing for the memory in quantities of 100 is \$60 each if a custom program is used or \$40 each with a standard character-generation program. Delivery is from stock.

National Semiconductor Corp., 2900 Semiconductor Way, Santa Clara, Calif. [444]

C/MOS 128-bit shift register has control logic on chip

When a company concentrates on high-performance devices in a given technology, the market limitations soon become apparent. In an effort to broaden its market in the high-level complementary-MOS field, Ragen Semiconductor Inc. has developed a C/MOS shift register that is aimed at industrial control jobs while preserving some of the high-performance characteristics of its premium-price military products.

The MS-625, a C/MOS 128-bit

New Materials

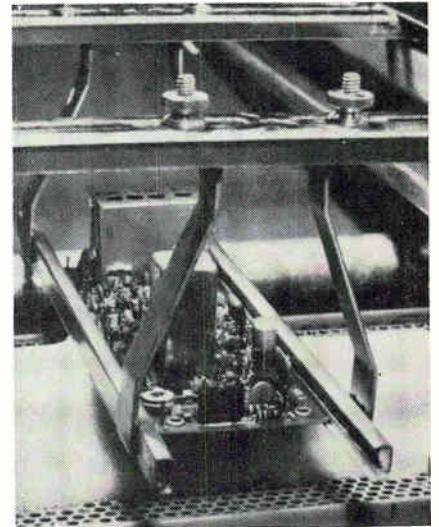

Foam flux called Milfoam 613 is a rapid, high-rising, mildly activated rosin flux that meets requirements of Type A of Mil-F-14256. It is electrically less conductive than fully activated fluxes and is suitable for most metals used in electronic assemblies. Alpha Metals Inc., 56 Water St., Jersey City, N.J. 07304 [381]

Acrylic coating dries fast in air, is solderable, and illuminates under ultraviolet light to show any defects that might have occurred during the coating process. Features of Metalclad DP-537 include moisture vapor impermeability, chemical resistance, abrasion resistance, and resiliency in thin films. Merico Products Division, Metchem Resins Corp., 530 Wellington Ave., Cranston, R.I. 02910 [382]

Tantalum capacitor powder has capacitances up to 8,000 microfarad-volts per gram. The powder permits a high degree of miniaturization and is available in three capacitance ranges: 6,000-8,000 μFV/g for type R-3; 5,000-7,000 μFV/g for type R-5; and 4,000-6,000 μFV/g for type R-10. Kawecky Beryllco Industries Inc., 200 E. 42nd St., New York, N.Y. 10017 [383]

Plastic spray waterproofs modular connectors with a clear coat that dries in one minute. It is chemically inert, and is virtually nonflammable. Polydip spray will withstand exterior exposure, shrinking, and aging. Communications Technology Corp., 2237 Colby Ave., Los Angeles, Calif. 90064 [384]

Low-viscosity liquid anhydride hardener for curing epoxy resins is a light-color, non-crystallizing material. It will cure all available liquid epoxy resins and is suitable where long pot life, heat curing and heat-resistant curing agents are desirable. Reichhold Chemicals Inc., RCI Bldg., White Plains, N.Y. 10602 [385]

Here's One Place Where Your Dollar Is Worth A Dollar

Two new HP oscillators are teaching the old standard new tricks in performance and value. Both the new HP 204C/D and HP 209A Oscillators have exceptional spectral purity ($<0.1\%$ -60dB). Both have FET's in the bridge for improved stability—balanced output—sync in/out. All this adds up to greatly improved performance. And, you get this extra value at only a modest increase in price over the old standard.

Both oscillators offer improvements that assure you of a consistent signal—test after test—time after time... whether you are testing on a production line, researching in a design lab, or instructing future engineers.

Portable, line or battery powered. The 204C is a clean, inexpensive oscillator with a frequency range of 5 Hz to 1.2 MHz. Output is 2.5 Vrms into 600 Ω , 5 Vrms into open circuit. Choose interchangeable power packs—line, rechargeable or mercury battery. Price HP 204C, \$260 to \$295.

The 204D has the added convenience of a built-in 80 db attenuator. Eliminates using an outside attenuator when you need clean low-level signals. Price: HP 204D, \$335.

High power output, sine or square wave. The 209A generates simultaneous sine and square wave outputs over a frequency range of 4 Hz to 2 MHz. Amplitudes are independently adjustable. Voltage output for a sine wave is double that of the 204—5 Vrms into 600 Ω , 10 Vrms into open circuit. Square wave output is 20 V peak-to-peak. Price HP 209A, \$355.

Get full value for your signal-source dollar. Consult your HP Instrumentation Catalog for full specifications and order your oscillator by calling your nearest HP telephone order desk. For additional data, write Hewlett-Packard, Palo Alto, California 94304. Europe: 1217 Meyrin-Geneva, Switzerland.

099-2 B

HEWLETT  PACKARD
S I G N A L S O U R C E S

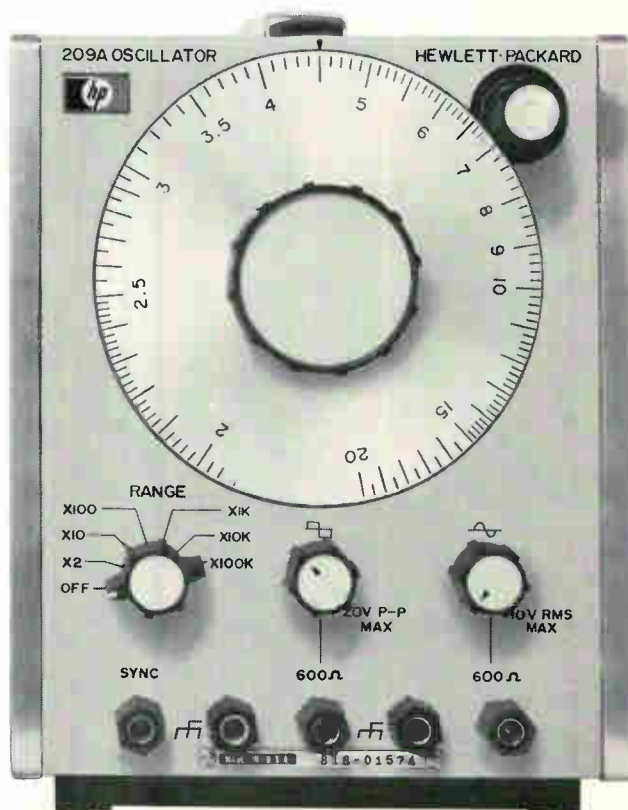
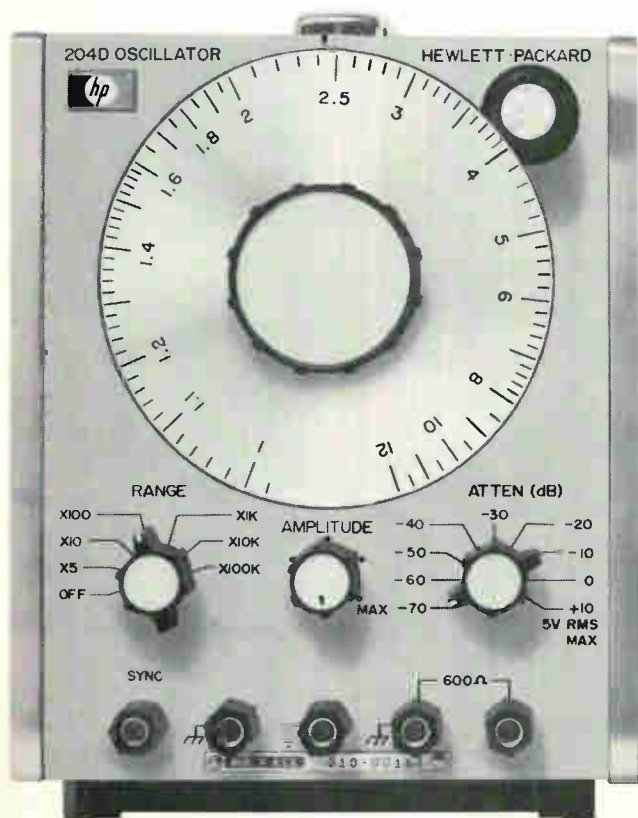

CLASSIFIED ADVERTISING



SEARCHLIGHT SECTION

BUSINESS OPPORTUNITIES
USED OR SURPLUS EQUIPMENT

Superb!

**Air Conditioned
One Story
341,000 Sq. Ft.**

Ultra-Modern Building
on 71.7 Acres
South Carolina

BINSWANGER
Southern Corporation

Consultants • Management • Appraisals
Commercial & Industrial Real Estate
1420 Walnut St., Phila., Pa. 19102
215-735-0202
New York, New York • Charlotte, North Carolina

CIRCLE 966 ON READER SERVICE CARD

RADAR SYSTEMS GROUND AND AIRBORNE. AUTOMATIC TRACKING ANTENNA SYSTEMS. NIKE AJAX. NIKE HERCULES. M-33. MSQ-1A. MPS-19. MPS-9. SCR 584. TPS-1D. TPS-28. FAA-ASR-2. AIRBORNE SYSTEMS. APN-84. APN-102. APS-20. APS-27. APS-45. DPN-19. DIGITAL COMPUTERS. IBM 650. IBM 704.

LARGEST INVENTORY OF RADAR AND MICROWAVE EQUIPMENT IN THE WORLD.



RADIO RESEARCH INSTRUMENT CO.
3 QUINCY ST., NORWALK, CONN. 06850 (203) 853-2600

CIRCLE 967 ON READER SERVICE CARD



**EMPLOYMENT
OPPORTUNITIES**

ADDRESS BOX NO. REPLIES TO: Box No.

Classified Adv. Dept. of this publication.
NEW YORK, N. Y. 10036: P. O. Box 12

POSITION WANTED

Top Engineer With Advanced Education. 17 years experience in applications research and Machine Designs. Strong personality, good organizer and manager, can handle large-scale operations. Chicago area only. Resume on request. George I. Breive, 1437 So. 49th Ave., Cicero, Ill. 60650.

BUSINESS OPPORTUNITY

Young Norwegian Electrical Engineer diversified experience leaving for Scandinavia June 18, will undertake representation, excellent connections. BO-4153, Electronics.

New products

static shift register, is one of the most flexible devices of its kind. It has full internal logic on the chip, which includes a four-bit digital compensator for chip select, a gate to disable the internal logic when the power is on, and clock outputs for driving additional shift registers. And that isn't all. There is an option for load or transfer to either recirculate data or introduce fresh information. And it can operate as a straight in-out register with true and inverted outputs. All this is done at shift rates of up to 10 megahertz, with static currents in the nanoampere range.

"It's a small memory system, for jobs where there is no need of random access features," says Albert Medwin, marketing manager at Ragen. One example is in comparators for control systems where the application requires the storage and comparison of register information.

The MS-625 includes 1,400 transistors on a chip that measures 0.150 by 0.118 inch. Standard models dissipate static current of less than two microamperes over the full supply voltage range. Medwin says this static current can be reduced even further in specialized models. "It could be lowered to the point where the device could operate across a battery and the battery wouldn't even see it," he says.

Four exclusive-NOR gates perform selection decoding for the register, permitting the user to connect as many as 16 MS-625s to provide a 2,048-bit storage system. By hard-wiring one set of inputs, any one of the 16 registers can be selected by a four-bit code.

The device's single-clock input has a capacitance of less than 5 picofarads, and its power requirement ranges from 5 to 16 volts, depending on speed of operation.

For 1 to 24 registers, the price is \$160 each; for 25-99, \$140; for 100-999, \$120; for 1,000-9,999, \$96; and for 10,000 or more, \$83. The MS-625 is available from stock in hermetically sealed 24-lead dual in-line ceramic or flat packs.

Ragen Semiconductor Inc., 53 South Jefferson Rd., Whippany, N.J. [445]

New literature

Capacitors. Republic Electronics Corp., 176 E. 7th St., Paterson, N.J. has published a 12-page catalog describing its line of subminiature ceramic capacitors. Circle 446 on reader service card

Load cells. BLH Electronics Inc., 42 4th Ave., Waltham, Mass. A selector guide for users of load cells provides information about precision, general-purpose and special purpose units. [447]

P-i-n diode switch. General Microwave Corp., 155 Marine St., Farmingdale, N.Y. 11735, offers a technical data sheet describing the model M870 SPDT p-i-n miniature diode switch. [448]

Precision instruments. Yewtec Corp., 1995 Palmer Ave., Larchmont, N.Y. 10538. A 20-page catalog includes technical specifications on the company's complete line of precision instruments, recorders and portable instrumentation. [449]

Laser systems. Holobeam Inc., 560 Winters Ave., Paramus, N.J. 07652. Design characteristics, performance characteristics and functional specifications are discussed in a six-page brochure on pulsed solid state laser systems: ruby, Nd:Glass, and Nd:YAG. [450]

Sequence control. Eagle Signal, 736 Federal St., Davenport, Iowa 52803 details its MT50 sequence control in a four-page bulletin. Instructions on how to program the control's diode matrix board are given, plus a circuit design chart and wiring diagrams. [451]

Fiber Optics. Applied Fiberoptics and Scientific Specialties Inc., 46 River St., Southbridge, Mass. 01550. A capabilities brochure is a source for design engineering and fabrication of high-precision electromechanical fiber optical instrumentation. [452]

Light diodes. Litronix Inc., 19000 Homestead Rd., Cupertino, Calif. 95014 has available a four-page application note on the fundamentals of photometry measurement criteria and factors influencing the application of LEDs. [453]

Push/pull solenoid. Ledex Inc., 123 Webster St., Dayton, Ohio 45401. A 27-page catalog, C-1100, gives detailed technical data on both conical and flat-face solenoids. [454]

Time code readers. Chrono-Log Corp., 2583 West Chester Pike, Broomall, Pa. 19008 has published a bulletin describing the operating details and specifications of the series 5,000 time code readers. They are IC units which accept time code inputs in both IRIG and NASA formats from analog magnetic tape playback, telemetry systems or direct wire transmission. [455]

NEW from **TECHNIPOWER, INC.**

LOW COST, HIGH PERFORMANCE POWER SUPPLIES
NOW IN **SINGLE** AND **DUAL** OUTPUT MODELS

"THE PRACTICALS"... they make systems engineers cost-efficiency experts!

**Out Specs All
Comparatively Priced Units**
AC-DC Regulated Power Supplies

Specifications:

Input voltage range: 105-125 volts.
Input frequency range: 47-420 Hz.
Regulation-Line and Load Combined: $\pm 5\%$
Ripple (RMS): (with either positive or negative terminal grounded): 10 mv.
Temperature Coefficient: (TYP.) 0.05%/°C or 5 mv/°C whichever is greater.
Polarity: May be used positive or negative.
Output voltage and current: See model listings.
Output adjustment range: See model listings.
Short circuit protection: Automatic circuit protects the power supply if the output is shorted continuously. Automatic return upon removal of short circuit.
Remote sensing: Provisions are made for remote sensing to eliminate effects of lead resistance on dc regulation.
Operating temperature: 0°C to +55°C for current ratings specified in model listings.
Storage temperature: -20°C to +85°C.
Recovery time: (TYP.) Less than 50 μ sec, 1/2 L to FL.
Ambient temperature rated: To 55°C.

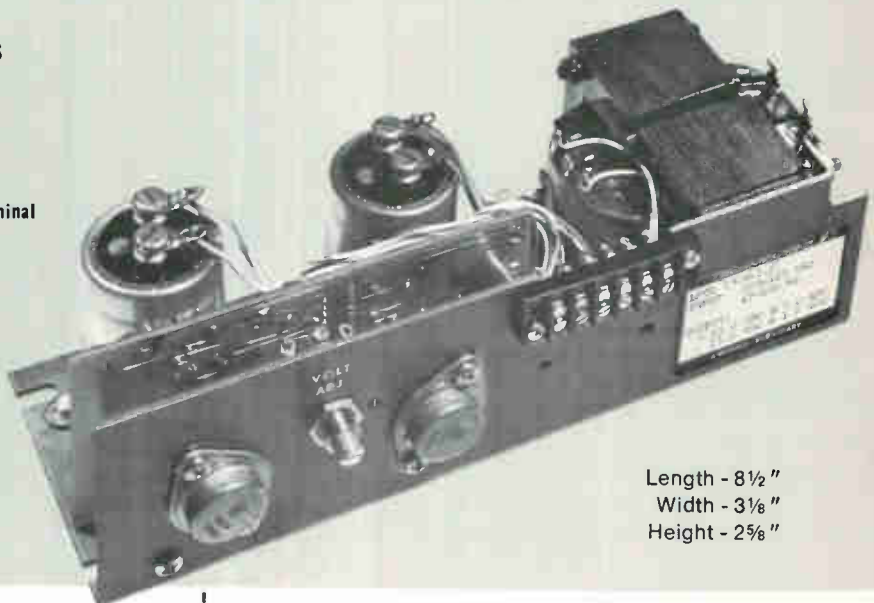

Length - 8 1/2"
Width - 3 1/8"
Height - 2 5/8"

SINGLE OUTPUT SERIES DESIGNED FOR BROAD COMMERCIAL APPLICATIONS

\$39⁷⁵ All Models
10 or more
combined units

VOLTAGE AND CURRENT RATINGS

ADJUSTABLE OUTPUT VOLTAGE	OUTPUT CURRENT	STANDARD MODEL NO.	PRICE 1-4 UNITS	PRICE 5-9 UNITS
5.0 $\pm 5\%$	5.0	LP5.0-5.0	\$49.75	\$44.75
6.0 $\pm 5\%$	4.5	LP6.0-4.5	49.75	44.75
12.0 $\pm 5\%$	2.5	LP12.0-2.5	49.75	44.75
15.0 $\pm 5\%$	2.0	LP15.0-2.0	49.75	44.75
24.0 $\pm 5\%$	1.5	LP24.0-1.5	49.75	44.75
28.0 $\pm 5\%$	1.2	LP28.0-1.2	49.75	44.75

All models available with overvoltage protection, add \$5.00. Prices for large quantities quoted upon request. Custom specifications to order.

DUAL OUTPUT TRACKING SERIES DESIGNED FOR OP-AMP AND OTHER COMMERCIAL APPLICATIONS

\$74⁷⁵ All Models
10 or more
combined units

VOLTAGE AND CURRENT RATINGS

ADJUSTABLE OUTPUT VOLTAGE	OUTPUT CURRENT	STANDARD MODEL NO.	PRICE 1-4 UNITS	PRICE 5-9 UNITS
$\pm 12.0 \pm 5\%$	1.2	LPDT-12.0-1.2	\$89.75	\$79.75
$\pm 15.0 \pm 5\%$	1.0	LPDT-15.0-1.0	89.75	79.75

Modification of standard output voltages can be provided over the range of ± 5 to ± 28 volts at slight additional cost. Voltages below ± 7 volts not available in Tracking models. Independent output adjustment provided at slight additional cost.

BOTH MODELS BACKED BY TECHNIPOWER 5-YEAR WARRANTY

Mr. Arthur Riley, Vice-President, Technipower, Inc.

Benrus Center, Ridgefield, Conn. 06877

Please have your representative call.

Please send me your complete power supplies Catalog and Data Book No. 701.

Name _____

Title _____

Company _____

Address _____

City _____ State _____ Zip _____

EL-1-71

Intel fields RAM team

Four new Schottky bipolar memory devices team up to make semiconductor memory systems faster, simpler and less costly than ever before.

Kingpin is Intel's 3101A, the fastest 64-bit bipolar RAM in the league. Address to output access time is 35 ns maximum. Chip select to output time is 17 ns maximum. Memory expansion is handled by Intel's 3205, a 1-of-8 chip-select decoder. Eight 3205's can link 256 RAMs into a 1024-word system. Enable to output time for a 3205 is only 18 ns maximum.

Fast data transfer is provided by our 3404, a 6-bit register that grabs data coming out in 12 ns, and lets our RAM cycle at speeds approaching access time. Enable-to-output delay is 17 ns maximum — twice as fast as any other latch.

Speeding the system even more is the job of our 3104, a 16-bit, content addressable memory that designers can use to take time-saving short cuts. With a 25 ns maximum access time, it's twice as fast as any other CAM.

All four members of our team interface as though they were made for each other—which they were. And all interface directly with DTL and TTL logic.

All devices except the CAM are available in both plastic and ceramic packages. Prices in 100-piece quantities are:

Type	Plastic	Ceramic
3101A RAM	\$9.00	\$11.25
3205 1 of 8 decoder	\$4.35	\$5.40
3404 6-bit register	\$4.35	\$5.40
3104 CAM	N/A	\$28.00

For immediate delivery call your local Intel distributor, Cramer Electronics, Hamilton Electro Sales, Industrial Components, or Electronic Marketing.

Intel Corporation is in high volume production at 365 Middlefield Road, Mountain View, Calif. 94040.



intelTM
delivers.

fastest

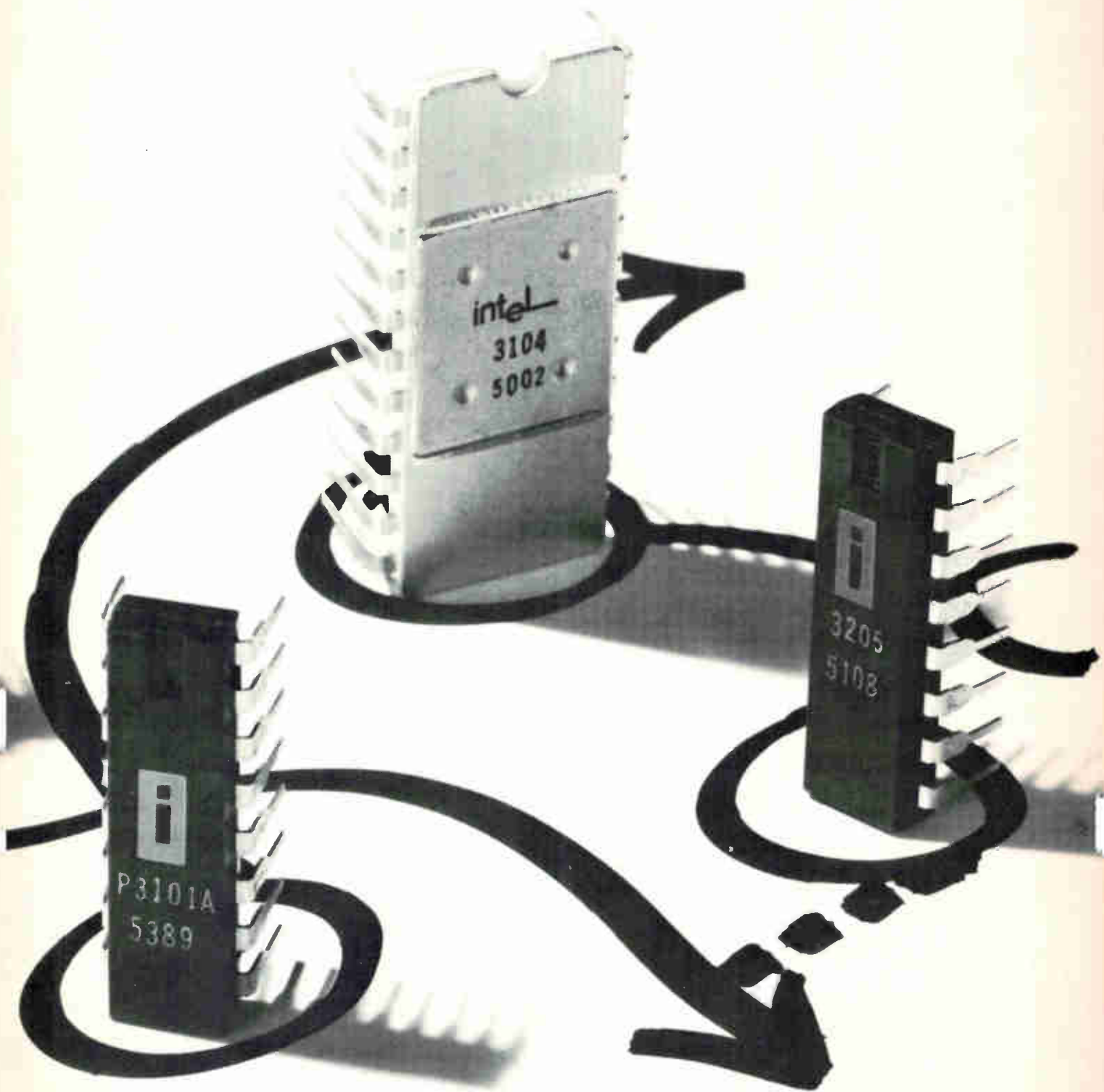

position wanted

Sophisticated electronic type with proven lab record desires full-time work. Broad capability over 0.2 Hz to 2 MHz range. Can generate sine, square and triangle waveforms. Can simulate amplitude modulation, frequency modulation, frequency shift keying, pulse amplitude modulation, pulse code modulation, phase reversal modulation, suppressed carrier amplitude modulation, and sine squared with usable output to 4 MHz. Calibrated output attenuation provided. Available immediately.

Lab assistant: \$595

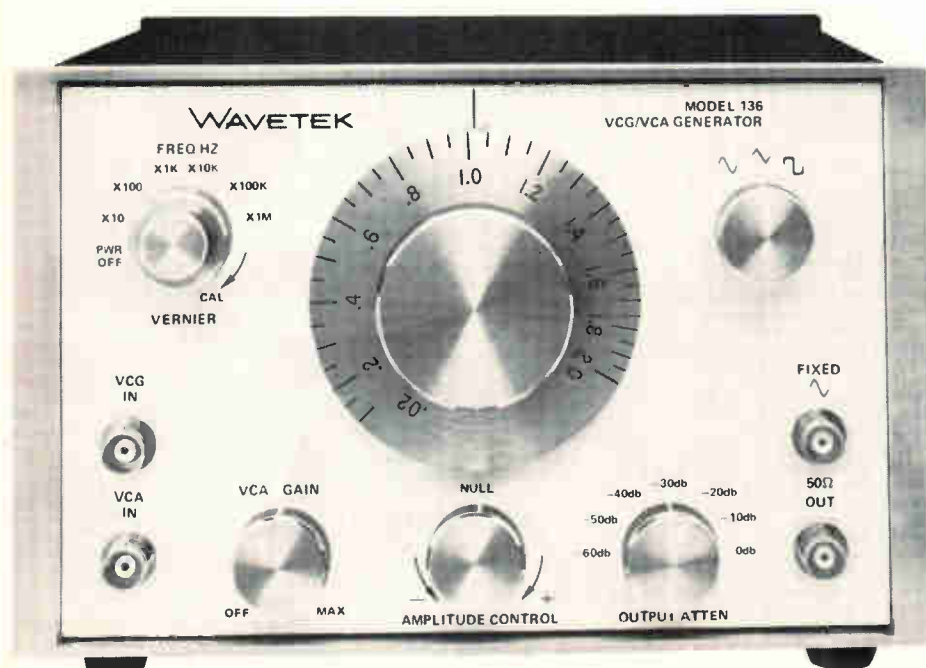

Ask for
Model 136
Voltage Controlled Generator.

WAVETEK[®]

P. O. BOX 651, SAN DIEGO, CALIFORNIA 92112
TELEPHONE (714) 279-2200. TWX 910-335-2007

International Newsletter

May 24, 1971

RCA opens Belgian semiconductor plant

Watch for RCA to step up its semiconductor effort in Western Europe. The company inaugurated its first Continental semiconductor plant at Liege, Belgium, this month and has backed up its 200 production-line workers with the nucleus of an applications engineering group.

Initially, RCA will concentrate on power devices: about 700,000 per month, all packaged in cans, are coming off the Liege line. The plant is about set, however, to start turning out plastic-packaged units, which eventually will account for the bulk of the Liege power-device production. RCA officials admit they'll be playing it by ear in adding new product lines at Liege. But William Hittinger, the company's top semiconductor executive, indicated at the inauguration ceremonies that rf transistors likely will be next.

French planners tap electronics for fastest growth . . .

Government and industry economic planners in France have singled out electronics as the kingpin growth sector during the new five-year plan, which runs through 1975. Growth target for electronics production is 17% annually; it would carry the industry's output from its current \$2.8 billion up to \$6.2 billion by 1975. The sector tapped for fastest growth is telecommunications: 23% yearly. Then come computers at 22%, consumer goods at 13%, components at 12%, and capital equipment at 9.7%. The latter's comparatively low growth target belies the planners' intense concern over heavy electronics equipment—the government, through its R&D spending, plans to speed a switch into nonmilitary markets, including oceanography, medical equipment, automation hardware, and civil avionics.

Also look for government efforts to keep the French electronics industry as French as possible. The economic guidelines call for a strengthening of native companies, which now account for about half the country's electronics output.

. . . as CII shows first native-designed mini

Meanwhile, France's major domestic computer firm, Compagnie Internationale pour l'Informatique, plans to beef up its position in the mini-computer market. CII this month introduced its first French-designed mini and at the unveiling made it clear it is counting on capturing 30% of the minicomputer market for automation, data transmission, card files, and big-computer simulation. The company had been servicing the minicomputer market with French-made versions of Xerox Data Systems' Sigma machines.

CII brass is convinced the new Mitra 15 minicomputer will remain a valid contender on the market through the mid-'70s. Architecture is highly modular: up to four processors can be tied into the main memory and each processor can handle up to 44 peripherals, with a microprogram for each peripheral. The basic machine, with a 4K memory, will sell for about \$13,500. Deliveries will start late this year.

Nixdorf and CDC talking cooperation

Negotiations between West Germany's Nixdorf Computer AG and the Control Data Corp., Minneapolis, have entered a "decisive phase," say officials, and a cooperative deal may be close. Both companies are exploring the possibility of a technical know-how exchange and mutual assist-

International Newsletter

ance in developing peripheral equipment and terminal devices. Also being discussed is exchange of equipment on an OEM basis. Both Nixdorf and CDC officials abroad stress that financial links are not a topic.

CDC specializes in large machines and Nixdorf is known for its strength in small computers, but it's hardly an unlikely match. West German industry insiders suspect that CDC, whose smaller machines aren't doing very well on domestic markets, is seeking a stronger involvement in small-class computers and terminals tailored to its large machines.

Russians buy Swedish control gear . . .

To help push Soviet machine tools in Sweden, the Russian gear will be equipped with Swedish-built Saab-Scania numerical control systems, according to AB Profila, the Swedish agent for Soviet machine tools. The USSR already has purchased about 15 Saab-Scania control systems for use on tools in the Soviet Union. The first tools to be offered in Sweden with Saab-Scania control units will be horizontal borers, with numerical control in three axes, and 90- or 110-millimeter spindle diameter. The machines will be supplied with tool-changing equipment for 100 tools. Profila notes that some Soviet machine tools sold in West Germany are equipped with Siemens numerical control systems.

. . . and Italians buy Swedes' computerized phone-switching net

Swedish telecommunications giant L M Ericsson has received an order for a multicomputer electronic telephone-switching exchange from the Italian telephone authority, Societa Italiana per l'Esercizio. It's the second order for an Ericsson system; the first, for the Dutch telecommunications agency, will go into operation in Rotterdam in June. The 14-computer Dutch system, which has a maximum capacity of 18,000 incoming and 18,000 outgoing lines, has been delayed about two years, but Ericsson claims it's a year ahead of an ITT multiprocessor system. The Naples operation will be Italy's first computer-controlled exchange.

Matsushita shows peripherals for minis

Matsushita Electric Industrial Co. has announced a line of five minicomputer peripherals just in time to show them at the Spring Joint Computer Conference. Noteworthy is a minidisk that achieves low price and fast access time by omitting the servo system usually used to position magnetic heads over tracks on the disk. Instead, Matsushita uses 32 heads, arranged in groups of eight on a ceramic button that floats over the disk, and electronic switching for track selection. Average access time is reduced to 8.8 milliseconds, or just half the time for one revolution, against well over 100 milliseconds for conventional units.

The new disk has 20 kilobits capacity per track and sells in 120K, 320K, and 600K versions for \$1,000, \$1,139, and \$1,278 in Japan.

Addenda

Swedish color TV owners who have been evading the \$56 annual license fee soon may be confronted by an electronic meter that can detect a color receiver from a distance of 10 to 15 yards—but not before a special commission rules on a complaint that the device violates personal integrity. . . . Philips and Siemens, which since 1962 have been cooperating in the phonograph record field, have set up two holding companies, one in Holland and the other in Germany, to strengthen their position in the video cassette market.

Thick film route leads to thin glow display tube

Sony prints anodes, cathodes, leads, and insulation all on one plane, then sandwiches together multidigit display

A printed circuit on a glass plate, with a second plate sealed on top by glass frit, is not the type of structure normally used to make electron tubes. But this is the method used by Sony to fabricate a new multidigit glow display tube.

The mesh anode in front of the numeral stack or segments of other glow display tubes is replaced by an anode in the same plane as the cathode segments. This change in configuration not only improves visibility but also sets the stage for a multiple-digit display with greatly reduced thickness.

Sony has given the name Planitron to this display. It consists essentially of a glass base and envelope that are sealed together to form the envelope after the electrodes have been fabricated on the base by thick film integrated circuit techniques. Glass frit is used to keep sealing temperatures low enough to prevent damage to electrodes and glass plates.

First device to be produced by Sony is a 16-digit-and-sign numerical display that it uses in a new calculator. Sony has squeezed this display into a package measuring 7 inches long by 1.8 in. wide by only 0.22 in. thick—with the exception of a projection at one point in the rear for the exhaust tip.

Sony claims that as production

rises it will be able to make the new display for about one-fifth the price of displays using 16 separate tubes to give the same number of digits. Even today, while production is only thousands of units per month, cost is less than a conventional display.

Numerals in the display are 0.3 in. high. They are based on seven cathode segments in a figure-eight pattern, with a decimal point following the digit. Anodes are located in the middle of each loop, with all anode electrodes for one digit connected together. Filling in the space between the digits is a shield electrode. Different electrode configuration will enable Sony to make alphanumeric units.

The display is designed for time-division pulsed operation to keep the number of external leads down to a manageable number. Terminals and external leads are extensions of the thick film interconnections inside the display, and are plugged into an edge connector similar to the type used for mounting computer circuit boards.

Fabrication starts with the printing of vertical connections and terminals using a silver-based conducting material. Next comes a layer of glass insulation, with through holes left. Horizontal interconnections and electrodes are printed in a second layer of conducting material. A second glass layer is printed over the exposed interconnections to prevent glow where it is not required. The exposed electrodes are plated with a layer of heavy metal that is not susceptible to sputtering in opera-

tion. A shaped cover plate and an exhaust tip tube are attached by glass frit and the unit is baked.

In operation the shield electrode is kept at a positive dc voltage lower than that needed to sustain a glow discharge and prevents the transfer of a glow discharge be-

All together. Low-melting-point glass frit seals cover to glass substrate.

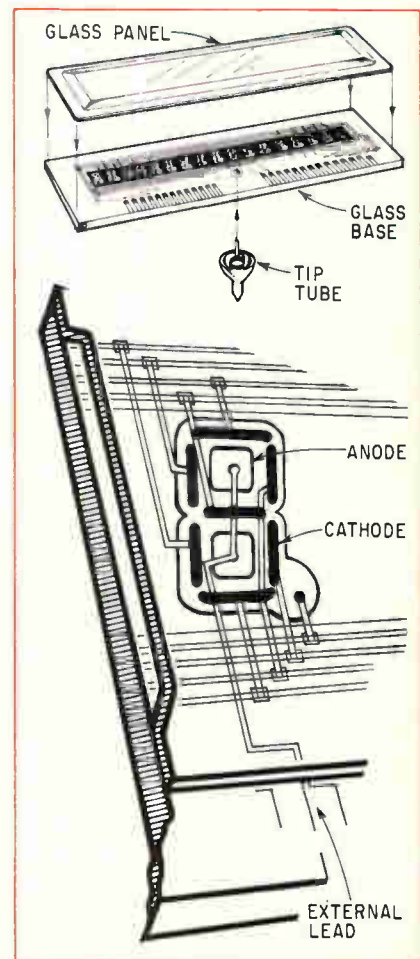

tween digits. Supply voltage is 175 volts, and average current is about 5 milliamperes. Brightness is 100 foot-lamberts.

France

Liquid crystal display is built on top of MOS drive

To integrate display and drive circuitry, researchers at the French Atomic Energy Commission's Grenoble laboratory have put liquid crystals on top of an MOS integrated circuit. The result is a display unit that is smaller than a standard liquid crystal configuration and, because of fewer connections, is easier to install.

The French unit is based on an MOS shift register that serves as a multiplexer to drive a 35-dot liquid crystal digit. The size of the IC is precisely the same as the alphanumeric character to which it is connected: 1.8 by 2.8 millimeters.

The designers first take a chip of silicon and build up an MOS shift register on it. They cover it with a layer of silicon dioxide with holes pierced to permit connection with the 35 dots of the display digit.

The liquid crystal dots, 300 microns in diameter, are then laid down and surrounded by a 1-micron wall of aluminum for electrical contact. A 10-micron aluminum wall surrounds the entire digit. Over this is placed a thin sheet of glass coated with a transparent electrode of tin oxide. Each dot in the display is hooked directly to the shift register, eliminating interconnections.

The French researchers are experimenting with one IC driving up to four digits. They found MOS technology well suited to liquid crystals because of the similar voltages involved. They use 24 volts in present experimental models but figure they could also use 12 V. And liquid crystals function on the low-power MOS supplies—in this case, less than 2 mW per dot.

Joseph Borel, director of the Grenoble laboratory's device physics group, who gave a paper on the

new integrated readout at a Society for Information Display symposium in Philadelphia early this month, figures the display is about six months away from possible commercial production.

Borel believes technical development is finished, but he wants to study the unit's lifespan before offering licenses for sale. He expects lifespan will be around 10,000 hours on ac operation, and perhaps 1,000 hours on dc. Cost should be only a bit higher than that of a standard, 35-point MOS shift register, Borel predicts.

Great Britain

Improving dual-gate MOS transistors

As communications amplifiers, MOS transistors have an important theoretical advantage over bipolars: their input-output transfer characteristics are more nearly linear. That means cross-modulation and intermodulation interference should be less, which could be very useful in high-selectivity communication equipment.

The main snag with the ordinary three-element MOS transistor is that feedback capacitance limits frequency and stability. And where power output is a factor, low drain-breakdown voltage is a problem. Nevertheless, there are applications—TV receivers are the most common example—where cross modulation can be a problem. A number of companies have developed MOS FET TV amplifiers using a tetrode, or dual gate, construction to limit feedback. However, these devices don't normally have useful gain above about 500 megahertz.

Britain's Ministry of Defence (Navy), always on the lookout for ways of improving military communications gear, is financing research at the Hirst Research Laboratories of General Electric Co. into ways of improving frequency and power performance. A team led by Richard Josephy has produced one promising device: a small-signal amplifier giving 10-

decibel gain and an 8-dB noise figure at 900 MHz. Josephy is also developing a power device and has made small-scale versions of a layout he thinks can be expanded to give 100 watts at 30 MHz from a chip 120 mils square.

Both devices use two gates, and the uhf amplifier also uses ion implantation. In this n-channel device, source and drain are diffused about 6 microns apart and 2 microns deep. An island strip 1.5 microns across is ion implanted along the middle of the channel, together with ion sharpening of the inside edges of the diffusions. This leaves two channels, each about 2 microns long, topped by the gates which have been used as implantation masks. Hence, there is virtually no gate overlap of source, drain, or island. The uhf signal is applied to the gate over the source-side channel, and the other gate is connected to a low bias voltage and to ground through a capacitor. According to Josephy, almost all feedback is shunted to ground and feedback capacitance is 0.02 picofarad. Mutual conductance is 12 millimhos. At 500 MHz the device gives 17-dB gain and a 4.7-dB noise figure, and at 900 MHz 10-dB gain and 8-dB noise. Josephy says it is entirely stable to 900 MHz.

Including the islands between the gates takes up space but keeps the processing as simple as possible. Josephy says there's only one stage more, implantation, than with ordinary MOS transistors. However, on a power device it's important to maximize output per unit area. Therefore the power process dispenses with the island and with implantation (it doesn't have to work beyond hf frequencies) and uses overlapping gates, which means two extra processing stages. The source gate is molybdenum topped by vapor-deposited oxide and then topped by the overlapping drain gate in aluminum. This approach keeps feedback capacitance down, and tests have shown that the tetrode structure raises drain breakdown voltage to 160 V compared with 85 V on a three-element device of similar construc-

tion, due to the isolating effect of the second gate. This device will be aimed at ssb transmitters. Josephy says that the three-element device gave 30 watts at 30 megahertz with intermodulation products of 30 dB and this performance should be easily exceeded on the tetrode.

From Northern Ireland: tunable dye lasers

Investment in laser manufacture is a bit like investment in advanced microelectronics: money must be pumped into new products before existing lines have paid off, but the volume market that will justify the effort always remains just around the corner. Nevertheless, the carrot apparently is as juicy as it ever was, and two Britons have found financial backing for a plan to make flash-lamp-pumped dye lasers in Northern Ireland and sell them worldwide.

The two argue that the xenon flash tube as a means of energizing a dye laser has never been given the attention it deserves. Its big plus is its cheapness compared to the established way of pumping the dye—using another laser, usually a pulsed nitrogen system. Given cheapness—\$7,000 for one of their systems, compared with around twice that for a laser-pumped system of similar performance—the men feel that potential users will take a deeper look at the unique advantage of all dye lasers, however pumped: their tunability.

The company is called Electro-Phonics Ltd. of Derriagh, County Antrim. Most of the research on which the company's lasers are based has been carried out at Queen's University, Belfast, by a team lead by Professor Daniel Bradley. Director Peter Morcombe's aim is to expand the company's present staff from nine to about 70 within five years.

Morcombe's view is that a reasonably cheap laser tunable over a useful portion of the visible waveband will be in demand for spectroscopy analysis in laboratories. But

in the long run it will be even more in demand as an easy means of measuring atmospheric pollution. The technique would be to tune through the wavelengths known to be the peak absorption wavelengths of the various pollutants—sulphur, carbon monoxide, etc.—measuring photon backscatter at each peak.

Powerful pulses are necessary to ensure the sufficient photons are scattered back. Morcombe says the flash-lamp-pumped system meets this requirement; pulses of 1 joule for 3 or 4 microseconds, equal to about 200 kilowatts, are routine. Further, where a train of very short pulses is suitable, the laser can be mode-locked, which means a standing wave effect is generated. This effect will produce pulses of only 5 or 10 picoseconds duration at a rate of several hundred megahertz, with a pulse power of 10 megawatts. Morcombe says that so much power makes harmonic multiplication into the ultraviolet region reasonably efficient, and some lab workers will welcome a tunable ultraviolet frequency source. In the lab, using amplification, he has seen 2-picosecond pulses of 200 megawatts, which he thinks may be a new record for a combination of high power and short time.

The tuning bandwidth is governed by the choice of dye: Xanthene dyes, for instance, are tunable from 5,600 angstroms to 6,300 Å and Coumarin dyes cover 4,350 Å to 4,850 Å. Fine tuning is carried out by either a diffraction grating, providing a line bandwidth of between 1 and 5 Å, depending on quality, or interferometers that in combination for extreme accuracy can get 0.0005 Å. Electro-Phonics is working on dye combinations that will provide 1,000-Å bandwidth and an efficiency rise from present 0.3% to around 1%.

The laser cavity is an elliptical section cylinder, with the flash tube at one focus and the laser tube at the other about 2.5 inches apart. Ordinary xenon flash tubes won't stand the voltage—20 kilovolts—and don't give a sufficiently short, clean-cut flash, so Queen's University developed a xenon-oxygen tube.

Electroluminescence: yellow now, blue and green to come

A small British firm—Phosphor Products Co. Ltd.—feels that it's well on its way to building practical, competitive electroluminescent displays. The company already has introduced its first product—a four-digit, 0.5-inch-high, yellow readout with seven-segment characters [*Electronics*, Apr. 26, p. 97]. Now company scientists have taken a step toward being able to offer a choice of colors by developing green displays and blue displays on an experimental basis.

The company is optimistic about the chances of electroluminescence competing successfully with light-emitting diodes and other display technologies. Electroluminescent readouts have a soft, easy-to-read appearance. They're based on a bulk rather than a junction phenomenon, and are therefore potentially inexpensive to make. Phosphor Products' yellow readout sells for \$5 per digit, or \$20 for the four-digit display. Volume production would substantially reduce that figure. Finally, although typically requiring 100 volts or more, the displays are low power units.

Another advantage of Phosphor Products' displays in particular is that they're dc units. Practically all previous attempts to build electroluminescent displays focused on ac drive. In fact, the only other commercial electroluminescent display, which is made by Sigmatron Inc., of Santa Barbara, Calif., is an ac unit. The dc approach means simpler multiplexing and compatibility with existing decoder/drive circuits.

The Phosphor Products display differs in two other ways from traditional electroluminescent readouts—the active material is a sulfide and not a phosphor, and it's deposited as powder rather than as a thin film. For the yellow readouts, a coating of zinc sulfide in a binder is placed onto an aluminum-on-graphite cathode. On top of the sul-

fide goes a transparent tin-oxide anode, which is covered by a glass plate. An electric field across the sulfide generates the yellow light. For the green display, the active material contains erbium, while for blue, thulium is used.

Lifetime of the displays depends on the magnitude of the applied voltage. For the yellow display, the rated life at the 10-foot-lambert level is 5,000 hours. At 100 ft-L, the figure is 1,000 hours.

Since the green and blue units have just been built, no lifetime data is available on them. At present their brightness is only 5 ft-L, while their efficiency, says Aren Vecht, founder of Phosphor Products, is 2% that of the yellow unit.

West Germany

Electroluminescence: wide-screen display

Electroluminescent alphanumeric displays have been around for quite some time, but no major effort has been made to use them in large-scale displays. One obstacle has been that reliable electroluminescent elements with sufficiently long operating life and adequate brightness weren't available.

One company that hasn't stopped looking into the possibilities of electroluminescence is West Germany's AEG-Telefunken. Using recently developed, highly reliable and long-life electroluminescent elements, its new display promises at least 10,000 hours of operation before its brightness falls to half its original value. And modular construction allows many screen sizes and a mixture of size and number of display elements.

Called Varisymbol, the display was introduced at the Hanover Fair. It stands as a highlight among the new electronic systems shown, measuring about 10 square feet in surface area and containing 256 display elements. AEG-Telefunken expects to have electroluminescent displays ready for the market by the end of this year. It's also working on liquid-crystal versions, but

they still suffer from slow response time and temperature instability.

The Varisymbol's basic building block is a 14-segment indicating device that's activated by an ac voltage to generate 63 different green-glowing symbols—36 alphanumeric characters and 27 special symbols, such as plus or minus signs, parentheses, markers, indicating arrows, and the like. Symbol generation takes only 50 microseconds. However, by using improved drive circuitry, the company expects to reduce that time to around 20 microseconds. At such speeds, up to 50,000 characters or special symbols could be illuminated and displayed in 1 second.

The elements come in six sizes from 0.75 inch to 4 in. tall. Standard-sized panels measure either 4 feet square or 5 ft square.

The display uses a 150-volt, 400-hertz power supply. Power consumption for a 10-square-ft panel is about 100 watts, of which only 8W is used by the elements themselves. AEG-Telefunken figures that each display element, including its individual drive and control circuitry, will cost somewhere between \$80 and \$95.

The Netherlands

Modular test system for TV set alignment

Television set makers generally are forced to go in for technological overkill when it comes to test setups for their production lines. The usual practice is to distribute video test signals throughout a plant from a central source that has laboratory precision. The test stations on the assembly lines, then, get a lot more signal quality than they really need.

That means some set makers have to pay out more than they really should for test hardware. The cost of outfitting a setmaking plant with video signal test points of course varies widely, but the rock-bottom figure works out to about \$25,000. In some cases, that's considerably more than the plant's

output of receiver warrants, but so far there's been nothing available but very-high-quality test equipment.

That state of affairs will soon end. At the Seventh International Television Symposium, running from May 21 to May 27 at Montreux, Switzerland, Philips Gloeilampenfabrieken has been making a stir with its new generation of test-signal generation equipment. Philips is at once a set maker, a test-equipment maker, and Dutch-practical in outlook. The company's new test gear cuts the bare-essentials investment for factory video test signals by half, and more in some cases. What's more, the new equipment can be run by relatively unskilled operators.

To get all these advantages, Philips took a new tack in TV test signal generation. The new hardware puts the signal sources on the spot. All that's needed to set up a test station—besides the equipment itself—is a power outlet and a few short cable interconnections. As for the hardware, it's built with industrial rather than lab precision so a worker need not be a skilled technician to align sets with it. Instead of the single complex video signal supplied by distributed-signal setups, Philips' new gear gives individual signals for specific alignment steps.

Four basic units are available in the new line: a monochrome test-signal generator (PM 5520), a PAL color test-signal generator (PM 5522), a vhf/uhf modulator (PM 5524), and an i-f modulator (PM 5527). The two test-signal generators together serve as the key equipment for testing video sections and time bases, and for aligning picture tubes.

When carrier signals are needed along with the video, the PM 5527 comes into play. It provides an i-f frequency of 38.9 megahertz or one of three channel frequencies in the band from 38 to 65 MHz. All are crystal controlled. More extensive carrier capability comes in the PM 5524. It provides two outputs on carrier frequencies in bands I, III, IV or V and 5.5-MHz fm sound.

PUSH.

The great American switch.

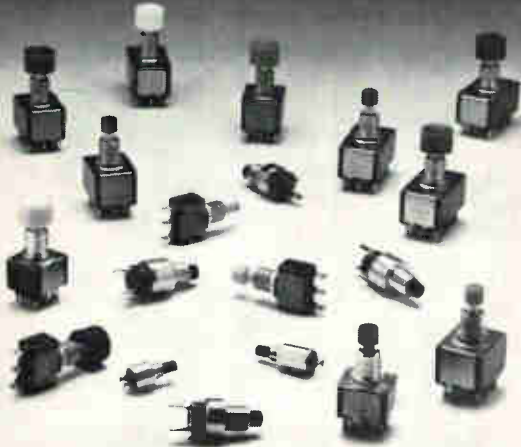

Sub- and micro-miniature pushbuttons by C&K. They're tough. And they're priced right. And they can beat anybody's delivery to any place in the world. Now there's a switch. Get the catalog (#800).

C&K COMPONENTS, INC.

103 Morse Street, Watertown, Mass. 02172

TEL: (617) 926-0800 - TWX: 710 327 0460

The great American switch company.

Also supplied: toggle catalog (#700) Rotary Print Switch catalog (#900)

Circle 129 on reader service card

The power supply you plan to build is built!



\$99 each

OTHER MODELS 3 to 50 V available

Low Cost-Reliable

It's on the shelf, ready for immediate delivery from Electrostatics. With specs proven in service. Low cost. Brief specs on our Model 200:

- 5V 15A DC Power Supply
- Input 105-125V, 47-420 Hz
- Regulation: Line 0.01% Load 0.1%
- Ripple: 500 μ V max.
- Temp: -20 to +71°C
- Foldback current limiting
- Size: 5.5" W x 5" H x 10.8" L

(\$114 with overvoltage protection)

For full information call Robert McCartney, Manager of Application Engineering, (714) 279-1414. Or circle the number below for our latest data sheet.

Electrostatics, inc.

7718 Clairemont Mesa Blvd., San Diego, California 92111

DEPT 111

Circle 130 on reader service card



GO FAIL FREE

LOWEST PRICE CO₂ CHAMBER... **\$395**



RW-1100

Now you can **Go Fail Free** without going broke! \$395 buys ATL's Model RW-1100 full range low/high temperature chamber, a compact bench unit lab-engineered specifically for small parts and assembly testing and quality control. ATL hasn't scrimped on quality at your expense either. Look at the full performance features you'll get: -100°F to +350°F range ($\frac{3}{4}$ ° stability)...half cubic foot work area... door-mounted temperature readout...solid state temperature control...liquid CO₂ cooling.

LOWEST PRICE MECHANICAL CHAMBER...

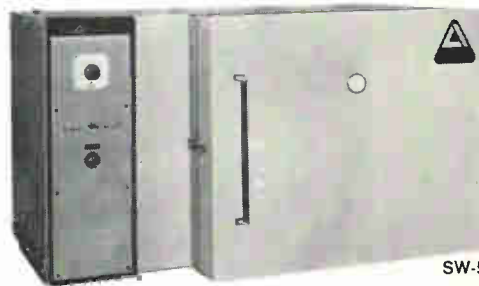

SW-5101

For a full range military testing capability, ATL's benchtop model SW-5101 extends from -100°F to +350°F at a phenomenally low cost. Add a host of other advantages such as single compressor design for simplified maintenance...all solid state control...high temperature fail-safe. **All for \$970!**

Both units are fully presented in the all-new, complete ATL Environmental Equipment Catalog M-7-2. Why not get the whole story today?



ASSOCIATED TESTING LABORATORIES INC.

200 ROUTE 46, WAYNE, N.J. 07470 • (201) 256-2800

NEW ENGLAND DIVISION:

NORTHWEST INDUSTRIAL PARK, BURLINGTON, MASS. 01803 • (617) 272-9050

NEPCON-EAST BOOTH 600

Circle 123 on reader service card D 1

Electronics advertisers

May 24, 1971

Advanced Micro Devices	19	Mostek Corporation	20
Keye/Donna/Pearlstein		Continental Communications Incorporated	
Advanced Micro Devices	17E	Motorola Semiconductor Products Inc.	34-35
Keye/Donna/Pearlstein		E.B. Lane & Associates Inc.	
AEI Semiconductor Limited	10E		
M C R Advertising Limited		■ National Semiconductor Corp.	9 to 12
Airco Speer Electronic Components	8	Chiat/Day Inc. Advertising	
Hazard Adv. Co., Inc.		North Atlantic Industries Inc.	80
Allen Bradley Company	40	Helme Associates Inc.	
Hoffman-York Inc.			
American Smelting and Refining Co.	14	Pearson Electronics	81
Clyne Maxon Inc. Advertising		Williams E. Clayton & Associates Inc.	
Amphenol Space and Missiles Systems,	33	□ Pignone SUD	20E
Bunker Ramo Corporation		Linea SPN	
Marsteller Inc.		□ Philips N. V. PIT T&M Division	2E, 11E
□ Acip	23E	Marsteller International S. A.	
D P Industrie		□ Polaroid Industrial International	19E
Associated Testing Labs. Inc.	D-1	Doyle Dane Bernbach Inc.	
A.D. Adams Advertising Incorporated			
		Raytheon Company, Microwave	
Bausch & Lomb Inc.	13	& Power Tube Division	92
Wolff Assoc., Inc.		Provandie Eastwood & Lombardi Inc.	
Bell & Howell Electronics &	27	RCA Electronic Components	4th Cover, 15
Instruments Group		Al Paul Lefton Company	
Coordinated Communications Inc.		□ Rhode & Schwarz	5E
□ Burndy Electra	12E		
Publicis		Sanken Electric Co. Ltd.	110
		Seikosha Adv. Inc.	
Centralab, Div. of Globe Union Inc.	78	Schauer Manufacturing Corp.	84
The Brady Co.		Nolan, Keelor & Stites	
C&K Components Inc.	D-1	semiconductor electronic memories Inc.	73
Van Christo Associates Inc.		Gumpertz, Bentley & Dolan Advertising	
Colorado Video Inc.	D-4	□ S.E. Laboratories Ltd.	18E
		Graphic Publicity Ltd.	
Data Control Systems Inc.	96	□ Sescosem	30E
Technical, Industrial &		Perez Publicite	
Scientific Marketing Inc.		□ SGS	25E
□ Dow Corning International Ltd.	6E-7E	Scuola Di Design Di Novara	
Marsteller International S. A.		Signetics Corporation Sub. of	
Dumont Oscilloscope Laboratories Inc.	6	Corning Glass Works	93
Barbetta Miller Advertising Inc.		Hall Butler Blatherwick Inc.	
DuPont De Nemours & Company,	55	□ Sodeco	8E-9E
Freon Division		D. P. Industrie	
N.W. Ayer & Son Inc.		□ Souriau & Cie	29E
		Ariane Publicite	
Elco Corporation	7	□ S. P. Electronica	26E
Mort Barish Associates Inc.		Studio Mangolini Lina Arcari	
Electrostatics	D-1	Sperry Information	
Junk & Russell Advertising		Displays Division	88-89
Electronic Arrays Inc.	36-37	N.A. Winter Advertising Agency	
Regis McKenna Inc.		Sprague Electric Company	5
Energy Conversion Devices Inc.	104	Harry P. Bridge Company	
Watkins Rogers Incorporated		Sylvania Electric Products Inc.	39
		Chemical & Metallurgical Div.	
		Doyle Dane Bernbach Inc.	
Garrett Airesearch Manufacturing Co.	77		
J. Walter Thompson Company		Technipower Inc.	113
General Electric Company,	100	Freeman Pratt Barrows	
General Purpose Motor Department		Advertising Associates	
Robert S. Cragin Inc.		■ Tektronix Inc.	59, 74
□ Grayhill Incorporated	D-4	Dawson Inc.	109
Carr Liggett Advertising Inc.		Teledyne Philbrick	
		Inqalls Associates Inc. Advertising	90
Hermes Electronics Ltd.	82	TRW Electronics, Capacitors Division	
Public & Industrial Relations Limited		The Bowes Company	
■ Hewlett Packard, Colorado Springs	1		
Division		UNISEM Subsidiary of	3rd Cover
Tallant Yates Adv. Inc.	111	United Aircraft Corporation	
■ Hewlett Packard, Loveland Division		Schaefer Advertising Inc.	
Tallant Yates Adv. Inc.	2	Unitrode Corporation	29
■ Hewlett Packard Company		Impact Advertising Inc.	
Lennen & Newell Inc.	86		
■ Hickok Electrical Instrument Company	98	Wavetek	116
Key Marketing Associates		Chapman Michetti Advertising	
Hughes Aircraft Company			
Foote, Cone & Beiding		Xintel Corporation	94
		Larry Courtney Company	D-3
Intel Corporation	114-115	Xerox Corporation	
Bonfield Associates		Hutchins Advertising Company Inc.	
Interstate Electronics Corporation	87		
Leland Oliver Company Inc.			
■ ITT General Controls	D-4		
MacManus, John & Adams Inc.	99		
ITT Semiconductors			
Hall & McKenzie Advertising			
Johnson Company, E. F.	102		
Martin Williams Advertising			
■ Ledex Inc.	103		
Advertising/Mervar			
□ MDS Deutschland	27E		
Publicitas GmbH			
■ Micro Switch Division of Honeywell	16		
N.W. Ayer & Son Inc.			
Mohawk Data Sciences Corporation	106-107		
The Lampert Agency Inc.			
Monolithic Memories	30		
Regis McKenna Inc.			
MOS Technology Inc.	2nd Cover		
Henry S. Goodsett Advertising Inc.			

Advertising Sales Staff

Pierre J. Braude [212] 971-3485
Advertising Sales Manager

Atlanta, Ga. 30309: Chariton H. Calhoun, III
1375 Peachtree St., N.E.
[404] 892-2868

Boston, Mass. 02116: William S. Hodgkinson,
James R. Pierce, 607 Boylston St.
[617] 262-1160

Chicago, Ill. 60611: Ralph Hanning,
Kenneth E. Nicklas, 645 North Michigan
Avenue, [312] MO 4-5800

Cleveland, Ohio 44113: William J. Boyle,
[716] 586-5040

Dallas, Texas 75201: Richard P. Poole,
1800 Republic National Bank Tower,
[214] RI 7-9721

Denver, Colo. 80202: Richard W. Carpenter
Tower Bldg., 1700 Broadway
[303] 266-3863

Detroit, Michigan 48226: Ralph Hanning,
2600 Penobscot Building
[313] 962-1793

Houston, Texas 77002: Richard P. Poole,
2270 Humble Bldg. [713] CA 4-8381

Los Angeles, Calif. 90017: Robert J. Riely,
Bradley K. Jones, 1125 W. 6th St.,
[213] HU 2-5450

Minneapolis, Minn. 55402: Kenneth E. Nicklas,
1104 Northstar Center [612] 332-7425

New York, N.Y. 10036
500 Fifth Avenue
Warren H. Gardner [212] 971-3617
Michael J. Stoller [212] 971-3616

Philadelphia, Pa. 19103:
Jeffrey M. Preston
6 Penn Center Plaza,
[215] LO 8-6161

Pittsburgh, Pa. 15222: Jeffrey M. Preston,
4 Gateway Center, [412] 391-1314

Rochester, N.Y. 14534: William J. Boyle,
9 Greylock Ridge, Pittsford, N.Y.
[716] 586-5040

St. Louis, Mo. 63105: Kenneth E. Nicklas,
The Clayton Tower, 7751 Carondelet Ave.
[314] PA 5-7285

San Francisco, Calif. 94111: Don Farris,
Richard R. Butera, 425 Battery Street,
[415] 362-4600

Paris: Alain Offergeld
17 Rue-Georges Bizet, 75 Paris 16, France
Tel: 720-73-01

Geneva: Alain Offergeld
1 rue du Temple, Geneva, Switzerland
Tel: 32-35-63

United Kingdom and Scandinavia
London: Keith Mantle, Brian Bowes
Tel: Hyde Park 1451
34 Dover Street, London W1

Milan: Robert Saidel
1 via Baracchini Phone 86-90-656

Brussels: Alain Offergeld
22 Chaussee de Wavre
Brussels 1040, Belgium
Tel. 13 65 03

European Special Project Manager: Oliver Ball
Tel: Hyde Park, 1451, London: 34 Dover Street

Frankfurt/Main: Fritz Krusebecker
Elsa-Brandstroem Str. 2
Phone 72 01 81

Tokyo: Masaru Wakeshima, McGraw-Hill
Publications Overseas Corporation,
Kasumigaseki Building 2-5, 3-chome,
Kasumigaseki, Chiyoda-Ku, Tokyo, Japan
[581] 9811

Osaka: Akihiko Kamesaka, McGraw-Hill
Publications Overseas Corporation, Kondo
Bldg., 163, Umegae-cho Kita-ku [362] 8771

Australasia: Warren E. Ball, IPO Box 5106,
Tokyo, Japan

Business Department

Stephen R. Weiss, Manager
[212] 971-2044

Thomas M. Egan,
Production Manager [212] 971-3140

Dorothy Carter, Contracts and Billings
[212] 971-2908

Frances Vallone, Reader Service Manager
[212] 971-6057

Electronics Buyers' Guide

George F. Werner, Associate Publisher
[212] 971-3139

Regina Hera, Directory Manager
[212] 971-2544

Classified & Employment Advertising

F.J. Eberle, Manager 212-971-2557

EQUIPMENT (Used or Surplus New) For Sale	
Binswanger	112
Radio Research Instrument Co.	112

■ For more information on complete product
line see advertisement in the latest Elec-
tronics Buyer's Guide

□ Advertisers in Electronics International

Xerox Oscillographic Papers: 31 B.C. (Before Copiers)



Forty-one years ago—31 years before copiers—Xerox made great oscillographic papers.

And we've been improving them ever since. You can order them direct from your local Xerox Product Specialist listed in your telephone directory for fast shipment from our Regional Supply Centers—our way of helping you save time and money, while solving storage and delivery problems. Check performance, price and service benefit that's yours with Xerox Astroprint DP90. Xerox Corporation, Business Products Group, Department HL, Rochester, New York 14603.

XEROX[®]

Xerox and Astroprint are registered trademarks of Xerox Corporation

Narrow-Band TV



- If you don't need motion in your TV pictures, but need:
- Low-cost, long-distance, transmission over standard voice-grade phone lines
 - Tape recording on standard 1/4" audio tape
 - Hard-copy printout
 - Magnetic disc image storage (multiple pictures or color too)
 - An interconnection to a computer

Investigate our 201-series Video Converters, which compress the bandwidth of standard TV signals to as low as 500 Hertz, and our 220-series Video Converters which utilize a unique disc memory technique to re-convert to conventional 525-line TV format.

cv

COLORADO VIDEO, INCORPORATED • P.O. Box 928 • Boulder, Colo. 80302 • (303) 444-3972 Video Data Acquisition • Processing • Display • Transmission

Circle 126 on reader service card

If we design it you can count on it being a winner.

Take our new Ink Ribbon Printer. We'll customize it to your special requirements. What do we have to start with? A printer that's front loading, with two spools and 200 inches of true ink ribbon, and a reliable automatic feeding and reversing mechanism. It has a typewriter ribbon advancing action that assures longer ribbon life, doesn't require pressure sensitive tickets or tape, and gives you up to 30 active digits for use with ticket or tape.

The rest is up to you to ask and us to design. Count on us. Write Product Manager, ITT General Controls, 801 Allen Avenue, Glendale, California 91201.



GENERAL CONTROLS

ITT

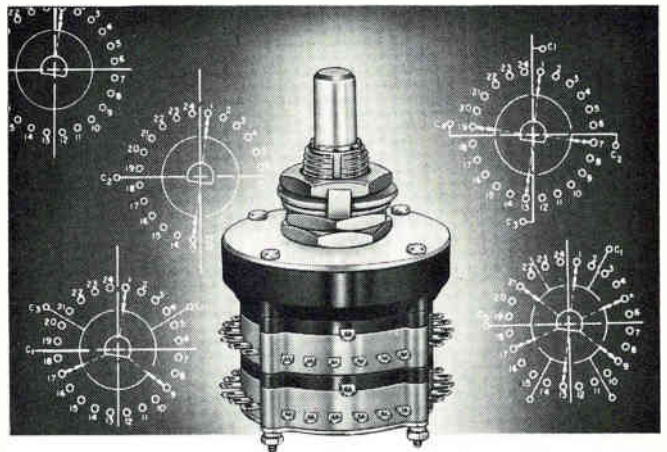

Little Giant Rotary Switches 16, 20, 24 Positions, 1-12 Decks

New military style, sealed rotary switches offer optimum capacity-to-size ratio. Up to 24 positions per pole available. Diameters from 1.125" to 1.281"; behind-panel depths from .916" (1 deck) to 4.829" (12 decks). Enclosed, with molded-in terminals. Fixed stop or continuous rotation. Raised contacts allow arc to make and break in the

air — prevent tracking across insulation material. Like to know more? Write, or phone for more details on Series 53, 57, 59 or our latest general engineering catalog: Grayhill, Inc., 523 Hillgrove Ave., La Grange, Ill. 60525 (312) 354-1040.

Grayhill

pioneers in miniaturization

I prefer one year at \$8 Payment enclosed Bill my company. Bill me

NAME _____ TITLE _____

COMPANY _____ DIV. or DEPT. _____

COMPANY ADDRESS _____

CITY _____ STATE _____ ZIP _____

Check here if you wish publication to be sent to home address. STREET _____ CITY _____ STATE _____ ZIP _____

Above rates apply only to those professionally engaged in electronic technology. All others \$25 per year. Questions below must be answered to qualify you for the professional rate. Professional rate is available to professors and senior graduate students for one-year subscriptions only.

Please check Product Manufactured or Service Performed

Please check your occupation and job function:

MANUFACTURING:

- Computer (CPU's), Computer peripheral equipment (terminals, memories, tape transports, etc.)
- Communications systems or equipment.
- Navigation, guidance or control systems.
- Aircraft, missiles, space, undersea, ground support equipment.
- Test and measuring equipment.
- Consumer electronic products, TV, Radio, Hi-Fi, Auto Radios, Recorders, etc.
- Consumer products that include electronic components or products (hand tools, major appliances, autos, etc.).
- Electronic industrial controls, systems, or equipment (automatic controls, computer controls, power controls, etc.).
- Industrial equipment containing electronic components or products (machine tools, materials handling, air conditioning, etc.).
- Electronic subassemblies to be incorporated in equipment or systems (OEM-type power supplies, amplifiers, regulators, etc.).
- Passive electronic components (resistors, capacitors, filters, networks, inductors, transformers, etc.).

- Active electronic components, including transistors, diodes, ICs, tubes, display tube, etc.
- Non-electronic parts or materials for use in electronic components or equipment (printed-circuit boards, connectors, chassis, wire and cable, plastics, compounds, ceramics etc.).
- Other manufacturing where electronic products, systems, or measurement equipment are used (Pharmaceuticals, plastics, steel, food industries, etc.).

NON-MANUFACTURING:

- Research and Development organization not related to manufacturing or educational institutions. Includes independent consultants.
- Research and Development organizations which are a part of an educational institution.
- U.S. Government, Armed Forces, DOD, NASA, FAA, etc.
- Utilities.
- Broadcasting, sound and motion pictures, and recording studios.
- Other commercial users of Electronic products (Railroads, pipeline companies, Police, airlines, etc.).

Occupation: _____ 51520

- Engineering Management; chief engineer, etc.
- Corporate Management; Officer, Owner, Partner, Gen'l. Manager, Staff Executive, etc.
- Operating Management; Division Mgr., Dept. Mgr. Plant Mgr., etc.
- Engineer or Technologist; Physicist, Chemist, Scientist, etc.

OFFICE USE ONLY

Job Function:

- Design Engineering.
- Research & Development.
- Systems Engineering.
- Applications Engineering/Project Management.
- Product Planning/Product Management.
- Test & Evaluation/Quality Assurance Reliability.
- Manufacturing or Production.
- Operations or Administration.
- Purchasing.

FIRST CLASS
PERMIT No. 42
HIGHTSTOWN, N.J.

BUSINESS REPLY MAIL

NO POSTAGE STAMP NECESSARY IF MAILED IN U.S.

Postage will be paid by

Electronics

McGRAW-HILL, INC.
SUBSCRIPTION DEPT.
P.O. BOX 514
HIGHTSTOWN, N.J. 08520



May 24, 1971

Electronics

Reader service

Use these handy post-cards for more detailed information on products advertised, new products, new literature.

Circle the number on the Reader Service postcard that corresponds to the number at the bottom of the advertisement, new product item, or new literature in which you are interested.

Please print clearly. All written information must be legible to be correctly processed.

If the cards have already been used, you may obtain the needed information by writing directly to the manufacturer, or by sending your name and address, plus the Reader Service number, to Electronics Reader Service Department, Box 444, Hightstown, N. J. 08520.

All inquiries from outside the U.S. that cannot reach Electronics before the expiration dates noted on the Reader Service postcard must be mailed directly to the manufacturer. The manufacturer assumes all responsibilities for responding to inquiries. Electronics merely provides and clears requests for information from inquirer to manufacturer.

Correct amount of post must be affixed for all mailings from outside the U.S.

Multi-product advertisements

For information on specific items in multi-product advertisements which do not have a specific Reader Service number indicated, write directly to manufacturer for information on the product in which you are interested.

To subscribe to or to renew Electronics

Fill in the subscription card adjoining this card. You need to send no money. Electronics will bill you at the address indicated on the card.

11	14	
*For employment inquiries fill in home address.		
May 24, 1971 Card Expires July 24, 1971		
Name _____	Title _____	
Company* _____		
Address _____		
City _____	State _____	Zip Code _____
1 22 43 64 85 106 127 148 169 190 211 232 253 274 295 316 337 358 379 400 421 442 463 484 960		
2 23 44 65 86 107 128 149 170 191 212 233 254 275 296 317 338 359 380 401 422 443 464 485 961		
3 24 45 66 87 108 129 150 171 192 213 234 255 276 297 318 339 360 381 402 423 444 465 486 962		
4 25 46 67 88 109 130 151 172 193 214 235 256 277 298 319 340 361 382 403 424 445 466 487 963		
5 26 47 68 89 110 131 152 173 194 215 236 257 278 299 320 341 362 383 404 425 446 467 488 964		
6 27 48 69 90 111 132 153 174 195 216 237 258 279 300 321 342 363 384 405 426 447 468 489 965		
7 28 49 70 91 112 133 154 175 196 217 238 259 280 301 322 343 364 385 406 427 448 469 490 966		
8 29 50 71 92 113 134 155 176 197 218 239 260 281 302 323 344 365 386 407 428 449 470 491 967		
9 30 51 72 93 114 135 156 177 198 219 240 261 282 303 324 345 366 387 408 429 450 471 492 968		
10 31 52 73 94 115 136 157 178 199 220 241 262 283 304 325 346 367 388 409 430 451 472 900 969		
11 32 53 74 95 116 137 158 179 200 221 242 263 284 305 326 347 368 389 410 431 452 473 901 970		
12 33 54 75 96 117 138 159 180 201 222 243 264 285 306 327 348 369 390 411 432 453 474 902 971		
13 34 55 76 97 118 139 160 181 202 223 244 265 286 307 328 349 370 391 412 433 454 475 951 972		
14 35 56 77 98 119 140 161 182 203 224 245 266 287 308 329 350 371 392 413 434 455 476 952 973		
15 36 57 78 99 120 141 162 183 204 225 246 267 288 309 330 351 372 393 414 435 456 477 953 974		
16 37 58 79 100 121 142 163 184 205 226 247 268 289 310 331 352 373 394 415 436 457 478 954 975		
17 38 59 80 101 122 143 164 185 206 227 248 269 290 311 332 353 374 395 416 437 458 479 955 976		
18 39 60 81 102 123 144 165 186 207 228 249 270 291 312 333 354 375 396 417 438 459 480 956 977		
19 40 61 82 103 124 145 166 187 208 229 250 271 292 313 334 355 376 397 418 439 460 481 957 978		
20 41 62 83 104 125 146 167 188 209 230 251 272 293 314 335 356 377 398 419 440 461 482 958 979		
21 42 63 84 105 126 147 168 189 210 231 252 273 294 315 336 357 378 399 420 441 462 483 959 980		

11	14	
*For employment inquiries fill in home address.		
May 24, 1971 Card Expires July 24, 1971		
Name _____	Title _____	
Company* _____		
Address _____		
City _____	State _____	Zip Code _____
1 22 43 64 85 106 127 148 169 190 211 232 253 274 295 316 337 358 379 400 421 442 463 484 960		
2 23 44 65 86 107 128 149 170 191 212 233 254 275 296 317 338 359 380 401 422 443 464 485 961		
3 24 45 66 87 108 129 150 171 192 213 234 255 276 297 318 339 360 381 402 423 444 465 486 962		
4 25 46 67 88 109 130 151 172 193 214 235 256 277 298 319 340 361 382 403 424 445 466 487 963		
5 26 47 68 89 110 131 152 173 194 215 236 257 278 299 320 341 362 383 404 425 446 467 488 964		
6 27 48 69 90 111 132 153 174 195 216 237 258 279 300 321 342 363 384 405 426 447 468 489 965		
7 28 49 70 91 112 133 154 175 196 217 238 259 280 301 322 343 364 385 406 427 448 469 490 966		
8 29 50 71 92 113 134 155 176 197 218 239 260 281 302 323 344 365 386 407 428 449 470 491 967		
9 30 51 72 93 114 135 156 177 198 219 240 261 282 303 324 345 366 387 408 429 450 471 492 968		
10 31 52 73 94 115 136 157 178 199 220 241 262 283 304 325 346 367 388 409 430 451 472 900 969		
11 32 53 74 95 116 137 158 179 200 221 242 263 284 305 326 347 368 389 410 431 452 473 901 970		
12 33 54 75 96 117 138 159 180 201 222 243 264 285 306 327 348 369 390 411 432 453 474 902 971		
13 34 55 76 97 118 139 160 181 202 223 244 265 286 307 328 349 370 391 412 433 454 475 951 972		
14 35 56 77 98 119 140 161 182 203 224 245 266 287 308 329 350 371 392 413 434 455 476 952 973		
15 36 57 78 99 120 141 162 183 204 225 246 267 288 309 330 351 372 393 414 435 456 477 953 974		
16 37 58 79 100 121 142 163 184 205 226 247 268 289 310 331 352 373 394 415 436 457 478 954 975		
17 38 59 80 101 122 143 164 185 206 227 248 269 290 311 332 353 374 395 416 437 458 479 955 976		
18 39 60 81 102 123 144 165 186 207 228 249 270 291 312 333 354 375 396 417 438 459 480 956 977		
19 40 61 82 103 124 145 166 187 208 229 250 271 292 313 334 355 376 397 418 439 460 481 957 978		
20 41 62 83 104 125 146 167 188 209 230 251 272 293 314 335 356 377 398 419 440 461 482 958 979		
21 42 63 84 105 126 147 168 189 210 231 252 273 294 315 336 357 378 399 420 441 462 483 959 980		

Electronics

Reprint service

Reminder: The Post Office now requires your ZIP CODE on all mail. Please include your ZIP CODE number when filling out your reply card.

Business reply mail

No postage stamp necessary if mailed in the United States

Postage will be paid by

Electronics

Reader service department
Box 444
Hightstown, N.J. 08520

First class
Permit no. 42
Hightstown, N.J.

Business reply mail

No postage stamp necessary if mailed in the United States

Postage will be paid by

Electronics

Reader service department
Box 444
Hightstown, N.J. 08520

First class
Permit no. 42
Hightstown, N.J.

Only Electronics editorial matter listed on this page available in reprint form:

You may order any of the below listed reprints by key number. Discounts on quantities over 10.

Bulk reprints of editorial matter can be ordered from current or past issues. The minimum quantity is 500 copies. Prices quoted on request: call 609-448-1700 Ext. 5494, or write to address below.

Special Report on Large Scale Integration. 54 pages. \$3.00.
Key no. R-010

Special Report on Gallium Arsenide. 7 parts. 32 pages. \$4.00. Key no. R-012

Special Report on The Transistor: Two Decades of Progress. 48 pages. \$3.00. Key no. R-016

Special Report on Ferrites. 16 pages. \$2.00. Key no. R-017

Active Filters: Part II, Varying the Approach. 8 pages. \$2.00. Key no. R-022

Special Report: Tomorrow's Communications. 32 pages. \$3.50. Key no. R-023

1970 Electronics Index to Technical Articles and Authors. \$1.00. Key No. R-32

1969 Electronics Index to Technical Articles and Authors. \$1.00. Key no. R-024

Consumer Hazards: Why they Happen, How they Can Be Fixed. 14 pages. \$2.00. Key no. R-027

The Seventies: super but seething. A 56-page business outlook prepared by McGraw-Hill's Business Week. \$1.00. Key no. R-026

Active Filter Chart & Infra-Red Detector Chart. 2 Electronics 1969 Special Guide Charts. \$1.00 includes both 4-color charts. Key No. R-033

Field Effect Transistors. Parts I, II, and III. 64 pages. \$4.00. Key no. R-64

Active Filters. 96 pages. \$4.00. Key no. R-032

Computer-Aided Design. 148 pages. \$4.00. Key no. R-11

Electronics Markets (1971). U.S.A. & European Combined Forecasts. 46 pages. 2 fold-out charts. Bound. \$5.00. Key No. R-13

Japanese Markets (1970). 16 pages. \$2.00. Key no. R-030

Circuit Designers Casebook. 217 pages. \$4.00. Key no. R-031

To order reprints or for further information, please write to:

**Electronics Reprint Department
P.O. Box 669
Hightstown, N.J. 08520**

Only orders with cash, check, or money order will be accepted. **No invoicing will be done.**

At 125° C, our 12-bit D/A converter is still a 12-bit D/A converter.

As long as you promise to keep the ambient down around a balmy 65°C, any number of people will volunteer to design and build a hybrid 12-bit D/A converter and stuff it into a reasonably small flatpack for you.

But why bother?

Ours is already sitting on the shelf. A 7-layer multi-layer in a 1.25" square flatpack.

Ready for service at any temperature within the MIL Spec (-55°C to +125°C) range. Without deviation from its $\pm 1/2$ LSB linearity.

You can put in up to 12 binary bits or 3 BCD digits (it's DTL and TTL compatible) and take out 0 to +5, 0 to +10, -5 to +5, or -10 to +10 volts. You get everything you might need for 8, 10, or 12-bit resolution—from input storage to output op amp. And if everything you might need is more than you actually need, we can leave some things out.

Like our temperature-compensated reference source. You only need one of these to handle up to 120 bits. So if you're using several D/A converters, we can put the reference source in one, leave it out of the rest. And save you a few bucks.

And if you'd rather use an external op amp in the output, we'll leave ours out. Or if all you want is our TaN ladder and IC switches, you can get them separately.

And, please, don't feel you're putting us out if you need a lot of any of these in a hurry. We can give you—quickly—any size or shape of hybrid you want, from a simple little thing tucked in a TO-5 package to a 30-IC, ten-layer MSI module. By the thousands.

The next step's up to you.

Want to try one of our D/A converters? Call, and our local man will give you a demo

right away. Learn a little more about them first?

Write, and we'll have data in the next mail.

Explore some hybrid problems or possibilities of your own? Ask for John Zucker, our resident hybridizer.

Any way you want to get us—or it—together, we're willing.

Unisem Corporation, P.O. Box 11569, Philadelphia, Pennsylvania 19116. Telephone: (215) 355-5000.

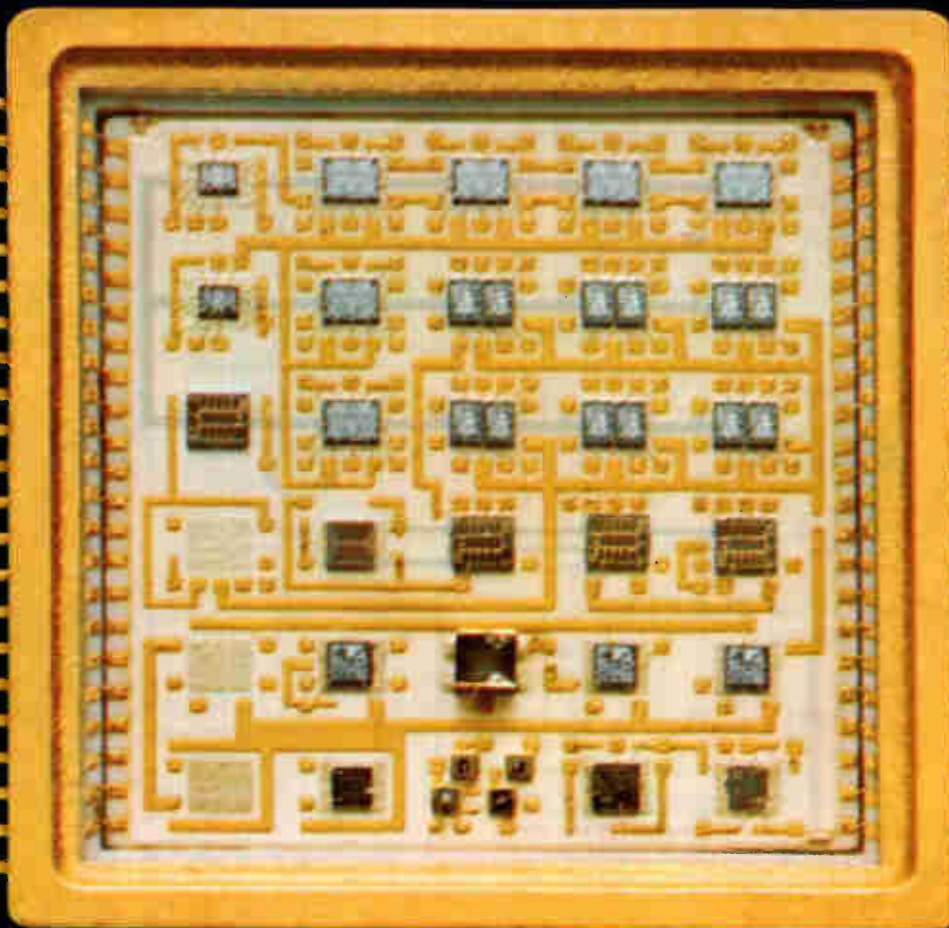
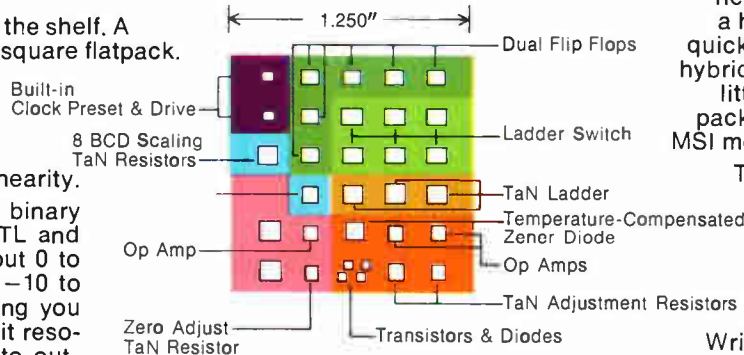

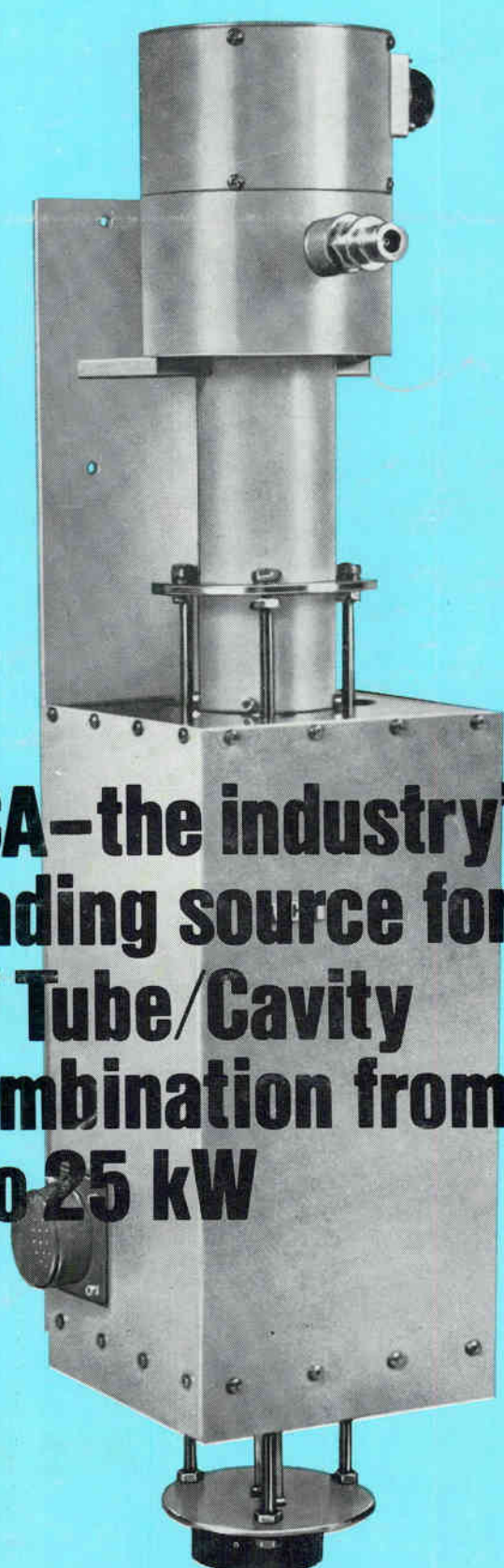

**RCA—the industry's
leading source for any
RF Tube/Cavity
combination from
1 to 25 kW**

RCA-developed RF tube/cavity assembly for operation at 410-460 MHz using RCA tube type 8226 (illustrated).



RCA offers both tubes and cavities. And RCA warrants performance levels and life for any coaxial cavity/tube assembly up to 25 kW. Here is single-source reliability . . . responsible leadership!

RCA's complete range of cavities assures optimum performance from its line of CERMOLOX[®] power tubes and VHF-TV tubes. To fill your requirements, you can choose single-tuned cavities; broadband, multiple-tuned cavities; large-power cavities, or cavity systems. Suitable for use either as oscillators, drivers, or as complete amplifiers, these cavities assure specified performance with fully engineered circuitry, minimum RF losses, simplified connections, and high over-all efficiency.

This line of cavities can augment and assure the proved performance, reliability, and efficiency of CERMOLOX tubes. In addition, if your requirements call for special parameters, RCA's Applications Engineers will gladly modify existing cavities or develop new ones to assure you of optimum equipment performance.

For more information on RCA RF tube/cavity combinations, see your local RCA Representative. For technical data, write: RCA, Commercial Engineering, Section 70E-24/ZR5, Harrison, N.J. 07029. International: RCA, Sunbury-on-Thames, U.K., or 2-4 rue du Lièvre, 1227 Geneva, Switzerland, or P.O. Box 112, Hong Kong.

RCA