

- Op amps save money in active-filter design 82
- Marrying MOS and bipolar integrated circuits 92
- Bigger Federal budget for electronics 117

Electronics®

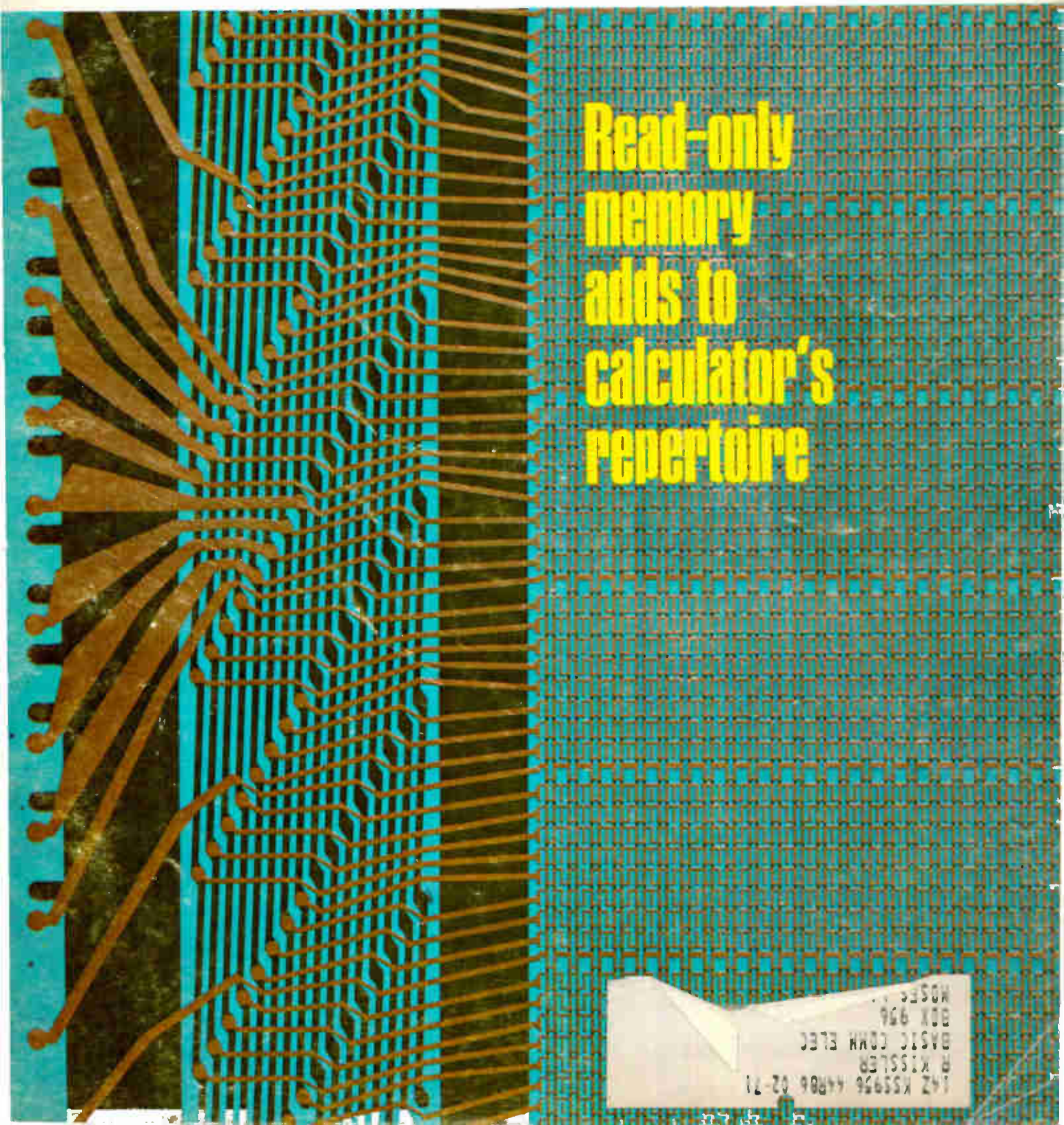

**Read-only
memory
adds to
calculator's
repertoire**

LAZ K55956 44806 02-71
R KISSLER
BASIC COMM ELEC
BOX 956
MOSCIE

Cornucopia

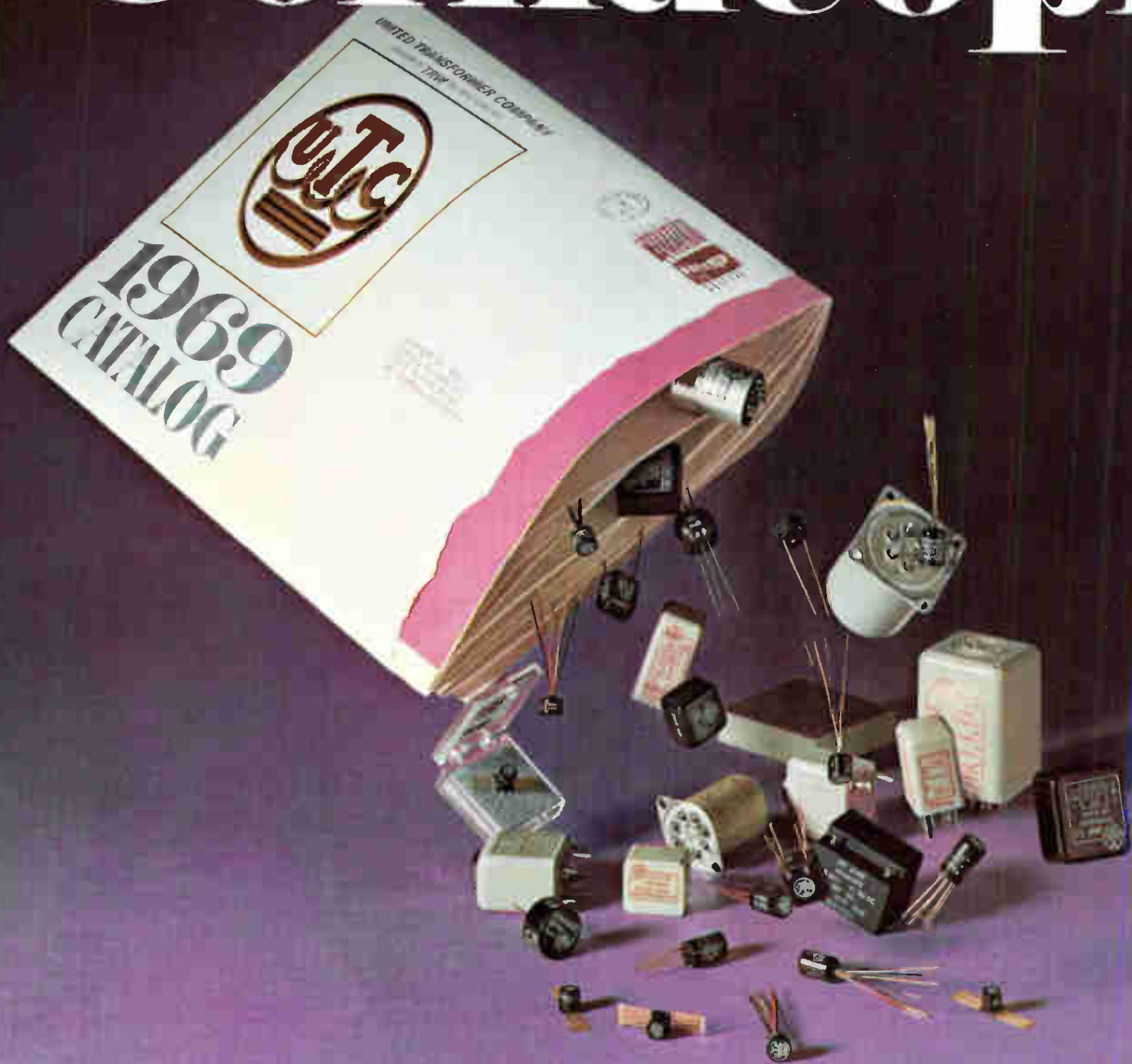

Get UTC's NEW 1969 Catalog – the quick-and-easy locator for transformers and filters.

UTC's 1969 Catalog is the most comprehensive in our history. Over 1350 standard parts, including audio, power and pulse transformers, inductors, electric wave filters, high Q inductors, magnetic amplifiers, saturable reactors, and similar iron-core inductance devices. Many of these new products are listed for the first time.

Eighty-eight clear pages make it easy to locate and specify the part you need: product lines categorized, product selection guide for each line, engineering specifications and applications, new

drawings, new curves, expanded charts.

Also included are: audio and power application circuitry, plus a lucid digest of the new MIL Specs (MIL-T-27C, MIL-F-18327C, MIL-T-21038B).

The "special" you need is probably a "standard" in the NEW UTC Catalog. All items are immediately available from your local distributor. For your copy of the catalog contact: United Transformer Company, Division of TRW INC., 150 Varick Street, New York, N. Y. 10013. **TRW**[®] UNITED TRANSFORMER COMPANY



100 picoseconds for 55¢. That's a switch.

You bet it is. Lowest price ever for a hot carrier diode. Fastest switching time available. And more. 70-volt breakdown. Low turn-on of 410 mV at 1 milliamp. Operating and storage temps of -65°C to 200°C . Applications are up to you. Too many possibilities to list here.

Trick is design. The HP 2800 Hot Carrier Diode eliminates earlier cat whisker technique. Low-cost assembly. Molybdenum barrier for high temp operation. The best pn junction features with hot carrier performance.

Impressed? Then switch to a hot carrier diode for 55¢, in quantities of 1000-4999. Call your local HP field engineer or write Hewlett-Packard, Palo Alto, Calif. 94304; Europe: 54 Route des Acacias, Geneva.

01814-A

HEWLETT  PACKARD

SOLID STATE DEVICES

01814

The Incredible Dodecameter...



Adds twelve programmable measurement functions to your system. You start with the basic dc unit and add options to fit your systems needs. You can use the new HP 3450A Multi-Function Meter for dc, ac and ohms measurements — ratio, limit tests, and ratio limit tests. The 3450A has autoranging on all functions — and all functions are fully programmable. This broad capability is contained in a 3½" high rack mount — ideal for systems.

The basic dc unit is integrating and fully guarded for excellent noise immunity. You can make 15 readings per second with a sensitivity of 1 μ V. Add the AC Voltage and AC Ratio Option to your basic dc unit and you can make true RMS ac measure-

ments from 45 Hz to 1 MHz — without the errors due to harmonic distortion.

Add the Ohms and Ohms Ratio Option for ohms measurements with 1 m Ω sensitivity. The four-wire ohms input provides sense and signal leads to reduce errors due to lead resistance.

Put in the Limit Test Option and you can preset two four-digit limits. Your system then can make simple comparisons without using a computer or digital comparator. Use the Digital Output Option with the Limit Test Option for nine columns of information including HI, GO, LO limit test decisions.

The Rear Input Terminal Option provides a set of guarded rear input terminals and a FRONT/REAR INPUT selector switch on the front panel.

If your requirements change, any of the options are field-installable (except rear input terminals). Call your nearest HP field engineer to learn how easily "the incredible dodecameter" adapts to your measurement system. For full specifications, write to Hewlett-Packard, Palo Alto, California 94304. Europe: 1217 Meyrin-Geneva, Switzerland.

Prices: Basic 3450A, \$3150; AC Option 001, \$1250; Ohms Option 002, \$400; Limit Test Option 003, \$350; Digital Output Option 004, \$175; Remote Control Option 005, \$225; Rear Input Terminal Option 006, \$50.

099/A

HEWLETT  PACKARD

DIGITAL VOLTMETERS

Circle 1 on reader service card



News Features

Probing the News

- 117 **Federal budget:** Fiscal 1970 spending plan bears LBJ brand
119 **Military electronics:** Strategic projects get green light
125 **Space electronics:** NASA budget in holding pattern
131 **Government electronics:** Upbeat outlook favors industry

U.S. Reports

- 39 **Advanced technology:** Silicon avalanche diodes amplify at subharmonics of X-band frequency; Getting color from the II-VI compounds
42 **Medical electronics:** The Xerox for emphasis
44 **Companies:** IBM and the antitrust suit
46 **Avionics:** Navigator for helicopters; More data for air recorders
50 **Government:** Research money
52 **For the record**

Electronics International

- 179 **Soviet Union:** An on-board computer will keep medical tabs on cosmonauts in space stations
180 **Italy:** ELDO's woes may lead to national space program
180 **International:** American union mounts campaign to stem the flow of U.S. companies to the Far East
181 **Sweden:** New state-owned conglomerate to change lineup in electronics
181 **West Germany:** Computer plots profiles of river bottoms
182 **Japan:** Photocells in garage floor tell if there's room for more

New Products

- 137 **In the spotlight**
137 Radiation-hardened IC's go commercial
141 **Components review**
141 Pots maintain low drift rate
143 Vertical-design relays save space
145 **Instruments review**
145 4-digit voltmeter shows low price
147 Rugged tiltmeter for field jobs
151 **Subassemblies review**
151 White-noise set tests radio nets
153 Scriber works from circuit sketch
157 **Microwave review**
S-band 3-barrier Schottky diode
Impatts' power, efficiency up
158 **Semiconductor review**
163 Op amp improved, sells for less

Technical Articles

- Computers** 70 **Read-only memory adds to calculator's repertoire**
Charles Near and Robert Watson, Hewlett-Packard
- Circuit design** 78 **Designer's casebook**
▪ Oscillator has transfilter as the resonant device
▪ Line-operated relay uses isolated actuating input
▪ Power supply breaker acts in 100 microseconds
▪ 4-pulse sequence generator built with 1 hex-inverter
▪ MOS field effect transistor stabilizes oscillator's output
- Design theory** 82 **Op amps save time, money in active filters**
Brent Welling, Motorola
- British IC's** 92 **Electron-beam testing: gentle and fast**
J.P. Flemming, Standard Telecommunication Laboratories
- 94 **Bulk-effect modules pave way for sophisticated uses**
George King and J.S. Heeks, STL
- 96 **MOS frequency soars with ion-implanted layers**
J.M. Shannon, Mullard, and James Stephen and J.H. Freeman, U.K. Atomic Energy Authority
- 100 **Integrated solid state display needs no complex circuitry**
Gordon I. Robertson and C.P. Sandbank, STL

Departments

- | | | | |
|----|--------------------------|-----|--------------------------|
| 4 | Readers Comment | 41 | Index of Activity |
| 8 | Who's Who in this issue | 57 | Washington Newsletter |
| 14 | Who's Who in electronics | 167 | New Books |
| 22 | Meetings | 168 | Technical Abstracts |
| 31 | Editorial Comment | 172 | New Literature |
| 39 | Electronics Newsletter | 177 | International Newsletter |

Electronics

Editor-in-Chief: Donald Christiansen

Senior staff editors

Technical: Stephen E. Scrupski
News: Robert Henkel
International: Arthur Erikson

Managing editor: Harry R. Karp
Art director: Gerald Ferguson

Senior associate editor: Joseph Mittleman
Assistant managing editors: Stanley Zarowin, Eric Aiken, H. Thomas Maguire
Senior copy editor: James Chang; Senior staff writer: Howard Wolff

Department editors

Advanced technology: William Bucci, Richard Gundlach
Communications: John Drummond, Raphael Kestenbaum
Computers: Wallace B. Riley, George Weiss
Design theory: Joseph Mittleman
Instrumentation: Owen Doyle, Walter Barney
Military/Aerospace: Alfred Rosenblatt, Paul Dickson
New products: William P. O'Brien
Solid state: George Watson, Stephen Wm. Fields

Domestic bureaus

Boston: James Brinton, manager; Gail Farrell
Chicago: Frederick Corey, manager
Los Angeles: Lawrence Curran, manager
San Francisco: Walter Barney, manager; Peter Vogel
Washington: Robert Skole, manager; Paul Dickson, William F. Arnold

Foreign bureaus

Bonn: John Gosch
London: Michael Payne
Tokyo: Charles Cohen

Copy editors: Larry Miller, Edward Flinn
Staff writer: Peter Schuyten

Assistant art director: Susan Hurlbut
Production editor: Arthur C. Miller

Editorial research: Anne Mustain

Editorial secretaries: Lorraine Longo, Claire Goodlin, Barbara Razulis,
Terry Kraus, Vickie Green

McGraw-Hill News Service

Director: Arthur L. Moore; Atlanta: Fran Ridgway; Chicago: Robert E. Lee
Cleveland: Arthur Zimmerman; Dallas: Marvin Reid
Detroit: James Wargo; Houston: Barbara LaRouax
Los Angeles: Michael Murphy; Pittsburgh: Louis Gomolak
San Francisco: Margaret Drossel
Seattle: Ray Bloomberg; Washington: Charles Gardner, Daniel B. Moskowitz,
Herbert W. Cheshire, Seth Payne, Warren Burkett, William Small, William D. Hickman

McGraw-Hill World News Service

Bonn: Robert Dorang; Brussels: James Smith; Hong Kong: Wes Perry;
London: John Shinn; Mexico City: Gerald Parkinson; Milan: Ronald Taggiasco, Jack Star;
Moscow: Jack Winkler; Paris: Robert E. Farrell, Stewart Toy
Rio de Janeiro: Leslie Warren; Tokyo: Marvin Petal

Reprints: Susan Nugent

Circulation: Isaaca Siegel

Publisher: Gordon Jones

Assistant to the publisher: Wallace L. Carmichael

Electronics: February 3, 1969, Vol. 42, No. 3

Published every other Monday by McGraw-Hill, Inc. Founder: James H. McGraw 1860-1948.
Publication office 99 North Broadway, Albany, N. Y. 12202; second class postage paid at Albany, N. Y.

Executive, editorial, circulation and advertising addresses: McGraw-Hill Building, 330 W. 42nd Street
New York, N. Y. 10036, Telephone (212) 971-3333, Teletype TWX N.Y. 710-581-4235. Cable address:
MCGRAWHILL N.Y.

Subscriptions solicited only from those professionally engaged in electronics technology. Subscription rates:
qualified subscribers in the United States and possessions and Canada, \$8.00 one year, \$12.00 two years,
\$16.00 three years; all other countries \$25.00 one year. Non-qualified subscribers in the U.S. and
possessions and Canada, \$25.00 one year; all other countries \$50.00. Air freight service to Japan \$50.00
one year. Single copies: United States and possessions and Canada, \$1.00; all other countries, \$1.75.

Officers of McGraw-Hill Publications: Joseph H. Allen, President; J. Elton Tuohig, Executive Vice President;
David J. McGrath, Senior Vice President; Operations, Vice Presidents: John R. Callahan, Editorial; Paul F. Cowie,
Circulation; John R. Emery, Administration; John M. Holden, Marketing; David G. Jensen, Manufacturing;
Jerome D. Luntz, Planning & Development; Robert M. Wilhelmy, Controller.

Officers of the Corporation: Shelton Fisher, President and Chief Executive Officer; John L. McGraw, Chairman;
Robert E. Slaughter, Executive Vice President; Daniel F. Crowley, Donald C. McGraw, Jr., Bayard E. Sawyer, Senior
Vice Presidents; John J. Cooke, Vice President & Secretary; Gordon W. McKinley, Vice President & Treasurer.

Title ® registered in U.S. Patent Office; © Copyright 1969 by McGraw-Hill, Inc. All rights reserved. The contents
of this publication may not be reproduced either in whole or in part without the consent of copyright owner.

Subscribers: The publisher, upon written request to our New York office from any subscriber,
agrees to refund that part of the subscription price applying to copies not yet mailed.
Please send change of address notices or complaints to Fulfillment Manager; subscription
orders to Circulation Manager, Electronics at address below. Change of address notices
should provide old as well as new address, including postal zip code number. If possible,
attach address label from recent issue. Allow one month for change to become effective.

Postmaster: Please send form 3579 to Fulfillment Manager, Electronics,
P.O. Box 430, Hightstown, New Jersey 08520

Readers Comment

Monolithic IC patents

To the Editor:

Texas Instruments and Fairchild are often—and justly—credited with being the first to demonstrate the commercial feasibility of monolithic integrated circuits. However, transistors and IC's with metal-over-oxide leads were first invented by Associated Electrical Industries Ltd. as a by-product of research on microwave silicon diodes in 1957-58. The first known semiconductor monolithic IC patent was in 1958 and was assigned to AEI. Counterpart U.S. patents were applied for in 1959.

The British inventions used an oxide of the semiconductor as an insulating support for mask-deposited metal strips, hermetic protection of the sides of a p-n junction by a refractory insulator, and epitaxial deposition to reduce spreading resistance.

William J. Scott

Chartered engineer
Rugby
England

No newcomer

To the Editor:

The article "Ground-station market flies high" [Nov. 25, 1968, p. 105] erroneously says that Canada's RCA Victor Ltd. has just entered the field.

RCA Victor Ltd. does communications satellite earth-station work world-wide through RCA Space Systems, which has a total technical work force of 250. RCA Space Systems, headquartered in Montreal, built Canada's first earth station at Mill Village, Nova Scotia, and is now completing the second earth station at this site. The Indian earth station at Poona represents the third earth station that RCA Space Systems will have completed.

RCA Space Systems is also one of the major world suppliers for specialty subsystems for earth stations: the intricate antenna feed system and the communications subsystem. RCA has sold feed sys-

Now from Sprague!

QUALITY
STABILITY
RELIABILITY
SMALL SIZE



All the advantages of tantalum in one **LOW COST** capacitor!

EPOXY-DIPPED TANTALEX® CAPACITORS...
For industrial, commercial, and entertainment electronic applications where tantalum capacitors were previously too expensive!

⊖ Type 196D Solid-electrolyte Tantalum Capacitors have special epoxy-dip coating which keeps costs down without sacrifice in dependability. Positively seals capacitor section while providing excellent electrical insulation. Protects against mechanical damage in handling.

⊖ Radial lead design for plug-in mounting on printed wiring boards. The .250" lead spacing will fit standard .125" grids.



⊖ High stability—very little capacitance change, even at outer limits of operating temperature range.

⊖ Low dissipation factor of these capacitors permits higher ripple currents.

⊖ Meet environmental test conditions of Military Specification MIL-C-26655B.

⊖ Prime capacitance and voltage ratings. Based on rating popularity of other types of solid tantalum capacitors.

⊖ Designed for continuous operation at temperatures from -55°C to $+85^{\circ}\text{C}$.

For complete technical data, write for Engineering Bulletin 3545 to Technical Literature Service, Sprague Electric Company, 35 Marshall Street, North Adams, Massachusetts 01247.

Now available for fast delivery from your Sprague Industrial Distributor

SPRAGUE COMPONENTS

CAPACITORS
TRANSISTORS
RESISTORS
INTEGRATED CIRCUITS
THIN-FILM MICROCIRCUITS
45C-4138R2

PULSE TRANSFORMERS
INTERFERENCE FILTERS
PULSE-FORMING NETWORKS
TOROIDAL INDUCTORS
ELECTRIC WAVE FILTERS

CERAMIC-BASE PRINTED NETWORKS
PACKAGED COMPONENT ASSEMBLIES
BOBBIN and TAPE WOUND MAGNETIC CORES
SILICON RECTIFIER GATE CONTROLS
FUNCTIONAL DIGITAL CIRCUITS

SPRAGUE®
THE MARK OF RELIABILITY

'Sprague' and '®' are registered trademarks of the Sprague Electric Co.



Need a "bench buddy"?

Get a Variac® adjustable
autotransformer

Every lab bench should have a source of continuously adjustable ac voltage. Like a Variac, for example. To be specific, the new cased W8MT3 Variac or its metered counterpart, the W8MT3VM. Both put ac line voltage control conveniently on your bench and at your fingertips.

Variac autotransformers are clean; unlike SCR's, they do not achieve low voltage by destroying waveform purity. A Variac simply lowers the amplitude of the sine wave and never adversely affects power factor. A Variac can be quite cool about it too; it transforms power instead of dissipating it as useless heat. And, because a Variac is clean, pure, and cool it has the strength of ten . . . it can withstand a short-time overload of as much as 1000% above rating.

So if you're looking for a "bench buddy"* get one that's clean, pure, cool and has the strength of ten . . . a Variac. It's the best friend you can have alongside you at a lab bench.

Specifications:

Input: 120 V, 50 to 60 Hz

Output: 0 to 140 V, 10A

Price: W8MT3 Variac, \$38.00; W8MT3VM
Variac with voltmeter, \$68.50.

*Do your voltage-control problems go beyond the bench? Write for complete information. We've got hundreds of models for thousands of applications.

IMMEDIATE DELIVERY!

GENERAL RADIO

W. Concord, Massachusetts 01781

Readers Comment

tems to Hughes Aircraft, Page Communications Inc., and STS SpA, Italy, and has furnished subsystems for stations in Argentina, Australia, Brazil, Morocco, Panama, the Philippines, Thailand, and the United States.

J.A. Collins

RCA Victor Ltd.
Montreal

Phosphide, not arsenide

To the Editor:

International Newsletter [Jan. 6, p. 250] says, "Matsushita Research Institute reports it has developed light-emitting gallium arsenide diodes with an external efficiency of 2%." We are using gallium phosphide, not gallium arsenide.

T. Nijo

Matsushita Research Institute
Tokyo

Laser displays, continued

To the Editor:

Electronics Newsletter [Nov. 25, 1968, p. 33] says the military has become "disenchanted" with laser television displays as a result of nearly two years of experiments with a feasibility system developed by Texas Instruments. You say the military believes that the technology is "still too crude." You conclude by quoting a civilian Air Force engineer as saying that the system introduced by General Tele-

phone & Electronics Laboratories in November "suffers from the same general technical problems" as the TI system.

If the military is disenchanted with the present technical approach to laser television displays, we are not aware of it.

Furthermore, the GT&E system does not "suffer from the same general technical problems." Our several years of work in the laser display field causes us to believe that the system has a number of advantages that will enable us to refine it even further in the future.

In this connection, I want to make two points. First, the GT&E experimental system uses only 0.4 watt to produce a 31-by-48-inch picture of 20 footlamberts. A 1-watt laser, which is well within the state of the art today, would result in a brightness of 50 footlamberts for the same size screen. This is a far cry from the 30 watts of laser power you say is required for a usable system. Second, the electro-mechanical dual-polarization scanning system that GT&E has developed provides an exceptionally stable raster with no scanning defects. It is a practical system that synchronizes within seconds, requires little power, and suffers little loss of light, since it is based on mirror reflection.

I believe, therefore, that laser tv systems are practical within today's technology.

Vernon J. Fowler

GT&E Laboratories
Bayside, N.Y.

Applications Power*



PUTTING CURRENT-LIMITER DIODES TO WORK

Problem: How to provide a linear voltage sweep?

Solution: Provide a constant charging current to a capacitor... with a Siliconix CL diode.

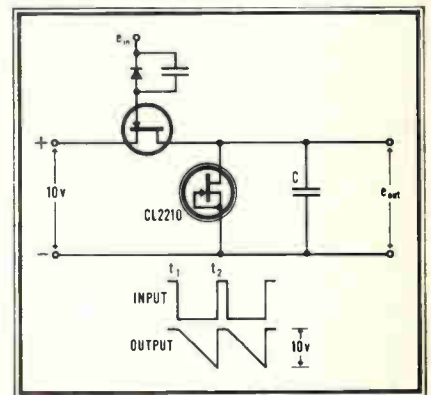

The FET switch is initially closed with C charged to +10v. At t_1 a -10v opens the FET switch. C discharges linearly, due to the constant current characteristic of the CL diode. At t_2 the switch is closed; C is again charged. Sweep time is determined by the values of C and the CL diode. Flyback time depends on C and the FET switch R_{ON} . FET switches are available with R_{ON} as low as 5 ohms!

For immediate applications assistance call the number below; ask for extension 19.

Siliconix
incorporated

1140 W. Evelyn Ave. • Sunnyvale, CA 94086
Phone (408) 245-1000 • TWX: 910-339-9216

*Applications Power: A wide product line and an in-depth applications team to help you over new design hurdles.

SUBSCRIPTION SERVICE

Please include an Electronics Magazine address label to insure prompt service whenever you write us about your subscription.

Mail to: Fulfillment Manager
Electronics
P.O. Box 430
Hightstown, N.J. 08520

To subscribe mail this form with your payment and check new subscription renew my present subscription

Subscription rates: qualified subscribers in the U.S.: 1 year \$8; two years, \$12; three years, \$16. Non-qualified: 1 year \$25. Subscription rates for foreign countries available on request.

CHANGE OF ADDRESS

ATTACH LABEL HERE

If you are moving, please let us know five weeks before changing your address. Place magazine address label here, print your new address below.

name

address

city

state

zip code

Our catalog sheet
says ...

Because Rotron controls the design and manufacture of every part of the Feather Fan, NO COMPROMISE HAS BEEN MADE IN ITS AERO-DYNAMIC DESIGN, THE DESIGN OF ITS MOTOR, OR IN THE SELECTION OF ITS MATERIALS.

and we
MEAN IT!!



**FEATHER[®]
FAN**

Got an application requiring large volumes of air to be delivered quietly, continuously, and reliably? The "Feather Fan" is your answer. It delivers up to 270 cfm at free delivery, measures 7" in diameter and only 27/16" thick, weighs only 1.5 pounds, draws only 22 watts, and air-flow is reversible by mounting on either face. Made of temperature resistant polycarbonate and available in 25 colors. Send today for descriptive catalog sheet, write to Rotron, Inc., Woodstock, New York, N.Y. 12498.

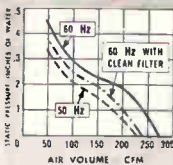

Who's Who in this issue



Watson

Near

Versatility highlights Chuck Near's career at Hewlett-Packard. He's co-holder of the patent on the read-only memory that enhances the performance of the desk calculator discussed in the article beginning on page 70. Chuck also engineered the computer-controlled facility that monitors the machine's production line, and he had a hand in the design of the company's 3440A digital voltmeter. Chuck's been with H-P since 1961, when he received his BS in electrical engineering from Michigan State; he also holds a master's degree from Stanford University.

Robert Watson, co-author of the article, is a group leader at H-P's Loveland, Colo., facility and has over-all responsibility for the new desk calculator and related products. Also an eight-year man with the company, he holds both a bachelor's and a master's degree from the University of Utah.

Communications networks have long interested Motorola's Brent Welling, who wrote the active filters article beginning on page 82. Brent heads his company's linear IC and communications department, which among other things is doing computer-aided design work on active filters incorporating op amps. In his spare time, Brent works on his master's thesis, dealing with digital frequency synthesizers, at Arizona State.

Another pride of British lions carries on with *Electronics'* special report on IC technology in England. J.P. Flemming of Standard Telecommunication Laboratories, who wrote the electron beam article beginning on page 82, works with instrumentation and display systems for the technique. Similarly, the specialized nature of the Gunn-effect article beginning on page 94 by Stuart Heeks and George King, also of STL, belies their broad-gauge efforts. They've been studying the physics of the phenomenon almost as long as it's been known, and are concentrating on practical device applications.

John Shannon of Mullard discusses on page 96 his company's joint ion-implantation venture with the U.K. Atomic Energy Authority. He came to Mullard from Brunel University, where he did research in semiconductor plasmas. Shannon's efforts dovetail with those of his AEA colleagues: James Stephen, a solid state veteran, and Harry Freeman, who specializes in machine design.

David Burt of Associated Semiconductor Manufacturers details his investigative effort to add bipolar transistors to MOS chips on page 97. And Charles Sandbank and Gordon Robertson of STL outline their work on domain-originated functional IC's in the concluding article that begins on page 100.

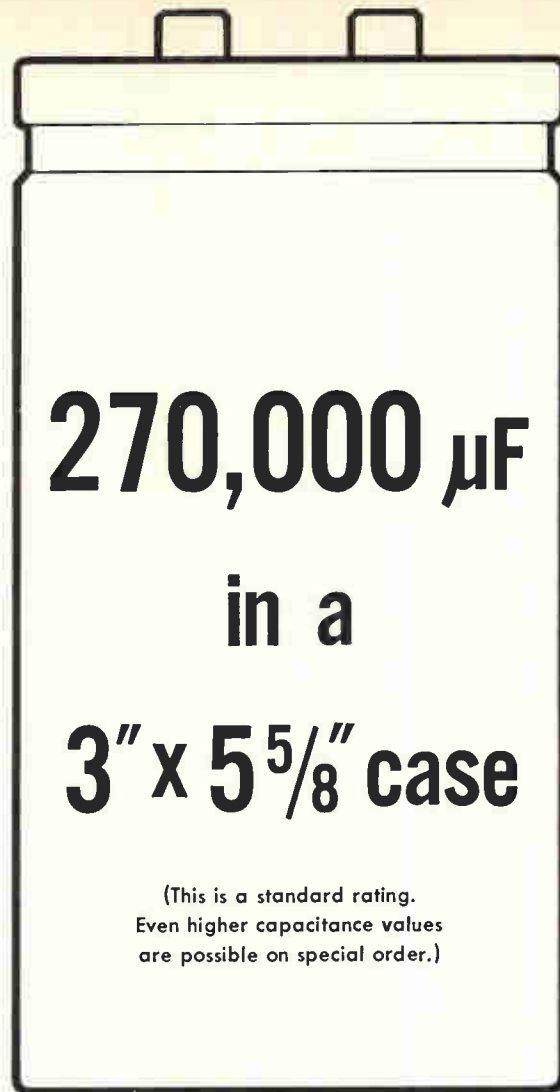

270,000 μ F

in a

3" x 5⁵/₈" case

(This is a standard rating.
Even higher capacitance values
are possible on special order.)

POWERLYTIC[®] CAPACITORS ARE PACKED WITH CAPACITANCE!

Improved Capacitance Capability

Type 36D aluminum electrolytic capacitors now have as much as 60% more capacitance in a given case size than previously available.

Higher Operating Temperature

Improved Powerlytic capacitors may now be operated at 85 C.

High Ripple Current Capability

Ideal capacitors for use in "brute-force" filtering and pulse discharge applications. Single capacitors are capable of handling up to 20 or more amps rms at 25 C, 120 Hz.



Superior Seal and Safety Vent

Beaded aluminum can is crimped onto a rubber gasket recessed in a rigid molded cover, providing an expected operating life in excess of ten years. Pressure-type safety vent employs silicone rubber for reliable, predictable release of excess pressure.

Choice of Insulating Tubes, Terminal Styles

In addition to the standard bare case, Type 36D capacitors are available with a clear plastic tube or with a Kraftboard tube. Tapped terminals in two different heights, as well as solder lug terminals are available.

For complete technical data, write for Engineering Bulletin 3431B to Technical Literature Service, Sprague Electric Co., 35 Marshall Street, North Adams, Mass. 01247

SPRAGUE COMPONENTS

CAPACITORS
TRANSISTORS
RESISTORS
INTEGRATED CIRCUITS
THIN-FILM MICROCIRCUITS

PULSE TRANSFORMERS
INTERFERENCE FILTERS
PULSE-FORMING NETWORKS
TOROIDAL INDUCTORS
ELECTRIC WAVE FILTERS

CERAMIC-BASE PRINTED NETWORKS
PACKAGED COMPONENT ASSEMBLIES
BOBBIN and TAPE WOUND MAGNETIC CORES
SILICON RECTIFIER GATE CONTROLS
FUNCTIONAL DIGITAL CIRCUITS



Sprague and "®" are registered trademarks of the Sprague Electric Co.

If you took all the low input current monolithic op amps in the world, you'd have our LM101A, 102 and 107

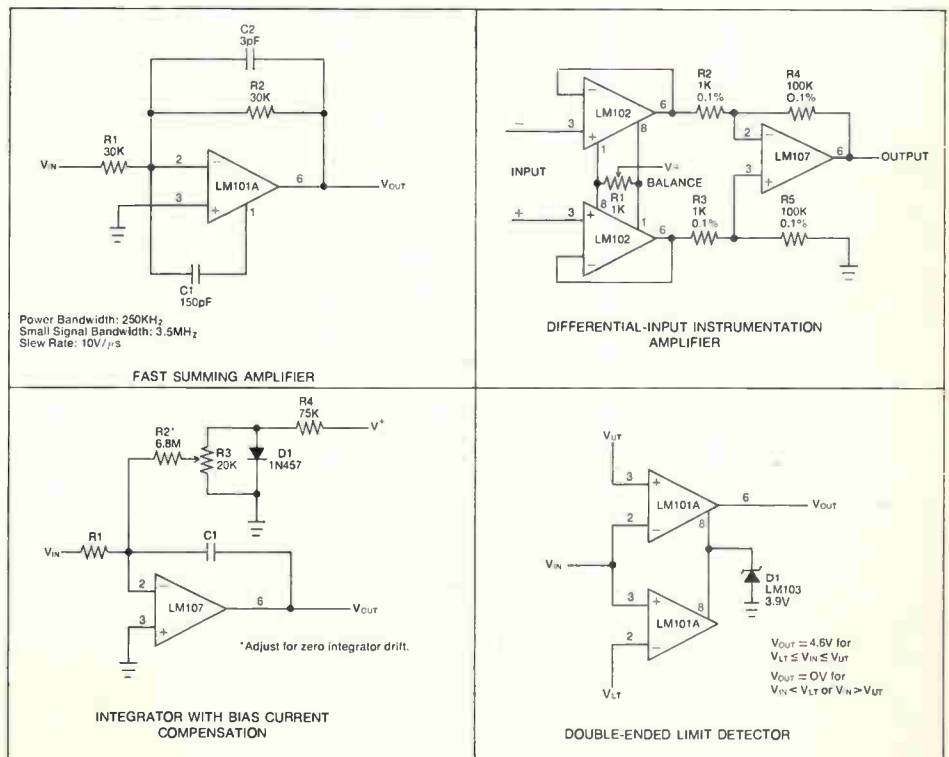

Three of our Op Amps have input bias currents untouched by anything else on the market. In fact, you can even use them to replace FET amplifiers.

With the LM102 Voltage Follower, 10 V/ μ sec slow rate couples with a maximum input bias current of 20nA, guaranteed over full mil temp range. The LM101A is extremely versatile; tailor its compensation to the application or even use it as a voltage comparator. Its partner, the LM107, is fully compensated and easiest to use. Both have input bias currents less than 100nA, offset currents less than 20nA, and offset voltages less than 3mV guaranteed over full mil temp range. All are immediately available off-the-shelf. Prices 100 piece quantities: full mil types: LM101A @ \$30.00, LM102 @ \$15.00, and LM107 @ \$33.00; instrumentation types: LM201A @ \$12.00, LM202 @ \$6.00, LM207 @ \$13.00; commercial types: LM301A @ \$3.45, LM302 @ \$3.00

Get the low down. National Semiconductor Corporation, 2975 San Ysidro Way, Santa Clara, California 95051 (408) 245-4320
 TWX: 910-339-9210
 Cables: NATSEMICON

National Linear

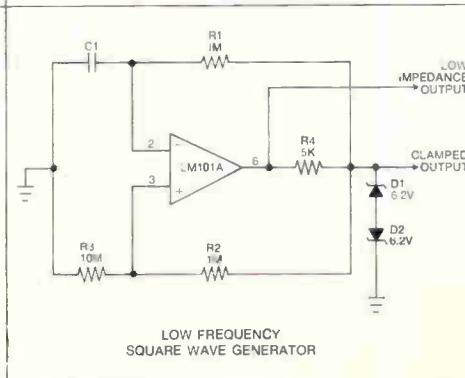
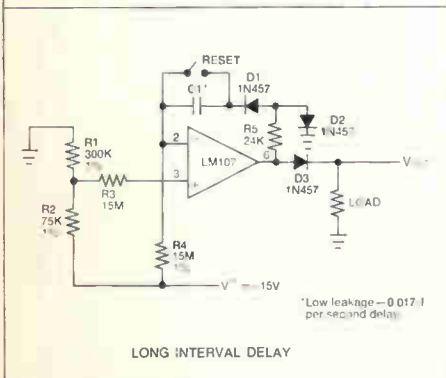
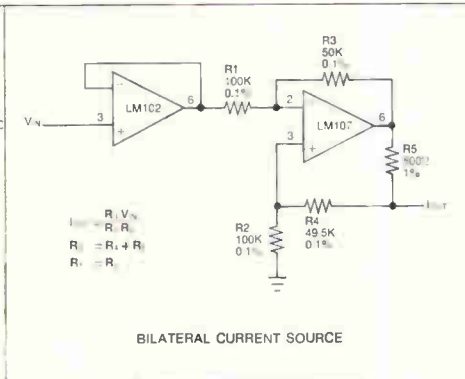
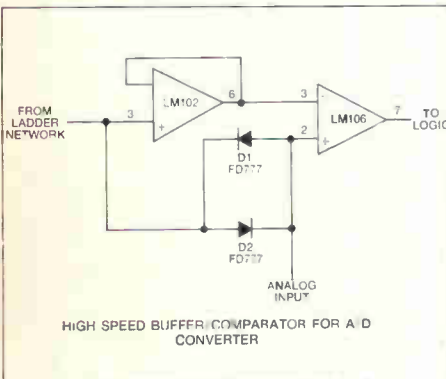

Elastic interconnection.

Ten years ago Hughes started inventing conductor systems that you could twist and curve and tie in knots if you wanted to.

Not many people wanted to. They had to see it work first.

Well, a series of Surveyors and a few Phoenix Missiles proved that electrical interconnection would never be the same again. Flexibility eliminated too many wiring errors. It saved too much space and weight and money.

The art of elasticity was underway at Hughes.

Today flat conductor cable is known as Contour™ Cable. And we have a whole division

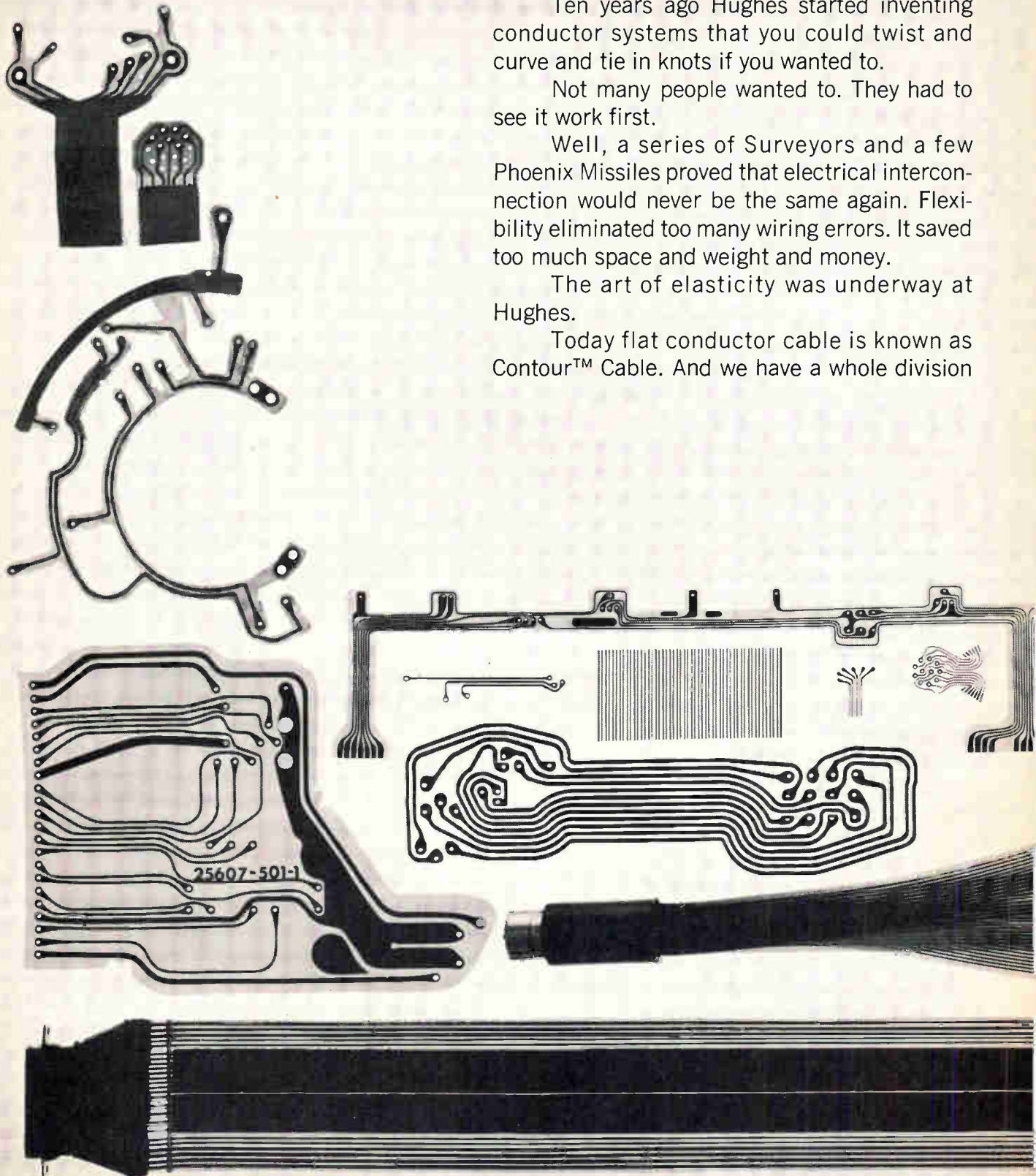

The start of the art.

devoted to it. Over 60 proprietary processes have already been developed for various commercial, military and space applications.

Today Hughes is the only place where you can buy all three versions of flexible cable — etched, collated and bulk assemblies.

We don't place limits on imagination.

Regardless of the circuit problems, our engineers seem to make a thing work.

The art has just started at Hughes.

Write Hughes Aircraft Company, 
Connecting Devices, 500 Superior Avenue,
Newport Beach, California 92663. Phone (714)
548-0671. TWX (714) 642-1353.

HUGHES
HUGHES AIRCRAFT COMPANY

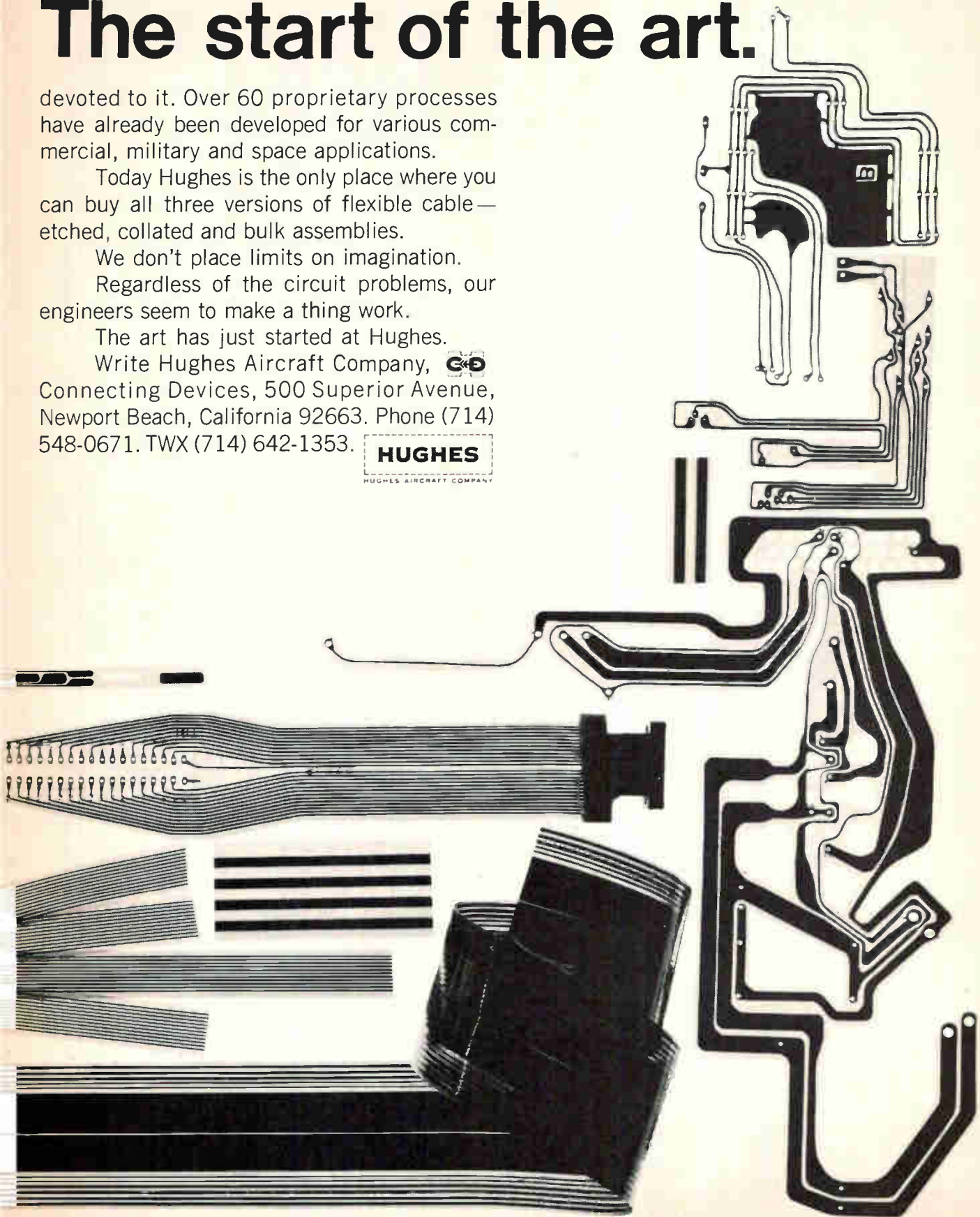

If it's happening in connectors,
it probably started at Hughes



Chapin

The full impact of Beckman Instrument's program to set up its Helipot division in the cermet trimming potentiometer business is only being felt today, eight years later.

Although the initial cermet impetus was for trimming potentiometers, customers began to ask for fixed resistors incorporating the same stable materials. As a result, Helipot engineers found themselves providing custom resistor networks. Once the market potential became apparent, Helipot's division manager, David McNeely, a Beckman vice president, asked Leslie W. Chapin, 46, to set up a microcircuits operation.

On its own. That was two years ago, and the growth has been swift. The operation is now a separate profit center within Helipot, with Chapin as its manager.

Chapin says, "We expected to operate at a loss for a year, but significant profits came after the first year—especially after our standard lines began to take hold." Those standard products, besides passive ladder networks, include hybrid thick-film voltage regulators, power amplifiers, lamp and relay drivers, and circuit protection devices.

"We wanted to have 10% of the hybrid and passive market within our first five years," Chapin asserts. "That market is between \$90 million and \$100 million a year now." With three years left on the timetable, Chapin sees no reason to alter the goal. He's counting on Helipot's cermet capability, plus the circuit design expertise of some key people he brought with him from Beckman's now-defunct Systems division.

"We're technology opportunists in hybrid microcircuits," he says. "We take the best characteristics of monolithic technology and use them in multichip form to achieve a certain function."

Special project. "In our standard products," he explains, "we look for jobs with a lot of resistors, some capacitors and pnp transistors because this kind of circuitry is difficult to do in monolithic form." A good example of technological opportunism is an analog-to-digital converter undertaken as a special task for a customer; eventually, that device will join the standard line. It includes a metal oxide semiconductor chip with more than 200 components, two integrated circuit chips, a number of discrete transistor chips, plus 32 precision resistors. "Here we've married our resistor and analog design skills around the MOS chip," he adds.

An infant firm is betting its future on ion implantation. The KEV Electronics Corp. is preparing to enter a low-cost, small-profit, quantity market for commercial varactor-tuner diodes.

"Nearly half of Europe's television sets use electronic (varactor) tuning," says William J. King, president of the new Reading, Mass., firm, "and the idea is about to catch on Stateside—we may have arrived at just the right time."

Price cut. "What this market needs is a 15- to 20-cent varactor with tight tracking tolerances for use in a-m, f-m, and tv tuners. If it were available, the market could

SEEK TRUTH

BUY A DIAL-A-STAT

Most resistance decades, ah, fib a little. Not ours. Our $\pm 0.01\%$ is conservative and usually means $\pm 0.005\%$.



DIAL-A-STAT: precision thumbwheel dial-able true-decade resistance units. The truth sayers, from 1 ohm to 11.1111 megohms. Two Series: for lab use (DSI) and militarized (DSM).

All available in 3, 4, 5, 6 or 7 decades with in-line numeric readout so that only the resistance dialed shows up in the readout. Low loss switches rated for 10^5 operations, make-before-break.

More truth: Two accuracies, $\pm 0.01\%$ or $\pm 0.025\%$, certified as traceable to NBS. **Stability:** $\pm 0.0025\%$ per year. **Power:** 3/4 watt per resistor; breakdown voltage 750 V, RMS. Over 45 models, available for the most part from stock.

Cost? Trifling for this much veracity: \$83 to \$239 depending upon model, number of decades and accuracy; f.o.b. Mt. Vernon, N.Y., domestic.

Seek truth. Buy a Dial-A-Stat.

General Resistance, Division of Chronometrics. 500 Nuber Avenue, Mt. Vernon, N.Y. (212) 292-1500. In Europe: 39 Rue Rothschild, Geneva, Switzerland (022) 31 81 80.



SPECIAL DELIVERY!

All the test equipment you need. Fast service direct from Electro Rents East or West Coast Facilities.

Keep projects moving. Electro Rents delivers everything you need, certified in-calibration, NBS-traceable, ready to plug in. No down-time.

All our equipment arrives functioning up-to-spec. (In our Metrology Labs expert technicians check out each instrument before it's shipped.)

What's more, while you're renting, we take care of maintenance, repairs, replacements. No project hold-ups, no capital expense: good reasons to rent from us. Need more? Get our brochure. Call, wire or write.

WEST COAST
(Main Office & Laboratories)
4131 Vanowen Place,
Burbank, Calif. 91504
Phone: (213) 843-3131

EAST COAST
(Warehouse & Laboratories)
17 Park Place,
Paramus, New Jersey 07652
Phone: (201) 265-7500

Other locations: San Francisco,
San Diego, Albuquerque, Denver,
Phoenix, Dallas

Los Angeles: "Call TWX 910-498-2238"
San Francisco: "Call TWX 910-338-0202"

A black and white photograph of a delivery person wearing a helmet and a dark jacket, riding a motorcycle. The motorcycle is carrying a large, rectangular piece of test equipment in a metal carrier on the back. The person is smiling and looking towards the camera. The background is a plain, light-colored wall.

Electro Rents

Heinemann's gift to the solid-state equipment designer:

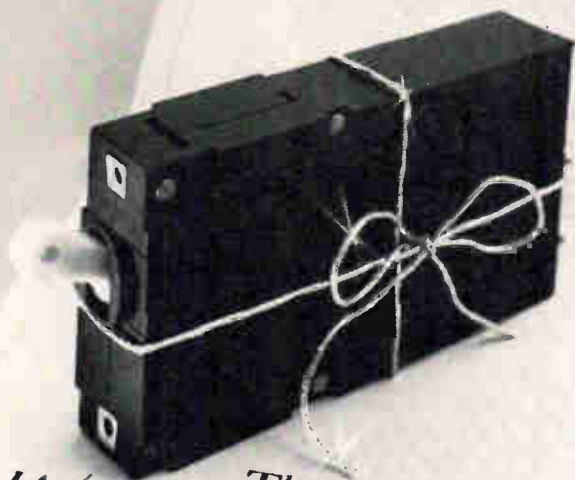

The
JA/Q electronics protector

All wrapped up in one neat little package, here's what you get:

- A device you can absolutely count on to protect semiconductors from transient and overvoltage puncture.
- An overcurrent protector built around Heinemann's well-known hydraulic-magnetic trip mechanism.
- The speed of semiconductor response with the reliability of electromechanical operation: transient response in 500 nanoseconds; equipment disconnect in as little as 10 milliseconds.

You get a lot of savings as part of the JA/Q package, too. Savings in design time. Screening. Testing. Assembly. Calibration. Installation.

These are the steps you'd have to perform if you decided to build it yourself. Instead of buying it from us.

Obviously, it makes more sense to buy it. We'll sell you as many as you want, with firing voltages from five to 50 VDC, and current ratings to 10 amp. With substantial OEM discounts.

And we'll make you a present of the savings.

For literature about the JA/Q electronics protector, write for Bulletin 3370. Heinemann Electric Company, 2600 Brunswick Pike, Trenton, N.J. 08602.

 **HEINEMANN**

Who's Who in electronics



King

reach 20 million units a year. Quantities now are nearly nothing, but we hope to get the market going in 1969," he says.

What makes high-quality varactors expensive?

For one, varactors made by diffusion are difficult to match. To get pairs or triplets that change capacitance with applied voltage to within 1% of each other, one must request computer matched pairs and pay the appropriate price. Even pairs matched to only 3% cost users up to \$5.

King blames these differences on variations in junction abruptness, diffusion depth, and dopant homogeneity, which occur even on the same wafer. "Properly applied, ion implantation controls each of these variations," he says. "And we can apply it properly." He feels that by year's end KEV will be producing varactors with voltage capacitance tracking within 1% of each other and selling near his 20-cent goal.

"We probably could have done it three years ago," he adds wistfully. At that time King and most of KEV's other employees worked at the Ion Physics Corp., a subsidiary of High Voltage Engineering. King was a vice president and director of the Solid State division; his new vice president, Thomas E. Peterson, was then marketing manager.

Out of the lab. Both men pushed hard for commercial products, or at least engineering development, but Ion Physics was an R&D house and its management was determined to keep it that way.

1st DUAL IN-LINE CERMET POTENTIOMETER

TRIMPOT® MODEL 3099



Designed for Automated Insertion . . . TC 150 PPM/°C* over entire resistance range of 10 ohms to 1 megohm!

The new Trimpot Model 3099 dual in-line cermet element potentiometer has standard DIP construction with a TO-116 case. Today's ever-accelerating computer industry requires dual in-line components for socket or modern state-of-the-art automated assembly. The Model 3099 utilizes this mounting and is completely compatible with manual or automatic insertion equipment.

Let us tell you the complete technical story on this newest potentiometer innovation in the industry! For full details on the Model 3099, please contact the factory, your local field office or representative!



Model 3099 is designed for use with DIP automatic insertion equipment.



Model 3099 in standard 14 pin DIP socket.

* 100 PPM/°C available



BOURNS, INC., TRIMPOT PRODUCTS DIVISION
1200 COLUMBIA AVENUE, RIVERSIDE, CALIFORNIA 92507
714 684-1700 • TWX: 910 332-1252 • CABLE: BOURNSINC

TRIMPOT® AND PRECISION POTENTIOMETERS • MINIATURE RELAYS • RESISTORS • ELECTRONIC MODULES • TRANSFORMERS • INDUCTORS AND CERAMICS

Circle 17 on reader service card

Fairchild can make more hybrids in

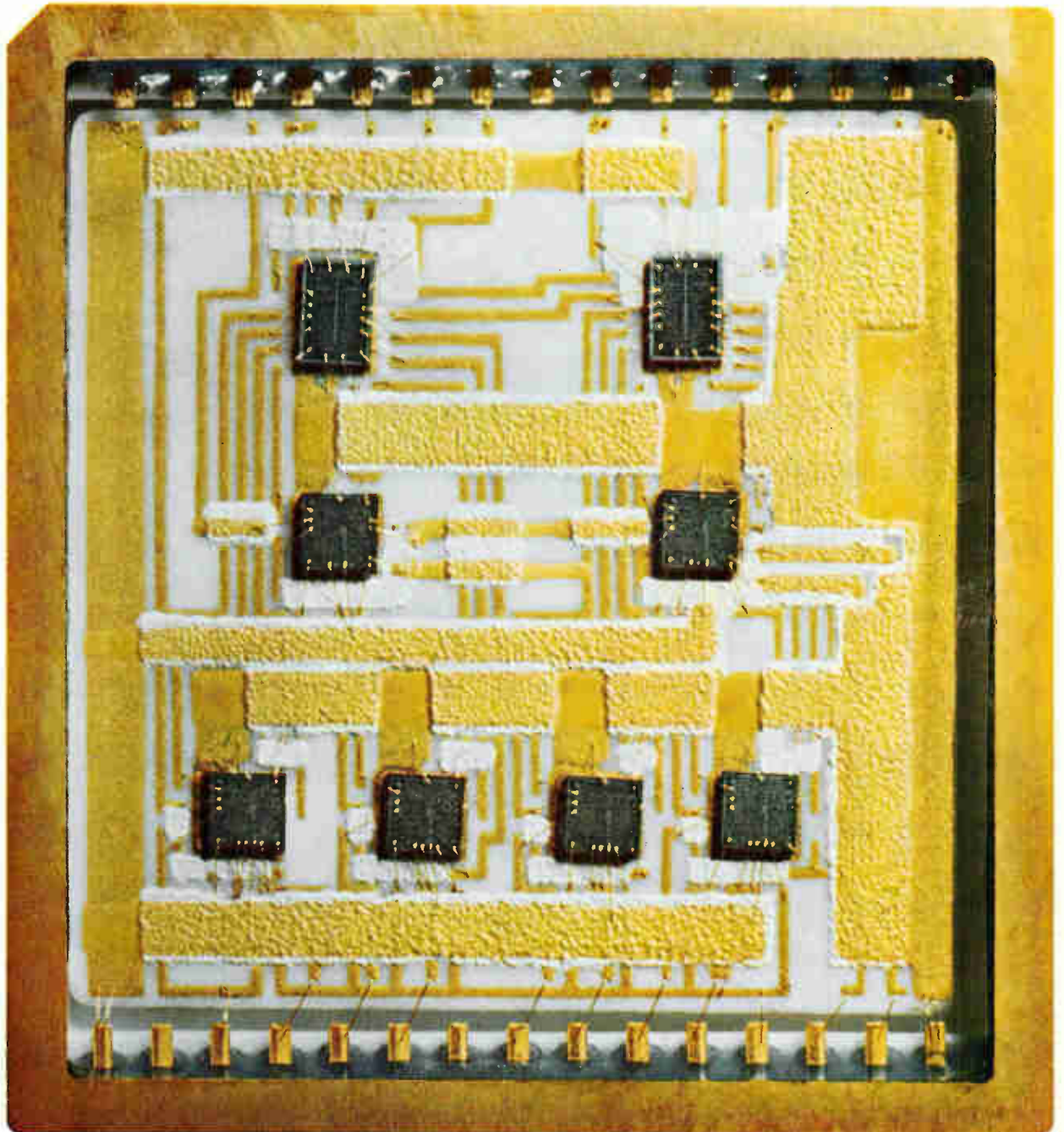

an hour than you can use in a month.



We can make any hybrid, in any quantity, using any method: Thick film. Thin film. Thin film on silicon.

We can make them faster than anyone in the industry. And deliver them quicker than anyone in the world.

We'll take any functions you need and package them any way you want. Our list of hybrid components has everything from a simple diode to a complex LSI array.

For your less complex applications, we have a line of off-the-shelf standard hybrids priced like discretes.

If this commitment makes sense in general, we'd like to send you the whole story in detail. Our brochure is called Fairchild Hybrid Microcircuits.

It can give you more ideas in an hour than you could use in a year. Write for it.

Fairchild Semiconductor/A Division of Fairchild Camera and Instrument Corporation//313 Fairchild Drive, Mountain View, California 94040 (415) 962-5011 TWX: 910-379-6435

FAIRCHILD
SEMICONDUCTOR

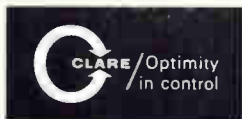

MATCH YOUR CIRCUIT NEEDS EXACTLY WITH CLARE LONG-LIFE GLASS-ENCAPSULATED RELAYS . . . REED OR MERCURY-WETTED

You can meet advanced circuit requirements with long-life, maintenance-free switching . . . and never compromise on essential characteristics. Clare's unequaled variety of products—mercury-wetted and reed—provide the broad range versatility you need. And you can choose your relays to fit your *cost* considerations, too.

Design in multi-billion operation service life . . . complete input/output isolation . . . freedom from sequence disruption and false operations due to electrical transients . . . essential standards of speed, sensitivity, and load. Select the contact form you need—in the physical configuration that fits your circuitry and packaging.

Choose from hundreds of models—superclean in construction . . . 100% operation-tested for maximum reliability. In design and in action, you can depend on Clare . . . without question or compromise.



COMPROMISE

on sealed contact relays?

WHY?

Clare offers maximum choice!



	REED	MERCURY-WETTED
Relay Types	CLAREED, MicroClareed, and the new Picoreed for industrial control, data logging and instrumentation, communication switching, ground control, and check-out systems. High speed: operate time as low as 0.5 ms.	Clare Mercury-Wetted Contact Relays for input analog switching, output power conversion switching, solid state input and output buffering. Low, constant contact resistance—no mechanical wear, erosion, or chatter.
Switch Types	General Purpose (standard size) Mercury-Wetted (standard size) High Voltage (standard size) MicroClareed (miniature) Picoreed (subminiature)	HGS—for fast switching, high sensitivity. Special models for low level, polar, and coaxial applications HG—for heavier contact loads
Contact Forms	A, B, and C with combinations up to 12 contacts	1 & 2 Form C or D—up to 6 Form D for wired assemblies
Contact Load Capabilities	Low level to 15 va (ac or dc)	Low level to 250 va
Operate Time	As low as 0.5 ms	As low as 1.0 ms
Sensitivity	As low as 30 mw	As low as 2 mw
Literature	For full specifications, circle Reader Service Number 279 ... or ask Clare for Clareed Bulletin 951, MicroClareed Data Sheet 961, and Picoreed Data Sheet 971—Write Group 2N9 	For full specifications, circle Reader Service Number 280 ... or ask Clare for Bulletin 801 (wired assemblies), and Bulletin 802 (printed circuit board models)—Write Group 2N8 

C. P. Clare & Co., Chicago, Illinois 60645
... and Worldwide

a GENERAL INSTRUMENT company



CLARE SEALED CONTACT REED RELAYS
MERCURY-WETTED CONTACT RELAYS



**SUPERIOR
COAXIAL
ATTENUATORS**

**general utility
high
performance**



Series 210, 210A, and 530A Attenuators employ the "lossy line" principle. They are useful in all applications requiring isolation between RF components and in the extension of the ranges of power meters. These attenuators can also be used to produce a known broadband mismatch when terminated by a short, and are useful in the calibration of directional-couplers, antenna patterns, and in path loss simulation.

	SERIES		
	210	210A	530A
Freq. Range (GHz)	1-12.4	0.4-18	0.4-12.4
Av. Pow. (W)	1-5	1-5	2-5
Peak Pow. (W)	1-10	1-10	2-10
Max. VSWR	1.25 to 1.35	1.25 to 1.50	1.25 to 1.30

All three series are available in standard nominal values from 1 to 10 dB and 20 dB. These rugged, high stability pads have an extremely low power and temperature coefficient. Full individualized and guaranteed calibration data is supplied with each attenuator.

Designers and
Manufacturers of Precision
Microwave Equipment

**WEINSCHEL
ENGINEERING**
Gaithersburg, Maryland

(68-8)

Meetings

IEEE: More a classroom than a showcase

Every year the IEEE International Convention tries to be all things to all men but never quite succeeds. This year is no exception, for while the 52 sessions cover a broad spectrum, the meeting is still more of a tutorial in state-of-the-art techniques than a showcase for new technological developments.

When the five-day conference opens March 24 in the New York Hilton and the Coliseum, those in attendance may have a hard time deciding which of the five to seven parallel sessions to attend. For example, sessions during a single morning include manufacturing technology for microelectronics, communications and computers, the interdisciplinary nature of design, filters for nonspecialists, and radiation damage and hardened device development.

Innovation. One new feature of the conference will be a series of sessions on microwave technology. R.H. Jackson, manager of Texas Instruments' solid state phased array radar program, dubbed MERA, will discuss fabrication and testing of large numbers of microwave integrated circuits. Gene Strull, manager of the Science and Technology division of Westinghouse Electric, will then analyze innovation in microwave integration.

The growth of information theory in the 20 years since Claude E. Shannon created the discipline will be covered in papers presented by Professors R. G. Gallagher of MIT and A. J. Viterbi of UCLA. Viterbi will assess the influence of information theory on digital communications systems.

J.A. Copeland, supervisor of the bulk-effects studies group at Bell Labs, will present a paper on the potential of semiconductors for millimeter- or submillimeter-wave generation. He will speak during the session covering materials that span infrared to microwave.

Thick and thin. The relative merits of thick and thin films will be compared in a session led by R.E. Thun, technical director of

the Industrial Components division of Raytheon.

Other sessions will cover industrial semiconductor devices, optical and semiconductor memories, instrument-computer systems, the use of LSI, medical electronics, acoustic signal processing, and computer-aided design.

For more information write J.M. Kinn, IEEE, 345 E. 47th Street, New York, N.Y. 10017.

Calendar

Tactical Missile Systems Meeting, AIAA; Redstone Arsenal, Huntsville, Ala., Feb. 10-12.

Transducer Conference (G-IECI), National Bureau of Standards; Twin Bridges Marriott Hotel, Washington, D.C., Feb. 10-11.

Symposium on Meteorological Observations and Instrumentation, American Meteorological Society; Washington Hilton Hotel, Feb. 10-14.

Winter Convention on Aerospace and Electronics Systems (Wincon), IEEE; Biltmore Hotel, Los Angeles, Feb. 11-13.

First National Conference on Electronics in Medicine, Electronics, Medical World News, and Modern Hospital Magazines; Statler-Hilton Hotel, New York, Feb. 14-15.

VTOL Systems Conference, AIAA, American Helicopter Society; Georgia Institute of Technology, Atlanta, Feb. 17-19.

International Solid State Circuits Conference, IEEE; University of Pennsylvania and the Sheraton Hotel, Philadelphia, Feb. 19-21.

West Coast Reliability Symposium, Century Plaza Hotel, Beverly Hills, Calif., Feb. 21.

Technological Influences on Communications Conference, IEEE; Washington Hilton Hotel, Washington, D.C., Feb. 24-25.

Electric Propulsion Conference, AIAA; Williamsburg, Va., March 3-5.

Particle Accelerator Conference, IEEE; Shoreham Hotel, Washington, March 5-7.

(Continued on p. 24)

whatever direction
your design takes...

Allen-Bradley thick film networks will put you out front in...

Packaging—Advanced manufacturing capability covers virtually every type and every configuration of resistive and/or capacitive networks—single or dual in-line, as well as flat-packs, with or without hermetic sealing.

Characteristics—Exclusive and patented formulations enable A-B to provide resistance values from 1 ohm to 5.0 megohm. Ratings to 20 watts/in² at 85°C. Capacitance values from 10 pfd to 0.5 mfd with voltage ratings to 50 volts. Applications include precision tuned circuits.

Performance—Standard resistance tolerance $\pm 10\%$. For critical circuitry, tolerances to $\pm 0.1\%$ can be furnished—with resistances and TC's matched. Temperature coefficient less than 250 ppm in all cases. Special units to 100 ppm or less. Load life stability of 1% in 10,000 hours can be achieved.

Reliability—Allen-Bradley has precise control over all raw materials and manufactures all basic components—glasses, organic materials, and substrates. Special machines—designed and built by A-B—assure uniform product quality—at a competitive price.

Timing—Allen-Bradley has unique in-plant ceramic facilities. Prototype networks—with or without holes—can be prepared to meet your specific needs. Quickly. Economically.

For more details, write Henry G. Rosenkranz, Allen-Bradley Co., 1315 S. First St., Milwaukee, Wis. 53204. In Canada: Allen-Bradley Canada Ltd. Export Office: 630 Third Ave., New York, N. Y., U.S.A. 10017.

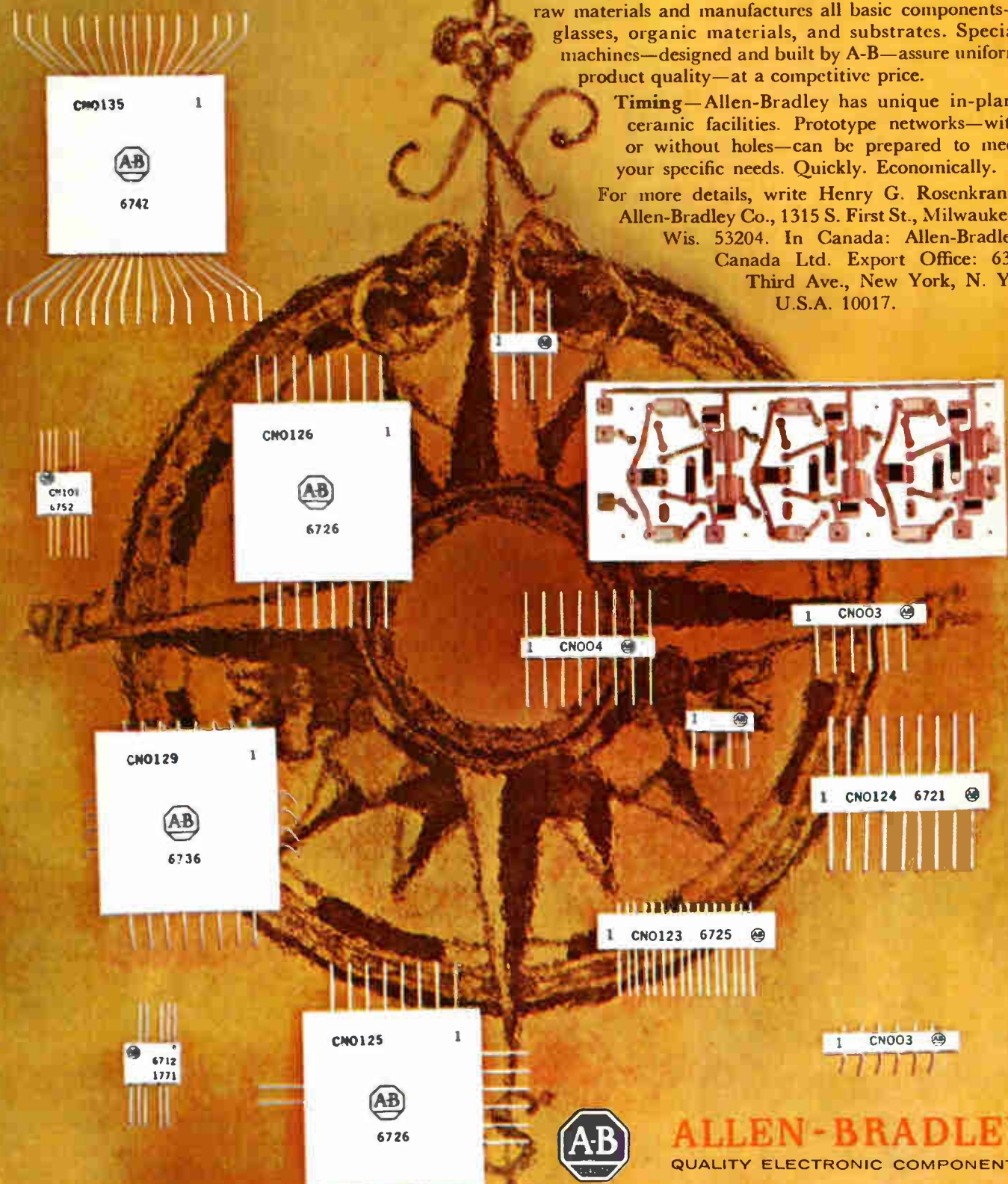

ALLEN-BRADLEY
QUALITY ELECTRONIC COMPONENTS

achievement
in
precision

to attain
new dimensions
in
drilling speed
and
precision



Model 108 Air Bearing Spindle Heads

**FOR CIRCUIT BOARD
PRODUCTION DRILLING**

- Sustained torque and speed . . . up to 100,000 RPM.
- Feeds . . . up to 15 feet/minute without use of bushings.
- Hole location . . . spindle compatible with drilling systems to provide hole-to-hole location within plus-or-minus 0.0005".
- Run-out . . . within 0.0002".

Air bearing supported spindle for absolute integrity in spindle rotation. Total freedom from vibration...harmonic and sonic. High frequency electric motor drive with balanced design, solid state frequency convertor for constant speed and torque. Individual air operated, self-feeding units supplied as optional equipment. Also available with air turbine drive. Write for Catalog AB68.

THE METAL REMOVAL COMPANY

1859 West Columbia Avenue • Chicago, Illinois 60626
Plants located in CHICAGO / LOS ANGELES / SAN JUAN



Meetings

(Continued from p. 22)

International Convention & Exhibition, IEEE; Coliseum and Hilton Hotel, New York, March 24-27.

Second International Laser Safety Conference, Medical Center of the University of Cincinnati; Stouffer's Cincinnati Inn, March 24-25.

Semiconductor Device Research Conference, IEEE; Munich, Germany, March 24-27.

Conference on Lasers & Optoelectronics, IEEE; Southampton, England, March 25-27.

Symposium on Engineering Aspects of Magnetohydrodynamics; Massachusetts Institute of Technology, Cambridge, Mass., March 26-28.

The Changing Interface: An IC Systems Seminar, Electronics/Management Center; Park Sheraton Hotel, New York, March 28.

Vibrations Conference, Association of Mechanical Engineers; Philadelphia, March 30-April 2.

Quality Control Conference, University of Rochester; Rochester, N.Y., April 1.

Numerical Control Society; Stouffer's Motor Inn and Convention Center, Cincinnati, April 1-3.

Mathematical Aspects of Electrical Network Analysis, American Mathematical Society; Providence, R.I., April 2-3.

International Symposium on Computer Processing in Communications. Polytechnic Institute of Brooklyn; Waldorf-Astoria Hotel, New York, April 8-10.

Computer Aided Design Conference, IEEE; University of Southampton, England, April 15-18.

Joint Railroad Conference, IEEE; Queen Elizabeth Hotel, Montreal, April 15-16.

International Magnetics Conference (Intermag), IEEE; RAI Building, Amsterdam, Holland, April 15-18.

International Geoscience Electronics Meeting, IEEE; Twin Bridges Marriott Hotel, Washington, April 16-18.

Conference on Switching Techniques for Telecommunications Networks, IEEE; London, April 21-25.

(Continued on p. 26)

ALLEN-BRADLEY
Metal-Grid resistor networks
combine a new measure of

precision, stability and performance in a sealed, compact package



Precision Metal-Grid resistor network shown
approximately 1½ times actual size



The advanced capabilities—developed from years of manufacturing Allen-Bradley Metal-Grid resistors—are now applied to a new line of resistor networks. This technology enables the production of complex resistive networks on a single substrate.

Allen-Bradley's exclusive simultaneous deposition method is used to obtain the best resistance tolerance and temperature coefficient matching. The reliability of interconnections on the common resistance plane is incomparable. Uniformity and quality are inherent in A-B networks. To illustrate, 2 PPM temperature tracking is normal.

A-B Metal-Grid networks offer a wide range of values—with individual resistances as low as 25 ohms and as high as 2.0 megohms. Both the inductance and capacitance are low, permitting efficient operation at high frequencies.

A-B engineers will be pleased to cooperate in developing networks for your specific need. For additional details, please write to Henry G. Rosenkranz, Allen-Bradley Co., 1315 S. First Street, Milwaukee, Wisconsin 53204. In Canada: Allen-Bradley Canada Ltd. Export Office: 630 Third Avenue, New York, N. Y., U.S.A. 10017.

BRIEF SPECIFICATIONS

Resistor Networks

Tolerances: $\pm 1.0\%$ to $\pm 0.01\%$
Resistance Matching: to 0.005%
Temperature Range: -65°C to $+175^{\circ}\text{C}$
Temp. Coef.: to ± 5 ppm/ $^{\circ}\text{C}$
Load Life (Full load for 1000 hr @ 125°C): 0.2% maximum change

Ladder Networks

Full Scale Accuracy: 10 bits or less, better than $\pm \frac{1}{4}$ least significant bit. More than 10 bits, better than $\pm \frac{1}{2}$ least significant bit.
Frequency Response: Less than 100 nanosecond rise time or settling time
Temp. Coef.: Less than 10 ppm/ $^{\circ}\text{C}$
Temperature Range: -65°C to $+175^{\circ}\text{C}$

ALLEN-BRADLEY
QUALITY ELECTRONIC COMPONENTS

The 100,000,000,000 ohm Nanosecond Switch

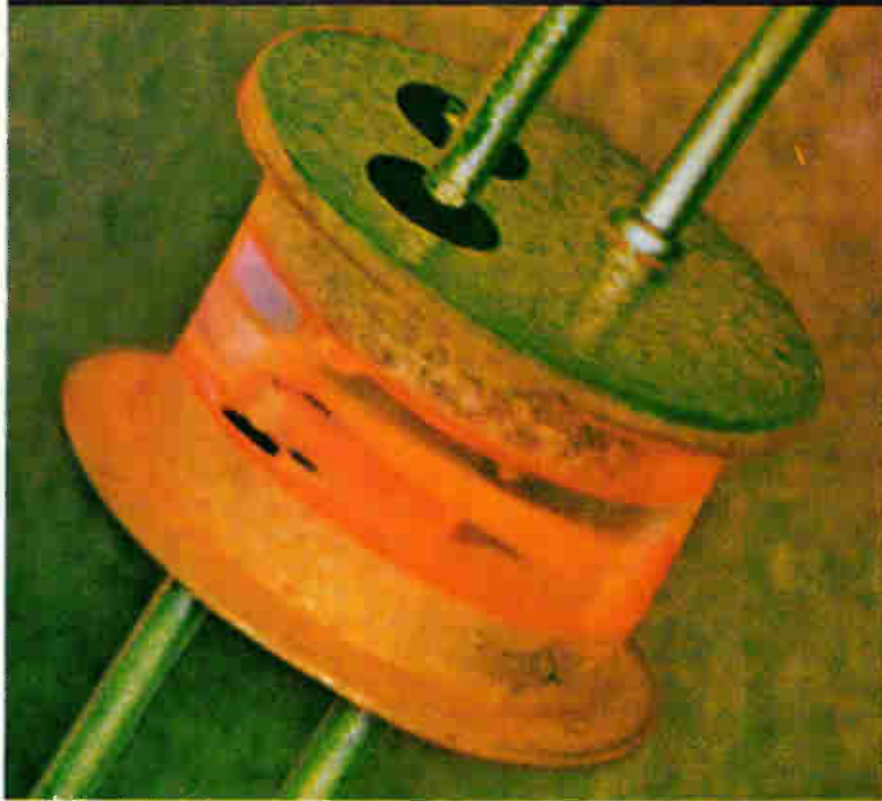

Model MCD 1 shown actual size

This new photodiode coupled pair offers the designer 5 ns rise and fall times together with over 3,000 volts isolation between input and output. The IR emitter and companion detector are optically coupled through clear epoxy—as seen here. The unit is then encased in opaque epoxy for

maximum dark resistance. It's ideal for high speed isolated switching and high voltage isolation

For additional information and applications write or call Monsanto Electronic Special Products, 10131 Bubb Road, Cupertino, Ca. 95014 (408) 257-2140.

Monsanto

Meetings

(Continued from p. 24)

Conference and Exhibit, Temperature Measurements Society; Hawthorne, Calif., April 21-22.

Spring Meeting, United States National Committee, International Scientific Radio Union, IEEE; Shoreham Hotel, Washington, April 21-25.

Southwestern Conference & Exhibition, IEEE; Convention & Exhibition Center, San Antonio, April 23-25.

Electrical & Electronic Measurement and Test Instrument Conference, Instrumentation & Measurement Symposium, IEEE; Skyline Hotel, Ottawa, Canada, May 5-7.

Short courses

Electrical engineering refresher, University of Wisconsin, Madison; April 24-26; \$50 fee.

Modern applications of semiconductors, University of California at Los Angeles; May 5-16; \$375 fee.

Semiconductor circuits, University of Michigan, Ann Arbor; June 2-6; \$225 fee.

Call for papers

Computer Science and Technology Conference, University of Manchester Institute of Science and Technology, London; June 30-July 3. Feb. 24 is deadline for submission of synopses to Conference Secretariat, Institution of Electrical Engineers, Savoy Place, London W.C. 2.

ACM National Conference & Exposition, San Francisco, Aug. 26-28. March 3 is deadline for submission of papers to Dr. Ward Sangren, program committee chairman, ACM 69, P.O. Box 2867, San Francisco 94126.

Aviation & Space Conference, Statler Hilton Hotel, New York, June 30-July 2. March 3 is deadline for submission of papers to Leo DeMarinis, Grumman Aircraft Engineering Corp., Plant #5, Bethpage, N.Y. 11714.

International Electronic Circuit Packaging Symposium, Wescon; San Francisco, Aug. 20-21. March 1 is deadline for submission of abstracts to H.J. Scagnelli, chairman, IECPS Papers Selection Committee, Wescon, 3600 Wilshire Blvd., Los Angeles 90005.



Cimron leapfrogs the DVM industry —and there's a reason!

A number of reasons, to be exact! The all-IC Model 6753 is the next generation in digital multimeters—the lowest-priced autoranging instrument that will read DC from 100 nanovolts to 1099.9 volts and DC ratios. A fast-tracker, too—ideal for systems work. The closed loop tracking logic continually samples output at the rate of 14 readings a second, with accuracies of $\pm 0.001\%$ full scale $+0.005\%$ of reading. Like to learn about automatic desensitization? repetitive mode? out-of-range indication? Just ask how they can

help you. Important to you is the basic design, featuring optional IC plug-ins to extend capability which you can install yourself without technical service! Options include a 4-range AC converter with 10 microvolt sensitivity, a 5-range ohms converter, remote programmability, five print-out options. You can't beat the base price of \$2990! Cimron's **customer concern** continues to provide what you really need at the lowest possible price. Write Cimron, Dept. C-122, 1152 Morena, San Diego, Calif. 92110.

LEAR SIEGLER, INC.



CIMRON DIVISION

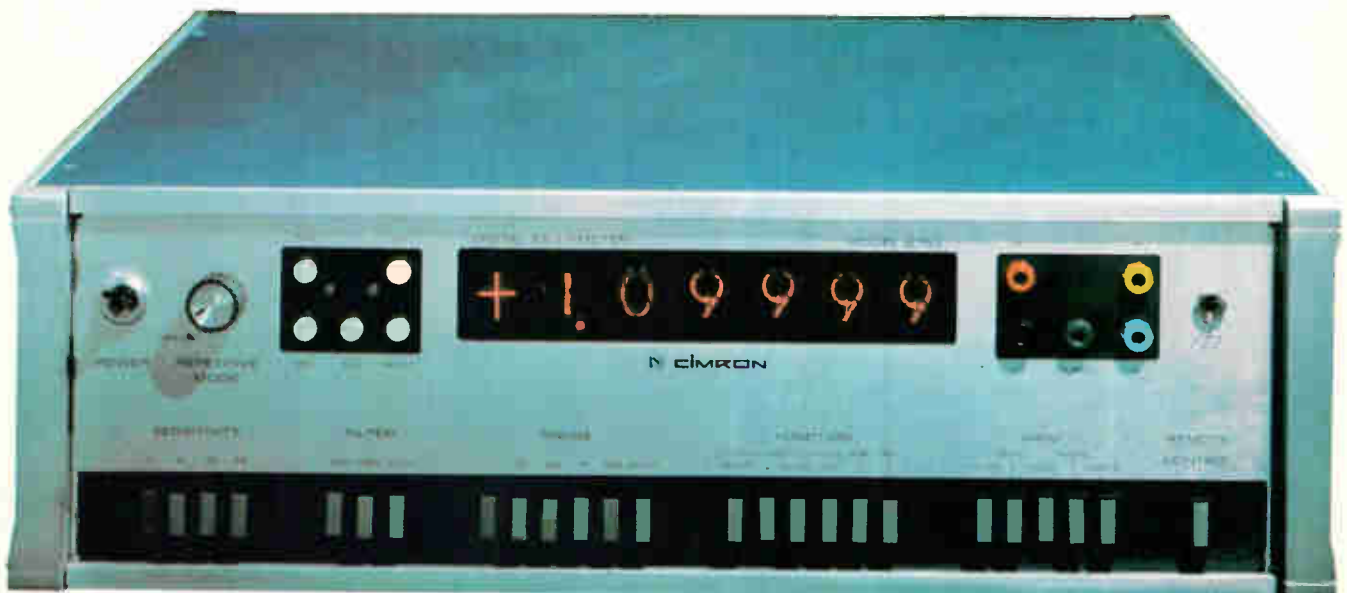

Doctors!

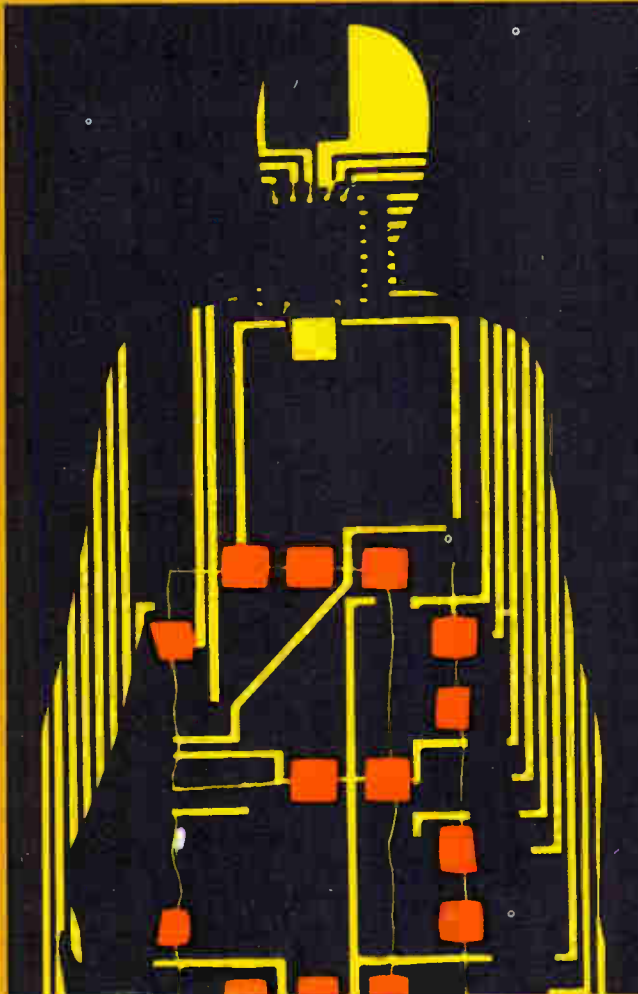

ADVANCE REGISTRATION

FIRST NATIONAL CONFERENCE ON ELECTRONICS IN MEDICINE
February 14-15 Statler-Hilton, New York, N.Y.

Registration Fee: \$125

Name _____

Address _____

City _____

State _____

Zip _____

Hospital or Company _____

Position _____

____ Please register the above for the **ELECTRONICS IN MEDICINE** Conference

____ Check enclosed ____ Send invoice

____ Mail an additional registration form with descriptive brochure.

NOTE: Attendance will be limited and applications will be handled on a first-come, first-served basis.

Make hotel reservations directly with the Statler-Hilton before February 1. Identify yourself as an attendee of this conference. A number of rooms are being held.

Mail registrations and make checks payable to:
**FIRST NATIONAL CONFERENCE ON
ELECTRONICS IN MEDICINE**
330 West 42nd Street, New York, N.Y.

Here's your chance to learn how electronics can help you care for your patients and manage your practice. Tell the nation's leading electronics firms what you really need for diagnosis, therapy, and monitoring. See the latest equipment demonstrated and critiqued.

FIRST NATIONAL CONFERENCE ON ELECTRONICS IN MEDICINE

February 14-15
STATLER-HILTON, NEW YORK, N.Y.

Presented by McGraw-Hill Publications:
ELECTRONICS / MEDICAL WORLD NEWS / MODERN HOSPITAL

CONFERENCE OUTLINE

Computers In Medicine

- Computers join the medical team
- What are computers doing in medicine?
- Diagnosis by computer
- Data processing in the doctor's office
- How to communicate with the computer
- Small computers—new para-medical aids

Engineers:

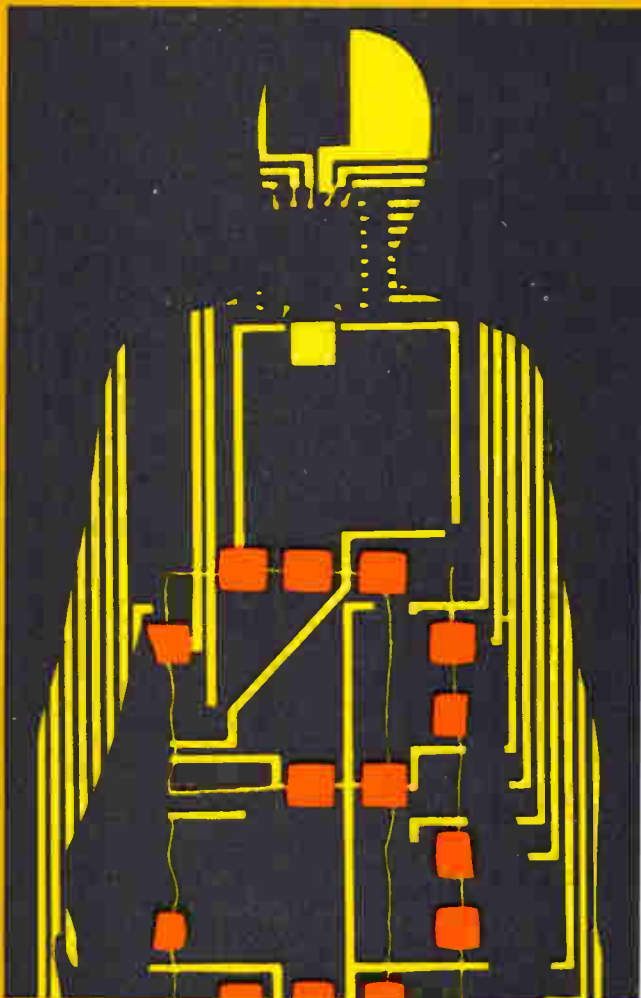

ADVANCE REGISTRATION

FIRST NATIONAL CONFERENCE ON ELECTRONICS IN MEDICINE

February 14-15

Statler-Hilton, New York, N.Y.

Registration Fee: \$125

Name _____

Address _____

City _____

State _____

Zip _____

Company _____

Position _____

____ Please register the above for the ELECTRONICS IN MEDICINE Conference

____ Check enclosed ____ Send invoice

____ Mail an additional registration form with descriptive brochure.

NOTE: Attendance will be limited and applications will be handled on a first-come, first-served basis.

Make hotel reservations directly with the Statler-Hilton before February 1. Identify yourself as an attendee of this conference. A number of rooms are being held.

Mail registrations and make checks payable to:
FIRST NATIONAL CONFERENCE ON
ELECTRONICS IN MEDICINE
330 West 42nd Street, New York, N.Y.

Make the most of this opportunity to help close the communications gap between medicine and electronics. Join the world's leading physicians and medical specialists in bilateral discussions. Help match their real needs to the dynamic capabilities of electronics.

Instrumentation In Medicine

- Is it being designed and used properly?
- Achievements and barriers
- Instrumentation in practical patient management
- Protecting the patient—standards and safety
- Government regulation

Medical-Engineering Relationships

- Why can't doctors and engineers communicate?
- What the hospital administrator wants

Systems Engineering

- Marshalling medical resources through systems
- Prescription for large-scale health care
- Remodelling the surgery department

Demonstrations

- Patient monitoring, and computer-aided diagnosis systems, xerographic mammography techniques, a pulmonary function analyzer, and an electric power monitor will be demonstrated and critiqued by a panel of physicians and engineers.

Put a MICRO SWITCH field man on your team and you've got a whole army of experts on your side.

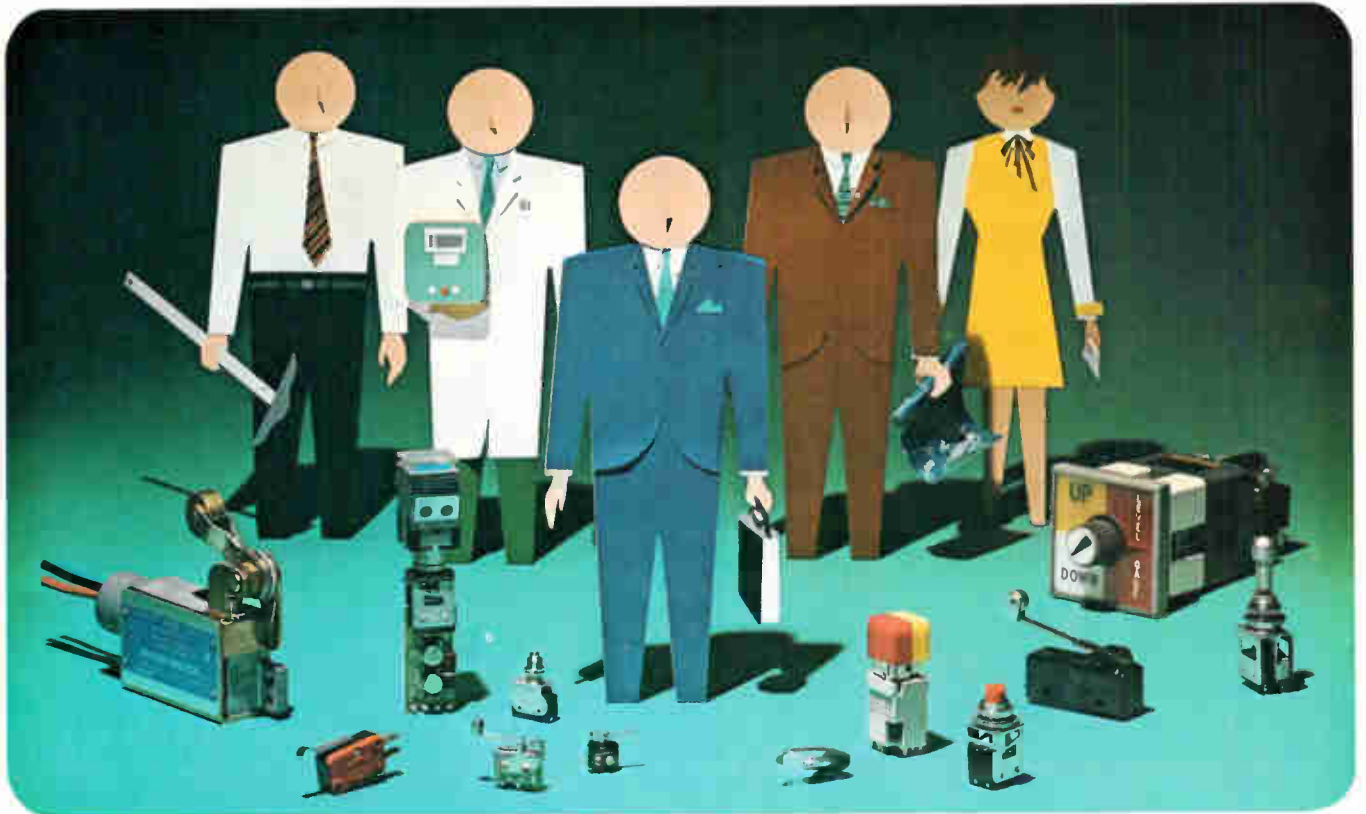

Special switching problems? MICRO SWITCH puts the largest field organization in the industry at your convenience. Our field engineers are especially trained to work on any aspect of your application requirements; from proper switch selection, including reliability and quality/cost factors, to proper switch installation and operation for maximum service.

When a field man tackles your problem, he's not working on it

alone. He is backed by a whole army of experts at the factory with many specialized talents.

For example, should you require a switch design to meet highly sophisticated specifications, he can tap the know-how of our experienced design engineering department. At the same time, he can dip into the world's largest selection of switches to find the device that's exactly suited to your needs.

Similarly, our extensive R&D facilities, advanced development

laboratories, and other engineering departments are continually developing new data and concepts to provide the most up-to-date sources of reference to serve you better.

Whatever your switching problem, large or small, call in the man who's experienced in problem solving... your MICRO SWITCH field man. You can reach him easily through a Branch Office or Authorized Distributor (Yellow Pages, "Switches, Electric").

MICRO SWITCH

FREEPORT, ILLINOIS 61032

A DIVISION OF HONEYWELL

HONEYWELL INTERNATIONAL • Sales and service offices in all principal cities of the world. Manufacturing in United States, United Kingdom, Canada, Netherlands, Germany, France, Japan.

Editorial comment

Federal budget has something for everyone . . .

Not great but good is the conclusion of one Washington analyst after study of the 1970 budget (see page 117 for *Electronics*' comprehensive analysis). Expert observers labeled it an "honest" budget, one that cannot be criticized—as could some in the past—for tricky accounting methods. For another thing, the budget is not based on the assumption that spending for the war in Vietnam will end on day "X." Nevertheless, the Defense Department plans to taper off on spending for tactical inventories and concentrate on such strategic items as new ships, aircraft, and missiles. In the short run, this may cut electronics and communications spending by about \$200 million. But there is still plenty of electronics in the Pentagon budget, which accounts for about half of Federal spending.

The civilian sector fared well in plans for electronics hardware and research spending. Most agencies withstood the Budget Bureau's critiques. The Post Office is up for an additional \$16 million

for research and engineering; some of this will be spent by LTV Electrosystems Inc. to build an automatic mail "factory." The Agriculture Department will spend \$2.8 million to equip an airplane with remote sensing devices such as infrared cameras to measure, for example, the moisture in soil.

The FCC's research budget is up to \$2.7 million. Most of that is earmarked for research in broadcast communications, frequency assignment and management, and land-mobile radio. R&D funding at the Environmental Science Services Administration is up a bit to \$25.7 million. The money will be used to study weather forecasting, flood prediction, mapping, communications, and sensors for satellites.

If any agency's budget can be called austere, it's NASA's. The agency's original request for \$4.7 billion was finally slashed to \$3.87 billion. Even in the face of the cuts, however, no particular group at NASA seems to have been unfairly treated.

. . . but NASA is not rewarded

The drama and perfection of Apollo 8's moon-girdling adventure seemed to inspire little, if any, extra consideration by the Budget Bureau when it came to reviewing NASA's proposals for fiscal 1970. When the bureau's editing was finished, projects representing nearly \$1 billion were scattered on the cutting-room floor. Among them were programs involving a number of exploratory satellites. Also reduced were funds for post-Apollo lunar exploration and aeronautics studies. Following the bureau's cuts, the Office of Science and Technology restored some of the money, thereby re-injecting important funds for post-Apollo applications, nuclear boosters, and earth resources satellites.

NASA had hoped to get a flying start on a National Space Station and to gear up for longer manned visits to the moon. But it got less than it sought in both cases. With the Russians calling the linked Soyuz 4 and 5 spacecraft "the world's first experimental space station," the new Congress may reconsider the cuts. As it stands today, however, NASA couldn't even begin ordering hardware for the space station until 1972 and could get it

into orbit by 1975 only under ideal circumstances. It had been hoped that a "rudimentary" station could be placed in orbit during 1971.

NASA is looking hopefully to the new Administration, of course, but the agency will have to contend with sharp scrutiny. For example, the grand tour (unmanned) to Jupiter, Pluto, Uranus, and Neptune will cost at least \$1 billion, and planning will have to begin now. But critics will ask NASA to clearly define the rewards from such a trip. Not to be overlooked is the fact that Robert Seamans, former deputy administrator of NASA, will now, as Secretary of the Air Force, be scrutinizing any duplication between NASA and Air Force projects.

On the bright side, V/STOL is scheduled for an increase of \$2.5 million, human factors systems for another \$3.9 million, and nuclear rockets an additional \$4.5 million. The Langley Research Center will get money to build an aircraft noise abatement laboratory, and the Electronics Research Center is slated to get \$8 million for a new computer research and information facility. ■

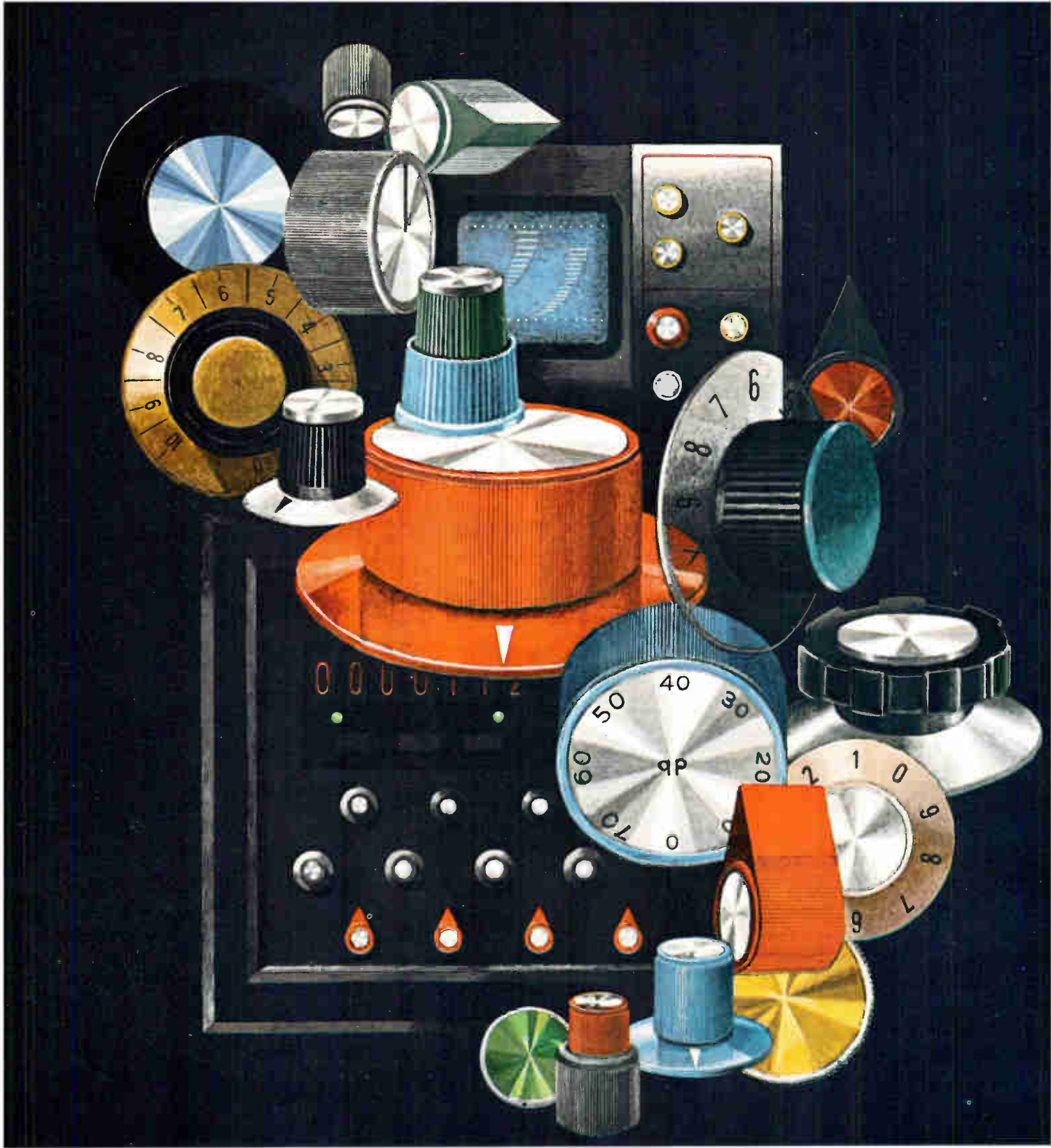

Rogan control knobs... tastefully complementary to your product

Modern in style . . . classical in appearance—that's important in a knob. Attractive in color . . . versatile in performance—that's important in a knob, too. These and many more features are found in the number one name in knobs—ROGAN—Rogan Control Knobs—knobs that add that "extra touch of taste" to your product.

Write today for new general color catalog or see us in Sweets or Thomas register.

Rogan

BROTHERS, INC.

8019 N. Monticello Ave. Skokie, Illinois 60076
Phone: (312) 675-1233

Electronics Newsletter

February 3, 1969

Pentagon buying to be reviewed . . .

Pressure to hold down allegedly excessive war profits is going to become intense even before the new Administration fully settles in. Pentagon critics, both in and out of Congress, are gearing up for a prolonged examination of procurement policies.

Critics can be expected to make good use of an unreleased Government report [*Electronics*, Nov. 25, p. 66] that says the Pentagon has been paying full, if not excessive, prices for heavily electronic systems that don't meet performance specifications. Reviewing 13 major weapons systems costing \$40 billion, the study says that only four, with a total cost of \$5 billion, met or exceeded specifications.

The report also looks into what it calls peculiar earnings of North American Rockwell and General Dynamics. It says their profits exceed the aerospace industry average—even though North American had four programs whose failure rates were four times those specified. General Dynamics built the unsuccessful F-111.

. . . Packard may be in hot seat . . .

The confirmation of David Packard as Deputy Secretary of Defense [*Electronics*, Jan. 20, p. 45] will mean that all future electronics procurement—and not only equipment from Hewlett-Packard—will come under closer Congressional scrutiny. Democrats, especially, will take a sharp look at what they consider high costs and profits from the sales of electronic gear to the Government. They will probably say that Packard, as an electronics expert, should be the one to correct such situations.

. . . military edgy over criticism

And the Pentagon appears worried that the long-time critic of its procurement policies, Vice Admiral Hyman G. Rickover, may finally find an audience in the Nixon Administration.

Evidence that the brass is getting edgy came shortly after the admiral's latest blast over what he considers excessive industry profits; the Pentagon apparently leaked a story about the admiral's own management problems. The story, obviously a counterattack, was of how Rickover's pet project—the NR-1, a nuclear research submarine—was \$70 million over its original estimated cost of \$30 million.

Rickover's criticism came in recently released testimony from secret hearings held by Congress' Joint Economic Committee last November.

Competition grows in time-sharing

Two more of the Big Nine are joining General Electric, IBM, and a bushel of smaller companies in providing time-sharing computer services.

Last week Honeywell established an Information Services division in Minneapolis to offer batch-processing services and software as well as time sharing. Honeywell tipped its hand two weeks ago when it introduced a time-sharing system comprising one DDP-418 and two DDP-516 computers, peripheral gear, and a pile of software. All of the equipment had been previously announced.

Meanwhile, the Control Data Corp., which has been in the service bureau business for some time, is expected to announce this week the completion of the last major link in a nationwide computer network. This link is the company's new 6600 computer, just installed in its New

Electronics Newsletter

York data center. It's the seventh of these giants to be so installed; the network ties all seven together, along with several smaller Control Data computers and a large number of remote terminals. Several private concerns, all with large computer installations of their own, are also connected into the network.

Honeywell gets pact for DC-10 computer

Honeywell has won the contract for the digital air data computer for the DC-10 airbus, according to reliable sources. This marks the first switch by a commercial aircraft manufacturer from an electromechanical analog machine, with its potentially unreliable moving parts, to an all solid state digital unit.

LSI, CAD expert to head Fairchild's instrumentation unit

A systems expert in large-scale integration and computer-aided design has been named to head the Instrumentation division of Fairchild. He is Robert J. Schreiner, who was manager of the custom arrays department at Fairchild's nearby Semiconductor division, and who reportedly had been one of the severest critics of the Instrumentation division's progress on LSI test equipment. Semiconductor test equipment accounts for about two-thirds of the division's sales of \$16 million to \$18 million.

Lowell plans to leave Autonetics

Arthur Lowell, the man who pushed Autonetics into the commercial microelectronics world through its MOS technology, will leave the North American Rockwell division within the next six months, probably to form his own company. Lowell, director of Microelectronic Applications and Advanced Products, has recently been beating the drums for Autonetics' MOS and silicon-on-sapphire (SOS) capabilities in large-scale integrated arrays.

Lowell believes the job he came to Autonetics almost four years ago to do—putting the firm in the microelectronics business—is nearly completed. A 40,000-square-foot production facility for MOS and SOS arrays is about to go on stream and “should be humming by the middle of next month,” Lowell says. He would like to start a company to translate advanced developments in the military communications and computer fields into commercial products.

RCA may scrap home facsimile plan

RCA is reportedly ready to scrap its experimental home facsimile news system, Homefax, partly because it expects stiff competition from pay tv operators when cable tv and over-the-air subscription tv operators start originating programs in June. Homefax would have broadcast information over the air to a printer in the subscriber's home or office. It would have used a “hitchhiking” technique, blending the facsimile and regular tv signals without affecting the tv reception.

Addenda

Monsanto, a major supplier of gallium arsenide, will soon jump into the Gunn oscillator business. In addition to its materials research, it has been heavily involved in microwave device development, some of it under Government sponsorship, and is now ready to offer a commercial line. . . . The Army is sponsoring a symposium on amorphous semiconductor technology [*Electronics*, Nov. 25, 1968, p. 49] from May 14 to 16 at New York's Holiday Inn.

Tough guys

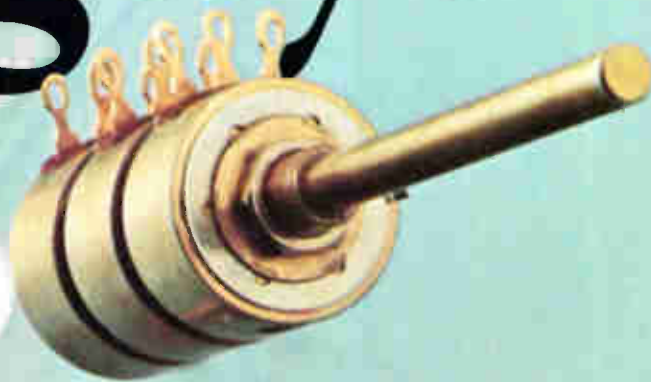

These variable resistors and trimmers from PEC are the tough guys. Tough electrically. Tough mechanically. Actually exceed mil specs. Designed to take it. Tested to prove it.

Insensitive to thermal shock and vibration. PEC potentiometers are hot-molded by an exclusive process incorporating resistive element, insulator, and collector in a rugged integral unit.

Heavy terminals, insulated supporting base and a bridging contact brush of honed carbon resist mechanical damage, thus assuring circuit integrity.

PEC's new metal ceramic trimmers are made from a specially developed material guaranteeing excellent temperature coefficient characteristics and resetability. These multi-turn trimmers offer infinite resolution and are tough enough to stand extended cycling without degradation.

If you're meeting tough specs with products destined for a tough life... call on PEC for tough guys to help.



From the passive innovators at PEC Ltd.

AN AFFILIATE OF **ARCO** Speer Electronic Components



PRECISION ELECTRONIC COMPONENTS LTD., manufacturers of variable resistors and trimmer potentiometers.
Bradford, Pa. 16701 (814) 362-5536; 19 Hafis Road, Toronto, Ontario (416) 241-4491

ELIMINATE DOWN-TIME ON ROTARY & THUMBWHEEL SWITCHES

and also get accurate, precise control

UNLIMITED APPLICATIONS

CDI switches offer fast sure settings and quick read-out for computer, automated and control equipment, and for test and programming applications, etc.

QUICK SERVICEABILITY

Unique 5-second wafer replacement obsoletes other switches. Simply lift out old wafer, slip in new wafer. No unsoldering . . . no disassembling . . . no wire removing.

EXTREME VERSATILITY

Regardless of size or shape needed CDI is well prepared to meet your every switch requirement.

THUMBWHEEL SWITCHES



Digital and Binary. Meet MIL-S-22710. For critical reliability applications. Available with internal lighting MIL-L-25467A. Switch modules with panel and switching elements separately sealed for complete protection are available. Bezel types have no visible screws when rear mounted.

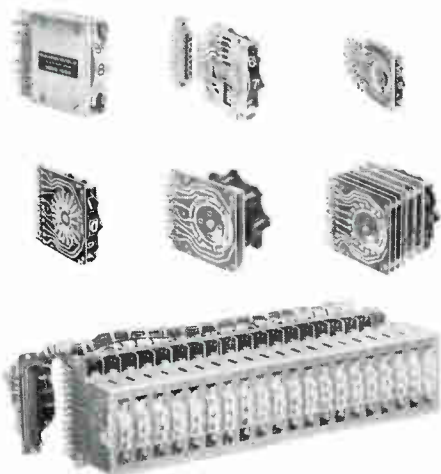

PUSHBUTTON SWITCHES



Completely impervious to dust and liquids with sealed front panels on Series PSB binary and decimal rotary push button switches. Ten Positions. Ideal for limited space requiring only 1" panel space per module. Simply press button to operate.

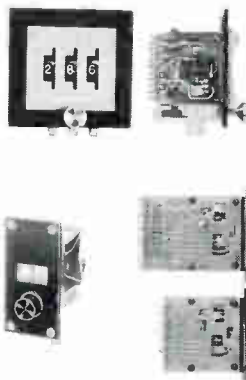

ROTARY SWITCHES

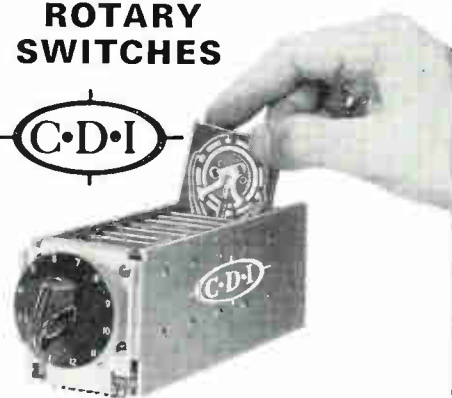

For critical reliability applications. Meet MIL-S-22710. Removable wafers permit quick changing of programs, configurations, circuits. CDI patented switches with dust covers available in sizes 2" x 2", 3" x 3" and 4" x 4" with lengths to accommodate up to 36 wafers. Operation may be manual, motor or solenoid.



Mfd. under Tabet U. S. Patents 2,841,660, 2,971,066, 3,015,000, 2,956,131, 2,988,607



CHICAGO DYNAMIC INDUSTRIES, INC.

PRECISION PRODUCTS DIVISION 1725 Diversey Blvd., Chicago, Illinois 60614. Phone 312, 935-4600

Helipot building blocks stack up to more convenience and economy.

Helipot's wide and expanding selection of *standard hybrid cermet microcircuits*—locally stocked throughout the country—give you reliable, inexpensive, off-the-shelf solutions to your complex design problems. In addition, Helipot building blocks help eliminate expensive design time and reduce purchasing, stocking, and production to their minimums. Whatever your need, you'll be interested in the new 48-page *Helipot Microcircuits Catalog*. For your copy, simply send a request on your company letterhead.

Beckman®

INSTRUMENTS, INC.
HELIPOT DIVISION

2500 HARBOR BOULEVARD
FULLERTON, CALIFORNIA • 92634

INTERNATIONAL SUBSIDIARIES: AMSTERDAM, CAPE TOWN, GENEVA, GLENROTHES, SCOTLAND,
LONDON, MEXICO CITY, MUNICH, PARIS, STOCKHOLM, TOKYO, VIENNA

Circle 37 on reader service card

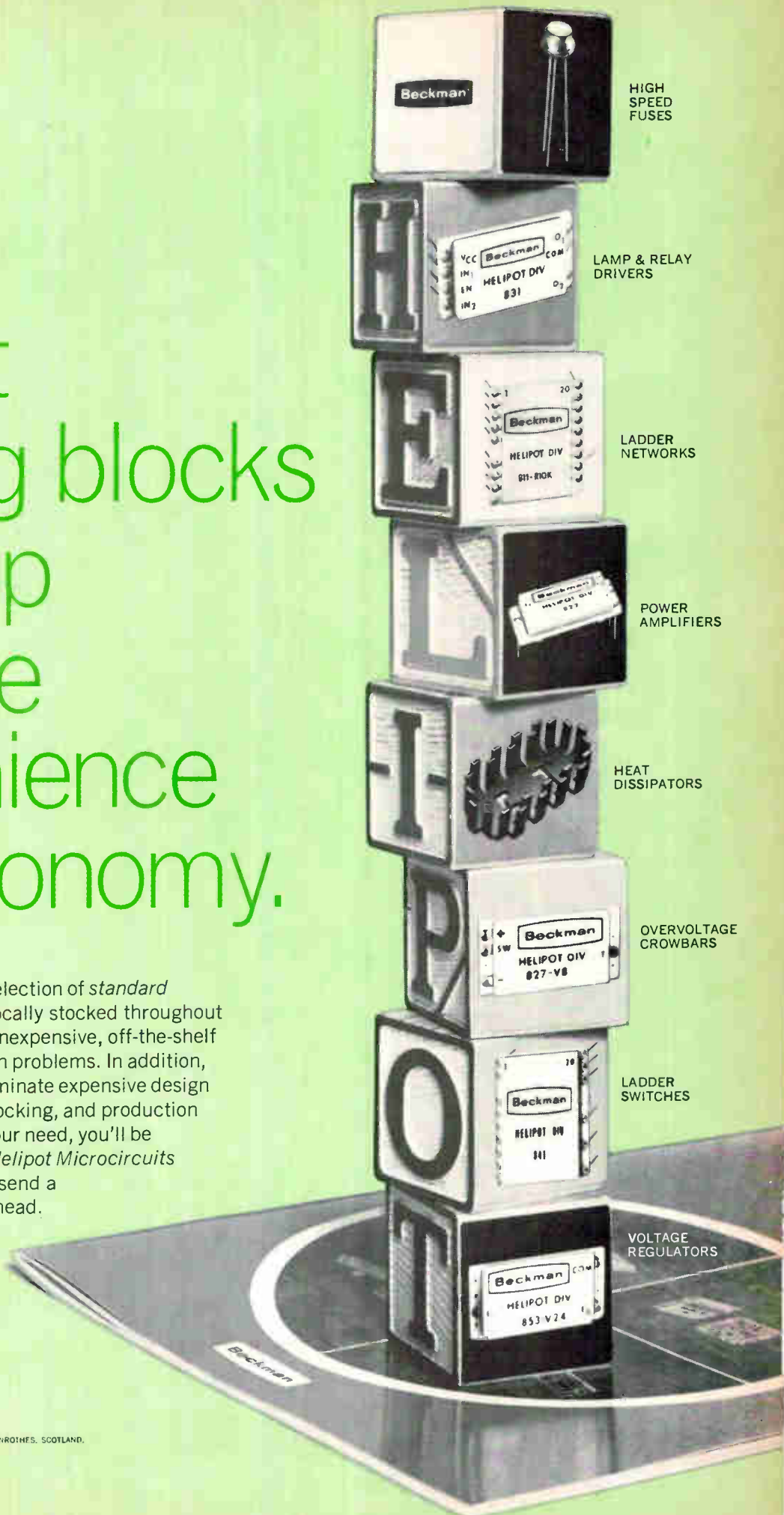

NEW TECHNIQUE IMPROVES LOW-LEVEL SIGNAL MEASUREMENTS

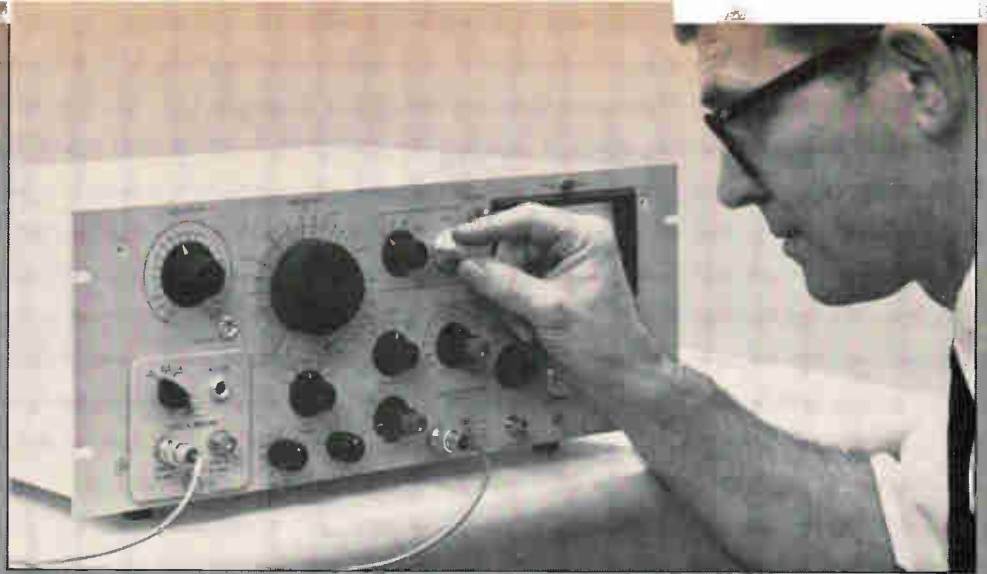

Where extremely low-level signals must be measured in the presence of obscuring noise, the use of a PAR™ Lock-In Amplifier can often transform a complex and sometimes futile investigation into a routine test procedure. For example, Lock-In Amplifiers can be used to:

MEASURE AMPLIFIER CROSSTALK TO ONE NANOVOLT

Where amplifiers are in close proximity in low level data processing systems, the minimum detectable signal is frequently limited by the crosstalk or mutual interference generated. By using a Lock-In Amplifier to measure crosstalk: (1) The source of feed-through can often be identified since very low-level crosstalk can be measured over a wide frequency range. (2) Further extraneous signal coupling errors are eliminated because no instrumentation other than the Lock-In Amplifier is necessary. (3) Crosstalk levels as small as one nanovolt can be detected. (4) The phase of the crosstalk can be identified.

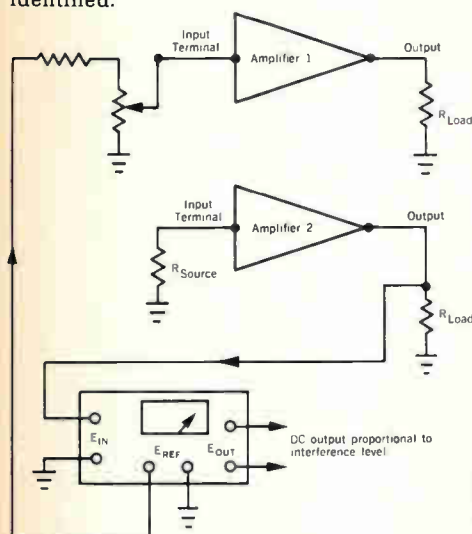

LOCK-IN AMPLIFIER
USED FOR AMPLIFIER CROSSTALK MEASUREMENT

IMPROVE BRIDGE SENSITIVITY TO ONE NANOVOLT (FS)

A Lock-In Amplifier improves bridge sensitivity without over-driving the bridge circuit. Excite the bridge with the Lock-In Amplifier's internal oscillator and connect the external null detector termination to the signal input to get: (1) Measurements over frequencies of 1.5 Hz to 150 kHz. (2) Optimum noise figures using available preamplifiers with input impedances of several ohms to 100 megohms. (3) One nanovolt full-scale sensitivity for improved null accuracy and extremely low power dissipation in critical circuits. (4) A dc signal proportional to the off-null condition for use in modifying bridge parameters or as a recorder input. (5) Detection of in-phase (resistive) and quadrature (reactive) bridge components which can be nulled independently (and simultaneously, if desired).

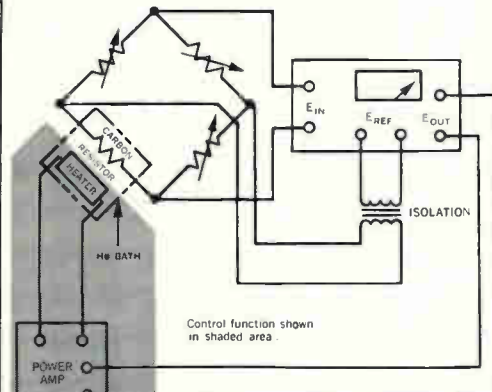

LOCK-IN AMPLIFIER
USED AS BRIDGE OSCILLATOR/NUL DETECTOR

MONITOR OP AMP SUMMING JUNCTION VOLTAGES TO 10 NANOVOLTS

The open-loop gain of op amps can be measured by monitoring the summing point voltage while operating the amplifier in its normal closed-loop configuration. The advantages of using a Lock-in Amplifier to make these measurements are: (1) Its self-contained oscillator serves as a signal source for the op amp over a wide frequency range. (2) Distortion and offset at the summing junction are minimized by the Lock-In Amplifier's high input impedance and low noise. (3) Summing junction voltages as low as 10 nanovolts can be measured and recorded to permit measurement of extremely high open-loop gains. (4) Phase shift can be measured.

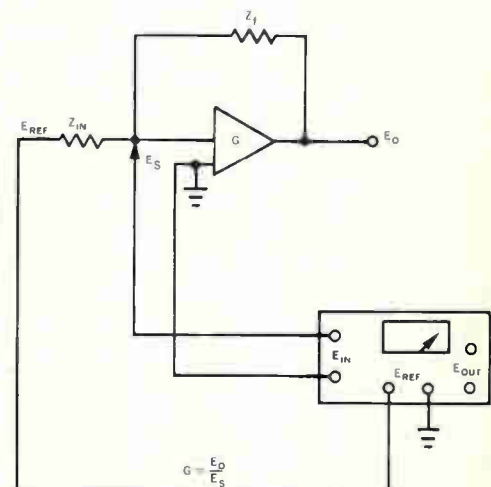

OP AMP OPEN-LOOP GAIN MEASUREMENTS
WITH LOCK-IN AMPLIFIER.

If you have a problem unearthing low-level signals buried in noise, why not call on a PAR applications specialist. He may be able to show you a better way to dig. Call him at (609) 924-6835, or write Princeton Applied Research Corporation, P.O. Box 565, Princeton, New Jersey 08540.

PAR

PRINCETON APPLIED RESEARCH CORPORATION

Silicon avalanche diodes amplify at subharmonics of X-band frequency

Cornell research group predicts 70% efficiency from devices operated in avalanche resonance pumped mode; high output power is expected

No matter what performance you want from an amplifier, the one thing you try to avoid is oscillation. But at Cornell University, a team of researchers say that they have come up with a device whose amplification modes depend on it oscillating.

Using silicon avalanche diodes that oscillate at what the Cornell group calls the avalanche resonance pumped frequency—usually in X band—they have measured pulse amplification at subharmonics of the X-band frequency. This mode is the same as the anomalous mode reported by RCA [*Electronics*, Jan. 20, p. 184] except that it uses the subharmonic modes for oscillators, whereas Cornell is concerned with amplifiers.

Intrigued with the idea that high-power, high-efficiency amplification for phased-array radar could be obtained with this mode of operation, Rome Air Development Center supported Cornell's work. The Air Force could now envision phased-array radars with 100 kilowatts of average power using only 1,000 elements, with little wasted power.

Cornell Professor Bernd Höfflinger claims that using a diode pumped at 10.4 gigahertz they have achieved a small signal gain of 19 db and a high power gain of 12 db for 6.5 watts output at an efficiency of 25% at 1.3 Ghz; at 3.2 Ghz the efficiency dropped to 15% for about 4 watts out. And he claims this is just the beginning.

Bright future. The Cornell researchers ran a computer program to predict what could be expected of this high-efficiency avalanche

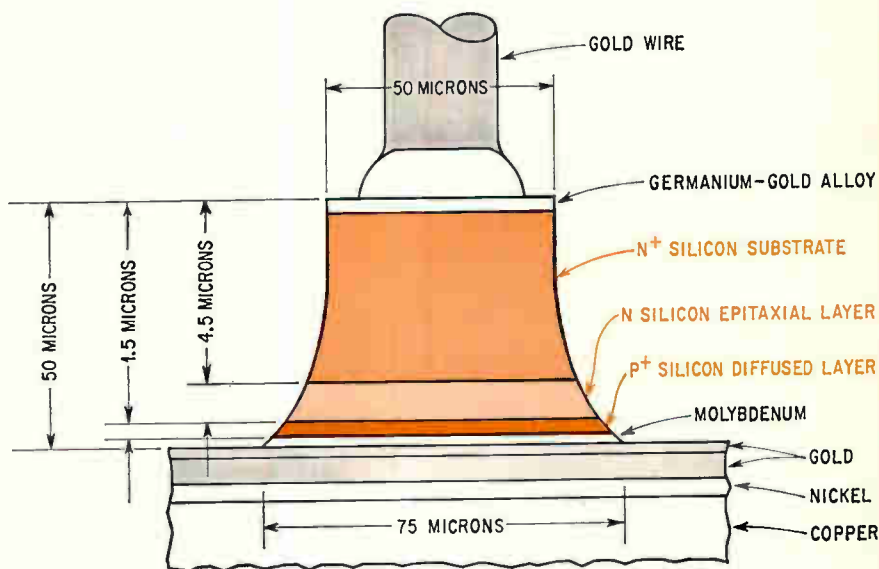

Promising contender. When used in a subharmonic mode, this silicon avalanche diode can amplify microwave input signals with efficiencies up to 70%.

resonance pumped amplification mode. The results showed that a silicon avalanche diode when operated at an avalanche resonance pumped frequency of 10 Ghz would amplify signals at 5 Ghz—the first subharmonic—with an efficiency of 70%. And, regardless of the subharmonic used, a power-times-impedance product of 600 watt-ohms could be realized with an efficiency of 50%.

According to Höfflinger, a continuous-wave output power of 100 watts could be achieved using a diamond heat sink, and 10 watts with a copper heat sink for an efficiency of 50% at subharmonics of 10 Ghz. He also claims that the gain-bandwidth products should be on the order of the amplifier's center frequency, and feels 5 watts of c-w output power at 5 Ghz is

possible by the end of this year. Even the most ambitious predictions for transistor power amplifiers don't come close to that.

Test circuit. The measurements were made on diodes placed at the end of a tunable coaxial cavity. The transit time frequency was monitored by a sliding probe, a high-pass filter, and a wavemeter. The output of a c-w signal generator was coupled to the microwave cavity through one arm of a three-port circulator; the amplified output was obtained through the other circulator port and measured with a wavemeter and sampling oscilloscope. The diode is biased on 60 times every second for 400 nanoseconds. When the diode in a properly tuned cavity is in active breakdown, it oscillates at the transit-time frequency, which depends on

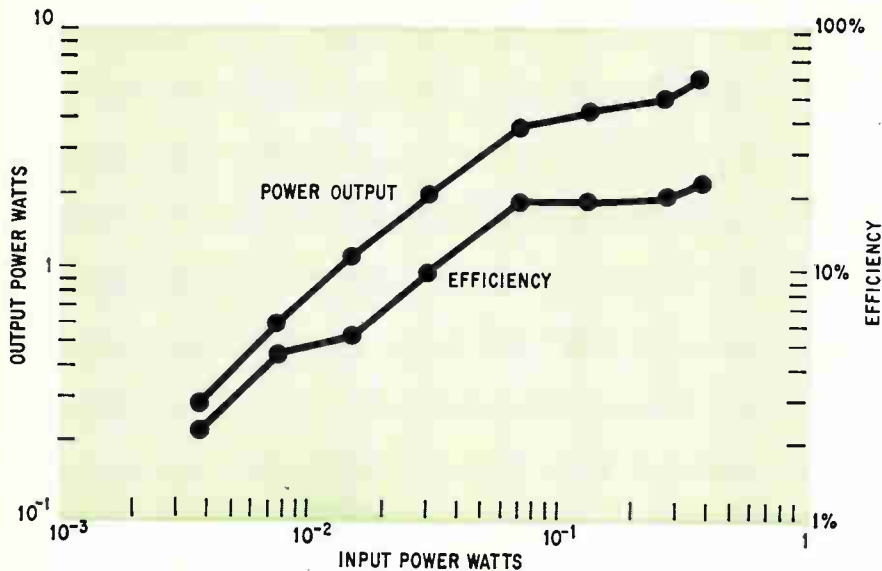

Projected view. Researchers at Cornell predict that the continuous-wave output power of silicon avalanche diodes, operated in a subharmonic mode, should exceed 100 watts at an efficiency of 50%. The output power for these silicon diodes as a function of frequency is shown in color, and the power-impedance product of germanium and silicon is plotted for the first subharmonic mode.

Showing gains. A silicon avalanche diode can amplify a 1.3-gigahertz signal with an efficiency of 25% when pumped at 10.4 Ghz. The output power and efficiency increase for larger input signal power.

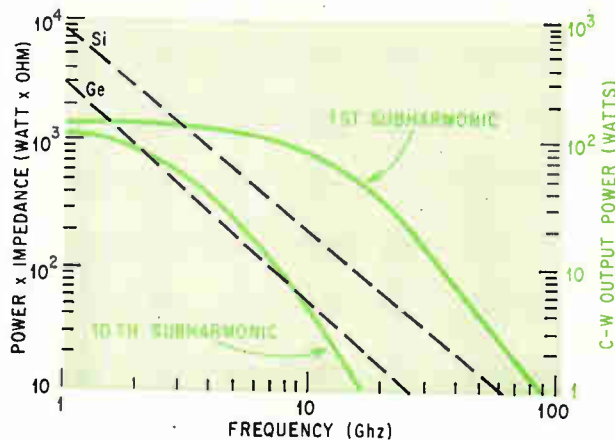

the diode fabrication. It is then that a reflection gain is noted at subharmonics of the frequency. The amplifier gain depends on the difference in impedance between the circuit and the diode.

Sandwich making. In making their diodes, the Cornell group obtained an n^+ antimony-doped silicon substrate upon which an n phosphorus-doped silicon epitaxial layer was grown. A boron doped p^+ layer is then diffused into the n epitaxial layer. This three-layer mesa structure formed the n^+np^+ diode. Molybdenum is sputtered on the p^+ material and a thin layer of gold is added to it. This gold layer is then thermally

compression-bonded to the gold layer on the nickel flashed copper stud.

Höfflinger says that Cornell has its own diffusion capability and will soon fabricate the complete diode structure starting from a commercial epitaxial layer of silicon.

Most of the remaining problems, says Höfflinger, center on such things as tolerances of the diffusion epitaxial thickness, and the depth and abruptness of the junction. Also, he adds, to minimize the diffusion of the n^+ impurities of the substrate material back into the n epitaxial layer, the p^+ diffusion step must be kept short.

Advanced technology

Color from the II-VI's

Many engineers working on flat-screen color displays figure that the first practical models will be made of light-emitting diode arrays. But the diodes now available, mostly III-V compounds, emit the wrong wavelengths: a few emit a deep red, but most operate in the nonvisible. Although the flat-screen color display may still be years away, work by two former Ion Physics Corp. researchers may bring it closer. Edward F. Pollard and Jerome L. Hartke, now of the KEV Electronics Corp. of Reading, Mass., have found a way to create p - n junctions in the II-VI compounds.

Diodes made of II-VI compounds could cover the visible spectrum with their emissions. Cadmium sulfide would emit yellow and green; zinc teluride would generate green and blue, and zinc selenide blue and purple. Together with a red-emitting III-V compound, an array of such diodes could produce most any color. However, until Pollard and Hartke's work the II-VI's resisted all attempts at p - n junction formation, whether by diffusion, melt, epitaxy, or ion implantation. The two scientists don't claim to have made light emitters. But they have made the II-VI's act electrically like diodes—showing high resistance in one direction and low resistance in the other, or showing low leakage (only about one microampere at 10 to 15 volts reverse bias).

Why they succeeded where others failed isn't clear, even to Pollard and Hartke, but they speculate that perhaps it was extra care. Before implantation, each sample was heat treated to establish its resistivity. In one case, samples were immersed in molten zinc at 1,000°C for 24 hours. "With known resistivities," says Pollard, "later measurements were more trustworthy."

"Afterward, we coated each sample with quartz, then bombarded it through this 'overcoat.' We used arsenic and phosphorus ions to create p -type areas in CdS and

ZnSe—both normally n-type materials. Fluorine-ion bombardment gave us n-type conversion of p-type ZnTe,” he says. (For more on KEV and its ion-implantation work, see page 14.)

Reverse twist. Normally after bombardment, the samples again would have been heat treated. But Pollard and Hartke bombarded the sample at high temperatures of several hundred degrees C in the first place and “not only sped up the implantation process,” says Pollard, “but also made later heating unnecessary. This later heat treatment may have destroyed junctions created by earlier researchers.”

After implantation the quartz layer was removed, having protected the surface against sublimation during bombardment and having sealed it against contamination. Formerly, surface contamination had made measurements of hoped-for diode characteristics ambiguous.

Work on the compounds has been temporarily stalled. The experiments were performed at Ion Physics, a subsidiary of the High Voltage Engineering Corp., Burlington, Mass. And because Pollard and Hartke have left Ion Physics, the work probably won't be continued there. The researchers now are trying to use ion implantation to make tuner varactors for radio and television sets. As a result, advanced research will have to wait while Pollard and Hartke work on the other end of the television receiver.

Computers

Simulating MOS

When a circuit designer tries to simulate an integrated circuit on a computer as part of a computer-aided design project, he often finds it pretty tough going. His task requires him to merge the talents of several widely divergent disciplines. Programing, of course, is the main requirement of a simulation, but the programmer requires the knowledge of both a

circuit engineer and a semiconductor engineer.

This is particularly true with metal oxide semiconductor circuits. The circuit designer's familiarity with resistance, capacitance, and inductance isn't enough; he must concern himself with such semiconductor topics as carrier mobility, diffusion depths, and doping concentration.

New program. RCA's advanced circuit technology department, however, has an unusual person, Albert Feller, whose background spans all these areas. And he developed a computer program, now in daily use at RCA, that simulates MOS circuits. Feller says it's the only one that does, even though many diverse circuit simulation programs have been devised. The

program works with both p-channel circuits and complementary circuits, or those containing p- and n-channel devices.

To use the program, the designer loads the computer with circuit parameters, such as threshold levels, input and output signal data, and component values. The device's operation is described in a set of nonlinear differential equations, which the computer solves in the conventional way by converting them to a larger set of linear differential equations—each valid over a small part of the total range of the variables involved. These linear equations are processed with standard routines for numerical integration, matrix inversion, and the like. Feller borrowed these routines from existing programs

Electronics Index of Activity

February 3, 1969

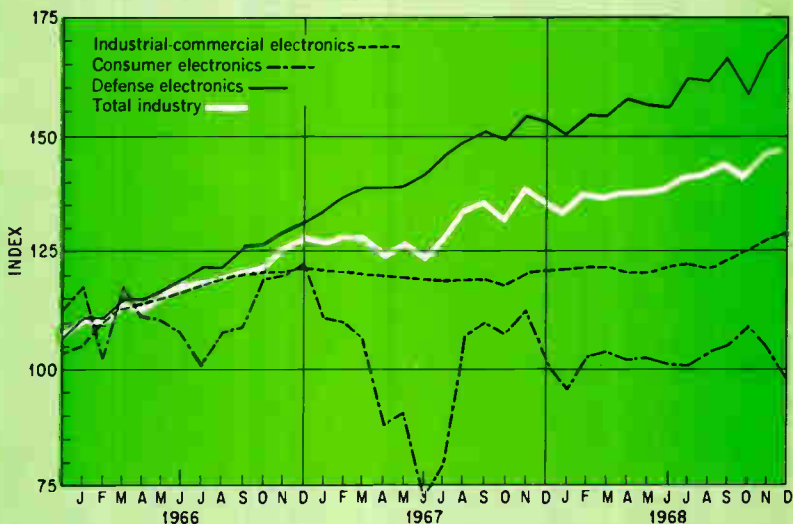

Segment of Industry	Dec. 1968	Nov. 1968*	Dec. 1967
Consumer electronics	98.4	105.7	102.9
Defense electronics	171.1	167.1	152.9
Industrial-commercial electronics	128.9	127.4	121.2
TOTAL INDUSTRY	146.3	145.0	135.1

Electronics production in December rose only 1.3 index points from the November level, but a whopping 11.2 points from a year earlier. The largest gains were registered in the defense area—4 points in the month and 18.2 in the year. Output in the industrial-commercial sector climbed 1.5 points from November and 7.7 points from December 1967. The consumer sector showed the only decline. Production in this area slipped 7.3 points from the month before and 4.5 from a year before.

Indexes chart pace of production volume for total industry and each segment. The base period, equal to 100, is the average of 1965 monthly output for each of the three parts of the industry. Index numbers are expressed as a percentage of the base period. Data is seasonally adjusted.
* Revised

written for other purposes.

The output describes the performance of the proposed MOS circuit—be it a simple logic block, a flip-flop, or even a relatively complex adder. Feller has even made the simulation work with a 24-bit dynamic shift register, although it took a long time to run because of the circuit's complexity.

Shortcuts. Nothing in the program limits the complexity of circuits it can analyze. Limits are established only by the size of the computer's memory and by the amount of time and money the designer has to spend on computer simulation. With enough memory and time the program could simulate an entire MOS computer.

Shortcuts have been taken to minimize running time. For example, leaving out decoupling circuits reduces the time drastically, but has very little effect on the circuit's operation.

Feller, who's been with RCA since 1951, will describe the program at the International Solid State Circuits Conference in Philadelphia later this month.

Medical electronics

Prescribing Xerox

The marriage of xerography and radiography isn't new; it's been used to detect flaws in metal, for example. Now the Xerox Corp. is applying xeroradiography to detect breast cancer in women. And although company executives are still cautious about the results, Dr. John Wolfe, head of radiology at Detroit's Hutzel Hospital—where the technique is being evaluated—insists that there is no reason "why xeroradiography can't soon replace conventional [photographic] mammography in the diagnosis of breast disease." Wolfe points out that xerographic mammograms are easier to read because diseased areas stand out more distinctly than they do on standard photographic X-ray plates.

The jury-rigged system being used at Hutzel Hospital consists of a standard X-ray machine and a 15-year-old Xerox recorder. Images are made as they are in any xeroradiographic recorder: a selenium-

coated plate receives a positive electrostatic charge and then is placed under the breast being X-rayed. Radiation passes through the breast and hits the plate, neutralizing some of the charge; the charge pattern on the plate is the X-ray image. A negatively charged powder is then sprayed on the plate, and by pressure or electrostatic-transfer techniques the now-visible image is transferred to a sheet of paper or plastic.

Better view. Besides providing better contrast, Wolfe points out, "xeroradiography detects small structures like tumor calcifications and magnifies them more than conventional film. I don't know why this happens, but it may have something to do with the particle size of the developing powder or with the fact that the electric field representing the structure may be larger than the object. Whatever the reason though, some structures not visible on X-ray film because of the size or their location in the breast can be seen on the Xerox mammograms."

Wolfe notes that although statis-

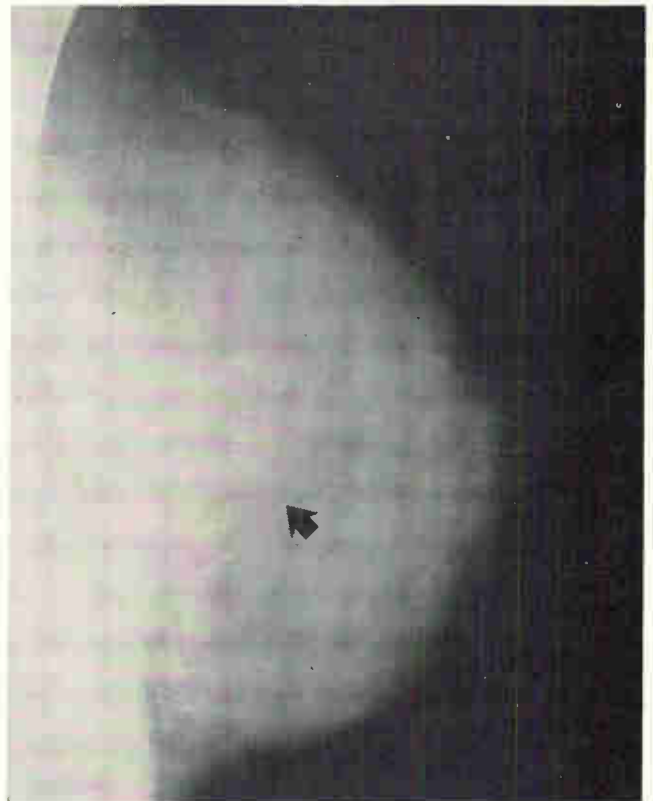
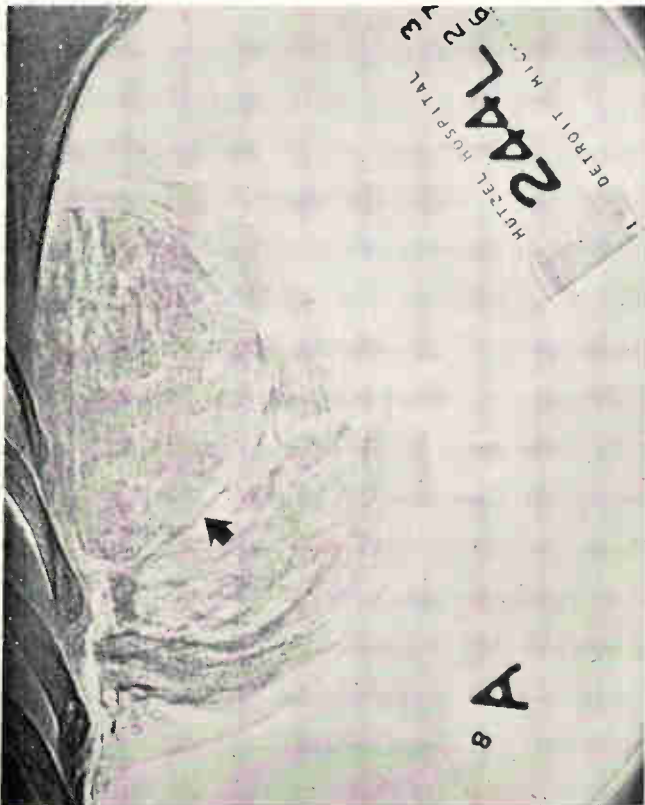

Distinct image. Xerographic mammogram, left, clearly shows presence of a breast tumor, identified by the arrow; whereas a conventional X-ray of the same breast, at right, is not as distinct.



ALPAC®

only
the high current
bridge rectifier
that stacks up —

**Performance
Packaging
Reliability
Price**

This power bridge rectifier is designed to out perform anything on the market. Years of reliable performance, in on-the-line operation, has proven the ALPAC concept. ALPAC is a Semtech design.

ALPAC utilizes a functional aluminum case to guarantee maximum thermal conductivity and light weight — replacing out-moded stud rectifiers and all the miscellaneous hardware associated with it.

ALPAC is easy to use. The devices are fitted with three way, universal terminals (insulated from the case) to minimize production costs.

Internally, ALPAC utilizes the Semtech high performance rectifiers — welded together for mechanical strength.

Average Output Current . . . 25 amps
Peak Inverse Voltage . . . 50 to 600 Volts
Thermal Resistance (Max.) . . . 1.5°C/watt

If you want quality "designed in" you'll buy ALPAC . . . another good idea from Semtech.

For immediate delivery see your representative:

San Francisco—941 E. Charleston, Suite 10, Palo Alto, California 94303 / (415) 328-8025

Chicago—140 N. La Grange Road, La Grange, Illinois 60525 / (312) 352-3227 / TWX: 910-683-1896

Dallas—402 Irving Bank Tower, Irving, Texas 75060 (214) 253-7644

New York—116-55 Queens Blvd., Forest Hills, New York 11375/(212) 263-3115/TWX: 710-582-2959

European Sales—Bourns A. G. Alpenstrasse 1, Zug, Switzerland / (042) 4 82 72/73

SEMTECH
CORPORATION

652 Mitchell Road, Newbury Park, California 91320
(805) 498-2111, (213) 628-5392 / TWX: 910-336-1264

© ALPAC is a registered trade-mark of the Semtech Corporation.

U.S. Reports

tically there has been only a slight improvement in the diagnosis of breast cancer—about 3%—along with a 6% increase in the detection of benign diseases, the technique's greatest value may be that those not trained in the reading of X-ray photographs can easily spot breast diseases.

Xerox, although not yet officially committed to building a commercial version of the system, has already completed preliminary designs for one.

Companies

To trim the giant

Pick an IBM area of activity—any of the below—and detach it from the rest; it's the game of antitrust. And it's the same game the Justice Department challenged IBM to play last month when it charged in Federal Court that the corporation was too big and should be trimmed down to a size where small companies might have a chance to get a bigger piece of the lucrative data processing industry action.

The suit surprised few in either industry or Government, and per-

haps least of all IBM. And in retrospect, industry sources say IBM really knew what it was doing when it hired Nicholas deB. Katzenbach to be its general counsel, who before he was Under Secretary of State was Attorney General in the Johnson Administration.

What was surprising, perhaps, was that the Government, in its brief, did not spell out its ideas on how the corporate structure should be modified to promote more competition in the industry. The petition simply seeks to have IBM divest properties and reorganize its operations in whatever way the court considers necessary. However, a top-level Justice official says that the specifics will evolve as the case proceeds.

If the suit fits. The Government's suit is the third of its kind to be filed within the last two months against the giant computer company. Both Control Data Corp. and Data Processing Financial & General Corp. have gone to the courts with private antitrust suits, asking for triple damages because of the company's alleged monopolistic practices. The Government's suit will probably aid these litigants by compiling data that will be usable in their cases. Harvey Goodman, president of Data Processing indi-

cated that while his firm would be "watching with interest" the Government's activities, the firm would be in no way bound by any kind of out of court settlement between IBM and Justice. In fact, Goodman says that Data Processing's areas of interest and the Government's are not identical and that he will proceed regardless of what the Government does.

Last minute. The timing of the Government's antitrust suit was believed to be politically motivated, coming as it did on the last full day of business before the Republicans took over. But a Justice Department spokesman noted that outgoing Administrations often file a suit in their waning hours. What effect the suit will have on the Nixon Administration is as yet unknown.

Richard W. McLaren, the new chief of the antitrust division, says that the Republicans have always had a good antitrust record and that he expects them to have even a better one at the close of his tenure. However, industry spokesmen are of the opinion that the Nixon Administration will certainly be friendlier to industry than the Democrats were and that this could have an effect on the case.

The suit itself was filed under

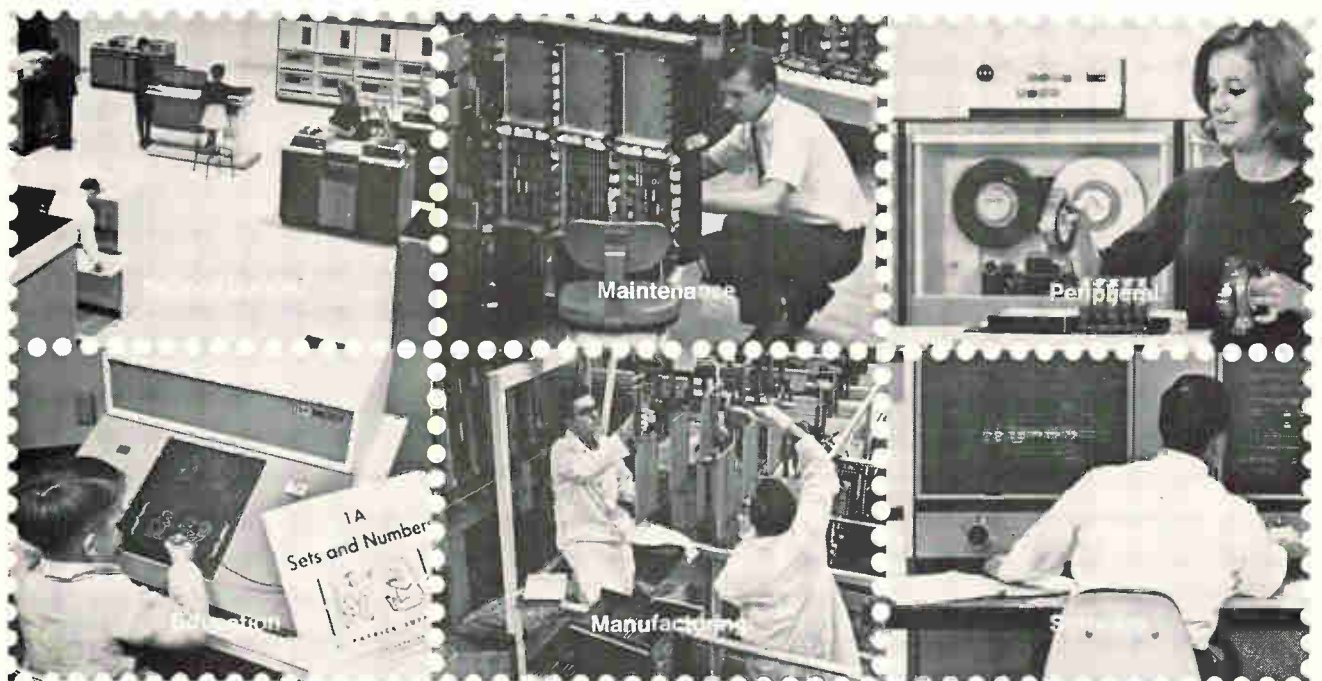

Cut out. Threatened by Justice Department suit, IBM may have to divest itself of one or more of these operations.

winning form

from the
form-factor
specialists
at Damon

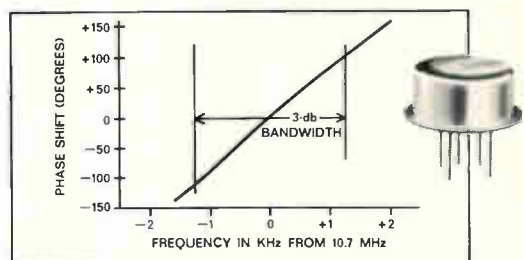

Take all the virtues of conventional Gaussian or Bessel filters . . . add monolithic construction . . . and you have the new **Damon line of Monolithic Gaussian Crystal Filters**. They're smaller, more reliable, and less costly than previous designs. And they're the ideal filters for minimum delay distortion in FM, non-overshooting pulse response in radar systems, and reduced ringing in swept-frequency applications.

The Damon Model 6354MA, for example, is a four-pole design housed in a cold-welded TO-8 enclosure. Specifications: Center frequency (f_c): 10.7 MHz. 3-dB bandwidth: 2.5 KHz. 40-dB bandwidth: 17.5 KHz max. Source impedance: 500 ohms resistive. Load resistance: 2 kilohms resistive. Insertion loss: 9-dB max. Impulse response: Gaussian shape, ringing >35-dB down. Package: TO-8 (.580" dia. x .260" high).

Whatever your signal shaping needs . . . from a Gaussian curve to a sharp rejection notch . . . rely on the form-factor specialists at Damon. Write: Electronics Div., Damon Engineering, Inc., 115 Fourth Ave., Needham, Mass. 02194, or call (617) 449-0800.

DAMON

High Voltage Rectifiers

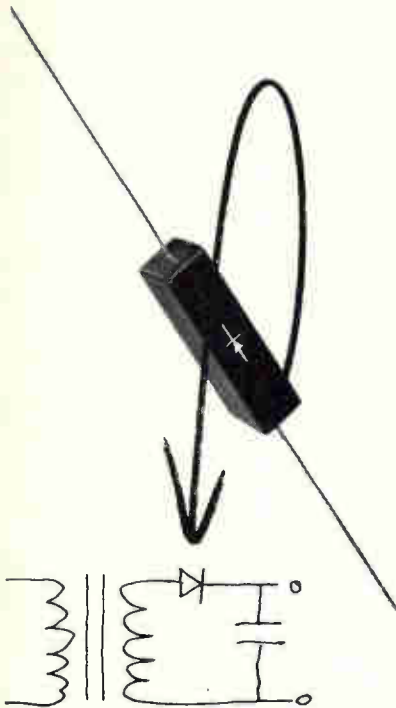

New! From Varo.

Silicon Rectifiers At Selenium Prices!

At last, economical high voltage silicon rectifiers. Ideal for use in all high voltage, low current applications.

- 5,000-40,000 Volts
- 5, 10, 25 milliamp ratings
- Standard and Fast Recovery
- In 1/4" square package.

These are the high voltage rectifiers that make completely solid state television circuits possible. Equally well suited for use in other cathode ray tube applications, electrostatic power supplies and voltage multipliers.

Only \$1.32

10,000V, 5mA rating. Quantity of 1,000. Complete details, applications, and price list available.



VARO

SEMICONDUCTOR DIVISION
2203 WALNUT STREET, GARLAND, TEXAS 75040
(214) 272-3561

U.S. Reports

section 2 of the Sherman Act—the antimonopoly statute. In it the Justice Department is not charging that IBM got in its monopolistic position through unlawful means, but rather that the company has maintained that position by using business techniques that are unlawful because of the position it has achieved.

Specifically the complaint alleges that beginning about eight years ago IBM attempted, successfully, to monopolize the digital computer business and that IBM's marketing policy has prevented the development or growth of competition in the following ways:

- Pricing hardware, software, and related support services in a lump sum—something competitors are unable to do.
- Marketing "loss leader" computers at less than the expected rate of return whenever competition threatened.
- Unlawfully dominating the educational computer market—important for growth because of its impact on ultimate purchasing decisions.

If the courts go along with the Justice Department, IBM will be forced to stop lump-sum pricing of its computer and computer services; to stop offering special allowances, buy-backs of computer time, or research grants in the sale or lease of any of its general purpose digital machines, and to stop announcing the development of new computer software or hardware until all the equipment has proceeded through the usual testing processes.

Although it will be months and perhaps years before the effects of the suits will be measurable, antitrust experts are making the following predictions.

- IBM will be forced to relinquish some of its properties and stop some of its business practices.
- Its time-sharing and software operations are the most vulnerable to court enforced divestment.
- The suit will never go to trial, but will be ended in a consent decree—an agreement between the Government and the company specifying certain changes needed to comply with the law.

▪ IBM will nevertheless continue to grow and dominate the computer business.

▪ The private antitrust suits now pending will be settled out of court and for a nominal amount.

Industry reaction, both here and abroad, has been mixed. In England, for example, where IBM's share of the computer market is about 30%, the industry opinion is that whatever the outcome of the suit, the consequences on the British computer market will be negligible. In France, where IBM holds about 65% of the market, the reaction is that, if anything, breaking up IBM would work to the detriment of the present market. In fact the fear among French industry officials is that a lot of little IBM's might be more aggressive and more supple in their management once the fear of antitrust action has been removed. The only companies that would benefit, were IBM knocked down to size, would be other U.S. firms, like Honeywell, that are trying to make inroads in the French market.

In the U.S., where estimates of IBM's share of the market run as high as 80%, skeptics doubt that the courts or the Government will make any real changes in the company's market position. Says one source, "I don't think anything will happen; IBM will get slapped on the wrist, and perhaps sign a consent decree." But Max Palevsky, president of Scientific Data Systems, says, "It looks like the Government is asking IBM to stop doing things the industry has been asking them to stop for some time now—not to pre-sell computers, and not to grant very large discounts to special customers—and it's about time!"

Avionics

Go it alone

For search and rescue operations far offshore a Coast Guard helicopter pilot needs a navigator to tell him where he is, but to put a navigator aboard to monitor navigation equipment would consume

Ask Amperex for the most reliable* 74N TTL's in the business.



SERIES 74N	DESCRIPTION	AMPEREX ULTRA RELIABLE IDENTICAL TYPE
GATES		
SN 7400N	Quadruple 2-input Nand Gate	FJH131
SN 7401N	Quad. 2-input Nand Gate (no collector load)	FJH231
SN 7402N	Quadruple 2-input Nor Gate	FJH221
SN 7410N	Triple 3-input Nand Gate	FJH121
SN 7420N	Dual 4-input Nand Gate	FJH111
SN 7430N	Single 8-input Nand Gate	FJH101
SN 7440N	Dual 4-input Nand Buffer	FJH141
SN 7450N	Dual And-Or-Not Gate Expandable	FJH151
SN 7451N	Dual And-Or-Not Gate	FJH161
SN 7453N	Single And-Or-Not Gate Expandable	FJH171
SN 7454N	Single And-Or-Not Gate	FJH181
SN 7460N	Dual 4-input Expander	FJY101
FLIP-FLOPS		
SN 7470N	Single J-K Flip-Flop	FJJ101
SN 7472N	Single J-K M/S Flip-Flop	FJJ111
SN 7473N	Dual J-K M/S Flip-Flop	FJJ121
SN 7474N	Dual D Latch Flip-Flop	FJJ131
SN 7475N	Dual J-K M/S Flip-Flop with P and C	FJJ191
HIGHER ORDER FUNCTIONS		
SN 7441N	BCD-Decimal Decoder/Driver	FJL101
SN 7475N	Quadruple Bistable Latch	FJJ181
SN 7490N	Decade Counter	FJJ141
SN 7492N	Divide-by-Twelve Counter	FJJ251
SN 7493N	4-Bit Binary Counter	FJJ211

*We've eliminated a major cause of failure in these devices, previously caused by bonding over steps in the oxide.

For data, write:
Amperex Electronic Corporation
Semiconductor and Microcircuits Division
Slatersville, Rhode Island 02876.

Amperex

TOMORROW'S THINKING IN TODAY'S PRODUCTS

LOW COST AUTOMATION takes many forms

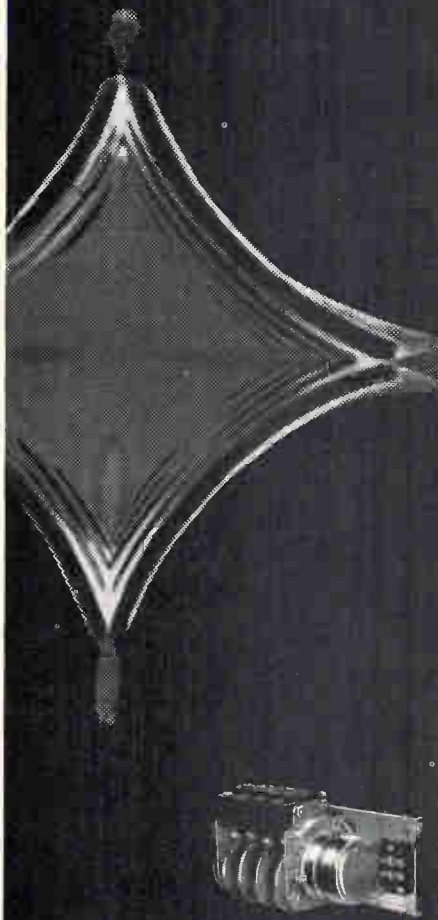

Our MP Repeat Cycle Timers inexpensively control up to 12 SPDT, 10 amp 120 VAC circuits from a common time base. Catalog 15 explains this and 560 other forms of low-cost automation. Send for it.

GW Eagle Signal Division
E.W. Bliss Company
Davenport, Iowa 52803
A GULF • WESTERN COMPANY

Service-In-Depth ...
Local Engineering, Stock, Repair

U.S. Reports

precious weight and space. Consequently, a helicopter has to be escorted by an airplane whose navigator gives the pilot his position fixes, making search and rescue a complicated operation.

Last month, however, the Coast Guard began operating three helicopters equipped with a programmable navigational computer that monitors such inputs as Loran, Tacan, or other data and displays direction information for the pilot. It will take a pilot from takeoff to 300 miles offshore, lead him through an intricate search pattern and return him to base. All the pilot must do is steer the craft [*Electronics*, Sept. 5, 1966, p. 105].

En route data. During the flight, the pilot punches a control console, and a display tells him various information: latitude and longitude, wind characteristics, range and bearing to destination, estimated time and distance en route, and ground speed and track angle. Also he can follow his flight path by watching a lighted "bug" (representing the copter) under a map display, which is essentially an x-y plotter run by the computer.

Heart of the system is a multiple-sensor digital converter that rapidly solves trigonometric equations based on a spherical approximation of the earth's shape. By using input from the craft's avionics system sensors the computer compares the actual position against the mathematical model. Among the inputs the computer can use are Loran A, C, and D, doppler radar, gyroscope magnetic heading, visual omnirange, and Tacan equipment. This means that a helicopter pilot can fly overland, too, without depending on landmarks for his position.

Conversion of the sensors' analog signals to digital information for computer use is handled by a Maddam unit (multiplexed analog to digital, digital to analog multiplexed). This unit processes all input and output signals through one hard-wired converter that is time-shared among the various sensors. Four standard search and rescue patterns are also hard-wired into the computer memory.

The long wait. Work on the com-

puter began in 1962 when the Federal Aviation Administration and the Coast Guard agreed to jointly investigate development of a hyperbolic coordinate converter that would use time differences to automatically compute geographic positions expressed in longitude and latitude. The Coast Guard continued breadboard work and let a production contract to the Instrument division of Lear Siegler for 30 of the AN/AYN-1 units, as it is now christened. The system that evolved weighs 70 pounds, 30 over target.

The Coast Guard, accustomed to buying in on the end of Pentagon equipment contracts, had to wait for the AN/AYN-1. Lear Siegler used it for ITT's AN/ARN-92 Loran C/D navigation system on the Air Force's B-52's and B-58's. The Coast Guard didn't mind the delay, however, since it helped lower the price to an attractive \$40,000 each. Because the versatile computer can also be used on a variety of airplanes, the Coast Guard is considering buying some for its C-130's.

The Coast Guard is thinking about other uses for it, also. Since not all of the computer memory is used, the Service believes that a unified avionics and control computer could be developed for the helicopter. This would lead to single-stick piloting, now a two-handed job.

19 clues

Ever since the in-flight recorder was introduced in the mid-1950's it has been an invaluable tool for determining the cause of aircraft accidents and has, subsequently, played an important role in preventing other accidents. Now the Federal Aviation Administration feels it is time to move on to more sophisticated recorders. The FAA has proposed that in the interests of air safety 14 additional variables be added to the five that are currently recorded in aircraft.

In general, the new recorded data would provide information on an airplane's altitude, response to aerodynamic forces, flight control

Can you spare less than one gram to solve your MIL-STD-704 surge protection problems?

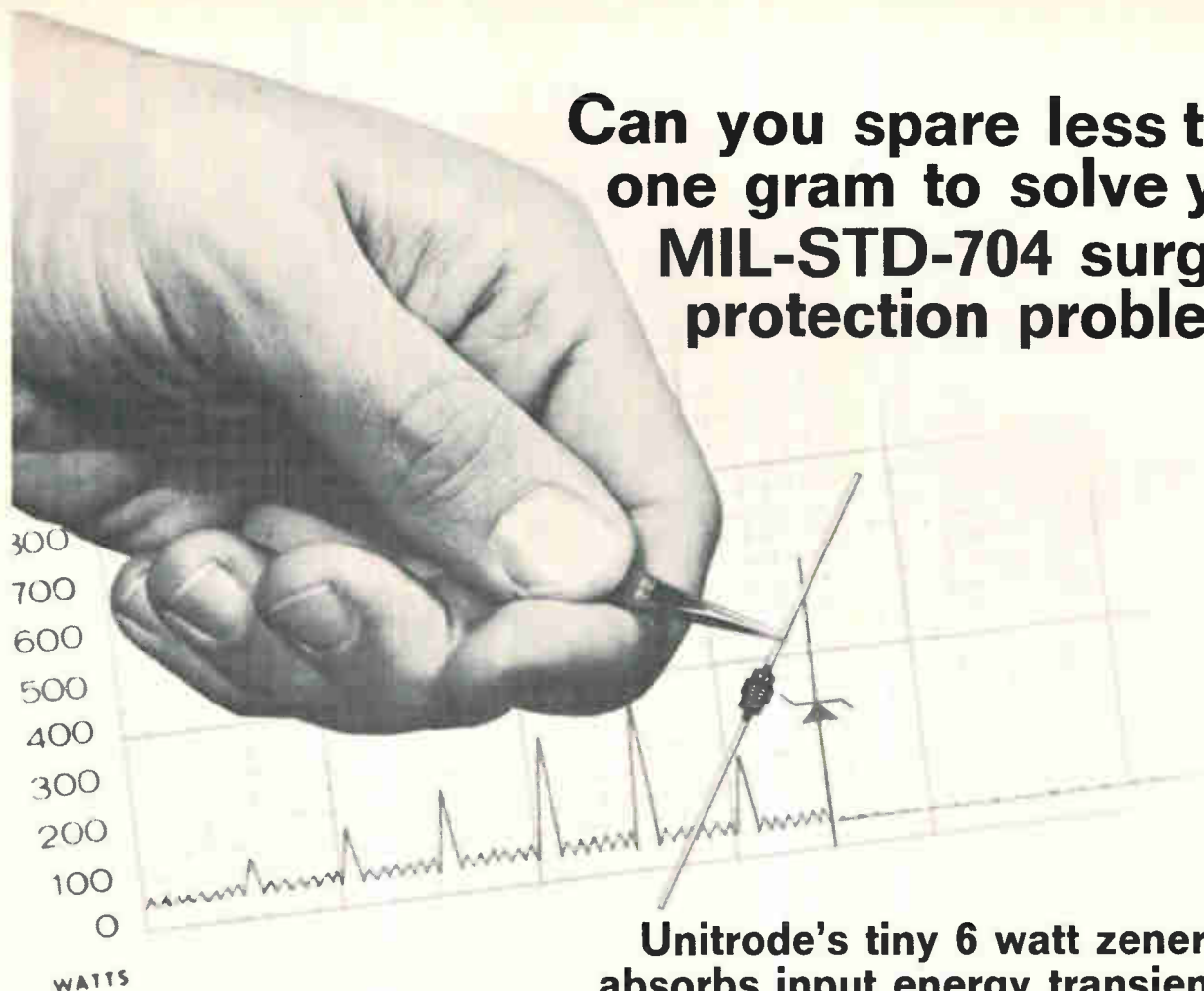

Unitrode's tiny 6 watt zener absorbs input energy transients up to 1000 watts for 1 microsecond.

- 350 watt surge capacity is 600% more than conventional 10 watt . . . 35% more than a 50 watt.
- Weighs less than 1 gram . . . 1/10th of a conventional 10 watt . . . 1/20th of a conventional 50 watt.
- Available in 10 watt rating, stud mounted.
- 6.8 to 100 volt range ■ low leakage current.
- Electrical characteristics remain stable throughout life, exceeding the environmental requirements of MIL-S-19500.

580 Pleasant St., Watertown, Mass. 02172 (617) 926-0404

UNITRODE

This one won't do it . . .



This one won't do it, either . . .



But this one will,



And so will this one . . .



Because it is built like this on the inside.

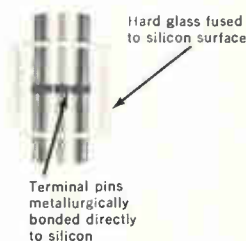

So . . . better get yourself a complete set of specs.



Check off the reply card number now or call Dave Green COLLECT at (617) 926-0404

SEE US AT THE IEEE SHOW

LOW COST AUTOMATION takes many forms

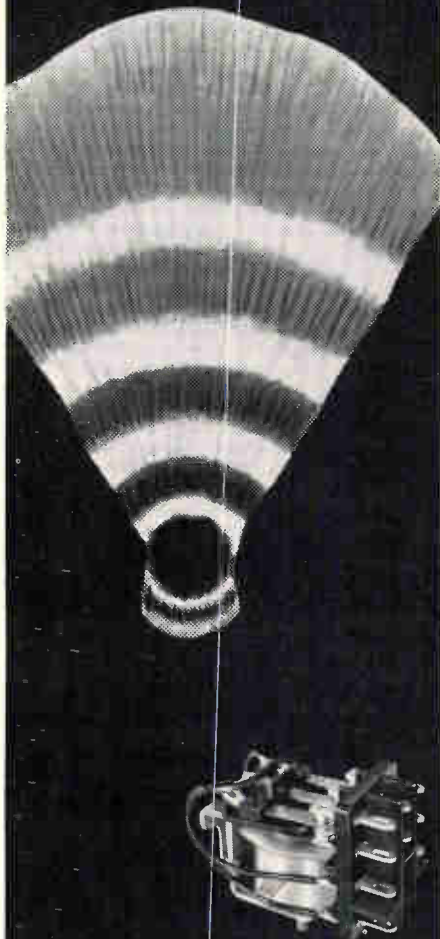

EAGLE control relays last longer! There are over 3000 models in our catalog RGC-1, ready to prove their superiority in your application. See them all. Send for your copy.

GW Eagle Signal Division
E.W. Bliss Company
Davenport, Iowa 52803
A GULF + WESTERN COMPANY

Service-In-Depth...
Local Engineering and Stock

U.S. Reports

Present information

Time
Heading
Altitude
Vertical acceleration
Air speed

Proposed additions

Angle of attack
Pitch attitude
Pitch rate
Roll attitude
Roll rate
Yaw attitude
Yaw rate
Pitch trim position
Control column or pitch control surface position
Control wheel or lateral control surface position
Rudder pedal or yaw control surface position
Thrust being developed by each engine
Positions of appropriate high-lift devices
Ambient air temperature

More in-flight data

surface positions, and engine performance. Also, the FAA has proposed that the new recorders contain an underwater locator that would go into operation when the recorder is submerged. Ironically, the FAA does not require locator beacons for crashed aircraft [*Electronics*, Jan. 20, p. 62].

Summer target. Although the new recorder is still a proposal, there is little doubt that the FAA will approve it. As it now stands, comments on the proposal can be made to the agency between now and April 18, and after that it will consider the comments and act on the proposal. According to an FAA official, the proposal could become a rule as early as next summer.

If the regulation is approved, the recorders would be required on aircraft built three years from now, and existing aircraft would have to be retrofitted within five. The FAA's timetable is based on the assumption that the equipment needed can be designed, approved, and produced within two years. There would be basically two types of equipment: completely new equipment for new aircraft and a "package" of new equipment that could be attached to existing flight recorders.

Priceless. The FAA has neither a prototype nor a breadboard of the new recorder, but says an official: "We have given this a lot of

thought and talked with all the major manufacturers of recorders. Advances in recent years in sensors, recording techniques and read-out have convinced us that all the elements needed for the new recorder are available. The major job to be done is putting all this together in one package and we're sure that manufacturers can do this."

Even though there is no doubt that a rule requiring a better recorder would be a boon to recorder manufacturers and their electronics suppliers, the FAA will not even hazard a guess as to the demand for or the cost of the recorder.

Government

No money basically

Two days before the release of the fiscal 1970 Federal budget, the National Science Foundation issued a report entitled *Technology in Retrospect and Critical Events in Science*. The budget and the report, when weighed against one another, yield an important message: the United States is undermining invention and discovery in the future by holding back on funds for "non-mission," or basic, research.

Taken alone, the report, prepared for the foundation by IIT Research

Ground station capacity in a portable recorder!

Our new MTR-3500 should start a revolution in the hinterlands. It not only records 2.4 billion bits of digital data but does so with virtually no errors. Using a unique new design technique called High Density Digital Recording (HDDR, patent pending), the 3500 packs 6,000 bits per track inch on 2400 feet of one inch, 14-track tape. And although we guarantee

an error rate of 1×10^8 , we've yet to drop a single bit with HDDR.

The new 3500 is ideal for field use. Rigid construction permits operation in such rugged environmental conditions as 10g—11ms $\frac{1}{2}$ sine shock, 10g rms random vibration, and 25g acceleration. It's compact (8.6" x 9.5" x 20"), and weighs only 54 lbs. Best of all, the new MTR-3500 with HDDR is available now.

For more complete information write Leach Corporation, Controls Division, Department E,
LEACH 717 North Coney Ave., Azusa,
Calif. 91702. (213) 334-8211.

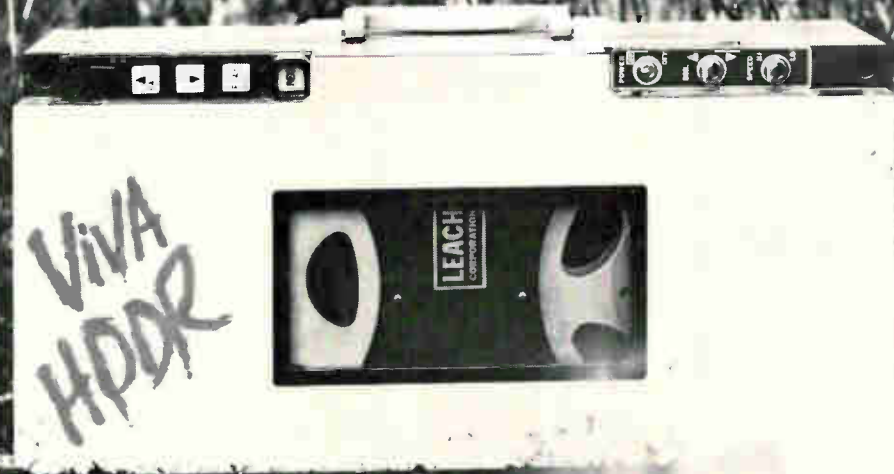

LOW COST AUTOMATION takes many forms



New plug-in Cycl-Flex 2 & 3 digit totally solid state I/C counters. 100% accurate. Up to 1200 counts per minute. Available in higher count rates. Easy-to-set thumb wheels.

Get Catalog 15, describing these and 560 other forms of low-cost automation.

GW Eagle Signal Division
E.W. Bliss Company
Davenport, Iowa 52803
A GULF + WESTERN COMPANY

Service-In-Depth ...
Local Engineering, Stock, Repair

U.S. Reports

Institute, takes five important recent discoveries and traces their origins. The five discoveries are magnetic ferrites, the video tape recorder, the electron microscope, the technique of matrix isolation, and the oral contraceptive pill. As its major conclusion the report states, "Nonmission research provided the origins from which science and technology could advance towards innovations which lay ahead." It further predicts: "Innovations for the next generations depend on today's nonmission research."

Key events. Each of the five discoveries is carefully charted back to its origin as a nonmission project—ranging from the pill's origin in the 1920's to the genesis of the electron microscope in the 1860's. An inverted pyramid is used to illustrate each discovery—beginning with a broad base of discoveries which narrow down to the specific discovery in the present era. One particularly pertinent graph in the report illustrates how industry depends on university and Government labs for discoveries. The chart describes the distribution of the key events in the five discoveries as follows:

	University & college	Nonprofit & Govt. labs	Industry
Nonmission	76%	14	10
Mission-oriented research	31%	15	54
Development and application	7%	10	83

In the fiscal 1970 budget request, funds for basic research in various agencies are either held to the same general levels as in the last few years or are lower than they were in the fiscal 1969 budget. Federal basic research funds have been held to about the same level for the last five years (after a marked period of growth) and the future looks even bleaker.

Ivan Bennett, acting head of the President's Office of Science and Technology, warned the research and development community during the last week of the Johnson Administration that it will get less funding in the future.

"If you want to apply an inflation factor, we're spending 16% to 20% less than we did in 1966," he said.

The squeeze. While it is all but impossible to pull out a basic research budget across all agency lines—since many requests combine basic and applied research as well as development—it is easy to see graphic examples of how basic research is being hit.

- Last year Congress knocked out a National Institutes of Health request for 600 research training grants. In fiscal 1970, only a dozen grants are being requested.

- Grants to be offered by the National Science Foundation are shifting away from nonmission to applied and "socially relevant" areas.

- Nonmission research in every category but one has been reduced for the AEC.

The situation looks even bleaker when one realizes that basic research was heavily hit by Congressional cutting last year, and there's evidence to suggest that the same thing will happen again.

Rep. Emilio Q. Daddario (D., Conn.) suggests the research and development is whipping boy of each Congressional economy move. In short, the National Science Foundation report, when coupled with the budget message for research, portends badly for technology and discovery.

For the record

Unicon ordered. The Precision Instrument Co. of Palo Alto, Calif., has announced the first order for its Unicon laser mass-memory system, which will have a computer on-line storage capacity of a trillion bits [*Electronics*, March 18, 1968, p. 50]. The Pan American Petroleum Corp. of Tulsa will receive the system in 1970 for use with an IBM 360 model 65 or 75; these computers, however, can't handle the system's retrieval rate of two megabits per second. The price of the Unicon hasn't been announced, but the company says a "typical" system will cost between \$500,000 and \$1 million.

Carpenter steel

**IS
NOW**

CarTECH

CARPENTER
TECHNOLOGY CORPORATION

Carpenter Technology Corporation is a new organization established to provide the expanded technological capabilities necessary to meet growing industries' needs for specialized materials. Our Steel Division will continue to provide the full line of Carpenter specialty steels including stainless steels, tool steels, high temperature alloys, electronic alloys and other special-purpose alloys.

We don't care whether you call us Carpenter Technology, Carpenter, or CarTech, as long as you call us when you need a specialty steel with improved reliability in fabrication and service. Our phone numbers have not changed. Carpenter Technology Corporation, Reading, Pa. 19603.

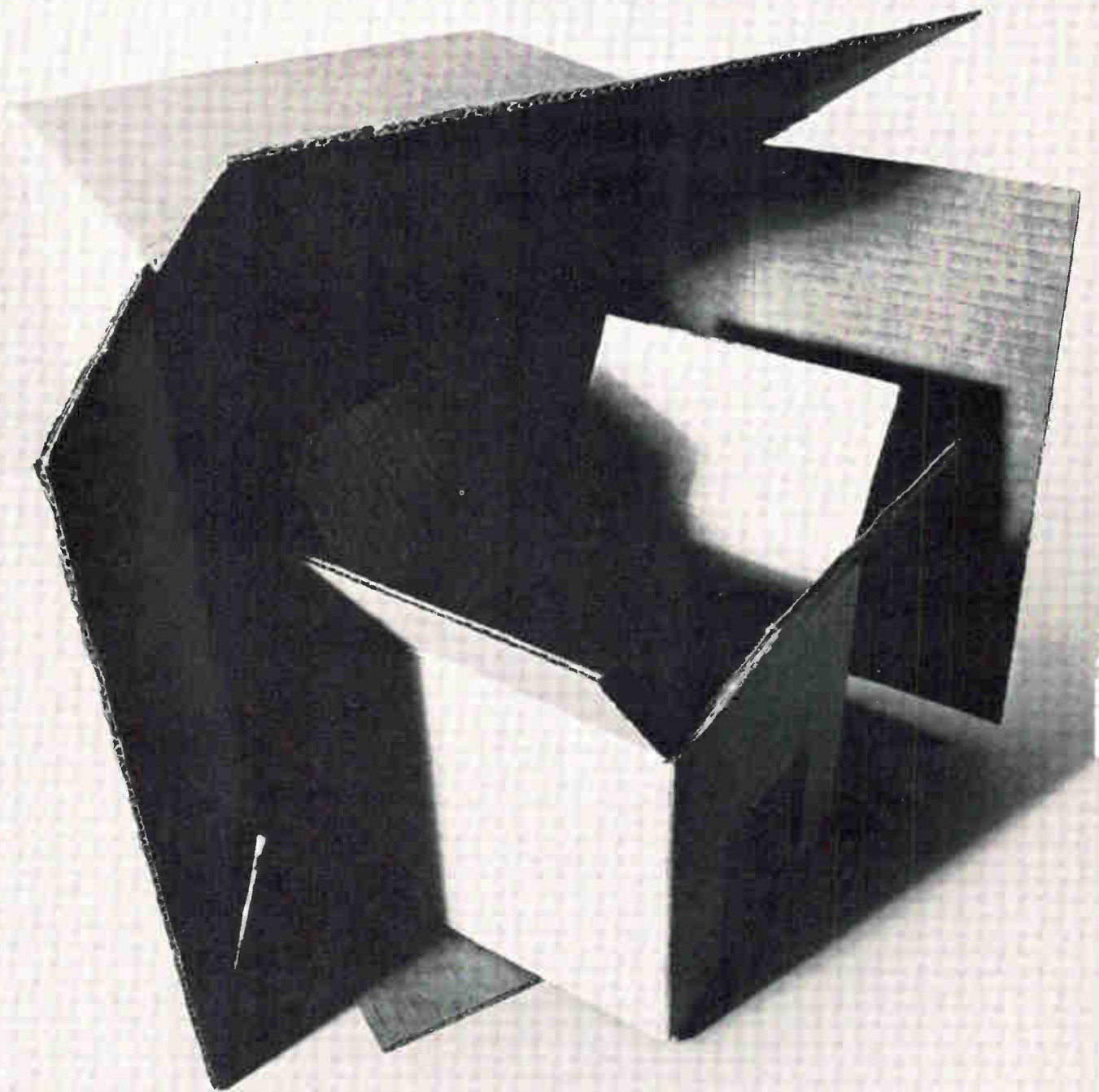

We made TTL half as big. And half as big is twice as good.

We had an idea you weren't getting all you could from T²L. If it were smaller we knew it would be better. And we figured we could make it smaller.

So we added a few circuit improvements, reduced our active chip area over 50%, and turned the problem over to our production line.

The result is Ray III. With no increase in power and far less parasitic capacitance, it's the fastest T²L available. Flip flops toggle up to 100 MHz. Gate propagation delay is only 5½ nsec maximum. Improved transfer characteristics and input clamp diodes guarantee more noise immunity than before. And it's in production now.

All because we had an idea how to squeeze the fat out of a T²L chip . . . and delivered!





MICROWAVE IC PROGRESS REPORT #6

PACT reduces losses 30% for C band microstrip ferrite phase shifters

One of the latest successes scored by Sperry's PACT (Progress in Advanced Component Technology) program is a marked improvement in loss performance of C band microstrip ferrite phase shifters. Non-reciprocal, latching devices in external loop configuration show an improvement in loss characteristics from 3 db to 2 db for 360° shift.

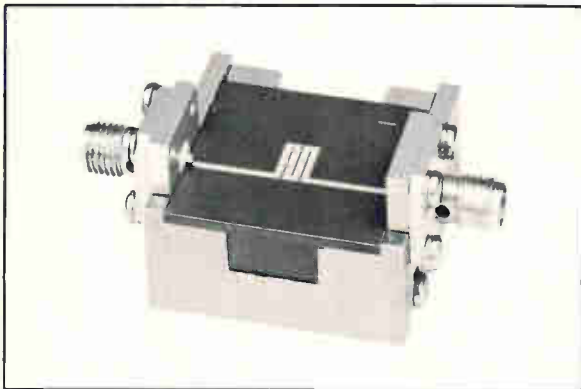

**C BAND, NON-RECIPROCAL FERRITE
PHASE SHIFTER IN TEST FIXTURE**

PACT engineers attacked the problem of improving ferrite planar phase shifter performance by concentrating on two troublesome areas: substrate materials selection and optimum configuration of the microstrip circuitry.

The search for materials was aimed at optimizing and controlling the material characteristics, thus minimizing loss and maximizing phase shift. It led eventually to the selection of aluminum-doped YIG as the most promising material. Circuitry investigations were directed toward maximizing the rf coupling to the ferrite substrate. Meanderlines have been one of the most promising approaches.

SPERRY
MICROWAVE ELECTRONICS DIVISION
CLEARWATER, FLORIDA

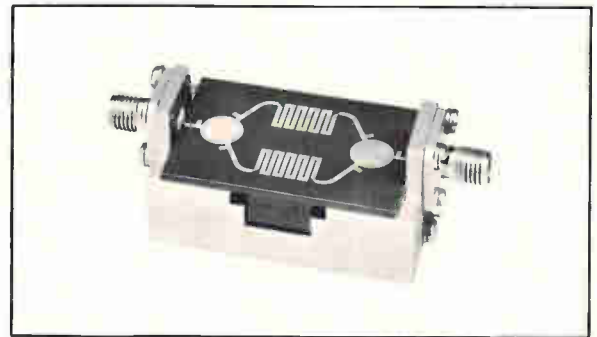

**C BAND RECIPROCAL FERRITE PHASE SHIFTER
IN TEST FIXTURE**

To optimize circuitry configurations, PACT personnel used calculations based on established filter theory for meanderline designs. Complexity of these calculations led to the establishment of a special computer program. The computer not only optimized configurations—it also generated large economies in design time and expense. As a result of the computer operations PACT people were able to increase line-to-line coupling of their devices and effect a considerable loss reduction.

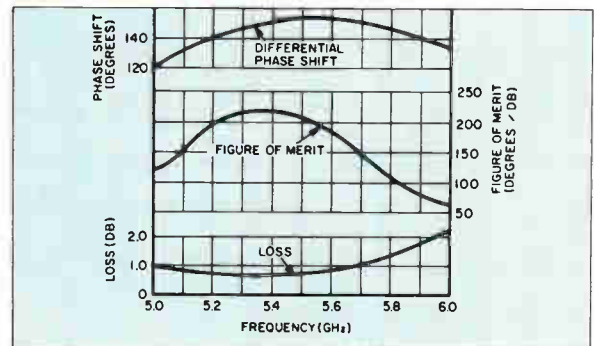

**TYPICAL PERFORMANCE OF PACT-DEVELOPED
PHASE SHIFTERS**

The results of this program have been applied to both reciprocal and non-reciprocal devices. They are also expected to speed Sperry's progress toward commercially available microwave integrated circuits.

To get more information about PACT progress in phase shifters and other areas of microwave IC technology for your application, contact your Cain & Co. representative or write Sperry Microwave Electronics Division, Sperry Rand Corporation, Clearwater, Fla.

*For faster microwave progress,
make a PACT with people
who know microwaves.*

Washington Newsletter

February 3, 1969

U.S. wants bidding on punch-card rentals

As if IBM doesn't have enough troubles with the Justice Department, the General Services Administration is trying to open its leasing of IBM-made punch-card machinery to bids on a multiagency basis. **Up to now, the only competition between IBM and independent leasing firms occurred when individual Government agencies contracted for the equipment.**

The GSA is now inviting about 50 leasing firms, all with IBM card punchers, to submit bids for equipment used by all agencies. The annual rental comes to about \$37 million. **This bidding hasn't been done before, say GSA officials, because up to now only IBM could provide the large quantities needed by the Government.** There is still a possibility that the contract will be split between several suppliers if substantial savings can be made.

A GSA official expressed regrets that IBM is the only maker of the equipment, but added: "Different leasing companies figure profits differently—so we may be able to make a savings even though it's all the same equipment." **Bids will be open Feb. 10, but there is a chance the deadline will be extended.**

Army in market for big copters

Watch for two new large-helicopter programs to take off during fiscal 1970. One is a new aerial crane that would carry only basic electronics. **But the other, a Utility Tactical Transport Aircraft System to replace the venerable and overworked Bell Iroquois, could provide additional platforms for Teledyne's Integrated Helicopter Avionics System.**

The Iroquois replacement is just at the contract definition stage, but production timing may be fast, because the Army wants to cut Iroquois production money by three-quarters in the new budget.

Approval nears for domestic satellite

There's a good chance that 1969 will be the year for approval of the pilot domestic communications satellite for the United States. **Three major clues point in this direction:** Federal Communications Commission chairman Rosel Hyde publicly stated that a decision of some sort must be made this year, and he noted that a decision should have been made last year; the FCC has just announced it is proposing to authorize satellite broadcasting in the 470-806 megahertz band, a proposal that is already opposed by the National Association of Broadcasters on grounds that it is "precipitate and premature;" and the final report of the President's Task Force on Communication Policy will recommend that the satellite system be launched by Comsat.

Comsat has been waiting since early 1967 for a go-ahead. [*Electronics*, Oct. 2, 1967, p. 52] The project has been shelved since then for several reasons, among them opposition from the Ford Foundation and the NAB, plus a decision to wait until the President's Task Force completed its work.

Project Themis to add 50 programs

Pentagon-sponsored academic research is in line for a big boost under the 1970 budget. **During the next two years, the Pentagon wants to add 50 projects to Project Themis, the program that scatters R&D seed money across smaller college campuses—most of them engineering schools—**

Washington Newsletter

in an effort to improve the quality of research in this country.

This will bring the total number of Themis programs to 150. The Pentagon had hoped to have 200 programs in operation by 1971, but budget cuts for fiscal 1969 slowed the project. The 1970 budget has \$33 million allocated for Themis, an increase of \$5 million over the 1969 appropriation.

In addition, the Pentagon wants \$96 million, compared with \$89 million for the current year, for academic research in the physical sciences. It also wants \$50 million, compared with \$45 million, for research in nuclear weapons effects, which probably includes a number of radiation hardening projects.

Air Force trying for F-106X again

The Air Force and Congress appear to be on a collision course again over what plane should be the interceptor for the Airborne Warning and Control System (AWACS), and it appears the legislators will get their way. The Air Force wants to develop an advanced F-106 because that, say the generals, would be quicker and cheaper. But Congress thinks the 12-year-old plane is too old; last year it rejected a \$28 million request and strongly suggested a new plane. Insisting that the F-106X is still the better choice, however, the Air Force now wants \$18.5 million for the X version in the new budget.

Chances are Congress won't buy the F-106X this time around either, which means that time is running out for the old fighter. If the X is shot down by Congress, the Aerospace Defense Command would need a new plane. One expensive possibility is Lockheed's F-12.

Even if the choice of an interceptor should be delayed still further, AWACS itself shouldn't be thrown off schedule because of problems that already exist in the land and airborne radar portions of the program.

Minority job gap in L.A. aerospace studied by EEOC

The U.S. Equal Employment Opportunity Commission will hold hearings in Los Angeles next month on minority employment practices of the aerospace industry. The Commission wants to find out why the aerospace industry hires a smaller percentage of Negroes and Mexican-Americans than other industries in the area.

In addition to hearing from companies with few employees from these minority groups, the Commission will hear "success stories" of a few firms which "provide equal employment opportunities on a wide scale." Research by the Commission reveals that more than half the L.A. aerospace firms have no black executives and more than one-third have no Mexican-American executives, while only about 2% of engineers and white-collar workers are members of these minority groups.

Addendum

The FCC might call formal hearings, as requested by the Justice Department, to work out details of who may provide foreign attachments to the telephone network. Meanwhile, the FCC's common carrier bureau is going ahead with plans for informal industry-government conferences on AT&T's new tariffs regarding foreign attachments and interconnections. . . . The Army is quietly working on a helicopter avionics and control system called Tags (Tactical Aircraft Guidance System), that would allow one-stick operation of choppers. Involved in development are AC Electronics, Boeing's Vertol division, Lockheed, MIT, and a Canadian company.

New precision dc power supplies with 0.1% + 1mV accuracy \$345⁰⁰



The QHS Series is composed of three instruments, each having:

- direct voltage programming to 6 digits
- 11 μ V resolution
- 0.1% + 1mV calibration accuracy
- constant voltage regulation of 1ppm + 30 μ V for 20% line voltage fluctuations
- constant voltage regulation of 5ppm + 50 μ V for 100% load changes
- 100 μ V p-p ripple (10Hz—500kHz)
- 10ppm + 100 μ V stability for 8 hours
- reset-ability of 30ppm or 200 μ V
- optional overvoltage protection
- 250 hour factory pre-aging.

The QHS 20-1 (0-20 Vdc @ 1A), QHS 40-.5 (0-40 Vdc @ .5A) and QHS 100-.2 (0-100Vdc @ .2A) are available for immediate delivery in a 3½" x 8¼" x 12¾" modular package suitable for rack mounting.

For more information contact your local Sorensen representative or; Raytheon Company, Sorensen Operation, Richards Avenue, Norwalk, Connecticut 06856.

Tel: 203-838-6571;

TWX: 710-468-2940;

TELEX: 96-5953



Discrete Semiconductors.

As of November 30, you
had 67,866* standard types
to choose from



*World-wide figure courtesy D.A.T.A. Inc.

It's high time somebody made your choice easier and safer

Somebody has.

Let's face it: there are just too many types of semiconductor devices to choose from today...and that can make your choice both difficult and hazardous.

Many "standards" no longer are. Many are in limited production and, consequently, are high-priced — you may settle on a \$3.00 device when a 30¢ one would do. Many are not readily available — understandable, with 67,866 types involved, but small consolation when you have to accept slow delivery. Many have been made obsolete by newer, low-cost devices with better performance characteristics.

To give you a lot more assurance in your device choices, we've come up with a bold, new concept. We call it our *Preferred Semiconductor* line, and it will pay off for you in simplified selection, faster delivery, lower costs, less inventory and reduced testing.

By *preferred* we mean *customer preferred*. After months of computerized demand analysis, we've zeroed in on 285 highly popular types that meet the vast majority of semiconductor requirements. These are the workhorses.

- All are in wide use today, known and proven.
- All are in volume production, and that spells low prices.
- All are readily available from TI distributors and factory stocks, so you can count on prompt delivery.
- All are recommended for either present or new designs.

These advantages make it worth your while to consider TI Preferred Semiconductors *first* for your new designs or system redesigns. You may still decide that you need a tailor-made device, or a more obscure standard. If so, we already make over 1500 other standard

types and some 13,000 specials which may meet your needs. If not, we'll make more. But the place to *start* is TI's Preferred line.

We've made it easy for you with a new Preferred Semiconductor and Components catalog. It contains detailed specs on all 285 types — small signal and power transistors, both germanium and silicon; diodes, thyristors, rectifiers, regulators, light sensors and resistors. All are indexed by both type number and application. There's a numerical listing to our full line of 1800-plus standards and an extensive cross-reference guide to products of other manufacturers. Application ideas are included, too. This could prove to be the most helpful semiconductor catalog you've ever used.

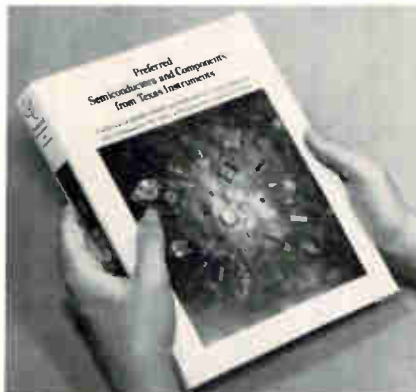

You can get a copy simply by asking. Ask your TI sales engineer. Ask your TI distributor. Or write us on your company letterhead or on the back of your business card: Texas Instruments, PO Box 5012, MS 308, Dallas, Texas 75222. Do it today; after all, isn't it high time you began bucking the trend?



TEXAS INSTRUMENTS
INCORPORATED

5 fast, effective ways to stop EMI:

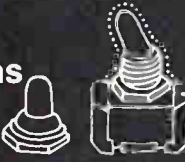
If you want to shield...

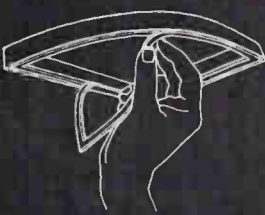
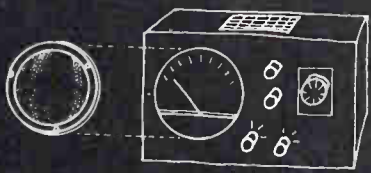
<p>Communications cables</p> 	use	<p>Metex "Zip-Ex"® zip-on metallic sheath. Provides 100% reliable electromagnetic shielding. Knitted mesh sheath zips on any shape before or after installation.</p>
<p>Switches/ push buttons (also keep out moisture)</p> 	use	<p>Metex Flex-Shield shielded rubber boots. Metal mesh, molded in flexible rubber, gives maximum reliability against RFI-EMI.</p>
<p>Electronic equipment (and vent it, too)</p> 	use	<p>Metex Shield-Cell honeycomb panels. It's designed to meet specific attenuation requirements over specified frequency ranges. Many standard sizes and materials are available.</p>
<p>Access doors & lids</p> 	use	<p>Metex Pola-Stick Wire imbedded in silicone. Pressure-sensitive adhesive keeps it securely in place during and after installation.</p>
<p>Viewing windows</p> 	use	<p>Shield-Vu™ Metex Your choice of monel, low carbon steel or etched metal laminated in plexiglass. Any color, size, or shape.</p>
<p>QUICKLY</p>	call	<p>(201) 287-0800 for design engineering service (for your rush rush requirements)</p>

For technical assistance on your particular requirements—write:

METEX CORPORATION 970 New Durham Road
Edison, New Jersey 08817
(201) 287-0800 • TWX 710-998-0578

West Coast: Cal-Metex Corp., 509 Hindry Ave., Inglewood, Calif. 90301 • (213) 674-0650 • TWX 910-328-6100

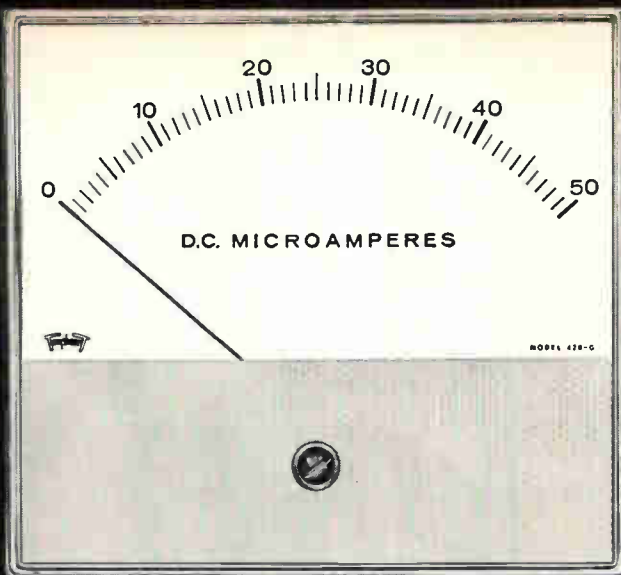

now you see it

now you don't

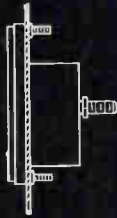

THE PANEL INSTRUMENT WITH BUILT-IN FLEXIBILITY

TWO NEW SIZES!

5½" and 1½" (Miniature)

TRIPLETT

New Triplett G-Series Panel Instruments offer a modern design that features a greater degree of flexibility and interchangeability.

1 Two types of mounting are available—conventional flush type or behind-the-panel with a bezel for modern picture window appearance. **2** The insert shield on the front of the meter can be custom painted or printed to meet customer's requirements.

3 Triplett's famous self-shielded Bar-Ring magnet, with one-piece die-cast frame, in all DC and DC suspension type instruments.

In five popular sizes: 5½" DC and AC; 4½" DC and AC; 3½" DC and AC; 2½" DC and AC; 1½" (conventional flush mounting only) DC and AC rectifier type.

Circle 63 on reader service card

NOW IN FIVE POPULAR SIZES:

1½" (Miniature); 2½"; 3½"; 4½"; & 5½".

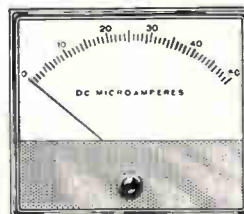
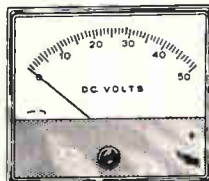

TRIPLETT ELECTRICAL INSTRUMENT COMPANY, BLUFFTON, OHIO

For high speed harnessing
with continuous lacing...

HERE IS THE WORK SPEEDING - MONEY SAVING -

GUDEBROD SYSTEM "C"

GUDEBROD FLAT TAPE BOBBINS—This special packaging of Gudebrod Flat Braided Lacing Tape is highly popular in the harness shop. Whether used in all hand tying or with the Cable-Lacer (for which it was designed) the bobbin makes conveniently available, high quality Gudebrod Tape in most of its many types—all engineered to lie flat, tie tight.

GUDEBROD CABLE-LACER®—This unique harnessing hand tool has proved a production speeder and harness improver. Makes up to 30 knots per minute. While making firmer harnesses with tighter, more uniform knots, it eliminates wear and tear on operator's hands because special brake takes strain of knot setting. Holds bobbin of Gudebrod Tape in handle.

LONGER WIRE HOLDING PINS—They make wire threading much easier, quicker (no repeated wire redressing between pins). In harness tying they preserve the layout while using the Gudebrod Cable-Lacer. Special case hardened pins, nail better, stay straight, no nailheads.

GUDEBROD SWIVEL-TILT HARNESS BOARD MOUNT—Two dimensional balanced mobility puts every section of the cabling within easy, natural reach of the operator. Work done in this unstrained manner goes faster, is better, all day through.

There it is, the Gudebrod System "C" solving the cable making problems in a speedy, economical, profit improving way. Ask about System "C" (If you use intermittent tying, ask about Gudebrod System "S").



Gudebrod's
Special, Longer
Case Hardened Pins

©T.M.—UNION SPECIAL
MACHINE CO.

GUDEBROD
Electronics Division

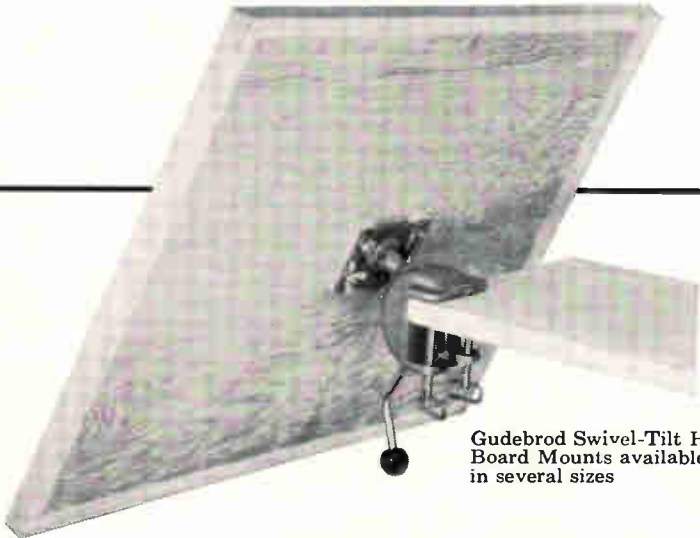

Gudebrod Swivel-Tilt Harness
Board Mounts available
in several sizes

GUDEBROD BROS. SILK CO., INC. Founded 1870, 12 South 12th Street, Philadelphia, Pa. 19107

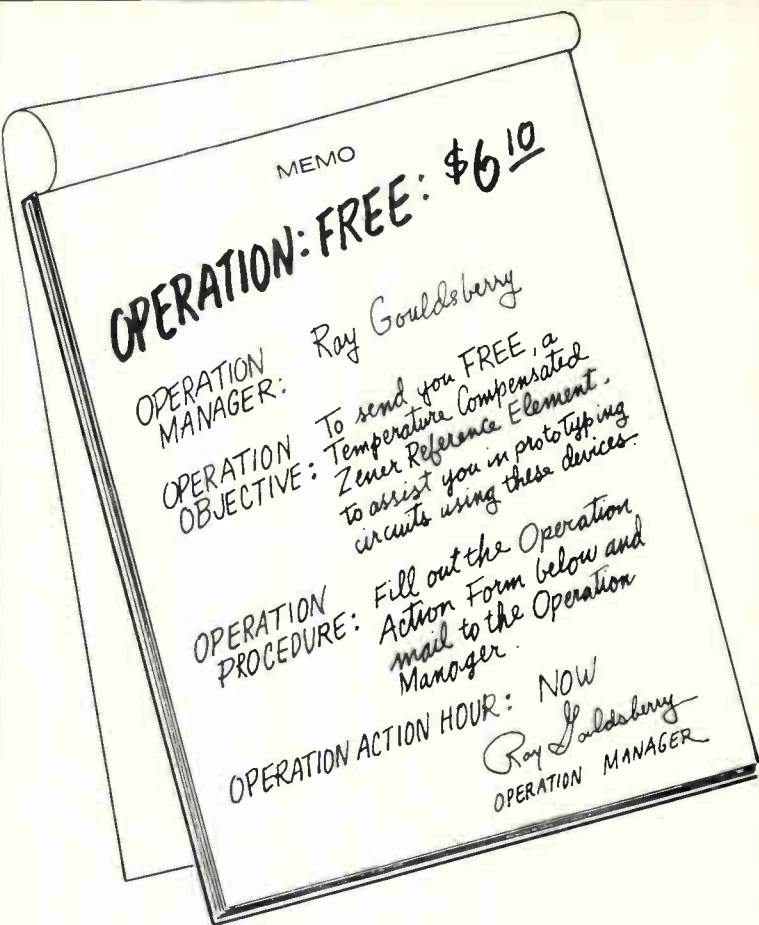
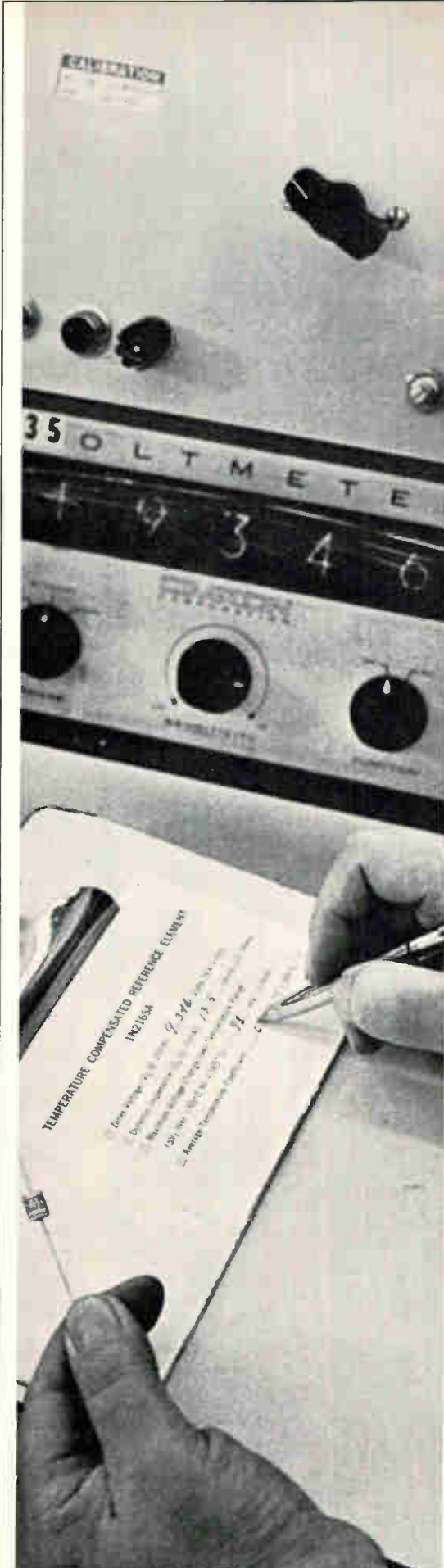

This high quality device selling for \$6.10 has these standard specifications:

- Zener Voltage (V_z): 9.4 Volts $\pm 2\%$
- Maximum Dynamic Impedance (Z_z): 15 Ohms
- Maximum Voltage Change Over Temperature Range (ΔV_z over -55°C to $+185^\circ\text{C}$): 115 mV
- Average Temperature Coefficient: .005%/°C

It will be sent to you free attached to card on which all critical parameters of your device have been recorded for you.

Operation Action Form

In what project will this device be used? _____

If this is a production project what quantity of Zener Reference Elements do you anticipate using? _____

Name: _____ Position: _____

Company: _____ M/S: _____

Street: _____

City: _____ State: _____ Zip: _____

Phone: _____ Ext: _____



3540 W. OSBORN RD. / PHOENIX, ARIZONA 85019
PHONE 602-272-7671 / TWX 910-951-1381



Dissecting the critical moment

There are many applications far too fast for conventional data acquisition systems. Studying impact and shock tests where masses of data come in a single burst; characterizing transient response of servo systems; or analyzing complex signals in vibrations and acoustics.

For these high-speed measurement applications, Hewlett-Packard gives you sampling rates up to 100 kHz and aperture times down to 50 nanoseconds. Plus the

ability to record, process and display the data... and perform closed-loop control. HP has all the system modules you need. Fully-specified analog front ends—digital computers—peripherals for printout, storage, display, interface and control.

Ask your HP field engineer for our brochure, "Computer Systems for Data Acquisition and Control." Or write Hewlett-Packard, Palo Alto, California 94304; Europe: 1217 Meyrin-Geneva, Switzerland.

HEWLETT  PACKARD

DATA ACQUISITION SYSTEMS

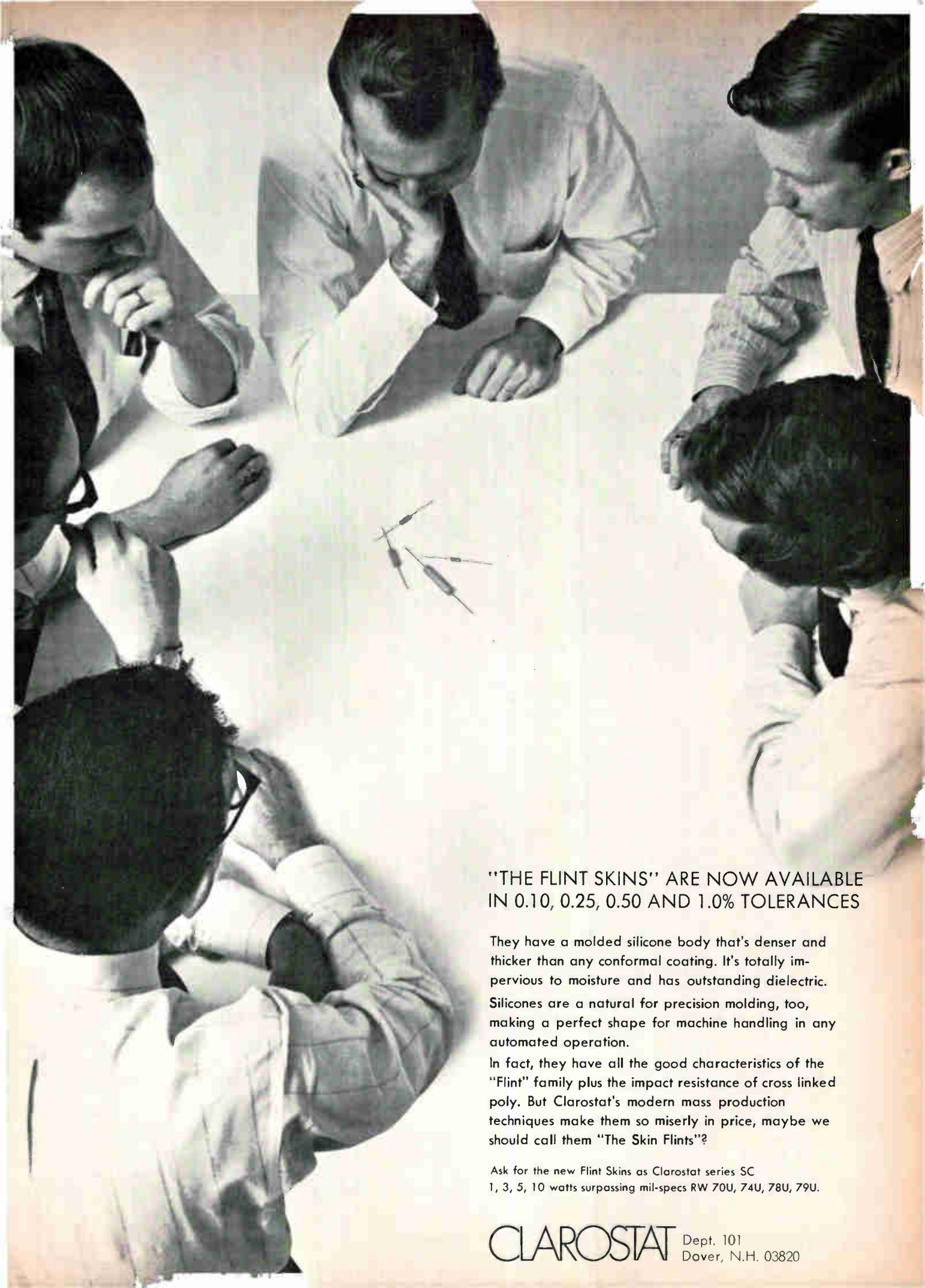

"THE FLINT SKINS" ARE NOW AVAILABLE
IN 0.10, 0.25, 0.50 AND 1.0% TOLERANCES

They have a molded silicone body that's denser and thicker than any conformal coating. It's totally impervious to moisture and has outstanding dielectric. Silicones are a natural for precision molding, too, making a perfect shape for machine handling in any automated operation.

In fact, they have all the good characteristics of the "Flint" family plus the impact resistance of cross linked poly. But Clarostat's modern mass production techniques make them so miserly in price, maybe we should call them "The Skin Flints"?

Ask for the new Flint Skins as Clarostat series SC
1, 3, 5, 10 watts surpassing mil-specs RW 70U, 74U, 78U, 79U.

CLAROSTAT Dept. 101
Dover, N.H. 03820

hybrid microcircuits

from the

“total capability”

source

There's a reason why Burroughs is a preferred source for hybrid microcircuits. It's TOTAL CAPABILITY. TOTAL CAPABILITY is the unique ingredient that keeps Burroughs ahead in hybrid circuit leadership and enables you to reduce system size with increased reliability.

Burroughs now offers the entire circuit package* and its components — all designed and fabricated under the eyes of experts in one complete in-house operation, providing economy, high reliability, quality control and prompt delivery.

■ Hermetic Packaging ■ MSI Capability ■ Computer Test Facility ■ Fully Documented to MIL-Q-9858A and MIL-I-45208

Buy your hybrid microcircuits NOW from Burroughs, and discover what Burroughs Total Capability can do for you.

Call or write Burroughs Corporation, Electronic Components Division,
P.O. Box 1226, Dept. H1, Plainfield, New Jersey 07061.
Tel. (201) 757-5000, or contact your nearest Burroughs
representative or sales engineer.

*Circuits are available in various configurations with resistors, capacitors, and discrete IC and MSI chips, mounted.

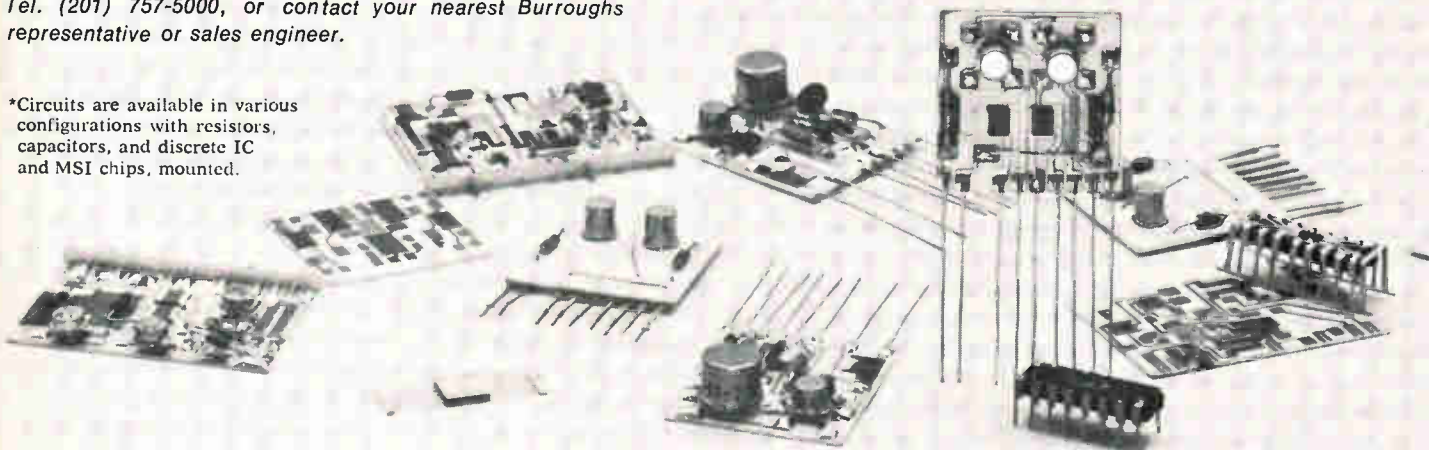

Burroughs 

Circle 88 on reader service card

Technical Articles

**Read-only memory adds
to calculator's repertoire**
page 70



Desk calculators, as well as computers, can be made more versatile, yet smaller and faster, with read-only memories. Until recently, however, there wasn't any design that was really practical for a desk calculator. Chuck Near, an engineer at Hewlett-Packard, worked on the problem and eventually invented a linear inductive array. Such an eight-layer assembly—one level of which appears on the cover—holds all the operating information in the company's new 9100A calculator. The machine also has a small ferrite-core memory that makes it faster than units with delay-line memories for complex calculations, such as trigonometric and logarithmic functions.

**Op amps save time, money
in active filters**
page 82

Operational amplifiers built with high-performance integrated circuits offer the engineer working with active filters a thoroughly practical way to solve his design problems. He can quickly fabricate almost any transfer function with a simple series or shunt resistance-capacitance network. In addition, such devices provide substantial blocks of gain and good circuit stability at very low cost—about 9 cents for each active element.

British IC technology
page 92

The second of two installments of *Electronics'* special report on integrated-circuit technology in Great Britain leads off with a look at electron-beam techniques to test devices as complex as LSI without mechanical contact. The second article discusses practical hybrid circuit modules for Gunn-effect devices; the third goes into IC's, operating on a moving-domain principle, that might eventually prove a solid state replacement for vidicon tubes. Ion-implantation techniques that can produce MOS transistors operating at uhf are the subject of the fourth article, while the last details a method for fabricating MOS and bipolar transistors on the same chip.

**Solid state microwave
leaving the lab**

Coming

A progress report, along with an analysis of obstacles still to be overcome, charts bulk-effect devices and avalanche diodes as they move from the development stage into practical systems applications.

Read-only memory adds to calculator's repertoire

Subroutines for new desk-top unit are stored in a linear inductive array that increases the number and complexity of functions the machine performs; speed is provided by a separate ferrite-core memory

By Charles W. Near and Robert E. Watson

Hewlett-Packard Co., Loveland, Colo.

Strong demands are made on electronic desk-top calculators by scientists and engineers. They need more than just an adder; they want a machine that can perform all the functions of a conventional log-log slide rule. It should also be able to evaluate complex combinations of functions with 10- or 12-place accuracy at high speed, and should be easy to operate.

With such a calculator, an engineer can tackle just about any problem except one requiring large amounts of data storage and manipulation—a problem best handled by a large computer. He can get iterative solutions as a function of one or more variables—such as frequency or time—in a reasonable time. And with a stored program capability he can solve these equations as simply as he can perform any function on the keyboard.

The design of such a calculator requires sufficient memory for both data storage and a sequence of arithmetic operations, along with fixed routines for the operations available from the keyboard.

The requirements in this case can be met best by a calculator that has two memories: a ferrite-core array for data and a read-only storage for routines. The latter memory has been implemented in a new design—a linear inductive array—that is physically small and inexpensive enough to be practical in this application.

The calculator that incorporates this array is the Hewlett-Packard 9100A, a machine with a keyboard from which 63 operations can be executed or stored for later execution. It uses three memories; besides a ferrite-core memory and the linear inductive array, it contains a read-only braid memory of conventional design to store the microinstructions that control the two other memories. The 9100A is built with discrete components and it displays its

answers on a small cathode-ray screen in either fixed-or floating-point notation; a printer and an x-y plotter are available for hard-copy output. Extensive computer-controlled testing of the calculator and its major subassemblies assures its reliability.

The random-access core memory can store or recall data in a submicrosecond cycle time for any computation at any time, and can thus execute iterative routines in seconds rather than minutes. This is one of its major advantages over the delay-line memories used in many other electronic calculators. Although a delay-line calculator can read a particular datum in a few milliseconds, and may generate the sine of a number in a few seconds, it can easily take minutes to evaluate complex equations involving many trigonometric functions.

The functions a calculator performs, of course, must be wired into it in some form. The difference between calculator and computer in this respect is that the functions are individually available through the calculator's keyboard as well as through the stored program. In computers, the value of using a read-only memory, rather than a collection of logic gates, to store routines has been amply demonstrated, and the same applies to a calculator.

The linear inductive array holds the key to the complexity of functions and the large number of fixed subroutines the 9100A can perform. This 32,768-bit memory—512 words of 64 bits each—contains all the internal programming for the basic operating subroutines, plus such stored constants as e and π for use in some of the mathematical functions, as well as character encoders and pattern generators for driving the crt display.

This read-only memory is compatible in speed with the core memory. Its data is randomly accessi-

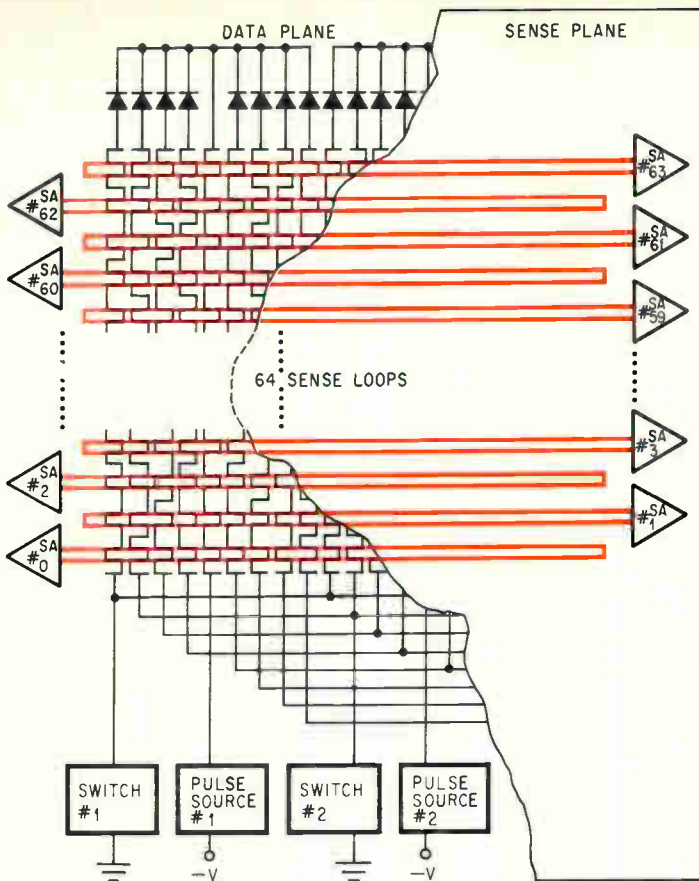

Inductive array. Pattern of rectangular loops stores data for all the calculator's operations. To read this data, one pulse source and one switch route a current pulse through a reference line and a data line. All the rectangular loops in the reference line are oriented to the right. Where the data loop is also oriented to the right, the two voltages induced in the adjacent sense conductor cancel each other and the output is a binary 0; where the data loop is to the left, the voltages add to produce a 1.

ble and is held after addressing in a 64-bit register. Power dissipation is less than 10 watts—about the same as an integrated-circuit array's and much less than that of a resistor matrix.

In the linear inductive array, the geometry of one set of conductors relative to another set determines the stored data. The use of magnetic coupling makes both ends of the word lines available for address selection, thus greatly simplifying the selection circuits. Specifically, the 512-word inductive array requires only 48 selection circuits—32 current sources at one end of the lines and 16 switches at the other. Turning on one of the sources makes current available to 16 word lines, but turning on one of the switches connects only one of these 16 to ground.

This approach wouldn't work with resistive or diode arrays because the 16 lines would all have paths to the sense amplifiers regardless of what

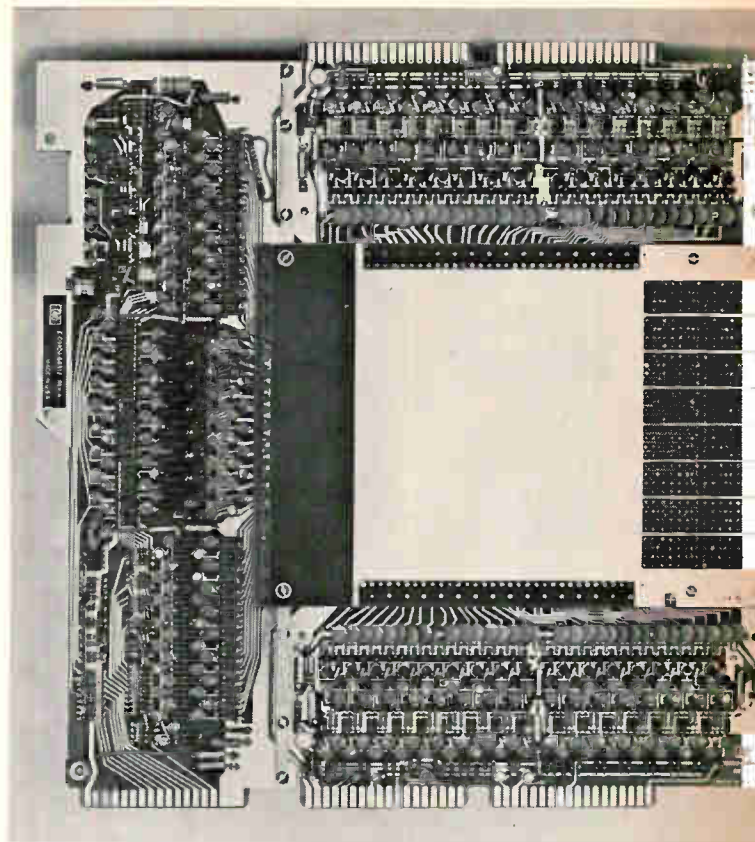

Read-only assembly. The multilayer memory board is the blank panel in the center. Drive circuits and sense amplifiers surround it.

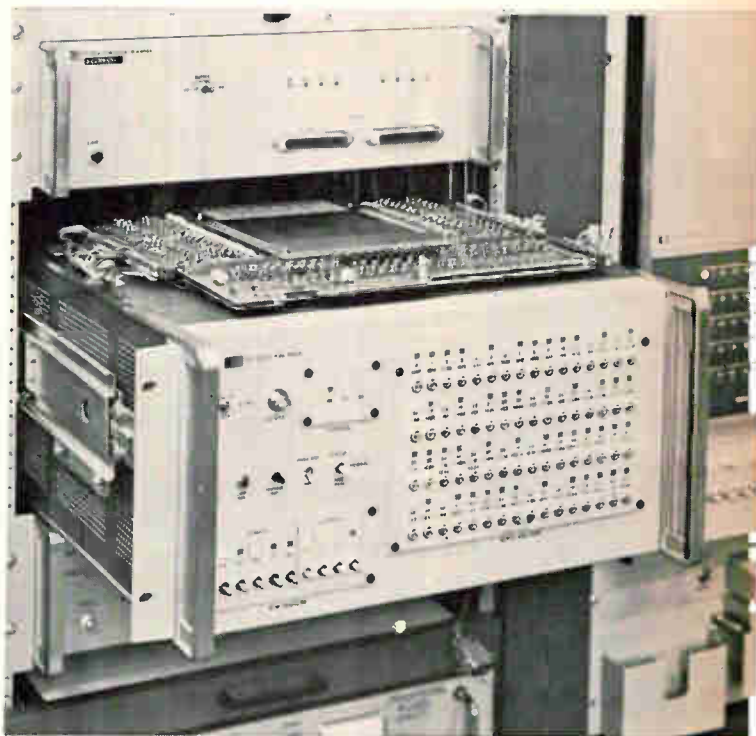

Memory tester. The read-only memory on top of the tester is compared with a perfect memory mounted inside the machine.



Margin profile. Failing sense amplifiers are listed over a range of sense-amplifier bias voltages. The open space in the middle indicates the width of the operating "window"—9.22 volts for the even-numbered amplifiers (left) and 9.66 volts for the odd-numbered ones.

switch was selected at the far end. Of course, the 15 unselected lines could be grounded at the input end, but in that case the source would have to supply 16 times as much current as was really necessary. Either of these techniques would thus require a 512-output decoder to select 512 lines. The approach would work with a capacitive array, in which a voltage signal is coupled to the sense lines; but when the input was switched to a different address a spurious pulse would appear at the output and would have to be blocked—an additional complication that doesn't arise with inductive coupling.

Also, the linear inductive design lends itself nicely to batch fabrication through printed-circuit techniques, so that its cost is low. And finally, its multilayer organization permits a high density of bits—more than 1,000 per square inch.

Double or nothing

The memory is made of eight double-sided printed-circuit layers. Six of these contain a total of eight etched data planes and four sense patterns in an arrangement that puts a sense plane adjacent to every data plane. The two outside layers carry two more sense planes. Each sense plane contains 64 sense loops, and each data plane contains 64 word lines and eight reference lines.

The linear inductive array's operating principle is that of an air-coupled transformer. Each combination of one word line and one reference line makes up a primary circuit; the sense loops form

the secondaries, as shown on page 71, top left, and on the cover.

The geometry of the word lines stores the fixed binary data in the form of 64 bit segments per word. Each reference line also has 64 bit segments, which induce reference signals in the sense loops. When the orientation of the bit segment is such that the induced signal adds to the reference signal, a logical 1 is generated. With the opposite bit orientation, the outputs cancel for a logical 0. Typical 1-to-0 current ratios are greater than 10:1.

The connection of eight word lines to each reference line on the data planes means the signal received by the sense amplifiers for a 1 is nearly twice what it would be if it were generated by the word lines alone. The arrangement also eliminates what would otherwise be an output of opposite polarity for a 0, but it requires an area only 1/8 larger than the word lines would take up alone. If the reference lines were left out and the jogs in the word lines were twice as large, the coupling would be doubled but the signal amplitude would suffer because the board would have to be larger and the sense lines longer, causing more inductance and attenuation.

The only components required on the multilayer board are single diodes per word line to isolate the line from sneak parallel paths.

Construction job

Using a photoresist process, the data planes and sense planes are etched from a thin copper-clad laminate. At this point, all layers are electrically tested for short and open circuits and visually inspected for other flaws. The eight printed-circuit layers and seven interleaved insulating layers are then precisely aligned in a multilayer fixture and bonded in a hydraulic press. The laminated multilayer board is drilled in an automatic machine, and the holes are plated through to establish interconnections between layers or diode pads. Finally, the outer surfaces are etched and the board is trimmed to size.

A computer checks the finished multilayer memory board for operating margins, and prints a margin profile record that indicates flaws within the board or processing changes that may reduce operating margins. Acceptable boards are loaded with 64 eight-diode packages, and drive and sense amplifier circuit boards are solder-connected to form the completed read-only memory assembly, shown at top right on page 71.

The method used to enter data in the memory is a major factor in the array's versatility. The artwork must contain a right-oriented segment for a logical 0 or a left-oriented segment for a logical 1 for each of the 32,768 bits in the array. Although all calculators produced are supposedly identical—so that the data theoretically has to be defined only once—engineering changes and the discovery of errors require new artwork to be prepared from time to time. Generating this artwork by conventional taping methods would be an extremely lengthy and costly process. But the use of a com-



Program card. An operator loads a magnetic card containing a previously written program into the calculator's card reader.

puter program to convert the desired data into precise digital plots gives both fast turnaround time and error-free results.

This program and a high-precision plotter lay out the complete pattern for one data surface in about one and a half hours—far faster than any manual process. And with the human element re-

moved from the data translation, the plots require only visual inspection and needn't be cross-checked on a bit-by-bit basis.

Computerized testing

All the 9100A calculator subassemblies, especially the read-only memories, are well suited to computer-controlled production testing. The process is complicated; complete checkouts require the following:

- Testing of output signals from many similar circuits.
- Testing of many output signals from a single circuit.
- Repetition of families of measurements over a range of power-supply variations to pinpoint the range of operation.

Also, the testing of the two read-only memories—inductive array and braid—is complicated by their addressing methods. In the array, for example, a single bad bit can be identified by an error in a single bit position at a specific address, whereas many errors in a single bit position indicate a bad sense amplifier and many errors in a single word may indicate an open-circuited diode or word line. A bad sense amplifier, for example, may show a 1 bit as a 0 but indicate 0's correctly, or vice versa, so that it doesn't show an error in every word. Many errors in a given 32-word group would indicate a bad selection switch, and in every 32nd word, a bad current source.

The computer must therefore store errors in as many as three dimensions—the 16 switches, the

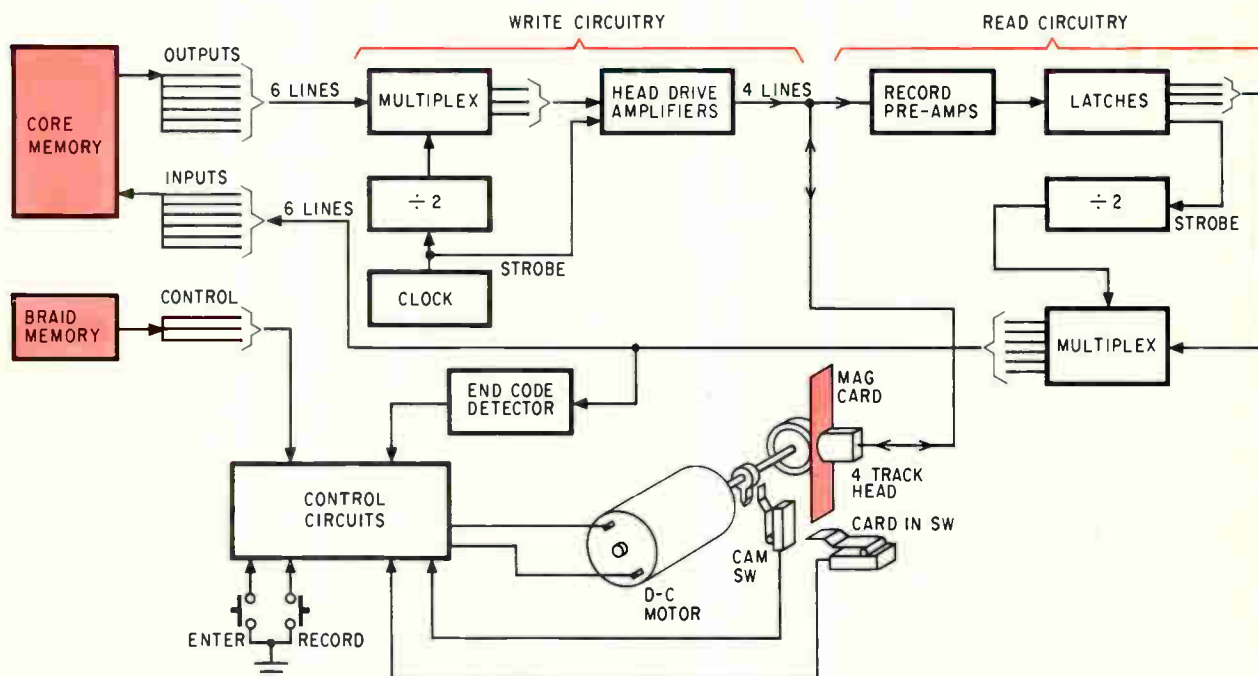

Card reader. A program in the calculator's core memory can be transferred to the magnetic card through the write circuits. When reading, data on the card is transferred to the core memory along paths parallel to those from the keyboard. The card records data on four tracks—three bits and a strobe; each code is recorded in two groups of three bits.

Calculator repertoire

Trigonometric

sin	arcsin
cos	arccos
tan	arctan

Hyperbolic

sinh	arcsinh
cosh	arccosh
tanh	arctanh

Common logarithm

Natural logarithm

Exponential

Conversions (for vector and complex-number manipulations)

Rectangular to polar
Polar to rectangular
True to absolute value

Miscellaneous

Enter π
Enter integer part of a number

32 current sources, and the 64 bits—to determine just what is wrong in an array that fails. Even so, it doesn't completely analyze all errors; it only narrows their source to a few possibilities so that a technician can finish the job.

The linear inductive array is tested at a maximum rate of 32,768 bit comparisons every millisecond. Many such 1-msec passes are made for each memory, varying a parameter such as sense-amplifier bias with each pass. The testing is against a hardware reference—that is, with a tester interface containing a known perfect assembly to which the array under test is supposed to be identical. The tester generates the clock rate and drives both assemblies in parallel, comparing the two outputs in hardware exclusive-OR gates or comparators. When errors occur, the tester stops, passes the error data to the computer, and proceeds.

This technique requires a rather complex tester interface but can yield a larger number of responses in a much shorter time than could a software reference—standards kept in a core memory—because the latter requires many accesses to the computer memory for every word tested, whereas the hardware-reference test can step word-by-word through the memory, stopping for a memory access only when it detects an error.

The read-only memory tester shown at the bottom of page 71 contains 64 exclusive-OR gates and 64 buffer flip-flops corresponding to the 64 outputs of the memory.

Word for word

As each of the 512 words are addressed in the testing, bit errors set one or more buffer flip-flops, causing the tester to halt with the error bits and address information displayed on its front panel. The computer records the error data and faulty address into its memory and continues the test.

Following the test, the computer analyzes the error data, looking to provide both failure diagnoses and performance-margin information. If errors occur at nominal test conditions, a diagnostic subroutine compares each error bit with the correct data to determine if the defective bit was a logical 1 or 0. If any of the 512 word lines had all 0 outputs—an abnormal condition for any word—the word address is printed with the message "Open word line." Any remaining errors are listed in table form, with rows corresponding to defective addresses and columns to defective bits.

If no errors are detected at nominal test conditions, the computer successively increments the bias current to the sense amplifiers, repeating the test and storing error data at each bias step. After a prescribed number of steps or after a specified number of failures are recorded, the bias current is returned to its initial value and decremented. Margin testing over a -50% -to- $+50\%$ range of bias currents typically involves more than a million bit comparisons.

When the margin testing is completed, a performance-margin profile is printed, as on page 72. Faulty sense amplifiers are plotted against bias voltage, with 1 printed wherever a logical 1 was missing and a 0 wherever an erroneous 1 occurred. The minimum acceptable error-free range is 7 volts, corresponding to a $\pm 35\%$ variation in bias currents, and 9 volts for any one sense amplifier.

The computer-controlled margin test is performed twice on each read-only memory. The first test is concerned only with a multilayer memory board using standard drive and sensing circuits; it detects any defects that hurt the performance of the memory, such as partially short-circuited bit segments within the array or improper layer-to-layer registration. The second test measures the complete memory assembly and locates any de-

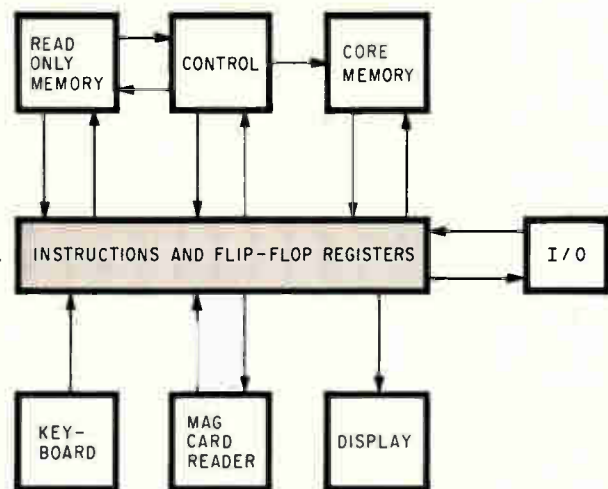

One-dimensional. Controlled by the read-only memory, each step in an operation alters the state of the flip-flop registers through a single level of logic—vastly simplifying circuit requirements.

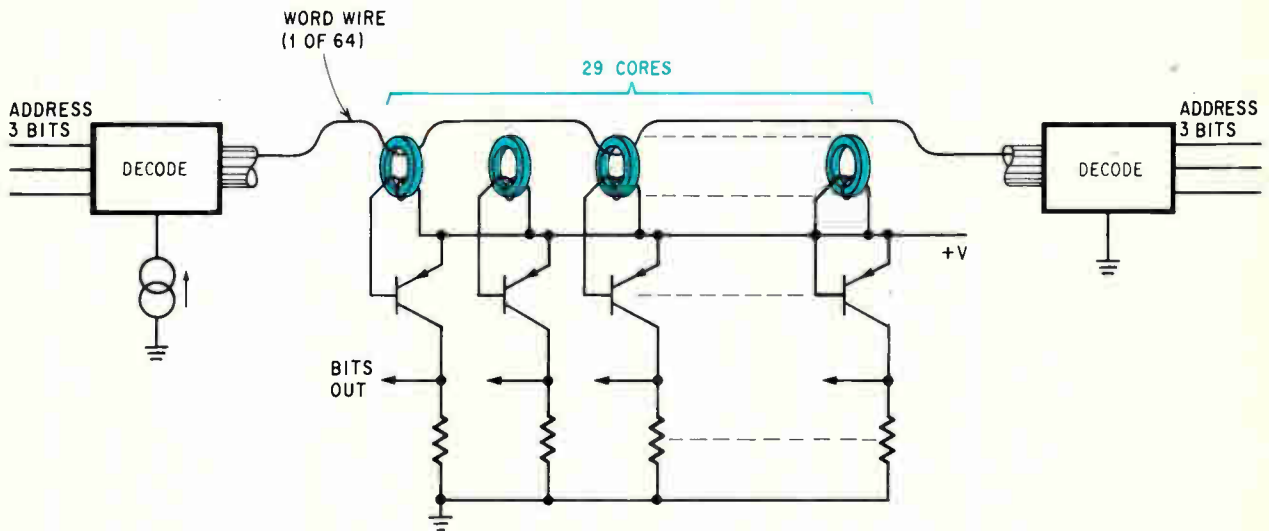

Braid memory. Microinstructions that control both the ferrite-core memory and the linear array are stored in a braid memory containing 64 words of 29 bits each.

fects in the drive and sense circuitry. It also establishes an optimum bias current for the sense amplifiers to assure operation over the widest possible range of environmental conditions.

Both nominal and margin test results are first punched on paper tape for later off-line printing, reducing test time from roughly 5 minutes to about 2. The operator can monitor the test without the printer by watching the bias-voltage meter. The needle first moves rapidly, then slows as errors occur and the tester pauses frequently to load error data into the computer.

Good turn of speed

The fact that a machine performs highly complex functions makes speed a particularly critical factor. The principal factors determining the basic speed of a computing device are the memory and the algorithms that are the basis of the machine's operation—with the memory system by far the more significant. The H-P calculator's random-access core memory provides speeds several hundred times greater than a delay line can offer.

The core array is a four-wire coincident-current memory holding 23 registers or words, each containing 16 characters of six bits. Seven of the 23 registers are used for arithmetic operations and display, while the remaining 16 are available for programing and storage. The cores are made of lithium-ferrite and are 30 mils in diameter. Their makeup assures high speed and operation over a wide temperature range, an important consideration because the calculator may be used in an instrumentation setup in a hot, dirty factory or carried in an engineer's car trunk in the winter. In either case, it should work as soon as it's plugged in.

There are several classes of functions common to many engineering problems. Those considered of prime importance in the design of the H-P cal-

culator are listed in the table on page 74.

But having common transcendental functions readily available at the push of a key is only part of the secret of machine performance. Usually the engineer wants the solution to an equation involving a combination of functions, or perhaps a locus of solutions as a function of one of the variables. With a stored-program capability, the calculator can solve the equation as simply as it performs any function on the keyboard—at least from the operator's point of view.

A calculator is inherently much easier to program than a general-purpose computer because the operator doesn't have to learn its "language." The language is the keyboard itself, plus a few simple condition branches and perhaps some control of external devices.

In cases where tabular data is desired, or where solutions are best presented in graphical form, the H-P calculator can control a peripheral printer and an x-y plotter. For example, an output plot of attenuation and phase versus frequency would be the best presentation of the frequency response of a bandpass filter.

Once this level of communication has been established between operator and machine, many other jobs become relatively simple. How the filter's characteristics vary with respect to component variations, for instance, can be observed simply by superimposing plots of the output response for different component values.

Nuts and bolts

The 9100A, which is diagramed opposite, is built with essentially a single level of conventional diode-resistor logic that feeds directly into flip-flop registers. The system operates in much the same way as a stored-program computer except that it gets microinstructions from a read-only memory.

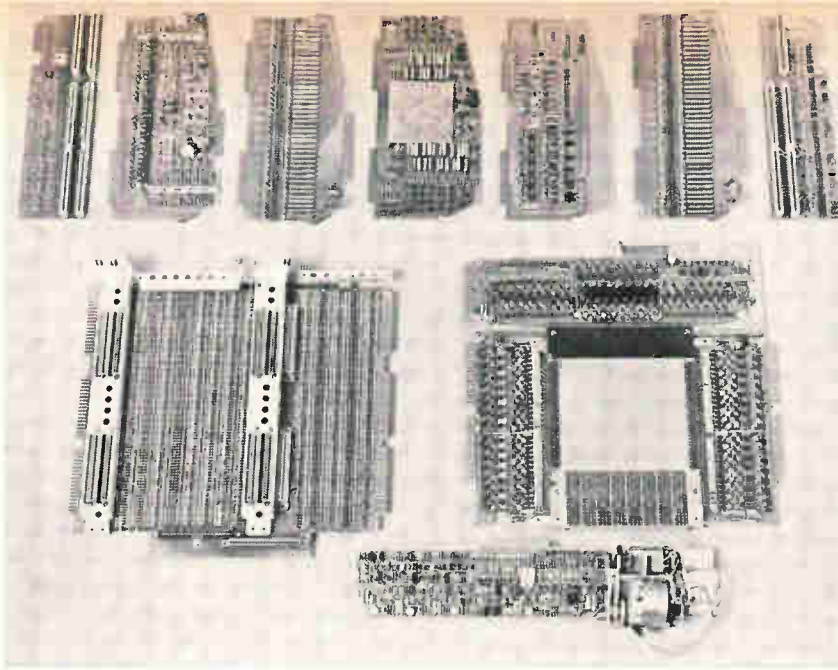

Calculator exploded. The multilayer board at left center contains all the calculator's logic gates plus sockets into which the five boards at top center plug in. The read-only memory, on the bottom of the calculator, is tied into the system through the small connectors shown at either end of the top row.

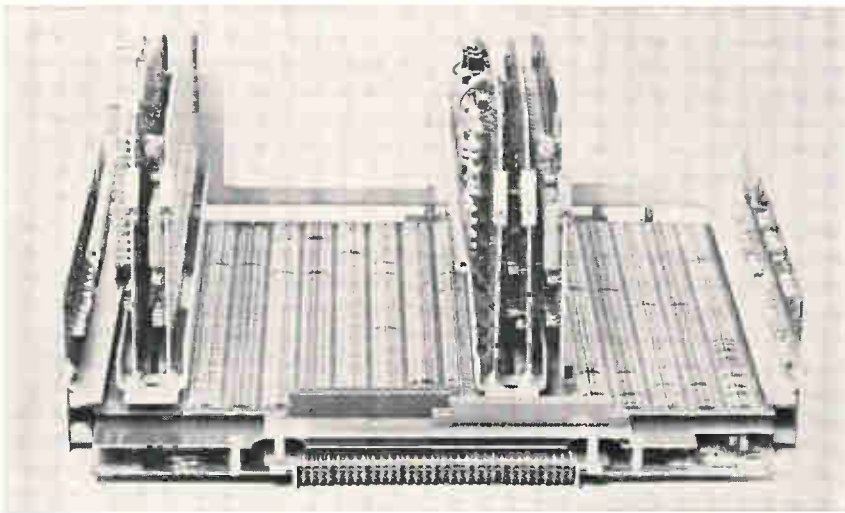

Calculator assembled. The parts shown above fit together as shown here, and are placed as a unit in the keyboard-cover assembly. In the cover are the crt and power supply, which occupy the gaps between the vertical plug-in cards.

Computer test facility. A Hewlett-Packard 2116B computer, shown below in the right-hand rack, controls two scanners, a digital voltmeter, and programable power supplies for production testing of the calculator. A logic assembly is shown ready for checkout; just above it is the read-only memory tester. Test results are displayed on the teleprinter.

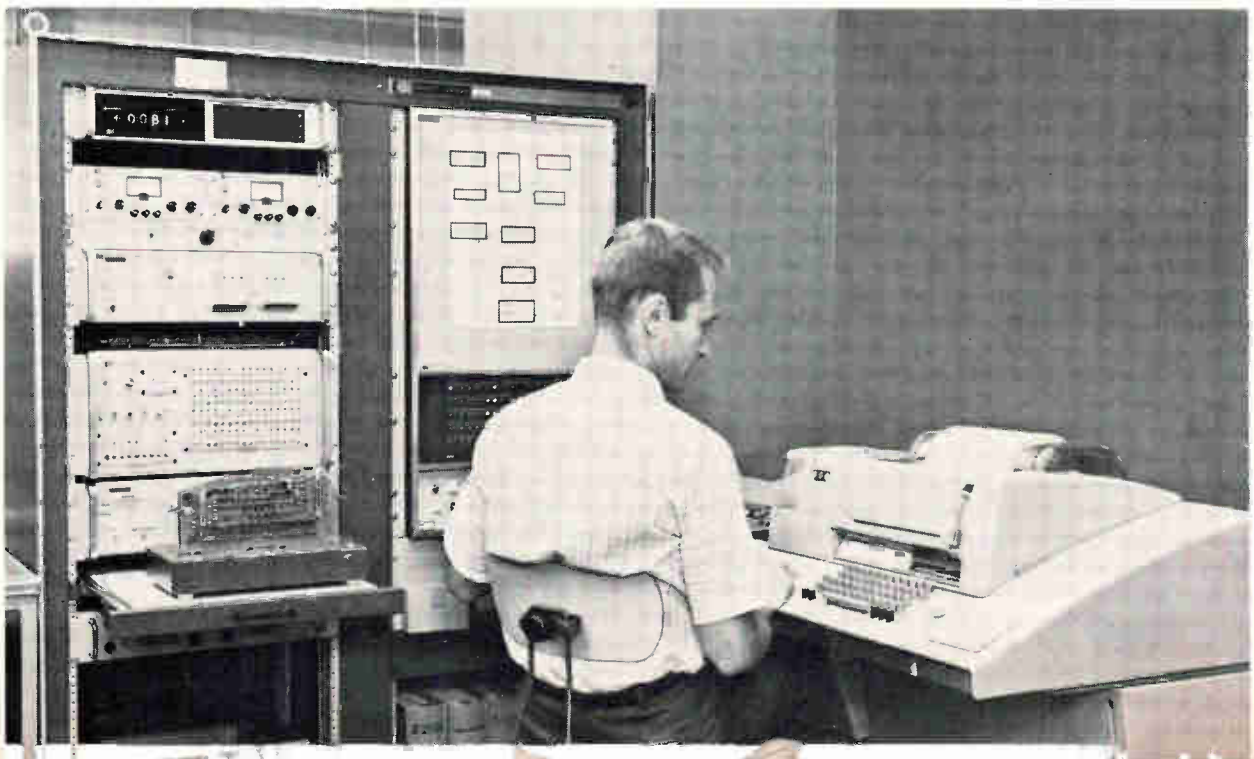

Internally, the calculator works serially by digit and in parallel by bit on four-bit binary-coded-decimal digits. Though this method is slower than straight binary for some operations, it avoids the need for binary-to-decimal conversion for display and trades speed for a simple design. It requires significantly less hardware, for example, because flip-flop registers handle only one digit at a time instead of a whole register.

The control circuitry contains a crystal oscillator that generates a three-phase clock at about 1.2 megahertz for machine timing. This circuit also issues microinstructions to both the core and inductive read-only memories. These instructions are generated by the small braided wire memory diagrammed on page 75, which is composed of 29 linear ferrite toroid cores and 64 wires, each threading some cores and bypassing others. Each wire generates a single 29-bit word made up of binary 1's from threaded cores and 0's from bypassed cores. A current passing down the selected wire generates a voltage pulse in sense windings on those cores it threads.

The control memory can also modify its own address, so it can perform some small subroutines more efficiently than the larger read-only memory, and less expensively than logic circuits.

The 350 logic gates that execute the calculator's instruction set contain 750 diodes and 325 resistors and are mounted on a single eight-layer board; this also acts as a motherboard for the remaining plug-in boards of the logic package [see top and middle photos on opposite page]. The six internal layers contain all the interconnections between individual gates and to and from the remainder of the system. For reliability, the two outer layers carry only solder pads—no interconnections.

The machine registers are composed of 40 identical J-K flip-flops, which function as address registers for the three memories, access registers for the core memory, temporary storages for arithmetic operations, and internal flags.

Thorough examination

It may seem unreasonable that a calculator designed to be small and light would not rely heavily on integrated circuits. But though it's true that many parts of the 9100A could be made smaller with IC's, the total system wouldn't benefit from the use of presently available IC's. Conventional diode-resistor logic is capable of great flexibility of configuration, and the fact that it can be gated on only when required eliminates any drain of standby power by unselected gates. Besides, the current and voltage requirements of the core memory and read-only array favored the use of diode-resistor logic and discrete transistors.

Four steps are taken to assure reliability. First, worst-case circuit design techniques ensure wide operating margins under normal or average conditions. Second, all transistors used in the 9100A are power-aged and stress-tested before being mounted on boards. Third, complete subassemblies are tested

by a computer, and actual operating margins are recorded to detect changes from run to run. And finally, each completed calculator is temperature-cycled in an environmental chamber between 25° and 55°C for several days prior to shipment.

The logic subassemblies in the calculator are tested, like the linear inductive array, under computer control [bottom photo, opposite], but because they require fewer test measurements than the memory, they are checked against a software reference.

The calculator's 40 flip-flops are mounted on two identical circuit boards. In testing them, the computer first compares the output voltages of all the flip-flops with programmed high and low limits. But it also makes an absolute voltage measurement to detect out-of-tolerance components that testing only the logic level would miss. If no faults are found, various other tests are conducted; and all these tests are repeated at various worst-case combinations of load and supply voltages to check only for logic states. A printed output lists all faults by the number of the defective flip-flop, the test in which failure occurred, and the load and supply voltage conditions. The 2,250 measurements and printed output typically require 35 seconds.

Also checked out by computer is the woven-wire braid memory. While the crystal-controlled clock circuit on the same board increments address flip-flops for the braid memory, a dynamic test is performed to detect excessive response times as well as logical errors. As each of the 1,856 data bits stored in the woven-wire array is fed to the computer, it's compared to a software reference. If found defective, it's stored with its associated address in computer memory.

Error analysis is done in much the same way as with the main read-only memory; any open- or short-circuited output transistors are listed, and the remaining error data is printed in table form. If no errors are detected at a voltage 10% above normal, the test is repeated at a voltage 10% below normal. A special circuit that prevents the loss of data by the core memory during power shutdown is included on this board and is computer-tested for turn-on time and shutdown voltage. The 4,000 test measurements performed per board typically take 50 seconds.

In another step to minimize total test time and ensure maximum reliability, all transistors are aged at 100% of rated power for 96 hours, and are then tested before subassemblies are loaded. But if the subassemblies weren't themselves tested, there would be little chance that an assembled calculator would perform perfectly when power was applied.

Test results have shown that less than half the logic subassemblies initially pass the computer test. But more than 90% of the fully assembled calculators with pretested subassemblies perform perfectly at initial turn-on. Thus, only a few machines need post-assembly debugging—a lengthy process, even for a skilled technician. These statistics enable the calculator to carry a one-year warranty. ■

Designer's casebook

Oscillator has a transfilter as the resonant device

By Charles Hartley

H&L Electronics, Medford, Ore.

Stable, low cost oscillators can be built that use transfilters instead of transformers as the coupling element. Transfilters are ceramic devices operating at certain resonant frequencies. In this application, the ceramic device formed the oscillating element in a 455-kilohertz intermediate frequency system. Since there is no d-c path across the element, coupling capacitors aren't needed.

The transistor can either be pnp or npn depending on the voltage of the power supply, but it should have a beta of 50-100, and a cutoff limit of 10 megahertz.

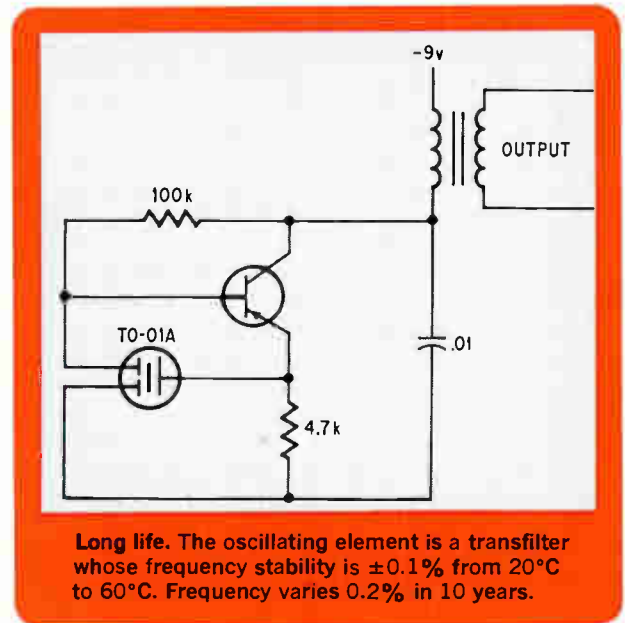

Line-operated relay uses isolated actuating input

By Jack B. Johnson

VA Southern Research Support Center, Little Rock, Ark.

Remote control switching of an a-c power line can be done by a solid state relay with an isolated actuating input. The isolation component is a transformer and the power line serves as the actuating circuit.

The unijunction transistor produces a pulse after each zero crossing of the line voltage. The transformer's reactance is high enough to prevent gating of the pulses to the silicon controlled rectifier when the primary winding is open. With the primary shorted, the secondary's impedance is reduced and the pulses fire the SCR. Turn-on occurs soon after each zero crossing of the line voltage because of the charging time of the capacitor in the unijunction gating circuit.

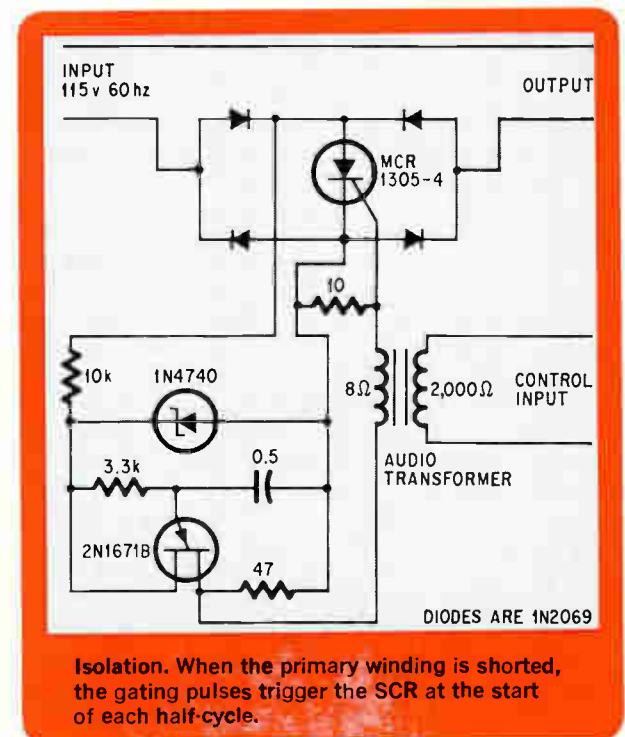

Power supply breaker acts in 100 microseconds

By C.J. Ulrick

Collins Radio Co., Cedar Rapids, Iowa

Slow reaction by power supplies in catching faults can cause trouble in a circuit. Printed circuits and interconnections are especially vulnerable; the leads can be ruined before the supply stops sending short-circuit current through them. This is especially true of lab work where the universal supplies are either unprotected or protected by slow fuses and magnetic breakers.

The breaker circuit shown trips within 100 microseconds of a shorted load condition and reduces the fault current to zero within 500 μ sec. It can be used in series with existing supplies.

Power transistor Q_1 is in series with the load. Control transistor Q_2 holds Q_1 in saturation during normal operation, and allows Q_1 to turn off when a fault is detected. R_2 determines the base current in Q_2 .

When the load R_L is shorted, Q_1 momentarily pulls out of saturation, and Q_2 's base voltage drops to zero. Q_1 shuts off and stays off because of Q_1 's regenerative action until a manual or automatic reset is applied.

If manual reset is used, the leakage current of Q_1 must be low enough to ensure that it doesn't turn itself on after a fault and reapply power to R_L before it is needed. Automatic reset will re-apply

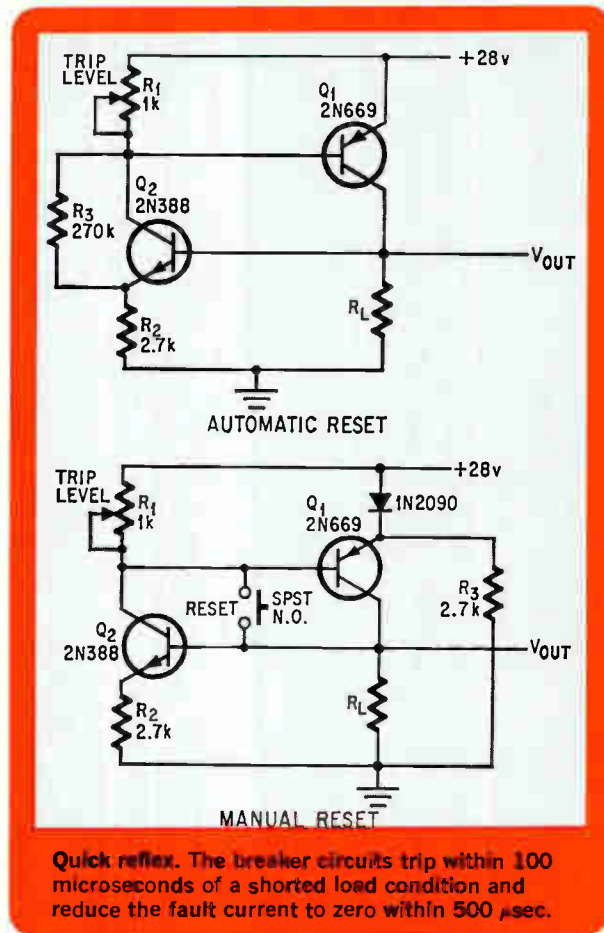

Quick reflex. The breaker circuits trip within 100 microseconds of a shorted load condition and reduce the fault current to zero within 500 μ sec.

power soon after the fault occurs, the time depending upon the leakage in Q_1 .

4-pulse sequence generator built with 1 hex-inverter

By Fred Cupp

General Dynamics, Rochester, N.Y.

Quickly built, low-cost sequential pulse generators are needed in many industrial applications. One RTL hex-inverter integrated circuit with interconnecting RC networks makes a 4-pulse generator with equal or independently variable pulse widths.

The basic pulse generator consists of inverters A, B, and C. The timing capacitor connected around

an even number of stages provides positive feedback, while the timing resistor around an odd number of stages makes the generator self-starting. The timing resistor must provide sufficient current to nearly saturate the first stage.

Inverter stages D, E, and F generate output pulses in a sequential manner, the duration of each pulse depending on the RC network at the inverter's input.

With the addition of the diodes and suitable circuit values for the output stages, a 20% duty cycle can be achieved. Since each pulse width in the design is 20% of the period, after each train of 4 pulses there is a dead period before the start of the next pulse train. This may be necessary for synchronization. The values of R and C may be altered for each stage, providing sufficient time

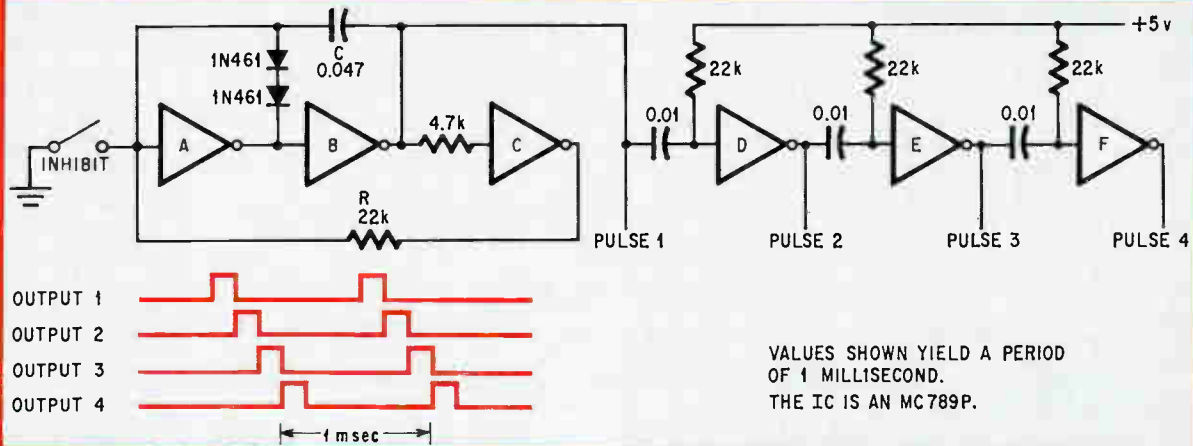

Repetition. Four sequential output pulses are developed, which can be of equal duration or can be independently variable. The duration of each pulse depends on the RC network at each inverter's input. Only the repetition rate constrains the number of stages that can be cascaded.

is allowed to charge the succeeding stage's capacitor. Frequencies in the low megahertz range are

possible. Several IC's can be cascaded to produce a 16-stage sequence generator.

MOS FET stabilizes oscillator's output

By Neal H. Brown

Solid State Electronics, Tucson, Ariz.

A stable output regardless of load and supply voltage changes can be achieved in a Colpitts

oscillator through the use of a metal oxide semiconductor field effect transistor. Waveform symmetry is also improved.

Part of the output is coupled back by capacitor C_1 through the clamp diodes and rectified to produce a negative d-c bias at the FET's gate. Any change in the output produces a corresponding and offsetting change in the gate bias to hold the output at a constant level.

The circuit can be frequency-locked to an external oscillator through the input coupling capacitor, as shown at the left of the diagram.

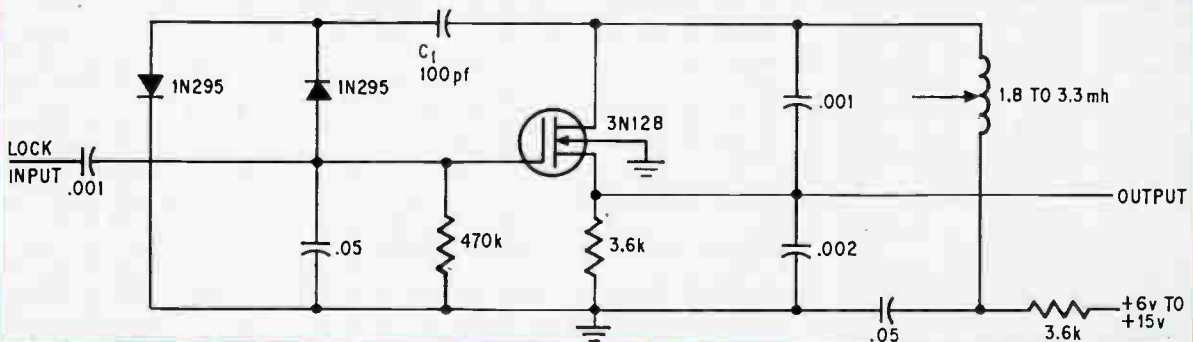

Feedback. Any change in the output level is fed back through capacitor C_1 to the diode rectifiers, producing a corresponding change in gate bias level to the FET. The output amplitude remains constant with load and supply voltage changes, and the waveform symmetry is considerably improved.



**You thought you knew Darlington—
until you needed power.**

**Now see Bendix
for power IC Darlington.**

They're unique—our new BHF Power Darlington and our new BHB Power Driver integrated circuits.

Both offer major benefits over their discrete counterparts—including greater reliability, and lower cost of use. Result: a series of highly reliable, relatively low-cost modular packages that combine Bendix in-house power semiconductor capability with the latest in thick-film know-how.

All Bendix Darlington circuits include an integral commutating diode for load clamping and an emitter leakage-drain resistor. There are seven to choose from, and we're the only company that offers an 80-volt, 10-amp Darlington. Typical applications? In regulator circuits, in power amplifiers, in hammer driver circuits.

Our four new power driver modules complement Bendix Darlington by providing a TTL or DTL logic interface in the form of a 3-input gate, with an expander. Producing 5 amps output current at 60 volts. In typical applications, they are used as stepper motor drivers, as relay drivers and as servo motor drivers.

It's a lot of power for a lot of applications. All from the real power in power: Semiconductor Division, The Bendix Corporation, Holmdel, New Jersey 07733.

DARLINGTON CIRCUITS

Part Number	Breakdown Voltage (V)	Output Current (A)	Input Current (mA)
BHF0002	40	10	250
BHF0003	60	10	250
BHF0004	80	10	250
BHF0005	80	10	250
BHF0006	60	10	250
BHF0007	80	10	250
BHF0008	80	10	250

POWER DRIVER CIRCUITS

Part Number	Maximum Output Current (A)	Output Voltage (V)	Input Leakage Current (μ A)
BHB0005	5	60	300
BHB0005A	5	60	100
BHB0006	3	40	300
BHB0006A	3	40	100

Bendix **Electronics**

Circle 81 on reader service card

Active filters: part 6

The op amp saves time and money

These devices provide large blocks of gain and good circuit stability, use fewer active components, and allow networks to be designed quickly

By Brent Welling

Motorola Semiconductor Products Inc., Phoenix, Ariz.

Synthesizing a dynamic circuit looks easy on paper. But fabricating a practical circuit is another matter. Active-filter designers can look to the integrated circuit operational amplifier to attain the transfer functions needed in the circuit. By adding simple series or shunt resistance-capacitance networks to the op amp, almost any transfer function can be constructed—at a remarkably low cost. For example, one high-performance op amp, when bought in quantities of 100 or more, costs the equipment designer 9 cents for each transistor in the unit—which includes the nominal cost of the resistors, wiring, design time, and specifications.

As the IC technology improves, op-amp performance will go up and cost down, making the use of operational amplifiers for active filters not only desirable but necessary.

By choosing the operational amplifier as a means for building an active filter, the engineer doesn't waste time selecting, from among the many active components, those which are needed by other techniques to achieve circuit stability and high accuracy. Moreover, operational amplifiers provide much larger blocks of gain and demonstrate good circuit stability. Since operational amplifiers provide a virtual ground, the engineer can design each network independently and not have to worry about any interactions when the networks are joined in a common configuration.

The basic operational amplifier configuration for an active filter usually calls for at least one RC arrangement as a feedback network across the op amp and one RC combination in series with each input source. Usually, only two RC networks are needed to produce a second-order transfer function. Higher orders are achieved by cascading several op-amp arrangements.

To design op-amp circuits into active filters, the engineer must first understand the operation of the device when feedback networks other than resistors are used in either an inverting or non-inverting mode of operation. Moreover, he needs a general equation for a closed-loop gain from which an active filter can be designed. Such an understanding can best be developed by examining an operational amplifier with input impedance, Z_1 , and feedback impedance, Z_2 .

This network tempts the engineer to state that the closed-loop gain is $e_o/e_{in} = -Z_2/Z_1$, but for the general case this expression is incorrect since it does not take into account that Z_1 and Z_2 can be active networks. And further, if these impedances are passive, which impedance in the four-terminal two port is Z_1 and Z_2 ? If the designer is content to always use resistors for Z_1 and Z_2 , this problem does not arise. However, for active-filter design, where both capacitors and resistors are used, a better understanding of the operational amplifier with feedback is necessary. Therefore, a better understanding of op-amp operation is developed using the diagram at the top of page 83. For this network, the following two-port equations can be written:

$$I_1 = y_{11a} E_1 + y_{12a} E_3 \quad (1a)$$

$$I_3 = y_{21a} E_1 + y_{22a} E_3 \quad (1b)$$

$$I_2 = y_{11c} E_2 + y_{12c} E_4 \quad (2a)$$

$$I_4 = y_{21c} E_2 + y_{22c} E_4 \quad (2b)$$

$$I_5 = y_{11b} E_5 + y_{12b} E_6 \quad (3a)$$

$$I_6 = y_{21b} E_5 + y_{22b} E_6 \quad (3b)$$

These equations can be manipulated to find the output voltage, E_o , as a function of the following:

E_1, E_2 , the y parameters, and the open-loop gain, A . However, this approach is somewhat rigorous and the resulting equation would be too complicated to be of any practical use. By making use of a few normally valid assumptions, the complexity of the solution for E_0 is greatly reduced and results in a very simple and easily used form.

One assumption is that the input impedance of the operational amplifier is very large with the result that $I_x \approx 0$ and $I_4 \approx 0$. From equation 2b

$$E_4 = -E_2 \left(\frac{y_{21c}}{y_{22c}} \right) \quad (4)$$

also, because

$$I_x \approx 0, I_3 \approx -I_5 \quad (5)$$

Then from equation 1b and 3a

$$y_{21a} E_1 + y_{22a} E_3 = -y_{11b} E_5 - y_{12b} E_6 \quad (6)$$

Because the amplifier is assumed to have an extremely large open-loop gain ($A \rightarrow \infty$), the differential input signal required, $E_3 - E_4$, is very small. Assuming that $E_3 \approx E_4 \approx E_5$, then from equation 4

$$E_5 \approx -E_2 \left(\frac{y_{21c}}{y_{22c}} \right) \quad (7)$$

and

$$E_3 \approx -E_2 \left(\frac{y_{21c}}{y_{22c}} \right) \quad (8)$$

Inserting equations 4, 7, and 8 into equation 6 gives the following expression for the output voltage, E_6

$$E_6 = -E_1 \left(\frac{y_{21a}}{y_{12b}} \right) + E_2 \left(\frac{y_{21c}}{y_{22c}} \right) \left(\frac{y_{11b} + y_{22a}}{y_{12b}} \right) \quad (9)$$

as a function of the input voltages and the feedback networks. Having obtained an expression for the closed-loop gain as a function of the y parameters, the designer need only know the y values of the RC network to properly design an op-amp active filter.

As a simple example that verifies equation 9, consider the amplifier at the center of this page. For this example,

$$y_{21a} = -\frac{1}{R_1} \quad y_{12b} = -\frac{1}{R_2} \quad y_{21c} = -\frac{1}{R_3}$$

$$y_{22a} = \frac{1}{R_1} \quad y_{11b} = \frac{1}{R_2} \quad y_{22c} = \frac{1}{R_3}$$

then from equation 9

$$E_0 = -E_1 \left(\frac{R_2}{R_1} \right) + E_2 \left(1 + \frac{R_2}{R_1} \right) \quad (10)$$

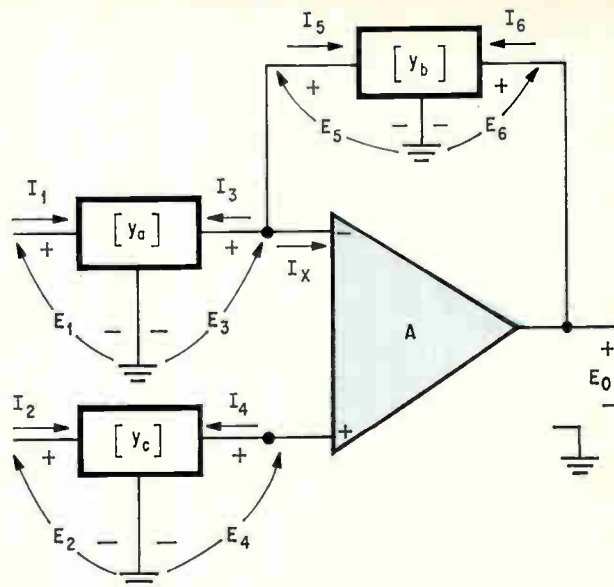

Feedback. Basic op amp containing feedback and two input signals is represented in block-diagram form. This configuration is used to produce second-order transfer functions.

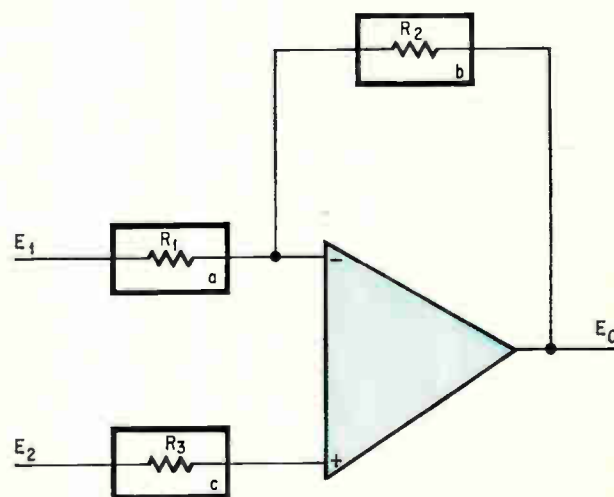

Verification. Resistors R_1, R_2 , and R_3 , connected to the op amp produce an output signal that is proportional to both input voltages and the feedback network.

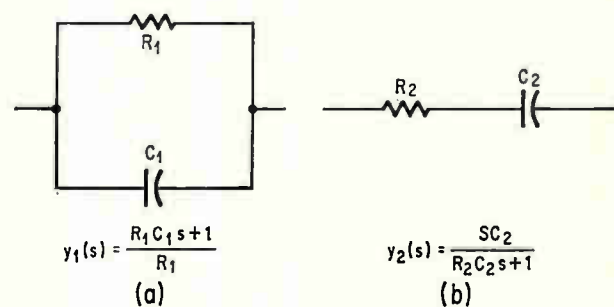

RC networks. Because of the electrical properties of the op amp—high input impedance, low output impedance, and very high gain—the engineer need only connect RC network combinations, such as these, to obtain a desired frequency response curve.

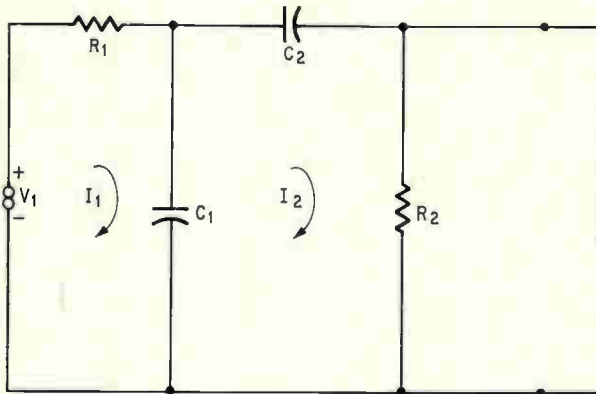
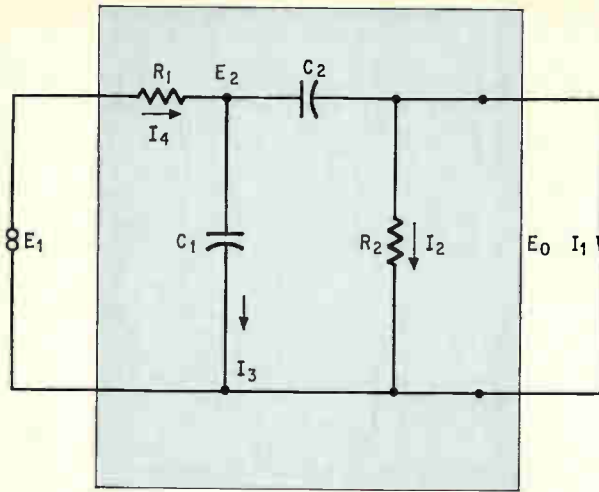

Working backward. To find the relationship between the short-circuit current and an impressed input voltage for a given circuit, the engineer assumes a 1-ampere current in the most right-hand branch and analyzes the current flow working back toward the source, top. Loop currents can also be used to find the relationship between the short-circuit current and the impressed input voltage, bottom.

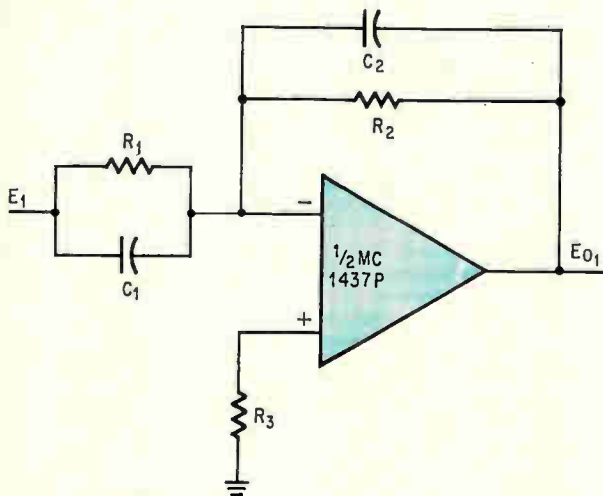

Isolation. By taking advantage of the isolation properties between amplifiers the engineer is able to apply this circuit to produce a second-order transfer function with a minimum of external components.

From this equation, if $E_2 = 0$, which is inverting amplifier condition, the closed-loop gain is the familiar expression

$$\frac{E_0}{E_1} = - \frac{R_2}{R_1} \quad (11)$$

Similarly for $E_1 = 0$, the noninverting gain is found to be

$$\frac{E_0}{E_2} = 1 + \frac{R_2}{R_1} \quad (12)$$

Active filter analysis

For the discussion to follow, the inverting amplifier mode of operation ($E_2 = 0$) will be used because of its simplicity as seen in equation 9. However, a similar discussion could be generated using the noninverting mode with $E_1 = 0$.

It should be noted that the expression for the closed loop gain in the inverting mode does not make any assumptions that networks $[y_a]$, $[y_b]$, or $[y_c]$ are passive. Indeed, these networks could be active. For the case at hand, however, these networks will be considered to be passive, in which case

$$y_{21b} = y_{12b} \quad (13)$$

and equation (11) becomes

$$\frac{E_0}{E_1} = - \left(\frac{y_{21a}}{y_{21b}} \right) \quad (14)$$

The synthesis of a particular frequency response curve will in most cases be designed using RC networks in various combinations. For most applications these networks will be combinations of series or parallel connected resistors and capacitors.

The problem of synthesizing filters with RC networks is not a difficult task.

From equation 1b and 3b

$$y_{21a} = \frac{I_3}{E_1} \Big|_{E_3 = 0} \quad \text{and} \quad y_{21b} = \frac{I_6}{E_5} \Big|_{E_6 = 0} \quad (15)$$

Thus, the synthesis problem reduces to that of finding the relationship between the input voltage and the short-circuit output current. The problem has been reduced in complexity from a two-port network to a one-port network.

Backwards method

For many circuits, the relationship between the short-circuit current and an impressed input voltage can be written by inspection. For more complicated networks, Laplace transform methods may be required, or perhaps even the use of signal-flow graphs, and matrix algebra. State variables are valuable in solving extremely difficult problems.

Another approach to finding the necessary y_{21} 's is to exploit a very simple, but often forgotten method of working backwards. The prime advantage of this method is that it does not require the use of long involved Laplace equations for loops or nodes, and greatly simplifies the algebra involved in the analysis.

This method is an outgrowth of the continued fraction expansion technique for finding transfer functions. The steps are as follows:

- A unit output is assumed, $V_o = 1$ volt, or $I_o = 1$ amp. Since it is the transfer admittance that is of interest in this case, a current of 1 amp is assumed at the output.

- The input, V_1 or I_1 , is then found by a step-by-step procedure involving the successive use of Kirchhoff's current and voltage law.

- Because the elements of the network are assumed linear, the input required to give a unit output is proportional to the input required to give any other output. Thus,

$$\frac{\text{unit output}}{\text{input for unit output}} = \frac{\text{general output}}{\text{input to give general output}}$$

This method is best explained with an example. Consider the network shown at the top of page 84, where it is necessary to find

$$y_{21} = \left. \frac{I_1}{E_1} \right|_{E_0 = 0}$$

Assume $I_1 = 1$ amp. Because of the shorted output, $I_2 = 0$. Thus, $E_2(s)$ can be expressed as

$$E_2(s) = I_1 \left(\frac{1}{sC_2} \right) = \frac{1}{sC_2} \quad (16)$$

$I_3(s)$ can be expressed as

$$I_3(s) = E_2(s) sC_1 = \frac{sC_1}{sC_2} = \frac{C_1}{C_2} \quad (17)$$

It is known that

$$I_4 = I_1 + I_3 = 1 + \frac{C_1}{C_2} \quad (18)$$

and

$$E_1(s) = E_2(s) + I_4 R_1 \quad (19)$$

$$E_1(s) = \frac{1}{sC_2} + \left(1 + \frac{C_1}{C_2} \right) R_1$$

or

$$= \frac{sC_2 R_1 \left(1 + \frac{C_1}{C_2} \right) + 1}{sC_2} \quad (20)$$

Since this is the voltage function that will produce

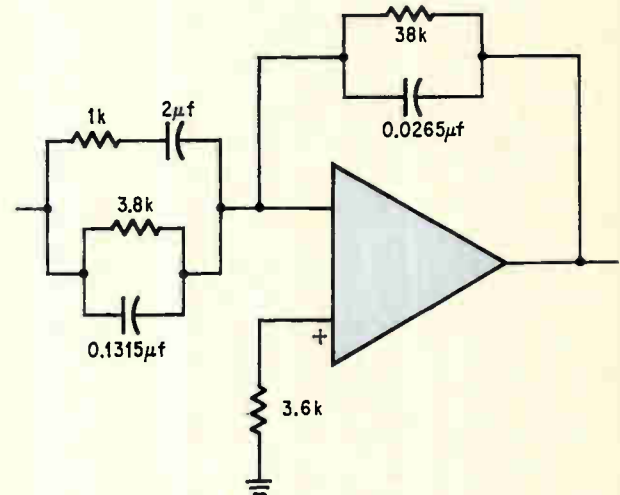
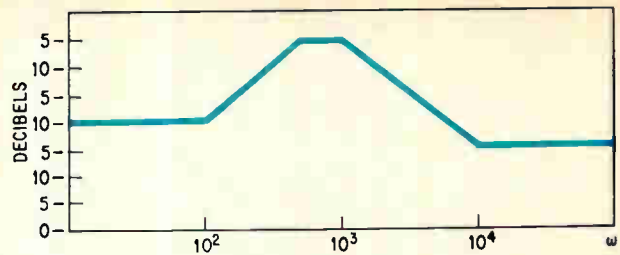

Bode plot. Straight-line approximation of a second-order transfer function indicates break frequencies at 100, 500, 1,000, and 10,000. Circuit at bottom is used to produce this transfer function.

$I_1 = 1$, then the ratio of I_1/E_1 becomes

$$\frac{I_1}{E_1} = \frac{sC_2}{sC_2 R_1 \left(1 + \frac{C_1}{C_2} \right) + 1} = y_{21} \quad (21)$$

However, in this equation the direction of the current for I_1 was assumed to be flowing in the opposite direction from the current derived in the two-port amplifier model, and hence, the sign on the transfer function must be changed. Then finally,

$$y_{21} = \frac{-sC_2}{sC_2 R_1 \left(1 + \frac{C_1}{C_2} \right) + 1} \quad (22)$$

General method

A procedure for finding the forward-transfer admittance for any network can be derived by applying Kirchhoff's voltage law with a slight modification. To demonstrate, consider a network consisting of k loops with I_1, I_2, \dots, I_k denoting the transforms of the loop currents, and V_1, V_2, \dots, V_k representing the transforms of the driving voltage in each loop, respectively.

Applying Kirchhoff's voltage law results in k simultaneous equations

$$\begin{aligned}
V_1 &= Z_{11} I_1 + Z_{12} I_2 + \dots + Z_{1k} I_k \\
V_2 &= Z_{21} I_1 + Z_{22} I_2 + \dots + Z_{2k} I_k \\
&\vdots \\
V_k &= Z_{k1} I_1 + Z_{k2} I_2 + \dots + Z_{kk} I_k
\end{aligned}
\tag{23}$$

where Z_{ii} is the total impedance around the i th loop and Z_{ij} is the total impedance common to the i th loop and the j th loop. For the case under discussion, only one voltage source, V_1 , is present and hence, $V_k = 0$ for $k \neq 1$.

The problem is to find I_k , the output current, when the output terminal is shorted. It should be noted that after shorting the output terminals, a modification to Z_{kk} must be made. Once this modification to Z_{kk} is made, the transfer function can be found by solving the determinant using Kramer's rule. This is demonstrated in the following example.

Example 1—Multiloop network

For the circuit at center of page 84,

$$\begin{aligned}
Z_{11} &= R_1 + \frac{1}{sC_1} \\
Z_{12} &= -\frac{1}{sC_1} \\
Z_{21} &= -\frac{1}{sC_1}
\end{aligned}
\tag{24}$$

With the output shorted Z_{22} becomes

$$Z_{22} = \frac{1}{sC_1} + \frac{1}{sC_2}
\tag{25}$$

Solving for I_2/V_1

$$\begin{aligned}
\frac{I_2}{V_1} &= \frac{\begin{vmatrix} \left(R_1 + \frac{1}{sC_1}\right) & 1 \\ -\frac{1}{sC_1} & 0 \end{vmatrix}}{\begin{vmatrix} \left(R_1 + \frac{1}{sC_1}\right) & \left(-\frac{1}{sC_1}\right) \\ \left(-\frac{1}{sC_1}\right) & \left(\frac{1}{sC_1} + \frac{1}{sC_2}\right) \end{vmatrix}} \\
&= \frac{sC_2}{sC_2 R_1 \left(1 + \frac{C_1}{C_2}\right) + 1}
\end{aligned}
\tag{26}$$

This is the same result obtained for the previous backwards example. The short-circuit transfer admittances for any network can always be determined with this method.

Though much has been done concerning the problem of passive network synthesis, most of the effort to date has been concerned with synthesis of driving point impedances, matching networks, and voltage transfer functions. Very little has been written about the synthesis of transfer admittances. However, a basic approach to the problem follows.

If networks $[y_a]$ and $[y_b]$ are passive RC networks, their poles will be on the negative real axis of the complex frequency plane. However, the zeros of the transfer admittance of $[y_a]$ and $[y_b]$ can be located anywhere in the complex frequency plane. From this, it can be concluded that if the poles of y_{21a} are the same as the poles of y_{21b} , the denominators of equation 14 will cancel and almost any desired pole-zero configuration can be synthesized.

In mathematical terms, this means that y_{21a} is chosen as

$$y_{21a} = \frac{P(s)}{Q(s)}$$

and

$$y_{21b} = \frac{R(s)}{Q(s)}$$

then

$$\frac{E_0}{E_1} = -\left(\frac{y_{21a}}{y_{21b}}\right) = -\frac{P(s)}{R(s)}$$

Although this is the general method, the prudent engineer should always take advantage of simple calculations where possible. For example, suppose it is required to synthesize the following filter response

$$\begin{aligned}
\frac{E_0}{E_1}(s) &= \frac{-5(s+100)(s+10,000)}{(s+500)(s+1000)} \\
&= \frac{-5(s^2 + 10.1 \times 10^3 s + 10^6)}{(s+500)(s+1000)}
\end{aligned}$$

The straight-line Bode approximation of this function is shown at the top of page 85. The following transfer admittance results when a parallel RC network is shunted across a series RC network.

$$y_r(s) = y_1(s) + y_2(s) = \frac{R_1 C_1 s + 1}{R_1} + \frac{s C_2}{R_2 C_2 s + 1}$$

or

$$y_r(s) = \frac{C_1 \left[s^2 + s \left(\frac{1}{R_2 C_2} + \frac{1}{R_1 C_1} + \frac{1}{R_2 C_1} \right) + \frac{1}{R_1 C_1 R_2 C_2} \right]}{\left[s + \frac{1}{R_2 C_2} \right]}$$

If this is the transfer function for y_{21a} , and a parallel RC network for the feedback y_{21b} is used, then the over-all transfer function becomes

$$\frac{E_0}{E_1}(s) = \frac{C_1 \left[s^2 + s \left(\frac{1}{R_2 C_2} + \frac{1}{R_1 C_1} + \frac{1}{R_2 C_1} \right) + \frac{1}{R_1 C_1 R_2 C_2} \right]}{C_3 \left[s + \frac{1}{R_2 C_2} \right] \left[s + \frac{1}{R_3 C_3} \right]}$$

For this problem

$$\frac{1}{R_2 C_2} = 500$$

$$\frac{1}{R_3 C_3} = 1,000$$

$$\frac{1}{R_1 C_1 R_2 C_2} = 10^6$$

$$\frac{1}{R_2 C_2} + \frac{1}{R_1 C_1} + \frac{1}{R_2 C_1} = 10.1 \times 10^3$$

Also, from the d-c gain considerations

$$\left. \frac{y_{21a}}{y_{21b}} \right|_{s=0} = 10 = \frac{R_3}{R_1}$$

or

$$R_3 = 10R_1$$

Since there are five independent equations and six unknowns, one unknown arbitrarily chosen, can be used to calculate the remaining five unknowns. Thus, let $R_2 = 1,000$. Then, $C_2 = 2 \mu\text{f}$, $C_1 = 0.1315 \mu\text{f}$, $R_1 = 3.8\text{k}$, $R_3 = 38\text{k}$, and $C_3 = 0.0265 \mu\text{f}$.

The circuit that synthesizes this transfer function is shown on page 85.

Thevenin resistance

The impedance that is used to terminate the non-inverting (+) input should be the d-c Thevenin equivalent resistance that is found at the inverting (-) input in the direction away from the amplifier. By doing this, the engineer eliminates the component of the d-c output offset voltage that is due to the bias current of the amplifier. Thus, for the first stage, the d-c Thevenin resistance is the parallel combination of the 3.8-kilohm resistor and the 38-kilohm resistor, hence this is approximately equal to 3.45 kilohms—a conventional value five percent resistor of 3.6 kilohms has been used.

Another approach to this problem would be to use a dual operational amplifier, such as the Motorola MC1437P, and take advantage of the isolation properties between the amplifiers. If this is done, the original transfer function can be broken up into two parts, making the calculations simple. That is,

$$\frac{E_0}{E_1} = \frac{E_{01}}{E_1} \times \frac{E_0}{E_{01}} \quad (30)$$

where

$$\frac{E_{01}}{E_1} = \frac{-5(s+100)}{(s+500)}, \quad \frac{E_0}{E_{01}} = \frac{-(s+10,000)}{(s+1000)} \quad (31)$$

For the first amplifier

$$\frac{E_{01}}{E_1} = \frac{-5(s+100)}{(s+500)} = \left(- \frac{y_{21a}}{y_{21b}} \right) \quad (32)$$

A parallel RC network for both networks provides the desired response.

$$\begin{aligned} \frac{E_{01}}{E_1} &= - \frac{y_{21a}}{y_{21b}} = - \frac{R_1 C_1 s + 1}{R_2 C_2 s + 1} \\ &= - \frac{C_1}{C_2} \frac{\left(s + \frac{1}{R_1 C_1} \right)}{\left(s + \frac{1}{R_2 C_2} \right)} \end{aligned} \quad (33)$$

where

$$\frac{C_1}{C_2} = 5, \quad \frac{1}{R_1 C_1} = 100, \quad \frac{1}{R_2 C_2} = 500.$$

When one of the components has been selected the others can then be found; therefore, suppose an additional requirement is imposed—the input impedance for a d-c input must be at least 10 kilohms. Since for the inverting operational amplifier the input impedance is the one which is placed between the voltage source and the inverting terminal, the d-c impedance is merely R_1 . The designer must then select components that are conventional. If R_1 is selected to be 16 kilohms, then $C_1 \approx 0.1 \mu\text{f}$ and $C_2 = C_1/5 = 0.02 \mu\text{f}$, from which R_2 is found to be 16 kilohms also.

The second amplifier can be analyzed in a similar manner with the resulting circuit shown at the top of page 88. Note that compensating networks are added to both amplifier stages because of the different d-c gains. This compensation is needed by the amplifiers to avoid instability. The d-c gain of the first stage is unity, and the amplifier has been compensated for unity gain; the d-c gain of the second stage is 10 and subsequently, the amplifier is compensated for a gain of 10.

Investigating stability

Almost any desired pole-zero configuration can be synthesized with active filters, but care must be taken to ensure that the network synthesized will be stable when used as a feedback network to an op amp. It is possible to correctly compensate an op amp to a -6 db per octave slope as suggested on the manufacturers data sheet and have the closed-loop system oscillate. The problem becomes one of investigating the closed-loop stability of the active filter in terms of the two-port y parameters.

To demonstrate how the designer compensates to stabilize a network, consider a conventional negative feedback circuit.

For this circuit, the closed-loop gain is given by

$$\frac{E_0}{E_1} = \frac{A(s)}{1 + A(s) \beta(s)} \quad (34)$$

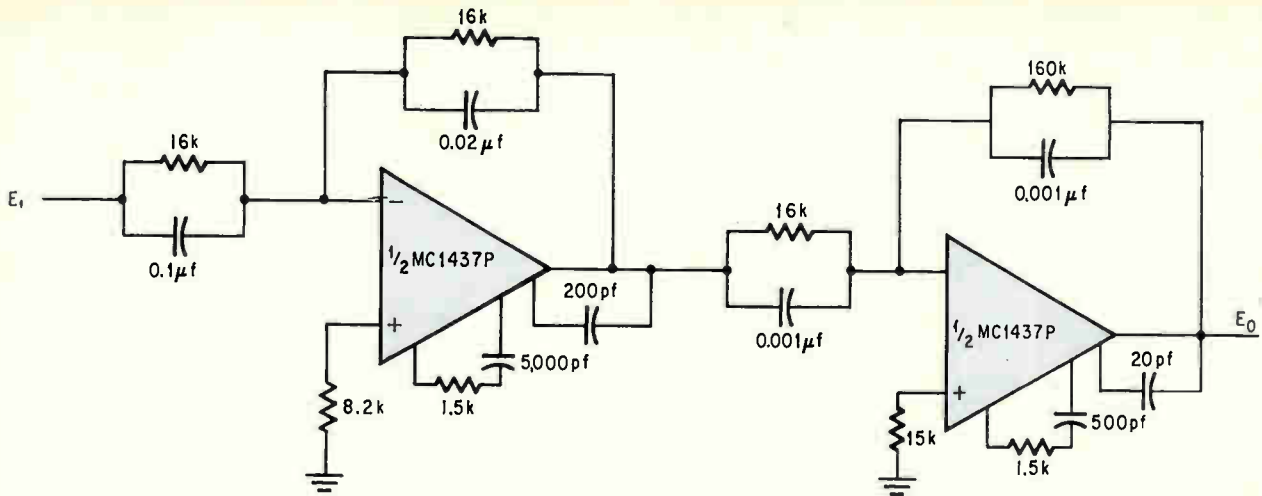

Compensation. Since the gain of the first stage is unity and the second stage is 10, compensation is required for each stage. Values indicated provide such compensation.

and the characteristic equation for stability is

$$C(s) = 1 + A(s)\beta(s) \quad (35)$$

When $C(s) = 0$,

$$A(s)\beta(s) = 1 \angle 180^\circ \quad (36)$$

and the closed-loop system is unstable. To investigate this, the problem becomes one of finding $\beta(s)$ in terms of the feedback y -parameters. By contrast the properly compensated open-loop amplifier function, $A(s)$, is usually known and can be approximated as

$$A(s) = \frac{-A\omega_0}{s + \omega_0} \quad (37)$$

where A is the d-c open-loop gain of the amplifier given on a manufacturer's data sheet as A_{VOL} and ω_0 is the open loop -3-dB break frequency for the compensated amplifier, usually given in curves on the data sheet for various compensation networks. By definition $\beta(s)$ is expressed by the following relationship

$$\beta(s) = \frac{E_3}{E_6} \quad (38)$$

From equation 1b, with $E_1 = 0$

$$\begin{aligned} I_3 &= y_{22a} E_3 \\ I_3 &= -I_5 \end{aligned}$$

and

$$E_3 = E_5$$

Inserting these expressions into equation 3a yields

$$-y_{22a} E_3 = y_{11b} E_3 + y_{21b} E_6$$

or

$$\frac{E_3}{E_6} = \frac{-y_{12b}}{y_{22a} + y_{11b}} = \beta(s) \quad (39)$$

Knowing $\beta(s)$, the designer can now find the sta-

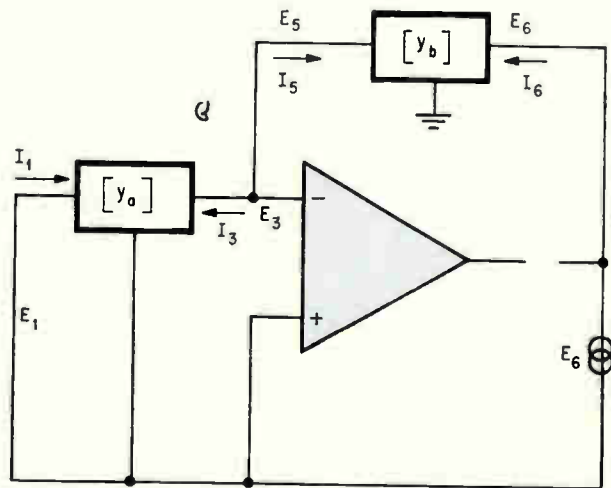

Feedback gain. By definition, the feedback gain is E_3/E_6 , based on this basic amplifier circuit.

bility conditions. From equation 36

$$\frac{A\omega_0}{s + \omega_0} \cdot \frac{y_{12b}(s)}{y_{22a}(s) + y_{11b}(s)} = 1 \angle 180^\circ$$

$$\text{For } \beta(s) = \frac{a_n s^n + a_{n-1} s^{n-1} + \dots + a_1 s + a_0}{b_m s^m + b_{m-1} s^{m-1} + \dots + b_1 s + b_0}$$

The stability criteria becomes,

- $m = n$ unconditional stability
- $m = n+1$ conditional or marginal stability
- $m > n+1$ usually unstable

As an example of this stability discussion, consider the filter network shown directly above.

For this network,

$$y_{22a} = 10^{-6} (s + 10^3)$$

$$y_{11b} = \frac{10^{-4} (s + 10^4)}{(s + 2 \times 10^4)}$$

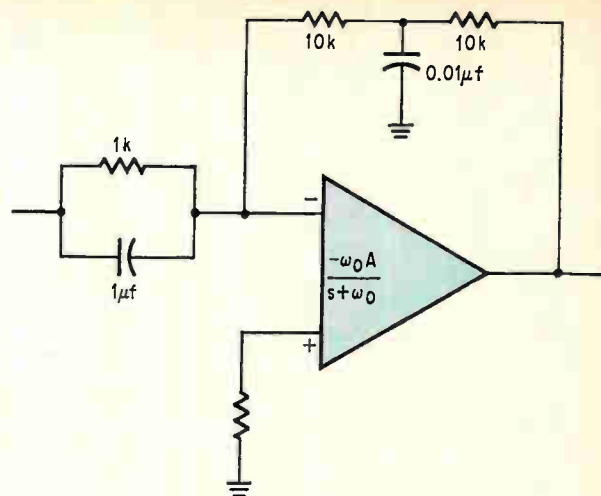
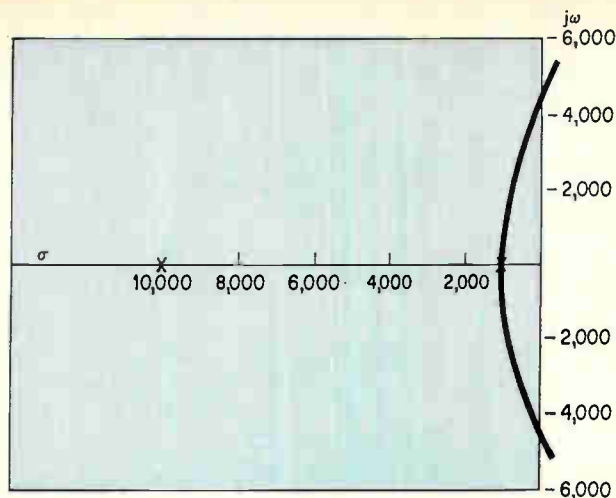

Stability. Root-locus plot for circuit indicates that open-loop gain, A, should be computed at 4,500 radians per second.

$$y_{12b} = \frac{-1}{(s + 2 \times 10^4)}$$

Solving for $\beta(s)$ gives

$$\begin{aligned} \beta(s) &= \frac{-10^2}{s^2 + 1.11 \times 10^4 s + 1.1 \times 10^7} \\ &= \frac{-100}{(s + 10^4)(s + 1.1 \times 10^3)} \end{aligned}$$

and

$$A(s) \beta(s) = \frac{100 \omega_0 A}{(s + \omega_0)(s + 10^4)(s + 1.1 \times 10^3)}$$

Assume that the operational amplifier has been compensated such that $\omega_0 = 10^3$ then

$$A(s) \beta(s) = \frac{10^5 A}{(s + 10^3)(s + 10^4)(s + 1.1 \times 10^3)} \quad (40)$$

The root locus for this function is shown directly above. From the root locus, the frequency at which the poles just cross the $j\omega$ axis is found to be 4,500 rad/sec. Letting $s = j4,500$ in equation 40 and setting the magnitude of the equation equal to unity determines the open-loop gain A that makes the system unstable.

$$1 = \frac{10^5 A}{|1 + j4.5| |10 + j4.5| |1.1 + j4.5| 10^9}$$

Solving for A,

$$A = 2.2 \times 10^6$$

From this result the designer deduces two things—most IC operational amplifiers on the market ($A_{OL} < 10^6$) would be stable in this application and an ideal op amp ($A_{OL} = \infty$) would oscillate.

Practical design example

A filter having a phase-locked loop was desired for a frequency synthesizer. The following specifications were given: d-c voltage gain +15 v/volt; reference frequency (5 khz) at least 70-db down

from d-c gain; second harmonic of the reference frequency (10 khz) at least 60 db down from d-c gain; all other harmonics of the reference frequency (15 khz, 20 khz, etc.) at least 50-db down; phase shift at 1 khz must be less than 50° .

Examination of network possibilities indicates that an infinite Q zero, for ideal components, can be achieved using the circuit shown on page 90. At the zero, a positive 180° phase shift occurs, with the over-all phase shift at $\omega \rightarrow \infty$ being 0° . It was decided that two such networks might be connected in tandem using the MC1437P dual operational amplifier with the first notch set at 5 khz and the second notch set at 10 khz. However, each network also contains two poles that must be taken into account to meet the high frequency roll-off requirements. It was then decided that the best way to handle this problem was to place a two section RC network on the output of the op amp and use a parallel RC network in the feedback to roll off the high frequency components.

For this circuit,

$$T(s) = \frac{K_R (s^2 + \omega_z^2)}{s^2 + \frac{\omega_P}{Q_R} s + \omega_P^2}$$

$$\text{where } K_R = \frac{1}{R_1}$$

$$\omega_z = \frac{1}{RC}$$

$$\omega_P^2 = \frac{[1 + (1 + \rho) a]}{R^2 C^2}$$

$$Q_R = \frac{1}{1 + \rho} \frac{\sqrt{1 + (1 + \rho) a}}{2 + a}$$

$$a = \frac{R}{\frac{R_1 R_2}{R_1 + R_2}}$$

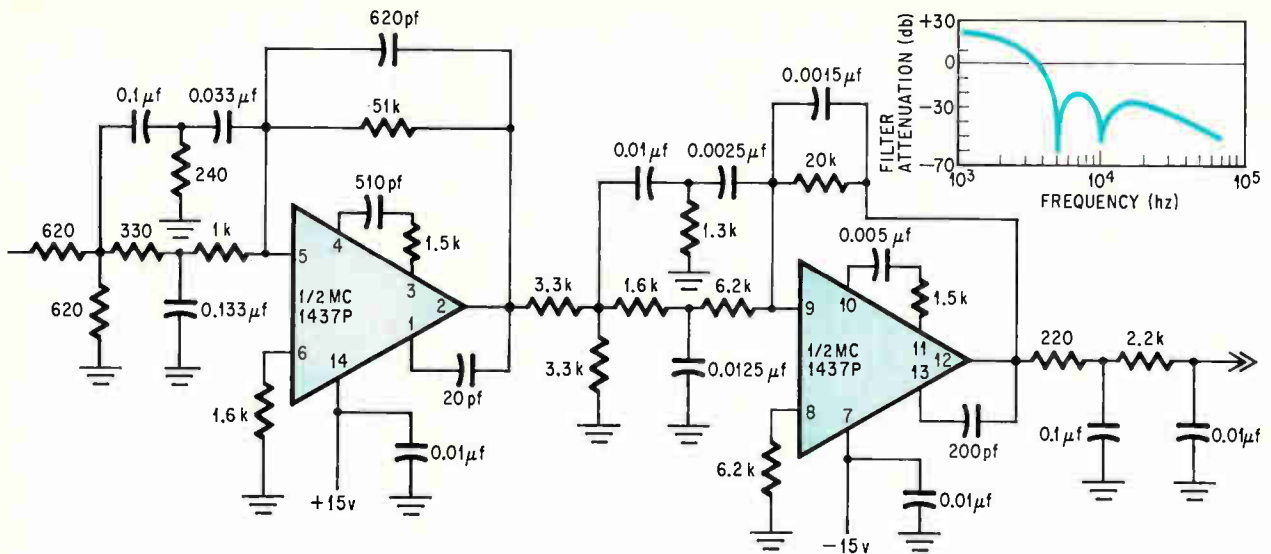

Two-section filter. Components are selected so that the two poles of this network occur at about 7 kHz and roll off at higher frequencies. The capacitors cause a -3 -db value at 5 kHz. Response plot confirms good design.

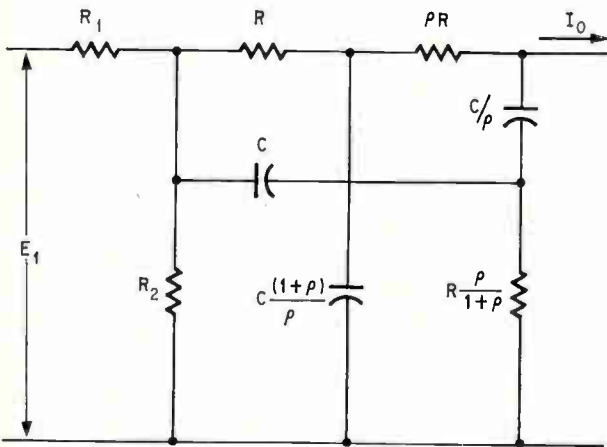

Frequency synthesizer. Infinite Q zero is achieved with a positive 180° phase shift occurring at the zero.

The calculations for the first network are as follows:

$$\omega_z = \frac{1}{RC} = (2\pi) (5\text{kHz}).$$

Arbitrarily select $R = 330$ ohms from which C is found to be $C \approx 0.1 \mu\text{f}$. Choose $R_1 = R_2 = 620$ ohms. Then "a" is calculated to be

$$a = \frac{R}{R_1 R_2} = \frac{330}{310} = 1.06$$

The next step is to find a value for p that will place the poles of $T(s)$ on both sides of the notch. By trial and error, a value of $p = 3$ was selected. For $p = 3$, the following were found

$$\omega_p = 2.29\omega_z = (2\pi) (11.45\text{kHz})$$

$$Q_R = 0.187$$

and the poles of $T(s)$ are

$$S_1 = (2\pi) (59\text{kHz})$$

$$S_2 = (2\pi) (2.29\text{kHz})$$

To reduce the noise, it is advantageous to put the majority of the over-all gain in the first stage. Therefore, a feedback resistor for the first stage was found that gave a d-c gain of 15 v/v. This calculation is straight forward and is explained as follows:

Setting $s = 0$ in the expression for $T(s)$ gives a d-c transfer admittance of

$$y_{21a} \Big|_{s=0} = \frac{\omega_z^2}{R_1 \omega_p^2}$$

Substituting the values of ω_z , ω_p , and R_1 into this equation gives

$$\text{Recall } y_{21a} \Big|_{s=0} = \frac{1}{3.28\text{k}}$$

$$\frac{E_0}{E_1} = 15 = \frac{y_{21a}}{y_{21b}} = \frac{1}{\frac{1}{R_F}}$$

Solving for R_F , $R_F = 49.3\text{ k}$

A standard value of 51 k was selected.

The calculations for the two-section RC network are straight forward. The criteria for component selection was to choose the two poles to both be about 7 kHz and roll off at the higher frequency harmonics. The feedback capacitors were each selected to give a -3 db point of about 5 kHz.

The design of the second active filter proceeds exactly as the previous explanation with the notch set at 10 kHz.

The second amplifier is operating at unity gain and is compensated for such operation. ■

Now—200 μ A Turns On 4 A—@-95°C-Case SCR Power Control At Low Cost!

MCR406 — turn it on with only 200 μ A . . . to 4 A RMS . . . to 95°C . . . for only 51¢!

Designed for low-cost, high-current applications in your rugged consumer, commercial and light industrial speed, light and heat control designs, this new SCR series has "better thyristor value" written all over it:

- High, 4 A RMS operation to 95°C case temperature (75°C higher than the nearest equivalent) — less costly, simpler heat sinking and thermal design considerations are possible because of this unique, higher-current-at-higher-temperature capability.
- Low, 200 μ A triggering — economical, low-level gate triggering is afforded from photo cells, thermistors and other small signal devices without additional stages of sensor signal amplification.
- Compact, Thermopad* packaging — the only plastic SCR package furnishing the shortest—0.032"—chip-to-heat-sink thermal path and low, 2.0°C/W thermal resistance for minimum derating.
- Exclusive, Annular† construction — maximum, long-term reliability and performance stability over a -40° to 110°C operating temperature range is ensured through oxide-passivated junction protection.
- Low, 1.6-volt-@ 4-ampere-@-110°C forward voltage — a traditional Motorola SCR advantage ensuring low power loss and minimum heat generation in all designs.

Scores of high-performance, new-design application possibilities can now be turned on with this new SCR — and, you have your choice of *two* economy price ranges for the widest possible cost/performance considerations!

Series	V_{FXM}/V_{RXM} —Volts	I_F —Amps	I_{FM} (Surge) —Amps	I_{GT} (max) @ 25°C — μ A	V_{GT} (max) @ 25°C —Volts	Price, 1000-Up
MCR406	30, 60, 100, 200	4	20	200	.8	\$.51‡
MCR407	30, 60, 100, 200	4	20	500	1.0	.47‡

‡30 V unit

For immediate technical data response —

Circle the reader service number below and we'll send you complete specs on the new MCR406/407 series sensitive gate SCR's . . . do it now!

For a personalized MCR406 design evaluation kit —

Write on your company letterhead specifying voltage desired — 30, 60, 100 or 200 V — and you'll receive a free device-design kit including specs and SCR ready for prototyping from one of our 64 franchised North American distributors. Send for one today!

Box 20912, Phoenix 85036

*Trademark Motorola Inc. †Annular semiconductors patented by Motorola

 **MOTOROLA**
Silicon Controlled Rectifiers

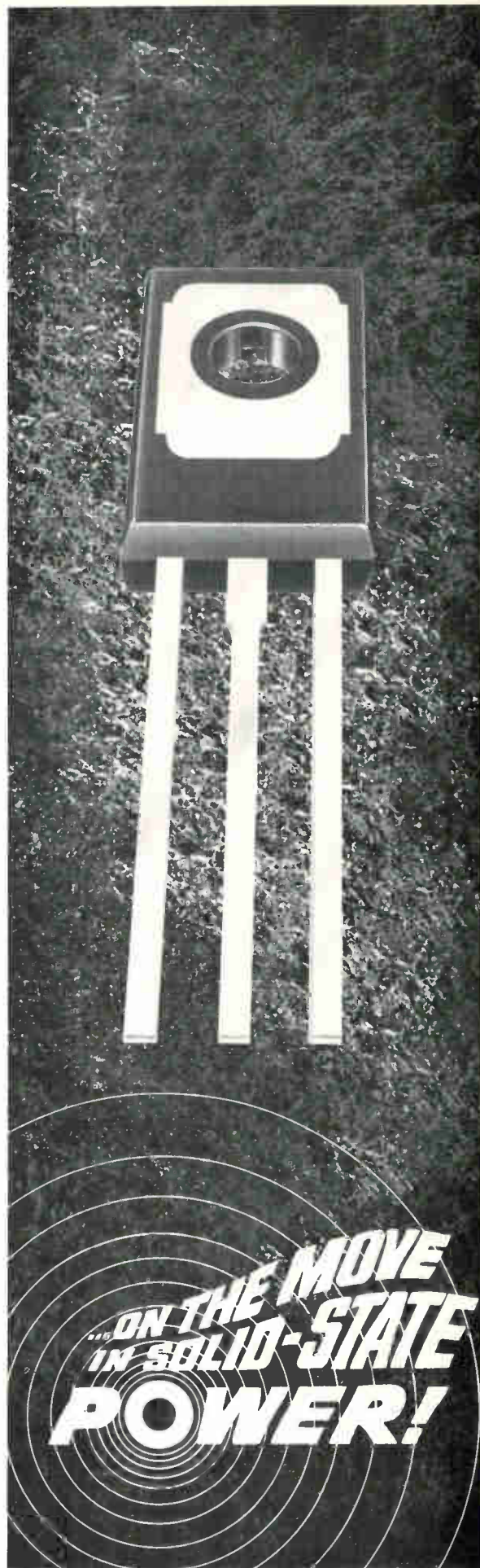

**ON THE MOVE
IN SOLID-STATE
POWER!**

The January 20 issue covered competition in the British IC market, computer-aided design, laser mask-making, and multilayer metalization. This concluding installment examines several additional efforts in British IC technology.

British IC's V

Electron-beam testing: gentle and fast

By J. P. Flemming

Standard Telecommunication Laboratories Ltd., Harlow, Essex

Being tested with a probe can be a traumatic experience for a semiconductor device in its formative hours. Although the probes of the testing machine look fragile and delicate to the operator, they seem large and clumsy to the device. They are potentially lethal instruments that can score the contact pads, damage oxide layers, diminish the reliability of wire bonds, and make it difficult to deposit good multilayer interconnection patterns.

A test system using a low-velocity beam of electrons instead of mechanical probes would have obvious appeal. The electron beam can't damage the device. It can be focused to a very small spot and positioned rapidly so that no movement of

the device is necessary.

At Standard Telecommunication Laboratories Ltd., a British subsidiary of ITT, the electron-beam probe is used to measure such transistor parameters as collector leakage current, base-collector and emitter-collector breakdown voltages, and collector-junction capacitance. The probe can also be used for integrated circuits and other semiconductor devices.

However, STL doesn't intend to replace all the functions of the mechanical tester; it's clear that the electron-beam machine can't make some tests, such as those that require two or more connections in parallel or need externally injected currents of

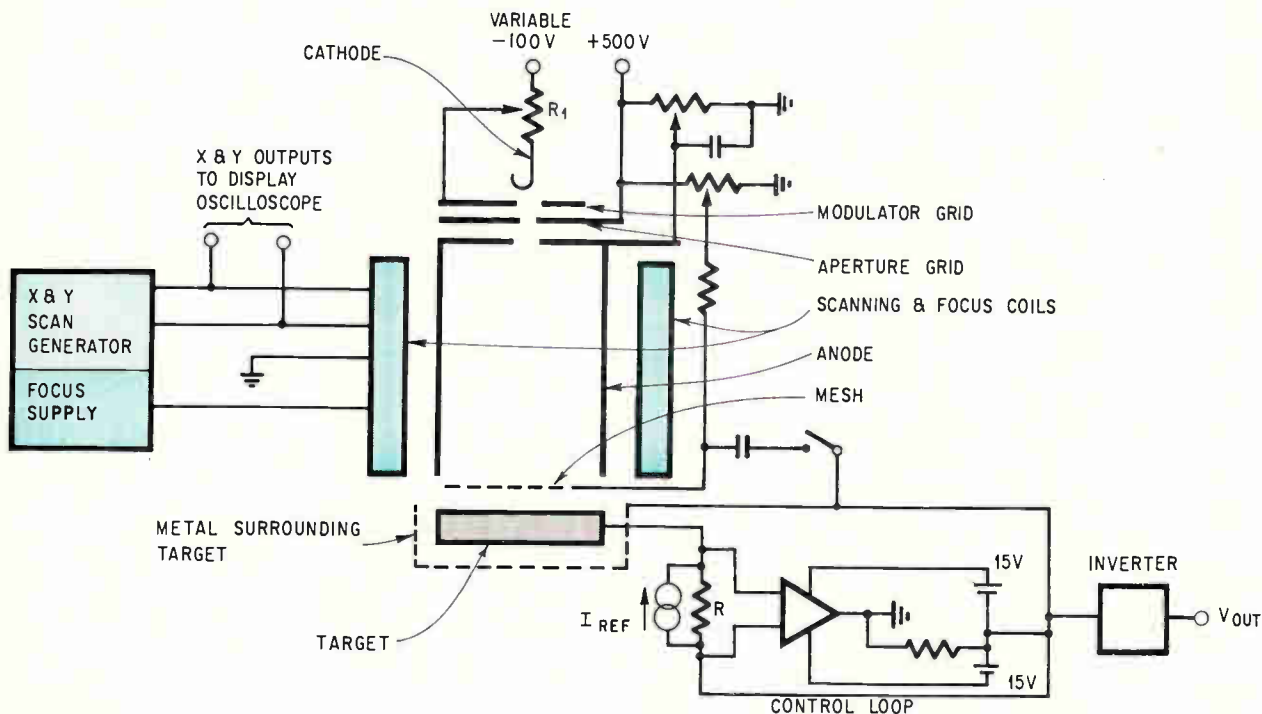

Soft touch. The electron-beam probe, unlike the mechanical type, can't damage the semiconductor device. The beam can be positioned and swept by conventional electron-beam techniques.

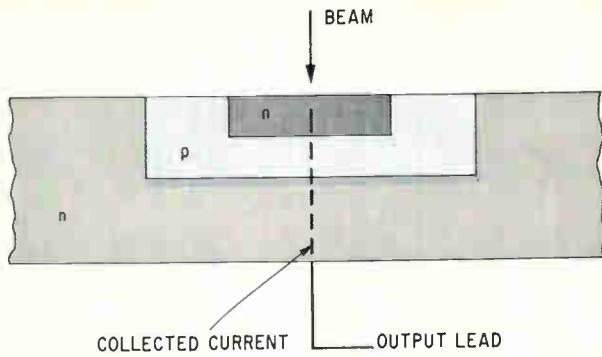

Beam bias. The simplest way of biasing the device is to use the beam to generate potentials across the junctions.

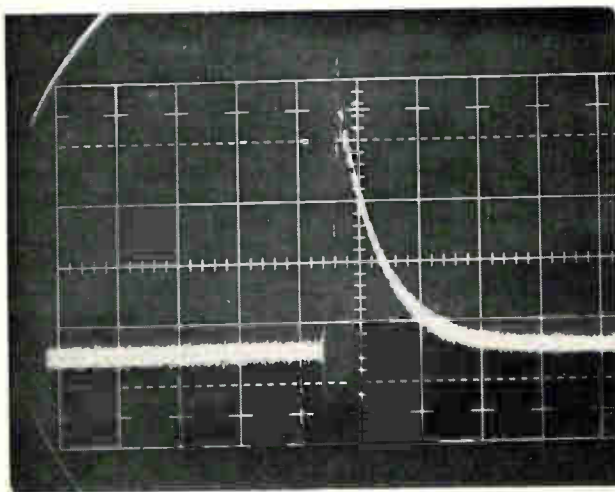

Junction capacitance. If the beam is suddenly switched on the base region of the device (the vertical step in the photomicrograph), the collector junction bias changes from an initial zero to the steady-state value. The time that this change takes indicates the capacitance of the collector junction. The vertical scale is 0.01 volt per large division; horizontal scale is 20 microseconds per large division.

more than a microampere. But its wide range of usefulness is equally clear: gross faults can be detected and go/no-go results obtained.

Going from a mechanical to an electron-beam probe, however, is far from a one-for-one transition. It is necessary to devise contactless methods of biasing that will cause characteristic voltages to appear between the contact regions of the device, to measure these voltages with the electron-beam probe, and then to predict empirically the behavior of the device in operation.

The electron-beam probe is similar to the vidicon television camera tube; it consists, in fact, of a vidicon tube mounted in a vacuum system with the photo target replaced by the device to be tested. Cathode and target are at approximately the same potential. The output of the tube is the

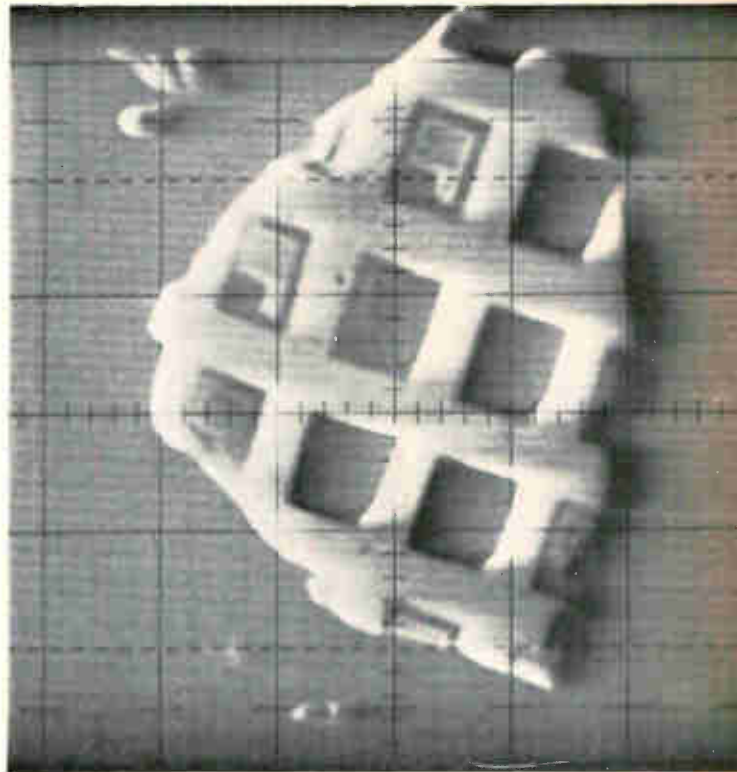

Good and bad. Tv-like picture uses output of control loop as video signal to reveal defective junctions in transistors. For demonstration purposes, oxides and metal were removed from the device surfaces.

part of the beam current collected by the target (part of the beam is collected by the electrodes of the vidicon); this output is a function of the potential between the cathode and the point where the beam hits the target. The target's potential is established by a control loop that stabilizes the collected current at a value equal to a reference current (less than a microamp). If the applied bias causes the potential between the measuring point and the target output lead to change by V , the control loop will change the potential of the target output lead by $-V$, thus keeping the collected current (and the potential between measuring point and cathode) at a constant value. Changes in target potential due to changes in applied bias are therefore reproduced at the output of the control loop. The STL electron-beam probe can measure potential differences as small as 5 millivolts.

The beam diameter is 25 microns. This is large by electron-beam standards, but the contact pads on the device are also large; a fine beam isn't needed at present. However, the Mark II version of the machine now being built will have an 8-micron spot—adequate for the smaller geometries of large-scale integration.

The probe itself is basically a simple instrument, but complications arise in electrically activating the device to be tested. Although there are as many methods of activation as there are circuits,

certain basic techniques have been found useful in one form or another at STL.

Biasing the device by collected beam current is an example. In an npn transistor structure, the collected beam current reverse-biases the collector junction. If the current is greater than the collector leakage current, the voltage across the junction will be the junction breakdown voltage.

With this technique, the collector leakage current can be measured directly, as can the base-collector or emitter-collector breakdown voltages (depending on whether the beam is positioned on the base or emitter contacts of the transistor). And by observing the rate of charging, the collector junction capacitance can be measured.

With electron-beam biasing, it's also possible to qualitatively determine whether the junctions are good or bad. Reversed-biased collector junctions cause a negative voltage to appear on the emitter and base regions; this negative voltage shows up as dark regions on the photograph. (All the collector junctions in the illustration on page 93, top right, are good.) Poor collector junctions—those with leakage current greater than the collected beam current—don't bias the base, which would therefore be indistinguishable from the surrounding material in a photograph.

The emitter region should also become biased, and therefore should not be visible in a photograph. The emitters (the L-shaped regions) that appear in the illustration indicate defective transistors. From the equal brightness of emitter and collector, it can be deduced that the emitter is short-circuited to the collector.

Sometimes devices are illuminated while they are subjected to the electron beam. This increases leakage currents and generates a voltage between the p and n regions that yields information about forward characteristics.

Frequency behavior

Another biasing technique that may prove useful is electromagnetic induction (so far, STL has used it only in dry runs with mechanical probes). Currents induced in the slice are rectified at junctions

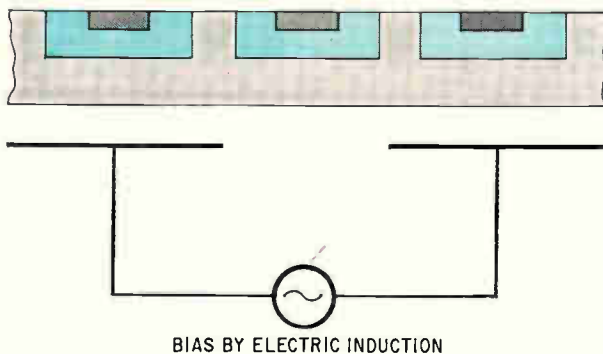

BIAS BY ELECTRIC INDUCTION

Induction bias. An oscillator connected to capacitive plates near the silicon can induce biases on the device junctions.

and cause characteristic potential differences to appear at the contacts of the device. The equipment for induction biasing is simple; all that's needed is an oscillator connected to capacitive plates near the device. With this technique, the frequency behavior of the device can be observed by varying the frequency of excitation and observing the corresponding voltage variations at the contacts.

Metalization put on the device especially for test purposes allows many variations—such as power connections—on the methods of activation. And special diagnostic devices can be incorporated in the silicon slice. These can be used to see whether the various processing stages were up to standard and to indicate the probable over-all yield of the device. ■

British IC's VI

Bulk-effect modules pave way for sophisticated uses

By George King and J.S. Heeks

Standard Telecommunication Laboratories Ltd., Harlow, Essex

Exploitation of bulk-effect oscillators on a large scale will require small, cheap, and robust microwave modules that incorporate the semiconductor device, filters, blocking capacitors, and impedance matching stubs. At Standard Telecommunication Laboratories, several such circuits have been designed and built to gain experience in handling the engineering problems. Using Gunn-effect oscillators, the company has built such circuits as X-band and S-band generators, both fixed-tuned and frequency-variable, on ceramic substrates with gold thin-film interconnections.

The circuits are fabricated on standard alumina substrates, 625 micrometers thick and metalized on both sides with a 5- μm layer of gold. One side of this substrate serves as a ground plane; the interconnecting paths are etched into the other side. A 50-ohm characteristic impedance is provided by a microstrip line 625 μm wide on the substrate. By appropriately laying out the microstrips, it's possible to make filters, matching stubs, and blocking capacitors simultaneously during a single sequence of photomasking and etching operations. Masks for the interconnections are designed quickly by computer and cut by a tape-controlled laser beam.

There are several ways of mounting the semiconductor microwave oscillator in the circuit, but the best—from a thermal standpoint—is to mount it in parallel with the microstrip line. In two such

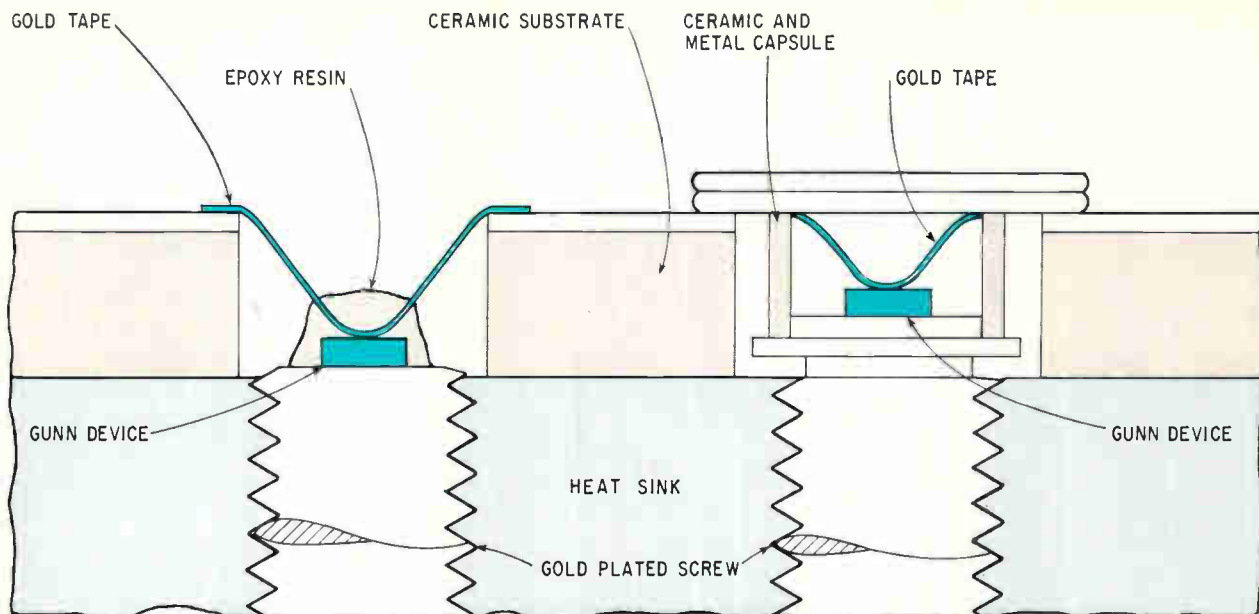

Epoxy or pill. In STL modules, the Gunn device is mounted on the ceramic substrate either in a ceramic pill package (right) or by a globule of epoxy resin. The gold-plated screw provides a thermally conductive path from the device to the heat sink.

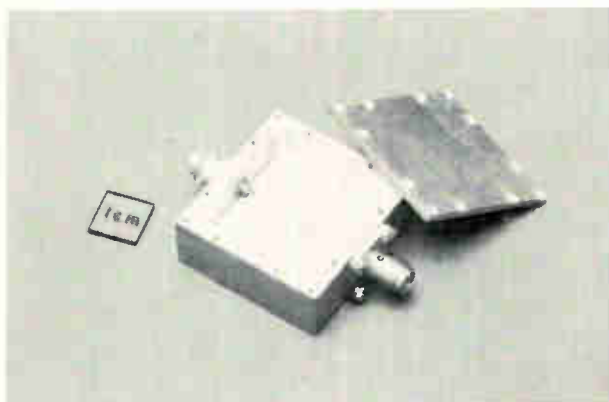

Hybrid IC. Complete fixed-tuned X-band module for c-w operation contains (left to right) bias input socket, low-pass filter, frequency-determining line with encapsulated Gunn oscillator, impedance-matching stub followed by $\lambda/4$ capacitor, and the microwave output socket.

parallel arrangements used by STL, as shown opposite, above, the device chip is either inserted directly into the substrate and bonded with an epoxy resin or mounted in a small ceramic-and-metal pill that can be screwed into the metal ground plane. Both methods ensure an efficient thermal path to the ground plane, which acts as a heat sink. The pill, of course, has an additional advantage: it can be replaced if the device fails.

A practical design requires knowledge of the effective complex impedance of the oscillating diode, since the load impedance should be the conjugate of the diode impedance.

A complete fixed-tuned X-band module, as shown

above, contains a bias input socket, a low-pass filter, the frequency-determining line with an encapsulated Gunn oscillator, an impedance-matching stub followed by a quarter-wavelength capacitor, and the coaxial microwave output socket. A typical module generates continuous-wave power of about 20 milliwatts at an input of 10 volts and 100 to 150 milliamperes. To some extent, the frequency of this unit can be varied electronically by changing the bias voltage; the device can be tuned over a range of 100 megahertz at 30 Mhz per volt. This frequency-voltage relationship can be used to provide a frequency-stabilizing error signal through a feedback loop. (However, the magnitude of the effect can vary from one device to another.)

It's difficult to provide for wide-range mechanical tuning in a microstrip circuit. However, a varactor diode can be included in the circuit to tune it electronically over a considerable range (see layout at top of page 96). The varactor is in a "LID" (leadless inverted device) package, mounted face down, and its position relative to the Gunn diode and the end of the circuit is chosen to give the widest tuning range. Such modules can be tuned over a 12% band—about 1,000 Mhz—in a unit designed for X band.

Similar modules have been developed for operation at S band. Because the varactor has lower parasitic reactances in this band, these modules can be electronically tuned over a much wider range; one such module is tunable over a 34% band with less than 3 decibels of power output variation. And if a high-power pulsed Gunn oscillator is used instead of a c-w type, the matching stub can be omitted because of the lower device impedance.

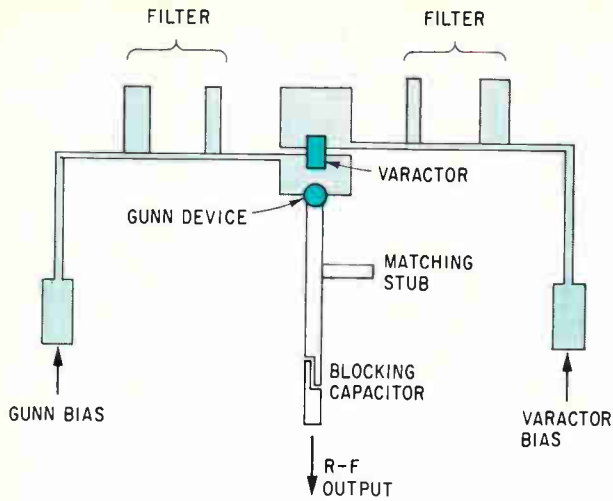

Electronic tuning. The varactor diode used for wide-range tuning requires provision for bias and filtering separate from that for the Gunn device. The gold film conductor layout shown here is slightly more than 2 cm wide in the actual module.

In all probability, the first application of modules like these will be as replacements for the small klystron, particularly as a local oscillator. But modules with wide tuning ranges will open up more sophisticated applications. The phased-array radar is the most ambitious system envisaged now, but a host of other fairly complex systems using doppler and swept doppler techniques immediately come to mind. The tunable module is also a possible substitute for the expensive range of backward-wave oscillator tubes.

Inevitably, oscillator modules will be developed that will also perform such functions as mixing, detecting, transmit-receive switching, and phase locking. The first steps in this direction have already been made with a radar module now being developed at STL. ■

British IC's VII

MOS frequency soars with ion-implanted layers

By J.M. Shannon

Mullard Research Laboratories, Redhill, Surrey
and James Stephen and J.H. Freeman

United Kingdom Atomic Energy Authority
Harwell, Didcot, Berkshire

The frequency limitations of metal oxide semiconductor transistors aren't part of the device itself; they result from inadequacies of conventional diffusion and masking processes. These inadequacies

can be overcome by ion implantation, a fabrication technique that has been used to make MOS transistors that operate at ultra-high frequencies at Mullard Research Laboratories in collaboration with the Atomic Energy Authority, Harwell.

Ion implantation improves the high-frequency performance of MOS transistors in two ways. The technique reduces the feedback capacitance, thus making the device more stable electrically. And, by reducing the effect of the parasitic drain capacitance that shunts the output of the device, ion implantation increases the output conductance. To date, a maximum frequency of oscillation (f_{max}) greater than 1 gigahertz has been obtained.

In ion implantation, of course, the silicon substrate is bombarded with ions of elements (boron or phosphorus, for example) to produce a required impurity concentration. The depth that the ions penetrate depends on their energy—that is, on the accelerating voltage between the ion source and the substrate. The energy, dose, and ion species can be controlled precisely, and the procedure is fast and takes place at low temperatures, so ion implantation is an attractive alternative to diffusion [Electronics, Aug. 7, 1967, p. 162].

The advantages of ion implantation will probably be realized most fully in integrated circuits, because of the sharp definition it provides even with intricate geometries. Hughes Aircraft, in fact, has had enough success with ion implantation to warrant its use in production of MOS digital integrated circuits [Electronics, Nov. 11, 1968, p. 55]. Although the Hughes process includes what Mullard and AERE call autoregistration, which reduces the feedback capacitance, it does not include implantation of a low-resistivity surface skin, which Mullard-AERE use to reduce parasitic drain capacitance.

In an MOS transistor made in the conventional way, the gate metal has to be defined over the gap between the source and drain diffusions. This must

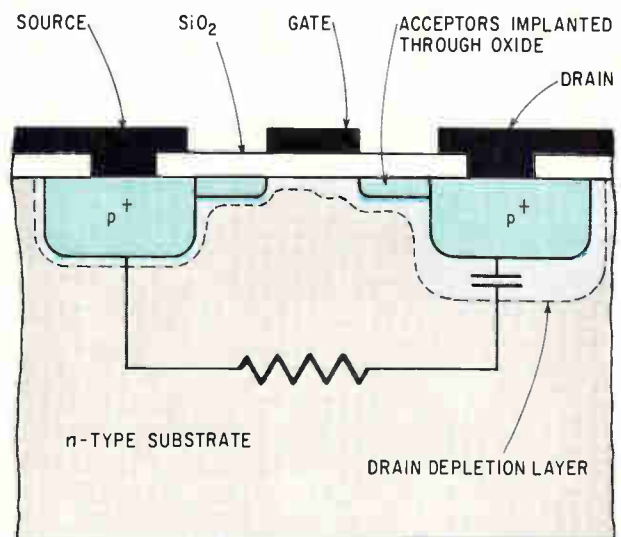

Autoregistered. With ion implantation, the drain and source can be aligned with the gate with little overlap.

Marrying MOS and bipolars

The marriage of metal oxide semiconductor and bipolar transistors in monolithic integrated circuits is an attractive technical proposition. In an operational amplifier, for example, the mos transistor can give high input impedance, while the bipolar transistor gives high gain.

Such ic's have been built at Associated Semiconductor Manufacturers in a feasibility demonstration sponsored by the British Ministry of Defense, Navy Department. For one thing, it was found that p-channel mos transistors and npn bipolar transistors are well suited to joint integration; both require the same n-type substrate and both can be formed during the same p-type diffusion. For another, simultaneous fabrication is scarcely more difficult than making a conventional linear ic.

The goals were to build a differential d-c amplifier with a voltage gain greater than 60 decibels, a common-mode rejection ratio greater than 60 db, and a gain roll-off that's stable with frequency. The input voltage offset and its temperature drift had to be low—comparable to those of a bipolar ic with high source impedance. All of these aims were realized [see table].

Lucky. The lucky coincidence that both types of device can use the same substrate stems from the fact that a bipolar device requires a high-resistivity substrate for a high collector-to-emitter breakdown voltage, and an mos device requires it for a low threshold voltage. (An mos threshold of less than 5 volts was decided on early in the design; this gave a bipolar breakdown of 30 volts.)

And both can use the same p-type diffusion because almost any p-type diffusion will suffice for the source and drain regions of an mos transistor; the doping level in these regions isn't critical. As it turns out, the bipolar transistor base-region diffusion is very similar to that used for the source and drain in mos ic's. The p diffusion, of course, also forms the resistors of the circuit.

The main problem in developing the circuit was forming a stable gate oxide. The silicon dioxide passivating layer formed on the ic is too thick—0.5 to 1.0 micrometer—to serve as the gate insulation; a 0.1 to 0.2 μm layer is needed. Fortunately, it was

found that the ambient oxygen used during the drive-in of the phosphorus in the bipolar n^+ emitter can produce just this thickness of oxide over the gate region.

Extra stage. There is a slight loss of freedom in fabricating the bipolar transistor because the emitter drive-in time must be long enough to allow growth of the required thickness of gate oxide. In practice, however, this is an inconsequential disadvantage; the typical emitter drive-in time is adequate for a 0.1-0.2 μm thickness.

Of course, an extra photoresist stage is necessary, since the rest of the circuit has to be masked while the thick oxide is etched away from the gate area to prepare it for the formation of the thin layer. This extra step adds slightly to the cost of the process.

Performance isn't the only advantage of the combination of mos and bipolar devices. To form stable mos transistors, a good interface between the oxide and the silicon substrate must be provided. This is beneficial to the circuit as a whole: the good interface minimizes the surface leakage on the chip, and it keeps the current gain high even at very low emitter currents.

David Burt
Associated Semiconductor
Manufacturers Ltd., Wembley

Circuit characteristics

Nominal supply voltage	± 15 volts
Gain	70 db
CMRR	70 db
Input offset voltage	5 to 50 mv
Thermal drift of offset	10 to 75 $\mu\text{V}/^\circ\text{C}$
Common-mode input range	± 5 volts
Output voltage swing, 5 kilohm load	± 7 volts, centered on 0 volts
Chip power dissipation	100 milliwatts

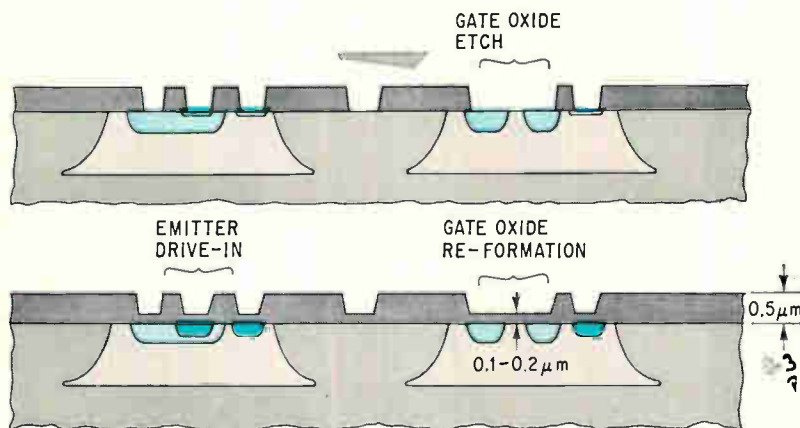

Thick and thin. The only extra process step needed to form MOS transistors along with bipolar ones is masking and etching to remove the thick oxide from the gate region (top). The much thinner oxide required for the gate insulation is formed during the subsequent emitter drive-in step. The bipolar transistor is on the left, the MOS transistor on the right.

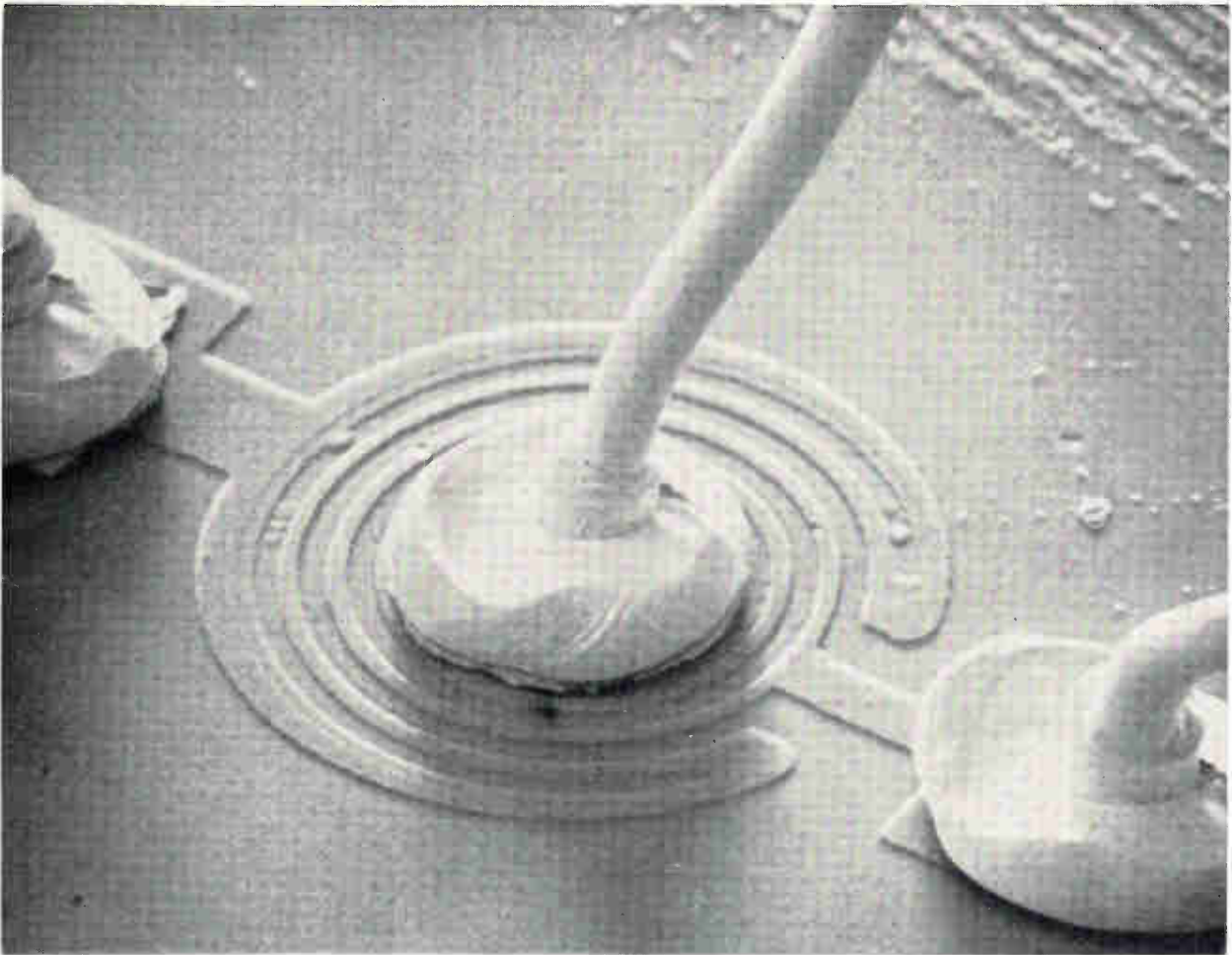

Concentric. Autoregistered drain and source encircle 3-by-20 micron gate. The structure has a maximum frequency of oscillation of 800 Mhz.

be done photolithographically, and because of the tolerances of the photolithographic process, the gate overlaps the drain by 2 or 3 microns. This overlap causes capacitive feedback, prohibiting stable operation at high frequencies.

But with ion implantation, the source and drain can be implanted through the surface oxide with the gate metal already deposited and acting as a mask, as shown on page 96. The ions are given enough energy to penetrate the oxide but not the gate metal, resulting in the automatic registration of the source and drain regions with the gate.

At Mullard, both n and p channel devices have been made with this autoregistration technique, using phosphorus and boron ions, respectively, at energies between 60 and 100 kiloelectron-volts. The implantations are carried out at Harwell in an electromagnetic separator by feeding boron or phosphorus trichloride into the ion-source discharge. The separator beam is focused as a sharp line approximately 4 centimeters long, and this line is scanned across the silicon slice by means of a 50-hertz sawtooth voltage superimposed on the ion-accelerating voltage. The electromagnetic separator can generate beams of several milliamperes,

but in most cases the intensity is reduced to several microamperes to give the required dose in 20 to 200 seconds. The divergence of the beam is 2° .

Using the autoregistration technique, Mullard has been able to make a gate that's 3 microns long and 230 microns wide and that encompasses a central drain pad, shown at top of page. Both depletion- and enhancement-mode MOS transistors can be made with this structure. The n-channel autoregistered MOS transistors made on 1-1-1 oriented silicon have a gain of about 18 decibels at 100 megahertz, and an f_{max} of 800 Mhz. The feedback capacitance of the device in a TO-18 package is only 0.040 picofarad.

The f_{max} of a conventional MOS transistor with the same design would be much lower (about 300 Mhz), but the main advantage of the autoregistered MOS transistor is that all the gain can be used without neutralization. The feedback capacitance of the conventional device would be about ten times that of the autoregistered MOS transistors.

One way to increase this frequency capability even further is to reduce the capacitance of the drain depletion layer, which shunts the output of the transistor when it's operated in the common

source-substrate mode and increases the output conductance of the device at high frequencies.

This drain capacitance can be reduced by placing the drain in a high-resistivity region; that is, by using high-resistivity material for the epitaxial layer. But then the channel would be in high-resistivity material too. The drain depletion layer would move rapidly toward the source as drain bias is increased, so the transistor would not only have a high output conductance but also punch through at low voltages. Fortunately, ion implantation can be used before growth of the gate oxide to form a thin, low-resistivity p layer that's shallower than the source and drain contact diffusions but deeper than the junctions formed during the autoregistration stage, shown at bottom of page. The channel, then, lies in the more highly doped layer, giving the device higher punchthrough voltage and lower output conductance. Most of the drain region lies in the high-resistivity epitaxial layer, for minimum capacitance.

The displacement current from the drain depletion layer finds a low resistance path back to the source-substrate connection through the low-resistivity p+ substrate thus minimizing the output conductance at high frequencies.

This ion-implanted surface layer would be extremely difficult to make by diffusion techniques because of the problems in controlling shallow diffusion when the concentration of impurities at the surface is low (about 10^{16} atoms per cubic centimeter).

As expected, the transistors with an implanted layer have better frequency response than the simple autoregistered devices. About 4 db of gain can be obtained at 1 ghz and f_{max} is 1.4 ghz. The small

feedback capacitance permits all the high-frequency gain to be used, without neutralization.

However, the breakdown voltage of the implanted-layer transistors made to date is not all that it could be (about 10 volts versus the desired 20 volts). The trouble is that the small radius of curvature of the autoregistered regions creates a region of concentrated field intensity. Fortunately, it should be possible to increase the radius of curvature, and thus the breakdown voltage, by using higher-energy ions in the autoregistration process.

How it's done

During autoregistration, all the gates on the slice are connected by a metalization layer and grounded to prevent them from charging and then discharging through the gate oxide. Other areas where implantation isn't wanted are also metalized. After implantation, the metalization is etched away and the slices are annealed to remove damage and make the ions electrically active in the lattice.

The number of acceptors created by the implanted ions increases with annealing temperature. In the case of implanted boron ions, this increase is rather slow. For an annealing temperature of 500°C , there is only one out of 400 boron ions active in a typical autoregistered region, giving a rather high sheet resistivity of 2.5 to 3 kilohms per square (for a mobility of $65\text{ cm}^2/\text{volt-second}$). If aluminum is used as the gate material, 500°C is the maximum annealing temperature; above this, diffusion of aluminum into the gate oxide becomes significant. Phosphorus, however, behaves quite differently and becomes active at lower temperatures, giving a sheet resistivity of about 300 ohms

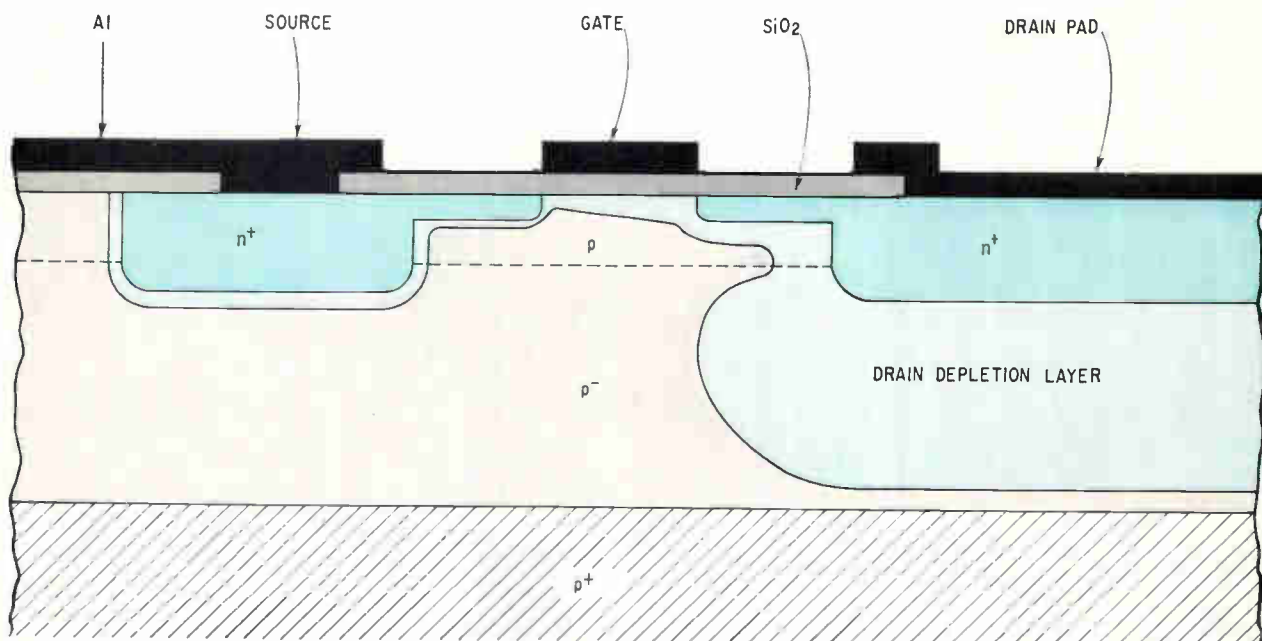

Better. With an ion-implanted p region in the epitaxial layer, frequency can be improved even beyond that of simple autoregistered devices; a maximum frequency of oscillation of 1.4 ghz has been achieved.

per square—much less than that of boron.

The implanted regions add series resistance, but this can be reduced by design to the point where it has only a negligible effect on device performance. For example, in the transistor shown on page 96, the resistance in series with the source due to the implanted region is about 25 ohms for a p-channel device and 3 ohms for an n-channel device. In both cases, the effect of this additional source resistance on the mutual conductance is inconsequential.

In the transistor illustrated on page 98, the source and drain diffused regions were extended to the edges of the gate by implanting 6×10^{15} boron ions per square centimeter at an energy of 60 keV through the 2,000-angstrom gate oxide. The overlap of the gate and drain has been found to be no more than $2,500^\circ\text{A}$.

Use of autoregistration does not affect device yield in any way. There is no evidence, for example, that implantation through the oxide surrounding the gate increases the number of gate shorts. And tests of threshold voltage stability at high temperature (on auto-registered devices passivated with phosphorus glass) indicate that the stability of the gate oxide isn't significantly different from that of a conventionally made MOS transistor.

To make the transistors with a low-resistivity skin for higher-frequency performance, 10^{13} boron ions per square centimeter are implanted in the silicon. An energy of 100 keV gives a penetration of about 0.6 micron. The resulting transistors operate in the enhancement mode and require about 1.5 volts to turn on.

The development of ion implantation techniques for fabricating uhf MOS transistors was sponsored by the Ministry of Defence, Navy Dept. ■

British IC's VIII

Integrated solid state display needs no complex circuitry

By Gordon I. Robertson and C.P. Sandbank

Standard Telecommunication Laboratories Ltd.,
Harlow, Essex

Most candidates for a solid state replacement for electron-beam imaging or display tubes take the form of a mosaic of small photodetectors or light-emitting devices, addressed and driven by circuits such as shift registers. The problem with such systems is that they require many complex circuits to address the mosaic. But a new approach to imaging and display is—potentially, at least—far

simpler and more direct. The approach is based on the interaction between light and a narrow high-electric-field domain moving through a semiconductor crystal.

In a display, the interaction generates a line-element of a picture in response to an electrical input. In an imaging device, the interaction produces an electrical signal in response to a line-element.

The controllable moving domains represent, for the first time in a semiconductor device, something akin to a moving electron beam. The devices thus offer the simplicity and versatility of the cathode-ray and vidicon tubes without their bulk and fragility.

Standard Telecommunication Laboratories has demonstrated the feasibility of using domains for solid state scanning. Although it's still too early to say whether the approach will lead to a practical system or what the main applications will be, the results encourage further work.

The main problems are in material preparation. Compound semiconductors, such as cadmium sulfide or gallium arsenide, are used, and there are some particularly tough doping requirements. Compared with the shift-register-driven arrays, construction is greatly simplified—one avoids the limitations of photolithography, and there are no individual elements to cause the yield problems associated with a large matrix—but one does make very severe demands on the properties of the starting material.

Domains and light

The possibility of using a moving electron domain to generate complex circuit output functions has been demonstrated at STL¹ and at Bell Labs.² The moving domain generates the function by "reading" inhomogeneities deliberately introduced along the drift path. For example, the domain can read the information in the drift path by interacting with variations in the local conductivity of the crystal. (STL calls such devices Dofic's, for Domain originated functional integrated circuits.) Since the domain scans the crystal it is reasonable to try to extend the Dofic principle to the interaction between domains and light for the purpose of reading or displaying an image.

Domains are formed in semiconductors such as gallium arsenide and cadmium sulfide when a high electric field is applied. As soon as the field reaches a critical value, electrons assume the shape of a well-defined bunch, which moves along the crystal. There are several mechanisms for this bunching, but the common factor is differential negative conductivity—that is, as the field is increased beyond the critical level, the current falls rather than rises. The bunches, which are called domains, were first observed by B.K. Ridley in gold-doped germanium.

In germanium, electrons are more likely to be trapped by the atoms when the field is high; electrons therefore move more slowly in a high field

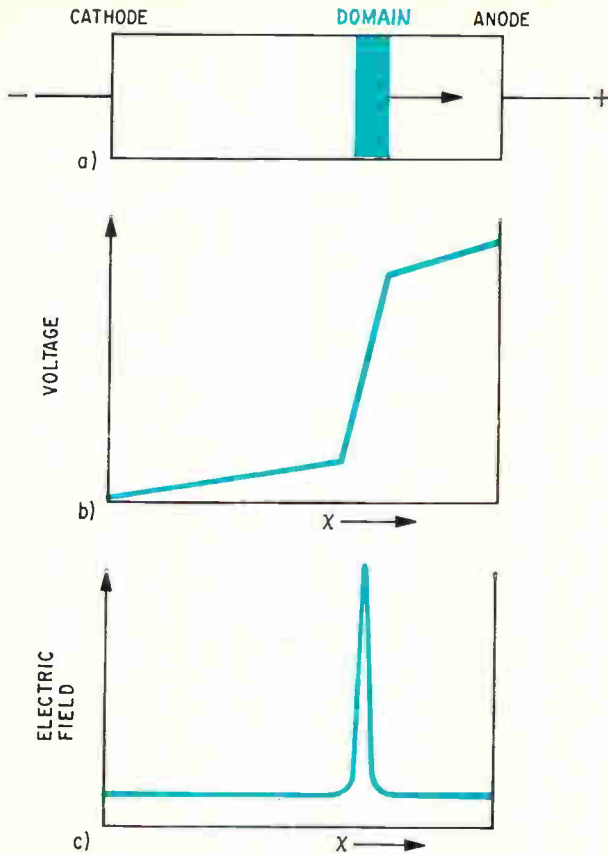

Electro-acoustic. A domain in a piezoelectric material moves through the crystal at the speed of sound. Most of the voltage drop across the crystal occurs within the domain, and the electric field within the domain is extremely high.

than in a low field. This causes them to bunch into a narrow dipolar layer consisting of an electron-rich region preceded by an electron-depleted layer.

There is a similar domain in J.B. Gunn's gallium-arsenide oscillator, but in this case the differential negative conductivity comes from the increase in the effective mass of electrons at high fields.

In cadmium sulfide, the differential negative conductivity arises from the piezoelectric nature of the CdS crystal. If sound of sufficiently high frequency is propagated in CdS, the piezoelectric effect generates an associated high-frequency a-c field. The a-c field travels at the velocity of the sound wave. Now, if a d-c voltage is applied to the CdS crystal, electrons will drift at a velocity determined by this d-c electric field and their mobility. The electrons exert a drag on the sound wave if they are traveling slowly, and they exert a pressure on the sound wave if they are traveling faster than it. These influences cause attenuation or amplification of the sound wave by the electron stream.³

In the high-conductivity crystals used in Dofic's, the sound wave can be amplified by many hundreds of decibels per millimeter along the propaga-

tion path. Therefore it isn't even necessary to inject the sound wave. The thermal noise in the crystal is enough; its high-frequency components will be amplified.

Soon after leaving the cathode, the acoustic wave has been amplified to such a high level by the drifting electrons that it begins to seriously hinder their passage. (The effective electron mobility drops accordingly; in other words, there is differential negative mobility.) Electrons start to bunch behind the sound wave, and the electric field builds up locally at the expense of the field in the rest of the crystal. This, in turn, increases the amplification, and a localized regenerative build-up of electric field occurs, forming a domain. The build-up continues until the electric field adjacent to the domain drops to the synchronous value (the value at which the electrons have the same velocity as the sound waves— 1.8×10^5 centimeters per second in CdS). The domain is then in equilibrium.

The net result of this entire process is an electro-acoustic domain, an extremely intense packet of acoustic energy at a frequency between 500 megahertz and 1 gigahertz, propagating with a high-electric-field packet, as shown at left.

This domain is a discrete entity that moves at a constant velocity through a length of crystal; in other words, it scans the crystal. If this entity could be made sensitive to light in some way, it would be possible to "read" one line-element of a picture projected on the crystal, and if it were possible to cause the domain to emit light, or to control the passage of light through it, a flying-spot light generator would be available.

These are the principles STL has used in the

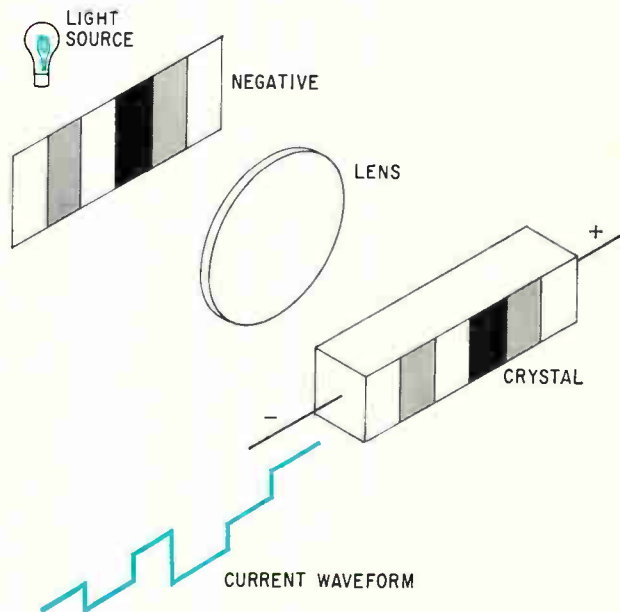

Video signal. Local variations in conductivity created by the projected image are reproduced in the output waveform as the domain travels along the crystal.

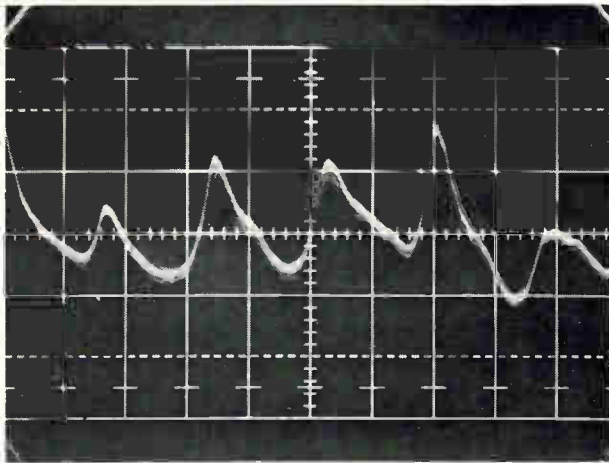
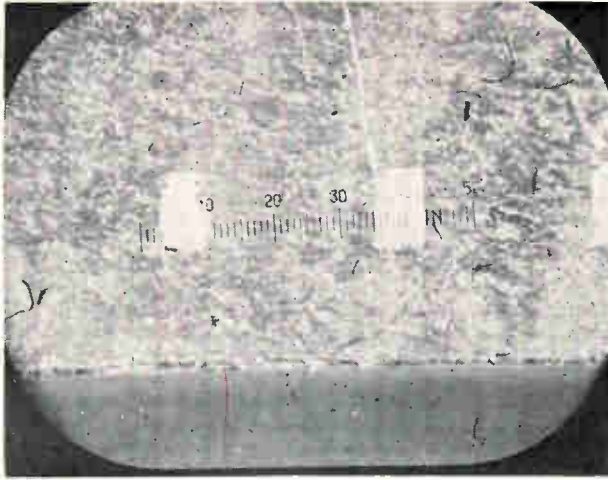

Demonstration. Dots of indium on the CdS crystal (top) simulate the local conductivity variations that would be caused by a projected image. Output current changes appreciably when the domain passes the dots, as indicated by the oscilloscope trace.

Dofic camera for reading a picture and the Dofic display for writing it.

One form of the Dofic camera exploits the photoconductivity of CdS. Light generates free carriers of CdS in approximate proportion to the light intensity, so the relative change in conductivity of the material depends on the number of free carriers already present and will be larger for low-conductivity material than for high-conductivity material. In other words, for maximum sensitivity to light, the conductivity should be low. Unfortunately, when the conductivity is low, the acoustic gain rate is not high enough for a domain to form, so it's necessary to compromise and select an intermediate conductivity—about 100 ohm-centimeters. At present, CdS is available only in resistivities above 10^3 ohm-cm and below 10 ohm-cm—not in the ideal range that simultaneously gives adequate photoconductivity and domain formation. (However, materials technology is constantly being advanced, and there is no reason why suitable CdS should not be available in the future.)

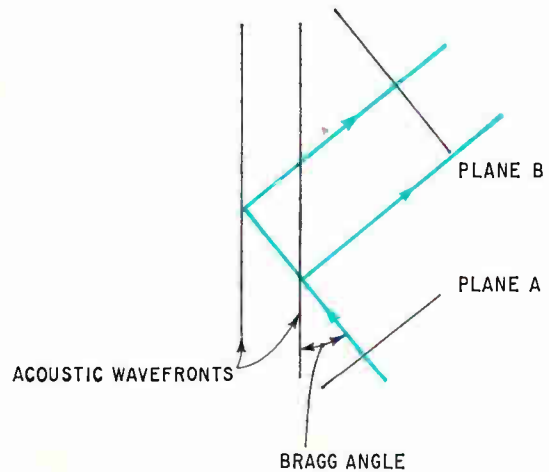
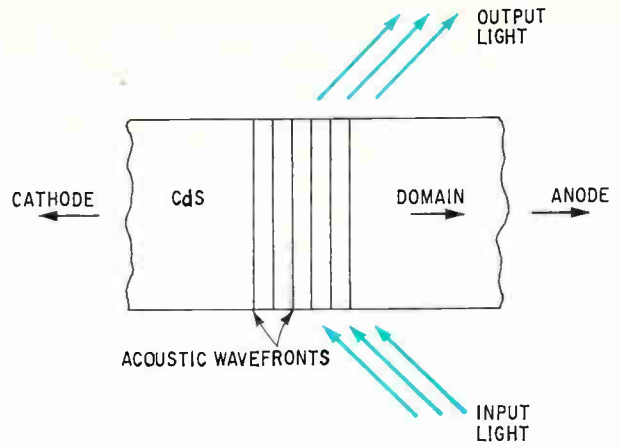

Bragg. When light impinges on the sound wave at the Bragg angle, it interferes constructively because the light reflected from different acoustic wavefronts (planes A and B) differs by an integral number of wavelengths.

Assume that a bar of the appropriate resistivity is available. A line-element of a picture is projected on it, as on page 101, bottom. The picture produces a variation in conductivity along the length of the bar, according to the local light intensity.

What happens when a domain propagates along the bar under these conditions? When a domain is formed, the field immediately outside the domain is held to the synchronous value, so the current through the crystal is at all times specified by the cross-sectional area and the conductivity in the vicinity of the domain. As the domain travels along the crystal, it scans the line-element of the picture, and the light information appears on the current waveform as variations in current with time, proportional to the variations in brightness with time (and distance along the crystal) experienced by the domain.

To circumvent the conductivity problem for demonstration purposes, STL altered the local conductivity of the CdS bar by evaporating dots of indium on a surface of the bar. These dots simulate the

effect of bright spots of light. The result, as on page 102, left, was enough current modulation to show what would happen with a crystal of the right resistivity.

With this method of imaging it is not necessary to use acousto-electric domains. The transferred electron domains in GaAs could be used, although, again, very special material is required to give both the high photoconductivity and the appropriate resistivity for domains. GaAs would be particularly suitable for very high scan rates (transferred electron domains in GaAs travel at 10^7 cm/sec) and for imaging at the longer wavelengths.

A new angle

To overcome the limitations of available materials, another Dofic camera principle was investigated. This principle exploits the intense acoustic energy in a CdS domain. The alternating compressive and tensile strains created in the crystal as the acoustic energy packet passes cause alternate changes in the refractive index of the crystal, so that, in effect, the domain is a moving diffraction grating. Ordinarily, the light passing through the domain gets distributed over a considerable angle, but at a certain angle of light input, the diffracted light can be made to interfere constructively, as on page 102, right.^{4,5} (This angle is called the Bragg angle.)

With a helium-neon laser and a photomultiplier (top of page) it's possible to detect the passage of a domain. Normally the beam passes straight through the crystal, but at the instant when a domain crosses the beam, light is diffracted toward the photomultiplier. In STL's experiments, the light was incident at the Bragg angle, and 50% to 75% of the light was deflected to the detector at an angle of 15° by the domain.

If the crystal is driven from a d-c bias source, then as each domain reaches the anode, another domain is initiated at the cathode. The new domain automatically moves toward the anode, so line-scan circuits aren't needed. And the waveform discontinuity during domain reformation provides a synchronizing pulse. Because the domain speed is constant, the line-scan time is similarly constant from camera to camera.

In STL's experimental Bragg-effect Dofic camera, the He-Ne laser beam was projected through a 35-mm photographic negative so that one line-element was focused on the crystal. The automatic-domain-generation mode of operation was not possible, because there is no CdS material yet available that can dissipate enough heat for continuous-wave operation. Therefore, the CdS crystal was driven from a pulse source that also controlled a stepping motor to provide the y scan. The photomultiplier output was used to intensify-modulate a crt. Quite good resolution was obtained (see lower figure, top of page): about 70 picture elements per line, which corresponds to a 10-Mhz modulation frequency. In CdS the ultimate modulation frequency is limited to 25 Mhz by the thick-

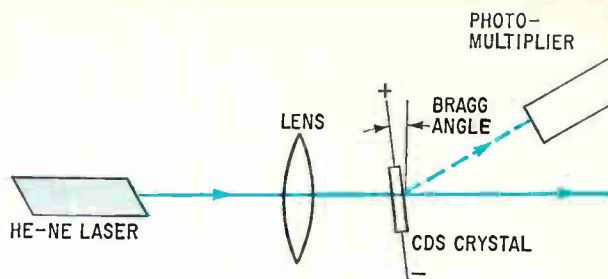

Another camera. When a domain crosses a light beam at the Bragg angle, it deflects the beam toward the detector.

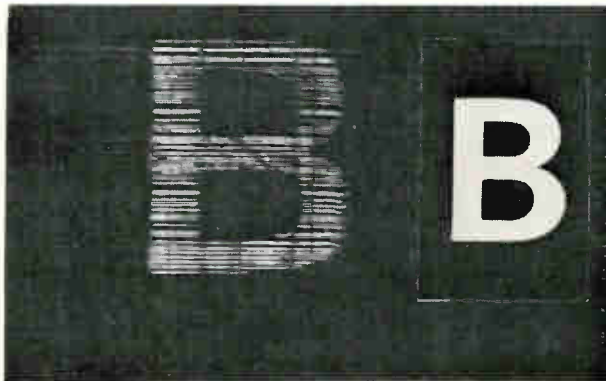

Resolution. The display at left was reproduced from the original letter by a Bragg-angle Dofic camera. Horizontal resolution is about 70 picture elements.

ness and velocity of the domain.

The method of scanning used is very similar to that used in scanning films for presentation on tv where the y scan is provided by the movement of the film and the x scan by the flying-spot camera. Of course, mechanical scan is not desirable for a normal camera, and STL is investigating means of obtaining the y scan by solid state techniques. However, apart from film scanning, the technique described would be suitable for high-speed facsimile or punched paper tape reading.

Dofic display

If the voltage across the CdS crystal is increased while a domain is in transit, all the extra voltage will appear across the domain, thus increasing the domain field.⁶ This effect provides a way of addressing the domain while it's in transit by superimposing the video signal on the bias. And since a change in field produces a local change in the index of refraction of crystal, it's also possible to address a beam of light passing through the crystal. This is the idea that STL has explored in its Dofic display.

A birefringent crystal splits light into two components, one perpendicular to the optic axis and the other parallel to it. Thus linearly polarized light projected on the crystal emerges as elliptically polarized light because of the changed phase

relation between the two components. The degree of ellipticity depends on the wavelength of the light, the difference in the refractive indexes in the parallel and perpendicular directions, and the thickness of the crystal.

Since an electric field changes one or both of the refractive indexes, it can also change the ellipticity of the light polarization. Ordinarily, the effect is negligible; very high fields are needed to make an appreciable change. Fortunately, such fields are available in a domain—the field can reach 30 kilovolts per centimeter inside a domain, but it's a mere 600 volts per cm outside.

In STL's display experiments, light from a He-Ne laser was focused on a spot on the crystal, and a

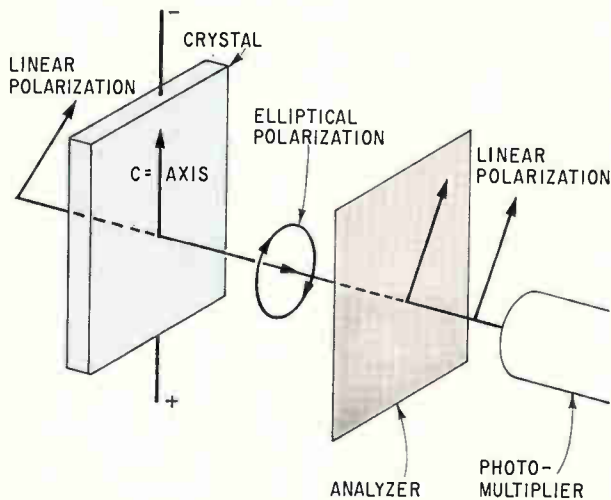

Display system. A domain increases the ellipticity of light passing through the crystal. The light can then be transmitted by the analyzer and detected.

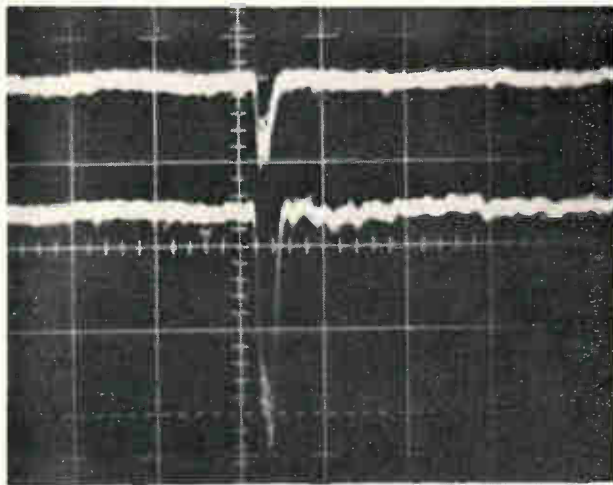

Addressable. Light can be addressed, or varied in intensity, by changing the bias on the crystal. The lower trace was made at 2.5 times the bias used for the top trace, and the pulse generated when a domain passed the light beam was correspondingly larger.

polarizing analyzer and a detector were placed behind the crystal, as at top left. The thickness of the crystal was selected to make the elliptically polarized light as close as possible to the limiting case of linear polarization, so that the light is almost completely cut off by the analyzer. But when a domain passes the laser spot, the ellipticity is changed and an output is seen by the detector.

What about addressing the domain, and thus the light beam? The amount of light transmitted by the analyzer is proportional to the voltage across the domain, which in turn is proportional to the voltage across the crystal. STL found that increasing the bias voltage 2.5 times produced a corresponding increase in the photomultiplier output, as at lower left. In other words, the light output varies linearly with the video voltage.

The external light source required in the experimental setup could be obviated if the domain generated light—ideally, by injection luminescence.

It should be possible to produce a suitable configuration, particularly in GaAs (but possibly also in ion-implanted CdS) whereby electrons injected from the domain into a p-type region recombine directly by a conduction to valence band transition. This is the same efficient mechanism that gives the intense light source of solid state lasers. In a Dofic display the radiating region would move with the domain and its brightness could be modulated by varying the externally applied voltage that varies the domain field.

It may be some time before there is sufficient control over the material to produce efficient injection luminescence, but it is always possible to obtain some radiative transitions in the presence of electron-hole recombinations. Thus the domain can initiate recombination in semiconductors where direct band gap transitions do not take place, for example in hetero-junctions,⁷ though not with the efficiency customary in solid state lamps.

Although the high fixed speed of the domain is a limitation when the scan system must be compatible with existing scan times, it can be a distinct advantage in other applications. For example, a very fast line scan is eminently suitable for a multichannel communication system in which time-division multiplexing is based on the line-scan. ■

References

1. C.P. Sandbank, "Synthesis of Complex Electronic Functions by Solid State Bulk Effects," *Solid State Electronics*, Vol. 10, pp. 369-380.
2. R.S. Englebrect, "Solid State Bulk Phenomena and their Application to Integrated Electronics," *ISSCC Digest*, February 1968, p. 38.
3. Hutson, McFee, and White, "Ultrasonic Amplification in CdS," *Physical Review Letters*, Vol. 7, No. 6.
4. R. Adler, "Interaction Between Light and Sound," *IEEE Spectrum*, May 1967.
5. Zucker and Zemon, "Frequency Spectrum of Giant Acoustic Wave Packets Generated in CdS by High Electric Fields," *Applied Physics Letters*, Vol. 9, No. 11.
6. M.R.N. Butler and C.P. Sandbank, "Characteristics and Applications of Domains in Semiconducting CdS," *IEEE Trans. on Electron Devices*, October 1967.
7. B. Hakki, "Solid State Acoustoelectric Light Scanner," *Applied Physics Letters*, Vol. 11, No. 5.

One better comparator:

Meet our new 526 High Speed Comparator: 33% faster than any other now available (propagation delay, 42ns maximum). It operates off standard 5V logic supplies, and provides a 4V common mode range. No additional cans are required for output buffering (the 526 provides a fan-out of 10 to DTL

and TTL inputs). And the 526 is more versatile, since the differential amplifier and NAND gate can be used independently. Available now in 3 package configurations: Flat pak, TO-5 and DIPs in both military and industrial temperature ranges. Prices start at \$4.15 (100-999) for industrial DIPs.

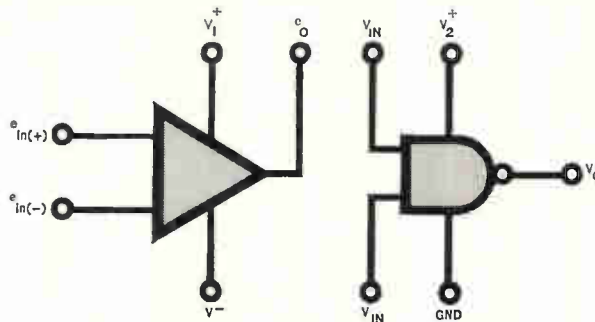

526 High Speed Comparator

Three perfect replacements:

Signetics now has pin-for-pin and spec-for-spec replacements for the 709, 710 and 711 in all established package configurations. They are available in volume at low, low prices starting at \$1.86 (100-999) in TO-5 industrial temperature types.

5709 Operational Amplifier

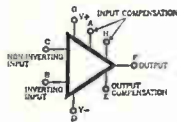

5710 High Speed Voltage Comparator

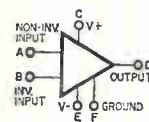

5711 High Speed Dual Voltage Comparator

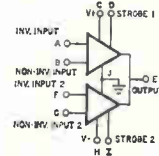

Signetics Integrated Circuits
A SUBSIDIARY OF CORNING GLASS WORKS

811 East Arques Ave., Sunnyvale, California 94086

SIGNETICS SALES OFFICES: Wakefield, Massachusetts (617) 245-8200; Trumbull, Connecticut (203) 268-8010; Poughkeepsie, New York (914) 471-3292; Syracuse, New York (315) 469-1072; Fort Lee, New Jersey (201) 947-9870; Radnor, Pennsylvania (215) 687-2660; Silver Spring, Maryland (301) 946-6030; Clearwater, Florida (813) 726-3734; Winter Park, Florida (305) 671-5350; Dayton, Ohio (513) 433-4133; Minneapolis, Minnesota (612) 920-3256; Rolling Meadows, Illinois (312) 259-8300; Richardson, Texas (214) 231-6344; Garden Grove, California (714) 636-4260; Burbank, California (213) 846-1020; Redwood City, California (415) 369-0333.

DISTRIBUTORS: Avnet Electronics Corp., Burlington, Mass. (617) 272-3060; Cesco Electronics, Ltd., Montreal, Quebec, Canada (514) 735-5511. Compar Corporation at the following locations: Huntsville, Alabama (205) 539-8476; Los Angeles, California (213) 245-1172; Burlingame, California (415) 347-8244; Hamden, Connecticut (203) 288-9276; Clearwater, Florida (813) 446-2991; Orlando, Florida (305) 855-3964; Park Ridge, Illinois (312) 692-4125; Baltimore, Maryland (301) 484-5400; Newton Highlands, Mass. (617) 969-7140; Minneapolis, Minnesota (612) 922-7011; St. Louis, Missouri (314) 542-3399; Albany, New York (518) 489-7408; Endwell, New York (607) 723-8743; Woodbury, New York (516) 921-9393; Fairport, New York (716) 271-2230; Syracuse, New York (315) 471-3356; Winston Salem, North Carolina (919) 723-1002; Seattle, Washington (206) 763-1550; Hamilton Electro Sales, Culver City, Calif. (213) 870-7171; Cherry Hill, N.J. (609) 662-9337; Hammond Electronics, Orlando, Florida (305) 241-6601; Kierulff Electronics, Seattle, Wash. (206) 763-1550; G. S. Marshall, San Marino, Calif. (213) 684-1530; Milgray-Delaware Valley, Inc., Philadelphia, Pa. (215) 228-2000; Pioneer Standard Electronics, Rockville, Maryland (301) 427-3300; Schley Electronics, Watertown, Mass. (617) 926-0235; Semiconductor Specialists, Inc., Elmhurst, Illinois (312) 279-1000; Terminal-Hudson Electronics, New York, New York (212) 243-5200; Universal Electronics, Inc., Houston, Texas (713) 781-0421; Wesco Electronics, Inc., Los Angeles, Calif. (213) 685-9525; Palo Alto, Calif. (405) 968-3475.

DOMESTIC REPRESENTATIVES: Compar Corporation at the following locations: Scottsdale, Arizona (602) 947-4336; Denver, Colorado (303) 781-0912; Southfield, Michigan (313) 357-5369; Haddonfield, New Jersey (609) 429-1526; Albuquerque, New Mexico (505) 265-1020; Albany, New York (518) 489-7408; Endwell, New York (607) 723-8743; Fairport, New York (716) 271-2230; Syracuse, New York (315) 471-3356; Rocky River, Ohio (216) 333-4120; Fairborn, Ohio (513) 878-2631; Dallas, Texas (214) 363-1526; Houston, Texas (713) 667-3420. Ozark Electronic Marketing, Inc., St. Louis, Missouri (314) 423-7200.

INTERNATIONAL SALES: France, Germany, Italy, Belgium, Holland, Luxemburg, Spain—Sovcor Electronique, 11, Chemin de Ronde, Le Vesinet. (S. & O.) France, United Kingdom, Ireland, Sweden, Denmark, Norway, Switzerland, Austria, Portugal—Electrosil Ltd., Lakeside Estate, Colnbrook-By-Pass Slough, Buckinghamshire, Great Britain. Australia—Corning, 1202 Plaza Building, Australia Square, Sydney, N.S.W. 27-4318. Canada—Corning Glass Works of Canada, Ltd., Leaside Plant, Ontario, Canada (416) 421-1500. Israel—Talvion, P.O. Box 3282, Tel-Aviv, Israel 236-666. Japan—ASAHI Glass Co., Ltd., Corning Products Sales Dept. No.14, 2-Chome Marunouchi, Chiyoda ku, Tokyo, Japan 211-0411.

Flame retardancy!

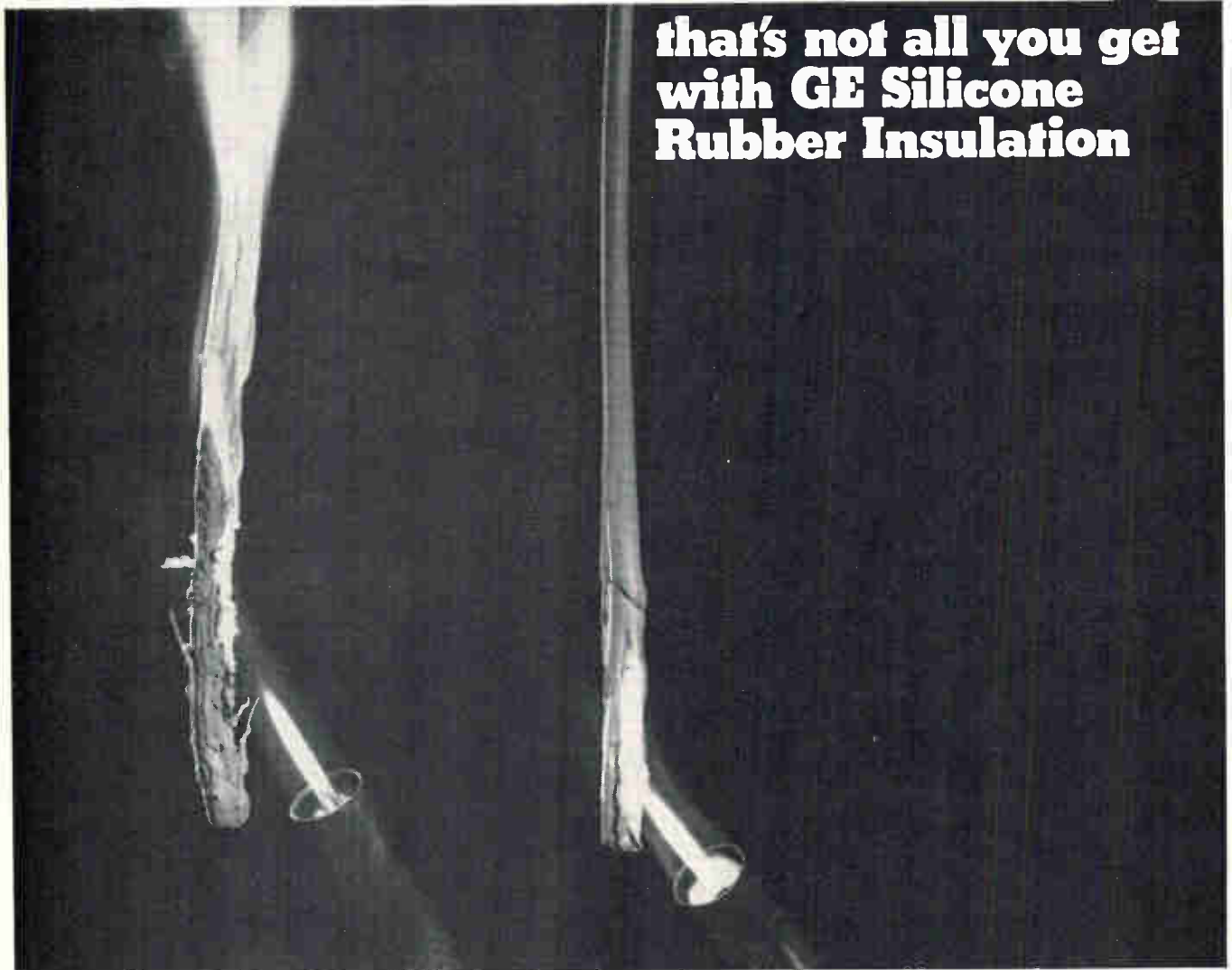

that's not all you get
with **GE Silicone
Rubber Insulation**

New ultra-tough SE-9090 braidless wire and cable insulation (right) doesn't support combustion like conventional insulation. It's shown here passing the UL vertical flame test. SE-9090 has both outstanding insulation resistance and dielectric strength.

The big news in silicone rubber this year is flame retardancy *plus* high physical strength.

But don't overlook the other design advantages of GE silicones: radiation, ozone, corona, and fungus resistance ... reliable performance from -150°F to 600°F ... and the proved dependability of silicones for the most demanding dielectric requirements. Weigh them all and you'll find that GE silicones offer the best combination of desirable values in insulation.

Versatile silicones take many shapes and forms to adapt to your specific problems. For a new booklet illustrating electronic applications for GE silicones, write Section N2294, General Electric Company, Waterford, N.Y. 12188.

GENERAL  **ELECTRIC**

Use GE flame-retardant silicones for...

Potting applications

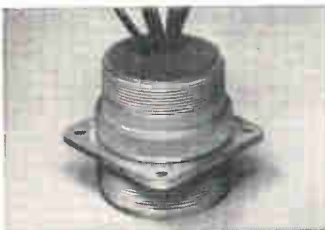

Conformal coatings



Wire & cable insulation

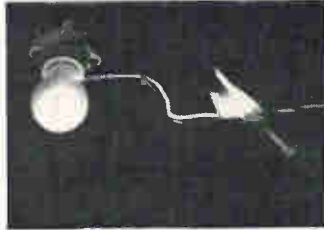

Fabricated parts

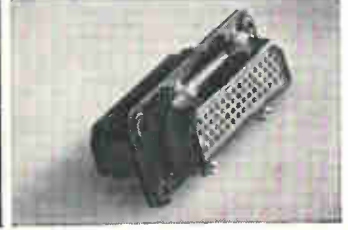

Oh, you'll put it together, all right, and after a while, it'll work, more or less. Then you'll take the prototype to engineering for board design, get it back, attach the components, test it, make a few compromises, try it again. What you have then is an engineering model.

Then the manufacturing design. Back to engineering for debugging. More testing. Parts procurement. Incoming inspection. Telephone calls. Late deliveries. More testing. Heartache. Final release and the module is ready for manufacture. Maybe.

All this time, an already designed, fully debugged, guaranteed, computer-tested, solid state module sits on Digital's shelf. Fifty engineers in offices around the country wait for your call to help. Application notes, installation drawings, catalogs sit in our mail room.

Power supplies, hardware, racks are piled high in the stock room.

M Series modules are the most complete, fully compatible, fast, all IC, TTL, inexpensive solid state logic available anywhere. With a few million modules in our recent history, and a few million dollars worth of test equipment, we really know how to put them out.

Read all about them in the new Logic Handbook. Free.

digital
COMPUTERS · MODULES

Hold it, right there.



DIGITAL EQUIPMENT CORPORATION,
Maynard, Massachusetts 01754. Telephone:
(617) 897-5111 / Cambridge, Mass. / New
Haven / Washington, D.C. / Parsippany, Palisades
Park, N.J. / Princeton, N.J. / Rochester, N.Y. / Long
Island, N.Y. / Philadelphia / Pittsburgh / Cleveland /
Dayton / Huntsville / Cocoa, Fla. / Chicago / Denver /
Ann Arbor / Salt Lake City / Houston / Albuquerque /
Los Angeles / Palo Alto / Seattle. INTERNATIONAL,
Carleton Place and Toronto, Ont. / Montreal,
Quebec / Edmonton, Alberta, Canada / Reading and
Manchester, England / Paris, France / Munich and
Cologne, Germany / Oslo, Norway / Stockholm,
Sweden / Sydney and West Perth, Australia.

NOW... the IC regulator you've been waiting for

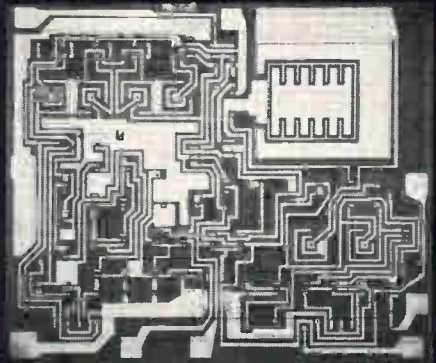

The TVR-2000 – Highest efficiency ... independent, programmable foldback ... 8-40V input range ... output to 200mA ... internal temperature compensated reference.

PROGRAMMABLE FOLDBACK — Exclusive, built-in circuit permits full control of foldback slope and short circuit current through selection of external resistors.

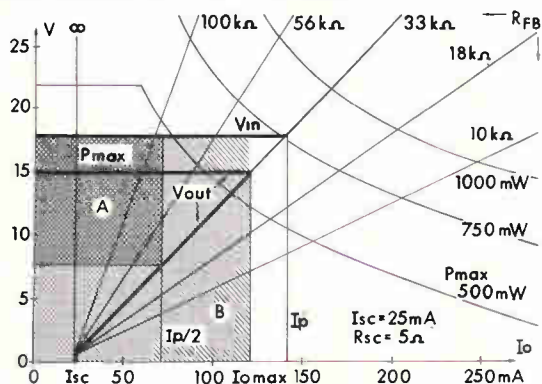

Peak power prediction for typical output characteristics. Programmable foldback permits maximum power dissipation ("A" above) only 1/3 that resulting from conventional current limiting ("B" above) or optionally, 3x greater output current with the same power dissipation.

LOWEST MINIMUM ΔV — Minimum input/output voltage differential is 2.2V ... lowest of all available IC regulators.

LOWEST MINIMUM INPUT VOLTAGE / BROADEST OPERATING RANGE — Input Voltages from 8V to 40V. Output voltages from 3V to 38V.

Minimum input-output voltage differential, output impedance, bandwidth, are constant over full output voltage range and not degraded by current limiting.

EXPANDABILITY — Current may be expanded, with external output transistor under full control of foldback circuit.

The TVR-2000 is designed for -55°C to $+125^{\circ}\text{C}$ operation. A commercial version, the TVR-2001, is available for 0°C to 70°C , with generally equivalent characteristics. Both available for immediate delivery in TO-100 (10 lead TO-5) packages.

Send for complete specifications

Transitron
electronic corporation
168 Albion Street Wakefield, Massachusetts 01880

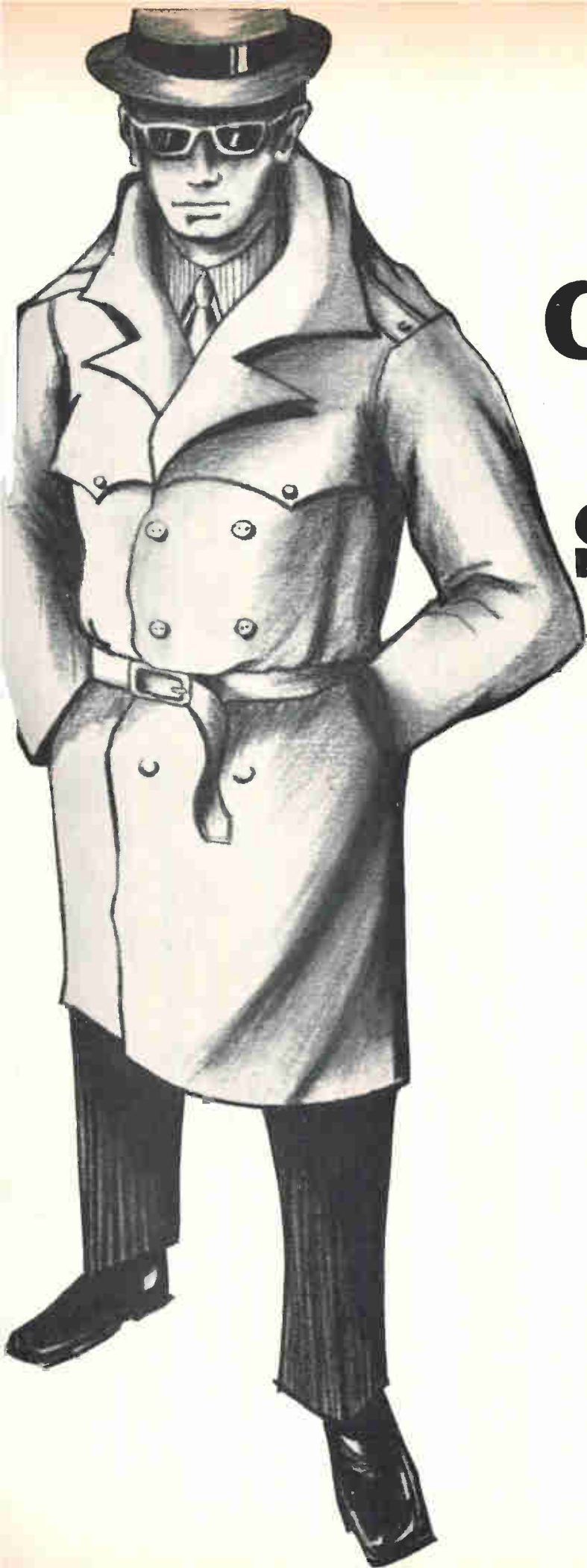

IS YOUR CONTACT MAN A SPECIAL AGENT ?

He is if he's backed by 100% concentrated effort. This is why Deringer specializes instead of trying to be all things to all people. All our effort is concentrated on providing our customers with the best in electrical contacts, contact sub-assemblies and assemblies. Our entire engineering and manufacturing attention centers on helping contact users solve their contact problems with the optimum contact for each particular application. Contact Deringer. We'll send one of our special agents right away.

D E R I N G E R

METALLURGICAL CORPORATION

1250 Town Line Road (Rt. 60) Mundelein, Illinois 60060

Circle 109 on reader service card

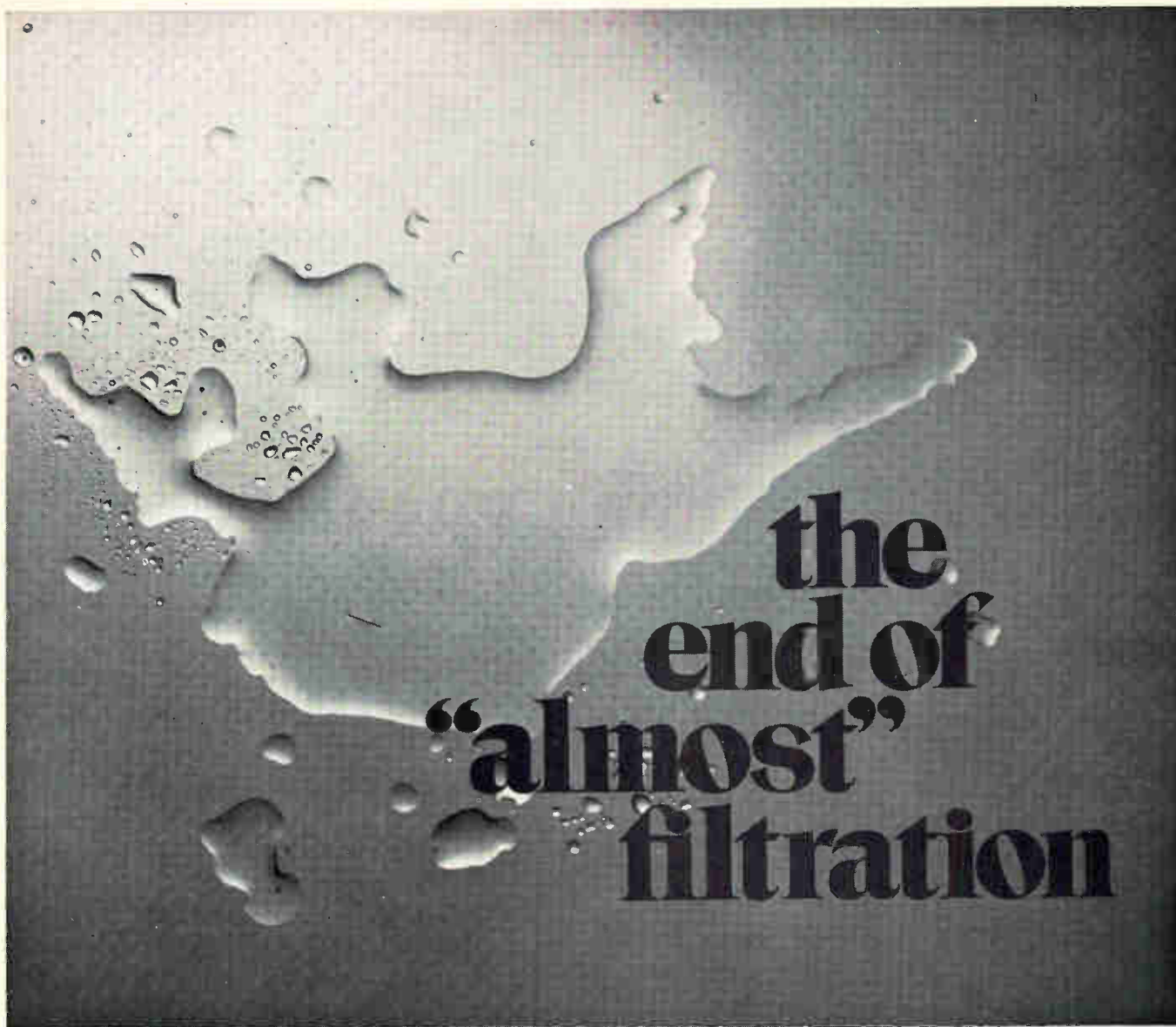

the end of “almost” filtration

You can *almost* remove every particle or microorganism larger than a specific size from fluids with “depth” filters. But the few that sneak through can ruin product quality. So can the many which may be dumped when a depth filter is shocked. And the microorganisms which can grow through. And the pieces of filter material which can break off and contaminate a filtrate.

Millipore filters remove every particle or microorganism larger than specific filter pore size — as small as 0.22 micron. They

have an *absolute* rating — no depth about it. And they contain no fibers or particles to work loose and contaminate a filtrate.

Now Millipore systems (including “depth” filters for *prefiltration*) make *absolute* filtration possible and practical in many industrial applications where a high degree of cleanliness is required.

In electronic production they are *increasing yields* by:

- providing 18 megohm rinse water free of particles to an *absolute* level of 0.45 micron.
- removing *all* particles larger than 1 micron from gases used for purging and drying.
- removing *all* particles from photo resists to sub-micron levels.
- removing *all* particles from coating solutions and wash water for cathode ray tubes.
- removing *all* particles from developers for I.C. masks to sub-micron levels.

Find out how you can put an end to “almost” filtration. Start now by writing for the Millipore Electronic Production Application Guide. Millipore Corporation, Bedford, Mass. 01730.

MILLIPORE
systems for analyzing and processing fluids

Soliton announces

300 VOLTS

5-AMP, PLANAR TRIPLE DIFFUSED TRANSISTORS

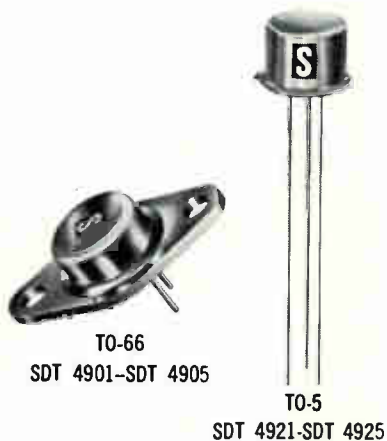

Soliton expands its line of high-rel, high voltage planar devices with new 5-Amp NPN Triple Diffused Transistors having voltages up to 300V. These transistors, the SDT 4901-5 and SDT 4921-5 Series, have the same construction technique as Soliton's popular 20-Amp SDT 8800 and 10-Amp SDT 7900 Series. This advanced planar construction results in stable performance at high temperature under reverse bias conditions. Available in the TO-66 and TO-5 case, they are designed for high voltage, fast switching applications such as telemetry, radar systems, high speed data transmissions, sweep circuits and TV deflection circuits.

Type Number TO-66	Type Number TO-5	RATED BREAKDOWN VOLTAGES			PERFORMANCE SPECIFICATIONS						
		BV _{CBO}	BV _{CEO} (SUS)	BV _{EBO}	h _{FE}		V _{CE} (sat) Volts	V _{BE} (sat) Volts	I _{CBO} μA	f _T MHz	
					@ I _C = 1.0A V _{CE} = 5.0V	@ I _C = 1.0A I _B = 0.1A	@ I _C = 1.0A I _B = 0.1A	Max.			Max.
		Min.	Min.	Min.	Min.	Max.	Max.	Max.	Max.	@V _{CB}	Typ.
SDT 4901	SDT 4921	225	200	8	20	60	0.4	1.2	1.0	100	40
SDT 4902	SDT 4922	250	225	8	20	60	0.4	1.2	1.0	100	40
SDT 4903	SDT 4923	275	250	8	20	60	0.4	1.2	1.0	100	40
SDT 4904	SDT 4924	300	275	8	20	60	0.4	1.2	1.0	100	40
SDT 4905	SDT 4925	325	300	8	20	60	0.4	1.2	1.0	100	40

To obtain additional information on these devices, Dial 1-800-327-3245 for a "No Charge" telephone call.

SEMICONDUCTOR DIVISION

Soliton
DEVICES, INC.

1177 BLUE HERON BLVD. / RIVIERA BEACH, FLA / TWX: (510) 952-6676

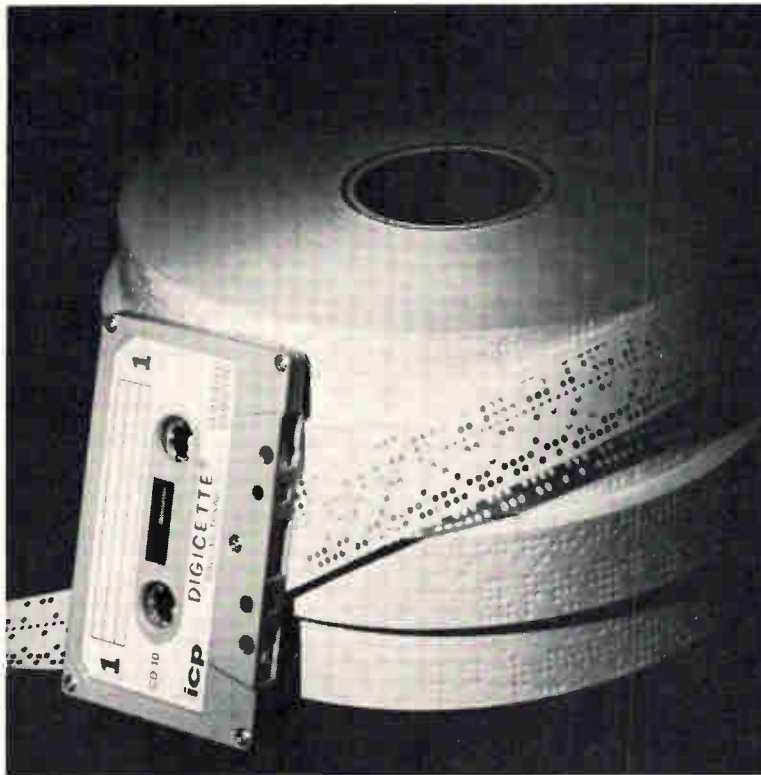

Stack ours against yours!

Speed, cost, capacity and space . . . why you should use the **DigiCorder** instead of a paper tape system. Even for the small and medium business which has never been able to afford the convenience of magnetic tape. **SPEED:** The **DigiCorder** reads and writes at 500 characters a second. What is the capability of your paper tape punch and reader? **COST:** Prices of the high-speed **DigiCorder** begin at \$840 (in quantity). What is the price of your paper tape punch, reader and controls? **CAPACITY:** The **DigiCorder** cassette stores up to 500,000 8-bit bytes. How many standard rolls of paper tape would it take to reach this capacity? More than four rolls? **SPACE:** The **DigiCorder** measures 17½ inches x 3½ inches x 14 inches. How much space is consumed by your paper tape punch, reader and controls? The **DigiCorder** cassette measures 4 inches x 2½ inches x ¾ inch. How much space is required to store 4 standard rolls of paper tape? If you now use paper tape, you need to know more about the **DigiCorder**. For specifications, contact:



icp

INTERNATIONAL COMPUTER PRODUCTS, INC.

P.O. BOX 34484 DALLAS, TEXAS 75234 214 239-5381

TWX: 910-860-5009 CABLE: ICPTX DALLAS, TEXAS

Three new A version linear ICs. Tightest specs you can get.

Raytheon is coaxing record performances from three veteran circuits with new advanced A versions. Compare these key maximum specifications, rated over the full military -55 to 125°C temperature range.

RM709A High Gain Op Amp. Offset voltage 2.0 mV , drift $6.0\mu\text{V}/^{\circ}\text{C}$. Low temp (-55°C to 25°C) offset current drift is $1.0\text{ nA}/^{\circ}\text{C}$, high temp drift only $0.3\text{ nA}/^{\circ}\text{C}$. (Best competitive specs: V_{os} 3.0 mV , drift $10.0\mu\text{V}/^{\circ}\text{C}$, $2.8\text{ nA}/^{\circ}\text{C}$.)

RM710A Differential Voltage Comparator. V_{os} is 1.5 mV , drift $5.0\mu\text{V}/^{\circ}\text{C}$. Low and high temperature offset current drift only 50 and $10\text{ nA}/^{\circ}\text{C}$, respectively. (Competition: V_{os} 3.0 mV , drift $10.0\mu\text{V}/^{\circ}\text{C}$ and $75\text{ nA}/^{\circ}\text{C}$.)

RM711A Dual Differential Voltage Comparator. Offset voltage is 1.5 mV . Low temp offset current drift $25\text{ nA}/^{\circ}\text{C}$, high temp drift $10\text{ nA}/^{\circ}\text{C}$. (Best elsewhere: V_{os} 4.5 mV , current drift N/A .)

And price? Surprisingly low. Only 10% over costs of standard mil-temp versions. Available now from Raytheon distributors across the nation. Send for data sheets and distributor list from the company that gets the ideas and delivers the goods. Raytheon Semiconductor, Mountain View, California, (415) 968-9211.

RAYTHEON

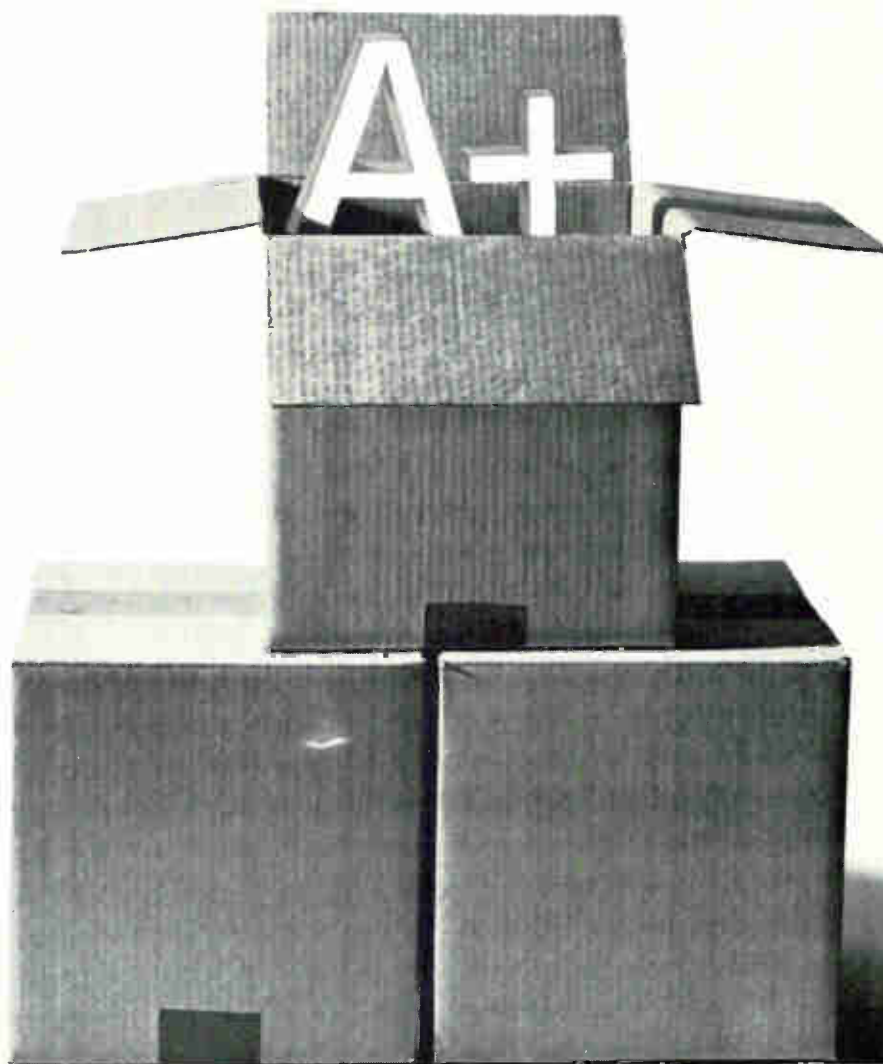

Talk about a choice in 10-amp relays... here, sample the Struthers-Dunn line-up!

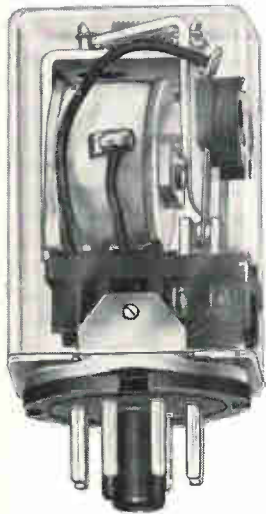

Enclosed, plug-in Type 314XB48P

Low-cost, UL Recognized industrial 10-amp relays

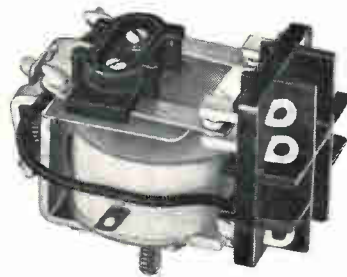

Open Type 314XBX

Frame 314, enclosed plug-in and open types. SPDT, DPDT, or 3PDT contacts; 10 million mechanical life. Medium-duty component for logic and load handling jobs for control of instruments, small motors, solenoid valves, heating elements, etc. Coils for 6, 12, 24, 115, 230Vac; 6, 12, 24, 115Vdc.

• • •

115Vac plug-ins available with neon lamp wired across coil inside clear plastic case to indicate when power is available. Speeds checkout, trouble shooting.

Bulletin B/5204

TWO rated for 600 volts



Money-saving, space-saving 4 and 8 pole, industrial Type SC. Only 2¾" sq. Mechanical life, 20 million. Both pole models in any combinations of normally-open, normally-closed contacts. Five contact variations with 4-pole models, nine with 8-pole. UL Listed. Optional timing modules, too!

Bulletin B/5630



Also . . . versatile, modular, Type MC accommodates 2 to 12 poles in only two base sizes. Solenoid operated with wide choice of ac or dc coils, latch and timing modules, dc contacts, etc. For convenience, adaptability and reliable control of full range of widely varying loads. Cut inventory, maintenance problems.

Bulletin B/5660

For Aerospace

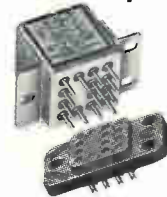

The space miser! At only one cubic-inch overall, the FCM-410 is one of the smallest 4P-DT, 10-amp hermetically sealed relays made. It's one of many Struthers-Dunn choices in 2 & 4 pole, hermetically-sealed, 10 ampere relays for MIL-spec and rugged industrial requirements.

Bulletin B/2460

Plus these... and more!

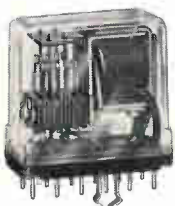

General purpose industrial. Highly reliable Frame 219 plug-in relays in eight contact arrangements for 150V service. Rugged 12 or 14 pin industrial sockets. Indicating lamp and manual actuator options.

Bulletin B/5219

Mechanical latch. Electrical re-set with heavy duty 12-pin plug and industrial socket for convenient plug-in use. Unique latching frame assures exact positioning of the two interfering armatures.

Bulletin B/5255

Sequence. Companion unit to our Frame 219 and latch relays. DP-ST or DP-DT. Standard contacts operate on energizing impulse. Can also be adjusted to operate when de-energized.

Bulletin B/5261



Get this data on Dunco 10-amp relays!

Check the Reader Service Card numbers shown for any or all Bulletins listed. For an idea of your wide choice at Struthers-Dunn, check them all!

- #512 Bulletin B/5204
- #513 Bulletin B/5630
- #514 Bulletin B/5660
- #515 Bulletin B/2460
- #516 Bulletin B/5219
- #517 Bulletin B/5255
- #518 Bulletin B/5261



STRUTHERS-DUNN, INC.

PITMAN, NEW JERSEY 08071

Canada: Struthers-Dunn Relay Div., Renfrew Electric Co., Ltd.



Portables with Performance

50 MHz

7-ns Risetime, Dual-trace

150 MHz

2.4-ns Risetime, Dual-trace



The Tektronix Type 453

Dual-trace, DC-to-50 MHz bandwidth with sweep delay in a compact 30-pound instrument. Rugged environmental capabilities are combined with performance features normally found only in multiple plug-in instruments. Vertical amplifiers provide 7-ns risetime, DC-to-50 MHz bandwidth, from 20 mV/div to 10 V/div deflection factor. At 5 mV/div deflection factor, risetime is 8.75 ns and bandwidth is DC to 40 MHz. Cascading Channel 1 and Channel 2 provides 1 mV/div deflection factor, DC-to-25 MHz bandwidth. The included Type P6010 miniature 10X probes preserve system bandwidth and risetime performance right to the probe tip. Front panel switching logic permits making 5 mV/div X-Y measurements. Jitter, time coincidence, pulse width and other measurements are easily made utilizing the calibrated sweep delay. Sweep rates are 5 s/div to 0.1 μ s/div, extending to 10 ns/div with the X10 magnifier. Solid-state design, with FET vertical inputs, provides low drift and fast stabilization time. AC powered.

Type 453 Oscilloscope \$1950

The Tektronix Type 454

DC-to-150 MHz bandwidth, 2.4-ns risetime! This oscilloscope is currently the fastest real-time, general-purpose instrument available. Dual-trace amplifiers provide 150-MHz bandwidth at 20 mV/div deflection factor. At 5 mV/div, risetime and bandwidth are 5.9 ns and 60 MHz respectively. Single-trace displays at 1 mV/div deflection factor permit viewing low level signals. The supplied P6047 10X probes preserve the 150-MHz bandwidth right to the tip of the probe. Sweep rates are 5 s/div to 50 ns/div, extending to 5 ns/div with the X10 magnifier. Calibrated sweep delay permits expanding specific portions of your waveform display for examination in detail. A photographic writing speed of 3200 div/ μ s (>2500 cm/ μ s) is provided by the Type 454 Oscilloscope, C-31 Camera, and 10,000 ASA film, without employing film-fogging techniques! X-Y displays, with calibrated deflection factors to 5 mV/div, are possible with the flick of two front panel switches. The Type 454 is mechanically designed to withstand environmental extremes and rough handling. AC powered.

Type 454 Oscilloscope \$2700

U.S. Sales Prices FOB Beaverton, Oregon

please turn page for additional information

Making the Measurement . . . with Tektronix Type 453 and Type 454 Portable Oscilloscopes

Portability

The Type 453 and Type 454 Oscilloscopes are designed to be easily transported. With the adjustable handle locked in the "carry" position, these instruments present a vertical form factor which enables them to be carried at the side using only one hand. The handle rotates to other fixed positions, providing a convenient tilt-stand for bench applications. A front cover prevents accidental damage to the operating controls and seals out dust and moisture while in transit. The cover also provides convenient storage for standard accessories. These compact high-performance instruments are lightweight—the Type 453 weighs 30 pounds and the Type 454 weighs 31 1/4 pounds, including panel cover and standard accessories. Both instruments are designed to withstand environmental extremes and rough handling. Specifications are valid over an operating temperature range of -15°C to +55°C.



The P6046 Differential Probe and Amplifier provide a CMRR of 1000:1 at 50 MHz with 1 mV/div deflection factor. When used with the Type 454, this same probe/amplifier combination provides 1 mV/div deflection factor at ≈ 70 -MHz bandwidth!

Extra Performance

Dual-trace vertical amplifiers, calibrated delaying sweep, full-bandwidth triggering, and probe-tip performance are standard features offered by both the Type 453 and Type 454 Portable Oscilloscopes. To enhance these performance features and provide additional measurement value, a complete line of compatible optional accessories are available.



The new P6042 DC Current Probe permits measuring current flow with bandwidth from DC to 50 MHz and deflection factors to 1 mA/div.



Repetitive or single-event waveform phenomena may be photographically recorded using the Type C-30A or C-31 Trace-Recording Camera. A minimum photographic writing speed of 3200 div/ μ s is provided by the Type 454 Oscilloscope with P11 phosphor, C-31R Camera and 10,000 ASA film—without employing film-fogging techniques!



The Type 200-1 Scope-Mobile® Cart is specifically designed for the Type 453 and Type 454 Portable Oscilloscopes. This cart occupies less than 18 inches of aisle space and provides storage at the base for accessories or associated instruments.

Type 453 Portable Oscilloscope	\$1950
Type 454 Portable Oscilloscope	\$2700
Type C-31 Camera	\$ 550
P6042 Current Probe	\$ 625
P6046 Differential Probe and Amplifier	\$ 725
Type 200-1 Scope-Mobile® Cart	\$ 85

U.S. Sales Prices FOB Beaverton, Oregon

Your Tektronix Field Engineer will demonstrate these products on your premises at your convenience. Please call him, or write Tektronix, Inc., Box 500, Beaverton, Oregon 97005.



Tektronix, Inc.

committed to progress in waveform measurement

Budget bears brand

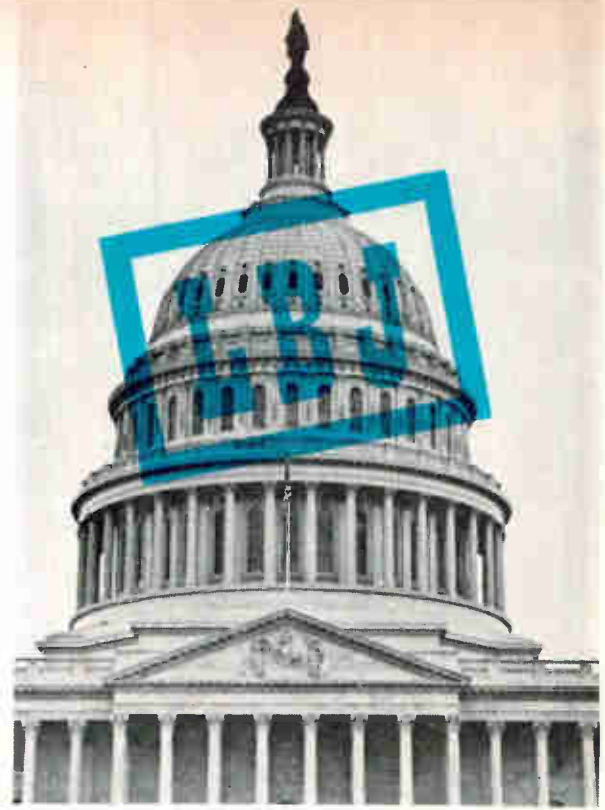

Nixon inherits a tight, realistic spending plan, based on assumption that the war in Vietnam will require fewer dollars during fiscal 1970; electronics prospects are good in most outlets

The budgetary swan song of Lyndon B. Johnson strikes a note of realistic optimism. In his sixth and final message to the Congress, Johnson passed on to his successor, President Richard M. Nixon, Government spending plans that add up to \$195.3 billion for the fiscal year beginning July 1, 1969.

The latest Federal budget has good news for electronics concerns on at least two counts. There's plenty of business in store in military, civilian, and even space outlets. And provisions are made for reducing inflationary pressures and strengthening the dollar—prospects that auger well in the struggle to preserve profit margins. Finally, there's a refreshing lack of the gimmickry that has characterized budgets in previous years, when, for one reason or another, the Administration found it expedient to inflate revenues or conceal anticipated expenditures.

Opposite numbers. During fiscal 1970, the budget projects, Government receipts will total \$198.7 billion—a year-to-year increase of \$12.6 billion. If realized, the anticipated \$3.4 billion surplus would be the second in a row. The departed Administration estimated current fiscal year outlays at \$183.7 billion, a level that would yield a surplus of \$2.4 billion.

For all its apparent candor, the 1970 budget depends, at least in

part, on some far-from-certain premises. For example, continued prosperity—a gross national product of around \$921 billion by the end of calendar 1969—is assumed, as is continuation of the 10% surtax and miscellaneous excise and user levies. In addition, planners figure on an inflation factor of only 3%, as against 3.8% a year earlier.

In areas of direct concern to the electronics industry, Federal spending plans are based on a lower level of battlefield activities in Vietnam. Charles J. Zwick, director of the Budget Bureau in the Johnson Administration, spelled it out this way: "Vietnam expenditures assume that 18 months hence we will have the same number of troops operating at the same level as we do at the moment. These estimates were based on the activity levels prevailing during the last six months of calendar 1968 when requirements were below those during the Tet offensive."

The hope is, of course, that the peace negotiations now under way in Paris will improve the situation long before June 30, 1970. But any sudden reversal to escalation could trigger buildups in ordnance, fuel, and aircraft inventories, throwing the whole scheme out of whack.

As budgeted, however, Vietnam is down for a \$25.4 billion slice of the \$81.5 billion defense pie, which is frosted with about \$1.5 billion

worth of unexpended funds from 1969. The \$3.5 billion "savings," and additional funds, are ticketed for other military projects, primarily in the strategic weapons systems area.

At least partially as a result of the Defense Department's desire to make up for lost time in nontactical areas, any windfalls from a disengagement in Southeast Asia remain a good way down the road.

Locked in. The 1970 budget will most likely retain the Johnson brand. For one thing, of the total \$11.6 billion increase in expenditures, \$8.6 billion will be automatic under legislation in force. Pay raises for the Federal work force, debt service charges, Social Security programs, and welfare projects are chief among the factors accounting for the year-to-year increase. The upshot is that the new President has precious little room to maneuver in.

There's evidence to suggest, however, that Nixon isn't particularly eager to take a meat ax to his predecessor's principal proposals. He's on record as deploring the country's "security gap," so a substantial cut in defense outlays appears unlikely. Space efforts still loom as a question mark under Nixon, but pruning, rather than slashing, appears in store at other agencies should the opportunity for choice arise.

Sealectro RF connectors, adaptors and cable assemblies are designed and manufactured to meet the most stringent requirements of military, space and commercial applications including MIL-C-22557 and MIL-C-39012, Series SMA. Microminiature Microhex connectors offer outstanding VSWR to 5 GHz . . . Sub-miniature Conhex connectors to 12.4 GHz . . . and the best performers of all . . . stainless steel SRM® connectors with low, low VSWR all the way to 18 GHz.

Over 350 standard connector and adaptor configurations with a wide selection of mating engagements and cable terminations are included in the Sealectro line to provide you with the widest selection and with the fastest possible delivery in the industry. And . . . Sealectro maintains complete custom cable assembly

facilities staffed by trained personnel to save you time and money.

Why not find out about Sealectro's complete RF connector line. Drop us a line or phone. We'll send you our complete set of RF connector catalogs and technical specifications.



RF COMPONENTS DIVISION

SEALECTRO CORPORATION

MAMARONECK • NEW YORK

PHONE: 914 698-5600 TWX: 710-566-1110

Sealectro Ltd. Portsmouth, Hants, England

Sealectro S.A. Villiers-le-Bel, Paris, France

The proof of the quality of our connectors is in their performance



Strategic projects get green light

Projected scaling back in Vietnam frees budget funds for new aircraft, missiles, and warships; allocations for tactical equipment will decline

By William F. Arnold and Alfred Rosenblatt

Associate editors

A year of transition is in store at the Pentagon in fiscal 1970 as a new Administration, less deferential to policies of the past, assumes and exercises power. The proposed Defense Department budget, which includes leftover funds, could approach \$83 billion if it gets through the Congress unscathed. What's more, allocations are beginning to reflect a scaling back of activity in Southeast Asia and an easing of restrictions on strategic programs. As a result, military planners are turning their attention to such electronics-laden projects as new aircraft, warships, and missiles.

The Pentagon, for example, is after \$700 million more than last year for the Air Force's Minuteman 3, the Navy's submarine-launched Poseidon, and the Army's Sentinel antiballistic missile system. And the Navy seeks \$1.6 billion more to start a new class of missile destroyers and frigates and to add to its submarine fleet. Also, good news for electronics firms lies in the fact that Defense Department research and development funds are up \$500 million; 80% of this sum is earmarked for five aircraft programs: the S-3 (the renamed VSX antisubmarine warfare plane), the F-14A and B (VFX), the E-2C, the F-15 (FX), and the advanced manned strategic aircraft (AMSA). Although the amount requested for AMSA totals only \$77 million, it's a three-fold increase from 1969.

Premises. Relative quiet on the Vietnam front explains the Pentagon's more varied shopping test. "The budget is based on the current situation projected indefinitely," says a top defense official.

"Indefinitely" translates into about an 18-month breather during which it won't be necessary to build up inventories of tactical equipment and aircraft. However, the electronics and communications category appears to be a war casualty to the tune of \$200 million because the military needs less field apparatus right now. Because of lower attrition rates some aircraft programs may suffer a bit as well. The large new programs will, however, more than make up the difference, either in 1970 commitments or as multi-year buys.

Strategic defense

Most existing Semiautomatic Ground Environment and Backup Interceptor Control Systems air

defense installations will be phased out when the Airborne Warning and Control System (Awacs), over-the-horizon radar, and modified F-106X interceptors are introduced during the mid-1970's. For Awacs, the Air Force Systems Command has \$40 million from 1969 and is asking \$75 million more. It expects to select Boeing or McDonnell Douglas for the engineering development work this summer.

The Pentagon is asking \$3 million for continued development of the back-scatter, over-the-horizon radars. The surface-to-air missile complement of Bomarc, Nike-Hercules, and Hawk is not due for any big shifts in emphasis.

The major missile defense system is Sentinel for which the Penta-

Where defense research dollars go
(Millions of dollars)

	Fiscal 1969	1970
Military sciences	586	631
Aircraft	987	1,354
Missiles	2,467	2,483
Military astronautics	1,168	1,151
Ships and small craft	344	346
Ordnance, vehicles, and related equipment	344	302
Other equipment	1,221	1,334
Program management and support	491	528
Emergency fund	49	50
Total research, development, testing, and evaluation	7,647	8,179
Estimated dollars for electronics	2,447	2,781

**350 cfm
performance
from this new
compact (7" SQUARE)**

TARZAN™ FAN



WITH NEW, PATENTED
**aerodynamic
design**

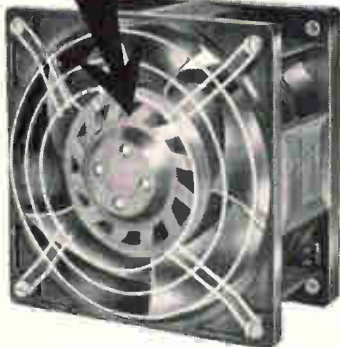

*Exclusive "air pump" motor cooling
for longer operating life

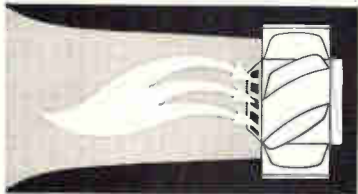

- Centrifugal blower performance in a compact axial flow fan
- Long maintenance-free life
- Designed to meet UL specifications (when thermally-protected)
- Five bladed air foil propeller design of polycarbonate
- Aluminum spider
- Fire retardant construction throughout
- Weighs only 5 pounds
- 60 cps performance on 50 cps (Model TN2)
- Ball bearings — lubricated for life.

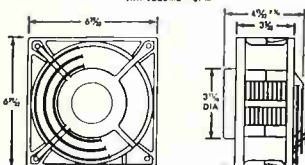
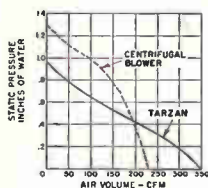

Write for design and performance details.
Priced as low as \$23.50 in quantity.



WOODSTOCK, NEW YORK 12498
914-679-2401

West Coast: Rotron/Pacific, Burbank, Calif.
Canada: Aerovox Canada Ltd., Hamilton, Ont.
Rotron Europa N.V. Breda, The Netherlands

Department of Defense: Where procurement dollars go (Millions of dollars)

	Fiscal 1969	1970
Aircraft	8,409	8,157
Missiles	3,390	4,115
Ships	1,207	2,849
Tracked combat vehicles	296	336
Ordnance, vehicles, and related equipment	7,403	6,116
Electronics and communications	1,592	1,374
Other procurement	2,158	2,177
Total procurement	24,455	25,124

gon is asking almost \$1.8 billion—up \$840 million. This figure includes \$335 million for research and development, \$736 million for procurement, \$647 million for construction, and \$70 million for operations. Requests for procurement of the two missile elements—the Sprint and Spartan—total \$33 and \$140 million, respectively, a huge increase from the combined 1969 total of \$37 million.

Besides Sentinel R&D funds, \$175 million is being requested for advanced ABM system development under the Nike-X advanced development program. This includes \$40 million formerly carried in the Advanced Research Projects Agency's Defender program. Another \$3 million is requested for continued studies on a sea-based ABM intercept system dubbed Sabmis.

On offense. Problems arising from the F-111's "commonality" deficiencies are causing the Pentagon to reshuffle strategic bomber forces. The FB-111 is too small, and becoming too expensive, to fill the important bombing role once intended for it. As a result, the Pentagon intends to stretch out production; it's asking only \$294 million in advanced procurement funds, as against \$587 million in 1969. Likewise, the F-111D fighter, equipped with advanced avionics, is being cut back to \$518 million from \$631 million.

Missile armory. As work on Boeing's Short-Range Attack Missile (SRAM) continues, the Pentagon expects to start developing a newer weapon—the Subsonic Cruise Armed Decoy (SCAD). B-58's and the

Hound Dog air-to-surface missile would be retained until SCAD becomes operational. AMSA could be designed to carry both the SRAM and the SCAD.

Long-range offensive missiles are set for a big financial boost in 1970. Funds for Minuteman 3 jump \$500 million to \$1.6 billion, and the Navy's Poseidon program is slated for \$1.2 billion. Congress okayed only two Polaris-to-Poseidon conversions last year until it was convinced that the Multiple Independently Targetable Re-entry Vehicle (MIRV) warhead had been proved out. To complete the scheduled conversion of 31 submarines by fiscal 1975, the department is requesting funds for six conversions plus money to begin advanced procurement for 1971.

General-purpose forces

Vietnam showed the Army that it needed an armed helicopter for close support. Lockheed's Cheyennes appear to fill this bill, and the service has earmarked nearly a third of its \$941 million aircraft budget for these craft, which carry sophisticated avionics and gun-control systems.

The Army's proposed missile procurement of \$1.3 billion is slightly ahead of year-earlier levels but a mixed bag nonetheless. On the plus side, last year's difficulties with LTV's Lance have been solved, and the missile will be bought to replace Sergeants and Honest Johns. Improvements in Philco-Ford's Chaparral/Vulcan will allow the service to reduce the inventory of older Hawk missiles.

But problems that cropped up with Philco-Ford's tank-mounted Shillelagh for the M-60 continue, so procurement is delayed. In addition, initial procurement for the man-carried McDonnell Douglas Dragon missile has been deferred due to development problems.

Aviary. Army research, development, test, and evaluation funds are programmed to rise slightly to \$1.8 billion. The SAM-D (Surface-to-Air Missile, Development), designed to be a follow-on to the Hawk and Hercules defense systems, is scheduled for \$75 million in 1970 to begin engineering development. A final go or no-go decision is expected later this year.

The Navy wants to spend \$1.7 billion more than in fiscal 1969; most of the boost is to go for vessels. On its shopping list are 19 new warships, up from eight in 1969, and the refurbishing of another 19, one more than last year. Among the new starts are a second Nimitz-class nuclear carrier, three fast nuclear submarines of a new class, a nuclear-powered guided-missile frigate (DXGN), and five DX-type escort ships. Proposed ship procurement totals \$2.9 billion, and a hefty percentage is ticketed for electronics equipment such as command and control, guidance, communications, countermeasures, radar, and related systems.

No firm date for contract definition work on the nuclear-powered frigate has been fixed by the Naval Ship Systems Command. This vessel will be smaller than the two

nuclear-powered frigates that are already operational, as well as the two under construction. Also still undecided is whether the new ship will have a single missile system or the two called for in the original design.

The Navy's Advanced Surface Missile System (ASMS) could very well be tied to the DXGN program. Three firms—RCA, Boeing, and General Dynamics—have each had \$6 million contract-definition phase studies since last October. Their proposals should be submitted in the middle of spring. And sometime this month will come the award to Litton, General Dynamics, or Hughes-Bath Iron Works team for the DX destroyers.

Air arm. The Navy's aircraft procurement will feature development of the new supersonic carrier-based fighter, the F-14A. Grumman Aircraft was selected last month as the prime contractor for the two-place, twin-engine plane—a replacement for the ill-starred F-111B. Some \$240 million is budgeted for the F-14, and there is roughly \$100 million of development money unspent from 1969. Some observers predict \$5 billion will be spent on the plane over the next 10 years.

The F-14A is scheduled to fly in 1971 and to go operational in 1973. It will have a new airframe but avionics systems and engines that have already been developed. Hughes Aircraft will supply its AWG-9 radar and fire-control system for the Phoenix air-to-air missile. The plane will be able to han-

TRYGON HAS THE POWER

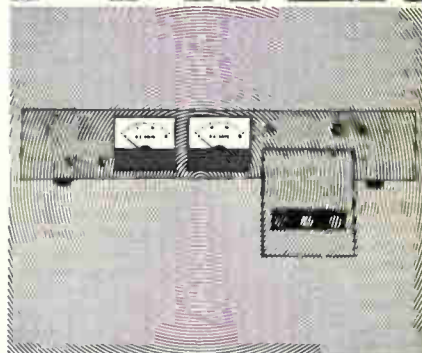

to deliver wide slot range performance in ratings to fit every system... from \$105.

- Rack mounted and modular.
- Meter and control options, integral.
- All silicon design—precision performance.
- Adjustable current limiting—optional overvoltage protection.
- Remote sensing and programming.

LIBERATORS from TRYGON...the ultimate in IC and transistor system power in minimum size at lowest possible cost. Specs like 0.5mV ripple, 3mV P-P noise, MIL Spec. performance and overvoltage protection.

FULL-RACK MODELS: voltages to 160V; output currents up to 40 A (3½") and 70 A (5¼"), 0.005% regulation and 0.01% stability, plus load share automatic paralleling.

SUB-RACK MODULAR MODELS: voltages to 160VDC, output currents from .25 A to 25 amps, 0.01% regulation and 0.03% stability. Write today.



TRYGON POWER SUPPLIES

111 Pleasant Avenue, Roosevelt, L.I., N.Y. 11575
 Trygon GmbH 8 Munchen 60, Haidelweg 20, Germany
 Write for Trygon 1968 Power Supply Handbook.
 Prices slightly higher in Europe.

Defense budget by mission (Billions of dollars)

	Fiscal 1969	1970
Strategic forces	9.1	9.6
General purpose forces	33.2	32.1
Intelligence and communications	6.0	6.2
Airlift and sealift	1.6	2.1
Guard and reserve forces	2.7	2.9
Research and development	4.7	5.6
Central supply and maintenance	8.8	9.0
Training, medical, etc.	10.2	10.7
Administration and associated activities	1.5	1.5
Military assistance	3.5	3.2
Total obligational authority	81.3	83.0

Lectrohm knows Resistors... We should, they're our only business!

Fixed or Adjustable
Standard or Custom



Specialization in the design and production of wire-wound resistors has established LECTROHM'S leader in the resistor field.

For example, LECTROHM type FP and XFP is one of the lowest cost power resistors available for P-C board applications. They can be inserted in 0.050" or 0.070" diameter holes. Center-to-center distance of prongs on terminals are variable from 0.5" to 2.5". Power rating is 4 watts per inch and resistance range is from 0.2 ohms per inch to 1,000 ohms per inch.

Check your resistor needs today . . . send specifications, prints or requirements, no obligation . . . you can trust LECTROHM to match those needs quickly and economically.



FREE!

Full line
LECTROHM
catalog.

Send for your
copy today!

Lectrohm, Inc.

A subsidiary of



COOK ELECTRIC

5562 Northwest Highway, Chicago, Ill. 60630

dle Sparrow and other armament as well. By about 1973, the B version of the F-14, with improved engines, will begin test flying. Not until the F-14C arrives at a still-to-be-determined date will the next generation of avionics go aboard.

Double play. Grumman will also be supplying two other relatively new planes to the Navy—the EA-6B electronic warfare aircraft and the E-2C advanced early warning aircraft. Funding for the former was low in 1969 because its new tactical jamming systems had to be successfully test-flown before the Navy would order the plane. The tests are apparently going well, because the 1970 budget has allocated close to \$250 million for buying the aircraft. The E-2C is down for some \$66 million, and Grumman will supply two prototype test beds for flight testing. This aircraft will replace the vintage E-2A Hawkeye, whose systems are built with vacuum tubes and discrete components. The new plane will take advantage of the latest developments in solid state circuitry, digital computer techniques, and an advanced long-range search and surveillance radar that may have overland, as well as overwater, capability.

The S-3 antisubmarine warfare plane is now being studied under contract definition awards at the Convair division of General Dynamics and by a team from Lockheed and LTV. Selection of the prime contractor for the four-place, two-engine craft, which will replace the 20-year-old S-2 Tracker, could come next month. The plane, with a new airframe, will have twice the speed and range of the S-2. Its avionics package could consist largely of the A-New system, developed for the Navy's P-3C.

For two straight years, Congress has nixed the start of a 30-ship Fast-Deployment-Logistic (FDL) fleet, which would give the Defense Department a global tactical supply. Undaunted, the Pentagon halved its goal and came back this year with a request for \$187 million to start three FDL's. Congress is likely to remain cool to the project.

Projections

Meanwhile, the Air Force is pushing development of a new fighter, the F-15 (formerly the

FX-1) to replace F-4's. It has \$45 million left from 1969 and is asking \$175 million this time around. Fairchild-Hiller, McDonnell Douglas, and North American Rockwell are competing for production contracts. The Air Force is also asking \$12 million for contract definition of the AX close-support attack plane.

Despite Congressional investigation of the C-5A program's mounting costs, the Air Force is raising the year-to-year ante \$300 million to a little over \$1 billion. In fact, just as the hearings began last month, the Air Force announced that it was ordering another 57 from Lockheed-Marietta.

Military space. The security-blanketed Manned Orbiting Laboratory (MOL) is slated to receive \$576 million—about one quarter of the total military space program. Designed to put two men in orbit for 30 days, presumably for reconnaissance, MOL is scheduled for its first unmanned launch late this year. The first manned launch could be as early as 1970.

Another key space program involves the second phase of the Defense Satellite Communications System (DSCS), designed to provide improved communications network. Procurement is expected to start in 1970, first launch in 1971.

Backup. About one-eighth of the Pentagon's \$8.1 billion research, development, test, and evaluation fund is intended for exploratory development—a slowly growing category. For example, the Advanced Research Projects Agency will get about \$190 million for such projects as Vela, an advanced nuclear detection surveillance system. Otherwise, funds are allocated to the Army for such efforts as night-vision apparatus, the Navy for submarine detection work, and the Air Force for guidance-and-control, communications, and power techniques.

Another eighth of the RDT&E budget is intended for advanced development projects. Funded programs include Mallard—the cooperative tactical communications system for the U.S., United Kingdom, Canada, and Australia—a number of deep submergence ocean vehicle systems, and the Advanced Ballistic Re-entry System.

Automatic Controls' Industrial Relays provide:

- * Advance Design
- * More Switching Capability
- * Mounting Versatility

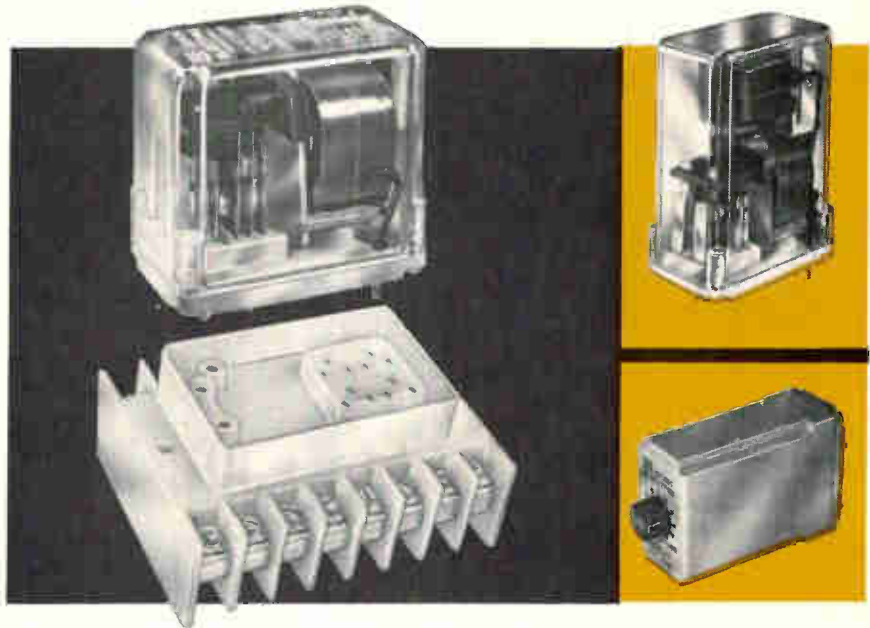

Automatic Controls' "Family" of industrial relays now available with front-connected screw terminal sockets, with nylon construction wiring without removal of relay terminals accommodate up to 2-#14 AWG wires — captive pressure plates.

Weigh the advantages of front-connected, behind panel quick disconnect termination with 4 PDT 10 Amp capacity; silver cadmium oxide contacts; epoxy encapsulated coil; and sturdy, dust-proof lexan bases and covers. Remember too, the improved design of these relays requires $\frac{1}{3}$ less volume, 20 percent less mounting space.

Match specific product needs with the industrial mechanical latch and time delay relays . . . Automatic Controls stocks them all to meet immediate needs!

Automatic Controls

Division



COOK ELECTRIC

200 East Daniels Rd., Palatine, Ill. 60067



FREE!
Automatic Controls
Industrial
Relay Booklet.
Send for your copy
today!

Pick the **BEST** IC for the job

Problem: Four DC to 30 kHz signals from high impedance sources must be summed into a $2k\Omega$, 100 pF load. The output is to be a guaranteed minimum ± 12 volts over the full frequency and military temperature range. The logical choice would be a Radiation RA-909. But amplifier offset current drift must not exceed $2 \text{ nA}/^\circ\text{C}$. Pick the Best IC for the job.

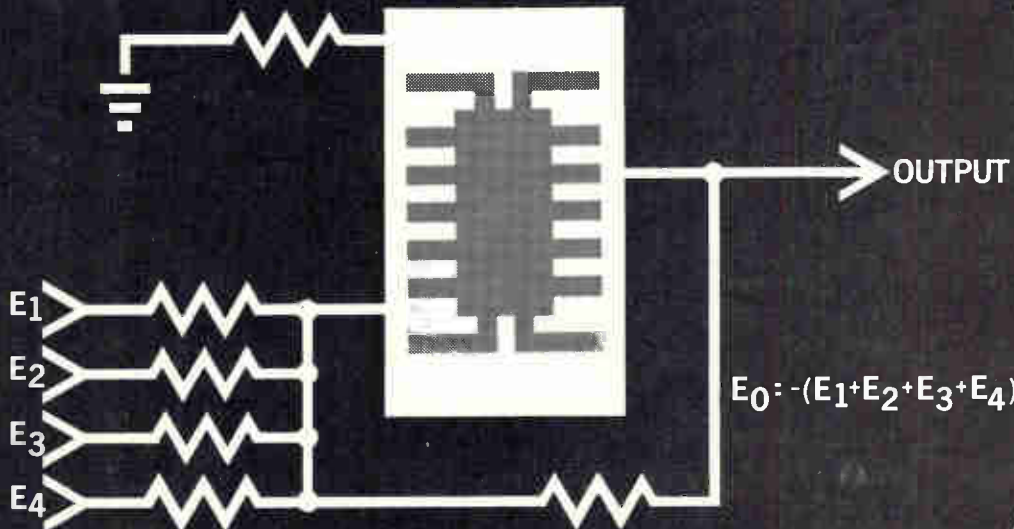

the **BEST** Solution:

THE NEW RA-909A COMPENSATIONLESS OPERATIONAL AMPLIFIER

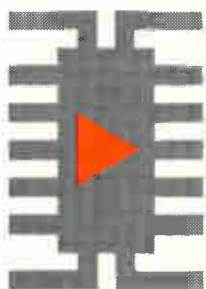

Drift error is very low in the new dielectrically isolated compensationless RA-909A. Between -55°C and $+25^\circ\text{C}$ offset current drift is a low $2 \text{ nA}/^\circ\text{C}$. From $+25^\circ\text{C}$ to $+125^\circ\text{C}$... an even lower $0.5 \text{ nA}/^\circ\text{C}$! And Radiation guarantees less than $15 \mu\text{V}/^\circ\text{C}$ offset voltage drift over the military temperature range. Compare this performance with any 709 type op amp over this extremely wide operating frequency range. You'll pick the Best op amp for the job. The RA-909A.

Like the RA-909, no external compensation is needed. Dielectric isolation and good circuit design eliminates the need for compensation. The RA-909A is in both a TO-99 package and a TO-86 flatpack configuration. A direct replacement for 709 type op amps.

Contact your nearest Radiation sales office. Let us help you pick the Best IC for the job.

WE MAKE THE **BEST** IC FOR THE JOB



RADIATION
INCORPORATED
SUBSIDIARY OF HARRIS-INTERTYPE CORPORATION
MICROELECTRONICS DIVISION

RADIATION SALES OFFICES: P.O. Box 476, Lexington, Mass. 02173, (617) 682-1055 • 600 Old Country Road, Garden City, N.Y. 11530, (516) 747-3730 • 2600 Virginia Avenue N.W., Washington, D.C. 20037, (202) 337-4914 • 6151 W. Century Boulevard, Los Angeles, California 90045, (213) 670-5432 • P.O. Box 37, Melbourne, Florida 32901, (305) 727-5430 • International Sales: Marketing Department, P.O. Box 37, Melbourne, Florida 32901, (305) 727-5412

NASA budget in holding pattern

Even before running Congressional gantlet, agency's requests have been pared to fiscal 1969 levels; officials plan to pass buck to Nixon for new-start decisions

By Paul A. Dickson

Associate editor

Great expectations are a thing of the past at the National Aeronautics and Space Administration, at least as far as budgets are concerned. And notwithstanding its recent triumphs, the agency has been forced to settle for a fiscal 1970 request of \$3.87 billion—a level that planners believe falls far short of requirements.

The kindest thing Thomas O. Paine, NASA's administrator, can find to say about this figure is that it's a "holding budget" which provides for progress in certain areas while buckpassing critical program and dollar decisions to the Nixon Administration.

The mourning after

"I don't mind saying this budget has already been trimmed heavily," says Paine. "We started by asking for \$4.7 billion, a figure that would provide for a good growth rate at the agency. But the President and the Bureau of the Budget told us that we would have to come up with something lower. We went back to them with a \$4.2 billion request, which we felt would cover the imperative new starts. But this figure was also rejected. We fought very hard and finally submitted a total close to what we were eventually granted for fiscal 1969. As a result, some new programs were lost and others ended up as compromises."

During the next few months NASA's fiscal 1970 allocation will definitely be modified. Congress will have the first go at making further reductions. Even a modest amount of slicing on Capitol Hill will mean that the space agency's funding will be in eclipse for the

NASA space science and applications (Thousands of dollars)

	Fiscal 1969	1970
Physics and astronomy	125,116	119,600
Supporting research/technology	19,900	19,600
Solar observatories	12,000	14,800
Astronomical observatories	36,900	28,600
Geophysical observatories	13,200	6,800
Explorers	19,616	26,000
Sounding rockets	20,100	20,100
Data analysis	3,400	3,700
Lunar and planetary exploration	81,800	146,800
Supporting research/technology	20,600	24,600
Data analysis	2,600	2,700
Pioneer	5,000	18,200
Mariner Mars 1969	27,200	4,900
Mariner Mars 1971	18,300	45,400
Viking*	8,100	40,000
Mariner Mercury 1973	—	3,000
Planetary explorers	—	8,000
Bioscience	32,700	32,400
Supporting research/technology	9,900	11,400
Planetary quarantine	1,300	3,000
Biosatellites	21,500	18,000
Space applications	98,600	135,800
Supporting research/technology	19,600	22,400
Tiros/Tos improvements	5,800	5,200
Nimbus	31,800	29,200
Meteorological soundings	3,000	3,000
Cooperative applications satellite	100	100
Applications technology satellites	24,700	44,200
Geodetic satellites	2,400	3,000
Earth resources survey (aircraft experiments and satellite program)	11,200	25,100
Synchronous meteorological satellites	—	3,600
Launch vehicle procurement	100,200	124,200
Supporting research/technology	4,000	4,000
Scout	12,600	15,700
Delta	24,000	33,700
Agna	11,900	7,300
Centaur	47,700	57,600
Titan 3 C	—	5,900
Total	438,416	558,800

*Formerly Mariner Mars 1973 and Titan Mars 1973

NASA spending (Thousands of dollars)

	Fiscal 1969	1970
Research and development	3,193,559	3,168,900
Construction of facilities	35,700	58,200
Research and program management (largely salaries)	648,261	650,900
Total budget plan	3,877,520	3,878,000

fifth consecutive year. Last year, Congress lopped \$500 million from NASA's original request of \$4.37 billion. Should this slicing act be encoered, the agency would be left with only \$3.3 billion in operating funds. Despite these grim, but very real prospects, officials hope the Nixon Administration will take a new tack. And Paine, in his budget presentation, challenged the incoming Administration with these words: ". . . the budget leaves the major new program decisions, especially in the manned flight area, for the next Administration. Early decisions are required on manned lunar exploration, on future space station development, and—after further studies are completed—on an unmanned expedition in 1977 or 1979 to the outer planets."

Breakdown. As NASA gets ready to face life with President Nixon and the new Congress, planners hope the austerity budget will keep the major project offices busy with ongoing programs and, here and there, a new start or study money for projects that could develop into worthwhile full-scale efforts. For example, the Office of Manned Space Flight has asked for \$2 billion for fiscal 1970. Much of this request covers familiar ground—money to make the first lunar landing, as well as additional sorties using equipment purchased for the Apollo program. In addition, officials are making a new effort to get funds for the Apollo Applications Program. But over \$1 billion of the office's proposed budget is earmarked to pay for Apollo spacecraft and Saturn 5 boosters that are already on order.

NASA is still determined to get the AAP rolling; it has requested \$308 million for this; vehicles will get \$138 million, experiments \$178 million. An extra \$36.8 million has

been requested under the heading of Space Flight Operations to be used for launch costs, tracking, and other nonhardware outlays involved with the program. The approved—but financially strained—venture provides for a Saturn 1 workshop to be launched in 1971 and an Apollo telescope mount, as well as several crew visits during the 1971-72 period. Last year \$439.6 million was requested for AAP, but Congress only approved \$150 million. The result was a one-year delay in the program. The fiscal 1970 request is, according to one NASA official, the "bare minimum" needed to get the program off the ground for the 1971-72 period. This source adds that another severe fiscal setback would cause a longer delay and might force the program to be scaled down.

Duo. There are two requests for new starts in the budget submitted by the Office of Manned Space Flight, but they fall far short of the development money that planners hoped for. The funds will accommodate only studies and preliminary design for a National Space Station, and equipment for longer manned visits to the moon. A scant \$9 million has been requested to start the space station, and \$11 million has been asked for support studies for new lunar exploration vehicles. These requests were much higher in the original proposal given to President Johnson.

The office is also requesting \$2.5 million in fiscal 1970 for advanced mission studies. This amount is being ticketed for work on advanced vehicles and revisions of earlier studies for manned planetary missions.

Count down

If the \$558.8 million request of the Office of Space Science and Applications stands up, the amount of money going into unmanned spacecraft will be the largest in three years. There are several new programs in the request and a few others in early stages which got strong boosts. However, some projects that were expected to get off

NASA research and development (Thousands of dollars)

	Fiscal 1969	1970
Manned space flight	2,177,500	2,007,700
Apollo	2,025,000	1,651,100
Space flight operations	150,000	354,100
Advanced missions	2,500	2,500
Space science and applications	438,416	558,800
Advanced research and technology	285,171	290,400
Basic research	21,000	21,400
Space vehicle systems	31,700	30,000
Electronics systems	34,771	35,000
Human factor systems	19,700	23,600
Space power/electrical propulsion systems	42,200	39,900
Nuclear rockets	32,000	36,500
Chemical propulsion	28,900	25,100
Aeronautical vehicles	74,900	78,900
Tracking and data acquisition	279,672	298,000
University affairs	9,000	9,000
Technology utilization	3,800	5,000
Total new obligational authority	3,193,559	3,168,900

to strong starts in 1970 were only included as supporting research and technology entries and will limp along as low-level studies. The new starts include:

- **Mariner Mercury 1973.** For openers, \$8 million has been asked for this \$87 million effort. The program features a Mariner-class mission in which the spacecraft is sent to Venus and on to Mercury with a payload that will include cameras to take pictures of the two planets.

- **Planetary explorers.** NASA has requested \$8 million to kick off a \$133 million program to put spacecraft in orbit around Mars and Venus. There will be five small, spin-stabilized satellites similar to the anchored IMP (Interplanetary Monitoring Platform) craft, which have successfully orbited the moon, in the series.

- **Synchronous meteorological satellites.** Details on this program are sketchy at the moment since NASA has not yet determined the type spacecraft to be used, but it has estimated that \$40 to \$50 million will be spent to get two satellites in orbit in 1971 and 1972. For fiscal 1970, \$3.6 million is being requested to get this program started in the next 18 months.

- **Titan 3C.** To prepare the vehicle for project Viking and other space science and applications missions—for example, advanced Applications Technology Satellites—\$5.9 million has been requested.

Earthwork

The potentially big and long-awaited Earth Resources Technology Satellite program gets a strong push in the new budget with a \$25.1 million request. Of this total, \$11 million will be spent on the aircraft program needed to develop sensors and \$14.1 million will go into the development of the two satellites—ERTS A and B. Additional funds will be coming from the Department of Interior and the Department of Agriculture. The former has requested \$3.8 million, the latter has asked for \$2.8 million for the earth resources program. The total cost of the program through ERTS A and B is about \$46 million.

Other programs slated for an increase in the fiscal 1970 budget are: Pioneer, Mariner Mars 1971, Viking, Applications Technology Satellites, geodetic satellites, and solar ob-



**Best way
to get rid of
unwanted
signals**

K-H multifunction filter.

Model 3202 all solid state filter with two independent channels gives you continuously adjustable high-pass, low-pass, bandpass or band reject functions over a 20 Hz to 2 MHz frequency range; provides the flexibility essential for complex frequency or time domain measurements.

Check these exclusive features. See for yourself why the Krohn-Hite Model 3202 is such an exceptional value at \$795.

FUNCTIONS: Low-pass — direct coupled with low drift. High-pass — upper 3 db at 10 MHz. Bandpass — continuously variable. Band rejection — variable broad band or sharp null.

TWO RESPONSE CHARACTERISTICS: (1) Fourth-order Butterworth or (2) simple R-C (transient free).

ZERO-db INSERTION LOSS: All-silicon amplifiers provide unity gain passband response. 24 db per octave slopes per channel extend to at least 80 db.

90-db DYNAMIC RANGE: Low hum and noise (100 micro-volts) eliminate costly preamplifiers.

There's more. Write for complete data. Contact your Krohn-Hite Representative for an eye-opening demonstration.

OVERSEAS SALES OFFICES: BELGIUM, C. N. Rood s. a.; DENMARK, SC Metric A/S; FRANCE, Antares; GERMANY, Nucletron Vertriebs-GMBH; HOLLAND, C. N. Rood n. v.; ITALY, Dott. Ing. Mario Vianello; SWEDEN, Teleinstrument; ISRAEL, R.D.T. Elect. Eng. Ltd.; JAPAN, Shoshin Shoji Kaisha, Ltd.; AUSTRALIA, Sample Electronics (Vic.) Pty., Ltd.

**KH KROHN-HITE
CORPORATION**

580 Massachusetts Ave., Cambridge, Mass. 02139, U.S.A.
Phone: (617) 491-3211 TWX: 710-320-6583

Oscillators / Filters / AC Power Sources / DC Power Supplies / Amplifiers

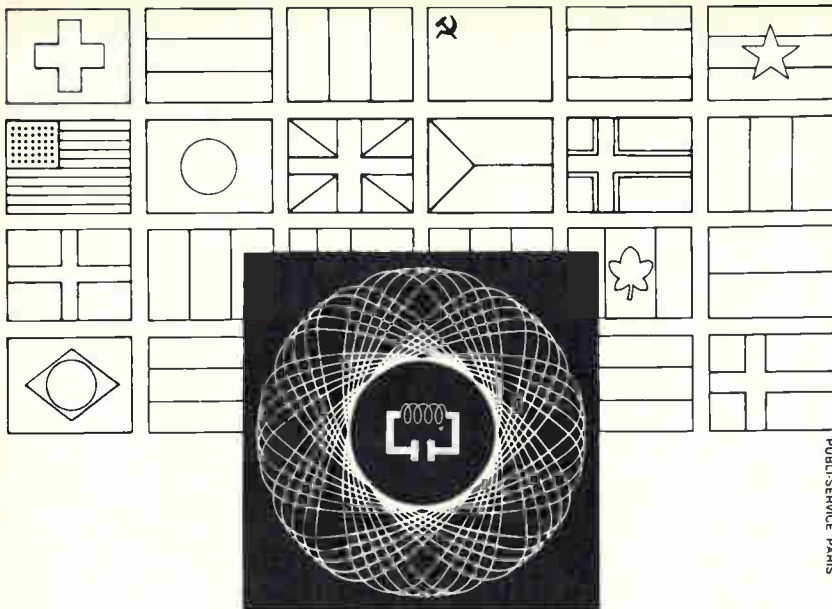

**150.000
electronic engineers
in Paris**

**This concerns
YOU DIRECTLY !**

SALONS INTERNATIONAUX DES
**COMPOSANTS
ELECTRONIQUES**

ET DE L'ÉLECTROACOUSTIQUE

FROM MARCH 28th TO APRIL 2nd 1969
PORTE DE VERSAILLES - PARIS



**INTERNATIONAL CONFERENCE ON
REMOTE DATA PROCESSING**

Scientific, technical and economic aspects
Programm and registration conditions on request
FROM MARCH 24th TO 28th 1969 - PARIS

S. D. S. A - RELATIONS EXTÉRIEURES 16, RUE DE PRESLES - 75 PARIS 15^e - FRANCE

CALL FOR INFORMATION : FRENCH TRADE SHOWS - NEW YORK - PHONE : (212) 582-4960-1

servatories. The Pioneer request of \$18.2 million covers a series of spacecraft which will be used to explore planetary areas as far away as Jupiter (in 1971 and 1972). Mariner Mars 1971 and Viking proposals represent comparatively large chunks of OSSA's prospective budget—\$45.4 million and \$40 million, respectively.

In the ATS program, the increase from \$24.7 million in fiscal 1969 to \$44.2 million in the current budget reflects sums which will be paid out for the F and G satellites. Tucked away in the request are also funds for studies of H and J versions, as well as a new species of Small Applications Technology Satellites.

Among the seed-money activities buried in the OSSA budget are requests to cover studies involving the World Weather Watch program, the next generation of operational meteorological satellites after Tiros M, and the advanced Nimbus craft.

A program which is budgeted for a low-level effort is the so-called grand-tour spacecraft which would travel to the outer planets—Jupiter, Saturn, Uranus, and Neptune. The fact that this program has been confined to studies is a source of disappointment to NASA officials. This ambitious project, which could be worth over \$1 billion dollars by the late 1970's, was expected to get off to a roaring start in the fiscal 1970 budget. According to John E. Naugle, the agency's associate administrator for space science and applications, major expenditures will have to be made in fiscal 1971—or 1972, at the latest—or the grand-tour concept will have to be dropped. The planets will not be properly aligned again for almost 200 years.

Short rations

Aside from the two major project offices which oversee NASA's manned and unmanned spaceflight activities, token increases are the rule. For example, the Office of Technology Utilization is down for \$5 million, as against \$3.8 million in fiscal 1969. And the Office of Tracking and Data Acquisition will increase its funds from \$276.9 to \$298.0 million. The Office of University Affairs will stay at the same \$9 million level as in fiscal 1969.

... there's \$35 million for electronics in OART budget ...

At the Office of Advanced Research and Technology, the jump will be only from \$285.1 million to \$290.0 million. Areas in which year-to-year gains were posted include human factor systems, nuclear rockets, vertical/short takeoff and landing technology, and advanced research on aeronautical vehicles. The rise from \$19.7 million to \$23.6 million in human factors is accounted for by the fact that NASA hopes to start the work needed for the National Space Station project. Nuclear rockets funding which is going from \$32 million to \$36.5 million will be invested in development of the flight-rated Nerva engine. The \$11.2 million for V/STOL research, up from \$8.7 million, will cover what one NASA official terms "an area where there is a very obvious need for continued and quick development." The \$21.7 million request for advanced aeronautical vehicles is allocated for such items as materials, advanced checks on fluid dynamics effects, and higher thrust engines.

What's up. Electronics systems have been budgeted at \$35 million and the emphasis will be on aeronautics, advanced sensors, and V/STOL avionics. Slight decreases have been planned for such general areas as space vehicle work, space power, and electric and chemical propulsion systems.

Three centers operating under the direction of the Office of Advanced Research and Technology will be getting more money and work if the fiscal 1970 budget is approved in toto. Langley Research Center, for example, will receive \$4.7 million to construct an aircraft noise abatement laboratory. The agency's Electronics Research Center is slated for \$8 million to cover additional lab facilities—a new computer and instrumentation complex with support installations. Some \$1.8 million has been requested to start an aerospace safety research facility at Lewis Research Center. Beside these proposed additions, the other centers are down for varying amounts for construction, for which the over-all total is pegged at \$58.2 million as against \$35.7 million in fiscal 1969.

Bring your design to life ...

... just plug it in!

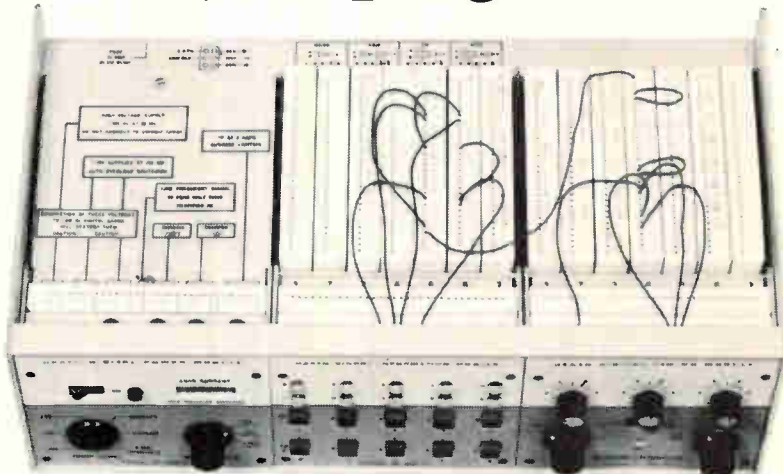

Heath Analog Digital Designer only ... \$435*

Achieve virtually anything you wish in digital and analog circuitry: design your own Counters, Frequency Meters, DVM, Precision Timers, Frequency Standards, Digital Interfaces ... and hundreds of other digital instruments. You can also investigate Counter, Scaling and DVM circuits, Adders, Subtractors, Digital Analog Interfaces and special circuits of your own. All you have to do is plug-in a few circuit cards and connect them ...

The Heath/Malmstadt-Enke Analog Digital Designer (ADD) EU-801A is a unique method of system and circuit "breadboarding" for experimentation. The ADD includes three factory-assembled modules (power supply, binary information and digital timing) and 13 TTL IC logic cards: NAND gates, J-K flip-flops, Comparator, V/F Converters, Monostable Multivibrators, Operational Amplifiers and Relays.

The cards plug into the modules and feature "wire-patch" solderless color coded connector boards to accept ordinary hook-up wire and component leads for simple and rapid assembly of your design.

The ADD may easily be expanded as new modules and cards are available. The Analog Digital Interfaces enable the ADD to accept and process external information. 10 lamp binary readout is built-in ... digital readout will be available shortly.

Just plug your design into the ADD ... optimize it and use the solution directly ... for only \$435. (Cards and modules are included, but may also be purchased separately.)

Many cards from the Heath EU-805 Universal Digital Instrument (UDI) may be used in the ADD increasing its capabilities. The UDI combines in one package a 12.5 MHz Multi-Purpose Counter/Timer and a 0.05% accuracy Integrating Digital Voltmeter to measure frequency, period, time interval, ratio, count events, and perform as a DVM and voltage integrator with unmatched versatility.



For more information send for the NEW HEATH Scientific Instrumentation Catalog

**HEATH COMPANY, Dept. 580-04
Benton Harbor, Michigan 49022**

Please send FREE New Scientific Instrumentation Catalog.

Name _____

Address _____

City _____ State _____ Zip _____

Prices & specifications subject to change without notice. EK-266

*Mail order prices; F.O.B. factory.

There's no gamble involved with MICOM's new system. It's a combination of specialized test equipment designed to meet the specific needs of people who calibrate and align magnetic tape recorders. Each instrument is human engineered to meet system requirements. The wilderness of dials, knobs, and switches associated with conventional systems is gone. The system's simplicity increases operator efficiency, assures correct test results, eliminates errors in operation that result from repetitive testing, and substan-

tially reduces panel space requirements.

A system made up of MICOM's specialized test instruments can drastically reduce the alignment and calibration time for magnetic tape recorder systems. This leads directly toward increased profit, since overhead can be considerably reduced without sacrificing accuracy.

A MICOM system can be as simple as one of our Model 8300 IRIG Standard Flutter Meters, our Model 6100 Test Set, our Model 6200 FM Calibrator, our Model 6300 Select-

able Stepping Oscillator, variable tuned filter, switch panel, pulse generator, and an oscilloscope.

Our engineers can work with you to develop a MICOM system to meet your specific requirements. For further information, contact us at 855 Commercial Street, Palo Alto, California 94303. Telephone: (415) 328-2961. TWX: 910-373-1179.



Take a look at our system... You can't beat it!



Upbeat outlook favors industry

Post Office and Weather Bureau, among others, have extensive shopping lists for hardware, and there's money for several projects with long-range potential

By Robert Skole

Associate editor

"Whatever it means for the electronics industry it's a damn good budget." This characterization of Lyndon Johnson's fiscal 1970 budget, offered by a staffer on the House Appropriations Committee, is typical of feelings in Washington. Moreover, with few exceptions, funds for electronics hardware and research projects—in the civilian sector, at least—came through the Budget Bureau's fine tooth comb in relatively good style.

As a matter of fact, there are even some fledgling programs at agencies where few electronics salesmen had ever bothered to call. For example, the Department of Agriculture's research service plans to spend \$2.8 million to lease an aircraft and outfit it with sensors to check crop yields, investigate the moisture content of soils, and perform other remote data-gathering experiments. The work is a prelude to future satellite systems. Although the aircraft project has been funded in the past several years, this is the first time there's been enough money to get it off the ground. The sensing devices to be purchased by the Agriculture Department are largely standard items—for example, infrared cameras.

Post haste. One of the biggest increases in electronics-oriented funding in the new budget is in the Post Office's research and engineering efforts. The Post Office is seeking \$51.8 million for this purpose in fiscal 1970—\$16 million more than in 1969 and \$28.7 million over 1968.

Part of the research money will go for the Post Office's first modular mail "factory" in Atlanta, Ga. LTV Electrosystems Inc. has re-

ceived a \$3.2 million contract to build the prototype—a set-up that integrates commercially available mail-handling machinery which has not previously been tied together.

In his final days as Postmaster General, W. Marvin Watson called for 483 installations in the 300 largest Post Offices; each, he estimated, would cost \$2.1 million. Once this project gets rolling, the Post Office will move from the suspect to prospect category as far as electronics procurement is concerned; the modular systems incorporate encoding and decoding machines, optical character readers, and control equipment.

The key concept in the system involves coding each piece of mail the first time it is handled. This would permit machine handling through final sorting for route carriers. As things now stand, each piece is handled manually three or four times before it gets delivered.

Volume mailers will be able to code their mail as they address it, thereby saving a step at the Post Office. Envelopes with addresses that can be scanned by optical character readers will be encoded by such equipment. Otherwise, the job will be done manually. The Post Office has not decided whether to use magnetic bars or alphanumeric for coding. But whatever's chosen will give a letter's destination down through individual carrier's route.

Clear track. Watson stresses that almost all the equipment needed for modular systems is already available. He also notes that machinery made in the United States is sold to foreign post offices. When he inquired why it

was not offered domestically, he was told there was too much red tape involved in selling to the U.S. Post Office. Now, however, the Post Office is trying to make things easier; it has even gone so far as to contract with two Australian postal experts to come to Washington to work on mechanized handling systems. This new "open door" policy is expected to continue under the Republicans. If President Nixon cuts back on any of the Johnson budget, it probably will not wound the research allocation for the Post Office.

Another project, although on a low level, on the Post Office's drawing boards is facsimile transmission of certain types of mail. Watson, in one of his farewell interviews, calls fax a definite "must" for the Post Office. "We have started some studies on facsimile," he says. "There are lots of problems. But I'm convinced that it will definitely be accepted and put to use—perhaps sooner than later."

Snow, sleet, rain. The Commerce Department's Environmental Science Services Administration—the Weather Bureau to laymen—is set for a modest budget trimming in fiscal 1970 with an allocation of \$166 million—some \$340,000 less than in fiscal 1969. The decrease is attributable to the longer lifetimes anticipated for the improved Tiros series of meteorological satellites. Five of the \$5.5 million spacecraft are on order from RCA and will be paid for with funds approved in previous years. ESSA scientists do not think it is necessary to begin placing replenishment orders in fiscal 1970, and this meant \$10.3

New Low Power AC Sources.



Prices even lower.

175 VA—\$565

350 VA—\$1120

CML has been making the best low power AC sources around. For years. Now low power hits a new low in price. All with interchangeable oscillator modules for fixed or adjustable output frequencies from 45 to 6000 Hz. All feature excellent frequency stability and load regulation, low distortion, and lightning-fast response. Write or call today.

	Model NS175 (175 VA)	Model NS350 (350 VA)
With fixed 400 Hz oscillator	\$565	\$1120
Adjustable 350-450 Hz	685	1225
Adjustable 45-6000 Hz	785	1385

CML, Inc.

A Subsidiary of
Tenney Engineering, Inc.

350 Leland Avenue
Plainfield, N.J. 07062

(201) 754-5502 • TWX 710-997-9529



93

Ups and downs

Federal money earmarked for research on sophisticated teaching machines in fiscal 1970 is about \$1 million below current-year levels. The Health, Education and Welfare Department's Office of Education expects to spend about \$5.5 million in this area during fiscal 1970, as against \$6.5 million in the current fiscal year and \$7 million in 1968. The bulk of the research spending by the Office of Education goes to contractors who submit proposals. If officials like the ideas that are outlined, they cough up funds.

However, a funding increase is in store for the National Library of Medicine, which will get \$22 million, an increase of \$4 million over the current year's spending. The boost is to get work started on a \$12 million center for a biomedical communications network. Eventually, the system will link computers for transmission and retrieval of biomedical data among centers in various parts of the country.

million less for weather satellites.

Research and development funds at ESSA will be \$300,000 ahead of the fiscal 1969 figure of \$25.7 million. Among other things, the money is earmarked for weather forecasting, river and flood checks, earth mapping, marine charting, communication techniques, and satellite sensor development work.

ESSA anticipates at least one new program: it will begin to provide meteorological support for air pollution forecasts to other Government agencies. Work will start in fiscal 1970 as a pilot program, and if successful, it could bloom into a major project.

Atomic power. The Atomic Energy Commission's request for \$2.4 billion in fiscal 1970 contains no significant shifts in emphasis from year-earlier programs. The only important category scheduled to rise is basic research in the physical and biomedical sciences, which is down for \$525 million—a \$22 million increase. The largest dollar drop will be in military activities, "cut" to \$1.09 billion—a decrease of \$178 million for fiscal 1969. However, defense efforts still represent the AEC's largest single program, accounting for 41% of the agency's budget. Other large cuts were made in space applications, slashed \$17 million to \$94 million; support of nuclear science and technology was cut \$24 million to \$148 million.

The AEC's space reactor activities will be cut 10%, bringing the total down to \$85 million. The slash is especially significant because the commission last year told Congress it would need at least

\$141.5 million for space activities in fiscal 1970. The proposed budget includes \$38 million for the AEC's share of development costs for the Nerva flight-rated engine. This means that development work will begin, after a two-year delay.

Little acorns. The General Services Administration, which buys or leases computers for civilian agencies, expects to spend about \$500 million on machines in fiscal 1970. There could be a more definite trend to leasing, rather than outright purchases, to get agencies past the shoals of tighter budgets.

The GAO's Office of Data Processing plans a new procurement test—perhaps as early as this spring—with funds from the fiscal 1970 budget. To date, bids have been put out for whole systems. The test procurement will seek separate bids for hardware and for software, with the idea of opening up the market to more companies and perhaps getting cheaper systems for the Government. The check is a sort of one-shot proposition; continuation depends on the results.

Money makers

The GAO is slated to spend \$20 million in fiscal 1970 for equipment and maintenance in its twelve computer sharing centers throughout the country. These facilities are expected to operate "at a profit" of almost \$4 million. Up to now, the GAO has been taking a beating on these centers, which are used by Federal agencies on a time basis. "Sales" of services to the agencies by the GAO centers are programed to increase from \$17 million in fis-

What would you call this new Microwave instrument?



Our project engineer calls it a "microwave multimeter."

Our marketing people call it a "universal microwave test set."

Our catalog calls it the HP 8410A Network Analyzer.

You'll call it the answer to your measurement problems. Here's why—

First, "it" measures all these microwave parameters: gain/attenuation and phase shift, i.e., complete transmission coefficients; magnitude and angle of reflection coefficient with polar or Smith Chart plots of impedance/admittance. With "it," you can characterize active and passive components or systems at single or swept frequencies.

Second, "it" features all these advantages: broad frequency coverage from 110 MHz to 12.4 GHz; more than 60 dB dynamic range with less than ten milliwatts drive signal; swept frequency operation over octave bands with automatic tuning; high accuracy and resolution; unparalleled ease of operation.

"It" is actually a modular system: a signal-processing mainframe with choice of two readout plug-ins; a wideband RF

converter unit; a full-range transmission test unit; and two reflection test units for 0.11 to 12.4 GHz coverage.

Whatever you measure with "it," you can do the job more accurately, more completely, in less time, with less work and fewer pieces of equipment at lower cost than ever before. "It" is a designer's dream.

The modules for transmission measurements, 0.11 to 12.4 GHz, cost \$6450. Add the capability for polar and Smith Chart displays of reflection characteristics, 0.11 to 12.4 GHz, for \$4100.

Ask your HP field engineer how the 8410A "microwave multimeter, universal test set, network analyzer" can answer your problems. Or write Hewlett-Packard, Palo Alto, Calif. 94304; Europe: 1217 Meyrin-Geneva, Switzerland.

HEWLETT  PACKARD

MICROWAVE NETWORK ANALYZERS

Circle 133 on reader service card

04804A

We've expanded our plant for the fourth time and doubled our multilayer production.

We will now be able to produce more boards of all types, including higher density multilayer boards. Our present experience is 36 layers. Our new 24 x 40 fully automatic press will increase versatility and capacity. Our new equipment includes a 28-foot camera—largest and most precise in the industry. Together with our 18 foot camera this gives us unique capability. We're steadily expanding our engineering staff to meet our customer's needs.

If you know us by our record, that's all we need say.

If not, we'll add that we are known as the leader in the PC board industry.

Our story is quality. We hire the best people, train them our own way. NASA, the "mil spec" people, the big computer and consumer producers— they all come to us. They demand skill, reliability. They get it. We're busy, but we're always interested in additional challenges. There's room for another wing out back.

CINCH-GRAFIK

DIVISION OF UNITED-CARR

200 South Turnbull Canyon Road, City of Industry (Los Angeles), Calif. 91744 • Phone (213) ED 3-1201. Sales offices in 33 principal cities throughout the United States, Great Britain, Canada, Australia and West Germany.

Our new plant - the house that multilayers built.



MEMBER

CONSISTING OF CINCH MANUFACTURING COMPANY, CINCH-GRAFIK, CINCH-MONADNOCK, CINCH-NULINE, UCINITE (ELECTRONICS) AND PLAXIAL CABLE DEPT.

cal 1969 to \$24 million.

The Federal Communications Commission is set for a hefty percentage increase in its research allocation—\$2.7 million, as against \$2.2 million in the 1969 budget. Although this amount appears small when compared with the outlays of most Government spenders, it could have great impact on the future of communications policies. The total FCC budget is \$24 million, compared with \$20.7 million in the current fiscal year. The increase is split fairly evenly among various bureaus of the commission.

The agency is planning research in such areas as broadband communications techniques, frequency assignment for microwave systems, and the "social and economic values" of communications. The commission also plans to probe the future requirements of all users of land mobile radio services. Funding levels for specific studies have not yet been determined.

The FCC also wants funds for the development of a data bank to make available additional technical information on licensed stations. This information will aid in developing ground rules for licensees and frequency management.

Study group. The Office of Telecommunications Management will also support an accelerated research effort on ways to better use the radio frequency spectrum. This agency's research budget is being expanded from \$554,000 to \$800,000; most of the hike is going for spectrum studies. The support budget for this small agency is virtually unchanged, at \$1.3 million. Efforts will be restricted to areas too broad for other Government agencies with communications responsibilities. In addition to spectrum work, the agency will also undertake studies on methods of interconnecting the communications systems of individual Government agencies and increasing the survival potential of equipment.

Although he talked a great deal about the need for air and water pollution controls and research, President Johnson did not back his words with big money increases in fiscal 1970. Air pollution control efforts, the province of the Department of Health, Education and Welfare, are slated for \$95.8 million in fiscal 1970—a \$7.4 million in-

crease over 1969. The water pollution control efforts, within Department of Interior, are down for \$306 million, an increase of only \$5 million over the current year. But the fiscal 1970 budget calls for no new programs in either area. For example, of the water pollution allocation, \$214 million will go for construction of treatment plants. The air pollution increase will largely support such ongoing activities as research into fuels and vehicles, grants to state and local agencies, enforcement, and technical assistance.

Crime does pay

Nearly \$300 million has been allocated for the Law Enforcement Assistance Administration in its first full fiscal year of operation. The infant agency is charged with aiding state and local bodies in controlling crime, violence, and related social ills. Agency officials predict that close to \$100 million of the \$300 million will go for new equipment, with computers, command-and-control centers, and other electronic apparatus heading the shopping list. The money won't flow directly to the companies; it will be parceled out to the local law enforcement agencies and spent only after they have agreed to match the Federal funds with local grants.

The Federal Aviation Administration is looking toward its first billion-dollar year. However, it's not going to get this kind of money without some sharp questioning in Congress. The agency's fiscal 1970 budget calls for a total of \$996 million to cover operations, equipment, research and development, operation and construction at national airports, and grants to local facilities. In addition, \$275 million is being sought for airway and airport development under legislation that will be proposed to Congress.

The fiscal 1970 budget has no money for the controversial supersonic transport, which got a \$142 million appropriation for the current year. The FAA, obviously embarrassed over the fact that the

Boeing Co. failed to come up a swing-wing design to do the job, explains: "Funding requirement will be determined at a later date based on the redesign of the aircraft." Boeing has just submitted a new version comparable to Lockheed's original fixed-wing plans, which were tossed out. However, the program has not ground to a halt; the FAA has \$92 million already authorized from previous years for the SST. This money will keep the project going, says the agency.

Other difficulties. Working this way, the FAA gets the SST problem temporarily out of its hair, while it concentrates on other problem areas. The proposed budget calls for operating outlays of \$772 million, an increase of \$66.6 million over fiscal 1969. Most of the rise is earmarked to pay for additional air traffic controllers and maintenance of new facilities.

There is, however, no money for automation of terminal control centers, although there is \$134 million for equipment for the en route portion of the air traffic control system. The reason for the lack of money for terminal automation in either the fiscal 1969 or 1970 budgets is simple: the FAA has been dawdling over the awarding of a contract, and has yet to spend a nickel of the \$14.5 million appropriated in fiscal 1968 for ARTS-3 (Automated Radar Terminal System). This delay is obviously going to attract flak in Congress, and the FAA is going to have to do some fast talking to explain it.

Reticence. The budget does include \$47.5 million for research and development, and the FAA says "program emphasis will continue to be devoted to improvements and automation of air traffic control system." But unlike previous years, the FAA is unwilling to go into detail on just what it has up its sleeve. The agency steadfastly refuses to talk about the program it has in mind.

One reason for this attitude is the fact that the agency has been working under what amounts to a double lame duck arrangement—President Johnson and acting administrator David Thomas. According to sources inside the agency, programs have been slowed to a crawl awaiting a new President and new administrator. ■

AIRPAX

MAGNETIC PICKUPS

*A great selection of types
to meet a wide range of applications*



SEALED POLE
3/4 - 20 UNEF - 2A THD



STANDARD
5/8 - 18 UNF - 2A THD



UL LISTED
For Hazardous Locations
3/4 - 20 UNEF - 2A THD



SUBMINIATURE
1/4 - 40 NS 2A THD



MINIATURE
3/8 - 24 UNF 2A THD



MICROMINIATURE
10-32 UNF 2A THD
(Shown Actual Size)

Illustrated
are a few of the pickups
designed and stocked by Airpax.
Types include units for operating
temperatures to 800° F and outputs
to 600 volts peak-to-peak. If your problem
is Positioning, Counting, Synchronizing,
Slippage Control or just straight Tachometry,
Airpax has the pickup and accessory
modules, including Digital Readout
units, to provide a complete system.
Data on operating principles,
curves, and characteristics
is available on
request.

AIRPAX ELECTRONICS

SEMINOLE DIVISION, FORT LAUDERDALE, FLORIDA 33310

Phone: 305 587-1100 TWX: 510 955-9866 TELEX: 051-4448

Radiation-hardened IC's go commercial

Anticipated DOD directive stimulates production of DTL and op amp circuits; dielectric isolation process makes devices 100 times more resistant

By George F. Watson

Associate editor

A billion-dollar market is in the offing over the next six years for radiation-resistant integrated circuits if the Department of Defense ever issues its much-discussed directive requiring radiation hardening of all military avionics equipment. And even without the impetus that the DOD directive would give, there are enough military programs extant—either in production or planning—to force a significant increase in hardened-IC sales.

The Navy's Poseidon program is probably the major reason for interest in radiation-hardened IC's among manufacturers. Radiation Inc., Fairchild Semiconductor, and Philco-Ford Microelectronics are supplying radiation-hardened IC's for the Poseidon missile guidance system.

Radiation Inc. has now decided to utilize its experience commercially; starting in April, the company will offer a line of radiation-hardened IC's off the shelf. The manufacturing and testing expenses will be reflected in the price of the circuits. Radiation Inc. estimates that the off-the-shelf family will cost three to six times more than their unhardened military counterparts.

Dielectric. A family of 930-series diode transistor logic, a 709 operational amplifier, a dual level shifter, and a dual four-input line driver will be offered. They'll be made by a dielectric isolation process. The company says that the IC's will drive the specified "worst case" load after exposure to neutron radiation of 3×10^{14} neutrons per square centimeter, and that they'll also perform satisfactorily at gamma-dot levels of 5×10^9 rads

(Si)/sec after exposure to the neutron flux. (Gamma dot is the time-rate of change of gamma radiation.) Although precise destruction levels haven't yet been determined, the firm's engineers believe that the IC's won't fail catastrophically even when exposed to dose rates in excess of 10^{12} rads (Si)/sec.

Protective layer. The radiation resistance is achieved through such provisions as dielectric isolation, thin film resistors over oxide, small device geometries, selective gold doping, and shallow diffusions. In dielectric isolation, each circuit element on the chip is surrounded by a thin layer of silicon dioxide which replaces the p-n junctions—a major source of potentially damaging photocurrents when the circuit is subjected to gamma radiation. The thin film resistors on the surface of the chip replace the conventional diffused resistors, and further reduce the susceptibility of the circuit to gamma radiation. The other provisions—small geometries, gold doping, shallow diffusions—are in-

tended to minimize the permanent effects of neutron radiation. The net result is a two-order-of-magnitude improvement in radiation hardness over conventional p-n junction isolated IC's.

Man the measure. Who needs radiation-hardened IC's? If the DOD releases its directive, virtually every manufacturer of aerospace equipment will. The directive reportedly requires that "the equipment be as hard as the man." Companies like Hughes, Raytheon, and Boeing will have to use radiation-hardened circuits in all their military avionics systems, not just in a few exotic systems. In fact, some system houses may be anticipating the trend. William A. Gould, manager of product planning for Radiation Inc.'s microelectronics division, says "People whom we didn't know were even involved in thinking about hardening now say, 'We'd like a couple of samples, we're working on something.' There's enough smoke."

It's not surprising, therefore, that

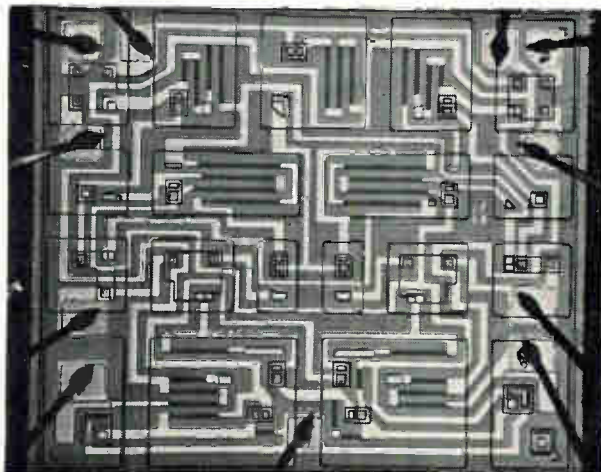

Shielded. Thin lines are dielectric isolation layers that protect circuit against radiation. Chip shown is the RD-945R clocked flip-flop.



Semiconductor Burn-in

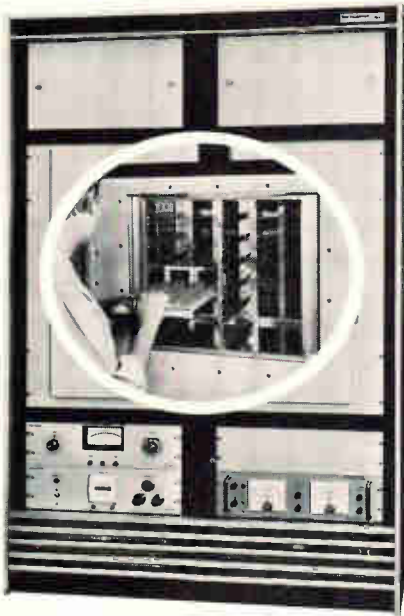

Economical TEC power aging and life test systems save you time and money

Test Equipment Corporation has for years designed and developed sophisticated environmental test equipment. This experience plus total "in-house" capabilities offers both manufacturer and user significant time and cost savings for semiconductor burn-in and life test.

Total "in-house" TEC manufacturing capabilities range from printed circuit boards, fixturing and socketing to NASA-approved machine shop, electrical assembly and micro-welding facilities. This makes possible extremely fast turn-around, thus saving valuable time and money.

In addition, TEC develops, builds and operates for customers complete "in-house" power aging and test facilities capable of meeting the most stringent requirements.

To discover how TEC burn-in systems and "in-house" facilities can help you, please write for this descriptive brochure.

Test Equipment

CORPORATION
P.O. BOX 20215, DALLAS, TEXAS 75220 • 214/357-6271

other IC makers are getting on the bandwagon. Motorola Semiconductor will introduce in late March, for off-the-shelf sales, eight radiation-resistant DTL IC's as direct replacements for the 930 series DTL, and will bring out a 709-type operational amplifier a few months later. [*Electronics*, Nov. 11, 1968, p. 33]. Motorola also uses dielectric isolation, thin-film resistors, and aluminum metalization (instead of gold, whose high atomic weight makes it more susceptible to radiation damage).

Need to know. Motorola will release specifications when the products are ready. The company expects that part of the specs will be classified, or available only on a need-to-know basis. This includes specification of the level of radiation and performance guarantees for the IC in a radiation environment or after radiation.

Another Poseidon supplier, Philco-Ford Microelectronics, is "enormously serious about the radiation-hardened business," according to Clarence G. Thornton, director of R&D, and will introduce off-the-shelf IC's around IEEE time. Like the other manufacturers, Philco makes a DTL family and a 709 op amp. Thornton feels that the market will be largely a custom-design one, but an off-the-shelf product line is needed to publicize the company's capability.

Philco has devised its own process for dielectric isolation. It does not require the critical lapping procedures that Radiation Inc. uses, and will prove to be more economical, Thornton claims.

All for Poseidon. Fairchild Semiconductor, as a supplier to the Poseidon program, also has a strong interest in dielectrically isolated radiation-resistant IC's. [*Electronics*, May 27, 1968, p. 197] The commercial end of it will have to wait, however. Thomas Dyer, senior project engineer for special products at Fairchild, says that Poseidon sops up all of Fairchild's radiation-resistant capability. A line of commercial products will have to wait until the third quarter of this year. "The question is how fast can you expand capacity with such a difficult process," Dyer says.

He adds that there's an intensive industry-wide effort to understand what happens to radiation-

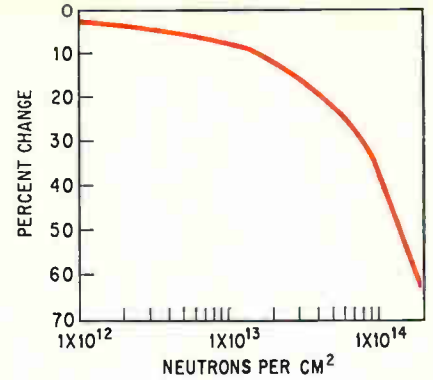

Falloff. Open loop gain of Radiation's hardened op amps drops rapidly near specified radiation limit.

resistant IC's under radiation bombardment. But the cost of testing is terrific, Dyer says; for instance, it costs \$2,600 a day to use a nuclear reactor.

Time to define. Right now, Fairchild is providing technical support for systems using DTL radiation-resistant circuits. By the time the systems are defined, Dyer says, Fairchild will have the capacity to fill the orders. Next out of the Fairchild chute will be TTL, by Fall.

At least one other manufacturer is eyeing the radiation-hardened market. Signetics, which developed a dielectric isolation process to give high-voltage capability to its consumer-tv IC's, is doing prototype work on hardened circuits. The company is discussing custom versions with several firms, and expects to start supplying them soon.

Radiation Inc. uses only the post-radiation performance data from its customers to evaluate its IC's. The specifications listed in the table below for a representative Radiation Inc. circuit are the values that the manufacturer tests to before shipment to the customer; post-radiation data is largely classified and will be furnished when there's a need to know.

Characteristics

Radiation-hardened clocked flip-flop RD-945R	
$T_A = 25^\circ\text{C}$	
Operating voltage	+5 volts, ± 0.5 volt
Input threshold	
0 level	1.1 volts max.
1 level	1.9 volts min.
Output voltage	
0 level	0.4 volt max.
1 level	3.1 volts min.
D-c loading	1.8 ma max.
Propagation delay	
t_{pd+}	35 to 85 nsec
t_{pd-}	30 to 85 nsec
Input leakage current	2 μa max.
Output leakage current	50 μa max.

Dual Darlington diff amp array

RCA-CA3050 and CA3051 now offer the circuit designer another significant opportunity to work with the inherent device match of monolithic construction PLUS the flexibility of RCA building-block arrays. On a single chip, in a dual-in-line package, each type offers:

- independently accessible inputs and outputs
- diode temperature compensation of constant-current-transistor bias
- high input impedance—460 K Ω typ
- low input offset current—70 nA max
- low offset voltage—5 mV max
- low input bias current—500 nA max

Get the feel of real design freedom with CA3050 or CA3051 for matched dual amplifiers, dual sense amplifiers, dual Schmitt triggers, doubly balanced detectors and modulators, and a multitude of applications that call for matched device performance from DC to 20 MHz.

For more information, contact your local RCA Representative or your RCA Distributor. For technical data, write RCA Electronic Components, Commercial Engineering, Sec. ICN-2-1, Harrison, New Jersey 07029.

Ask About These Linear Transistor Arrays from RCA

CA3018	Darlington pair, plus 2 independent transistors	\$.98 (1,000 units)
CA3018A	Tight-spec version of CA3018	\$1.35 (1,000 units)
CA3026	High gain dual diff ampl array for DC to 120 MHz	\$1.25 (1,000 units)
CA3036	Dual Darlington array	\$.89 (1,000 units)
CA3045	Darlington pair plus 3 transistors in dual-in-line ceramic package	\$1.50 (1,000 units)
CA3046	Dual-in-line plastic package version of CA3045	\$.98 (1,000 units)

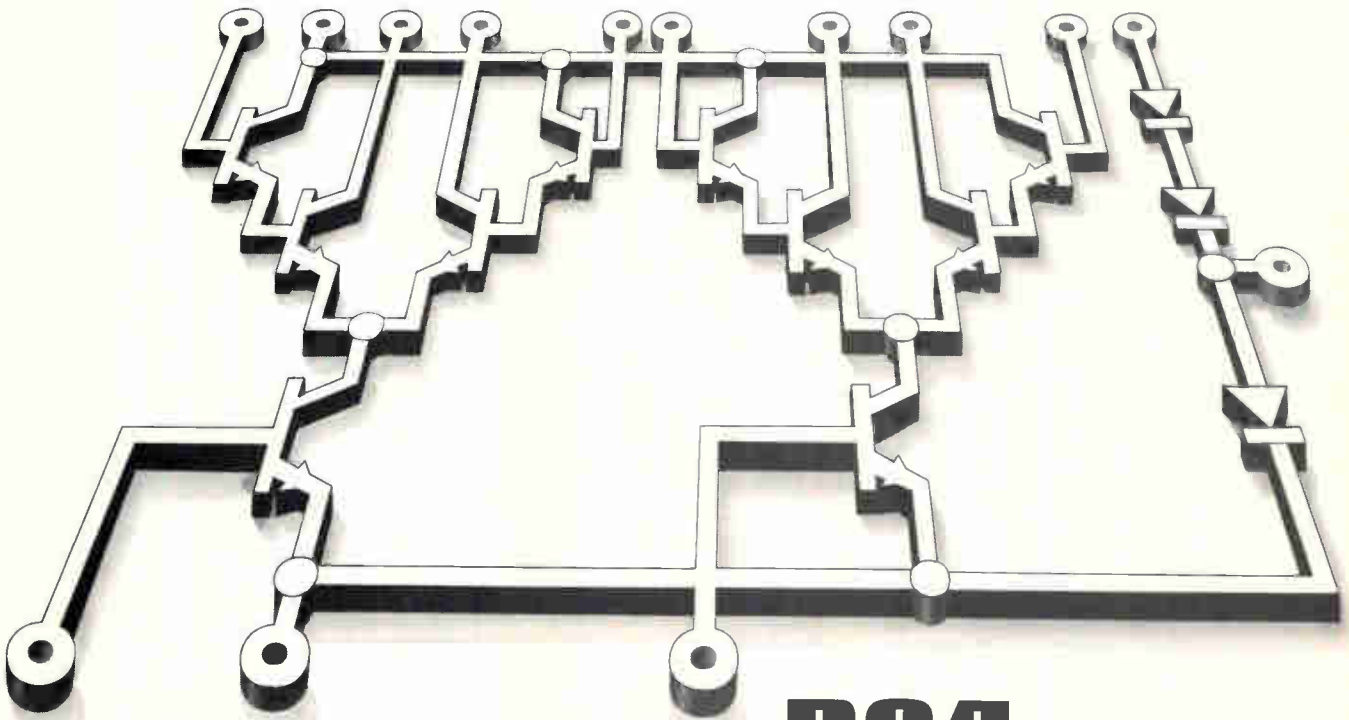

RCA-CA3050 in 14-lead dual-in-line ceramic pkg \$2.25 (1000 units)

RCA-CA3051 in 14-lead dual-in-line plastic pkg \$1.65 (1000 units)

RCA
Integrated
Circuits

IRRAVINTM

INSULATED WIRE

Designer's new wire that production can't complain about.

Ever had to re-design because production is having problems and calling for your head as the solution? That's why we've come up with IRRAVINTM irradiation cross-linked PVC hook-up wires. You release the design knowing that wire complaints are stopped before they start.

IRRAVIN insulated hook-up wire continuously withstands temperatures up to 115°C, and higher for short periods of time. So there's no shrink back from hot solder-iron contact. Production doesn't waste time replacing wire just installed. Advantage: use higher density packaging without fear of accidental solder iron damage. And, you can specify IRRAVIN hook-up wire for applications where only costly high-temperature insulations were used before.

Consider crush and abrasion resistance. Our IRRAVIN insulation has four times the crush resistance of that other high temperature stuff. You eliminate lacing cut through, assembly damage, future



Unretouched photo of design engineer being greeted by production engineer after specifying IRRAVIN insulated hook-up wire.

breakdown from undetected cuts and other production grumbles.

Couple this with 5,000 foot lengths, pre-tinned conductors, and you can see why IRRAVIN insulated hook-up wire can be worked fast and safely through automatic processing equipment.

Or we could mention the advantage of having 27 striped and solid colors in stock. Or the 600, 1000 and 3000-volt rated wires con-

forming to MIL-W-16878 and carrying Underwriters' Laboratories, Inc. listings.

Most important, though, IRRAVIN hook-up wire costs less than half that of the other higher temperature wire. Unless you really need the additional degrees why put up with the additional price?

So, be a hero. Get a sample of IRRAVIN insulated hook-up wire and try it. Of course, it's free. Contact ITT Wire and Cable Division, Surprenant Products, International Telephone and Telegraph Corporation, Pawtucket, R.I. 02862.

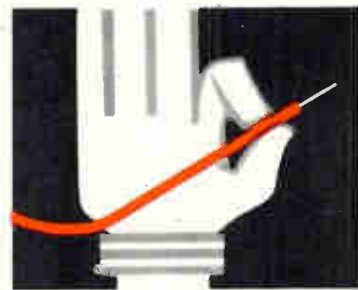

IRRAVIN—the wire
that stops the grumbles.

WIRE AND CABLE **ITT**

These pots are not driftless, but they drift less

Cermet potentiometers for computer, instrument, process control circuits maintain temperature coefficient of only ± 150 ppm/ $^{\circ}\text{C}$ over wide resistance range

For design engineers who want improved stability in component values and higher packaging density at a lower price, Bourns Inc. has developed two new cermet potentiometers.

Unlike commercially available pots which generally have a temperature coefficient of ± 250 parts per million/ $^{\circ}\text{C}$ at 1 megohm and ± 500 ppm/ $^{\circ}\text{C}$ at 10 ohms, the

new devices offer ± 150 ppm/ $^{\circ}\text{C}$ over a resistance range from 10 ohms to 1 megohm.

Model 3329 is a single-turn unit, $\frac{1}{4}$ inch in diameter, and 0.190 inch high. Model 3099 is a lead-screw potentiometer in a plastic dual in-line package. They are designed for use as trimming components on printed-circuit boards in computers, test equipment, and process

control systems. Temperature coefficients of 100 ppm/ $^{\circ}\text{C}$ are available for both at extra cost.

The company's development engineers say the temperature coefficients are the lowest in the industry over the entire resistance range. These units represent part of a company effort to duplicate in cermet the characteristics of the more popular wire-wound trimming po-



Magnetically actuated spst switch is for positive operation as low as -423°F and under vibration conditions of 45 G. It senses any linear or rotary valve, shaft or rotor position. Shock to 100 G will not result in a discontinuity greater than 10 μsec . The contact is rated at 2 amps inductive at 28 v d-c. Kinetics, a Teledyne Co., 410 S. Cedros Ave., Solana Beach, Calif. 92075. [341]



Magnetic circuit breakers series 51MC come in ratings from 0.020 to 50 amps, a-c or d-c, in single and multipole versions. Multipole types have an internal tripping action so that a fault in any pole will trip all poles. Units are available in relay and shunt-type configurations as well as the standard series type. Texas Instruments Inc., 34 Forest St., Attleboro, Mass. [342]

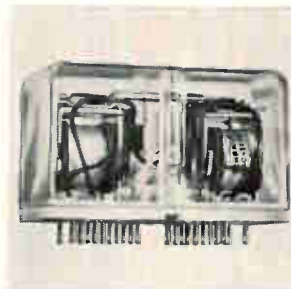

Dual coil latching relay type CBF has a plug-in base for ease of mounting. Each relay operates on a momentary impulse on either coil held in set position until released by an impulse on the other coil. Nominal coil voltages are from 6 to 110 v d-c and 6 to 230 v a-c. Coil resistances run from 2.9 ohms to 4,500 ohms. Schrack Electrical Sales Corp., 1140 Broadway, N.Y. [343]



Double pole, subminiature reversing snap-switch model ML2-70 has two butterfly double-break mechanisms. Use of snap-action provides a quick make-and-break of controls in each circuit. Current rating is 3 amps at 125/250 v a-c; operating force, 75 to 100 grams; lever length, $\frac{3}{8}$ in.; life cycle, 500,000. Alco Electronic Products Inc., P.O. Box 1348, Lawrence, Mass. 01843. [344]



Heat sink model LP12 measures 1.60 x 1.60 x 0.75 inch with less than 1 mil surface smoothness. It will dissipate 16 w for 100 $^{\circ}\text{C}$ temperature rise. It can be ordered with no finish, conversion coating, gold iridite, black or hard anodized insulated for 500 v, and can be stamped for TO3 or TO66 transistor outline. TOR Inc., 16329 East Arrow Highway, Irwindale, Calif. 91706. [345]



Plastic case $\frac{3}{8}$ -inch square trimmer model 51 meets MIL-R-27208. It is available with resistances in the 10 to 50,000 ohm range. Features include light weight (1.5 grams, max.), a 200-cycle rotational life, resistance tolerance of $\pm 5\%$, and a power rating of $\frac{3}{4}$ w at 85 $^{\circ}\text{C}$. Price in 1-9 quantities is \$4.81. Spectrol Electronics Corp., E. Gale Ave., City of Industry, Calif. [346]

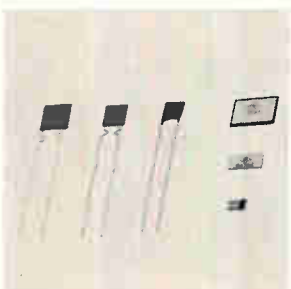

Chip Ultra-Kap capacitors come as small as 0.135 inch square. Rated at 25 v d-c maximum, they have values ranging from 0.01 to 0.10 μf in both standard and polarized types. Maximum dissipation factor is 5% at 1 khz. Units are most useful for operation under 10 Mhz. Centralab Electronics Div., Globe Union Inc., 5757 N. Green Bay Ave., Milwaukee. [347]



Variable high-frequency inductors feature a Q of 500. Types VHI-1 through VHI-10 have an inductance range of 1 mh to 50 mh, and a frequency range of 50 khz to 500 khz. Types VHI-11 through VHI-22 have an inductance range of 9 μh to 600 μh and a frequency range of 100 khz to 10 Mhz. Freed Transformer Co., 1718 Weirfield St., Brooklyn, N.Y. 11227. [348]

WHICH DEFLECTION YOKE FOR YOUR DISPLAY ?



Consult **SYNTRONIC**

YOKE SPECIALISTS

Syntronic's team of experts knows more about yoke design, engineering and quality control than anyone else. A solid 10-year record of leadership—acknowledged throughout the industry. Benefit from it.

syntronic **INSTRUMENTS, INC.**
100 Industrial Road, Addison, Illinois
Phone: Kingswood 3-6444

Circle 189 on reader service card

40 pages of
profit-keyed
information
every site-
seeking
company
should have

For your FREE copy, write Stanton Allen, Manager, Economic Development Dept., Room E-1, Chamber of Commerce, Phoenix, Arizona 85004.

dynamic
Phoenix 
PROFIT CENTER OF THE SOUTHWEST

... package is sealed
against solder flux ...

tentiometers, and also develop new proprietary designs. The firm's model 3329 will be competing with the 62 series devices made by the Beckman Instruments Inc.'s Helipot division.

Gary Kounkel, supervisor of application engineering in Bourns' Trimpot division, says the 3329 can be used where fast adjustment is needed, that the package size is widely used, and can't be decreased without sacrificing power rating. Its height, he says, is lower than most competitive devices, and makes it compatible with the popular p-c board spacing of 0.2 inch.

Sizable chunk. That fact, plus its low temperature coefficient—especially at the extremes of the resistance range—is expected to win it a sizable chunk of the market. The model 3329 will sell for \$1 in high volumes—thousands or more.

Kounkel says the unit is completely sealed for immersion to meet military specification MIL-R-22097. He claims it's the first low-cost commercial single-turn trimming potentiometer to meet this specification. "In wave soldering of p-c boards," he observes, "the first step involves use of a flux on the board's bottom. The flux can move up through the board's holes, get on the resistance element and cause an open wiper circuit."

Model 3329 delivers 0.5 watt at 70°C; Kounkel says the military specification requires only 0.25 watt at 85°C. Temperature range is -55 to 150°C, equivalent to the specification.

Pop housing. The principal advantage claimed for the model 3099 is that it's the first cermet trimming potentiometer housed in the popular TO-116 DIP, which will make it attractive to computer and instrument makers using automatic insertion equipment.

Model 3099 is also a low profile unit, with a maximum height of 0.2 inch. It is rated at 0.75 watt at 25°C, has a temperature range of -55 to 125°C, and will cost \$2.50 in volume quantities.

Bourns Inc., Trimpot Products Division, 1200 Columbia Ave., Riverside, Calif. 92507 [349]

New components

Relays upended to save space

Vertical-design types are for cramped boards where height is no problem

"Take a look inside a Japanese transistor radio and see how the components are upended to save board space," suggests Nathan Paulson during a discussion of his Verti-Reed relays.

The example is apt, but Paulson, chief engineer of Douglas Randall Inc., a division of Walter Kidde & Co., says the inspiration for the vertical-design components actually came from a customer who had very little board space to spare in the device he was designing for computer input/output equipment. "We tackled the problem by vertical design which required special tooling, and now we're producing this type of relay for off-the-shelf marketing," says Paulson. He expects the principal applications to be in data processing equipment, including computer memories and many peripheral devices—"anywhere small-voltage switching is required."

The Verti-Reed takes up only 0.16 square inch on a printed-circuit board. It's 0.4 inch on a side and 0.9 inch high.

Contact ratings. The range of contact arrangements includes 1A, 2A, 1B, 1C, and 1A-latching. Form A and B relays have contact ratings of 10 watts or 12 volt-amperes, 250 volts d-c or 0.5 ampere maximum. Form C contacts are rated 3 watts or 3 volt-amps, 28 volts d-c or 250 amps maximum. Standard coil voltages are 6, 12, and 24 volts d-c.

Prices for the relays, quoted in lots of 500 units, range from \$1.80 each for the 1A type to \$3.60 each for the 1C.

Delivery is from stock for some items, and 2 to 3 weeks for new designs.

Douglas Randall Inc., Division of Walter Kidde & Co. 6 Pawcatuck Ave., Westerly, R.I. 02891 [350]

The Lasertron[®] Lineup

Select the one you need from these permanently aligned, adjustment-free He-Ne lasers.



The Lasertron[®] Tube A coherent light bulb, it is the heart of every U/L laser. Never needs adjustment or maintenance. Simply switch it on or off. Resonator mirrors are permanently aligned inside a rigid pyrex envelope. Unaffected by dust, humidity, vibration, temperature or aging. Available as an OEM component or as part of complete instruments, as shown.

MODEL 200
\$195 0.6 mW. Built-in power supply. Ideal for student use.

MODEL 201
\$255 1.0 mW. Built-in power supply. For educational and experimental use.

MODEL 240
\$295 1.0 mW. Separate detachable power supply. Research grade laser. Tripod included.

MODEL 241
\$385 2.0 mW. Separate detachable power supply. Ideal general purpose laser. Tripod included. Model 22 Precision Mounting Base optional at \$185.

MODEL 261
\$545 4.0 mW. Separate detachable power supply. An all-purpose low-cost laser. Tripod included.

MODEL 270
\$1580 10 mW. Separate detachable power supply. Precision 4-cone mount included. A higher power general purpose laser for imaging and display tasks.

All models produce in TEM₀₀ mode, wavelength 6328 Angstroms. Solid-state power supplies. Full-year warranty with no restriction on operating hours. More than 3000 in use throughout the world!

MAIL COUPON TODAY!

University Laboratories / 733 Allston Way, Berkeley, Calif. 94710

Gentlemen:

Please send complete information on He-Ne lasers and accessories

Please send information on Lasertron tubes for OEM applications.

Name _____

Position _____ Dept. _____

Organization _____

Address _____

City, State _____ Zip _____

University Laboratories

733 Allston Way, Berkeley, Calif. 94710 / Tel (415) 848-0491

TRW 5-WATT - 2 GIGAHERTZ MICROWAVE TRANSISTOR

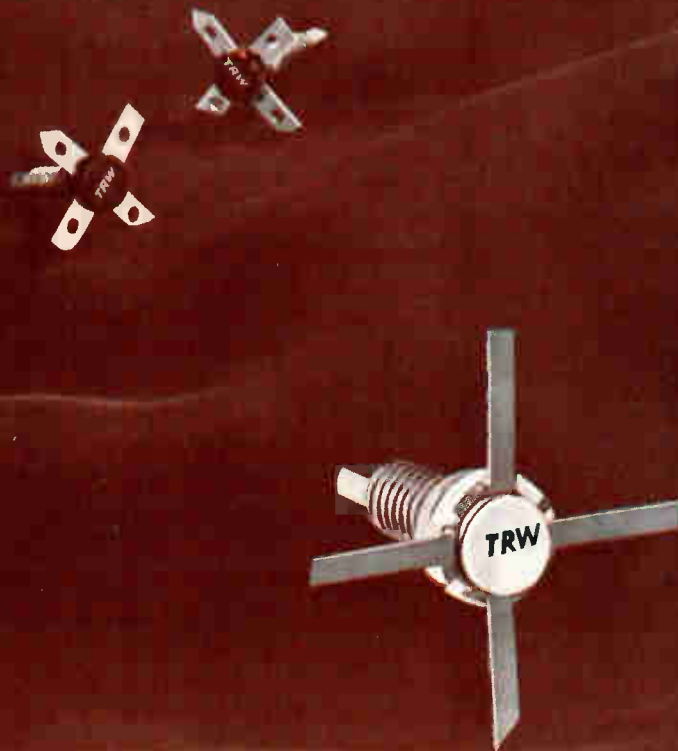

28 volts...33% efficiency...stripline design

A 5 watt 2 GHz microwave transistor in a hermetically sealed ultrac ceramic stripline package!

The new TRW 2N5483 provides 4 db gain at 2 GHz with 33% efficiency in simple, straightforward circuits. Two new companion transistors for input and driver stages deliver 1 watt at 6dB and 2.5 watts

at 5 dB. All operate from a 28V source.

Delivery is immediate . . . in production quantities. Order from the factory or any TRW distributor.

For complete information and applications assistance contact TRW Semiconductors, 14520 Aviation Blvd., Lawndale, California

90260. Phone: (213) 679-4561. TWX: 910-325-6206. TRW Semiconductors Inc. is a subsidiary of TRW INC.

TRW®

Four-digit voltmeter shows a low price

Dual-input dvm sells for \$1,000; instrument has five ranges, from 99.99 mv to 999.9 volts, and accuracy of 0.01%

If morning cups of coffee and family cars were like digital voltmeters, the cost of living would be lower. For while the prices of coffee, cars, and almost everything else continue to rise, the prices of dvm's are falling.

Take the case of the Trymetrics Corp.'s 4250A, a four-digit dvm whose accuracy is 0.01%. Robert Smyth, the company's general man-

ager, says that at \$1,000 the 4250A is priced \$300 under equivalent dvm's.

To explain the reason for the low price, Smyth says: "The heart of any dvm is the a-d converter. We've been making the same converter for quite a time for other meters, so we can turn them out quickly and inexpensively.

"Experience shows up in a cou-

ple of other areas," he says. "We paid a lot of attention to customer feedback when we built this meter." One thing the customers want is dual inputs; this allows an operator to feed the 4250A two signals, and look at either one by flicking a front-panel switch. This feature, combined with the instrument's automatic-ranging capability, makes the 4250A a useful device for



Portable bridge model TRB-1 is designed to measure temperature rise where a change in resistance method is normally used. Conductors are either copper or aluminum and accuracy is within $\pm 1^\circ\text{C}$ over a range of 0° to 120°C . Applications include testing generators, electric motors, solenoids and coils. Beckman Instruments Inc., 89 Commerce Road, Cedar Grove, N.J. [361]

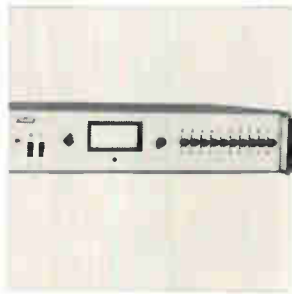

Spectrum analyzer model 814 contains all the basic elements for spectral analysis of a complex waveform in real time. Each unit contains 10 filter channels, and as many units as desired may be interconnected by plug-in cables to cover all or any part of the 0.1 hz to 100 khz spectrum in 1-, $\frac{1}{2}$ -, $\frac{1}{3}$ -, $\frac{1}{6}$ -octave segments. Tracor Inc., 6500 Tracor Lane, Austin, Texas. [362]



Portable milliohmimeter model 502A offers 30 μohms sensitivity and less than 2 μw power dissipation. Accuracy is 3% of full scale. Full scale ranges are from 0.001 to 1,000 ohms. Maximum voltage across sample is 25 mv peak-to-peak. The unit is battery operated with a minimum of 360 hours battery life. Price is \$495. Keithley Instruments Inc., 28775 Aurora Road, Cleveland. [363]



Operating modes of the model 104A counter include: direct totalization from 1 to 10^5 ; preset totalization, with all 5 decades presettable from 0 to 9; "rate", in which gate times are selectable from 1 μsec to 100 sec for normalized readings. Basic counting range is from 5 hz to 8 Mhz. Price is \$850. Monsanto Co., 620 Passaic Ave., West Caldwell, N.J. 07006. [364]

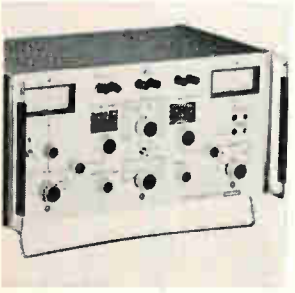

Impedance bridge model IX307A is designed for laboratory or production line use. It can be balanced visually by means of a null amplifier and built-in meter. Resistance range is 0.01 ohm to 10 megohms in 8 ranges; capacitance range, 0.1 pf to 10,000 μf in 8 ranges. Price is \$832; delivery, 10 days. Advanced Technology & Systems Corp., 199 Sound Beach Ave., Old Greenwich, Conn. [365]

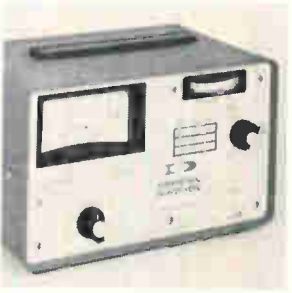

Vibration Surveyor model 4400 is a portable instrument that will measure the amplitude and frequency of vibration. Amplitude is measured in units of displacement and acceleration. Displacements of a few microinches can be detected and peak acceleration of 200 micro G's can be measured. Frequency covered is 50 to 100,000 cpm. Dytronics Co., Evanswood Dr., Columbus, Ohio. [366]



Portable potentiometric recorder's chart speeds can be changed with a finger-tip selection feature with electrical selection of inches per hour or inches per minute. This gives a choice of 10 different chart speeds. Maximum accuracy is assured with readings of 0.25% of full scale or $\pm 5 \mu\text{v}$, whichever is greater. West Instrument Corp., N. River Road, Schiller Park, Ill. 60176. [367]



Solid state function generator PM5168 offers 3 simultaneous fixed amplitude waveform outputs (square-, triangle- and sine wave) over 7 frequency ranges, from 0.0005 hz to 5 khz. A fourth output can be switched to provide any of the 3 waveforms with adjustable amplitude and d-c reference level. Philips Electronic Instruments, 750 S. Fulton Ave., Mount Vernon, N.Y. [368]

SPERRY GaAs LASER DIODES AND ARRAYS NOW AT NEW LOW PRICES



Increased demand and greater production capacity now permit reductions of up to 60%.

Here is a laser that's the solution to many of today's IR source problems in intrusion, communications, navigation and station keeping, fusing, optical radar, tracking and guidance, braking and docking, and anti-collision. And the Electro-Optics Group of the Sperry Gyroscope Division has made it available for immediate delivery in a full range of diodes and arrays (with compatible modulators), all now available at new low prices. For example, our 10 watt array is now \$20 per unit in quantities of 100.

These units:

- provide peak power up to 2 watts/mil (equivalent to 4Mw/cm²)
- emit into 0.1 steradian angle (f/3 lens collects all radiation)
- radiate at approximately 9160 Å, with a half-power width ± 50 Å
- operate at room temperature
- are small, compact and simple to operate
- are available off the shelf

The line of lasers ranges from a 10 watt peak power diode through an 800 watt array. The triangular-package diodes are available in 10, 14, 18 and 30 watt peak power outputs.

Three arrays are available, providing 200, 400 and 800 watts peak. The 200 watt array has a diameter smaller than a dime and is less than 1/2" high. These uncooled units emit invisible infrared (9160 Å) radiation into a 20° cone angle.

For additional information write to the *Electro-Optics Group, Sperry Gyroscope Division, Great Neck, New York 11020*. (Telephone: 516-574-2292)

SPERRY
GYROSCOPE DIVISION
GREAT NECK, NEW YORK 11020

 **SPERRY RAND**

checking amplifiers.

Experience shows that customers also want a print-command output that looks before it speaks, says Smyth. "In many meters with automatic ranging, when there's a sudden voltage change, you get a lot of rubbish printed out until the meter finds the right range," he says. "Our meter doesn't send the print command until the right range has been found."

Print-command output is an option and adds \$95 to the price.

The 4250A has five ranges, from 99.99 millivolts to 999.9 volts, and there's 20%-overscale readout on each range.

Either a front-panel knob or an external trigger sets the sample rate; top speed is 10 samples per second.

Also on the front panel is a three-position switch that adds fil-

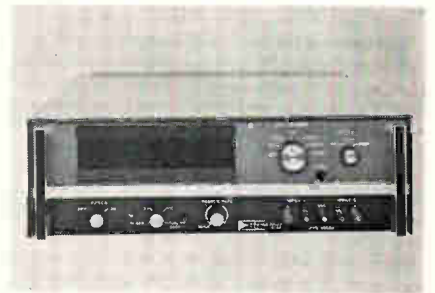

Double take. The dvm accepts two separate inputs. A switch setting determines which of them is displayed.

ters to the input circuit. Attenuation of a 60-hertz signal can be set to 20, 40, or 80 decibels. If, for example, the instrument is running at its fastest sample rate, the meter's response times for the filter settings are 0.1 second, 1 second, and 2 seconds respectively.

Common-mode rejection when the meter is set to the 99.99-mv scale is 110 db for both d-c and 60 hz; for the 999.9-volt scale the rejection is 50 db for d-c and 40 db for 60 hz.

Long-term stability is 0.05% for 6 months, and temperature coefficient is 0.001% per degree centigrade.

The instrument is 5 1/4 by 17 by 13 1/4 inches, weighs 15 pounds and draws 35 watts. Delivery time is one to two months.

Trymetrics Corp., 204 Babylon Turnpike, Roosevelt, N.Y. [369]

Tiltmeter goes to the field

Small, rugged device for surveys and gyro work has 0.0005-arc-sec resolution

Hurricane warnings start coming in days before the storm slams into a city, and people usually get a few hours to dig in before a tornado blows through. But scientists can do little to predict when an earthquake will occur.

The situation isn't likely to change soon, but Gary Latham, president of Rockland Laboratories Inc., feels that an instrument developed by his company may bring the day of early earthquake alarms a little closer.

The model 2162 tiltmeter sits on a flat surface and measures the tilt of two perpendicular axes with a maximum resolution of 0.0005 arc second. Rockland built the instrument to help geophysicists survey and search for minerals and to help engineers test gyros on stable piers. In fact, the Bendix Corp. has already bought one for gyro work.

Swinging. But now Latham is suggesting a way to use the 2162 to predict quakes. His idea—put tiltmeters on both sides of a fault. Possibly, the crust around the fault starts to move in a characteristic way long before the quake begins.

Other tiltmeters, according to Latham, can't go out into the field and stay there because they lack the resolution, small size, ruggedness, and direct readout of the Rockland instrument.

The 2162 runs on line voltage or 15 to 25 volts d-c. It can be connected to a battery, or be powered by its own rechargeable nickel-cadmium batteries.

The 2162 has two parts, a sensor head and a control box. Inside the head is an inverted pendulum, a long, thin bar tied at the bottom to a wire and at the top to two thin metal plates, each having an area of 2 square inches on a side.

On the level. Also in the head are two bridges, one for each axis

To turn off rejects of 3rd generation circuits:

Turn on Barnstead's New Micro-Cleaner

There's no better way to make micro-circuits come clean!

Barnstead's new microelectronic cleaning station provides an ultra-pure final rinse — in a totally clean environment — at minimum cost.

Write for Bulletin 211, describing this 3rd generation cleaning station.



225 Rivermoor St.
Boston, Massachusetts 02132



Positive-pressure hood keeps work area free of airborne contaminants, with absolute air filter; quiet, spark-free blower. Meets or exceeds applicable MIL SPECS.

Five hot, cascading pure water rinses in tinlined monel tanks do a thorough cleaning job. Final rinse, measuring 18 megohms/cm @ 25°C and free of organics, gases, biologicals — is much purer than demineralized water.

Purity meter checks quality of rinse water, both "upstream" and "downstream" from final rinse.

To make a few gallons do the work of thousands, water is continuously recirculated, repurified. System includes . . .

Demineralizer. Automatic still. Organic removal bed. 0.1 micron particle filter. Sump, protected by ultraviolet unit, Ventgard® air filter. Regenerative heat exchanger. Cuts electrical load by more than 50%

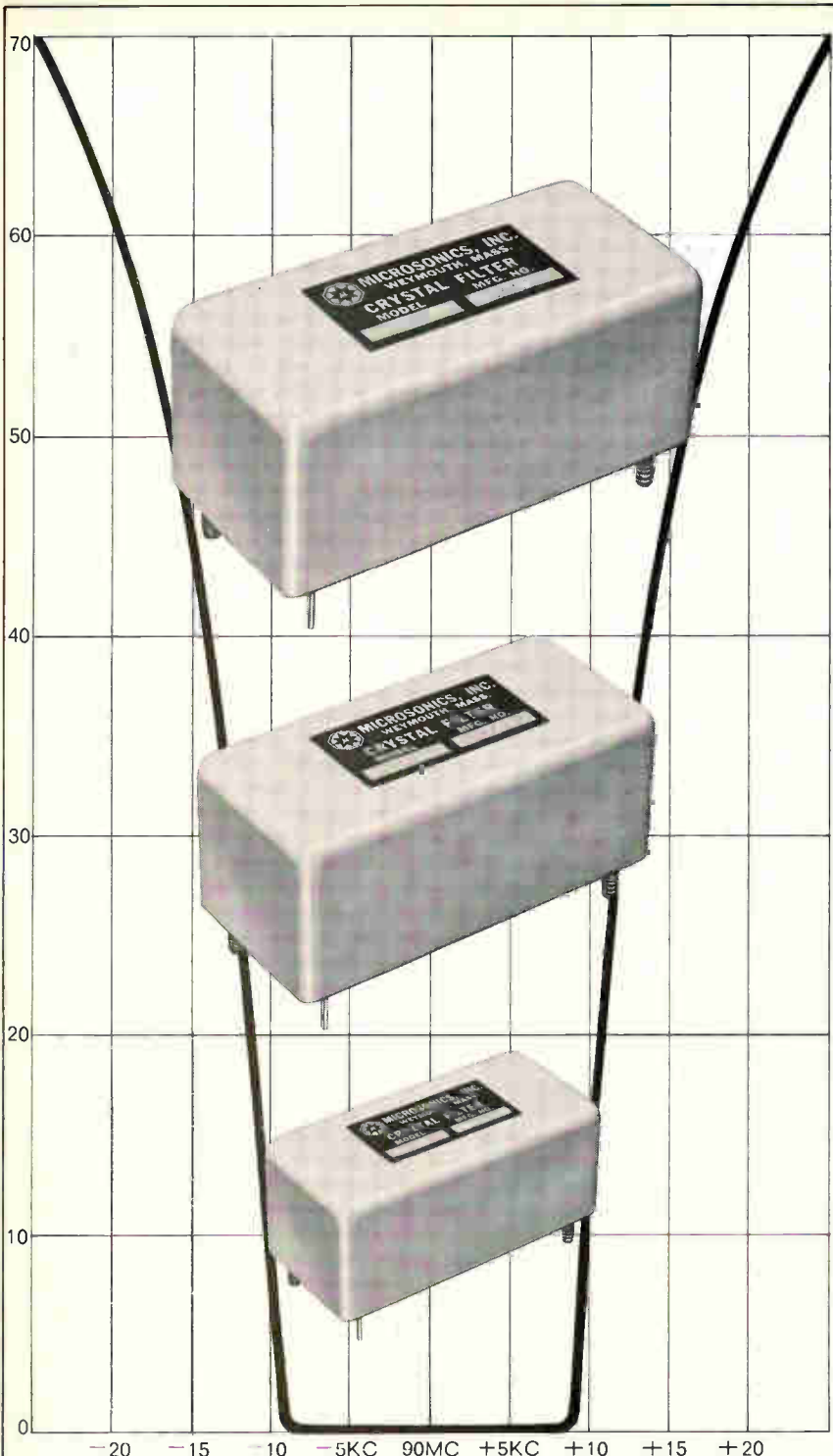

MICROSONICS
*for proven design, reliability &
 performance in*
CRYSTAL FILTERS



Write for Bulletins today
MICROSONICS
 60 Winter Street, Weymouth, Mass. 02188
 Tel: 617 337-4200
 A division of the Sangamo Electric Company



List. How much the sensing head (top) tilts along two axes is shown on the control box. A cable connects the two units.

on which tilt is measured. In one arm of each bridge is a capacitor, one of whose plates is one of the 2-inch plates attached to the pendulum.

The head is filled with oil that damps the pendulum and protects the components. Drivers for the bridges, controls, and two meters are in the control box.

The sensor head sits on three legs whose heights are adjusted with thumbscrews. When setting up the instrument, the user first crudely levels the head by looking at the spirit level built into the top of the head and by turning thumbscrews to zero the meter. Next he selects the instrument's least sensitive range—10 arc minutes full scale—and zeroes again. He repeats this step until the instrument is zeroed on the desired scale. The other full-scale settings are 1 arc minute, 10 arc seconds, and 1 arc second.

Pressure problem. The instrument is built to measure slow changes; the fastest signal it can track is 1 hertz. Drift is 0.1 arc second per day. The effect of temperature change is small, but how small is something Rockland engineers have not yet been able to measure. "The problem is distinguishing between drift caused by small temperature changes and drift caused by barometric changes," says Latham. "A cloud comes over, and Manhattan island tilts a little and throws off our readings. Right now we're setting up in a mine to get away from these changes."

The price of the 2162 is \$2,750; extra heads are available for \$1,500 each. Delivery time is 45 days.

Rockland Laboratories Inc., Box 57, Tappan, N.Y. 10983 [370]

Only Magnetics Inc. gives you all three of these advantages in photo-etched parts:

1. Metals processed to your specification
2. Guaranteed magnetic performance properties
3. Total quality control, raw metal to finished part

There is nothing new about chemically milling small, thin metal parts. Dozens of companies can photo-etch any part that can be drawn. What sets Magnetics Inc. apart in photo-etching is our capability of processing the metal to close tolerances.

Magnetics' completely integrated

production system for Photofab® parts is all-inclusive. We can custom blend basic metals into special alloys, or we can start with stock metal. We follow through with whatever it takes to match your specifications—precision rolling or flattening or strip annealing. As long-time specialists in magnetic materials, we have the facilities and the expertise needed to provide the ultimate in dimensional accuracies, at the same time guaranteeing the magnetic properties of your parts.

We augment our production capa-

bilities with uptight quality control. This means the most advanced laboratory and test equipment, manned by a staff of nit-picking experts. When you take delivery on Photofab parts, you can be sure that they've passed our constant surveillance, from basic metal through shipment in custom-designed packaging.

If you've been looking for a supplier who can offer single-source responsibility on photo-etched parts, you've found us. For more information, write Magnetics Inc., Dept. EL-110, Butler, Pa. 16001.



Photofab example—
words photo-etched
in a sheet of .001
beryllium copper.

TAPE, POWDER, BOBBIN, FERRITE CORES • LAMINATIONS • PHOTO-ETCHED PARTS • SPECIALTY METALS • ENGINEERED CONTROL SYSTEMS

SEMPER PARATUS

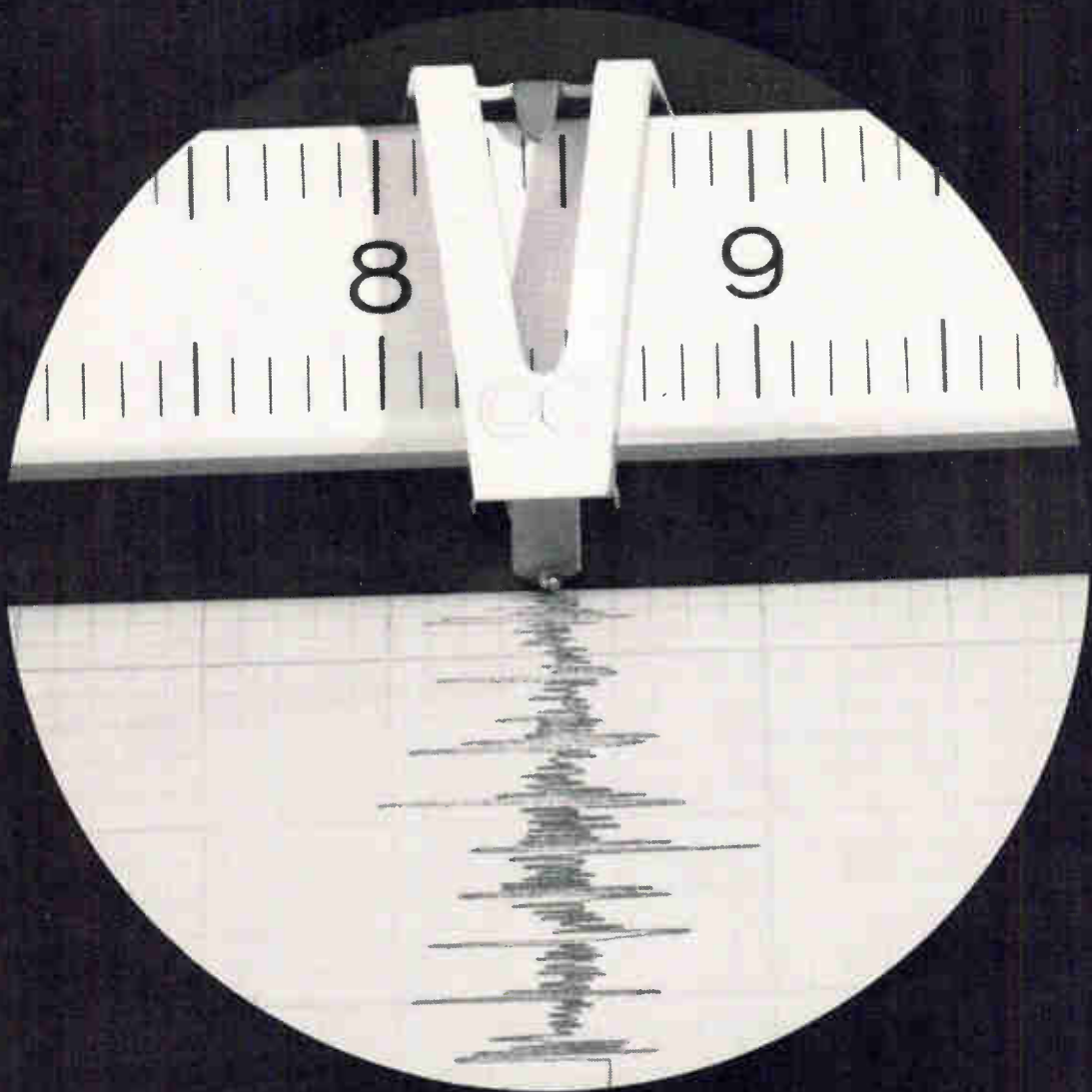

There are times when electric writing is best. Lots of times. Like when you can't be around to check your ink supply. When you've got an unattended station in a remote area. When your recorder may be on standby for long periods, yet must start and stop instantly to catch a one-shot event. When you have to be certain your records will be permanent. When environmental conditions may threaten the readability of your traces. Or, to put it more simply, when the odds are against a standard pen stylus.

Hewlett-Packard's electric writing option

degree of dependability to data gathering operations around the world. The technique uses special electrosensitive paper and a low-voltage writing stylus. It gives you records that are impervious to heat, pressure or light. Altitude and vibration can be tolerated; no priming is necessary before operation. With very low chart speeds you can record data 24 hours a day, seven days a week, for extended periods of time. Yet it costs only \$75 to add this option when you buy either the HP 680 five-inch recorder or the 7100 series ten-inch recorder.

Find out more about this remarkably sim-

ple way to make certain your records will be there even if you're not. Just call your local HP field engineer. Or write Hewlett-Packard, Palo Alto, Calif. 94304; Europe, 1217 Meyrin-Geneva, Switzerland. We'll send you a sample of electric writing.

HEWLETT  PACKARD
GRAPHIC RECORDER

New subassemblies

U.S. company enters a noisy market

Ready in the spring will be the first American system that uses white noise to test radio networks

One way to find out how well a multiplexed radio network resists noise is to modulate the transmitter with white noise, notch out certain channels at the sending end and measure harmonic and intermodulation distortion at the receiving end. The market for systems that do this is quite small, so U.S. companies have left the field to the Europeans, principally Marconi

and Siemens.

But networks are becoming more complex and more networks are being built. The resulting increased demand for test systems has lured a U.S. company into the market. This spring the Sierra Electronic operation of Philco-Ford will offer the first home-grown white-noise test system.

The equipment consists of a noise

generator, banks of high-pass, low-pass and bandstop filters, and a receiver. The generator's output is flat to within 1 decibel for any selected bandwidth in the range of 4 kilohertz to 13 megahertz. The receiver, which accepts up to six bandpass filters, measures the relative noise level of the network under test.

The system loads all channels



Solid state analog multiplier M501, featuring 1 Mhz bandwidth, employs the transconductance principle to give smooth continuous multiplication from ± 10 v through 0 v. The unit has 0.5% linearity over any range of operation. Applications include high speed dividers, displays, and radar control. Price (1 to 9) is \$295. Intronic Inc., 57 Chapel St., Newton, Mass. 02158. [381]

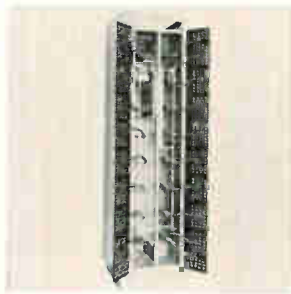

Multitapped delay line system type 420 offers 500 inputs and a single output. Total delay is 35,000 μ sec with a tolerance of ± 1 μ sec. Tap separation is 70 μ sec with a tolerance of ± 1 μ sec. Input and output pulse width is a nominal 1 μ sec. Operating temperature range is 68° to 104°F. The 19-in. relay rack is 8 ft high. Tyco Laboratories Inc., 200 Michael Dr., Syosset, N.Y. [382]



Q-switching system PCD15 is a Pockels-cell module suited for solid state lasers. It is capable of generating pulses up to 300 Mw without detrimental effects to the crystal and is compatible with most existing laser systems. The unit is available with apertures to $\frac{3}{4}$ in., suiting it for $\frac{5}{8}$ in. diameter rods. Spacerays Inc., Northwest Industrial Park, Burlington, Mass. 01803. [383]

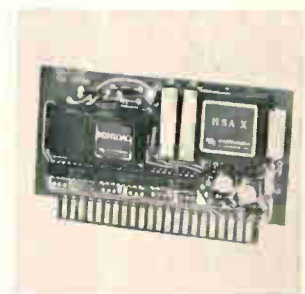

General purpose digital-to-analog converter DAC T series accepts a binary code of up to 12 bits, stores this number in an internal register upon command of an external strobe, converts and holds the number as an output voltage until the next strobe command. Price is \$270 and up; delivery stock to 30 days. Pastoriza Electronics Inc., 385 Elliot St., Newton Upper Falls, Mass. [384]



D-c to d-c converter series A02 is capable of sustained full load operation at 71°C. It converts 28 v d-c to any required output voltage from 5 to 590 v d-c at 2 w. Package size is 1½ x 2 x 2 inches and weight is less than ½ lb. Price is as low as \$205 each; normal delivery, 4 to 6 weeks. Abbott Transistor Laboratories Inc., 5200 W. Jefferson Blvd., Los Angeles 90016. [385]



Digital-to-resolver/synchro converter 538/20 offers 16-bit digital resolution, 0.01° angular resolution, and 0.01° output accuracy and repeatability. It develops data rates up to 20,000°/sec, feeding out synchro or resolver data in response to digital commands at rates up to 2,000,000 discrete steps/sec. North Atlantic Industries Inc., Terminal Dr., Plainview, N.Y. [386]



D-c differential amplifier series 5000 is available with filter cut-off frequencies from 0.1 hz to 50 khz with either 2 or 3 pole Butterworth or Gaussian characteristics from either single or dual, 3 or 4 wire output configurations. Linearity is $\pm 0.005\%$, drift less than 1 μ v/°C, gain 1 to 5,000, accuracy $\pm 0.1\%$. Bay Laboratories Inc., 20160 Center Ridge Road, Cleveland. [387]

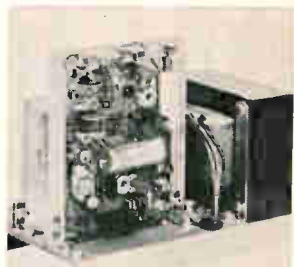

General purpose, dual output d-c power supply model D-OEM-1 provides a 24-v at 2-amp output for relays and other d-c loads while its 5-v at 1-amp output includes overvoltage protection especially designed for IC loads. Dimensions are 8.3 x 5.7 x 4 inches. Weight is 9 lbs. Price is \$95 in quantities of 1 to 9. Wanlass Electric Co., 1540 E. Edinger Ave., Santa Ana, Calif. [388]

Hickok CRO 5000 25 MHz Oscilloscope (all solid state)

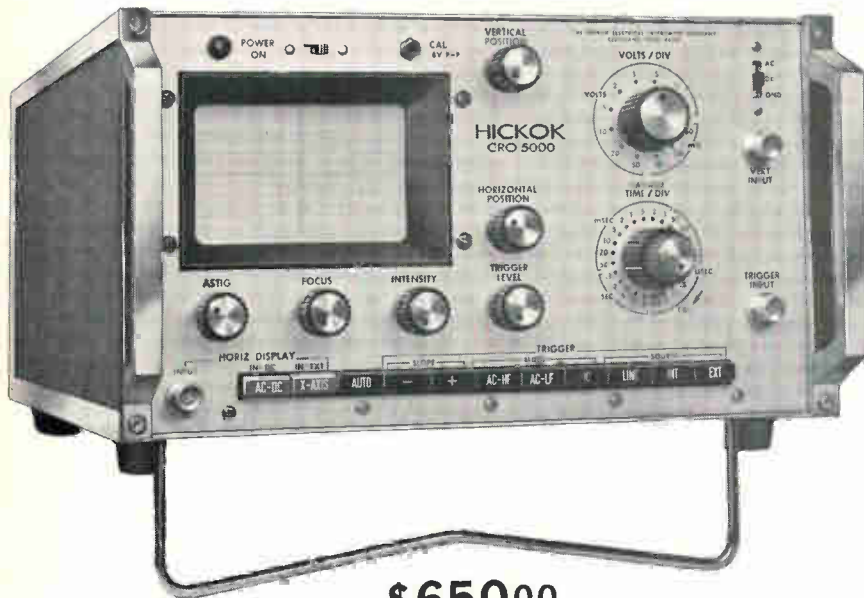

\$650⁰⁰

This high-precision laboratory oscilloscope equals the basic performance of higher priced, sophisticated 'scopes, yet meets the industry need for such performance in the \$600 price range. Emphasis has been placed mainly upon those characteristics most important in precise measurements, eliminating some of the more exotic and somewhat superfluous functions found in higher priced instruments. The result is an all-solid-state instrument in the medium price range with extraordinary stability, sensitivity, bandwidth, sweep-speed range, trigger capability, reliability, and ruggedness.

- 25MHz vertical bandwidth (to 3db down points)
- Usable to 50MHz
- All solid state for high stability and reliability
- 12 calibrated vertical attenuator ranges
10 mv/div to 50 volts/div ($\pm 3.0\%$ accuracy)
- 24 calibrated sweep ranges
0.05 microseconds/div to 2 sec/div ($\pm 3.0\%$ accuracy)
- Vertical delay line assures viewing of full leading edge of pulses
- "Sweep Delay" of up to 40 divisions
- Sweep speed continuously variable between ranges
- X-axis channel bandwidth DC — 5MHz
- 4" flat-faced CRT, 6 x 10 division graticule
- 3.8 kv HV provides sharp, bright trace
- Vertical amplifier will handle overloads, with negligible distortion of waveforms increased to 5 times screen height
- Internal 1.0% calibration squarewave
- Fast, convenient push-button selection of trigger modes
- Positive, solid triggering on all displays
- Small — 11 $\frac{1}{4}$ " W, 6 $\frac{7}{8}$ " H, 19" D; 24 pounds



Noisemaker. Test set measures distortion in voice network.

with white noise. The operator adjusts an input attenuator so that there's a null at one of the test bands. Then he switches a blocking filter into the generator; the filter knocks down noise on the test band by 80 db, removing power on the corresponding band at the receiving end. The amount of gain that must be applied at the receiving end to regain the null point determines the noise-to-power ratio. In the Sierra set, the ratio is read directly from the attenuator dial.

The blocking and bandpass filters are the heart of the test system. "Bandstop filters," notes Andre Lubarsky, designer of the generator, "are anything but common. We went to many filter manufacturers and no one wanted to build to our specs." Sierra therefore built its own, in a 5-pole Tchebycheff configuration.

Pull out. Sierra builds its own bandpass filters up to 3 Mhz and buys filters for higher frequencies. Each filter has a crystal-controlled local oscillator which keeps the center of a 3-khz equivalent voice channel stable to within 1 or 2 hertz. The signal coming into the receiver beats against the output of a local oscillator, producing another signal that passes through a 1.5-khz low-pass i-f filter. Measurements are referenced to 1 milliwatt and given in rms.

All filters can be pulled out of the receiver's front panel. The system, called the 330A, will test multiplexed networks of from 12 to 2,700 channels.

The test system will sell for \$4,500 to \$5,500, depending on the filters required.

Philco-Ford Corp., Sierra Electronic Operation, 3885 Bohannon Drive, Menlo Park, Calif. 94025 [389]

HICKOK ELECTRICAL INSTRUMENT COMPANY, 10514 Dupont Ave., Cleveland, Ohio 44108

Taking the picture out of p-c boards

Scriber makes master directly from rough sketch of circuit

As electronic miniaturization becomes more important in circuit design, the fabrication of more complicated printed-circuit boards to carry scores of components and interconnections becomes more expensive.

A New Jersey company, Techne Inc. of Princeton, took a look at the p-c board manufacturing process and decided that a lot of money could be saved by eliminating several steps. Those steps are the preparation of a master sketch of the circuit by a draftsman—done several times actual size to reduce drafting errors—and the photographic reduction of that sketch to the correct size. They're eliminated by a new instrument called the Tecan Master Scriber, a two-axis manually operated tool that cuts the mask rapidly and conveniently. It enables the engineer to go directly to a final mask from a rough sketch.

No talk. The scriber not only saves time, money, and materials but also does away with the need for the engineer and draftsman to talk over the drawing; this too often results in errors being drawn into the master. Finally, says Techne, the instrument relegates the following problems to the junk heap of bad memories:

- Photographic errors in the reduction process, such as scaling mistakes and improper registration between two sides of a board
- The very high cost of photo equipment
- Considerable delay in incorporating modifications or correcting errors

On the positive side, says Patrick H. Summers, sales manager, the Master Scriber is simple to operate; a relatively complicated board can be prepared in about an

THE *TROPEL* MODEL 330 LIGHT DETECTOR

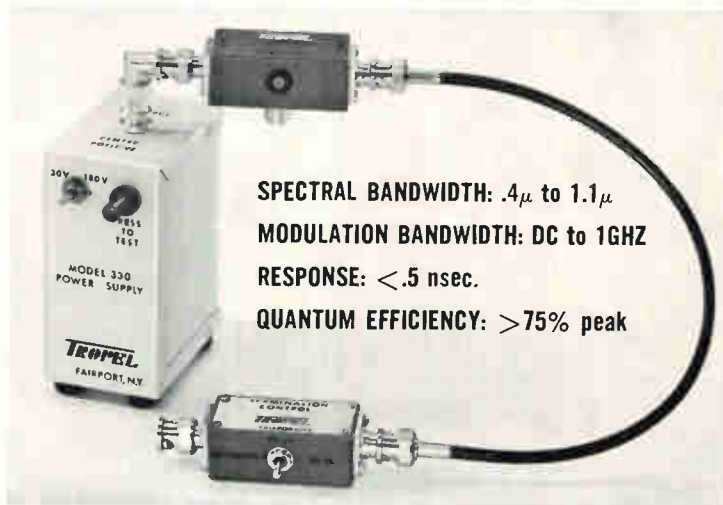

SPECTRAL BANDWIDTH: $.4\mu$ to 1.1μ
MODULATION BANDWIDTH: DC to 1GHZ
RESPONSE: $<.5$ nsec.
QUANTUM EFFICIENCY: $>75\%$ peak

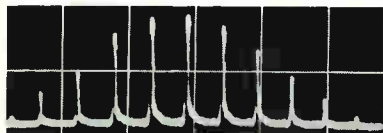

Output from a Q-switched mode-locked Nd: Glass Laser (1.06μ)
Vert: 10V/cm.
Horiz: 20 nsec./cm.
Scope: Tektronix Model 519

Note ability of Detector to provide unsaturated output in excess of 10 volts (into 125Ω) while at the same time resolving subnanosecond pulse widths.

Output from a Mode-Locked He-Ne Gas Laser
Vert: 50mV/cm.
Horiz: 0.5 nsec./cm.
Scope: Tektronix Type 1S1 Sampling Unit

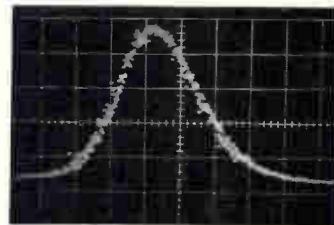

The TropeL Model 330 Light Detector consists of three sub-assemblies: Power Supply, Detector Head, and Termination Box. These units may be used with direct connections via BNC connectors or may be located remotely from one another. Cables and other accessories are supplied along with a photograph indicating performance of the individual unit.

POWER SUPPLY: 2 year life with press to test battery indicator and 3 position switch.

DETECTOR HEAD: Has convenient $\frac{1}{4}$ -20 receptacle at right angle to photo-diode. BNC plug-jack receptacles on both ends of case.

TERMINATION CONTROL: Output designed for connection directly to scope's vertical amplifier. 3 position switch offers terminations of 50Ω , $5K\Omega$ or 0.01 sec. (integrating termination).

PRICE: complete with power supply, detector, termination control, BNC Cable, right angle BNC adaptor and post mount.

F.O.B. Fairport, N.Y.
Price subject to change without notice.

\$289.00

For further information contact

TROPEL, inc.

Designers and Manufacturers of Precision Optical Systems and Instruments

52 WEST AVENUE • FAIRPORT, N. Y. 14450

PHONE: (716) 377-3200

The **FM-2400C** provides an accurate standard frequency signal for testing and adjustment of mobile transmitters and receivers at predetermined frequencies between 25 and 500 MHz. Up to 24 crystals may be inserted into the meter. The frequencies can be those of the radio frequency channels of operation, and/or of the intermediate frequencies of the receivers between 5 MHz and 40 MHz. Frequency stability (standard) $\pm .001\%$ from 32° to 122°F . Frequency stability with built-in thermometer, calibrated crystals and temperature corrected charts, $.00025\%$ from

+ 25°F to + 125°F . (.000125% special 450 MHz crystals available)

FM 2400C
(Meter Only).....\$445.00

RF Crystals
Hi Band.....\$24.00 ea.
Lo Band..... 15.00 ea.

IF Crystals..... 8.00 ea.

Write for free catalog.

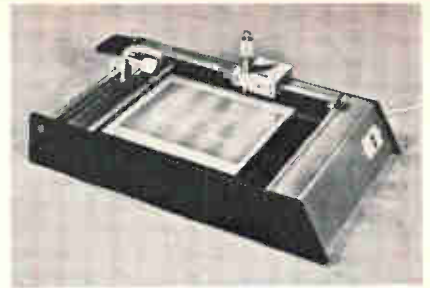

Push, pull. Scriber eliminates photographic reduction step in fabrication of printed-circuit boards.

hour. And a design engineer can operate the device without training, preparing a final master that meets his standards. Moreover, the actual-size preparation has an accuracy of ± 0.005 inch. This means that high line densities—0.015-inch wide at 0.025-inch centers—with accompanying layout flexibility, can be obtained.

The cost of the Scriber—\$675—is less than that of an electronic multimeter, says Summers; firms relying on outside contractors to prepare p-c masters could recover the initial cost of the machine after making three masters.

What is it? The Master Scriber has a heavy duralumin base supporting a plate glass table illuminated by four fluorescent lamps. A stainless steel shaft attached across one end carries a sliding block, giving movement along the y axis, to which is fixed a hardened steel bar. A second block slides along this bar, giving movement along the x axis and carrying the interchangeable tools.

The master is prepared by removing portions of the top layer of a dual-layer scribing film with a tungsten carbide tool bit. The top layer of the film is opaque red; the base layer is transparent and dimensionally stable.

To make the board, a piece of copper-clad laminate is coated with photoresist. The board is then placed in an exposure frame beneath the master; the red film must touch the photoresist layer. After ultraviolet exposure, the board is immersed in developer. Unexposed areas are then washed away, leaving the board ready for etching. The resist is then removed and the board lacquered.

Techne Inc., 661 Brunswick Pike, Princeton, N.J. 08540 [390]



Now With Solid State Circuitry & Rechargeable Batteries

IGM FM-2400C frequency meter...

- Completely Portable
- Tests Predetermined Frequencies 25 MHz - 500 MHz

You don't need a degree to test op amps.

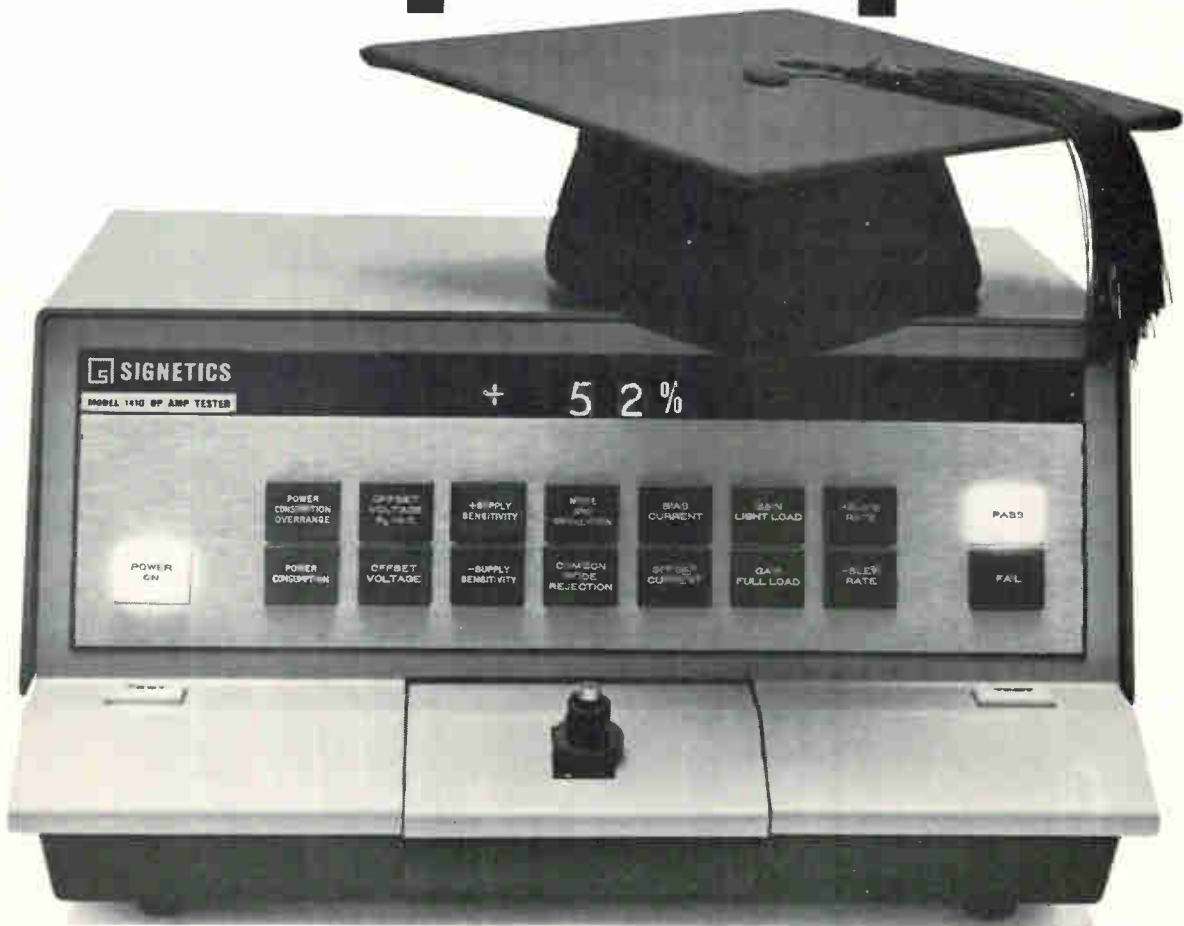

Signetics' new Model 1410 is the most comprehensive, definitive, easy-to-use op amp tester on the market. And we can prove it.

Rather than shout about its many features, let us just tell you how it works and what it does:

First, you simply insert a program board (manufacturer's spec or your own) for the op amp to be tested. Plug in the device. All operations are now performed by pushing illuminated test buttons. Push the top left button and the lights immediately indicate what tests will be performed. Next, push the "Test" button. If all tests are passed all button lights go out and the "PASS" indicator lights up. If any test is failed, the button corresponding to that test stays lit and the fail light comes on.

Now, if you want to know to what degree a given parameter passed or failed its test, just push the button corresponding to that specific test. The

answer is read out immediately as a percentage of the specified test limit.

We call this real "decision language."

There are fourteen tests: power consumption overrange (greater than 200%), power consumption (less than 200%), offset voltage (source resistance zero ohms), offset voltage (source resistance programmed), + supply sensitivity, - supply sensitivity, common mode rejection, bias current, offset current, gain (programmed light load), gain (programmed heavy load), noise and oscillation. And for the first time there are tests you won't find on testers selling for ten times our price: + slew rate, - slew rate.

The Model 1410 has no knobs to turn or meters to interpret. Your secretary could learn to use it in about one minute. Optional input/output boards allow you print-out or data log complete

parameter measurement.

And there's more. But suffice it to say for now that we believe the 1410 represents a major breakthrough in linear testing. Many who have wanted to test op amps can now afford to do so because the 1410 makes op amp testing practical and cost-efficient.

We know that there are some prospects out there who could profit by paying eighty or ninety thousand for this tester.

We're happy to say that the price will not be more than a tenth of that. Plus tax.

See us at IEEE, booth number 3A01 to 3A04.

SIGNETICS CORPORATION
MEASUREMENT/DATA
A subsidiary of Corning Glass Works

For detailed information or a demonstration write Signetics, Measurement/Data, 811 E. Arques Ave., Sunnyvale, Calif. 94086, or contact one of the following:

AUTHORIZED SIGNETICS REPRESENTATIVES (Measurement/Data) **Alabama** and **Tennessee** Col-Ins.-Co., Inc., Huntsville (205) 539-1771 **California** L and M Engineering, Inc., Inglewood (213) 678-5409; Santa Clara (408) 243-6661 **Connecticut** Ditech Associates, Inc., New Haven (203) 624-7291 **District of Columbia** (see Silver Spring, Maryland) **Florida** Col-Ins.-Co., Inc., Orlando (305) 423-7615 **Georgia** Col-Ins.-Co., Inc., Marietta (404) 422-8327 **Illinois** Carter Electronics, Inc., Chicago (312) 776-1601 **Indiana** Carter Electronics, Inc., Indianapolis (317) 293-0696 **Maryland** QED Electronics, Inc., Silver Spring (301) 598-8134 **Massachusetts** Ditech Associates, Inc., Newtonville (617) 969-9710 **Minnesota** Carter Electronics, Inc., Minneapolis (612) 869-3261 **Mississippi/Louisiana** Col-Ins.-Co., Inc., St. Louis (504) 833-1116 **New Jersey** QED Electronics, Inc., Camden (215) 925-8711 **New York** QED Electronics, Inc., Mt. Vernon (914) 664-2080 **J. A. Reagan Co., Inc.**, Albany (518) 489-4777; Binghamton (607) 723-9661; Newburgh (914) 561-4510; Syracuse (315) 471-7274; Utica (315) 732-3775; Rochester (716) 473-2115 **North Carolina** Col-Ins.-Co., Inc., Winston-Salem (919) 765-3650 **Ohio** WKM Associates, Inc., Cleveland (216) 895-5616; Dayton (513) 434-7500 **Pennsylvania** WKM Associates, Inc., Pittsburgh (412) 892-2953 **Michigan** WKM Associates, Inc., Detroit (313) 892-2500

Autonetics plays a vital role in three of the nation's most important defense programs. Here are two of them.

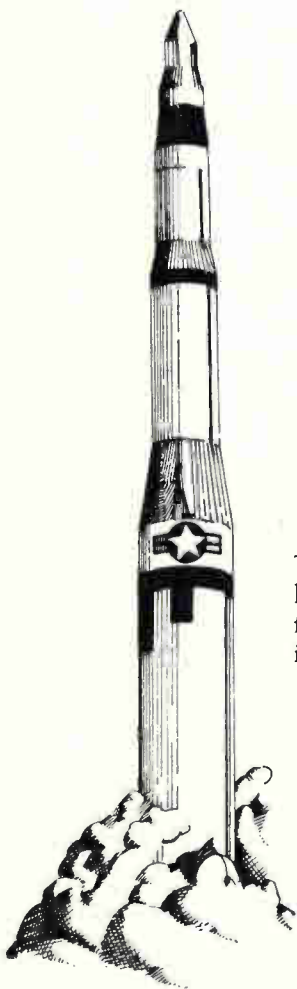

Take the advanced avionics systems we developed for the F-111D and FB-111A aircraft. They're acknowledged to be the most advanced airborne systems around. They give F-111 crews electronic tools never before available to pilots. Yet, with no sacrifice in performance, they fulfill all of the less spectacular (but equally important) requirements established jointly with the Air Force. Major sub-systems are made up of plug-in modules for uncomplicated field replacement. Computer capacity reserve is uncommitted so that future requirements can be accommodated without major retrofiting. There's even an onboard recorder that "remembers" any system malfunction for later use by ground crews. This is a lot of system.



The guidance systems we designed for Minuteman II and III had a tough act to follow. Minuteman I. It's our country's first major weapon system to use microelectronics. Therefore, it weighs less, uses less space but it's more accurate. It has enough additional computer capacity to perform most of its own check-out, simplifying silo test stand requirements. And, it's one of the most reliable weapon systems ever produced. Autonetics is the Air Force's associate prime contractor for guidance and controls. The third?

It's Ships Inertial Navigation System (SINS)—for the Navy's Polaris-Poseidon program—more about this later. For more information write: Autonetics, 3370 Miraloma Avenue, Anaheim, California 92803.



Autonetics

Division of North American Rockwell

Three-barrier Schottky diode reaches S band

Lower capacitance results in high speed over wide dynamic range; design advances seen expanding applications outside microwave field

The job list for a Schottky diode has usually been limited to low-voltage assignments in mixers and video detectors.

A group of three-barrier Schottky diodes in production at Microwave Associates (West) may change this. The diodes, in four models, have a capacitance of only 1 picofarad. The resulting high-frequency—or high-speed switching—operations

are seen by designers as a first step toward broadened applications: "High-voltage switching jobs in d-c to d-c converters, for example," says Jan Black, product sales manager at the West Coast company. "In addition, since they have high voltage-breakdown ratings they can better withstand transient r-f energy." These diodes, and others on the drawing board, can take

large voltage swings and are expected to be used in microwave modulators, phase detectors, pulse shapers, and sampling gates.

Quick as a wink. The diodes operate up to 4 gigahertz and at switching speeds that Black claims are "too fast to be measured." They are about three times as expensive as earlier devices. A year ago, Hewlett-Packard Associates announced



Waveguide switches series 77 are driven by a 28 v d-c solenoid actuator and held in place by a holding circuit. They cover the frequency range of 2.6 to 40 Ghz. Units are available in four port, E or H plane versions, with both interlock circuiting and fail-safe return mechanism. Prices range from \$365 to \$995. Waveline Inc., P.O. Box 718, West Caldwell, N.J. [401]



Solid state voltage controlled oscillators series FS-18 are available in C and X band with two options. The standard FS-18 will cover any selected 500 Mhz band within 4.8 to 11 Ghz with power output of 5 to 25 mw. The FS-18 W has an 1,100 Mhz bandwidth capability within 8.5 to 11 Ghz with power output of 1 to 5 mw. Frequency Sources Inc., N. Chelmsford, Mass. [402]

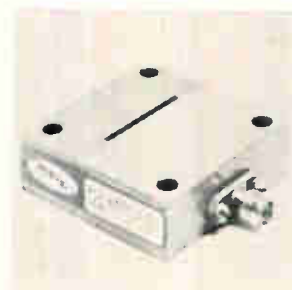

C-w microwave power sources AV01658, utilizing avalanche diodes for direct conversion of d-c power to r-f power, are useful for paramps. Frequency range is 8.2 to 12.4 Ghz. C-w/r-f power is 10 mw minimum at 25°C. Operating temperature range is -25°C to +50°C. Typical d-c voltage is 50 to 100 v; current, 10 to 30 ma. American Electronic Laboratories Inc., Colmar, Pa. [403]



Tunable transmission reference cavity 40A141700 covers 5.925 to 6.425 Ghz with a stability of ±250 khz over a temperature range of -15°C to +65°C and stability of ±0.0005%. Insertion loss is 2.0 db max. Nonoperating environmental conditions include 20G shock and 10 to 55 hz vibration at 10 G acceleration. Frequency Engineering Laboratories, Box 527, Farmingdale, N.J. [404]



Six-section gang-tuned filter model G642 has a maximal flat response and is tunable from 3.7 to 4.2 Ghz. Rejection is 40 db minimum at a resonant frequency of ±70 Mhz, 60 db minimum at a resonant frequency of ±120 Mhz. Insertion loss is 0.6 db max. Maximum vswr over a resonant frequency of ±18 Mhz is 1.4:1. Gombos Microwave Inc., Webro Road, Clifton, N.J. [405]

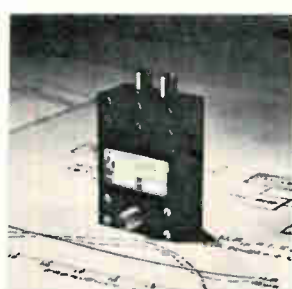

Ku-band coaxial balanced mixers feature Schottky diodes. Frequency range is 12 to 18 Ghz. Over this range, noise figure is 10.5 db maximum, vswr is 2.0 maximum, and isolation is 6 db minimum. Moderate i-f bandwidths can be provided up to 120 Mhz. The mixers, models 22663 and 22661, are suited for ECM receivers. Sage Laboratories Inc., Natick, Mass. 01760 [406]



Miniature coaxial switch features high isolation over its entire zero to 12.4 Ghz operating range. The spdt units provide 60 db minimum of isolation at 12.4 Ghz. Vswr at this frequency is 1.5 and insertion loss is 0.5 db maximum. Units are rated at 50 w of r-f power with an operating time of 15 msec. Amphenol RF Division, Bunker-Ramo Corp., E. Franklin St., Danbury, Conn. [407]



Coaxial switch model M405 covers 1 to 18 Ghz with over 40-db isolation above 8 Ghz, 0.5 to 2.5 db insertion loss, and 2 w c-w and 100 w peak power. Applications include: general-purpose 50-nsec laboratory switch, pulse modulator and shaper, amplitude modulator, limiter, automatic gain and level control. Somerset Radiation Laboratory Inc., 2060 N. 14th St., Arlington, Va. [408]

New!
14-bit
D-to-A Converter
<2 μ sec
conversion time



4.85" x 4.85" x 1"

MODEL DAC-14T: a high speed, high resolution, 14-bit, integrated circuit Digital-to-Analog Converter with a 0.006% accuracy. It features a unique controlled transition output which insures that the output signal changes with negligible pre-shoot and overshoot monotonically from one value to another.

Applications include precision scope displays such as information displays or signal recognition and analysis. Also applicable for integrated circuit testing requiring low transient errors proportional to signal magnitude. High speed of settling time is compatible with high speed testing where computer control and evaluation is employed.

Essentially a miniaturized programmable power supply, DAC-14T may be placed in close proximity to the device being excited — a necessity if high precision and high resolution are to be maintained.

All elements, including reference supply, switches, network, storage registers, output amplifier, gain and offset adjustment, are packaged within a single printed circuit card plug-in.

Write or call for prices and complete specifications.

PASTORIZA
 ELECTRONICS, INC.
 385 Elliot St., Newton, Mass. 02164 • 617-332-2131

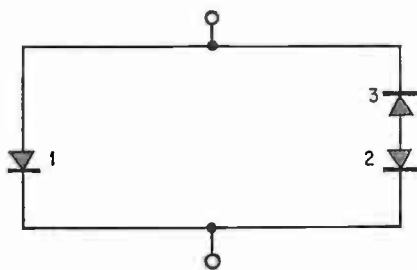
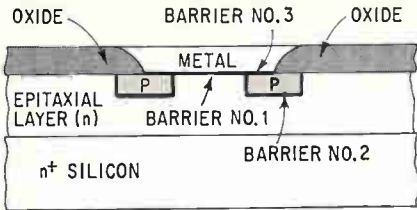

One more. The 3d barrier is in series with the 2d, but opposite in direction.

a line of three-barrier Schottky diodes which sold for under a dollar and had a breakdown voltage of 70 volts. Their operation was limited, however, to 500 megahertz.

The planar technique that originally permitted passivation of high-voltage Schottky diodes also introduced, in parallel with the Schottky barrier, a second barrier. This p-n junction—between the diffused p-type guard ring and the n-type epitaxial layer—will store charge. A further modification of the passivation process—accomplished at several laboratories—created the third barrier.

The new series from Microwave Associates has the same topography as the H-P line. However, the devices are physically smaller, have less capacitance, and operate up to 4 gigahertz. Instead of the normal ohmic contact between the metal and the p region, they have a metal-to-p barrier which contributes to high-speed operation at high frequencies.

The triple-barrier diodes are the first product of Microwave Associates' new semiconductor facility in the former Huggins Laboratory building in Sunnyvale, Calif. Mason A. Clark, a former director of device development at H-P, is vice president for semiconductor operations.

Tight tolerance. Standard semiconductor processes are used to make the diodes, Clark says; but tolerances are extremely tight (one micron resolution), and as a result some diffusion and evaporation processes have been modified.

Fabricating a barrier against ohmic contact was one difficulty. The solution required changes in the process for diffusing the p region, in the surface preparation before metalization, and in the metalization step itself.

There are four devices in the series, two operating at 30 volts minimum breakdown and two at 20 volts. Breakdown voltage can be increased by growing a thicker epitaxial layer, Clark says; but this step also increases series resistance. If one attempts to overcome the high resistance by making the device larger, capacitance increases and frequency decreases.

The Microwave Associates' diodes are about one mil in diameter. The p-guard ring is 0.1 mil wide, and about 0.5 micron deep. On the surface, the silicon dioxide is 0.5 micron and the molybdenum metalization 0.2 micron. The devices are available in an axial-lead glass package; contact is made through a ribbon lead bonded to a gold button on top of the metal. They are also available in ceramic packages and in chip form.

Microwave Associates (West) 999 East Arques Ave., Sunnyvale, Calif. 94086 [409]

New microwave

Varian doubles its impatts' power

X-band diode oscillator delivers 500 milliwatts, K-band units reach 300

Hunger for power is spurring the development of new impatts, with the latest entries in the competition coming from Varian Associates. The company's solid state products operation is offering three new silicon diode oscillators that provide at least twice the power of the firm's former first-line products [*Electronics*, Feb. 5, 1968, p. 165].

The most powerful of the three, the VSX-9504B, typically delivers 500 milliwatts or more and pro-

When it comes to big plans...



Colorado is choice country for a growing boy.... or a growing business

Little boys have big dreams. So do growing businesses. One of the things it takes to make those dreams come true is know-how.

Colorado scores high in that area. That's because the State's schools are among the most outstanding in the country, from the primary grades to the PhD level. And over one quarter of Colorado's annual budget goes toward making them even better. The State ranks second in the nation for per capita spending for education. What's more, local school districts make every effort to maintain high educational standards.

Coloradoans believe in education. In the 25 and older age group 10.7% of the State's residents have 4 years

of college... the highest percentage in the nation. The State's colleges and universities offer a wide choice of advanced courses in a vast number of fields. And 90,000 Coloradoans take advantage of adult education programs every year.

If you'd like to learn more about a state that emphasizes educational excellence from grade school to grad school, we'll send you a complimentary copy of our 66 page "Industrial Colorado." Address inquiries to William C. Hacker, Director of Industrial Research & Development, State of Colorado Division of Commerce and Development, 1045 State Capitol Annex, Denver, Colorado 80203.

Make Industrial Colorado Your Choice

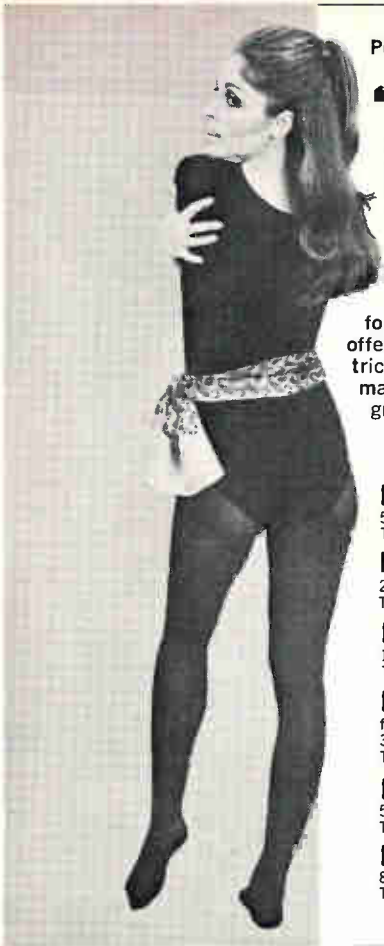

Pert Mag, the PERMAG girl, says:

“Handling is chore-less with Magnets!”

And Permag has just the right magnet for your material handling problem. Permag offers permanent magnets, assemblies, electrical alloys, flexible magnets, soft magnetic materials and ferrites. Also, special precision grinding and cutting. And full magnetizing and engineering facilities.

PERMAG PACIFIC CORP.

5441 WEST 104th ST., LOS ANGELES, CALIFORNIA 90045
Telephone Area Code (213) 776-5656 TWX |910| 328-6547

PERMAG SOUTHWEST CORP.

2720 TAYLOR STREET, DALLAS, TEXAS 75226
Telephone Area Code (214) 748-6909

PERMAG CENTRAL CORP.

1213 ESTES AVE., ELK GROVE VILLAGE, ILL. 60007
Telephone Area Code (312) 956-1140

PERMAG MAGNETICS CORP.

formerly EMPIRE MAGNETICS
3130 SOUTH AVENUE, TOLEDO, OHIO 43609
Telephone Area Code (419) 385-4621

PERMAG NORTHEAST CORP.

50 THAYER ROAD, WALTHAM, MASSACHUSETTS 02154
Telephone Area Code (617) 484-0550

PERMAG CORP.

88-06 VAN WYCK EXPRESSWAY, JAMAICA, N.Y. 11418
Telephone Area Code (212) 657-1818 TWX |710| 582-2952

Circle 160 on reader service card

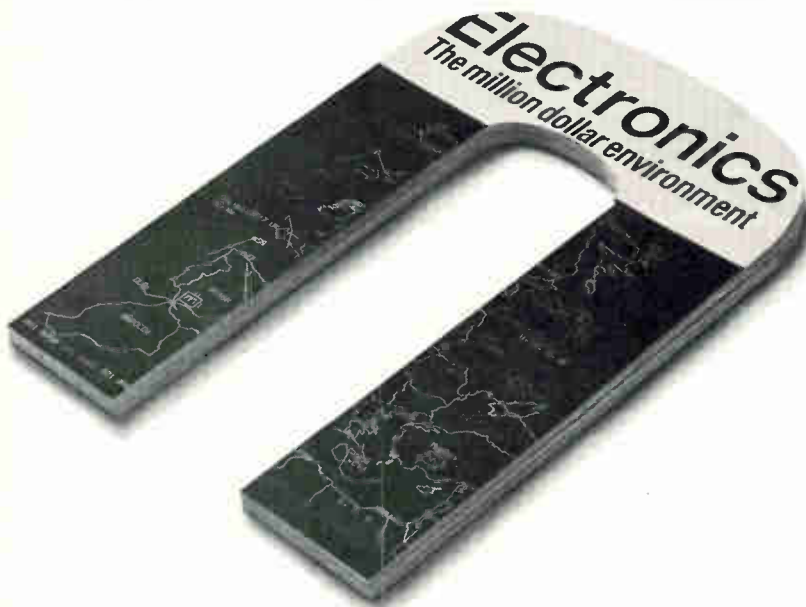

Every year, ELECTRONICS attracts requests for over 125,000 editorial reprints.

They're like interest payments on our million-dollars-a-year editorial principle.

That's how much we spend annu-

ally to produce timely, authentic, and useful articles like those listed on the reader service card as reprints currently available.

Investment and interest make both ELECTRONICS and its readers more meaningful to its advertisers.

... avionics markets opening for impatts ...

duces at least 400 mw. Its waveguide mount allows 100 megahertz of mechanical tunability within the diode's upper X-band range of 10 to 12.4 gigahertz.

The other two units operate in K band. The VSU-9505B spans 12.4 to 15 gigahertz and typically generates some 250 to 300 mw or a minimum of 200 mw. It's also mechanically tunable over a 100-Mhz range, as is its higher-frequency companion, the VSU-9505A. This Ku-band device covers 12.4 to 17.5 gigahertz with a 150-mw typical output and a 100-mw minimum.

Three-way stretch. All three units owe their improved performance less to a dramatic breakthrough in technique than to evolutionary advances in design and manufacture, according to Eric Van Der Kaay, manager of applications engineering at the Varian operation. The company, he explains, has made the most of a three-way trade-off in diffusion, playing off diffusion depth, junction abruptness, and epitaxial-layer thickness against one another to boost efficiency and power output.

Varian is silent about the results of its tradeoffs, but the efficiency of the VSX-9504B is listed as 4% to 6%, with 5% to 9% no rarity. A year ago, the company's impatts (and those of other firms too) had to strain for 4% maximum efficiencies and even then could squeeze out only half as much power as these latest devices.

Varian is considering avionics markets for its new impatts. The devices are qualified for airborne use under military environmental standard MIL-E-5400, class I, according to Van Der Kaay. He says they operate over a -54 to $+71^{\circ}\text{C}$ temperature range and easily meet the spec's requirements for resistance to shock and vibration.

Prices aren't fixed because the company expects to be selling the impatts as custom devices. A ballpark figure of \$1,000 is quoted. Delivery time is 45-60 days.

Varian Associates, Solid State Products Operation, Salem Road, Beverly, Mass. 01915 [410]

Now, METAL GLAZE resistors for MIL-R-10509

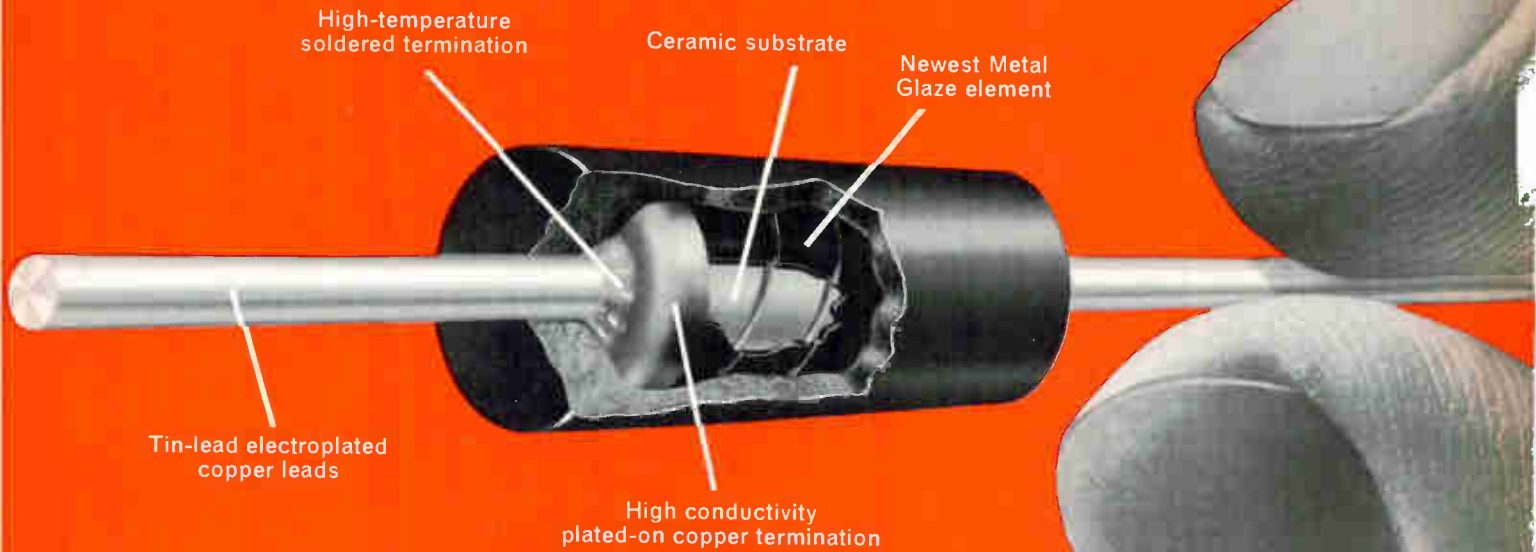

100ppm, 1% plus thick-film stability

IRC's newest Metal Glaze resistors offer the most economical approach to MIL-R-10509 requirements. They have precision performance, plus the added benefits of thick-film stability and reliability.

These resistors feature IRC's latest generation of Metal Glaze resistance material. This improved thick-film element provides the electrical stability and mechanical ruggedness that tin oxide types can't achieve. And, their tough molded bodies resist solvents and the pounding of automated inserting equipment.

Metal Glaze resistors have withstood over 15 million unit hours of testing. In addition to MIL-R-10509, they also meet or exceed MIL-R-22684 and MIL-R-39017. For complete data and prices see your IRC Qualified Industrial Distributor. Or, write IRC, 401 North Broad Street, Philadelphia, Pa. 19108.

CAPSULE SPECIFICATIONS

MIL STYLE	Type T-55	Type T-60
RESISTANCE	RN55	RN60
TOLERANCE	10 Ω thru 90K	10 Ω thru 200K
TEMP. COEFF.	$\pm 1\%$	$\pm 1\%$
POWER	$\pm 100\text{ppm}/^\circ\text{C}$	$\pm 100\text{ppm}/^\circ\text{C}$
	$\frac{1}{2}$ watt @ 70°C	$\frac{1}{2}$ watt @ 70°C
	$\frac{1}{2}$ watt @ 125°C	$\frac{1}{2}$ watt @ 125°C
	(derate to zero at 165°C, no load)	



DIVISION OF TRW INC.

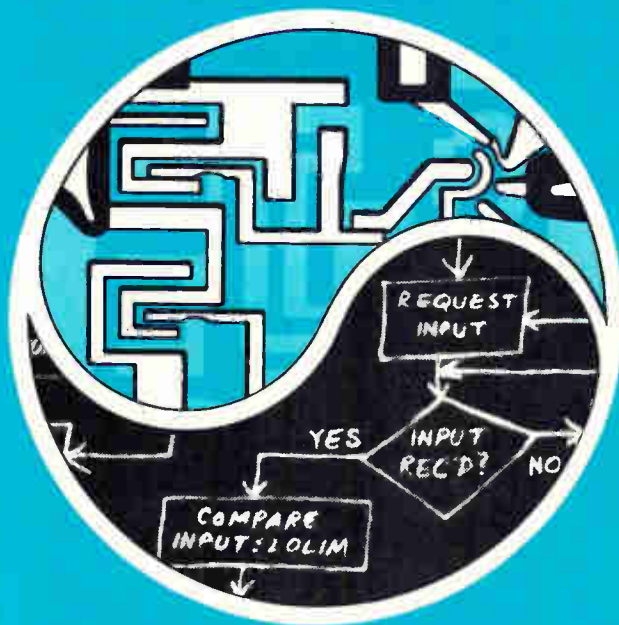

THE CHANGING INTERFACE

...an IC/Systems Seminar

March 28, 1969 - Park Sheraton, New York
 Conducted by the Electronics Management Center

The new generation of integrated circuits is producing a serious communications gap in electronics design. The complexities of LSI and its implications for systems design are shaking the traditional relationships between components suppliers and systems builders.

Engineers in every function from research and development to final packaging must come to grips with the continuing merger of circuit design and process technology.

Companies considering sweeping new product directions are aware that immediate steps must be taken to minimize risks.

At the CHANGING INTERFACE Seminar, the men who create, produce, market, and use components and systems will gather to examine the important questions together. Questions such as:

How can the systems design capabilities of the user be coupled more effectively with the supplier's device design know-how?

Circle 162 on reader service card

Is the emphasis shifting from circuitry to systems design?

How can design automation reduce the gap between systems and technology houses?

Will LSI become largely a custom market, or will standard off-the-shelf items be developed?

How will design changes be provided for?

What is the testing interface? Who is responsible, for how much?

The CHANGING INTERFACE Seminar has been scheduled on the day following the annual IEEE Convention to make efficient use of your time. Plan ahead. Make your trip to New York this March a little more productive. Registration fee \$65.00. Send your reservation request to:

THE ELECTRONICS MANAGEMENT CENTER
 330 West 42nd Street, New York, New York 10036
 An Information Service of McGraw-Hill, Inc.

Op amp betters price-performance ratio

Circuits of discrete device have been extensively designed to improve capabilities and reduce over-all costs

Most designers improve operational-amplifier performance by adding components. Analog Devices Inc. took the opposite approach with its model 119, eliminating a gain stage included in most previous op amps. At the same time, it has redesigned circuits to improve open-loop d-c gain, bandwidth, full power response, common-mode rejection,

input impedance, and overload recovery time.

The key to these improvements and to the elimination of the gain stage is the company's use of an active element—which the firm will not identify—to simulate a high input resistance and thus increase the input-stage transistor's collector impedance.

"The important thing about the

119 is its price-performance ratio," says Ray Stata, senior vice president at Analog Devices. "We've brought together things like a slewing rate of 6 volts per microsecond and a full power bandwidth of 100 kilohertz in a unit that sells for about \$23." Earlier op amps in the category from Analog Devices cost about \$50.

The company's principal consid-

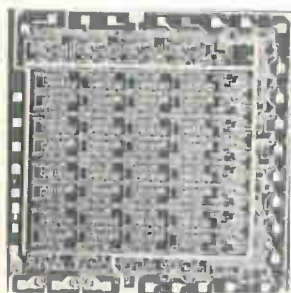

Random access read/write memory TT μ L9035 has a 285-gate complexity organized in a 16-word by 4-bit format. It features a read access time of 35 nsec and a 25 nsec write time. It is designed for scratch pad memories and other applications where rapid access temporary storage is desired. Fairchild Semiconductor, 313 Fairchild Dr., Mtn. View, Calif. 94040. [436]



Audio amplifier IC in a TO-78 package is applicable to any product or system requiring low distortion audio output power from milliwatts to the one-watt level. It is operable from a 6 to 20 v d-c supply, temperature compensated from 0° to +85°C, and has an input impedance of 400 kilohms. Trans-Tek Manufacturing Co., 4405 S. Clinton Ave., South Plainfield, N.J. 07080. [437]



Complementary npn and pnp transistors in both TO-5 and MD-14 packages are available at up to 800 v. Average beta of the NPN's is 15,000 at a collector-to-emitter voltage of 10 v and collector current of 20 ma. Average beta of the pnp's is 20,000 at a collector-to-emitter voltage of 10 v and collector current of 10 ma. Industro Transistor Corp., 35-10 36th Ave., L.I.C., N.Y. [438]

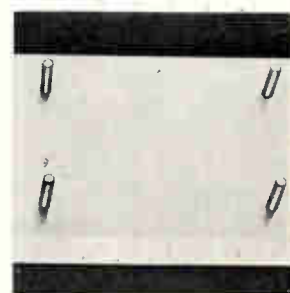

Seven power IC Darlington modules designated BHF0002-BHF0008 offer 25 w of dissipation and voltage ranges from 25 to 80 v. They combine power semiconductor and power IC technologies. Emitter-base breakdown voltage is 5 v. Output current is 10 amps. Gain at 5-amp output current is greater than or equal to 2,000. Bendix Semiconductor Div., Holmdel, N.J. [439]

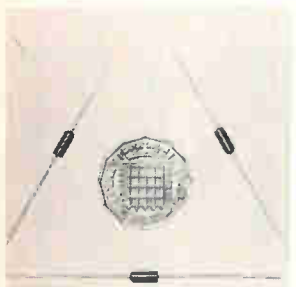

Zener diodes types BZX61 and BZX70 have power ratings of 1 and 2.5 w respectively, and voltage tolerances of $\pm 5\%$. The BZX61's are enclosed in a modified DO-7 plastic encapsulation, and are available with voltage ratings from 6.8 to 75 v. The BZX70's are wire-ended and enclosed in a plastic encapsulation, and cover 10 to 75 v. Mullard Ltd., London W.C.1. [440]



PNP epitaxial base chopper transistors series 2N2944, -5, and -6 feature breakdown voltage ranges up to 60 v, offset voltage as low as 200 μ v and typical beta of 50 to 250. Typical "on" resistance is 6 ohms. Units come in the TO-46 case. Typical uses include modulators, servos, telemetry systems and multiplexing. Solitron Devices Inc., Blue Heron Blvd., Riviera Beach, Fla. [441]

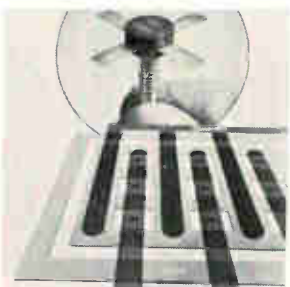

Emitter-grid transistors types A270 through A277 are available for supply voltages of either 12.5 or 28 v and are intended for use in commercial and military mobile and airborne transmitters operated at 175 Mhz. Power output ranges from 3 w to 22 w. Types A270 and 274 come in TO-39 cases; the other 6 in strip-line packages. Amperex Electronic Corp., Slatersville, R.I. [442]



Monolithic voltage regulator type MC1560 is designed to deliver load current up to 500 ma without use of an external power transistor. It has 0.002%/v typical regulation with changes in input voltage, and 20 milliohms output impedance for excellent load regulation. Power dissipation is 10 w max. at 65°C. Motorola Semiconductor Products Inc., Box 955, Phoenix 85001. [443]

EG&G SILICON DIFFUSED PHOTODIODE

- HIGH QUANTUM EFFICIENCY
- WIDE SPECTRAL RANGE • FAST RESPONSE TIME • LOW NOISE



SINGLE CELL



BI-CELL



QUAD-CELL

SGD-444 SERIES

The SGD-444 Series complements the versatile EG&G SGD-100A Photodiode. Improved diffused guard ring construction permits higher sensitivity, lower noise and faster response factors than ever before available in large (1 cm² active) area diodes.

Bi-cell and quadrature cell configurations with isolations of greater than 20 to 1 are standard. The photodiodes are oxide-passivated and hermetically sealed in a TO-36 package.

Sensitivity 0.5 μ A/ μ W @ 0.9 μ (70% Quantum Efficiency)
Spectral Range 0.35 to 1.13 μ
Leakage 0.5 μ A @ 100 volts
Rise Time 10 nanoseconds
NEP 1.0 x 10⁻¹² watts
Linearity of Response Over 7 decades

Applications include CW, pulsed light and laser detection and measurement, star tracking, optical navigation and guidance, and range-finding systems. The SGD-444 series is in quantity production for fast delivery at low price.

For information, write EG&G Inc., 166 Brookline Avenue, Boston, Massachusetts 02215. Or phone 617-267-9700. TWX: 617-262-9317. On West Coast, telephone 213-464-2800.



ELECTRONIC PRODUCTS DIVISION



Ready. Improved op amp with trimmed price challenges IC's for system jobs.

eration, of course, is competition. Says Stata: "We want to keep ahead of the integrated-circuit makers. To stay in the game, we have to increase our performance levels and create new markets."

The 119 is similar to the model 118 announced by the firm last August; the primary difference is that the 118 has an output current rating of 5 milliamps while the 119 is rated at 20 ma. Achieving this difference, according to the company, was not simply a matter of using bigger transistors in the output stage. The internal heating caused by the higher output current presented a major problem.

An op amp is only as useful as its d-c stability; the amplifier's accuracy depends on its ability to maintain zero output for zero input, and stable output at other fixed levels of input as temperature varies. The internal heat dissipation caused by the higher output current produces temperature gradients within the amplifier that complicate the stabilizing methods. And the temperature gradients vary with input drive voltage. A new signal level will change the output current, setting up a new pattern of temperature gradients and thus creating an output offset.

Compensation. This problem is solved in the 119 by a new dual transistor and a proprietary output configuration. The dual transistor—with two chips in a single can—provides straight-line warm-up characteristics and reduces the output signal drift.

The amplifier is available in two versions. The \$23 type, the 119A, has a drift of 25 microvolts per degree centigrade. The 119B, at \$32, has a drift of 5 μ V/°C.

Analog Devices Inc., 221 Fifth Street, Cambridge, Mass. 02142 [444]

STABILITY & QUALITY MATSUO

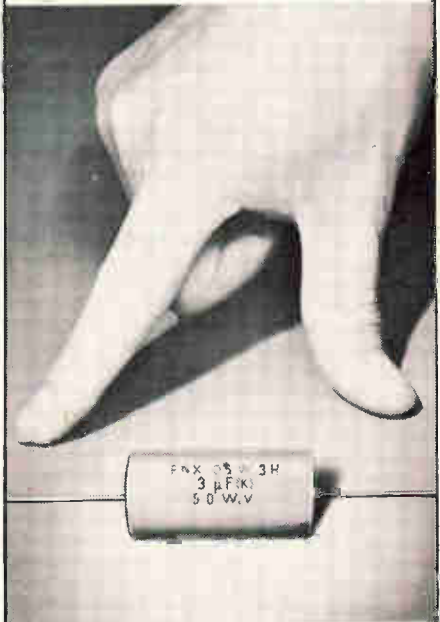

METALLIZED POLYESTER FILM CAPACITOR - "TYPE FNX-H"

Sub-miniature size and oval section ideal for space economy. Lightweight, self-healing and with high insulation resistance. Capacitance values up to 10 MFD. Outer wrap of tough polyester protects against moisture. Perfect in both transistorized and low voltage tube circuits and others where size and cost are paramount.

Specifications:

Operating Temperature Range: -40°C to +85°C
Standard Voltage Rating: 100V, 200V, 400V, 600V
Standard Capacitance Value: .1 MFD to 10 MFD.
Standard Capacitance Tolerance: \pm 20% (available \pm 10%)

MATSUO'S Other Capacitors Include:
Solid Tantalum Capacitors: MICROCAP

for hybrid ICs, Type TAX hermetically sealed in metallic case, Type TSX encased in metallic case and sealed with epoxy resin, Type TSL encased in metallic case and sealed with epoxy resin
Polyester Film Capacitors: Type MFL epoxy dipped, Type MFK epoxy dipped non inductive, Type MXT encased in plastic tube non inductive.

For further information, please write to:

MATSUO ELECTRIC CO., LTD.

Head Office: 3-5, 3-chome, Sennari-cho, Toyonaka-shi, Osaka, Japan

Cable: "NCCMATSUO" OSAKA Telex: 523-4164 USA

Tokyo Office: 7, 3-chome, Nishi-Gotanda, Shinagawa-ku, Tokyo

**Faster, easier
set-ups with**



**advanced "AGREE"
chambers**

Tenney's "AGREE" Chambers have always offered the utmost in performance to meet and exceed all test levels of MIL-Std-781A. Now you also get the utmost in operator convenience. Tenney's exclusive "Redi-Seal" (patent applied for) provides a soft cushion of foam to seal between the chamber and L.A.B. or comparable vibration testing machines. No more cumbersome diaphragms...no removable chamber sections...just roll the table in place. Save set-up time. Fully automatic operation of chamber, vibrator, and test item. Make it easy for yourself. For complete information on the latest in "AGREE" testing, write or call



Tenney
ENGINEERING, INC.

1090 Springfield Rd., Union, N. J. 07083 • (201) 686-7870
Western Div.: 15721 Texaco St., Paramount, Calif. 90723

487

Circle 191 on reader service card

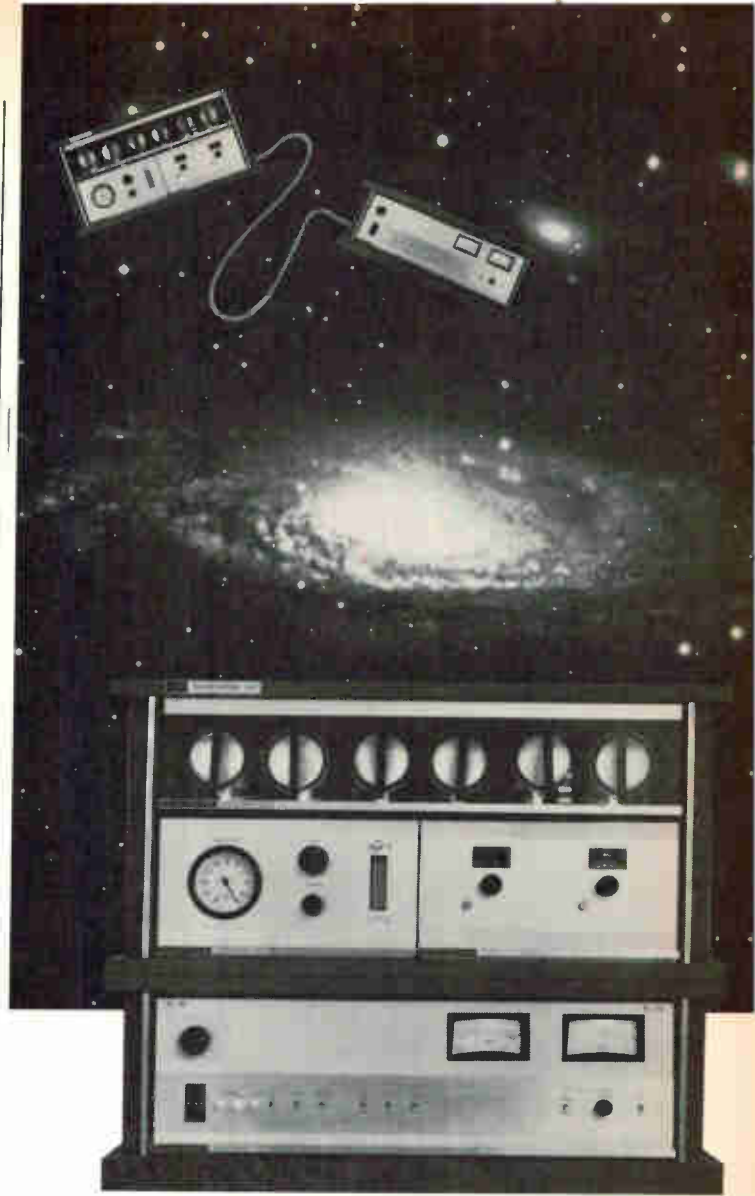

**New...Cool,
Plasma Wafer Stripping**

IPC Plasma Machine removes photoresists and organics at a rate exceeding 100 wafers every 5 minutes at low temperature. The machine develops a plasma (dry medium), which performs in a chemical (oxidation) and mechanical (radio-frequency sputtering) mode. Ultra reliable electronic components assure 24-hour dependability.

Optional Pyrex or quartz reactors, six 3" I.D.x6" long, or a single 3" I.D. by 40" long, permit unimpeded visual monitoring. Use of quartz eliminates any question of boron or sodium contamination. Removal is thorough, with residues loosened by high-powered ion bombardment and removed by a vacuum system. Conservatively rated at 1000 Watts, the machine has a variable capacity to suit your particular application or load factor.

Modular design permits separation of control and treatment consoles, or stacking in any required combination of the modules.

The plasma machine can be used for silicon oxide and nitride growth and can do plastic and mineral surface rearrangements. Dynamic plasma. To know more about this versatile, safe, easily operated machine, write to Monte Toole



Associates, 25222 Cypress Ave., Hayward, California 94544 or phone (415) 783-2067.

International Plasma Corporation

PATENTS PENDING

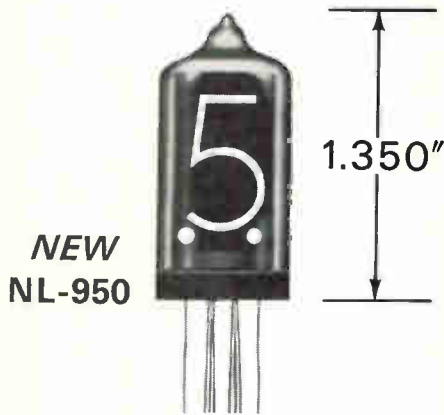

**NEW
NL-950**

**NATIONAL® shortened
the NL-5750 to save space**

- maximum overall height 1.350"
- made in Geneva, Illinois U.S.A.
- \$3.95 in 1000 quantity

NATIONAL
ELECTRONICS, INC.

a varian subsidiary

PHONE: (312) 232-4300 • GENEVA, ILLINOIS 60134

Circle 192 on reader service card

Circle 165 on reader service card

165

The Complete Line of Fuseholders For All Applications

Panel mounted, in-the-line, lamp indication, signal-activating, visual indicating . . . with solder terminals, quick connect terminals. Also holders to meet Military Specifications under MIL-F-19207B.



HMR RF shielded holder for 1/4 x 1 1/4 in. fuses.



HPC Panel mounted holder for 13/32 x 1 1/2 in. fuses. Rated 30 amperes for any voltage up to 600.



HKP panel mounted holder for 1/4 x 1 1/4 in. fuses.

HKA lamp-indicating, signal activating holder.

Write for BUSS Form SFB



BUSSMANN MFG. DIVISION, McGraw-Edison Co. St. Louis, Mo. 63107
Circle 193 on reader service card

The Complete Line of Signal-Indicating Alarm-Activating Fuses

For use on computers, microwave units, communication equipment, all electronic circuitry.



BUSS GLD-1/4 x 1 1/4 in. Visual-Indicating, Alarm-Activating.



BUSS Grasshopper Fuse, Visual-Indicating, Alarm-Activating.

BUSS GBA-1/4 x 1 1/4 in. Visual-Indicating.



BUSS MIC-13/32 x 1 1/2 in. Visual-Indicating, Alarm-Activating.



BUSS ACH Aircraft Limiter, Visual-Indicating.

BUSS MIN-13/32 x 1 1/2 in. Visual-Indicating.



FNA FUSETRON Fuse 13/32 x 1 1/2 in. slow-blowing, Visual-Indicating, Alarm-Activating. (Also useful for small motors, solenoids, transformers in machine tool industry.)



BUSS GMT and HLT holder, Visual-Indicating, Alarm-Activating.

Write for BUSS Form SFB



BUSSMANN MFG. DIVISION, McGraw-Edison Co. St. Louis, Mo. 63107
Circle 193 on reader service card

BUSS: The Complete Line of Fuses and . . .

Let's keep electronics clean

Here are some of the products that help keep electronic devices clean during production and in use. You'll find them on assembly lines and flight lines, in laboratories and on launch pads . . . wherever dirt, grease or foreign matter could degrade the quality or performance of electronic hardware.

If you'll tell us (on your letterhead) which of them you'd like to evaluate, we'll send you a free sample. For literature only, use the bingo card.

ms miller-stephenson chemical co., inc.
Route 7, Danbury, Conn.



Circle 166 on reader service card

New Books

Reliable guide

Probabilistic Reliability,
an Engineering Approach
Martin L. Shooman
McGraw-Hill Book Co.,
525 pp., \$16.50

If he was basically aiming to produce a textbook on this subject, Prof. Shooman has certainly exceeded his goal. In fact, he has provided the first treatment of reliability that can be read and understood by neophytes in the field.

Until now, reliability experts have been "numbers magicians" in the eyes of most design engineers, performing their mystical art behind a cloud of statistics that everyone suspects can be manipulated at will. The result: many electronics engineers have felt the reliability experts could use their statistics to convince customers of the worth of just about any new circuit. And this assumption has gen-

erally served to slow progress towards truly reliable equipment.

Shooman rightly emphasizes that reliability should be designed into new equipment. But this requires that the designer work closely with the reliability people and that he be relatively well-versed in reliability concepts himself. Shooman's eminently readable book can provide that needed grounding. The author has anticipated readers' questions and his book clarifies difficult points as they arise.

Reliability is bound up with mathematical probability and statistics, and more than 100 pages of the book are devoted to mathematical background. This excellently done section prepares the reader for the material to come. Subsequent topics include combinatorial reliability and such applications and extensions of this theory as catastrophic failure models and system reliability. Designers

will also benefit from the discussions of reliability improvement—including the uses of redundancy—and of such analytical tools as drift failures, component tolerances, and parameter variations.

However, the final chapter, covering reliability physics models and statistical parameter estimation, will be of more interest to the man who intends to pursue a career in reliability than to the working design engineer.

Joseph T. Finnell Jr.

Avco Corp.
Wilmington, Mass.

Recently published

Introduction to Switching Theory and Logical Design, Frederick J. Hill and Gerald R. Peterson, John Wiley & Sons Inc., 449 pp., \$14.50

Balances mathematical theory with practical design considerations and contains advanced material to facilitate graduate-level work. Heavy emphasis on sequential circuit design; one chapter on threshold logic.

Fuseholders of Unquestioned High Quality

THE COMPLETE LINE OF *Small Dimension* FUSES

For The Protection of All Types of Electronic and Electrical Circuits and Devices . . .

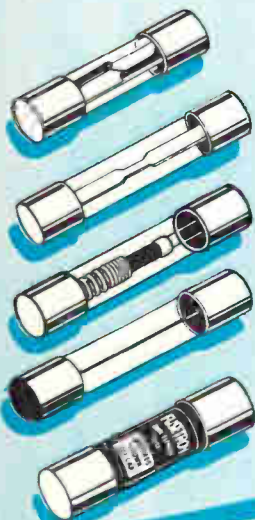

. . . includes dual-element "slow-blowing", single-element "quick-acting" and signal or visual indicating types . . . in sizes from 1/500 amp. up.

For special fuses, clips, blocks or holders, our staff of fuse engineers is at your service to help in selecting or designing the fuse or fuse mounting best suited to your requirements.

Write for BUSS Form SFB

INSIST ON

BUSS QUALITY

FUSES

BUSSMANN MFG. DIVISION, McGraw-Edison Co. St. Louis, Mo. 63107
Circle 167 on reader service card

SUB-MINIATURE FUSES

Ideal for space tight applications, light weight, vibration and shock resistant. For use as part of miniaturized integrated circuit, large multi-circuit electronic systems, computers, printed circuit boards, all electronic circuitry.



TRON Sub-miniature Pigtail

Fuses — Body size only .145 X .300 inches. Glass tube construction permits visual inspection of element. Hermetically sealed. Twenty-three ampere sizes from 1/100 thru 15.



BUSS Sub-miniature GMW Fuse and HWA Fuseholder

Fuse size only .270 X .250 inches. Fuse has window for visual inspection of element. Fuse may be used with or without holder. 1/200 to 5 amp. Fuses and holders meet Military Specifications.

Write for BUSS Form SFB

INSIST ON

BUSS QUALITY

FUSES

BUSSMANN MFG. DIVISION, McGraw-Edison Co. St. Louis, Mo. 63107
Circle 167 on reader service card

How'd you like to
drill carbon plates
6 times faster?
Pinpoint accuracy—
even for unskilled
operators with the
new multi-spindle

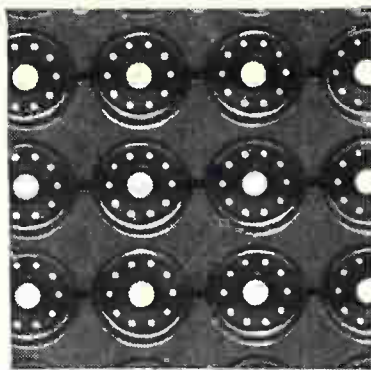

Engravograph[®]

Speed transistor mounting! Now anyone can drill six carbon plates in one operation from one template with registration and depth of hole controlled to a plus-or-minus .001" tolerance.

Drill up to 1600 holes per minute. Save time, labor... and especially costs.

For details write: Dept. 175.

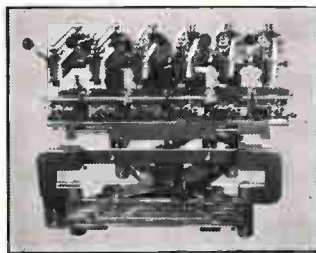

new hermes engraving machine corp.

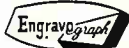

20 Cooper Sq., N.Y., N.Y. 10003 • Chicago, Atlanta, Los Angeles, Oallas, Montreal, Toronto, Mexico City

Circle 194 on reader service card

Technical Abstracts

A bit dense

New horizons for magnetic bulk-storage devices
Frank D. Risko
Bryant Computer Products
Walled Lake, Mich.

The second- and third-generation bulk-storage peripherals now appearing on the computer market are—to the surprise of many—still taking the form of rotating magnetic media devices. Actually with 15 years of technology behind them, these recorders should dominate the market for yet another 10 years before giving way to newly developed optical-type devices such as lasers.

With future memory capacities projected at from 500 million bits to 10 billion—and even to a trillion bits in large bulk memories—tapes, disks, or drums will be storing massive amounts of data. However, comparisons among these devices are significant only when access time is taken into consideration for a given application.

Very large stores generally have access times of more than 75 milliseconds because they usually consist of moving-head elements or moving strips used with electro-mechanical and electrohydraulic positioning devices. Sales surveys indicate that users are now sacrificing access time for greater storage capacity and reduced costs, but the increasing need for faster data acquisition should change that situation.

Time-shared computer systems provide an interesting problem in this context, since storage requirements here depend on how each user achieves his results with his share of the computer. Different applications require different storage capacities, and the users of future systems will probably have to queue up their requests during the access period.

The most feasible solution would be to install a certain number of access position devices that would give a limited number of users access to the bulk storage at one time. This would be less costly than doubling storage capacity or

*Unlocking
the Future*

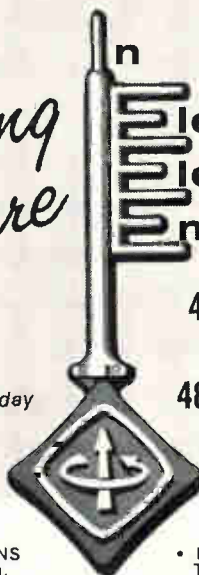

**ELECTRICAL
ELECTRONICS
ENGINEERING**

**4 FLOORS OF EXHIBITS
NEW YORK COLISEUM**

**48 TECHNICAL SESSIONS
NEW YORK HILTON**

• 48 TECHNICAL SESSIONS at the New York Hilton. Hours: 10:00-12:30; 2:00-4:30.

• FOUR FLOORS OF EXHIBITS at the N. Y. Coliseum including over 600 firms. Hours: 10 a.m.-8 p.m. 4 Days.

• GALA ANNUAL BANQUET—Wednesday 7:15 p.m. N. Y. Hilton Grand Ballroom — \$18.00.

• FREE SHUTTLE BUSES between the Hilton and the Coliseum — every few minutes.

• REGISTRATION — Good all days — Technical Sessions and exhibits. In and out privileges. — IEEE Members \$3.00. Non-members \$6.00. Ladies \$1.00. High School Students \$3.00 if accompanied by an adult — One student per adult; Thursday only — limit of 3 students per adult.

• REG-IDENT CARD speeds request for exhibitors' literature. Ask for one when registering.

• ESCALATORS/EXPRESS ELEVATORS to the Fourth Floor.

IEEE '69  **INTERNATIONAL
CONVENTION & EXHIBITION
MARCH 24-27, 1969**

When Only Excellent is Adequate TURN to Grayhill

WHAT'S NEW ABOUT THIS SWITCH?

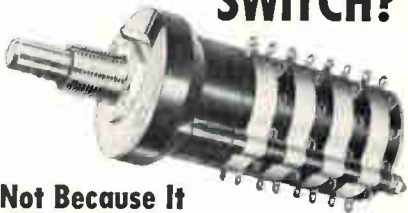

It's Not Because It

- 1) is explosion proof.
- 2) has up to 12 positions/deck.
- 3) could have up to 6 poles/deck.
- 4) comes in shorting or non-shorting versions.
- 5) is available in sealed, military or standard versions.

No...These are Standard Grayhill Rotary Switch features.

IT'S NEW BECAUSE

one or more positions may be ISOLATED from normal shaft turning techniques. It has its own built-in shaft turning SAFETY feature.



For details on this and other Switches Ask for Catalog G-304-A



523 Hillgrove Avenue
LaGrange, Illinois 60525
Area Code 312, Phone 354-1040

The Difference Between Excellent and Adequate

Circle 195 on reader service card



Every year, ELECTRONICS attracts requests for over 125,000 editorial reprints.

They're like interest payments on our million-dollars-a-year editorial principles.

That's how much we spend annually to produce timely, authentic, and useful articles like those listed on the reader service card as reprints currently available.

Investment and interest make both ELECTRONICS and its readers more meaningful to its advertisers.

SILICON RECTIFIER ASSEMBLIES

YOUR SPECIAL REQUIREMENTS MAY BE A TUNG-SOL STANDARD

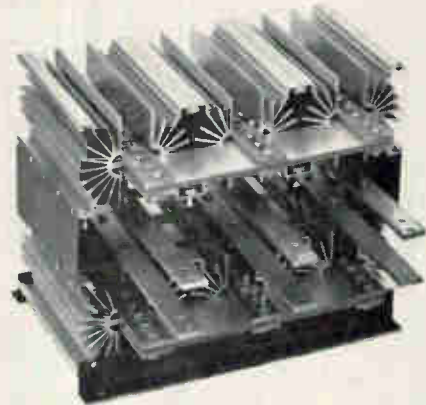

High current, three phase bridge. 1400 amps continuous.

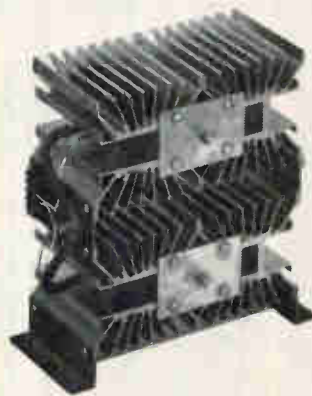

Silicon rectifier and SCR hybrid. Up to 270 amps continuous.



Single phase or three phase bridge. Up to 31 amps D.C. and PVR's up to 1KV.

Controlled avalanche. Available to 150KV at 3 amps, single phase, halfwave.

Tung-Sol design capability encompasses wide power range. Write, describing requirements. No obligation. Tung-Sol Division, Wagner Electric Corporation, One Summer Ave., Newark, New Jersey 07104.

TUNG-SOL[®] SILICON RECTIFIER ASSEMBLIES

© REG. T.M. WAGNER ELECTRIC CORPORATION

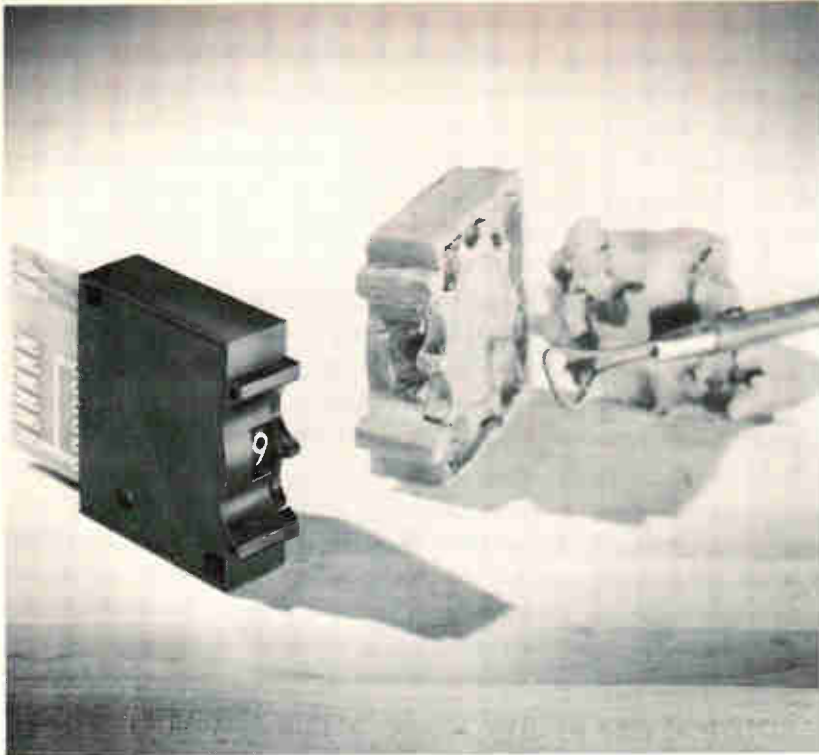

You can imitate a Digiswitch but you can't duplicate it.

You can't duplicate a Digiswitch® any more than you could duplicate a sculpture by Rodin.

Make a fair copy? Sure, but the knowledge, experience and skill that went into the original would be missing.

Digitran pioneered thumbwheel switches, and years of experience and improvement have established

Digiswitch as the industry standard. And, nobody comes close to duplicating our service organization, application library or scope of product.

Insist on an original. Digiswitch. The switch you can count on.

More information about the original is yours for the asking.

THE DIGITRAN COMPANY
Subsidiary of Becton, Dickinson and Company 

855 S. Arroyo Pkwy./Pasadena, Cal. 91105
Tel: (213) 449-3110/TWX 910-588-3794

Circle 170 on reader service card

Every year, **ELECTRONICS** attracts requests for over 125,000 editorial reprints.

They're like interest payments on our million-dollars-a-year editorial principle.

That's how much we spend annually to produce timely, authentic, and useful articles like those listed on the reader service card as reprints currently available.

Investment and interest make both **ELECTRONICS** and its readers more meaningful to its advertisers.



providing each user with his own access mechanism.

Magnetic recording is currently done on 5-mil track widths with 7.5-mil centers, giving a packing density of 250,000 bits per square inch. However, advances in this area are far from over. Working with 1-mil-wide pole pieces, IBM has packed 1,000 to 1,500 bits per inch in the laboratory. But the 1-mil pole piece raises a question about the positioning tolerances needed to keep off-track and peak shifting problems from affecting playback. The positioning mechanism would have to be at least two orders of magnitude better than present devices to accommodate this kind of head. Such a hundredfold improvement may be difficult to accomplish unless manufacturing methods improve considerably.

Development work indicates that the next generation of bulk storages will employ 2.5-to-3-mil tracks spaced on 3.75-mil centers. Packing densities of a million bits per square inch should be possible next year, but the positioning device will have to be much more accurate than at present in terms of track selection and repeatability.

By 1972, time-shared systems may have 16 multiple-access, moving-head bulk stores with a total capacity of 50 billion bits. From then on, capacities will probably increase logarithmically to 100 billion bits and eventually to 100 trillion bits.

By 1975, the memory head will be batch fabricated rather than individually assembled, and the pre-amplifiers will probably be deposited on the head assembly.

It should be noted, though, that the person who wants a huge bulk store will pay just as much for it in 1975 as he would now. Increasing manufacturing and material costs will push up unit prices, but advances in packing densities will keep the average cost per bit at about the present level. The major difference is that the storage will take up only $\frac{1}{16}$ th the floor space now needed.

Presented at the Fall Joint Computer Conference, San Francisco, Dec. 9-11, 1968.

evening classes won't fit your schedule?

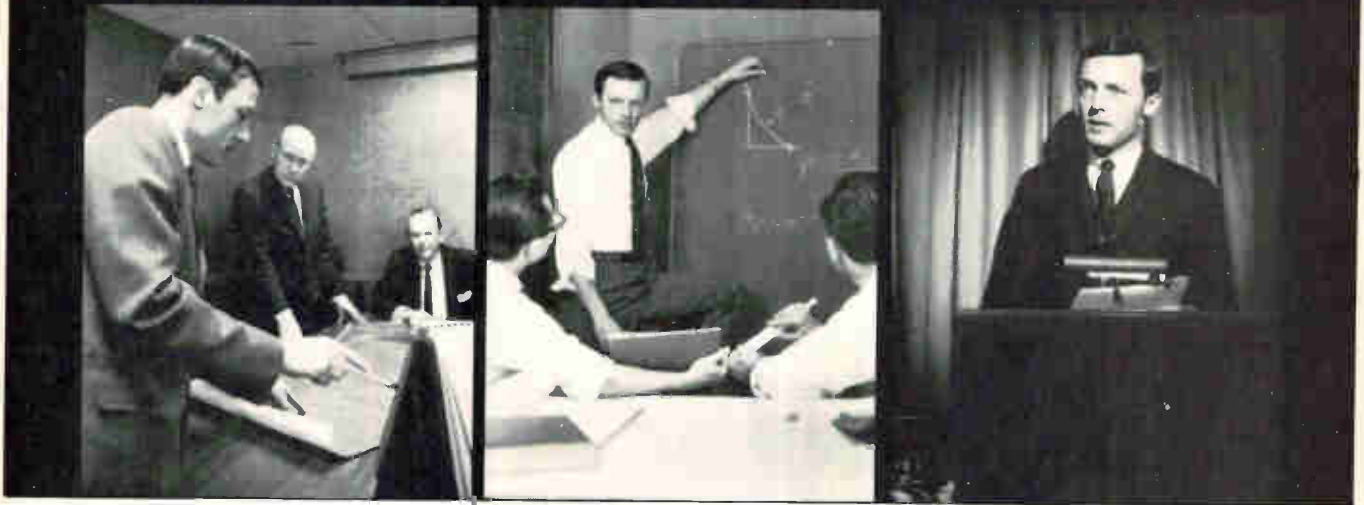

here's a practical way to keep up with new developments

Are irregular hours, travel and family obligations keeping you from attending classes—even though you worry about becoming technically obsolescent? Check into the Special Programs in Electronics for Engineers developed by CREI, the Home Study Division of the McGraw-Hill Book Company.

These are not simply courses, but comprehensive programs in advanced electronics offering major electives in such fields as:

Communications Engineering, Aeronautical and Navigational, Television Engineering, Automatic Control Engineering, Missile and Spacecraft Guidance, Radar and Sonar Engineering, Nuclear Instrumentation and Control, Computers.

Industry-recognized CREI Programs make it possible for you to catch up on new developments in electronics through study in your own home, at your own pace,

your own schedule. Free book gives complete information and details of technical material covered. For your copy, mail coupon below or write: CREI, Home Study Division, McGraw-Hill Book Company, Dept. 1852H, 3224 Sixteenth St., N.W., Washington, D.C. 20010.

Founded 1927



Accredited Member of the National Home Study Council



CREI, Home Study Division, McGraw-Hill Book Company
Dept 1852H, 3224 Sixteenth St., N.W.
Washington, D.C. 20010

Send me free brochure describing CREI Programs in Electronics for Engineers.

NAME _____ AGE _____

ADDRESS _____

CITY _____ STATE _____ ZIP CODE _____

COMPANY _____

TITLE _____

New Literature

Audio mixer. Ampex Corp., 401 Broadway, Redwood City, Calif. 94063. Bulletin A322 lists features and specifications of the model AM-10 audio mixer. Circle 447 on reader service card.

Integral driver switches. Sanders Associates Inc., P.O. Box 907, Nashua, N.H. 03060, has available a data sheet covering the DS-300 series miniature integral driver switches. [448]

Integrated circuits. National Semiconductor Corp., 2950 San Ysidro Way, Santa Clara, Calif. 95051, has published its 24-page 1969 integrated circuit short form catalog. [449]

Hybrid devices. Anzac Electronics, Division of Adams-Russell Co., 39 Green St., Waltham, Mass. 02154, has released a brochure describing a series of subminiature hybrid devices for use with p-c board, mini-strip, and strip transmission line mounting. [450]

Residual gas analyzer. Veeco Instruments Inc., Terminal Drive, Plainview, N.Y. 11803, has available a 20-page brochure on its GA-4R residual gas analyzer. [451]

D-c power supplies. Sorensen Operation, Raytheon Co., Richards Ave., Norwalk, Conn. 06856. An eight-page illustrated catalog covers the QSA series of modular, wide range, convection cooled, d-c power supplies for system applications. [452]

Photo-etched metal parts. Chem/Mach Division, Jordan Controls Inc., 3235 W. Hampton Ave., Milwaukee 53209, has released an illustrated pamphlet on precision photo-etched metal parts. [453]

Dual linear amplifier. LeCroy Research Systems Corp., 126 N. Rt. 303, West Nyack, N.Y. 10994. A technical data sheet offers a comprehensive description of the model 133B nanosecond bipolar dual linear amplifier. [454]

Charge amplifier. Endevco, subsidiary of Becton, Dickenson and Co., 801 S. Arroyo Parkway, Pasadena, Calif. 91109. A broad array of user-oriented design features of the model 2720 charge amplifier are detailed in a six-page brochure. [455]

Reed switch keyboard. Micro Switch, a division of Honeywell, Freeport, Ill.

61032, offers a product sheet describing the 51RW2-1 reed switch keyboard. [456]

Drum memory system. Bryant Computer Products, 850 Ladd Rd., Walled Lake, Mich., 48088, has published a four-page brochure on the CLC-1 rotating drum memory system with read/write and select electronics. [457]

Current-controlled resistor. Hewlett-Packard Co., 1501 Page Mill Rd., Palo Alto, Calif. 94304. A four-page bulletin contains technical data on the model 5082-3003 current-controlled r-f resistor. [458]

Electrolytic capacitors. Cinefot International Corp., One Park Ave., New York 10016, has available a booklet describing Wicon electrolytic capacitors for electronic photo flash equipment. [459]

H-f antenna system. Sanders Associates Inc., 11101 Sunset Hills Rd., Reston, Va. 22070, has issued a brochure on the Parasol h-f antenna system, which provides simultaneous reception from as many as 72 fixed or moving signal sources. [460]

CTS series 750 cermet resistor networks with snap-in formed leads . . . for either automatic insertion or hand mounting.

- Available in 3 sizes and an infinite number of circuit combinations.
- Extremely good environmental specifications.
- 5 lbs. pull strength on leads.
- Available with or without active devices.

Delivery: 2 weeks for prototypes; 4-6 weeks for production quantities.

Order from: CTS of Berne, Inc., Berne, Indiana 46711. (219) 389-3111.

CTS CORPORATION
Founded 1896

Series 750	4-pin 3 resistors	6-pin 5 resistors	8-pin 7 resistors
1,000 piece price	29.6c ea.	40.6c ea.	50.9c ea.
10,000 piece price	15.5c ea. (5.2c/ resistor)	21.0c ea. (4.2c/ resistor)	26.1c ea. (3.7c/ resistor)

These prices are based on $\pm 5\%$ tolerance, $\pm 300\text{ppm}/^\circ\text{C}$ standard TC, and 50 ohms thru 100K ohms resistance range with all resistance values being within a 10:1 ratio per side.

CERMET RESISTOR

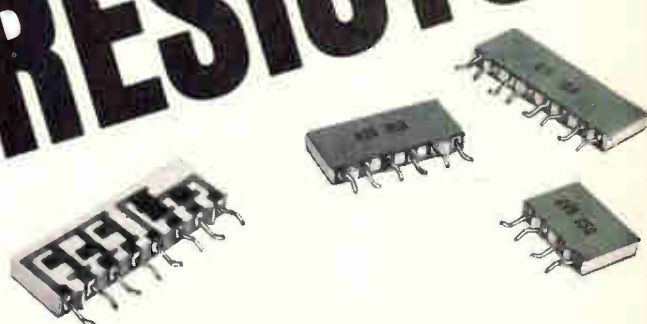

Polyester film adhesives. Celanese Plastics Co., 2056 Highway No. 22, Scotch Plains, N.J. 07076. How to adhere polyester film to aluminum or copper foil, chipboard, cellulose acetate, and to itself is given in detail in technical bulletin D2A. [461]

High-Q ferrites. Indiana General Corp., Crows Mill Road, Keasbey, N.J. 08832. Magnetic properties of Ferramic Q-1, Q-2, and Q-3 nickel-zinc type ferrite materials are presented in three new two-page bulletins. [462]

Video accessories. Ampex Corp., 2201 Lunt Ave., Elk Grove Village, Ill. 60007. Video accessories to improve performance of closed circuit videotape recorders and cameras used in education, industry, medical, and government applications are described in a recent brochure. [463]

Ceramic capacitors. U.S. Capacitor Corp., 2151 N. Lincoln St., Burbank, Calif. 91504, has available a 12-page catalog of general-purpose miniature ceramic capacitors. [464]

Adjustable speed drives. Reliance Electric Co., 24701 Euclid Ave., Cleveland

44117. Series 1000 d-c adjustable speed drive systems from 7½ to 75 h-p are featured in data sheet D-2543. [465]

Screen printer. Aremco Products Inc., P.O. Box 145, Briarcliff Manor, N.Y. 10510. Product bulletin 3100 describes the Accu-Coat automatic screen printer for ultraprecise substrate metalizing. [466]

D-c magnetic amplifiers. Airpax Electronics Inc., P.O. Box 8488, Fort Lauderdale, Fla. 33310. Bulletin 8E-1 covers a line of miniature, low-level d-c magnetic amplifiers. [467]

Signal data conversion. Vernitron Corp., 59 Central Ave., Farmingdale, N.Y. 11735. A 20-page catalog contains a complete list of analog-to-digital converters, d-a converters, and shaft encoders. [468]

Power supplies. Analog Devices Inc., 221 Fifth St., Cambridge, Mass. 02142. A data sheet describes models 901 and 902 dual-output d-c power supplies designed for exciting most types of discrete-component operational amplifiers. [469]

Animated computer education. Edutronics of California Inc., 2790 Harbor Blvd., Costa Mesa, Calif. 92626, offers a brochure describing a method of teaching complex data processing concepts, using animated motion, color, and sound to explain complex and simultaneous functions of a computer system. [470]

Zone controlled plating. Burton Research Laboratories, 11240 Playa Court, Culver City, Calif. 90230, offers a brochure detailing the principles, advantages, and case histories relating to its zone controlled plating techniques. [471]

D-c regulators. Kepco Inc., 131-38 Sanford Ave., Flushing, N.Y. 11352, has published a 16-page catalog supplement containing full product information on six groups of d-c regulators that make major use of monolithic IC technology. [472]

Differential transformers. Kimberley-James Inc., 1422 Chestnut St., Philadelphia 19102. Bulletin KJ4705 contains specifications and prices for 70 models of linear variable differential transformers. [473]

NETWORKS

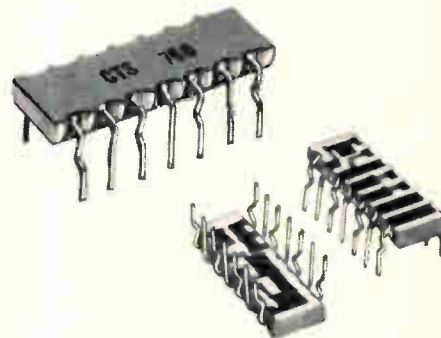

CTS Series 760 cermet resistor network or thick film hybrid circuit is mechanically compatible with standard 14 lead dual-in-line package . . . simplifying automatic insertion

and reducing assembly costs accordingly. The networks can also be easily hand mounted.

Series 760 provides:

- Up to 13 resistors per module with an infinite number of circuit combinations.
- Extremely good environmental specifications.
- 5 lbs. pull strength on leads.

Delivery: 2 weeks for prototypes; 4-6 weeks for production quantities.

Order from: CTS of Berne, Inc., Berne, Indiana 46711. (219) 589-3111.

Series 760	9 resistors	11 resistors	13 resistors
1,000 piece price	82c ea.	86c ea.	90c ea.
10,000 piece price	41c ea. (4.5c/resistor)	43c ea. (4c/resistor)	45c ea. (3.5c/resistor)

Prices shown are based on ±5% tolerance, ±300ppm/°C standard TC, and 50 ohms through 100K ohms resistance range with all resistance values within a 5:1 ratio per side.

CTS CORPORATION



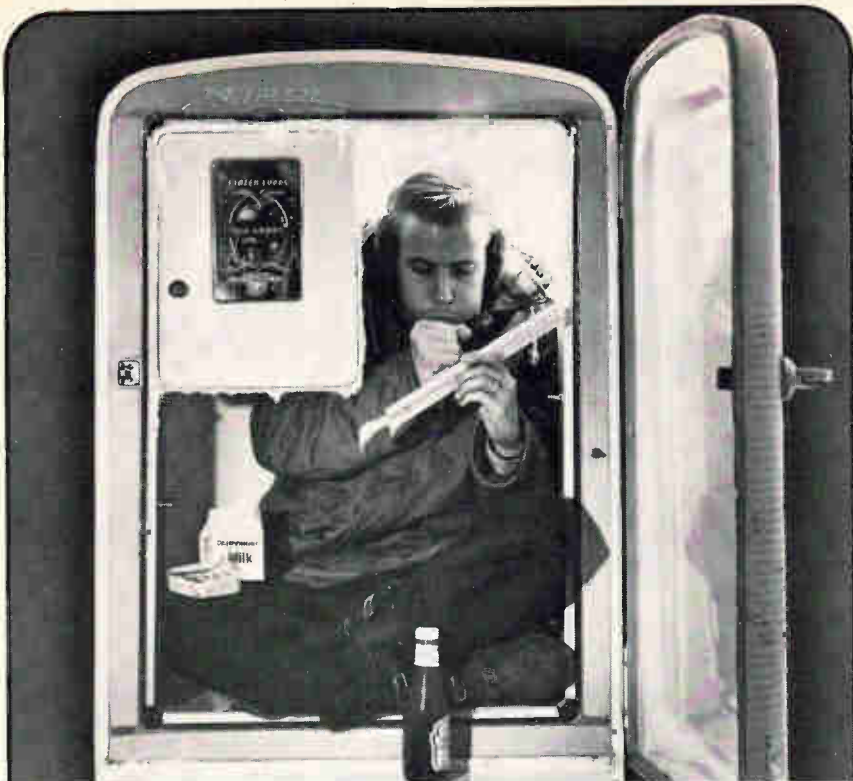

frigid air is for leftovers!

Is that what you are? . . . Left over from the great American population shift to the Southwest sun country? Why not warm up in Phoenix, the sun-fun capital of the world where the whole year is for fishing, golf, tennis or most any other sport.

Why buy overcoats and snow shovels when you could spend your money for a new rod and reel? Motorola in Phoenix provides a warm climate and a long growing season for engineers and scientists. Forty years of leadership in electronics systems engineering and unmatched technical facilities can be your place in the sun. If you provide the brainpower, nearby Arizona State University will provide the ticket for that unfinished Master's or PhD.

Make one more trip into the frigid air and mail us your resume . . . and while you're out, take a look at a new spinning reel; it costs just about the same as a new snow shovel.

Specific opportunities are:

Space Communications ■ Radar Systems ■ Tracking & Telemetry ■ Fuzing
Digital Data Transmission ■ Guidance & Navigation ■ Radar Transponders
ECM & Elint ■ Coherent Transponders ■ Integrated Electronics ■ Antennas
& Propagation ■ Advanced RF & Microwave Techniques ■ Ground Support
Equipment ■ UHF/VHF Communications Equipment ■ Display ■ Digital
Multiplex ■ Troposcatter ■ Readout ■ Undersea ■ Mechanical Design ■ Reli-
ability & Components

in PHOENIX



MOTOROLA

Government Electronics Division

Write: Paul Ahler, Recruitment Mgr., Dept. 65, Box 1417, Scottsdale, Arizona

AN EQUAL OPPORTUNITY EMPLOYER

CIRCLE 966 ON READER SERVICE CARD

BIOMEDICAL EQUIPMENT ELECTRONICS ENGINEERS (2)

Highly desirable career openings with Hamilton Standard, a recognized leader in this dynamic field. Attractive location in central Connecticut. Assignments involve R&D programs related to the design of highly sophisticated biomedical products and systems for commercial markets.

Do you have a background or interest that would qualify you for one of these positions?

DESIGN ENGINEER, RF Systems. Experience required in the design of telemetry components, solid-state receivers, and/or low-power transmitters. Must have working knowledge of VHF communication systems, radiators and fields, components. Experience with physiological monitoring systems useful but not required.

DESIGN ENGINEER, Controls. Experience required in the design of digital and analog circuits for instrumentation and controls, including timing and logic circuits, etc. Experience in design for commercial markets preferred. Cost-consciousness and good knowledge of components state-of-the-art necessary attributes. These positions offer an opportunity to participate in a dynamic, promising field of technology and to work closely with eminent hospitals and medical schools.

TO INTERVIEW, please forward your resume, stating your present salary, to Mr. A. R. Baldwin, Personnel Department, Hamilton Standard, Windsor Locks, Connecticut 06096.

An Equal Opportunity Employer

Hamilton Standard

U

DIVISION OF UNITED AIRCRAFT CORP.

A®

CIRCLE 967 ON READER SERVICE CARD

ADDRESS BOX NO. REPLIES TO: Box No.
Classified Adv. Dept. of this publication.
Send to office nearest you:
NEW YORK, N. Y. 10036: P. O. Box 12
CHICAGO, Ill. 60611: 615 N. Michigan Ave.
SAN FRANCISCO, Cal. 94111: 255 California St.

EMPLOYMENT SERVICES

Florida/Nationwide EEs, MEs, IEs . . . Electronic, Aerospace, Industrial, Sales & Mfg. \$9-18,000. Tech Div Brodeur Personnel Service, Inc., 3947 Blvd., Center Drive, Jacksonville, Fla. 32207.

BUSINESS OPPORTUNITIES

Capital Contacts—Before you try Public or Private Placements to Underwriters, Investment Banking Houses, write for free helpful information to Confidential Consultant, 817 51st St., Brooklyn, N.Y.

Capital to Invest in new cos., to expand existing cos., (all with view of going public), to buy existing cos. Size no object. BO-7475, Electronics.

FOR INFORMATION

about
classified advertising,
contact the McGraw-Hill
office nearest you

ATLANTA, 30309
1375 Peachtree St., N.E.
404-875-0523

BOSTON, 02116
607 Boylston St.
617-262-1160

CHICAGO, 60611
645 No. Michigan Avenue
312-664-5800

CLEVELAND, 44113
55 Public Square
216-781-7000

DALLAS, 75201
1800 Republic Nat'l, Bank
Tower
214-747-9721

DENVER, 80202
1700 Broadway, Tower Bldg
303-255-5483

DETROIT, 48226
856 Penobscot Building
313-962-1793

HOUSTON, 77002
2270 Humble Bldg.
713-224-8381

LOS ANGELES, 90017
1125 West Sixth Street
213-482-5450

NEW YORK, 10036
500 Fifth Avenue
212-971-3594

PHILADELPHIA, 19103
Six Penn Center Plaza
215-568-6161

PITTSBURGH, 15222
4 Gateway Center
412-391-1314

ST. LOUIS, 63105
7751 Carondelet Avenue
314-725-7285

SAN FRANCISCO, 94111
255 California Street
415-362-4600

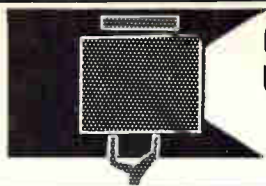

SEARCHLIGHT SECTION

• CLASSIFIED ADVERTISING • BUSINESS OPPORTUNITIES
• USED OR SURPLUS EQUIPMENT

AUTOTRACK MOUNT

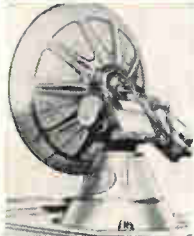

360 degree azimuth, 210 degree elevation sweep with better than 1 mil. accuracy. Missile velocity acceleration and slewing rates. Amplidyne and servo control. Will handle up to 20 ft. dish. Supplied complete with control chassis. In stock—immediate delivery. Used world over by NASA, USAF, MP-61-B. Type SCR 534. Nike Ajax mounts also in stock.

PULSE MODULATORS

MIT MODEL 9 PULSER 1 MW—HARD TUBE
Output 25kv 40 amp., 30kv 40 amp. max. Duty cy .002. .25 to 2 microsec. Also 5 to 5 microsec. and 1 to .5 microsec. Uses 6C21. Input 115v 60 cycle AC. Mfg. GE. Complete with driver and high voltage power supply. Ref: MIT Rad. Lab. Series, Vol. 5, p. 152.

2 MEGAWATT PULSER
Output 30 kv at 70 amp. Duty cycle .001. Rep rates. 1 microsec 600 pps. 1 or 2 msec 300 pps. Uses 5948 hydrogen thyratron. Input 120/208 VAC 60 cycle. Mfr. GE. Complete with high voltage power supply.

250 KW HARD TUBE PULSER
Output 16 kv 16 amp. Duty cycle .002. Pulses can be coded. Uses 5D21, 715C or 4PR60A. Input 115 v 60 cy. AC \$1200 ea.

18 MEGAWATT PULSER
Output 150KV at 120 amps. Rep rate: 50-500 PPS. Pulse length: 5 msec. 15KV 120 amp. into pulse transformer Rise time 1.5 msec. Filament supply 5V 80 amp. incl. 17.5KV 1.5 amp DC power supply. Input: 220V 60 cy AC.

INDICATOR CONSOLES

AN/SPA-4A, PPI 10", range to 300 mi.
VJ-1 PPI 12" Range to 200 mi.
VL-1 RFI 12" to 200 mi. 60K ft.

HIGH VOLTAGE POWER SUPPLIES

100 KV, 200MA, DC, \$5500; 27 KV, 100MA, DC, \$2200; 15KV, 2 amp. DC, \$3800; 12KV, 1200MA, DC, \$1400; 8KV, 800MA, DC, \$975.

SCR 584 AUTOTRACK RADARS

Our 584s in like new condition ready to go, and in stock for immediate delivery. Ideal for telemetry research and development, missile tracking, satellite tracking. Fully Desc. MIT Rad. Lab. Series, Vol. 1, pps. 207-210, 228, 284-286. Comp. Inst. Bk available \$25.00 each.

ANTI-AIRCRAFT GUN MOUNT

Will handle 6,000 lbs. rapid slew through 360° azimuth, 180° elevation. Mobile.

MICROWAVE SYSTEMS

200-2400 mc. RF PKG

Continuous coverage, 30 Watts Cw nominal output. Uses 2C39A. Price \$575.

L BAND RF PKG.

20 KW peak 900 to 1040 MC. Pulse width .7 to 1.2 micro sec. Rep. rate 180 to 420 pps. Input 115 vac incl. Receiver \$1200.

200-225 mc RADAR SYSTEM

1 Megawatt output. 200 nautical mile range for long range detection of medium and high altitude jet aircraft as well as general search. AN/TIP5 28.

SURVEILLANCE DRONE RADAR SYSTEM

X-Band tracking system with plotting boards. Type AN/MPQ-20. Drone also in stock.

5 MEGAWATT C-BAND

Klystron RF package delivering nominal 5 megawatt pulse RF. Complete with pulser and power supply.

500 KW L BAND RADAR

500 kw 1220-1359 msc. 160 nautical mile search range. P.B.I. and A scopes. MITI thyratron mod 5328 magnetron. Complete system.

AN/GPG-1 SKY-SWEEP TRACKER

3 cm. automatic tracking radar system. Complete package with indicator system. Full target acquisition and automatic tracking. Input 115 volts 60 cycle. New. In stock for immediate delivery. Entire System 6' long, 3' wide, 10' high. Ideal for Infrared Tracker, Drone Tracker, Missile Tracker, R. & D.



C Band Autotrack

1 Megawatt 10 ft. Parabola. Sperry.

RADAR SYSTEMS GROUND AND AIRBORNE AUTOMATIC TRACKING ANTENNA SYSTEMS. NIKE AJAX, NIKE HERCULES M 33 MSQ-1A MPS-19, MPS-9 SCR 584 TPS-1D TPS-28 FAA-ASR-2 AIRBORNE SYSTEMS APN-84 APN-102 APS-20 APS-27 APS-45 DPN-19 DIGITAL COMPUTERS IBM 650, IBM 704

LARGEST INVENTORY OF RADAR AND MICROWAVE EQUIPMENT IN THE WORLD.
RADIO RESEARCH INSTRUMENT CO.
45 WEST 45TH ST. N. Y. 10036 212-JU 6-4691

CIRCLE 968 ON READER SERVICE CARD

WELDING HAND TOOL

TW 17 A
\$ 48.00



Replaceable Tips—Adjustable Pressure
AC and Stored Energy Power Supplies

EWALD Instruments Corporation

Kent, Conn. 06757

CIRCLE 972 ON READER SERVICE CARD

Don't forget

THE BOX NUMBER

when answering the classified advertisements in this magazine. It's our only means of identifying the advertisement you are answering.

Webber Low & High Temperature TEST CHAMBER

Chamber 30" x 30" x 42"
Minn. Honeywell Control Chart
(2) Condensing Units
5 HP and 4 HP
Minus 90° F Plus 400° F
Stainless Steel Exterior
Bargain

KINGS COUNTY MACHINERY EXCHANGE
67-55 Woodhaven Boulevard
Rego Park, Queens, New York 11374
Tel: (212) 459-5800

CIRCLE 969 ON READER SERVICE CARD

ELECTRON TUBES

KLYSTRONS • ATR & TR • MAGNETRONS
SUBMINIATURES • C.R.T. • T.W.T. • 5000-
8000 SERIES
• SEND FOR NEW CATALOG A2 •
A & A ELECTRONICS CORP.
1063 PERRY ANNEX
WHITTIER, CALIF.
696-7544

CIRCLE 970 ON READER SERVICE CARD

SURPLUS IBM EQUIPMENT

FREE catalog of powers supplies, light & switch panels, semiconductors, test equipment, IC's, optics, etc.

GADGETEERS SURPLUS ELECTRONICS, Inc.
5300 Vine St. Cincinnati, Ohio 45217

CIRCLE 971 ON READER SERVICE CARD

Immediate Delivery!*

AUTOMATED SWEPT-RECEIVERS for S-T-R-E-T-C-H-I-N-G MANPOWER

- SURVEILLANCE
- COMMUNICATIONS
- RFI/EMC
- FIELD STRENGTH TESTS
- TUNABLE RF VOLTMETER
- CIRCUIT ANALYSIS

SOLID STATE EMC-25 FUNCTIONS FROM PRE-SET PROGRAM.

Whether used alone or with one of its specially-designed peripheral instruments, Interference Analyzer Model EMC-25† is the most advanced receiver system currently available. Hundreds of these varactor-swept instruments are already in field and laboratory use, speeding up tests and monitoring, and relieving manpower shortages. It has outstanding sensitivity and two bandwidths throughout the full range. Fully remotely controllable...digitally over telephone lines if required.

With its accessory programmer, the full range of 14 kHz to 1000 MHz can be plotted on a single sheet of pre-calibrated paper in minutes.

When used with the accessory Display Module, a full octave band dispersion can be shown on the CRT at one



14 kHz to 1000 MHz IN SINGLE
COMPACT PACKAGE—BATTERY POWERED

†Military Nomenclature AN/URM-178; FSN 2Z6625-115-2775

time...or any selected portion... in linear or log!

When combined into the fully automated Spectrum Surveillance System, all these functions are performed, plus many more.

Hundreds of EMC-25's, with and without peripheral equipment, are being used all over the world. Contact your Fairchild/Electro-Metrics representative for your catalog, to see how you too can s-t-r-e-t-c-h your valuable manpower.

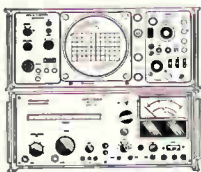

BAND-BY-BAND SPECTRUM DISPERSION

By displaying the EMC-25's 15 octave bands, one at a time, on the CRT of Display Module SPD-125, the full range of 14 kHz to 1 GHz is visually displayed.

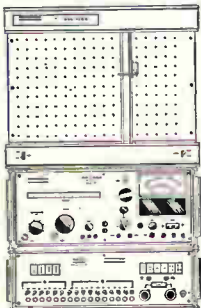

FULL FREQUENCY RANGE AUTOMATIC PLOTTING

The ESC-125A Programmer adds the capability of plotting the EMC-25's 14 kHz to 1 GHz range on a single sheet of pre-calibrated graph paper, and with automatic antenna selection.

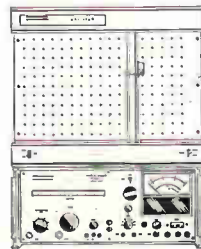

BAND-BY-BAND SPECTRUM PLOTTING

Built-in electronic sweep in EMC-25 provides push-button control of octave-band plots on the EXY-125A X-Y Plotter.

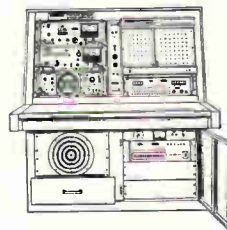

DUAL-SYSTEM FSS-250

For full 20 Hz to 1 GHz range:

Here is a system with both visual CRT octave dispersion and automated X-Y plotting...plus built-in calibrator control, amplifier and speaker, and many optional operator controls.



EMC-10 for VLF

Interference Analyzer EMC-10 covers the frequency range from 20 Hz to 50 kHz. It also is solid-state, battery operated and electronically scannable. Category A approved; FSN 6625-911-0840 and (for "E" model) 6625-937-6523.

FAIRCHILD

ELECTRO-METRICS

CORPORATION

A SUBSIDIARY OF FAIRCHILD CAMERA AND INSTRUMENT CORPORATION

100 CHURCH STREET, AMSTERDAM, N.Y. 12010

International Newsletter

February 3, 1969

U.K. burglars Gunned down by new alarm

A small West London company now looks like the first quantity customer—military-equipment producers excepted—for Gunn diodes. Memco Engineering Ltd. has an order for “as many as it can make” of its Gunn-powered radar burglar alarm. Memco’s systems are going to one of England’s biggest security companies, Associated Fire Alarms Ltd.

Associated figures it could use 200 of Memco’s doppler alarm units every month if it could get them. Memco, meanwhile, has ordered 500 diodes from Mullard Ltd. and 500 from Plessey. Even larger follow-up orders are being negotiated.

Memco’s alarm is battery-operated and measures 8 by 5 by 3 inches. It operates at a frequency of 10.675 gigahertz and has separate antennas for transmitting and receiving. Both are coupled to a mixer diode that responds to very low frequencies—1 to 50 hertz. When an intruder causes a doppler shift, the mixer-diode output is amplified by an integrated circuit whose output opens a reed relay in the alarm circuit.

The twin antenna scheme, says Memco, cuts costs by eliminating the need for directional couplers and circulators. Each antenna is a parabolic section fabricated by die-casting to further hold down costs.

Soviets to sit in on Intelsat talks

Western space officials are now taking a new view of last year’s announcement by the Soviet Union of plans to set up an “Intersputnik” communications satellite network. They’ve become convinced the announcement was made mainly to add leverage to the Soviet bloc’s bargaining power in a bid to join Intelsat.

The Russians let out late in January that they would send Deputy Communications Minister N.V. Talyzin to the 62-nation meeting in Washington starting Feb. 24. Bulgaria and Yugoslavia will also send delegations. Intelsat invited the Soviet bloc countries to send observers to the meeting if there was a “serious possibility” that they might join.

German tv exports expected to rise

The Bonn government’s pseudo revaluation late last year seems to be having little effect on German exports of television sets. Industry sources expect exports to climb about 10% this year to 700,000 sets, despite the harsher tax treatment the government imposed on exports in an effort to reduce the trade surplus.

Some marketing experts think exports would rise even more if components shortages weren’t creating production bottlenecks. They say the tax changes have had practically no impact abroad, because importers didn’t pass on the Kennedy-round tariff reductions and thus can easily absorb the extra taxes.

Malaysia may buy French armaments

French military-hardware makers, dejected by President de Gaulle’s embargo on arms shipments to Israel, are taking cheer from a large weapons order that seems in the offing from Malaysia. Snubbed in their effort to buy advanced fighters from Britain, the Malaysians have turned to France and are dickering to buy 16 Dassault Mirage jets, an undetermined number of helicopters, mobile radars, and anti-aircraft guns.

The order would go a long way toward making up for the \$50 million in lost orders that Dassault president Bruno Vallieres figures the Israeli

International Newsletter

embargo will cost the French arms industry this year. Dassault has already closed a plant in Bordeaux that was developing missiles for Israel. Industry executives say de Gaulle's fast-dealing with Israel not only lost one well-heeled customer but also makes France's delivery pledges suspect among other potential buyers.

Intelsat 4 repeater a four-nation job

Only one Intelsat 4 satellite will carry a communications repeater made in the U.S.

Hughes Aircraft, prime contractor for the four-satellite job, will design and build the first repeater. Then Hughes will turn to foreign firms for the remaining three. Canada's Northern Electric Co. has the contract for the second repeater. The Nippon Electric Co. and AEG-Telefunken will build the other two.

The repeater is worth about \$1.25 million and is one of the trickier items of satellite hardware.

Computer to link German realty men

A computer will keep tabs on a good part of West Germany's \$15-billion-a-year real estate market starting this spring. A Univac 418 III, to be run by a Frankfurt company, will store all available buy and sell offers. The fee for a tie-in to the computer will be \$155 monthly. Eventually, about 2,500 real estate agencies are expected to subscribe.

GEC to sell share in ASM, keep ties

As part of tidying-up operations that are following its takeover first of Associated Electrical Industries and then of the English Electric Co., Britain's General Electric Co. is expected to sell its one-third share in Associated Semiconductor Manufacturers to Mullard Ltd., which already owns the other two-thirds.

But it's almost equally sure that GEC will retain special ties with ASM after selling out. GEC is a heavy buyer of ASM products, many of them custom designs. At the same time, some 60 GEC researchers are doing work in basic semiconductor materials and integrated circuits for ASM. So Mullard could lose access to this R&D work if the break with GEC were too sharp.

Germans plan subs and destroyers

Military-hardware makers will have a good customer in the German Navy over the next few years. The Kiesinger government's budget committee has authorized construction of a dozen 450-ton submarines and four electronics-packed 3,600-ton destroyer escorts.

All told, the authorization amounts to some \$335 million, with perhaps 25% of that destined for electronics. The ships will be built in Germany, but Defense Ministry spokesmen say the electronics hardware contracts are still up for grabs, except for the Tartar missile control systems, which will be made in the U.S.

Computer to track nuclear materials

Japan's Science and Technology Agency plans to turn to a computer system to help it keep track of nuclear materials in the country. The agency will install a teletypewriter terminal at each facility handling uranium, plutonium, and similar substances. The terminals will be linked to the computer, and all facilities will be required to report every movement of the radioactive materials they handle.

Soviets plan new hardware for manned space flights

An on-board computer may be used for medical checks to save power; narrow-spectrum radio receivers could have a range of 1,000 light-years

For their mid-January spectacular—putting together two Soyuz spacecraft in orbit to form a space station—the Soviets played it safe and stuck largely to electronics gear that had been proved out on earlier flights. But there were a few electronic firsts during the four-day, four-astronaut flight. And more important, Soviet space officials, in their post-splashdown exhilaration, let on that they were ready with new hardware for later flights.

Future manned spacecraft, the Russians say, will carry on-board computers to handle medical data picked off cosmonauts in orbit. The Russians are thinking, too, of communicating by lasers in space and are working on narrow-spectrum radio receivers with a range of up to 1,000 light-years.

Power play. There's still no indication, though, that the Soviets have made much progress on one of their major shortcomings—spacecraft power supplies. Instead of the fuel cells that U.S. craft carry, the Soyuz capsules use solar-cell panels and auxiliary batteries. The combination, the Soviets concede, leaves them power-shy. But in the rash of technical articles that the Russian press printed during the flight, nothing was said of any planned switch to fuel cells.

In fact, the medical computer that's in the works was designed largely to save power. It will reduce the amount of biomedical data relayed back to earth to one hundredth of the volume transmitted—at a heavy power drain—during the January flight.

In addition to its main task, though, the computer will do some simple doctoring for the astronauts,

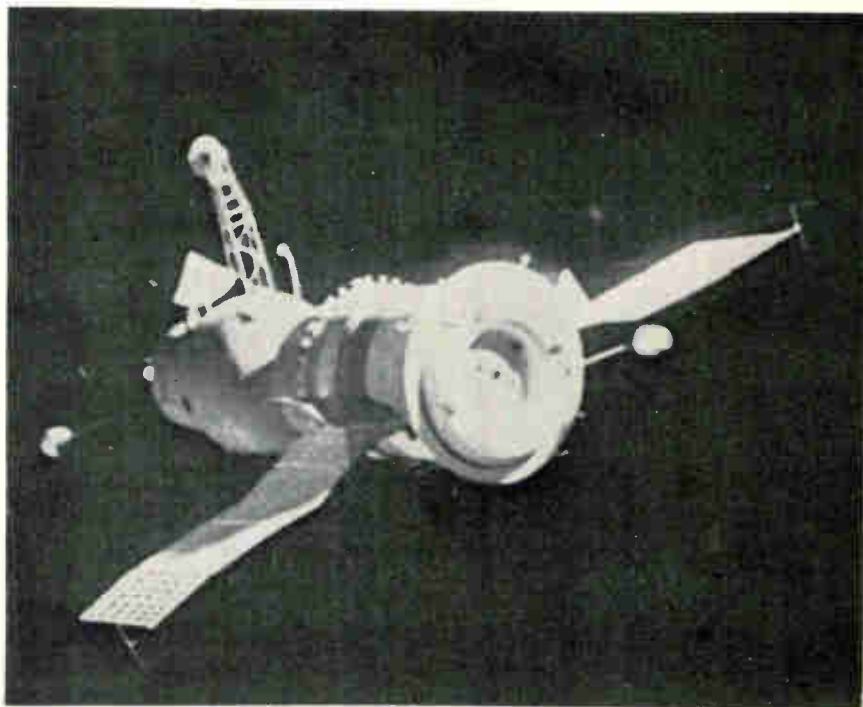

Paddling along. Full-scale model shows how Soyuz spacecraft looks in orbit. Although Russians have some new electronics hardware ready for future flights, they apparently have yet to develop the fuel cells that would let them do away with large solar-cell panels.

warning them when something starts to get out of kilter and even prescribing simple remedies. Also coming up for cosmonauts is an electronic belt that will monitor basic medical parameters and transmit them to a receiver on the spacecraft. The belt will bring an end to the skin electrodes used so far, which sometimes irritate cosmonauts and limit their mobility. Similar equipment is now used to test athletes in the USSR.

Sized up. For docking, the Soviets used the same computer-controlled radio homing systems that were first tried during the linkup

in 1967 of the unmanned Cosmos 186 and Cosmos 188 spacecraft. But for the delicate last 100 yards of the approach of the January flight, Vladimir Shatalov, alone in Soyuz 4, flew it manually until it was joined with Soyuz 5, which carried three cosmonauts. And during their space walk, Yergeni Khrunov and Alexei Yeliseyev had dual headsets that let them talk with each other and with the other two cosmonauts in the space station.

After the flawless linkup and safe return of the astronauts, Axel Berg of the Soviet Academy of Science,

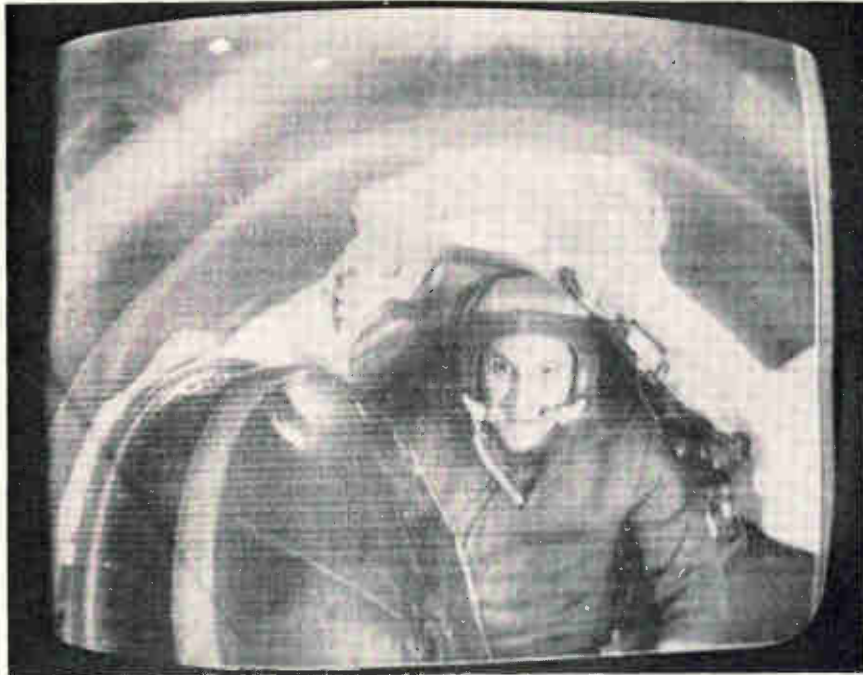

On camera. Soviets got their best tv coverage so far from space during their mid-January Soyuz spectacular. Here's how Boris Volynov looked to viewers.

hailed the electronics hardware carried aboard the Soyuz pair. And the television coverage was indeed the best yet seen on Soviet screens. Along with shots of the launchings, there were transmissions from space showing the linkup and the transfer of two cosmonauts from Soyuz 5 to Soyuz 4.

The tv coverage, however, indicated that the Russians may not yet have a space-qualified miniature tv camera. One that was transferred between the two space craft looked to be about 2½ feet by 2 feet by 9 inches to viewers watching the space spectacular.

Italy

Lost in space?

Like all aware Europeans, Italian industrialists have been troubled for some time by the gap they see between their technology and that of their U.S. competitors. And now the country's small but savvy aerospace industry has another gap to worry about—one between itself and the rest of Europe.

The new fissure started to open up last month, when the moribund

European Launcher Development Organization (ELDO) cut off funds for the perigee-apogee satellite—Italy's big job in the ELDO program. Under the setup, Great Britain, France, and West Germany each developed one stage of the launch vehicle. ELDO is having its own financial troubles [*Electronics*, Nov. 25, 1968, p. 143].

Extras. Along with the ELDO backing, the Italian group on the satellite job—the Consorzio Industriale Aerospaziale—had picked up additional financing from the National Research Council to pay for extra experiments on the bird.

Much to the annoyance of the Consorzio—which numbers among its members some of the country's largest companies, such as Fiat, Finmeccanica, and Montecatini-Edison—all the satellite work came to a halt when the ELDO money stopped coming in. A strong effort to get the government to put up the \$10 million to \$12 million needed to fly the satellite has since been mounted.

There's still been no decision, but the money Italy had earmarked for ELDO this year might end up being diverted into a national program. NASA, certainly, would launch the Italian bird—for a fee.

The three main experiments the Italians have in mind involve high-frequency telecommunications, a study of the Van Allen radiation belt, and a study of electromagnetic waves. The Italians are convinced that these basic experiments would help them keep up in satellite communications with the French and the Germans, who are going ahead with their Symphonie project.

International

Union label

Management men for some time have been aware of the charms of such low-wage places as Taiwan, South Korea, and Hong Kong for "labor intensive" operations. Now it's the turn of union officials to turn their attention to the Far East. In the union view, the shift of U.S. companies to the Far East has indeed become too intensive.

The most determined opponent to the outflow at the moment is the International Union of Electrical, Radio, and Machine Workers (AFL-CIO). Up in arms over recent layoffs at Westinghouse Electric and Philco-Ford that came after operations were moved to the Far East, the union has begun a strong drive to keep firms in the U.S. The major efforts:

- A month-long mission now in progress by top union officials to Japan, Hong Kong, Taiwan, and Korea to learn more about the overseas operations of electronic companies and meet with Oriental union leaders to help them get a firmer footing in the electronics industry.

- A push for new labeling regulations covering products made overseas. The union will propose legislation in both houses of Congress within the next few weeks that would make conspicuous labels, such as "Made in Hong Kong," mandatory for items made by American firms overseas. Union officials have pushed for this legislation and expect it to be passed.

- A drive for other legislation that would tend to make U.S. firms

stay home. The union is now collecting data it feels will help its lobbying. It's compiling a rundown of how many of its members have been laid off in recent years as a result of the opening of foreign subsidiaries.

The union's most effective weapon may be its liaison with Oriental unions. Several days before the union announced that it would send its delegation to the Far East, the Oak-Electro/Netics Corp. announced that it was closing its television tuner assembly plant in Korea and moving it to Hong Kong. The Illinois-based firm closed the plant because the Korean Metal Workers Union had demanded a 60% wage increase. Said an IUE official when told about Oak's move, "I'm delighted to hear about it—you know that some American firms in Korea are paying workers as little as seven cents an hour."

Sweden

Nordic conglomerate

Ask someone what's the biggest company in Sweden and chances are he'll answer, rightly enough, "SKF" or "Volvo." These are firms with annual sales of about \$750 million each. Starting in October, though, that answer will probably be wrong. By then, a state-owned holding company with yearly sales of about \$1.2 billion should be operating.

The conglomerate, which will run like a privately owned diversified company, is being put together from 28 existing state-owned enterprises, which are now under the wings of several ministries. Under the new setup, Minister of Industry Krister Wickman will control them all.

Wide swath. The government-owned giant will be involved in an eye-opening range of businesses. It will have, for example, a nationwide monopoly on wine and liquor sales. The national lottery, too, will be part of the company, as will such competitive enterprises as the papermaking and steel plants that

the government now owns.

Wickman, though, expects the greatest initial impact to be in the electrical-equipment and electronics industries. This is because the National Telecommunications Administration, which runs the country's communications network, will expand its manufacturing activities. So far, the administration has dabbled in manufacturing, largely to hold down the prices that its suppliers ask for standard telecommunications equipment.

Stepping out. Now there's the prospect that the administration will move up several notches in



Swedish Information Service

Czar. Industry Minister Krister Wickman will head Swedish government's new holding company.

technology. It has already built a semiautomatic electronic telephone exchange, and through this effort it picked up some computer know-how. This points to a move to new fields by the administration.

"There is a good deal of technical knowledge and market knowledge in both these operations that is not now being exploited to create production," says Wickman, speaking of the State Power Board and the administration.

Wickman also sees the state-owned company as a potential

prime mover in joint ventures with both Swedish and foreign firms. The keynote would be advanced technology; the pattern would be a venture set up late last year by the government's defense-equipment factory and two private firms. They have acquired a license from Philips' Gloeilampenfabrieken to develop and manufacture Philips' Stirling-cycle engine.

Another aim of the government giant, which will have 34,000 employees at the outset, is to eliminate pockets of unemployment. And there'll be action in industries that need restructuring to keep up with technology. Both these objectives lay behind the government's recent move to buy three small machine-tool makers and merge them into one. The merged company will be located in Wasteras, where a forthcoming shutdown of a state-owned defense plant will make new jobs necessary.

West Germany

Bed check

One job that keeps hydrographers busy—and bored—is keeping tabs on the bottom profiles of river beds, harbor basins, and channels that tend to silt up and make navigation through them hazardous. Plotting the reams of data gathered by survey ships can take weeks, possibly months. Even then, the plot of a bottom may not be as detailed as desired.

Aware of this shortcoming, Atlas-Elektronik has devised a system that does the job digitally. A data plotter connected to a computer ashore traces out the bottom profile after the computer digests the inputs gathered aboard a survey ship. Working this way, it takes only several days to complete the survey of a large area.

Atlas-Elektronik, a subsidiary of Fried. Krupp GmbH, has already tested its system—called Susy for survey system—on the Rhine. Later this month, Susy will be demonstrated at the International Oceanological Equipment and Services Exhibition in England. Atlas has



In depth. Depth-distance logged by survey ship gets converted into river-bottom profile by shore-based computer. System does the job in days; hand plotting takes weeks or months.

already landed two overseas orders for its \$50,000 system; one is going to the U.S., another to the Netherlands.

Back and forth. In a typical surveying job, a ship works its way from riverbank to riverbank, checks depth as it goes, and keeps track of its position at each sounding. Then the ship moves downstream and makes another crossing, and then another, and then another.

In the Susy method, the depth and position data is obtained by conventional sounding and radio techniques. The information is converted into digital data and sorted aboard ship. This is done by triggering the depth recorder with a pulse put out by the distance recorder about every 20 inches of the ship's journey. The data then is converted to computer format and punched into a tape.

For position-keeping, a reference point is set up temporarily on shore. It consists of a small antenna and a portable microwave-relay unit that weighs about 40 pounds. Aboard ship, a transmitter broadcasts an unmodulated 34.3-megahertz signal that is picked up by the relay unit, which amplifies the signal, modulates it in amplitude, doubles the frequency, and retransmits it. A receiver aboard ship picks up the 68.6-Mhz signal and compares its phase to a same-frequency signal generated on board. The phase difference between the

two is a measure of the distance to the reference point.

On the mark. The sorted depth-distance data punched into the tape is fed into the computer along with information on river current, water level, hour-of-day, and the like. With this, the computer can drive a profile plotter. After several profiles have been obtained, a chart of the river bottom is made.

Because the automatic data evaluation is so fast, survey ships can make crossings every 75 feet or so instead of the usual several hundred feet. The accuracy on soundings is 10 centimeters at depths to 14 meters. Distance data is accurate within 0.1%.

Japan

Parking lights

The tribulations of Japanese motorists don't necessarily end when they finally get into a parking lot.

Throughout the crowded, space-tight country, there's a trend to underground parking garages designed for cramming in cars. The parking spaces in these garages are reached by narrow alleys between pillars, and all too often a driver finds himself up a blind alley with no place to park.

The Matsushita Communications Industrial Co. has found a way to end this particular frustration without burying induction loops in con-

crete floors or using high-cost detectors. The company's idea: put cadmium-sulphide photocells in the parking area—which is lit anyway with fluorescent lights—and use them to control a two-transistor circuit that switches indicator lights on the pillars on and off. When a slot is occupied, none of the overhead light hits the corresponding CdS cell below. It therefore develops no output, and the transistor circuit keeps the indicator light off.

The indicator lamps are grouped in threes, the number of parking slots between pillars. One photocell is used at the next-to-pillar slots. For the center slot, though, two cells are used since people tend to pay less attention there to the lines showing where to park.

Matsushita Communications, a subsidiary of the Matsushita Electrical Industrial Co., has installed one of these systems in a Yokohama underground lot and expects to sell many more. Because the biggest attraction of the scheme is its low cost, the company intends to keep it simple. But there's one refinement under consideration. As it is now, a garage equipped with the system must station an attendant at the entrance to each alley to keep out cars if all "slot empty" indicator lamps are off. In later versions, all the indicator lamps will be mounted on a central control panel and one attendant will be able to direct traffic for all the alleys.

Electronics advertisers

February 3, 1969

Airco Speer Electronic Components Hazard Adv. Co., Inc.	35	E/MC—Medical Electronics Seminar Slesar & Kanzer, Inc.	28, 29	Miller-Stephenson Chemical Co., Inc. Michel-Cather, Inc.	166
Airpax Electronics, Inc. Welch, Mirabile & Co., Inc.	136	Fairchild/Electro-Metrics Herbert Lindauer Associates	176	Millipore Corp. Czyryca/Design, Inc.	110
Allen-Bradley Co. Fensholt Adv. Agcy.	23, 25	Fairchild Semiconductor, Inc. Chiat/Day, Inc.	18, 19	□ Molex Products Co. Fensholt Adv., Inc.	4E, 5E
■ Amperex Electronics Corp., Div. of North American Phillips Co. Sam Groden, Inc.	47	■ General Electric Co., Silicone Products Div. Ross Roy of New York, Inc.	106	Monsanto Co. Michel-Cather, Inc.	26
Automatic Control Division, Cook Electric Co.	123	General Radio Co. Horton Church & Goff, Inc.	6	Monte Toole Associates Hal Lawrence, Inc.	165
Sander Rodkin Adv. Agcy., Ltd.		General Resistance, Div. of Chronetics J.S. Lanza & Associates	14	□ Morgan Group, The Scientific Adv. & Marketing, Ltd.	6E
■ Barnstead Subsidiary of Ritter Praudler Corp. Creamer, Trowbridge, Case & Basford, Inc.	147	■ Grayhill, Inc. Merchandising Adv., Inc.	169	Motorola Semiconductor Products Inc. Lane & Bird Adv., Inc.	91
■ Beckman Instruments, Inc., Hellpot Div. Hixson & Jorgensen, Inc.	37	■ Gudebrod Brothers Silk Co., Electronics Div. Ramsdell-Bickley & Co.	64	■ National Electronics, Inc. Connor-Sager Associates	165
Bendix Corp., Semiconductor Products Div. MacManus, John & Adams, Inc.	81	■ Heath Co., Sub. of Schlumberger Ltd. Advance Advertising Service	129	National Semiconductor Corp. Hall Butler Blatherwick, Inc.	10, 11
Bourns, Inc., Trimpot Div. The Lester Co.	17	Heinemann Electric Co. Thomas R. Sundheim, Inc.	16	New Hermes Engraving Machine Corp. Lester Harrison Adv., Inc.	168
■ Burroughs Corp., Electronic Components Div. Conti Adv. Agcy., Inc.	68	■ Hewlett Packard, H.P. Associates Lennen & Newell, Inc.	1	North American Rockwell, Autonetics Div. Campbell-Ewald Co.	156
■ Bussmann Mfg. Div. of McGraw Edison Co. Henderson Adv. Co.	166, 167	■ Hewlett Packard, International Div. Lennen & Newell, Inc.	186	Pastoriza Electronics Co. L.K. Frank Co.	158
Carpenter Technology Corp. Beaumont Heller & Sperling, Inc.	53	■ Hewlett Packard, Loveland Div. Tallant/Yates Advertising	2	■ Permag Corp. Schneider, Allen, Walsh, Inc.	160
■ Chicago Dynamic Industries, Inc. Burton Browne Advertising	36	■ Hewlett Packard, Microwave Div. Lennen & Newell, Inc.	133	□ Phillips N.V. PIT/EMA Div. Marsteller International S.A.	2E, 7E
Cimron Div. of Lear Siegler, Inc. Phillips Ramsey, Inc.	27	■ Hewlett Packard, Palo Alto Div. Lennen & Newell, Inc.	66	Phoenix Chamber of Commerce Jennings & Thompson Adv.	142
Cinch Graphik Div. of United Carr Fastener Co. Reach McClinton & Co.	134	■ Hewlett Packard, San Diego Div. Lennen & Newell, Inc.	150	Princeton Applied Research Corp. Mort Barish Assoc., Inc.	38
Clare & Co., C.P. Reincke, Meyer & Finn Adv., Inc.	20, 21	■ Hickok Electrical Instrument Co. Parsells Adv. Service	152	Radiation, Inc. W.M. Zemp & Assoc., Inc.	124
Clarostat Mfg. Co. Horton, Church & Goff, Inc.	67	Hughes Aircraft Co. Foote, Cone & Belding	12, 13	Radio Corporation of America Al Paul Lefton Co.	4th Cover, 139
■ CML Div. of Tenny Engineering Co. Keyes, Martin & Co.	132	IEEE (Institute of Electrical & Electronic Engineers) Alpaugh Advertising	168	Raytheon Semiconductor Botsford, Constantine & McCarty, Inc.	54, 55, 113
Colorado, State of, Industrial Development Div. Buchen Adv., Inc.	159	International Computer Products, Inc. Mike Engleman Communications	112	■ Rogan Brothers, Inc. Christopher Adv., Inc.	32
CREI, Home Study Div. of the McGraw-Hill Book Co. Henry J. Kaufman & Associates	171	■ International Crystal Mfg. Co. Robert V. Freeland & Associates	154	Rotron Mfg. Co. Lescarboura Adv., Inc.	8, 120
■ CTS Corp. Reincke, Meyer & Finn, Inc.	172, 173	IRC Incorporated Gray & Rogers, Inc.	161	□ Schneider R.T. Noirclerc Publicite	11E
■ Dale Electronics, Inc., Sub. of Lionel Corp. Swanson, Sinkey, Ellis, Inc.	3rd Cover	ITT Wire & Cable MacManus, John & Adams, Inc.	140	S.D.S.A. Publi-Service	128
Damon Engineering, Inc. L.K. Frank Co., Inc.	45	Krohn-Hite Corp. L.K. Frank Co., Inc.	127	Sealectro Corp. Lescarboura Adv., Inc.	118
Derlinger Metallurgical Corp. R.B. Advertising	109	■ Leach Corp. Chiat/Day, Inc.	51	Semcor Div. Components, Inc. Marketing & Corporate Communications, Inc.	65
DI-Acro Corp., Div. of Houdaille Industries, Inc. Charles E. Brown Adv. Agcy.	184	Lectrohm, Inc., a Subsidiary of Cook Electric Co. Sander Rodkin Adv. Agcy., Ltd.	122	■ Semtech Corp. Burruss Advertising	43
Digital Equipment Corp. Kalb & Schneider, Inc.	107	■ Magnetics, Inc. Lando Adv. Agcy., Inc.	149	Signetics Corp., Sub. Corning Glass Works Cunningham & Walsh, Inc.	105, 155
Digitran Co., The Precise Ink Adv. Service	170	□ Marconi Instruments, Ltd. Taylor Adv., Ltd.	8E	Siliconix Inc. Graphics West	7
■ Eagle Signal Div. of E.W. Bliss Co. Feeley & Wheeler, Inc.	48, 50, 52	■ Matsuo Electric Co., Ltd. Daiko Adv., Inc.	164	Soliton Devices, Inc., Transistor Div.	111
E G & G Incorporated Culver Adv., Inc.	164	Metal Removal Co., The Advertising Producers Associates	24	Haselmire Pearson Adv., Inc.	111
Elco Corp. Fien and Schwerin, Inc.	185	Metex Corp. Keyes, Martin & Co.	62	■ Sorensen Operation Raytheon Co. Urrutia & Hayes, Inc.	59
Electronics Management Center, The Slesar & Kanzer, Inc.	162	Micom, Inc. Lennen & Newell, Inc.	130	Sperry Gyroscope Co., Div. of Sperry Rand Corp.	146
Electro Rents Wyman Anderson-McConnell Adv. Agcy., Inc.	15	■ Microsonics, Inc. S. Gunnar Myrbeck & Co.	148	Sperry Rand Corp., Sperry Microwave Electronics Div. Neals & Hickok, Inc.	56
		■ Micro Switch, Div. of Honeywell N.W. Ayer & Son, Inc.	30	Sprague Electric Co., The The Harry P. Bridge Co.	5, 9
				Struthers Dunn, Inc. The Harry P. Bridge Co.	114
				Syntronic Instruments, Inc. Burton Browne Advertising	142
				□ Technique et Produits Ste de Publicite de Films et de Documentaires	12E

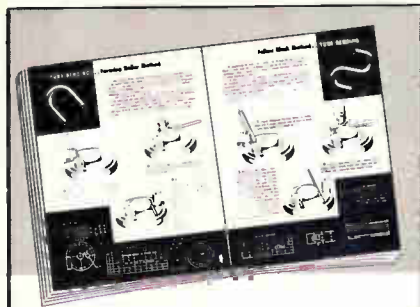

How to form it by **BENDING...**

Free Manual shows techniques of forming round, square, or hex bar stock... tubing... channel... angle... flat and other materials.

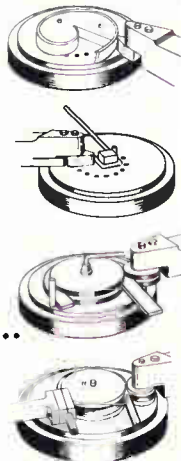

Di-Acro Hydra Power Bender

It's easy to bend a wide variety of material when you know how—profitable too because bending can simplify product design—make one curved piece do the job of two or more. Bending can improve product appearance and lower your production costs!

This 32-page illustrated manual shows how to make center eye and off center bends, circles, zero radius bends, scrolls, squares, springs and coils, loops and spirals—all with *one versatile machine*. Booklet also tells how to tool for tubular, channel, angles and other special bending needs.

Order your free copy today. See your nearest Di-Acro distributor or write us.



- Tektronix, Inc. 115, 116
- Dawson, Turner & Jenkins, Inc. 165
- Tenney Engineering, Inc. 138
- Keyes Martin & Co.
- Test Equipment Corp.
- Dean & Bain Adv., Inc.
- Texas Instruments Incorporated, Components Group 60, 61
- Don L. Baxter, Div. of Albert Frank-Guenther Law, Inc.
- Transitron Electronic Corp. 108
- Larcom Randall Adv., Inc.
- Triplett Electrical Instrument Co. 63
- Burton Browne Advertising
- Tropel, Inc. 153
- Mathison Adv., Inc.
- TRW Semiconductors, Inc. 144
- Fuller & Smith & Ross, Inc.
- Trygon Electronics, Inc. 121
- Kameny Assoc., Inc.
- Tung-Sol Div., Wagner Electric Corp. 169
- Feeley & Wheeler, Inc.

- United Transformer Co., Div. of TRW, Inc. 2nd Cover
- Fuller & Smith & Ross, Inc.
- Unitrode Corp. 49
- Silton Brothers, Inc.
- University Laboratories, Inc. 143
- West Associates

- Varo, Inc. 46
- Tracy-Locke Co., Inc.

- Watkins-Johnson Co. 3E
- William C. Estler Public Relations
- Weinschel Engineering Co. 22
- E.G. White Advertising, Inc.

Classified Advertising

F.J. Eberle, Manager

EMPLOYMENT OPPORTUNITIES

- Hamilton Standard 174
- Motorola 174

EQUIPMENT (Used or Surplus New) For Sale

- A & A Electronics Corp. 175
- Ewald Instruments Corp. 175
- Gadgets Surplus Electronics, Inc. 175
- Kings County Machinery Exchange. 175
- Radio Research Instrument Co. 175

- For more information on complete product line see advertisement in the latest Electronics Buyer's Guide
- Advertisers in Electronics International

Electronics Buyers' Guide

- George F. Werner, General Manager [212] 971-2310
- Robert M. Denmead, Midwest Regional Manager [312] MO 4-5800
- Regina Hera, Directory Manager [212] 971-2544
- Thomas M. Egan, Production Manager [212] 971-3140

Circulation Department

Isaaca Siegel, Manager [212] 971-6057

Research Department

David Strassler, Manager [212] 971-6058

Advertising Sales Staff

- Frank E. LeBeau [212] 971-6464 Advertising Sales Manager
- Wallis Clarke [212] 971-2187 Assistant to sales manager
- Donald J. Austermann [212] 971-3139 Promotion Manager
- Warren H. Gardner [215] LO 8-6161 Eastern Advertising Sales Manager
- Atlanta, Ga. 30309: Michael H. Miller, 1375 Peachtree St., N.E. [404] 892-2868
- Boston, Mass. 02116: William S. Hodgkinson McGraw-Hill Building, Copley Square [617] CO 2-1160
- Cleveland, Ohio 44113: William J. Boyle, 55 Public Square. [216] SU 1-7000
- New York, N.Y. 10036 500 Fifth Avenue
- James R. Pierce [212] 971-3615
- John A. Garland [212] 971-3617
- Michael J. Stoller [212] 971-3616
- Philadelphia, Pa. 19103: Jeffrey M. Preston
- Warren H. Gardner. 6 Penn Center Plaza, [215] LO 8-6161
- Pittsburgh, Pa. 15222: Warren H. Gardner, 4 Gateway Center, [412] 391-1314
- Rochester, N.Y. 14534: William J. Boyle, 9 Greylock Ridge, Pittsford, N.Y. [716] 586-5040
- Donald R. Furth (312) MO 4-5800 Midwest Advertising Sales Manager
- Chicago, Ill. 60611: Kenneth E. Nicklas Ralph Hanning 645 North Michigan Avenue, [312] MO 4-5800
- Dallas, Texas 75201: Richard P. Poole, 1800 Republic National Bank Tower, [214] RI 7-9721
- Houston, Texas 77002: Robert Wallin, 2270 Humble Bldg. [713] CA 4-8381
- Detroit, Michigan 48226: Ralph Hanning, 856 Penobscot Building [313] 962-1793
- Minneapolis, Minn. 55402: 1104 Northstar Center [612] 332-7425
- St. Louis, Mo. 63105: Kenneth E. Nicklas, The Clayton Tower, 7751 Carondelet Ave. [314] PA 5-7285

James T. Hauptli [415] DO 2-4600

- Western Advertising Sales Manager
- Denver, Colo. 80202: Joseph C. Page, David M. Watson, Tower Bldg., 1700 Broadway [303] 255-5484
- Los Angeles, Calif. 90017: Ian C. Hill, John G. Zisch, 1125 W. 6th St., [213] HU 2-5450
- Portland, Ore. 97204: James T. Hauptli, Thomas McElhinny, 218 Mohawk Building, 222 S.W. Morrison Street, Phone [503] 223-5118
- San Francisco, Calif. 94111: James T. Hauptli, Thomas McElhinny, 255 California Street, [415] DO 2-4600

Pierre Braude Tel: 225 85 88: Paris

- European Director
- Paris: Denis Jacob 88-90 Avenue Des Champs-Élysées, Paris 8
- United Kingdom and Scandinavia
- London: Oliver Ball, Tel: Hyde Park 1451 34 Dover Street, London W1
- Milan: Robert Saidel 1 via Baracchini Phone 86-90-656
- Brussels: F.I.H. Huntjens 27 Rue Ducale Tel: 136503
- Frankfurt/Main: Hans Haller Elsa-Brandstroem Str. 2 Phone 72 01 81
- Geneva: Denis Jacob 1, rue du Temple Phone: 31 95 60
- Tokyo: Takeji Kinoshita, McGraw-Hill Publications Overseas Corporation, 1 Kotohiracho, Shiba, Minato-ku, Tokyo, Japan
- Osaka: Akihiko Kamesaka, McGraw-Hill Publications Overseas Corporation, Kondo Bldg., 163, Urmegee-cho Kita-ku [362] 8771

Business Department

- Stephen R. Weiss, Production Manager [212] 971-2044
- Thomas M. Egan, Assistant Production Manager [212] 971-3140
- Oorothy Carmesin, Contracts and Billings [212] 971-2908
- Frances Valone, Reader Service Manager [212] 971-2865

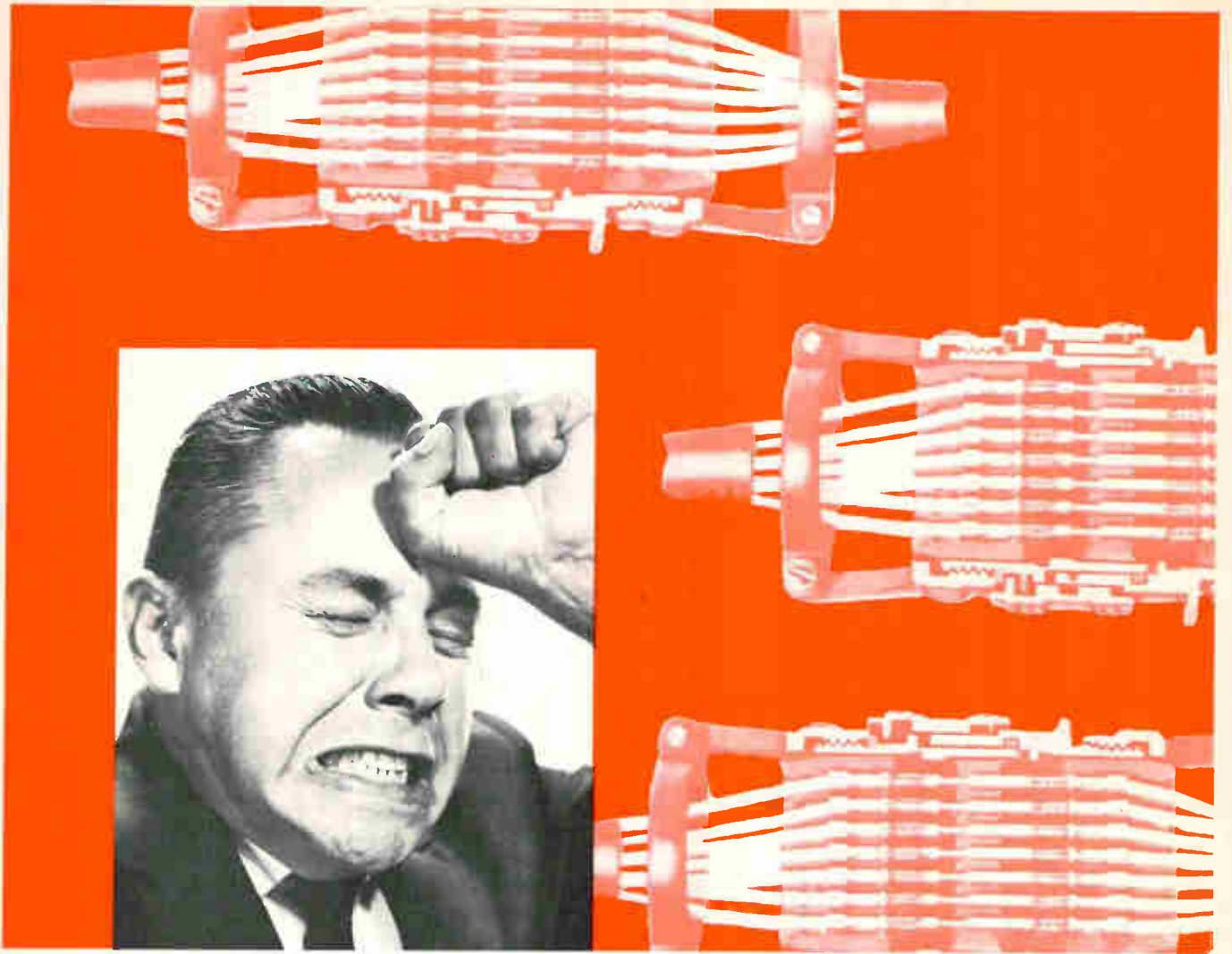

for fast, **FAST,** **F-A-S-T** RELIEF

OF YOUR MIL-26500 CYLINDRICAL CONNECTOR HANG-UPS.

When poor delivery and poor product are your problems, we can provide the relief you require. Fast delivery. Plus superior performance in our high-density, high-temperature miniatures. Dry film lubricant to insure continued low-friction, non-chafing surfaces. Special aluminum hardcoat to produce an extremely hard corrosion-resistant, non-conductive surface. (Also available with conductive finish). Crimp, removable contacts — both rhodium and gold per Mil-C-26636 (USAF). Rigid or resilient insert faces. All shell sizes and contact arrangements. Stop reaching for aspirins and reach for our Catalog instead. It'll always be there after you write, wire, call or TWX us for your copy. Elco Corporation, Willow Grove, Pa. 19090; 215-659-7000; TWX 510-665-5573.

P.S.—FREE SAMPLE? Let us know after you read one literature. We'll be delighted to send you one.

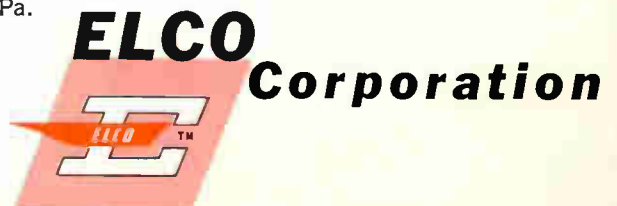

The Hewlett-Packard 4204A Digital Oscillator in one instrument gives you an accurate frequency source of measured amplitude. It provides 0.2% frequency accuracy in highly stable test signals for both lab and production applications. Low distortion, 0.01% frequency repeatability and a flat frequency response of 0.3% variation add to your dollar value.

The 4204A allows you to select any frequency between 10.0 Hz and 999.9 kHz to four significant figures... 36,900 discrete frequencies are available. One vernier

control provides infinite resolution and extends the upper frequency limit of the 4204A Oscillator to 1 MHz.

This oscillator also has a built-in impedance voltmeter to measure output. It is calibrated to read volts or dBm into a matched 600 ohm load. The output attenuator has an 80 dB range and is adjustable in 10 dB steps with a 20 dB vernier. Price is \$695.

Call your local HP field engineer for more information, or write Hewlett-Packard, Palo Alto, California 94304. Europe: 54 Route des Acacias, Geneva.

Stable and repeatable signal accuracy

HEWLETT  PACKARD
S I G N A L S O U R C E S

18701



Electronics reader service

Warning: The Post Office now requires your ZIP CODE on all mail. Please include your ZIP CODE number when filling out your reply card.

Use these handy post cards for more detailed information on: products advertised, new products, new literature.

Circle the number on the Reader Service post card that corresponds to the number at the bottom of the advertisement, new product item, or new literature in which you are interested.

Please print clearly. All written information must be legible to be efficiently processed.

If someone has beaten you to the post cards, you may obtain the needed information by writing directly to the manufacturer, or by sending your name and address, plus the Reader Service number, to Electronics Reader Service department.

All inquiries from outside the U.S. that cannot reach Electronics before the expiration dates noted on the Reader Service post card, must be mailed directly to the manufacturer. The manufacturer assumes all responsibilities for responding to inquiries. Electronics merely provides and clears requests for information from inquirer to manufacturer.

Correct amount of postage must be affixed for all mailings from outside the U.S.

To subscribe to or to renew Electronics

Fill in the "For Subscriptions" area on the card if you desire to subscribe to or renew your present subscription to Electronics. Send no money. Electronics will bill you at the address indicated on the Reader Service post card.

Multi-product advertisements

For information on specific items in multi-product advertisements which do not have a specific Reader Service number indicated write directly to manufacturer for information on precise product in which you are interested.

3 *For employment inquiries fill in home address. February 3, 1969 Card Expires April 3, 1969 14

Name _____ title _____

Company* _____

Address _____

City _____ State _____ Zip Code _____

For Subscriptions
 new renewal
 3 years \$16.00
 1 year \$8.00

1	20	39	58	77	96	115	134	153	172	191	210	229	248	267	286	305	324	343	362	381	400	419	438	457	476	495	514	962
2	21	40	59	78	97	116	135	154	173	192	211	230	249	268	287	306	325	344	363	382	401	420	439	458	477	496	515	963
3	22	41	60	79	98	117	136	155	174	193	212	231	250	269	288	307	326	345	364	383	402	421	440	459	478	497	516	964
4	23	42	61	80	99	118	137	156	175	194	213	232	251	270	289	308	327	346	365	384	403	422	441	460	479	498	517	965
5	24	43	62	81	100	119	138	157	176	195	214	233	252	271	290	309	328	347	366	385	404	423	442	461	480	499	518	966
6	25	44	63	82	101	120	139	158	177	196	215	234	253	272	291	310	329	348	367	386	405	424	443	462	481	500	900	967
7	26	45	64	83	102	121	140	159	178	197	216	235	254	273	292	311	330	349	368	387	406	425	444	463	482	501	901	968
8	27	46	65	84	103	122	141	160	179	198	217	236	255	274	293	312	331	350	369	388	407	426	445	464	483	502	902	969
9	28	47	66	85	104	123	142	161	180	199	218	237	256	275	294	313	332	351	370	389	408	427	446	465	484	503	951	970
10	29	48	67	86	105	124	143	162	181	200	219	238	257	276	295	314	333	352	371	390	409	428	447	466	485	504	952	971
11	30	49	68	87	106	125	144	163	182	201	220	239	258	277	296	315	334	353	372	391	410	429	448	467	486	505	953	972
12	31	50	69	88	107	126	145	164	183	202	221	240	259	278	297	316	335	354	373	392	411	430	449	468	487	506	954	973
13	32	51	70	89	108	127	146	165	184	203	222	241	260	279	298	317	336	355	374	393	412	431	450	469	488	507	955	974
14	33	52	71	90	109	128	147	166	185	204	223	242	261	280	299	318	337	356	375	394	413	432	451	470	489	508	956	975
15	34	53	72	91	110	129	148	167	186	205	224	243	262	281	300	319	338	357	376	395	414	433	452	471	490	509	957	976
16	35	54	73	92	111	130	149	168	187	206	225	244	263	282	301	320	339	358	377	396	415	434	453	472	491	510	958	977
17	36	55	74	93	112	131	150	169	188	207	226	245	264	283	302	321	340	359	378	397	416	435	454	473	492	511	959	978
18	37	56	75	94	113	132	151	170	189	208	227	246	265	284	303	322	341	360	379	398	417	436	455	474	493	512	960	979
19	38	57	76	95	114	133	152	171	190	209	228	247	266	285	304	323	342	361	380	399	418	437	456	475	494	513	961	980

3 *For employment inquiries fill in home address. February 3, 1969 Card Expires April 3, 1969 14

Name _____ title _____

Company* _____

Address _____

City _____ State _____ Zip Code _____

For Subscriptions
 new renewal
 3 years \$16.00
 1 year \$8.00

1	20	39	58	77	96	115	134	153	172	191	210	229	248	267	286	305	324	343	362	381	400	419	438	457	476	495	514	962
2	21	40	59	78	97	116	135	154	173	192	211	230	249	268	287	306	325	344	363	382	401	420	439	458	477	496	515	963
3	22	41	60	79	98	117	136	155	174	193	212	231	250	269	288	307	326	345	364	383	402	421	440	459	478	497	516	964
4	23	42	61	80	99	118	137	156	175	194	213	232	251	270	289	308	327	346	365	384	403	422	441	460	479	498	517	965
5	24	43	62	81	100	119	138	157	176	195	214	233	252	271	290	309	328	347	366	385	404	423	442	461	480	499	518	966
6	25	44	63	82	101	120	139	158	177	196	215	234	253	272	291	310	329	348	367	386	405	424	443	462	481	500	900	967
7	26	45	64	83	102	121	140	159	178	197	216	235	254	273	292	311	330	349	368	387	406	425	444	463	482	501	901	968
8	27	46	65	84	103	122	141	160	179	198	217	236	255	274	293	312	331	350	369	388	407	426	445	464	483	502	902	969
9	28	47	66	85	104	123	142	161	180	199	218	237	256	275	294	313	332	351	370	389	408	427	446	465	484	503	951	970
10	29	48	67	86	105	124	143	162	181	200	219	238	257	276	295	314	333	352	371	390	409	428	447	466	485	504	952	971
11	30	49	68	87	106	125	144	163	182	201	220	239	258	277	296	315	334	353	372	391	410	429	448	467	486	505	953	972
12	31	50	69	88	107	126	145	164	183	202	221	240	259	278	297	316	335	354	373	392	411	430	449	468	487	506	954	973
13	32	51	70	89	108	127	146	165	184	203	222	241	260	279	298	317	336	355	374	393	412	431	450	469	488	507	955	974
14	33	52	71	90	109	128	147	166	185	204	223	242	261	280	299	318	337	356	375	394	413	432	451	470	489	508	956	975
15	34	53	72	91	110	129	148	167	186	205	224	243	262	281	300	319	338	357	376	395	414	433	452	471	490	509	957	976
16	35	54	73	92	111	130	149	168	187	206	225	244	263	282	301	320	339	358	377	396	415	434	453	472	491	510	958	977
17	36	55	74	93	112	131	150	169	188	207	226	245	264	283	302	321	340	359	378	397	416	435	454	473	492	511	959	978
18	37	56	75	94	113	132	151	170	189	208	227	246	265	284	303	322	341	360	379	398	417	436	455	474	493	512	960	979
19	38	57	76	95	114	133	152	171	190	209	228	247	266	285	304	323	342	361	380	399	418	437	456	475	494	513	961	980

3 *For employment inquiries fill in home address. February 3, 1969 Card Expires April 3, 1969 14

Name _____ title _____

Company* _____

Address _____

City _____ State _____ Zip Code _____

For Subscriptions
 new renewal
 3 years \$16.00
 1 year \$8.00

1	20	39	58	77	96	115	134	153	172	191	210	229	248	267	286	305	324	343	362	381	400	419	438	457	476	495	514	962
2	21	40	59	78	97	116	135	154	173	192	211	230	249	268	287	306	325	344	363	382	401	420	439	458	477	496	515	963
3	22	41	60	79	98	117	136	155	174	193	212	231	250	269	288	307	326	345	364	383	402	421	440	459	478	497	516	964
4	23	42	61	80	99	118	137	156	175	194	213	232	251	270	289	308	327	346	365	384	403	422	441	460	479	498	517	965
5	24	43	62	81	100	119	138	157	176	195	214	233	252	271	290	309	328	347	366	385	404	423	442	461	480	499	518	966
6	25	44	63	82	101	120	139	158	177	196	215	234	253	272	291	310	329	348	367	386	405	424	443	462	481	500	900	967
7	26	45	64	83	102	121	140	159	178	197	216	235	254	273	292	311	330	349	368	387	406	425	444	463	482	501	901	968
8	27	46	65	84	103	122	141	160	179	198	217	236	255	274	293	312	331	350	369	388	407	426	445	464	483	502	902	969
9	28	47	66	85	104	123	142	161	180	199	218	237	256	275	294	313	332	351	370	389	408	427	446	465	484	503	951	970
10	29	48	67	86	105	124	143	162	181	200	219	238	257	276	295	314	333	352	371	390	409	428	447	466	485	5		

Reprint service

All Electronics editorial matter available in reprint form:

For reprints of special reports and feature articles see list on right side of this page. Send your order to Electronics Reprint Department at the address indicated. To expedite mailing of your order for single reprints please send cash, check or money order with your order. Allow 3-4 weeks for delivery.

Bulk reprints of editorial matter can be ordered from current or past issues. The minimum quantity is 100 copies. Prices quoted on request: call 212-971-2274, or write to address below.

Warning: The Post Office now requires your ZIP CODE on all mail. Please include your ZIP CODE number when filling out your reply card.

3

Business reply mail

No postage stamp necessary if mailed in the United States

Postage will be paid by

Electronics
Reader service department
Box 444
Hightstown, N. J. 08520

First class
Permit no. 42
Hightstown, N. J.



2

Business reply mail

No postage stamp necessary if mailed in the United States

Postage will be paid by

Electronics
Reader service department
Box 444
Hightstown, N.J. 08520

First class
Permit no. 42
Hightstown, N. J.



1

Business reply mail

No postage stamp necessary if mailed in the United States

Postage will be paid by

Electronics
Reader service department
Box 444
Hightstown, N.J. 08520

First class
Permit no. 42
Hightstown, N. J.



To order reprints or for further information, please write to: **Electronics Reprint Department, 330 West 42nd Street, New York, N.Y. 10036.**

You may order any of the below listed reprints by key number. Discounts on quantities over 10.

- Key no. R-01 Computer-aided Design: Part I, The Man-machine Merger. 16 pages. \$1.25.
- Key no. R-02 Vietnam Communications Network Growing Into Southeast Asia's Best. 3 pages. 25¢.
- Key no. R-04 Multilayer Circuit Boards: Sharpening An Imperfect Art. 7 pages. 50¢.
- Key no. R-05 Topology Cuts Design Drudgery. 12 pages. 50¢.
- Key no. R-06 Report on Japanese Technology: Sony. 20 pages. 50¢.
- Key no. R-010 Special Report on Large Scale Integration. 54 pages. \$1.50.
- Key no. R-011 Medical Electronics (1967). 8 part series, 44 pages. \$1.25.
- Key no. R-012 Special Report on Gallium Arsenide 17 parts. 32 pages. \$2.00
- Key no. R-016 Special Report on The Transistor: Two Decades of Progress. 48 pages. \$1.50.
- Key no. R-017 Special Report on Ferrites. 16 pages. \$1.00.
- Key no. R-018 European Electronics Markets 1969 20 page forecast report with a 6 page foldout. \$1.00
- Key no. R-019 U.S. Electronics Markets 1969 32 page forecast report with 4 page foldout. \$1.00
- Key no. R-020 1968 Electronics Index to Technical Articles and Authors Free.
- Key no. R-87a The Packaging Revolution in Microelectronics. Parts I through VI. 64 pages. \$2.00.
- Key no. R-79 MOS Integrated Circuits. 12 pages. 50¢.
- Key no. R-78 The Overlay Transistor. 15 pages. 50¢.
- Key no. R-75 Biotelemetry. 2 part series, 16 pages. 50¢.
- Key no. R-64 Field Effect Transistors. Parts I, II, and III. 64 pages. \$1.00.

Competitively priced

Dale Econo-Trims

let you choose wirewound or film T-Pots in both 3/4" and 1" styles – sealed or unsealed!



3/4"

ECONO-TRIM

2400 SERIES/WIREWOUND
8400 SERIES/FILM

SPECIFICATIONS

Dimensions: .31" H x .16" W x .75 L

Standard Resistance: 2400 = 10 ohms to 50K ohms; 8400 = 10 ohms to 2 Megohms

Resistance Tolerance: 2400 = $\pm 10\%$;
8400 = $\pm 10\%$ 100 ohms thru 500K ohms,
 $\pm 20\%$ all other values

Power Rating: 2400 = 1 watt at 40° C;
8400 = .75 watt at 25° C

Operating Temperature Range: -55° C to 125° C

Mechanical Adjustment: 20 turns nominal

Mechanical Stops: None. Clutch permits overtravel without damage

Models: Sealed or unsealed with gold-plated PC terminals

DALE ELECTRONICS, INC.

1300 28th Avenue, Columbus, Nebr. 68601
In Canada: Dale Electronics Canada, Ltd.

1"

ECONO-TRIM

2300 SERIES/WIREWOUND
8300 SERIES/FILM

SPECIFICATIONS

Dimensions: .36" H x .28" W x 1.00" L

Standard Resistance: 2300 = 10 ohms to 50K ohms; 8300 = 10 ohms to 2 Megohms

Resistance Tolerance: 2300 = $\pm 10\%$;
8300 = $\pm 10\%$ 100 ohms thru 500K ohms,
 $\pm 20\%$ all other values

Power Rating: 2300 = 0.5 watt at 25° C;
8300 = .75 watt at 25° C

Operating Temperature Range: -55° C to 105° C

Mechanical Adjustment: 15 turns nominal

Mechanical Stops: None. Clutch permits overtravel without damage

Models: Sealed or unsealed. Gold-plated PC terminals or gold-plated hook type solder lugs

DALE ELECTRONICS, INC.

1300 28th Avenue, Columbus, Nebr. 68601
In Canada: Dale Electronics Canada, Ltd.

**You can do more with
Dale T-Pots... call 402-564-3131 today**



First Photomultiplier with a Gallium Phosphide Dynode— Offers Order of Magnitude Improvement in Electron Resolution

Electron Resolution Capability of photomultipliers formerly attainable.

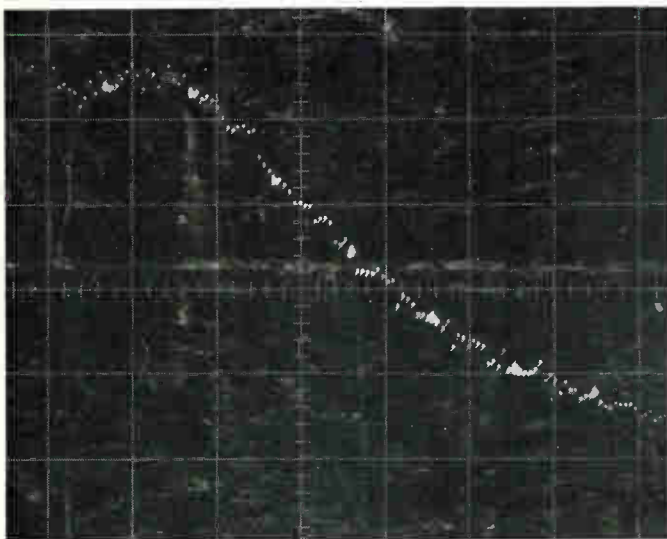

1e 2e 3e 4e 5e 6e
Pulse Height-Photoelectron Equivalents

Electron Resolution Capability of RCA — C31000D.

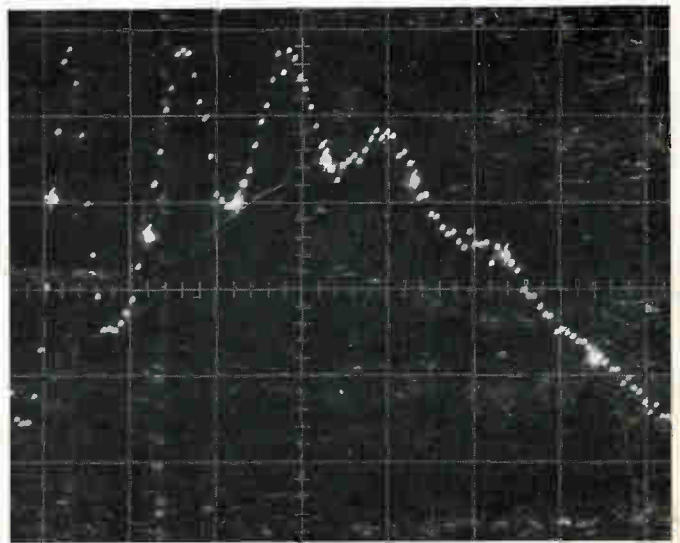

1e 2e 3e 4e 5e 6e
Pulse Height-Photoelectron Equivalents



It's new...even revolutionary! It's the C31000D—a photomultiplier employing a new dynode material for extremely low-light-level applications, such as photon and scintillation counting, with a pulse height resolution so outstanding you can distinguish with ease single, double, triple, and quadruple photoelectron events.

Gallium Phosphide does it! Providing up to an order of magnitude increase in gain over conventional dynode materials, this gallium phosphide approach must be considered at the forefront of new photomultiplier designs for greatly improved low-light-level performance. In addition to improvements in electron resolution, Gallium Phosphide promises lower values of rise time and transit time in future photomultiplier designs.

RCA-C31000D is a 12-stage, bi-alkali, photocathode type photomultiplier utilizing Gallium Phosphide as the first dynode secondary emission material. At a cathode to dynode No. 1 voltage of 900 volts, the first dynode secondary emission ratio is typically 45.

For more information on RCA Photomultipliers and RCA-C31000D in particular, see your RCA Representative. For technical data, write: RCA Electronic Components, Commercial Engineering, Section No. B-19T-1, Harrison, New Jersey 07029.

RCA