

Electronics®

Product development at IEEE: page 88
Making thin-film circuits in East Germany: page 110
Employment survey: where the jobs are: page 156

March 7, 1966

75 cents

A McGraw-Hill Publication

Below: Microwave heating finds
industrial applications: page 123

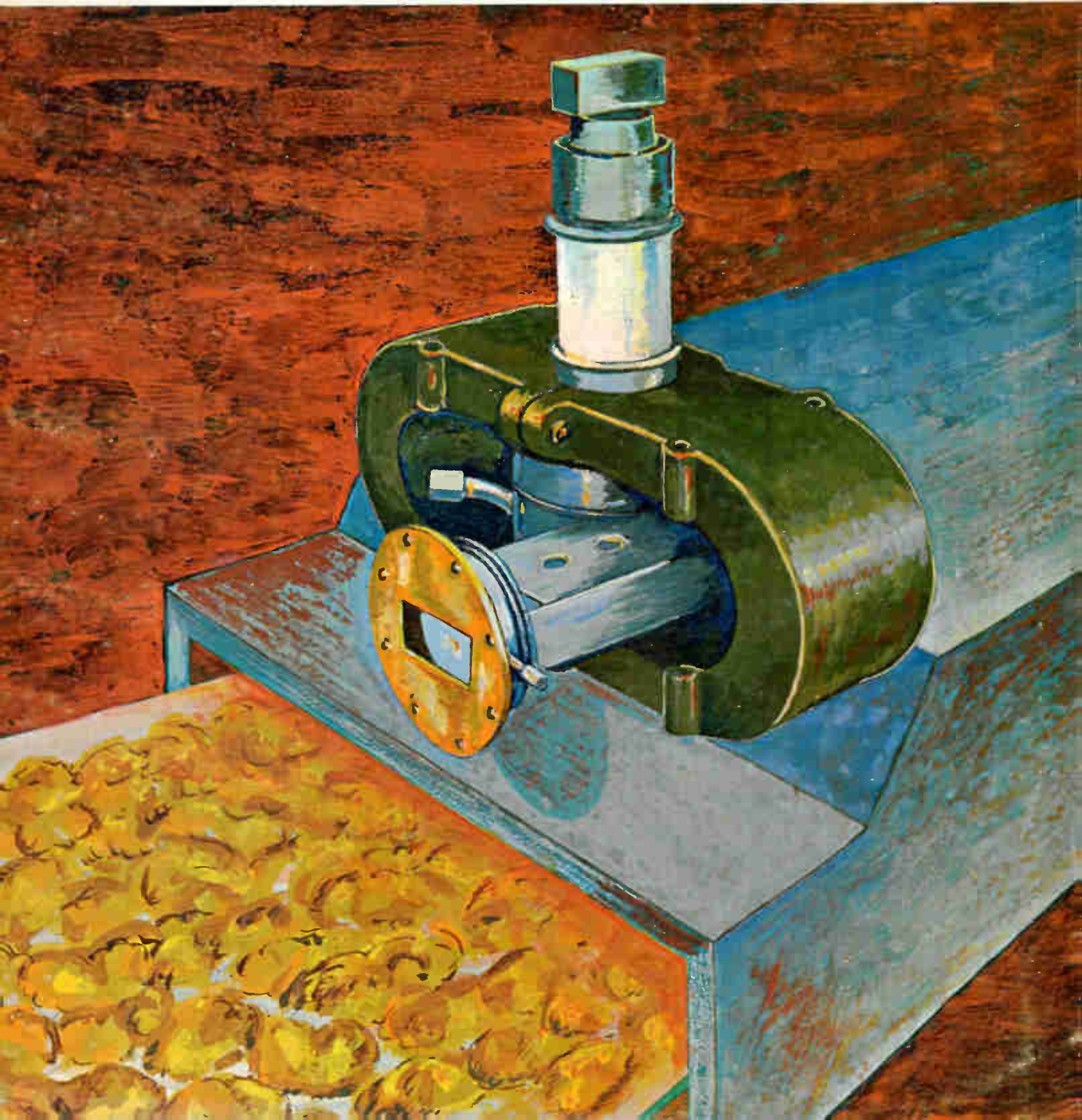



HI-FI



Transistor output; matches any PP transistor to 4, 8, 16 Ω speaker. Primary 48, 36, 12 Ω C.T.; 20 \sim to 20 KC; 40 watts.

MINIATURE MIL TYPE



Metal case hermetically sealed to MIL-T-27B. Gold Dumet leads spaced on 0.1 radius, for printed circuit application.

CHOPPER



Magnetic shielded plus electrostatic shield for voltage isolation of 2×10^6 . Primary 200K C.T. to within 0.1%. Secondary 50K.

HIGH POWERED AUDIO



Low distortion 2.5 KW output transformer, PP 450 TH's 18,500 ohms C.T. to 24/6 ohms, 20 KV hipot. 520 lbs.

CATHODE FOLLOWER OUTPUT



Provides equal voltages to 5 loads. Primary inductance maintained to 5% with 20% change in DC unbalance and 30% change in AC voltages.

"SPECIAL" CUSTOM BUILT AUDIO TRANSFORMERS TO YOUR SPECIFICATIONS

HI-FREQUENCY CARRIER TO MIL-T-27B



Electrostatically shielded, humbucking, +30 dbm level. With in .5 db 250 cycles to 110 KC. 600/135: 600 centertapped to .1% tolerance.

HYBRID TRANSFORMER



Two transformers each 600 Ω primary. 40K Ω C.T. secondary 250 cycles to 5 KC within 1/4 db. 40 db isolation over band.

MICROMODULE



Life tested per micromodule specs.: no failures. 10K Ω C.T. to 10K Ω , 100 mw from 400 \sim to 20KC.

Exceptional quality and reliability is provided in all UTC designs. Over 30 years of engineering knowledge and experience substantiated by extensive field performance assure the highest quality and most reliable components in the industry. Complete environmental testing facilities are incorporated to prove out new designs. Full analysis and evaluation of materials are conducted in UTC's Material and Chemical Laboratories. Rigid quality control measures coordinated with exhaustive statistical findings and latest production procedures results in the industry's highest degree of reliability. Range covered in Audio Transformers is from 0.1 cycles to 400 MC . . . microwatts to 50 KW.

SUBMINIATURE MOLDED TRANSFORMER



Grade 3 with printed circuit leads for transistor application. 150 Ω to 150 Ω at 10 dbm level. Size 1/2 x 1/2 x 1/2"; weight 5 grams.

BOLOMETER TRANSFORMER



Primary 10 ohms, secondary 530K ohms, 230:1 ratio, response from 1/2 cycle to 25 cycles. 120 db magnetic shielding, plus full electrostatic shielding.

ULTRA-MINIATURE



Electrostatically & magnetically shielded output transformer 1/2. D. x 1/4" H. Pri. 15K CT, Sec. 8K CT; max. level 50 mw; audio range response. To MIL-T-27B, grade 4.

MILITARY AND COMMERCIAL TYPES FOR EVERY PHASE OF THE ELECTRONICS ART

- POWER TRANSFORMERS
- AUDIO TRANSFORMERS
- INDUCTORS
- PULSE TRANSFORMERS
- ELECTRIC WAVE FILTERS
- LUMPED CONSTANT DELAY LINES
- HIGH Q COILS
- MAGNETIC AMPLIFIERS
- SATURABLE REACTORS
- REFERENCE UNITS

Write for catalog of over 1,300 UTC TOP QUALITY STOCK ITEMS IMMEDIATELY AVAILABLE from your local distributor.



UNITED TRANSFORMER CORP.
150 VARICK STREET, NEW YORK 13, N. Y.

PACIFIC MFG. DIVISION: 3630 EASTHAM DRIVE, CULVER CITY, CALIF.
EXPORT DIVISION: 13 EAST 40th STREET, NEW YORK 16, N. Y. CABLE: "ARLAB"

NEW DVM



This special version of the popular, field-proven Hewlett-Packard 3460A Digital Voltmeter provides an accuracy and stability that makes 1 ppm resolution realistic.

ACCURACY—The H04-3460A can measure up to 1200 v and maintain an absolute accuracy of $\pm 0.002\%$ of reading or $\pm 0.0004\%$ of full scale for 24 hours after calibration. Long-term absolute accuracy is $\pm 0.005\%$ of reading or 0.0005% of full scale, guaranteed for 90 days (over 20°-30°C).

STABILITY—Typical stability of the internal reference is 0.001% per month. Readings are typically repeatable to better than 2 ppm.

USES—Low-level (strain gauge, thermocouple, transducer) measurements with an absolute accuracy not obtainable before (0.005% of reading at 100 mv). Semiconductor temperature coefficient and long-term stability monitoring. Standard cell intercomparison with 1 μv resolution (ten times more than previously available). Null detection applications with typical 2 μv error.

Besides programmability and BCD output, the H04-3460A has front and rear isolated inputs so that measurements can be compared against a rear-connected standard cell by using the convenient front-panel switch.

With the low price of \$4250, you may want to call your Hewlett-Packard field engineer or write for more information to Hewlett-Packard, Palo Alto, California 94304, Tel. (415) 326-7000; Europe: 54 Route des Acacias, Geneva.

**1 μv in 1 v,
1 mv in 1000 v—
six full digits,
plus a seventh
for 20%
overranging!**



HEWLETT  **PACKARD**
An extra measure of quality

Data subject to change without notice. Price f.o.b. factory.

See it at IEEE, 3rd floor New York Coliseum, March 21-24

1189



new disciplines in DC



take the model that leads a double life

Functions as power supply or amplifier DC output is variable through zero

As a DC Power Supply, Model 6823A can be controlled from the front panel, or remotely programmed with resistance or voltage; the low output drift and noise combined with high speed programming adapt this supply to a wide variety of laboratory and production testing applications.

As a DC coupled Power Amplifier, the unusually low output impedance, distortion, ripple and noise make the 6823A useful in servo systems, as a pulse or oscillator amplifier, and for motor control. Constant Current output is readily achieved by connecting a current monitoring resistor to the rear terminal barrier strip—makes an ideal driver-amplifier for deflection coils!

All Semiconductor Design • Short Circuit Proof, Current Limited Output
 No Overshoot for Turn-On, Turn-Off, or Power Removal • Rack Mounting
 Hardware Available • Two Fixed Auxiliary Outputs, -20V and +20V
 @ 0-100 MA, for powering auxiliary circuits.

High Speed Programming DC Power Supply	10-Watt Peak Output DC Power Amplifier
Output: -20 to +20 VDC @ 0-0.5A Load Regulation: 0.02% +5 MV Line Regulation: 0.02% +5 MV Ripple & Noise: 2 MV rms Programming Speed: Less than 100 μ sec for a 40V output change	Output: 40 volts P-P @ 0-0.5A Voltage Gain: Variable 0-10 (20 DB) Frequency Response: At full output ± 3 DB from DC to 20 KHZ Distortion: 0.02% at 1 KHZ Input Impedance: 2000 Ohms
Size: 3½" H x 13" D x 8¼" W—half rack width Weight: 16 Pounds Price: Model 6823A—\$194.	

Contact your nearest Hewlett-Packard Sales Office for full specifications.

HEWLETT
 PACKARD HARRISON
 DIVISION

100 Locust Ave., Berkeley Heights, New Jersey 07922 AREA CODE 201 464-1234 TWX 201-464-2117

See it at I.E.E.E.—March 21 Through 24 Third Floor at the New York Coliseum

Electronics

March 7, 1966
Volume 39, Number 5

Page	4	Readers Comment
	8	People
	14	Meetings
	16	Meeting Preview
	23	Editorial
	25	Electronics Newsletter
	49	Washington Newsletter
	196	Reprints
	207	New Products
	273	New Books
	278	Technical Abstracts
	294	New Literature

Electronics Review

Page	33	Monolithic hybrids	36	Explaining the budget
	34	Perspective on tv	40	Extras for Vietnam
	35	Electron beam's new field	41	C-5A race continues
	35	Bloodless surgery	42	Braking the copying habit
	36	Kraftsmanship for Apollo	44	The copper squeeze
			46	Electronics notes

Probing the News

151	Washington dims CATV picture
156	Wanted: electronics engineers
169	Narrowing the search for information
178	Satellite's hidden talent
189	Navy gives rescue sub top priority

Electronics Abroad

299	Tighter defense	302	Diamond in the sky
300	Cores by deposit	304	New memories
300	Growth industries	306	Bitter patent medicine
301	Mountain-top fuel cells	308	Around the world

Technical Articles

Product development	88	IEEE Show: no surprises New products reflect continuing technical trends rather than startling innovation
Circuit design	104	Designer's casebook <ul style="list-style-type: none">▪ Adapter for curve tracer tests FET's at high voltage▪ High-speed level shifter▪ Low-current alarm▪ Thermistor regulator responds quickly▪ Adjustable current limiter regulates power supply
Manufacturing	110	Automated electron beams process thin films East German scientists have developed techniques that promise high volume production M. von Ardenne, Siegfried Schiller and Ulrich Heisig, Manfred von Ardenne Research Institute
Instrumentation	117	Noise simulators spot power-line defects How to build in safeguards against disturbances in power sources M.L. Tandon, International Business Machines Corp.
Industrial electronics	123	Microwaves on the production line (cover) After a lot of talk about the possibility, microwaves are finally doing process heating P.W. Crapuchettes, Litton Industries
Circuit design	133	Powerful logic from power-less circuits Inexpensive transistors acting as switches eliminate external power sources P. Abramson and A.X. Widmer, IBM

Title R registered
U.S. Patent Office;
© copyright 1966
by McGraw-Hill, Inc.
All rights reserved,
including the right to
reproduce the contents
of this publication,
in whole or in part.

Electronics

Editor: Lewis H. Young

Senior editors

Technical: Samuel Weber

News: Kemp Anderson Jr.

Senior associate editors: John F. Mason, George Sideris

Department editors

Advanced technology: Joan Blum

Avionics: W.J. Evezia

Computers: Wallace B. Riley

Consumer electronics: Richard Lipkin

Electronics abroad: Arthur Erikson

Electronics review: Stanley Zarowin

Instrumentation: Carl Moskowitz

Manufacturing: George Sideris

Military electronics: John F. Mason

New products: William P. O'Brien

Solid state: Jerome Eimbinder

Space electronics: Robert Henkel

Regional editors

Domestic

Boston: Thomas Maguire, editor; Robin Carlson

Los Angeles: William B. Wallace, Walter Barney, editors; June Ranill

San Francisco: Laurence D. Shergalis, Edmond G. Addeo, editors; Mary Jo Jadin

Foreign

European: Derek Barlow, (London)

Bonn: John Gosch

Tokyo: Charles Cohen

Copy editors

Howard Rausch, Sally Powell, Kenneth Munn, James J. Moran

Graphic design

Art director: Saul Sussman

Assistant art directors: Donna M. Griffiths, Ann Mella

Production editor: Arthur C. Miller

Editorial secretaries: Claire Benelli, Mary D'Angelo, Lynn Emery, Lorraine Fabry, Kay Fontana, Lorraine Longo, Carolyn Michnowicz

McGraw-Hill News Service

Director: John Wilhelm; Atlanta: Fran Ridgway; Chicago: Reck Johnson;

Cleveland: Arthur Zimmerman; Dallas: Marvin Reid;

Detroit: N. Hunter; Houston: Ron Lovell; Los Angeles: Michael Murphy, Gerald Parkinson;

San Francisco: Margaret Ralston;

Seattle: Ray Bloomberg; Washington: Arthur L. Moore, Charles Gardner,

Herbert W. Cheshire, Seth Payne, Warren Burkett, Warren Kornberg

McGraw-Hill World News Service

Bonn: John Johnsrud; Brussels: Arthur Erikson; London: John Shinn;

Mexico City: Bruce Cross; Milan: Ronald Taggiasco;

Moscow: Donald Winston; Paris: Dan Smith;

Rio de Janeiro: Leslie Perry; Tokyo: Marvin Petal

Circulation manager: Hugh J. Quinn

Reprints: T.M. Egan

Publisher: C.C. Randolph

Electronics: March 7, 1966, Vol. 39, No. 5

Printed at 99 North Broadway, Albany, N.Y., 12207
Second class postage paid at Albany, N.Y.

Subscriptions are solicited only from those actively engaged in the field of the publication. Position and company connection must be indicated on orders. Subscription prices: United States and Possessions and Canada, \$6.00 one year, \$9.00 two years, \$12.00 three years. All other countries \$20.00 one year. Single copies, United States and Possessions and Canada 75¢. Single copies all other countries \$1.50.

Published every other Monday by McGraw-Hill Inc. 330 West 42nd Street, New York, N.Y. 10036. Founder: James H. McGraw, 1860-1948. Corporate officers: Shelton Fisher, President; John J. Cooke, Secretary; John L. McGraw, Treasurer.

Subscribers: The Publisher, upon written request to our New York office from any subscriber, agrees to refund that part of the subscription price applying to copies not yet mailed. Please send change of address notices, subscription orders or complaints to Fulfillment Manager, Electronics, at the address below. Change of address notices should provide old as well as new address, including postal zone number if any. If possible, attach address label from recent issue. Allow one month for change to become effective.

Postmaster: Please send Form 3579 to Fulfillment Manager, Electronics, P.O. Box 430, Hightstown, New Jersey 08520

Readers Comment

A missing link

To the Editor:

In your report on Japan [Dec. 13, 1965, p. 100] you say:

"When NTT [Nippon Telephone and Telegraph Public Corp.] completed its first broadband 4-Gc/s system in 1954, the telephone company was the first in the world with a traveling-wave tube in a commercially operated repeater."

Our records show that in 1952 Standard Telephones and Cables Limited installed a microwave link between Manchester and Edinburgh for the British Post Office, and the repeaters used traveling-wave tubes.

Geoffrey Charlish

Standard Telephone
and Cables Ltd.
London

Wrong steer

To the Editor:

As the research engineer in charge of the electronic system for the automatic steering car at the Government Mechanical Laboratory in Japan, I was delighted to see the description of our "Automobile pilot" [Aug. 23, 1965, p. 168].

Though the story was an excellent description of our system, a few minor errors crept in. They were: the pumping frequency (we called it the exciting frequency) is 300 kc/sec, rather than 600 kc/sec; the inductance loops are activated by the oscillating current of the parametrons—its frequency is 150 kc/sec, rather than 300 kc/sec; and finally, one input to the detecting parametron is a 150 kc/sec signal—not 300 kc/sec from an inductance loop. The other input from a pure resistance gives a threshold level to the parametron at the same frequency, but 180° out of phase.

Shuntetsu Matsumoto

Government Mechanical
Laboratory
Tokyo

Computer talk

To the Editor:

In the article entitled "Time sharing: one machine serving many

Did you know Sprague makes...?

UNICIRCUIT® RCTL INTEGRATED CIRCUITS

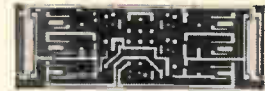

(8x actual size)

Sprague Series US-0100 . . . a complete line of monolithic digital building blocks featuring low power consumption (2 mW typ.)

Circle 561 on reader service card

UNICIRCUIT® RTL INTEGRATED CIRCUITS



TO-5 CASE

Types US-0708 through US-0721 . . . Fully interchangeable mW digital building blocks featuring power consumption of 4 mW/node and propagation delay of 40 nanoseconds.

Circle 562 on reader service card

DIFFERENTIAL AMPLIFIER TRANSISTOR PAIRS

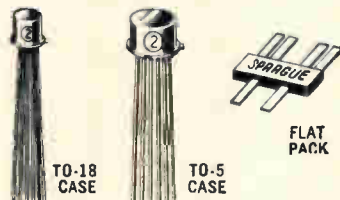

NPN or PNP • Matched characteristics.
 $h_{FE} = 10-20\%$. $\Delta V_{BE} = 5-20$ mV.
 $\Delta V_{BE}/Temp = 5-20$ $\mu V/^{\circ}C$.

Circle 563 on reader service card

MULTIPLE TRANSISTORS (NPN-PNP PAIRS/QUADS)



AMPLIFIERS SWITCHES CHOPPERS

Pairs		Quads	
2 NPN		4 NPN	
2 PNP		4 PNP	
1 NPN—1 PNP		2 NPN—2 PNP	

Circle 564 on reader service card

UNICIRCUIT® CUSTOM HYBRID CIRCUITS



Combine monolithic silicon circuits with Ni-Cr alloy resistors. Close resistance tolerances, low temperature coefficient, $\pm 2\%$ resistor matching.

Circle 565 on reader service card

LOW-COST HERMETICALLY- SEALED PLANAR TRANSISTORS

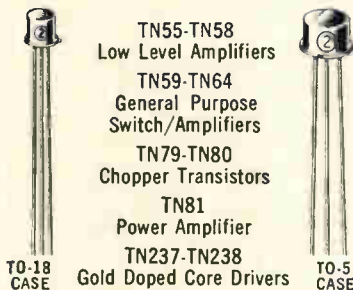

TN55-TN58
Low Level Amplifiers
 TN59-TN64
General Purpose
Switch/Amplifiers
 TN79-TN80
Chopper Transistors
 TN81
Power Amplifier
 TN237-TN238
Gold Doped Core Drivers

Circle 566 on reader service card

SILICON ALLOY REPLACEMENT TRANSISTORS

FULL PLANAR RELIABILITY

2N327A	2N945	2N1026
2N328A	2N946	2N1469
2N329A	2N1025	2N1917

Sprague makes 82 standard high-emitter-voltage full planar silicon alloy replacement types.

Circle 567 on reader service card

DUET* HIGH-VOLTAGE DUAL-EMITTER TRANSISTORS



New Type 3N123 low-cost transistor with 25-volt rating now available.

Sprague makes more dual-emitter chopper transistors than any other source.

★Trademark

Circle 568 on reader service card

TWIN DUET* DUAL-EMITTER TRANSISTORS IN FLAT PACKS

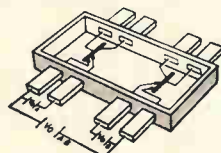

Sprague leads again with two dual-emitter chopper transistors in one flat-pack case, with tight V_{OFF} matching of both devices.

★Trademark

Circle 569 on reader service card

For complete technical data on any of these products, write to Technical Literature Service, Sprague Electric Company, 35 Marshall Street, North Adams, Massachusetts 01248.

455-5152

SPRAGUE
THE MARK OF RELIABILITY

*Sprague and "©" are registered trademarks of the Sprague Electric Co.



The Coherent Tone Burst

...an interrupted periodic wave... invaluable for audio and ultrasonic testing

Useful for: Recovery-from-overload tests of wide-band amplifiers. • Amplifier peak-power tests which avoid overloading the power supply, shifting the bias points or excessive power dissipation. • Sonar-signal simulation for testing and training. • Determining distortion and envelope rise and fall times in narrow-band amplifiers. • Calibrating transducers, such as sonar projectors. • Measuring the transient response of bandpass filters without the ringing effects associated with pulse waveforms. • Loudspeaker distortion tests, such as the measurement of "hangover" time. • Reverberation-time measurements of concert halls and acoustic enclosures. • Measuring transmission loss in acoustic materials. • Determining efficiencies and time constants of detector, AGC, and rectifier circuits. • Testing low-speed digital equipment with bursts of square or rectangular waveforms. • Measuring meter ballistics. • Stimulating the subject in physiological experiments. • Generating calibrated ac transients.



The Type 1396-A

Tone-Burst Generator. \$490 in U.S.A.

This instrument is basically an electronic gate that alternately passes and blocks a selected number of cycles of any input waveform from dc to 500 kHz. Burst durations are adjustable from one cycle to 128 cycles of input signal. Aperiodic signals may also be gated with or without an auxiliary timing signal.

Open- and closed-gate durations can be independently set to 2, 4, 8, 16, 32, 64, or 128 cycles (or periods) of timing signal, and to 1, 3, 7, 15, 31, 63, or 127 cycles with the aid of a "MINUS ONE" switch. Gate-closed interval can also be set in one-period increments over a 1-millisecond to 10-second range. Maximum output level with gate open is ± 7 volts. Feedthrough with gate closed is less than 140 mV, peak-to-peak (-40 dB, with maximum signal input).

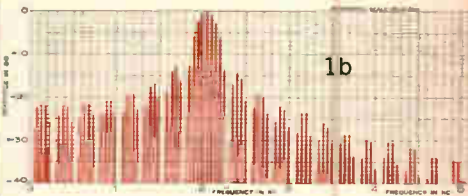
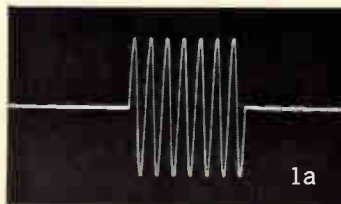

Tone-Burst Shaping for Narrow-Band Applications

When making tests of auditoriums and concert halls, acoustical engineers often must separate, identify, and measure room resonances that may be quite close together in frequency. For these tests, a filtered tone burst with very low spectral content can be helpful. Figures 1a and 1b show an unfiltered sinusoidal tone burst and its corresponding spectral distribution. This 2.0-kHz sine wave is gated on for 7 cycles and gated off for 32 cycles. Figures 2a and 2b show the same signal after it has passed through a one-third-octave filter. Note the reduced spectral content, which permits greater resolution in searches of closely spaced resonant frequencies. The burst nature of the original signal is preserved to allow observation of the echo signal for reverberation-time measurements.

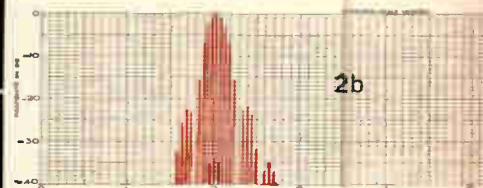
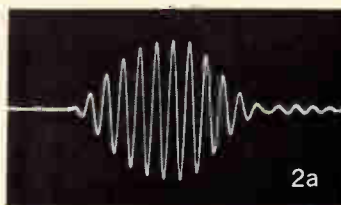

TONE-BURST TESTING OF RECTIFIER CIRCUITS

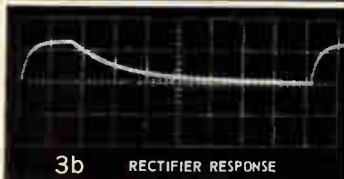
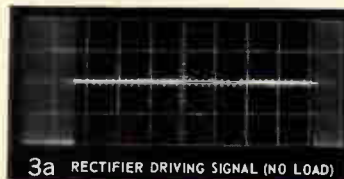
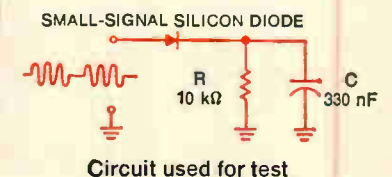

Figure 3a shows a 10-kHz tone burst of 32-cycle duration. Scope scales are 2 V per major vertical division and 2 ms per major horizontal division. Figure 3b shows the resulting output waveform across the capacitor. Scope scales remain the same. Note how easily the time constants of the circuit can be determined.



BOSTON • NEW YORK • CHICAGO • PHILADELPHIA • WASHINGTON, D.C.
SYRACUSE • DALLAS • SAN FRANCISCO • LOS ANGELES • ORLANDO
CLEVELAND • TORONTO • MONTREAL
GENERAL RADIO COMPANY (Overseas), ZURICH, SWITZERLAND
GENERAL RADIO COMPANY (U.K.) Ltd., BOURNE END, ENGLAND

GENERAL RADIO
WEST CONCORD, MASSACHUSETTS

masters" [Nov. 28, p. 72] reference is made to "problem-oriented languages." The article implies that Cobol and Fortran are examples of such problem-oriented languages.

In the vernacular of the digital computer professional, such usage or definition of the term problem-oriented language is contrary to the accepted practice.

A procedure-oriented language is one which is oriented toward explicit specification of procedures for the solution of general problems, e.g. Fortran, Cobol, etc.

A problem-oriented language is one which is designed to solve a particular type of problem. The procedures to be followed are implicit in the language and are not normally stated by the user. Cobol and Fortran are not problem-oriented languages since they are for general problem solving and rely on explicit procedures. Problem-oriented languages are usually limited to a specific problem area, e.g. data retrieval languages, numerical machine-tool languages, and others.

The distinction between these two types of languages is not a semantic one and I believe a clarification of your loose terminology is warranted.

Jason I. Adleman

NASA
Electronics Research Center
Cambridge, Mass.

▪ Reader Adleman is correct. However, the article referred to programing languages that let a user concentrate on his problem without having to remember all the details of a computer's instruction set. This is true of both procedure-oriented and problem-oriented languages.

It figures

To the Editor:

I was very interested in the article "Big increase in military spending to aid electronics" [Dec. 27, 1965, pp. 92-94]. because it gives a very good idea of the effort being made in France in the electronics field.

Nevertheless, I found that the figures shown on pages 92 and 93 are very much higher than those forecast by the French professional organization, Syndicat des Industries de Matériel Professionnel Electronique et Radioélectrique, SPER.

I am assuming that the item, computers and related equipment, amounting to \$203.4 million in 1965 and \$250.6 million forecast for 1966 in Electronics, is related only to business machines and not to scientific machines. I would be very grateful to you if you could help me in getting a clearer view of the French electronics market in:

1) Confirming the assumption that computers and related equipment are only business machines.

2) Giving me, if possible, the names of the French documents from which Electronics' figures were taken—for instance, such as the Fifth Plan, 1966-1970.

R. Sagnial

Seine, France

▪ The discrepancy occurs because Electronics' figures are for consumption, a term which includes both production and imports. SPER's figures are limited to production only. To obtain the figures in the Dec. 27 issue, Electronics conducted a large number of personal interviews at industrial companies, trade associations and government agencies in France.

YOU GET EXACTLY WHAT YOU PAY FOR— WITH A PLUS— WHEN YOU ORDER OUR RHODIUM SOLUTION



Every bottle of our Rhodium Plating Solution you order is accompanied by a signed certificate stating its exact Rhodium content. Every batch of solution we make is checked by chemical analysis in our laboratories . . . We always add an extra amount to the content of each bottle. Result: when you order a 10 gram bottle of Sigmund Cohn Rhodium Solution, you get 10 grams plus (the plus at no additional charge).

SIGMUND COHN Mfg., Co., Inc.
121 So. Columbus Avenue,
Mt. Vernon, New York



Consult our staff about plating problems . . .
65 years of specialization

SUBSCRIPTION SERVICE

Please include an Electronics Magazine address label to insure prompt service whenever you write us about your subscription.

Mail to: Fulfillment Manager
Electronics
P.O. Box 430
Hightstown, N.J. 08520

To subscribe mail this form with your payment and check new subscription renew my present subscription

Subscription rates: in the U.S.: 1 year, \$6; two years, \$9; three years, \$12. Subscription rates for foreign countries available on request

CHANGE OF ADDRESS

ATTACH LABEL HERE

If you are moving, please let us know five weeks before changing your address. Place magazine address label here, print your new address below.

name _____

address _____

city _____

state _____

zip code _____

Circle 7 on reader service card →

VACUUM + CERAMIC

People

"The Vietnam war has shown there is a definite need for better detectors and other devices for identifying targets," says **John L. Wilson**, a 20-year veteran of research and development in the Army Signal Corps. He has spent the last five years managing electronics programs in industry.



Now, as general manager of Honeywell, Inc.'s Radiation Center in Boston, the 50-year-old Wilson will be supervising stepped-up activity in detector techniques and materials for use at hands from radio-frequency through ultraviolet, during the day, the night and under adverse weather conditions.

The Radiation Center is one of two R&D facilities serving the Military Products group of Honeywell. A division in Minneapolis stresses systems R&D, while the Boston center concentrates on radiation devices and subsystems. These include millimeter, infrared and visible radiation detectors, and the applications of lasers and electro-optics in general to military problems.

The center develops advanced components and subsystems for reconnaissance surveillance and high-frequency signal processing. It does a minimum of production work.

Wilson goes to Boston from St. Petersburg, Fla., where he was director of space systems for Honeywell's Florida Aeronautical division. Before that, he was general manager of the Semiconductor Products division at Riviera Beach, Fla., until Honeywell sold that division to Solitron Devices, Inc. Wilson joined Honeywell in 1961 and became manager of the company's Gemini inertial guidance program before going to the Semiconductor division.

A graduate of the Georgia Institute of Technology, Wilson received a master's degree in electrical engineering at the Massa-

JENNINGS TYPE	RF10A	RJ2A	RJ1A
Operating Voltage (16 mc)	10 KV Peak	8 KV Peak	2 KV Peak
Test Voltage (60 cycle)	20 KV Peak	18 KV Peak	5 KV Peak
Continuous Current (16 mc)	30 Amps RMS	15 Amps RMS	7 Amps RMS
Interrupting Rating (dc resistive loads)	50 KW (up to 5 amps or 10 KV)	1 KW (up to 1 amp or 1 KV)	1
Weight (oz.)	16	3	1

Vacuum plus ceramic adds up to a new line of Jennings vacuum relays that brings you (1) High voltage hot switching capability (2) Highest RF current carrying ratings (3) Shock resistance (4) Small size and light weight (5) Greater reliability (6) Low unchanging contact resistance.

These new relays eliminate the necessity to redesign circuits in order to avoid difficult switching problems. Now small lightweight systems can be designed in the sure knowledge that the new Jennings vacuum relays offer as much as or more reliability and high performance than any other component in the circuit.

The RF10A relay features high power dc interrupting capability up to 50 KW.

The RJ2A and RJ1A are essentially rf relays capable of withstanding high voltage and carrying high rf currents. Even so the RJ2A will interrupt a rather remarkable 1 amp at 1000 volts for many thousands of operations.

Jennings also offers many glass vacuum relays, each designed to provide maximum performance to the particular segment of the electronic field for which they were created.

Our new catalog 102 describing our complete line of vacuum relays is available at your request.

Jennings Radio Manufacturing Corporation — Subsidiary of International Telephone and Telegraph Corporation, 970 McLaughlin Avenue, P.O. Box 1278 San Jose, California 95108.

ITT Jennings

Did You Know Sprague Makes 32 Types of Foil Tantalum Capacitors?

125 C TUBULAR TANTALEX® CAPACITORS



Type 120D polarized plain-foil
Type 121D non-polarized plain-foil
Type 122D polarized etched-foil
Type 123D non-polarized etched-foil

ASK FOR BULLETIN 3602C

Circle 332 on reader service card

85 C TUBULAR TANTALEX® CAPACITORS



Type 110D polarized plain-foil
Type 111D non-polarized plain-foil
Type 112D polarized etched-foil
Type 113D non-polarized etched-foil

ASK FOR BULLETIN 3601C

Circle 333 on reader service card

RECTANGULAR TANTALEX® CAPACITORS



Type 300D polarized plain-foil
Type 301D non-polarized plain-foil
Type 302D polarized etched-foil
Type 303D non-polarized etched-foil

ASK FOR BULLETIN 3650

Circle 334 on reader service card

TUBULAR TANTALUM CAPACITORS TO MIL-C-3965C



CL20, CL21 125 C polarized etched-foil
CL22, CL23 125 C non-polarized etched-foil
CL24, CL25 85 C polarized etched-foil
CL26, CL27 85 C non-polarized etched-foil
CL30, CL31 125 C polarized plain-foil
CL32, CL33 125 C non-polarized plain-foil
CL34, CL35 85 C polarized plain-foil
CL36, CL37 85 C non-polarized plain-foil

Circle 335 on reader service card

RECTANGULAR TANTALUM CAPACITORS TO MIL-C-3965C



CL51 polarized plain-foil
CL52 non-polarized plain-foil
CL53 polarized etched-foil
CL54 non-polarized etched-foil

Circle 336 on reader service card

For comprehensive engineering bulletins on the capacitor types in which you are interested, write to:
Technical Literature Service
Sprague Electric Company
35 Marshall Street
North Adams, Mass. 01248

45C-5181

SPRAGUE®
THE MARK OF RELIABILITY

Sprague and ® are registered trademarks of the Sprague Electric Co.

People

chusetts Institute of Technology. He retired from the Army as a colonel in 1961. His military work concerned what he calls "the non-communications areas of the Signal Corps: radar, avionics and surveillance."

Manfred von Ardenne, one of the authors of a technical article in this issue on the use of electron beams (pp. 110-115), is among the leading scientists in East Germany and heads a large research laboratory that was named after him, in Dresden.



Von Ardenne, who was in the vanguard of electron-beam technology, wrote several articles on cathode-ray-tube technology for Electronics between 1936 and 1940. This is his first article for the magazine since then.

Under the Nazis, von Ardenne developed radar techniques and engaged in atomic research. After the war he went to Russia and received the Stalin Prize for his work on that country's first cyclotron.

His interests include other fields of science and technology as well as electronics and nuclear physics. In 1956 he invented a device which, when swallowed, transmits data on disorders in the stomach and digestive tracts.

Von Ardenne has been critical of the East German educational system and recently complained about the low level of knowledge of university freshmen.

He has his pick of coworkers from the 17,000 students at the Dresden Technical Institute. Although he reportedly prefers, in his own work, to surround himself with a small elite group, believing that scientific achievements are gained this way, he now has about 270 coworkers.

Machlett is the word for power in transistorized circuitry...

Use Machlett planar triodes:

for Pulse Power: 1 kw, 2 kw, 3 kw, 4 kw to 10 kw
for CW Power: 100 watts at 2.5 Gc .5 watts in C Band
for High Resistance to Radiation
for Low Noise/Frequency Ratio
for Low Operating Cost

Choose from 2 Machlett planar triode lines (conventional, miniature)

Frequency: 6 Gc and higher
Pulse Power: grid pulse to 8000v, 5a
 plate pulse to 10000v, 5a
Modulator Service: dc voltage to 8000v
 peak pulse voltage
 to 10000v



Anode Cooling: new pin radiator: 150 watts and higher,
 FAC, both conventional
 and miniature
 new water jacket: 400 watts and higher
 with water cooling

Write now for data on the industry's strongest line of planar triodes—
Machlett: The word for power in transistorized circuitry.

Address: The Machlett Laboratories, Inc., Springdale, Conn. 06879.



**Planar II
is the purest
manufacturing
process ever
put into mass
production.**

**By 1970 every
semiconductor
manufacturer
will use it.
You can wait.
Or get it now
from Fairchild.**

Planar is a patented Fairchild process.

CRYSTAL FILTERS

MODEL
P119BA



Microsonics manufactures crystal filters that provide high selectivity with excellent temperature stability and a wide range of frequency characteristics. Center frequency of the filters range from 10 KC to 150 mc. Bandpass, band reject, and linear discriminators are produced to the highest standards including qualification to MIL-F-18327.

Microsonics has unique ability to design and measure actual phase characteristics of crystal filters to a tolerance of a fraction of a degree. For example the characteristics of our Model P119BA are shown below:

SPECIFICATIONS

Center Frequency	10.7 mc ± 1 kc
Bandwidth	at 1 db47 kc min
	at 3 db50 kc ± 1 kc
	at 60 db100 kc max
Differential phase between two filters over 3 db bandwidth	$\pm 3.5^\circ$ max
Phase slope over the 3 db bandwidth	$\pm 400^\circ$ approx.
Insertion Loss	3 db max
Ripple	0.5 db max
Z in / Z out	400
Operating Temperature Range	-45°C to +85°C

Write for Bulletin 6350, P119BA



MICROSONICS, INC.

a subsidiary of the
SANGAMO ELECTRIC COMPANY

60 Winter Street
Weymouth, Massachusetts 02188
Area Code 617 337-4200

Meetings

Application of Computers to the Problems of a Metropolitan Society Conference, ACM; Statler-Hilton Hotel, New York, March 18.

Automation 66, Finish Automatic Control Society; Helsinki, Finland, March 21-24.

International ISA Aerospace Instrumentation Symposium, ISA, College of Aeronautics; College of Aeronautics, Cranfield, England, March 21-24.

International Convention and Exhibition of the IEEE; New York Hilton Hotel and the Coliseum, New York, March 21-25.

Microwave Measurement Symposium, Weinschel Engineering Co.; Essex House Hotel, New York, March 21-24.

Seminar on Computers and Automation in Europe, Lomond Systems, Inc.; Washington, and European tour, March 21-April 7.

National Association of Broadcasters Convention, NAB; Conrad Hilton Hotel, Chicago, March 27-30.

International Conference on Electronic Switching, Union of International Technical Associations, Societe Francaise des Electroniciens et des Radioelectriciens; UNESCO Conference Hall, Paris, France, March 28-31.

Digital Electronics Seminar, RCA Institutes, Inc.; Hotel New Yorker, New York, March 28-April 1.

Physics Exhibition, Institute of Physics; Alexandra Palace, London, March 28-31.

Automatic Control in Electricity Supply Meeting, IEE; Renold Building, Manchester College, England, March 29-31.

Conference on Analysis and Synthesis of Networks, IEEE-NTG; Stuttgart, West Germany, March 31-April 1.

Industrial Engineering Conference, AIEE; Hotel Pontchartrain, Detroit, March 31-April 1.

Symposium on Computer Graphics, University of California; Los Angeles, April 4-6.

Advanced Seminar for Automatic Data Processing, International Computation Center; International Computation Center, Rome, April 6.

Symposium on Electron and Laser Beam Technology, IEEE, University of Michigan; Ann Arbor, Mich., April 6-8.

Conference on Ground-Based Aeronomic Studies of the Lower Ionosphere, AFCRL, DRTE; Defense Research Telecommunications Establishment, Ottawa, Canada, April 11-15.

IEEE Region III Convention, IEEE; Mariotta Motor Inn, Atlanta, April 11-13.

Cleveland Electronics Conference, Cleveland section of IEEE; Engineering and Scientific Center, Cleveland, April 12-14.

Symposium on Remote Sensing of Environment, Office of Naval Research; University of Michigan, Ann Arbor, April 12-14.

Quantum Electronics Conference, IEEE Groups on Electron Devices and Microwave Techniques; Towne House, Phoenix, April 12-14.

International Symposium on Generalized Networks, Polytechnic Institute of Brooklyn, AFOSR; Hotel Commodore, New York, April 12-14.

International Conference on Magnetism (INTERMAG), Magnetism Group of the IEEE, Stuttgart, Germany, April 20-22.*

Call for papers

National Electronic Conference and Exhibition, NEC; McCormick Place, Oct. 3-5. May 1 is deadline for submission of 75-word abstract and 15 copies of 700-word summary on all scientific and engineering aspects of electronics, problems in antennas, circuit theory, and magnetism, to John C. Hancock, School of Electrical Engineering, Purdue University, Lafayette, Indiana 47907.

American Vacuum Society Annual Symposium, American Vacuum Society; San Francisco Hilton, Oct. 26-28. July 1 is deadline for submission of 150-word abstract on high-vacuum technique and its application to electronics and physics to E. E. Donaldson, department of physics, Washington State University, Pullman, Washington 99163.

* Meeting preview on page 16

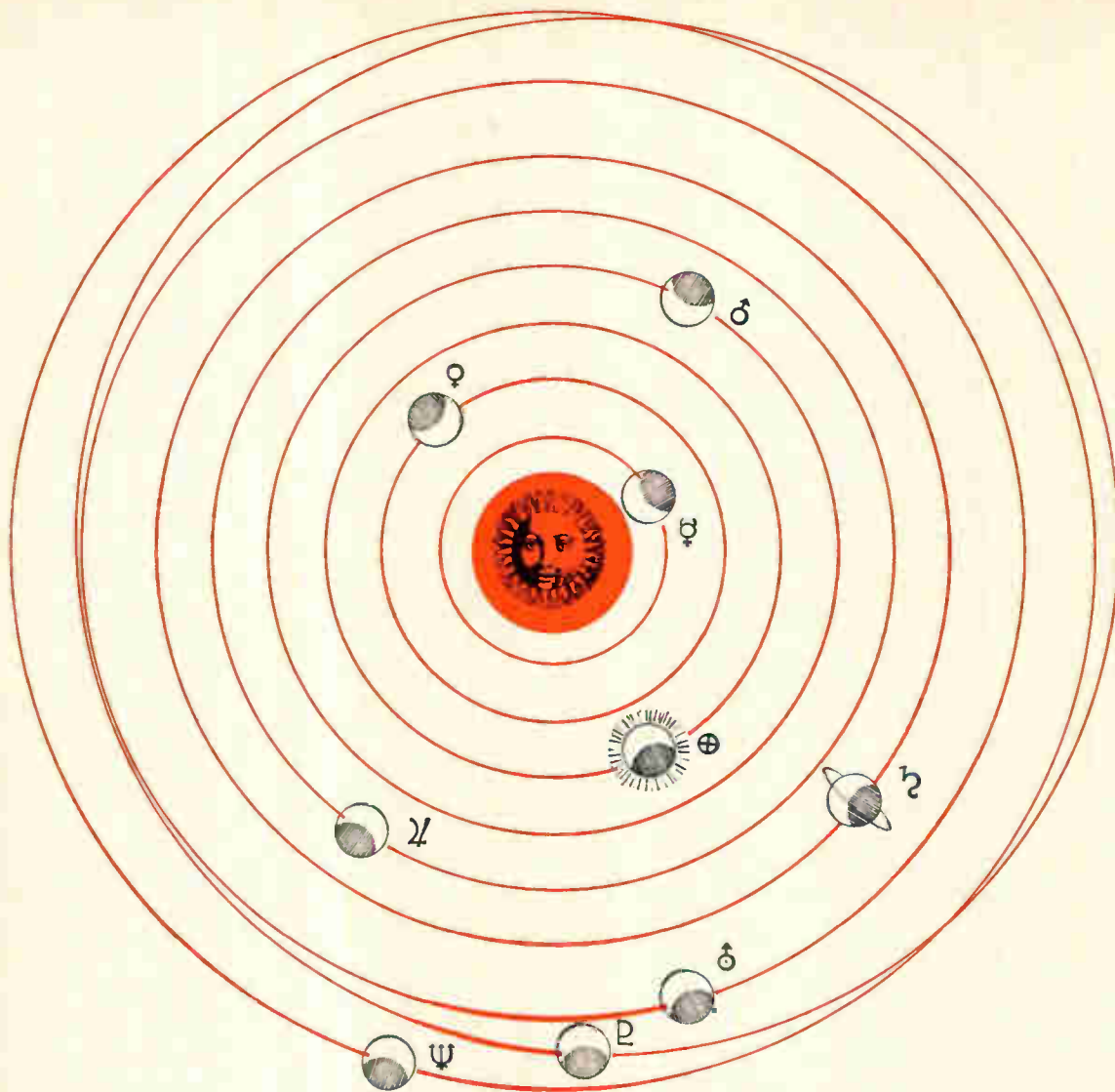

Chances are 9999999 to 1 this system's **on the air**

A new target figure for reliable uptime (.9999999) is now being demonstrated with an Astrodata system in one of this nation's key defense communications networks. Unlike other instruments and equipment with high reliability for limited intervals, Astrodata's Model 6600 Timing System is designed to be up and available around the clock.

Chances that it will be off the air even momentarily are one in 10^7 . This outstanding availability is the result of several design concepts:

Triple redundancy and majority logic ensure that the 6600 will continue functioning before, during and after component failure. Triple redundancy is designed into power, oscillation, and all other functional components. Majority logic (best two out of three) is used for all

divider circuitry at every stage of the system.

The 6600 need not go off the air for maintenance. Alarms, both audible and visible, are energized upon failure of any component. Localized error condition lights on each circuit card enable the operator to pinpoint any malfunction immediately. And the test point of any circuit card may be accessed from the front without making another circuit card inaccessible.

Whether redundant or non-redundant design, Astrodata has supplied well over 50 percent of the free world's timing instrumentation.

For more information concerning timing, data acquisition, processing, telemetry, hybrid, or analog computer techniques, please write for our timing and/or systems experience brochures.



ASTRODATA

P.O. Box 3003 ■ 240 E. Palais Road, Anaheim, California ■ 92803

5MC LABORATORY FREQUENCY STANDARD



5×10^{-10} per day frequency stability.
 1×10^{-9} temperature stability over
 -15°C to $+65^{\circ}\text{C}$ ambient.

Output frequency can be adjusted to an exact value with a resolution of approximately 1×10^{-10} per minor division.

The standard uses silicon transistors and a polished, high precision, fifth overtone quartz crystal having a Q in excess of 3 million. Model JKTO-66 features a double proportional control oven with a Dewar flask to provide maximum temperature stability.

Chassis is ruggedly constructed to withstand shock and vibration. Front panel mounting.

Write for Data Sheet JKTO-66 for complete specifications.



CTS Knights, Inc.

of Sandwich, Illinois
(formerly The James Knights Co.)
a subsidiary of CTS Corporation, Elkhart, Indiana

Meeting preview

Intermag goes abroad

About 600 scientists and engineers, including 150 from the United States, are expected to participate in the Fourth International Conference on Magnetism in Stuttgart, Germany. The three-day meeting, April 20 to 22, is sponsored jointly by the Institute of Electrical and Electronics Engineers Magnetism Group and the German Arbeitsgemeinschaft Magnetismus (study group on magnetism). Host society is the Verband Deutscher Elektrotechniker. This year's Intermag Conference will be the first held outside the U. S.

Experts, including some from Eastern bloc countries, will discuss computer magnetism, ferrite microwave devices and magnetic material properties. Other subjects will be magneto-optics, magnetic recording and superconducting devices.

Of special interest will be a 40-minute paper on the "Special Applications of Magnets" by Gerhard R. Hennig of the electrical engineering department at the Oskar Von Miller Polytechnikum in Munich. One part of his paper will deal with the use of magnets-field-dependent semiconductors, magnetic resistors and hall generators. The author will also discuss applications of magnets in brushless d-c motors, signalling devices and brushless variable resistors.

The other part of Hennig's paper will deal with measurements on three groups of permanent magnet systems at temperature ranges from 300° Kelvin down to 4° Kelvin, the point at which helium becomes a liquid.

Superconductivity. K. J. R. Wilkinson of the Associated Electrical Industries in Rugby, England, will present a paper on the possibilities of applying superconductivity phenomena to transformers and cables. A paper by B. H. Burnier of Alstom, an electrical firm in Paris, will deal with pure metals for a-c application at cryogenic temperatures. J. Volger of the Philips Research Laboratory at Eindhoven, Holland, will discuss the progress made in superconductivity.

34k-3988

for every application

EARTH TO MOON

DEFENSE OR PEACE

... there is a WATERS time-tested and proven potentiometer.

WATERS' extensive line of potentiometers enables you to select: ■ thin-film design using Waters MystR® element with infinite resolution, low noise and extremely long life ■ wirewound design with thermo-welded connections, long rotational life, and wide resistance range ■ potentiometers to meet your specification with a minimum of characteristic compromise ■ potentiometers offering excellent stability under varying environmental conditions ■ the most economical potentiometer for your specific application . . .

Of a wide choice of manufacturers, only WATERS gives you an experienced background in depth — 15 years of advanced design, development, and manufacture of industrial, commercial and military potentiometers. WATERS potentiometers have been engineered to a wide range of electrical, mechanical and environmental specifications.

You too can depend on WATERS proven line and quality engineered potentiometers. Thousands of our customers are doing it now.

Application engineering assistance available through qualified local representatives or directly from the factory.

• Write to Waters Manufacturing, Inc., Dept. EP-1, 533 Boston Post Road, Wayland, Mass. for your illustrated 40-page brochure.



For copy of 40-page brochure see address above
See us at Booth IB23, IEEE Show, March 21-24

EXPORT: Contact Charles Reed, Export Director, Waters Manufacturing, Inc., Wayland, Mass. 01778, U.S.A.

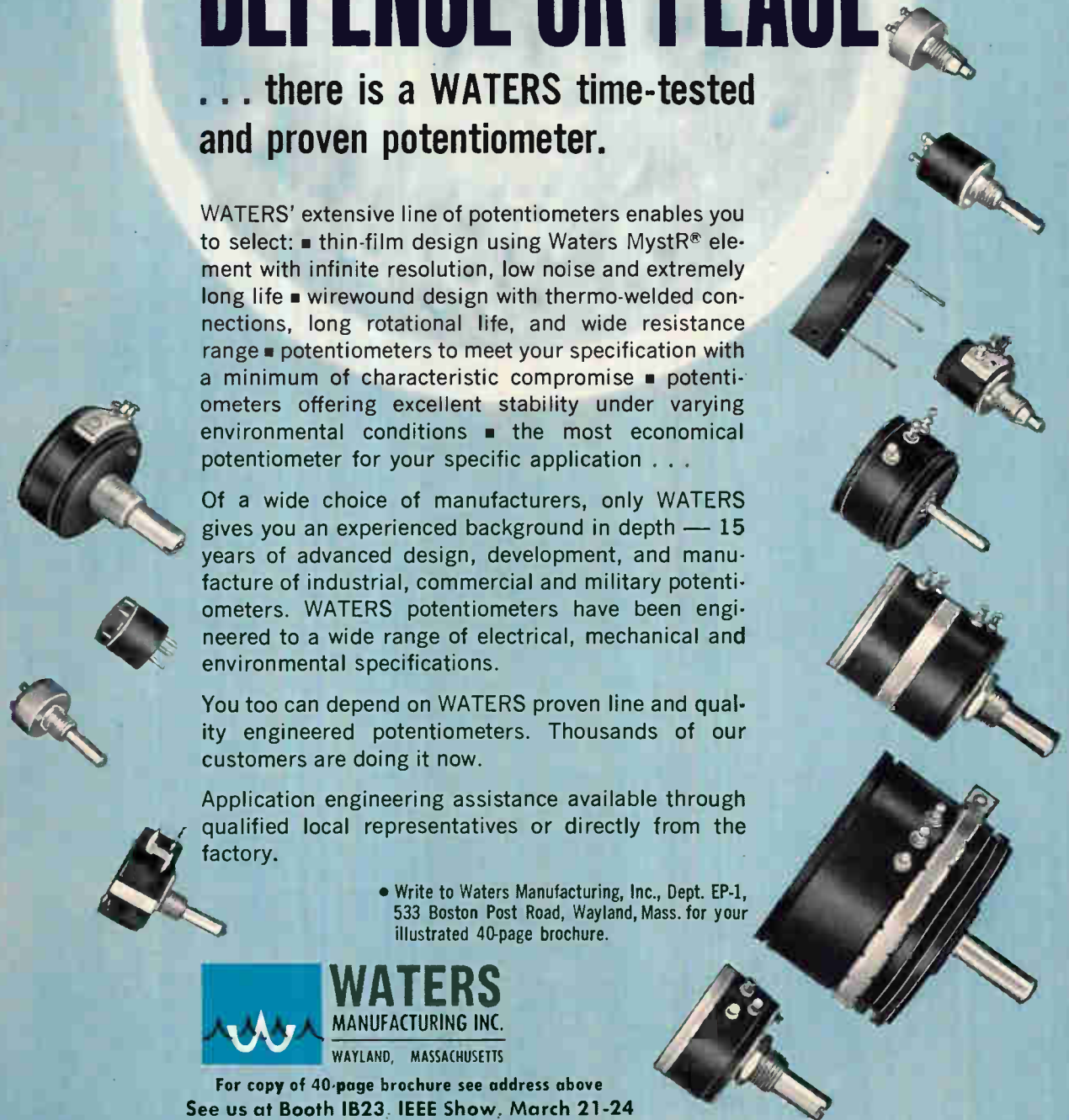



We've been keeping 5,180 low-cost precision motors under our hat.

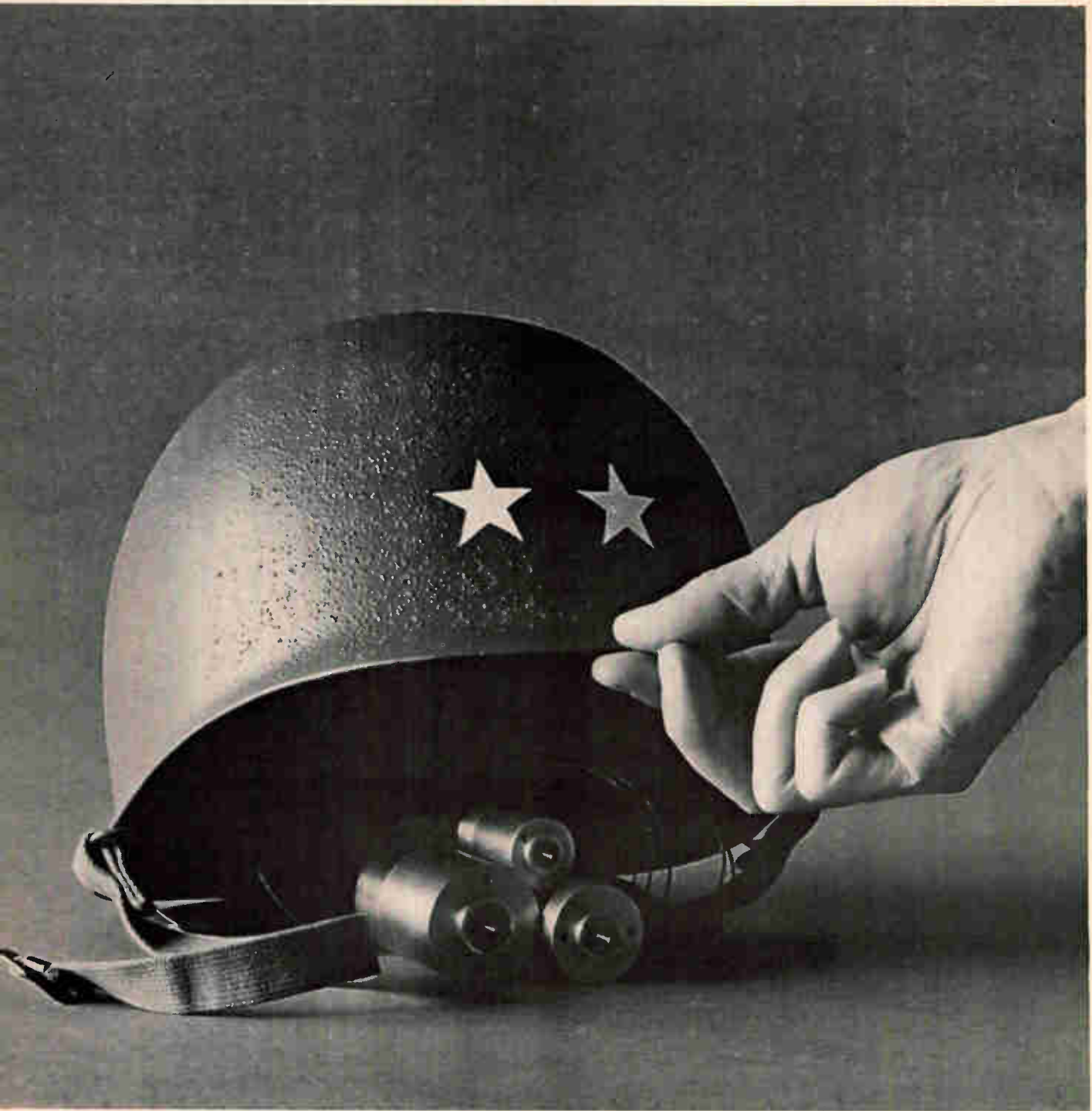

Here they are.

That's right, three of them. Which is why we've been keeping it quiet. You see, we developed a method of manufacturing custom-designed motors at off-the-shelf prices. But we wanted to test it before talking. By making ultra-high precision motors for some of the most critical communications, computer, and space programs. We did, and it worked.

Now, we can offer you precision motors in $\frac{3}{8}$ ", $1\frac{1}{4}$ ", and $1\frac{1}{2}$ " diameters at realistically economical prices.

With delivery in 6 to 8 weeks instead of the normal 12.

How do we do it? By mass-producing most of the motor components. Only the few variables needed to meet individual specs are ever made special. And that doesn't happen very often. We can produce 5,180 motors from standard components. Chances are one will be your custom-design.

Are they really high precision? Well, they're made under a "Zero Defects" program. Tolerances are

often held to .0001". And they're assembled in a "clean room."

We'll be glad to send complete technical details on our low-cost $\frac{3}{8}$ ", $1\frac{1}{4}$ " and $1\frac{1}{2}$ " diameter precision motors. Plus information on the gear-heads available with each. Write to R. D. Wright, Manager of Sales, Indiana General Corporation, Electro-Mechanical Division, Oglesby, Ill.

INDIANA GENERAL 
COPYRIGHT 1966, INDIANA GENERAL CORPORATION.



LOOK TO THE LEADER
IN INTEGRATED CIRCUITS

Tl Adds Linear Integrated

1 SN723 General-purpose Differential Amplifier

TYPICAL CHARACTERISTICS

Voltage gain (Differential)	2500
Input impedance	10 k Ω
Input offset voltage	2 mV
D-c drift referred to input	5 μ V/ $^{\circ}$ C
Output signal swing, single-ended	\pm 6.5 V
Common-mode rejection	90 dB
Temperature range	0 $^{\circ}$ to +70 $^{\circ}$ C

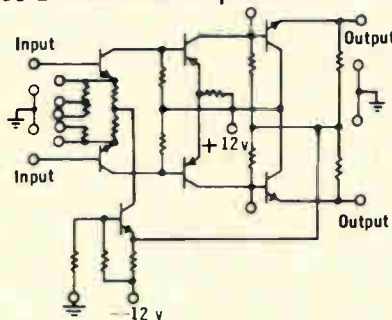

2 SN724 General-purpose Operational Amplifier

TYPICAL CHARACTERISTICS

Voltage gain	1200
Input impedance	1 M Ω
Input offset voltage	12 mV
D-c drift referred to input	20 μ V/ $^{\circ}$ C
Output signal swing, single-ended	\pm 7.5 V
Common-mode rejection	55 dB
Temperature range	0 $^{\circ}$ to +70 $^{\circ}$ C

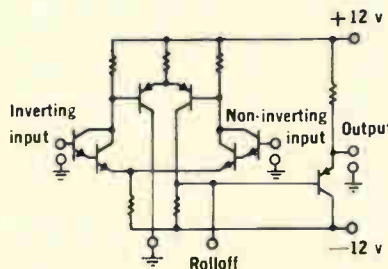

3 SN7500 Magnetic-core Sense Amplifier

TYPICAL CHARACTERISTICS

Input threshold voltage level	17 mV
"Off" output level	3.2 V
"On" output level	0.3 V
Common-mode rejection	2 V
Propagation delay	70 nsec
Temperature range	0 $^{\circ}$ to +70 $^{\circ}$ C

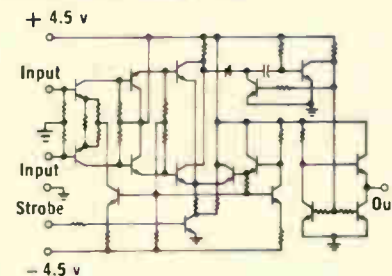

Two general-purpose amplifiers and a sense amplifier have been added to 39 digital units in TI's line of economy integrated circuits for industrial applications.

SN723 and SN724 integrated circuits from Texas Instruments are limited-temperature versions of linear circuits first offered for high-reliability military applications. Temperature range — 0 $^{\circ}$ C to 70 $^{\circ}$ C — is adequate for industrial environments, yet makes possible prices competitive with discrete-component amplifiers of equivalent performance.

Applications include buffer amplifiers, comparators, differential amplifiers, differentiators, integrators, level detectors, multi-vibrators, summing amplifiers, and voltage regulators.

1 The SN723 features both differential inputs and differential emitter-follower outputs, providing considerable design flexibility. The amplifier is designed with a resistance network in the emitters of the input stage, allowing gain to be adjusted over a wide range (40 to 70 dB) simply by shorting various lead combinations. Frequency response is typically dc to 150 kHz.

2 The SN724 features an unusually high input impedance, resulting from the Darlington-type connection of the input transistors. It has a large dynamic output range providing an input common-mode voltage range of \approx 5 volts, which permits a high degree of flexibility in circuit design. In addition to the standard flat pack, the SN724 is available in a TO-78 package (modified TO-5)

3 The SN7500 is a complete sense amplifier, including strobe gate and pulse-shaping output circuits. It detects bi-polar differential input signals from a magnetic-core memory and provides a one-shot output interface between the memory and logic circuitry. It can be used for other applications requiring signal-level detection with an extremely sharp threshold.

39 Digital Industrial Circuits

4 TI's expanding line of IC's also includes 39 digital circuits. Typical gate characteristics

Circuits to Industrial Line

for each of the five logic families are listed in the table at right.

5 Types of circuits available are also listed at right. All these circuits, except Series 70, are reduced-temperature (0° to +70°C) versions of established military integrated circuit lines. They feature the same high performance, same high reliability, and same multi-function economies.

By fabricating two, three and four circuits simultaneously in a single silicon bar, the cost-per-circuit-function is drastically reduced. Reductions are also obtained in the number of circuit packages, interconnections, and circuit boards—and in inventories, testing, and handling.

New Plug-in Industrial Flat Package

6 TI's new 16-pin plug-in flat package (shown right) has been developed to reduce handling and assembly costs for industrial applications. The two rows of sturdy plug-in pins with 100-mil spacing facilitate automatic handling, assembly, and flow soldering to industrial-type PC boards. The hermetic package is designed for excellent reliability as well as for handling convenience and economy.

The new package is available at no additional cost for Series 74, 74 930, 1580, and most units in Series 73. Standard package for all series is the five-year-proved 1/4" x 1/8" flat pack.

New Integrated Circuits Designer's Kits Available

7 Now, you can get everything you need for a headstart in modern logic design. TI Designer's Kits include a useful selection of integrated circuits, breadboarding sockets, applications guide, and performance data for Series 73 or Series 74 digital or Series 72 linear circuits.

Demonstrate for yourself the many economies and the high performance inherent in integrated-circuit design. Start now to design and breadboard integrated-circuit assemblies. Order your designer's kit today from the TI distributor in your area.

Parameter	Series 73	Series 74	Series 74 930	Series 70	Series 1580
Propagation delay, nsec	30	13	13	5	25
Power dissipation, mW	10	10	10	40+	5
Fan-out	10	10	10	N/A	8
Noise immunity, mV	300	1000	1000	250	750
Supply voltage, V	3 to 4	4.75 to 5.25	4.75 to 5.25	+1.25, -3.5	4.5 to 5.5
Temperature range, °C	0° to +70°	0° to +70°	0° to +70°	0° to +70°	0° to +70°

	Series 73 Modified-DTL NAND/NOR	Series 74 TTL NAND	Series 74930 TTL (Replaces 930 DTL)	Series 70 ECL OR/NOR	Series 1580 DTL NAND
J-K Flip-flop	SN7300 SN7301	SN7470	SN74 948		SN1590 SN1591 SN1593
Dual J-K Flip-flop	SN7302 SN7304				
Quad gate	SN7360	SN7400	SN74 946		SN1583
Triple gate	SN7331	SN7410	SN74 962		
Dual gate	SN7311 SN7330	SN7420 SN7440	SN74 930 SN74 932	SN7000 SN7001	SN1581 SN1584
Single gate	SN7310	SN7430	SN74 965		
Dual EXCLUSIVE-OR	SN7370	SN7450/51	SN74 966		
Expander	SN7320	SN7460			
Inverter, Buffer	SN7350				SN1580
"One Shot"	SN7380				SN1582

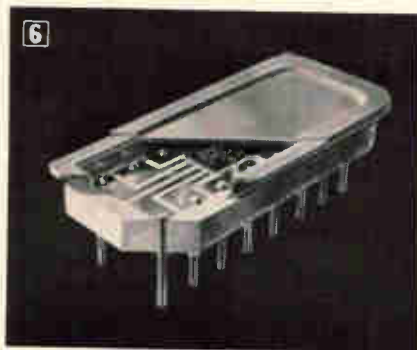

6 Cut-away view of TI's new 16-pin plug-in package, optional for all 39 digital industrial circuits.



7 TI Designer's Kit for integrated circuits. Three different kits are offered by TI distributors.



TEXAS INSTRUMENTS
INCORPORATED
13500 N. CENTRAL EXPRESSWAY
P O BOX 5012 • DALLAS 22, TEXAS

SEMICONDUCTOR PLANTS IN BEDFORD, ENGLAND • NICE, FRANCE • DALLAS, TEXAS

IN HIGH POWER MODULES



MAKES THE DIFFERENCE!

MORE OUTPUT WATTS PER POUND PER DOLLAR... PER CUBIC INCH!

- Wide coverage of fixed output voltages from 4.5V dual to 120V single
- Kepeco patented Flux-O-Tran® provides line regulation and current limiting
- -20° C to + 55° C ambient operating temperature
- Highly reliable MTBF > 140,000 hours
- Convection cooling
- Short circuit proof
- All silicon rectifiers
- Dual output and extra filtered models
- Versatile mounting (cased and uncased)
Rack adapters available to mount 1 to 5 units

Applicable Patent Nos. furnished on request

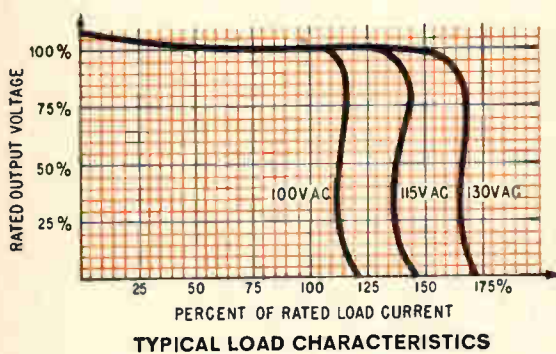

TYPICAL LOAD CHARACTERISTICS



NEW 52 PAGE CATALOG
CONTAINING COMPLETE
SPECIFICATIONS AND
APPLICATIONS NOTES
IS NOW AVAILABLE

WRITE FOR YOUR
FREE COPY!

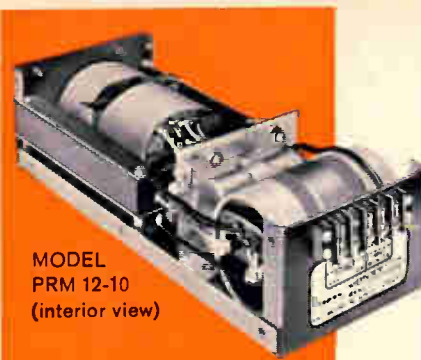

MODEL
PRM 12-10
(interior view)

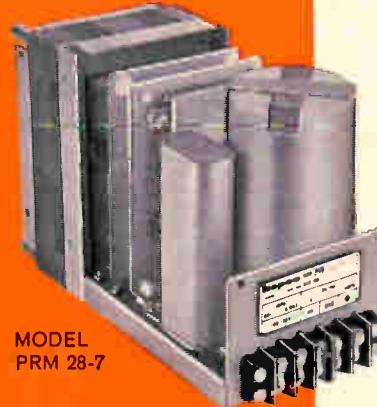

MODEL
PRM 28-7

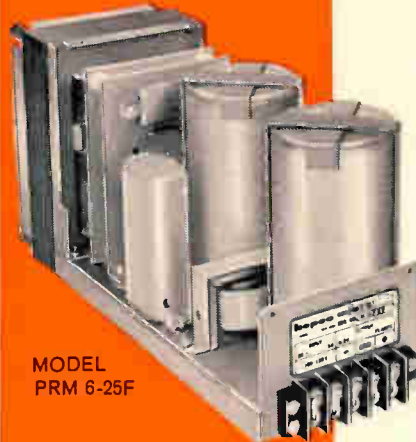

MODEL
PRM 6-25F



MODEL
PRM 2X48-3



SIZE "B" — 120 SERIES
CASED UNIT — \$99.00**
3 1/2" H x 5" W x 13 1/8" D

MODEL	DC OUTPUT VOLTS	AMPS
PRM 6-15	6.3	0-15
PRM 12-10	12	0-10
PRM 18-6.7	18	0-6.7
PRM 24-5	24	0-5
PRM 28-4.3	28	0-4.3
PRM 36-3.3	36	0-3.3
PRM 48-2.5	48	0-2.5
PRM 60-2	60	0-2
PRM 120-1	120	0-1

**Available cased only

SIZE "A" — 180 SERIES
UNCASED UNIT — \$119.00*
6 3/4" H x 4 3/4" W x 10 3/8" D

PRM 6-25	6.3	0-25
PRM 12-15	12	0-15
PRM 18-10	18	0-10
PRM 24-8	24	0-8
PRM 28-7	28	0-7
PRM 36-5	36	0-5
PRM 48-4	48	0-4
PRM 60-3	60	0-3
PRM 120-1.5	120	0-1.5

EXTRA FILTERED MODELS

SIZE "C" — 180F SERIES
UNCASED UNIT — \$169.00*
6 3/4" H x 4 3/4" W x 14 3/8" D

PRM 6-25F	6.3	0-25
PRM 12-15F	12	0-15
PRM 18-10F	18	0-10
PRM 24-8F	24	0-8
PRM 28-7F	28	0-7
PRM 36-5F	36	0-5
PRM 48-4F	48	0-4
PRM 60-3F	60	0-3
PRM 120-1.5F	120	0-1.5

DUAL OUTPUT MODELS
SIZE "C" — 300 SERIES
UNCASED UNIT — \$179.00*
6 3/4" H x 4 3/4" W x 14 3/8" D

PRM 2X 4.5-20	4.5	0-20
PRM 2X 6-20	6.3	0-20
PRM 2X 12-12	12	0-12
PRM 2X 15-10	15	0-10
PRM 2X 18-8	18	0-8
PRM 2X 24-6	24	0-6
PRM 2X 28-5	28	0-5
PRM 2X 36-4	36	0-4
PRM 2X 48-3	48	0-3
PRM 2X 60-2.5	60	0-2.5

*Case optional — add \$10.00 to price

KEPCO, INC. • 131-38 SANFORD AVENUE • FLUSHING, N.Y. 11352 • Phone: (212) 461-7000 • TWX #212-539-6623 • Cable: KEPCOPOWER NEWYORK

SEE OUT LATEST PRODUCTS AT IEE • BOOTHS 2F48-2F50

Editorial

The search for instant experts

In its annual survey of employment opportunities (pp. 156 to 166), Electronics finds the welcome mats are out for job-hunting engineers at almost every electronics company in the country. Personnel men are calling today's engineer market the tightest since the wild recruiting days of 1955, 1956 and 1957 when there was a severe shortage of engineers as a result of the explosive growth of the electronics industry.

Once inside the plant gate, however, the job seeker is likely to find that the job opportunities are not as unlimited as the advertisements painted them. The personnel men are looking for the instant expert, the man who can fill a specific narrow specialty with no additional training or orientation. Few companies are willing to spend the time or money to train well-grounded engineers or to upgrade their own. The engineers at whom recruiters are aiming their most seductive pitches are currently working for competitors, doing the same job the recruiter is trying to fill.

At the very moment personnel men are calling today's shortage of engineers the worst in history they are ignoring a huge body of available men, preferring to pirate the employees of competitors.

A Chicago personnel recruitment firm, for example, is looking for a chief engineer to head the technical effort of a company that makes magnetic core equipment for computers. Says the president of the recruiting firm, with no embarrassment at all, "The man we are looking for is now the chief engineer of a company that makes magnetic core equipment for computers. He's happy and hasn't thought about changing jobs. Give us his name and we'll persuade him to switch." That same attitude pervades hundreds of employment agencies and personnel departments of electronics companies.

The reason for the interest in the instant expert is easy to see but hard to justify over the long pull. To the personnel man, hiring the instant expert is an easy out—there's no worry about whether the new man can do the job since he has been doing the same job for a competitor. If he doesn't work out, it's clearly the engineering department's fault, not personnel's.

"We hire a first rate linear-circuit engineer

who knows microelectronic processing and we are in the microcircuit business," goes the reasoning. Or, "One expert in navigation systems engineering and we will have a whole new business going." Or, "A varactor diode expert can spearhead the development of our new communications systems." But this reasoning is specious.

The search for the instant expert is expensive. One personnel man estimated it costs nearly \$5,000 to find and hire such a specialist. It would be much cheaper to hire a well-grounded engineer with talent and energy and less expertise in the narrow specialty. It would even be cheaper to upgrade a competent engineer already on the company's payroll, even if he had to go to graduate school for three months or six months to bone up on the particular technology.

Companies like to kid themselves into believing that the instant expert won't require any time to learn their procedures and ways of doing business. The facts are that it takes a new engineer, even an expert, from three to six months to get acclimated depending on how complicated it is to order items from pencils to prototype transistors. A Ph.D. fresh from the campus is likely to take even longer to get into production.

Pirating instant experts is likely to open the door to a raft of legal problems too. The courts now take a dim view of an engineer carrying proprietary information from one employer to another. The surge of pirating currently taking place among electronics companies will benefit only the lawyers and load up the court dockets.

Probably the one bright spot in this picture is that many engineers are examining these tantalizing offers carefully, and then rejecting them. There is not the mobility there once was. Too many engineers remember the layoffs of 24 months ago. Out on the West Coast, personnel managers complain that many Eastern engineers won't even listen to their blandishments because of the reputation the industry out there has earned for severe ups and downs.

Clearly everybody—companies and engineers—would benefit if electronics firms ended their search for instant experts and, instead, tried to build engineering departments of competent men with talent and energy. Part of this building would include upgrading current employees so they could keep pace with advances in technology.

The really crushing blow is that in three or five years these companies will be laying off the experts they are hiring today and searching for the current instant experts. The practice, like a cat chasing its tail, is exercise but it's not very productive.



ONE

STOP

SHOPPING
FOR ALL MAGNETIC MATERIALS
at IEEE Booths 2D15-2D17

PERMANENT MAGNETS: Cast Alnico, Sintered Alnico and Ceramic Magnets (Arnox). **MAGNETIC CORES:** Silectron-C Cores and Distributed Gap Cores. Tape Wound Cores of Deltmax, Supermalloy, Permalloy, Supermendur and Silectron. **POWDER CORES:** MO-Permalloy Powder Cores, Iron Powder Cores and MSS Iron Powder Cores. **TRANSFORMER LAMINATIONS AND HARDWARE:** Nickel-Iron, Silicon-Steel Laminations, Transformer Cans and Hardware, Tube Shields. **SPECIAL MAGNETIC MATERIALS:** Vicalloy, Permendur and Vibralloy.

And they are all precision engineered. The Arnold engineering facilities are among the world's largest and most complete, devoted exclusively to helping solve your magnetic device problems.

In addition, Arnold is a prime source for precision metal rolling . . . ferrous and non-ferrous strip, close tolerances and ultra-thin gauges . . .



ARNOLD
SPECIALISTS in MAGNETIC MATERIALS

THE ARNOLD ENGINEERING COMPANY, Main Office, MARENGO, ILL.
BRANCH OFFICES and REPRESENTATIVES in PRINCIPAL CITIES

Electronics Newsletter

March 7, 1966

Synchronous orbit gets Comsat nod

Proponents of the synchronous, or so-called stationary, orbit of communications satellites have won out over backers of near-synchronous, random and high- or low-altitude orbiting systems. Last week the Interim Communications Satellite Committee (Intelsat) gave its approval to synchronous orbit for its global communications system. The Communications Satellite Corp. acts as manager on behalf of Intelsat.

The decision will be an empty victory for the Hughes Aircraft Corp., which lost the Comsat global system contract to TRW, Inc., last December. Hughes has been a steadfast supporter of synchronous orbit and in the early days of communications-satellite planning stood alone in backing that approach.

Comsat's decision to give the contract to TRW was reportedly based on its desire to have more than one company in the communications satellite business and TRW's promise to subcontract some of the satellites' subsystems to foreign electronics companies.

Following the committee's approval of the synchronous system, Comsat filed a request with the Federal Communications Commission for authority to build six advanced communications satellites for the global system. Each satellite will have a capacity of 1,200 or more voice channels. Four satellites will be orbited sometime in 1968; two will be held in reserve.

Move to launch MOL at Vandenberg sparks debate

The Air Force's plan to launch the manned orbital laboratory (MOL) from Vandenberg Air Force Base in California is bringing cries of protest from Florida congressmen. Members of the Florida delegation argue that Cape Kennedy has adequate facilities to launch the Titan-3 booster to be used by MOL, and building new facilities at Vandenberg would be a duplication. They estimate the extra cost at more than \$150 million.

However, the Air Force considers Vandenberg the best spot in the U. S. to achieve a polar orbit without overland flights. Conceding it could attain a polar orbit from Cape Kennedy, the Air Force points out that this would require a dogleg maneuver to avoid land. The maneuver would require reducing the payload.

A political fight will probably develop in a month, when the Air Force will bring to Congress its request for authorization to build facilities at the Western Test Range.

Soviet lands probe on Venus

Evidence is piling up fast that the Soviet Union has caught up with—and perhaps outdistanced—the United States in space electronics. Last week, as Soviet scientists were recording biomedical data telemetered from two dogs in orbit, the Venus 3 probe landed. It was the first interplanetary hit ever made.

The Russians launched Venus 3 last autumn and corrected its course on Dec. 26. Venus 2, launched a few days earlier, missed Venus by 150,000 miles; but the Russians claimed it was not meant to hit the planet.

Westinghouse offers materials guide

The Westinghouse Electric Co. is offering a 70-volume guide to more than 10,000 raw materials, 500 machine parts and 1,000 finishes and tests. The 17,000-page loose-leaf guide will be updated every two weeks. The

Electronics Newsletter

service is priced at \$25,000 a year, with duplicate guides costing \$1,350. Microfilm will eventually replace the guide, which is called Empis, for engineering materials and process information service. Later, says Westinghouse, the data will probably be placed on tape for use with time-shared computers.

FTC ruling cuts tv tubes down to size

The Federal Trade Commission has ruled that, starting July 1, television tube manufacturers will have to change the way they measure the size of a tube. Under the ruling, producers must give the corner-to-corner distance of the picture area; they now include outside areas in their measurements.

The ruling will cut the advertised size of most black-and-white tubes by one inch and the size of most color tubes by two inches if measurements are rounded off to the nearest inch. The deadline for compliance with the new ruling is July 1. However, the Electronics Industries Association is expected to ask for a postponement because most manufacturers have already printed tube-size specifications for this year.

Television disk? CBS says it isn't so

Despite denials from Columbia Broadcasting Systems, Inc., reports persist that the company is working on a system that uses a metal disk—instead of magnetic tape—to store television programs. In London, Dennis Gabor, a professor at the Imperial College, says he has been working for many years on theories of compressing the bandwidth of tv signals so they could be recorded on a metal platter. Gabor commented that he has been “in touch” with CBS. He says that all his efforts so far have “been on paper” and further discussion now would be premature.

In the rumored CBS system, a 33-minute tv show was said to have been stored on a disk. A pick-up, similar to a phono pick-up, was said to transmit the signal to the set's antenna for reproduction on the screen.

The rumors caused CBS's stock to rise sharply on the New York Stock Exchange, even after trading was halted long enough to advise brokers and investors of CBS's denials.

Night and day weather watch

A second operational weather satellite, Essa 2, was orbited last week, giving the world an around-the-clock team of global weather watchdogs. Essa 2 will flash weather pictures every five minutes to any ground station within its range. Essa 1, orbited Feb. 3, works differently: it photographs the earth's cloud cover and stores the pictures on tape for feedback to stations at Wallops Island, Va., and Fairbanks, Alaska.

Incoherent light pumps maser

A team of researchers at the Radio Corp. of America has produced millimeter waves by pumping a solid state maser with an incoherent light source. The work is under the direction of Henry Lewis, director of RCA's quantum electronics division. He says the next step is the production of submillimeter waves with an incoherent light source.

The experiments presage the development of simple, low-noise millimeter and submillimeter wavelength amplifiers.

Lewis's group used a mercury arc lamp to activate doped calcium fluoride crystals. The solid state material was placed in a microwave cavity and cooled to 4°K.

THINK RELAYS



Think of Cornell-Dubilier

CDE RELAYS

MINIATURE GENERAL PURPOSE: Ideal for commercial and light industrial applications. Available in single pole (A, B or C) or 3 pole (2C-1A) contact combinations; AC or DC coils (15,000 ohms max.); standard, intermediate or ultra sensitive models; contacts dry circuit to 5 amps 26VDC/115VAC resistive. Wide variety of mountings, terminals and enclosure options. Standard types stocked by many CDE Authorized Industrial Distributors.

GENERAL PURPOSE RELAYS: CDE general purpose relays incorporate significant design improvements for added reliability and life expectancy. Available in type 30 (open) and types 31 and 32 (enclosed); 1, 2 or 3PDT; 5 or 10 amps 26VDC/115VAC resistive contacts; AC or DC coils (10,000 ohms max.). Available with a wide variety of optional terminals, mountings and enclosures. Standard types stocked by many CDE Authorized Industrial Distributors.

PROGRAM AND BI-STABLE RELAYS: Unique program relays provide up to 5 SPST contacts and 2, 3, 4, 6 or 12 step sequential switching. Designs based on reliable intermediate (1450) or miniature (1403) telephone type frames. Bi-stable relays on intermediate frame available with up to 6 form C contacts. Contacts rated dry circuit to 5 amps 26VDC/115VAC resistive; AC or DC coils (20,000 ohms max.); wide variety of mountings, terminals and enclosures. Standard types stocked by many CDE Authorized Industrial Distributors.

TIMERS AND TIME DELAY RELAYS: Rugged solid state circuitry insures accurate time delays, excellent repeatability and fast reset time. Available as timers or time delay relays; knob or screw driver adjustable, fixed delay or remote resistor adjustable. Timing range 200 milliseconds to 300 seconds. Reset time less than 25 milliseconds. Stability $\pm 10\%$; accuracy $\pm 10\%$; repeatability $\pm 2\%$. Available for AC or DC input with a wide variety of optional enclosures, mountings and configurations to meet individual application requirements.

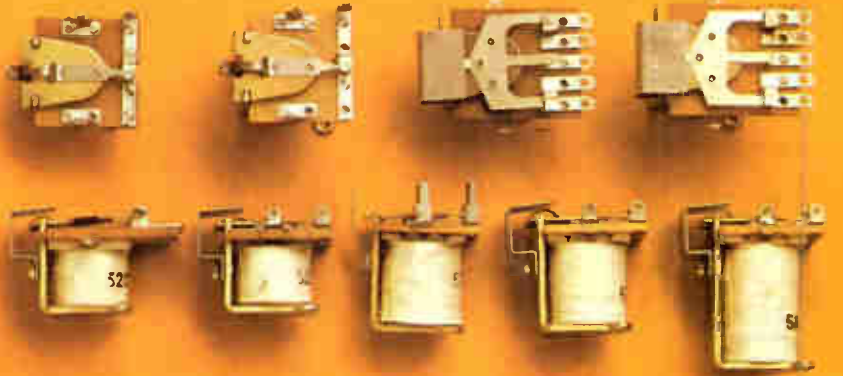

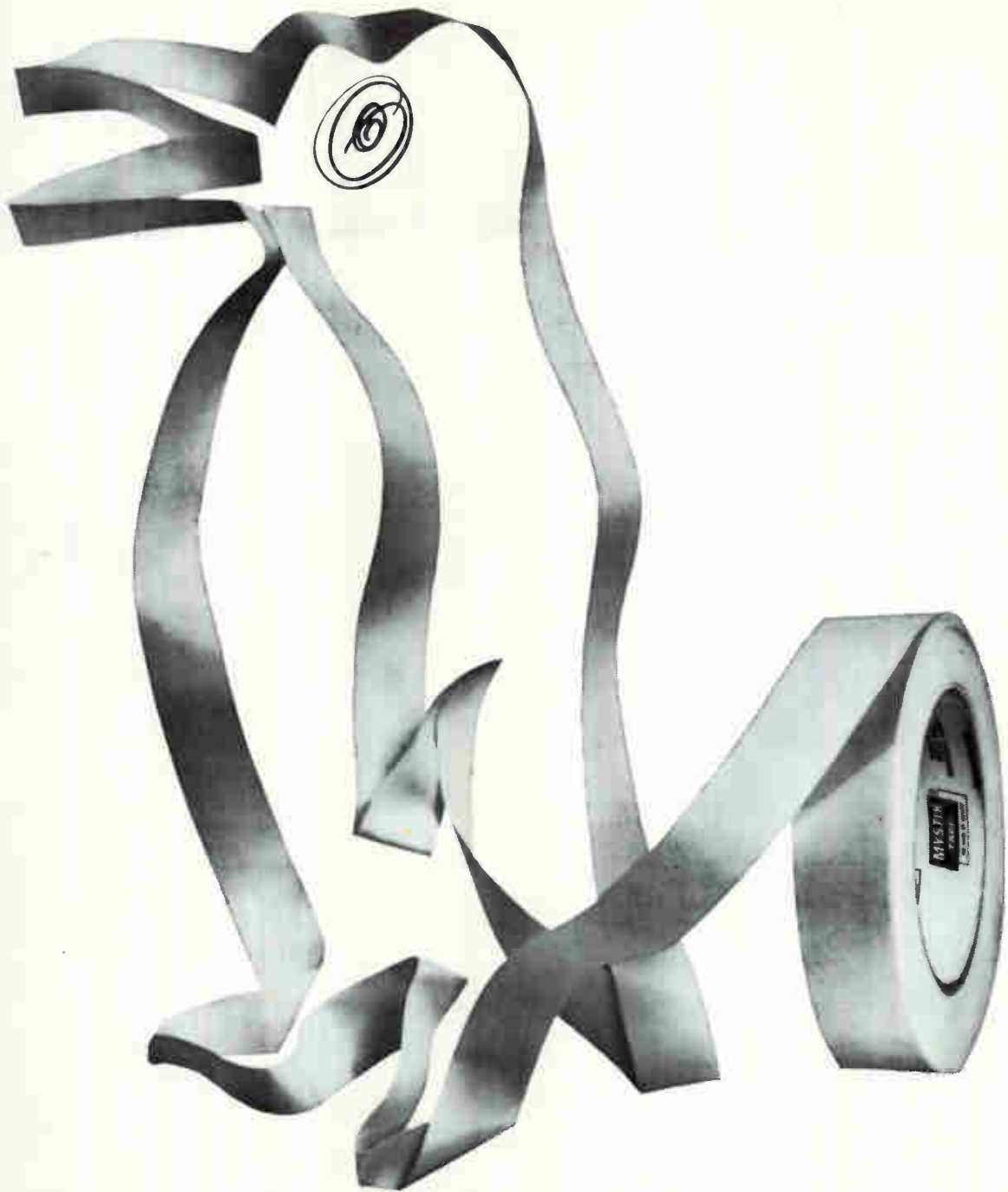

For hot and cold insulation... Mystik 7000!

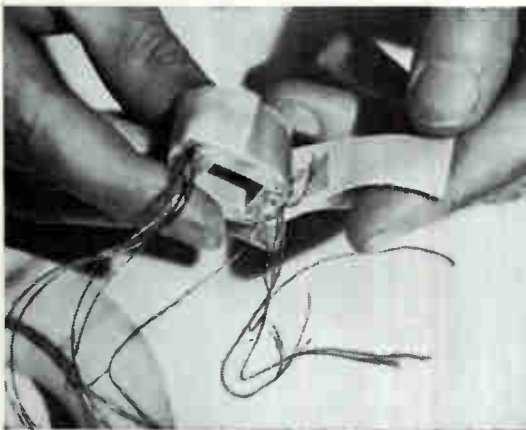

Superior thermal and electrical properties make Mystik 7000 suitable for an unusual range of cryogenic and elevated temperature applications. Uniquely inorganic, it has a tightly woven high tensile glass cloth backing with a pressure-sensitive silicone adhesive. Mystik 7000 has exceptionally high dielectric strength and offers high conformability and excellent shear resistance.

Here is a remarkable tape, perfect for insulating motors, generators or other components which must perform in critical operating environments.

This is only one of the Mystik family of tapes for the electrical industry. If you have an insulating problem or extreme temperature requirement, call your Mystik distributor. He's in the Yellow Pages under "Tape". Or write: The Borden Chemical Company, Mystik Tape Div., 1700 Winnetka Ave., Northfield, Illinois.



**BORDEN
CHEMICAL**

NOW!

P&B Quality in a full line of

Precision Snap Switches

Engineered in the tradition of P&B relays. Same pride of craftsmanship, same excellent cost-to-quality ratio. Specify with confidence in our ability to deliver the switches you want when you want them.



A New Reliable Source for Your Precision Snap-Action Switch Needs

P&B's new line of precision snap-action switches is designed to meet or exceed industry standards for electrical ratings and life characteristics.

Operating forces, actuating characteristics and mounting dimensions make these switches directly interchangeable with many competitive types. P&B precision snap-action switches meet Underwriters' Laboratories and Canadian Standards Association requirements.

Wide Variety of Stock Switches for New Applications and Direct Replacements

A wide variety of types is carried in P&B's stock. These include: General purpose, miniature, subminiature, and appliance. All four basic types are available with various actuators, terminals, and contact arrangements. They can be used for both AC and DC voltages. Mounting holes, terminals, operating and release forces, pretravel, overtravel, differential travel and pertinent dimensions meet industry standards.

Precision General Purpose

P&B general purpose snap-action switches are recommended for applications where loads may be heavy and space is not the primary consideration. They are available for 15 and 20 amperes with a broad variety of actuators, such as pin and overtravel plungers, rigid lever, roller lever, panel mount plunger and others.

Precision Miniature

P&B miniature snap-action switches are highly sensitive and especially suited for compact installations where precision is a primary factor. Their small size and high electrical capacity recommend them for appli-

cations of multiple installations in limited space. Available with various contact and terminal arrangements.

Precision Subminiature

Designed for applications requiring exceptionally small size and low operating forces. Especially suited for electronic equipment, business machines, military apparatus and other precision electrical equipment. Available for operation by pushers, cams, or lever actuators with or without rollers. Solder, turret and quick-connect terminals are available.

Precision Appliance

Economical, reliable and durable, P&B appliance switches are compact and easy to install. A white nylon enclosure gives protection for most applications. Quick-connect terminals are furnished in side or front-connected configurations. Pin plunger, plain lever, formed lever and panel-mount actuators are available.

For complete information and engineering assistance, contact your local P&B representative or call direct (812) 385-5251. We'll be happy to send you Catalog 1-A on request.

**P&B Precision Switches
are available
at leading
Electrical and
Electronic
Distributors.**



POTTER & BRUMFIELD

Division of American Machine & Foundry Co., Princeton, Ind.
Export: AMF International, 261 Madison Ave., New York, N.Y.

Circle 31 on reader service card

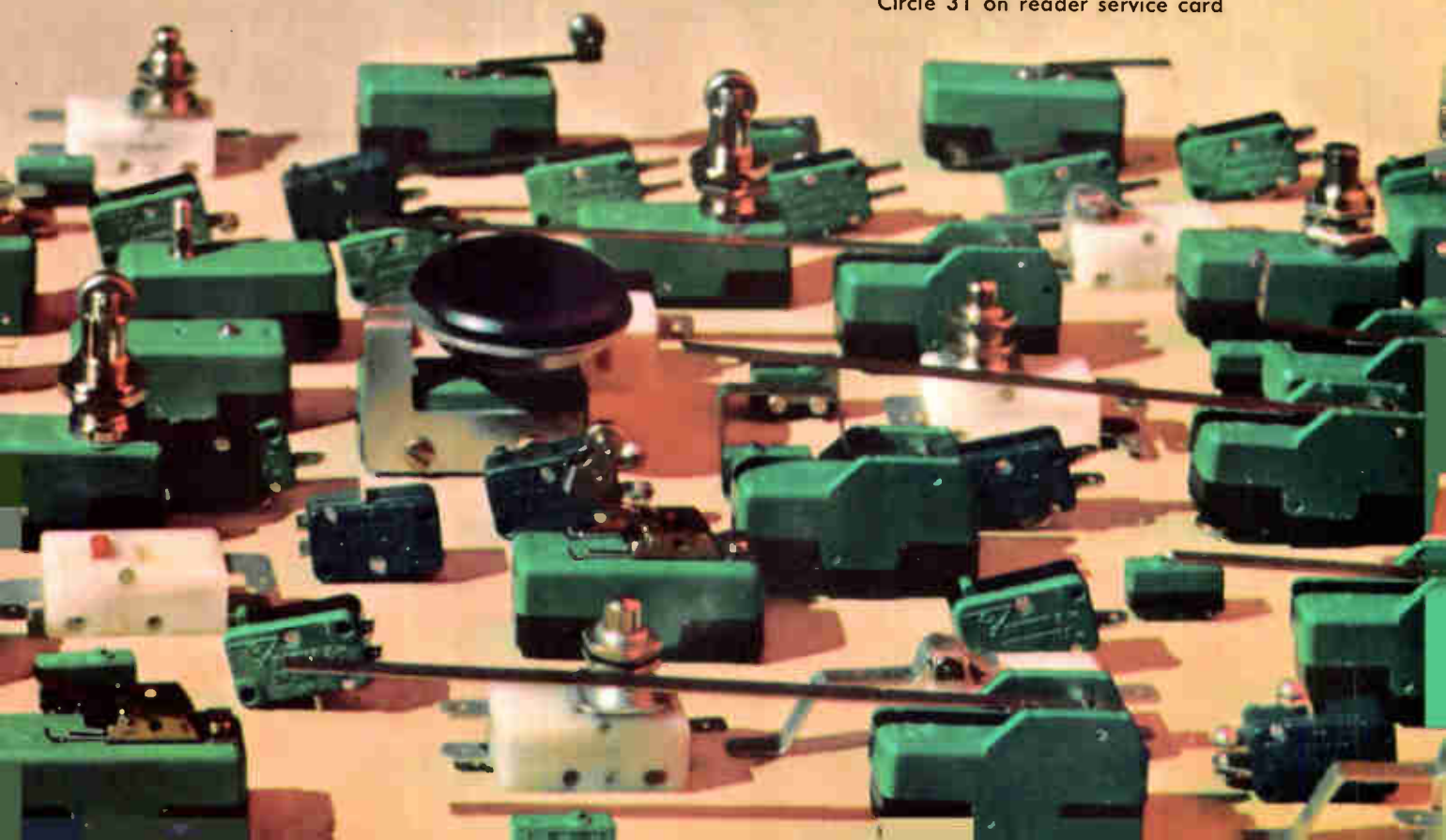

New PAR Lock-In Amplifier Measures Signals in the Presence of Noise by Crosscorrelation



Transistorized Lock-In Amplifier — Model HR-8

The PAR Model HR-8 Lock-In Amplifier represents a significant advance in signal processing equipment for experimentalists who must measure low-level signal intensities in the presence of noise. It employs the theoretically optimum technique for signal recovery, and can be incorporated into a large class of experiments in which the signal of interest is, or can be made periodic, and in which a reference voltage related in frequency and phase to the signal can be obtained. The Model HR-8 first amplifies and bandlimits the input signal and then crosscorrelates it with the reference signal, suitably phase shifted and shaped. The crosscorrelation of input and reference signals yields a DC output voltage proportional to the signal of interest, while the crosscorrelation of the reference and noise results in no net DC voltage. The system can also be described as a continuously integrating, highly sensitive, phase conscious voltmeter, the response of which is "locked" to that particular frequency and phase at which the signal information has been made to appear.

Technical Features:

Frequency Range: 1.5 cps to 150 KC continuously tunable in 5 ranges.

Time Constants: 11 values in 1-3 sequence extending from 0.001 to 100 seconds. Single or double section RC filtering.

Pre-Amplifiers: Interchangeable low-noise pre-amplifiers, operable either within the HR-8 or remotely, are used.

Type A: Differential 10 megohm input.

Type B: Low impedance transformer input for low source impedances.

Sensitivity: 21 calibrated full scale ranges in 1-2-5 sequence.

With Type A Pre-Amplifier: 100 nanovolts to 500 millivolts rms.

With Type B Pre-Amplifier: 1 nanovolt to 5 millivolts rms.

Output: ± 10 volts full scale, single-ended with respect to ground. Will drive galvanometric and servo recorders.

Frequency Selective Amplifiers: Notch network in negative feedback loop used in both signal and reference channel tuned amplifiers. Reference channel Q of 10. Signal channel Q adjustable from 5 to 25 with calibrated dial (no gain change with Q adjustment).

Phase Adjustment: Calibrated 360° phase shifter, providing continuous rotation as well as a four position quadrant switch which shifts phase in 90° increments.

Price: \$2,250 with either Type A or Type B Pre-Amplifier.

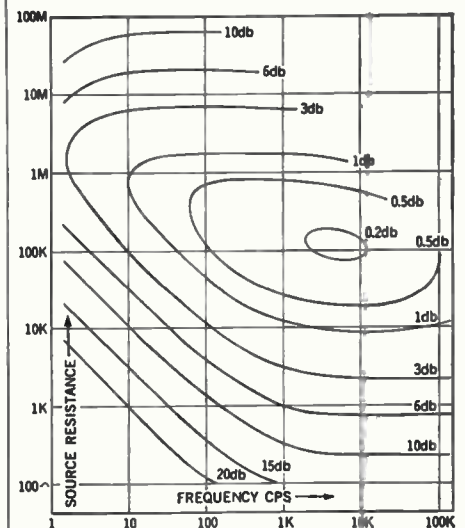

Contours of constant noise figure for a typical PAR Type A preamplifier plotted to show dependence on frequency and source resistance at 300° K. Amplifier operated single-ended.

Write for bulletin No. 120 on the HR-8 or ask for information on PAR's complete line of Lock-In Amplifiers and accessories.

PAR PRINCETON APPLIED RESEARCH CORP.
Dept. D
Box 565, Princeton, N. J., Tel. (608) 799-1222

Integrated circuits

Monolithic hybrids

A new form of dielectric isolation for integrated circuits—one which mates hybrid and monolithic techniques to gain the performance advantages of hybrid IC's and the processing advantages of monolithic IC's—is being evaluated by the Radio Corp. of America.

The company has high hopes that the new technique will speed up the use of linear IC's in radio and television sets, radar and other microwave systems, and in communications equipment in general.

Scientists at RCA's David Sarnoff Research Center in Princeton, N. J., have made experimental arrays of radio-frequency circuits by binding together thousands of silicon chips in a high-quality dielectric matrix of glassy ceramic. In this respect, the arrays resemble the hybrid circuits now used for high-voltage, high-frequency linear circuits. However, RCA doesn't process the chips and then assemble them on an insulating substrate—it uses bare chips and then processes the entire array as though conventional monolithic IC's were being made in a wafer of single-crystal silicon, including the deposition of thin-film interconnections.

The technique is expected to allow monolithic processing methods to produce circuits with frequencies beyond 100 megacycles per second, by providing a tenfold reduction in parasitic capacitances and a hundredfold increase in breakdown voltages that can be tolerated between devices of a circuit or between stages of complex circuits.

Few linear monolithic IC's are usable beyond 100 Mc or at high voltage at present because of isolation problems. RCA's dielectric is said to retain its isolation properties well into the microwave frequencies.

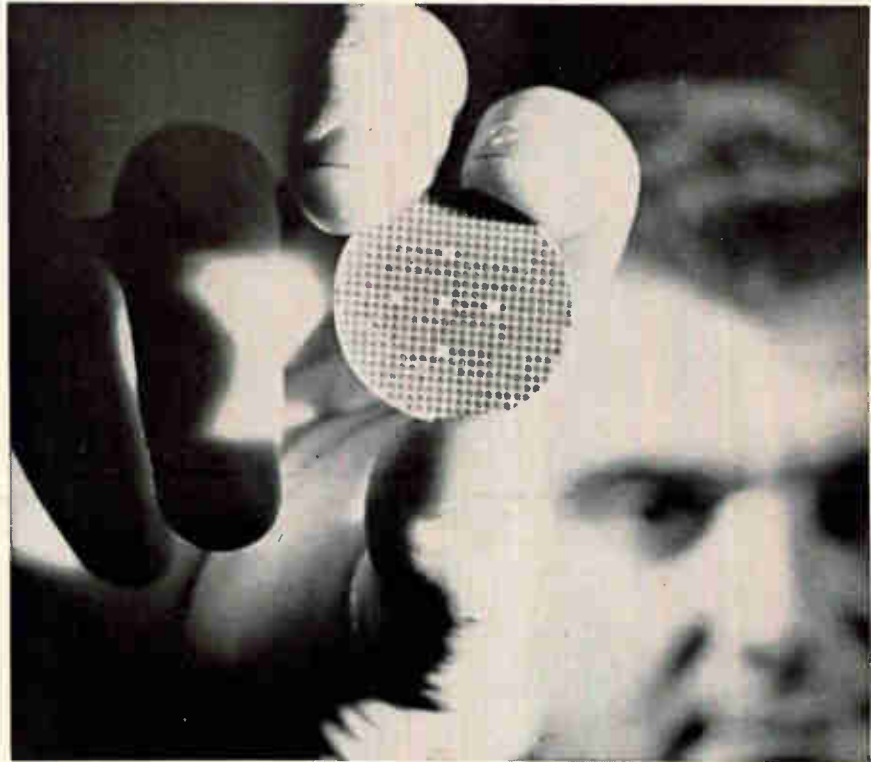

Ceramic mosaic contains 8,000 silicon tiles. The small squares that are visible in this picture are groups of tile. The entire array will go through semiconductor diffusion and metalization processes and will emerge as 440 intermediate-frequency amplifiers.

Tile setters. RCA calls its arrays "mosaics" and its chips "tiles" because the isolation process resembles tile-setting. The chips are arranged in the desired pattern and the dielectric is molded around the chips, leaving a bare, virgin layer of epitaxial silicon on each chip. The method was conceived by Arthur I. Stoller of the RCA Labs.

One of RCA's experimental mosaics contains 440 r-f mixer circuits, each composed of 10 pin-point-size tiles. However, RCA still hasn't determined what circuit designs are best suited to the process.

"We are on the threshold of a new kind of substrate for circuits that people haven't designed as yet," says Nicholas Wolff, who is head of materials processing research. Adds the lab's vice president, James Hillier, "This can lead to radical advances in the design, capability and economy of many

types of systems."

Multistage circuits. One type of circuit that could be built, according to Wolff, is a multistage amplifier. Such high-gain amplifiers require voltage and feedback isolation.

Conventional isolation—back-biasing to block current flow or forming oxidized silicon barriers—break down at about 60 volts. Wolff says the dielectric isolation can "easily withstand several thousand volts." This overcomes the coupling problems which exist when there is a large difference in gain between one side of an amplifier and another.

Another type of isolation now used to make monolithic IC's is the formation of polycrystalline moats between silicon "islands" [Electronics, June 14, 1965, p. 40]. That works for digital IC's but not linear r-f circuits, Wolff continues. The

polycrystalline silicon becomes very lossy when frequency rises to 100 Mc, causing impedance-mismatch problems.

The RCA dielectric is a low-loss material with a dielectric constant of five to six. The composition of the dielectric has not been revealed. But Wolff says it is a glass-ceramic whose thermal coefficient of expansion can be adjusted to exactly match that of the silicon chips, a necessity if the mosaic is to hold together during temperature changes in processing and use.

Complex circuits. The technique is not restricted to a single form of chip. Wolff says the sizes of the tiles and the combinations of base crystals and epitaxial layers can readily be changed. These factors determine the nature and size of the devices or circuits bonded together by the dielectric. The mosaic can be cut up into groups of tiles.

It would be feasible, Wolff adds, to make complex circuits by reserving some tiles for IC's, some for r-f power devices such as overlay transistors, and some as substrates for precision, thin-film passive components. The ceramic is a good heat sink, but Wolff thinks that if high-power circuits are made, the most effective way of cooling them would be to use an inert refrigerant such as Freon.

Shorter diffusion. Although the tile-setting procedure adds one step to the regular monolithic IC processing procedure, it can avoid those now employed to provide isolation. Making a polycrystalline moat requires deposition and etching, while isolation based on deep diffusions into the silicon requires lengthy heat treatment. Wolff says it takes 16 hours to make a typical diffused isolation.

The new process is being developed as part of a long-range process research and development program directed by C. Price Smith, of the labs. The evaluation is being done at RCA's Electronic Components and Devices group at Somerville, N. J., where RCA designs and makes its production IC's.

Industrial electronics

New perspective

Imagine trying to thread a needle with remote-control manipulators by watching what you're doing on a television screen. If the needle stood upright before the camera, with its eye hidden from view, it would be difficult to determine its distance from the camera; or if the needle was seen from above, it might be impossible to find the eye at all. But if the tv camera could be moved in such a way that the viewer was able to change his angle of view—or perspective—he'd have much less trouble guiding the thread through the eye.

On the head. A tv viewing system that provides just this kind of flexibility—by allowing the viewer to change his perspective with respect to the object being manipulated, simply with a natural movement of his head—has been developed by the National Argonne Laboratory. The system is composed of a tv camera and monitor that are slaved to a lightweight headpiece worn by the operator. When the operator moves his head, the camera and monitor follow suit. If, for instance, he moves his

head to the left to gain a new perspective, the camera pans to the left; at the same time, the viewing screen moves to the left and remains in front of the operator's eyes. Technicians testing it were able to perform tasks satisfactorily after an hour of practice.

The system is designed to improve the way scientists and technicians can watch their work in areas inaccessible to them, such as in a radioactive chamber. Other devices still under development by Argonne will allow the operator to zoom in for a closeup of his work by moving his head toward the monitor.

Ray Goertz, director of the Remote Control Engineering division at Argonne, says the objective now is "to make it work pretty much the way your own head and eyes do."

'Dead zone.' Originally, the system was designed so that the monitor and camera closely and accurately followed the motions of the operator's head. But small inadvertent head motions produced annoying effects. These were eliminated by creating a slight "dead zone" in which the operator's head could move without causing a movement of the camera or monitor.

Argonne National Laboratory, which is operated by the Univer-

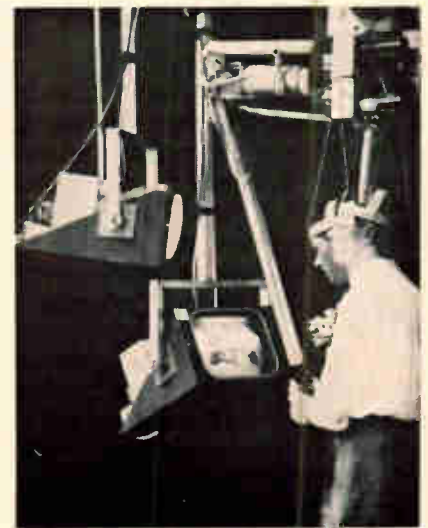

Motion of the head, as shown in this double exposure, produces a similar movement on a television camera and the monitor, providing a change of perspective for the operator of a remote-controlled manipulator. If the operator moves his head to the left, the camera that's trained on the "hands" of the manipulator (picture on the left) moves to the left and the tv monitor also moves to the left, remaining within the operator's field of view.

sity of Chicago for the Atomic Energy Commission, has helped develop the conceptual design for much of the equipment used in the nuclear-controls industry.

Electron beams' new field

For the past several years electron beams have been used on a limited scale in industrial applications. Their job has been mostly in welding, cutting and vaporizing metal. Now, the Ford Motor Co. has developed a process that may lead to a host of other applications: curing of paints and plastics and the production of printed-circuit boards and multilayer boards [Electronics, Feb. 21, p. 25].

Crucial to the Ford process was the development of a chemical that's sensitive to electron beams. When the chemical—its composition is proprietary—is mixed with paint, and an electron beam is trained on the wet paint, the electron beam cures the paint by polymerizing it. In conventional paints, which contain solvents, heat cures the paint by evaporation; the curing is usually done in ovens—typically at 150°F for about 10 minutes. With the Ford process, curing is accomplished in three seconds at room temperature.

Another use. William J. Burlant, manager of Ford's Scientific Research Laboratory's materials applications department, concedes that his lab is now exploring the possible application of the process for production of printed-circuit boards. This work is being done in conjunction with the Philco Corp., a subsidiary of Ford.

Although Burlant declines to disclose the specific areas of exploration, they presumably would include both the curing of laminating adhesives and curing or developing etching and plating resists.

At present, heat and pressure are required to bond the laminate materials. If the laminating can be done without heated presses, it may lower tooling costs, avoid the problems of material degradation and stress-warping—which make control of the laminating process difficult—and make it possible to use

new materials for the laminates.

The simplest way of using the beam in the etching process would be for rapidly curing printed resist patterns. Currently, printed resists are air-dried, which requires handling and storage, or the laminate is heated. One automatic printed-circuit production line now in use has an oven 13 feet long.

Making patterns. The process might also be used as a substitute for photographic development of resist patterns. Experimenters in other laboratories have been using electron beams to trace microcircuit wiring patterns in photoresist [Electronics, Nov. 16, 1964, p. 82]. Researchers are using a pinpoint beam controlled by a flying-spot scanner to polymerize the photoresist. Ford might be able to achieve the same effect, on the much larger scale required for printed-circuit boards—by polymerizing patterns in a plastic coating and by better scanning the beam or directing it through a mask.

Part of the problem in developing the paint-curing process involved designing a rugged electron gun that provided a wide beam. The gun that was produced emits a quarter-inch wide beam that exits through a cooled window that's 33 inches wide.

To achieve the broad beam, Ford physicist Allen Turner installed a-c scanning coils below the electron accelerator. The coils deflect the beam over a 33-inch arc, producing the effect of a beam 33-inches wide. The gun's accelerating voltage is 300 kilovolts, but Burlant declined to state the beam current.

In its first industrial application, the beam is being used to cure the paint on the metal steering columns of automobiles.

The electron-beam curing process also provides a stronger bond between the paint and the surface on which the paint is applied. In one experiment, for example, paint cured on a wood surface withstood immersion in boiling water for up to 15 minutes without blistering. Conventional paint would have peeled away, the Ford scientists say.

The broadest application, a Ford

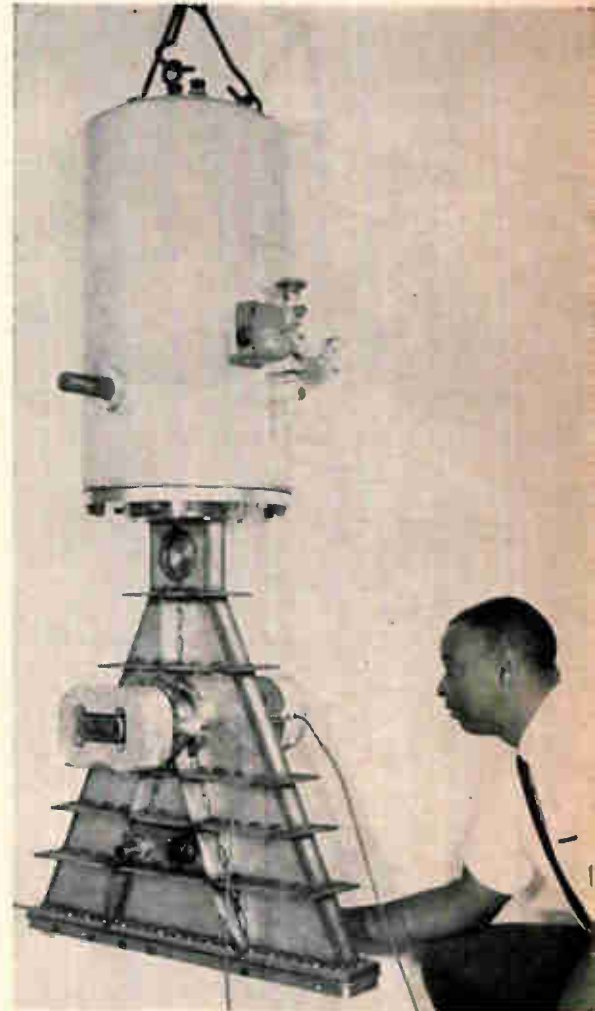

Ford physicist Allen Turner makes adjustment on electron-beam gun developed by company to cure paint on wood, metal and plastic. The process may be adapted for producing printed-circuit boards and multilayer boards.

spokesman says, will be for curing paint on wood and plastic because these materials can't withstand the heat of conventional heat-curing ovens.

Ford has signed an agreement with the Boise Cascade Corp., licensing it to use the process for factory prefinishing of wood for the building industry.

Medical electronics

Bloodless surgery

In January a 50-year-old man was wheeled into surgery at Chil-

dren's Hospital in Cincinnati. Considering the relatively simple surgery involved—removal of a tumor in his thigh—the operating-room team was unusually large: five men plus the usual complement of nurses. However, two of the men weren't doctors; they were engineers from Bell Telephone Laboratories and they were making the final adjustments on what may be the forerunner of medicine's newest and handiest tool: a laser knife.

Within two hours the laser beam had bloodlessly burned through the several roots of the tumor and the growth was removed. As the beam moved through the leg tissue, its heat left a clean cut and simultaneously cauterized the wound, eliminating one major problem in surgery—tying off small blood vessels and sponging up spilled blood.

Two-watt output. The laser, developed by Eugene Gordon, a physicist at Bell Labs, was an argon-gas device with a maximum continuous-wave output of two watts.

To aim the instrument, Gordon and his associates, E. F. Labuda and A. M. Johnson, rigged up a mirror that swiveled on a gimbal. The mirror reflected the beam from the laser cavity onto the patient's thigh. The surgeon guided the beam by aiming the mirror.

The surgeons, under the direction of Dr. Leon Goldman, a pioneer in medical applications of lasers, reported they were delighted with the results.

Goldman, however, added cautiously: "We've got to make many more tests before we can be sure of the instrument. Right now we're waiting to find out how effective our treatment was."

This is not Goldman's first experience with laser surgery. In developing the technique, he performed tests on dogs, including heart surgery. Goldman plans to test the laser-beam technique in animal brain surgery.

In selecting the wavelength of the laser, the Bell Laboratories researchers selected two that exhibit the strongest power levels of transmission: 4,800 and 5,145 angstroms.

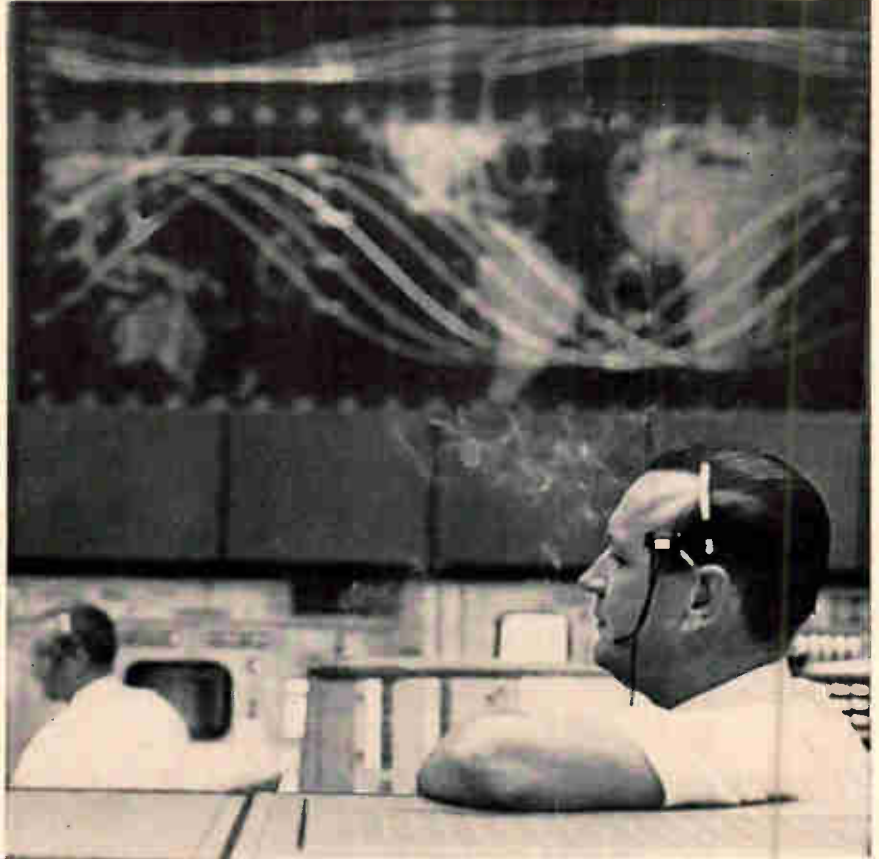

Christopher C. Kraft, flight director for the Gemini series, is moving out of his job and over to a new one: flight director for the Apollo mission.

Space electronics

Kraftsmanship for Apollo

When Gemini 8 takes to the air in mid-March, a familiar figure will be missing from the flight director's console in the Mission Control Center at the Manned Spacecraft Center in Houston. Christopher C. Kraft will be preparing for his new job as flight director on Project Apollo—the mission to place a man on the moon by the end of this decade. However, Kraft will continue to function in his primary post, as assistant director of the MSC for flight operations of future Gemini flights.

Kraft, 42 years old, has been around mission control centers for the entire manned flight program. He was flight director for all the Mercury flights.

He first joined the staff of the old National Advisory Council for Aeronautics in 1945 and was one of the 35 people assigned to the

Manned Spacecraft Center when it was formed in 1958.

In addition to his mission control duties, Kraft also supervises mission analysis and recovery operations work.

Military electronics

Explaining the budget

Defense Secretary Robert S. McNamara laid before Congress last week a 220-page rationale of the \$58.3-billion military budget for fiscal 1967, beginning July 1. These highlights of the posture statement emerged:

- McNamara has changed his mind about cutting back the Navy's aircraft carrier fleet over the next five years.

- He has decided to convert another Army division into a helicopter-borne unit.

- The potential of satellites for

TRW IGFET

24 DB gain / 120 DB dynamic range at 100 Mc

The TRW 2N4038/PT200 Insulated Gate Field Effect Transistor has many unique characteristics that will intrigue and inspire the resourceful designer.

- **N CHANNEL:** Enhancement or Depletion Types.
- **HIGH G_m** ($\approx 2000 \mu mho$): RF/IF Amplifiers, AC/DC Amplifiers.
- **LOW NOISE** (3 DB): RF/IF Amplifiers, Mixers, AC/DC Amplifiers.
- **LOW FEEDBACK** ($C_{gd} = 0.2pf$): Choppers, Multiplexers, RF Amplifiers.

- **TRUE SQUARE LAW DEVICE:** Product Detectors, AGC Amplifiers.
- **HIGH INPUT R** ($10^{15} \Omega$): Logic Circuits, Instrumentation.

If you have an unusual circuit design problem, TRW IGFET technology may solve your problem. Get your IGFET at local distributors or write TRW Transistor Plant, 14520 Aviation Boulevard, Lawndale, California 90260.

TRW designs and manufactures high performance transistors for the communications industry and specialized types for military and industrial applications.

TRW SEMICONDUCTORS

tactical communications will be exploited.

- More emphasis will be placed on anti-aircraft missiles.

- An airborne warning and control system will be pushed for both continental defense and tactical use.

A series of advanced-planning briefings based on the posture statement will be given for defense contractors over the next few months. Pentagon officials will speak in Atlanta March 9 and 10, St. Louis March 16 and 17, San Francisco April 12 and 13, and Washington April 27 and 28.

McNamara also said that studies of the antisubmarine threat indicate a need for 68 attack submarines and possibly more. To reach 68, 11 more must be built; McNamara is seeking funds for five in

The program to improve the Hawk anti-aircraft missile and to make it self-propelled will also be stepped up. The improved Hawk will substitute for the Mauler missile, which should have been in operation but was canceled after developmental problems.

Looking ahead. The Army is beginning development of a new anti-aircraft missile, known as Sam-D, for the 1970's. The missile will be capable of knocking down short-range ballistic missiles as well as planes.

Development will begin on a new Navy missile system to supplement three other programs intended to straighten out the Navy's air-defense muddle. The programs constitute an effort to correct deficiencies in the Tartar-Talos-Terrier family of missiles on ships built

Giving warning. McNamara's earlier doubts about efforts to develop an airborne warning and control system have abated, and he is allowing the program to proceed. It will require development of an aircraft as a semiautomatic command post from which both air-strike and air-defense operations could be directed—a kind of "flying Sage" system. Along with the plane would be developed a radar capable of detecting and tracking airborne targets over land despite severe ground clutter.

McNamara seeks \$3 million in fiscal 1967 to undertake contract definition leading to two aircraft prototypes and \$12 million to be added to \$9 million already spent on radar development for them. The Air Force plans to flight-test five different types of radar during the coming year.

After summarizing plans to put up an interim satellite system for strategic communications in the next six months and plans for a more advanced system later, McNamara said the time has come to consider satellite communications for tactical use.

Strategic systems will use satellites of relatively simple design and sophisticated ground terminals. But now, says McNamara, technology makes possible complex and heavy satellites and small, highly mobile terminals for tactical use.

McNamara also disclosed that:

- The short-range attack missile being developed for the strategic bomber version of the F-111 won't be utilized on the G and H models of the B-52. But development work will be continued to permit use in B-52's "if it should become desirable later."

- The Air Force will undertake engineering development and test of a new terminal guidance system for the Hound Dog air-to-ground missile, which will be used by B-52's remaining in the bomber fleet.

- Though he still sees no need to order production of a new manned interceptor for continental defense, work on the experimental YF-12A will continue and \$5 million will be spent for "certain improvements"



Navy's only nuclear-powered aircraft carrier, the Enterprise, stationed off the coast of Vietnam, will soon have three sister ships. One is already in the budget and defense chief McNamara last week approved plans for two more.

fiscal 1967. This fleet does not include the 41 Polaris missile submarines that are either at sea or being built.

Flying Army. The decision to convert a second Army division into an air-mobile unit similar to the First Air Cavalry Division in Vietnam will require the purchase of more than 400 helicopters.

McNamara emphasized air-defense missiles. The Army plans to "increase very substantially" the number of new air-defense battalions, which use 32 20-millimeter guns and 32 Chapparral missiles. The Chapparral program, which began last year, involves conversion of the air-to-air Sidewinder to the air-defense role.

or under construction; development of a new and more effective "standardized" missile for use on Tartar and Terrier launchers, and development of an advanced surface-missile system for the 1970's.

The supplementary program will provide a ship-based version of the air-to-air Sparrow missile (called a Sea Sparrow) to provide "close in" air defense for combat ships and give a missile capability to amphibious ships now armed only with anti-aircraft guns. McNamara said preliminary tests with the Sea Sparrow system have been encouraging and that it can be developed quickly, using existing hardware and possibly some components from Mauler.

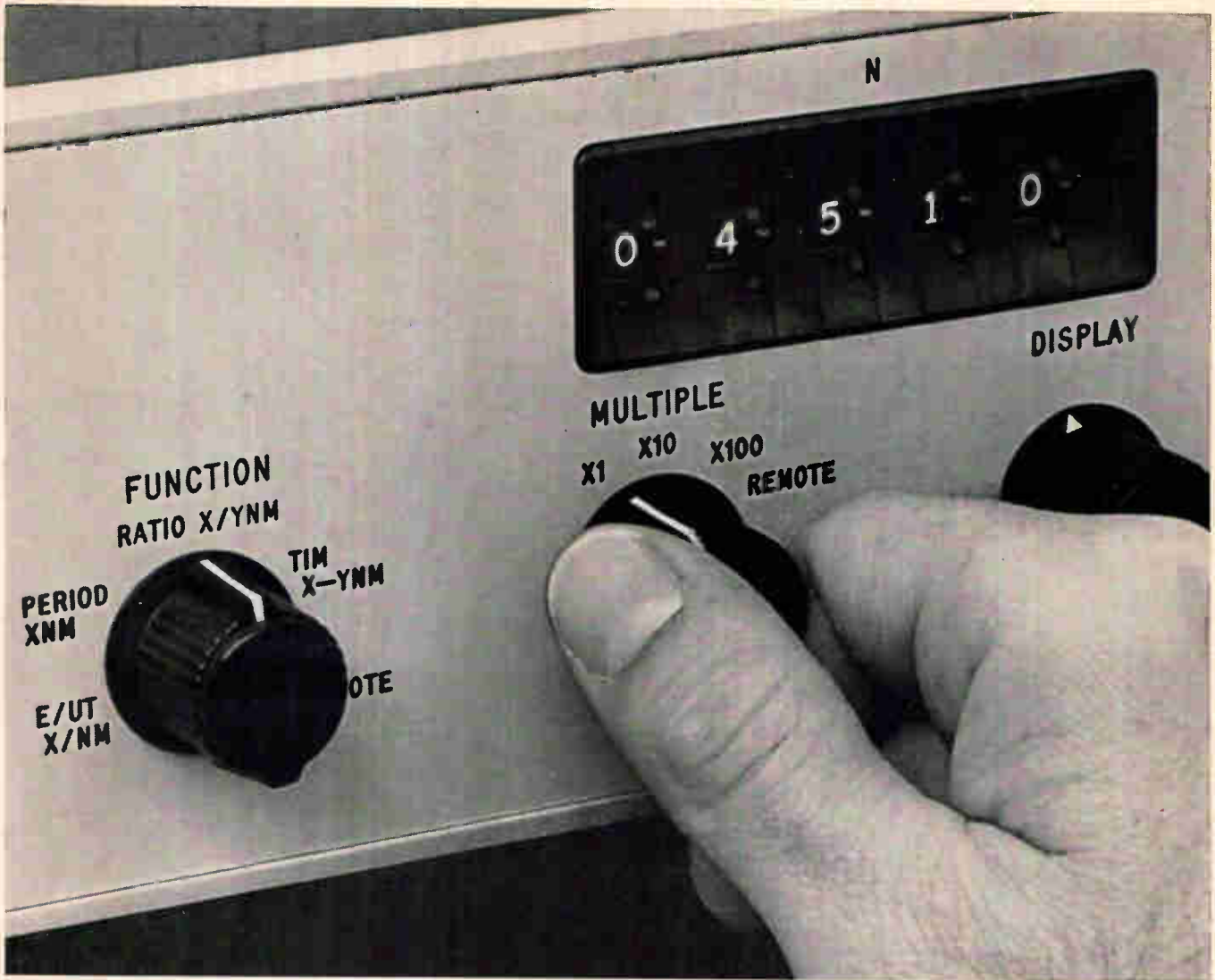

For the engineer who wants everything

The Beckman Model 6030 is the most versatile solid-state 2-mc Preset EPUT® & Timer available. This extraordinary all-in-one instrument gives you frequency, period, ratio, and time interval measurements... plus preset switches. And the universal 6030 will measure in rpm, gpm, etc., giving rationalization of engineering units. Pulse width, multiple pulse ratio, pulse repetition rate... all are no problem for the 6030. Neither are incremental multiple units, expansion of periods and time, expansion of frequency ratios... they're all yours in

the Model 6030 for only \$1,540. If you're an engineer who wants everything, get a Beckman Model 6030 Preset EPUT & Timer... and you've got it! Your Beckman Berkeley sales engineer has all the details. Call or write today.

Beckman® INSTRUMENTS, INC.
 BERKELEY DIVISION
 RICHMOND, CALIFORNIA • 94804

INTERNATIONAL SUBSIDIARIES: GENEVA; MUNICH;
 GLENROTHES, SCOTLAND; TOKYO; PARIS; CAPE TOWN; LONDON



ARE YOU YOUR OWN COMPUTER?



Rules of three, percentages, multiplications, divisions, currency conversions... with its circular slide-rule, the Chronomat calculates them all!

This amazing chronograph is very much more than simply a high-precision timepiece. It is a working tool indispensable to your profession, to your technical studies, to your hobbies. It is made by Breitling of Geneva.

For my information, please send me, free:

- the amazing world of chronographs
- the special catalogue of Breitling models (Mark a cross where applicable)

Name: First name:

Profession*:

City: State:

E 2

Breitling-Wakmann
15 West 47th street, New York 36, N.Y.

Electronics Review

in the ASG-18/AIM-47 fire control and missile system it employs.

▪ Another \$23 million will be spent in fiscal 1967 on top of the \$42 million outlay in fiscal 1966 for over-the-horizon radars.

▪ Problems in development of the Phoenix air-to-air missile and the airborne missile-control system for the Navy version of the F-111 "have not as yet been fully resolved and some delay in the F-111B program appears inevitable."

▪ Also, \$4 million is being requested to start studies on a new antiradar missile that looks beyond ARM-1, which is a missile being developed by the Navy as a follow-on to Shrike.

Extras for Vietnam

Aircraft, helicopters and air-to-ground missiles dominate the military's shopping list which is to be financed by new appropriations now being sought from Congress to support the war in Vietnam.

Congress is expected to approve the extra \$12.3 billion requested by President Johnson despite the current debate over the war and despite any attempt by opponents to

rescind the 1964 resolution authorizing the President "to take all necessary steps" for the war.

Once it gets the money, the Defense Department will begin placing contracts for aircraft still in production—the McDonnell F-4 for both the Air Force and Navy; the Grumman A-6A Intruder and the Douglas A-4E Skyhawk for the Navy, and the Grumman OV-10 Mohawk for the Army. In addition, it will commit itself to the first production orders of the Ling-Temco-Vought A-7A for the Air Force and the North American OV-10A for the Marines and Air Force.

The A-7A and OV-10A are now in the prototype testing stage. The A-7A was developed for the Navy, and the first procurement for that service was decided upon earlier.

Buying new COINS. The OV-10A, called COIN, for counterinsurgency aircraft, will become operational in mid-1967 and the A-7A, late this year. The OV-10A is a light armed-reconnaissance plane that will be used primarily for directing air strikes in support of ground troops. The A-7A is an attack aircraft that will aid ground forces by carrying out strikes against heavily fortified targets.

The Pentagon will also buy re-



Damaged by Viet Cong fire, a Chinook helicopter gets a lift from a Skycrane back to a military base for repairs. Production of both craft will be stepped up for the military.

connaissance versions of the F-4 for the Air Force, training versions of the A-4E and the North American T-28C trainer for the Navy, and modifications of the Boeing B-52 bomber and the Fairchild C-123 transport for the Air Force. The bomb-carrying capacity of the B-52 will be enlarged, but the increase is classified.

The helicopter purchase will include the Bell UH-1B and D Iroquois, the Vertol CH-47A Chinook, the Sikorsky CH-544 Skycrane, the Bell TH-13T instrument trainer and the Beech U-8F utility transport, all for the Army. The Navy and Marines will get additional Vertol CH246A Sea Knights, Sikorsky CH-53A Sea Stallions and the Bell UH-1E. The Air Force will buy Sikorsky CH-3E transports and HH-3E rescue helicopters, as well as Helio U-10A Couriers.

Missiles, too. In missiles, the Pentagon will buy more Maxson air-to-ground Bullpups, Texas Instruments' Antiradar Shrike missile and Raytheon ground-based Hawk anti-aircraft missiles. In addition, the Air Force will receive additional target drones to train pilots in the use of the Raytheon Sparrow-3 air-to-air missiles.

The exact quantities of the aircraft, helicopter and missile orders are secret.

New research-and-development funds for Vietnam will finance modifications of the F-4 and A-7A "to improve their effectiveness for close troop-support missions"; continued development of the Grumman EA6B electronic countermeasures aircraft; an electroluminescent runway lighting system; an aircraft photo-flasher system to light the ground for night photography, and additional work on airborne electronic warfare equipment. Details on these projects are classified.

Avionics

C-5A race continues

Last October, when the Lockheed Aircraft Corp. won the \$1.4-billion

basic measuring tools from

**HEWLETT
PACKARD**

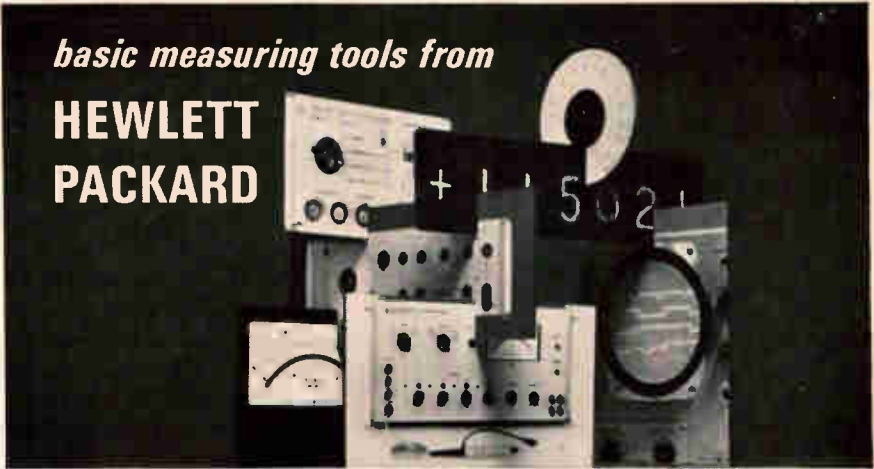

hp 3439A Plug-in Digital Voltmeter

versatile, 4-digit DVM—for only \$950 plus plug-in accuracy better than $\pm 0.05\%$ of reading ± 1 digit, $\pm 15^\circ\text{C}$ to $\pm 40^\circ\text{C}$ with line voltage variation of $\pm 10\%$

5% overranging, high ac rejection (30 db at 60 Hz)

signal common floatable up to 500 v dc from chassis ground
automatic ranging

Use it for:

mv to kv dc autoranging voltage measurements: thermocouple, bridge measurements, production and maintenance testing

μa to a dc current measurements: power supply currents, collector and base currents, leakage currents

mv to kv ac voltage measurements: average responding (rms with hp 3440A), servo measurements, turns ratios

ohms to megohms resistance measurements
programmable ac, dc voltage ranges

Plug-in capability makes this DVM an economical bench instrument with a wide range of uses. The basic instrument, priced at \$950, offers high accuracy, dc isolation, speed (readings in a fraction of a second), ac rejection, economy, reliability. Plug-ins permit manual range selection 10 v to 1000 v full scale (3441A); automatic range selection with remote range feature (3442A); measurement ranges 100 mv to 1000 v full scale, with automatic and remote ranging (3443A); voltage (100 mv to 1000 v), current (100 μa to 1 amp) and resistance (1000 Ω to 10 M Ω) measurements (3444A); ac/dc measurements, 10 v to 1000 v full scale with manual, automatic

and remote ranging (3445A), and remote function and/or ranging (3446A). Plug-ins priced from \$40 for the manual ranging unit (required) to \$525 for the ac unit and \$575 for the multi-function unit.

Your Hewlett-Packard field engineer will give you a demonstration of the voltmeter and the plug-ins most useful for your application. Just give him a call. Or write for complete specifications to Hewlett-Packard, Palo Alto, California 94304, Tel. (415) 326-7000; Europe: 54 Route des Acacias, Geneva.

*Data subject to change without notice.
Prices f.o.b. factory.*

HEWLETT  **PACKARD**
An extra measure of quality

908

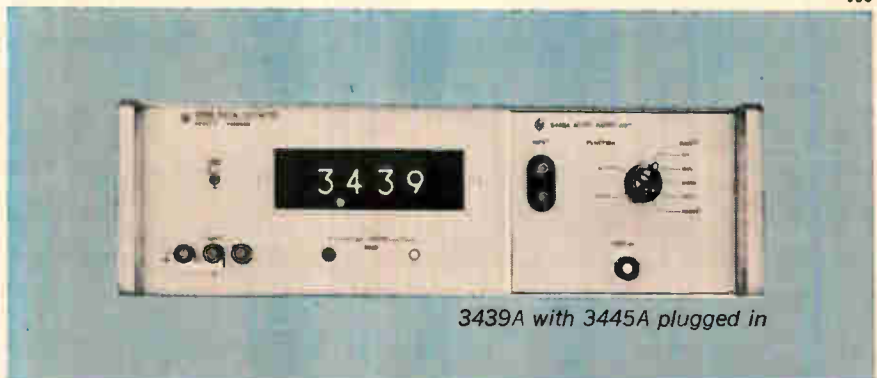

3439A with 3445A plugged in

THINK RATS

... for electrical power.

Garrett-AiResearch Ram Air Turbine Systems (RATS) give you auxiliary electrical power from 150 watts to 30 kw.

Externally or internally stored RATS provide power on demand—full-time or intermittent loading—speed control within $\pm 5\%$ of the rated electrical frequency.

Think RATS for reliable electrical power for countermeasures, communications, control, guidance, weapons systems, and other aircraft and missile needs. Operate over a broad environmental range. Low weight. Low drag. Backed by AiResearch single-source responsibility and service.

For design and application data on RATS for electrical, hydraulic, pneumatic, and mechanical power, write: AiResearch Manufacturing Company, 9851 Sepulveda Blvd., Los Angeles, California 90009.

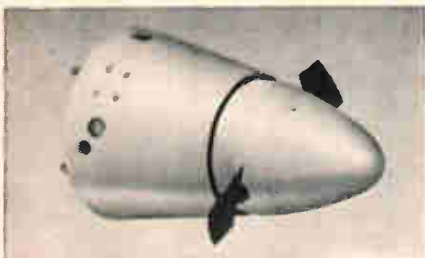
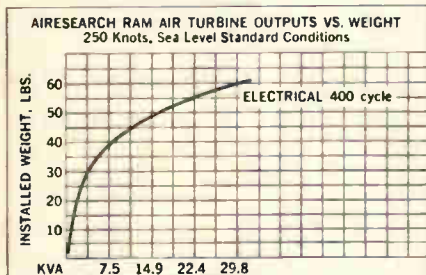

**AIRESEARCH
RAM AIR TURBINE
SYSTEMS**



Electronics Review

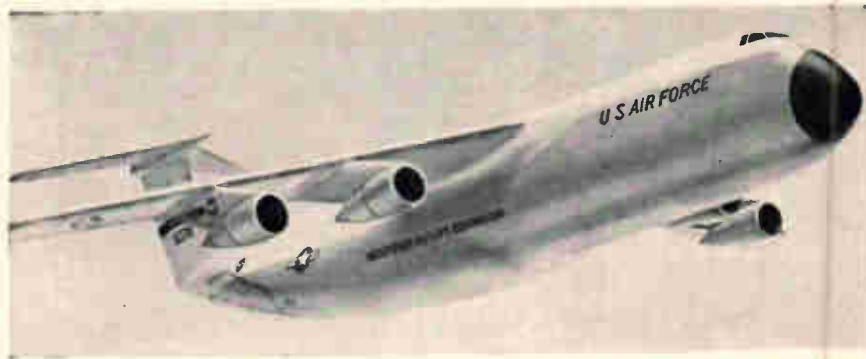

Drawing of the C-5A, which is being built for the Air Force.

contract for the Air Force's C-5A cargo plane, it looked as if the losing competitors, the Boeing Co. and the Douglas Aircraft Co., were out many millions of dollars—the cost of preparing their complex proposal—and that the C-5A competition between the three aerospace companies was over. Not so. Last month the three giant companies indicated that the competition will continue, and perhaps intensify. Lockheed announced it plans to produce a commercial version of the C-5A, labeled the L-500, which could carry as many as 900 passengers, 140 tons of cargo, or a combination of both. Boeing and Douglas hinted that they, too, were considering a commercial version of their designs.

'Excellent' reaction. The Boeing and Douglas designs, however, will probably be scaled-down versions of the behemoth, capable of carrying between 350 and 550 passengers. Boeing and Douglas executives have already approached the major airlines with the proposal for the scaled-down models.

Boeing's model, called the 747, "has received an excellent" initial reaction, says a Boeing spokesman. A decision, however, on whether to produce the aircraft isn't likely until next month, the Boeing spokesman says.

Lockheed also is weighing the market for a scaled-down version of the C-5A: it's considering a craft that would haul about 400 passengers.

The designs of all the giant airplanes are based on the companies' research on the C-5A project.

Lockheed's C-5A is scheduled for delivery to the Air Force in 1968. Lockheed's vice president

and program manager of the C-5A, T. R. May, says the company "fully expects" to have the L-500 on regular air routes by the early 1970's. He adds: "Our predictions indicate that the market would support 30 to 40 all-passenger airplanes of this type in the 1970's." In addition, he says, a hundred or so all-cargo planes will probably be sought by the airlines.

The electronics industry is awaiting the decision on production of modified C-5A's with more than casual interest; the sophisticated electronics such giant planes would require would mean big new business.

Electronic systems. Lockheed's C-5A, for example, will contain a malfunction detection system that gathers information on breakdowns and potential malfunctions for use both in-flight and during check-out on the ground. The system will collect data on about 1,000 points throughout the aircraft and relay the information to the flight engineer. Aside from pinpointing trouble, the system will indicate whether spare parts are on hand and what special tools are needed to install them.

The C-5A will also carry station-keeping equipment and multimode radar that will handle such jobs as ground mapping, terrain avoidance and navigation.

Consumer electronics

Braking the habit

Office managers complain that copying has become so much a part

of office life that secretaries have forgotten how to use carbon paper, which is much cheaper, and that employees now feed everything—from junior's term paper to instructions for knitting a sweater—into the voracious copying machines.

To put the brakes on the copying habit, cost accountants for some companies have required that users sign charge sheets and indicate the number of copies they've made; but employees falsify, forget or just don't bother to sign the charge sheet. Now, two inventors at the Savin Business Machines Corp. of New York, Frank LaBella and Robert Peisner, have developed what they believe is a fool-proof automatic billing machine for electrostatic office copiers—called the Copytrol. If they are right, Copytrol should become as ubiquitous as the copiers themselves.

Can't stop it. The biggest producer of electrostatic copying machines, the Xerox Corp., can't be too happy with the development since it will tend to cut down on the number of copies that are made. But Xerox can't do a thing about it because Copytrol isn't connected to the copying machine—except that the copying machine's power cord is plugged into Copytrol.

The Copytrol is a small cabinet with rows of key-operated switches—one key switch for every group or individual authorized to use the copier. The copier will not work unless a key, inserted in one of the switches, turns it on. Underneath each key switch is a meter that registers the number of copies or the cost to the user, depending upon the type of copier.

The secret of Copytrol's operation is a current-measuring circuit that detects a current surge inherent in each copying cycle. Since this current surge will vary from one machine to another and with local line voltages, the threshold of the trip-current is adjustable.

No cheating. In the case of the Xerox 914, a popular model, the machine runs for about 50 seconds after the last copy is made to allow its belts and drums to cool. To protect the copier, Copytrol also has a time-delay mechanism that con-

Electronic Relays



AEROSPACE



DRY REED



WETTED REED

Commercial Relays



COMPACT



CONTROL



POWER

Industrial Relays



PLUG-IN



600V



MOTOR STARTERS

9 CLUES TO FINDING A RELAY... FAST!

Notice the range of the relay types above. You'll get an idea of what's available in the world's largest line of relays . . . at Struthers-Dunn. Including standards and specials. In fact, if we can't come up with the relay you're looking for, well . . . we have a feeling you'll be in for a long, hard hunt. Write for details on any type.

STRUTHERS-DUNN, Inc.

Pitman, New Jersey 08071

tel: 609-589-7500

twx: 609-589-1548



SALES ENGINEERING OFFICES IN: Albuquerque • Atlanta • Belmont, Calif. • Birmingham, Ala. • Boston
Buffalo • Cedar Rapids • Charlotte • Cincinnati • Clearwater, Fla. • Cleveland • Clifton • Dallas • Encino
Englewood • Glen Ellyn, Ill. • Houston • Kansas City • Las Vegas • Memphis • New York • Phoenix • Pitts-
burgh • St. Louis • St. Paul • Salt Lake City • Richardson, Tex. • Seattle • Southfield • Towson, Md.
Wichita • Wilmette. Canadian Licensee: Renfrew Electric Co., Ltd., Toronto. Export Dept.: 1505 Race St.,
Philadelphia, Pennsylvania 19102, U.S.A.

At the IEEE Show see us at Booth 2J41 and 2J43

**We're into electronics
up to our ears...**

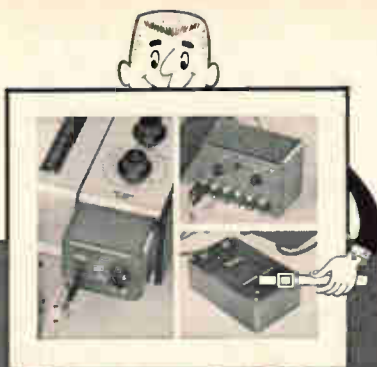

**that's why
Bausch & Lomb V.O.M. Recorders
ASSURE YOU
outstanding performance!**

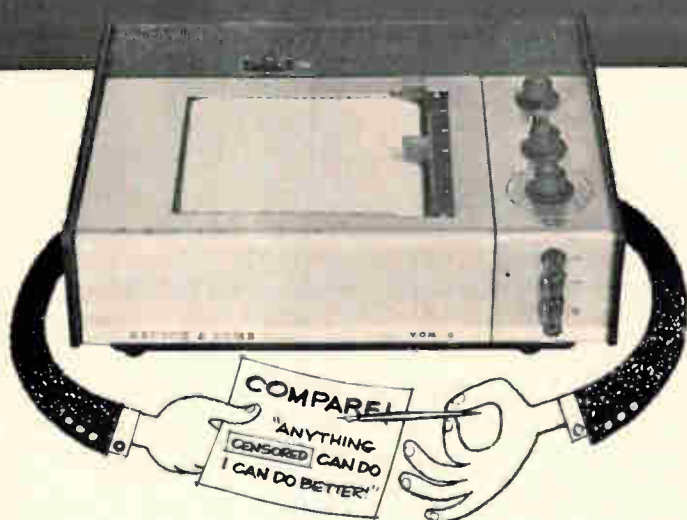

V.O.M. Recorders are backed by years of experience in engineering the most sophisticated electronic circuitry for a wide variety of precision scientific instruments. An entire division is devoted exclusively to the development and production of electronic products. Result? Outstanding performance and reliability... with exclusive important advantages for you at surprisingly low cost. Like recording multiple inputs... volts, ohms, milliamps... directly, without extra converters. Or the 5 chart speeds, and many more. People who buy them, like them and buy more. The V.O.M. Recorder in use is its own best salesman!

	V.O.M.-5	V.O.M.-6	V.O.M.-7	V.O.M.-8
Voltage range:	10 mv-500 v DC	2.5 mv-125 v DC	0.5 mv-10 v DC	Absorbance/ Transmittance Measurement (voltage, current, resistance ranges same as V.O.M.-5)
Current range:	10 μ a-100 ma	2.5 μ a-25 ma	1 μ a-10 ma	
Resistance range:	1 ohm-100 K ohms	0.25 ohms-25 K ohms	1 ohm- 100 K ohms	
Prices: (suggested list)	\$595 COMPLETE	\$700 COMPLETE	\$885 COMPLETE	\$900 COMPLETE

We also have the capability of designing special recorders... modified to handle whatever applications you wish. For complete information on our standard recorders and the many time-saving accessories available for them, write for Catalog 37-2068. Let us know if you are interested in modification for special needs. Bausch & Lomb, 99727 Bausch Street, Rochester, New York 14602.

BAUSCH & LOMB 
ELECTRONICS DIVISION

Visit our Booth 3K43 at the IEEE Show, N. Y. C., March 21-24

tinues to provide power to the copier for 50 seconds after the operating key has been removed.

However, if someone tries to cheat the machine by making a copy during this cool-off period, the machine will turn off, trapping the unauthorized copy within the machine. The next person to insert a key into the Copytrol will get charged for the unauthorized copy but since he will get a copy of the document it should be easy for him to identify the person who preceded him.

Copytrol units have been designed for just about every electrostatic copier on the market. The price varies depending on the copier for which it is used and the number of key switches desired. An eight-key unit for a Xerox 914 will cost about \$540 and for a roll-fed machine about \$375. For some types of machines, an eight-key unit will cost only about \$225.

The metering machine is being produced by Copytrol, Inc. and initially it's being distributed by Savin.

Copytrol, Inc., has already applied for a patent on a similar automatic billing machine for time-shared computer terminals. Its name? Datatrol.

Manufacturing

The copper squeeze

For the past few years the copper shortage has been getting tighter and tighter. Until recently, the squeeze affected only the large industrial users of the metal. But now electronics companies are beginning to feel the pinch.

So far, the tight market for copper hasn't reached crisis proportions, but it's making the life of purchasing agents—whose job is to find, among other things, supplies of copper—a bit livelier. Typical of the comments heard from agents around the country is this one from John E. Morgan of the Collins Radio Co.: "We used to get (copper) magnet wire in four to six

weeks, but now we face a delay of eight to ten months."

Wait, wait. The delays in getting orders filled and the spiraling prices of some copper items is more of an inconvenience to electronics companies than a hardship.

Says a spokesman for the General Radio Co.: "The rising price (of some copper) is somewhat of a (problem), but we're bothered much more by the scarcity. . . . The price of copper in our equipment is small compared with the overall cost."

Adds Edward Mason, purchasing manager of the Giannini Controls Corp.: "Orders for hook-up wire take from 12 to 14 weeks to fill, when only a month ago it was an off-the-shelf item."

Generally, producers of priority military equipment aren't affected by the pinch. If a military-equipment company runs into trouble getting copper, the company's purchasing agent simply calls Washington's Business and Defense Service Administration, and a government purchasing agent tracks down the required metal. In addition, the military-gear producers are able to write off the copper price rises in their bill to the government.

Something else. The tight market is having other effects. For example, explains Ray Kondrat, marketing manager for the Metal Products Group of the Metals and Control division of Texas Instruments Incorporated: "We've been 'stretching' copper by using copper-clad metals—such as copper-clad aluminum and copper-clad steel—to replace solid copper in some applications."

Other companies, convinced that the end to copper shortage isn't in sight, are stepping up efforts to find substitutes.

George Paterson, purchasing director for the Simplex Wire & Cable Co., notes that there has been a "heavy influx" of aluminum as a substitute for copper.

The federal government has taken several steps recently in an effort to hold down the price of copper. In November, for example, the White House ordered the release of some 200,000 tons of stock-

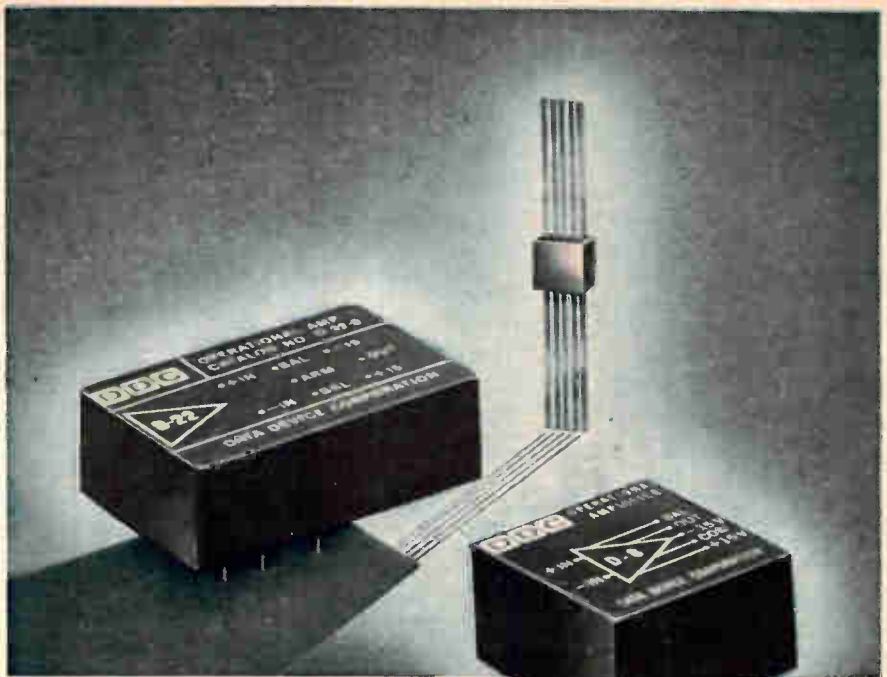

The new Op Amps up front are bigger. And better.

There's no comparison between DDC's new *Assured Reliability* Operational Amplifiers and that flat pack—unless you *must* trade off size for far inferior offset current. And stability. And output current. And voltage swing. And ease of installation. And price. And so on.

But don't just limit your comparison to IC amplifiers—check DDC's parameters and prices with *whatever* you're using.

Check the specs of our new economical D-8. And our new high-current, high-stability D-22. And their costs. Optional configurations let you drop a DDC amplifier right into your present PC board or connector.

Both amplifiers are all silicon. They're virtually indestructible, and need no external components to make them stable. And delivery, happily, is usually from stock.

OPERATIONAL AMPLIFIERS

CHARACTERISTICS @ 25° C

	D-8	D-22-9
V _{OUT} (P-P).....	±11 V (min).....	±10 V (min)
I _{OUT}	±2.2 ma (min).....	±20 ma (min)
V _{GAIN}	90 db (typ).....	103 db (typ)
I _{OFFSET}	20 nA (max).....	10 nA (max)
V _{DRIFT/TEMP}	20 μV/°C (max).....	15 μV/°C (max)
Freq. for Full Output.....	18 Kc (min).....	10 Kc (min)
Price (1-9).....	\$29.....	\$85
Standard Packages.....	5/8" H x 1 1/8" x 1 1/8".....	D-22: 5/8" H x 1 1/8" x 1 1/8"*
(Optional Configurations).....	0.4" H x 1 1/8" x 1 1/8".....	D-22-9: .8" H x 1.2" x 1.8"***

*(.1" grid) **(.3" grid)

Check? Now check the reply card, or check us direct—
call or write for complete information, free Applications Booklet.



DATA DEVICE CORPORATION

240 Old Country Road, Hicksville, L. I., N. Y. 11801

516-433-5330 TWX 516-433-5779

See us at IEEE Booth 2807-09

UNLIMITED FLEXIBILITY

WASP® AND
MINI-WASP®
MODULAR
CONNECTORS
CAN BE
GROUNDED
ANYWHERE IN
THE CIRCUIT
WITH
NEAR ZERO
RESISTANCE

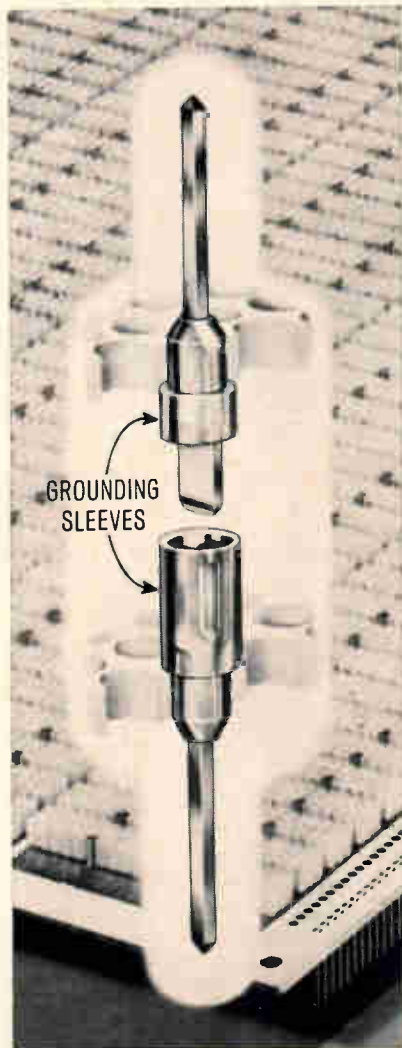

With the new grounding sleeve you can ground your circuit anywhere in the WASP or MINI-WASP Connector System with 1 milliohm or less resistance. This adds an additional feature to the system's unmatched flexibility.

The Malco Plate-Type Connector System starts with an aluminum matrix on which you can plot your connectors to suit your specific applications; add mating Wasp or Mini-Wasp components as you need them. Terminals can be wire wrapped, welded or soldered to a density of up to 100 connectors per square inch. They ground directly to the aluminum matrix, eliminating the need for wiring.

Just tell us how you want it—we'll convert your concept into a reliable, compatible system ready for automatic wire wrapping as it comes from the package.

WRITE FOR COMPLETE INFORMATION

VISIT BOOTH 1A33 AT IEEE SHOW



PRECISION ELECTRONIC TERMINALS AND CONNECTORS

MALCO MANUFACTURING COMPANY INC
4049 WEST LAKE STREET • CHICAGO, ILLINOIS 60624

Electronics Review

piled metal to the domestic market, and in January a virtual embargo was ordered on shipments abroad.

The government is continuing its efforts to alleviate the copper shortage. Moves that are in the works:

- Congress will probably move quickly to suspend the 1.7-cent-a-pound import duty on copper.

- Another stockpile release is likely—perhaps as much as another 200,000 tons—despite the fact that the stockpile level is already below the quotas set by the Office of Emergency Planning.

- And the government may act to subsidize inefficient mines in order to get marginal copper-producing facilities operating.

Electronics notes

- **Apollo's first.** A Saturn IB rocket fired an unmanned Apollo moon capsule from Cape Kennedy 5,500 miles down the Atlantic test range in the Apollo's first sub-orbital flight test. The payload, a 37,500 pound capsule, was the heaviest ever lofted by the U. S.

- **Aiming a missile.** A laser-assisted guidance system will stretch out the range of an antitank missile now under development by the British Aircraft Corp. and Belgium's Fabrique Nationale d'Armes de Guerre for the North Atlantic Treaty Organization. At ranges up to one mile, the missile runs so true that it can be aimed dead on the target and needs no guidance. The antitank laser-assisted system takes over for longer ranges. Then, the missile is fired in a trajectory over the tank. A laser near the launcher marks the target with an infrared beam. About 100 yards from the target, sensors in the missile war-head pick up the reflected laser beam; this triggers the firing circuit for a small explosive, embedded in the missile, which kicks the missile down onto the target.

- **Japanese tv sets.** Japanese color-television set producers have agreed to establish minimum export prices. This year at least eight Japanese producers will be exporting color-tv sets to the U. S.

LOW COST HI-VOLTAGE

NPN SILICON TRANSISTORS

**300 VOLT VCER
HFE > 40 IC=20 MA VCE 10V
5 WATTS 25° C CASE**

70¢

TRS 301LC

TRS 301LC
TO-5 PACKAGE

TRS-3015LC



15 WATT MD14

TRS-3016LC



15 WATT
TO 66 FLANGE

Also available
LOW COST
400V
500V
600V

INDUSTRO

For complete specifications
contact any Industro
distributor or
sales office

TRANSISTOR CORPORATION

35-10 36th Ave., Long Island City, N. Y. 11106 • Phone (212) 392-8000

REPRESENTATIVES: Alpine Industries, 2236 Hepburn Ave., Dayton, Ohio, 513-CR 8-5861 • Argus Associates, Inc., P. O. Box 68, Warminster, Penna., 215-675-4131 • Domac, Inc., 1950 Bank St., Ottawa, Ontario, Canada, 613-733-3390 • Dorado Elec. Reps., 13615 Victory Blvd., Van Nuys, Calif., 213-873-4124 • Al Hubert Associates, P. O. Box 143, Brookline, Mass., 02145, 617 CO 2-0027 • J. R. Sales Eng'g Co., 6446 W. Bloomingdale Ave., Chicago, Ill., 312-889-6662 • Machine & Products (European Export), 52 Wall St., New York, N. Y., WH 4-4370 • Melvin Sales, 113 Camino Real, Millbrae, California, 415-697-6922 • W. J. Stulgis Co., Inc., 698 W. Crockett St., Seattle, Washington, ATwater 2-7870 • Western Elect. Components, 4301 Birch St., Newport Beach, Calif., 714-540-1322 • White Sales Co., P. O. Box 8432, Minneapolis, Minnesota, 929-5710

INTERNATIONAL RECTIFIER

PROUDLY PRESENTS
THE CONTROLLED RECTIFIER FAMILY
WITH RATINGS UP TO

350/550

AVERAGE AMPS.

AMPS.-RMS

UP TO 1200 VOLTS PRV EPITAXIAL SCR

1,000,000 TO 1 RATIO, FIRING POWER TO RATED POWER

Proven performance backed by years of intensive
research and environmental testing.

World's most advanced line of

HIGH POWER EPITAXIAL SCRs UP TO 1200 VOLTS PRV

- 350 Amps epitaxial SCR
- 300 Amps epitaxial SCR (standard)
- 300 Amps epitaxial SCR (fast switching)
- 250 Amps epitaxial SCR

IR opens new vistas in the field of power control and conversion with these compact SCRs. They are indispensable tools of the engineer in meeting demanding design requirements for higher performance. Increased efficiency, increased reliability, reduced size and reduced weight are merely a few of the advantages engineered into IR's high power SCR line.

The inherent capabilities in the design of these devices, combined with the application experience of our engineering staff offers you an opportunity to utilize the most advanced SCR technology available today in the design of your high power equipment.

350 Amps - Bulletin A 116
300 Amps (standard) - Bulletin A 114
300 Amps (fast switching) - Bulletin A-115
250 Amps - Bulletin A 113



CALL MR. RECTIFIER

He is your Sales Engineer. He's experienced. Understands your problems. Has the answers. Works closely with you. You can deal in confidence with "Mr. Rectifier" - your rectifier specialist. Call him.

*Average DC ampere



WORLD'S LARGEST RECTIFIER SPECIALISTS



INTERNATIONAL RECTIFIER

EL SEGUNDO, CALIFORNIA

Washington Newsletter

March 7, 1966

**DOD may regroup
its own R&D labs . . .**

A plan to reorganize the Defense Department's research and development laboratories, under discussion since early 1964, is picking up speed. Any changes that might be approved aren't expected to result in an expansion of the Pentagon's in-house research role, but could involve the creation of "technical centers," under whose roof some smaller labs might be grouped. Such centers might be full-spectrum institutes that would be involved with major projects—such as space exploration—from the earliest basic research to testing and contractor relations. Firm plans for the centers, however, must await the outcome of Pentagon surveys just getting under way.

The Defense Department operates 147 laboratories housing 30,000 scientists and engineers. The plan does not cover the not-for-profit firms, such as the Aerospace Corp. However, Pentagon sources say a reshuffle of the military's in-house labs might result in some changes in its use of the nonprofit companies.

The current reexamination was originally proposed while Harold Brown, now Secretary of the Air Force, was director of the Pentagon's research and engineering office. Under his successor, John S. Foster Jr., each of the services has, within the last month, hired a new director of laboratories to supervise a reshuffle. For the Army it's Jay Tol Thomas, former chief scientist and director of research at the Northrop Space Laboratories, a division of the Northrop Corp., of Hawthorne, Calif., the Navy has Gerald W. Johnson, former associate director of the Lawrence Radiation Laboratory, and the Air Force reportedly is hiring a Midwestern university physicist.

**. . . widen research
by spreading funds
over more colleges**

The Defense Department will soon begin to spread its support of academic research in electronics and other sciences among a wider group of universities [Electronics, May 3, 1965, p. 37]. It is acting in response to congressional concern over the concentration of government research in a relatively small number of the larger schools. It will tie its effort in with the program of the President's Office of Science and Technology to develop centers of technical excellence in all parts of the country.

Defense research officials plan to visit colleges that have not bid on military research, determine their capabilities and counsel them on preparing proposals.

**Pilots may get
altitude warnings
by audio signal**

The Boeing Co. is testing whether an electronic aid, originally designed for military planes, can be adapted as a possible safety device for the 727 jet. The device—aimed at meeting suggestions that the airliner's high rate of descent may have played some role in recent 727 crashes—would provide pilots with audible signals as their altitude changes.

The altitude-warning package would link a radar altimeter with an audio apparatus. As the plane's altitude changes, pilots would be warned by a beep or possibly even a prerecorded woman's voice. Similar, and more complex, devices have been designed for military planes to give warnings of trouble in various flight systems. Boeing declined at this time to make

Washington Newsletter

public estimates of installation cost. Up to one-third of the 727's now coming off production lines already are equipped with radar altimeters for use in bad-weather landings.

Boeing has discussed the idea with the Federal Aviation Agency, but the FAA and industry sources indicate that if the plane's descent rate is indeed involved, the cockpit device alone would not solve the problem—and could have some practical drawbacks.

Investigations of the four 727 crashes—three in the United States and one in Japan—are still in their early stages, and no "probable cause" has been assigned. But officials insist there are no grounds for suspecting the airworthiness of the three-engine jet. Late last month the FAA held a conference with airlines representatives and suggested that they study possible changes in operating procedures to make the pilots more aware of the plane's rate of descent.

Industry unit seeks to streamline total-package bids

The Defense Industry Advisory Council is setting up a subcommittee to aid the Defense Department in its future application of the total-package procurement concept. The total-package technique involves buying under a single, competitively awarded contract that wraps together development, production and follow-on support.

The council group will study the possibilities of reducing the massive volumes of data required in bidding on such huge contracts, of reducing bidding expenses and of obtaining better labor and material cost indexes to cover the long periods of the contracts.

Is the Pentagon fairly rewarding efficient producers?

The Defense Department plans to collect data from 50 to 60 contractors over the next six months to determine whether its procurement policies are promoting a healthy defense industry and are adequately rewarding efficiency.

The Pentagon hopes to learn the impact of incentive contracting and the application of weighted guidelines on profits. Under incentive contracts, a target cost, target profit and ceiling price are negotiated at the outset; after performance, final cost and price are determined.

Weighted guidelines set forth a wide range of factors to be considered in arriving at an acceptable profit and assign a percentage weight to each. Among other things, the guidelines take into account the difficulty of the job and the degree to which the contractor accepts risk.

High Court stiffens patentability rules

The Patent Office and the courts that review its decisions will have to revise their requirements for a patentable invention as the result of last month's Supreme Court decision. The court broke 15 years of silence to demand "strict observance" of standards of invention.

Strict observance, according to patent specialists, means that an invention has to represent some advance over prior art. It will also mean that both patent applicants and Patent Office examiners are going to have to make a thorough search of prior art before filing or acting on a patent application.

The decision comes at a time when a Presidential commission, due to report late this year, is reviewing the function and structure of the Patent Office.

Powder Metal Products only asked Blackstone and FREON® to solve a cleaning problem...

...but got a new product as a bonus!

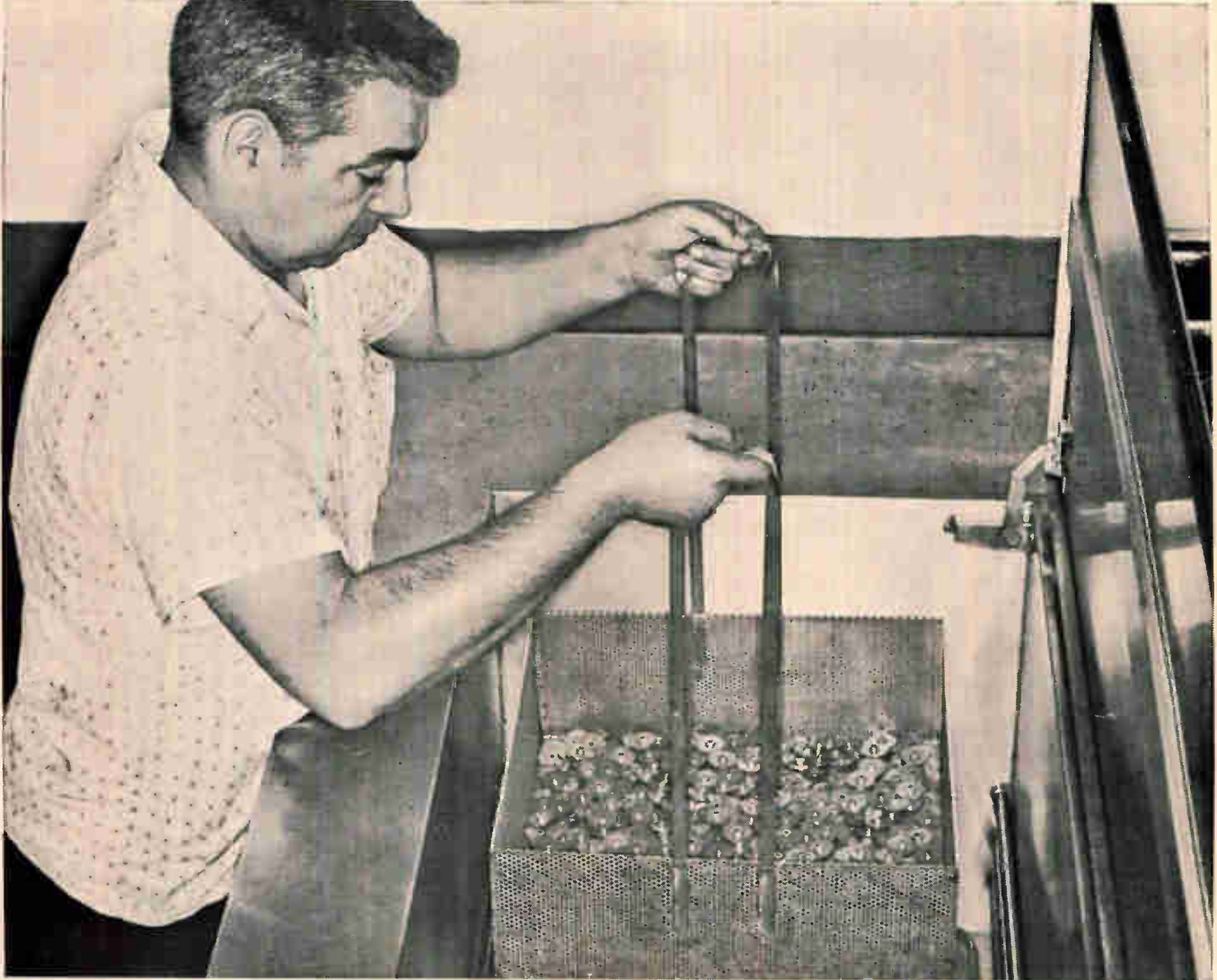

Powder Metal Products, Inc., St. Marys, Pa., makes gears, bushings and bearings for motors in phonograph turntables, car heater fans and other fractional horsepower equipment. All types of soils—even microscopic remnants of grease, oil, ash and metal particles—must be completely removed to insure trouble-free, noiseless operation. Standard degreasing couldn't do the job alone.

Now, FREON-TF solvent in a Blackstone ultrasonic vapor degreaser meets this critical cleaning requirement. It gets parts so clean, they operate noticeably longer and quieter. So quiet, in fact, that Powder Metal Products can now turn out parts for more demanding tape recorder motors.

Like all FREON fluorocarbon solvents, quick drying FREON-TF offers low surface tension to completely penetrate the smallest pores and crevices . . . high density to loosen and carry away particulate matter . . . excellent stability to permit repeated distillation for reuse. It requires no extra safety precautions, because it is nonflammable and relatively nontoxic.

FREON solvents could be the answer to cleaning problems for your products. And, like Powder Metal Products, it might even help you market a new one. For more information on FREON solvents, mail the coupon today.

BETTER THINGS FOR BETTER LIVING
... THROUGH CHEMISTRY



Du Pont Co., Room 3678
Wilmington, Delaware 19898.
Please send me more information on
FREON solvents for use in cleaning

Name _____

Company _____

Address _____

City _____ State _____ Zip _____

(In Europe, mail to Du Pont de Nemours International S.A., "Freon"
Products Div., 81 Route de l'Aire, CH1211 Geneva 24, Switzerland.)

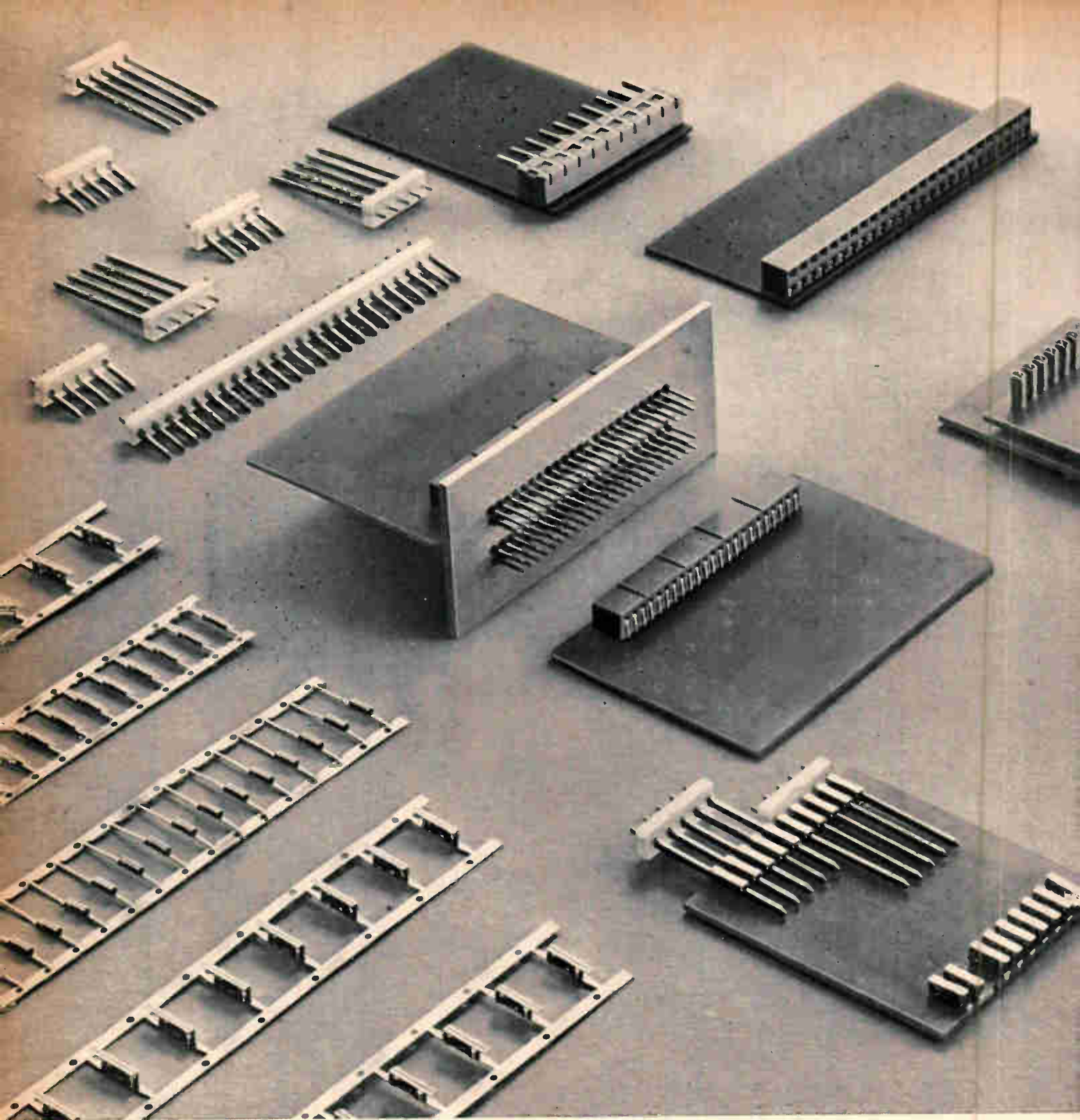

Go modular the easy way

This entirely new approach to modularization is the AMPMODU* Interconnection System. It permits almost unlimited design flexibility, high production speed, and economies resulting from automation and low per line cost.

Specifically designed for modular applications using printed circuit boards, it enables mounting module cards at 90° to a mother board, stacking them, or putting them end to end. The female contacts may be staked directly to a printed circuit board or enclosed in molded housings. Male contacts may be staked directly to a printed circuit board, used in nylon incremental connectors, or mounted with nylon bushings in aluminum grid plates. Two sizes of contacts are available: the standard size, which uses .031 x .062" posts for mounting on .156" centers, and the miniature size, which uses .025 x .025" posts for mounting as dense as .100". Electrical and mechanical efficiency are enhanced by the simplicity of the female contact design, which includes dual cantilever-beam springs for redundant contact action and anti-overstress devices to ensure reliability. The long life of the phosphor bronze contacts is a result of AMP's special gold plating. New modular ideas don't have to dead-end at the design stage. For information on how you might use the AMPMODU Interconnection System to modularize your product and lower your costs, write us today.

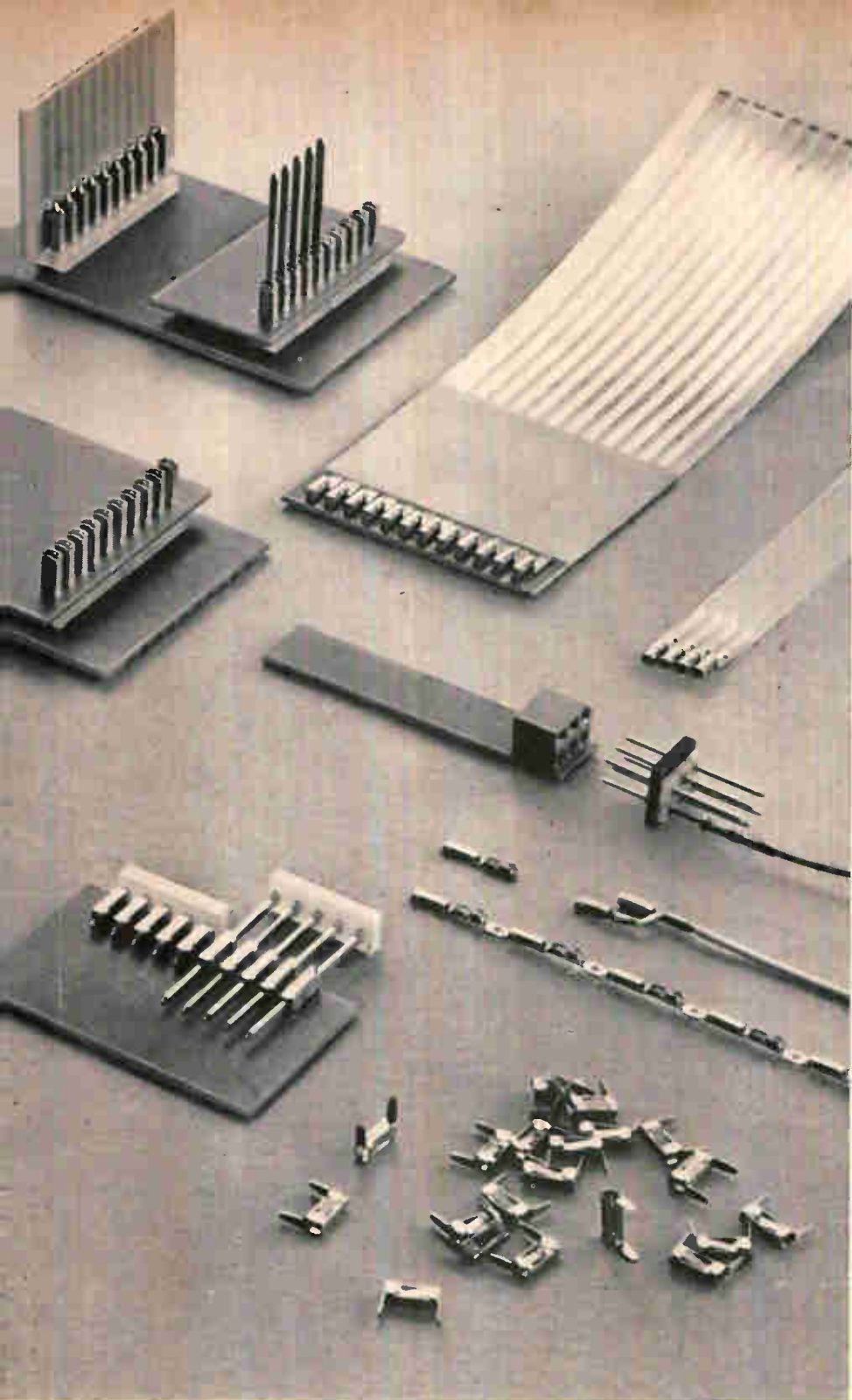

Automatic machines can stake contacts to printed circuit boards at rates of up to 1800 an hour

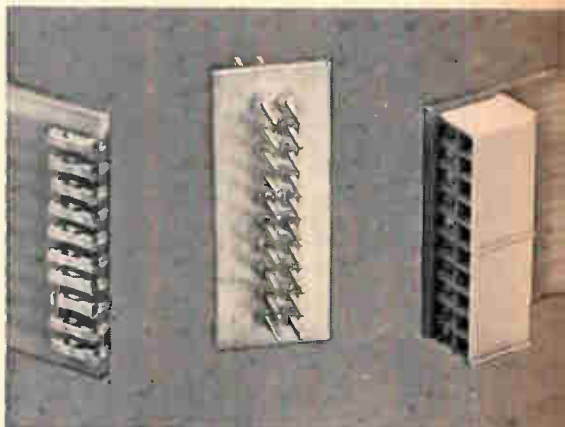

Miniature AMPMODU contacts may be mounted ten to the inch

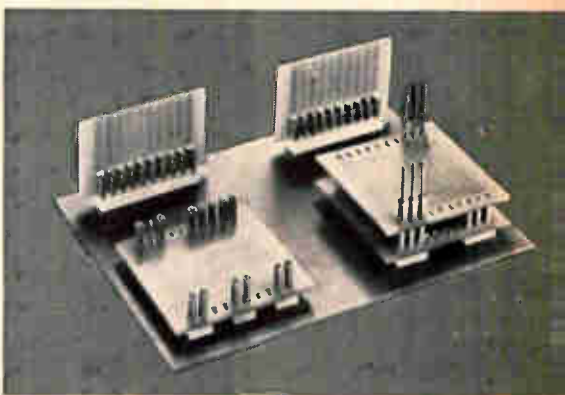

The AMPMODU female contacts may be mounted in one of three ways for modular connection versatility

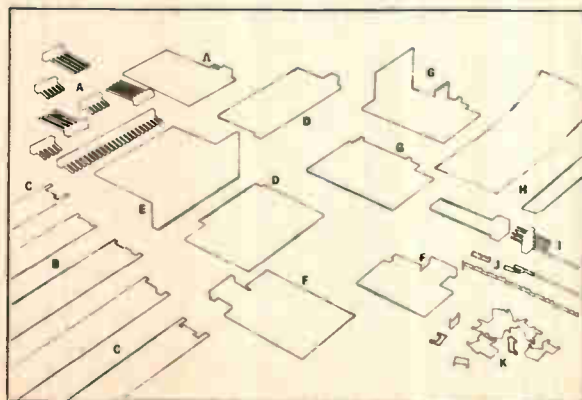

- A. AMPMODU Male Incremental Connectors
- B. Miniature AMPMODU Female Contacts in strip form
- C. Standard AMPMODU Female Contacts in strip form
- D. Miniature contacts in two-row housings
- E. Grid Plate Header
- F. Horizontally staked AMPMODU Contacts with incremental connectors
- G. Vertically staked AMPMODU Contacts
- H. Flexible tape cable AMPMODU Connectors
- I. Molded-in AMPMODU Pin Header and printed circuit board connector
- J. Miniature Crimp-Barrel AMPMODU Female Contacts
- K. Individual Standard AMPMODU Female Contacts

Visit us at The IEEE Show
Booths 2E45-2E49
March 21-24, 1966

AMP
INCORPORATED
Harrisburg, Pennsylvania



→ 8A



→ 9

→ 9A

→ 10



→ 10A



→ 11A

→ 11



→ 11A

→ 11



→ 15A



→ 19A

→ 19



→ 19A

→ 20

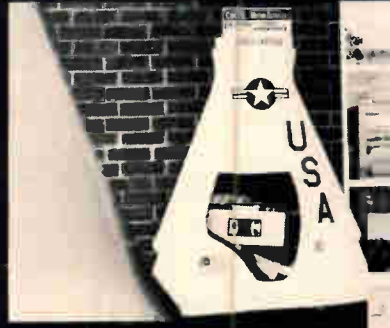

→ 20A



→ 23A

→ 24



J H

→ 25



→ 25A

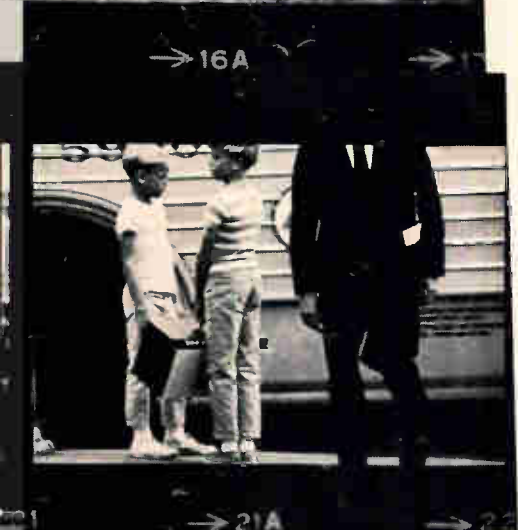

Tough Recorder Environments: Kid Stuff!

Try leaving a couple of kids alone for ten minutes with a brand new toy. Result: the kind of chaotic environment Leach recorders thrive on. Like in-flight testing, automotive torture tests, hydrofoil recordings, etc. . . . if you can keep a transducer on it, we'll monitor the output.

Take the MTR-3200 for example. For a modest power input of as little as 50 watts at 28VDC, this compact 44 pound package records, stores and reproduces data under the toughest conditions. Conditions like 10g shock with less than a 3% peak to peak flutter. 10g vibration with less than a 6% peak to peak flutter. 25g acceleration. -40° to 71° C operating temperatures. 95% humidity. 150,000 foot altitude. Check these specs against any other recorder/reproducer and see if they'll operate through conditions like that.

And the MTR-3200 is versatile, too. Plug in electronic modules provide up to 14 analog and FM or 16 digital channels usable in any combination. Six tape speeds are selectable in speed pairs. Even data bandwidths are extended beyond IRIG standards, and the entire unit is compatible with IRIG standard data reduction equipment. For those special applications, Leach offers a wide range of little luxuries such as analog to digital, serial to parallel and parallel to serial conversion equipment.

If these specs meet your immediate requirements, or if you have a highly improbable environmental situation to be challenged and accommodated, write us. No one knows more about high environmental tape recorders than Leach Corporation, Controls

LEACH Division, 717 North Coney Avenue, Azusa, California Phone: (213) 334-8211. Export: Leach International, S.A.

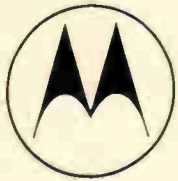

Semicondu

“ANNULAR TRANSIST PLANAR TYPE DEV

FOUR PATENTS ISSUED ON ANNULAR DEVICES

PHOENIX, ARIZONA — A series of four patents covering generic developments in the design and manufacture of semiconductor devices has been issued to Motorola's Semiconductor Products Division. The patents, according to Dr. C. Lester Hogan, vice president and general manager of the Division, cover annular semiconductor devices which, he says, represent the only practical method for making passivated, high-voltage PNP transistors and related products.

According to Hogan, Motorola's invention of annular semiconductors overcomes some of the basic functional limitations of passivated semiconductor devices. Prior to this invention, he said, it was impossible to manufacture these widely used device types to operate above approximately 30 volts without seriously degrading their performance and reliability capabilities. With annular construction, however, Motorola is already marketing transistors capable of operating at several hundred volts while maintaining, in all other respects, the highest level of performance currently achievable



Jack C. Haenichen (right), inventor of the annular transistor, receives congratulations and formal copies of the U.S. patents on annular semiconductor devices from Foorman Mueller, patent attorney for Motorola Inc.

ANNULAR SEMICONDUCTORS TO GIVE MOTOROLA SILICON TRANSISTOR LEAD

PHOENIX, ARIZONA — Motorola Semiconductor Products Inc., a company which, until 1961 had not produced and marketed any silicon transistors, now claims to have out-distanced all of its competitors in the silicon transistor field. The company now says it manufactures silicon transistors for more different applications than any other single



Dr. Hogan general manager of Motorola's Semiconductor Products Division, was the

semiconductor manufacturer.

The major reason for this advance, according to Dr. C. Lester Hogan, vice president and

invention of the annular structure.

The annular invention, he pointed out, made it possible for Motorola to introduce a steady stream of improved devices, in both the NPN and PNP transistor areas. It led to new breakthroughs in the high-voltage area, making such devices ideal for the production of line-operated equipment for which high-

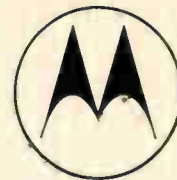

TRANSISTORS ARE REPLACING MESAS" - MOTOROLA

DEMAND FOR HIGHER VOLTAGE SPURS USE

PHOENIX, ARIZONA — Motorola's patented silicon annular transistors, which now offer much higher voltage ratings than previously available, are replacing many planar devices in newer state-of-the-art designs, according to Dr. C. Lester Hogan, vice president and general manager of Motorola's Semiconductor Products Division in Phoenix, Arizona.

Motorola's development was successful in solving the channeling problem which limits the voltage rating achievable with PNP planar transistors to some relatively low value and annular devices have proved equally successful in providing similar advantages for silicon NPN types as well.

According to Dr. Hogan, Motorola has almost universally applied the annular device structure to its silicon transistors and the tell-tale "ring" that is characteristic of those devices is seen with increasing frequency in silicon devices.

"This is not surprising," he said, "because the Motorola-invented annular structure represents the only known method for conquering the high-voltage limitation of planar transistors while providing the advantages of low-leakage protection."

For example, the company presently manufactures both PNP and NPN annular transistors with voltage ratings as high as 300 volts! And, Motorola says even higher voltages are in the offing. An important aspect of these transistors is that the high-voltage rating has been achieved without any sacrifice in gain and collector saturation resistance — normal trade-offs for high voltage with other device structures. The 300-volt transistors (types 2N3742 and 2N3743) are designed for either amplifier or switching applications and feature the multifinger geometry of Motorola's Star transistor line. They are packaged in a solid-header TO-5 package.

The annular device structure is also applicable to silicon semiconductor devices.

ANNULAR DEVICES A "GIANT STEP"

"Ever since the invention of the transistor," according to Jack C. Haenichen, inventor of the Annular structure for semiconductor devices, "we have been searching for a way to manufacture devices whose characteristics were not limited by process considerations. Thus, we have seen the many variations of the



Haenichen

grown-junction transistor give way to the improved characteristics of alloy and diffused-base micro-alloy devices, which yielded higher-frequency response but were limited to low-breakdown voltages. These, in turn, were superseded by the mesa structure with its high-speed, high-voltage capabilities which, for

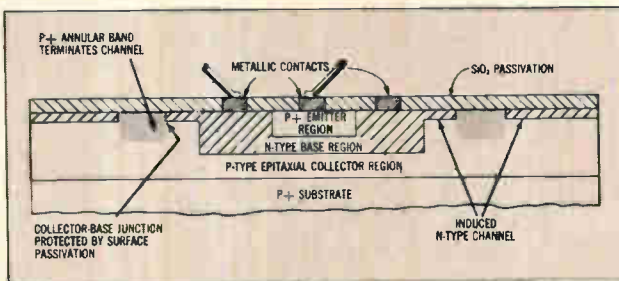

PNP Annular Transistor Structure

awhile promised to be the ultimate structure.

Although the silicon transistor with a passivating film was advertised as the answer to the shortcomings of the mesa transistor, it too fell short of the "ideal device". The passivating film gave rise to a phenomenon called "channeling," which limited such transistors to low-voltage applications.

Channeling is a random effect that tends to invert the conductivity type of the col-

lector region underneath the SiO_2 film and, therefore, produces a channel that extends the base region from underneath the film to the unprotected edges of the transistor. When this occurs, the apparent leakage current rises to a point where the transistor becomes useless.

Even in low-voltage structures, the tendency towards channeling is present and its random nature can affect transistor stability even before junction deterioration is

We'll be looking for you at the IEEE Exhibit in Booths M22-25 March 21-24, 1966

*If it's your job
to evaluate and specify
electronic test instruments...*

***YOUR JOB
JUST GOT EASIER***

*Figure it on features or price...
Monsanto's new line adds up to "buy"*

ELECTRONICS



PULSE GENERATOR

- Extremely clean waveforms
- Independent width and delay on double pulse mode
- Both pulses referenced to the same trigger in double pulse operation
- Provides sweep delay for oscilloscopes not so equipped
- Three trigger output signals, all available in both single and double pulse operation.



All-silicon, solid-state instrument provides both single and double pulse operation. A great number of the active circuits are integrated for reliability and performance in a compact package only 3½ inches high. **\$1,100.00**

20 MHz COUNTER/TIMER

- Stored Display
- Modular Construction
- Front panel only 3½ inches high
- Weight only 16 pounds
- Versatile instrument measures frequency, frequency ratio, period, and time interval.

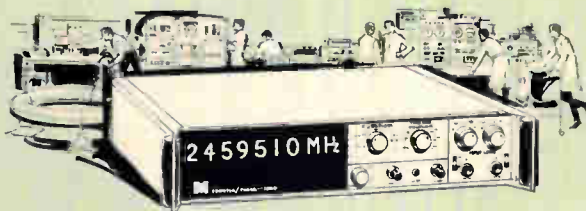

Reliability, accuracy and compactness because Monsanto designs this counter-timer with 90% integrated circuits. Seven of its sixteen printed circuit boards are interchangeable for easy maintenance. **\$1,975.00**

5 MHz COUNTER/TIMER

- Time base range from 1μ second to 100 seconds in decade steps
- Resolution for frequency measurement of 0.01 Hz.
- Compact, light package—only 3½ inches high and 16 pounds.

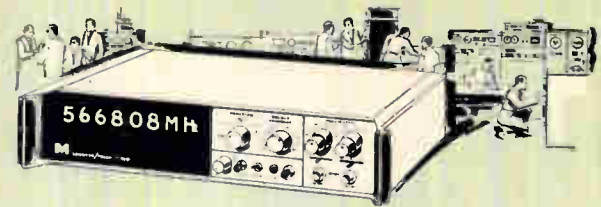

Integrated circuits in 90% of the active circuits build big performance into a small package. Plus speed, accuracy, reliability, and easy maintenance. Six of the 13 printed circuit boards are interchangeable. **\$1,575.00**

DIGITAL VOLTMETER

- Fully floated and guarded
- Input impedance—10 megohms (all ranges)
- Accuracy .01% on all ranges
- 4 digits + 100% over-range digit
- Common mode rejection: DC > 140 DB ; AC > 120 DB at 60 Hz.

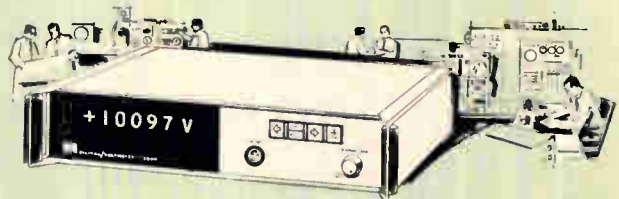

Auto-ranging digital voltmeter with integrated circuits that hold size down to 3½ inches high and only 20 pounds. Automatic operation—ranging, decimal point and polarity—built in at the basic price. **\$1,975.00**

Let us fill you in with details.
Just return the coupon.

**Monsanto Electronics Department
St. Louis, Missouri 63166**

Details, please, on the

- | | |
|----------------------------------------------|-----------------------------------------------|
| <input type="checkbox"/> Pulse Generator | <input type="checkbox"/> 20 MHz Counter/Timer |
| <input type="checkbox"/> 5 MHz Counter/Timer | <input type="checkbox"/> Digital Voltmeter |

Name/Title _____

Company _____

Address _____

City _____

State _____ Zip _____

One dozen good reasons for you to specify AE

Buy from AE, and you never have to settle for a relay that's only "marginally" right.

You can choose *exactly*, from a line that's broad enough to give you what you're after — in weights, types, dimensions, configurations, mountings.

And you always get the benefit of AE's experience. Decades of experience in product design, manufacturing techniques, and methods of quality control.

Want some helpful, detailed design information? Ask for Catalog 4071: Selection Guide to AE Relays and Switches. Just drop a line to the Director, Relay Control Equipment Sales, Automatic Electric, Northlake, Illinois 60164.

AUTOMATIC ELECTRIC
SUBSIDIARY OF
GENERAL TELEPHONE & ELECTRONICS **GTE**

Maximum life
and reliability

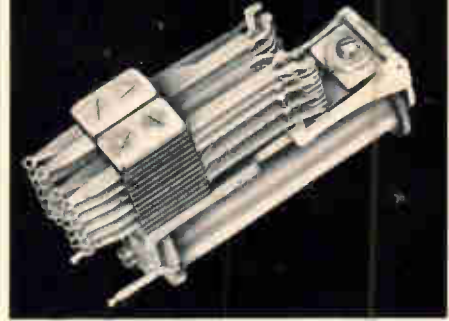

CLASS B RELAY. Finest quality telephone-type. Provides hundreds of millions of operations under all mounting and service conditions — with unflinching contact reliability. Combines sensitivity, contact stability, and circuit adaptability. Bifurcated twin-contacts. Long or short armatures for wide range of practical timing. Also for quiet AC operation.

Minimum size
and weight

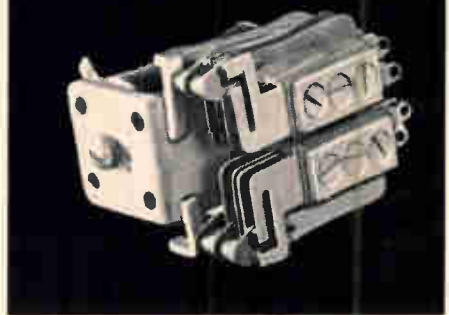

CLASS S RELAY. Miniaturized telephone-type for aircraft and similar applications. Small mass, low self-inductance. Provides high contact pressures and absolute contact reliability under extreme vibration, shock and humidity.

Minimal size,
large contact
capacity

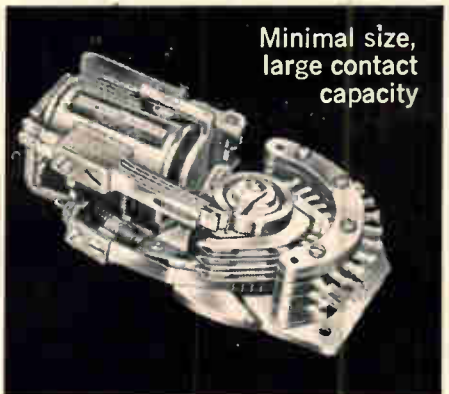

TYPES 40, 44, 80 and 88 ROTARY STEPPING SWITCHES. Small switches with large, flexible capacities. Fit almost any DC application. Provide swift, sure, impulse-controlled response . . . plus self-interrupted operation that's smooth and trouble-free. Up to twelve 10- or 11-point levels. Prewired, hermetically sealed units available.

**High performance,
small size**



**Economical
telephone-type**

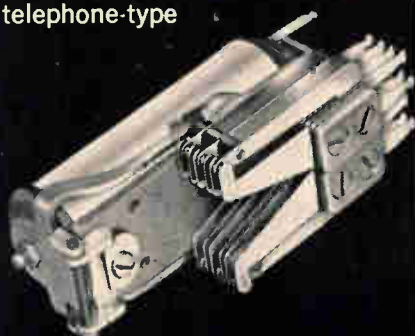

**Premium quality
space-saver**

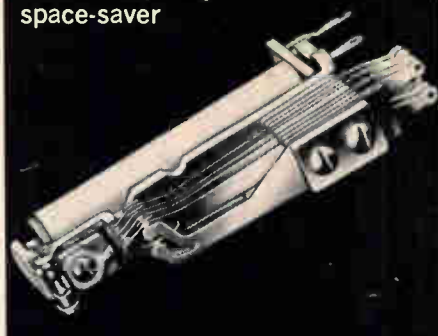

CLASS E RELAY. A lightweight space-saver with most of the features of the Class B. Life exceeds 200 million operations. Industry's widest terminal options: taper pin, integral socket, conventional solder, taper-tab, solderless wrap and printed circuit terminals.

CLASS A RELAY. Sturdy and dependable. Can be mounted in any position. The original "workhorse" telephone relay — recommended when the extremely high performance of the Class B is not mandatory.

CLASS C RELAY. Incorporates many of the features of the Class B relay—but is only half as wide. Use where quality is a must, but space is at a premium. Quick- and slow-acting types, for operation at up to 150 volts DC. Two to twelve contact springs.

**Economy and
small size**

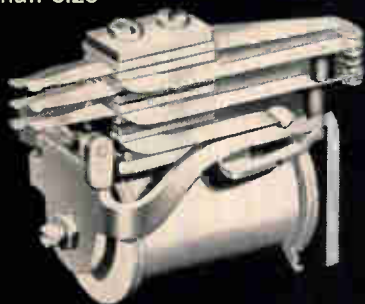

**Multiple circuit
transfers**



**Customized
programming**

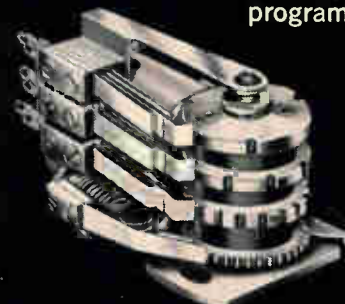

CLASS Z RELAY. Small and lightweight, but designed for service where flexibility is most important. Provides adequate coil volume to permit slugging for long operate and release timing. Four types for DC, one for AC, and two with snap-action contacts.

CLASS W RELAY. 17, 34 or 51 form C contact-spring combinations. Features low loss insulation, high insulation resistance. Extremely low inter-spring capacitance. Life in excess of one billion operations. Gold contacts available for low-level switching.

SERIES OCS RELAY. Compact and low in cost. For "packaged" programming: will follow or initiate a prescribed series of events at 30 steps per second impulse-controlled — or 65 per second self-interrupted. Much better than an interlock relay — when you're designing for shock, vibration or easy field maintenance.

**Maximum capacity—
unusual versatility**

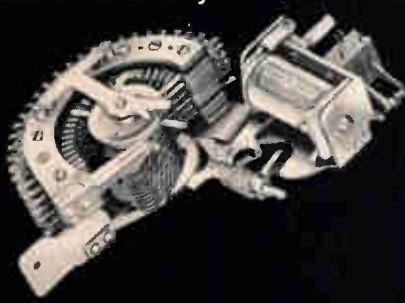

**High-speed
control**



**Dry reed switches
for printed
wiring boards**



TYPE 45 ROTARY STEPPING SWITCH. Larger capacity: up to twelve 25-point levels, eight 50-point levels. For any DC voltage up to 110, or 115 volts AC with rectifier. Can be impulse-controlled or self-interrupted. Available with normally open or normally closed circuits (Type 45NC). Also available as prewired, hermetically sealed units.

CLASS V MERCURY-WETTED RELAY. For computers, data processing and control equipment. Up to 200 operations per second. No contact erosion, no bounce. Over 1 billion operations without change, maintenance or adjustment. Can be operated within 30° of vertical. Polarized and nonpolarized versions. 1 pole to 4 pole double throw contact forms.

PRINTED CIRCUIT CORREEDS.* Strong, moisture-resistant, compact. Unstressed contact leads provide firm, positive connections. Glass-filled plastic bobbins prevent moisture absorption. Low profiles and magnetic shielding permit high density within standard PC terminal spacing (multiples of 0.200 inches). Available with 1, 2, 3 and 5 capsules and magnetic latching. Contact forms A, B, & C.

*U.S. Patent applied for

A design advance

**Broadest line of standard
silicon modular power
supplies for fixed
voltage applications**

UP TO 60 VDC • UP TO 90 AMPS

Features and Data

Meet Mil. Environment Specs.

RFI—MIL-I-16910

Vibration: MIL-T-4807A

Shock: MIL-E-4970A • Proc 1 & 2

Humidity: MIL-STD-810 • Meth. 507

Temp. Shock: MIL-E-5272C •
(ASG) Proc. 1

Altitude: MIL-E-4970A • (ASG) Proc. 1

Marking: MIL-STD-130

Quality: MIL-Q-9858

Convection cooled—no heat sinking or
forced air required

Wide input voltage and frequency
range—105-132 VAC, 45-440 cps

Regulation (line) 0.05% plus 4MV
(load) 0.03% plus 3MV

Ripple and Noise—1MV rms, 3MV p to p

Package G

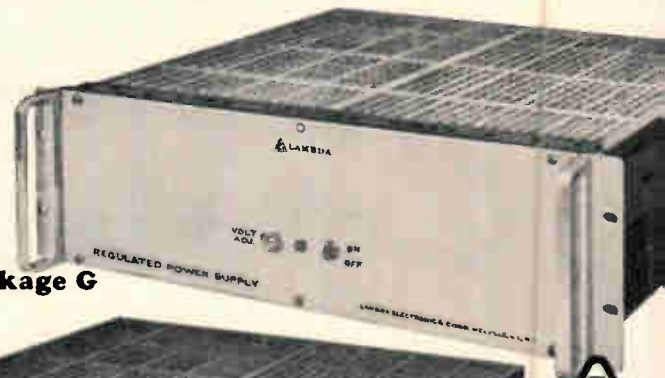

Package F



Package E



Package D



Package C

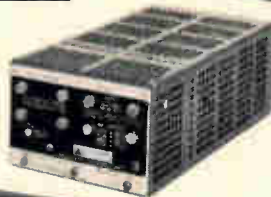

Package B



Package A



PATENTS PENDING

Circle 62 on reader service card



RACK ADAPTERS



LRA-5—3½" height by 2⅞" depth.
Mounts up to 4 A package sizes;
3 B or C package sizes; or 2 A and 1 B or
C package sizes. Price \$35.00

LRA-4—3½" height by 14" depth.
(For use with chassis slides)
Mounts up to 4 A package sizes; 3 B or C
package sizes; or 2 A and 1 B or C
package sizes. Price \$55.00

LRA-3—5¼" height by 2⅞" depth.
Mounts up to 4 A, B or C package sizes;
2 D or 2 E packages sizes; or 2 A, B or C
and 1 D or 1 E package sizes. Price \$35.00

LRA-6—5¼" height by 14" depth.
(For use with chassis slides)
Mounts up to 4 A, B or C package sizes;
2 D or 2 E packages sizes; or 2 A, B or C
and 1 D or 1 E package sizes. Price \$60.00



LAMBDA ELECTRONICS CORP.

515 BROAD HOLLOW ROAD • MELVILLE, L. I., NEW YORK • 516 MYRTLE 4-4200

from Lambda

Ordering Information

METERS— $\frac{3}{2}$ " Metered panel MP-3 is used with rack adapters LRA-4, LRA-5 and packages A, B and C.

$\frac{5}{4}$ " Metered panel MP-5 is used with rack adapters LRA-6, LRA-3 and packages A, B, C, D and E.

To order these accessory metered panels, specify panel number which MUST BE FOLLOWED BY the MODEL NUMBER of the power supply with which it will be used.

Examples For Lambda Panel Model No.
Metered Panels Model and Price
MP-3 LM-B2 MP-3-LM-B2 \$40
MP-5 LM-B2 MP-5-LM-B2 \$40

Note—F and G LM Packages are full rack power supplies available metered or non-metered. For metered

OVERVOLTAGE PROTECTION—Externally mounted adjustable crowbar type overvoltage protection accessory for use with A, B, C and D packages—\$25.

E, F and G packages available with built-in overvoltage protection. To order crowbar type overvoltage protection for E, F and G packages, add suffix OV to the model no. and \$60 to the E package price and \$90 to the F and G package price.

FIXED VOLTAGES—In addition to the fixed voltages listed, any fixed voltage is available up to 65 VDC at moderate surcharge.

models, add suffix M to the Model No. and \$30 to the non-metered price.

Package A $3\frac{3}{16}'' \times 3\frac{3}{4}'' \times 6\frac{1}{2}''$

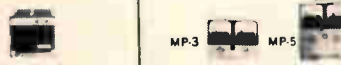

Accessory Metered Panels: \$40.00

Model	ADJ. VOLT. RANGE VDC	I MAX. AMPS ¹				Price
		40°C	50°C	60°C	71°C	
LM-201	0-7	0.85	0.75	0.70	0.55	\$ 79
LM-202	0-7	1.7	1.5	1.4	1.1	99
LM-203	0-14	0.45	0.40	0.38	0.28	79
LM-204	0-14	0.90	0.80	0.75	0.55	99
LM-205	0-32	0.25	0.23	0.20	0.15	79
LM-206	0-32	0.50	0.45	0.40	0.30	99
LM-207	0-60	0.13	0.12	0.11	0.08	89
LM-208	0-60	0.25	0.23	0.21	0.16	109

Package B $3\frac{3}{16}'' \times 4\frac{1}{16}'' \times 6\frac{1}{2}''$

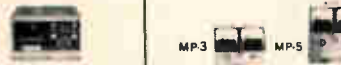

Accessory Metered Panels: \$40.00

Model	ADJ. VOLT. RANGE VDC	I MAX. AMPS ¹				Price
		40°C	50°C	60°C	71°C	
LM-217	8.5-14	2.1	1.9	1.7	1.3	\$119
LM-218	13-23	1.5	1.3	1.2	1.0	119
LM-219	22-32	1.2	1.1	1.0	0.80	119
LM-220	30-60	0.70	0.65	0.60	0.45	129
LM-B2	2 ±5%	3.4	3.0	2.3	1.4	119
LM-B3	3 ±5%	3.4	3.0	2.3	1.4	119
LM-B4	4 ±5%	3.4	3.0	2.3	1.4	119
LM-B4P5	4.5±5%	3.3	2.9	2.2	1.4	119
LM-B5	5 ±5%	3.3	2.9	2.2	1.4	119
LM-B6	6 ±5%	3.2	2.8	2.2	1.3	119
LM-B8	8 ±5%	3.0	2.7	2.2	1.3	119
LM-B9	9 ±5%	2.7	2.5	2.1	1.3	119
LM-B10	10 ±5%	2.6	2.4	2.1	1.3	119
LM-B12	12 ±5%	2.4	2.3	2.1	1.3	119
LM-B13	15 ±5%	2.1	1.9	1.7	1.2	119
LM-B18	18 ±5%	1.8	1.6	1.5	1.2	119
LM-B20	20 ±5%	1.6	1.4	1.3	1.1	119
LM-B24	24 ±5%	1.3	1.2	1.1	1.0	119
LM-B28	28 ±5%	1.2	1.1	1.0	0.90	119
LM-B36	36 ±5%	1.1	1.0	0.90	0.85	129
LM-B48	48 ±5%	0.90	0.85	0.80	0.75	129

Package E $4\frac{1}{16}'' \times 7\frac{3}{4}'' \times 11\frac{3}{4}''$



Accessory Metered Panels: \$40.00

Model	ADJ. VOLT. RANGE VDC	I MAX. AMPS ¹				Price
		40°C	50°C	60°C	71°C	
LM-E2	2 ±5%	18.0	16.0	15.0	10.0	\$269
LM-E3	3 ±5%	18.0	16.0	15.0	10.0	269
LM-E4	4 ±5%	17.0	16.0	15.0	10.0	269
LM-E4P5	4.5±5%	16.0	15.0	14.0	10.0	269
LM-E5	5 ±5%	16.0	15.0	13.0	10.0	269
LM-E6	6 ±5%	15.0	14.0	12.0	10.0	269
LM-E8	8 ±5%	14.0	13.0	12.0	9.5	269
LM-E9	9 ±5%	13.5	12.5	11.0	9.5	269
LM-E10	10 ±5%	13.0	12.0	10.0	9.2	269
LM-E12	12 ±5%	12.0	11.0	9.5	9.0	269
LM-E15	15 ±5%	11.0	10.0	9.0	8.5	269
LM-E18	18 ±5%	10.5	9.5	8.5	8.1	269
LM-E20	20 ±5%	10.0	9.0	8.3	7.7	269
LM-E24	24 ±5%	9.0	8.5	7.7	7.0	269
LM-E28	28 ±5%	8.5	8.0	7.3	6.6	269
LM-E36	36 ±5%	6.8	6.3	5.9	5.2	279
LM-E48	48 ±5%	5.0	4.6	4.3	3.9	299

Package C $3\frac{3}{16}'' \times 4\frac{1}{16}'' \times 9\frac{3}{4}''$



Accessory Metered Panels: \$40.00

Model	ADJ. VOLT. RANGE VDC	I MAX. AMPS ¹				Price
		40°C	50°C	60°C	71°C	
LM-225	0-7	4.0	3.6	3.0	2.4	\$139
LM-226	8.5-14	3.3	3.0	2.5	2.0	139
LM-227	13-23	2.3	2.1	1.7	1.4	139
LM-228	22-32	2.0	1.8	1.5	1.2	139
LM-229	30-60	1.1	1.0	0.80	0.60	149
LM-C2	2 ±5%	4.9	4.2	3.5	2.4	139
LM-C3	3 ±5%	4.9	4.2	3.5	2.4	139
LM-C4	4 ±5%	4.9	4.2	3.5	2.4	139
LM-C4P5	4.5±5%	4.9	4.2	3.4	2.4	139
LM-C5	5 ±5%	4.8	4.1	3.3	2.4	139
LM-C6	6 ±5%	4.6	4.0	3.1	2.4	139
LM-C8	8 ±5%	4.4	3.8	3.0	2.0	139
LM-C9	9 ±5%	4.2	3.6	3.0	2.0	139
LM-C10	10 ±5%	4.0	3.5	2.9	2.0	139
LM-C12	12 ±5%	3.8	3.3	2.8	2.0	139
LM-C15	15 ±5%	3.4	3.2	2.7	1.8	139
LM-C18	18 ±5%	3.0	2.8	2.5	1.7	139
LM-C20	20 ±5%	2.9	2.7	2.4	1.7	139
LM-C24	24 ±5%	2.5	2.4	2.2	1.5	139
LM-C28	28 ±5%	2.3	2.1	2.0	1.4	139
LM-C36	36 ±5%	2.0	1.8	1.7	1.3	149
LM-C48	48 ±5%	1.6	1.4	1.3	1.0	149

Package F $3\frac{3}{4}'' \times 19'' \times 16\frac{1}{2}''$



For metered models, add suffix (M) to model number and \$30.00 to the price below.

Model	ADJ. VOLT. RANGE VDC	I MAX. AMPS ¹				Price
		40°C	50°C	60°C	71°C	
LM-F2	2 ±5%	44.0	39.0	32.0	24.0	\$425
LM-F3	3 ±5%	44.0	39.0	32.0	24.0	425
LM-F4	4 ±5%	44.0	39.0	32.0	24.0	425
LM-F4P5	4.5±5%	44.0	39.0	32.0	24.0	425
LM-F5	5 ±5%	44.0	38.0	31.0	24.0	425
LM-F6	6 ±5%	43.0	37.0	30.0	23.0	425
LM-F8	8 ±5%	40.0	34.0	28.0	22.0	425
LM-F9	9 ±5%	38.0	32.0	26.0	21.0	425
LM-F10	10 ±5%	36.0	31.0	25.0	20.0	425
LM-F12	12 ±5%	30.0	26.0	21.0	16.0	425
LM-F15	15 ±5%	25.0	22.0	18.0	15.0	425
LM-F18	18 ±5%	23.0	20.0	17.0	13.0	395
LM-F20	20 ±5%	21.0	19.0	16.0	12.0	395
LM-F24	24 ±5%	18.0	16.0	13.0	10.0	380
LM-F28	28 ±5%	17.0	15.0	13.0	9.5	380
LM-F36	36 ±5%	13.0	11.0	10.0	7.5	395
LM-F48	48 ±5%	10.0	9.0	7.5	6.0	425

Package D $4\frac{1}{16}'' \times 7\frac{3}{4}'' \times 9\frac{3}{4}''$



Accessory Metered Panels: \$40.00

Model	ADJ. VOLT. RANGE VDC	I MAX. AMPS ¹				Price
		40°C	50°C	60°C	71°C	
LM-234	0-7	8.3	7.3	6.5	5.5	\$199
LM-235	8.5-14	7.7	6.8	6.0	4.8	199
LM-236	13-23	5.8	5.1	4.5	3.6	209
LM-237	22-32	5.0	4.4	3.9	3.1	219
LM-238	30-60	2.6	2.3	2.0	1.6	239
LM-D2	2 ±5%	13.1	11.3	9.2	6.2	199
LM-D3	3 ±5%	13.1	11.3	9.2	6.2	199
LM-D4	4 ±5%	13.1	11.3	9.2	6.2	199
LM-D4P5	4.5±5%	13.1	11.3	9.2	6.2	199
LM-D5	5 ±5%	12.6	10.8	9.2	6.1	199
LM-D6	6 ±5%	12.4	10.6	8.9	6.0	199
LM-D8	8 ±5%	12.2	10.3	8.8	5.9	199
LM-D9	9 ±5%	11.3	10.0	8.6	5.7	199
LM-D10	10 ±5%	10.8	9.7	8.5	5.7	199
LM-D12	12 ±5%	10.0	9.2	8.3	5.7	199
LM-D15	15 ±5%	9.0	8.4	7.9	5.3	209
LM-D18	18 ±5%	7.9	7.4	6.9	5.0	209
LM-D20	20 ±5%	7.4	6.9	6.5	4.9	209
LM-D24	24 ±5%	6.7	6.3	5.8	4.8	219
LM-D28	28 ±5%	6.0	5.6	5.2	4.7	219
LM-D36	36 ±5%	5.4	5.0	4.7	4.3	239
LM-D48	48 ±5%	4.1	3.9	3.6	3.1	239

Package G $5\frac{1}{4}'' \times 19'' \times 16\frac{1}{2}''$



For metered models, add suffix (M) to model number and \$30.00 to the price below.

Model	ADJ. VOLT. RANGE VDC	I MAX. AMPS ¹				Price
		40°C	50°C	60°C	71°C	
LM-G2	2 ±5%	90.0	83.0	62.0	43.0	\$575
LM-G3	3 ±5%	85.0	80.0	62.0	43.0	575
LM-G4	4 ±5%	77.0	71.0	61.0	43.0	575
LM-G4P5	4.5±5%	72.0	68.0	60.0	43.0	575
LM-G5	5 ±5%	68.0	64.0	59.0	43.0	575
LM-G6	6 ±5%	60.0	55.0	52.0	43.0	525
LM-G8	8 ±5%	59.0	54.0	48.0	39.0	525
LM-G9	9 ±5%	58.0	53.0	47.0	37.0	525
LM-G10	10 ±5%	56.0	52.0	44.0	35.0	525
LM-G12	12 ±5%	48.0	44.0	37.0	29.0	525
LM-G15	15 ±5%	39.0	37.0	31.0	24.0	525
LM-G18	18 ±5%	32.0	30.0	27.0	21.0	525
LM-G20	20 ±5%	30.0	28.0	25.0	20.0	525
LM-G24	24 ±5%	27.0	25.0	20.0	16.0	480
LM-G28	28 ±5%	25.0	23.0	19.0	15.0	480
LM-G36	36 ±5%	22.0	20.0	16.0	13.0	525
LM-G48	48 ±5%	17.0	14.0	12.0	9.0	575

¹ Current rating is from zero to I max. Current rating applies for input voltage 105-132 VAC 55-65 cps. Current rating applies over entire output voltage range. For operation at 45-55 cps and 360-440 cps derate current rating 10%.

CASE FOR THE MAN FROM E.A.G.L.E.

STROKE... STROKE... STROKE...

What sounds like a helmsman's cry is really the objective of a leading drug manufacturer. To operate his compacting equipment for a preset number of strokes, index and reset, the man from E.A.G.L.E. suggested the beautifully simple system shown at left. START button activates a Cycl-Flex® counter which energizes an oscillating cylinder. After correct strokes, counter shuts off the cylinder and resets. HZ170 Series Cycl-Flexes are available in 40 and 80 count ranges. They have famous plug-in feature for removal and replacement in seconds. Full details are in Bulletin 725, for a copy use Reader Service Card, circle number 101.

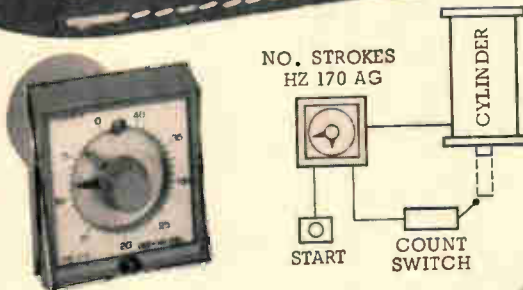

IN WINE THERE IS TRUTH...

Although Pliny the Roman lived nearly 2,000 years ago, he must have known the vintner for whom the man from E.A.G.L.E. developed the system at the left. Nature's gently programmed portion in the work of wine making must be aided by exacting man-made blending techniques and quality procedures. To control these, Cycl-Flex HG100 timers are used as follows: the first timer fills the main vat from various pressings to create desired blend. During its adjustable "OFF" period, a second timer draws a precise sample. HG-100 series offer ranges from 60 seconds to 30 hours, features plug-in designs. Complete details are in Bulletin 321, for a copy use Reader Service Card, circle number 102.

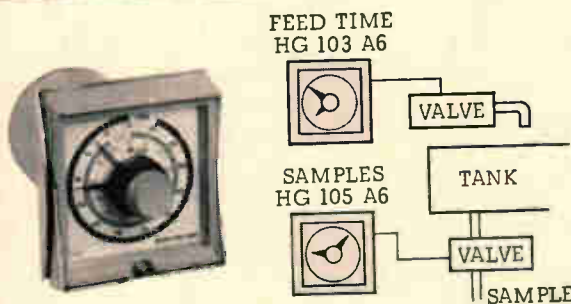

POSITION IS EVERYTHING...

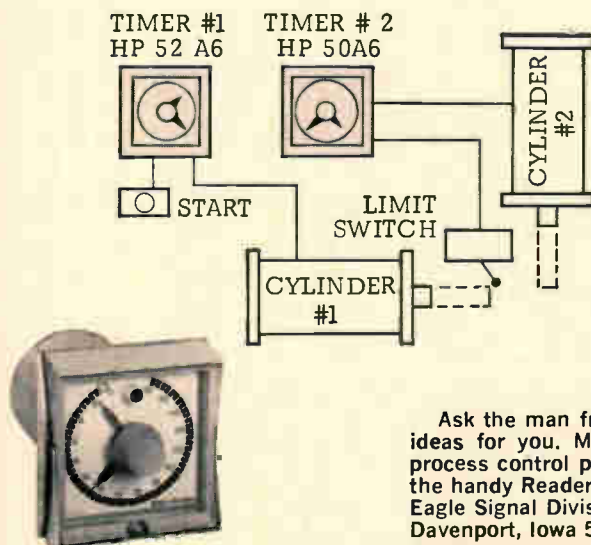

At least, that's what a machine tool manufacturer told the man from E.A.G.L.E. It seems he wanted to position a workpiece automatically within a jig. The action must be positive and reproducible as the pieces vary in size. The man from E.A.G.L.E. suggested the system at the left. Push button starts timer #1 which permits cylinder #1 to advance to a preset position, tripping the limit switch which activates timer #2. Cylinder #2 is then extended into the desired position by timer #2. Although interconnected, both timers have separate dial adjustments to accommodate various sized workpieces. HP5 dial ranges extend from 5 seconds to 60 hours. They also offer famous plug-in design. Interested in the details? Write for Bulletin 125, use Reader Service Card, circle number 103.

Ask the man from E.A.G.L.E. to open his "showcase" of ideas for you. Many of these ideas may help solve your process control problems. Want our complete catalog? Use the handy Reader Service Card, circle number 000, or write: Eagle Signal Division, E. W. Bliss Company, Federal Street, Davenport, Iowa 52803.

BLISS



EAGLE SIGNAL

A DIVISION OF THE E. W. BLISS COMPANY

UNDERCOVER OPERATOR

22AP Plug-in General Purpose Relay



... the epitome of relay craftsmanship and design. Versatile to the Nth degree on loads to 10 amps. Available in 8- and 11-pin styles for AC, DC and plate circuit requirements. Features include: forms to 3PDT plus specials on request; standard units have gold-plated contacts for longer shelf life; lower pull-in voltages (DC: 70% of nominal, AC: 75% of nominal); AC operating voltages 0.5 to 250, DC 0.2 to 130 in current ranges from .005 to 10 amp. Complete information is in our new relay bulletin. For your copy, use Reader Service Card, circle number 104.

SPECIFICATIONS

- Contacts: SPDT, DPDT, 3PDT
- Contact Rating: 5 and 10 amps.
- Pull-in: 22 milliseconds average
- Drop-out Speed: 12 milliseconds average
- Size: $1\frac{1}{8}'' \times 1\frac{1}{32}'' \times 1\frac{1}{2}''$
- Weight: 3 ounces

POWERFUL PARTNER

25PS Medium Power Relay



... toss your toughest medium-power-handling assignments to this workhorse. 25PS types carry loads to 20 amps. on a fast duty cycle in a breeze. UL listed. Features include: rugged $\frac{3}{8}''$ diameter silver cadmium oxide alloy contact; lower pull-in voltages (DC: 75% of nominal, AC: 76% of nominal); AC operating voltages 4 to 250, DC 1 to 130 in current ranges from .02 to 10 amp. For full technical information on this and other Eagle Signal general purpose and medium power relays, use the Reader Service Card, and circle number 105.

SPECIFICATIONS

- Contacts: SPDT
- Contact Rating: 20 amps. 115/230 VAC 60 cycle resistive • 1 HP @ 115/230 VAC motor-inductive
- Pull-in: 50 milliseconds max.
- Drop-out Speed: 30 milliseconds max.
- Size: $2\frac{1}{4}'' \times 1\frac{1}{32}'' \times 1\frac{1}{16}''$
- Weight: 3 ounces

RELAY DESIGNERS' RELAY

25AA Open Frame General Purpose Relay

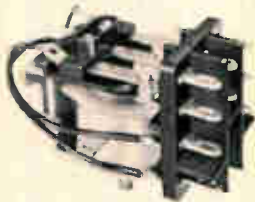

... and boy what a relay it is! Versatile, dependable, economical. You'll find hundreds of uses for these 5 or 10 amps., UL listed high-reliability types. Standard units have gold-plated contacts which permit longer shelf life. Other significant features include: lower pull-in voltages (DC: 70% of nominal, AC: 75% of nominal). AC operating voltages 0.5 to 250, DC 0.2 to 130 in current ranges from .005 to 10 amp. Detailed specifications on these and other Eagle Signal general purpose relays are given in a new technical bulletin. For your copy, use Reader Service Card, circle number 106.

SPECIFICATIONS

- Contacts: SPDT, DPDT, 3PDT
- Contact Rating: 5A and 10A @ 115 VAC • 5A-1/10 HP @ 115 VAC, 1/6 HP @ 230 VAC • 10A-1/6 HP @ 115 VAC, 1/3 HP @ 230 VAC
- Pull-in: 22 milliseconds average
- Drop-out Speed: 12 milliseconds average
- Size: $1\frac{1}{8}'' \times 1\frac{1}{32}'' \times 1\frac{1}{2}''$
- Weight: 2 ounces

Ask the man from E.A.G.L.E. to open his "showcase" of ideas for you. Many can help solve your process control problems. Want our complete catalog? Use the handy Reader Service Card, circle number 000, or write: Eagle Signal Division, E. W. Bliss Company, Federal Street, Daventry, Iowa 52803.

BLISS



EAGLE SIGNAL

A DIVISION OF THE E. W. BLISS COMPANY

Visit with The Man From E.A.G.L.E. Booth 4M33-4M34 IEEE Show March 21-24

GUDEBROD LACING TAPE CAN SAVE YOU MONEY—



**HERE'S
WHY-**

1 SPECIAL FINISHES SPEED HARNESING

Gudebrod has Lacing Tape that almost laces itself—the worker guides it instead of having to fight it. *Work goes fast!*

2 BETTER HARNESSSES —FEWER REJECTS

Gudebrod Lacing Tape makes proper ties that do not slip. *Saves money on assembly! Saves costly rejects!*

3 WORKER SAFETY APPRECIATED

Gudebrod Lacing Tape is easy on the hands, feels good to work with . . . so the work goes better, is faster. *Saves money on harnessing time!*

4 GUDEBROD CABLE-LACER another money saver

Handle holds bobbin of lacing tape, feeds tape as needed, grips it for knotting. Speeds harnessing. Has paid for itself in a day. *Another money saver.*

Gudebrod Lacing Tape is engineered for the job it has to do—saves money where it counts—in the harness room. More than 200 different tapes in the Gudebrod Line—Write for our Product Data Book!

Area Code 215, WA 2-1122



GUDEBROD BROS. SILK CO., INC.

FOUNDED IN 1870

Electronics Division



12 SOUTH 12th STREET, PHILADELPHIA, PENNSYLVANIA 19107

**NEW SUBMINIATURE
ERIE RFI FILTERS**
Feature **INSERTION LOSS OF**

670 DB/IN³@150 KC.

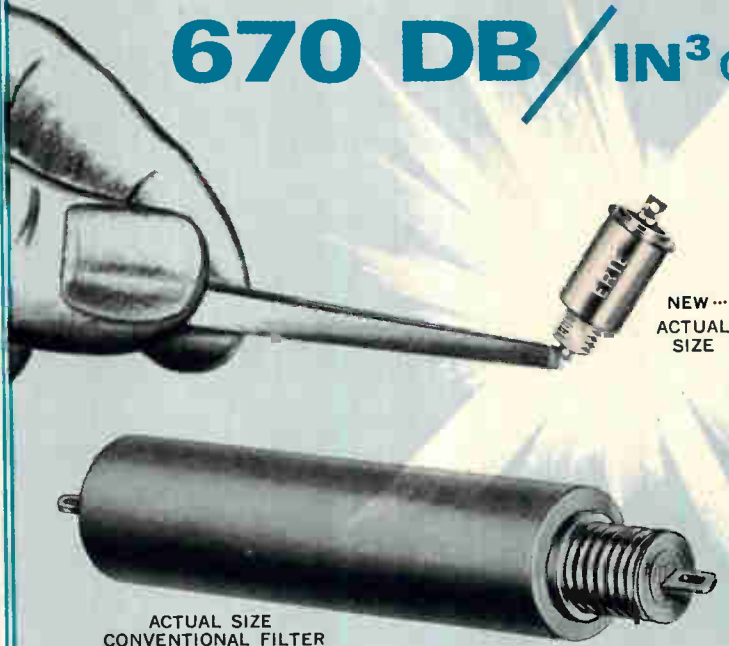

...LESS THAN 1/13 The Volume

ERIE'S NEW FILTER TECHNOLOGY PERMITS DRASTIC REDUCTION IN SIZE

Now, from Erie's Project "ACTIVE" (Advanced Components Through Increased Volumetric Efficiency) comes a new line of subminiature high pass, low pass and band rejection L, π and T Section Filters.

Volume reduction of these high reliability filters ranges to 13 times smaller than conventional filters of equal capability. Weight is correspondingly reduced, thus providing ideal RFI (electromagnetic interference) Filtering for equipment in aerospace, military and commercial markets.

Erie's new filter technology permits insertion loss ratios of 670 DB/cubic inch at 150 KC ... volumetric efficiencies which were never before possible.

In addition to the standard line filters described at right, Erie offers a full line of compact Bypass Capacitor Systems for transmitting tubes. Also, if you have particular electromagnetic interference problems not covered by standard Erie filters, we will be happy to custom design a filter connector package to suit your application.

Write TODAY for Bulletin 9000 and the name of your nearby Erie Field Sales Engineer.



**AIR FLOW SOCKET SYSTEM AND
SCREEN GRID BYPASS CAPACITORS**

Erie now provides effective and reliable capacitive bypassing and coupling or filtering of all RFI signals in the range of 10 to 3,000 megacycles and beyond. Screen grid values from 1000 pf. to 10,000 pf. at 1000 WVDC. Variety of systems to meet your design requirements. Write for Bulletin 9800.

Erie's Project "ACTIVE"
Advanced Components Through Increased Volumetric Efficiency

Actual Size

**HERMETICALLY SEALED
BROAD SPECTRUM
REJECTION
FILTERS**



100 Volts DC line Filter; For L, π and T Circuits; Insertion Loss...67 DB at 150KC DC Current Ratings to 8.0 Amp. 1/4-28 Thd. mounts in chassis.



115 Volts AC @ 60 cycles; 500 Volts DC. For L, π and T circuits; Insertion Loss...26 DB for AC; 1/4-28 Thd. mounts in chassis.

**SUBMINIATURE
STRIPELINE FILTERS**



**HERMETICALLY SEALED
AIR DIELECTRIC STRIPLINE
FILTER AND DIODE HOLDER**

Two components in one for π circuits... 1. Precision capacitor values for selective bias... 2. Signal line filter network. Isolation shaped as required.



**SUBMINIATURE STRIPLINE
T and π SECTION FILTERS**

Ribbon leads; DB @ Mega-cycles. Excellent VSWR. Effective filtering beyond 4 GC.

ERIE

TECHNOLOGICAL

PRODUCTS, INC.

ERIE

Erie, Pennsylvania

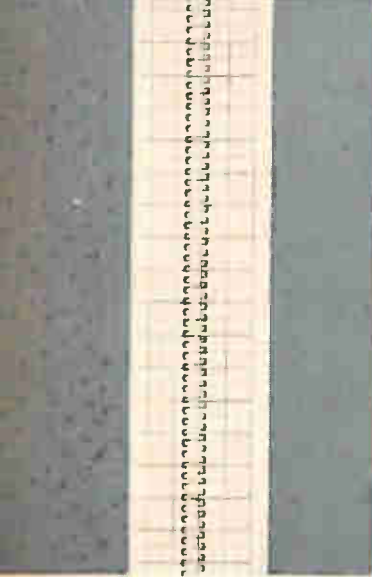
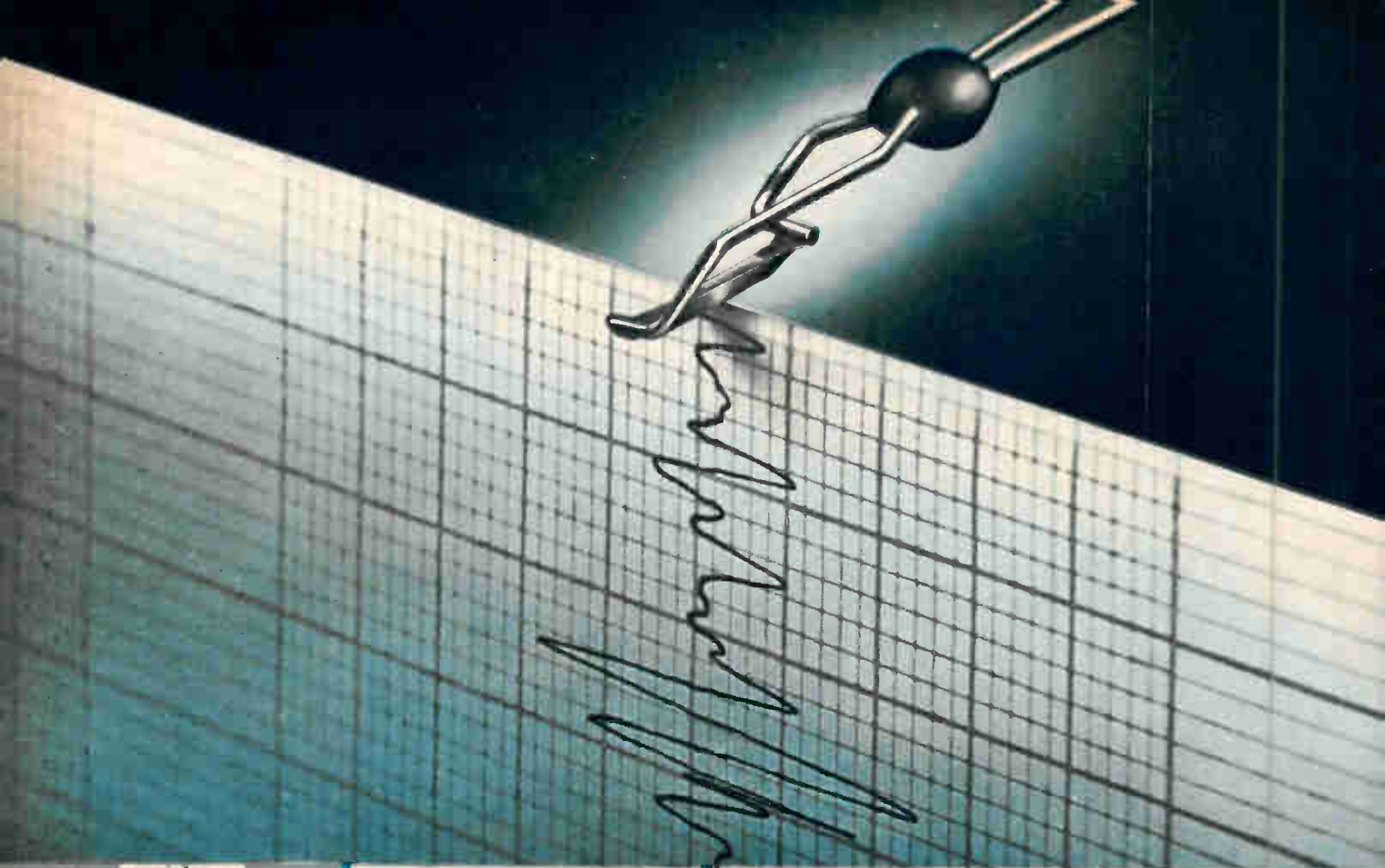

SINGLE-CHANNEL

Economical "briefcase-size" recorders. □ MODEL 7701A — 100 mm chart. Frequency Range DC to 30 cps. Linearity 0.5%. Sensitivity (depending on "8800" Preamp used) 1 uv/div to 5 v/div. Four chart speeds, 4 more optional. With case: \$1,325 plus preamp. □ MODELS 299, 301 — 32 mm chart. Frequency Range DC to 100 cps. Linearity 0.625%. Sensitivity 10 mv/div (Model 299), 10 uv rms/div (Model 301). 2 chart speeds. Model 299: \$800, Model 301: \$850.

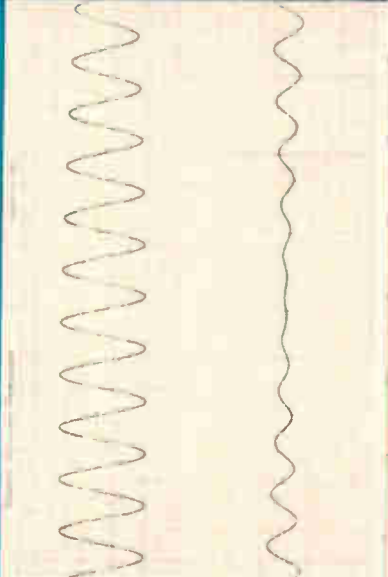

DUAL-CHANNEL

In portable, rack-mount, or mobile cart units. □ MODEL 7702A — Two 50 mm channels. Frequency Range DC to 125 cps. Linearity 0.5% Sensitivity (depending on "8800" Preamp used) 1 uv to 5 v/div. Four chart speeds, four more optional. \$1,675, plus preamps. □ MODEL 7712A — Uses "350" Preamps. Sensitivity 2 uv to 5 v/div. With mobile cart: \$1,770, plus preamps. □ 320 SERIES — Two 50 mm channels. Frequency Range DC to 125 cps. Linearity 0.5%. Sensitivity: 0.5 to 20 mv/div and v/cm (Model 320), 10 uv rms/div to 2 mv/div (Model 321), 10 mv to 10 v/div (Model 322). Four chart speeds, more on special order. Model 322 has zero suppression. Prices with cases: Model 320: \$1,650, Model 321: \$1,650, Model 322: \$1,395.

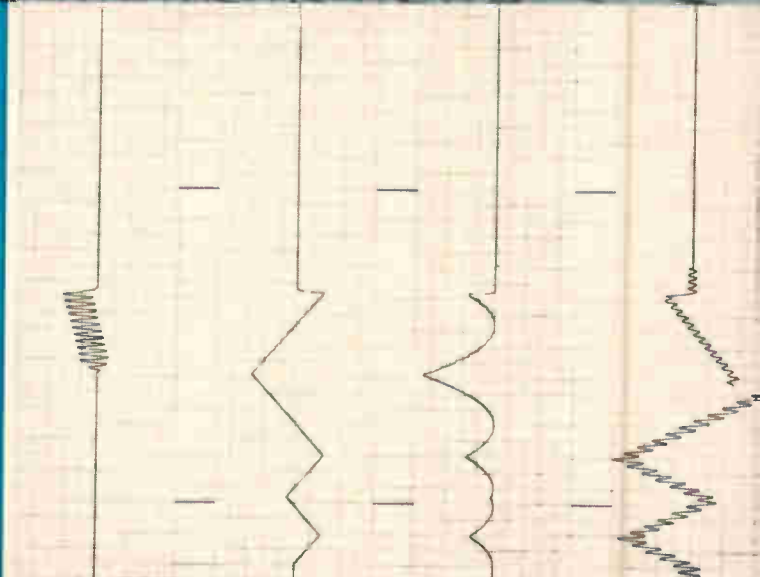

FOUR-CHANNEL

Sanborn MODEL 7704A recorder provides improved overall reliability, wider dynamic range, higher gain and more versatility through all solid-state "8800" Series preamps. Frequency range DC to 150 cps. Linearity 0.5%. Horizontal chart plane, nine chart speeds. Sensitivity (depending on "8800" preamp used) 1 uv/div to 5 v/div. In vertical cabinet, \$4,020 plus preamps. □ MODEL 7714A combines the convenience of horizontal chart plane with the flexibility and high performance of interchangeable individual-channel 350 Series preamps. Four 50 mm channels. Frequency range DC to 150 cps. Linearity 0.5%. Sensitivity (depending on "350" preamp used) 2 uv/div to 5 v/div. Nine chart speeds. With vertical cabinet, \$3,970 plus preamps.



See all measurements — down to the last microvolt

with high resolution Sanborn thermal writing oscillography

Resolve and read the smallest variations in your test parameters — even at *higher* frequencies, *small* amplitudes, and at *slow* chart speeds. Sanborn heated stylus oscillographic recording on matching Permapaper® charts gives you an immediate, permanent and clear record of test variables . . . lets you make "straight across" comparisons and correlations of multiple channels quickly and accurately because of rectangular coordinate traces . . . lets you clearly see what happened — as it is happening, and at any future time for more study or proof of performance.

The advantages of Sanborn thermal writing are available in many combinations of standard catalog system choices. The extensive Sanborn line allows you to select the number of channels, chart speeds, and the type of signal conditioning circuits you need, and to choose the packaging method that best suits your facilities. The wide range of signal conditioners includes low-cost built-in units, all-channels-alike amplifiers in six or eight-channel modules, and two series of individual channel plug-in units — miniaturized solid-state signal conditioners and highly sophisticated, maximum performance units.

Check the brief specifications of the systems shown below or call the H-P field engineering office in your locality for complete technical data and application engineering assistance. Offices in 47 U.S. and Canadian cities, and major areas overseas. Sanborn Division, Hewlett-Packard Company, Waltham, Massachusetts 02154. Europe: Hewlett-Packard S.A., 54 Route des Acacias, Geneva, Switzerland.

**HEWLETT
PACKARD**  **SANBORN
DIVISION**

See H-P at IEEE—March 21-24, Third Floor—New York Coliseum

Circle 69 on reader service card

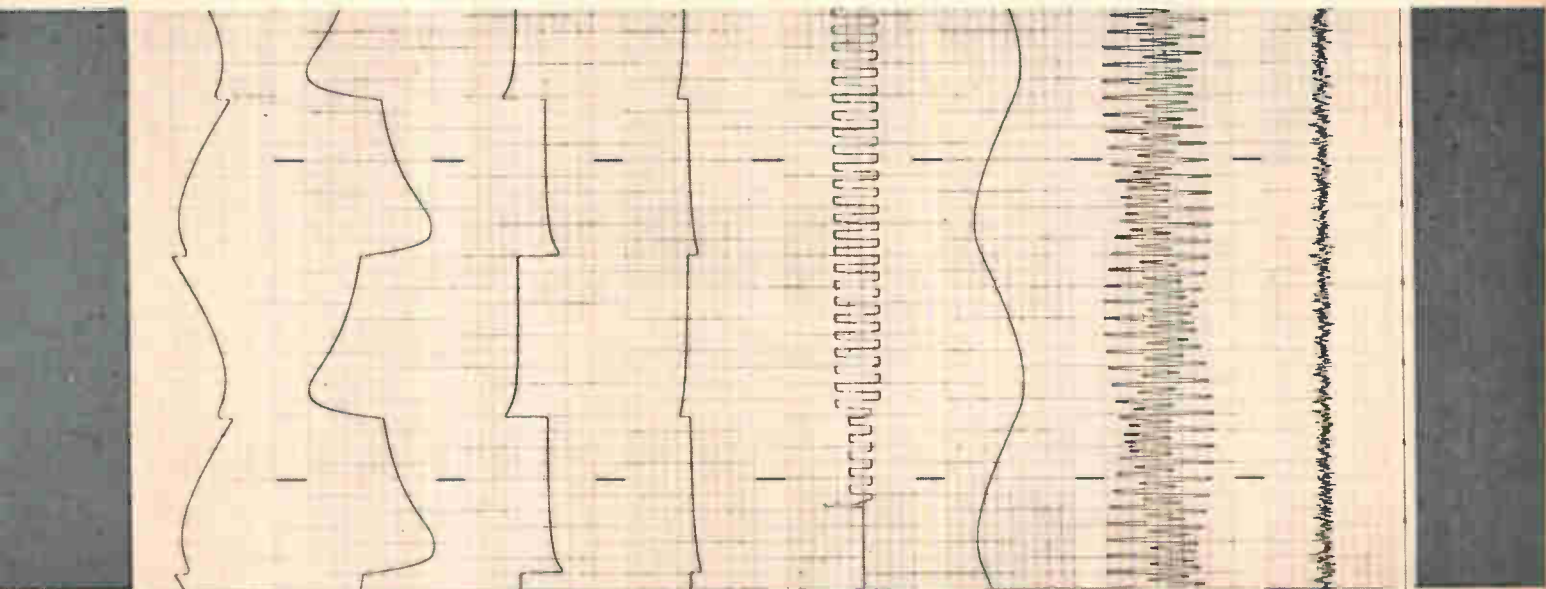

SIX AND EIGHT-CHANNEL

These versatile recorders have a wide range of input capacities, are completely integrated from signal input to galvanometer, and field-proven electronics. Six channel systems have 50 mm charts, and eight channel systems have 40 mm charts. All have DC to 150 cps frequency range. Linearity 0.5%. Nine chart speeds, nine more optional. □ MODELS 7706A, 7708A — Sensitivity (depending on "8800" preamp used) 1 uv/div to 5 v/div. With 6-channel cabinet (7706A) \$4,820 plus preamps, with 8-channel cabinet (7708A) \$5,495 plus preamps. □ MODELS 7716A, 7718A — Sensitivity (depending on "350" preamp used) 2 uv/div to 5 v/div. With 6-channel cabinet (7716A) \$5,325 plus preamps, with 8-channel cabinet (7718A) \$6,350 plus preamps. □ MODEL 7728A — Sensitivity (depending on "950" amplifier used) 10 uv/div to 5 v/div. With 8-channel cabinet \$3,425 plus amplifiers. □ MODEL 7709A 8-channel "control panel" recorder for basic inputs such as telemetry and computer outputs and other relatively high level ac-dc signals. Economical system uses no preamps, but has individual-channel front panel controls for gain, position, sensitivity selection (7 positions) and calibration. Polarity reversal is optional. Frequency range DC to 150 cps. Linearity

0.5%. Sensitivity 50 mv/div to 250 v/div. Nine chart speeds, nine more optional. Solid-state power amplifiers, constant 1 megohm input impedance, low drift. In vertical cabinet \$5,030.

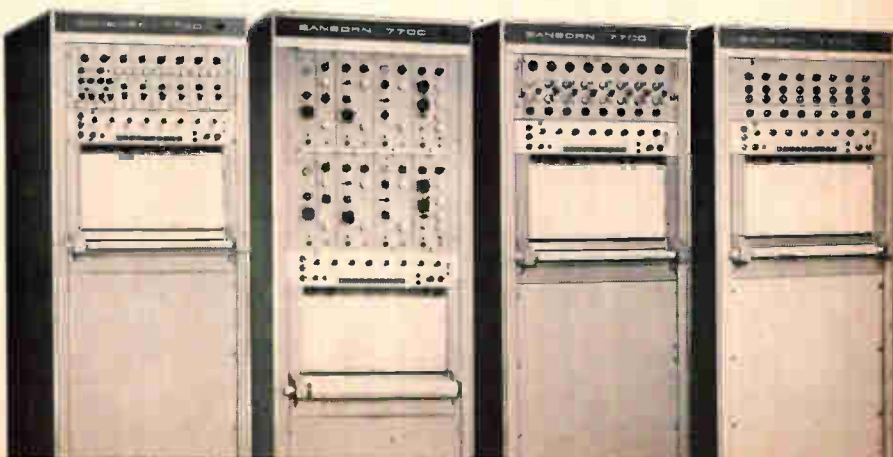

ranges has been completely eliminated.

Type A467 is designed for forward gain controlled stages and features a typical feedback capacity of 150 mpf. Type A473

purpose silicon planar transistors — the design engineer with a range of silicon planar small signal transistors unequaled in the industry on price and performance.

A415 | 200 Mc | 0.7 pf | — | — | 30 db

Amperex

If we at Amperex could develop a transistor that wouldn't have to be neutralized....

EXPANDED

DTL line

7 nsec at 10

speed ↑
isolation ↑ dissipation ↓

All Radiation integrated circuits are *dielectrically* isolated.

See all measurements — down to the last microvolt

with high resolution Sanborn thermal writing oscillography

Resolve and read the smallest variations in your test parameters — even at *higher* frequencies, *small* amplitudes, and at *slow* chart speeds. Sanborn heated stylus oscillographic recording on matching Permapaper® charts gives you an immediate, permanent and clear record of test variables . . . lets you make "straight across" comparisons and correlations of multiple channels quickly and accurately because of rectangular coordinate traces . . . lets you clearly see what happened — as it is happening, and at any future time for more study or proof of performance.

The advantages of Sanborn thermal writing are available in many combinations of standard catalog system choices. The extensive Sanborn line allows you to select the number of channels, chart speeds, and the type of signal conditioning circuits you need, and to choose the packaging method that best suits your facilities. The wide range of signal conditioners includes low-cost built-in units, all-channels-alike amplifiers in six or eight-channel modules, and two series of individual channel plug-in units — miniaturized solid-state signal conditioners and highly sophisticated, maximum performance units.

Check the brief specifications of the systems shown below or call the H-P field engineering office in your locality for complete technical data and application engineering assistance. Offices in 47 U.S. and Canadian cities, and major areas overseas. Sanborn Division, Hewlett-Packard Company, Waltham, Massachusetts 02154. Europe: Hewlett-Packard S.A., 54 Route des Acacias, Geneva, Switzerland.

HEWLETT
PACKARD  SANBORN
DIVISION

See H-P at IEEE—March 21-24, Third Floor—New York Coliseum

Circle 69 on reader service card

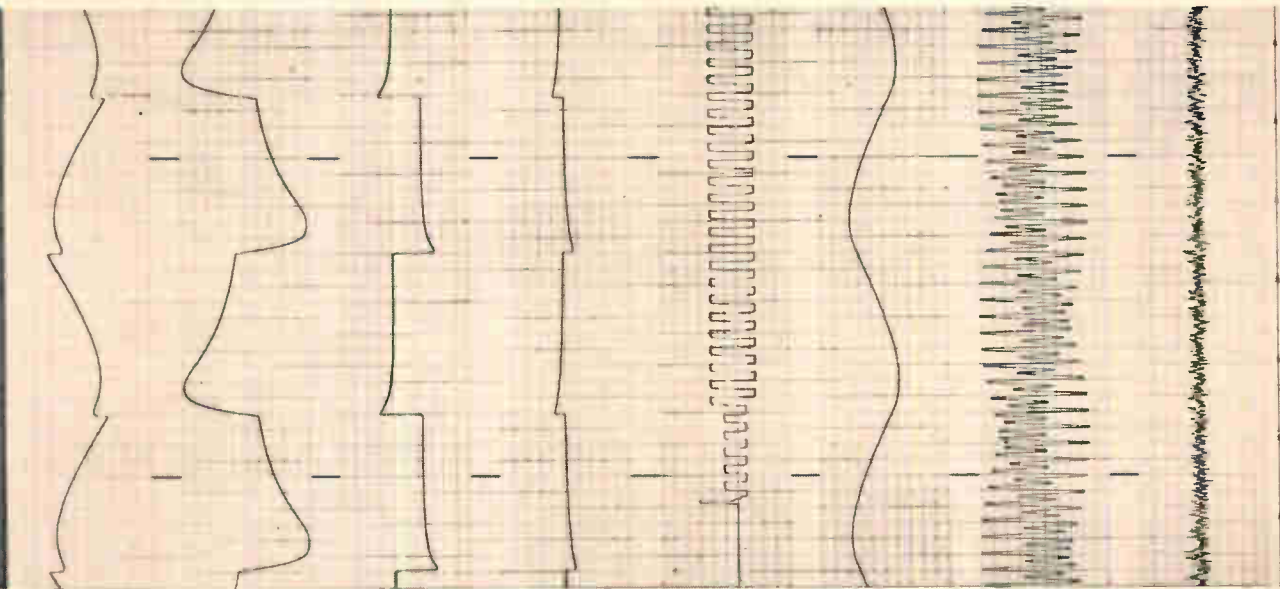

SIX AND EIGHT-CHANNEL

These versatile recorders have a wide range of input capacities, are completely integrated from signal input to galvanometer, and field-proven electronics. Six channel systems have 50 mm charts, and eight channel systems have 40 mm charts. All have DC to 150 cps frequency range. Linearity 0.5%. Nine chart speeds, nine more optional. Solid-state power amplifiers, constant 1 megohm input impedance, low drift. In vertical cabinet \$5,030.

□ MODELS 7706A, 7708A — Sensitivity (depending on "8800" preamp used) 1 uv/div to 5 v/div. With 6-channel cabinet (7706A) \$4,820 plus preamps, with 8-channel cabinet (7708A) \$5,495 plus preamps. □ MODELS 7716A, 7718A — Sensitivity (depending on "350" preamp used) 2 uv/div to 5 v/div. With 6-channel cabinet (7716A) \$5,325 plus preamps, with 8-channel cabinet (7718A) \$6,350 plus preamps. □ MODEL 7728A — Sensitivity (depending on "950" amplifier used) 10 uv/div to 5 v/div. With 8-channel cabinet \$3,425 plus amplifiers. □ MODEL 7709A 8-channel "control panel" recorder for basic inputs such as telemetry and computer outputs and other relatively high level ac-dc signals. Economical system uses no preamps, but has individual-channel front panel controls for gain, position, sensitivity selection (7 positions) and calibration. Polarity reversal is optional. Frequency range DC to 150 cps. Linearity

0.5%. Sensitivity 50 mv/div to 250 v/div. Nine chart speeds, nine more optional. Solid-state power amplifiers, constant 1 megohm input impedance, low drift. In vertical cabinet \$5,030.

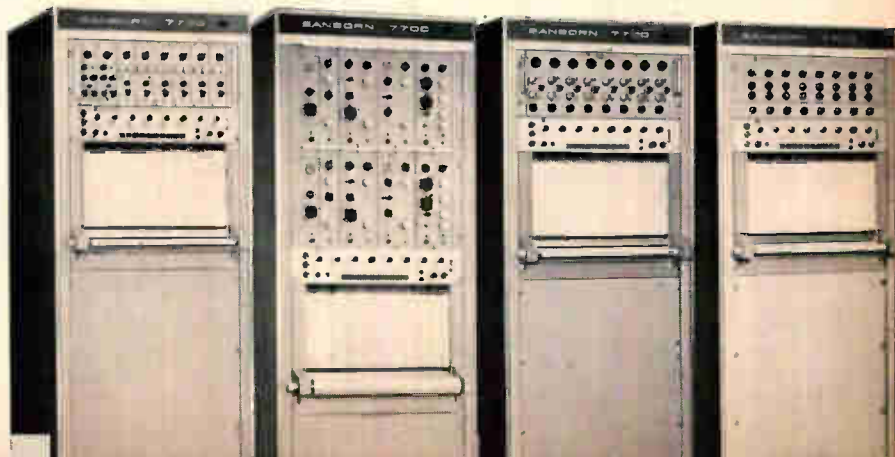

If we at Amperex could develop a transistor
that wouldn't have to be neutralized....
we'd all have something to smile about!

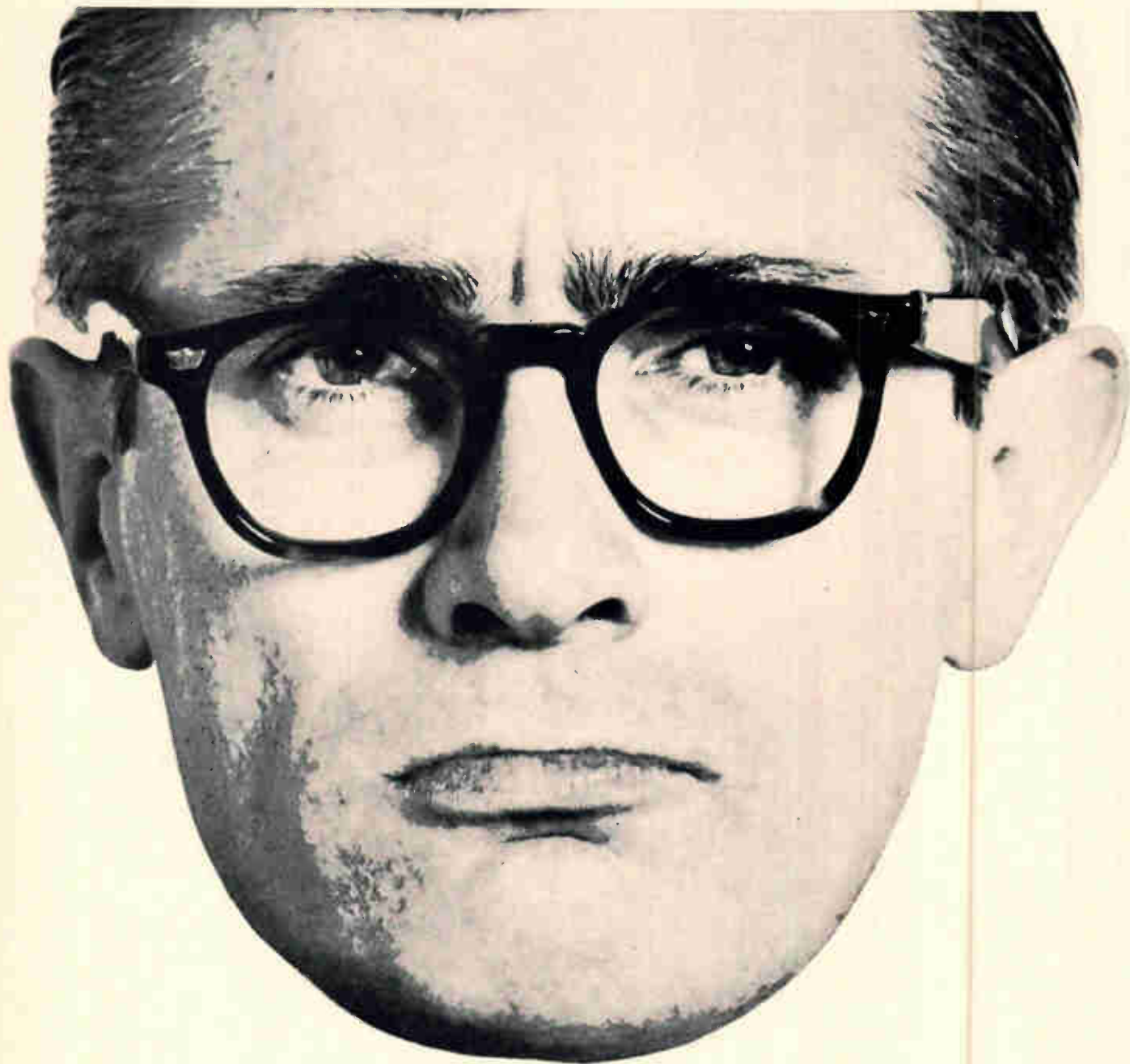

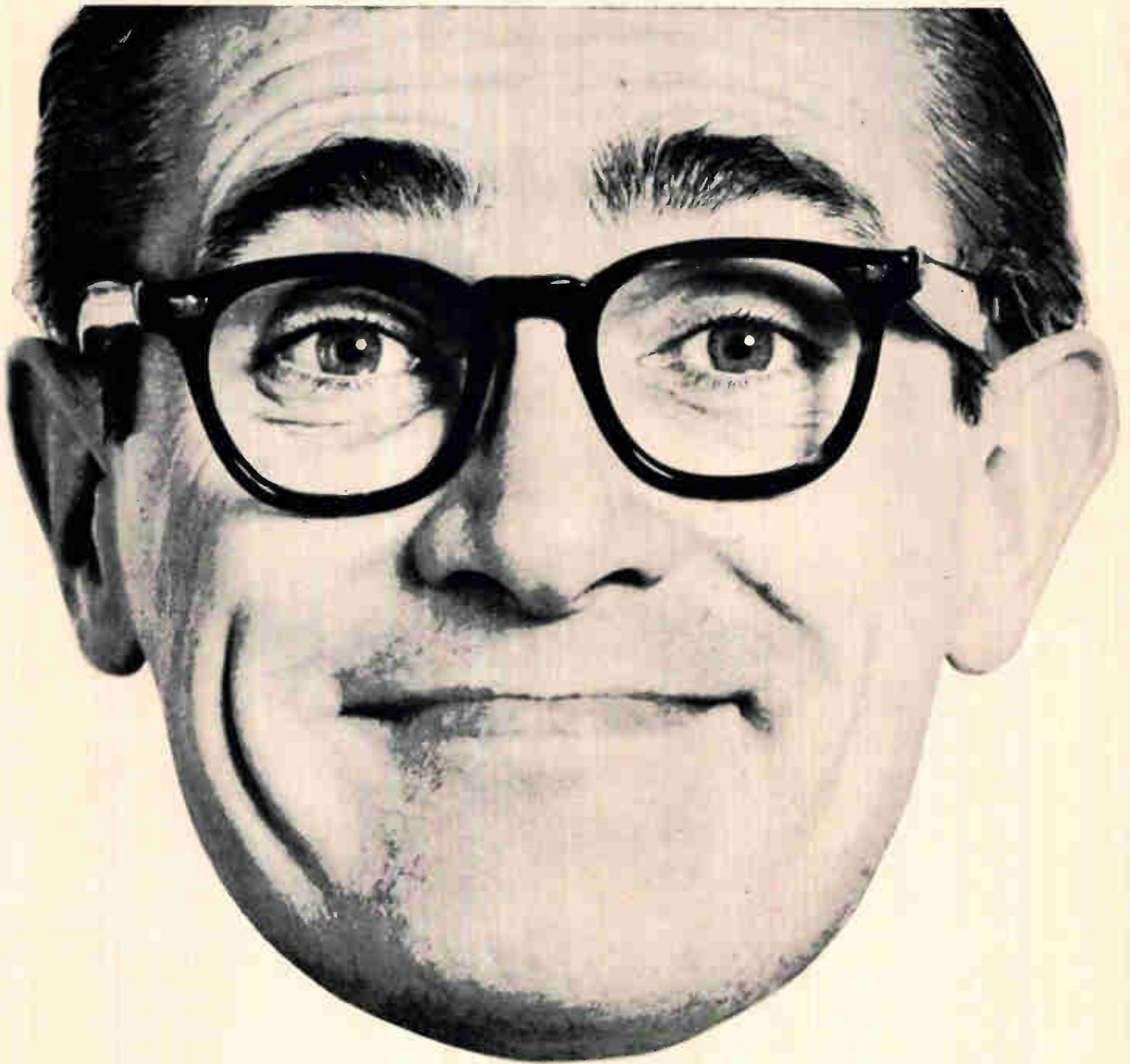

We've solved the circuit designer's problem of how to utilize the maximum available gain of his system and still maintain good stability. We've made this possible with the introduction of the first two of a series of extremely low-feedback-capacity silicon planar transistors in hermetically sealed TO-18 envelopes. With these transistors, types A467 and A473, the need for neutralization within their operating frequency ranges has been completely eliminated.

Type A467 is designed for forward gain controlled stages and features a typical feedback capacity of 150 mpf. Type A473

is designed for output stages where power handling capability is of paramount importance. Typical feedback capacity of type A473 is 230 mpf.

Typical applications include Television IF amplifiers, Wideband Radar IF amplifiers and premium performance FM-IF and RF service.

Types A467 and A473 combined with the new Amperex high performance general purpose silicon planar type A415 provides the design engineer with a range of silicon planar small signal transistors unequalled in the industry on price and performance.

For complete data on these and other Amperex silicon planar epitaxial RF amplifier transistors, write: Amperex Electronic Corporation, Semiconductor and Receiving Tube Division, Dept. 371, Slatersville, Rhode Island 02876.

Type	f_T	C_{re}	AGC Range	45 Mc Useable Gain	10.7 Mc Useable Gain
A467	330 Mc	150 mpf	55 db	33 db	—
A473	550 Mc	230 mpf	—	34 db	36 db
A415	200 Mc	0.7 pf	—	—	30 db

Amperex®

EXPANDED DTL line 7 nsec at 10

speed ↑
isolation ↑ dissipation ↓

All Radiation integrated circuits are *dielectrically* isolated.

provides mw

Having procurement problems? Check our delivery time on monolithic DTL circuits!

Why compromise on DTL performance or delivery? Radiation offers immediate shipment of industry's finest line of circuits! Radiation's dielectric isolation technique assures the best combination of speed, power dissipation and noise immunity.

And Radiation supplies a full line of DTL integrated circuits—17 in all. They include Series 200 and 300, designed for military use, and Series 500 for industrial applications. Compatible fan outs in each series are maintained over the full specified temperature ranges.

Other characteristics include: 7.0 nsec propagation delay (t_{pd}); 250mv "0" output voltage (V_{sat}); and 10.0na "1" input current (I_{inT}).

All circuits are specially engineered to provide superior performance for their specific applications. All are supplied in TO-84 flat packages.

Why not keep up to date on the latest advances in integrated circuits! Write or phone for our data sheets which include worst-case limits, and contain all information required by design engineers. We'll also send a brochure describing our broad range of engineering and manufacturing capabilities.

Radiation Incorporated, Physical Electronics, Department EL-03, Melbourne, Florida 32901. Phone: (305) 723-1511, extension 554.

Expanded Radiation DTL Line*

Circuit	RD 200 SERIES		RD 300 SERIES		RD 500 SERIES	
	Type	FO†	Type	FO†	Type	FO†
Gates						
Dual 4	210	8	310	5	510	8
Triple 3	205	8	305	5	505	8
Quad 2	206	8	306	5	506	8
RS Flip Flop	208	7	308	4	508	7
Line Driver	209	12	309	8	509	12
Expander	111	—	111	—	711	—

*New high-speed JK Flip Flop soon to be introduced.
†Maintained over full temperature range.

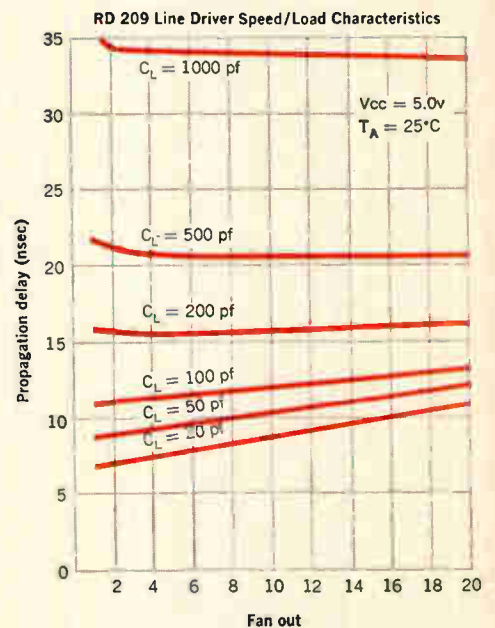

See these and other Radiation products at the IEEE Show, March 21-24 (Booth 2B34 & 2B36)



**RADIATION
INCORPORATED**

Sales offices: 650 North Sepulveda Blvd., Suite 622, El Segundo, Calif. (213) 772-6371—600 Old Country Road, Suite 438, Garden City, N. Y. (516) 747-3730

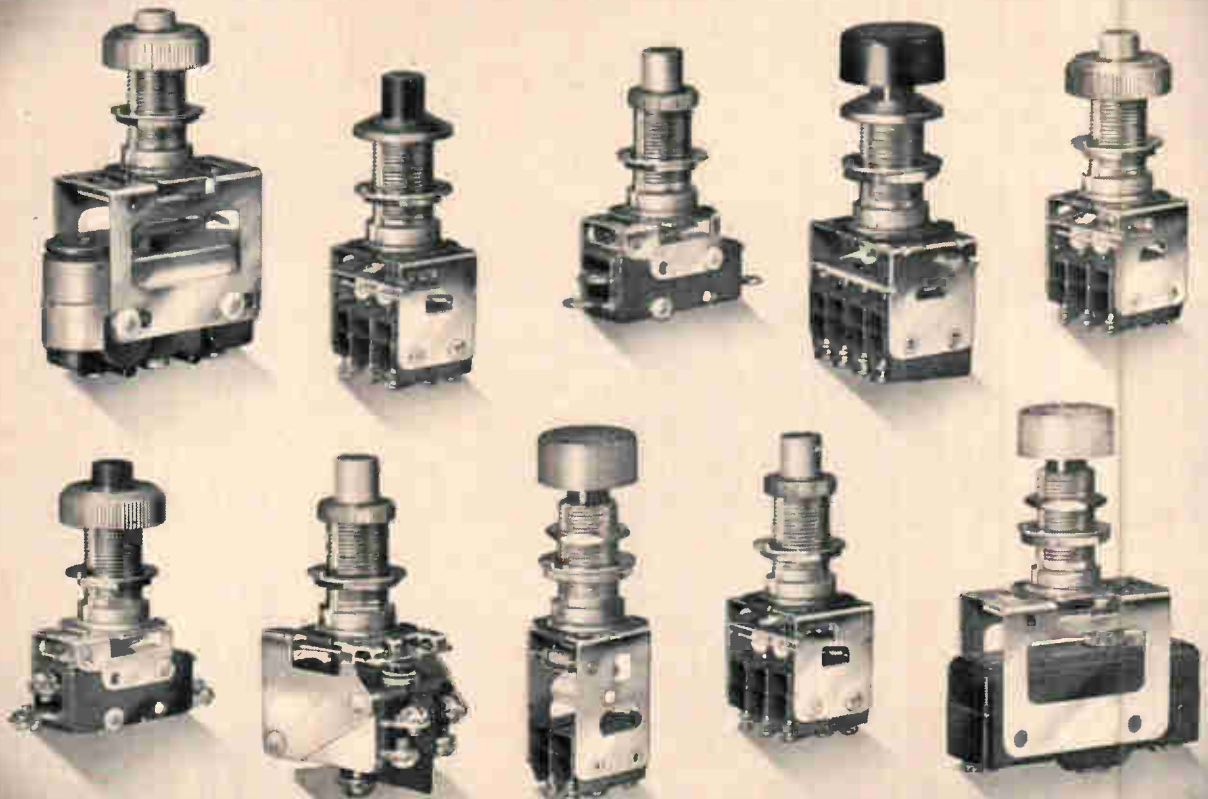

New Modular Pushbutton Switches

8 pushbutton units in 3 colors



3 facenuts with optional seal



30 switch units with wide selection of operating characteristics contact arrangements and circuitry.

New Series 6 modular components are making it practical to custom-build pushbutton switches on a growing variety of jobs—both small and large.

Pushbutton units, buttons, facenuts, and switching units are all off-the-shelf items. They may be assembled in hundreds of different combinations—all without special tools.

Series 6 offers a wide array of operating characteristics. Either momentary or alternate contacts. Enclosed snap-action switch units for dry circuit or heavy-duty power requirements. Switch units available with 1, 2, 3, or 4-pole double-

throw, and 2-circuit double break. Optional coil-equipped modules provide magnetic detent with remote release of contacts. Optional sealing facenut seals panel-to-bushing, bushing-to-button. Modules are easy to assemble without special tools.

For information call a MICRO SWITCH Branch Office or Distributor (see Yellow Pages). Or write for Data Sheet 233.



MICRO SWITCH

FREEMONT, ILLINOIS 61033

A DIVISION OF HONEYWELL

IN CANADA HONEYWELL CONTROLS LIMITED, TORONTO 17, ONTARIO

CONSIDER THE SOURCE!

Avoid systems problems by careful evaluation of klystrons vs. solid-state

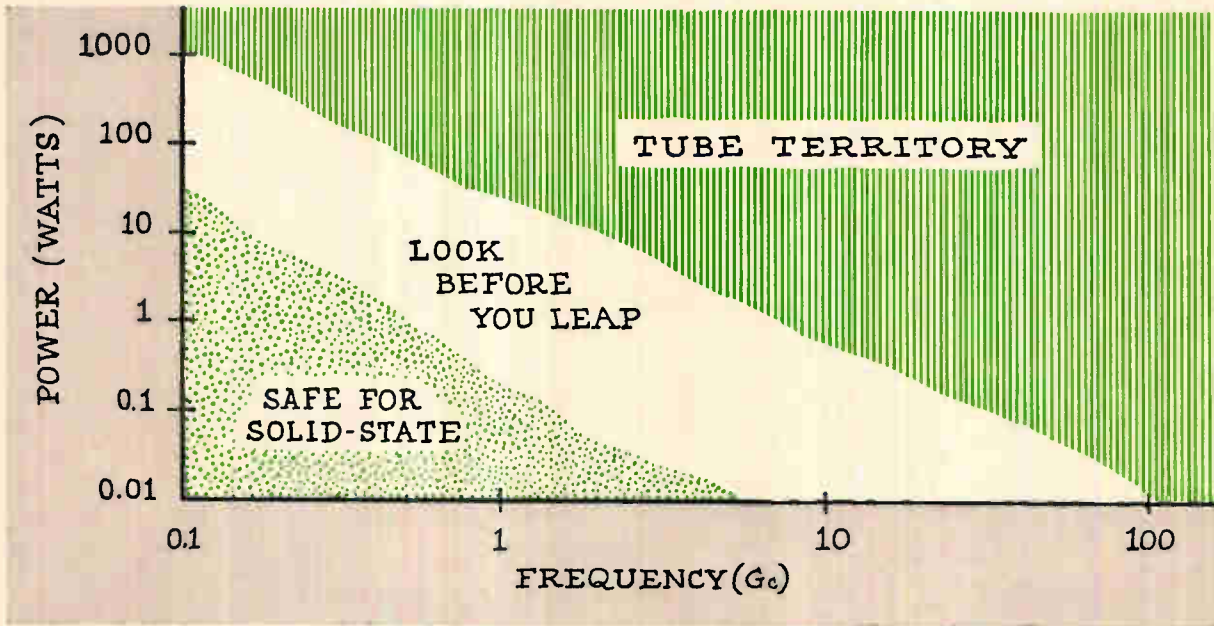

A premature stampede to solid-state for microwave power sources can cause serious problems for system designers. This is the major finding of recent Sperry studies which objectively compared solid-state sources with klystron oscillators.

While substantial solid-state progress cannot and should not be denigrated, comparative data prove that the era of the klystron is far from over. For system designers, the net result is this: microwave source selection now demands more careful attention than ever.

The drawing above approximates today's state-of-the-art. Solid-state sources show clear superiority only at low levels. The dominance of the klystron is unchallenged for high-level applications, and source selection in the large mid-range area demands extremely careful consideration.

In general, power-frequency requirements will be the most influential factors in making the choice. Solid-state devices offer many

advantages when operated well within the design envelope. However, when solid-state devices are applied too near their state-of-the-art, some performance degradation and loss of reliability must be accepted. Power handling considerations are particularly critical, because of the extreme temperature sensitivity of solid-state devices.

Klystrons, on the other hand, still enjoy numerous inherent advantages. At frequencies of X band or higher they are usually the more attractive choice, even for low- and medium-power applications.

In general, klystrons satisfy bandwidth requirements better than solid-state sources. They also offer superior AM and FM noise characteristics, much better temperature stability and longer, more predictable life.

Details of Sperry's comparative studies are available on request. For your free copy of this unusually useful technical paper, contact your Cain & Co. representative or write today to Sperry, Gainesville, Florida.

When system designers need a basis for comparison of complex alternatives, where can they turn? To Sperry's Storehouse of Knowledge. Objective, in-depth technical information is a major advantage of keeping in touch with the world's first builder of klystron tubes.

SPERRY

DIVISION OF
SPERRY RAND
CORPORATION

SPERRY ELECTRONIC TUBE DIVISION, Gainesville, Fla.

National Representatives: Cain & Co., Los Angeles, 783-4700; Boston, 665-8893; Arlington Heights, 253-3578; Dallas, 357-8645; Dayton, 228-2433; East Chester, 337-3445; Philadelphia, 828-3861; San Francisco, 948-6533; Syracuse, 463-0462; Washington, 296-8265; South Amboy, 727-1900; Huntsville, 534-7955; Montreal, 844-0089.

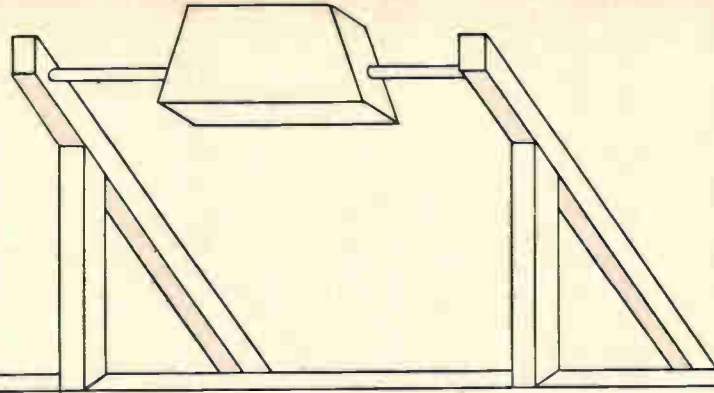

VARIAN CENTER

electron tube and device group

IEEE 2nd Floor

BOMAC division

Palo Alto Tube division

EIMAC division

S·F·D Laboratories, Inc.

LEL division

Varian of Canada, Ltd.

over 100 NEW microwave products



PROTECTS AGAINST • Bent Pointers • Burned-Out Resistors
 • Damaged Pivots • Overheated Springs • Burned-Out Meter
 • Changes in Accuracy Due to Overheating

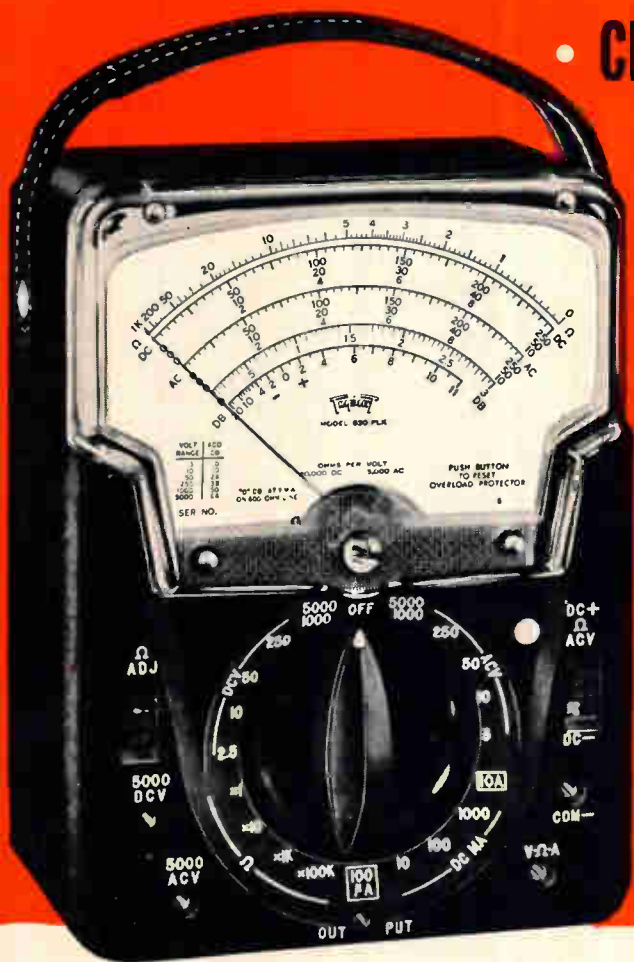

Model 630-PLK

BURNOUT PROOF V-O-M

\$85.00

Suggested
U.S.A. User Net

USES UNLIMITED

School Classrooms • Field Engineers • Application Engineers
 • Electrical, Radio, TV, and Appliance Servicemen • Electrical
 Contractors • Factory Maintenance Men • Industrial Elec-
 tronic Maintenance Technicians • Home Owners, Hobbyists

FACTS MAKE FEATURES:

- 1** Comprehensive overload protection.
- 2** One selector switch minimizes chance of incorrect settings
- 3** Polarity reversing switch

Additional protection is provided by Model 630-PLK's new transistorized relay circuit. Transistorized overload sensing device does not load circuit under test, eliminating the possibility of damaging circuit components. A special meter shorting feature on "off" position offers high damping when moving tester. The exclusive patented Bar Ring Movement provides self-shielding and is not affected by stray magnetic fields. Wider spread scales, and unbreakable clear plastic window assure maximum readability. Diode network across meter protects against instantaneous transient voltage.

TRIPLET ELECTRICAL INSTRUMENT COMPANY, BLUFFTON, OHIO

RANGES	
DC Volts:	0-2.5-10-50-250-1,000-5,000 at 20,000 ohms/volt. 0-0.25 at 100 microamperes.
AC Volts:	0-3-10-50-250-1,000-5,000 at 5,000 ohms/volt.
Decibels:	-20 to +11, +21, +35, +49, +61, +75; "0" DB at 1 MW on 600 ohm line.
DC Microamperes:	0-100 at 250 Mv.
DC Milliamperes:	0-10-100-1,000 at 250 Mv.
DC Amperes:	0-10 at 250 Mv.
Ohms:	0-1,000-10,000 (4.4-44 at center scale).
Megohms:	0-1-100 (4,400-440,000 at center scale).

Output Volts (AC): 0-3-10-50-250-1,000 at 5,000 ohms/volt; jack with condenser in series with AC ranges.

CARRYING CASE

Model 639-OS black leather carrying case, built-in stand, Flaps open to permit use of tester in the case. Suggested U.S.A. User Net.....\$13.00

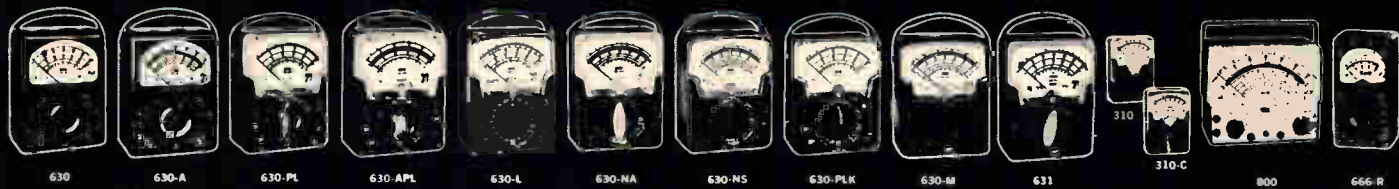

THE WORLD'S MOST COMPLETE LINE OF V-O-M'S. AVAILABLE FROM YOUR TRIPLET DISTRIBUTOR'S STOCK

WHEN SOMEONE LOWERS PRICES ON HIGH-FREQUENCY GERMANIUM TRANSISTORS BY AS MUCH AS 91%...

That's News!

The reason we did it is really very simple. Since we first announced our new "selective metal etch" process for fabricating germanium mesa transistors, we've found our production yields going up, up, up — and, at the same time, we found such added benefits as lower noise performance, narrower beta spread, and tighter overall parameter distributions on both switching and amplifier types.

When you add to this the fact that we can now obtain complete freedom of emitter geometry and, at the same time, achieve much better resolution and closer spacing than ever before — with obvious improvement in all high-frequency characteristics — you'll understand why Motorola is now able to announce significant price reductions on line and core driver transistors and small-signal RF and IF amplifier devices!

Take that order you have *right now* and call your Motorola representative — and be sure you get the most device for the price. If you would like detailed technical information on any of these types, simply drop a note to the Technical Information Center, Motorola Semiconductor Products Inc., Box 955, Phoenix, Arizona 85001.

HERE ARE THE BOLD NEW PRICE CHANGES:

	Old Price	New Price ^o	Reduction %
Line and Core Drivers			
2N1204, 2N1204A	\$ 4.25	\$ 1.10	74
2N1494, 2N1494A	5.00	1.45	71
2N1495	5.35	2.20	62
2N1496	5.70	2.55	55
2N2096	4.75	1.10	76
2N2097	6.50	2.20	66
2N2099	3.50	1.45	58
2N2100	5.25	2.55	51
2N2381	5.00	3.10	38
2N2382	5.70	3.45	39
2N3883	1.50	.90	40
RF and IF Amplifiers			
2N2415	17.50	4.00	77
2N2416	25.00	2.25	91
2N3279	5.00	3.00	40
2N3280	4.50	2.75	38
2N3281	3.00	1.75	41
2N3282	2.70	1.45	46
2N3283	1.40	1.00	28
2N3284	1.35	.95	29
2N3285	1.20	.75	37
2N3286	1.10	.65	40
2N3323	.70	.60	14
2N3324	.65	.55	15
2N3325	.60	.50	16
2N3783	30.00	20.00	33
2N3784	20.00	10.00	50
2N3785	9.95	4.50	54

^o 100-999 quantities



MOTOROLA VISIT **IEEE** BOOTHS 1A18-1A24
Semiconductor Products Inc.

BOURNS TRIMPOT® POTENTIOMETERS

World's largest selection — longest record of reliability

Units shown approximately 3/5 actual size.

TRIMPOT® POTENTIOMETERS—UNSEALED



General-Purpose Wirewound Model 200. Max. temp. 105°C / L, S, P terminals / 0.50 watt at 70°C / 10 ohms to 100K.



General-Purpose RESISTON® Carbon Element Model 215. Max. temp. 125°C / L, S, P terminals / 0.25 watt at 50°C / 20K to 1 Meg.



High-Temperature Wirewound Model 260. Max. temp. 175°C / L, S, P terminals / 1.0 watt at 70°C / 10 ohms to 100K.

TRIMPOT POTENTIOMETERS—HUMIDITY PROOF



General-Purpose RESISTON Carbon Element Model 235. Max. temp. 135°C / L, S, P terminals / 0.25 watt at 50°C / 20K to 1 Meg.



General-Purpose Wirewound Model 236. Max. temp. 135°C / L, S, P terminals / 0.8 watt at 70°C / 10 ohms to 100K.



Micro-Miniature High-Temperature Wirewound Model 3000. Max. temp. 175°C / P terminals / 0.5 watt at 70°C / 50 ohms to 20K.



Micro-Miniature High-Temperature RESISTON Carbon Element Model 3001. Max. temp. 150°C / P terminals / 0.20 watt at 70°C / 20K to 1 Meg.



Sub-Miniature High-Temperature Wirewound Model 220. Max. temp. 175°C / L, W terminals / 1.0 watt at 70°C / 10 ohms to 30K / Mil-Spec style RT10 and meets MIL-R-27208A.



High-Temperature Wirewound Model 224. Max. temp. 175°C / L, S, P terminals / 1.0 watt at 70°C / 10 ohms to 100K / Mil-Spec style RT12 and meets MIL-R-27208A.



Ultra-Reliable High-Temperature Wirewound Model 224-500. Max. temp. 150°C / L, P terminals / 0.5 watt at 70°C / 100 ohms to 20K. Performance and reliability statistically verified to customer.



High-Temperature, High-Resistance RESISTON Carbon Element Model 3051. Max. temp. 150°C / L, S, P terminals / 0.25 watt at 50°C / 20K to 1 Meg / Mil-Spec style RJ11 and meets MIL-22097B.



High-Temperature High-Resistance PALIRIUM® Film Element Model 3052. Max. temp. 175°C / L, P terminals / 1.0 watt at 70°C / 20K to 1 Meg.



High-Temperature, Low-Resistance PALIRIUM Element Model 3053. Max. temp. 175°C / L, P terminals / 0.5 watt at 70°C / 2 ohms to 100 ohms.



High-Temperature Wirewound Model 3010. Max. temp. 175°C / L, P terminals / 1.0 watt at 70°C / 10 ohms to 100K / Mil-Spec style RT11 and meets MIL-R-27208A.



High-Temperature RESISTON Carbon Element Model 3011. Max. temp. 150°C / L, P terminals / 0.25 watt at 50°C / 20K to 1 Meg / Mil-Spec style RJ11 and meets MIL-R-22097B.



High-Temperature High-Resistance PALIRIUM Element Model 3012. Max. temp. 175°C / L, P terminals / 1.0 watt at 70°C / 20K to 1 Meg.



3/8" Square Wirewound Model 3280. Max. temp. 175°C / L, P, W terminals / 1.0 watt at 70°C / 10 ohms to 50K.



3/8" Square RESISTON Carbon Element Model 3281. Max. temp. 150°C / L, P, W terminals / 0.5 watt at 50°C / 20K to 1 Meg.



1/2" Square, High-Temperature Wirewound Model 3250. Max. temp. 175°C / L, P, W terminals / 1.0 watt at 70°C / 10 ohms to 50K / Mil-Spec style RT22 and meets MIL-27208A.



1/2" Square High-Temperature RESISTON Carbon Element Model 3251. Max. temp. 150°C / L, P, W terminals / 0.50 watt at 50°C / 20K to 1 Meg / Mil-Spec style RJ22 and meets MIL-R-22097B.

BOURNS® SINGLE-TURN POTENTIOMETERS



3/16" Diameter Micro-Miniature High-Temperature Humidity-Proof Wirewound Model 3300. Max. temp. 175°C / W, P, S terminals / 0.5 watt at 70°C / 10 ohms to 20K.



3/16" Diameter Micro-Miniature High-Temperature Humidity-Proof RESISTON Carbon Element Model 3301. Max. temp. 150°C / W, P, S terminals / 0.25 watt at 70°C / 10K to 1 Meg.



Sub-Miniature Wirewound Model 3367. Max. temp. 105°C / P, S terminals / 0.5 watt at 70°C / 10 ohms to 20K / meets steady-state humidity.



Sub-Miniature RESISTON Carbon Element Model 3368. Max. temp. 105°C / P, S terminals / 0.25 watt at 50°C / 20K to 1 Meg / meets steady-state humidity.

LOW-COST COMMERCIAL POTENTIOMETERS



Wirewound TRIMIT® Potentiometers Models 271, 273, 275. Max. temp. 105°C / L, S, P terminals / 0.5 watt at 25°C / 50 ohms to 20K.



RESISTALOY® Carbon Element TRIMIT Models 272, 274, 276. Max. temp. 105°C / L, S, P terminals / 0.2 watt at 25°C / 20K to 1 Meg.



Wirewound E-Z-TRIM® Potentiometer Model 3067. Max. temp. 85°C / S, P terminals / 0.5 watt at 25°C / 50 ohms to 20K / Priced under \$1 in production quantities.



Carbon Element E-Z-TRIM Potentiometer Model 3068. Max. temp. 85°C / S, P terminals / 0.2 watt at 25°C / 20K to 1 Meg.

SPECIAL-PURPOSE POTENTIOMETERS



High-Power (2 watts) High-Temperature Wirewound Model 207. Max. temp. 175°C / L terminals / 2 watts at 50°C / 100 ohms to 100K. As Rheostat Model 208, available 100K to 200K.



High-Power (5 watts) Humidity-Proof Wirewound Model 3020. Max. temp. 200°C / L terminals / 5.0 watts at 25°C / 100 ohms to 50K.



Dual-Element Wirewound TWIN-POT® Potentiometer Model 209. Max. temp. 135°C / L terminals / 0.50 watt (each element) at 70°C / 10 ohms to 50K.

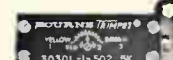

15 watts, High-Temperature Wirewound Model 3030. Max. temp. 265°C / L terminals / 15 watts at 25°C / 10 ohms to 10K.



Radiation-Resistant, High-Temperature Wirewound Model 3040. Max. temp. 350°C / W terminals / 150 megard / 5 x 10¹⁵ neutrons per sec. / 5.0 watts at 70°C / 500 ohms to 20K.

PANEL-MOUNTED POTENTIOMETERS

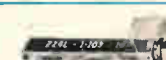

Most models are available with panel mounting. Unique design permits quick factory assembly to "on-the-shelf" units. In addition, mounting screws, brackets and clip brackets are available to meet almost any mounting requirement.

KEY TO TERMINAL TYPES

- L=Insulated stranded leads
- S=Solder lugs (includes panel-mounting bushing on Models 3367S, 3368S, 3300S and 3301S only)
- P=Printed-circuit pins
- W=Uninsulated wires (edge-mounting 3250, 3251, 3280 and 3281).

Write today for detailed specifications on any model in the large Bourns® Potentiometer and TRIMPOT® Potentiometer line and a list of Factory Representatives.

TRIMPOT® means BOURNS, BOURNS means QUALITY, so remember...

Don't MIL-SPECulate... SPECify BOURNS.

TRIMPOT is a registered trademark of Bourns, Inc.



MANUFACTURER: TRIMPOT® & PRECISION POTENTIOMETERS, RELAYS; TRANSDUCERS FOR PRESSURE, POSITION, ACCELERATION PLANTS: RIVERSIDE, CALIFORNIA; AMES, IOWA. TORONTO, CANADA

NEW CONVENIENCE AND ACCURACY IN MICROWAVE POWER MEASUREMENT

The new Hewlett-Packard 431C Power Meter offers 1% instrumentation accuracy, plus a front-panel control that lets you set in the correction factor indicated by nameplate efficiency charts on each Hewlett-Packard thermistor mount. No calculation necessary for major accuracy improvement in microwave power measurements, 10 microwatts to 10 milliwatts full scale. All sources of error are taken into account.

The hp 478A and 486A Thermistor Mounts contain nameplate calibration of both Effective Efficiency and Calibration Factor (which takes into consideration thermistor mount swr) ... calibration of the mounts is directly traceable to the National

Bureau of Standards, where applicable.

Now 431C *instrumentation* accuracy has been improved, coupled with convenience that lets you "normalize" measurements for the efficiency plots indicated on your thermistor mounts.

The 431C offers the same low drift characteristics of its predecessor, the 431B, plus one zero setting for all ranges, automatic and direct readings, solid-state design, grounded recorder output and linear power scale, plus portable operation with optional battery pack. Accuracy is enhanced with a taut-band, mirror-backed, individually calibrated meter, with the milliwatt scale greater than 3/4" long, for increased resolution.



Efficiency-calibrated thermistor mounts

+ New 1% Microwave Power Meter!

Performance in the presence of RF fields is dependable: the 431C meets MIL-I-6181D interference specs. A voltmeter output permits increased resolution of the reading with the appropriate digital or differential voltmeter, and a dc calibration input jack permits calibration of instrument and thermistor mount with the companion 8402B Power Meter Calibrator (see description).

Check out the brief specifications here, then call your Hewlett-Packard field engineer for a demonstration or for complete specifications. Or write for full details to Hewlett-Packard, Palo Alto, California 94304, Tel. (415) 326-7000; Europe: 54 Route des Acacias, Geneva.

Major specifications, 431C Power Meter

Instrument type: automatic, self-balancing power meter for use with temperature-compensated thermistor mounts

Power range: 7 ranges, 10 μ w-10 mw full scale; also calibrated in 5-db steps, -20 dbm to +10 dbm full scale

Accuracy: $\pm 1\%$ of full scale, +20°C to +35°C; $\pm 2.5\%$ of full scale, 0°C to +55°C

Calibration factor control: 13-position switch normalizes reading to account for thermistor mount Calibration Factor (or Effective Efficiency); range, 100% to 88% in 1% steps

Zero carryover: less than 0.5% of full scale when zeroed on most sensitive range

RFI: meets all conditions specified in MIL-I-6181D

Additional features:

- outputs for precision dc differential or digital voltmeter and for recorder/leveler
- input for precision dc calibration (using hp 8402B)
- optional rechargeable battery pack

Price: \$475

Data subject to change without notice. Prices f.o.b. factory.

With the 8402B Calibrator, you can quickly and easily calibrate your 431C Power Meter—including determination of thermistor operating resistance—with an overall uncertainty of only 0.16% (20° to 30°C). And with an appropriate dc voltmeter and the 8402B, you can establish dc substitution power levels between 1 μ w and 10 mw with less than 0.15% uncertainty. Model 8402B, \$475.



HEWLETT  **PACKARD**
An extra measure of quality

Visit Hewlett-Packard at IEEE, 3rd Floor
New York Coliseum—March 21-24



What is it ?

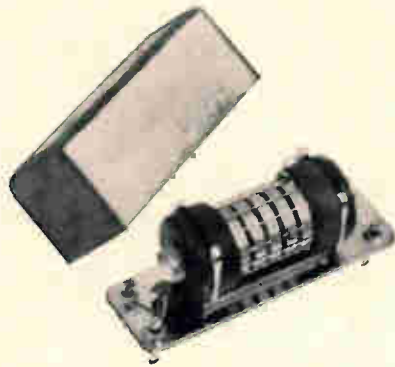

Clue No. 1: Its development made application of single sideband practical.

Clue No. 2: Its applications range from Citizens Band radios to such highly complex telemetry systems as that of the Saturn Rocket.

Clue No. 3: It offers the greatest combination of selectivity, simplicity, compactness and reliability ever developed in a component designed for its particular purpose.

Clue No. 4: It resists aging to such a remarkable degree in accelerated tests that aging need not be a consideration.

Clue No. 5: It's a classic circuit component associated universally with the Collins name.

Answer: It's the Collins Mechanical Filter. It's used in single

sideband applications. High performance transmission and receiving equipment. Missile guidance systems. Multiplexing equipment. Frequency synthesizers. Doppler radar. Data transmission systems. Precision navigation equipment. Spectrum analyzers. FM communication receivers and Citizens Band transceivers.

It's available in frequencies from 60 KC to 600 KC, and in bandwidths of .1% to 10%.

If you build any of this equipment and have a selectivity/reliability requirement, call Collins Radio Company, Components Sales Department, 19700 Jamboree Road, Newport Beach, Calif. Phone: (714) 833-0600. Or call your authorized Collins components sales representative.

See these and other advanced components at New York IEEE, Booths 2H18 and 2H20.



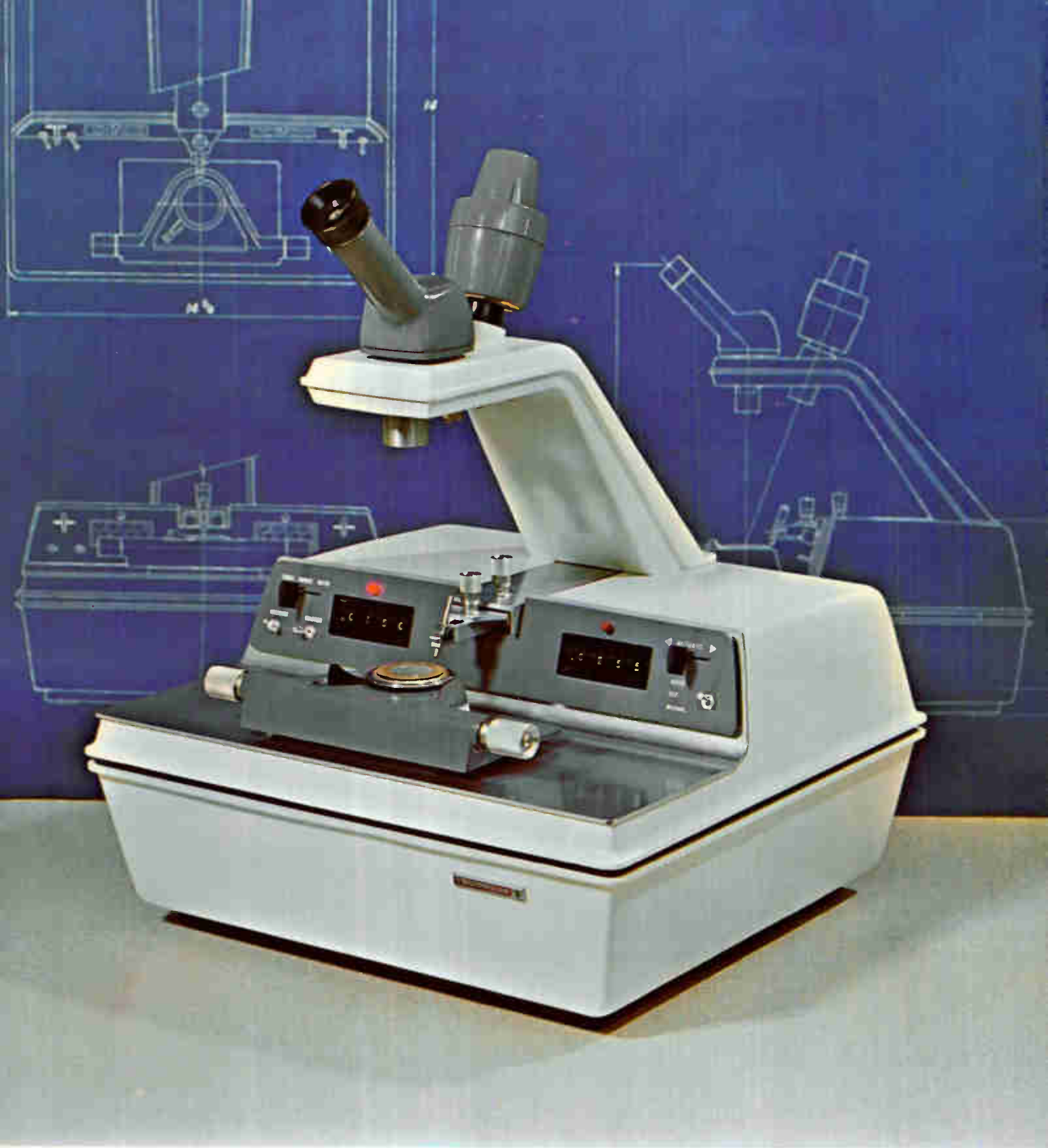

From all viewpoints... better, faster, more economical scribing

THE NEW TEMPRESS SCRIBING MACHINE, WITH SELECTIVE ELECTRONIC CONTROL, BRINGS NEW EFFICIENCY TO SEMICONDUCTOR MANUFACTURE. One microscope... one group of positioned sequence controls... one streamlined package as small as an office typewriter... these are advantages you can see at a glance. Look closer and you will find all electronic circuitry on easy-access circuit boards, silent life-lubricated mechanical components, and a surprisingly low price. The Tempress

Scribing Machine, in development for over two years, would not be offered today, if it did not effectively set a new standard, comparable to the Tempress line of diamond scribes, lead-bonding tools, diamond lapping points, and other miniature semiconductor manufacturing tools. Let us arrange a demonstration at your early convenience.



TEMPRESS

Tempress Research Co., 566 San Xavier Ave., Sunnyvale, California

Achieve optimum strike potential with Ferranti F1600

The family of computers that permits initiation of real-time retaliation within two radar sweeps.

Before the antenna has completed its second sweep the F1600 carries out a thorough threat evaluation and presents Central Command with an overall picture of the national defence situation. Subject to human decision, retaliation can proceed instantly.

This is how member nations of NATO can achieve strategic superiority with a defence system based on the *F1600* — organised in a radically new mode pioneered by Ferranti to make it the world's fastest and most powerful computer for advanced military applications.

The *F1600* compiles 'track files' on attacking aircraft and missiles, evaluates the state of readiness, performance and location of individual units in the defence network, and selects the most likely weapon for effective combat from the nation's armoury. Performs all these functions in micro-seconds.

Based upon information gathered from surveillance radar the *F1600* then calculates and transmits vital

'kill point' data to a fighter aircraft before it leaves the ground, to a fighter already in the air, or to a surface-to-air missile complex.

This very high speed stored program computer has been chosen to form the heart of the British Royal Navy's *Action Data Automation System (ADA)* for the new generation of aircraft carriers and guided missile destroyers.

Within a few hours flight of every European capital, Ferranti have unequalled experience in the creation of real-time computer-based systems to meet specific Service requirements. Having worked closely and successfully with members of NATO, Ferranti are uniquely qualified to provide an individual solution to problems of national defence.

Ferranti Ltd., Digital Systems Department, Moston, Manchester 10, England.

DSD Research and Development Laboratories, Bracknell, Berkshire, England.



FERRANTI
DIGITAL SYSTEMS:
F1600 SERIES

DS8

New F-111 uses 50 miles of wire jacketed with Kynar.*
Why? Primarily because KYNAR is tough. Its mechanical strength and abrasion resistance make it possible to use thinner jacketing without compromising performance. Result: savings in space...savings in weight amounting to several hundred pounds per plane. Wire jacketed with cross-linked KYNAR is described in MIL-W-81044.

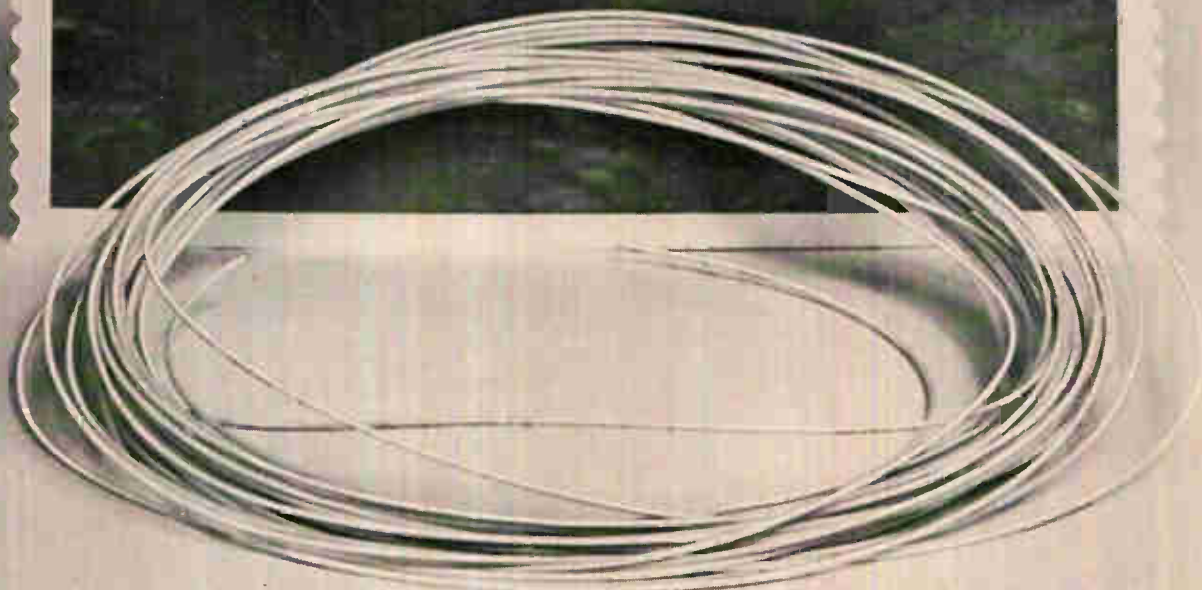
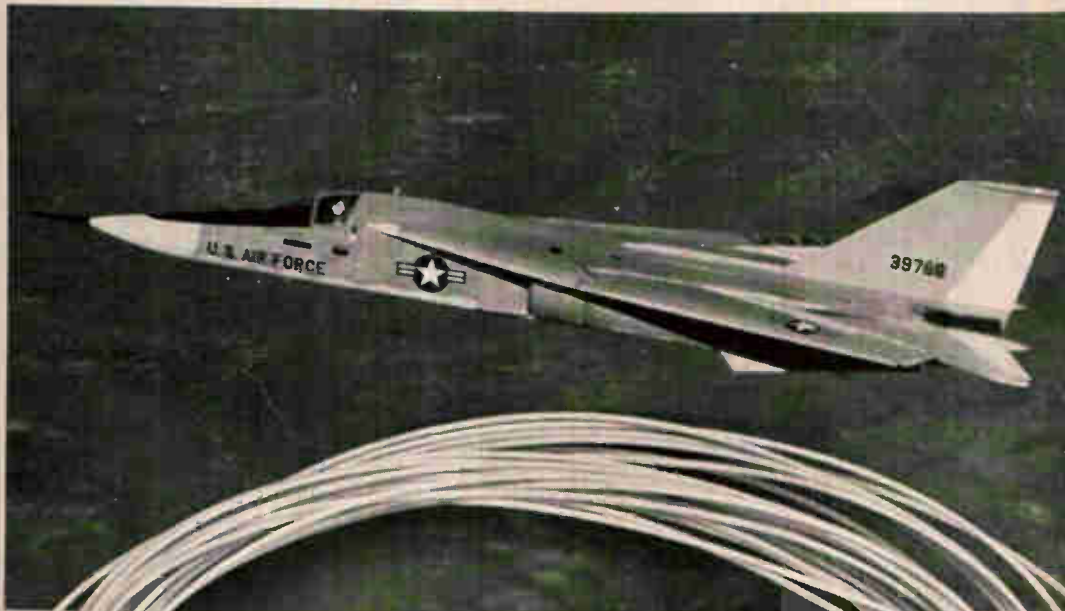

If you have a problem with space, weight, cut-through, abrasion or temperature, consider using wire insulated and/or jacketed with KYNAR. For detailed information, write Pennsalt Chemicals Corporation, 3 Penn Center, Philadelphia, Pa. 19102.

Kynar...the fluoroplastic that's tough!

*Registered trademark of Pennsalt Chemicals Corporation for its vinylidene fluoride resin.



CHEMICALS ■ EQUIPMENT

Technical Articles

**No product surprises
at IEEE:
page 88**

With order backlogs building up, many electronics firms are more concerned with meeting deliveries than developing radically new products. In the main, products at the show will reflect continuing trends. Instruments are becoming easier to use and more flexible; more commercial products are using microcircuits; and the frequencies and power handling capabilities of semiconductor devices continue to rise.

**Automated electron beams
process thin-film
components:
page 110**

One of the pioneers in electron beam technology, Manfred von Ardenne, has applied the electron beam to the manufacture of thin-film components in East Germany. With two associates he has written a rare report on Eastern European production. Though the techniques are not surprising, they have been combined in an unusual way that should lead to high production rates.

**Microwaves on the
production line:
page 123**



After a lot of talk about using microwaves for chemical and food processing, a few applications are actually under way. Designing for proper heating and coupling is still an inexact, trial and error procedure. For the cover, Art Director Saul Sussman painted an imaginary microwave installation for food processing.

**Powerful logic from
power-less circuits:
page 133**

Inexpensive silicon transistors act as controlled switches to eliminate external power sources. The resulting circuits are simpler and more efficient than those built with diodes.

**Coming
March 21**

- Pacemaker powered by body fluids
- FET's make better tv tuners
- Some analog microcircuits
- New approach to space navigation: the star tracker

IEEE Show: few surprises

This year's products will continue the trends started last year. Order backlogs are building up, so companies are concentrating on increasing production rather than on radically redesigning products

At the annual exhibit of the Institute of Electrical and Electronics Engineers, March 21 to 25, there will be few radically new products or surprises. Rather, most companies with new offerings will be unveiling products that continue trends started last year: instruments are being made easier to use, measure with higher accuracy, and are more versatile and flexible; more commercial products are using integrated circuits; frequencies are being raised; and larger numbers of components are being squeezed onto the substrates of microelectronic circuits.

Behind the slowdown in radical innovations is the tremendous business surge the industry is enjoying. Because order backlogs are building up, more companies are concentrating on increasing production than on radically redesigning products. The pressure that many companies felt last year from declining military sales has been dissipated this year by Vietnam buying, the continuing mush-

rooming sales of color-television receivers and the record general prosperity the economy of the United States is enjoying. In fact, at this year's IEEE show, some of the keenest interest will be on new production equipment—machinery that will make electronic components and products faster and cheaper, such as the automatic flatpack welder developed by the Weldmatic division of the Unitek Corp. and described on page 102.

Electronics' reports on a sampling of the new products to be shown two weeks from today at the IEEE show begins on this page and continues to page 103. More new products appear on pages 207 to 270. Tracing how the ideas for many of these new products originated, Electronics' reporters found that suppliers were becoming increasingly involved with the problems of their customers. By solving these problems, and by listening to customers' new product ideas, companies developed many of the products that will be displayed.

Instruments

Differential voltmeter balances itself

For convenience as well as improved accuracy, man is diminishing his role in laboratory measurements. He is relying more on automatic instruments such as a digital voltmeter introduced by Ballantine Laboratories, Inc. The voltmeter does away with the multiknob adjustments and nulling operations required with differential voltmeters that have to be balanced manually.

An electromechanical system provides a readout of four significant figures, with over-range to five



figures, using only one range knob and one expansion knob.

Ballantine's Model 353, designed for fast and accurate d-c voltage measurements, features a servomotor-driven, three-digit counter. The position of the last digit can be estimated to the nearest tenth, avoiding the ± 1 -digit ambiguity of fully digitized displays. A rotating counter wheel permits slowly varying signals to be observed.

The incoming signal to the instrument is passed first through a dividing network, or range selector. A comparator circuit matches the attenuated input signal with a signal derived from a variable reference supply. Any difference is amplified and used to drive a servomotor, which in turn adjusts the reference supply until its voltage is equal to that of the input. The motor shaft is coupled to a mechanical counter which provides the in-line digital display.

Ballantine's engineers increased the accuracy and resolution of the instrument by adding a number of precision resistors in series with the potentiometer in the reference supply. As these resistors are switched into the balancing circuit one by one, the reference-voltage range is narrowed in discrete steps, and errors introduced by the potentiometer are minimized. The resistors are manually added to the balancing circuit by what is known as an expand dial on the instrument's front panel. The dial is backlighted to display the number of discrete steps added.

To measure an unknown voltage, the range switch is first set to the expected value. With the mode selector in the normal position, the precision resistors are not in the balancing circuit and only the most significant digits of the on-scale reading appear on the counter. The expand dial is then set to the first digit of this reading.

When the dial is turned, an internal signal is generated which disables the servomotor drive circuit to prevent the counter from rotating during this manual operation. Once the expand dial is set at the desired digit, the hold circuit is deactivated and the meter rebalances in an expanded mode, displaying the unknown voltage to four significant figures.

Since it is possible for the reference supply potentiometer to approach the upper or lower limits of the expanded range, it is necessary to provide a means for changing the manually set digit to the next higher or lower number, preferably without having to reset the expand dial and make the meter rebalance itself.

The 353 incorporates a torqueless digit transfer which gives these overlapping ranges and still provides the correct reading quickly.

The reference step display is made opaque, with three rows of transparent numbers around the circumference of the dial. Each number, from 1 to 10, in the middle row has the next highest number on its left and the next lowest on the right. A three-square by three-square flag, with clear squares along the diagonal, is positioned behind the

dial. If the potentiometer is at the high or low end of the range, the flag is moved up or down and the next higher or lower number from the one manually set in the expanded range is visible.

The switch of the stepped reference supply, expand selector, and the switch in the input dividing network, range switch, are electronically coupled so that the attenuation in the input network is decreased in a decade step the moment the expand switch is set to any position other than the normal mode. This keeps the difference-signal magnitude constant. No change is needed in the gain of the difference amplifier and motor circuits, the reference supply voltage, or the input dividing network to compensate for the decreased reference signal. This allows making a coarse measurement in the normal mode and a fine measurement in the expanded mode with the same range setting. The decimal point and range display are coupled to the range selector.

Specifications

Voltage range	0 to 1,000 v d-c
Accuracy	0.02% of reading plus 0.01% of full scale
Input impedance	10 megohms
Weight	7.7 lbs
Price	\$490
Ballantine Laboratories, Inc., Boonton, N. J.	

Low-power regulator cleans up noise

Not only is the customer always right; he frequently shows the way to new products. Late last year, the Wanlass Electric Co., brought out a different kind of high-power voltage regulator [Electronics, Dec. 27, 1965, p. 119]. Now the company is following it up—at customer suggestion, says the president—with a low-power, low-cost voltage regulator line.

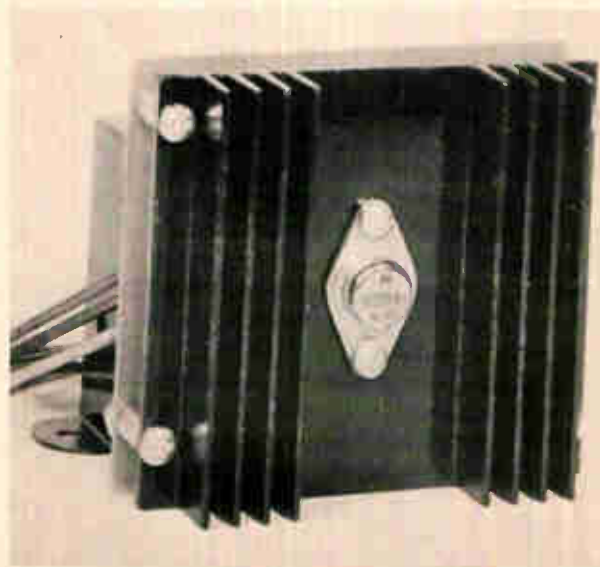

The instruments are strictly a Wanlass family affair. "Six years ago, we made our younger brother Kent an offer," says S. Dean Wanlass, president. "We agreed to pay him a competitive wage to go into the laboratory and be clever." Kent came up with the high-power regulator, so Dean and Chris quit the Philco Corp. and set up a family company. Chris then developed the new low-power regulator. "And next month, it's my turn to be the inventor," says Dean.

The first regulator included a new development, a variable inductor, operating at power levels from 1 to 10 kilovolt-amperes. The new instrument, rated from 15 to 250 volt-amperes, consists simply of a transformer, a heat sink, transistors, passive components and a zener reference. "The trick is in the circuitry," says Dean Wanlass. The circuitry provides a response time of less than 50 microseconds, compared with 25 milliseconds for a typical 60 va transformer of the ferroresonant type. The response time, says Wanlass, effectively cleans up noise; it prevents voltage spikes from riding through a power supply and triggering digital circuitry by accident.

The low-power regulator operates over the fre-

quency range from 47 to 63 cycles per second. Its output is a symmetrically clipped sine wave. Spikes are eliminated by clipping them, much as the sine wave is flattened. Details of the clipping technique are not disclosed. "It is not a conventional operation, where the zener diode shorts everything above a certain level to ground," says the company president.

The new line, designated R-3200, stresses economy, light weight and small size. R-3200 is designed primarily to hold peak voltage constant, and the manufacturer says it is relatively insensitive to power fluctuation. It will go out of regulation to accommodate voltage surges, and will blow a fuse if subjected to a sustained overload.

Specifications

Nominal input voltage	100 to 130 v
Line regulation	±1%
Load regulation	±1%
Power factor	Intensive up to ± 0.7
Weight	2.5 lbs.
Size (approximate)	3 in. by 3½ in. by 3½ in.
Price	\$22 (60-va rating)
Delivery	30 days

Wanlass Electric Co., Santa Ana, Calif.

Insertion loss measured to 0.02 db

When a systems engineer is struggling for each decibel, as in advanced military radar and radio astronomy, he needs to know the precise loss in received signal strength for each component he inserts in a system.

This loss can be determined to an accuracy as high as 0.02 decibel with instrumentation developed by Weinschel Engineering, Inc.

The swept-frequency insertion-loss measuring system, Model 1850, operates at frequencies from 500 megacycles to 12.4 gigacycles, depending on

which of four radio-frequency packages is used.

The system also has a wide dynamic range. It measures losses over a 30-db span. According to Weinschel, this can be extended to 40 db with only a slight degradation in accuracy.

The r-f package which determines the frequency range also provides the means for leveling the power source. A power splitter divides the r-f signal almost evenly between the reference and measurement channels. The difference signal between the reference and measurement channels is displayed on a synchronous differential null detector. An additional unit resets the d-c potential in the synchronous detector to develop an unbalanced d-c voltage which drives a pen recorder.

The entire system uses improved type N connectors. The voltage-standing-wave ratio of the source and reference load is below 1.05 from 500

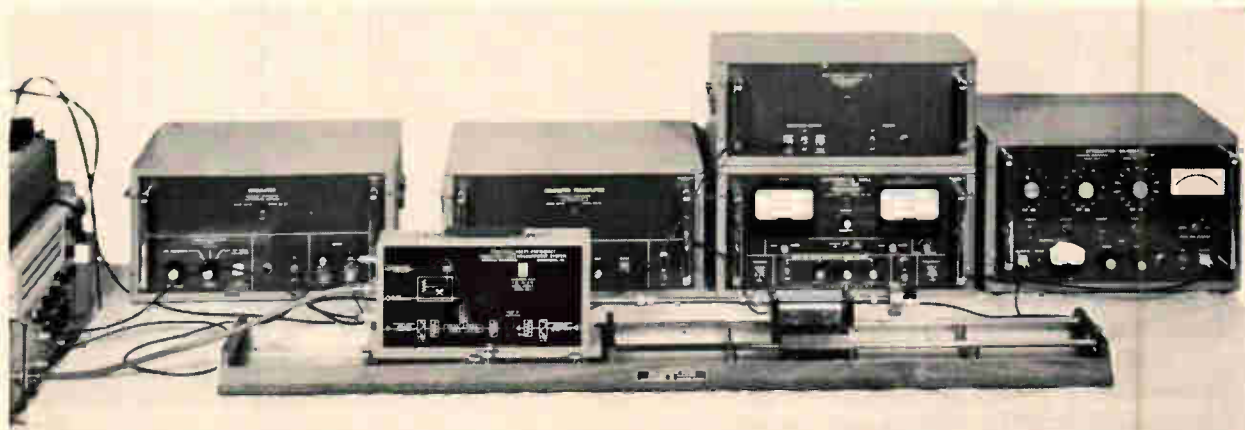

Versatile, sensitive measuring system operates over wide range of high frequencies to pinpoint insertion losses.

Mc to 4 Gc and below 1.10 from 4 Gc to the upper limit of 12.4 Gc. This minimizes errors from reflected signals.

Weinschel's system is based on the substitution method. To make a measurement, it is first necessary to use the attenuator in Weinschel's model BA-5 attenuation calibrator. The setting of the attenuator is made slightly higher than the anticipated value of the insertion loss of the component under test. The sensitivity of the model ND-2 differential null detector and of the chart recorder is set so that the expected variation of the insertion loss over the frequency range of interest does not exceed the recorder's limits. Reference lines are then drawn with the recorder according to the desired resolution. For example, if the attenuator has an expected loss of 0.3 db over the frequency band, seven reference lines would be drawn to achieve a resolution of 0.05 db. With test unit inserted, the attenuation calibrator is reset to zero. The actual insertion loss is then recorded on the same plot on which the reference lines were previously drawn.

The long-term stability of the system is such

that the reference lines will be valid over a period of one hour to an accuracy of better than 0.01 db. In this way, over 20 unknown items, each having about the same frequency sensitivity, can be tested by sweep measurements.

Insertion loss measurements can be made to an accuracy of 0.02 db over the limited range of 1 db or to 0.07 db over the maximum range of 30 db. Additional errors are introduced by the connector, but with the improved type N connectors, this error is kept to 0.05 db at 10 Gc.

The system, including the four r-f sources, sells for \$13,260. The only additional units needed are a pen recorder and a sweep oscillator.

Specifications	
Frequency range	500 Mc to 12.4 Gc
Signal	100% square wave modulated by 1 kc
Stability	greater than 0.01 db/hr
Resolution	To 0.02 db/cm for small dynamic ranges
Sensitivity	Variable up to 0.005 db (0.005 db is sensitivity which displaces seven minor divisions on recorder)
Power input	105 to 125 v, 60 cps, approximately 575 v-amps
Weinschel Engineering, Inc., Gaithersburg, Md.	

Simple, high-rate pulse generator

The reaction against complexity—virtually a crusade in systems engineering—is making itself felt in instrumentation, too.

Reflecting this trend is a 100-megacycle pulse generator that will sell for less than \$1,000. The General Radio Co. says the instrument's performance characteristics are comparable to those of units costing twice as much.

The "how" is simplicity, according to General Radio. For pulse delays, model 1394-A has coaxial cable delay lines cut to precision lengths, in place of more expensive electronic circuits. The unit's pulse-repetition-frequency (prf) oscillator is a simple one, with two transistors. Says James Skilling, the General Radio engineer who designed the instrument: "The waveform of the prf oscillator never appears at the output—so you can live with a simple one," which keeps the cost down.

The 1394-A, high-rate pulse generator has rise and fall times of 2 nanoseconds, the output amplitude is variable in 0.5 volt steps to 4 volts. Also, all the output pulse controls are calibrated so that continuous oscilloscope monitoring is unnecessary.

During operation, a train of pulses from the prf oscillator is simultaneously applied to the first cable-delay circuit, which introduces delay T_1 as shown in the top diagram on page 92, and to the instrument's synchronization signal output. This output can trigger an oscilloscope's horizontal signal

if required. The delayed pulse train, applied to a bistable output circuit, initiates the output pulse at the same time it is applied to a second delay line, introducing an additional delay, T_2 .

Pulses from the second delay line reset the bistable output circuit, turning off the output. The first delay controls the period between the synchronizing pulse and the leading edge of the output pulse; the second controls the duration of the output pulse.

The pulse rate is selected by a front-panel dial which is used to vary the capacitor of an LC tuned circuit in the prf oscillator. The delay circuits, coaxial cables cut to lengths corresponding to

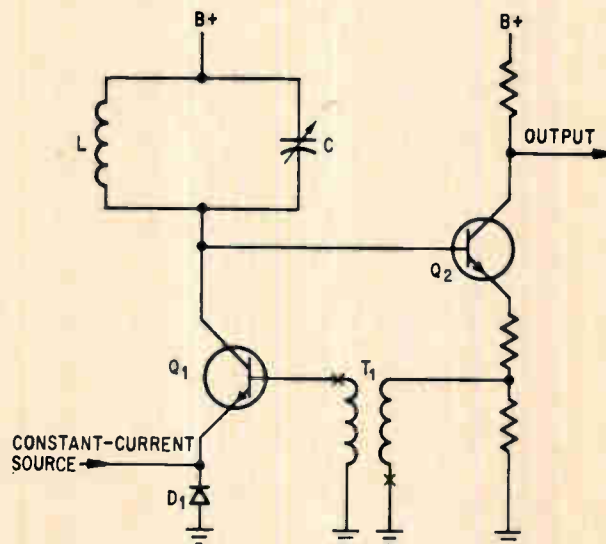

Simple LC tuned circuit determines the frequency of pulse repetition oscillator. The feedback to sustain oscillation is fed to Q_1 through inverted transformer.

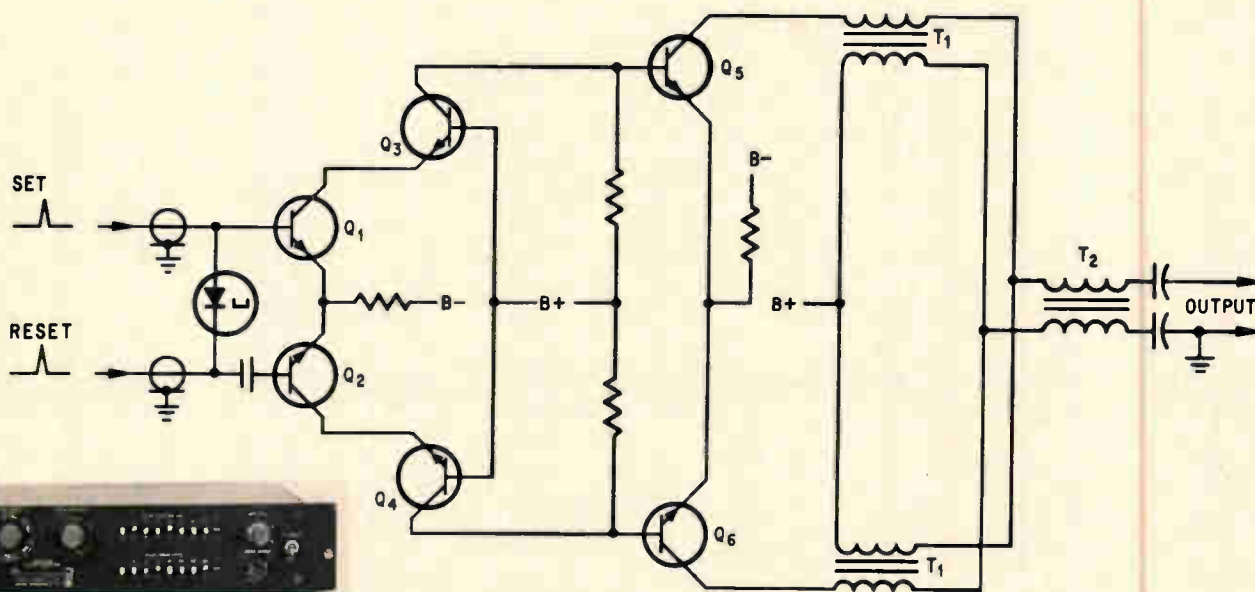
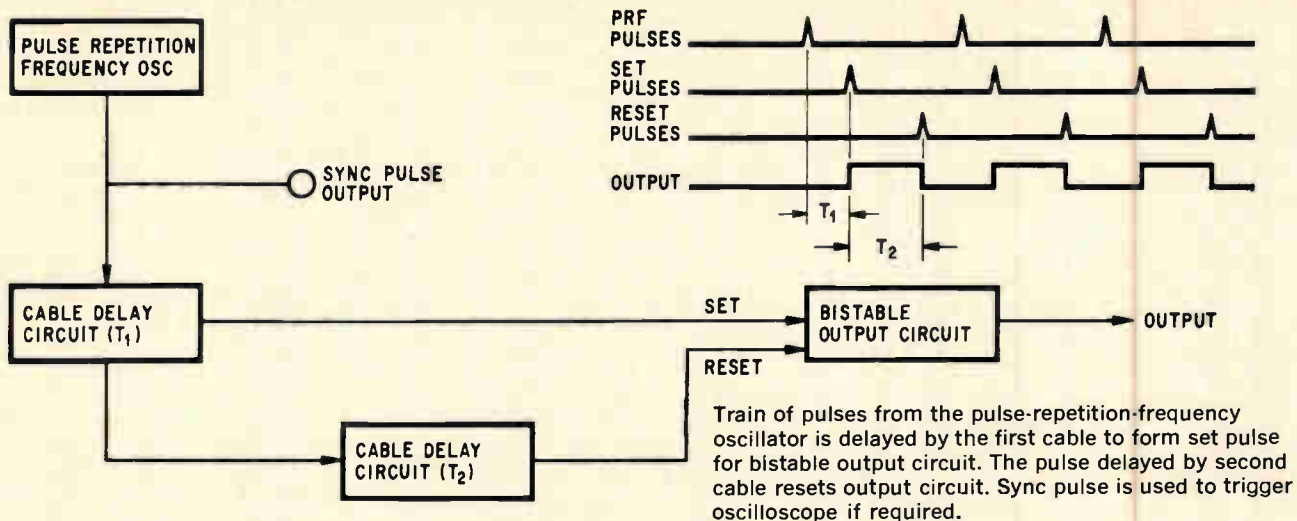

In bistable output circuit, the set and reset pulses are kept from appearing at the output by the differential amplifier, which allows only the difference voltage at the bases of Q_1 and Q_2 to be amplified.

delays of 1, 2, 4, 2, 10, 20, 40 and 20 nanoseconds, are switched in and out of the signal path by rows of front-panel miniature-toggle switches to control both delays, T_1 and T_2 . In this way, delays of 1 nanosecond to 99 nanoseconds can be introduced in 1-nanosecond increments.

A distinct advantage of the cable delay over conventional methods is the lack of restriction on duty cycle and the improved accuracy.

In the prf oscillator, a constant-current source is switched between the diodes D_1 and transistor Q_1 by the large signal that appears at Q_1 's base. A square wave current appears at the collector of Q_1 . The LC-tuned circuit filters out the fundamental to produce a large-amplitude sinusoidal voltage at the base of Q_2 . This voltage is amplified by Q_2 . A portion of this output voltage provides the feedback necessary to sustain oscillation. The feedback is applied to the base of Q_1 through the wideband, inverting transformer T_1 . This design

has the advantage of being able to use a simple tuned circuit. Also, because the signal amplitude is proportional to the constant-current generator's magnitude—in this case, the collector of a transistor in the automatic gain control circuit—keeping the output amplitude constant is easy.

To compensate for any waveform degeneration caused by the coaxial delay lines, the pulses are amplified by a class-A video amplifier before being applied to the output circuit. Passing this amplified signal through a bistable tunnel diode re-establishes the high-frequency content of the original, undelayed pulses.

The set and reset pulses are then applied to tunnel diode D_1 in the bistable output circuit through a 100-ohm coaxial cable. Only the difference voltage, appearing at the bases of the two transistors, Q_1 and Q_2 , is amplified. So, the set and reset pulses do not get amplified and do not appear at the output terminals. Q_3 and Q_4 are grounded-

base stages that drive a second differential amplifier whose output is transformer-coupled in the output terminals of the generator.

A pulse-offset control unit, available from the company as an accessory, inserts a d-c component in the output pulse so the base line of the pulse can be continuously adjusted, if desired, from -2 to $+2$ volts.

Specifications	
Pulse repetition frequency	1.0 Mc to 100 Mc, $\pm 5\%$ of setting
Internally generated	d-c to 100 Mc
Externally controlled	Bipolar pulse, 4-ns duration, 250 mv peak-to-peak
Synchronizing pulse	4 to 99 ns, 2.5% of setting ± 1 ns, duty ratio limited only by sum of rise and fall times.
Output pulse (50-ohm load)	0 to 4 v in 0.5 v steps
Duration	rise and fall times 2 ns $\pm 20\%$, 12% typical overshoot
Amplitude	100 to 125/200 to 250 volts,
Waveshape	\$50 to 400 cps, 20 watts
Power	Price \$995
General Radio Co., West Concord, Mass.	

VAW meter rated as accurate to .5%

A single instrument to measure an applied a-c voltage, the load current and the absorbed power is available from the Greibach Instruments Corp. The volt-ampere-watt meter concept is not new. But, Greibach's VAW meter, a passive instrument inserted between an a-c source and its load, is more sensitive and accurate, has a wider frequency response and can withstand greater overloads than other VAW meters, including electronic ones, the company says.

The meter can measure rms voltages to 250 volts, currents to 1,000 milliamperes, and power to 10 watts. The current and watt ranges can be extended to 100 amperes and 10 kilowatts by adding a small current transformer the company provides. The meter has an accuracy of 0.5% and measurements can be made over the frequency range of 30 cycles per second to 10 kc.

The complete absence of active electronic elements—amplifiers and power supplies—contribute to the accuracy, reliability and long-term stability

Greibach claims for its model 560 VAW meter. Simplicity is stressed in the watt meter configuration—essentially the system consists of a coupling transformer which feeds a pair of matched true rms transducers whose outputs are fed into the coils of a sensitive differential d-c microammeter. The coupling transformer supplies a voltage proportional to the line voltage, precision shunts supply a millivolt drop proportional to the load current, and the differential meter registers the difference between the outputs of the two transducers, which is proportional to power.

The success of the meter hinges on two of Greibach's developments in the instrument field—the Transquare true rms transducer and the bifilar suspension meter movement.

The transducer is a solid state voltage-to-current analog squaring component that is completely passive. It is made up of stable solid state elements arranged and matched in a network so that the instantaneous output current is proportional to the square of the instantaneous input voltage. Thus the transducer's output is a true parabola. A d-c meter movement integrates this output and gives an analog reading proportional to its true rms value.

The meter movement overcomes the limitations caused by friction in conventional pivot and jewel movements. With Greibach's system, the moving coil is suspended on two taut wires which are



VAW meter is a multirange, multifunction instrument that is moved from the current to voltage mode by a single knob which switches the precision shunt in or out of the circuit. The power measurements are made with both the shunt and multipliers in the circuit; the coil current is proportional to the product of the applied voltage and current.

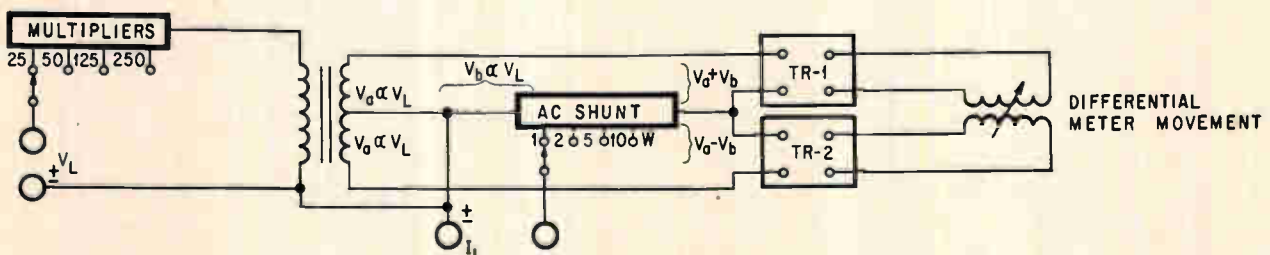

parallel to and symmetrically arranged about the coil's axis of rotation. The opposite end of each pair of suspension wires is precisely anchored in a spiral disc spring which supplies a restoring torque. This suspension system not only reduces friction greatly but permits use of a differential coil with both windings completely insulated from each other without the cumbersome and friction-inducing springs and strips found in conventional coils. A mirror on the movable coil reflects a light beam on a scale as the coil turns.

The torque developed by a d-c meter coil is proportional to the coil current. As shown in the diagram, a precision shunt is used in the ammeter configuration, a precision multiplier in the volt-meter configuration and both in the wattmeter.

The input voltage to the instrument is applied across the primary of the transformer, altered only by the range setting of the multiplier. The input current is applied to the shunt resistor. The voltage across the shunt is added to one-half of the secondary voltage and subtracted from the voltage in the other half. The sum of these two voltages is

fed into one of the Transquare transducers and the difference into the other. The output currents are then fed into the coils of the differential meter. Since one of the voltages is proportional to the applied voltage and the other to the applied current, the current difference is proportional to the product, or the power absorbed by the load. Unlike the readings in the voltage and current configuration which are directly related to the output of one of the transducers, the meter reading in the power measuring setup is linear.

Specifications

Voltage ranges (for both volt and watt measurements)	25, 50, 125, 250 vrms
Input impedance	One kilohm/volt
Current ranges (for current measurements)	100, 200, 500, 1,000 ma at 50 mv
Watt ranges	1, 2, 5, 10 w at 25 v
Frequency response	30 cps to 10 Kc
Accuracy	±0.5% full scale over frequency range and power factors from 1.0 to 0.5 lead and lag

Greibach Instruments Corp., 315 North Ave., New Rochelle, N.Y.

Curve tracer sensitive to 1 microampere

A transistor curve tracer with sensitivity to one microampere per scale division provides a finer readout than in any previous instrument, according to its manufacturer, the Fairchild Camera & Instrument Corp.

Up to now, complexity, lack of sensitivity and somewhat ambiguous readouts have restricted such tracers to testing a limited number of semiconductors.

The base-driving current of the Fairchild tracer can be adjusted down to 330 nanoamperes, about

one-third the amplitude of the lowest base drive found in other curve tracers, according to Fairchild.

This low value requires that noise and transients be held to a minimum. The instrument's mechanical layout is designed to minimize stray capacitance, leads are kept as short as possible and reed relays perform the switching at critical points.

The step-voltage generator for the base bias has a maximum of 10 steps in each range from 10 microamperes per step to 10 milliamperes per step. Each of these ranges can be multiplied by factors of 0.3 to 3.3 with a continuously adjustable control on the tracer's front panel. It is possible to reduce the steps with front-panel knobs that control the number of the first and last step between 0 and 10. The operator can reduce testing time by eliminating any curves not pertinent to a particular test. The bias voltage can be either positive or negative.



Calibrated controls beside curve-tracer screen provide unambiguous readout of vertical and horizontal sensitivity.

Fairchild's tracer can be operated under test in a pulsed condition. Power devices can therefore be tested without dissipating excessive power since the duty cycle is about 10%. Also, elaborate heat sinks are not required to test power transistors in this way.

Called the Fairchild curve trader Model 6200, the unit consists of two synchronized power supplies and a cathode-ray tube monitor. Both the vertical and horizontal sensitivity can be programmed remotely. Sensitivity of the vertical amplifier is adjustable from one microampere to 200 milliamperes per division. The horizontal amplifier is adjustable to give the following display ranges: collector voltage from 0.1 volt to 20 volts, base voltage from 0.1 volt to 0.5 volt. Peak collector voltage is also adjustable. Price is \$1,500.

Specifications

Base step generator:		Twice the line frequency	
Frequency	Number of steps	Maximum of 10. First and last steps independent variable between 0 and 10.	
Type of steps	Current or voltage		
Ranges	Current	Voltage	
	1 μ a per step	0.01 v per step	
	10 μ a per step	0.10 v per step	
	100 μ a per step	1.00 v per step	
	1 ma per step		
	10 ma per step		
Programming accuracy	$\pm 3\%$ of programmed value	$\pm 4\%$ of programmed value	
Collector sweep generator:		Twice line frequency	
Frequency	Continuously variable		
Sweep voltage	0 to 20 v, 2 amps max		
Range	0 to 200 volts, 200 ma max		
Power	115 v, 50 to 60 cps, 250 watts		
Fairchild Camera & Instrument Corp., 844 Charleston Rd., Palo Alto, Calif. 94303			

RC circuit controls oscilloscope camera

The Hewlett-Packard Co., which sells just about all kinds of oscilloscope accessories except a camera, has now come up with the first electronically controlled oscilloscope camera.

In oscillography, pictures are taken at slower speeds than in general photographic work, but standard cameras modified to work with oscilloscopes are most accurate at faster shutter speeds.

To overcome this problem, H-P's Model 197A is accurate at slower speeds. An electronically operated shutter includes RC timing circuits which provide exposure times from 1/30 second to four seconds. The camera is operated from a side panel, whose knobs control the f stop and the shutter speed. The shutter may also be tripped remotely. In addition, an output signal from the camera can trigger the oscilloscope sweep at the instant the shutter opens; this signal also can be used to synchronize other equipment with the camera.

A variable-intensity ultraviolet light source, part of the camera system, excites the phosphor on the cathode-ray tube face, causing it to glow softly and making the graticule lines show up black in contrast to the trace. Oscilloscopes usually have lighted graticule lines which blend with the trace. Waveform axis crossings can be located more accurately with the ultraviolet feature, according to the manufacturer.

The camera back can be rotated from its normally horizontal position to a vertical position while the lens remains fixed so small pictures can be taken on one frame.

Model 197A, which weighs 10 pounds, can be mounted on the face of any oscilloscope and it swings out of the way when not needed.

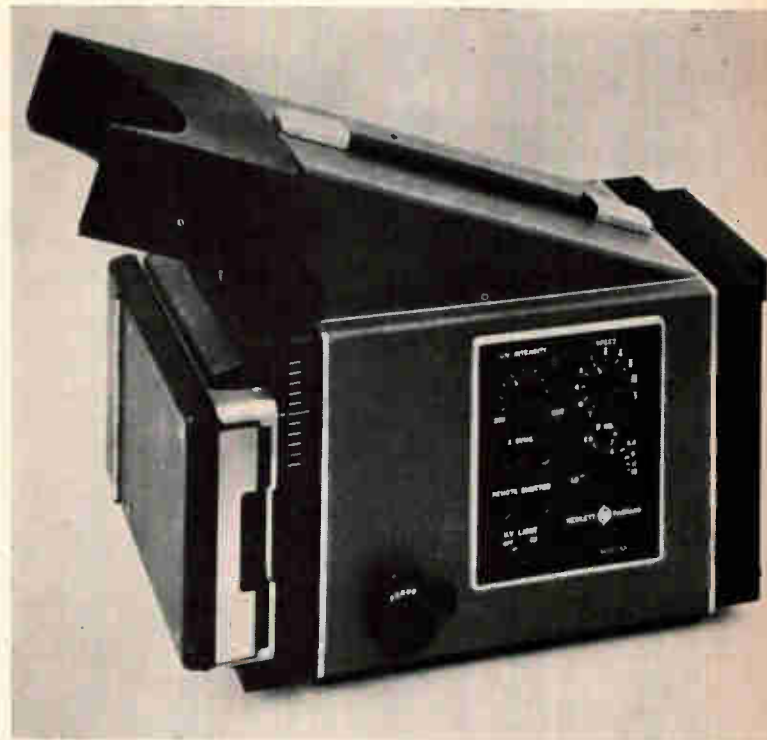

Timing circuits of camera can vary shutter action throughout range of speeds in oscilloscope work.

Specifications

Lens	75 mm, f/1.9 Optional: 88 mm, f/1.4
Shutter	Speeds of 1/30, 1/15, 1/8, 1/4, 1/2 and 1 sec, 2, 4 seconds; time and bulb, X synchronization contact closure; input jack for remote operation.
Camera back	Polaroid Land camera using pack film, type 107 Optional: Graflok 4x5-in. back
Multiple exposure	Moves vertically through 11 detented positions at 1/2 cm. per detent at 1:0.9 object-to-image ratio
Focus	Adjustable with lock
Power	115 V \pm 10%, 60 cps, 6 w
Price	\$475 for standard model 197A \$425 without ultraviolet source
Hewlett-Packard Co., 1501 Page Mill Rd., Palo Alto, Calif.	

Tunnel diodes add speed to hybrid IC's

Many electronic equipment manufacturers are reluctant to design pulse and switching circuits with tunnel diodes. In the face of this resistance, however, one component manufacturer, the Hoffman Electronics Corp., is willing to take a risk, offering a line of silicon tunnel-diode chips for fast switching circuits.

Most users have two objections to tunnel diodes: their costliness in most designs and the difficulty of finding a tunnel diode with the particular characteristic a designer has in mind.

For example, some maintain that because of the tunnel diode's susceptibility to parasitics, they are not practical in computers other than in the tiny scratch-pad memories of small, fast computers.

Tunnel diode and switching circuits have been tried in radar, telemetering, pulse communications, and data-processing equipment.

Typical circuits in which they are employed are relaxation oscillators, inverters, frequency dividers and wave shapers.

Hoffman's decision to offer the chips was based on the growing market for hybrid circuits that use uncased chips for active devices on ceramic substrates. William R. Haymond, marketing director for the company's Semiconductor division says:

"The use of thick-and thin-film passive elements

on ceramic substrates is already widespread," he says. "Many of these applications need a compatible tunnel-diode chip for very fast switching. In some cases circuit designers have attempted to avoid the use of a tunnel diode by using multiple-transistor chips." According to Raymond, this imposes additional cost and sacrifices some reliability because more components are required. "And usually the performance of the tunnel diode is not quite duplicated," he adds.

For now, Hoffman is making four chips available: designated the CTD100, CTD200, CTD300, and CTD400. A one-mil-diameter platinum lead is attached. The base of the tunnel diode is the other contact. The units may be attached to a substrate by using conductive silver-base epoxy or paste.

The chips have an epoxy protective coating. The base measures 0.045 inch maximum; the maximum height is 0.06 inch.

The chips carry maximum forward current ratings of 1.0, 1.5, 5 and 10 milliamperes at 25°C. The maximum reverse currents, respectively, are 2, 4, 20 and 30 milliamperes. The maximum operating temperature range is -40° to +125°C.

The price per unit in quantities from 1 to 99 is \$12.50; they are available immediately.

Specifications

	CTD100	CTD200	CTD300	CTD400
Peak current	0.47	1.0	4.7	10 ma
Valley current	.170	.35	1.7	3.5 ma
Peak voltage	80	80	85	85 mv
Valley voltage	490	500	520	530 mv
Forward voltage:				
minimum	670	680	700	700 mv
maximum	1,000	1,000	1,000	1,000 mv
Forward current	.52	1.1	5.17	11.0 ma
Series resistance	3.0	2.0	1.0	1.0 ohm
Capacitance	100	150	250	400 pf

Hoffman Electronics Corp., El Monte, Calif.

225-diode circuit contained in a chip

Single chips are carrying more and more functions in response to increased demands of airborne information processing for military systems.

Radiation, Inc., now puts as many as 225 silicon diodes in a monolithic chip and houses the structure in a 32-lead flatpack. And that's far from the end.

A year ago, the company decided to test the market for diode-matrix integrated circuits by making available a 40-diode, 14-lead IC. "We found that nearly all the users of the diode-matrix needed several of them in their applications," says William R. Weir, director of marketing at the company's physical electronics laboratory. Since large matrices would mean fewer interconnections, better reli-

ability and less space, it was decided to extend the multifunction concept further.

Weir says that other packages besides the flat-pack are being considered, but there are no plans to build arrays with more than 225 diodes. "However," he cautions, "a year ago when we announced the 40-diode matrix, we didn't foresee a need for matrices with more than 100 diodes."

Radiation plans to explore integrated-circuit matrices with higher current ratings during 1966. Each of the diodes in the 225-unit matrix carries a maximum current rating of 100 milliamperes.

After talking to customers, Weir says, the company also found that the recovery speed of the individual diodes in the 40-diode matrix was not fast enough for some applications. As a result, the reverse recovery time of the individual diode in the new 225-unit matrix has been reduced to 10 nanoseconds from the 125 nanoseconds of the 40-unit matrix.

The 225-diode integrated circuit is designated the RM50. First, the diodes are connected in 5-by-

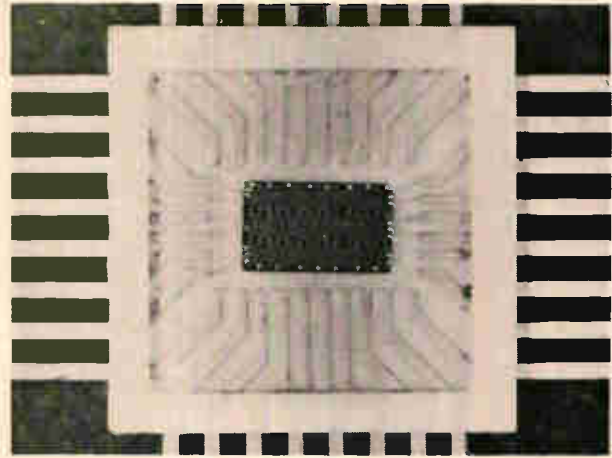
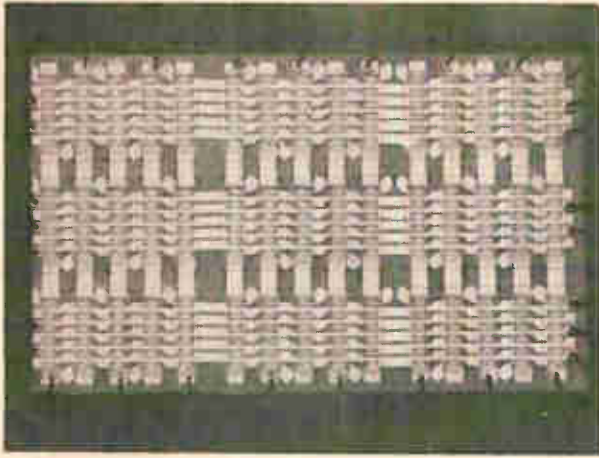

Array of identical diodes gives multifunction capability to integrated circuit. Left photo shows 225-diode matrix in unpackaged detail. At right, it is housed in 32-lead flatpack.

5 banks to form a 15-by-15 diode array. To form desired interconnection patterns, unwanted diodes can be removed by passing high currents through key points. The elimination is similar to the burning out of a fuse. The current required to remove a diode connection is more than four times the maximum operating current, so short surges during normal operation won't accidentally remove a diode connection.

Practically all the interest in the 40-diode integrated circuits has been displayed by builders of military airborne computer systems. But, says Weir: "We hope the low cost per diode of the 225-unit matrix and the reduction it permits in packages will make it possible for us to penetrate the industrial-equipment market."

Radiation will deliver the RM50 with all diodes working or with diode connections arranged according to the customer's specifications. Automatic programmed equipment is used to check custom interconnection patterns.

Matrices of 5 by 5, 5 by 10, 5 by 15, 10 by 10, and 10 by 15 are also being made available. Prices start below \$25.

Specifications

Reverse voltage	60 v
Maximum forward current	100 ma
Reverse leakage current	4 na
Reverse recovery time	10 nsecs
Forward voltage drop at 20 ma	1 v

Radiation, Inc., Melbourne, Fla.

Microwave

Latching phase shifter is also reciprocal

For designing some phased-array systems, microwave engineers often have wished for a variable ferrite phase-shifter with capabilities that seem to be incompatible. The component would have reciprocal properties—the same phase shift in either direction of propagation—and a latching capability to reduce power; once the ferrite is pulsed into a magnetic state, it should remain in that state when the driving power is removed.

Such a shifter has been built by Scientific-Atlanta, Inc., which says this is the first such component to be offered commercially.

The device, of strip transmission line design, operates at 5.4 to 6.0 gigacycles per second and al-

lows microwave signals to be phase-shifted in discrete steps of $22\frac{1}{2}^\circ$ over a range of 0° to $337\frac{1}{2}^\circ$.

It was developed for the Army Electronics Laboratory at Fort Monmouth, N.J., for use with a phased-array antenna. Because of its reciprocal properties, there is no switching time required in going from transmit to receive conditions. As a result, targets that are relatively close to the antenna may be monitored in range. Because of the latching property, power is required only to scan the



Ferrite phase shifter with reciprocal and latching properties is switched in $22\frac{1}{2}^\circ$ increments by low-power pulses.

beam; therefore, the total d-c power required for the array is reduced considerably. Simple, high-speed digital control, in which the phase shift is changed in discrete steps, is a result of using four sections of ferrite, each of different length and each with a latching capability. Principles involved in developing the phase shifter are also useful in developing reciprocal ferrite switches, scanners and modulators.

In a conventional reciprocal device, a requirement for latching imposes problems because an attempt to latch to two different magnetic states produces no change in phase shift. The problem could be overcome by making the magnitude of the field different in the two states, but Scientific-Atlanta chose a technique called orthogonal switching, whereby the magnetic state is changed from one in which the field is perpendicular to the axis of the transmission line to a state in which the field is parallel to the axis. Both the longitudinal and transverse states are reciprocal, but the phase shift in each state is different, so there is a differential phase shift when switching between states.

Orthogonal switching is accomplished in the Scientific-Atlanta device by supplying one driving-current circuit along the center conductor of the strip-transmission line and another in a phase per-

pendicular to the center conductor.

Digital operation is achieved by combining four ferrite sections whose lengths correspond to phase shifts of 180°, 90°, 45° and 22½°. In the specified frequency range, the ferrites produce a 100° phase shift per inch. For the ferrite used in this device the figure of merit is 212° of phase shift per decibel of attenuation. This corresponds to a 1.6-decibel insertion loss. By using improved ferrite material in future units, the insertion loss probably will be reduced to 1.2 db, Scientific-Atlanta says.

Switching time is less than one microsecond and requires less than 50 microjoules of energy for a 180° bit. The phase shift is reciprocal to within 1°, the measurement accuracy of the equipment used to test the device.

A phase shifter is also being developed for S band.

Specifications

Designation	Reciprocal TEM latching ferrite phase shifter
Frequency range	5.4 to 6.0 Gc
Phase shift steps	22½°
Total phase shift	337½°
Insertion loss	1.6 db
Figure of merit	212° per db

Scientific-Atlanta, Inc., Box 30324, Atlanta, Ga.

High-power r-f load is portable and shelf-size

Miniaturization is invading the high-power transmission field, but in contrast to the semiconductor field it's a matter of scaling down from, say, the size of a man to the size of a bowling pin.

In broadcasting and telemetry stations, engineers frequently have to test the transmitter without sending the power out through the antenna. They dissipate the energy in a huge dummy load. If the transmitter is too large to be moved, an extra length of bulky cable must be connected between the line and the load.

A 50-ohm radio-frequency coaxial load, developed by the Bird Electronic Corp., simplifies the task. The device can dissipate 50 kilowatts continuously, yet it can be carried by hand and is small enough to be stored on a shelf.

Bird developed the new load to extend the power capability of its Termaline series. The company claims that model 8762 is 75 times lighter and 450 times smaller than coaxial loads with the same power rating. It weighs 13 pounds—light enough to be bolted to the end of a transmission line—and measures approximately 3 inches in diameter by 18 inches in length. The load can be operated in any position. Voltage standing-wave ratio is 1 to 1,



Coaxial load held by the model can dissipate the same 50,000 watts of power as the larger load. The smaller load is cooled by water flowing at half the rate and at twice the temperature required for the larger load.

extending over a frequency range from d-c to 500 megacycles per second.

Like its lower-power predecessor in the Terma-line series [Electronics, March 8, 1965, p. 88], Model 8762 is water-cooled. The water passes through the inside of a dielectric tube, cooling the resistor, which is deposited on the tube's outer diameter. Directly water cooling the resistor in this way eliminates dielectric coolants, heat exchangers, pumps and motors, which are usually required for high-power coaxial loads.

The inlet water temperature can be as high as 60°C at a flow rate of 10 gallons per minute. The larger 50-kw load manufactured by the Bird Electronic Corp. requires inlet water at a temperature not higher than 30°C at a flow rate of 20 gallons per minute.

For protection against coolant flow failure, the

Model 8762 contains a flow switch that activates when the flow rate is less than required. The switch can be interlocked to shut off the transmitter when this happens.

The connector type for the Model 8762 is a 3/8-inch flange, as designated by the Electronic Industries Association. For 51.5-ohm, unflanged lines, the company can supply 50-kw loads, Model 8763, on special order.

Specifications

Power dissipation	50 kw continuous
Frequency	D-c to 500 Mc per second
Voltage standing wave ratio	1.1 to 1
Impedance	50 ohms
Coolant	10 gpm, water at 60° C
Connector type	3/8-in. EIA flange

Bird Electronic Corp., 30303 Aurora Rd., Cleveland (Solon), Ohio

Half-inch YIG filters do job of 3-inchers

A line of yttrium-iron garnet filters one-half inch in each dimension does the work of a three-inch line which has been on the market for some time, according to the developer, the Watkins-Johnson Co. The YIG filter can be electronically tuned.

Available on special order, these miniature YIG filters are suitable for electronically tuned receivers that must be designed to a minimum size and weight, regardless of cost. One application might be for airborne receivers programed by a computer to tune to a specific frequency at various intervals—a method of circumventing jamming and eavesdropping.

A line of 1.4-inch YIG filters, introduced by Watkins-Johnson a few months ago, costs five times less.

The small filters were made possible by changes in the design of the magnetic circuit that provides the flux for tuning the YIG crystal. The magnetic circuit is provided by a permanent magnet: platinum-cobalt disks form the magnet's pole pieces. The YIG crystals are located in the air gap between the pole pieces. The other ends of the pole pieces are connected to the filter's housing, which is a high-permeability material providing the return path for the flux.

The flux provided by the permanent magnet is enough to bias the crystal at a frequency within its tuning range, usually at the lower end. The coil inserted over the pole pieces provides only the additional flux required to vary the filter frequency over the range.

With the permanent magnet used in this way, a smaller coil and less current is required for tuning

than is required for filters having a nonpermanent magnet. Also, less power is dissipated in the coil.

Since the filter's housing is a high-permeability material, which offers a path of much lower reluctance to magnetic flux than air, very little flux leaks from the filter; thus, a separate magnetic shield is unnecessary.

The length of the air gap containing the YIG crystals was also reduced, resulting in better linearity over the tuning range.

Cost and delivery upon request.

Specifications

Frequency	S band (2 to 4 Gc)
Connector	Type OSM
Insertion loss	2 db maximum
Selectivity	12 db per octave
Linearity	0.1%

Watkins-Johnson Co., Palo Alto, Calif.

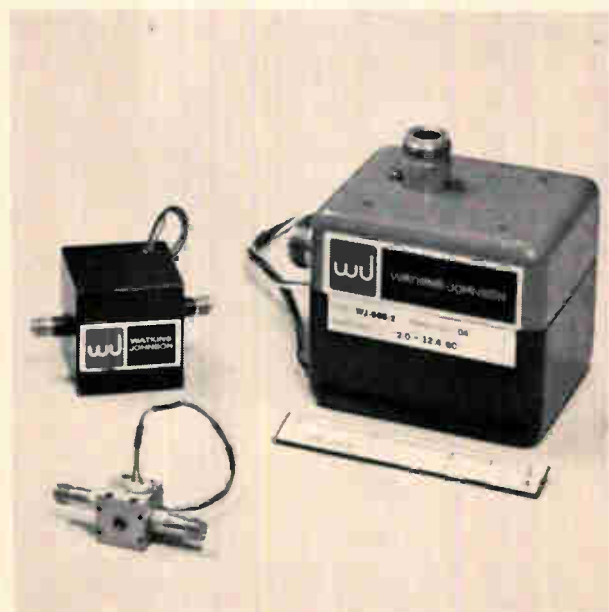

Reduction in YIG filter size is shown by the Watkins-Johnson Co.'s standard, compact and miniature filters.

Three-port circulator has double bandwidth

One component of a communications or radar system can limit the bandwidth of the entire system—and this weakest-link role is usually played by the circulator, which connects the transmitter and receiver to a common antenna.

When broadband performance is called for, it has been customary to push narrowband circulators beyond their rated limits. The penalty is reduced isolation between ports at frequencies beyond the rated passband.

To avoid this, Huggins Laboratories, Inc., has developed four circulators that operate over bands from 3.95 to 5.85 gigacycles, 5.85 to 8.2 Gc, 7.0 to 10.0 Gc and 8.2 to 12.4 Gc. Each circulator has a minimum 20-decibel isolation across its bandwidth. According to the company, the new circulators have twice the bandwidth of any other available circulator.

The devices are three-port waveguide circulators with 0.3-db insertion loss and a voltage standing-wave ratio of 1 to 20.

The company says that for applications requiring only 10% bandwidth, the new circulators can be adjusted to reduce the insertion loss to 0.1 db and the vswr to 1.05. The customer must specify such narrowband applications, because the adjustment is made at the factory.



Other than indicating that the spurious modes of oscillation were analyzed and suppressed, Huggins does not disclose how bandwidth was doubled.

The circulators can be operated over a temperature range from 0° to 60°C.

Specifications

Type	Frequency range	Flange type
HC-8166	3.95 to 5.85 Gc	UG149A/U
HC-8167	5.85 to 8.2 Gc	UG344/U
HC-8168	7.0 to 10.0 Gc	UG51/U
HC-8169	8.2 to 12.4 Gc	UG39/U
Full bandwidth		
Isolation		20 db minimum
Insertion loss		0.3 db
Voltage standing-wave ratio		1.20
Ten percent bandwidth		
Isolation		20 db minimum
Insertion loss		0.1 db
Voltage standing-wave ratio		1.05
Delivery		30 days

Huggins Laboratories, Inc., 999 East Arques Ave., Sunnyvale, Calif.

Components

Coaxial connector called the smallest

A Southern California company aptly named the New Twist Co. came up recently with a pin design for a coaxial connector. Shortly after, New Twist was purchased by Microdot, Inc., and the new pin became a vital part of Microdot's newest connector, the Lepracon.

Described as the smallest coaxial connector available, the Lepracon is $\frac{1}{8}$ inch in diameter and $\frac{1}{2}$ inch long for each half. Microdot says the limiting

factor on further size reduction is the size of the wire to which the connector is attached. The Lepracon will replace the discontinued 62-series connector, which was also a subminiature but which was produced only in small quantities.

The 62-series coaxial connector had a center pin that was an extension of the center conductor of the coaxial cable to which it was attached. This proved unsatisfactory because the pin had a tendency to bend when being inserted into the receiving socket.

The new pin design has a core consisting of three strands of 39-gauge wire, twisted to the left in a tight helix. This core is overlaid with seven strands of 36-gauge wire twisted in a slightly looser helix to the right. The free ends of the two helices are welded together.

Before connection the overlay helix has a slight bulge, as shown in the sketch. The outside diam-



Strands, carefully twisted, form counterwound helices to give connector pin added rigidity and reliability.

eter of this pin is slightly larger than the inside diameter of the receiving socket.

As the pin enters the socket, the helix is forced tighter to reduce its diameter. This self-tightening serves a dual purpose: the force tending to unwind the helix acts to lock the pin in the socket, and the same force keeps the pin's strands in line contact with the socket. The counterwound helices supply rigidity to the tiny pin.

Two models of the connector are available: a straight-line and a right-angle type. The price will be less than \$1 for each half of the straight design and slightly more for the right-angle version.

Specifications

Wire size: RG 178 B/U or RG 196 A/U coaxial cable
Voltage drop: 25 mv at 3 amps
Microdot, Inc., 220 Pasadena Ave., South Pasadena, Calif.

Thick-film circuits for low-cost amplifier

An ever-increasing number of device manufacturers are resorting to the thick-film process, rather than the much-heralded thin-film process, because they feel thick-film provides better components at lower cost. Nexus Research Laboratory, Inc., the latest such company, is producing operational amplifiers with a hybrid thick-film technique.

The thick-film process uses a screen deposition process instead of evaporation to construct the circuits. This, says Alan Pearlman, company vice president, permits more ohms per square, providing a wider range of resistor values. Closer tolerances are also possible with thick-film: 10% as compared with 30%, which is considered good for

thin film.

A wider range of component values is possible with thick films. In thin-film amplifiers, capacitors are usually limited to a few hundred picofarads. No such problem exists with hybrid thick-film circuits. Besides the technical problems, thin-film circuits are expensive to make.

Although the Nexus amplifier's volume is slightly larger than its thin-film counterparts, the mounting surface is the same. The unit has a volume of 0.191 cubic inch and its performance is comparable to discrete component devices, says the company.

The Nexus amplifier is self-contained, including the damping network which is usually external to the thin-film amplifier package. Damping stabilizes the amplifier loops to prevent oscillation. Any size advantage of the thin-film amplifier is usually offset by the disadvantage of the damping network components.

Nexus' device is direct-coupled with no chopper in the input circuit. The company says this eliminates the need for another power source and eliminates problems such as compensating for the chopper voltage. The unit has low drift—on the order of ± 10 microvolts per degree centigrade and a closed loop gain of 50,000. The gain can be very closely set to the nominal value by trimming the gain-setting resistance. The Nexus amplifier uses a ceramic substrate to dissipate heat effectively.

Specifications

Supply voltage	± 15 v (nom.)
Supply current at full output	Less than 8 ma
Open loop gain at d-c ($R_L = 10$ K)	50,000
Output current	200 na (max.)
Drift	± 10 μ v per $^{\circ}$ C
Operating temperature range	-25° C to $+85^{\circ}$ C
Bandwidth	Better than 1 mc
Output voltage range ($R_L = 5$ K)	± 10 v at ± 2 ma
Input impedance (differential)	0.1 megohms
Price	\$30 (1 to 9)

Nexus Research Laboratory, Inc., 480 Neponset St., Canton, Mass. 02021

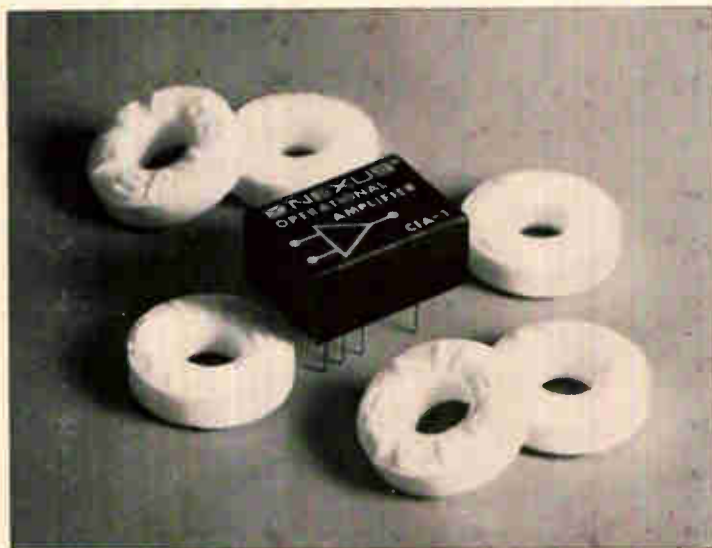

Optically programmed flatpack welder

The electrodes of flatpack-lead welders are usually aimed by a pair of human eyes, aided by a binocular microscope. Since there is a limit to the time that the operator, usually a woman, can stare into a microscope without becoming fatigued, mistakes occur.

In a new welder, called the Autobond, a pair of tireless electronic eyes replaces both microscope and human eyes.

Developed by the Weldmatic division of the Unitek Corp., the parallel-gap welder is optically programmed to make as many as 300 welds a minute, which is much faster than the conventional hunt-and-peck, manually operated welder. All the operator needs to do is put film transparencies of the weld pattern, together with a circuit board, on the machine's X-Y table and then push the right buttons. The table's motions are controlled by the optical reader, as shown in the diagram below.

A prototype has been operated in experimental runs by Librascope, a division of General Precision, Inc. After several months of tryouts, Librascope says, there was no machine or weld failure. Librascope's test-welding boards have three circuit strips. When simulated leads were welded to the strips and the leads pulled, the strips were torn off the board or the leads broke before any weld failed.

The welding electrodes are two wheels $\frac{1}{16}$ inch in diameter, mounted on a compliant arm. As the table moves the circuit board under the electrodes, the wheels roll down each row of leads in turn. The table pauses momentarily as each weld is made. The flatpacks are glued to the board in aligned rows before the board is placed on the table.

The table is stepped laterally in preadjusted increments after each row of leads is welded. The motion along the rows is controlled by a photocell-sensing system that is programmed by an opaque mask with transparent slots at weld locations. The mask can be an etched sheet of metal foil or a photographic negative. To assure accurate matching of weld positions on the mask with those on the circuit board, the board pattern can be used to prepare the masks photographically.

There are two photocells, to compensate for the slope of the photocell output and the system's hysteresis. One cell controls the table as it moves forward and the other controls the reverse motion. The flatpack leads can be accurately positioned with respect to the electrodes by matching the firing thresholds on the photocell outputs.

On the prototype machine, the gain of each cell can be separately adjusted to balance them. On production models, the output of one cell will be fixed at optimum and the other adjusted to match, avoiding a balance at less than optimum gain.

Another problem encountered during development was weld sputtering. This was solved by adding a dispenser which puts a drop of alcohol on the weld area just before the weld pulse is fired. By cleaning the weld area, the alcohol improves the electrical contact of the electrodes and the lead. It also helps dissipate heat.

A third problem developed when rolling electrodes damaged the lead or board. This was solved by a force transducer that presses the electrodes on the lead as the weld is made, but relaxes the pressure while the table is moving.

Specifications

Pulse duration	three ranges: 1 to 10 msec, 2 to 20 msec and 4 to 40 msec
Weld rate	up to 300 welds per minute at 10-msec pulse duration, 200 at 20 msec and 35 at 40 msec
Input power	100 to 130 v
Circuit board size	maximum is 5 by 7 in.
Electrode spacing	0 to 0.03 in.
Price	\$11,985
Weldmatic division, Unitek Corp., 950 Royal Oaks Drive, Monrovia, Calif.	

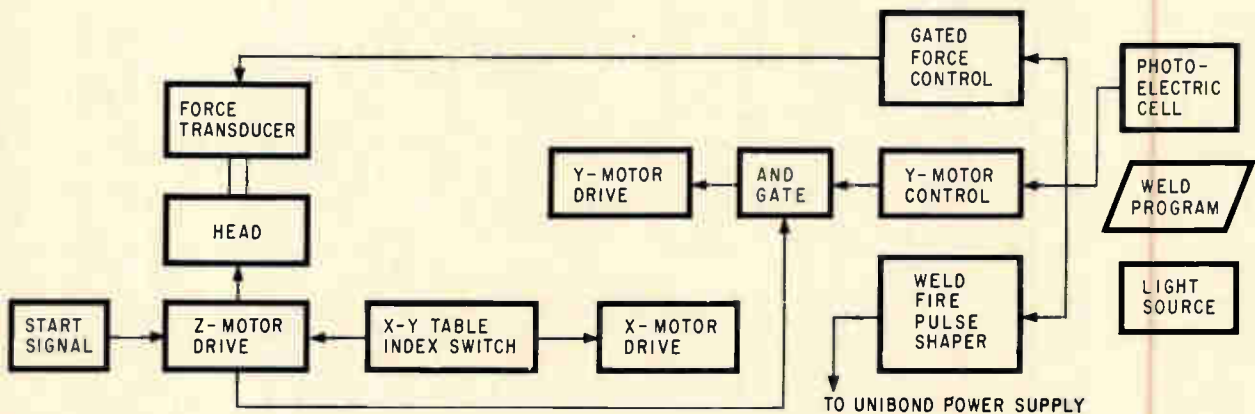

Pushbutton microwelder is controlled by an optical reader. A film pattern of the weld locations and the assembly being welded are placed on a table that moves the assembly under the welding head and pauses each time a weld is to be made.

Diamond saw cuts at compound angles

A simple crystal-holding fixture permits a low-cost diamond saw to cut semiconductors and other materials at compound angles in the vertical and horizontal planes simultaneously.

"Ingeniously simple" is the way Navan Products, Inc., describes its holder, which consists of two crossed bars. The horizontal bar, which carries the crystal, can be moved up and down, or rotated by turning the vertical bar. These motions allow cuts to be made at compound angles within a range of 60° vertically and 45° horizontally. The angles of the cut are set by dials.

The angles can be set to within 0.5°, allowing semiconductors, sapphire, ruby and other materials to be cut along the crystal plane. The saw is designed for quality control and laboratory applications.

A moving table brings the diamond saw to the

crystal. Circular saws with their cutting edges on either the inside or outside diameter are used. The wafers sawed can be as thin as the material will allow, and as thick as an inch.

Navan, the invention-marketing subsidiary of North American Aviation, Inc., developed the saw at the request of companies which had bought Navan's Hamco saw, a production-line machine which cuts on one plane. The customers asked for a less expensive, more versatile machine for lab work.

The target price for the lab version is \$5,000, half that of the Hamco saw. The one that will be shown at the IEEE Show is a prototype. Navan won't promise to deliver machines in less than six months.

Specifications

Saw travel	13 in. at speeds of 0 to 5 in. a minute
Wafer thickness	Up to 1 in., calibrated to 0.001 in.
Cutting angles	60° range in vertical plane; 15° left and 30° right in horizontal plane
Power required	Line current and shop air (60 psi min.)
Spindle bearings	Class 7
Navan Products Inc., 1320 E. Imperial Highway, El Segundo, Calif. 90246	

Materials

Snowballs for semiconductors

In the highly competitive semiconductor business, cost is crucial—from crucible to shipping room.

To reduce the cost of the containers used in the melting of silicon, the General Electric Co.'s Lamp Glass department has developed semiopaque quartz crucibles. The crucibles are called snowballs, because of their color and texture, but are formally designated type 510.

Single crystals are drawn from the molten silicon in the crucibles, so the quartz must be extremely pure to avoid contamination of the semiconductor material.

Like crucibles made from clear quartz, the type 510 containers have impurities of less than 80 parts per million, GE says.

The new crucibles cost about 25% less than GE's line of clear-quartz units.

The company says the semiopaque quartz performs well at high temperatures, resisting thermal shock and remaining chemically inert. The material can withstand temperatures as high as 1,200°C.

It is produced by further purifying an already high-purity quartz in a series of steps which GE considers proprietary.

The containers are then formed by fusing powdered quartz over hot molds.

Specifications

Sizes	Up to 6-in. diameter, 6-in. height
Price:	\$11 (3½-in. diameter)
Coefficient of thermal expansion	5.5×10^{-7}
Delivery:	Four weeks

General Electric Co., Lamp Glass Department, 1133 East 152nd St., Cleveland, Ohio

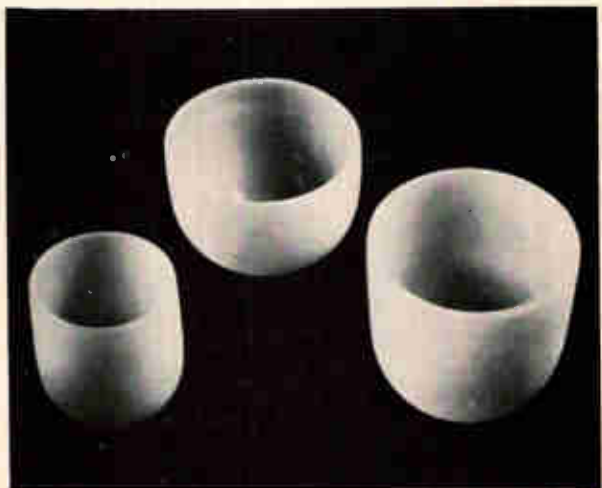

Semi opaque quartz crucibles contain molten semiconductor material during crystal formation process. Crucibles are contaminant-free and virtually non-breakable.

Designer's casebook

Designer's casebook is a regular feature in Electronics. Readers are invited to submit novel circuit ideas, packaging schemes, or other unusual solutions to design problems. Descriptions should be short. We'll pay \$50 for each item published.

Adapter for curve tracer tests FET's at high voltage

By Robin Williams

Philips Laboratories, a division of North American Philips, Inc., Briarcliff Manor, N. Y.

When a field effect transistor has to be tested at relatively high gate and drain voltages, an adapter circuit is used with a standard transistor curve tracer such as Tektronix 575 or equivalent to convert input current steps from the curve tracer into output voltage steps for the FET gate. Output voltages from ± 0.1 volt/step to a total of ± 80 volts allow a wide range of testing conditions making it a useful circuit to check FET parameters.

The circuit, shown below, is simple and symmetrical. The input stage consists of two similar circuits, connected back to back. The curve tracer supplies input current steps to the emitter of Q_1 or Q_2 , positive current to Q_1 and negative to Q_2 . The emitter current is passed to the collector according to the common base transfer ratio, approximately 0.980 to 0.995. Voltage steps proportional to the

input current steps are thus developed across the collector load. For Q_1 , this load consists of the parallel combination of R_3 , $(R_1 + 100 K)$ and the input impedance of Q_3 —which is between 20,000 and 200,000 ohms. Q_2 has an equal load. The voltage developed across this load is approximately $10 I$, where I is the input current in milliamperes.

The second stage, Q_3 , or Q_4 , has a gain of 10 and a common load resistance, R_L . The value of R_L can be adjusted so that the output voltage will be equal to $-100 I$, where the factor 100 represents the total gain of both stages. Q_3 and Q_4 should be selected to have approximately equal gain so that positive and negative signals will be amplified equally within $\pm 5\%$.

At zero input current, R_1 and R_2 are adjusted so that Q_3 and Q_4 just conduct and are in their linear ranges; simultaneously, Q_3 and Q_4 collector currents are made equal. Under these conditions, the collector currents will cancel out in R_L to give zero output voltage.

Because the circuit is intended only for FET measurements and the gate terminal has a high impedance—typically greater than 1 megohm— R_2 will not be loaded down appreciably and the output voltage will be accurate. A small power supply is shown to the right of the adapter, making the unit complete and self-contained.

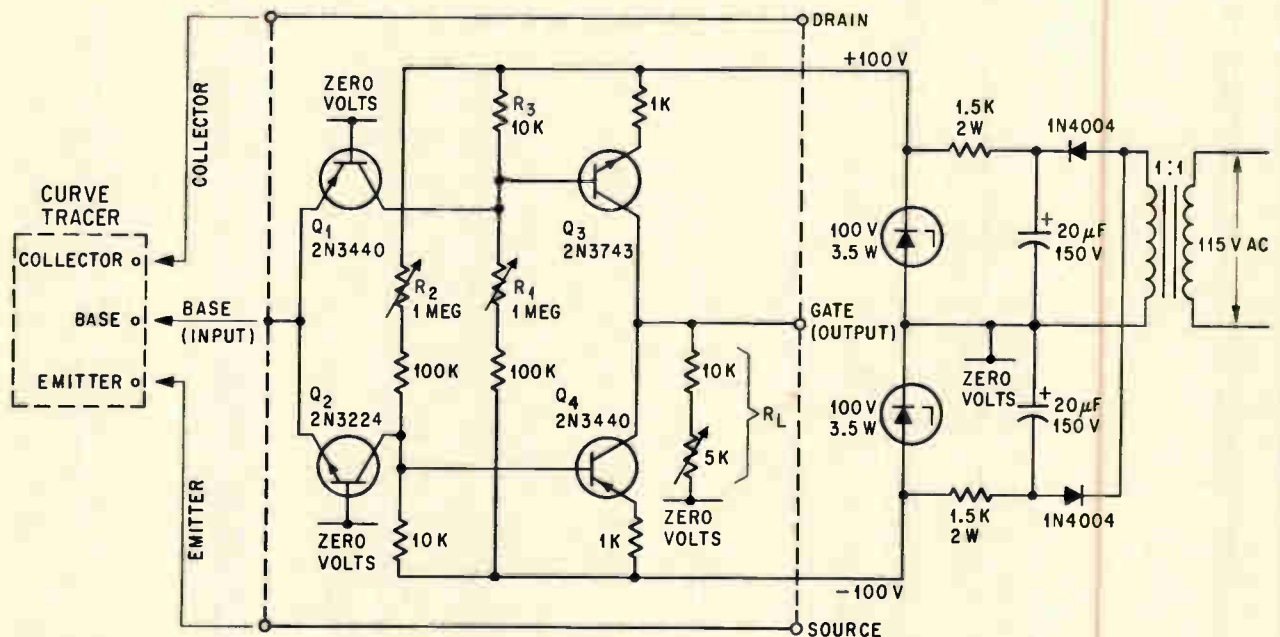

Adapter converts input current steps from curve tracer into output voltage steps for FET gate.

The only adjustments required are the usual ones made on the curve tracer. The voltage scales for the FET gate are then derived from the base current scale of the curve tracer according to the simple formula:

Volts/step at gate output = $-100 \times$ base current in milliamperes.

For example, if the base current switch on the

curve tracer is set at 0.1 milliamperes per step, this gives an output gate voltage of $-100 \times 0.1 = -10$ volts/step. The negative sign is caused by the signal inversion in the circuit; this is necessary to retain simplicity and a zero voltage datum line.

The circuit was tested and found to be stable in gain and insensitive to ambient temperatures from 0° to 50°C .

High-speed level shifter

By Gilbert Marosi

General Precision Inc., Palo Alto, Calif.

Transistor Q_2 in the common emitter circuit below, shifts logic level from a plus 6.8 volts to a negative level of 6.8 volts. Rise and fall times of 60 nanoseconds are easily attained.

The collector of Q_1 , which might be the output of a flip-flop or a monostable is tied to the base of Q_2 . When Q_1 is turned on it causes 15 milliamperes to flow through the emitter of Q_2 . This lowers the voltage at the collector of Q_2 to ground. When Q_1 is turned off, Q_2 also turns off. The collector of Q_2 then tries to rise to -30 volts, but is clamped to -6.8 volts by the diode D_2 . Capacitor C_2 decreases the rise and fall time of Q_2 .

The shifting of the level occurs in the circuit within the dotted lines. The output circuit, Q_3 acts as a buffer for the emitter follower.

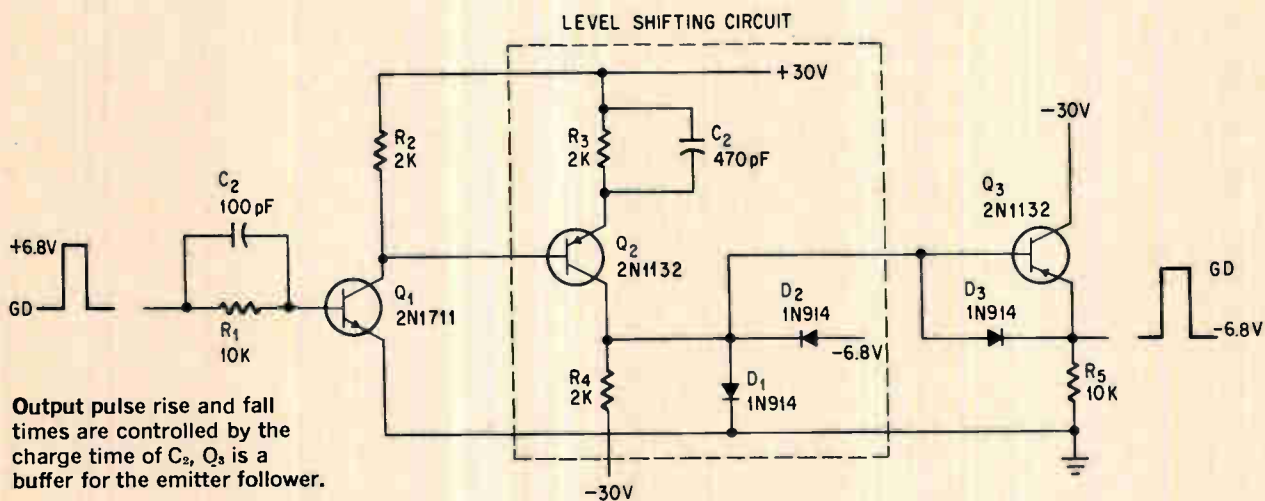

Output pulse rise and fall times are controlled by the charge time of C_2 , Q_3 is a buffer for the emitter follower.

Low-current alarm

By W. Vollenweider

National Research Council, Fort Churchill, Manitoba, Canada

A transistorized intruder alarm, on page 106, has a current drain of only 500 microamperes, and requires only one $1\frac{1}{2}$ -volt battery in the protector loop. This results in versatility, low operating cost

and long life, making the alarm particularly useful for protecting homes or stores.

The alarm may be used with a continuous wire or foil loop as a sensor. If the loop is either open-or short-circuited, the circuit will trigger. Because of the low loop current, loop resistance is not critical, and may range up to 1,000 ohms before the system fails to operate.

Normally, transistor Q_1 is held at cut-off by the protector battery B_1 , which is connected to the emitter of Q_1 through diode D_1 and to the base through R_1 . The collector of Q_1 is coupled through C_1 to the gate of the silicon controlled rectifier, Q_2 .

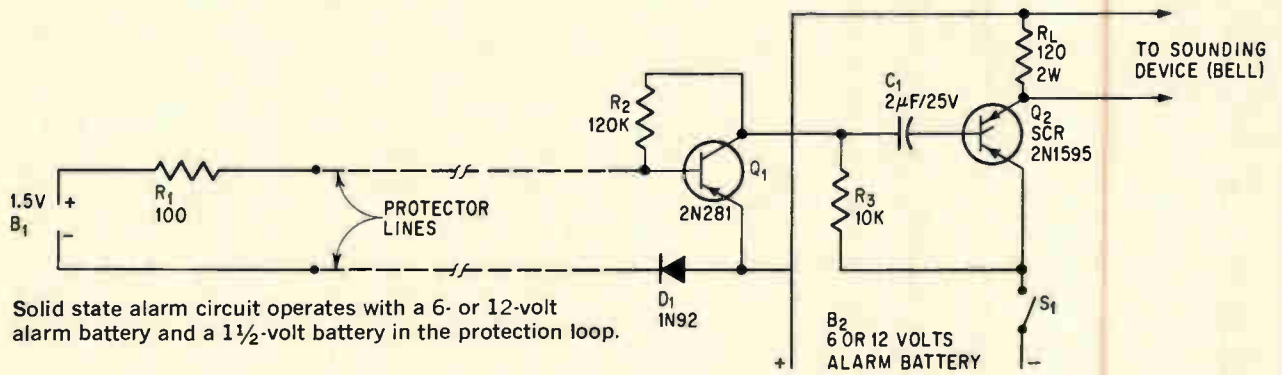

Solid state alarm circuit operates with a 6- or 12-volt alarm battery and a 1½-volt battery in the protection loop.

Holding resistor R_L is required if a conventional alarm bell is used.

After turning on the circuit with key switch S_1 , current flows in the protector loop. If the loop is broken, Q_1 is triggered into conduction through R_2 ; then a pulse appears across R_3 and triggers the scr into conduction, sounding the alarm.

If the protector loop is short-circuited, current from the protector battery is limited by R_1 , and D_1 keeps Q_1 conducting. Q_1 is triggered into conduction through R_2 as before.

The circuit is reset by turning the key switch S_1 off momentarily and then on again.

No moving parts add to unit reliability.

Thermistor regulator provides fast response

By Gregory A. R. Trollope

Department of Chemical Engineering, University of Birmingham, England

A sensitive but inexpensive temperature regulator with a fast thermal response, is provided by the circuit shown below. This circuit was evolved

around an F22 glass-encapsulated, germanium-bead, thermistor made by Standard Telephones & Cables Ltd., a subsidiary of the International Telephone & Telegraph Corp. With the main power supply fed from a constant voltage transformer, drift became negligible after about an hour.

An unconventional chopper circuit, V_1 and V_2 , is used in the amplifier, where the chopper oscillator plate modulates the power supply to the chopper circuit. When the output of the thermistor-bridge circuit is zero and the chopper circuit has been balanced by VR_1 , the plate voltages of the chopper tubes V_1 , V_2 fluctuate with the same amplitude,

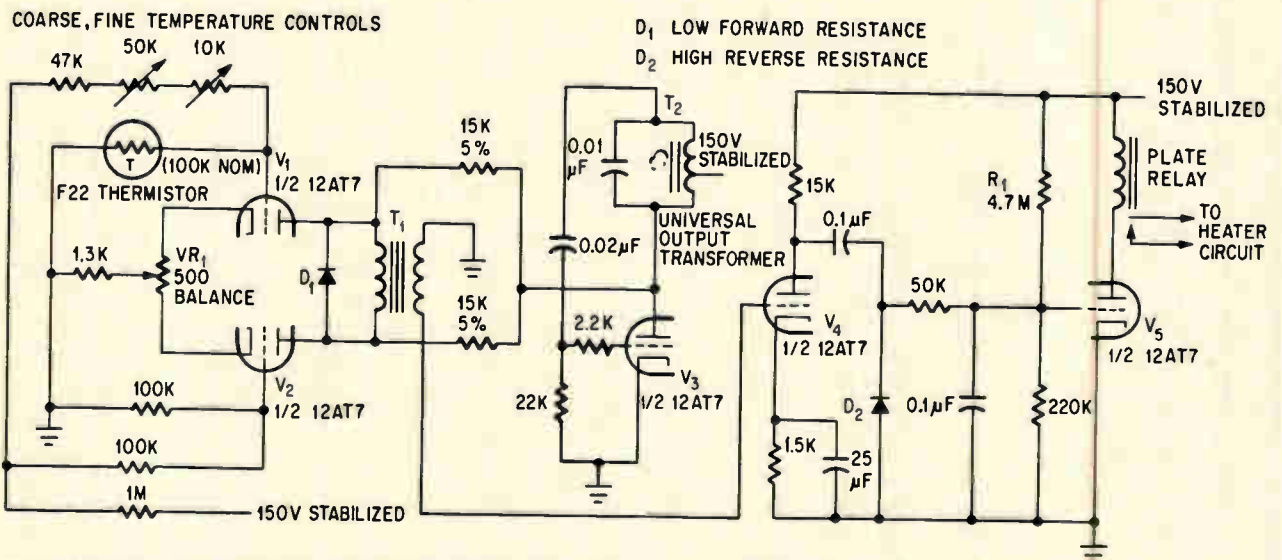

Temperature regulator uses high-resistance thermistor in bridge circuit. Variation of its resistance unbalances chopper circuit, generating pulses to control heater circuit.

so there is no output from the transformer T_1 . Variation of the thermistor resistance unbalances the circuit, creating positive- or negative-going pulses between the plates of the tubes. However, positive-going pulses with respect to V_1 are considerably damped by the low forward resistance diode D_1 . An output is obtained from the chopper circuit only when the temperature of the thermistor is below the set-point.

The circuit using V_3 is a Hartley oscillator operating at a frequency determined by the inductance of the primary of T_2 and the 0.01 microfarad in parallel with it. This frequency is approximately

400 cycles per second. T_2 acts as a plate modulation choke so that the plate supply to the tubes V_1, V_2 is about 250 volts d-c plus 50 volts a-c.

After the V_4 stage of amplification, the signal is rectified by D_2 and fed to tube V_5 , which in turn operates a plate relay, controlling the heater circuit.

The transformer T_1 , a small shielded audio inter-stage transformer, must have a good common mode rejection. Some adjustment of R_1 may be necessary, depending upon the actual plate relay used.

Not all 12AT7 tubes function equally well in the chopper circuit but it is not difficult to find one which operates as required.

Adjustable current limiter for regulated power supply

By Paul Galluzzi

Transistor Automation Corp., Cambridge, Mass.

The pass transistor in a series-regulated power supply is protected from excessive power dissipation by the current limiting circuit below. The circuit includes a 1-ampere, 12-volt regulated supply; the current limiting section is within the dotted lines.

This protective circuit automatically resets when the overload is removed. The two transistors in the limiter do not degrade the power supply regulation.

The limiter operates by turning Q_1 on when V_s exceeds 0.7 volt. This, in turn, switches Q_2 on. The base of Q_6 is then effectively grounded, pre-

venting any significant current flow in Q_8 .

R_1 is the current-sensing resistor and R_2 selects the portion of the sensed voltage (V_s) required to turn on Q_1 . Potentiometer R_2 is adjusted so that the limiter functions at just above the normal load current, in this case one ampere. Resistor R_3 limits the base current in Q_1 while R_4 and R_5 perform a similar function in the base of Q_2 .

Under normal operating conditions, Q_1 and Q_2 remain off, allowing Q_6 and Q_8 to function in the conventional manner. The limiter also serves as a short-circuit protector since a direct short at the power supply output terminals will shut off the regulator. Regulated output voltage reappears when the overload is removed.

This current-limiter circuit may be designed for use at higher or lower current levels through the proper selection of components.

This current limiting circuit may be easily incorporated into existing power supply designs. Its small number of components makes it simple to package and it is an inexpensive protective feature.

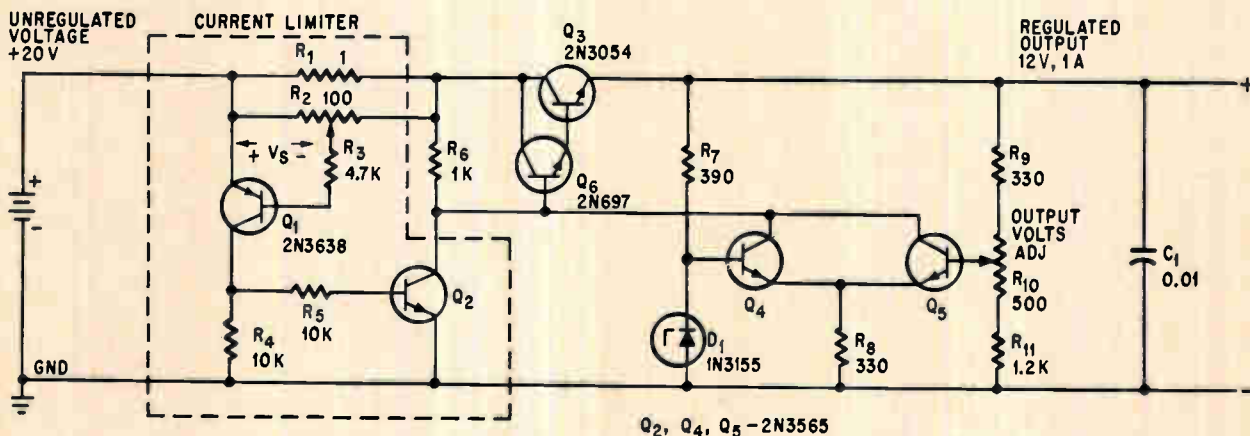

Current-limiting protection is added to a series-regulated power supply. The two transistors, shown within the dotted lines, accomplish the protection without degrading the performance of the power supply.

GLASS-K

New CORNING® GLASS-K Capacitor
gives you 100,000 pf in this case size



with performance stability and reliability
that no conventional CK-type can match

SS-K

Compare these unretouched photomicrographs of cross-sections of three CK-type capacitors:

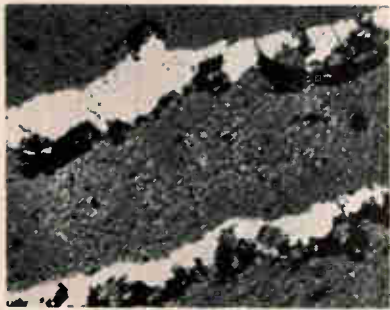

Dielectric of a conventional CK ceramic

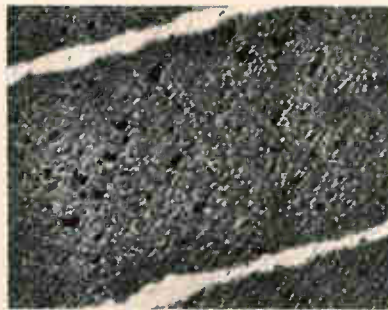

Dielectric of a second make of conventional CK ceramic

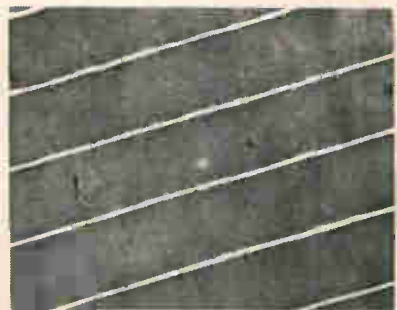

Dielectric of CORNING GLASS-K Capacitor

No holes in the Glass-K dielectric means greater uniformity—so we can make thinner dielectric layers, put more pf in a smaller case size.

No holes in the Glass-K dielectric—so naturally the Glass-K gives you more stable performance . . . less change because of environmental fluctuation.

No holes in the Glass-K means uniformity in the dielectric—which means greater performance predictability.

No holes in the Glass-K means greater dielectric density and less chance for failure—so naturally, it gives you more reliability.

That's the reason you get all these good characteristics in the Glass-K:

- ΔC in life as tight as 2%
- IR greater than 10,000 megohms
- D.F. of 2.5% maximum
- pf ranges from 1000 to 51,000 in just .250" x .100", from 21,000 to 100,000 in just .250" x .140"

As you can see, now there is a material difference in CK-type capacitors. Yet Glass-K prices are competitive.

Send for complete data today to Corning Glass Works, 3911 Electronics Drive, Raleigh, N.C.

CORNING
ELECTRONICS

Automated electron beams process thin-film components

East German scientists feed substrates continuously into systems that reduce variables and cut costs; the goal is uniform fabrication of integrated circuits as well

By Manfred von Ardenne, Siegfried Schiller and Ullrich Heisig

Manfred von Ardenne Research Institute, Dresden-Weisser Hirsch, East Germany

Two thin-film production machines—both electron-beam systems—have been automated so that thin-film components can be produced at high speed under uniform vacuum-processing conditions. One machine is for film deposition and the other for film shaping.

Continuous-transfer mechanisms that feed substrates uninterrupted through the vacuum chambers make the processing rapid—which is good economy, since vacuum processing is expensive. The continuous transfer, plus process controls, also eliminates the need to shut down the vacuum system between production batches. This ensures that processing is uniform, which is desirable because component characteristics vary when process conditions vary.

The machines are the first equipment developed

at the Manfred von Ardenne Institute for a multi-station plant that eventually will make various thin-film components and thin-film integrated circuits.

Initially, the two systems will be used for the production of close-tolerance resistors and resistor networks resembling those on page 114. One system employs electron-beam vaporizers designed for the continuous deposition of thin-film materials during long production runs. The system, shown in the photograph on page 112, can handle one resistor substrate every three seconds and is designed to produce 2 million to 5 million square centimeters of film area a year. The other system, at the right, employs an electron beam to balance as many as three resistors on a substrate automatically in 2.4 seconds and has an annual production rate of about 5 million substrates.

East Germany's fast films

This article, submitted to *Electronics* by three East German scientists, is a rare look at Eastern European production technology. It clearly indicates that thin-film production is well advanced in East Germany and that tooling up for the mass production of hybrid integrated circuits has begun.

Individually, the techniques described are not novel. The surprise is the way in which they have been combined and the high production rates predicted. The accomplishment should provoke some second thoughts on the American consensus that it doesn't pay to invest in high-cost, continuous-process vacuum equipment for thin-film circuits because such circuits are usually required only in small quantities. The trend in the United States has been away from thin-film circuits to thick-film and other types of circuits that do not require vacuum processing.

The East Germans are certainly aware of this, yet they are bucking the trend. Why?

The simplest answer may be that they can justify

equipment cost by concentrating production in state-owned plants. But the versatility designed into the equipment indicates that they expect it to pay off in small-lot production, so long as total production volumes are high.

United States producers also face small lot, but high volume production of hybrid circuits and passive networks. It's a safe bet that more of those will be needed as more monolithic integrated circuits are used, because the hybrids and monolithics supplement each other.

Another point worth thinking about is whether American producers have shied away from electron-beam micromachining because the equipment is exotic as well as expensive. The authors of this article are matter-of-fact about it, probably because of long familiarity with such equipment. Manfred von Ardenne wrote his first paper on electron-beam metalworking in 1938.

G. Sideris

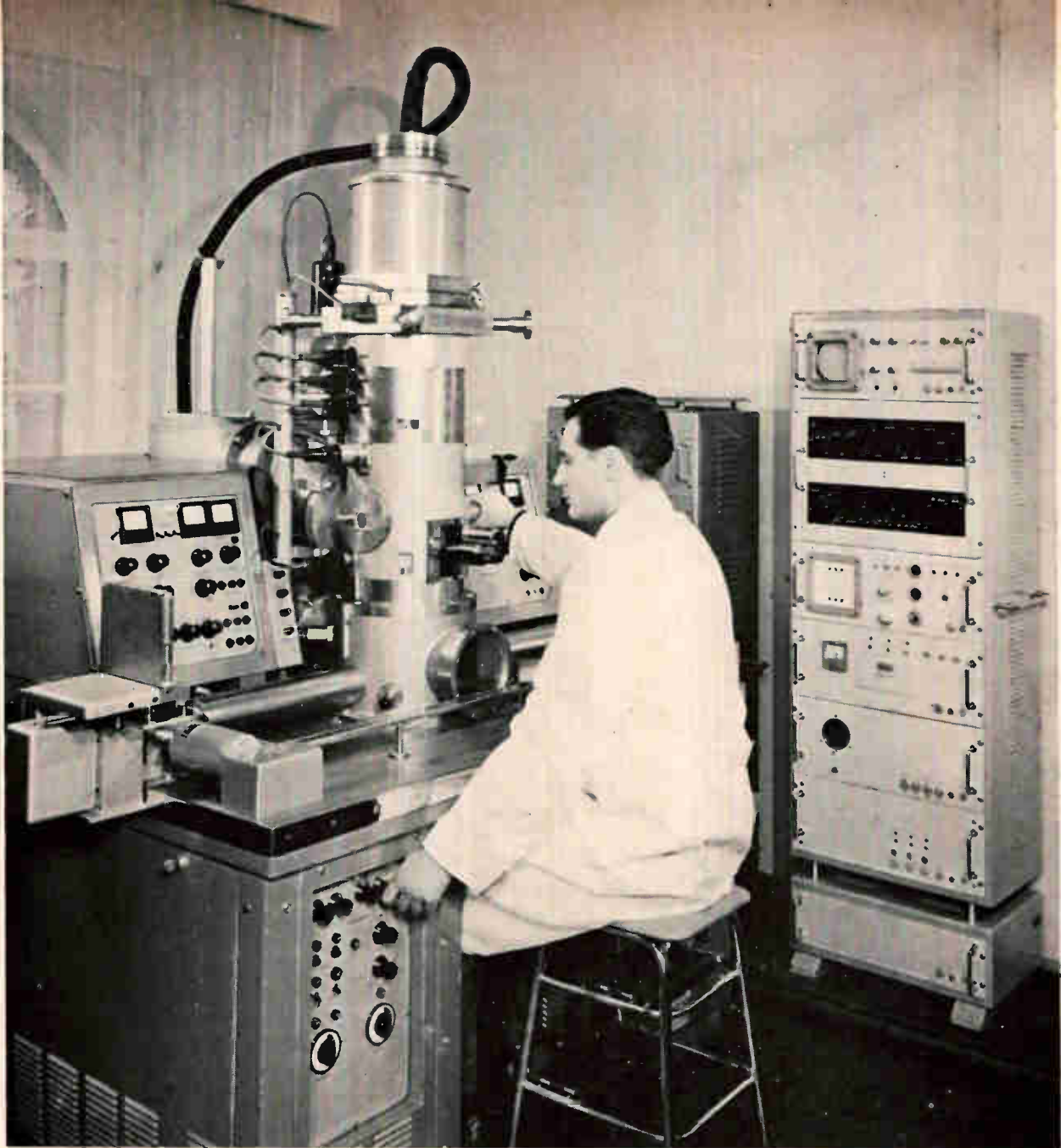

Electron-beam machining system trims thin-film resistors a rate of one substrate every 2.4 seconds. Substrates are fed continuously into the vacuum system over the track in front of the operator. The programmer is at right.

Continuous-transverse deposition

Systems that are periodically loaded are uneconomical for production of large lots at the rate, for example, of 1,000 substrates an hour. The systems become too complicated; moreover, opening a vacuum chamber periodically to load it with fresh substrates causes process variations. For example, it is impossible to make uniform the length of time between the outgassing of the substrates and deposition or the time interval between deposition and exposure to the air.

Not only does a continuous-transverse system avoid such problems but it allows several processes to be performed in sequence without exposing the substrate to air and contamination between processing stations.

Among the continuous-transverse systems in the

United States is one with which the Western Electric Co. makes sputtered-tantalum resistors,¹ and another with which the International Business Machines Corp. makes thin-film circuits.

The systems developed by the authors have an electromagnetic transfer mechanism. The substrates and deposition masks are loaded into transfer blocks that move through the system in a guide track, as diagramed on page 113. The track is the rectangular course shown in the photograph on page 112. After deposition, the blocks are unloaded and reloaded as they return to the starting point at the left in the photograph.

The blocks are moved around the course by electromagnetic drives at the corners of the course. Each block pushes the one in front of it, so that the substrates are not subjected to mechanical stress. The drives and the process stations are controlled

Thin-film deposition system. The substrates move continuously through the vacuum chambers on the rectangular course at a rate of one substrate every three seconds.

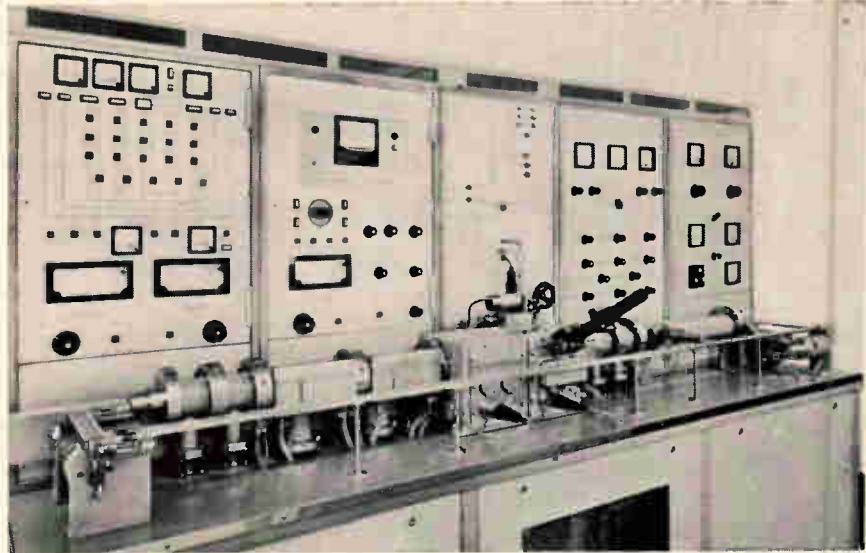

by central timing and programming equipment.

The present maximum substrate size is 10 by 15 millimeters.

The vacuum system

This mode of transfer prevents hermetic sealing of the vacuum chambers since the chamber ends must be open to permit entry and exit of the blocks. However, a high vacuum is maintained in the inner chambers by restricting the gap between the transfer blocks and the course to 100 to 200 microns (millionths of a meter) and by connecting roughing pumps to the two pairs of fore and aft chambers.

The system diagram below shows the arrangement and pumping speeds S of the six pumps used. One roughing pump (S_1) is shared by the input and output chambers; the other roughing pump (S_2) is

shared by the second and next-to-last chambers. Rough pumping speed is given in cubic meters per hour; high-vacuum pumping speed is in liters per second.

The two baking chambers, in which the substrates, masks and transfer blocks are heated and outgassed to remove contaminants, are separated from each other and from the deposition chambers to prevent recontamination of the substrates and excessive load on the high-vacuum pumps.

Electron-beam vaporizers

There are electron-beam vaporizers in the first deposition chamber, currently used to deposit resistor films of nickel-chrome alloy, and in the second deposition chamber, where a protective film of silicon dioxide is applied. The vaporizer design is

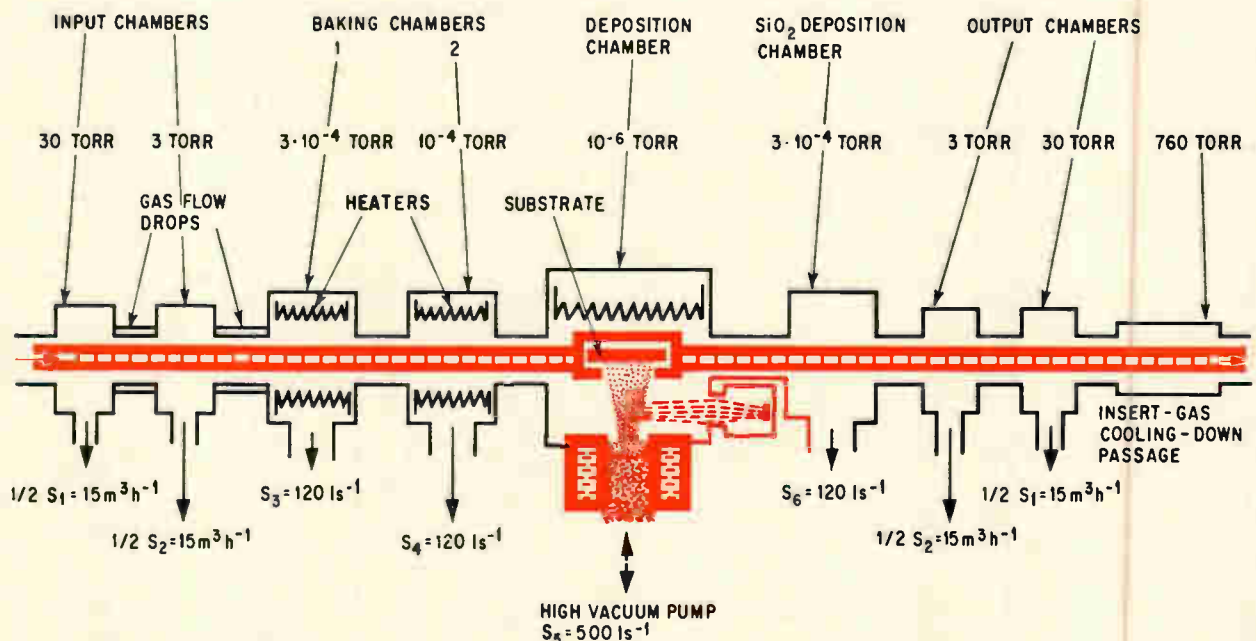

Vacuum chamber arrangement in the deposition system. Vacuum pumping speed and pressure for each chamber are in the lower part of the drawing. The substrate-transfer mechanism and the electron-beam vaporizer are in color.

shown schematically on the following page.

The electron beam is deflected 90° by the electromagnetic field of a coil outside the vacuum chamber.² The beam's energy vaporizes the surface of the material to be deposited, which is continuously fed up through a water-cooled copper crucible. This inverse extrusion is a reliable method of feeding material during long evaporation periods. The method also keeps constant the level of the molten material in the pump and the vaporizing plane.

Process controls include a power-stabilizing unit for the electron beam, resistance heaters that maintain the substrate at a uniform temperature, and monitoring of the film's resistance during deposition. A device at the end of the system detects films that are unsatisfactory and removes them.

The system can be adapted for deposition of other materials, including tantalum. In other projects, sputtering is accomplished by glow discharge and by focused ion beams. The electron-beam vaporizers can be replaced with resistance-heated wire vaporizers. The beam requires 5 kilowatts of power; a wire vaporizer requires up to 500 watts.

Electron-beam processing

The use of electron-beam energy for machining thin films, welding and bonding materials and other processes is well known. The institute has been working in this field for a number of years³⁻⁶ and has published several reports on laboratory processing of resistors.⁷⁻⁹ Others have also reported developments.^{10, 11} Electron beams can process thin films at beam working speeds of several meters per second and the energy applied to the film can be readily controlled.

However, an electron-beam system is expensive

Beam operating characteristics

Electron-gun power	150 watts
Accelerating voltage	adjustable in steps of 25 kilovolts from 25 to 150 kv
Spot size (beam diameter at the workpiece)	adjustable from 5 to 50 microns
Beam power density	1 megawatt to 100 megawatts per square centimeter, depending on spot size and rate of beam deflection

because it requires electron-optic, vacuum and electronic equipment. If it is to be economical in production, full use must be made of the beam's high working speed. Generally, the beam can machine or bond in less time than it takes to load substrates into the vacuum chamber and prepare the system.

To overcome this lag, the authors designed the electron-beam processor for a high rate of output. Workpieces are continuously transferred through the vacuum chamber in which the beam operates under the control of a digital programming system.

Scribing path in film

The institute's thin-film concept includes electron-beam processing and balancing (known as trimming in the United States) of components to the specific values required by specific circuits.

The electron-optical system is shown on page 115, and the table above gives the system operating

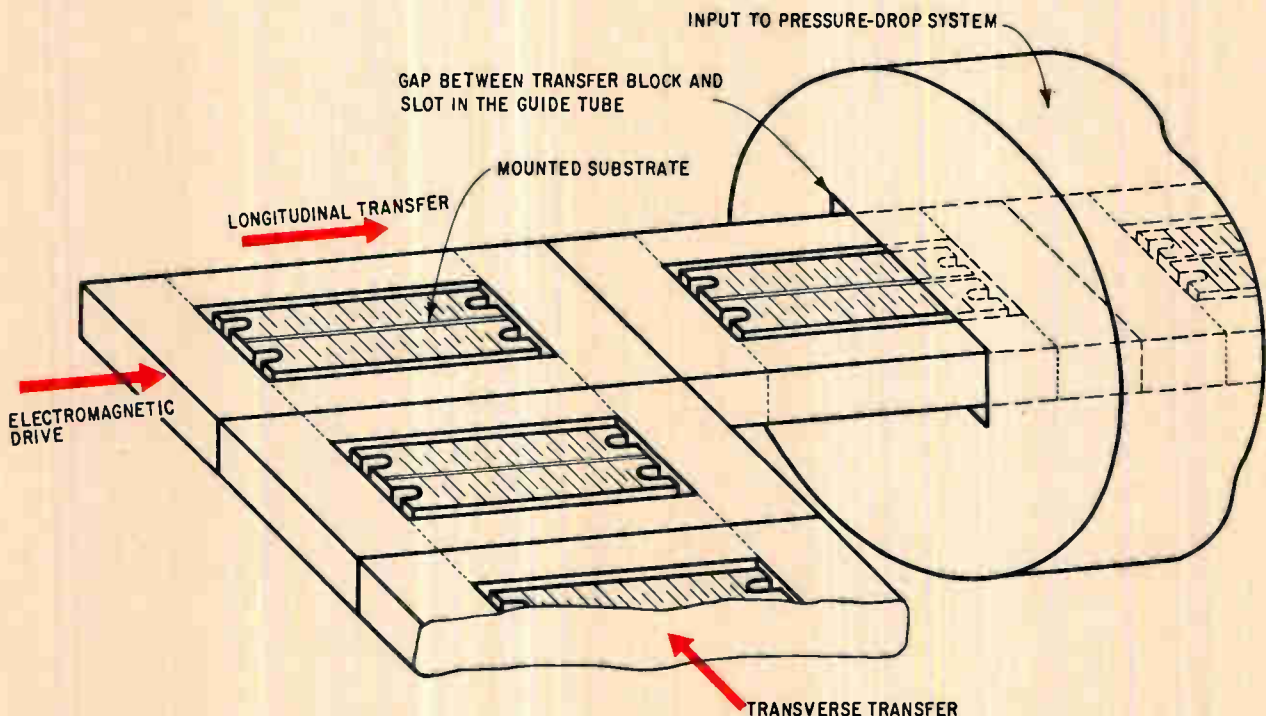

Transfer mechanism employed in the vacuum systems. The transfer blocks are pushed by electromagnetic drives.

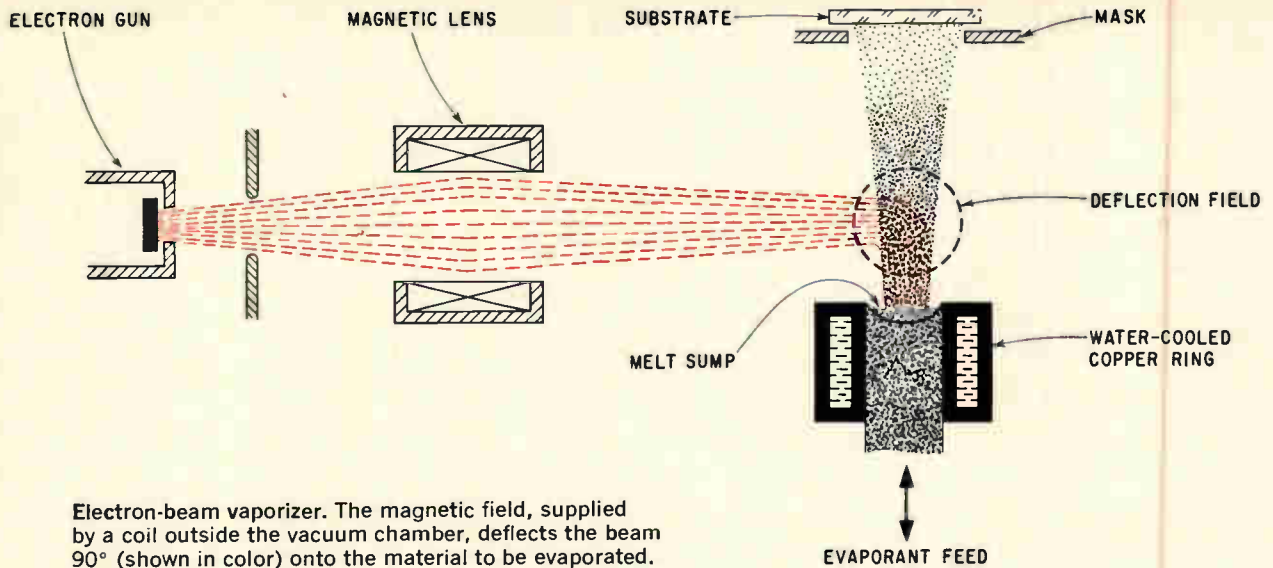

Electron-beam vaporizer. The magnetic field, supplied by a coil outside the vacuum chamber, deflects the beam 90° (shown in color) onto the material to be evaporated.

characteristics. An accelerating voltage of 25 to 75 kilovolts is sufficient for thin-film machining. The ability to vary beam characteristics will enable other operations to be performed with the beam.

For resistor balancing, the beam is used as a machining tool to scribe a meander geometry in the resistive film. This increases the resistor value by increasing the resistive path. Some examples of balanced resistors are shown on this page. Tolerances of less than 0.5% have been achieved in 85% of resistors, up to 100,000 ohms in value, with the electron-beam balancing system. Resistors having final values of 100 ohms to 1 megohm can be produced.

The continuous-traverse mechanism for the substrates is like the mechanism of the deposition system. Pressure stages also are used to isolate the high-vacuum processing chambers. This requires only two supplementary low-vacuum pumps, each with a pumping speed of 10 cubic meters an hour.

The programmer digitally controls beam deflection, which determines the locations and lengths of the lines scribed in the film and therefore the final value of the resistors.

The machining pattern for up to three resistors

on a substrate is stored as push-switch positions on a patchboard (the second rack from the top in the control cabinet to the rear of operator in the photograph on page 111). The switch positions represent the end points of the scribed lines. The distances between these points are read in the X and Y coordinates, as binary numbers up to 1,000, by digital counters. Each distance counted is converted to a corresponding beam-deflection current.

To balance the resistors accurately, allowances must be made for minor variations in film resistivity. The control system does this by stopping the scribing when a preset resistor value is reached. The counter is essentially a series of electronic switches operated in a programmed time schedule. When the resistor reaches value, the program is interrupted by means of a bridge circuit, which monitors the value of the resistor as the meander pattern is scribed.

The machining operation takes 0.6 second. The total cycle time of 2.4 seconds includes substrate transfer and other auxiliary operations. Resistors that do not meet specifications are automatically rejected by a sorting mechanism as they leave the vacuum chamber.

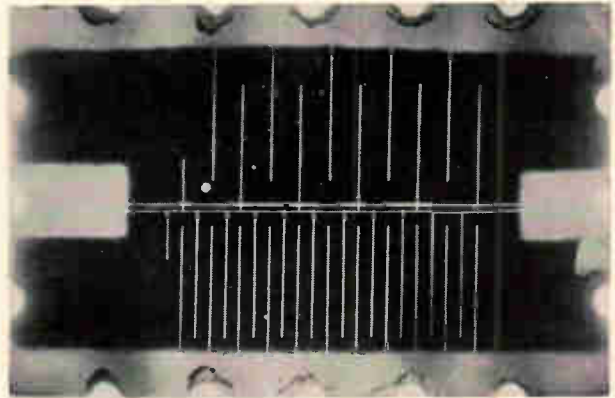
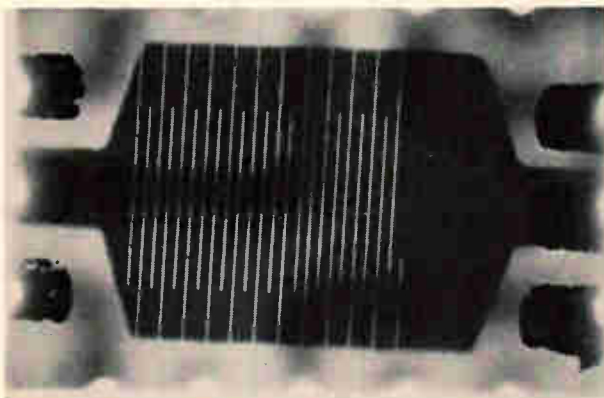

Thin-film resistors of the type made at the VEB Ceramics Works in Hermsdorf. Film with a resistivity of 300 ohms per square has been scribed to form a 100,000-ohm resistor (left). The two resistors at the right have values of 5,000 and 50,000 ohms and were cut from 200-ohm film. The lines, scribed with an electron beam, are 30 microns wide.

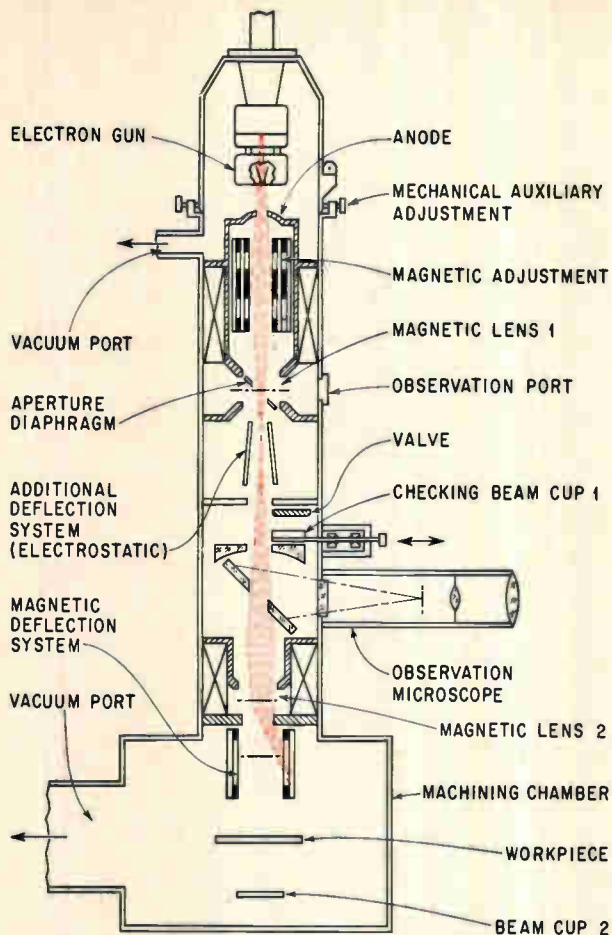

Electron-optical system of the electron-beam machining equipment. It is similar to the Carl Zeiss equipment which is being used in the United States for microwelding and micromachining of electronic components. The beam is in color.

Further development

The deposition and balancing systems were developed for the thin-film component production program of the VEB Ceramics Works at Hermsdorf. The systems have been taken over by the Elektromat of Dresden for further development and production. Elektromat builds production equipment for the Ceramics Works and other plants.

At present, the deposition and balancing systems are operated individually. Production could be improved by joining the two with an intervening system in which the deposited films can be tempered and stabilized before the components are balanced. The substrates could then be continuously transferred through all processing stages under uniform vacuum conditions. Equipment with all the processes needed to make thin-film passive circuits could justifiably be called a vacuum-processing line.

The institute is also investigating other thin-film processing techniques and is developing a deposition system with higher capacity than the one described. The new system would be suitable for fabrication of both resistors and capacitors on a single substrate.

Editor's note: In the manuscript submitted, the authors did not discuss production of components other than resistors. However, they previously reported experimental fabrication of thin-film capacitors and inductors.

The capacitors can be made by vacuum depositing or sputtering metal electrodes on dielectric bodies of deposited dielectric materials or anodized aluminum or tantalum. Similar methods are used in the United States. To adjust precision capacitors, the institute removes a portion of the top layer with an electron beam.

Inductors are made by depositing films of magnetic and conductor materials. Spiral-shaped grooves can then be cut in the films with the electron beam to shape the inductors and balance them. G.S.

References

1. S.S. Charschan and H. Westgaard, "Thin Film Continuous Vacuum Processing Machine," *Electrochemical Technology*, Vol. 1, 1964, p. 5.
2. M. v. Ardenne, "Tabellen der Elektronenphysik, Ionenphysik und Ultramikroskopie," Vol. 2, Deutscher Verlag der Wissenschaften, Berlin, 1956, p. 640, and "Tabellen zur angewandten Physik," Vol. 1, Dtsch. Verl. Wiss., Berlin, 1962, Haupttypen von Elektronen-Richtstrahlern, p. 137.
3. *Ibid.*, p. 312.
4. S. Schiller, S.K. Panzer and U. Heisig, "Der Elektronenstrahl als thermisches Mikrowerkzeug," *Nachrichtentechnik*, Vol. 13, 1963, p. 128.
5. M. v. Ardenne, U. Heisig, S. Panzer, "Thermische Mikrobearbeitung mit Elektronenstrahlen," *Feingeratetechnik*, Vol. 13, 1964, p. 293.
6. M. v. Ardenne, "Some New Contributions in the Field of Electron-Beam, Ion-Beam and Plasma-Beam Technology," in R. Bakish, "Electron- and Ion-Beam Science and Technology," John Wiley & Sons, Inc., New York, 1965, p. 270.
7. F. Schleich, Carl-Zeiss, Oberkochen, private correspondence.
8. P.A. Einstein, R. Harvey and P.J. Simmons, "The Design of an Experimental Electron-Beam Machine," *Journal of Scientific Instruments*, Vol. 40, 1963, p. 562.
9. Prospekt Electron-Beam Machining Equipment JEBB 2, Japan Electron Optics Laboratory Co.
10. H. Kimura, H. Tamura, K. Ikegami and K. Sakashita, "Fabrication of Microelement Resistors by Electron Beam, Their Characteristics," in Bakish, *op. cit.*, p. 283.
11. D.J. Garibotti and L.R. Ullery, "Production-line packaging of solid state circuits," *Electronics*, Sept. 7, 1964, p. 73.

The authors



Manfred von Ardenne has in the past 40 years headed three scientific institutes, published 26 books and more than 275 papers, and received more than 550 patents. His main field is electron physics. His institute also does research in ion and atomic physics, medical electronics and microscopy.



Siegfried Schiller has been with the von Ardenne Institute since his graduation from the Karl Marx University of Leipzig in 1956. He has worked in plasma physics and electron-beam technology. He received his doctorate at the Technical University of Dresden in 1960.



Ullrich Heisig, also a physicist, has been developing electron-microscope and electron-beam machining methods at the von Ardenne Institute. He also studied at the Technical University of Dresden.

GET SET...



Kay 121-C
500 KHz to 1700 MHz

This solid-state instrument is an electronically swept VHF-UHF wide-sweep and marker generator which accepts a variety of UHF plug-ins to provide extended frequency ranges and sweep widths. With its plug-ins, the 121-C covers a range of 500 KHz to 1700 MHz, offers octave-wide sweeps at low UHF frequencies where most generators in this range are limited to narrow widths. Narrow sweep and wide sweep plug-ins cover special applications such as UHF-TV — full 440 to 920 MHz in a single wide sweep. A digital frequency dial provides smooth center frequency control and remarkable vernier adjustment for narrow sweep operation.

Performance characteristics include line-lock, cw, manual and variable sweep rates, and external input.

External modulation from dc up to more than 15 KHz, a built-in detector and switched attenuator are standard features.

Wide-Sweep



RF OUTPUT... *Set*

0.5 volt rms into 50 ohms
Flat: $\pm .25$ db to 800 MHz
 $\pm .5$ db to 1700 MHz



FREQUENCY... *Set*

digital frequency dial;
vernier control at all frequencies



SWEEP WIDTH... *Set*

5 KHz to 500 MHz
VHF: 50 KHz to 300 MHz
UHF: *P-121 — 124 Plug-ins

Marker Generator



harmonic (picket) birdie markers



single-freq. type birdie markers



*P-121: 200 MHz to 1050 MHz
Sweep: 35 KHz to 350 MHz @ 800 MHz
5 KHz to 50 MHz @ 220 MHz



*P-122: 900 to 1300 MHz
Sweep: 200 KHz to 400 MHz



*P-123: 100 to 1000 MHz
Sweep: 5 KHz to any octave



*P-124: 1300 to 1700 MHz
Sweep: 500 KHz to 400 MHz

KAY ELECTRIC COMPANY

Pine Brook, Morris County, New Jersey • (201) 227-2000

Visit Kay at the IEEE Show, Booths 3C11 - 3C17

Noise simulators help find peril in power-line defects

Designers can use testers to build in safeguards against disturbances in power sources before sensitive equipment goes to customer

By Manohar L. Tandon

International Business Machines Corp., San Jose, Calif.

Power-line disturbances such as voltage dips and high-frequency transients—a cause of unpredictable effects on high-speed circuits—can now be created artificially in the laboratory through devices known as noise simulators. With these units, designers can anticipate and tame effects of unwanted electrical signals that often plague equipment such as data processors after installation.

Although established techniques exist to shield low-level signals in systems against internal and radiated noise, the hazard of power-line noise has not been properly understood. Its control is important as the use of sensitive equipment continues and grows.

The San Jose system development laboratory of the International Business Machines Corp. has built two portable noise simulators. These units reproduce noise environments similar to those encountered by the electronic equipment through the power source in its eventual location.

The random nature of conducted power-line noise rules out conventional diagnostic techniques since waiting for repetition of a random occurrence is rarely feasible. The transitory nature of the disturbance further inhibits careful analysis.

Without a noise-simulation check, the effects of erratic electrical noise from the power line could reduce the value of technological improvements.

The author



A member of the development laboratory staff since 1963, Manohar L. Tandon is engaged in component analysis and the application of simulation techniques to data-processing equipment.

With the check, many potential problems can be counteracted before the system is installed at the customer's facility.

In early design stages, the simulators can evaluate problems which might otherwise go undetected. At later stages of development, a noise simulator can help check machines in a system against a standard which has been established after extensive field surveys of typical noise environments. If it fails to meet requirements, the system can be modified before it leaves the laboratory. During production, simulators can aid quality control. Production line samples can be subjected to noise simulation to make certain they meet acceptable performance levels.

Even after the equipment has been installed, the simulators are useful. They offer the field engineer a simple, economical tool for determining whether a machine malfunction is due to power-line noise. He can then isolate the suspected areas or expose marginal components, and immediately evaluate any corrective measures he takes.

Defining noise

Electrical noise is any unwanted signal. It can be generated from within the electronic equipment, from external radiation or from the primary power source. Although there are well established design techniques to shield a system against radiated noise and suppress internal noise, conducted power-line noise has not been well understood. And the transitory nature of this type of disturbance has forestalled a simple solution. Increased use of electrical power by industry for heavy-duty equipment and office services has added to the problem. A fluorescent light, for example, can cause a transient with an amplitude of approximately 1,000 volts; and merely starting a heavy motor can drop the nominal line voltage as much as 80% for up to 30 cycles.

To design the simulators, IBM divided conducted power-line noise into two categories of irregularities—low-frequency or power-line voltage dips, and high-frequency or switching transient noises. Both noise types can alter power regularity sufficiently to produce costly shutdowns or processing errors. In fact, a study showed that a large proportion of all intermittent machine failures at data processing installations can be traced to these irregularities.

The voltage dip

Voltage dips are characterized by sudden drops of short duration in the nominal line voltage of the power-distribution system. The duration of such a drop depends on the type of protective equipment on the power system and the value of the fault current. Dips as short as 0.5 cycle have been found to affect functioning of data-processing systems.

The magnitude and waveshape of a voltage dip at any given point is a function of variables including the power-system configuration, impedance of the load on the system and the point where the event causing the dip takes place.

A voltage dip can originate on the transmission lines or at the customer's location. Electrical storms, objects falling on power lines and improperly coordinated protective relays cause power-line dips. At industrial sites, dips are also caused by resistance welders, arc furnaces, large motors and other loads which draw heavily on the power source. Compressors and punch presses—with their fluctuating loads—cause periodic dips.

While the scope of the voltage-dip problem is difficult to determine, a 1954 study of 47 utility companies did give some idea of its impact.¹ At that time, it was reported that over three-fourths of these companies received complaints from customers about production losses resulting from voltage fluctuations, primarily voltage dips. In light of the growth of the data processing field since 1955, and the increasing sensitivity of the equipment, voltage-dip effects pose an ever-increasing problem.

Simulating a voltage dip

An instrument called the cycle sag simulator has been designed to simulate these dips. The device is the first adaptation of simulation techniques to the problem.

The main components of the cycle sag simulator, see the diagram on next page, are a 24-volt, 500-milliampere power supply, power silicon-controlled rectifiers (SCR), three power resistors in tandem and a time-delay circuit.

Gate pulses from the Sprague Electric Co. cross-over switches, series VZS-1000, turn on the SCR's. They remain on during normal operation. Two phases of the three-phase line synchronize the firing circuits' output pulses for each of the power SCR's. These pulses occur every time the phase angle of the a-c inputs to a Sprague circuit is zero and so long as the d-c bias voltage from the time-delay circuit appears at the terminals of the firing circuit.

To initiate the voltage dip, the reset switch S_3 is pressed. This discharges the time-delay capacitor C and turns SCR₄ off by short-circuiting it. Releasing S_3 removes the d-c control voltage from the firing circuits, which in turn causes the power SCR's to turn off. These SCR's are turned on again after a period controlled by time constant $(R_4 + R_5) \times C$ which begins at the instant of turn-off. This time constant controls the duration of the dip and can be varied by changing the value of R_4 . This is the time it takes for the capacitor C to reach a voltage value sufficient to cause the unijunction transistor Q_1 to fire, which provides the gate pulse needed to turn on SCR₄ and reestablish the control voltage to the firing circuits.

Magnitude of the dips can be controlled if the cycle sag simulator is switched from the 100% mode to a partial dip mode by closing S_2 . This places the three power resistors R_A , R_B and R_C in parallel with the power SCR's. A control on the front panel of the simulator changes the values of the three resistors simultaneously. The amount

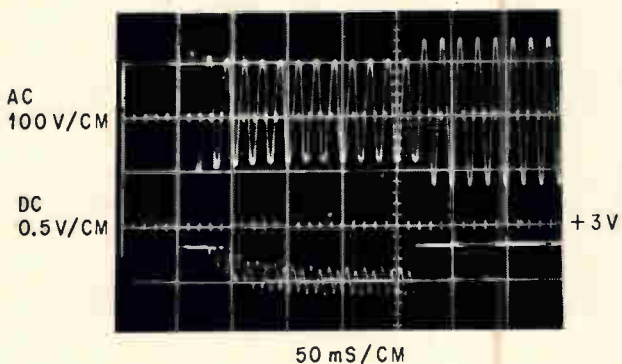
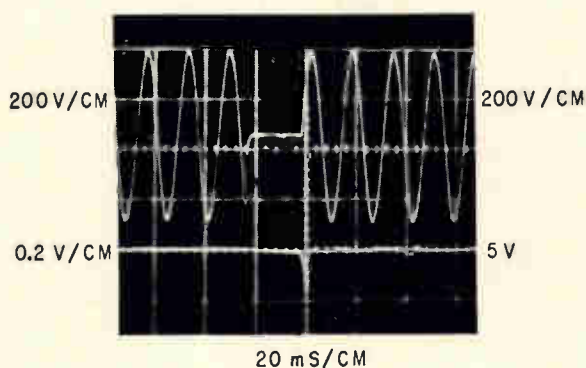

Simulated voltage dips are useful in measuring the degree of sensitivity of system components. A 100% dip in the 60 cps input to the 6-volt d-c power supply creates a transient on d-c output which could have detrimental effect on other system functions. In the right photograph, the 60-cps input to the entire system was subjected to a 32% voltage dip for approximately 13 cycles. The lower trace in the photograph shows the subsequent drop in the output of the system's 3-volt d-c supply. The d-c drop was about 0.5 volt, but more significant was the detection of the oscillation.

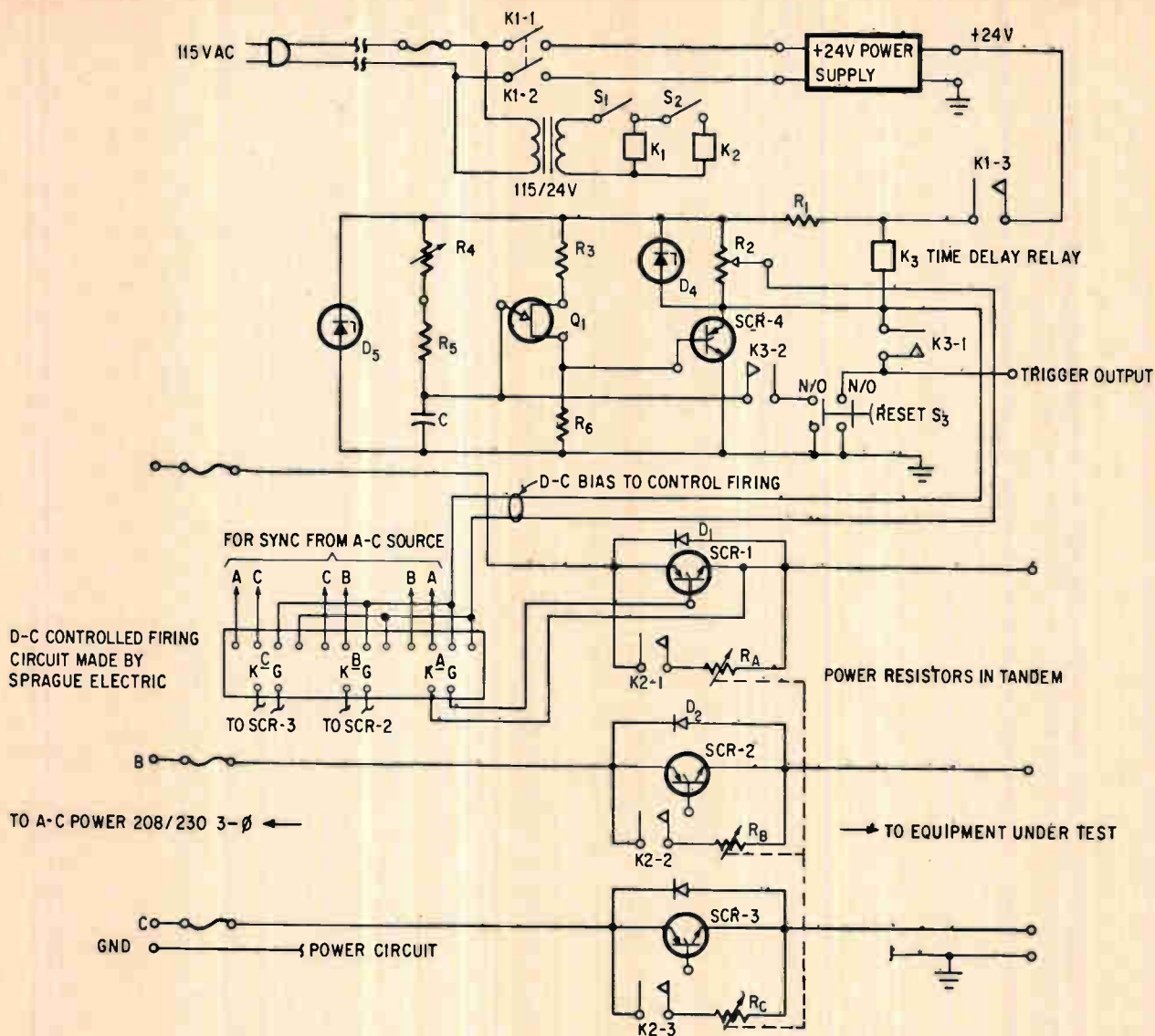

Resistor R_1 is varied to change the voltage-dip duration. The three SCR's, SCR-1, 2 and 3, are turned off to achieve a 100% dip while the resistors, R_A , R_B and R_C , can be switched into the circuit to attenuate the dip's magnitude.

the dip is altered depends on the system under test, since the voltage drop across the resistors is a function of the load current.

Turning on the power SCR's when the phase angle of the a-c input to the firing circuit is zero eliminates any high-frequency transients which might be generated during the test period since there is no voltage step applied to the distributed capacitance and inductance of the load. If this were not done, it would not be clear whether the system malfunction occurred because of the voltage dip or the high-frequency transients created by the test equipment itself.

Since it would be too costly to design a voltage-dip simulator which could handle heavy currents at 230 volts and simulate a variety of wave shapes, with various delays and rise times, the cycle sag simulator is designed to cause only an abrupt voltage dip, or step function. The objective was an economical, portable instrument, simple to operate and yet capable of controlling the amplitude and

duration of the dip. The step-function mode was selected because the effect of step-function dips on a data-processing system is more pronounced than waveforms of the exponential type. If the systems can operate properly under step-function mode simulation, it is safe to assume reliable operation will continue after an exponential disturbance pattern.

Sensitivity varies

The cycle sag simulator aids equipment design by determining which functions of the system are most sensitive to voltage dips. In data-processing systems, the vulnerability of various components to voltage dip varies. Typically, it depends on the sensitivity of the power-control circuitry, the response characteristics of a-c motors, the filtering and regulation of the d-c power supplies and the allowable voltage limits of logic and memory circuits. For example, the shutdown sensitivity of a system depends upon the sensitivity of the power

High-frequency pulses are generated in electrical noise simulator by discharging a charged coaxial line. The traveling pulse is started by closing the mercury-wetted relay R_1 . 100% reflection occurs at the 1-megohm resistor and the pulse appears across the 50-ohm terminating resistor. It is coupled to the system through the three capacitors, C.

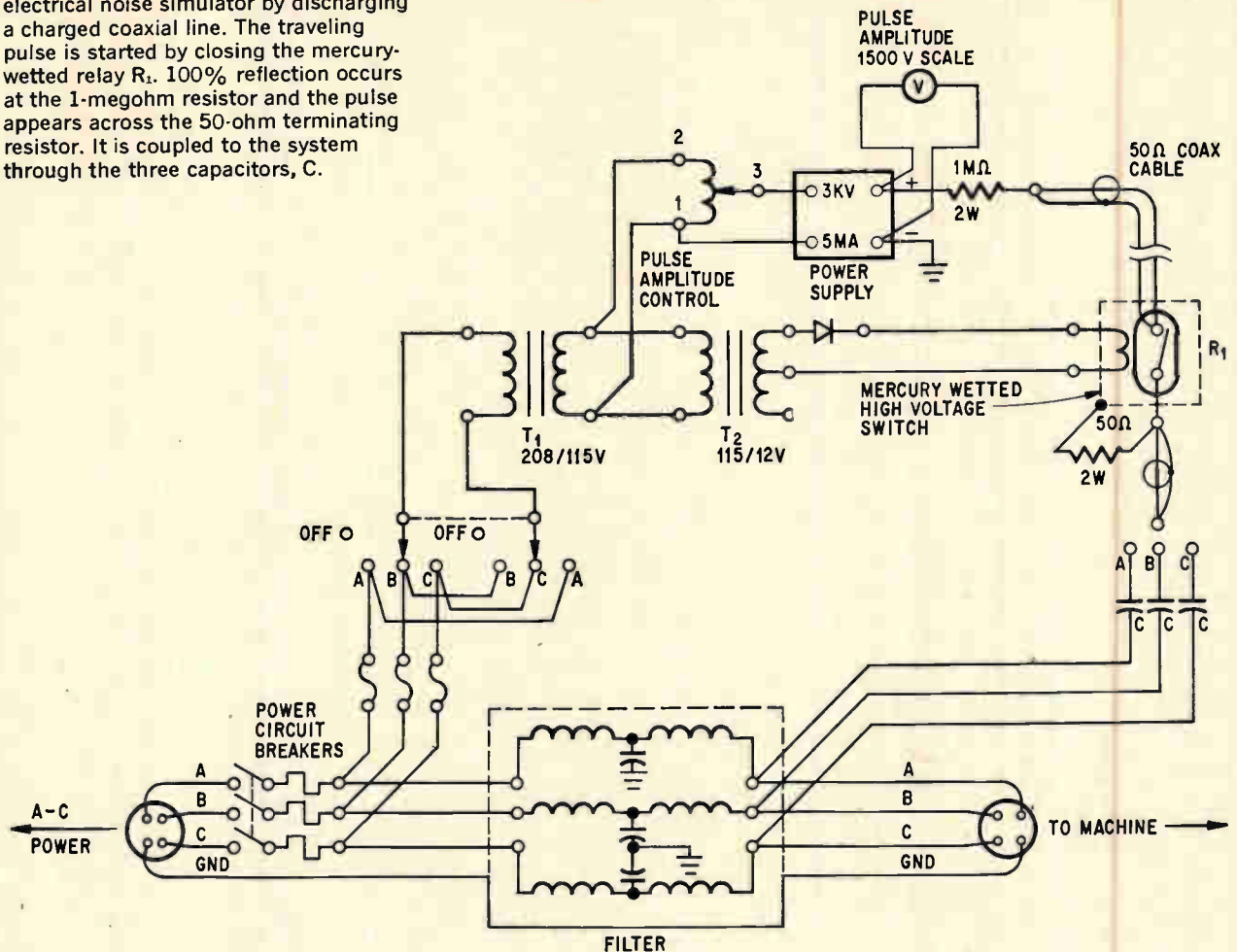

contactors and sequencing relays. Even if a voltage dip passes through the regulator and power supplies without causing a machine shutdown, it still may affect the logic circuits and memory, causing random errors in the programming operations.

In a typical design problem at the San Jose Development Laboratory, testing under simulated noise conditions led to the discovery of a flaw in the design of a complex data-processing system. One of the sequencing relays was found to be particularly sensitive to voltage dips. This sensitivity was traced to a relay whose coil voltage just fell within its tolerance limits. Correcting the voltage decreased the system's sensitivity to dips by 10%.

Another potential sequencing problem detected by the cycle sag simulator required a more extensive design change. In a particular sequencing arrangement, one relay provided a path for fast discharge of the filter capacitors in a power supply when the system power was turned off. It was discovered that a large-amplitude dip of short duration tripped the relay prematurely, starting the discharge of a large d-c current. At the end of the dip, the relay was reactivated but before the power supply was completely discharged. As a result, the relay contacts were damaged by arcing and burn-

ing. Redesign of the energizing sequence circuits eliminated the problem.

Second problem-transients

High-frequency transients present another problem to the reliable functioning of high-speed systems. These transients are trains of high-frequency pulses that are produced on the power line each time the current through an inductive component is interrupted. The pulse trains can reach repetition rates as high as 20 megacycles per second with amplitudes of 1,000 volts and durations as short as 10 nanoseconds. Rise times as fast as two nanoseconds and train lengths as long as three milliseconds have been observed.² The sensitivity of data-processing equipment to this type of noise depends on the energy content and frequency spectrum of the noise pulse.

The San Jose development laboratory spent three years studying the cause of high-frequency noise and its effects on data-processing systems. A practical result, the portable electrical noise simulator, is shown in the circuit diagram above.

This simulator generates high-voltage pulses with short rise times and injects them onto the power line of the equipment under test. The simu-

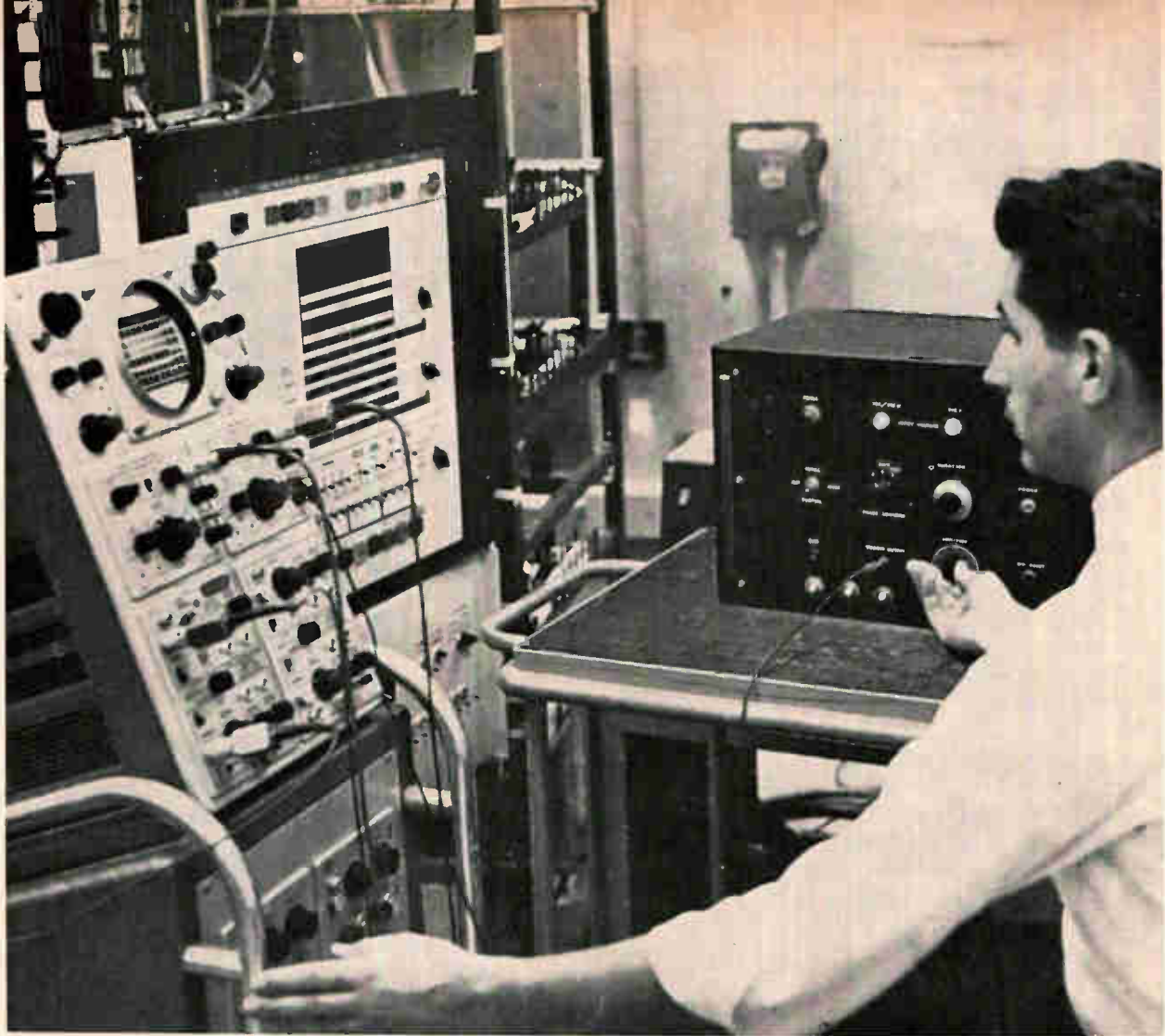

System in the background is subjected to voltage dip from cycle sag simulator, right. The design engineer monitors the simulator's output and a system parameter on oscilloscope.

lator design is based on the principle of a charged delay line. In this method, a length of coaxial line is charged to a given voltage. The mercury-wetted relay R_1 is closed, initiating a pulse which travels in the direction of the one-megohm resistor. The resistor appears as an open circuit to the pulse, 100% reflection occurs, and the pulse travels back to the output of the coaxial line and is dissipated in the terminating 50-ohm resistor. A voltage appears across this impedance for the time it takes for the pulse to travel the length of the coaxial line and back.

The amplitude of the pulse generated is one half that of the voltage to which the coaxial line has been charged. This pulse is coupled to the equipment by the three 0.1 microfarad capacitors C. A filter isolates the noise pulse to eliminate the possibility of interference with equipment not being tested.

Like the cycle sag simulator, the transient generator has proven reliable throughout extensive application. In addition to evaluating over all system and component sensitivity, the transient generator is particularly helpful in evaluating grounding, filtering and shielding designs. It can be used at various stages of system design.

In one case, it was necessary to test circuitry under sustained noise simulation to locate an intermittent error. The investigation revealed that an 8-volt peak-to-peak noise signal was being coupled with a 10-volt signal line, causing the error. Further examination showed the cause of the coupling was a broken shield.

Another situation in which the portable noise simulator played an important role, was to detect an intermittent fault that caused a data-processing system to switch programs and sometimes even cease operations. Line transients were thought to be the cause of this malfunction and the simulator was connected into the a-c line of the system's storage unit. The fault was made to reoccur at a simulator output voltage of 1,250 volts and was subsequently traced to a defective logic card in the connecting data channel. Detecting malfunctions of this sort without the simulator would have been difficult.

References

1. Minutes of 65th meeting, transmission and distribution committee, Edison Electric Institute, October, 1954.
2. W.B. Hayter, "High-voltage, Nanosecond Duration Power Line Transients," Tenth Tri-service Conference on Electro-magnetic Compatibility, Illinois Institute of Technology, November, 1964.

In some businesses it pays to be slow

That's right, slow. You just don't need that hot .5 μ sec or 2 μ sec memory you've been dreaming about if your digital applications are data transmission, process control, data display or any of hundreds of other commercial and military applications.

It costs a lot of money to make fast stacks and add the electronics that will keep them honest. We know. We make them. For businesses that need them.

But what plenty of businesses need is wide operating margins, low cost and reliability. What you get with slower memories.

Take our 8 μ sec core memory systems. They may be fast enough to do the job you need done. And they have wide operating margins over a broad range of environmental conditions.

(Our FX-12 system shown here has wide oper-

 **FERROXCUBE CORPORATION OF AMERICA**
Saugerties, New York

Tel—(914) 246-2811

ating margins over a 0° to +65°C temperature range even with a 10% variation in dc input voltages.) You save money (about 50% in fact) because with slower memories we're able to use fewer components. Less critical components. And our production and testing techniques are simpler.

We're ready to support everything we've said through actual

demonstration. We do it every day. We know more about memory system construction than anyone else in the business, and are prepared to deliver new concepts in design, packaging and organization.

Send for our Bulletin 3003, and tell us about the application you have in mind. Just a few lines on your company letterhead will do. **Think slow. But act fast.**

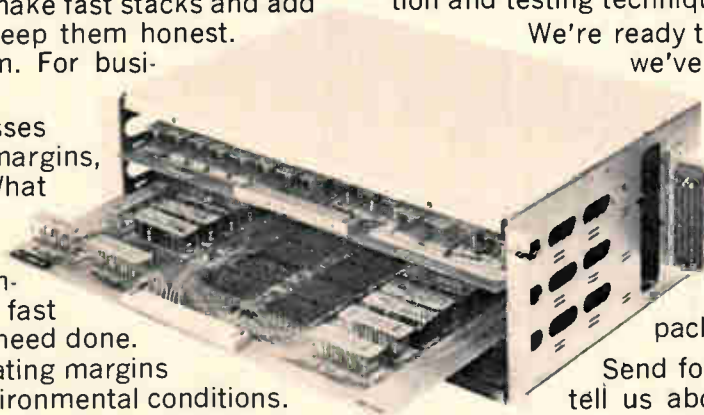

Microwaves on the production line

They're already cooking potato chips and removing solvents from magnetic tape with easily controlled speed and precision.

Next they may be mining for gold and knocking down old buildings

By Paul W. Crapuchettes

Electron Tube division, Litton Industries, Inc., San Carlos, Calif.

Microwave technology is expanding beyond the kitchen into the factory. Electromagnetic radiations of 1 to 22 gigacycles per second are already cooking food in large institutions, roadside cafeterias and even in some homes. Recently microwaves have also begun to find industrial applications in drying paper, removing solvents from magnetic tapes, and controlling pasteurization with a precision that is impossible with any other method. One day, proponents predict, microwaves will be helping to demolish buildings and to mine for minerals.

Microwave heating has several attractive advantages: because it entails no thermal lag, it can be turned on or off instantly and adjusted precisely. Because it acts directly on the object to be treated, rather than working through a transfer medium such as air, the container and surrounding area can be kept cooler. Even cost, which until now has been a disadvantage, may become an argument in favor of microwave if the price of electricity remains fairly constant while other energy sources continue to become more costly.

Other disadvantages are less subject to economic solution. One is the limitation on microwave's power capabilities, imposed by beam breakup when the density of current at the cathode becomes too high. Another drawback is the variable nature of the dielectric—in this case, the substance being heated. When most substances undergo heating,

their dielectric characteristics change, thereby altering the energy transfer and the magnitude of the fields in the modes that are excited in the heating cavity. Wide changes in these fields can result in uneven heating. Polystyrene foam, for example, starts as a thick soup which absorbs microwave energy readily. At a certain temperature, however, it is mostly gaseous and transparent to microwaves.

Economics and potato chips

Granny Goose Foods, Inc. recently became interested in microwave for the final cooking of its product. Quality control is a problem in this industry; potatoes vary in sugar and moisture content from season to season and from potato-field to potato-field, yet the customer expects a yellow chip, not one that is brown or black. Waste can be as high as 25%.

Microwave could afford tighter control of color and of moisture content. If this could be done at a moderate increase over deep-fry costs—less than 2.8 cents per pound of chips produced—Granny Goose figured it would be worthwhile. The company estimated the costs, including amortization of the microwave equipment, at one cent per pound. Result: Litton Industries, Inc., is building an 80-kilowatt microwave system for Granny Goose's potato-chip plant in Oakland, Calif.

The process begins with a partial cooking in a conveyorized deep-fat vat until the moisture content is reduced to about 8%. The chips are then transferred to the microwave dryer, where four kilowatts of microwave energy finish drying 100 pounds of chips each hour. There is also an increase in yield and a saving in labor cost of one cent per pound. The application of the right amount of energy at the right frequency removes most of the water from the chips without requiring heating oil and the resultant continuation of cooking. Chips

The author



Paul W. Crapuchettes is a vice president and technical director of Litton Industries' Electron Tube division. He has 19 patents in the microwave field.

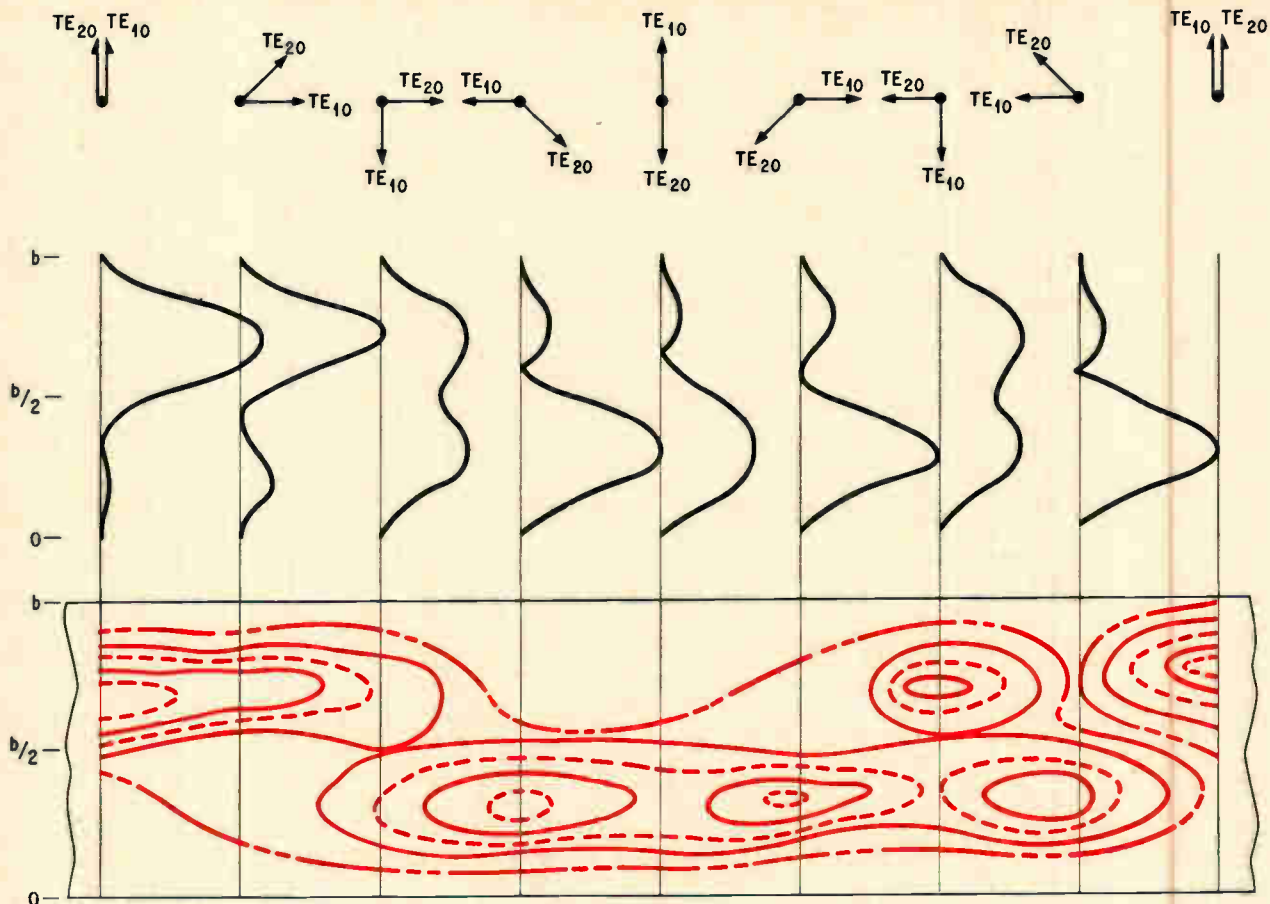

Development of contours for the average heating density is shown for a waveguide carrying the TE_{10} and TE_{20} modes. Vectors at the top indicate the relative time phase of the two modes in planes perpendicular to the direction of power flow. Heating density (see equation 3) in these planes is shown in center illustration. Contours of equal heating density are shown in bottom drawing.

with varying moisture content come out of the dryer with a uniform moisture content because the process is self-limiting; that is, as the moisture content decreases, the microwave energy that couples into that part of the load also decreases.

Companies in other fields have said microwave processing is worth considering when the product costs more than 30 cents a pound. One promising application is in the manufacture of thin films such as those placed on paper and plastic. A producer of magnetic tape is trying microwave heating for removing solvents.

In conventional production, iron oxide is deposited on sheets of mylar in a binder system that contains a solvent which must be evaporated. Removal of the solvent cures the binding system and makes the iron-oxide particles adhere uniformly to the mylar base. The solvent is evaporated by drawing the tape through a hot-air drying system while applying microwave heat. Because microwaves do not transfer heat energy to mylar or to the iron oxide, the solvent can be evaporated rapidly without any heat damage to the tape. The company says the microwave heating has resulted in higher yield, increased productivity, reduced size and cost of processing equipment, less and simpler peripheral equipment and an appreciably better product.

In the paper industry, the application of micro-

wave energy is more limited. Paper pulp cannot be completely dried by microwaves because the process requires a great deal more heat than microwaves can produce. For quality papers, however it is possible to finish the drying with microwave energy; precise temperature control permits removal of wet spots without scorching the rest of the paper. Related applications under study include the treatment of chemical compounds on paper bases and the setting of resinous materials on plastic films. Applicators already have been designed for such treatment, studies of the processes are well under way.

Custom-designing magnetrons

The development of competitive microwave equipment begins with the design of each component for its specific use. Reliability and ease of operation are particularly important because customer demands warranties and require that the equipment be capable of installation and operation by nontechnical personnel.

When engineers began to adapt military magnetrons to microwave heating, they found a new set of problems and design considerations. Military equipment is often over-designed for every possible combination of operating conditions; and it is usually operated and serviced by people who are

trained in theory and practice. In commercial situations, however, the equipment is generally operated by people who are concerned only with the end product and who are trained in its processing, not in the theory of microwave energy. Therefore, until the use of microwave energy becomes more common, reasonable service will continue to be available only from the manufacturer and his licensees who are properly trained.

The chief problem in adapting a military tube to a commercial application is the greater variation in voltage standing-wave ratio (vswr) encountered in civilian applications. High vswr causes mode instability in magnetrons. Magnetrons in military use seldom encountered a vswr in excess of 1.5 to 1. In a typical domestic microwave oven, on the other hand, impedance changes can produce a vswr of 6 to 1.

These impedance variations result from variations in the dielectric constant and power absorption characteristics of the material being treated. Furthermore, a material's microwave properties change considerably with temperature. Until this problem is solved, magnetron will continue to operate at far below their capacity in commercial heating.

Only reentrant-beam devices, which return unmixed electrons to the interaction, can maintain efficiency under such wide variation in load swings. This is why magnetrons and amplitrons are the principal tubes used in microwave heating.

However, microwave heating equipment using klystrons as well as magnetrons and amplitrons is being produced by the Crydry Corp. of San Ramon, Calif., a subsidiary of Armour & Co. Matching is still a problem, however, in applying any of these tubes to microwave heating. The use of ferrite isolators is not a satisfactory solution because they are too expensive.

A typical magnetron for microwave heating is the Litton L-3189, which is made in air-cooled and water-cooled versions. This tube, produced by Litton Industries, produces one kilowatt at 2,459 megacycles per second. At 6.5 kv on the anode, with a magnetic field supplied from a regulated electromagnet, the tube operates efficiently under a variety of loading conditions.

Microwave tubes generally work into fixed, predictable loads which can be optimized for maximum energy transfer. Microwave heating, however, presents an altogether different set of conditions, because the load's dielectric characteristics change as it is heated. The load's shape, size and state—liquid or solid—all affect the energy transfer.

These unavoidable changes in load produce variations in the magnitude of the electromagnetic fields of both the principal and higher modes that exist in the heating cavity. Uncontrolled, this multimode operation can produce hot and cold spots in the load, resulting in uneven heating. One of the big problems in using microwave heating devices is controlling the energy distribution and phase of the various modes.

Definitions of symbols

Vector fields are designated **E** with subscripts to indicate the axis to which the vector is parallel. Additional subscripts **m**, **n** and **p** define the mode under discussion.

b	= length of the vessel in the x direction, in meters
a	= length of the vessel in the y direction, in meters
c	= length of the vessel in the z direction, in meters
f	= operating frequency, in cycles per second
f_{co}	= cutoff frequency of the waveguide
f_o	= unperturbed resonant frequency
Δf	= frequency change caused by perturbation
Δf_s	= separation between modes
j	= $\sqrt{-1}$
m	= for x
n	= for y
p	= for z
	{ integers which can have all positive values including zero, and which describe the number of half sine-wave variations along the related axis.
P	= power in watts per unit volume
A	= a constant expressing peak amplitude of the fields, in volts per meter
Q_D	= quality factor of dielectric alone
Q_c	= quality factor of loaded cavity
V	= volume of cavity, in cubic meters
ΔV	= volume of load
tan δ	= loss tangent of material
ε	= complex permittivity of material
ε_v'	= real permittivity of material
ε_v"	= loss factor of material
λ	= free-space wavelength, in meters
λ_g	= guide wavelength, in meters
η	= impedance of free space ($\sqrt{\mu/\epsilon}$)
μ	= permeability of the material
γ	= propagation constant
x	= distance in x direction, in meters
y	= distance in y direction, in meters
z	= distance in z direction, in meters

All microwave heating cavities are encased in metal containers to prevent the microwave fields from radiating. The modes within a container are established by the operating frequency of the tube, the dimensions of the enclosure, and the nature of the material to be treated. Heating is uniform only when the phase relationship among the various modes is made to vary continuously. In addition, some materials require that the energy be spread uniformly among the various modes; in others uniform heating can be achieved only if energy is distributed unevenly.

Although precise calculations are seldom possible, the energy distribution for uniform heating may be approximately proportioned by calculating the probable modes that are present and their resonance frequency; and by determining either the position of the material or the design of the feed needed to produce the changes in phase relations

When various modes are combined

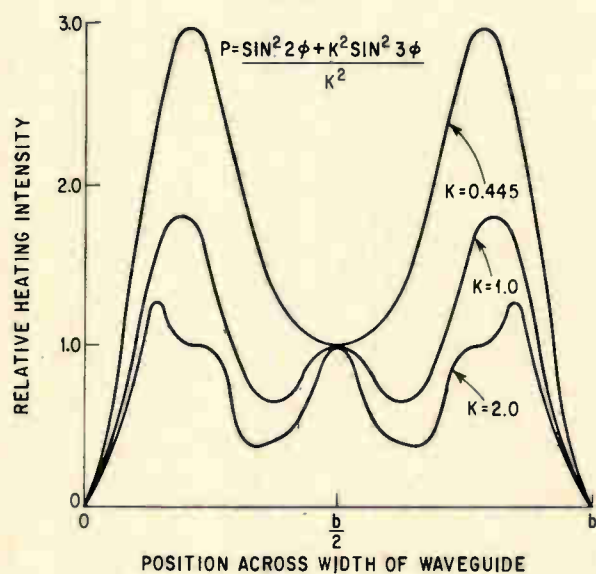
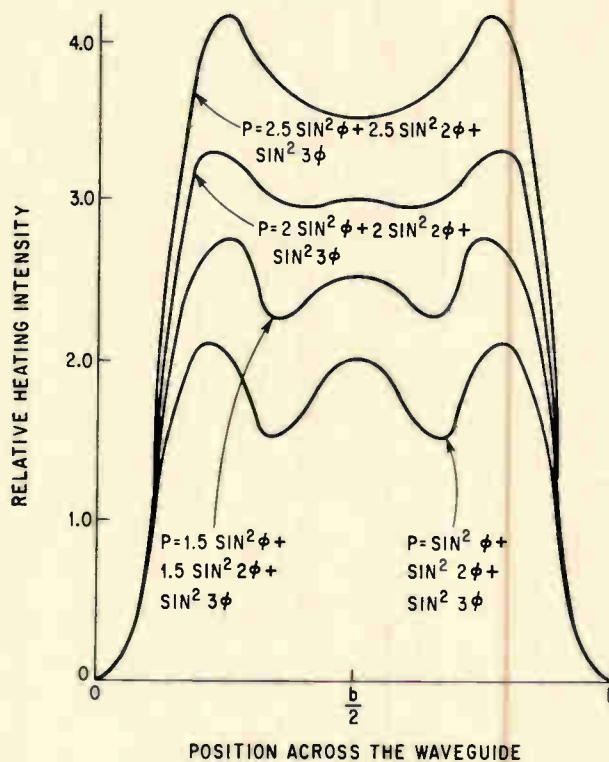
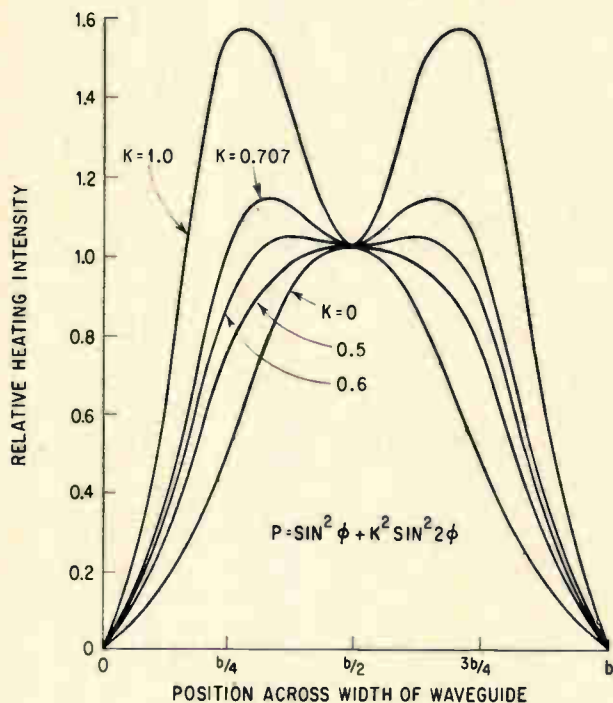

Heating-intensity patterns in waveguide are altered by controlling the number of modes and their relative intensity. In pattern at top left, for the combination of TE_{10} and TE_{20} modes, K is the ratio of the amplitude of the higher-order mode to the amplitude of the lower-order mode. Curves at lower left show relative heating intensity when the waveguide contains TE_{20} and TE_{30} modes. As the number and order of modes are increased, heating becomes more uniform. Curves at right show heating distribution for various proportions of all three modes. The second curve from the top, uniform within 5.5% across the range of interest, is considered optimum.

among the various modes. Such calculations can be made if two conditions are assumed; that the load has uniform predictable boundaries and that all of its properties are isotropic and independent of temperature.

Delivering energy to the load

Before discussing design solutions to specific problems in microwave heating, we shall describe a typical system, in which the energy is carried from the tube to the load through waveguide. The load is placed in resonant cavity or in the waveguide itself. This basic configuration can be changed to accommodate individual heating problems. Some variations include:

- A long, hollow pipe containing microwave energy and filled with the load. The pipe may also

contain a coaxial conveyor belt moving at uniform velocity.

- A metallic container completely filled with a material that is translucent to microwaves.

- A metallic container partially filled with a translucent material.

- A metallic container partially filled with material that is effectively opaque to microwave energy.

- Totally unbounded process equipment using the near fields of nonradiating devices such as specially designed antennas or split-folded waveguides.

Designing with waveguide

Determining the best approach for effective transfer of microwave energy starts with the

analysis of the modes which exist in waveguide. Then the calculations are adapted to practical situations.

Waveguide conditions are directly applicable to conveyor-belt ovens. They also apply when the heating apparatus has a configuration of a split-folded waveguide as in drying ovens for thin films. The same equations are applicable to cavities which are a special case of higher-order mode waveguides with large values of vswr. In deriving the simplified equations or curves predicting heating uniformity, conventional rectilinear coordinates will be used.

If a waveguide is filled with material of dielectric constant ϵ , whose dimensions are such that only the TE_{m0} ($m = \text{any integer}$) modes are capable of propagation and all other modes are cut off, the electric fields, E , are oriented only in the Y-direction:

$$E_y = j\eta \left(A \frac{f}{f_{co}} \right) \sin \frac{m\pi x}{b} \sin (\omega t - \gamma z) \quad (1)$$

$$f_{co} = \frac{1}{2b\sqrt{\epsilon\mu}} \quad \text{and}$$

$$\gamma = j \frac{2\pi\sqrt{\epsilon}}{\lambda} \sqrt{1 - \left(\frac{f_{co}}{f} \right)^2}$$

where E_y is the field in the y direction which is transverse to the axis of the guide and perpendicular to the width b . Dimension b is parallel to axis x .

The modes are excited by a fixed coupler—located at the input to the guide—which can be adjusted for optimum distribution of energy in the modes. At the point of excitation, the phase relationship of the modes is also established by the coupler.

Because the modes may have different wavelengths, the phase relationship between the modes varies continuously along the waveguide. Thus, the total vector field at a given coordinate in the cross-section of the guide varies with axial position. Because the energy dissipated at a certain point is the product of the loss tangent of the dielectric material and the square of the vector sum of the fields acting at the point, the energy will be distributed unevenly as shown in the diagram on page 124.

In this example the waveguide dimensions and operating frequency were chosen so that only the TE_{10} and TE_{20} modes could propagate. For these conditions the height, a , of the waveguide must be less than $\lambda/2$. It was also assumed that the modes were equally excited and that the guide wavelengths were related by:

$$\lambda_{g20} = 2\lambda_{g10} \quad (2)$$

requiring that

$$\left(\frac{\lambda}{2b} \right)^2 = \frac{1}{5}$$

The time average heating density per unit volume at any point (x,y,z) is then given by:

$$P = \frac{\epsilon A^2}{2} \left(\sin \frac{\pi x}{b} \sin \frac{4\pi z}{5\lambda} + \sin \frac{2\pi x}{b} \sin \frac{2\pi z}{5\lambda} \right)^2 \quad (3)$$

The heating patterns represented by equation (3) are typical of any situation that can be analyzed by waveguide equations. Even though the analysis assumes that there are no reflections from a termination, there still is an apparent standing wave pattern which produces uneven heating. Several ways to keep the heating uniform will now be discussed.

Four paths to uniform heating

If the material is moved through the waveguide at such a rate that it traverses the complete standing-wave pattern several times, the peaks and valleys of heat energy will be smoothed. The result is as if the material is stationary but the vector fields are not coherently related, that is, the fields are asynchronous. Thus, in the more general case where modes of the form $TE_{m,n}$ are considered, at any point (x, y, z) the heat deposited is

$$P = \sum_{m=0}^{\infty} \sum_{n=0}^{\infty} \epsilon''_v (E_{x_{mn}}^2 + E_{y_{mn}}^2 + E_{z_{mn}}^2) \quad (4)$$

If each mode is excited by a separate source, and if the frequencies of these sources are not precisely related, the same smoothing takes place, even with a stationary load. This is called the multiple-source approach.

Another approach employs tuned phase-shifters. If each mode is excited independently and if each of the several lines to the couplers contains a 360° phase shifter which is varied in some random manner, then the desired smoothed or asynchronous heating pattern will result.

Moving the coupling device through the fields will cause the coupling coefficients and relative phase of the several modes to vary in the desired manner. This is the moving-feed approach.

All of these solutions produce similar patterns. The curves at the upper left on page 126 show patterns (valid for all z) computed when TE_{10} and TE_{20} modes with different amplitude ratios are asynchronously excited.

Comparing the curves with those obtained from various combinations of TE_{10} and TE_{20} and TE_{30} , it is clear that both an optimum amplitude ratio exists and the portion of the waveguide which can be uniformly heated increases as the number of modes increases.

When the dielectric is irregular

If the actual loading is uniform, representative patterns can be calculated even if the load does not fill the waveguide. When the load is not uniform (either the dielectric constant varies or the shape is irregular) or when the load's dielectric constant is greater than 2, no mathematical solution is known. The reason for the latter qualification is that a load with a high dielectric constant represents less impedance to the field. The fields tend to con-

verge on the item resulting in field patterns that are badly distorted, and making it impossible to exactly calculate the heat density.

If the waveguide is filled with material of dielectric constant ϵ the waveguide can be smaller and the guide wavelength in all the modes can be made shorter. In fact, at infinite frequency

$$\lambda_g = \frac{\lambda}{\sqrt{\epsilon}} \quad (5)$$

In a waveguide of given dimensions, the addition of dielectric material also increases the number of modes which may be propagated. When, for a given higher-order mode, the length of the dielectric material in the direction of propagation is shorter than $\lambda_g/2$, the dielectric may become a foreshortened resonator if the boundaries are so shaped that suitable reactances exist. In fact, some particular geometries of dielectric materials can become self-resonant; these are called "ghost" modes. Under these circumstances, the surrounding waveguide or cavity acts as part of a coupler that directs the energy into the dielectric. The fields in the dielectric can be much higher than those in the surrounding waveguide or cavity—in much the same way that the fields in the cavity, because of

its Q, are much higher than the fields in the exciting waveguide.

The transition from the simplified calculations to the practical situation is straightforward. Since asynchronous without help—from a suitable asymmetry in the cavity. The load may accomplish mode may be considered as an independent heat source, rather than as element of a vector field. This makes the calculation simpler, because the heat derived from each mode can be computed separately and then all heating components may be arithmetically added together.

As the number of modes increases, asynchronous mode conditions are achieved more easily. However, almost all degenerate modes refuse to become asynchronous without the aid of an asymmetry in the cavity. The load may accomplish this; sometimes the addition of a small screw in the cavity helps.

Having established asynchronous modes in the guide, the modes are then identified by inspection of the heat patterns. If it is desired to change the heating pattern, the relative amplitude and phase relations among the modes is altered by the techniques previously described.

Cavity resonances

If a section of waveguide is closed off at both ends, it is called a cavity. The metallic boundary at each end of the waveguide reflects energy. In the absence of a load, the system has a series of resonant frequencies determined from the wavelength in the expression:

$$1 = \left(\frac{m\lambda}{2b}\right)^2 + \left(\frac{n\lambda}{2a}\right)^2 + \left(\frac{p\lambda}{2c}\right)^2 \quad (6)$$

where a and b have the same significance attached to them as equation (1) and where c is the length of the cavity in the z direction.

Many values of λ will satisfy the equation, each value corresponding to a particular set of integral values for m, n and p. In an unloaded cavity, the resonant frequencies can be computed accurately. Furthermore, the frequency separation between resonant modes is large when low-order modes are used. However, when the sum of m, n and p is greater than 10, the frequency spacing between modes Δf , becomes smaller and is given by:

$$\Delta f_s = \frac{f}{8\pi V} \quad (7)$$

The impedance of each of the various modes to the source is given in terms of Q and cavity impedance $Z_o = L/C$ by

$$Z = Z_o \left(\frac{1}{Q} + j \frac{2\Delta f}{f_o} \right) \quad (8)$$

which is shown graphically in the curve at the left in terms of phase (ϕ) and amplitude (A), relative to the deviation (Δf) from resonant frequency (f_o). At resonance, the peak current and voltage in the cavity are in phase with the excitation. Below resonance, the peak voltage leads the exciting cur-

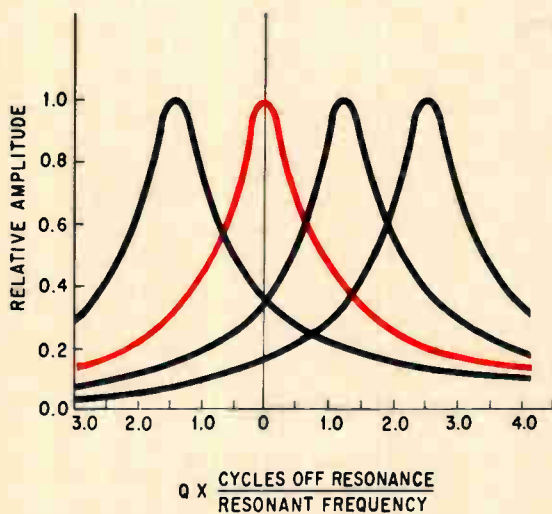
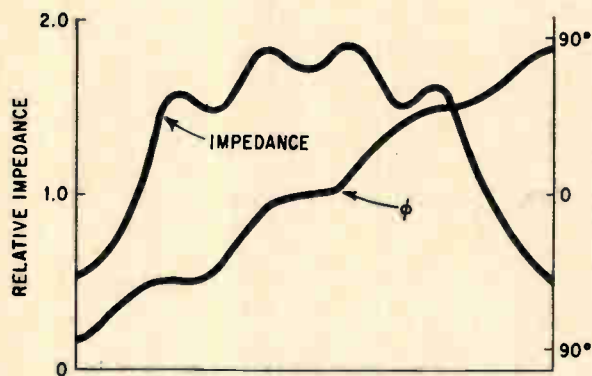

Adding universal response curves of several cavity resonances vectorially, lower sketch, results in a smoother conductance curve, top, which is the frequency characteristics of the cavity.

Estimating cavity Q in microwave heating

The estimation of the Q of a loaded cooking cavity, Q_c , is important to determine the input impedance as a function of frequency.

Power supplied to the cavity is dissipated in the skin losses of the cavity wall, the mode stirrer, the feed system, the door seal as well as the load. Normally 10% to 30% of the energy is absorbed outside the load.

The losses associated with the load can be determined analytically only for precisely defined loads, and then only with difficulty. The values of coefficients of two infinite series would have to be matched at the interface and at the enclosure. This is an extremely difficult problem.

However, even with an irregularly shaped load, there is an approximation, subject to large error, which is useful in predicting Q_c .

Approximate method

Since the volume over which energy and loss are integrated are the same regardless of boundary, within a dielectric of any shape and for all field patterns, $Q_D = 1/\tan\delta$, where Q_D is the Q of the dielectric and $\tan\delta$ is the loss tangent. It remains,

then, to determine the division of energy between the empty cavity region and the load.

The fields, in the dielectric shown in the left drawing, are the same as those outside, so the energy density inside the dielectric is ϵ times that outside the cavity. When the fields are oriented differently, as in the center sketch, the energy density outside the dielectric is ϵ times that inside the dielectric. If a small volume, ΔV of the dielectric is added between the two plates as shown in the sketch on the right, the field inside is about equal to the field outside of the dielectric because of the effects of fringing. Thus, when the dielectric is inside the cavity, within the limits of the approximation

$$Q = \frac{V}{\Delta V \tan\delta}$$

with a possible, although not probable, error of ϵ^{-1} .

A typical value of ϵ for steak at 2,450 Mc is 40, and its loss tangent at that frequency is 0.30 with a value of Q of 1,000 in a 1.5-cubic-foot cavity. A rough estimate of ϵ for vegetables at that frequency is 75.5, with a loss tangent of 0.24 and a Q of 360.

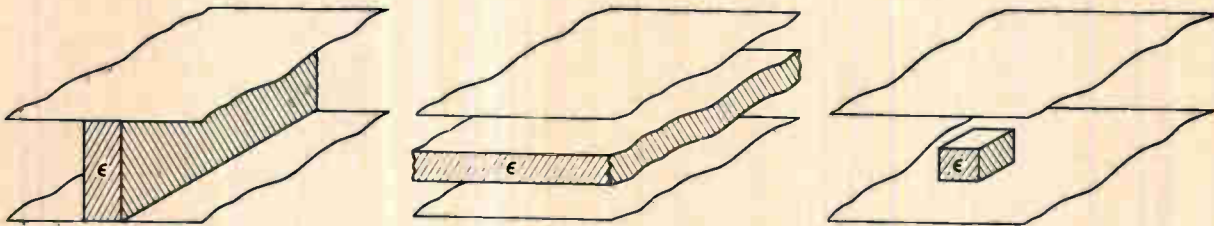

rent; above resonance, the peak voltage lags.

In a multimode cavity operating at a single frequency, the impedance of the individual resonance is obscured by the skirts of several adjacent modes. However, the phase of the maximum field in the cavity in each mode, relative to the exciting current, is the same as it would be if no other modes were present.

As viewed from the source, the impedances of the various modes are connected in parallel and, if the modes are close enough together, the impedance presented to the source becomes more uniform. Thus, the variation in input vswr to the cavity is greatly reduced if many closely-spaced modes are present, all having low Q. Also, the field is more uniform because of the overlapping simultaneous excitation of the resonances.

When the load is introduced, accurate determination of the resonant frequencies is impossible. If the load's dimensions are comparable with the wavelength, a useful approximation for the shift, Δ , in the resonant frequency of the modes is given by

$$\Delta = \frac{\epsilon f \Delta V}{2V} \quad (9)$$

where V is the volume of the cavity and ΔV is the volume of the load. This shift is always toward lower frequencies, and is a function of the size

and position of the load relative to the individual mode pattern.

For illustration, the calculated energy distribution patterns for a uniform load are shown on page 130. The pattern shows more uniform heating than would a single TE_{101} mode pattern. If the pattern is to be produced as shown, the frequency separation must be much smaller than indicated in the diagram, preferably even smaller than the value given in (9), so that variations in each mode's resonant frequency will cause the response curve to be swept through the source frequency, thereby producing the asynchronous mixing.

Effect of asynchronism

Several things happen when some material is heated in the cavity. Detuning of the cavity by the introduction of a load has already been mentioned. The motion of the load or of a stirrer within the cavity changes the resonant frequency of the several modes relative to the driving frequency. Either motion, or that of the feed, causes a shift in the phase of each mode relative to the exciting current and to each other—producing desired averaging effects. For peak effectiveness, the motion of load or stirrer should be distinctly asymmetric so that the resonant frequency of the higher-order modes are certain to be tuned through the driving frequency; this requirement can be fulfilled by

an offset, crank-driven rotary-device.

Changes in frequency—caused by either changes in the magnetron's operating current or by effects of the load's resistance—may contribute to or hinder the production of desirable phase shifts, depending on whether the frequency change increase or decreases the separation between modes.

Coupling systems

Coupling systems connect the microwave source with the cavity to produce uniform heating in the load regardless of the size and nature of the load.

In most cases, this means that all modes should be uniformly excited by the chosen coupling scheme. One sure way to provide uniform coupling in a cavity is to place a coupling loop in any of the cavity's eight corners, because all modes are susceptible to current excitation at those points.

The cavity can be coupled to the microwave source in several ways. By calculating resonant frequencies and mode patterns that are likely to be encountered, the engineer can determine the location of the source and the means of exciting the cavity to avoid the excitation of undesirable modes. A convenient way to visualize the relationships is to calculate, for each mode, an antinode diagram for the wall of the cavity through which the power is to be coupled. Current excitation at a node point will provide more coupling to that mode: voltage excitation at an antinode point provides no coupling. If uneven coupling is desired, the degree of coupling can be adjusted by choice of a feed point that proportions the energy suitably among the modes. Thus the designer is free to choose the most desirable coupling location.

Another consideration when choosing a coupling point is the fact that food and most other objects heated in microwave ovens are lossy dielectrics with a specific depth of microwave penetration. When the object is placed directly in line with radiation from the point of excitation, it may capture all or part of the energy incident upon it, depending on whether it is thicker than the critical depth—the "skin" depth. If the object captures all the incident energy, the heat pattern will be dominated more by the location of the food relative to the point of excitation than by cavity resonance. Thus, the point of excitation should be diffused and chosen so that it does not directly illuminate any of the food. If a mode-stirrer is used, it should be positioned so that it may change the direction of radiation by reflecting the microwave energy from the stirrer blades. Motion of the feed system, or interruption of the feed pattern by a stirrer, is desirable because a direct change in phase is produced, independent of a change in frequency.

When many modes whose input impedances are connected in parallel are excited simultaneously, v_{swr} is reduced if Q of the load is low enough. If the Q is not low enough, sharp regions of high v_{swr} will exist between modes. Losses in the feed system, stirrer and door seal must then be high enough so that the maximum value of v_{swr} remains

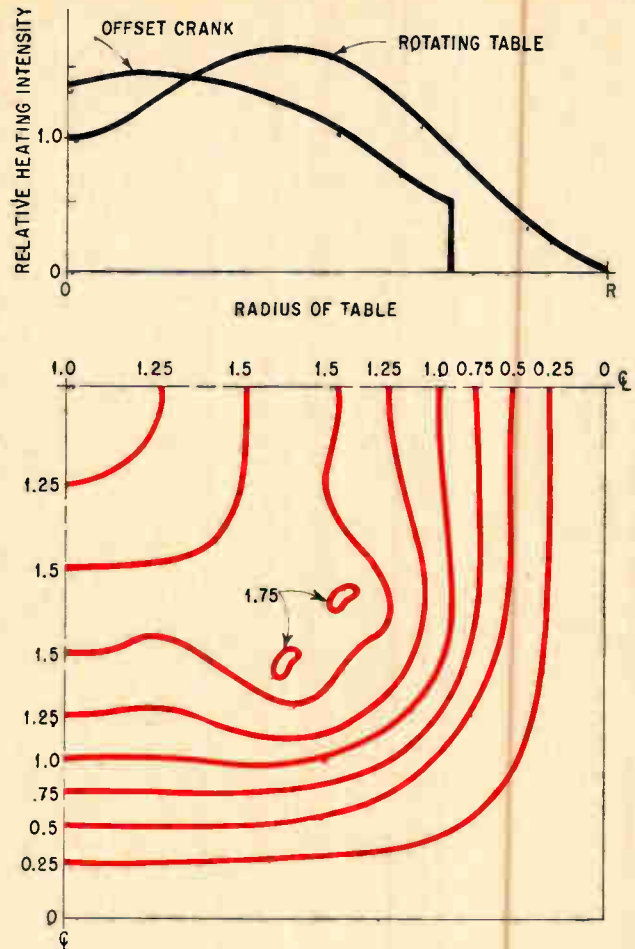

Contours of equal relative heating-intensity in a quadrant of a square cavity illuminated by equal amounts in the TE_{111} mode (1,000 Mc), TE_{112} mode (2,450 Mc), TE_{211} mode (2,450 Mc) and the TE_{212} mode (4,000 Mc) illustrate smoothing of contours when several resonant modes are present. Fairly uniform heating is obtained over a major portion of the oven. If the load is placed on a rotating table, differences in heating intensity within the load will be averaged out as the table revolves. If the table is mounted on an offset crank that rotates at one-fifth the rate of the load, the differences can be decreased further.

within limits acceptable to magnetrons. The feed-system length and the coupling coefficients must be such that the magnetron can operate without damage into heavy or light loads.

Food frequently thaws unevenly in a microwave oven. Since frozen food is less lossy than warm food, uneven heating is customarily attributed to local melting caused by slight irregularities in the heating pattern resulting in the melted food absorbing the major portion of the energy. However, there are circumstances in which the frozen material acts as a dielectric resonator, producing a very uneven energy distribution in an otherwise perfect oven. Such a dielectric resonator acts as a cavity within a cavity. The resonant dielectric prefers boundary conditions that establish low E-fields at the boundary, which build up to very high values at the antinodes of the modes in the dielectric. Fortunately, this undesirable resonance condition can be corrected by a change in the package's dimensions.

If you ever
wished for a versatile,
easy-to-work-with
dielectric FILM,
with all the
electrical properties,
environmental resistance
and unsurpassed reliability
of Du Pont TEFLON[®]—

What are you waiting for?
Mail this coupon!



BETTER THINGS FOR BETTER LIVING
... THROUGH CHEMISTRY

TEFLON[®] FEP fluorocarbon film

See TEFLON[®] FEP FILM at the I.E.E.E. Show, March 21-24—Booths 4F03 & 4F05.

Du Pont Company, Room 3716
Wilmington, Delaware 19898

Please send me complete information
on Du Pont TEFLON FEP fluorocar-
bon film. I am particularly interested
in evaluating this film for the follow-
ing area(s) of application:

- flexible, single and multilayer
printed circuits
- laminated, flexible, flat cable
insulation
- high-temperature, high-dielectric-
strength insulation

Other application _____

Name _____

Title _____

Company _____

Address _____

City _____

State _____ Zip _____

Business Phone _____

ADD

*new capabilities
to your*

SM-2000

SWEEP GENERATOR



These two new plug-in oscillators permit fast or slow scanning rates with built-in frequency indication and they're both solid-state.

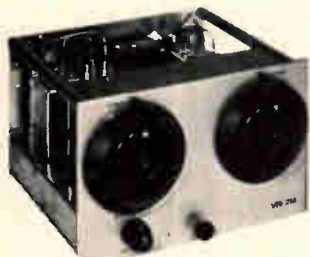

VR-2M Plug-in Oscillator

200 Hz to 12 MHz

- Variable Sweeping Rate
- Ultra-stable Oscillator
- Built-in Variable Marker
- 1 V RMS Output

Here's the quickest route to direct determination of frequency response from audio through AM, FM, IF and video frequencies all in a single oscillator. The VR-2M gives the SM-2000 control unit a whole new degree of versatility in checking amplifiers, tuners, oscillators and other wide and narrow band devices. Sweeping rate of the unit may be varied from 0.01 to 100 Hz, and its integral marker system provides precise frequency location over the entire range. Output may be scope displayed or X-Y recording in slow mode, providing db vs. frequency, precisely and directly.

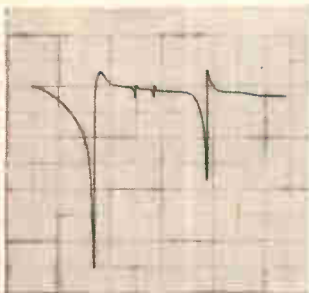

CRYSTAL FILTERS?

A primary application of the VR-2M is check-out of crystal filters. Exceptional stability and slow-sweep rates permit precise recordings of frequency response, as shown in the chart reproduction at left.



VR-50M Plug-in Oscillator

500 to 1000 MHz

- Sweeps 5 MHz to Full Octave
- Variable Sweeping Rate
- Solid State Dependability

The combination of an SM-2000 Controller with the new VR-50M oscillator can deliver a display of frequency vs db over its entire range of 500 to 1000 MHz in a single trace. It can also sweep any portion of that range from 5% up, and at a rate variable from .01 to 100 Hz. It provides fast answers for check-out, alignment and testing of frequency response in IF, RF, and broad-band video devices.

Combine all that performance with the VR-50's solid-state reliability, a .3v RMS level output, an integral, continuously variable frequency marker, and you have another reason why the SM-2000 is the most useful, inexpensive investment in swept instrumentation today.

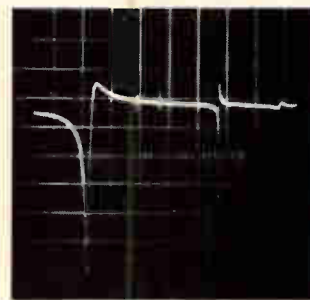

Detailed specification on these two new oscillators, the SM-2000 control unit and 18 other plug-in heads will be sent on request, or contact your nearest Telonic representative.

SWEPT FREQUENCY APPLICATIONS

An invaluable collection of data sheets covering swept frequency applications is also available—send for your set now.



INDUSTRIES, INC.

60 North First Avenue, Beech Grove, Indiana
Tel: (317) 787-3231 TWX: 810-341-3202

See Telonic at IEEE, booths 3K24-3K26

Powerful logic from power-less circuits

Inexpensive silicon transistors acting as controlled switches eliminate external power sources and result in simpler more efficient circuits than those built with diodes

By Paul Abramson and Albert X. Widmer

International Business Machines Corp., Yorktown Heights, N.Y.

An input signal—about one milliwatt—supplies all the power needed to operate a variety of new transistor logic and gate circuits. These designs eliminate the costly chore of providing external power to circuits scattered through a plant or along a traffic-control route.

Signal-powered diode circuits are common, but these new circuits, made up of inexpensive silicon transistors acting as controlled switches, perform many more functions.

And because of their simple configuration, they can easily be built as integrated circuits.

Familiar signal-powered circuit.

Signal-powered diode circuits, like the OR gate shown on the next page, require no power other than

an input signal at either gate to perform the OR function. However, to perform more complex logic, diode circuits require a power supply.

Common-base circuit

The fundamental building block of all the signal-powered transistor circuits is the common-base circuit shown on page 134. A positive signal V_e applied to the emitter appears across the load resistor R_L . The input voltage must drive enough base current through resistor R_b so that most of the input current can pass through the collector to R_L . In this condition the transistor operates in the saturated mode. That is, the collector-to-emitter resistance is minimum, resulting in minimum signal attenuation through the transistor. The relationship between collector current and base current for saturation is

$$I_c \cong \beta I_b$$

where β is the transistor's common-emitter forward current gain.

This relationship can also be expressed in terms of the circuit's voltages and resistances as follows:

$$R_B \cong \beta R_L \left[\frac{V_e - V_{eb}}{V_e - V_{ec}} \right]$$

In a typical application, the emitter-collector voltage V_{ec} will not exceed several tenths of a volt; whereas the emitter-base voltage V_{eb} may approach 1 volt. Therefore, the factor $[(V_e - V_{eb})/(V_e - V_{ec})]$ is always less than one.

For input voltages less than one volt, it may be necessary to eliminate R_b , permitting sufficient base current to saturate the transistor.

The basic transistor signal-powered circuit is

The authors



Paul Abramson joined the International Business Machines Corp. in 1960. He is an advisory engineer for the company's Advanced Systems Development division, in the field of data transmission and acquisition. Abramson is a graduate of the City College of New York.



Albert X. Widmer is a staff engineer with IBM's Advanced Systems Development Division. Since joining the company in 1959, he has worked on logic design for peripheral computer equipment. Widmer is a graduate of the Federal Institute of Technology, Zurich, Switzerland.

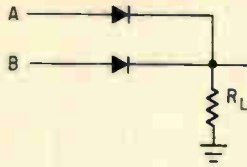

Conventional diode OR gate needs only the power of input signal. More complicated logic functions performed by diode circuits, however, require a power supply.

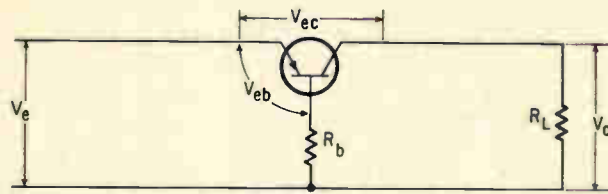

Transistor in common base configuration is basic circuit used to perform many logic functions with no power supply. These circuits use only the signal power.

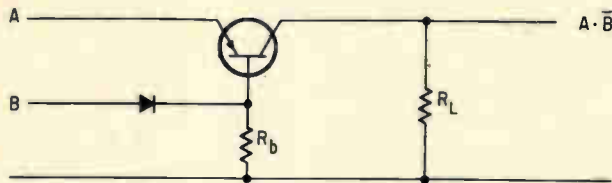

Signal-powered inhibit gate requires that voltage level B be slightly larger than A. Diode isolates signal A from B.

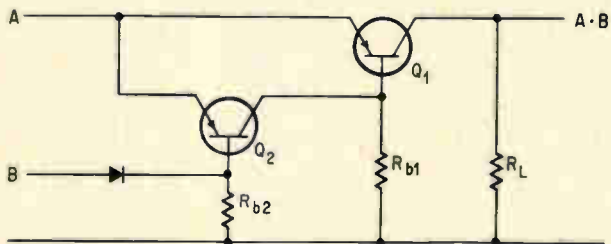

Signal-powered AND gate needs signal B to take Q₂ out of saturation, which permits Q₁ to saturate and allows signal A to pass to output.

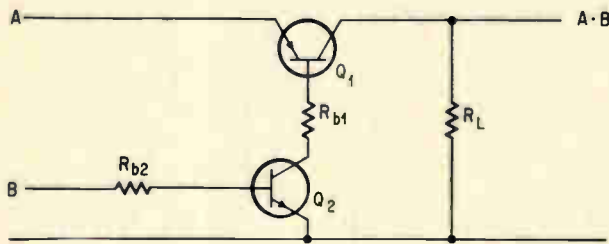

AND gate with Q₂ in the base circuit of Q₁ permits a lower voltage at B than at A to function.

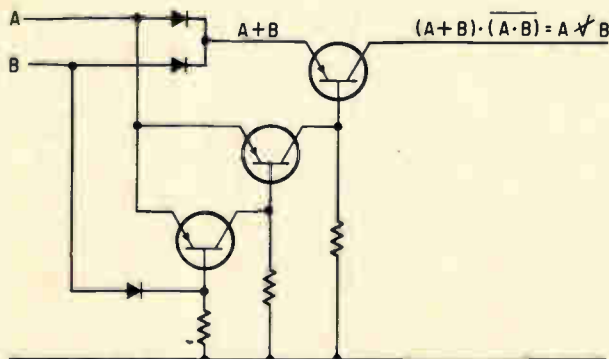

Exclusive OR gate is one of the many complex logic circuits that can be built with transistors operating in the common-base configuration.

different from the diode signal-powered circuit in the following respects:

- Signal transmission through a transistor depends on the flow of adequate base current, as well as the polarity of the signal; conduction through a diode depends only on the polarity of the signal.

- A negative signal applied to the output terminals of the basic transistor signal-powered circuit is not transmitted to the input terminals; on the other hand, a positive signal will be transmitted in the reverse direction but with less efficiency than in the forward direction. In the diode circuit, a positive voltage applied to the output terminals will not appear at the input terminals, but a negative voltage will.

- Offset voltage from input to output is less for the transistor circuit than for the diode circuit because the saturated collector-emitter voltage drop is less than a diode's forward voltage drop.

Because the signal-powered circuits use the common base configuration, in which there are little or no stored charges in the base-emitter junction, they yield very fast response. These circuits can switch in less than a microsecond.

Gating circuits

Because signal transmission depends on base current, various kinds of gating circuits can be designed. For example, in the third circuit from the top, at the left, suppressing the base current also suppresses the collector current, resulting in negligible voltage across the load. This circuit is called an inhibit gate. Signal A is inhibited by signal B. To inhibit, voltage B must be more positive than A. The diode is needed in this circuit to isolate signal A from terminal B.

The same idea can be extended to form an AND gate, as shown in the fourth diagram at the left. Again, signal B must exceed signal A. If signal B is not present and A is positive, transistor Q₂ saturates, maintaining the emitter-base voltage of transistor Q₁ at a low level and preventing Q₁ from conducting. This is because the saturated emitter-collector voltage of Q₂ is less than the conduction threshold voltage of Q₁'s emitter-base junction. But when input voltages A and B are applied, voltage B inhibits Q₂ from conducting, in turn, allowing Q₁ to transmit A to the output terminal.

Another signal-powered AND gate is the second from bottom. In this circuit, Q₁'s collector current is pinched off to a low value by increasing the impedance in the base return path, Q₂ to a very high value. If the voltage between input B and the common terminal is zero or negative, transistor Q₂ is turned off and signal A cannot pass through Q₁.

As might be expected, control signal B turns off Q₁ more slowly than in the previously shown AND gate, because of the stored charges in the base-emitter junction of Q₂. If the base current of Q₁ cannot be suppressed completely due to leakage current through the collector to emitter of Q₂, a signal will appear at the output when there should be none. Speed can be improved and false output

signals lessened by connecting a resistance of about 1,000 ohms between the emitter and base of Q_1 . The leakage current from collector to emitter in Q_1 is reduced roughly by a factor β .

For these circuits, as a transistor's reverse bias decreases, the junction capacitances increase. Thus, inputs with fast rise times will be differentiated at the output, appearing as spikes. The amplitude of these spikes is usually about 10% of the input step amplitude for an R_i equal to 1,000 ohms.

Another common feature of signal-powered transistor gates is the unequal source impedances at the two input terminals. This means that a high current signal A can be controlled by a low current signal B. Moreover, for the AND gate shown at the left, bottom, signal voltage B can be very low compared with A. In this respect the circuits compare with relays, which use low-power signals to control high-power signals.

More complex logical functions can be performed by combinations of the circuits shown so far. For example, the diagram at the bottom of page 134 shows an implementation of the exclusive-OR function. The circuit provides an output signal only if either signal A or B is applied, but not if applied simultaneously. Again, signal B must exceed A for proper operation.

OR circuit works for bipolar pulses

A circuit that makes use of the high-reverse impedance properties of the fundamental signal-powered circuit is shown below. This simple circuit, which actually consists of a pair of complementary circuits, provides an OR function for input signals of opposite polarity—this could not be done with diode logic circuits. Positive pulses are applied to the emitter of Q_1 , a p-n-p transistor, and negative pulses are applied to the emitter of Q_2 , an n-p-n transistor. Either signal produces an output pulse. Positive pulses do not feed back into the negative pulse-generating circuit, nor negative pulses into the positive pulse source.

This circuit can also be used to provide a bipolar output pulse train from oppositely polarized input

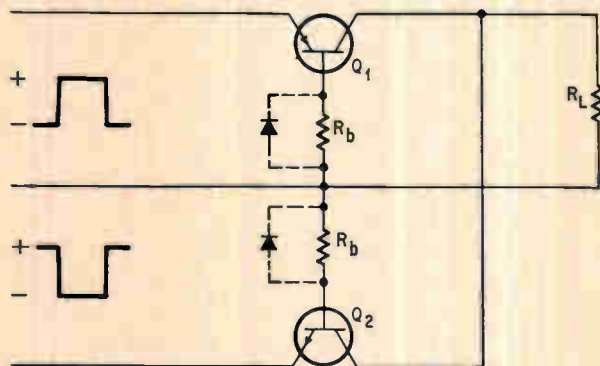

Signal-powered OR circuit provides an output pulse for a positive voltage at A or a negative voltage at B. When either transistor is nonconducting, its high reverse impedance prevents pulses of the opposite polarity from reaching the source.

pulses. Of course, in this application, the positive and negative pulses should not occupy the same time slot since they could cause a large current to flow from the positive to negative sources through Q_1 and Q_2 , and the pulses would cancel at the output.

Spurious transients feeding through the collector to the emitter can be greatly reduced by adding diodes in parallel with the base resistors. The diodes shunt the reverse transient voltages to the common terminal without affecting normal operation, since these transients are back-biased with respect to forward input voltages.

For either of these applications, a circuit couldn't be built with diodes because a diode, forward-biased for one polarity in one direction, is also forward-biased for the opposite polarity in the other direction.

Common-mode noise eliminator

Another useful scheme that exploits the high-reverse impedance properties of the basic signal-powered circuit is shown on the next page. This circuit solves the problem of coupling high-speed pulse data with a large d-c component through a transformer. One application is the rejection of common-mode noise in a data collection system using telephone lines for signal transmission.

For inputs V_i consisting of bipolar data pulses, positive and negative pulses are transmitted to the output through separate and identical transformer circuits. For unipolar data pulses, only one transformer circuit is needed.

The circuit separates the positive and negative components of the input and produces them as two separate positive pulse trains, V_{o1} and V_{o2} , referred to the common terminal. Output V_{o1} is derived from the positive portion of the input and V_{o2} from the negative portion.

Since the positive and negative sections of the circuit operate in the same way, operation will be explained for one section, the positive section, comprising Q_1 , T_1 , D_1 and D_2 . The primary of transformer T_1 is fed by the basic signal-powered circuit in which the base resistor has been replaced by a diode, D_1 .

The circuit alternates between two states—transmission and recovery. During transmission, Q_1 and D_2 conduct when a positive pulse exceeding about $\frac{1}{2}$ volt is applied to the input. Assuming a relatively low source impedance, the time constant of the transformer is much longer than the pulse duration and the pulse is therefore transmitted with little droop. Resistor R_1 in the secondary circuit has a high value compared with the impedance of Q_1 and D_2 , when conducting, and it can be ignored for the transmission mode.

When the input pulse disappears, the circuit goes into the recovery state. Q_1 and D_2 are now nonconducting so that the transformer time constant depends on R_1 , which is short enough to enable the transformer to recover completely between successive pulses.



Common mode signal-powered circuit decouples positive and negative pulses from the d-c component of a bidirectional pulse train. The transistor and diode in the secondary circuit are back-biased after passing a pulse.

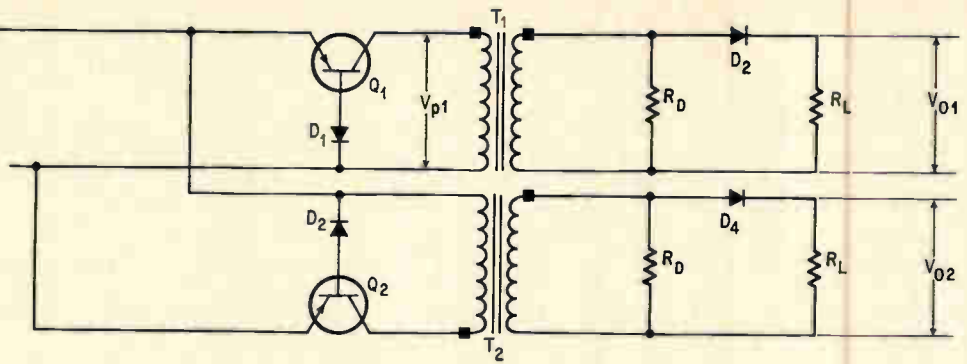

The back-voltage generated across the transformer terminals by the collapsing magnetic field is prevented from entering the source by Q_1 and from entering the load by D_2 , which are now back-biased during recovery.

The most important feature of this circuit is that its transmission and recovery-time constants alternate without the help of external sensing and control circuits.

Designing common-mode circuits

For negligible pulse droop, the inductance of the transformer must be large compared with the impedance of the transistor and diodes when they are conducting. Droop, d , is the ratio of the decrease in amplitude between a square wave's leading and trailing edges to the maximum amplitude of the square wave.

The primary inductance L required for minimum droop can be derived from the following equation, which can be easily verified by realizing that L/R is the circuit's time constant:

$$L \geq \frac{Rt_p}{d}$$

where

L is in henries,

t_p = pulse duration in seconds,

$$\text{and } R = \frac{R_1 R_2}{R_1 + R_2} \text{ in ohms}$$

R_1 is the total resistance in the primary circuit of the transformer and R_2 is the total resistance in the secondary circuit of the transformer referred to the primary.

The equation shows that when Q_1 is conducting, the time constant L/R must be much larger than the pulse duration, t_p .

When a voltage is impressed on a transformer winding, the flux density in the core changes in proportion to the voltage. The concept of an imaginary magnetizing current i_m is introduced to account for the net flux, since not all of it is attributable to winding currents. If E is the external primary voltage, the magnetizing current follows the familiar form,

$$E = -L \frac{di_m}{dt}$$

The value of i_m at the end of pulse duration can be

found by integration. Because the saturated collector-emitter resistance and the primary winding resistance are low, the voltage applied at the circuit's input terminals V will be nearly equal to the voltage E induced in the transformer. Therefore, if i_m is initially zero, it will reach the following peak value at the end of a pulse

$$i_{m(\text{peak})} = \frac{Et_p}{L}$$

The peak flux density generated by i_m must not exceed the peak flux density rating B_{max} of the core material used. This can be assured for a given core material and pulse voltage if the number of primary turns, N_p , is chosen so that:

$$N_p = \frac{Et_p}{A B_{max}} \left[\frac{R_2}{R_1 + R_2} \right]$$

where A = core area in square meters and B_{max} is the flux density in volt-seconds per square meter.

In the circuit shown, E cannot exceed about one volt because of the clipping effect due to the forward voltage drop of D_1 .

To assure that the transformer always operates on the linear portion of its B-H characteristics, the magnetizing current i_m must be reduced to near zero between pulses. This is accomplished by decreasing the time constant L/R .

If the input voltage falls below the threshold value required to forward bias the emitter-base junction of Q_1 , the transistor goes into cutoff. The rapidly collapsing flux in the transformer generates a reverse voltage that back-biases D_2 . However, when Q_1 and D_2 are nonconducting, it still may be necessary to insure that the circuit is overdamped, a condition in which the circuit cannot oscillate. Damping factor k is given by

$$k = \frac{1}{2R} \sqrt{L/C}$$

where C is the capacitance of the transformer winding and circuit wiring in farads.

If the calculated value of k is less than 1, the underdamped case, the circuit will oscillate. Resistor R_D can be decreased in value to insure the overdamped condition, $k > 1$. However, the value of R_D must still be large enough so that the recovery time constant is much shorter than the interval between successive pulses.

FAIRCHILD LOW POWER LOGIC

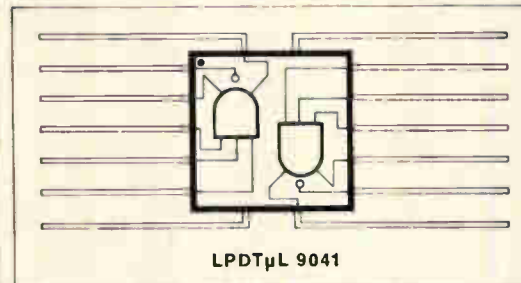
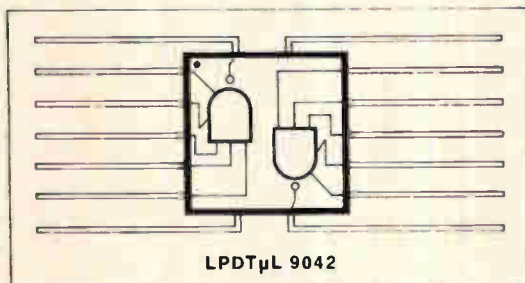
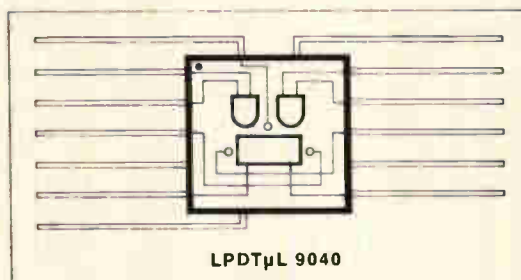
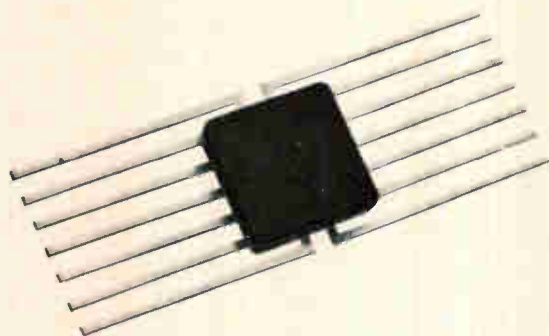

FEATURES:

Low Power drain	less than 1mW/gate (typ.) @ 50% duty cycle less than 4mW/clocked flip-flop
Single power supply requirement	5V optimum, 4.5V to 5.5V range
Guaranteed noise immunity	450mV min. at temperature extremes
Logic propagation delays	60nsec. typical
Binary clock rate	2.5Mc
Full temperature range	-55°C to +125°C

LPDT μ L LOW POWER DIODE-TRANSISTOR MICROLOGIC™ CIRCUITS

Fairchild LPDT μ L integrated circuits offer high performance in the low milliwatt range. High resistance values and small chip geometry hold down power consumption. The flip-flop element operates either in the R-S or J-K mode, with maximum dissipation of 6mW at a 2Mc toggle rate. Gates provide fan-out capability of 10 LPDT μ L low power logic unit loads, or one standard Fairchild DT μ L diode-transistor logic unit load. (Standard Fairchild DT μ L logic circuits can be used to extend the fan-out capability still further). The circuits come in Fairchild's Cerpak flat package, and can be used in satellites, battery-operated field equipment, or other instruments where reliability and high performance must be achieved with limited power. Fairchild LPDT μ L low power integrated circuits are available in evaluation quantities from distributors. For complete information write to:

FAIRCHILD
SEMICONDUCTOR

The most
advanced coil
winding equipment
in the world
today!

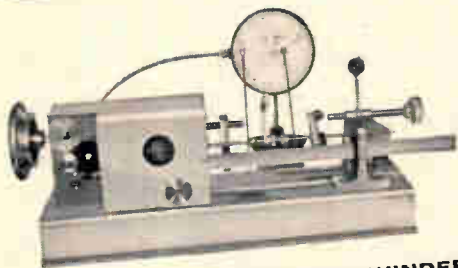

MODEL WX LABORATORY WINDER

The world's most versatile winding machine for all types of radio frequency coils as well as bobbins, transformers, resistors, etc. Features continuous gain or feed adjustment and our exclusive adjustable cam.



MODEL CK-SL AUTOMATIC WINDER

The machine illustrated produces more than 20 completed coils a minute without operator attention. This is one of a large family of completely automatic or semi-automatic machines.

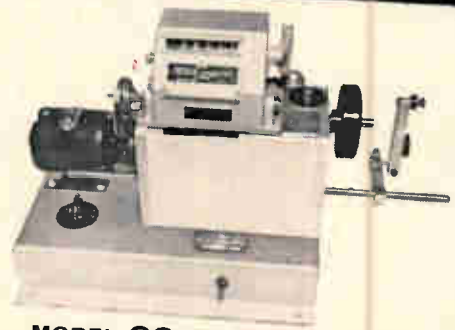

MODEL CS BOBBIN WINDER

Pictured is the current version of our most popular bobbin winder having increased capacities. A complete line of single and multiple units is available.

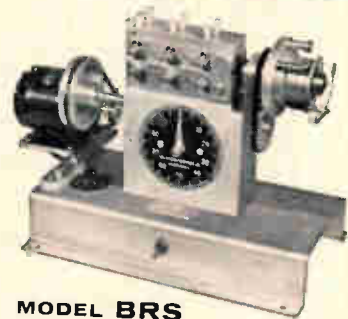

**MODEL BRS
PRECISION STRIP WINDER**

This is one of a group of single-layer machines to wind on continuous or pre-cut strips or mandrels of various shapes.

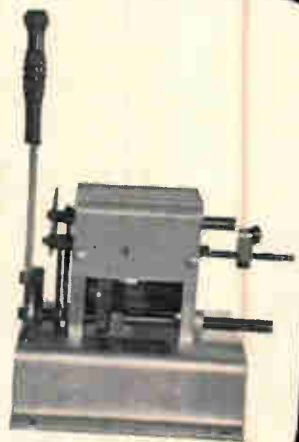

**MODEL MP
HAND WINDER**

Coils with up to 60 turns produced in a single stroke of the lever.

Write today for complete literature

Representatives in all major electronic market areas throughout the country

COIL WINDING EQUIPMENT CO.

OYSTER BAY, NEW YORK - WALNUT 2-5660



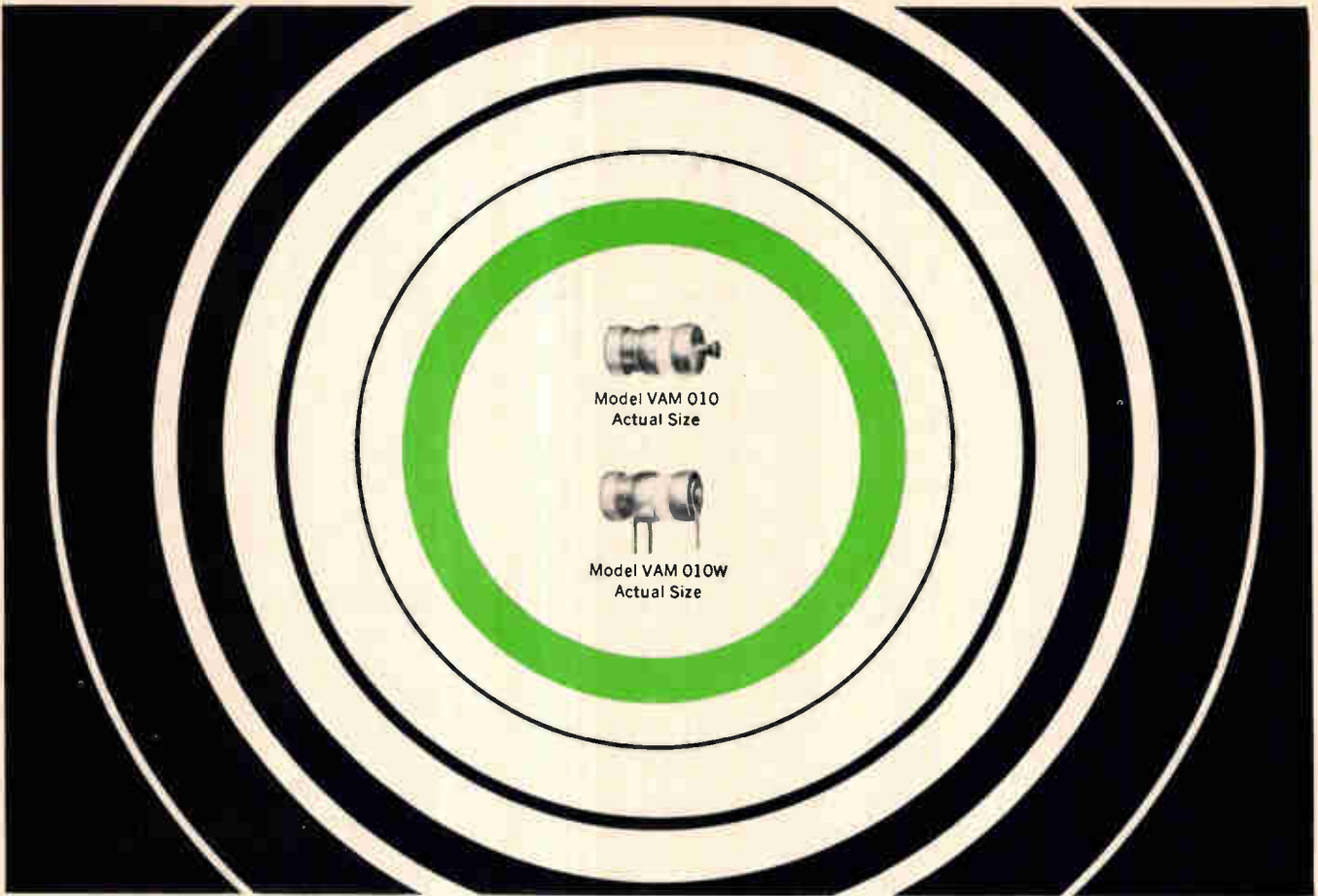

New JFD Air Variable Capacitors offer higher frequencies with negligible loss of Q

Plus

- Ultra Stability
- Highest Q
- Small Size
- Rugged Construction

Now JFD air variable capacitors offer circuit designers the advantages of extremely high "Q" and greater capacitance values in a rugged miniature size unit. Offered in both a printed circuit (VAM 010W) and a panel mounting model (VAM 010), the new units operate at far higher frequencies with negligible loss of "Q" in comparison to other types.

Internal air meshing shells are silver plated to provide good surface conductivity and to prevent corrosive effects. Three internal contact springs assure positive electrical contact of rotor at all times. Leads on printed circuit model are tinned for ease in soldering.

The high density insulator between stator and rotor has excellent electrical properties and contributes to overall structural strength. Rubber gasketed threaded end caps effectively seal the units against dirt entrance or atmospheric contamination after tuning.

WRITE FOR JFD BULLETIN VAM-65

JFD 120-A

JFD ELECTRONICS CORPORATION
THE \neq AMERICA KNOWS BEST!

Components Division
JFD ELECTRONICS CORPORATION, 15th Ave. at 62nd St., Brooklyn, N. Y. 11219
Tel: 212 DE 1-1000
JFD NORTHEASTERN, Ruth Drive, P. O. Box 228, Marlboro, Mass. 07152
JFD NEW YORK-NORTHERN, Damiano Pl., P. O. Box 96, New Hartford, N. Y. 13503
JFD MID-ATLANTIC, P. O. Box 5055, Philadelphia, Pa. 19111
JFD MID-ATLANTIC-MARYLAND, P. O. Box 7676, Baltimore, Md. 21207
JFD MIDWESTERN, 6330 W. Hermione St., Chicago, Ill. 60646
JFD MIDWESTERN-OHIO, P. O. Box 8086, Cincinnati, Ohio 45208
JFD WESTERN, 9 Morlan Place, Arcadia, California 91006
JFD ISRAEL LTD., Industrial Area B, Bldg. 23, Azor, Israel
JFD ELECTRONICS, EUROPE S A, 7 Rue de Rocroy, Paris, 10, France

Precision Piston Trimmer Capacitors ■ Metalized Inductors ■ LC Tuners ■ Ceramic Fixed and Variable Capacitors ■ Fixed and Variable Distributed and Lumped Constant Delay Lines
Visit JFD at IEEE Booth IE12



There's only one way to go...computerized filter and transformer design



Here's the newest, shortest way to accuracy and top performance in filters and transformers: design by computers.

It's your fastest route. Computer designs take minutes instead of hours. No crossroads or by-passes, either. Computer design explores possible approaches, guides you straight to the best solution when you're in a hurry. And no detouring for trial-and-error prototype costs. Designs are "performance tested" before production starts. Genisco's computer method searches through existing designs and singles out any that can be used. Your filters and transformers arrive on time and at lower shipping cost because Genisco plants are on the map in key market areas. Price quotations are fast and accurate. There's never any guessing about costs with Genisco computer design of filters and transformers.

Find out how this new design capability can put you on the right track. Write today for complete information.

TRANSFORMERS

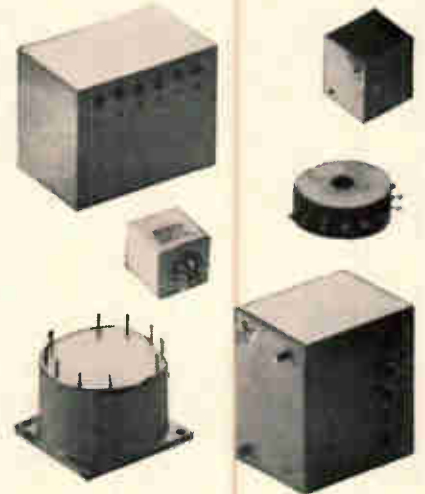

RFI & ELECTRONIC WAVE FILTERS

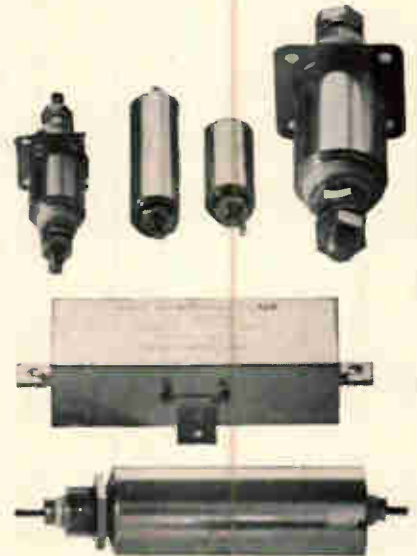

RESISTORS & NETWORKS

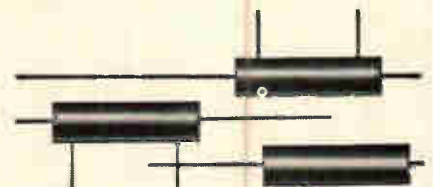

Genisco

TECHNOLOGY CORPORATION



ELECTRONIC COMPONENTS DIVISION / GENISTRON DIVISION

LOS ANGELES
6320 West Arizona Circle
Los Angeles, Calif. 90045
Phone: (213) 776-1411 TWX: 213-670-4765

CHICAGO
3223 Armitage Avenue
Chicago, Ill., 60647
Phone: (312) 227-3130 TWX: 910-221-1390

WASHINGTON, D.C.
10774 Tucker Street
Beltsville, Md. 20705
Phone: (301) 345-8900 TWX: 710-828-9712

SEE US AT BOOTH NO. 1G-30, 1ST FLOOR, IEEE SHOW, MARCH 21-24.

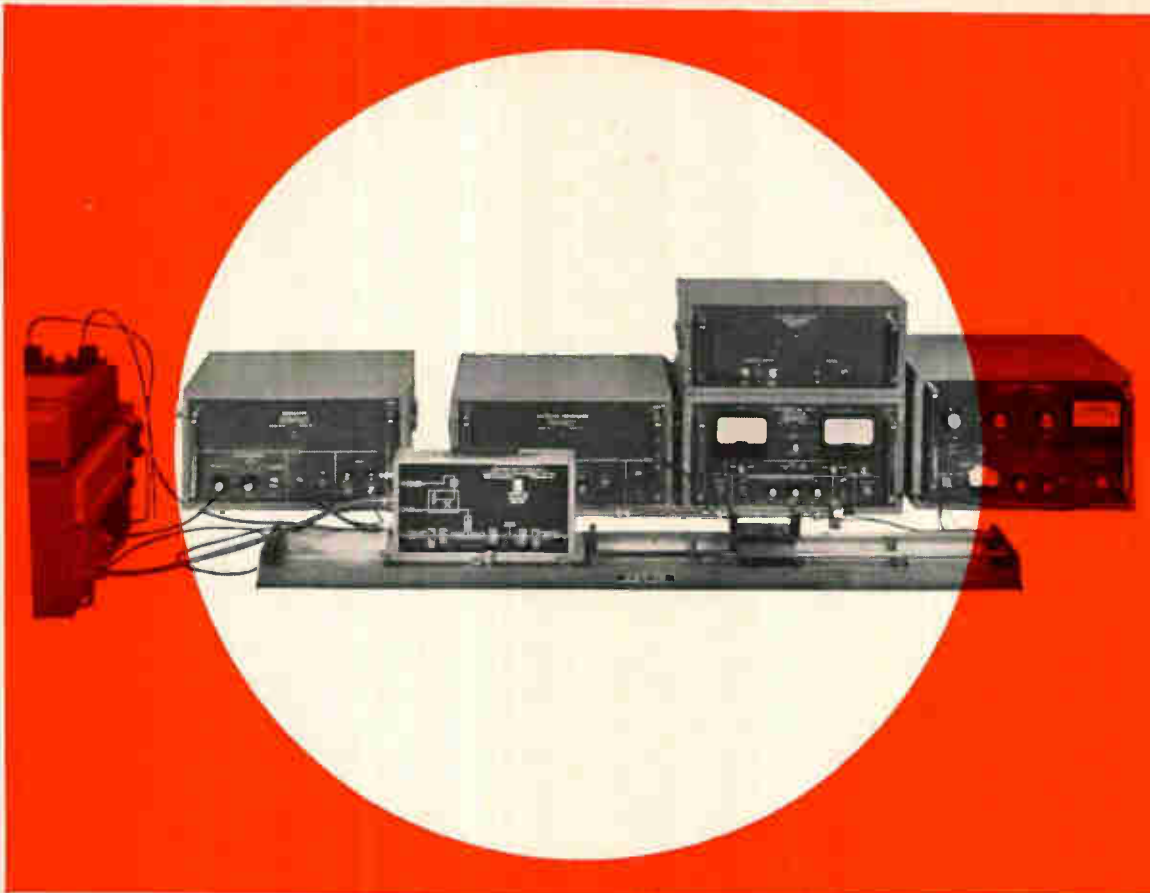

A HIGH RESOLUTION SWEEP-FREQUENCY INSERTION LOSS MEASUREMENT SYSTEM . . . WITH FIXED FREQUENCY MEASUREMENT ACCURACY

Now, in an adaptation of the widely accepted Ψ Dual Channel Insertion Loss Measurement System, Weinschel Engineering offers swept-frequency measurement of insertion loss to accuracies associated up to now only with fixed frequency measurements. The new Ψ 1850 system greatly speeds precise insertion loss measurement of microwave component characteristics over octave ranges.

For use in coaxial systems, the Ψ 1850 has available 4 microwave heads for octave ranges for use with an instrument package composed of proven Ψ Dual Channel System Instruments. Existing Ψ Dual Channel System Instruments can be adapted for use in the Ψ 1850 Swept System. Use of the dual channel arrangement with the selected and matched RF components composing the microwave head permits resolution of .02 db/cm for small dynamic ranges and accuracies of .02 db for small insertion loss values. Insertion loss variations are displayed on a graphic recorder.

For additional information or a demonstration of the Ψ 1850 System contact your local Weinschel sales engineer or Weinschel's home office.

SPECIFICATIONS

IMPEDANCE: 50 ohms
 FREQUENCY RANGE: 0.5—12.4 Gc (4 bands)
 SIGNAL: 100% square wave modulated at 1 kc
 INSERTION LOSS RANGE: Up to 30 db
 SYSTEM ACCURACY (includes resolution and repeatability):
 .02 db for values to 1 db
 .03 db for values to 10 db
 .05 db for values to 20 db
 .07 db for values to 30 db
 MAXIMUM DYNAMIC INSERTION LOSS VARIATION: 6 db
 RESOLUTION: to 0.02 db/cm for small dynamic ranges
 SENSITIVITY: Variable to $\pm .005$ db

STABILITY: > 0.01 db/hr.

VSWR AT INSERTION POINT:

<1.05, 0.5—4.0 Gc
 <1.1, 4.0—12.4 Gc

INSERTION POINT CONNECTORS: Type N (other connectors available)

REQUIRED ACCESSORIES: Sweep Oscillator and recorder

PRICE:

Model 1850E—Instrument Package (Includes BA-1D, BA-5, MO-1C, MB-1, ND-2 Mod., ND-2Z, and interconnecting cables) \$4,900.00

Model 1850-1	
0.5—2 Gc Microwave Head	\$2,090.00
Model 1850-2	
1.0—4 Gc Microwave Head	\$2,090.00
Model 1850-3	
4.0—8 Gc Microwave Head	\$2,090.00
Model 1850-4	
8.0—12.4 Gc Microwave Head	\$2,090.00

Be sure to attend WEINSCHTEL ENGINEERING MEASUREMENT CLINIC

Blue Room, Essex House Hotel, Central Park South, New York City, March 21-24, open Noon—7 P.M., papers presented 2—4 P.M. Continuous equipment demonstrations, including the important Ψ Model 1850 Swept Frequency Insertion Loss Measurement System. Also, see our equipment at the IEEE Show, Booth M-14.

DESIGNERS AND MANUFACTURERS OF PRECISION MICROWAVE EQUIPMENT



WEINSCHTEL ENGINEERING

GAITHERSBURG, MARYLAND

TEL.: 301/948-3434

TWX: 301-926-3730

SANTA MONICA, CAL., 1318 Second St.

TEL.: 213/394-1154

TWX: 213-879-0490

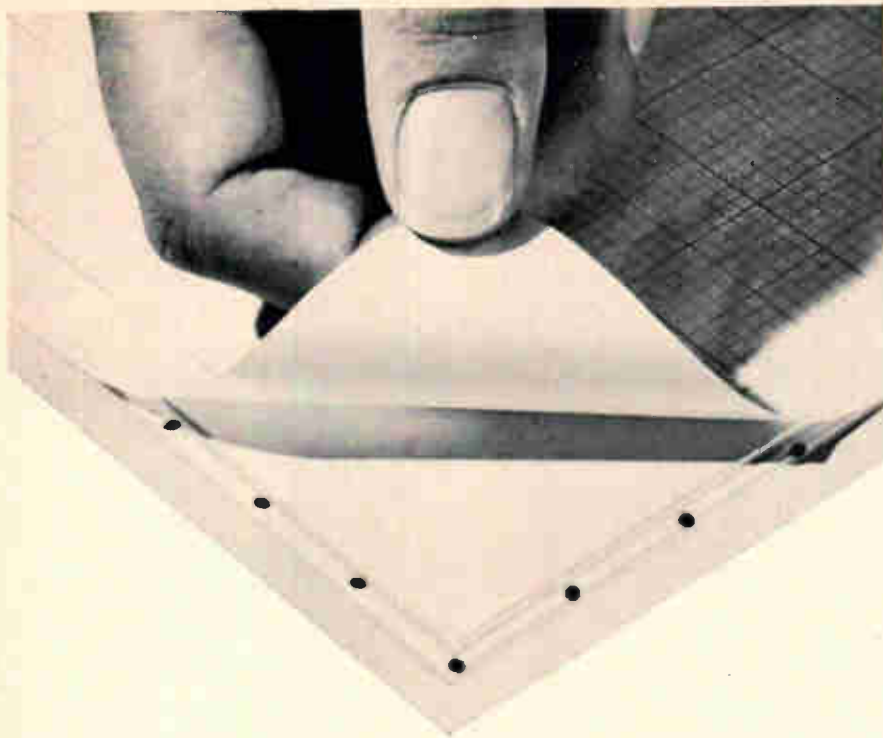

IN X-Y PLOTTERS IT'S THE HOLD-DOWN (GRAPH PAPER, THAT IS) THAT COUNTS

Paper hold-down is an important element in your plotter... graph paper, that is... not stamps, business cards, etc.

Our new low-pressure vacuum hold-down system was designed with just this requirement in mind. No clog... no dust or dirt problems... maintenance free operation. This system holds your graph paper effectively, and it will perform efficiently at sea level or on any mountain you pick.

There are varied approaches to this problem; all good, depending on what you want to hold. We chose our low-pres-

sure system because it is the most reliable, most economical method of securing standard graph paper. Your graphic output is our business, and we pay particular attention to see that only the pen moves on PLOTAMATIC plotters.

Check our complete line of PLOTAMATIC* X-Y Plotters for your applications... 8½" x 11" and 11" x 17" models, to 16 d-c input, greater recording periods and plotting rates, continuously variable time sweeps and that new paper hold-down system we've been talking about. Write or call for immediate information.

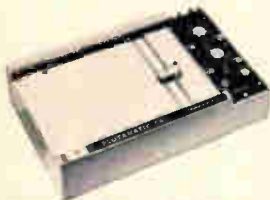

PLOTAMATIC Model 690



PLOTAMATIC Model 800A



PLOTAMATIC Model 850, with exclusive Symbol Printer

DATA EQUIPMENT COMPANY
DIVISION OF BBN CORPORATION (DELAWARE)
2126 South Lyon Street, Santa Ana, California 92705
Tel: (714) 546-5300 TWX: 714 546-0437



SEE OUR NEW PLOTAMATICS
IN ACTION AT
IEEE BOOTH NO. 3K31

DE
DATA EQUIPMENT
COMPANY

REPRESENTATIVES

INSTRUMENT ASSOCIATES, INC.

(Maine, New Hampshire, Massachusetts, Connecticut, Rhode Island, Vermont)
30 Park Ave., Arlington, Mass.
(617) 648-2922 TWX: (617) 648-0095
742 Asylum Ave., Hartford, Conn.
(203) 246-5686 TWX: (203) 278-1458

J. A. REAGAN

(Up State New York)
419 Central Ave., Albany, N.Y.
(518) 436-9649 TWX: (710) 441-8224

GAWLER-KNOOP CO.

(Virginia, Maryland, Delaware, New Jersey, Dist. of Columbia, E. Pennsylvania, New York City Area)
1751 Rockville Pike, Rockville, Md.
(301) 427-3950
14 Beaufort Ave., Roseland, N. Jersey
(201) 226-4545
P.O. Box 414, Richboro, Penna. 18954
(215) 925-7550

TECHNICAL ASSOCIATES, INC.

(No. Carolina, So. Carolina, Tennessee, Mississippi, Alabama, Georgia, Florida)
2319 E. South St., Orlando, Fla.
(305) 424-5681 TWX: (305) 841-3556
P.O. Box 1443, Huntsville, Ala.
(205) 881-8495 TWX: (205) 533-1279

S. STERLING CO.

(Michigan, W. Pennsylvania, Ohio, W. Virginia, Kansas, Missouri, Kansas, So. Illinois)
21250 10½ Mile Rd., Southfield, Mich.
(313) 357-3700 or 442-5656
TWX: (313) 357-4615
5827 Mayfield Rd., Cleveland, Ohio
(216) 442-8080 TWX: (216) 449-0697
3300 So. Dixie Dr., Dayton, Ohio
(513) 298-7573 TWX: (513) 944-0358
7849 N. Linbergh Blvd., Hazelwood, Mo.
(314) 837-1221
4232 Brownsville Rd., Pittsburgh, Pa.
(412) 884-5515 TWX: (412) 343-2844

BARD ASSOCIATES, INC.

(No. Dakota, So. Dakota, Indiana, Minnesota, Illinois, Kentucky, Wisconsin)
La Grange Industrial Park, La Grange, Illinois
(312) 354-0660 TWX: (312) 352-7782
6806 No. Farmleigh Dr., Indianapolis, Indiana
(317) 849-2723 TWX: (317) 571-8343
7700 Morgan Ave., Minneapolis, Minn.
(612) 866-1700

NOAKES ENGINEERING

(Oklahoma, Arkansas, Texas excluding El Paso, Louisiana)
2338 MacArthur Blvd., Irving, Texas
(214) 255-0441
2128 W. Alabama, Houston, Texas
(713) 529-6213

D. E. BOND ASSOCIATES

(Colorado, El Paso County in Texas, New Mexico, Utah, Wyoming, Montana, Idaho)
5670 E. Evans Ave., Denver, Colorado 80222
(303) 756-1234
P.O. Box 1485, Las Cruces, New Mexico
(505) 524-0410
P.O. Box 11331, Albuquerque, New Mex. 87112
(505) 247-3442

MOXON ELECTRONICS CORP.

(California, Nevada, Arizona)
2311 Pontius Ave., Los Angeles, Calif.
(213) 272-9311 TWX: (910) 342-6345
15 W. 41st Ave., San Mateo, Calif.
(415) 345-7961 TWX: (910) 374-2355
2054 Garnet St., San Diego, Calif.
(714) 274-6525

FRATHOM CO., INC.

(Export Agent—All Overseas)
202 E. 44th St., New York, N.Y.
(212) 687-9390

ATLAS INSTRUMENT CORP., LTD.

(Canada)
50 Wingold Ave., Toronto, Ontario, Canada
RUssel 1-6174

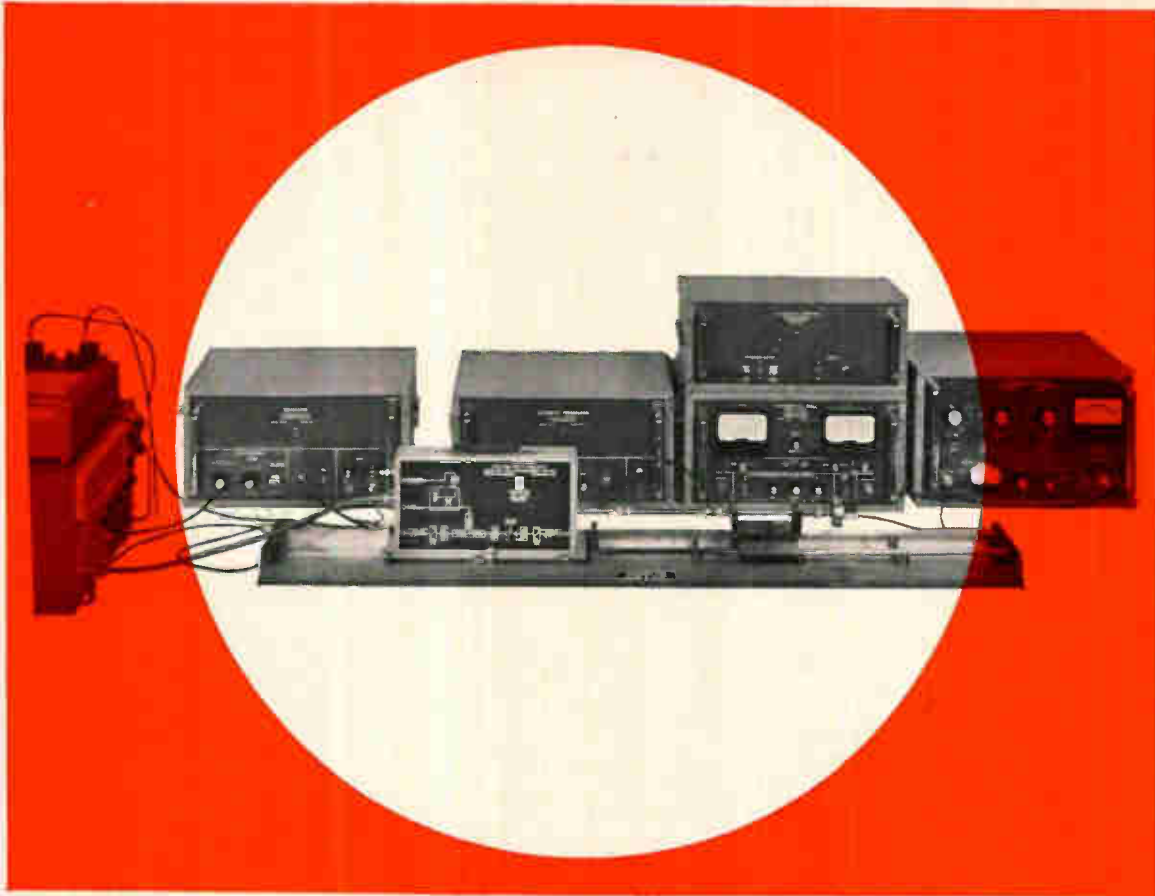

A HIGH RESOLUTION SWEEP-FREQUENCY INSERTION LOSS MEASUREMENT SYSTEM... WITH FIXED FREQUENCY MEASUREMENT ACCURACY

Now, in an adaptation of the widely accepted Ψ Dual Channel Insertion Loss Measurement System, Weinschel Engineering offers swept-frequency measurement of insertion loss to accuracies associated up to now only with fixed frequency measurements. The new Ψ 1850 system greatly speeds precise insertion loss measurement of microwave component characteristics over octave ranges.

For use in coaxial systems, the Ψ 1850 has available 4 microwave heads for octave ranges for use with an instrument package composed of proven Ψ Dual Channel System Instruments. Existing Ψ Dual Channel System Instruments can be adapted for use in the Ψ 1850 Swept System. Use of the dual channel arrangement with the selected and matched RF components composing the microwave head permits resolution of .02 db/cm for small dynamic ranges and accuracies of .02 db for small insertion loss values. Insertion loss variations are displayed on a graphic recorder.

For additional information or a demonstration of the Ψ 1850 System contact your local Weinschel sales engineer or Weinschel's home office.

SPECIFICATIONS

IMPEDANCE: 50 ohms
 FREQUENCY RANGE: 0.5—12.4 Gc (4 bands)
 SIGNAL: 100% square wave modulated at 1 kc
 INSERTION LOSS RANGE: Up to 30 db
 SYSTEM ACCURACY (includes resolution and repeatability):
 .02 db for values to 1 db
 .03 db for values to 10 db
 .05 db for values to 20 db
 .07 db for values to 30 db
 MAXIMUM DYNAMIC INSERTION LOSS VARIATION: 6 db
 RESOLUTION: to 0.02 db/cm for small dynamic ranges
 SENSITIVITY: Variable to $\pm .005$ db

STABILITY: > 0.01 db/hr.

VSWR AT INSERTION POINT:

<1.05, 0.5—4.0 Gc
 <1.1, 4.0—12.4 Gc

INSERTION POINT CONNECTORS: Type N (other connectors available)

REQUIRED ACCESSORIES: Sweep Oscillator and recorder

PRICE:

Model 1850E—Instrument Package (Includes BA-1D, BA-5, MO-1C, MB-1, ND-2 Mod., ND-2Z, and interconnecting cables) \$4,900.00

Model 1850-1

0.5—2 Gc Microwave Head \$2,090.00

Model 1850-2

1.0—4 Gc Microwave Head \$2,090.00

Model 1850-3

4.0—8 Gc Microwave Head \$2,090.00

Model 1850-4

8.0—12.4 Gc Microwave Head \$2,090.00

Be sure to attend WEINSCHTEL ENGINEERING MEASUREMENT CLINIC

Blue Room, Essex House Hotel, Central Park South, New York City, March 21-24, open Noon—7 P.M., papers presented 2—4 P.M. Continuous equipment demonstrations, including the important Ψ Model 1850 Swept Frequency Insertion Loss Measurement System. Also, see our equipment at the IEEE Show, Booth M-14.

DESIGNERS AND MANUFACTURERS OF PRECISION MICROWAVE EQUIPMENT



WEINSCHTEL ENGINEERING

GAITHERSBURG, MARYLAND

TEL.: 301/948-3434

TWX: 301-926-3730

SANTA MONICA, CAL., 1318 Second St.

TEL.: 213/394-1154

TWX: 213-879-0490

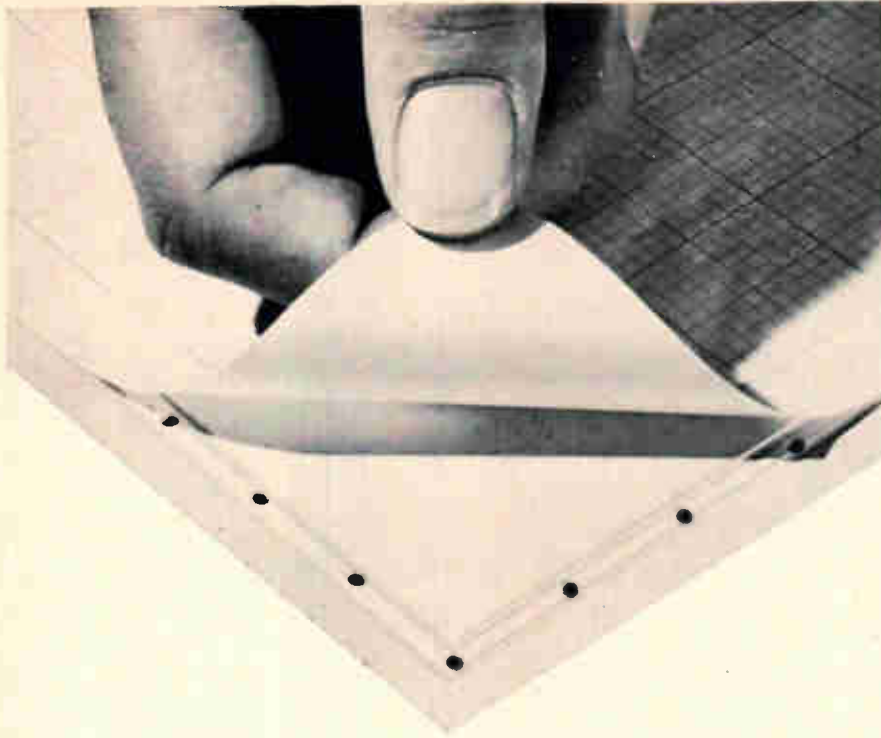

IN X-Y PLOTTERS
IT'S THE
HOLD-DOWN
(GRAPH PAPER, THAT IS)
THAT COUNTS

Paper hold-down is an important element in your plotter... graph paper, that is... not stamps, business cards, etc.

Our new low-pressure vacuum hold-down system was designed with just this requirement in mind. No clog... no dust or dirt problems... maintenance free operation. This system holds your graph paper effectively, and it will perform efficiently at sea level or on any mountain you pick.

There are varied approaches to this problem; all good, depending on what you want to hold. We chose our low-pres-

sure system because it is the most reliable, most economical method of securing standard graph paper. Your graphic output is our business, and we pay particular attention to see that only the pen moves on PLOTAMATIC plotters.

Check our complete line of PLOTAMATIC* X-Y Plotters for your applications... 8½" x 11" and 11" x 17" models, to 16 d-c input, greater recording periods and plotting rates, continuously variable time sweeps and that new paper hold-down system we've been talking about. Write or call for immediate information.

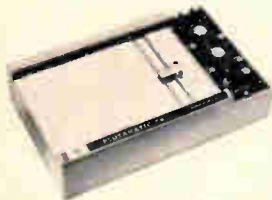

PLOTAMATIC Model 690



PLOTAMATIC Model 800A



PLOTAMATIC Model 850, with exclusive Symbol Printer

DATA EQUIPMENT COMPANY
DIVISION OF BBN CORPORATION (DELAWARE)
2126 South Lyon Street, Santa Ana, California 92705
Tel: (714) 546-5300 TWX: 714 546-0437



SEE OUR NEW PLOTAMATICS
IN ACTION AT
IEEE BOOTH NO. 3K31

*T.M. DATA EQUIPMENT CO.

DE
**DATA EQUIPMENT
COMPANY**

REPRESENTATIVES

INSTRUMENT ASSOCIATES, INC.
(Maine, New Hampshire, Massachusetts, Connecticut, Rhode Island, Vermont)
30 Park Ave., Arlington, Mass.
(617) 648-2922 TWX: (617) 648-0095
742 Asylum Ave., Hartford, Conn.
(203) 246-5686 TWX: (203) 278-1458

J. A. REAGAN
(Up State New York)
419 Central Ave., Albany, N.Y.
(518) 436-9649 TWX: (710) 441-8224

GAWLER-KNOOP CO.
(Virginia, Maryland, Delaware, New Jersey, Dist. of Columbia, E. Pennsylvania, New York City Area)
1751 Rockville Pike, Rockville, Md.
(301) 427-3950
14 Beaufort Ave., Roseland, N. Jersey
(201) 226-4545
P.O. Box 414, Richboro, Penna. 18954
(215) 925-7550

TECHNICAL ASSOCIATES, INC.
(No. Carolina, So. Carolina, Tennessee, Mississippi, Alabama, Georgia, Florida)
2319 E. South St., Orlando, Fla.
(305) 424-5681 TWX: (305) 841-3556
P.O. Box 1443, Huntsville, Ala.
(205) 881-8495 TWX: (205) 533-1279

S. STERLING CO.
(Michigan, W. Pennsylvania, Ohio, W. Virginia, Kansas, Missouri, Kansas, So. Illinois)
21250 10½ Mile Rd., Southfield, Mich.
(313) 357-3700 or 442-5656
TWX: (313) 357-4615
5827 Mayfield Rd., Cleveland, Ohio
(216) 442-8080 TWX: (216) 449-0697
3300 So. Dixie Dr., Dayton, Ohio
(513) 298-7573 TWX: (513) 944-0358
7849 N. Linbergh Blvd., Hazelwood, Mo.
(314) 837-1221
4232 Brownsville Rd., Pittsburgh, Pa.
(412) 884-5515 TWX: (412) 343-2844

BARD ASSOCIATES, INC.
(No. Dakota, So. Dakota, Indiana, Minnesota, Illinois, Kentucky, Wisconsin)
La Grange Industrial Park, La Grange, Illinois
(312) 354-0660 TWX: (312) 352-7782
6806 No. Farmleigh Dr., Indianapolis, Indiana
(317) 849-2723 TWX: (317) 571-8343
7700 Morgan Ave., Minneapolis, Minn.
(612) 866-1700

NOAKES ENGINEERING
(Oklahoma, Arkansas, Texas excluding El Paso, Louisiana)
2338 MacArthur Blvd., Irving, Texas
(214) 255-0441
2128 W. Alabama, Houston, Texas
(713) 529-6213

D. E. BOND ASSOCIATES
(Colorado, El Paso County in Texas, New Mexico, Utah, Wyoming, Montana, Idaho)
5670 E. Evans Ave., Denver, Colorado 80222
(303) 756-1234
P.O. Box 1485, Las Cruces, New Mexico
(505) 524-0410
P.O. Box 11331, Albuquerque, New Mex. 87112
(505) 247-3442

MOXON ELECTRONICS CORP.
(California, Nevada, Arizona)
2311 Pontius Ave., Los Angeles, Calif.
(213) 272-9311 TWX: (910) 342-6345
15 W. 41st Ave., San Mateo, Calif.
(415) 345-7961 TWX: (910) 374-2355
2054 Garnet St., San Diego, Calif.
(714) 274-6525

FRATHOM CO., INC.
(Export Agent—All Overseas)
202 E. 44th St., New York, N.Y.
(212) 687-9390

ATLAS INSTRUMENT CORP., LTD.
(Canada)
50 Wingold Ave., Toronto, Ontario, Canada
RUssell 1-6174

Stable transconductance

FROM -55°C TO $+250^{\circ}\text{C}$

RCA-7586 nuvistor
Heater Voltage $E_h = 6.3\text{ V}$
Plate Supply Voltage (E_{bb}) = 75 V
Cathode Resistor (R_k) = 100 Ω

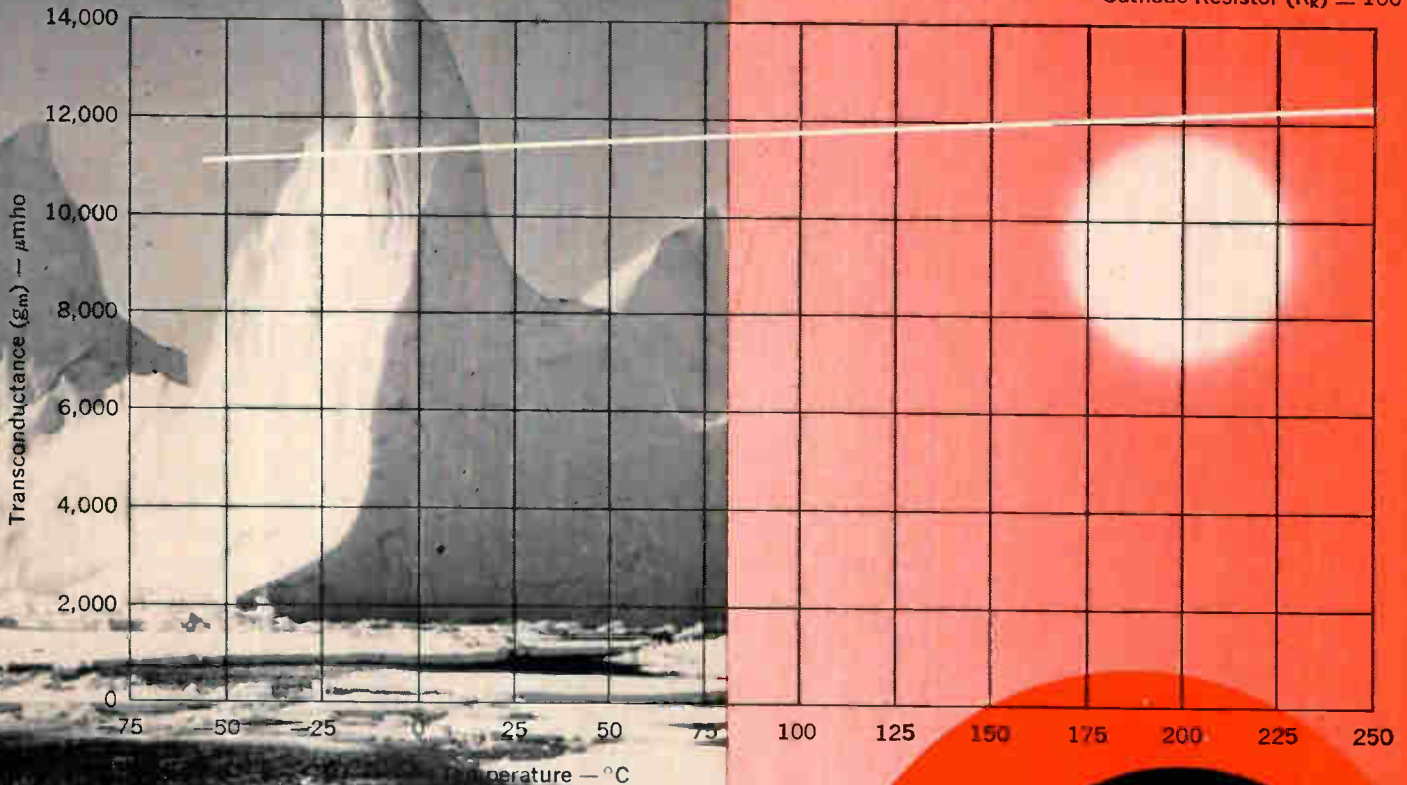

Temperature stability of highly-reliable RCA nuvistors minimizes frequency drift in electronic equipments and permits operation over wider temperature ranges. Change in transconductance per degree change in shell temperature is approximately 4 micromho per degree C.

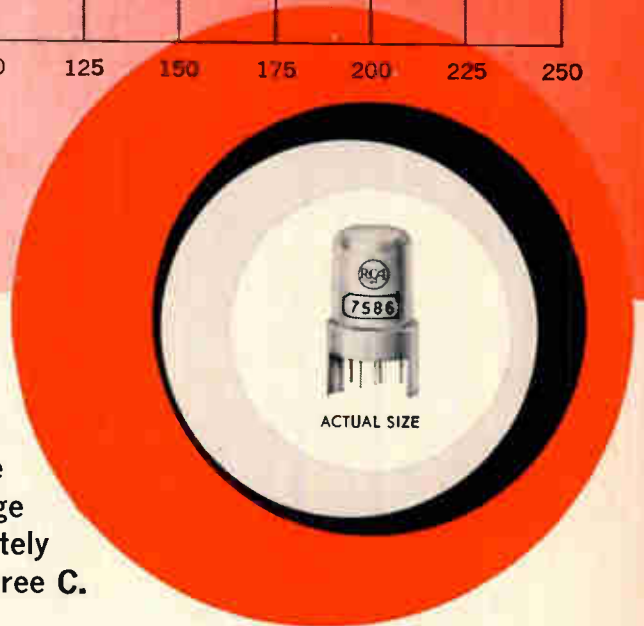

RCA nuvistors are exceptionally reliable in other ways, too: RCA-7586 nuvistors have demonstrated life-test reliability of 99.901% per 1,000 hours to 30,000 hours of operation.

Whenever you need a device that will provide high-level performance at practical costs in sophisticated applications, be sure to evaluate nuvistors. For specifics, call your nearest RCA District Office or write to RCA Commercial Engineering, Harrison, N. J. 07029.

RCA DISTRICT OFFICES—OEM SALES: EAST, 2075 Millburn Ave., Maplewood, N. J. 07040, (201) 485-3900 • MID-ATLANTIC, 605 Marlton Pike, Haddonfield, N. J. 08034, (609) 428-4802 • MID-CENTRAL, 2511 East 46th St., Bldg. Q2, Atkinson Square, Indianapolis, Ind. 46205, (317) 546-4001 • CENTRAL, 446 East Howard Ave., Des Plaines, Ill. 60018, (312) 827-0033 • WEST, 6363 Sunset Boulevard, Hollywood, Calif. 90028, (213) 461-9171 • INTERNATIONAL OPERATIONS, RCA International Division: Central and Terminal Aves., Clark, N. J. 07066, (201) 382-1000 • 118 Rue du Rhone, Geneva, Switzerland, 35 75 00.

RCA nuvistors are also available through your local RCA distributor.



RCA ELECTRONIC COMPONENTS AND DEVICES, HARRISON, N. J.

The Most Trusted Name in Electronics

Circle 143 on reader service card



Take a close look at coater claims before you buy. Most companies advertise their vacuum evaporators on the basis of empty chamber pump-down curves. Selling out of an empty chamber strikes us as a curious approach when it's the system performance with work in the bell jar that the user is interested in. Our pump-down curves are deliberately conservative because we don't believe in getting people all excited and then disappointing them. Net pumping speed at the base plate on this NRC 3114 coater is 20 percent higher than with any other four-inch pumping system on the market. The price is \$2,995. Other features in this compact (31" by 33½") system include . . . log and linear scaled NRC 720 gauge control with an ionization gauge tube, two thermocouple gauge tubes . . . raised base plate with bell jar, nonmagnetic, guard and gasket . . . circular chevron multi-coolant baffle/cold trap combination. The electrical control center and gauge control are mounted on a hinged panel which may be lowered to provide complete system accessibility from the front of the unit. Many NRC standard components, including a feedthrough ring, are adaptable for greater flexibility.

The NRC 3114 general purpose coater for microcircuit production and research was introduced just six months ago. It is in use today across the U.S. and Canada in surface physics and solid state research and electronics development and production operations. Write for details or call for a sales engineer today.

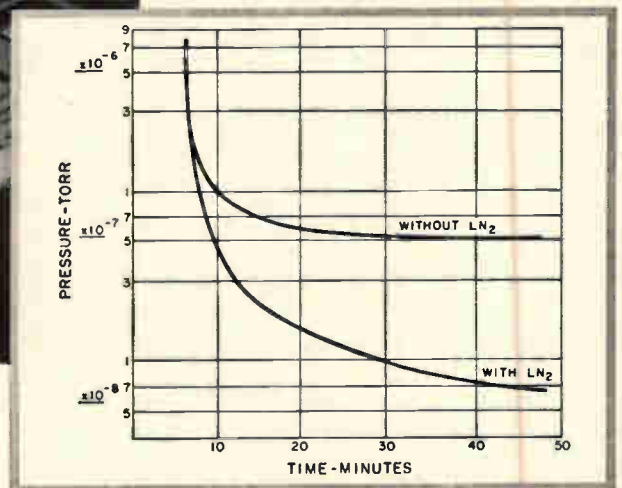

Take a close look at coater claims

EVAPORATORS • PUMPING STATIONS • POWER SUPPLIES
FEEDTHROUGHS • CRYSTAL PULLERS • LEAK DETECTORS
ELECTRON BEAM HEAT SOURCES • TUBULAR FURNACES



EQUIPMENT DIVISION
NATIONAL RESEARCH CORPORATION
A SUBSIDIARY OF NORTON COMPANY

160 Charlemont Street, Newton, Massachusetts 02161



Booth # 1823, 1825 IEEE Show

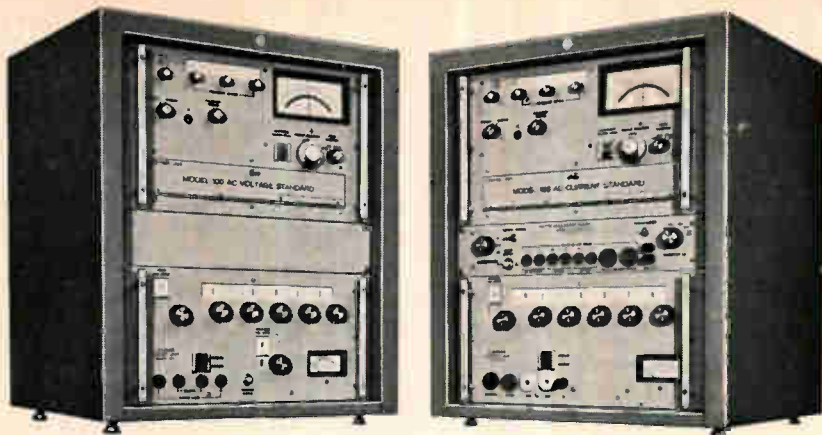

Only the new RFL Model 100 AC Voltage and Current Standards perform separately or together for current, voltage and power!

RFL's remarkable new Model 100 solid state system supplies sine wave emf from 1 MV to 1000 V at frequencies from 50 Hz to 10 kHz and current from 1 MA to 50 A at frequencies from 50 Hz to 3 kHz. Long term (one year) accuracy, traceable to NBS, is better than .04% over most ranges at full rated burden.

A special feature for reading the percent error of a meter directly makes the Model 100 particularly suitable for rapid calibration and standardization of precision AC meters and digital voltmeters. Resolution is practically infinite. Other uses include gyro navigation system calibration and computer programming as well as resolver, capacitor, inductor, amplifier, transformer and filter testing.

Automatic Operation—Set the dials for the desired output and take your time . . . there's no drifting. Output stays constant until you dial another value. Long term (one year) stability is better than .01%.

Saves Time—Output frequency is set by 3 digital reading dials and output emf or current by 5 dials; the decimal point is automatically set by the range selector. The percent of output deviation indicator saves you the time and trouble of calculating full scale and downscale % error when you're checking meters.

Flexible Design—Get either the Voltage or Current Stan-

dard . . . add the other later. Each has its own power supply. Add an accessory panel to either and both units can be interconnected for AC wattmeter calibration at various phase angles. Units fit standard 19-inch racks.

... and All This

- Safety interlocks protect both operator and equipment being tested.
- Thermally lagged built-in standard cell as reference check for zener diode working source.
- Panel meter indicates burdens to 20 VA.
- 4-terminal sensing eliminates errors usually caused by leads at high burdens.
- Output frequency continuously variable over entire range.
- Standby switch allows circuits to "idle" . . . ready for instant use.
- Optional 10-line code for digital print-out of dial setting.
- Calibration certificates traceable to NBS help maintain long term history.

FREE TRIAL—Try the Model 100 system, or either unit, under your own plant conditions without cost or obligation. Call Jack Janicke at RFL (tel: 201-334-3100) for complete specifications and information on in-plant trial. Or call the nearest RFL representative listed below.



Radio Frequency Labs., Inc.

Boonton, New Jersey 07005 • U.S.A.

Designers and Manufacturers of Electronic Equipment since 1922.

For complete specifications, call these RFL representatives direct:

Needham Heights, Mass.
Cowperthwait & Brodhead
817-444-9410

Skaneateles, New York
L-Tron Corporation
316-886-8172

Huntsville, Alabama
Space Engineering Sales, Inc.
205-837-6080

Chicago, Illinois
Hugh Marsland & Co., Inc.
312-878-1100

Dallas, Texas
Scientific Sales Co.
214-528-0553

N. Hollywood, California
O'Halloran Associates
213-877-0173

Washington, D.C.
ARCO Engineering Co.
202-298-8735

Saddlebrook, New Jersey
L & M Associates
201-343-3070

Cleveland, Ohio
Electro Sales Associates
218-488-1140

Denver, Colorado
Hytronic Measurements, Inc.
303-733-3701

Seattle, Washington
Dewar & Associates
206-722-1724

Palo Alto, California
O'Halloran Associates
415-969-9144

See us at IEEE Show, New York Coliseum, Booth #3800

MYCALEX

establishes new
design horizons in
COMMUNICATIONS
NUCLEONICS
AEROSPACE
COMPUTERS
ELECTROMECHANICAL
DEVICES
ELECTRONICS

Mycalex® glass-bonded mica
Supramica® ceramoplastics
Synthamica® synthetic mica

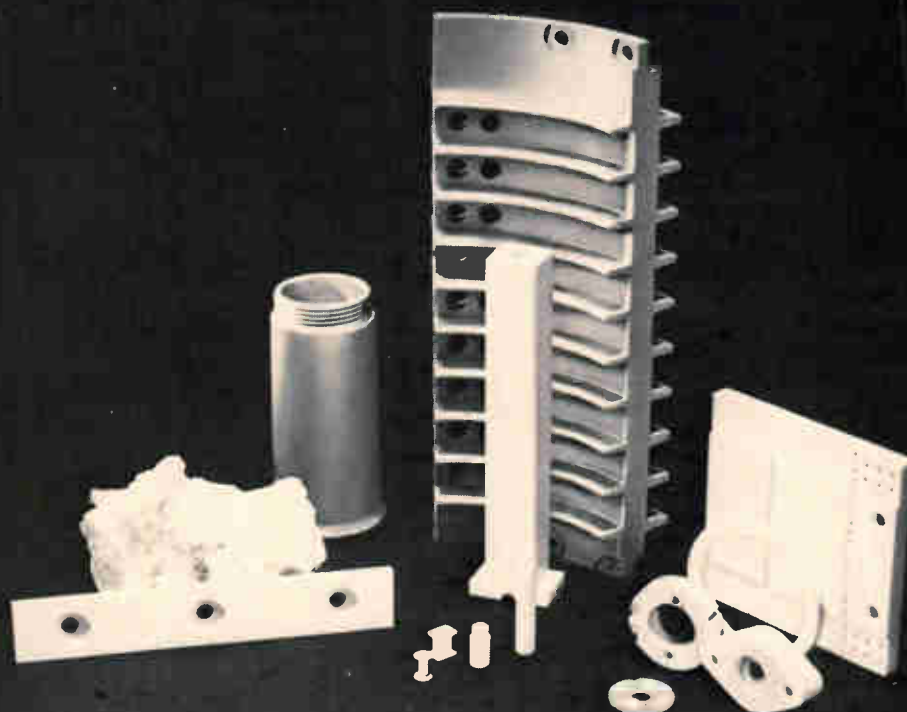

For almost half a century, MYCALEX CORPORATION OF AMERICA has pioneered in the development of materials with unique characteristics for the sophisticated requirements of insulation technology. The combination of properties inherent in MYCALEX® GLASS-BONDED MICA, and in SUPRAMICA® CERAMOPLASTICS has made possible production of components meeting the requirements of reliability and complexity of present, and future design concepts.

MYCALEX products provide this combination of characteristics:

Closely controlled insulation values equal to those of other ceramic materials

Moldable or machinable to close dimensional tolerances

Thermal expansion equivalent to that of many metals, permitting molding with metallic inserts without voids, cracks or shrinkage

Arc resistant, non-tracking, non-combustible
Complete, permanent dimensional stability throughout the entire temperature range
Impervious to moisture

High strength, and good impact resistance
Capable of withstanding temperatures from 700 deg. F. to 1500 deg. F., depending on grade.

Can be used for true hermetic seals, in a variety of design situations.

A comprehensive 36 page catalog provides complete technical and design information. Write or call for your copy.



MYCALEX
CORPORATION OF AMERICA

World's largest manufacturer
of ceramoplastics, glass-bonded mica
and synthetic mica products

125 Clifton Boulevard, Clifton, N.J.

Strain instruments from BLH...

PRECISE • PORTABLE • PRICED RIGHT



DIGITAL STRAIN INDICATOR—MODEL 120C

Easier to read, simpler to operate. Digital readout eliminates interpolations from dials and meters. Squarewave strain gage excitation to minimize cable capacitance problems. Wide angle null balance meter. Phase demodulator output jack for external dynamic indicator or recording. Wide gage factor control of 1.50-4.50. Accepts gage resistance of 60-2,000 ohms. Battery or AC operation. Durable Formica case. Weighs only 18 lb.



PRECISION CALIBRATOR—MODEL 625

Provides a multiplicity of highly accurate and stable MV/V or millivolt settings. Used to calibrate strain gages, strain gage transducers, or millivolt instruments. Highly stable circuitry and resistance components provide 55 precision MV/V output signals in five ranges of 11 points each. Available in three different models to supply resistance of 60, 120, 240, and 350 ohms. Durable Formica case. Weighs only 3 $\frac{3}{4}$ lb. for ease of portability.



10-CHANNEL SWITCHING UNIT—MODEL 220

For use where a series of strain gages must be switched into a single strain indicator and measurements taken from individual gages during a limited period of time. Up to 10 active and compensating gage pairs may be used, or one dummy gage can serve as compensation for the entire group. Particularly suitable where initial balancing is not required. Also suited for switching low-level signals from devices such as thermocouples. Durable Formica case. Weighs only 6 lb.



SWITCHING AND BALANCING UNIT—MODEL 225

Designed for switching gages or gage configurations into the BLH Strain Indicator or other strain-measuring instruments requiring full or half-bridge inputs. Provides for initially balancing each bridge to zero and quickly switching active and compensating gages into the instrument. Durable Formica case. Weighs only 12 lb.

For complete information write BLH ELECTRONICS or contact your nearest BLH Sales Engineering Representative. BLH ELECTRONICS, a division of Baldwin-Lima-Hamilton, Waltham, Mass. Plants in Waltham, Mass., Pasadena, Calif., and Darmstadt, West Germany.

BALDWIN • LIMA • HAMILTON
A subsidiary of Armour and Company

BLH
ELECTRONICS

Strain Gages • Temperature Sensors • Load Cells • Pressure Cells • Torque Pickups • Recorders • Instrumentation • Integrated Systems

35 pounds of economic excellence

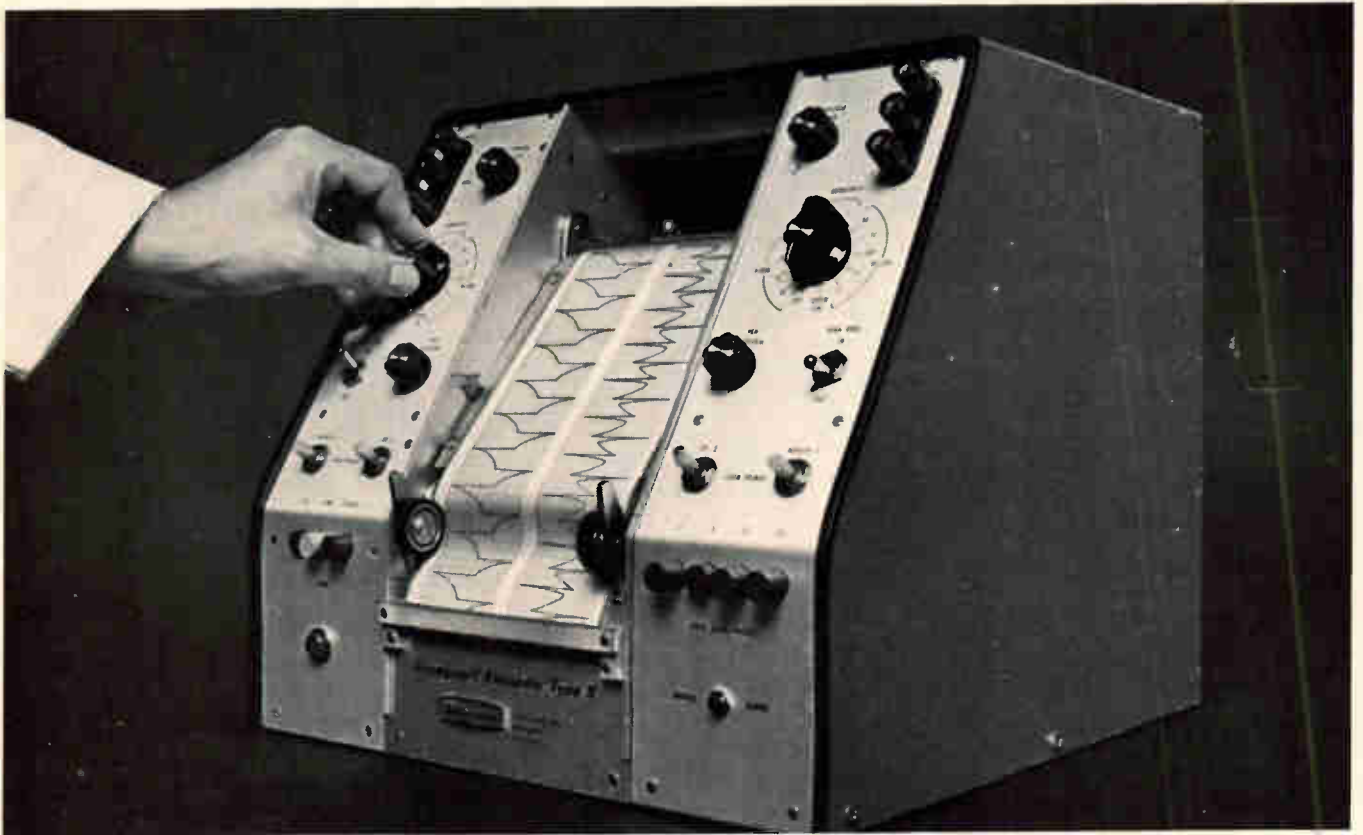

The Beckman Type K Dynograph® Recorder is a completely portable, two-channel, direct-writing oscillograph that incorporates every major feature of its larger counterparts without sacrificing accuracy, quality, or dependability...and the standard ink curvilinear version costs only \$1,295. It is simple to operate and maintain, and is ideally suited for applications in research and development laboratories, production and field tests, or servicing and maintenance.

All silicon solid-state, the extremely sensitive Type K provides ink or heat rectilinear, or ink curvilinear recording media; two analog plus two event channels; large capacity common ink reservoir, with push-button pen primers; simple paper loading; and chart speeds up to 100mm per second.

As for specifications, check these. Sensitivity range: 2mv/div to 10v/div; measurement range: 0.002 to 400v;

linearity: 0.5%; common mode rejection: 1000 to 1 or better.

Your local Offner Division Sales Engineering Representative has the full story on this lightweight, rugged, highly sensitive Type K Dynograph Two-Channel Portable Recorder. Contact him for details, or write direct.

Beckman®

INSTRUMENTS, INC.

OFFNER DIVISION

SCHILLER PARK, ILLINOIS 60176

INTERNATIONAL SUBSIDIARIES: GENEVA; MUNICH; GLENROTHES, SCOTLAND; TOKYO; PARIS; CAPE TOWN; LONDON

ENVIRONMENTAL PROOF
is what we call it . . .



 **Stackpole Rotary Switches**
Specially Designed to Guard Against
EXPOSURE—CONTACT CONTAMINATION—PRODUCTION DAMAGE

COMPETITIVELY PRICED— This completely enclosed, rugged switch costs no more than the open clip type.

SAMPLES IN 3 DAYS—to your exact specifications. Send your drawing and prove it to yourself.

ORDERS IN 2 TO 3 WEEKS—On-time delivery of uniform, high quality production quantities to meet your schedule.

SEND YOUR DRAWING FOR A QUOTATION AND SAMPLE. Take advantage of Stackpole quality, price and service. For additional information and technical data write: Electro-Mechanical Products Division, Stackpole Carbon Company, St. Marys, Pennsylvania 15857. Phone: 814-834-1521. TWX: 510-693-4511.



STACKPOLE
ELECTRO-MECHANICAL
PRODUCTS DIVISION



REEVES-HOFFMAN "chips" away at the space problem with new COLD-WELDED CRYSTALS

Reeves-Hoffman's newest series of crystals, packaged in cold-welded TO-5 transistor cans, are designed for operation at frequencies from 3 to 125 MHz. Frequency tolerance over the temperature range from -55°C to $+105^{\circ}\text{C}$ is $\pm 0.004\%$. (Upon special request, $\pm 0.0025\%$ can be provided.) Shock and vibration ratings exceed the requirements of MIL-Spec 3098D. Aging at 65°C is 6 parts in 10^6 per year.

Cold welding eliminates solder and attendant flux and heat, removes undesirable damping and corrosion, solves problems of thermal isolation. Leak rate is better than 10^{-9} cc of helium per second. The results: substantial increases in the reliability and stability of crystal units, oscillators and filters; further opportunity for miniaturization.

For example, by using microminiature circuitry "chips," it is possible to produce a cold-welded crystal oscillator that occupies the space normally used for the crystal alone. The oscillator shown at left, for example, is in the A-4 holder shown below. Can this new micromodule technique solve space problems for you? We invite your inquiry.

IEEE Booth 1B02

A-4

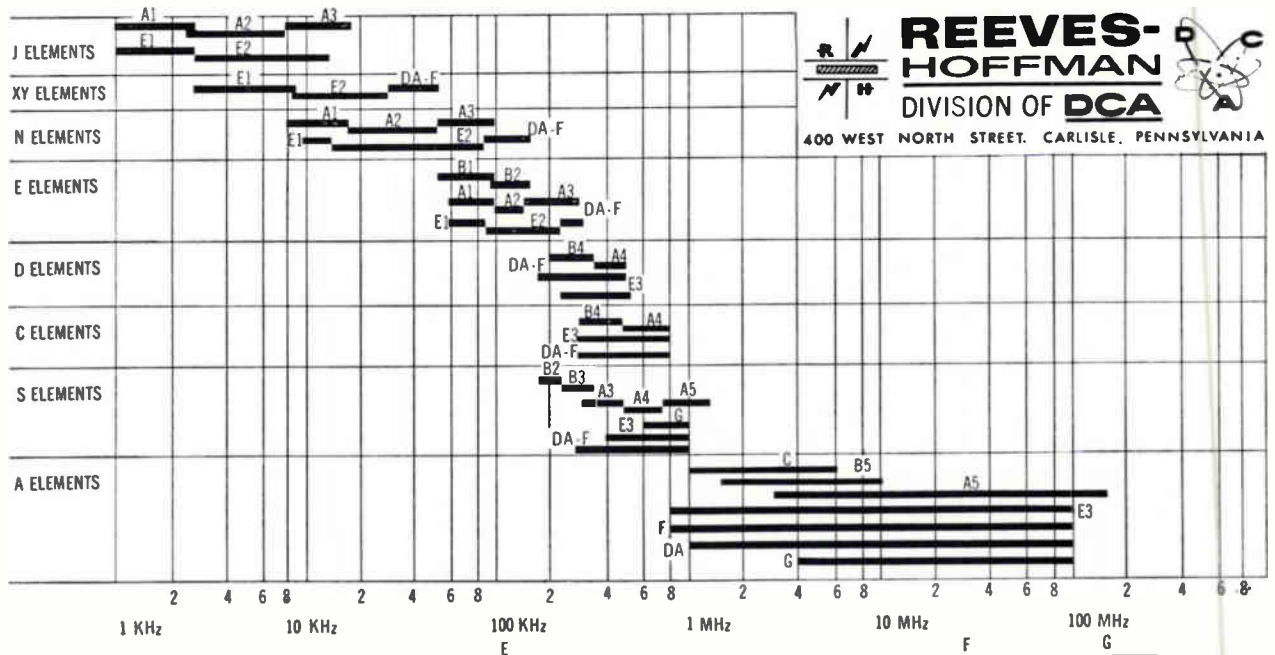
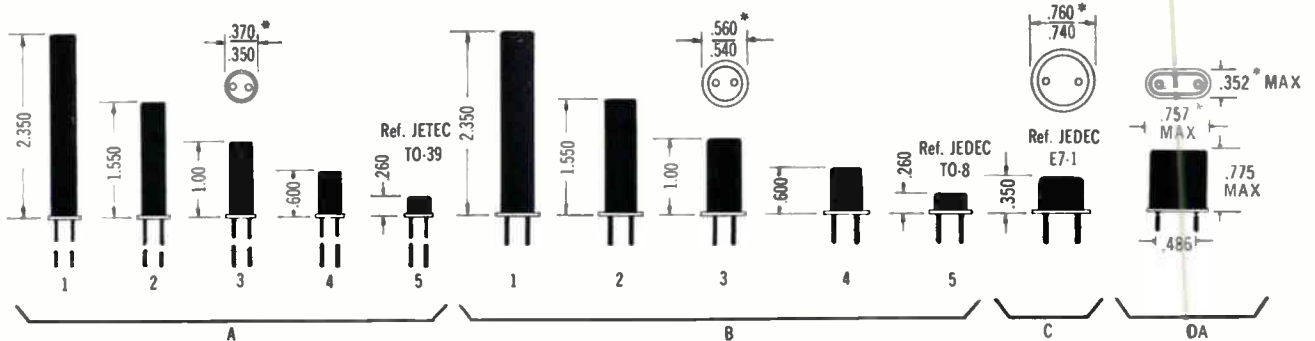

REEVES-HOFFMAN
DIVISION OF **DCA**
400 WEST NORTH STREET, CARLISLE, PENNSYLVANIA

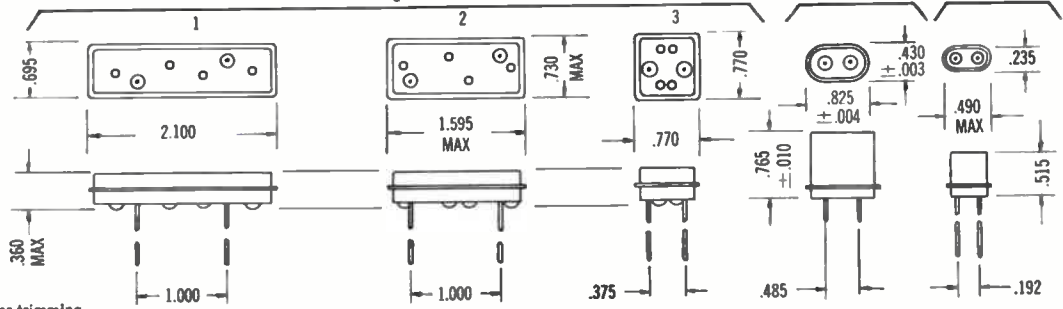

*Dimensions after trimming.

Probing the News

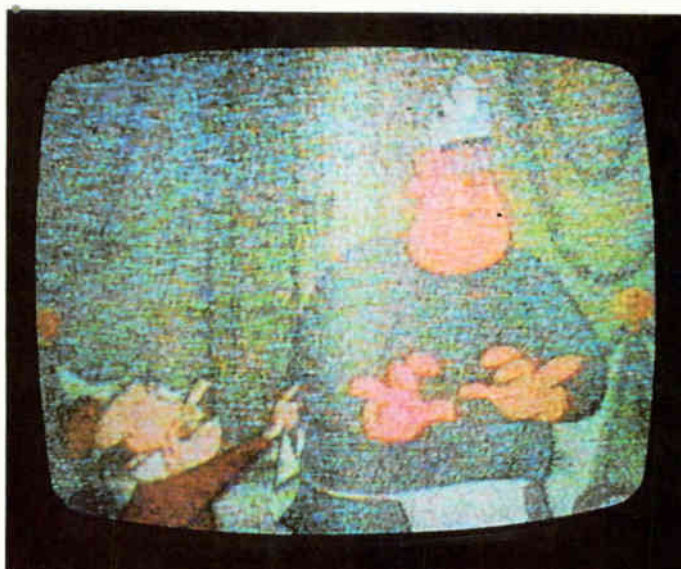

Richard Saunders

CATV system feeding a tv receiver in a poor reception area provides an excellent color signal (left) while high-gain outdoor antenna feeding an identical tv set in the same room produces a noisy picture.

Consumer electronics

Washington dims CATV picture

Regulations issued by the Federal Communications Commission have already been challenged on the floor of Congress.

The next challenge may come in the courts

After 15 years of nearly unchecked expansion, the fastest-growing fragment of the television industry is worried that its growth may be slowed by the Federal Communications Commission. On Feb. 15 the FCC asserted its jurisdiction over all community-antenna television systems and asked Congress to clarify the agency's authority.

The FCC also issued eight rulings pertaining to CATV; the most controversial of these would limit community antenna television to carrying broadcasts by local stations in each of the 100 biggest tv markets. These markets contain 90% of all tv receivers in the United States.

From a standing start 15 years ago, CATV has become a lucrative business in which 1,500 systems

serve about two million subscribers, each paying about \$5 a month for the service. Another 250 CATV systems are under construction. Last year the six biggest producers of CATV gear sold about \$17 million of equipment. CATV operators spend a similar amount for installation, according to Ira Kamen, president of Kamen Associates, a New York consultant to CATV owners and to manufacturers of community-antenna equipment.

I. In court and in Congress

Within the CATV industry, reaction to the FCC rulings ranged from rage to disappointment. Bruce Merrill, president of Ameco, Inc., of Phoenix, predicted that test cases would be brought by the CATV in-

dustry. "We don't expect to accept FCC jurisdiction by fiat without doing something about it," he said. Ameco operates CATV companies and manufactures equipment.

Edgar Smith, vice president of Time-Life Broadcasting, Inc., which owns five CATV systems and part of one being built in New York, said the ruling "will only stymie efforts in the 100 cities for the time being." Irving B. Kahn, president of Tele-Prompter, Inc., declared, "We have always stated that CATV should be regulated," but that "this should be accomplished by an act of Congress."

Repugnant. The first reaction in Congress was the introduction of a bill in the House of Representatives that would prohibit regulation of



Good pictures are received when cross-modulation and noise are 48 db or more below the signal level.



Noise randomly triggers color circuitry, causing confetti-like pattern on the television screen.

CATV. Its sponsor, Walter E. Rogers (D. Tex.), contends that the FCC is authorized to regulate only the transmission of broadcast signals, not their reception. Charging the agency with "seeking to expand its jurisdiction without the approval of Congress," Rogers declares "it is absolutely repugnant to the American system of free broadcasting."

The opposite position is taken by Commissioner Kenneth A. Cox, a member of the majority in the FCC's 4-to-1 vote. Cox favors "an approach which would bar new systems—for a specified period—from extending a station's signal beyond its Grade B contour, except upon authorization by the commission in certain carefully defined situations." In a Grade B contour, the quality of the picture is expected to be satisfactory to the median observer at least 90% of the time for at least 50% of the receiving locations within the contour.

II. The lure of the city

CATV companies, in increasing numbers, are seeking to enter metropolitan areas. A few years ago the typical CATV system served a rural region, far from tv transmitters, or areas of poor reception. In these regions are the 10% of the tv audience outside the 100 biggest markets, as defined by the American Research Bureau. Today, 74 of the 100 big markets have either an operating CATV system, a system under construction or an application for a franchise.

Prior to the FCC ruling, Kamen predicted that sales of CATV equipment would triple this year, and soar to \$75 million in 1967. That forecast may still be valid, he says.

Kamen's optimism is based on the premise that cities will continue to encourage CATV despite the FCC's apparent opposition to bringing in distant signals. The big impetus, he believes, should be the rapid growth of color tv and its requirement for better reception. (See photos on page 151.) Color tv requires higher signal levels than does black-and-white, he explains; also, color tv is much more sensitive both to phase variations caused by poor antenna patterns and to reflections of tv signals from buildings. Only CATV can assure high-quality reception, Kamen says.

Contrary to the FCC's fear that CATV would create dangerous competition to the struggling ultra-high-frequency stations, Kamen believes CATV may actually help them. CATV can extend the coverage of uhf stations just as it does other stations.

Receptive cities. Municipal governments generally welcome CATV. Most of the operating systems pay 1% to 3% of their gross revenues to the municipality. Moreover, in cities where tv can already be received without special assistance, community-antenna systems, in addition to improving local reception, try to provide signals on all of the 12 vhf channels that are available for use in a tv receiver.

Down with interference. When a

system offers all 12 channels, a strong signal at one frequency can interfere with a weaker signal on an adjacent channel. To prevent this, the CATV system must adjust both the sound and the picture carrier in each channel to insure that all signals are at about the same level. The adjustments are made at the head end—the point nearest the CATV's antenna—before the signals are combined and sent down the trunk line. If the signal-to-noise ratio is high and if the amplifiers are operating linearly, a good quality color picture appears on the screen, as in the photograph at the top of this page.

The number of amplifiers on the line, and therefore the length of the line, is limited by the degradation in picture quality caused by thermal noise and by the cross-modulation distortion added by each amplifier.

For example, on a long CATV line the additional amplifiers needed to compensate for line attenuation may add so much noise that the resulting noise spikes randomly trigger the video circuitry. In a black-and-white tv receiver this produces the effect called "snow"—a random pattern of white dots on the tv screen. In color tv sets, it results in a similar effect—only in color—called "confetti" as shown above in the photograph on the right.

Cross-modulation, the more serious of the problems, is caused by nonlinearities in the amplifiers, resulting in sum and difference products of the tv signals. As the signals go through additional amplifiers,



Cross-modulation components that are 43 db below signal level produce noticeable interference.

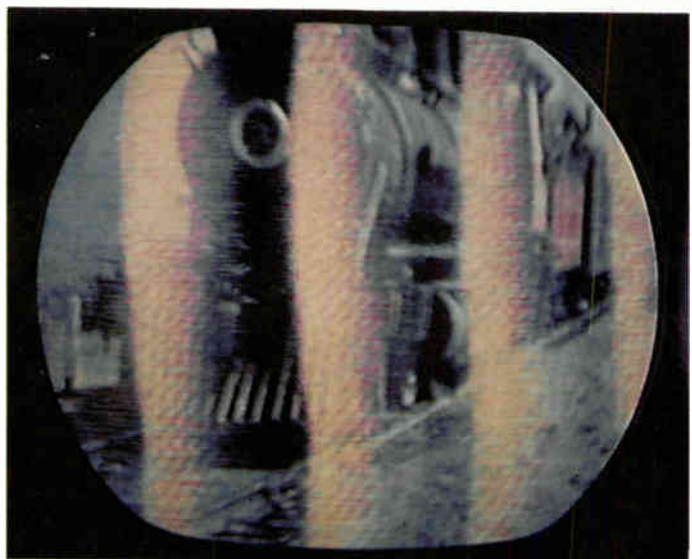

Windshield-wiper effect appears when cross-modulation components are 40 decibels below signal level.

TRW Semiconductors

the cross-modulation terms increase, and eventually produce a form of distortion known as the windshield-wiper effect, in which a solid line moves back and forth across the picture tube. The degradation of color pictures resulting from cross-modulation is illustrated in the photographs on this page. To improve linearity, class A amplifiers are used; large amounts of feedback are introduced; and the transistors are operated at a fraction of their rated capacity.

Custom-made transistors. Transistor characteristics determine both thermal noise and cross-modulation. CATV producers are searching for low-noise, high-frequency transistors with high output-power capabilities. Generally, the makers of CATV equipment have to select from among transistors that have been developed for other branches of electronics. In the past, systems have included transistors such as the type 2N3866 overlay transistor, manufactured by the Radio Corp. of America and Motorola, Inc., and the type 2N3137 made by Motorola and Fairchild Semiconductor, Inc., a division of the Fairchild Camera & Instrument Corp.; and the type 2N4041 made by TRW, Inc. TRW and Texas Instrument Incorporated are planning to market new transistors, designed specifically for CATV, which will have higher output capabilities.

III. The profit picture

Four groups that profit from CATV include operators (owners)

of systems, companies that install systems, equipment manufacturers and the component suppliers. Except for the component suppliers, many of the firms are involved in more than one phase of CATV. Major equipment manufacturers, for instance, may also build systems as well as own and operate them and CATV owner-operator companies will install systems for other owners.

Owners-operators. Among the larger CATV owner-operating firms, at least 10 companies each have more than 30,000 subscribers and serve 25% of the two million CATV subscribers in the country.

Systems owners reap the largest share of the profits in the CATV industry with profits in excess of 20% of invested capital being the general rule. Recently Robert J. McGeehan, president of Entron, Inc., which owns and operates systems and is one of the larger equipment manufacturers, said that the prospects were very good for receiving an average profit of 25% to 35% over a seven-year period.

IV. Equipment manufacturers

Six companies are estimated to sell over 80% of the electronic equipment bought by the CATV industry. The major company in the field is probably the Jerrold Electronics Corp., a subsidiary of the Jerrold Corp. of Philadelphia.

Ameco Inc. of Phoenix is rated second largest. Others in the top six include the Kaiser Aerospace and Electronics Corp., a subsidiary of

Kaiser Industries, the Viking Cable Co. of Hoboken, N.J., Entron, Inc. of Silver Spring, Md., and the Spencer-Kennedy Laboratories Inc. of Boston.

Each of these six companies did over \$2 million dollars last year but this includes the installation of systems as well as the sale of equipment. In the case of Viking, the total amount includes the sale of cable. The Jerrold Corp. had over \$30 million dollars in sales but this figure also includes two subsidiary companies: the Technical Appliance Corp. (Taco), a manufacturer of antennas and the Harmon-Kardon Inc., which makes high-fidelity equipment. Although unwilling to break down sales among its various companies, Jerrold did indicate that it sold about \$6 million in equipment at the CATV industry show held in Denver. Ameco claims \$10 million dollars in sales, and Viking over \$12 million. No figures were available for the Kaiser firm, although its CATV equipment sales has been estimated at \$2.5 million.

Microwave relay equipment, used to bring distant stations to the CATV system, adds to the total sales figure. A representative of the Collins Radio Co. in Dallas, indicated that the CATV industry purchased about \$6 million in equipment last year. Collins would not indicate its share of the market except to say that it was the largest single supplier of microwave equipment to CATV and that in any given year it generally provides equipment for over 50% of the permits granted by

IF YOUR COMPUTER SYSTEM REQUIRES A-D or D-A Conversion

where:

**A=resolver or
synchro**

D=10 to 16 bits

**JUST PICK UP
THE PHONE.**

North Atlantic
offers a complete line of
resolver/synchro interfaces
for computer systems,
aircraft/space vehicle simulation,
antenna position/programming,
and airborne use.

All silicon solid-state, 10 to 16 bits,
multi-speed, multiplexed inputs/outputs,
60 cps to 10KC.

As we said, just pick up the phone.



NORTH ATLANTIC
industries, inc.

TERMINAL DRIVE, PLAINVIEW, NEW YORK • (516) 681-8600

See us at IEEE—Booths 3A40—3A41

the FCC. Other companies selling microwave equipment include Jerrold Electronics, the Lenkurt Electric Co., San Carlos, Calif., a subsidiary of the General Telephone and Electronic Corp., Motorola Inc., Franklin Park, Ill., and the Raytheon Co., Lexington, Mass.

V. System equipment

A CATV system consists of three parts:

- The receiving or head end of the system, comprising the antennas, microwave relay and signal processing equipment.

- The trunk line which carries the signals from the head end to the distribution points within the community.

- Distribution lines that carry the signals to the vicinity of the home; there, connections are made to the subscriber's tv set by means of a "cable drop."

The equipment is intended to convert the incoming signal's frequency, where necessary, and to amplify such signals without adding seriously to system noise and distortion. The general criteria is that at the tv set the signal-to-noise ratio be at least 42 decibels to receive an excellent tv picture and that cross-modulation components and co-channel interference be at least 48 db below the signal level. These criteria are based on data compiled by the Television Allocation Study Organizations (TASO). In the TASO study the subjective responses of many viewers were used to grade the pictures.

Antenna. A separate high-gain antenna, or an antenna array, is usually put up for each channel to be received, allowing each antenna to be adjusted for optimum reception of the signal. As in outdoor home-antennas, the conventional Yagi antenna is most frequently employed.

Antennas are mounted on towers placed at some favorable receiving point above the surrounding terrain. If possible, the towers are mounted in areas that are far from sources of man-made interference and from structures that can cause multiple path signals which result in multiple images (or ghosts) on the tv screen.

In CATV systems that receive signals from two stations operating on the same channel, a separate antenna array may be used for receiving each of these channels and each

array can be so phased that the radiation pattern has a null in the direction of the undesired station. The ability to null an undesired signal in this manner is dependent on the angular distance between the co-channel stations. As the angular separation increases, the interfering signal may be removed more easily.

Head-end equipment. Connected to each antenna is a head-end amplifier which will adjust the signal level and, if necessary, also convert the incoming signal to another frequency—that is, to another channel. Each signal is handled separately.

Frequency conversion is required when two signals from different tv stations are received on the same channel or when uhf signals (channels 14 to 83) are received. In the first case, frequency conversion is necessary to prevent co-channel interference. In the second case, the uhf signal must be converted to vhf because existing CATV line equipment is not capable of compensating for the increased cable attenuation that occurs at uhf frequencies. Another reason, but not the determining one, for converting uhf to vhf is that many existing tv receivers are not able to receive uhf unless a special frequency converter is added to the set.

Heterodyne process. The frequency conversion process is basically a simple heterodyne process in which the signal is first converted to a lower standard intermediate frequency and then heterodyned up to the desired channel. In a 12-channel CATV system where there will be a signal on adjacent channels, excellent frequency stability is essential to prevent the signal from shifting and overlapping into another channel.

Within the receiver itself, adjacent channel signals received from the antenna may be removed by filter networks that have linear phase characteristics to prevent distortion of color information.

Tilt control. Signals from the head-end amplifiers are combined for distribution down the line. In general, the signal level at the output of the equipment is about one volt. To compensate for the increased line attenuation at the high end of the band, the low-frequency signal levels are reduced in amplitude. This amplitude equalization is called "tilt" control because the am-

plitude response of the combined signals is made to increase linearly with frequency. Tilt control insures that all signals will be at the same level when received at the first line amplifier, allowing the amplifier to operate at maximum gain.

Head-end equipment is generally tube equipment rather than transistorized, although most manufacturers are now coming out with transistorized head-end equipment. Tube equipment is suitable in this section of the system because the head-end equipment is in one place and can be monitored or checked periodically to prevent breakdown.

Trunk-line equipment. Trunk-line equipment is transistorized to take advantage of the lower weight and power requirements and the smaller size of the equipment. To use a single cable to transmit the signals, the amplifiers must operate over the entire frequency range from channel 2 to 13 (54 to 213 Mc).

Cable attenuation is compensated at each amplifier by adjusting the amplitude tilt across the frequency band. Cable attenuation will also vary with temperature and is compensated by thermal equalizers spaced along the line.

Amplifiers supplied by the various companies have noise figures in the range from 8 to 14 db and gains in the order of 22 to 30 db. Output signal levels range from 45 to 60 decibels above a millivolt for a single amplifier but recommended operating levels are reduced as more amplifiers are added to the line. These operating levels generally correspond to the generation of cross-modulation components that are approximately 57 db below the signal level.

Distribution line. A bridging amplifier splits the signal into a number of distribution lines. Cable drops are connected to the line through some form of tap, such as a capacitive probe. However, in large systems where reflections are a problem and where signals fed back from the receiver must be eliminated, a directional coupler is used to isolate the cable drop from the distribution line.

The final connection to the tv set is made through a balun which converts the unbalanced 75-ohm coaxial line impedance to the 300-ohm balanced input required at the tv antenna terminals.

TTC



$\pm 100 \text{ ppm}/^\circ\text{C}$

What else is new with the CTS Series 185 Cermet Trimmer?

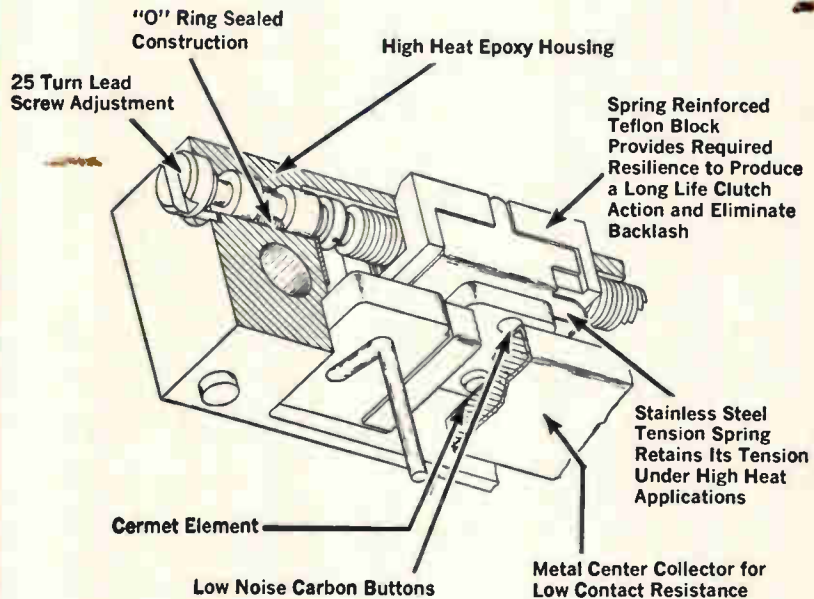

Meets MIL-R-22097B, Char. C, Style RJ11.

Rugged, sealed construction keeps out dust and water—reduces noise. Lower cost (\$2.95 ea. in 1000 quant.) due to 1/3 fewer parts than CTS Series 180.

Highly reliable cermet resistance element provides: high wattage (1 Watt @ 85°C), stability under extreme environments, wide resistance range (25 ohms to 1 megohm), low noise, long life and infinite resolution.

Printed circuit or wire leads; bushing mounting with printed circuit, wire or hook leads also available.

Request Data Sheet 3185.

Founded 1896



CTS MICROELECTRONICS, INC.

LAFAYETTE, INDIANA

Subsidiary of CTS CORPORATION, Elkhart, Indiana

Wanted: electronics engineers

Shortage unleashes coast-to-coast recruiting scramble; companies bid for college graduates, stalk conventions and cry 'piracy' in seller's market

By Thomas H. Maguire

Boston Regional Editor

When an engineer newly recruited by the Lockheed-Georgia Co. arrives with his family in Atlanta, his first stop is a company-furnished apartment where a full-time hostess helps the family settle, offering everything from household tips to discounted restaurant tickets.

This genteel welcome is a sign of the times. For the shortage of electronics engineers, intensified by the Vietnam buildup, is acute, and the search for young and up-to-date electronics engineers is in full swing from coast to coast.

The recruitment drive is reminiscent of the wild scrambling of 1955-57, when there was a severe shortage of engineers, says a West Coast personnel manager. And charges of stockpiling and pirating, along with steadily rising salaries, are back.

From a survey by Electronics these facts emerge:

- Although some stockpiling of engineers is taking place, the shortage is real, and not caused by misuse of qualified people.

- The demand for more trained men—in practically all branches of the technology—is pressuring upward both salary scales and fringe benefits; it is doubling recruitment activity on campuses, and once more employers are zeroing in on technical conventions to track down the engineers they need.

- The word "pirating" is used frequently in the industry, but it

always refers to the practices of other companies, not to those of the company complaining. Yet most employment managers admit that "referrals" are their prime source of experienced men, that the company initiates the contacts, and that 80 to 85% of the prospects are already employed.

- In-plant retraining for new skills is not widespread. And, despite the demand, companies balk at hiring engineers over 45 years of age.

I. Seller's market

The search for engineers has no boundaries. "It's the most acute shortage in 15 years," says Robert A. Martin, manager of employment for the Aerospace Group division of Hughes Aircraft Co., which needs 210 engineers.

In San Francisco, Lockheed Missiles and Space Co., like Lockheed-Georgia a division of Lockheed Aircraft Corp., needs 500 engineers

and wants to add 1,000 before the year is out. In Minneapolis, Control Data Corp., needs 75 to 100 in the next five months. A Chicago employment agency claims 5,000 more electronics engineers will be needed in the Midwest by the end of 1966 because of expanded production of color television and an expected increase in government work. Raytheon Co. needs 300 to 400 in its Massachusetts plants.

Name your spot. The search is across-the-board, with the recruiters focusing efforts on the up-to-the-minute specialist in microwave, in digital design, in spaceborne systems, in packaging and production, in antennas, in telemetry, in all kinds of computer-oriented skills—and in comparatively new areas like electro-optics and photo-optics.

"The highest demand is for circuit designers and hardware-oriented people," says Gordon Moore, head of a Palo Alto personnel



Contributions to this nationwide roundup were made by Robin Carlson, Boston; William B. Wallace and Michael J. Murphy, Los Angeles; Edmond G. Addeo and Mary Jo Jadin, San Francisco; Marvin Reid, Dallas; Ronald P. Lovell, Houston; Reck Johnson, Chicago; Jim Rubenstein, Cleveland; Ken Berglund, Minneapolis; Fran Ridgway, Atlanta; Hal Rusten, Philadelphia; Anne Hughes, Washington; and Erwin Leitner, New York.

agency. "Guidance and control people are hardest to come by," according to Charles E. Storm, employment manager of Lockheed-Georgia Co.

II. The why of it

"There is no more a shortage of EE's than there is of other engineers," according to Louis Rudzinsky, personnel manager at Itel Corp., Lexington, Mass. "Things are tight across the board. Everybody's building or growing in some way. The economy is reaching a state of full employment."

Some in the electronics industry will give him an argument, but most would agree that the shortage arises partly from the fact that the economy is expanding rapidly.

However, this does not fully explain the magnitude of the shortage, nor does the push for tactical weaponry for Vietnam, nor does the demand created by huge programs like the C-5A and the Manned Orbiting Laboratory.

Somewhat overlooked, says Stanley Stroud, supervisor of employment at Aerojet-General Corp., a subsidiary of the General Tire and Rubber Co., is that some EE's have left the industry, feeling that employment is too cyclical and that high wages do not compensate for layoffs. Prospects from the East, says Martin of Hughes, show deep concern about security and Martin blames "over-publicity given West Coast layoffs."

The cutbacks of a few years ago discouraged college enrollment in engineering, and this, too, is considered an important reason for today's shortage.

Stretchout. Engineering-trained students are staying longer on campus. "The trend toward five years' of college preparation will make a noticeable dent in the availability of engineers over the next few years," according to L. P. Kilgore, manager of professional recruitment, Douglas Aircraft Co.

At the Massachusetts Institute of Technology, 75% of the senior class now goes on to graduate school. "Industry puts a fat premium on graduate degrees," MIT placement director Thomas W. Harrington points out.

III. Hunting grounds

Company recruiters look to three places principally for the engineers

A job sampling, coast to coast

East	Types of engineers	Total sought
Sperry Gyroscope Co.	instrumentation, computer	200
RCA Semiconductor	circuit, applications	50
Lockheed Electronics Co.	airborne radar, circuit	40
RCA	communications	500
Philco Corp.	communications	360
New England		
Sylvania Electronic Systems	lasers, radar, antennas, circuit	165
Raytheon Co.	radar, microwave, sonar, computer	400
Avco Corp.	instrumentation	100
Mitre Corp.	communications, telemetry, radar	85
Southeast		
Lockheed-Georgia Co.	instrumentation, avionics	106
Radiation, Inc.	systems, ground tracking, computer	150
Electronic Communications Inc.	rf, circuit, instrumentation	35
Sperry Rand Corp. (Huntsville)	communications, avionics, microwave	50
West Coast		
Western Development Labs, Philco	systems designers	250
Lockheed Missiles & Space Co.	avionics, flight control, R&D	500
Fairchild Semiconductor	circuit, applications, product	250
Hewlett-Packard Co.	circuit designers	250
Sylvania Electric Products Inc.	systems, circuits	150
Hughes Aircraft Co.	circuit, component design	210
ITT Gilfillan, Inc.	computer, microwave, crt display	73
TRW Systems	communications, guidance, circuit	1000
Motorola Semiconductor	circuit, process	100
Southwest		
Texas Instruments	circuit, applications	133
Collins Radio Co.	data systems, circuit, avionics	190
Ling-Temco-Vought, Inc.	computer, radar, circuit	230

they want: their own plant, someone else's plant, and campuses.

They tend to concentrate on campuses and other people's plants—not necessarily in that order.

Companies do surprisingly little retraining. They do help pay for postgraduate work, but only the younger engineers seem to take advantage of these programs.

But one of the aerospace giants on the West Coast has a formal retraining program for teaching different engineering disciplines to its employees, and apparently prizes the program. The corporation treats it as proprietary, and refuses to approve any conference papers on the subject.

Other companies are skeptical about the benefits of making a mechanical engineer over into an electronics man, or of retreading an

electronics specialist. "Many kinds of engineers are in demand," says James Lacy, director of professional recruitment, TRW Systems, a division of TRW Inc., "particularly the broad range of aeronautical engineers. Many of our openings call for a good education and a number of years of experience. A training program won't turn out these types of engineers."

At Vitro Corp. of America, on the other hand, a program has been developed to train employees in specialties the company needs.

A professional career development program at Hughes helps certain specialists to break out of their field into a new one.

In Phoenix, at Motorola Semiconductor, a division of Motorola Inc., training to shift a man's specialty "consists of throwing him

NEW MAGNETIC RELAY plugs into your PC board!

NO Springs, NO Wiring,
NO Sockets, NO Soldering,
NO Mechanical Linkage

Printact®

Standard Series G
Latching Series LS/LD



(actual size)

Plated Conductors on Your PC Board are the Fixed Contacts

Save SPACE, MONEY and MANHOURS with these new small, lightweight, highly reliable Standard and Latching PRINTACT Relays.

Available with Bifurcated Palladium or Gold Alloy contacts for more than 10 million cycle 2 or 3 pole switching. Handles up to 3 amp. res. loads. Coils for 6, 12, 24 and 48 vdc at 500 mw. Operating temperature -30°C to $+95^{\circ}\text{C}$. Operate time 7 ms. The little gem is an 0.8 oz. $\frac{7}{8}$ " cube.

Quality features include: double-break contacts; balanced armature, enclosed housing, plug-in application; encapsulated coil; self-wiping contacts and inherent snap-action — and the cost is lower than you think!

Executone

MAIL COUPON TODAY

PRINTACT RELAY DIVISION
47-37 Austell Place
Long Island City, N.Y. 11101

- Send Printact data and prices.
 Have your local rep. call.

Name _____ Title _____

Firm _____ Tel. # _____

Address _____

City _____

into the cauldron and watching to see if he sinks or swims," says E. W. Brown, Jr., manager of professional recruitment and training. "If we get a computer man and want to make him a solid state circuit designer, he is assigned to a group and it is up to the supervisor to give him the direction he needs. It takes six months to tell if we have a winner or a loser."

Bids soar. Electronics companies are increasing their college recruitment programs this year by 30 to 60%. "We seem to be adding two or three new companies to our list every day, says Massachusetts

Institute of Technology placement director Harrington. Georgia Tech estimates it graduates just about half the number of EE's that industry could use. A recruiter for Aerojet-General says it's not uncommon for a qualified senior to receive 12 to 15 offers by graduation day.

"It's getting to be like the colleges' bidding for athletes," comments Cliff Lawson, administrative engineer at Oak Electro-Netics Corp., Crystal Lake, Ill. "We had a graduate engineer in here from the University of Wisconsin. He had 42 offers from around the country, many of them with open plane

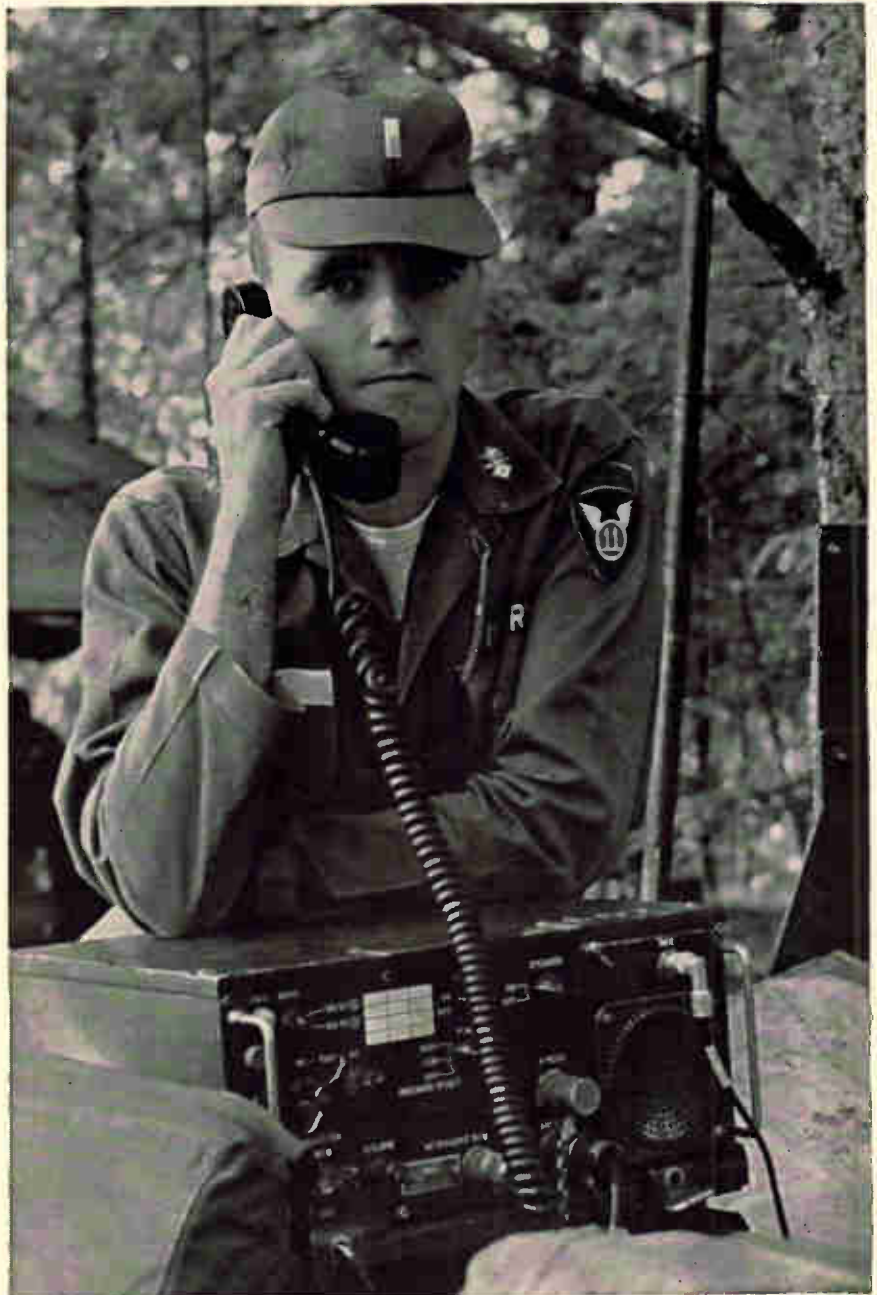

The war in Vietnam has created a growing demand for communications equipment such as this AN/VRC-12 jeep-mounted radio being used by the First Air Cavalry Division. Companies making such gear are actively seeking engineers.

tickets, open offers, not even a salary decision."

The man who visits colleges for Motorola's Semiconductor division is an alumnus wherever possible. Colleges supply about 20% of Motorola's new men.

Companies are spending more time on campus today, with faculty as well as students. Says Harry Keplar, recruitment specialist for Space and Information Systems division, North American Aviation, Inc.: "Today's better student, with his eye on an advanced degree, requires more bird-dogging. And faculty people believe—rightly so—that companies should contribute to, as well as gain from, the educational system by making qualified speakers available and presenting films on industry work."

"One of the things we're trying to get across to the college kids," says Norman J. Skelton, professional employment manager for Fairchild Semiconductor division, "is that you don't necessarily have to be an electronics engineer to work in the semiconductor business. An EE around here spends only 30% of his time in his specialty; the rest cuts across many disciplines.

"I'd get a big argument from our marketing people," he says, "but I'm sure a man trained in psychology or business administration or social sciences could fill many of the marketing jobs. We don't have the chance to prove this, because they're not applying. For instance, when we visited the California Institute of Technology, all we got were EE's—nobody else took us seriously."

Most wanted lists. To reach the untold numbers of engineers who pour onto Los Angeles freeways in the morning and evening, Douglas Aircraft Co. uses radio spot announcements. If there are defense cutbacks in an out-of-town area, Douglas sets up a hotel suite there. "But our competitors are doing the same," says Kilgore of Douglas. "The competition is fierce."

In addition to radio and billboard advertising, some overseas recruitment, renewal of convention recruitment and publications advertising, companies are turning to employment agencies.

And the agencies are busier than

JUST HOW SMALL CAN YOU MAKE A SUB-MINIATURE POWER RESISTOR?



PRETTY SMALL!

Consider this SAGE SILICOHM® 1 watt unit in comparison to the vintage grid leak drip pan* pictured above. What's more, this tiny resistor, designed to operate hot, provides stability and precision features ordinarily associated with the finest of low power precision resistors.

SAGE Type SB styles feature superior heat dispersion by means of beryllium oxide cores, as first used in Advanced Minuteman parts. Assigned wattage ratings are 1 to 15 watts at 25°C ambient, thus offering dramatic new circuit miniaturization possibilities for commercial and regular military applications.

**As a matter of fact, we don't make grid leak drip pans.*



Write for complete details.



SAGE

SAGE ELECTRONICS CORP.
BOX 3926 • ROCHESTER, N. Y. 14610

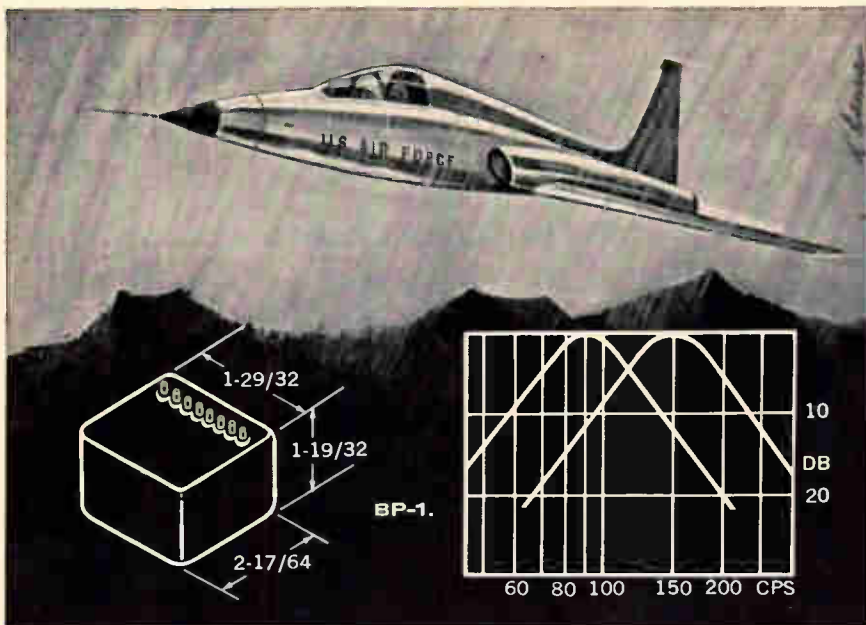

FILTER RELIABILITY—PROVEN IN 10^{6+} AIR HOURS

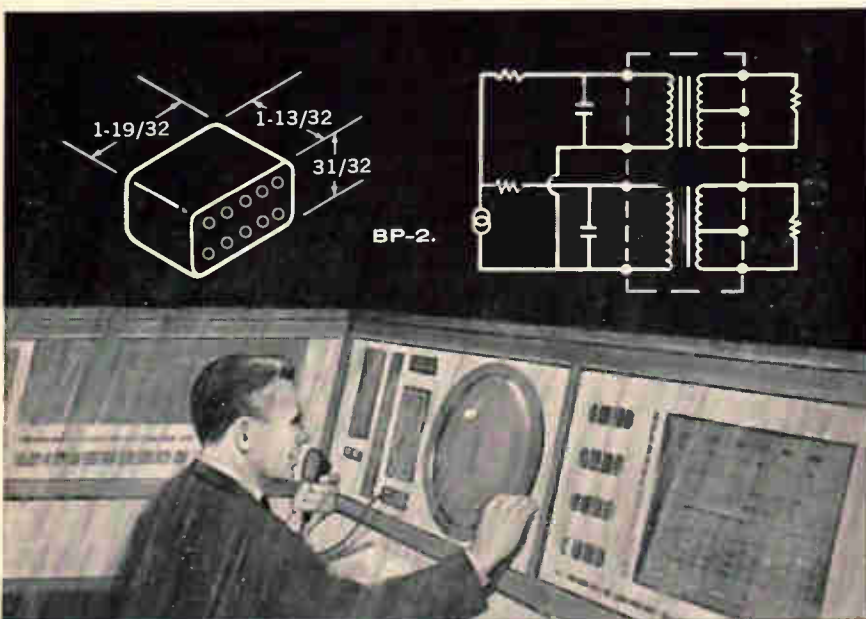

Before aerospace technology fostered the formal concept of reliability, the aircraft industry translated their requirements for filter performance to ADC in terms of *dependability*. ■ Illustrated here are two of the many types of dependable ADC filters that have operated in various aircraft electronic equipment during the past decade ■ ADC's filter design staff combines computer-assisted design techniques with years of experience in the highly important area of optimum selection of network components ■ This combination assures you the most economical and dependable solution to your filter problems.

SPECIFICATIONS

BP-1. 90 and 150 cps pass band filter for use in commercial air-borne ILS system. Constructed for extreme reliability over -40°C to $+72^{\circ}\text{C}$ temp. range, and under all environmental conditions of Mil-F-18327B.

BP-2. Dual 30 cps tuned transformer, for Omni Range radio. Has ultra-stable primary to secondary phase characteristics from -55°C to $+85^{\circ}\text{C}$, and over 5 db input range.

ever. There is resentment in industry over the practices of few employment agencies, but some companies which had been holdouts, admit that they have been "obliged" to deal with agencies and pay them fees for recruiting.

Musical chairs. An executive of Communications Electronics, Inc., Rockville, Md., bitterly protests the use of private employment agencies, which he terms "parasitic." Some of them, he says, accept the applications of a young engineer, place him in a large company, collect a fee, and then in a year or so recontact him with a new job offer for slightly more money.

Of all the means of finding new employees, personal contacts are still considered the best. Although some say the word "referral" is a misnomer for "pirating," its practice is widespread. The recruitment manager for a company in the West says that referrals account for 10 to 15% of his new engineers. He pays \$100 a head to the referring employee. The prospect is solicited by phone, and about 50% of those reached are hired. The recruiter is proud of his low cost per employee hired: \$800 against the \$1,500 to \$2,000 which he says is average for the West Coast.

In its Evendale, Ohio, plant, General Electric Co. offers a \$200 bonus to an employee if an engineer he referred is hired. Howard Hand of ITT Gilfillan, Inc., says that employee referrals are its best source of new engineers. The company insists that an employed prospect must initiate the contact, but the company will allow its own employee to put a dinner on his expense account in an effort to get the prospect to make the contact.

The over-all industry philosophy is neatly summed up by William Spears of Hickok Electrical Instrument Co.: "The electronics engineer is very scarce, and we use every possible route to try to find him. We advertise like mad, we go through agencies, and we also do some stealing."

"Everybody's fighting for the same people," says Chuck Moody, employment manager of Ampex Corp. "Pretty soon, the engineer thinks he is pretty damned important, so he adds a few thousand to his salary retirement. Then we all sit around and blame each other

ADC

ADC PRODUCTS, INC.

6325 CAMBRIDGE ST. ■ MINNEAPOLIS, MINNESOTA 55426

for the high-cost situation."

IV. Pay goes up

In the Boston area, Raytheon Co. says the starting salary has gone up, since a year ago, about 3%, to \$685 a month. In other regions, employers cite a \$662 average, up \$30. Offers start at \$652 in the New York area.

On the West Coast, the new BSEE graduate gets from \$650 to \$750 a month. An engineer with a master's degree can get another \$100, and an engineer with a doctorate will start at about \$1,200. "But the spread is getting wider," according to Skelton of Fairchild Semiconductor, a division of Fairchild Camera & Instrument Corp. "And that's partly what's causing our problems. A guy thinks he has to go on to a higher degree for more money, and he's off the market for four more years."

Salaries tell only part of the supply-and-demand story. Tuition refund allowances, profit-sharing plans, stock purchase options are among the fringe benefits. "I'm at a disadvantage in recruiting because I can't offer a profit-sharing plan," says the employment manager of a large Los Angeles area company.

According to Hand of ITT Gilfillan, a division of the International Telephone and Telegraph Corp., most of the prospects in the \$10,000 to \$15,000 range ask about company stability, the types of projects in-house, educational benefits, "and the usual domestic problems like housing and school for the kids. Men in higher brackets are more concerned with stock options and advancement potential."

V. Around the circuit

The problems and practices by regions:

West Coast. The employment situation in the San Francisco area has changed radically since a dead period 18 months ago.

Lockheed Missiles and Space Co. has openings for 500 electronics engineers and may have trouble meeting contract schedules if it can't get them. Needed are men with avionics, flight control, design and research experience.

Norman Williams, professional recruiting manager for Hewlett-Packard Co., which is looking for

BURR-BROWN FUNCTION MODULES

dependable building blocks
for a variety of analog systems

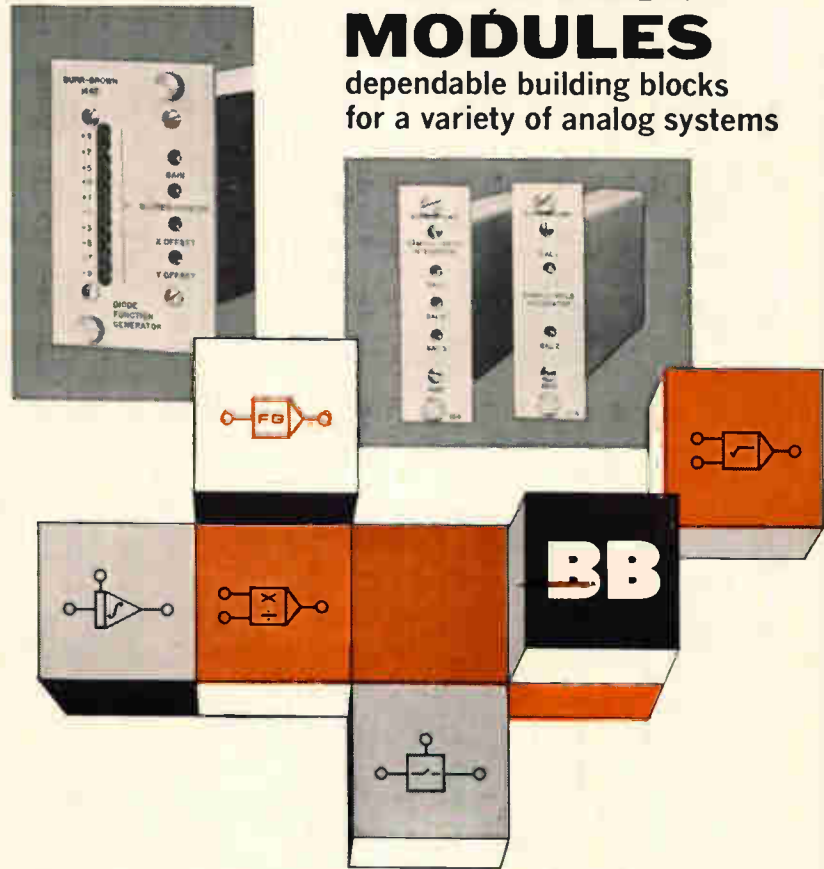

■ Whether you're building systems to control, measure, compute, test, or analyze, Burr-Brown's new analog function modules with built-in operational amplifiers give you unlimited design flexibility. And, these versatile, solid-state units have the level of accuracy and reliability to match your most critical requirements.

■ Currently, Burr-Brown is supplying twelve off-the-shelf function modules including four hybrid units designed for interface between analog and digital circuits. By combining additional operational amplifiers with selected function modules, an endless variety of economical general and special purpose systems may be developed.

FOR COMPLETE TECHNICAL INFORMATION, write, wire, or phone for six-page catalog describing Burr-Brown Function Modules and Instrumentation Amplifiers.

SEE THE NEWEST
BURR-BROWN
OPERATIONAL AMPLIFIERS
AND FUNCTION MODULES
AT IEEE BOOTH #3A26-27

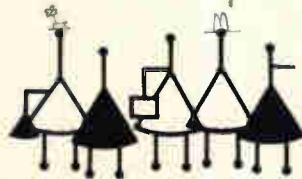

MODEL	DESCRIPTION	HIGHLIGHT SPECIFICATIONS	PRICE
1661	MULTIPLIER/DIVIDER	Transfer Function $E_o = - \frac{XY}{10}$ or $E_o = - \frac{10X}{Y}$ switch selected Transfer Error: < 1%	\$595
1662	FUNCTION GENERATOR	11 segment convenient front panel adjustment	\$625
1663	FAST SAMPLE & HOLD/ SWITCHED INTEGRATOR	Aperture Time: 50 nsec Drift in HOLD: $\pm 100 \mu\text{v}/\text{ms}$ Reset Time: 10 μsec	\$355
1664	SAMPLE & LONG HOLD/ SWITCHED INTEGRATOR	Aperture Time: 200 nsec Drift in HOLD: $\pm 10 \text{mv}/\text{sec}$ Reset Time: 100 μsec	\$295

OTHER MODULES AVAILABLE INCLUDE: Log Converter, Log Ratio Converter, Antilog Converter, Squaring Modules, Precision Rectifier, and Electronic Switches.

ENGINEERING REPRESENTATIVES ALA. MADISON (205) 772-6981 ALASKA ANCHORAGE (907) 272-5231 ARIZ. PHOENIX 602-254-6085 B.C. VANCOUVER (604) RE 6-6377 CALIF. GLENDALE (213) 245-9501 CALIF. SAN JOSE 415-968-1608 COLO. DENVER 303-388-4391 CONN. MILFORD 203-874-9222 FLA. ORLANDO (305) 423-4856 FLA. MIAMI (305) 444-1118 ILL. CHICAGO (312) 245-4870 MD. SILVER SPRING (301) JU 8-8134 MASS. WAKEFIELD (617) 245-4870 MICH. DETROIT (313) 353-3822 MO. ST. LOUIS 314 JA 4-4800 N.J. CAMDEN (609) 365-2450 N.Y. ALBANY 518-436-8224 N.Y. BINGHAMTON (607) 723-9661 N.Y. BUFFALO 716-632-2727 N.Y. NEW HARTFORD (315) 732-3775 N.Y. MT. VERNON 914-YO 8-2200 N.M. ALBUQUERQUE 505-255-1638 N.C. BURLINGTON (919) 584-6129 OHIO CINCINNATI 513-761-5432 OHIO CLEVELAND 216-884-2001 OHIO DAYTON 513-277-8911 OKLA. TULSA (918) TE 5-2481 ORE. PORTLAND (503) 292-8762 ONT. AGINCOURT 416-293-7011 TEX. DALLAS (214) EM 3-1571 TEX. HOUSTON (713) WA 8-5251 UTAH, SALT LAKE CITY (801) 466-8709 WASH. SEATTLE (206) MA 2-0177 EUROPE, Frazer & Hansen Ltd., P.O. 85, 3030 Bern 9 Switzerland.

BURR-BROWN

RESEARCH CORPORATION
INTERNATIONAL AIRPORT INDUSTRIAL PARK
BOX 11480 TUCSON ARIZONA 85706
PHONE 602-94-1431 • TWX 910-952-1111

**STABILITY 5×10^{-9}
ONE MEGACYCLE**



**TYPE CCO-23MD
CRYSTAL
OSCILLATOR**

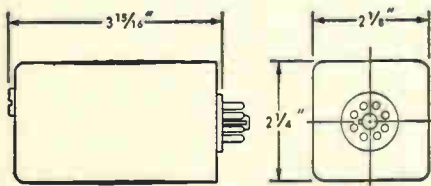

Select Type CCO-23MD for an ultra stable time base. Compact plug-in unit incorporates a high Q glass sealed crystal and full proportional temperature control. Solid state oscillator and oven circuitry assure long term reliability.

*Request Bulletin 540A
for complete information.*

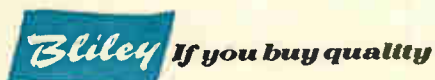

BLILEY ELECTRIC COMPANY
Union Station Bldg. • Erie, Pennsylvania

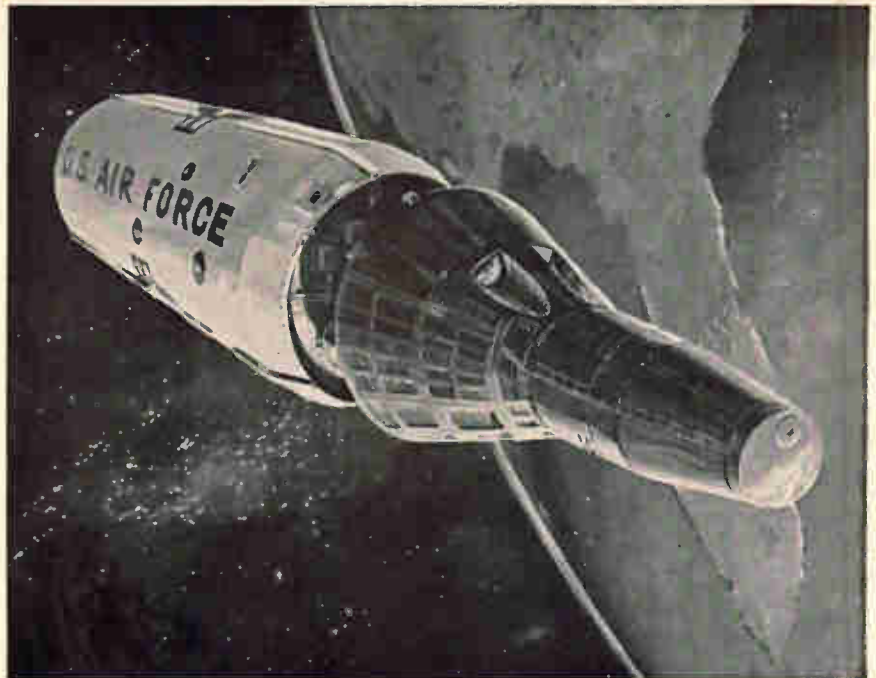

Department of Defense programs such as the Manned Orbiting Laboratory are creating part of the demand that has caused a shortage of engineers.

250 engineers, says: "We can use every man we can get—at our current rate, not our expected rate." Fairchild Semiconductor division is looking for 250 engineers.

In the Los Angeles area the seller's market has worsened in the last 10 months and it will get even tighter. Fierce is the word for the competition.

TRW Systems has 1,000 openings in EE work—particularly communications, guidance and circuits. Ray Phillips, personnel manager for Ryan Aeronautical Co., San Diego, says he's looking for 30 engineers.

Aeronutronics division of Philco is hiring specialists in electro-optics and radar. The division expects to add 150 engineers, all told, in the next two months.

Hughes Aerospace Group is looking for more than 200 engineers, particularly in solid state circuit, test equipment design, and component design.

Southwest. Accelerated space activity and increased demands for seismic instrumentation has put the squeeze on engineering manpower in the Houston area. "The arrival of the NASA Manned Spacecraft Center has hurt us locally," says C. A. Rosenthal, personnel director, electronics division, Schlumberger Well Surveying Corp.

The Manned Spacecraft Center has authorization to add 400 more

professional employees by June, to bring its quota up to 4,800. Of the 400, an estimated 100 will be EE's.

In the Dallas area, Texas Instruments, Incorporated, has openings for 113 engineers and will need 500 for the year.

Collins Radio Co. has openings for 193 engineers, most of them in research and development. By the end of 1966, Collins will need 400 new engineers.

General Dynamics/Fort Worth needs 50 engineers and Ling-Temco-Vought, Inc., says it will need 230 electronics engineers at its Dallas operations in 1966.

Southeast. Lockheed-Georgia Co.'s bonanza contract for the C-5A, expected to escalate to \$2 billion, has pushed its needs to 106 electronics engineers: in instrumentation, guidance, servomechanisms and avionics.

Scientific-Atlanta, Inc., advertises heavily in the Florida, Midwest and East Coast newspapers.

At Radiation, Inc., Palm Bay, Fla., there are openings for 150 EE's. In the Cape Kennedy area, missile stage and support service contractors need about 120 electronics engineers, 60 of them communications specialists.

The Florida State Employment Service estimates that 300 jobs in electronics will open by July at Cape Kennedy Space Center.

At Huntsville, Ala., the Space



Hard glass to metal seals . . .

and not a leaker in the lot.

Other alloys promise it. But only Carpenter Nicoseal delivers it . . . lot after lot with predictable performance and uniform results. • Carpenter Nicoseal is a low expansion alloy developed specifically for making hermetic seals with harder pyrex glasses and ceramic materials. It is induction vacuum melted in 10,000 pound heats from high purity material. This assures a high degree of uniformity. • Nicoseal is

processed from ingot to finished size under the strictest quality controls. This assures a good surface condition for deep drawing and uniform oxidation formation. And that's not a promise. It's a fact. Comparison proves it. Proves also that Nicoseal offers greater internal cleanliness providing improved die life. • Nicoseal has a low gas content. It provides high reliability under thermal shock . . .

excellent deep drawing characteristics . . . and satisfactory machinability. • It's available as seam-free wire, strip and bars. • Complete technical data and assistance are available from your local Carpenter representative, or write us direct: *The Carpenter Steel Company, 170 West Bern St., Reading, Pa. 19603.*

Carpenter steel
IN A WORD, CONFIDENCE

*dynamic
positioning
in*

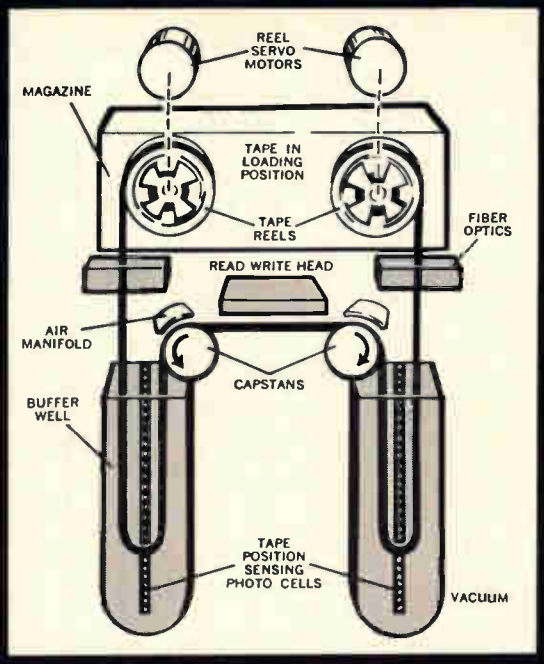

DIGITAL TAPE TRANSPORTS

*Inland's Standard DC Direct-drive Torque Motors Solve
MOBIDIC Tape Transport Problems*

Faced with meeting the rugged requirements of military operation, Sylva-
nia's Electronic Systems Division of
General Telephone & Electronics Corp.

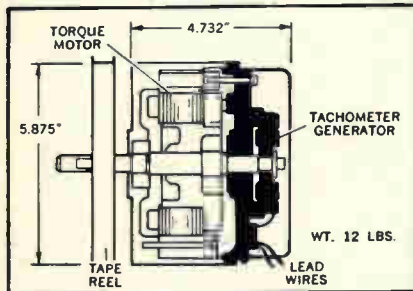

turned from conventional tape transport designs and developed a unique militarized system capable of optimum tape handling without damage or distortion. This modern, miniaturized design provides rapid reversal (less than 6 milliseconds) so programming is not restricted, high controlled acceleration and deceleration, (empty reel: 570 rad/sec², full reel: 270 rad/sec²), wide dynamic speed ranges (1000/1).

Sound impossible? Not to Inland Motor. Inland's standard Model TT-4005,

tachometer generator-torque motor combination surpasses these performance requirements. Featuring a peak torque output of 3.5 lb.-ft., the DC direct-drive torque motor, with damping enhanced by a DC directly-driven tachometer generator, furnished the linear speed/torque characteristics required over these ranges. Easily controlled by current limiting, it also provided the desired acceleration. Dynamic braking assisted the quick reversal. Since it was direct-drive, the operation was smooth and back-lash free.

Whatever your servo application may be, you can rely on INLAND to meet your most demanding requirements.



TORQY SAYS:

If you'd like complete details on this unusual application and other interesting facts on Inland direct-drive servo components, write today.

INLAND MOTOR

CORPORATION
RADFORD, VIRGINIA
703-639-3973

SUBSIDIARY OF **KOLLMORGEN**
IEEE Show Booths 2A05 and 2A07

Support division, Sperry Rand Corp., needs 50 communications, telemetry and flight-control systems engineers.

Midwest. The supply of electronics engineers is tight, but not as severe as on the West Coast and along the Eastern seaboard. However, a Midwest recruiter says the "booming sales" of color tv sets has had a big impact. These sales make it possible for companies to spend "fantastic" amounts on R&D—"That's what's drawing the engineers," he says.

B. A. Watts, manager of salaried personnel at Goodyear Aerospace Corp., Akron, Ohio, says the company needs 150 additional electronics engineers in 1966.

East. In the New York-New Jersey area, there is a heavy demand for engineers in solid state microwave techniques, radar, servo applications for optics, aircraft control, and digital technology.

Grumman Aircraft Corp. on Long Island has been successful in recruiting electronics engineers despite the shortage, and claims to have a long-range manpower turnover only one-quarter that of the aerospace industry nationally. Grumman hired 780 electronics engineers last year.

International Business Machines Corp. is close-mouthed about the number of engineers it is hiring and wants to hire, but takes full-page ads in the New York Times to tell of its needs. As might be predicted, IBM uses a computer program—it's known as IRIS—to match applicants with current job openings. Sperry Gyroscope Co., a division of Sperry Rand Corp., is looking for 100 experienced engineers, and it is interviewing for 100 graduates in the class of 1966.

In Philadelphia, Radio Corp. of America is seeking about 500 engineers. Of these, 275 will be new graduates. For some types of engineers, RCA is recruiting in foreign countries.

Jerrold Electronics Corp., Philadelphia, expects to double its engineering force in the next two years. The company has a cooperative program with Drexel Institute of Technology, in which students attend school six months and work the other six.

Also in Philadelphia, Philco Corp., a division of Ford Motor

OUTSTANDING PERFORMANCE... AT REASONABLE COST HIGHEST ACROSS-THE-BOARD

PERFORMANCE AVAILABLE FROM A WIDEBAND DIFFERENTIAL DATA AMPLIFIER

New Hewlett-Packard 2470A Differential Data Amplifier... \$585

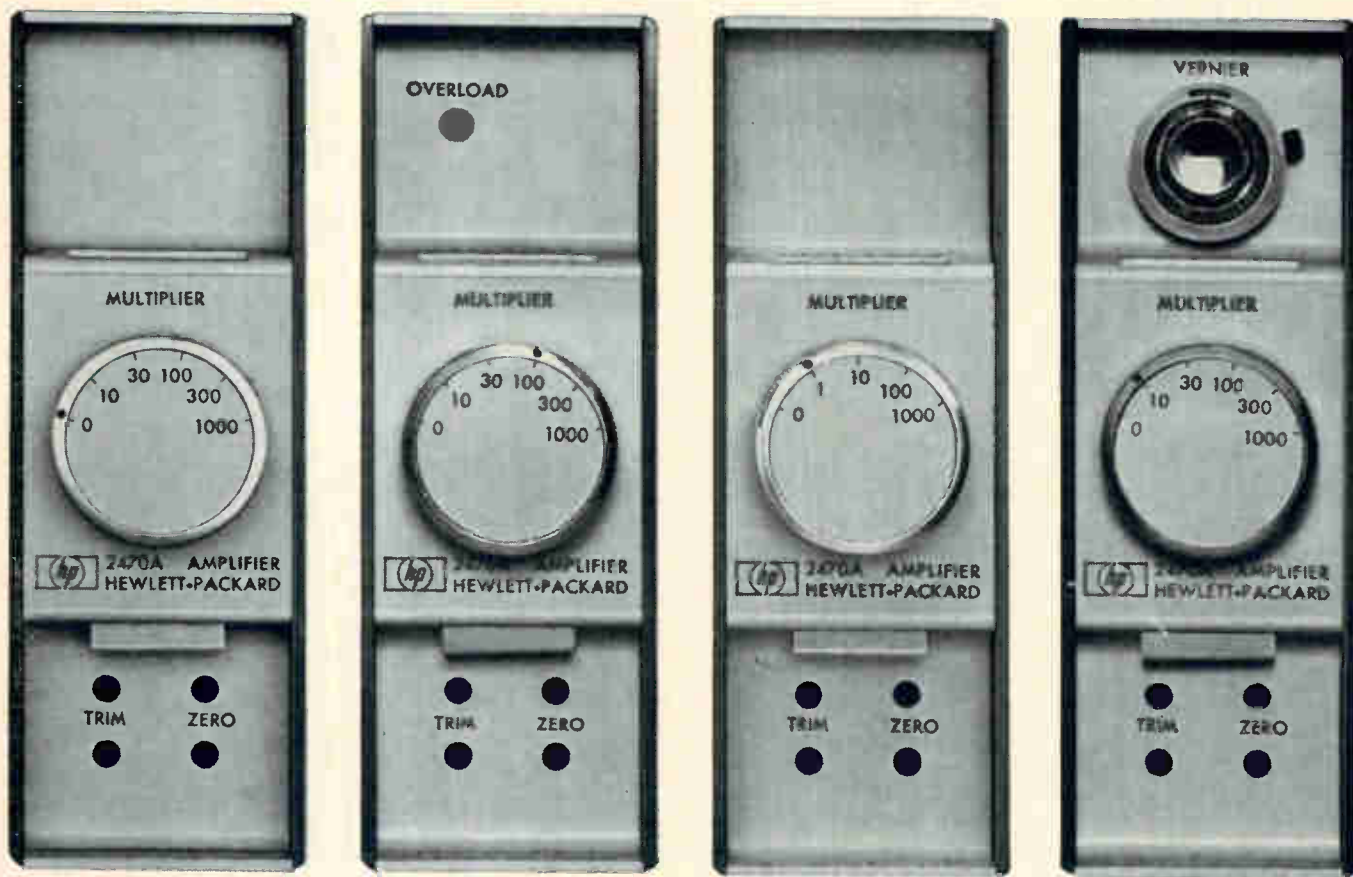

Top electrical performance: Compare, spec to spec—DC gain X10 to X1000 (optional precision vernier, X1 gain), output ± 10 v, 0-100 ma. Gain accuracy $\pm 0.02\%$ range; constant 50 kHz bandwidth. Differential input for low drift, high cmr (120 db at 60 kHz on gains down to x30, 90 db at x1). Full output across full bandwidth (10^7 v/sec RTO). High 1000-meg input impedance all gain settings, output impedance 0.1 ohm $+10 \mu$ h. DC linearity of 0.002% on both polarities; dc gain stability of 0.005% per month achieved without chopper stabilization. Low drift and noise. Fast 100 microsecond settling, 100 microsecond overload recovery, excellent overload protection, optional overload indicator. Input and output isolated by internally driven guard shields; dual output available with fixed 2-pole filter.

Built-in reliability: The predicted MTBF of the 2470A is in excess of 20,000 hours. Silicon transistors are used throughout, and passive and active components are selected for dependability, as well as performance. Amplifier meets spec at 95% humidity at 40°C. Critical parameters (zero drift, full-scale accuracy, common mode rejection) are verified after 100 hours of "run-in" at elevated temperature.

Packaging for value, compactness: Amplifier and self-contained power supply are enclosed in a unique, rugged molded dielectric case. Combining case, bench stand, power and signal cables, plus many other accessories, are available.

Use if for: Amplifying signals from low-level resistive transducers, such as thermocouples, strain gages. High input and low output impedance make it ideal for amplification over long transmission lines; use it, with resistive or reactive loads, such as x-y, strip-chart or oscillographic recorders, digital voltmeters, null detectors and servo systems, telemetry systems... or use it as a high-performance bench amplifier.

Call your Hewlett-Packard field engineer for complete information or write the Dymec Division of Hewlett-Packard, 395 Page Mill Road, Palo Alto, California 94306, Tel. (415) 326-1755; Europe: 54 Route des Acacias, Geneva.

Price f.o.b. factory.
Data subject to change without notice.

**HEWLETT
PACKARD**  **DYMEC
DIVISION**



See it at IEEE, 3rd floor New York Coliseum, March 21-24

1806

**YOU CAN'T
OVERLOOK US!
...WE INTEND TO
BE PERSISTENT!**

**SOUTH
DAKOTA**

Let Us Send You The Facts On
**PROFIT-LIVABILITY!
FOR ELECTRONICS FIRMS!**

70 South Dakota communities have industrial development corporations ready to assist you in locating your new plant. We believe that you'll be pleasantly surprised with the advantages South Dakota has to offer new and expanding industry.

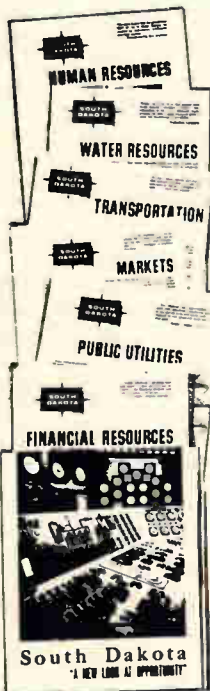

**PROVED LABOR
PRODUCTIVITY**

Value added by manufacture per worker is one of the nation's highest. Eager, alert labor force with work stoppages at absolute minimum.

FINANCING & TAXES

Local development corporations ready to serve all industries. Revenue bond financing available. Debt-free state with no corporate or personal income tax... plus a free port law!

CENTRAL LOCATION

You're closer to everyone and everywhere in South Dakota, geographical center of the U.S. and the heartland of the entire North American continent.

ENERGY FOR YOU
Electrical power available at low cost rates from hydro, fossil and atomic plants to serve the most demanding production needs.

**GREAT OUTDOOR
ADVENTURE**

The beautiful Black Hills, Missouri Great Lakes, fantastic fishing, fabulous big and small game hunting, water resources that challenge the imagination... all combine for a recreation bonanza at your doorstep.

GET THE
**SOUTH DAKOTA
STORY**

CALL OR WRITE

JAMES W. MONROE, DIRECTOR
Industrial Development Expansion Agency
ROOM E

PIERRE, SOUTH DAKOTA 57501
PHONE 224-5911 EXT. 307 AREA CODE 605

Coliseum is off limits

With the shortage of engineers, it's inevitable that company and agency recruiters will be on the prowl during the IEEE International Convention at the Coliseum in New York. Though IEEE regulations forbid recruitment there and at the New York Hilton, the talent scouts will be working the hotels nearby.

The convention committee itself will police the Coliseum and at the Hilton will depend upon the management to enforce the nonrecruiting policy.

Co., is seeking 360 engineers, 100 of them in communications.

In the Washington area, the Department of Defense, the National Aeronautics and Space Administration and private companies—with a handful of exceptions—say they are searching fruitlessly for engineers.

Melpar, Inc., in Falls Church, Va., needs between 50 and 60 engineers.

New England. Boston-area companies are looking for engineers by the hundreds, with a particularly lively search on for electro-optics and photo-optics people.

Raytheon Co., largest in the area, needs 300 to 400 engineers.

Sylvania's electronic systems division is looking for 165 engineers for work on lasers, radar systems, antennas, satellites, counter-measures, and circuit design.

The research and development division of Avco Corp., which recently received \$34 million for missile re-entry work, is looking for 100 electronics engineers.

Government laboratories in the Boston-Cambridge area are also hiring steadily. The NASA electronics research center, located in temporary Cambridge quarters before its building program gets under way, has 371 engineers and scientists on the payroll and hopes to have 550 by August.

Mitre Corp., Lexington, the non-profit company whose principal work is for the Air Force electronic systems division, plans to hire 85 engineers by August, and 10 a month after that. They will be specialists with advanced degrees or exceptional experience in communications, telemetry range data systems and radar.

See GRC at the IEEE—Booths 4B04-4B06

FASTENERS FROM



NOW . . .

Widest Range of
Styles & Sizes In

WING NUTS

DIE CAST ZINC ALLOY



- DIE CAST ZINC ALLOY
- Wing Nuts
- Cap Nuts
- Thumb Nuts
- Thumb & Wing Screws
- MOLDED NYLON & DELRIN
- Screws
- Hex Nuts
- Washers
- Screw Insulators

- Hundreds of stock sizes
 - Thousands of blank and thread combinations up to 3/8"
 - Exclusive recessed finger grip
 - Smooth acting washer bases
 - Bright Corrosion-resistant finish
 - Modern, attractive appearance to help sell your product
- Write, wire, phone for samples, prices.

GRC's NEW INDUSTRIAL FASTENER CATALOG.



GRIES REPRODUCER CO.

Division of Coats & Clark Inc.
151 Beechwood Ave.,
New Rochelle, N.Y.
(914) NEW Rochelle 3-8600

World's Foremost
Producers of Small
Die Castings and
Plastic Moldings

Circle 553 on reader service card

**LOOKING FOR
PROFIT?**

**THE FACTS FAVOR
NEBRASKA**

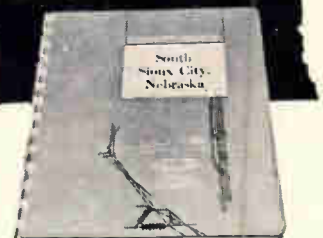

Sample the facts in a free survey.

Authoritative studies give you the facts on labor, taxes, resources, utilities, local economy, services in 57 Nebraska communities. If the information you want about Nebraska is not at hand, we'll research it for you.

CONSUMERS POWER DISTRICT
Community Development Dept.
1401 O Street, Lincoln, Nebr. 68508

Send sample survey and basic data sheet to:

NAME _____
ADDRESS _____
CITY _____
STATE _____ ZIP _____
(Please attach specific requests for other data.)

Circle 554 on readers service card



Great editorial is something he takes to a meeting

(What a climate for selling!)

Electronics

A McGraw-Hill *Market-Directed* Publication
330 West 42nd Street, New York, N.Y. 10036

MEMBER: AUDIT BUREAU OF CIRCULATIONS, AMERICAN BUSINESS PRESS

If you're recording data off-the-air,



get the full spectrum on the tape with total recall

MEMOREX
PRECISION MAGNETIC TAPE

Since you must capture the data right the first time, you'll appreciate the extra margin of reliability in every reel of Memorex tape. Because of exceptional uniformity in Memorex oxide coating formulations, there's little chance you'll ever find a dropout where you expect to find data. The superior bond between oxide particles means you can forget about oxide shedding, head build-up, and gap smear. You

can expect, reel after reel, multi-pass stability of performance unequalled by any other tape.

If you write Memorex Corporation at 411 Memorex Park, Santa Clara, California 95052, we will be pleased to send you instrumentation tape specification data and a bibliography of technical information available without obligation from the Memorex library of reprints.

Memorex Branch Offices in New York, Philadelphia, Washington, Atlanta, Orlando, Dayton, Chicago, Detroit, Dallas, Los Angeles, San Francisco; Offices and Affiliates in London, Cologne, and Paris.

Narrowing the search

Computers are tackling the job of guiding scientists and engineers through a bewildering paper maze to the information they seek

By Wallace B. Riley

Computer Editor

In a few weeks, scientists and engineers at Bell Telephone Laboratories will get a new daily service as welcome as a coffee break. Every day, each technical employee interested in mathematics and the computing sciences will receive a copy of all internal technical memos written in those fields. In time, this service will cover all technical areas.

This helpful time-saver will be handled by a minimum of personnel. Every day, certain details of each new memo will be fed into a computer and there matched against a profile of the needs of each employee who gets the service. Then, the computer will designate which papers go to whom, print out the distribution list, and even address the labels. Abstracts or complete copies of the memos, according to the employee's preference, will then be mailed to those on the computer-prepared list.

The new service will be in addition

to one that Bell Labs has been operating for several years. The computer now prints a permuted title index, as illustrated below and described on page 170, of all internal memos and papers written by Bell Labs technical personnel. This index is prepared monthly and mailed to all scientists and engineers in the laboratory. Another index of papers and articles written by people outside the laboratories is now manually prepared and distributed twice a month.

Within a year, the outside index will also be prepared by the computer together with a cover letter for each employee getting the index. The cover letter will tell him what he should look for in the index.

In time, Bell employees will be able to ask their information-retrieval system to search for material on complicated combinations of subjects with a number of delimiters, or restrictions. For example,

he might ask for a list of papers that deal with the effect of microstructure on the transition temperatures of intermetallic superconductors. He might say that he wants all authors except those who work for the XYZ Co., because he is familiar with their work; he wants nothing written prior to 1960; nothing in Italian or Japanese, because he can't read either language; and nothing from certain technical journals. He might also stipulate that he is mainly interested in papers dealing with the theoretical aspects of the subject rather than experimental or state of the art work. Then, he might tell the computer that if the list reaches 100 papers it should let him know before it begins printing out the titles, so he can specify more delimiters.

Paper mountains. Bell is only one of the many companies and government agencies creating information retrieval systems to cope with

ANALYSIS AND DESIGN OF LINEAR NETWORKS WITH ADJUSTABLE PARAMETERS USING ON LINE SIMULATION.	T 137 1051
ADVANCES IN PHOTOELECTRIC RAMAN SPECTROSCOPY.	T-151-1098
A LANGUAGE AND SYSTEM FOR SYMBOLIC ALGEBRA ON A DIGITAL COMPUTER.	T-121-1483
NEW SUP	T-116-1048
ERCONDUCTORS BY RAPID QUENCHING OF REACTIVE AND REFRACTORY ALLOYS.	P-116 1030
RAPID QUENCHING OF REACTIVE AND REFRACTORY ALLOYS FROM THE LIQUID STATE.	
STRENGTH OF COMMERCIAL ALUMINA CERAMICS BY THE DIAMETRAL COMPRESSION TEST.	MECHANICA T-283-1043
THE NEW LOOK IN COMPUTATION.	T-132-1002
A LANGUAGE AND SYSTEM FOR SYMBOLIC ALGEBRA ON A DIGITAL COMPUTER.	T-121-1483
COMPUTER MUSIC CONCERT.	T-012-1054
COMPUTER PRODUCED MOVIES.	T 137-1049
PSYCHO-ACOUSTIC MUSIC STUDIES WITH A COMPUTER -	
DIFFUSION IN SEMICONDUCTORS.	T 264 1077
DIGITAL COMMUNICATION SYSTEMS.	P-531-1071
TECHNIQUES FOR ADAPTIVE EQUALIZATION OF	T-121-1483
A LANGUAGE AND SYSTEM FOR SYMBOLIC ALGEBRA ON A DIGITAL COMPUTER.	T-012-1054
AN EXPERIMENTAL DIGITAL CORRELATOR.	T-531-1074
SOME PRACTICAL CONSIDERATIONS IN THE REALIZATION OF LINEAR DIGITAL FILTERS.	P-137 1054
EXIBILITY FOR CHANGE AND GROWTH.	
SOME EXPERIMENTAL STUDIES OF LANGUAGE AND COMMUNICATION.	T 150 1022
LABORATORY DESIGN FEATURES TO PROVIDE MAXIMUM FL	T-122-1178
DIGITAL COMPUTER.	T-121-1483
VIEW - SOME ASPECTS OF THE RELATIVE EFFICIENCIES OF INDIAN LANGUAGES.	BOOK RE P-122-1176
ALTERNATIVE INTERPRETATION OF ROTATION RATE SENSING BY RING LASER.	A P 251 1071
ETIZATION.	
NO. 1 ELECTRONIC SWITCHING SYSTEM.	T-241-1024
ON THE REDUCTION OF SWITCHING TIME OF A FERRITE TOROID BY CROSS-MAGN	T-632-1021
A LANGUAGE AND SYSTEM FOR SYMBOLIC ALGEBRA ON A DIGITAL COMPUTER.	T-121-1483
AUTOMATIC SYNCHRONIZATION RECOVERY TECHNIQUES FOR BINARY C	T-531-1072
HIGH PRESSURE SYNTHESIS AND CRYSTAL STRUCTURE OF ALPHA-LITHIUM	P 114 1070
CYCLIC CODES.	
ALUMINATE.	

Permuted title index used at Bell Telephone Laboratories. The index is an alphabetical listing of titles, with each title entered separately under each significant word in its paper. Lines in color are entries listed under several key words,



Ultra-sensitive relays

HELPFUL DATA FOR YOUR CIRCUITRY IDEA FILE

The circuit drawing below indicates just one of the hundreds of ways many manufacturers utilize Micropositioner® polarized relays to solve complex control problems.

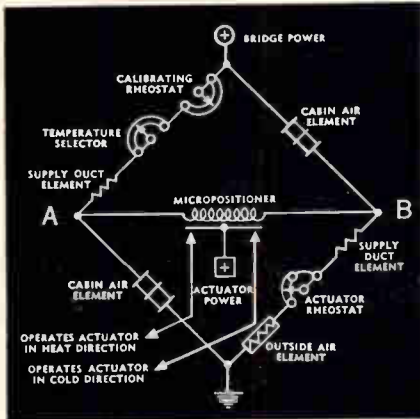

TEMPERATURE CONTROL

One of the most common applications of the Barber-Colman Micropositioner is in Wheatstone Bridge control circuits. In the above diagram of a temperature control application, the bridge arms incorporate temperature-sensitive transducers.

The Micropositioner is a polarity sensitive relay, so the direction of current flow in AB will close one or the other of its contacts from the normally floating neutral position. This causes a reversible control valve actuator to make desired temperature corrections in the supply air. A rheostat coupled to the actuator provides position feedback.

The same technique can control cycling (on-off) of an electrical heater. By using potentiometers or fixed resistors, the basic Wheatstone Bridge circuit adapts to positioning and synchronizing controls, or to automatic impedance test instruments.

BARBER-COLMAN MICROPOSITIONER®

POLARIZED D-C RELAYS
Operate on input power as low as 40 microwatts. Available in null-seeking and magnetic-latching "memory" types of adjustment. Also transistorized types with built-in preamplifier. Write for our latest catalog with full information on polarized relays.



BARBER-COLMAN COMPANY
Electro-Mechanical Products Division
Dept. B, 12167 Rock Street, Rockford, Illinois

the mountains of technical material that grow higher by the day. Every year, approximately 100,000 technical journals are published in the United States and abroad; the U. S. government issues about that same number of studies each year, as well as some 450,000 articles and papers. Scientists find that keeping up with material in their fields is an impossible task.

The White House Office of Science and Technology has also been studying the problem. Recently, some 250 reports on the subject were being prepared simultaneously and may themselves need an information-retrieval system. These studies are part of a government-wide scientific and technical information program that is costing about \$400 million this year. The \$50 million being spent on research alone will be increased to \$60 million in the 1967 fiscal year.

I. Compiling an index

Present computer systems are limited to compiling indexes of documents, rather than storing copies of the documents themselves. The computer produces an index arranged by title, author, subject or any other classification; some systems also store abstracts of indexed items.

There are two basic approaches to indexing: controlled vocabulary, which requires preliminary screening and classification of documents by someone who can understand them, and the uncontrolled-vocabulary approach, which results in a greater number of titles being loaded into the computer's memory by relatively unskilled clerical personnel.

Controlled vocabulary. The Engineers Joint Council, an association of engineering societies, employs the controlled-vocabulary, or key-word approach in compiling parts of its Engineering Index. Before indexing, each document is read and key words are selected, under which it is to be indexed. Frank Y. Speight, director of the council's information services, says this approach uses the computer most efficiently because it requires the computer to search only among lists of standard key words to find references to documents.

Since January, 1965, a computer has produced a list of authors and

subjects of two sections of the council's index—plastics and electrical and electronics engineering. The indexes also include the name of the publication where each article appeared, and an abstract of the article, all produced manually.

All controlled-vocabulary systems require a thesaurus which contains all the key words and several synonyms for each, all extensively cross-referenced. It is accessible to the computer and to the professional compiler, but not to the user of the system.

Uncontrolled vocabulary. The uncontrolled-vocabulary approach puts a heavier burden on the engineer using the system; he must know rather precisely what he wants when he requests a search.

An example of the uncontrolled-vocabulary approach is the Kwic index, originated at International Business Machines Corp. and used by several organizations. Kwic stands for key word in context. Titles of documents are entered into the computer, together with a serial number that also identifies the general subject of the document and its date; also recorded are the author's name, the publication, and an abstract. The computer lists each item in numerical order; it can then generate author indexes or other types of indexes, based on data in its memory.

The principal feature of the Kwic index is its permuted title listing, reproduced on page 169. It lists each title several times, once for each significant word in the title. The listing is printed with the significant words aligned alphabetically down the middle of the page and the remainder of the title to the right. If an entire title cannot be contained in the half-line, then it is continued at the left. If even a full line cannot contain the title, the overflow is omitted, with a slash to show the omission.

Kwic to Kwoc. IBM makes little use of the Kwic index, which is not suited to the gigantic volumes of data now handled by the IBM Technical Information Retrieval Center. Some groups within IBM have modified Kwic to Kwoc, for key word out of context; Kwoc, basically a subject index, puts the key word in the left margin.

A variation of the Kwic index is in operation at the Esso Research



They told us we couldn't get all these parts into this little box
(and they were right)

We wanted to give you an operational amplifier that would have *optimum size* — small enough to slip into high density assemblies without crowding . . . big enough for easy handling and fast assembly.

We wanted you to have an amplifier that would be completely self-contained — one that required *no external R-C networks* to provide unconditional loop stability.

We wanted you to have an amplifier with a *cost low enough* to permit general use in commercial applications.

We wanted, in short, an amplifier that would sell like hot cakes.

But we couldn't get all the parts needed for performance into the optimum-size package —

So we went thick-film hybrid when we built the new CIA-1.

Result: A miniature, low-profile operational amplifier with a performance equal to or better than that of discrete-component units (± 10 volt input common-mode swing, for example), and a versatility far exceeding that of currently available integrated circuit op amps. And the CIA-1 costs *only \$30* in quantities from 1 to 9 . . . substantially less in larger quantities.

While we were at it, we also produced the model CHA-1, which is an undamped version of the CIA-1, allowing greater design freedom with external damping networks. Price of this unit is \$24 in quantities from 1 to 9.

NEXUS
 RESEARCH LABORATORY, INC.
 480 NEPONSET STREET, CANTON, MASS. 02021
 TEL: (617) 828-9000 TWX (617) 828-1022

Full details, including quantity prices, on these new subminiature amplifiers are available on request. Write today to: Prices F.O.B. Canton, Mass. Prices slightly higher outside North America

IEEE SHOW — BOOTH 2 H 45

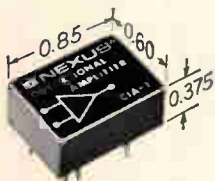

TYPICAL ELECTRICAL CHARACTERISTICS
 (at 25°C unless otherwise stated)

Supply voltage	±15 volts (nom.)
Supply current @ full output	less than 8 ma.
Open loop gain @ d.c. ($R_L = 10K$)	50K
load differential offset current	10 na
$I_{osd}/\Delta T$ (-25° to +85°C)	0.2 na/°C
differential offset current T. C	±10uv/°C
$\Delta E_{os}/\Delta T$ (-25°C to +85°C)	-25°C to +85°C
Operating temp. range	-55°C to +100°C
Storage temp. range	better than 1 mc.
f_t unity gain crossover frequency	±10v @ ±2 ma.
Output voltage range ($R_{LL} = 5K$)	0.5 megohms
Input resistance (differential)	f_p max. frequency for full output swing . . . better than 10kc



Throw this at trio/lab.[®]

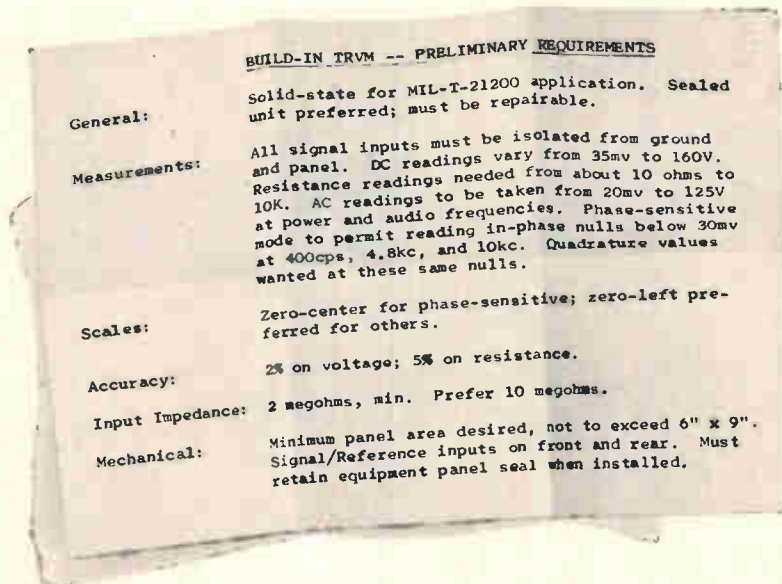

Here's what you get back.



A custom build-in TRVM.

As simple or as complex as you need it. We make it for you at production price and delivery, from a stock of thousands of Build-in-Bloc modules, all solid-state: AC preamp and ranging network, AC amplifier, DC-to-AC converter, resistance scaler, current shunt, bridge rectifier, ring demodulator, phase shifter, power supply.

You enjoy state-of-the-art developments; known characteristics; field-

proven, factory-tested reliability; avoidance of variations inherent in unproven designs; MIL performance at industrial prices.

You also enjoy peace of mind. We pioneered the build-in electronic panel meter. 90% of all build-ins are made by trio/lab.

Write or call for design help or a free copy of our handbook/catalog.

Trio Laboratories, Inc., Plainview, L.I., New York. (516) OV-1-0400. TWX: (510) 221-1861.



© 1966, TRIO LABORATORIES, INC. • ORIGINAL CONCEPTS IN INSTRUMENTATION

See us at IEEE Booths 3G06 and 3G08

& Engineering Co., a subsidiary of Standard Oil Co. (New Jersey). The company enters documents into its computer system by title and a one-sentence abstract. Esso also borrows from the thesaurus idea by occasionally referencing under alternative expressions as well as under the key words in the title. "Cathodic Protection With Magnesium Anodes," for example, would be indexed under its title, also under a sentence such as "Corrosion of an underground oil storage tank can be reduced with an electric current through a magnesium anode and the tank." The list can also include references to nonstandard terms, such as "Ethyl alcohol—see ethanol." Ethanol is the standard chemical name for ethyl alcohol.

Special services. A service that finds legal precedents for lawyers is being set up by Law Research Service, Inc., in New York. An attorney anywhere in the United States can have access to the system through Western Union's Telex system. Through a teleprinter in his office, he requests information about any and all precedents for a particular legal situation, using a code that he obtains from a thesaurus. The computer looks up the precedents, which may have been set in any state or federal court, and sends back a specific reference to a book or document that the lawyer can consult in his own law library.

Some information-retrieval systems notify individuals of articles that are of special interest. The Bell Labs system is an example. These systems contain "profiles" of the professional interests of every technical person in the organization. Key words of each document entered into the system, either in a controlled or uncontrolled vocabulary, are matched against the profiles of employees; whenever a document matches an employee's interest, he is reminded to look it up.

II. Retrieving facts

Present information-retrieval systems can search for documents, but generally not for specific facts. For instance, a user can say, in effect, "Get me the paper by John Johnson on tunnel diodes published about six months ago," and the computer can give him the specific

New from Carborundum at IEEE Booth 2147-2149

New space-saver thermistors and varistors

New lead configurations eliminate conventional bulky end caps. Electrical and thermal specs are identical with present devices, let you substitute and save space. Designed, packaged for mechanized insertion in printed-circuit boards.

New Boron Nitride resists moisture

This improved high-purity Boron Nitride gives you a material for furnace parts or fixtures that eliminates spalling from thermal shock. Eliminates contamination problems. Is readily machinable on the job. Has natural lubricity.

You'll also want to see our exhibit of components at work. Our special display furnace shows typical electronic manufacturing applications for refractories and heating elements and alumina-silica ceramic fiber. Also don't miss the filmstrip that shows you how we run a "zero defects" production operation for alumina substrates. Refractories and Electronics Division, The Carborundum Company, Niagara Falls, N. Y. 14302.



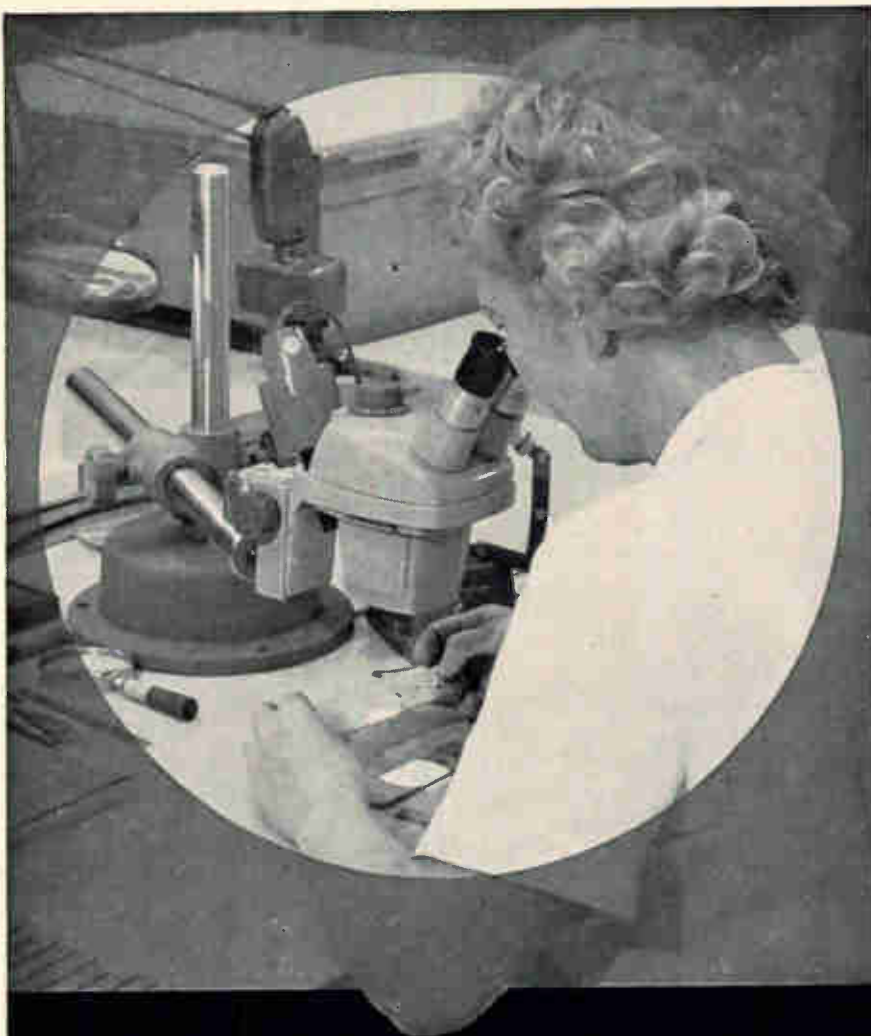

*To find micro-size voids, pits,
porosity and nodulation...*

**WESTINGHOUSE DEPENDS ON
BAUSCH & LOMB STEREOZOOM®**

The Aerospace Division of Westinghouse found StereoZoom ideally suited for spotting defects in Printed Circuit Boards with plated-through holes. The three-dimensional viewing it offers is the only way these holes can be checked properly. The bright, clear, magnified detail simplifies the inspector's work. With StereoZoom, breaks in circuit and shorts between layers can be clearly seen. Pinholes, dents and scratches can be found. To do this, many changes of magnification are required. StereoZoom adjusts its continuously variable magnification quickly and easily. The flexibility of the mounting parts and stand of StereoZoom allows complete freedom of movement of the parts under visual inspection.

For your quality assurance, choose a StereoZoom. There are 24 complete models as well as selected components. Call your dealer or write for Catalog 31-15, Bausch & Lomb, 61427 Bausch Street, Rochester, New York 14602.

BAUSCH & LOMB 

Visit our Booth 3K43 at the IEEE Show, NYC, March 21-24

reference, including Johnson's co-authors, the exact title, the book, magazine or journal in which the paper appeared, and perhaps an abstract of the paper. Or the user can say, "I want all the papers that deal with high-voltage power supplies, but not those using vacuum tubes, nor voltages above 500."

Some systems can find some kinds of facts; IBM's Iris (for IBM Recruitment Information System) personnel information system, for instance, can give the names of all engineers in the company who have masters' degrees from Midwestern universities, or who have specific experience in the field in question.

But no current system can search for an answer to a question such as, "How is stabilized voltage gain related to forward gain and percent feedback?" The engineer with such a question would have to remember that he saw the answer in an article about feedback in *Electronics* early in 1966, and ask the computer to find that article. The computer would reply, "Electronics, Jan. 24, 1966, p. 66."

Some prototype systems being developed permit such fact retrieval, but full realization depends a great deal on improved knowledge of linguistics, or the science of meaning. This is the same problem that blocks computer translation of language.

Encyclopedia on tape. The System Development Corp., for example, has worked out a method for fact retrieval. The entire text of the Golden Book Encyclopedia has been stored in the memory of an IBM computer at SDC. All important words in the text are stored in a list which specifies every location that the word occupies in the text, and gives a relative value to each word depending on how specific is its meaning.

Questions put to the system in ordinary English are compared with the word list, and an attempt is made to find phrases in the text that most closely match the words in the question, in the same order and with the same spacing. All matches are checked for a probability of validity, using the relative word values; if the probability is less than some predetermined value, the match is rejected. All remaining matches are printed out as probable answers to the question.

The system does reasonably well, but there are still problems. In answer to the question "Where was George Washington born?" it may reply, hypothetically, "George Washington was borne across the Delaware in a rowboat."

Equipment. The most efficient computer system for an information retrieval application include, direct-access equipment such as magnetic disk files or large magnetic drums. But some systems rely on serial-access magnetic tape. With direct-access equipment, information stored at any location is accessible within milliseconds; in disks, this time is determined by mechanical motion of the read-write heads and by the time of rotation of the spinning disks. Magnetic tapes are serial-access, because to reach data at the center of a reel of tape the computer must read all the data from the outside in, a process that takes four to five minutes. Some systems use tape because of the experimental nature of the system, the cost of direct-access equipment, or because the only available computer system is one that was not set up specifically for information retrieval.

Esso, for instance, uses a tape-oriented IBM 7094/1401 system whose main function is routine data processing and problem solving for Esso personnel. The 7094 is a large-scale computer that does the actual searching on magnetic tape. The 1401 is a small computer often used with large systems for peripheral operations such as printing, card punching or card reading. The 7094 searches for the requested information on a reel of tape, and writes its findings on another tape, which is then put on the 1401 to be printed out.

III. Looking ahead

The ultimate information retrieval system may be a national network. Government and private enterprise are trying to develop such a system, but much of the financing will be federal—for several reasons:

- The government is the source of much of the information that is to be retrieved.
- A federal agency might be a suitable coordinator of activities among various private enterprises.
- Government agencies are as in-

See the NEWEST in SLIDES and CABINETS



INDIANAPOLIS, INDIANA

IEEE BOOTH 4F14

4TH FLOOR - NEW YORK COLISEUM

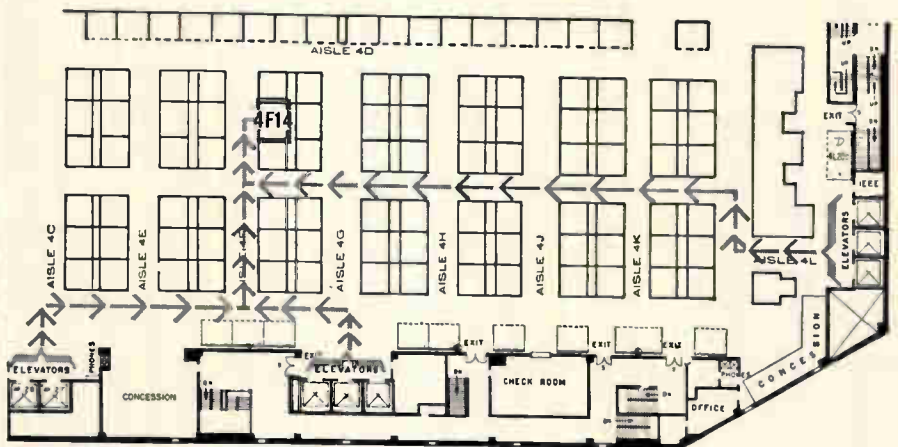

FOLLOW THIS MAP TO THE NEW CHASSIS-TRAK BOOTH

... where you will find the newest ideas and designs in slides and cabinets available in America today. Don't miss this opportunity to spend a few minutes exploring tomorrow's sophisticated enclosures and hardware.

AT THE IEEE BOOTH 4F14

March 21 through March 24



525 South Webster Avenue
Indianapolis, Indiana

FUNCTION MODULE NEWS



REPORT NUMBER 1

Algebraic modules solve mass flow equation $Q_T = Q_1 + Q_2 = D_1 F_1 + D_2 F_2$ at low cost



19-301

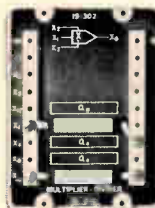

19-302

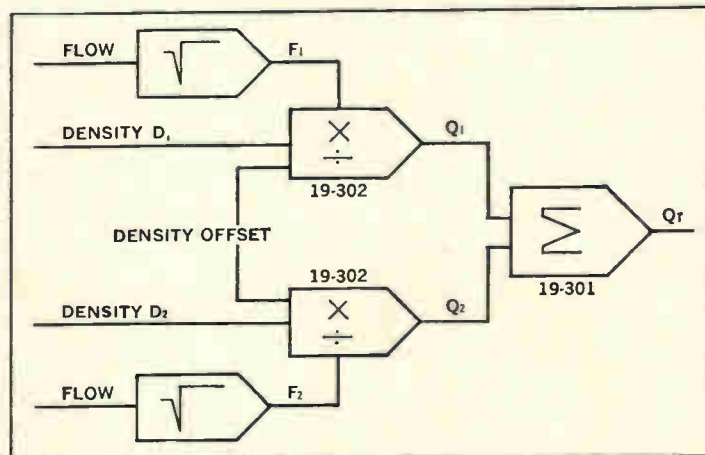

The summed mass flow of two process streams is calculated by a field-proven combination of CEC-DEVAR MODULES. The multiplication-division module, 19-302, multiplies the analog density and flow signals for each stream to obtain mass flow. The addition-subtraction module, 19-301, adds the two mass flows to obtain an output (0-10 v d-c) equal to total mass flow. The modules are readily assembled and interwired in building-block fashion. Scale factors relating analog inputs and outputs to engineering units can be either fixed or adjustable and are readily selected.

Accurate. The accuracy of the calculated total mass flow is better than 0.17% without trimming for process changes up to ten cycles per second.

Versatile. Both the 19-301 and 19-302 Modules are capable of performing complex operations in a single module. The 19-301 will accept six inputs which may be added or subtracted in any desired combination. The multiplier-divider will divide the sum of two inputs and multiply the quotient by a third input and subtract an offset input.

This offset feature is desirable for inputs which never reach zero.

$$E_0 = a_0 \left(\frac{a_1 E_1 + a_2 E_2 E_4 - a_3 E_3}{E_3} \right)$$

Further, the latter module will perform squaring and square root functions. Input and output signals are 0-10 v d-c @ 20 ma.

Low Cost. The low cost of CEC - DEVAR FUNCTION MODULES (typical \$50.00 - \$350.00) provides discrete process loop computation and control without elaborate programing expense. Scale factor changes in the field (by replacing a coefficient) eliminate the danger of obsolescence. Permanent calibration insures interchangeability and rearrangement for new equations.

Call your local CEC/Devar Sales Representative today for complete information on CEC/Devar instruments, instrument systems and Function Modules, or write for CEC Bulletin Package 9044-X4.

CEC

Devar-Kinetics Division

CONSOLIDATED ELECTRODYNAMICS

706 Bostwick Avenue • Bridgeport, Connecticut 06605
A SUBSIDIARY OF BELL & HOWELL COMPANY

terested as any other organization in retrieving information out of the mass of generated data.

Project Intrex. One preview of the retrieval system of the future may be project Intrex (for information transfer and exchange) at the Massachusetts Institute of Technology. Intrex is concerned with storing copies of documents, rather than references to them.

Project Intrex makes use, in part, of the facilities and techniques of Project Mac [Electronics, Nov. 29, 1965, p. 83]; and one of its long-range goals is the extension to information retrieval of on-line computing techniques developed in Project Mac. Other goals are the development of a national network and the evolution of the traditional library into a repository of quickly accessible information.

Experiments conducted in Project Intrex include one aimed at developing a means of augmenting the traditional card catalog, with electronics, to extend the indexing capabilities of cards.

Related studies in Intrex are aimed at broader knowledge of such concepts as an information-retrieval system's educational function, its utility for browsing, techniques for selective dissemination, ways to publish data on-line so that current information is really current, and ways of selective updating, so that file space is not wasted on obsolete data.

Continuous revaluation. The Engineers' Joint Council has long-range plans of its own, in addition to complete computer preparation of the Engineering Index. To prevent its files being cluttered with obsolete data, it is working on techniques of critical evaluation and review by experts—presumably the same ones who initially review the input data. The feasibility of incorporating engineering data is also being studied; this data would back up the published reports of experimental work. Sources would be the laboratory reports from which technical papers are prepared.

There is little doubt that computers will eventually provide efficient and easy access to data. When that day comes, scientists and engineers will be better equipped to perform the more demanding tasks that await them.

familiar faces from the world's broadest line of indicating relays

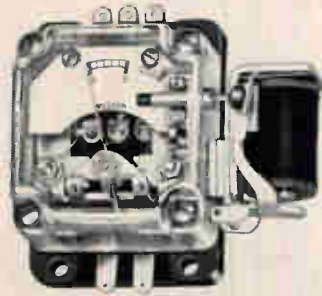

Model 813 Miniature — compact and lightweight; sensitive and Sensitrol (magnetic) contacts; single or double contact; ranges as low as 2-0-2 μa .

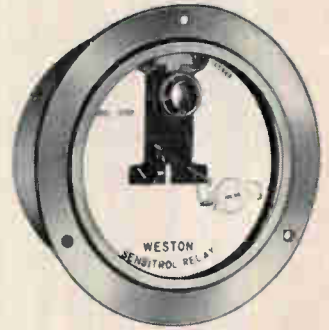

Model 1092 Sensitrol—low cost; all purpose; magnetically shielded; wide range adjustability; ideal for use in engineering breadboard circuits.



Model 705 Sensitrol—highly sensitive; surface or flush mounted; single or double, fixed or adjustable contact; ranges as low as 0.5-0-0.5 μa .



Model 723 Sensitrol—sealed; shielded; internal reset; solder terminals; single or double magnetic contact; ranges as low as 1-0-1 μa .



Model 1097 Ruggedized 3 1/2" Relay—LCCA type fully meets applicable portions of military ruggedized spec; sealed; long scale; shielded; solder terminals; single or double adjustable contacts.



Model 1075 Photronic—operates without physical contact; single or double adjustable set points; continuous reading beyond set point; taut band frictionless mechanism; solid state switching circuit; ranges from 10 μa .

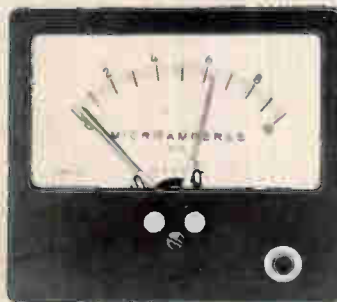

Model 1073 Mag Trak — long scale; shielded; positive contact; combines LCCA with magnetic attraction; self-contained reset; single or double adjustable contacts, ranges from 10 μa .

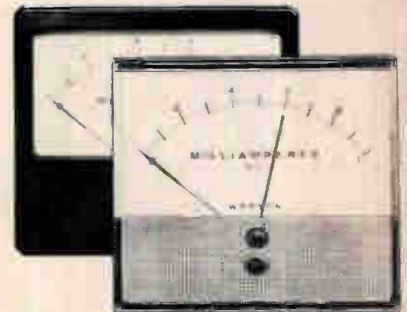

Model 1930/1940 Photronic—3 1/2" and 4 1/2" in either bakelite or plastic front; low cost; add-on power supply and solid state switching circuit; shielded; non-physical, adjustable contact.

Weston Instruments, Inc. • Newark Division • Newark, N.J. 07114

WESTON® prime source for precision . . . since 1888

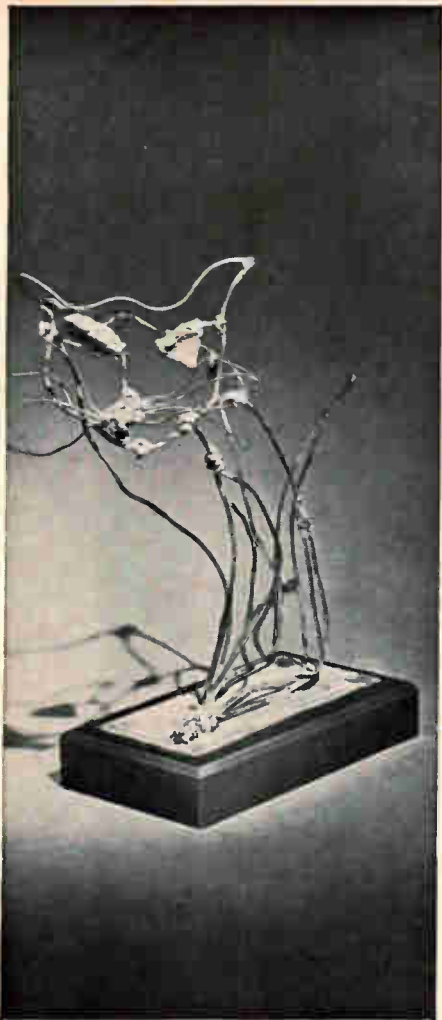

Art Wire four slides may not be able to produce *this* wire form.

But they'll make a valiant try!

Art Wire's four slides try harder. They *like* impossible delivery dates, ridiculous tolerances and unbelievable forms. After all, that's what a vendor is for.

Send your wire form and small part stamping headaches to Art Wire. We take over your down-time, overhead and inventory problems and make them our own. You'll probably save money, too.

Send us a part or a print. If you're in a hurry, phone 201-621-7272.

Bulletin 501 shows what we can do. Use the inquiry card for your copy.

ART WIRE & STAMPING CO.

227 Boyden Place
Newark, New Jersey 07102

Military electronics

Satellite's hidden talent

Navy's Navigation Satellite has already provided accurate navigational data to ships, subs and aircraft; now it's being acclaimed as an accurate, inexpensive surveying tool

By Walter Barney

Los Angeles Regional Editor

The Navy talked about its Navigation Satellite system, formerly called Transit, for the first time late last month and revealed some surprising details about a system that has been operational for several years. It not only provides navigational fixes that are accurate to within 100 meters—so that the captain of a ship can specify “bow or stern” when he asks the navigator for his position—but it has also calculated a new geodetic model of the earth that can be used to pinpoint any spot within five meters—10 times more accurate than other models.

There were more surprises: An aircraft with a new inertial navigation system had used the Navigational Satellite and obtained extremely accurate position fixes—errors as small as a quarter of a mile. Since a big factor in accuracy is how precisely the navigator knows his own vehicle velocity—an error of one knot ground speed throws the fix off as much as 0.2 nautical mile—the aircraft obviously had an inertial system better than any known to date. The system, it was learned, was developed by the Aeronautical division of Honeywell, Inc. Its drift is only 0.4 nautical mile every hour.

These details were given by Richard B. Kershner, of John Hopkins University's Applied Physics Laboratory, at the American Astronautical Society's recent meeting in San Diego.

Disbelief. Besides its navigational application, Kershner was enthusiastic about the geodetic capabilities. The Department of Defense spent \$200 million on surveying last year and Kershner says the job could have been done

faster and cheaper with accuracy to 5 meters with the satellite.

Potential users haven't taken full advantage of the system yet, even though it has been operational on some Navy ships and several Polaris submarines, Kershner says. Technicians at the Western Test Range, for example, don't try to track missile splashdowns near Kwajalein Atoll more accurately than 400 feet because the area can't be surveyed more precisely with current techniques. With the Navigational Satellite this could be changed. “But,” Kershner says, “they don't believe it yet.”

I. On board ship

To use the satellite, a receiver on board ship or in an aircraft must know its own ground speed and the satellite's position. With this

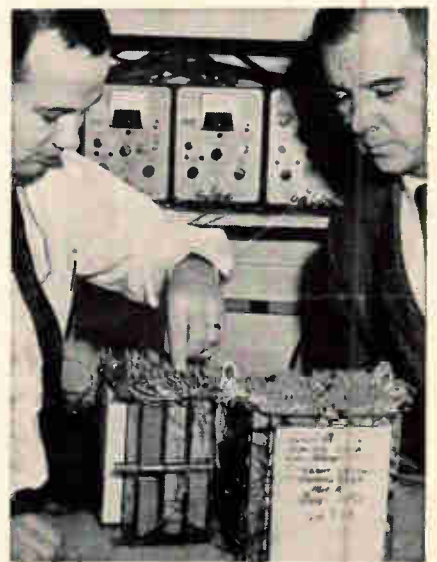

Satellite memory, designed by James C. Perschy, left, and Leo C. Miller of Applied Physics Laboratory, enables the satellite to tell ships and aircraft where it is.

RESOLVER/SYNCHRO INSTRUMENTATION

A very short course for engineers engaged in testing and evaluation of resolvers and synchros as components or as system transducers.

Selecting a resolver/synchro test instrument for any engineering, production or system requirement is remarkably simple from North Atlantic's family of resolver and synchro instrumentation. Because this group has been developed to cover every area of need in both manual and automatic testing, obtaining the desired combination of performance and package configuration usually demands no more than 1) determining what you need and 2) asking for it.

Remote Readout of Angular Position

For remote indication of resolver or synchro transmitters in system testing, North Atlantic's Angle Position Indicators (Figure 1) provide the advantages of low cost and continuous counter or pointer readout. These high-performance instrument servos are accurate to 4 minutes of arc, with 30 arc seconds repeatability and 25°/second slew speed. Dual-mode capability, multi-speed inputs, integral retransmit components and other optional features are available to match application needs. Priced from \$895.



Figure 1. Angle Position Indicators are available in half-rack, quarter-rack and 3-inch round servo packages.

High-Accuracy Testing Of Receivers And Transmitters

Measuring receiver and transmitter performance to state-of-art accuracy is readily accomplished with North Atlantic's Resolver/Synchro Simulators and Bridges (Figure 2). Each of these dual-mode instruments tests both resolvers and synchros, and provides direct in-line readout of shaft angle, accurate to 2 arc seconds. Simulators supply

from 11.8 to 115 volts from either 26 or 115 volts excitation, and so can be used to test any standard receivers. Bridges have constant null voltage gradients, making them ideally suited for rapid deviation measurements. Simulators and Bridges each occupy only 3½ inches of panel height and are available in a choice of resolutions. They are priced in the \$1500 to \$3000 range.



Figure 2. Resolver/Synchro Simulator provides ideal source for receiver testing.

Automatic Measurement And Conversion

Where systems require continuous or on-command conversion of resolver or synchro angles to digits, North Atlantic's Automatic Angle Position Indicators (Figure 3) handle the job without motors, gears or relays. These solid-state automatic bridges accommodate all standard line-to-line voltages and provide both Nixie display and printer output, accurate to 0.01° and with less than 1 second update time. Many variations, including 10 arc second accuracy; binary, BCD or decimal outputs; multiplexed channels and multispeed operation, are available for specific requirements. Ballpark price: \$5900.



Figure 3. Model 5450 Automatic Angle Position Indicator. It measures shaft angles, converts them to digital data.

Measuring Electrical Characteristics

Combine a Resolver/Synchro Bridge and a Simulator with a North Atlantic Ratio Box, a Phase Angle Voltmeter and a test selection panel and you have an integrated test facility for determining all electrical characteristics of resolvers and synchros in component production or Quality Control. An example is the North Atlantic Resolver/Synchro Test Console shown in Figure 4. It measures phasing, electrical zero, total and fundamental nulls, phase shift and input current, as well as angular accuracy. Standard North Atlantic instruments are used as modules, making it a simple matter to fill the exact need. The unit shown sells for about \$7500.



Figure 4. Model RTS-573 Test Console is a complete facility for the production line or in quality control.

If you require performance, reliability and convenience in resolver and synchro testing, we want to send you detailed technical information on these instruments (also on related instruments for computer system interface). Or, if you prefer, we will arrange a comprehensive technical seminar at your plant. Simply write to: North Atlantic Industries, Inc., 200 Terminal Drive, Plainview, N.Y. 11803 • TWX 516-433-9271 • Phone (516) 861-8600.



INTERCONNECTION FLEXIBILITY

**SINGLE
SIGNAL
SELECTION**

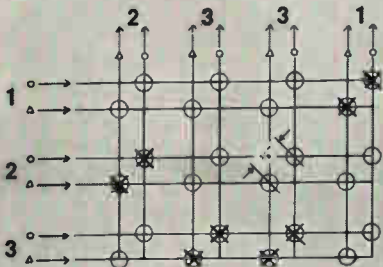
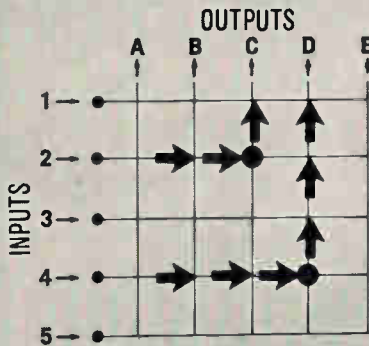

**OR
PROGRAMMING
"PAIRS"**

SEAELECTOBOARD



Meet every programming requirement . . . without patch-cord clutter . . . from single channel digital or DC programming to multiple channel audio programming. Single and multiple pins provide exceptional ease and simplicity of operation with drastic reductions in hardware and space.

Complete programming or multi-switching operations are performed by the mechanically simple, ruggedly constructed "Seaelectroboard". A single pin insertion completes the program switching operation and provides a visible indication of all of the programmed interconnections.

"Seaelectroboards" are offered in 2, 3, or 4 deck versions for single or multiple shorting and skip pins as well as for diode holding pins. Modular and custom designs including special program area and pin color coding are also available. Write today for your free copy of the complete, 12 page "Seaelectroboard" catalog.

*U.S. Patent No. 3027534 and other patents pending.



PROGRAMMING DEVICES DIVISION

SEAELECTRO CORPORATION

HOYT STREET • MAMARONECK • NEW YORK
PHONE: 914 698-5600 TWX: 710-566-1110

Seaelectro Ltd., Portsmouth, Hants, England

Visit Seaelectro IEEE Booths 2G43-45

information plus precise measurement of the doppler shift from the satellite's signal, the problem can be resolved. To determine the vehicle's own velocity, inertial navigation can be used. For the satellite's position, the same signal that provides the doppler shift is phase modulated to disclose the satellite's position at two-minute intervals. This information is provided the satellite twice a day from a computing center at Pt. Magu, Calif. Pt. Magu gets its information from quad helix antennas in Maine, Minneapolis, Hawaii and Pt. Magu that track the satellite as it comes over each one's horizon.

Shipboard equipment on a Polaris sub is complicated, since it is integrated with the inertial system for the missile and the vehicle. But for a surface ship all that is required is a receiver, a data processor, and a special-purpose computer. In the case of a large ship, its big general-purpose computer can be used. The navigator picks up the satellite signal for six minutes during a pass, and 15 seconds later gets a printout of latitude and longitude information as of the time the pass ends.

The shipboard equipment is about as big as two portable television sets and costs about \$60,000. Eventually, Kershner says, by eliminating the computer, the costs can be cut to \$5,000. Two years of operation have provided the Navy with a much clearer idea of the exact shape of the earth, so that the satellite orbit can be determined a year in advance and need not be updated twice a day. A set of charts could thus replace the computer.

II. Satellite package

The satellite itself is principally a memory and a transmitter/receiver. It is a 140-pound octagonal cylinder, 18 inches across and 12 inches high, with solar-cell panels extending from four of the eight faces. The nickel-cadmium cells provide 30 watts on launch, and after five years in space will still produce 25 watts, which is enough to power the satellite. One model has been working for 4½ years.

The electronics package contains 35,000 magnetic cores and 6,200 other components, and to squeeze them into the available space, welded cordwood construction was

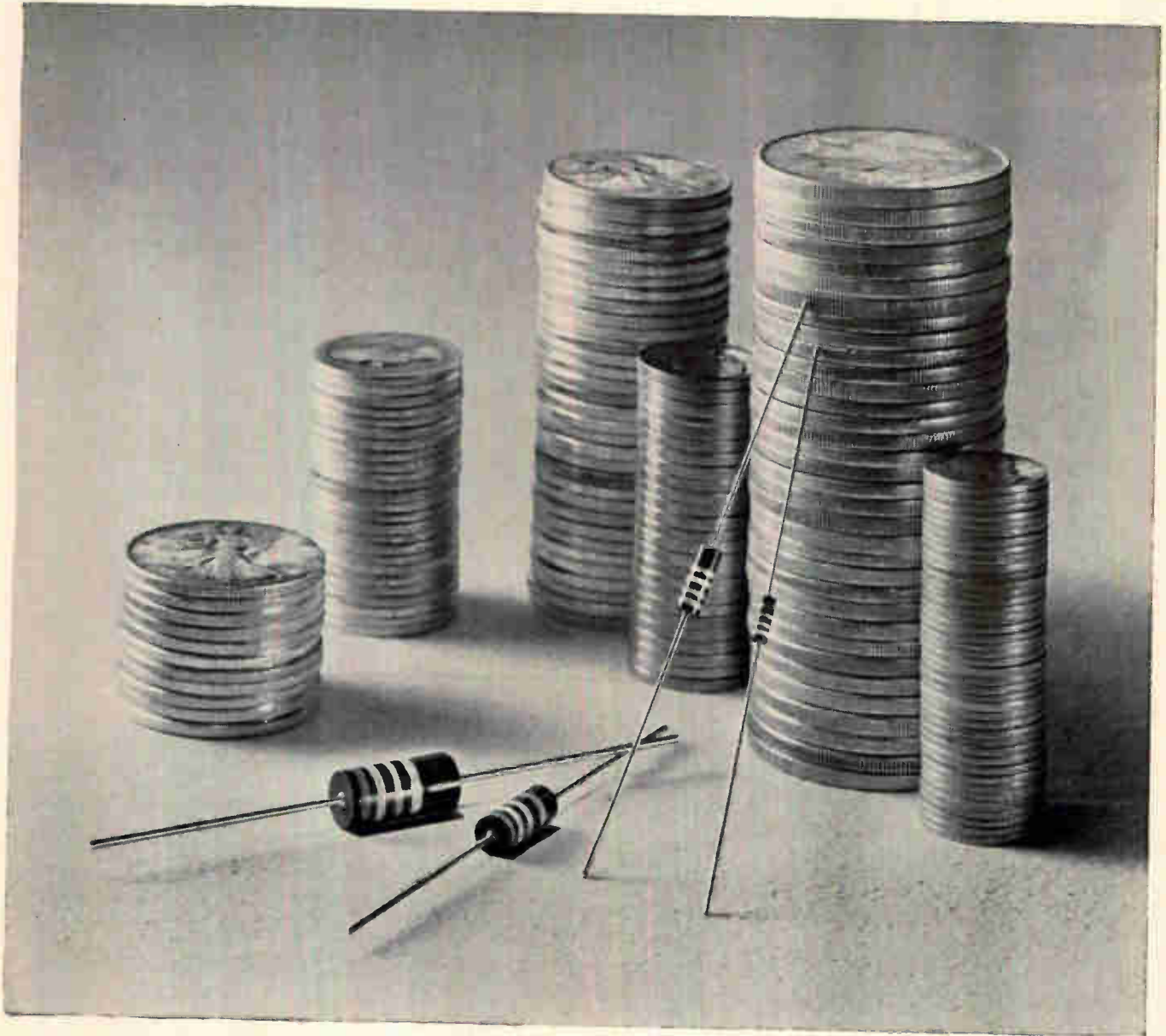

Quality Need Not Be Expensive

Some people would have you believe that to buy the best, you must pay the most. This is not necessarily true. Price is only a measure of value—never a substitute for it.

At Stackpole, the real value of any resistor is determined by a combination of its performance record and its price. Perhaps this is why so many of our customers continue to specify Stackpole resistors year after year to maintain top performance for established products and for their new ones, too. Such confidence and loyalty cannot be based on price alone.

Uniformity has become the accepted characteristic of Stackpole resistors. Unique production methods, coupled with in-depth experience in manufacturing and testing are your assurance that Stackpole resistors will give you absolute performance. The resistors you order today will be identical in every way to your last order.

Most leading manufacturers of electronic equipment have long recognized Stackpole resistors for reliability.

Whether it be the rugged demands of portable television or the critical tolerances of space age communication and tracking equipment, Stackpole resistors deliver the performance you expect—the kind of dependability that builds a reputation for your products.

Why continue to pay a premium for quality? Let us prove that you get value from Stackpole. Quality resistors, economically priced, are delivered promptly and backed up by our complete corporate facility. Next time, specify Stackpole. There's a family of fine resistors available in sizes of 2, 1, ½ and ¼ watts. For samples and additional information, write: Stackpole Carbon Company, Electronic Components Division, Kane, Pa. Phone: 814-837-7000 — TWX: 510-695-8404.





MEASURE
100,000 VOLTS AC or DC

Kilovoltmeters

Completely transistorized with anti-drift circuitry for sensitivity in the order of a few microamperes for minimum circuit loading. Large 6-inch precision mirror scale meter, ideal for lab or field testing. Panel mounted trimmers provide for recalibration when required. Accuracy is $\pm 1\%$ of full scale on DC, $\pm 2\%$ of full scale on 60 cycles. Probe accuracy is $\pm 2\%$ on the 5 and 10 KV range and $\pm 4\%$ on the 50 and 100 KV range.



Insulation test sets

New portable models offer big test set features, combined with compact convenient size. Reads both applied test voltage and leakage current simultaneously. Dual instruments available with both AC and DC measurement facilities.

Beckman INSTRUMENTS, INC.

CEDAR GROVE OPERATIONS
89 Commerce Road
Cedar Grove, New Jersey 07009

Formerly Industrial Instruments, Inc.
See us at IEEE Booth 3D15-17

New inertial navigator

"Honeywell had the only inertial navigational system accurate enough to meet the stringent velocity measurement requirements needed to use the Navigation Satellite to navigate an aircraft." Thus, in describing the satellite, it was disclosed that an airborne inertial navigation system had been developed that is more accurate than any existing airborne system. The developer was the Aeronautical division of Honeywell, Inc. The speaker was Richard B. Kershner, of the Applied Physics Laboratory, Johns Hopkins University, at the American Astronautical Society meeting in San Diego, last month.

"We found that we could determine the position of a plane within a quarter of a mile," Kershner said. The actual test, it was learned later, took place in December, 1965, aboard a P-3A Orion aircraft based at the Patuxent, Md., naval air station. In it, a Honeywell H-386 precision inertial navigator was mated with the Navy's SRN/9 satellite receiver and, even though the equipment was not designed for the P-3A, it performed brilliantly.

The drift error of the H-386 is reported to be an unprecedented 0.4 nautical mile per hour. It consists of an inertial measuring unit—a gimbaled platform with accelerometers and a gyroscope—and Honeywell's Mark 3 computer, a general-purpose serial binary computer which grew out of one the company developed for the now cancelled Air Force Satellite Interceptor program known as Saint.

The computer uses integrated circuits for all digital functions. It has a drum memory and a comparatively slow clock rate of 180 kilocycles. Its speed is improved, however, by a free-running arithmetic section which can multiply or divide at the same time that it adds or subtracts.

Honeywell developed the system with its own funds, and originally intended it to work with a star tracker. But when the Navy began looking for a super-accurate navigation system to test its satellite navigation program aboard a plane, Honeywell offered the H-386.

Negotiations are now under way between the Navy and the company for a follow-on study toward integrating the two systems.

used wherever possible. There are 46,000 permanent electrical joints, of which 40,000 are welds. "Generally," Kershner says, "except in telemetry functions which can be lost without destroying the operational usefulness, redundant wiring and redundant solder connections were used."

Stability. The use of connectors was kept to a minimum, and where they had to be used in critical circuitry, complete redundancy was provided. In most places, wire-wrapped connections, which have proved highly reliable, were employed. The APL has been making the satellites in-house, but plans to hunt for an outside contractor soon.

The satellite is launched on a Scout booster, and is gravity/gradient stabilized by means of a 100-foot boom with a 3-pound weight on the end. "But," Kershner says, "since the gravity-gradient method is likely to stabilize the satellite upside down, we used magnetic stabilization as well." The magnetic method employs two thin metal rods that have considerable magnetic hysteresis to stop the satellite from spinning and an electromagnet which aligns the satellite with

its bottom face, where the antennas are mounted, toward the earth. Then the boom is extended and gravity-gradient stabilization takes over.

Transmission is on two coherent frequencies, 150 megacycles and 400 megacycles, so that the Pt. Magu computer can calculate the refraction effect of the ionosphere.

Although the Navy plans to operate its system with up to four satellites, there are at present only two in orbit. Sometimes, Kershner says, one of the satellites will fail, and the ships will get along with only one. The satellites are in 600-nautical-mile, circular, polar orbits, and a ship can get 4 to 5 fixes a day from one of them, or 8 to 10 from both satellites.

III. Checking the orbit

One of the most serious problems affecting accuracy is determining the satellite's orbit. Besides tracking with the quad helix antennas, the doppler shift is also used to determine the satellite's position—measured to a few hundredths of a cycle; this corresponds to a distance determination of under 10 meters. But to determine an orbit from these measure-

Why do the world's leading electronic firms come to HULL?

For superior systems to encapsulate electronic components,* small or large ... that's why

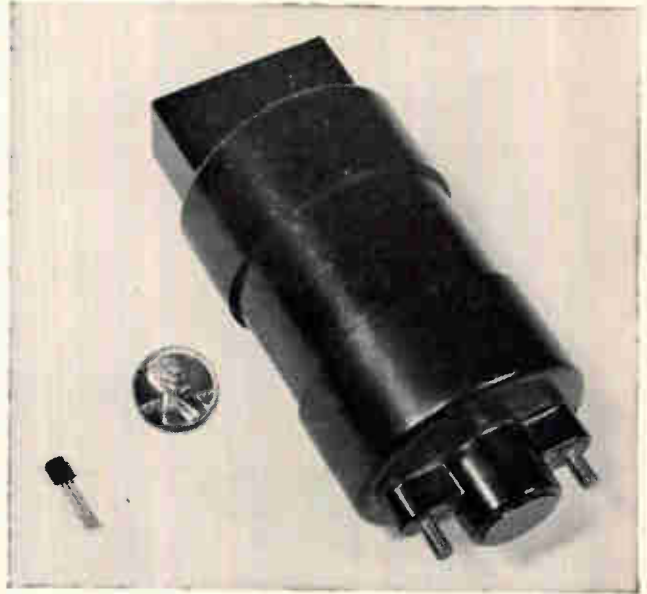

Here's "The HULL Story" in brief: There's more to it than simply building better machines. "The HULL Story" of superiority in encapsulation starts back in 1956. We got our feet wet helping Western Electric package their varistors in the then new "short-cure" resins. The resultant process proved ideal.

The decade that followed saw rapid developments in new electronic components and circuits. These required new methods and materials of encapsulation. More for love than money, at first, we worked in strict confidence with many electronic companies . . . helping them solve their encapsulation problems, and learning with them.

Today, several hundred installations later, we're proud to claim unques-



This 25-ton 359D packaged system includes molds, loading frames, and controls for economical, direct encapsulation by transfer molding.

tioned leadership in the field of encapsulation, offering a *complete system capability*. Our list of customers reads like a "Who's Who" in electronics: Texas Instruments, General Electric, IBM, Motorola, Philips, Fairchild Semiconductor—to name a few.

You can easily gain the benefits of Hull's techniques

Essentially, there are three major steps in the solution of your specific encapsulation problem:

1. We conduct a feasibility study—even while your product is still at the bread-board stage. Details of lead wires, coatings, welding, soldering, etc, are included.
2. Your component is produced in our laboratory. Molding compounds and machine requirements are determined. You get samples to test, and a full report on the development work.
3. If you're satisfied, we propose a *packaged system*—complete with machine, molds, and all accessories—to meet your production needs, present and future. This may be a smaller system (say, 12- or 25-ton size) for lower-volume production; or a larger system (50, 75, 100 and 150 tons) for high-volume production.

There's no better way to adopt this rapid, precise, economical, and modern technique for packaging your electronic component or circuit. Why not contact us today to get started? (Circle 605 on reader service card.)

*Such as transistors, integrated circuits, capacitors, resistors, modules, transformers, and coils.

Encapsulation by transfer molding . . .

means pushing a molten thermosetting plastic, such as an epoxy or silicone, through channels into the mold where encapsulation takes place. The process is fast . . . at most a few minutes. It can match practically any production rate you want and provides a precise, dense, void-free covering over even the most delicate component.

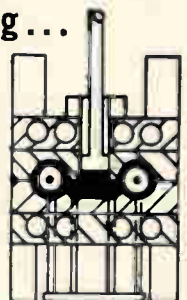

Other Hull systems for quality electronic production

- Precision, high-volume molding systems for thermoset plastic parts (Circle 606 on reader service card.)
- Systems utilizing vacuum technology . . . for impregnating, upgrading, drying, heat treating, potting, etc. (Circle 607 on reader service card.)
- Continuous proportioning, mixing, and dispensing ("Blendmaster") Systems. (Circle 608 on reader service card.)

Visit us in Booths 1J13-15 at the IEEE Show

See a 50-ton encapsulation system in operation; also a vacuum potter and the "Blendmaster".

HULL CORPORATION

6032 Davisville Rd., Hatboro, Pa. 19040
Telephone: (215) 675-5000
Export: 1505 Race St., Phila., Pa. 19102



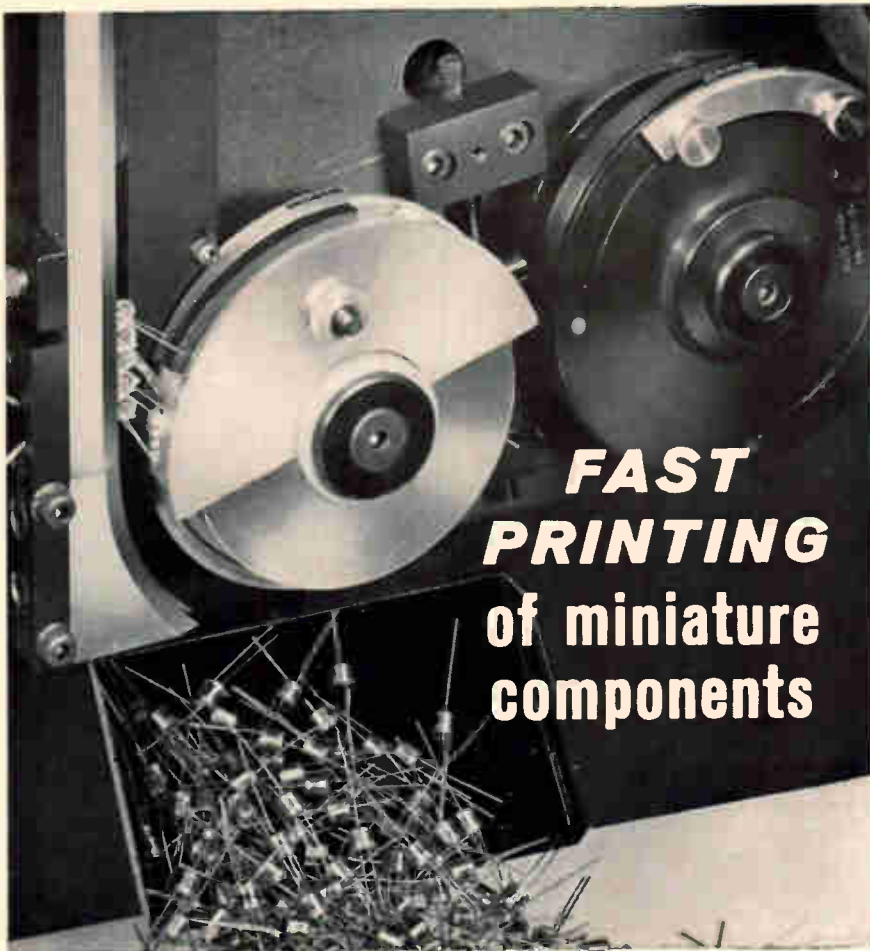

FAST PRINTING of miniature components

Variable Speed Controls and a printing-inking system designed for rapid action, permits you to synchronize marking, coding, and identification with your production rates up to 10,000 pph.

Only a rubber blanket roll touches your product, to deposit a quick drying impression. And—since the blanket roll receives a fresh ink supply for each mark from precision steel type, clear legibility is assured.

Part handling fixtures are designed to handle round or flat configurations, and inks are available for solvent and high temperature resistance.

WRITE FOR NEW BULLETIN



JAS. H. MATTHEWS & CO.
Industrial Marking Products Division
6788 PENN AVE. • PITTSBURGH, PA. 15206

VISIT BOOTH 4B21 IEEE EXHIBIT MARCH 21-24

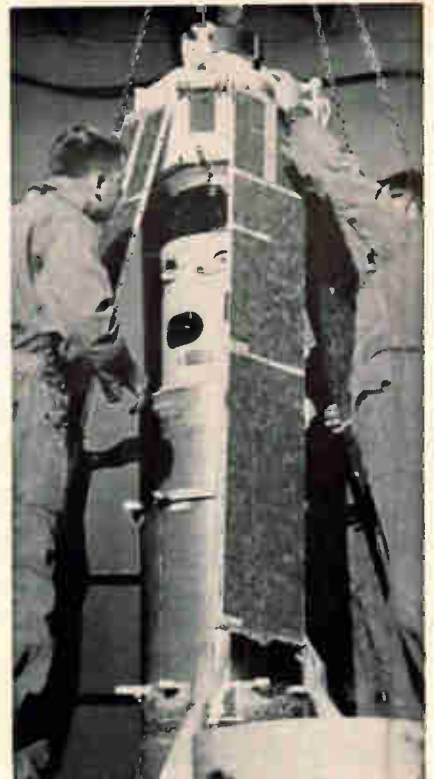

Navigation Satellite is attached to the Scout fourth stage for spin-balancing.

ments, an accurate knowledge of the forces acting on the satellite is required, and that knowledge depends on a good understanding of the gravitational field of the earth.

Accordingly, the Navy Astronautics Group, which runs the navigational program, and the APL have devoted considerable effort to deducing a more accurate gravitational field model. Fifteen special tracking stations were established, and a number of experimental satellites launched solely to collect the required data.

The earth's shape. It was already known that far from being a regular oblate spheroid, the earth is somewhat pear-shaped; the results of the Navy program were a series of equations containing the values for all terms through the eighth order (reflecting hills and valleys as a function of latitude) and degree (reflecting them as a function of longitude), plus special "resonance" terms of the 13th and 14th order. The resonance terms were needed to eliminate erratic errors in the calculations of the orbits, which have periods of between 1/13 and 1/14 of a day.

The APL plans to continue the study to determine all terms

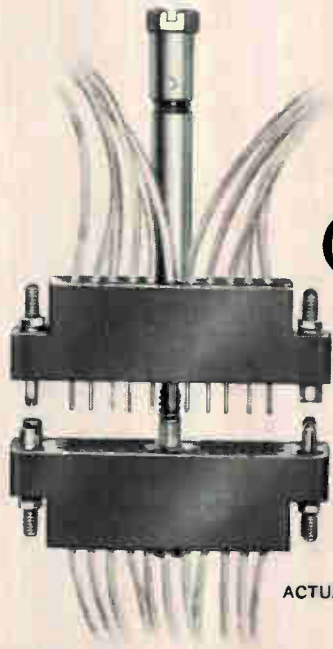

ACTUAL SIZE

50 CONTACTS
MICRO-MINIATURE
CRIMP REMOVABLE
CENTER SCREWLOCK
CONNECTOR
SERIES 25MM

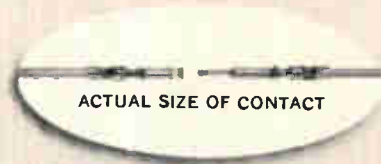

ACTUAL SIZE OF CONTACT

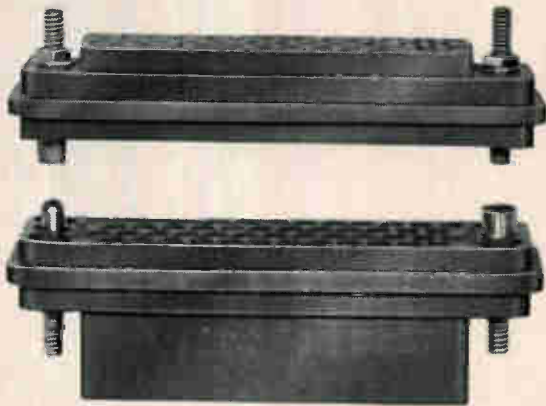

ACTUAL SIZE

50 CONTACTS
MINIATURE
CRIMP REMOVABLE
CONNECTOR
SERIES 25



ACTUAL SIZE OF CONTACT

MICRO-MINIATURE • SUB-MINIATURE • MINIATURE • PRINTED CIRCUIT • RIGHT ANGLE PIN & SOCKET • CENTER SCREWLOCK

CONTINENTAL



CONNECTORS

CONTINENTAL CONNECTOR CORPORATION • WOODSIDE, NEW YORK 11377

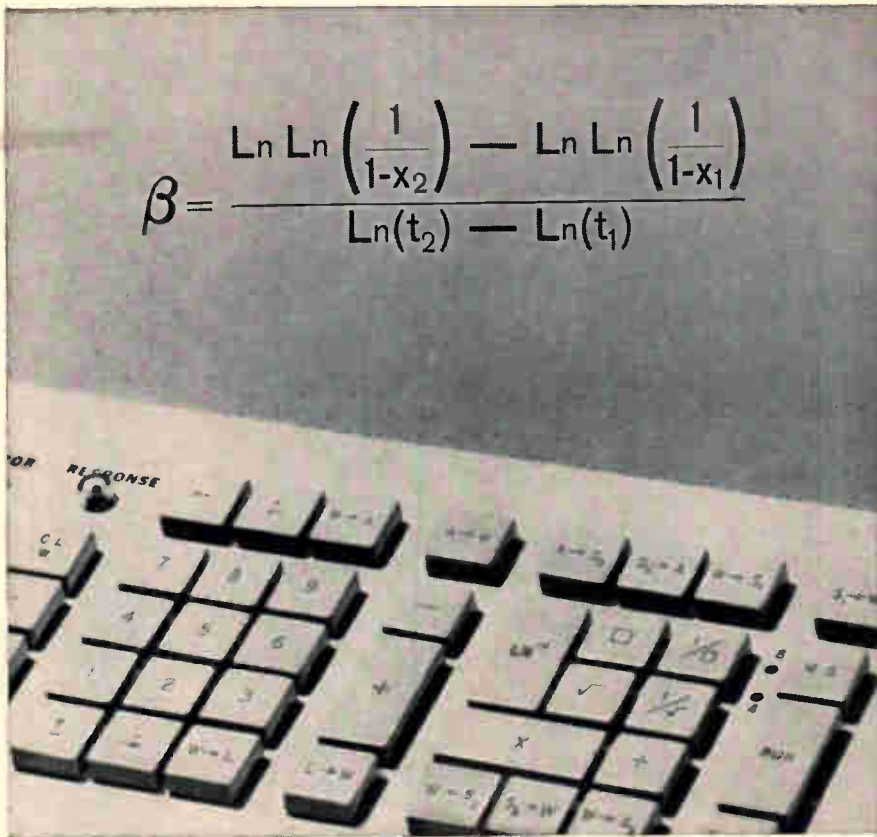

You can solve for β in seconds...with LOCI-2

LOCI-2, the most powerful desk-top computer ever devised, makes short work of expressions like this one for failure rate coefficient β . This new programmable instrument provides broad computer capabilities combined with the immediacy and simplicity of a slide rule. Designed specifically for the personal use of scientists and engineers, LOCI-2 owes its computational power to the fact that it utilizes an absolutely unique logarithmic approach to data manipulation which results in extraordinary versatility and simplicity of operation.

LOCI-2 is programmed by means of pre-scored tab cards (no keypunch needed). It is furnished with a total of 19 storage registers, which provide a program flexibility exceptional for a unit of desk-top size. In the manual mode it may be operated as an extended calculator, capable



To solve for β in the above expression:
(with appropriate program card in the LOCI-2 reader)
1. Enter value for x_1 (press "P₀" key)
2. Enter value for x_2 (press "Run" key)
3. Enter value for t_1 (press "Run" key)
4. Enter value for t_2 (press "Run" key)
The value of β is automatically displayed.

of performing addition, subtraction, multiplication, division, and exponentiation, as well as taking logarithms and extracting roots. In the automatic, programmed mode, it has a flexible and powerful repertoire of commands with which iterative procedures are easily and compactly coded.* There are also commands for making decisions and constructing program loops.

LOCI-2 is even used "on-line" as an extremely economical means of data acquisition and reduction,

in many applications such as controlling process variables, reduction of nuclear scaler readings, etc.

LOCI-2 prices range from \$2570 to \$8450. If you would like to learn more about this remarkable instrument, write for complete descriptive literature.

*An extensive library of scientific and mathematical programs is furnished free of charge to LOCI-2 purchasers.

WANG
LABORATORIES, INC.

DEPT N-3, 836 NORTH STREET, TEWKSBURY, MASS. 01876 — TEL: (617) 881-7311

through the 10th order and degree within a few months. Kershner says that the computing program for the problem, which must handle 157 items, is the most complicated he knows. But the result will be the ability to calculate a satellite orbit accurately a year in advance. The points on the orbit will be correct, although Kershner says there will be an uncertainty of 20 to 30 seconds after a year in estimating when the satellite will arrive at a given point.

IV. Omega

The release of data on the satellite system comes as the Navy is preparing to install an entirely different sort of navigational system, Omega, which employs underwater radio waves [Electronics, Aug. 9, 1965, p.27]. Kershner says that Omega, while not as accurate as the satellite system, will still be of great value because it will provide continuous information and is a cheaper and simpler system.

Further, there is a question as to just how accurate a ship's navigational system needs to be. It is clear that for firing a Polaris missile, the Navy cannot have too much accuracy. Steering a surface ship into port is another matter.

Oceanographic expeditions, too, want to know their position with accuracy. The system has been tried out aboard a vessel from the Woods Hole Oceanographic Institute in Massachusetts.

Air traffic control. The airplane experiment with the Honeywell inertial system indicated applications in airborne navigation, but Kershner is dubious as to the Navigation Satellite's value in air traffic control. "You could determine traffic lanes accurately," he says, "but you would need better communications to change the distribution of those lanes before that method of control becomes practical."

Whatever the practical nonmilitary applications, he adds, the system has already provided enough surveying information to tell us more accurately than ever "what a terrible shape the world is in." If anybody's interested—and the Navy certainly is—it isn't round at all, nor is it really pear-shaped; the APL's contour maps show that it is a cross between a sphere and a tetrahedron.

Ever see this before?

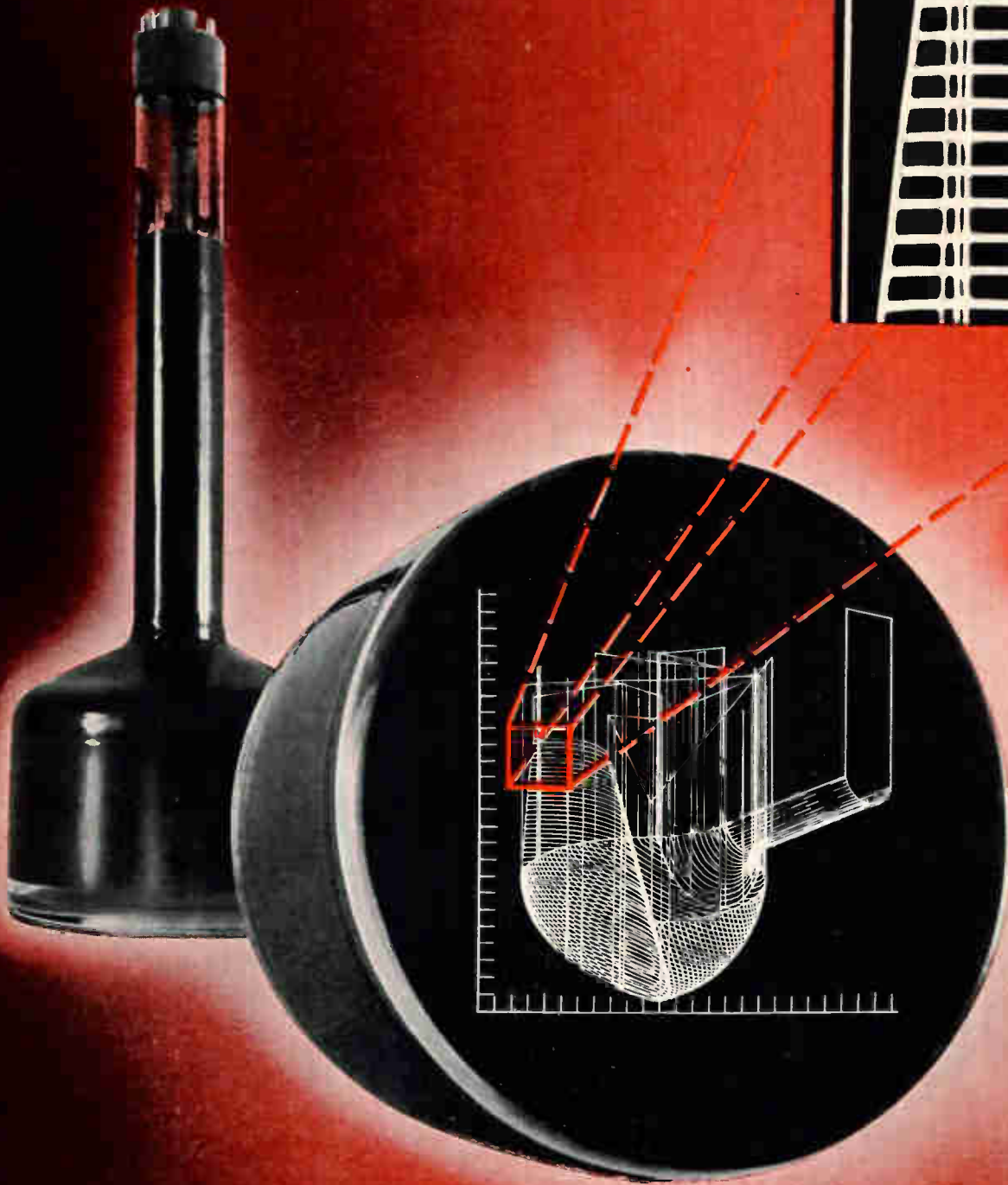

Above: Unretouched photo of detail enlarged six times from Benson-Lehner Model BL-120 High-Speed Digital Printer/Plotter.

(Not unless you're using the new, high-resolution Du Mont Type KC2515 CRT!)

With resolution of 0.0015 mils, our new KC2515 5-inch CRT represents the furthest advance yet made in man/machine interface.

Here's how we obtain it:

- a deflection angle of only 26° (which virtually eliminates deflection defocusing!)
- the faceplate is optically finished to within 0.005 in. (which minimizes parallax)
- a new electron optical design, employing a specially designed electrostatic focus and magnetic deflection gun.
- a significant reduction in phosphor grain size.

Such resolution enables systems designers to employ more sophisticated and more useful techniques of analog and digital presentation. Direct-photography applications are enhanced. So are those of flying-spot scanning.

Such advances in the cathode-ray tube are what you can expect from Du Mont, with our years of experience in design and manufacture. Call in a Du Mont sales engineer for *informed* applications assistance on the new KC2515 or on 4,000 other types of tubes in stock, or write for Technical Bulletin KC2515.

WORLD'S LEADING MANUFACTURER OF DISPLAY TUBES

FAIRCHILD

DUMONT ELECTRON TUBES

A DIVISION OF FAIRCHILD CAMERA AND INSTRUMENT CORPORATION

CLIFTON, N.J.

Circle 187 on reader service card



Combine this Digital Readout System with your preferred Rotary Table to accomplish precise angular measurement for inspection and machining operations. The Digital Readout System is designed to be used as an input device for positioning or as a readout device.

NOW olivetti-farrand

INCREASES ROTARY READOUT SPEEDS TO

100 degrees/sec.

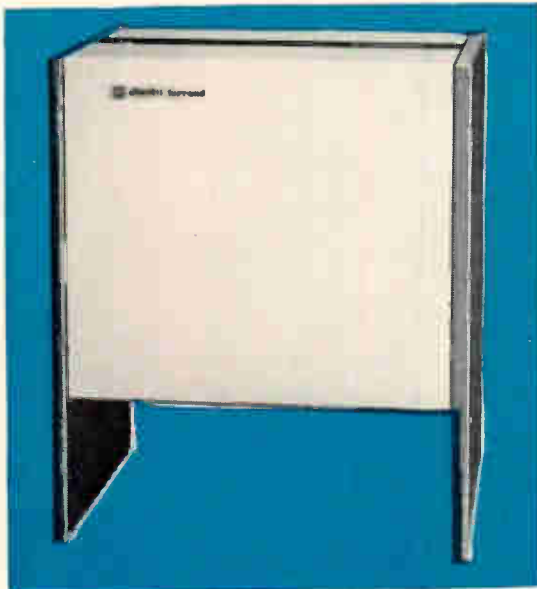

Compare these Olivetti-Farrand Readout specifications for high quality machining, increased production and low cost:

- Display: Linear or Rotary to three or four decimal places
- Limit of Travel: None
- Limit of Speed: 100 deg./sec. Rotary or 6000 ipm Linear
- Accuracy: ± 0.0001 inch or ± 0.001 degree

OPTIONAL FEATURES AVAILABLE:

- Automatic printout with sequence number
- Decimal output connector
- B C D output connector
- Manual digit set buttons for set-up at dimensions other than zero

HIGH SPEED . . . Rapid readout response at speeds up to 100 deg./sec. far exceeds any comparable system on the market today.

EASY INSTALLATION . . . Modular Design Electronics and Readout can be located remotely or in any convenient position around your machine.

The ideal combination of Olivetti's silicon solid state electronics and Farrand's INDUCTOSYN[®] technology offer the most outstanding Digital Readout System now available to the aerospace field. Farrand's rotary and linear basic data elements are the most accurate on the market. The INDUCTOSYN and its moving slide are independent of the usual lead screw or gear mechanical coupling and counting problems. This electrical scale direct readout eliminates the critical optical conversion used in other systems. Zero reference can be selected wherever convenient. Numerical display is easily restored after shutdown — therefore no need to worry about power failure!

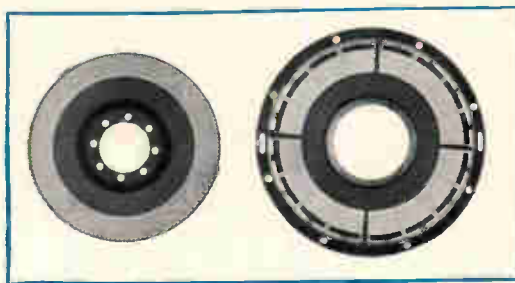

The rotary INDUCTOSYN is the basic data element for rotary applications. The Read-Out System consists of these data elements, Electronics Package and Display Package. It converts analog measurements to digital indications and is designed for simple mounting on a machine.

Additional Systems available from Farrand Controls . . . send for complete information on

- Continuous Path Numerical Control Systems
- Point-to-Point Numerical Control Systems
- Zigzag Numerical Control Systems
- Two and three axis Coordinate Inspection Machines

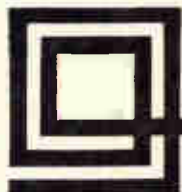

FARRAND CONTROLS, INC.

99 WALL STREET • VALHALLA, NEW YORK 10595

TELEPHONE: 914-761-2600

Navy gives rescue sub top priority

Four-part deep submergence program will cost nearly \$50 million in fiscal 1967—more than three times this year's budget. Contracts will be let for rescue, salvage, man-in-the-sea and search programs

By Seth Payne

Washington News Bureau

Now that its feet are wet after starting work on its Deep Submergence Systems Project (DSSP) last year, the Navy expects to probe deeper into the ocean and to award many more electronics contracts this year. The DSSP is a \$200 million to \$300 million, four-part program to develop capabilities by 1970 for rescuing crewmen from stricken submarines well below 3,500 feet, salvaging large objects down to 600 feet, permitting men to live and work at 600 feet and for searching and recovering small objects down to 20,000 feet. Although the war in Vietnam was responsible for cutting the Navy's request for fiscal 1967 from \$66 million to \$49.3 million, this is still a big jump from the \$13.9 million

being spent in fiscal 1966.

Work in all four areas will be stepped up in fiscal 1967:

- Aware of the possibility of another disaster like the loss of the nuclear-powered Thresher that went down in 1963, the Navy will put its effort in the deep submergence program this year on development of a small deep submergence rescue vessel (DSV). In a matter of days, a big contract will be awarded for a prototype of the DSV. It will be 40 feet long, 8 feet in diameter, carry a two-man crew, and descend to well below 3,500 feet. It will mate with a stricken submarine and rescue 12 to 14 men at a time. A second contract will be awarded for a short-range sonar system, essential for the last few

crucial feet before the rescue vessel mates with the submarine.

- By the end of this year, a contract amounting to about \$1 million will be awarded for a life-support system for divers engaged in salvage work.

- Work continues on equipment for living and working on the ocean floor. Sealab 3, a modified Sealab 2, will go down early next year, and a fourth Sealab, called Seahab, is being planned (see drawing below).

- Most affected because of the shortage of funds is the search vehicle. Instead of starting development of a new vehicle that could descend to 20,000 feet to search for and recover small objects, the Navy will modify Trieste 2 with

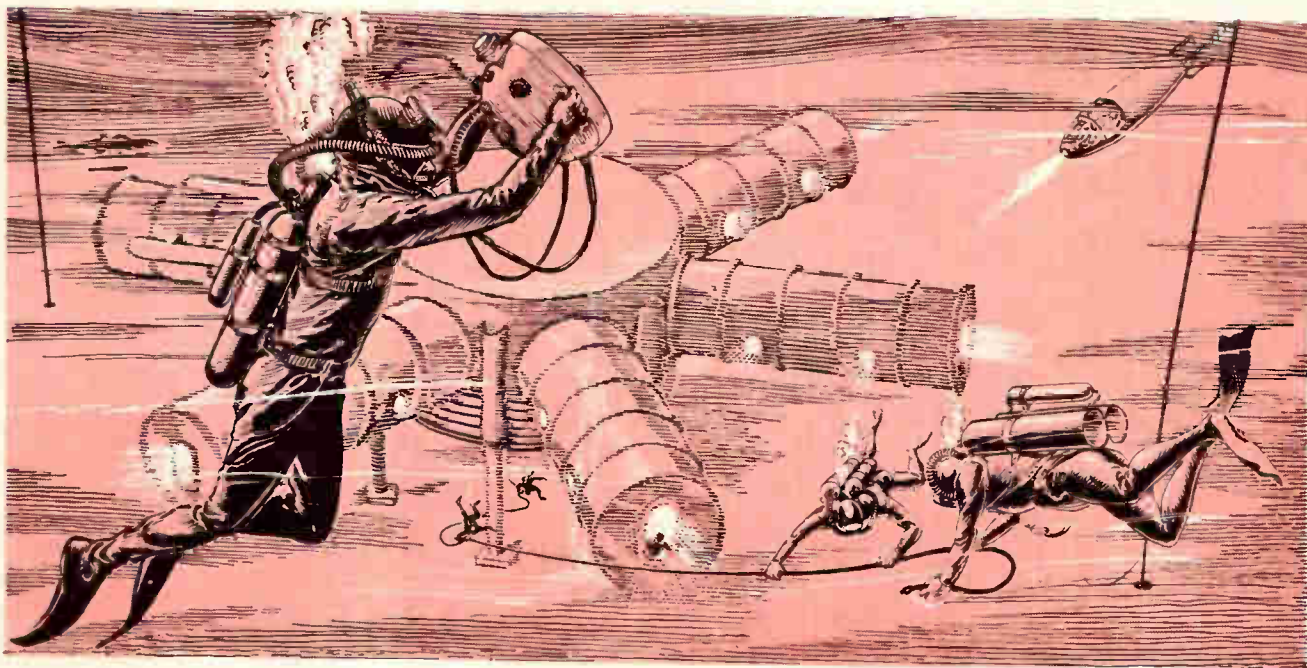

By 1968, the Navy hopes to have a 40-man experimental colony on the continental shelf, 600 feet deep. Darkness will require advanced hand-held sonar for navigating to work and back home to the octopus-shaped Seahab. The divers will need navigation, communications and other hydronic equipment for the small wet subs that will transport them to more distant work areas. Gear still must be developed for diver-to-diver and diver-to-Seahab communications.

FOR ANALOG TAPE UNITS...



1
**PINPOINT
EVENTS
PRECISELY**



2
**LOCATE
DATA
QUICKLY**

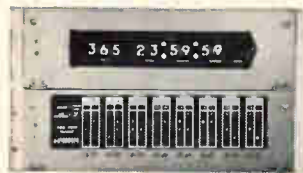

If you want to . . .

- Easily locate and isolate portions of data recorded on tape . . .
- Read time code formats from magnetic tape running forward or backward at fast or slow speeds . . .
- Record real-time or elapsed time on oscillographs during recording or playback of tapes . . .

. . . then, you will want to learn all about **CHRONO-LOG**
TIME CODE GENERATORS and TIME CODE READERS.

Each model has many outstanding design and construction features . . . solid state circuitry, front panel test controls, front and rear panel accessibility for checking and servicing, modular design that provides many optional features.

Write now for technical literature . . . or call (215) EL 6-6771.



CHRONO-LOG CORP.

2583 WEST CHESTER PIKE, BROOMALL, PA.

Circle 550 on reader service card

semi-elements YOUR PRIME SOURCE FOR

- INJECTION LASER DIODES . . . Price breakthru now permanent
- LASER DIODE SYSTEMS Room temperature operation
- RUBY LASER RODS
- GAS LASERS
- SECOND HARMONIC CRYSTALS, . . . Such as Lithium Niobate
- ELECTRO-OPTIC CRYSTALS ADP • KDP • KTN • HMTA
Cuprous Chloride

For literature write Dept. EL-2



semi-elements, inc.

Saxonburg Blvd., Saxonburg, Pa., 16056

Phone: 412-352-1548

See you at
the IEEE Show—
Booth No. 2A21

new equipment to handle this job.

1. Rescue

This month, a contract to build a 25-ton, battery-powered rescue vehicle prototype will be let to one of three competing companies—the Electric Boat division of the General Dynamics Corp., North American Aviation, Inc. and the Lockheed Aircraft Corp. The contract, which will be a cost-plus-fixed-fee arrangement, will require the company to deliver the prototype eight months after the contract is awarded. The Navy wants the vessel in operation by 1968. Eventually, a fleet of six vehicles will be available for rapid air transport to any port in the world, where a nuclear-powered mother submarine will take it to the disaster area.

Electronic systems. The small rescue ship will be equipped with underwater television and an elaborate control system. If the water surrounding the stricken submarine is turbulent and muddy—in some cases, visibility is as low as four inches—the television may be ineffective. The Navy is therefore planning to develop a new short-range sonar.

The sonar equipment would operate with a computer and control system. Attitude data from the navigation system would be fed into the system for the mating between the DSV's rescue skirt and the stricken submarine's escape hatch. An underwater television camera and view port would also be used if possible.

The sonar must not only be able to distinguish the features of the escape hatch, but the sonar display on the integrated display and control panel must provide the DSV operator with a means of centering the vessel's rescue skirt on the submarine escape hatch within the limits of the hatch's mating ring.

Design standards for the sonar are high: the equipment must withstand the rigorous marine environment, including the effects of continual vibration, roll, pitch and yaw of the ship and salt-laden atmosphere over long periods with limited maintenance.

The reliability of the sonar will be measured by a mean-time-between-failures (MTBF) in conjunction with a confidence factor. The equipment's MTBF will be 2,000

hours minimum with a 60% confidence factor for an indefinite failure sample.

The major equipment overhaul interval will be in excess of three years with an equipment design life—including maintenance, repairs, and modifications—of 15 years.

Other equipment. Equipment that will be on the DSV, but not part of the sonar contract, consists of a rescue skirt, a tv camera, an integrated control and display panel, a digital computer, a navigation system, and a view port.

The short-range sonar system includes short-range transducers, long-range transducers, a scanning mechanism, sonar electronics, a power supply, a package for displays and controls, and cables.

The sonar equipment will operate with 28 volts d-c within the steady state tolerance of plus or minus 15% in voltage from nominal value specified. All external short-range sonar equipment will operate satisfactorily over the pressure range from 0 to 14,000 psi.

Performance requirements. The sonar must make two orthogonal scans, fore-aft and port-starboard, each covering a 90° sector centered on the vertical. Active scans must take place alternately with a one-second period for each. Mechanical scanning of the transducer assembly will be driven by an oil-flooded motor. Transducers for the two systems will be driven by a common scan mechanism.

II. Salvage operations

The second part of the Navy's deep submergence systems program is to perfect a capability for salvaging objects as large as ships down to 600 feet. The Navy is spending \$900,000 for salvage this fiscal year and plans to spend \$11 million in fiscal 1967.

Last September, the initial work on the salvage program was completed when the Electric Boat division of the General Dynamics Corp. made an over-all study of the problem under a \$200,000 contract.

The Navy's proposed salvage system calls for a diver ship, from which the divers will descend to the bottom to prepare the ship for raising, and two other surface ships fitted with lifting winches.

The Navy hopes to develop un-

E Z TO READ VISIMAX

A NEW DIMENSION IN PANEL METERS

See the high-visibility presentation of the new Visimax* V-15 panel meter at the IEEE Show, Booth Number 2H13, or write for a copy of Bulletin 396.



international instruments inc.

8703 Marsh Hill Road • Orange, Connecticut 06477

*TRADEMARK OF INTERNATIONAL INSTRUMENTS INC.

INTEGRATED CIRCUITS?

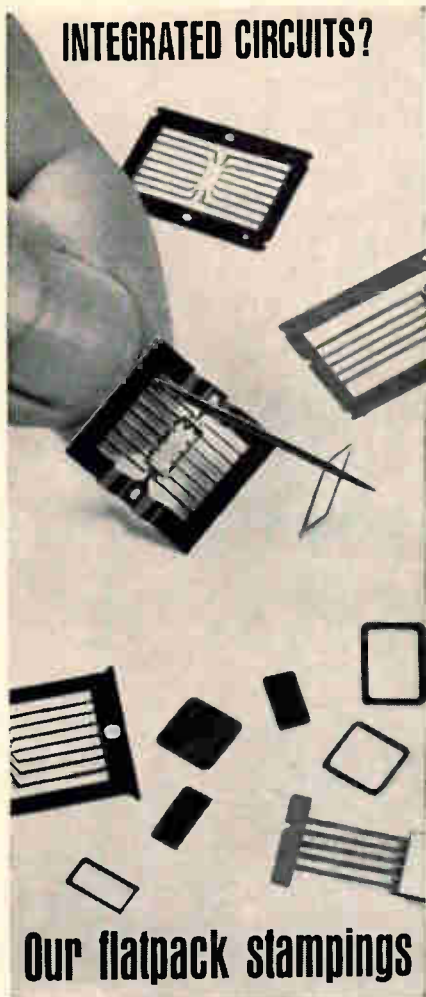

Our flatpack stampings give you that critical edge

Must metal parts for integrated circuits be produced by chemical etching . . . slowly . . . expensively?

No. Volkert stamps and forms these thin, critically precise components—in high volume, and at less cost. No secondary forming is needed.

Volkert's specialized facilities meet your most exacting tolerances for lead frames, frames and bases. We are aware of your design and production requirements as to burr, flatness, finger widths and center distances. And we work with Kovar, Rodar and clad materials. Lead frames can be formed in a continuous strip for automatic assembly.

For your next big job, in flatpacks or any other microminiature electronic components, think Volkert. Where your small stampings get that critical edge. Call or write today.

Volkert STAMPINGS, INC.

222-35 96th Avenue
Queens Village, L.I., N.Y. 11429
Telephone (212) HO 4-8400

derwater housing systems that would permit divers to work at 600 feet for six-hour periods. Today, divers don't go lower than 380 feet where they can work for no longer than 30 minutes.

Underwater housing. As the Navy envisions its salvage operations, four divers would descend to the ocean floor in a personnel transfer chamber—a four-man, five-ton sphere about seven feet in diameter. Then, two divers would exit and work on the salvage operations, temporarily resting from time to time in a rest and refuge tent. This tent would be a rubberized fabric structure, about seven feet in diameter, that would be lowered from the surface and erected on the ocean bottom by the divers.

The Navy is now negotiating with General Dynamics' Electric Boat division and Ocean Systems, Inc., an affiliate of the Union Carbide Corp. and the General Precision Equipment Corp., to develop the \$1 million life-support system for the personnel transfer chamber and the rest and refuge tent. System design is to be completed by mid-June with construction of the first prototype to start by July. Construction is to be completed by the year's end. The Navy plans to use the equipment in its Sealab 3 experiment.

As for the actual lifting operation, objects will be raised by cable suspended between two surface ships, each with a capability to lift 100 tons.

Electronics' role. Although the lifting operation is mainly mechanical, electronics will play an important role. To collect pressure data, sensors will be installed throughout the object to be salvaged.

The Navy will store all of the salvage information about its submarines and smaller surface ships on tape. In an emergency, this taped information can be fed into a computer. The tape will tell salvage directors information about the stricken ship such as the location of all valves and watertight bulkheads and the various load strengths of the vessel.

The Navy wants to have two sets of salvage equipment in operation by 1970. One unit will be kept on the East Coast, the other on the

West Coast. Each unit will consist of a diving ship plus two conventional type salvage ships with some modifications. The Navy will modify existing ships where possible. Total cost of the salvage program is estimated to run to about \$35 million.

III. Man-in-the-sea

The Navy wants the equipment for its man-in-the-sea program perfected by 1969, with a full operational capability by 1970. Ultimately, plans are to increase the working depth from the present 400 feet to 600 feet. The Navy is spending \$2.2 million on the program this year and will increase the amount to \$5.3 million in fiscal 1967.

The next step in this program is Sealab 3, which will be a modified Sealab 2 that will be lowered into 400 feet to 500 feet of water near San Clemente Island off San Diego early next year. It will remain down for 30 to 45 days with six- to eight-man teams staying down for 15-day periods.

Following Sealab 3, the Navy may increase the underwater laboratory depth to 600 feet, requiring designing and building an underwater sea habitat, using much of the equipment perfected for Sealab 3. If the Navy decides to go ahead with the project, called Seahab, the work probably will be done in late 1968.

Equipment needs. The Navy has a list of equipment it needs at once to support the Sealab 3 experiment, plus some long lead-time items that will be needed for later projects. Almost without exception, the equipment must be developed because there is almost no off-the-shelf equipment available. The new equipment must function in 800 feet of water and in a helium atmosphere of 400 psi.

Requests for industry proposals will be issued in the next few months. A top-level steering committee for the man-in-the-sea program met early last month and came up with a number of equipment needs:

- A regenerative life-support system for the live-in vehicle. A lithium hydroxide system was used with Sealab 2 at its 205-foot depth, but logistical reasons rule this out for the 400-foot to 500-foot depths

at which Sealab 3 will be operating.

▪ A one-package atmosphere control system for the live-in vessel that is fully automatic with manual overrides. The system must control heat, humidity, carbon dioxide, breathing gas supply and contaminant removal.

▪ An underwater power package. This will not be used with Sealab 3, but will be needed about three years from now for Seahab. Requests for industry proposals will be issued in May. The Navy wants a 60-kilowatt power package for a maneuverable vehicle, and possibly for bottom-mounting use. It is now looking at the relative merits of fuel cells, a modified nuclear reactor or isotopic power sources.

▪ Helium-speech unscrambler. The basic work on helium speech unscramblers has been done in-house by the Navy's Applied Science Laboratory in Brooklyn. DSSP now wants these unscramblers reduced to cigarette package size. Mainly, the need is for the aquanauts while they are inside their living vessel. As far as diver-to-diver communication while they are outside of the living vessel, "it's nearly a hopeless problem but it isn't a critical item at this time anyway," says Capt. George F. Bond of the Navy Medical Corps.

▪ Diver-carried depth gauges workable to 800-foot depths. Requests for industry proposals are due to go out in March. Present gauges work at 300-foot depths, but there are no reliable off-the-shelf gauges for 800 feet.

▪ Internal and external lighting systems. The internal system for the live-in vessel must function in a helium atmosphere. The external system must have a wet-bulb changing capability.

IV. Search

The most difficult problem in the DSSP is finding an object on the ocean floor. While performing this job, it's also necessary to avoid colliding with undersea obstructions. Although development of the search vessel is being delayed, the Navy will continue work on components and related equipment for navigation, observation and terrain clearance. Spending for the search program in fiscal 1966 is \$4.3 million; in fiscal 1967, the

LIKE SILVER DOLLARS— WORTH MORE THAN FACE VALUE...



New Duncan Model 3233 —
a Commercial, 7/8" 10-Turn Precision
Wirewound Potentiometer. (Actual Size)

...AND THEY'RE NOT SCARCE— BUT AVAILABLE OFF THE FACTORY SHELF!

CHECK THESE VALUES...

2,000,000 Shaft Revolutions
 ± 0.25 Linearity
10 Ω to 200K Ω ($\pm 3\%$) Resistance Range
2.5 Watts at 40°C
-55°C to +105°C Temperature Range
100 oz.-in. Stop Strength
Uniform Torque

AND THESE BONUSES...

High-Impact Plastic Housing
Rugged Metal Lid and Clamp Bands
1/4" Stainless Steel Shaft
3/8-32 Coated Brass Bushing
Welded Terminations
Gold Plated Terminals

COST?... ONLY 7 CARTWHEELS and CHANGE—

\$7.13, that is, when you buy 250 at a crack
... and that's less than you'd pay
anywhere for a comparable pot.



Now for the first time, a rugged high-performance 10-turn precision potentiometer — backed by Duncan's engineering and production capability as one of the nation's leading manufacturers of high-reliability potentiometers for aerospace systems—available for your commercial/industrial applications. Don't flip a coin to select your pot source. Contact Duncan for complete technical data or prompt off-the-shelf delivery.

Look to Duncan for your "spec pots" too: linear, non-linear, single-turn multi-turn and multi-section.



DUNCAN electronics, inc.

2865 Fairview Rd., Costa Mesa, California • Tel.: (714) 545-8261 • TWX: 910-595-1128

PLACE THE STYLUS, PUNCH A HOLE ○ PLACE THE
 STYLUS, PUNCH A HOLE □ PLACE THE STYLUS, PUNCH A HOLE △
 PLACE THE STYLUS, PUNCH A HOLE ○ PLACE THE STYLUS, PUNCH A HOLE ○ PLACE

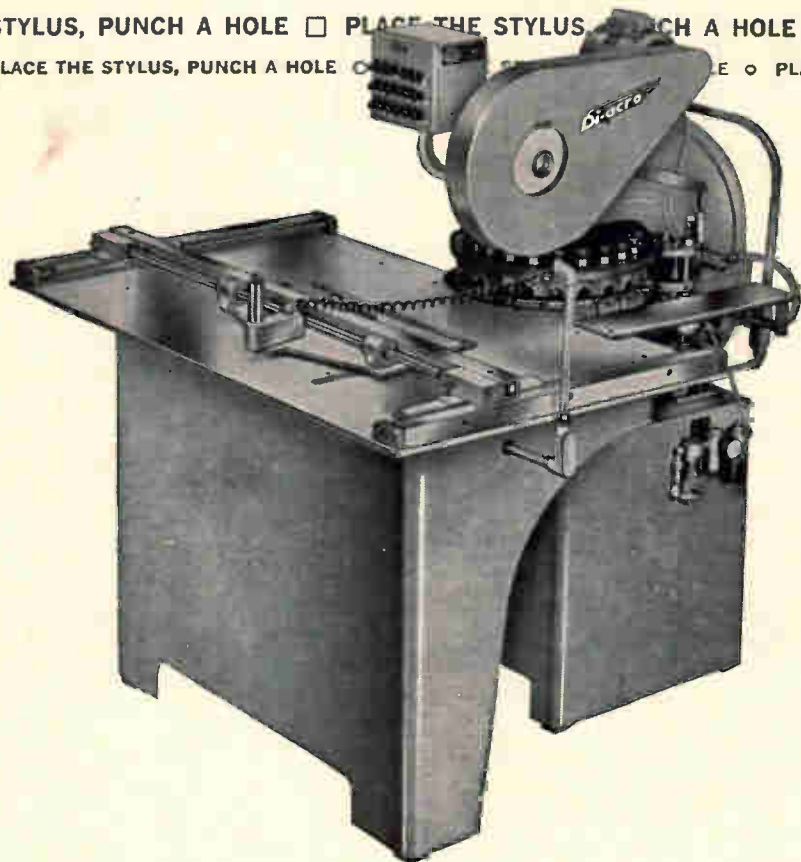

FASTER THAN A HOLE A SECOND!

This is a brand new turret punch press. Electrically linked to a floating stylus. Trace the template, touch the button — punch your holes.

The feather-touch stylus floats on recirculating ball bearings. Accurate within .005" of the template. Eighteen punch and die sets always ready, always perfectly aligned. Change

setups fast as you can drop in a new template.

Capacity: up to 2" dia. hole in 14 ga. steel blank up to 19"x24". Over 500 standard and "special" punches and dies from stock. Custom shapes to your order.

Call your Di-Acro distributor for the big 44-page Punching Catalog. It's brand new, too!



DI-ACRO

A Division of Houdaille Industries, Inc.
 433 Eighth Avenue, Lake City, Minnesota

Di-Acro manufactures a complete line of benders, rod parters, brakes, press brakes, press brake dies, shears, notchers, rollers, punch presses, layout machines, spring winders and punches and dies. Write for catalog.



budget will go up to \$8 million.

So far, the most precise bottom-referenced navigation system consists of a network of beacon transponders 300 feet above the ocean floor held in place by cables anchored to the bottom. The transponders are laid out in a series of adjacent equilateral triangles, about three miles to a side. The beacons will be designed to reject noises, to respond to interrogation by the search vessel and to be identified by their transmitted frequency.

The system has drawbacks; it is expensive and is affected by currents and other deep-sea disturbances. The system is accurate within a few feet, however, and this makes it attractive to the Navy.

The Navy is working on the system with the Marine Physical Laboratory of Scripps Institution of Oceanography and Straza Industries of El Cajon, Calif.

Doppler sonar. Another navigation system that has been tested and is under analysis uses doppler sonar and dead reckoning. The Navy says the tests appear to work within an acceptable 3% error factor of the distance traveled in depths of 2,000 feet.

For further navigational tests, the Trieste 2 is being outfitted by the Navy in the San Francisco Naval Shipyard. The Trieste can descend to 20,000-foot depths. The submarine is being fitted with a navigational system that includes a self-contained, dead-reckoning capability and a position-fix ability, using bottom-reference transponders.

In addition, the vessel is being fitted with automatic controls for position keeping and for maintaining a fixed level above the bottom and a new control system, including a microelectronic digital computer—the first ever installed on a naval vessel.

Other Trieste equipment includes a doppler sonar, a gyrocompass, an analog plotter and a sonar interrogator/receiver for use with the beacon transponders. The computer will resolve the doppler sonar velocities with the gyrocompass heading into components of velocity in the x and y directions in the bottom-fixed reference system. This will make navigation accurate near the ocean floor, independent of water currents.

Wouldn't it be great if you could buy a 2N3055 with this lifetime guarantee?

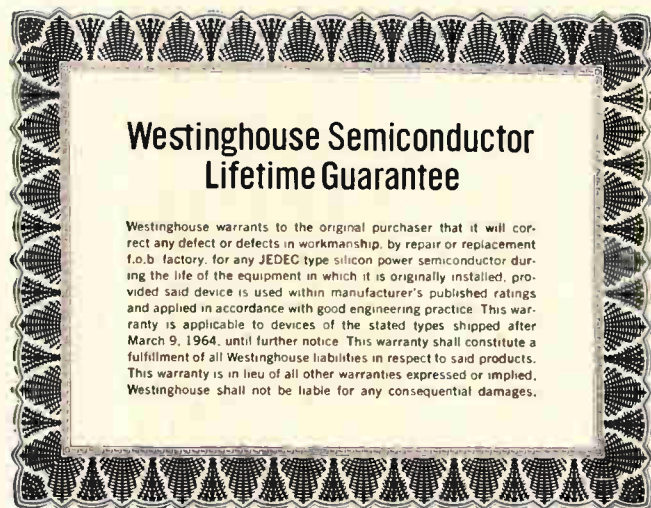

SC-2056

Now you can!

(2N3232-5 and 2N3442 too-call your Westinghouse distributor.)

You can be sure if it's Westinghouse



How to make measurements far faster and a lot easier:

**Use the Below Coupon To
Order Editorial Reprints
From Electronics!**

Fill in, cut out the coupon, insert in envelope
and mail to:

Electronics Reprint Department
330 West 42nd Street, New York, N.Y. 10036

Reprints Available:

(Price: 50¢ each unless otherwise noted.)

- Key no. **R-85** U. S. Electronics Markets 1966 24 page forecast report with 6 page fold-out chart.
- Key no. **R-84** European Electronics Markets 1966, 16 pages with 4 page foldout chart.
- Key no. **R-83** A Look at Japanese Electronics Technology, 36 pages.
- Key no. **R-82** Computer Time Sharing, 20 pages
- Key no. **R-80** The Packaging Revolution In Microelectronics (2 part series, 32 pages.) \$1.00.
- Key no. **R-79** MOS Integrated Circuits Save Space and Money, 16 pages.
- Key no. **R-78** The Overlay Transistor, 4 color special feature, 15 pages.
- Key no. **R-77** Cold Cathode Tubes (3 part series, 28 pages).

Reprint order form

(See the above list, please order by key number.)

To help expedite mailing of your reprints, please send cash, check, or money order when you order.

Send me reprint(s) of key no(s) at ¢ each.

Name

Number & Street

City, State, Zip Code

Get the extra capability, greater reliability, and longer useful life of Rohde & Schwarz!

Since 1933, Rohde & Schwarz' group of unusually creative engineers have been designing electronic instruments that are truly unique. These instruments are constantly ahead of what is considered to be the state-of-the-art. They are more precise. They are easier to use and read. Many perform extra functions. Some do jobs never done before. All are constructed with uncompromising quality—drastically reducing maintenance requirements. As a result, they do not become obsolete as fast as ordinary instruments—they provide more years of useful life. As you might expect, you pay a little more initially for some of these—but an investment in Rohde & Schwarz saves you plenty in the long run!

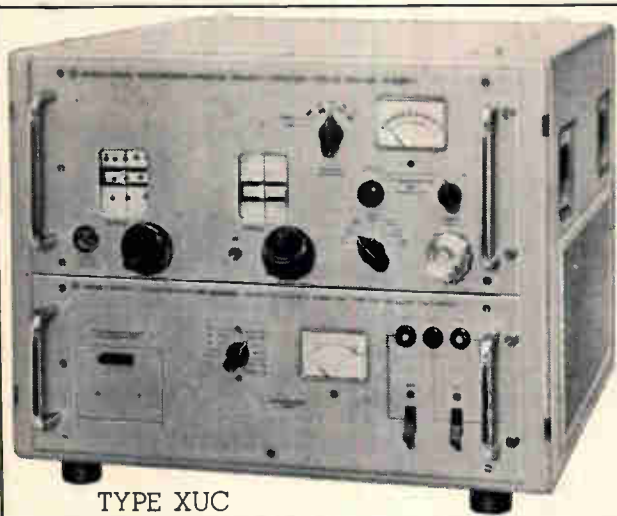

TYPE XUC

Solid State Frequency Synthesizer Covers 470 to 1000 MHz!

The only synthesizer in the industry to offer 3 V at 1000 MHz with unwanted spurious and noise components suppressed by 80 dB. Ideal for synchronization of microwave generators. Also the instrument for frequency measurements in the GHz range.

Plus—all these features:

- Accuracy is 10^{-9} .
- Maximum output EMF of 3 V RMS. Output impedance, 50 Ω .
- Precision attenuator permits output voltage attenuation by 70 dB.
- Noise and spurious frequencies —80 dB.
- Can be operated from external 12-V battery.

For complete specifications,
CIRCLE 80 ON READER SERVICE CARD.

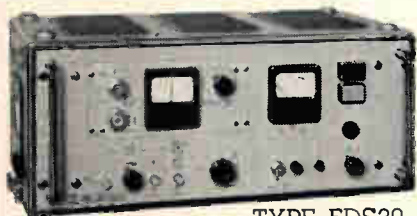

TYPE FDS30 Regulation

New Microwave Frequency Synchronizer also Useable for Voltage and Current Regulation

Type FDS30 Frequency Synchronizer uses a 30 MHz (± 3 MHz) input from appropriate mixers with a 100 μ V sensitivity. Now synchronize klystrons, carcinotrons, and microwave generators up to 80 Gz!

FEATURES

- Plug-in unit for klystron synchronization:
Control voltage: ± 18 V (phase discriminator combined with frequency discriminator ± 3 V)
Max. admissible reflector voltage: 5 kV
- Plug-in unit for carcinotron synchronization:
Control voltage: 23.5 V ± 18 V (phase discriminator combined with frequency discriminator ± 3 V)
Internal resistance: 10—20 Ω
Current: +5 to +100 mA

For complete specifications,
CIRCLE 81 ON READER SERVICE CARD.

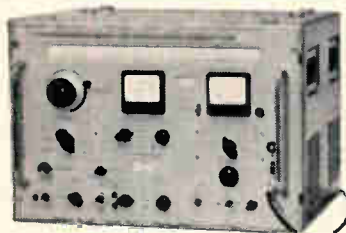

TYPE SMAR

New Wide-Range Signal Generator Is Four Instruments in One!

Rohde & Schwarz's TYPE SMAR combines the features of a Low Frequency Generator, a High Frequency Generator, a High Power Generator and a Microvolt Generator, and can function as any one of these.

The SMAR offers extremely wide frequency and voltage ranges; internal and external synchronization; and modulation provisions for AM as well as Frequency Shift Keying. Perfect for R & D work in communications systems of all types; studies of modulation and demodulation covering from 0.1-80% and 0.1 μ V to 10 V; accurate measurements of bandwidth, etc.

- ### FEATURES
- Frequency range 29 Hz to 31 MHz
 - Output EMF 0.1 μ V to 10 V plus fixed output 200 mV
 - Five selectable output impedances from 50 to 600 Ω
 - Can be AM modulated up to 80% with extremely low distortion
 - Can be FM modulated for telegraphy (simplex, duplex)

For complete specifications,
CIRCLE 82 ON READER SERVICE CARD.

Rohde & Schwarz, 111 Lexington Ave., Passaic, N.J. 07055 Phone: (201) PRescott 3-8010
Inquiries outside the U.S.A. should be directed to: Rohde & Schwarz, Muehldorfstrasse 15, Munchen 8, West Germany

Mincom recorders and the Apollo Program

Instrumentation recorders used for telemetry tracking in the Apollo program will be supplied by Revere-Mincom, under a series of contracts awarded in 1965.

Fifty wideband and thirteen intermediate-range recorders to NASA-Goddard SFC for a global network of ground-based and shipboard tracking stations. Seventeen Mincom recorders to The Bendix Corporation for airborne telemetry in ARIA (Apollo Range Instrumentation Aircraft).

With existing installations, these contracts make Revere-Mincom one of NASA's largest suppliers of instrumentation tape recorders.

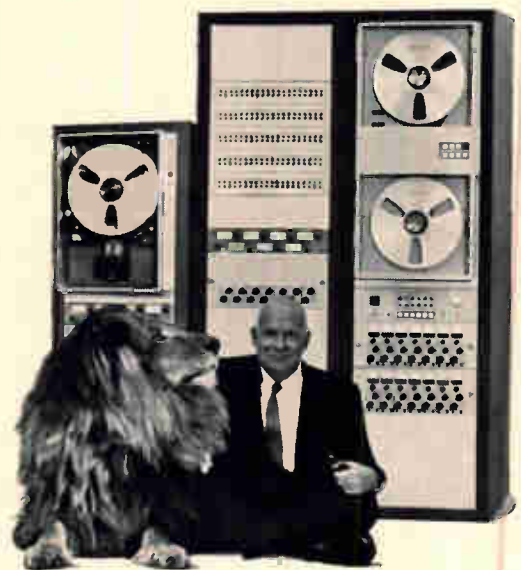

Revere-Mincom Division **3M**
COMPANY

300 South Lewis Road, Camarillo, California 93010

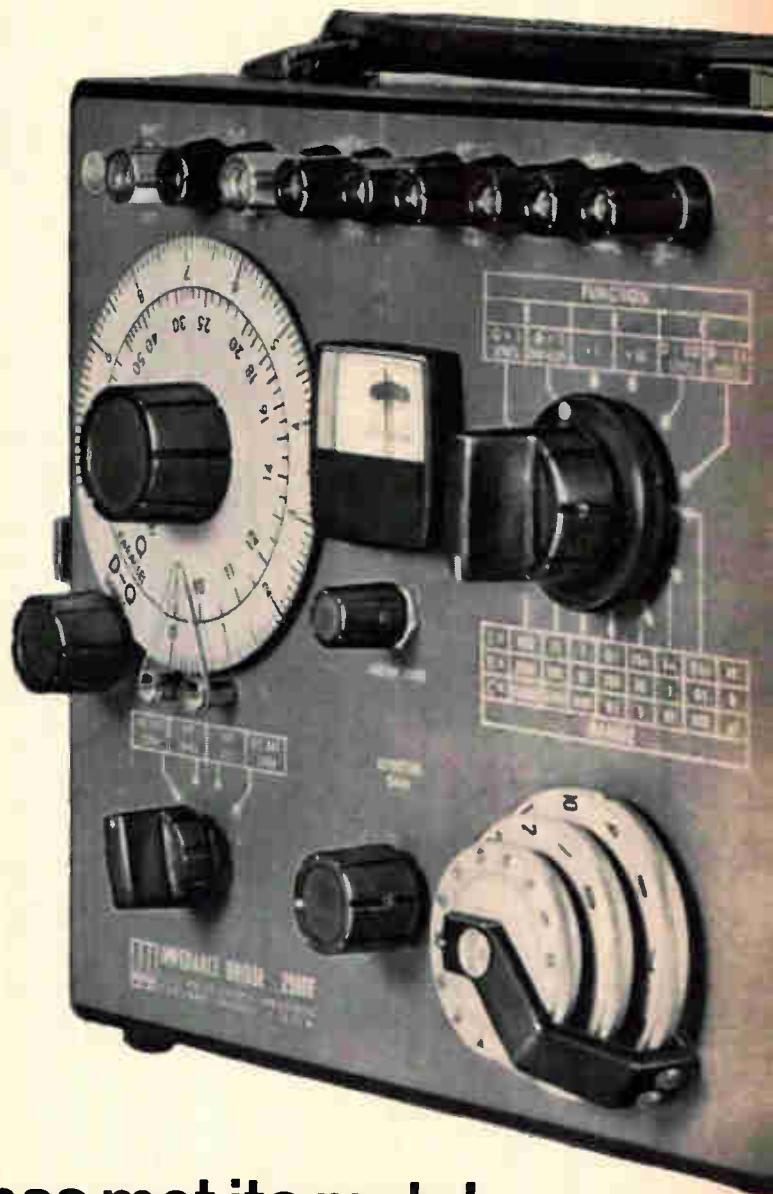
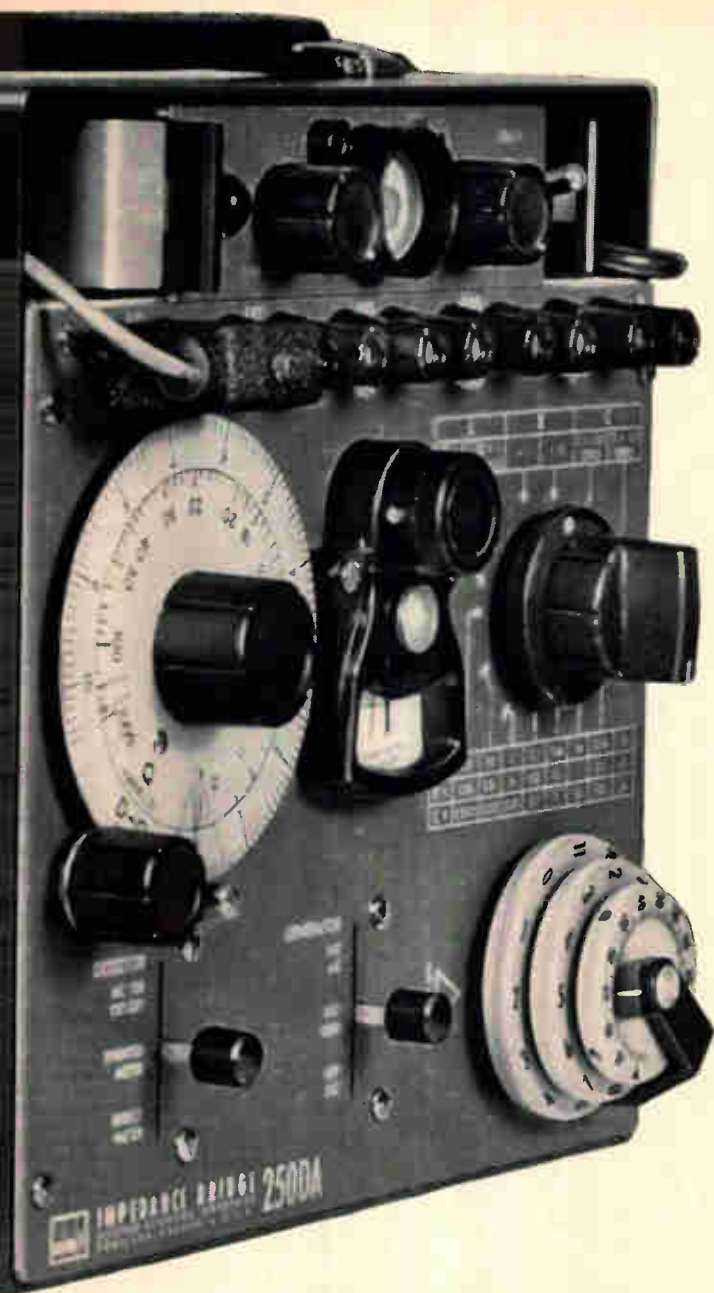

The old master has met its match.

For more than twelve years, our 250 DA Universal Impedance Bridge ruled supreme in its field. No instrument could match its measurement performance.

Now along comes a serious challenger—our new 250 DE. It has all of the reliability and accuracy of the classic model. As you can see, they look alike from the outside.

But inside, we've made many improvements. The new 250 DE is completely self-reliant on its four flashlight batteries. It has a new solid-state detector with greatly improved sensitivities: better than 20 microvolts on DC, 10 microvolts on AC. For simplicity, there is a single meter null detector on the front panel. And for versatility, some useful front terminals have been added.

Why did we improve on the old master when it has delighted so many thousands with its performance in countless plants, laboratories and schools? Well, we figured eventually somebody would make a truly portable

impedance bridge even better than the 250 DA. And we wanted it to be us. ESI, 13900 NW Science Park Drive, Portland, Oregon (97229).

250 DE Portable Universal Impedance Bridge Specifications

Range: Resistance: 0 to 12 Megohms
 Capacitance: 0 to 1200 Microfarads
 Inductance: 0 to 1200 Henrys
 Resistance: 0.1% + 1 dial division
 Capacitance: 0.2% + 1 dial division
 Inductance (Series and Parallel): 0.3% + 1 dial division
 Sensitivity: Better than 20 microvolts DC, 10 microvolts AC
 Frequency: 1kc internal (External terminals provided.)
 Batteries: 4 D size flashlight batteries provide 6 months of normal service.
 Weight: 12 lbs. Price: \$470.00

Note: The 250 DA features exactly the same accuracy specifications as the 250 DE. However, the 250 DA is AC line-operated. Price: \$495.00.

See ESI at IEEE Booth Nos. 3A 48-49-50

Electro Scientific Industries, Inc. **esi**

Circle 199 on reader service card

New Ultronix D/A Converter Ladder Networks Are Faster...

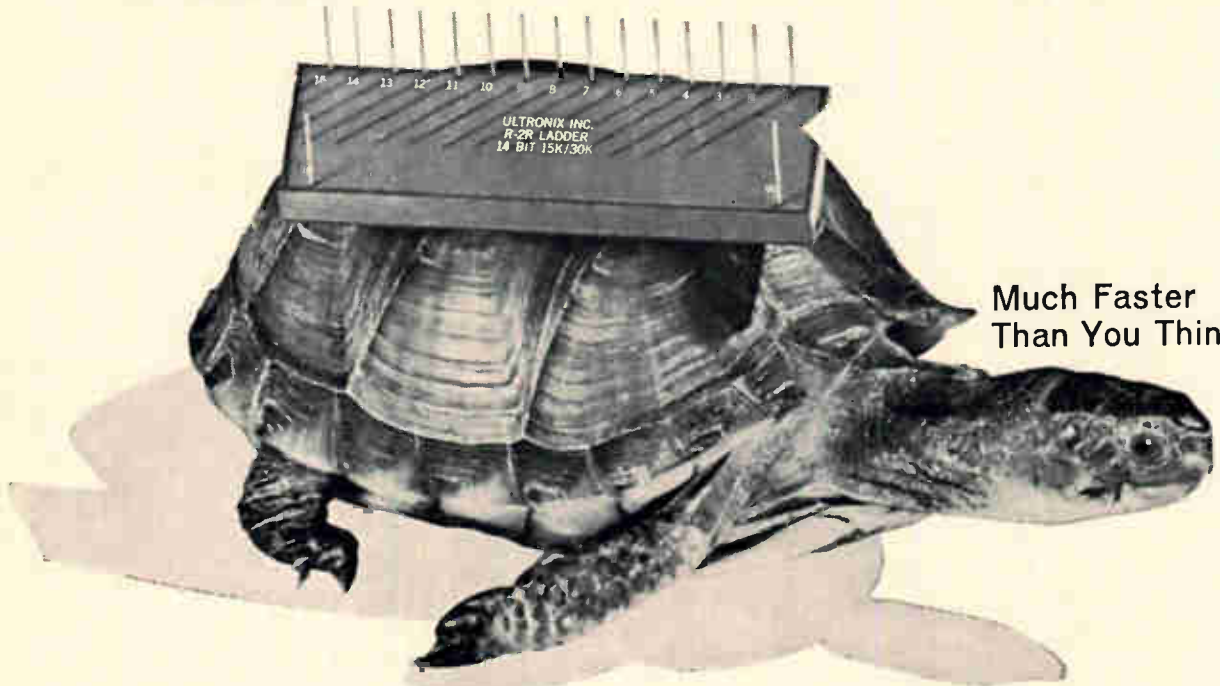

Much Faster
Than You Think!

For most users, 0.1 to 2.0 μ sec settling time in Ultronix R-2R digital/analog ladder networks is more than adequate. For the vast majority of computer designers who can use these speeds, we add the unquestioned precision of wire-wound resistors! These benefits include ultra-stable voltage output, 4 to 14 bits, $\pm 1/2$ least significant bit accuracy over wide temperature ranges, proven high reliability, low price and fast delivery. And, these benefits cannot be matched by metal film resistor networks!

- Compare Accuracy:** Straight binary conversion, 4 to 14 bits, giving recognition to 1 part in more than 30,000 ($\pm .003\%$) over widely varying temperatures.
- Compare Stability:** Highly stable voltage output. Change in output voltage ± 10 ppm, one year operating, referenced to input voltage. Standard temperature stability ± 2 ppm/ $^{\circ}$ C (± 0.5 ppm/ $^{\circ}$ C available).
- Compare Reliability:** Resistors used in these R-2R networks have accumulated over 450,000,000 part-hours at the field level, with no failures — giving a failure rate of .00022% per 1,000 hours (assuming one failure).
- Compare Size:** All packages — 4 through 14 bits — have standardized height of 0.250" to make units compatible with standard packages for high density circuitry.

For complete information on the new Ultronix R-2R Ladder Networks, request Data Sheet N266 from Ultronix, Inc., 461 North 22nd St., Grand Junction, Colo. 81502.

ULTRONIX

MANUFACTURERS OF THE ULTIMATE IN STABLE, WIRE-WOUND RESISTORS

No short circuits on the way to the stars



Radiographs help IBM maintain high-quality standards for System/360. Any tiny flaw in a circuit board is detected before it can cause a short circuit.



Although it is too small to be seen in this reproduction, the original radiograph revealed a tiny imperfection (arrow) in the circuit board. The radiograph thus served as a guide for repair and saved rejection of the entire costly board.

The new IBM System/360 can plot a rocket's path to the stars . . . help probe the earth's crust for new oil fields . . . or even add two five-digit numbers 2,500,000 times in a single second.

Microminiaturized circuits—products of IBM's advanced Solid Logic Technology—carry and control electrical impulses representing numerical information. By significantly reducing size and complexity of micro-electronic circuits, the circuit distances a pulse must travel are reduced . . . giving the System/360 nano-second (billionth of a second) operating speeds.

Only three years ago, when tests showed a short circuit in a multilayered circuit board, the costly component was scrapped. By radiographing faulty circuit boards with KODAK Industrial X-ray Film, Type R (ESTAR Base), microsized internal imperfections are now quickly located and repaired. This helps IBM maintain

production schedules in addition to avoiding expensive scrap.

IBM and other successful companies use radiographic inspection techniques for hundreds of electronic research and quality-control applications. Radiography can help save you time and money . . . and build a reputation for quality products. Ask your Kodak x-ray dealer about it. Or write us to have a representative from Kodak's Radiography Markets Division call.

Three outstanding KODAK Industrial X-ray Film

- Type AA—Fast, fine grain with high contrast. A wide used film, for most purposes.
- Type M—Extra-fine grain. High contrast. Used highest quality, production radiography.
- Type R—Ultrafine grain. Very high contrast. Used for highest quality, critical radiography.

EASTMAN KODAK COMPANY

Radiography Markets Division, Rochester, N.Y. 14650

Photocircuits can solve your PRINTED CIRCUIT PROBLEMS

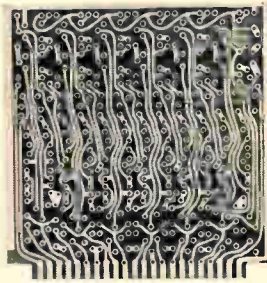

*Here are the solutions
to some typical problems
we have recently received.*

SOLDERABILITY TROUBLE

PROBLEM: We manufacture low-cost radios and intercoms. In the past 6 months, soldering problems have substantially increased manufacturing costs, through excessive inspection and touch-up time required after wave soldering. Nothing seems to help. Have you a suggestion?

SOLUTION: The new CC-4 printed circuit process may be your solution. This patented technique deposits ductile copper which, according to one user's letter, "solders like a dream." As to cost-cutting — customers report an up-to-80% reduction in after-soldering touchup and inspection costs as a result of CC-4 using printed circuits.

MINIATURIZING WITH MULTILAYER

PROBLEM: Five years ago we considered converting some of our miniaturized designs to incorporate your newly-developed multilayer printed circuits. We found the price too high. Has today's price-picture changed?

SOLUTION: The situation has changed radically. Chances are the cost of what you need would be about 50% lower today — although an exact figure would be unrealistic without seeing your actual boards. Multilayer use is increasing so rapidly that we anticipate another 50% cost reduction during the coming year. *Cautions:* Be sure not to compare the cost of one 8-layer multilayer to the cost of four two-sided boards with an equal interconnection capability. Many manufacturers adopt multilayers to reduce system interconnection costs, including such things as hardware, reduced assembly labor, and — all important cost-cutting advantages — printed circuits.

them. Our men are faced with specifying printed circuit base materials, platings and tolerances. How can we train some of them so they can intelligently design and specify printed wiring boards?

SOLUTION: Our Standard Circuit Division was specifically set up to help medium-quantity users of printed circuits who need to cut through time-consuming procurement procedures. It manufactures a range of boards with a limited number of choices of such variables as base materials, platings, tolerances, etc. These can be combined to fulfill a wide variety of manufacturing requirements — with the least possible loss of time, and at the lowest possible cost. The Standard Circuit Division greatly simplifies your procurement, permits a minimum of paperwork, reduces board costs and delivery times, and completely eliminates tool charges! It even permits published price lists, so you can figure your own printed circuit costs in advance.

PRINTED CIRCUIT PATTERNS FROM PENCIL SKETCHES

PROBLEM: Our Drafting Department prepares our printed circuit artwork-masters from pencil sketches provided by Engineering. Every time we have a rush program, the workload in Drafting always seems to be abnormally heavy and we fall 2 or 3 weeks behind schedule waiting for artwork. Is there a way to get printed circuit patterns faster?

SOLUTION: Oversized master artwork for printed-circuit patterns is not only slow, but subject to error — and unnecessary! The Master Circuit System, developed by Photocircuits, converts an engineer's pencil-sketch into accurate 1:1 circuit patterns quickly and inexpensively, by means of recently-developed automatic equipment. Documentation is greatly simplified, too. Photocircuits' six MCS machines can handle over 300 patterns per week, to handle your rush requirements. Incidentally, the Master Circuit System slashes time and costs for multilayer artwork even more drastically.

 **Photocircuits**
CORPORATION
Glen Cove, New York • Anaheim, California

i/c's and modules tested...



DYNAMICALLY!

Now you can perform important *dynamic* tests in addition to ordinary static (dc) tests with TI's Model 553 *Dynamic Test System*. Measure propagation delay and noise feed-through; *dynamically* determine "fan-in"/"fan-out" ratios, and noise immunity; assess the effects of transients. Now, measure switching times in terms of percentage or absolute values. You save money by performing more tests at high speed with handling reduced by single-socket testing.

The 553 *Dynamic Test System* is designed for integrated circuits, transistors, diodes, thin films, logic cards, other circuit elements with 10, 20, 50, or more active leads. Testing can be done from dc to 50 mc, thereby simu-

lating actual operating speeds. Time or voltage is measured anywhere *on* or *between* pulses (widths from 10 ns to 1 ms) with a resolution of .000001%. Jitter is less than 50 ps; accuracies better than 2%.

Modular design and variable word-length program logic provide for infinite system expansion. Simplified programming language allows operators to learn to program in 45 minutes. Data as well as double-ended hi-lo limits can be produced at test rates faster than go/no-go systems with a wide variety of output recording techniques available.

For detailed information about the 553, contact your TI Field Office or the Test Equipment department, Houston.

INDUSTRIAL
PRODUCTS
GROUP



TEXAS INSTRUMENTS
INCORPORATED

P. O. BOX 66027 HOUSTON, TEXAS 77006
118 RUE du RHONE GENEVA, SWITZERLAND



new portable 50 MHz oscilloscope

- **DUAL-TRACE DISPLAYS**
20 mV/div through 10 V/div, dc-to- > 50 MHz.
10 mV/div, dc-to- > 45 MHz.
5 mV/div, dc-to- > 40 MHz.
- **SINGLE-TRACE DISPLAYS**
1 mV/div, dc-to- > 25 MHz (channels cascaded).
- **X-Y OPERATION**
5 mV/div through 10 V/div, dc-to- > 5 MHz.
- **OPERATING MODES**
Channel 1 only; Channel 2 only (normal or inverted); Added Algebraically ($\geq 20:1$ CMRR up to 20 MHz, linear dynamic range $\geq 20X$ indicated sensitivity); Alternate; Chopped (500 kHz $\pm 20\%$ chopping rate).
- **SWEEP RATES**
5 sec/div to 0.1 μ sec/div (Time Base A), 0.5 sec/div to 0.1 μ sec/div (Time Base B), with 10X magnifier extending fastest sweep rates to 10 nsec/div.
- **SINGLE SWEEP**
Time Base A.
- **PRECISION SWEEP DELAY**
50 sec to 1 μ sec.
- **DISPLAY FEATURES**
4-inch rectangular tube; 6 x 10 div display area (1 div/0.8 cm); internal, illuminated graticule; 10 kV accelerating potential; P31 phosphor.
- **TRIGGER SYSTEM**
To 50 MHz, from Channel 1 or combined signals (both sweeps). Trigger modes include AC, AC LF REJ, AC HF REJ, DC, AUTO. Trigger sources include INT, LINE, EXT, EXT $\div 10$.
- **POWER REQUIREMENTS**
96-127, 103-137, 192-254, or 206-274 V ac (≈ 100 W) 45 to 440 Hz.
- **MECHANICAL FEATURES**
Net weight is ≈ 28 lbs. including panel cover; shipping weight is ≈ 36 lbs. Overall height including feet is 7 $\frac{1}{4}$ "; overall width including handle is 12 $\frac{1}{2}$ "; overall length including rear feet and front cover is 20 $\frac{1}{2}$ ", including rear feet and extended carrying handle is 22 $\frac{3}{8}$ ". Carrying handle may be set in any one of a number of positions for viewing convenience. Feet on rear provide for vertical operation.
- **ENVIRONMENTAL FEATURES**
Ruggedly designed to operate reliably under environmental conditions encountered in portable use.

Type 453 Oscilloscope . . . \$1950
Rack Mount Type R453 . . . \$2035

U.S. Sales Prices f.o.b. Beaverton, Oregon



A compact, high-performance oscilloscope, the Type 453 operates almost anywhere, and under severe environmental conditions—giving sharp bright displays. The Type 453 offers dual-trace and sweep-delay for accurate and reliable measurements over the dc-to-50 MHz range.

For a demonstration, call your Tektronix field engineer.

Tektronix, Inc.

SEE THE LATEST TEKTRONIX INSTRUMENTS AT IEEE—BOOTH 3F09-3F17

Circle 204 on reader service card

now



All welded construction

Inherent wirewound stability

Precision tolerances as close as $\pm 0.05\%$

Low temperature coefficient, $\pm 10 \text{ ppm}/^\circ\text{C}$

Exclusive thermacoat silicone coating

TC Assured to $\pm 10\text{ppm}$

IRC Type AS Resistors Save Space and Money, Too

These precision power resistors are now available with an *assured* maximum hot side temperature coefficient of $\pm 10\text{ppm}/^\circ\text{C}$ in standard ranges above 50 ohms. This offers greater design stability with the added benefits of miniaturization and economy.

Type AS resistors provide the stability, close tolerances and superior performance of premium metal films costing 20% to 45% more. And at comparable prices you can replace axial lead vitreous enamel types with space and performance advantages.

Special AS resistors can be used as squib fuses. Inductive designs are also available for fixed rise time applications. Send resistance, wattage, frequency and rise time requirements for evaluation samples.

Write for literature and prices to: IRC, Inc., 401 North Broad Street, Philadelphia, Pennsylvania 19108.

CAPSULE SPECIFICATIONS

POWER:	1, 2, 3, 5, 7, 10, 15 watts @ 25°C ½, 1, 2, 3, 5, 7, 10 watts @ 125°C
TOLERANCES:	$\pm 0.05\%$, 0.1%, 0.25%, 0.5%, 1%, 3%, 5%
TEMPERATURE COEFFICIENT:	$\pm 10\text{ppm}/^\circ\text{C}$ above 50 ohms $\pm 20\text{ppm}/^\circ\text{C}$ below 50 ohms
RESISTANCE:	0.1 ohm to 175K ohms
MIL-R-26:	Characteristics G and V. Withstands 350°C hot spot.
MIL-R-23379:	RWP18, 20, 21
LEADS:	Alloy-coated copperweld. Special types available.



NINE-IN-LINE

CIRCUIT PROTECTION and CIRCUIT CONTROL by AIRPAX ELECTRONICS

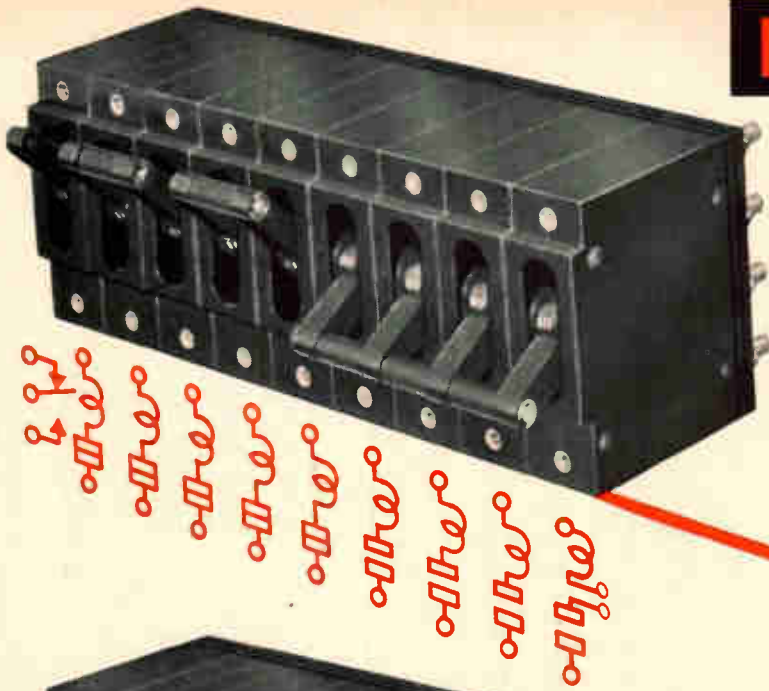

Step 1 is ON
Step 2 is ON
Step 3 is ON
Step 4 is waiting.

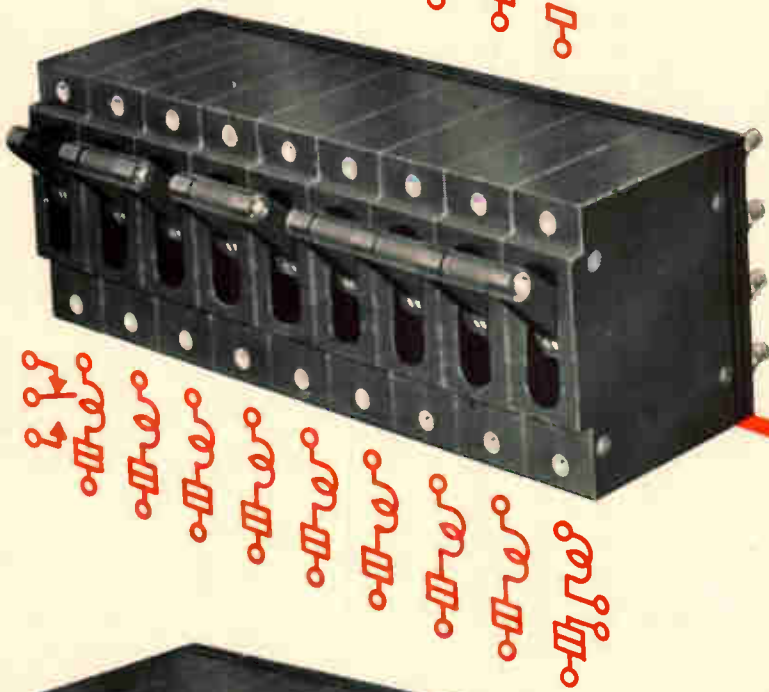

All steps are on
and all functions
are protected.

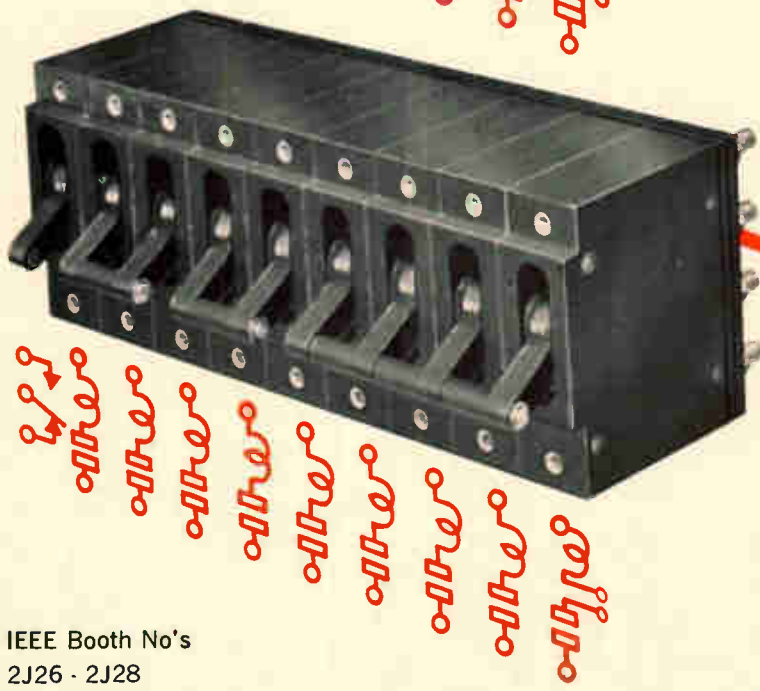

One circuit overloads.
All protectors trip open.
All safe.

AIRPAX ELECTRONICS incorporated

CAMBRIDGE DIVISION, CAMBRIDGE, MD.
(301) 228-4600

IEEE Booth No's
2J26 - 2J28

206 Circle 206 on reader service card

Electronics | March 7, 1966

GaAs diode oscillates in X and Ku bands

Sylvania's microwave source has a guaranteed power output of 1 mw, high efficiency and weighs only 2% as much as a reflex klystron

The D5540 microwave oscillator diode has the highest combination of power and efficiency at 8 to 18 Gc of any solid-state microwave source available commercially, says the manufacturer, Sylvania Electric Products, Inc. Other solid state sources which operate at these frequencies have about 1/10 the power or efficiency of the Sylvania diode. Sylvania is a subsidiary of the General Telephone & Electronics Corp.

Researchers at the U.S. Army Electronics Command at Fort Monmouth, N. J., recently reported that they had obtained continuous-wave oscillations with a power of 25 mw at 13 to 14 Gc and an efficiency of 5% to 6% from commercially available varactors. They were using Sylvania tin-doped, epitaxial diffused gallium arsenide diodes which had been driven into avalanche by a direct-current excitation.

Now, Sylvania has selected those varactors that behave as continuous-wave oscillators and is offering them commercially for \$150 each. Although the diodes are capable of up to 25 mw at 8 to 18 Gc (X and Ku bands), the manufacturer guarantees a minimum of 1 mw at 12 to 14 Gc. At 3-mw output, an efficiency of at least 1% can be expected, says the manufacturer.

The pn junction diode with a contact bonded to it is mounted inside a miniature metal-ceramic package which is hermetically sealed. It measures 0.1 inch wide by 0.2 inch long, and is electronically tunable over a range of 40 to 50 Mc.

Those Sylvania varactors that are capable of emitting c-w microwave radiation have a breakdown voltage over 20 v and a minimum capacitance of 0.4 pf to 1.5 pf at zero bias. They are mounted in a tuned microwave cavity and their oscillations are detected by a crystal detector or a thermistor.

The solid state oscillator should permit a weight reduction in many



Gallium-arsenide diode is mounted in a metal-ceramic package; the pn junction oscillator can do the work of a low-power klystron tube 50 times as heavy.

microwave systems of about 98% over klystrons, says the manufacturer. The oscillator also eliminates virtually all the heat created by such tubes. Potential applications include radar systems to dock spacecraft and satellite stations, automobile and boat collision-control units, missile-tracking systems, tv transmission between orbiting spacecraft, and devices to track aircraft during landing approaches. With the new diode, such systems can be made smaller and cheaper, says Sylvania.

In operation, oscillation starts in the diode at a threshold current of a few milliamperes when biased into the reverse breakdown region. Output power increases with d-c power input, making it possible to superimpose amplitude modulation on the generated microwave signal.

The feasibility of a microwave communications system using a solid state oscillator has been demonstrated by General Telephone & Electronics Laboratories, Inc., which has developed a model of a system capable of short-range transmission of tv signals. In the experimental system, the D5540 is

powered by a standard 30-volt battery. A tv signal is superimposed on the microwave beam and transmitted to a receiving horn-type antenna. The picture signal is then separated from its microwave carrier and fed into a tv receiver for display on the screen, with little or no loss in picture quality.

The experimental microwave closed-circuit tv system will be shown as part of Sylvania's exhibit at the Institute of Electrical and Electronics Engineers Show in New York City from March 21 to 25.

Specifications

Breakdown voltage	-20 to -40 v at -10 μ a
Total capacitance	0.4 pf to 1.5 pf at 0 bias
Minimum output as oscillator	1 mw at 12 to 14 Gc
Maximum power dissipation	300 mw
Maximum reverse current	10 ma if maximum power dissipation is not exceeded
Threshold current (dependent upon tuning)	5 ma
Price	\$150
Delivery	One week

Sylvania Electric Products, Inc., Semiconductor Division, 100 Sylvan Rd., Woburn, Mass.

Circle 350 on reader service card.

Let Bulova solve your servo problems!



You've got more important things to do.



Bulova makes servo products faster, better, and at less cost than anyone! It's our business.

Don't take your engineers off vital programs to home-brew! Developing your own electronic components to meet servo system requirements wastes time, money and key men, while chances are Bulova's group of engineering specialists have already tackled—and solved—a problem similar to yours.

Bulova offers a full line of solid-state electronic servo products—off-the-shelf or custom designed: servo amplifiers • resolver booster ampli-



fiers • modulators • demodulators • quadrature rejection amplifiers • pre-amplifiers • isolation amplifiers • variable-gain amplifiers • two-speed switching amplifiers • DC torquer amplifiers.

What's more, you get prototypes as fast as you need them, and production units to your schedule! Write for complete specifications. Address: Dept. E-18.

BULOVA SERVO PRODUCTS

ELECTRONICS DIVISION
OF BULOVA WATCH COMPANY, INC.

61-20 WOODSIDE AVENUE
WOODSIDE, N.Y. 11377, (212) DE 5-6000

New Components and Hardware

Double-pronged pot structure

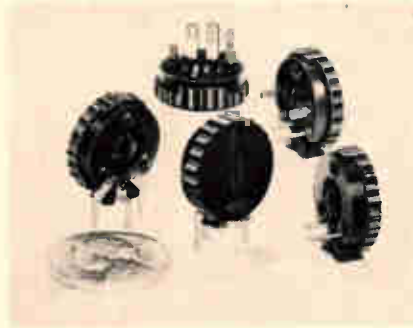

A miniature potentiometer offers both a double-tine construction to reduce contact noise and a dust-proof housing. According to its manufacturer, the Centralab division of Globe-Union Inc., it is the least expensive unit of its type and size.

The potentiometer, for trimmer applications, provides a variety of lead configurations for different mounting arrangements and screw-driver slots for adjustment from either side. Units are available for parallel plug-in, perpendicular plug-in, and parallel stud mounting, with a choice of printed-circuit terminals and solder lugs. The unit is designated Model 9.

Both linear and nonlinear (or audio) tapers are available. Resistance values range from 100 to 10 megohms in the linear versions and 200 ohms to 1 megohm, when measured at the 50% rotation point, in nonlinear versions. Standard resistance tolerances are $\pm 20\%$, but $\pm 10\%$ tolerances are offered as an option. Rotational life of the units is in excess of 25,000 cycles.

Power ratings are 1/5 watt for the linear units and 1/10 watt for the nonlinear units. For both units the ratings are at 40°C and require a derating to 0 watts at 85°C. Both have a maximum operating voltage of 250 volts d-c. They are available in standard torque of 1 to 3 ounce-inches but torques as high as 8 ounce-inches can be supplied.

Space is available on the cylindrical knob surface for stamping 1/16-in-high characters that can

be used to identify the unit in circuits.

To be exhibited at IEEE show.

Specifications

Type	Model 9
Taper	Linear or nonlinear
Resistance range	
Linear	100—10 ⁷ ohms
Nonlinear (at 50% rotation)	200—10 ⁶ ohms
Power rating	
Linear	1/5 watt
Nonlinear	1/10 watt
Max operating voltage	250v d-c
Dimensions	0.696 in. diameter by 0.250 in. deep
Minimum rotational life	25,000 cycles
Price at 1,000 units	\$30 each

Centralab, Division of Globe-Union, Inc.
P.O. Box 591 Milwaukee, Wis. [351]

Tiny resistor meets military standards

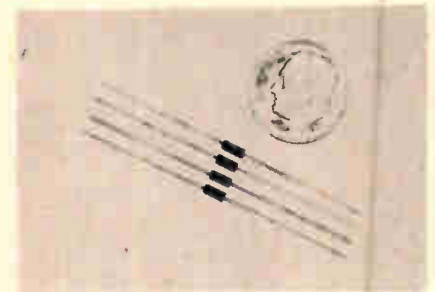

The EE-1/20 precision resistor conforms to all requirements of MIL-R-10509F and MIL-R-55182B, styles RN50 and RNR50, respectively, and features high-density molded environmental protection over a subassembly of rugged cap and lead construction. It measures 0.068 in. in diameter and 0.156 in. in length. Leads, 0.016 in. in diameter and 1 in. in length, are available in tinned copper, gold-plated dumet, or bare nickel.

Rating is 200 v and 1/20 w at 125°C with a resistance range from 10 ohms to 110,000 ohms. Standard is $\pm 1\%$ tolerance and 0 ± 50 ppm/°C temperature coefficient. Tolerances as low as $\pm 0.05\%$ and temperature coefficients as low as 0 ± 10 ppm/°C also available. Temperature coefficient and/or tolerance can be matched.

Prices range from 54 cents to



WHAT IS A TAPE RECORDER DOING IN FC-77 COOLANT?

Playing!

This traffic-stopping demonstration of the completely inert dependability of FC-77 coolant has been featured at several national electronic trade shows. An ordinary "right-out-of-stock" tape recorder is lowered into a tankful of FC-77, plugged into an electrical outlet and a hand reaches in and pushes the button to start a practically continuous concert that plays during the show.

All this time, recorder parts of steel, copper, chrome, plastic, rubber, elastomers, glass, nylon, adhesives, as well as recording tapes are directly immersed in FC-77 coolant. Nevertheless the recorder plays on. When at the end of a show, the player is removed from the tank none

of its components are affected. How's that for "inertness"!

All members of 3M's fluorochemical coolant family have this exceptional compatibility with most materials (even at temperatures above the maximum permissible with other dielectric coolants). This "easy-to-get-along-with" coolant, incorporated into your system can bring about better reliability. *Want more?* These coolants have wide liquid ranges, excellent electrical properties, thermal and chemical stability, are non-flammable, non-corrosive, non-toxic. Write and ask about them, particularly our new, economical FC-77. 3M Company, Chemical Division, Dept. KAX-36, St. Paul, Minn. 55119.

Chemical Division **3M**
COMPANY

H·S·I

**ADMITS
NOT TELLING
ALL ABOUT
THE 6100 ▶
AND
6300 ▶
SWITCHES**

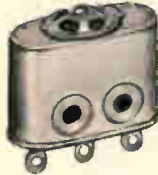

**New Interesting Facts
Now Brought To Light!**

HSI Catalog 72 outlines conservative ratings for the 6100 and 6300 series switches. We haven't publicized the fact that:

... while the switches are normally rated 5 amp resistive, 3 amp inductive, we can furnish variations capable of handling 15 amp resistive 8 amp inductive loads, and the same switch will carry 100 amp squib load for 50 ms.

... while our standard rating for vibration is 20g 10-2000 CPS, the switches have actually performed under vibration conditions of 65g 10-2000 CPS.

... while the catalog doesn't specify contact resistance, superior cleaning and sealing techniques enable us to supply switches when required with consistently low contact resistance such as 30 milliohms initially and 40 milliohms over the life of the switch.

HSI emphasizes that performance characteristics such as operating and release forces, differential, pretravel, overtravel, etc. can be tailored to meet the specific requirements of an application.

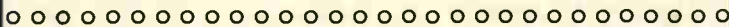

Or if you have a really tough requirement, perhaps our 6200 series hermetically sealed switch with glass



to metal and Heliarc® metal to metal seals will solve the problem. Since no flux is used in the sealing process and there are no organic materials inside the switch, we can furnish the unit for high temperature operation up to 660° F or with different contact materials for low level work where the contact resistance will be exceptionally low and remain constant over the life of the switch.

H·S·I

HAYDON SWITCH & INSTRUMENT, INC.

Building Confidence Through Dependability

1500 MERIDEN ROAD, WATERBURY, CONN. 06720

AREA CODE (203) 756-7441

New Components

\$2.06. Samples and small quantities are available from stock; production quantities will take from 2 to 5 weeks.

American Components, Inc., 8th Ave. at Harry St., Conshohocken, Pa. [352]

**Thin, flexible
laminar busbar**

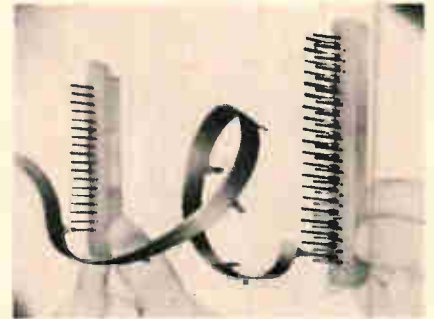

A thin, flexible, ribbon-like laminar busbar named Flexi-bar can be formed, twisted and bent to fit the requirements of electronic rack equipment circuitry. It has the ability to interconnect nonsymmetrical terminations and relieve the tolerance assemblage buildup of rack and panel connectors.

The new product can be adapted to connectors with 0.032 in. by 0.062 in. wire-wrap terminals, as used in multicircuit computer applications. The Flexi-bar utilizes pressure-fit female terminals to pick up the common pins in a complex circuit configuration. Because of its versatility of design, the Flexi-bar can be used as either the signal or current carrying medium or as a common ground.

The Flexi-bar, designated series 111565, is aimed at computer and data processing equipment circuitry, numerically controlled machine tool and devices circuitry and other commercial low-voltage, low-amperage electronic circuit uses. Flexi-bar is available in lengths from 12 in. to 3 ft., in widths across the insulation ranging from 1/4 in. to 1 1/2 in. wide, and in thicknesses ranging from 0.005 in. to 0.015 in.

The flexible conducting medium is bonded between two layers of insulation. For special signal carrying applications, Flexi-bar can be

in

meters

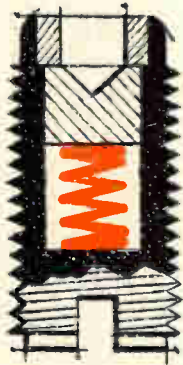

look for this

watch out for this



SPRING-BACKED JEWELS (left above) dissipate much of the shock energy on a movement's moving part. This prevents damage to the jewel and avoids subsequent "stickiness" or inaccuracy. In contrast are the two constructions shown above right... so-called cushion-backed and fixed jewels. The fixed absorbs no shock at all. The cushion-backed protects a little, but still won't do the job under the rugged use to which most of us put meters and test equipment. ■ On the other hand, a spring-backed jewel permits full deflection with less than 20% increase in pivot pressure. Simpson makes a complete selection of spring-backed meter movements as well as fixed. The spring-backed type costs only about 20¢ more than a cushion-back, and 40¢ more than a fixed jewel. Is the spring-backed jewel worth the small extra amount? You bet it is, say most of our customers. ■ Write for Stock Catalog No. 2073 which lists 1400 sizes and types. It may well be the cure for meter headaches and complaints in your equipment.



Simpson
INSTRUMENTS THAT STAY ACCURATE

SIMPSON ELECTRIC COMPANY
5209 W. Kinzie Street, Chicago, Ill. 60644 . Phone: (312) ESTebrook 9-1121
Representatives in Principal Cities See Telephone Yellow Pages
Export Dept.: 400 W. Madison St., Chicago, Ill. 60606 Cable, Simelco
In Canada: Bach-Simpson Ltd., London, Ontario
In India: Ruttonsha-Simpson Private Ltd., Vikhroli, Bombay

WORLD'S LARGEST MANUFACTURERS OF ELECTRONIC TEST EQUIPMENT

NEW BATTERY POWERED, OPERATES 1500 VOLTS OFF-GROUND ELECTROMETER



MODEL 601

- 1 mv f.s. to 10v, with $10^{14} \Omega$ input resistance
- 10^{-14} amp. f.s. to 0.3 amp.
- 100 ohms f.s. to 10^{13} ohms
- 10^{-12} coulomb to 10^{-6} coulomb
- 200 μ v/hr, zero stability
- 1,000-hour battery life even when recording
- \$595 with input leads

Everything about this handy portable is new . . . except the name electrometer! Its 3-terminal input allows complete low terminal isolation, full high terminal guarding, from the case. It also permits 1500 volt off-ground capability—a feature offered only by the 601. Extra flexibility is provided by 73 ranges for measuring voltage, current, resistance, charge and three outputs, highlighted by a 0.005% accuracy unity-gain amplifier. And perhaps best . . . now measure continuously for 1000 hours while using a 1 ma recorder! Makes recharging interruptions during long-term experiments unnecessary. These are only a few reasons why the carry-around 601 electrometer is outstandingly new. More are detailed in our free Engineering Note. Send for it today!

K

**KEITHLEY
INSTRUMENTS**

12415 Euclid Ave. • Cleveland, Ohio 44106
EUROPE: 14th Ave. Villardin, 1009 Pully, Suisse

New Components

produced with layers of shielding. It is insulated to withstand 500 v rms and can operate in ambient temperatures to 65°C.

Prices of the new concept in laminar busbars, which help eliminate the complexity and time consumption of hand-wired circuitry, are expected to range from 75 cents to \$5, depending on the desired range and number of terminations. Delivery is 6 to 8 weeks from receipt of order and specifications.

To be exhibited at the IEEE show.

Methode Mfg. Co., 1700 Hicks Road, Rolling Meadows, Ill. [353]

Class K connector resists environment



A Class K connector has been developed that is capable of withstanding MIL-C-26500 environments, in addition to meeting flame requirements of MIL-C-5015. The series 238 connectors are for use in missiles, ground support equipment and engine firewalls in high performance jet aircraft. The new K units will also withstand short time exposures up to 800°C, thermal shock cycling from -55° to 260°C and are resistant to moisture, ozone and corrosion type environments.

The environmental performance capability is achieved by employing resilient sealing members that provide interfacial sealing and shell "O" ring seals at the coupling surfaces. Contacts and wiring are individually sealed by the elastomer grommets. The rear sealing grommet has three sealing risers which provide a seal around the jacket of the individual wires. These sealing members are made of a flame retardant silicon elastomer capable

Solve any CCTV problem with one of these seven basic systems from Cohu.



High-fidelity color

1000 Series system includes the first CCTV camera with built-in references for correct registration and color balance. Compact, rugged, low-cost and easy-to-operate.



Miniaturized

Series 2000 cameras feature 3" outside diameter cylindrical housings that will accommodate remote-controlled 4:1 zoom lens. Many lens options available, including 10:1 zoom. Operate on 10 or 20 megacycle bandwidths.



High-resolution self-contained

Modular-designed 3100 Series offers choice of plug-in sync generators for EIA 525 or 729, 873 or 945-line scan rates. Automatically compensates for light level variations to 10,000:1.



Industrial self-contained

Complete with all camera control circuits, Model 20/20 cameras need only video cabling and any standard TV monitor to make a complete CCTV system. Highly versatile.

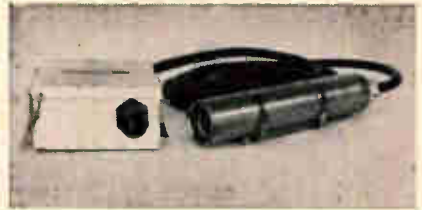

Radiation-tolerant

Get top quality TV pictures from radiation environments up to a cumulative dosage of 10^8 roentgens and/or 10^{12} neutrons/cm² with 3-inch diameter 2500 Series cameras. Readily de-contaminated.



Airborne

3" or 6" diameter cameras weigh as little as 5 lbs. Unaffected by extremes of temperature, humidity, dynamic pressure, altitude, noise, vibration, shock or acceleration, within broad limits.



Environment-resistant

3000 Series cameras provide continuous-duty operation in up to 100% humidity, at temperatures from $-20^{\circ}\text{C}.$ to $+60^{\circ}\text{C}.$, ocean depths to 250 feet and altitudes out to deep space. Meet military explosion-proof specifications. Operate on 10 or 20 megacycle bandwidths.

Which one solves yours?

For details on the industry's most complete CCTV line—including monitors, accessories and video switching systems—contact Cohu or your nearest Cohu representative.

Visit our Booth 3F02 at IEEE Show, March 21-24

BOX 623 • SAN DIEGO, CALIFORNIA 92112 • PHONE: 714-277-6700



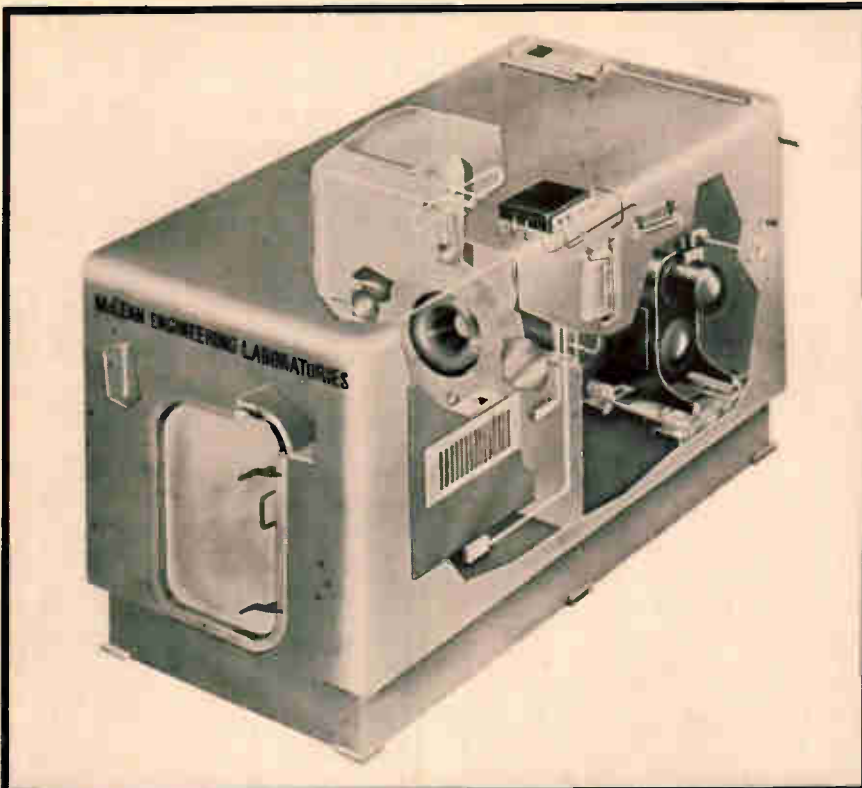

Come in and use any of McLean's modern "lab" facilities any time! They're at your disposal without cost. This Air Flow Test Chamber, for instance, is for new product development and quality control and testing. Provides sure knowledge of pressure drop and air flow requirements to cool specific loads.

WHO ELSE

CAN DESIGN RELIABLE COOLING SYSTEMS?
 MAINTAIN THE BEST "LAB" FACILITIES?
 GUARANTEE BLOWER LIFE?
 PROVIDE APPLICATION ASSISTANCE?

Any job shop can help you pick hardware . . . knock stock parts together . . . throw in an untested motor . . . and call it cooling equipment. We're called upon to replace equipment like that every day.

So who else but McLean offers true reliability in packaged cooling? Who else but McLean can take over the job from start to finish? Who else has the personnel, equipment, and facilities to

(1) analyze your requirements, (2) develop cooling systems to answer those needs, (3) recommend units that are most practical, efficient, and lowest in cost, and (4) establish the life of a given blower under most operating conditions?

Remember, no one knows more about the cooling of electronic systems than McLean. And no one can insure their total reliability through packaged cooling except McLean.

Who else but McLEAN?

SEND FOR
 NEW 1966
 44-PAGE
 CATALOG



McLEAN ENGINEERING
 LABORATORIES

P.O. Box 228, Princeton, N. J. 08540
 Phone 609-799-0100 • TWX 609-799-0245
 TELEX 083-4345



See us at I.E.E.E. Show, Booth IC26

New Components

of withstanding the design temperature limits of the connector $+200^{\circ}$ and -55°C for 1,000 hours.

The mating face of the female insert body has the closed entry design feature called out in MIL-C-38300. The face of the hard ceramic insert encloses the front of the socket contacts and provides lead-in chamfers to guide mating pin contacts. Should a male contact be bent or misaligned, lead-in chamfers realign the contacts during mating.

Another feature is the Poke-Home contacts used which give the user the reliability and cost advantages of crimped contacts with no need to be concerned about using special high-temperature brazing or solder materials.

To be exhibited at the IEEE show.

Amphenol Connector Division, Amphenol Corp., 1830 S. 54th Ave., Chicago, Ill., 60650. [354]

Subminiature lamps feature molded base

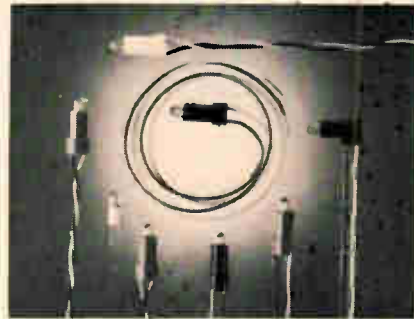

A subminiature incandescent lamp with an integrally molded base, designed for the specific requirements of the computer industry, differs from conventional lamps because it has a nylon base molded to a standard bulb. This replaces not only the separately attached metal base but also the mated socket which it requires.

With the integrally molded base, the bulb and socket can't separate as in conventional metal base lamps, says the manufacturer. All leads are internally sealed against corrosion, and exposed leads can be of corrosive-resistant material. Since the base is its own socket,

Everyone's talking about

Delevan's

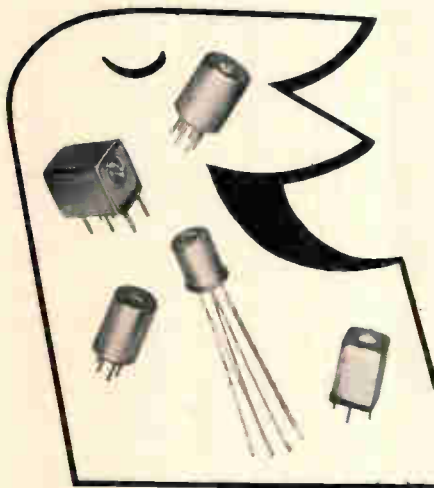

BROAD RANGE OF SHIELDED COILS & TRANSFORMERS

Here's why!

- 1 Only Delevan offers 12 mechanical designs from which to choose depending upon the environmental characteristics required to satisfy a specific need.
- 2 Standard RF and IF transformers offering similar electrical characteristics for all designs including standardized 30 MC, 10.7 MC and 455 KC, IF transformers. Also tunable units in RETMA values from .1 uh to 10 mh.
- 3 A wide pricing range from \$5.00 for units used in HIGH REL. space programs to as low as \$1.00 for commercial applications.

The industry's widest selection

12 MECHANICAL DESIGNS

Delevan Electronics Corp.

Subsidiary of American Precision Industries Inc.
270 Quaker Road, East Aurora, N. Y. 14052

an additional connection is eliminated. Color coding is possible, thereby simplifying replacement procedures.

Apart from the elimination of the costly metal base, the new lamps reduce the total production-procurement-installation cycle. The most important advantage of the new lamp is probably its ability to make entire lamp assemblies on a single piece of equipment for direct installation into a system. Present production units include: printed-circuit board indicators, long lead photocell actuators, and complex shaped packages.

To be exhibited at the IEEE show.

Tung-Sol Industries, Inc., Newark, N.J. [355]

Adjustable and tapped wirewound resistors



Two commercial resistor styles—adjustable and tapped power wirewounds—are now available. The HLA (adjustable) and HLT (tapped) series have the added precision and load-life stability made possible by a multilayer silicone coating. They replace vitreous enamel tapped and adjustable resistors.

All models in both series are wound on hollow, tubular ceramic cores and are of the type used in voltage dividing applications. Made according to MIL-R-19365C, the HLA series has 12 models. Power rating of the series is from 12 to 225 w; the resistance range is from 1 ohm to 100,000 ohms. HLA resistors are constructed with a slot in the silicone coating which exposes the resistance element from terminal to terminal. Odd resistance values can be quickly obtained by moving an adjustable lug to the desired point on the element. Stand-

What Kind of Panel Meter Do You Need ?



crisp, classic Horizon Line?



trim, built-in Horizon Line?

You can get it...from General Electric's full line

Built-in or front-mounted, G-E HORIZON LINE® panel meters add quiet sophistication that accents, never dominates, your electronic equipment. All ratings are available in 2½", 3½", and 4½" sizes. See the complete General Electric panel meter line at your dependable electronic distributor. 592-26

GENERAL  ELECTRIC

VISIT BOOTH 4E12

SEE FOR YOURSELF
HOW WELL PARTS CAN
BE FABRICATED FROM
THIN-WALL TUBING

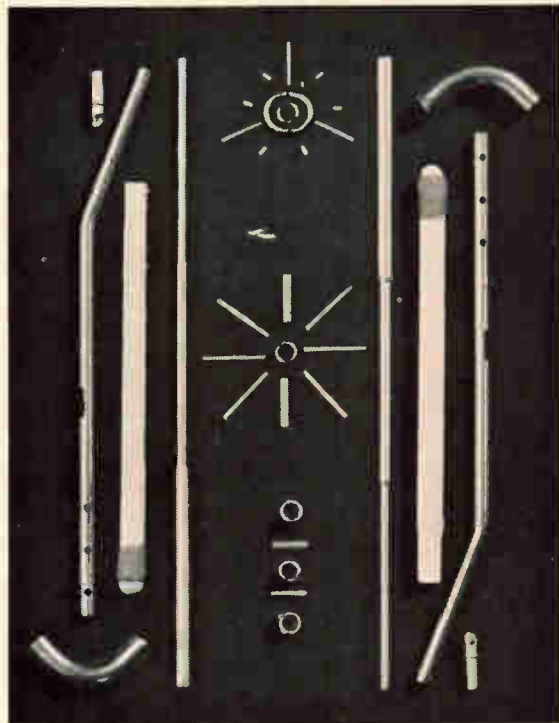

Some electronic parts such as cathode sleeves can be made only from thin-wall tubing. Other parts such as contact fingers for RF connectors may be machined from bar stock, but it is faster and cheaper to fabricate them to specification from thin-wall tubing.

Time and time again, UNIFORM TUBES has turned out parts for electronic manufacturers that were beyond the capabilities of other suppliers. Perfectionists in tubing and tubular parts, our craftsmen have the special tools and experience to accomplish the unusual.

Starting with fine tubing with O.D.'s from 0.020" to 0.375" and wall thicknesses from 0.035" down to 0.005", UNIFORM makes perfect bends of any degree on radii as small as 0.03". There's no distortion or wall-thinning in these bends. Flaring, flanging, spinning... bending, bulging, beading... grooving, drilling, tapping... threading, coining, notching... and cutting are performed to exacting specifications within close tolerances.

UNIFORM will fabricate parts from tubing of any ductile metal including stainless steels, copper and nickel alloys, beryllium-copper, glass-to-metal sealing alloys, precious metals, columbium and tantalum. Depending upon the fabrication steps required, maximum O.D. for this tubing is 0.625" and the minimum O.D. is 0.005". The wall thickness may be a maximum of 0.050" or a minimum of 0.001". Tubing in many alloys with O.D.'s from 0.010" to 0.375" is also available with Ultra-Thin walls down to 0.0005". Commercial tolerances are standard. When applicable, tolerances of ± 0.00005 " can be held.

If you can't make it to the show, drop us a line; and we'll send you appropriate literature.

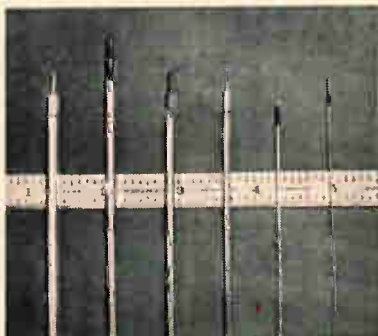

*Trade Name of Uniform Tubes, Inc.

Besides an interesting array of fabricated tubular parts, you can examine these solid-shielded MicroCoax* cables, X-Band Micro-Delay* lines and microwave time delay systems and subsystems.

UNIFORM TUBES, INC.

Collegeville, Pa. 19426

Phone: (215) 489-7293

TWX: 510-660-6107

New Components

ard tolerance for the HLA series is $\pm 5\%$.

The HLT series contains 13 models in sizes ranging from 11 to 225 w with a resistance range from 1 ohm to 1.1 megohms. Depending on size, HLT models can be furnished with taps that divided them into 2 to 14 sections with the resistance and power rating of each section according to customer specification. Standard tolerance is $\pm 10\%$ for the total resistor and for each of its sections. Lower tolerances are available. The fixed lug terminals used on the HLT are available in widths of $\frac{1}{8}$ in., $\frac{1}{4}$ in. and $\frac{3}{8}$ in.

Price for the HLA is 39 cents, and for the HLT, 27 cents. Both prices depend on quantity, tolerance and value. Delivery is about 3 to 4 weeks after receipt of order.

To be exhibited at the IEEE show.

Dale Electronics, Inc., 1357 28th Ave., Columbus, Neb. [356]

Connectors feature high reliability

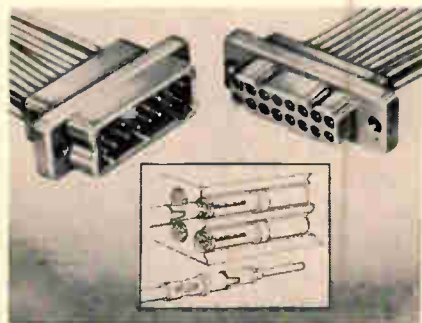

Quadricon connectors, available with rectangular or trapezoidal mating arrangements, provide MIL performance at commercial prices. They offer the reliability of a one-piece insulator, the convenience of crimp-on snap-in contacts, and the economy of a one-piece insulator that requires no shells, brackets, or other mounting hardware. Performance characteristics include low-insertion force, low-contact resistance, high current and voltage ratings and high-insulation resistance.

The company credits a one-piece, high shock-resistant polycarbonate

36-R

ELGENCO Noise Generators



Model 610A

SOLID STATE NOISE GENERATORS

Model 602A 5 cps to 5 mc, 3 Ranges \$ 290
 Model 603A 5cps to 5 mc, 3 Ranges \$ 495
 Model 610A 5 cps to 5 mc, 8 Ranges \$1,175
 Series 624 (Fixed frequency) 5 cps to 500 kc
 \$245 to \$490. Write for details on frequency
 ranges and spectral flatness.



Model 312A

VACUUM TUBE NOISE GENERATORS

Model 301A DC to 40 cps \$1,995
 Model 311A Two outputs DC to
 40 cps and 10 cps to 20 kc \$2,395
 Model 312A Two outputs DC to
 120 cps and 10 cps to 20 kc \$2,495
 Model 321A DC to 120 cps \$2,095
 Model 331A 10 cps to 20 kc \$1,275

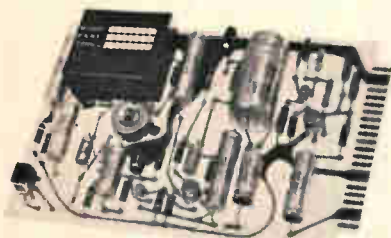

Model 3602A

NOISE GENERATOR CARDS

Series 3602, 3603, and 3606 \$144 to \$389
 Various frequency ranges and output flat-
 ness available. Size: 4½" x 6½" x 1". Write
 for details.

ENCAPSULATED NOISE SOURCE MODULES

Series 1602, 1603, and 1606 . \$95 to \$340
 Various frequency ranges and output flat-
 ness available. Size: 1¾" x 1½" x ¾". Write
 for details.

ELGENCO INCORPORATED



1550 Euclid Street
 Santa Monica, California
 Phone: (213) 451-1635
 TWX: (213) 879-0091

For a more complete listing, write for
 our short form catalog.

insulator for the reliability of these connectors. This reliability is augmented by manufacturing the connector with a one-piece female contact and a simple retention clip on the male contact, thus providing the minimum number of parts possible for a high-performance connector with less than 0.002-ohm contact resistance (even when measured after salt spray corrosion tests).

A "dual diameter" feature on the female contact provides two spring sections for gripping the inserted male contact and two additional spring sections that grip the inside diameter of the insulator bore firmly. The dual-diameter female contact maintains closed entry. The contact cavity inside diameter limits tine spread, effectively protecting against over-size probe insertion and providing superior contact retention. The two tines that engage the male pin provide a safer spherical engaging surface, and low, uniform mating force.

To be exhibited at the IEEE show.

Cinch Mfg. Co., 1026 S. Homan Ave.,
 Chicago, Ill., 60624. [357]

Versatile air blower comes in 3 models



The Duplex Spiral blower provides greater air flow—up to 94 cfm—or greater pressure characteristics—up to 2 psig—than the single Spiral blower. It is available in three versions: the SL4 achieves higher pressures by internal ducting of the airflow from the two impellers; the SL5 extends the airflow range; and the SL6 provides an economical source of two independent high pressure air streams, which can be utilized at

What Kind of Panel Meter Do You Need ?

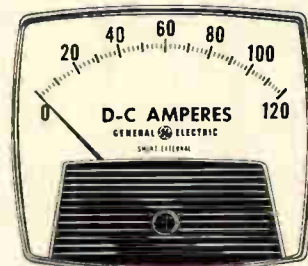

distinctive Big Look?

You can get it...from General Electric's full line

Add bold, exciting, truly distinctive styling to your electronic equipment with General Electric's BIG LOOK® panel meters. All ratings are available in 1½", 2½", 3½", 4½" sizes. See the complete General Electric panel meter line at your dependable electronic distributor.

592-27

GENERAL ELECTRIC



VACTEC PHOTOCELLS

*Vital Components in the Electronic Scoreboard that Electrifies Sports Fans in Houston's Fabled*Astrodome*

Do they go to the Astrodome to see the game, or to enjoy the scoreboard? This \$2,000,000 electronic marvel puts on a show that really turns a crowd on. And Vactec is proud to be selected as supplier of approximately 11,000 matched cadmium sulfide photoelectric cells that are an integral part of the picture transmission system.

Specifically, the varying sensitivities of the Vactec cells control the brightness of the individual lamps

that transmit images on the scoreboard's huge center TV screen. Another example of Vactec's versatility and skill in the design and production of precise photosensitive devices.

Vactec provides a complete line of Se photovoltaic cells as well as CdS and CdSe photoconductive cells. Or Vactec will custom-design a unit for your application.

* Used by permission of Houston Sports Assn., Inc.

VACTEC



INC.

2423 Northline Industrial Blvd. Maryland Heights, Mo. 63045
Area Code 314, HE 2-4200

Circle 502 on reader service card

INNOVATION
INNOVATION
INNOVATION
INNOVATION
INNOVATION



In Electrical Electronics Engineering

- 80 Technical sessions, 300 papers — all at the New York Hilton
- 4 floors of exhibits — all at the New York Coliseum. Four days only — Monday - Thursday
- Gala IEEE Banquet—Wednesday, 7:15 p.m., New York Hilton Grand Ballroom — \$15.00
- Free shuttle busses between the Hilton and the Coliseum — every few minutes
- Registration — Members \$2.00 — Non-members \$5.00. Ladies \$1.00. Good for all days — Technical Sessions and Exhibits. In and out privileges.

EXHIBITS (4 days only)

Monday through Thursday
11:30 a.m. - 9:30 p.m.

NEW YORK COLISEUM

TECHNICAL SESSIONS

Monday through Friday
NEW YORK HILTON

MARCH 21-25, 1966

Students (over 14) accompanied by adult will be admitted to Exhibits Thursday only. \$2.00. (Not more than 3 per adult)



IEEE EXHIBITION

New Components

different pressure levels.

In computer applications, the Duplex Spiral model SL6 uses its two independent air paths to serve two separate functions; one for magnetic tape slack control and the other for capstan motor cooling.

Other models for the Duplex Spiral are said to be ideal for document and card handling equipment, paper tape and card reading equipment, laser head cooling and printed circuit motor cooling. The new blower can also be used for waveguide pressurization or cooling, actuation of machine elements, microwave cavity cooling and for air bearings for tape and film.

The high performance characteristics of the Duplex Spiral are achieved by directly driving the impellers from an integrally mounted induction motor. No sliding vanes or seals, or speed increasing devices are employed. The only points of contact between rotating elements are in the precision cartridge-width ball bearings, thus assuring maximum life.

The manufacturer says the absence of brushes and commutators makes the blower incapable of generating troublesome r-f noise and its low motor speed of 3,300 rpm also insures long life.

To be exhibited at the IEEE show.

Rotron Mfg. Co., Inc., Woodstock, N.Y., 12498. [358]

Numeric readout tube costs less than \$5

Type B-5440 Nixie tube will sell for \$4.95 in quantities of 1,000. The numeric readout tube is a side-viewing tube with a 0.750-in. maximum bulb width for 0.8-in. center-to-center spacing and a 0.6 in. character height in a bulb only 1.8 in. in maximum height to minimize instrument panel dimensions.

The stem of the tube has been designed for maximum printed-circuit line width and spacing of the associated circuitry, permitting maximum p-c board packaging density. New sockets, which per-

NEW ZERO SPACE SERIES

RFI SHIELDED ALUMINUM
CABINETS
TO NASA AND MIL SPECS

A Complete Line of
Vertical, Slope Front and
Low Silhouette
Aluminum Enclosures

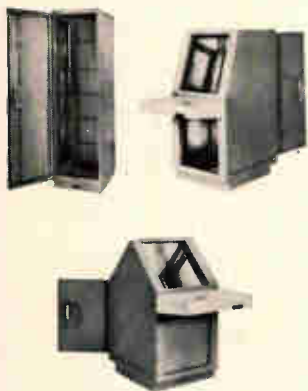

Manufactured Under NPC-200-3
Quality Control Procedures

More than 5,000 of these cabinets have been manufactured and installed at the Saturn V Apollo Moon Launch Facility, Cape Kennedy and at Marshall Space Flight Center. Narrower width allows 10% more cabinets in a given area and all aluminum construction gives 50% weight savings over comparable steel enclosures. Ideal for installations requiring RFI integrity, space and weight savings.

Now Available!
New Catalog SS 65
Send for it today!

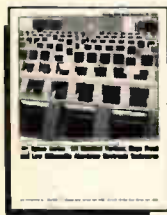

Zero Manufacturing Co.

1121 Chestnut Street,
Burbank, California 91503
Telephone (213) 849-5521
TWX 910-498-2237



Factories in Burbank, Calif. and Monson, Mass.

mit flush mounting of the tube for up-front viewing, are available for wiring applications and p-c applications.

Internal, independently-operable decimal points that are positioned on both sides of the numeral are an optional feature of the tube design. Another version of the tube, providing "plus" and "minus" indications, is also available.

This Nixie tube is expected to replace many other kinds of numerical readouts, such as projection and electroluminescent types, in numerous applications because of its simple operation, brightness, long life and lower cost.

To be exhibited at the IEEE show.

Burrhoughs Corp., Electronic Components Division, Plainfield, N.J. [359]

Tunable LC networks in TO-5 enclosures

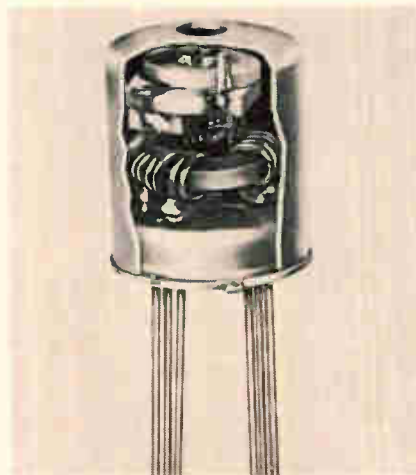

Series MTLC tunable circuits are complete networks housed in a TO-5 outline enclosure. Typically, these miniature circuits consist of toroidal transformer, a Modutrim variable ceramic capacitor, and Uniceram fixed ceramic capacitor all within the same enclosure.

Ten standard tunable L-C networks are available. Their specifications include center frequencies within the range from 3 to 250 Mc, tuning ranges from 2.8 to 3.3 (for 3-Mc center frequency) to 220 to 325 Mc (for 250-Mc center frequency), bandwidths (3 db down) ranging from 0.04 to 4 Mc, and minimum unloaded Q (3 db down) from 60 to 95. Temperature range is -55 to $+90^{\circ}\text{C}$.

The networks are good for

What Kind of Panel Meter Do You Need ?

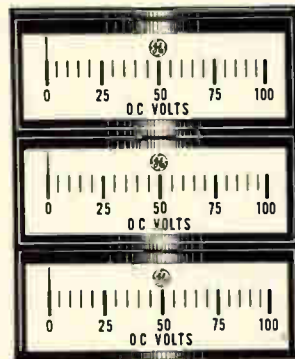

smart, slim
edgewise?

You can get it...from
General Electric's full line

Besides saving you valuable panel space, General Electric slim-line $2\frac{1}{4}$ " Type 185 EDGEWISE panel meters add exceptional styling and readability to your electronic equipment. Mount individually or in clusters of two, three, or more. See the complete General Electric panel meter line at your dependable electronic distributor. 592-28

GENERAL  ELECTRIC

Now! Get 2½ watts @ 1GHz.

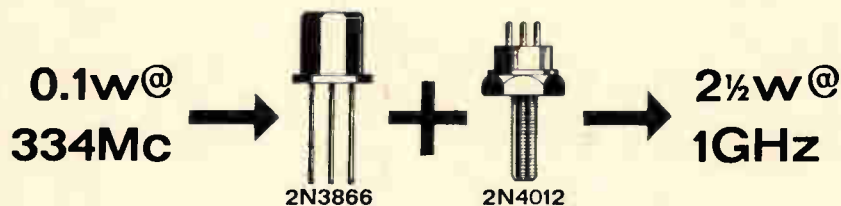

- With our new transistor, you can get 2.5 watts output at 1 gigahertz for use as a UHF band frequency multiplier.
- Used in combination with Vector's 2N3866 NPN silicon power transistor, the new 2N4012 features a conversion gain of 4.0 db with collector efficiency of greater than 25%.
- The structure of these epitaxial silicon transistors consists of many parallel microscopic emitter areas, interconnected by advanced metalization and photoengraving techniques. The 2N4012 is packaged in a JEDEC TO-60 with isolated electrodes. Stud mounting provides maximum thermal capability.
- Both components available now, in quantity, to provide a most economical power team.

For additional information, call Vector Solid State Laboratories, (215) 355-2700.

See us at Booths 2C43-50, IEEE Show.

Vector DIVISION OF UNITED AIRCRAFT CORPORATION
SOUTHAMPTON, PENNSYLVANIA

**U
A**

New Components

miniature or hybrid microcircuits in applications such as L-C tuning, phase detection, f-m discrimination, phase cancelling, impedance matching, frequency multiplication, i-f amplification, band-pass and band-stop filtering, and oscillator circuits.

Delivery time for small quantities in TO-5 configurations is approximately 2 weeks after receipt of order.

To be exhibited at the IEEE show.

JFD Electronics Corp., 15th Ave. at 62nd St., Brooklyn, N.Y., 11219. [360]

Turret attenuators for d-c to 1,200 Mc



For the frequency range from d-c through 1,200 Mc and attenuation between zero and 50 db, this line of precision turret attenuators offers electrical characteristics of pull-and-turn attenuators three times their price, according to the manufacturer. An important packaging consideration for the design engineer is that each module occupies less than a 3-in.-cube space on an equipment rack or in a test-unit chassis.

Each unit provides the accuracy of the best pull-and-turn drum attenuators with the mechanical convenience of rotary or progressive-addition type devices. Accuracy is ± 0.5 db; feed through, 0.1 db maximum at 1.2 Gc. All contacts are coin silver. Carbon disk and rod pad resistors assure accuracy and stability. Spring-loaded ball-bearing detent mechanism, precision-machined solid aluminum rotor and brass bearing inserts add up to minimum wear and faultless performance.

The attenuators are currently

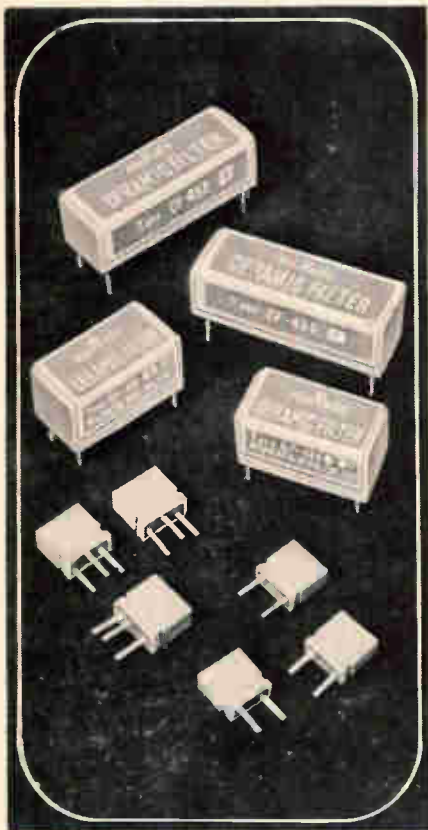

Combination of economy
with excellent performance

CERAMIC FILTER

Murata ceramic filters include the series type, the by-pass type and ladder type.

These filters are compact, require no alignment or tuning, remain perfectly flat regardless of temperature changes and stay in A-1 operating condition for years. And they're designed to provide effective operation beyond the scope and capacity of iFT.

Write today for detailed information to:

muRata

**MURATA
MFG. CO., LTD.**

Nagaoka, Kyoto, Japan
Cable Address: MURATA KYOTO

MURATA CORP. OF AMERICA
440 Park Avenue, South New York
N. Y. 10016

available in three models. Model ATV-50 (0 to 50 db in 10-db steps) costs \$195; the ATV-9 (0 to 9 db in 1-db steps), \$250; the ATV-1 (3 to 4 db in 0.1-db steps), \$280.

To be exhibited at the IEEE show.

Jerrold Electronics Corp., 15th and Lehigh Ave., Philadelphia, Pa. [361]

Cathode-ray tube uses fiber optics



A 3-inch diameter, magnetic deflection, high voltage focus crt is available with over 100 million glass fibers in the useful screen area to carry the light from the phosphor screen to the faceplate surface. Fiber optics insures maximum recording of the crt's light output by direct contact to light-sensitive material.

The KC2287P is primarily designed for an airborne radar application to convert circle to line scan. Its design is ruggedized, requiring no external components other than the deflection yoke.

Physical characteristics include a maximum length of 12 $\frac{1}{4}$ in., a useful screen dimension of 2 $\frac{1}{4}$ -in. diameter, a 5-micron fiber optic faceplate (flat) and a deflection angle of 40°. Electrical characteristics include a 0.0007-in. spot size at 10-kv accelerating voltage.

To be exhibited at the IEEE show.

Fairchild DuMont Electron Tubes, a division of Fairchild Camera & Instrument Corp., 750 Bloomfield Ave., Clifton, N.J., 07015. [362]

Triggered spark gaps of ceramic metal

A line of triggered spark gaps are designed for electronic crowbar applications and for energy transfer. Type F810-F831 ceramic-metal gaps are compact and rugged and will operate over a wide range of

What Kind of Panel Meter Do You Need ?



style-matched time meters?

You can get it...from General Electric's full line

The distinctive styling of the G-E BIG LOOK® panel meter line is yours with "look-alike" elapsed time meters. These accurate time meters measure hours or minutes and are offered with or without a reset knob. All ratings are available in 2 $\frac{1}{2}$ " and 3 $\frac{1}{2}$ " sizes. See the complete General Electric panel meter line at your dependable electronic distributor. 592-29

GENERAL  ELECTRIC

**Need a portable recorder
to read and write
IBM computer
compatible tapes
at 200,
556,
800
bits**

**per
inch?**

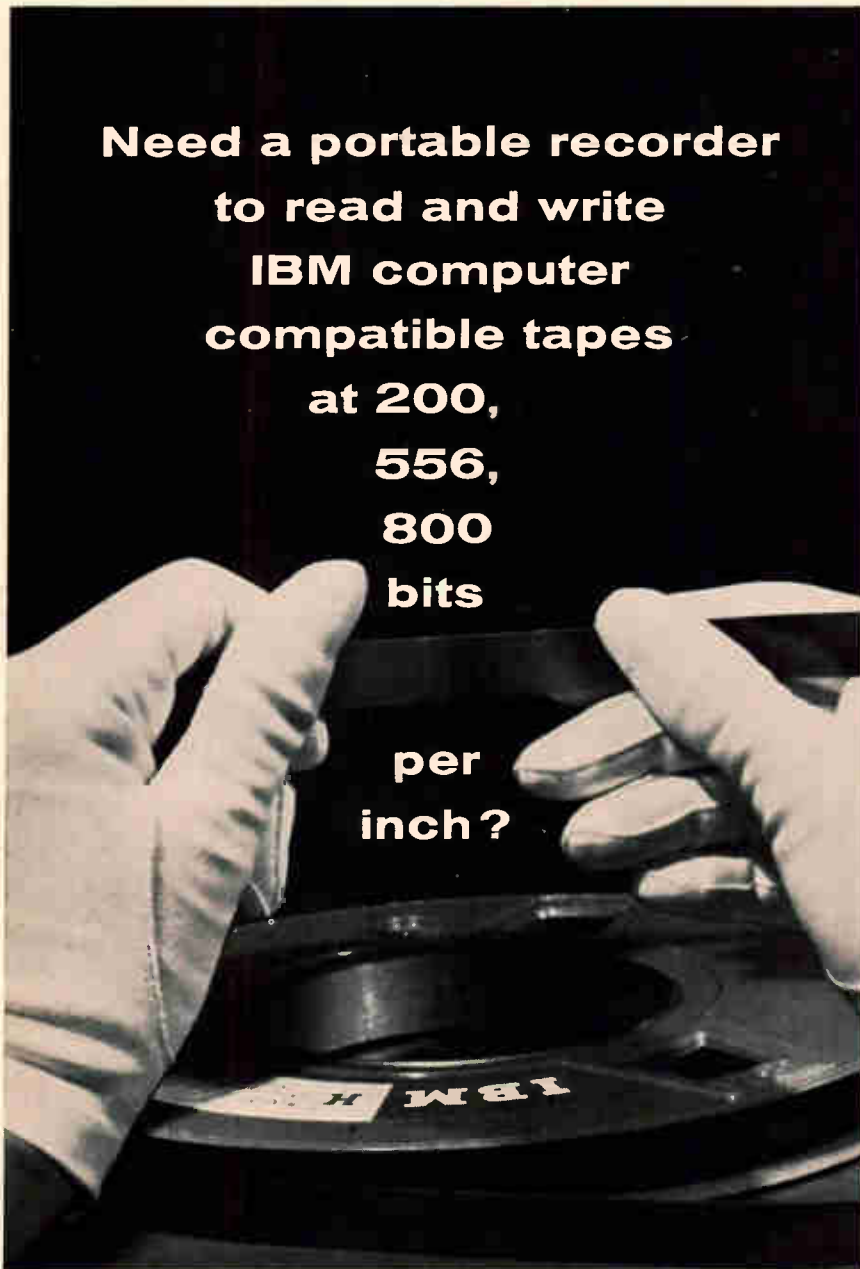

Maybe the Parsons DR 1200 is what you've been looking for. This new digital recorder is compact, weighs only 45 pounds, operates with only 100 watts of power and reads and writes IBM computer compatible tapes with tape speeds up to 120 inches per second. Recording format is 7 or 9 track data on IBM reels. Overall dimensions: 19 in. x 14 in. x 7.5 in.

Its rugged construction, precision performance and fail-safe features make the DR 1200 an ideal instrument for field or fixed installations in virtually any kind of environment. Best of all, it is priced considerably lower than you would expect to pay for a comparable unit. It is now in production and deliveries can be made within six weeks.

Dial 213-681-0461 (or drop us a line) and tell us what you need. Chances are the DR 1200 can be adapted to meet your optional requirements at a price you are ready to pay. For the white glove treatment, contact Jim Vallely, Sales Manager, at



**THE RALPH M. PARSONS
ELECTRONICS COMPANY**

151 S. DE LACEY AVE., PASADENA, CALIF.
A subsidiary of The Ralph M. Parsons Company

LOS ANGELES
NEW YORK
WASHINGTON

OFFICES IN OTHER
PRINCIPAL CITIES
THROUGHOUT
THE WORLD

New Components

temperatures without applying extra heat.

The gaps contain two primary high-power electrodes and a trigger electrode that is generally fired through a step-up pulse transformer by a simple low-energy pulse. The trigger probe and main electrodes are of special refractory material to ensure reliability and long life. Particular care has been taken in their design to minimize electrical field stress for maximum high-voltage hold-off capability.

They are available in a range of sizes handling from 200 to 4,000 joules with voltage hold-off to 100 kv.

To be exhibited at the IEEE show.

ITT Electron Tube division, International Telephone and Telegraph Corp., Easton, Pa. [363]

Three-phase cores improve transformers



A wide range of improved cores is available for three-phase transformer applications. Of the "Y" and hexagonal "Y" design, the three-phase cores are being offered in sizes ranging in diameters from 1 7/8 in. to 7 in. for the "Y" type and from 7 in. to 16 in. for the hexagonal "Y" types.

The new cores will provide certain advantages, including accurately balanced three-phase transformers because of symmetrical magnetic paths for each of the three core loops. Another advantage is a physical separation of 120° for each coil, resulting in less heat interchange between coils and better heat dissipation and more winding or window area for a given core weight. This makes it possible to

SRL VAP

video audio pulse

**LABORATORY
FILTER**
20 cps. to 4 mcps.



**CONTINUOUS CONTROL
IN FOUR MODES**

- high pass
- low pass
- band pass
- band reject

SKIRT ATTENUATION
Over 40 db/octave

50 μ volt NOISE FLOOR

INSERTION LOSS: 0 db

TRANSIENT OVERSHOOT
less than 1%

**BANDWIDTH IN
PASS BAND**
20 cps.-7 mcps.

SOLID STATE

DIMENSIONS
7 x 19 x 12 (HWD)

PRICE
\$2250.00

write for complete specs

**SYSTEMS RESEARCH
LABORATORIES, INC.**
500 WOODS DRIVE, DAYTON, OHIO



reduce over-all weight in many designs.

Price of the new cores is dependent upon size required. Delivery is from 3 to 4 weeks from receipt of order.

To be exhibited at the IEEE show.
The Arnold Engineering Co., Box G,
Marengo, Ill. [364]

Electromechanical time delay relay

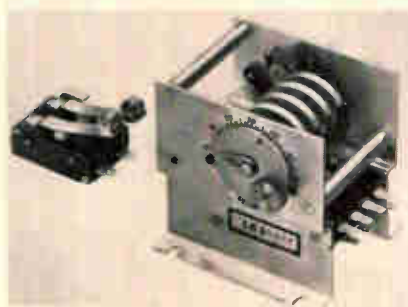

A motor-driven, clutch-actuated time delay relay is especially designed for industrial/commercial applications requiring dependable operation and long service at low initial cost. Thirteen basic models offer a wide choice of standard time ranges from 0 to 12 seconds up to 0 to 60 hours. The timers are provided with a dial to display the over-all delay range and a setting indicator for adjusting the longest delay desired. A moving progress pointer indicates the time remaining after initiation of the delay period.

Up to four single-pole, double-throw, 125-250 v a-c switches—rated at 15 amps or two similar switches rated at 25 amps—can be provided. These may be either factory pre-set or field adjustable as desired. Factory set units are accurate to $\pm 2\%$ of the maximum dial reading. Repeat accuracy is $\pm 1\%$ of the maximum dial reading. The switches are mounted in snap-in/snap-out banks for easy replacement.

The drive motor is synchronous and operates on 115 v a-c, $\pm 10\%$, 60 cps and draws 3 watts. The clutch solenoid is rated for continuous duty and draws 5 watts.

To be exhibited at the IEEE show.

The A.W. Haydon Co., 232 N. Elm St.,
Waterbury, Conn., 06720. [365]

What Kind of Panel Meter Do You Need ?



bright, bold meter relay?

You can get it...from General Electric's full line

Add years-ahead BIG LOOK® styling to your equipment with G-E Type 195 contactless meter relays, featuring solid-state, light-sensitive switching for the ultimate in simplicity and readability. All ratings are available in 2 1/2", 3 1/2", 4 1/2" sizes with single or double set-points. See the complete General Electric panel meter line at your dependable electronic distributor.

592-30

GENERAL ELECTRIC

SIZE AND PRICE CANNOT BE DRASTICALLY REDUCED SIMULTANEOUSLY WITHOUT SACRIFICING MAJOR PERFORMANCE!

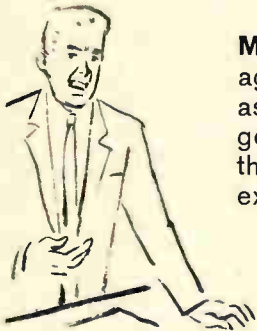

MELCOR agrees, but as with most generalities, there are exceptions.

The MELCOR Model 1573 DC Differential Operational Amplifier is an exception.



In 0.2 cubic inches and for \$19.00 (even for one piece) the MELCOR Model 1573 Amplifier performs substantially as well as the one cubic inch units at twice the price.

CHARACTERISTICS

Supply Voltage	± 15 VDC
Rated Output Voltage	± 10 VDC
Rated Output Current	± 2 ma
Open Loop Gain	75 db min
Common Mode Rejection	60 db min
Unity Gain Crossover	1 mcs min
Power Bandwidth	10 KCS min
Input Offset Voltage vs Temperature	± 1 mv max from 0°C to 50°C
Input Offset Current Differential	75 na max
Temperature Range	-25°C to +85°C

For complete specifications write to MELCOR. Ask for bulletin 1573. We make a complete line of Solid State Operational Amplifiers, including units with ±100V output and extremely low input offset voltages and currents. MELCOR invites your inquiries.



MELCOR ELECTRONICS CORPORATION

1750 NEW HIGHWAY
FARMINGDALE, NEW YORK
TEL: 516-694-5570

AMPLIFIERS FOR INDUSTRY

New Instruments

Portable voltage source for calibration

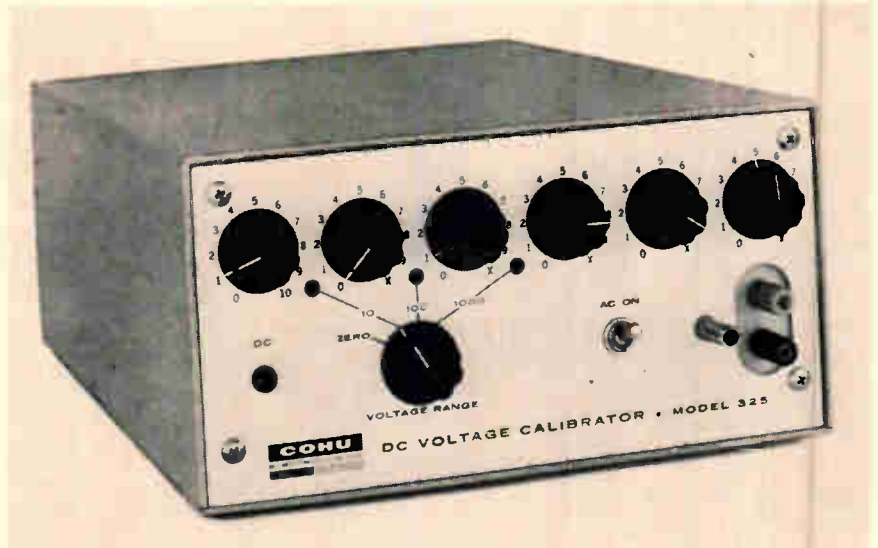

Precision d-c instruments can now be calibrated even at remote test sites with Cohu Electronics, Inc.'s portable d-c voltage calibrator. The instrument provides d-c voltages accurate to 0.02% and is adjustable from zero to 1,111.11 volts in increments as small as 10 microvolts. The output voltage is selected by a range multiplier dial and a six-place decade dial on the front panel. The range dial has a zero-volt position and full-scale positions of 10, 100 and 1,000 volts. Decimal point placement is indicated by the range dial.

The model 325 has an isolated output with noise and hum lower than 100 microvolts rms. The output impedance of the d-c source is less than 0.001 ohm. And the voltage output is stable within 30 parts per million for 24-hours, or within 50 ppm for 30 days.

The stable output is achieved by using a low-drift, wideband amplifier system that has high gain, combined with a highly stable reference voltage supply, and precision range and feedback resistors.

The reference voltage, the input to the amplifier system, is a six-volt d-c supply. A highly stable, temperature-compensated zener diode is the reference voltage element. The amplitude of the reference voltage is set by the range multi-

plier dial, which changes the value of the range resistors in series with the supply. These resistors are coupled to keep the load on the reference circuit constant as they are switched from one setting to the next.

A complex amplifier system boosts the reference voltage to its maximum value of 1,111.11 volts. The closed-loop gain of this system is determined by the selected resistors in the decade dial in the feedback loop. For the calibrator to have a constant output independent of load variations, a 60-cps suppressed carrier amplifier and a wideband a-c coupled unit drive the d-c amplifier in parallel. These units sample a portion of the output current and compensate for load changes by adjusting the loop gain of the amplifier system. Two amplifiers provide the frequency response needed for the system to sense and correct fast changes in the load.

Interstage coupling networks, low leakage current and high internal feedback shape the amplifier system response characteristics to provide stability. This stability, coupled with a nominal loop gain at d-c of one million, make the accuracy of the output voltage independent of all external influences except those emanating from the

reference voltage supply and the accuracy of the range and feedback resistor settings.

Cohu has even built a self-checking feature for linearity into the model 325. Overrange positions on each dial make it possible to obtain the same output voltage with different dial settings on each range.

A protective circuit, a Schmitt trigger, opens the main regulating circuit if the output current exceeds 25 milliamperes.

The model 325 will be shown for the first time at the IEEE International Conference and Exhibit in New York starting March 21.

Specifications

Output voltage range	0 to 1,111.11 v d-c
Output current (max)	25 ma
Output impedance	0.001 ohm
Power	110/220 v, 50-60 cps
Price	\$995

Cohu Electronics, Inc., Box 623, San Diego, Calif. [376]

Battery-operated semiconductor tester



This semiconductor tester checks diodes, rectifiers, transistors, and field-effect transistors in, or out-of-circuit rapidly and safely. It measures both transistors and diodes, in-circuit, for reverse leakage down to 500 ohms of loading. It also measures field effect transistors for leakage and transconductance, and both low and high power transistors for 1,000 cycle beta (h_{fe}) within a range of 1 to 1,000. Other measurements include the resistance across the emitter-to-base, collector-to-base, and collector-to-emitter electrodes of transistors. An optional feature available is an automatic beta calibration circuit which sets the collector current of each transistor under test at 1 ma.

To withstand rough environmental use, the model 259 is housed in a drip-proof, high-impact

Ballantine AC-DC Digital Voltmeter ...and DC/AC Voltmeter/Ohmmeter



Model 355
Price \$590

Ever hear of so many features in a Digital Voltmeter such as this?

BALLANTINE'S MODEL 355 AC/DC DIGITAL VOLTMETER HAS THESE OUTSTANDING FEATURES: Measures full scale ac to 10 mV • Measures ac & dc from 0 to 1,000 V • ¼% accuracy f.s. for ac & dc voltages up to 500 and for mid-band frequencies • Large, well-lighted readout with illuminated decimal point, mode and range information.



Model 345
Price \$375

Or in a DC/AC Voltmeter/Ohmmeter like this?

BALLANTINE'S MODEL 345 DC/AC VOLTMETER/OHMMETER GIVES YOU THESE ADVANTAGES: Measures 0 - 1,000 V dc; 0 - 350 V ac (20 Hz to 1,000 MHz); 0 - 5,000 MΩ • One easy-to-read voltage scale instead of four as in many volt-ohmmeters • Unrivaled accuracy and high resolution: 1% of indication for dc; 2% of indication for ac; and 3% of indication for ohms • Built-in calibrator.

Write for brochures giving complete details

— Since 1932 —



BALLANTINE LABORATORIES INC.
Boonton, New Jersey

CHECK WITH BALLANTINE FIRST FOR DC AND AC ELECTRONIC VOLTMETERS/AMMETERS/OHMMETERS, REGARDLESS OF YOUR REQUIREMENTS. WE HAVE A LARGE LINE, WITH ADDITIONS EACH YEAR. ALSO AC/DC LINEAR CONVERTERS, AC/DC CALIBRATORS, WIDE BAND AMPLIFIERS, DIRECT-READING CAPACITANCE METERS, AND A LINE OF LABORATORY VOLTAGE STANDARDS FOR 0 TO 1,000 MHZ.

Hunting a pulse generator that combines lab quality with production line convenience— at a price that makes sense? YOU'VE FOUND IT!

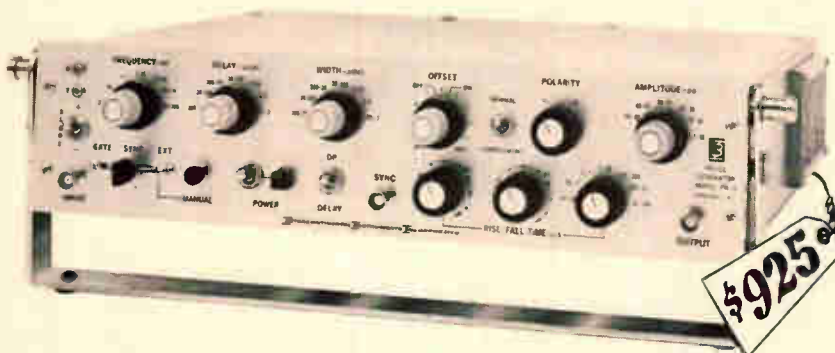

Intercontinental's PG-2 Pulse Generator has been updated to provide just about every feature you're likely to need for either laboratory or production line measurements—including some previously unobtainable in a general purpose pulser.

For example: output to 24 volts from 50 ohms, less than 2% overshoot at any attenuator setting, variable baseline on both positive and negative pulses. Repetition rate goes down to 1 c/s. up to 16 mc/s, output can be delayed single or double pulses or one-shot, with independent adjustment of delay, width, and linear rise and fall times. There's a wide range of control for triggering on external signal, with slope, sensitivity and threshold readily adjustable. Only 3½ inches high, it mounts conveniently on the bench or in a rack.

The PG-2 carries the unbeatable price tag of \$925. Why not request a demonstration. You'll be mighty impressed.



Attenuator Characteristics
Upper trace: 30mv
Lower trace: 10V

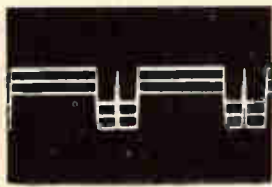

Variable base line,
negative double pulse

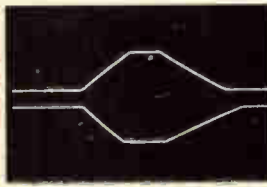

Independently variable
rise and fall time.



INTERCONTINENTAL INSTRUMENTS INC.

500 Nuber Avenue, Mount Vernon, N.Y. 10550
(914) 699-4400

See us at IEEE—Booth 3A13

New Instruments

plastic case, with cover. Battery operated, the unit is ruggedly built, lightweight, and has a meter readout. An optional one-hand-operated, in-circuit test probe is available.

To be exhibited at the IEEE show.

American Electronic Laboratories, Inc.,
P.O. Box 552, Lansdale, Pa. [377]

Analyzing equipment covers 20 Mc to 18 Gc



By providing swept frequency and wide dynamic range over the 20 Mc to 18 Gc frequency range, this new analyzer replaces tiresome manual methods of making all-important phase, amplitude and impedance measurements. The single analyzer, with its companion resolver, replaces slotted lines, reflectometers, insertion loss measuring instruments, impedance plotters, and impedance bridges.

Applications include the building of modern antennas, component development, filter testing, transistor testing, and twt development. Three out of four radar types require this sort of equipment for design and test of the microwave and i-f parts. It is particularly suited for testing modern f-m communications systems which have to be controlled as to phase and impedance. The new analyzer is used for satellite communications equipment, f-m multiplex transmission, and microwave telemetering.

Best-case accuracy for the equipment over the whole frequency range of 20 Mc to 18 Gc is 0.1°. This best case is determined by the

And now E-I is *expanding* its Engineering Service on **CUSTOM and SPECIAL SEALING**

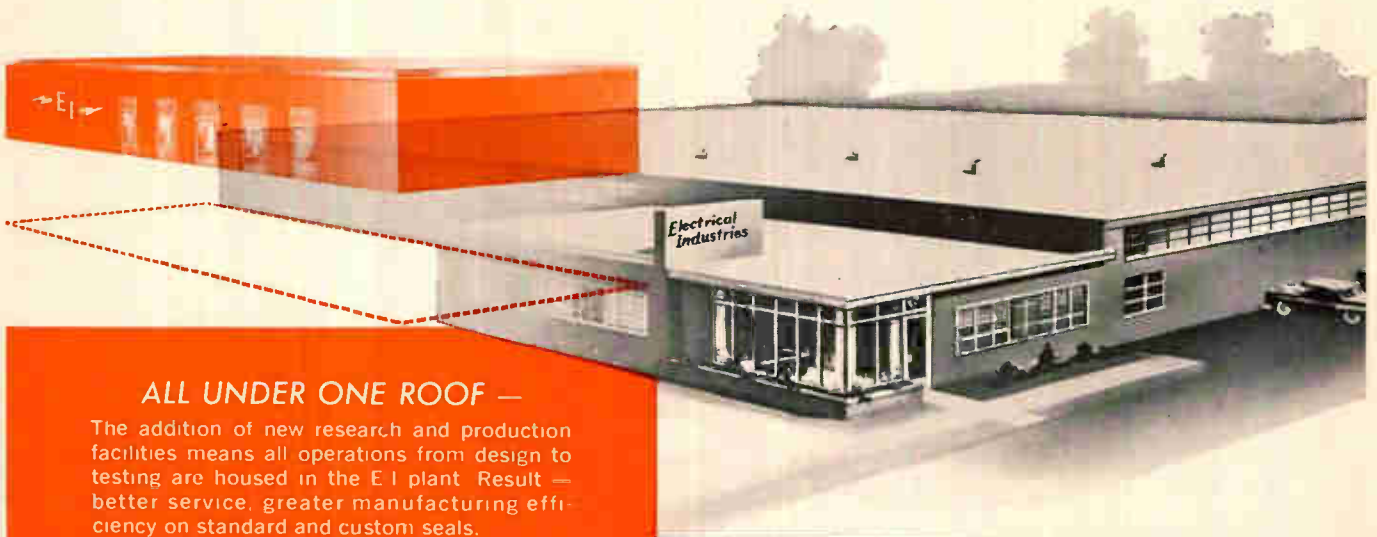

ALL UNDER ONE ROOF —

The addition of new research and production facilities means all operations from design to testing are housed in the E-I plant. Result — better service, greater manufacturing efficiency on standard and custom seals.

See us at the I.E.E.E. Show
Booths 2F31-2F33

Industry's Most Complete Line of Sealed Terminations *plus* On-the-spot Engineering Assistance Nationwide!

The Electrical Industries line of hermetically sealed components is recognized industry-wide for high reliability and broad design versatility. E-I offers designers the flexibility and economy of standardized production on all types of seals from single and multilead terminals to subminiature closures.

For proven performance in both commercial

equipment and space age projects, specify the seals employed by leading manufacturers. Fast nationwide field service is available to help work out your design problems.

Write on company letterhead for a copy of the new Electrical Industries Catalog GC 65, or send details or sketches for recommendations on any sealing requirements.

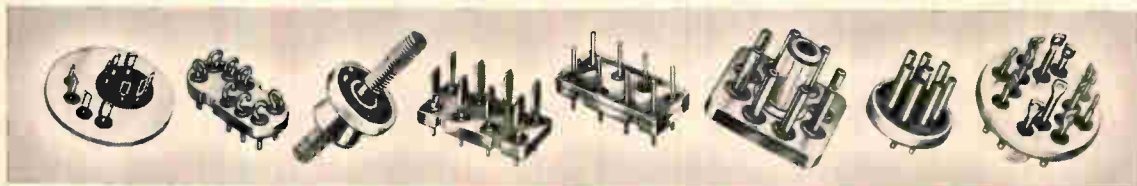

The products illustrated above are typical of the thousands of special-application hermetic seals and components made to customers' exacting

specifications; also shown are customer-manufactured parts that have been hermetically sealed by Electrical Industries.

A Division of Philips
Electronics and
Pharmaceutical
Industries Corporation



ELECTRICAL INDUSTRIES

MURRAY HILL, NEW JERSEY 07971—Telephone: (201) 464-3200

PATENTED IN U.S.A., NO. 3,035,372; IN CANADA, NO. 523,390; IN THE UNITED KINGDOM, NO. 734,583; OTHER PATENTS PENDING

RMC

DISCAPS

*the complete
Ceramic Disc
line*

Over the years Radio Materials Company has maintained its leadership in the production of ceramic disc capacitors. A complete line offering outstanding quality has been the key to continuing growth.

STANDARD

Type C, B, BA, JF, JL and JE

SUBMINIATURE

Type SM, BT, TA and Magnacaps

GREENCAPS

Type CG, JG, and BG

SPECIAL

U.L. Listed Discaps, T.C. High Voltage, High K High Voltage and Dual Section By-Pass

RMC
.0039

FOR INTRODUCTION AT IEEE

SOLDER-IN T.C. DISCAPS

For application in equipment where lead inductance effects must be reduced to an absolute minimum.

U.L. LISTED T.C. DISCAPS

Should be specified when the use is an integral part of an antenna coupling network where compliance with Underwriters' Laboratories specifications are required.

DISCAP
CERAMIC
CAPACITORS

RMC

RADIO MATERIALS COMPANY

A DIVISION OF P. R. MALLORY & CO., INC.
GENERAL OFFICE: 4242 W. Bryn Mawr Ave., Chicago 46, Ill.
Two RMC Plants Devoted Exclusively to Ceramic Capacitors
FACTORIES AT CHICAGO, ILL. AND ATTICA, IND.

New Instruments

resolution of the equipment and occurs for small angles and small frequency excursions. Worst case accuracy is $\pm 2^\circ \pm 4\%$ of phase angle with maximum error under any condition under 2° . For impedance plotting, the resolution is 1% allowing a 1.02 vswr measurement or a 40-db return loss. This corresponds to a 40-db directivity at all frequency ranges. For measurement of insertion loss the accuracy is 0.5 db \pm 0.1 db per each 10 db up to 50 db.

Price of the complete analyzer (illustrated with resolver) is \$8,800.

To be exhibited at the IEEE show.

Wiltron Co., 930 East Meadow Drive, Palo Alto, Calif., 94303. [378]

Battery-operated insertion-loss tester

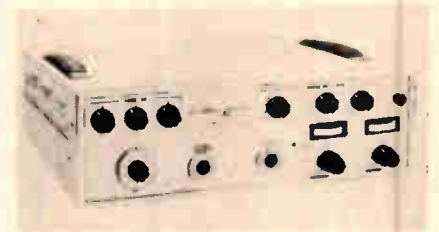

A direct-reading, battery-operated insertion-loss measurement set is announced. Model DB-3000-3 is capable of measuring insertion loss with ± 0.007 -db absolute accuracy and ± 0.002 -db relative accuracy, up to 1.0 db. Measurements of ± 0.01 db are obtainable over one-third of its 29-db dynamic range.

A front panel readout dial indicates insertion loss directly in db, eliminating the need for reference to ratio transformer calibration charts.

The battery used is a rechargeable nickel-cadmium type with life of three to four years. The test set is completely portable and is ideal for field measurement of receiver front ends and antenna feed system loss. It is also available rack mounted, for laboratory applications. Conversion to operation from standard 115-v line current is accomplished with a rear-panel switch.

Dimensions are 5½ in. high by

We want to thank

the microwave engineering community for its immediate and enthusiastic acceptance of our new

Modular Microwave Signal Generators & Sources. **Polarad**

generator / source sales are soaring, & everyone who adopts the PEI modular rack / stack (or "more instrumentation for your instrument dollar") Philosophy Becomes a Logical Prospect for Modular Spectrum Analyzers, Modular SSB Analysis Systems, and the World's Finest RFI Equipment. Want More Signal Capability per Dollar?

Call Your Local Polarad Sales Engineer or Call Us Directly at (212) EX 2-4500 for a Demo or a Quote.

Model 1107/1108



Signal Generators

3.80-11.0 GC
+3 dbm to -127 dbm
(+10 dbm uncalibrated)

Model 1205



Source

0.95-2.40 GC
Varies from 50 to 320 mw depending on frequency.

Model 1206



Source

1.95-4.20 GC
Varies from 50 to 230 mw depending on frequency.

Model 1207/1208



Sources

3.80-11.0 GC
Varies from 25 to 200 mw depending on frequency.

Model 1509/1510



Doublers

10.0-21.0 GC
0 dbm to -100 dbm; max. input 200 mw; conversion loss < 18 db.

Model 1001



Modulator

Sufficient level to modulate all modular generators and sources.
Pulse, Square Wave & Sawtooth FM.
Pulse width: 0.2-10 μ sec.
Repetition rate: 10 to 10,000 pps.
Sync delay: 0 and 2-2,000 μ sec.

Model 3815



Phase-Lock Frequency Stabilizer

Stabilization of any oscillator—BWO, VTM, or Reflex Klystron, up to 12.4 GC.



World Leader in
Microwave
Instrumentation

POLARAD ELECTRONIC INSTRUMENTS

A Division of Polarad Electronics Corporation
34-02 QUEENS BOULEVARD
LONG ISLAND CITY, NEW YORK 11101

Circle 229 on reader service card

Why *Crush* Ice?

"THE AUTOMATIC ICE-BATH"
makes the old-fashioned ice bath obsolete!

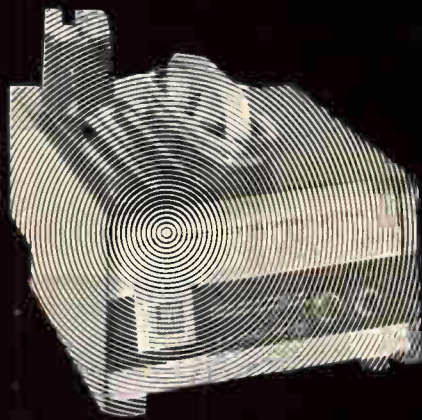

The common ice bath melts over a period of time, losing its temperature stability. "The Automatic Ice-Bath" maintains $\pm 0.025^\circ\text{C}$ temperature stability indefinitely. "The Automatic Ice-Bath" pays for itself by eliminating man power required to make and maintain necessary ice.

Any type of thermocouple material can be interchanged. NBS Traceability.

Send for Catalogue 114.



JOSEPH KAYE & COMPANY, INC.
737 CONCORD AVE. • CAMBRIDGE, MASSACHUSETTS 02138
TELEPHONE: 617-868-7080 • TWX: 617-499-9154

Circle 506 on reader service card



**LIGHT
TO FIGHT
BY...**

*Portable military shelters require a
very special kind of interior lighting.*

WE MAKE THIS KIND.

Literature on request



BRUCE INDUSTRIES, INC. 1528 West 178th Street, Gardena, California

230 Circle 230 on reader service card

New Instruments

17 in. wide by 15½ in. deep. Weight is 22 lbs. Price is \$2,495; availability, four weeks.

To be exhibited at the IEEE show.

DeMornay-Bonardi, division of Data-pulse Inc., 780 S. Arroyo Parkway, Pasadena, Calif., 91105. [379]

Frequency synthesizer covers 470 to 1,000 Mc

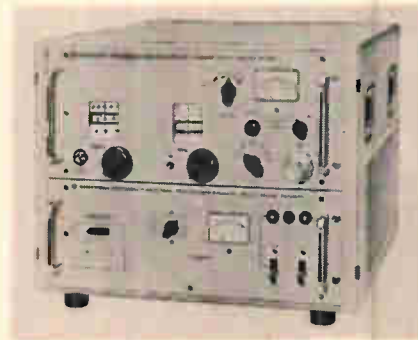

A solid-state frequency synthesizer generates frequencies from 470 to 1,000 Mc directly. Type XUC is said to be the only instrument in the industry to cover this frequency range. It thus eliminates the problem encountered with low frequency synthesizers, where output must be multiplied, with corresponding degradation. The output frequency is made up of two components. One is derived from the frequency of the crystal-controlled frequency standard and can be locked in 10-Mc steps and the other is furnished by an interpolation oscillator which is tunable within these steps. Resolution is 5 kc.

The built-in frequency standard is accurate to 2 parts in 10^9 . It can also be operated from an external 12-v battery.

The output voltage of type XUC is accurately adjustable in steps and continuously between 250 μv and 1.5 v into 50 ohms. The suppression of nonharmonic spurious frequencies is more than 80 db; spurious frequency deviation is less than 0.5 cps. Frequency fluctuations due to external influences (within the tolerable limits of supply voltage, supply frequency and ambient temperature) are less than 2 (10^{-9}). The mean daily frequency



ULANO EUROPEAN TECHNICAL CENTER FOR GRAPHIC ARTS

Ulano's technical center in Switzerland is headed by the very capable Mr. Henri Kunz. He is qualified by his many years of experience in the Screen Process and Graphic Arts fields. Demonstrations and technical seminars are held in many languages throughout the year. Complete laboratory facilities have been installed to provide demonstrations of the complete Ulano line. Large stocks of all famous Ulano films are available for immediate delivery to all parts of the world.

You are invited to contact Mr. Henri Kunz at ULANO A.G., Untere, Heslibachstrasse No. 22, Kusnacht 8700, Switzerland, Telephone 905959. It is our pleasure to serve you.

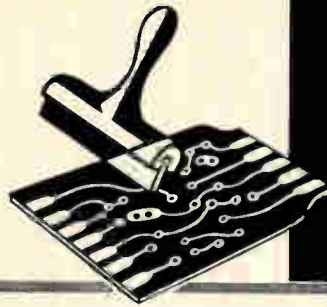

**DO YOU USE
SCREEN PROCESSING
IN THE PRODUCTION OF
COMPLEX
PRINTED
CIRCUITRY?**

**TWO NEW PRESENSITIZED FILMS TO
SPEED PRODUCTION — LOWER COSTS**

Ulano



Write today on
your letterhead
for free Special
Sample Kit 5248

HI-FI RED HEAVY-DUTY INDUSTRY PROVED

Presensitized photo film used by many leading electronic firms for clean, sharp, tough, durable, almost indestructible screens of unmatched quality. Adheres tightly to wire, silk, nylon and dacron.

PREP® PRESENSITIZED FOTO FILM

.002 Polyester support guarantees good register. Does not require a dark room. Very good resolution—suitable for halftones. Excellent adhesion to silk, nylon, dacron and metal mesh. Tough, strong emulsion—good for machine printing and long runs.

J. ULANO & COMPANY, INC.

610 Dean Street, Brooklyn, N. Y. 11238, U.S.A.
Cable address: "UlanoFilm"
In Europe: ULANO A.G., Untere, Heslibachstrasse No. 22
Kusnacht, Zurich, Switzerland

HERE'S HOW...



**LITHOGRAPHERS, ENGRAVERS, ARTISTS, SCREEN PROCESSORS ALL USE
THESE FAMOUS MASKING FILMS TO SEPARATE COLOR, ELIMINATE
OPAQUING, PREPARE DROPOUTS, SAVE TIME, REDUCE JOB COSTS**



Cut a piece of the desired film large enough to cover area to be masked. Tape it down firmly at the top with dull-side up.



With sharp blade, outline the areas to be masked. *Do not cut through the backing sheet.* The Ulano Swivel Knife does the job quickly, easily.

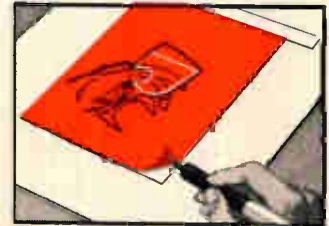

Using the tip of the blade, lift up a corner of the film thus separating it from the backing sheet.

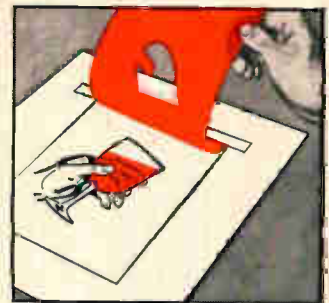

Now carefully peel off the film. Your art work is now separated with the "second color" on a clear Mylar overlay ready for camera and in perfect register.

Ulano T.M.

RUBYLITH T.M. • AMBERLITH T.M.

HAND CUT MASKING FILMS FOR THE GRAPHIC ARTS

ULANO RUBYLITH . . . a revolutionary knife cut red film is laminated to a stable transparent plastic backing sheet. The red film is "light safe" so that when contacted to a sensitized emulsion and exposed to a suitable light source, light passes through the cut-out portions only . . . not through the red film. ■ The mylar* backing is absolutely stable . . . insures perfect register. ■ Special effects such

as crayon tones, paste ups, benday sheets, and opaquing are easily combined with versatile ULANO RUBYLITH. *T.M. Dupont Polyester Film

ULANO AMBERLITH . . . a companion to Rubylith serves as a color separation medium used as the master on camera copy board to secure negatives or positives.

Available in Rolls and Sheets

ulano

610 DEAN ST., BROOKLYN, N. Y. 11238

NEW YORK • CHICAGO • ZURICH



Write today on your letterhead for free Special Sample Kit 5348

draw yourself a circuit
to control **SPEED**

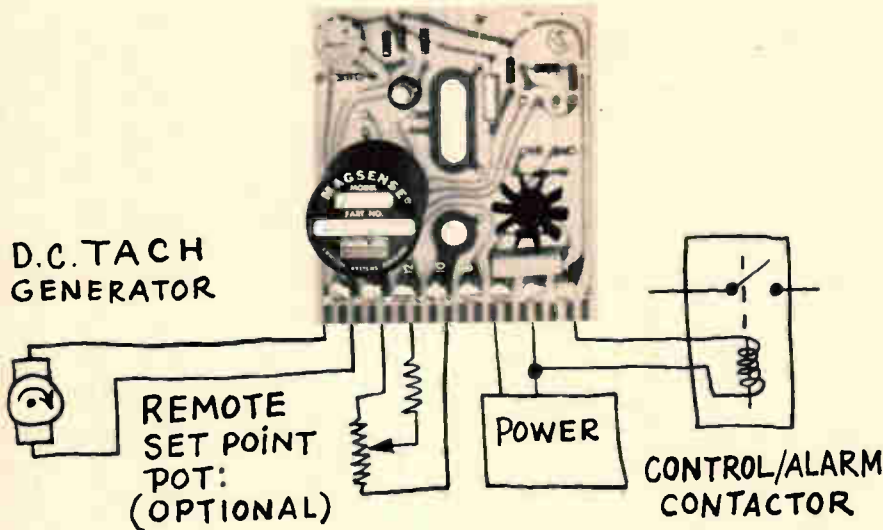

PUT MAGSENSE® IN THE MIDDLE

Connect your D.C. tach generator to one side of a MAGSENSE controller/alarm and a relay or power contactor to the other. It's just about that simple to control *speed* accurately and reliably. Solid-state MAGSENSE controllers have a 100-billion power gain and will accept the output of the transducers directly *without amplifiers*. Set point or dual set points are adjustable. Transducer excitation voltage is available from the MAGSENSE where transducers require it. Examine these specifications for the Model 70. Versions to meet Mil E-5272 and a variety of special application controllers are also available. Prices are from \$60 up, with quantity discounts.

BRIEF SPECIFICATIONS FOR MODEL 70

- RESPONSE TIME: 100 ms max., 50 ms typical (10 ms max. available)
- POWER REQUIRED: 10 to 14 V DC at approx. 30 ma exclusive of load current.
- OUTPUT: Non-latching for inputs with ranges of 100 μ a, 1 ma, 10 ma or 100 ma. Latching or pulse outputs also available.
- SIZE: 3" x 3.35" x 1.25"
- WEIGHT: Approx. 3 ounces
- DELIVERY: From stock

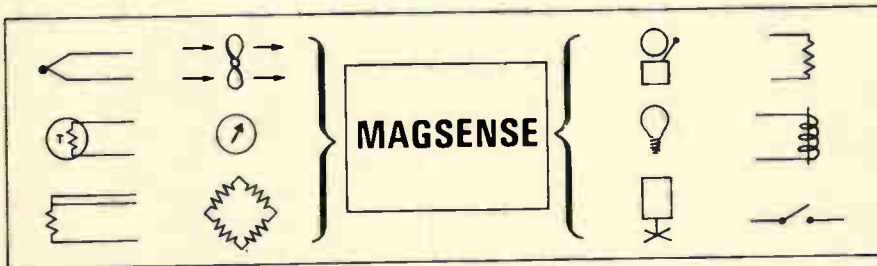

FOR INFORMATION about the complete line of MAGSENSE products for military and industrial applications, circle the inquiry number below or contact MAGSENSE Products, Dept. 121, La Jolla Division, Control Data Corporation, 4455 Miramar Rd., La Jolla, California (Area code 714, 453-2500)



4455 Miramar Road, La Jolla, Calif.

New Instruments

drift after constant use is less than $1 (10^{-9})$.

Type XUC is equipped for mounting in 19-in. racks and, with the exception of five uhf disk-seal triodes, uses transistors. It is priced at \$7,700, with delivery in April.

To be exhibited at the IEEE show.

Rohde and Schwarz, 111 Lexington Ave., Passaic, N.J. [380]

**True absolute
a-c voltage standard**



Model AV10 a-c voltage standard features a continuously variable internal oscillator with a range of 38 to 11,000 cps. Its output voltage range is 0 to 511.110 volts rms. The unit has a true absolute accuracy, including one-year stability and temperature effects, 15° to 35°C, of 0.025%. Harmonic distortion is 0.01% and the solid state, modular unit is convection cooled.

Designed for calibration of precision a-c voltmeters, the AV10 eliminates the "add-on" distortion, instability and error contributions of external oscillators. It has a calibration accuracy, included in the absolute accuracy, of 0.01% from 380 cps to 1 kc. Resolution is 1 mv from 380 to 11,000 cps, 100 μ v from 38 to 379 cps. There are six fully switched decades with over-ranging.

Model AV10 standard has a warm-up time of 30 minutes from room temperature for full rated specifications and three hours at or from 0°C. Maximum full load regulation is $\pm 0.01\%$ from 151 to 511.110 v, $\pm 0.01\%$ for 10-v steps from 51 to 150 v and ± 20 milliohms for 10-v steps from 1 to 50 v. Short circuit or excessive loading

No matter what the test, Du Pont has a photorecording product to document the results:

(And if you don't see what you need
contact your nearest
Du Pont Technical Representative.)

Lino-Writ Chemicals

Rapid processing kit (powder)—
processing of conventional papers in
stabilization processing equipment.

Liquid processing kit—
processing of conventional papers in
stabilization processing equipment.

Lino-Writ Developer—
conventional processing developer.

Rapid-access developer—
development by applicator-type processor.

Direct Writing Liquid Kit Type 1—
for processing unphotolyzed records on
direct writing photorecording papers.

Direct Writing Liquid Kit Type 2—
for making permanent records of photolyzed data
on direct writing photorecording paper.

High-speed stabilization chemicals (powder)—
for processing Lino-Writ 200 series papers.

Lino-Writ Photorecording Papers

Lino-Writ 1—3,000 i.p.s.†

Lino-Writ 2—6,000 i.p.s.

Lino-Writ 3—30,000 i.p.s.

Lino-Writ 4—50,000 i.p.s.

Lino-Writ 201 (Rapid Processing)—3,000 i.p.s.

Lino-Writ 202 (Rapid Processing)—6,000 i.p.s.

Lino-Writ 203 (Rapid Processing)—30,000 i.p.s.

Lino-Writ 5 (Direct Writing, Blue Sensitive)—
50,000 and 75,000 i.p.s.

Lino-Writ 7 (Direct Writing, Orthochromatic)—
85,000 i.p.s.

CRONAR* Photorecording Films

Lino-Flex Recording Film—Medium Speed, Light Matte

CRONAR Recording Film—High Speed, Clear Base

†inches per second

*Du Pont's registered
trademark for its
polyester photographic film



Photo
Products
Department



Better Things for Better Living . . . through Chemistry

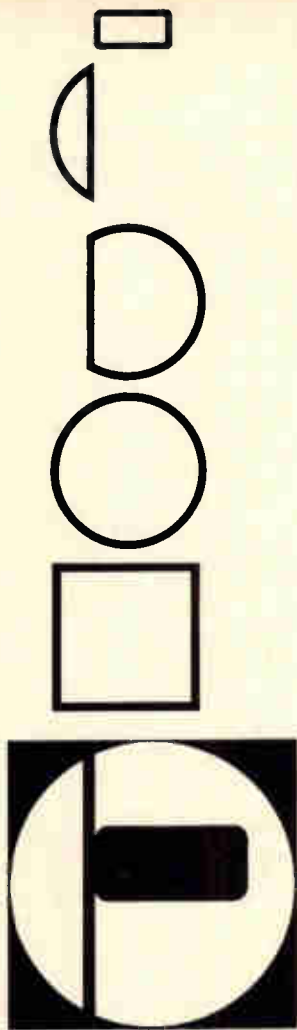

PRECISION

This new corporate mark of Precision identifies the world's most dependable source for nonferrous metal tubing, Bourdon and pointer tubing, custom-fabricated tubular parts, "Coaxitube" semirigid coaxial cables. And it symbolizes the precision for which these products are known throughout the industrial and scientific world. May we send you our catalog?

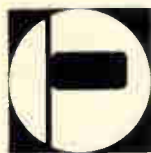

PRECISION TUBE COMPANY, INC.
 Tube Mill Division • Special Products Division
 North Wales, Pennsylvania 19454

234 Circle 234 on reader service card

New Instruments

protection is provided by an internal cartridge fuse. No recalibration is required after replacement of the fuse if overloading occurs. Maximum output inductance of the AV10 is 0.2 millihenry, typically 2 microhenries below 50 volts.

To be exhibited at the IEEE show.

Weston Instruments, Inc., Weston-Rotek division, 11 Galen St., Watertown, Mass., 02172. [381]

Oscilloscope cameras offered in 3 models



Three new Beattie-Coleman oscilloscope cameras are available. Model MIIA Oscillotron (illustrated) is especially designed for use under severe operating conditions in field test instrumentation. Special locks protect against focus change. An electric shutter permits synchronizing picture with phenomena. It has wide object-to-image recording ratio, 1:1 to 1:05 without special lenses.

Model 565A can be used for recording nanosecond traces under the same conditions as the MIIA. It features an extremely fast $f/1.2$ 86-mm lens. A bulb-type synchronous electric shutter holds open for focusing, closes when power is released.

Model K5R is a compact camera for use in areas where space is at a premium. It features direct viewing through a dichroic mirror. There is no parallax. The film back rotates for horizontal or vertical format.

All three cameras are available

Finest primary-type pressure standard



The CEC 6-201 Primary Pressure Standard is universally accepted as the "standard" of all pneumatic piston gages.

Here are some of the reasons why:

- Resolution—better than 0.002% of reading.
- Thermal coefficient of sensitivity—0.0012% of reading per degree F.
- Pressure ranges—0.015% of reading for 1.5, 5, 15, 50 psi; 0.025% of reading for 150 or 500 psi.
- Humidity—0 to 80% relative.
- Lightweight, portable, weighs only 22 lbs. complete.
- Accuracy not dependent on operator technique.

Plus this important accessory:

A specially designed filter has been perfected which minimizes piston-cylinder cleaning of CEC Primary Pressure Standards.

The filter, which is included with each new 6-201 basic assembly, attaches directly to the input pressure fitting. Furthermore, the filter assembly is available to all of the present 6-201 users for retrofit at a nominal cost.

For complete information, call or write for CEC Bulletin 6201-X14.

Data Instruments
Division

CEC

CONSOLIDATED ELECTRODYNAMICS
 A SUBSIDIARY OF BELL & HOWELL/PASADENA, CALIF. 91109
 INTERNATIONAL SUBSIDIARIES: WOKING, SURREY, ENGLAND
 AND FRIEDBERG (HESSEN), W. GERMANY

Circle 507 on reader service card

REMI*

(REmovable, REEntrancy, Miniature)
sleeve-fitted closed-entry crimp-type
contact connectors.



U.S.C. REMI sleeve-fitted closed entry crimp-type contact connectors snap in—snap out quickly, simply and surely. Contacts do not ride in bare plastic of the connector body. Both male and female spring phosphor bronze contacts snap into and out of heat-treated beryllium copper sleeves for positive solid connection. Mechanical stresses are confined between metallic elements. ■ No. of Contacts: 7, 14, 18, 20, 21, 26, 34, 41, 42, 50, 75, 104, 123, 150, 225. ■ Wire Sizes Accommodated: AWG #14 to #30 and MIL-W-16878A #16 to #32. REMI contacts are ordered separately. Crimping by MIL-T-22520A (WEP) ■ Class I or II tools ■ Military Specifications: (Contacts) MIL-C-23216, MIL-C-26636, MS3190. (Connectors) MIL-C-8384, and MIL-C-25955. [Latest Revisions] U.S. Patent Nos. 2,761,108; 2,979,689 & Five International Patents ■ Write for REMI catalog.

Golden RUMI

(Removable Ultra-Miniature)
Crimp-Contact Series



Adds removable crimp-contact connector versatility to any micro-miniature system—now. Can be incorporated immediately into any established or advanced system. Interchanges with any other Ultra-Miniature connectors—positively and economically. Contacts are machined of top quality spring temper phosphor bronze per Federal specification QQ-B-750. RUMI contacts are ordered separately. U.S. Pat. No. 2,761,108. ■ Write for RUMI catalog. ■ No. of Contacts: 7, 11, 14, 20, 26, 29, 34, 44 and 50. Wire Sizes Accommodated: AWG #24, 26 and 28 ■ Current Rating: 5 amps

Take Your Choice of These REMOVABLE CRIMP-CONTACT CONNECTOR SERIES from U.S.C.

Here, from one source is a complete family of performance-proved removable crimp-contact connectors. Whether you select the REMI®, RUMI, URC or REPC series you get extra reliability plus the highest possible performance-to-size ratio.

URC Series

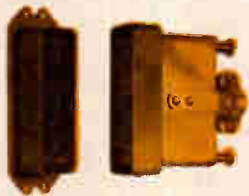

Developed especially for compact marine, aircraft, missile and computer electronic packages. Saves replacement and installation time. Removable contacts facilitate replacement of defective contacts and circuit changes without disruption. Contacts can be replaced with standard hand crimping tool or automatic type in seconds. (URC contacts are ordered separately.) U.S. Pat. No. 2,761,108 ■ Write for URC catalog. No. of Contacts: 14, 20, 34, 42, 50, 66, 75 and 104. Wire Sizes Accommodated: AWG #14 thru #30. ■ Current Rating: 13 amps. ■ Military Specifications: MIL-C-22857C & related drawings. ■ Also Available: Four other pairs of size 16 contacts, from AWG #14 through #28. Also, complete series of 6 pairs of size 20 contacts from AWG #16 through #30.

REPC

(REmovable, REEntrancy, Printed Circuit)
removable crimp-contact connectors.

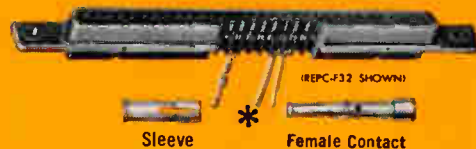

Another first from U.S.C. Meet tri-service specs MIL-C-23353/9 and MIL-C-23353/10 ■ Uses the unique REMI concept that confines mechanical stresses between metallic elements only. REMI sleeves are now specified as MS18135 (per MIL-C-23216) with U.S.C. Part No. 1242-9 (female crimp-barrel socket contact MS18134 per MIL-C-23216), on both new military specifications sheets. ■ U.S. Pat. 2,979,689 & five international patents. ■ Write for UPCC-REPC catalog. ■ REPC-F SERIES ■ No. of Contacts: 7, 11, 15, 19, 23, and 32 ■ Wire Sizes Accommodated: AWG #14 to #30. Current Rating: 7.5 amps ■ Military Specifications: MIL-C-23353/9 ■ REPC-SGF SERIES ■ No. of Contacts: 11, 17, 23, 29, 35 ■ Wire Sizes Accommodated: # 14 to #30 ■ Current Rating: 7.5 amps ■ Military Specifications: Connector—MIL-C-23353/10 ■ Contacts per MIL-C-23216 ■ REPC contacts are ordered separately.

TODAY—JOIN AMERICA'S LEADING COMPANIES WHO
RELY ON U.S.C. FOR CO-RELIABILITY!



U. S. COMPONENTS, INC.

1320 ZEREGA AVENUE, BRONX, N. Y. 10462
TEL. 212 TA 4-1600

Cable Address: COMPONENTS NYK.

TELEX: 1-2411TWX—212-824-6990

See What's New at U.S. Components IEEE Booth #2H07

LAPP GAS FILLED CAPACITORS

ARE DESIGNED FOR

HIGH
VOLTAGE

HIGH
CURRENT

HIGH
CAPACITANCE

APPLICATIONS

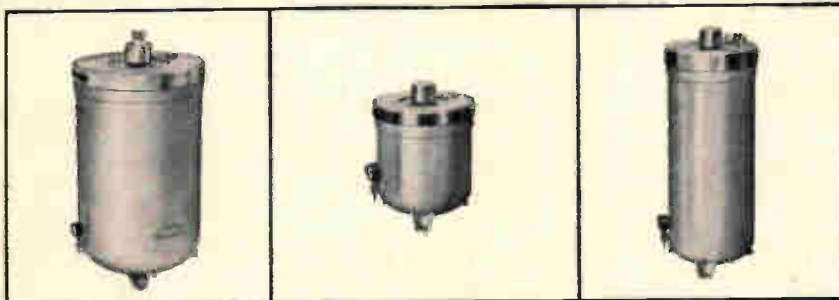

These uniquely designed Lapp Gas-Filled Capacitors are completely unaffected by atmospheric or dust conditions. They are precision built and of extra strong construction to assure years of accurate, trouble-free operation. ■ Lapp Gas-Filled Capacitors are available in either fixed or variable models. All are equipped with an external safety gap to protect against internal flashover on excess voltage peaks. Capacitance available up to 30,000 mmf, safety gap settings up to 85 kv peak and current ratings up to 400 amps at 1 mc. ■ Write for Bulletin 302... get our complete Gas-Filled Capacitor story. Lapp Insulator Co., Inc., Radio Specialties Division, 242 Sumner St., LeRoy, N.Y. 14482.

Lapp

New Instruments

with interchangeable Polaroid or 4x5 backs.

To be exhibited at the IEEE show.

Coleman Engineering Co., Inc., Box 1974, Santa Ana, Calif., 92702. [382]

High-precision pot for general lab use

A guarded high-precision potentiometer, known as the K-5 model, is designed for general laboratory use. Internally the circuit contains improvements over the earlier K-3 model and has a new self-checking feature. Externally the range switch and balancing controls are aligned from left to right in order of normal usage.

Direct reading in volts to five or six digits is accomplished with three decades of step switches and a detented slidewire having 115 main divisions. Releasing the detent allows interpolation to six or seven digit readings. The high range unit of error is notably small: $\pm(0.003\%$ of reading $+2\mu\text{v})$.

In the bench-top model, the K-5 has a dual angle case that holds the faceplate at about 30° for standing operators, or can be raised to about 50° for seated work. Another version is available for rack mounting.

To be exhibited at the IEEE show.

Leeds & Northrup Co., 4901 Stenton Ave., Philadelphia, Pa., 19144. [383]

A-c source calibrates all types of meters

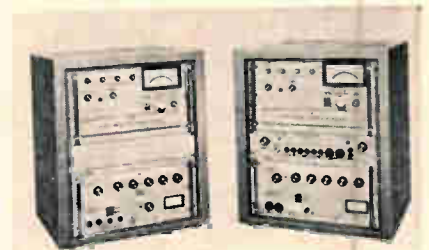

An unusual a-c source of voltage and current is announced. Developed primarily for calibration of voltmeters, ammeters and wattmeters, the model 100 system is

Before specifying these components...



in your circuit, consider...

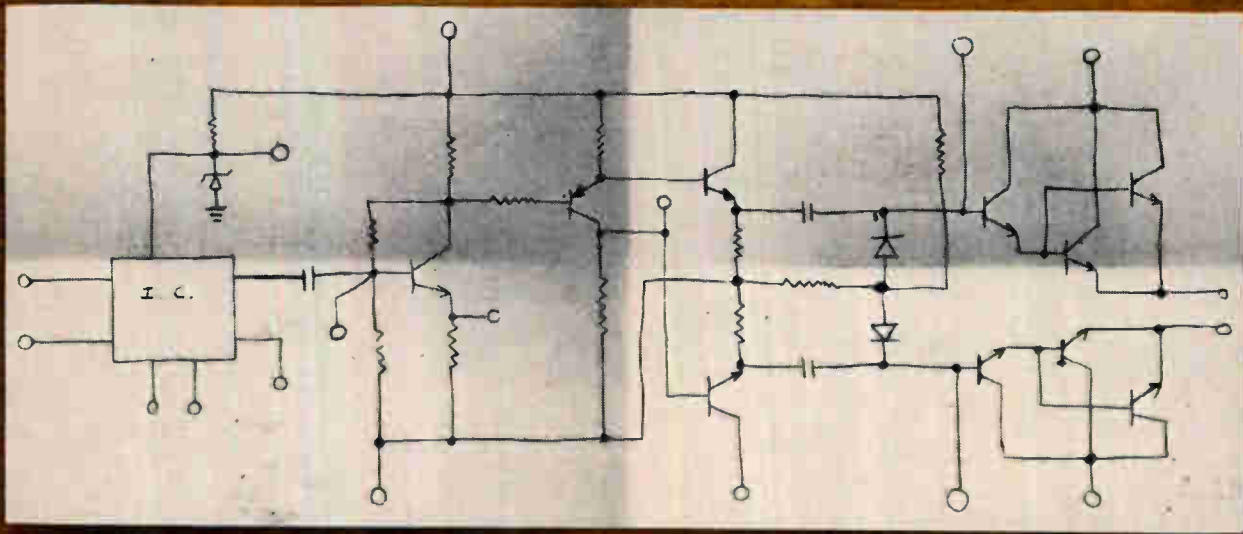

**Hamilton Standard
could give you the function...**

...in this microelectronic package.



The Hamilton Standard advanced microelectronic packaging technology permits interconnecting and intermixing monolithic integrated circuits, transistors, diodes, thin film, thick film and discrete components.

It facilitates the use of matched transistors and often solves tight TCR tracking requirements.

- Reliability is enhanced through the

use of welded interconnections and a welded hermetically sealed package.

- Weight and volume of circuit are reduced.

- Design, component testing, and system assembly are simplified through use of this functional package. It has axial leads for soldering, welding, or plug-in to a connector.

Whether your circuit is analog or

digital, integrated or hybrid, you can probably benefit and profit from the use of this advanced packaging technology.

Talk it over with our experienced design team by contacting our Marketing Manager at the Electronics Department, Hamilton Standard, Broad Brook, Connecticut 06016, or call 203/623-1621, Ext. 6106.

On display at IEEE, N.Y. Coliseum,
March 21-24, Booths 2C43-2C50

Hamilton Standard DIVISION OF UNITED AIRCRAFT CORPORATION

**U
A**

ELECTRONICS • ATTITUDE CONTROLS • STABILIZATION SYSTEMS • ENVIRONMENTAL CONTROLS • FUEL AND AIR INDUCTION CONTROLS
ELECTRON BEAM MACHINES • PROPELLERS • STARTERS • TURBOMACHINERY • GROUND SUPPORT EQUIPMENT • OVERHAUL AND REPAIR



WRITE, WIRE OR PHONE FOR THIS **FREE** ARTHUR D. LITTLE REPORT

Informative and candid, this study by Arthur D. Little, Inc., presents an analysis of the Electronic Components and Electrical Machinery Industry. It reports on business structure, consumption, employment trends, location and market aspects, marketing opportunities, industry forecast, and equipment suppliers.

This revealing report is bound in book form and will be sent to you promptly. Just attach coupon to your letterhead.

MISSOURI
KEEP MISSOURI IN THE CENTER OF YOUR THINKING

Mr. Henry C. Maddox, Director
Missouri Division of Commerce and Industrial Development
Jefferson Building, Dept. E3-7-66, Jefferson City, Mo.
Phone No. 314-636-7185

PLEASE SEND ME A COPY OF THE ELECTRONIC COMPONENTS AND ELECTRICAL MACHINERY REPORT

Name _____ Title _____

Company _____

Street _____ City _____ State _____

claimed to be the first a-c voltage and current standard capable of separate or combined performance.

It is a solid state, ultraprecise sine wave source of a-c emf from 1 mv to 1,000 v at frequencies from 50 cps to 10 kc and a-c current from 1 ma to 50 amps at frequencies from 50 cps to 3 kc. Output frequency is continuously variable and is set by three digital reading dials. Output emf or current is selected by five dials featuring digital readout and moving decimal point. Both units employ an aged, temperature-controlled zener diode d-c working source, plus a thermally lagged, built-in standard cell as a basic reference and self-checking feature with a 0.005% long-term stability. Long-term accuracy (one year) traceable to NBS is better than 0.04% over most ranges at full rated burden.

A special feature for reading the percent error of a meter directly makes the model 100 particularly suited for the rapid calibration and standardization of precision a-c meters and digital voltmeters with practically infinite resolution. Other uses include gyro navigation calibration and computer programing as well as resolver, capacitor, transformer and filter testing.

Starting with either the basic voltage or current standard, accessory panels can be added according to needs without replacing the original equipment or making any of the functions obsolete. Since each basic standard has its own supply, it can be interconnected and an accessory panel added to the current unit to permit a-c wattmeter calibration at various phase angles.

Featuring four-terminal sensing, which enables the current to pass to the device being tested on one pair of leads and the voltage drop to be measured by another pair, high burdens can be accommodated without additional error due to lead losses. Other features are safety interlocks; panel meter indicating burdens to 20 v-a; optional 10-line code for digital print-out of dial setting; and calibration certificates traceable to NBS for all ranges at selected frequencies for

maintaining a long term history.

Model 100 system is priced at \$14,500, or the voltage and current standards, priced at \$7,250 each.

To be exhibited at the IEEE show.

Radio Frequency Laboratories, Inc.,
Boonton, N.J. [384]

Precision phase meter with 3 plug-ins

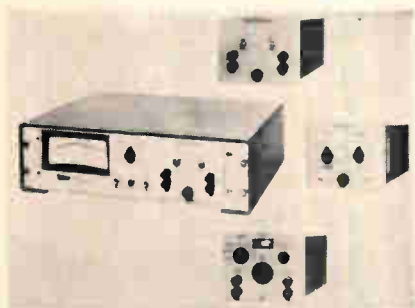

Three plug-in modules greatly extend the usefulness, versatility and applicability of a new precision phase meter. The basic meter 329-B is read directly in degrees (0° to 360°), and has twelve 30° scales for accurate and unambiguous indications in a useful frequency range of 10 cps to 300 kc.

Applications include phase measurement in amplifiers; analog computers; servo components such as synchros, resolvers, transformers, potentiometers and others; vibration; phase drift between standard and test frequencies; and other phase meter applications at both laboratory and production levels.

Plug-in A is a buffer amplifier with accuracy to $\pm 0.5^\circ$ in a 30-cps to 35-kc range from inputs of 0.2 to 150 v. Plug-in B is a high-gain preamplifier for use with inputs from 1 mv to 300 v in a 20-cps to 50-kc range. Plug-in C is a variable-input phase shifter with an accuracy of $\pm 0.5^\circ$, 20 cps to 20 kc. The manufacturer says additional plug-ins can be designed to meet more specialized needs.

The basic meter and all plug-ins are completely solid-state, and the instrument has its own power supply for operation on 115 v a-c. The 329-B is available with either a table-top enclosure or for standard 19-in. rack mounting.

Acton Laboratories, Inc., subsidiary of Bowmar Instrument Corp., 531 Main St., Acton, Mass. [385]

JUST CUT TO PATTERN

Netic & Co-Netic Magnetic Shields



HAND FORM IN SECONDS

A great convenience to design engineers, packaging engineers, R/D, etc. A fast inexpensive empirical tool to determine and shield the necessary components of systems. Use multiple layers if needed. Thicknesses from .002". Also widely used in automated or manual production line techniques.

Netic attenuates high intensity fields, Co-Netic low intensity fields. Permanently Pre-Annealed. Not affected by bending, vibration or shock. Minimum retentivity. Increases systems reliability



Module Shielding

Reed Relay



Wain Bridge Oscillator

Peelback Adhesive Foil

MAGNETIC SHIELD DIVISION

Perfection Mica Company

1322 N. ELSTON AVENUE, CHICAGO, ILLINOIS 60622

ORIGINATORS OF PERMANENTLY EFFECTIVE NETIC CO-NETIC MAGNETIC SHIELDING

Circle 508 on readers service card

New! 5 Megacycle



MODEL 650
is only 3½" H,
14" D and 17" W.
Displays 4 to 8
digits and polarity.

Bidirectional Preset Counter with all silicon, integrated circuitry

The Model 650 counts at a 5 Mc rate in either direction, through zero, or during reversing. This instrument can be used with many Position Encoders including Laser Interferometers with high frequency, low-level, quadrature outputs.

To provide system flexibility, many modes of operation are available. These include: 1. Count either A input or B input. 2. Count A input —B input. 3. Count to a predetermined number in either direction and reset automatically or hold the count until reset is initiated either manually or externally. 4. Quadrature input (available as an optional feature).

Coincidence circuits prevent false triggering if pulses appear simultaneously or at less than the minimum resolving time. Many other outstanding options are available.

Write for Model 650 Bulletin.



JANUS CONTROL CORPORATION

296 Newton Street, Waltham, Mass.
Tel. 891-4700

automate coax switches™

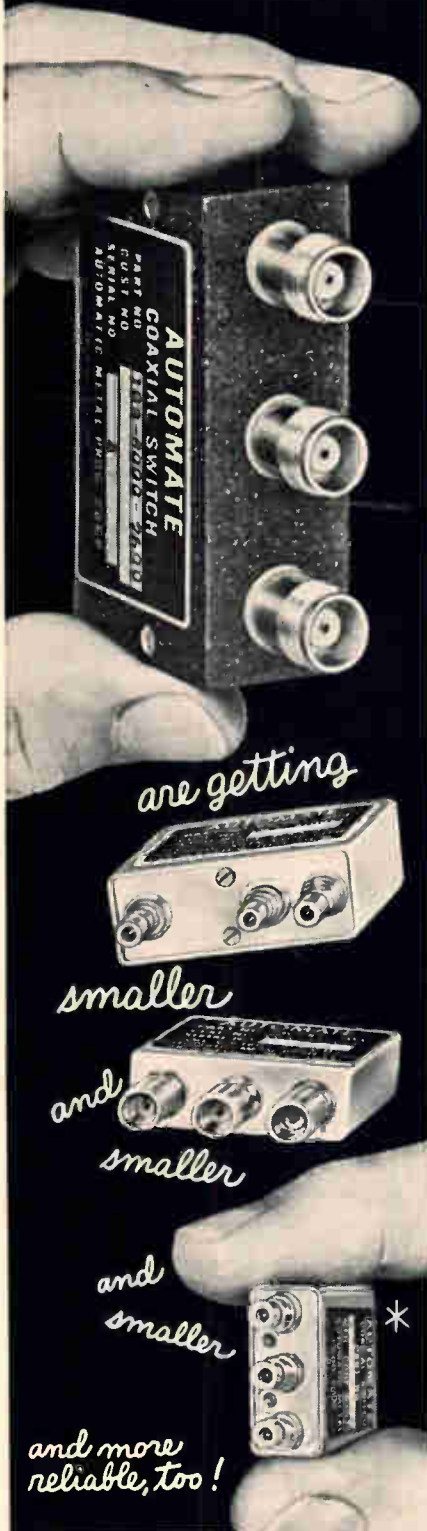

***TYPICAL SPECIFICATIONS**
 DC — 2.5GC* • VSWR: 1.3:1 max.
 Crosstalk > -80db • Shock: 100G, 11 milliseconds
 Sinusoidal Vibration: 20G 55-2000CPS, 0.6" D.A. 10-55CPS.
 Random Vibration: 0.13G* CPS 20-2000CPS.
 *Usable to 4GC.

Literature available, write to:

automatic
 METAL PRODUCTS CORPORATION
 323 Berry Street, B'klyn 11, N. Y. Tel: (212) EV 8-6057
 SEE US AT THE IEEE SHOW • N.Y. COLISEUM

New Subassemblies and Systems

Laser provides 10 watts of c-w power



Molecular gas laser with continuous-wave infrared output has a variety of potential applications, including welding, surgery and communications.

A molecular gas laser introduced by the Perkin-Elmer Corp. has a continuous-wave power output of 10 watts, about five times greater than any other commercial gas laser, and a higher energy-conversion efficiency—5%.

The plasma in the laser is a mixture of carbon dioxide, nitrogen and helium. The addition of helium increases efficiency, but the laser's developers say that they really don't understand why.

As a bonus, the wavelength of the emitted radiation falls in a "window" of the atmosphere at 10.6 microns, where atmospheric attenuation is minimal.

The manufacturer says that model 6200's high efficiency and power, combined with its infrared output, make it useful for just about any application, including welding, electronic production, high-speed evaporation, cutting of both organic and inorganic materials, spectroscopy and chromatography, terrestrial and interplanetary communications, biochemistry and surgery.

Power output from the laser is high enough to melt most materials readily. Even a highly refractory material, such as thorium oxide, which has a melting point of 3300°C, fuses in the focused light beam.

The laser's capability of delivering controlled power to an extremely small area, providing up to one million watts per square centimeter, enables it to perform a variety of cutting, fusing, and heating operations. Metals that are reflective and have high thermal

conductivity can also be melted or vaporized by the beam.

The model 6200 has a 10-millimeter-diameter beam. For convenience, the beam is folded 90° by an optical attachment that directs the energy down onto an asbestos sample platform. The folding optics can be removed. The platform can be equipped with a micropositioner accessory for convenient movement of a sample under study.

The laser system includes a self-contained power supply and is operated from a separate 25-pound, meter-equipped console measuring 7-in. high by 12-in. wide by 14½-in. deep.

To be exhibited at IEEE show.

Specifications

Size	12 in. by 12½ in. by 60 in.
Weight	175 pounds
Input power	115 volts a-c, 60 cycles
Price	\$8,950.00
Delivery	Immediately

Perkin-Elmer Corp., Electronic Products Division, Main Avenue, Norwalk, Conn. [390]

Regulated supplies have 0.05% stability

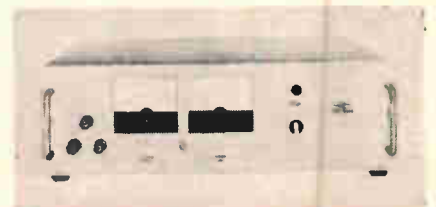

The LR series power supplies has been expanded to include these



New EI-85 Digital Multimeter* in **one encoding
makes $\pm .005\%$ measurements in 10 ms !
and it stays there ■**

Accurate, full 5 digit measurements are now possible in 10 msec with the EI-85's successive approximation logic.

Why the "one encoding"? Because unlike other high speed instruments which are allowed to encode before their input circuitry settles to full accuracy, the EI-85 contains a sensing circuit which acknowledges settling of its high impedance input section to $\pm .001\%$ of final value before allowing its logic circuitry to encode. All *within* 10 msec! Repeat encodings are not necessary to obtain that "last digit of accuracy" with this high speed DVM. This assures you consistent repetitive readings.

Noise Rejection—Not forgetting the effect of noise, the EI-85's guarded differential input and active Bessel filter provides 160 db of CMR and 60 db NMR at 60 Hz while maintaining a *constant* high input impedance of

greater than 10,000 megohms to 10 volts F.S. This means, of course, no loss of accuracy due to noise or source loading during encoding!

Whether your need is for accurate high speed measurements of dynamic fast changing signals, high speed system operation (100 readings/second) or a versatile accurate multimeter for general purpose use, the EI-85 fills the bill!



* DC, Ratio, AC, Resistance, Pre-Amplifier

Other Features—Complete multimeter capability utilizing plug-in card accessories • DC and Ratio comprise the basic instrument • 10 μ volts basic resolution without preamplifier (1 volt F.S.) • Differential guarded input on *all* modes of operation • Autorange and

polarity in *all* modes • Storage in read-out prevents "blinking" • Storage in electrical outputs allows time sharing operation • Isolated BCD and 10-line decimal outputs and remote control are standard • AC converter—5 digit, 10 μ volt resolution, 10 Hz to 100 KHz • Resistance converter—.01 ohms to 10 megohms • Preamplifier—for 1 microvolt resolution • Priced from \$5000.00.

Complete EI-85 High Speed System—

A complete line of EI system modules can be added to your EI-85. Signal conditioning, scanning, comparison, timing,



automatic programming and peripheral outputs such as computer compatible paper or magnetic tape are typical capabilities. Write for our complete systems brochure.

Electro Instruments, Inc. 

8611 Balboa Avenue, San Diego, California 92112

41 Emmastraat, Veldhoven, Holland

econocable *

* We couldn't think of a good word to dramatize the competitive economy of Foamflex coaxial cable, so we made one up.

Foamflex is a semiflexible cable construction consisting of a copper inner conductor, a formed polyethylene dielectric and thin wall outer aluminum conductor. A black pigmented polyethylene jacket can be supplied for added protection. As the original "foamed" dielectric, Foamflex is the ideal low cost answer in extremely demanding applications: telemetry, missile guidance, microwave, delay lines and an endless variety of airborne and GSE installations where high performance, light weight and absolute reliability are required.

You'll find Foamflex available, from stock, in 1/4", 3/8", 1/2", 7/8" and 1 3/8" diameters, 50 ohm impedance. Lengths may also be custom cut or fabricated into highly sophisticated assemblies, to your specification.

May we tell you more about Foamflex? Write for Bulletin FF, Issue 3.



PHELPS DODGE ELECTRONIC PRODUCTS
NORTH HAVEN, CONNECTICUT



New Subassemblies

new ranges: LR5-40, to 5.5 v d-c at 40 amps; LR8-35, 6.5 to 9 v d-c at 35 amps; LR 10-30, 8.5 to 11.5 v d-c at 30 amps; LR 12-30, 11 to 14 v d-c at 30 amps; LR 14-30, 13.5 to 16.5 v d-c at 30 amps; LR 17-30, 16 to 19 v d-c at 30 amps; and LR 21-20, 17 to 26 v d-c at 20 amps.

The new supplies are designed to fit a 19-in. rack in a space 5 1/4 in. high. They include automatic foldback overload protection to provide safety for all circuits by automatically decreasing the current to a safe value as the load is increased beyond the normal rated capacity of the unit. A front panel indicator light is also provided to give a visual warning of any overload condition.

The units feature 0.01% line and load regulation, voltage programmability, remote sensing, 1 mv rms ripple, 0.05% stability (with 0.01% stability optionally available), and an ambient operating temperature range of -20° to +60° C. Price is \$475.

To be exhibited at the IEEE show.

Trygon Electronics, Inc., 111 Pleasant Ave., Roosevelt, L.I., N.Y., 11575. [391]

Punched tape reader block storage

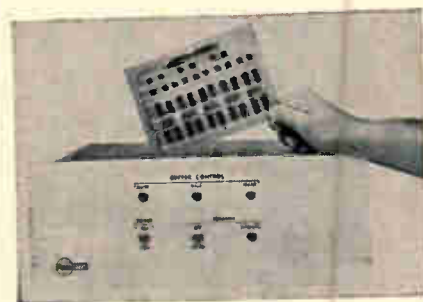

Model RBC is a buffer storage employing integrated circuit components for converting line-at-a-time punched-tape information into parallel block outputs. It features a modular storage approach that is expandable, character by character, to as many as 40 characters. All circuitry required for control of the associated line reader is included within the buffer.

Standard outputs are suitable for

NEW

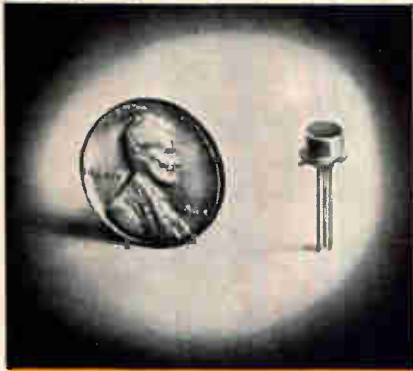

small-size, low-cost planar SCR family

■ Transtron's 2N4145 family of TO-52 packaged silicon controlled rectifiers has been developed for high volume switching applications in which small size, high reliability and low cost are prime considerations.

■ The series includes the following four types:

2N4145	30V
2N4146	60V
2N4147	100V
2N4149	200V

■ All types provide low leakage, low holding current and low-level gate firing. Planar construction permits fast anode recovery (typically less than 10 microsec. in commutating turn-off circuits).

CHARACTERISTICS

Average forward current.....	250ma @ 75°C
One cycle surge (60cps).....	8 amp @ 25°C
Maximum I_s and I_T	10 μ a @ 25°C
Maximum I_g	200 μ a @ 25°C
Maximum V_g	0.8V @ 25°C
Maximum I hold.....	5.0ma @ 25°C

New, low-cost power SCR



Just announced... two new, low-cost power silicon controlled rectifiers for use on 120 volt (2N3228) and 240 volt (2N3525) line supplies respectively. Available in a standard TO-66 package, each unit will handle loads up to 3.2 amps average.

Send for complete data on Transtron's new planar and power SCR's.



Transtron
electronic corporation
Wakefield, Massachusetts
IEEE SHOW — BOOTH 1 B 03 — 1 B 11

use in the most sophisticated integrated circuit systems. Optional amplifier outputs are available which will provide sufficient current for virtually all interface needs, presently supplied by fixed block readers.

Since the Model RBC will function at the very high data input rates available with present photo-cell punched tape readers, the speed restrictions of fixed block readers are not encountered.

The block storage weighs approximately 15 lbs. Price is \$1,340 for a ten-character storage. Other capacities and options will be quoted on request.

To be exhibited at the IEEE show.

Remex, a division of Ex-Cell-O Corp.,
5250 W. El Segundo Blvd., Hawthorne,
Calif., 90250. [392]

Chopper-stabilized operational amplifier

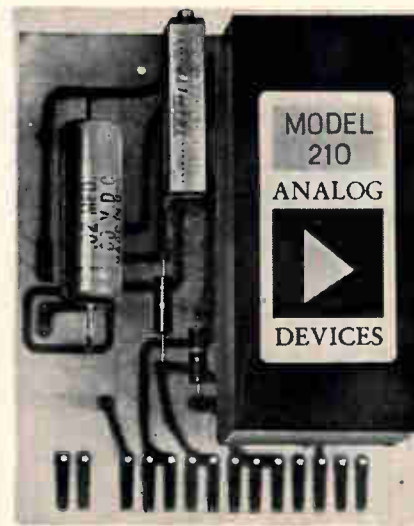

A chopper-stabilized operational amplifier, now available in the same price range as premium differential-type operational amplifiers, gives an order-of-magnitude voltage-drift improvement and two orders-of-magnitude better current-drift performance. (D-c drift determines circuit accuracy, establishes the smallest input signals that can be resolved).

Model 210 amplifier also provides state-of-the-art noise and response specifications at no extra cost. Normally, 3- μ v peak-to-peak noise, or 100 v/ μ sec slewing rate, are obtained only by purchasing a premium-priced amplifier that sa-

NEW



high-power transistors handle 100 watts at 100°C

■ Two new 20-ampere power transistors, the 2N4211 and 2N4210, have been announced by Transtron. Both planar units are designed for continuous operation at 100 Watts at 100°C case temperature.

■ Minimum sustaining voltages, BV_{CEO} , of 80 volts at 400 ma. and 60 volts at 400 ma. are guaranteed for the 2N4211 and 2N4210 respectively. Both units feature excellent beta linearity over the current range from 100 ma. to 20 amperes. A low collector-emitter saturation voltage results in efficient performance at high currents. Both units are packaged in the popular TO-63 7/8" stud for outstanding thermal performance.

RATINGS

	2N4211	2N4210
BV_{CEO} ($I_c = 400$ ma).....	80V	60V
h_{FE} (20A, 6V).....	10 min. 10 min.	10 min. 10 min.
h_{FE} (10A, 6V).....	20 to 100	20 to 100
h_{FE} (100ma, 6V).....	15 min. 15 min.	15 min. 15 min.
$V_{CE(sat)}$ (10A/1A).....	1.0V	1.0V
$V_{CE(sat)}$ (20A/2A).....	3.0V	3.0V

New high-voltage power transistor

Transtron now offers the high-voltage ST7726, with a minimum BV_{CEO} of 140 volts, in a TO-66 package. The 2.5 ampere current rating, 25 Watt dissipation, 10 mc f_t , and 2.0 volt $V_{CE(sat)}$ at 2 amps, makes this an excellent general purpose device for amplifier and switching applications. A lower voltage series, including the 2N3054, is also available.

Send for complete data on these new transistors.



Transtron
electronic corporation
Wakefield, Massachusetts
IEEE SHOW — BOOTH 1 B 03 — 1 B 11

TRYLON HLP T-45 LOG PERIODIC ANTENNA

Single-layer, horizontally-polarized,
for 3 to 30 mc. 45° take-off angle;
11 db/iso gain; VSWR: less than 2:1;
power to 100 kw.

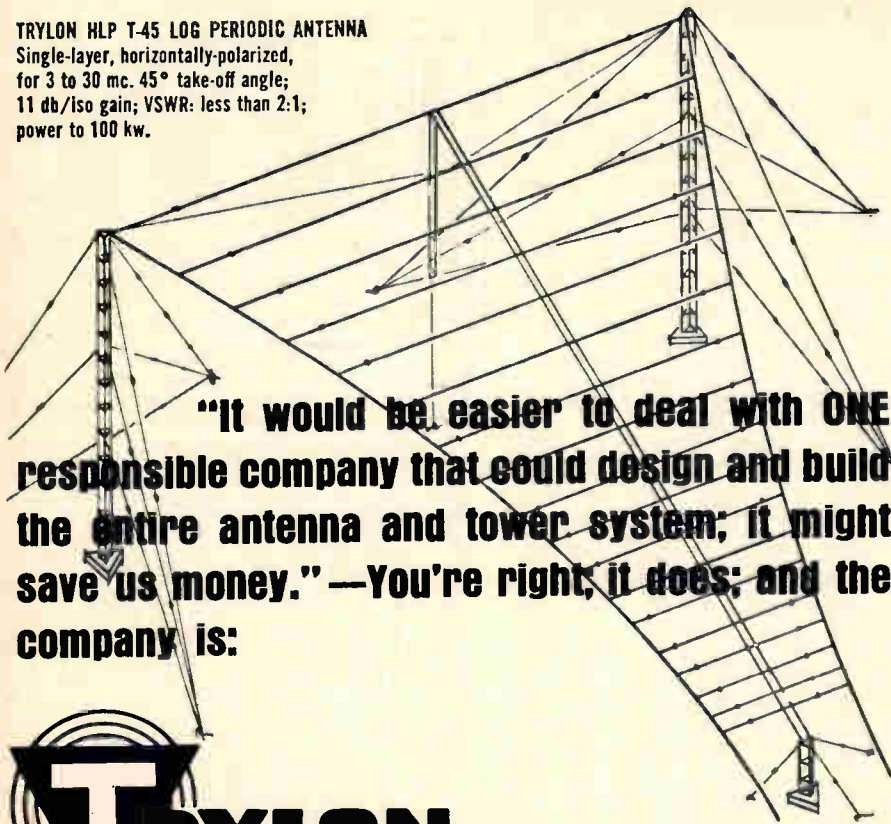

"It would be easier to deal with ONE responsible company that could design and build the entire antenna and tower system; it might save us money." —You're right, it does; and the company is:



Elverson, Pa. 19520 (215) 942-2981

Circle 510 on readers service card

New Subassemblies

crifices other specifications to give optimum noise or response characteristics, according to the manufacturer. Gain of 10⁸ (160 db) and 20-Mc bandwidth also stand out.

A built-in chopper-drive operates from the amplifier's ±15 v d-c supply, eliminating auxiliary chopper-excitation voltages that are a notorious source of noise pickup and spurious offset. An internal saturation protection network puts the amplifier back to work within 0.2 μsec of input overload. The amplifier comes in a rugged, short-proof, 3-cu-in. epoxy-encapsulated module that mounts right alongside circuit components on the user's own p-c board.

Some of the actual circuits in which the amplifier will be used include: transducer amplifiers and signal processors, low-noise biomedical amplifiers, wideband d-c amplifiers, servo-preamplifiers, current/voltage converters and vice-versa.

Price for 1 to 9 is \$157.

To be exhibited at the IEEE show.

Analog Devices, Inc., 221 Fifth St., Cambridge, Mass. [393]

Crystal oscillators offer high stability



High-stability crystal oscillators that cover the stability range of 1 part in 10⁸ per day through 5 parts in 10¹⁰ per day are being marketed. Each oscillator employs proportional oven control and a low jitter oscillator circuit to provide exceptional short term, as well as long term, stability.

The oscillators maintain a high degree of frequency accuracy over a broad range of temperature and over extreme conditions of shock and vibration. Therefore, these

**For
Production
Efficiency**

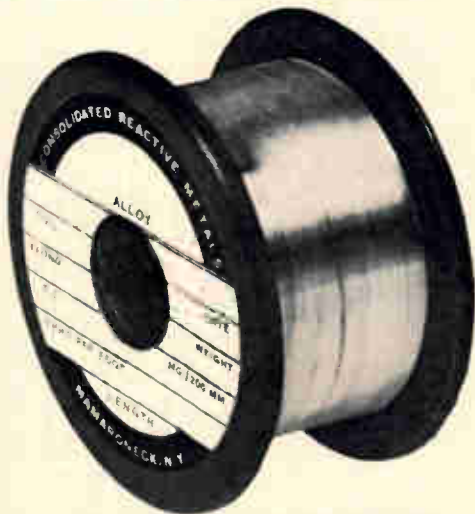

CRM FINE WIRE
for **ULTRASONIC BONDING —**
ALUMINUM & ALUMINUM ALLOYS

featuring

Cleanliness • Strength • Uniformity

Contact CRM engineers for recommendations for your application.



Write for Data.

CONSOLIDATED REACTIVE METALS, inc.

115 Hoyt Avenue — Mamaroneck, N. Y. — OWens 8-2300 — TWX 914-835-3380

Visit Booth 4J14 at IEEE Show

NEW

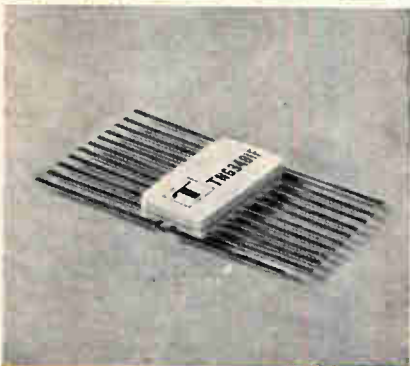

quad 4-input Nand /Nor gates dual master slave JK flip-flops

Now available in 22-Lead Flat Pack

■ A number of Transitron's new high level, transistor-transistor logic circuits are now available in a high-reliability, 22-lead flat pack which provides broad design flexibility.

■ Circuits available in the new, hermetically-sealed package include: Quad 4 input Nand/Nor Gates (TNG3481F through TNG3484F); and Dual Master Slave JK Flip-flops (TFF3181F through TFF3184F). The new package extends the already broad list of packaging options for Transitron's rapidly-growing HLTL line. Additional HLTL functions which will soon be available in this package include 2-stage shift register circuits and 2- and 4-stage counter circuits.

New integrated diode arrays

Also available in the new 22-lead flat pack (as well as in other packages) is Transitron's new line of planar integrated diode arrays, in both common-cathode and common-anode configurations. Arrays can be provided with from 2 to 16 ultra-stable diodes, with recovery times of 1 to 5 nsec, capacitances from 2 to 6 pf, and forward voltage drops less than 1.0V at 100 ma.

Typical 16-diode matrix

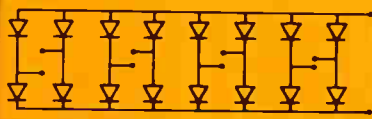

Send for complete data on new HLTL circuits and diode arrays in the 22-lead flat pack.



Transitron
electronic corporation
Wakefield, Massachusetts
IEEE SHOW — BOOTH 1 B 03 — 1 B 11

small units are well suited for airborne, shipboard, and mobile, as well as fixed station applications. Despite their low current drain the oscillators afford fast warm-up, thus permitting high stability shortly after being energized. Among the options available in these crystal oscillators are voltage frequency control and self-contained frequency dividers which permit generation of special frequencies.

At the top of the new line is the model FFO-160, which provides a stability better than 5 parts in 10^{10} per day and 1 part in 10^8 per month. This $4\frac{1}{2}$ in. x $2\frac{1}{4}$ in. x $2\frac{1}{4}$ in. unit is claimed to be the highest stability crystal oscillator in so small a package.

To be exhibited at the IEEE show.

Manson Laboratories division, The Hallcrafters Co., 77 Danbury Road, Wilton, Conn., 06897. [394]

A-c/d-c power supply offers dual source



A line of power supplies to be used for operational amplifiers features twin outputs. The 2MS series incorporates two separate power sources in a single, compact case, typically $3\frac{5}{16}$ x $3\frac{7}{8}$ x $4\frac{1}{2}$ in.

These models may be obtained with either of two options: the first has individual output voltage adjustments, while the other, with a voltage tracking option, permits a single control to operate both outputs. With this option, output B is slaved to output A so that temperature, line or load variations do not destroy the preset balance between the two outputs.

Input frequency is 50 cps to 400 cps; input voltage, 105 to 125 v a-c; output voltage range, 6 to 50 v d-c; output current range, 50 to 250 ma; output impedance, less than 0.02 ohm at 1 kc, less than 2 ohms at 100 kc; regulation, 0.05% typical,

NEW

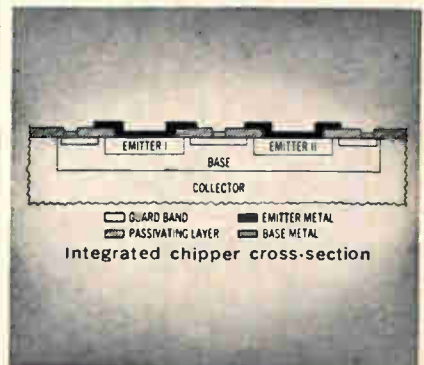

integrated "chipper" offers low offset, low leakage, fast switching

■ The 3N127 "Chipper", Transitron's new small-geometry, dual-emitter chopper, has been designed to provide an optimum combination of low offset voltage, low thermal drift, very low leakage, high voltage, and fast switching.

■ A 20-volt minimum BV_{EBO} and .5 picoamp maximum leakage make the 3N127 an ideal device for multiplex use. Because of the low offset voltage of 10uv max., coupled with a 20uv maximum change from 0°C to 100°C, the unit is excellent for low-level chopper amplifier applications. The minimum f_r of 60 mc, and very low C_{EB} of 2 pf minimize spiking and offset in high speed switching applications.

■ Reliability is assured in this NPN epitaxial construction by incorporating channel-stopping guard rings around each emitter, metal over oxide covering the emitter junctions to prevent ion drift and an all aluminum system using ultrasonic wire bonding to totally eliminate purple plague.

CHARACTERISTICS

High BV_{EBO}	20 volts
Low offset.....	10uv
Low drift.....	20uv max. over 0° — 100°C
Low dynamic resistance.....	50 ohms
Low C_{EB}	2 pf

Send for complete data on Transitron's new Chipper.



Transitron
electronic corporation
Wakefield, Massachusetts
IEEE SHOW — BOOTH 1 B 03 — 1 B 11



We make this airmover unit,

Vaneaxial gas bearing fan, ultra-high reliability, used in *Minuteman*. Only IMC produces it.



and this unit,

The Boxer, standard sized, distributor-stocked. Rugged metal frame, our own impeller and motor, moves air economically and reliably.



and this unit,

Tubeaxial, the IMCool is distributor stocked in 10 types, inputs of 60, 400, and 1000 cps, air delivery from 18 to 108 cfm.



and this unit,

Rackmounted double blower. This one installed right in the broadcast area, delivers 500 quiet cfm to a high-power broadcast transmitter.



but this unit will design and build an airmover to fit your specifications.

IMC is the single-source specialist for airmovers. We design and build the entire system—motor, blade, bearing, housing—and can assume full responsibility in meeting your needs. For quick response, contact Sales Dept., Eastern Division, Telephone (516) 334-7070, or TWX 516 333-3319.

Plants: Westbury, N. Y.; Maywood, Calif.; Rochester, N.H.; and Tempe, Ariz. Products: Airmovers; induction, hysteresis, synchronous, torque, servo, and stepper motors; synchros; solenoids; pressure switches; hydraulic and pneumatic valves; and fuel atomizers. For more data, write:



IMC Magnetics Corp. Marketing Division, 570 Main Street, Westbury, N.Y. 11591.



Haven't you enough to worry about... without this?

Insulation tubing shouldn't be a design engineer's worry anyhow. But it's vital to your product's performance... so you worry! Why not unload this worry on us? Just give us the facts about your insulation need and we'll come up with the right tubing to do the job. This way, you'll have one less worry! You can take our word for it... because we've been insulation specialists for 44 years.

THERE'S FLEXITE® TUBING TO MEET YOUR SPECIFICATIONS

Markel FLEXITE extruded tubings are manufactured of Teflon, silicone rubber, vinyls, polyethylene, Nylon and other plastics. Special formulations provide properties to meet the widest range of applications and operating conditions... at continuous temperatures as low as -70°C and as high as 250°C. Every type and grade meets the highest standards of dielectric and mechanical reliability. Included in the FLEXITE line are Shrinkdown Heat Shrinkable Tubings and TGL Triangular Guide Line Wrapping Tape. We'll gladly send you specifications and Sample File on the full FLEXITE line... just write.

L. FRANK MARKEL & SONS
SINCE 1922

Norristown, Pa.

215-272-8960

INSULATING TUBINGS & SLEEVINGS • HIGH TEMPERATURE WIRE & CABLE

NEW

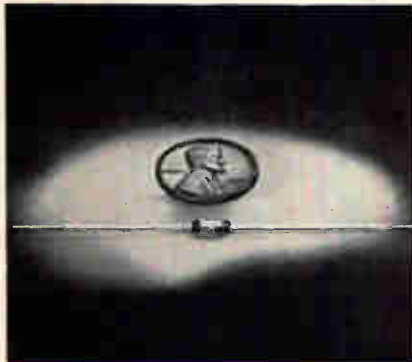

certified reference diodes provide ± 5 ppm stability

■ Documented proof of long-term stability to as great as ± 5 parts per million is provided with Transitron's new line of ultra-stable voltage references. Each certified unit is individually numbered, and is accompanied by a certificate indicating successful completion of a rigid 1000-hour acceptance test.

■ Developed for use in high-precision measuring instruments, aerospace navigation and guidance systems, telemetering systems, etc., the precision diodes feature extremely low leakage, low noise, low dynamic impedance, and linear temperature coefficients.

■ Designed to replace the commonly-used chemical standard cell, the Transitron ultra-stable reference is much smaller and lighter, is not position or vibration sensitive, has unlimited service life, and is unaffected by high current drain or short circuit.

Certified Voltage Stability for 1000 hrs. @ 7.5 mA, 80°C	Type	Breakdown Voltage @ 7.5 mA, 25°C	Maximum Temperature Coefficient @ 7.5 mA, +25 to 100°C
ppm		Vz	T.C. %/°C
± 20	SV7401	6.2 to 6.5	$\pm .001$
± 20	SV7402	6.2 to 6.5	$\pm .0005$
± 10	SV7403	6.2 to 6.5	$\pm .001$
± 10	SV7404	6.2 to 6.5	$\pm .0005$
± 5	SV7405	6.2 to 6.5	$\pm .001$
± 5	SV7406	6.2 to 6.5	$\pm .0005$

The following specs apply to all types shown above:
Maximum Dynamic Impedance @ 7.5 mA, 25°C, (Z_d) ... 12 Ω

Maximum Breakdown Voltage Fluctuation @ 7.5 mA, 80°C, (δV_z) ... $\pm 10 \mu V$

Maximum Breakdown Voltage Noise Density @ 7.5 mA, 25°C, (Nd) ... $0.1 \mu V / \sqrt{Hz}$

Send for complete data on Transitron's Certified voltage references.



Transitron
electronic corporation
Wakefield, Massachusetts
IEEE SHOW — BOOTH 1 B 03 — 1 B 11

New Subassemblies

0.1% maximum,, 0.01 in Z series; ripple, less than 0.1% peak to peak; stability, 0.02% per ° C; operating temperature, 0 to 71° C; response time, 50 μ sec or less, no load to full load; price range, from \$125.

To be exhibited at the IEEE show.

Elasco Inc., 33 Simmons St., Boston, Mass., 02120. [395]

Data amplifier housed in molded case

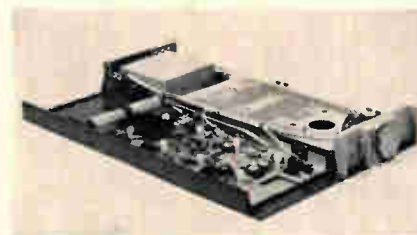

Molded material—the kind used in telephones—is used, for the first time, in the case for a data amplifier. The molded package is lighter than one made of metal, is less expensive and has lower assembly costs. Dymec, the amplifier manufacturer, says that the total cost of the case, panel and assembly is about one-tenth that of the standard H-P package. It has a hinged design for ease in servicing.

Model 2470A is a wideband differential amplifier with low drift and noise specifications. It is solid state, using only silicon semiconductors.

Although the molded package achieves cost savings, there is no degradation of unit quality or reliability. The unit comes with a predicted mean time before failure of 20,000 hours at 25° C. The manufacturer has made a worst case analysis of the circuit design and investigated history of performance of all components. Additionally, each amplifier is "burned-in" for 100 hours at 55° C after test and calibration, then all units are rechecked prior to shipment.

Other features include a shielded toroidal power transformer to prevent generation of stray magnetic fields. Also, connectors are used as means for connecting to the ampli-

NEW

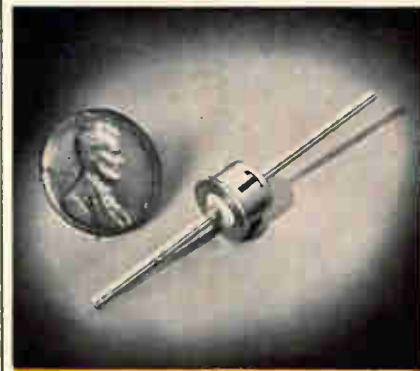

axial-lead, 3-amp silicon rectifiers are rugged, economical

■ This series of axial-lead, silicon rectifiers provides new flexibility for designers of a broad range of industrial and commercial equipment.

■ Rated at 3 amperes, with peak inverse voltages from 50 to 1000 volts, the series provides high surge current ratings and rugged construction at extremely low quantity prices.

■ The new series fills the gap between conventional lead-mounted rectifiers and stud-mounted types. To insure maximum dependability, it incorporates many of the design and manufacturing techniques used in other Transitron high-reliability rectifiers.

■ Typical applications include motor drive systems, power supplies, battery chargers and appliance rectifiers.

Type	Peak Reverse Voltages (volts)	Average Forward Current amps @ 75°C	Average Forward Current amps @ 125°C	One Cycle Surge Current amps
1N4719	50	3.0	1.5	300
1N4720	100	3.0	1.5	300
1N4721	200	3.0	1.5	300
1N4722	400	3.0	1.5	300
1N4723	600	3.0	1.5	300
1N4724	800	3.0	1.5	300
1N4725	1000	3.0	1.5	300

Send for complete data on the new axial-lead, 3-amp rectifier line.



Transitron
electronic corporation
Wakefield, Massachusetts
IEEE SHOW — BOOTH 1 B 03 — 1 B 11

**Look
to the
Leader
PERMACOR[®]**

**For Every
Electronic
Powdered**

**IRON CORE
Need**

Whether it's a stock item or a custom-designed iron core for a specific application, we have the experience, facilities and capability to produce for you. As you might expect from the world's largest producer of iron cores, Permacor assures you of prompt delivery on orders of any size or quantity. Write for complete information today!

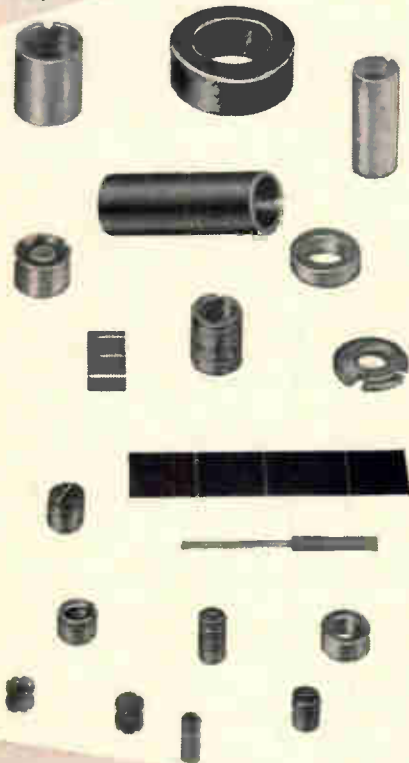

PERMACOR[®]
A Division of Radio Cores, Inc.
9540 Tully Ave., Oak Lawn, Ill.
Phone: 312 - HI 5-7333

New Subassemblies

fier and this method passes the H-P five-day soak at high humidity.

The 2470A is designed for monitoring resistive type sources only. Typical applications are amplification of strain gage bridges, thermocouples and other low resistance sensors. It is not suitable for monitoring capacitive-type devices such as crystal accelerometers. Outputs are provided for recording galvanometers and oscilloscopes.

To be exhibited at the IEEE show.

Dymec Division, Hewlett-Packard Corp.,
315 Page Mill Rd., Palo Alto, Calif.
[396]

Operational amplifier uses FET input

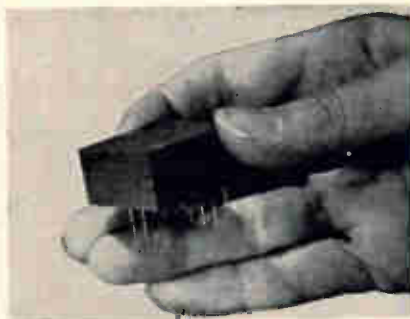

An FET-input differential operational amplifier has improved overall performance at a lower price than previously available units. Model 132 has an input offset current of 0.1 nanoamp. This figure is 10 times lower than FET-input units announced last year and a third lower than any other state-of-the-art amplifier previously announced, according to the manufacturer. Also, the model 132's minimum gain bandwidth product is said to be 3 to 5 times better than any other, and its voltage drift is very low with a maximum of 20 $\mu\text{V}/^\circ\text{C}$, and 10 $\mu\text{V}/^\circ\text{C}$ is typical. D-c gain is 10^5 and slew rate is 10 $\text{V}/\mu\text{sec}$ typically.

Model 132 is packaged in a small module for p-c card use. Its size is 1.125 x 1.125 x 0.625 in. Price is \$95 in quantities of 1 to 9. The unit is expected to have many applications where a high impedance load is required, such as piezoelectric and capacitive transducers, sample

**FOR
DRILLING
AND ROUTING
CIRCUIT BOARDS
AND
REINFORCED
RESINS**

**SOLID
CARBIDE**

◀ **DRILLS**

◀ **FLUTED
ROUTERS**

◀ **FIBERGLASS
ROUTERS**

**UNEQUALLED METAL REMOVAL
COMPANY SERVICE, QUALITY
AND SELECTION INCLUDING:**

1. World's largest inventory of centerless ground drill blanks and finished tools ready-for-shipment.
2. Fifteen centerless grinders in production of drills and rotary carbide tools.
3. Every size carbide drill, ground from-the-solid . . . the smallest — .008" diameter to the largest — 1.500" diameter.
4. Precision ground to 5 micro-inch finish or better.
5. Delivery from stock, through our distributors, of any standard solid carbide tool in 48 hours.

Your assurance of product quality, lowest cost and dependable service is the fact that the nation's leading carbide tool users are placing their tool contracts with The Metal Removal Company.

THE METAL REMOVAL COMPANY
1859 W. Columbia Avenue
Chicago, Illinois 60626
Plants Located in CHICAGO • LOS ANGELES • SAN JUAN



**MASTER TOOL AND WHEEL
MAKERS FOR THE WORLD**

ONLY 3C OFFERS TOTAL INTEGRATED CIRCUIT CAPABILITY: μ -PACS, MEMORIES, AND COMPUTERS

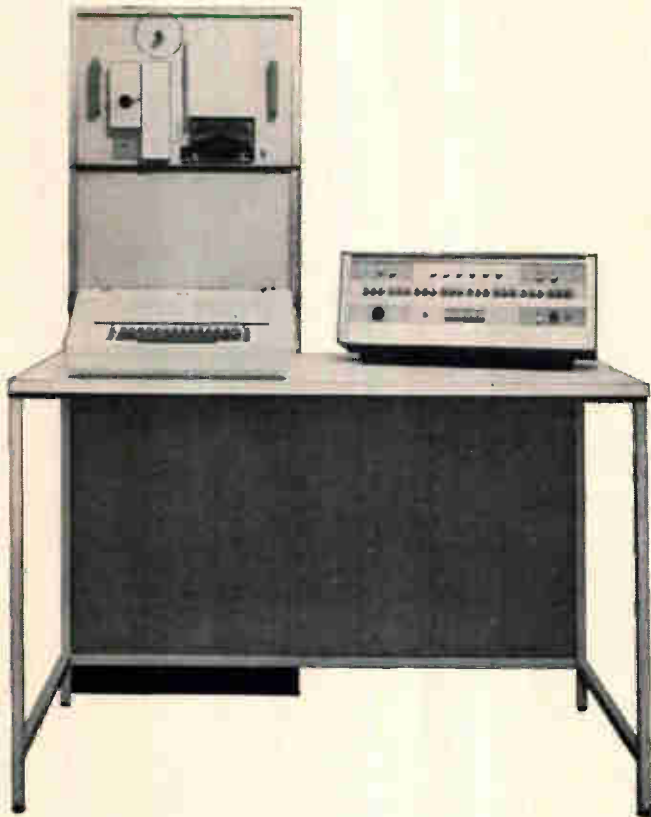

MICROCIRCUIT DDP-124

24-bit word DDP-124 features monolithic integrated circuit μ -PAC[™] construction; fast, reliable, and flexible logic configuration — binary, parallel, sign/magnitude, single address with indexing, powerful command structure. Over 285,000 computations per second. MEMORY: 8192 words (expandable to 32,768) directly addressable; cycle time 1.75 μ secs. INPUT-OUTPUT: Typewriter, paper tape reader and punch. (Strong optional I/O capability and broad range of peripheral equipment.) SOFTWARE: FORTRAN II and IV, assembler, executive, utility and service routines. Fully program compatible with DDP-24 and DDP-224 general purpose computers.



INTEGRATED CIRCUIT 1 μ SEC CORE MEMORY

New ICM-40 microcircuit, coincident current, random access core memories feature full cycle operation in 1 μ SEC (less than 500 nsec access time). ICM-40's feature price, size and reliability advantages of integrated circuit μ -PAC[™] logic. Word capacities to 16,384 in a 5 $\frac{1}{4}$ " high unit for mounting in a standard relay rack. Design permits pull out front rack access. Operating temperatures from 0°C to +50°C, with broad margins. Clear/Write, Read/Restore and Read/Modify/Write are standard modes of operation. ICM-40 interfaces comfortably with both discrete component and integrated circuit systems. Low power dissipation.

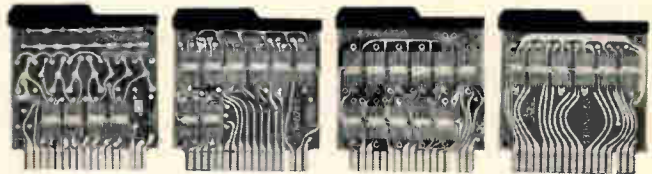

μ -PAC LOGIC MODULES

3C is the world's largest supplier of digital logic modules. With several years of in-house funded research and design, 3C has developed a broad line of standard, fully integrated, monolithic, 5mc circuit modules with the flexibility of 3C's long established discrete package lines. This has been achieved while retaining advantages inherent in the integrated circuit — price, size, reliability.

See us at IEEE, Booth No. 3D109, 11 and 13



COMPUTER CONTROL COMPANY, INC.
OLD CONNECTICUT PATH, FRAMINGHAM, MASSACHUSETTS 01702

3C SALES OFFICES: NEEDHAM, MASS.; FOREST HILLS, N.Y.; LEVITTOWN, PA.; SYRACUSE, N.Y.; SILVER SPRING, MD.; HOUSTON, TEXAS; HUNTSVILLE, ALA.; COCOA BEACH, FLA.; DES PLAINES, ILL.; DETROIT, MICH.; WEST CARROLITON, OHIO; LOS ANGELES, CALIF.; KENT, WASH.; ALBUQUERQUE, N.M.

CL905HL • CL907 • CL907N • CL907L • CL907H • CL907HN • CL907HL • CL904L • CL904N • CL904H • CL903L • CL903A • CL903N • CL903AN • CL902L • CL902N • CL902H • CL902HN • CL902HL • CL905L • CL905H • CL905HN • CL905HL

**WIDEST
RANGE OF
MINIATURE
(TO-18)
PHOTOCELLS**



Clairex now offers the broadest selection of miniature CdS and CdSe Photoconductive Cells available anywhere. 23 types of CL 900 series offer:

- Resistance values from 2K to 1.4 megohms at 2 ftc
- Voltage ratings from 100 to 250 volts
- All cells hermetically sealed in low-profile TO-18 transistor case. If you need a miniature, high-reliability photocell, send for new Photocell Design Manual.

CLAIREX

"The LIGHT Touch in Automation and Control"
 1239 Broadway, New York, N.Y. 10001
 212 MU 4-0940

CL-108

Circle 515 on reader service card

YOKE SPECIFYING PROBLEM?

**ASK AN
EXPERT...**

**A SYNTRONIC
DEFLECTION
YOKE SPECIALIST**



Since we make more types of yokes than anyone else, it's natural enough for our team of experts to know more about yoke design, application engineering, and quality control.

Specifying can be a challenging problem, and with this in mind, we put our experience at your disposal. Don't hesitate to call or write us when you're puzzled as to the right deflection yoke for your display.

syntronic

INSTRUMENTS, INC.

100 Industrial Road, Addison, Illinois
Phone: Area 312, 543-6444

New Subassemblies

and hold uses, etc.

To be exhibited at IEEE show. Zeltex Inc., 2350 Willow Pass Rd., Concord, Calif. [397]

Amplifier modules for high power use

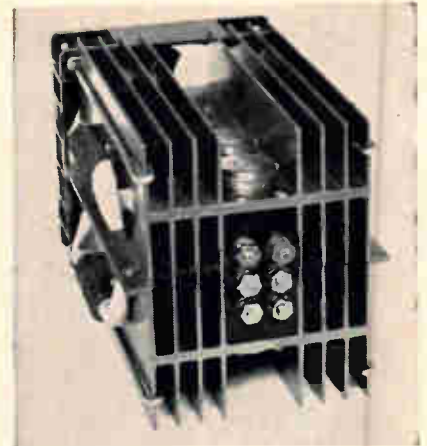

Three basic high-power operational amplifiers are announced. Model OA-111 (illustrated) is an economical high-power operational amplifier with limited frequency response. This basic amplifier module has an output of ± 10 v with maximum current capabilities of 10 amps. Frequency response is 7.5 kc with a d-c open loop gain of 40,000. Voltage drift is 100 μ v/hour and peak to peak noise is less than 50 μ v.

Model OA-112 is a high-frequency, high-power, operational amplifier for applications up to 200 kc. It has an output of ± 10 v with maximum current capabilities of 10 amps. Frequency response at full output is 200 kc with a d-c loop gain of typically 100,000. Voltage drift and peak to peak noise are the same as the OA-111.

Model OA-113 is a high-voltage, high-power, operational amplifier with self-contained power supply. This basic amplifier module has an output of ± 100 v with maximum current capabilities of 1 amp. Frequency response is 10 kc with a d-c open loop gain of typically 500,000.

Physical Dynamics Corp., 1683 Hawthorne Road, Grosse Pointe Woods, Michigan, 48236. [398]

DIGITAL INSTRUMENTATION



Model 201



Model 500



Model 610-620

SEE ALL THE
DIGITEC INSTRUMENTS
AT THE IEEE SHOW
BOOTHS 3A34-3A35

DIGITEC

UNITED SYSTEMS CORPORATION

918 Woodley Road Dayton, Ohio 45403

Stocking representatives throughout the world

DIGITAL DC VOLTMETERS

- 9 Models offering F.S. ranges of 10 MV to 1000 V • Certified accuracy to .1% F.S. • Floating or grounded input • Reliable silicon transistor circuitry • Individually calibrated and certified • Available options include BCD output, retransmitting pot., auto-polarity, minimum or maximum retention.

From \$315.00

DIGITAL PRINTERS

- BCD 1-2-4-8 low level parallel input
- Prints 8 columns in 2 banks of 4
- 45 line/minute print rate • Uses standard 2 1/4" paper tape • Remotely programmable • Designed for use on all "DigiTec" instruments with BCD coded output and other instruments with compatible coding.
- Time, Identification and Scanning Accessories available.

From \$750.00

DIGITAL THERMOMETERS

Precision digital measurement of temperature reading directly in degrees C or F.

THERMISTOR BASED (Series 500)

- Ranges covering -50 to +100° C.
- Accuracy to 0.15° 18 interchangeable probes.

PLATINUM BULB (Series 530)

- Ranges covering -390° to +1000° F. • Accuracy to 0.70° F.
- Interchangeable probes.

THERMOCOUPLE (Series 560)

- Ranges covering -300° to +2000° F. • Accuracy to 1.5° F.
- Reading resolution to 0.05°.
- For use with ISA Type "J," "K" and "T" thermocouples.

From \$345.00

Circle 516 on reader service card

New reliability in radio and teleprinter communications from Mitsubishi

Mitsubishi Electric presents a recently developed parametric ARQ terminal system designed to increase the reliability of radio telegraph circuits. Designated the TZ-4 ARQ, this equipment reduces error rates in teleprinter traffic, while bringing a level of accuracy in radio traffic that approaches that of the cable circuit.

Model TZ-4 ARQ provides a duplex system (2 x 2 ch.) or a quadruplex system (1 x 4 ch.) in a single cabinet. Eight-extensors and four-subdividers are also included. Model TZ-4 ARQ is designed in accordance with new CCIR recommendation No. 342. For further information, a card bearing your name and address and sent to Mitsubishi Electric, Tokyo, Japan, will bring full particulars.

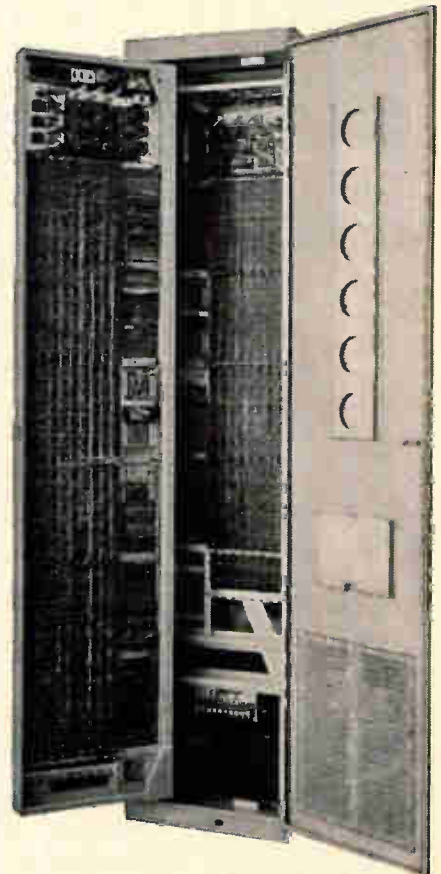

MITSUBISHI ELECTRIC CORPORATION
Head Office: Mitsubishi Denki Bldg., Marunouchi, Tokyo. Cable Address: MELCO TOKYO

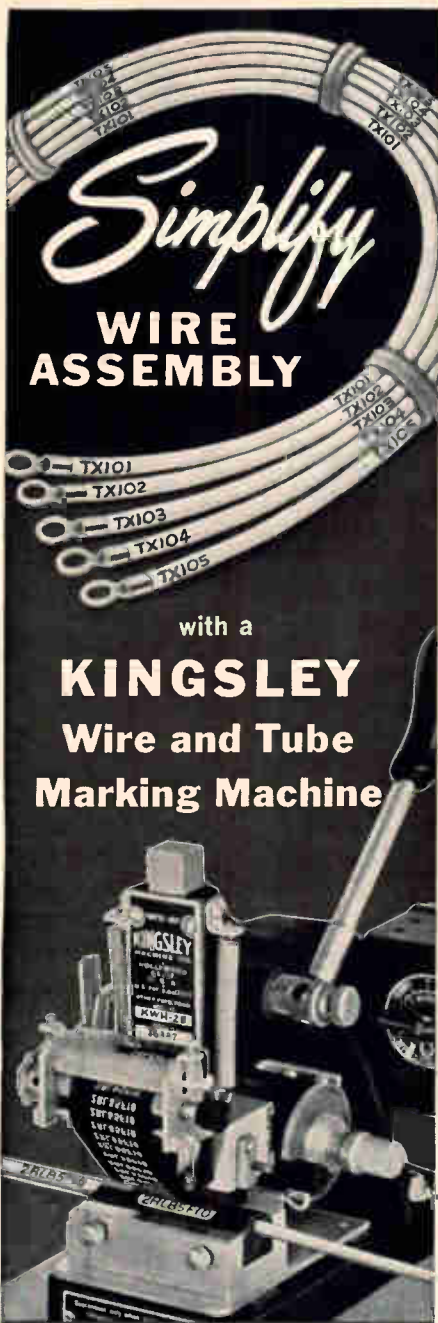

Simplify
**WIRE
ASSEMBLY**

with a
**KINGSLEY
Wire and Tube
Marking Machine**

Now you can mark each wire or piece of plastic tubing with its own circuit number... quickly...economically, right in your own plant.

You reduce wire inventories because you need only one color of wire for as many circuits as necessary.

Simplify your assembly methods and speed production with the same machine that has proven so successful in the aircraft and missile field. Write for details.

KINGSLEY MACHINES
850 Cahuenga · Hollywood 38, Calif.

See us at Booth 4D18—IEEE Exhibition

New Microwave

Coax switch actively transfers 2 kw

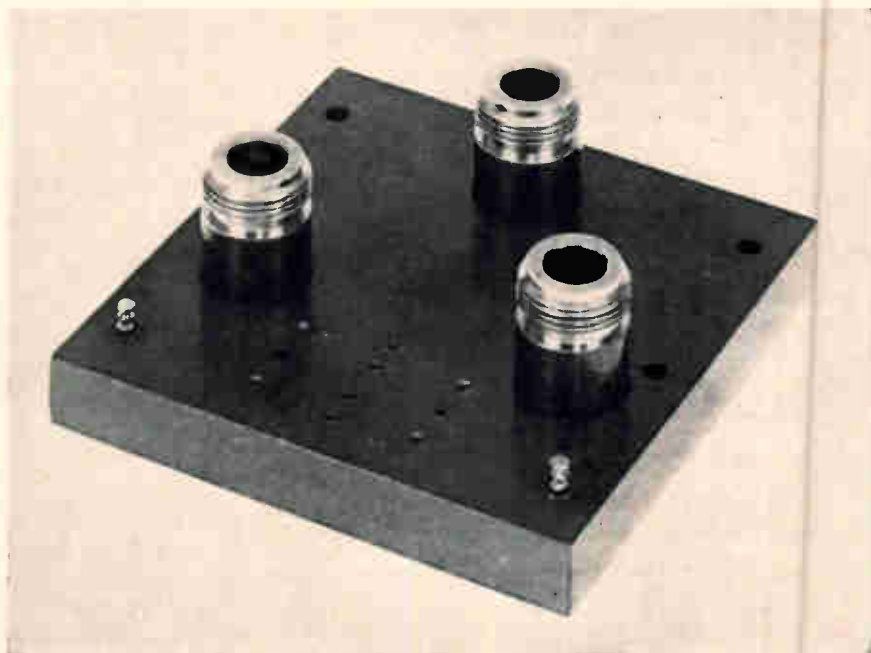

A coaxial diode switch, originally developed on special order for a customer building an airborne identification-friend-or-foe system, is now being marketed commercially. Microwave Associates, Inc., has designated the eight-ounce switch type MA-8306-2L21N and claim it can handle more power than any other switch of the same size and operating at the same frequency.

Excluding connectors, the single-pole, double-throw switch measures $3\frac{1}{4}$ by $3\frac{1}{4}$ by $\frac{7}{16}$ inches. It can handle 5,000 watts peak and 5 watts average power for frequencies between 1,030 Mc and 1,090 Mc. Other coaxial diode switches with the same power rating at the same frequency are about six times larger.

A unique feature is the switch's capability for "hot switching." That is, it can actively transfer a certain amount of peak power between ports—an important feature when pulses, separated in time by as little as 200 nanoseconds, must be switched. Between such pulses, some power always remains in the pulses' trailing and leading edges. The new switch can handle up to 2,000 watts of such power.

The company can supply the

switch with type N, TN, or TNC connectors depending on the customer's specifications.

Price and delivery upon request.

To be exhibited at IEEE show.

Specifications

Type	MA-8306-2L21N
Operating frequency	1,030 to 1,090 Mc
Insertion loss	0.7 db
Isolation	25 db
Switching current	100 ma
Military specification	MIL-E-5400

Microwave Associates, Inc., Burlington, Mass. [406]

Quadrature hybrids are microminiature



The QHM series of microminiature quadrature hybrid couplers is designed for use with high-density electronic equipment or plugged

into p-c boards. The devices are made by using microwave techniques and applying lumped element devices to achieve the more conventional microwave scattering matrices.

The four-port quadrature network typically exhibits greater than 30 db isolation between input and isolated ports. The hybrids split signals applied to the input port equally in amplitude between the two output ports within 0.3 db. The phase difference between the two outputs is held to within 2° of perfect quadrature (90°).

In application, the hybrid networks are extremely useful in image reject mixer networks and for achieving single sideband modulators. In image rejection, the hybrids combine the outputs of two balanced mixers into a desired signal and an image signal. By virtue of the phasing properties of the hybrid, the image is separated and terminated while the desired signal is the useful output and is then fed to the i-f amplifier section. In single sideband systems, the hybrid internally splits the combination of carrier and i-o (or information) modulator into a higher-than-carrier and a lower-than-carrier frequency component. Depending on the relative frequencies of carrier and information modulation and the respective inputs, either the lower-or higher-frequency component cancels.

Various models are designed to perform with bandwidths from 10% to an octave, from arbitrarily low frequencies to more than 300 Mc center frequency. Impedance is usually 50 ohms, with other impedance levels available. To preserve the miniature size advantage, the new hybrids are offered with solder-pin terminals. Variations of bandwidth, center frequency, and connectors are readily available.

To be exhibited at IEEE show. Merrimac Research & Development, Inc., 517 Lyons Ave., Irvington, N.J., 07111. [407]

Crystal protector covers 16 to 17 Gc

The BLT-111 crystal protector, designed for operation over the 16 to 17 Gc frequency range, is warranted for 2,000 hours, and has a

MEC's pioneering efforts in high power TWT technology produced the first practical 100-watt traveling wave tubes. Now MEC has doubled power output! This C-band TWT delivers a healthy 200 watts across its full octave frequency, 4-8 GHz. It's a dependable 200 watts, too, because MEC's unique method of mounting the helix provides adequate heat dissipation. Like all MEC high power TWTs, the new 200-watt tube features PPM-focusing, rugged metal ceramic construction, depressed collector operation, low cathode loading and use of a dispenser cathode to assure long operating life. Applications? ECM, communications, troposcatter systems.

MEC is now delivering TWTs which provide from 20 to 200 watts of CW power over octave frequency ranges at S, C and X-bands. Many will meet military system requirements. For details, please contact your MEC engineering representative (listed in EEM) or write to us. Internationally, contact Frazar and Hansen, Bern, Switzerland.

Exceptional opportunities on our technical staff for qualified engineers and scientists. An equal opportunity employer.

ANOTHER HIGH POWER FIRST: 200 WATTS CW BROADBAND

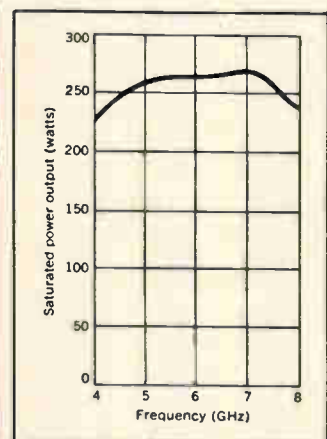
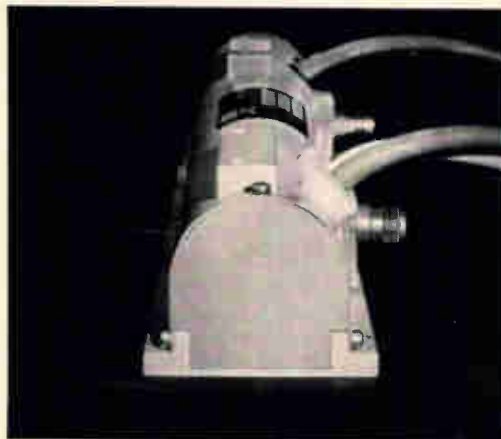

Microwave Electronics

3165 Porter Drive
Palo Alto, California

a division of Teledyne, Inc.

Keep up to Date Professionally with

ELECTRONICS BOOKS FROM ADDISON-WESLEY

All Available on 10-Day FREE Examination

SEMI-CONDUCTOR PHENOMENA AND DEVICES (3070)

BY LLOYD P. HUNTER, *University of Rochester*

Traditionally this subject has been approached by introducing the main consideration of semi-conductor devices with a relatively lengthy presentation of background material which often amounts to a short course in solid state physics. This semi-graduate level text approaches the main subject material by the shortest possible path which will allow an understanding of semiconductor phenomena and devices.

218 pp, 86 illus (1966) \$8.95

NONLINEAR NETWORKS AND SYSTEMS (7275)

BY THOMAS E. STERN, *Columbia University*

This book is essentially concerned with the mathematical aspects of nonlinear systems. It requires a good foundation in matrix theory and network formalism, and will be of interest to research engineers as well as to graduate students of electrical engineering. Of particular interest is the material on stability and Lagrangian formulation.

594 pp, 309 illus (1965) \$18.50

ELECTROMAGNETIC FIELD THEORY:

An Introduction for Electrical Engineers (7342)

BY ROBERT D. STUART, *Northeastern University*

Intended for the first course in field theory—or microwave theory—for electrical engineers, this text requires a background in general physics, vector algebra, and differential equations. It is essentially concerned with developing from first principles the properties of electric and magnetic fields, and the interaction of these fields with charged particles.

214 pp, 91 illus (1965) \$8.95

TIME-DOMAIN ANALYSIS AND DESIGN OF CONTROL SYSTEMS (1603)

BY RICHARD C. DORF, *University of Santa Clara*

This book is designed to introduce the student of control theory to analysis and design in the time domain. Covers the formulation and solution of equations describing the performance of control systems. The analysis and design is accomplished in the time domain and is useful for digital computer calculation.

194 pp, 144 illus (1965) \$8.95

LINEAR DATA SMOOTHING AND PREDICTION IN THEORY AND PRACTICE (0610)

BY R. B. BLACKMAN, *Bell Telephone Laboratories, Inc.*

This book is essentially concerned with methods of data-smoothing and prediction which have been considered for practical use—many of which have actually been put to practical use. The subject is approached from the transmission point of view.

210 pp, 72 illus (1965) \$11.75

INDUSTRIAL MANAGEMENT IN THE ATOMIC AGE (5745)

BY V. L. PARSESIAN, *Rensselaer Polytechnic Institute*

This volume presents features of atomic and industrial development of interest to those who exercise managerial, project, legal, or administrative responsibility within industry and government. Detailed are patterns, restraints, opportunities, and trends in government-sponsored technology as experienced in Atomic Energy development. Designed also for graduate students of industrial management.

374 pp, 39 illus (1965) \$10.75

New Microwave

design life of 5,000 hours. High-temperature fabrication and processing provide long life and stable operation over a wide temperature range.

Maximum input vswr is 1.3:1; maximum breakdown power, 200 mw; noise figure, 0.8 db; flat leakage, 40 mw; spike leakage, 0.1 erg; recovery time, 1.0 μ sec; insertion loss, 0.4 db; weight, 3.25 oz; pressurization, 35 psig; operating temperature, -55° to $+125^{\circ}$ C; and vibration, 10 g.

To be exhibited at the IEEE show.

Bomac Division, Varian Associates, Salem Road, Beverly, Mass. [408]

Precise phase shifter is direct-reading

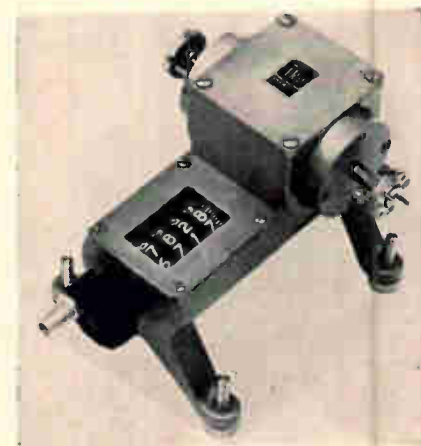

Series 528 direct-reading phase shifter is available in the standard waveguide bands from 12.4 to 110 Gc. This precision instrument, with integral stand and adjustable legs, consists of two quarter-wave plates separated by a rotary half-wave plate in circular waveguide. Rotation of the center section produces a phase shift equal to twice the angle of rotation.

Readout of phase shift in degrees is provided by means of a counter that cycles from 0 to 10,000°. The unit dial is subdivided into 0.2° intervals. Accuracy is within 3° in the K_u, K, B, and A bands and 4° in the V, E, and W bands. Variation of insertion loss with rotation is less than 0.4 db.

Model 528 was developed in re-

Whether your need is for expanded knowledge of theory or immediate and practical solutions to everyday problems, there is an Addison-Wesley text that can help you.



ADDISON-WESLEY
PUBLISHING COMPANY, Inc.
Dept. A-558
Reading, Mass. 01867

Please send for my inspection and approval, a copy of each book I have checked. (I understand that I can return the books in ten days if I decide not to keep them.)

- () Hunter, SEMICONDUCTOR PHENOMENA AND DEVICES (3070) \$8.95
- () Stern, NONLINEAR NETWORKS AND SYSTEMS (7275) \$18.50
- () Stuart, ELECTROMAGNETIC FIELD THEORY: An Introduction for Electrical Engineers (7342) \$8.95
- () Dorf, TIME DOMAIN ANALYSIS AND DESIGN OF CONTROL SYSTEMS (1603) \$8.95
- () Blackman, LINEAR DATA SMOOTHING AND PREDICTION IN THEORY AND PRACTICE (0610) \$11.75
- () Parsegian, INDUSTRIAL MANAGEMENT IN THE ATOMIC AGE (5745) \$10.75

Name Title
Affiliation
Address
City State Zip Code

Please extend College Professor's discount. Payment enclosed. (We pay postage if you enclose check—same inspection privilege)

CUT BREADBOARDING TIME 4 WAYS

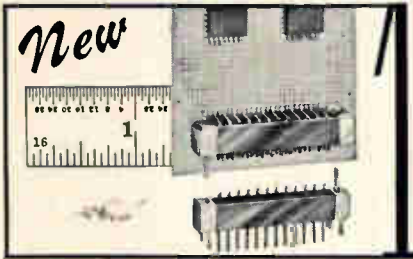

New **MICRO PLUGBORDS** with subminiature connectors. The .042" or .025" dia. holes on .1" or .05" centers allow greater packaging density than possible before with pre-punched boards. Available also without connectors and in copper clad epoxy glass.

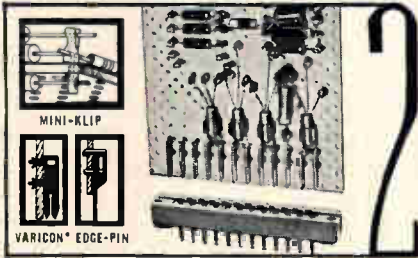

Pre-punched **PLUGBORDS** with Varicon® or Vector Edge-Pin contacts ready for your components. Insert Mini-Klip Push-In terminals where needed. JEDEC hole spacing matches transistor leads. ©Elco Trademark.

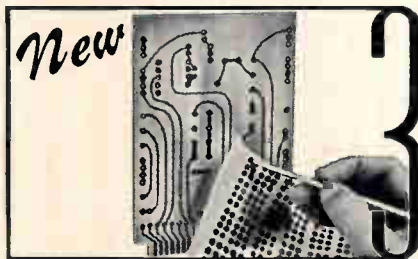

ETCHED CIRCUIT KITS 27X and 27XA provide all materials for making quick, inexpensive etched circuits. New 27XA has time-saving Vectoresist, the "rub-on" transfer resist sheet with lines, circles, ellipses, pads and standard .156" contacts, plus Vectorbord and unpunched copper clad cards and ready-to-use etch bags.

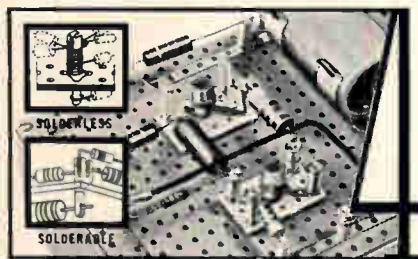

Large and small **BREADBOARD KITS** with complete hardware systems for faster breadboarding in Lab. or school experiments. Complete with solderless Springclip, solderable push-in terminals, transistor and tube sockets. New Hi Frequency breadboard kit now available.

May we send you literature and prices?

VECTOR ELECTRONIC CO. INC.
1100 Flower St., Glendale, Calif. 91201
Phone (213) 245-8971 • TWX (213) 240-2162

sponse to many inquiries for a direct-reading phase shifter for use in millimeter r-f bridge networks. Price is \$1,000 to \$2,400 depending on frequency range; availability, 90 days.

To be exhibited at the IEEE show.

TRG, a subsidiary of Control Data Corp., 400 Border St., East Boston, Mass., 02128. [409]

Solid state, plug-in spectrum analyzers



Two microwave plug-in spectrum analyzers are announced. The PSA-510 is for use with Tektronix letter series oscilloscopes; and the PSA-530, for use with Hewlett-Packard 140A/141A scopes. Both units are designed for use with an external swept local oscillator and have a broad frequency range of from 10 Mc to 15 Gc, while even higher frequencies can be displayed employing external mixers. Thus, the combination of scope, microwave sweeper and the PSA-510 or PSA-530 results in high performance, versatile microwave spectrum analysis capability, at low cost.

The silicon solid state constructed units have a wide range of scan widths of from 0 to 1 Gc, while resolutions of 5, 10, 20 and 100 kc are readily selectable from a front panel switch. Residual responses in both analyzers are at least -70 dbm and above about 500 Mc are typically -90 dbm. Linear, 60 db log and 13 db square law displays are provided as are two positions (0.1 and 1 msec) of video filtering. Both models have an i-f attenuator of 51 db in 1-db steps and a 40-db i-f gain control. A panel meter indicating mixer current is provided so that input power



. . . 35 YEARS LEADERSHIP
IN ROTARY SWITCHES

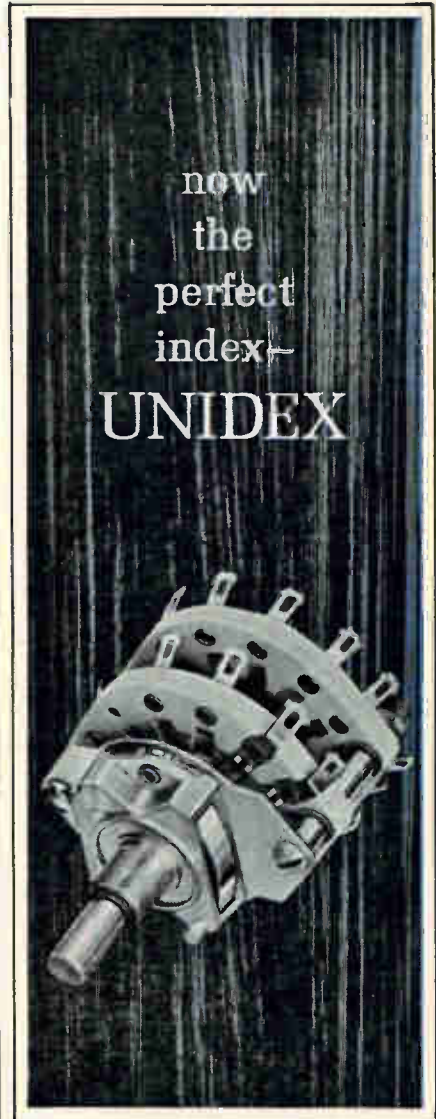

now
the
perfect
index—
UNIDEX

UNIDEX™ is the universal index for Oak rotary switches. Its revolutionary new method of operation provides a consistent "velvet-feel" torque for the life of the switch, a longer index life—by many thousands of operations, a lubrication reservoir and a sturdy one-piece housing that guarantees electrical continuity.

Only Oak® offers you Unidex . . . and at no extra cost. For more information write for Bulletin SP 178.

OAK MANUFACTURING CO.

A DIVISION OF OAK ELECTRO-NETICS CORP.
CRYSTAL LAKE, ILLINOIS 60014 • Telephone: 815-459-5000
TWX: 815-459-5628 • Cable Address OAKMANCO

LATCH on to the EXCITEMENT in MICROELECTRONICS and SILICON DEVICE DEVELOPMENT at DELCO RADIO

Enthusiasm is running high at General Motor's Delco Radio Division.

Exciting developments in microelectronics and silicon devices have spawned a rapidly expanding research effort. New buildings . . . new equipment . . . and most importantly, new people!

The dynamic pace of accomplishment at Delco is pushing the state of the art clear out of sight. The opportunity is here for those who choose to capitalize on it.

Microelectronics

Circuit oriented EE's—0 to 5 years experience. Here's a chance to get in on the excitement in microelectronics. Research programs in both linear and digital circuitry embrace monolithic . . . thick film . . . thin film . . . and hybrid microcircuits.

Silicon Device Development

Lots of room here for the BS, MS, PhD in Physics, Chemistry, Physical Chemistry, or related fields. Development programs are underway in these areas:

Low power and very high power monolithic and hybrid circuits.

Silicon Transistors—from very high

frequency 10 milliamper through 25 ampere, 1000 volts.

Thyristors—from 50 milliamper through 500 ampere, 2000 volts.

Zener Diodes.

Silicon Rectifiers—from milliamper through 250 ampere, 3000 volts.

Continuing R&D efforts already have led to Delco's leadership in high power, high voltage silicon transistors. Delco rectifiers—rated at 250 amps, 2000 volts—are going into alternators designed to handle the full power generated by the latest Diesel-electric locomotives.

Full-size, fully-transistorized TV sets now are in production, thanks to a Delco high powered transistor in the horizontal and vertical deflection circuits.

A tremendous momentum is building at Delco. The time is ripe—now—to join this outstanding research group.

If you'd like more information immediately, pick up the phone and call us collect, Area Code 317/459-2808. Ask for C. D. Longshore. Or, send your resume to Mr. Longshore, Salaried Employment, Dept. 102, Delco Radio Division, General Motors, Kokomo, Indiana.

An equal opportunity employer

Metronix



**REGULATED
DC
POWER
SUPPLIES**

**MODEL
521A**

RIPPLE: 3mVp-p

MODEL	VOLTS	AMPS	REGULATION (line or load)
521A	1~18V	0.5A	± 20mV
541A	1~35V	0.25A	± 20mV
543	1~35V	0.5A	± 20mV
531B	0~35V	1A	± 10mV
535C	0~35V	5A	± 3mV

Metronix corp.

76, CHOFU-CHIDORI-CHO, OTA-KU, TOKYO, JAPAN

Circle 518 on reader service card

Primo

Super High Sensitivity
**SOUND LEVEL
METER MICROPHONE
(DYNAMIC TYPE)**



Specifications

- Frequency Response:
20~16,000c/s ±1.5dB
- Impedance: 100Ω ± 10%
- Sensitivity: -80dB ± 2dB
- Dimensions: 3.5φ x 220mm
- Weight: 7.30gm.

DM-1332

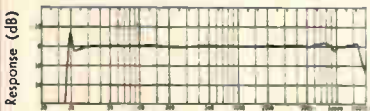

For catalog write to

PRIMO COMPANY LTD.

2043 MURE, MITAKASHI, TOKYO, JAPAN
TEL. 0422-3-3121 (Calling from Tokyo)

Circle 519 on reader service card

New Microwave

can be monitored. Maximum input power is 0 dbm, and input impedance is 50 ohms.

Minimum sensitivity is -95 dbm over the 10 Mc to 4 Gc range and -90 dbm over the 4 to 8 Gc range when fundamental mixing is used. Harmonic mixing sensitivity is slightly less than that for fundamental mixing up to 8 Gc and is -75 dbm minimum from 8 to 15 Gc. A signal identifier—a front panel push button—is provided to readily determine the actual frequency of the input signal. The direction of displacement, either right or left, identifies the signal as being above or below the 500 Mc first i-f, respectively. The distance of displacement, at a known dispersion, determines fundamental or harmonic mixing and the exact harmonic involved.

Models PSA-510 and PSA-530 are priced at \$1,250 and \$1,350 respectively, and delivery is stock to 30 days.

To be exhibited at the IEEE show.

Nelson-Ross Electronics, 5-05 Burns Ave., Hicksville, N.Y. [410]

**Coaxial attenuators
provide high accuracy**



A line of very flat, low vswr coaxial attenuators has been developed. The price (\$45 to \$50) is claimed to be approximately one-half the average industry price for this high quality.

The attenuators are available in attenuation values of 3, 6, 10, 15, 20, 30 and 40 db, each covering a frequency range from d-c to 12.4

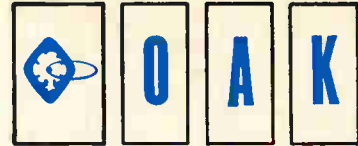

... 35 YEARS LEADERSHIP
IN ROTARY SWITCHES

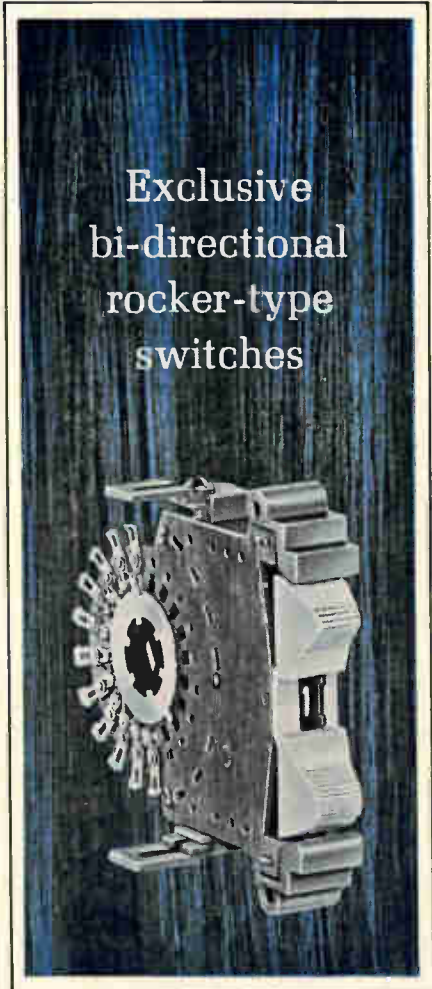

Exclusive
bi-directional
rocker-type
switches

New Oak® Rocker Switches are ideally designed for panel mounting. Module principle permits mounting a single switch, or horizontal or vertical module arrangements of as many switches as desired. All have sturdy mounting frames. Fingers never touch readout characters—Oak's exclusive recessed numerals assure continued legibility. You get bi-directional, multi-position operation, choice of alpha or numeric readout. Can be read from right or left. Can be operated with gloves on for military use. Made with Oak-pioneered double-wiping action contacts.

For full details, write for Bulletin SP-202.

OAK MANUFACTURING CO.

A DIVISION OF OAK ELECTRO/NETICS CORP.
CRYSTAL LAKE, ILLINOIS 60014 • Telephone: 815-459-5000
TWX: 815-459-5628 • Cable Address OAKMANCO

Circle 257 on reader service card

257



The 5 faces of an Avionics Systems Engineer.

How you, too, can put on a happy one.

We're looking for Avionics Systems Engineers with split personalities—split five ways. Well-rounded engineers who can literally do the work of five.

Engineers who can fill the roles of conceptual innovator, scientist and engineer, trade-off analyst, hardware specialist and economist—all in one.

Hard to find? You bet they are. But somewhere out there are the people we're looking for. Maybe you.

IBM's Electronics Systems Center in Owego, New York, has immediate openings for engineers in one of the most exciting areas of engineering there is—Systems Engineering.

It will be their job to carry a project from concept through operational utilization.

They'll define what type of components, equipments and subsystems are mutually compatible to make avionics systems most effective, most economical.

So what will the engineer get out of all this?

Total involvement. For example you'll configure avionics systems, identify and mechanize sensor and computer interfaces, define guidance equations, prepare math flows, establish computer memory and speed requirements, assist in first-cut programming requirements definition and perform systems engineering parametric analyses and trade-off studies. Equally important, you'll work for the leader in the major growth industry—information processing and control.

Sound intriguing? It is.

If you think you may qualify, send your resume to:
Mr. J. R. Raftis, Dept. 554-04
IBM Electronics Systems Center
Federal Systems Division
Owego, New York 13827
... and if you do qualify, let us intrigue you some more.

With facts about things like job stability. And personal, tangible rewards. And your future potential.

It's your chance to be a Jack-of-all-trades, master of all. Why not write us today?

IBM is an Equal Opportunity Employer.

IBM®

TAIYOHM

FIXED COMPOSITION RESISTOR

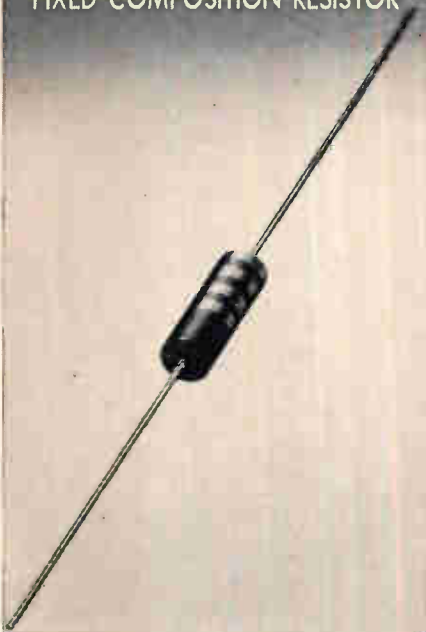

TAIYO DENKI CO., LTD.

1-12, 3-chome, Sunamichi,
Sakai C., Japan.
Phone: Sakai-3-6 8 4 1

Circle 520 on reader service card

Transformer for MICROPHONE

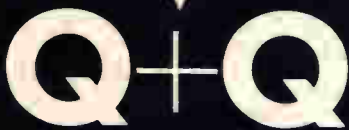

YOUR assurance of best quality
and quantity
The secret 2-Q's
behind
every Nishimura products



Nishimura Musen-Denki Co., Ltd.

21, Owodo-cho, Shibuyō-ku,
Tokyo, Japon

Circle 521 on reader service card

New Microwave

Gc. The units up to 20 db are less than 2 in. long—the smallest in the industry, according to the manufacturer. All models exhibit a vswr of 1.35 maximum for all frequency ranges.

Accuracy is $\pm 3/4$ db for 3 to 20 db attenuation values, and ± 1 db for 30 and 40 db units. The units are available with N or TNC connectors, male and female. All type TNC weigh 1 oz or less; most type N weigh 2.4 oz. All are available for immediate delivery.

To be exhibited at the IEEE show.

Microlab/FXR, Livingston, N.J. [411]

Rotary joint uses circular mode



This rotary joint employs the circular electric mode to achieve superior bandwidth and power handling characteristics. The development, an outgrowth of the firm's work in satellite communications terminals, is designed to operate in the frequency range of 5.9 to 8.4 Gc.

The rotary joint consists of four sections: a TE_{10} rectangular waveguide model to TE_{01} circular waveguide mode transducer, a mode filter, a rotary section, and a second mode transducer to return to rectangular waveguide. The key components are the transducers, or mode launchers.

The mode launcher is designed in three sections, each one a smooth broadband transition from one mode to another. The inside cross sectional area increases from the rectangular waveguide end continuously to the large circular waveguide end making the launcher capable of power levels equal to the rectangular waveguide power capacity.

The mode filter, which consists



... 35 YEARS LEADERSHIP
IN ROTARY SWITCHES

Moduline
rotary switches...
one week delivery
on 2 million
variations!

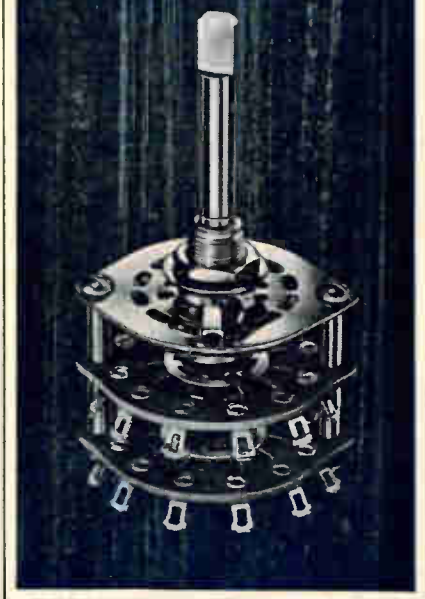

How does Oak® do it? Simple. We break a rotary switch down to four basic elements. Then we stock all possible variations of each element in our Moduline assembly room . . . ready and waiting for your order. Your order comes, we start assembling—from 1-99 switches to your precise specs. Over 2 million variations with one week delivery.

Only Oak offers you Moduline™ switches—made with the same precision quality to military specs as custom-made. Will break 1 amp @ 28 vdc, 0.5 amp @ 110 vac or carry 5 amps.

For full details, write for Bulletin SP-205.

OAK MANUFACTURING CO.

A DIVISION OF OAK ELECTRO/NETICS CORP
CRYSTAL LAKE, ILLINOIS 60014 • Telephone: 815-459-5000
TWX: 815-459-5628 • Cable Address OAKMANCO

Circle 259 on reader service card

259

CAPTURE and Hold Break Point Peaks with **Peak Lok**

Measure pulses shorter
than 1 μ s to 1% absolute accuracy

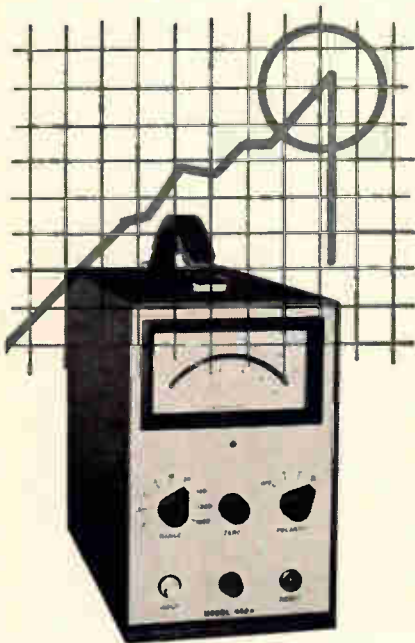

Now you can be specific about the break point in varying voltage, temperature, acceleration, shock pressure, or other quantity being measured. The Model 440A Peak Lok Voltmeter reads and holds the peak signal received over any selected period of time—even pulses shorter than 1 μ s. DC coupling is provided and input ranges are from 0.1 volt to 1000 volts. Output for logging—low impedance 0 to 5 volts with 1% absolute accuracy.

Got a problem? Let us help you solve it. Contact PEAK LOK Dept. 106, La Jolla Division, Control Data Corporation, 4455 Miramar Road, La Jolla, California. (Phone: 714, 453-2500)

CONTROL DATA
CORPORATION

4455 Miramar Road, La Jolla, Calif.

New Microwave

of alternate conducting and absorbing rings, is used to remove the minute amount of energy in unwanted modes and thus eliminate resonances. The rotating section of the joint is simply a section of waveguide cut circumferentially and coupled through a precision double race ball bearing. Performance of the unit, according to the company, removes the restriction imposed by rotary joints to operation at full waveguide power ratings over full waveguide bandwidths.

Measured results of the complete joint assembly exhibit a vswr of less than 1.5 to 1 over the frequency range 5.9 to 8.4 Gc and less than 1.2 to 1 over the satellite communication bands 5.9 to 6.4 and 7.2 to 8.4. Insertion loss over this frequency range is less than that of a length of rectangular waveguide, size WR137, equal to the length of the complete rotary joint assembly.

The component has been successfully operated at a power level of 22 kw c-w without cooling, the manufacturer reports.

Radiation, Inc., P.O. Box 37, Melbourne, Fla. [412]

Constant attenuation from d-c to 12.4 Gc



A series of fixed coaxial attenuators, with either 10 or 20 db nominal value, are substantially flat in attenuation vs frequency characteristic from d-c to 12.4 Gc. Model 8491A attenuators are individually swept-frequency tested for attenuation and swr. Exact attenuation at 0, 4, 8, and 12.4 Gc is recorded on the label. Accuracy of attenuator

maintenance

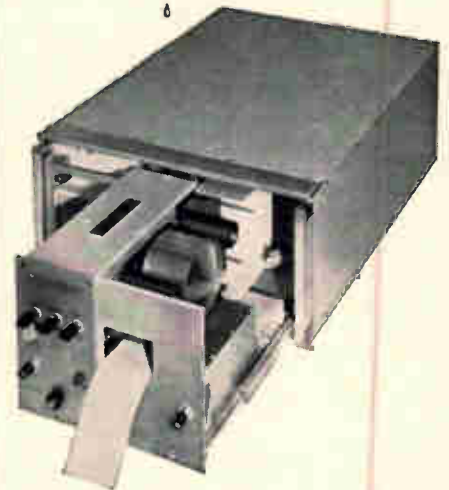
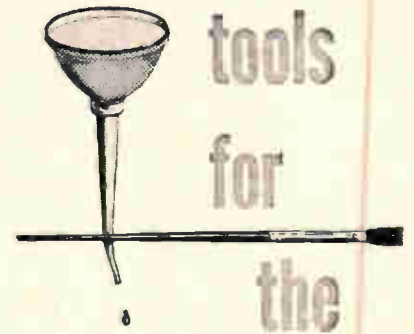

World's Fastest, Low-Cost Digital Printer

Apply several drops of oil to the drive-motor shaft-ends each year (or every fifty-million lines). Brush out any accumulated dust or lint. Clean the air filter periodically.

That's the extent of maintenance for a Franklin Model 1000 . . . the only digital printer that offers a printing rate of 40 lines per second (or less) at low, low, OEM prices.

REQUEST BULLETIN 2301

FRANKLIN
electronics, inc.

East Fourth St. • Bridgeport, Pa. 19405
A Division of the Anelex Corporation

Smallest 3-Phase Electronic Frequency Converters Ever Made!



Now, from CML, comes a series of the smallest 3-phase Electronic Frequency Converters ever made... featuring fixed or adjustable plug-in oscillators at frequencies ranging from 45 to 6,000 cycles. Write today for details on Models T500A through T2500A!

Model	3 ϕ Output VA	Dimensions (For standard 19" relay rack mounting)
T500A	500	8 $\frac{3}{4}$ " h x 21" d
T750A	750	14" h x 21" d
T1200A	1200	14" h x 21" d
T1750A	1750	14" h x 21" d
T2500A	2500	14" h x 21" d



CML, Inc.

A Subsidiary of Tenney Engineering, Inc.
350 Leland Avenue • Plainfield, New Jersey
Telephone (201) 754-5502 • TWX: 201-756-2064

Circle 544 on reader service card

• YOUR •
FREE PASS

to instant information on
the most complete line of
Semiconductor Heat Sinks.

ADMIT ONE

WAKEFIELD DISTRIBUTOR PRODUCTS CATALOG

available at:

• Booth # 2A25, IEEE SHOW

• Or from an authorized Electronic Distributor who stocks: milliwatt to high power coolers, extrusions, thermal joint compound, thermally conductive adhesive.

• Or, write to . . .

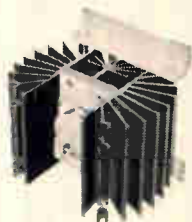

WAKEFIELD ENGINEERING, INC.

139 FOUNDRY ST. / WAKEFIELD, MASS. (617) 245-5900 • TWX 617-245-9213



Circle 545 on reader service card

Grayhill®

Miniature Rotary Switches...

... the Difference
Between
Excellent
and
Adequate ...

Select Materials:

- **Contacts:** Silver Alloy, Silver Plated Brass, Gold Flash where needed
- **Terminals:** Brass, Silver Plated, Gold Flash where needed
- **Bases:** Molded Thermosetting Plastic to Mil Specs
- **Detent Spring:** Tinned Music Wire
- **All other Metal Parts:** Stainless Steel

Typical Specifications:

- Explosion Proof
- Contact Resistance .010 ohms
- Make or Break 1/4 Amp. to 15: 115 VAC Resistive
- 1 to 6 Poles per Deck
- 2 to 12 Positions per Pole
- 1 to 12 Decks

Rating:

- Life Expectancy 100,000 Cycles

... in
**Design
Materials
Construction**



Send for
Engineering
Data Book

Push Button—
Rotary Switches and
Other Components



523 Hillgrove Avenue
LaGrange, Illinois 60526
Area Code 312, Phone 354-1040



“PIONEERS IN MINIATURIZATION”

Circle 261 on reader service card

261

the DA 410



Frequency Response Analyzer

Measures frequency response from 0.001 to 1000 cps

- performs servo analysis automatically—with speed, accuracy and ease of operation never before achieved . . .
- provides results from 1 to 1½ cycles of test frequency .001 to 1 cps, 2 secs. from 1 to 1000 cps
- displays phase and amplitude on direct digital readout
- achieves 40 db of noise and harmonic rejection
- accurate to 1% in amplitude and 1° phase
- carrier and dc operation
- has No drift adjustment
- high-speed, automatic operation
- self-check, self-calibrating
- all solid state, only 7"x17"x16" in size
- weighs just 38 lbs.
- and costs but \$6840.00
- options for automatic operation, point-to-point, printout, etc.

See it at IEEE Booth 3K06
or write for Bulletin DA410

Weston Instruments, Inc.
BOONSHAFT AND FUCHS DIVISION
Hatboro, Penna. 19040

New Microwave

calibration is specified at ± 0.5 db to 7 Gc, ± 1 db from 7 to 12.4. Swr specification is less than 1.2 to 7 Gc, less than 1.3 from 7 to 12.4 Gc.

The attenuators are $2\frac{7}{8}$ in. long, $\frac{1}{8}$ in. in diameter, and are equipped with type N connectors (one male and one female). Their maximum input power is 2 watts average. Price, for either the 10 or 20 db unit, is \$50 each. Current delivery estimate is 2 weeks after receipt of order.

To be exhibited at the IEEE show.

Hewlett-Packard Corp., 1501 Page Mill Rd., Palo Alto, Calif., 94304. [413]

Microwave sources are solid state

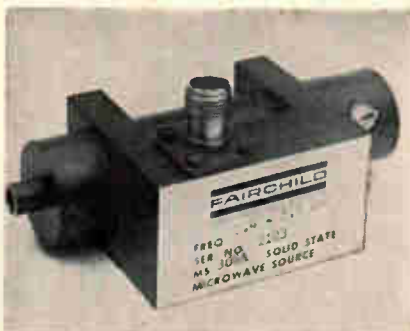

Two solid state, microwave signal sources provide a minimum of 5-mw power output over their specified tuning ranges. The MS-306A and MS308A both offer low residual f-m noise (typically less than 2 cps rms), which makes them ideal for local-oscillator applications in telecommunication systems.

The MS306A is single screw tunable over a 4.4- to 5.0-Gc range; and the MS308A is single screw tunable over a range of 5.4 to 5.9 Gc. Both can be voltage tuned. The sources are rated for operation from -55° to $+100^{\circ}$ C. Spurious harmonics are at least 60 db below output within the specified tuning ranges, and 50 db below output outside the specified tuning ranges.

Price is \$400 each.
Fairchild Semiconductor, a division of Fairchild Camera and Instrument Corp., 2513 Charleston Road, Mountain View, Calif. [414]

the DA 450

60 Point Programmed Frequency Response Analyzer plus



the DA410 Frequency Response Analyzer

- automatically programs 60 test conditions: in frequency — .001-1,000 cps, in amplitude — .01-1.0 F.S.
- output: phase and amplitude accuracy — 1°, 1%
- BCD coded to printer
- 40 db of noise and harmonic rejection
- test time: 1½ cycles of test frequency to 1 cps, 2 secs/pt above 1 cps
- automatic operation with all printers to give permanent record of results
- test conditions may be changed fast and easy
- options available to match your Automatic Control System Frequency Response Analysis requirements

Write for Bulletin DA450

Weston Instruments, Inc.
BOONSHAFT AND FUCHS DIVISION
Hatboro, Penna. 19040

WESTON® prime source
for precision . . . since 1888

**IMPROVE YOUR PRODUCTS WITH
COMPONENTS GOOD ENOUGH
TO WALK IN SPACE!**

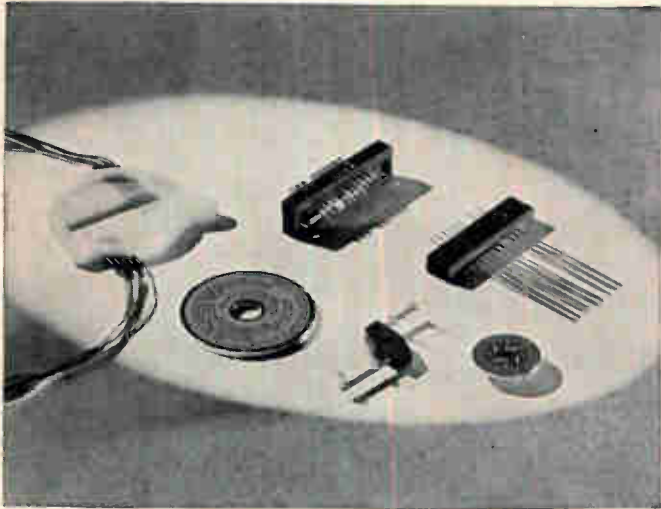

**NEY CONTACTS
NEYETCH® COMMUTATORS
BRUSH ASSEMBLIES**

In our Nation's first famous walk in space, the suit's equipment included Ney precious metal contacts. It is hard to think of a situation where reliability took so much responsibility. Would that kind of reliability improve your products?

Neyetch Commutators, shown above, give you a pattern of SOLID PRECIOUS METAL ALLOY (Neyoro G) bonded to a rigid insulator. Solid metal means positive control of physical properties, greater strength, hardness and wear resistance, extended shelf life, and elimination of common plating defects such as porosity, flaking, peeling, pits and inclusions. In other words, you get built-in RELIABILITY.

To work with Neyoro G commutators, Ney makes brushes of a matching precious metal alloy, Paliney 7. Both alloys are high in noble metal content, yet hard and strong, and very resistant to wear when used together. They provide low electrical noise, low contact resistance and high corrosion resistance. **SEND FOR ILLUSTRATED CATALOG**

**WE MAKE OUR OWN
PERFECTLY MATCHED ALLOYS**

**NEYORO® G for commutators
PALINEY® 7 for brushes**



THE J. M. NEY COMPANY

MAPLEWOOD AVE., BLOOMFIELD, CONN.

Circle 523 on reader service card

**414
STANDARD
MODELS...**

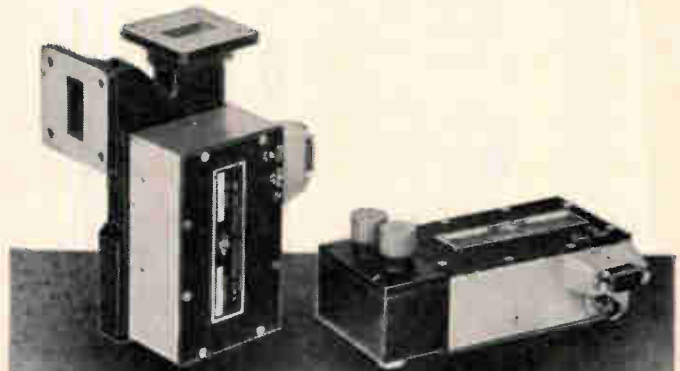

**RHG MIXER
PREAMPLIFIERS**

FEATURING

- SSB Noise figures to 7.0 db • "G" Series or "hot-carrier" diodes • MIL Grade • RFI Protected • Coaxial or Waveguide • Ultraminiature models

RANGE OF SPECIFICATIONS

RF Frequency:	250 MHz to 36 GHz
IF Frequency:	10 MHz to 300 MHz
IF Bandwidth:	2 MHz to 250 MHz
Gain:	20 db to 80 db
Price:	From \$525

Utilizing a complete complement of microwave test instrumentation backed by engineering know-how, an additional **346 CUSTOM DESIGNS** have been produced. The solution to your problem may be on file in our library now.

For specials, test our ONE-DAY-QUOTE Service. For standards, see complete listing in EEM Section 3400.

RHG

RHG ELECTRONICS LABORATORY, INC.

94 Milbar Blvd., Farmingdale, N.Y. 11735
(516) 694-3100

MICROWAVE FM and AM RECEIVERS • MICROWAVE MIXER PREAMPS
LINEAR and LOG IF AMPLIFIERS • RF and OCTAVE AMPLIFIERS

Circle 263 on reader service card

When Motor Specifications
demand

- HIGH INITIAL TORQUE
- FLEXIBLE SPEEDS
- CONTINUOUS USE
- RESISTANCE TO HEAT OR COLD



turn the job over to
SYNCHRON® MOTORS!

No matter whether you need a motor that can "do tricks" or handle simple routine work, think of a SYNCHRON Motor first. Here at Hansen Manufacturing Co., we've helped designers and production people solve problems ranging from unusual cycling patterns, to meeting swiftly varying temperatures, and a hundred other special applications. And of course we've supplied industry with literally millions of motors for uncomplicated designs. We can help you, too; write or phone us!

HANSEN

MANUFACTURING COMPANY, INC.



PRINCETON,
INDIANA

HANSEN REPRESENTATIVES: CAREY & ASSOCIATES, Houston, Tex., R. S. HOPKINS CO., Sherman Oaks, Calif., MELCHIOR & MACPHERSON, INC., San Carlos, Calif., THE FROMM CO., Chicago, Ill., H. C. JOHNSON AGENCY, INC., Rochester, N. Y., WINSLOW ELECTRIC CO., Essex, Conn., Narberth, Pa., and New York, N. Y. EXPORT DEPARTMENT, 64-14 Woodside Ave., Woodside, N. Y.

New Production Equipment

Automated wave-soldering for p-c boards

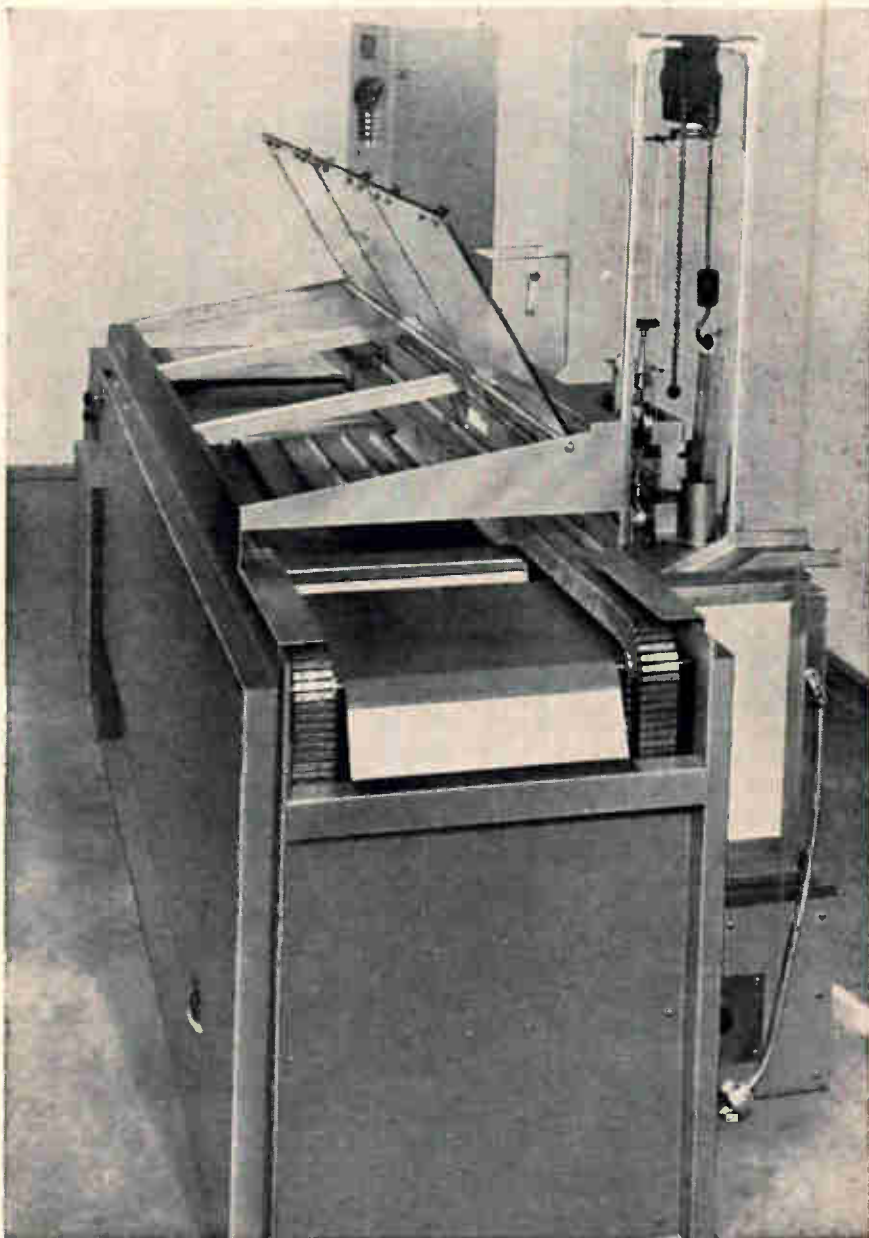

Stainless-steel fingers on wave soldering equipment transport pallets from p-c board assembly line through the wave-soldering process.

A wave-soldering system can be directly integrated into present printed-circuit board assembly lines. In a typical assembly line, the p-c boards are first inserted into pallets or frames and then pass through component insertion stations. They are then hand-carried to the soldering station.

In Electrovert, Inc.'s 346-15 system, the same pallet carries the p-c board from the beginning—component insertion—to the final opera-

tion—soldering. Thus, the loading procedure previously required between these two operations is now completely eliminated and operator intervention in the assembly procedure is avoided—contributing to a more reliable and efficient assembly process.

A continuous belt of stainless-steel fingers accepts the pallets from the assembly line conveyor. The fingers are designed to accept slotted pallets which carry boards

New, low-cost Philbrick Operational Amplifiers



Philbrick has always produced a wide variety of cool, reliable, solid state operational amplifiers for measurement, computing, control, data processing and testing. They provide premium performance and are priced accordingly. Their specified operating temperature exceeds -25° to $+85^{\circ}\text{C}$. Now Philbrick also offers economical equivalents of many of the most popular types in a utility grade, at substantially reduced prices. Savings generally exceed 50%. Yet, these utility grade amplifiers have identical performance with their premium grade equivalents within a limited temperature range, usually 0° to 60°C , but operate over the full range. And they too carry a two-year warranty. For a chart giving detailed comparative specifications of more than 60 Philbrick Operational Amplifier types write, wire or phone: Philbrick Researches, 22H Allied Drive at Route 128, Dedham, Massachusetts. Telephone (617) 329-1600.

Engineering Representatives

Ala.: Huntsville (205) 536-8393, Mobile (205) 954-9298; Ariz.: Phoenix (602) 265-3629; Cal.: Los Angeles (213) 937-0780, Palo Alto (415) 326-9800, San Diego (714) 222-1121; Colo.: Denver (303) 733-3701; Conn.: West Hartford (203) 233-5503, Greenwich (203) 661-5140; Fla.: Ft. Lauderdale (305) 564-8000, Orlando (305) 425-5505; Ill.: Chicago (312) 676-1100, (312) 676-1101; Ind.: Indianapolis (317) 356-4249; La.: New Orleans (504) 242-5575; Md.: Baltimore (301) 727-1999; Mass.: Wakefield (617) 245-5100; Mich.: Detroit (313) 838-7324; Minn.: Minneapolis (612) 545-4481; Mo.: St. Louis (314) 741-3779; N. M.: Albuquerque (505) 268-3941; N. Y.: Buffalo (716) 835-6186, DeWitt (315) 446-0220, Valley Stream (516) 561-7791; N. C.: Winston-Salem (919) 725-5384, (919) 725-5385; Ohio: Dayton (513) 298-9964, Westlake (216) 871-8000; Okla.: Tulsa (918) 627-6199; Pa.: Philadelphia (215) 277-0559, Pittsburgh (412) 371-1231; Tex.: Dallas (214) 526-8316, Houston (713) 781-1441; Utah: Salt Lake City (801) 466-4924; Va.: Alexandria (703) 836-1800; Wash.: Seattle (206) 723-3320.
EXPORT: N.Y.: New York (212) 246-2133.
CANADA: Quebec: Montreal (514) 482-9750, Ontario: Toronto (416) 789-4325.

ELECTRONIC ANALOG COMPUTING EQUIPMENT for MODELLING, MEASURING, MANIPULATING and MUCH ELSE



PHILBRICK

SCIENTIFIC and TECHNICAL BOOKS FROM McGRAW-HILL

1. PHYSICS OF QUANTUM ELECTRONICS, CONFERENCE PROCEEDINGS. Edited by P. L. Kelley, B. Lax, and P. E. Tannenwald. As the collected papers of the Physics of Quantum Electronics Conference held at San Juan, Puerto Rico in June, 1965, this book provides a unique source of recent basic research information. The contributors include many of the world's foremost authorities (including Russian and Japanese). They incorporate material not previously treated in the literature of quantum electronics and provide extensive coverage of nonlinear phenomena, as well as laser spectroscopy, and many other new laser developments and applications. 700 pp., \$24.00.

2. RANDOM-PROCESS SIMULATION AND MEASUREMENTS. By Granino A. Korn. Emphasizing up-to-date computer techniques, this book provides an uniquely authoritative and comprehensive presentation of random-process simulation and measurements. It examines modern methods utilizing analog, digital, and hybrid analog-digital computers. Instrumentation and computing procedures as well as theory are thoroughly described. Engineers and scientists in the areas of control, guidance, communication, detection and instrumentation will find this unified treatment, and the inclusion of new techniques, of unusual value. So will programmers, digital-control engineers, and all who are interested in statistical data processing. 224 pp., \$12.50.

3. APPLICATIONS OF ELECTRONICS, 2ND EDITION. By Bernard Grob and Milton S. Kiver. Expanded, updated, this book thoroughly covers principles and applications in the most important phases of electronics and communications. 592 pp., \$11.50.

4. FOUNDATIONS FOR MICROWAVE ENGINEERING. By Robert E. Collin. This thorough introduction to microwave devices and electronics requires no previous knowledge of the field. The book covers a large variety of important devices without resort to complicated mathematics. 589 pp., \$18.00.

5. HOW TO BECOME A PROFESSIONAL ENGINEER, 2ND EDITION. By John D. Constance, P.E. Here an eminent registration consultant brings you the facts you need to become a professional engineer and share in the professionals' greater opportunities. He shows you how to simplify your quest for a license, how to prepare for examination, what examiners look for, what to avoid, and how to keep down emotional stress during your examination. 320 pp., \$7.50.

6. THE COMPLEAT STRATEGYST, REVISED EDITION; BEING A PRIMER ON THE THEORY OF GAMES OF STRATEGY. By J. D. Williams. This fascinating book "puts an ace up your sleeve" by showing you how games of strategy—and real-life situations—can be analyzed to determine the strategies available, and to pick the one most likely to win. Requires no more than ordinary mathematics. 288 pp., \$6.95.

7. FUNDAMENTALS OF VACUUM SCIENCE AND TECHNOLOGY. By Gerhard Lewin. This book provides a comprehensive, yet brief description of modern vacuum techniques and equipment, based on wide experience and advanced developments at the Plasma Physics Laboratory at Princeton University. 248 pp., \$11.50.

8. THE MACHINERY OF LIFE. By Dean A. Wooldridge. A brilliant, compellingly logical case for the evolution of life from the inanimate molecules of primordial times to its present forms. Fact- and theory-filled, yet easy to read and understand. 224 pp., \$7.95.

SEE THESE BOOKS AT YOUR BOOKSTORE OR SEND COUPON FOR
10 DAYS FREE EXAMINATION

McGRAW-HILL BOOK CO., Dept. 23-L-228
 330 West 42 Street, New York, N. Y. 10036

Send me the book(s) encircled below for 10 days on approval. In 10 days I will remit for book(s) I keep, plus a few cents for delivery costs, and return unwanted book(s) postpaid. Save money: we pay delivery costs if you remit with this coupon. Same examination and return privilege. Include local sales tax if applicable.

1 2 3 4 5 6 7 8

NAME (print) _____

ADDRESS _____

CITY _____

STATE _____

ZIP CODE _____

For prices and terms outside U.S. write McGraw-Hill Int'l. NYC

Dept. 23-L-228

Production Equipment

up to 15-inches wide. These pallets slide onto the moving belt of the wave-soldering machines. The belt of stainless steel fingers then carries the pallets through the complete soldering operation. Retractable Pyrex glass panels over the soldering operation area trap fumes and vapors; they also permit visual observation of the soldering process.

The Electrovert 346-15 combines all the necessary features for automatic processing of p-c boards, including a system to "jet dry" the flux by evenly circulated hot, dry air at low temperatures. This contributes to more reliable soldering by drying off the flux solvents and leaving only the solid flux agent. Once through the flux dryer, the board passes over a radiating heater plate for thermal conditioning of the board before the soldering.

The soldering station has a reservoir tank with a capacity of 750 pounds. It forms a double-sided, laminar wave which is adjustable to $\frac{3}{4}$ inch high with a tolerance of $\frac{1}{32}$ inch. Wave temperature is precisely controlled and maintained within 1°C at the crest of the wave. The system also includes thermostatic overheat and underheat controls, plus a 7-day clock. It includes a centrally located vent to evacuate fumes, vapors and heat.

To be exhibited at the IEEE show.

Electrovert, Inc., 86 Hartford Ave., Mount Vernon, N.Y. [455]

Hand crimping tools are precision devices

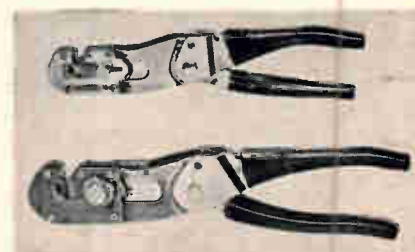

A series of die-type hand crimping tools is announced. Developed to meet military requirements, the C-

**PROVEN RELIABILITY—
SOLID-STATE POWER INVERTERS,
over 260,000 logged operational hours—
voltage-regulated, frequency-controlled,
for missile, telemeter, ground support,
135°C all-silicon units available now—**

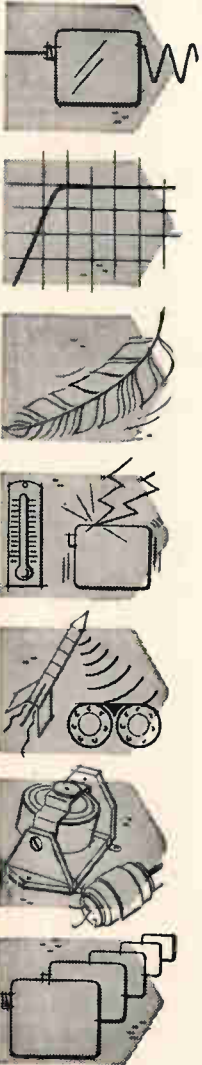
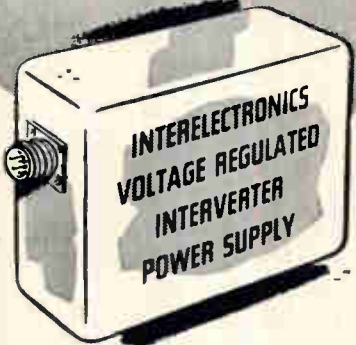

Interelectronics all-silicon thyatron-like gating elements and cubic-grain toroidal magnetic components convert DC to any desired number of AC or DC outputs from 1 to 10,000 watts.

Ultra-reliable in operation (over 260,000 logged hours), no moving parts, unharmed by shorting output or reversing input polarity. High conversion efficiency (to 92%, including voltage regulation by Interelectronics patented reflex high-efficiency magnetic amplifier circuitry.)

Light weight (to 6 watts/oz.), compact (to 8 watts/cu. in.), low ripple (to 0.01 mv. p-p), excellent voltage regulation (to 0.1%), precise frequency control (to 0.2% with Interelectronics extreme environment magnetostrictive standards or to 0.0001% with fork or piezoelectric standards.)

Complies with MIL specs. for shock (100G 11 msec.), acceleration (100G 15 min.), vibration (100G 5 to 5,000 cps.), temperature (to 150 degrees C), RF noise (I-26600).

AC single and polyphase units supply sine waveform output (to 2% harmonics), will deliver up to ten times rated line current into a short circuit or actuate MIL type magnetic circuit breakers or fuses, will start gyros and motors with starting current surges up to ten times normal operating line current.

Now in use in major missiles, powering telemeter transmitters, radar beacons, electronic equipment. Single and polyphase units now power airborne and marine missile gyros, synchros, servos, magnetic amplifiers.

Interelectronics—first and most experienced in the solid-state power supply field produces its own all-silicon solid-state gating elements, all high flux density magnetic components, high temperature ultra-reliable film capacitors and components, has complete facilities and know how—has designed and delivered more working KVA than any other firm!

For complete engineering data, write Interelectronics today, or call 914 Elmwood 8-8000.

INTERELECTRONICS CORP.

700 U. S. Route 303 Congers, New York 10920

Circle 546 on reader service card

The Finest Precision Coaxial Connectors



GRFF produces TNC, TM (Miniature), GM (Microminiature), and Series 2900 (which mate with OSM, BRM and others) connectors in a wide range of standard and crimp configurations; also TPS connectors; and specialized microwave components to individual customer requirements. Complete descriptive literature is immediately available.

General RF Fittings, Inc.

702 BEACON ST. / BOSTON, MASS. 02215
Telephone: 617 267-5120

Circle 267 on reader service card 267

NEW! The only bench type pantograph with 1:1 RATIO

Drills PRINTED CIRCUITS pneumatically
Engraves up to 100:1

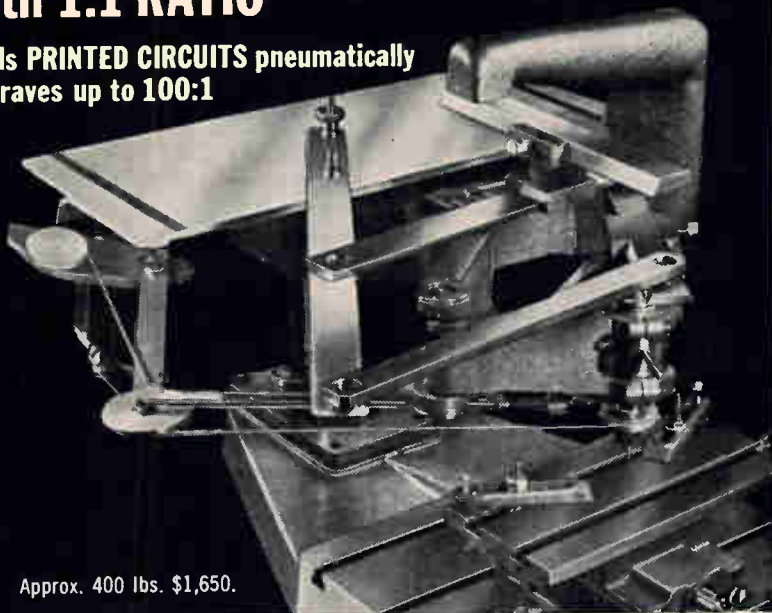

Approx. 400 lbs. \$1,650.

The most versatile machine tool for pantographic production drilling and routing. Reproduces your printed circuit prototype in full scale or in any ratio to 100:1. Ideal for unskilled labor. No changing of tools. One tool for all diameter holes and profiles. Close tolerances. Send for catalog # 139

new hermes engraving machine corp.

154 WEST 14th STREET, NEW YORK 11, N. Y. Chicago. Atlanta, Dallas, Los Angeles, Dayton, Detroit, Mexico City, Montreal

Circle 526 on reader service card

90% of all Japanese ITV cameras use COSMICAR lenses.

COSMICAR
INDUSTRIAL TV LENSES



For your vidicon, image orthicon and professional movie cameras, Cosmucar lenses are available in focal lengths from 12.5mm up to 1000mm.

New zoom lenses are now available.



ICHIZUKA OPTICAL CO., LTD.

2-568, SHIMOOCHIAI, SHINJUKU-KU, TOKYO

CABLE ADDRESS: "MOVIEKINO TOKYO"

Production Equipment

series tools also fill an urgent commercial and industrial demand for precision, easy-to-operate, cycle controlled, lightweight, compact yet strong tools for crimping terminals, lugs, splice fittings, r-f fittings, connectors, and special devices requiring special customized dies. These tools are available in standard and miniature sizes in three categories.

The CT type has many applications including MS-25036 terminal lugs and MS-25181 through splices. The CT-S standard tool accommodates fittings ranging in size from 12-10 through 26-24. The CT-M miniature tool covers sizes 16-24 through 26-24. Both models have a dial-for-size selector knob for obtaining precise crimp depth settings over a wide range of applications.

CH tools are for coaxial and shielded fittings and connectors. The CH-S standard and CH-M miniature tools feature hex interchangeable dies for either MS or special applications. The CH-S tool is said to be popular for BNC, TNC and N series connectors. The smooth precision action of the in-line die system is claimed to require much lower handle closing pressure than is presently found on competitive tools.

The CD tools may be supplied with blank dies for custom applications. Special dies can be made available as required. The same standard and miniature "C series" crimp tool frames are used.

To be exhibited at the IEEE show.

Buchanan Electrical Products Corp.,
1065 Floral Ave., Union, N.J. [456]

Automatic, drag-type soldering machine



Model SSM automatic drag-type soldering machine is especially geared for the small and medium

Solder 14 Flatpack Leads In 2 Seconds!

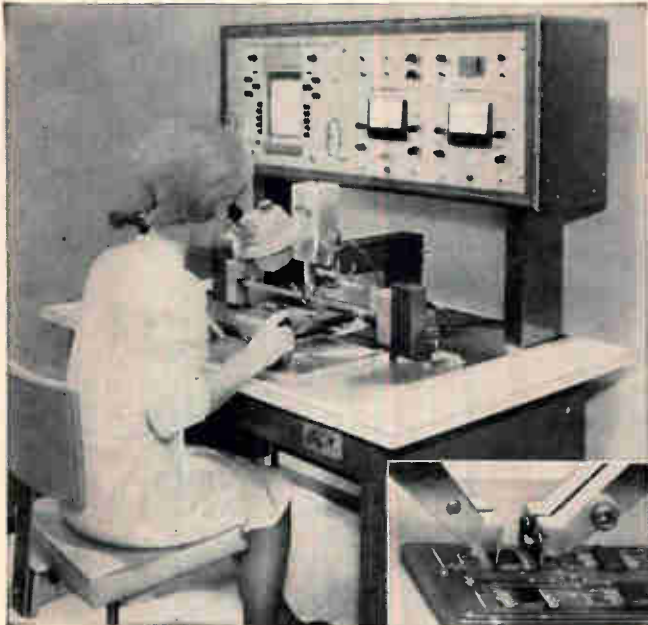

Weltek's new semi-automatic MODEL 900 solders all 14 leads of a flatpack to a p.c. board in just 2 seconds. A proven product, capable of full automation. Send for details.

Weltek

MICROJOINING MACHINES
by **WELLS ELECTRONICS, INC.**

1701 S. Main Street, South Bend, Indiana, U.S.A.

Circle 527 on reader service card

**WE CUT THE SIZE ...
WE CUT THE COST ...
WE KEPT THE PERFORMANCE**
to give you the best value in
LAB POWER SUPPLIES

8 3/8" 5 3/16"
2 15/16"

VOLTAGE CURRENT ON
+ - G

MODEL EA-10-1
NOW ONLY \$129⁰⁰ SILICON...71°C

Brand NEW FROM **HICKOK**

DMS-3200 Digital Measuring System



DMS-3200 Main Frame \$320
(shown with DP-100)

HIGHLIGHT FEATURES

3-digit Biquinary Tube Read-out
Plug-in Flexibility
All-electronic
Fully-transistorized
Modular Design
Fully Field-tested
Automatic Polarity Indication
Automatic Decimal Point Indication

AS A DIGITAL DC VOLTMETER (DP100 Plug-in)
Range 0.1 millivolts to 1000 volts
Accuracy $\pm 0.1\%$ FS, $\pm 0.1\%$ of reading
True integrating voltmeter design
10 megohms input impedance at all times

AS A DIGITAL 1 MC COUNTER (DP150 Plug-in)
 $\pm 0.005\%$ accuracy; Resolution 1 part in 10^7
(Overrange capability with sector read-out permits 3-digit display to be equivalent of a 7-digit instrument)
Frequency measurement range 0.1 cps to 1 mc
Period measurement range 0.1 ms to 999 seconds

AS A DIGITAL OHMMETER (DP170 Plug-in)
Range 0.01 ohm to 1,000 megohms
Accuracy $\pm 0.1\%$ FS, $\pm 0.2\%$ of reading

AS A DIGITAL CAPACITY METER (DP200 Plug-in)
Range 1.0 picofarad to 10,000 microfarads
Accuracy $\pm 0.1\%$ FS, $\pm 0.2\%$ of reading

The DMS-3200 is designed for rugged Industrial and laboratory applications. By utilizing a design which has the optimum combination of accuracy capability and number of digit display, the DMS-3200 meets the general purpose measurement needs of industry for reliable, precision digital measurement equipment in the \$400-\$500 price range.



DP-100
DC Voltmeter
Plug-in
\$175

DP-150
1 MC Counter
Plug-in
\$175

DP-170
Ohmmeter
Plug-in
\$240

DP-200
Capacity
Meter
Plug-in
\$240

THE HICKOK ELECTRICAL INSTRUMENT CO. • 10514 Dupont Avenue • Cleveland, Ohio 44108

Circle 528 on reader service card

Deltron

ED SERIES (12 automatic crossover models)
EA SERIES (12 current limiting models)

You won't find a better value in lab power supplies (voltage ratings up to 100 V . . . current ratings up to 2 A) . . . with these important features.

- 0.01% regulation
- ED units feature DUET twin amplifier system for continuous voltage or current control with automatic electronic crossover.
- EA units have continuously adjustable current limiting
- Completely protected and automatic recovery from overload and short circuit conditions.
- PLUS floating output . . . no overshoot . . . remote sensing . . . remote programming . . . automatic series and parallel operation . . . and many other advanced features.

FOR COMPLETE INFORMATION WRITE TO . . .

Deltron inc.

WISSAHICKON AVE., NORTH WALES, PA. 19454
PHONE: (215) 699-9261 TWX: (510) 661-8061

Circle 269 on reader service card

269

WITH THIS HEAT SINK...

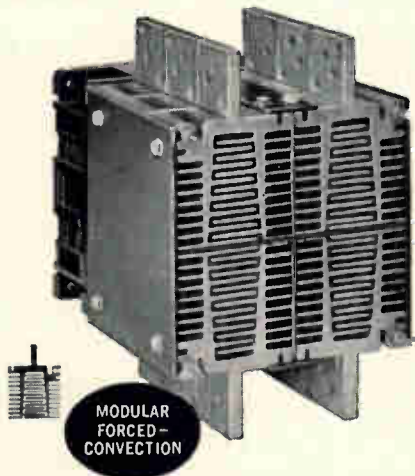

2 to 3 times previously achievable ratings

for power transistors
and power diodes

FLEXIBILITY permits easy design of custom packages using side panels as terminal boards or for component mounting.

ACCESSIBILITY of mounted components for installation, maintenance, or replacement on easy-to-get-at transistor shelves. (Specify any mounting pattern)

CIRCUIT EFFICIENCY with reduction of number of transistors needed and decrease of compensating capacitors and resistors.

LIGHT WEIGHT and high strength/weight ratio of aluminum permits use of combined unit as an integral part of component design.

COMPACT BLOWER is standard, commercial unit providing forced convection for banks of 4, 8, 12, 16 or more individual heat sinks.

One of over 80 Astrodyne standards, this "building block" design provides more heat transfer surface in less space than most other devices.

Astrodyne (successor to Astro Dynamics Heat Sink Div.) Representatives and Distributors throughout the USA and Europe are prepared to assist with immediate price and delivery information. Call, wire or write for detailed information.



astrodyne, inc.

SUBSIDIARY OF ROANWELL CORP. 207 CAMBRIDGE ST.
BURLINGTON, MASS. (617) 272-3850

Circle 548 on reader service card

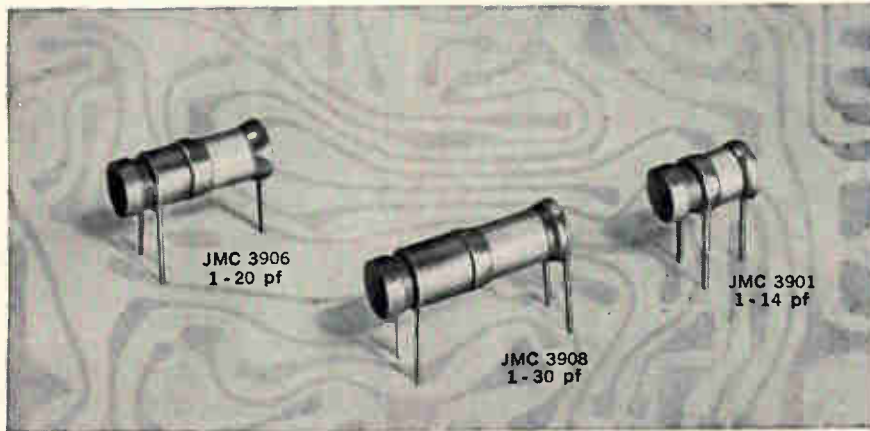

High Q Air Capacitors!

Get accuracy and tuning stability with Johanson Variable Air Capacitors. High Q—Low Inductance makes units suitable for VLF to UHF applications. Low temperature coefficient.

Working Voltage 250 V DC at from -55°C to $+125^{\circ}\text{C}$. All units are hermetically sealed.

Here's top reliability for military and industrial applications.

Write for catalog on

Johanson

**VARIABLE AIR CAPACITORS
MANUFACTURING CORPORATION**

400 ROCKAWAY VALLEY ROAD, BOONTON, N. J. • Phone: (201) DEerfield 4-2676

Production Equipment

sized manufacturer of p-c boards. Fully adjustable to speeds of 5 to 25 ft per minute without bridging problems, the machine requires no pumps for solder and oil thus permitting maintenance-free operation. It comes with a choice of two carriers that can accommodate printed-circuit boards up to 8 in. x 9 in.

The unit is easily adaptable to conveyORIZED lines, and commercially available fluxing and cleaning equipment can be adapted. The SSM measures 72 in. long x 18 in. wide x 15 in. high. The solder bath is accurately controlled to $\pm 5^{\circ}\text{F}$. Solder level is not critical because the p-c boards actually float on the solder surface, preceded by a skimmer that removes all oxides and other impurities.

Price is \$2,600; delivery, six weeks.

To be exhibited at the IEEE show.

Zeva Electric Corp., 11 Park Place, New York, N.Y., 10007. [457]

Automatic dipper for IC's and flatpacks

Automatic dipping equipment model ADT tins both leads of components at a rate of 1,000 to 4,000 or more an hour, depending on size of components and cycle time. It can be used for integrated circuits and flatpacks. ADT is used with the model 1147 ultrasonic solder pot.

Depth of immersion, dwell time, and speed of withdrawal are adjustable. The operator places a pre-loaded clip in place and presses a foot pedal. The unit immerses bottom component leads, dwells for a predetermined time, rises at a controlled rate, rolls over, immerses top component leads, dwells, rises, and rolls over to original position. The operator then unloads the clip.

Unit construction is aluminum, stainless, or chrome-plated steel. Size is 21 by 24 by 16 in. over-all. Power input is 115 v, 60 cycles, 2 amps.

The Redford Corp., 1092 Catalyn St., Schenectady, N.Y., 12303. [458]

TAPE PUNCH
LIST PRICE
\$695.

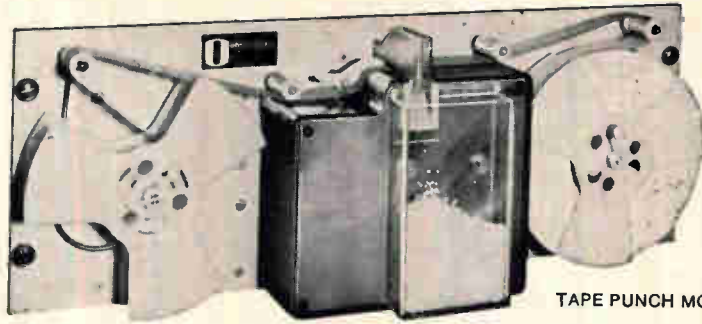

TAPE PUNCH MODEL 110R

Here is what the Series 110 Punch will do for you:

Punches at 30 characters per second asynchronously

Punches 5 to 8 channel paper or mylar tape

Two adjustable cam switches for interlocking with connected equipment

Reversing electro-magnet for backspacing of tape
24 or 48 volt vdc

Contacts on electro-magnets for error checking, pulse stretching or holding for multi-punch operation

Can inhibit punching in event of error

One year warranty

Standard 19" panel mount

Impossible to punch elongated hole

If you need more information, please contact us.

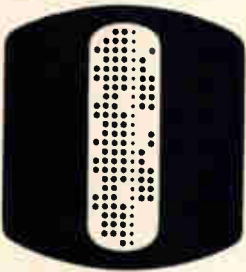

other **ohr-tronics** products:

SERIES 119 tape readers

SERIES 117 encoding keyboards

SYSTEM 80 for inventory control

TAPE PREPARATION SYSTEMS

ohr-tronics INC.

Dept. 6D

Time & Life Bldg. / 111 West 50th St. / New York, N. Y. 10020 / 212 CO 5-3067 / 212-581-3570 / twx #201 391-5118

Manufacturing and Engineering: Montvale / New Jersey

in Great Britain: Hodford House / High Street / Hounslow / Middlesex / England / HUDson 0777

Circle 530 on reader service card

NCC to be Sure

POLYESTER FILM CAPACITORS

Type MXT.



In Plastic Tube.

Capacitance

Range : .001 MFD to .22 MFD.

Voltages : 100v, 200v, 400v, 600v DC.

Type MFL.

dipped Flat Shape.
Capacitance

Range : .001 MFD to .47 MFD.

Voltages : 35v, 50v, 100v, 200v DC.



Type MFK.

dipped Flat Shape.

Non-Inductive Construction.

Capacitance

Range : .01 MFD to .22 MFD.

Voltages : 100v, 200v, 400v, 600v DC.

METALLIZED POLYESTER FILM CAPACITORS

Type FNX-H



Mylar Wrapped Semoval
With Epoxy End Seal.

Capacitance

Range : 1 MFD to 10 MFD.

Voltages : 50v DC.

SOLID TANTALUM CAPACITORS

Type TAS.

Sealed with Epoxy Resin.



Capacitance

Range : 1 MFD to 220 MFD.

Voltages : 3v, 6v, 10v, 15v, 20v, 25v, 35v DC.

Type TAX.

MIL-C-26655A Hermetically Sealed.

MATSUO ELECTRIC CO., LTD.

HEAD OFFICE: 3-chome, Sennari-cho, Toyonaka-shi, Osaka, Japan.

Cable Address "NCC MATSUO" OSAKA

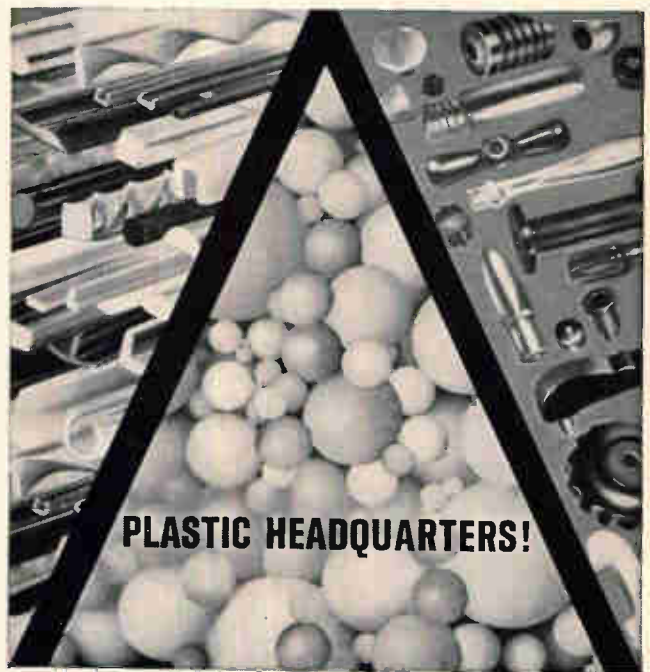

PLASTIC HEADQUARTERS!

Extrusions, balls and parts

SINCE 1931
EXTRUDERS
A
FABRICATORS
ACE

ACE is one of America's leading mass producers of an almost unlimited variety of plastic products. Extrusions, seamless balls, fabricated parts, etc.—in almost any size, quantity, color, tolerance, shape, form or plastic including nylon, teflon*, acrylic or you name it. Small runs or large runs. In stock or specials. Write, wire or call for samples, price lists and technical bulletins. *Teflon is DuPont's registered trademark for Fluorocarbon resin.

ACE PLASTIC CO., INC. (91-20) VAN WYCK EXPWY., JAMAICA, N.Y. • (212) JA 3-5500

Circle 531 on reader service card

Circle 271 on reader service card

Does this look like an answer to global problems of ignorance, disease and physical deprivation?



Not yet. But we're getting closer.

Behind this movement is a simple statistic with startling implications for all of us—*if you count all the scientists and engineers since the beginning of recorded history, ninety percent are alive today!*

We are now in the midst of the result—an incredible explosion of information from every corner of the globe. And somewhere within this explosion will be the ultimate answers to mankind's oldest, and newest problems.

The challenges are many. First, to understand the nature of this giant intellectual force. Then, to find the best way to collect it, classify it, store it... and distribute it appropriately

and instantly to the people who need it.

In this light, you might consider today's Xerox products early and primitive steps along a difficult but fascinating path. You'd be right. Yet, has anyone taken these steps before us?

Your degree and background may be more appropriate to our advanced work than you imagined. We're as interested in talking with communication systems specialists as electromechanical designers, organic chemists as much as program analysts. This list is as broad as it is long. Maybe broader. You'll find several specific (and urgent) openings outlined at the right. If they suggest a possible community of interest, send us your resume. An equal opportunity employer (M&F).



The Xerox 914 Copier revolutionized the office copying industry when it was introduced in 1959... and really started us on our way.



Less than 3 years later, the 813 further extended low-cost, quality office copying. One-seventh the volume of the 914, it does just about everything the 914 does except copy solid, 3-dimensional objects.



Another revolution. An electro-mechanical-chemical-optical device called the 2400 because it produces 2,400 copies per hour directly from an original document. No stencil or "master" of any kind. You press a button.

XEROX

TOP PHOTO: LDX (Long Distance Xerography) scans, transmits and reproduces images over distances limited only by the transmission medium. Something like it may print the morning paper at your breakfast table some day, or help you manage a global business.

XEROX, 914, 813, 2400 AND LDX ARE TRADEMARKS OF XEROX CORPORATION

Does this look like an answer to your career problems?

ELECTRONIC DEVELOPMENT ENGINEERS. Will assist in the development of new techniques and in the design of electronic circuits and devices for government contract and development projects. Experience in two or more of the following areas is required: automatic test equipment design, analog/digital circuits, electro-optical subsystems, display technology, information theory, signal processing, sensors, light modulation, imaging and laser devices. BSEE required.

COMPUTER PERIPHERAL SYSTEMS ENGINEERS. Electrical or mechanical engineers, with experience in the peripheral equipment area for data systems or computer systems including development work on magnetic tape, magnetic drums, punched card equipment, electromechanical printers. Should also have been involved with systems planning and/or systems integration of computer peripherals with computer systems.

LIAISON ENGINEER. Experience in product engineering and manufacturing field liaison work and familiarity with manufacturing processes and cost reduction techniques concerned with the manufacture of electromechanical equipment.

These positions are in Rochester, New York. Send resume, including salary history to Mr. Gerald L. Swanson, Dept. ZDC-118, Xerox Corporation, P.O. Box 1540, Rochester, N. Y. 14603.

XEROX

An Equal Opportunity Employer (M&F)

New Books

Microwaves

Electromagnetic Field Theory
R.D. Stuart
Addison-Wesley Publishing Co., Inc.,
214 pp., \$8.95

In an attempt to introduce the reader as rapidly as possible to electromagnetic theory, the author takes too many short cuts. For example, although lumped- and distributed-parameter circuits and fields are covered in logical sequence, no discussion of the theory of transmission lines, essential to understanding electromagnetic field theory, is given. Despite its title, only about half the book is devoted to fundamental electromagnetic theory. The remainder deals with more advanced topics such as nuclear accelerators, ionized gases, electron beams and plasma physics. In fact, the book as a whole leans more toward physics than engineering. A positive feature is the clear mathematical analysis throughout.

Field concepts are lucidly introduced in terms of circuit theory. Interpretations of the properties of the electromagnetic medium in terms of circuit elements, and the calculation of the element values, are clearly presented and are instructive. After this introduction, the author discusses static fields, waves and radiation. The brief treatment of the solution of the scalar and vector Poisson's equation clearly defines the general boundary value problem.

The concept of electrical polarization and magnetization is introduced here and the discussion on waves and radiation is carried out straightforwardly. Unfortunately, the antenna theory is only mentioned and the notion of retarded potential is not explained.

In discussing the properties of waves, power flow, and equivalent circuits for waveguide systems, particular attention is paid to waveguides and cavities with rectangular geometry.

The second half of the book covers special devices. Information on the motion of charged particles in fields is applied to cathode-ray tubes, mass spectrographic devices, nuclear accelerators, and diodes. In

treating ionized gases and ferrites, relations for magneto-ionic media are derived, and wave propagation in several media is discussed. The operation of isolators and gyrators are also described; the theories of waves in electron beams and waves in periodic structures are developed and applied to explain the operation of traveling-wave tubes. The book concludes with an explanation of basic plasma physics, including treatment of the motion of charged particles in a plasma medium, the theory of magneto-hydrodynamics and the radiation pressure of electromagnetic waves.

The coverage is often brief, but much ground is covered, making the book more useful as a quick reference than as a source of detailed information. It is clearly written, up to date, and relatively free of errors.

Chien H. Tang

Raytheon Co.
Wayland, Mass.

Communications

Principles of Communication Engineering. John W. Wozencraft and Irwin Mark Jacobs. John Wiley & Sons, 720 pp., \$17

The authors have taken on the formidable job of presenting to the communications engineer a vast body of knowledge which has accumulated piecemeal in the journal literature. Wozencraft and Jacobs indicate that they were motivated by three related objectives: to establish a sound frame of reference for further study in communication, random processes and information and detection theory; to make the central results and concepts of statistical communication theory accessible and meaningful to the practicing engineer; and to illuminate the engineering significance and application of the theory and to provide a quantitative basis for the compromises of engineering design.

However, these objectives would have been more accurately expressed by the title, "Communication Theory with Engineering Applications." The actual title implies that the book is about planning and

New Books

constructing communication systems, rather than providing a background for further study. The authors show adequately how the theory is an important and necessary adjunct to the background of the communications engineer. Much of the material concerns digital communications, but because of the desire to present complex ideas in the simplest possible context, the book is primarily concerned with Gaussian channel disturbances and performance bounds obtainable from mathematical deductions. Thus, the authors have limited the possibility of solving practical problems. Probably few people will agree with the authors' statement: "Extension to more general channels and tighter bounds requires additional techniques, but little that is new in the way of concept." A few new concepts are very much needed in the application of complex codes to actual communication systems.

After the introduction, the authors plunge immediately into the complex problems of advanced probability theory. An undergraduate course on probability is required before studying this chapter, which discusses deriving statistical relationships from a theoretical viewpoint in a system where the individual statistical bounds of the components are known, and obtaining the statistical relationships concerning the complete system.

After a discussion of probability theory, the authors discuss random waveforms and cover random processes, filter impulse noise, the multivariate central limit theorem, the Gaussian process, correlation functions and matrix notation. These two mathematical chapters on statistical relationships take up nearly one third of the 711-page book. Unfortunately, optimum receiver principles—an extremely important subject for communications engineers—is given only 74 pages. Such important subjects as modem design, transmission systems, modulation characteristics, switching systems, signaling and supervision, which are important for communications engineers, are discussed

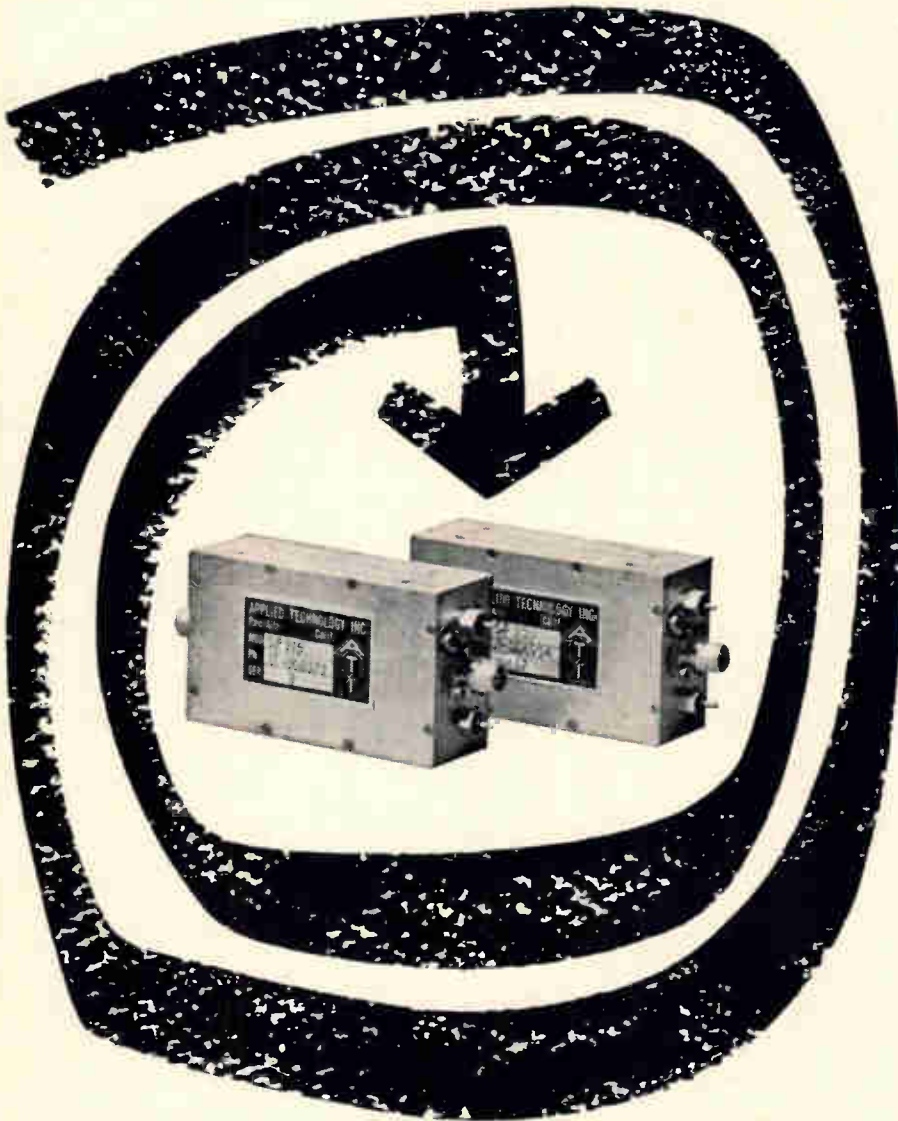

Seems strange that such small preamplifiers could offer linear power output to **+20 dbm**

and frequency coverage to 400 mc . . . while still featuring a low-noise figure. But they do. The SP-200 series can be used in octave bandwidth applications where a wide dynamic range and a noise figure of 5 to 6 db is required. ■ Today the reliable SP-100 preamplifier family from 100 mc to 1000 mc is also more attractive. ATI reduced prices up to 34% on the entire line on February 1, 1966. ■ Nice, isn't it?

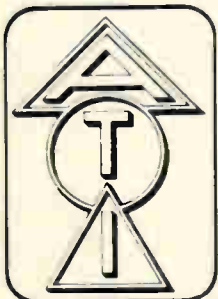

For complete details please contact ATI at 3410 Hillview Avenue, Palo Alto, California. Telephone, (415) 321-5135; Cable APTEC, Washington, D. C. office, (703) 532-8188.

APPLIED TECHNOLOGY INCORPORATED

Active Countermeasures • Reconnaissance and Surveillance • Special Communications Techniques

Admiral's new 9" tube-chassis portable TV is small, but very reliable.

Capacitors of MYLAR® help make it that way.

"And they meet all standard voltage ratings up to 600 volts," says David Oliva, Admiral's Chief Components Engineer.

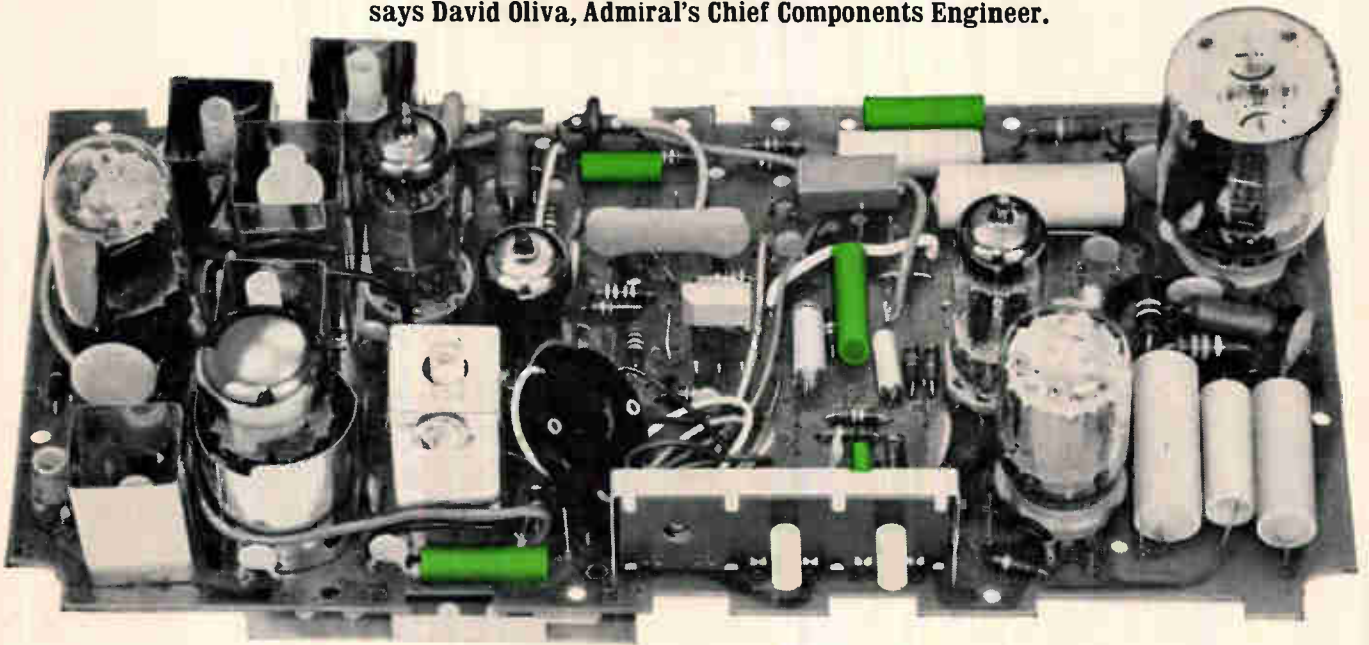

The new Admiral "Playmate" is America's first 9" portable TV with a tube chassis. It weighs only 12 pounds because components were selected not only for reliability, but also for savings in size and weight. That's why Admiral Corporation chose capacitors of MYLAR* polyester film.

Mr. Oliva puts it this way: "Capacitors of MYLAR are really rugged. They meet all standard volt-

age ratings up to 600 volts. In our tests, they withstood rough handling, excessive humidity and high-altitude conditions far beyond anything you'd expect to find in normal TV usage. Because MYLAR has high dielectric strength in thin gauges, it makes a smaller, lighter capacitor. Compared with paper, capacitors of MYLAR give us far more reliability at the same or less cost per microfarad."

Chances are you can take advantage of the greater reliability and design potential offered by capacitors of MYLAR. For complete information write to: Du Pont Co., Room 3667A, Wilmington, Delaware 19898. (In Canada: Du Pont of Canada Ltd., P.O. Box 660, Montreal, Quebec.)

*DU PONT'S REGISTERED TRADEMARK FOR ITS POLYESTER FILM.

Better Things for Better Living
... through Chemistry

only DU PONT makes
MYLAR®
POLYESTER FILM

See the dielectric properties of "MYLAR" demonstrated at the I.E.E.E. Show, Booths 4G03-4G07

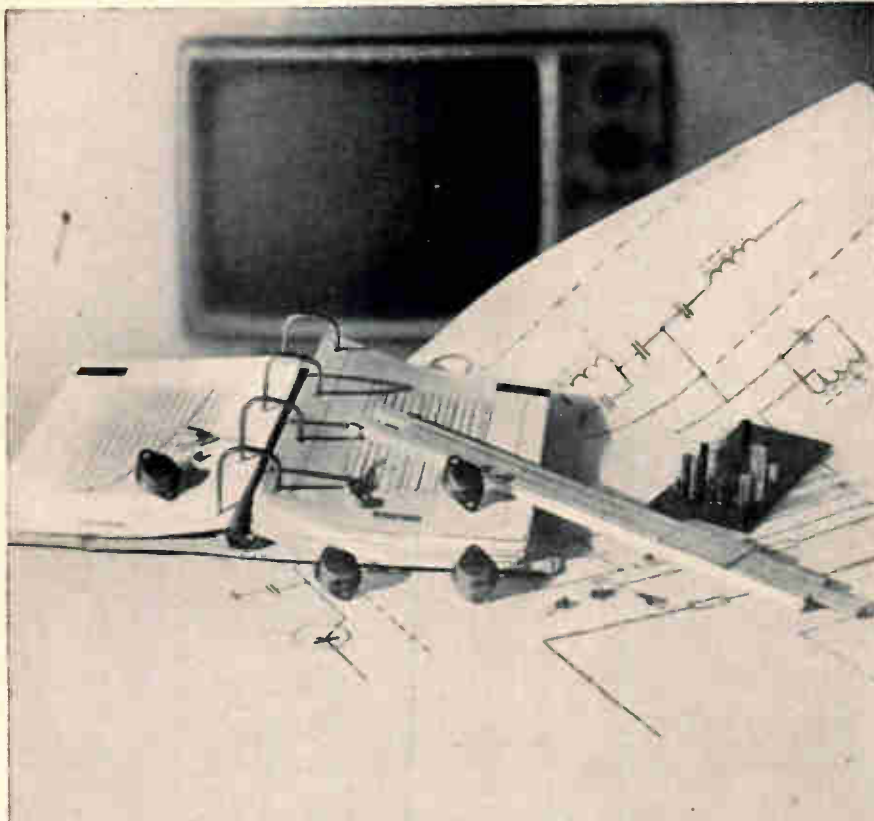

ATES SEMICONDUCTORS FOR SOLID-STATE TV RECEIVERS

For the solution to every one of your TV problems, we have selected the best techniques available in Europe and in the United States.

Increased reliability, improved overall performance, reduced service costs and power consumption will make your solid-state large-screen TV receiver the hit of the year.

With Germanium Mesa, High-Voltage Power Drift, Silicon Planar, PNP/NPN Complementary pairs and others, ATES transistors cover every application in the entertainment field.

ATES

COMPONENTI ELETTRONICI S.p.A.
Sales Dept. - Via Tempesta 2 - Milan (Italy) - Phone 4695651 (4 lines) - Telex 31481

New Books

only briefly, or are not even mentioned. However, the treatment of the subjects included is excellent and the subjects are important ones for the communications engineer.

A good fundamental discussion of coding for digital communications is given. The authors, who are expert in this field, have done a commendable job. However, the amount of discussion on coding is overdone for a book on communication engineering. Furthermore, by limiting the discussion to Gaussian channel disturbances, the authors have severely limited the ability of the reader to apply the results to actual channels. The space given to what the authors call waveform communications, a system where the set of possible input messages is defined on a continuum—referred to by others as analog systems—is less than 100 pages. For the present-day engineer—who must deal primarily with transmissions of this type—this coverage is inadequate.

It is also a little disturbing to see the authors use digital numbers, 1 and 0, to indicate finite sample spaces and letters, A and B, to indicate digital probability. Thus the equations which are normally used for digital relationships appear with the A, B notation; the equations which are normally used for finite sample spaces appear with the 1, 0 notation. Most authors prefer to use their own notations, but this makes it more difficult for the student who is accustomed to more standard notations from the technical journals. Incidentally, the authors use a definition of a K-dimensional vector of random variables which differs from that ordinarily encountered in elementary vector analysis. It is not clear just how this definition of a K-tuple set helps in the reader to understand calculation of communication relationships.

As a first book for engineers interested in analyzing and designing digital communication systems, however, the book is highly recommended.

Nathan Marchand
Marchand Electronic Laboratories
Greenwich, Conn.

Select Your Place In The Spectrum...

Job opportunities cover the
complete communications spectrum.

At SYLVANIA ELECTRONIC SYSTEMS the work range — from gamma rays to radio waves. Satellite tracking radars, UHF telemetry systems, lasers for optical communications, data processing and display systems, dc communications switching — Sylvania Electronic Systems is advancing the state-of-the-art across the complete spectrum of communications techniques and equipment.

The Sylvania Electronic Systems complex — east, central, and west: suburban Boston, Buffalo and San Francisco, respectively — covers the complete range of systems capabilities — from basic research through development, systems engineering, product and field engineering. This means that a complete range of opportunities exists for scientists and engineers interested in technical specialization, technical management, or program/project management.

Here's your challenge for increasing your personal and professional dimension. Current openings exist for highly capable technical specialists with BS/MS/PhD — in areas of interest that span the complete communications spectrum — from man-portable combat posts to satellite antennas. If you qualify and would like to receive more specific information on the type of work, send your resume to: Manager, Professional Staffing, Sylvania Electronic Systems, Division of Sylvania Electric Products Inc., 55 Sylvan Road, Waltham, Mass. 02154.

GT&E

GENERAL TELEPHONE & ELECTRONICS
Total Communications from a single source through

SYLVANIA ELECTRONIC SYSTEMS

RESEARCH • SYSTEMS DEVELOPMENT • PRODUCT & FIELD ENGINEERING
An equal opportunity employer mlf

The complete spectrum of opportunity — work range, location, professional satisfaction — is awaiting you at Sylvania Electronic Systems.



PORTABLE RADIO COMMAND PACK



SPRINT

MULTI-FUNCTION ARRAY RADAR



TRANSPORTABLE SAT COM TERMINAL



HIGH-POWER SINGLE-FREQUENCY LASER BEAM

VISIBLE

Technical Abstracts

Solid state source

A 10% voltage-tunable high-power solid-state source at S-band
C.J. Beanland and E.F. Scherer
Microwave Associates,
Burlington, Mass.

A solid state S-band source has been developed for use as a driver of very high power, linear-beam or crossed-field tube amplifiers in chirp radar, phased array, frequency diversity and coherent systems. The source has an output power of 2 watts at 3,000 megacycles. In addition, it is electronically tunable over a bandwidth slightly greater than 10%.

The source consists of several different sections—a voltage-controlled oscillator, an amplifier, two frequency multipliers and a stripline isolator. Each of the sections was designed to have an impedance level of 50 ohms at the point

of interconnection to simplify the testing of the individual units.

The stripline isolator decouples the two multiplier stages which boost the vco's fundamental frequency of 333 Mc to the S-band frequency of 3,000 Mc. The decoupling is necessary to insure stable operation while operating over the whole band.

The source requires a 32-volt d-c power supply for the high-power amplifier and a ± 12 -volt supply for the oscillator and low-power amplifier stages. Over-all d-c to radio frequency efficiency is 7%.

The low-power, voltage-tuned oscillator is a two-terminal negative resistance type. The negative and positive supply permits the base terminal to be at ground potential, providing the proper d-c and a-c return path for the tuning varactor. This prevents changes of the varactor bias due to a floating base po-

tential. A buffer stage isolates the oscillator from effects of load changes. A positive temperature coefficient resistor in the emitter stage of the oscillator provides for a frequency stability of better than 5×10^{-4} from -20°C to 80°C .

The oscillator frequency should be high enough to minimize the number of stages required for amplification, thereby reducing the filtering and stability problems. However, the decrease in gain, the power handling capability and the collector efficiency of the transistors set the upper limit for this frequency. The 333-Mc frequency represents the best possible compromise between the design goals and the characteristics of available transistors.

The power amplifier has five stages, all arranged with common emitters, instead of the common base configuration, for more stable operation. The first two stages work as class A amplifiers and the rest as class C. The collector efficiency of the final transistor is 50%. A



small resistor, in series with the base choke, limits the base current under excessive drive conditions and improves stability.

The first multiplier is an integral part of the amplifier module. It uses a high-power stud-mounted varactor in a conventional lumped component circuit.

The final multiplier has a welded pill varactor combined with a new multiplier design concept which includes an integrated, nonresonant idler circuit and a line coupled multisection filter. The output filter section can be detached from the multiplier assembly for the initial tuning of the filter.

Presented at the 1966 International Solid State Circuits Conference, Philadelphia, Feb. 9 to 11.

High-efficiency power amplifier

Modulated pulse audio and servo power amplifiers
H.R. Camenzind, P.R. Mallory & Co.,
Burlington, Mass.

Audio and servo power amplifiers, which are almost always designed

to operate as class A or B, pose serious problems if they are designed as integrated circuits. They have limited theoretical efficiency—50% for class A and 78% for class B—and it becomes increasingly difficult to dissipate large amounts of wasted power while maintaining reliability and small size. Also, these designs need stable biasing currents. In conventional circuits, this problem can be overcome with coupling transformers, or capacitors and selected components. But, transformers or large capacitors are not available in integrated circuits and the components that can be made have large tolerances and temperature coefficients.

A method which reproduces and amplifies audio frequency signals with a theoretical efficiency of 100%, and with careful design eliminates biasing currents and external components, can take full advantage of the benefits of integrated circuits. Such a method, called variously two-state ampli-

fication, pulse-width modulation or class-D amplification, has been known for years but has not been used because it requires a large number of active devices. These objections are no longer valid with integrated circuits because transistors now cost less than resistors.

The two-state amplifier produces a train of high-frequency pulses instead of amplifying the signal linearly. Although various waveforms are possible, the most promising approach employs a width-modulated square wave. The two-state amplifier alternately connects an inductive load to the positive and negative terminals of the power supply at a rapid rate—approximately 150 kilocycles. With a 50% duty cycle, the high impedance of the load prevents current from flowing. But the duty cycle can be changed by a signal at the input to the amplifier, allowing an average low-frequency current to flow into the load.

Compared with class B amplification, pulse width modulation

SINGER
INSTRUMENTATION



The elegant engineering solution to 20-15,000 Hz electromagnetic interference measurement problems:

Solid-State NF-315

Noise and Field
Intensity Meter

Here in one light, compact package is everything you need to perform rapid EMI measurements with confidence:

- ☐ Solid-state dependability
- ☐ Internal frequency and amplitude calibrators for on-the-spot checking
- ☐ 0.005 microvolt sensitivity
- ☐ Greater than 70 db spurious response rejection
- ☐ Signal range 180 db
- ☐ 8 hours continuous portable operation with built-in rechargeable battery
- ☐ Highly-stabilized circuits to eliminate recalibrations when tuning to new frequencies. All-in-all, the sophisticated simplicity which adds up to engineering elegance.

The EMPIRE NF-315 is a fast, precise, sensitive instrument with all the characteristics you need, backed by a company with an unparalleled dependability record. Military and civilian government agencies, major aerospace contractors insist on the NF-315. You should, too!



THE SINGER COMPANY
METRICS DIVISION

915 PEMBROKE ST., BRIDGEPORT, CONNECTICUT
PHONE (203) 366-3201 • TWX 710-453-3483

Design and production of PANORAMIC • SENSITIVE RESEARCH • EMPIRE • GERTSCH Instruments for measurements

High Reliability STYROFLEX® Capacitor Film

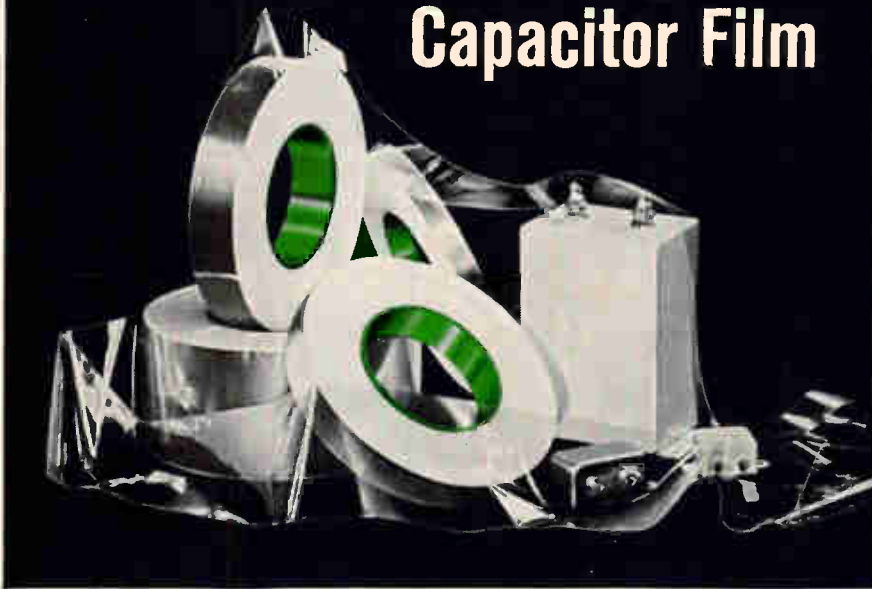

- Controlled Orientation
- Ultra High Purity
- Greater Dielectric Reliability
- Far Greater Yields
- Reduced Manufacturing Costs

Now you can manufacture close tolerance capacitance units with greatly improved yields. For new techniques permit more accurate measurement and closer control of the degree of orientation imparted to Styroflex capacitor film. In addition, as a result of highly improved raw material selection techniques, Styroflex gives capacitors truly exceptional insulation resistance values. These improvements plus continued exacting quality control procedures and the use of the latest radioactive thickness gauges produce an improved product in all respects. You will find Styroflex film is easier to use and gives you a better product at substantially lower manufacturing costs. Styroflex® is available in thicknesses from 0.00025" to 0.006" and widths from 1/2" to 10".



Natvar CORPORATION
201 Randolph Avenue, Woodbridge, New Jersey 07095
Tel.: 201 388-8800 • TWX: 201-381-8056
Cable Address: Natvar, Rahway, New Jersey

Circle 537 on reader service card

Meet the Miniature SLIDE REGULATOR from Matsunaga

(Valuable Voltage Transformer)

Small as a cigarette pack, these regulators are manufactured on an automated line. Quality is uniform from unit to unit, performance high and durable. Extensively used in copying machines, electric computers and other office machines. For detailed information please write today.

25VA Input	0.5A 50V or 117V
Output	0 ~ 117V

**MATSUNAGA
MANUFACTURING CO., LTD.**

No. 7, 2-chome, Himonya, Meguro-ku, Tokyo

promises four advantages in integrated circuits. These are: higher efficiency, resulting in lower power dissipation and smaller surface area; fewer critical components because the operation is either fully on or fully off, eliminating bias and permitting wider tolerances; improved stability because variations in transistor gain do not affect linearity of the amplifier; all stages are d-c coupled, so that the low cutoff frequency is essentially zero.

The two-state amplifier described by the author is a modified astable multivibrator driven by a differential amplifier. The capacitors in the astable multivibrator are charged by a constant current. The negative-going voltage at the base of the transistors is clamped at a level determined by the differential amplifier. As this level varies, the discharge times of the two capacitors are altered.

The output stage is a bridge configuration, avoiding the need for coupling capacitors and center-tapped power supplies. Also, the grounded collectors permit the use of common islands when constructing the circuits and prevent the transistors from saturating. In this way, the base current is derived from the load current. Diodes prevent damage from inductive load transients.

The final circuit uses only transistors, diodes, large tolerance resistors and small deposited capacitors, yet operates with an efficiency of 85%. In addition, the two-state amplifier has a frequency response from d-c to 15 kc and distortion of less than 1%.

Presented at the 1966 International Solid State Circuits Conference, Philadelphia, Feb. 9 to 11.

Microwave oscillators

Current understanding of high-field instabilities in bulk semiconductors
Alan Chynoweth
Bell Telephone Laboratories, Inc.
Murray Hill, N.J.

The last few years have seen the development of several kinds of solid state microwave sources. Microwave oscillations have been generated by semiconductors such as Gunn oscillators and Read di-

SUBMINIATURE TOGGLE SWITCHES

SERIES 7100/SPDT
subminiature toggle switches
(one of the smallest made in
America!) provide maximum
reliable performance in a tiny
but precisely fabricated com-
ponent!

SERIES 7200/DPDT
subminiature toggle
switches will meet high
reliability standards in a
wide range of ground/aero-
space applications where the
utilization of small space is
a positive requirement!

A competitively priced, made-in-America product. Write for literature today!

C&K quality electro-mechanical products
103 Morse Street, Newton, Massachusetts 02158
Telephone: 617 926-0800
COMPONENTS, INC.

C&K also manufactures a quality line of magnetic code converters, timers and logic elements.
Circle 538 on reader service card

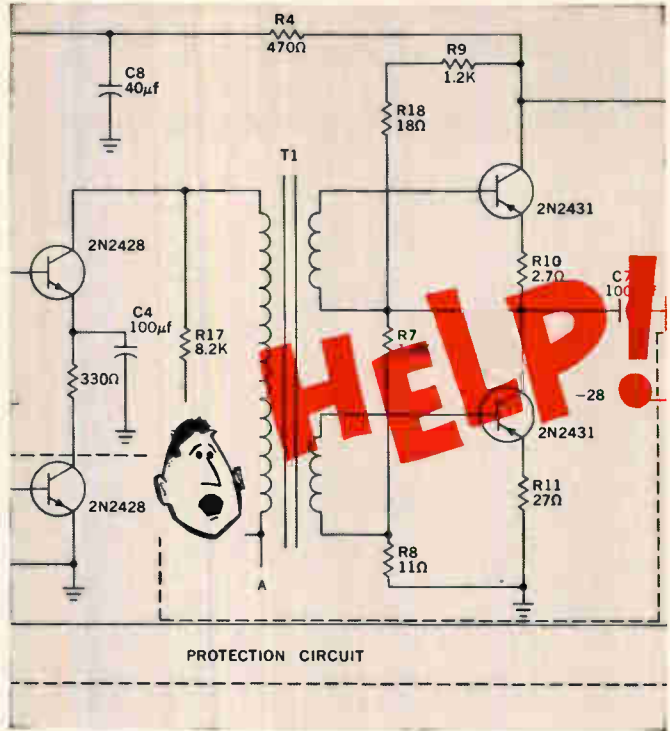

Drafting room backlog piling up? Cost of engineering drawings and technical documentation soaring? Mergenthaler has an answer to these problems.

In recent months, aggressive managers have been looking at The Diagrammer, a practical approach to automating drafting. The demonstrations they attended showed:

- A 400% time saving over manual drafting.
- "Better than inked" quality; ideally suited to microfilming.
- Ease of operation—minimum operator training.
- Matchless flexibility—adapts to most types of drawings.
- Low initial cost—ease of maintenance.

Interested? A call or a note on your letterhead will bring the help you need: the full story of The Diagrammer.

**For full information on the
Mergenthaler Diagrammer,**
call or write:

Charles L. Houpt, Manager
Advanced Systems Marketing
Mergenthaler Linotype Company
29 Ryerson Street
Brooklyn, New York 11205
Telephone: (212) UL 5-0300



Mergenthaler

THE DIAGRAMMER

See it in operation at the IEEE show in
the New York Coliseum, March 21-24



give...so more will live
HEART FUND

THE NEWEST DEVELOPMENTS
IN ELECTRICAL PROTECTION
WILL BE SHOWN AT THE

I.E.E.E. SHOW BOOTH 2G46

If you can't make the show, but have a problem in electrical protection, our staff of fuse engineers is at your service to help you solve it. In any event, be sure to get latest information BEFORE final design is crystallized.

JUST CALL OR WRITE,

INSIST ON **BUSS**
QUALITY

BUSSMANN MFG. DIVISION, McGraw-Edison Co., ST. LOUIS, MO. 63107

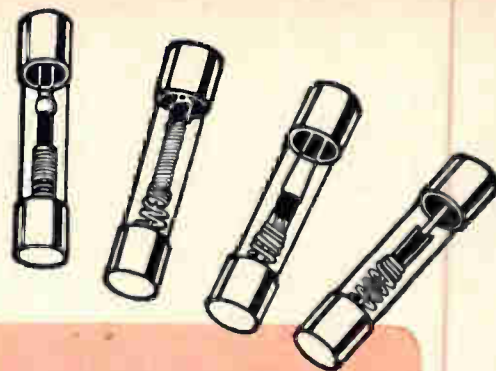

FUSETRON dual-element Fuses *slow blowing*

Write for
BUSS
Bulletin SFB

"Slow blowing" fuses prevent needless outages by not opening on harmless overloads—yet provide safe, protection against short-circuits or dangerous overloads.

INSIST ON **BUSS**
QUALITY

BUSSMANN MFG. DIVISION, McGraw-Edison Co., ST. LOUIS, MO. 63107

BUSS: The Complete Line of Fuses and . . .

Circle 283 on reader service card

Circle 283 on reader service card



NEW FROM CRAMER...

CRAMER **LIFT-LOK** Stools

adjust to every worker like fine tools!

Because Cramer Lift-Lok is infinitely adjustable! Just lift the seat and stop at the most comfortable height. It takes less time than to read this sentence. Since fatigue is a critical factor in efficiency of seated workers, it makes good sense to provide tools that minimize fatigue. With Lift-Lok every worker can seek exactly his own efficient level. Available in four base types, steel, wood or plastic seats, contoured or flat, adjustable or flexible backs. To find out about the stools that qualify as production tools, write:
V.P. Sales, Cramer, 625 Adams, Kansas City, Kan. 66105.

CRAMER

CRAMER INDUSTRIES INC. • KANSAS CITY, KANSAS

Fine seating—safety ladders—stands and related products for office, industry and institutions.

Industrial supplier
inquiries invited.

CAN YOU ASSUME A MORE RESPONSIBLE POSITION

Our clients, leading national engineering organizations, are seeking engineers of proven ability to assume design and management positions. As these are extremely responsible positions, interested engineers must be able to demonstrate significant systems or circuit design accomplishment in one of the following areas:

Airborne and Spaceborne Radar — Microwave Antenna Systems — Phased Array Strip Line Techniques — Radar Transmitters and/or Receivers — RF Feed Systems — Waveguides — Antenna Drive Systems — Servo Systems — ECM Systems — EMI Systems & Techniques.

Fees and relocation expenses paid by client companies.

If you qualify for these positions offering remuneration up to \$30,000, you are invited to direct your resume in confidence to:

Mr. Vincent A. Nickerson
Dept. E-3



"EMPLOYMENT SPECIALISTS"
Serving the engineering community for over 40 years.
150 Tremont Street
Boston, Massachusetts 02111
HAncock 6-8400

Technical Abstracts

odes and their related avalanche transit-time (ATT) derivatives as well as by solid state plasmas and the acoustoelectric effect. Gunn oscillators, ATT diodes, and some solid state plasmas have also been operated as amplifiers. Acoustoelectric effects and drift instabilities in solid state plasma are still being investigated. They are considered to be in the research stage because the amounts of power they produce are very low or their mechanisms are unknown. An example of emission from a solid state plasma is the microwave generation from bars of indium antimonide which have been driven into avalanche breakdown; such plasmas have generated a few nanowatts of power. At the present time, no good explanations exist for this phenomenon.

Gunn oscillations occur when electrons transfer at high fields from high to low-mobility valleys in the semiconductor's conduction band. One problem keeping this type of oscillator from delivering larger amounts of power lies in the contacts. At present, it is customary to keep them well away from the high-voltage region of the bulk material—usually gallium arsenide.

Read diodes consist of a narrow high-field region, where avalanche breakdown occurs, next to a medium intensity field, or drift region. Such a structure was recently made to emit a low-frequency radiation (180 megacycles) by researchers at Bell Telephone Laboratories. Various types of pn junctions have also been made to generate microwave power at higher frequencies.

Computer-generated motion pic-

tures have been used to give insight into the physical mechanism of microwave-generating semiconductors. These pictures are produced by feeding equations representing electron transfer at high fields into a computer. The results show the conditions necessary for the generation of accumulation, depletion, or dipole space-charge layers as well as the motions of these layers in a crystal. With the aid of the movies, the effects of varying various parameters—such as the doping profile—to obtain optimum device design can be demonstrated in a few hours. Previously, this analysis would have occupied a team of researchers for about a year.

Presented at the 1966 International Solid State Circuits Conference, Philadelphia, Feb. 9-11.

Fuseholders of Unquestioned High Quality

BUSS SHIELDED FUSEHOLDERS

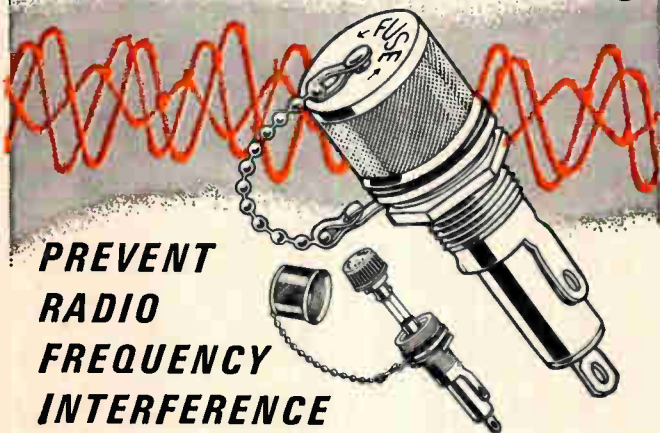

For use where fuse and fuseholder could pick up radio frequency radiation which interferes with circuit containing fuseholder—or other nearby circuits.

Fuseholder accomplishes both shielding and grounding.

Available to take two sizes of fuses— $\frac{1}{4} \times 1\frac{1}{4}$ " and $\frac{1}{4} \times 1$ " fuses. Meet all requirements of both MIL-I-6181D and MIL-F-19207A.

Write for BUSS Bulletin SFH-12

**INSIST ON BUSS
QUALITY**

BUSSMANN MFG. DIVISION, McGraw-Edison Co., ST. LOUIS, MO. 63107

Circle 283 on reader service card

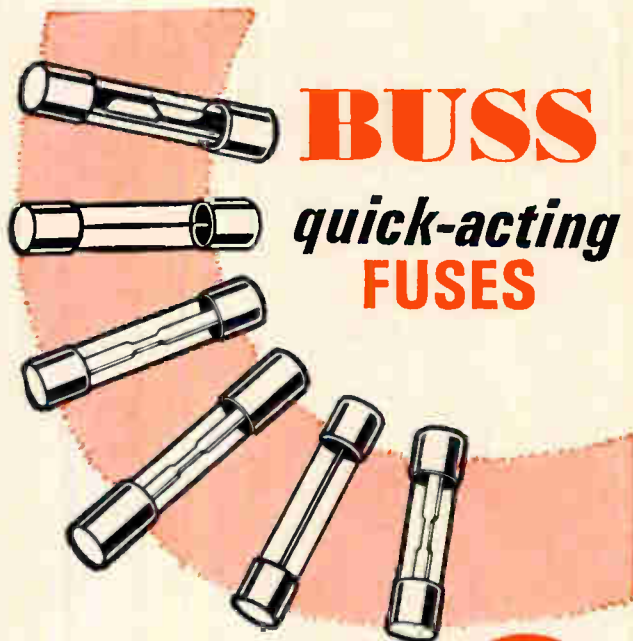

"Quick-Acting" fuses for protection of sensitive instruments or delicate apparatus;—or normal acting fuses for protection where circuit is not subject to current transients or surges.

Write for
BUSS
Bulletin SFB

**INSIST ON BUSS
QUALITY**

BUSSMANN MFG. DIVISION, McGraw-Edison Co., ST. LOUIS, MO. 63107

Circle 283 on reader service card 283

NEW

Direct-recording Oscillograph

VISIGRAPH-F

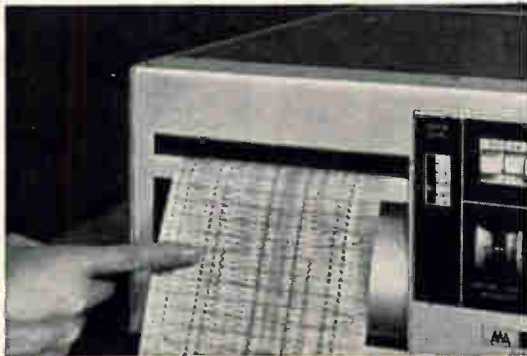

- * Standardized for moderate price.
- * Sharp, clear traces recorded directly.
- * Has grid lines at 2mm intervals.
- * Timing lines extend through width of paper.
- * Compact, light and sturdy construction.
- * Efficient service with high-performance galvanometer.
- * Easy operations with push button switch.

For further information, please write to:

SAN-EI INSTRUMENT CO., LTD.

Specialist in the field of oscillography
1-89 Kashiwagi, Shinjuku-ku, Tokyo, Japan
Cable: "SANEIINSTRUMENT" Tokyo

Circle 540 on reader service card



Reed Relays

Basic and special REED RELAYS and/or CDILS for high reliability and sophisticated switching

Operating Inputs: low as 1mA. and 15mW.
Standard Coil Voltages: 6, 12, 24, 32, 48V in stock for immediate delivery.
Special Voltage or Resistance, multiple windings for flip flop, memory and crosspoint selection applications — to customer specifications.
Relay Contacts in Form A, B, C and latching. Also high vacuum type 5000V Form A.

Write for Bulletin and Prices

Coto-Coil

COMPANY INC.
61 Pavilion Ave.
Providence, R. I. 02905
Phone: (401) 941-3355

MICO

NEW MODEL 885 SEVEN RATIO WIDE-RANGE ENGRAVER

NO. 885

FOR LONG AND MULTI-LINE WORK

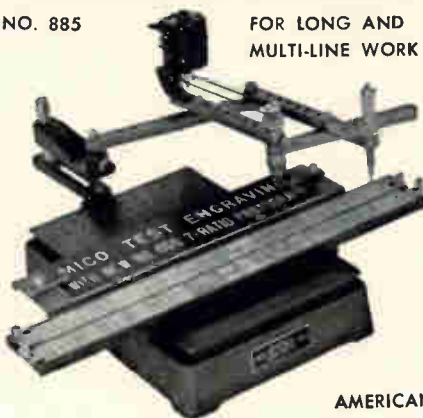

AMERICAN MADE

- A time-saver for large plate work.
- Engraves 3" x 19" area in one set-up.
- Seven pantograph ratios—from 1.5:1 to 6:1.
- Choice of 3-ball-bearing spindle assemblies for 1/8", 3/16" or taper-shank cutters.
- HSS, COBALT and Solid Carbide Cutters.
- Single and multi-line copy carriers for holding blanks 3/4" to 3 1/4" high.
- Accommodates Mico standard accessories.

Send for bulletins and prices

MICO INSTRUMENT CO.
77 Trowbridge St. Cambridge, Mass. 02138
Circle 541 on reader service card

Beam pen is faster than light

The beam pen: a novel high-speed, input/output device for cathode-ray-tube display systems

Donald R. Haring
Electronic Systems Laboratory,
Massachusetts Institute of Technology,
Cambridge, Mass.

Cathode-ray tubes are becoming more important for displaying computer outputs. An input device often used with a crt is a light pen, which senses a spot of light on the face of the crt and transmits a signal to the computer. But the light pen's speed is limited by the response times of the light-producing phosphor, and of the amplifier in the light pen. The maximum plotting speed with a light pen—one point about every eight microseconds—is too slow to display a complicated picture without flicker.

A new approach, called a beam pen, can operate at higher speeds, up to one point every 1.5 microseconds, instead of sensing the spot of light on the phosphor, as the light pen does. The beam pen senses the electron beam that generates the spot. The coupling between the electron beam and the pen is capacitive; but the inside surface of the phosphor is one-half inch from the outside surface of the plastic safety screen protecting the crt, so the capacitance between the beam and the pen is less than 0.1 picofarad, requiring a very sensitive amplifier with a high input impedance. Because of this thickness, the pen detects the presence of the beam even when it is not directly opposite. The amplifier's output is an analog pulse whose amplitude decreases as the pen moves from the beam.

In the system described here, the crt's unblanking pulse is modulated with a 10-megacycle sine wave to permit noise suppression and the pen amplifier contains a 10-Mc bandpass filter. The amplifier's output passes through a detector to remove the sine-wave component from the pulse, then into a Schmitt trigger to digitize the pulse. The trigger's output goes to the digital computer.

Presented at the Fall Joint Computer Conference, Las Vegas, Nev., Nov. 30 to Dec. 2.

INFRARED ENGINEERS AND SCIENTISTS:

Can you contribute to the development of products like these?

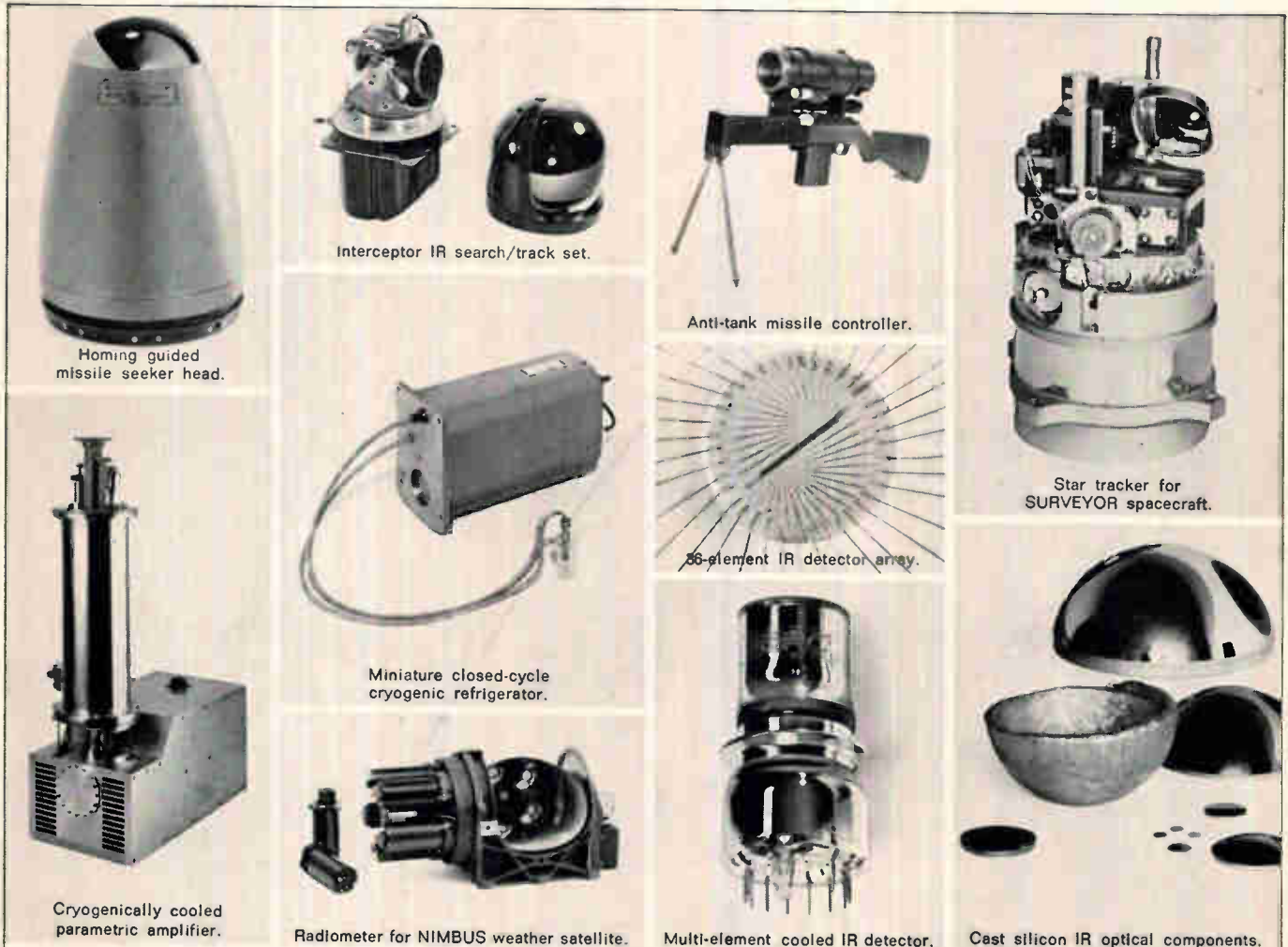

Rapid growth of Hughes infrared activities in the Aerospace Divisions and the Santa Barbara Research Center has created many responsible positions for qualified engineers and scientists in all phases of IR systems development from conception through production engineering.

Immediately available assignments include openings in such diverse technologies as optical design, semiconductor physics, cryogenics, mechanical engineering, precision electro-mech-

anisms, electronic circuit design, servo systems... and many other areas.

Current Hughes IR contracts include advanced systems for: space exploration, weather satellites, anti-ballistic missile defense, night reconnaissance, aircraft and space vehicle defense, and tactical weapon guidance and fire control.

Professional experience, an accredited degree and U.S. citizenship required.

For immediate consideration, please air-mail your resume to:

Mr. Robert A. Martin
Head of Employment
Hughes Aerospace Divisions
11940 W. Jefferson Blvd.
Culver City 44, California

HUGHES
 HUGHES AIRCRAFT COMPANY
 AEROSPACE DIVISIONS

An equal opportunity employer

SEATTLE

UNITED CONTROL

Living is great in the Pacific Northwest. We have year-round golf, five months of excellent mountain skiing within 45 miles, hunting, fishing . . . REAL OUTDOOR LIVING. A wonderful place to raise your family. Good housing available five minutes from the office.

ELECTRONIC ENGINEERS

(Several Levels)

Capable of preliminary design and equipment development involving advanced systems concepts and hardware techniques for control equipment used in aircraft and missiles. Analysis of closed loop control systems and computer simulations. Must have demonstrated ability in design—both analytic and hardware—development, and preparation for release to manufacturing of hardware consisting of such special basic building blocks as: Integrating amplifiers, logic circuitry, voltage comparators, inverters, flip-flops, choppers, and other special purpose circuitry.

United Control Corporation, together with its 650 employees, enjoys the reputation of being one of the Pacific Northwest's most modern, well equipped, financially sound, professionally managed firms in the electronic industry.

Send your resume in confidence to:

Don Vawter

UNITED CONTROL

OVERLAKE INDUSTRIAL PARK
REDMOND, WASHINGTON 98052

An equal opportunity employer

YOU'RE HIRED!

Do you need electronics engineers or technical management men? Electronics magazine is the way to recruit them. Electronics is designed specifically for the working engineer. 68,000 subscribers and an additional 133,000 pass-along readers turn to it to keep up with their industry. You can find the man that meets your qualifications with an advertisement in the Employment Opportunities Section.

For rates & information write: Electronics, a McGraw-Hill Publication. Classified Advertising Division, Post Office Box 12, New York 10036.

Employment Electronics Opportunities QUALIFICATION FORM FOR POSITIONS AVAILABLE

ATTENTION: Engineers, Scientists, Physicists

This Qualification Form is designed to help you advance in the electronics industry. It is unique and compact. Designed with the assistance of professional personnel management, it isolates specific experience in electronics and deals only in essential background information.

The advertisers listed here are seeking professional experience. Fill in the Qualification Form below.

Strictly Confidential

Your Qualification Form will be handled as "Strictly Confidential" by Electronics. Our processing system is such that your form will be forwarded within 24 hours to the proper executives in the companies you select. You will be contacted at your home by the interested companies.

What To Do

1. Review the positions in the advertisements.
2. Select those for which you qualify.
3. Notice the key numbers.
4. Circle the corresponding key number below the Qualification Form.
5. Fill out the form completely. Please print clearly.
6. Mail to: Classified Advertising Div., Electronics, Box 12, New York, N. Y. 10036.

COMPANY	PAGE	KEY	COMPANY	PAGE	KEY
ABBOTT'S OF BOSTON Boston, Mass. 02111	282	1	KING WHITNEY, JR. Stamford, Conn.	288	14
AMPEX CORP. Redwood City, Calif. 94063	292	2	KOLLSMAN INSTRUMENT CORP. Elmhurst, New York 11373	287	15
ATOMIC PERSONNEL INC. Phila., Pa.	288	3	LAWRENCE RADIATION LABORATORY Livermore, Calif.	288	16
BAUSCH & LOMB Rochester, N. Y. 14602	290	4	MITRE CORP. Bedford, Mass.	309	17
BOOZ ALLEN APPLIED RESEARCH INC. Chicago, Ill.	290	5	NATIONAL CASH REGISTER Electronics Div. Hawthorne, Calif.	200-201*	18
DOUGLAS AIRCRAFT Missiles & Space Div. Santa Monica, Calif. 90406	310	6	NEW YORK STATE DEPT. OF CIVIL SERVICE Albany, N. Y. 12226	229*	19
ELECTRO-MECHANICAL RESEARCH INC. Sarasota, Fla.	291	7	PAN AMERICAN WORLD AIRWAYS INC. Cocoa Beach, Fla.	231*	20
GENERAL ELECTRIC CO. Heavy Military Electronics Dept. Syracuse, N. Y.	230*	8	PHILADELPHIA NAVAL SHIPYARD Phila., Pa. 19112	288	21
GENERAL ELECTRIC CO. Television Receiver Dept. Syracuse, N. Y.	208*	9	SANDERS ASSOCIATES INC. Nashua, New Hampshire	289	22
GENERAL MOTORS CORP. Deleo Radio Div. Kokomo, Ind.	256	10	TELEDYNE INDUSTRIES GeoTech Div. Garland, Texas 75040	290	23
HAMILTON STANDARD DIV. United Aircraft Corp. Windsor Locks, Conn.	191*	11	UNITED CONTROL Redmond, Washington 98052	286	24
IBM CORPORATE HEADQUARTERS Armonk, N. Y.	221*	12	XEROX CORP. Rochester, N. Y. 14613	272-273	25
IBM ELECTRONICS SYSTEMS CENTER Federal Systems Div. Owego, N. Y. 13827	258	13	P 8687 P 8692	291 288	26 27

* These advertisements appeared in the February 21st issue.

(cut here) ----- (cut here)

Electronics QUALIFICATION FORM FOR POSITIONS AVAILABLE

(Please type or print clearly. Necessary for reproduction.)

Personal Background

Name
Home Address
City Zone State
Home Telephone

Education

Professional Degree(s)
Major(s)
University
Date(s)

Fields of Experience (Please Check)

3/7/66

- | | | |
|----------------------------------------------|----------------------------------------------|---------------------------------------|
| <input type="checkbox"/> Aerospace | <input type="checkbox"/> Fire Control | <input type="checkbox"/> Radar |
| <input type="checkbox"/> Antennas | <input type="checkbox"/> Human Factors | <input type="checkbox"/> Radio-TV |
| <input type="checkbox"/> ASW | <input type="checkbox"/> Infrared | <input type="checkbox"/> Simulators |
| <input type="checkbox"/> Circuits | <input type="checkbox"/> Instrumentation | <input type="checkbox"/> Solid State |
| <input type="checkbox"/> Communications | <input type="checkbox"/> Medicine | <input type="checkbox"/> Telemetry |
| <input type="checkbox"/> Components | <input type="checkbox"/> Microwave | <input type="checkbox"/> Transformers |
| <input type="checkbox"/> Computers | <input type="checkbox"/> Navigation | <input type="checkbox"/> Other |
| <input type="checkbox"/> ECM | <input type="checkbox"/> Operations Research | <input type="checkbox"/> |
| <input type="checkbox"/> Electron Tubes | <input type="checkbox"/> Optics | <input type="checkbox"/> |
| <input type="checkbox"/> Engineering Writing | <input type="checkbox"/> Packaging | <input type="checkbox"/> |

Category of Specialization

Please indicate number of months experience on proper lines.

	Technical Experience (Months)	Supervisory Experience (Months)
Research (pure, fundamental, basic)
Research (Applied)
Systems (New Concepts)
Development (Model)
Design (Product)
Manufacturing (Product)
Field (Service)
Sales (Proposals & Products)

Circle Key Numbers of Above Companies' Positions That Interest You
1 2 3 4 5 6 7 8 9 10 11 12 13 14 15 16 17 18 19 20 21 22 23 24 25 26

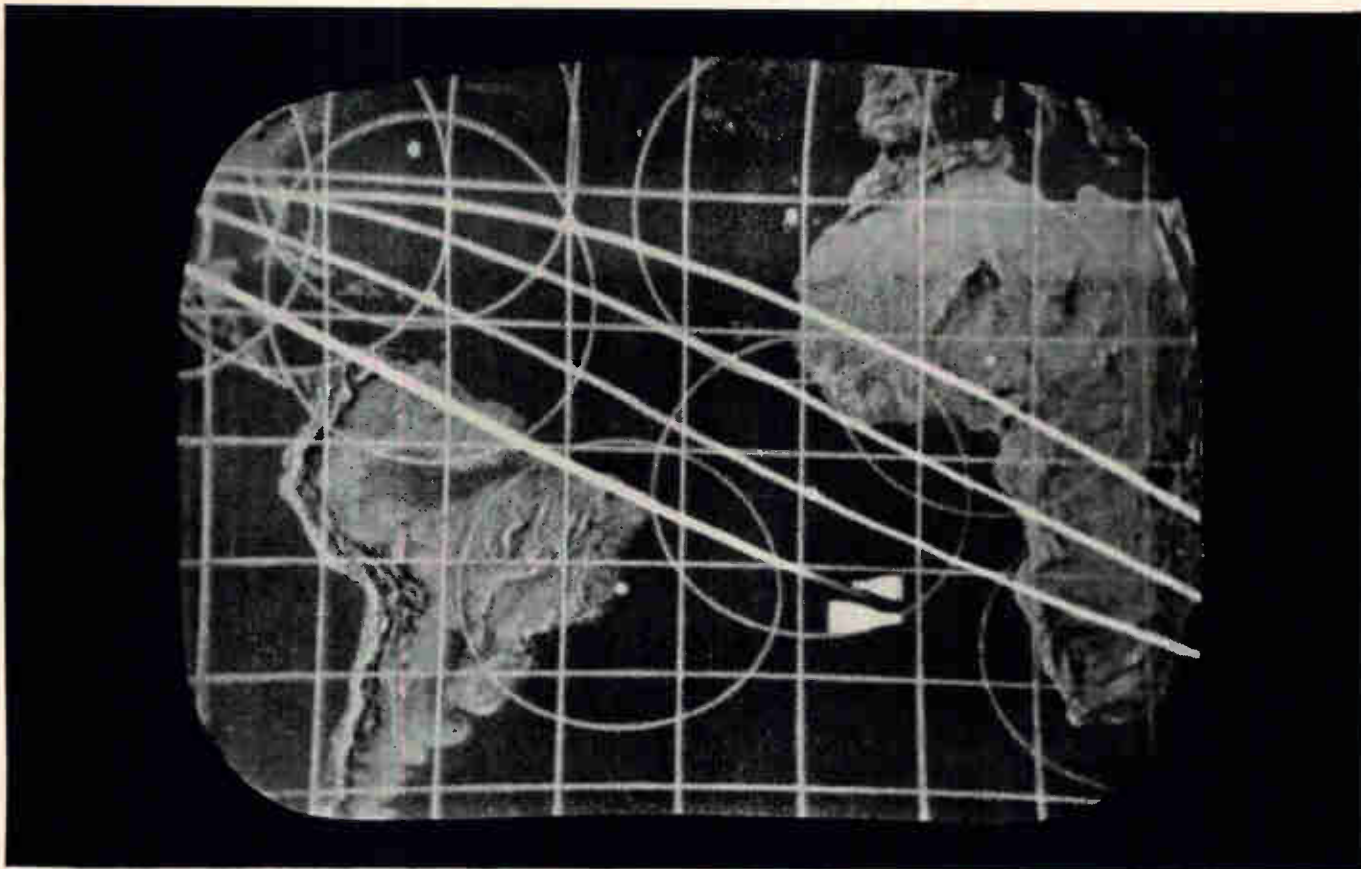

You will see CBS NEWS track the flight of Gemini 8

Traced vividly on the screen, Gemini 6 slowly approached Gemini 7 as they orbited the earth. This exciting moment in history was viewed by millions of people on the Kollsman Orbital Map. Once again the Kollsman Orbital Map will be shown—on the CBS NEWS Gemini 8 telecast.

This map is one version of Kollsman's Data Display System, Delphic II. Originally designed to solve the needs of military command centers, this system displays visual information on a background up to 40 x 40 feet in size—from radio, radar, telemetry systems, data links, computers, teletypes and other sources.

There are many challenging opportunities now open at Kollsman. Opportunities to work on some of the most advanced engineering programs going today in space optics, aero-instrumentation, guidance

and navigation, solid-state electronics, lasers.

Specifically, programs like the Goddard Experiment Package, optics for LEM, star trackers for aircraft and space vehicles, Apollo guidance and navigation system, space simulators, aircraft instrumentation systems, high-speed airborne surveying systems—and well, the list goes on and on.

What's the work like? Broad and free-swinging rather than nailed into specialized niches. The kind of endeavors that insure against technical obsolescence in your field. The Total Systems Concept that means working with every discipline. You participate from inception to hardware . . . in day-to-day work at the highest level of your ability. It's the kind of working environment that would keep any engineer stimulated.

Our projects are so broad-based that if you have a top-level technical skill, you can probably find a good spot with us. We want scientists who are oriented to practical results. Engineers who are comfortable in an R&D environment. We're looking for creative talent in optics, electronics, mechanics, computers, navigation, guidance, tracking, astronomy, photography, systems, mathematical modeling. We can use technical management, special skills such as reliability engineering, and skills that combine two or more disciplines.

To arrange a personal meeting to discuss the advantages of a professional association with the Kollsman Space Division, located in an ideal suburban community 30 minutes from New York City, apply or write to Mr. David McQuade, Underhill Boulevard and Jericho Turnpike, Syosset, L. I., N. Y. 11791 (516 WA 1-4621).

For assignments with the Avionics Division, the Systems Management Division or the Corporate Technology Center, conveniently located just 15 minutes from Manhattan, direct your resume or phone call to Mr. Donald Svenson, 80-08 45th Ave., Elmhurst, Queens, New York 11373 (212 TW 9-5600).

An Equal Opportunity Employer.

IEEE Interviews March 21-24 Americana Hotel. Tel.: 765-9076

Kollsman 
 INSTRUMENT CORPORATION
 ELMHURST, NEW YORK 11373
SUBSIDIARY OF
 STANDARD TELEGRAM
 INDUSTRIES INC.

Electrical and Electronic Engineers:

Naval expansion offers you a career in ship and shore system design, research, development and evaluation

Starting salaries up to \$10,619 depending on experience.

Many exciting opportunities for engineers are being created by the expansion of the Philadelphia Naval Shipyard, the major facility for new ship construction on the East Coast, and expansion of the activities of the Office of Industrial Manager, Fourth Naval District. These are career Civil Service positions with regular salary increases and generous benefits including 13-26 days of vacation, 13 days of sick leave, 8 holidays, inexpensive health and life insurance, and an unusually liberal retirement plan.

Electrical and electronic engineers are offered a variety of challenging assignments in every phase of ship and system design ranging from electrical power and light to fire control, communications, radar, and instrumentation, etc. Also offered are laboratory assignments in research and development of stress, sound and vibration, measuring equipment and their application; assurance engineering and reliability engineering covering the field of shipbuilding systems and equipment; and development, design, instrumentation, and installation planning of electronic systems for U. S. Naval activities ashore.

Philadelphia and its suburbs offer housing accommodations for every taste. This historic city has museums, libraries, spacious parks, 27 colleges and universities, and is within an hour's drive of excellent ocean beaches and famous mountain resorts.

If you have a degree in engineering, send a resume or Standard Form 57 (available at any Post Office) to the Industrial Relations Office, Code 175-F



Philadelphia Naval Shipyard
Philadelphia, Pennsylvania 19112

An Equal Opportunity Employer

electronics field engineers

Opportunity for qualified Weapons or ECM Systems Engineers to become associated with a leading Aerospace Manufacturer.

Applicants must be experienced in search and track radars, computers, inertial guidance systems and be familiar with digital techniques and transistor applications.

BS degree in Electronics or Physics, with a minimum of 6 years' experience desirable, but candidates demonstrating the equivalency will be considered. In-plant training will be given to the applicants chosen.

This is a career opportunity for outstanding men only.

SALARY to \$15,000

In accordance with background and experience

Arrange interview. Send detailed resume in strict confidence to P-8692 Electronics Class. Adv. Div. P.O. Box 12, NY, NY 10036

"An Equal Opportunity Employer"

ENGINEER OR RECENT GRAD

New Product Development

Unique opportunity for recent graduate with EE degree or major in solid state physics to learn & participate in the development of new products with progressive company currently manufacturing electronic circuits, devices & systems for machinery control. Train under supervision of head of department of R&D & develop engineering know-how through multi job responsibilities.

SALARY OPEN

Please write to:

KING WHITNEY, Jr.

500 Summer St.,

Stamford, Conn.



E.E.'s WRITE US FIRST

for FEE-PAID positions

Use our confidential application for professional, individualized service. A complete national technical employment agency. We are "Experienced Engineers Working Full Time . . . For You"

ATOMIC PERSONNEL, INC.
Suite L, 1518 Walnut St., Phila., Pa.

PROFESSIONAL SERVICES

GIBBS & HILL, Inc.

Consulting Engineers

Systems Engineering
Operations Research • Development
Field Studies • Design • Procurement
Power • Transportation • Communications
Water Supply • Waste Treatment

393 Seventh Avenue

New York 1. N. Y.

UNIVERSITY OF CALIFORNIA

LAWRENCE RADIATION LABORATORY

ELECTRONICS ENGINEERING POSITIONS

B.S., M.S., Ph.D.

solid state circuit design

microcircuitry

microwave

digital computers

nuclear instrumentation

APPLIED RESEARCH PROGRAMS:

• BIO-MEDICAL

radiation effects on the biosphere

• PLOWSHARE

peaceful applications of nuclear explosives

• PROPULSION

reactors for propulsion and power in space

• SHERWOOD

controlled thermonuclear fusion

• WHITNEY

nuclear weapons for national defense

For further information about our programs and a listing of current openings, write:

B. R. Graf

P. O. Box 808 18-36

Livermore, California 94551

U. S. Citizenship Required

An Equal Opportunity Employer

ENGINEERS

Ever come up with an elegant solution only to discover that nobody appreciated the thorniness of the problem let alone the subtleties of your approach to it?

It's not likely to happen at Sanders.

ELECTROMECHANICAL DESIGN & DEVELOPMENT ENGINEERS

To be responsible for D&D of state-of-the-art inertial instruments. Requires BSME with 2 to 5 years experience in D&D of precision electromechanical inertial instruments, gyros or accelerometers, with knowledge of materials, bearings and assembly techniques, and ability to carry concept through to hardware stage.

PRODUCT ENGINEER

To be responsible for production processing, production improvement, preparation of methods and process sheets, design tooling and test equipment, cost and schedule estimates, and preparation of technical reports on precision parts fabrication and assembly. Requires BSME with 3 to 5 years experience in electromechanical instrumentation, hydraulic components or precision inertial instrumentation.

SENIOR ECM STUDY ENGINEER

To join a group engaged in the theoretical and practical evaluation of ECM systems problems. Will develop simple analytical models, bench and flight tests to verify models and study advanced radar and ECM systems and techniques. The most desirable background for this work would be 3-5 years in the development of radar hardware coupled with analytical experience in such phases as external parameters, system error, operations and use, or any aspect of system performance and trade-offs. ECM, Elint, or communications work will also be considered. Military experience highly desirable. BSEE or MSEE preferred.

SENIOR CIRCUIT DESIGN ENGINEER

Candidates should have 3 or more years in circuit design and analysis using vacuum tubes, transistors, and other solid state devices. Background should include extensive experience in the design and engineering of circuits of these types: digital and logic, video and pulse, RF and audio, power supplies and regulator circuits, etc., for military systems. Advanced degree desired.

SENIOR RECEIVER DESIGN ENGINEER

Require 5 or more years in the design and development of complex receivers for communications, radar and missile systems. These receivers are generally airborne, covering frequency ranges through UHF, and requiring the application of solid state devices. Must have specific experience designing sophisticated AFC, phase-lock loops, low noise front ends, stable local oscillators, IF strips, etc. Will supervise other engineers and technicians. BSEE or Physics with 5 or more years experience.

MECHANICAL ENGINEER—

Heat Transfer & Packaging. Desired background would include 5 or more years experience in military electronics involving high-density packaging of electronic equipment, design of components for severe shock and vibration, heat transfer as related to packaging, refrigerating and liquid coolants and applications of structural design. Assignment fields may include radar, missiles, ECM, ASW, communications systems or others. BSME required.

Write in confidence to Mr. Lloyd Ware, Staff Engineer.

sanders associates, inc.



NEW DIRECTIONS IN
ELECTRONICS SYSTEMS

An Equal Opportunity Employer

(M&F)

NASHUA, NEW HAMPSHIRE



Bausch & Lomb has openings for
ELECTRONIC ENGINEERS

B.S. or M.S. with one to five years experience in the design of analog and digital circuits and systems. Good theoretical background in math, physics and network analyses desirable. Experience in control systems and low signal level circuit techniques helpful. Projects involve development of sophisticated instruments in bio-medical, chemical, optical and electronic fields at the applied research stage.

Please send resume in confidence, including salary requirements to: E. J. Walter, Employment Specialist, Bausch & Lomb, 620 St. Paul St., Rochester, N. Y. 14602.

BAUSCH & LOMB 
An Equal Opportunity Employer

**DEVELOPMENT ENGINEERS
 SYSTEMS ENGINEERS**

Mechanical Engineers • Physicists • Electronics Engineers

CLEVELAND, OHIO

Once again we find we must expand the personnel requirements of the mechanical and electronic commercial/industrial hardware, systems, and process development programs being performed within our Development and Design Division facilities in Cleveland, Ohio.

As a division of an extremely fine and reputable nation-wide applications research analysis and development firm our Development and Design Division, with multiple and confining programs, offers an outstanding opportunity to enhance professional growth; career opportunities exist.

We are seeking creative individuals who believe themselves to be well trained, experienced, operationally strong, and by virtue of their education, ability, interest and temperament, to be top-flight generalists.

We are not an easy firm for which to work. We are not, for that matter, an easy firm to get into, though many have been good enough. Excellence will demand excellence. Salary is definitely open, benefits are competitive and we tend to recognize accomplishments and results more than stability, acceptability or seniority.

If the above information seems to reflect an engineering and organizational environment that appeals to you, and if the Cleveland area is attractive to you, contact: Robert Flint, Director of Staff Selection

BOOZ-ALLEN APPLIED RESEARCH, Inc.

Development and Design Division

**135 South La Salle Street, Chicago, Illinois 60603
 312 — FR 2-1728**

An Equal Opportunity Employer



We are expanding our capability to provide analog and digital data acquisition and processing systems in all areas of applied geophysics, marine science, and industrial instrumentation. This growth requires the addition of a number of professional personnel to our staff. We need engineers and scientists with experience in:

GEOPHYSICS

•

STATISTICS

•

OPTICS

•

**MAGNETIC TAPE
 RECORDING**

•

**SMALL MECHANISM
 DESIGN**

If you think you can become as enthusiastic as we are about the chances for an outstanding future, please send me your qualifications.

Jack W. Hamilton

Vice President, General Manager

**TELEDYNE INDUSTRIES
 GEOTECH DIVISION**
DEPT. 108, 3401 SHILOH RD.
 GARLAND, TEXAS 75040



"Geotech Serves the Sciences"

ELECTRONIC TEST ENGINEERS

Challenging career opportunities available at New York City area Aerospace Manufacturer for: thoroughly experienced Electronic Test Engineers to establish initial test planning and requirements for space electronics systems and associated ground support equipments. Responsibilities include the follow-thru in the detail test and debugging of these equipments. Specific assignments are available in the following areas:

• Radar • Communications • Guidance & Control • Manned & Unmanned Mission Instrumentation • Integrated Electronics Systems Test

Minimum of B.S. in E.E. or Physics plus comprehensive test experience is required.

SALARY to \$13,000
commensurate with background and experience

Arrange an immediate interview send detailed resume, in strict confidence to P-8687—Electronics Class Adv. Div. P.O. Box 12, NY, NY 10036

"An Equal Opportunity Employer"



CLASSIFIED ADVERTISING

SEARCHLIGHT SECTION

BUSINESS OPPORTUNITIES
USED OR SURPLUS EQUIPMENT

TEST EQUIPMENT (For BUCK SAVERS)

400 CYCLE GENERATORS
30 KW 3 phase, 220 440 3 ph cy 80 HP driver, Hollingsworth \$650.00, 5 KW 1 phase, 115 230 V AC Driver, Horitek \$250.00, 6 VA or 30 VA or 100 VA Inverters, 28V DC Input \$12.50 ea. Many others available from Chicago stock. Electronics type rectifiers, generators & regulators. Line voltage to DC: 12V thru 10,000 V. Line to AC hi-cycle, 12V, to 115 V. Panel or modular, Shockster, 210g peak Acceleration, Barry Mod, 20V-1, Exotica; Rate gyros; pressure transducers; Temp. sensors; accelerometers, etc. Harber Industrials • 812 W. Lake St. • Chicago 7, Ill.

CIRCLE 954 ON READER SERVICE CARD

ELECTRONIC COMPONENTS

For Production and Research
Write for new catalog

A. B. INDUSTRIES 743-5006
3133 West Jarloth Ave., Chicago 60645

CIRCLE 955 ON READER SERVICE CARD

BIG CATALOG
World's "BEST BUYS"
in GOV'T. SURPLUS
Electronic Equipment

FULL OF TOP QUALITY ITEMS—
Transmitters, Receivers, Power Supplies,
Inverters, Microphones, Filters, Meters,
Cable, Keys, Phones, Antennas, Chokes,
Dynamotors, Blowers, Switches, Test Equipment,
Headsets, Amplifiers, etc., etc. SEND
25¢ (stamps or coin) for CATALOG and
receive 50¢ CREDIT on your order. Address
Dept. E-6.

FAIR RADIO SALES
P.O. Box 1105 • LIMA, OHIO • 45802

(Additional "Searchlight" on pages 292-293)

ABILITY: is yours being used?

HAVE YOU CONSIDERED EMR AS A CAREER EMPLOYER? YOU SHOULD! EXPERIENCED ENGINEERS WITH EXCEPTIONAL ABILITY ARE INVITED TO EXPLORE THESE OPPORTUNITIES: RELIABILITY, QUALITY CONTROL, MECHANICAL, LOGIC DESIGN, PRODUCT DEVELOPMENT, RF ENGINEER, CIRCUIT DESIGN, ELECTRONIC SYSTEMS, APPLICATIONS, ELECTRONIC PACKAGING. SEND RESUME TO J. B. APPLDORN, PROFESSIONAL STAFFING, BOX 3041, SARASOTA, FLORIDA. **ELECTRO-MECHANICAL RESEARCH, INC.** 

AMPEX CORPORATION

Exciting opportunities have developed at Ampex for creative engineers who will make significant contributions to our new VIDEOFILE systems, which use video tape for the storage and retrieval of documents in large file systems. Typical of our openings are these:

LOGIC DESIGN: State-of-the-art circuits in computer equipment and systems for document storage and retrieval.

CIRCUIT DESIGN: Video circuits, distribution amplifiers or VHF circuits. Knowledge of electron optics desirable.

APPLICATIONS ANALYSIS: Develop new market applications for Videofile systems, and evaluate and translate customer inquiries into new systems. Must have commercial company background, thorough exposure to computer technology and office system methods.

These positions represent opportunities to move into greater responsibility, and you will find our compensation and benefit plans as progressive as our products.

C. R. MOODY
Employment Manager

AMPEX CORPORATION

401 Broadway • Redwood City, California 94063

An equal opportunity employer.

SEARCHLIGHT SECTION

CENTRIFUGAL BLOWERS—GEAR REDUCER MOTORS—MOTORS PROPELLER EXHAUST FANS—ELECTRIC HEATERS—AIR COMPRESSORS

Partial listings of our large stocks:

CENTRIFUGAL BLOWERS FOR COOLING & VENTILATING	
—AC/115 volts/continuous duty:	Price
ROTRON 2½" x 1½", 115/230v, 40 CFM	13.00
DELCO 3" x 2", 60 CFM	14.00
VENTILAIRE 4" x 2", 165 CFM	16.00
ILG 6" x 4", 600 CFM	55.00
ELECT INDIC/ILG, 3" x 2" 200CFM	65.00
REDMOND Twin 3" x 2" ea. 200CFM	12.00
—DC/continuous duty:	
WESTINGHOUSE 3" x 2" 115v., 100CFM	30.00
REMSSELL 3" x ½", 24 v., 12CFM @ 12"	32.00
SERIES 3" x 2" 115v., 100CFM (AC/DC)	9.00
REDMOND TWIN 3" x 2" ea. rotor 6v.	12.00
GEAR REDUCER ELECTRIC MOTORS	
BARCOL 14 watts 115vAC 9RPM	13.00
LIVEL 1/60HP 115v AC 75RPM	3.75
LIONEL 1/50HP AC/DC 115v. 588RPM	13.00
GE/BOSTON ¼HP AC115v 72 RPM	45.00

BODINE ¼HP 115vDC 150RPM SHUNT	95.00
MASTER ½HP 220/440 3-ph. 16RPM	110.00
GEAR REDUCERS	
WINSMITH ¼HP to 1HP, 10; 20; 30; 40; 50-1 Ratios	
BOND for 1/6 to 1/3 HP, 30:1	25.00
BOSTON/flange mount to 1/3HP, 24:1	30.00
ELECTRIC MOTORS	
R&M 1/100HP 115vDC 2000RPM shunt	13.00
BODINE 1/150HP 115vDC 1800RPM GOV.	20.00
R&M 1/50HP AC/DC 115v 1600RPM	16.50
REDMOND 1/70HP AC 230v 1000RPM	16.50
BODINE 1/8HP DC115v 1800RPM	55.00
G.E. DC115v 1/8HP 34000RPM	55.00
PRESSURE BLOWERS	
AMERICAN PADDLE, 6" ½HP 3ph	125.00
CHAMPION HI-PRESSURE, 7" 1½HP	155.00
Also thousands of others. Catalogue sheets, photos or other data on request.	

ELECTRIC TRADING CO. ONE MERCER STREET
NEW YORK 10013, N.Y.

CIRCLE 963 ON READER SERVICE CARD

TEST EQUIPMENT

For over 20 years specializing in top brands only. Write for our latest listing. We buy complete inventories.

NORMAN

ELECTRONIC SALES

1413 Howard Street, Chicago, Illinois 60626
Telephone ROgers Park 4-0600

CIRCLE 951 ON READER SERVICE CARD

New
for picking up miniature parts

\$7.50 ea.



Selected Distributorships available.

PHILIP FISHMAN COMPANY
7 CAMERON ST., WELLESLEY, MASSACHUSETTS

CIRCLE 952 ON READER SERVICE CARD

DIGITAL RECORDERS

H.P. 561B, never used, \$550 each. Electro Instruments Inc., mod. 500 XY recorder, nul detector. Mod. 472, never used, \$600. Misc. tec. tec. plugs and g.r. lab equip. Mepco prec. resis. .01%.

W. D. CONTRACTING ENGINEERS
5437 West Division Chicago, Illinois 60651
Phone: (312) 378-7461

CIRCLE 953 ON READER SERVICE CARD

DEQUITS RESULTS
BUYERS TURN TO THE SEARCHLIGHT SECTION IN ELECTRONICS

MILLIVAC INSTRUMENT CO.	
Model MV-18C, R.F.—V.T.M.	95.00
Model MV-27-D, DC Micro Voltmeter	95.00

FXR Universal Ratiometer	
Model B-811A	185.00
Power Meter Type B-831A	95.00

NARDA CORP. E-H Toner	
Model E-957	125.00
Coaxial Couplers—Model 3002-30	45.00
Model 3002-10	45.00

COMPUTER MEASUREMENTS CORP.	
Digital Printer Model 400-C	150.00

HEWLETT-PACKARD	
Preset Counter Model 5214-L New	1000.00

VHF Signal Generator	
Model 616-A Freq. Range 1.8 to 4.2 GC	575.00
Test Oscillator Model 650 AR	275.00

ITT Swept Frequency Generator	
Model 200K 20 Cps to 200Kc	875.00

Hughes Memo Scope	
Model 104-D, with plug ins WB/4D, HS/6A, WB/D1/11	850.00

LUMATRON CO.	
Pulse Generator, Model 303	
Trigger Rate Converter, Model 602	
Sampling Unit, Model 220	295.00

KAY ELECTRIC CO.	
Vari-Sweep Model Radar, 1D MC to 145 MC	225.00

RADA-PULSER SR, Model 570 A	275.00
-----------------------------	--------

See previous issues for more equipment.
Send for Flyers.

All material in excellent condition. All prices F.O.B., San Francisco, Cal. subject to prior sale. Send for Listing and Flyers.

Marty's Mart

1236 Market St., San Francisco 3, California
Phone: UNderhill 3-1215

CIRCLE 956 ON READER SERVICE CARD

Electronics | March 7, 1966

AUTOTRACK ANTENNA MOUNT

360 degree azimuth, 210 degree elevation sweep with better than 1 mil. accuracy. Missile velocity acceleration and slewing rates. Amplidyne and servo control. Will handle up to 20 ft. dish. Supplied complete with control chassis. In stock—immediate delivery. Used world over by NASA, USAF. TYPE MP-61 R. SCR-584. NIKE AJAX mounts also in stock plus several airborne trackers.

SCR 584 AUTOMATIC TRACKING RADARS

Our 584s in like new condition, ready to go, and in stock for immediate delivery. Ideal for telemetry research and development, missile tracking, satellite tracking, balloon tracking. Used on Atlantic Missile Range, Pacific Missile Range, N.A.S.A., Wallops Island, A.B.M.A. Write us. Fully Desc. MIT Rad. Lab. Series. Vol. 1, pps. 207-210, 228, 284-286. (Comp. Inst. Bk. avail. \$25.00 each.

AN/GPG-1 SKYSWEEP TRACKER

3 cm. automatic tracking radar system. Complete package with indicator system. Full target acquisition and automatic tracking. Input 115 volts 60 cycle. Nev. in stock for immediate delivery. Entire System 6' long, 3' wide, 10' high. Ideal for Infrared Tracker, Drone Tracker, Missile, Tracker, R. & D.



PULSE MODULATORS

MIT MODEL 9 PULSER

1 MEGAWATT-HARD TUBE
Output 25 kv 40 amp. Duty cycle .002. Pulse lengths .25 to 2 microsec. Also .5 to 5 microsec, and 1 to 5 microsec. Uses 6C21. Input 115v 60 cycle AC. Mfr. GE. Complete with driver and high voltage power supply. Ref: MIT Rad. Lab. Series. Vol. 5, pps. 152-160.

2 MEGAWATT PULSER

Output 30 kv at 70 amp. Duty cycle .001. Rep rates: 1 microsec 600 pps, 1 or 2 msec 300 pps. Uses 5948 hydrogen thyratron. Input 120/208 VAC 60 cycle. Mfr. GE. Complete with high voltage power supply.

MIT MODEL 3 PULSER

Output: 144 kw (12 kv at 12 amp.) Duty ratio: .001 max. Pulse duration: .5, 1 and 2 microsec. Input: 115 v 400 to 2000 cps and 24 vdc. \$325 ea. Full desc. Vol. 5, MIT Rad. Lab. series, pg. 140.

250KW HARD TUBE PULSER

Output 16 kv 16 amp. duty cycle .002. Pulses can be coded. Uses 5D21, 715C or 4PR60A. Input 115 v 60 cycle ac. Incl. 11V pwr supply \$1200 ea.

200 KW LINE PULSER

16 KV 16A .25 micro-sec 4000 PPS. Duty .0012, 5C22 thyr. Input 115V 60 cy AC. \$450.00.

MICROWAVE SYSTEMS

E-4 FIRE CONTROL SYSTEM

Hughes Aircraft X Band. Complete. In stock.

C-BAND RADAR

250 KW output, C-band, PPI indicator, 5C22 thyratron modulator. Antenna hi gain parabolic section. Input 115 volts 60 cycle AC. complete \$2750.00.

300 TO 2400CM RF PKG.

300 to 2400 MC CW. Tuneable. Transmitter 10 to 30 Watts. Output. As new \$475.

500W "L" BAND RADAR

500 kw 1220-1359 mcs. 160 nautical mile search range P.P.I. and A Scopes. MTI. thyratron mod. 5J26 magnetron. Complete system.

PHILCO MICROWAVE LINKS

C Band Microwave Link terminal bays and repeater bays in stock. New \$1500 each or \$2500 per pr.

100-800MC. CW SOURCE

150 watts CW nominal output 115 V 60 Cy AC Input. \$1600.

100W 3CM. RADAR

Complete 100 kw output airborne system with AMTI, 5C22 thyr. mod. 4J52 magnetron, PPI, 360 deg az sweep, 60 deg. elev. sweep, gyro stabilizer, hi-gain revr. Complete with all plugs and cables.

M-33 AUTO-TRACK RADAR SYSTEM

X band with plotting board, automatic range tracking, etc. Complete with 1 megawatt acq. radar.

SEND FOR OUR NEW 8 PAGE CATALOG LISTING THE LARGEST INVENTORY OF RADAR AND MICROWAVE EQUIPMENT IN THE WORLD.

PPI CONSOLE

Complete plan position indicator, 10", with 115 volt 60 cy input pwr supply. Also nits. synchro for RHI readout. Type AN/TPA-25. \$1200.00 ea.

RADAR MAPPING CONSOLE

Complete with 115 volt 60 cy AC pwr supply. Mfr: IBM/Bendix. \$1200.00 ea.

PHILCO MICROWAVE LINKS

C Band Microwave Link terminal bays and repeater bays in stock. New \$1500 each or \$2500 per pr.

3KW RCA PHONE & TELEG XMTR

2-30 MC. 10 Autotone channels plus MO. Input 220 vac. 50/60 cycles.

60MC I.F. 5MC

Bandwidth, 130db gain. Sensitivity 95dbm. Uses 9 6AK5's 1 6AL5. Mfr: Texas Instr. Price \$55.00.

MICROWAVE TUBES

CM-710A CARCINOTRON

2400 to 3100 mc tuneable, 200 watts CW output nom. Mfr: CSE. Govt. acq. cost \$6000.00 Price \$975.00.

1154 RCA T.W.T.

1.5 to 4.5 gc. L-S-C Band 10 milliwatts output. Wide band low level amp. u/w AN/ALQ-19 Countermeasure Set. Govt. Acq. cost \$4000.00 Price \$250.00.

1161 RCA T.W.T.

1.9 to 4.1 gc: 1 watt output grid controlled. Wide Band medium pwr amp. Pulse or CW operation. u/w AN/ALQ-19 Countermeasures Set. Govt. Acq. cost \$4000.00 Price \$250.00.

C BAND KLYSTRON

7125 to 7425 mc. Tuneable. 1 watt CW output. Mfr: Sylvania.

5MC-11A KLYSTRON

4640 in 4670 mc. Amplifier-multiplier, 1 watt CW output Req. 773 to 778 mc driver. Mfr: Sperry.

5M-32 KLYSTRON

9 to 10.5 kmc. Amplifier multiplier, 2 watts CW output. Req. 4500 to 5250 mc driver. Mfr: Sperry.

VA-800 KLYSTRON

1.7 to 2.4kmc. Tuneable. 10 kw Cw output. Mfr: Varian.

RADAR AUTO-TRACK & TELEMETRY ANTENNA PEDESTALS 3 & 10 CM. SCR 584 AUTOTRACK RADARS. M-33 RADAR TPS-ID SEARCH. APS-45 TPS-10D HT. FINDERS. WX RADARS. FPN-32GCA. APS-10 APS-15B APS-27 (AMTI) SEARCH. APR-102 DOPPLER. DOZENS MORE CARCINOTRONS. P.F.N.S. 25.5-1-2-3-6 MEGAWATT PULSE MODULATORS. CAVITIES. PULSE TRANSFORMERS. IF STRIPS. WAVEGUIDE. BENDS 200 MC. 1 KMC. 3 KMC. 6 KMC. 9 KMC. 24 KMC. RF PKGS. 550 5TH AVE., NEW YORK 36, N. Y. JU 6-4691

GET IT from GOODHEART!

EVERYTHING UNCONDITIONALLY GUARANTEED!

The Best Air-to-Ground Radio Receiver: URR-13 is continuous tuning AM superhet 225-400 mc plus 1 xtl-control channel. 2 stages HF, 5 stages IF, Si-lencer, Noise limiter, 3 stages AF, 120 v 50/60 cy pwr sply. With tech. data, aligned. 149.50 OK grtd. fob Los Angeles.

TWO LV XFRMRS each 115v 60 cy. connect for 115 or 230v. Gives 4 separate 6.3vct 35A sec. connect for 23.2vct rms 35A or 12.6vct 70A or 6.3vct 140A. 2 weigh 542. Rallex or Truck collect. remit for two. 14.50

ALL-BAND SSB RCVR BARGAIN: Hallicrafters R-45/ARR-7 550 kc to 43 mc continuous. Voice, CW, MCW, aligned. grid. w books. 2-RF, 2-IF's, S-meter; noise lmt; 3 xtl, 3 non-xtl selectivity choices. 149.50 Less pwr sply: 120.00 60 cy pwr sply: \$30. SSB product detector: \$20.

TIME PAY PLAN: Any purchase totaling \$100.00 or more, down payment only 10%

- R-23/ARC-5 Command rcvr 190-550 kc 14.95
- A.R.C. 12 #22 Command rcvr 540-1600 kc 17.95
- ARR-5 rcvr 60 cy, am/fm, 27-140 mc 179.50
- APR-4Y AM/FM Rcvr mod. to 115 v 50/60 cy, with pwr plug, book, tuners 38-100mc 250.00
- P.U.R. for tuners 975-2700 and 2175-4000 mc. RA-62-B is AC pwr sply for SCR-522, only 17.95
- LM-14 freq. meter. 0.1% 125 kc-20 mc 57.50
- TS-323/UR freq. meter 20-480 mc. .001% 169.50
- Berkeley Counter-Timer counts to 1 mc 495.00
- H.P. 524D/525A, B/526C/540A: Count to 5Gc Period. Mult. adds accuracy 2175.00
- H.P. 522B (DY-2501) counts to 120 kc 450.00
- Tektronix 514AD scope dc to 10 mc 395.00
- Bonton 160A Q-meter similar to 260A PUR
- Stoddart Noise & Field Strength Meters PUR
- H.P. 608B Signal Generator modified, to same or less incidental FM as 608D 395.00
- 1KVA Line Volt. Regul. holds to 0.1% 149.50
- 3 KVA Line Volt. Regul. holds to 0.1% 279.50
- Cubic Water Calorimeter RF Wattmeter PUR
- TS-418A/U sig. gen. to 0 dbm 0.4-1.0 gc 395.00
- Hewlett-Pack. #616A Sig. Gen. 1.8-4.0 gc 795.00
- Borg-Warner High-Power sig. generators PUR
- SLRD sig. gen. 275-2750 mc. 20 watts PUR

AND MUCH MORE! We have many other Signal Generators, many Meters, VTVM's, Line Voltage Regulators, Regulated Power Supplies, Precision Bridges, ac & dc Voltage Dividers, Galvons, Calorimetric & Indicating RF Wattmeters, Other Spectrum Analyzer, Etc. WRITE, or WIRE PHONE YOUR SPECIFIC NEEDS!

WE RENT EQUIPMENT! WE BUY EQUIPMENT!

R. E. GOODHEART CO. INC.

Box 1220-E, Beverly Hills, Calif. 90213

Phones: Area 213, office 272-5707, messages 275-5342

CIRCLE 959 ON READER SERVICE CARD

ELECTRON TUBES

KLYSTRONS • ATR & TR • MAGNETRONS
SUBMINIATURES • C.R.T. • T.W.T. • 5000-6000 SERIES

• SEND FOR NEW CATALOG A2 •

A & A ELECTRONICS CORP.

1063 PERRY ANNEX
WHITTIER, CALIF.
696-7544

CIRCLE 960 ON READER SERVICE CARD

CIRCLE 957 ON READER SERVICE CARD

CASH REWARD!!!

YOU will be rewarded with cold, hard cash by selling us your new, used, excess or unwanted electronic equipment. WE WANT TO BUY YOUR: AN/ARN-21, AN/ARC-34, AN/ARC-52, -55, any ARN or ARC equipment, ID indicators, Military Type Test Equipment, Collins and Bendix equip., Instruments and instrumentation. Tell us what you have—collect the reward!

J. J. CANDEE CO. Dept. E
2525 W. Burbank Blvd., Burbank, Calif. 91505

CIRCLE 961 ON READER SERVICE CARD



FREE CATALOG!
NEARLY 4,000 BUYS
FOR INDUSTRY

OPTICS! SCIENCE! MATH!
GIANT 148 PAGES

Many on-the-job helps... Quality Control Aids! Write for this completely new, 1965 Catalog. New items, new categories, new illustrations. 148 easy-to-read pages packed with hundreds of charts, diagrams, illustrations. A treasure-house of optical and scientific information... unusual bargains galore. Optics for industry, research labs, design engineers, experimenters, hobbyists! Instruments for checking, measuring—to speed work, improve quality, cut production costs. We give you facts: what it is—how it works—where it's used!

COMPARATORS, MAGNIFIERS, MICROSCOPES

Hard-to-get war surplus bargains—ingenious scientific tools—imported—domestic. Thousands of components: lenses, prisms, wedges, mirrors, mounts—accessories of all descriptions. Dozens of instruments: magnifiers, stereo microscopes, telescopes, binoculars, infrared equipment, photo attachments. Shop by mail. No salesman will call. Use the Catalog of America's greatest Optics—Science—Math Mart. Known for reliability. Mail coupon below for catalog "EX". No obligation.

EDMUND SCIENTIFIC CO.
Barrington, N. J.

MAIL COUPON FOR FREE CATALOG "EX"!

EDMUND SCIENTIFIC CO., Barrington, N. J. 08007

Please send FREE Giant 148-page Catalog "EX"

NAME

ADDRESS

CITY..... STATE..... ZIP CODE.....

CIRCLE 962 ON READER SERVICE CARD

GOOF-PROOF INTER-WIRING

Garlock Free-Flex® circuits minimize rework and trouble-shooting because it's impossible to hook them up wrong.

LOOK

All Garlock Free-Flex circuits are flexible circuit assemblies . . . pre-engineered mechanically and electrically so all terminations naturally go on the right terminals . . . make it impossible to miss a connection.

■ Materials and configurations to meet your specifications and the Government's.

■ Write us for your copy of *Flexible Circuits in "Teflon" FEP*. Have Come of Age reprinted from *The Journal of Teflon*, published by E. I. du Pont de Nemours and Company . . . and for the FREE-FLEX Circuitry Manual.



GARLOCK
ELECTRONIC PRODUCTS
GARLOCK INC.
CHERRY HILL, N.J. 08034

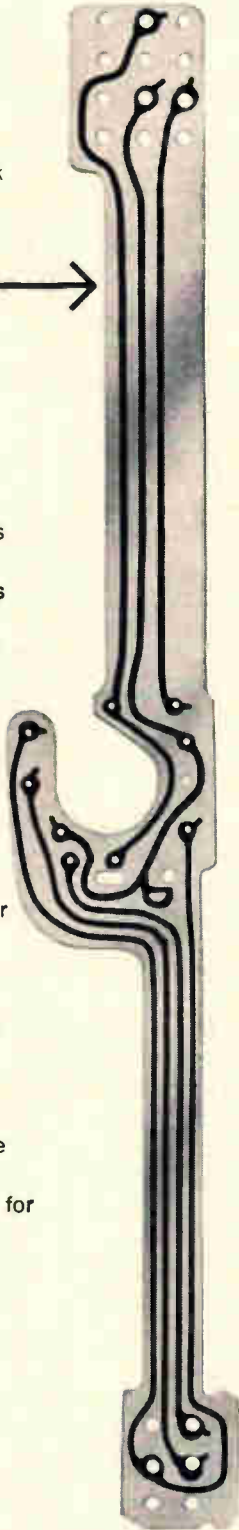

New Literature

Synchro follower. Industrial Control Co., Central Ave. at Pinelawn, Farmingdale, L.I., N.Y., 11735. Description, specifications and applications of the model 771-E two-speed synchro follower are contained in a two-page bulletin.
Circle 420 on reader service card

Miniature glass capacitor. Corning Electronics, Corning Glass Works, Raleigh, N.C., 27602. Reference File CE-1.02 covers the Glass-K, a miniature stable capacitor that exhibits a high capacitance-to-volume ratio. [421]

Oscillographic recorders. Beckman Instruments, Inc., Offner Division, 3900 River Road, Schiller Park, Ill., 60176. The versatile and highly accurate S series, pressurized-ink, rectilinear, oscillographic recorders are described in bulletin 653. [422]

Screenable solder creams. Alpha Metals, Inc., 56 Water St., Jersey City, N.J., 07304. A technical bulletin covers three new solder creams with noncurable rosin bases, which are especially formulated for miniature component soldering applications through silk screens, etched masks and other similar devices in any desired thickness. [423]

Miniature selector switch. Ohmite Mfg. Co., 3668 Howard St., Skokie, Ill., 60076, offers bulletin 403 on the model 711 selector switch featuring a 1 1/8-in. body diameter, and having the ability to break 7 amperes at 125 v a-c, and carrying 15 amps a-c or d-c. [424]

Integrating digital voltmeter. Data Technology Corp., 2370 Charleston Road, Mountain View, Calif., has released a brochure on the DVX-315, an integrating digital voltmeter with 10 different plug-ins. [425]

Printed-circuit connectors. Continental Connector Corp., 34-63 56th St., Woodside, N.Y. Form RTA-1065 is a 14-page technical catalog covering an expanded group of right-angle plug and socket connectors for printed-circuit applications. [426]

Integrated circuits. Transatron Electronic Corp., 168 Albion St., Wakefield, Mass., has available a brochure on its complete line of high-level transistor-transistor-logic integrated circuits. [427]

Elapsed time indicators. The A.W. Haydon Co., Waterbury, Conn. Newsletter No. 125 describes the 42200 series of a-c elapsed time indicators for industrial/commercial use. [428]

Indicator lights. Dialight Corp., 60 Stewart Ave., Brooklyn, N.Y., 11237.

A 12-page catalog presents a full line of two-terminal, fully insulated, subminiature indicator lights for mounting in 15/32-in. and 17/32-in. clearance holes. [429]

Precision commercial motors. Globe Industries, Inc., 2275 Stanley Ave., Dayton, Ohio, 45404. Bulletin E-10 describes a line of precision commercial motors and includes a chart giving speed/torque/output relationships for miniature motors. [430]

Iron core components. United Transformer Corp., 150 Varick St., New York, N.Y., 10013, has released two catalogs of iron core components. Volume 1 covers transformers, inductors, and magamps; volume 2, electric wave filters, high Q coils and inductors. [431]

Pulse generator. Datapulse, division of Datapulse, Inc., 509 Hindry Ave., Inglewood, Calif., 90306. A 40-Mc, fast rise pulse generator is illustrated and discussed in technical bulletin 109. [432]

IC flatpack assembly. Engineered Electronics Co., 1441 E. Chestnut Ave., Santa Ana, Calif. A four-page brochure describes the Micro-System technique for assembling flatpack integrated circuits. [433]

Noise limit indicator. B&K Instruments, Inc., 5111 W. 164th St., Cleveland, Ohio, 44142, has available an eight-page brochure on the model 2212 noise limit indicator. [434]

Multilayer circuitry. Formica Corp., Cincinnati, Ohio, 45232, offers a booklet containing an introduction to multilayer circuitry, an electronic packaging concept designed to save weight and space and to provide for the interconnection of integrated circuits. [435]

Laser systems and accessories. H Nu Systems, Inc., 470 San Antonio Road, Palo Alto, Calif., has published a brochure describing the wide range of laser systems and accessories produced by the manufacturer. [436]

Insulating wafers. Perfection Mica Co., 1322 No. Elston Ave., Chicago, Ill., 60622. Data sheet K-7 illustrates and describes a variety of low-price, high-shear-strength Mica or Teflon insulating wafers which electrically isolate transistors from the heat sink. [437]

Vibration measuring system. Gulton Industries, 212 Durham Ave., Metuchen, N.J., 08840. A portable, low level vibration measuring system is described in data sheet ACT5. [438]



"molding" makes the difference in axial-lead wire-wound resistors

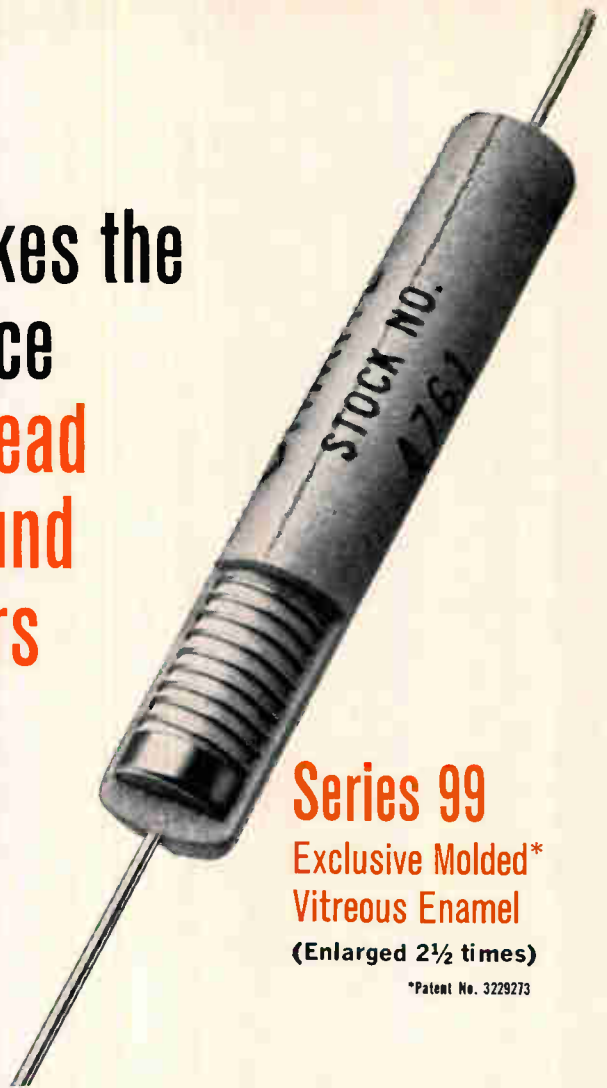

Series 88
Molded Silicone-
Ceramic
(Enlarged 2½ times)

Series 99
Exclusive Molded*
Vitreous Enamel
(Enlarged 2½ times)

*Patent No. 3229273

"Molding" provides superior electrical insulation (1000 VAC minimum breakdown) plus exceptional protection against abrasion and rough handling because it produces a thicker, more dense coating. The size and shape uniformity of Ohmite molded resistors is valuable in the automated assembly of equipment, as well as facilitating mounting in metal clips. The latter capability can provide a heat-sink advantage of up to 100%. Molded Series 88 and 99 units provide durability unsurpassed in axial-lead resistors today.

Series 88—Low temperature coefficient and overall excellent stability. Patented "Ohmicone®" coating is tough, resilient, moisture-resistant, silicone-ceramic of high dielectric strength. Three types available . . . for specification MIL-R-26, commercial power, and high stability, precision-power applications. *1% units stocked in 526 resistance values. Write for Bulletin 101.*

Wattage Ratings: 1.5, 2.25, 3.25, 6.5, 9, 11 watts at 25° C.
Resistance Range: 0.1 to 226K ohms.

Tolerances: To 0.05%. Std. commercial tolerance, 3%.
Temperature Coefficient: 0±20 ppm/° C, 10 ohms and above.
Stability: Av. 0.213% Δ R after 2000 hours of cyclic testing for Type 884.

Series 99—Exclusive "molded" vitreous enamel coating withstands applied temperatures of 1500° F without distortion. Vitreous markings, fired into coating, stand up under cleaning solvents, abrasion, and burnout overloads. Supplied in three types . . . for MIL-R-26 styles, commercial, and precision, high stability applications. *Commercial units are stocked in 5 sizes and 146 resistance values. Write for Bulletin 103.*

Wattage Ratings: 1.5, 2.25, 3.25, 5, 6.5, 9, 11 watts at 25° C.
Resistance Range: 0.1 to 187K ohms.
Tolerances: 0.25% to 5%.
Temperature Coefficient: 0±30 ppm/° C at 25° C to +350 C for 10 ohms and above.
Stability: Less than ±2% Δ R after 2000 hours of cyclic testing for Type 994.

RHEOSTATS • POWER RESISTORS • PRECISION RESISTORS • VARIABLE TRANSFORMERS • RELAYS
TAP SWITCHES • TANTALUM CAPACITORS • SEMICONDUCTOR DIODES • R.F. CHOKES

OHMITE

MANUFACTURING COMPANY
3610 Howard Street • Skokie, Illinois 60076
Phone: (312) ORchard 5-2600



For testing, life aging,
breadboarding, production . . .



ONLY CHEMELEC DUAL IN-LINE TFE SOCKETS HAVE 3-LEAF CONTACTS FOR EXTRA RELIABILITY

Unique contact design gives Chemelec sockets their extra reliability: In each pin hole are three beryllium copper leaves that bow in toward the center. When you insert a lead, the leaves deflect to let it slide in easily—but press firmly against it to assure good contact. A built-in barb keeps the contact in when you pull out the lead.

- 14, 16, 18, 20, 22, 24 pins
- contacts are hard gold plate over nickel plate on beryllium copper
- TFE fluorocarbon plastic bodies are practically "everything proof"
- long life—100,000 insertions
- low contact resistance—0.10 ohm

Write for literature.



GARLOCK
ELECTRONIC PRODUCTS
GARLOCK INC.

Cherry Hill, N.J. 08034 • Phone (609) 424-1470

New Literature

Clad metal wires. Metals & Controls Inc., a corporate division of Texas Instruments Incorporated, 34 Forest St., Attleboro, Mass., 02703. Technical data bulletin WT-17 describes the clad metal wires available for glass-to-metal sealing applications. [439]

Coaxial connectors. Amphenol RF Division, Amphenol Corp., 33 E. Franklin St., Danbury, Conn., 06813. A 240-page catalog (CC-5) covers nearly 1,400 types of coaxial connectors. [440]

Modular-packaged reed relays. Magnecraft Electric Co., 5565 North Lynch Ave., Chicago, Ill., 60630. A modular design concept in reed relays for printed-circuit applications is the subject of a new four-page illustrated brochure, No. PDB661. [441]

Thermoplastic adhesives. G.T. Schjeldahl Co., Northfield, Minn., 55057. Brochure EP301 illustrates different sealing procedures and describes the excellent bonding characteristics of a polyester resin adhesive available in thermoplastic and thermosetting forms. [442]

Conformal coating. Columbia Technical Corp., Woodside, N.Y., 11377, announces a specification sheet on a new Humi-Seal coating designed specifically for protection of electronic assembly and components against extreme temperatures. [443]

Instrument-positioning equipment. Quick-Set, Inc., 8121 Central Park Ave., Skokie, Ill., 60078, offers a brochure on a complete line of tripods, pan heads, dollies, etc., for tv, remote control, high speed or instrumentation usage. [444]

Precision switches. Potter & Brumfield, Princeton, Ind., has released catalog 1-A, which gives detailed information on a broad line of precision snap-action switches. [445]

Thermal expansion differentials. Electronic Products Division, Corning Glass Works, Raleigh, N.C. A handy two-page bulletin tabulates expansion differentials between possible pairs of materials for glass-to-glass, glass-to-metal and glass-to-ceramic seals. [446]

Microminiature digital computer. The Marconi Co. Ltd., Radar Division, Chelmsford, Essex, England. A 34-page brochure illustrates and describes the Myriad microminiature digital computer. [447]

Delay lines. PCA Electronics, Inc., 16799 Schoenborn St., Sepulveda, Calif., 91343. "Design Guide for Electromagnetic Delay Lines" is a 12-page catalog covering basic data in this field. [448]



Revolutionary electronic calculator

- Unmatched speed, versatility
- Simple to operate
- Single keystrokes provide all these functions

+	-	÷	x	x ²	√x	e ^x	log _e x
---	---	---	---	----------------	----	----------------	--------------------

- Two independent accumulators for random data entry and retrieval
 - **LOW PRICE — FROM \$1690 to \$2095**
- Additional keyboard units from \$450
 ■ Time sharing units also available
 Write for complete details

 **WANG**
LABORATORIES, INC.

Dept. HH-3 836 North St., Tewksbury, Mass. 01876
Tel. (617) 851-7311

Circle 542 on reader service card

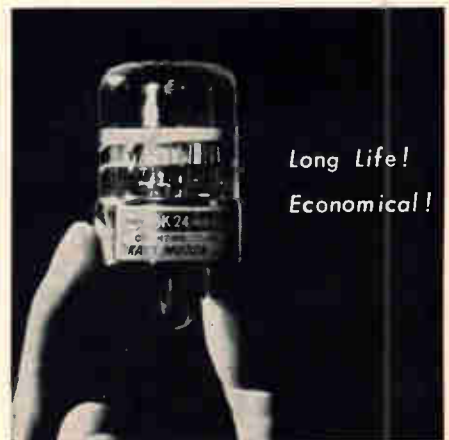

Long Life!
Economical!

COUNTING TUBE

Single-pulse type counting discharge tubes that make most ingenious use of glow discharge are used in various applications as tubes provide means for decode counting up to 20 KC with simple circuits and as tubes indicate directly the counted values by the positions of glows.

Model	Scale	Count-Rate	Description
DK 23	10	20,000 pps	Single pulse
DK 24	10	20,000 pps	"
DK 25	8	20,000 pps	"
DK 26	6	20,000 pps	"
DK 27	10	4,000 pps	Double pulse
DK 28	10	4,000 pps	"

 **OKAYA
MUSEN CO., LTD.**

2-2 Kamidori Shibuya, Tokyo, Japan
Tel: (400) 8 5 1 1

Circle 543 on reader service card

Low Cost Test Signals

10 MHz to 1000 MHz

—with the **3200B VHF OSCILLATOR**

Using the new Frequency Doubler Probe 13515A

Features:

±0.002% Frequency
Stability

External AM and
Pulse Modulation

Waveguide-Below-
Cutoff Output
Attenuator

Solid-State Power
Supply

Data subject to change
without notice.

See us at I.E.E.E. Show
Booths 3E01-3E18



The VHF Oscillator Model 3200B is designed for general purpose laboratory use including receiver and amplifier testing, driving bridges, slotted lines, antenna and filter networks, and as a local oscillator for heterodyne detector systems in the frequency range from 10 to 500 mc.

The push-pull oscillator is housed in a rugged aluminum casting for maximum stability and extremely low leakage; six frequency ranges are provided for adequate bandsread on the slide-rule dial. Internal CW operation is provided; AM and pulse modulation may be obtained through the use of a suitable external source. The RF output is coupled through a waveguide-below-cutoff variable attenuator; in addition, an electrical RF level vernier is included as a front panel control.

An optional accessory Frequency Doubler Probe, Model 13515A incorporates a solid-state doubler circuit and provides additional frequency coverage from 500 to 1000 mc.

SPECIFICATIONS 3200B

Frequency range: 10 to 500 Mc (MHz)
in six bands: 10 to 18.8 Mc; 18.5 to 35 Mc;
35 to 68 Mc; 68 to 130 Mc; 130 to 260 Mc;
260 to 500 Mc.

Frequency accuracy: within ±2% after
½ hour warmup (under 0.2 mw load).

Frequency calibration: increments of
less than 4%.

**Frequency stability (after 4-hour warmup under
0.2 mw load):** short term (5 minutes)
±0.002%; long term (1 hour) ±0.02%;
line voltage (5-volt change) ±0.001%.

RF output:
Maximum power (across 50-ohm external load):
>200 mw (10 to 130 Mc);
>150 mw (130 to 260 Mc);
>25 mw (260 to 500 Mc).

Range: 0 to >120 db attenuation from
maximum output.

Load impedance: 50 ohms nominal.

RF leakage: sufficiently low to permit
measurements at 1μv.

Amplitude modulation: externally modulated.
Range: 0 to 30%.
Distortion: <1% at 30% AM.
External requirements: approximately 15 volts
rms into 600 ohms for 30% AM,
200 cps to 100 Kc.

Pulse modulation: externally modulated.
External requirements: 1 volt peak pulse
into 2000 ohms. 5-volt rms sine wave will
provide useable square-wave modulation.

Power: 105 to 125 v or 210 to 250 v,
50 or 60 cps, 30 w.

Dimensions: 7½½" wide, 6½" high,
12½½" deep (198 x 165 x 318 mm.)

Weight: net 15 lbs. (6, 8 kg),
shipping 19 lbs. (8, 6 kg).

Accessories available: 13515A Frequency
Doubler Probe; 501B, 514B, 517B Output
Cables; 502B, 506B Patching Cables.

Price: Model 3200B, \$475.
F.o.b. factory.

13515A FREQUENCY DOUBLER PROBE

Frequency range: 500 to 1000 Mc (MHz) with
the 3200A/B operating at 250 to 500 Mc.

Harmonic suppression: (at 4 mw output):
fundamental: >16 db down;
higher order: >16 db down (500 to 800 Mc);
>14 db down (800 to 1000 Mc).

RF output: more than 4 mw across external
50-ohm load, controlled by probe depth.

Weight: net 4 oz. (110 gms),
shipping 8 oz. (220 gms).

Price: Model 13515A, \$95.
F.o.b. factory.

For more information contact your local Hewlett-Packard field engineer or write Hewlett-Packard, Green Pond Road, Rockaway, N. J. 07866; Europe: 54 Route des Acacias, Geneva.

HEWLETT  **PACKARD**
An extra measure of quality

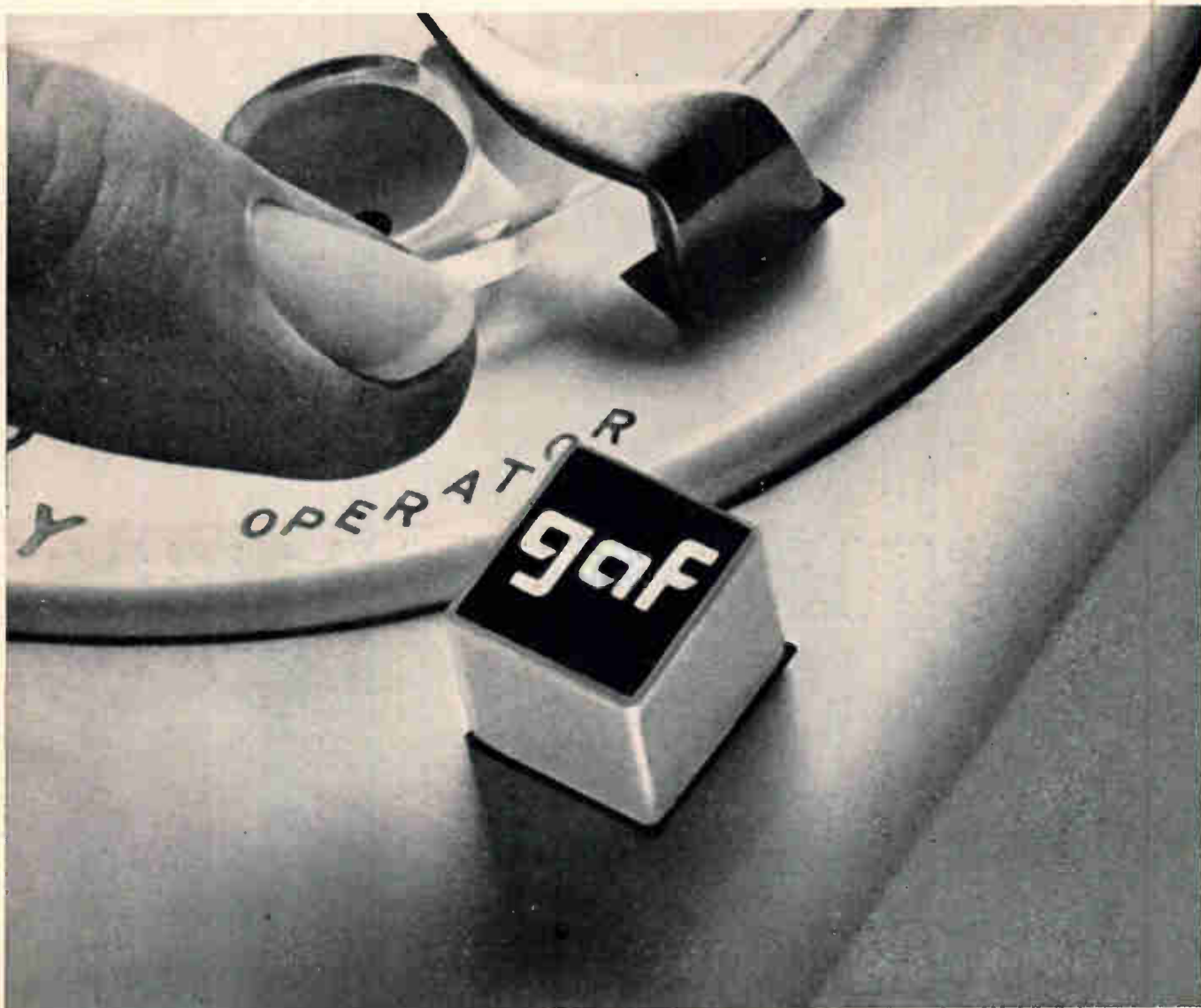

Your hot line to expert service on x-ray films and chemicals

Call your local GAF Representative when you need expert advice or prompt, professional service on industrial x-ray products.

GAF makes a complete line of industrial x-ray films designed to detect flaws in anything from electronic components to weldments and specialized castings. There's a GAF industrial film with

matched chemistry to meet any job requirement for both manual and automatic processing.

So dial the hot line to your GAF X-ray Representative. He's a trained specialist in industrial radiography—with the right answers for matching the right products to the right job, or write GAF Industrial X-ray Sales Dept., Box E-37.

gaf

GENERAL ANILINE & FILM CORPORATION

140 WEST 51 STREET · NEW YORK 10020

Great Britain

Tighter defense

It brought dismay to the Senior Service and provoked the resignation of the First Sea Lord, but the long-awaited White Paper spelling out British defense policy over the years to come didn't turn out to be the shocker many thought it would be for the electronics industry.

In the White Paper, Britain's Labor government detailed a new—and much more restrained—defense posture for the future. It will whittle down military spending by 1970 to a level of \$5.6 billion yearly, based on current prices. Once there, the government intends to hold the line on defense budgets except for modest increases to cover rising prices.

A good part of the cutback in spending will come from a slash in overseas forces; this move, however, won't trouble the industry particularly. Far more crucial were the decisions to

- Buy 50 variable-wing F-111 fighter bombers from the General Dynamics Corp.

- Phase out of the Royal Navy's aircraft carriers during the mid-1970's.

- Rely heavily on joint projects with other Atlantic Alliance countries to develop costly, complex new weapons.

After mulling over these and the other key decisions in the policy statement, British defense-market experts generally figured electronics would get a growing share of the shrinking military budgets. To a large extent this reassuring assessment of the situation stemmed from the heavy accent military planners put on sophisticated weapons systems. And electronics company executives saw an encouraging sign for the long run in the 10% boost—to \$770 million—in funds earmarked for defense research and development in the



Fifty F-111 intercontinental fighter bombers from the U.S. will cost Great Britain nearly \$300 million. Paradoxically, the purchase eases impact of pared-down U.K. defense budgets on the electronics industry. To close the F-111 deal, the Pentagon agreed to buy \$300 million worth of British military equipment and a good share will be electronics hardware.

budget proposed for the upcoming fiscal year. Said one, "It looks as if the government is aware of the importance of maintaining a high level of competence in the industry."

Vanishing flat-tops. The new defense posture brought black news for the Royal Navy, hypersensitive about its dwindling importance. The service was stunned by the decision to build no more aircraft carriers and to ground the fleet air arm after carriers now plying the seas reach retirement age in the mid-1970's.

Linked to this decision was a sharp reduction in the number of F-4 Phantom carrier planes Britain will buy from the U. S. Had Britain continued with carriers, the buy from the McDonnell Aircraft Co. might have totalled 600 Phantoms. It's now estimated the order will only cover about 200 planes. This means less potential defense business for U. K. companies that had electronics hardware contracts in the arrangement to put as much British content as possible into Royal Navy phantoms.

Buy British. The F-111 purchase, though, should make up for the set-

back and then some. The 50 intercontinental fighter bombers will cost Britain \$5.95 million each, or nearly \$300 million for the batch. There's a strong chance that the F-111 money will flow back indirectly to U. K. military equipment manufacturers, and electronics producers can count on a substantial share. To close the F-111 deal, the Pentagon agreed to buy \$300 million worth of British gear—if it meets U. S. cost and performance standards—over the next few years.

For this business, British companies will bid head-to-head with their U. S. competitors. The Defense Department's "buy American" price differential of 50% for foreign purchases won't apply. The Pentagon already has in hand a list of more than 100 items Britain wants to sell; the full list hasn't been released but it's known that it includes radar systems, communications equipment and navigational systems.

Orders should start coming soon; unofficially, the Pentagon has set a goal of \$150 million worth of contract awards for British equipment over the next six to eight months. This may tone down British com-

plaints about the Pentagon's restrictive buying practices, which shut out foreign companies.

Togetherness. The Labor government made it clear though, that the F-111 would be a stopgap aircraft and not the mainstay of its new-posture aircraft program for the long term. An Anglo-French swing-wing fighter bomber, slated to fly in the mid-1970's, fills that bill. It holds future promise for electronics production as well as systems development contracts.

Joint projects, in fact, may become a way of life for U. K. military electronics suppliers. With a tight lid on defense spending, Britain can't afford to go it alone in developing sophisticated new weapons systems. Instead the government wants to share costs with other countries. Already underway are an Anglo-Dutch three-dimensional radar and an Anglo-French air-to-ground missile.

Cores by deposit

To pair with the faster, smaller, cheaper circuit packages now going into arithmetic units, computer makers are clamoring for something better than wire-threaded ferrite cores, the workhorse device for mass memories over the past 15 years.

Researchers of Britain's Royal Radar Establishment (RRE) and the British Scientific Instrument Research Association (SIRA) have hit on a technique that may well quell the clamor. Instead of threading wires through tiny ferrite cores, the plan to deposit ferrite electrochemically on prewired matrices. That way, they will get smaller cores and a triple benefit: faster switching time, lower drive current, and inherent fabrication cost-cutting. Although the technique is still at its beginnings, its developers have high hopes it will lead to cheap 16,000-word memories with cycle times of less than one microsecond.

Migrating ferrites. The experimental process developed jointly by RRE and SIRA starts with a stable suspension of square-loop manganese-magnesium ferrite par-

ticles in alcohol, with additives that allow the ferrite to acquire an electrical charge. Electrodes are inserted in the suspension and a field of 4 volts per inch is applied. The field makes the charged ferrite particles migrate to the electrode with the opposite polarity. Thick, highly even layers of ferrite build up on the electrode at a rate of 0.005 inch in two minutes. Once deposited, the ferrite loses its charge, which leaks away. In first experiments on wires of 0.015 inch diameter, the deposited ferrite—fired at 1380°C—showed a squareness ratio of 0.8, coercive force of 2 oersteds and a switching constant of 1 oersted/microsecond.

Biax and cores. To fabricate experimental single-element memory units using the new technique, the RRE and SIRA researchers put a pair of 0.005-inch diameter wires in a ceramic jig that holds them at right angles.

For a Biax element, the small space between the two wires is filled with ferrite during deposition. Imbedded in ferrite, the two wires form a miniature element that operates as a nondestructive-read device with read times as fast as 0.05 microsecond. Drive current required for write-in and interrogation is 300 milliamperes.

For a core configuration, the space between the wires is first filled with a deposit of inert ceramic. Ferrite deposited around this crossover point then forms a core structure. So far, only single core elements have been made, with ferrite layers 0.001 inch thick.

Next steps. Now that the electrochemical ferrite process looks highly feasible, RRE and SIRA hope to push it along to the point where painstaking and costly core-by-core assembly will be just a memory. Already, squareness ratios and switching constants of the deposited manganese-magnesium ferrites have been bettered, although the tests still are not far enough along to say conclusively just how much better. Then, too, a program is in the offing to try out ferrites other than the manganese-magnesium type used for the initial work. And an 8-by-8 matrix of Biax elements will be tried, say RRE and SIRA.

But one big problem still has to be solved—fabrication yield. Failure during fabrication of any one core can mean that a whole line of the memory unit won't work. When the yield problem is licked, threaded cores will be on their way to obsolescence.

Another promising British approach to better memories is complementary metal-oxide-semiconductor transistors in an integrated circuit chip. Experimental models capable of storing 32 words of 32 bits are under study at Mullard Research Laboratories Ltd. The whole unit, complete with address coding-decoding network, is contained on a single 2-centimeter silicon wafer. To overcome yield problems, spare elements are provided; an electron-beam system will make the interconnection pattern, skipping over any defective elements.

Japan

Growth industries

Companies are banking on the demand for silicon semiconductors and for color television to pull Japan's components industry out of the doldrums.

Production of four million silicon transistors and three million diodes set records in February. These figures are still dwarfed by those of companies in the United States, which produced a total of 29.9 million silicon transistors and 67.8 million silicon diodes in November. Nevertheless, the Japanese industry expects increased production of the silicon devices, and the subsequent price reductions, to mark a resurgence in sales of semiconductors.

As for color television, the Asahi Glass Co., the nation's only producer of bulbs for color picture tubes, predicted that February shipments would top 30,000, compared with less than 20,000 in October. In the United States, production of color-tv sets is expected to be over 4.5 million this year. Each of four American companies

expects to exceed Japan's production of picture tubes in 1966: the Radio Corp. of America with 2 million tubes, Zenith Radio Corp., 1 million, National Video Corp., 1 million, and Sylvania Electric Products, Inc., 900,000; Sylvania is a subsidiary of the General Telephone & Electronics Corp.

Price break. Two trends account for Japan's gains in silicon semiconductors:

- Prices are now low enough to compete with vacuum tubes and with germanium devices in Japan's big consumer-electronics industry.

- New computers, calculators and communications equipment require the high speed and performance that are best attainable with silicon transistors and diodes.

Most of Japan's electronics companies make consumer products. They have been reluctant to design with high-priced silicon components in this highly competitive field, particularly in view of the recent glut of germanium transistors on the market. Recently, however, the cost of some silicon planar transistors has fallen below that for mesa and other types of germanium semiconductors needed for high-frequency stages of f-m and tv sets. Silicon transistors also are gaining ground in high-power stereo sets because their higher temperature ratings simplify design.

The predominance of entertainment electronics in Japan has held diode production to one-third that of transistors. But with the increase in output of commercial equipment requiring digital circuits, diode production is expected to increase faster than transistor production.

The big three. Japan's three principal producers of silicon transistors are the Nippon Electric Co., Sony Corp. and Hitachi, Ltd. Of these, only Nippon Electric makes extensive use of American technology, through agreements with the General Electric Co. and with the Fairchild Camera & Instrument Co. Sony's share of the market will decline if the company continues its policy of restricting its manufacture of semiconductors almost entirely for Sony's own use.

Other Japanese companies active in semiconductor manufacture with

silicon are Fujitsu, Ltd., the Tokyo Shibaura Electric Co. (Toshiba), Matsushita Electronics Corp., Sanyo Electric Co., Mitsubishi Electric Corp. and the Kobe Corp.

Fast color. Even faster than the increase in silicon-device manufacture is the rise of color-tv production—to an average of 33,000 sets a month this year compared with a high of 15,273 sets reached last year in November.

At present almost all color picture tubes are made by three companies: Toshiba, Hitachi and Matsushita. Nippon Electric plans to begin production in April. In addition, Sony is making about 200 units a month of its 19-inch, 3-gun Chromatron tube, and Kobe Kogyo is making about the same number of its tinyvision Colornetrons.

West Germany

Mountain-top fuel cells

Villagers in remote valleys of the Black Forest may soon be getting television broadcasts from mountain-top relay stations powered by

fuel cells, an electricity source best known for its use in spacecraft.

Suedwestfunk, the Southwest German broadcasting network, is trying out fuel cells at a 250-milliwatt relay station near Baden-Baden. Officials of the network think use of the cells might turn out to be the cheapest way to power isolated relay stations, often miles from the nearest power line. These stations pick up signals from a main transmitter, change their frequency in a low-power converter, then relay them to areas where reception of the original signal is difficult or impossible. In a program to extend coverage to small communities, Suedwestfunk plans to add many more relay stations to the 150 already in service.

The network also sees in fuel cells a chance to cut down maintenance costs. Conventional independent power sources like batteries and motor-generator sets require frequent checks and are prone to breakdown. Fuel cells, on the other hand, normally run for many months without trouble, a big advantage for hard-to-get-to stations.

Alcoholic. Brown-Boveri & Cie, a Swiss firm, developed the fuel cells

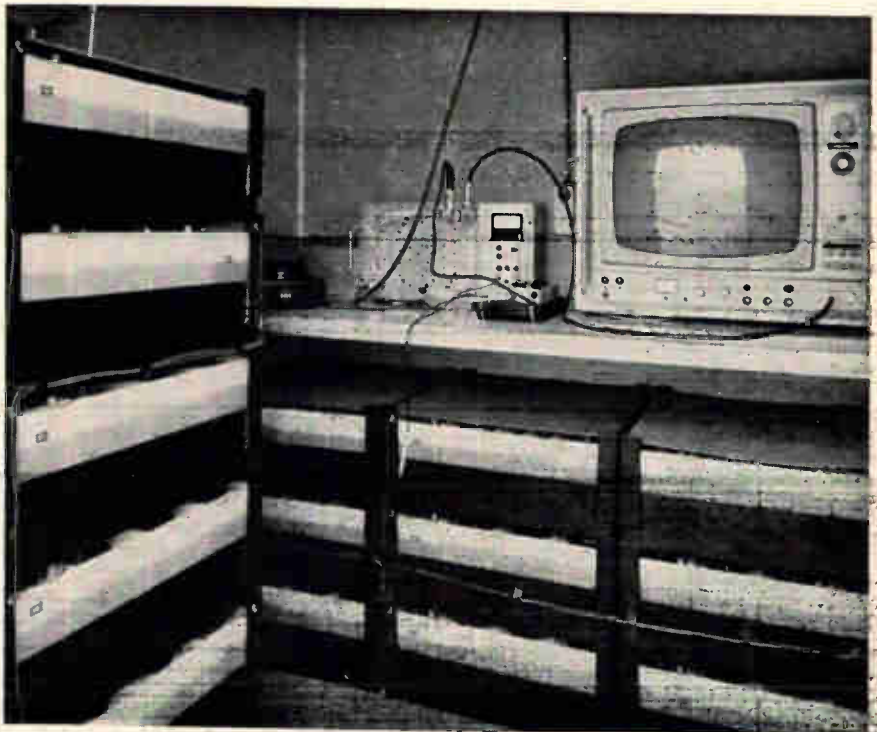

Fuel cells power transistorized frequency converter in television relay station near Baden-Baden.

now under test near Baden-Baden. Energy carriers—in an electrolyte of potassium hydroxide—are methyl alcohol and another chemical which Brown-Boveri won't disclose. Methyl alcohol is an energy-rich liquid with an equivalent heating value of about 5,300 kilocalories per kilogram. It oxidizes at the anode, which collects the liberated electrons. This process is sometimes called "cold combustion" because chemical energy is converted into electrical energy without generating heat.

The power supply consists of 240 cells, each of which develops a nearly constant current of 0.2 amperes at 0.6 volts. The cells are connected in series-parallel to get a source that delivers, under no-load conditions, 2.5 amps at 9.6 volts. This output is stepped up to 24 volts $\pm 2\%$ direct-current by a stabilized d-c/d-c converter. Energy capacity is 160 kilowatt-hours.

Teething troubles. Despite the promise of the Baden-Baden experiment, Suedwestfunk sees one big and several small problems that must be cleared up before it can start widespread use of fuel-cell power supplies.

The big problem is cost. The complete power supply costs about \$8,750. One network official figures the current price has to drop by one-third to one-half before fuel-cell power supplies become competitive with overhead power lines. Brown-Boveri says its price will come down as more units are built.

Then, too, Suedwestfunk wants longer service-free life than it has had with the experimental station. Although the Brown-Boveri specifications called for 7,000 hours of continuous operation between refills, the Baden-Baden unit had to be replenished after only a few weeks of operation. Brown-Boveri says that overloading the power supply during cold weather was to blame. Nevertheless, the company is considering some modification of the properties of the electrolyte to improve performance.

Suedwestfunk, for its part, plans to stretch out the refill life of the power supply by switching to a frequency converter with an output of 100 milliwatts, roughly $2\frac{1}{2}$

times lower than the power of the first unit. The network believes 100 milliwatts is adequate for signal transmission to smaller areas. Also under consideration is automatic shutdown of power stages in the converter when the main station is off the air. When these remedial steps are taken, Suedwestfunk expects the fuel cells will operate for a year without refill.

France

Diamond in the sky

France considerably strengthened her position as the world's third power in space with the D-1A satellite launched last month from a complex deep in the Algerian Sahara.

For the first time an all-French space shot—from the tailpipe of the launch vehicle to the tip of the satellite's antennas—went off without a major hitch. In their maiden attempt last year, the French managed to put into orbit an experimental satellite but its transmitters went dead minutes after lift-off. As D-1A went on the air and stayed on, French officials clucked happily over their newly won "independence" in space. Their boast: most of the components in the satellite didn't even exist in France three years ago.

The D-1A success puts France well ahead of her competitors for the top spot in space behind the United States and Russia, which are in a class by themselves. Other countries like the United Kingdom, Canada and Italy have to rely on U.S. vehicles and bases to launch their satellites. Only Japan is trying to match France's ambition to develop her own launchers for small satellites. But Japan is handicapped because she has no military missile program—as has France—to spawn rockets.

France expects to move even further ahead with two more D-1 satellite launchings over the next 18 months. In addition, French and U.S. authorities are talking

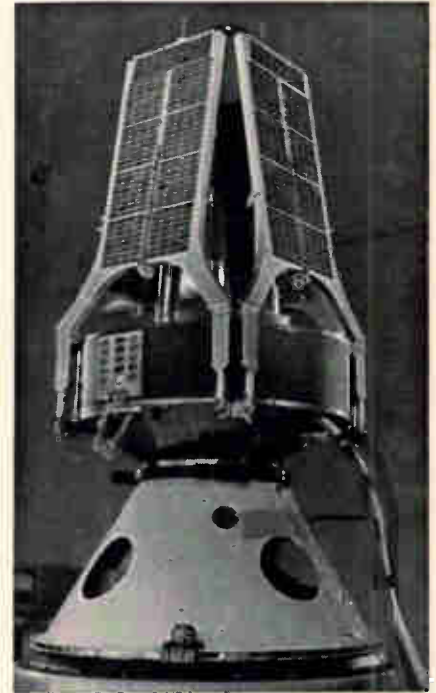

Folded solar-cell panels on all-French satellite D-1A open out when spacecraft goes into spin-stabilized orbit. Cone-shaped structure below satellite is instrument package for trajectory data telemetering, separates from satellite 13 minutes after lift-off.

about a 1968 launching of a French meteorological satellite, probably employing a National Aeronautics and Space Administration Scout booster from a U.S. base.

Seeking flaws. The main mission of D-1A was to check out performance of satellite hardware, the Diamant (French for diamond) launch rocket and the French tracking and telemetry range which stretches from Bretigny in France to Pretoria, South Africa. Also, the 40-pound satellite is fitted out with a geodesic experiment. It's designed to develop data for triangulations on the earth's surface and to spot variations in the earth's gravity field.

Along with the satellite, the payload included an instrument package to relay back to the tracking station data on the Diamant's third stage trajectory. The package—as planned—separated from the satellite 13 minutes after lift-off.

Constant check. To keep tabs on the performance of satellite hardware, D-1A continuously transmits temperatures, voltages and current

Recording and controlling versatility,
with accuracy to 40 cps —
proven in 2 years
of field applications!

DURANT UNISYSTEM

HI-SPEED COUNTING CONTROL

On thousands of applications, under a wide range of operating conditions, these count/control systems are delivering the high accuracy required for electrical, electronic recording and controlling.

Is yours a batching application? Solid or liquid flow control? Produc-

tion control? Testing? One of the many Unisystem models available can meet your specific needs. They provide sequential counting, single and multiple level predetermining, repeat cycle predetermining, remote electrical readout, data storage and more — all at low cost. Functions which also can be used in processing, converting, scaling, printing and manufacturing of all types.

The "heart" of the Durant Unisystem is our unique Unipulser, a single-decade, high speed electromechanical counter — and our Uniset 10-step selector switch for fast, push-button settings. Its available with a choice of number of digits and type of mounting. Catalog 90 tells the complete Unisystem story. Write Durant Manufacturing Company, 612 N. Cass Street, Milwaukee, Wisconsin 53201.

Life of Unisystem is not subject to hours of usage. Accumulated data is retained even if power fails.

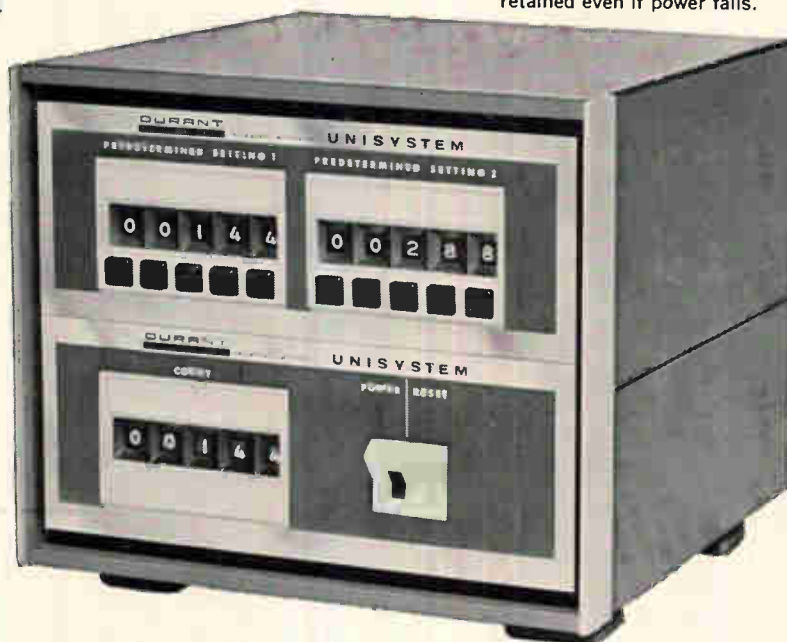
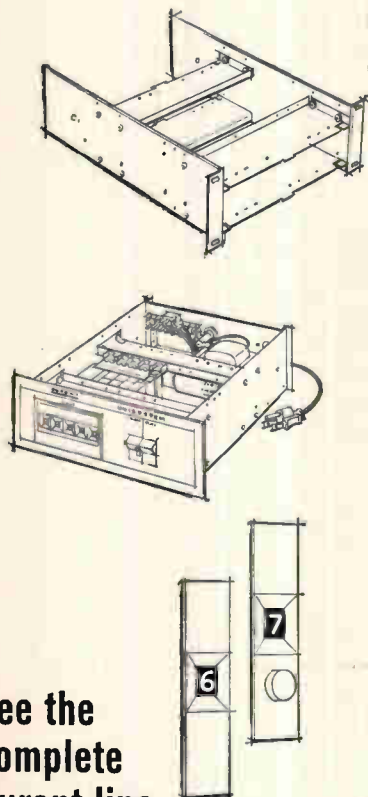

See the
complete
Durant line
at Booth M18-19,
IEEE Show

DURANT
MANUFACTURING COMPANY

MILWAUKEE, WISCONSIN
In Europe: Durant (Europa) N. V. Barneveld, Netherlands

DUAL OUTPUT POWER SUPPLIES



Dual output power supplies are housed in one case 3-5/16" x 4-5/32" x 4-11/16" high. Identical or different output voltages from 1.5 to 75 are available in 1 volt increments for each of the DC outputs. The graph below furnishes maximum current corresponding to output voltage. Select the two outputs needed and telephone Acopian for all the details — plus guaranteed 3-day shipment after receipt of your order.

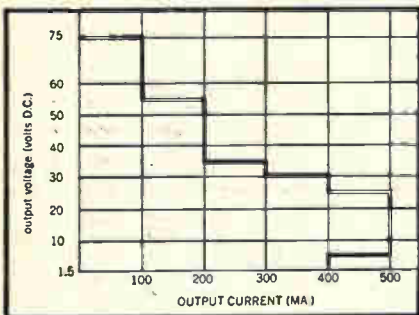

TYPICAL SPECIFICATIONS

- Input Voltage: 105 to 125 VAC
- Line Regulation: ± 0.5 to $\pm 0.05\%$ (depending on model)
- Load Regulation: ± 1.0 to $\pm 0.05\%$ (depending on model)
- Ripple: 5 to 1 mv (depending on model)
- No additional external heat sinking required.

Write for Acopian's 16-page catalog and price list to: Acopian Corp., Easton, Penna., or call collect (215) 258-5441.



levels of kingpin components like the solar-cell panels, the main oscillator, the nickel-cadmium battery and the 122.9-megacycle remote-control receiver used to turn the geodesic experiment on and off. The data is sampled on 30 channels and transmitted on a carrier frequency of 136.98 Mc by pulse frequency modulation. The pfm technique was perfected by NASA for the Explorer series of satellites.

In the hardware check-out, the French space agency Centre National d'Etudes Spatiales (CNES) is paying special attention to the silicon solar cells, which more than anything else determine how long small satellites will stay on the air. Along with measurements on the quartet of winglike "working" panels that carry a total of 2,304 individual cells, CNES will test three five-cell groups mounted on a special small panel. One group has no protection; the second group has glass filters 150-microns thick, like the working cells; the third group—for reference—was bombarded with a dose of 10^{16} electrons at 1 million-electron-volt level before the launch. The three-group comparison, CNES expects, will give it new insight into the damage wrought on solar cells by particles in the Van Allen belt.

On and off. CNES' geodesic experiment centers on Doppler-effect readings taken by the ground stations from signals emitted by a pair of highly stable transmitters in the satellite. A ground-station command signal switches the transmitters on when the satellite comes into range, turns them off again after a 15-minute pass.

To measure with an accuracy of 1 part in 1,000 the orbital speed of D-1A, frequency variation of the two transmitters is held to less than 2×10^{-9} by a quartz-controlled oscillator common to both. One transmitter broadcasts at 149.70 Mc using the same quartet of quarter-wave whip antennas as the telemetry transmitter. The other Doppler-effect transmitter operates at 339.20 Mc and has its own stub antenna.

Follow on. The French appetite for strictly Gallic space achievements was merely whetted by the

success of D-1A. Before they evacuate their Algerian Sahara space complex in mid-1967 and move to a new launch center in French Guiana, the French plan to put two more satellites in orbit.

D-1C is slated for launching before the end of the year. It will differ from its predecessor in just one major respect—the addition of radar-beam reflectors for more accurate satellite-position measurements (D-1B, a backup bird for D-1C, won't be launched). The last of the series, D-1D, is still in the study stage.

New memories

Among European computer makers, keeping up with the competition these days frequently means rushing an integrated-circuit machine onto the market. Bull-General Electric, however, is trying something different in its attempt to compete with the International Business Machines Corp. computers that dominate the European market.

Instead of putting IC's into the new Gamma 140 and 141 computers, Bull shrunk the size and cost by clever programing and by using two new forms of memory. As a result, says George Lepicard, chief designer of the systems, the Gammas will outperform equivalent-sized IBM 360 computers "in well over 50% of the applications" for small computers and cost less. The machines will rent for \$5,000 to \$10,000 a month.

The software techniques and the two new memories—one a resistor matrix and the other a woven-wire matrix—give the computers performance features that have previously been available only in large machines, Lepicard claims. Another reason that Bull is not using IC's, he says, is that the company plans to begin delivering the machines early in 1967 and did not want to risk delaying production until quantities of suitable IC's were available.

Waiting room. A kingpin feature of the computer's organization is the way it handles priority interrupt signals. When these are fed

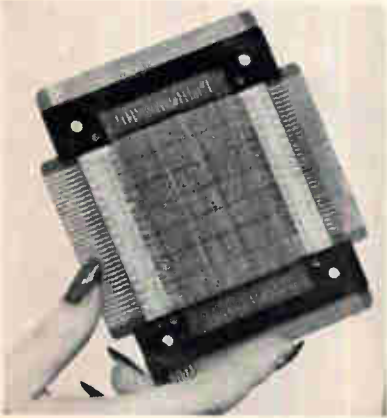

Scratch-pad memory for Gamma 140/141 computers uses Permalloy-plated wires as magnetic elements, woven wires for the matrix.

to the computer faster than the system can handle them, the extra ones are stored in the main core memory. The system processes them asynchronously as capacity becomes available.

Except for real-time applications, Lopicard says, this technique is acceptable and, along with other design features, prevents overloading of the processing channels and loss of the extra interrupts. Data-chaining in the core memory allows the incoming data to be stored wherever room is available.

The operation of the computer is arranged to suit each particular case by microprogramming techniques.

On the program. The main memory is made up of ferrite cores. There is also a fixed program memory, a matrix of printed wiring and resistors that are flat-packaged in groups of eight. Locations of the resistors in the wiring matrix control the flow of pulses through the matrix.

This memory contains the stored logic needed to execute basic instructions in the user's program. It can be extended to allow the Bull computers to run programs written for other machines and to carry our floating-point operations. The cycle time of 155 nanoseconds, says Lopicard, is faster than that of the transformer-type memories on American machines.

The operation of the fixed memory is synchronized with a woven-wire, scratchpad memory. This is also a high-speed memory. It can

INSTANTANEOUS, AUTOMATIC READING AND VERIFICATION OF PUNCHED CARDS BY IBM®

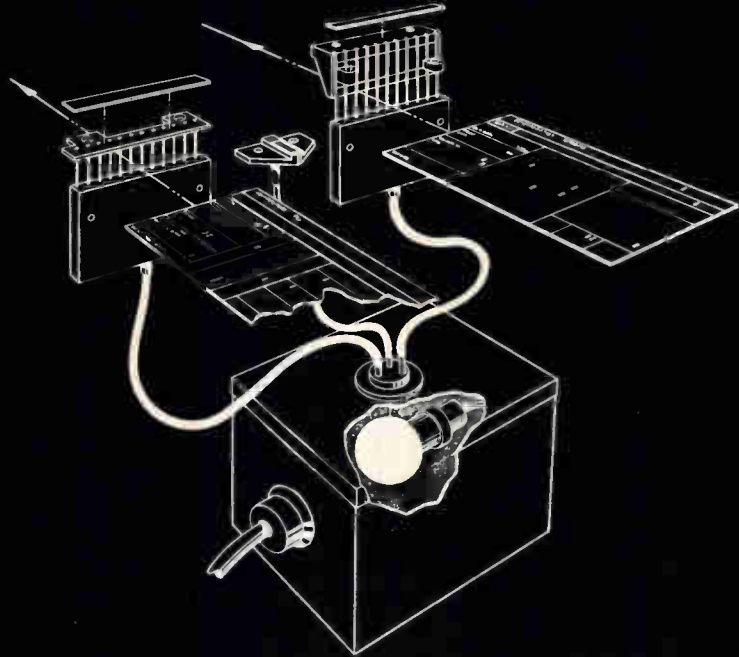

**with Bausch & Lomb
FIBER OPTICS LIGHT WIRES®**

The sensing units in the IBM 59 Card Verifier have been changed from a mechanical to an optical system, utilizing Bausch & Lomb Light Wires* Result? Speed and reliability are increased. Plus . . . no mechanical failures, no parts to wear out.

The IBM development uses three Light Wire bundles connected to a common light source. The fibers in two of the bundles are each divided into twelve separate output points corresponding to the hole locations of the data cards. When cards are in reading (or sensing) position of the Verifier, light is transmitted through the punched hole, via the Light Wires, to an attached photo cell. Non-punched areas, being opaque, do not transmit. The other assembly, the emitter, serves as a timing mechanism.

Because of their unique properties, Bausch & Lomb Light Wires can do many things—simply and efficiently. Light Wires transmit light from a single source to multiple receptors. Pipe beams over and around obstacles. Bring light into tiny openings. Transform the shape of a beam. Monitor CRT tubes and radar screens. Illuminate explosive areas safely.

We will work with your engineers on fiber optics applications. Our capability extends from design and development to prototype and production of fiber optics and requisite hardware. Send for Catalog 32-2045, Bausch & Lomb, 62327 Bausch Street, Rochester, New York 14602.

*Bausch & Lomb Light Wires are incoherent fiber optics that transmit light. We also manufacture Flexiscope® which transmits images through coherent fiber optics.

Visit our Booth #3k43 at the IEEE Show, NYC, March 21-24

BAUSCH & LOMB 

HIGHEST Q's
COMBINED WITH
HIGHEST C-V
SENSITIVITY

Pi ParaCaptm
TUNING VARACTORS

WIDE RANGE adapts Parametric Industries' line of tuning varactors to unlimited applications in space, military and commercial use. For example, the PC1430D offers minimum Q's of 500 at 50 mc with 4 volts bias and a capacitance ratio of 10 minimum from 0 to 120 volts. Other positive features include low inductance ribbon leads and reproducible square-law C-V variation.

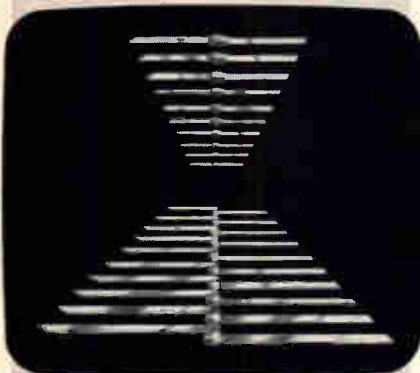

Proven Performance in

- F-M modulation in military and commercial radar altimeters
- Microwave tunnel diode oscillator tuning
- VHF-UHF Sweep Generator tuning
- Varactor multiplier tuning
- UHF Oscillator AFC

More Performance at
lower cost
with ParaCaps . . .

Pi **PARAMETRIC INDUSTRIES**

DEPT. 90D • 63 SWANTON STREET
WINCHESTER, MASS. (617) 729-7333

read, modify and regenerate a character in 155 nanoseconds. The memory (see photo) looks like a piece of cloth mounted on a circuit board. It is built of Permalloy-plated wire, for the magnetic elements, interwoven with conductors.

The statistics. The Gamma 140 has a core-memory capacity of 8,192 to 32,768 characters and a cycle time of 2.8 microseconds per character. In the Gamma 141, the numbers are 16,384 to 65,536 and 2.1 microseconds.

Fortran, Cobol or a special auto-code, or mixtures of these symbolic languages can be used for programming.

To link them to peripheral equipment, the computers have two to five high-speed channels and a multiplex channel with eight sub-channels.

Canada

Bitter patent medicine

For years, Canadian television set makers have prospered in a domestic market all their own. Along with the usual tariff barriers, a cozy little patent pool kept outsiders right where indigenous manufacturers like to see them—outside.

Now, though, Dominion tv makers have begun to fret over the solidity of their protective wall. It will be cracked for sure in three months when a basic television patent expires. Some fear the crack may grow into a gaping hole.

The patent on which time is running out is the so-called Parker patent, first filed in the United States in 1948 (U. S. Pat. No. 2,448,908). It covers intercarrier sound circuitry—basically a common intermediate frequency amplifier for both sound and video—which keeps the sound from drifting and eliminates one intermediate-frequency chain in the receiver, making it cheaper.

Tight little market. All Canadian television set makers use this basic patent, licensing it from Canadian Radio Patents Ltd. (CPRL) as the pool is known. Canadian patent

law protects native set makers against competition from imported receivers—notably American and Japanese—having the same basic circuitry. The patent, and the shelter it afforded, expires on June 14.

After that, nobody knows for sure. The tv-set industry, dominated by subsidiaries of U. S. companies, isn't yet crying catastrophe. But there's general agreement that the patent pool will become much less effective as a bar to imports. Set makers have, though, started to plump for an end to the 15% excise tax on receivers. They say it hits them harder than outsiders because of the way it's applied to imports. The tax on imports is figured on duty-paid value, set by customs officials; domestic sets are taxed on the basis of the maker's price to the distributor, which is higher.

And there's pressure building up to get the government to set quotas for Japanese imports. A big worry is that the portable tv-set market will be cornered by Japanese producers as was the transistor radio market.

The industry also has long-term worries about patent protection by the CRPL pool. Its principal stockholders are the Canadian General Electric Co., Canadian Westinghouse Ltd., Standard Radio Mfg. Corp. Ltd., Canadian Marconi Co. Ltd., the Canadian affiliate of Philips Gloeilampenfabrieken N.V. of Holland, and Northern Electric Co. Ltd. of Montreal, an affiliate of Bell Telephone Company of Canada. The pool licenses rights to all the patents it holds as a package—a single royalty payment covers all.

Indirect attack. This practice has been attacked indirectly by the Zenith Radio Corp., one of the top two American tv-set producers. Zenith last year won a \$19.9-million court award in Chicago for damages it claimed it suffered in Canada because of the pool. Zenith sued the Hazeltine Corp., which holds U. S. rights to many basic patents. Hazeltine is not itself a member of the pool, but the court ruled the company worked closely with CRPL and therefore had violated U. S. antitrust law. Zenith also won an additional \$15 million

There are over 100,000* versions
of Standard Telonic Filters
that can be shipped 3 days A.R.O.

Specials take a few minutes longer!

TELONIC RF and MICROWAVE FILTERS

30 MHz to 6 GHz • Low Pass • Band Pass •
Tubular • Cavity • Interdigital • Tunable

Telonic's modular method of construction permits fast response to your normal filter requirements, and greatly simplifies production of non-standard units. Chances are, however, your "special" is actually a filter that we've built before; and even if it's a special-special, our computer facility can deliver the design to manufacturing literally in minutes, assuring you of rapid order processing.

Combine that kind of service with the dependability and performance Telonic Filters always deliver and it's apparent why they are consistently specified by leading O.E.M.'s and service agencies.

SPECIFICATION SUMMARY:

SERIES	FREQUENCY RANGE	INSERTION LOSS	VSWR	NOM. IMPEDANCE
TLP, TLA, TLC, TLR, TLS Low Pass Tubular	30 Mc to 3 Gc (Cut-off)	.05 to .2 db/ Section	1.5/1 Max (Pass Band)	50 ohms
TBP, TBA, TBC Band Pass Tubular	30 Mc to 2.5 Gc (Center Frequency)	.05 to 2 db/ Section	1.5/1 Max	50 ohms
TCF, TCA TSF, TIF, TCC Band Pass Cavity & Interdigital	30 Mc to 6 Gc (Center Frequency)	.15 to 1.0 Typical Loss Constant	1.5/1 Max	50 ohms
TTF, TTA Band Pass Tunable	48 Mc to 3000 Mc (Full Octave)	0.5 to 3 db/ Typical	1.5/1 Max	50 ohms

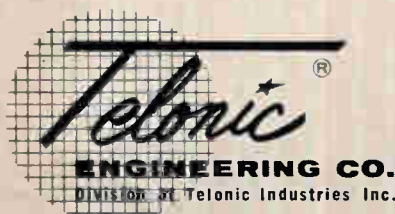

* FILTER DESIGN RULE



This new Filter Design Slide Rule enables quick determination of the exact Telonic filter model to meet your requirements, standard or special. It's yours for the asking—just write, wire or call.



award for damages caused by similar pools in Great Britain and Australia. Hazeltine has appealed, but Zenith's indirect attack eventually could put the Canadian pool in jeopardy.

Around the world

Australia. A worldwide scramble is underway to land the contract for a \$4.5 million telecommunications system the Postmaster General's Department plans to set up across the Nullarbor Plain between Adelaide and Perth. A call for bids brought 28 tenders from companies in the United States, Canada, Japan, West Germany, Italy, Holland, and Australia.

Great Britain. Transistorized radar transponder beacons are being installed off the Scottish and Irish coasts. The 3-centimeter wavelength beacons are going into 11 lighthouses and one lightship. Associated Electrical Industries Ltd. has the \$270,000 contract for the transponder job.

Japan. Tokyo Shibaura Electric Co. expects to strengthen its hold on the Japanese light-dimmer market with an 80-ampere Triac it has developed. Triacs, developed originally by the General Electric Co., are similar to silicon controlled rectifiers but can control current in two directions. Triacs for that reason have an edge over scr's in dimming circuits because only half as many are needed.

Spain. The government-owned Spanish telephone system has launched a crash \$300 million, two-year program to give the country 300,200 badly needed additional telephones. Bulk of the money is earmarked for cross-bar switching equipment and line installation, but the program includes microwave links joining Madrid to Perpignan, across the border in France.

Sweden. Scandanavia's first secondary air surveillance radar (SSR) will be installed at Stockholm's Brooma airport. The system will have six interrogation modes—three for civil use, two for military use, and one combination mode.



U. S. Navy (AUTEK) Master Timing System



NASA Mississippi Test Facility (MTF) Master Timing System



NASA Wallops Island Terminal Time Systems

Hyperion

the name for Precision Time Indexing and Automatic Search Equipment and Systems

Hyperion's Timing Equipments are being used on many major Range Facilities including NASA, Mississippi Test Facility (MTF), U. S. Navy Underwater Range (AUTEK), NASA, Wallops Island, etc.

Hyperion's Technical Staff represents 100-man years of technical experience in the field of Precision Timing and a broad background in the field of Ultra-Stable Oscillators, Automatic Time Synchronization with LORAN-C, VLF, and WWV Time Transmission Equipment, Precision Time Equipment includes Precision Time Code Generators and Countdown Clocks, and Fully Automatic Tape Search Equipments for Ground and Airborne environments.

Write or call Hyperion for your precision range time indexing and search requirements

Hyperion

INDUSTRIES CORPORATION

DIGITAL PRODUCTS DIVISION

134 COOLIDGE AVENUE, WATERTOWN, MASSACHUSETTS 02172
 TWXN: 617-924-9272 TEL: 617-WA6-0140

NEW YORK INTERVIEWS MARCH 21-25

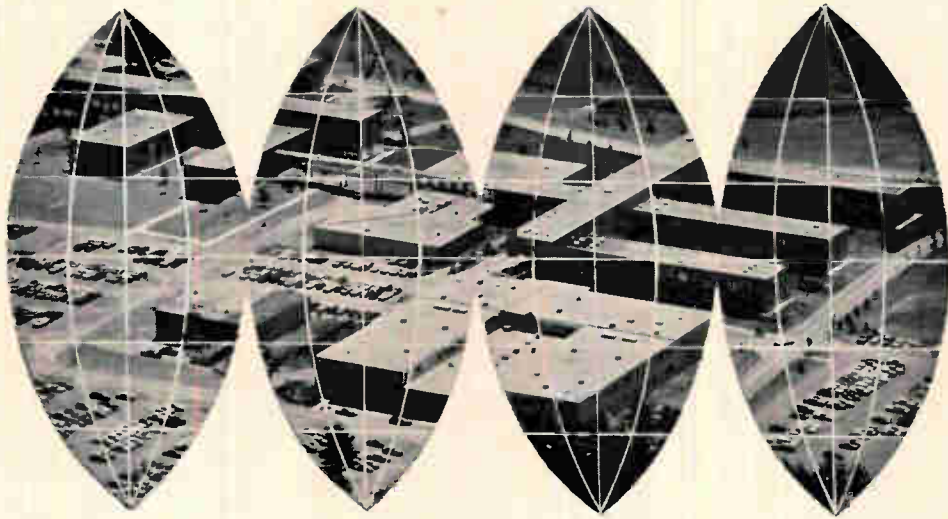

Why in the world would anybody want to work at MITRE ?

There could be several reasons. Maybe it's because we're working on the cutting edge of many disciplines associated with electronic systems . . . that we're helping to develop today's most important information systems . . . that we have a high level of professional competence . . . or that we offer a rare degree of intellectual freedom . . . or that we're located in a modern complex just 25 minutes west of downtown Boston, close to some of the finest cultural, recreational and educational facilities in the United States. Or maybe it's all of these things . . . and more!

If this appeals to you and you are curious about the "more", check the openings below.

COMMUNICATIONS — We need people who can help conceive new communications systems, recommend development programs to achieve these, and analyze special communications requirements generated by new systems concepts. Work areas include systems planning, analysis, simulation and design for command and control systems, missile and space systems and test range and weapons support systems, engineering of communication networks, range instrumentation, tactical air control, and survivable communications.

SENSOR SYSTEMS — Scientists and engineers are now needed to conduct theoretical and experimental programs on advanced radar and optical detection and tracking systems. Work includes advanced radar systems planning, design and analysis with emphasis on radar signal design, signal processing, parameter estimation, target radar characteristics, and radar coverage. Basic studies are to be conducted of sensor systems and sub-systems with focus on receiver techniques, spectrum analysis, delay-line techniques, signal processing, pulse compressors, MT and HF propagation.

NATIONAL MILITARY COMMAND SYSTEM — We need people for systems analysis and feasibility studies, communications system analysis, systems design, integration and design verification of the NMCS. This "capping system" contains all the facilities, equipment, doctrine, procedures, and communications needed by national command authorities to give them strategic direction of the armed forces. MITRE's main concern is with the technical design and integration aspects of the NMCS and the communications between NMCS and various other command systems, including the World-Wide Military Command and Control System — a group of systems operated by the unified and specified commands

TACTICAL SYSTEMS — One of our current systems engineering projects is 407L TACS (Tactical Air Control System) — a system encompassing all mobile communications systems, electronics systems and operating facilities required for command and control of deployed USAF tactical forces. Openings are available for Systems Engineers who have experience, or training in a combination of several of the following: digital data processing and displays; system test planning, instrumentation and evaluation; ground based radar systems; communications (voice and data transmission); operations analysis.

TELEMETRY — Engineers are needed to work with telemetry and instrumentation. Particular work areas include telemetry standards, systems, and techniques for both airborne and ground applications. Experience should include design or analysis of telemetry systems as well as modulation theory, RF techniques and receiving and transmitting antenna systems.

RANGE DATA TRANSMISSION — Engineers are needed to work on range data transmission. Particular work areas include digital data transmission, systems analysis and testing. Experience with switching systems, modulation and information theory, and coding is desired.

If you have at least three years' experience and a degree, preferably advanced, in electronics, mathematics or physics, contact us. Write in confidence to Vice President — Technical Operations, The MITRE Corporation, Box 208BC, Bedford, Massachusetts.

MITRE also maintains facilities in Washington, D. C., Patrick Air Force Base and Tampa, Florida, as well as Colorado Springs. MITRE's overseas facilities are in Paris and Tokyo.

Senior members of MITRE's Technical Staff will conduct New York interviews during the IEEE Show, March 21 through March 25. For interview information, see our ad in the New York Times on March 20.



An Equal Opportunity Employer (M & F)

Pioneer in the design and development of command and control systems, MITRE was formed in 1958 to provide technical support to agencies of the United States Government. MITRE's major responsibilities include serving as technical advisor and systems engineer for the Electronic Systems Division of the Air Force Systems Command and providing technical assistance to the Federal Aviation Agency and the Dept. of Defense.

Electronic Engineers: Move ahead with Douglas Missile & Space Systems Division

If you are looking for growth potential and the opportunity to work with some of the best professionals in your field, come to Douglas. Challenging opportunities await you in Electronic Engineering if you are:

INSTRUMENTATION ENGINEERS — You will analyze measurement requirements for transducer characteristics, determine selection of transducers and formulation of detailed procurement and testing specifications. Positions require BS/MS EE or Physics degree.

INERTIAL INSTRUMENTS ENGINEERS You will assist in the development, evaluation, and testing of gyroscopes and accelerometers for missile reference and autopilot systems. Mechanical or Electrical Engineer with BS or advanced degree and 3 to 6 years experience in inertial instruments.

CIRCUIT DESIGN ENGINEERS — You will perform detailed circuit design and analysis primarily in the analog circuit design area, including AC and DC amplifiers, regulators, inverters, and demodulators. BS in EE, MS in EE desirable, and minimum of 3 years experience in circuit design.

TELEMETRY SYSTEMS ENGINEERS — Your responsibilities will include system engineering and design of on-board PCM telemetry systems. You will determine requirements on the system to allow sizing and format selection, and determine multiplexing techniques and define interface requirements with other vehicle systems. Requires BS/MS EE or Physics degree.

DIGITAL TIMING SYSTEM DESIGNERS Your responsibilities will include the

determination of requirements for the system design of an airborne central timing system and programmer to be used for control of vehicle subsystems. Positions require BS/MS EE or Physics degree.

RECORDING SYSTEMS DESIGNERS — You will determine requirements for system design of airborne recording systems, voice through video, and airborne search and control systems. Analog and digital recording systems experience desired with BS/MS EE or Physics degree.

ELECTRO MAGNETIC COMPATIBILITY ENGINEERS — You must be familiar with EMC specifications, experienced in practical circuit and large system design, and possess mathematical analysis capability in EMC. BSEE degree with 3 to 5 years experience required.

See you at the IEEE Show, March 21-24. We'll be at the City Squire Motor Inn, Broadway between 51st and 52nd. To arrange for an appointment with our engineering managers, complete and return this coupon to D. R. MacDonald, Douglas Missile and Space Systems Division, 2700 Ocean Park Blvd., Santa Monica, California 90406.

NAME _____ HOME PHONE _____
 ADDRESS _____
 CITY _____ STATE _____
 Degree(s) _____
 Field(s) _____
 Specialty(ies) _____
 U.S. Citizen Yes No

You gain by going to

DOUGLAS

MISSILE & SPACE SYSTEMS DIVISION
 An equal opportunity employer.

Electronics advertisers

March 7, 1966

Keithley Instruments Inc.	212
Bayless Kerr Company	
Kingsley Machine Company	252
Nides Cini Advertising Company	
■ Lambda Electronics Corporation	62, 63
Michel Cather Inc.	
■ Lapp Insulator Company Inc.	236
Wolff Associates Inc.	
■ Leach Corporation	54, 55
Jay Chiat and Associates	
Machlett Laboratories	11
Fuller & Smith & Ross Inc.	
Malco Mfg. Co. Inc.	46
Symonds, Drimilla & Company Inc.	
■ Markel & Sons L. Frank	246
George Moll Advertising Inc.	
Matsunaga Mfg. Co. Ltd.	280
Asia Adv. Inc.	
■ Matsuo Electric Co. Ltd.	271
Fuji Agency	
Jas. H. Matthews & Co.	184
W.S. Hill Company	
McGraw-Hill Book Company	266
■ McLean Engineering Laboratories	214
Healy Advertising Agency	
■ Melcor Electronics Corporation	224
Samuel H. Goldstein	
Memorex Corporation	168
Hal Lawrence Incorporated	
Mergenthaler Linotype Company	281
Merlin Advertising	
■ Metal Removal Company	248
Advertising Producers Associated Inc.	
Metronix Inc.	257
Standard Advertising Inc.	
Mico Instrument Company	284
Microsonics Inc.	14
■ S. Gunnar Myrbeck & Company	74
Microswitch Inc.	
Batten Barton Durstine & Osborn Inc.	
Microwave Electronics	253
Bonfield Associates Inc.	
Minnesota Mining & Mfg. Co.	209
Chemical Div.	
MacManus, John & Adams Inc.	
Minnesota Mining & Mfg. Co.	198
Revere Mincom Div.	
Reach McClinton & Co. Inc.	238
Missouri Div. of Commerce & Industrial Development	
Frank Block Associates	309
Mitre Corp.	
Bresnich Co.	
■ Mitsubishi Electric Corporation	251
Hakuhodo Incorporated	
Monsanto Company,	58, 59
Chemical Division	
Foote, Cone & Belding	
Motorola Semiconductor Products Inc.	56, 57, 78
Lane & Bird Advertising Inc.	
■ Murata Mfg. Co. Ltd.	221
Dentsu Advertising	
■ Mycalex Corporation of America	146
Ray Ellis Advertising Corporation	
NRC Equipment Division	144
S. Gunnar Myrbeck & Company	
Natvar Corporation	280
Keyes, Martin & Company	
New Hermes Engraving Machine Corporation	268
Doner-Harrison Inc.	
■ Ney Company J.M.	263
Peck-Adams Incorporated	
■ Nexus Research Laboratories Inc.	171
Larcom Randall Advertising Inc.	
Nishamura Musen	259
Nichiden Adv. Agency	
North Atlantic Industries Inc.	154, 179
Murray Heyert Advertising	
Oak Mfg. Company	255, 257, 259
Buchen Advertising Inc.	
■ Ohmite Mfg. Co.	295
The Fensholt Advertising Agency	
■ Ohr-Tronics Inc.	271
Herbert M. Rosenthal	
Okaya Musen Company	296
K.K. Kyoei Kokoku Sha Adv. Agency	

Parametric Industries	306
Advertising Production Service	
Parsons Electronics Company, Ralph M.	222
Hammer & Ormsby Advertising	
■ Pennsalt Chemicals Corporation	85
The Aitkin Kynett Company Inc.	
Perfection Mica Co.	239
Burton Brown Co.	
■ Permacor Div. of Radio Cores Inc.	248
Sander Rodkin Advertising Ltd.	
Phelps Dodge Electronics Products Corp.	242
Smith, Dorian & Burman Inc.	
■ Philbrick Research Inc.	265
Culver Advertising Inc.	
Photocircuits Corporation	202
Duncan Brooks Inc.	
■ Polarad Electronic Instruments	229
Keyes Martin & Company	
■ Potter & Brumfield Mfg. Co.	30, 31
Grant Schwenck & Baker Inc.	
■ Precision Tube Company Inc.	234
George Moll Advertising Inc.	
■ Primo Co. Ltd.	257
General Adv. Agency	
Princeton Applied Research Corporation	32
Mort Barish Associates Inc.	
RHG Electronics Laboratory Inc.	263
S.M. Sachs & Associates Inc.	
Radiation Inc.	72, 73
Basford Incorporated	
Radio Corporation of America	4th Cover, 143
Al Paul Lefton Company	
■ Radio Frequency Laboratories Inc.	145
Keyes Martin & Company	
■ Radio Material Company	228
Edro Advertising Inc.	
■ Reeves Hoffman	150
Adams Associates	
Rohde & Schwarz	196, 197
Ted Gravenson Inc.	
S. D. Industrial Development	166
Maurice Paulson Adv.	
■ Sage Electronics Corp.	159
Scrivner & Company	
San-Ei Instrument Co. Ltd.	284
Standard Advertising Inc.	
Sealectro Corporation	180
Lescaboura Advertising, Inc.	
■ Semi-Elements, Inc.	190
Cavanaugh Morris Advertising	
Siemens American	313
Mann Wisley Inc.	
Simpson Electric Company	211
The Fensholt Advertising Agency Inc.	
■ Singer Co. (Metrics Div.)	278, 279
Hepler & Gibney Incorporated	
Sperry Electronic Tube Div.	75
Sperry Rand Corp.	
Neals & Hickok Incorporated	
Sprague Electric Company	5, 10
The Harry P. Bridge Company	
Stackpole Carbon Company	149, 181
Meek and Thomas, Inc.	
Struthers-Dunn Inc.	43
The Harry P. Bridge Company	
Sylvania Electronic Systems	277
Briant Advertising	
■ Syntronic Instruments, Inc.	250
Burton Browne Advertising	
Systems Research Laboratories, Inc.	223
Robert Frame Advertising, Inc.	
TRW Semiconductor	37
Fuller & Smith & Ross Inc.	
■ Taiyo Denki Co., Ltd.	259
Sanko Sha Advertising Agency Co., Ltd.	
■ Tektronix, Inc.	204
Hugh Dwight Advertising, Inc.	
■ Telonic Engineering Co.	132
Jansen Associates, Inc.	
■ Telonic Industries, Inc.	307
Jansen Associates, Inc.	
Tempress Research Co., Inc.	83
Hal Lawrence Incorporated	
Texas Instruments Incorporated	203
Robinson-Gerrard/Inc.	
Horton, Church & Goff, Inc.	
Texas Instruments Inc., Semiconductor Div.	20, 21
Don L. Baxter, Inc.	
Dacey, Wolff & Associates, Inc.	
Transitron Electronic Corp.	243, 245, 247
Larcom Randall Advertising, Inc.	
Trio Laboratories, Inc.	172
Zam & Kirshner, Inc.	

Triplett Electrical Instrument Co.	77
Burton Browne Advertising	
■ Trylon, Incorporated	244
George Moll Advertising, Inc.	
J. Ulano & Co.	231
Byrde, Richard & Pound, Inc.	
Ultronix Corporation	200
Tallant/Yates Advertising, Inc.	
■ Uniform Tubes, Inc.	216
Michener Company	
■ U.S. Components, Inc.	235
Delphi Advertising, Inc.	
United Systems Corporation	251
Advertising & Merchandising, Inc.	
■ United Transformer Corp.	2nd Cover
Philip Stogel Company Inc.	
■ Vactec, Inc.	218
Ron Coleman Agency	
Varian Associates	76
Hoefler, Dieterich & Brown, Inc.	
Vector Electronics Company	255
Van Der Boom, McCarron, Inc., Advertising	
Vector Div. of United Aircraft Corp.	220
Cunningham & Walsh Inc.	
Volkert Stampings Inc.	192
Fred Wittner Company, Inc.	

Wakefield Engineering, Inc.	261
Sales Promotion Services	
Wang Laboratories	186, 296
Larcom Randall Advertising Inc.	
Waters Manufacturing	17
Briant Advertising	
Weinschel Engineering Co.	141
George T. Petsche Advertising	
Wells Electronics Inc.	269
Weeco Advertising	
Westinghouse Electric Corp.	195
ITSM Div. of McCann-Erickson, Inc.	
Weston Instruments, Inc.	177, 262
Arndt, Preston, Chapin, Lamb & Keen, Inc.	

Xerox Corporation	272, 273
Deutsch & Shea	

Zero Manufacturing Company	219
Guerin, Johnstone, Gage Inc.	

Classified advertising

F.J. Eberle, Business Mgr.	
EMPLOYMENT OPPORTUNITIES	286-291
EQUIPMENT	
(Used or Surplus New)	
For sale	291-293

ADVERTISERS INDEX

A & A Electronics Corp.	293
A.B. Industries	291
Ampex	288
Atomic Personnel Inc.	288
Bausch & Lomb	290
Booz Allen Applied Research Inc.	290
Candee Co., J.J.	293
Edmund Scientific Co.	293
Electric Sales	291
Electro-Mechanical Research	292
Fair Radio Sales	291
Fishman Co., P.	292
Goodheart Co., Inc., R.E.	293
Harber Industrials	288
King Whitney	287
Kollman Instrument Corp.	288
Lawrence Radiation Laboratory	288
Marty's Mart	292
Norman Electronic Sales	288
Philadelphia Naval Shipyard	293
Radio Research Instrument Co.	289
Sanders Associates Inc.	290
Teledyne Industries, Geotech Div.	286
United Controls	292
W.D. Contracting Engineers	292

■ For more information on complete product line see advertisement in the latest Electronics Buyers' Guide

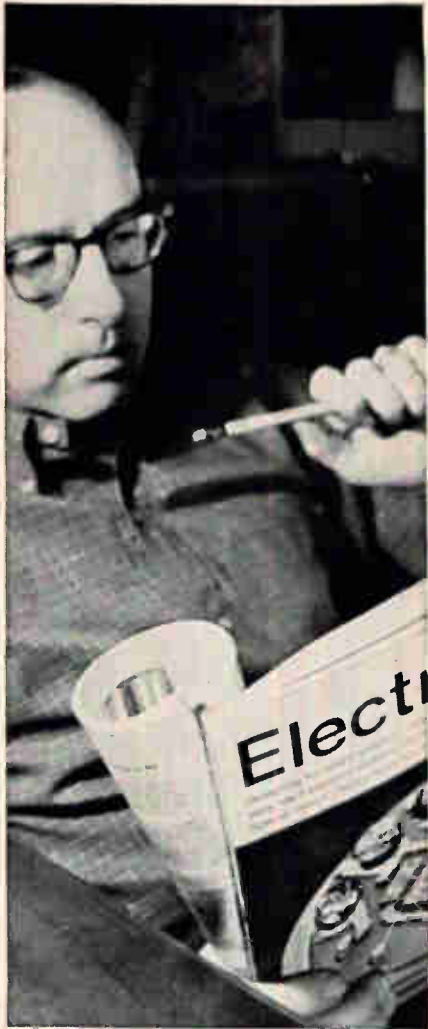

Great editorial
is something
he takes
home

(What a climate for selling!)

Electronics 
A McGraw-Hill Market-Directed Publication
330 West 42nd Street, New York, N.Y. 10036

Electronics | March 7, 1966

Siemens surge voltage protectors

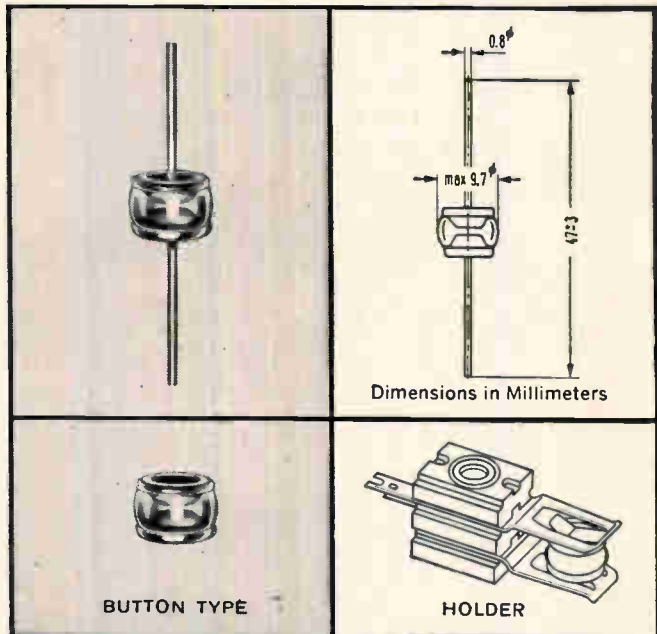

The cost of surge voltage damage to delicate equipment runs high. Telecommunications and signaling apparatus, the entire range of solid state circuitry are completely vulnerable to uncontrolled surges, causing immediate damage. Due to short circuits, lightning flashes, electrical overloads or static charging, surge voltages may range from 200 to several thousand volts. In a community wide test, up to 600 surge voltages were recorded in a 10,000 hour period.

Low cost surge voltage protectors developed by Siemens give instant reaction—in .4 microseconds! Protectors shown here cost under one dollar in quantity. All fully protect valuable equipment and do a job that cannot be done by air gap or carbon block protectors.

These gas-filled glass protectors, installed between supply line and equipment, not only absorb the surge but reset automatically for continuous protection. In this price range the only proven arc-suppressors with a current carrying capacity up to 5,000A. Low capacitants (2 p F) for HF use. Standard models have a nominal DC striking voltage of 230V to 800V.

Immediate delivery from stock in White Plains, N.Y. 14 standard models available. Custom - designed also for particular applications.

Write now for full information on Surge Voltage Protectors

SIEMENS AMERICA INCORPORATED
350 Fifth Avenue, New York, N.Y. 10001

A Corporation of THE SIEMENS GROUP IN GERMANY
Berlin • Munich • Erlangen

In Canada:
SIEMENS CANADA LIMITED
407 McGill Street, Montreal 1, P.Q.

New

FROM

AD-YU

ELECTRONICS INC.

249 TERNHUNE AVE., PASSAIC N. J.

PHONE 472-5622 (AREA CODE 201)



Advertising sales staff

Gordon Jones [212] 971-2210
Advertising sales manager

Atlanta, Ga. 30309: Gus H. Krimmier,
Michael H. Miller, 1375 Peachtree St. N.E.,
[404] TR 5-0523

Boston, Mass. 02116: William S. Hodgkinson
McGraw-Hill Building, Copley Square,
[617] CO 2-1160

Chicago, Ill. 60611: Robert M. Denmead,
J. Bradley MacKimm
645 North Michigan Avenue,
[312] MO 4-5800

Cleveland, Ohio 44113: Paul T. Fegley, 55
Public Square, [216] SU 1-7000

Dallas, Texas 75201: Richard P. Poole, The
Vaughn Building, 1712 Commerce Street,
[214] RI 7-9721

Denver, Colo. 80202: Joseph C. Page, David
M. Watson, Tower Bldg., 1700 Broadway,
[303] 255-5484

Detroit, Michigan 48226: Paul T. Fegley
856 Penobscot Building
[313] 962-1793

Houston, Texas 77002: Kenneth George,
2270 Humble Bldg.,
[713] CA 4-8381

Los Angeles, Calif. 90017: Ian C. Hill,
John G. Zisch, 1125 W. 6th St.,
[213] HU 2-5450

Minneapolis, Minn. 55402: J. Bradley
MacKimm 1104 Northstar Center
(612) 332-7425

New York, N. Y. 10036:
Donald R. Furth [212] 971-3615
Frank LeBeau [212] 971-3615
George F. Werner [212] 971-3615
500 Fifth Avenue

Philadelphia, Pa. 19103: William J. Boyle,
Warren H. Gardner, 6 Penn Center Plaza,
[215] LO 8-6161

Pittsburgh, Pa. 15222: Paul T. Fegley,
4 Gateway Center, (412) 391-1314

Portland, Ore. 97204: James T. Hauptli,
Pacific Building, Yamhill Street,
(503) CA3-5118

St. Louis, Mo. 63105: Robert M. Denmead
The Clayton Tower, 7751 Carondelet Ave.
[314] PA5-7285

San Francisco, Calif. 94111:
James T. Hauptli, 255 California Street,
[415] DO 2-4600

London W1: John W. Patten, Edwin S.
Murphy Jr., 34 Dover Street,
Hyde Park 1451

Milan: 1, via
Baracchini Phone: 86-90-617
86-90-656

Frankfurt/Main: Gerd Hinske, Joseph
Wuensch, 85 Westendstrasse
Phone: 77 26 65 and 77 30 59

Geneva: Michael R. Zeyne,
1, rue du Temple
Phone: 31 95 60

Paris VIII: Denis Jacob, 17 Avenue
Matignon ALMA-0452

Tokyo: Nobuyuki Sato, 1, Kotohiracho
Shiba, Minato-Ku (502) 0656

Osaka: Ryosi Kobayashi, 163, Umegae-cho,
Kita-ku [362] 8771

Hugh J. Quinn: [212] 971-2335
Manager Electronics Buyers' Guide

David M. Tempest: [212] 971-3139
Promotion manager

Milton Drake: [212] 971-3485
Market research manager

Wallace C. Carmichael [212] 971-3191
Business manager

Theodore R. Geipel: [212] 971-2044
Production manager

DIGITAL PHASE METER

Type 524A2



Type 524A2 with indicator. Computer alone (bottom panel) can produce analog output to drive recorder and d.c. digital voltmeter. Price \$965.

FEATURES:

Phase reading directly in degrees in 5 digits (or 4 digits).

No amplitude adjustment from 0.3v to 50v.

No frequency adjustment up to 500 kc.

Analog output available for recorder or programmable system.

USES:

Plot phase vs. frequency curve of unknown network.

Plot envelope delay curve with RF sweep oscillator.

A standard phase meter with 5-digit readout.

VIDEO and RF PHASE METER

Type 422A



USES:

Plot envelope delay curve of I.F. amplifiers up to several hundred megacycles with sweep oscillator modulated by 1 mc crystal oscillator. Measure phase characteristics of antenna arrays.

Plot phase curve of amplifiers and networks.

20 CPS to
10 MEGACYCLES

FEATURES:

Phase reading independent of amplitude fluctuation.

Analog output for plotting phase characteristic curve.

No frequency adjustment from 20 cps to 10 mc. Relative accuracy 1/4°, absolute ±1°.

HF NANOSECOND PHASE DETECTOR
Type 205B1-4



Accuracy ±0.05° or ±1%; 15 mc to 1700 mc

VECTORLYZER
Type 202-202A



Accuracy ±0.02°; full scale sensitivity 1°, 2° up to 180°; 20 cps to 100 kc.

TRANSISTORIZED PRE-AMPLIFIERS
Type A102 Series



Gain over 40 db; bandwidth 1 cps to 17 mc.

CONTINUOUSLY VARIABLE FILTERS
Type A103 Series



40 cps to 100 kc; continuously adjustable.

See Our Booth No. 3d05-3d07 at the IEEE Show

Another Brush Innovation in Recording:

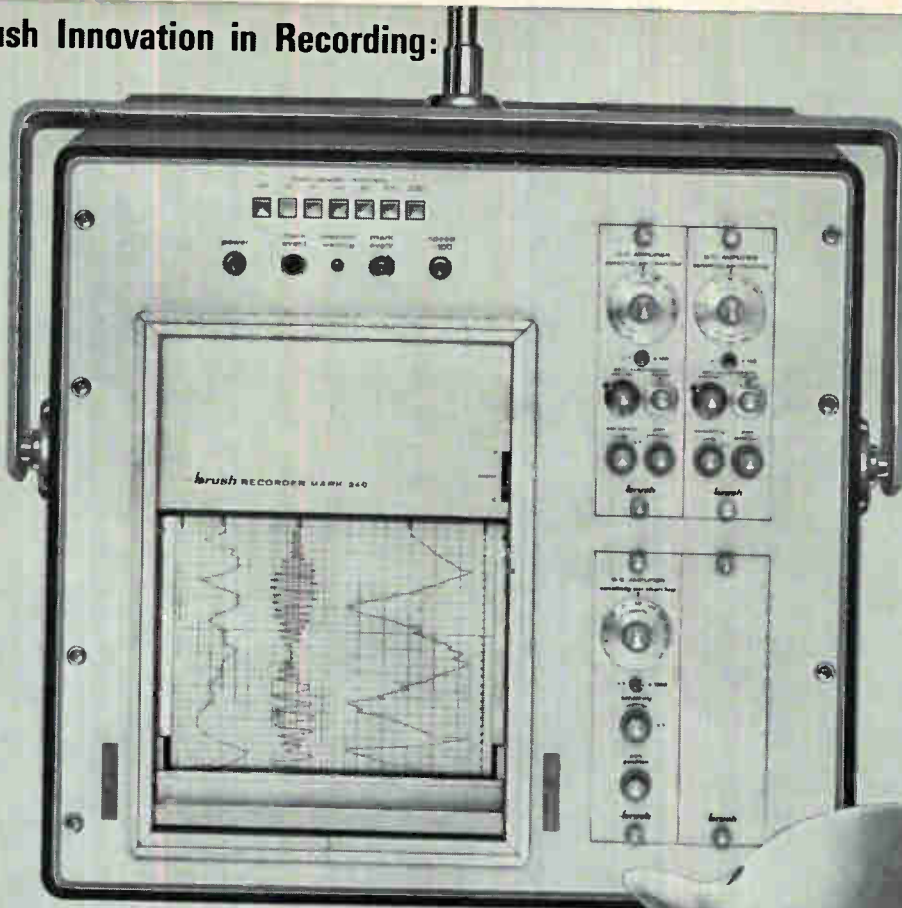

The Brush Mark 240

**If you can't record it
with this recorder,
chances are
it didn't happen!**

What we've done is this:

We took our famous Mark 200 Recorder and made a 'compact' version for general purpose and medical requirements. Performance? The new 240 will do everything the Mark 200 will do. And as Aerospace people will tell you, that's plenty: System linearity better than $\frac{1}{2}\%$. Pressurized fluid writing system assures incredibly crisp traces on low cost chart paper. Presentation is true rectilinear and there's push-button choice of 12 chart speeds.

Cost? The Mark 240 runs about

half as much as a Mark 200. Still, you have a choice of either four 40 mm analog channels, two 80 mm channels, or a combination* of two 40s and one 80. (You can also have 8-channel event-marker modules). There's a choice of 17 plug-in pre-amplifiers, too. High gain d-c units, straight-through couplers and strain-gage and demodulator types. The Mark 240 is just $17\frac{1}{2}$ " high x 19" wide x $20\frac{1}{2}$ " deep. Mount it vertically or horizontally in standard 19" racks to RETMA specs, on table-top carts or you name it!

If your kind of recording calls for the utmost in resolution, precision and recording flexibility, ask your Brush representative for complete details about the new Brush Mark 240. There's nothing else like it . . . anywhere! Brush Instruments Division, Clevite Corporation, 37th & Perkins, Cleveland, Ohio 44114. *Just out! Three information-packed booklets on strain recording, temperature recording and techniques of low-level recording. Write us today for your copies. They're yours for the asking!*

*see photo

brush INSTRUMENTS DIVISION
CLEVITE

Handle Every Power Stage in AM/FM Aircraft and Mobile Transmitters with Rugged RCA "overlay" Transistors

TYPE	FRE- QUENCY Mc/s	POWER OUTPUT WATTS (Min)	V _{CC} VOLTS	GAIN dB (Min)	EFF. % (Min)	PKG.
40340	50	25	13.5	7	65	TO-60
40341		30	24	10	60	TO-60
40290	135	2*	12.5	6	70	TO-39
40291		2*		6	70	TO-60
40292		6*		5	70	TO-60
40280	175	1	13.5	9	60	TO-39
40281		4		6	70	TO-60
40282		12		5	80	TO-60
2N3553	175	2.5	28	10	50	TO-39
2N3632		7.5		6	70	TO-60
2N3375	400	3	28	5	40	TO-60
2N3733		10		4	45	TO-60

*AM Carrier Power

For RF applications from 27 Mc/s To More than 400 Mc/s. "Overlay" is the RCA technology that brings high power and gain at high frequencies to the solid-state mobile and aircraft communications market. This high performance is available in a series of reliable and economical "overlay" transistors, offering the industry's widest choice of voltage, power and frequency performance for rf driver, pre-driver, and final amplifier stages.

Whatever RCA "overlay" type you select for your designs, you can be sure of efficient, rugged performance. Each "overlay" transistor undergoes Power-Rating Test (PRT) at maximum power levels for

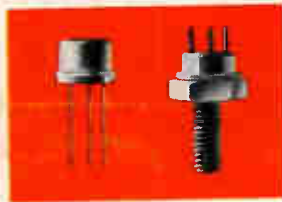

one second. Both AM aircraft and FM mobile types are designed specifically to withstand load mismatch conditions. This capability means simpler design of the final stage and no need for protective circuits. In addition, types for AM aircraft display excellent modulation capability as well as high-voltage breakdown characteristics.

See your RCA representative for the full story on RCA "overlay" transistors for AM aircraft and FM mobile, as well as other types for citizens' band radio, military communications, and microwave applications. For technical data on specific types, write: RCA Commercial Engineering, Section I-N-3-1, Harrison, N. J.

Also Available From Your RCA Distributor

RCA Electronic Components and Devices



The Most Trusted Name in Electronics

Visit RCA at the IEEE Show, March 21-24, and see premiere of "THE OVERLAY TRANSISTOR— The Challenge and The Answer," a new 16-mm color film.

Circle 902 on reader service card