

# Electronics®

**Compromise: radiation and second breakdown: page 48**

**Breadboarding integrated circuits easily: page 58**

**Digital transducer measures liquid variables: page 65**

October 19, 1964

75 cents

A McGraw-Hill Publication

Below: Special ferreed relays  
for electronic switching, page 71

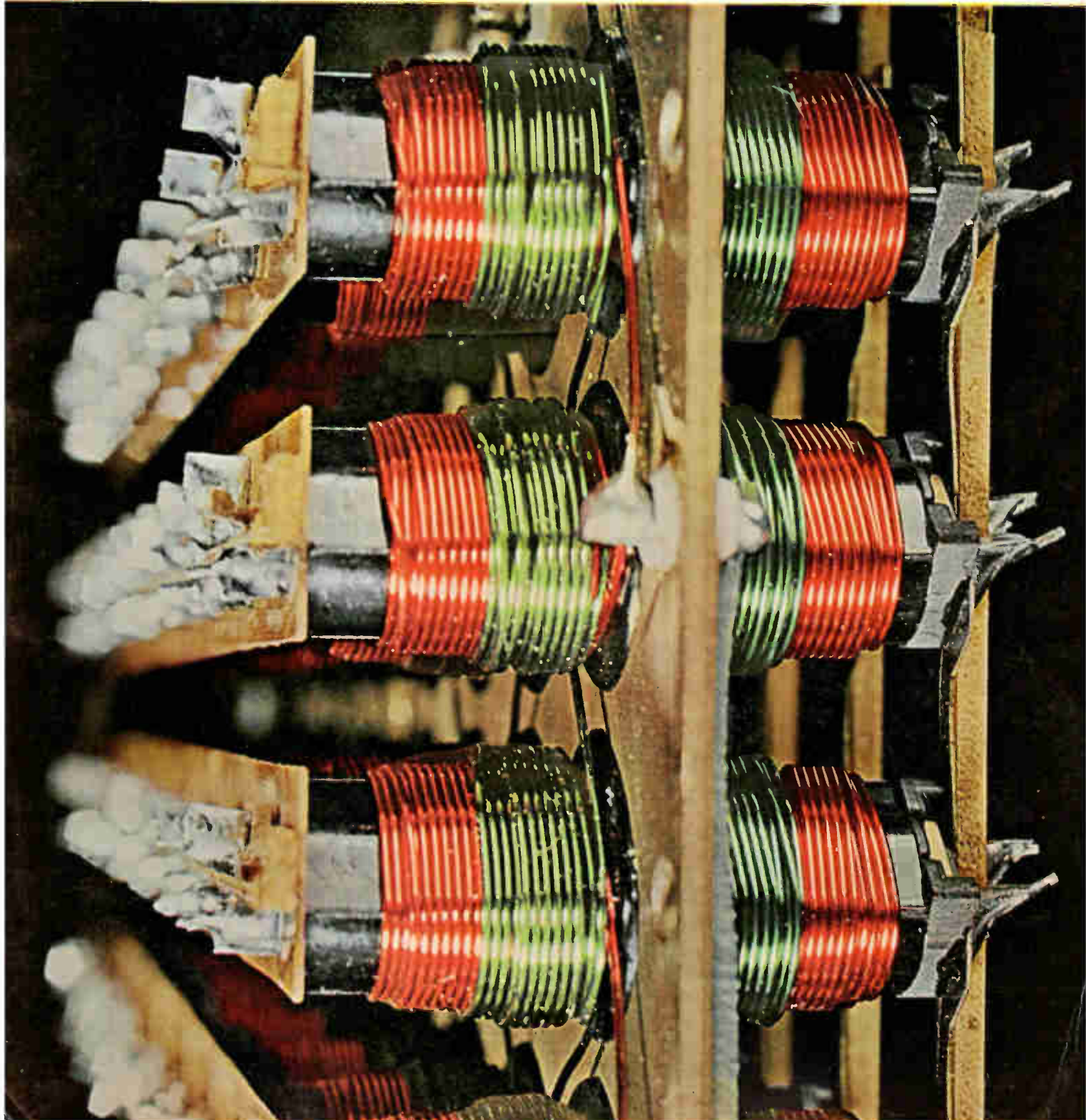



# "SPECIAL" (CUSTOM BUILT) FILTERS

## TO YOUR SPECIFICATIONS

ILLUSTRATED ARE  
TYPICAL SPECIAL FILTERS

RANGE OF FREQUENCIES ON SPECIAL UNITS  
IS FROM 0.1 CYCLE TO 400 MC.

Over thirty years of experience in the design and production of special filters have resulted in UTC being a first source for difficult units. Present designs both military and commercial incorporate a wide variety of core structures, winding methods, and capacitors to provide maximum performance, stability, and reliability. Fully experienced, top engineering talent backed by complete environmental testing and life testing facilities assure the highest standard in the industry. Full analysis and evaluation of materials are conducted in UTC's Material and Chemical Laboratories. Rigid quality control measures coordinated with exhaustive statistical findings and latest production procedures results in the industry's highest degree of reliability.

MILITARY AND COMMERCIAL TYPES FOR  
EVERY PHASE OF THE ELECTRONICS ART

POWER TRANSFORMERS • AUDIO TRANSFORMERS • INDUCTORS • PULSE TRANSFORMERS • ELECTRIC WAVE FILTERS • LUMPED CONSTANT DELAY LINES • HIGH Q COILS • MAGNETIC AMPLIFIERS • SATURABLE REACTORS • REFERENCE UNITS

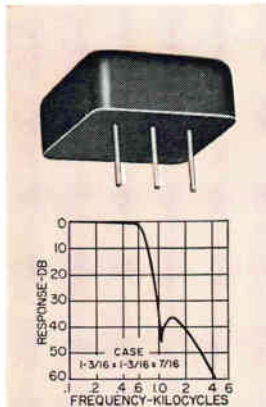

560 — Telemetering low pass filter. Available from 400 — to 70 KC.  $\pm 7.5\%$  bandwidth flat to 1 db. Attenuation greater than 35 db beyond the 2nd harmonic of  $\pm 7.5\%$  frequency. Impedance 47K ohms. MIL-F-18327B. Wt. 0.8 oz.

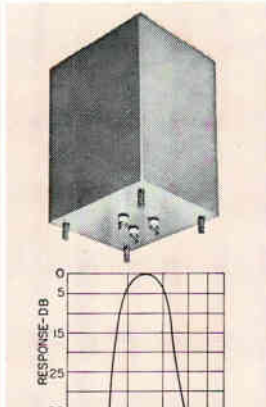

Low frequency band pass filter. Designed for 2.5 cps center frequency. At 2 to 3 cps within 3 db. At 1.5 cps and lower, and 4 cps and higher, greater than 30 db. Source and Load 10K ohms. Size: 4 x 4-11/16 x 6". MA MIL case, MIL-F-18327B.

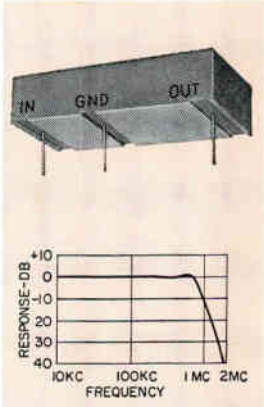

High frequency low pass filter. Zero to 700 KC within 1 db. 1.95 mc to 10 mc 40 db minimum. Source and Load 1000 ohms. Molded flat construction for printed circuit applications. Size: 1 x 2 x 1/2"; Wt: 1 oz. MIL-F-18327B.

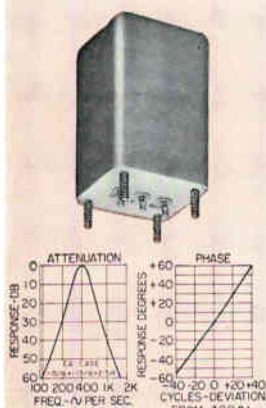

Band pass 400 cycle Gaussian filter. Linear phase response in pass band. Attenuation 380 cps to 420 cps within 0.5 db. 2nd harmonic down 25 db. 3rd harmonic down 45 db. Source and load 5K ohms. MIL-F-18327B Wt., 0.9 lbs.

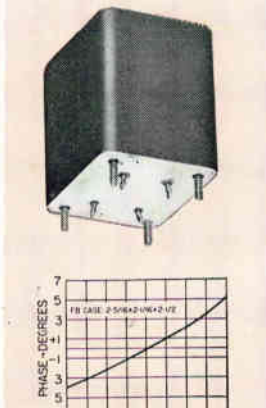

Minimum phase shift 400 cycle band pass filter. Within  $\pm 1.5$  db 370 to 430 cycles, greater than 45 db beyond 1100 cycles. 1K ohms to 100K ohms. MIL-F-18327B; 1 lb.

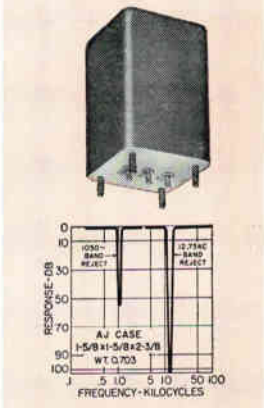

Band reject filters (two shown). The 1050 — filter has 50 db attenuation and is only 3 db at 950 and 1150 cycles. The 1275 KC filter has more than 100 db attenuation and is only 3 db at 10.8 and 15 KC. Source and load 600 ohms, both are MIL-F-18327B.

Write for catalog of over  
1,200 UTC HIGH RELIABILITY  
STOCK ITEMS  
IMMEDIATELY AVAILABLE  
from your local distributor.



## UNITED TRANSFORMER CORP.

150 VARICK STREET, NEW YORK 13, N. Y.

PACIFIC MFG. DIVISION: 3630 EASTHAM DRIVE, CULVER CITY, CALIF.  
EXPORT DIVISION: 13 EAST 40th STREET, NEW YORK 16, N. Y. CABLE: "ARLAB"

Circle 900 on reader service card

NEVER BEFORE  
SO MUCH  
INSTRUMENT

TO PERFORM  
SO MANY TASKS  
SO WELL

AT SO GREAT  
A VALUE

Stability: Better than 0.002% per day; 0.003% per month

DC standard: 0.01% accuracy

Differential voltmeter: Zero to 1000 v dc, accuracy

$\pm 0.01\% \pm 1 \mu\text{V}$

High-impedance electronic voltmeter: 1  $\mu\text{V}$  to 1000 v full scale

Power amplifier:  $\pm 0.01\%$  accuracy to 60 db

Voltage amplifier: 120 db gain

Guarded for all modes of operation

Complete field calibration in minutes

Calibrate digital and differential VM's

Use as high-voltage dc standard source

DC standard for transfer measurements

Standard cell comparisons

Low-level null detector

Precision transducer, thermocouple measurements

Accurate drift measurements off-null

**Price: \$2350**

New concepts in circuitry make the new 740A DC Standard and Differential Voltmeter the most useful instrument of its type at a remarkably low cost. Get the facts and a demonstration from your nearest hp field office or write Hewlett-Packard, Palo Alto, Calif. 94304, Tel. (415) 326-7000; Europe: 54 Route des Acacias, Geneva; Canada: 8270 Mayrand St., Montreal.

*Data subject to change without notice. Price f.o.b. factory.*

**HEWLETT  
PACKARD**



*An extra measure of quality*



# New!

# VHF

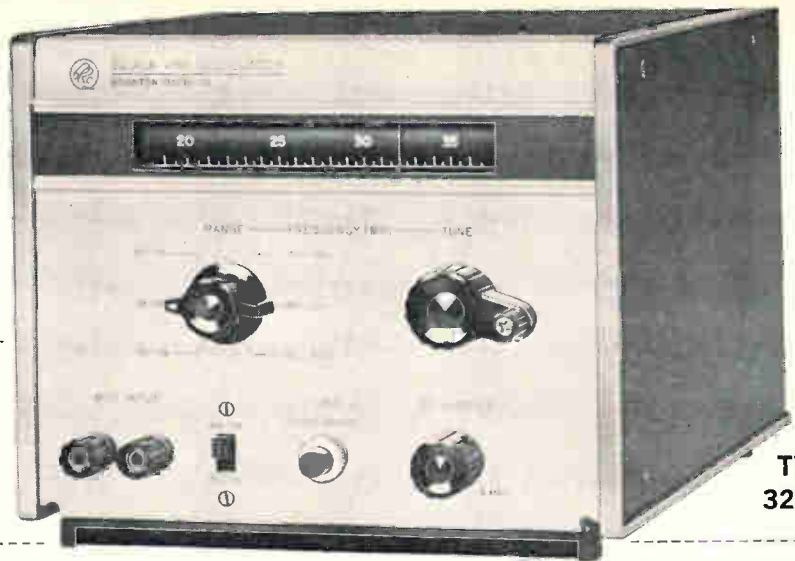

TYPE  
3200A

# OSCILLATOR

## 10 Mc - 500 Mc

### Features:

$\pm 0.002\%$  Frequency  
Stability

External AM and Pulse  
Modulation

Waveguide-Below-Cutoff  
Output Attenuator

Solid-State Power Supply

The VHF Oscillator Type 3200A is designed for general purpose laboratory use including receiver and amplifier testing, driving bridges, slotted lines, antenna and filter networks, and as a local oscillator for heterodyne detector systems in the frequency range from 10 to 500 mc.

The push-pull oscillator is housed in a rugged aluminum casting for maximum stability and extremely low leakage; six frequency ranges are provided for adequate bandsread on the slide-rule dial. Internal CW operation is provided; AM and pulse modulation may be obtained through the use of a suitable external source. The RF output is coupled through a waveguide-below-cutoff variable attenuator; in addition, an electrical RF level vernier is included as a front panel control.

A solid-state power supply furnishes all necessary operating voltages including regulated dc to the oscillator heaters for minimum hum modulation and maximum tube life.

### Specifications:

#### Radio Frequency Characteristics

RF RANGE: 10 to 500 mc

RF ACCURACY:

$\pm 2\%$  (after 1/2 hour warmup)

RF STABILITY:

Short Term:  $\pm 0.002\%$  (5 minutes)

Long Term:  $\pm 0.02\%$  (1 hour)

Line Voltage:  $\pm 0.001\%$  (5 volts)

\*After 4 hour warmup, under 0.2 mw load

RF OUTPUT:

Maximum Power:

> 200 mw\* (10-130 mc)

> 150 mw\* (130-260 mc)

> 25 mw\* (260-500 mc)

\*Across external 50 ohm load

Range: 0 to >120 db attenuation from maximum output

Load Impedance: 50 ohms nominal

RF LEAKAGE: Sufficiently low to permit measurements at 1  $\mu$ v

#### Amplitude Modulation Characteristics

AM RANGE: 0 to 30%

AM DISTORTION: <1% at 30% AM

EXTERNAL AM REQUIREMENTS: Approx. 30 volts RMS into 600 ohms for 30% AM

#### Pulse Modulation Characteristics

EXTERNAL PM REQUIREMENTS: 140 volts peak negative pulse into 2000 ohms for maximum power output; typically 10 volts peak (except 50 volts on 260-500 mc range) for 1 mw peak power output

#### Physical Characteristics

DIMENSIONS: Height: 6 1/2" (16.5 cm)

Width: 7 3/4" (19.8 cm)

Depth: 12 1/2" (31.8 cm)

#### Power Requirements

105-125/210-250 volts, 50-60 cps, 30 watts

Price: 3200A: \$475.00

F.O.B. Rockaway, New Jersey



## BOONTON DIVISION

PRECISION ELECTRONIC INSTRUMENTS SINCE 1934

GREEN POND ROAD, ROCKAWAY, NEW JERSEY 07866



Hewlett-Packard  
Company

TELEPHONE: (201) 627-6400 • TWX: (201) 627-3912 • CABLE ADDRESS: BOONRACO

# Electronics

Page 4	Readers Comment
8	People
10	Meetings
15	Editorial
17	Electronics newsletter
37	Washington newsletter
111	New products
142	New books
144	Technical abstracts
149	New literature

## In this issue

Title R registered  
U.S. Patent Office;  
© copyright 1964  
by McGraw-Hill, Inc.  
All rights reserved,  
including the right to  
reproduce the contents  
of this publication,  
in whole or in part.

### Electronics review

Page 25	Commands from above	28	Electron and laser
25	New computer circuits	28	Unetched wiring
26	Measuring limitations	30	Cold soldering
26	Controlled dyeing	32	Radar in 3-D
26	Minor monitoring jobs	32	Tricky space design
27	Monitoring radar		

### Electronics abroad

Page 151	Olympic telecasts	153	Meteor at sea
151	Heart monitor	153	Go East, look West
152	Instant anesthesia	154	Component show
152	Checkout on tape	154	Then there was one
152	Engineers for export	154	Scene stealer
153	Into the lion's den		

### Probing the news

Page 93	Politics and military communications
96	Laser welders out of the lab
102	Shake-up in spectrum analyzers

### Technical articles

#### I. Design

**Solid state 48** **Compromise: second breakdown and radiation resistance**

Trading off to make the most of transistors in severe environments

B. Reich and E.B. Hakim, Army Electronics Laboratory

**Circuit design 52** **Checking oscillation in cathode followers**  
A quick way to identify and remove an unwanted, and sometimes unexpected, circuit effect  
Phillip D. Blais, Erie Technological Products, Inc.

**Circuit design 54** **Designer's casebook**  
Thermistor measures dielectric gas content; junction diode regulates low-voltage supply; variable phase polyphase from single phase supply

#### II. Manufacturing

**Breadboarding 58** **An easy way to make linear microcircuits**  
Linear integrated circuits are scarce, but you can now make your own easily for development work  
D.D. Robinson, North American Aviation, Inc.

#### III. Application

**Instrumentation 65** **Digital transducers for the Savannah**  
First nuclear merchant ship uses digital transducers for reliability and easy maintenance  
D. Gertz and L. Leavitt, Sperry Rand Corp.

**Communications 71** **Telephony goes electronic (cover)**  
Alexander A. McKenzie, communications editor

72 **1. Bell's spectacular advance**  
In the U.S., Bell's system uses twistors for memory and ferreed relays for reliability

74 **2. Telephony primer**  
How telephone switching works in its basic form

84 **3. How other companies do it**  
Telephone companies in various countries have many different hardware approaches

# Electronics

**Editor:** Lewis H. Young

**Senior editors**

**Technical:** Samuel Weber

**News:** Kemp Anderson, Jr.

**Senior associate editors:** John F. Mason, George Sideris

**Department editors**

**Advanced technology:** George V. Novotny

**Avionics:** W.J. Evanzia

**Circuit design:** Michael Elia

**Communications:** Alexander A. McKenzie

**Components:** Michael F. Tomaino

**Computers:** Stephen B. Gray

**Industrial electronics:** Louis S. Gomolak

**Instrumentation:** George J. Flynn

**Manufacturing:** George Sideris

**Military electronics:** John F. Mason

**New products:** William P. O'Brien

**Solid state:** Jerome Eimbinder, G.G. Tirellis

**Space electronics:** Joel A. Strasser

**Staff writers:** Leon H. Dulberger, Peggy Jackson

**Regional editors**

**Boston:** Thomas Maguire, editor; Susan Turner

**Chicago:** Cletus M. Wiley, editor; Leslie Krimston

**Los Angeles:** June Long

**San Francisco:** Laurence D. Shergalis, editor; Mary Jo Jadin

**London:** Derek Barlow, editor

**Copy editors**

Howard Rausch, Sally Powell, Stanley Zarowin

**Graphic design**

**Art director:** Saul Sussman

**Assistant art director:** John C. Wright, Jr.

**Editorial production:** Ann Mella, Sandra A. Le Mond

**Editorial secretaries:** Claire Benell, Mary D'Angelo, Lynn Emery, Kay Fontana, Carolyn Michnowicz, Lorraine Rossi, Lorraine Werner

**McGraw-Hill news service**

**Director:** John Wilhelm; **Atlanta:** Fran Ridgeway; **Chicago:** Bruce Cross;

**Cleveland:** Arthur Zimmerman; **Dallas:** Marvin Reid;

**Detroit:** Donald MacDonald; **Los Angeles:** Michael Murphy,

Ron Lovell; **San Francisco:** Margaret Ralston, Ed. Addeo;

**Seattle:** Ray Bloomberg; **Washington:** George Bryant Jr., Glen Bayless, Charles Gardner

**McGraw-Hill world news service**

**Bonn:** Richard Mikton; **Brussels:** Arthur Erikson; **London:** John Shinn;

**Mexico City:** Wesley Perry; **Milan:** Bruce Bendow;

**Moscow:** Donald Winston; **Paris:** Dan Smith;

**Rio de Janeiro:** Leslie Warren; **Tokyo:** Marvin Petal, Charles Cohen

**Circulation manager:** Hugh J. Quinn

**Reprints:** T.M. Egan

**Publisher:** C.C. Randolph

**Electronics:** October 19, 1964, Vol. 37, No. 27

Printed at 99 North Broadway, Albany, N.Y.

Second class postage paid at Albany, N.Y.

Subscriptions are solicited only from those actively engaged in the field of the publication. Position and company connection must be indicated on orders. Subscription prices: United States and Possessions and Canada, \$6.00 one year, \$9.00 two years, \$12.00 three years. All other countries \$20.00 one year. Single copies, United States and Possessions and Canada 75¢. Single copies all other countries \$1.50.

Published every other Monday by McGraw-Hill Inc., 330 West 42nd Street, New York, N.Y. 10036. Founder: James H. McGraw, 1860-1948.

**Subscribers:** The Publisher, upon written request to our New York office from any subscriber, agrees to refund that part of the subscription price applying to copies not yet mailed. Please send change of address notices, subscription orders or complaints to Fulfillment Manager, Electronics, at the address below. Change of address notices should provide old as well as new address, including postal zone number if any. If possible, attach address label from recent issue. Allow one month for change to become effective.

**Postmaster:** Please send Form 3579 to Fulfillment Manager, Electronics, P.O. Box 430, Hightstown New Jersey 08520

## Readers Comment

### Raising antennas

Regarding "Electronics in the Me-kong Delta" [Sept. 7, p. 114], those concerned with raising antennas in the jungle might be interested to know that the Coast Guard has for many years had a type of gun that serves to put a line across an off-shore ship in distress, so that a breeches buoy can be rigged to take off the crew. Such a gun, or possibly even a mortar, can be used to carry an antenna above the treetops.

A balloon such as that shown on page 122 would have only a 1-in-20 chance of getting more than its own diameter above the ground in the tropical rain forest that I know. Perhaps the mass necessary to provide the stored energy to carry the line aloft might be a folded parachute of Mylar or other transparent film, which would be programed to open above the treetops and catch on them as it descends, to keep the radiator up where the attenuation is less severe.

Charles P. Hedges  
Technical Military Planning  
Operation  
General Electric Co.  
Santa Barbara, Calif.

### Insect control

I have read with interest your article in the Sept. 21 issue [p. 86] on potential microwave applications, "A comeback for wireless power?" The statement concerning possible destruction of insects in a nonheating application was of particular interest, because we have been exploring possible stored-grain insect control applications in the 1-to-50-megacycle range.

Our findings to date indicate that insect mortality can probably be explained by selective dielectric heating. Any nonthermal r-f destructive mechanisms could be of real benefit in reducing energy costs and thereby improve the economics of practical application.

We are interested in investigating higher frequency ranges for insect control, and would appreciate learning of any research being conducted or of anyone having a real

## Solid Tantalum Capacitors with Constant Height and Width Save Space on Printed Boards

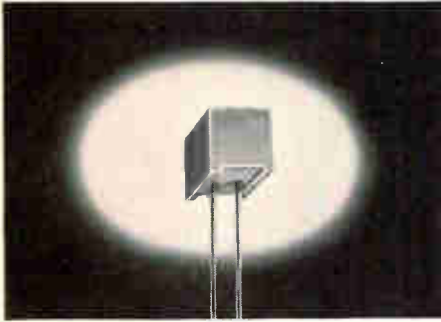

Type 190D Solid Tantalex® Capacitors are especially qualified for applications such as printed circuits, where board space is at a premium and must be fully utilized. Available in four different case sizes, their height (0.350") was carefully selected to correspond with the most acceptable maximum height in normal printed board spacing. Their uniform width (0.375") permits neat, space-saving alignment on the wiring board. Only their depth changes from case to case. The constant height and width of Type 190D Capacitors makes them extremely well-suited for automatic insertion.

Another *first* for Sprague in the tantalum capacitor field, new Type 190D Rectangular Molded Solid Tantalum Capacitors have radial leads with .200" spacing, conforming to standard printed wiring board grids. In anticipation of the 0.125" grid, these rectangular capacitors will also be available with new lead spacing when required by future circuit designs.

Encapsulated in tough molded cases with excellent dielectric properties, Type 190D Capacitors fully meet the environmental test requirements of Specification MIL-C-26655A.

Stand-off feet at the base of these capacitors permit complete circulation of air, preventing moisture and solvent traps around their leads.

Unlike many solid tantalums, these new capacitors exhibit the low impedance at high frequencies desired for high-speed computer applications. Their low dissipation factor (high Q) permits higher ripple currents. They are available with capacitance values from .01  $\mu$ F to 330  $\mu$ F in a voltage range of 6 to 50 vdc.

For complete technical data write for Engineering Bulletin 3531 to Technical Literature Service, Sprague Electric Company, 35 Marshall St., North Adams, Massachusetts 01248.

Circle 5 on reader service card

# Did you know Sprague makes...?

## MAGNETIC LOGIC DEVICES



Core-diode and core transistor magnetic shift registers and magnetic counters for switching and storage applications in computer and logic circuitry.

CIRCLE 277 ON READER SERVICE CARD

## MOLDED PULSE TRANSFORMERS

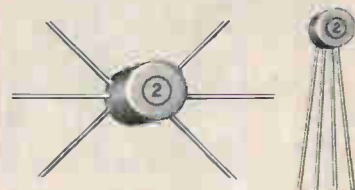

Miniature Pulse Transformers with tough molded cases for increased protection against physical damage and severe atmospheric conditions.

CIRCLE 278 ON READER SERVICE CARD

## NANOSECOND PULSE TRANSFORMERS IN TO-5 TRANSISTOR CASES

Special design offers distinct advantages: (1) Mini-fied size. (2) Welded hermetic seal. (3) Increased reliability. (4) Compatibility with transistor mounting techniques.



CIRCLE 279 ON READER SERVICE CARD

## SOMETHING NEW IN COUNTING TECHNIQUES

Simple yet versatile, low-cost yet reliable counters available for predetermined (2 to 11) or selectable (5 through 10) counting cycles.



CIRCLE 280 ON READER SERVICE CARD

## DYNACOR® BOBBIN CORES



Series "300" Cores with logical flux values in popular physical sizes are stocked in production quantities for fast delivery. They're value engineered for quality with economy!

CIRCLE 282 ON READER SERVICE CARD

## HERMETICALLY-SEALED TO-5 ENCASED SWITCH CORES

Designed especially for high-speed, low-power switching up to 100 kc, adaptability with conventional transistor packaging techniques, and performance under MIL-S-21038 environmental conditions.



CIRCLE 281 ON READER SERVICE CARD

## ELECTRONIC MODULES TO CUSTOMER REQUIREMENTS

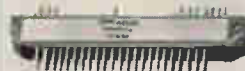

Custom packaging is no novelty at Sprague's Special Products Division, where "specials" are continually being developed and produced with countless variations in electrical characteristics and mechanical configurations.

CIRCLE 283 ON READER SERVICE CARD

For application engineering assistance (without obligation, of course) on any of the above products, write or call the Special Products Division, Sprague Electric Company, 35 Union Street, North Adams, Massachusetts.

45SP-111-63 R4

# SPRAGUE®

THE MARK OF RELIABILITY

"Sprague" and "Ⓢ" are registered trademarks of the Sprague Electric Co.

# EXTRALYTIC\*

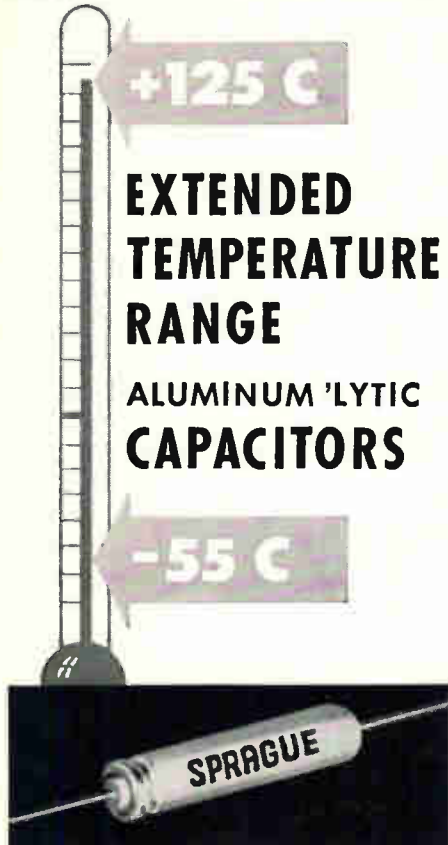

- Voltage ratings to 150 vdc, unlike other so-called "wide temperature range" aluminum electrolytics with compromise voltage ratings only to 60 volts.
- Capacitance stability over entire temperature range. Even at  $-55^{\circ}\text{C}$ , capacitance drop is very small.
- Operating and shelf life comparable to or better than that of foil tantalum capacitors.
- Less expensive than foil tantalum capacitors, yet meet electrical requirements of proposed military specification MIL-C-39018.
- Smaller and lighter than tantalum capacitors in equivalent capacitance values and voltage ratings.

For complete technical data, write for Engineering Bulletin 3455 to the Technical Literature Service, Sprague Electric Co., 35 Marshall St., North Adams, Mass. 01248

45C-4144

\*Trademark



'Sprague' and '®' are registered trademarks of the Sprague Electric Co.

interest in applying microwave energy for insect destruction.

S.O. Nelson

Agricultural Research Service  
U.S. Dept. of Agriculture  
University of Nebraska  
Lincoln, Neb.

## Optional control

I would like to make a correction to the interesting article "Electronics in the Mekong Delta" [Sept. 7, p. 114].

With reference to the AN/PRT-7 beacon [being developed by Matrix Systems, Inc.], it was stated that it operates on only a single frequency. This is true when an internal crystal is used as a frequency standard. However, in addition to the crystal control, there is now an option consisting of a 1½-pound plug-in synthesizer designed for this beacon. This permits the choice of any integral kilocycle frequency from 200 to 400 with stability comparable to that of the crystal.

Ralph E. Bolgiano

U.S. Army  
Limited War Laboratory  
Aberdeen Proving Ground  
Aberdeen, Md.

## Weight problem solved

In "Electronics in the Mekong Delta" you mentioned our weight problem with beacons.

Subsequent to developing our present beacon we received information on Army requirements indicating substantially lower operating life. This reduction, combined with our continued effort towards developing a microcircuit frequency synthesizer and encoder, plus elimination of our integral back-pack rack, has enabled us to develop a beacon with the same operating characteristics, at well under 30 pounds. This device will be available in the near future.

John A. Majane

Tridea Electronics Inc.  
Arlington, Va.

## Lesson from Europe

Your editorial, "Lesson from Europe" [May 4, p. 15], calls for comment, both laudatory and critical.

Europe's economic circumstances can certainly be classified as peculiar. A typical peculiarity, for ex-

ample, is that West Germany has laws and an enforcing agency (Kartellamt) that permit and sanction price-fixing agreements for which people in this free-enterprise country would be thrown in jail.

The competitive situation varies widely throughout Europe, but nowhere is a branch of the economy nearly as competitive as in the United States. Thus, profits can be handsome without business having to accept the high risks typical for a rapidly progressing, highly competitive industrial nation. No government research and development funds are required if the consumer's income can be tapped directly by the manufacturer and distributor of goods via inflated prices.

A color-television set, for example, costs at least two months' wages of an average worker in Germany. Thus, the initial demand will necessarily be low, limited to the thin crust of high-income people. Is it any surprise, therefore, that manufacturers withhold investments in color-tv production lines as long as possible? Furthermore, more profit can be wrung from established black-and-white tv production facilities, if there is no prospect of competition with a new, more advanced system such as color tv.

The earning power of European engineers and scientists is between one-half and one-fifth that of the equivalent in this country. European R&D would therefore be considerably less costly than its U.S. counterpart—if it were not padded with wasteful internal company administration and hidden profits. During my eight years of experience as an engineering physicist in the German electronics industry, this experience has clearly emerged.

I therefore want to caution anybody who uses the European situation as an example worth following. Some aspects are good; there are quite a few dangerous ones, which should be avoided. Among the good ones: an intense, broad preparation for the skilled technical and professional trades all through high school and advanced educational courses for the nations' youth is one of the most noteworthy and obvious.

Fred Walter

Giannini Scientific Corp.  
Santa Ana, Calif.



1954

**REL Tropo Scatter equipment makes possible world's first operational tropo system:**

BAFFIN ISLAND—LABRADOR—  
NEWFOUNDLAND, CANADA

1964

**REL Tropo Scatter equipment operates in:**

BAHAMA ISLANDS  
CANADA  
DENMARK  
FAEROES ISLANDS  
FRANCE  
GREECE  
GREENLAND  
HAWAII  
ICELAND  
ITALY  
LEEWARD ISLANDS  
LIBYA

MOROCCO  
NORWAY  
OKINAWA  
PHILIPPINE ISLANDS  
SPAIN  
TAIWAN  
TURKEY  
UNITED KINGDOM  
UNITED STATES  
SOUTH VIETNAM  
WEST GERMANY  
WINDWARD ISLANDS

Radio Engineering Laboratories (REL) is the only company devoted exclusively to the design, development, and production of radio relay equipment for microwave and tropo scatter systems:

- Operating frequencies in the 400, 900, 2000, 5000, and 8000 mc bands.
- Voice channel capacities from 1 to 300.
- Power outputs from 10 watts to 100,000 watts.
- Noise figures as low as 2 db.

- Span lengths from quasi-optical to 600 miles.
- Advanced solid-state equipment—**new REL 2600 Series.**
- Fully-developed FM feedback threshold extension techniques.

Today, as for more than 40 years, REL continues to provide engineering and performance leadership for worldwide telecommunications requirements.

Please write for additional technical data and detailed specifications.



**RADIO ENGINEERING LABORATORIES**  
Division of Dynamics Corporation of America  
Long Island City 1, New York



# [ SUPER POWER TRIODE ]



**New ML-8549 Super Power Triode provides extremely favorable output/drive ratios. Typical power capabilities:**

- 60 Mw pulse power . . . approximately 70 kw drive
- 10 Mw rf power, plate pulsed . . . approximately 33 kw drive
- 2.5 MW rf power, CW . . . approximately 10 kw drive
- 1.1 MW rf power, CW-plate modulated . . . approximately 4 kw drive

These extremely favorable output/drive ratios result from a novel beaming principle which permits a typical plate-to-grid current division of 100 to 1. Because of the very high power gain afforded, drive requirements are unusually low. Unique design of the ML-8549 utilizes two concentric anode cylinders permitting double-sided cathode operation resulting in low internal tube drop and highly efficient operation. Pulsed efficiencies higher than 90% are achieved. For data write: The Machlett Laboratories, Incorporated, Springdale, Connecticut. An affiliate of Raytheon Company.



## People

For the first time in its history, the Raytheon Co. has an engineer at the helm. He is **Thomas L. Phillips**, 40 years old, former vice president, who succeeds Charles Adams as president. Adams becomes chairman. Phillips joined Raytheon as an engineer in 1948, the day Adams became president. He later became general manager of the Missile and Space division, playing a major role in developing the Army's Hawk and the Navy's Sparrow III missiles.



Phillips' promotion underscores recent statements by Adams that Raytheon intends to stay firmly in the defense business but that it also intends to exploit the growth possibilities of space.

Before joining Raytheon, Phillips taught electrical engineering at several universities. Executive talent seems to run in the family. Phillips' oldest daughter is president of her college class.

**H. Brainard Fancher** will be general manager of two of the four computer subsidiaries jointly owned by the General Electric Co. and the Compagnie des Machines Bull: Compagnie Bull General Electric and Societe Industrielle Bull General Electric.



Fancher had been general manager of GE's Apollo Support Department and a director of a French semiconductor company in which GE has an interest. He joined GE in 1936 as a test engineer.

To France he'll bring his wife, two of his four children (the other two are in college), and GE's hopes of challenging the International Business Machines Corp.'s domination of the European computer market.



**Everybody but Sze Chin likes our SOAR specified germanium transistor lines.  
He's sick and tired of them.**

Before SOAR can be used to select the right transistor, somebody has to plot the charts. Sze Chin. He has to compute and draw all the SOAR (Safe Operating Area) envelopes for every one of our germanium power transistors. And we have over 125 different SOAR specified types, with more coming. Sze's getting tired.

We put a lot of emphasis on SOAR because it's important to you—and us—as a positive, simple method of specifying switching transistors. As long as a given device is operated within its SOAR envelope, secondary breakdown does not occur. A look at the specs in the chart will give you some idea of just how many different switching applications can be solved with our germanium line.

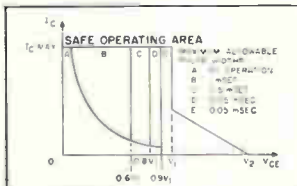

TYPE NUMBER	Ic MAX A	V1 V	V2 V	Ppeak W	I/J-C C/W
2N677C, 2N678C	25	60	80	2000	0.8
2N1031C, 2N1032C	3	30	60	180	3.75
2N1038, -1, -2	3.5	60	90	315	3.75
2N1045, -1, -2	15	35	60	900	0.5
2N1120	10	50	80	800	1.2
2N1136B, 2N1138B	20	45	70	1400	0.8
2N1146C, 2N1147C	25	45	75	1875	0.8
2N1166A, 2N1167A					

Of course, we have a lot other than SOAR. All of our germanium transistors are proven reliable (since we're one of the oldest manufacturers, we have special reliability data on many 2N types as well as meeting military specifications on several). They all have very linear current gain characteristics as well as (in each series) being available with various gain ratings and voltage breakdown ratings to fit almost any sort of application.

For more detailed data on our germanium line and a full list of 2N types, contact any Bendix Semiconductor sales office or your distributor.

And ask for the SOAR charts, too. We don't want Sze to feel he's wasting his time.

**Bendix Semiconductor Division**  
HOLMDEL, NEW JERSEY



Baltimore (Towson), Md.—(301) 828-6877; Chicago—(312) 637-6929; Dallas—(214) 357-1972; Detroit—(313) Jordan 6-1420; Holmdel, N. J.—(201) 747-5400; Los Angeles—(213) 776-4100; Miami Springs, Fla.—(305) 887-5521; Minneapolis—(612) 926-4633; San Carlos, Calif.—(415) LYtell 3-7845; Syracuse, N. Y.—(315) 474-7531; Waltham, Mass.—(617) 899-0770; Export—(212) 973-2121, Cable: "Bendixint," 605 Third Avenue, New York; Ottawa, Ont.—Computing Devices of Canada, P.O. Box 508—(613) TALbot 8-2711.

**from Sprague, of course!**

**SEPT**®

**SILICON  
PLANAR  
EPITAXIAL  
TRANSISTORS**

**Conforming to  
ALL requirements of**

**MIL-S-19500/251A(EL)**  
**2N2219**



**and**

TO-5 CASE

**MIL-S-19500/255A(EL)**  
**2N2222**



TO-18 CASE

For complete technical data, write to:  
**TECHNICAL LITERATURE SERVICE  
SPRAGUE ELECTRIC COMPANY,  
35 MARSHALL ST.  
NORTH ADAMS, MASS.**

45T-4128

**SPRAGUE**®  
**THE MARK OF RELIABILITY**

\*Sprague and ® are registered trademarks of the Sprague Electric Co.

## Meetings

**Unconventional Inertial Sensors Symposium, BuWeps, Republic Aviation Corp.; Long Island Graduate Center, Polytechnic Institute of Brooklyn, Farmingdale, N.Y., Oct. 19-20.**

**Human Factors Society Annual Meeting, HFS; Mayflower Hotel, Washington, Oct. 19-21.**

**National Electronics Conference and Exhibition, IIT, IEEE, Inc., Northwestern University, University of Illinois; McCormick Place, Chicago, Oct. 19-21.**

**ASM Metals/Materials Exposition and Congress, American Society for Metals; Philadelphia Trade and Convention Center and Bellevue-Stratford Hotel, Philadelphia, Oct. 19-23.**

**BEMA Annual Business Equipment Exposition/Conference, Business Equipment Manufacturers Association; Los Angeles Memorial Sports Arena, Los Angeles, Oct. 19-23.**

**Air Force-Industry Conference on Data Management, ASE/WPAFB; Biltmore Hotel, Dayton, Ohio., Oct. 20-22.**

**Science and Engineering Annual Symposium, OAR, AFSC; Aerospace Medical Division, Brooks AFB, Tex., Oct. 20-22.**

**Ultrasonic Manufacturers Association Annual Meeting, UMA; Penn Center Inn, Philadelphia, Oct. 21.**

**Aerospace and Navigational Electronics Annual East Coast Conference, IEEE; Emerson Hotel, Baltimore, Oct. 21-23.**

**Western Technical Appliance Conference, IEEE; Roger Young Auditorium, Los Angeles, Oct. 27.**

**Standards Conference on Materials for Electron Devices and Micro-Electronics, ASTM; American Society for Testing and Materials Headquarters, Philadelphia, Oct. 27-28.**

**Welded Electronic Packaging Conference, SAE; Belmont Plaza Hotel, New York, Oct. 27-28.**

**Fall Joint Computer Conference, AFIPS; San Francisco Civic Center, San Francisco, Oct. 27-29.**

**Nuclear Science Symposium, PTGNS/IEEE, NASA, USAEC; Philadelphia, Oct. 28-30.**

**Electron Devices Meeting, PTGED/IEEE; Sheraton-Park Hotel, Washington, Oct. 29-31.**

**Society of Photographic Scientists and Engineers Symposium, SPSE; Marriott Twin-Bridges Motor Hotel, Washington, Oct. 29-31.**

**Fall Data Processing Conference and Business Exposition, DPMA; Hilton Hotel, San Francisco, Nov. 3-5.**

**Northeast Electronics Research and Engineering Meeting (NEREM), New England Section of IEEE; Commonwealth Armory and Somerset Hotel, Boston, Nov. 4-6.**

**US Army Material Command and Institute of Environmental Sciences Joint Meeting, USAMC, IES; Aberdeen Proving Ground, Md., Nov. 5-6.**

**Optical and Electro-Optical Information Processing Technology Symposium, ONR, ACM, PTGEC/IEEE, OSA, Somerset Hotel, Boston, Nov. 9-10**

**University and Industry: Partners in Education and Research, University of Rochester, N.Y. State Advisory Council for the Advancement of Industrial R&D; University of Rochester, Rochester, N.Y., Nov. 9-10.**

**National Electrical Manufacturers Association Annual Membership Conference, NEMA; Americana Hotel, New York, Nov. 9-12.**

**The Road to Commercial Electronics: A Conference on Converting Military Capabilities to Civilian Markets. Electronics Magazine, IIT Research Institute; Grover M. Hermann Hall, Chicago, Dec. 12.**

## Call for papers

**Telemetry National Conference, AIAA, IEEE, ISA; Shamrock Hilton Hotel, Houston, Tex., April 13-15. Deadline is Nov. 1 for submitting a 35-word abstract together with a 500-word summary to R. W. Towle, NTC 65 Program Chairman, 26493 Weston Drive, Los Altos Hills, Calif. 94022. Fields of interest include aerospace, biomedicine, oceanography, industrial telemetry.**

**American Power Conference, IEEE; Chicago, April 27-29. Nov. 2 is deadline for submitting a 150-200 word abstract to Larry Dwon, Chairman, Power Engineering Education Committee, American Electric Power Service Corp., 2 Broadway, New York, N.Y. 10008.**

# ASTRODATA

## ADVANCED SOLID STATE AMPLIFIERS FOR YOUR CONTROL AND INSTRUMENTATION APPLICATIONS



ASTRODATA advanced design instrumentation amplifiers raise state-of-the-art standards to higher levels for measurement... conditioning... monitoring... indicating... control.

For custom designs, Astrodata's extensive experience provides a well-qualified capability for satisfying your specific performance needs.

Model 884 Wideband (dc to 100 kc) Floating, Guarded Amplifier...

Model 885 Wideband (dc to 10 kc) Differential, Isolated Amplifier...

high-gain/performance amplifiers for low-level, wideband systems at lowest cost. Completely transistorized, these state-of-the-art amplifiers use field-effect transistors in place of mechanical choppers to achieve lowest drift rate, freedom from microphonics and maximum reliability. Gain range to 3000 and a continuously adjustable 10-turn vernier control are provided as standard features. Two differential models with  $\pm 10$  ma or  $\pm 100$  ma output current from a low impedance can drive long lines, A to D converters, multiplexers, galvanometers or tape recorders. Transfer characteristic is optimized to provide wide frequency response with minimum overshoot, fastest settling and overload recovery times, and minimum phase shift. Common mode rejection is greater than 120 db with up to  $\pm 300$  volts dc or peak ac common mode voltage.

All models have built-in power supplies, feature drift less than  $1 \mu\text{V}$  per week, wideband noise less than  $4 \mu\text{V rms}$ , linearity better than 0.02%. Can be used either separately or in the same rack module with Model 1155 Universal Signal Conditioning Unit or Model 890 Electronic Filter to form complete, isolated signal conditioning channels.

**Model 885-135 Differential Amplifier** to drive multiplexers, tape recorders and A to D converters.

GAIN RANGE: 1 to 3000  
INPUT RESISTANCE: 100 megohms  
BANDWIDTH: dc to 10 kc  
OUTPUT:  $\pm 5$  volts at  $\pm 10$  ma  
DRIFT:  $\pm 1 \mu\text{V}$  for 40 hours  
TEMP. COEFF:  $\pm 0.2 \mu\text{V}/^\circ\text{F}$   
NOISE:  $2 \mu\text{V rms}$



**Model 885-235 Differential Amplifier** to drive data systems, long lines and galvanometers.

GAIN RANGE: 3 to 3000  
INPUT RESISTANCE: 100 megohms  
BANDWIDTH: dc to 10 kc  
OUTPUT:  $\pm 10$  volts at  $\pm 100$  ma  
DRIFT:  $\pm 1 \mu\text{V}$  for 40 hours  
TEMP. COEFF:  $\pm 0.2 \mu\text{V}/^\circ\text{F}$   
NOISE:  $2 \mu\text{V rms}$



**Model 1155 Universal Signal Conditioning Unit**

Uses plug-in circuit cards to supply excitation or bias, attenuation, circuit completion, balancing, filtering and calibration. Used with low-level or high level signals from thermocouples, strain gages, resistance temperature sensors, thermistors, potentiometers and voltage sources. Can function separately or in same rack module with Models 884 or 885 Amplifiers or Model 890 Filter to provide complete conditioning, calibration and normalizing of transducer signals.



**Model 126-101 Charge Amplifier.** All solid-state unit with internal dynamic calibration.

INPUT RESISTANCE: 10,000 megohms  
INPUT RANGE: 1 to 10,000 psi, g lbs  
GAGE FACTOR RANGE: 1 to 11 or 10 to 110 pcmb per psi, g or lb, continuously adjustable  
FREQUENCY RESPONSE: 0.3 cps to 150 kc  
STATIC CALIBRATE MODE: Extends response virtually to dc for dead weight testing.



**Model 120 Nanovolt Amplifier** gives you high-gain/low-noise amplification for seismic transducer signals, cryogenic studies, thermocouple or strain gage signals.

GAIN RANGE: 200 to 1,000,000  
BANDWIDTH: dc to 100 cps  
NOISE:  $0.05 \mu\text{V rms}$   
INPUT RESISTANCE: 1 megohm  
OUTPUT LEVEL: 0 to  $\pm 5$  volts at  $\pm 5$  ma



**Model 121Z Nanovoltmeter** provides  $0.1 \mu\text{V}$  full scale bridge balance detector or thermocouple indicator for standards and calibration work, in the field and in laboratories.

FULL SCALE RANGES:  $\pm 0.1 \mu\text{V}$  to  $\pm 100$  mv  
INPUT RESISTANCE: 1 megohm  
ZERO SUPPRESSION:  $\pm 0.5 \mu\text{V}$  to  $\pm 5$  mv  
AMPLIFIER OUTPUT: Gain 30 to 3 million, delivers  $\pm 5$  volts at  $\pm 5$  ma  
Overload Indicator



Contact your Astrodata engineering representative for a demonstration... or write today for technical literature giving complete specifications.



**ASTRODATA INC.**

P.O. Box 3003 • 240 E. Palais Road, Anaheim, California • 92803

TEL. (714) 772-1000 • TWX 714-776-3760 • FAX • TELEX 06-78828 • CABLE ADDRESS - ASTRODATA, Anaheim

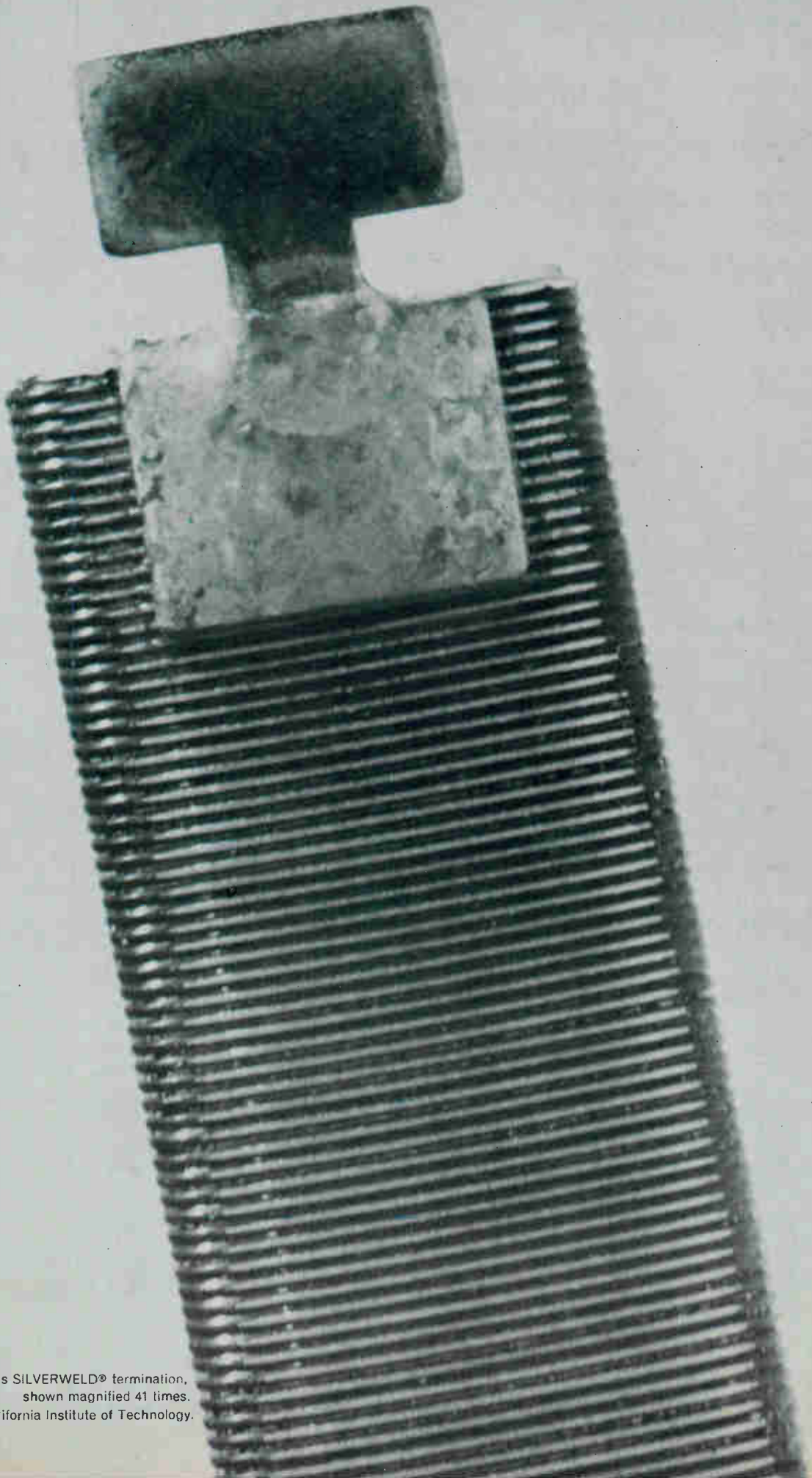

Exclusive Bourns SILVERWELD® termination,  
shown magnified 41 times.  
Photo by California Institute of Technology.

The termination that ended the chief cause of potentiometer failure...a typical example of

## BOURNS TOTAL VALUE

Probably ninety per cent of potentiometer failures were once the result of fragile terminations. If the connection between the end of the resistance element and the terminal couldn't take the slam and shake of a missile ride or hold up reliably under years of use in industrial instrumentation, the potentiometer and its dependent functions became casualties.

With the creation of its exclusive SILVERWELD® termination in 1959, Bourns ended the fragility problem. The new termination proved virtually indestructible. To create it, Bourns fused a broad band of metal to many turns of the resistance element, and fused the external

terminals to the band. A continuous electrical circuit from one external terminal to the other. *No solder, no rivets, no spot welds, no tabs, no pigtailed, no weak spots, no hot spots.* The bond could not be broken without the destruction of the element itself. Used with ceramic-card elements, SILVERWELD termination has been tested to 1000°F and cycled from room temperature to 450°F without failure.

Problem-solving innovations of this caliber mean extra reliability in the potentiometer—and receipt of total value for your potentiometer dollar. When the performance *must* match the promise, remember . . . TRIMPOT means Bourns—Bourns means quality.

THIS IS BOURNS TOTAL VALUE / Always your best value in potentiometers

### EXCLUSIVE RELIABILITY PROGRAM

The Bourns Reliability Assurance Program is the only one of its kind in the potentiometer industry. Its primary goal is reliability! It frequently requalifies all standard models to insure conformance with published specifications. It also makes available free test data, saving you the time and expense of quality verification. Conducted in *addition* to quality control, it makes Bourns potentiometers the most thoroughly inspected and tested units available.

### SUPERIOR QUALITY CONTROL

One-fifth of all Bourns employees work in quality control or reliability monitoring. This is one of the highest personnel ratios of QC employees and inspectors in the electronics industry. In addition, all standard Bourns products undergo extensive in-process and 100% final inspection. These facts help account for the company's return rate of only 0.2% (2 units returned of each 1000 shipped!), one of the lowest on record.

### MOST ADVANCED PRODUCTS

As the pioneer in adjustment potentiometers, Bourns has set the standards for an entire industry—in new products, in product improvements, in materials, in processes. Innovations such as the RESISTON® carbon and PALIRUM® film

elements and the virtually indestructible SILVERWELD® termination demonstrate that Bourns is constantly pushing the standards higher.

### LARGEST SELECTION

Bourns offers the world's largest selection of potentiometers and an extensive line of precision potentiometers, relays and micro-components. This single-source capability means less shopping around, avoidance of costly specials.

### BEST AVAILABILITY

The factory maintains a constant reserve of more than 500,000 units. In addition, more than sixty distributors across the nation carry complete stocks of Bourns adjustment potentiometers. Whatever you need in potentiometers, you can depend on Bourns for an off-the-shelf answer.

### OUTSTANDING APPLICATIONS HELP

Bourns maintains a staff of ten professional Application Engineers whose sole job is to give you technical assistance. Each of these specialists serves a specific geographic area. All are extremely able and anxious to help you cut time, corners and costs.

### LONGEST EXPERIENCE, RELIABILITY

Bourns—originator of the TRIMPOT® lead-screw-actuated potentiometer—has

been making adjustment potentiometers longer than any other manufacturer. Bourns products have the longest reliability record, too, having performed successfully in every major U.S. missile and space program. And the record continues: in today's world-wide markets, far more adjustment potentiometers bear the Bourns label than any other.

### COMPETITIVE PRICES

Depth of product line and high production efficiency allow Bourns to meet or beat the prices of competitors—despite its heavy extra expenditure for product reliability. Furthermore, Bourns "holds the line" on prices while continually upgrading its products. In those cases where a Bourns unit is slightly more expensive, you can be sure that the small extra cost means considerable extra value. It is a firm Bourns policy *never* to compromise quality for price.



# BOURNS

BOURNS, INC., RIVERSIDE, CALIFORNIA

Manufacturing Facilities  
RIVERSIDE, CALIFORNIA; AMES, IOWA  
Subsidiaries  
TORONTO, CANADA; ZUG, SWITZERLAND

TRIMPOT is a registered trademark of Bourns, Inc.

MANUFACTURER: TRIMPOT® & PRECISION POTENTIOMETERS, RELAYS; TRANSDUCERS FOR PRESSURE, POSITION, ACCELERATION

©1964, BOURNS, Inc.

# Silicon Planar

## NEW DIODE-TRANSISTOR MICROLOGIC

### Epitaxial DT $\mu$ L with noise immunity greater than 1 volt

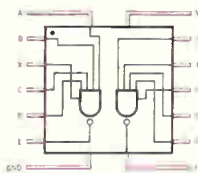
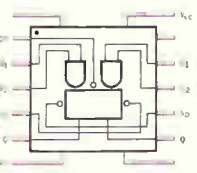
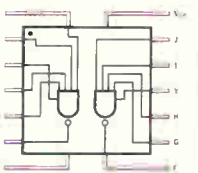
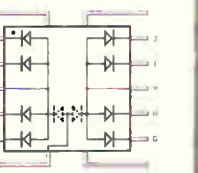
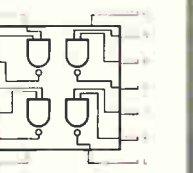
 <p><b>DUAL GATE — DT<math>\mu</math>L 930.</b> Dual 4-input gate. Noise immunity 1 volt @ 25°C. Propagation delay: 25 ns. P<sub>DIS</sub> (@ 25°C): 5mW. Fan-out: 8 min.</p>	 <p><b>FLIP-FLOP — DT<math>\mu</math>L 931.</b> RS or JK clock gated flip-flop. Noise immunity &gt; .6V @ 25°C. Propagation delay: 50 ns. P<sub>DIS</sub> (@ 25°C): 20mW. Fan-out: 7 min.</p>	 <p><b>DUAL BUFFER — DT<math>\mu</math>L 932.</b> Dual 4-input buffer and low impedance line driver. Noise immunity 1 volt @ 25°C. Propagation delay: 35 ns. P<sub>DIS</sub> (@ 25°C): 25mW. Fan-out: 25 min.</p>	 <p><b>GATE EXTENDER — DT<math>\mu</math>L 933.</b> Dual-4 Diode extender to be used with Dual Gate or Buffer when increased fan-in is required.</p>	 <p><b>QUAD GATE — DT<math>\mu</math>L 946.</b> Quad 2-input gate. Noise immunity 1 volt @ 25°C. Propagation delay: 25ns. P<sub>DIS</sub> (@ 25°C): 5mW. Fan-out: 8 min.</p>
--	--	--	--	---

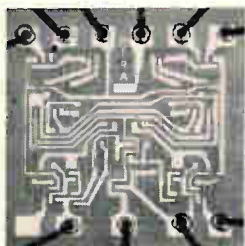
\* DT $\mu$ L is a Fairchild trademark.

#### Highest DTL Noise Immunity—

Because of the epitaxial construction of Fairchild DT $\mu$ L\*, the difference between threshold voltage and saturation voltage is the greatest of any diode-transistor logic. DT $\mu$ L is the only silicon Planar epitaxial DTL family now available. Worst-case noise immunity curves are contained in the data sheet. Photo at left shows the 931 element—two flip-flops connected as a “master-slave” combination, eliminating the need for circuit delay elements.

Photo at left shows the 931 element—two flip-flops connected as a “master-slave” combination, eliminating the need for circuit delay elements.

**Low Power, High Speed Combination —** DT $\mu$ L was designed to complement Fairchild's existing digital integrated circuit line—already the widest in the industry. For diode-transistor logic, it offers the industry's best combination of high noise immunity, low power dissipation, and low propagation delay. DT $\mu$ L elements are available in Fairchild's new CERPAK flat ceramic package.

#### FRANCHISED DISTRIBUTORS

AVNET Toronto, Canada. 789-2621 • BOHMAN Orlando, Fla., 425-8611 • CRAMER ELECTRONICS Newton, Mass., WO 9-7700; Hamden, Conn., 288-7771 • CRESCENT ELECTRONIC SALES Orlando, Fla., 423-8586 • DART SALES Clarence, N.Y., 874-1212; Syracuse, N.Y., GL 4-9257 • DENNY-HAMILTON San Diego, Cal., 279-2421 • EASTERN SEMICONDUCTOR Syracuse, N.Y., 454-9247 • E. C. ELECTRONIC SALES Minneapolis, Minn., 888-0102 HAMILTON Phoenix, Ariz., 272-2601; Los Angeles, Cal., 870-0236; Palo Alto, Cal., 321-7541; Seattle, Wash., 282-3836 • HYER Denver, Colo., 761-0754; Albuquerque, N. Mex., 268-6744; Salt Lake City, Utah, 322-5849 MARSHALL Scottsdale, Ariz., 946-4276; San Marino, Cal., MU 1-3292; San Diego, Cal., BR 8-6350; Redwood City, Cal., EM 6-8214 • NORVELL Oallas, Tex., FL 7-6451; Houston, Tex., MO 5-0558 • POWELL Beltsville, Md., 474-1030; Philadelphia, Pa., 724-1900 • SCHLEY Watertown, Mass., WA 6-0235 • SCHWEBER Westbury, L.I., N.Y., ED 4-7474 • SEMICONDUCTOR SPECIALISTS Chicago, Ill., 622-8860; Minneapolis, Minn., UN 6-3435; Dearborn, Mich., LU 4-5901 • SHERIDAN Cincinnati, Ohio, 761-5432; Cleveland, Ohio, 884-2001; Dayton, Ohio, 277-8911 • SOLID STATE Chicago, Ill., 889-8033 • STANDARD Buffalo, N.Y., TT 3-5000 SUMMIT DISTRIBUTORS Buffalo, N.Y., 884-3450 • TAYLOR Baldwin, L.I., N.Y., BA 3-8000 • TEC-SEL Huntsville, Ala., 534-7304 • VALLEY Winter Park, Fla., 647-1216; Baltimore, Md., NO 8-4900; Cherry Hill, N.J., NO 2-9337.



**NOW AVAILABLE!**  
**FAIRCHILD'S NEW MICROCIRCUIT HOLDER**  
Facilitates microcircuit handling for testing and shipping. Can be used with TO type as well as flat packages. Immediately available in quantity.

#### PRICES

DEVICES FOR FULL MILITARY TEMPERATURE RANGE (–55°C to +125°C)

	1-24	25-99	(Mixed) 100-999	(Single) 100-999
Dual Gate DT $\mu$ L 930	\$22.80	\$18.20	\$16.00	\$15.30
Flip-Flop DT $\mu$ L 931	30.00	24.00	21.00	20.00
Dual Buffer DT $\mu$ L 932	26.80	21.40	18.75	18.00
Gate Extender DT $\mu$ L 933	10.50	8.40	7.35	7.05
Quad Gate DT $\mu$ L 946	28.00	22.40	19.60	18.75

AVAILABLE DIRECTLY FROM DISTRIBUTOR STOCKS

# FAIRCHILD

## SEMICONDUCTOR



---

Editorial

---

# The world is your market

From outside the United States these days, we hear glowing stories of good business. Though there are many reasons, one fact emerges loud and clear: Consumers around the world want to buy more than food and shelter. And they have the money to do it.

The electronics industry stands to benefit from this worldwide situation as much as, if not more than, any other industry. In many lands, the buyer's first choice is electronics for entertainment—radio, television and record players. In West Germany, a stereo fad has started. In the Netherlands, France, Britain and other European countries, tv viewers are increasing so fast that there's pressure for more channels. Throughout Asia, excluding Communist China, radios and television sets are eagerly sought.

In addition, the general economic glow has boomed the manufacture of all kinds of goods, so other industries are expanding and modernizing too. Expansion has come so fast that there are serious labor shortages in some countries, notably Germany and the Netherlands. The search for productivity without manpower has led to more and more automatic operations and a rich market for electronic controls that run machines and processes automatically.

Technical activity is mushrooming in electronics everywhere. Obviously the export market is an attractive one for U. S. electronics companies. However, if his products and his technology are to compete abroad, the U. S. electronics engineer has to keep up with what's happening to electronics abroad. That's why you'll find an Electronics Abroad section (p. 151) in Electronics from now on.

In this new section, we'll report significant developments in electronics technology as they happen abroad, as well as nontechnical developments that affect the technology. For example, it may not be news that German television companies are pushing the phase alternation line (PAL) system of color television. What is news is that they're pushing it in the Soviet bloc. Approval by the Russians might well be the deciding factor when the rest of Europe tries again next year to pick a color tv system.

Similarly, this month we found the Portuguese sending television sets to Malaysia, Italian engineers worrying about their country's job outlook, the British checking out airplanes with a tape-programmed tester, the Germans getting ready for an electronics show that was forced on local companies by U. S. concerns, the Swedes enjoying a boom in electronics sales, and the Canadians using a new solid-state heart monitor.

People like to say that competing in Europe requires a whole new outlook. Certainly there are some differences from ways of doing business in the U. S., but there are more similarities than differences.

The customer still wants a product that is properly engineered. That means a product that solves a real consumer or industrial need, one that will do what its advertising promises, that is designed for reliable performance and easy maintenance, that can be manufactured economically, and that is as modern as the technology and economics can make it.

And don't shun labor-saving, automatic, or so-called luxury features. Experience shows that customers in Europe and Asia want them as badly as do their counterparts in the U. S.

For engineers whose companies are competing in world markets, the key is knowing what's going on.

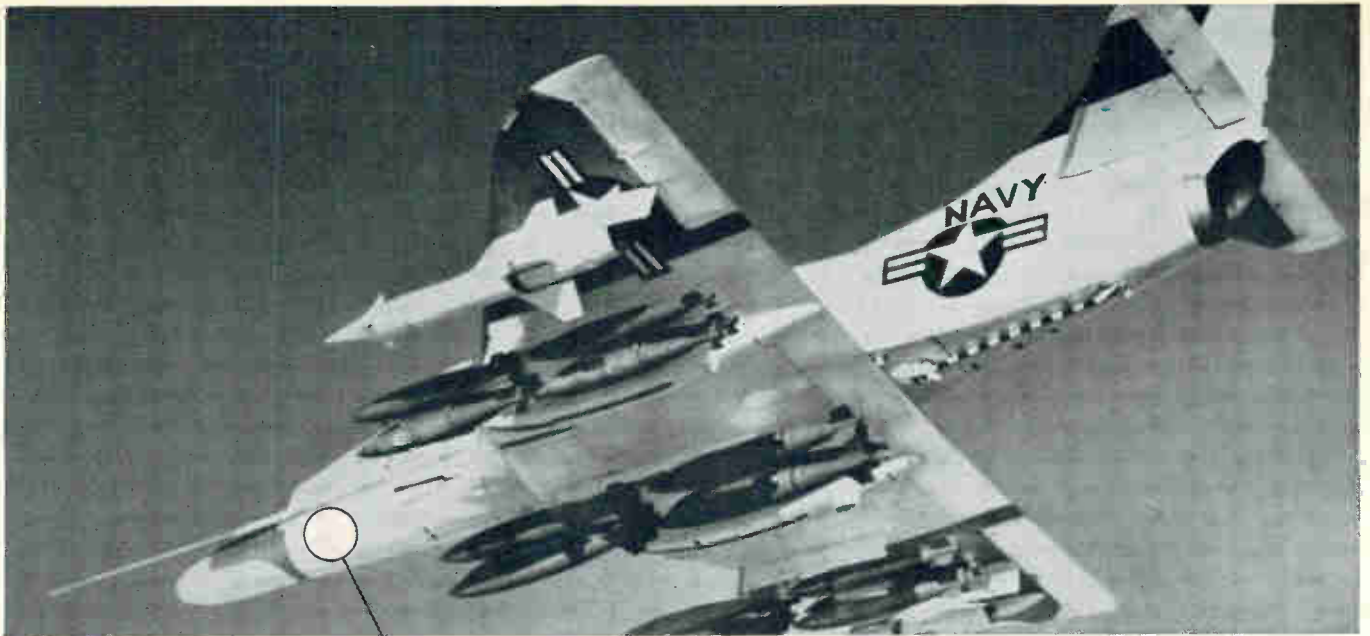

## Zero defects=100% reliability

The new industry standard means exactly what it says—no rejects whatever . . . 100% reliability. And it's not impossible!

Zero Defects, the DOD program for quality control, set the standard for the Martin-Orlando Bullpup missile. In its vitally important, pilot controlled guidance system, Martin-Orlando chose the AMP-MECA★ Interconnection System as a stable means of mechanically interconnecting the transmitter's electronic functions. These weldable modules provided the packaging design with the reliability they were looking for—over 100,000 components delivered with Zero Defects. Not a reject in the lot—a record acknowledged by the Martin Quality Supplier Award.

You can zero in on the same kind of reliability when you choose the AMP-MECA Interconnection System for your packaging design. The reliability is built in . . . in the ease with which you

can design circuits on the graph layout sheets, the rugged and precisely built cells of various increments, the sturdy siderails within which the cells are locked and finally, in the specially designed AMP-MECA contact which offers four point redundancy to assure dependable performance . . . the kind of performance that will give your equipment Zero Defects Awards, too!

If your packaging requirements call for reliability, pluggability and complete ease of maintenance, look into the AMP-MECA product story. Write for complete details, today.

★Trademark of AMP INCORPORATED



AMP\* products and engineering assistance are available through subsidiary companies in: Australia • Canada • England • France • Holland • Italy • Japan • Mexico • West Germany

---

# Electronics Newsletter

---

October 19, 1964

## Soviet space feat: What'll be next?

Orbiting space station or flight to the moon? Nobody's sure what the Russians were preparing for with their three-man space shot that made 16½ orbits of the earth during a 24-hour trip last week. One certainty is that they leapfrogged ahead of United States spacemen.

The ship—the Voskhod, or Sunrise—was obviously a new type, the first to carry a scientist and physician aboard as well as a pilot. On this trip, the Russians gathered volumes of biological data—how three people react to weightlessness, vibration and acceleration—and performance information about big boosters. The same kind of ship, however, could be used for additional scientific research, military reconnaissance or a base for launching weapons.

Launching the three men and recovering them safely put the Russians two to three years ahead of the U.S. in the race to the moon. Not until 1966 will the U.S. propel a three-man Apollo craft around the earth. Even two-man flights are not scheduled until early next year.

Russians on the ground were able to watch the three-man crew of Voskhod on television, though video-tape reproductions seen in New York were of poor quality. When the U.S. launches its two-man Gemini craft next year, there will be no television. Officials of the National Aeronautics and Space Administration didn't think the results were worth the \$2 million to \$5 million cost.

While the three were in orbit they kept busy checking their capacity for work and interaction during space flight, investigating conditions of space flight, studying effects of different aspects of space flight on man's organism, and carrying out tests of the new multiseat piloted spaceship.

## A chemical test of semiconductors

A transistor or integrated circuit can be tested for 0.1 cent by a non-destructive chemical test used at the Norden division of the United Aircraft Corp. And the test is so simple that the inventor, Edwin A. Corl, supervisor of assembly and selective masking in Norden's solid-state group, received an ovation this month at a Chicago symposium on the physics of failure.

Corl puts a drop of reactive chromate solution on the device being tested, turning the device into a miniature galvanic cell similar to a Daniel cell. Anions migrate to positively charged regions on the surface of the device and are repelled from electronegative regions, forming a brown deposit on the thin-film conductors. If there is a break in the conductor, the conductor is brown in front of the break and shiny along the rest of its length. Even pinholes show up clearly. A trained eye can also see other faults in the device.

## New spurt is seen in process control

Industrial instrumentation and control is in for a quiet electronic revolution, experts were saying Oct. 12 to 15 at the Instrument Society of America meeting in New York. Solid-state components and solid-state techniques are working their way into devices ranging from recorders to controllers. This revolution appears to be headed for more commercial success than the noisy one that fizzled in 1959 and 1960, when buyers of industrial control turned thumbs down on electronic gear. The main reason for the optimism is that lower prices of solid-state components

---

# Electronics Newsletter

---

make this equipment economical at last.

One sign of the times: The International Business Machines Corp. has invaded the process-control market. It introduced an electronic set-point station that converts digital output to an analog signal for linking a computer to an analog control system; it also showed a new thermocouple transmitter. Even more significantly, IBM has formed a separate marketing group for instruments. Industry observers say this means IBM will introduce additional electronic control as fast as it can be developed. Top management is already reviewing a proposal to build a special computer for direct digital control. IBM was one of those suppliers bitten by the electronic-control bug in 1959, but folded its plans before they got to the hardware stage. Major systems planned were for automatic warehousing. IBM's product plans now are indicative of the new receptive attitude shown by users of industrial instruments and controls.

Another intriguing prospect: The Eastman Kodak Co. is looking for electronics companies interested in manufacturing a Kodak-designed Photologger, a device that converts analog data to digital, supplying hard copy immediately.

## Thin-film circuits on sapphire bases

Sapphire looks like the key to practical a method of making thin-film circuits complete with transistors and diodes. At least two companies have successfully deposited single-crystal silicon on sapphire substrates.

Last week, the Autonetics division of North American Aviation, Inc., reported it had made insulated-gate field-effect transistors (FETs). N-/channel FETs of both enhancement-depletion and enhancement-only types will be used in a high-frequency amplifier. The amplifier requires high input impedance and radiation resistance.

The first silicon-on-sapphire insulated-gate FETs were reported in July by the Radio Corp. of America. RCA began working on silicon FETs early this year [Electronics, Feb. 21, p. 23]. RCA has also made diodes and simple thin-film circuits, and is confident it can make bipolar transistors. The silicon crystals are produced by heating silane gas until it decomposes. The silicon deposits on the sapphire and crystallizes.

Germanium and intermetallic FETs have been made, but silicon is a better semiconductor for most applications.

## Diode doubler handles 12 watts

A tiny pill-shaped varactor diode for frequency-doubling, developed by Motorola, Inc., handles 12 watts of radio-frequency input power at one gigacycle.

The device, 0.16 inch in diameter, has silicon double-diffused epitaxial construction. Its efficiency for doubling a 12-watt input from 1 Gc to 2 Gc is 60%. Gerald Schaffner, Motorola group leader of microwave-device research, development and application, says, "This unit will allow many circuit designers to replace traveling-wave tubes with a solid-state device."

## Another FET

Joining the lengthening list of companies making discrete field-effect transistors (FETs) of the insulated-gate, metal-oxide-semiconductor type is Texas Instruments, Inc. TI is supplying samples of a silicon p-channel enhancement type rated at 25 volts and 300 amperes. It has four leads and is housed in a TO-18 case.

# All air cargo services are fast from airport to airport.



## Only Air Express is so fast between the airport and you.

Give or take a few minutes, once in the air your package travels as fast on one air cargo service as another.

But what happens on the ground—that's a different story. And it's there Air Express shines.

Only Air Express has 10,500 delivery trucks to speed deliveries between you, the airports and your customers. Air Express has the

edge getting aboard planes, too. It receives top priority after air mail on all 39 scheduled airlines. Think of what that means during peak night rush hours!

Other Air Express exclusives worth thinking about: Pickup within 2 hours of your call. Superfast delivery to any of 21,000 U.S. cities. One call, one waybill. Even armed surveillance for valuable

packages, if you wish.

What's more, Air Express is often your cheapest way to ship by air as well.

So if you ship from 5 to 50 pounds anywhere in the U.S.A., you're missing a bet unless you check Air Express. Call your local REA Express office and see.

Air Express outdelivers them all... anywhere in the U.S.A.

**Air Express**  
Division of REA Express





## SPECIAL (??) SHEET METAL ENCLOSURES

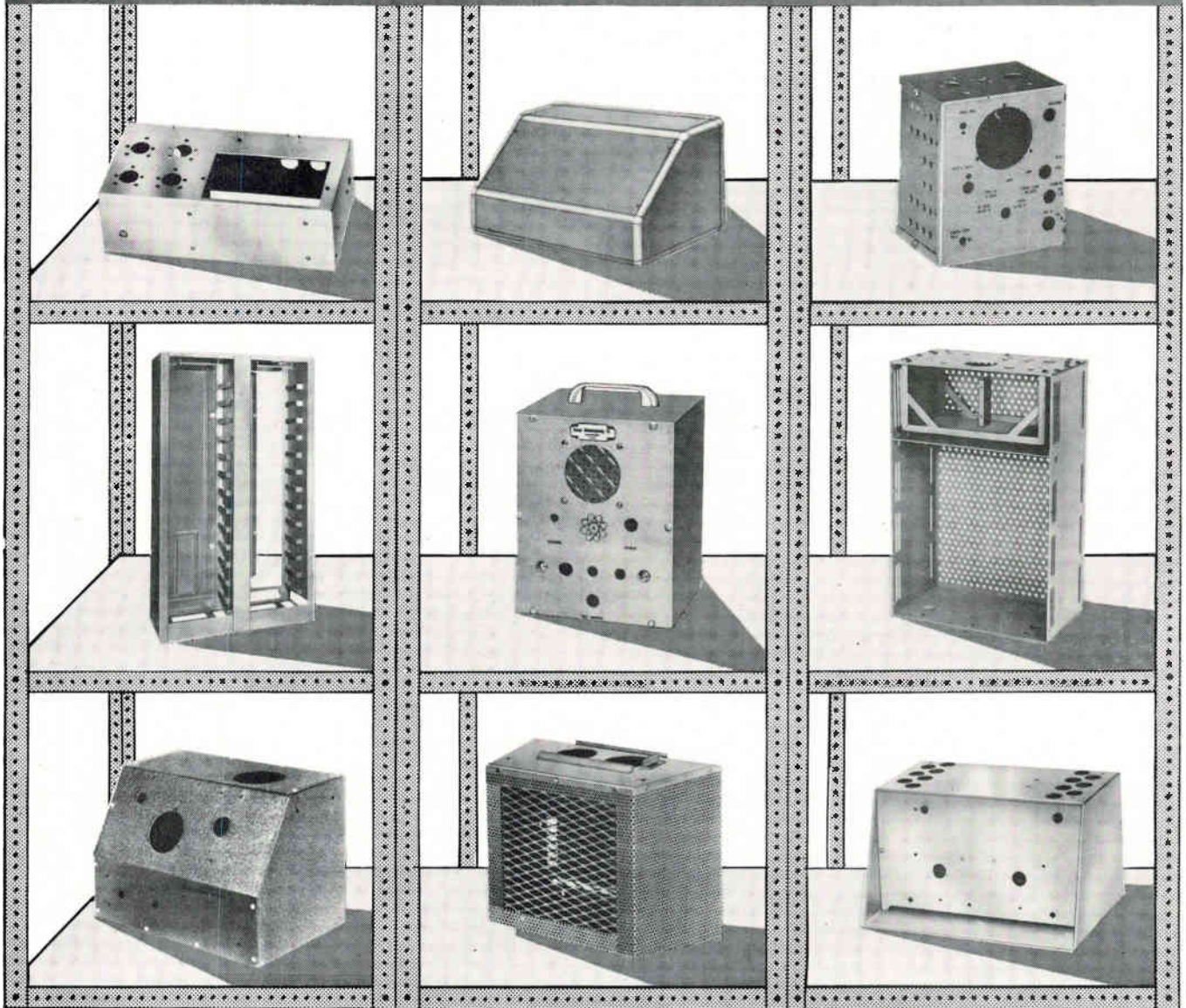

# Off the shelf?

This is not an irresponsible claim if your special requirement can be modified from one of the thousands of enclosures we regularly make.

Many producers of instrumentation have found that a very minor revision of a standard Bud product has suited their needs exactly and at the same time saved them considerable time and money.

If you have a housing problem that you think is special, talk to your Bud distributor about it first or submit your problem direct to us.



## BUD RADIO, INC.

WILLOUGHBY, OHIO

# BREADBOARD

with this solid state operational amplifier

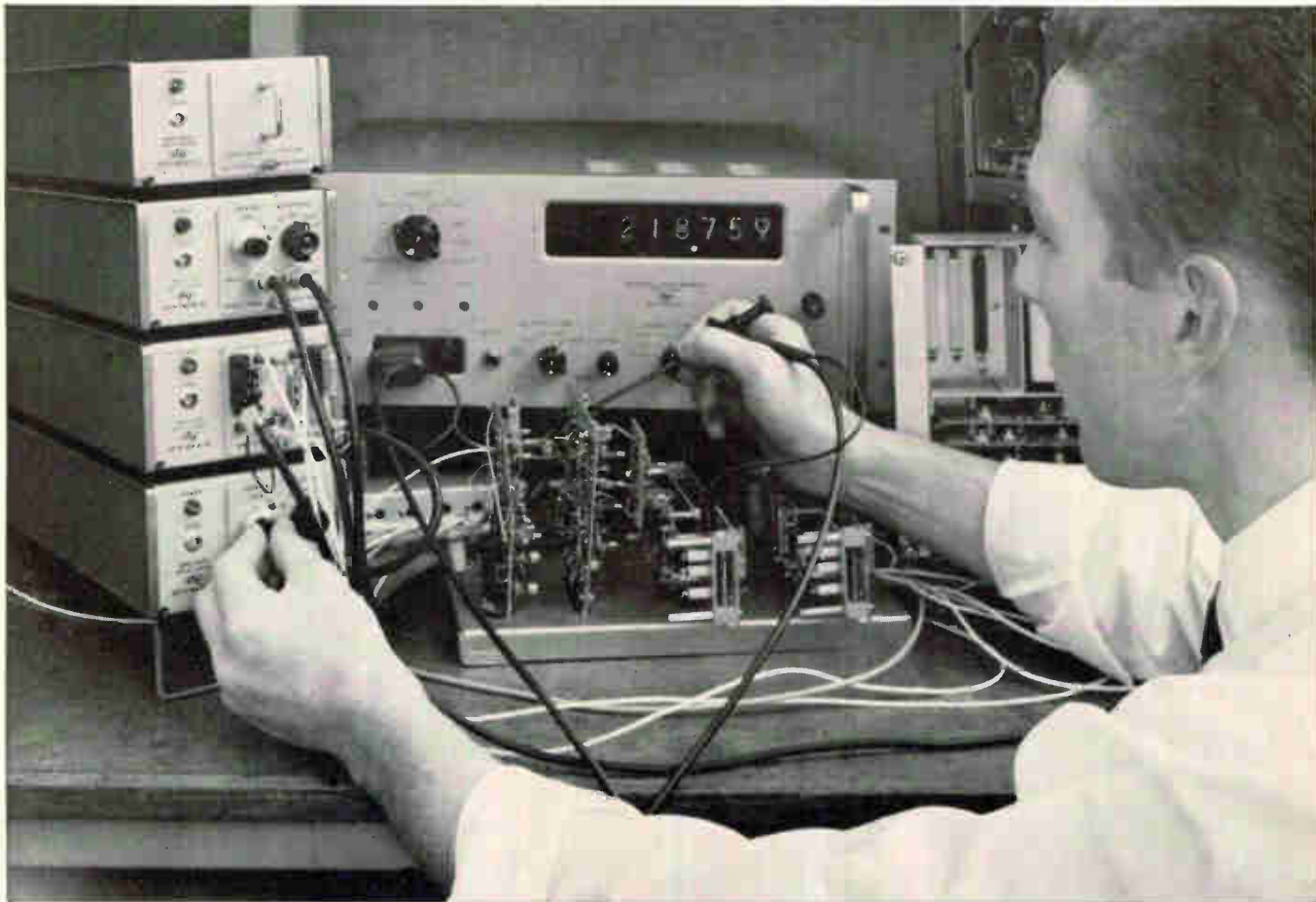

Use the DY-2460A as an active element of your newly designed circuits...

**AMPLIFIER ■ SUMMER ■ HIGH IMPEDANCE ISOLATOR ■ INTEGRATOR ■ INVERTER**

Check out new design concepts and ideas in a hurry with the DY-2460A DC Amplifier as a circuit element. This wideband, solid state instrument is ready-made for a wide variety of circuit applications which will save you time and effort.

The low-cost DY-2460A is designed for general purpose use. Amplitude and phase response are properly controlled beyond unity gain to permit a variety of feedback networks. A self-contained power supply in each instrument provides highest isolation when operating a group of amplifiers at different potentials. A non-synchronous photoconductive chopper eliminates all effects of ac pickup.

Plug-in design of the 2460A increases its versatility. A patch unit plug-in brings input, output, summing point and feedback circuit to the front panel; other plug-ins

provide switchable gains in steps from 1 through 1000, vernier adjustment through 11,000, and a high-accuracy plus-one configuration with greater than  $10^{10}$  ohms input resistance.

The 2460A will supply an output of  $\pm 10$  v peak at 10 ma. Zero drift is less than  $1\mu\text{v}$  per week, noise less than  $4\mu\text{v}$  peak to peak.

Ask your Dymec/Hewlett-Packard field engineer for all the details on how the DY-2460A can make your breadboarding easier.

Price: DY-2460A Amplifier, \$445. DY-2461A-M1 Data Systems Plug-in, \$85; DY-2461A-M2 Bench-use Plug-in, \$125; DY-2461A-M3 Patch Unit Plug-in, \$75; DY-2461A-M4 Plus-one Gain Plug-in, \$35.

Data subject to change without notice. Prices f.o.b. factory.

## DYMEC

A DIVISION OF HEWLETT-PACKARD COMPANY

DEPT. E-10, 395 PAGE MILL ROAD, PALO ALTO, CALIF. ● PHONE (415) 326-1755 TWX 415-492-9363



Think you're  
saving money  
with  
aluminum  
electrolytic  
capacitors?





# Here are 5 reasons why they'll never match low-cost KEMET "C" Series Solid Tantalums.



**ELECTRONICS**



**1. Electrical Parameters.** Up to 10 times lower ESR than equivalent aluminum electrolytics from  $-55^{\circ}\text{C}$  to  $+85^{\circ}\text{C}$ ...superior A.C. ripple current characteristics...low D.C. leakage.



**2. Life.** KEMET "C" Series are truly solid state...contain no wet electrolyte...eliminate risk of premature deterioration on shelf or in circuit.



**3. Packaging.** Up to 88% smaller than equivalent aluminum electrolytics.



**4. Temperature Characteristics.** Outstanding capacitance stability over wide temperature range...available in 20%, 10%, 5% tolerances...less than 10% capacitance shift from  $-55^{\circ}\text{C}$  to  $+85^{\circ}\text{C}$ .



**5. New Low Cost.** Fire retardant, transfer-molded epoxy cases, made with automated production techniques, make KEMET "C" Series capacitors competitively priced with aluminum electrolytics.

Available in capacitance range from .10 to 330  $\mu\text{fd}$  in 6 to 75 volts.

For additional information, contact your nearby KEMET Distributor or write to: Kemet Department, Union Carbide Corporation, 11901 Madison Avenue, Cleveland 1, Ohio.

"Kemet" is a registered trade mark of Union Carbide Corporation.



**LOW COST**

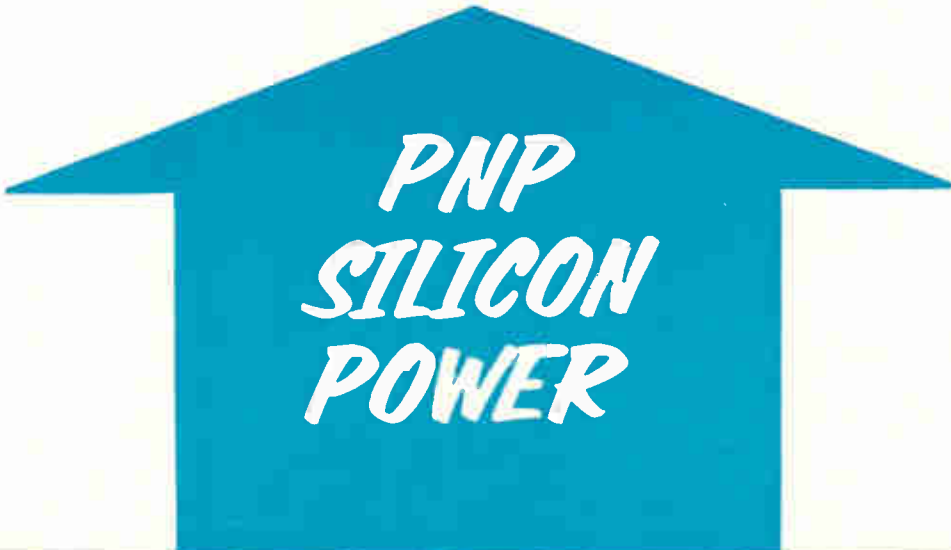

**PNP  
SILICON  
POWER**

## **PNP SILICON POWER INDUSTRIAL TRANSISTORS**

A new series of low cost PNP silicon power transistors in the TO-5 package from Silicon Transistor, STC5648 through STC5652, have been added to our low cost industrial silicon power transistor line.

The new series consists of five basic types with D.C. power capability of 8.75 watts @  $T_c = 25^\circ \text{C}$ .  $BV_{CE0}$  ratings from 40 to 100 volts. Maximum collector current from 1.0 to 3 amps. Maximum  $V_{CE}(\text{sat})$  from 1.0 to 0.75 ohms @  $I_c = 200 \text{ ma}$  and 1.0 amps respectively.

Designed as direct replacements for PNP germanium transistors, these PNP silicon power transistors may be used as complementary drivers to the popular industrial NPN silicon power transistor series 2N3232 through 2N3240.

For complete specifications and information on reducing your silicon power transistor cost in industrial applications, contact:

**SILICON TRANSISTOR CORPORATION**

CARLE PLACE, L. I., NEW YORK 516-Pioneer 2-4100



DISTRICT LONG BEACH 2, CALIF., 217 ELM AVE. (213) 437-2788. TWX 213-549-1972.

OFFICES: DAYTON 19, OHIO, 49 PARK AVE. (513) 298-9913. TWX 513-944-0372 HUNTSVILLE, ALA., POST OFFICE BOX 1467. (205) 881-4793

## Military electronics

### Commands from above

The Tactical Air Command has put a command and control center aboard a C-130E cargo plane and will test its usefulness for limited-war operations. The center will be used by military commanders to survey and direct ground operations. The Temco Aerosystems division of Ling-Temco-Vought, Inc., built the system under a \$2.4-million Air Force contract.

**Tied to reconnaissance.** Unlike the airborne control centers of the Strategic Air Command, which are intended to direct the various elements of SAC to carry out already-established war plans, the tactical control center would permit an on-board commander to see what is happening in the field and issue his orders accordingly.

Present plans call for the center to be integrated with the "See Fast" reconnaissance concept now being developed by the Tactical Air Reconnaissance Center. This plan would have one or more RB-66 aircraft fly over enemy territory to collect intelligence through television, infrared photo and side-looking radar facilities. The data would be transmitted to the airborne commanders who would see exactly what the sensors of the RB-66 see—and at almost the same time.

**In the war room.** Information

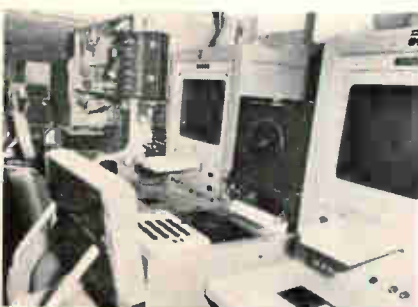

Inside command and control center.



Command center is loaded aboard C-130E cargo plane.

transmitted by radio to the Tactical Air Command's war room aloft can be recorded on tape for future playback and study. A semiautomatic system displays visual data on battle status, weather conditions and the status of preplanned missions.

The on-board communications network allows constant contact with other operations: tactical air control centers and army command posts, ships at sea, tactical fighters and assault transports as well as reconnaissance planes and helicopters. The system has high-frequency, ultrahigh-frequency and very-high-frequency radio capability as well as uhf and vhf relay capability.

**Data link.** C-band data-link equipment can accept transmissions, demodulate the signals and provide the video inputs used by the data recorders.

For video reception of surveillance data, a General Electric television monitor will receive signals by means of a data link from a television camera in the RB-66. The camera views the terrain and produces a corresponding signal that is transmitted at C-band frequency back to the airborne command center.

**Removable module.** The entire command module—about 47 feet long, 9½ feet wide and 8 feet, 4 inches high—with its electronic equipment, galley, rest areas and air

conditioning, can be removed from the aircraft, permitting the plane to perform a standard mission.

## Solid state

### New circuits for computers

The use of integrated circuits in commercial computers should pick up momentum next month. That's when Texas Instruments, Inc., will begin marketing its new series of high-speed digital integrated circuits.

The new product line, including seven multifunction positive NAND gates and a J-K flip-flop, features propagation delays as low as 15 nanoseconds, with power dissipation of only 10 milliwatts.

Howard Moss, general manager of the company's integrated-circuit department, says "the speed is high enough for virtually all military computers and many commercial computers [most commercial computers need speeds of about 12 nanoseconds], while power requirements are low enough for the majority of aerospace systems."

The new line, called Series 54, uses Texas Instruments' multifunction packaging concept. As many as four circuit functions are put into a single monolithic bar of silicon. Typical prices, Moss says,

will be under \$5 per circuit function.

**Wide range.** In addition to their high speed and low power dissipation, the new circuits have fan-out of 15, and a noise margin of 800 millivolts. They can operate in temperatures from  $-55^{\circ}$  to  $+125^{\circ}\text{C}$ .

The J-K flip-flop in the series is the first such circuit to be fabricated in the transistor-transistor logic configuration. It will toggle at frequencies in excess of 20 megacycles. Moss says the extra transistor gain allows wider component tolerance and increases yield.

**Proprietary process.** The company achieved the high-speed, low-power characteristics by using a "proprietary" etching process. It says this shrinks transistor-emitter geometries to as small as one-fourth mil in width. The process, plus new high-resolution photomask techniques for the reduced resistor areas, increase the speed by cutting parasitic capacitances in the substrates. Multiple-emitter transistors with fast turn-off characteristics further increase the speed.

Because of their low output impedance in both on and off conditions, the company expects the circuits to operate at high speeds even when driving high-capacitance loads.

Gold-to-gold bonding is used between the deposited interconnection pattern and the package leads. Moss says, "This new refractory contact system eliminates the possible formation of 'purple plague' compounds that tend to deteriorate aluminum-to-gold interfaces when exposed to high temperatures over extended periods of time."

### Measuring limitations

A way to measure some of the limitations of semiconductors at frequencies above 30 gigacycles has been developed by Keith S. Champlin of the University of Minnesota.

One result of Champlin's work is that more exact equivalent circuits for high-frequency devices may be derived.

According to Champlin, the conductivity of semiconductors at frequencies above 30 gigacycles is

decreased by the inertia of charge carriers (electrons and holes), which causes their velocity to be  $90^{\circ}$  out of phase with the electric field. At lower frequencies, scattering collisions destroy the out-of-phase current component before it can have a significant effect on an oscillation. But at higher frequencies—where the collision rate is nearly equal to the frequency—the inertial effect begins to dominate and produce a phase difference between the current and the applied voltage.

**Microwave bridge.** Champlin measured the conductivity of a p-type germanium semiconductor at 24 gigacycles with a microwave bridge, and observed that the microwave conductivity fell below the d-c conductivity. He was able to obtain precise measurements of the decrease in conductivity, apparently a fundamental property of all semiconductor materials.

**Third circuit element.** To explain the effects of his measurements Champlin gave the example of an equivalent circuit of a varactor diode, usually considered by circuit designers as a simple resistance-capacitance circuit. The pn junction is represented by a junction capacitance in series with a resistor representing the bulk and contact resistance of the semiconductor material.

According to Champlin, a third element, representing the carrier inertia, should be included; and, since the electrical representation of inertia is inductance, the equivalent circuit should be an r-c-l series circuit, not a simple r-c circuit. Otherwise, at high frequencies, cut-off frequency of a varactor diode calculated by using the r-c circuit may be invalid.

---

## Industrial electronics

---

### Controlled dyeing

The first process-control computer for the textile industry has been ordered from Honeywell, Inc.

Honeywell's special systems division will install a 610 computer in

the Lyman, S.C., plant of the Lyman Printing & Finishing Co. to direct closed-loop operation of textile dyeing. Dyeing is done both in batches—in tanks called becks—and in a continuous process, on dye ranges. Lyman is a subsidiary of M. Lowenstein & Sons, Inc., the country's fourth-ranking textile producer.

J. F. Magarahan, vice president and general manager of the textile company, expects the computer to eliminate many of the uncertainties of the finishing operation. Dyeing is a critical phase of finishing because of the large number of interrelated processes that must be precisely controlled.

**Data-logging too.** In addition to controlling the process, the computer system will print out information on process conditions in the form of typewritten summaries of what is taking place. These will then be used as guides for future operations.

The computer system is being designed with the capability of eventually controlling other dye becks and ranges, bleach and finishing ranges and to perform on-line color or chemical blending. Installation is expected early next year.

**Major market.** W. F. Boone Jr., of Honeywell's special systems division, estimated a potential market of 50 to 100 textile companies. By 1970, the market for process-control systems in the textile industry could be between \$10 million and \$15 million. This industry has lagged behind others—the chemical, power, oil and steel industries, for example—in adopting computer control, mainly because of the lack of engineers and scientists on the company staffs. To prepare for its own installation, Lyman sent some of its people to Honeywell's special systems school for several weeks.

### Minor monitoring jobs

Most digital remote-control systems are too big for many applications.

General Precision, Inc., has come up with a \$6,000 system that will monitor one function—pressure,

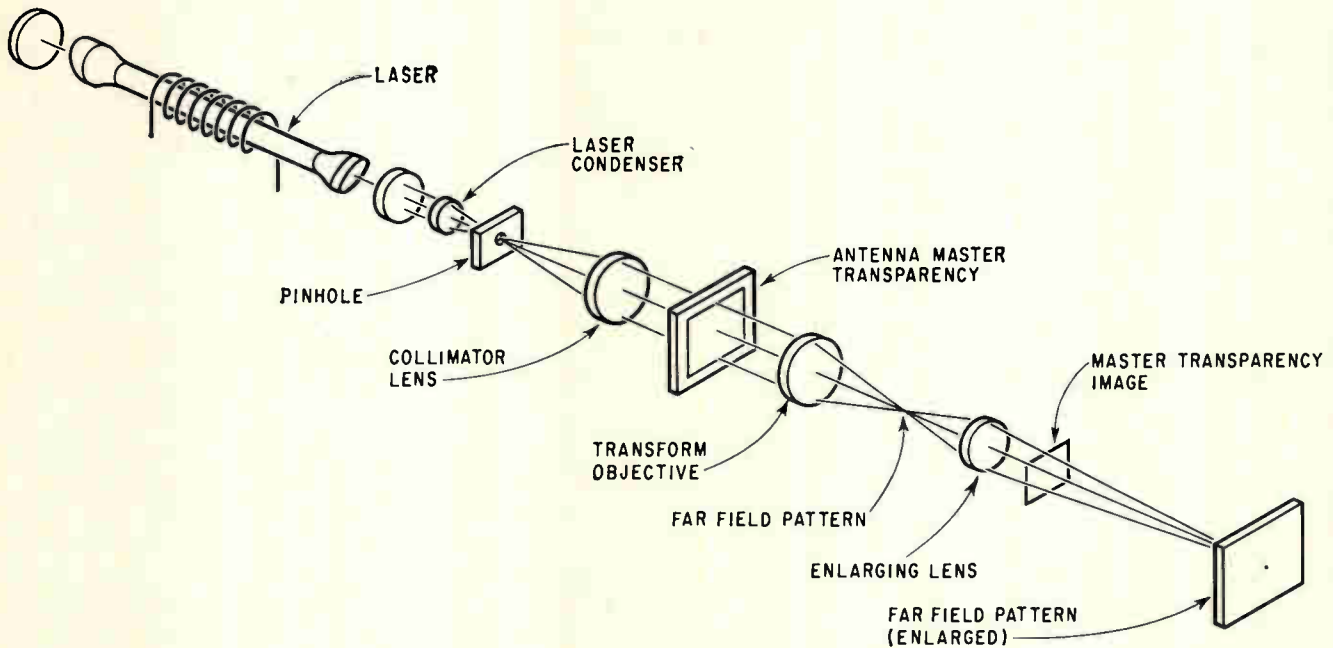

Laser system accurately measures antenna patterns.

for example—at 10 different places. Thus, an oil company can measure the pressure in 10 petroleum tanks with a relatively small investment. And by altering the module, its capacity can be boosted tenfold. Additional modules also can be added.

The manufacturer, a subsidiary of the General Precision Equipment Corp., said it already has orders for its Telepulse II from 10 oil companies.

General Precision says its system is designed “for the guy who wants telemetry but can’t justify the price of an installation to control 1,000 tanks if he only has 20.”

**For bigger jobs.** In another development, the General Electric Co. introduced a telemetering system called GETAC that is designed primarily for larger installations. GE declined to disclose the price.

GE said it sold one model to the Universal Atlas Cement Co., a subsidiary of the U. S. Steel Corp. GETAC also is modularly constructed; one console is designed to control 1,000 points.

For a tank-farm installation, the General Precision system works like this:

Data from the tank is telemetered to the control room where an oper-

ator, to obtain a reading, presses a button on the receiver that corresponds to the tank and function in question. The information appears on a digital display on the receiver. If the reading indicates an abnormal situation, the operator can actuate a valve to correct it. The system can also incorporate an alarm device to warn automatically of any abnormal situation.

Telemetering can be by telegraph, teletype, telephone, microwave or very-high-frequency transmission. Telepulse II can also include data logging—either automatic print-out or punched tape or cards—and could be tied to a computer for automatic control.

### Advanced technology

#### Monitoring radar

How do we know that a radar system is capable of sending out the right kind of signals for a specific investigation?

Up until now we didn't.

A neon-helium gas laser system developed by Arthur Ingalls of Conductron, Inc., has been designed to provide the first accurate picture of both near and distant

patterns transmitted by a large antenna. The optical system, in essence, simulates the patterns on a small scale, giving the engineer an opportunity to review a pattern many thousands of miles away. An area as large as 1½ miles in diameter can be reduced to a 25-millimeter photographic transparency for investigation.

**Takes a picture.** The system consists of a laser, a laser condenser, an optical lens and a film transparency, aligned in the order shown in the figure. The transparency—a photograph of a drawing of the antenna—acts as an optical model of the actual antenna. The condenser focuses the laser's beam at a pinhole, which filters the beam and allows only the correct spatial mode to pass through. The light then expands and passes through a collimator lens that converts the beam to a plane wavefront which illuminates the transparency.

Master transparencies may be made on photographic plates or on film. Both phase and amplitude patterns may be obtained by varying the thickness of the transparency material. If two-dimensional phase-delay patterns are used, the new laser system also permits the study of atmospheric effects on

the antenna pattern.

**Down Under first.** The first pattern to be measured was from an Australian antenna array that is used to scan the surface of the sun. That array is made up of 96 elements arranged in a circle a mile and a half in diameter. Each element is a 45-foot-diameter parabolic dish. The antenna configuration was reduced to a scaled drawing, 50 centimeters in diameter, with a dot for each parabola. This drawing was then photographed to produce a transparency 25 mm. in diameter. Using this scale, the laser wavelength of  $6.328 \times 10^{-4}$  mm. represented the actual operating wavelength of the antenna—four gigacycles. The photographs show the effects on the pattern of the antenna array itself, as well as the effects of the interference between various elements of the array.

### Electron-pumped laser

A gallium arsenide laser, cooled to liquid-helium temperature and pumped by an electron beam rather than a high current pulse, has been operated successfully at the Lincoln Laboratory of the Massachusetts Institute of Technology.

The electron-beam technique hopefully will permit scientists to achieve laser action in other wide band-gap materials, among which they expect to find suitable semiconductor lasers for the visible region of the spectrum. Although electron-beam pumping had previously been used by researchers in France to achieve laser action in indium arsenide and indium antimonide, this is the first time that the technique has been successfully applied to gallium arsenide. Electrical injection heating is not suitable for these three semiconductor materials because it is difficult to make good p-n junctions. Even when junctions are made, the high inherent resistance of the materials causes excessively high temperature when current is applied.

**Action at 8,410.** The laser sample at Lincoln Laboratory was prepared from p-type gallium arsenide by cleaving a face perpendicular

to the two parallel polished faces of a slice of gallium arsenide 0.21 millimeters thick. The beam from an electron gun, of the type used in a television projection kinescope, was focused on the cleaved end of the sample, emitting light perpendicular to the polished faces which formed the optical cavity. The beam current was supplied in 0.2-microsecond pulses at a repetition rate of 1,000 per second. The diameter of the focused beam was about 0.5 mm and the energy was low enough to avoid inducing radiation.

The emission spectra centered at 8,410 angstroms. At low beam current, the intensity of the emitted radiation varied linearly with the current. Above two microamperes, the intensity rose rapidly, indicating the onset of laser action.

---

## Manufacturing

---

### Unetched wiring

An electroless plating process that the Photocircuits Corp. has been developing since 1955 was finally described publicly, in a paper that corporation executives prepared for delivery at the National Electronics Conference in Chicago on Oct. 19.

The chemical process promises to set the printed-circuit manufacturing field on its ear and may well result in a fallout of companies whose profits have been marginal. Competition is murderous and slim profits are the rule, not the exception, for custom producers of printed-circuit boards. According to the Institute of Printed Circuits, the trade association, average profits over the past three years have been less than 3%.

Robert Swiggett, executive vice president, and F.W. Schneble, director of research of Photocircuits, say this is because practically everybody in the business makes printed-circuit boards by the same process—etching—from the same types of insulator and copper-foil laminates that everyone else uses.

**Slashes costs.** The Photocircuits

process, called CC-4, performs radical surgery on material costs and has several design advantages built in. The circuits are plated directly on an insulator or on metal sheets that have been coated with an insulator. The price differential between a typical etched board material, XXXP clad with copper, and the unclad XXXP is 22 to 25 cents a square foot, Swiggett points out. Etching costs are about eight cents a square foot.

With the new plating process, Photocircuits claims, finished circuits are produced at equal or less cost than that of the clad materials for etched wiring boards. Plating thicknesses match that of foils, and the copper is ductile and purer than copper foil.

"It solders like a dream," said a company spokesman.

**Catalytic ink.** The process differs from previous circuit-plating processes—usually more expensive than etching—in the use of an adhesive that acts as a catalytic ink. In the basic technique, the circuit pattern is silk-screened on the board with this ink. The board then goes into a chemical plating bath. The copper in the solution adheres to the ink, but nothing else.

There are numerous variations of the technique. The board can be punched, completely coated with the ink, and masked. The copper will deposit only on the circuit pattern and in the holes. Glass cloth can be impregnated with the catalyst, punched, masked and plated to make flexible circuits with plated holes. Multilayer laminates can be made with solid copper "pins" joining the layers through plated holes.

Photocircuits says it has a family of catalytic materials, masking materials and plating baths, but won't reveal their composition. However, one type of ink is disclosed in a patent (Patent No. 3146125). Cuprous oxide powder is mixed with a resin binder. In the bath, the oxide reduces to metal and the metal provides a base for plating. Power content can vary from 0.25% to 80% of the ink.

**Open secret.** Insiders in the industry have known about the process for some time. Photocircuits,

# Only New JFD Modutrim ceramic variable capacitors give you...

Modutrim Model #	Capacitance Ranges (PF)
MT 100	5 to 15
MT 120	2 to 20
MT 130	3 to 30
MT 140	4 to 40
MT 150	5 to 50
MT-100 at 500 vvdc. All others at 50 vvdc.	
<b>widest <math>\Delta C</math></b>	

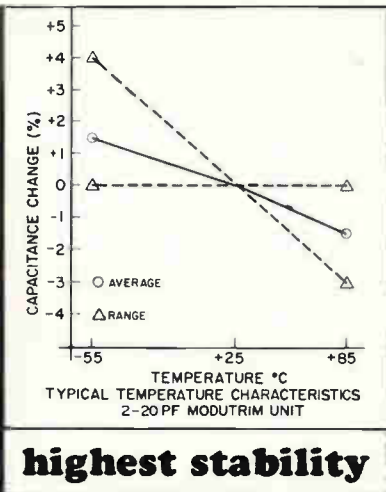
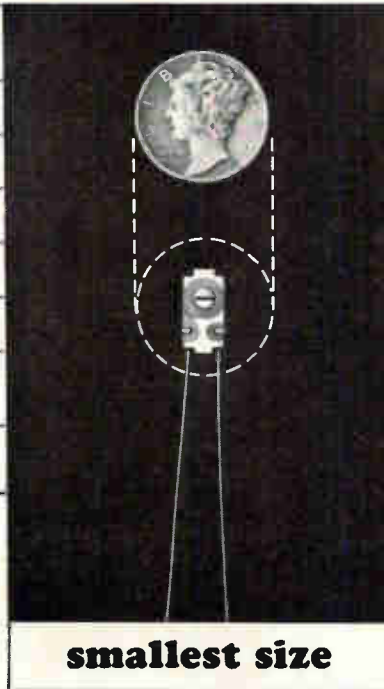

• If you are designing micromodule or hybrid circuits, this new MT Series of Modutrim micro-miniature ceramic variable capacitors offers three exclusive features.

(1) Note that  $\Delta C$  is extended to as high as 5-50 pf. (2) **Highest stability** results from the use of both a special ceramic material (developed in JFD's own Glass and Ceramic Laboratories) and a unique monolithic rotor. (3) These Modutrim units are the **smallest** available. Standard unit size is only 0.208 in. x 0.401 in. x 0.120 in. thick.\*

Other Modutrim Advantages:

1. Capacitance adjustment is approximately linear for 180 degree rotation.
2. Temperature coefficient of capacitance is  $-250$

$\pm 250$  ppm/ $^{\circ}C$ , exact values depending on the capacitance range. (Exception: Model MT150, temperature coefficient  $-700 \pm 250$  ppm/ $^{\circ}C$ )

3. Capacitance drift is 0.75% of maximum capacitance for temperature cycling, from  $-55$  to  $+85^{\circ}C$ .

4. Guaranteed minimum Q of 500 at 1MC. (Exception: Model MT 150 has minimum Q of 300 at 1MC)

5. Adjust torque is 1 to 5 in. ounces.

6. Dielectric strength test: 1000 volts for 500 volt rating; and 100 volts for 50 volt rating.

7. Modutrim units meet or exceed all requirements of Military Specification MIL-C-81A.

\*(Units as small as 0.208 x 0.280 x 0.120 in. thk. can be furnished upon special order. Other configurations are also available.)

WRITE FOR BULLETIN MT-64

**JFD ELECTRONICS CORPORATION**  
THE  AMERICA KNOWS BEST!

Components Division

JFD ELECTRONICS CORPORATION, 15th Ave. at 62nd St., Brooklyn, N. Y. 11219  
 JFD NORTHEASTERN, Ruth Drive, P. O. Box 228, Marlboro, Mass. 07152  
 JFD NEW YORK-NORTHERN, Damiano Pl., P. O. Box 96, New Hartford, N. Y. 13503  
 JFD MID-ATLANTIC, 313 E. Broad St., Palmyra, N. J. 08065  
 JFD MID-ATLANTIC-MARYLAND, P. O. Box 7676, Baltimore, Maryland 21207  
 JFD MIDWESTERN, 6330 W. Hermione St., Chicago, Illinois 60646  
 JFD MIDWESTERN-OHIO, P. O. Box 8086, Cincinnati, Ohio 45208  
 JFD WESTERN, 9 Morlan Place, Arcadia, California 91006  
 JFD CANADA LTD., 51 McCormack Street, Toronto, Ontario, Canada  
 JFD ISRAEL LTD., Industrial Area B, Bldg. 23, Azur, Israel  
 DUCON CONDENSER PTY., LTD., Christina Road, Villawood, N.S.W., Australia  
 LCC STEAFIX, 128 Rue de Paris, Boite Postale 51, Montreuil-sous-Bois, Seine, France  
 MURATA MANUFACTURING CO., LTD., Nagaoka Otokuni, Kyoto, Japan  
 STANDARD TELEPHONE & CABLES LTD., Footscray, Sidcup, Kent, England

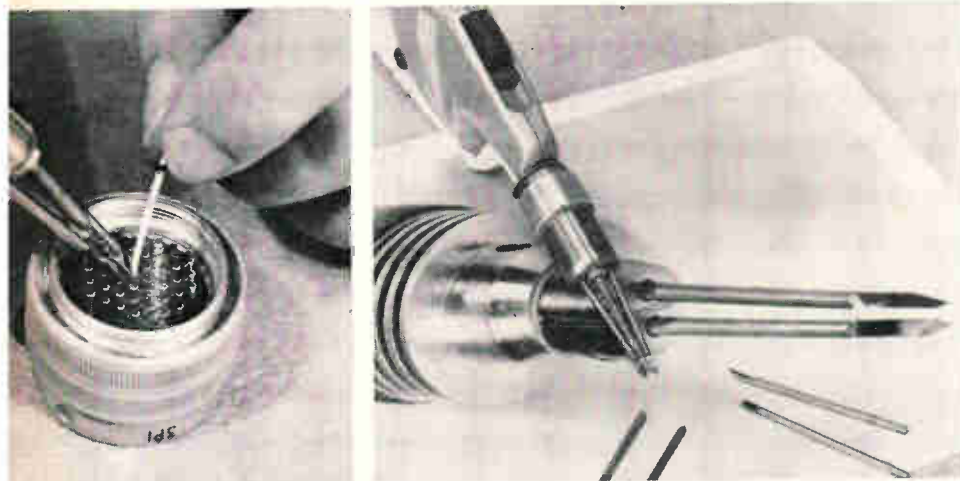

Two versions of a new soldering gun: solder feed and pencil type. At left, the feed-type gun is used to solder a wire into a connector pin.

however, would not make any public disclosure until it got its patents squared away. It has now been granted several patents and is applying for a long list of others.

So far, the major licensee is the Western Electric Co.; it is mass-producing circuits on resin-coated metal blanks, for use in pushbutton-telephone relays.

Four licensees in Germany and one in Italy are in production and other foreign licensees are installing equipment.

One major foreign application is expected to be in radio and television. Radio-tv manufacturers can trim costs by using platings 0.0007 inch thick instead of the usual 0.001 and can reduce costs further by using plated-through holes and two-sided boards.

Photocircuits' people are talking up the process among radio and tv firms in the United States. At its Glen Cove, N.Y., plant, Photocircuits can produce 20,000 square feet of the boards a day. A pilot plant for flexible circuits has been set up.

### Cold soldering

Imagine a soldering iron that doesn't get hot, yet practically eliminates cold-solder joints. Or one that lets a man or machine solder a terminal to a lead wire in a second. Or one that needs no maintenance.

The Westinghouse Electric Corp.

says it has invented a soldering gun with these advantages, and about a dozen more. The all-thumbs editor who tested the gun this month isn't arguing. Before they let him try it, solderers at the company's Aerospace division had made 261,410 test joints.

**Drama.** At the conclusion of the year-long test, C. J. Geating, superintendent of methods engineering, said the results were "dramatic." Compared with the conventional iron, soldering time is reduced an average of 38% and up to 65% in some applications. The time it takes to make a joint in a multipin connector, for example, is reduced from 0.0005 hour to 0.0003 hour. Similar results were obtained on standoffs, tube sockets and ground lugs.

**Girls aren't shocked.** The girls using the gun, Geating says, overwhelmingly approved it because it doesn't burn either their fingers or wire insulation when they are working in confined spaces, it doesn't shock them, it's lightweight, and it doesn't require dressing or tinning.

Geating says it's easy to train green hands to use the gun, but experienced solderers have to be taught to abandon conventional soldering tricks. Some girls, for example, preferred a pencil-type gun to a one-hand version with built-in solder feed. They like the pencil gun because they were used to holding an iron in one hand while manually applying solder

with the other (see photos). These girls had to learn one-hand soldering before the feed gun felt comfortable.

"We may in the near future be able to completely eliminate the human element from the making of a production solder joint," Geating says. The new tool has been successfully operated by an experimental automatic machine.

**Knife-edge resistance.** The gun is a 60-cycle resistance soldering tool, but the workpiece and solder get hot by conduction, not by resistance heating. The soldering tips aren't heated, either—they stay cold.

The only places where heat is generated are at the small spots where knife-edges on the two tips touch the workpiece. Heat flowing from there along the surface of the workpiece can be hot enough to melt high-temperature solder.

All the operator does is position the gun so the work is in the "V" formed by the two tips. When contact is made, a bulb lights up and illuminates the work. On the feed-type gun, the operator presses a ratchet with her thumb; flux-cored solder wire comes out between the tips and touches the hot workpiece. If a firm contact has not been made, the work stays cold and so does the solder. If there is oxide on the work, the edges cut through it.

**Low-voltage circuit.** Westinghouse calls the tool Positerm (positive termination) to indicate how it works. Every part of the electrical circuit has very low resistance—transformer secondary, cabling, connector and tips—except for the tip-to-workpiece contact. Because the tips have knife-edges, and because contact resistance is inversely proportional to contact area, contact resistance is high and heat is generated at the contact points.

The tips are made of thoriated tungsten, a long-wearing material that is also a good electrical conductor. Tips are shaped so heat won't flow back into them.

Voltage requirements are low. Open-circuit voltage ranges from 0.95 to 1.65 volts. Six heating rates provide the equivalent of irons



# 150°C\*

# 4 WATT POT



\* Rated at a true full 4-watts at 40°C,  
and de-rated to zero power at 150°C.

**NEW** — compact, 4-watt Series 45 potentiometers in a  $1\frac{1}{8}$ " case diameter — no larger than that of an ordinary 2-watt pot. These Series 45 potentiometers have greater power handling capabilities for restricted space applications. They are available in a resistance range of 10 ohms to 15K ohms linear at a standard tolerance of  $\pm 10\%$ . Choice of standard bushing mounting, or split-locking bushing for set-and-forget applications.

Let us send you complete information so you can evaluate the advantage of Clarostat Series 45 Potentiometers for your products. Just write ...

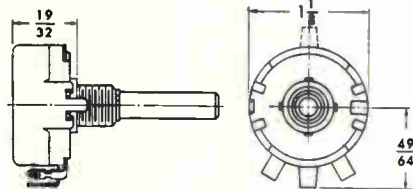

# CLAROSTAT

CLAROSTAT MFG. CO., INC. DOVER, NEW HAMPSHIRE

rated at 20 to 120 watts. One version is powered by 60-cycle line power and another by a rechargeable battery.

---

### Communications

---

#### Radar in 3-D

A few miles out over the Atlantic, an Air Force C-130 from Hanscom Field, Mass., flies at a known altitude from the Isle of Shoals to Cape Ann. On shore a rotating parabolic torus antenna at an Air Force field site in coastal Ipswich scans the ocean, and, in a nearby shack, engineers from the Air Force Cambridge Research Laboratories track the plane. Their goal—three-dimensional radar. The research team headed by Carlyle J. Sletten of the laboratories' microwave physics section is seeking a relatively simple technique for getting rapid electronic information on target height as well as range and direction.

The technique, based on work done at AFCRL a decade ago to develop present L-band search radars, simplifies the acquisition of electronic information in three dimensions. It requires a single transmitter and two receivers. The elevation is obtained by phase comparison of signals from the two receiving terminals of the antenna. Distance and direction are obtained as usual. The experimental model works in S-band with a central frequency of 2800 megacycles.

**Slotted array.** The parabolic torus reflector—parabolic in the horizontal plane and spherical in the vertical—is fed by a special slotted array that circles the vertical plane of the reflector. The reflector and the array together produce the phase function. A signal from the target travels along two different paths, and the phases of the two received signals are detected and compared. A pulse-limiting circuit removes amplitude variations before the signals from the two channels are compared, permitting only the phase to be measured. In the vertical radiation pattern, the phase-in-space is lin-

ear with the angle of elevation. The relative phase-in-space function is largely determined by the spacing of the slotted radiators in the array.

The aircraft's range and azimuth are seen on one of two scopes—a conventional plan position indicator. The target of interest is selected from this indicator by means of a gating circuit, and return echos from the target show up as voltages on the second radar scope, which acts as a height indicator. Phase comparison of signals from the antenna provide the elevation coordinate, and this is displayed both as a pulse and as a numerical readout.

Sletten says this 3-D phase comparison technique should provide height indicator accuracy of several hundred feet to a range of 20 to 30 miles.

**Clutter problem.** As with all radars, ground clutter occurs in earth-surface applications. The engineers plan to experiment with moving target indicator techniques, and will also try to get rid of terrain echoes by phase-nulling at zero degrees in elevation.

The system could be used for weather radar, air traffic control, and surveillance systems.

---

### Space electronics

---

#### Tricky design in space

Designing communication and tracking equipment for the Apollo command module and its lunar excursion module (LEM) involves such problems as simultaneously transmitting vast amounts of data from two spacecraft over a distance of about 240,000 miles.

To accomplish this the National Aeronautics and Space Administration has established the Apollo unified s-band program. It calls for placing all television, voice communications, command, tracking and telemetry between Apollo and ground stations on a single frequency band. The network includes about 15 ground stations, a number of aircraft and ships.

**Can be solved.** NASA engineers

concede that the design is tough, but not insurmountable. The thorniest problems involve the spacecraft.

The system in the craft will operate on 20 watts, basically at frequencies between 2,000 and 2,300 Mc. The frequencies used in transmitting to earth will be 2287.5 Mc pulsed-modulated and 2272.5 Mc frequency-modulated for the Apollo command module, and 2282.5 pm-fm for LEM. The frequencies from the earth will be 2101.8 Mc for LEM and 2106.4 Mc for the command module.

Antenna design is proving to be tricky, also, according to James D. Shaughnessy, chief of the Manned Spacecraft Center's systems analysis branch. NASA wants high-gain (27-db) antennas that would be mounted on the side of the spacecraft and erected in orbit, but they haven't been designed yet. Shaughnessy believes the final configuration will be some type of cross-slot antenna, flush mounted, that can be switched in pairs (one receiver and one transmitter) by the Apollo crew.

An omnidirectional antenna could be used up to 12,000 miles from earth, but the high-gain antennas will be needed farther out. The antennas on the spacecraft will have infrared sensors to keep them pointed toward earth.

**Portable cameras.** Apollo will have a 10-frame-per-second, 320-line-per-frame television system that will be compatible with 400-kc bandwidth. Cameras can be taken out of LEM and used on the surface of the moon.

Plans call for 30-foot antenna stations at Cape Kennedy, Bermuda, Australia, Hawaii, Mexico, Texas, Guam, Ascension Islands and Guatemala. Three other 30-foot stations may be added. There will probably be 85-foot stations at Madrid and NASA's Goddard Space Flight Center and in Mexico, as well.

Some of the 30-foot antenna stations will be single facilities, while the other 30-foot stations and all the 85-foot ones will be capable of communicating simultaneously with both the Apollo spacecraft and LEM.

# For Microwatt Power Consumption, Specify

Type	Function	Circuit
<b>MODULE A</b> Two NOR; One Inverter. Fan-out, 5 Fan-in, 1 Power Dissipation, 180 Microwatts		
<b>MODULE C</b> Two High Current NOR. Fan-out, 30 Fan-in, 5 Power Dissipation, 816 Microwatts		
<b>MODULE F</b> Bistable Multivibrator. Fan-out, 4 Fan-in, 1 Power Dissipation, 180 Microwatts		
<b>MODULE G</b> Exclusive OR. Fan-out, 5 Fan-in, 1 Power Dissipation, 180 Microwatts		
<b>MODULE J</b> Two 3-input NOR. Fan-out, 5 Fan-in, 1 Power Dissipation, 180 Microwatts		
<b>MODULE K</b> ✓ Monostable Multivibrator. Fan-out, 25 Fan-in, 5 Power Dissipation, 408 Microwatts		
<b>MODULE U</b> Bistable Multivibrator. Fan-out, 25 Fan-in, 5 Power Dissipation, 408 Microwatts		
<b>MODULE Z</b> Modified Flip-Flop. Fan-out, 25 Fan-in, 1 Power Dissipation, 528 Microwatts		

## Microelectronic Logic Modules from CBS Laboratories

CBS Laboratories, pioneer in microelectronic technology, has developed a series of off-the-shelf logic modules, ready for installation in spaceborne or other systems requiring an absolute minimum of power consumption.

Measuring approximately 7/16 by 3/8 by 1/16-inch, these modules operate on **microwatts of power**, rather than milliwatts.

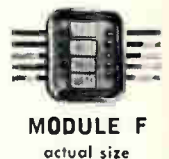

Typical modules, as shown in the table to the left, may incorporate one or several logic functions.

For complete information on these and other microwatt microelectronic circuits, modules and systems, contact the Microelectronic Sales Department, CBS Laboratories, Stamford, Connecticut.

# CBS LABORATORIES

A Division of Columbia Broadcasting System, Inc.

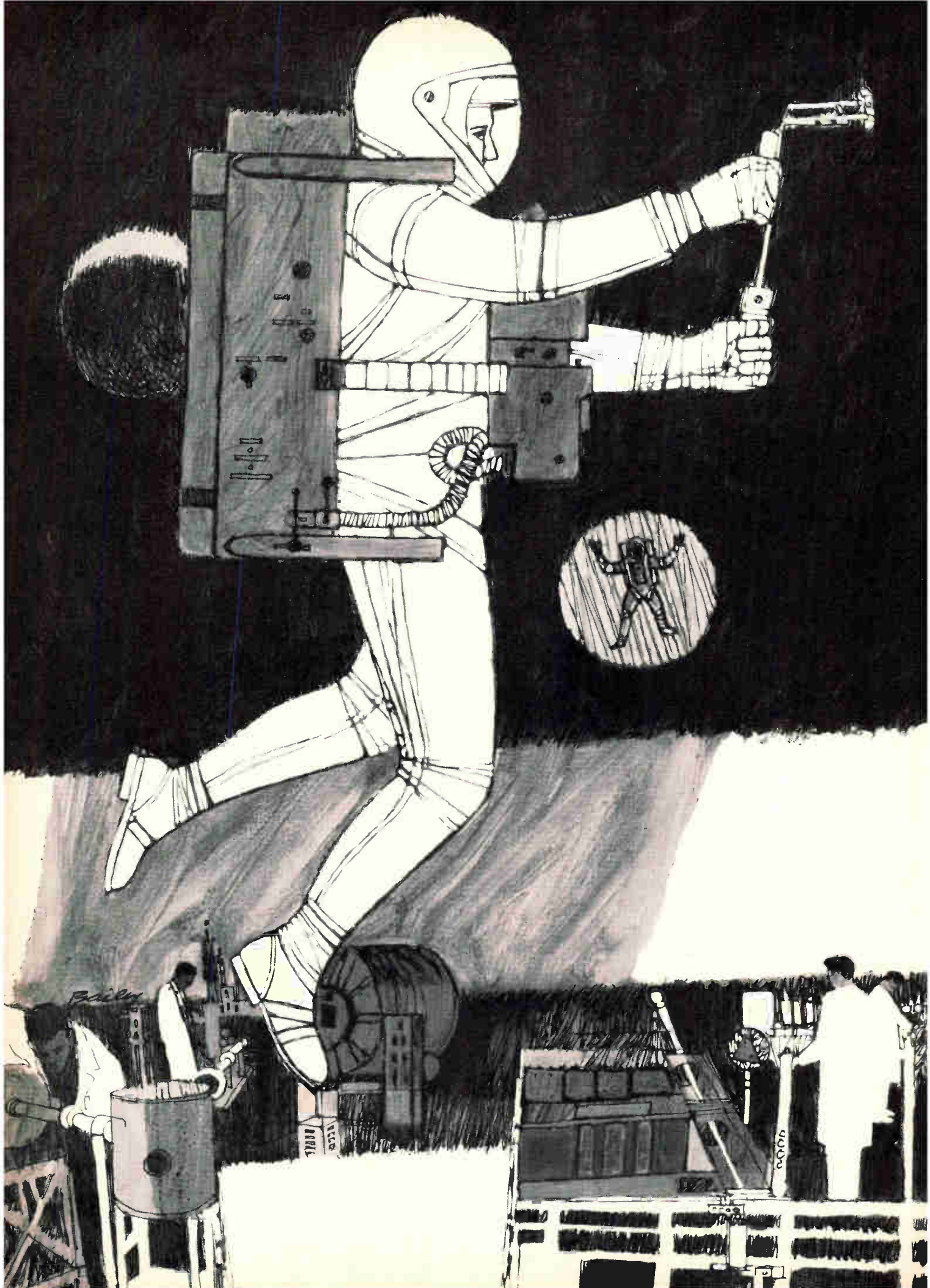

# RESEARCH...THE POWER OF INQUISITIVE THINKING

The inquiring mind is "top priority" at LTV, where heavy investments in research and development have risen by 100 per cent in the last four years.

How can man maneuver and work in the topsy-turvy environment outside his spacecraft? LTV's work in this field has led to an Air Force contract to develop a compact space pack which promises to convert an astronaut into a one-man space vehicle for assembling and servicing spacecraft in orbit, transferring from one vehicle to another and performing numerous other tasks in space — all independent of his parent spacecraft. Its first use is scheduled in the NASA two-man Gemini program.

LTV's electronic research bridges the electromagnetic spectrum, including the region with exciting new potential — visible light and the laser. At the other end of the spectrum, LTV is a world leader in acoustic R & D.

Applied microelectronics research is aimed at production of smaller and more reliable microcircuits for many LTV products.

With a Van de Graaff nuclear accelerator, LTV scientists devise space radiation detectors and determine effects of radiation on space vehicles. The company also conducts advanced research in astro and aerophysics, life sciences, energy sources, space-age mechanics and materials.

R & D programs in LTV's divisions are backed by LTV Research Center at the corporate level. This "power of inquisitive thinking" is the key to the versatile store of science and technology at LTV, leader in electronics, aircraft, missiles, space, mobile ground vehicles, ground and airborne communications, and range services. Ling-Temco-Vought, Inc., Dallas, Texas.

Divisions and subsidiaries: LTV Altec • LTV Astronautics • LTV Continental Electronics • LTV Ling Electronics • LTV Michigan • LTV Military Electronics • LTV Range Systems • LTV Research Center • LTV Temco Aerosystems • LTV University • LTV Vought Aeronautics • Kentron Hawaii, Ltd.

Circle 35 on reader service card

**LTV**  
LING-TEMCO-VOUGHT, INC.

Hypersonic wind tunnel tests new designs for re-entry vehicles, other advanced hardware.



LTV pioneers ultra-sensitive acoustic devices and high-intensity sound equipment.



How mobile and dexterous is a man in full pressure suit? LTV is finding the answers.



Research in "thin film" microcircuitry leads to smaller, more reliable LTV products.



Boundary layer channel opens new avenues of knowledge in basic flight phenomena.



# TEST YOUR ZENER IQ!

See answers at bottom of page

**QUESTION 2:** Voltage regulator diodes with a breakdown voltage rating ( $V_Z$ ) of approximately 6 volts and below, are manufactured by the \_\_\_\_\_ process.

- A — diffused
- B — double-diffused
- C — alloyed



IR manufactures Zener diodes both ways — alloyed Zeners to have a sharper knee characteristic down as low as 2 volts and diffused Zeners that go as high as 200 volts.

**QUESTION 5:** Generally speaking, the noise voltage generated by a voltage regulator diode \_\_\_\_\_ as the breakdown voltage rating ( $V_Z$ ) increases.

- A — increases
- B — decreases
- C — remains constant



Subminiature glass Zeners from IR are in 150, 200, 250 and 400 mw series with 5, 10 and 20% voltage tolerances.

**QUESTION 3:** Defining the "knee" characteristic of a voltage regulator diode is best accomplished by specifying \_\_\_\_\_

- A —  $I_R$  (@  $V_R = 98\%$  of  $V_Z$ ) and the knee impedance
- B —  $I_R$  (@  $V_R = 80\%$  of  $V_Z$ ) and the knee impedance
- C —  $I_R$  (@  $V_R = 50\%$  of  $V_Z$ ) and the knee impedance



Diffused-junction Zeners span the voltage range of 6.8 to 200 volts with IR's 1 watt flangeless (1N1767-1802 and 1N3016-3051 series) and 10 watt stud-mounted (1N2970-3015, 1N1805-1836 and 1N1351-1375 series) units. Stud-mounted 50 watt Zeners are in the 1N3305-3340 series.

**QUESTION 6:** The noise voltage generated by a voltage regulator diode \_\_\_\_\_ as Zener current increases above 0.5 milliamperes.

- A — increases
- B — decreases
- C — remains constant



Rugged, stud-mounted IR voltage regulator diodes in 3.5 and 10 watt alloyed packages are available in the popular 1N1588-1598 and 1N1599-1609 series. Axial-leaded, alloyed Zeners come in the 750 mw 1N1507-1517 and the 1 watt 1N1518-1528 series.

**QUESTION 1:** The dynamic impedance of a voltage regulator Zener diode \_\_\_\_\_ with an increase in current.

- A — increases
- B — decreases
- C — remains constant



Dependable voltage regulation begins with IR's subminiature glass Zeners at 150 milliwatts and continues up to rugged, stud-mounted 50 watt units to include almost all popular JEDEC types.

**QUESTION 4:** Temperature-compensated reference elements are actually two or more diodes connected in series. One diode is a standard \_\_\_\_\_

- A — diffused rectifier
- B — alloyed rectifier
- C — voltage regulator

IR's reference elements consist of series-connected voltage regulator diodes—one with a positive temperature coefficient operating in a reverse direction, the others with negative temperature coefficients in a forward direction. The result is a near-perfect cancellation of any drift as the temperature changes.

**QUESTION 7:** The stability of a reference element is greatly affected by \_\_\_\_\_

- A — the ambient temperature
- B — the stability of the reverse operating current through the diode
- C — the thermal resistance of the diode



You get immediate delivery on IR's lines of temperature-compensated reference diodes—from the 1N821-827 (5.9 to 6.5 volts) and 1N3154-3157 (8.0 to 8.8 volts) glass series, to the stud-mounted 1N430 and 3-leaded 1N1530 types. Delivery's immediate with the other lines, too.

**HOW GOOD A ZENER MAN ARE YOU?** If you got all the answers right, or even just 6 out of 7, you certainly do know your Zeners. But do you know, too, that IR has portable Zener diode Lab Kits that can save you both time and money during your breadboarding? The kits—there are three types—contain a wide sampling of the more than 640 types of IR Zeners. They're there when you need them—with each diode hand calibrated, and their cost? Well, they can save you as much as 60% compared to the individual 1-99 Zener prices! Write for IR's Zener Lab Bulletin ZL-100A and 1964 Short Form Catalog. Only IR Zeners give you this performance assurance...99.988% demonstrated industrial reliability!



# IR<sup>®</sup> INTERNATIONAL RECTIFIER

INTERNATIONAL RECTIFIER CORP., EL SEGUNDO, CALIF., PHONE OR 8-6281 • CABLE RECTUSA • REGIONAL OFFICES IN NEW YORK CITY, CH 4-0748 • FORT LEE, N. J., WI 7-3311 • SYRACUSE, N. Y. HE 7-8495 • CAMBRIDGE, MASS., UN 4-6520 • ARDMORE, PA., MI 9-3667, GR 3-3932 • SILVER SPRING, MD., JU 9-3305 • MIAMI, FLA., 445-5201 • CHICAGO, ILL., OR 6-4090 • CLEVELAND, OHIO, 734-4100 • DAYTON, OHIO, 223-7691 • HUNTINGTON WOODS, MICH., LI 8-1144 • ST. LOUIS, MO., TE 8-6333 • MINNEAPOLIS, MINN., 920-1200 • DALLAS, TEX., LA 1-0110 • LOS ANGELES, CALIF., 750-0550 • IN CANADA: TORONTO, ONT., PL 9-7581 • MONTREAL, QUE., 861-0562

Contact the International Rectifier Regional Office nearest you for the Authorized Distributor in your area.

Answers: 1B; 2C; 3B; 4C; 5A; 6B; 7B

---

# Washington Newsletter

---

October 19, 1964

## Stalled satellites may get nudge

The Pentagon is smarting over Congressional criticism that its budget-mindedness has caused delays in getting a satellite communication network off the ground. Now the rumor filtering through the Defense Department is that Secretary Robert McNamara is about to take a step that was expected in August—naming a company to produce the satellites. [story on p. 93].

The Philco Corp. remains the front-runner for the two dozen near-synchronous altitude satellites that should provide the worldwide coverage McNamara wants.

Critics maintain that aside from two years of delay in this area, McNamara has tied the system to the still unproven Titan III-C booster program. This, they say, makes the system susceptible to still more delays. A House committee wants McNamara to revert to the original satellite plan, okayed in 1962 by the Joint Chiefs of Staff, that calls for using medium-altitude, random-orbiting satellites launched by the Atlas-Agena booster.

In addition, the committee wants the department to take immediate steps to have the National Aeronautics and Space Administration perfect satellite stabilization by using gravity-gradient techniques. And it wants the Pentagon to design and procure small mobile land and shipboard terminals for test use with the satellite system.

## Reprieve granted for citizens' band

New rules designed to put tight clamps on unauthorized use of citizen-band radios won't go into effect on Nov. 1 as originally planned by the Federal Communications Commission.

Equipment producers protested against the stiff rules, and the agency will let them air their objections.

Supporting the agency's demand for cracking down on the misuse of the radios were a host of reports in the New York area that chattering youngsters using citizens' band were disrupting the sound and picture on video receivers.

Lafayette Radio Electronics Corp., Syosset, N.Y., and Polytronics Laboratories, Inc., West Caldwell, N.J., two of the several equipment producers that are protesting the new rules, contend the FCC doesn't understand the problem. They want the FCC to step up police action to stop illegal radio use, while providing an additional 100 channels for legitimate users.

## Trade barriers under fire

New U. S. trade barriers that may involve millions of dollars worry some segments of the construction industry but apparently not the electronics industry.

In a nutshell, the new Commerce Department edict requires friendly foreign importers of strategic U. S. technology to pledge that the technical data won't be sent or sold to Communist countries.

The National Constructors Association argues that if the data or processes involved can be obtained by the importer from some other country, there is no need for the U. S. control. But the Commerce Department, although agreeing in principle, contends that if the process is significantly

# Washington Newsletter

cheaper than the foreign counterpart, such versions aren't comparable.

The association, which has been pressing several major electronics concerns to join them in the battle, says these companies consider the issue too complex and time-consuming to warrant much interest.

## Bigwigs plug radios in ears?

Not only rock 'n' rollers and baseball fans, but top-echelon officials will have their ears glued to transistor radios if security aides have their way.

The problem is this: If tragedy befalls the President, the man who would inherit his national security responsibilities must be reached immediately. Security officials are plugging the tiny transistor radio idea, but they don't disclose details or their success.

Lacking a vice president, President Johnson's next-in-line is Speaker John W. McCormack (D., Mass.). Though he has a hot-line connection with the White House from his office, home and car, his movements are considerably less restricted than the President's, thus the need for the tiny radio, which is tuned into the military command and control network.

## Computers can't talk to each other

Communication among bureaucrats has always been a problem, but now, apparently, the government's computers don't even "talk the same language."

The Warren Commission, which probed the assassination of President Kennedy, uncovered faulty coordination among the Federal Bureau of Investigation, Secret Service, State Department and the Central Intelligence Agency. The report disclosed that the electronic data-processing systems of the CIA and the FBI can't "talk" to each other, even if their officials want them to. And the Secret Service doesn't even have such a computer system.

A commission demand that a study be launched to determine the feasibility of teaching the computers the same language, leaves the agencies sputtering. Some fear it would poke holes in the cloaks surrounding their secrecy.

Meanwhile, the Secret Service is asking \$100,000 for an initial study for a computer system. The agency is getting technical advice from the Rand Corp.—a nonprofit company that researches national security problems—the International Business Machines Corp. and CIA specialists.

## Speed is sought on getting patents

Streamlining the time-consuming patent process may get high-priority action.

At the request of the Patent Office, Commerce Secretary Luther Hodges may ask the President to name a commission on patents. Such a panel might suggest anything from minor revisions to an overhaul of the present system.

One of the most controversial possibilities would be the elimination of lengthy pre-patent searches, substituting the European system of relying on court challenge and review to determine patent validity.

Other ideas being studied or implemented: pilot operations between U. S. and foreign patent offices to exchange search results on companion applications; interviews between patent attorneys and examiners; and guidelines for patentability in areas where courts have disagreed or have not ruled.



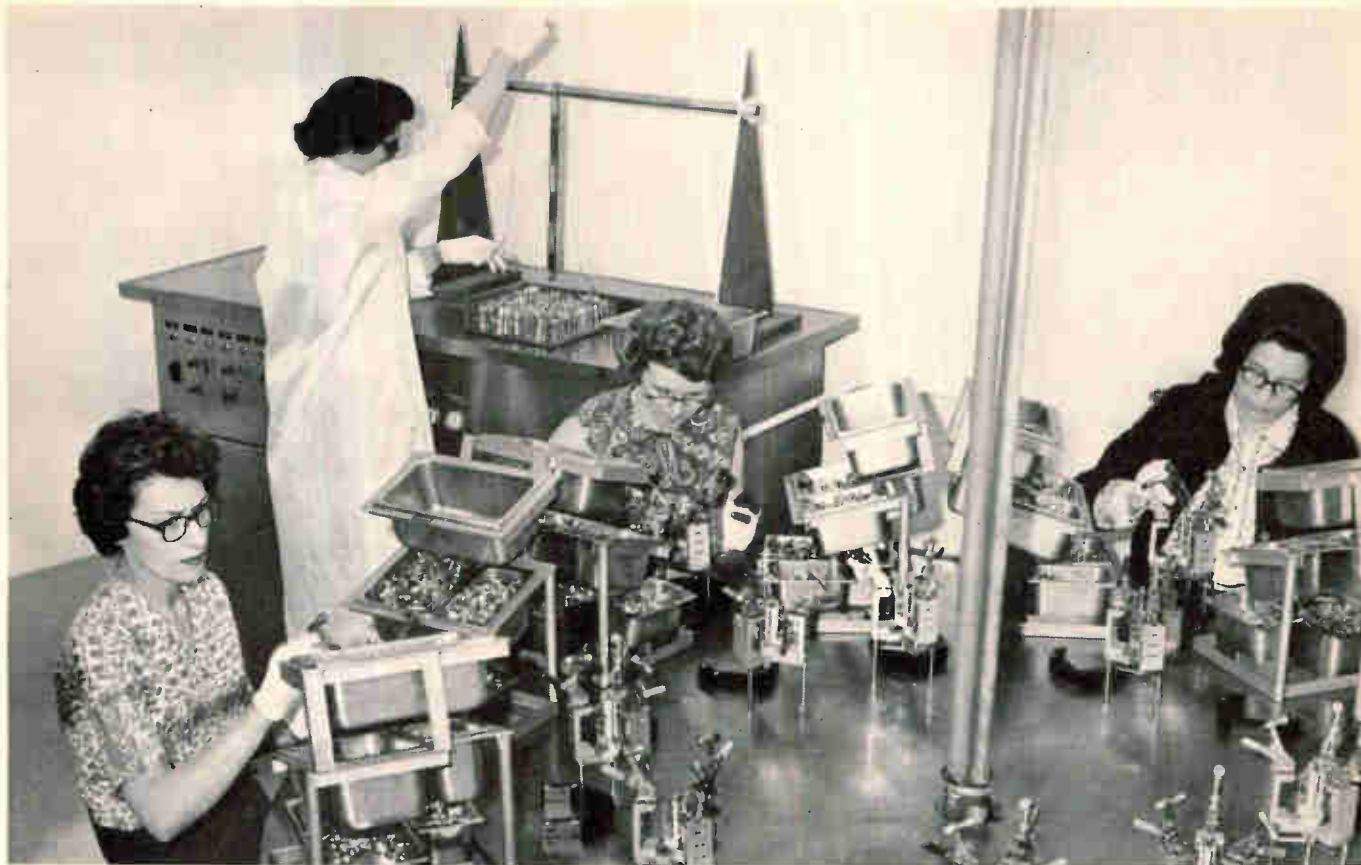

Because FREON solvents are nonflammable, virtually nontoxic and free from irritating odors, Rauland Corp. can safely locate its cleaning equipment directly at the end of its assembly line for maximum efficiency.

## Rauland uses FREON® TF to "super-clean" color-TV picture-tube subassemblies

Cleaning of color-TV tube gun subassemblies is a critical operation because of the extremely high voltages to which they will be subjected. Any particulate matter not removed

could cause arcing and a blown tube . . . any leftover lubricants would seriously affect the rise time and service life of the tube. For this critical cleaning operation, the Rauland Corporation, Chicago—a division of Zenith Radio Corporation—uses FREON TF solvent.

Now, cleaning of the subassemblies is a quick, simple, low-cost operation . . . thanks to a cleaning system engineered and installed by a FREON solvent sales agent. This cleaning system uses FREON TF. The combined action of extremely low surface tension and high density enables FREON TF to penetrate minute crevices and effectively release and float away soils . . . even particulate matter. This results in complete, residue-free cleaning.

If you would like to investigate the many ways you can use FREON solvents in your cleaning operations, mail the coupon at the right.



This combination cleaning system was engineered specifically for the Rauland Corporation by G. S. Blakeslee Co., Chicago, Illinois. It is just another example of the complete cleaning system engineering you can expect from your representative for Du Pont FREON®.



After being cleaned in quick-drying FREON TF, the residue-free subassembly is ready immediately for final processing.

**FREON®**

SOLVENTS

Better Things for Better Living . . . through Chemistry

**DUPONT**  
THE DU PONT COMPANY

Du Pont Co., "Freon" Products Division  
N-2430 E-2, Wilmington, Delaware 19898

Please send information on FREON solvents.  
I am interested in cleaning \_\_\_\_\_

Name \_\_\_\_\_ Title \_\_\_\_\_

Company \_\_\_\_\_

Address \_\_\_\_\_

City \_\_\_\_\_ State \_\_\_\_\_ Zip \_\_\_\_\_

# MALLORY

P. R. MALLORY & CO. INC., INDIANAPOLIS 6, INDIANA

## High-reliability battery packs for beacon transmitters



The battery pack shown here is typical of literally hundreds of power supplies which Mallory Battery Company has been designing and manufacturing for nearly 20 years for all branches of the military. This particular pack goes into a radio beacon which is small enough to be carried in an airman's jacket, packed in a para-

chute harness, or inserted in a life vest. Rated nominally at 1200 milliampere-hours, it will supply 24 hours of steady operation of a pulsed transmitter, at ambient temperature of 0°C. Ten of our No. 3 wound anode mercury cells go into the pack.

The utmost in reliability at temperatures ranging from Arctic to tropic, is demanded of this class of emergency rescue equipment. The Mallory wound anode mercury cell is particularly applicable to many emergency packs, because of its ability to deliver high milliampere-hour capacity at sub-freezing temperatures. Equally important is the excellent shelf stability of the mercury system. Military depots have issued mercury batteries stored over three years and these batteries still provided the specified service life requirements.

Call on Mallory Battery engineers for analysis of your requirements and for custom design of the most effective pack for your equipment.

**CIRCLE 240 ON READER SERVICE CARD**

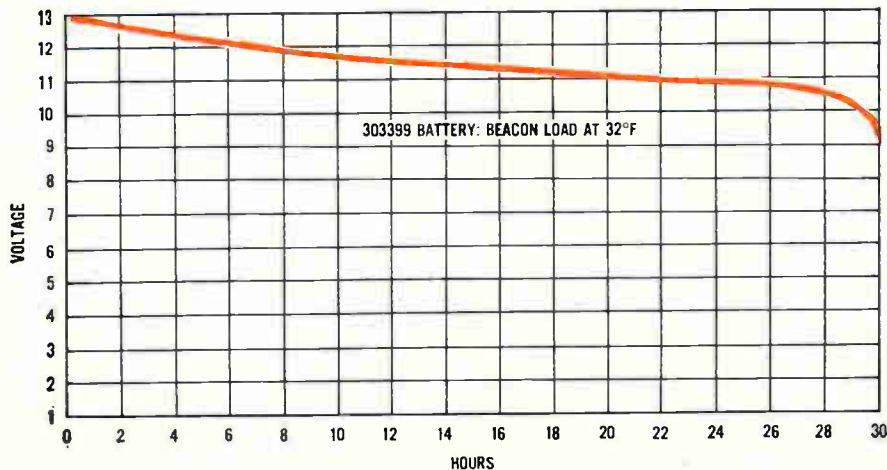

Service life characteristic of typical beacon pack.

## Multi-cam timer has cycle adjustable without tools

An industrial sequence timer developed by Mallory can be adjusted to provide a broad range of time cycles without need for tools. You simply move a set of spring-loaded cams apart with your fingers, turn them to the desired cycle, and release. New settings lock into place, won't slip out of adjustment.

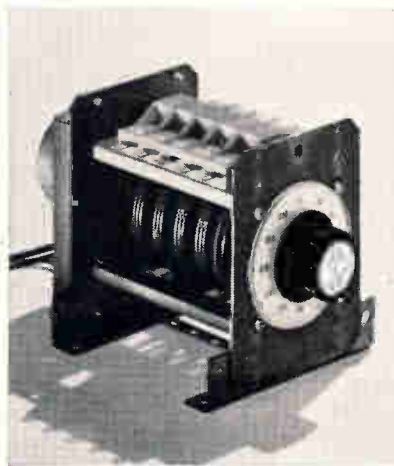

Cams actuate snap-action switches rated 15 amps, 125 VAC, tested for over 1 million cycles. Switches can be replaced in seconds in the event of damage from overloads.

For use in prototype work, for laboratory or production line controls, Mallory Industrial Distributors stock both a variety of assembled timers, and a selection of the timer frames and drive motors from which you can quickly put together the timer you need. Timer frames come with 5, 10 or 15 cams. Drive motors cover the range from one minute to 24 hours per revolution.

**CIRCLE 241 ON READER SERVICE CARD**

# DESIGNER'S FILE

## New Solid Tantalum Capacitors Rated for 200°C Service

The new THS line of Mallory capacitors is the first solid electrolyte tantalum type to be rated for 200°C. They were originally developed by us to provide a miniature capacitor capable of reliable performance in oil well instruments, which are subjected to high temperatures during deep hole surveys. The THS capacitors are hermetically sealed in tin-plated cases with gold plated leads. To assure uniform high quality, we subject them to 100% screening tests on critical electrical characteristics at 200°C.

Voltage ratings are dependent on operating temperature (see derating chart). Nominal values cover the range from 220 mfd. 6 VDC to 15 mfd. 50 VDC, with low capacity values down to .0047 mfd. Four different case sizes are available, from 0.125" diameter by 0.250" long, to 0.341" diameter by 0.750" long (uninsulated case dimensions). Capacitors can be supplied with Teflon\* insulating sleeves.

\*Registered Du Pont trademark

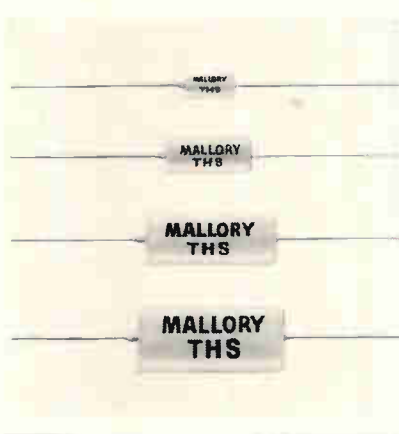

## New Push-Pull Line Switches



Attractive styling and excellent performance go together in this new line of Mallory switches. Their cone-shaped anodized aluminum knob is an integral part of the control shaft; no added hardware is needed.

Switch action is pull "on", push "off". Electrical rating is 6 amperes at 125 VAC, U.L. approved. The switch is enclosed in a  $1\frac{5}{16}$ " diameter cup. SPST, DPST and SPDT models are available, at prices comparable to standard toggle switches.

VOLTAGE DERATING CHART		
WVDC @ 25°C	WVDC @ 200°C Continuous Duty	WVDC @ 200°C 50% Duty Cycle*
6	2.4	4.8
10	4.0	9.0
15	6.0	12.0
20	8.0	16.0
25	10.0	20.0
35	14.0	28.0
50	20.0	40.0

\*Duty cycle of 2 hours on voltage @ 200°C followed by 2 hours off voltage @ 25°C.

CIRCLE 242 ON READER SERVICE CARD

When you need a lot  
of microfarads...

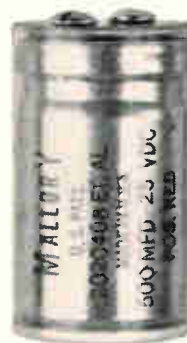

Occasionally, when you're working out a prototype, you may run into a circuit that needs microfarads by the thousands. How do you get what you need, in compact size, at compact prices?

The answer is a Mallory Computer Grade (Type CG) capacitor. They were originally developed for use in computer power supplies, but you don't need to be designing computers to use them. They're made of materials—foil separator, electrolyte—that meet highest specifications for purity. And they are assembled with extra care, in a construction which gives unusual reliability.

Their life is exceptional. We have tested them for the equivalent of 20 years service at room temperature, without failure. Equivalent series resistance and DC leakage are remarkably low and stable.

In a single case (largest size 3" dia. x 5 $\frac{5}{8}$ " ) you can get up to 115,000 mfd. at 3 volts, or 2000 mfd. at 350 volts... at a cost considerably less than that of conventional electrolytics paralleled together.

CIRCLE 243 ON READER SERVICE CARD

CIRCLE 244 ON READER SERVICE CARD

# CONSIDER COLORADO

*...where research and education are industry's partner...*

Directly. Indirectly. From government, university and private sources...

Consider 103 research organizations located in the state... headed by a total of 3500 graduate scientists who guide the efforts of 23,000 employees to discover the unknown. Everything from economics and marketing to cryogenics and advanced nuclear research and neutron generator performance.

In close support of science, research and industry are Colorado's educational institutions: 12 colleges and universities; 7 junior colleges. Plus an increasing number of vocational and trade schools whose primary mission is to serve the needs of Colorado and the nation's industry.

If research and education are important to your business, consider industrial Colorado for your expansion or relocation. Complete information is available from Dwight E. Neill, Director, Division of Commerce and Development, 14 State Services Building, Denver, Colorado.

## INDUSTRIAL COLORADO



**new  
compact  
Tektronix  
oscilloscope**

# easily adapted to particular needs

Here's a high-performance oscilloscope featuring operational simplicity and versatility through a new series of plug-in units. Presently, you can select from 12 amplifier units and 5 time-base units.

Knowing your application area, you select those units that fit your needs. Some of the plug-in unit combinations available include those for low-level, differential, multi-trace and sweep-delay applications.

Special-purpose plug-in combinations equip the oscilloscope for sampling applications, in which the instrument becomes a low-drift sampling system as easy to operate as a conventional oscilloscope, but with sensitivity and bandwidth possible only through sampling.

With any combination of plug-in units in the oscilloscope—including the same type amplifier units in both channels for X-Y displays—this new value package provides you with "no-parallax" displays and sharp trace photography.

## OSCILLOSCOPE FEATURES

NEW CRT with an internal graticule and controllable edge lighting • regulated power supplies • regulated dc heater supply • Z-axis input • 3.5-kv accelerating potential • amplitude calibrator • and operation from 105v to 125v or 210v to 250v. (The Type 561A operates from 50-400 cps and the Type RM561A operates from 50-60 cps.)

Type 561A (shown in low-level application) ..... \$500  
Type RM561A (shown in sweep-delay application) ..... \$550

*Oscilloscope prices without plug-in units.*

Plug-In Units: Prices as low as \$105 for vertical amplifier and \$210 for time-base generator.

U.S. Sales: Princeton, N.J. Beaverton, Oregon

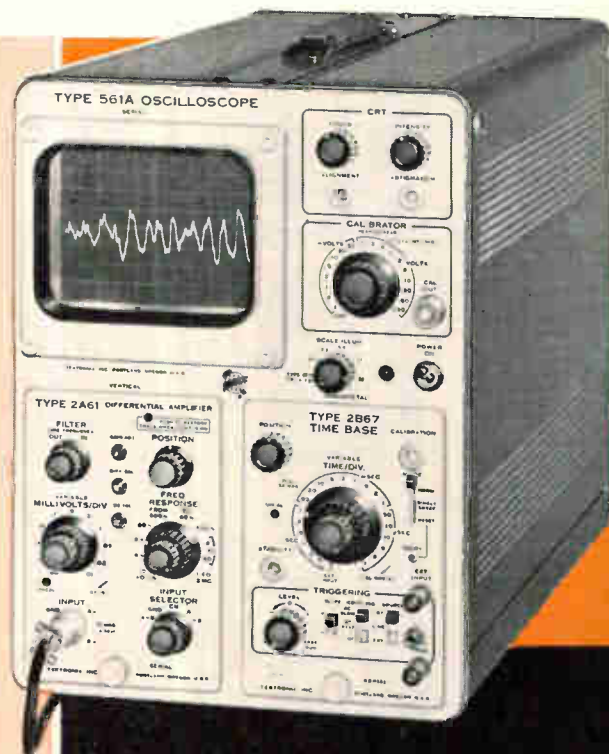

The 2A61/2B67 Plug-In Unit combination—illustrated with Type 561A—equips the oscilloscope for low-level differential applications.

The 3A1/3B3 Plug-In Unit combination—illustrated with the rack-mount model, Type RM561A—equips the oscilloscope for high-sensitivity, dual-trace operation and sweep-delay applications.

The rack-mount model occupies only 7 inches of standard rack height.



FOR MORE INFORMATION ON EITHER MODEL OF THIS NEW OSCILLOSCOPE AND ANY COMBINATION OF PLUG-IN UNITS, PLEASE CALL YOUR TEKTRONIX FIELD ENGINEER.

**Tektronix, Inc.**

P.O. BOX 500 • BEAVERTON, OREGON 97005 • Phone: (Area Code 503) Mitchell 4-0161 • Telex: 036-691  
TWX: 503-291-6805 • Cable: TEKTRONIX • OVERSEAS DISTRIBUTORS IN 25 COUNTRIES  
TEKTRONIX FIELD OFFICES in principal cities in United States. Consult Telephone Directory

Tektronix Australia Pty., Ltd., Melbourne; Sydney • Tektronix Canada Ltd., Montreal; Toronto

Tektronix International A.G., Zug, Switzerland • Tektronix Ltd., Guernsey, C. I. • Tektronix U. K. Ltd., Harpenden, Herts



In Lancaster we have many things you wouldn't expect to find in our factory. The forging hammer, for one, belongs to our Precision Metals Division. It's used to reduce ingots and bars as the first step in production of extremely close-tolerance strip, foil and wire. We work with some 50 different alloys.

This facility is a completely integrated metals processing operation. We can furnish anything in precision metals from experimental prototypes, to a limited run or to large volume production from raw materials to finished products. Write for our Precision Metals brochure or visit our facilities.

PRECISION METALS DIVISION—ONE OF THE MANY DIMENSIONS OF THE  
**HAMILTON WATCH COMPANY**  
Lancaster, Pennsylvania

## What's a forging hammer doing in a watch factory?

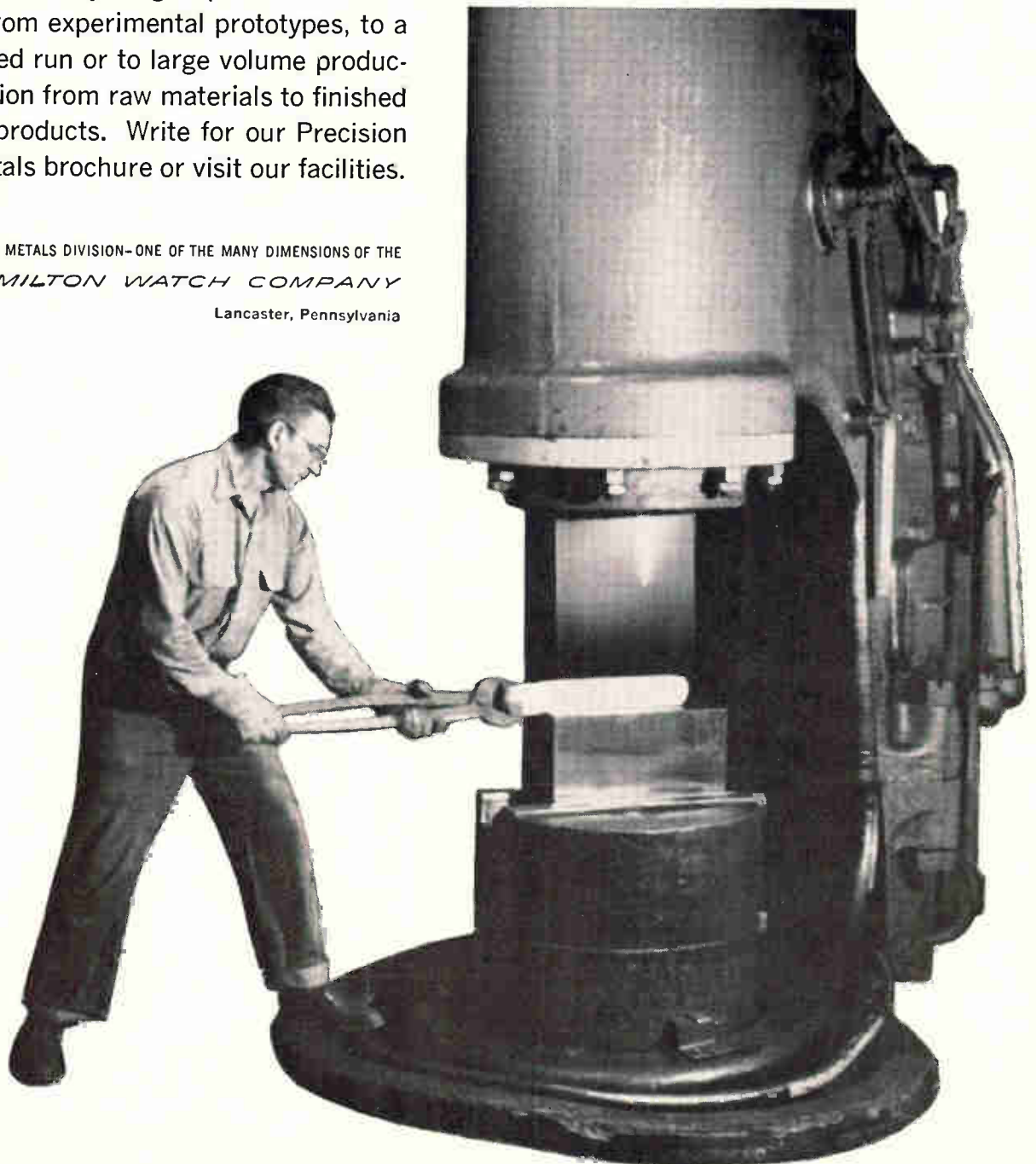

# 200,000

# OHMS PER VOLT

## NEW AND THE FIRST

**\$99.50**



**Model 630-NS**  
**VOLT-OHM-MICROAMMETER**

### TRIPLET SUSPENSION MOVEMENT

*no pivots . . . no jewels . . .  
no hair springs . . . thus NO FRICTION.*

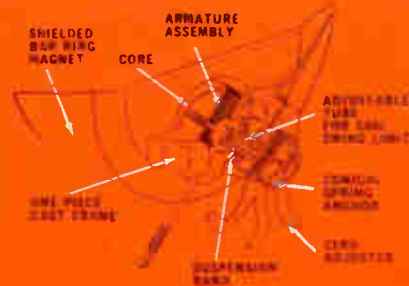

## FACTS MAKE FEATURES

- 1** 200,000 OHMS PER VOLT D.C. for greater accuracy on high resistance circuits. 20,000 OHMS PER VOLT A.C.
- 2** 5 $\mu$ A SUSPENSION METER MOVEMENT. No pivots, bearings, hair-springs, or rolling friction. Extremely RUGGED. Greater sensitivity and repeatability.
- 3** 62 Ranges, usable with frequencies through 100 Kc. Temperature compensated. 1 $\frac{1}{2}$ % D.C. ACCURACY, 3% A.C.

Low voltage ranges and high input impedance make the 630-NS especially useful in transistor circuit measurement and testing. Input impedance, at 55 volts D.C. and above, is *higher than most vacuum tube voltmeters.*

The unit is designed to withstand overloads and offers greater reading accuracy. Reads from 0.1 $\mu$ A on 5 $\mu$ A range. Special resistors are rigidly mounted and directly connected to the switch to form a simplified unit. Carrying cases with stands are priced from \$9.90.

### 62 RANGES

D.C. VOLTS	0-0.6-3-12-60-300-1200 at 100,000 Ohms/Volt. 0-0.3-1.5-6-30-150-600 at 200,000 Ohms/Volt. 0-0.150 at 60 $\mu$ A
A.C. VOLTS	0-3-12-60-300-1200 at 10,000 Ohms Volt. 0-1.5-6-30-150-600 at 20,000 Ohms Volt.
DB	-20 to 77 in 10 ranges.
D.C. MICRO-AMPERES	0-5 at 300 MV. 0-60-600 at 150 MV. 0-120 at 300 MV.
D.C. MILLI-AMPERES	0-6-60-600 at 150 MV. 0-1.2-12-120-1200 at 300 MV.
D.C. AMPERES	0-6 at 150 MV. 0-12 at 300 MV.
OHMS	0-1K-10K-100K (4.4-44-440 at center scale)
MEGOHMS	0-1-10-100 (4400-44,000-440,000 Ohms center scale)

OUTPUT: Condenser in series with A.C. Volt ranges.

**TRIPLET ELECTRICAL INSTRUMENT COMPANY, BLUFFTON, OHIO**



**THE WORLD'S MOST COMPLETE LINE OF V.O.M'S. AVAILABLE FROM YOUR TRIPLET DISTRIBUTOR'S STOCK**

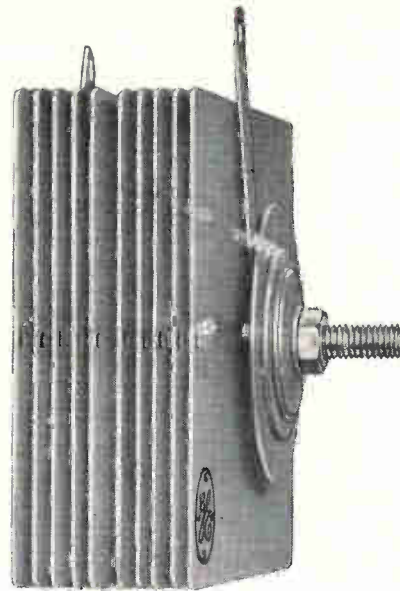
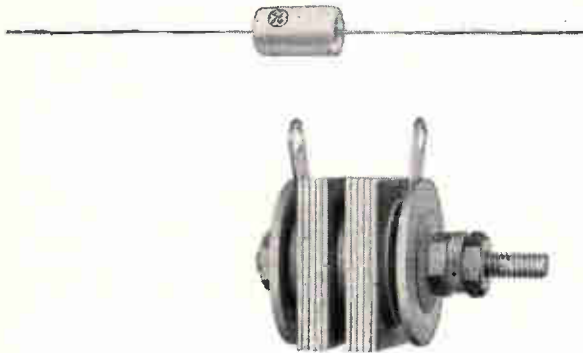

**Of course a G-E thyrector diode isn't the only low-cost transient voltage protection available**

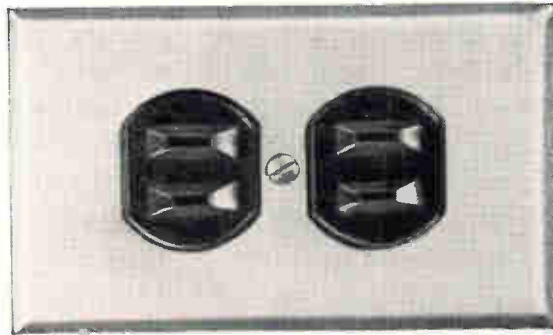

**you can always pull the plug**

But one Thyrector Diode can often save you 10, 20, or even 100 times its cost. And recent extensive unbiased laboratory tests (as well as countless commercial and industrial applications) have shown that Thyrector Diodes respond to transient voltages *just as quickly* as the voltage reaches the diode's breakdown level. In other words, it takes time, *as determined by the  $dv/dt$  of the transient*, before clamping begins to take place. *That's as nearly instantaneous as a device can be!*

This instantaneous response is doubly important to you since transients exist in *all* low voltage distribution systems, and originate both inside and outside the system. Without protection,

damage is very likely to occur to connected loads in the system, particularly semiconductors, lamps, clock motors, and other electronic devices, when high level transients occur.

Tests show that it is usually better to lower the transient voltage "risk" level of a rectifier circuit by adding series diodes than by increasing the PRV of the existing one. The *best* way to do it, however, is to limit the transient voltage... and that's where you need the Thyrector Diode. As an added benefit, you can also reduce rectifier PRV. If you want *super-reliability* against voltage transients, couple the Thyrector Diode to a circuit using the series diode scheme.

Thyrector Diodes are available in sizes from 9/32" diameter lead mounted units to large 5" x 6" plates for light industrial, consumer, and heavy industrial applications. So, if you want to increase your circuit reliability at lower cost, call your G-E Semiconductor District Sales Manager and tell him you'd like someone to help you out with your transient voltage problems. Or write directly to Rectifier Components Department, Section 16J142, General Electric Company, Auburn, New York 13022 and ask for bulletins 180.30 through 180.37.

**Available Through Your G-E Semiconductor Distributor**

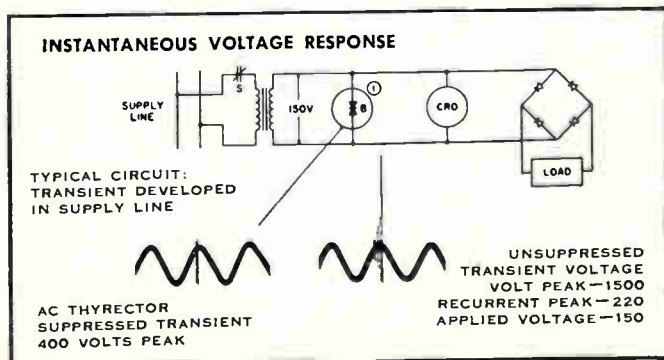

**GENERAL  ELECTRIC**



# Technical articles

---

## Highlights

---



**Compromising secondary breakdown and radiation resistance: page 48**

Transistors with good radiation resistance almost always have poor second-breakdown characteristics. The authors describe how transistors react to both radiation and second breakdown and suggest a compromise for effective design.



**Breadboarding analog microcircuits: page 58**

Standard digital integrated circuits are readily available, but an engineer may have to do without if he wants linear units. Now a new technique makes it possible to breadboard your own and reduce the cost of producing them in small quantities.

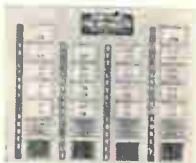

**Digital transducers on the Savannah: page 65**

On the U.S.'s first nuclear powered merchant ship, digital transducers measure variables. In this highly automated ship, such a unique approach means ease of maintenance and big advantages in reliability.

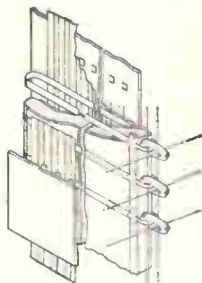

**Telephone switching goes electronic: page 71**

Not since the Bell System started installing dial phones has it made a technological change as big as the contemplated conversion from electromechanical to electronic switching. The requirements for long life, reliability and mass production make the electronic components interesting to other engineers. This three-part article covers the design and operation of Bell's electronic switching system, a primer of telephone engineering, and electronic switching around the world.

---

**Coming  
November 2**

- Applications for power transistors
- Analyzing circuit designs by computer
- Using radiometry in space
- A new operational trigger

# Trading off radiation resistance and second-breakdown performance

Transistors with the best radiation resistance usually do not have good characteristics for second breakdown. It takes a compromise to produce satisfactory equipment

By Bernard Reich and Edward B. Hakim

Army Electronics Laboratory, Fort Monmouth, N.J.

**In military applications** these days, heavy stress is being laid on electronic equipment's resistance to radiation. Designing solid-state circuitry with good radiation resistance is complicated by the phenomenon of secondary breakdown. Unfortunately, transistors that withstand radiation best usually do not have good second-breakdown characteristics. The best the engineer can do is to compromise.

An initial assessment of these requirements indicates that the transistor with a high-frequency response gives the best radiation-resistance performance. But because it has the poorest secondary-breakdown performance the compromise involves choosing another transistor with a frequency response less than the highest value possible. Design curves (right) provide a relatively simple method to determine the optimum value of frequency response.

A second phase of the compromise or trade-off comes from dynamic considerations. The same design curves enable the circuit designer to trade-off radiation protection for better second-breakdown performance. For example, if the radiation specifications call for a design to withstand an integrated neutron dose of  $10^{12}$  nvt (neutron flux, nv, multiplied by time, t), the designer must realize that if a safety factor of 10, 100 or 1,000 is used, protection from second breakdown will be sacrificed. A compromise with regard to both frequency response and the trade-off between second-breakdown and radiation protection is necessary.

## Second breakdown

Device failure from second breakdown is manifested by either a short circuit between collector

and emitter; drastically reduced collector-base or collector-emitter breakdown voltage, or open-circuited transistors. These failures result from high temperatures in the active part of the transistor, causing melting and re-alloying of the materials. For example, in a silicon planar transistor, where aluminum is often used for making contact with the silicon material, it is possible for a hot spot to develop in the silicon under the metalized area. Such hot spots can reach a temperature high enough to cause alloying of the aluminum through the base region. The end result of this process is a collector-emitter short and a burned-out transistor.

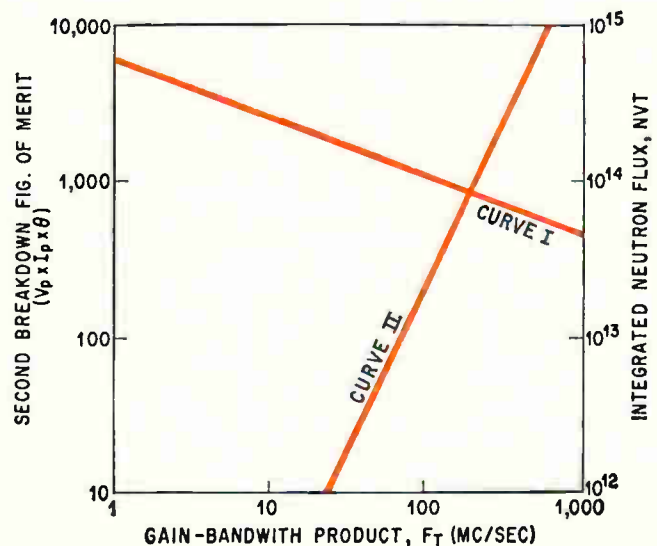

Curve I is the second-breakdown figure of merit (FM) versus the gain-bandwidth product  $f_T$ . Curve II represents the neutron-radiation resistance of the transistor as a function of  $f_T$ .

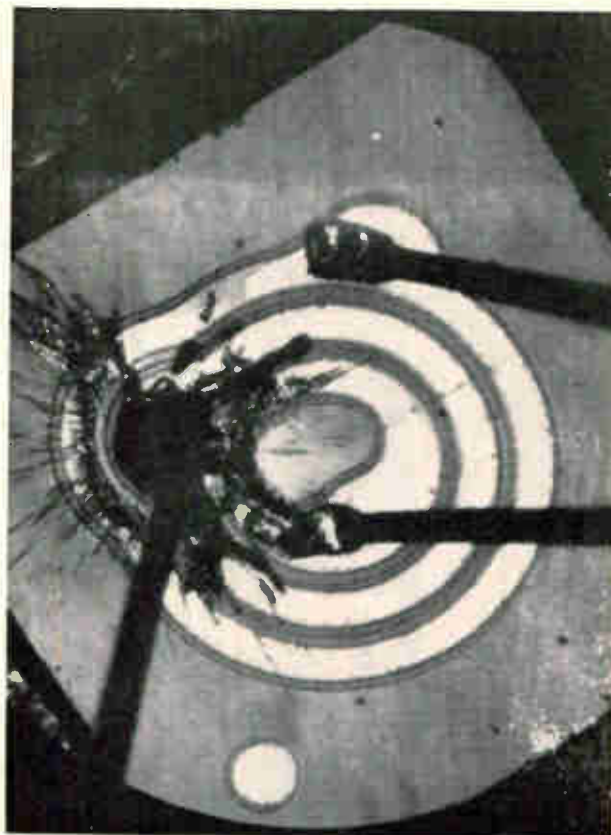
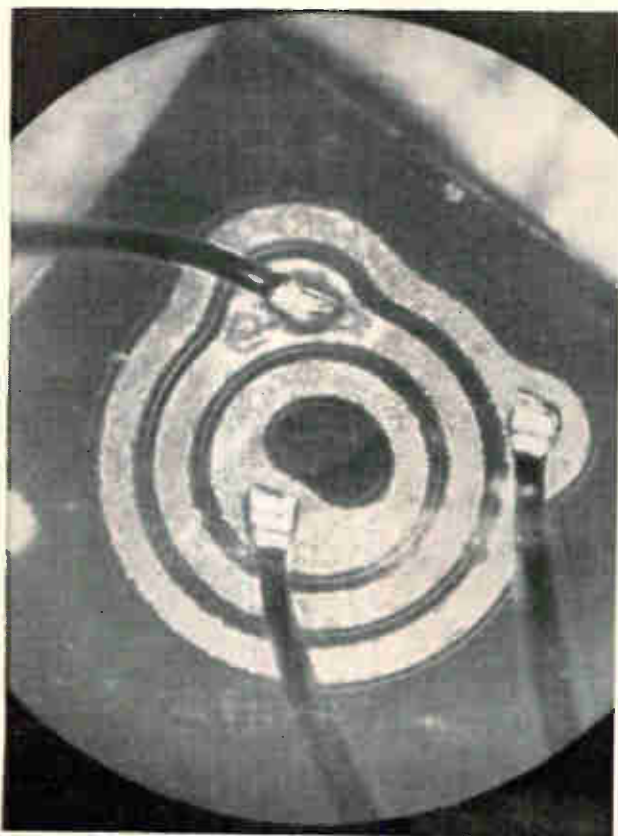

Before the silicon planar epitaxial transistor is destroyed by second breakdown (right), it exhibits performance degradation. Second breakdown is just beginning to be visible in the darkened area around the top lead (left).

Two causes of second-breakdown that result in device destruction are the effects induced by current and voltage modes of operation. In both cases, catastrophic failure is preceded by localization of current either in the collector or emitter, which causes reduction of the power-handling capability of the device.

The current mode of failure is associated with the rapid fall-off of current gain at high-current levels. The voltage mode is associated with reduced device power-handling capability at or near the point where collector-base breakdown occurs. Both modes eventually result in the formation of hot spots within the device. The association of these two modes with measurable device parameters influences the basic design of the transistor. One of the parameters important in obtaining satisfactory second-breakdown performance is good current-gain linearity with increasing collector current. This is particularly true in the current-mode of second breakdown.

#### Radiation effects

In a test for current-gain linearity, silicon single-diffused transistors were subjected to neutron radiation. As expected, the current gain was greatly affected and, in addition, the second-breakdown performance was severely degraded. Verification will be found in the test data shown in the tables on the following page.

The characteristic of semiconductor material

most sensitive to neutron radiation is minority carrier lifetime,  $\tau$ . Degradation of this characteristic effects the current gain of the transistor.

At the same time, the higher the alpha cutoff frequency of a device, the less susceptible the device is to damage from a given neutron exposure. The fact that current gain is the parameter of importance both for satisfactory second-breakdown performance and neutron-radiation resistance suggests a relationship and warrants further examination.

#### Frequency response

To understand the interplay of the two conflicting requirements on a transistor, simultaneous plots are made of nuclear-radiation resistance and second-breakdown performance as a function of frequency response (preceding page).

Curve I is a plot of the second-breakdown figure of merit as a function of the gain-bandwidth product or frequency response.

Curve II represents the neutron-radiation resistance of the transistor as a function of  $f_T$ .

The second-breakdown figure of merit (FM) is the product of:

$$V_p \times I_p \times \theta_{j-a} = FM \quad (1)$$

where:  $V_p$  and  $I_p$  are the peak voltage and peak current applied to the transistor to produce second-breakdown and  $\theta_{j-a}$  is the total (junction-to-ambient) thermal resistance.

The transistor characteristic ( $V_p I_p$ ) chosen for the determination of the figure of merit was obtained

## Radiation's effects on transistors

Second-breakdown current degrades severely when a transistor is exposed to neutron radiation. Annealing at 200°C results in recovery.

Unit	Initial	After exposure	% Change	Anneal 72 hrs.	Anneal 120 hrs.	Dosage
1	600 ma	225 ma	62.5	600 ma	650 ma	~10 <sup>13</sup> n/cm <sup>2</sup>
2	650	250	61.5	600	500	
3	600	250	59.3	550	600	
4	700	400	43.0	650	700	~10 <sup>12</sup> n/cm <sup>2</sup>
5	500	350	30.0	500	600	
6	500	300	40.0	450	450	
7	550	350	36.3	450	500	~10 <sup>11</sup> n/cm <sup>2</sup>
8	600	400	33.3	500	500	
9	700	600	14.6	700	800	
10	500	450	10.0	450	450	

The current gain degrades after a transistor has been exposed to neutron radiation. The collector-to-emitter voltage is held constant at 2 volts.

Unit	Initially			After exposure			After 72 hours		
	1ma	200ma	500ma	1ma	200ma	500ma	1ma	200ma	500ma
1	10.0	25.0	20.0	0.83	1.82	1.66	2.2	6.7	5.9
2	10.0	16.7	12.5	0.83	1.82	1.66	2.2	7.4	5.9
3	8.3	20.0	16.7	0.56	2.0	1.66	2.2	6.7	5.9
4	8.3	18.2	13.9	3.2	6.1	5.9	5.6	12.5	9.1
5	14.3	22.2	20.0	2.0	4.8	4.5	6.3	11.8	11.1
6	8.3	18.2	16.1	2.86	6.1	5.9	5.9	12.5	11.1
7	5.3	15.4	12.5	5.0	11.1	10.0	7.1	25.0	20.0
8	8.3	18.2	14.3	6.25	13.3	10.0	7.7	16.6	15.1
9	7.15	19.0	15.1	6.25	12.5	10.0	6.65	20.0	16.1
10	9.1	20.0	15.1	5.0	13.3	10.0	8.3	22.2	16.7

Devices examined were fabricated of silicon materials. Average results are for second-breakdown figure of merit (FM) and frequency response ( $f_T$ ).

Device type	$V_{pI_p}$ watts	$\times \theta_{j-a}$ °C/w	= FM $\times 10^3$	$f_T$ MC SEC
Single diffused I.....	23.0	280	6.4	1.0
Single diffused II.....	40.0	155	6.2	1.0
Single diffused III.....	84.0	72	6.1	1.0
Alloy diffused I.....	160	23	3.7	5.5
Alloy diffused II.....	24.5	100	2.45	10.0
Alloy diffused III.....	120.0	23	2.8	10.0
Grown junction.....	10.0	180	1.8	20.0
Triple diffused I.....	12.0	77	0.92	140.0
Triple diffused II.....	4.5	170	0.76	225.0
Planar epitaxial.....	6.7	155	1.04	125.0

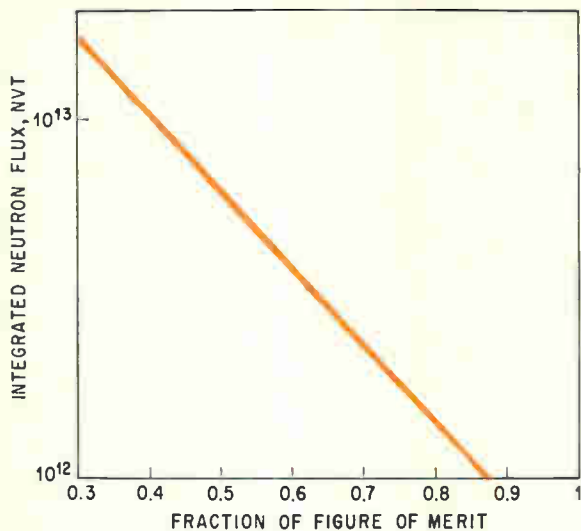

Collector-to-emitter characteristic was used to assess the second-breakdown performance of the transistor.

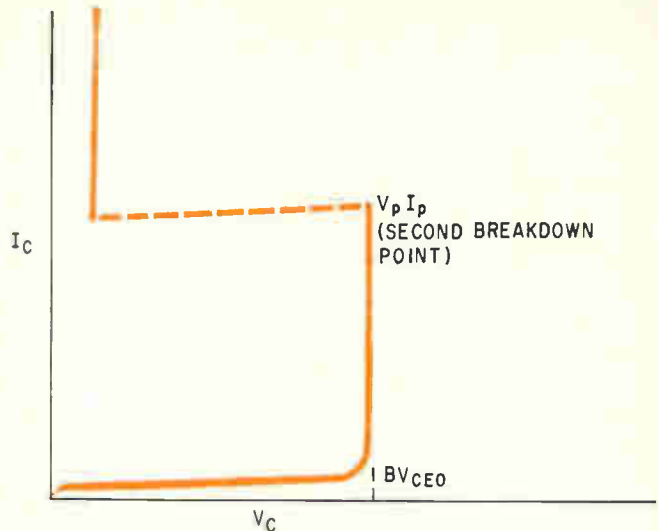

Second-breakdown performance of silicon single-diffused transistor is a function of neutron radiation.

on a 120 cps curve tracer and the characteristic used is shown above. The types of devices examined (all were fabricated of silicon), along with the average data, are summarized in the bottom table at the left. The average data represented by Curve I yields the relationship between second breakdown and frequency response:

$$SB_{PM} = K f_T^{-0.38} \quad (2)$$

This is in excellent agreement with previously reported results.<sup>2</sup>

The averaged data also shows that the second-breakdown performance varies inversely with total thermal resistance. This is clearly evident in the performance of the three single-diffused transistor types and the two alloy-diffused types. Each class of transistors was chosen so that all transistors within a class had the same frequency response.

The neutron-radiation resistance curve is represented by Curve II of the plot. The permanent degradation of current gain is used as the failure criterion. The over-all curve is based on data obtained over a period of time. It is apparent from Curves I and II that second breakdown and nuclear-radiation resistance are in conflict, if the best device gain-bandwidth product is sought. The best second breakdown performance and nuclear-radiation resistance can be obtained, simultaneously, from a

device with a gain-bandwidth product in the vicinity of the intersection of Curves I and II. A device with  $f_T$  of approximately 200 Mc yields a radiation resistance of approximately  $8 \times 10^{13}$  nvt.

### Second breakdown vs. neutron radiation

An experiment was conducted to determine the variation of  $V_p I_p$  (equation 1) with neutron radiation. Three groups of single-diffused transistors were subjected to neutron exposures of approximately  $10^{12}$ ,  $4 \times 10^{12}$  and  $10^{13}$  nvt. The degradation of the second breakdown with increased neutron radiation is shown above. The devices tested were single-diffused transistors with  $f_T$ 's of approximately 1.0 megacycle per second. The results indicate that for these devices severe second-breakdown degradation occurs over a short range of neutron-radiation exposure.

### References

1. E. B. Hakim and B. Reich, "The Effects of Neutron Radiation on Secondary Breakdown," Proc IEEE (Corr), June, 1964.
2. Z. F. Chang and C. R. Turner, "Characterization of Secondary Breakdown in Silicon Transistors," RCA Application Note SMA-21.
3. B. Reich, "New Aspects of Second Breakdown in Transistors," Solid State Design, April, 1964.
4. E. B. Hakim and B. Reich, "Transistor Characterization and Derating for Second Breakdown," Solid State Design, May, 1964.

### The Authors



Bernard Reich has been with the Army Electronics Research and Development Laboratory since 1948 except for one year in private industry. Since 1961 he has been in the Solid State and Frequency Control division where he works on semiconductor device reliability. He is a senior member of IEEE and a representative to the NATO Working Group on Semiconductor Devices.



Edward B. Hakim received his master's degree in physics from the University of Connecticut. He has been at Fort Monmouth for two and a half years, working in the field of transistor reliability and radiation effects.

# Checking oscillation in cathode followers

A quick way to find and remedy a problem whose existence is too often overlooked

By Phillip D. Blais

Erie Technological Products, Inc., Erie, Pa.

**Careful analysis** of cathode-follower circuits discloses a tendency to oscillate. When such an analysis shows oscillations, they can be suppressed by adding a resistor in the input lead.

The cathode follower circuit is generally considered to be straight-forward, having a gain less than unity, high input impedance and low output impedance. The assumption of a gain less than unity implies circuit stability, and the possibility of oscillation is usually ignored by circuit designers. But this assumption is not always valid.

## Comparison with Colpitts oscillator

The tendency to oscillate will be shown by comparing the high-frequency equivalent circuit of the cathode-follower with a simple Colpitts oscillator.

The top, left diagram on page 53 shows a typical cathode follower circuit with parasitic capacitances. At low frequencies these capacitances can be ignored. At high frequencies they become important and must be included in the complete circuit.  $C_{gp}$  is the equivalent capacitance between the grid and plate of the circuit, and includes stray capacitance due to the external wiring. Similarly,  $C_{gk}$  is the equivalent grid-to-cathode capacitance.  $C_{out}$  is the heater-to-cathode capacitance including the output lead stray capacitance.

## The author



Phillip D. Blais is engineering manager of Electron Research, Inc., a division of Erie Technological Products, Inc. He received a master's degree from the University of Minnesota in 1958.

As the frequency under consideration is increased, the susceptance of the parasitic capacitances predominates, and the resistors may be neglected in the equivalent circuit. The plate power supply,  $E_{bb}$ , generally is made to present a low impedance at high frequencies with by-pass capacitors, and for this analysis, the power supply may be considered as a short circuit.  $C_{gp}$  is effectively across the input, and the cathode-follower high-frequency equivalent circuit is shown top, center.

This circuit will now be shown to be identical with the Colpitts oscillator. In the Colpitts oscillator circuit shown, top, right, the inductance of  $L_2$  is normally large, and its reactance generally high enough to be neglected. The power supply may also be ignored because it is isolated from the circuit by  $L_2$ .

Capacitor  $C_3$  is generally of large value and merely serves as a blocking capacitor to isolate the plate voltage from the grid circuit. The reactance of  $C_3$  is very small in properly designed circuits and may be ignored for a-c circuit analysis.

The simplified Colpitts oscillator is shown in the circuit diagram, bottom, left. This circuit is almost identical to that of the equivalent high-frequency cathode-follower circuit. It may be concluded that a cathode follower is converted into a conventional Colpitts oscillator when an inductance is placed across its input. The inductance may be introduced in the form of a transformer secondary, a tuned circuit or even a long lead. A length of wire has considerable inductance above 100 megacycles.

## Eliminating oscillation

The input impedance as a function of the circuit parameters can be derived from the Kirchhoff equations for the high-frequency cathode-follower equivalent circuit. This equation results in a nega-

tive real term. A resistor, whose value is calculated from the real term, can be added in the input lead to suppress oscillations.

The Kirchhoff equations for the high-frequency circuit of the cathode-follower (bottom right) are:

$$\begin{aligned} e_{in} &= i_1(-j/\omega C_1 - j/\omega C_2) + i_2(-j/\omega C_2) \\ \mu E_g &= i_1(-j/\omega C_2) + i_2(r_p - j/\omega C_2) \\ E_g &= i_1(-j/\omega C_1) \end{aligned}$$

Solving these three equations for  $e_{in}/i_1$  results in the input impedance given by

$$\begin{aligned} Z_{in} &= \frac{e_{in}}{i_1} \\ &= -j \left[ \frac{C_2 + C_1}{\omega C_1 C_2} - \frac{C_1(C_1 - \mu C_2)}{\omega C_2(\omega^2 C_1^2 C_2^2 r_p^2 + C_1^2)} \right] \\ &\quad + \left[ \frac{r_p(C_1 - \mu C_2)}{C_1(\omega^2 C_2^2 r_p^2 + 1)} \right] \end{aligned}$$

The imaginary first term in the expression above is the capacitive reactance of  $C_1$  and  $C_2$  in series, as modified by the tube current through  $C_2$ . The real term is the term of interest. Since  $\mu$  is usually quite large and  $C_1$  and  $C_2$  are of the same order of magnitude, the term  $\mu C_2$  is larger than  $C_1$  and the total term is negative.

Negative resistance implies that the circuit at the input terminals is capable of generating power. Any inductance placed across the input terminals will cause the circuit to oscillate if the equivalent series resistance of the inductor is less than that of the negative real term.

The frequency of oscillation is determined by the resonant frequency of the inductor in combination with the equivalent input capacitance given by the first term. This frequency can become very high when the grid of the cathode follower is, in effect grounded by a short length of wire.

Parasitic oscillation in cathode followers may be eliminated in two ways. The first is to make  $C_1$  greater than  $\mu C_2$  so that the second term of the impedance equation is positive. This increases the total input capacitance to the cathode follower and is not generally desirable.

The second method is to insert a series resistor in the grid lead as close to the tube socket as possible. This resistance value must be greater than the negative value of the real term of  $Z_{in}$ .

As an example, examine the real term of the above equation for a typical 12AT7 triode.

$$\begin{aligned} g_m &= 6000 \mu\text{mhos} & r_p &= 9400 \text{ ohms} \\ C_1 &= C_{gk} + C_{\text{wiring}} = 0.7 + 4.0 = 4.7 \text{ picofarads} \\ C_2 &= C_{kb} + C_{\text{wiring}} = 2.4 + 4.0 = 6.4 \text{ picofarads} \end{aligned}$$

It is assumed that the circuit is constructed with short leads and that the natural resonant frequency is 200 megacycles. Substituting these values into the expression for the real term indicates a negative resistance of 137 ohms. A series resistor of 137 ohms, placed in the grid circuit, will effectively suppress oscillation in this design example. Generally, a value of 500 ohms will suppress oscillation in most cathode-follower circuits. In cases where large inductances are present in the input, this resistance should be increased to  $\mu r_p C_2 / C_1$ .

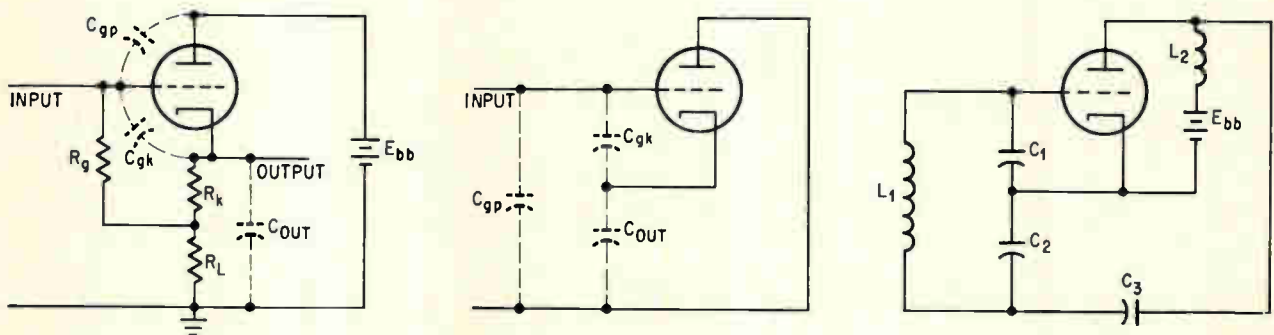

Cathode follower circuit at left reduces to an equivalent high-frequency circuit (center), which is shown to resemble the Colpitts oscillator (right).

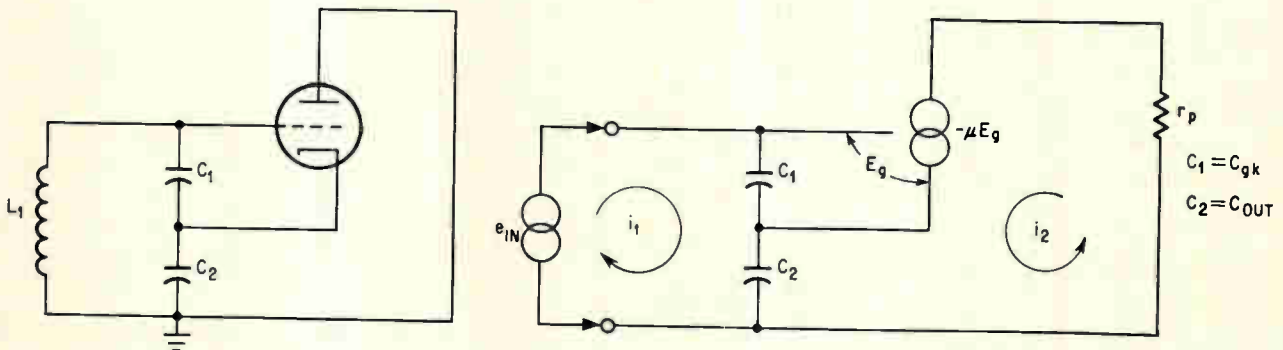

Input lead has significant inductance at high frequencies, and the cathode follower is similar to the reduced Colpitts oscillator at left. The input impedance is derived from the loop equations of the high-frequency cathode follower circuit at right.

# Designer's casebook

Designer's casebook is a regular feature in Electronics. Readers are invited to submit novel circuit ideas, packaging schemes, or other unusual solutions to design problems. Descriptions should be short. We'll pay \$50 for each item published.

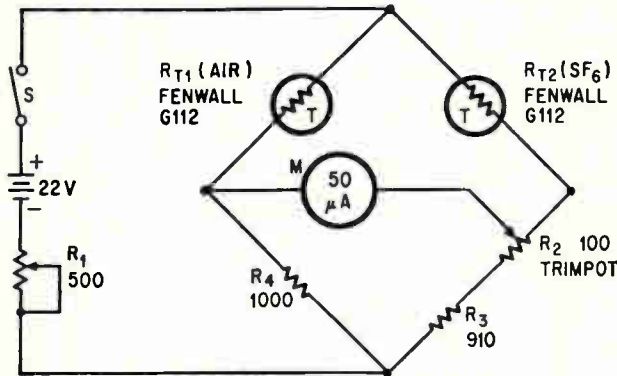

The resistance of thermistor  $R_{T2}$  varies with the percentage of  $SF_6$  mixed in its environment. The percent of  $SF_6$  is indicated by the deflection of meter, M.

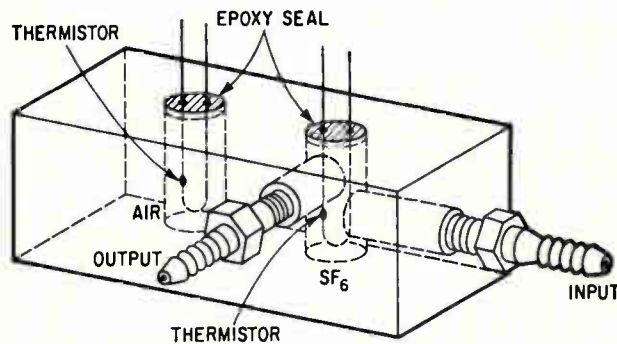

The aluminum-block thermistor assembly equalizes the temperature of both chambers. The air in the reference chamber is permanently contained by the epoxy seal.

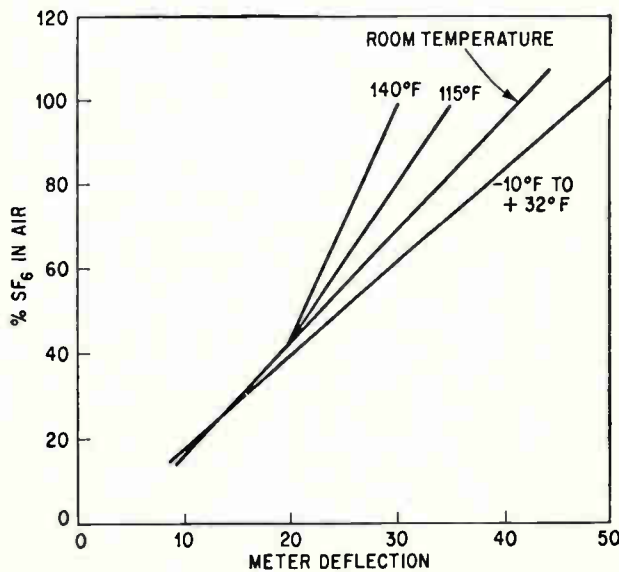

Meter calibration curves for various thermistor assembly temperatures

## Thermistor measures dielectric gas content

By Edward B. Murphy

Lincoln Laboratory, M.I.T. Lexington, Mass.

Sulfur hexafluoride ( $SF_6$ ) is a dielectric gas commonly used to suppress arcing in high power radar waveguides. A simple device called a sulfur hexameter has been developed that can be used to measure or to continuously monitor the amount of  $SF_6$  present in a waveguide or in any application using this gas as a dielectric.

The device, like most simple gaseous detectors, is based on the difference in the thermal properties of air and  $SF_6$ . Although the thermal conductivity of  $SF_6$  and air are approximately equal, the heat-transfer coefficient of the gas is greater than that of air. Thermal conductivity is the rate at which heat is conducted through a given thickness of a substance when a temperature difference exists between the surfaces of the substance. Heat-transfer coefficient is the rate at which heat is transferred from the surface of a substance to the surrounding medium when a temperature difference exists between the surface of the substance and the surrounding medium.

The sulfur hexameter consists of two small thermistors connected in the arms of a bridge circuit as shown in the circuit diagram above. The thermistor used in the circuit has a resistance of 8,000 ohms at room temperature and 220 ohms at 150°C. In the circuit,  $R_1$  is adjusted so that the current through the thermistors will heat them to approximately 150°C (2 volts at 7 ma). Initially, both thermistors must be in an air environment. Resistor  $R_2$  is adjusted to balance the bridge circuit so that the microammeter deflection is zero. When one of the thermistors is placed in an  $SF_6$  environment, it will transfer heat from its surface to the  $SF_6$  more easily than the other thermistor can transfer heat from its surface to the air. The temperature of the thermistor in the  $SF_6$  environment decreases, its resistance increases (negative coefficient of resistance), and the bridge becomes unbalanced causing a deflection on the microammeter.

Calibration of the device was accomplished by placing one of the thermistors in measured  $SF_6$ -air mixture environments of 20%, 40%, 60%, 80%



and 100%. The microammeter deflection was recorded for each SF<sub>6</sub>-air mixture and a calibration curve was plotted.

The final thermistor assembly consists of a single aluminum block (pg. 54, middle fig.) having two separate thermistor chambers. One chamber contains a thermistor in an air environment,

as a reference. The other chamber in which the SF<sub>6</sub> sample is to be measured, has an inlet and an outlet nozzle. This facilitates flushing out a previous sample with forced air, and introducing a new sample. When the SF<sub>6</sub> sample in this chamber is static, the switch, S, in the bridge circuit is closed and the sample is measured.

## Junction diode regulates low-voltage supply

By Allan K. Scidmore

Dept. of Electrical Engineering,  
University of Wisconsin

Because few zener diodes have reference levels below 2 volts some other device possessing a non-linear voltage-current characteristic is needed to provide the reference voltage when designing a low-voltage regulated power supply. This problem is significant if the d-c energy is derived from a low-voltage source such as a fuel or solar cell.

The forward volt-ampere characteristics of a conventional junction diode or point-contact diode resemble those of a zener diode. The dynamic output resistance of these diodes can be made comparable to the dynamic resistance of low-power zener diodes. As indicated by the forward V-I characteristic for a small silicon diode, above, right, the "knee" of the V-I curve at 25°C is in the range of 0.5 to 0.7 volts. However, unlike zener diodes, the forward voltage drop across the diode at a given current varies quite markedly with changes in diode temperature. At constant current, the voltage variation with temperature,  $V(T) = \Delta V/\Delta T$ , is in the neighborhood of  $-1$  to  $-2$  mV/°C. As a result, temperature compensation must be introduced.

In a typical regulator circuit, shown below, a fraction of the output voltage  $V_B$ , is obtained from a voltage divider and compared to a reference voltage,  $V_R$ , by a common-emitter difference amplifier. A difference amplifier can be designed to be virtually insensitive to temperature changes by using

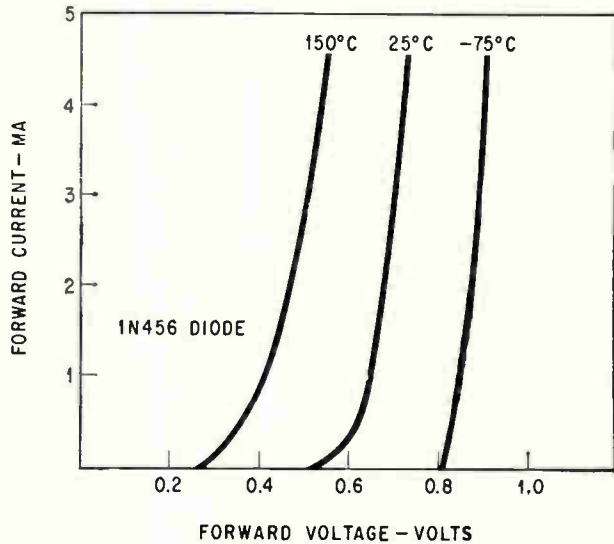

The forward voltage drop across the diode decreases as the temperature rises.

a matched pair of transistors that have base-emitter voltage variations with temperature,  $V_{BE}(T)$ , which are approximately equal.

When using a conventional diode as a reference voltage source, one method of compensating for the  $V(T)$  of the diode is to cancel the diode voltage variations with that of an identical diode. A better method is to make use of transistor base-emitter voltage variation with temperature,  $V_{BE}(T)$  as shown by the temperature-compensating comparator (dashed lines) in the regulator circuit on page 56. The polarities of  $V(T)$  resulting from an increase in temperature are indicated for both the reference diode and the comparator transistor. Unfortunately,  $V(T)$  and  $V_{BE}(T)$ , in general, will not be identical; perfect compensation will not be obtained by merely maintaining the polarities of the temperature variation of these junction voltages. The magnitude of  $V(T)$  depends upon the junction area, the material composition of the junction and most importantly, upon the current carried by the junction. The magnitude of  $V(T)$  of a junction decreases with increasing current. By varying the diode or transistor current, the  $V(T)$  of each is adjusted to improve temperature compensation.

This method of temperature compensation was designed into a simple regulator circuit. The particular application required a regulated output of 3 volts at 5 to 100 milliamps from an unregulated supply of approximately 4.8 volts. Although the circuit is rather simple and straightforward, a load

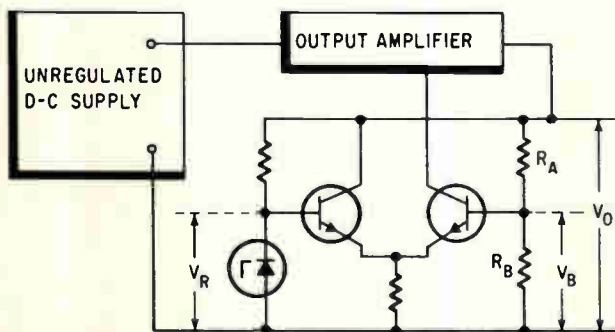

Typical voltage regulator circuit

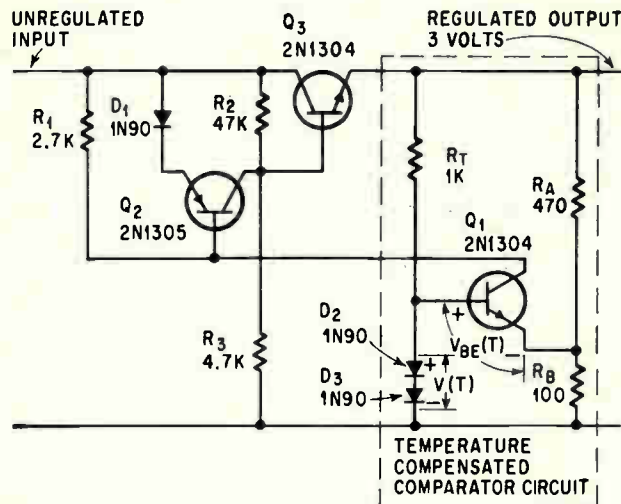

A simple temperature-compensated regulator circuit. The resistors in the comparator circuit are selected so that the currents through the diodes and the base-emitter junction will make  $V(T)$  equal to  $V_{BE}(T)$ .

regulation of about 1% and a line regulation of about 0.5% was obtained with very inexpensive transistors and diodes. The stability of the regulator with respect to temperature changes is shown by the output voltage-temperature characteristics at bottom. The measured output voltage regulation was within 2% for a temperature range of  $-60^{\circ}\text{C}$  to  $+50^{\circ}\text{C}$ , and within 1% for a temperature range of  $-50^{\circ}\text{C}$  to  $+40^{\circ}\text{C}$ . In the temperature compensated regulator shown, the transistor base-emitter junction carries a much smaller current than the reference diodes, and consequently  $V_{BE}(T)$  is larger than  $V(T)$  for a single diode. Therefore, two diodes in series were used to obtain a reference source with a  $V(T)$  which matches the  $V_{BE}(T)$  of the transistor. The compensation provided by these two diodes is evidenced by the constant output at lower temperatures. At higher temperatures the effect of  $V_{BE}(T)$  of  $Q_1$  is masked by the increase of  $I_{co}$  of germanium transistors.

The resistance  $R_T$  determines the current in the

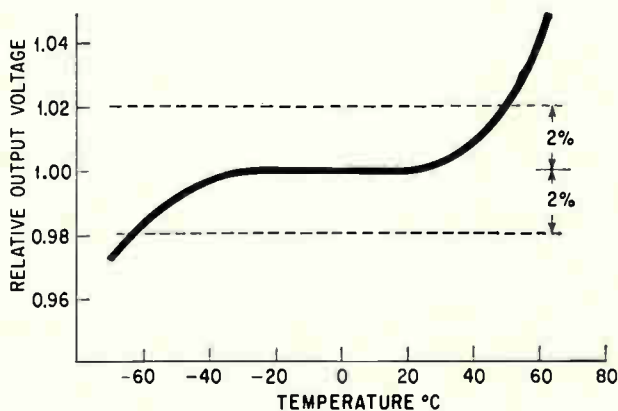

Measured output voltage temperature characteristics for the temperature compensated regulator circuit.

diodes,  $D_2$  and  $D_3$ , and its value is chosen so that the  $V(T)$  of these diodes matches the  $V_{BE}(T)$  of the transistor.  $R_A$  and  $R_B$  make up the resistor voltage divider which provides the voltage for the comparator transistor. Because of the variation in forward voltage drop and  $V(T)$  among different types of diodes and transistors, the selection of  $R_T$ ,  $R_A$ , and  $R_B$  depends upon the semiconductor types chosen for the comparator circuit.

## Variable-phase, polyphase from single-phase supply

By John J. Vithayathil

Indian Institute of Science, Bangalore, India

A variable-phase, polyphase system derived from a single-phase supply could have many useful control applications. For example, by varying the firing angle of thyratrons or silicon controlled rectifiers, the power output of polyphase converter circuits can be controlled.

A constant-magnitude, variable-phase voltage can be obtained from a single-phase supply when a capacitor and a variable resistor are connected across a center-tapped transformer as shown in the circuit diagram (pg. 57, top). A voltage is obtained between the midpoint of the applied voltage and the junction of the resistor and capacitor. This voltage has a magnitude that is half that of the applied voltage. Its phase is dependent on the values of  $R$  and  $C$ . In the phasor diagram (same fig.), the angle  $\psi = \arctan E_C/E_R$  can be varied approximately from  $90^{\circ}$  to  $0^{\circ}$  as  $R$  is varied from zero to infinity. The phase angle,  $\theta$ , of phasor  $E_{DF}$ , varies from  $0^{\circ}$  to  $180^{\circ}$  as  $\psi$  is varied from  $90^{\circ}$  to  $0^{\circ}$ .

This same idea can be extended to obtain a polyphase system from a single-phase supply. The circuit diagram at the right shows a balanced three-phase system composed of reactance circuits with values chosen to produce voltage phasors  $E_{OP1}$ ,  $E_{OP2}$  and  $E_{OP3}$  which are fixed  $120^{\circ}$  apart. With the values indicated for  $R_1$ ,  $C_1$ ,  $R_2$ ,  $C_2$ ,  $R_3$  and  $C_3$ , phasor  $OP_1$  lags  $DF$  by  $30^{\circ}$ , phasor  $OP_2$  lags  $DF$  by  $150^{\circ}$ , and phasor  $OP_3$  leads  $DF$  by  $90^{\circ}$ . The phasor diagrams shown with the circuit diagram demonstrate that the result is a balanced three-phase system. The phase of voltage phasor  $DF$  is made variable with a phase-shifter circuit consisting of  $R$  and  $C$  connected across terminals  $A-B$ , as in the single-phase circuit. When the value of  $R$  or  $C$  is varied, phasor  $E_{DF}$  shifts with respect to phasor  $E_{AB}$ , transferring this phase shift to the three phase-voltages. In this case, the three-phase system can be shifted approximately from  $0^{\circ}$  to  $180^{\circ}$  as  $R$  is varied from zero to infinity.

The load effect on balance of the three-phase

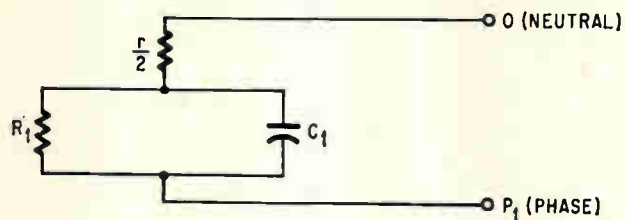

The source impedance per phase can be approximated by the above circuit (shown for phase  $OP_1$  when  $R$ ,  $1/\omega C$  and the single phase source impedance are small.)

The voltage at terminals D-F is half the magnitude of the transformer secondary voltage. Its phase varies as the value of  $R$ . In the phasor diagram, angle AFB is always a right angle,  $\alpha = 90^\circ - \psi$ ,  $\theta = 2\alpha = 180^\circ - 2\psi$ , or  $\theta = 180^\circ - 2 \arctan 1/\omega RC$ .

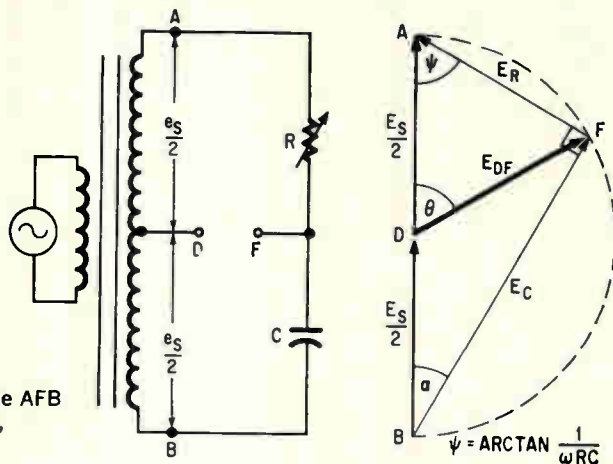

The phasor diagrams above the reactance legs show the relation of the individual phasors  $OP_1$ ,  $OP_2$  and  $OP_3$  fixed in relation to the variable phasor DF. The composite phasor diagram for the three-phase system is shown at the output terminals.

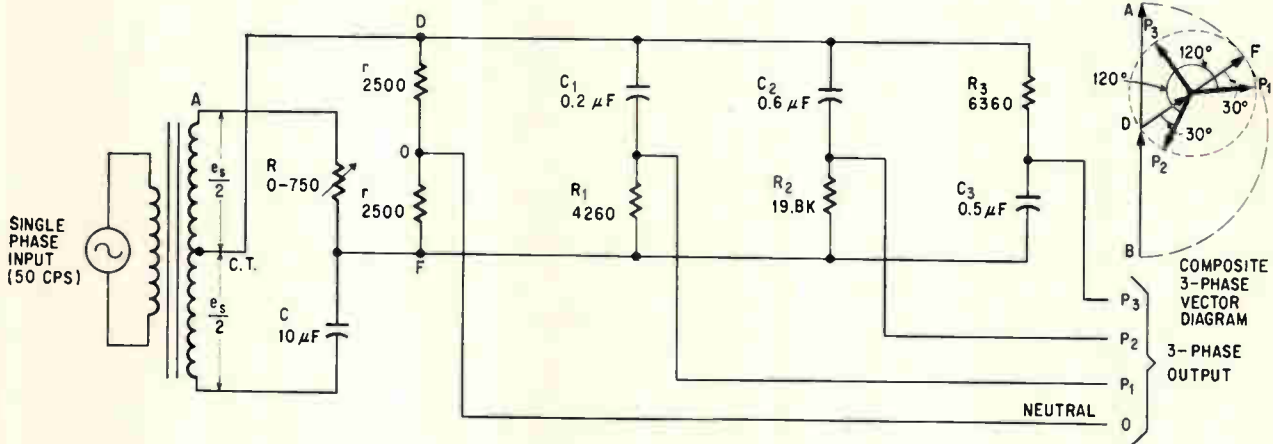
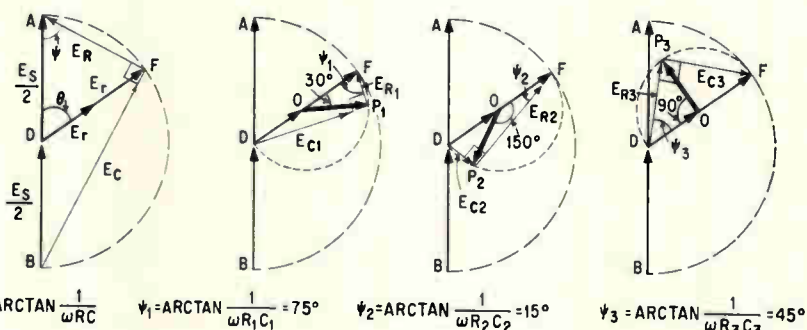

system will be negligible if the load impedances are larger than the impedances of the phase-shifter.

When the impedance of the phase-shifter circuit,  $R$  and  $1/\omega C$ , and the impedance of the single-phase input system including the transformer, are smaller than the load impedances, the internal impedance per phase as viewed between the neutral and a phase terminal, can be approximated by the circuit shown above, left. The equivalent circuit for the source impedance per phase is useful in selecting the values of the resistors and capacitors forming the polyphase system or in modifying the output load impedance.

Inductive reactances can also be used instead of capacitive reactances. A three-phase system can be obtained by using only two R-C circuits, but the load effect on system balance is significant.

The particular method of obtaining the phase shift will depend on the nature of the application and the degree of control required. For example, the firing angle of scr's or thyratrons can be controlled by a phase shifter consisting of a resistor and a variable inductance, where the inductance is varied by the d-c current in a control winding on the same magnetic core. The control current can be taken from the rectified output, making a closed-loop control system. Another application is a temperature-control system in which the firing angle of the scr's or thyratrons is determined by the temperature-dependent characteristics of a resistor or a thermistor.

Note: The capacitive reactances in this circuit are based on a 50 cps source voltage

# Linear microcircuits scarce? Now you can breadboard your own

Master-dice technique converts any integrated circuit into a parts kit. With special thermocompression-bonding methods, the kit can be reconnected as a new circuit at low cost

By D.D. Robinson

Autonetics Division, North American Aviation, Inc., Anaheim, Calif.

**There are times** when an equipment designer can profitably ignore the fact that an integrated circuit is basically a monolithic block of single-crystal silicon. One such instance is when an equipment manufacturer wants to produce a small number of analog-type systems with integrated circuits quickly and at minimum cost. His problem is that only a few of the required linear circuits are available as standard off-the-shelf circuits.

The designer's solution is to consider each available circuit as a kit of component parts, and use the kit to breadboard new circuits.

If the new circuit works, the manufacturer can produce an integrated circuit at little additional cost merely by substituting a new interconnection pattern for the standard pattern. The revision can be accomplished in a matter of days, while it may take months to produce a wholly new circuit.

This approach, known as the master-dice technique, is especially applicable to linear circuits. In fact, the master-dice program was initiated at the Autonetics division of North American Aviation, Inc., in May, 1963, to overcome problems that turned up when the company started developing linear integrated circuit-applications.

Many digital-system needs can be satisfied by

the available families of standard logic circuits. This is not true for analog systems; they often require special linear circuits tailored to a system. Also, characteristics and tolerances of linear circuits are more exacting than digital circuits and more difficult to attain.

As a result, linear integrated circuits are costly unless they are being produced in high volume for a major military program like the Minuteman II missile. Most cost more than equivalent circuits made with discrete components.

The limited variety of available circuits also restricts their applicability to analog systems. If they are to make optimum use of integrated-circuit technology, designers of analog systems must have a method of designing circuits for their specific needs.

The master-dice program promises solutions to these problems. The circuits shown demonstrate that only a few types of master dice are required to breadboard a wide variety of new circuits.

In addition, the master-dice program has given engineers valuable integrated-circuit experience enabling them to move on from discrete-component technology. They are learning to recognize the pitfalls and problem areas, and to design around such obstacles as semiconductor isolation and coupling characteristics.

## Why costs are lowered

The components of an integrated circuit are produced by a complex series of carefully controlled masking, etching and diffusion processes. Interconnection of the components is one of the last steps. The key to minimum cost for a new circuit, therefore, is the use of existing diffusion patterns and custom-designed interconnection pat-

## The author



Donald Robinson heads development of advanced microminiaturization techniques at Autonetics' Navigation Systems division. He coined the phrase "master dice" while working on linear circuits for the Minuteman II missile. He has been with Autonetics for nine years and has a masters' degree in physics from Purdue University.

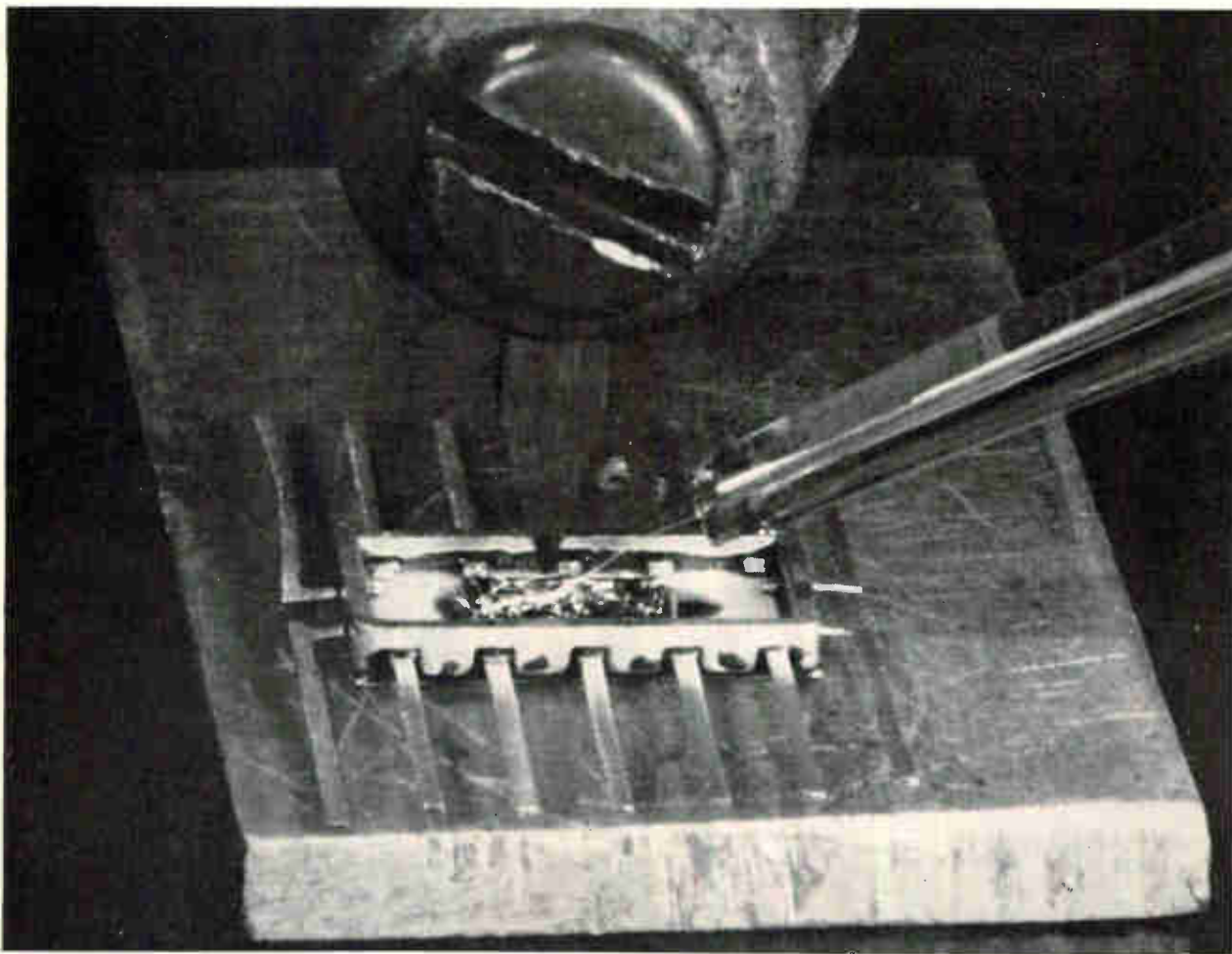
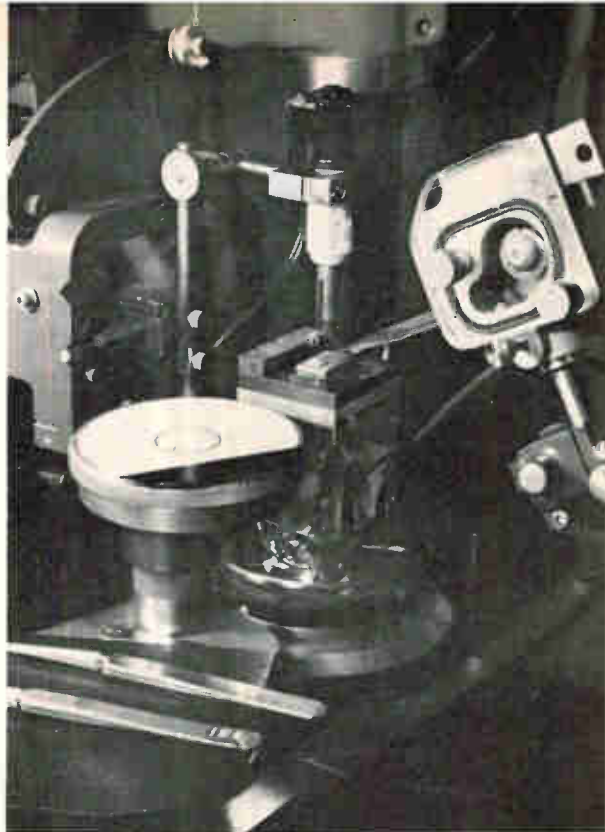

Thermocompression bonder was modified by the addition of a bonding tip headed with a soldering-iron heating element, and a gas ejection system in the capillary tube that feeds the wire. The operator visually locates the wire and tip on the bonding pads of the master dice. The modifications are incorporated in a multipurpose bonder made by the Kulicke & Soffa Manufacturing Co.

Steps in preparation of a master-dice breadboard.

Circuits are fabricated on a silicon slice, without interconnections but with bonding pads for each component. The slice is diced and the dice mounted in a header. A table of parts characteristics is drawn up and used to design a circuit. Dice components are shown inside the shaded area of the schematic; external resistors and capacitors are added. The wire interconnections to be made on the dice are sketched on a worksheet that shows the location of parts and the resistor values. Wires are bonded to the dice. The completed circuit is a four-stage differential current amplifier.

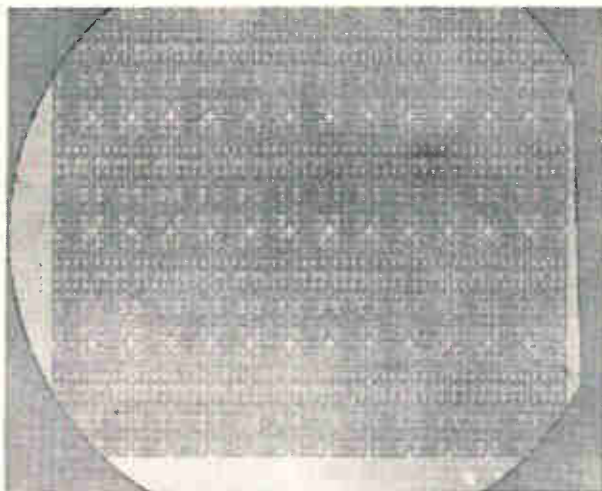
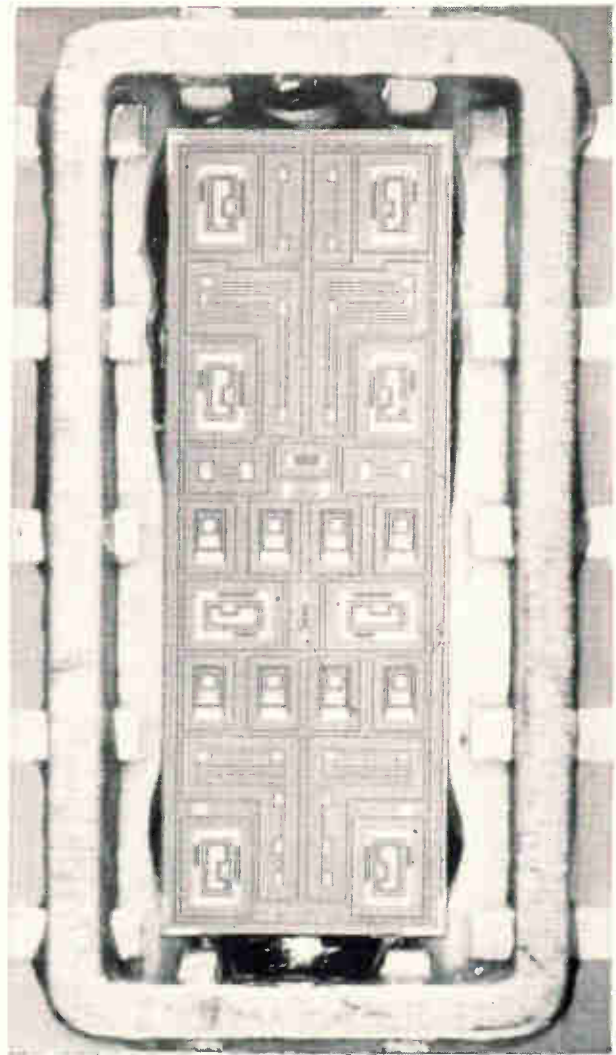

Slice

MD-T1 2  
(Driver switch dice)

Number of parts: 8 transistors (NPN)  
8 diodes  
10 resistors

Resistor characteristics

Quantity	resistors	total resistance
2	70K, 1.1K, 20K, 2.2K	15 K
2	1.1K, 1.1K, 1.7K, 1.7K	21 K
2	350	350 ohms
2	2K	2 K
2	2K	

Transistor characteristics (8 transistors)

BVCBO	Ic= 3ma	30 to 35v
BVCES	Ib= 1.5ma	70 v typ.
BVCBO	Ic= 2ma	70 v typ.
Vce Sat	Ic= 3ma	0.25 v
Vce Sat	Ic= 2ma	0.10 to 0.15 v
hfe	Ic= 3ma	30 to 50
	Ic= 2ma	25 to 45

Diode characteristics (8 diodes)

$V_e = 9v$

Table of parts characteristics

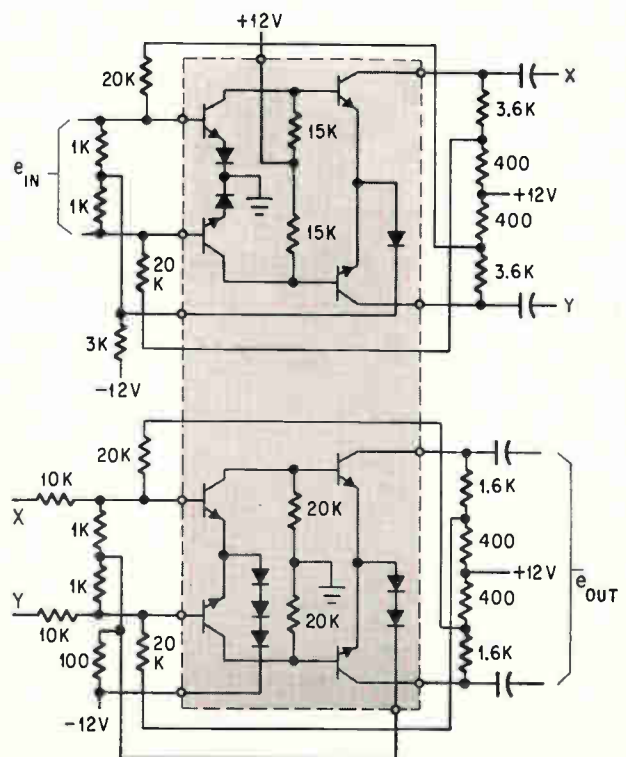

Schematic of circuit

... to work sheet

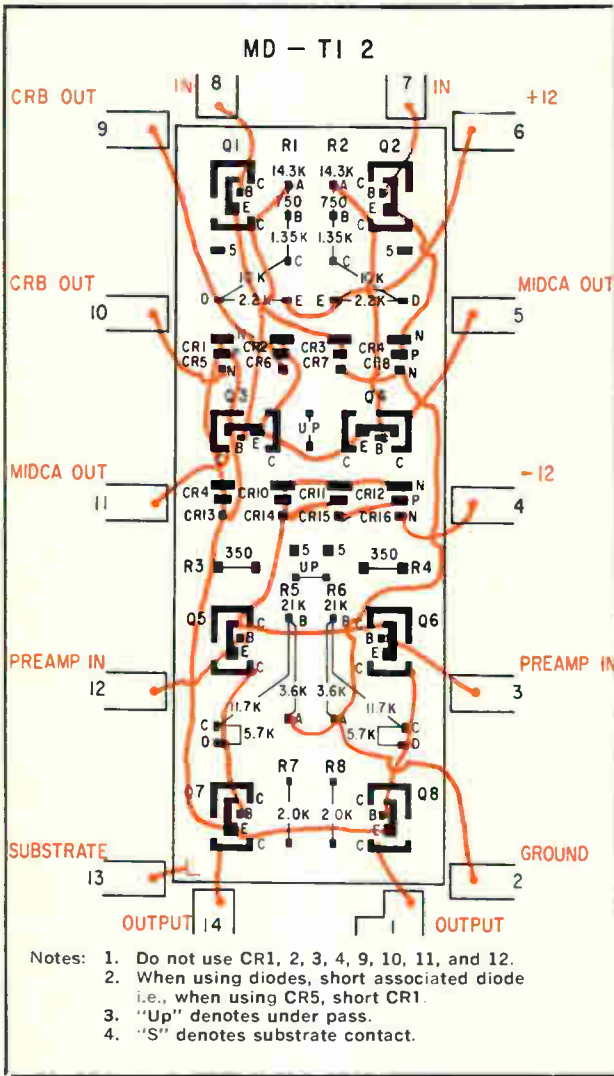

... and breadboard.

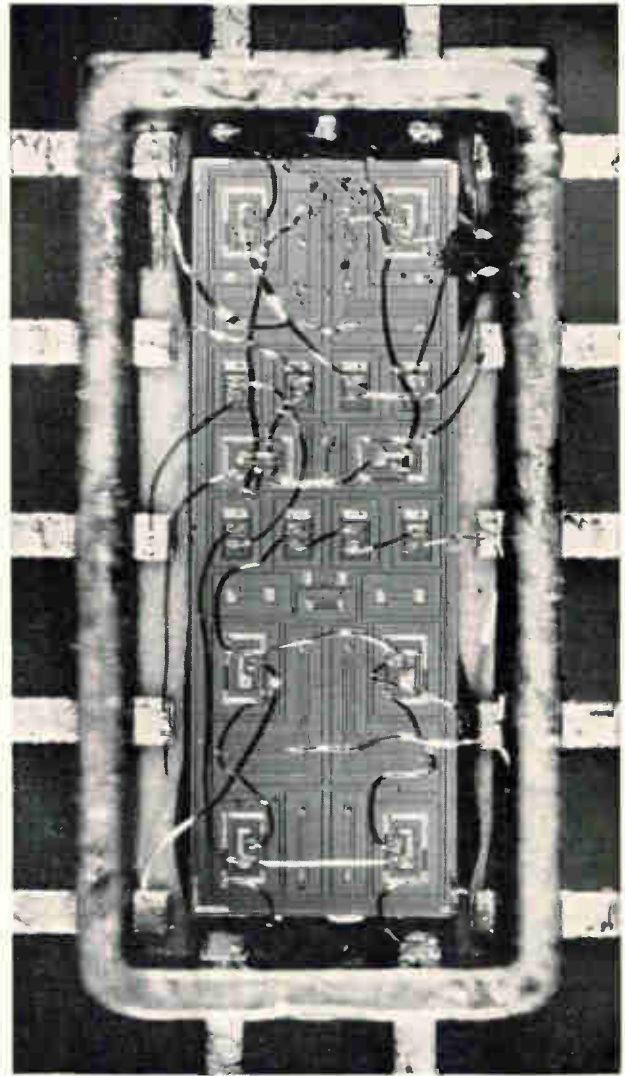

terns. When a circuit is already in production there is no additional cost for development of device characteristics and diffusion patterns.

Interconnection of the diffused components is accomplished by vapor-depositing aluminum over the entire circuit—actually over groups of circuits on a slice of silicon crystal. An aluminum-removal mask is then used for etching off the excess aluminum, leaving an interconnection pattern and pads for lead bonding. The only cost for changing the interconnection patterns is the cost of this mask.

The charge for the half-dozen or so diffusion masks required for a new circuit design ranges from \$3,000 to \$20,000. They are much more difficult to make than an aluminum-removal mask. Since only one aluminum-removal mask is needed, the cost of producing a revised circuit by the master-dice method is reduced proportionately.

Linear integrated circuits now cost from \$40 to \$100 in small quantities. With the master-dice program Autonetics hopes to reduce the cost per circuit to \$10 to \$15 in quantities of 50 or more, and the removal-mask cost to \$200 to \$500.

Prices quoted by vendors indicate that in quantity production the master-dice technique results

in lower costs for new circuits than any other technique. Quotations for large quantities—between 1,000 and 10,000 circuits—indicate that vendors would redesign diffusion masks as well, for higher yield; this cost is readily amortized by high-volume production.

Some manufacturers are offering standard circuits in master-dice form. The dice are inexpensive because they are merely circuit chips, supplied on headers unconnected and unsealed. The standard interconnections are eliminated by using an aluminum-removal mask having only aluminum pad terminals at each component. These pads, as small as one mil square, are used by the customer for thermocompression bonding of wire leads.

Any integrated circuit can be converted to a master dice ("dice" is used in this context as a singular noun, instead of "die," for simplicity), by preparing a suitable aluminum-removal mask. In a pinch, an actual circuit chip can be used if the existing interconnections are scribed open.

#### Breadboarding the circuit

Integrated-circuit manufacturers have been using the master-dice technique for in-house design of

The light-colored photograph at right is the MD-N1 dice, shown under its worksheet. In the center is the first circuit breadboarded at Autonetics, a dual diode-coupled Schmitt trigger that is similar to the T11 circuit on page 64. In the next row (left), the N1 and N2 are combined, with the N1 operating in the logic section of a logic and buffer amplifier. This circuit is driven by the dual Schmitt trigger. At the right are two circuits made with the MD-N3. The upper one is a high-gain audio preamplifier with strong negative feedback and a built-in power-supply series regulator. The second circuit (bottom right) is an output buffer amplifier with an external pnp transistor. The values of the parts in the three master dice are given in the table on the next page. The shaded areas of the schematics indicate the dice.

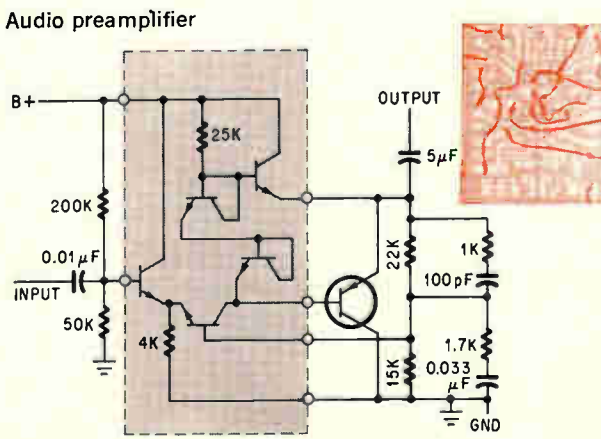
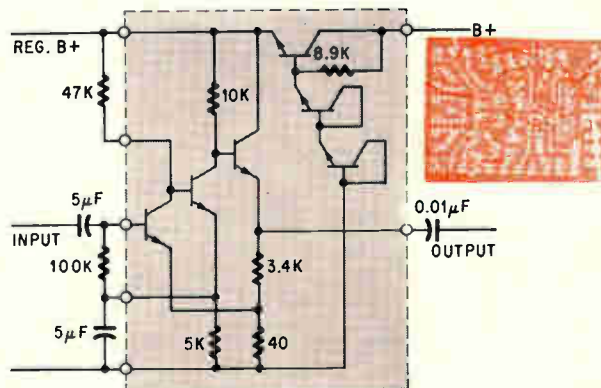
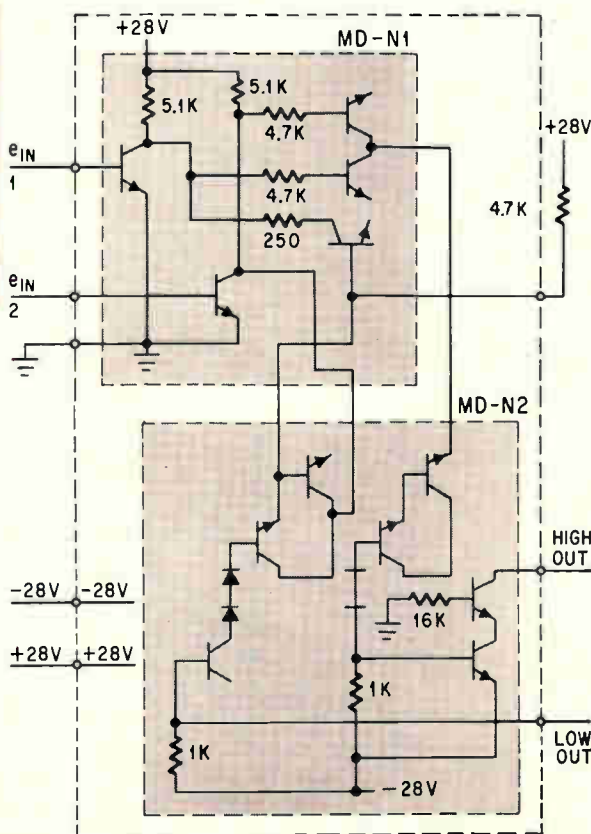
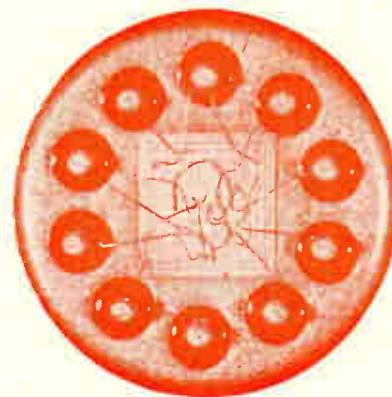
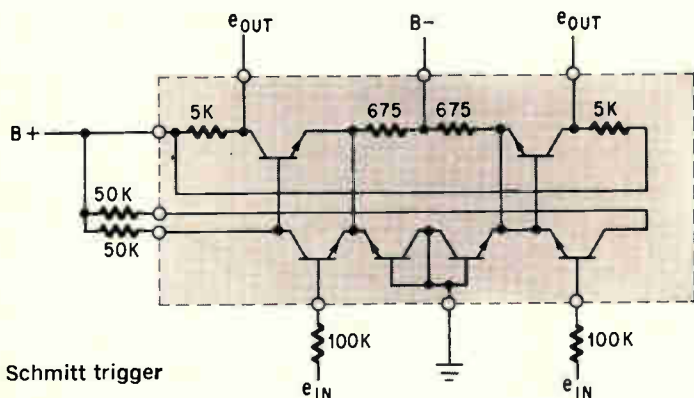
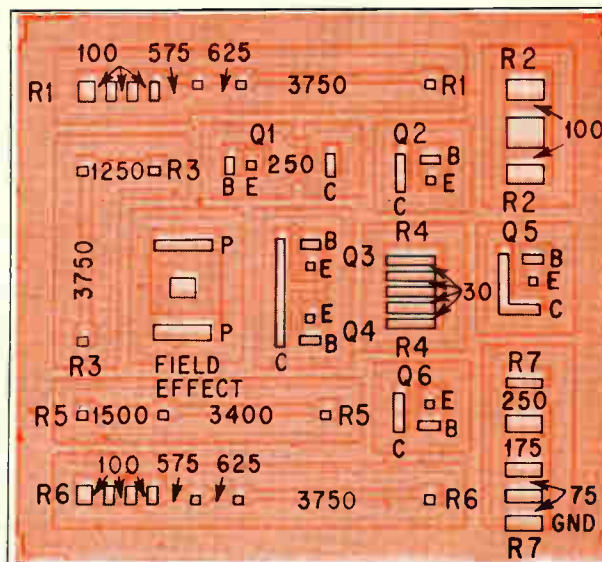



custom circuits. The Norden division of the United Aircraft Corp., for example, has developed more than a dozen different amplifier, comparator, trigger and switching circuits from a single circuit.

Now the system manufacturers' engineers can get back into the design loop by breadboarding their own integrated circuits. The steps are illustrated on page 60. As a preliminary, a trial circuit is breadboarded with discrete components with values equivalent to the components in the master dice. This circuit is refined conventionally.

The wiring pattern is translated to a hookup diagram for the master dice. Following this diagram, the engineer hooks up the dice components by thermocompression-bonding 0.7-mil gold wire to the pads on the dice and header pins. He then applies power to the breadboard to test circuit variables under integrated-circuit operating conditions. Probes can be used to check voltages at various points in the circuit.

If the tests indicate the circuit must be modified, the wiring can be changed by the engineer. By wiring the circuit himself, he develops confidence that it can be built as an integrated circuit.

### Wedge and ball

Thermocompression bonding—pressing two

heated meals together so they coalesce—is the standard method of attaching leads to circuit chips. There are two basic techniques: wedge and ball. In wedge bonding, a wedge-shaped tool presses a small section of the lead wire onto the bonding pad. In ball bonding, a flame severs the wire as it leaves a capillary feed tube. The molten end of the wire solidifies as a ball, which is pressed by the tube end against the bonding pad.

Special wedge-bonding techniques have been developed by Autonetics for use on master dice. Wedge bonding is used because a single wire can interconnect several components. If ball bonding were used, the first connection could be a ball bond but subsequent connections would have to be wedge bonds made with the end of the capillary tube. Pressure adjustments would have to be made at each changeover from one type of bond to the other. Another objection is that in the ball bonding, the end of the tube blocks the view of the operator from the smaller pads. He has to see the pad to make the bond in the right location.

Although crossover leads are avoided in the actual layout of the aluminum-removal mask, it is more convenient during breadboarding to make loops and crossovers. This requires improved wire feeds. Nitrogen gas fed into the tube blows the

## Characteristics of components in master dice MD-N1, N2 and N3

	N1	N2	N3	Notes
Transistors	6 npn	8 npn	7 npn	a) Typical, at $V_{CE} = 5v$
Diodes, base-emitter		4		b) At $I_C = 5 \text{ ma}$ , $I_B = 0.5 \text{ ma}$ .
Resistors	7	5	13	All voltages in this line are maximum.
Substrate breakdown, minimum	200 v	200 v	R-35 v Q-80 v	c) Six resistors: 100, 100, 110, 550 and 520 ohms and 3.05 K.
Transistor characteristics				d) Four resistors: 40, 30, 30 and 35 ohms
$BV_{CBO}$ minimum	30 v	70 v	30 v	e) Six resistors: 110, 100, 105, 510 and 530 ohms and 3.1 K
$BV_{CEO}$ minimum	20 v	40 v	15 v	f) Four resistors: 210, 120, 70 and 70 ohms
$BV_{EBC}$	$12.2 \pm \frac{1}{2} v$	$10.7 \pm \frac{1}{2} v$		g) Fourteen resistors: 4.75 K, 175, 380, 920, 920, 300, 290, 290, 285, 925, 905, 390 and 165 ohms and 4.75 K
$BV_{CEB}$ minimum			20 v	h) R3 and R6 are combined, totaling 10 K
$B_{dc}$ @ $V_{CE} = 6v$ , $I_C = 100 \mu a$	$2.5 \pm 20\%$	$15 \pm 20\%$		i) Nominal accuracy of resistors in MD-N1 and MD-N2 is $\pm 30\%$ and ratio accuracy is $\pm 10\%$
$I_C = 1 \text{ ma}$	$50 \pm 20\%$	$30 \pm 20\%$	60 <sup>a</sup>	
$I_C = 10 \text{ ma}$	$75 \pm 20\%$	$45 \pm 20\%$		
$V_{CE sat}$ @ $I_C = 10 \text{ ma}$ , $I_B = 1 \text{ ma}$	1.7 v	2.0 v	0.8 v <sup>b</sup>	
$V_{BE sat}$ @ $I_C = 10 \text{ ma}$ , $I_B = 1 \text{ ma}$	1.0 v	1.0 v	0.8 v <sup>b</sup>	
Diode characteristics				
BV		$10.7 \pm \frac{1}{2} v$		
$V_f$ @ $I_f = 10 \text{ ma}$ , maximum		1.0 v		
Resistors: R1	4.43 K <sup>c</sup>	580+485	3.9 K	
R2	110+60	560+495	3.9 K	
R3	1.1 K+2.9 K	240+200	5 K <sup>b</sup>	
R4	135 <sup>d</sup>	15.4 K <sup>e</sup>	250	
R5	1.25 K+2.7 K	760	250	
R6	4.46 K <sup>c</sup>		5 K <sup>b</sup>	
R7	470 <sup>f</sup>		5 K	
R8			3.9 K	
R9			750	
R10, R11			250	
R12, R13			25 to 40	
R14 and R15			1.7 K+2.7 K	

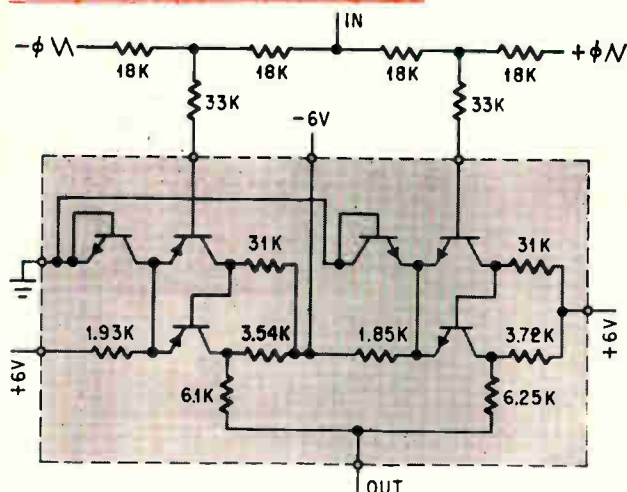

Complementary npn and pnp transistors of the MD-TI 1 are used in a complementary dual Schmitt trigger that provides inverting and noninverting outputs for use in pulse-width modulation.

wire out of the capillary. The rate of gas flow is adjusted to avoid vibration of the wire while the wire is ejected from the tube at an adequate speed. Gas ejection prevents the hair-like wire from running back into the tube and permits forming slack loops above the dice.

The wedge-bonding setup is a simple one. The precision bonding tip is heated by fastening it to the heating element of a 47½-watt soldering iron. The element's a-c power supply is calibrated and regulated to maintain tip temperature at 320° C, ±2° C. Tip pressure is set for 45 grams applied for six seconds.

#### New circuits from old

The circuits on pages 60, 62 and 64 are examples of circuits made at Autonetics with master dice. Seven basic types of master dice are presently in use or development. Types MD-N1, N2 and N3 (pages 62 and 63) are made by Norden. The N1 was originally a sense amplifier and the N2 was the active dice in a multichip servo-amplifier. The N3 is an improved, version of the N1.

Types MD-TI1, TI2, TI3 and TI4 are made by Texas Instruments Inc. and were originally developed for use in the Minuteman II missile. They are the modes 1 and 2 general-purpose amplifier, driver switch, modes 3 and 4 amplifier and demodulator-chopper, respectively. Examples of circuits made with the TI1 and TI2 are illustrated.

The TI3 and TI4 are being evaluated. The TI3 contains five npn transistors and seven resistor groups, while the TI4 has four npn transistors, six diodes and five resistor groups. As yet, little breadboarding has been done with either dice. One circuit being developed is a chopper-driver circuit that

## MD-TI 1

Number of parts	5 npn transistors
	2 pnp transistors
	8 resistors (p type)

#### Resistor characteristics

R1 and R2	9.6 K (390, 390, 650 ohms; 1.95, 6.24 K)
R3 and R4	50.5 K (9.9, 4.8, 10.3, 10.1, 4.9, 10.5 K)
R5 and R6	6.1 K (780, 650, 650 ohms; 4.03 K)
R7 and R8	10.4 K (7.4, 3 K)
Breakdown voltage to substrate 40 v minimum	
Initial tolerance ±20%	
Resistor ratio tracking ±2%	

#### Transistor characteristics

npn type		
$BV_{CEO}$		20 v typ.
$V_{CE sat}$	$I_C = 3$ ma	1 to 3 v
$H_{FE}$	$I_C = 1$ ma	20
	$I_C = 100$ ma	60
$H_{FE}$	$I_C = 1$ ma	80
	match	30%
$V_{BE}$	match	5 mv
$V_{BE}$	tracking	10 mv/°C
NF	$I_C = 10$ ma, 10 KRg	3 db
	$I_C = 1$ ma $V_{ce} = 6$ v	60 Mc
f <sub>T</sub>		
pnp type		
$BV_{CEO}$		55 v typ.
$V_{CE sat}$	$I_C = 1$ ma	1 to 2 v
$H_{FE}$	$I_C = 5$ ma	30

takes advantage of the TI4's very fast transistors.

The first circuit breadboarded at Autonetics was a dual diode-coupled Schmitt trigger (page 62). Made from the N1, it provides two very low-offset, low-hysteresis Schmitt triggers. Various amplifiers have also been made with the N1.

Note that in some of the circuits made with master dice, additional components have been added. Extra discrete components external to the integrated circuit were needed because components with the required values were not available on the dice. However, for purposes of miniaturization this is still better than making the circuits wholly from discrete components.

The N2 is not as generally useful as the N1 because it has fewer resistors (see table, page 63). The one high-value resistor is in the same isolation region of the dice as the collector of one of the transistors; this results in undesirable and unavoidable coupling. However, the N1 and N2 can be combined as illustrated by the circuit on page 62. The N2 is the logic section of a logic and buffer amplifier used in a pulse-width-modulated amplifier to drive a 2-ampere power switch. It is driven by the Schmitt trigger.

Circuits made with the N3 are also shown. The audio-frequency output buffer (page 62) requires an external pnp transistor since all transistors on the dice are an npn type.

The TI1 is the only available integrated circuit with both npn and pnp transistors in the same dice. This feature is put to use in the circuit shown above. The TI1 has also been used as a buffer amplifier with complementary transistors in the output, and as a low-noise preamplifier to drive the buffer.

# Problem: standardizing instruments— Solution: digital systems

Data from back-up monitoring system in nuclear ship Savannah obtained in digital form, simplifying maintenance

By Donald Gertz and Lionel Leavitt

Ford Instrument Co., division of Sperry Rand Corp., Long Island City, N. Y.

Aboard the N.S. Savannah, the world's first nuclear merchant ship, a set of unique instruments is being tested that may solve a maintenance problem becoming increasingly troublesome on land as well as at sea.

What's being used here are digital transducers to monitor temperature, pressure and water level.

If, for example, an instrument fails aboard the Savannah while it is out at sea, a crew member may not be able to make the repairs from a limited reserve of spare parts before the vessel reaches port. And on land, instrumentation systems of an oil refinery also may be too complex for quick and easy repairs.

A promising approach for standardizing complex instrumentation systems appears to be the use of digital techniques. But a major disadvantages of digital systems is the need, in most cases, to convert analog data to digital. Where in the data flow path is the conversion to be made? How is it to be made? Ideally, if data could be obtained in digital form in the first place, no conversion process would be required.

A new approach to this ideal transducer concept has been used in a standardized and essentially digital instrumentation system using ultrasonic pulses. Transducers based on this concept are being used as back-up monitors for several parameters in the power-generating system of the Savannah.

This operating experience will influence future development of the concept.

The major advantages in using standardized equipment for sensors and data processing are high reliability, simplified maintenance and fail-safe and unambiguous readout.

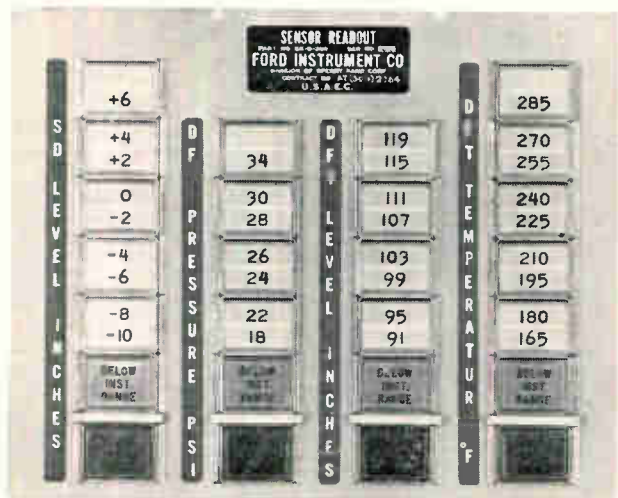

Prototype equipment aboard the Savannah is a back-up for conventional instruments and is used to obtain performance data. Display for the digital sensors are lights calibrated in terms of the measured variable.

## Digital sensors

The monitoring system is built around one basic digital sensor. As shown in the drawing on page 66 for the liquid-level sensor, the liquid rises in the sensor tube, covering the faces of ultrasonic drivers and pick-up elements. All the drivers are excited with narrow 3-Mc pulses 60 times per second. Sound energy is propagated efficiently through the liquid but poorly through air, so only those receivers covered by liquid receive enough energy to provide detection. The signal from each sensor is eventually routed to data-processing equipment.

Pressure sensors use the same basic concept of a liquid column with ultrasonic drivers and re-

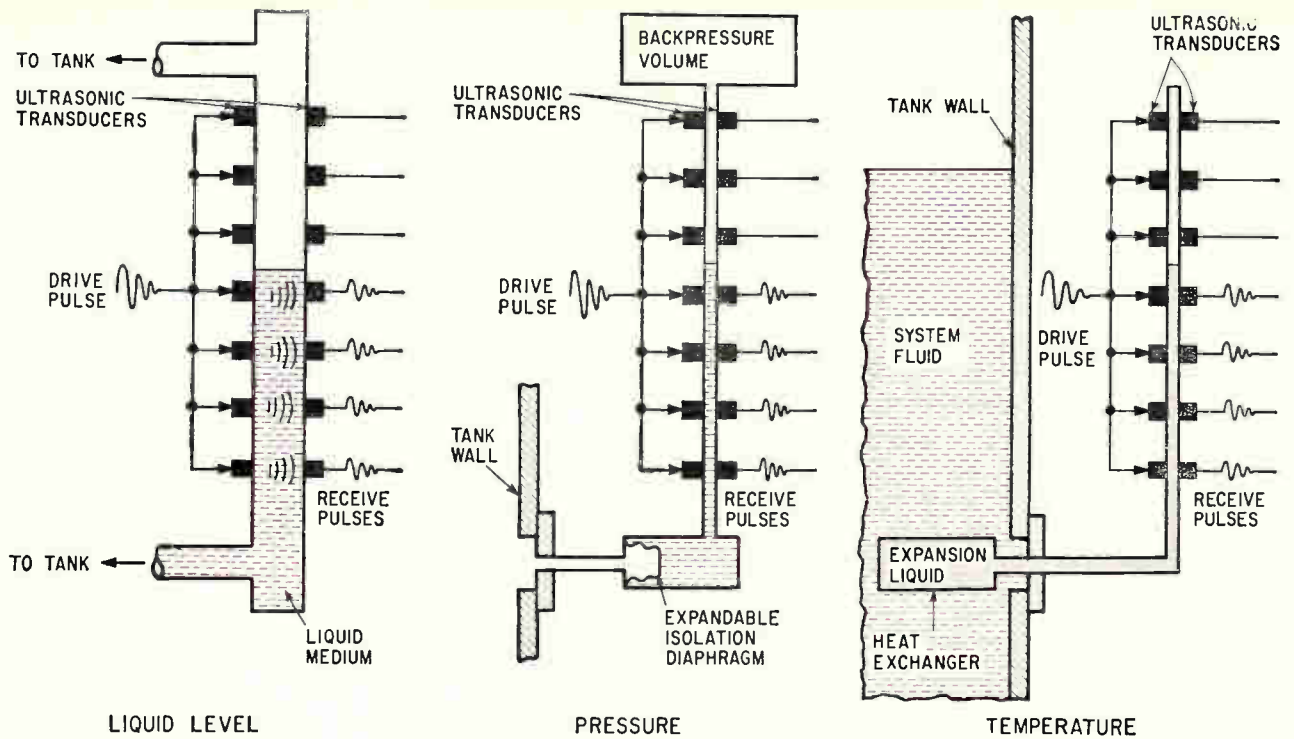

Digital liquid-level sensor (left) transmits ultrasonic pulses to those receivers covered by the liquid. In the pressure sensor (center) the back pressure keeps the expandable diaphragm at minimum volume until the pressure being measured exceeds the back pressure. Temperature sensor (right) uses a fluid with a high temperature coefficient of expansion. Data from all three types of sensors are in the same form and ultrasonic transducers are interchangeable

ceivers, as shown above. In this case, however, an expandable isolation diaphragm is used to separate the fluid of the system—which can be gas or liquid—from the liquid of the sensor. Back pressure of gas is used with the sensor and acts both as a zero set-point and sensitivity control. As long as the back pressure is greater than the pressure being measured, the isolation diaphragm has minimum volume and the well fluid does not rise in the tube. But when the measured pressure exceeds the back pressure, the diaphragm expands, forcing liquid up the column. While the level of fluid in the sensor is a function of the difference of two pressures, the output signal from the sensor is identical to that from the liquid-level sensor and can be processed the same way.

The digital temperature sensor is a variation on the same idea. Expanding-liquid temperature sensors of various types have been used in many industrial applications, so the innovation here is the way the output signal is developed. It is, of course, the same type of signal that is obtained from the liquid-level and pressure sensors.

### Resolution

The digital sensors are flexible: they can be used with only one or two sensing points to give go/no-go information or they can activate alarms and they can be used to produce a linear or nonlinear output by varying the spacing between the transducers. The resolution also can be varied by altering the number of transducers. Transducers developed for use on the Savannah, however, use probes

spaced between one and four inches apart.

### Ultrasonic system

The decision to use ultrasonics as a switching or coupling signal was based on the several factors, including the advances made in this area in recent years and the extensive data available on acoustic transmission through liquids, metals and gases. More significant is the fact that the ultrasonic cartridges are interchangeable throughout the system. In addition, the sensors are essentially stationary; they are attached simply with a dry bond to the external metal wall of the sensor well and they produce the type of pulse operation desired.

Transducer cartridges—see photo page 68—have approximately ¼-inch diameter faces and use lead-zirconate-titanate piezoelectric material. Crystal mounting is designed to reduce the Q of the circuit to about 2, since this gives the receivers a bandwidth of 1.5 Mc around the transmitter frequency of 3 Mc; thus the frequency selectivity is deliberately made low so that frequency-matching problems are nearly nonexistent. One receiver cartridge is used for each transmitter cartridge—receivers and transmitters are interchangeable—and the distance the signal travels through the sensor liquid is about ¼ inch or less. Using one transmitter at the bottom of the sensor well—instead of one opposite each receiver—has been found to produce unsatisfactory results because of small particles in the liquid, thermal gradients and dissimilar receiver patterns caused by multiple reflections. The

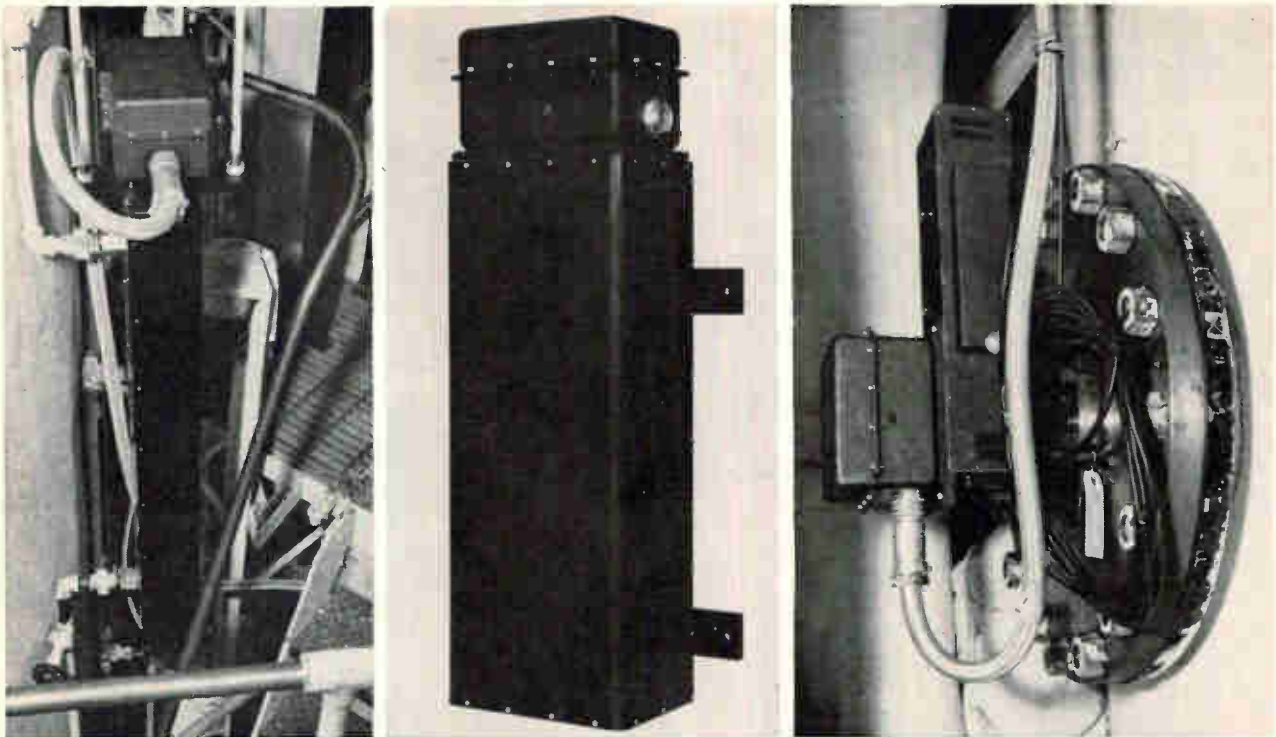

Sensors monitoring nuclear reactor secondary system. The liquid-level sensor (left) has a range of several feet and operates up to 500°F. at up to 600 psi. The pressure sensor (center) has a range of 0 to 50 psig. The temperature sensor (right) measures from 165°F. to 285°F. Driver and receiver circuits are in the junction boxes.

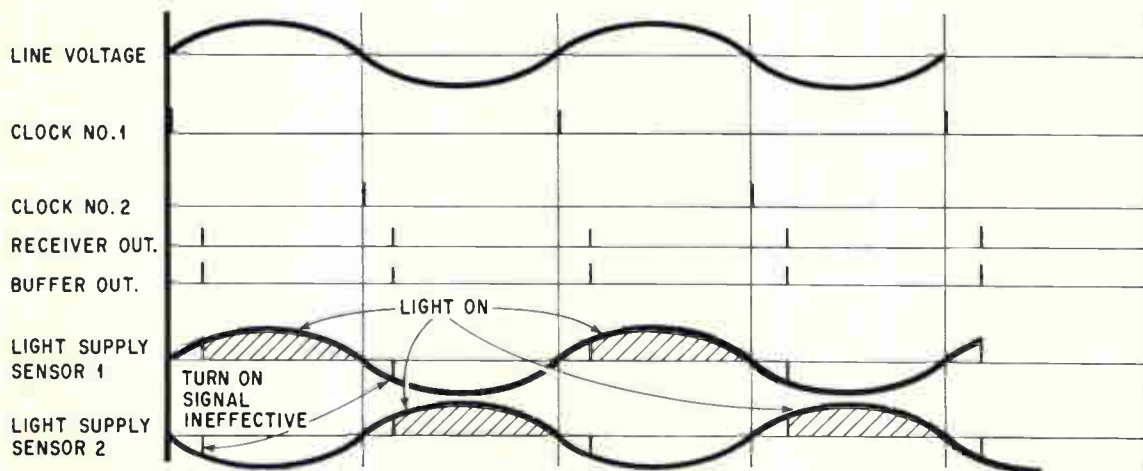
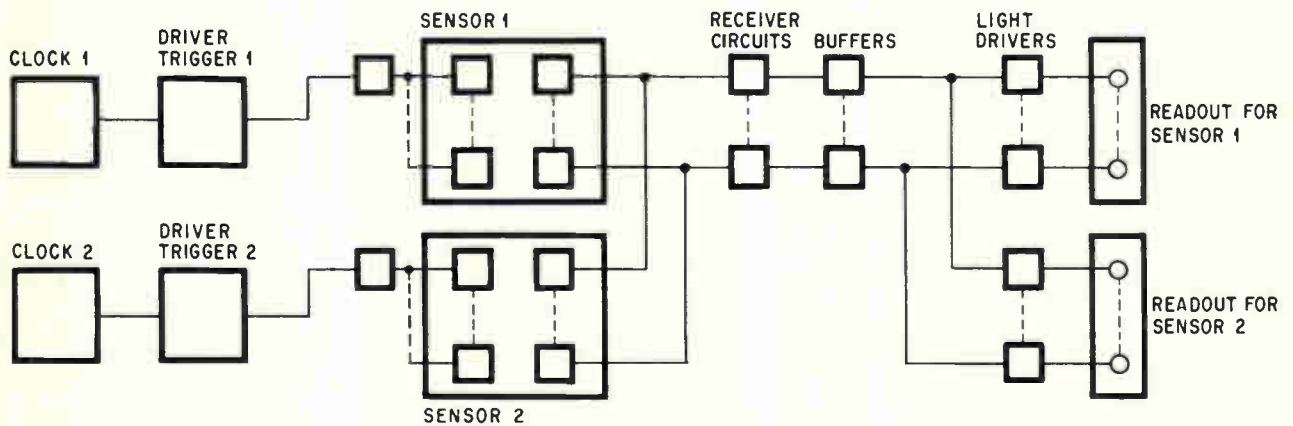

Multiplexing some of the circuits can be accomplished by operating readout lights on alternate half-cycles of the supply voltage. As shown by the waveforms, the lights will not go on unless the supply voltage is positive when the turn-on pulse occurs.

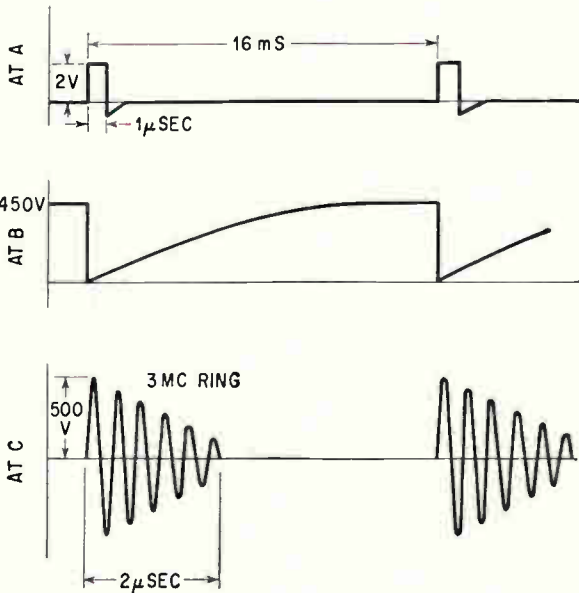
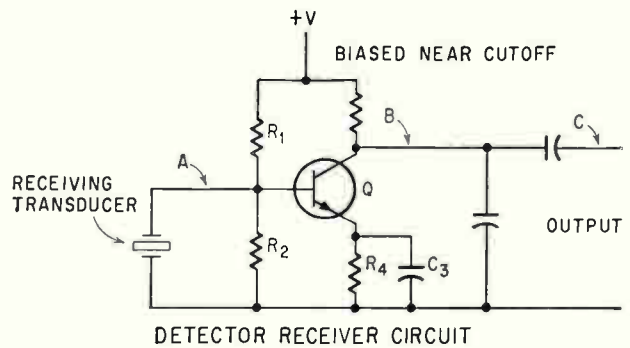
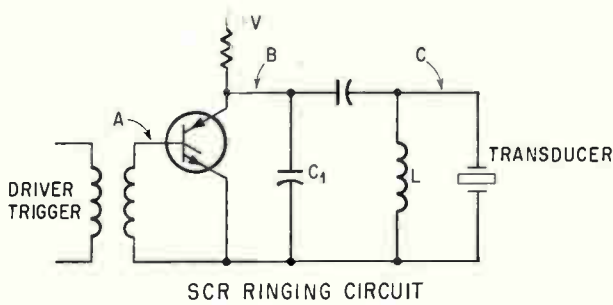

Simple ringing circuit using a silicon-controlled rectifier drives the ultrasonic transducers. Driving frequency of 3 Mc lasts only a few microseconds.

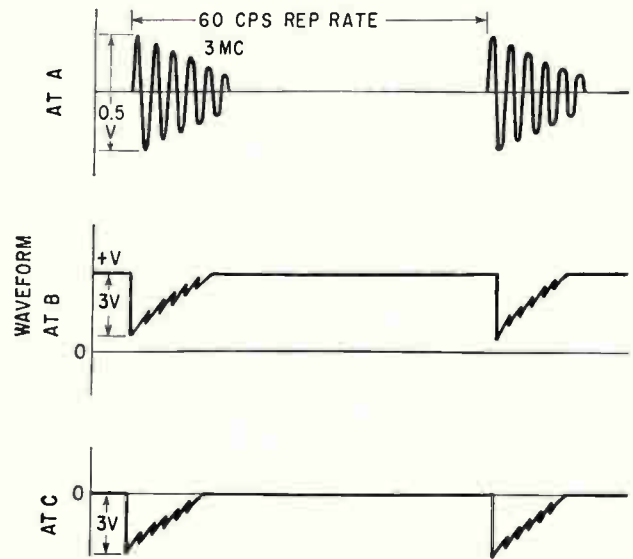

Receiver circuit is biased near cutoff to provide both amplification and demodulation.

close spacing of the transmitter-receiver pair also essentially eliminates problems of beam patterns and directivity.

Sensor resolution is determined primarily by the spacing between one transducer pair and the next. The resolution of a given transducer pair is limited by the coupling of energy from a part of the transmitter face to a part of a receiver face. As shown by the drawing on page 70, a pulse is developed by the pair if approximately 50% of both elements of the combination is covered by the sensor liquid.

Sensor response time is limited electronically by the sampling rate—60 per second in this case—and mechanically by the rate of change of liquid level in the sensor well. The mechanical factors are predominant in these sensors and response time is a few seconds for full scale charges but it is adequate for the application.

#### Ultrasonic driver

The great advantage of the digital instrumentation system stems from the simple circuits that are used and the fact that only a few different types of circuits are required. This greatly simplifies maintenance and also reduces the inventory of spare parts.

The driver circuit—common to all the digital sensors—is a simple silicon-controlled rectifier ringing circuit, as shown above. One driver circuit is used in each sensor and there may be as many as 10 transmitters in each sensor. Energy is stored in capacitors  $C_1$  and  $C_2$  from the supply; when the trigger pulse is applied it turns on the scr and connects point B in the diagram to ground. Ringing frequency is determined by  $C_1$ ,  $C_2$ ,  $L$  and the impedance of the crystal and the amplitude of the ring signal is determined by the turn-on time of the scr, which varies from 0.05 to 0.1 microsecond. The ring signal is damped out in about 2



Replaceable ultrasonic cartridge attaches with a dry bond to the outside metal wall of the sensor well. The pin provides an electrical connection.

microseconds; current through the scr soon drops below the value needed to keep it turned on and the circuit resets before the next pulse.

### Receiver circuit

The voltage developed by the receiver transducer is nearly 0.5 volt peak to peak, as shown in the sketch, giving a signal-to-noise ratio of about 30 db. One stage of amplification is sufficient to produce a reliable signal for the data-processing circuits. Signal detection, or demodulation, is accomplished in the same stage by half-wave detection as shown by the waveforms in the drawing.

A compromise in transistor biasing was made to meet the requirements of gain plus detection. Satisfactory operation is obtained by biasing the transistor slightly above cutoff.

One receiver circuit is used for each point on the sensor.

### Information display

The most straightforward type display—and one that is satisfactory for many applications—is to use a set of lights for each sensor, with one light per sensor point. The system uses a pulse generator, or clock, that sends out 60 pulses per second. The pulses feed through the system to the lights and arrive at the light driver circuits early enough in the 60 cps supply cycle to turn on these circuits for most of the positive half-wave.

Circuits to operate the light-display system are simple. The clock simply clips the line frequency, and by high amplification produces a 100-microsecond pulse within a few microseconds after the input enters the positive half-wave of the cycle. The input transistor saturates, and since there is no further rate of change across the capacitor, the output falls to zero and remains there until the next positive excursion of the input.

This pulse is fed to a driver trigger, which is similar to the driver circuit used with the transducers except that it is overdamped and produces only one output pulse. The output is coupled by a transformer to the transducer driver. This type coupling presents a low d-c resistance to the scr gate circuit and prevents spurious triggering. Each trigger circuit has enough power to drive five sensors.

The signals propagate through the sensors as described above and are fed to simple buffer circuits. A single saturated transistor is used in the buffer and produces a 40-microsecond pulse; the leading edge of this pulse lags the leading edge of the clock pulse by about 20 microseconds. This signal then turns on the light driver circuit; the total delay is 20 microseconds plus the negligible turn-on time of the light driver scr.

Fault detection is included in the system. The driver that excites the ultrasonic transmitters in each sensor also energizes a special test pair that is coupled by a metal rod instead of the sensor liquid. The signal from the test pair inhibits an

instrument fault light and keeps it dark. The fault light operates if there is a failure in either the clock, driver trigger, driver, clock power supply or driver power supply. Failure of a channel for an individual sensor is indicated when the light for that point fails to go on.

### Multiplexing

It was stated above that one receiver circuit is required for each receiver transducer in each sensor. But this is true only during the few microseconds during each cycle of line voltage that the sensor is being interrogated. During the rest of the cycle the receiver circuit is inactive, waiting for the next interrogation pulse.

During this inactive period a given set of receivers can be used to service one or more additional transducers.

As the first step in multiplexing, consider two sensors, each with 10 readout points. Receiver and buffer circuits are multiplexed as shown in the block diagram on page 67. The second clock drives the interrogation circuits of sensor 2 on the negative half-waves of line voltage. The sensor, receiver and buffer circuits operate with d-c and thus are indifferent to the phase relationship between the interrogating pulse and the line voltage. But the clocks and lights operate at line frequency and the lights won't go on unless the supply voltage is positive when the turn-on pulse occurs. Important phase relationships are shown by the waveforms in the drawing.

Multiplexing can be carried further by increasing the number of clocks and increasing supply frequency accordingly. The clocks still operate with one output pulse for each cycle of fundamental line voltage—typically 60 pulses per second—but lights are powered by a phase-shifted line frequency. If, for example, 25 clocks are used so that 25 sensors use the same set of receiver and buffer circuits, the individual sensor lights must be supplied with a voltage that goes positive at the same time as its clock.

The individual sensor readout lights are energized during an interrogation cycle, and they appear to be on continuously because of the frequency of the cycle.

The driver trigger circuits shown feeding one sensor each in the block diagram on page 67 can feed five sensors each. This provides another approach to multiplexing but leads to a more complicated logic network because the signal pulses from five sensors will all be in phase. This phasing problem can be solved by providing five sets of receiver, buffer and light-driver circuits, and tying the sensor outputs in groups of five. The application will determine how the circuits are multiplexed in a given case.

### Data acquisition

The data-acquisition system uses the basic sensor electronics plus logic circuits to provide a printed record of the parameters measured. The

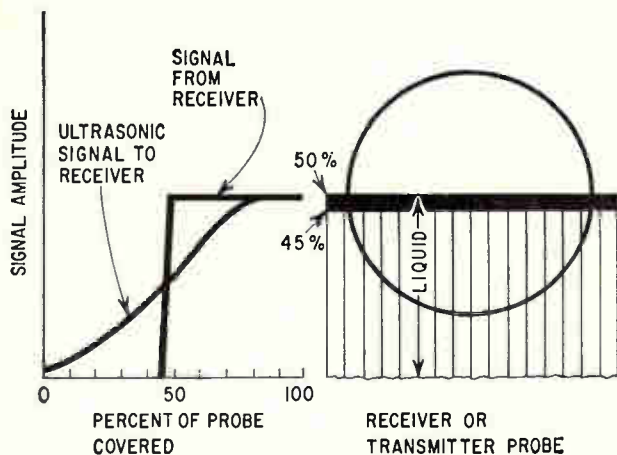

Output signal is developed by the sensor pairs when approximately 50% of the probe faces are covered by liquid.

basic logic elements used are a NOR block and an a-c coupled flip-flop with d-c set and reset lines. A typical system consists of a series of multiplexing gates controlled by a scan counter. Pulses from the sensor are entered in parallel into the shift register, as shown above, where they are stored. When the register is cleared, the pulses feed out serially and drive an impulse counter, which is connected to a wheel type printout device. Since the data from all the sensors appear identical at the input to the index register, the conversion to temperature, pressure or level can be made easily on the print wheel itself. For example, five pulses from sensor 1 may mean 27 inches of liquid, five pulses from sensor 2 may mean 280 F.; five pulses from sensor 3 may mean 150 psi. The only items unique to a given parameter in the entire data-processing equipment are the sensor and the print wheel. This system provides the basis for an extremely simple and flexible system. A complete printout can be initiated periodically or at the demand of the operator. Since the sensors can be scanned at a rate far exceeding the print cycle, a series of off-normal gates can be used to activate a print-out when any particular parameter exceeds its normal limits. In this way the system can provide a rapid indication of abnormal parameters, a periodic or demand review of all parameters, as well as a continuous log of the information displayed.

#### The authors



In 1951 Don Gertz received his bachelor of mechanical engineering degree from NYU, in 1954 his master's. But he has worked almost exclusively in electronic instrumentation for nucleonics, power plants and process industries. He is a member of Tau Beta Pi and Pi Tau Sigma.

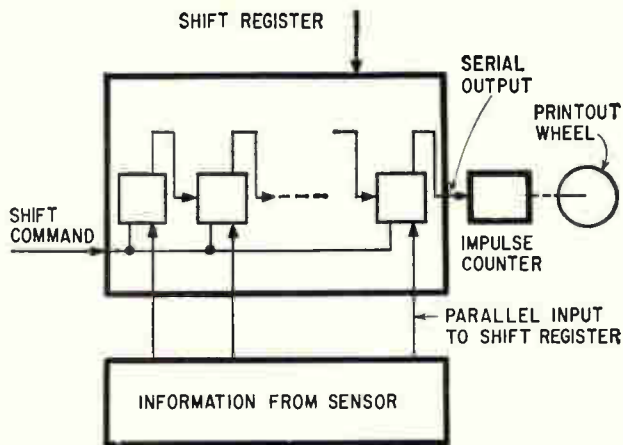

Shift register converts parallel signals from sensors to serial string of pulses. The pulses drive a print wheel as in an impulse counter.

Care was taken to provide minimum downtime for the system. Fault detection circuits check each major block in the data-acquisition system that could cause a catastrophic failure. A malfunction in any one particular channel, however, isn't considered a catastrophic failure. When a fault is detected the operator can switch to an auxiliary operating mode to display parameter data directly, by-passing the main logic. Entire blocks of the system, such as the index register or the control logic, are constructed as modules and are easily replaced. Logic cards for a particular block are packaged together and use a common subsystem connector.

The system was designed only to monitor, but control can be added in various ways. The simplest type of control is on-off, which is easily implemented with the digital sensors. More sophisticated control would require additional logic in the data-acquisition system.

At present, the development phase has essentially been completed for the three major process parameters: pressure, temperature and level. Performance characteristics have been obtained in the laboratory and are now being tested aboard the Savannah. The electronic systems are designed to meet high military standards.

In addition, work is proceeding on the development of digital sensors for other important process parameters.



Lionel Leavitt received his bachelor of electrical engineering from NYU in 1956, his master's from Brooklyn Polytechnic Institute in 1959. He has worked primarily in control system and sensor design and has several patents pending.



# New era in telephony: Electronic switching

## Part 1. Bell's spectacular advance

Computer-run system is replacing electromechanical switching center in the Bell System

## Part 2. Primer of telephone switching

Every switching system, from the simplest electromechanical to the latest electronic network, has several basic functions in common

## Part 3. What's happening elsewhere

Outside the Bell System, both in the U.S. and abroad, other companies are moving into electronic switching

By Alexander A. McKenzie\*

Communications Editor

\* With reports from Paul Catz in Amsterdam, Richard Mikton in Bonn, Arthur Erikson in Brussels, Nicholas Landon in London and Robert Skole in Stockholm

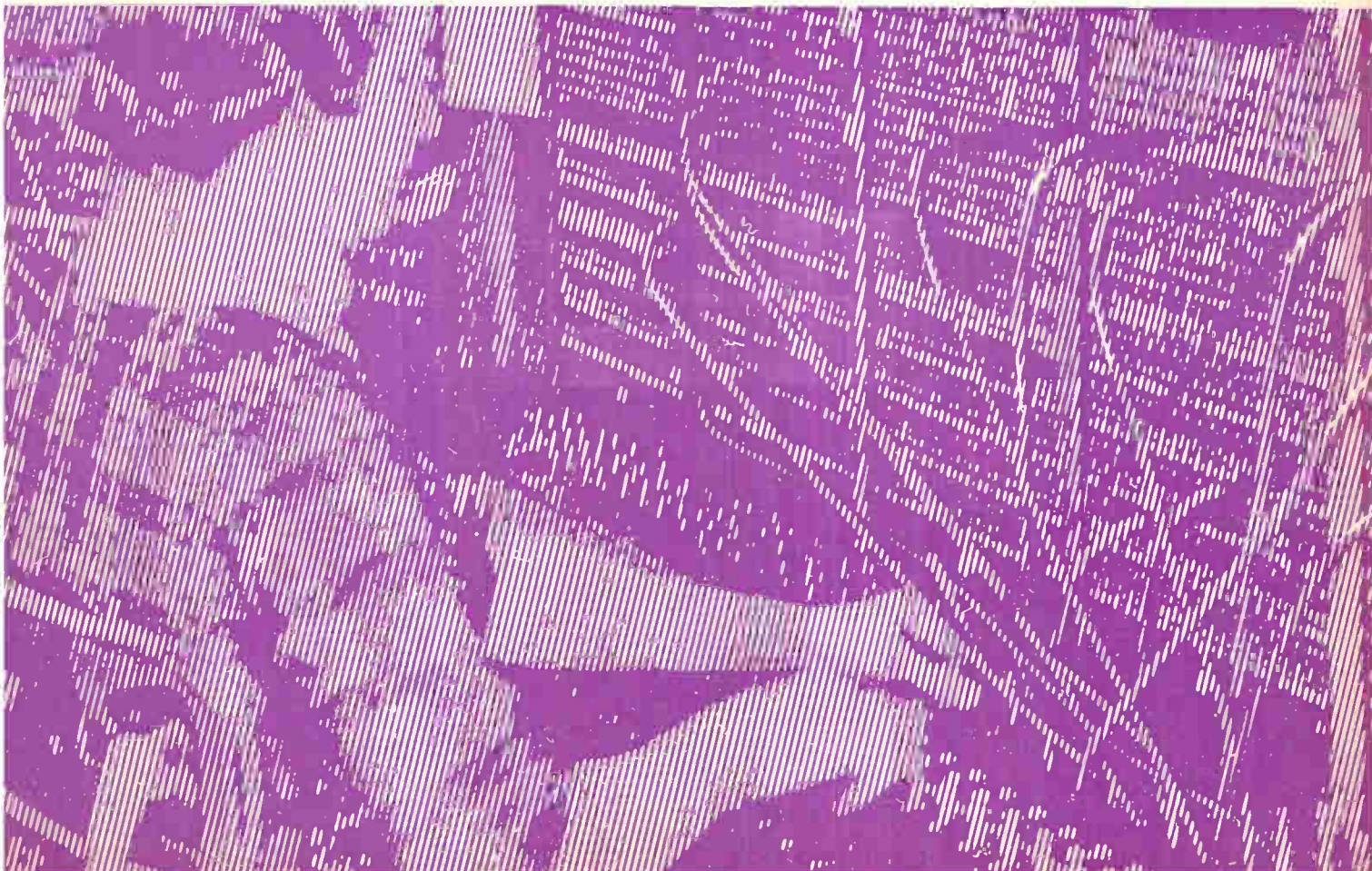

# Bell's spectacular advance

New services will add new terms to the language:  
dial conference, abbreviated dialing, add-on  
conference, variable call transfer

**Tiny Succasunna, N. J.**, population 5,000, is about to become a trend setter. One day early in 1965, the Bell System will open the first commercial electronic switching center there. By the year 2000, central offices of the type planned in Succasunna are expected to replace all electromechanical centers in the Bell System.

The radically new system will open the era of electronic switching, in which high-speed computers run systems that can perform more services faster, more reliably and with greater flexibility than was thought possible only a few years ago.

It will replace manual switchboards, step switches, panel switching and even the electromechanical crossbar introduced 29 years ago.

The phone company makes a change of this magnitude only once in a generation. What the telephone engineers have done is also useful in other areas of engineering because telephone equipment demands practical design, high performance, extraordinary reliability and long life, with permissible outages totaling only a few minutes in 40 years.

Because the requirements are so stiff, the new system is really semielectronic. Encapsulated dry-reed switches will make the actual voice connections [see "Primer of telephone switching," p. 74]. But the main functions are performed electronically, and in real time. A high-speed electronic data processor directs the activities of the central office and performs all the information handling. A stored memory contains the program-switching logic, and a temporary memory stores the transient information necessary for processing a call, such as the digits dialed and whether a line is busy. Inputs to the computer come from an electronic scanning system that uses ferrite sensors.

## More services and faster

The telephone companies and subscribers will both benefit from the electronic center, which is currently designated No. 1 Electronic Switching System. The company will be able to handle far more traffic faster, and the electronic switching center occupies less than half the space of an electromechanical center. Routine chores such as maintenance, coin collection and message accounting can be done easily at less cost. The electronic system's greatest economic advantage may be that it ties up less equipment when people are

talking, requiring less equipment at the exchange. The savings are big enough so that the Bell System can hope to recover its \$125 million development cost.

For subscribers, the electronic center means more telephone services. For example, customers of the Succasunna office will have these services available: abbreviated dialing, using three digits instead of seven for a list of frequently called numbers; dial conference, involving as many as four telephones; add-on conference, or dialing a third party into an existing conversation; variable call transfer, to switch an incoming call to another telephone at another location, and fixed-call transfer, which automatically switches calls to one of several other preselected locations. All these services are accomplished by dialing special codes without going through an operator.

Centralized control's flexibility is shown in the new tasks it can perform. Dialing additional digits from telephones already connected has the effect of asking the switching equipment to reverse its operation. This action is impossible with most telephone central-office equipment now in use, employing wired logic, relays without memories or mechanically locked switches.

Less special equipment than usual is required with centralized control, because such equipment can be briefly connected and then disconnected for use on other calls, through the fast action of electronic information processing, operating with recorded switching instructions.

## How the center works

In simple terms, the switching center has two main functions: to connect lines and trunks served by the center, and to provide access to the associated services needed to handle calls—ringing sources, signaling detectors and tone sources. A block diagram of the electronic switching center [p. 73] shows the principal components: the switching network with its associated terminal circuits that perform the physical functions needed to make connections, detect and generate signals; the high-speed central computer; a scanner and distributor that supply input and output communication for the central data processor; and the processor's stored program, comprising the instructions for performing all the switching tasks, arranged in ordered lists of words.

The newest aspect of the center is the computer-like central control unit and two kinds of memories—semipermanent and temporary. It directs and controls the actions of a central office on a time-shared basis.

The temporary memory or "call store" stores transient information used in processing calls. For example, it retains the digits dialed by a caller, and records whether the line is busy.

The Bell System's semipermanent memory or "program store" is unique because it is the first large-scale twistor memory. It stores the programs that direct the switching logic and translation information. Included in the first portion are the lists of instructions for performing all the services. These are part of the basic design of the machine and do not change from installation to installation. Any change in these is equivalent to re-designing and rewiring an electromechanical office. The big difference is that the change can be made by the computer without interfering with operation.

In the translation section of the semipermanent memory, on the other hand, are the specific layouts of the particular office: the association of subscriber directory numbers with the equipment loca-

tions of their lines, the classes of service to be provided—such as individual, two-party, coin, extended area dialing or touch-tone—and the specifications of trunk routes, their locations and alternate routes. All this information must be changed periodically as subscribers or their demands change.

An unusual feature of the computer's central control is that logic for performing information processing is wired, while the logic for telephone switching is contained in the computer program.

As a result, the hardware of the control complex, unlike that of a stepping-switch office, is independent of the type of telephone service to be provided. The same equipment can be used with different programs to provide additional services.

Input information for the central processor comes from scanners—wire-wound ferrite rods that have their magnetic saturation changed by the presence or absence of line currents. These scanners are connected to the various points in the system where information must be obtained: the lines, trunks and signal receivers. The scanners are directed periodically to the lines to detect service requests, to the trunks to detect incoming calls, and to signal receivers to detect digits and other control information. Recognizing this information involves periodic interrogation of all scanners, at random or in sequence, and recording the results of these scans in the temporary memory.

The signal distributor is the inverse of the scanner. It is connected to the various points in the system where actions must be controlled by the central processor. Central control can address the distributor to a particular terminal where a flip-flop or other memory device can be set to start an action. Later, central control can address the distributor to terminate this action.

In the No. 1 Electronic Switching System, distributor action is handled through two types of units. One is the central pulse distributor, which is all-electronic and is used for high-speed actions. The other, the signal distributor, makes use of a relay tree to perform lower-speed actions such as the control of trunk relays.

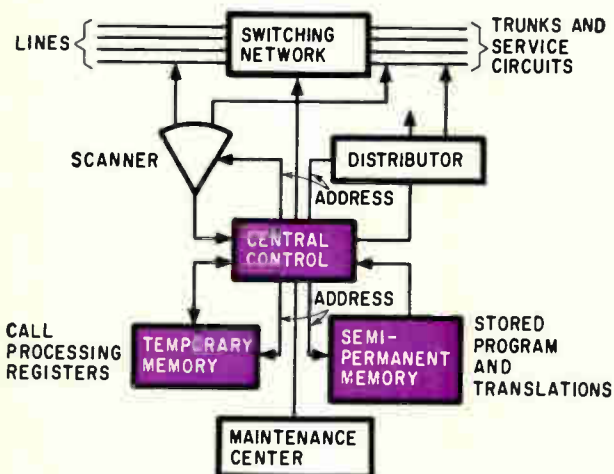

Central information processor in new electronic switching system depends on temporary and semipermanent memory. Program is stored in the semipermanent memory.

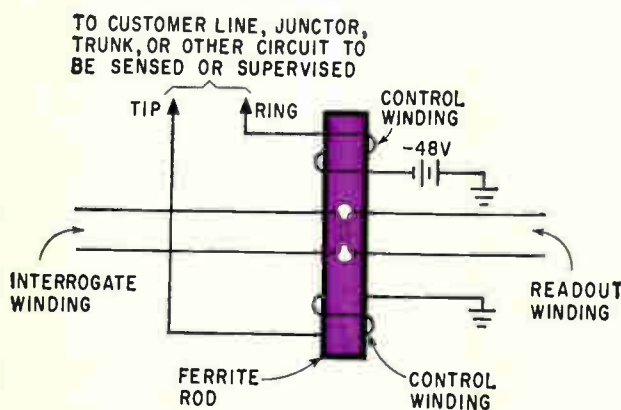

Typical ferrod used for sensor in scanning changes its characteristic when direct current flows through tip-ring connection.

### Central control

By far the most sophisticated portion of the new switching system is the central processor.

The memory stores both data and instructions, and a logic unit monitors and controls peripheral equipment by performing a set of operations dictated by a sequence of program instructions.

For the central processor to handle traffic in offices serving from 5,000 to 60,000 subscribers (the design range for No. 1 ESS switching), the number of memory units in the system is expandable over a wide range. To provide growth capability, the central processor's address registers, memory word size and address buses are designed to accommodate the largest office.

The stored program has to be error-free to as-

Continued on page 78

# Primer of telephone switching

Every telephone system, no matter how simple, must perform at least five basic functions. It must allow a caller to alert an operator or the party he wants to talk to; it must let him know if the called line is busy; it must get his message through; and it must signal completion of the call. It must also alert him to incoming calls.

The simplest telephone system for connecting two points as far apart as 10 miles is the magneto, or local battery type (diagram below). It has provided reasonably good rural service, even when connected into a network of fence wires or used with a single wire and earth ground.

Although only two stations are shown interconnected, rural communities have been served with 10 to 25 such telephone sets connected in parallel. Often, when such a system had no interconnection with any other, the operator's telephone was simply another magneto set connected across the line.

## First turn the crank

A hand-cranked magneto performs the alerting function. Because of its low impedance, it cannot be connected directly to the line except for ringing. While generating an alternating current, it activates a switch that is integral with the mechanical crank and gearing. When the crank is released the switch opens. A high-impedance alternating current bell is permanently connected across the line, sometimes in series with a large capacitor. When the magneto is cranked, each bell bridged across the line rings in synchronism.

The busy test is performed before ringing, simply by listening to determine if the line is in use. When the receiver—or in modern equipment the handset—is removed from the switch hook, the line is automatically connected through the secondary winding of the transformer or induction coil. At the same time, the primary circuit of the transformer, including the battery, is closed through the carbon-granule microphone or “transmitter.” The common connection of one end of primary and secondary through the switch hook simplifies switching.

When the user speaks into the microphone, his voice jars the carbon granules, causing a fluctuating

current from the battery to flow through the primary winding of the transformer. A resultant alternating current in the secondary is impressed across the line, and can be picked up by any receiver that is “off-hook” and bridged across the line. The speaker also hears his own voice; this effect is known as side tone. The conversation can be heard by anyone on the line.

## Switchboards for central control

As more telephones are added to the system, centralized control becomes necessary. Early switchboards used multipoint switches to interconnect a few lines. The technique of terminating lines on jacks and making interconnection with plugs and cords came early and still finds wide usage, especially for small telephone systems.

Each line is connected to a series of jacks connected in multiple that appear sequentially before each operator's position. She is thus able to make a connection to any telephone line in the central office. In addition, each line is connected to an answering jack with an associated line lamp that lights when the subscriber lifts his receiver off the hook. The line numbers do not necessarily appear in sequence at the operator positions; these can be rewired through cross connections if calls become too frequent or long in an existing grouping.

In principle, the plug-and-jack switchboard differs radically from a vast system of switches that could individually connect each telephone with any other telephone. It provides flexibility with a minimum of equipment. Although there aren't enough cord pairs to interconnect all pairs of lines at any instant, the number of delayed calls is light, even during emergencies. The multiple switchboard also makes it possible for every operator to have access to every line (up to about 10,000) without using an intermediate line or trunk that was required with early switchboards.

## Trunking between offices

The method of handling calls manually between telephone central offices is shown in the figure at the bottom of page 75. One office is designated Wal-

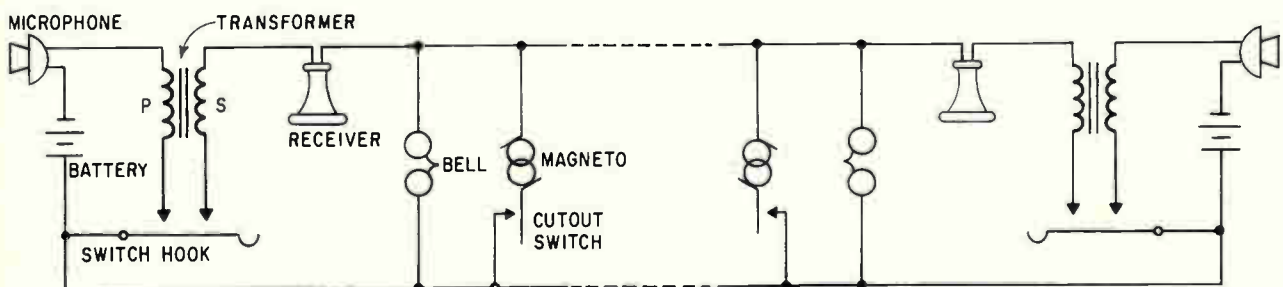

Two-station telephone system in which control is in the hands of users

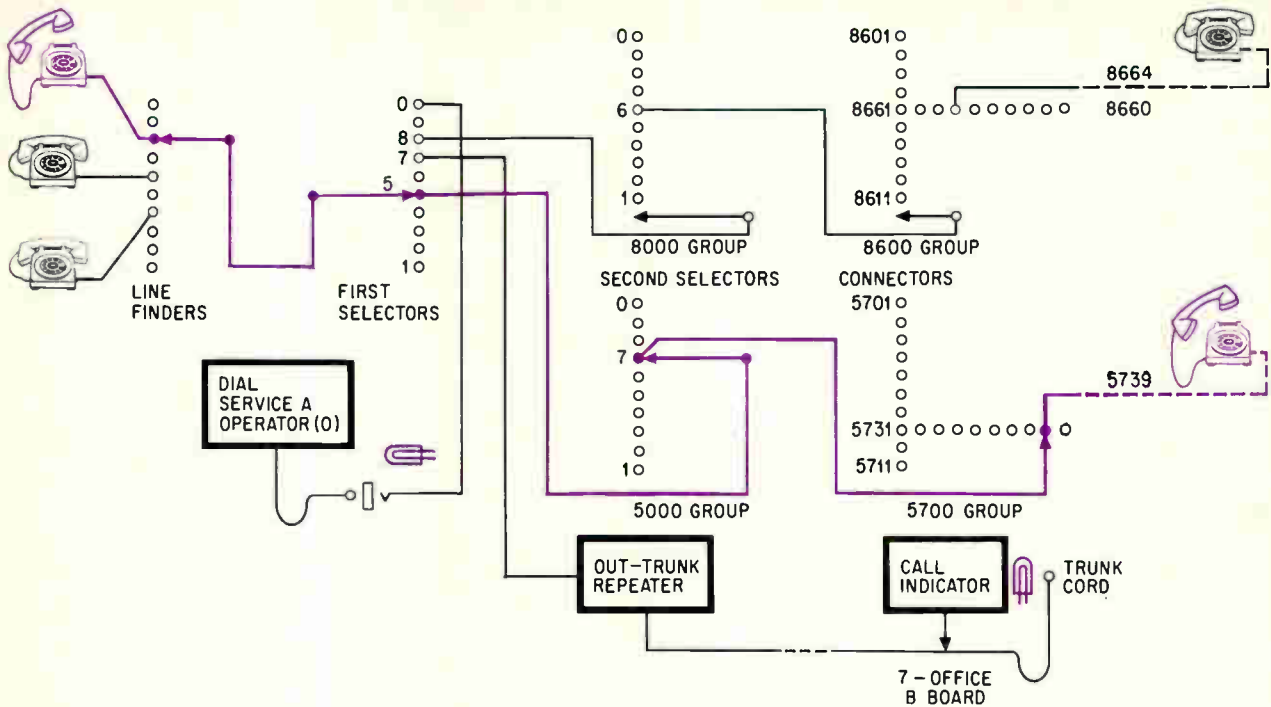

Step-by-step switching, with path between two lines shown in color.

nut, the other Hickory. Each office is equipped with two separate switchboards. The A board in each office is the same as that described previously, and handles calls originated by subscribers. Trunks to other offices are accessible to each A operator. The B operator has access to every subscriber in her office through a duplicate multiple-jack field, but she speaks only to other operators.

Since the trunking of calls between a multiplicity of offices in a congested area can require many trunks, some of which are seldom used, tandem offices are often provided. In principle the tandem office, interconnecting several offices indirectly resembles a central office in which many lines are interconnected without a requirement that each telephone be provided with a pair of wires to every other telephone.

### Switching step by step

The first automobiles were considered "horseless carriages" and had many features of carriages, including a whip-socket. In the same way, it was inevitable that the first telephone-switching machines should follow the methods of manual interconnection. However, the early development of step-by-step machine switching was sound. Today many thousands of step switches are in use and more are being installed.

A representative step-by-step central office is shown in the diagram above. The switches shown as circles, to which a moving arrow makes contact, are two-dimensional, as suggested by the two connector units at the extreme right. A vertical stepping mechanism lifts the wiping contacts to the desired level under the control of dial impulses. Connectors are then rotated by additional dial pulses; the selectors move automatically to a suit-

able contact at the horizontal level chosen. Customarily, stepping switches have 10 levels of 10 contacts each, numbered 11 through 00. However, several sets of wiper arms may be moved simultaneously on the same shaft to make separate connections with several banks of contacts.

When a subscriber lifts his instrument and closes the switch-hook contact, a line relay in the central office actuates a line-finder. The line-finder steps vertically, then rotates until it comes to rest on the contact representing the calling party. Similar contacts appear in different locations on about 20 line-finders that serve about 200 subscribers. In this way, when the first-choice switch is already in use,

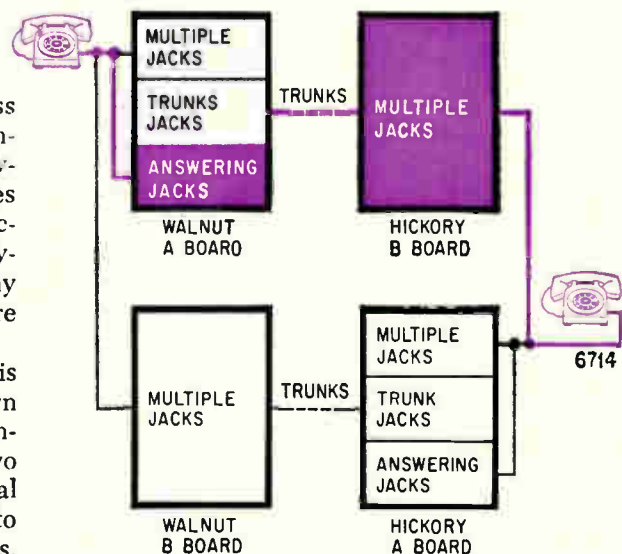

Trunk connection between two central offices from outgoing (A) board to incoming (B) board.

the second-choice switch takes only a little longer to find the line.

The step-by-step switching system uses a simple logic whose wiring corresponds to the voice communication path. Although it is properly known as a central office, the control is actually in the hands of the subscriber who dials the connections, digit by digit.

Once the switches are committed to the performance of the logical function, they must remain in position to provide the speech path. As a telephone system grows, and concepts like direct-distance dialing come into being, the simple digit-by-digit approach of step switching becomes cumbersome and requires supplementary equipment.

**Panel switching**

As the number of telephone subscribers increases, the interconnection of groups of subscribers—trunking—takes on new significance.

Step-by-step switching initially removed constraints imposed upon trunking by the manual switchboard. As neighborhoods merge, central-office designations become meaningless. In many places these designations have been eliminated in favor of straight numbering.

The necessity for even the numbers, or at least for allowing the subscriber to dial them to pulse specific selectors, becomes a new constraint upon trunking. It is conceivable that in a large, complex telephone system there is a better and more effective way to trunk calls between central offices than by a fixed pattern of dialed digits.

Recognition of these problems resulted during the 1920's in the development and installation of panel-type switching systems in large cities like New York, Boston and Chicago. Panel switching is highly mechanical and requires heavy maintenance, but it is still in use. Historically, it is important as the first common control system, a forerunner of the modern systems by which it is being replaced.

- In the panel system, the line finder makes use of the "big switch" concept by which many lines can

be concentrated to reduce the number of switching stages. A motor-driven switch, called a selector, moves upward to select a line, or trunk, and downward to return to normal. The motor runs continuously, and a smooth motion is imparted to the selector rod by a system of solenoid-operated clutches. Within the vertical frame comprising a unit, there are five panels, each containing 100 sets of terminals arranged vertically. By proper choice of wiper contact arm, each vertical selector rod has access to 500 terminals. There are generally 30 selector rods in each frame.

When a telephone in another central office is called, the decoder interprets the central-office number in terms of a preferred route, whose number may have no relation to the office number. Once the route is established, the sender transmits the remaining four subscriber digits of the original number and releases as soon as the connection is established.

Besides its central control features, the panel system is notable for having broken with the decimal system. Switch terminals are arranged in 500's rather than in a 10-by-10 array. The sequence switch used in control circuits is a cumbersome but effective mechanical device that performs the function of a computer subroutine even though invented years before modern computer equipment.

**Crossbar switching**

The first crossbar installation in a central office was made in 1937, less than 20 years after the first panel office was opened. This event marked a new direction in telephone switching.

The switch itself, shown in the diagram at the right, resembles an array of relay contacts. Although the actuating mechanisms are electromechanical, the switch mechanics have been reduced to a minimum. The heavy wire fingers attached to the horizontal select bar are positioned to actuate either the upper or lower multiple contacts, depending on whether the lower or upper select magnet is energized to rotate the bar. The contacts are closed only after the "hold" magnet pulls the vertical hold bar against the select finger. A crossbar switch comprises 200 sets of contacts, each uniquely chosen by operating the proper horizontal and vertical magnets. It is possible to establish 20 sets of connections at any time.

The No. 5 crossbar central office, described by telephone engineers as the most sophisticated electromechanical gadget ever built, has been installed in many locations since 1947. The crossbar switch establishes a speech path by direction of the marker [top of page 77] and is held in operation for the duration of the conversation; but it is not involved in the switching logic. For the example shown, eight sets of switching crosspoints are employed to connect the calling party with a telephone served by the same central office.

The system is based on a principle of highly centralized control in which control units, called markers, registers and senders, are used on an individ-

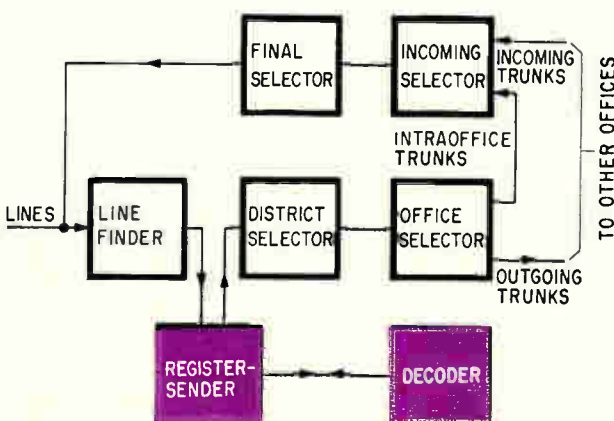

Panel-type switching is the first real step toward central control.

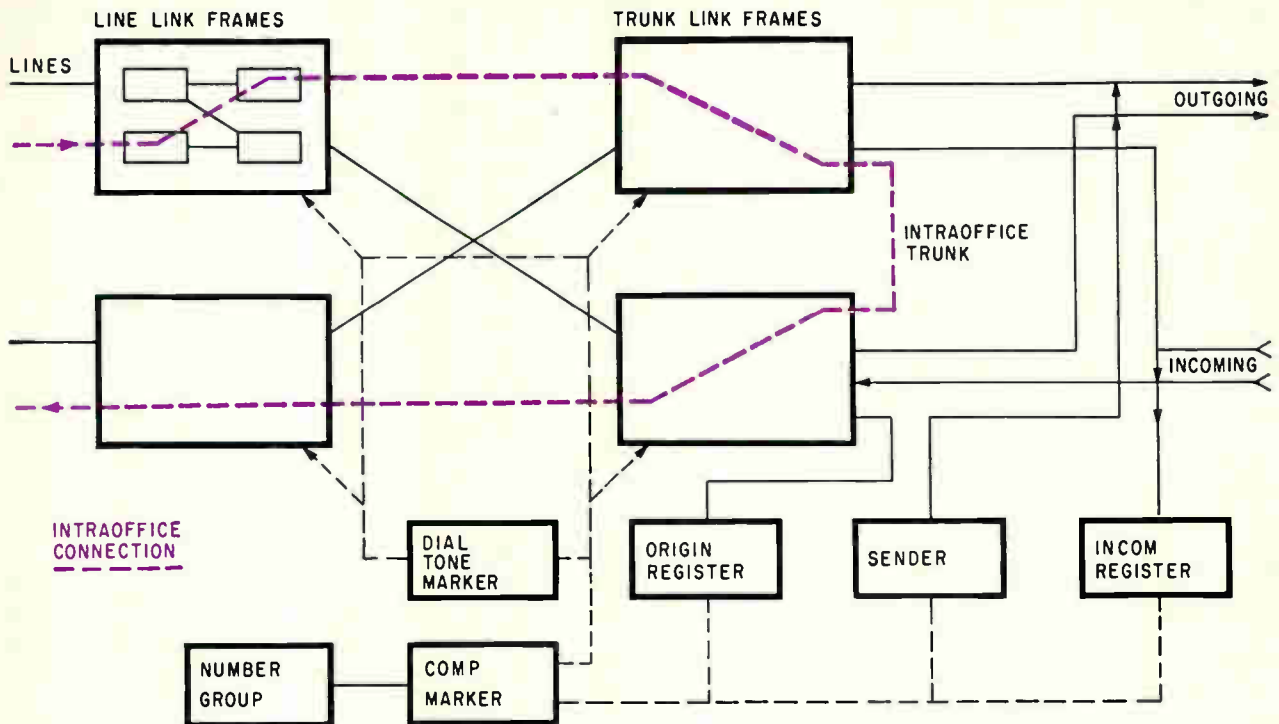

Crossbar office interconnection. Frames shown in color are held during a call. Other equipment is freed for new calls.

ual call only for the time required to perform specific functions and then are released to be used on other calls.

With the crossbar office, some elements of automatic data processing can be incorporated. For example, automatic message-accounting equipment can be connected into the circuits long enough to record basic billing information.

### Limitations

Telephone engineers think of No. 5 crossbar as the latest and best large-scale telephone switching system of its kind. Despite the improved and more flexible crosspoints and the radical centralization of

control, the system is taxed to keep up with the expanding needs for new service features and more complex trunking patterns. For example, instead of returning a busy tone, it might be desirable to allow the calling party to wait until the called party's line is free. In all present switching systems, the equipment becomes committed to a given condition and cannot "back up." Even when additional features can be engineered and hardware can be built, the additional costs of new features become prohibitive.

For these reasons if for no other, a new approach to machine switching had to be found. Because of the heavy investment in existing central offices, the newest equipment must not only do a better job but must compete economically. While Bell System operating companies plan an orderly replacement of their central office plant by the latest electronic switching, scientists and engineers are planning still another generation of telephone switching.

In the meantime, magneto telephones are still giving service all over the world. The Bell System alone still uses about 5,500 magneto sets. Although many small communities have been provided with machine switching in neat, unattended buildings, there are still 200 manual boards out of a total 12,000 central offices. But these are scheduled for replacement before 1970.

Panel switching offices were declared obsolete about 1937. Few new installations have been made since then. However, additional equipment necessary to keep service up to date and provide for growth in existing offices has been produced in quantity every year since.

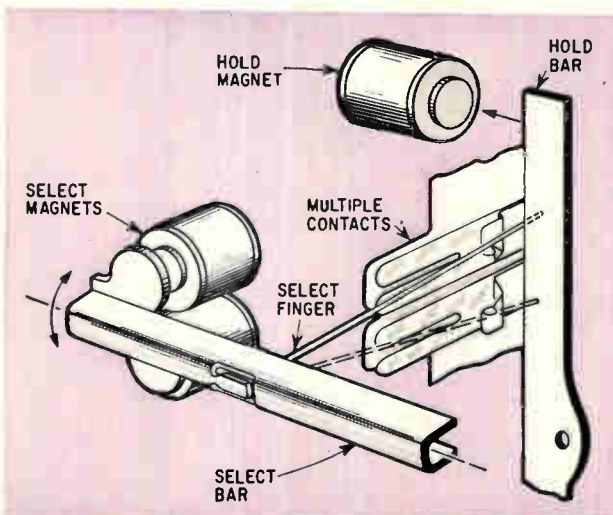

Crossbar select magnets operate finger up or down; hold-bar closes the contact.

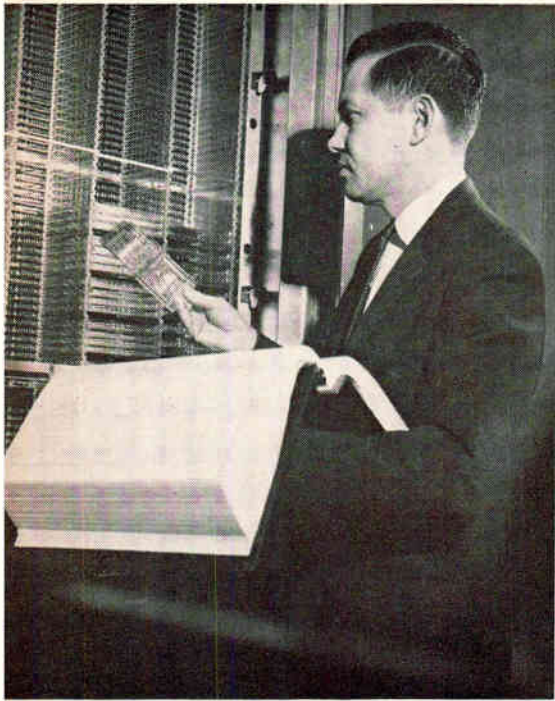

**R.W. Ketchledge** locates faulty equipment with a "trouble dictionary".

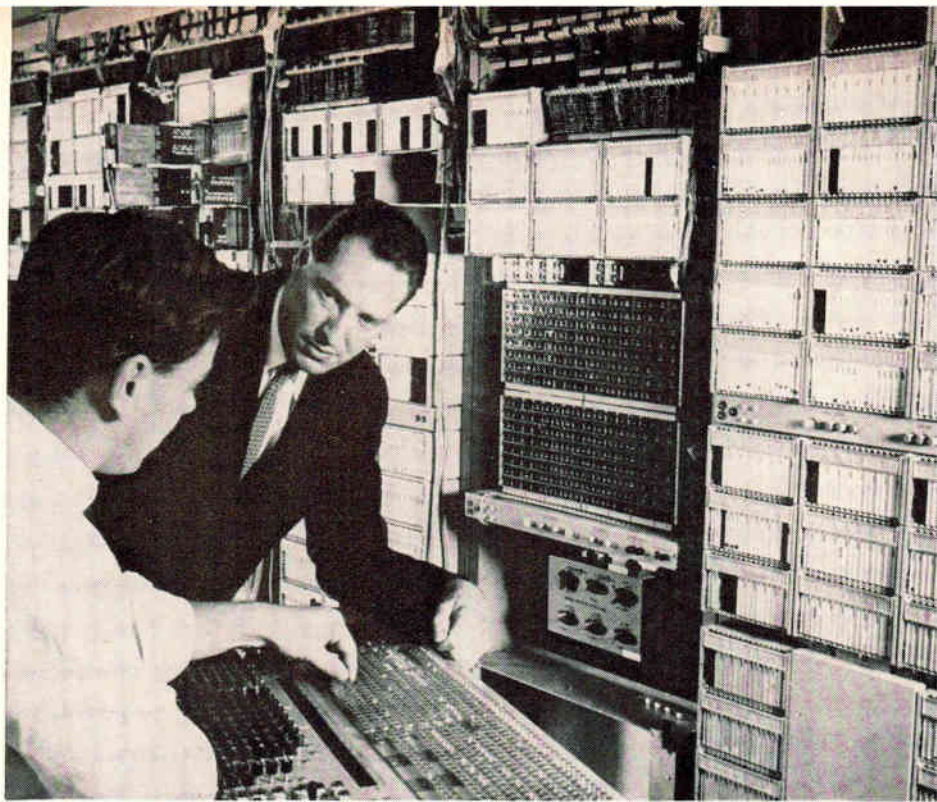

**Keywagon** used in initial testing of Succasunna, N.J. office traces faults on a unit-by-unit basis.

Continued from page 73

sure reliable telephone service.

For this reason, it is stored in semipermanent memory (the program store), which requires off-line operations to change it. In addition, there is a high-speed readable and writeable memory (the call-store) that stores call-progress data.

### Memory size

The semipermanent memory (program store), using twistors, operates on the basis of 44-bit words. Each unit memory card contains 64 such 44-bit words; 128 cards make up a standard module, and 16 modules form a unit store, the standard equipment unit. Two or more stores will be used in each central office. Each unit store thus is equivalent to a 256-by-256 matrix. Each matrix position can give access to two words, for manufacturing economy, so that the total capacity of each unit store is 131,072 words of 44 bits each.

Each 44-bit word consists of seven bits for parity and error-checking codes, 23 data bits and 14 operation bits. The parity and error codes are capable of detecting double errors and of automatically correcting any single errors that may exist in either the word bits or the word address.

All program-store information is stored in duplicate. In fact, double the necessary twistor-memory capacity is provided.

In the temporary ferrite-sheet memory (call store), 24-bit words are used, with one bit for parity check and 23 information bits. The call-store unit has a capacity of 196,000 bits, or 8,192 words of 24 bits each.

### The twistor memory

The semipermanent program store, as described, has a unit capacity of 5.8 million bits organized into 131,072 parallel words, randomly accessible in a single matrix. For the memory elements, Bell selected the twistor as the basic unit.

Reasons for using the twistor, rather than cores, tapes or other storage methods, included its economy of manufacture, short access time (the program-store cycle is 5.5 microseconds), small size, random-access capability, nondestructive readout, and the fact that the content is not affected by any kind of electrical failure. Even if the twistor wire itself is burned out by excessive current, its information will be preserved—an important factor in telephone-exchange operation.

The twistor element used here is essentially a read-out device; no writing is done electrically. The information is actually stored in the form of presence or absence of magnetization in a small permanent Vicalloy magnet placed near the twistor. The magnet controls the twistor's response when interrogated. The magnets, mounted on aluminum program cards, are programmed off-line in a machine whose function is analogous to that of a punched-card machine.

The twistor element itself consists of a thin (0.003 inch) copper wire with a tape of molybdenum permalloy wrapped helically around it at a 45° angle. A copper ribbon, the solenoid, runs at right angles to the wire. Thus two currents can be applied: a current through the copper wire of the twistor, or a current through the ribbon solenoid. The first produces a longitudinal magnetic field





Memory unit of No. 101 ESS time-division exchange uses a twistor memory similar to that in larger offices.

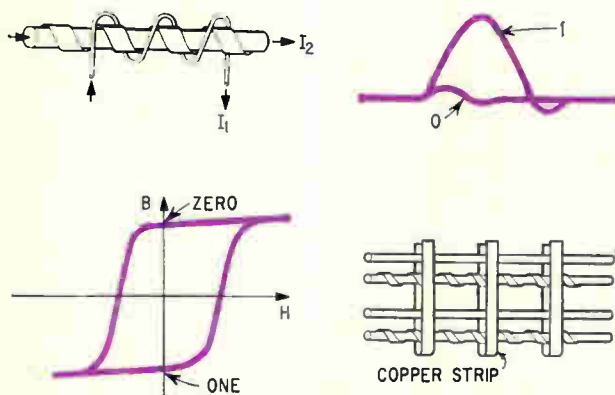

Conventional twistor operation depends on currents  $I_1$  and  $I_2$  producing a helical direction of magnetization in the moly-permalloy helix with a rectangular hysteresis loop. Large voltage is induced in reading a one and much less for a zero. Copper strips crossing twistor wires at right angles form word coils (Top, right). The new switching system uses a readout-only type of twistor, controlled by a small permanent magnet.

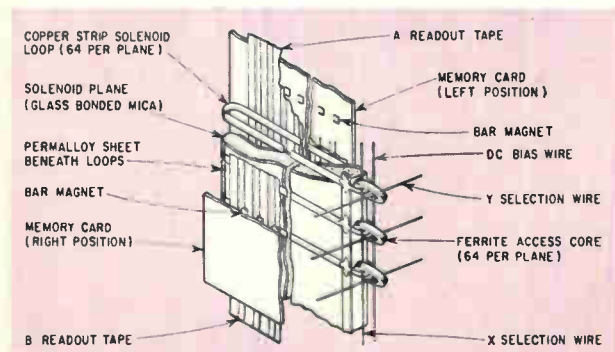

Basic elements of the permanent magnet twistor memory used in electronic switching equipment.

parallel to the twistor wire; the second gives a circular magnetic field normal to the copper wire. If both currents are applied at the same time, a helical field is produced in the direction of the permalloy tape. The permalloy is chosen to have an essentially square hysteresis curve.

If a program card containing the tiny permanent magnets is aligned so the magnets fall just above the intersection of each twistor wire and copper strip, the magnets exert a strong field on the twistor wire, preventing it from changing state. If the magnetic state of the twistor wire does not change when it is interrogated by applying both currents, there will be no output. Thus, a zero is stored in a bit by having a magnetized Vicalloy spot over it. To store a one, the Vicalloy spot on the program card is left unmagnetized.

The twistor modules used in the electronic switching system are shown (below left) in cut-away form. Coupled to the word strips or solenoid is a biased core switch matrix. A core is switched by the combined action of a horizontal and vertical half-select current, which overcomes a common bias current. The word solenoids are attached to the surface of an insulating board over which thin sheets of permalloy have been placed.

If the magnet is magnetized, it saturates a region of the twistor wire beneath it. The magnets are always magnetized in the same direction as the initial field of the word solenoid. When an individual word solenoid is selected by applying a half-select current to individual horizontal and vertical access wires, a current pulse is induced in the word solenoid. The resulting magnetic field acts on the twistor wire.

Because of the orthogonal geometry, no significant voltage is induced in the wire unless the magnetic material of the twistor wire is switched between states of magnetization. This can occur only at the sites containing nonmagnetized magnets. When the half-select currents are removed, the common bias current switches the selected access core back to its initial state. The resulting word solenoid pulse restores the twistor's initial conditions of magnetization.

For uniform outputs from the memory, the magnetic field applied to the twistor should completely switch its magnetization. In these modules, the magnetic field produced by the solenoid is concentrated onto the twistor wire by two mechanisms. The first is the underlying permalloy sheet, providing a low-reluctance return path for the field. The second is the conductivity of the aluminum magnet card which produces, through eddy currents, a magnetic barrier above the twistor wire. These two mechanisms help to reduce the drive currents required and the interaction between bits.

Each semipermanent memory module contains 64 boards with 64 solenoids apiece. Through the module, in accordion fashion, run two flat plastic belts, each containing 44 twistor wires and 44 adjacent return wires. A section of each tape is cemented to one side of each board. Each module provides space

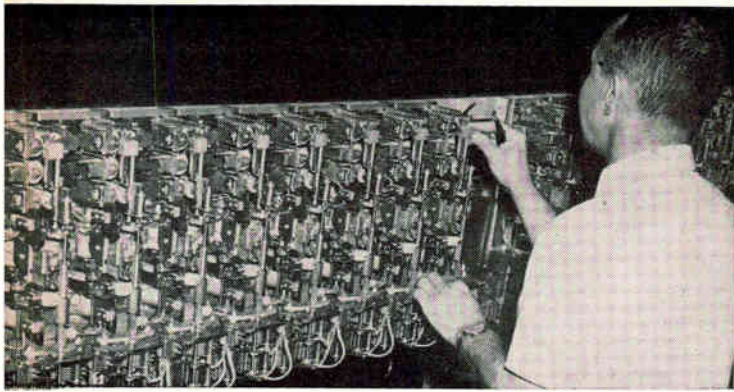

Bank of step-by-step switches under test by General Telephone & Electronics. This type of connector is still the backbone of dial telephone switching.

for 128 magnet cards. Each aluminum card carries 64 columns of 45 permanent magnets. Each column represents a word and each of the first 44 magnets (the 45th row is not used here) represents a bit of the word.

### Call store

The primary function of the call store is to provide an erasable storage for all call-related temporary information processed by the electronic switching system. Large capacity is required to handle conventional functions and others involving administration, maintenance, automatic message-accounting, teleprinter buffering and network control by map and queue techniques. Depending upon central office size, anywhere from 100,000 to 4,000,000 bits must be accommodated. For a compatible solution, a specific size was chosen as a modular building block. In practice, two stores are used with common-access circuits for both. Each information block is duplicated in the other store. Redundancy insures system reliability.

The basic memory medium is a multibit ferrite sheet with a 16-by-16 array of holes. A plated copper conductor forms the equivalent of a wire threading all 256 holes in series. Although some hand-wiring of stacks is necessary, the plating technique allows economical manufacturing.

The organization of a single-call store is chosen to provide a capacity of 8,192 words of 24 bits, or a total storage of 196,608 bits. The 24-bit word length and the 5.5-microsecond cycle do not exploit the maximum capability of the memory but are dictated by other system considerations. A median-size office of 10,000 lines with a calling rate of 13,000 calls per busy hour would need only two basic stores and another pair for redundancy. Smaller offices will require one store and a duplicate; large offices may need up to 40 call stores.

### The switching network

The use of the ferreed switch in an array that is comparable to a crossbar relay illustrates two interesting points. Despite progress in the design of semiconductor switching devices, none is yet avail-

able with sufficiently low capacitance and high resistance for use in a large switching matrix. Even in much smaller matrices, costs are high.

For the No. 1 Electronic Switching System, the ferreed switch is designed to be made economically as an array, not an assembly of individual crosspoints. Instead of winding the control coils individually and then connecting them in series, they are wound in rows and columns from continuous lengths of wire.

The basic ferreed switch unit is a glass-enclosed dry reed, so called to differentiate it from the mercury-wetted type. It is free from the effects of dust, corrosive atmospheres and ambient pressures, and relatively independent of temperature effects. Its contact resistance is less than 0.2 ohm during a million operations, its open-circuit resist-

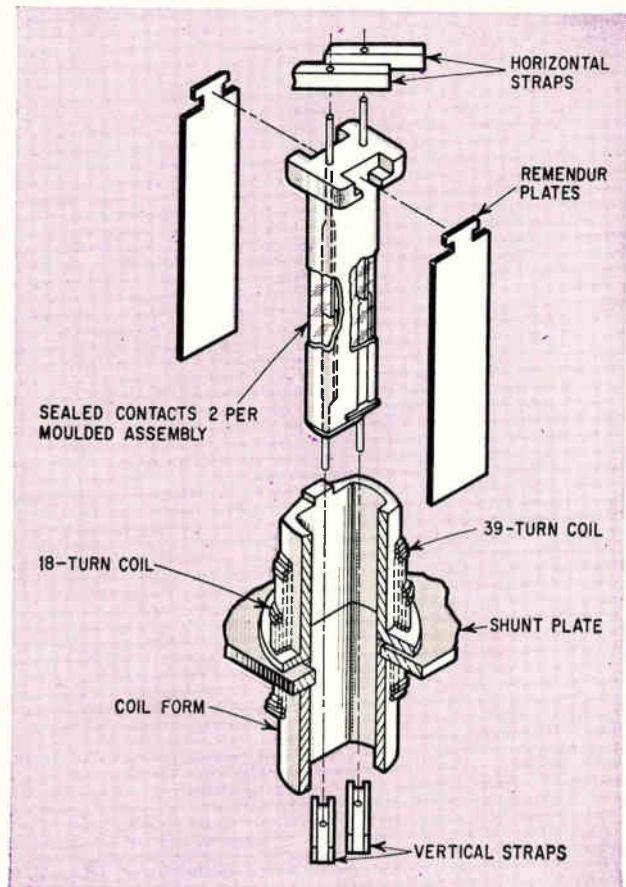

Two-wire crosspoint ferreed can be manufactured automatically, as this exploded view indicates.

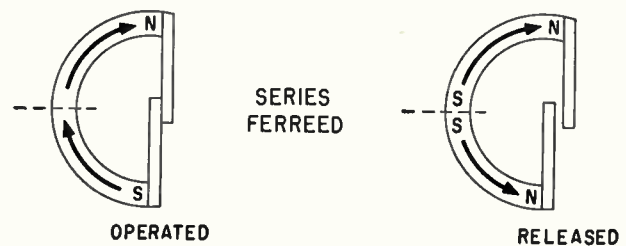

When magnetic windings aid, the ferreed switch is closed; a pulse that energizes windings in opposition releases the contacts.

ance is practically infinite and capacitance under the same conditions is about a picofarad. In combination with the proper devices, such a reed switch can be made to open or close with pulses as short as five microseconds.

Because the average telephone call between two subscribers requires the closing of eight sets of these contacts to establish a speed path, it is desirable that the contacts have a "memory" and remain closed without continued application of a holding current. At the conclusion of the connection, they must be capable of being restored or unlatched instantaneously.

The memory feature is accomplished by making the reeds of magnetic material and providing an external magnetic circuit or path containing high magnetic remanence. Operation or release of the contacts is controlled by setting the remanent members in one of two magnetic states with short current pulses.

The members currently in use are Remendur, a cobalt-iron-vanadium alloy with a square hysteresis loop that enables it to be switched with relatively low power. Far more temperature-stable than a ferrite used in earlier designs, Remendur has a remanent flux density of 16,000 to 21,500 gauss and a coercive force of 20 to 60 oersteds.

The series ferreed configuration used is shown simply at the left. When the magnetic fields are arranged in series to aid each other, the ferreed contacts close and remain closed. When they are in opposition, the contacts open and remain open.

The construction of a switching unit for a two-wire crosspoint is also shown there. The reeds are molded together in plastic to form a single piece and the two Remendur plates are positioned by the notches. The combined assembly is inserted

into plastic coil forms molded onto a steel mounting plate for the whole array, typically eight by eight units. The plate also acts as a common magnetic shunt, dividing each crosspoint into two controllable halves. This technique reduces the energy required to produce the release state, in which the two halves of the remanent members are magnetized in opposing directions.

### Coil connection

A differential excitation mode provides coordinate addressing crosspoints, at the same time automatically releasing other crosspoints associated with the same row or column. Each winding in a row comprises two opposed windings; the lower one has twice the number of turns. Each dual winding in a column is similar to the row windings, except that the double winding of a column is paired with the single winding of a row on one side of the steel mounting plate. The double-row winding forms a pair with the single-column winding beneath the steel plate.

When all the coils in a row are energized in series, each pair of ferreeds is released because the fields above the steel plate are opposed to those below. Similarly, when all the column coils are energized in series, all contacts in the column will release.

If a current pulse of the same polarity is introduced to the column and to the row of the desired coordinate at the same time, the effect of the double winding always overcomes that of the single winding. The composite effect in this case can be thought of as the upper column coil working in series, aiding the lower row coil to close the ferreed contacts at this point, and to release all other contacts in the same row and column.

---

## Choosing the hardware

**Equipment for telephone service** needs the reliability of space hardware but the mass-production design of consumer electronics gear.

It must have the reliability of an orbiting satellite device to last about 40 years—under a maintenance program—with outages totaling no more than a few minutes. Although the equipment and its construction cannot be compared to a mass-produced line of television receivers, the size of the telephone equipment market requires a high degree of economical mass production with high quality.

Because of the volume of components—to add a million lines would require 15 million diodes, 5 million transistors, 1.5 million circuit packages and 15 million ferreed crosspoints—engineers tend to standardize components.

An example of device standardization is the limi-

tation to only two kinds of transistors, the low-power 29A and the higher-power 20D. The low-power, low-current unit is used in logic circuits, audio amplifiers and oscillators and broadband feedback amplifiers and regulators. The 20D, which can handle up to 1.5 amp, is used primarily for memory access.

The choice of relays to actuate ferreed switches by high-current pulses is typical of a cost-conscious approach. A control structure had been designed using diodes and pnpn triodes, but it was rejected because it was too expensive.

### Design for dependability

The design of a machine to provide perfect service for 40 years with practically no outages requires among other things, redundancy, a main-

tenance and test program, and ability to repair by substituting components. In the new switching system, every system unit required to maintain service is duplicated. Moreover, all units must be monitored continuously; otherwise unrepaired faults may occur in duplicate units at about the same time.

The system is organized to allow rapid reestablishment of an operational machine. On a less urgent basis, the system itself diagnoses the defective unit and prints out the results on a maintenance teletypewriter. When offices are unattended during part of the day, an alarm is sounded at another location, where personnel are continually in attendance. If the trouble is minor, the repair can be deferred. A defective trunk circuit can be taken out of service with a teletypewriter message. Major troubles require dispatching personnel to the office location.

More than half the stored program instructions are used for maintenance programs. Some programs in conjunction with logic wired into the hardware detect and report faults. Other programs control routine tests and emergency actions, either eliminating faulty subsystems or reorganizing usable subsystems into a new operating combination.

Various classes of maintenance programs are arranged in a hierarchy of interrupt levels, such that when an error is detected the control system stops what it is doing, records where it stopped and, after proper maintenance, restores itself to proceed with normal operation.

### Errand boy

A maintenance man can ask the system, through the teletypewriter, to print out the contents of a particular memory location or to trace a call through the network from a given line or trunk. He can type in a directory number and ask the system to print out the associated equipment number as well as all other information the system has pertaining to that directory number. He can also order the system to perform a diagnostic test on some part of the system.

### Call-store buffer

In communicating with peripheral units, central control is able to transmit or receive a multibit word every 11 microseconds. By contrast, the teletypewriter can send or receive information at only one bit every nine milliseconds. A call-store buffer bridges the speed barrier as shown in the diagram on page 83. The buffer register can store as many as 60 teleprinter characters, or one line of type. After the complete message is assembled, it is withdrawn from the register, converted to electronic switching-machine language and delivered to the proper client program. The second stage of the buffer, with a capacity of 200 24-bit words, is used to assemble outgoing messages.

### Solving universal problems

Although many of the problems in central-office electronic switching are unique to the telephone

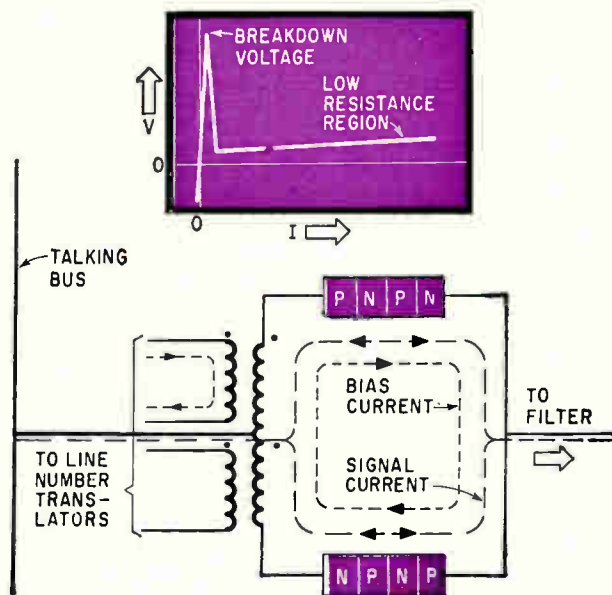

In time-division switching gate, when the diodes are in a low-resistance state owing to circulating bias current, bilateral signal flow is possible between the speed bus and filter. Graph shows breakdown characteristics of the pnpn device.

industry many of the solutions are of interest to other engineers because they solve switching and data-processing problems that are likely to appear elsewhere.

The advent of nanosecond logic circuits necessitated much closer cooperation between circuit and equipment designers than for relay switching systems. Wiring patterns and rules were developed to insure satisfactory switching speeds, circuit crosstalk protection and a consistent manufactured product. The 23-bit bus systems used for data-handling within the central control required unconventional circuit-pack organization because no bus-bit lead could exceed six feet in length.

In the program store, readout connections are made from the front, with cable running in shielded ducts, some running vertical and others horizontal. The cables are further protected from noise pickups by using close-twisted pairs and limiting to two inches the unshielded length of leads that connect to the twistor tapes.

Current regulators, at the top of the mechanical supporting frames (for heat dissipation), control access and bias near the diode matrix and access-switch circuits used with the semipermanent memory. Such control is important because tracking circuits on these units must maintain a 2-to-1 relationship between currents for bias and access drive.

Three conductors, carrying +24 volts, -48 volts and a common ground, run from power fuses to each power-distributing frame where low-impedance shunt filters (35,000-microfarad capacitor banks) are connected.

Individual equipment frame filters, usually choke-input L-type or capacitor-input pi-section,

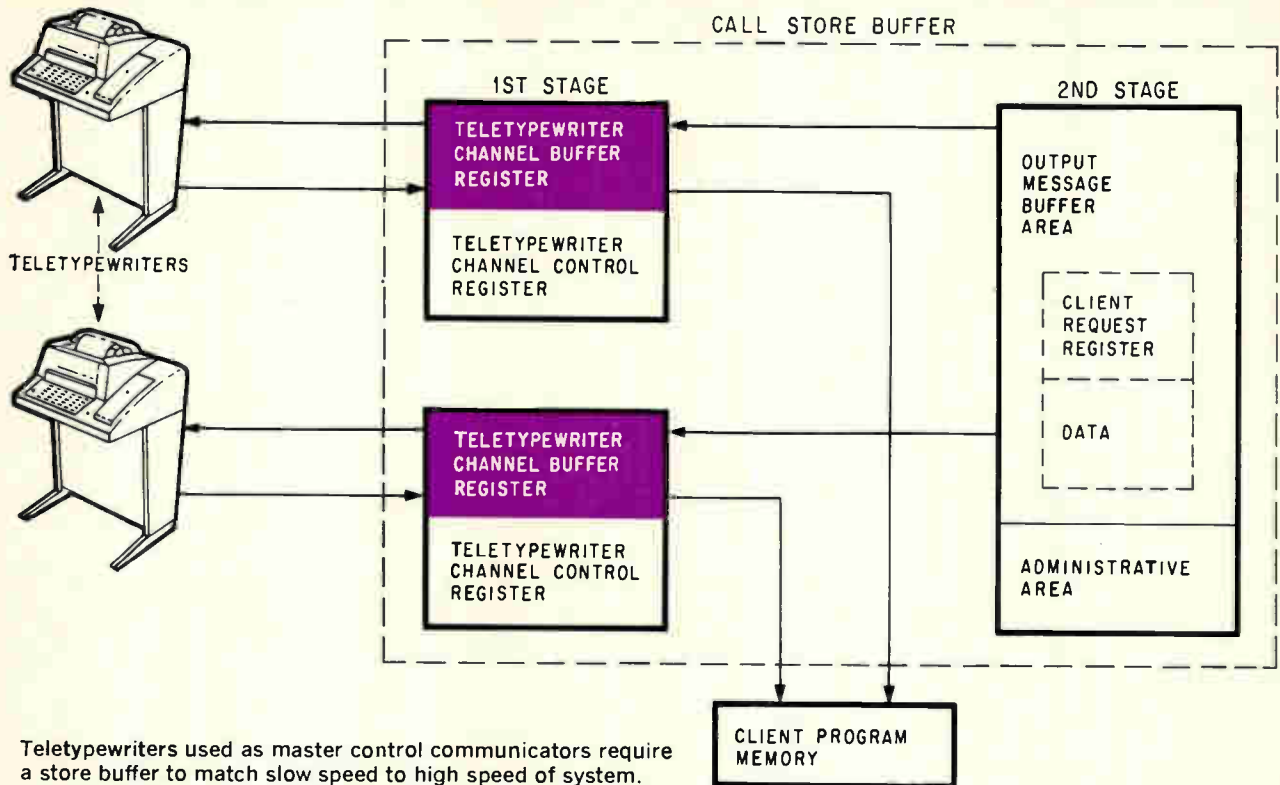

restrict the rate of change of current in the frame-supply feeders to less than 0.1 ampere per microsecond. This limits the noise produced at the power-distributing frame filter to less than one volt. The central filter can adequately attenuate the noise transmitted to other frames to less than 0.5 volt.

To minimize noise caused by stray ground circulating currents or by transient noise potentials within the building, all frames and the cable rack are insulated from the building at the time of installation. The frames and rack are bolted together and individually bonded to a No. 6 frame-aisle ground conductor. This ground network connects to the ground bars of the power-distribution frames to protect personnel. The power frames are interconnected with 750,000 circular-mil cables. This ground network is connected at only one point to the central-office ground, the protection-frame ground and the a-c power-entrance ground.

Pulse-signaling cables are relatively long and could pick up relay noise and carry it into vulnerable areas of logic. They are run as balanced circuits and brought into each frame through shielded transformers.

Interframe cabling uses a compartmented cable rack. The 0.5-microsecond unipolar and bipolar pulse leads are run in one compartment and the scanner cables are run in a shielded channel at the front of the cable rack. Separate cross-aisle racks maintain separation between the different classes of leads.

### Time division

Another variation on the electronic switching system employed by the Bell System is the No. 101.

Equivalent to a small PBX (private branch exchange) system, the No. 101 has been in operation in several locations, including World's Fair.

While the central-office system described earlier operates on space-division techniques, the 101 uses time-multiplexing, so that one channel can carry up to 50 conversations simultaneously.

The 101 consists of a central exchange with the necessary control and memory capacity, and controls up to 32 "satellite" switch units that may be located, say, at the offices of business customers. Each satellite switch unit has a memory capacity of up to 200 lines, and can handle as many as 50 calls simultaneously. Time-switching is done by the time-division network of each switch unit.

At the heart of the time-division switch are two pnpn diodes (diagram above). These devices have both a high-resistance state, during which the switch is open, and a low-resistance state, when the switch is closed. Normally, the diodes are in their high-resistance state. At a critical breakdown voltage they switch to low resistance, and are then kept in this condition by a circulating bias current. The bias current and the initial breakdown voltage surge are supplied by a line-number translator at the central office, through a primary transformer winding in the switch unit.

To complete the connection between any two lines, both lines are simply assigned to the same time slot by the central exchange. The switch samples each connected line 12,500 times a second, for a duration of 3.2 microseconds. Each bus can thus accommodate up to 50 lines. The sampling rate and time-slot width are more than sufficient to preserve fidelity of speech.

# How other companies do it

**While the AT&T System** may be the most extensive telephone organization in the world, it has plenty of company in its field. There are five other makers of switching equipment in the United States and about 12 in the rest of the world.

A few of these companies are also seeking more sophisticated switching systems. Because competition is fierce, most of these concerns tend to be reluctant to discuss pending developments.

There are also extensive governmental systems, but most of these are shrouded in military secrecy.

Bell serves all of the United States, with other companies connected into the nationwide Bell System. That confronts Bell with greater problems of distance than for any other major company except the state-owned Soviet system.

When you leave the United States, the number of telephones in any country falls sharply. There are 81 million phones in the U.S., about nine million each in Britain and Japan, seven million in West Germany and 6.3 million in Canada.

## Independent manufacturers

Among the manufacturers of non-Bell telephone switching equipment in the United States are the Automatic Electric Co., a subsidiary of the General Telephone & Electronics Corp.; ITT Kellogg Communications Systems and ITT Kellogg Telecommunications divisions of the International Telephone and Telegraph Corp.; the North Electric Co., and the Stromberg-Carlson division of the General Dynamics Corp.

General Telephone expects to cut-over a 2,400-

---

## Present systems called 'semielectronic'

Most people and organizations working on electronic systems are currently exploiting semielectronic systems with metallic crosspoints to establish the desired voice paths.

An invention or discovery is needed before fully solid-state matrices become practical in large central offices. The ideal crosspoint matrix will reduce crosstalk to acceptable levels, will have very-low loss in the forward direction, and will handle the alternating-current ringing power required by existing standard telephone sets.

Formulating the program for a fully stored-program system is both time-consuming and costly. Efforts are being made to reduce this complexity by using partly wired and partly stored programs as well as through use of both main and subroutines.

There are some indications that current success in miniaturizing electromechanical components will make them attractive for continued use in semielectronic switching systems.

The systems we know and those that are on the drafting boards are still not the ultimate in electronic switching.

Oscar Myers

Director of Switching Development

International Telephone and Telegraph Corp.

line high-speed semielectronic switching office in Portage, Ind., this month. The Automatic Electric development is called E-A-X for electronic automatic exchange. Subscribers will be offered call-forwarding, conference calls, call-waiting tone, abbreviated dialing and authorization codes that prohibit placement of unauthorized direct-distance-dialing calls from a telephone.

Crosspoints are three encapsulated reed switches called correeds. Two windings are used, one to operate and the other to hold. Two of the contacts establish the transmission path while the third locks the correed in its operated position.

Electronic controls are designed around germanium-alloy medium-speed transistors. These are generally pnp, 150-milliwatt types with their npn complements. Gold-bonded germanium diodes and some silicon diffused-junction diodes are also used. A register-sender memory of ferrite cores records the routing information contained in a magnetic drum and uses this information to direct the switches. The magnetic drum has a capacity of 12,000 40-bit words.

## Diode crosspoints

ITT Kellogg Communications Systems has produced over 30 electronic automatic central offices for the military, and the ITT Kellogg Telecommunications division is marketing a commercial version. Although space-division switching is used, in which signals travel on separate paths, it is provided by a matrix of four-layer pnpn diodes. When the actual matrix inlet and outlet are actuated by voltages, a string of diodes becomes automatically conductive across a multiple-stage matrix to form a speech path. Crosstalk for military equipment is better than 60 decibels from 300 to 3,500 cycles for small matrices. Register and translator memories are ferrite devices of an undisclosed nature.

## Time and space

Switching centers developed by North Electric for the Air Force were completed in 1962. Since time-division switching is employed, in which signals occupy different time slots over the same path there are no electromechanical crosspoints and the system is more entirely electronic. The speech path is controlled by ferrite memories.

The directory number, class marking, route numbers and related information are stored in a non-destructive memory, inexpensively constructed with normal single-aperture ferrite cores using a technique invented at Telefon AB L. M. Ericsson of Sweden. Broad studies are in progress in time-division multiplexing, common control organization and integrated circuits, with the idea of applying the results to commercial as well as military applications, but no details are available yet.

## Delay line

Stromberg-Carlson's EPBX is based on a time-divided speech-crosspoint array made up of a 100-channel highway with a sampling repetition rate of 10 kilocycles. The speech transmission circuits and the common control use the same time base. Magnetostriction delay lines are used for memory.

Stromberg-Carlson put an electronic community dial office into operation in Etna, N. Y., in 1962. Work is also going on in space-division systems. The company has also introduced electronics into independent central offices through a register sender that provides common controls for existing step-by-step switching offices.

## The Netherlands

At Hilversum, engineers at Philips Gloeilampenfabrieken N.V. are working on what they call experimental electronic central offices. One office will soon go into operation in Utrecht, the Netherlands, and another in Copenhagen, Denmark. At these locations, and in other experiments, space-division switching is used with pnpn transistor crosspoints. Ferrite core memories of an undisclosed form are used for storing subscriber information as well as program. The common control equipment works on a time-division basis.

Information read out from the memory cores has to be rewritten separately and therefore must be temporarily stored in an auxiliary memory. The switching network resembles a crossbar in that it consists of four switching stages, but is different in that the speech path passing through four transistors is single-wire (to save transistors) and thus requires transformers to match paired lines to unpaired speech paths. The exchange has a capacity of 1,000 directory numbers.

## West Germany

In West Germany, Siemens & Halske A.G., in Munich, Standard Elektrik Lorenz A.G. (an ITT affiliate) at Stuttgart and Telefonbau und Normalzeit GmbH of Frankfurt have contracts with the Post Office covering prototype installations in their respective cities. Telefunken is negotiating for a government contract. The post office operates the telephone company in many European countries.

The Siemens installation in Munich handles 3,000 subscribers in a space-division system with encapsulated gas-filled reed contacts. Called ESM-II, the system uses a relay-register memory.

Standard Elektrik calls its HE-60 system quasi-electronic. It uses hermetically sealed contacts surrounded by relay coils to perform the path-switching function in space division. Germanium and silicon semiconductor devices are used. Ferrite ring storage is used for both the register and the routing translator. The register is released when the call has been assigned a path.

Telefunken is working on a small semielectronic telephone exchange that uses so-called ordinate holding switches, employing unencapsulated contacts in contrast to the protected contacts more

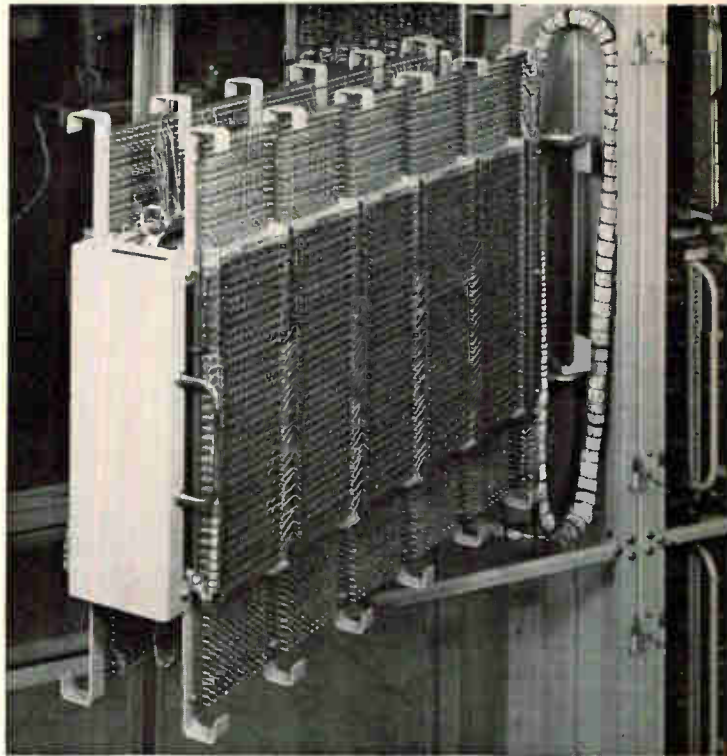

Temporary memory module of an experimental electronic telephone exchange built by Philips Gloeilampenfabrieken, N. V., at Hilversum in the Netherlands.

generally used. But Telefunken engineers believe they have a highly competitive device because of small size and economical manufacture. The company describes the system using the new switches as one-at-a-time division rather than space division. No decision has been made on the type of memory since their small systems need none. Large systems will probably use ferrite cores.

Telefonbau und Normalzeit will put into service in Frankfurt at the end of the year a 1,000-line office using FSK flat-reed space-division crosspoints. The gas-encapsulated contactors have a reed cross-section half the size of conventional types, and employ a flexible gold-diffused metal reed. The register employs a core memory. Wired logic elements are used in the translator to set up the dialing-code translations. Changes are made by replacing the printed-circuit logic cards.

## Belgium

The Bell Telephone Manufacturing Co., an ITT affiliate, started studies for a full electronic telephone switching system in 1956. Previously, gas tubes and selenium diodes had been used for functions such as call detection (replacing line and cut-off relays). Later, electron tubes, gas tubes and selenium diodes were also employed for switch-outlet selection and crossbar-switch control. At present, the company has control equipment capable of serving 10,000 subscribers, using transistor crosspoints in a time-division system. Group slave memories use nickel delay lines. Ferrite stores handle assembly and storage of dialed digits, and capacitive

read-only stores, which are inexpensive, are used for such functions as line translation.

### Great Britain

The General Post Office is the main customer in Britain for electronic telephone exchanges and the main initiator of research and development programs. In December, 1962, the first British electronic exchange was put into operation at Highgate Wood, London. An experimental installation, it ran as an alternate to the existing electromechanical exchange, being switched in and out for tests. It operated satisfactorily, but was not economical. Because it used a special version of time division, it required a large amount of ancillary equipment to make it compatible with existing equipment.

As a result of this qualified success, five companies were asked to develop a space-division central office: Associated Electrical Industries, Ltd., Automatic Telephone and Electric Co., Ericsson Telephone, General Electric, Ltd. and Standard Telephones and Cables, Ltd., an ITT affiliate. Two additional time-division exchanges were cancelled at that time. The office being built for Leighton Buzzard will use reed-relay cross-points.

Pye Telecommunications, Ltd., has a private automatic exchange using gas-tube diodes, and is anxious to move into the field of large exchanges. Other manufacturers are experimenting with solid-state or cold-cathode electronics, but are unwilling to discuss their equipment.

### Sweden

The Swedish Telecommunications Administration estimates that electronic switching is about three years away. It will not be the same as Bell System equipment because the speed path will be established through crossbar switches or the code-bar types rather than reed relays. Some of the development will be done by Ericsson.

### France

Government and industry cooperate in running a telephone development laboratory in Brittany. The Aristote system, using pnpn transistor cross-points, is its foremost switching development but has not been installed in service anywhere. Advanced experimental and military work in pulse-code modulation systems has been done by Laboratoire Central de Telecommunications.

### Japan

The most recently installed telephone equipment in Japan is up to date; some of it is the most modern crossbar built under license. The value of central control is recognized, and researchers are investigating many different electronic approaches, including stored programs. There's good reason for this interest in small modern equipment. Telephone usage in Japan is expanding at a rate of more than a million telephones a year, and land prices in overcrowded urban areas are fantastically high. Owing to earthquake hazard, the present prac-

tical limitation to building height is about 10 stories.

Of particular interest is the Nippon Electric Co. type NS-2A, 60-line semielectronic PABX, units of which are already in service. The principal components are crossbar switches, reed relays for tree circuits and connectors, wire-spring relays for trunk and line circuits, mercury-contact relays and semiconductor packages. There is a core memory matrix, a ring translator and a metal-card permanent memory.

### Acknowledgment

The author is grateful to the many individuals in the telephone industry for information they have supplied, with particular thanks to W. Keister and R.W. Ketchledge of Bell Telephone Laboratories and Oscar Myers of International Telephone and Telegraph Corp.

### Bibliography

- E.G. Andrews, "Telephone switching and the early Bell Telephone Laboratories computers," Bell System Technical Journal, March, 1963, p. 341.
- R.M. Averill and R.C. Stone, "No. 101 ESS: the time-division switch unit," Bell Laboratories Record, Dec., 1963, p. 425.
- Bell System Technical Journal, Sept., 1964, Parts I and II.
- A.H. Bobeck, "A new storage element for large-sized memory arrays—the twistor," Bell System Technical Journal, Nov., 1957, p. 1319.
- E.M. Deloraine, "Telecommunications in Western Europe", Globecom VI, available from International Telephone and Telegraph Corp.
- H.S. Feder and A.E. Spencer, "Telephone switching," Scientific American, July, 1962, p. 132.
- A. Feiner, "The ferreed," Bell System Technical Journal, Jan., 1964, p. 1.
- R.A. Higonnet and R.A. Grea, "Logical design of electrical circuits," McGraw-Hill, New York, 1958.
- Waldo Holcombe, "Relays that challenge semiconductors," Electronics, Mar. 23, 1964.
- E.G. Hughes and R.G. Taylor, "The No. 101 ESS control unit," Bell Laboratories Record, Feb., 1964, p. 61.
- W. Keister, A.E. Ritchie and S.H. Washburn, "The design of switching circuits," D. Van Nostrand, Princeton, N.J., 1951.
- A.C. Keller, "Recent developments in Bell System relays—particularly sealed contact and miniature relays," Bell System Technical Journal, Jan., 1964, p. 15.
- A.D. Starbird, "Automation and the Defense Communications System," Signal, May, 1964, p. 26.
- G.R. Stibitz and J.A. Larrivee, "Mathematics and Computers," McGraw-Hill, New York, 1957.
- O.H. Wilford, "The No. 101 electronic switching systems," Bell Laboratories Record, Nov., 1963, p. 374.

### The cover

In the Bell System's electronic switching center, the ferreed switch is manufactured as an array, rather than as an individual unit. The photo shows how these units are built commercially.

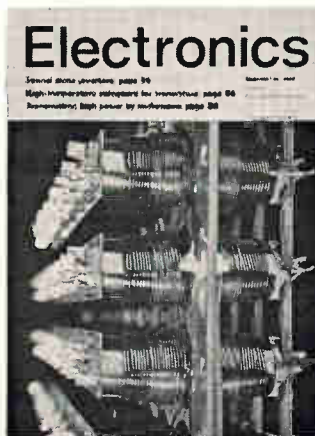

Reprints of this article are available. Use the reader service card at the back of this issue.

© copyright 1964 Electronics © A McGraw-Hill Publication



# LOOK TO THE LEADER...

## for dielectric solutions such as these...

Solve your electrical and electronic insulation problems with the family of the world's most *nearly perfect* insulation materials! They offer a unique combination of advantages: inorganic formulations; *total* dimensional stability; high-dielectric strength; true hermetic seals; high-arc resistance; high-temperature resistance; thermal expansion close to that of stainless steel. Send today for new 36-page, color catalog.



**MYCALEX**  
CORPORATION OF AMERICA

*World's largest manufacturer  
of ceramoplastics, glass-bonded mica  
and synthetic mica products*

125 Clifton Boulevard, Clifton, N.J.



**SUPRAMICA® 560** ceramoplastic — precision-molded insulation, specified for thin-wall sections and low specific gravity. Shown: gyro component.



**SUPRAMICA 620 "BB"** ceramoplastic — precision-molded insulation, specified for high-insulation resistance and true hermetic seal. Shown: accelerometer header.



**SUPRAMICA 555** ceramoplastic — precision-molded insulation, specified for ability to mold-in metal inserts and dimensional stability. Shown: coil form.

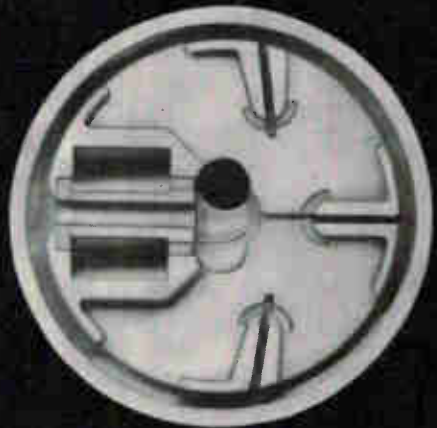

**MYCALEX® 410** glass-bonded mica — precision-molded insulation, specified for detail choice and arc quenching characteristics. Shown: lightning arrester component.

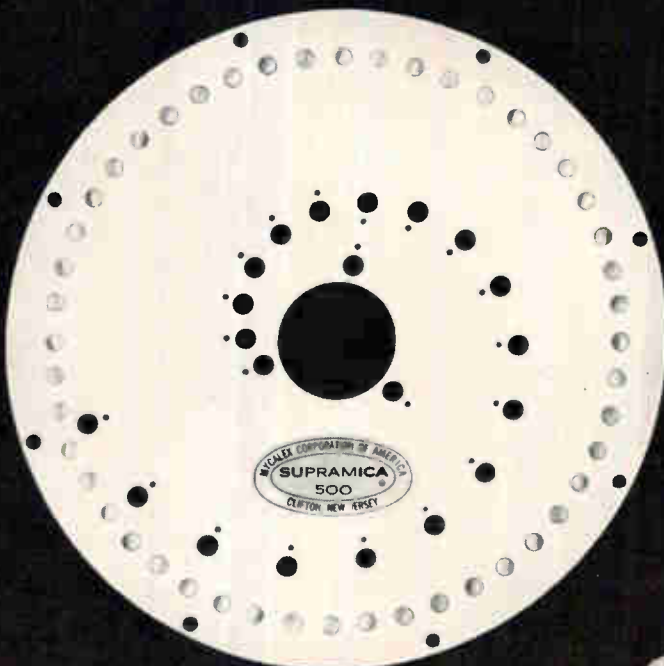

**SUPRAMICA 500** ceramoplastic — precision-machineable insulation, specified for dimensional stability and machineability. Shown: sonar scanning disc.

**SUPRAMICA 620** ceramoplastic — precision-machineable insulation, specified for operating temperatures to 1550°F. Shown: insulating bushing.



**MYCALEX 400** glass-bonded mica — precision-machineable insulation, specified for dimensional stability and machineability. Shown: printed-circuit memory panel.



## **Productivity Index**

*(How do your people rate?)*

North Carolinians are an independent lot; you've got to earn their loyalty. Then they stick like cockleburs. Their interest in their jobs shows up in figures like indexes of productivity (highest in the nation)—and profit and loss statements. Eager to learn, eager to complete the transition from farm to factory, the North Carolina worker is one of the best reasons why plants located here thrive. Access to major markets, availability of good plant sites, excellent transportation facilities . . . they're all parts of a picture you should study. Write Governor Terry Sanford, Raleigh, for an industrial information package . . . free (and confidential) of course.

**GO NORTH  
CAROLINA**

WHERE GOOD GOVERNMENT IS A HABIT



## psi in the sky

### Or, the reasons why so many aerospace contractors insist on this CEC Pressure Transducer

CEC's 4-390 is a chamber-type instrument that assures absolute and gage measurements of fluids and gasses in pressure ranges of 0-100 psi to 0-5000 psi.

Success of the 4-390 is due, of course, to its advanced design. For it is a high-output, unbonded strain gage transducer with integral, solid-state power supply and amplifier.

And just look at the 4-390's specifications!

- Excitation circuit isolation — 100 megohms min. between output and primary power ground at 50 volts d-c.
- Linearity and hysteresis —  $\pm 0.5\%$  max. of full range output, combined effects.

- Frequency response — flat within 0.1 db from d-c to 10,000 cps.
- Compensated temperature range —  $30^{\circ}\text{F}$  to  $200^{\circ}\text{F}$ .
- Repeatability — 0.1% of full range output.
- Altitude — 0-60 psia ambient without effect.
- Shock — 100 g half-sine-wave for 10  $\pm 5$  ms without damage.
- Weight — 10 oz. max., excluding mating connector.

Obviously, CEC's 4-390 is made to order for maintaining superior performance characteristics in extreme acceleration, vibration and shock environments.

Equally important, the 4-390 is a quantity produced standard item. Variations are also available for specialized environments or unusual structural applications. And, CEC has the facilities and design capability to produce even more advanced instrumentation to meet the ever-changing demands of pressure measurement.

For complete information about the 4-390 High Output Pressure Transducer, call or write for Bulletin CEC 4390-X16.

**CEC** Transducer Division

**CONSOLIDATED ELECTRODYNAMICS**  
A SUBSIDIARY OF BELL & HOWELL/PASADENA, CALIF. 91109  
INTERNATIONAL SUBSIDIARIES: WOKING, SURREY, ENGLAND  
AND FRANKFURT/MAIN, GERMANY

Circle 89 on reader service card

# What makes us think we can enter the highly competitive counter field?



## A GREAT COUNTER, OF COURSE!

Here's good news for users of electronic counters — a new line of competitively-priced counters with the finest quality available at any price. The 2 mc and 300 kc models launching the line (50 mc coming soon) prove the point beautifully by providing traditional NLS quality at lower cost.

*And that's why we have the audacity to enter the crowded counter field.*

You've got to look at an NLS counter to see what we mean by NLS quality. You'll find no production short cuts. Virtually all circuits are mounted on plug-in boards (only exceptions are some power supply components, front panel switches, a few resistors) . . . boards themselves are beautifully constructed on epoxy fiberglass . . . all-transistor design with 25 w. dissipation eliminates any need for a fan. Both the 2 mc and 300 kc models measure frequency, frequency ratio, period and multiple period average as well as totalize.

Features? They're loaded with them. Input sensitivity of 0.1 volt . . . input impedance of 1 meg and 60 pf . . . selectable ranges of 1/10/100 v . . . digital output in decimal or BCD . . . stability of 5 parts in  $10^7$ /month . . . wide range for both  $f_1$  and  $f_2$  in frequency ratio (2 cps to 300 kc in 300 kc model and 2 cps to 1.2 mc in 2 mc model). All amplifiers, all decades, and all gates are self-checking.

All this plus unsurpassed service to protect your instrument investment — from NLS engineering/service centers throughout the country.

**SEE AN NLS COUNTER IN ACTION.** No obligation . . . no pressure. The instruments will do our talking for us.

NLS 2810 (2 mc) complete: \$1,240

Other Series 2800 counters are available with 300 kc range, or with less accuracy and fewer features — at lower prices, of course.



*Originator of the Digital Voltmeter*

**non-linear systems, inc.**

DEL MAR, CALIFORNIA

Phone: (714) 755-1134

**AUGUST 27, 1962**

**Mariner II interplanetary probe launched from Cape Kennedy; successful midcourse correction of orbit brings it close to Venus.**



Many of the outstanding achievements in science and technology during the past 10 years have been recorded, analyzed and preserved on tapes of "Mylar." When reliability counts, count on "Mylar." \*Du Pont registered trademark for its polyester film.



BETTER THINGS FOR BETTER LIVING ... THROUGH CHEMISTRY

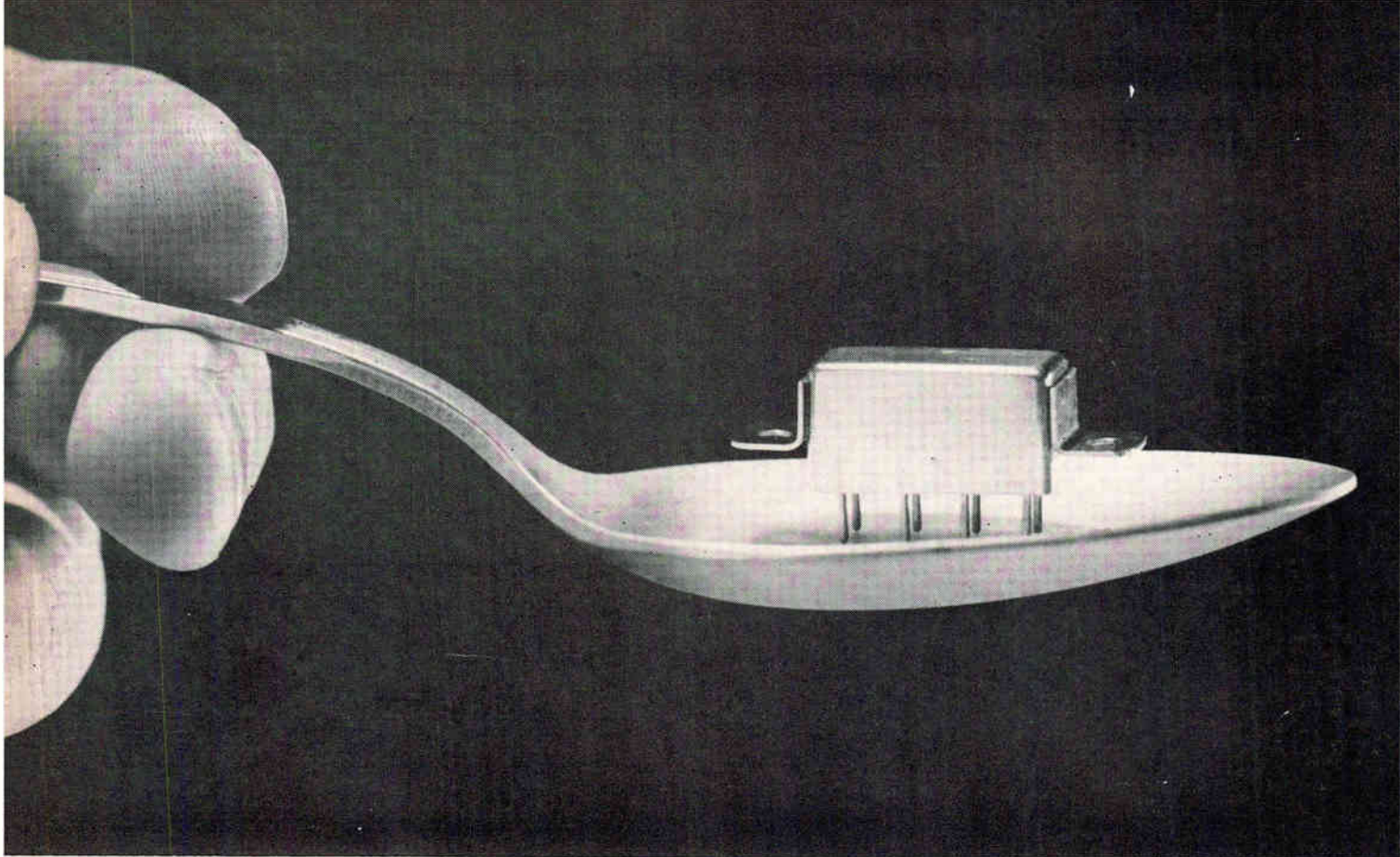

*New from Cook — Half Size Crystal Can Relay*

# Prescription for printed circuits!

*New from the manufacturer of military approved components with 24 years of experience*

Now, the unique design of new Cook half size and full size crystal can relays provides extra dependability in 2 amp 2 PDT switching for electronic control and aerospace applications.

**Trouble-free.** These new relays are designed with a single coil and use homogeneous contact material to reduce troublesome heat rise. Teflon insulated wire guards against contamination. Produced under precisely controlled "white room" conditions for maximum reliability.

**Vibration-proof.** Balanced armature design eliminates problems resulting from shock and vibration.

**Low power operation.** Highly efficient magnetic circuit allows operate sensitivity of 300 mw.

**Compact.** Half size relay is only .400" high and .800" long. Full size relay is .875" high and .800" long. Ideal for use in the close quarters of printed circuits.

**Meets MIL-R-5757D.** Cook crystal can relays are rigorously tested to meet or exceed MIL-R-5757D. Available in a variety of standard mounting configurations to serve your particular printed circuit needs. *Send for your copy of Cook's new Component Catalog today.*



2700 N. Southport Ave. • Chicago, Ill. 60614

See us in Booth 605 at the NEC

# Probing the News

Military communications

## Through the political fog: hard facts about our military communications

Dangerous weaknesses in the worldwide network have become political fodder; the Pentagon, under attack by Democrats and Republicans, is taking action to remedy them

With the Presidential campaign getting hotter, debate on the military's communication network is at the boiling point. Through all the political steam, one fact emerges—the worldwide system does have some dangerous weaknesses. Now, the Pentagon is rushing to remedy them.

The rhubarb started over a simple question:

In the event of a crisis, can a message from a United States commander in some far-off jungle always reach the President fast enough for effective action?

Yes, asserts Defense Secretary Robert S. McNamara, the U.S.'s worldwide communication network can put a commander in touch with the President in two minutes under any circumstances.

No, claims Republican Presidential candidate Barry Goldwater, and he glibed, after the latest Tonkin Gulf incident: "With the great communications system which McNamara is always bragging about, they are waiting for an airmail letter to find out just what happened."

### I. Politics versus facts

To what extent have politics colored these two contradictory statements? Does McNamara have his eye on Nov. 3 when he says our communication network isn't vulnerable to enemy countermeasures?

Does Goldwater have all the information on the network? When the Presidential campaign opened,

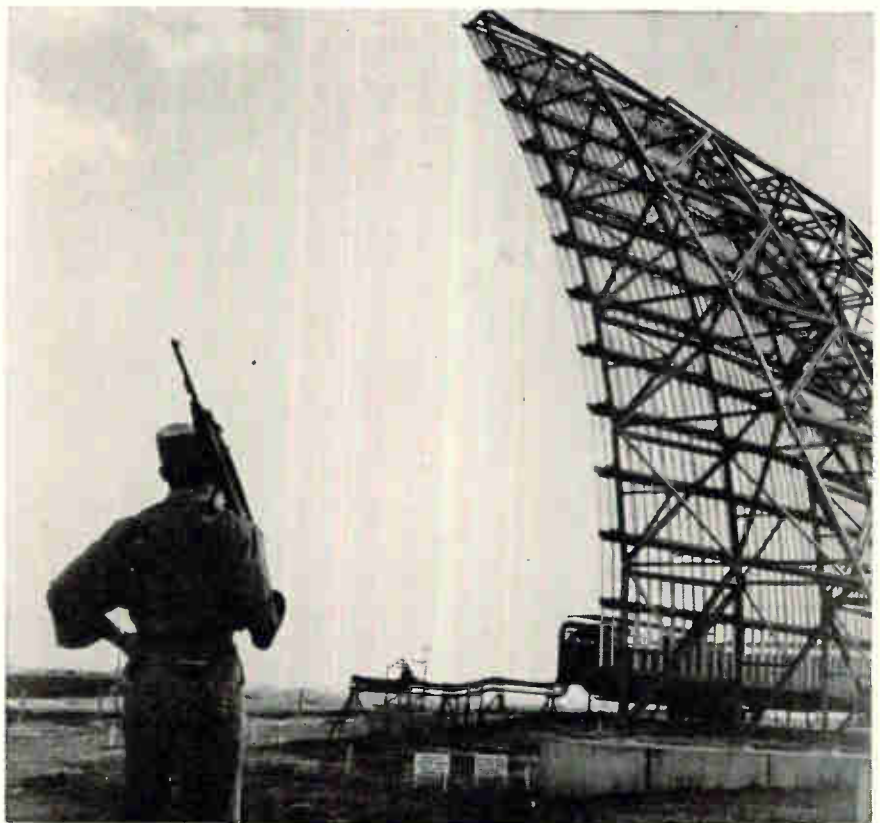

Back Porch's tropo antennas in Nha Trang point to Saigon in southern South Vietnam. Here a tie-in to Wet Wash will carry messages directly to Washington.

he rejected President Johnson's offer to review top-secret information.

To be sure, under most conditions, the U.S.'s communication network works adequately, but a penetrating look at the current setup—and a long-range look at what's being built and what's on the drawing board—provides some chilling and surprising information:

▪ **Fact:** Vital legs of the worldwide communication network can be effectively blocked either by an enemy, by accident, by bad weather, or by a phenomenon of nature.

▪ **Fact:** The Pentagon, recognizing the limitations of the network, is working frantically to patch the holes and block potential enemy

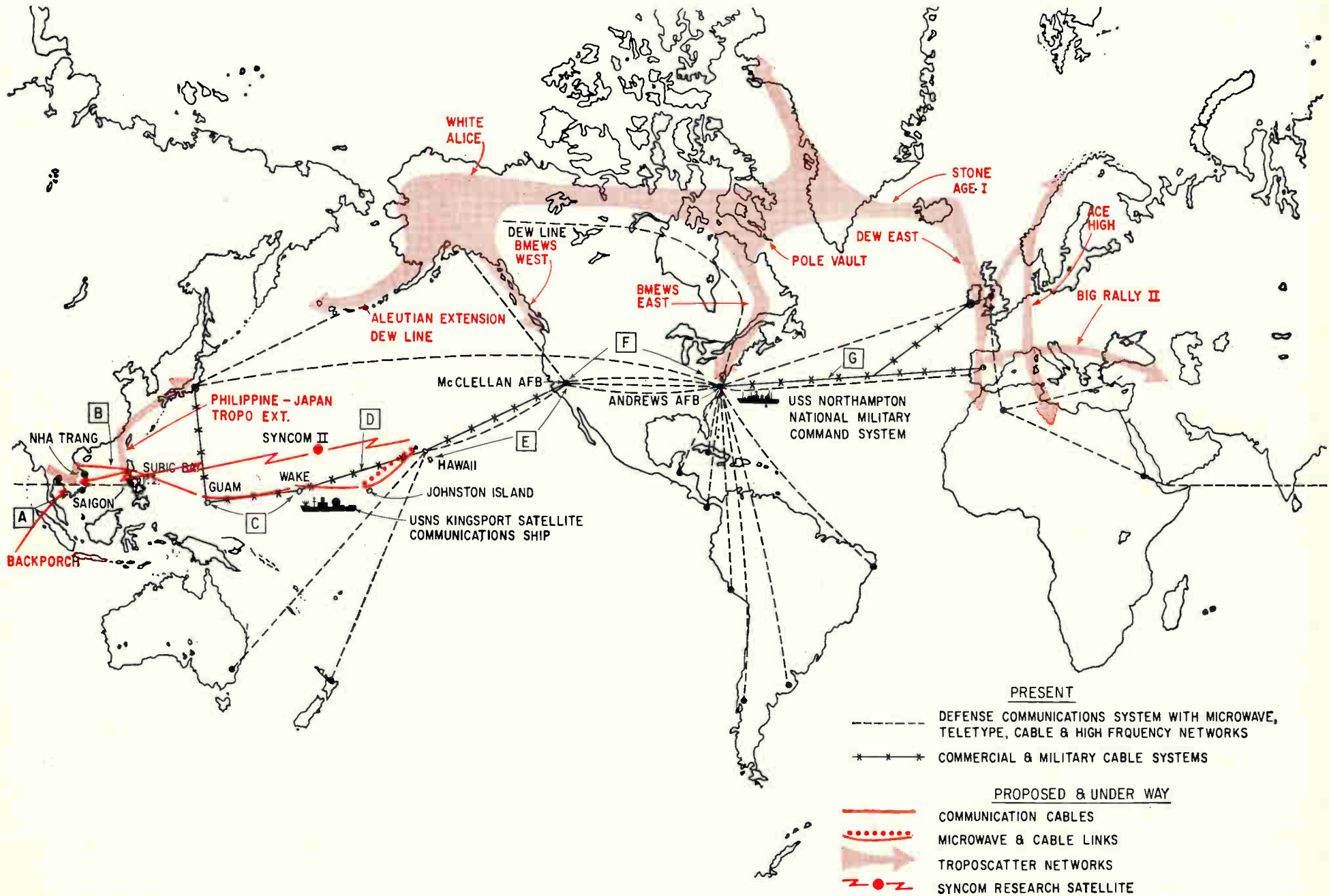



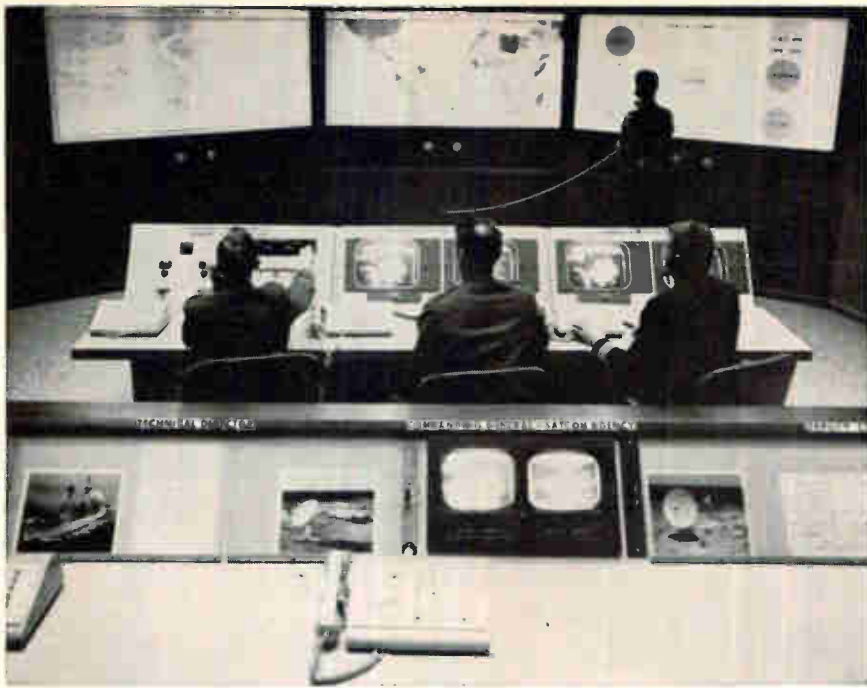

Satellite Communications Test Operations Center. This is the focal point for managing and evaluating satellite communications experiments through NASA's Syncom 11 satellite.

countermeasures.

- **Fact:** An atomic bomb detonated in the ionosphere creates a blanket of ionized particles that seals off radio waves for hours.

- **Fact:** Present systems require manual routing of all messages.

- **Fact:** Present relay satellites—although effective for leapfrogging television signals of the Olympic Games from Tokyo to America—can be jammed by an enemy if the satellite is used in a last-ditch effort to route a vital message to the President.

- **Fact:** Atmospheric disturbances, from sun spots, for example, can obliterate communications in huge areas.

- **Fact:** Enemy vessels can cut underwater cables, slicing huge holes in the network.

## II. Yet another view

In the midst of the debate, a House subcommittee clobbered the Pentagon with a far-reaching report that labeled McNamara as “too timid and uncertain” in exploiting satellite technology for military communications. The report is a product of the Military Operations subcommittee of the House Government Operations Committee headed by a liberal, Chet Holifield (D., Calif.), long a friend of the Administration.

The study, a toned-down version to accommodate the Pentagon, accused the Defense Secretary of letting his economizing drives “throttle” some programs. In hearings last spring, the subcommittee disclosed a series of decisions by

McNamara that repeatedly changed the approach to military communications. In 1962 the Secretary cancelled the four-year-old program to develop a synchronous satellite because it was trouble-ridden. He ordered the Air Force and the Navy to work on the less-difficult medium-altitude satellite. But then in October, 1963, he again switched routes, proposing that the fledgling Communication Satellite Corp. work out a dual military and commercial network. But because the Department feared the setup would lack the required top-level security, that fairly simple approach was scrapped.

**A wall of silence.** The backbone of America's communication system, says Brig. Gen. George P. Sampson, deputy director of the Defense Communication System, is high-frequency gear. Unfortunately, such radio signals are highly susceptible to natural atmospheric disturbances, such as electrical storms and fluctuations in the ionosphere. Such factors may leave the equipment reliable only 70% of the time. But, because of their widespread use, high-frequency radios have the advantage of redundancy—many alternate paths for getting a radio dispatch around the world.

Thus, if one leg of the system fails or is disrupted by the enemy, the signals can be manually rerouted on yet another path on the web. And this process can be repeated, funneling the message through a maze of communication systems until, hopefully, it reaches the President's ear.

But this takes time.

## III. The Pentagon's programs

The Pentagon has some top-priority programs in the works that

## ◀ Defense Communications Network

**A** Back Porch; a troposcatter network extending from Saigon in the south to Nha Trang in northern South Vietnam. A tropo link also connects our forces in Thailand. This system became operational about January 1963.

**B** Wet Wash, an 800-mile multichannel cable link between Nha Trang and the Naval Base in Subic Bay, Philippines. Here additional troposcatter and microwave links maintain communications with such places as Formosa, Okinawa and Japan. The cable portion of the project is now being installed.

**C** Guam and Wake Island will be way stations for a communications cable connecting Johnston Island with the Philippines 5,000 miles to the west. This portion of the Wet Wash extension is about to be started.

**D** The final link of the Wet Wash extension will run from Johnston Island to Hawaii, and will consist of microwave towers and two-way submersible cables. The contract for the system is still in the negotiating stage.

**E&F** Systems exist in these areas for communications with the mainland and on to Washington. However, they will be improved by the Autovon (automatic voice network) and the Autodin (automatic digital network). Cables now carry messages between Hawaii and mainland U. S.

**G** Teletype and voice cables are also primary message carriers between the U. S. and Europe. These will be supplanted by the Autovon and Autodin systems as they become operational.

are designed to solve these problems:

▪ **Computers**—linked to existing radio systems—that will be able to swiftly and automatically guide messages through this maze. The first such system, called Autovon (automatic voice switching network) is slated to start operating by the end of 1966. Another system, called Autodin (automatic digital switching network) is faster and has a higher message capacity than the Autovon system and should be plugged in by 1968. Yet a third system, Autosevocom (automatic secure voice communications) will add by 1965 cryptographically secure voice communications by using a combination of wide- and narrow-band voice digitizing technique. It will be used until Autodin becomes operational.

▪ **Troposcatter radio networks**, which bounce radio signals off the troposphere, are less subject to electronic countermeasures and are negligibly affected by atmospheric disturbances. Because of these advantages, the Defense Department is rushing to install them in areas where we are vulnerable. Enough of these systems, for example, are operating to permit immediate communication between the most eastern end of Turkey, the farthest tip of the Aleutian Islands and the White House. But major flaws remain: the area from Turkey eastward to Japan; the area south of Vietnam; the area between South and North America; and middle and lower Africa.

▪ **Satellites**, designed to be virtually jam-proof, will be launched early in 1966 to provide the final link to a 99% reliable system. A network of 24 satellites will hover 19,000 miles above the earth in a near-synchronous orbit, providing an umbrella capable of catching and relaying information from anywhere around the globe.

**Ugly possibilities.** Taken as a group, these future plans sound reassuring but, as the military readily concedes: We can block the enemy's efforts to silence our communications only when we know their tactics.

So defense scientists spend full time dreaming up ugly possibilities and candidates make political hay.



Most aerospace electronics companies are experimenting with laser welding for microcircuit assembly. This test setup at the Autonetics division of North American Aviation, Inc., uses a laser made by Hughes Aircraft Co.

## Manufacturing

# Laser welders: out of the lab and into the factory

First production application, flatpack lead welding, will be set up next year

By George Sideris

Manufacturing Editor

**For several years**, glowing predictions have been made about the future of laser welding—and the lasers have stayed in the labs. It looks now like the laser is ready to graduate from the lab.

The jokes about the laser being a solution in search of a problem have subsided. With the advent of microcircuits, problems of rapidly and reliably spot-welding thin foils and wires have arisen. That's one job the laser has learned to do well.

Pulsed ruby lasers will soon be set up on a new production line at the Westinghouse Electric Corp.'s Aerospace division near Baltimore. The lasers will be used, starting next year, for such chores as spot-welding flatpack leads to conductors on printed-wiring boards. This will mark the first routine production use of laser welders, according to Harry Thurman, who heads Westinghouse's development

and marketing of laser welders.

The Hughes Aircraft Co. has a laser welder in operation on a "semiproduction basis" at its semiconductor facility in Newport, Calif. Hughes began experimentally welding the internal leads of transistors more than a year ago.

The Linde Co., a division of the Union Carbide Corp. and a major power in the welding-equipment field, last month announced plans to sell a type that can automatically make 1,200 welds an hour. It plans to come out next January with a microcircuit welder.

### I. Getting a head start

Companies developing laser welders are looking beyond their own needs. The prize is a head start in a market that may prove to be larger than any other potential laser market.

"There's lots of potential and

# VHF / UHF POWER GOES ECONOMY

## HIGH GAIN 27 TO 260 MC

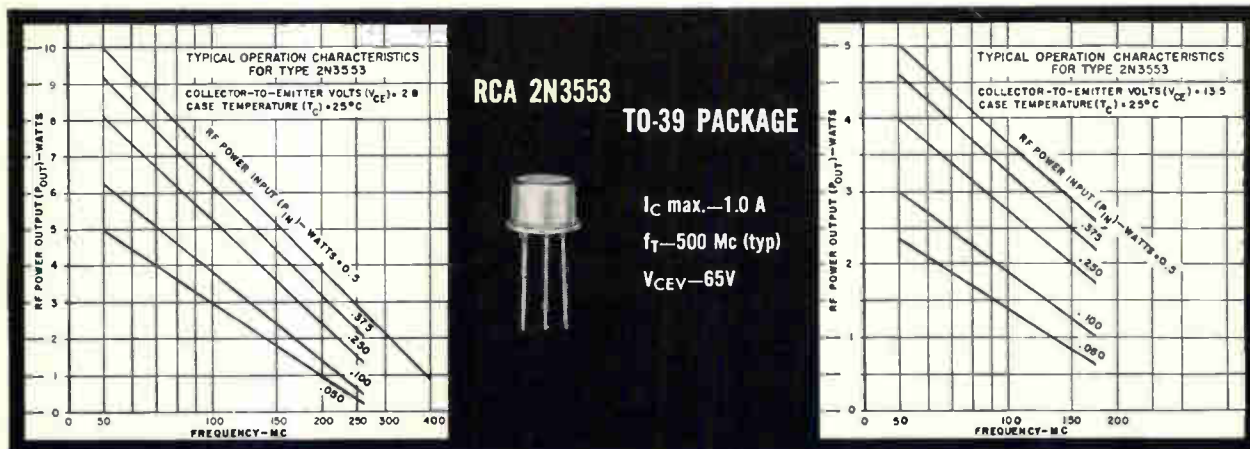

## RCA 2N3553 offers the big VHF/UHF performance of overlay construction at low-cost

RCA introduces the new 2N3553, VHF/UHF silicon overlay transistor—general purpose economy version of RCA 2N3375. This epitaxial planar NPN unit offers today's biggest value in RF performance per dollar.

COMPARE 2N3553 FOR PERFORMANCE AND PRICE	
50 Mc	$P_{out}$ (typ)*—5 watts, 20 db gain
175 Mc	$P_{out}$ (min)*—2.5 watts, 10 db gain
260 Mc	$P_{out}$ (typ)*—2.5 watts, 7.5 db gain

\*Unneutralized common-emitter Class C amplifier with  $V_{CE}$ —28 volts

RCA 2N3553 offers: overlay performance • low price • up to 500 Mc straight-through • up to 2 KMc as a multiplier

Applications: pre-driver, driver, output, multiplier, video amplifier in mobile, portable equipment, aircraft systems, sonobuoy, telemetry.

For Critical Applications RCA 2N3375  
 $P_{out}$ —3 Watts Min @ 400 Mc;  
7.5 Watts Min @ 100 Mc

- RF Stud Package
- All Elements Isolated
- Not Second Breakdown Limited
- Available In Quantity

For complete price and delivery information, see your RCA Representative today. For technical data on specific types—write: Commercial Engineering, Section IN 10-3, RCA Electronic Components and Devices, Harrison, N. J.

AVAILABLE THROUGH YOUR RCA DISTRIBUTOR  
RCA ELECTRONIC COMPONENTS AND DEVICES



The Most Trusted Name in Electronics

Circle 97 on reader service card

lots of interest," Thurman says. "I'm not going to tell you if we have made any outside sales yet—nobody else will either—but I can tell you that we have made many quotations" for production lasers.

Other laser manufacturers are not so optimistic. Refining machines and techniques to fit specific applications, and justifying the relatively high cost of laser welding, have been an uphill fight.

The laser that Hughes is using is a 1-joule model that it has been selling for more than two years. Last spring, Hughes introduced a 2-joule model, but had to send its engineers back to the drawing boards to speed up the pulse rate and improve repeatability. The rate was 9 pulses a minute at 2 joules. Hughes is continuing laser-welder development, but views the market cautiously.

**Seek applications.** Off-the-shelf lasers haven't sold well. Sales have been of the let's-try-one-and-see variety—frequently by one company division to another. Technical Research Group, Inc., has dropped its microwelder and is

now concentrating on heavy-duty lasers. The Raytheon Co., one of the first to propose laser welding, is now selling a 10-joule model for high-speed drilling, but declines to discuss its plans for welders.

The General Electric Co., which has a large laser research program, has not yet found any good applications for laser welding within its own divisions.

Maser Optics, Inc., makes five models, with outputs between ½ joule at 20 pulses a second to 50 joules at 1 pulse a second. But the company has announced only two sales of production systems, both for resistor trimming—a micromachining, not a microwelding application.

## II. Competition for lasers

Electron-beam welders are cutting into laser welders' potential sales. Electron and laser beams share the distinction of being the most intense energy sources available; but the electron beam got out of the lab first.

The Autonetics division of North American Aviation, Inc., for exam-

ple, is studying the use of laser welders. But it plans to use an electron-beam system that will make 1,100 welds in a single pass.

**Taming the laser.** Spot-welding of materials thinner than 20 mils is the only application that has proved itself [Electronics, Oct. 25, 1963, pp. 88] so it is primarily in electronics that laser welders are coming into use. Lasers had to be tamed before they could weld reliably. Pulsed ruby lasers, the only type practical for welding today, have a natural talent for burning holes. Early lasers proved it by puncturing razor blades. A laser beam will vaporize diamond; it can easily spatter any metal.

Laser designers had to cool beam intensity down to the point where the beam would merely melt metal. Then they had to stretch pulse length so the molten spot would go deep enough to weld two pieces of metal together. Spot-welding a flat-pack lead, for example, requires a beam energy of about 3 or 4 joules delivered to the spot over a period of around 4 to 6 milliseconds.

With proper energy-time control,

**PAKTRON'S NEW 50-volt capacitors are**

the beam will weld combinations of metals with widely dissimilar melting points, such as aluminum and tungsten, or tantalum and copper. These combinations frequently occur in electronic components.

**Try one and see.** As a result, companies interested in buying lasers for production use, prefer lasers that are tailored to the application and can be easily set to the proper energy level.

Westinghouse uses four prototype welders to determine the requirements of a production model. The smallest, costing \$10,000 to \$15,000, puts out a maximum of two 4-joule pulses a second, or one 8-joule pulse. Pulse times range from 1 to 8 milliseconds. Next is a laser with similar characteristics but rated at 10 joules and costing \$25,000 to \$35,000.

Thurman recommends these for microwelding. For lead welding, he points out, a pulse stronger than 4 joules causes spatter while 1 or 2 joules hasn't enough power.

Then there are two big models—100 and 200 joules—that Westinghouse sells like diamonds for \$1,000

a joule. They can be used for spot-welds up to ¼-inch thick.

Linde's production lasers are modifications of a \$39,000 lab model that was developed by Linde and Korad Corp., another Union Carbide subsidiary. The lab model can put out ½ to nearly 20 joules. The production model costs about \$20,000 but will go up to only 5 joules.

While the production machines will be simplified versions of the lab model, they retain two important features. One is an internal, automatic control system that adjusts pulse intensity and length; the operator has only a single setting for joules. The second is a combined optical system for the beam and the operator. Using a microscope-type eyepiece, the operator brings the work into focus. This also focuses the beam. If the operator can see the workpiece, he can weld it.

As with all of the newer welders, the operator's eyes are protected from the laser beam. Linde has a flip-down mirror in the optical system.

### III. Microwelding economics

Linde estimates welding cost at 3 to 5 cents per "pop" if the operator makes 1,000 welds an hour, including overhead and maintenance.

But laser welding is cheap if the weld can't be made any other way, says R. J. Frick, Linde's laser manager, or if "10 cents worth of welding requires \$1 worth of inspection."

All laser welds are surface welds. If a weld is made with a laser, it can be seen. And if the weld nugget is bright and shiny, which it almost invariably is, the weld is good.

J. E. Jackson, Linde welding engineer, maintains that setting up the laser welder is simple compared with resistance welding. Approximately the same joule setting can be used for different materials of the same size. The size-to-joule relationship is a straight line on a graph.

**Right on the nose.** Jackson says he can set up a laser welder with the joule-control knob by making



New miniature high performing Mylar\* film/foil capacitor for quality transistorized circuits. Epoxy coated for excellent moisture resistance. Uniform size. Capacitance value to 0.47 mfd with tolerance to ± 5%.

The "white" series has an internal design to protect the high performance Polyester film and an external design to satisfy any circuit construction system.

Detailed information available on request.

\*DuPont

**Working Voltage:** 50v DC

**Tolerance:** ± 5%, ± 10%, ± 20%

**Dissipation Factor:** 4 x 10<sup>-3</sup> max. @ 25° C, at 1 KC

**Temperature Stability:** 4% max. deviation from 25° C value in range of 0° C to 85° C, at 1 KC

**i t PAKTRON**  
**w** DIVISION ILLINOIS TOOL WORKS INC.  
 1321 LESLIE AVENUE • ALEXANDRIA, VIRGINIA

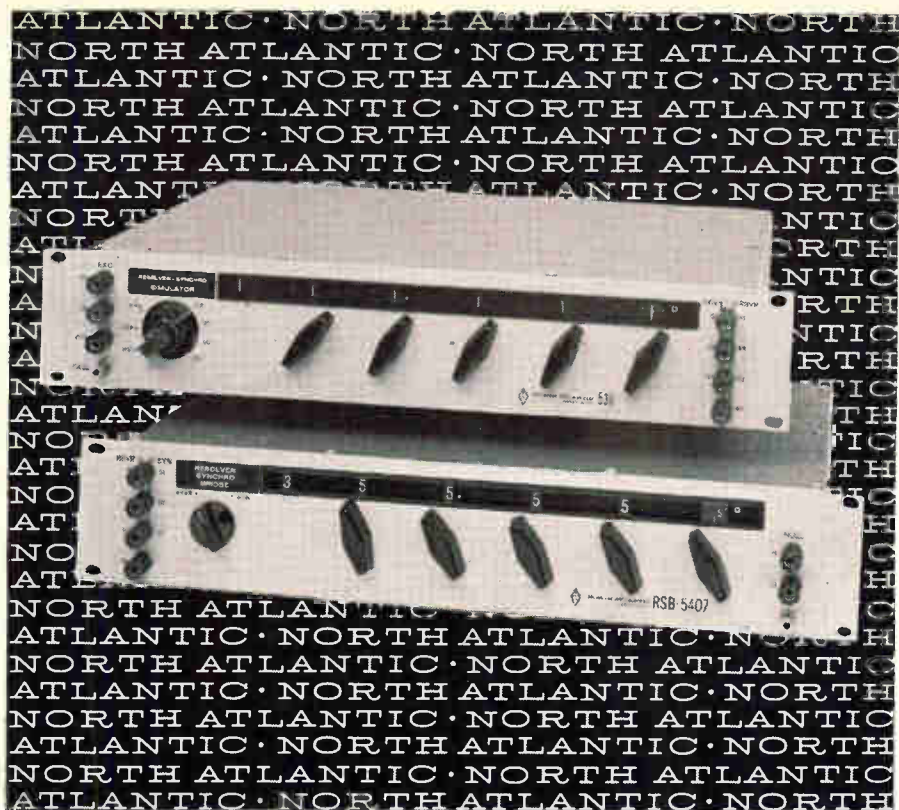

## you are looking at the state-of-the-art in resolver/synchro testing

These two instruments provide the widest measurement capability available today for resolver/synchro testing. Each is a dual-mode unit, measuring both resolvers and synchros. Series 530 Simulators are ideal transmitters, and Series 540 Bridges are ideal receivers.

In addition to their dual-mode capability in 3½" of panel space, both series provide in-line decimal readout continuously switched through 360°, 2 second accuracy at any angle, and input/output isolation.

### SERIES 530 SIMULATORS FEATURE

- Resolution 0.001°, 1°, or 5°
- Dual 26/115 volt excitation
- Switch selected line-line voltages 11.8, 26, 90, and 115 volts
- Low matched output impedance

### SERIES 540 BRIDGES FEATURE

- Resolution 0.0001°, 1°, or 5°
- 500K input impedance
- Constant null-voltage gradient at all line-line voltages
- Unaffected by null detector loading

Prices range from \$1480.00 to \$2680.00

The flexibility of these instruments meets every need for rapid and accurate testing in the engineering laboratory, in production, and in ground support equipment. Used with a Phase Angle Voltmeter, they provide a complete facility for component or system test.

Programmable models with decade or binary input are also available. Your North Atlantic representative will be glad to arrange a demonstration. Call or write him today.



**NORTH ATLANTIC industries, inc.**  
TERMINAL DRIVE, PLAINVIEW, L. I., NEW YORK • OVERbrook 1-8600

just three trial pops—"one over, one under, one right on the nose." Setting up an automatic welding line is no great problem either, he adds. The parts to be welded don't have to fit precisely and they can be as much as five mils apart. Molten metal can bridge the gap.

Laser welding specialists generally recommend laser welding only in special applications: when the spot must be tiny, when heat must be kept away from components, when high-conductivity metals must be welded and when the parts can't tolerate mechanical pressure.

One trick impossible for conventional methods is welding through transparent materials like glass or clear plastics, or "if you want to build ships in bottles," says J. E. Anderson, Linde lab supervisor.

There are practical applications of this. Assemblies can be welded after encapsulation, to avoid fixturing, for example.

**Microcircuit welding.** Another hoped-for laser application is welding leads to thin-film and integrated circuits, as well as semiconductor devices. Lasers with relatively short pulses and beam energies measured in fractions of a joule can do this.

Westinghouse is already doing it experimentally and anticipates production use. "It's tricky," says Thurman, "but we get excellent results."

According to Harry E. Franks, president of Maser Optics, the attachment of lead wires as fine as ½ mil—0.0005 inch—is no problem for a laser. The laser works so fast that there is no damage to heat-sensitive semiconductors, and no electrode contamination or substrate fracturing.

Techniques that will effectively multiply the welding rate are needed. Linde is considering an optical mask. The beam would shine through holes in a mask over the circuit, to make six or eight welds simultaneously.

If rapid bonding methods are developed, manufacturers may turn to high-temperature connective materials and laser welding. Present techniques are fast, but usually require low-temperature materials.

### IV. Seam-welding dilemma

Laser developers are still hunt-

ing for an effective way of continuously welding seams. Seams can be welded now by making a series of overlapping spots, but it is a slow process at best. A production engineer would have to be desperate to consider it.

Foils can be seam-welded by low-energy lasers; some now in development can pulse 100 times a second or faster. However, to weld thick plates with a pulse laser requires massive and expensive power supplies such as the system developed by TRG [Electronics, Jan. 10, 1964, pp. 11] to investigate the problems involved in thick-seam welding.

One possibility for reducing power-supply expense is doped-glass lasers, which are easier to lase. As yet no glass laser can supply the required energy and withstand 100,000 pulses without fracturing—the minimum reliability needed. Another possibility is replacing the flashlamps with burning chemicals [Electronics, Jan. 17, 1964, pp. 48].

**Turn to c-w.** The ultimate solution will probably be a continuous-wave laser. Present gas lasers aren't powerful enough. Ruby has enough energy, but no one has succeeded in making a continuous-wave ruby laser.

Nevertheless, at least two companies, Linde and Hughes, say they are working on c-w laser welders. For seam-welding foils, average output would have to be around 100 to 500 watts; for welding metal plates, outputs of 1 to 10 kilowatts will be needed.

Such welders would again have to compete with the electron-beam welders now being used to weld exotic metals. Electron-beam welders employ a technique called hole translation so the beam can dig deep into the metal. First, a high-intensity beam melts and vaporizes metal to create the hole, then the hole is moved up the seam while the molten metal fills in behind the hole.

Laser designers call this the drill-fill techniques. Some machines now use it to get a spot-weld, instead of a long, steady pulse. The welds can be three times as deep as they are wide. But as for a c-w laser that can translate a hole up a seam: "There ain't any such animal yet," a Korad source says.

# THESE ARE THE FEATURES OF THE NEW

**Acme ACME Electric**

## VOLTROL\* STABILIZER

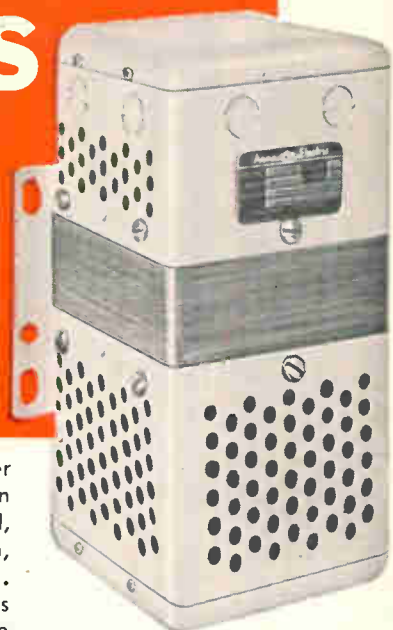

We've spent years developing a new stabilizer that incorporates all the improvements that can be expected from improved lamination steel, improved magnet wire, improved insulation, improved capacitors and improved design. As a result, the new VOLTROL Stabilizer is far advanced in performance. These are some of the features you can expect in the new VOLTROL Stabilizer.

✓ **FAST RESPONSE TO LINE VOLTAGE FLUCTUATION** Voltage recovery in milliseconds on ordinary 3% to 5% line voltage fluctuations. Not more than 2 cycles (1/30th second) on sudden voltage drops or voltage surges of 15%.

✓ **AUTOMATIC PROTECTION AGAINST OVERLOADS** Short circuit in the powered equipment or severe overload causes output voltage to drop to zero, automatically protecting stabilizer and equipment.

✓ **AUTOMATIC ADJUSTMENT OF LOW VOLTAGE OR HIGH VOLTAGE** A continuous, low voltage or high voltage input is corrected to nominal,  $\pm 1\%$ , without causing excessive heating or other damage to stabilizer.

✓ **OUTPUT TAPS FOR RECTIFIER CONNECTION** Most types are available with output taps to supply a regulated voltage to a rectifier.



### UNENCLOSED TYPES FOR OEM APPLICATIONS

The VOLTROL Stabilizer can be supplied without end covers for use as part of the equipment system. Unenclosed types cost less.

Write for Bulletin 09-B03 which describes and illustrates the many features incorporated in the VOLTROL Stabilizer to provide added advantages to you.

**Acme ACME Electric**

**Engineers and Builders of...**

3110 WATER STREET, CUBA, NEW YORK  
Canadian Representative: Palygan Services, Ltd.  
50 Northline Rd., Toronto 16, Ont.

\*VOLTROL is a registered trademark of Acme Electric Corp.

SAE 3808-3114

REGULATED POWER SUPPLIES  
STATIC POWER RECTIFIERS  
VOLTAGE STABILIZERS  
VOLTAGE REGULATORS

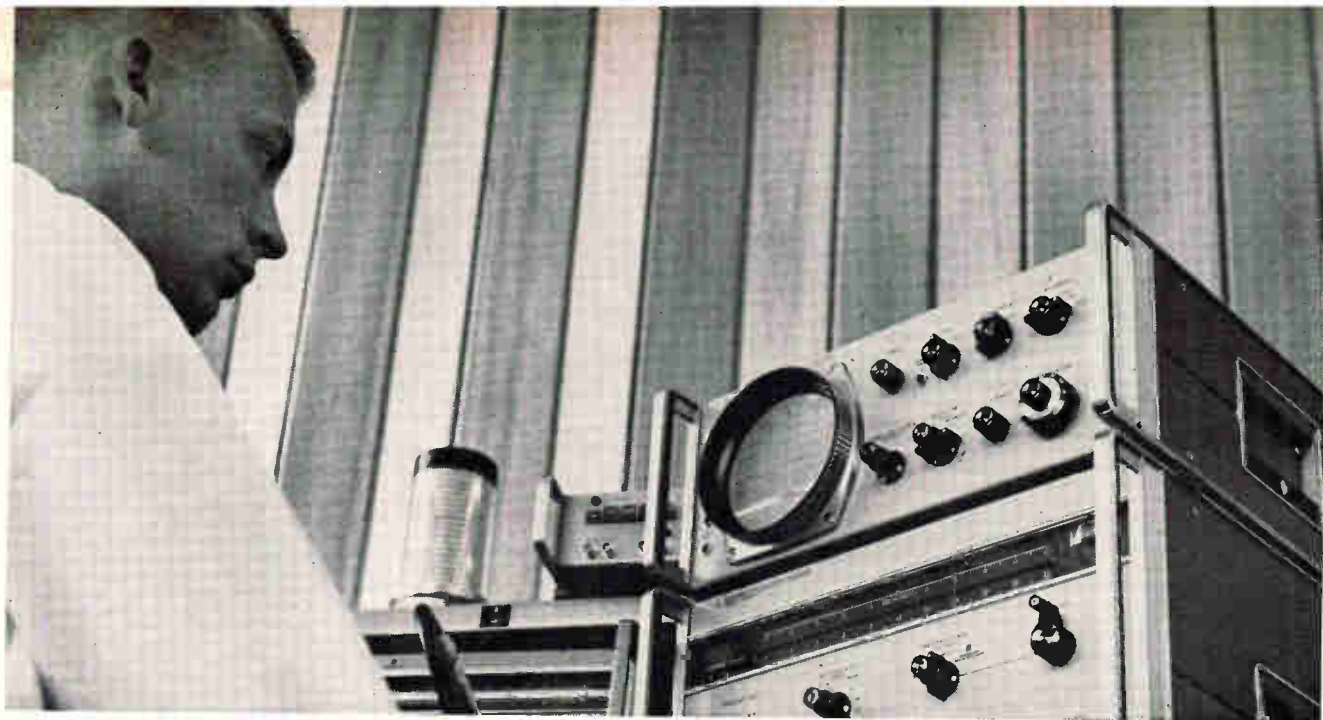

Sales so far for Hewlett-Packard's 2-gigacycle microwave spectrum analyzer are for spectrum-surveillance, signature-analysis and radio-frequency-interference studies. Surprising interest has come from microwave semiconductor developers.

## Instrumentation

# Shake-up in spectrum analyzers

When Hewlett-Packard entered the field, competition stepped up; Polarad vies for market in wide sweeping-bandwidth instruments

By Leon Dulberger

Staff writer

Something suddenly happened in the \$15-million spectrum-analyzer field.

For years, makers of spectrum analyzers—an instrument that sweeps and displays electromagnetic radiation—have produced equipment that could serve only specific and limited needs. But about six months ago, the Hewlett-Packard Co., a giant in the electronics industry, introduced its first spectrum analyzer, a highly versatile design.

At about the same time, the Polarad Electronics Corp.'s Polarad Electronic Instrument division, long experienced in the spectrum analyzer field, introduced an instrument that competes with the Hewlett-Packard model—and the interest of the industry was ignited.

Since then, Panoramic Instruments of the Singer Co.'s Metrics division, another company with ex-

perience in this field, said it planned to start shipping next year an instrument that would compete with the Hewlett-Packard and the Polarad models.

### I. New weapons

This new interest is providing the electronic detective hunting down elusive, troublemaking electromagnetic radiation some improved weapons: modular instruments that can simultaneously monitor bandwidths up to 2 gigacycles over a frequency range up to nearly 100 gigacycles. Such instruments replace a whole family of analyzers that are limited to small portions of the spectrum.

With the new instrument, for example, engineers scanning the radiation band surrounding a missile control center, would be able to more effectively locate and analyze spurious radiation that could

accidentally trigger a rocket. Previously, a complex of bulky equipment had to be used to scan the same radiation range—and this took time.

And equally important, the new instruments give the engineer a quantitative answer, not merely a relative one. Thus, the frequency and amplitude of a group of signals under observation can be measured directly and accurately.

Hewlett-Packard says most of their sales have been at missile test sites for spectrum surveillance studies. In fact, the company has already sold 15 of the new 2-gigacycle microwave analyzers for use at the White Sands Missile Range in New Mexico.

**Catching the errors.** The next biggest markets Hewlett-Packard says are for: spectrum signature analysis, displaying all signals being emitted by an antenna of a





## Now... a really new s-c tester featuring digital programming and low cost

TI's Model 658 Transistor/Diode Test System has many new features to make production/inspection testing easier, faster, more economical. An out-of-the-way digital programming section uses digit-switch and rotary selectors for choosing test conditions. Both d-c and pulse tests can be performed with each module. Up to 48 plug-in modules may be mounted vertically or in slide-out drawers. Tests may be programmed in any sequence. Test duration is independently adjustable from 50 milliseconds to 5 seconds.

The 658 features digital control of test circuitry; close proximity of clamps and limiters to device under test; Kelvin connections eliminating IR drop errors; front panel lights displaying go/no-go results; memory storage permitting sorting and classification into 16 categories with an accessory sorter; swing-out card racks and plug-in assemblies for simplified maintenance and long-term reliability. Bias and reference supplies are digitally programmable with repeatability better than 1/2%. Readout accuracy is 1/2%.

Write for information.

INDUSTRIAL  
PRODUCTS  
GROUP



**TEXAS INSTRUMENTS  
INCORPORATED**

P. O. BOX 66027 HOUSTON, TEXAS 77006  
7 RUE VERNONNEX GENEVA, SWITZERLAND

690

# what difference does that make?

Quite a bit. The probe you see (a) is the new business end of our PEL 626 RF Millivoltmeter.

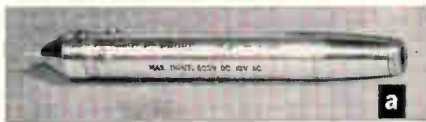

This new probe permits us to offer improved specifications (b). Read them carefully.

PEL 626 SPECIFICATION IMPROVEMENTS		
Parameter	Standard	Improved
Frequency Accuracy	3% from 50 KC to 100 MC 5% to 300 MC 20% to 2000 MC	5% 10 to 20 KC 3% to 100 MC 5% to 300 MC 10% to 1000 MC 20% to 2000 MC
VSWR	Less than 1.2 to 1200 MC, less than 1.3 to 2000 MC	Less than 1.2 to 2000 MC

If you followed our advice, you may wonder why we bothered to improve our specs. The PEL 626 (c) already had the greatest sensitivity and widest range of any instrument of its kind. We bothered because we insist that our instruments provide maximum performance, even if it means competing with ourselves.

Find these facts hard to believe? Don't. They're all verified in black and white in our new brochure. Send for your copy today.



Every PEL 626 is accompanied by an individually charted record of both frequency response and VSWR. No other RF Millivoltmeter is sold with a record of its own performance.

**PORTER**  
ELECTRONIC LABORATORIES

BOONTON, NEW JERSEY

*Instruments that advance the art*



Portable instrument by Singer Metrics' Panoramic monitors noise level versus frequency on an aircraft engine during field test.

single system—both the desired signals and undesired ones; and for radio frequency-interference studies, where all electromagnetic outputs from a system, including antenna radiation, are analyzed.

Third on the market scale, the concern adds, is in the design and manufacture of microwave semiconductor devices. And this area is expanding markedly. The new instruments guide the engineer in locating and eliminating spurious and parametric oscillations during the design and production of the semiconductors.

Although the market for wide-range spectrum analyzers this year is estimated at only \$1 million, market experts expect that figure to triple by 1970. Microwave analyzers of all types make up about \$10 million of the current market. About \$5 million of the market is taken up by instruments that operate in the sub-audio, audio, video and lower radio frequencies.

## II. Hewlett-Packard's model

Hewlett-Packard said it decided to enter the spectrum-analyzer field about four years ago because it felt this portion of the instrument market was poorly covered and it believed there was a "crying need for a good" spectrum analyzer.

Hewlett-Packard chose a frequency range between 10 megacycles and 40 gigacycles, with calibrated sweeping bandwidths of 100 kilocycles through 2 gigacycles.

Polarad's instrument was designed to cover a frequency range between 10 megacycles and 91 gigacycles and has calibrated

sweeping bandwidths of 10 kilocycles to 2 gigacycles.

The local oscillator in the Hewlett-Packard 2 Gc-bandwidth analyzer is a backward-wave oscillator tube chosen for its low noise and relative freedom from frequency shift. To correct for the inherent nonlinear tracking characteristics of the backward-wave oscillator, a shaping circuit is included in the sweep voltage applied to the tube, and this results in a linear sweep over the bandwidth.

The instrument uses a triple-conversion superheterodyne format. The first mixer uses a silicon diode, and an intermediate frequency of 2 Gc, chosen to provide 4 Gc image separation. The second and third local oscillators are fixed-tuned, crystal-controlled circuits operating at 1,800 and 180 Mc, respectively. A phase-lock system is used to stabilize the backward-wave oscillator for narrow spectrum applications. The instrument has a 60 decibel dynamic amplitude range.

## III. Polarad's view of market

Polarad has been producing various types of spectrum analyzers for years and has been regularly expanding the sweep bandwidth of its instruments. The company says its new 2 Gc analyzer has been in development for five years. It is an outgrowth of an instrument introduced in 1958 and sold to military agencies. The early design covered 10 Mc to 40 Gc, and was housed in a six-foot-high rack panel. The new instrument is a bench-top instrument for use as a lab and field analyzer. It uses

compact three-module packaging.

The company is committed to the concept of modularity in its equipment design. The basic 2 Gc analyzer consists of three self-contained modules: a display and intermediate frequency module, a swept front-end module and a phase-lock module. The first two comprise a spectrum analyzer with a minimum sweep width of 10 Kc. By adding the phase-lock module, stability at 10 Kc sweep width is assured.

According to Polarad, "Government agencies, big users of spectrum analyzers, are eager to buy only what's needed. Adding modular packages as required appeals to their tight-budget practices."

**Expanding the view.** The phase-lock module permits expanding a 10 Kc portion of the spectrum under study to full screen width for evaluation of such things as signal monochromotisity and frequency stability.

Input to the Polarad spectrum analyzer is through one of three mixers. The low range of 10 Mc to 1.7 Gc is covered by a solid-state balanced mixer, used to avoid local oscillator feed-through back to the input. The mid-range mixer covers 1.5 to 11 Gc. The high-range mixer consists of a coaxial-to-waveguide adapter with a built-in crystal. It covers the 8 to 91 Gc range with a series of six interchangeable waveguide sections.

**Linear characteristic.** A voltage-tunable magnetron is used as a local oscillator, chosen because it provides a sweep-versus-voltage characteristic linear to within 1%.

The Polarad analyzer uses a 2.26

MODULES POTTED IN

# TIMONIUM

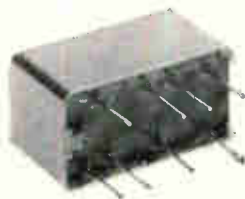

Most modules are circuit-oriented.  
EMC's modules are system-oriented.  
This simplifies your engineering.



Extremely wide bandwidth spectrum analyzer, developed by Polarad Electronics, can sweep a 2-gigacycle portion of the microwave spectrum.

- Standard digital module families to 250 KC and 2 MC
- Power supplies
- Special function boards
- Specialized designs at "off-the-shelf" cost and delivery

# EMC

ELECTRONIC  
MODULES  
CORPORATION

1949 GREENSPRING DRIVE • TIMONIUM, MD.  
Clearbrook 2-2900 TWX-301-252-0723



## For \$10 you can become a relay expert all at once.

The book does it. *Relay Engineering*. (When relay engineers do things by the book, this is the book they do them by.) 654 fact-crammed pages. Applications. Theory. Schematics. The whole works. And the only book of its kind, written by Struthers-Dunn engineers, of course. You can have your own copy for ten bucks. Which is pretty cheap, considering it took 40 years to write. Use the coupon.



## Or you can let us solve your problems a dime at a time.

The dime goes to the telephone company. They'll connect you with your local Struthers-Dunn sales engineer, who knows a few things that aren't even in the book. What's more, he has the relays to back it up. 5,348 types. More than anybody else makes. He'll solve your problem today, get the right relay to you tomorrow. Try it. See if he doesn't.

*Relay problems? Ask the people who wrote the book.*

# STRUTHERS-DUNN, Inc.

Pitman, New Jersey 08071 • Phone: 609-589-7500

**Gentlemen:**

- Ten bucks sounds about right. Mine is enclosed. Send me *Relay Engineering*. While you're at it, gold stamp my name on the front cover.
- Ten cents is too much. Have your sales engineer call me.

Name \_\_\_\_\_ Position \_\_\_\_\_

Company \_\_\_\_\_

Address \_\_\_\_\_

Go first intermediate frequency, chosen to move images up to 4.52 Gc away from the carrier. The main i-f is coupled to a second mixer stage. The second i-f signal is coupled to the display and intermediate frequency module. The design of this module permits it to be used as a complete, swept i-f, spectrum analyzer with a bandwidth of 10 Kc to 100 Mc.

### IV. Singer's portable unit

Singer has a low-frequency spectrum analyzer that is battery-operated. Thus, the device can be used in the field or aboard aircraft. In the past, engineers who must monitor the vibrations of a plane's engine, have tape recorded the sounds and then analyzed the results later in a laboratory—a time-consuming process.

The portable instrument uses solid-state components. It covers the range of 20 cycles per second to 27.5 megacycles and employs interchangeable plug-in modules.

**Uses for the portable.** The telephone industry finds extensive use for the portable spectrum analyzer. For multiplexed telephone carrier systems, where thousands of conversations may be impressed on a single microwave carrier, monitoring pinpoints missing or malfunctioning channels.

### V. Other contenders

Another development in the spectrum-analyzer field was the purchase last spring by Tektronix, Inc., of the Pentrix Corp., Brooklyn, N. Y., makers of plug-in adaptors to convert oscilloscopes into spectrum analyzers. Tektronix will offer refined versions of all the instruments Pentrix had been making, plus a few new designs.

The plug-in adaptors convert Tektronix's oscilloscopes into microwave analyzers at a fraction of the cost of new instruments.

The company has no firm plans for entering the 2 Gc sweepwidth field, but is studying the market.

DuMont Laboratories division of the Fairchild Camera & Instrument Corp. introduced a line of plug-in analyzer adaptors at the Wescon show. The three units convert the Fairchild solid-state, high-frequency oscilloscopes into spectrum analyzers that cover the range of 10 cycles per second to 500 Kc.

TIME BASE CORRECTION

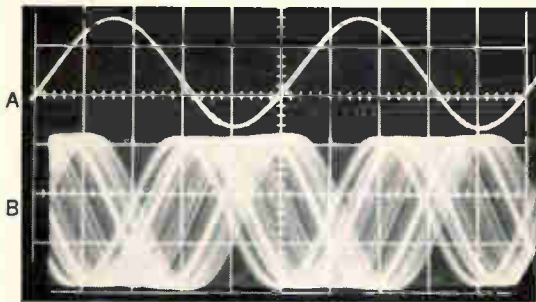

CONVENTIONAL

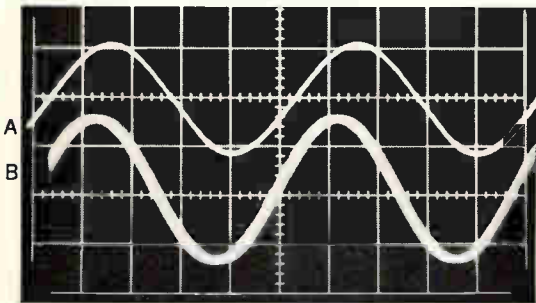

TICOR II

TRACE A: 100-kc oscillator reference signal  
 TRACE B: 100-kc line driver output, track 13  
 One-inch tape, speed 60 ips. Sweep rate: 2.0  $\mu$ sec/cm,  
 Photo exposure: 1/25 sec.

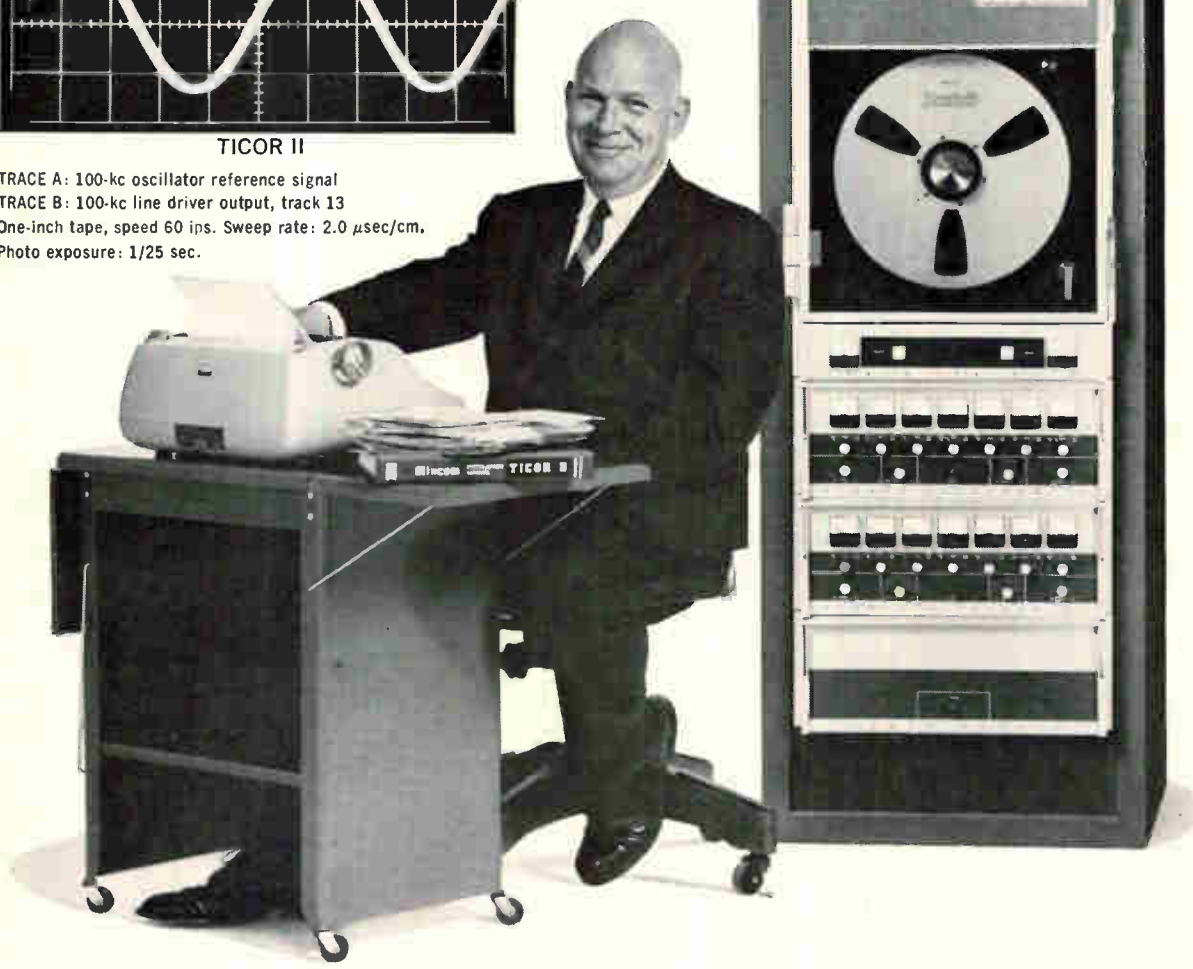

**EXCLUSIVE STORY ON MINCOM'S NEW 1.5-mc TICOR II**

On playback, lock in your tape reference track to TICOR II's reference oscillator signal — the traces above demonstrate a time-base correlation between events holding well within  $\pm 0.5 \mu$ sec, continuously anywhere on the tape. This unique and exclusive Mincom 1.5-mc recorder/reproducer immediately updates any existing data reduction center. It opens new doors to data analysis in radar recording, single sideband, serial PCM and other systems dependent on precise time-base stability. Flutter components below 200 cps are essentially removed. Rapidly convertible from 1/2-inch to 1-inch tape, all solid state, one equipment rack, RFI-shielded. Write for specifications.

**Mincom Division** **3M**  
COMPANY

300 South Lewis Road, Camarillo, California • 320 Shaw Road, South San Francisco, California • 529 Pennsylvania Building, 425 13th Street, N.W., Washington, D.C. • 135 West 50th Street, New York, New York • Post Office Box 272, Fairborn, Ohio • 1230 Orange Avenue, Winter Park, Florida • 2121 Santa Anna Avenue, Dallas, Texas • Eltron Engineering Sales, Inc., 246 Walnut Street, Newtonville, Massachusetts

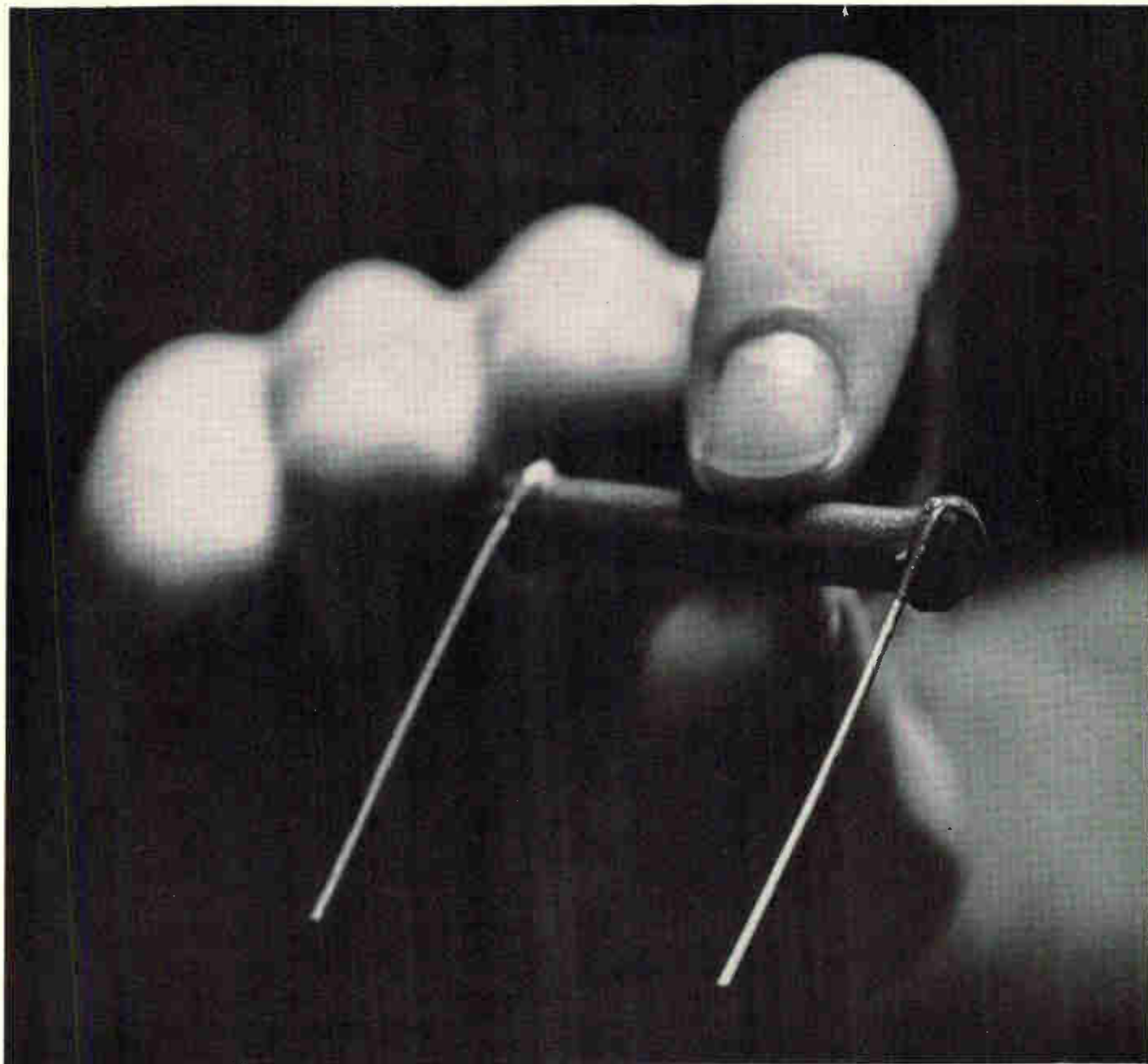

## Anyone for a 30 year old resistor?

*(the ones we make now are better)*

Modern electronic components weren't created overnight. They're the result of many, many years of patient research and development (not to mention blood, sweat, toil and tears).

That's one big reason why Speer and Jeffers customers come back time after time. We've been in the passive components business more than long enough to know the importance of product uniformity and reliability.

We've learned, for example, to take *nothing* for granted. Our inspectors are notoriously hard to please. One out of every eight production employees has a quality-assurance job.

Mil specs? We can recite MIL-R-11-E from memory forwards or backwards. And we keep right on going where it leaves off. This year,

141,912,000 unit life test hours are scheduled for Speer resistors and 40,003,156 for Jeffers coils. And what's more, we're now busy knocking down walls so we can double our in-plant quality assurance facilities.

But, proud as we are of the resistors and coils we're turning out today, we have a suspicion that they might be a bit quaint by 30-years-from-now standards. And so we have a multi-million dollar research and development program to keep us from getting too set in our ways.



Dept. 4810 St. Marys, Penna. 15857  
Speer Carbon Co. is A Division of Air Reduction Company, Inc.

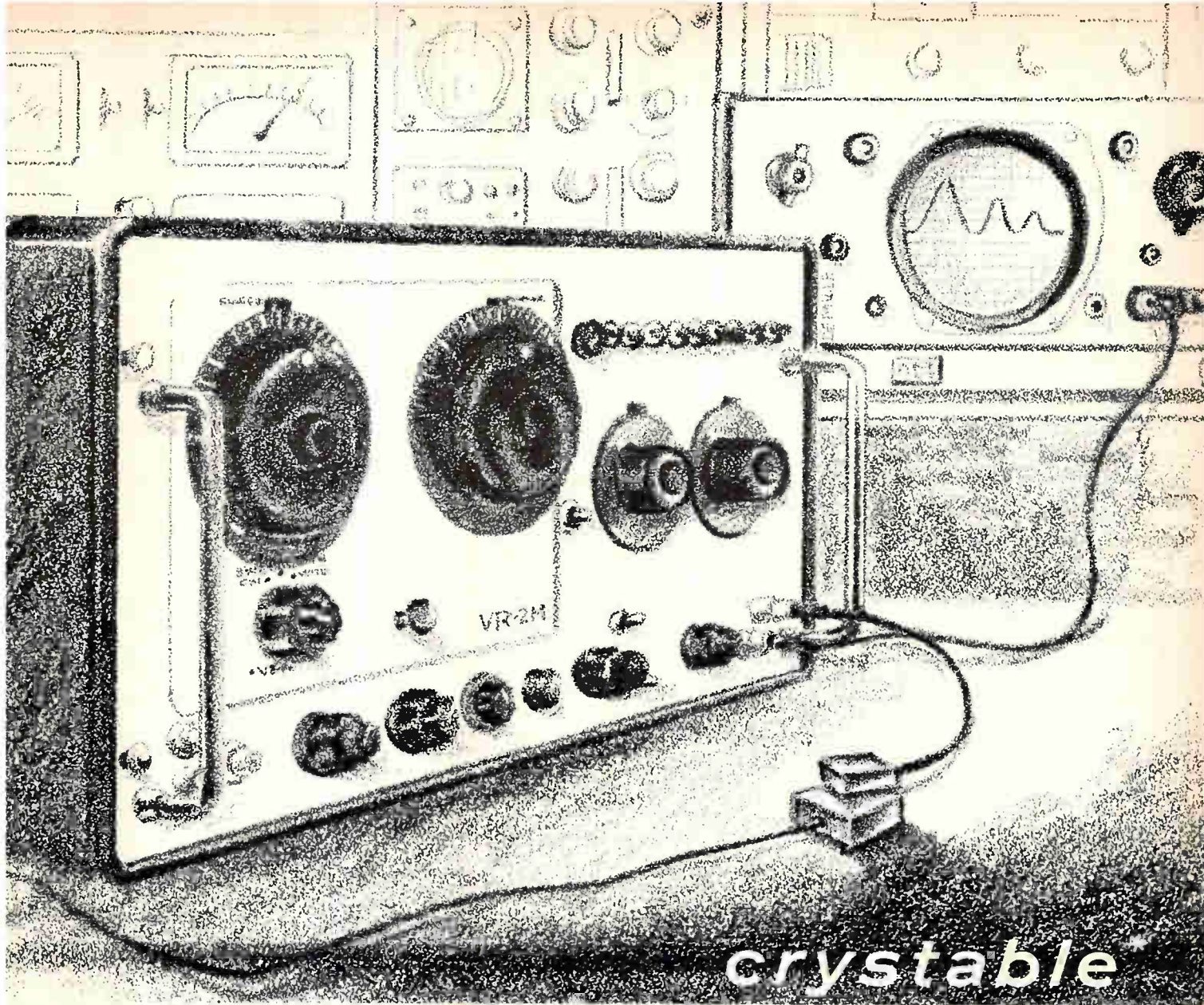

*crystable*

# New, Video Sweeping Oscillator Head — \$950<sup>00</sup>

\* That's the kind of stability now available with Telonic's new VR-2M sweep oscillator. This new plug-in unit for the SM-2000 Sweep Generator has less than 50 cps residual power supply hum at minimum sweep width and is guaranteed to maintain stability within 10 kc over an hour operating time — dependable for even the most demanding application.

With its varactor sweep circuit and non-contacting tunable inductance the VR-2M can cover 200 cps to 12 mc providing two ranges of sweep width, plus CW operation. A variable frequency marker system is an integral feature of the instrument.

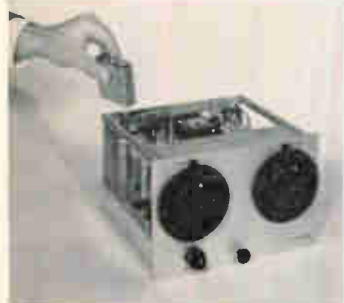

The VR-2M also embodies significant advances in mechanical design to minimize servicing. Solid state circuits are employed to maximize operating life and plug-in modular construction allows quick check out and replacement.

### SPECIFICATIONS

CW and Sweep Frequency Range	..... 200 cps to 12 mc
Sweep Width—Narrow range	..... 100 cps to 400 kc
Wide range	..... 200 cps to 10 mc
Sweep Rate, Variable	..... 0.01 cps - 100 cps
Output	..... 1 VRMS
Linearity	..... 1:1.2
Flatness	..... ±0.25 db
Marker Accuracy	..... ±150 kc
Stability, Short term (1 min.)	..... 1 kc
Long term (1 hour)	..... 10 kc

Are you testing crystal filters or any other device requiring a high order of frequency stability, wide range, and variable sweep width? Ask your local Telonic representative for a demonstration of the VR-2M.

*Telonic* INDUSTRIES, INC.  
 60 NORTH FIRST AVENUE  
 BEECH GROVE, INDIANA  
 PHONE (317) STATE 7-3231  
 TWX 317-635 4748

\*Having the necessary stability to determine the precise frequency characteristics of a crystal filter.

◆ SWEEP GENERATORS

◆ RF ATTENUATORS

◆ DETECTORS

◆ COAXIAL SWITCHES

# NOW... A COMPLETE A-TO-D CONVERSION IN 900 NANoseconds

**Newest Member of the Adage VOLDICON Family**  
**Operates at a ONE MEGACYCLE Rep Rate.** Based on a novel design combining techniques of successive approximation and parallel-threshold decoding, the new VF7-AB makes 8-bit conversions faster and more accurately than any competitive model. VOLDICON™ all-solid-state, high-performance A-to-D and D-to-A converters, manufactured since 1957, are part of Adage's complete line of analog/digital data systems components.

*Other Voldicon models:*  
**VS Series A-to-D Converters**  
2  $\mu$ sec. per bit conversion time  
14-bit binary or 16-bit BCD  
 $\pm 0.01\%$  accuracy

**D-to-A Converters**  
 $\pm 150v$  output  
 $\pm 0.01\%$  accuracy  
14-bit resolution

*Other Adage data systems components are:*

### Series VMX™ Multiplexers

100,000 samples per second  
 $\pm 0.002\%$  offset spread;  $0.01\%$  gain spread  
— no adjustments required  
Systems-organized flexible programming

### Sample-and-Hold Amplifier, Model SA3

Tracks within  $0.01\%$  in 10  $\mu$ sec. for FS input step change  
100 nanosec. aperture  
100  $\mu$ sec. recovery from 10X FS overloads

### Operational Amplifier, Model OP3

Over 5 MC gain-bandwidth product  
Approximately 100 pico-amps leakage current  
Less than 30  $\mu v$  offset drift

### HZA™ Isolation Amplifiers

100,000 megohms input impedance  
 $\pm 150v$  input voltage range  
1 part in 1,000,000 gain accuracy  
Single-ended and differential with 120 db. common mode rejection

### Digital Logic

Designed for analog/digital system requirements  
Compatible modules for digital control, decoding, formatting, and interfacing

Next time, get a quote from Adage — for components or complete systems. We think you'll like our prices, too. Call or write I. R. Schwartz, Vice President, 617-UN 4-6620.

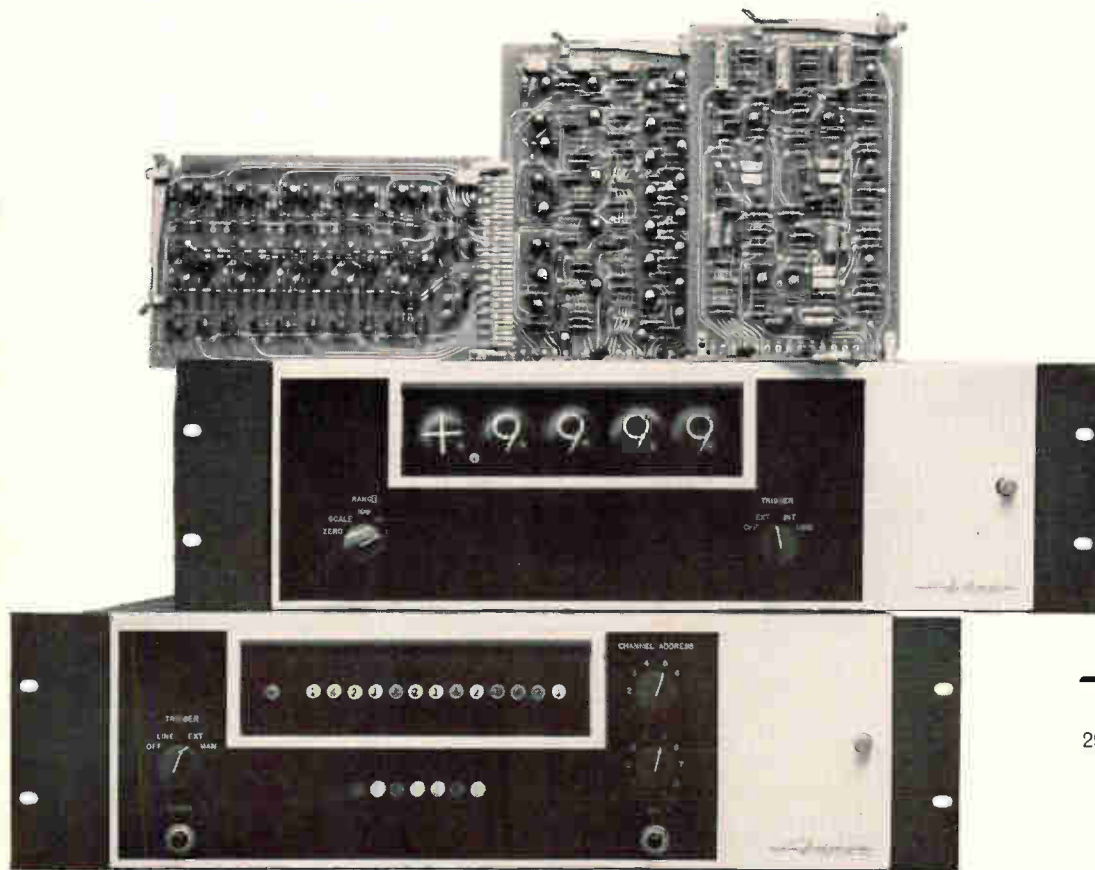

**Adage**  
INC

Main Office and Factory  
292 Main Street, Cambridge,  
Massachusetts 02142

West Coast Plant  
1145 East Ash Avenue,  
Fullerton, California 92631

Adage, Inc. welcomes employment inquiries from professional engineers.



# Long-life reed switch rated for 5,000 volts

Low-cost vacuum reed switch withstands high-voltage transients; is useful in wide range of applications

Since most automation and mechanization applied in industry uses electrical or electronic circuits with high inductive loads, a need has developed for an inexpensive reliable switch that is able to withstand high-voltage transients.

A small, new high-voltage vacuum reed switch fulfills this need. It is positive in action, has relatively long life (operations are guaranteed to perhaps a million or more), is fast compared with mechanical relays, and is reliable. In addition, its price—under \$5—satisfies the important requirement of low cost.

Type 2VR15 switch contains a pair of magnetic, overlapping, contact bearing, cantilever reeds. The reeds are sealed in an evacuated tube. The switch is designed to be operated with an external magnetic field and features minimum contact bounce and long life. This 5,000-volt unit opens the door to high-voltage test equipment and digital voltmeters.

Other ratings include: carrying current of 3 amperes; contact rating of 15-volt-amperes; pull-in of  $113 \pm 20$  ampere turns; drop-out of  $55 \pm 10$  ampere turns; and maximum contact resistance of 0.05 ohm. Average life characteristics will be rated in millions of operations, depending on test conditions and recommended operating conditions. The manufacturer currently is conducting life tests which con-

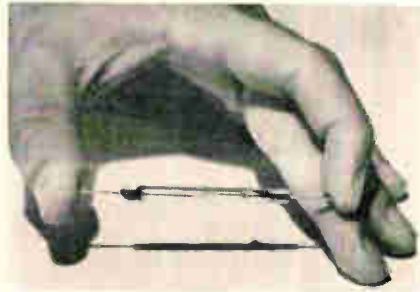

Type 2VR15 high-voltage vacuum reed switch

stitute relatively heavy duty for dry reed switches. Switching 5,000 v d-c and  $500 \mu\text{a}$  at 5 cps at 50% duty, the new high-voltage reed switches have exceeded 250,000 operations without failure. Life tests at higher current ratings are continuing.

The accompanying diagram shows a typical inductive circuit in which a switch such as the 2VR15 is useful. Closed, the switch will carry 3 amps of current. Open, it is rated to hold off 5,000 v. The capacitors and resistors indicated in the diagram, basically transient suppressors, can be adjusted according to the needs of a specific circuit. If relatively high speed and long life are not a requirement, these R and C components can be smaller (perhaps even eliminated, depending on the rest of the circuit) than when the emphasis must be placed on life and speed. For even a high voltage switch,

like any component, will last longer the more it is protected.

Another advantage is the opportunity to employ a remote, low-voltage control line far removed from the equipment's transients, heat, noise or whatever other undesirable environment exists at the site of operation. Here again, the device is useful for working into automated equipment with a complexity of control lines, panels and associated input signal devices.

While not at liberty to describe the areas of interest shown by prospective customers, the manufacturer has revealed that the general scope of application is very wide—ranging from pure motor control equipment to highly complex communications, signal and radio-frequency systems.

Maximum length of the 2VR15, including leads, is 3.210 in.; excluding leads, 2.100 in. Maximum diameter, excluding tipoff, is 0.215 in. It mounts in any position. Contact arrangement is normally open. The switch is priced at \$2.75 to \$5, depending on quantity.

General Electric Co., Tube Department, Owensboro, Ky.

Circle 301 reader service card

## Oscilloscope plug-in attains 100 Mc

A new plug-in permits a standard high-frequency oscilloscope to handle signals of 100 Mc with a pulse rise time of 3.5 nsec. Type 79-02A plug-in, which fits all the company's 765 and 765H series oscilloscopes, features dual-trace performance with 10 mv/cm sensitivity. As a single trace plug-in, a  $500 \mu\text{v}/\text{cm}$  sensitivity can be obtained with bandwidth greater than 30 Mc.

Fairchild Camera & Instrument Corp., DuMont Laboratories Divisions, Scientific Instrument Dept., Clifton, N.J. [302]

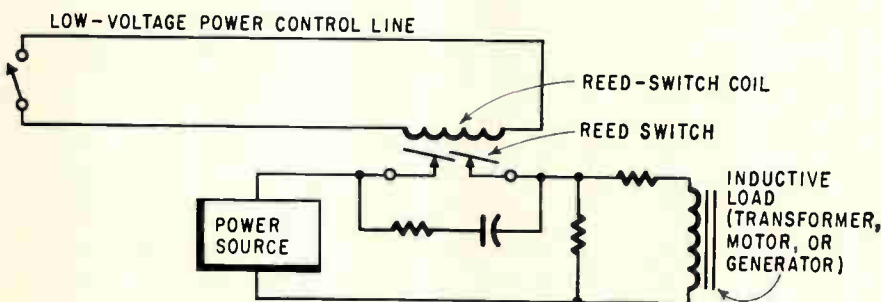

Typical inductive-loaded circuit using a reed switch

# UNIQUE...

*first low level solid-state unit joins industry's most versatile line of telegraph relays*

Radiation's new solid-state low level to high level neutral relay is the first of its kind. The unit, Model 9338, is designed for such applications as conversion of low level computer outputs to higher telegraph levels, and for computer/computer switching.

This advanced relay features modular construction and unlimited service life without maintenance. Because it operates at an input level of  $\pm 6$  v at 50 to 100  $\mu$ a, conducted and radiated RFI are greatly reduced.

**Radiation Telegraph Relays** are supplied with octal bases in three standard models (at right). They can replace all electromechanical units except in rare applications. These versatile units are completely solid state, and are powered by input loop current alone.

**Special Plug-In Adapters** are available in all popular types (examples at right), and permit you to update your present system easily and quickly. Radiation can also supply special adapters, units wired for direct replacement, or devices on plug-in printed circuit cards.

All **Radiation Solid-State Relays** operate at speeds up to 2400 bits/second with less than 3% distortion. Input is essentially resistive. They do not induce transients in the line as do electromechanical units. And a unique Radiation circuit protects inputs against abnormal line conditions such as spikes and overvoltages.

In addition, Radiation Relays are extremely resistant to environmental extremes. They require no adjustment, and will operate for an indefinite period of time without attention.

Radiation engineers will be glad to assist if you have a unique application or would like help in evaluating system requirements. Write for information, or describe your needs. Products Division, Dept. EL-10, Radiation Incorporated, Melbourne, Florida.

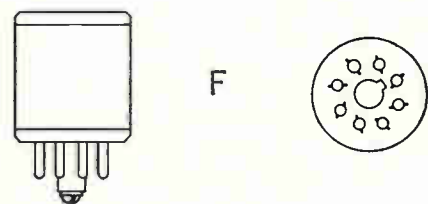
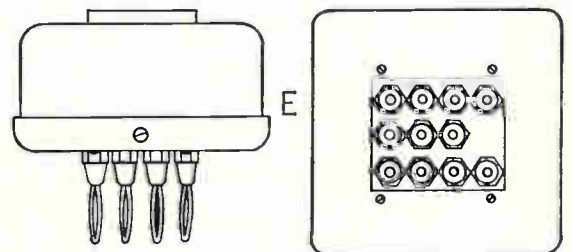
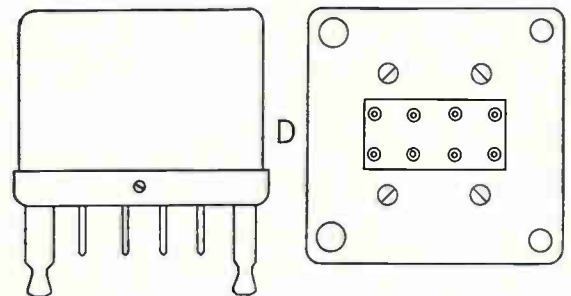
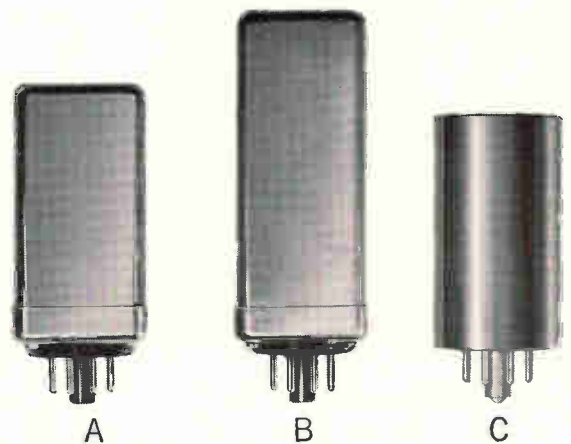

## RADIATION SOLID-STATE RELAYS

Type	Model	Body Size	Figure
Neutral	9214	1.46 x 2.86	A
Neutral	9220	1.46 x 2.86	A
Polar	9212	1.46 x 3.66	B
Univ.	9218	1.38 x 2.63	C
Low Level	9338	1.38 x 2.63	C

Note: Other configurations are available, including plug-in circuit cards.

### Standard Plug-In Adapters

Octal-to-Western Electric 255-A	D
Octal-to-Western Union 202-A	E
Octal-to-Octal	F

Note: Other adapters are available, or units can be wired for direct replacement.



## New Components and Hardware



### Heavy-duty relay in tiny package

A line of heavy-duty contact structure relays features a rugged ceramic header seal. The units are well suited for areas where space is a problem and high current is required. Dynamically designed for low-bounce operation, the relay will switch 2 amps resistive load (28 v d-c) at 125°C in excess of the requirements of MIL-R-5757. The HD is one-seventh the size of a standard crystal can relay and less than one-third the size of a half-size crystal unit, yet it offers generally the same switching capacity. Both dpdt and spdt configurations are available.

Hi-Spec Electronics Corp., 14713 Keswick St., Van Nuys, Calif. [311]

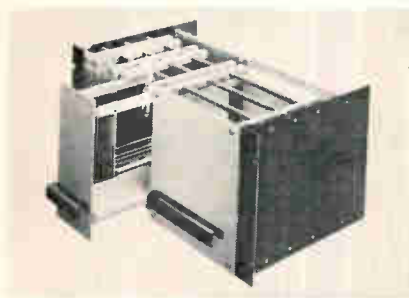

### Module rack shows versatility

A new module rack has been developed to provide a quick and inexpensive way of unit construction. Using only a minimum number of precision made standard components, each of which is available in a range of sizes, an assembly

can be built to meet exact circuit requirements. Standard components are made to give four different module panel widths of 1 in., 2 in., 4 in. and 8 in. and two module depths of 7¼ in. and 10¼ in. The overall width of the complete unit is 19 in. with heights of either 7 in. or 8¾ in. and depths of either 11 in. or 14 in. Well over 300 variations are possible and the module rack will accommodate a combination of Veroboards or any other circuit card and modules. Only a screwdriver is needed to build the complete assembly and the result is a rigid and permanent construction. Price is approximately \$60.

Vero Electronics, 48 Allen Blvd., Farmingdale, N.Y. [312]

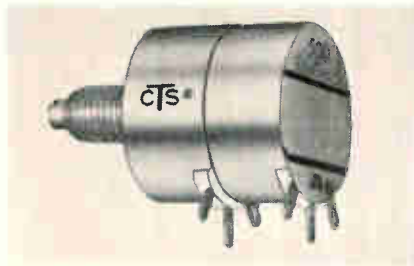

### Dual-construction variable resistor

A new dual-construction, ¾-in. diameter Cermet variable resistor is announced. Both the front and rear sections operate together from a single shaft. Series 500 Tandem, in quantities over 1,000, costs considerably less than two comparable single units and takes up less panel space. All units have a standard resistance tolerance of ±10% and a temperature coefficient of ±250 ppm. Price for 1,000 through 1,749 units is \$8.10 each.

CTS of Berne, Inc., Berne, Ind. [313]

### Sealed transformers cover wide band

Designated FA and GA, these hermetically sealed transformers have a typical frequency range of 100 kc to 100 Mc. New case styles are less

One ZENER replaces all

One zener for six wattage ratings! Now just one miniature axial-leaded zener — Unitrode's general purpose, universal UZ type — replaces *all* devices for applications between 400 mw and 3 watts.

That means only one type of zener to buy, to work with, to stock, to test. You can even specify the test current you want, simply by changing a part number suffix. Yet these "in-plant" savings cost no compromise in performance. Operating characteristics are better at every wattage rating . . . in a device no bigger than:



For performance/profit proof, just turn the page.

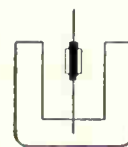

UNITRODE

# ANNOUNCING

PRICE LIST  
MICROCIRCUIT LOGIC MODULES  
July 1964

## a modest PRICE REVISION

Module types on this list are grouped into speed-categories within each category, they are listed in order of increasing speed. The above table provides cross-reference information and size pricing based on the 1000 pieces shown. The maximum discount is based on a 1000 piece lot factor. It is the intent of Intellux to continue to provide the majority of these types.

500 KC LOGIC MODULES		1-25	26-50	51-100	101-200	201-500
<b>FLIP FLOPS</b>						
FF1013A	\$15.00	\$12.00	\$9.00	\$6.50	\$7.00	
FF1133A	17.00	14.00	11.00	8.00	12.00	
FF1133P	20.00	17.00	14.00	10.00	12.00	
FF1133R	19.00	16.00	13.00	9.00	11.00	
<b>DOUBLE NON GATES</b>						
GG1513A	\$13.50	\$10.50	\$8.00	\$6.00	\$8.00	
GG2513A	13.00	10.00	8.00	6.00	7.00	
<b>GATE BUFFERS</b>						
GB1513R	\$5.00	\$4.00	\$3.00	\$2.50	\$3.00	
<b>AND GATES</b>						
GA1133A	\$75.00	\$60.00	\$45.00	\$35.00	\$45.00	
GA1513P	25.00	20.00	15.00	12.00	15.00	
GA1513R	30.00	24.00	18.00	14.00	18.00	
<b>MULTIVIBRATORS</b>						
MV1513A	\$18.00	\$14.00	\$10.00	\$7.50	\$6.50	
<b>DELAY MULTIVIBRATORS</b>						
DM2513A	\$7.50	\$6.00	\$4.50	\$3.50	\$4.50	
<b>SCHMITT TRIGGER</b>						
ST1513A	\$11.00	\$9.00	\$7.00	\$5.50	\$7.00	
<b>UP DOWN (FLIP FLOP) MULTIPLETS</b>						
UD1513A	\$15.00	\$12.00	\$9.00	\$7.00	\$7.00	

**intellux**  
INCORPORATED

POST OFFICE BOX 929  
SANTA BARBARA, CALIFORNIA  
PHONE (805) 966-1585

(Continued on p. 114)

EFFECTIVE 1 OCTOBER 1964, OUR MICROCIRCUIT LOGIC MODULE PRICE LIST WILL REFLECT REDUCTIONS OF:

- 45% FOR THE 1 Mc MODULES WHICH HAVE DEMONSTRATED COMPLIANCE WITH ALL APPLICABLE MIL SPECS.
- 51% FOR OUR 1 Mc (0 - 85°F) LINE OF DIGITAL LOGIC MODULES
- 61% IN THE 5 Mc LINE OF DIGITAL CIRCUIT LOGIC MODULES.

*NOW, may we help you?*

We also offer an annual  
Quantity Discount

**intellux**  
I N C O R P O R A T E D

30 S. SALSIPUEDES STREET ● SANTA BARBARA CALIFORNIA  
AREA CODE (805) 966-1585

## New Components

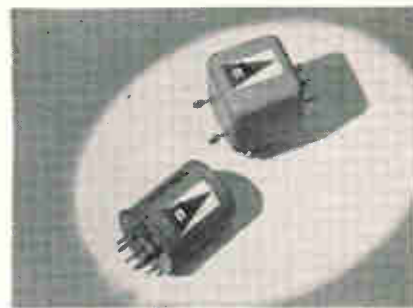

than one-fourth the size of the company's standard line. Both FA and GA packages are rated at ½ w. Series GA is cylindrical in shape and plugs into a conventional 7-pin socket. Series FA comes with two 4-40 studs for mounting purposes. Specifications for custom wideband transformers may be submitted for quotation.

North Hills Electronics, Inc., Alexander Place, Glen Cove, L.I., N.Y. [314]



## Cermet trimming pot rated ½ w at 85°C

Helitrim trimming potentiometer model 61 is a ¼-in. diameter single-turn unit with bottom pins on a 0.10-in. grid. Cermet resistance element offers essentially infinite resolution and power rating of ½ w at 85°C, derating to 0 at 150°C. Standard resistances are from 10 ohms to one megohm. The unit weighs only about ½ gram, measures 3/16 in. high and occupies less than 0.1 cu in. of mounting space. New design features longer stainless steel housing which completely encloses the resistance ele-

**Manufacturing  
Quality Resistors  
under Rigid  
Reliability  
Control**



**Rohm**

METAL FILM RESISTOR  
CARBON

**TOYO  
ELECTRONICS  
INDUSTRY  
CORPORATION**

P. O. BOX 103 CENTRAL  
KYOTO, JAPAN

ment and is sealed to meet immersion tests of MIL-R-22097B. Pins are 5/16 in. long. Price is approximately \$5.

Helipot Division of Beckman Instruments, Inc., 2500 Harbor Blvd., Fullerton, Calif. [315]

**High-Q capacitors  
are voltage-variable**

A series of low-cost, voltage-variable capacitors, designated PC 1400, features Q's of 400 at 50 Mc with 4-v negative bias. Breakdown voltages are available up to 150 v. Capacitance-voltage sensitivity is approximately square-law up to maximum working voltage. The units are provided with low-inductance gold-plated ribbon leads to achieve high self-resonance. Body dimensions are 0.070 in. maximum by 0.150 in. maximum. Price is \$1 to \$10 depending on type and quantity.

Parametric Industries, Inc., 63 Swanton St., Winchester, Mass. 01890. [316]

**Heat sinks offer  
variety of mountings**

These heat sinks include over 80 standard configurations from 1/2 in. square to 2 1/4 by 4 1/2 in., in any length to 5 ft. Suitable for applications involving either natural or forced convection, they can be used in systems involving r-f power amplifiers, high-power audio amplifiers, servo amplifiers, converters and inverters, motor control equipment, temperature-regulating de-

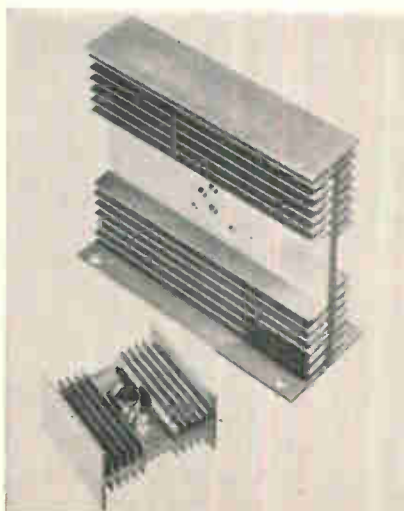

**One ZENER  
outperforms  
all**

The only all-purpose zener — the Unitrode miniature universal UZ type — is also your one *best* zener for superior electrical characteristics. Operating at up to 3 watts, in ratings from 6.8 to 400 volts, Unitrode zeners are electrically "shock-proof" — withstand repeated 50-watt surges. Even so, they're smaller than 250-mw types — in fact, so big:

These remarkable properties result from unique whiskerless construction, with the junction fused in glass to maintain characteristics *permanently*, regardless of operating conditions.

Now, how much more do you pay for so much more performance in a single zener type? Turn the page again — you're in for a surprise!

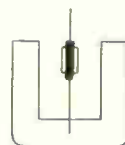

**UNITRODE**

# LAPP HEAVY-DUTY ANTENNA INSULATORS

...in all these standard sizes to save you time and money

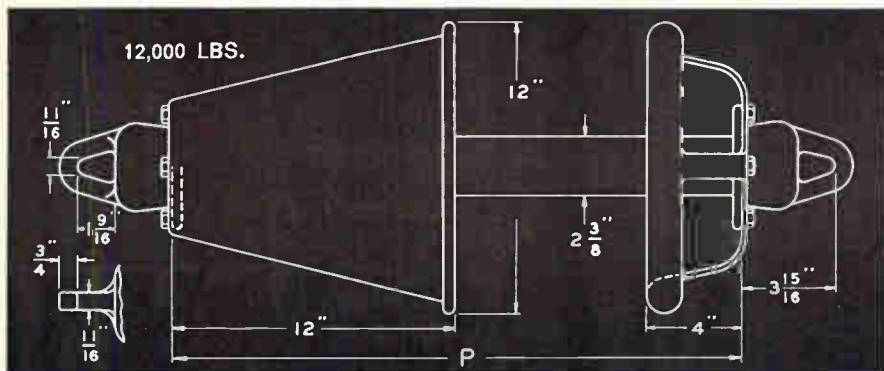

No. 9171, without ring or shield, for most high-strength applications. Standard "P" dimensions: 12, 16, 20, 24, 30 inches.

No. 9172, with two grading rings to raise voltage at which corona starts, and to distribute voltage to reduce heating of porcelain. Standard "P" dimensions: 20, 24, 30 inches.

No. 9173, with corona ring and rain shield, preferred for vertical installations. Standard "P" dimensions: 24 and 30 inches.

9,000 and 10,500 LBS.

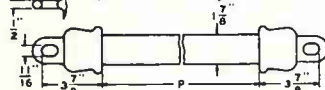

No. 43812 in porcelain (rated at 9,000 lb. average ultimate strength) or No. 43813 in steatite (10,500 lbs.), in standard "P" dimensions of 12, 14, 16, 20 inches.

6,000 and 7,000 LBS.

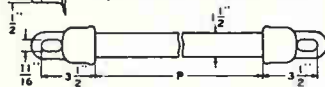

No. 43810 in porcelain (rated at 6,000 lb. average ultimate strength) or No. 43811 in steatite (7,000 lbs.), in standard "P" dimensions of 10, 12, 14, 16 inches.

4,000 and 5,000 LBS.

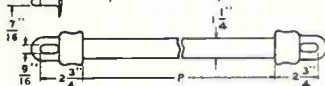

No. 43808 in porcelain (rated at 4,000 lb. average ultimate strength) or No. 43809 in steatite (5,000 lbs.), in standard "P" dimensions of 8, 10, 12, 14 inches.

## FLASHOVER AND RADIO RATINGS

WET FLASHOVER 60 $\mu$ KV eff.				RADIO RATING KV eff.		
"P" Inches	All except No. 9172 No. 9173	No. 9172	No. 9173	All except No. 9172 No. 9173	No. 9172	No. 9173
8	45			21		
10	54			22		
12	62			23		
14	70			24		
16	77			24		
20	88	88		25	34	
24	96	96	60	27	37	34
30	108	108	108	28	40	38

Steatite Insulators will have the same Flashover but twice the Radio Rating.

# Lapp

WRITE for Bulletin 301-R.  
Lapp Insulator Co., Inc.,  
223 Sumner Street, LeRoy, N. Y.

## New Components

vices and semiconductor components and devices. Manufactured from 6063-T5 aluminum extrusion, the sinks feature a wide variety of mounting possibilities.

Tor Mfg. Co., 16329 E. Arrow Hwy., Irwindale, Calif. [317]

## Sealed transformers for low-voltage use

A new hermetically sealed transformer is announced for use with transistors and other low-voltage applications. The HSM-248 may be used in full-wave bridge rectifier circuits providing 14.5 or 29 v d-c. Transformer primary voltage is 105/115/125 v, 50-60 cycles. Prices range from \$26.10 in quantities of 1 to 9, to \$17.56 in quantities of 250 or more.

Triad Distributor division of Litton Industries, 305 North Briant St., Huntington, Ind. [318]

## Toggle switch gives positive snap-action

A subminiature, spdt, two-position toggle switch is announced for military and commercial instrumentation. Type T4203 measures  $\frac{1}{8}$  in. in diameter by  $\frac{2}{5}$  in. overall including an  $\frac{1}{8}$ -in. bat handle. The unit mounts in a  $\frac{1}{4}$ -in. hole. Potted, 10-in. No. 28 flexible leads are used in place of terminals. The switch is rated for a minimum of 10,000 operations at 120 v a-c or 28 v d-c under 1-amp resistive loads,  $\frac{1}{2}$ -amp inductive loads, or  $\frac{1}{4}$ -amp lamp loads. Its positive snap-action mechanism provides good "feel"

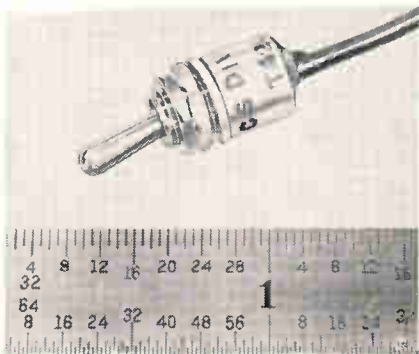



**FREE-FLEX\*  
CIRCUITRY  
BREAKTHROUGH**

**SOME PEOPLE  
THINK THIS IS  
A PARABOLIC  
ANTENNA!**

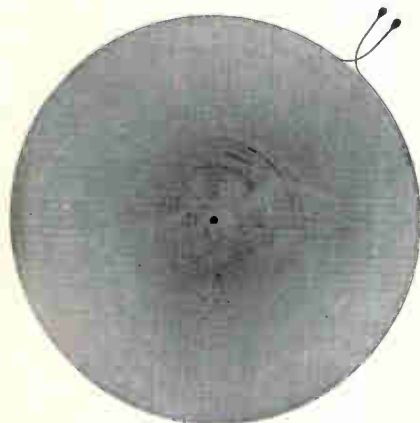

Visualize this "way out" idea. 5 mil wide copper lines laid in a mere 2 1/8" diameter circle with 5 mil wide spacing! It's just one small example of how Garlock FREE-FLEX\* Circuitry is allowing engineers everywhere new design freedom, new reliability, new economy! FREE-FLEX\* is setting new standards in point-to-point wiring, basic circuitry, inter-chassis circuitry and countless other applications.

By the way, that isn't a parabolic antenna, but if you have had difficulty reducing fresh, new "way out" ideas to realistic applications, why not let Garlock lend a helping hand?

**FREE-FLEX\* ENGINEERING HANDBOOK**

This new handbook gives complete technical and practical data on Garlock FREE-FLEX\* Circuitry. Your free copy is waiting, just write to:

\*Garlock Trademark

**GARLOCK**  
ELECTRONIC PRODUCTS

CAMDEN, NEW JERSEY 18101

Circle 203 on reader service card

and reliable operation over an ambient temperature range from -65 to +71°C.

Control Switch Division, Controls Co. of America, 1420 Delmar Drive, Folcroft, Pa. 19032. [319]



**Cadmium selenide cells  
show high sensitivity**

Highly sensitive cadmium selenide photoconductive cells have been introduced. They have a dark resistance of 5 megohms or greater. This figure decreases to 10,000 ohms at 2 footcandles. Response time for the new line is relatively short—an approximately 1,000-to-1 change in resistance in 10 millisecond when 25 footcandles are applied to cells previously held in the dark. The new units act as either light-controlled rheostats or relays without contact surfaces. Applications include photoelectric devices, counters, exposure meters, and furnace controls. The cells are available in both glass-metal case and plastic encapsulated construction. Two case sizes are available; 3/8 in. and 1/2 in. diameters. The 1/2-in. hermetically sealed units type Y-1206, are rated typically at 250 v with 250 mw dissipation. The 3/8 in., type Y-1332, are rated typically at either 30 or 60 v depending on the maximum pattern width. Maximum dissipation is 75 mw. The 1/2-in. plastic encapsulated units, type C425P1, are rated typically at 250 v with 150 mw dissipation. Peak spectral response of the cadmium selenide cells is 7,400 angstroms. Prototype units are available immediately and are priced from 90 cents to \$1.75 for hermetically sealed units and 45 cents to 80 cents for the plastic encapsulated models. Prices depend on quantity.

General Electric Co., Owensboro, Ky. [320]

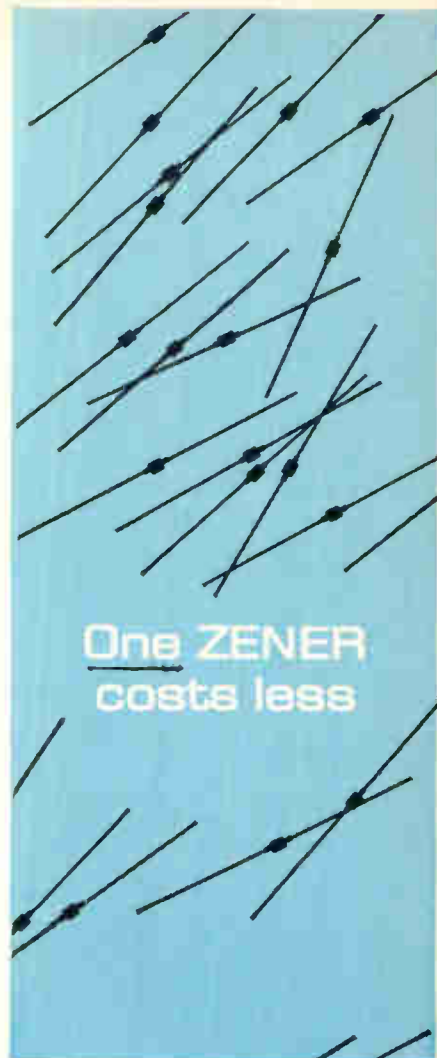

**One ZENER  
costs less**

Now you pay less for *all* the zeners you need! Ordering just one type — Ultra-reliable Unitrode Universal UZ zeners — for all your requirements between 400 mw and 3 watts, you profit from volume price reductions. What's more, for even greater quantity discounts, you can combine voltages . . . even place blanket orders with deliveries scheduled over 12 months!

These price advantages guarantee you *direct savings*, plus the operating economies you gain using the only zener offering unmatched characteristics — fused permanently in glass — in a unit this small:

One all-purpose type, a generation ahead in design, yet actually at lower cost . . . Shouldn't this triple-threat zener be working for you? Contact Unitrode Corporation, 580 Pleasant St., Watertown, Mass. 02172. Tel: (617) 926-0404, TWX: (617) 924-5857.



**UNITRODE**

## New Instruments



### Capacitance bridge is fully automatic

This automatic capacitance bridge selects range, achieves balance, and presents the measured value in digital in-line form. Type 1680-A, including built-in transistor oscillator (120, 400, and 1,000 cps) as well as bridge and detector circuits, measures parallel capacitance from 0.01 pf to 100  $\mu$ f at 400 and 1,000 cps, and from 100 pf to 1,000  $\mu$ f at 120 cps. Basic accuracy is  $\pm 0.1\%$  of reading. The bridge also measures dissipation factor from 0.0001 to 1.0 and parallel conductance from 0.1 nanomho to 1.0 mho. Measurement results (capacitance and loss) are displayed, complete with decimal point and units, on an in-line Numerik digital readout. The same information is also supplied in binary-coded decimal form (1-2-4-2 BCD) for use by printers and other data-handling equipment. The entire balance takes about one-half second.

General Radio Co., West Concord, Mass. [351]



### Pressure transducer in modular package

This strain-gage pressure transducer provides a number of different output voltages plus the most complete internal electronic packages available in the industry,

according to the manufacturer. Highly accurate sensors, utilizing piezoresistive silicon semiconductors, provide infinite resolution, temperature compensation, high reliability and repeatability plus compatibility with most liquid and gaseous elements. Complete modular electronics packages permit the inclusion of such features as regulator, isolator, amplifier and calibration all in the small 1-in. diameter case. The TF1 has a special temperature compensation range available from  $-65^{\circ}\text{F}$  to  $+200^{\circ}\text{F}$ . It can be supplied with either a 100 mv output or 5 v output full scale. Standard output (unamplified) of the normal 0 to  $150^{\circ}\text{F}$  temperature range transducer is 250 mv. Because of its solid state design, the TF1 is unusually stable under excessive environmental conditions, and has a thermal zero and sensitivity shift of  $\pm 0.01\%$  per degree F standard. Combined linearity and hysteresis deviation is no greater than  $\pm 0.25\%$ .

Fairchild Controls, 225 Park Ave., Hicksville, L.I., N.Y. [352]

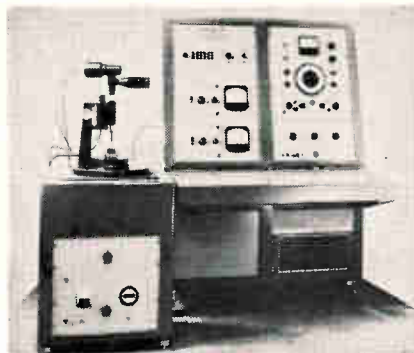

### Calibration system for accelerometers

Absolute calibration of accelerometers at frequencies up to 50 kc and accurate measurement of very small dynamic displacements is now possible using a new calibration system. Ease of operation, including setup time of under five minutes, makes the model KA-2826 system ideal for lab or production use. Wave form distortion is less than 2% to 20 kc, 5% to 50 kc. The system is composed of an interfer-

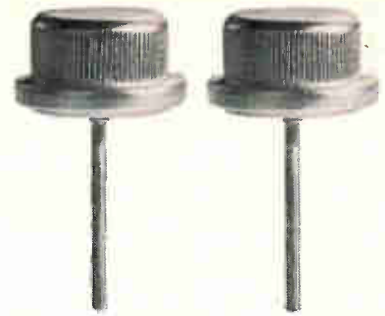

### AVAILABLE AT THESE DISTRIBUTORS

#### EAST

Binghamton, N. Y.—Federal Electronics  
P. O. Box 208/PI 8-8211

Philadelphia 23, Penn.

Almo Industrial Electronics, Inc.  
412 North 6th Street/WA 2-5918

Pittsburgh 6, Penn.—Radio Parts Company, Inc.  
6401 Penn Avenue/361-4600

Newton 58, Mass.—Greene-Shaw Company  
341 Watertown Street/WO 9-8900

Clifton, N. J.—Eastern Radio Corporation  
312 Clifton Avenue/471-6600

New York 36, N. Y.—Harvey Radio Company, Inc.  
103 West 43rd Street/JU 2-1500

Baltimore 1, Md.—Radio Electric Service Company  
5 North Howard Street/LE 9-3835

#### SOUTH

Birmingham 5, Ala.—Forbes Distributing Company, Inc.  
2610 Third Avenue, South/AL 1-4104

West Palm Beach, Fla.—Goddard, Inc.  
1309 North Dixie/TE 3-5701

Richmond 20, Va.—Meridian Electronics, Inc.  
1001 West Broad Street/353-6648

#### MIDWEST

Detroit 3, Mich.—Glendale Electronic Supply Company  
12530 Hamilton Avenue/TU 3-1500

Battle Creek, Mich.—Electronic Supply Corporation  
94 Hamblin Ave./P.O. Box 430  
Phone: 965-1245

Minneapolis 16, Minn.—Admiral Distributors, Inc.  
5305 Cedar Lake Road, St. Louis Park/545-0223

Indianapolis 25, Ind.—Graham Electronics Supply, Inc.  
122 South Senate Avenue/ME 4-8486

Cleveland 1, Ohio—The W. M. Pattison Supply Co.  
Industrial Electronics Division  
777 Rockwell Avenue/621-7320

Chicago 30, Ill.—Merquip Electronics, Inc.  
4939 North Elston Avenue/AV 2-5400

Cincinnati 10, Ohio—United Radio, Inc.  
1308 Vine Street/241-6530

Kansas City 11, Mo.—Walters Radio Supply, Inc.  
3635 Main Street/JE 1-7015

St. Louis 17, Mo.—Electronic Components for Industry Co.  
2605 South Hanley Road/MI 7-5505

#### WEST

Dallas 1, Texas—Adleta Company  
1907 McKinney Ave./RI 1-3151

Houston 1, Texas—Harrison Equipment Company, Inc.  
1422 San Jacinto Street/CA 4-9131

San Diego 1, Cal.—Electronic Components of San Diego  
2060 India Street, Box 2710/232-8951

Los Angeles 15, Cal.—Radio Products Sales, Inc.  
1501 South Hill Street/RI 8-1271

Los Angeles, Cal. 90022—Kierulff Electronics  
2585 Commerce Way/OV 5-5511

Mountain View, Cal.—Kierulff Electronics  
2484 Middlefield Road/968-6292

Denver, Colo.—L. B. Walker Radio Company  
300 Bryant Street/WE 5-2401

Seattle 1, Wash.—C & G Electronics Company  
2221 3rd Avenue/Main 4-4355

Phoenix, Ariz.—Midland Specialty Co., Inc.  
1930 North 22nd Ave./258-4531

Albuquerque, N.M.—Midland Specialty Co., Inc.  
1712 Lomas Blvd., N.E./247-2486

Tucson, Ariz.—Midland Specialty Co., Inc.  
951 South Park Ave./MA 4-2315

Ask for a complete catalog

**DELCO RADIO** 

DIVISION OF GENERAL MOTORS, KOKOMO, INDIANA

Circle 118 on reader service card

Electronics | October 19, 1964



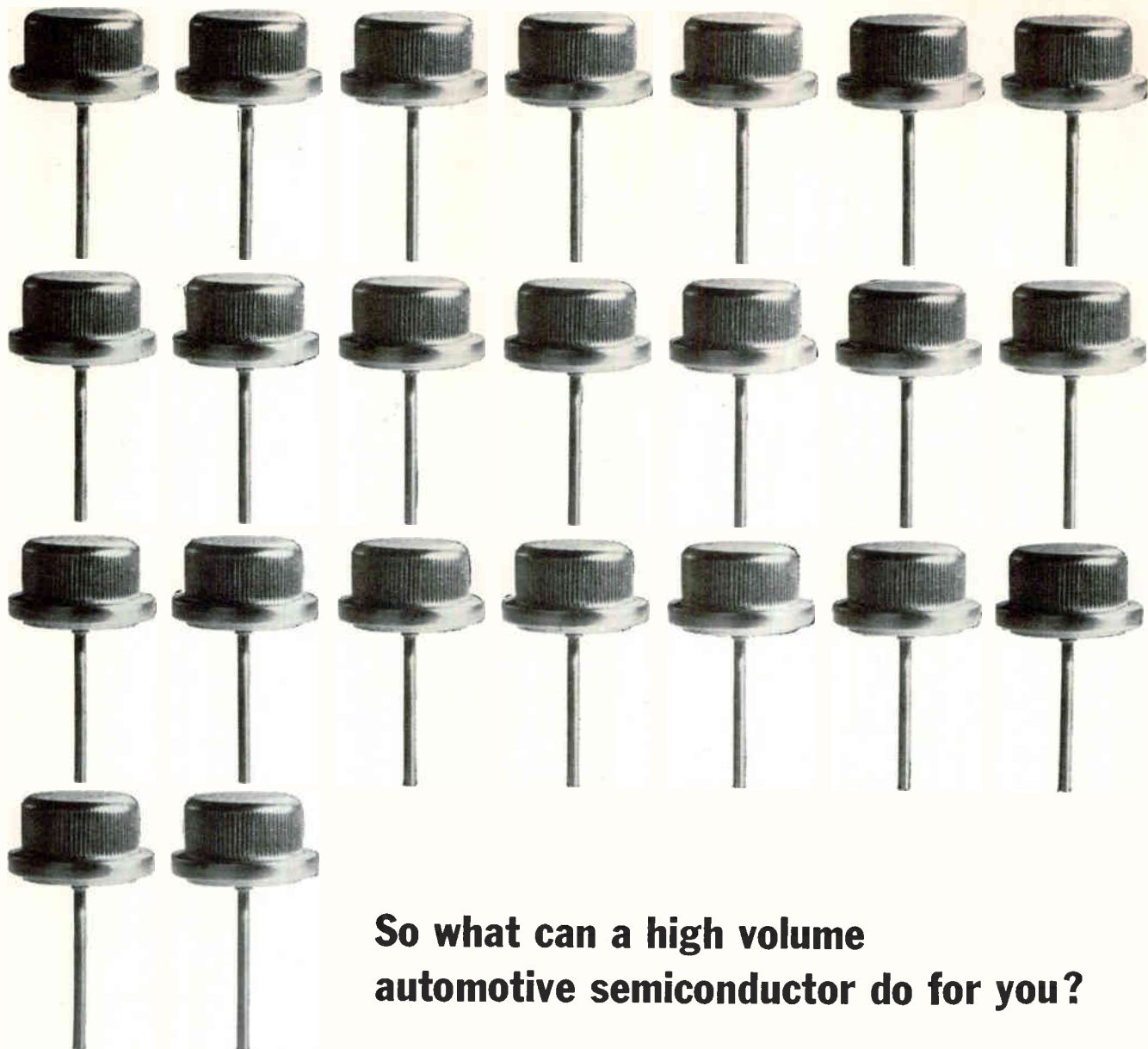

## So what can a high volume automotive semiconductor do for you?

### Save you money, for one thing.

Consider Delco Radio's press fit and stud base rectifiers.

They're designed and built for rugged automotive applications, where devices don't stick around long unless they're especially reliable—(successful operation for several billion device hours insure this)—and they don't get used at all unless their price is low.

The 18-ampere 1N3491-93 press fit series in 50, 100 and 200 P.R.V. ratings will withstand current surges to 300 amperes. Hermetic sealing and extensive thermal cycling assure stability of operation from  $-65^{\circ}\text{C}$  to  $+175^{\circ}\text{C}$ —for as low as two cents an amp.

For stud mounting, the same basic rectifier is avail-

able in the 15-ampere 1N3208-10 series with stud package. They will maintain full-rated peak reverse voltages of 50, 100 or 200 volts to  $+175^{\circ}\text{C}$  which extends through the forward current derating range of  $150^{\circ}\text{C}$  to  $175^{\circ}\text{C}$ .

Or maybe you'd be interested in other rectifiers being readied for high volume applications such as: our new high voltage 250-ampere DRS-250 series.

For the full story on delivery, price and reliability advantages these high volume devices can offer you, contact any Delco Radio sales office. They'll supply you with data, prices and applications assistance.

\*Union, New Jersey  
324 Chestnut St.  
(201) 687-3770

Detroit, Michigan  
57 Harper Ave.  
(313) 873-6560

Palo Alto, California  
201 Town & Country  
Village  
(415) 326-0365

\*Santa Monica, Cal.  
726 Santa Monica  
Blvd.  
(213) 870-8807

Syracuse, N.Y.  
1054 James St.  
(315) 472-2668

\*Chicago, Illinois  
5151 N. Harlem Ave.  
(312) 775-5411

**DELCO RADIO**   
DIVISION OF GENERAL MOTORS, KOKOMO, INDIANA

\*Office includes field lab and resident engineer for applications assistance. General Sales Office: 700 E. Firmin, Kokomo, Ind., (317) 452-8211—Ext. 500

# WHEN INDICATION IS NOT ENOUGH...

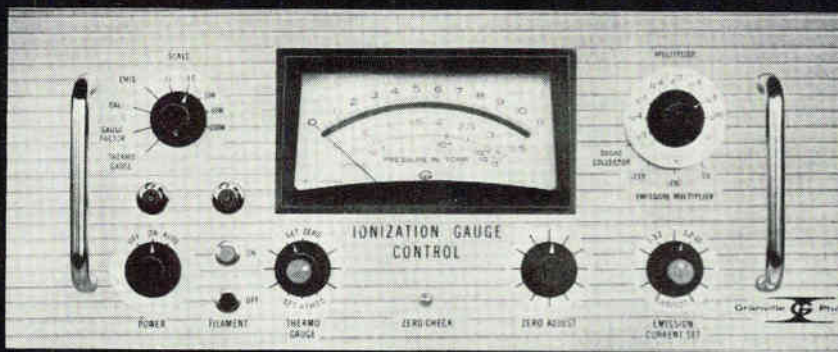

## Get measurement with the new Granville-Phillips Ion Gauge Controller

Today with more than 20 ion gauge controllers on the market, why should you buy the new Granville-Phillips Series 236 Gauge Controller?

Frankly, this same question bothered us a year ago and we'd like to tell you why we decided to market this new control.

For some unexplained reason ion gauge controllers haven't kept pace with other sophisticated developments in electronics and measuring techniques. Such performance limiting factors as partially regulated power supplies, 5% measuring resistors, negative feedback circuits with low loop gain and battery charger type meters may have been suitable for some applications in the past, but these pressure indicators simply do not meet today's need for critical low pressure measurement.

So... Granville-Phillips set out to design the best gauge controller available, and we did it. The Series 236 Controller is the most versatile, accurate, stable low pressure measuring instrument available—and the price is modest too.

Look at this list of features you'll find in the 236: Pressure range 10 Torr to  $10^{-11}$  Torr with one gauge tube. Automatic range switching. Continuously variable emission current. Electron bombardment degassing. Accurate low drift electrometer circuit. Plug-in solid-state circuitry. And over 30 other useful features fully described in our brochure.

Next time don't be satisfied with less. Specify the Granville-Phillips Series 236 Ion Gauge Controller.

**Granville-Phillips Company**  
5675 EAST ARAPAHOE • BOULDER, COLORADO 80301



## New Instruments

ometer, piezoelectric vibrator and driver. The interferometer has a useful frequency range of 500 cps to 50 kc and can measure absolute displacements from  $4 \times 10^{-6}$  in. to  $45 \times 10^{-6}$  in. The vibrator of stacked piezoelectric wafers, bonded together, contains a monitoring standard accelerometer and provides for mounting either a mirror or the accelerometer to be calibrated. Noting the output of the standard accelerometer at fringe disappearances (observed in the interferometer) provides known and absolute displacement of the vibrator. The vibrator can then be used, separate from the interferometer, to calibrate other accelerometers by simply driving the vibrator at known acceleration levels as indicated by its standard accelerometer.

Gulton Industries, 212 Durham Ave., Metuchen, N.J. [353]

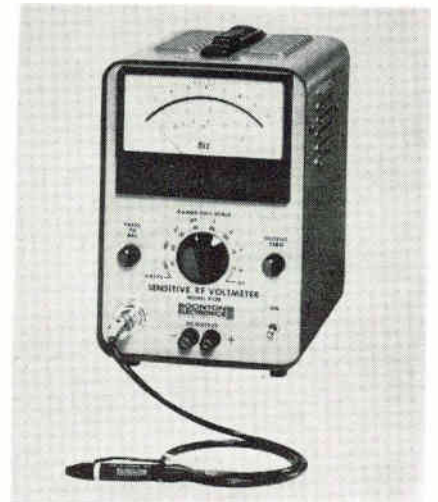

## R-f voltmeter offers 2% basic accuracy

A broadband r-f voltmeter has been developed with a basic accuracy of 2% and a voltage measuring capability of  $300 \mu\text{v}$  to 300 v over a frequency range from 20 kc to 1,200 Mc. Model 91DA provides true rms response for inputs up to 3 v, gradually approaching peak reading (calibrated on the meter scale in rms) above this level. It is characterized by high input resistance, low input capacitance, excellent

stability and low noise. The 6-in. meter of model 91DA is calibrated in volts and db; a scale calibrated in volts and dbm (50 ohms) is available at no extra cost. The instrument is normally supplied for 60-cps operation. Units for either 50-cps or 400-cps operation can also be provided, and either bench or rack mounting versions of all models are available. Model 91DA is supplied with a solid-state detector probe and probe tip as standard equipment. A variety of accessories, including a 100:1 voltage divider, tee adapter, and a selection of terminated and unterminated adapters is also available for use with the instrument. Price of the 91DA is \$650.

Boonton Electronics Corp., Parsippany, N.J. [354]

### Data viewing system with optional scaler

Designed for fast, accurate analyses of strip chart records up to 16 in. wide, this data reduction system includes two separate components: a data viewer and a data scaler. The viewer is a console, 4 ft wide by 4 ft high and 21 in. deep, with a 17 in. by 26½ in. back-lighted viewing area. Records are held on ½ in. hex spindles at either end of the viewing area. They are transported in either direction at speeds from 0 to 500 fpm by an electrical drive with positive braking action and static tension. Cost of the data viewer model 500 is \$675. The data scaler may be purchased separately or as an attachment to the data viewer (as shown). Ideal for quick-look work, spot checking or thorough analyses, this data scaler permits direct reading of records without the need of a calculator to correct



# get the whole story...

on this miniature, dust-covered, telephone-type relay, a uniquely reliable product, entirely manufactured in our own plant. Write today for your copy of this catalog, containing detailed drawings and specifications. Relays available in several series to meet varied applications in communications, computers, and industrial controls. Write Relaymatic Incorporated, Sag Harbor, L. I., N. Y.



# RELAYMATIC

INC.

SAG HARBOR, LONG ISLAND, NEW YORK

# IMAGINATION

At Space Craft, Inc. imagination is an ingredient in successfully achieving our objectives in Theoretical Studies, Systems Analysis, Systems Synthesis, Operations Analysis, and Conceptual Design. We integrate imagination with *practical experience* in structures, propulsion, thermodynamics, cryogenics, performance and computing. This *imagination plus* insures that our customers receive the right solution to their systems problems on time and at realistic cost.

If your company is currently facing a systems problem why not get the full details on how the Astran Division can assist in solving it? Your communication will bring us running.

tion has always been a priceless achieving our objectives in Analysis, Systems Synthesis,



Astran Division  
**Space Craft, Inc.**  
8620 S. MEMORIAL PARKWAY, HUNTSVILLE, ALABAMA

Circle 204 on reader service card

## New Instruments

for scale factors. Slopes can be drawn on the data scaler's plastic overlay so that single or multiple channels of information can be directly evaluated, with each channel having its own zero reference and scale factor. Both the rectilinear and curvilinear records can be read and the data scaler handles the linear and nonlinear calibrations with ease. All readings for each channel are given in a 3-digit counter. The data scaler costs \$395, plus \$95 for a mounting attachment to the data viewer. The entire system costs \$1,165.

Data Scaler, Westfield, Mass. [355]

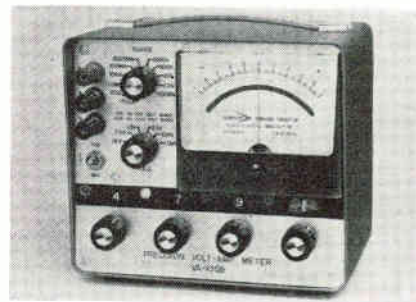

## Volt-amp meter is solid state

A new 0 to 1,000-v precision d-c volt-amp meter has been developed with voltage accuracy of  $\pm(0.05\%$  to  $+5\mu\text{v})$  absolute and current from  $1\mu\text{a}$  to 1 amp with accuracy of  $\pm 0.1\%$  and  $\pm 0.2\%$  absolute. The solid-state model VA-100B features stability of 0.05% for a 10% line change from 105 to 125 v a-c, 50-60 cps, and stability of the zener reference of  $\pm 0.001\%/^{\circ}\text{C}$ ,  $\pm 0.05\%$ /year. The unit provides standards engineers with a dual purpose instrument, capable of very precise measurements of d-c voltages and currents. When measuring currents, the maximum voltage drop across the shunts is 100 mv. Continuously self-calibrating (60 times per sec), the VA-100B removes the inherent error due to recalibration. In addition, it obsoletes the time-consuming operation of recalibration each time the instrument is turned on, moved from one location to another, or during

## CUT CONSTRUCTION DELAY

### with pre-punched **VECTORBORD, PLUGBORD and Push-in TERMINALS**

Make circuits the fast, easy way . . . simply insert Vector push-in terminals (wide variety available) and component wires into pre-punched Vectorbord, or use punched copper clad for do-it-yourself etching; and, for production, we're geared to omit the holes not required and assemble terminals, eyelets, etc. to your specifications. Seven patterns available with .062" and .093" holes, in XXXP phenolic, glass silicone, glass or paper epoxy and copper clad. Plugbords supplied in many sizes with etched pads, .040" dia. Edge-Pins or Elco Varicon contacts.

Save time — Save work — Save money!

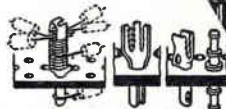

Send for complete literature

**VECTOR ELECTRONIC CO., INC.**

1100 Flower St., Glendale 1, California; Phone: CHapman 5-8971

long-term measurements. For ease of operation and accuracy, it incorporates a five-digit readout with the last two digits read out on a precision potentiometer, decimal lights, a polarity reversal switch and recorder and reference outputs. Calibration Standards Corp., 1031 Westminster Ave., Alhambra, Calif. [356]



### Positioning device for integrated circuits

The Micro-Positioner, model DR-100, is designed to establish fast and accurate probe contacts to sub-miniature areas such as present in microcircuits, thin-film circuits and other semiconductor devices, without having to adjust a multitude of micro-screws. By means of a single joy-stick handle an almost instant probe contact can be established on areas as small as 0.0005 in. in diameter, reducing troubleshooting and testing time to a bare minimum. Probe pressures can be setscrew adjusted over a continuous range of 4 to 200 grams. The DR-100 is being incorporated in all semiconductor test stations marketed by the company. It is recommended for testing on laboratory as well as production scale. The Dumas Instrument Co., P.O. Box 422, Costa Mesa, Calif. [357]

### Time interval unit used with counter

A new time interval unit, model LA-952B, when plugged into the LA-82 frequency counter provides direct measurement of time intervals from 1  $\mu$ sec to  $10^8$  sec. Input voltage is 0.3 v peak-to-peak; input impedance is a function of the multiplier setting (varies from 10,000 ohms to 10 megohms resistive,

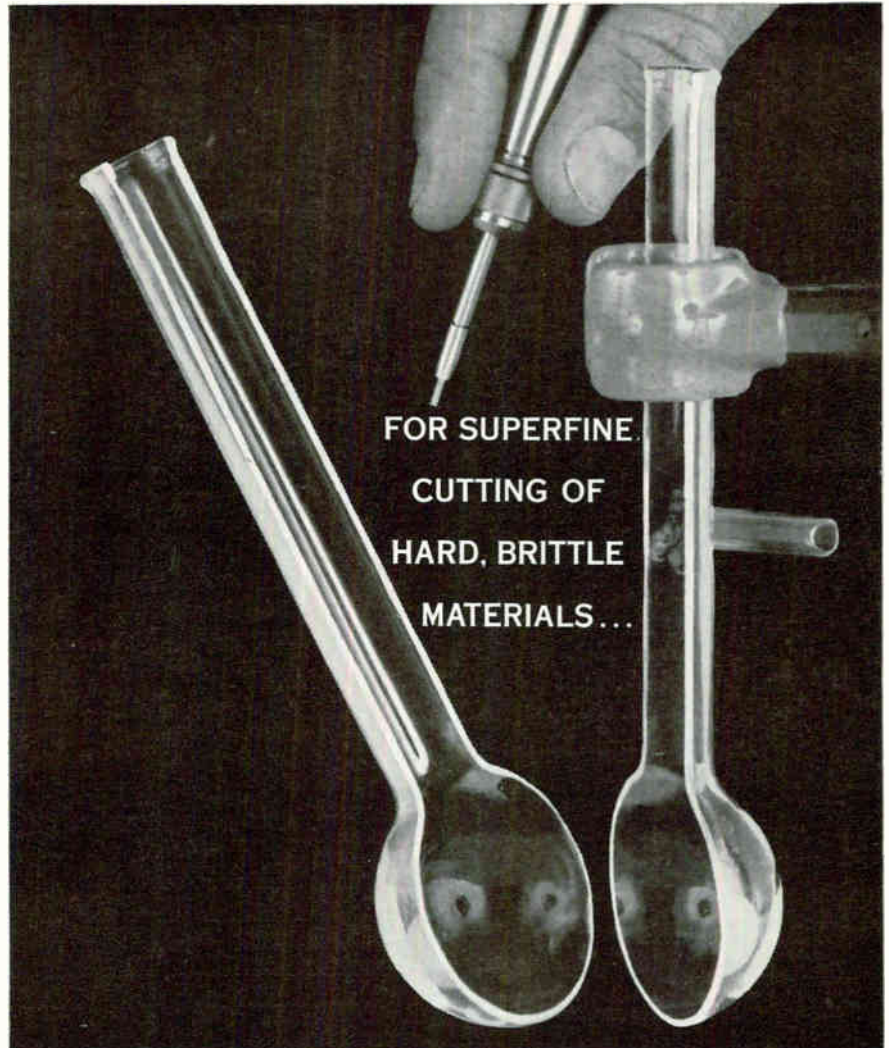

## THE S. S. White Airbrasive® Unit

Can you imagine slicing something as brittle as a flask right in half with a mechanical tool? Of course not! Only the Airbrasive can cut hard, fragile materials with such complete safety.

**The secret** of its cool, completely shockless cutting action is a precise stream of gas-propelled particles. It shapes, cuts, abrades, cleans or deburrs with ease such hard-to-work materials as germanium, tungsten, glass, ferrites, ceramics. Does a variety of jobs in the laboratory or on the production line. Frequently the Airbrasive pays for itself on the first application by eliminating rejects, reducing handwork, or by simply doing a job that you had previously thought impossible.

**The cost is low.** For under \$1000 you can set up an Airbrasive cutting unit in your own plant or lab.

*Let us make a free trial for you. Send samples for test or telephone collect for a demonstration.*

SEND FOR BULLETIN 6407A Complete information.



**S. S. WHITE INDUSTRIAL DIVISION**

Dept. EU, 10 East 40th St., New York 16, N.Y. • Telephone MU 3-3015 collect.

**S. S. White INDUSTRIAL AIRBRASIVE®**



*New*

# 50 MICROVOLT DC RELAY

- DC METER RELAY
- THERMOCOUPLE TRIP
- TEMP. CONTROLLER
- VOLTAGE TRIP
- CURRENT TRIP
- SORTING DEVICES
- STRAIN GAUGE TRIP
- ALARMS-MONITORS'



MODEL 370  
(Cover removed)

A new type of Magnetic-SCR, solid-state DC relay. Has two isolated inputs, built-in Zener reference. DC input change of 50  $\mu$ v or 0.5  $\mu$ a operates DPDT output relay or solid-state, plug-in adaptor.

Supplied from stock, ready-to-use, with enclosure. Only \$119.85 for 1-5 units. OEM quantity discounts on request.

Request Technical Bulletin No. 37..



**ACROMAG**  
INCORPORATED

15360 TELEGRAPH ROAD DETROIT, MICHIGAN, 48239  
TELEPHONE (313) 538-4242 TELETYPE 313-538-4536

Circle 205 on reader service card

## New Instruments

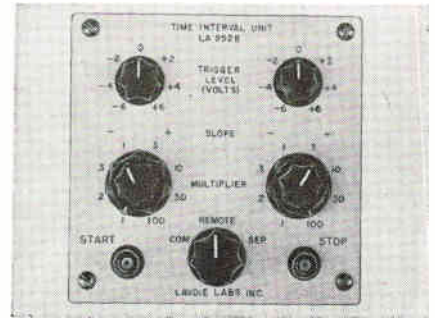

plus 20 to 80 pf shunt capacity). The trigger slope is positive or negative for either channel and the trigger level is adjustable from -250 v to +250 v on each channel. Display readout is in seconds, milliseconds, or microseconds; the decimal is automatically placed. The LA-952B has two identical channels, each with a video amplifier and trigger, which are used to to start and stop the frequency counter. A marker output pulse is supplied by each channel at the instant the signal voltage to be measured triggers the unit.

Lavoie Laboratories, Inc., Morganville, N.J. [358]

## Panel meters use optical projection

An advance in basic meter display (right) compresses into a 2½ inch width the analog presentation which previously required approximately a 9-in. wide meter for the same degree of accuracy and resolution. The moving pointer of ordinary panel meters has been replaced by a moving scale and optical projection. Light from a 6.3 v lamp is projected upward through the etched scale, then through a lens system giving 8× magnification, and is then reflected off a mirror to the ground glass viewing

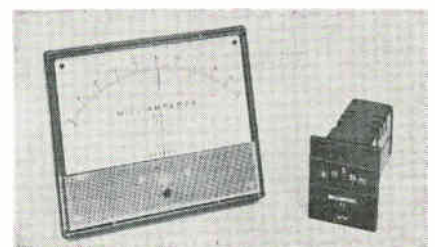

**CHRISTIE**

SINCE 1929

# XENON

## & XENON MERCURY ARC LAMP D-C POWER SUPPLIES



4.5 - 180 amp  
11.5 - 65 vdc  
1% Reg & Ripple

150 - 5000 watt  
MIL & RFI Specs  
Silicon



From Stock:  
Various Ratings  
and Styles

Igniters  
Also  
Available

Also 200 other Models of Power Supplies & Battery Charges • Write for Catalog

**CHRISTIE ELECTRIC CORP.** 3400 West 67th Street, Los Angeles 43, Calif.

window. The hairline is a mark on the viewing plate. The large reduction in required panel space means that many portable electronic meters can be made smaller. Also, one operator can now monitor up to four times as many meters as before. There is no parallax so tv monitors for banks of meters are practical. Color can be added to the readout with simple filters. The actual meter movement is conventional but the projection technique allows motion to be restricted to the linear region of about 50° rotation instead of entering the non-linear region as required by 105° movement of conventional meters. Input signal ranges, full scale, are from 50  $\mu$ a to 50 ma, and 10 to 200 v d-c. For 2% full scale accuracy, price is \$32 in lots of 100; \$35 for 1%. For comparison, a conventional 7½-in. panel meter sells for \$26 in the same quantities. Weston Instruments, Inc., 614 Frelinghuysen Ave., Newark 14, N.J. [359]



## H-v power supplies with adjustable output

This company's BRE line of regulated h-v power supplies has been designed to meet the exacting demands of electron microscopy, x-ray spectrometry, twt and klystron applications. The manufacturer says that performance characteristics are virtually independent of line voltage variations or load current changes. The output voltage is adjustable in increments of 10 kv, 1 kv, 100 v, 10v, 1 v and 0-1 v. Typical performance specifications are: line regulation, 0.1%; load regulation, 0.1%; ripple 0.01% rms; short term stability, 0.02%; long term stability, 0.05%. Units are available with voltage ratings up to 70 kv and power in excess of 12 kw.

Universal Voltronics Corp., 17 S. Lexington Ave., White Plains, N.Y. [360]

## Tried tuning forks to solve frequency or optical control problems?

*Latest advances from BULOVA — the leader — can help you!*

AMERICAN TIME PRODUCTS, now a part of Bulova Electronics, has pioneered just about every major advance in the use of tuning forks in the last 20 years. AMERICAN TIME PRODUCTS — ATP for short — leads the industry with the most complete and advanced group of units to meet your frequency needs. For example, *only* ATP gives you:

- Fork units up to 25 kc.
- Complete fork oscillators in sizes as small as .35 cu. in. or in flat cans only .35 in. high for circuit board mounting.
- Operating temperature range from -65°C to 125°C — higher, if necessary.
- Tuning forks that chop, scan, modulate and otherwise manipulate light or energy beams — including torsional forks.
- Forks that withstand vibration and shock better because of unique construction.
- Tiny iso-elastic Accutron forks.
- Both magnetic or dynamic drives.
- All this, with stabilities as high as .001%.

This is what BULOVA does! Want to see how tuning forks can solve your problems? Just drop us a line — or better, call us — and outline your needs. Address: Dept. E-11.

## Light Chopper! Dark Chopper!

Want to manipulate a beam of light? Or invisible ions? Chances are you'll do it better — or only — with an AMERICAN TIME PRODUCTS Optical Chopper. Using the balanced, vibrating times of a tuning fork, the ATP chopper offers these advantages:

- No lubrication needed
- Minimum space requirements
- Extremely lightweight — 3 ounces max.
- Minimum power requirements — as low as 300 MW
- Operating temperature range of -65°C to 125°C
- Reference signal voltage available
- No wearing parts

It's so new, here are some of the uses to date:

- Star trackers • Spectrophotometers • Horizon sensors
  - Film deposition control • Industrial process control
  - Colorimeter • Densitometer
- Call or write us to discuss your problem. We'll make a unit to fit your needs.

**BULOVA** / **ELECTRONICS DIVISION**  
WATCH COMPANY, INC. 61-20 WOODSIDE AVE., WOODSIDE 77, N.Y., 212 NE 8-5700

# NOW, a new, low cost FREQUENCY RECEIVER

- Simplified Operation
- Accurate Measurement
- Minimum Circuitry



60 K C

Model SR-60

## PHASE COMPARATOR RECEIVER

FOR FREQUENCY STANDARDIZATION TO  
THE NATIONAL BUREAU OF STANDARDS

The Model SR-60 is the first low cost VLF Phase Comparison Receiver designed to permit phase comparison measurements between a local oscillator and the National Bureau of Standards transmitted 60 Kc/s from WWVB, Fort Collins, Colorado. The receiver is a straight-forward Tuned Radio Frequency receiver and can be used in any location in the United States with highly satisfactory results.

The SR-60 permits accuracy measurements to parts in  $10^{10}$ , with relative short measurements. Phase difference is displayed on a front panel meter or on a strip chart when more precise measurements are made over a long period of time. Since the phase difference is a "beat," lower accuracies can be monitored aurally, using the sound from the speaker. As the local standard gets closer, the visual "beat" on the front panel meter is most useful. When this meter is moving too slowly for reasonable timing, the "beat" can then be monitored on the recorder.

### SPECIFICATIONS:

<p><b>Input Frequency:</b> W W V B 60 Kc/s</p> <p><b>Local Standard Input:</b> 100 Kc (other frequencies available).</p> <p><b>Sensitivity:</b> 1 <math>\mu</math>v to antenna coupler provides usable output for strip chart recording and visual monitoring.</p> <p><b>Bandwidth:</b> 2 Kc for 3 db.</p> <p><b>Input Impedance:</b> High impedance or 50 Ohms.</p>	<p><b>Phase Output:</b> Sine wave corresponding to fractional error of local oscillator.</p> <p><b>Outputs:</b> Phase output for external recorder: Audio Received 60 Kc output Multiplied 60 Kc output—300 Kc Multiplied local oscillator output—300 Kc</p> <p><b>Recorder:</b> Rustrak Model 88, supplied with chart paper and gear train for <math>7\frac{1}{2}</math>" per hour speed. Other gear trains available.</p> <p><b>Oscilloscope:</b> One inch tube for quick indication of frequency drift and the direction of drift.</p> <p><b>Size:</b> 5<math>\frac{1}{2}</math>" x 19" Rack Panel 17<math>\frac{1}{2}</math>" Depth behind Panel 17" Width behind Panel</p>
--	---

PRICE  
\$850

Write for detailed information  
**SPECIFIC PRODUCTS**

P.O. BOX 425 21051 COSTANSO ST.  
WOODLAND HILLS, CALIF.  
DIAMOND 0-3131 AREA CODE: 213

Prices & specifications subject to change

## New Semiconductors

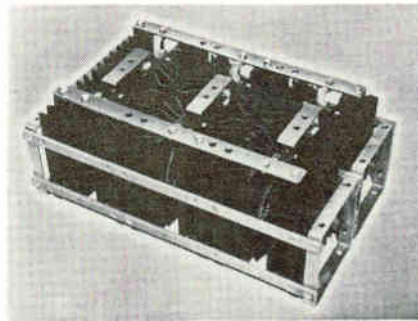

### Scr assemblies rated to 130 amps

Silicon controlled-rectifier assemblies are available with single-phase ratings to 104 amps, and three-phase ratings to 130 amps. The assemblies use 70-amp diodes (JEDEC series 1N1183A) and 70-amp silicon controlled rectifiers (JEDEC series 2N1910) and are available in many circuit configurations, including single- and three-phase bridges, and series or parallel combination arrangements. The units are designed for either natural-convection or forced-air cooling. Anodized extruded-aluminum heat sinks and other materials used have been chosen to insure performance at high ambient temperatures. Prices range from \$23 net each for 50-v single-phase, half-wave assemblies to \$480 net each for three-phase, full-wave assemblies in quantities of 1 to 24. Westinghouse Semiconductor Division, Youngwood, Pa. [331]

### New zener diode offers high thermal stability

The Super/Reg zener diode offers all the capabilities of the zener principle without the limitation imposed by the unalterable characteristics of the silicon atom. Like the zener, the Super/Reg can be connected across a d-c voltage source to provide a regulated d-c output that is stabilized at a fixed level despite variations in the source voltage and/or variations in the current drawn by an external load.

Unlike the zener, however, the Super/Reg diode provides an output voltage that can be adjusted  $\pm 10\%$  from its nominal value, without derating, or degrading its performance. The device exhibits a zener impedance in the order of a few milliohms, compared to an impedance of an ohm or more in an equivalent power zener diode; a typical 12-v unit exhibits a voltage change of 0.006 v for a 2-amp load swing, compared with the 2-v change exhibited by an equivalent zener diode under the same circumstances. Thermal stability is said to be in most cases 100 times better than that of the standard zener diode. The 75TE series offers a power dissipation of 75 w at 25°C case temperature, a maximum zener current of 3 amps, maximum junction temperature of 175°C, and a case temperature operating range from -55°C to +100°C. An extremely sharp zener knee permits regulation at currents down to 10 ma. Ten types are offered with zener voltages from 10 to 56 v d-c, each adjustable  $\pm 10\%$  by addition of an external impedance.

Trio Laboratories, Inc., 80 Dupont St., Plainview, N.Y. [332]

### Silicon transistors for vhf-uhf use

Silicon npn transistors have been designed for large-signal, high-power vhf-uhf applications. Type 2N3375 are multi-emitter planar epitaxial devices intended for class A, B, or C amplifier, frequency multiplier, or oscillator operation. In amplifier operation, their rated r-f power output into a 50-ohm load at 400 Mc is a minimum of 3 w, and at 100 Mc is a minimum of 7.5

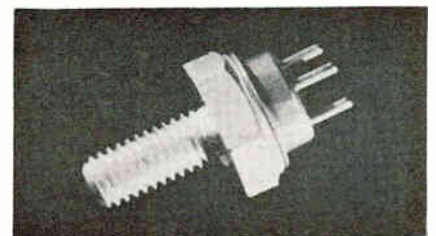



w. These transistors will typically produce 5 w at 250 Mc and at better than 40% overall operating efficiency. In oscillator operation, their rated r-f output into a 50-ohm load at 500 Mc is 2.5 w. Collector isolation is made possible by the use of high thermal-conductivity ceramic insulation between the collector and the mounting stud. All three electrodes are electrically isolated from the case. The transistors are available in a 7/15 in. hex package with a heavy copper mounting stud for effective contact with a heat sink. Their pin terminals are arranged on a 0.200 in. pin-circle diameter to fit commercially available sockets.

Vector Solid State Laboratories, Dept. of Norden Div. of United Aircraft Corp., Southampton, Pa. [333]

## High-power scr's handle 110 amps rms

A five-device series of silicon controlled rectifiers are capable of handling 110 amps rms and rated from 400 to 1,200 v. Designated TICO1-TICO5, they will find use in large



a-c and d-c variable-speed motor controls, high-power inverters and high-current power supplies. They will also serve as replacements for ignitrons and thyratrons. High di/dt and dv/dt (response to sudden transient inputs) ratings, controlled avalanche characteristics, 1,000-amp surge current capability and low gate current requirements are important operating advantages. The devices feature a cold-weld hermetic seal and high-temperature alloy contacts for high reliability. Texas Instruments Inc., 13500 North Central Expressway, Dallas, Texas. [334]

# PINPOINT SELECTIVITY

YOU CAN NOW SELECT TO MORE SPECIFIC RANGES FROM GENERAL ELECTRIC'S COMPLETELY REVISED GLOW LAMP LINE that includes 12 new lamps, some deletions and tighter electrical limits throughout.

You get greater versatility, plus rugged, long-lived lamps at prices competitive to other glow lamps and solid state devices. Also, they're available when and where you need them from General Electric—the name you know.

Check the chart below. Chances are it includes a glow lamp tailor-made for *your* circuit needs. For full details, write General Electric Co., Miniature Lamp Dept. M 4-25, Nela Park, Cleveland, Ohio 44112, and ask for Circuit Bulletin 3-4336 and/or Indicator Bulletin 3-4335. Or call your nearby G-E sales office for expert glow lamp assistance.

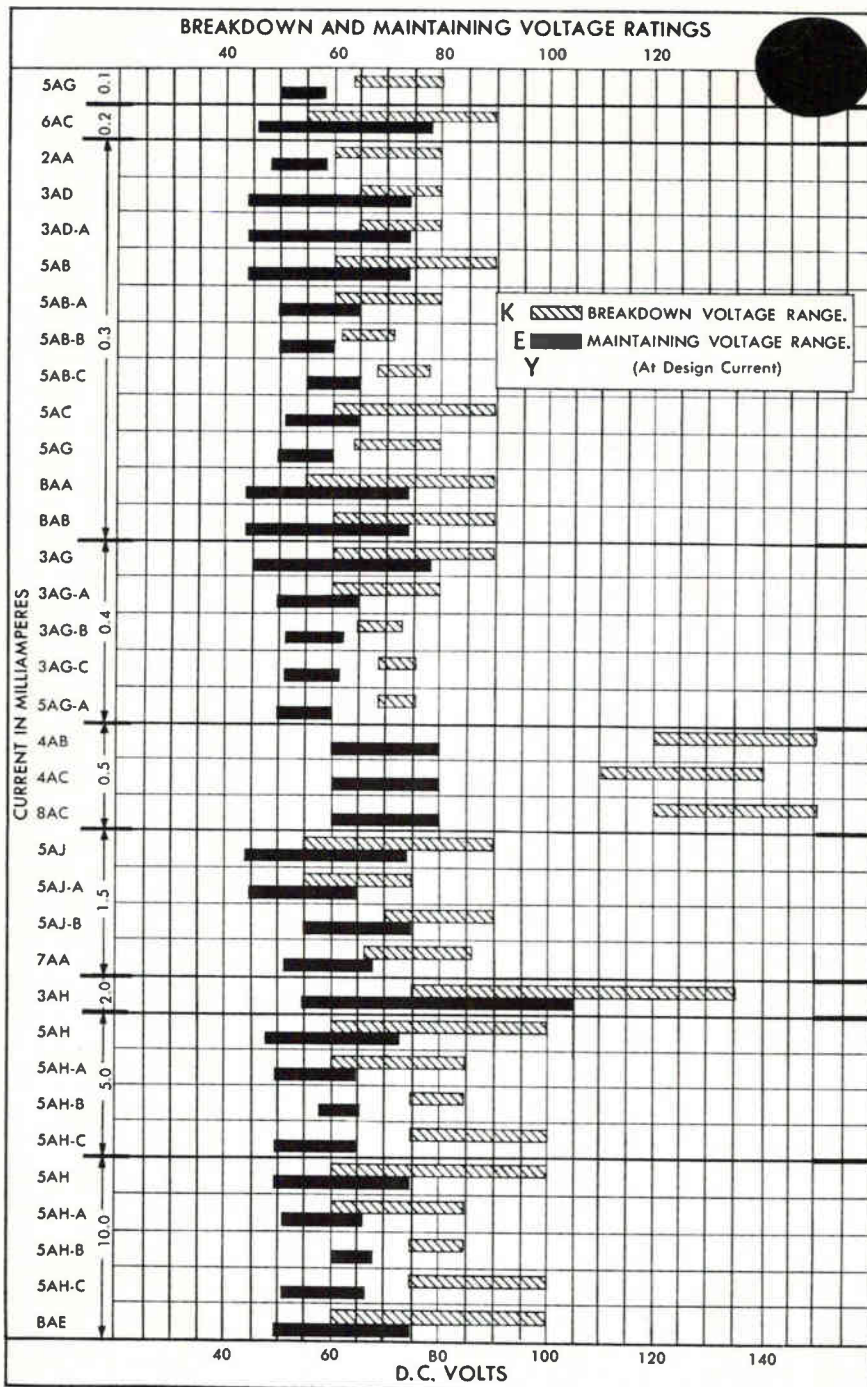

Progress Is Our Most Important Product

**GENERAL ELECTRIC**

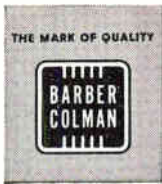

# Ultra-sensitive relays

## HELPFUL DATA FOR YOUR CIRCUITRY IDEA FILE

The circuit drawing below indicates just one of the hundreds of ways many manufacturers utilize Micropositioner® polarized relays to solve complex control problems.

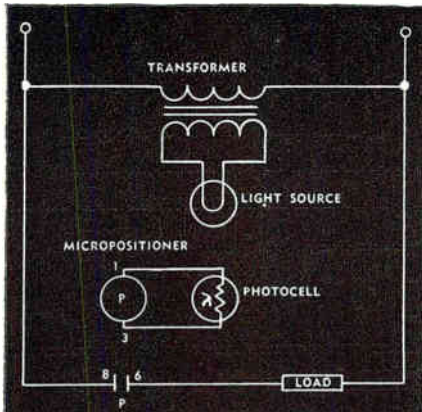

### PHOTOELECTRICITY APPLICATION

Many stages of electronic amplification in photoelectric controls can be completely eliminated with a Barber-Colman Micropositioner, since a current generating photocell alone provides sufficient power to operate this relay directly.

A Micropositioner operating on 50 microwatt input (with fine silver contacts rated at 1 ampere, 110 volt 60 cycle, resistive load) is essentially a tubeless amplifier capable of two million times amplification.

Among the many applications for this simplified, nonelectronic photocell control are punch press safety controls . . . emergency lighting controls . . . door openers . . . burglar alarms . . . level controls . . . packaging, sorting, filling, and materials handling controls . . . plus many other automation functions.

If you are developing an application calling for photocell control, why not make a test with a Micropositioner designed for circuits similar to that shown above? Write for technical bulletins F7279 and F3961.

### BARBER-COLMAN MICROPOSITIONER® POLARIZED O-C RELAYS.

Operate on input power as low as 40 microwatts. Available in three types of adjustment: null seeking . . . magnetic latching "memory" . . . and form C break-make transfer. Also transistorized types with built-in preamplifier. Write for new quick reference file.

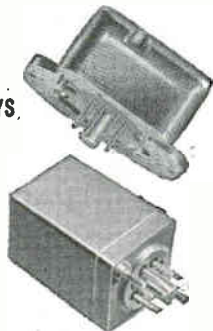

**BARBER-COLMAN COMPANY**  
DEPT. H, 1259 ROCK STREET, ROCKFORD, ILLINOIS

## New Subassemblies and Systems

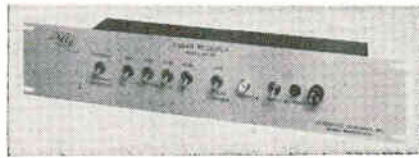

### Pulse receivers handle radar or backscatter

A series of solid-state pulse receivers has been particularly designed for radar or backscatter application. Model PR-40 is a dual-channel unit in the 40-Mc band for use in meteor scatter communications. It features a specially designed i-f amplifier at 5.2 Mc that may be switched to either linear or logarithmic operation. The receiver also contains a precision attenuator, covering a 55-db dynamic range, or exhibits a sensitivity of  $0.3\mu\text{v}$ . Other receivers in this series cover a frequency range from 10 to 120 Mc at various i-f bandwidths.

Aerospace Research, Inc., 130 Lincoln St., Boston, Mass. 02135. [371]

### Oscillator package covers 1.5 to 31Mc

A temperature-controlled, precision crystal oscillator package covers the 1.5 to 31-Mc range, with stability of 1 part in  $10^6$ . Believed to be the first such package to cover such a wide frequency band, the solid-state EROS-450 provides a linear 0.1-v rms output into a 200-ohm load across the entire band, simply by changing crystals operating on the fundamental mode. The unit consists of a zener-regulated crystal oscillator, an amplifier which



stabilizes the output voltage level providing uniform output, and a decoupling buffer stage to minimize the effect of loading on frequency stability. A variable capacitor is provided for trimming the crystal to the exact frequency desired. No other adjustments are required, and the trim range is sufficient to accommodate a minimum of 2 years' crystal aging. The EROS-450 standard design includes an a-c or d-c oven which is controlled by a snap-action thermostat. An scr switch with snap-action thermostat control may be supplied for improved performance and reliability. The unit cost of the standard package with one crystal is \$174.50.

Electronic Research Co., Division of Textron Electronics, Inc., 10,000 West 75th St., Overland Park, Kansas 66204. [372]

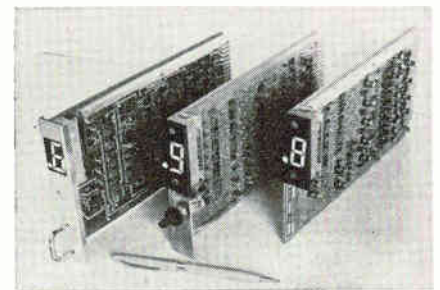

### Narrow decade counters with in-plane display

A series of narrow decade counters is designed with preset capabilities for start-stop counting functions. Designated series F111, units are available with counting rates of 200 kc, 1Mc and 10 Mc. Models are available in four configurations, including built-in single preset for start or stop function after a preset number of pulses, and dual preset for combined start and stop. Units mount on 1-in. centers. They are completely solid state, employing silicon transistors in a bi-quinary circuit for counting logic. Glass epoxy circuit boards are used, with output connections for 10-line coinc, 1-2-4-8 binary, staircase, and pulse output to drive other decades. The in-plane, segmented type numerical display is  $\frac{3}{4}$  in. high. Bright, 100,000-hr-life



This is the world's smallest rotary switch for military applications.



This is the world's smallest rotary switch for commercial applications.

## We make both.

Take your choice! Daven now offers two subminiature switches—Series G for military applications and Series K for commercial applications.

The renowned Series G has been redesigned to give increased reliability, higher dielectric strength and longer life. Manufactured in clean room environment, it meets applicable Mil specs on temperature, humidity, corrosion, vibration, acceleration, shock and immersion, as well as being explosion-proof and waterproof.

Now the new Series K gives you the same size, quality and electrical specifications as the Series G—but at a much lower

cost—from \$4.85 to \$3.85 each, depending upon quantity. It was developed to meet instrument and commercial applications where low cost is important and the most exacting Mil specs need not be met. Yet it is a completely enclosed unit, offering such quality features as long life, low contact resistance, high dielectric strength, wide operating temperature range, positive detent action and resistance to corrosion, shock and vibration.

Both Series G and Series K switches are available in single deck, shorting and non-shorting. They may be obtained in various combinations up to 4 poles and 10 positions.

For complete details on either, write today!

**DAVEN**   
LIVINGSTON, NEW JERSEY  
(201) WYman 2-4300 • TWX 201 992-7356 • Cable: DAVEN LIVINGSTON N J



# Helium

PUREST OBTAINABLE

## ALL YOU NEED

—from the foremost producer of atmospheric gases!

- Produced under continuous mass spectrometer control.
- Fast nationwide delivery.
- Guaranteed ultra-high purity.
- Scientifically blended and tested mixtures for any need.
- Quality based on more than 50 years of rare gas know-how.
- Complete technical service.

SEND FOR NEW 20-PAGE ONE-SOURCE RARE GAS BOOKLET

First comprehensive price and specification list for all rare gases and mixtures...



CLIP COUPON—ATTACH TO BUSINESS LETTERHEAD

Rare Gases, Dept. E-103  
Union Carbide Corporation  
Linde Division  
270 Park Avenue, N. Y., N. Y. 10017

- Please send a copy of your booklet listing prices, specifications, and information on LINDE Rare Gases.
- Have a representative contact me.



"Linde" and "Union Carbide" are registered trade marks of Union Carbide Corporation.

## New Subassemblies

incandescent lamps are used for high visibility and wide-angle viewing. Prices for sample quantities range from \$117 to \$260.

Allegany Instrument Co., a division of Textron Electronics, Inc., 1091 Wills Mountain, Cumberland, Md. [373]



## Directional couplers now in two models

Dual directional couplers now available are compact and provide instant broadband response. The Di-Tect directional couplers, models CH-50 and CH-75, provide extremely flat coupling (20 and 30 db units available) over the entire operating range from 2 to 100 Mc. Stable response over a broad frequency range suits them for accurate measurement of reflection coefficient in operational systems. Di-Tect couplers do not affect the parameters of the system being measured. Good directivity of the couplers provides high isolation of the coupled arms (typically 50 db). The two models—50 and 75 ohms—occupy less than 1½ cu in. and weigh 2 oz. Insertion loss is 0.5 maximum on the 30 db units and 1.5 maximum on the 20 db units. Price is \$132.

Adams-Russell Co., Inc., 280 Bear Hill Road, Waltham, Mass. 02154 [374]

## Phase-modulated telemetry sender

A crystal-controlled, phase-modulated transmitter has been designed specifically for telemetry from earth-orbiting satellites. Model T-10 incorporates all solid-state circuitry and is fully flight-qualified. It is specially suited to pulse-free-

## Servo-Chart Recorders Don't Have To Be Costly!



## This Heath-Built Recorder Costs Just \$199!

Completely Factory Assembled & Tested!

Ready to use. True potentiometric input. Five adjustable ranges: 10, 25, 50, 100 & 250 mv plus plug-in 5-pin connectors for special ranges. Rapid chart advance; pen lift; paper tear-off guide; optional motor speeds; 10" chart; 1 sec. response. For full details on the famous Malmstadt-Enke Lab Series Free, simply tear out coupon and mail.

Assembled EUW-20A, Recorder, 20 lbs... \$199.00

**HEATH Built**

**HEATH COMPANY, Dept. 67-10-1**  
Benton Harbor, Mich. 49023

Please send Free Folder on Malmstadt-Enke Lab Series and Free 1965 Heathkit Catalog.

Name \_\_\_\_\_ (Please Print)

Address \_\_\_\_\_

City \_\_\_\_\_ State \_\_\_\_\_ Zip \_\_\_\_\_

EK-169

Circle 206 on reader service card

## Reed Relays

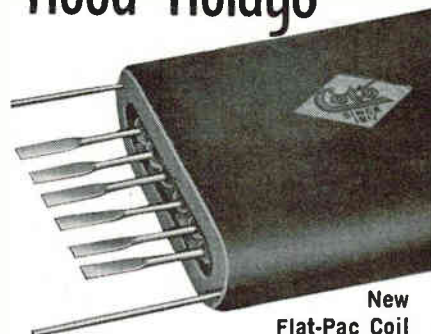

New Flat-Pac Coil

accommodates 3, 4, 5 or 6 Form C reed switches. Ideal for encapsulation or direct tie-down to printed circuit board or chassis, its shape is more compatible with advanced packaging. (Shown actual size)

## New Double Pole, Double Throw

miniature relay contains 2 Form C reeds, operates as low as 96 milliwatts. (Shown actual size)

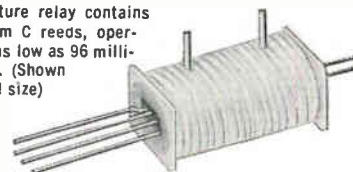

Write for catalog and prices of our standard line of magnetic reed relays. For special requirements, give complete details for quotation.

**Coto-Coil COMPANY INC.**  
65 Pavilion Ave.  
Providence, R. I., 02905  
Phone: (401) 941-3355

Circle 207 on reader service card  
Electronics | October 19, 1964

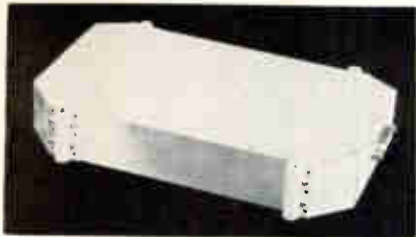

quency modulation and similar time-multiplex telemetry systems. For an input power of 900 mw at 12 v d-c, the model T-10 provides more than 250 mw of power to a 50-ohm load for a greater than 25% efficiency. Operating frequencies may lie in the range of 136 Mc to 137 Mc while frequency stability is better than  $\pm 0.005\%$  over a rated operating temperature range of  $-20^{\circ}\text{C}$  to  $+50^{\circ}\text{C}$ . The transmitter weighs less than 17 oz, is priced at less than \$2,000. Electro-Mechanical Research, Inc., Sarasota, Fla. [375]



### Shaft encoder uses magnetic probes

A size 11, noncontact shaft encoder has been introduced. The 3-oz. device converts analog data to 13 binary digits by using magnetic probes to sense the passage of a rotating encoded disk. In earlier shaft encoders brushes rode on commutator disks. Operating life of the new MAD 11-13A encoder is a minimum of 200,000,000 revolutions. The new unit is designed for advanced aerospace computer systems requiring high reliability and fast interrogation speeds. It is directly interchange-

## NEW 30,000 V 20 MA POWER SUPPLY

Model PSA 30-20



COMPACT—10½ Inch Panel Height

LIGHT WEIGHT—65 Lbs.

WRITE FOR COMPLETE DETAILS

- Portable or Rack Mount
- Adjustable .05% Resolution
- 4½ in. Meters 2% Accuracy
- Control Function Indicator Lights
- Low Ripple
- Low Regulation
- Air Insulation
- External Interlock
- Reversible Polarity
- Solid State Rectification
- Conservatively Rated
- Over and Under Current Trip
- Over and Under Voltage Trip
- Surge Limiting
- Zero Interlock
- Multi-Range



### ELECTRONICS DIVISION

RESEARCH-COTTRELL, INC., BOUND BROOK, NEW JERSEY  
CHOICE REPRESENTATIVE TERRITORIES AVAILABLE

RC-279E

Circle 208 on reader service card

## COMINCO

clip and save

HIGH PURITY METALS  
AVAILABLE FORMS

Product	ALUMINUM	ANTIMONY	ARSENIC	BISMUTH	CADMIUM	GOLD	INDIUM	LEAD	SILVER	TIN	ZINC
BARS	✓	✓	✓	✓	✓	✓	✓	✓	✓	✓	✓
SHEETS	✓				✓	✓	✓	✓	✓	✓	✓
WIRE	✓				✓		✓	✓		✓	✓
POWDER		✓	✓	✓	✓	✓	✓	✓	✓	✓	✓
SHOT		✓		✓	✓	✓	✓	✓	✓	✓	✓
ROD	✓			✓	✓		✓	✓	✓	✓	✓
RIBBON							✓	✓			
PRE-FORMS	✓				✓	✓	✓	✓	✓	✓	✓
SALTS					✓		✓				

## COMINCO PRODUCTS, INC.

electronic materials division

818 West Riverside Avenue, Spokane, Washington 99201  
Phone Area Code 509 RI 7-6111 • TWX 509 328-1464

3602



## CORNING CAPACITORS!



It's a wise bird who uses CORNING CYFM and CYFR glass capacitors where stability counts—and relies on Milo to wing them to him on schedule. For coupling, decoupling, filtering, timing, switching or computer circuits, CORNING capacitors provide ultra-stable electrical performance. This stability is inherent in their fused glass and aluminum foil capacitive elements. CYFR models exceed requirements of MIL-C-11272B. Their homogeneous, controlled production yields capacitor reliability second to none. CYFM models provide fusion-sealed, environment-proof performance at cost savings. Electrically and environmentally interchangeable with CYFR models, they meet MIL-C-11272B. Both CYFR and CYFM are available in four sizes, from 0.5 to 10,000 pf.

For highest level service on all your CORNING capacitor requirements, rely on Milo. One phone call will get you exactly what you need at direct factory price, and on the fly—because we really care about your needs, and take extra care to meet them.



BRANCH WAREHOUSES AND SALES OFFICES  
IN PRINCIPAL INDUSTRIAL AREAS

## New Subassemblies

able with contact size 11 devices. Operating principles employed are expected to lead to development of encoders for commercial and industrial control systems where minimum maintenance is essential. Range is 8,192 binary counts for 64 revolutions of the input shaft. Interrogation speed is 10  $\mu$ sec. for a 13-bit parallel word. Tested to meet all appropriate military specifications, the MAD 11-13A has a length of only 1.8250 in. and diameter of 1.062 in.

Litton Industries, 7042 Woodley Ave., Van Nuys, Calif. [376]

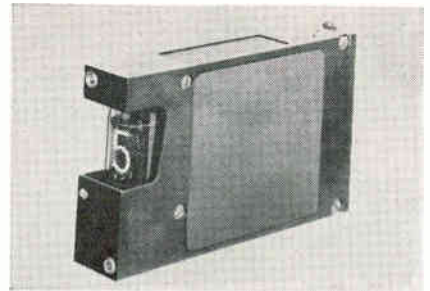

ification in timing systems, industrial control systems, ranging and tracking systems, or wherever high-speed, high-reliability counting is required. Other features of the all-silicon device include an easy-to-read, in-line numerical display and a built-in decimal point. Counting rate is from zero to above 2 Mc. The output code is 8-4-2-1 binary-coded decimal, with bipolar excursions provided for each bit, to represent binary -1 and binary 0. Quantity price of the counter is \$84.50.

Janus Control Corp., Hunt St., Newton 58, Mass. [378]

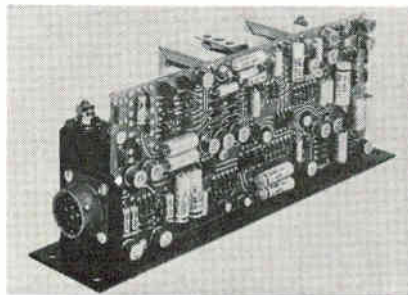

## Servo amplifier provides up to 4 kw

Model A570 servo amplifier is designed to drive d-c servo motors up to 1 h-p. The output of the amplifier features smooth, full wave, bi-directional control with linear operation through null. The maximum output current can be set by an adjustment potentiometer. The amplifier has a voltage gain of 1,000 with a 100,000-ohm input impedance, and will provide up to 4-kw output power from a package only 2 $\frac{3}{8}$  by 8 $\frac{5}{8}$  by 3 $\frac{1}{8}$  in.

Westamp Inc., 11529 Pico Blvd., Los Angeles 64, Calif. [377]



## Proportional-control crystal oscillator

This solid-state crystal oscillator, model 621, is a 28-v proportional-controlled unit available from 75 kc to 20 Mc. It offers frequency stability to  $\pm 0.01$  ppm depending on frequency and ambient temperature range. Output is available at 2 and 4 v peak-to-peak and sine or square wave depending on frequency. The unit is designed for vibration of 10 to 2,000 cps, 15 g and MIL-I-26600, MIL-E-5272 airborne equipment applications. Monitor Products Co., Inc., 815 Fremont, South Pasadena, Calif. [379]

## Floating-circuitry decade counter

A new high-speed decade counter features a floating-circuitry design that permits the completely arbitrary setting of the unit's supply voltage levels. This feature, according to the manufacturer, makes the module a truly universal device that can be installed without mod-

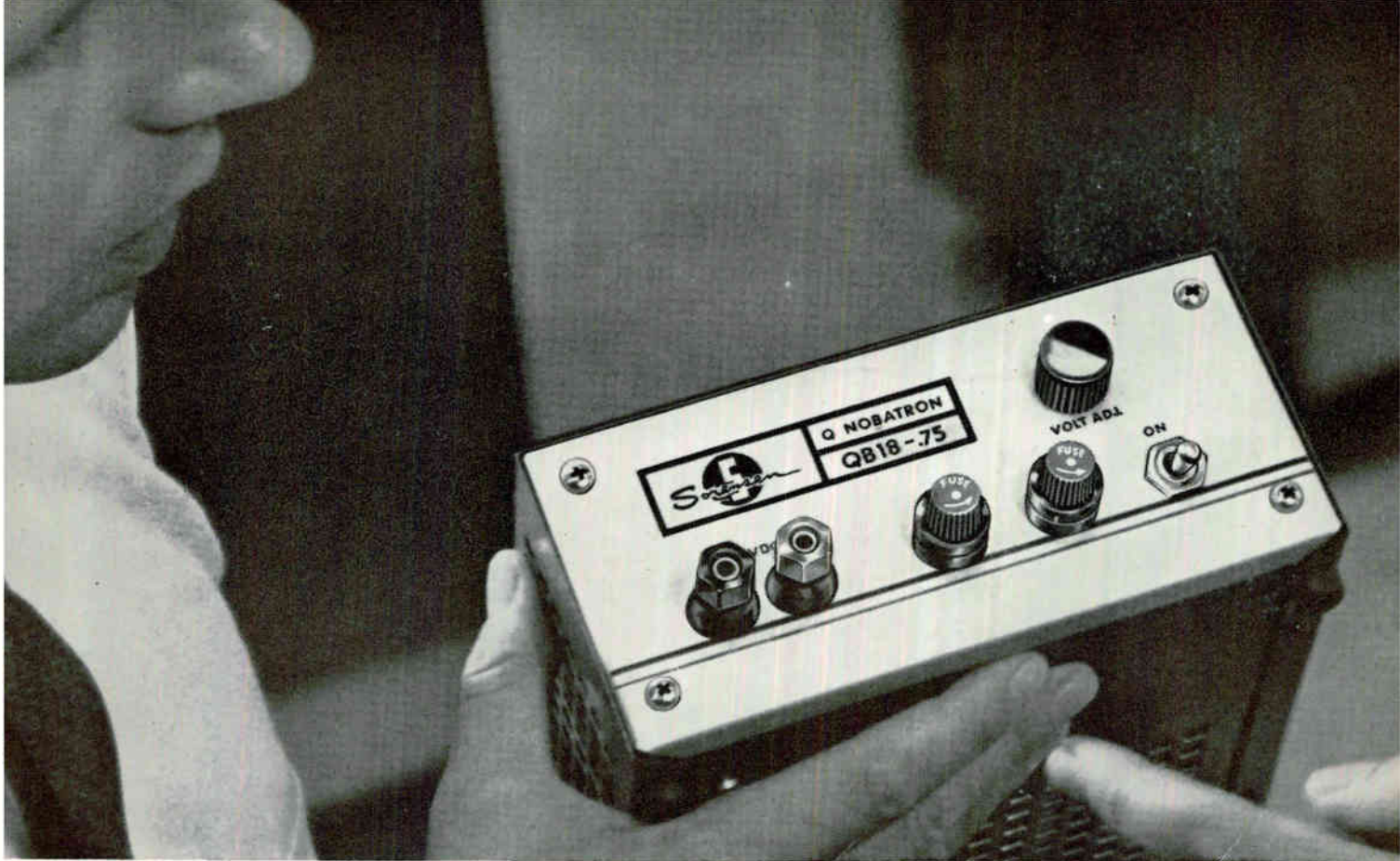

**"Only \$98?"**

**Yes! Sorensen's QB Series (transistorized DC power supplies) are available off-the-shelf for as little as \$98. Every one of the 24 models in this line provides:**

- Constant current (Regulation  $\pm 0.01\%$ , line and load combined)
- Voltage regulation  $\pm 0.01\%$  (line and load combined)\*
- Extended voltage range, 2:1
- RMS ripple less than 300 microvolts
- Transient response 25 microseconds or less
- Temperature coefficient 0.015% /°C
- Drift typically less than 0.025% for 8 hours
- Output impedance as low as  $25\mu$  ohms +  $0.3\mu$  h
- No turn-on, turn-off overshoot
- Remote sensing
- Programmability
- Series or parallel operation

\*Regulation for 6-volt models  $\pm 0.02\%$

**For complete specification and application information on the QB Series, and all other Sorensen products, send for the new 140-page Controlled Power Catalog and Handbook. Contact your local Sorensen representative, or write Sorensen, Richards Avenue, South Norwalk, Conn. Or, use reader service number 200.**

**ELECTRICAL SPECIFICATIONS**

MODEL NUMBER	OUTPUT VOLTAGE RANGE (VDC)	MAXIMUM OUTPUT CURRENT (AMPS.)	PRICE	MODEL NUMBER	OUTPUT VOLTAGE RANGE (VDC)	MAXIMUM OUTPUT CURRENT (AMPS.)	PRICE
QB6-2	5-9	2	\$ 98	QB28-2	18-36	2	\$160*
QB12-1	9-18	1	98	QB50-1	40-60	1	160*
QB18-.75	13-26	.75	98	QB6-15	5-9	15	215*
QB28-.5	18-36	.5	98	QB12-8	9-18	8	215*
QB6-4	5-9	4	108	QB18-6	13-26	6	215*
QB12-2	9-18	2	108	QB28-4	18-36	4	215*
QB18-1.5	13-26	1.5	108	QB50-2	40-60	2	215*
QB28-1	18-36	1	108	QB6-30	5-9	30	285*
QB50-.5	40-60	.5	108	QB12-15	9-18	15	285*
QB6-8	5-9	8	160*	QB18-12	13-26	12	285*
QB12-4	9-18	4	160*	QB28-8	18-36	8	285*
QB18-3	13-26	3	160*	QB50-4	40-60	4	285*

\*Optional volt and ammeters \$30



Circle 200 on reader service card

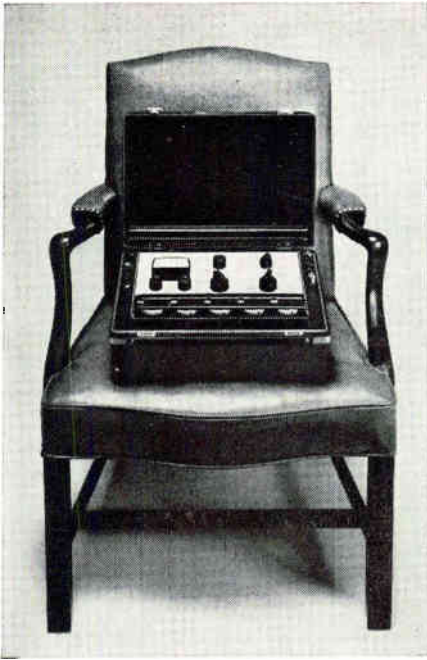

**"I solemnly swear to tell the truth  $\pm .003\%$ "**

Our new Portametric Voltmeter testifies to an accuracy several times better than most laboratory potentiometers. This means it can easily double as a voltage calibration system for laboratory potentiometers, digital and differential voltmeters.

Everything you need to start making measurements is conveniently built into the portable case, and you buy the works for one low price—\$895.

Up to now, there has been nothing on the market at this price with this kind of accuracy. We offer it as witness to ESI measurement capabilities and invite you to be the judge. *ESI, 13900 NW Science Park Drive, Portland, Oregon (97229).*

**Model 330 Portametric Voltmeter**  
**Voltmeter Ranges:** 5–1 microvolt to 1200 volts.  
**Potentiometer Accuracy:**  $\pm 10$  ppm of reading  $\pm 1$  ppm full scale on each range.  
**Voltbox Accuracy:**  $\pm 10$  ppm.  
**Standard Cell Accuracy:**  $\pm 10$  ppm.  
**Input Impedance:** Infinite at null on ranges 1, 2 and 3. 10 megohms on ranges 4 and 5.  
**Battery Life:** Approximately 1000 hours.  
**Null Detector:** High-gain solid-state guarded detector; more than 5 microvolts dc sensitivity; input impedance: about 1 megohm.



## New Microwave

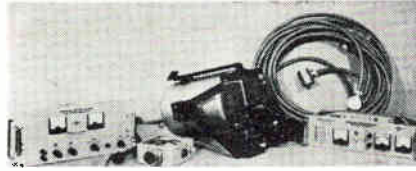

### Parametric amplifier in X-band design

Of nondegenerate design, the X-14 parametric amplifier offers ultra-low noise amplification with great sensitivity at liquid nitrogen temperature. Intended for 48-hour operation on a single charge of liquid nitrogen, the unit is supplied with a highly stable klystron power supply, parametric amplifier in a  $\pm 45^\circ$  tiltable dewar and remote monitor with bias power supply. Signal frequency is 7.5 through 8.05 Gc with gain of 15 db nominal and instantaneous bandwidth of 20 Mc to 1.0 db points. The unit is primarily for radio astronomy, space communications, or advanced radar applications. The paramp unit is suited to special design modifications for room or liquid helium temperature operation, or military temperature ranges—with closed cycle refrigerator cooling also possible. Microwave Physics Corp., 420 Kirby St., Garland, Texas 75040. [391]

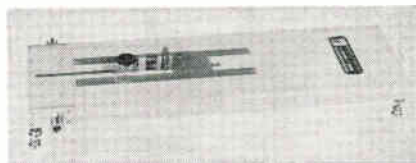

### Phase shifters span 1 to 12 Gc

Two new precision calibrated phase shifters are available. Models 1504 and 1505 are similar except that the 1505 has built-in 3-db attenuator pads behind the connectors on both input and output sections. These pads isolate the vswr of the connectors and the system from the line stretcher, thereby improving the accuracy of measurement of phase bridges. Frequency range of

both models is 1 to 12 Gc with more than  $360^\circ$  phase shift down to 1 Gc. Readout is obtained by using either a metric or degrees per Gc scale. Displacements along the metric scale can be resolved to 1/20 mm of actual line stretch. Resolution of the degree per Gc scale is  $0.1^\circ$  at 1 Gc. Readings taken on this scale are multiplied by the frequency in Gc to obtain degrees of phase shift. Two modes of adjustment are provided. A rapid push-pull, sliding action is used for large coarse adjustments. Final adjustment is made by locking the mechanism and using a thumbwheel-actuated lead screw. Prices are \$590 for the model 1504, and \$725 for the 1505.

Weinschel Engineering, P.O. Box 577, Gaithersburg, Md. [392]

### Tunnel diode receiver for 6,500-Mc region

A low-noise, miniature tunnel-diode receiver is available for microwave applications in the 6,500-Mc region. Originally designed for space communications, the receiver has an r-f bandwidth of 500 Mc and consists of a tunnel diode amplifier, tunnel diode mixer, i-f preamplifier and varactor tuned tunnel diode local oscillator integrated into a single package weighing 10 oz and occupying less than 20 cu in. The receiver has a noise figure of 5.5 db max and an r-f/i-f gain of 35 db with over-all gain of 30 db. Additional parameters are: i-f, 100 Mc; i-f bandwidth, 20 Mc; and power drain,  $\pm 12$  v and 30 ma. This front end is suitable for satellite, airborne and manpack communications receivers. It is easily adapted

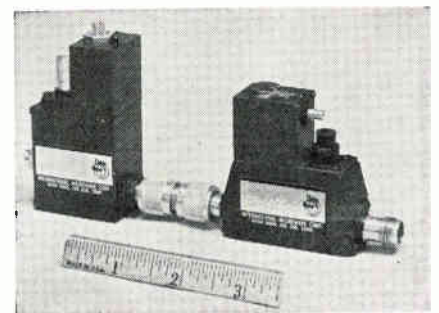



for antenna mounting to provide a low-noise frequency down converter for the back of the antenna pedestal.

International Microwave Corp., a subsidiary of Microwave Associates, Inc., Burlington, Mass. [393]

## Switching diodes feature high speed

A low-cost microwave diode features 2-nsec switching speed and a switching ratio of 46 at 1,250 Mc in strip transmission line series configuration. Diode insertion loss is 0.4 db at 10 ma forward bias and isolation is 18.5 db at 30 v reverse bias. At 3,000 Mc, the switching ratio is 25. The diode has low inductance, gold-plated ribbon leads. Type designation is PL1401. Body dimensions are 0.070 in. by 0.150 in. Price is \$10 to \$25 depending on quantity.

Parametric Industries, Inc., 63 Swanton St., Winchester, Mass. 01890. [394]

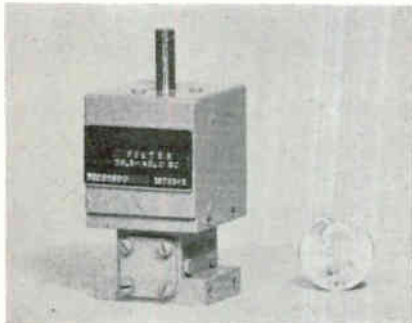

## Bandpass filter has broad tuning range

Model A2650 c-w bandpass filter is tunable over the entire WR28 waveguide range from 26.5 Gc to 40.0 Gc with less than 20% variation in bandwidth. The 3-db and 30-db bandwidths are 26 Mc and 125 Mc respectively. Insertion loss is 9.0 db max and vswr is 1.5:1. Standard filters are available in 2, 3 or 4 sections for proper selectivity. Because of its broad tuning range and accuracy, this filter is useful in development laboratories as well as operational equipment. Price range is from \$1,125 to \$1,500.

Frequency Engineering Laboratories, Farmingdale, U.J. 07727. [395]

## NEW 1/2 INCH TWO WATT PHOTOCELLS



AVAILABLE NOW!

Additional data plus new 16 page photocell manual for design engineers free on request.

Clairex now offers a new "5M" Series of photoconductive cells with two watts power dissipation in a rugged, hermetically sealed metal case only .490" in diameter. Available in all standard Clairex CdS and CdSe photosensitive materials offering numerous combinations of response time, sensitivity and spectral response. Suitable for direct relay operation and many other applications.

# CLAIREX

"The LIGHT Touch in Automotion and Control"

8 West 30 Street, New York, N. Y. 10001, 212 MU 4-0940

Circle 209 on reader service card

## WIDE RANGE diode test set



Model 1808

.05 to 2000 volts...  
... $2 \times 10^{-9}$  to 3 amperes

Write for catalog on our complete line of semiconductor test equipment.

### DYNATRAN

electronics corporation

178 HERRICKS ROAD  
MINEOLA, N. Y. 11501

516-741-4141

Circle 210 on reader service card

## TYPE ANY SYMBOL perfectly in 4 seconds

write today for free catalog

Gentlemen:

TYPIT<sup>®</sup> is the perfect way to type any technical, foreign or numerical symbol -- easy as  $\pi$ . Over 1,000 symbols like  $\sqrt{-1}$ ,  $\infty$ ,  $\Omega$ ,  $\square$ ,  $\Sigma$ ,  $\gg$ ,  $\#$ ,  $\approx$  to choose from. A standard typewriter + TYPIT<sup>®</sup> is

all you need. It's clean, inexpensive and fast.

**typit<sup>®</sup>** manufactured by  
mechanical enterprises, inc.

3127 Colvin St., Alexandria, Va., Dept. EO

Please send free catalog.

Give me a demonstration soon at no obligation.

Name \_\_\_\_\_ Title \_\_\_\_\_

Company \_\_\_\_\_

Address \_\_\_\_\_

City \_\_\_\_\_ State \_\_\_\_\_

Circle 135 on reader service card

135

NOW AVAILABLE FROM TI



## EPITAXIAL GALLIUM ARSENIDE

### R&D or Production Requirements

- Highly uniform N-type epitaxial layers in any thickness from one micron to 15 mils
- Carrier concentrations from  $5 \times 10^{15}$  to  $5 \times 10^{18}$  per cc
- Wide choice of TI gallium arsenide substrates, including semi-insulating material, in (1-1-1) or (1-0-0) orientations
- Slices 0.5-inch to 0.8-inch nominal diameter and 20 mils thick
- P-type epitaxial layers also available

### DELIVERY: TWO WEEKS

For your single crystal requirements TI also supplies gallium arsenide, indium arsenide and indium antimonide. Immediate shipment.

FOR INFORMATION WRITE:

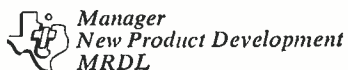

TEXAS INSTRUMENTS  
INCORPORATED

MATERIALS & CONTROLS DIVISION  
P. O. Box 5010 Dallas 22, Texas

## New Production Equipment

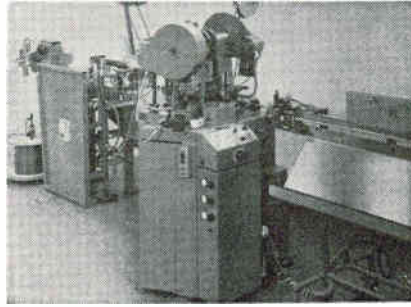

### Lead-making machine works automatically

Production capacity of up to 5,700 fully terminated leads per hour is possible with the Ampomator automatic lead-making machine. The machine handles wire completely from supply reel to finished lead. It handles end-to-end, side-by-side or insulation-piercing terminals and accommodates a wide range of terminal types. Quick change crimping dies and cutting blades facilitate production changeover and permit the use of a variety of insulations. Stranded wire from No. 24 to No. 12 Awg or solid wire in the smaller gages is fed, stripped, measured, cut, then terminated at the rate of up to 11,400 per hour, depending on lead length. A gear shift transmission with variable speed control permits variable lead length settings from 3 in. to 10 ft. Stripping length is also adjustable from  $\frac{1}{8}$  in. to  $\frac{3}{8}$  in. Fail-safe control circuitry shuts off power to the machine in the event of wire or terminal strip jam-up or depletion. AMP Inc., Harrisburg, Pa. [421]

### Positioning control for machine tools

A new, low-cost positioning control is built in one configuration with five plug-in options. As standard equipment the Mark Century 120 control features solid-state proportional d-c drives with feed rate control for straight line milling in addition to point-to-point capability. Other standard features are absolute data input based on a

machine-zero reference point, and backlash takeup to improve final positioning accuracy of the machine. The plug-in options include: manual data input; sequence number readout; a choice of silicon-controlled rectifier d-c servo drives rated up to one horsepower; steering-milling control allowing rough contour milling under manual operation; and Accupin linear transducer for direct measurement of machine-tool position. Data input resolution is 0.0001 in. Tape-commanded auxiliary functions are offered as standard equipment to provide maximum flexibility for machine operation. Other standard equipment includes a photoelectric tape reader which reads one-inch-wide eight-channel tape at the rate of 100 characters per sec, rapid traverse of up to 300 in. per minute giving short hole-to-hole time, and full-range zero offset to provide quick adaptation of a prepared program to an over or under-size casting.

General Electric Co., Waynesboro, Va. [422]

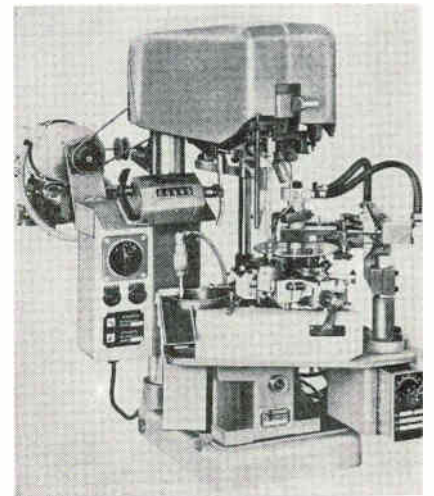

### Automatic winder for air-core coils

A coil winder has been designed to deliver a complete coil—bonded, tinned, with terminals formed, and ready for assembly. The Kinomat BV3-G can produce from 750 to 1,400 coils per hour, depending on wire size, pitch and number of

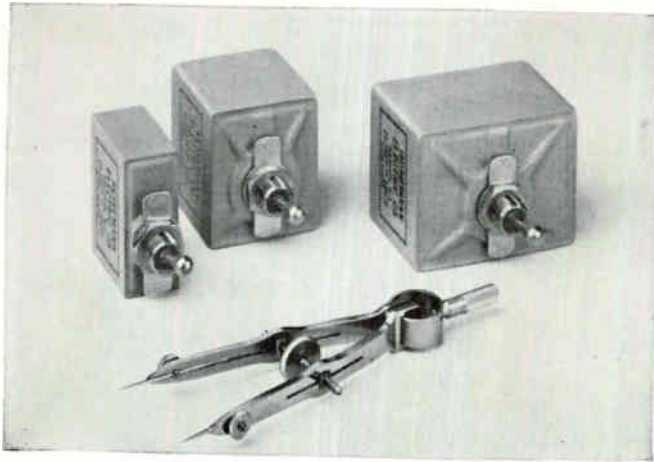

*for HAZARDOUS areas . . .*

**HERE'S A HERMETICALLY-SEALED CIRCUIT BREAKER**

The Heinemann Series SM is a subminiature breaker that will probably land on the moon in a U.S. manned capsule. Its hermetic seal makes the SM suitable for a number of earth-bound hazardous environmental applications as well: hospital operating rooms, petro-chem plants, graneries, aircraft facilities, and bulk oil terminals to name some. If you need overcurrent protection in a hazardous area, get all the facts on the SM. They're in Bulletin 3504.

Specs in brief: 0.050 to 20 amps • 240VAC, 60 or 400 cycles; 50VDC • 1-, 2-, 3-pole models • optional SPDT auxiliary switch.

**HEINEMANN ELECTRIC COMPANY**

2600 Brunswick Pike, Trenton, N. J. 08602



SA2948

Circle 211 on reader service card

NEW  
FREE  
DIRECTORY

ELECTRONIC PRODUCTS FROM JAPAN

Over 450 listings —  
New fully indexed guide to  
Japanese electronics manufacturers  
and their products.

Get your copy at  
**NEC Booth 844**

ELECTRONIC INDUSTRIES  
ASSOCIATION OF JAPAN

Electronics Division  
Japan Light Machinery Information Center  
437 5th Avenue, New York 16, N. Y. • MU 6-0731

Circle 212 on reader service card

**APPLICATION  
NEWS from EPL**

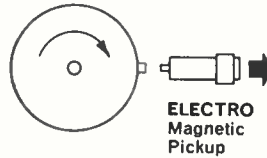

**SINGLE PROJECTION**

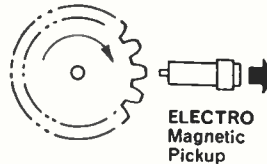
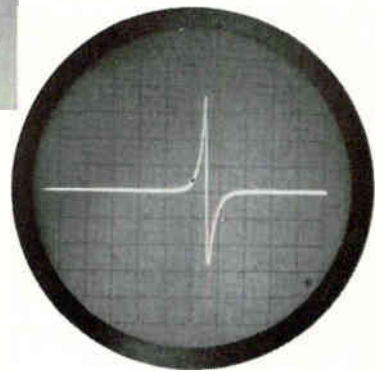

**COARSE TOOTH GEAR**

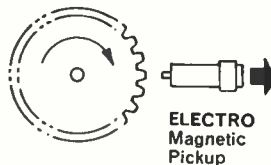
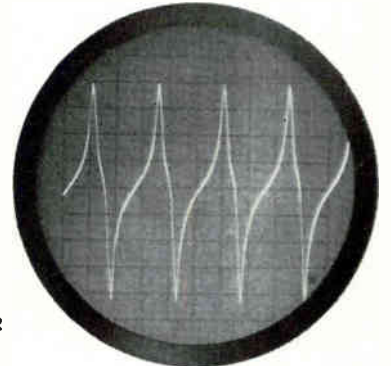

**FINE TOOTH GEAR**

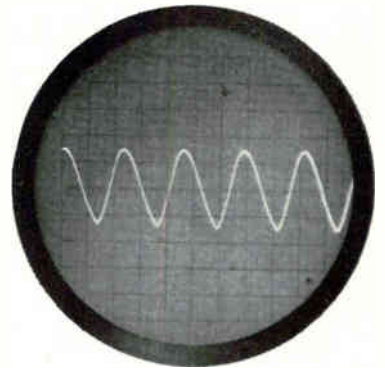

Typical waveforms from three of any number of actuating profile-pickup model combinations.

# Pulses for Sale!

Need pulses for controlling, counting, triggering, positioning, telemetering or whatever else?—either digital or analog output?

Try an ELECTRO Magnetic Pickup, the small-sized, non-contacting voltage/frequency generating device. Over 15 models available from stock. R/D facilities for special pickups.

Write, phone for Performance & Application Guide



**ELECTRO PRODUCTS  
LABORATORIES**

6125-F Howard, Chicago (Niles), Ill. 60648  
Phone: 312/775-5220

Canada: Atlas Instruments Corp., Toronto

Proximity Switches • Magnetic Pickups • Pres-Con Controls  
Tachometers • Dynamic Micrometers • DC Power Supplies

4218

Circle 137 on reader service card

# LASER DIODES and SYSTEMS

## Room Temperature CW Laser Crystals

### Laser Diodes

		Output
Seld 1	\$ 85	8400 Ang.
Seld 2	985	8400 Ang.
Seld 3	225	7200 Ang.
Seld 4	1975	7200 Ang.

## COMPLETE LASER DIODE SYSTEM

Includes Seld 1 or 3 Diode and Dewar	<b>\$495</b>
Includes Seld 2 Diode and Dewar	<b>\$2495</b>
Includes Seld 4 Diode and Dewar	<b>\$3495</b>

**Guaranteed CW Room  
Temperature Laser Rod**  
3 mm dia. x 1" long. **\$995**

## CW GAS LASER SYSTEMS

MKIA complete	<b>\$995</b>
MKIC complete	<b>895</b>

Many Others

Write For Complete List



# semi-elements, inc.

Saxonburg Boulevard, Saxonburg, Pa.  
Phone: 412-352-1548

**GENALEX**  
**2way**

**PRECISION  
STEPPING SWITCH**

for circuits which require a switch that steps positively, in either direction, around a bank of 25 contacts. **FEATURING:**

- self-cycle or remote control operation
- 65 steps per second on self-interruption
- bridging or non-bridging wipers
- 20 steps per second from external impulses

*Over 10,000,000 steps in each direction without replacement.*

for complete data on this and other unique GENALEX switches, write:

**IMTRA**  
CORPORATION

11 UNIVERSITY ROAD, CAMBRIDGE 38, MASS.  
U. S. AGENTS FOR THE GENERAL ELECTRIC COMPANY, LTD. OF ENGLAND

Circle 213 on reader service card

## NOTHING ELSE LIKE IT!!

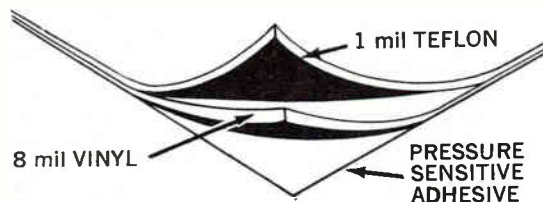

OTHER GAUGES OF TEFLON AND VINYL ON SPECIAL ORDER

### NO. T-18 LAMINATE *the ONLY SUPPORTED* TEFLON-VINYL LAMINATE

The Super-release TEFLON\* Surface to which NOTHING will Stick creates unlimited types of application.

#### SOME PROVEN APPLICATIONS . . .

- Spiral Wrap for Coating Rolls
- Spray Booth Liner
- Clean Room Wall Covering
- Covering for Shoe Lasts
- Washers, Gaskets and Seals
- Candy and Bakery Machinery
- Chem. Lab. Bench Tops
- Friction-free Feed on all types of Machinery
- Grain Chutes
- Container and Tank Linings
- File Drawer Channel Linings

AVAILABLE IN 25" CONTINUOUS ROLLS . . . TAPES FROM 1"

BRING YOUR LAMINATING PROBLEMS TO . . .

**Lamart Corporation**

YOUR PRIME SOURCE FOR CUSTOM QUALITY LAMINATIONS  
16-24 RICHMOND STREET • CLIFTON, N. J. 07015 • (201) 772-6262

\*DUPONT Registered Trademark

## New Production Equipment

turns. In operation, it automatically winds a coil, then drops it down to the first of six stations on an indexing table. On the table, or carousel, it is automatically sprayed for bonding, then carried to a solder pot where both terminals are dipped. Finally, successive forming operations shape the terminals to specifications, and the finished coil is automatically ejected from the mandrel. The BV3-G accepts bare, enameled, served or thermoplastic wire from 0.010 in. to 0.040 in. in diameter. Coil i-d can range from 0.020 in. to 0.360 in., and terminal lengths from 0.320 in. to 1.1 in. Winding direction is clockwise, with counter-clockwise operation available as an option.

Associated American Winding Machinery, Inc., 750 St. Ann's Ave., Bronx, N.Y. 10456 [423]

## NC machine assembles printed-circuit boards

This machine for assembling printed-circuit boards employs the solid-state electronic Centrepoint 200 numerical-control system to achieve fast positioning. Assembling can be done at up to 70 insertions per minute. Features include tape selection of depth stops to accommodate different diameters of components in sequence in a single setup, and elimination of load time with a dual-station work loader. Components can be supplied to the machine manually or preprogramed in magazines or on continuous lead-taped belts. In the more efficient lead-taping system, the insertion device cuts the component from the tap, forms the leads and guides them through drilled holes in the board. A supporting unit beneath the board cuts the leads to the proper length and clinches them to secure the component. The board is then positioned at the next location. The NC system positions the circuit board to an accuracy of  $\pm 0.002$  in. with repeatability of 0.001 in. System resolution is 0.001 in.

Controls division, Centre Circuits, Inc., 1101 North Atherton St., State College, Pa. [424]

# LITTLE CHOPPER



# BIG PERFORMER

Where component space is limited—Bristol's Subminiature Chopper offers:

- 0.1 cu. in. size
- complete shielding
- radiation resistance
- airborne environmental ratings
- lowest noise level

Write for detailed spec sheet. **The Bristol Company**, Aircraft Division, 152 Bristol Road, Waterbury, Conn. 06720.

A subsidiary of American Chain & Cable Company, Inc. 4.7

**BRISTOL** . . . engineers for precision, builds for reliability



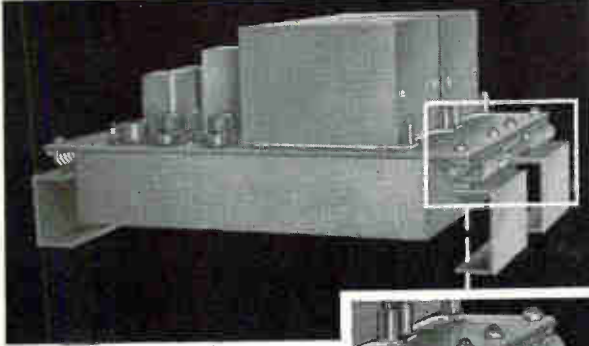

**TO BEAT  
VIBRATION PROBLEMS  
USE ALL  
ATTITUDE  
ISOLATION**



Aeroflex Laboratories' Helical Isolation systems offer safe All Attitude isolation in a broad spectrum of environmental conditions. In addition the Helical Isolation Systems possess the following characteristics:

- isolator sizes available for wide load range requirements
- resonant frequency assured at specified loads and inputs
- broad temperature range stability
- provides greater 3-axis protection than conventional isolators
- excellent damping characteristics
- exceptional service life—infinite shelf life.

*For more information on Helical Isolation Systems and their many applications, write to Dept. RB 107*



**AEROFLEX LABORATORIES**  
INCORPORATED  
South Service Road, Plainview, L. I., New York  
(516) MYrtle 4-6700

Circle 215 on reader service card



**"VITREOSIL" is the word  
for VITREOUS-SILICA  
(PURE FUSED QUARTZ)**

No other material has the unusual properties of VITREOSIL pure fused quartz. It takes temperatures up to 1100°C, is unaffected by thermal shock, resists most acids, has excellent light transmission and electrical and heat insulation characteristics. Write for more details.



**THERMAL AMERICAN FUSED QUARTZ CO.**  
RT. 202 & CHANGE BRIDGE RD. MONTVILLE, NEW JERSEY

Circle 216 on reader service card

**MICO**

**PRECISION DRILL PRESSES**



**FEATURES**

1. Durable, accurate, sensitive, variable speed;
2. Four models—with various size bases and throat dimensions from 6 1/2" to 12 1/2";
3. Ball bearing spindle assemblies with built-in dust protectors. Spindles with taper-oilless bearings available.
4. Drill head can swing radially and is adjusted vertically.

Send for illustrated catalogs

**MICO INSTRUMENT CO.**

77 Trowbridge St. Cambridge 38, Mass.

140 Circle 140 on reader service card

**TR MICRO TV TUNER**

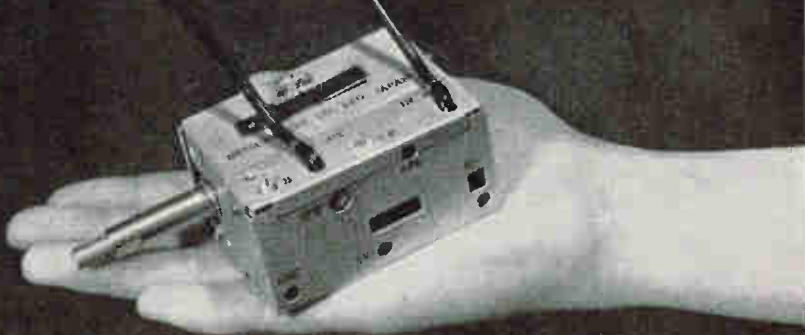

**MODEL TU-15U**

This MICRO TV TUNER, using 3 transistors, provides you with excellent performance while keeping high quality stability, thanks to our latest technical advancement. Spurious radiation meets the requirements of FCC and is guaranteed for performance of more than 40,000 operations. We also offer you many other lines of components for your use. Please write us asking for catalogs available on the following products:

**Main Products**

Polyvaricon, IF Transformers, Oscillator Coils, Antenna Coils, Variable Resistors, FM Tuners, TV Tuners, Micro-motors, Sockets.



**MITSUMI ELECTRIC CO., LTD.**

Head Office Komae, Kitatama, Tokyo, Japan.  
New York Office 11 Broadway, New York 4, N.Y., U.S.A.

Circle 217 on reader service card

## New Materials

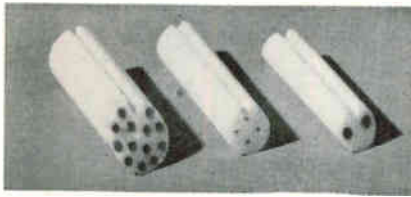

### Teflon tubing with extruded key slots

A method has been developed for extruding key slots in single- and multiple-hole Teflon tubing, eliminating another end-user machine operation. The tube-socket manufacturer, for example, may now purchase Teflon tubing in 10 to 12-ft lengths with all the required socket holes and key slots extruded to fine tolerances thereby reducing his cost considerably. Surf Chemical Inc., a subsidiary of Driver-Harris Co., 201 Middlesex St., Harrison, N.J. [411]

### Epoxy adhesive cures quickly

Barco Bond Instant is a 60-second epoxy adhesive designed for a wide variety of bonding, patching and filling applications where quick cure is desired. It sets up one minute after mixing begins, curing to a solid with lap-shear strength of 2,500 lb and an electrical strength approaching 4,000 v per mil. It is packaged in self-metering tubes that take all guesswork out of the mixing process. A \$15 trial kit of 12 different Barco Bond adhesives is available.

Astro Chemical Co., 2063 Baker Ave., Schenectady, N.Y. 12309. [412]

### Activated rosin for foam fluxing

A high-rising material called Reliafoam No. 807 has been especially formulated for foam fluxing of printed-circuit boards and other electronic assemblies. The new flux is a stable, homogeneous solution

of pure water-white rosin in a multi-component solvent to which has been added a small amount of a very effective, trouble-free activating agent. Requiring low air pressures for a constant, adjustable head of fine bubble foam, it maintains its instant foaming, fluxing and wetting properties during continuous exposure to aeration. Applied with any existing foam fluxing equipment, Reliafoam No. 807 has proven highly effective on brass, bronze, cadmium plate, copper, lead, nickel plate, silver solder plate, terne plate tin and tin zinc plate. The solid content of No. 807 is very small and what little residues are left on p-c boards after soldering will not impair the electrical characteristics of the board. Should residue removal be desired, Alpha No. 563 rosin flux remover, alcohol or carbon tetrachloride will easily remove it. If necessary, a subsequent water rinse will totally remove all ionizable materials. Reliafoam No. 807 is available in 1, 5 and 54 gallon containers.

Alpha Metals, Inc., 56 Water St., Jersey City, N.J. 07304. [413]

### Silicone compound transfers heat

Heat transfer properties three times better than silica filled greases and about twice that of filled epoxy are provided by a new grease-like silicone dielectric compound, according to the manufacturer. The material, identified as Insulgrease G-640, is designed for use as a heat transfer compound in semiconductors, tube coils and other electronic and electrical equipment where overheating is a problem. G-640 is a white, opaque material that exhibits less than 1% bleed and evaporation at 200°C after 24 hours. Used inside a semiconductor device case, G-640 protects the junction from shock and vibration and provides for efficient heat transfer. The compound sells for \$3 per lb. Evaluation samples are available.

General Electric Co., Silicone Products Department, Waterford, N.Y. [414]

GLASS ENCLOSED

# AMPERITE

## Thermostatic DELAY RELAYS

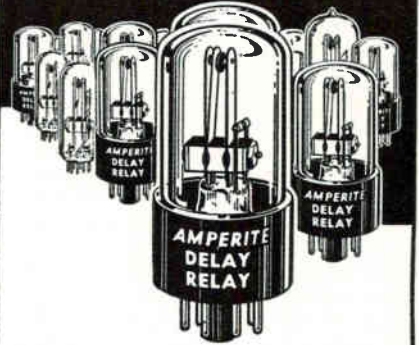

Offer true hermetic sealing  
-assure maximum stability and life!

**Delays: 2 to 180 seconds . . .** Actuated by a heater, they operate on A.C., D.C., or Pulsating Current . . . Being hermetically sealed, they are not affected by altitude, moisture, or climate changes . . . SPST only—normally open or normally closed . . . Compensated for ambient temperature changes from -55° to +80° C . . . Heaters consume approximately 2 W. and may be operated continuously . . . The units are rugged, explosion-proof, long-lived, and—inexpensive!

TYPES: Standard Radio Octal, and 9-Pin Miniature.  
List Price, \$4.00

PROBLEM? Send for Bulletin No. TR-81

# AMPERITE

## BALLAST REGULATORS

Hermetically sealed, they are not affected by changes in altitude, ambient temperature (-50° to +70° C.), or humidity . . . Rugged, light, compact, most inexpensive.

List Price, \$3.00

Write for 4-page Technical  
Bulletin No. AB-51

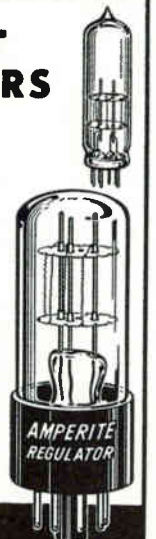
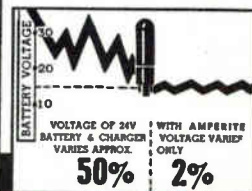

# AMPERITE

600 PALISADE AVE., UNION CITY, N.J.

Telephone: 201 UNION 4-9503

In Canada: Atlas Radio Corp., Ltd.,  
50 Wingold Ave., Toronto 10

## Unusual stability

in miniature, surface-mounted platinum temperature sensors

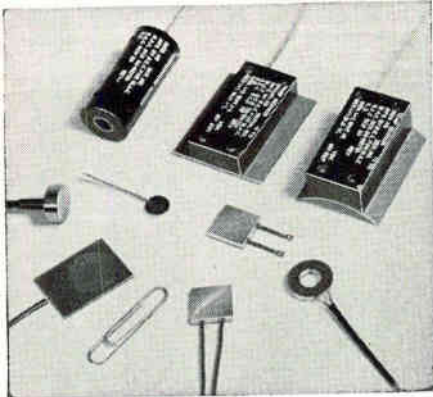

Performance is excellent for such small sensors in the REC line of miniature surface sensors. Range covered is from  $-435^{\circ}\text{F.}$  to  $+1800^{\circ}\text{F.}$  Repeatability after 10 consecutive shocks from  $-320^{\circ}\text{F.}$  to  $300^{\circ}\text{F.}$  is within  $\pm 0.1^{\circ}\text{F.}$

The easily attached sensors can be cemented, spot welded or clamped to surfaces. Cylindrical models fit around standard small pipe sizes.

REC surface sensors have elements of highest purity platinum wire, fully annealed and mounted so that the resistance wire is well isolated from any strain in the surface. Outer cases are platinum, stainless steel, epoxy compounds, or ceramic. Some have interchangeable bridge networks.

Write for Bulletin 9625.

### A complete precision line

Rosemount designs and manufactures high quality precision equipment in these lines:

- Air data sensors
  - Total temperature
  - Pitot-static tubes (de-iced)
- Immersion temperature sensors (including cryogenic)
- Surface temperature sensors
- Pressure sensors
- Accessory equipment and aeronautical research

For more information please write for the REC catalog. Specific questions welcomed.



**ROSEMOUNT  
ENGINEERING  
COMPANY**

4900 West 78th St. • Minneapolis 24, Minn.

## New Books

### Survey of Servomechanisms

Servomechanism Fundamentals and Experiments by members of the staff of Philco Technical, Corp. Prentice-Hall, Inc. Englewood Cliffs, N.J. 1964, 248 pp., \$10.65.

A comprehensive survey of the fundamentals of servomechanisms is offered in this volume, although the book deliberately doesn't dig very deeply.

The text is nonmathematical and will be useful for students, and perhaps for technicians, because its authors are seeking to provide the basic information the reader needs in the field.

Its 10 chapters cover synchro and resolver principles, follow with representative synchro and resolver control systems and then explain how a variety of transducers and servo components work. They also describe typical servos and their characteristics, and outline measurement and maintenance techniques.

Every chapter contains a quiz to test the reader's grasp of the subject and to underscore important points. Samples: "Why are geared synchro systems preferred over one-speed systems?" from Chapter 2 on synchro systems. Again: "What effect does backlash in a gearhead have on servo-system operation?" from Chapter 8, entitled "Servomotors and Rate Generators." Answers are provided at the end of the book.

The authors also outline experiments for the reader to perform. Circuit diagrams with lists of equipment are given, together with "cookbook" instructions. But the tests rely almost entirely on special Philco apparatus, which probably isn't accessible to most readers. Since the test apparatus is identified by parts numbers rather than by technical specifications, individual pieces are not readily duplicated from available equipment; but this is a minor drawback.

A list of further readings guides the student who wishes to dig deeper in any area.

There is one omission that might be remedied in any future books

CALIFORNIA  
WATER  
PROJECT

## CHIEF ENGINEERING COMPUTATIONS BRANCH

New Position in the California State Department of Water Resources. The California Water Project (now under construction by the Department of Water Resources) envisions a system of reservoirs, aqueducts, pumping plants, and other hydraulic facilities throughout the state.

This newly established position in a rapidly growing organization is for an engineering or scientifically trained individual with knowledge of engineering programs. He must have sufficient experience in the use of digital and analog computers and their application to the solution of engineering problems of this nature.

The Chief, Engineering Computations Branch, will plan, organize, direct, and promote a centralized program of electronic computing and data processing for use in relation to engineering design, construction, and utility operations, including automation of State Water facilities.

Requires more than five years of broad and extensive professional engineering experience, at least two of which must have included responsibility for directing the application of digital and analog computer methods to the solution of major engineering problems; and a college degree in science, preferably in engineering.

The position is in Sacramento, in smog-free Central California. Interviews held in California only.

**SALARY RANGE: \$1,111  
TO \$1,351 PER MONTH**

For details please contact

**C. S. Warner**

Engineering Personnel Services, State Personnel Board,

801 Capitol Mall, Sacramento, California 95814

Phone (916) 455-3033



prepared by the Philco staff: The name of a Philco spokesman to whom questions or suggestions can be sent isn't included in this edition.

Stanley Froud  
Industrial Communications  
New York

### Solid-state theory

Quantum Theory of Solids

C. Kittel

John Wiley and Sons, Inc.,  
New York, 435 pp., \$13.50.

Quantum Theory of Solids, a companion volume to the author's Introduction to Solid State Physics, is a one-year graduate textbook for the theoretical physicist. Its up-to-date presentation of the unifying principles of solid-state theory should help experimental physicists and electrical engineers interpret their research.

The first part of the book uses the field-theory approach. Topics such as phonons, plasmons, magnons, polarons and electron fields and their interactions are discussed. Although mathematical language is used frequently, each chapter has an excellent introduction where terms are defined and sufficient background is presented. The problems at the end of each chapter contain important results.

The theory of superconductivity is presented as a successful example of the quantum theory of solids developed in part one. Then the book moves into a treatment of Fermi surfaces and electron wavefunctions in metals, alloys, semiconductors and insulators, with emphasis on the theory of some important experiments on the optical properties of semiconductors.

Part three deals with determination of time-dependent effects in solids by use of correlation functions. To make the book more accessible to experimentalists, the method of Green's functions is avoided until the last chapter, where a brief introduction is given. Several detailed subjects are omitted by the author because they are treated so fully in other textbooks—for example, Wilson's transport theory, Peierl's phonon interactions and Abragam's nuclear magnetism.

Gus Tirellis  
Solid State Editor

## NEW MAGNETIC



## COMPONENTS

It's New...

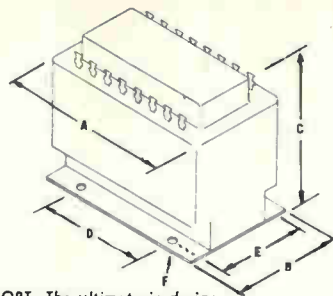

\*OPT. The ultimate in design to achieve smaller construction at additional cost.

### SINGLE AND THREE PHASE Hermetically Sealed • Epoxy Molded POWER TRANSFORMER

Thermex transformers have been engineered to meet all the rigid environmental requirements of MIL-T-27B Grade 5. These transformers have identifications and circuit diagrams printed on the face of the unit in accordance with MIL Specifications. The following sizes as shown in the tables can be fabricated from available stock molds.

#### THERMEX MOLDED — SINGLE PHASE — TYPE M1

DIMENSIONS (Approx. In.)						VA RATING (CPS)			SERIES	Approx. Wgt. Lb.
A	B	C	D	E	F	50/60 NOM. DESIGN	380/420 *OPT.	380/420 *OPT.		
1.50	1.62	2.12	1.00	1.06	6/32 x 3/8	8	40	56	100	.6
2.00	2.25	2.87	1.50	1.75	8/32 x 3/8	26	120	165	200	1.5
2.87	3.00	3.37	2.00	2.37	10/32 x 1/2	55	200	275	300	3.3
3.19	3.50	4.12	2.19	2.50	10/32 x 1/2	110	400	500	400	5.7

#### THERMEX POWER — THREE PHASE — TYPE M2

3.63	2.50	2.63	2.00	2.00	.171 Hole	75	375	560	100	2.8
3.63	3.00	2.63	2.00	2.50	.171 Hole	110	550	800	150	3.2
4.50	2.75	4.16	3.50	2.25	.171 Hole	200	820	1130	200	5.9
4.50	3.38	4.16	3.50	2.88	.171 Hole	300	1200	1800	250	7.3
6.19	3.38	4.88	5.00	2.38	.187 Hole	450	1900	2700	300	11.5
6.19	4.38	4.88	5.00	3.63	.187 Hole	650	2800	4200	350	15.0

VA Ratings are based upon nominal voltages and two winding design. VA Ratings will decrease with additional windings, high secondary voltages, and high insulation voltages.

## INDUSTRIAL TRANSFORMER CORP.

GOULDSBORO, PENNSYLVANIA • Tel.: (717) Victor 2-2111 • New York (212) Walker 5-9860

Circle 218 on reader service card

See GRC at NEC/Booth #352

## GRC tiny parts



die cast  
ZINC ALLOY

molded  
PLASTICS



Coil Bobbins  
Gears & Pinions

"SMALL ZINC  
DIE CASTINGS"

Get GRC's fact filled brochures. GRC's methods give you quality and accuracy in small parts of die cast zinc alloy, Nylon, Delrin, other engineering thermo-plastics. Exclusive automatic single cavity, techniques allow new designs, new production and assembly shortcuts. Write, wire, phone for samples and bulletins. Send prints for quotations.

NO MINIMUM SIZE! Maximum sizes: Zinc Alloy—  
2" long, 1/2 oz. Plastic—  
1 3/4" long, .05 oz.

GRIES REPRODUCER CORP.

World's Foremost Producer of Small Die Castings and Plastic Moldings  
151 Beechwood Avenue, New Rochelle, New York  
Phone (914) New Rochelle 3-8600

Circle 219 on reader service card

## DC POWER SUPPLIES



CONTINUOUS VOLTAGE COVERAGE — 4.7 to 60 vdc.

Input: 105-125 vdc, 50-400 cps  
Regulations: From  $\pm 0.05\%$   
Ripple: From .002% or 1 mv, rms  
Temp. Coeff.: From  $\pm 0.01\%/^{\circ}\text{C}$   
Voltage Adjustments:  $\pm 5\%$   
Max. Temp. of Base:  $65^{\circ}\text{C}$

- WIDE VARIETY OF CURRENT RATINGS
- ELECTRONIC SHORT CIRCUIT PROTECTION
- FULLY REPAIRABLE
- 7 STANDARD SIZES (OVER 450 MODELS)
- PRICE RANGE **\$45-\$225**



INSTRUMENTS: EEM ('63-64 Pg. 902)  
EBG (1964 Pg. 462)

POWER SUPPLIES: EEM ('64-65 Pg. 1341)  
EBG (1963 Pg. 307)

VOLTAGE STANDARDS: EEM ('64-65 Pg. 929)



**DYNAGE, inc.**

390 CAPITOL AVE., HARTFORD, CONN.

Circle 143 on reader service card

143

# FREE! NEW!

# NEWARK

## 1965

# INDUSTRIAL ELECTRONICS

# CATALOG!

**CDE** CORNELL-DUBILIER

## CAPACITORS

**FACTORY PRICES  
TO 999 PIECES**

- *Electrolytics*
  - *Ceramics*
  - *Micas*
  - *Tubulars*
  - *DC oils*
  - *Metallized*
  - *Tantalum*
- *Immediate Delivery from Stock  
Factory OEM Prices*

### NEWARK CATALOG 80

- Industry's Most Complete Catalog
- Over 640 Pages • Over 70,000 Items
- Over 600 Standard Brand Lines
- Eight Stocking Warehouses
- Over \$6,000,000 Industrial Electronics Inventory

### NEWARK ELECTRONICS CORPORATION

Main office and warehouse • Dept. 000  
223 West Madison • Chicago, Ill. 60606

Authorized Cornell-Dubilier  
Warehouses in:

**CHICAGO, ILL.**  
(312) ST 2-2944

**CINCINNATI, OHIO**

(513) 421-5282

**DENVER, COLORADO**

(303) SK 7-3351

**DETROIT, MICHIGAN**

(313) JO 4-5490

**GRAND RAPIDS, MICHIGAN**

(616) 452-1411

**LOS ANGELES AREA**

(213) OR 8-0441

**SAN FRANCISCO AREA**

(415) 593-1881

**NEW YORK CITY**

(212) AL 5-4600

## Technical Abstracts

### Comsat handover

Communications handover for medium-altitude satellite systems.\*  
Andrew Werth, ITT Federal Laboratories, Nutley, N.J.

If telephone signals are to be transmitted to medium-altitude communication satellites, constant uninterrupted communications must be maintained while transferring the signal path from one satellite to another. When one satellite is about to pass out of range, and another becomes visible, the signal must be switched to the visible satellite. This is called handover.

Instantaneous handover can be accomplished with a delay-compensation method based on satellite-range information. Special equipment introduces variable delay factors to equalize the length of transmission paths and to permit telephone signals to be transferred from satellite to satellite without affecting any conversation that may be in progress.

The delay compensation must be introduced into the path of either satellite, or both, so that the output of both paths will be synchronous to within an acceptable, predetermined tolerance when it becomes necessary to switch between paths. This delay compensation must also be varied continuously as a function of changing path length to provide constant length for all paths independent of time, satellite position or delay variations caused by different pieces of equipment.

The delay-compensation method described permits the communication-path delay between any two line terminals to remain constant, using any satellite in the 5,000-mile-high system. The solution calls for compensating both the receiver and transmitter ends of the link, using measured slant-range information supplied in digital form. A maximum delay of 18 milliseconds is introduced at each end of the communication path. During all phases of communication, a maximum delay of 48 milliseconds is maintained, including artificial and actual delay. This results in a total one-way maximum path delay of 96 milliseconds.

Two methods of generating range information are discussed. One method uses a computer and the other measures transmission time.

### Automatic reconnaissance

Target recognition in aerial photography.\*  
L.N. Kanal and N.C. Randall.  
Philco Corp., Blue Bell, Pa.

This paper describes studies and an experimental system for screening aerial photographs to identify certain specific military targets, such as tanks or trucks.

The recognition mechanism operates on a two-level statistical decision basis. Sample photographs of the desired type of targets, processed to show only black-and-white elements, are presented to the system, and each of the system's detection elements forms a statistical expectation that favors a white or a black square when the desired target is seen.

The elements are connected into a two-level voting system, so that their responses average out. With a sufficiently large number of elements, a 100% correct response is obtained on test photographs.

An experimental system was built to simulate this type of recognition behavior. Its goal was to detect M-48 tanks, and it used actual tactical photographs. The images were processed in a specially constructed scanner, Imitac (Image Input to Automatic Computer), each 3-by-3-inch image being sampled at 1,024 points. The data was processed on a Philco 2000 computer. The final samples prepared for the recognition network consisted of 32 rows of 32 elements each. The recognition network scanned these in 24 overlapping "feature blocks," each feature block having eight rows of eight elements each. A discriminant function for the network was obtained by processing 50 samples of photographs of M-48 tanks. The function was then applied to 50 more photographs, and the system classified these with 100% accuracy.

\*Presented at the 1964 Western Electronic Show and Convention (Wescon), Aug. 25-28, Los Angeles

# NEW!

**ADJUSTABLE  
TIME  
DELAYED  
SNAP  
SWITCH**



TIME DELAYED  
LIMIT SWITCH

**\$4.50 to \$17.50**



PUSHBUTTON SWITCH



PRESSURE  
VACUUM SWITCH



TIME DELAY RELAY

## NOW! TIME DELAYED SNAP SWITCHES

Pneumatically adjustable time delayed switches, time delay relays and pressure-vacuum switches are now available at remarkably low cost . . . by combining almost any snap action switch with a unique air damping dash pot called Airpot. Prices range from \$4.50 to \$17.50. Send for literature and prices today.

**AIRPOT CORPORATION**  
522 PEARL STREET  
NORWALK, CONNECTICUT

Circle 220 on reader service card

## LEGAL NOTICE

STATEMENT OF OWNERSHIP, MANAGEMENT AND CIRCULATION  
(Act of October 23, 1962, Section 4369, Title 39, United States Code)

1. Date of filing: October 1, 1964.
2. Title of publication: ELECTRONICS.
3. Frequency of issue: Biweekly.
4. Location of known office of publication: 330 West 42nd St., City, County and State of New York—10036.
5. Location of the headquarters or general business offices of the publishers: 330 West 42nd St., City, County and State of New York—10036.
6. Names and addresses of publisher, editor, and managing editor: Publisher, Charles C. Randolph—330 West 42nd St., New York, N. Y.—10036; Editor, L. H. Young—330 West 42nd St., New York, N. Y.—10036; Managing Editor, None.
7. The owner is McGraw-Hill, Inc., 330 West 42nd St., New York, N. Y., 10036. Stockholders holding 1% or more of stock are: Donald C. McGraw, Elizabeth McGraw Webster, Donald C. McGraw, Jr. & Harold W. McGraw, Jr., Trustees under Indenture of Trust m/b James H. McGraw, dated 1/14/21 as modified; Donald C. McGraw & Harold W. McGraw, Trustees under an Indenture of Trust m/b James H. McGraw, dated 1/14/21 as amended; Donald C. McGraw, Individually; Donald C. McGraw and Catharine McGraw Hook as executors of the Estate of Mildred W. McGraw, all of 330 West 42nd St., New York, N. Y., 10036.
8. Known bondholders, mortgages, and other security holders owning or holding 1 percent or more of total amount of bonds, mortgages or other securities: None.
9. Paragraphs 7 and 8 include, in cases where the stockholder or security holder appears upon the books of the company as trustee or in any other fiduciary relation, the name of the person or corporation for whom such trustee is acting, also the statements in the two paragraphs show the affiant's full knowledge and belief as to the circumstances and conditions under which stockholders and security holders who do not appear upon the books of the company as trustees, hold stock and securities in a capacity other than that of a bona fide owner. Names and addresses of individuals who are stockholders of a corporation which itself is a stockholder or holder of bonds, mortgages or other securities of the publishing corporation have been included in paragraphs 7 and 8 when the interests of such individuals are equivalent to 1 percent or more of the total amount of the stock or securities of the publishing corporation.
10. This item must be completed for all publications except those which do not carry advertising other than the publisher's own and which are named in sections 132.281, 132.282, and 132.283. Postal Manual (Sections 4355a, 4355b, and 4356 of Title 39, United States Code).

	Average No. Copies Each Issue During Preceding 12 Months	Single Issue Nearest to Filing Date
A. Total No. Copies Printed (Net Press Run).....	65,554	67,342
B. Paid Circulation		
1. To term subscribers by mail, carrier delivery or by other means.....	50,862	62,000
2. Sales through agents, news dealers or otherwise.....		
C. Free Distribution (Including samples) by mail, carrier delivery, or by other means.....	5,214	5,345
D. Total No. of Copies Distributed (Sum of lines B1, B2 and C).....	65,046	67,345

I certify that the statements made by me above are correct and complete.

McGraw-Hill, Inc.

By JOHN J. COOKE,  
Vice President & Secretary



do you have an impossible varactor spec?

then CHEER UP!



**AEL** now offers you

# CUSTOM HIGH PERFORMANCE VARACTOR DIODES

**HERE IS ALL YOU DO:** Specify breakdown voltage, junction capacitance and cut-off frequency . . . and AEL will build special varactor diodes to your exact requirements. AEL's advanced state-of-the-art capability in this field guarantees you just about any special type of varactor diode you may need. Here are a few reasons why:

- Breakdown voltages up to 160 volts.
- Highest cutoff frequencies available — up to 300 Gc @ —6 volts.
- Cleanest I-V characteristics — breakdown voltages measured at 1 $\mu$ a.
- High reliability . . . diodes tested in-circuit show no deterioration after 4000 hours.

**NOW... WHAT IS YOUR SPECIAL REQUIREMENT?**

Let us know and we'll give you price, delivery and guaranteed specs. Write or call . . .



**American Electronic Laboratories, Inc.**  
P. O. BOX 552, LANSDALE, PENNA. 19446 (215) 822-2929



## A little look at electronics in

# Atlanta

**High productivity.** For every dollar of wages paid, an Atlanta manufacturer of electronic measuring instruments can expect \$3.76 in value added by manufacture. In Chicago he would gain only \$2.90; in New York-New Jersey, \$2.64 (U. S. Census figures). Atlanta's large labor pool also permits a high degree of selective hiring.

**Trained engineers and technicians.** In 1964 Atlanta's 19 colleges and universities will grant over 1300 Bachelor of Science degrees — more than 200 in electrical engineering and physics. Nearly 300 technicians graduate here yearly.

**Proximity to aerospace and atomic energy installations.** Atlanta is at the center of some 26 military. NASA, AEC, and airframe manufacturing installations, including Thiokol Solid Rocket Booster Plant, Marshall Space Flight Center, Cape Kennedy.

**Transportation.** Close liaison between manufacturer and customer and rapid freight service are guaranteed by Atlanta's transportation facilities. Seven airlines offer non-stop service from Atlanta to more than 50 cities; 75 truck lines provide scheduled service to every major market in the nation; 7 railroads operate into and out of the city over 13 main lines.

**Independent research capabilities.** Georgia Tech's Engineering Experiment Station, Emory University, the University of Georgia, plus a number of private companies offer a wide range of research capabilities on a contractual basis to business and industry.

Ask for an analysis of your company's probable success in Atlanta as prepared by Georgia Tech's Industrial Development Division. Check coupon; mail with your company letterhead. All inquiries confidential.

Please send me the following reports and other information as checked below:

1.  Calculators and Computers—A Manufacturing Opportunity in Atlanta
2.  Electronic Testing and Measuring Instruments—A Manufacturing Opportunity in Atlanta
3.  Electronics—A Manufacturing Opportunity in Georgia
4.  I would like information on the following aspect(s) of Atlanta's economic and general make-up (list) \_\_\_\_\_
5.  I want to know my company's prospects for success in Atlanta as analyzed by Georgia Tech's Industrial Development Division. We would be interested primarily in a new  plant  warehouse  sales office  other \_\_\_\_\_



"Forward Atlanta"  
Paul Miller, Development Manager  
Atlanta Chamber of Commerce  
1318 Commerce Building  
Atlanta, Ga. 30303 Phone: 521-0845

Name \_\_\_\_\_ Title \_\_\_\_\_  
 Company \_\_\_\_\_  
 Product \_\_\_\_\_  
 Street \_\_\_\_\_  
 City \_\_\_\_\_  
 State \_\_\_\_\_ Zip Code \_\_\_\_\_

CONFIDENTIAL

**AUTOTRACK ANTENNA MOUNT**

360 degree azimuth, 210 degree elevation sweep with better than 1 mil. accuracy. Missile velocity acceleration and slewing rates. Amplidyne and servo control. Will handle up to 20 ft. dish. Supplied complete with control chassis. In stock—immediate delivery. Used world over by NASA, USAF, TTTC, MP-61 B, SCR-584, NIKE AJAX mounts also in stock.

**SCR 584 AUTOMATIC TRACKING RADARS**

Our 584s in like new condition, ready to go, and in stock for immediate delivery. Ideal for telemetry research and development, missile tracking, satellite tracking, balloon tracking. Used on Atlantic Missile Range, Pacific Missile Range, N.A.S.A. Wallops Island, A.B.M.A. Write us. Fully Desc. MIT Rad. Lab. Series, Vol. 1, pps. 207-210, 228, 284-286. Compl. inst. Bk. avail. \$25.00 each.

**PULSE MODULATORS**

**MIT MODEL 9 PULSER**

**1 MEGAWATT—HARD TUBE**

Output 25 kv 40 amp. Duty cycle, .002. Pulse lengths .25 to 2 microsec. Also .5 to 5 microsec. and 1 to 5 microsec. Uses 6C21. Input 115v 60 cycle AC. Mfr. GE. Complete with driver and high voltage power supply. Ref: MIT Rad. Lab. Series, Vol. 5, pps. 152-160.

**500KW THYRATRON PULSER**

Output 22kv at 28 amp. Rep. rates: 2.25 microsec. 300 pps, 1.75 msec 550 pps, .4 msec 2500 pps. Uses 5C22 hydrogen thyatron. Complete with driver and high voltage power supply. Input 115v 60 cy AC.

**2 MEGAWATT PULSER**

Output 30 kv at 70 amp. Duty cycle .001. Rep rates: 1 microsec 800 pps, 1 or 2 msec 300 pps. Uses 5948 hydrogen thyatron. Input 120/208 VAC 60 cycle. Mfr. GE. Complete with high voltage power supply.

**15KW PULSER—DRIVER**

Biased multivibrator type pulse gen. using 3E29. Output 3kv at 5 amp. Pulse lengths .5 to 5 microsec. easily adj. to .1 to 5 msec. Input 115v 60 cy AC. Full desc. Vol. 5, MIT Rad. Lab. series, pg. 140.

**MIT MODEL 3 PULSER**

Output: 144 kw (12 kv at 12 amp.) Duty ratio: .001 max. Pulse duration: .5, 1 and 2 microsec. Input: 115 v 400 to 2000 cps and 24 vdc. \$325 ea. Full desc. Vol. 5, MIT Rad. Lab. series, pg. 140.

**250KW HARD TUBE PULSER**

Output 16 kv 16 amp. duty cycle .002. Pulses can be coded. Uses 5D21, 715C or 4PR60A. Input 115 v 60 cycle ac. \$1200 ea.

**5949 THYRATRON AGING RACK**

Compl. Chatham Electronics Console incl. 15 kv power supply & PFN's. \$1800.

**H.V. POWER SUPPLIES**

1) 12 kv 75 amps nominal \$1400 ea. 2) 22 kv 100 ma nominal \$2200 ea. Std. 60 cycle inputs.

**MICROWAVE SYSTEMS**

**E-4 FIRE CONTROL SYSTEM**

Hughes Aircraft X Band. Complete. In stock.

**C-BAND RADAR**

250 KW output, C-band, PPI indicator, 5C22 thyatron modulator. Antenna hi gain parabolic section. Input 115 volts 60 cycle AC, complete \$2750.00.

**300 TO 2400MC RF PKG.**

300 to 2400 MC CW. Tuneable. Transmitter 10 to 30 Watts. Output. As new \$475.

**500KW "L" BAND RADAR**

500 kw 1220-1359 mcs. 160 nautical mile search range P.P.I. and A Scopes. MTI. thyatron mod. 5J29 magnetron. Complete system.

**10 CM. WEATHER RADAR SYSTEM**

Raytheon, 275 KW output S Band. Rotating yoke P.P.I. Weather Band. 4, 20 and 80 mile range. 360 degree azimuth scan. Price \$975 complete.

**10KW 3 CM. X BAND RADAR**

Complete RF head including transmitter, receiver, modulator. Uses 2I42 magnetron. Fully described in MIT Rad. Lab. Series Vol. 1, pps. 616-625 and Vol. II, pps. 171-185. \$375. Complete System \$750.

**50KW 3 CM RADAR**

Airborne radar. 50 kw output using 725A magnetron. Model 3 pulser. 30-in. parabola stabilized antenna. PPI scope. Complete system. \$1200 each. New.

**100KW 3CM. RADAR**

Complete 100 kw output airborne system with AMTI. 5C22 thyr. mod. 4J52 magnetron, PPI. 360 deg az sweep, 60 deg. elev. sweep, gyro stabilizer, hi-gain rctv. Complete with all plugs and cables.

**M-33 AUTO-TRACK RADAR SYSTEM**

X band with plotting board, automatic range tracking, etc. Complete with 1 megawatt acq. radar.

**400 CYCLE SOURCE**

Output: 115v 400 cycle 1 ph 21.7 amps cont. duty input: 208v 60 cycle 3 ph. req. 30v dc static exc. New. \$325 ea.

**3KW RCA PHONE & TELEG XMTR**

2-30 MC. 10 Autotone channels plus MO. Input 220 vac. 50/60 cycles.



CIRCLE 950 ON READER SERVICE CARD

Additional Searchlight con't on following page

**PERT (Program Evaluation and Review Technique) Provides Blueprint Visibility to Space Managers during the Production Planning Phases.**



*space architects*



**A Motorola RF Receiver Subsystem for DSIF will Provide Communication Links Between Earth and Vehicles on Future Interplanetary Flights.**

PERT charts provide the foundation and framework for the development by scientists and engineers at the Western Center of Motorola's Military Electronics Division of history-making space communications systems. Examples: Mariner and Ranger 7.

Motorola, a part of NASA's space-conquering team, is now at work on the RF Subsystem that will be the heart of the DSIF system. Other state-of-the-art projects now on the drawing board or in the blueprint stage of development include communication equipments for the Apollo and future flights to Mars and Venus. Write today to learn how you can join our Motorola staff of space architects. Specific opportunities are:

- Antennas & Propagation
- Solid State R.F.
- Microwave Techniques
- Missile & Space Instrumentation
- Operational Support Equipment
- Integrated Circuitry
- Reliability Analysis
- Parts Reliability
- Reliability Program Coordination
- Data Acquisition, Processing & Display
- CW Transponders
- Radar and Radar Transponders
- Guidance & Navigation
- Command & Control
- Space Communications
- Signal Processing
- ECM, CCM & Surveillance
- Tracking & Telemetry

Contact Phil Nienstedt, Manager of Recruitment, Department 6510



Military Electronics Division • Western Center • P.O. Box 1417, Scottsdale, Arizona  
MOTOROLA ALSO OFFERS OPPORTUNITIES AT CHICAGO, ILLINOIS — AN EQUAL OPPORTUNITY EMPLOYER

# SEARCHLIGHT SECTION

(Classified Advertising)

BUSINESS OPPORTUNITIES

EQUIPMENT - USED or RESALE

DISPLAYED

RATES

UNDISPLAYED

The advertising is \$27.25 per inch for all advertising other than on a contract basis. AN ADVERTISING INCH is measured 7/8" vert. on a column, 3 cols.—30 inches—to a page. EQUIPMENT WANTED or FOR SALE ADVERTISEMENTS acceptable only in Displayed Style.

\$2.70 a line, minimum 3 lines. To figure advance payment count 5 average words as a line.

BOX NUMBERS count as one line additional.

DISCOUNT of 10% if full payment is made in advance for four consecutive insertions.

Send NEW ADVERTISEMENTS or Inquiries to Classified Adv. Div. of Electronics, P. O. Box 12, N. Y. N. Y. 10036

## INDUSTRIAL ELECTRON TUBES

0A2	.75	4CX300A	35.00	12AU7WA	1.35	807W	2.50	5777	100.00
0A2WA	1.50	4D32	12.50	12AX7W	1.15	809	3.00	5778	100.00
0A3	.85	4E27	10.00	12AY7	1.10	810	18.85	5787	1.25
0B2	.65	4J50	90.00	12SA7GT	1.00	811	2.25	5800	6.00
0B2WA	1.25	4J52	50.00	12SK7Y	1.00	811A	4.50	5803	4.00
0B3	.90	4J63	100.00	12SY7	1.00	812A	4.50	5814WA	1.25
0C3	.70	4PR60A	50.00	X-13	175.00	813	12.50	5825	12.50
0D3	.50	4X150A	11.75	C16J	30.00	814	4.00	5829WA	1.35
C1A	7.50	4X250B	22.50	HK-24	4.00	815	4.00	5836	40.00
1AD4	2.00	5ABP1	20.00	25T	8.50	816	2.50	5837	40.00
1AE4	1.25	5BP1A	15.00	26A7GT	3.50	826	15.00	5840	1.50
1B24A	10.00	5C22	17.50	2675W	1.25	828	17.50	5841	3.50
1B35A	2.50	5CP1	5.00	28D7W	3.50	829B	10.00	5845	3.50
1B63A	10.00	5CP1A	10.00	35T	10.00	832A	7.50	5876	6.75
1D21/SN4	6.00	5J26	50.00	83	1.25	833A	30.00	5879	1.25
C1K	6.00	5LP1	12.50	KU-99	16.50	837	3.50	5886	4.00
1P21	30.00	5R4GY	1.35	101D	1.00	838	7.50	5899	1.50
1P28	16.50	5R4WGB	5.00	101F	2.25	847	50.00	5906	3.00
1Z2	3.50	5R4WGY	2.50	101L	2.25	845	75.00	5915	1.95
2-01C	10.00	5RP1A	30.00	FG-105	25.00	849	5.00	5927	15.00
2AP1A	8.50	5Y3WGT	1.35	242C	15.00	851	2.00	5948 1754	50.00
2AS15A	6.00	6AC7W	7.50	249B	10.00	866A	1.35	5949 1907	75.00
2BP1	10.00	6AG1WA	1.50	249C	8.85	872A	5.00	5963	.75
2C39A	8.50	6AG7Y	1.25	25CR	15.00	884	2.00	5965	.60
2C40	10.00	6AH6WA	3.00	250TH	3.00	902A	1.75	5987	6.00
2C43	10.00	6AJ5	1.00	251A	28.50	902A	2.00	5993	4.00
2C51	1.00	6AK5W	1.00	259A	35.00	913	5.00	6012	4.00
2C53	8.00	6AK5WB	2.50	V-262	2.50	920	2.00	6080	4.00
2D21	.75	6AL5W	.60	262B	200.00	923	1.75	6080WA	2.85
2D21W	1.00	6AM6	1.55	FP-265	3.50	927	2.00	6080WB	10.00
2E24	3.50	6AN5	1.50	271A	15.00	931A	5.00	6082	4.00
2E26	3.00	6AQ5W	1.00	274A	2.50	R-1130B	12.00	6080	4.00
2J42	60.00	6AR6	.75	275A	5.00	1603	3.75	6080WA	10.00
2J51	50.00	6AS6W	1.25	276A	7.50	1612 6L7	3.50	6080WB	10.00
2J55	70.00	6AS7G	2.00	279A	175.00	1613 6F6	1.25	6082	3.35
2K22	25.00	6AU6WA	1.00	287A	2.50	1614 6L6	2.00	6115A	50.00
2K25	12.50	6AU6WB	1.75	300P	4.50	1619	2.00	6120 3C45	6.50
2K26	25.00	6BA4	4.50	304TH	35.00	1670 6J7	3.50	6146	3.00
2K28	20.00	6BA6W	.85	304TL	35.00	1674	1.00	6146A	3.75
2K29	25.00	6BE6W	1.25	310A	3.50	1675	.75	6146B 8798A	4.25
2K33A	200.00	6BF7E	1.75	311P	5.00	1655 6SC7	.85	6146W 7212	4.75
2K41	20.00	6BP6W	2.75	311A	5.00	20F0	1.35	6159	3.50
2K44	150.00	6B16	20.00	328A	5.00	ZP-2200	200.00	6161	50.00
2P21	25.00	6BM6A	25.00	348A	3.50	5545	20.00	6197 6CL6	1.25
2X2A	1.35	6CA4WA	.85	349A	3.50	5550/415	35.00	6226	2.25
3B4	1.50	6C21	35.00	35CR	3.50	5557 FG-17	4.50	6276	95.00
3B24 (WE)	1.00	6D4	1.00	35TA	10.00	5559 FG-57	7.50	6752	16.50
3B24W	3.50	6D18	1.85	35TA	7.50	5560 FG-95	16.50	6793	4.50
3B25	3.00	6F4	3.50	371R	2.50	5609A	2.50	6799	37.50
3B28	3.00	6GJ	7.50	401B	3.00	5647	2.00	6716	50.00
3C22	30.00	6J4	2.00	404A	5.00	5647	3.00	6736	6.50
3C23	4.00	6J4WA	2.50	407A	3.75	5611	.85	6736A	9.75
3C24	4.00	6J6W	.85	408A	2.25	5654 6AK5W/	1.50	6786	6.00
3C45	6.50	6C61	7.50	411P	17.50	6096	1.50	6390	80.00
3CY1CCAS	12.50	6L4	2.50	417A	6.00	5667 889PA	150.00	6442	17.50
3D21WA	10.00	6L6GAY	1.15	420A	3.00	5670	1.00	6578	9.00
3D22	7.50	6L6VGB	2.25	G1-604A	25.00	5677	1.10	6550	3.50
3DPIA	5.00	6Q1C	3.50	450TP	47.50	5675	1.50	6678 6UBA	1.35
3E29	10.00	6S47Y	1.50	450TL	50.00	5678	1.50	6700	30.00
3GP1	3.50	6S47Y	.85	VA-11E	350.00	5686	1.75	6807	20.00
C3J/A	10.00	6SK7Y	.85	QK-5-1	45.00	5687	1.00	6879	8.35
3J21	125.00	6SL7WGT	1.25	QK-5-2	45.00	5687WA	2.00	6879	8.35
3KP1	9.75	6SN7W	.65	QK-5-49	45.00	5691	4.50	6883	3.00
3RP1	8.50	6SN7WGT	1.15	575A	15.00	5692	3.00	6893	3.25
3WP1	15.00	6SU7GTY	1.00	675	15.00	5693	3.00	6929	18.85
4-65A	10.00	6V6GTY	1.00	677	4.00	5696	1.00	7077	1.30
4-125A	25.00	6V6Y	2.25	711B	4.50	5702WA	2.50	7167	1.30
4-250A	27.50	6X4W	.70	715C	25.00	5703WA	2.50	7586	2.35
4-400A	38.00	6X5WGT	.85	719A	15.00	5704	1.50	7895	2.35
4-1000A	75.00	6Y6	.75	721B	5.00	5718A	.75	8007R	25.00
4B 31	15.00	7MP7	25.00	725A	25.00	5719	6.5	8008	6.00
4C 35	17.50	10KP7	25.00	BL-800	25.00	5721	70.00	8013A	5.00
4C 35A	22.50	10UP14A	35.00	803	6.50	5751	1.15	8121	17.50
4C X250B	25.00	10WP7	25.00	804	10.00	5762/7C24	150.00	9003	2.00
4C X250K	50.00	12A77WA	1.15	805	10.00	5763	1.75	9095	3.50

4C ALL TUBES ARE UNUSED, INDIVIDUALLY CARTONED, FULLY GUARANTEED

TELEX or TWX:  
916-581-3061  
Telephone:  
916-685-9582

### western engineers

ELK GROVE, CALIFORNIA  
SUPPLIERS OF ELECTRONIC DEVICES SINCE 1932

Orders for  
less than  
\$25 cannot  
be processed

CIRCLE 954 ON READER SERVICE CARD

BALLANTINE Electronic Voltmeter, Model 311	125.00
TEKTRONIX Time-Mark Gen., Model 180 A	275.00
WAYNE KERR LAB. V.H.F. Admittance Bridge, Type B 801	250.00
ELECTRONIC RESEARCH Dual Transistor Supply Model 510 M	59.95
TEKTRONIX SCOPE Type 515	450.00
ELECTRO-PULSE, INC. Pulse Generator, Model 2125 B	125.00
POLYTECHNIC RESEARCH Wave Detector, Model 219, 100 to 1000 MC	150.00
POLARAD Receiver Microwave, Model R, with Model RKS Tuning Unit, 9500 to 15000 MC	2000.00
H.P. POWER SUPPLY Type 712 B	195.00
H.P. SIGNAL GENERATOR Type 626 A	1250.00
POLYTECHNIC FREQUENCY METER 587 A	125.00
TEKTRONIX SCOPE Model 541 with dual trace pre-amp	850.00
JOHN FLUKE POWER SUPPLY Model 406	125.00
HEWLETT PACKARD Model 340 A, Noise Figure Meter	295.00
POLYTECHNIC RESEARCH Model 904, Noise Generator	195.00
GENERAL RADIO Type 1151 A, Decade Voltage Divider	75.00

See previous issues for more equipment. Send for Flyers.  
All material in excellent condition. All prices F.O.B. San Francisco, Cal., subject to prior sale. Send for Listing and Flyers.

### Marty's Mart

1236 Market St., San Francisco 3, California  
Phone: Underhill 3-1215

CIRCLE 951 ON READER SERVICE CARD

OVER 2,000,000

## RELAYS

IN STOCK!

Send for Catalog 55  
**Universal RELAY CORP.**

42 WHITE ST., N.Y. 13, N.Y. • WALKER 5-6900

CIRCLE 952 ON READER SERVICE CARD

SURPLUS

3 PHASE 400 CYCLE GENERATORS  
AND MOTOR GENERATORS FROM  
1 1/2 to 50KW.

Write for full details  
Principals Only

P. O. Box 387, Sayville, L. I., N. Y.

CIRCLE 953 ON READER SERVICE CARD

## PROFESSIONAL SERVICES

GIBBS & HILL, Inc.  
Consulting Engineers

Systems Engineering  
Operations Research • Development  
Field Studies • Design • Procurement  
Power • Transportation • Communications  
Water Supply • Waste Treatment

393 Seventh Avenue New York 1, N. Y.

## New Literature

**Microminiature connectors.** Continental Connector Corp., 34-63 56th St., Woodside 77, N.Y., has available an 8-page catalog on series MM-22 microminiature rack and panel electronic connectors. Circle 451 on reader service card

**Iron core components.** United Transformer Corp., 150 Varick St., New York City 10013. Two new 1964-1965 catalogs of iron core components have been released. Volume 1 features 52 pages of transformers, inductors and magamps. Volume 2 devotes 24 pages to electric wave filters, high-Q coils and inductors. [452]

**Taper technique.** AMP Inc., Harrisburg, Pa. Taper technique catalog No. 162 describes the special advantages of the taper wedge principle applied to the termination of electrical/electronic circuits. [453]

**Micromultimeter.** Cohu Electronics, Inc., Kin Tel Division, Box 623, San Diego, Calif. 92112. Nine industrial and laboratory applications for a micromultimeter are described with individual photographs in a 4-page bulletin. [454]

**Laser diodes and pulse generators.** Maser Optics, Inc., 89 Brighton Ave., Boston 34, Mass., offers a technical bulletin describing both its new laser diodes and its related DLP laser diode pulse generators. [455]

**R-f shielding products.** Emerson & Cuming, Inc., Canton, Mass., has issued a new comprehensive, 4-page pamphlet on its r-f shielding products. [456]

**Ferrite components** Melabs, 3300 Hillview Ave., Stanford Industrial Park, Palo Alto, Calif., has available a catalog describing ferrite components for use between 30 Mc and 72 Gc. [457]

**Laser welders.** Union Carbide Corp., Linde Division, 270 Park Ave., New York, N.Y. 10017. Information on the functioning of laser welders, together with operating and physical characteristics of the K-15W Linde welder, is presented in a 6-page brochure. [458]

**Coil winders.** Gorman Machine Corp., 480 So. Main St., Randolph, Mass. Five new coil winders are illustrated and described in a series of technical data sheets now available. [459]

**Miniature trimmer.** Helipot Division of Beckman Instruments, Inc., 2500 Harbor Blvd., Fullerton, Calif. Data sheet 64752 deals with a 1/4 in. round trimming potentiometer with cermet resistance element. [460]

**Silicon rectifiers.** Edal Industries, Inc., 4 Short Beach Road, East Haven 12, Conn., has published bulletin 107 offering details on its full line of silicon rectifiers. [461]

**Capacitors.** Electron Products Division of Marshall Industries, 1960 Walker Ave., Monrovia, Calif. A complete line of military and high grade commercial capacitors is described in a new condensed catalog. [462]

**Silicon mixer diode.** Microwave Associates, Inc., Burlington, Mass. Four new engineering specification sheets describe in detail a series of high-reliability silicon mixer diodes. [463]

**Foam flux.** Alpha Metals, Inc., 56 Water St., Jersey City, N.J. 07304. Technical bulletin No. 25 deals with Reliafoam flux No. 807, a rapid, high rising material designed for foam fluxing of printed circuits and other electronic assemblies. [464]

**Space winders.** Geo. Stevens Mfg. Co., Inc., 6001 No. Keystone Ave., Chicago, Ill. 60646, has published a catalog on model 931-PM variable pitch and/or linear 7/8 in. space winder, and model 918-PM linear/nonlinear 3 1/2 in. space winder. [465]

**Crt recorder.** Interstate Electronics Corp., 707 E. Vermont Ave., Anaheim, Calif. A brochure describes the Videocan—a precision, high-speed crt recorder said to provide data analysis that up to now was impossible. [466]

**Pulse transformers.** Technitrol, Inc., 1952 E. Allegheny Ave., Philadelphia 34, Pa., has released a technical bulletin on a new line of temperature stabilized pulse transformers called Genie-R units. [467]

**Phase-attenuation plotter.** Alford Mfg. Co., 299 Atlantic Ave., Boston, Mass. 02110. An 8-page brochure on the type 33 automatic phase-attenuation plotter describes the equipment, theory of operation and system accuracy. [468]

**Power supplies.** Electronic Research Associates, Inc., 67 Factory Place, Cedar Grove, N.J. A 2-page catalog describes a line of silicon/hybrid high-voltage power sources. [469]

**Digital modules.** Digital Equipment Corp., 146 Main St., Maynard, Mass. 01754. An illustrated handbook describes Flip Chip modules—an innovation in circuit packaging to aid automated system construction. [470]

**Modular subsystems.** Motorola Semiconductor Products Inc., P.O. Box 955, Phoenix, Ariz. 85001. "The Modular Approach to Electronic Control" is a pictorial review of solid-state subsystem custom assembly capabilities. [471]

**Potting and encapsulating systems.** Armstrong Products Co., Inc., Warsaw, Ind. Bulletin 864 covers a series of seven epoxy-resin potting and encapsulating systems. [472]

# FIELD ENGINEERS

Interesting permanent assignments are offered to qualified electronics engineers with BSEE degrees. Experience on airborne weapons control systems is desirable.

The field assignments involve technical liaison during installation, field tests and customer overhaul programs.

Assignments are within the U.S. Prefer single men but will consider married men with few dependents.

Completion of military obligation is desirable.

U. S. CITIZENSHIP REQUIRED

For immediate consideration and to arrange for an interview please airmail resume to:

MR. PAT RAMSTACK  
Employment Manager

**HUGHES**

HUGHES AIRCRAFT COMPANY  
FIELD SERVICE & SUPPORT DIV.

P. O. BOX 90515D  
LOS ANGELES, CALIF. 90009

An equal opportunity employer.



Secretary, using key board and EI X-Y Recorder, now handles engineering laboratory plotting work as part of her typing function.

# Classic Jobs of Measurement

*Performed by  
Electro Instruments*

## Secretary and X-Y Recorder Save Bosses 1000-Hour Job!

Practically all of today's manufacturing firms insist that any study aimed at testing and evaluating products be accompanied by a final, written report. This is true whether the study be conducted by an independent testing organization or within the manufacturer's own organization. For that reason, this experience of a major testing laboratory\* will have interest for manufacturers generally.

In the laboratory involved, it was found that the report phase was occupying 60% of the time of the engineer assigned to the study. And that as much as 10% of this (125 hours per year) was given over to drawing of graphs to accompany the final document.

### EI Men See Chance To Save

Consultations with EI Sales Engineers were begun. These men came up with a feasible plan for having X-Y Recorders take over the laborious plotting job; in many instances being operated by a secretary as a part of her report typing. The lab estimates savings at over 1,000 engineering manhours—and thousands of dollars—yearly. \*(Name on request)

### THE EI VIEWPOINT

by Dr. Walter East  
President, Electro Instruments, Inc.

An associate has chided me for talking digital instruments so often. "You are leaving the impression these are all we make," he warns.



Dr. East

"We have a broader product line than anybody in our field. For heaven's sake, why not let somebody know it!" I'll oblige—with comment about our X-Y Recorders. I give them the nod for two reasons. The first is my honest conviction that ours are the most carefully designed and built X-Y Re-

orders on the market. The second is the ever increasing use being made of the simple, two dimensional (or X-Y) graph by scientists, engineers, and business in general.

No one has ever disputed the superiority of a pictorial presentation over a routine listing of figures. The trouble has been the amount of work and skill that had to be expended in the creation of the presentation.

### Automatic Plots Possible

This is the wasteful chasm our X-Y Recorders can bridge so beautifully. For almost any operator, using a keyboard, can convert numerical figures into appropriate electrical impulses, with these being passed along to the Recorder for instantaneous graphing. A major testing laboratory's experience in this area is the subject of the story appearing above. I cite it as another case in which talking over a measuring problem with an EI Sales Engineer has paid off handsome dividends.

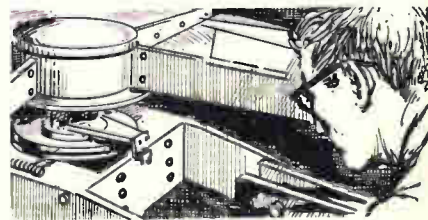

### Unique Use Of DC Amplifier Ended Centrifuge Downtime

It was practice at aerospace firm, prior to each test, to disassemble and clean centrifuge low level signal slip rings. Wear on rings introduced undesirable interference on low level signal channels. EI DC amplifiers, installed directly in centrifuge, increased signal level to point where noise was no problem. The savings in time which have been effected have more than offset the investment involved.



**Electro Instruments, Inc.**

8611 Balboa Avenue, San Diego 12, California

EI SALES, SAN DIEGO, CALIF. • ELECTRO INTERNATIONAL, INC., ANNAPOLIS, MD. • TRANSFORMER ENGINEERS, SAN GABRIEL, CALIF.



# Electronics Abroad

## Japan

### Olympic telecasts

All the advance planning paid off when the Olympic games got on the air without a hitch and with picture resolution only slightly below the norm.

There had been doubts. Syncom III, after all, was not designed for commercial-quality television transmission. But failure of the wider band Telstar and Relay satellites left Syncom III as the last chance for live relaying of the Olympics from Tokyo.

The video signal transmitted to the satellite is frequency-modulated with a peak deviation of slightly over four megacycles—the satellite's bandwidth limitation.

**Test passed.** Before opening-day, the National Broadcasting Co. received test pictures at Point Mugu, Calif., of about 2.1-megacycle resolution, which is close to the 2.5-megacycle capability claimed for the system.

The commercial video-tape recorder, in which frequency modulation is also used, is a good basis for comparison. Its maximum carrier deviation is about five megacycles, producing a black-and-white picture with resolution of about three megacycles.

Despite the technological success of live telecasts, however, NBC used videotape because the Olympic schedule would have interfered with previously scheduled commercial programs.

**Bandwidth compression.** To best use the available bandwidth of Syncom III and to reduce noise, the Japanese Broadcasting Corp. (NHK) employed various methods of bandwidth compression. The horizontal synchronizing pulses, normally negative voltages corresponding to the black region, were inverted in polarity to be on the same side as the video information

in the white region. With positive sync, the video signal has considerably less swing and the entire bandwidth is filled with usable picture information. Recovering a positive-sync pulse is beyond the capability of home receivers, so the negative sync must be restored before the program is broadcast.

Besides being a method of bandwidth compression, sync inversion reduces noise considerably. An NBC official said that when transmission was tested using the standard sync, the picture was so noisy that the question of resolution became academic.

**Noise problem.** To reduce noise further, a preemphasis circuit is used to reinforce the lower-energy higher-frequencies before transmission. Of course, a corresponding deemphasis circuit flattens the signal at the receiving point.

To limit noise even more, and to lessen the chance of over-modulation caused by the preemphasis, a

signal-shaping circuit is also used. This distributes the f-m transmission noise in the picture so that the noise is less noticeable. It does this by concentrating the noise in the regions of sharp variations in level and reducing it.

**No slow-scan.** It was feared that noise problems and the bandwidth limitations of Syncom III would force NHK to use its slow-scan process of bandwidth compression. Slow-scan is largely experimental so it was held as a last resort. Fortunately, it wasn't needed.

## Canada

### Heart monitor

An electronic monitoring system for patients undergoing heart operations is in use at the Toronto Western Hospital in Canada.

The system uses miniaturized

Heart monitor's preamplifier is connected in operating room. It strengthens body-condition signals from patient, for transmission to control console in room at rear.

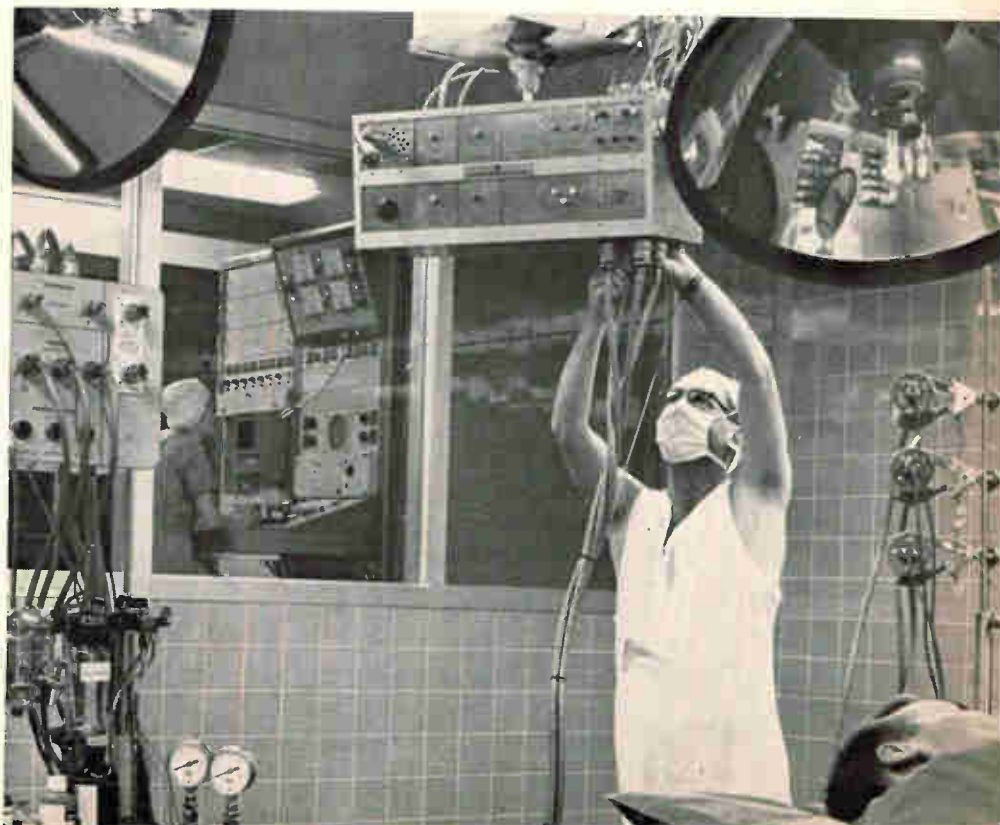

solid-state circuitry in plug-in modules, including a special circuit that allows a sterile electrode to be placed directly on the heart to determine the best location for a pacemaker. A pacemaker is a device for stimulating the heart with current pulses or reestablishing the rhythm of a heart whose beat is irregular.

The system is used during and after heart surgery. It continuously measures heart rate, brain waves and blood pressure in arteries and veins. The information is displayed to the surgical team either as numbers or as waveforms on a large cathode-ray oscilloscope mounted close to the ceiling of the operating room.

**Fewer people needed.** The system was made by the Canadian General Electric Co., a division of the General Electric Co. E. J. Holloway, the company's specialist in medical electronics, says the system's main advantages are speed and accuracy. "It will also reduce the number of people required in the operating room," he says. For example, no electronics technicians are needed at the operation. Solid-state circuitry is thoroughly tested and aged, he continues, to assure long-term stability.

Electrocardiograph readings, pressure waveforms and other variables are displayed in analog form on the scope. A continuous photographic galvanometer keeps a permanent record of all body functions. The operating console is kept in a control room next to the operating room.

---

### South Africa

---

#### Instant anesthesia

An electronic anesthetizer, said to have practically no undesirable side-effects, has been developed by a Johannesburg doctor and an electronics researcher.

The device has already been used on animals and on five human volunteers.

Here's how it works. Electrodes are placed on both sides of the

patient's head, and a tiny current—about 15 to 20 milliamperes—is sent through the brain at 1,500 cycles a second. The level of anesthesia can be changed by altering the current.

Anesthesia is said to be instantaneous, and is not followed by nausea, as with chemical anesthesia.

Veterinarians have been using prototypes for about three months. Wide use among humans requires approval by medical authorities.

---

### Great Britain

---

#### Tape-recorded checkout

Now they're putting aircraft-system checkout procedures on magnetic tape.

Smiths Aviation, Ltd., has developed a tester that uses tapes and a multitrack portable player. The tape player is controlled by a handheld remote controller with three buttons labeled "yes," "no" and "repeat." The controller also contains a set of cards describing possible faults and instructions for finding the cause and cure.

The tape contains step-by-step instructions for testing each system.

**Step by step.** The operator loads the tape cartridge and presses the start button. He then hears instructions for activating the system being tested. Next, the voice on tape gives him his first set of test instructions. Then the tape player stops.

After the test is performed, the operator decides whether it was satisfactory; if so, he presses the "yes" button. This advances the tape for the next instructions.

If the system fails and the "no" button is pressed, the tape describes a fault-tracing procedure that leads the operator, by yes-or-no steps, to one of a series of fault-tracing cards. If the fault persists, the tape then refers the operator to the wiring diagram of the fault area, printed on the reverse side of the card.

**More sophistication.** Compared

with the Smiths approach, a system now being delivered to the Swedish Air Force by Elliott-Automation, Ltd., is highly sophisticated. Designed for automatic checkout of electrical and electronic systems, it uses punched paper tapes to control a checkout program of 50,000 test instructions.

In addition to providing a record of the test results, it prepares a punched tape for subsequent computer analysis. This determines the rate of system deterioration, the minimum number of spare parts required, and other information. When a fault occurs, its nature is printed out as well as the storage-reference number of the part to be replaced.

---

### Italy

---

#### Engineers for export

Italy, for many years an exporter of unskilled labor, may soon be sending its electronics engineers abroad too.

Until this year, competition for new graduates ranged from keen to cutthroat. Giuseppe Calogero, personnel director of Ing. C. Olivetti & Co.'s electronics division, says: "We used to arrange 10 appointments with new graduates every day because we knew only two would turn up. Now there seem to be a dozen candidates for every position."

Unemployment among electronics engineers is estimated at 500. The sudden surplus is considered more political than economic. It's true that makers of radios, television sets and office equipment have put off expanding their engineering staffs during Italy's present recession. But other firms, such as producers of components and instruments, are hiring as usual.

**Research frozen.** Emilio Gatti, professor of nuclear electronics at Milan's Polytechnic Institute, blames the government's reorganization of its scientific program. He cites particularly the National Nuclear Energy Commission, which has frozen all its research activi-

ties pending an investigation of an alleged misappropriation of funds. The agency formerly hired several engineering graduates a year.

Gatti also notes that Italian universities only adopted electronics as an official curriculum four years ago, and that many of the better graduates are kept on the schools' teaching and research staffs. This year the academic need leveled off, sending more graduates out into the job market.

Gatti says recent foreign affiliations, such as the General Electric Co.'s acquisition of Olivetti's electronics division, will mean more jobs for Italian engineers. Foreign companies used to send their own engineers to Italian affiliates; now qualified Italian engineers are available.

The duration of the present surplus depends largely on how quickly, and to what extent, the government resumes its scientific programs.

## Portugal

### Into the lion's den

The Japanese have a phrase for it: "minohodo shirazu," meaning roughly "to bite off more than you can chew."

The term is heard frequently when Tokyo electronics people discuss a Portuguese company that is trying to compete in Malaysia, a market now considered to be safely within the Japanese orbit.

Standard Electrica S.A.R.L., of Lisbon, has delivered its first shipment of television receivers to the Cycle and Carriage Co. of Singapore, which plans to sell wholesale in that city, Penang and in Kuala Lumpur, capital of Malaysia. But there are serious doubts whether any Western company can compete with the Japanese so close to Japan.

**Compact design.** Standard Electrica, a subsidiary of the International Telephone and Telegraph Corp., says the sets are of high quality and compactly designed for small homes in the Orient. Antonio

de Carvalho Fernandes, the general manager, declined to tell the price or how many sets were shipped. Friends in the industry suspect that his reticence indicates that the shipment was a small one. Nineteen-inch sets are selling for about \$200 in Singapore, which has Malaysia's only commercial tv transmitter.

## West Germany

### Meteor at sea

Even from a distance it is apparent that West Germany's recently launched Meteor is a ship full of electronics.

Designed and constructed at a Bremerhaven shipyard, the 370-foot, 2,615-ton diesel-powered vessel sailed on her maiden voyage early this month. The six-month research trip will carry 50 German oceanographers from 13 institutes through the Red Sea and along the coast of East Africa to the Arabian Gulf.

A towering array of antennas above the bridge includes installations for direction-finding, Decca navigators, radar and loran. Below the bridge, the variety of equipment is even more extensive. The ship was designed for the convenience of 24 scientists working aboard, and it has a permanent crew of 55.

**Controlled aquariums.** For their research activities, scientists have the use of climate-controlled aquariums, pressure chambers, dark-rooms, laboratories, and a wide range of automatic and electronic test, measuring and recording units. These include underwater cameras, underwater closed-circuit television, sediment echographs, curve-evaluation units with card-punch and magnetic tape recorders, units to measure current and wind speeds, thermographs and echo sounders.

Radio technicians and mechanics are among the crew; they can repair practically any piece of equipment that may go out of order while at sea.



One of the more important tasks assigned to the Meteor is the continuous monitoring of the sea's radioactivity.

### Head East, look West

A West Germany company is showing its color-television system all over the Soviet bloc, but industry observers suspect that Telefunken A.G. is making this effort in the East with one marketing eye still cocked toward Western Europe.

Walter Bruch, Telefunken's research chief, recently completed demonstrations of the phase-alternation line (PAL) in Sofia, Bulgaria, and took off for Moscow on the second leg of his Eastern journey.

Telefunken's is one of three systems being considered for adoption as standard in Western Europe. The others are Secam, championed by la Compagnie Francaise de Television of France, and the American system approved by the National Television System Committee (NTSC).

**High stake.** The prize in the West will be large—about \$50 million in royalties by 1975, according to one source. Adoption in the East, with the prospect of an all-European setup on both sides of the Iron Curtain, might enhance

PAL's chances in the West.

Telefunken calls PAL an improvement on the NTSC system, and offers a converter for transferring between the two approaches. But PAL has been criticized for a "ghost"-like distortion.

PAL transmits color information with four signals, two to a line [Electronics, Aug. 2, 1963, p. 22]. Telefunken says the system is insensitive to band limitation such as single-sideband distortion. Color reproduction is said to be faultless, making it unnecessary to adjust a receiver when changing color channels.

### Component show

A show of electronic components, inspired by United States companies and opposed by major German concerns, gives every indication that its Oct. 21-29 run in Munich will be a big success.

An official of the fair says 408 exhibitors from 14 countries are signed up, including 189 companies from America. Germany will have 106 exhibitors, Britain 42, France 19 and Switzerland 15.

Judging from previews, no startling developments are likely at the fair, called "Electronica."

**A 'first'.** Heinz Seifert, an organizer of the fair, says he is getting 30 to 40 requests a day for tickets and fair catalogs.

Electronica, the first show of its kind in Germany, was an issue for a long time between American and German companies. A U.S. trade group, the International Electronics Association, pushed for the show. It was opposed by the powerful Association of German Electrotechnical Industries on the ground that existing fairs meet the needs of Europe's electronics companies.

Leo Steipe, director of the Munich subsidiary of the Amphenol-Borg Electronics Corp., contends that none of the present fairs serves the component industry.

**Too diversified.** The Salon des Composants Electroniques in Paris, he says, covers France but only 20% of the German market. Interkama at Dusseldorf shows no elec-

tronic components. The Hanover Fair, Germany's biggest, is "superlative for the all-round purchasing agent," Steipe declares, "but too big and too diversified to meet the requirements of the electronics specialist."

Space limitations at Hanover have kept foreign companies at arm's length from the lush German electronics market.

**Trailing in transistors.** German companies are generally believed to have caught up with international technical developments in ferrites, ceramics and condensers, but to trail slightly in transistors, connectors and system packaging.

As Electronica draws nearer, both the American and German groups are careful not to pour oil on the fire. Their comments have become moderate and conciliatory.

Germany's four biggest electronics companies are boycotting Electronica. But one positive result already has appeared: The German association has set up a subgroup on electronics.

### And then there was one

The big shakeout continues among Europe's computer manufacturers.

This time Zuse K.G., a 28-year-old West German company with 950 employees, was swallowed up by Brown-Boveri & Cie, Switzerland's largest maker of electrical and mechanical equipment. That leaves Telefunken A.G. the only major German computer company that's independent of foreign control.

In West Germany, Zuse's process-control computers outsell even those made by the International Business Machines Corp. Its \$5-million sales last year put Zuse third in Germany, behind Siemens & Halske A.G. and Telefunken A.G., in the computer industry.

But Zuse isn't the first European electronics company to find that it couldn't afford the high cost of competition. In July the French Compagnie des Machines Bull sold a big piece of its business to the General Electric Co. GE also acquired the data-processing operations of Ing. C. Olivetti & Co. in

Italy in August. Last month the Radio Corp. of America confirmed plans for a joint venture with Siemens & Halske [Electronics, Sept. 21, p. 100].

Brown-Boveri estimates its own assets at \$26 million.

---

## Sweden

---

### Uncle Sam: scene stealer

United States electronics technology stole the show at the Stockholm Technical Fair that ended Oct. 8.

The U.S. exhibit, largest at the fair, was devoted entirely to electronics. This was a result of a U.S. Commerce Department market survey that extolled the Swedish market as one of the best for sophisticated equipment and components.

The survey showed that the Swedish electronics market has been growing 25% a year. It is expected to climb to \$468 million by 1966, almost double the \$239 million of last year.

Swedish industry supplies less than one-half of the country's electronics needs. The U.S. supplies 25% of Sweden's components.

**Biggest ever.** Forty-four U.S. companies exhibited, the biggest electronics showing ever arranged by the Commerce Department.

Two West Coast companies, showing their wares abroad for the first time, received particular attention from fairgoers. The Signetics Corp., a subsidiary of the Corning Glass Works, exhibited integrated circuits. And Astrodata, Inc., showed time-code generators, translators and tape-search gear.

In its government procurement, Sweden shows no distinction between domestic and foreign companies.

Many U.S. exhibitors obviously aimed at the military market, which includes Europe's fourth-largest air force. Triton Electronics, Inc., was reported to be having a brisk sale of magnetic tape for recorders and computers. This was the first fair at which American commercial exhibitors followed up with a sales effort.

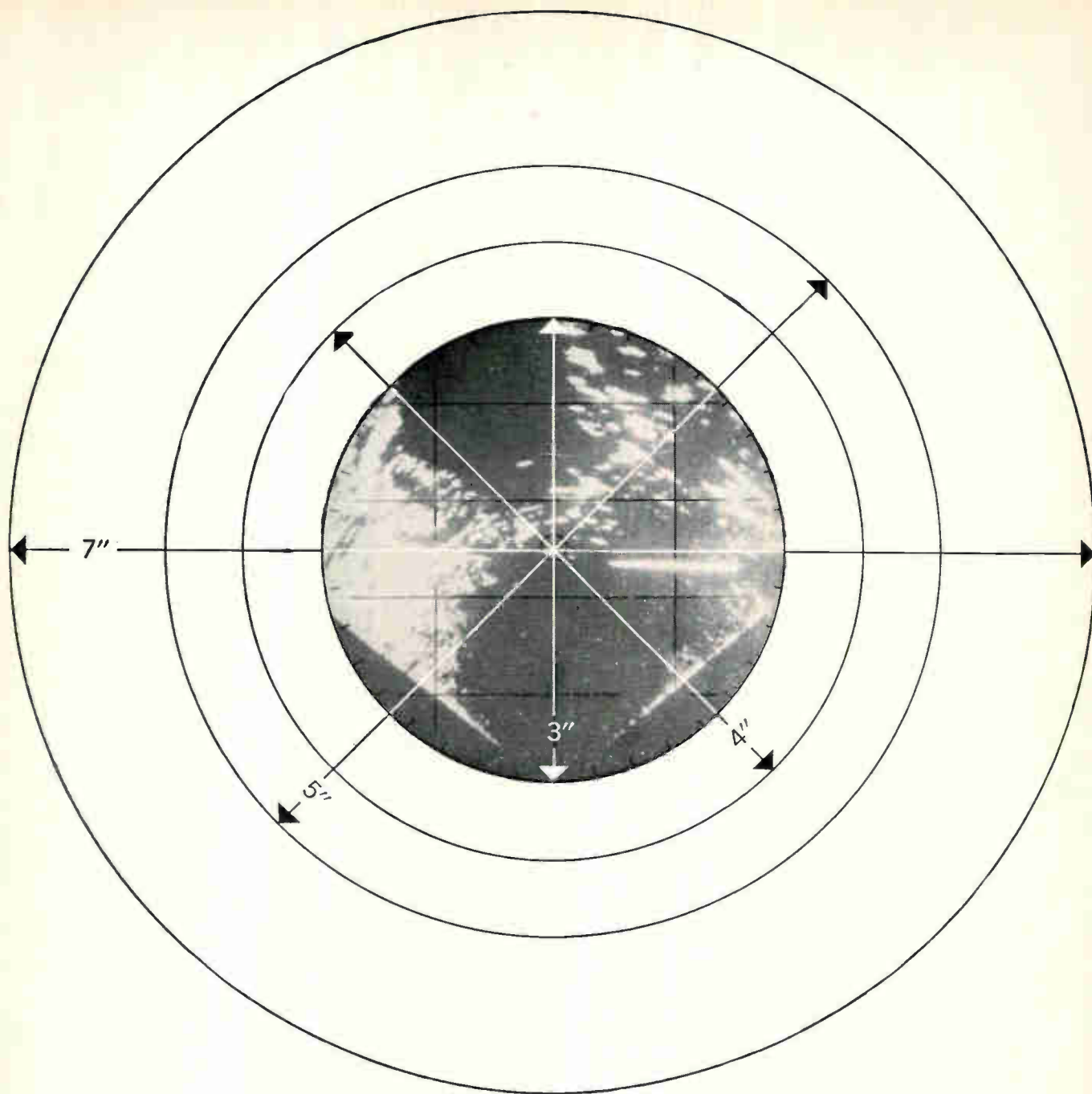

**Now there's a whole family of  
high-contrast storage tubes that take 85 volts  
instead of 10,000 to remove background brightness**

Now you can get a dark background *without* switching the phosphor high voltage—thanks to a patented new Westinghouse design. This reduces weight, volume and demand on the power-pulse source from a 10,000-volt pulse to 85 volts.

These new storage tubes bring "TV contrast" to radar display by combining extremely high contrast with the ability to reproduce as many as seven half tones (shades of gray).

And if it's rugged, long-life reliability you're looking for, look no further! Westinghouse display storage tubes withstand up to 10 G's vibration and 30 G's of

shock—2,500 operating hours, and  $-65^{\circ}\text{C}$  to  $150^{\circ}\text{C}$ . At 120 lines per inch, their resolution leads the industry.

Diameters of 3", 4", 5" and 7" can be made with writing speeds to 1,000,000 inches per second, brightness to 3,000 foot Lamberts and storage times to 60 seconds. For complete data, write Westinghouse Electronic Tube Division, Elmira, N. Y. Or Westinghouse International Corp., 200 Park Avenue, New York, New York.

You can be sure if it's Westinghouse



ET-4105

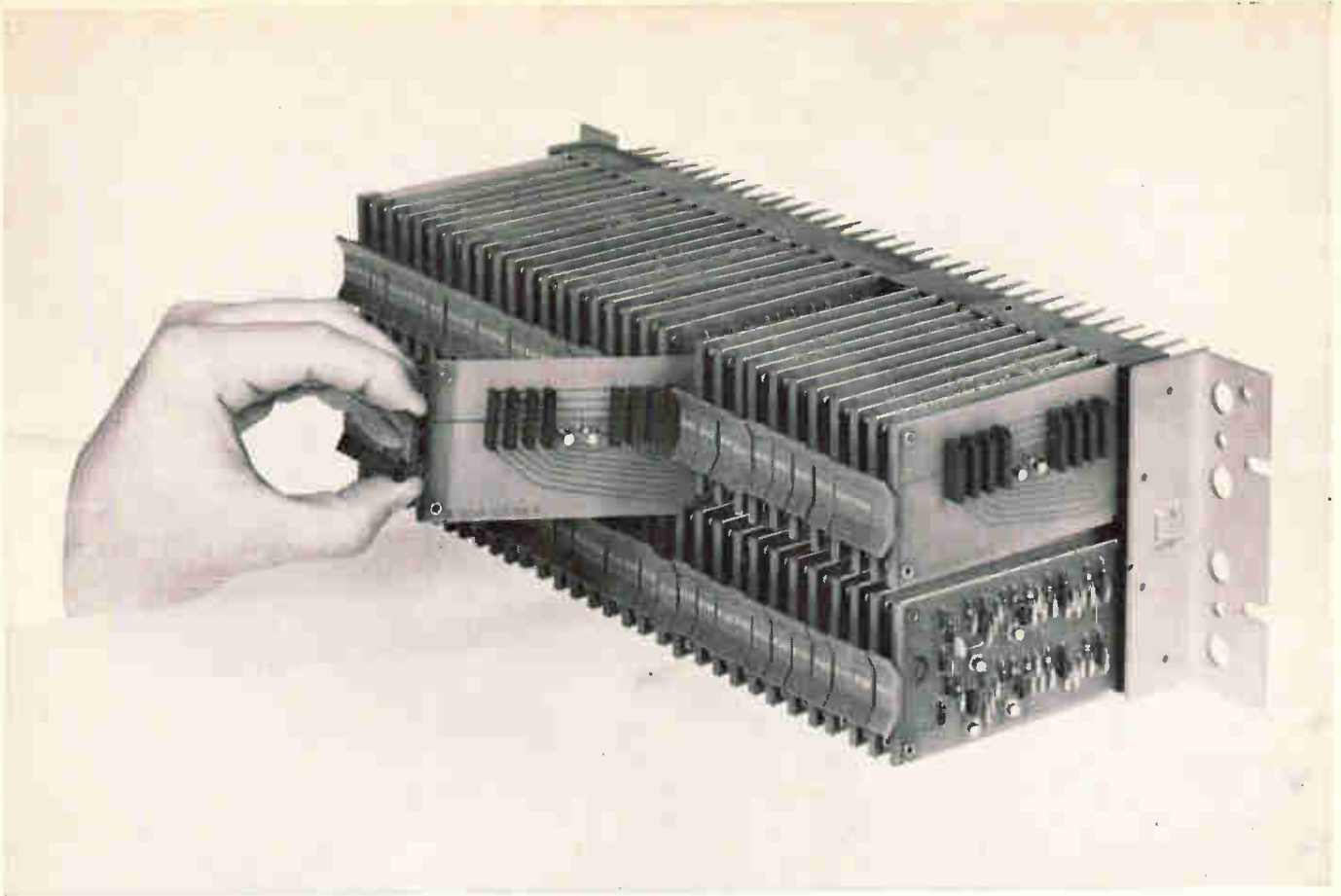

## DIGITAL FLIP CHIP™ MODULES

Digital's proven-performance circuits are now available in a family of compact FLIP CHIP MODULES specifically designed for mass production to minimize systems construction costs.

This unique new product line features:

- Film circuits and discrete components combined for optimum performance and reliability
- Completely assembled, fully tested packages ready to plug in
- Simplified loading rules suitable for computer-aided design applications
- Mounting panels precision engineered for automatic wiring procedures

Four series of FLIP CHIP MODULES offer the designer a wide choice of most needed circuits, including basic 0-2 megacycle DTL silicon logic circuits, basic 0-10 megacycle silicon logic circuits, and silicon analog-digital modules.

For complete technical specifications and applications data, contact your nearest Digital sales office.

FLIP CHIP is a trademark of Digital Equipment Corporation

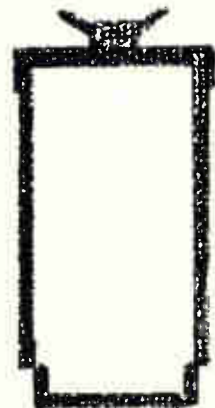

**digital**

**EQUIPMENT  
CORPORATION**

MAYNARD, MASSACHUSETTS

Washington, D.C. • Parsippany, N.J.  
Los Angeles • Palo Alto • Chicago  
Ann Arbor • Pittsburgh • Huntsville  
• Orlando • Carleton Place,  
Ont. • Reading, England • Munich,  
W. Germany • Sydney, Australia

# Electronics advertisers

October 19, 1964



■ AMP Inc. Garceau, Hargrave & McCullough Inc.	16	Fairchild Semiconductor Johnson & Lewis Inc.	14	Radio Engineering Laboratories, Div. of Dynamics Corp. of America Arthur Falconer Associates Corp.	7
■ Acme Electric Corp. Scheel Adv. Agency	101	■ Garlock Electronic Products Inc. Atlantic Industrial Adv.	117	Relaymatic Inc. Conti Advertising Agency Inc.	121
Acromag Incorporated Tri-Art Associates	124	■ General Electric Company, Miniature Lamp Division Batten, Barton, Durstine & Osborn Inc.	127	Research-Cottrell Inc. Michel Cather, Inc.	131
Adage Inc. Fuller & Smith & Ross Inc.	110	■ General Electric Company, Rectifier Components Div. Ross Roy Inc. Advertising	46	■ Rosemount Engineering Co. Midland Associates, Inc.	142
Aeroflex Laboratories Groody Advertising Agency Inc.	140	Granville-Phillips Company Tool & Armstrong Advertising	120	■ Semi-Elements, Inc. Axelbrand & Brown Associates	138
Air Express Div. of REA Express Ketchum, MacLeod & Grove Inc.	19	Gries Reproducer Corp. Harold Marshall Adv. Co.	143	Silicon Transistor Corp. A.D. Adams Adv. Inc.	24
Airpot Corporation Lauf Piliro Graphics Inc.	145	Hamilton Standard, Div. of United Aircraft Corporation Cunningham & Walsh Inc.	44	■ Sorensen & Co. Div. of Raytheon Co. Fuller & Smith & Ross Inc.	133
American Electronic Laboratories Inc. Benn Associates	145	■ Heath Company Advance Advertising Service Inc.	130	Space Craft Inc. Preiss and Brown Adv. Inc.	122
Amperite Company H.J. Gold Co.	141	Heinemann Electric Company Thomas R. Sundheim Inc.	137	Specific Products Stoneham Advertising	126
Astrodata Inc. Bonfield Associates, Inc.	11	■ Hewlett-Packard Company L.C. Cole Company Inc.	1	Speer Carbon Company Hazard Advertising Company Inc.	108
Atlanta Chamber of Commerce Tucker Wayne & Company	146	■ Hughes Aircraft Company Foote, Cone & Belding	149	Sprague Electric Co. The Harry P. Bridge Company	5, 6, 10
Barber-Colman Company Howard H. Monk & Associates Inc.	128	Ichizuka Optical Co. Ltd. Matsushita Inc.	158	State of California Gerth, Brown, Clark & Elkus of Sacramento Inc.	142
Bendix Semiconductor Products MacManus, John & Adams Inc.	9	■ Imtra Corporation S. Gunnar Myrbeck & Company	138	Struthers-Dunn, Inc. The Harry P. Bridge Co.	106
■ Boonton Division of Hewlett Packard George Homer Martin Associates	2	■ Industrial Transformer Corp. Intellux Inc.	143	Tektronix Inc. Hugh Dwight Adv. Inc.	43
■ Bourns Inc. Allen, Dorsey & Hatfield Inc.	12, 13	■ International Rectifier Corp. Communication Associates	36	■ Telonic Industries Inc. Burton Browne Advertising	109
Bristol Co., The Chirurg & Cairns, Inc.	139	JFD Electronics Corporation Michel Cather Inc.	29	Texas Instruments Incorporated Industrial Products Group Robinson-Gerrard, Inc.	103
Bud Radio Inc. Allied Advertising Agency Inc.	20	Lamart Corporation Raymond-Nicholas Advertising	138	Texas Instruments Incorporated Metals & Controls, Div. Horton, Church & Goff, Inc.	136
■ Bulova Watch Company Carpenter, Matthews & Stewart Inc.	125	■ Lapp Insulator Co., Inc. Wolff Associates, Inc.	116	Thermal American Fused Quartz Co. Inc. Kniep Associates	140
CBS Laboratories James A. Ford Advertising Agency	33	Linde Division of Union Carbide Corp. J.M. Mathes Incorporated	130	■ Toyo Electronics Ind., Corp. Dentsu Advertising	115
■ Christie Electric Corp. Len Woolf Company	124	Ling-Temco-Vought Wyatt, Allen & Ryan Inc.	34, 35	Triplett Electrical Instrument Company Burton Browne Advertising	45
■ Clairex Corporation S. Paul Sims Company	135	Machlett Laboratories, Inc. The Fuller & Smith & Ross Inc.	8	Union Carbide Corporation, Kemet Dept.	22, 23
■ Clarostat Mfg. Co. Lescarboursa Advertising Inc.	31	■ Mallory & Co. Inc. P.R. The Aitkin-Kynett Co.	40, 41	J.M. Mathes Incorporated	
Cohu Electronics, Kin Tel Division	3rd Cover	Mechanical Enterprises Inc. George T. Petsche Adv.	135	■ United Transformer Corp. Bradley Rosen & Kaus Adv. Inc.	2nd Cover
Colorado Div. of Commerce & Development Buchen Advertising Inc.	42	Mico Instrument Company	140	Unitrode Corporation Chirurg & Cairns Inc.	113, 115, 117
Cominco Products Inc. McKim Adv. Limited	131	Milo Electronics Corp. Industrial Marketing Associates Div. of J.M. Schrier, Inc.	132	Vector Electronics Company M. Dorsey and Associates	122
Consolidated Electrodynamics Corporation Hixson & Jorgensen, Inc.	89	Minnesota Mining & Mfg. Co. Mincom Division Reach, McClinton & Co., Inc.	107	Westinghouse Electric Corp. ITSM	155
Cook Electric Company Lawrence U. Nelson Advertising	92	■ Mitsumi Electric Co., Ltd. Dentsu Advertising Ltd.	140	White, S.S. W.L. Towne Co. Inc.	123
Coto Coil The Williams Company	130	■ Mycalex Corporation of America Feeley Advertising Agency Inc.	87		
Daven, Div. of McGraw Edison Keys, Martin & Company	129	Newark Electronics Corporation Stral Advertising Company Inc.	144		
■ Delco Radio Campbell-Ewald Company	118, 119	Non-Linear Systems, Inc. Barnes Chase Advertising	90		
■ Digital Equipment Corp. Loudon Adv., Inc.	156	North Atlantic Industries, Inc. Murray Heyert Associates	100		
DuPont de Nemours & Co., Inc., E.I. Batten Barton Durstine & Osborn Inc.	39, 91	North Carolina Dept. Conservation & Development Bennett Advertising Inc.	88		
■ Dymec Div. of Hewlett Packard Co. L.C. Cole Company Inc.	21	Paktron, Div. Illinois Tool Works Inc. Raymond E. Finn & Associates	98, 99		
■ Dynage, Incorporated The F.W. Prella Co.	143	Porter Electronic Laboratories Conti Adv. Agency Inc.	104		
■ Dynatran Electronics Corp. Charles F. Saladino	135	■ Radiation Inc. G.M. Basford Company	112		
■ Electro Instruments Inc. Teawell Inc. Adv.	150	Radio Corporation of America Al Paul Lefton Co.	97, 4th Cover		
Electro Products Laboratories, Inc. C.M. Gotsch, Advertising	137				
Electro Scientific Industries Inc. Nadler and Larimer Inc.	134				
Electronic Industries Association of Japan George J. Walsh & Company	137				
Electronic Modules Corp. Ray Thompson & Associates Inc.	105				

## Classified advertising

F.J. Eberle, Business Mgr.	
Professional services	149
Employment opportunities	147
Notices Legal	149
Equipment (Used or Surplus New) For Sale	147-148

## Classified advertisers index

Marty's Mart	148
Motorola	147
■ Radio Research Instrument Co.	147
■ Universal Relay Corp.	148
■ Western Engineers	148

Executive, editorial, circulation and advertising offices: McGraw-Hill Building, 330 West 42nd Street, New York, N.Y., 10036. Telephone Area Code 212-971-3333. Teletype TWX N.Y. 212-640-4646. Cable: McGraw-Hill, N.Y. Officers of the Publications Division: Shelton Fisher, President; Vice Presidents: Joseph H. Allen, Operations; Robert F. Boger, Administration; John R. Callahan, Editorial; Ervin E. DeGraff, Circulation; Donald C. McGraw, Jr., Advertising Sales; Angelo R. Venezian, Marketing. Officers of the Corporation: Donald C. McGraw, President; Hugh J. Kelly, Harry L. Waddell, L. Keith Gookrich, Executive Vice Presidents; John L. McGraw, Treasurer; John J. Cooke, Vice President and Secretary. Title R registered U.S. Patent Office; © copyright 1964 by McGraw-Hill, Inc. All rights reserved, including the right to reproduce the contents of this publication, in whole or in part.

90% of all Japanese ITV cameras use COSMICAR lenses.

**COSMICAR**  
INDUSTRIAL TV LENSES



For your vidicon, image orthicon and professional movie cameras, Cosmicar lenses are available in focal lengths from 12.5mm up to 1000mm.

*New zoom lenses are now available.*



**ICHIZUKA OPTICAL CO., LTD.**

2-568, SHIMOOCHIAI, SHINJUKU-KU, TOKYO

CABLE ADDRESS: "MOVIEKINO TOKYO"

Circle 158 on reader service card

### SPECIAL OFFER: Reprints of Special Reports from Electronics

Now, for your reference file—a complete set of Special Reports reprinted from the pages of Electronics in the past year. A total of 155 pages of valuable and informative articles combined in an attractive folder. The reports are individually bound. The special discount price for the reports is \$2.50 which includes both handling and shipping costs. Order now, using the coupon below. The following reprints are included in this offer:

Oceanography 15 pages.	Digital Instrumentation 16 pages.
Magnetics 24 pages.	Modern Electronic Packaging 16 pages.
Electronic Markets New Directions 1963-64-67 24 pages.	
Today's Semiconductors 24 pages.	
Materials for Space Age Electronics 16 pages.	
Radio Frequency Interference 24 pages.	

Send your order to: Electronics Reprint Dept. McGraw-Hill Inc.  
330 W. 42nd Street, New York, N.Y. 10036

#### Reprint order form

For reprints of feature articles or special reports fill in below:

Send me ..... reprints of Key No.(s) ..... at ..... ¢ each.

For prices and listing please see the reader service card.

Send me ..... complete set(s) of special reports listed above at \$2.50 per set.

Name .....

Number of street .....

City, State, Zip code .....



### Advertising sales staff

**Gordon Jones:** [212] 971-2210  
Advertising sales manager

**Atlanta, Ga. 30309:** Gus H. Krimsier,  
Michael H. Miller, 1375 Peachtree St. N.E.,  
[404] TR 5-0523

**Boston, Mass. 02116:** William S. Hodgkinson,  
McGraw-Hill Building, Copley Square,  
[617] CO 2-1160

**Chicago, Ill. 60611:** Robert M. Denmead,  
Daniel E. Shea, Jr., 645 North Michigan  
Avenue, [312] MO 4-5800

**Cleveland, Ohio 44113:** Paul T. Fegley, 55  
Public Square, [216] SU 1-7000

**Dallas, Texas 75201:** Richard P. Poole, The  
Vaughn Building, 1712 Commerce Street,  
[214] RI 7-9721

**Denver, Colo. 80202:** John W. Patten, David  
M. Watson, Tower Bldg., 1700 Broadway,  
[303] AL 5-2981

**Houston, Texas 77025:** Kenneth George,  
Prudential Bldg., Halcombe Blvd.,  
[713] RI 8-1280

**Los Angeles, Calif. 90017:** Ashley P.  
Hartman, John G. Zisch, 1125 W. 6th St.,  
[213] HU 2-5450

**New York, N.Y. 10036:**  
Donald R. Furth [212] 971-3616  
Frank LeBeau [212] 971-3615  
George F. Werner [212] 971-3617  
500 Fifth Avenue

**Philadelphia, Pa. 19103:** William J. Boyle,  
Warren H. Gardner, 6 Penn Center Plaza,  
[215] LO 8-6161

**San Francisco, Calif. 94111:**  
James T. Hauptli, 255 California Street,  
[415] DO 2-4600

**London W1:** Edward E. Schirmer, 34 Dover  
Street, Hyde Park 1451

**Frankfurt/Main:** Matthee Herfurth, 85  
Westendstrasse Phone: 77 26 65 and  
77 30 59

**Geneva:** Michael R. Zeynel,  
2 Place du Port 244275

**Paris VIII:** Denis Jacob, 17 Avenue  
Matignon ALMA-0452

**Tokyo:** Nobuyuki Sato, 1, Kotohiracho,  
Shiba, Minato-ku (502) 0656

**Osaka:** Kazutaka Miura, 163, Umegae-cho,  
Kita-ku [362] 8771

**Nagoya:** International Media Representa-  
tives, Yamagishi Bldg., 13,2-Chome,  
Oike-cho Naka-ku

**Hugh J. Quinn:** [212] 971-2335  
Manager Electronics Buyers' Guide

**David M. Tempest:** [212] 971-3139  
Promotion manager

**Milton Drake:** [212] 971-3485  
Market research manager

**Richard J. Tomlinson:** [212] 971-3191  
Business manager

**Theodore R. Geipel:** [212] 971-2044  
Production manager



# Electronics reader service

Use these handy post cards for more detailed information on: products advertised, new products, new literature.

Circle the number on the Reader Service post card that corresponds to the number at the bottom of the advertisement, new product item, or new literature in which you are interested.

Please print clearly. All written information must be legible to be efficiently processed.

All foreign inquires that cannot reach Electronics before the expiration dates noted on the Reader Service post card, must be mailed directly to the manufacturer. The manufacturer assumes all responsibilities for responding to inquiries. Electronics merely provides and clears requests for information from inquirer to manufacturer.

Correct amount of postage must be affixed for all foreign mailings.

## To subscribe to or to renew Electronics

Fill in the "For Subscriptions" area on the card if you desire to subscribe to or renew your present subscription to Electronics. Send no money. Electronics will bill you at the address indicated on the Reader Service post card.

## Multi-product advertisements

For information on specific items in multi-product advertisements which do not have a specific Reader Service number indicated write directly to manufacturer for information on precise product in which you are interested.

27 Please give complete information 1

Name \_\_\_\_\_ title \_\_\_\_\_ Oct. 19, 1964

Company \_\_\_\_\_ Card Expires \_\_\_\_\_

Address \_\_\_\_\_ Dec. 19, 1964

1 19 37 55 73 91 109 127 145 163 181 199 217 235 253 271 289 307 325 343 361 379 397 415 433 451 469 487 98  
 2 20 38 56 74 92 110 128 146 164 182 200 218 236 254 272 290 308 326 344 362 380 398 416 434 452 470 488 98  
 3 21 39 57 75 93 111 129 147 165 183 201 219 237 255 273 291 309 327 345 363 381 399 417 435 453 471 489 98  
 4 22 40 58 76 94 112 130 148 166 184 202 220 238 256 274 292 310 328 346 364 382 400 418 436 454 472 900 98  
 5 23 41 59 77 95 113 131 149 167 185 203 221 239 257 275 293 311 329 347 365 383 401 419 437 455 473 901 98  
 6 24 42 60 78 96 114 132 150 168 186 204 222 240 258 276 294 312 330 348 366 384 402 420 438 456 474 902 98  
 7 25 43 61 79 97 115 133 151 169 187 205 223 241 259 277 295 313 331 349 367 385 403 421 439 457 475 951 98  
 8 26 44 62 80 98 116 134 152 170 188 206 224 242 260 278 296 314 332 350 368 386 404 422 440 458 476 952 98  
 9 27 45 63 81 99 117 135 153 171 189 207 225 243 261 279 297 315 333 351 369 387 405 423 441 459 477 953 98  
 10 28 46 64 82 100 118 136 154 172 190 208 226 244 262 280 298 316 334 352 370 388 406 424 442 460 478 954 98  
 11 29 47 65 83 101 119 137 155 173 191 209 227 245 263 281 299 317 335 353 371 389 407 425 443 461 479 955 98  
 12 30 48 66 84 102 120 138 156 174 192 210 228 246 264 282 300 318 336 354 372 390 408 426 444 462 480 956 98  
 13 31 49 67 85 103 121 139 157 175 193 211 229 247 265 283 301 319 337 355 373 391 409 427 445 463 481 957 98  
 14 32 50 68 86 104 122 140 158 176 194 212 230 248 266 284 302 320 338 356 374 392 410 428 446 464 482 958 98  
 15 33 51 69 87 105 123 141 159 177 195 213 231 249 267 285 303 321 339 357 375 393 411 429 447 465 483 959 98  
 16 34 52 70 88 106 124 142 160 178 196 214 232 250 268 286 304 322 340 358 376 394 412 430 448 466 484 960 98  
 17 35 53 71 89 107 125 143 161 179 197 215 233 251 269 287 305 323 341 359 377 395 413 431 449 467 485 961 98  
 18 36 54 72 90 108 126 144 162 180 198 216 234 252 270 288 306 324 342 360 378 396 414 432 450 468 486 962 98

For Subscriptions:  New  Renewal, [check one box] Domestic and Canada,  3 years \$12.00,  1 year \$6.00

First class  
Permit no. 42  
Hightstown, N. J.

**Business reply mail**

No postage stamp necessary if mailed in the United States

Postage will be paid by

**Electronics**  
**Reader service department**  
**Box 444**  
**Hightstown, N.J. 08520**

27 Please give complete information 1

Name \_\_\_\_\_ title \_\_\_\_\_ Oct. 19, 1964

Company \_\_\_\_\_ Card Expires \_\_\_\_\_

Address \_\_\_\_\_ Dec. 19, 1964

1 19 37 55 73 91 109 127 145 163 181 199 217 235 253 271 289 307 325 343 361 379 397 415 433 451 469 487 98  
 2 20 38 56 74 92 110 128 146 164 182 200 218 236 254 272 290 308 326 344 362 380 398 416 434 452 470 488 98  
 3 21 39 57 75 93 111 129 147 165 183 201 219 237 255 273 291 309 327 345 363 381 399 417 435 453 471 489 98  
 4 22 40 58 76 94 112 130 148 166 184 202 220 238 256 274 292 310 328 346 364 382 400 418 436 454 472 900 98  
 5 23 41 59 77 95 113 131 149 167 185 203 221 239 257 275 293 311 329 347 365 383 401 419 437 455 473 901 98  
 6 24 42 60 78 96 114 132 150 168 186 204 222 240 258 276 294 312 330 348 366 384 402 420 438 456 474 902 98  
 7 25 43 61 79 97 115 133 151 169 187 205 223 241 259 277 295 313 331 349 367 385 403 421 439 457 475 951 98  
 8 26 44 62 80 98 116 134 152 170 188 206 224 242 260 278 296 314 332 350 368 386 404 422 440 458 476 952 98  
 9 27 45 63 81 99 117 135 153 171 189 207 225 243 261 279 297 315 333 351 369 387 405 423 441 459 477 953 98  
 10 28 46 64 82 100 118 136 154 172 190 208 226 244 262 280 298 316 334 352 370 388 406 424 442 460 478 954 98  
 11 29 47 65 83 101 119 137 155 173 191 209 227 245 263 281 299 317 335 353 371 389 407 425 443 461 479 955 98  
 12 30 48 66 84 102 120 138 156 174 192 210 228 246 264 282 300 318 336 354 372 390 408 426 444 462 480 956 98  
 13 31 49 67 85 103 121 139 157 175 193 211 229 247 265 283 301 319 337 355 373 391 409 427 445 463 481 957 98  
 14 32 50 68 86 104 122 140 158 176 194 212 230 248 266 284 302 320 338 356 374 392 410 428 446 464 482 958 98  
 15 33 51 69 87 105 123 141 159 177 195 213 231 249 267 285 303 321 339 357 375 393 411 429 447 465 483 959 98  
 16 34 52 70 88 106 124 142 160 178 196 214 232 250 268 286 304 322 340 358 376 394 412 430 448 466 484 960 98  
 17 35 53 71 89 107 125 143 161 179 197 215 233 251 269 287 305 323 341 359 377 395 413 431 449 467 485 961 98  
 18 36 54 72 90 108 126 144 162 180 198 216 234 252 270 288 306 324 342 360 378 396 414 432 450 468 486 962 98

For Subscriptions:  New  Renewal, [check one box] Domestic and Canada,  3 years \$12.00,  1 year \$6.00

# Reprint service

All Electronics editorial matter available in reprint form:

For reprints of special reports and feature articles see list on right side of this page. Send your order to Electronics Reprint Department at the address indicated. To expedite mailing of your order for single reprints please send cash, check or money order with your order.

Bulk reprints of editorial matter can be ordered from current or past issues. The minimum quantity is 100 copies. The higher the quantity ordered, the more economical the cost per copy. Prices quoted on request.

To order reprints or for further information, please write to: **Electronics Reprint Department, 330 West 42nd Street, New York, N.Y. 10036.** Telephone: Area code 212 971-3140.

You may order the following reprints by key number using order form on page 158

Prices for the below listed reprints unless otherwise specified are 1-10 copies 50¢ each; 11-24 copies 35¢ each; 25-99 copies 25¢ each; price for 100 or more is 20¢ each.

- Key no. **R-62** Electronic Telephone Switching, 16 pages.
- Key no. **R-61** Direct Digital Control In Industry, 24 pages.
- Key no. **R-60** Transistor Heat Dissipators, Part II, 8 pages 25¢
- Key no. **R-59** Transistor Heat Dissipators, Part I, 24 pages.
- Key no. **R-58** Oceanography, 15 pages.
- Key no. **R-57** Magnetics, 24 pages.
- Key no. **R-56** The Case For Magnetic Logic, 8 pages. 35¢
- Key no. **R-55** Voltage Variable Capacitors Used For Electronic Tuning, 9 pages. 35¢
- Key no. **R-53** Digital Instrumentation, 16 pages.
- Key no. **R-49** Injection Laser Systems, [2 part series] 12 pages. 35¢
- Key no. **R-48** Modern Electronic Packaging, 16 pages.
- Key no. **R-47** Electronic Markets New Directions 1963-64-67, 20 pages.
- Key no. **R-45** Today's Semiconductors, 24 pages.
- Key no. **R-42** Materials for Space Age Electronics, 16 pages.
- Key no. **R-41** Telemetry Today, 7 pages. 25¢
- Key no. **R-40** Tunnel Diodes, [4 part series] 26 pages.
- Key no. **R-39** Radio Frequency Interference, 24 pages.
- Key no. **R-38** Family Tree of Semiconductors, [22" x 11" foldout chart].
- Key no. **R-31** 1962 Electromagnetic Spectrum Chart, [22" x 30" foldout chart]. \$1.00
- Key no. **R-30** Graphical Symbols For Electronic Diagrams, [29" x 11" foldout chart].
- Key no. **R-26** Lasers Devices and Systems, [1961 4 part series] 23 pages. \$1.00
- Key no. **R-19** Medical Electronics, [1961 7 part series] 42 pages. \$1.50

**Business reply mail**  
No postage stamp necessary if mailed in the United States

Postage will be paid by

First class  
Permit no. 42  
Hightstown, N. J.

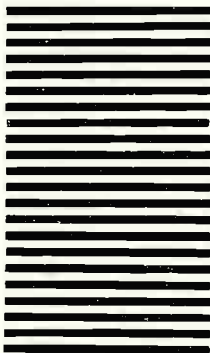

**Electronics**  
**Reader service department**  
**Box 444**  
**Hightstown, N. J. 08520**

7 Please give complete information

14

Name \_\_\_\_\_ title \_\_\_\_\_

Oct. 19, 1964

Company \_\_\_\_\_

Card Expires

Address \_\_\_\_\_

Dec. 19, 1964

19	37	55	73	91	109	127	145	163	181	199	217	235	253	271	289	307	325	343	361	379	397	415	433	451	469	487	963
20	38	56	74	92	110	128	146	164	182	200	218	236	254	272	290	308	326	344	362	380	398	416	434	452	470	488	964
21	39	57	75	93	111	129	147	165	183	201	219	237	255	273	291	309	327	345	363	381	399	417	435	453	471	489	965
22	40	58	76	94	112	130	148	166	184	202	220	238	256	274	292	310	328	346	364	382	400	418	436	454	472	900	966
23	41	59	77	95	113	131	149	167	185	203	221	239	257	275	293	311	329	347	365	383	401	419	437	455	473	901	967
24	42	60	78	96	114	132	150	168	186	204	222	240	258	276	294	312	330	348	366	384	402	420	438	456	474	902	968
25	43	61	79	97	115	133	151	169	187	205	223	241	259	277	295	313	331	349	367	385	403	421	439	457	475	951	969
26	44	62	80	98	116	134	152	170	188	206	224	242	260	278	296	314	332	350	368	386	404	422	440	458	476	952	970
27	45	63	81	99	117	135	153	171	189	207	225	243	261	279	297	315	333	351	369	387	405	423	441	459	477	953	971
28	46	64	82	100	118	136	154	172	190	208	226	244	262	280	298	316	334	352	370	388	406	424	442	460	478	954	972
29	47	65	83	101	119	137	155	173	191	209	227	245	263	281	299	317	335	353	371	389	407	425	443	461	479	955	973
30	48	66	84	102	120	138	156	174	192	210	228	246	264	282	300	318	336	354	372	390	408	426	444	462	480	956	974
31	49	67	85	103	121	139	157	175	193	211	229	247	265	283	301	319	337	355	373	391	409	427	445	463	481	957	975
32	50	68	86	104	122	140	158	176	194	212	230	248	266	284	302	320	338	356	374	392	410	428	446	464	482	958	976
33	51	69	87	105	123	141	159	177	195	213	231	249	267	285	303	321	339	357	375	393	411	429	447	465	483	959	977
34	52	70	88	106	124	142	160	178	196	214	232	250	268	286	304	322	340	358	376	394	412	430	448	466	484	960	978
35	53	71	89	107	125	143	161	179	197	215	233	251	269	287	305	323	341	359	377	395	413	431	449	467	485	961	979
36	54	72	90	108	126	144	162	180	198	216	234	252	270	288	306	324	342	360	378	396	414	432	450	468	486	962	980

Subscriptions:  New  Renewal, [check one box] Domestic and Canada,  3 years \$12.00,  1 year \$6.00

**Business reply mail**  
No postage stamp necessary if mailed in the United States

Postage will be paid by

First class  
Permit no. 42  
Hightstown, N. J.

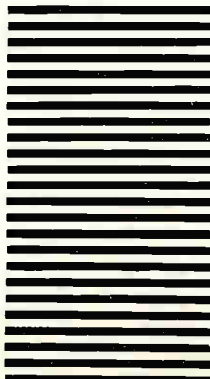

**Electronics**  
**Reader service department**  
**Box 444**  
**Hightstown, N.J. 08520**



attention: standards labs  
 precision dc voltage standards  
 now available with—  
 accuracies to 0.003%  
 stability to 15 ppm  
 from Cohu Electronics

■ **KIN TEL'S NEW MODEL 304 DC VOLTAGE STANDARD:** an exceptionally accurate and stable source with a wide range of voltages at extremely low output impedance. Output voltages from 0 to  $\pm 1222.2221$  volts in 3 ranges, with steps as small as  $1\ \mu\text{v}$ , and accuracy of 0.003% of setting; output current to 50 ma; stability within 15 ppm for 7 days, 25 ppm for 6 months; noise and hum less than  $20\ \mu\text{v}$  RMS.

■ **MODEL 303B DC VOLTAGE STANDARD:** highly accurate, direct setting, stable output over a wide range of voltages. Specifications: output voltage accuracy to within 0.01% of setting; output voltage from 0 to  $\pm 1111.1110$  volts in 3 ranges, steps as small as  $1\ \mu\text{v}$ ; output current to 25 ma; stability within 25 ppm for 7 days, 50 ppm for 6 months; noise and hum less than  $40\ \mu\text{v}$  RMS.

■ **MODEL 313 PROGRAMMABLE DC VOLTAGE STANDARD:** from 0 to  $\pm 1111.1110$  volts in any desired sequence. The instrument automatically responds to any program applied to it in the form of parallel entry, 1-2-4-4 BCD signals; output voltage accuracy is within 0.01%; stability is within 25 ppm for 8 hours and 50 ppm for 30 days; noise and hum is less than  $40\ \mu\text{v}$  RMS; current up to 25 ma; maximum settling time of output approx. 1 second.

■ **MODEL 321/323 DC VOLTAGE STANDARDS:** accurate, stable voltages to 25 ma of current in rackmount or cabinet configurations. Voltage range 0 to  $\pm 1111.110$  volts with steps as small as  $10\ \mu\text{v}$ ; output voltage accuracy within 0.01% of dial settings; stability is within 25 ppm for 8 hours and 50 ppm for 30 days; output noise and hum less than  $40\ \mu\text{v}$  RMS; Model 321 (rackmount) or 323 (cabinet) versions available with or without nullmeter.

■ **MODEL 302 DC VOLTAGE STANDARD AND NULL VOLTMETER:** range 1.000 to 502.110 v; short term stability,  $\pm 25\ \text{ppm}$   $\pm 25\ \mu\text{v}$ ; up to 20 ma output at any voltage; accuracy within 0.01% of setting  $\pm 200\ \mu\text{v}$ .

■ **MODEL 301 DC VOLTAGE STANDARD AND NULL VOLTMETER:** cabinet or rackmount configuration. Voltage output capability from 1.00 to 501 volts, at up to 20 ma with an accuracy of 0.02% or 2 mv.

Send for complete product information on these DC voltage standards, or any of Kin Tel's line of precision instruments. Representatives in all major cities.



Box 623, San Diego, California 92112  
 Phone (714) 277-6700

# See how easy it is to go solid state...

ROLAND KISSLER  
BOX 956  
ROCKY MOUNT, N.C.

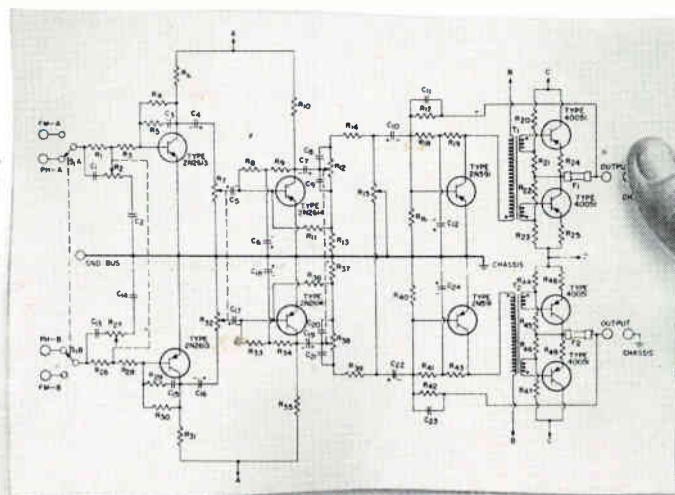
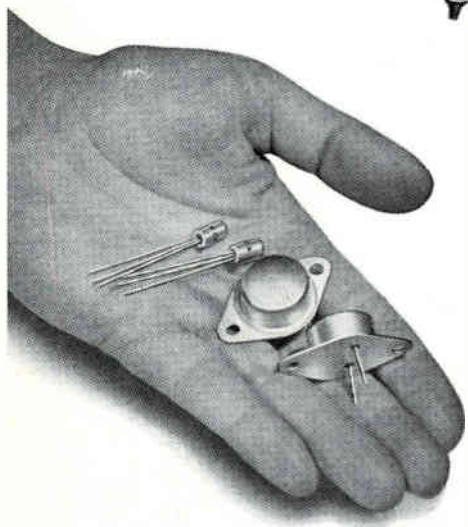
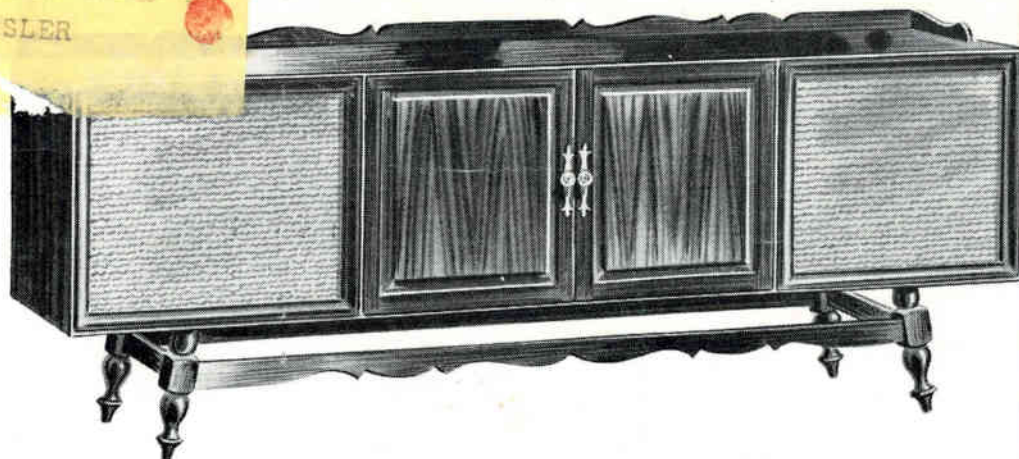

## try these mass-produced RCA hi-fi transistors and this simple circuit

With this 5-transistor-per-channel solid-state amplifier circuit, you can make popularly-priced sets for today's big solid-state audio market.

This RCA-developed circuit can be driven by a tuner output or by standard ceramic phonograph pick-ups.

Despite its simplicity and low cost, this stereo amplifier circuit gives excellent performance: high gain with low distortion over a wide frequency range (response flat from 30 cps to 12,000 cps  $\pm$  3 db). It delivers 50 watts (RMS continuous) output power (75 watts music power) with a 4-ohm load.

These four low-cost, mass-produced RCA germanium transistors... specially designed for hi-fi applications make this a practical reality:

**INPUT STAGE:** RCA-2N2613 high-gain, low-noise (4 db max) P-N-P alloy-junction small-signal audio amplifier transistor.

**PREDRIVER STAGE:** RCA-2N2614 P-N-P high-gain, high-voltage alloy-junction small-signal audio amplifier transistor.

**DRIVER STAGE:** RCA-2N591 P-N-P high-gain, large-signal driver transistor.

**OUTPUT STAGE (Class B):** Two RCA-4005 P-N-P alloy-junction power transistors featuring excellent linearity.

Together, this RCA complement makes up the best hi-fi transistor value on the market today.

For full technical information request your copy of Advanced Application Note ST-2650 from your nearest RCA Field Office, or write to RCA Commercial Engineering, Section CN 10-3, Harrison, N. J.

**AVAILABLE THROUGH YOUR RCA DISTRIBUTOR**

RCA ELECTRONIC COMPONENTS AND DEVICES, HARRISON, N. J.



**The Most Trusted Name in Electronics**

Circle 902 on reader service card