

# electronics

*Microcircuit designers (below) use circuit-oriented approach to prepare art work for today's products. This makes contemporary layout technique compatible with circuits of tomorrow. See p 72*

A McGraw-Hill Publication 75 Cents

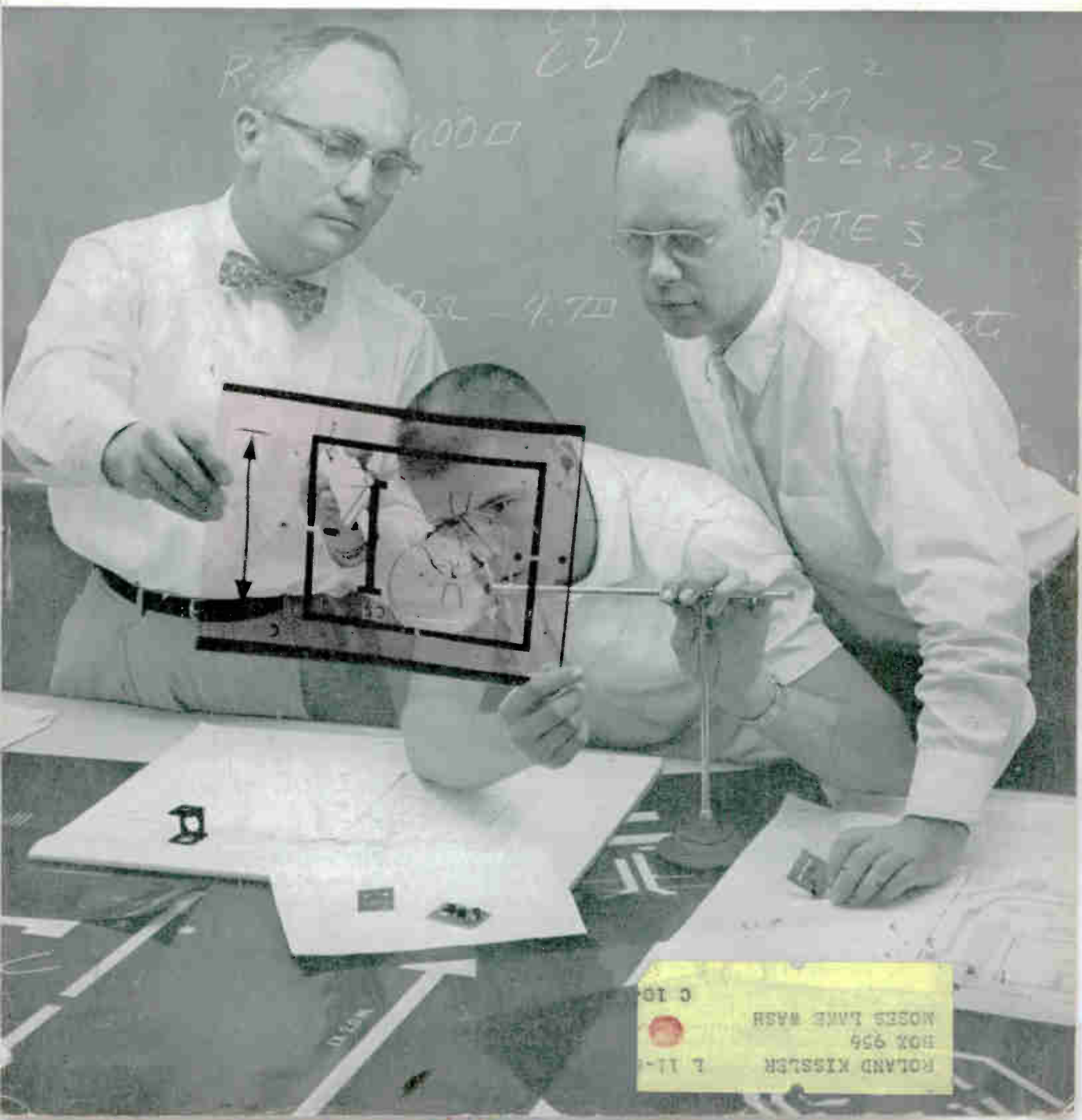

ROLAND KISSLER  
E. 11-  
HOX 956  
MOSES LANE WASH  
C 10



# PULSE TRANSFORMERS

## FROM STOCK

MINIATURE STABLE WOUND CORE

HERMETIC MIL-T-27A TYPE TF5SX36ZZ

UTC miniature, wound core, pulse transformers are precision (individually adjusted under test conditions), high reliability units, hermetically sealed by vacuum molding and suited for service from  $-70^{\circ}\text{C}$ . to  $+130^{\circ}\text{C}$ . Wound core structure provides excellent temperature stability (unlike ferrite). Designs are high inductance type to provide minimum of droop and assure true pulse width, as indicated on chart below. If used for coupling circuit where minimum rise time is important, use next lowest type number. Rise time will be that listed for this lower type number . . . droop will be that listed multiplied by ratio of actual pulse width to value listed for this type number. Blocking oscillator data listed is obtained in standard test circuits shown. Coupling data was obtained with H. P. 212A generator (correlated where necessary) and source/load impedance shown. 1:1:1 ratio.

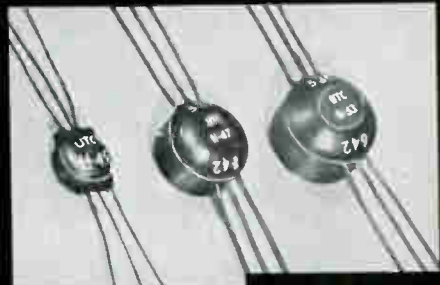

### DEFINITIONS

**Amplitude:** Intersection of leading pulse edge with smooth curve approximating top of pulse.  
**Pulse width:** Microseconds between 50% amplitude points on leading and trailing pulse edges.  
**Rise Time:** Microseconds required to increase from 10% to 90% amplitude.  
**Overshoot:** Percentage by which first excursion of pulse exceeds 100% amplitude.  
**Droop:** Percentage reduction from 100% amplitude a specified time after 100% amplitude point.  
**Backswing:** Negative swing after trailing edge as percentage of 100% amplitude.

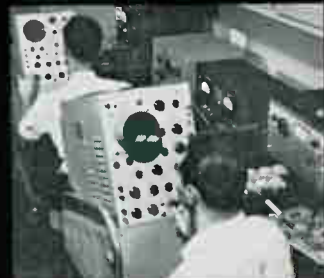

Type No.	APPROX. DCR, OHMS			BLOCKING OSCILLATOR PULSE					COUPLING CIRCUIT CHARACTERISTICS						
	1-2	3-4	5-6	Width $\mu$ Sec.	Rise Time	% Over Shoot	Droop %	% Back Swing	P Width $\mu$ Sec.	Volts Out	Rise Time	% Over Shoot	Droop %	% Back Swing	Imp. in, out, ohms
H-45	3	3.5	4	.05	.022	0	20	10	.05	17	.01	20	0	35	250
H-46	5.5	6.5	7	.10	.024	0	25	10	.10	19	.01	30	10	50	250
H-47	3.7	4.0	4	.20	.026	0	25	8	.20	18	.01	30	15	65	500
H-48	5.5	5.8	6	.50	.03	0	20	5	.50	20	.01	30	20	65	500
H-49	8	8.5	9	1	.04	0	20	10	1	24	.02	15	15	65	500
H-50	20	21	22	2	.05	0	20	10	2	27	.05	10	15	35	500
H-51	28	31	33	3	.10	1	20	8	3	26	.07	10	10	35	500
H-52	36	41	44	5	.13	1	25	8	5	23	.15	10	10	45	1000
H-53	37	44	49	7	.28	0	25	8	7	24	.20	10	10	50	1000
H-54	50	58	67	10	.30	0	20	8	10	24	.25	10	10	50	1000
H-55	78	96	112	16	.75	0	20	10	16	23	.40	5	15	20	1000
H-56	93	116	138	20	1.25	0	25	10	20	23	.6	5	10	10	1000
H-57	104	135	165	25	2.0	0	30	10	25	24	1.5	5	10	10	1000
H-60	.124	.14	.05	.05	.016	0	0	30	.05	9.3	.012	0	0	20	50
H-61	.41	.48	.19	.1	.016	0	0	30	.1	8.2	.021	0	0	15	50
H-62	.78	.94	.33	.2	.022	0	0	18	.2	7.4	.034	0	5	12	100
H-63	1.86	2.26	.70	.5	.027	2	10	20	.5	7.5	.045	0	20	25	100
H-64	3.73	4.4	1.33	1	.033	0	12	25	1	7	.078	0	15	23	100
H-65	6.2	7.3	2.22	2	.066	0	15	25	2	6.6	.14	0	10	20	100
H-66	10.2	12	3.6	3	.087	0	18	30	3	6.8	.17	0	10	20	100
H-67	14.5	17.5	5.14	5	.097	0	23	28	5	7.9	.2	0	18	28	200
H-68	42.3	52.1	14.8	10	.14	0	15	28	10	6.5	.4	0	15	30	200

Vacuum Tube Type Ratio 1:1:1

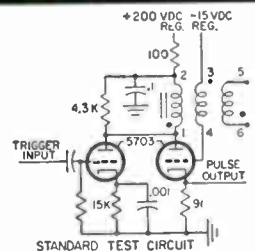

Transistor Type Ratio 4:4:1

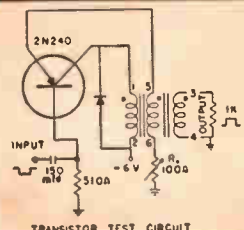

H-45, 46, 60 thru 68 are 3/8 cube, 1 gram      H-47 thru 52, 9/16 cube 4 grams      H-53 thru 57, 5/8 cube 6 grams

**AND SPECIAL UNITS TO YOUR SPECS**

While stock items cover special units to customers' low level uses only, most needs, ranging from low of UTC's production is on levels to 10 megawatts.

Write for Catalog for full details on these and 1000 other stock items

**UNITED TRANSFORMER CORPORATION**

150 Varick Street, New York 13, N. Y.

PACIFIC MFG. DIVISION: 4008 W. JEFFERSON BLVD., LOS ANGELES 16, CALIF.  
 EXPORT DIVISION: 13 EAST 40th STREET, NEW YORK 16, N. Y.      CABLES: "ARLAB"

# electronics

A McGraw-Hill Publication 75 Cents



W. W. MacDONALD, Editor

J. M. CARROLL, Managing Editor

SENIOR ASSOCIATE EDITORS: Samuel Weber, Roland J. Charest. ASSOCIATE

EDITORS: Frank Leary, Michael F. Tomaino, Sylvester P. Carter, William P. O'Brien, John F. Mason, William E. Bushor, Thomas Emma, Sy Vogel, Leslie Solomon, M. M. Perugini, George J. Flynn. ASSISTANT EDITORS: Michael F. Wolff, Nilo Lindgren, Stanley Froud, Stephen B. Gray, Roy J. Bruun, George V. Novotny, Leon H. Dulberger.

REGIONAL EDITORS: Harold C. Hood (Pacific Coast, Los Angeles), Thomas Maguire (New England, Boston), Cletus M. Wiley (Midwest, Chicago).

BUYERS' GUIDE EDITOR: George Sideris. ART DIRECTOR: Harry Phillips; Howard R. Berry. PRODUCTION EDITOR: John C. Wright, Jr. EDITORIAL ASSISTANTS: Gloria J. Filipponi, Arlene Rudd, Bernice Duffly, Lorraine Rossi, Virginia T. Bastian, Lynn Emery, Avis Pomeranz, Florence Hajaistran.

JAMES GIRDWOOD, Publisher

## BUSINESS

Electronics In Czechoslovakia. Exclusive story and photographs	24
Dynasoar: A \$1-Billion Market By '66. More subcontracts due	26
Medical Equipment in Spotlight. Report on ISA conference	29
Nike-Zeus Radar Ready for Tryout. To track ICBMs	30
Are Semiconductor Tests Hard Enough? Some makers wonder	32
Air Force Urges More Space Reliability. Astro society meets	34
Crosstalk	4
Financial	20
Comment	6
25 Most Active Stocks	21
Electronics Newsletter	9
Meetings Ahead	36
Washington Outlook	14

## ENGINEERING

Art work patterns for deposited microcircuits are reduced photographically from the large drawings shown. Techniques at Lear, involved in producing precise microcircuits for today's problems, are discussed on p 72	COVER
Subsurface Communication for Survival. Security against natural and artificial hazards. By R. N. Ghose	43
Medical Electronics Part II: Diagnostic Systems and Visualization. Discussion of latest systems for processing physiological data and equipment for pictorially displaying human tissue. By W. E. Bushor	46
Using Thermistors as Servo Elements. Thermistors have applications as versatile control elements. By I. C. Hutcheon	52
New Sonar Thumper Charts Ocean Subbottom. Yields information on sediment layers and bedrock	56
Digital Tone Filter has Infinite Rejection Slope. Its circuit properties are difficult to duplicate with passive elements. By A. Corbin	58
Graphical Method Predicts Radio Interference. Reduces interference computations for crowded spectrums. By J. H. Vogelman	60

## DEPARTMENTS

Research and Development. Fields Vary Transistor Gain	68
Components and Materials. Practical Microcircuits	72
Production Techniques. Air Speeds Cable-Making	76
New on the Market	80
People and Plants	96
Literature of the Week	94
Index to Advertisers	105

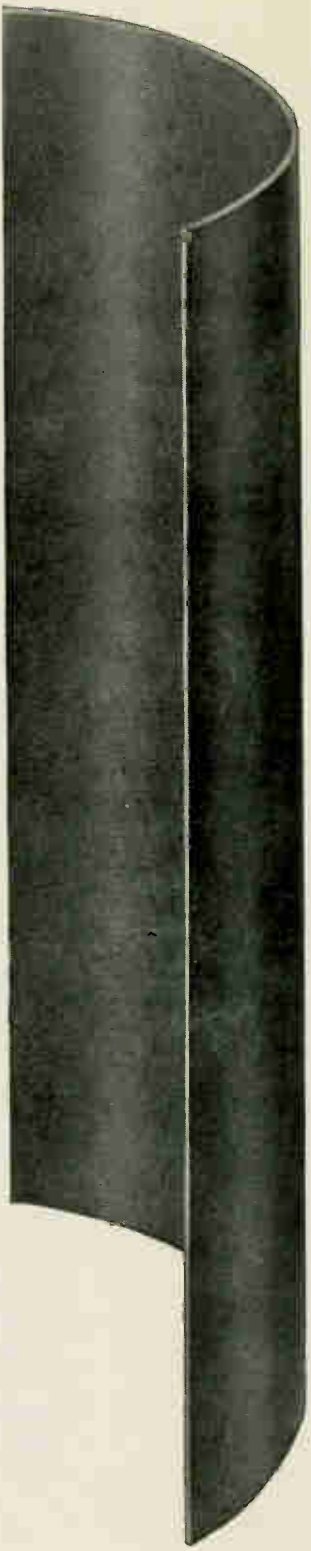

**Born to live a short life,**  
this missile guidance component  
must perform as if it had to last forever!  
CDF molded this part under high  
pressure from glass fabric epoxy  
laminates to meet rigid military  
electro/mechanical requirements.

**Result:** a panel with excellent  
electrical insulating properties and  
high mechanical strength that provides  
significant savings in space and weight,  
helps minimize vibration.



CONTINENTAL-DIAMOND FIBRE

## Shrinker Cum Laude



Know ye that we, the corporation of Burnell & Co., upon the recommendation of our customers in the electronics industry do hereby inaugurate the esteemed order of Shrinker Cum Laude.

Be it further known that, (without undue modesty), the Shrinker Cum Laude award has been made to Burnell for displaying the highest degree of shrinkmanship in the design and utilization of microminiature, subminiature and miniature toroids, filters and related networks.

The Shrinker Cum Laude award has also been tendered for signal

achievement in reducing developmental costs while increasing performance range—a feat accomplished by the designers of the new Burnell high selectivity, high attenuation, 1 kc crystal filter which possesses the following unique characteristics:

Attenuation — 3 db bandwidth — 3.8 cps

Shape Factor 60/6 — 4½:1

Input — 500 ohms

Output Impedance—500,000 ohms  
Meets MIL-C 3908 B vibration standards

Other Burnell crystal filters available in frequencies up to 30 mcs with

considerable latitude in impedance range. Write for Bulletin XT 455.

See the complete line of Burnell components at Booths 2919-2921 IRE Exhibit, March 20-23.

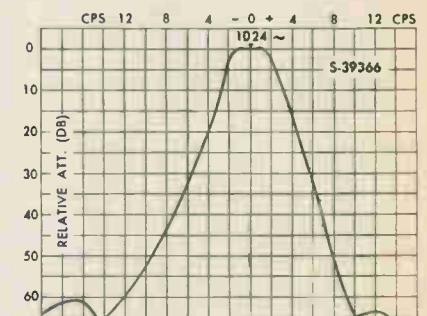

COPYRIGHT 1961 - BURNELL & CO., INC.

*Burnell & Co., Inc.*

PIONEERS IN microminiaturization OF TOROIDS,  
FILTERS AND RELATED NETWORKS

EXECUTIVE OFFICE  
AND PLANT  
DEPT. E-31  
PELHAM, NEW YORK  
PELHAM 8-5000  
TELETYPE PELHAM 3633



PACIFIC DIVISION  
SOUTH PASADENA, CAL.  
MFD. IN CANADA  
BY EDO (CANADA) LTD.  
CORNWALL, ONT.  
WELLINGTON 2-6774

Published weekly, with Electronics Buyers' Guide and Reference annually, as part of the subscription, by McGraw-Hill Publishing Company, Inc. Founder: James H. McGraw (1860-1948).

Title registered U.S. Patent Office; Copyrighted 1961, McGraw-Hill Publishing Company, Inc. All rights reserved, including the right to reproduce the contents of this publication, in whole or in part.

Executive, editorial, circulation and advertising offices McGraw-Hill Building, 330 West 42nd Street, New York 36, N. Y. Telephone Longacre 4-3000. Teletype TWX N.Y. 1-1636. Cable McGrawhill, N.Y. Printed in Albany, N. Y.; second class postage paid.

**OFFICERS OF THE PUBLICATIONS DIVISION:** Nelson L. Bond, President; Shelton Fisher, Wallace F. Traendly, Senior Vice Presidents; John R. Callahan, Vice President and Editorial Director; Joseph H. Allen, Vice President and Director of Advertising Sales; A. R. Venezian, Vice President and Circulation Coordinator.

**OFFICERS OF THE CORPORATION:** Donald C. McGraw, President; Joseph A. Gerardi, Hugh J. Kelly, Harry L. Waddell, Executive Vice Presidents; L. Keith Goodrich, Vice President and Treasurer; John J. Cooke, Secretary.

Subscriptions are solicited only from those actively engaged in the field of the publication. Position and company connection must be indicated on orders. Subscription rates: United States and Possessions, \$6.00 one year; \$9.00 two years; \$12.00 three years. Canada, \$10.00 one year. All other countries \$20.00 one year. Single Copies, United States and Possessions and Canada 75¢; Buyers' Guide \$3.00; Single Copies all other countries \$1.50; Buyers' Guide \$10.00.

The Publisher, upon written request from any subscriber to our New York Office, agrees to refund that part of the subscription price applying to copies not yet mailed.

Subscribers: Please address all correspondence, change of address notices, subscription orders or complaints to Fulfillment Manager, Electronics, at above address. Change of address notices should provide old as well as new address, including postal zone number if any. If possible, attach address label from recent issue. Allow one month for change to become effective.

Postmaster: Please send Form 3579 to Fulfillment Manager, Electronics, 330 West 42nd Street, New York 36, New York.



Audited Paid Circulation

# CROSSTALK

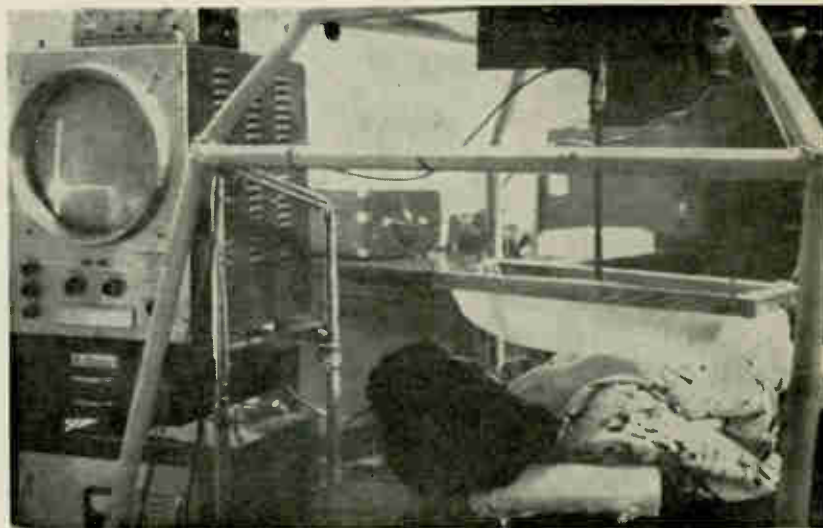

**MEDICAL ELECTRONICS**—Among promising electronic developments pertaining to medical diagnosis is the ultrasonograph. Associate Editor Bushor has gathered together in his second medical electronics article a number of ultrasonograms that indicate the degree of definition obtainable with this comparatively new technique. Although it may serve as an alternative to x-ray visualization, ultrasonography can also give physicians a powerful tool for visualizing soft tissue. The system in the photo was developed at the Juntendo University School of Medicine in Japan to detect and diagnose breast tumors.

Another development, and one about which there is some discussion, is the use of computers in diagnosis. Some physicians have even viewed this development with alarm. However, computers will never replace the physician, but will merely serve him. Computers are presently being used by the medical profession through the Commission on Professional and Hospital Activities at Ann Arbor, Michigan. This group codes clinical information from member hospitals and supplies statistical information on request. The System Development Corp. in collaboration with the Veterans Administration are working on a program, termed Project Medic, which will assist doctors with diagnosis and prepare statistical studies. Last December a new group called Biological Information-processing Organization (BIO) was organized. Its aim is to encourage and expedite the exchange of information concerning the use of digital computers in biology and medicine, to create an awareness of the potentialities of digital computers, and to stimulate the use of digital computers and related technology in biomedical research and medicine. The National Academy of Sciences—National Research Council is sponsoring a monograph on the application of computers to biology and medicine.

## Coming in Our February 10 Issue

**DESIGNING AGAINST RADIATION.** Effect of nuclear radiation on electronic equipment is receiving increasing attention as designers strive for circuits capable of functioning in such environments as nuclear-powered aircraft and the Van Allen radiation belts. Next week, J. W. Clark, T. D. Hanscome and H. L. Wisner of Hughes Aircraft Co. in Los Angeles discuss techniques for resisting transient radiation effects.

We think you'll find this informative article a valuable addition to the series of **ELECTRONICS** articles that has included description of radiation effects on materials (p 155, May 1, 1957), transistors (p 55, Nov. 27 and p 38, Dec. 25, 1959), systems (p 69, April 22, 1960) and tunnel diodes (p 32, May 6, 1960).

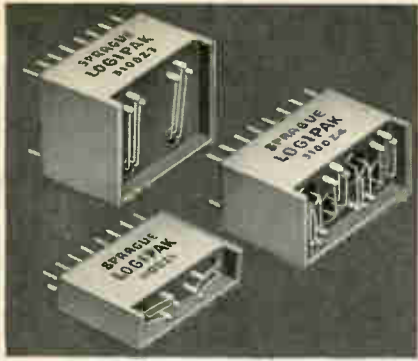

Sprague LOGIPAK\* encapsulated packages have standardized shapes equally suitable for prototype or production use.

## Versatile Logiline\* Circuitry for Digital System Design

Sprague Logiline digital system circuitry is based on a series of 5 Mc transistor switching circuits in building block form. These offer either the flexibility of encapsulated packages or the versatility of conventional wiring board construction.

Basically a pulse-level system, Logiline circuitry performs digital computer functions, including combinational logic, temporary storage, pulse source, and pulse amplification. Incorporating standardized switching circuits, they save hours of design time. Their plug-in feature is another noteworthy time saver.

Sprague Logipak\* encapsulated packages have standardized configurations—ideal for prototype design, equally suitable in final production—and they're smaller and priced lower than conventional wiring board assemblies. Transistors are readily accessible. Pins have standard 0.1" grid module spacing.

As a further aid to interchangeable digital circuitry, Sprague offers epoxy-glass etched Logicard\* wiring boards with 22-pin connectors in aluminum frames. These insert into prewired rack mounted panels. They are completely interchangeable with comparable units.

For complete Logiline data or digital design application assistance write: Special Products Division, Sprague Electric Company, 35 Marshall St., North Adams, Massachusetts.

LOGICARD\* wiring board card for conventional equipment assembly.

\*Trademark

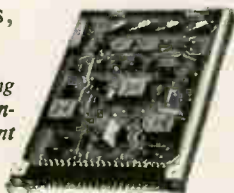

CIRCLE 200 ON READER SERVICE CARD  
February 3, 1961

Something  
**NEW**  
in counting  
techniques!

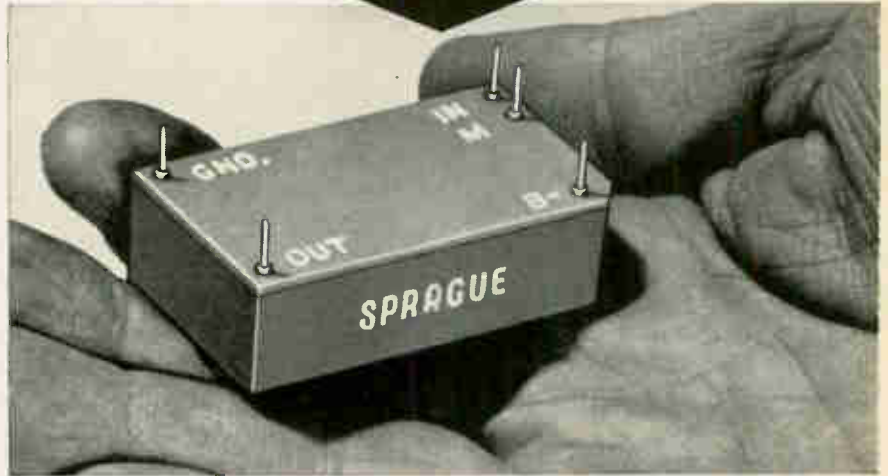

## Sprague type 73Z1 core-transistor DECADE COUNTERS

Sprague's Special Products Division, the largest and most complete facility in the magnetics industry, offers a simple yet versatile, low-cost yet reliable component for counter applications. Counting to speeds of 10 kc, the 73Z1 decade counter provides an output signal for every 10 input pulses, then resets in preparation for the next cycle. For higher counting, two or more counters may be cascaded. Typical characteristics are shown in the following table:

CHARACTERISTIC	INPUT	OUTPUT
Amplitude	1.5 to 8 volts	6.5 volts min.
Pulse Width	1 $\mu$ sec min.	50 $\mu$ sec nom.
Impedance	100 ohms	20 ohms

Utilizing two rectangular hysteresis loop magnetic cores and two junction transistors to perform the counting operation, the 73Z1 counter is encapsulated in epoxy resin for protection against adverse environmental conditions. It has five terminals—B+ (12v  $\pm$  10%), input, output, ground, and manual reset.

The 73Z1 decade counter is available as a standard item. However, "customer engineered" designs can be supplied when other counting cycles, speeds, and package configurations are required for special applications.

Other Special Products Division components for the digital equipment industry include: LOGILINE 5 mc/s digital circuits; 1  $\mu$ sec access time memory; magnetic shift registers and logic components; computer pulse transformers; switching transformers; precision toroidal inductors.

For complete technical data or application assistance on the 73Z1 counter or other Sprague components, write to Special Products Division, Sprague Electric Co., 35 Marshall Street, North Adams, Massachusetts.



CIRCLE 5 ON READER SERVICE CARD 5

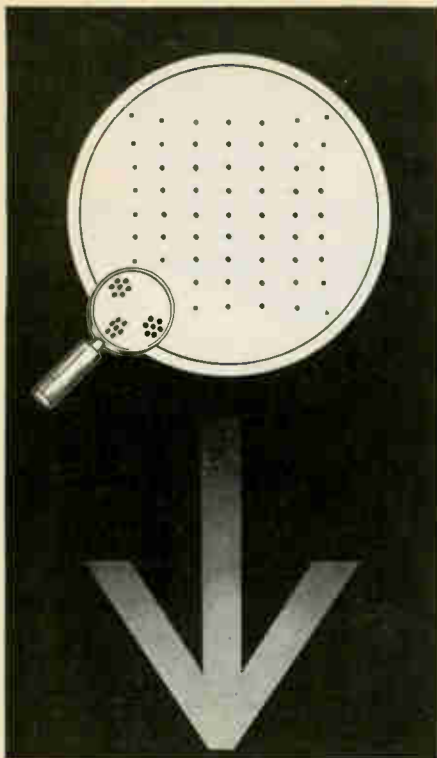

# WHY

## MAJOR C. R. TUBE MFGRS. RECOMMEND SYNTRONIC YOKES

Exceptional manufacturing uniformity. Achieved by unique pepperpot tube testing—the most comprehensive method known for precise measurement for spot uniformity . . . to attain extremely accurate focusing. For technical details, request ELECTRONIC INDUSTRIES reprint #6-57 from Syntronic Instruments, Inc.

Call your nearest SYNTRONIC REP today

Boston-New Eng.:	NOrwood 7-3164
New York Area:	OXford 5-0255
Phila. Area:	MOhawk 4-4200
Wash.-Balt. Area:	APpleton 7-1023
Indianapolis:	Victor 6-0359
Los Angeles:	CUMberland 3-1201

*syntronic*  
**INSTRUMENTS, INC.**

100 Industrial Road, Addison, Illinois  
Phone: Kingswood 3-6444

The Industry's broadest yoke line . . . already tooled for quantity production. Or, yokes can be custom designed to your precise requirement.

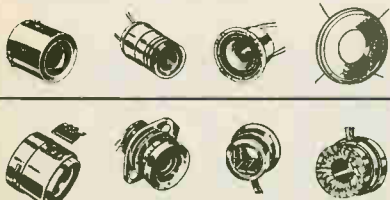

## COMMENT

### Imports and Shortsightedness

After reading several items in *ELECTRONICS* about the threat to the domestic electronics industries, I feel that I should report a recent case of shortsightedness peculiar to businessmen enjoying a bullish market.

Recently a local electronics distributor, who provides us with miscellaneous parts, was asked to obtain an equipment of specific manufacture. The parent company referred him to their entertainment distributor. They in turn refused to sell the item unless a tie-in sale of other material was included, a sale of a mere \$1,000. A long-distance call ended by the local man being told to go to (not Hades) Sony.

This kind of Detroit myopia leads down strange paths, and is why my road car comes from Stuttgart and my other car from Goteburg.

I am happy to report that the people who employ me would never indulge in such tactics. And let me add that the controls industry has plenty of competition. When the market was our oyster after the last large unpleasantness, customers were always given the royal treatment; big or little, they were *customers*.

Perhaps some clear voice should address the industry about the necessity of studying the market, supplying service, and stressing that old-fashioned virtue, quality.

WALDEN C. PIERSON

ROCKFORD, ILL.

### Platyphonic Sound

In his letter published in the Dec. 16 '60 issue (Comment, p 6) your reader K. Melonas suggested the first truly acceptable antonym to *stereophonic*: *platyphonic* . . .

K. H. OLBRICHT

ROSENTHAL ISOLATEREN GMBH

SELB (OBERFRANKEN), GERMANY

I want you to know that K. Melonas is not the only person who objects to the current propensity to corrupt the English language by battering its Greek roots. One may dismiss the "modern language"

heard on television as the work of semiliterates or advertising men (these may be one and the same), but it is difficult to excuse presumably educated engineers or scientists for similar errors. One need not be erudite to give a clear description; one need only be correct.

As Mr. Melonas states, *monophonic* means "one-voiced," not "one single source of sound." This is really a serious error because it represents an inaccuracy. Modern technology is based on eliminating inaccuracies, is it not? Germanium and silicon have been around for a long time; were it not for eliminating the inaccuracies of purification processes for these materials, we would not have transistors.

Clearly, at this stage the correct *platyphonic* will not be adopted to indicate sound coming from a single source; *monophonic* has been irrevocably adopted by the layman. It has, in fact, been adopted because the public follows the technical man blindly. They have the faith to assume that we name things correctly. Thus, you see, those of the technological community are leaders. Have we no qualms about leading astray?

If neither the responsibility for accuracy or description nor leadership appeals to you, think for a moment about the jeopardy in which we place as yet unnamed phenomena. What happens when we give an incorrect name to phenomenon A today only to find tomorrow that we have discovered phenomenon B which correctly warrants the name given to A? We have two alternatives; we can rename A and give B its rightful name, or we can commit another error and name B erroneously also. Thus we confound the public or compound the error.

A minor point, perhaps. But many years ago, a bright light of science said "It is only those things which one can accurately describe that one can truly understand."

NAOMI S. SULOWAY

OAK PARK, ILL.

*In justice to the industry, perhaps we should point out that the word monophonic seems first to have been used by promoters of stereo, not engineers.*



# SHARPEST ZENERS AVAILABLE!

NOW...

**G** OFFERS YOU A COMPLETE LINE  
OF QUALITY ZENER DIODES

## NEW 10-WATT ZENERS...

- Extremely low Dynamic Impedance
- Superior Case Design
- Up to 175° C Operation
- Diffused Junction Type
- 100% Scope Tested

**Outstanding Quality**—New line of superior quality 10-watt zener diodes provides dependable uniformity of electrical characteristics... completes the family of General Instrument zeners. Unique case design, which employs thermal matching of silicon and package, enables units to withstand rapid temperature cycling and thermal shock. Low junction operating temperature

means high reliability and long life. Conservatively rated diodes show extreme stability under life tests at maximum parameters.

**New Diodes Available for Immediate Delivery** in Types 1N1808; 1N2044 through 1N2049; and 1N1351 through 1N1362. Voltage ranges from 7.5 to 30 volts (higher upon request).



REPRESENTATIVE GROUP  
OF SUPERIOR

ZENERS FOR  
YOUR MOST EXACTING  
CIRCUIT REQUIREMENTS...  
10 WATTS TO ¼ WATT

(Standard types supplied  $\pm$  10% of stated value;  $\pm$  5% tolerances available except as indicated.)

New 10-Watt Zeners				3.5-Watt Stud Mount†			1-Watt Axial Lead†				¼-Watt Axial Lead				
Type	Zener Voltage (V)	Test Cur. @ 25°C (ma)	Max. Dyn. Imp. (ohms)	Type	Zener Voltage (V)	Test Cur. @ 25°C (ma)	Max. Dyn. Imp. (ohms)	Type	Zener Voltage (V)	Test Cur. @ 25°C (ma)	Max. Dyn. Imp. (ohms)	Type	Zener Voltage (V)	Test Cur. @ 25°C (ma)	Max. Dyn. Imp. (ohms)
1N1808	9.1	500	1	1N1588	3.6-4.3	150	2.6	1N1518	3.6-4.3	50	9	1N708	5.6	25	3.6
1N1351	11	500	2	1N1589	4.3-5.1	125	2.3	1N1519	4.3-5.1	40	8.5	1N714	10	12	8
1N1352	11	500	2	1N1590	5.1-6.2	110	1.4	1N1520	5.1-6.2	35	5.5	1N718	15	12	13
1N1353	12	500	2	1N1591	6.2-7.5	100	.58	1N1521	6.2-7.5	30	1.6	1N721	20	4	20
1N1355	15	500	2	1N1592	7.5-9.1	80	.5	1N1522	7.5-9.1	25	1.1	1N723	24	4	28
1N1357	18	150	3	1N1593	9.1-11	70	.7	1N1523	9.1-11	20	1.5	1N731	51	4	115
1N1358	20	150	3	1N1594	11-13	50	1.4	1N1524	11-13	15	2.4	1N735*	75	2	240
1N1359	22	150	3	1N1595	13-16	40	3.4	1N1525	13-16	13	5.4	1N738*	100	1	400
1N1360	24	150	3	1N1596	16-20	35	6	1N1526	16-20	10	11	1N742*	150	1	860
1N1361	27	150	3	1N1597	20-24	30	9	1N1527	20-24	9	18	1N744*	180	1	1200
1N1362	30	150	4	1N1598	24-30	25	3	1N1528	24-30	7	28	1N745*	200	1	1400

\*Supplied with  $\pm$  10% tolerance only.  
†Intermediate values supplied with  $\pm$  5% tolerances on order.

CONTACT GENERAL INSTRUMENT for full technical information on the complete line of zener diodes, and for applications assistance on all your semiconductor needs.

**GENERAL INSTRUMENT**  
**GENERAL TRANSISTOR**  
TRANSISTORS, DIODES, RECTIFIERS

**G SEMICONDUCTOR**  
DIVISION OF GENERAL INSTRUMENT CORPORATION  
65 Gouverneur Street, Newark 4, New Jersey



IN CANADA: General Instrument—F. W. Sickles of Canada Ltd., P.O. Box 408, 151 S. Weber Street, Waterloo, Ontario, Canada. Sherwood 4-8101.

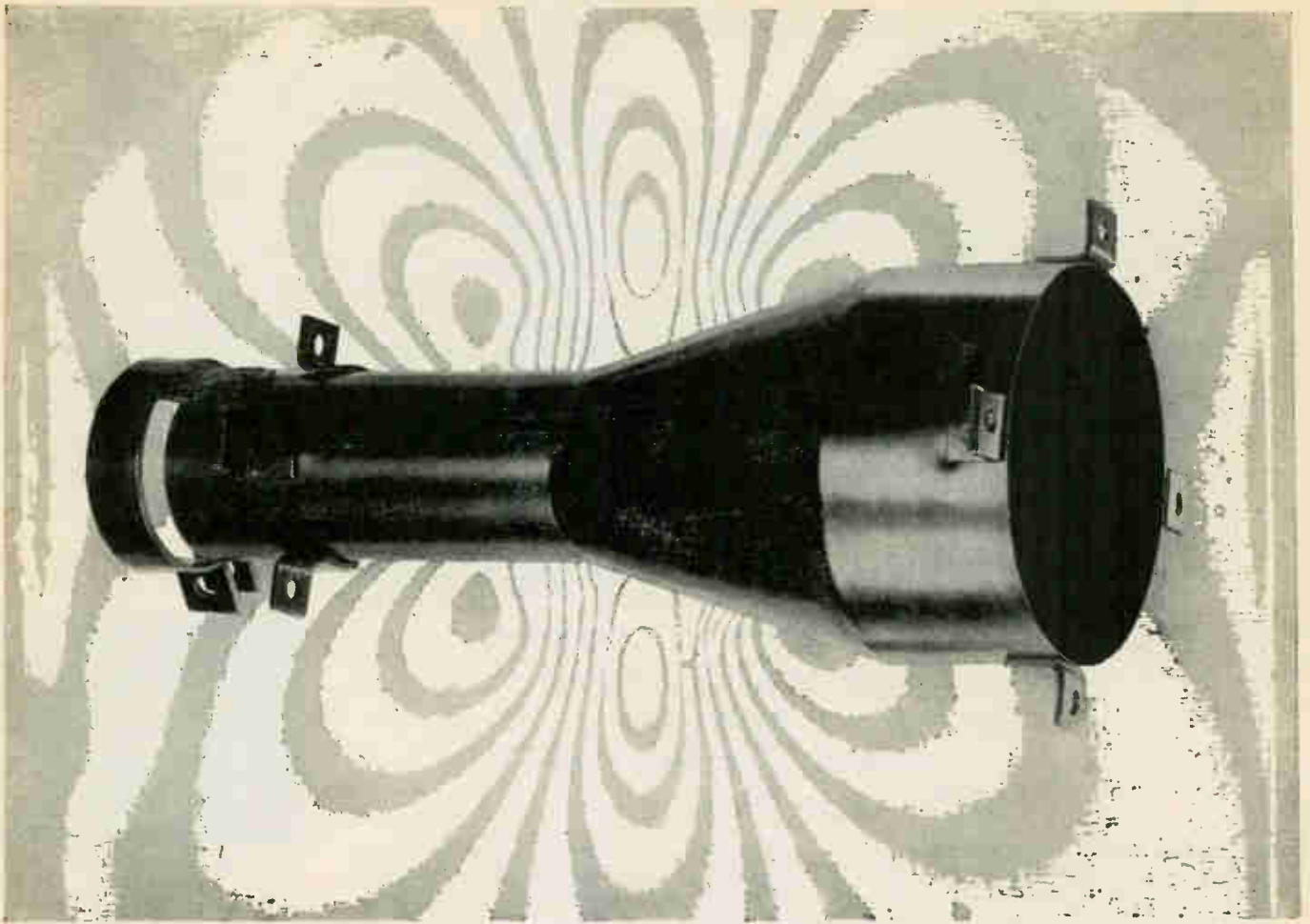

## keep your signals clean with engineered magnetic shielding

Keep stray magnetic fields out of your high gain input transformers and cathode ray tubes. Keep your signals free of noise, hum, cross-talk and distortion. You can do it only with *engineered* magnetic shielding.

These **high-permeability shields** are made from existing tools in a broad variety of single and multiple structures—cylinders, spheres, truncated cones—for applications ranging from dc into the audio range and higher. They can be used with almost all conventional transformer core and coil assemblies to provide any degree of magnetic, electrostatic or RF shielding against undesired signals of

all classes. Reduction of field strengths to 100 db and beyond is common.

**With Magnetic Metals shielding**, both the electrical and mechanical engineering is already done for you. Simply let us know your requirements . . . We'll engineer the exact type of shielding you need. In selection of raw material, design, fabrication, annealing, testing and gaging, Magnetic Metals has amassed a great backlog of shielding experience. For a better understanding of shielding and help in specifying it, write for our informative booklet, "Magnetic Shielding of Transformers and Tubes."

**MAGNETIC**  
 **METALS**

### *Magnetic Metals Company*

Hayes Avenue at 21st Street, Camden 1, N.J.

853 Production Place, Newport Beach, California

*transformer laminations • motor laminations • tape-wound cores  
powdered molybdenum permalloy cores • electromagnetic shields*



# ELECTRONICS NEWSLETTER

## Project Haystack to Get Powerful Radar, Communications

CONTRACT to build "the most powerful communications transmitter and most effective radar transmitter in the world" for Project Haystack was awarded recently to Radiation Inc. The contract is valued at \$800,000; a second order for identical equipment is expected shortly.

Haystack is an Air Force project to develop a versatile radar system for space surveillance and a flexible communications system for use in various satellite-bounce experiments. Sites are at Tyngsboro, Mass., and in California.

Radiation Inc. is also building the pulse-code modulation telemetry system for the nonmilitary Nimbus satellite program.

## Third Radar Hazard Reported In France

PARIS—Visiting the research laboratories of Compagnie Francaise Thomson Houston at Bagneux near here last week, Electronics editor W. W. MacDonald saw a new super-power radar under development, heard about a third physiological hazard involved when such powers are used—the hazard of narcosis not unlike "rapture of the deep" experienced by skin divers. It develops when a man remains too long near an ozone-generating spark gap operating in any confined area.

## Persistent Internal Polarization May Have Practical Value

PRACTICAL APPLICATIONS for the phenomenon of persistent internal polarization in luminescent materials were demonstrated this week by researchers at New York University's solid-state physics lab.

Phosphorescent and luminescent materials can be loaded with electrical energy, which will remain in storage until released by exposure to radiation. The PIP phenomenon occurs when luminescent phosphors

are exposed to nonvisible radiation—ultraviolet, infrared, gamma or electron radiation, for example. The charge carriers in the phosphor separate and set up a polarized field which remains after the radiation source is removed; exposure to visible light releases the stored energy.

This nuisance phenomenon is now seen as potentially useful for high-speed computer memory. A laboratory device built at NYU operates at 100 microseconds; with fast flashes of intense light, it can be made to operate at less than a microsecond. Other potential uses seen by NYU scientists include photography in radioactive or infrared environments, dry-copy photography, and energy storage similar to that now done with capacitors.

## Computers Communicate Over High-Speed Microwave Link

EXPERIMENTAL microwave link between two Control Data Corp. plants in Minneapolis is testing high-speed digital data transfers at 1.2 million bits per second. Checked data are being sent at that speed directly from the magnetic-core memory of a desk-size CDC160 at one location to the memory of a large-scale CDC1604 three miles away.

Control Data is using a Motorola 12-Gc broadband system for the test. The experiment takes advantage of the Federal Communications Commission ruling last October extending the use of private microwave at 6 and 12 Gc. CDC says the microwave system is cheaper and faster than land-line hookups between computers or from computer to peripheral gear. System can work into unattended repeaters to jump the horizon.

## Seek X-Band Masers For Project West Ford

X-BAND MASERS are under development at MIT's Lincoln Laboratory for Project West Ford, the new name for what the Air Force for-

merly called Project Needles. West Ford proposes a global microwave communications system using tiny reflective tuned dipoles orbited in belts around the earth (ELECTRONICS, p 43, Sept. 30 '60).

Under tests for the masers is a new superconducting magnet designed to set up a horizontal field. Maser material has been cut for this new field orientation in order to minimize magnetic gap and thus the size and weight of the magnet.

Orbital scatter technique will eventually be tried out with the 120-ft Haystack Hill transmitter and receiver under construction at Tyngsboro, Mass.

## Portable Gyro Orientor Aids Army Artillery

U. S. ARMY ARTILLERY battalions are hoping to improve their battlefield mobility and increase firing accuracy with the help of a portable gyroscopic direction-finder now being produced by Autonetics division of North American Aviation.

Army has contracted for 100 of the units at a cost of \$3.5 million. The baseline orientor is basically a precision gyrocompass which determines true north to less than 30 seconds deviation in twenty minutes or less. Operation requires no formal training. Transistor circuits packaged in six plug-in modules ease maintenance problems; a multimeter is incorporated in the electronic unit. True east-west line is read out on a conventional theodolite mounted on the alignment head.

Conventional survey for artillery field pieces sometimes requires days to establish a baseline from which officers can securely level fire.

## Wireless Microphone Uses Six Components

DIRECT frequency-modulated crystal oscillator is the heart of a pocket-sized microphone-transmitter to be announced this spring by Electro Products division of Itek. The Cambridge, Mass., firm plans to market the device first in the entertainment industry; potential uses also include communications from firemen inside a building to an outside command station.

Itek says a new method of gener-

*an  
excellent  
mixer*

The Model M-3

from MELABS

BROADBAND RESPONSE	0.5-11 kmc untuned
HIGH CONVERSION EFFICIENCIES	6-10 db
L. O. POWER	1-2 mw
LOW COST	\$97.00 without crystal

Mount can also be used for harmonic mixing, modulation of rf signals or for diode parametric amplifiers and up-converters.

*Melabs*

• 3300 Hillview Avenue • Stanford Industrial Park • Palo Alto, California •

VT2  
VT2N



VT2E



VT2F



Popular, small Model VT2 (with overvoltage). Volts output: 0-120/132; amps output: 1.5... Model VT2N (without overvoltage). Volts output: 0-120; amps output: 1.8. This model delivers more current than existing transformers of comparable size and price.

VT4  
VT4N



VT4E



VT4F



Models VT4 and VT4N Model VT4 (with overvoltage). Volts output: 0-120/140, amps output 3.5... Model VT4N (without overvoltage). Volts output: 0-120; amps output: 4.75.



# OHMITE

## VARIABLE TRANSFORMERS

Complete Line Now Available  
from Stock

VT8  
VT8N



VT8E



VT8F



VT8G



Models VT8 and VT8N offer the heavy capacity demanded for general laboratory and industrial applications. Model VT8 (with overvoltage). Volts output: 0-120/140; amps output: 7.5... Model VT8N (without overvoltage). Volts output: 0-120; amps output 10.0. Units available for 240-volt input also.

Now you can get *fast delivery from stock* on 38 different models of Ohmite variable transformers. This newly expanded selection covers a high percentage of industrial needs. In it you will find single and three-phase units, two and three-in-tandem assemblies (not shown above), plus a variety of other cased and uncased models.

Ohmite "v.t." variable transformers combine fresh thinking in design with traditional Ohmite quality. For example,

positive current transfer is achieved with direct brush to slip-ring, pig-tailed connection. Adjustable shafts on sizes VT4 and VT8 extend either to the brush or the base side. These two models also are *interchangeable* with competitive makes of comparable ratings. The "N" types in all three models provide additional current without overvoltage. The next time you need variable transformers, select from the line with advanced design—Ohmite.

**NEW 36-volt, high-current units for transistor circuit applications... write for Bulletin 151**

RHEOSTATS    RESISTORS    RELAYS  
TAP SWITCHES    TANTALUM CAPACITORS    DIODES  
VARIABLE TRANSFORMERS    R. F. CHOKES



**OHMITE MANUFACTURING COMPANY**  
3610 Howard Street, Skokie, Illinois

# SPRAGUE PIEZO- ELECTRIC CERAMIC ELEMENTS



**ELEMENTS  
FOR ALL  
APPLICATIONS  
AS WELL AS  
COMPLETE**

**TRANSDUCER ASSEMBLIES  
FOR MOST APPLICATIONS,  
SUCH AS UNDERWATER  
SOUND AND  
VARIOUS ORDNANCE AND  
MISSILE DEVICES.**



Sprague-developed mass production and quality-control techniques assure lowest possible cost consistent with utmost quality and reliability. Here too, complete fabrication facilities permit prompt production in a full, wide range of sizes and shapes.

Look to Sprague for today's most advanced ceramic elements—where continuing intensive research promises new material with many properties extended beyond present limits.



**YOUR INQUIRIES  
ARE INVITED**

**WRITE FOR  
LITERATURE**

**SPRAGUE ELECTRIC COMPANY**  
35 Marshall Street, North Adams, Mass.

**SPRAGUE®**  
THE MARK OF RELIABILITY

## WASHINGTON OUTLOOK

PROPOSAL for liberalized foreign trade policy has been made to President Kennedy that may ease some of the problems of electronics producers in the U. S. without upsetting international patterns of trade. This one comes from the staff of the Senate Interstate and Foreign Commerce Committee headed by Sen. Warren Magnuson (D., Wash.).

*The President has not formally endorsed the proposal, but he surprised Magnuson by asking that a summary of it be made public, indicating a more than routine interest.*

The report calls for remedies other than import restrictions to alleviate injury to domestic industry where the national interest argues against restrictions. The government would aid the distressed industry with a program of "adjustment assistance." The program is not spelled out in detail, but presumably would include industrial aid in the form of government loans, fast tax writeoffs, perhaps a guaranteed income to U. S. producers.

Peril point and escape clause procedures now used by the U. S. Tariff Commission would be modified. The Commission would act as an economic board of appeals to investigate cases of distress where the adjustment program does not give sufficient help.

*Restrictions on imports would be the last remedy, even where domestic producers argue that their work is essential to national defense. U. S. loans to other governments would require purchases of goods here as infrequently as possible. "Buy American" policies of U. S. procurement agencies would be restricted to those areas in which the national security or the priorities of labor-surplus areas were affected.*

Recommendations of the Magnuson staff have much in common with other recent advice to the President, including a private report prepared by Adlai Stevenson and new Undersecretary of State for economic affairs George Ball. Consequently there is a growing belief in Washington that Kennedy will fight for a liberalized trade policy.

LEGALITY of union boycotts against Japanese-made goods is undergoing scrutiny in Washington. Besides the threat by Chicago Local 1031 of the International Brotherhood of Electrical Workers not to handle electronic parts from "low-wage countries" after May 1 (ELECTRONICS, p 11, Jan. 27), boycotts have been announced by California aircraft workers on Japanese tools and dies, and in other industries.

*Some officials here believe that the actions of the IBEW local may fall under the "hot cargo" provisions of the Landrum-Griffin reform law. Under this law, refusal to handle hot cargo of an employer with whom a union has a dispute can be a secondary boycott. Other regulations of which the union actions may run afoul are the secondary boycott provisions of Taft-Hartley, restraint-of-trade prohibitions of the Sherman Antitrust act, and rulings of the Federal Trade Commission defining unfair trade practices.*

None of these has yet been tested either in the courts or before the National Labor Relations Board insofar as goods of foreign producers are concerned. Review of statements by Congressmen during the pre-enactment debate on the Landrum-Griffin law indicates that the law was not meant to interfere with either the "Buy American" program or efforts by unions to protect jobs threatened by foreign imports.

RESEARCH AND DEVELOPMENT by the electrical equipment and communications industry rose from \$1.9 billion in 1958 to \$2.2 billion in 1959, according to the National Science Foundation. Close to 75 percent of the industry's R&D funds stemmed from government sources. Almost \$60-million worth of the industry's R&D activity was devoted to what NSF classes as basic research.

*a revolutionary  
new wire stripper  
from*

# UTICA

Strip fast and clean! Eliminate nicking! Reduce insulation marking to an absolute minimum! Handle any wire size from #12 to #26 (Teflon as well as most other solid or stranded wire insulations). And do it all with Stripwright®... Utica's revolutionary new wire stripper. There's never been anything like it. This versatile, lightweight, pistol-grip tool is engineered for efficiency and ease of handling in limited access areas as well as for open production lines. Stripwright is designed to the same high standards of quality as all other Utica tools. Hundreds are now in service.

Write for complete information.

Cam action dial adjusts strip diameter to the finest variation.

Plastic handles... strong, light, comfortable.

Slim nose design makes it possible to reach into the most closely confined areas, strip fast and sure.

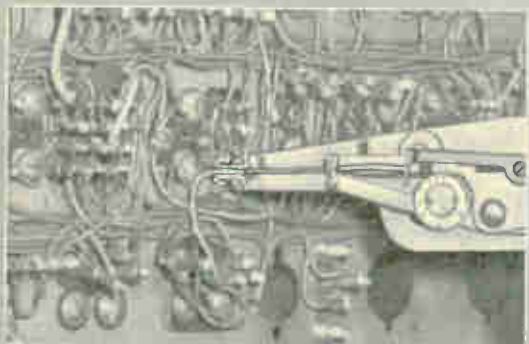

Adjustable stop permits stripping of any length up to  $\frac{7}{8}$ " per stroke.

UTICA DROP FORGE & TOOL DIVISION,  
KELSEY-HAYES COMPANY, UTICA 4, N. Y.

# BUSS FUSES

PLUS  
CLIPS—  
BLOCKS—  
& HOLDERS

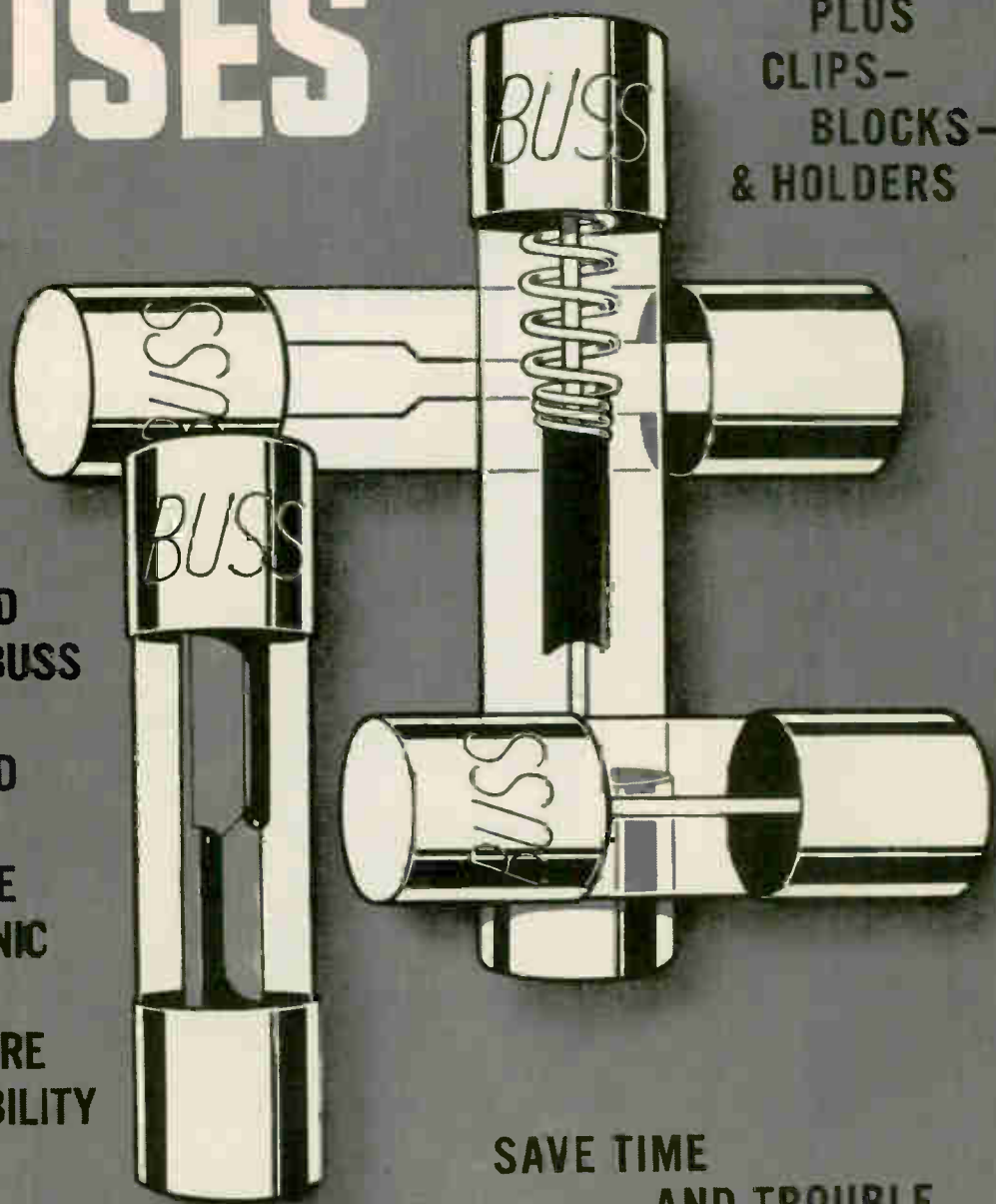

EACH AND  
EVERY BUSS  
FUSE IS  
TESTED  
IN A  
SENSITIVE  
ELECTRONIC  
DEVICE  
TO ASSURE  
DEPENDABILITY

SAVE TIME  
AND TROUBLE . . .

by standardizing on BUSS fuses. There's a right fuse for every need in the complete line. Write for the BUSS bulletin on small dimension fuses (Form SFB) to get full data for your files.

Bussman Mfg. Division McGraw-Edison Co.  
University at Jefferson, St. Louis 7, Mo.





# You can forget about this tube

*... for up to 10,000 hours  
in remote and unattended  
microwave installations!*



**Amperex**<sup>®</sup>  
EC157

Amperex<sup>®</sup>  
EC157

**This is the new microwave triode developed specifically for exacting common carrier requirements... providing far greater reliability, gain and power, than any other disc-seal, wide-band microwave triode available today!**

Expected life, 10,000 hours — guaranteed life, 6000 hours.  
When used as a narrow-band CW amplifier... gain is 18 to 19 db,  
with a power output of 0.5 watt at 4000 Mc.

As a broadband amplifier... gain is 12 db, with a power output of 0.5 watt at 4000 Mc.  
Saturation power output... as high as 2.5 watts.  
Required operating voltage... a low 180 volts, to simplify power supply, insulation and safety problems. And it can also be used for telemetering, industrial and test equipment applications... as an amplifier, oscillator, doubler or tripler to over 6000 Mc.

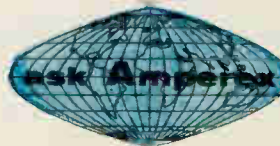

about common carrier and other applications with the EC157

**AMPEREX ELECTRONIC CORPORATION**  
230 Duffy Avenue, Hicksville, L. I., N. Y.  
In Canada: Rogers Electronic Tubes & Components,  
116 Vonderhoof Ave., Toronto 17, Ont.

# WANTED

# IN FLORIDA

## YOUR COMPANY TO JOIN WITH US IN PINELLAS COUNTY

Here's one of the few areas in America where it is possible to attract personnel in every category without difficulty.

Why? — No executive or employee need be more than 15 minutes away from home and garden, from fresh and salt water, fishing, bathing, boating, water skiing... no more than 15 minutes away from schools, churches, shopping centers, recreational and social activities.

All this, plus a favorable business climate...and SUN-sational living all year, in this enchanting land of flora and fauna.

Executive decisions, after extensive site location surveys in many areas of the nation, have resulted in major companies locating here. Their managements will gladly give you the result of their findings.

**NOTE:** Persons seeking positions please write Florida State Employment Service, 1004 First Avenue North, St. Petersburg.



For complete information communicate in confidence with:

**GREATER ST. PETERSBURG - CLEARWATER INDUSTRY COUNCIL**  
GREATER ST. PETERSBURG CHAMBER OF COMMERCE

Jack Bryan, Industrial Director / Department E, St. Petersburg, Florida

Clearwater  
Dunedin  
Gulfport  
Indian Rocks  
Largo  
Madeira Beach  
Oldsmar  
Pass-a-Grille Beach  
Pinellas Park  
Safety Harbor  
St. Petersburg  
St. Petersburg Beach  
Tarpon Springs

# CHANGE NOTICE

SUBJECT: **Test Instruments\***

DATE OF EFFECTIVITY: **At Once**

WAS



IS



\*Hathaway Denver, recognized for quality in design, development and manufacture of measuring, testing and control instruments, announces the acquisition of the test instrument line formerly produced by Dresser Electronics, SIE Division (formerly Southwestern Industrial Electronics Company).

## MEMO TO: **Test Instrument Buyers**

The line of test instruments formerly produced by SIE will now be manufactured and distributed by Hathaway Denver and will carry the Hathaway Denver label. The line includes:

### **VOLTMETER** (Model R-2)

This completely new voltmeter offers more in a single instrument, in terms of functional versatility, range and accuracy, than has ever been available in an electronic voltmeter.

- 1 MV-1000 V AC and DC
- 10 ohms-10 megohms midscale
- Frequency range 10 cps-1 mc
- DC Distend—upper 10% or 1% of any DC volts range can be expanded to cover the full meter scale.

### **MICROSOURCE** (Model K-1)

Can be used in conjunction with any standard oscillator in the frequency range of 10 cps-1 mc to produce small, known, controlled test signals. An internal battery and associated polarity reversing switch allow testing of high gain DC amplifiers. Direct reading voltmeter; 10 volts maximum output; continuously adjustable.

### **SIGNAL GENERATOR** (Model N-2)

Continuously variable over the frequency range from 1 cps to 1 mc in 6 overlapping bands, each having a ratio of over 10:1, this signal generator operates from 115 volt line and produces an output of 0 to 10 volts rms at less than 1% distortion.

- Resistance Meters
- Vibration Meters
- Audio Response Plotters
- Comparison Bridges



Write for bulletins on these products

**HATHAWAY DENVER**

5802 East Jewell Ave., Denver 22, Colo.

A division of HATHAWAY INSTRUMENTS, INC.

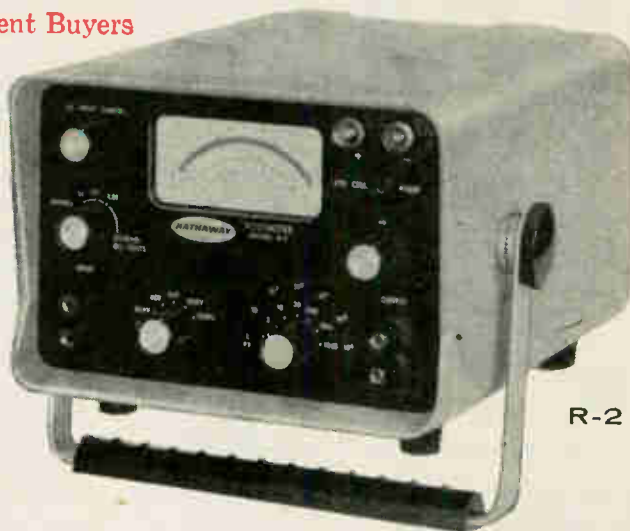

R-2



K-1



N-2

## Main Exchanges Show New Listings

TALLIES of the nation's four major stock exchanges show that about one fourth of 1960's new listings were electronics companies—49 of an all-industry total of 207.

Chicago's Midwest Stock Exchange had the highest ratio of electronic to general industry. Of 13 new listings, six were electronic. Two companies, General Dynamics and Servel, Inc., are New York based. The others, Bell & Gossett, Jefferson Electric, Universal Match and Emerson Electric are headquartered in the midwest.

Servel entered the electronics industry in 1958 through the \$17-million purchase of Burgess Battery. Company directors say their Chicago listing was made to provide a convenience to common shareholders in the midwest. The number of new listings on the Midwest board was higher in 1960 than in 1959, rising from 10 to 13.

The Pacific Coast Stock Exchange announced 29 new listings in 1960, 22 in 1959. There were nine electronics companies appearing on the PCSE board in 1959, however, as against six last year.

First on the west coast listings last January was Bell and Howell, which derives about 50 percent of its income from electronics. In April, Cohu Electronics was listed, followed by Norris-Thermador, Amphenol-Borg and Controls Company of America. In December of 1960 the final electronics listing for the year was International Rectifier.

In 1959, when the ratio of electronic to all-industry was 10 to 22, the new listings from our industry were Ampex, Avnet Electronic, Electronic Specialty Corp., Monogram Precision, Packard Bell, Thompson Ramo Wooldridge, Topp Industries, Universal Match, Varian Associates and Westinghouse.

The New York Stock Exchange showed a marked increase in new listings in 1960 as compared with 1959. The total went from 44 to 65. The number of electronics listings for both years, however, was the same—nine.

The new NYSE names for 1959 were Amphenol-Borg, Ampex, Packard-Bell Electronics, Varian Associates, Lear Inc., Controls Company of America, Consolidated Electronics Industries, AMP Inc. and Collins Radio.

In 1960, these companies went on:

United Industrial Corp. was listed on Jan. 4. Two days later, Marquardt Corp. became listed, followed in February by Transiron. In June International Resistance Corp. obtained listing privileges followed in August by Ling-Temco.

International Rectifier, Perkin-Elmer, Avnet Electronics and Burndy Corp. became listed in December. Avnet and International Resistance came to the NYSE from the American Stock Exchange, the other companies had previously had their stocks traded over-the-counter.

Last year on the American Stock Exchange, 22 of the 100 new listings were electronic.

Polarad led off in January with 850,876 shares going on the board. In February Textron Electronics was listed with a total of 2,410,000 shares. March saw two new entries, National Video Corp. with 646,667 shares and Giannini Controls with 439,190 shares.

In April Cohu Electronics and Pentron Electronics became listed with 1,614,141 and 815,000 shares respectively. In June six companies were listed: Andrea Radio—256,200 shares, Gulton Industries—1,011,342, Lafayette Radio Electronics—1,075,000, Sunair Electronics—710,000, Electronic Assistance Corp.—591,014, Telectro Industries—758,333.

Associated Testing Laboratories and Reeves Broadcasting and Development joined in August with 491,732 and 1,598,893 shares respectively. In September Electronic Research Associates (336,594 shares) and Hycon Mfg. (3,885,562) became listed, followed in October by Espey Mfg. & Electronics with 330,721 shares and

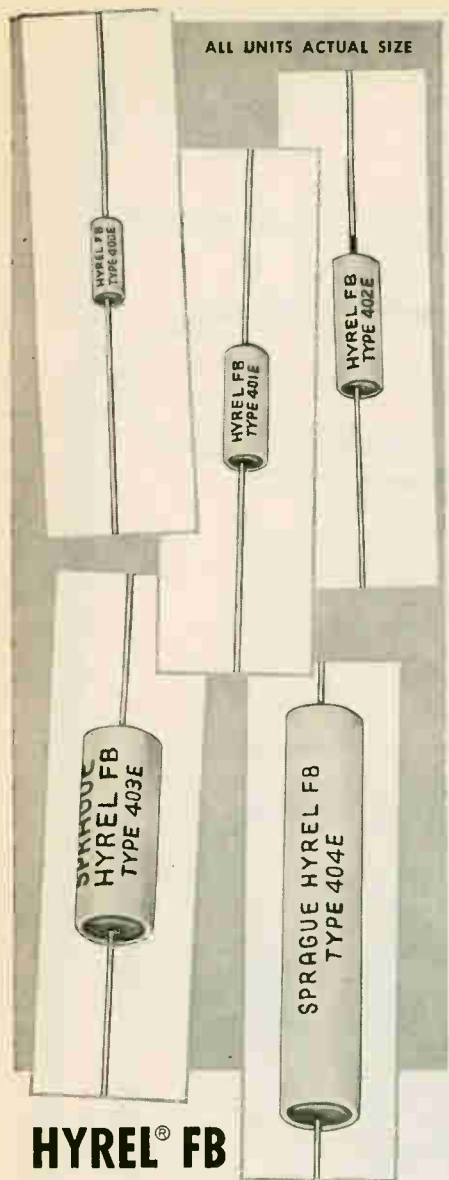

ALL UNITS ACTUAL SIZE

**HYREL® FB**

DEPOSITED CARBON RESISTORS

**UNMATCHED FOR PERFORMANCE**

... hermetically sealed in ceramic jackets against moisture and vapor... safely protected against mechanical abuse.

The Hyrel FB series is intended for applications in military, commercial and telephone equipment where long life under high humidity, small size, and stability of electrical characteristics are important.

WRITE FOR ENGINEERING BULLETIN 7010B

**SPRAGUE ELECTRIC COMPANY**

35 Marshall Street, North Adams, Mass.

Made to far exceed MIL-R-10509C Specifications

**SPRAGUE®**  
THE MARK OF RELIABILITY

Arco Electronics with 862,000 shares. In November Terminal-Hudson Electronics joined the list with 963,304 shares.

The last entries were in December, as Textron with 600,000 shares and Technical Operations Inc. (680,357 shares) became eligible for listing.

In comparison with 1960's 100 new listings for the American Stock Exchange, there were 63 in 1959.

PRIVATE STOCK placement by Sanders Associates, Nashua, N. H., to the value of \$1½ million has been announced. Funds will be used to finance expansion in anticipation of sales volumes of more than \$50 million. Over the past 18 months blocks of Sanders stock have been purchased by the One William St. Fund, the Lehman Corp. and the Wellington Equity Fund. The company is currently adding two plants, one in Plainview, L. I., one in Burlington, Mass., to existing facilities in a \$2-million growth program. Net earnings for fiscal 1961 are expected to top \$750,000, a rise of about 70 percent over fiscal 1960. Earnings are expected to reach 85 cents a share.

## 25 MOST ACTIVE STOCKS

	WEEK ENDING JANUARY 20, 1961			
	SHARES (IN 100's)	HIGH	LOW	CLOSE
Gen Elec Co	2,749	70½	67	67¼
Sperry Rand Corp	2,261	24½	23½	23¾
Ling-Temco	1,764	33	29	29¾
Ampex Corp	1,743	22½	21	21½
Westghse El Corp	1,635	48	45	45¼
Gen Tel & El Corp	1,190	27½	26½	26¾
RCA	1,153	51½	49½	51½
Republic Aviation	1,002	33	30	32¾
Sonetone Corp	1,000	13¾	9½	13¼
Universal Control	982	16½	15	16¼
Reeves Sndcrt	978	7¾	6¾	7½
Spartan Corp	940	9¾	7¾	9½
Standard Kollsman	903	28½	25½	28½
Int'l Tel & Tel	799	48½	46½	48½
Raytheon Co	732	41½	37½	40
Burroughs Corp	730	31¾	28½	31½
Nuclear Corp of Am	675	5	4¾	47½
CBS	632	37¾	36	37¼
Loral Elec	549	36¾	31¾	357½
Transitron	501	35½	327½	33¾
Avco Corp	495	14½	14	14½
Gen Dynamics Corp	490	44½	42¼	44½
Elec & Mus Ind	461	6½	5¾	6
Lockheed Aircraft	423	29	28½	28¾
Zenith Radio Corp	422	111½	100¾	107¾

The above figures represent sales of electronics stocks on the New York and American Stock Exchanges. Listings are prepared exclusively for ELECTRONICS by Ira Haupt & Co., investment bankers.

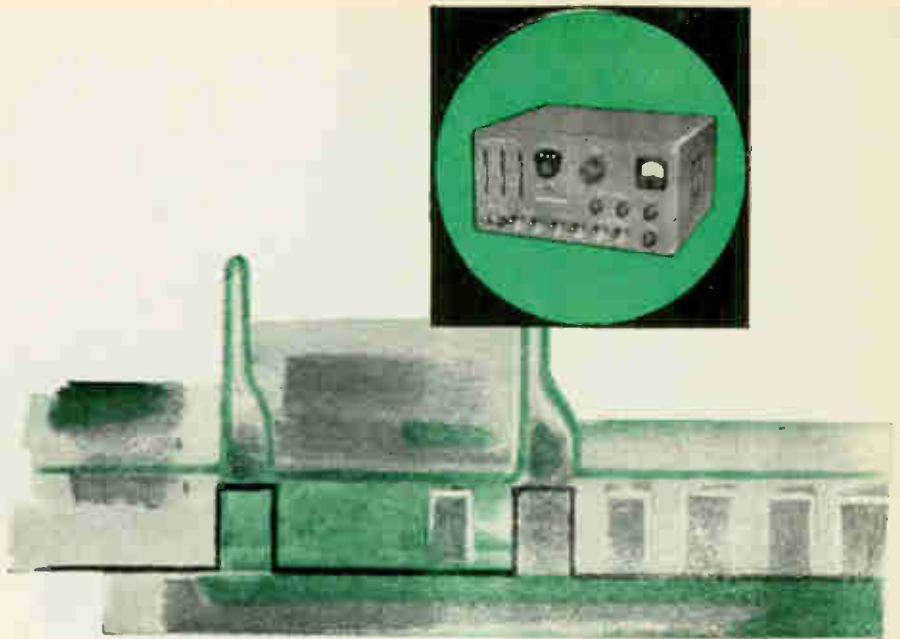

### PULSE TIMER . . . PROVIDES ACCURATE NO-JITTER DELAY MEASUREMENTS

Countdown — blast-off — and another "bird" soars gracefully skyward. But preceding its flight are countless component and system checkouts. And at the launching pad as on the production line, Crosby-Teletronics is on the job. One piece of test hardware, the Model PT-244 Pulse Timer, is standard on Bomarc and many other current missile programs. This paired trigger generator delivers a fixed and delayed pulse to provide no-jitter delay measurements up to 10,000 microseconds with an accuracy of ±0.02 microseconds. Results are read directly from a combination of decade counters and a digital dial. The PT-244's stability and reliability is typical of Crosby-Teletronics . . . a leader in long range communications, vacuum research and precision-built

# test equipment



Crosby-Teletronics Corporation • 54 Kinkel Street • Westbury, Long Island, New York

**your  
invisible  
employee . . .**

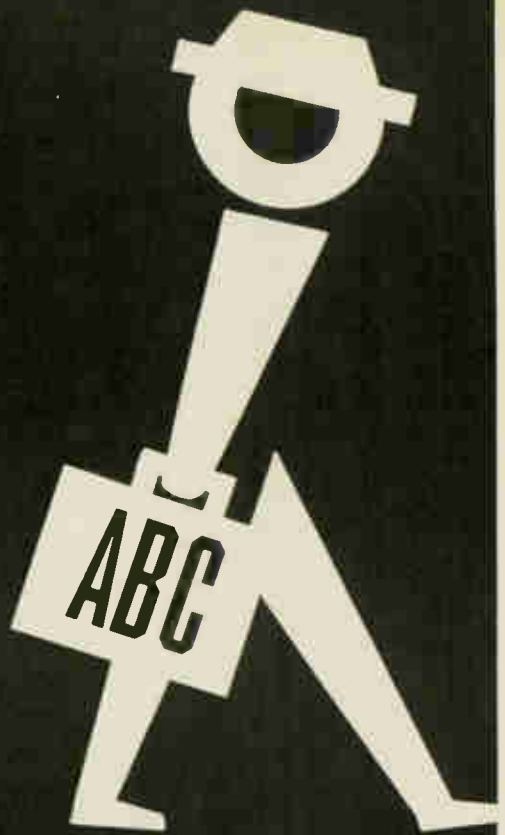

He's not on your payroll . . . he takes up no desk space in your office . . . and he doesn't hang around the water-cooler talking to your secretaries. But this man works for you — and for every other advertiser.

What does he do? He helps to safeguard your advertising investments in print media — by providing audited circulation facts and figures on 2,900 publication members of the Audit Bureau of Circulations\*. Assuring an accurate accounting, he tells you how many people purchased the publication . . . where they live . . . how much they paid . . . and the answers to many other questions about the publications and your markets.

He gives you factual marketing information as the basis for your advertising investments. He walks into every ABC-member publication's office and audits its circulation — just as carefully and as objectively as a financial auditor might check your books.

When he is finished, the guesswork is gone! He gives you facts — no opinions, pleasant statistics, *maybe* projections, or fancy figures — just plain old fashioned circulation facts.

Who is he?

He is the ABC auditor — and he works for *you!*

# electronics

A MCGRAW-HILL PUBLICATION • 330 W. 42nd ST. • NEW YORK 36, N. Y. 

\* Through the reports issued by the Audit Bureau of Circulations, this publication, along with other publisher members of ABC, voluntarily and regularly give the buyers of advertising more verified factual information than is available for any other media at any time.

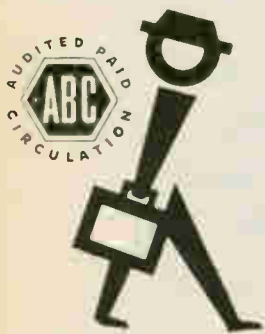

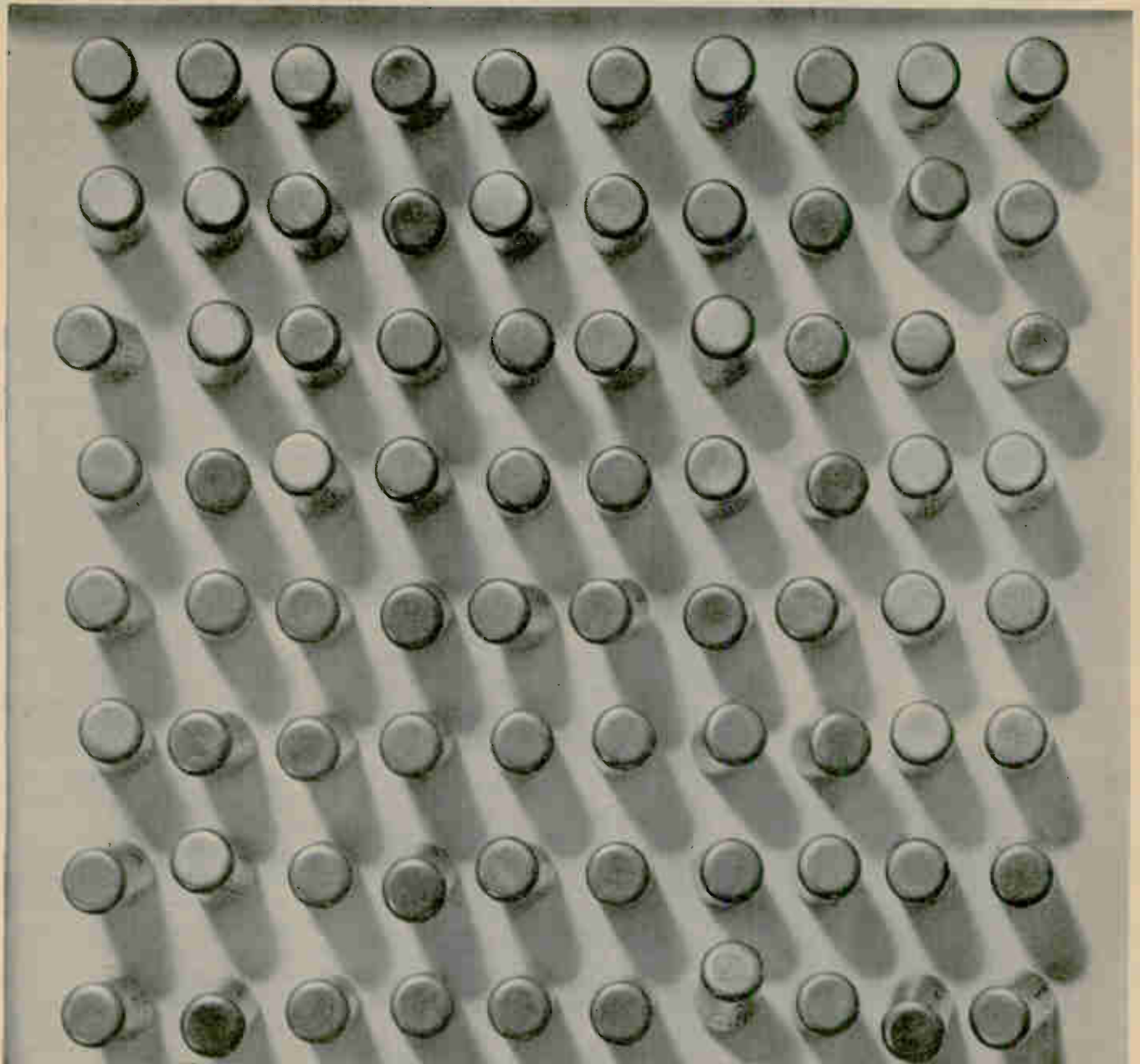

## Germanium PNP Alloy Type **TRANSISTORS**

2S26 For Audio Frequency Power Amplification  
 2S45 For Intermediate Frequency Amplifier Service  
 2S52 For Converter Service  
 2SA49 For Intermediate Frequency Amplifier Service  
 2SA50 For Switching Purpose  
 2SA52 For Converter Service  
 2SA53 For Intermediate Frequency Amplifier Service  
 2SB26 For Audio Frequency Power Amplification  
 2SB47 Low Noise Factor with Audio Frequency Amplifier  
 2SB54 For Low Frequency Amplifier Service

2SB56 For Audio Frequency Power Amplifier Service  
 2SB189 For Medium Power Output Service

### Germanium PNP Alloy Type **DRIFT TRANSISTORS**

2SA57 For High Frequency Amplifier Service  
 2SA58 For High Frequency Amplifier Service  
 2SA59 For High Frequency Amplifier Service  
 2SA60 For Converter Service  
 2SA92 For Local Oscillator Service  
 2SA93 For Mixer Services  
 2SA175 For High Frequency Amplifier Service

*Toshiba*

For complete information, write to  
**TOKYO SHIBAURA ELECTRIC CO., LTD.**  
 2, Ginza Nishi 5-chome, Chuo-ku, Tokyo, Japan

# ELECTRONICS

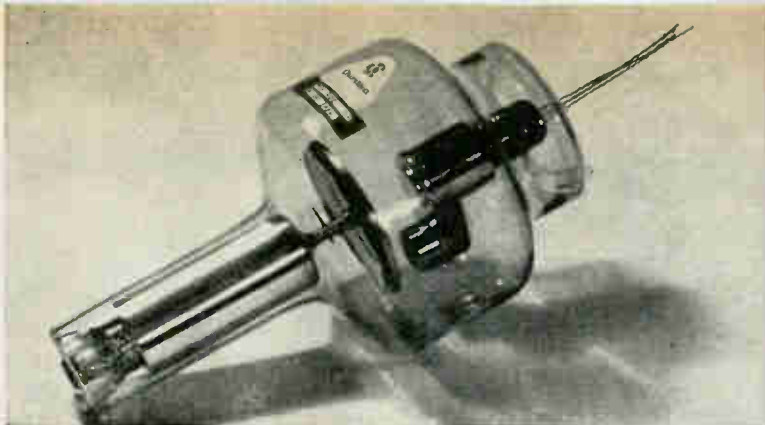

*Rotating anode x-ray tube*

through Ministry of Internal Trade, which serves as a clearing house for district wholesale distributing state agencies. Consumption is planned one year ahead.

Foreign trade is impossible directly with producing firms. Kovo, National Corporation, is state foreign sales agency representing all electronics firms. Exports are planned ahead—with fellow East Bloc countries usually within five-year goods exchange agreements—or with Western countries on annual goods exchange agreements.

Czechoslovakia's Academy of Sciences has an Electronics Section which operates institutes and laboratories for theoretical research. Each of the manufacturing firms (and some branch plants) have company development laboratories working in applied research in close cooperation with the Academy of Science and "State Committee for Technical Development". The latter is an advisory organ reporting to the government on matters of new technology involved at home and—especially—abroad.

An engineer earns between 2,000 and 2,500 Czech crowns per month (\$277 to \$347), while unskilled labor gets about 1,400 Czech crowns (\$194).

Tesla Corp. plants account for almost 100 percent of production. Semiconductors include germanium diodes, junction rectifiers, power rectifiers, transistors and photocells.

Production of radios and television sets reflects government's thinking on overall economic strategy. Radio output in 1948, for example, was 267,697 units. This dropped by government order to only 102,334 sets in 1955—when rapid build-up of heavy industry was paramount effort of economy—but improved due to government's "soft course" to 280,522 units in 1959. 1960 output was planned at 330,000 units.

Nearly every village in Czechoslovakia has a centrally-governed loudspeaker system, and sales of radios and television are booming now. Tv output (starting slowly in 1953) reached 17,250 units in

VIENNA, AUSTRIA—Czechoslovakia covers 49,345 sq mi. has 14 million persons and an electronics industry made up primarily of five state concerns: Tesla, Metra, Aritma, Krizik and Chirana.

Tesla has a string of plants throughout the country. Here's where they are, what they make:

Tesla-Roznov (tubes, cathodes, computers), Tesla-Holesovice (vacuum tubes), Tesla-Pardubice (transistors, receivers), Tesla-Brno (electronic measurement instruments, microscopes), Tesla-Laudskron (radio components, vacuum tubes), Tesla-Bratislava (radios), Tesla-Valasske Mesirici (loudspeakers, amplifiers).

Metra is in Blanko-Brno and makes measuring instruments. Aritma, in Prague, makes punch-card systems and teleprinter punch tape systems. Krizik, also in Prague, produces electrical measuring, regulating and protective instruments. Chirana, in Prague, makes medical gear, x-ray tubes.

Products of the electronics industry are distributed domestically

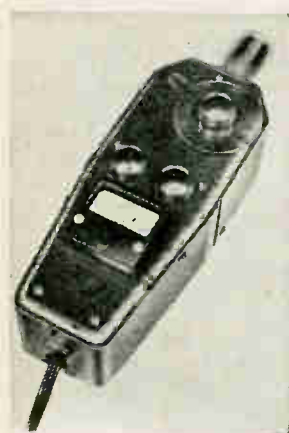

*Resonance meter*



*L-C-R meter*

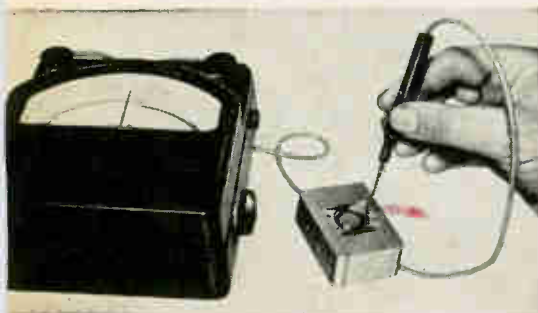

*Gaussmeter with germanium probe*



*Table-type electron microscope*



# IN CZECHOSLOVAKIA

By F. H. BAER

McGraw-Hill World News

1955, and as much as 196,609 units in 1959. Goal for 1960 was 410,000 units.

Three major business categories are measuring instruments, electronic microscopes and radio and tv transmitters. Less prominent groups include punch-card systems, computers, and control instruments for automation. Two firms, Tesla-Brno and Metra, are key producers of measuring instruments.

Tesla has developed a special test bench (MS/111/59) with calibrated rules and standards serving for adjustment, measurement and calibration of single-phase and three-phase meter at  $\pm 0.05$  percent transformer error,  $\pm 3$  percent lowest phase shift ratio error.

Tesla's internationally best-known product is electronic microscope BS-242-A.

Czech telecommunications equipment is installed in more than a dozen foreign countries. Kovo says, pointing out Tesla's main sales items: UTU automatic telephone exchange for branch offices, upwards from 40 extensions. Fitted to it is TVO-54 voice-frequency device, at 2,280 cps for long-distance calling. There's a portable automatic branch exchange for 10 public lines and up to 60 private extensions.

Tesla teleprinter circulation system serving between 24 and 32 subscribers from any four automatic transmitters are included in this system. Teleprint test transmitter, part of the system, serves for continuous maintenance of network. The JVT-2 single-band telephone serves duplex telephone traffic on 110 or 220 kv carrier lines with up to five JVT-2 sets per one metal-connected circuit.

Communication measurement gear includes transmitter and receiver for medium-frequency (12-X-J-035 and 12-X-J-042). Set checks into parameters of carrier currents within 0.2 to 552 kc range. Another device serves for measuring phase angle, attenuation and gain for passive and active four-terminal networks.

Transmitters include universal short-wave KUV-25 unit for 1.7 to

29.0 mc; output lies between 80 and 250 w depending on type. Twenty-four-volt remote control is possible up to 12 mi through four-wire cable. Air communications equipment includes R1-2-D airport radio locator with 25 mi radius, 150 to 200 kw and frequency from 9,400 to 9,600 mc. Latter set is connected to Tesla 15-channel tape recorder with  $\frac{3}{4}$ -in tape permitting 14 independent tracks plus one time track.

Aritma is the Czech firm for punch-card systems. Latest development expands into alphanumerical card punching. Interesting development is simultaneous (international five-track) tape punching during typing of invoices or bills, while using business calculating machines, or master card-punch machines.

Tesla-Pardubice turns out a few analog computers "AP-3" and "AP-4"—but declines to reveal details. General information indicates that the "AP-3" is a two-rack (AP-31 and AP-32 unit) with each rack usable alone, too. It contains 64 universal operational units, 4 diode multipliers, 4 arbitrary diode function generators, 10 voltage level switches, 6 time switches, 8 servomultipliers, 16 diode limiters, 16 diode function changers, and 2 patch panels.

The "AP-4" is a small accurate analog computer with an intuitive program desk. It is equipped with 16 operational units, 4 diode limi-

ters, 4 diode function changers  $x^2$ , 2 diode current limiters, 2 diode function changers  $x^3$ , 2 diode function changers  $\sin-x$  and a chopper auxiliary adjustment device.

The computers can be fitted with any of these plug-in units: operational amplifier, impedance unit, diode limiter, diode function changers, time switch, voltage level switch, diode nonlinearities control panel, arbitrary function generator's control panel, arbitrary function generator, diode multiplier control panel, console plug-in unit frame, main switchboard and stabilized power supply.

Design work undertaken at the CKD Factory of Prague deals with power application of semiconductor rectifiers. Two series of germanium power rectifiers (25 kw and 300 kw) are being produced. Silicone is a wide field of R&D. Silicon rectifiers for heavy electrolysis operate at 6,000 amp/300 v, the device using 96 to 120 UKA-15 tubes. Silicone rectifying equipment for underground converter substations in mines is able to stand 100 percent overload at standard 500 amp/275 d-c v. For use in a locomotive equipment for 1,025 amp/750 d-c v permanent current load was designed. Silicone power tubes with aluminum cooling body are used for 150 amp/300 to 400 v.

Selsyns in new production lines are used primarily for a-c, seldom in d-c. Main use is as indicating rather than power selsyn.

## Exchange to Buy Stock Quote System

AMERICAN STOCK EXCHANGE recently signed contracts for a \$3-million electronic quotation system that will report stock figures to members in either straight figures or by canned voice report.

Network was developed by Tele-register, is scheduled to be in operation in two years. It will give figures for opening, high, low, and closing bid and asked prices; volume to the moment and size of bid or ask offerings.

Subscribers dial a code number

on a special telephone that interrogates a drum storage unit; in two seconds the response is translated into English words by a vocabulary storage which contains spoken versions of the alphabet, numerals zero through nine, and such words as *bid*, *offer*, *eight*, *none*. The message then goes to the subscriber.

Alternate teleprinter output operates at higher speeds since no translation is needed. Capacity of the system is 2,000 securities at the inquiry rate of 72,000 an hour.

# Dynasoar: A \$1-Billion Market By '66

*Development pace of USAF's manned aero-spacecraft weapons system is expected to pick up as Boeing awards seven subcontracts by mid-April*

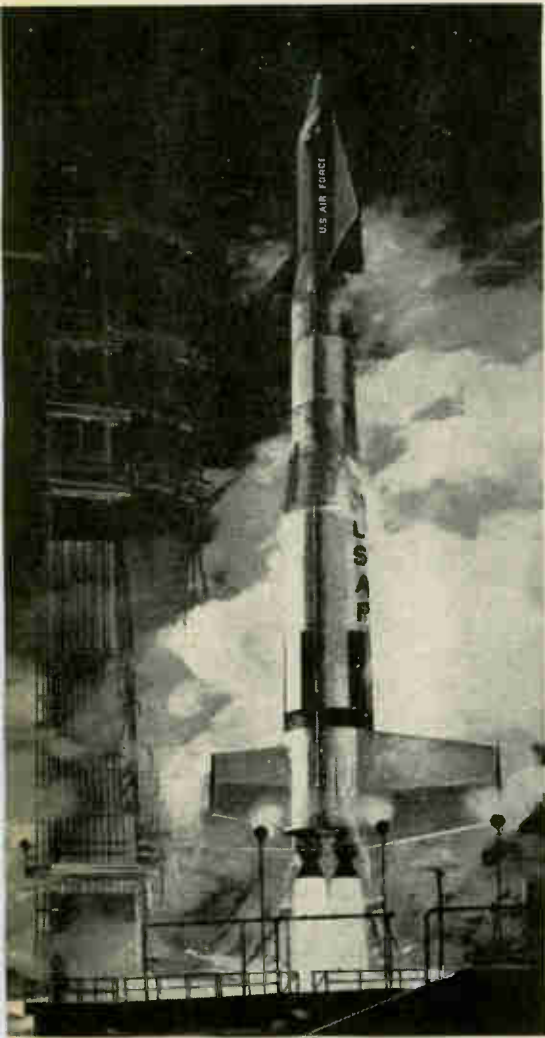

*Artist's concept of how glide vehicle will be boosted into space by modified Titan ICBM*

OVER THE NEXT few months, Boeing, prime contractor for the Dynasoar boost glide aerospace vehicle, will award a number of subcontracts. Plans for the project call for no off-the-shelf hardware.

Under the direction of USAF's Wright Air Development Division, Boeing will contract for work on a secondary attitude reference early this month. Toward the end of February, subs will be awarded for the power unit, reaction control

system for stabilizing and orienting the glider in space, generator and controls, and the hydrogen cooling equipment.

Contract for the rocket motor and test instrumentation subsystem will be announced in mid-April.

A test instrumentation subsystem involves instruments for gathering and recording data from Dynasoar flight tests, expected to begin sometime in 1963.

A magnetic tape recorder, operating continuously, will store the data. Data also will be transmitted from the glider to the ground. Telemetry ground equipment must provide a quick look at selected data, then prepare the information for computer processing.

Boeing has already awarded the following subcontracts: Minneapolis-Honeywell, \$2.7 million for a six-month development program for inertial guidance and \$2 million for flight-control electronics; RCA for communications and tracking; and Chance Vought for test models for nose caps.

One of the big communications and tracking problems will be maintaining contact with the vehicle during reentry. The plasma, or ionized air, that surrounds the vehicle on reentry distorts the radiation patterns of the onboard communicating antenna.

Martin is prime contractor for the modified Titan ICBM that will boost the glide vehicle into space during phase I of the joint Air Force-National Aeronautics and Space Administration program.

Funding thus far for Dynasoar has amounted to \$111 million: \$58 million for fiscal year 1961; \$29.7 million for 1959 and 1960; and \$23.3 million prior to 1959. Former President Eisenhower stated in his recent budget message that appropriations for 1962 would be somewhat higher than the \$58 million for 1961.

Cost of research, development, test and evaluation through 1966 has been estimated at \$638 million plus a possible \$300 million more for procurement through 1965. Dynasoar is expected to cost more than \$1 billion by 1966.

Dynasoar represents USAF's leap from manned atmosphere aircraft to manned controllable aerospacecraft.

USAF's Deputy Chief of Staff-Development Lt. Gen. R. C. Wilson says, "The Air Force considers Dynasoar the most important R&D project it has. It will open a new era. It is the first step toward practical man-in-space flights."

Dynasoar will be a large multi-stage rocket that will boost a manned delta-winged glider to orbit the earth, descend through the atmosphere and land like a conventional airplane.

To reenter the atmosphere, the pilot will use aerodynamic controls. The craft will dip into the atmosphere, then skip out again like a rock skipping off the surface of a pond.

"The reentry vehicle," ARDC Commander Lt. Gen. B. A. Schriever said, "will be designed so that its pilot retains full control of his maneuvers once he has reentered the atmosphere at a speed of around 15,000 mph. . . . Later versions can be made to orbit the earth many times and then reenter the atmosphere for a specific mission. Such a vehicle could be used as a satellite interceptor to inspect, board and disable hostile satellites." Schriever also foresees civilian application for a Dynasoar-like vehicle.

The project is divided into three steps: (1) The Boeing glider will be dropped from a B-52 near Edwards AFB, Calif. in late 1963; it will be boosted by a Titan ICBM in early 1964; and finally, it is planned that a manned glider will

be boosted by an ICBM early in 1965.

(2) Larger boosters will be used and determinations made of military uses of such a system.

(3) Studies of weapons systems growing out of the Dynasoar development will be made.

The manned gliders will be launched from Cape Canaveral, Fla. and land at the islands down the missile range. Flight tests, data acquisition, reduction and dissemination will be supervised by committees composed of personnel from the Air Force Flight Test Center and the NASA Flight Research Center.

### FCC Plans to Defend Space-Frequency Action

NEXT TUESDAY in Washington, D. C., the Federal Communications Commission will file a report with the U. S. Court of Appeals describing Commission actions on frequency allocations for space communication.

The filing was triggered by an appeal by the American Rocket Society seeking to nullify FCC's decision last summer not to set aside exclusive frequencies for space communications.

The society's position is that exclusive frequencies for space must be established on a worldwide basis. A. G. Haley, general counsel for ARS, says if exclusive channels are not made available interference from other countries will destroy the possibility of worldwide broadcasting and communications.

Reply from commercial users came early in January. The National Association of Manufacturers and the American Trucking Associations, Inc. jointly moved to dismiss the ARS appeal on the grounds that the FCC decision is not final and that the Society is not "a party aggrieved" by the decision.

At press time there was no statement forthcoming from FCC on any plans involving contesting the suit. The Commission, however, has not been idle. There are presently two investigations in progress to examine the technical aspects of interference possibilities.



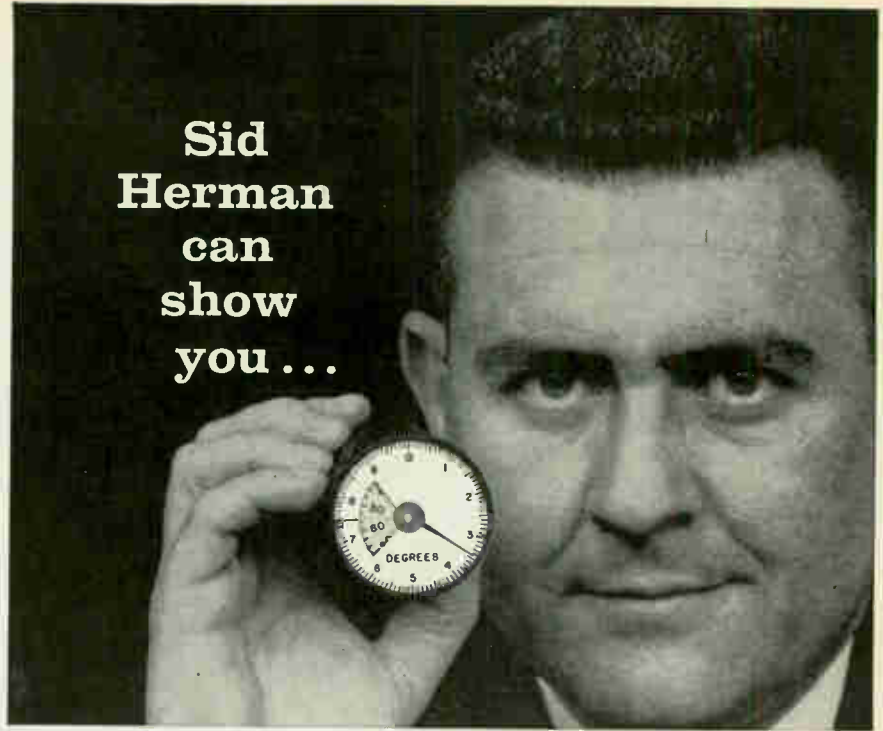

**Sid  
Herman  
can  
show  
you ...**



## how North Atlantic's instrument servos fill the five major systems jobs ... exactly.

Measurement, remote display, data conversion, control, computation ... Name the task and it's probable that the North Atlantic man can show you how to meet it precisely from NAI's comprehensive line of 3" and 2" vacuum tube and all solid state instrument servos.

Production models are available for high- and low-level ac, dc, synchro, strain gage, thermocouple, resistance bulb and other inputs. Most can be supplied with choice of pointer, counter, torque shaft or digitizer outputs. All utilize flexible design that permits any combination of input-output features to be supplied rapidly to user requirements, for both ground and airborne applications. Some are described below.

SBI-201 Single Pointer DC Ratiometer	SBI-401 A-to D Converter	SBI-501 Shaft Position Repeater	SBI-502 Three-Digit Counter Readout	SBI-509 Dual Scale Readout
				
<b>Input</b> Denom. 5-50v Num. 10 mv-100v <b>Accuracy</b> $\pm .2$ to $\pm .5\%$ fs <b>Resolution</b> .1 to .2% <b>Response</b> .25 sec. fs	<b>Input</b> 10 mv to 100v dc <b>Accuracy</b> $\pm .1\%$ fs <b>Resolution</b> from 0.05%* <b>Response</b> from 2 sec fs* *depending on encoder used	<b>Input</b> ac, dc or synchro <b>Accuracy</b> $\pm .1$ to $\pm .5\%$ fs <b>Resolution</b> .05 to .25% <b>Response</b> 7 sec. @ 15 oz-in	<b>Input</b> ac, dc, or synchro <b>Accuracy</b> $\pm 0.5$ to .1% fs <b>Resolution</b> .02 to .05% <b>Response</b> 15 sec. fs	<b>Input</b> ac, dc, or synchro <b>Accuracy</b> .05 to .1% fs <b>Resolution</b> .02 to .05% <b>Response</b> 6 sec. fs

If there's a critical job for an instrument servo in your system design, it will be worth your while to talk to your North Atlantic engineering representative. For his name, call or write today. Or request Catalog SFC-1 for complete data.



**NORTH ATLANTIC industries, inc.**  
TERMINAL DRIVE, PLAINVIEW, L. I., NEW YORK • Overbrook 1-8600



# RF PRODUCTS

## PRODUCES MORE AND DELIVERS FASTER FAMOUS AMPHENOL COAXIAL CABLE AND WIRE

As a new decentralized division of Amphenol-Borg Electronics Corporation, R F PRODUCTS now has responsibility for the engineering, manufacture and marketing of Amphenol Coaxial Cable and Wire. To the electronics industry—and to you—this means more and faster deliveries from factory inventory of the world's largest selection of approved, high quality RG type cable.

R F PRODUCTS also means the consolidation of three great names in radio-frequency components—Amphenol Coaxial Connectors and Cable, IPC Coaxial Connectors, and DK Coaxial Switches. The integration of these related component lines makes possible the engineering-in-depth needed to stay abreast of your demands in this exacting field.

Whether you require sub-miniature coaxial cable, high-temperature flexible cable, large special-purpose multi-conductor cable—or any of hundreds of other varieties—you'll find that R F PRODUCTS offers a comprehensive, single-source supply.

**IRE Show: Booth 2501-03**

A DIVISION OF AMPHENOL-BORG ELECTRONICS CORPORATION



# R F PRODUCTS

DANBURY, CONNECTICUT • Pioneer 3-9272



# Medical Equipment In Spotlight

ST. LOUIS, MO.—An electronic converter driving a synchronous motor from a portable battery source has kept a dog alive up to 15 hours with natural heart removed and replaced by intercorporeal heart pump. This was recently described by R. C. Eggleton during the three-day Instrument Society of America conference here.

Replacement for right and left ventricles weighs four pounds, plus another pound for electronics package, as described in the paper Eggleton prepared with Drs. William and Francis Fry of Inter-science Research Corp., Champaign, Ill. New power supply under development should increase efficiency from 50 percent to 80 percent, Eggleton said.

Five biomedical instrumentation papers occupied first full day of the meeting, which presented nearly 40 papers during 15 technical sessions. Strain gage workshop featured five papers in the morning session, followed by an afternoon instructional session conducted by the authors. Data handling presentations covered morning and afternoon sessions on the closing day.

Unique conductive rubber sensor which changes resistance when stretched as harness for chimpanzee was described by Earl J. Brown, McDonnell Aircraft, in a paper on systems to sense physiological information on astronauts and primates of Project Mercury.

"Floating" steel electrodes, 1½ inch in diameter, are sandwiched between cork discs to reduce electrical noise resulting from muscular movements. Thermistor rectal probe serves as temperature sensor. Other thermistors detect respiration rate and depth.

Constant current 100-cycle oscillator stimulator featuring special trigger circuits to study physiology of the brain was described by George Johnson and John Roth, M.D., of University of Oregon Medical School, Portland.

Harry Stierli, National Institutes of Health, Bethesda, Md., described thermocouples, potentiometers, gas chromatographic apparatus and other instruments for

testing hospital and lab equipment. Instrument system for measuring total energy, metabolism and related human phenomena was described by Drs. R. H. Thompson and E. R. Buskirk, also of N.I.H.

"Transponder—a New Concept in Low-Level Data Acquisition," was presented by Vincent Van Praag, William Stanke and David Van Mindeno, Electro-Logic, Venice, Calif. High sensitivity, simplicity of analog-to-digital system eliminate need for other analog equipment, so reduce cost, size and power while increasing accuracy and reliability, the authors said. The system should broaden scope of computer control systems, the authors added.

Coordination of digital process computer with test operators to gain best advantage from desirable features of each in automating quality control methods was described by J. L. Carlson, Librascope, Burbank, Calif.

E. J. Kovalcik, Allison division, GMC, described design of central data acquisition facility which uses manpower and equipment more efficiently, speeds test setups, improves reliability and has reduced maintenance 50 percent.

Automation of photogrammetric

processes, one of least developed areas, was urged by Q. S. Johnson, Union Instrument Corp., Plainfield, N. J., for extracting useful information from photos by automatic measurement and interpretation of the images they contain.

New type of heterodyne wave analyzer which overcomes limits of conventional types and is more stable over a greater range of applications was described by Laurie Burrow, Jr., Convair, San Diego.

New approach replaces tunable high frequency local oscillator with crystal controlled oscillator, to improve stability.

Sideband is eliminated for wave analysis by filter, in high frequency regions, or by phase cancellation for lower frequencies. While unit described has been used primarily in 5 to 2,500 cps range for vibration analysis of rotating machinery, second unit, now under construction, will operate from 1 to 25,000 cps.

A. E. Bernhard, Applied Research Labs, Glendale, Calif., described "Some On-Line Applications of X-Ray Fluorescent Spectrometers," and Laurence Maley, Waters Associates, Framingham, Mass., "Continuous Analysis by Flame Photometry."

## Teeth for Britain's Atom Smasher

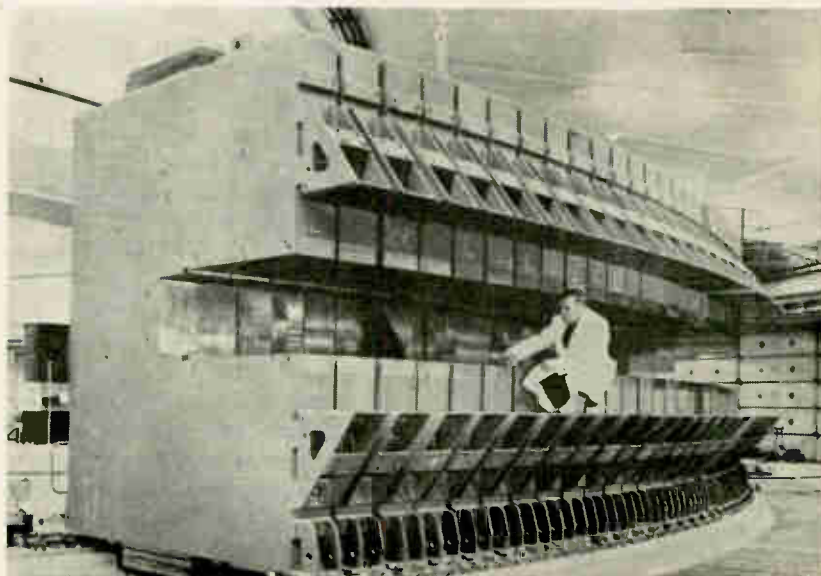

Section of Britain's largest magnetic core (160-ft diameter) goes into 7 Bev proton synchrotron at Harwell, England

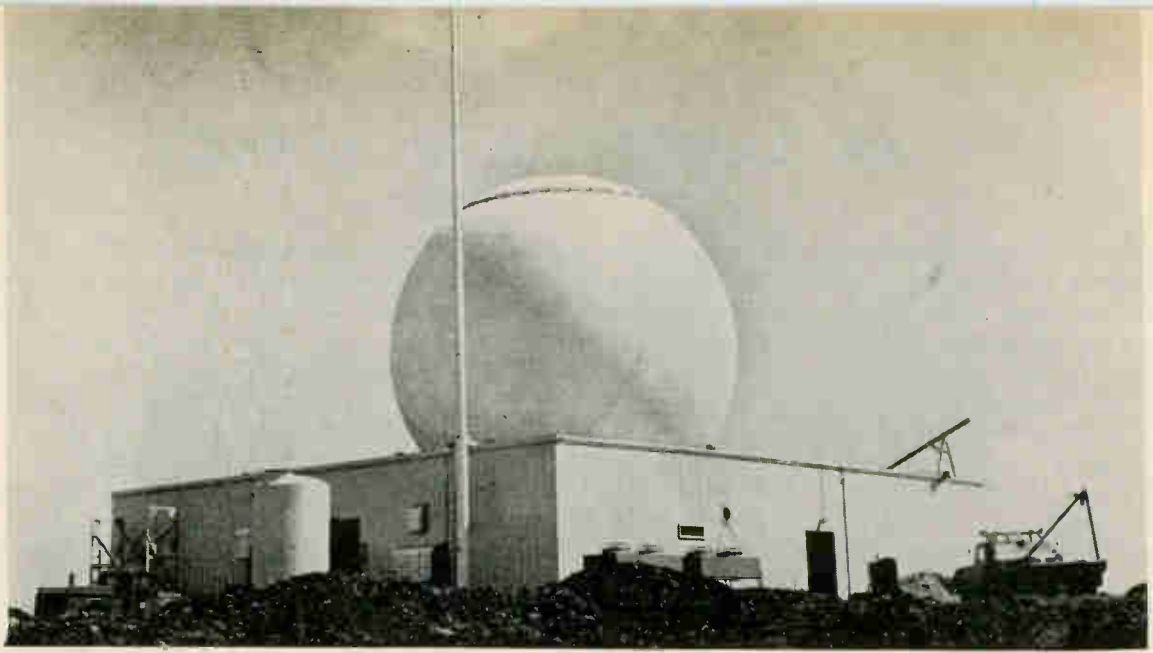

Target track radar uses 24-ft dish, 200,000-lb mount

## Nike-Zeus Radar Ready for Tryout

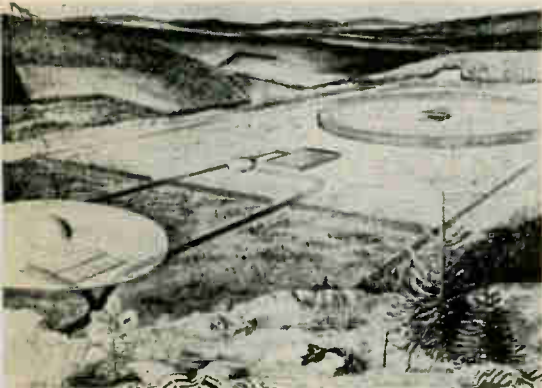

Acquisition radar receiver (left) is separated from triangular transmitter (right) because of the transmitter's enormous power



Portion of site shows target tracking, discrimination, Zeus tracking radars and (rear) Zeus being launched

NIKE-ZEUS target track radar is now set up on Ascension Island in the South Atlantic to track ICBMs launched downrange from Cape Canaveral, Fla., 4,500 mi northwest. (ELECTRONICS, p 24, Jan. 13.)

A plastic radome houses both the dish-shaped 24-ft antenna and its 200,000-lb mount.

Function of the installation is to track and record on magnetic tape ICBM trajectory radar data from the live launchings, and ship the tape to Zeus test ranges for simulated intercept target practice. Zeus missiles will be fired from White Sands Missile Range, New Mex. and Point Mugu, Calif.

Since firing ICBMs toward either White Sands or Point Mugu is not possible, the tape will be used to simulate them.

The target intercept computer, which tells the defending Zeus missile where the target is in space, and where the antimissile missile must go to intercept the target, will utilize the data recorded on the Ascension Island tapes.

Zeus will take off from its launcher, roar through the sky and follow a course back to earth. Recording instruments will indicate the success of the Zeus in intercepting the ghost target based on information fed into the target intercept computer by the Ascension Island tapes.

The target-track radar is one of the four principal radars used in the Zeus system. A broad-beamed acquisition radar, (see artist concept) capable of searching millions of cubic miles of space, will first locate the attacking ICBM warhead. The target will then be transferred automatically to the target-track radar which follows it, supplying the precise location data required for interception.

A discrimination radar will provide the accurate measurements necessary to identify real warheads among the decoys which might be ejected by an incoming missile. A fourth unit, the missile-track radar, will follow the defending Zeus, feeding precise location data continuously to control computers which issue steering commands to the antimissile missile.

Army is now installing a complete Nike Zeus system on Kwajalein Island in the Pacific for firing Zeus against live ICBMs launched from California.

The Ascension Island radar was produced by Bell Telephone Laboratories, contractor for Zeus design and development. Continental Can made the radar mount. Army Rocket and Guided Missile Agency is technical supervisor for the program.

Western Electric is prime system contractor.



## THEY RELIED ON RADIATION TO TRANSMIT AND RECEIVE TIROS' WEATHER DATA

Now that the performance record is complete, it can be reported factually. All cloud cover pictures were telemetered to earth by two Radiation Model 3115 FM Telemetry Transmitters. Over 90% of the pictures from NASA's *Tiros I* were received on Radiation antennas. Both the transmitters and the antennas have proved their reliability in several major missile programs.

The two automatic tracking antennas which recovered the weather pictures are located at Ft. Monmouth, N. J., and Kaena Point, Hawaii. Radiation designed and built the Kaena Point antenna, converted the one at Ft. Monmouth to automatic tracking. During the 1600 orbits completed by *Tiros* in 3½ months, push-button antenna operation gave automatic satellite acquisition and tracking.

Transmitters and antennas . . . electronic data acquisition and processing systems . . . radar . . . instrumentation . . . all these are areas in which Radiation's capabilities have materially aided the defense program, industry and the advancement of electronic technology. For a closer look at the things we do . . . and can do . . . write for our "Capabilities Report". Radiation Incorporated, Dept. E-2, Melbourne, Florida.



**RADIATION**  
INCORPORATED

# Are Semiconductor Tests

**GREEN  
PANTOGRAPH  
ENGRAVERS**

● **ELIMINATE DELAYS!**

● **KEEP YOUR OPERATING COSTS WHERE THEY SHOULD BE!**



**PORTABLE  
40-POUND  
BENCH MODEL 106**

*You Make  
Your Own  
Engraved  
Nameplates!*

Here is a speedy, economical 2 or 3-dimensional engraver used by thousands of dollar-conscious companies. It features 5 positive, accurate pantographic ratios; ball bearing spindle with 3 speeds up to 14,000 rpm. Is supplied with one copy carrier that accepts all standard master type sizes. Will actually work up to 10" by any width. Height of pantograph and position of cutter are continuously adjustable.

**MODEL D-2 HEAVY-DUTY  
2-DIMENSIONAL**

*Pantograph for milling, drilling and engraving.*

Vertical adjustment of copy table automatic with Pantograph. Features: unobstructed on 3 sides to take large work; micrometer adjustment for depth of cut; ball bearing construction throughout; spindle speeds up to 26,000 rpm for engraving or machining, vertical range over 10"; ratios 2 to 1 to infinity — master copy area 26" x 10"

**NEW**

**MODEL D2-201  
PNEUMATIC  
ATTACHMENT**



for use with Model D2 Pantograph Engraver to rapidly drill holes in printed circuits by tracing templates. Drills as many as 100 holes per minute. Equipped with foot switch, spindle air cylinder; regulating valve and pressure gauge; filter and oiler. It's ready to use as soon as it's attached to an air compressor

*Write or call for full  
details and prices.*

**GREEN INSTRUMENT  
COMPANY, INC.**

Dept. 363, 295 Vassar St.,  
Cambridge 39, Mass. Tel. Eliot 4-2989

SEMICONDUCTORS were critically reviewed by both device and equipment manufacturers at the recent New York City conference on the reliability of semiconductor devices. The conference was sponsored by the IRE Working Group on Semiconductor Devices. Twenty-five papers were presented. The conference theme was the need for more valid accelerated life testing in determining expected reliability of semiconductors.

Until recently, high temperature storage of transistors under test has produced higher failure rates during testing than operating tests produced on most products tested by General Electric, says Conrad H. Zierdt, Jr. of the company's Semiconductor Products dept. However, improved work in device design and construction over the last three years has extended survival in storage tests to the point that the tests no longer yield maximum information. Operating tests, such as the cyclical application of voltage and the cyclical exposure to high-temperatures, now produce higher failure rates. Furthermore, these higher failure rates occur at substantially lower junction temperatures. This may be attributed to different transistor failure mechanisms than those revealed during high-temperature storage testing.

Increases in small-signal current gain  $h_{FE}$ , for example, may be annealed out in high temperature storage tests. Such increases in gain during use would be responsible for oscillation in amplifier circuits and regeneration in switching circuits.

The increasing use of gettering techniques for absorbing harmful gaseous and vapor-phase contaminants (particularly water vapor) inside transistor housings, plus the higher preal processing temperature have improved transistor survival in high temperature storage testing, says Zierdt.

It is Zierdt's belief that the primary failure mechanism accelerated by increasing storage temperature is the movement of ionic contaminants sealed within a transistor housing, and that the rate of increase of the median value of re-

verse current (with time) at high temperatures is an exponential function of increasing storage temperature. Better processed (cleaner and drier) transistors, he says will have lower slopes at any given temperature; the onset of degradation will thus be extended in time.

He says that operating tests now produce higher failure rates by mechanisms that appear to be more closely related to actual operating stresses. For example, alternating application of collector voltage at high temperatures with varying periods of high-temperature storage to produce changes in collector reverse current ( $I_{CBR}$ ) accounted for relatively high failure rates of silicon-grown junction transistors.

Through laboratory analysis, the major failure mode was found to be formation of a heavy  $n$  channel across the  $p$ -type base region of  $n p n$  devices. This effectively connects the collector and emitter junctions so that the collector-to-base reverse current at high voltage is constantly increased by addition of current through the emitter junction.

The source of the  $n$  channel is not the gaseous ambient, but appears to be a complex rearrangement of ionic contaminants in the

## Drawbridge Monitor



*Closed-circuit, wide-angle television by GE aids operator in Chicago to watch other side before raising bridge*



# Hard Enough?

immediate vicinity of the base region. The nature of this failure mechanism makes it susceptible to attack by different methods of junction cleaning to reduce the ionic contaminant level. It was also found that certain elements in the gaseous ambient cause *p*-type channeling at the collector junctions and that this was responsible for some of the smaller hysteresis effects observed during the testing cycle.

Receiving tube improvement programs can be carried into semiconductor devices, says William H. von Alven of ARINAC Research Corp. There is not as much test data on power transistors as there should be, and future controlled tests will give better figures, he says.

Reliability of a broad line of advanced design diffused silicon transistors and diodes designed by Bell Labs was reported on by L. E. Miller and I. M. Machikntosh. Material and encapsulating atmospheric factors result in parameter drift rather than catastrophic failures, they say. Nitrogen is a better encapsulating medium than oxygen, their studies indicated.

## Japanese Firms Get Ready To Produce Sidewinders

TOKYO—Four Japanese companies have decided to prepare for the production of air-to-air Sidewinder missiles during this year. The decision was made despite the fact that there has still been no official decision as to whether Sidewinder-equipped units in Japan will continue to import from the U. S. or rely on local manufacture.

With Toshiba as representative, the group—Fuji Precision, Tokyo Aviation Instruments, Japan Wells and Fats Inc.—will negotiate this month with Philco and General Electric through Mitsui Bussan Kaisha for an engineering tieup.

According to Japanese government circles, Japanese industry is capable of producing 400 Sidewinders as well as 200 Falcons a year. If Japan's air force decides to equip itself with these missiles, 1,500 to 1,600 missiles would be needed.

February 3, 1961

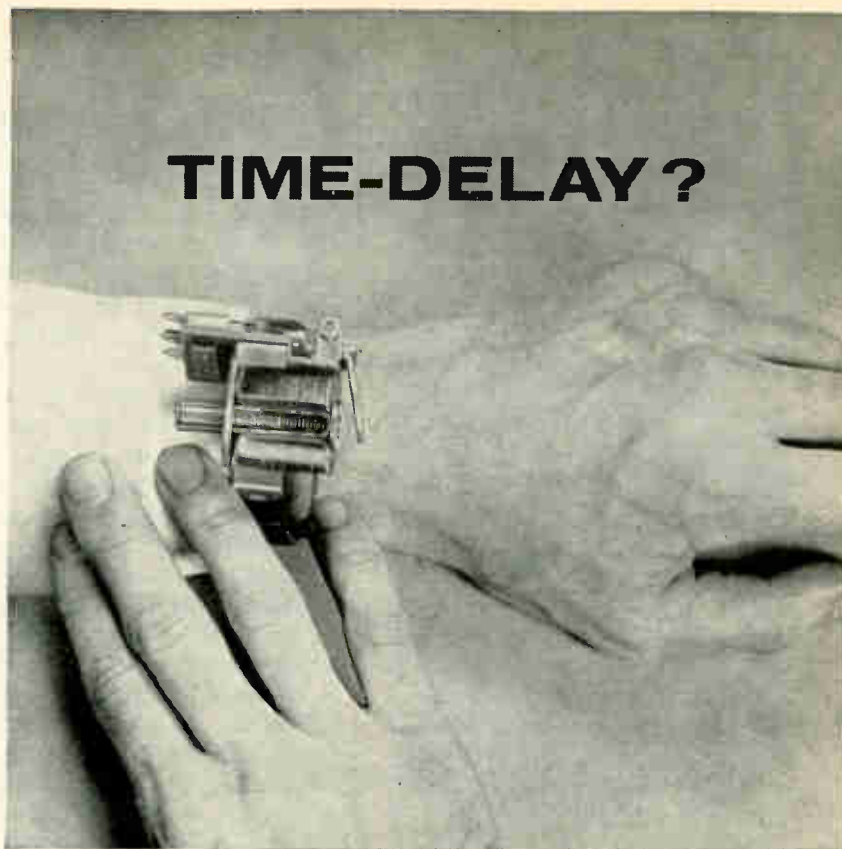

Heinemann can give you any set delay from a quarter-second wink to a two-minute yawn, all wrapped up in a relay no bigger than a healthy ice cube. Called the Type A Silic-O-Netic Relay, this three-ounce time-delay unit offers S.P.D.T. or D.P.D.T. switching, with up to three amps' contact capacity. All of which is pretty good, but the real clincher is the continuous-duty coil. It permits the relay to be energized continuously, to serve as a load relay, too. This eliminates the need for auxiliary lock-in circuits. Result: substantial savings in space, wire, solder—and dollars. Bulletin 5003 gives detailed specifications; a copy is yours, of course, for the asking.

## HEINEMANN ELECTRIC COMPANY

176 PLUM STREET



TRENTON 2, NEW JERSEY

2175

CIRCLE 33 ON READER SERVICE CARD

33

Let us  
show you  
how our  
precision  
wire forms  
**CUT  
COSTS!**



**TERMINAL  
LEADS FOR RESISTORS, DIODES,  
TRANSISTORS, CAPACITORS, ETC.**

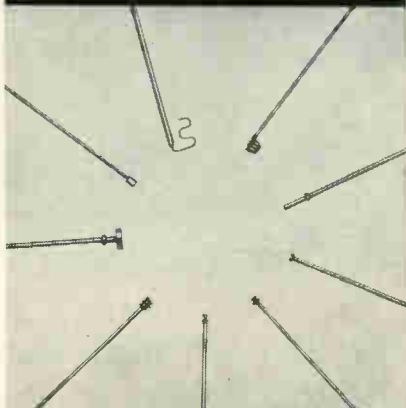

**FOR THE HERMETIC SEAL INDUSTRY**

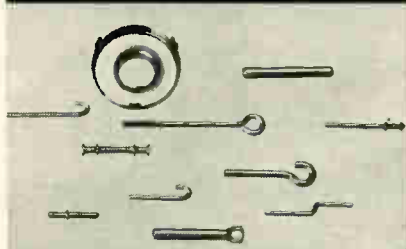

Send a  
sample or blue print  
for estimates.

When Art Wire tackles the job, big gains in precision and uniformity are possible on small components . . . resulting in big savings in time and production costs. In addition, Art Wire's modern production methods produce a wide variety of components more economically.

Art Wire specializes in wire forms designed for today's automatic production lines . . . manufactured to assure the economy of an uninterrupted work flow.

**ART WIRE AND STAMPING CO.**

18 Boyden Place, Newark 2, N. J.

**Air Force Urges More Space Reliability**

DALLAS—THE MILITARY would like an increase of 10 or more in the reliability factor of electronic equipment used in its space work says Lt. Gen. B. A. Schriever, commander of the Air Research and Development Command.

Schriever was here recently for the 7th annual meeting of the American Astronautical Society. He called for space systems having capabilities of warning, communication and observation.

Meanwhile, there was news about simulators and other research advances at the meeting:

Chance Vought Corp. announced it plans a space-on-earth simulation center at its Dallas plant. It will start the center by installing a manned space flight simulator, space environment simulator and automatic controls evaluation simulator. CV will use the units for its own work, sell their use on a time basis to government agencies and other firms.

The Martin Co. displayed a model of a Lunar Housing Simulator its management has given the go-ahead to build. This will be a 35-ft diameter outer spherical shell containing an inner spherical chamber.

Northrop Corp. reported direct

measurement of continuous thrust from a magnetogasdynamics engine. In working with the experimental MGD engine, ionized nitrogen is injected into a 20-ft vacuum tank at 16,000 ft per second. As it enters the chamber, this plasma is directed into a region of crossed electric and magnetic fields where it is accelerated to 40,000 fps. Thrust levels on the order of 2 lb have been maintained for one minute.

Three Chance Vought men delivered a paper on the costs of a manned lunar landing and return mission. They estimated total costs at \$3,068,000,000, said the cost of repeating the mission would be \$200 million.

**French Researchers Build Prototype X-Ray Microscope**

TOULOUSE—Researchers at the Centre National de la Recherche Scientifique have developed a prototype X-ray microscope with resolution of 3/10 micron and useful magnification better than 1,000.

The instrument has enough resolution, according to its builders, so that all points of thick objects appear in focus. Researchers say the key to the improved functioning of their device is a keener point source of the X-rays. Observations are made at atmospheric pressure, require only a few minutes and no special preparation of the specimen is necessary.

An electron gun forms the point source on an anticathode. A sheet of gold foil 2/10 or 3/10 micron thick is used for this purpose. Two magnetic lenses, a condenser and an objective reduce by 1/1,000 the image of the crossover point of an electron beam emitted by a 1/10-mm diameter tungsten filament. In early observations, the potential difference applied between the filament and the accelerating anode varied from 3,000 to 20,000 volts. X-rays emitted at these voltages varied in wavelength from one to six angstroms.

**Computer Aids Army**



*Mobidic, mobile digital computer developed by Sylvania, will be used by Seventh Army in Europe*

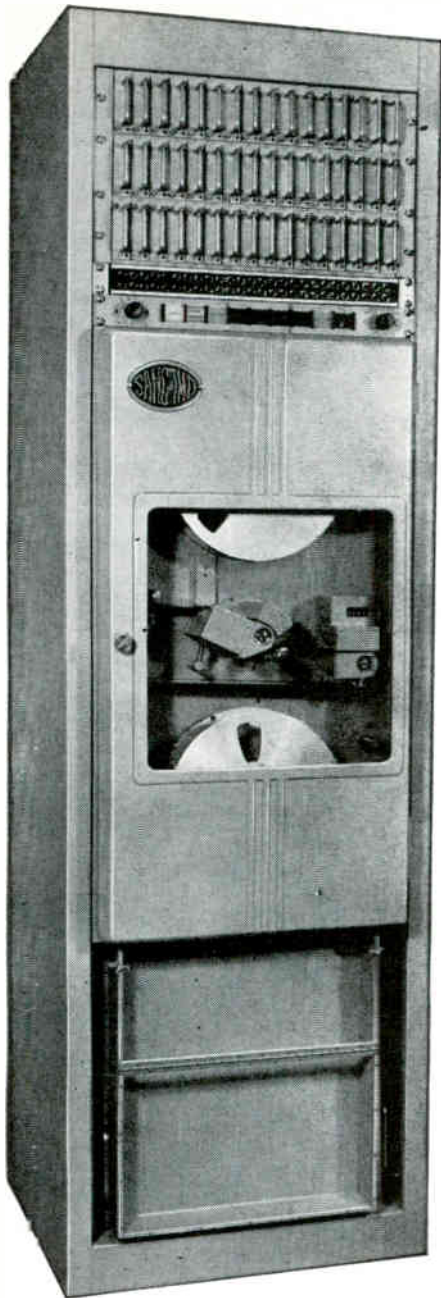

*superior  
accuracy  
and  
reproducibility  
with the*

## **SANGAMO 460-SERIES TAPE TRANSPORT**

The Sangamo 460-Series is a fully transistorized magnetic tape Recorder/Reproducer for application in direct analog, wideband FM, PDM, and PCM instrumentation systems.

➤ Magnetic tape instrumentation system accuracies heretofore considered unattainable have been achieved by Sangamo as a result of reduced instantaneous and long-term record-playback speed deviations. The 460-Series Tape Transport accomplishes this by combining a very low inertia D. C. capstan drive with a high-response, tape-speed, servo control system.

➤ A unique vacuum tension/cleaning pad located immediately in front of the recording or reproducing head provides gentle, but firm and precise, tape tension. The head in turn is mounted almost in contact with the drive capstan. This arrangement results in a very short span of tape that requires controlled positioning. The combination of these features results in minimum skew, less flutter, and fewer dropouts.

➤ Additional features of the Sangamo 460-Series Tape Transport are: Reel-to-reel or loop operation with the same machine • Ability to handle all tapes, from 1/4" to 2" in width, 1.0 to 1.5 mil base • All D. C. drives • Fully transistorized •

Sangamo 460-Series Magnetic Tape Record/Reproduce systems are sold through technically qualified Sangamo agents specially selected for their ability to assist you in magnetic tape instrumentation applications. In addition, Sangamo Application Engineers are available to provide further technical assistance wherever necessary. For complete details on the Sangamo 460-Series Record/Reproduce system, write for Bulletin H-460A or contact your nearest Sangamo representative.

**BROGAN ASSOCIATES, INC.**  
Mineola, L. I., New York  
Chestnut Hill, Mass.

**DATRONICS, INCORPORATED**  
Houston, Texas  
Dallas, Texas

**J. E. CUESTA COMPANY**  
Paoli, Pa.  
Washington, D. C.

**MEDCO, INCORPORATED**  
Melbourne, Florida  
Huntsville, Ala.

**PERLMUTH ELECTRONIC ASSOCIATES**  
Los Angeles 16, California  
San Diego, California  
Palo Alto, California

### **SANGAMO 460-SERIES PERFORMANCE CHARACTERISTICS:**

START TIME: 1.0 second max. to synchronism with servo speed control at 60 ips up to 1" wide tape.

STOP TIME: 0.2 seconds max. from 60 ips.

INSTANTANEOUS TIME DISPLACEMENT ERROR: 25.0 microseconds max. at 60 ips.

LONG-TERM TIME DISPLACEMENT ERROR: ±0.01% max.

INTER-CHANNEL TIME DISPLACEMENT ERROR: ±2.0 microseconds at 60 ips between outside tracks on 1" tape.

SERVO SPEED CONTROL RANGE: ±15% nominal tape speed.

SERVO RESPONSE: ±15% speed change per second.



# **SANGAMO ELECTRIC COMPANY**

**SPRINGFIELD, ILLINOIS**

6C60-9

New molding design provides absolute maximum torque resistance for screw lock operation.

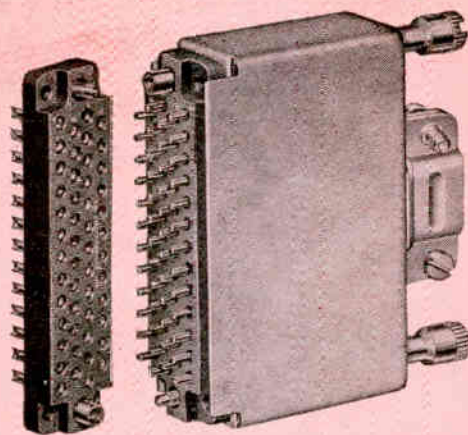

5 7 11 14 20 26 34 42 50 75

Contact Configurations

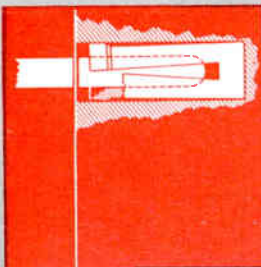

**"SMI"**

# SUBMINIATURE CONNECTORS

*...the complete line*

Only U. S. Components offers you a **standard** line of Draw Pull, Hooded, Hooded Screw Lock, and Hoodless Knob-type Screw Lock connectors, each available in ten different contact configurations.

- Connector bodies supplied in glass and/or on-filled diallyl phthalates, alkyd, asbestos and glass-filled melamines
- Wire solder or solderless terminals
- Silver or nickel plated contacts with 24 carat or antimony gold flash
- Meets or surpasses all applicable MIL specs.

### SPECIFICATIONS

Contacts ..... 5-7-11-14-20-26-34-42-50-75;  
other configurations upon request

Wire size ..... #20AWG wire

Voltage breakdown between contacts—  
sea level ..... 1950 V.A.C. RMS

Current rating ..... 7.5 amps

U.S. Pat. No. 2,761,108 Additional Patents Pending

Write today for complete SMI subminiature catalog.



**U. S. COMPONENTS, INC.**  
1320 Zerega Ave., New York 62, N. Y. TAlmadge 4-1600

## MEETINGS AHEAD

Feb. 1-4: Electronic Representatives Assoc., Annual Convention; Ambassador Hotel, Los Angeles.

Feb. 3-4: Industrial Engineering, Annual, Latest Development in R&D; Univ. of California, Berkeley, Calif.

Feb. 7-9: Electrical Manufacturers Assoc.; Veteran's Memorial, Columbus, O.

Feb. 13-15: Better Writing for Science & Industry, American Industrial Writing Institute; Statler-Hilton Hotel, Los Angeles.

Feb. 13-16: Information Storage and Retrieval Machine Indexing; American Univ., Washington, D. C.

Feb. 14-16: Nondestructive Testing of Aircraft & Missile Components, Southwest Research Institute, South Texas Section of the Society for Nondestructive Testing Inc.; Gunter Hotel, San Antonio, Tex.

Feb. 15-17: Solid State Circuit Conf., International, PGCT of IRE, AIEE; Univ. of Penn. & Sheraton Hotel, Philadelphia.

Feb. 20-25: Semiconductor Exposition, International, Societe Francaise des Electroniciens et Des Radio-Electriciens; Maison de L'Unesco, Paris.

Feb. 26-Mar. 1: Pacific Electronic Trade Show; Great Western Exhibit Center, Los Angeles.

Mar. 1-2: Society of Vacuum Coaters, Thin-Film Structures; Conrad-Hilton Hotel, Chicago.

Mar. 9-10: Engineering Aspects of Magnetohydrodynamics, PGNS of IRE, AIEE, IAS; University of Penn., Philadelphia.

Mar. 11: Quality Control, American Society for; Hart House, Univ. of Toronto, Ontario.

Mar. 20-23: Institute of Radio Engineers, International Convention, All PG's; Coliseum & Waldorf-Astoria Hotel, New York City.

▶ "addo-x" model 3541 printing calculator with accumulating register



*Versatility—that's what printing calculator 3541 can give you. Multiply—add—subtract—fast, with this quiet operating, compact, double register machine. No re-entry problems, accumulates totals. Has decimal point indicator, saves time on percentage calculations. Just one of time-proven "addo-x" adding and calculating machines—backed by nation-wide service facilities. Demonstrations, without obligation, arranged at your convenience. Just see your dealer for on-your-job proof or write directly to "addo-x" 300 Park Avenue, New York 22, NY*

[pronounced: add-oh-ex]

addo-x



*Dr. David Van Meter  
Manager of Litton's Advanced Development  
facility in Waltham.*



## celestial Noise

Non-Gaussian, non-white, non-stationary, and non-additive noise conditions, as they affect performance of correlation receivers, are currently under investigation in our Advanced Development facility in Waltham. Another important program currently under investigation is the further development of techniques for classificatory analysis and the subsequent application of these techniques to automatically-learned recognition of spoken words and hand-written alphanumeric characters.

The Senior Staff of Litton's Waltham facility is a uniquely qualified and experienced scientific team with extensive background and practical experience in the application of statistical communication theory, decision theory, interference analysis and control, and modulation and detection theory. The Staff's background has included R & D to answer such questions as...

Can space communications systems be shielded against the interference of direct and earth-reflected *celestial noise* and man-made interference?

Can the properties of objects in space be determined from trajectory information supplied by earth-based sensors?

What characteristics of a target can be classified so that the target can be determined as ICBM, non-ICBM or decoy-ICBM? Can pattern recognition theory and learning theory be applied against this problem?

Can we, by properly shaping the ambiguity function of a radar signal, improve radar measurement of ballistic orbits and more accurately estimate ballistic impact point and time until impact?

Can a communication system be made secure by using multiple channel transmission as a means of adding redundancy to digital communications?

We are now applying advanced theory against such problems as synchronization techniques, pattern recognition, pictorial data, data compression, coding theory, etc. If you feel you can make original contributions in any of these areas, or in computer and control systems, inertial guidance and navigation, or tactical data processing systems, you are invited to contact Mr. Harry Laur, at our Advanced Development facility, 221 Crescent Street, Waltham, Massachusetts. Telephone TWInbrook 9-2200.



**LITTON SYSTEMS, INC.**

Beverly Hills, California

*"Right! You're sure of  
reliability with **DALE**  
Type WW or HW Resistors"*

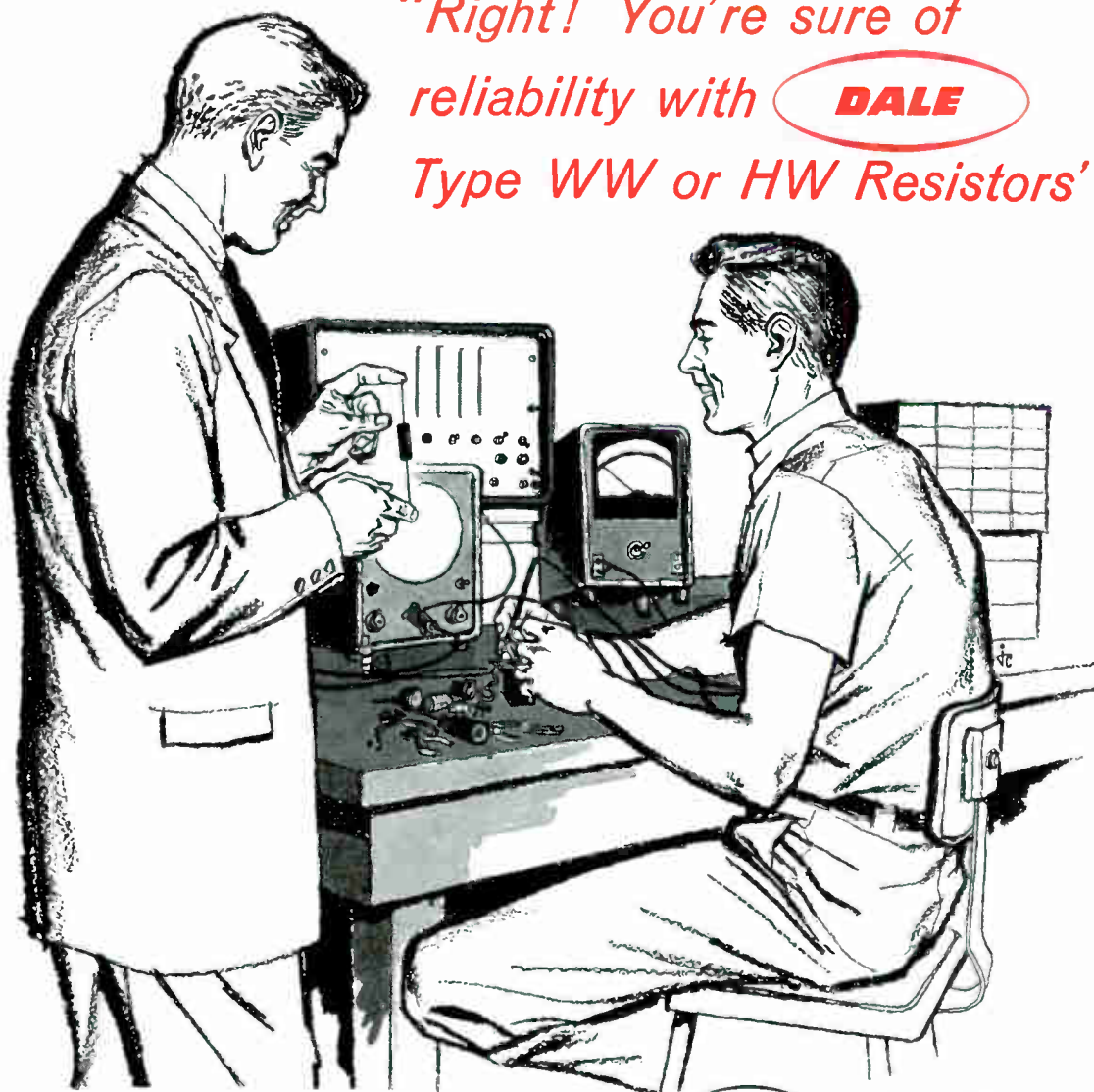

In planning any circuit, even the most advanced, you can check off one question mark the minute you specify Dale precision resistors.

Resistor reliability in that circuit is assured, under any and all conditions, because of Dale's advanced design and methods of manufacture . . . methods which have reached new levels of achievement as part of Dale's super-high reliability development program.

**SPECIAL PROBLEMS?** Let us help you with your requirements for special resistance products. We make modifications of standard products, resistor networks, matched pairs, etc. Send us your specs.

**PROMPT DELIVERY:** Whether your need is for a short "test run" or a large production release, Dale offers prompt service, direct from the factory and through a widespread network of distributors.

*Write for Bulletin R-26 with handy cross reference file card*



**DALE ELECTRONICS, INC.**

1300 28th Ave., Columbus, Nebraska, U.S.A.

*A subsidiary of HATHAWAY INSTRUMENTS, INC.*

**DALE TYPE WW & HW RESISTORS**

WIRE WOUND • BOBBIN • ENCAPSULATED

Dale bobbin type resistors are impervious to salt spray, humidity, moisture and corrosive gases and vapors. The encapsulating material has very high di-electric strength. The resistors have excellent non-inductive characteristics. They are made to surpass functional requirements of MIL-R-93B. (Some sizes and ranges not included in Mil Specs.) WW prefix meets requirements of characteristic A; HW prefix meets requirements of characteristic C.

- RESISTANCE RANGE: 0.1 ohm to 6 meg-ohms, depending on size.
- TOLERANCE:  $\pm 0.02\%$ ;  $\pm 0.05\%$ ;  $\pm 0.1\%$ ;  $\pm 0.25\%$ ;  $\pm 0.5\%$ ;  $\pm 1\%$ ;  $\pm 3\%$ .
- RATED AT: 0.1 watt to 2.5 watts, depending on size, type and tolerance.
- TEMPERATURE COEFFICIENT: 0.00002 per degree C.
- TERMINALS: WWA and HWA — axial leads; WWP and HWP — parallel leads; WWR and HWR — radial leads; WWL and HWL — lugs.
- SIZES: Complete range from sub-miniature 5/64"x5/16" to 1/2"x2".



# Which of These 4 Major Improvements Is Most Important To Your Business?

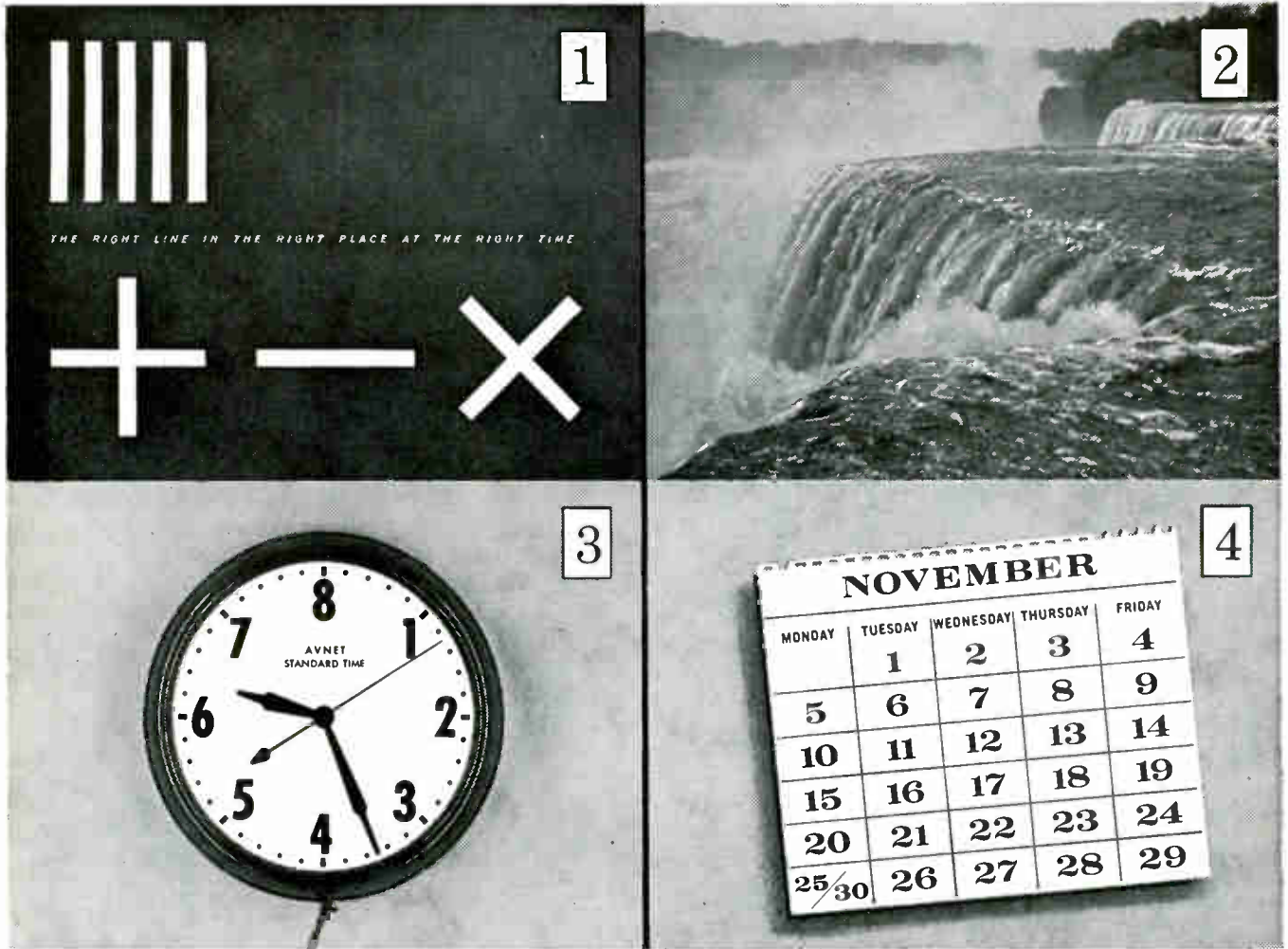

## The Avnet System

is based on New Concepts, Major Improvements in Service

The Avnet System *IS* a system of improvement, newness, change for the better. That's how progress is made. That's how—and why—Avnet is America's major source of supply in electronic components. Of the many new practical concepts Avnet has introduced, four are symbolized above. Which of them are important in your business?

- 1 A NEW CONCEPT OF PLACING the Right Line—in the Right Place—at the Right Time. The Avnet System supplies not only the components themselves but a wealth of application information, saving the user hours of costly research time.
- 2 A NEW CONCEPT OF SUPPLY—an available supply that is overwhelming in its size. Avnet's supply of electronic components is vast—in breadth and in depth. It is also carefully anticipated to meet your demands of tomorrow, next month, next season.
- 3 A NEW CONCEPT OF TIME. Avnet ships your orders about  $\frac{1}{3}$  faster than any other major source of supply, hence  $\frac{1}{3}$  of the hours can be cut from your waiting time. Although the 8 hour clock is symbolic, it is symbolic of a fact.
- 4 A NEW CONCEPT OF SCHEDULING. Once your order is given to Avnet, it knows no "weak-ends." Within a given period, Avnet ships more orders than any other source for electronic components, giving your specific order quicker delivery, faster use.



- 5 THE CONCEPT OF NEW CHALLENGE. Avnet doesn't know what the next decade will bring. But Avnet is very ready, willing and able to meet the challenge with *more* improvement in service, *more* newness, *more* changes for the better. For this is the very basis of The Avnet System.

**AVNET**  **THE AVNET SYSTEM**  
Men / Methods / Materials / Management  
AVNET ELECTRONICS CORP.

Avnet Service Centers and Stocking Facilities: Los Angeles, Cal. • Sunnyvale, Cal. • Seattle, Wash. • Salt Lake City, Utah • Chicago, Ill. • Dayton, Ohio • Westbury, L. I. • Burlington, Mass.

Avnet distributes from its stocking facilities: BENDIX SCINTILLA CONNECTORS, SPERRY SEMICONDUCTORS, RHEEM SEMICONDUCTORS, ELECTROSNAP AND HETHERINGTON SWITCHES, GREMAR CONNECTORS, CLARE RELAYS, ROBERTSON SPLICE & CONNECTOR CASES, BABCOCK RELAYS, KING SUBMINIATURE HI-TEMP CERAMIC CAPACITORS, TIC PRECISION TRIMMERS, VIBREX FASTENERS by GENERAL TIRE & RUBBER CO., U. S. SEMCOR SEMICONDUCTORS, SANGAMO CAPACITORS, SPRAGUE CAPACITORS



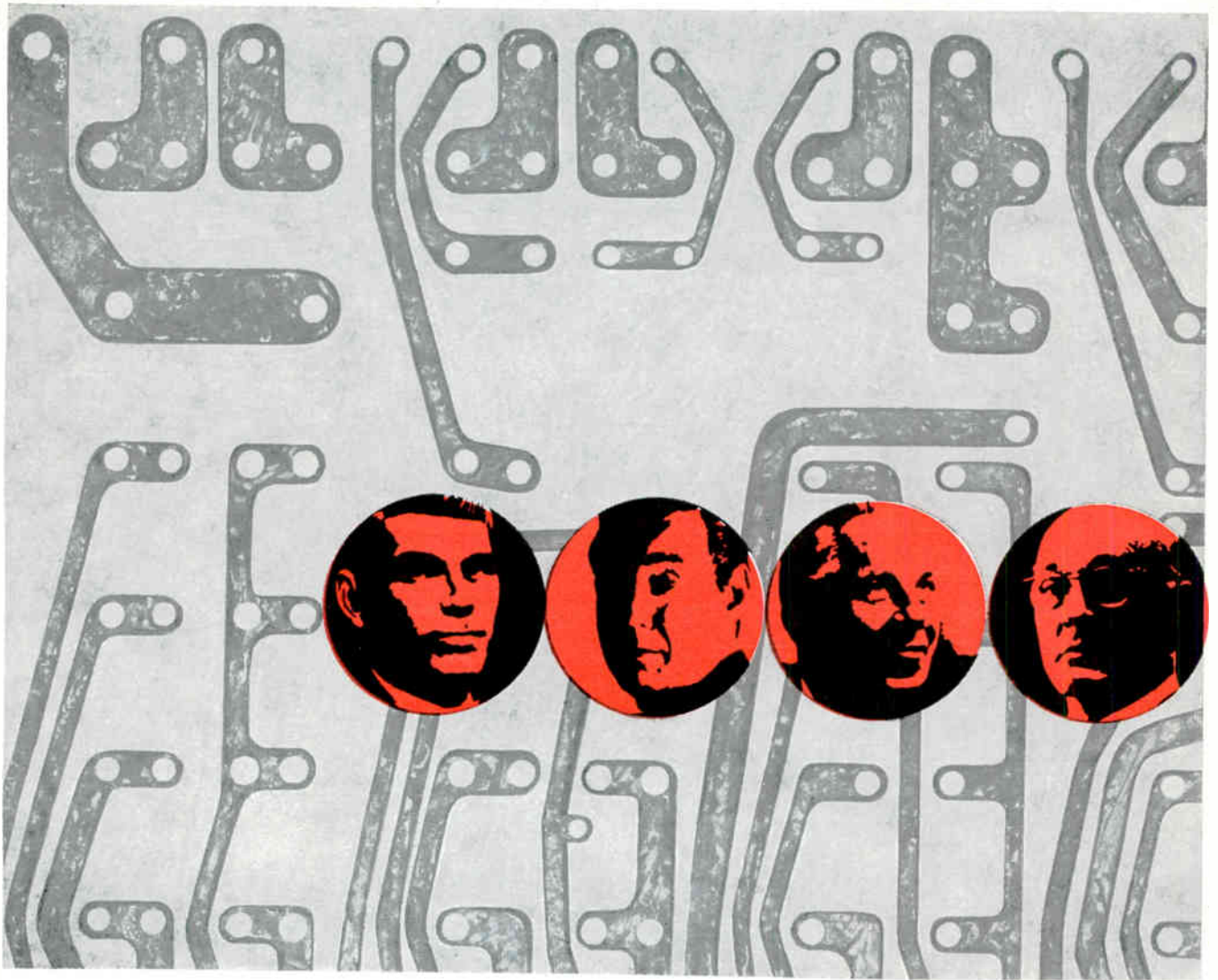

**electronics** sells the engineering team...

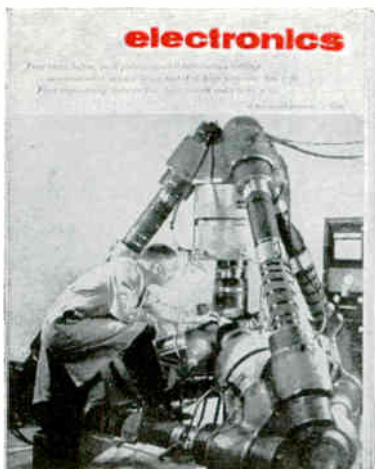

**KEEP YOUR EYE ON THE BOX SCORE!**  
 Circulation: 52,286  
 Editorial: 3,487 pages in 1960  
**electronics Buyers' Guide:** 648 advertisers make 53rd issue of **electronics** (EBG) the "electronics Social Register."  
 Costs: \$980 a page (13 time rate, B&W)

...in Research  Design   
 Production  and Management 

As any electronics manufacturer will tell you, in the electronics market you must sell a buying team. This is the big difference! Engineering trained electronics men work in research, design, production or management. The electronics man may wear one, two, three or four hats, working in any or in all of the four areas. And **electronics** is edited to interest and influence the electronics man. Like manufacturers' salesmen, your advertising in **electronics** sells the buying team. Works harder. Sets up more sales. Effectively penetrates today's fast-changing, highly competitive electronic market. 0.23



A McGraw-Hill Publication, 330 West 42nd St., New York 36, N. Y.



# Subsurface Communication For Survival

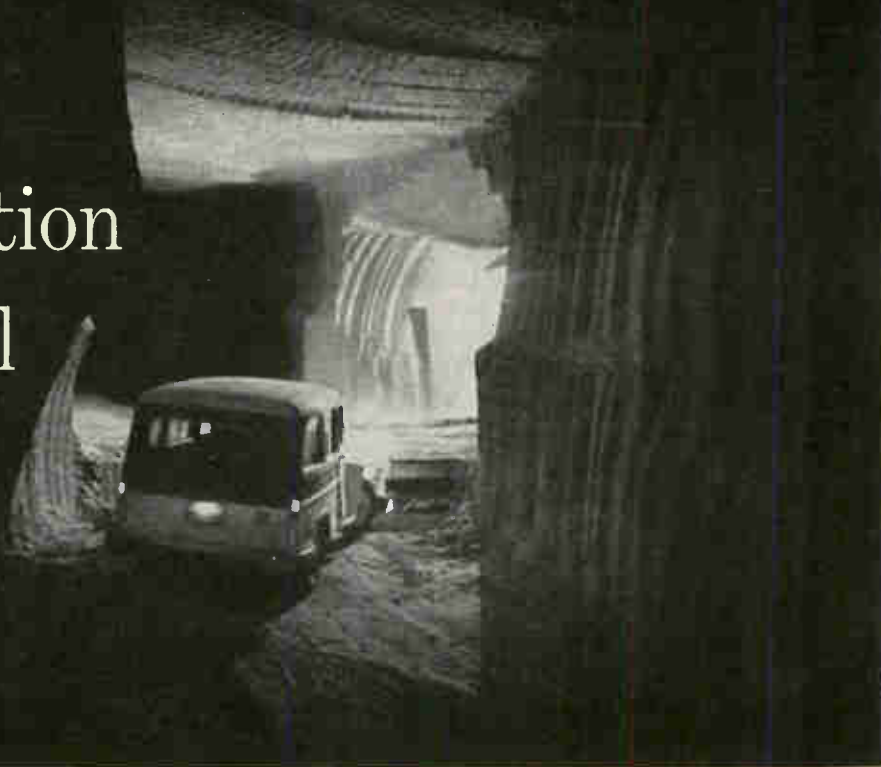

Mojave desert mine shaft serves as site of underground transmitter station

*Low-frequency point-to-point or broadcast communication from an underground transmitter provides survival security against natural and artificial hazards*

By RABINDRA N. GHOSE,  
Space Electronics Corp., Glendale, Calif.

SUBSURFACE COMMUNICATION, defined here as a system of communicating information from an underground source to an underground receiver by low-frequency electromagnetic signals, offers an excellent survival potential against natural hazards such as cyclones and tornadoes, and hazards resulting from a nuclear bombardment, where conventional means of communication may be ineffective, if not impossible.

The principle of subsurface communication is similar to that of radio since they both use electromagnetic waves, and unlike telephones, the transmitter and receiver are not connected by a material link. However, the medium and means by which the information is conveyed from the

transmitter to the receiver in the two cases are different. For ordinary radio communications from one point to the other on the earth's surface, for example, electromagnetic waves conveying the information usually travel through a non-conducting medium bounded by the earth's surface and the ionosphere. Consequently, little energy contained in the waves is dissipated or lost in the medium.

In a practical subsurface communication system, however, the transmitter and receiver antennas are located under the surface of the earth. Since the earth is a good electrical conductor at frequencies of interest in subsurface communications, some energy of the transmitted signal is always dissipated in the propagating medium.

The electromagnetic field that results from an underground antenna (A) may be considered to consist

of a set of primary and secondary waves. The field strength of the primary waves, traveling through the earth, varies with distance  $r$  as  $\exp(-\gamma r)/r$ , where  $\gamma$  is the complex propagation constant for the earth. The real part of  $\gamma$  is equal to  $1/\delta$ ,  $\delta$  being the skin depth. (For a typical ground conductivity of  $10^{-2}$  mho per meter, the skin depths are 50 meters at 10 Kc and 25 meters at 40 Kc.) Thus, when the distance of the transmitter from receiver is appreciably larger than the skin depth, the primary wave contributes only negligibly to the received signal because of the exponential attenuation.

Another component of the primary wave travels from the underground source toward the earth's surface where the electromagnetic parameters of the medium are discontinuous. A set of secondary waves result from this discontinuity.

ity. These secondary or scattered waves propagate along the earth's surface and undergo an attenuation that is different from the attenuation encountered by the primary waves. For ranges much greater than the sum of the depths of the transmitter and receiver antennas, and particularly at ranges greater than about one-sixth of the free-space wavelength, the secondary waves constitute essentially the received signal when the receiver is close to the earth's surface.

Basic problems that are peculiar to subsurface communications are the determination of the propagation characteristics from underground or under water sources, coupling of energy from the transmitter antenna to the medium and the noise environment.

A typical subsurface transmitter antenna is shown in (B). The electrodes at the end of the horizontal antenna are used for impedance matching, particularly when the physical length of the antenna is small in comparison with the half-wave length. An approximate expression for the electric field intensity resulting from the antenna is given by

$$|E_h| \cong \frac{p}{2\pi\sigma_e \rho^3} e^{-(d_t+d_r)/\delta} \left| 1 + j\beta_2 \rho - \beta_2^2 \rho^2 \right| \cos \phi \text{ volt/meter} \quad (1)$$

where  $p$  = dipole moment of the antenna in amp-meters,  $\sigma_e$  = average earth conductivity at the transmitter and receiver locations in mho per meter, (geometric mean),  $d_t, d_r$  = depths of transmitter and receiver antenna, respectively, in meters,  $\rho$  = distance between the transmitter and receiver in meters,  $\delta$  = skin depth in meters,  $\beta_2 = 2\pi/\lambda$  (free-space wavelength in meters),  $\phi$  = azimuthal angle of the receiver measured from the transmitter antenna axis, and  $E_h$  = radial, horizontal component of the electric field.

In Eq. 1 the earth has been assumed flat and the effect of the ionosphere on  $E_h$  has been neglected. These approximations are justified for frequencies less than 100 Kc and for distances less than about 70 miles. A comparison of the measured electric field, where the transmitter antenna was located 90 meters underground, with that computed from Eq. 1 is shown in (C).

For long ranges, the effect of the ionosphere cannot be neglected. For simplified propagation analysis, the ionosphere may be regarded as a dielectric region containing electric charges such as ions and free electrons. Under the influence of passing electromagnetic waves the charges have imparted to them an oscillatory motion that both absorbs and reradiates some of the energy of the waves. This effect causes the ionosphere to be considered as a charge-free but imperfect dielectric having a dielectric constant  $\epsilon_i$  and an effective conductivity  $\sigma_i$ . Ordinarily the ionosphere is diffuse and anisotropic, and has values of  $\epsilon_i$  and  $\sigma_i$  that are functions of position; however, for frequencies in the order of 16 Kc or less the ionosphere may be regarded, at least for subsurface propagation analysis, as a sharply-bounded isotropic medium. Propagation characteristics of electromagnetic waves that result from an underground transmitter antenna and travel along the earth's surface are affected by the presence of this sharp boundary.

The expression for the electric field resulting from the antenna, shown in (B) for the spherical earth and ionosphere, is involved. The waveguide-like structure formed by the earth and ionosphere results in an infinite number of TE and TM-type spherical modes and theoretically all these modes are to be accounted for to compute the electric field. Ghose<sup>1</sup> has shown that the approximate expression for the field resulting from the antenna can be expressed as

$$|E_h| \cong \frac{2\pi p}{\sigma_e \lambda^2 \rho} \left[ \frac{\rho/a}{\sin(\rho/a)} \frac{\rho \lambda}{H^2} \right]^{1/2} e^{-d/\delta} \sum_{n=0}^{\infty} \delta_n S_n^{3/2} e^{-j\beta_2 S_n \rho} \cos \phi \text{ volts/meter} \quad (2)$$

where  $H$  = average height of the ionosphere in meters,  $\lambda$  = free-space wavelength in meters,  $\delta_n = \frac{1}{2}$  for  $n = 0$ ,  $\delta_n \cong 1$  for  $n \neq 0$ ,  $d = d_t + d_r$ , and  $S_n$  is the complex mode function that depends on  $n$ ,  $\sigma_e$ ,  $\sigma_i$ ,  $\epsilon_e$ ,  $\epsilon_i$ ,  $H$  and the electron density  $N$  in the ionosphere.

The imaginary part of  $S_n$  introduces an exponential attenuation factor for increasing range. Graphical plots of  $S_n$  for different earth and ionospheric parameters are given by Wait.<sup>2</sup> Approximate variations of the electric field during

the daytime, at long ranges, and at 16.6 Kc for typical earth and ionospheric conditions are shown in (D).

The coupling of electromagnetic energy from an underground or underwater transmitter antenna, surrounded by a highly conducting medium, constitutes a problem in subsurface communications. Ordinarily, coupling is obtained by placing the antenna in a air-filled cavity. The electrodes are needed for impedance matching, particularly when the length of the antenna is small in comparison with a half-wavelength in the antenna. The wavelength in the antenna is considerably smaller than the free-space wavelength for a given frequency, and is a function of the dimensions of the air-filled cavity, the antenna core, and the conductivity of the medium surrounding the antenna. Further discussions and analysis on subsurface antenna characteristics, such as the radiation pattern,  $Q$  and the input impedance are given by Ghose.<sup>3</sup>

Unlike free-space antennas, the input resistance of a short subsurface antenna is given by

$$R_{in} = \frac{300L}{\lambda} + R_1 + R_2 \text{ ohms} \quad (3)$$

where  $L/\lambda$  = length of the antenna in terms of the free-space wavelength,  $R_1$  = ohmic resistance of the antenna in ohms, and  $R_2$  = resistance of the electrodes in ohms.

The radiation pattern of a subsurface antenna is also different from the free-space antenna. More exactly, the electric field is maximum along the direction of the subsurface antenna, as shown in (E).

As in most communication systems, the capability of the subsurface communication is limited by the noise. However, the characteristics of the noise that is important in subsurface communication are not the same as those at high radio frequencies. The atmospheric noise that constitutes essentially the noise in the subsurface communication system is impulsive and its amplitude for any frequency varies widely with geographical locations, time of day, and season.

Essential parameters that affect subsurface communications are the depths and lengths of the transmitter and receiver antennas, ground conductivity, operating fre-

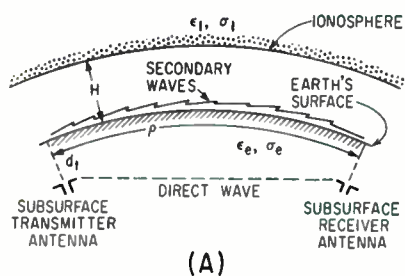

(A)

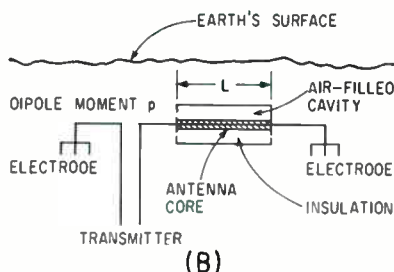

(B)

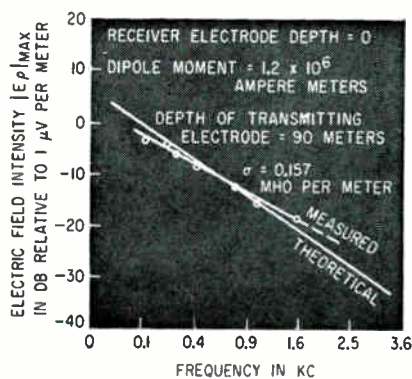

(C)

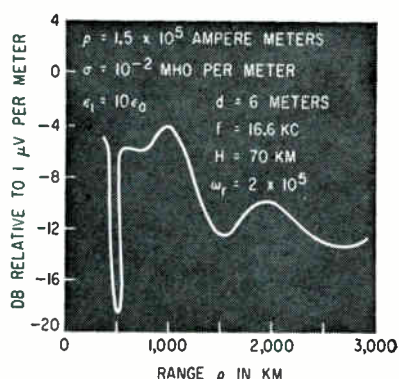

(D)

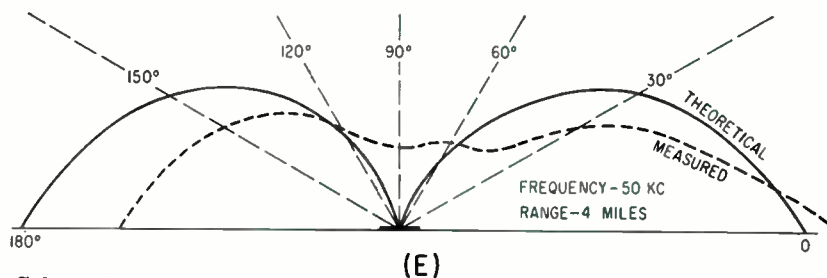

(E)

Schematic arrangement of the subsurface communication system (A); typical underground or underwater subsurface antenna (B); comparison of the theoretical and computed electric field intensities due to a subsurface antenna at 7 miles from the antenna (C); expected horizontal component of electric field at long ranges from a subsurface antenna for typical earth and ionospheric conditions (D); and a comparison of the theoretical and measured radiation pattern of a subsurface antenna (E)

quency, range, noise, receiver bandwidth, ionospheric characteristics and the transmitter power. Thus the field strength may be increased at a given range by increasing the length of the transmitter antenna, (which is true when the operating frequency range is such that a practical transmitter antenna becomes much shorter than a half-wavelength), or the dipole moment or increasing the transmitter power. Furthermore, the field strength may be increased by reducing the depth of the transmitter or receiver antennas or by reducing the information bandwidth while other parameters remain the same.

For a predetermined field strength or a required signal-to-noise ratio at a given range, it is possible to have combinations of

values of the parameters although the communication system efficiencies or costs for all systems are not likely to be the same. Besides, in a practical communication system using subsurface propagation, some system constraints are likely to exist, which limit ranges of variations of these parameters. The depth of the transmitting and receiving antennas and the ground conductivity become fixed when a particular degree of physical invulnerability of the communication system is required against natural and artificial hazards, and when the transmitter and receiver sites are selected.

Similarly, the receiver bandwidth may be fixed depending on the required data transmission rate. The only flexible parameters that exist

for the system optimization are the operating frequency, available transmitter power, lengths of transmitter and receiver antennas, and the radiating antenna impedance.

The choice of operating frequency for the subsurface communication at a given range is important in the communication system. Expressions of the field intensity, both at short and long ranges, when the depths of the transmitting and receiving antennas are very large compared to skin depth, show that it will be necessary to choose a low operating or carrier frequency for a practical and economical communication system. If, however, the depths of the antennas are small the exponential depth attenuation factor becomes nearly equal to unity for expected values of ground conductivity, and for frequencies not exceeding 30 Kc.

The requirement of transmitter power for subsurface communication at a given range and for a preassigned acceptable signal-to-noise ratio is determined from the field strength at the receiver, receiver bandwidth, and the noise. An estimate of the required transmitter power for a given range can be obtained directly from the noise spectrum and Eq. 2.

The signal-to-noise at the receiver is usually unaffected by the length of configuration of the receiving antenna, and hence any receiving antenna is acceptable for subsurface communications provided the receiving antenna provides an input voltage at the receiver that is adequate for the receiver sensitivity.

The feasibility and practicality of the subsurface communication have been established recently by the Space Electronics Corporation. Optimization of some system parameters, such as the operating frequency, appropriate modulation techniques, and improved antenna configurations are likely to make the system more attractive for both civilian and military uses.

## REFERENCES

- (1) R. N. Ghose, The Long Range Sub-Surface Communication System, Sixth National Communications Symposium, Utica, New York, Oct. 1960.
- (2) J. R. Wait and H. H. Howe, The Waveguide Mode Theory of VLF Ionospheric Propagation, *Proc IRE*, 45, p 95, Jan. 1957.
- (3) R. N. Ghose, The Radiator-to-Medium Coupling in an Underground Communication System, IRE National Electronics Conference, Oct. 1960.

# MEDICAL ELECTRONICS

## Part II: DIAGNOSTIC SYSTEMS AND VISUALIZATION

*Methods and equipment for monitoring, analyzing and interpreting physiological data and for viewing the internal structure of the body are described*

By WILLIAM E. BUSHOR,  
Associate Editor

MEASUREMENT of physiological parameters (discussed in Part I) represents only one element of diagnosis. Monitoring, analysis and interpretation of one or a combination of measured variables are often required. Also, techniques for visualizing the internal structure of the body are indispensable to modern medicine.

*Monitoring Systems*—The trend both here and abroad is toward development of multipurpose devices capable of detecting and recording simultaneously a number of physiological variables. Most systems now in use display slowly changing variables such as temperature, average blood pressure, pulse rate and breathing rate on meters, fast changing variables such as eeg, eeg, emg and pulse pressure waves on an oscilloscope. Equipment used in operating rooms must be designed for use in the presence of

explosive anesthetic gases, to meet sterility requirements and to avoid interference with surgical procedures.<sup>1</sup>

Sanborn has marketed a completely transistorized monitoring system that uses a 17-in. oscilloscope capable of displaying up to eight different phenomena simultaneously. Leads from the patient pass through a junction box switch with which the surgeon can select the desired displays.

A surgical master monitor system developed by Epsco is capable of detecting, recording and displaying critical measurements defining a patient's condition from the time he is anesthetized until he awakens in the recovery room. Only a small multichannel oscilloscope and required meters are mounted in the operating room to eliminate clutter and explosion hazards, all data processing and amplifying equipment is located at a remote central station.

Equipment intended primarily for use during intensive care of

post-operative and critically ill patients received considerable attention as 1960 drew to a close. Epsco introduced a system similar to their surgical monitor which will continuously monitor temperature, pulse rate, respiration rate, eeg and eeg of eight patients from a central control station.

The Heiland div. of Minneapolis-Honeywell has developed a body-function recorder capable of automatically measuring and recording temperature, pulse rate, respiration rate, and diastolic and systolic blood pressure at periodic intervals of two minutes. An audio-visual alarm is provided in case of power failure, or if preset limits are exceeded or transducers displaced.

An automatic electronic physiological monitoring system announced by Gulton Industries will monitor from 1 to 12 patients for seven parameters—respiration rate and flow, eeg, heart sounds, body temperature (rectal), systolic blood pressure and external temperature (feet or hands). Information is presented on digital readout devices and both printed numerical and graphical records can be made.

A system developed by Invengineering, called the Recordisplay, will record temperature, CO<sub>2</sub> content of expired air, mechanical movement, eeg, cardiometer output, emg, blood pressure, eeg and pH of body liquids. Records of fast changing variables are made only when events of interest occur.

In Italy, the Galileo firm is producing a multichannel recorder that simultaneously records phonocardiograms, plethysmograms, pneumograms, sphygmograms, pressure waves in the heart chamber and, through a preamplifier, eeg. The

*Experimental model of GE's Teletrol system for fluoroscopic examination. Lead glass window permits observation of patient while shielding operator from radiation exposure*

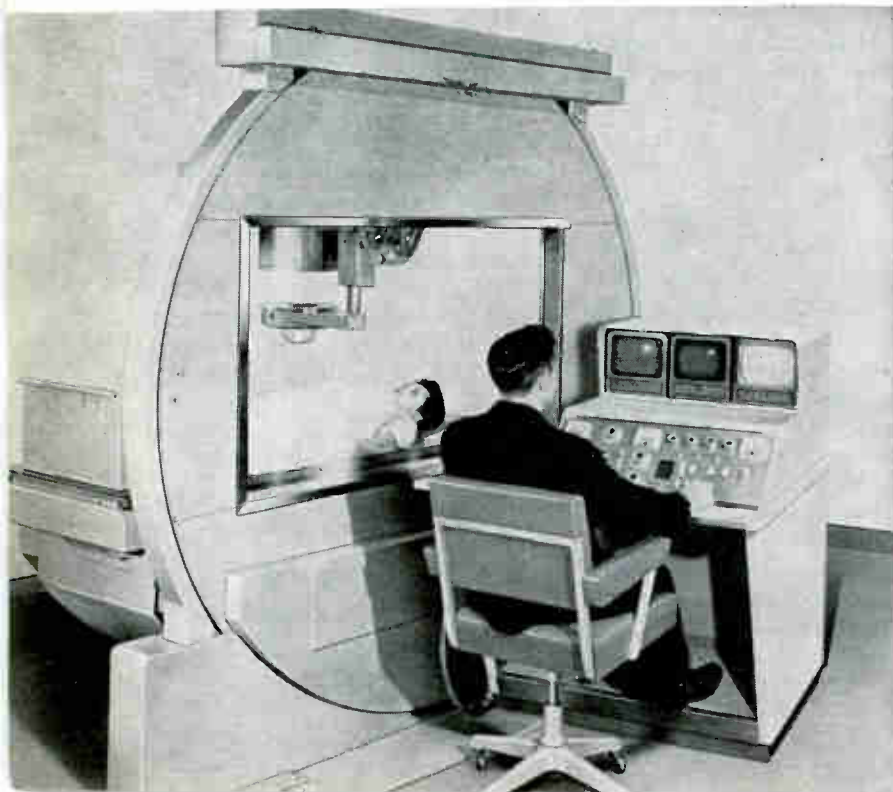



*Sanborn's monitoring system displays physiological condition of patient to surgeons throughout operation. Seventeen-inch oscilloscope shows an electrocardiogram (top) and a sphygmograph (bottom)*

Swiss firm of Fenes and Gut has marketed a similar system.

*Data Analysis and Interpretation*—Subjective and empirical analysis and interpretation of physiological data are being made obsolete by the trend toward machine evaluation. The two approaches used are statistical and correlation techniques.

The averaging technique is the most used statistical method. Non-critical random time fluctuations are eliminated by taking a time average of the signal. Thus, variations in heart rate from beat to beat are averaged out by counting beats by the minute.<sup>2</sup> Also, the average, mean and median frequencies can serve as indices of an eeg because they are fairly constant for each individual although the wave pattern is constantly changing.<sup>3, 4, 5</sup>

The Electromedical div. of Faraday Electronic Instruments in England has developed a low-frequency wave analyzer that breaks up an eeg pattern into 25 bands of frequencies and averages the output in each band over a period of ten seconds. Lockheed Missiles and Space Division has evolved a system for the detection of arteriosclerosis. Heartbeat pulsations of suspected

victims are detected by plastic cuffs attached to the wrist and ankles. Sounds recorded on a magnetic tape are converted into mathematical terms and then into points and lines on a graph by a digital computer. Data are analyzed statistically to detect abnormalities.

Techniques involving cross-correlation and auto-correlation functions are now being used extensively. Two similar functions will have a large cross-correlation factor while two dissimilar functions will have a small cross-correlation factor. Auto-correlation is cross-correlation of a signal with itself. One of the applications of cross-correlation is in comparing eeg and eeg signals to recognize abnormal conditions. Auto-correlation has been widely used to classify eeg waveforms in terms of a dominant frequency or frequencies thus eliminating random time variations and simplifying diagnosis. Georgetown U. has used this technique to determine fetal heart rate from samples of less than ten seconds.<sup>6</sup>

The National Bureau of Standards is using high-speed digital computers to compare and analyze heartbeat data.<sup>7</sup> The eeg signals used are mutually perpendicular

components of the heart vector obtained from the head, chest and ankle. These signals are recorded on magnetic tape as continuous waveforms and then changed to digital form. After being recorded on another magnetic tape, the digitized signal is crosscorrelated with a normal record.

A prototype diagnostic computer that answers questions about ailments of the gastrointestinal system has been devised by Dr. Gustav Martin in cooperation with Princeton Science Associates. The interrelationship of the disease symptoms is the basis of operation—five or six symptoms put in by punched cards being required to make a diagnosis. If inadequate information is put in, a listing of alternative diseases is given.

Eight hundred symptoms of different diseases of the cornea of the eye have been stored in an electronic calculating machine in France. A definite diagnosis based on a comparison of a group of input symptoms against the memory store is returned.

The Russians are building at least two diagnostic computers. One will be specifically for the diagnosis of cardiac diseases susceptible to

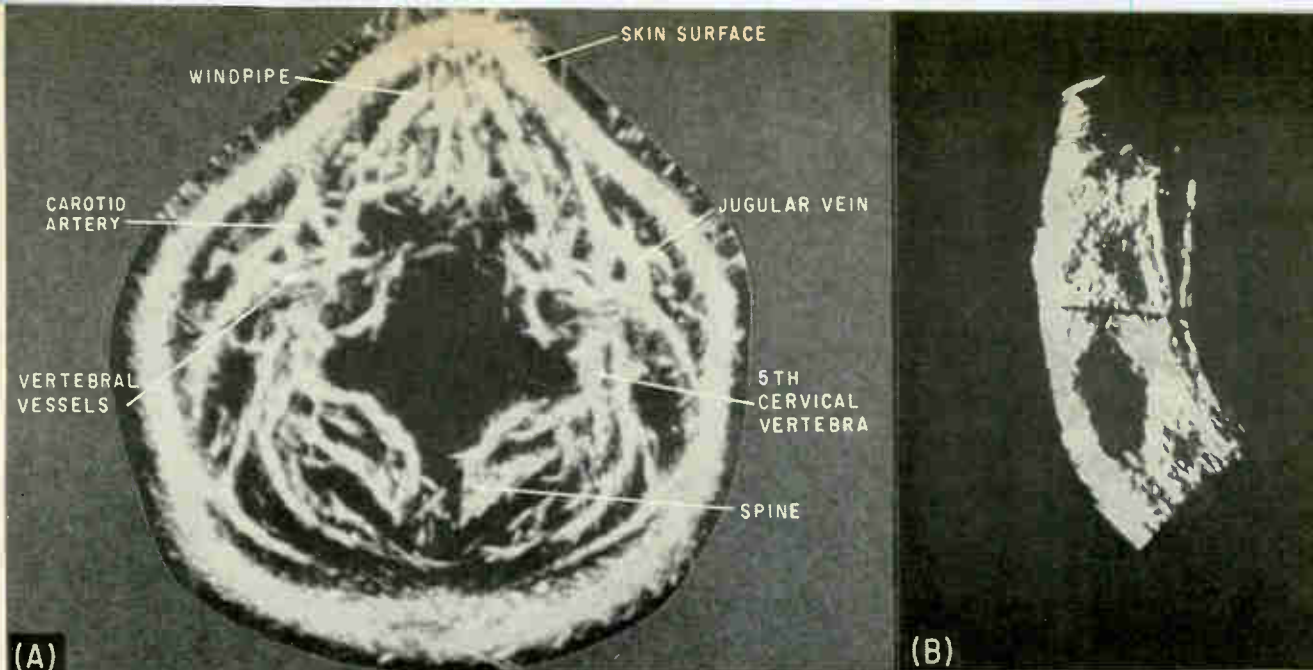

*Ultrasonogram of a normal neck (A) and breast (B) made at the U. of Colorado by Doctors Howry and Holmes. Extremely fine detail of neck was achieved using compound circular scanning technique. Clear black area surrounded by reflection from tissue in the breast picture represents a cyst that was 3 by 5 cm in size when surgically removed*

surgical intervention, the other will diagnose 100 common illnesses. The Cybernetics Laboratory in the USSR Academy of Medical Science is also investigating the possibility of using computers capable of processing physiological data during operations and drawing conclusions based on its analysis.<sup>8</sup>

**X-ray Visualization**—The x-ray machine projects a beam from an x-ray tube through the patient, to the degree permitted by intervening body structures. These structures cast a shadow picture on an image device designed to make the shadow picture visible. In radiography, photographic film serves as the image device and the viewer is limited to a still picture. In fluoroscopy, a fluorescent screen serves as the image device and the observer can see internal motion.

Major emphasis at present is to develop techniques for reducing exposure time and energy. Image intensifiers, optical-tv magnifying systems and bioelectric exposure control offer at least partial solutions to the problem.

There are three types of intensification—tv intensifier systems, direct-viewing intensifier tubes and solid-state intensifier panels. The first two show promise of providing large-field intensification without appreciable loss of information. The third is still in the experimental stage and suffers from two serious defects, lag and background.<sup>9</sup>

A new system, called Teletrol,

has recently been introduced by GE. This is a remote control device that permits the radiologist to work without protective clothing while being able to observe the patient, view the fluoroscope on closed-circuit tv and make motion pictures. The patient and table are moved rather than the heavy x-ray equipment. An electronic timer used with a movie system controls the total time that current passes through the x-ray tube and thus the time during which x-rays are emitted.

In Japan, Toshiba announced late last year the development of a tv x-ray system. The visible image on an x-ray intensifier screen is magnified by an optical lens and projected on the photocathode of an image-orthicon tube. The tv signals generated are sent to a viewfinder and 17-in. tv monitor. This combination of intensifier and image orthicon camera gives better definition than direct optical magnification of the intensifier image.

A tv scanning and magnetic storage technique introduced by Deutche Philips in Germany permits a continuous display of bright, well contrasted x-ray pictures with low patient exposure. The picture on the x-ray screen is scanned by a tv camera and converted into linear pulses (or dots) of varying intensity. These pulses magnetize a rotating coated disk which builds up one picture during each revolution. A pickup head collects the impulses that are fed to a tv receiver where

the initial picture is restored in highly intensified form on a monitoring screen. If used with closed-circuit or transmitted tv systems this device could permit diagnosis from x-ray pictures made at remote points.

Shimazu, Miura and Fujimoto of Japan have developed a bioelectric control system by which x-ray photographic exposures of the heart are made at predetermined instants of the cardiac cycle. The device is triggered by a characteristic spike-wave potential picked up from the heart. A variable-delay timer and crt monitoring system set the instant of exposure precisely with reference to the spike.

**Radioisotope Scanning**—This technique provides pictures that help determine the existence, location and nature of diseased tissue. For this purpose, a radioactive substance is introduced into the patient's body. Radiation given off by the substance can be registered on specially devised detecting counters and made to produce visual images in two dimensions.

The Hadassah Medical Organization in Israel has diagnosed coronary thrombosis using radioactive iodine and a Geiger counter to locate the clots. This method tells the physician whether a patient has had a heart attack or not—informaton not given by an ecg.

A radioactive technique for measuring blood flow in arteries of the heart to detect heart disease



has been developed by the U. of California Medical Center. A small amount of radioiodine is injected into a vein. Two scintillation counters, one placed over the heart, one over the brain, follow progress of the radioiodine into the heart vessels. In coronary heart disease some blood vessels of the heart are blocked, the degree of blockage controlling the amount allowed through.

Tullamore Electronics, subsidiary of Victoreen Instrument Co., has developed a spectrometer that automatically distinguishes between background radiation and radioactivity being detected. This delineation is accomplished by two supersensitive scintillation crystals, one for the sample itself and the other to keep tabs on normal radioactivity in the area. A magnetic core memory stores information that can be read during the actual test by either an analog display on a crt or by neon digital indicators.

A scanning machine was recently described that will present pictorially and quantitatively the distribution of radioisotopes in a human.<sup>10</sup> The patient is automatically moved beneath a fixed scintillation counter. Marks are made on a recording paper each time a preselected number of pulses have been counted. The color of the mark is determined by the mean pulse rate. The resulting graph is a pictorial display of radioisotope distribution, changing count rates being shown by changing colors.

Distribution of gamma ray emitters has been visualized by a sensitive pinhole camera.<sup>11</sup> Sodiumiodide

crystal scintillations are detected by a bank of 7 to 19 phototubes and reproduced as flashes on a crt. By photographing the flashing over a period of time, a picture of gamma-ray distribution can be made. If a gamma-ray counter is placed on the opposite side of the subject and a coincidence circuit used, scintillation distribution from positron emitters can be visualized.

**Ultrasonography**—Ultrasonic visualization techniques will probably replace x-ray devices for some purposes, primarily because of the comparisons noted in the table. Before this can take place, however, people will have to be trained to read ultrasonograms as they have roentgenograms.<sup>12</sup>

Two basic types of diagnostic ultrasound devices are used in medicine—the sonic reflection system and the through transmission system. The reflection system operates on a radar-like principle. Ultrasonic pulses emitted by a crystal generator are transmitted through a liquid, usually water, to the body. Upon striking the various layers of tissue, the pulses are echoed back, detected by the crystal and displayed on a crt or recorded. The through system uses a transmitter of ultrasonic energy on one side of the part being examined and a receiver on the other. The transmitter and receiver are caused to move synchronously and systematically over the part, the difference in intensity of the received signal forming a shadow picture similar to a roentgenogram.

Researchers at the U. of Colorado

have devised a reflection instrument, termed a Somascope, which is helpful in diagnosing internal ailments.<sup>13</sup> A scanning technique is used wherein, when all the echoes have returned from one pulse of energy, the beam path is changed slightly and the process repeated. By producing over 1,000 pulses a second (and their echo trains) while the transducer is scanning, a continuous two-dimensional cross-sectional picture of the object can be presented on an oscilloscope. A 5,000-v pulse of  $\frac{1}{4}$   $\mu$ sec duration is used to drive an x-cut quartz crystal transducer. Pulse rate is 2,000 pulses a sec, but is not critical. Average power is approximately 1 mw. Operating frequency is 2 Mc; however experiments are being conducted in the 180 Kc to 20 Mc range.

Simple time-varied gain used in radar cannot be used in ultrasonography. A keyed-time gain is used so that the gain curve of the receiver starts when the first echo returns. The first major echo triggers the gain compensator, which permits amplifier gain to increase in a quasilog fashion. Thus, echoes are received at identical intensities regardless of the time that they arrive.<sup>14</sup>

By incrementally moving the transducer normal to its scan plane, a series of cross-sectional pictures can be obtained that give a profile of the tissue. However, this technique requires many ultrasonograms—in the neighborhood of 48 taken at different levels are required just to adequately study the breast. The U. of Colorado re-

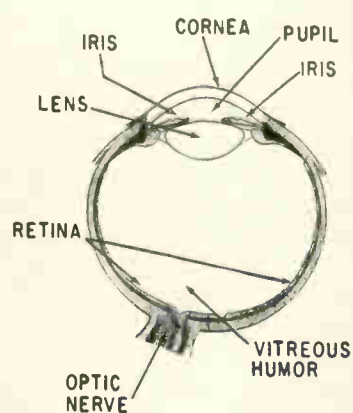

(A)

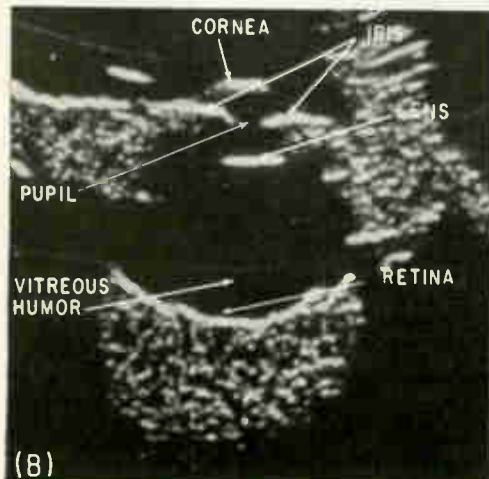

(B)



(C)

Cross-sectional drawing of human eye (A), and ultrasonograms of a normal human eye (B) and human eye with detached retina (C) made by Dr. G. Baum of Bronx Veterans Administration Hospital and I. Greenwood of General Precision Labs. Horizontal lines are range markers one centimeter apart

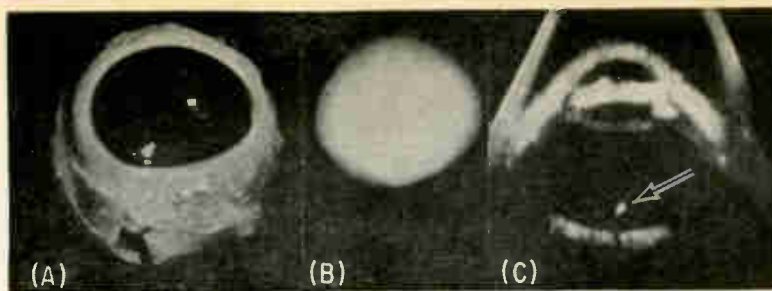

Comparison of gross (A), x-ray (B) and ultrasonic (C) appearance of bull's eye containing a piece of wood in the vitreous. Arrow points to sonic image of wood invisible to x-rays. Position of foreign body in depth and azimuth can be found directly using GPL's ultrasonograph

#### ADVANTAGES OF ULTRASONIC OVER X-RAY VISUALIZATION<sup>a</sup>

Ultrasonography	X-Ray Radiography
Soft tissues visualized directly without contrast media; detail is equivalent to low-power photomicrograph	Contrast media required because soft tissues have uniform density to x-rays; detail does not equal ultrasonograms
Safe at levels used for visualization; no immediate, cumulative or delayed effects	Danger of x-ray exposure and cumulative effects many times greater than radioactive fallout <sup>b</sup>
Depth and angular location can be directly measured without markers	Markers required
Most forms of foreign materials may be visualized and localized (see photo)	Many substances possess same x-ray density as soft tissues in which they are embedded and cannot be visualized
Visualization and localization may be performed in any part of eye or orbit	Radioisotope localization and identification of tumors dependent upon their anterior location and selective uptake
Ultrasonographs will visualize ligaments, tendons, nerves and muscles	Soft tissue surrounding a bone (ligaments, tendons, nerves, muscles) are barely visible; true structural details are never seen
No known case of ultrasound energy causing malignancies	X-ray treatments of the head and neck of children is associated with cause of thyroid cancer <sup>c</sup>

(a) taken in part from article by G. Baum and I. Greenwood, *Ultrasound in Ophthalmology*, *Am Jnl of Ophthalmology*, 49, Feb. 1960 (b) from report by Britain's Medical Research Council (c) findings of Dr. Crile of the Cleveland Clinic Foundation

searchers have devised a technique that combines abilities of ultrasound to separate structures with the advantages of volume projection. These three-dimensional pictures are obtained by moving the level of the transducer head with a lead screw that is constantly and progressively turned as the horizontal scanning takes place. A potentiometer in a crt input circuit is rotated by the lead screw, varying the d-c potential applied to the vertical plates of the crt in the oscilloscope. With the vertical sweep voltage potentiometer set at its zero position and the vertical centering potentiometer at its maximum position, a full frontal projection is obtained. For reversed positions, a top-view projection is obtained. Intermediate positions result in a projectional rotation.

Researchers at the U. of Pa. have been working with substantially the same circuits but at an operat-

ing frequency of 15 Mc over a full 60-db range.<sup>15</sup> Although the definition obtained is not as good as with the U. of Colorado system, the principal aim of the work is to detect rather than diagnosis diseases.

The Japanese are diagnosing brain tumors using equipment much like that of the U. of Colorado, operating in the 1 to 10-Mc range.<sup>16</sup> The transducer is brought into direct contact with the head. Examination at the temporal part of the skull has been found to be easiest. The ultrasonic waves travel near the base of the brain and reflect from the opposite side of the skull. The difference in acoustic impedance between a tumor and normal brain tissues cause reflection of sound energy from the interface. The Japanese have also diagnosed breast cancer using ultrasound in the 5 to 10-Mc range.<sup>17</sup>

German experimenters have distinguished tumors in the left

atrium of the heart from narrowing of the mitral valve whose symptoms are similar.<sup>18</sup> Ultrasound in the range of 1 to 2.5 Mc is transmitted into the chest in pulses of approximately  $10^{-5}$  second duration and at a rate of 200 a second. Sound waves reflected from the cardiac and vascular walls are shown on a crt.

The Russians claim to have used ultrasonic techniques to detect cancerous cells up to one millimeter in size.<sup>19</sup> The operating principle is similar to that used at the U. of Colorado except that the operating frequencies are 2.5, 5, 10 or 15 Mc, pulse width is one or two  $\mu$ sec and pulse rate is 1,000 pulses a second. The equipment is now being evaluated at the Moscow Onkological Institute and, if found technically sound, will be placed into quantity production in the USSR.

*Ultrasonic Ophthalmology*—The Bronx Veterans Administration Hospital and the GPL div. of General Precision have developed an ultrasonograph for examining tissues of the eye.<sup>20</sup> This technique permits visualization of the interior of a light-opaque eye. The average power used is only 0.07 watts per sq cm<sup>2</sup> and no immediate, cumulative or delayed effects have been noted. Exposure to doses in excess of this value have been proved safe for as long as 45 minutes.<sup>21</sup> Frequency used is 15 Mc.

An acoustically focused shock-excited X-cut quartz crystal is used as the transducer. Ultrasonic energy is coupled to the eye by using a rubber condom filled with degassed water, by fluid contained in a funnel or by direct transducer contact. The basic scanning motion is a fast sector scan that produces an intensity-modulated image on the crt. Permanent records are made by photographing the indicator tube. Compound scanning is currently under development. This technique will slowly and continuously move the transducer in a 90-degree arc around the eye while fast sector scan is taking place.

*Infrared Ophthalmology*—As in ultrasonic visualization, infrared radiation will permit viewing of the interior of the eye in the presence of dense opacity of the cornea.

A system developed by J. Fried-

man of Brooklyn uses a tungsten light as an energy source and a deep infrared filter to eliminate visible light.<sup>22</sup> Thus, the pupil will dilate fully and the observer can watch spontaneous eye movements without introducing distracting visible light into the patient's field of vision. The infrared light reflected from the eye is passed through an ophthalmic instrument to an ir receiver containing an ir converter tube that displays the image to the observer. Information obtained helps evaluate the status of the iris, transparency of the lens and turbidity of aqueous humor.

**Tv Ophthalmology**—Color motion pictures of the back of a sighted human eye have been obtained using a field-sequential color tv ophthalmoscope developed jointly by CBS Labs and a medical research team from the National Institutes of Health. The eye is illuminated with a filtered light source and the reflected image picked up on a retinal camera. The image is then passed through a color wheel to an RCA wide-spaced orthicon tube that requires very little light. Permanent records are made in color using a motion-picture camera. By selecting a single line electronically from the television picture, blood vessel diameters can be displayed as peaks and valleys on a cathode ray oscilloscope and dynamic changes in these dimensions recorded on magnetic tape for later analysis. Since the system is more sensitive to light than is the human eye, long exposures are possible without damaging the retina or optic nerve.

This system has been used to investigate tissues and blood vessels of the eye in the diagnosing circulatory disturbances related to heart disease and arteriosclerosis. Also, retinal flaws have been observed and cancerous tumors in the eye detected. Ultraviolet and infrared rays that are invisible to the eye can be used and may reveal more than does visible light.

**Endoscopy**—Endoscopes are used to examine interior body cavities. Electronics has entered this field through the fibroscope, a flexible cable consisting of a bundle of fine light-transmitting glass filaments,

that provides good quality images and is more flexible than conventional endoscopes. Each fiber picks up and transmits by multiple internal reflections one dot of light. A mosaic of dots appears at the other end of the cable, forming an image of the object viewed.

The Franklin Institute has extended their work beyond the optical features of the design and have developed a technique for controlling the configuration of the fibroscope so that the physician can easily view what would otherwise be inaccessible places. American Cystoscope has developed a fibroscope for viewing the duodenum (first part of the small intestine) nonsurgically. The instrument uses a 10-v bulb and lens system in the head of the cable to serve as a light source. Armour Research Foundation is working on infrared fiber optics that may have applications in endoscopic work.

A system developed by Avco for dental monitoring uses a fingertip-size lens arrangement at the probe end of a fiber optic cable and a closed-circuit tv camera at the other end.<sup>23</sup> A distortion-free image of a tooth or other oral features can be magnified up to 35 times. Dynamic scanning is used to avoid loss of resolution caused by black spots resulting from broken fibers.

#### REFERENCES

- (1) C. L. Hebert, Physiological Monitoring of Patients, *Dig of Tech Papers, 13th Ann Conf on Elect Tech in Med and Bio*, Oct-Nov, 1960.
- (2) J. R. Richard, Jr., Frequency Spectra of Some Normal Heart Sounds, *Am Heart J*, 53, p 183, Feb, 1957.
- (3) D. Ellis, Bases of Major Mammalian Bioelectric signals, Litton Industries RAD-TM-11 Series, Nov 16, 1959.
- (4) J. F. Davis and W. R. D. Ross,

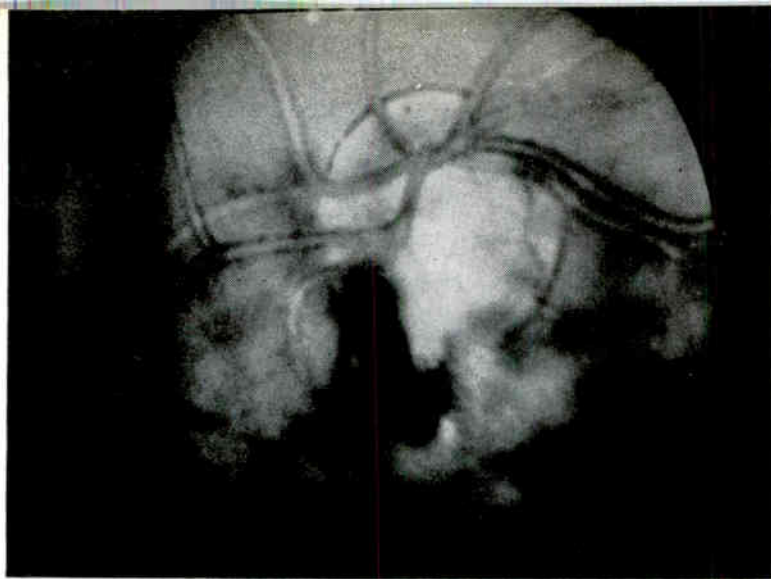

Black and white photo of back of living, sighted human eye made with color tv ophthalmoscope developed by CBS Labs and NIH

SARA (Still Another Response Averager), *Dig of Tech Papers, 13th Ann Conf on Elect Tech in Med and Bio*, Oct-Nov, 1960.

(5) H. W. Shipton, Averaging and Correlation Techniques Applied to Neurophysiological Measurements, *Third Int Conf on Med Electronics*, July, 1960.

(6) A. G. Favret and J. D. Casolaro, Application of Correlation Analysis to the Fetal Electrocardiogram, *Dig of Tech Papers, 13th Ann Conf on Elect Tech in Med and Bio*, Oct-Nov, 1960.

(7) R. J. Arms, Digital Analysis of Vectrocardiographic Readings, *Dig of Tech Papers, 13th Ann Conf on Elect Tech in Med and Bio*, Oct-Nov, 1960.

(8) V. V. Parin, Certain Outcomes and Future Prospects of Radioelectronics Employment in Medicine and Biology, *Vestnik Akademii Meditsinskikh Nauk, SSSR*, No. 5, p 27, 1959.

(9) R. L. Beurle, M. C. Kennedy and N. A. Slark, Large-Field X-Ray Intensification—A Comparison of Methods, *Third Int Conf on Med Electronics*, July, 1960.

(10) J. R. Mallard and C. J. Peachey, A Scanning Machine for Presenting Pictorially and Quantitatively the Distribution of Radio-isotopes in Vivo, *Third Int Conf on Med Electronics*, July, 1960.

(11) H. O. Anger, Visualizing the Distribution of X-Ray and Positron Emitters, *Third Int Conf on Med Electronics*, July, 1960.

(12) Personal communication with Dr. J. H. Holmes, University of Colorado School of Medicine, Denver, Colo.

(13) D. H. Howry and J. H. Holmes, Techniques Used in the Ultrasonic Visualization of Soft Tissue Structures, *Dig of Tech Papers, 12th Ann Conf on Elect Tech in Med and Bio*, Nov, 1959.

(14) D. H. Howry, Techniques Used in Ultrasonic Visualization of Soft Tissues (from "Ultrasonid in Biology and Medicine" published by the American Institute of Biological Sciences, Washington, D. C.).

(15) J. M. Reid, Diagnostic Applications of Ultrasound, *PROC IRE*, p 1963, Nov, 1959.

(16) K. Tanaka, K. Ito, Y. Kikuchi and R. Uchida, Ultrasonic Diagnosis of Brain Tumor, *Third Int Cong on Acoust*, Sept, 1959.

(17) Y. Kikuchi, R. Uchida, K. Tanaka and T. Wagai, Early Cancer Diagnosis Through Ultrasonics, *Jnl Acoust Soc Am*, 29, July, 1957.

(18) S. Effert and E. Domanig, The Diagnosis of Intra-atrial Tumours and Thrombi by the Ultrasonic Echo Method, *German Med Monthly*, IV, Jan, 1959.

(19) M. D. Gurevich, Apparatus for the Diagnosis of Tumors with the Aid of Ultra-Sound, *Meditsinskij Prom*, SSSR, No. 2, p 52, 1959.

(20) G. Baum and I. Greenwood, Ultrasonic Visualization of the Eye, *Dig of Tech Papers, 12th Ann Conf on Elect Tech in Med and Bio*, Nov, 1959.

(21) G. Baum, The Effect of Ultrasonic Radiation: Upon the Eye and Ocular Adnexa, *Am Jnl of Ophthalmology*, 42, p 696, Nov, 1956.

(22) J. Friedman, Penetration of Corneal Opacities by Infrared Electronics, *Dig of Tech Papers, 12th Ann Conf on Elect Tech in Med and Bio*, Nov, 1959.

(23) H. P. Hovnanian and D. E. Haswell, An Electro-Optic Dental Monitor, *NEREM*, Nov, 1959.

# USING THERMISTORS

*Indirectly heated thermistors can be substituted for mechanical servo units in some applications. Basic circuit is a thermistor potentiometer*

By I. C. HUTCHEON, Chief Electronics Engineer, George Kent Limited, Luton, Bedfordshire, England

ALTHOUGH THERMISTORS were originally developed as temperature sensing devices, the addition of a heater extended their use to purely electrical circuits, and thus opened new applications. Some of these are well known; amplitude stabilization of variable-frequency oscillators is a good example.

The applications discussed below are all based on the indirectly heated thermistor considered as a

solid-state servo mechanism element.

In Fig. 1A a single thermistor is heated by the raw demodulated output of a chopper-type d-c amplifier, and controls a smooth direct output current. Demodulation must be phase-sensitive, and overall d-c feedback stabilizes the gain of the whole system, so that the output current is an accurate measure of the input voltage. The gain must

be high enough to swamp the effect of ambient temperature variations on thermistor characteristics, and in this use the thermistor gives but little advantage over the resistor-capacitor smoothing circuit.

In the more valuable applications the controlling signal is a-c and the output is reversible, or at least can be reduced to zero. Best results are achieved by using two thermistors in series and driving

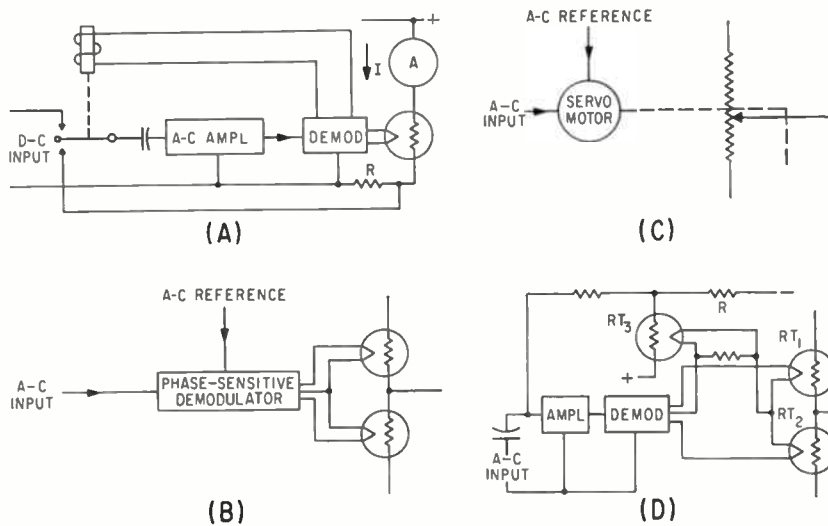

FIG. 1—Thermistor controls d-c current, (A); two differentially driven thermistors do same in (B); result is analogous to mechanical servo (C). Added thermistor compensates for temperature effects, (D)

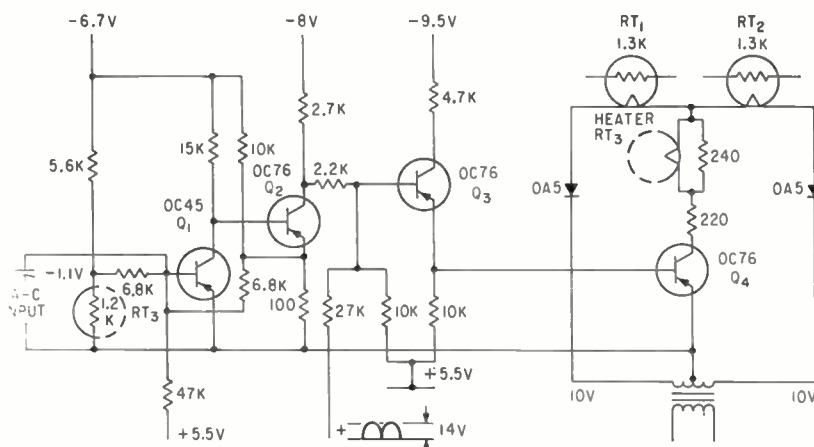

FIG. 3—Circuit diagram of device shown in Fig. 2

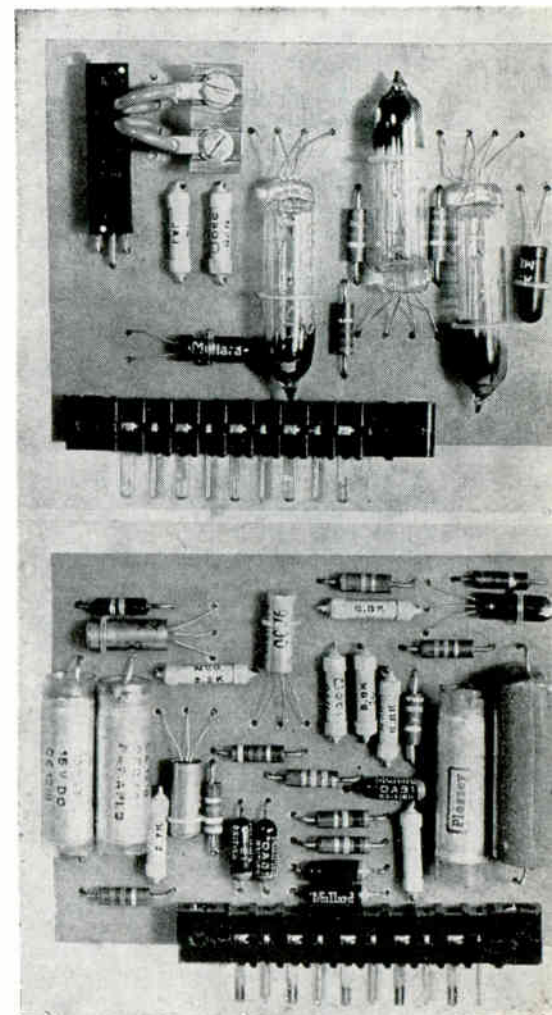

FIG. 2—Thermistor servo device, complete except for power supply

# AS SERVO ELEMENTS

their heaters, differentially by a phase-sensitive demodulator as shown in Fig. 1B.

In this circuit, under no-signal conditions both thermistors are heated equally and their resistances remain balanced in spite of ambient temperature changes. When an a-c signal is applied, it raises one resistance and lowers the other, so that the common point moves toward one or the other end of the total resistance, according to the phase of the signal. Thermal inertia in the thermistor beads prevents significant modulation of the bead resistance at signal frequencies above a few tens of cycles a second, and the device is directly analogous to the servo motor and mechanical potentiometer combination shown in Fig. 1C. There is no position output, of course, and the total series resistance varies somewhat with the signal, but in many applications these features do not matter.

A disadvantage of the simple circuit of Fig. 1B is its sensitivity to changes in ambient temperature. Although temperature changes do not unbalance the potentiometer, they may cause wide variation in its resistance and thus create practical difficulties in designing associated circuits.

This disadvantage can be overcome by adding a third similar thermistor as shown in Fig. 1D. In this arrangement<sup>1, 2, 3</sup> the demodulator is preceded by a direct-coupled transistor amplifier, and the third thermistor  $RT_3$  supplies overall negative d-c feedback to control the total power supplied to output thermistors  $RT_1$  and  $RT_2$ . Thus, in Fig. 1D, the heater of  $RT_3$  is shunted so that all three heaters dissipate the same power under no-signal conditions. Consequently, all three thermistors have the same resistance whatever the ambient temperature, and the feedback maintains this at a predetermined value in relation to fixed resistance  $R$ . An a-c input to the circuit causes equal positive and negative changes of dissipation in the output heaters, and the characteristics of the device can therefore be calculated. Thermal inertia in

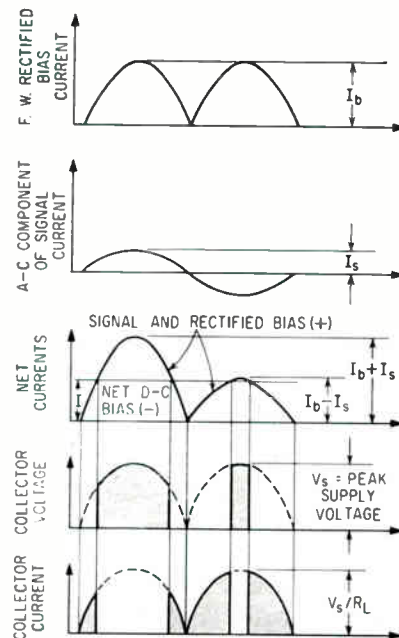

FIG. 4—Demodulator waveforms for circuit of Fig. 3:  $I_b$  is peak full-wave rectified bias current applied to  $Q_1$  base,  $I_s$  is peak a-c drive applied to  $Q_1$  base;  $R_L$  is  $Q_1$  collector load resistance, and  $I$  is net steady d-c bias applied to  $Q_1$  base

the third thermistor prevents any a-c feedback through the d-c feedback path.

Figure 2 shows a practical device built on the above principle. The unit includes two plug-in printed-circuit boards, which are normally bolted together. The circuit is given in Fig. 3. Transistors  $Q_1$  and  $Q_2$  form the a-c preamplifier, and  $Q_3$  and  $Q_4$  operate in switched mode as a demodulator. Figure 4 shows the demodulator waveforms. All transistors are stabilized simultaneously by the overall d-c feedback; this eliminates the effect of collector leakage and drifts in d-c characteristics. The a-c gain is defined by feedback around  $Q_1$  and  $Q_2$ . All transistors can be inexpensive germanium types, since they operate at low power levels. Operation is substantially unaffected by changes in ambient temperature from 0 to 60 C.

Figure 5A shows the steady-state input-output characteristic of the unit; gain is substantially for outputs up to  $\pm 75$  percent of the theoretical maximum. The input re-

quired to provide this output is  $\pm 1$  microampere rms at a few hundred microvolts. The curves in Fig. 5B show typical response to step changes of input signal. Although several seconds are required for a large change in output, it is often possible to use only a fraction of the available swing and obtain a faster-operating system.

The difficulty of obtaining a perfect balance in mechanical a-c servo systems is well known.<sup>4</sup> Pickup, or phase shifts in transformers and transmission lines give rise to a quadrature component in the input signal that cannot be balanced out by the feedback signal. As a result, when the system has reached equilibrium, a finite residual signal exists that is approximately in quadrature with the reference. Figure 6 shows the problem in vector form;  $V_r$  and  $V_s$  are the reference and quadrature components of the input signal,  $V_f$  the feedback and  $\phi$  the angle at which the servo motor has maximum response.

The effect of the residual signal is twofold. Small amounts of signal drive the servo motor unless it is accurately phased (that is,  $\phi = 0$ ) thus causing an error in the servo output. Larger amounts may block the servo amplifier, putting the system out of action.

Stable quadrature effects can be eliminated by manually adjusted phase correction, but this is inadequate if the effects are variable. Variable quadrature may arise from pickup, or from the interaction of line capacitance and a variable source resistance. An example of the latter is the electromagnetic flowmeter<sup>5</sup>, used with fluids of different conductivity.

The problem is solved by a thermistor potentiometer connected to suppress the residual signal, as shown in Fig. 7A. The suppression signal must be accurately phased at 90 deg to the a-c reference so that no error is introduced, and  $C$  must therefore be small. On the other hand, phase errors in the servo amplifier and in the drive circuit of the thermistor potentiometer are of secondary importance. Even phase errors in the main a-c feedback sig-

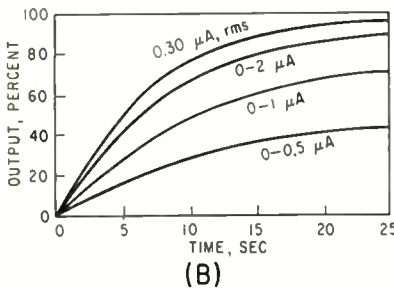
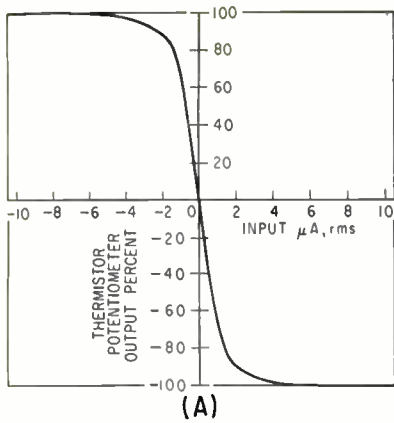

FIG. 5—Steady-state characteristic of circuit in Fig. 2 is shown in (A); response to step changes of input shown in (B)

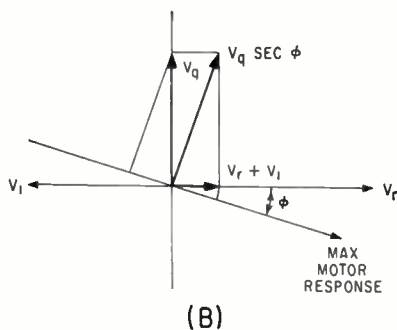
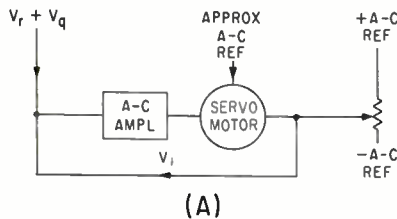

FIG. 6—Servo system without quadrature suppression, block diagram (A), vector diagram of signals at amplifier input (B)

nal have little effect, since any quadrature component which they cause is also suppressed. The residual signal is reduced by a factor equal to the gain of the quadrature loop, and a value of about 100 gives adequate suppression in almost all practical cases, together with a good margin of system stability.

Another and somewhat similar application is shown in Fig. 7B. In this arrangement two thermistor potentiometers balance the components  $I_p$  and  $I_q$  of an input current, which are in phase and in quadrature with an a-c reference of the same frequency. The two components can be displayed simultaneously on two a-c meters, or on a single meter switched alternately between the two positions. The meter impedance must be low compared to the reactance of the phase shifting capacitor  $C$ , to obtain an accurate 90-deg shift. Phase errors in the common preamplifier are of little significance, and the feedback resistance and capacitance do not have to be stable.

Another arrangement described by Winter<sup>6</sup> and White<sup>7</sup> facilitates measurement from large numbers of strain-gage transducers in vibration studies of aircraft structures.

Strain-gage bridges are supplied with a-c, and the output of any one generally contains both a quadrature component of the carrier signal, due to stray electrical effects, and an in-phase component of constant or slowly varying magnitude, due to bridge unbalance. To avoid manual balancing of each bridge before each observation, the measuring apparatus contains two thermistor circuits that suppress both components. Since the thermistors are slow-acting, rapid changes in the in-phase component amplitude are unaffected and can be amplified for display.

Many physical measurements are made by transducers whose output is a small a-c signal, ultimately derived from the power line and subject to its variations. Examples are the measurement of electrical conductivity of fluids by comparing the resistance of a conductivity cell with that of a fixed resistor, and measurement of volume flow rate by electromagnetic flowmeters. In both cases, d-c supplies cannot be used because polarization would affect accuracy.

In such cases it is necessary to measure the ratio of two a-c signals of the same frequency, and this is conventionally done by a self-balancing a-c potentiometer. This, however, gives a position output, and modern process control may require a d-c output that can be transmitted over a long distance,

or used to operate control devices directly.

Figure 8A shows how this may be done using thermistors and frequency-sharing techniques. A thermistor potentiometer takes the place of an a-c servo motor and slide wire, and provides the a-c feedback to balance the input signal. Since the potentiometer has the a-c reference  $V_{a-c}$  applied across it, its gain  $K$  is automatically adjusted so that  $K \times V_{a-c}/R_2 = V_{in}/R_1$ , that is,  $K = (R_2/R_1) \times (V_{in}/V_{a-c})$ . Since the thermistor potentiometer does not have a position output, some means of extracting the value of  $K$  must be provided. This is done by superimposing an additional direct reference voltage  $V_{d-c}$  across the potentiometer in series with  $V_{a-c}$ . Provided that both  $V_{a-c}$  and  $V_{d-c}$  have low source impedances, the whole of each appears across the potentiometer whose output is therefore  $K(V_{a-c} + V_{d-c})$ . The two components are separated, and the final d-c output,  $K V_{d-c} R_4/R_3 = (R_2/R_1) \times (R_4/R_3) \times (V_{in}/V_{a-c}) \times V_{d-c}$  provides the measure of the ratio of the two a-c signals. Response of the system is restricted to that of the thermistors, but this is not serious and may even be an advantage if the input is noisy. A third thermistor can be added to give quadrature suppression.

A number of analog computing devices can be made if time-sharing techniques are adopted. Typically, two or three synchronous switches are required, and these may be conventional mechanical choppers. One such device is the four-quadrant multiplier<sup>8</sup>, for d-c or low-frequency a-c inputs, shown in Fig. 8B.

Here, two thermistors form a potentiometer shared alternately between two circuits; its gain is adjusted automatically in one circuit in relation to two input voltages, and used in the other to multiply a third input. Thermal inertia prevents any significant change in the gain during a half-cycle, and the switches also act as choppers so that the control amplifiers work on a-c. This eliminates drift problems.

Whenever the switches are in position 1, the output of the shared potentiometer is  $KE_1$ , and if this is not equal to  $E_2$ , the left-hand control amplifier receives a square-wave error signal. This signal adjusts  $K$  until  $KE_1 = E_2$  after a

number of cycles, that is,  $K = E_3/E_1$ . Whenever the switches are in position 2, the output of the same potentiometer is  $KE_2 = E_3E_2/E_1$ , and, by a similar process, the final d-c output takes up this value.

The switches need not be synchronized perfectly, provided that  $S_v$  always works within the other two, so that the potentiometer output voltage is always established before  $S_v$  is connected to the amplifier. Quantity  $K$  can take positive or negative values, and operation is maintained for any combination of polarities of  $E_1$ ,  $E_2$  and  $E_3$ .

A simpler two-quadrant multiplier can be built, using only two choppers; it does not require  $E_1$  and  $E_2$  to be balanced inputs. The device has a slow response but is potentially accurate.

A common requirement in servo systems is that the gain should increase at low frequencies, to reduce steady-state error without causing unstable operation. In d-c servos this is done by resistance-capacitance networks to shape the frequency response, but the problem is more difficult in carrier-type a-c servos.

It is necessary to demodulate the a-c error signal, insert a delay network, and remodulate at the carrier frequency. Solbakken<sup>6</sup> has described how this can be done with thermistors.

He uses the circuit shown in Fig. 9A, where demodulation is carried out by a bridge circuit containing two thermistor heaters, and remodulation by another bridge containing the beads. It is possible to achieve a steady-state gain about ten times greater than that of a parallel proportional amplifier.

Figure 9B shows an arrangement that has been used successfully to measure thermistor characteristics. Production spreads in these devices are wide and it may be necessary to select matched pairs or threes for use in potentiometers.

Acknowledgment is made to D. N. Harrison who has developed several of the devices described.

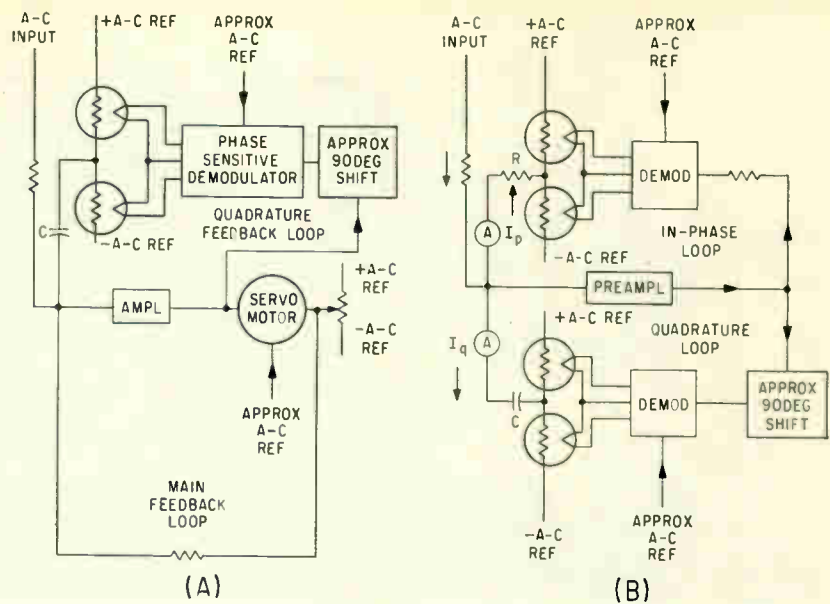

FIG. 7—Quadrature suppression applied to a mechanical a-c servo (A), phase measurement (B)

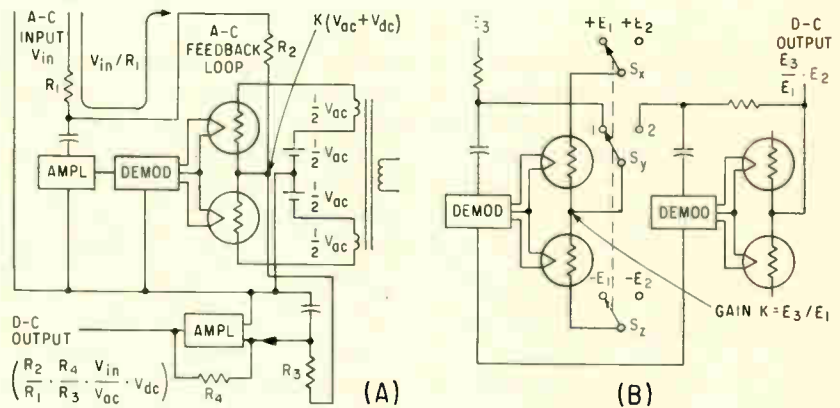

FIG. 8—A-c ratio to d-c converter (A); four-quadrant multiplier (B) for d-c or low-frequency a-c inputs

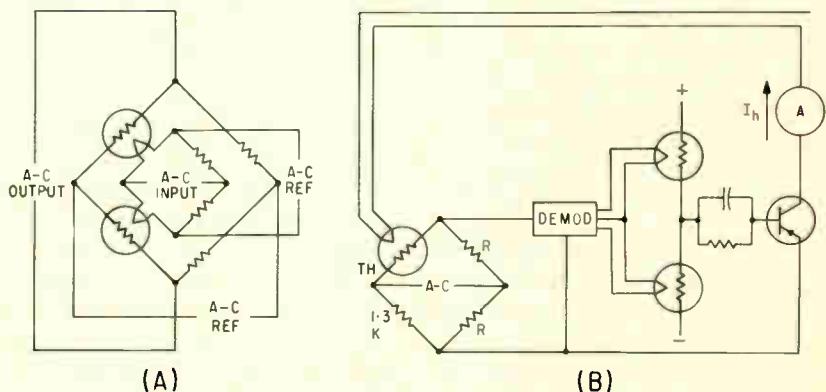

FIG. 9—Two-thermistor integrator for a-c servos (A), device built for selection of production-line thermistors (B)

## REFERENCES

- (1) I. C. Hutcheon and D. N. Harrison, A Transistor Quadrature Suppressor for a-c Servo Systems, *Proc IEE*, 107, Part B, No. 31, Jan. 1960.
- (2) I. C. Hutcheon and D. N. Harrison, A Transistor-Thermistor Feedback Quadrature Suppressor, *Electronic Engineer-*

*ing*, 32, p 87, Feb. 1960.

(3) British Patent application No. 13560/59.

(4) *Control Engineer's Handbook*, Section 6.1.8, p 77, McGraw-Hill.

(5) I. C. Hutcheon, Some Problems of Magnetic Flow Measurement, *Instrument Engineer*, 3, No. 1, April 1960, George Kent Ltd., Luton, England.

(6) W. A. Winter, Letter in *Electronic Engineering*, 32, p 383, June 1960.

(7) B. J. White, Letter in *Electronic Engineering*, 32, p 574, Sept. 1960.

(8) Brit. Pat. application No. 32526/57.

(9) A. Solbakken, Use of Thermistors for Error Integration in Carrier-type Servomechanisms, *Instrument Practice*, June 1960.

# New Sonar Thumper Charts Ocean Subbottom



*High-speed underwater photo of transducer, showing cavitation on the aluminum disk during the back phase of motion*

OCEANOGRAPHERS ARE EXPERIMENTING with the sonar thumper, a new instrument for ocean subbottom investigation. The thumper generates a high-power sound pulse able to penetrate sediment layers under the sea, and beyond into the bedrock. Unlike conventional ocean depth sounders, instruments for subbottom investigation operate at lower frequencies, below several kilocycles. Late in June the research vessel *Chain* of Woods Hole Oceanographic Institution began an extensive cruise of northern European waters. Directed by Dr. J. B. Hersey for part of the cruise, the ship carried out a program of general oceanographic and geophysical investigation, including seismic reflection and echo sounding studies.

The *Chain* carried a large model of the thumper among its instruments. While in the English Channel, successful penetration beyond the soft sediment into the naturally cemented, consolidated sediment layer was made, yielding recordings of good definition. Penetration into rock was also achieved.

High-power shock waves for subbottom investigation have long been made using dynamite exploded underwater. Penetration miles below the ocean floor is easily made, but the explosions are not readily repeatable. Multiple seismic or hydrophone pickup of reflections are used to plot the subbottom.<sup>1</sup> Con-

tinuous graph recordings are not possible because of the inaccurate timing of the blasts.

Instruments that provide repeatable sound energy include the gas popper, the sparker, magnetostrictive transducers and recently, the thumper. Reflected pulses from the subbottom are picked up on hydrophones and recorded on continuous graphs providing a profile of various layers as the ship progresses.

The gas popper explodes a mixture of gases such as propane and oxygen in a chamber towed underwater, open end facing the sea bottom. An ignition coil triggered at the recorder provides a spark to fire the mixture at rates up to several times a second. One design<sup>2</sup> incorporates a flashback baffle to prevent continuous burning of the gases.

The sparker technique requires a high-voltage power supply which energizes a bank of capacitors. A trigger signal initiates discharge of the capacitors across a spark gap towed in the water, producing a pulse of high intensity sound. The spark electrodes wear, requiring replacement of the assembly. In one design using 8,000 volts, replacement is made every 6 to 9 hours.<sup>3</sup> Higher voltages to 25,000 volts are often used. Spark repetition of several times a second is possible. The sparker is used more extensively than the popper, and gives a more detailed recording of the subbot-

tom due to the greater high frequency content in its pulse.<sup>3</sup> It generally does not penetrate as deeply as the popper. Both methods may be included in one shipboard design, the desired one energized at will. A variable filter can be used to limit the recorder bandwidth for each sound generator, improving the signal to noise ratio.

Magnetostrictive devices are also used, but at the low frequencies required for subbottom work they become large and unwieldy.

The sonar thumper was developed under contract by Edgerton, Germeshausen and Grier, Boston, Mass. for the Woods Hole Oceanographic Institution. Much of the work was done at the M.I.T. laboratory of Dr. H. E. Edgerton, with Samuel Raymond, Gary Hayward and Carl Morey contributing to the design. Several units have been tested at WHOI, and the work aboard the *Chain* indicates the thumper may one day replace dynamite, which is presently used to penetrate beyond roughly one mile.

The standard sonar thumper<sup>4</sup> consists of an aluminum plate held against an encapsulated coil by a bolt and spring retainer. The circuit of the thumper is given in figure. The entire assembly measures 20 inches across. When a bank of capacitors charged to 4,000 volts is connected to this coil by an electronic triggering circuit synchro-



*Force produced by capacitor discharge into encapsulated coil produces movement of underwater aluminum plate, generates low-frequency sound pulse at high energy for marine geological surveys*



**Sonar thumper.** In foreground is transducer, with aluminum plate resting against epoxy-encapsulated coil. When 0.1-ohm coil is energized, motion is about  $\frac{1}{2}$  inch in water. Background: capacitor bank and trigger (l.), power supply (r.)

nized with a recorder, the resultant current surge repulses the plate powerfully. If the transducer were fired unloaded, that is in air, the aluminum plate would leap 40 feet into the air. Fired in water, it generates a pressure pulse able to penetrate deeply into the subbottom. Hydrophone pickup is made as in the popper or sparker. Capacitance in the standard design totals 160

$\mu\text{F}$ . The pulse contains frequencies from about 75 cps to above 5 Kc, based on investigations by Dr. Hersey. Maximum energy is at roughly 300 cps. The high-frequency content provides fine resolution that has been proven in using the transducer. Recorder filters can favor high frequency detail or low frequency echoes. Rates up to two thumps per second are possible with

the standard model, the impedance of the ship's power supply being the major limiting design factor in capacitor charging time, and thus the pulse rate.

The unit used aboard the *Chain* has a larger aluminum plate, some three feet in diameter, and additional capacitors to increase energy to the coil. Cycling time is one thump in five seconds, based on the ship generator impedance. The lower operating voltage of the thumper compared to the sparker allows a higher safety factor in electrical cables and connectors to be realized. The thumper does not require shipboard storage of dangerous fuel as in the popper. Construction of a sonar thumper using a movable portion of a ship's hull as the thumper transducer is now being considered at WHOI. Industrial applications of the thumper include off shore oil drilling projects, and general overwater construction such as bridge and dam building. Texas Towers also require extensive investigation of the subbottom.—LHD

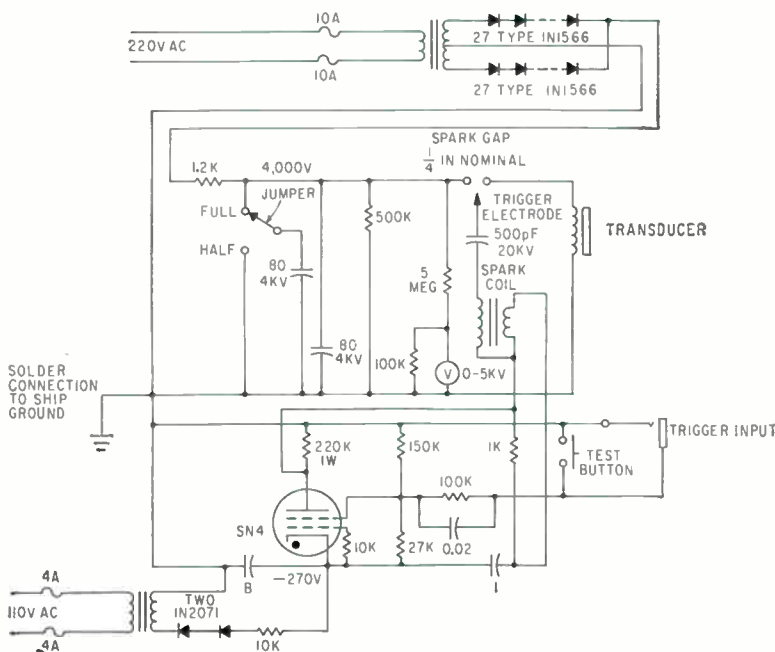

*In sonar thumper, a contactor at recorder energizes spark coil with a strobtron circuit. Spark is fed to trigger electrode that ionizes the spark gap, discharging the main capacitors into transducer. Positive 180-v pulse can do triggering*

#### REFERENCES

- (1) R. Cole, "Underwater Explosions," Princeton University Press, 1948.
- (2) W. Beckman, et al, Sub-bottom Depth Recorder, *Geophysics*, October 1959.
- (3) S. T. Knott and J. B. Hersey, High-resolution Echo-sounding Techniques and their use in Bathymetry Marine Geophysics and Biology, *Deep-Sea Research*, volume 4, 1956.
- (4) Dr. J. B. Hersey, Dr. H. E. Edgerton, S. Raymond, G. Hayward, Sonar Uses In Oceanography, Instrument Society of America conference preprint No. 21-60 Sept. 1960.

# Digital Tone Filter With Infinite Rejection Slope

By ALFRED CORBIN, Chief Digital Systems Engineer, Canoga Electronics Corp., Fort Walton Beach, Fla.

A WELL KNOWN LOGIC design is to cascade a fixed-delay element and a gate to produce an interval-sensitive gate, or time-interval selector. This circuit, sometimes known as a slot filter, is often used to detect a unique time relationship in a pulse train, for example, recognizing a pulse spaced exactly  $T$  second after the preceding pulse. As such, the slot filter often finds application in reading ONES and ZEROS in a wide-coded binary word.

Used as a frequency or tone filter, this circuit exhibits properties difficult to duplicate with passive elements. In the extreme, a bandpass slot filter can be adjusted to a bandwidth of zero cycles, and infinite rejection slope. In addition, this filter has a buildup time of one cycle, regardless of input frequency or selectivity.

A slot filter is shown in Fig. 1A. One-shot multivibrators  $OS_1$  and  $OS_2$  and the coincidence gate operate on positive polarity. Assume that  $OS_1$  is adjusted for a delay of

950  $\mu$ sec and  $OS_2$  for 100  $\mu$ sec. Driving the circuit with a constant repetition rate will produce a delayed output from  $OS_1$ , 950  $\mu$ sec after each input pulse. Each output of  $OS_1$  triggers  $OS_2$ . The output from  $OS_2$  is taken from the complementary side, enabling the AND gate for 100  $\mu$ sec. An output will be produced if any pulse occurs between 950 and 1,050  $\mu$ sec after its preceding pulse.

The extremes, 950 and 1,050, correspond to a frequency of  $1/950 \mu$ sec and  $1/1,050 \mu$ sec, or  $1 \text{ Kc} \pm 50$  cycles. Figure 1B shows the waveforms when the circuit is driven by a signal that starts at 1 Kc, then switches to 666 cps.

The center frequency of the slot filter may be set by adjusting the delay time of the first one-shot, while the bandwidth is a function of the duration of the second one-shot. The minimum passband is limited by jitter in  $OS_1$ , and therefore is related to the quality of the one-shot. The ratio of delay time to jitter can be held to 1,000:1 with-

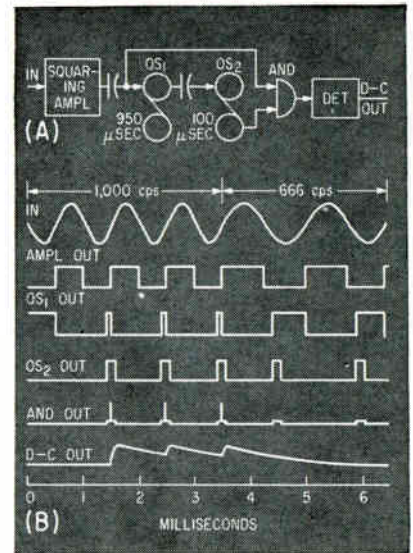

FIG. 1—Slot filter (A) and wave-shape time relationships (B)

out difficulty, yielding an effective  $Q$  of 1,000.

Although the slot filter is designed to pass pulses separated by a unique interval, that same interval exists between 2 pulses of the second harmonic and 3 pulses of the third harmonic. Harmonic rejection is accomplished by a low-pass filter at the input. The filter is required only to attenuate the second harmonic to below the trigger point of  $OS_1$ .

Figure 2 shows a circuit for detecting a tone from 4,900 to 5,100 cycles. The low-pass filter has a break frequency of 5 Kc. The filtered input waveshape is squared and fed to the first one-shot that is adjusted to 196  $\mu$ sec. One-shot  $OS_1$  drives  $OS_2$ , which is adjusted to 8  $\mu$ sec. The output of  $OS_2$  enables the AND gate, which operates on the squared input signal. The output is detected and filtered.

The most stringent design requirement is imposed on the first one-shot. The application demands that the one-shot have a high duty cycle capability, since the duty cycle [on time/(off time + on time)] is equal to  $[(T \text{ period} - \frac{1}{2} T \text{ slot}) / T \text{ period}]$ . In the circuit this equals  $196/200$  or 98 percent, requiring a fast recovery one-shot, or two cascaded one shots.

In a more sophisticated, and more expensive, slot filter, the first one-shot may be replaced by a digital delay circuit, using a clock and counter to generate the first delay.

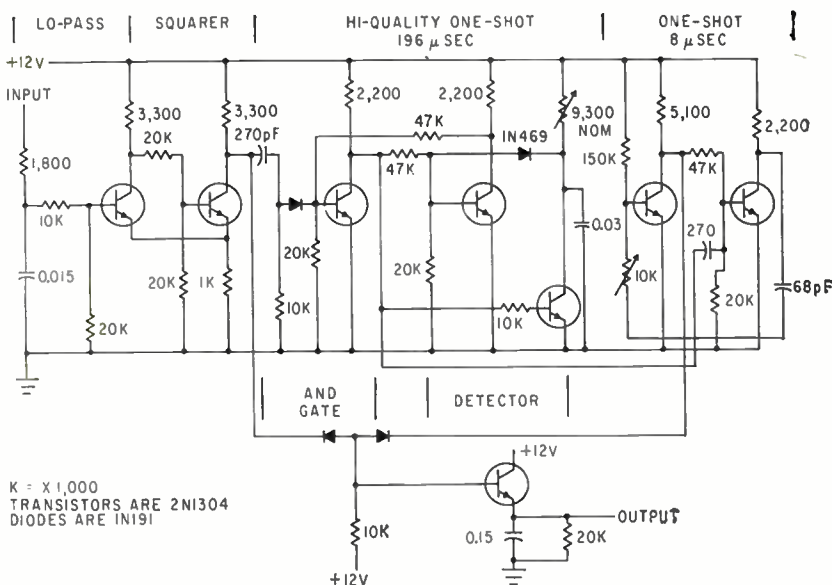
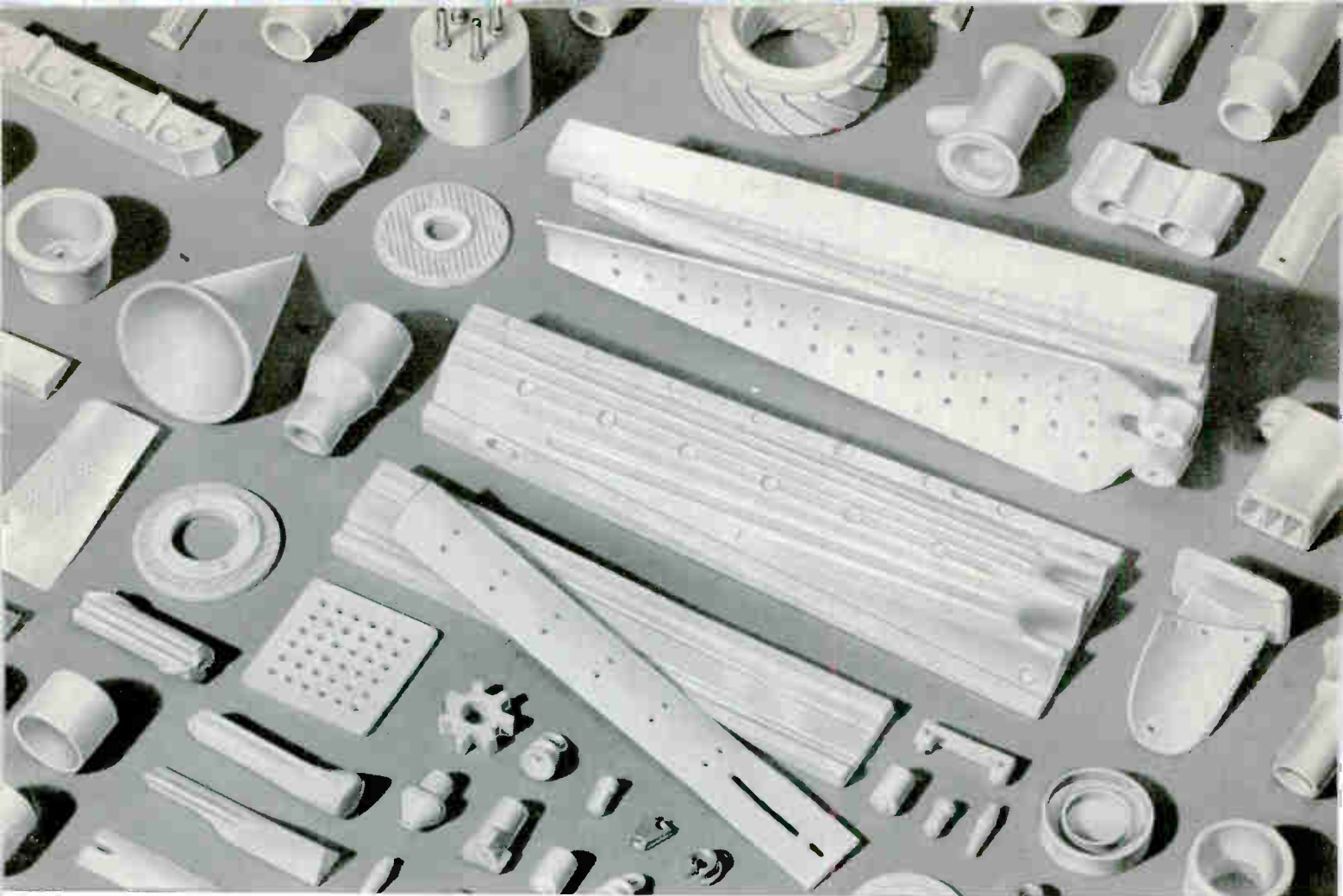

FIG. 2—Slot filter detects tone from 4,900 to 5,100 cycles



## Highly complex shapes,

internal and external, formed in one operation to close tolerances in

# ALSiMAG<sup>®</sup> CERAMICS

### NEW SHAPES NOW PRACTICAL

Technical ceramic parts formerly impossible or available only by expensive machining and grinding are now practical and can be produced in volume to close tolerances and with great uniformity. They include complex and compound curves, thin walls and other difficult design features. This injection molding process is particularly suited to volume production which readily permits amortization of initial tooling costs.

### MATERIALS

ALSiMag 614 (High Alumina) and ALSiMag 704 (Porous and Leachable)

have found widest use. Other ALSiMag ceramic compositions are available. See Property Chart, sent on request.

### APPLICATIONS

include but are not limited to:

**Electronic and Electrical**, such as conical micro-wave tube windows, envelopes, complex internal insulators, cups, encapsulating devices, semi-conductor assembly boats and plugs.

**High Temperature, Mechanical and Heat Shock** uses such as welding nozzles.

Precision Investment Casting cores of great dimensional accuracy.

Guides for wire and textile machinery.

The use of these ALSiMag ceramics is indicated when high frequencies, high temperatures, heat shock, chemical attack or mechanical wear are involved.

### EXPERIENCE

More than two years of steadily increased production from this equipment has given us practical experience which enables us to promptly and accurately answer most inquiries involving complex and difficult shapes. Send blue prints or sketches. Chances are that your "impossible" designs are now practical in ALSiMag ceramics.

A Subsidiary of  
Minnesota Mining and  
Manufacturing Company



## AMERICAN LAVA CORPORATION

CHATTANOOGA 5, TENN.

60TH YEAR OF CERAMIC LEADERSHIP

For service, contact American Lava representatives in Offices of Minnesota Mining & Manufacturing Co. in these cities (see your local telephone directory): Boston: Newton Center, Mass. • Chicago: Bedford Park, Ill. • Cleveland, Ohio • Dallas, Texas • Los Angeles, Cal. • New York: Ridgfield, N. J. • Philadelphia, Pa. • St. Louis, Mo. • St. Paul, Minn. • So. San Francisco, Cal. • Seattle, Wash. All other export: Minnesota Mining & Manufacturing Co., International Division, 99 Park Ave., New York, N. Y.

"BOOTH 4401 at I.R.E."

# Graphical Method Predicts Radio Interference

*Steps given here show  
how to reduce labor of  
arriving at a prediction*

By **JOSEPH H. VOGELMAN**,  
Vice President, Research,  
Development & Engineering,  
Capehart Corp., Richmond Hill, N. Y.

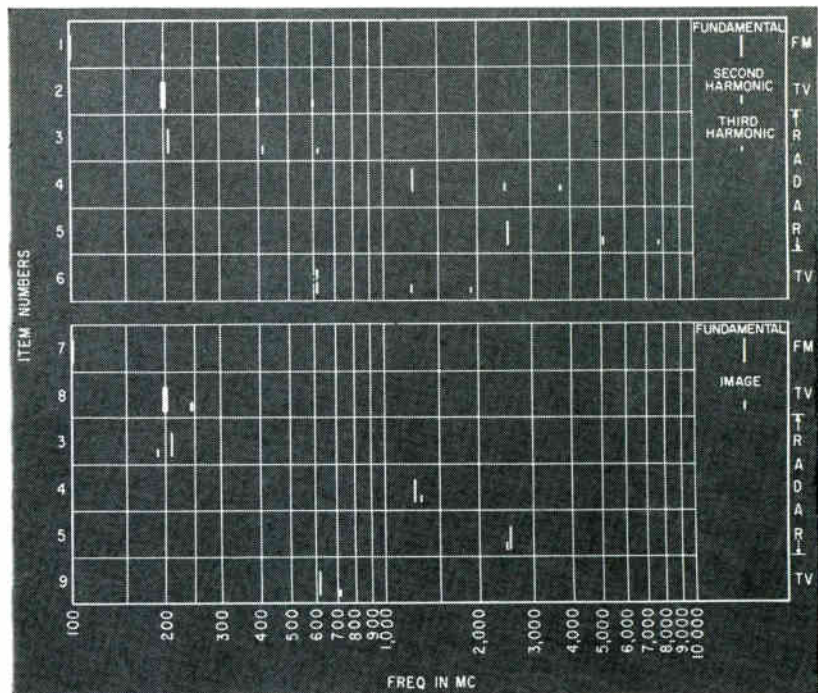

*This frequency chart helps reduce the number of equipments suspected as possible sources of interference*

SERIOUS r-f interference problems have arisen with the introduction of new electronic equipments and systems into crowded spectrum.

The problems arising from the introduction of a new electronic device can be categorized in the seven classes listed in Table I. The first two items are usually controlled within the equipments themselves, and will not be considered further. The remaining items are of great significance.

A complete prediction of interference requires practically an unlimited amount of experimental data as well as complex mathematical manipulations. In practice, however, a relatively simple though conservative, method can be used.

The r-f interference that a receiver picks up from an interfering transmitter within radio line-of-sight is the result of three possible effects or their combination. These are:

(1) spurious response of the

receiver to the operational frequency of the transmitter; (2) harmonic or spurious transmission of the transmitter at the operational frequency of the receiver; (3) harmonic or spurious response of the receiver to the spurious transmission of the transmitter. Usually, the major contributors of interference are the first two effects, item 3 being relatively negligible. As a result of major efforts in the suppression of spurious transmissions and special filtering of receivers, the spurious response to spurious transmission (item 3) has proven to be most important under certain geographic and equipment combinations; item 3 has been ignored by most investigators.

The general approach of the graphic-manual method of interference prediction that is described in this article is a series of sorting operations in which the interference pairs (interfering and interfered-with) are

gradually reduced in number until only the significant ones remain.

The basic operations involved are listed in Table II.

The successive operations require successively increased amounts of information and successively increased accuracies of the measured or analytical characteristics. The number of items remaining for further analysis decreases in the processing. Approximations have been used whether a reduction in computation or any increase in ease of understanding the predictions result. In every case, the approximations are conservative so that they always tend to make predictions of interference where it will not necessarily occur. The method assumes line-of-sight propagation for the initial prediction. Such simplifications are corrected as the calculations proceed. Since field measurements are expensive, time consuming and subject to frequent change,

# Raytheon Transformer Talk

**New Raytheon transformer will resist nose cone temperatures to 1,100° F**

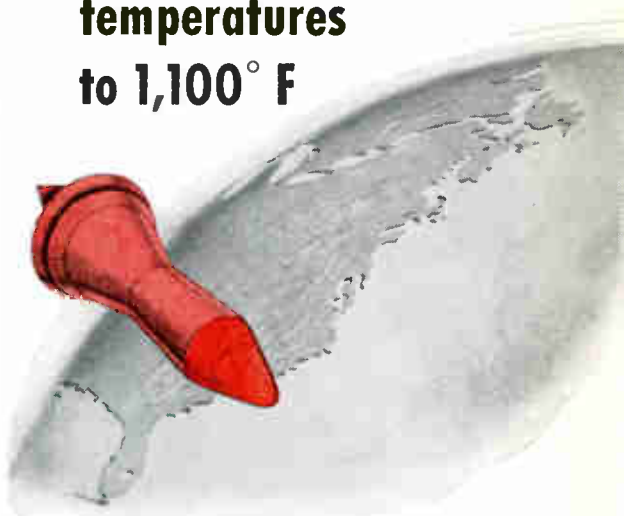

Raytheon is now building transformers capable of withstanding temperatures such as those encountered in a re-entering missile's red-hot nose cone.

The unit pictured at left resists temperatures up to 1,100° F which is 700 degrees higher than units presently in use. The goal for units now under construction at Raytheon is a minimum operation time of 2,000 hours with an internal temperature 200 degrees above the ambient of 900 degrees.

To accomplish this, Raytheon has developed new construction techniques and high-temperature resisting wire and insulating materials.

For further information on high-temperature transformers please write, stating your specific requirements, to Raytheon Company, Magnetics Operations, Microwave & Power Tube Division, Waltham 54, Massachusetts. In Canada, Waterloo, Ontario.

**COLLOIDAL SILICA SOL** impregnation and/or foam-potting with hollow ceramic spheres.

**GLASS FIBER INSULATION**, mica or aluminum winding forms, heat cleaned to remove organic residues.

**VOLATILES REMOVED** by degassing in high vacuum at high temperature.

**BLACK OXIDE FINISH** on interior and exterior surfaces of case for better heat transfer.

**CONTROLLED ATMOSPHERE** inside hermetically sealed enclosure.

**HELIARC WELD** sealing inspected by helium mass-spectrometer leak detector.

**PURE SILVER** or chromium-plated copper wire insulated with a glass fiber or ceramic coating.

**ALUMINA TERMINALS** protected against oxidation by special plating process.

**STAINLESS-STEEL** construction of case and structural members for minimum weight.

**WITHSTANDING DULL-RED HEAT CONDITIONS** is one of the requirements for the new transformers now being developed at Raytheon. The nine construction features that make this possible are indicated above.

**WRITE FOR 16-PAGE BOOKLET** on Raytheon transformers or for specific help on your particular requirements.



**RAYTHEON COMPANY**

# ELECTRONICS REFERENCE SHEET

**TABLE I—CAUSES OF RADIO INTERFERENCE**

- Conducted interference resulting from common sources of power and other common auxiliary facilities
- R-f radiation from modulators, local oscillators and other internal circuits
- Spurious transmitter radiation at both frequencies adjacent to and far removed from the assigned transmitter frequency
- Harmonic radiation from transmitters
- Spurious response of receiving equipment at frequencies outside of the design pass-band
- Overloading of receiver front ends as a result of high-energy off-frequency pulses
- Mixer crystal burnout

**TABLE II—INTERFERENCE-SORTING OPERATIONS**

- | Step | Operation   |
|------|---|
| A    | Survey of electronic equipment to determine which items radiate and which items receive   |
| B    | Frequency indexing of all surveyed items  |
| C    | Preliminary sorting by frequency of potential interference pairs  |
| D    | Detailed characteristic measurement and analysis of those equipments remaining as potential interference or interfered with items |
| E    | Final frequency sorting of interference pairs   |
| F    | Preliminary power calculations  |
| G    | Geographic sorting  |
| H    | Detailed calculations   |
| I    | Tabulations of results  |
| J    | Final predictions   |

it is important to make a preliminary prediction on the basis of a minimum of data so that the major measurement effort can be concentrated on those equipments where the data would be significant.

The first step (A, Table II) is to make a survey of all equipment expected to contribute to the interference problem. Table III is an example of a survey chart listing equipments and factors associated with an electronic environment.

In the frequency-indexing step, a preliminary frequency chart is drawn (see the chart).

In the preliminary sorting, a transparent matrix is used to select the transmitters which must be considered in the analy-

sis. The transparent matrix consists of three lines logarithmically disposed at one, two and ten. When the two-line is placed at the operating frequency of the receiver for which interference is to be analyzed, all transmitters falling between the two extremes are included for further analysis. In addition to the fundamental frequencies, harmonics of the transmitter are included on the frequency chart and are treated as if they were fundamental sources with the restriction that they are considered only when they occur within 10 bandwidths of the receiver fundamental.

For the residual items, evaluation data forms are filled out (D, Table II), using data from tech-

nical orders, specifications and prior measurements. This data is utilized in the subsequent sorting operations, additional data being called for as required on those items which survive the sorting sequence.

The final frequency-sorting process (E, Table II) consists of preparing a series of cards for each receiver and transmitter which remain for consideration as an interference pair. The cards contain information obtained from the detailed characteristic measurement and analysis. A card is made for each fundamental frequency, second and third harmonic of every transmitter. The cards also contain the item number, expected or measured signal bandwidth, nomenclature or model number and geographic location. For the receivers, a card is made for the fundamental and the image frequency. These cards are the basis for a frequency-sorting operation in which all frequencies corresponding to the criteria given above remain for further consideration, and all others are dropped. Only harmonic responses at or near the fundamental or image frequency of the receiver are considered, unless the fundamental has been dropped for other reasons. All

**TABLE III—ELECTRONIC INVENTORY CHART**

Item No.	Sector Identity	Map Identity	Nomenclature	Model No.	Operational Use	E <sup>a</sup>	O <sup>b</sup>	I <sup>c</sup>	Ra <sup>d</sup>	Re <sup>e</sup>	NE <sup>f</sup>	S <sup>g</sup>	P <sup>h</sup>	T <sup>i</sup>	Pl <sup>j</sup>	Remarks
1	A	1.2A2.0	F-M Trans	185	C.* Broadcast	X			X				X			100.5 Mc-6 am-Mid
2	F	1.2F22.8	Tv Trans	622A	C. Broadcast	X			X				X			198-204 Mc-6 am-1 am
3	C	4.6C10.5	Radar	Type X	Experimental	X			X	X				X		209-214 Mc-1 am-6 am
4	E	5.2E18.0	Radar	Search	Airport Control	X			X	X			X			1,245-1,255 Mc-24 hrs/day
5	E	5.2E19.0	Radar	GCA	Landing	X			X	X			X			2,555-2,565 Mc-24 hrs/day
6	F	1.2F23.9	Tv Trans	627B	C. Broadcast	X			X	X			X			620-626 Mc-6 am-6 pm
7	A-F	0.0A0.0 to 6.0F21.0	Home F-M Rec	All Types	C. Broadcast	X				X			X	X		100.5 Mc-6 am-Mid
8	A-F	0.0A0.0 to 6.0F21.0	Home Tv Rec	All Types	C. Broadcast	X				X			X	X		198-204 Mc-6 am-1 am
9	A-F	0.0A0.0 to 6.0F24.0	Home Tv Rec	All Types	C. Broadcast	X				X			X	X		620-626 Mc-6 am-6 pm

(a) Electronic; (b) Optical; (c) Infrared; (d) Radiate; (e) Receive; (f) Nonelectronic; (g) Structure; (h) Permanent; (i) Transitory; (j) Planned; (k) Commercial

■ A production reality based on 20 years of crystal engineering experience...

# Miniature Wide Band-Pass Crystal Filters Delivered In Quantity...To Specification

Filters just recently considered as "state of the art" are now a *production* reality. In addition to its many stock narrow band filters, Midland offers prototype and production quantities of practical Miniature Wide Band Filters in the .5 to 30 mc range. These filters are of exceptional quality.

They are essentially free from unwanted spurious modes which have previously limited the realization of many types of wide band filters. Small quantities for engineering evaluation are available *immediately* from stock. Consultation is available at any time to potential filter users.

Shown below are specifications for ten of our stock wide band filters, as well as actual characteristic response curves. These filters are actually being delivered to major weapons system manufacturers in quantities — to specification.

## THESE ARE NOT LABORATORY CURIOSITIES OR IN PROTOTYPE DEVELOPMENT STAGE

Type	Center Freq.	3db Bandwidth Minimum	40db Bandwidth Max.	60db Bandwidth Max.	75db Bandwidth Max.	Ultimate Discrim. Minimum	Insertion Loss Max.	Impedance ohms	Inband Ripple Max.	Package Type
NJ-1	7.2MC	160KC	300KC			60db	6db	13K	1db	A
NJ-1B	7.2MC	160KC	300KC			60db	6db	13K	.5db	B
NJ-2	7.4MC	160KC	300KC			60db	6db	13K	1db	A
NJ-2B	7.4MC	160KC	300KC			60db	6db	13K	.5db	B
NG-1	5.09MC	160KC	350KC			60db	6db	20K	1db	A
NG-1B	5.09MC	160KC	350KC			60db	6db	20K	1db	B
NB-1	10.7MC	200KC		450KC		75db	12db	50	1db	A
NB-1B	10.7MC	200KC		450KC		85db	8db	50	.5db	B
RL-1	11.5MC	80KC		160KC	200KC	85db	6db	50	.5db	C
RL-1B	11.5MC	80KC		160KC	200KC	90db	5db	50	.5db	B

Operating Temp.: -55°C to +90°C

Shock: 100g

Vibration: 15g to 2Kc

Units hermetically sealed

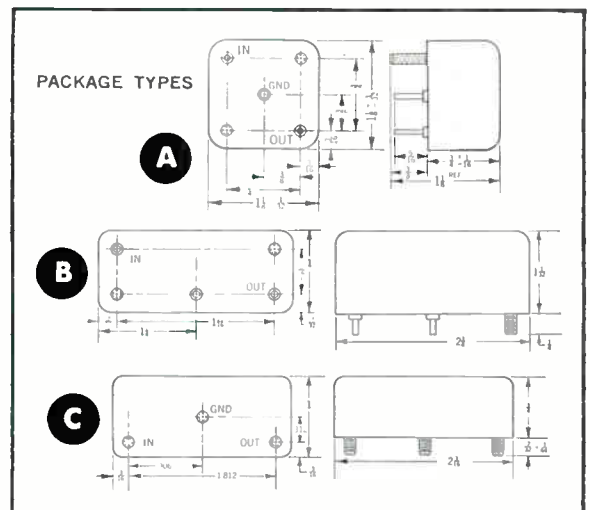
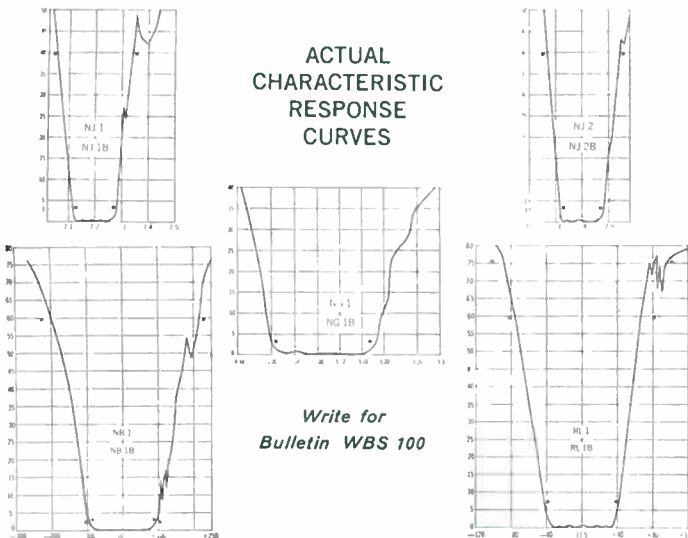

A limited number of opportunities for filter and communications engineers and technicians are available. Write Mr. Robert A. Crawford, Chief Engineer, Filter Division.

**Midland**

MANUFACTURING COMPANY • 3155 Fiberglas Road, Kansas City 15, Kansas

WORLD'S LARGEST PRODUCERS OF QUARTZ CRYSTALS  
DIVISION OF PACIFIC INDUSTRIES, INC.

MID 1-61

February 3, 1961

CIRCLE 63 ON READER SERVICE CARD

63

# ELECTRONICS REFERENCE SHEET

TABLE IV—DATA ON EQUIPMENTS 4, 5 and 6 of TABLE I

Radar Transmitter (Item 4)	Radar Rec (Item 5)	Tv Transmitter (Item 6)
Freq: 1,245-1,255 Mc	Freq: 2,555-2,565 Mc	Fund freq: 620-626 Mc
Power out: 1 Mw peak	Intermediate freq: 30 Mc, local osc tuned below fund	Power out: 100 Kw peak
2nd h: 80-db down from fund	Minimum discernible sig: 103 dbm	2nd h: 60-db down from fund
3rd h: 105-db down from fund	Rec bandwidth: 2 Mc	3rd h: 90-db down from fund
Spurious out: 120-db down from fund	Spurious response: 60 db at $\pm 2.5$ Mc from fund or image	Spurious out: 100-db down from fund
$\approx 10$ Mc removed from fund or harmonics	80 db $\pm 5$ Mc from fund; 100 db elsewhere	$\approx 20$ Mc from fund or harmonics
Spectral bandwidth: 2 Mc	Image rejection: 20 db	Spectral bandwidth: 6 Mc
Antenna gain: Main lobe: 36 db, Hor polarization	Antenna gain: Main lobe: 32 db, Hor polarization	Antenna gain: 6 db, omnidirectional in hor, hor polarization
1st side lobe: 10 db; Back lobe: -3 db; Off-freq gain: 30 db	1st side lobe: 10 db; Back lobe: -3 db; Off-freq gain: 26 db	

TABLE V—DATA OBTAINED FROM TABLE IV

Symbol	Rec (Item 5) and Radar (Item 4)	Rec (Item 5) and Tv (Item 6)
$P_T(f_T)$	$10^6$ w	$10^6$ w
$S'_R(f_T)$	-100 db	-100 db
$R_R$	2 Mc	2 Mc
$R_I$	2 Mc	6 Mc
$S'_T(f_R)$	-120 db	-100 db
$S'_T(f_S)$ at Image	-80 db	-100 db
$S'_R(f_S)$ at Image	-20 db	-20 db
$G'_{TS}(\theta)$	36 db	6 db
$G'_{RS}(\theta)$	26 db	26 db
$R$	1,000 ft	6,320 ft
$f_T$	1,245-1,255 Mc	620-626 Mc
$G'_{TS}(\theta)$	30 db	6 db
$G'_{RS}(\theta)$	32 db	32 db
$f_R$	2,555-2,565 Mc	2,555-2,565 Mc
$G'_{TS}(\theta)$ at Image	30	6
$G'_{RS}(\theta)$ at Image	26	26
$f_S$ at Image	2,495-2,505 Mc	2,495-2,505 Mc

spurious responses of the operating frequencies of the receiver are retained.

The preliminary power calculation ( $F$ , Table II) assumes that the total radiated energy of the transmitter is fed to the receiver. The available power to the receiver is a function of transmitter power and receiver rejection at the transmitter frequency. This results in an interference power due to the receiver's spurious response to the operational frequency of the transmitter. The second preliminary calculation proceeds in the same manner but includes the spurious transmitter output. The third set of calculations includes the image response to the transmitter spurious or harmonic. This sorting operation eliminates those combinations where the spurious suppression or the transmitter power is insufficient to produce interference under any condition. It also eliminates interference pairs where the receiver rejection characteristics are sufficient to suppress the transmitter fundamental below the noise level.

For the interference pairs still remaining, the distance between the transmitter and receiver as well as the individual gains of

the transmitter and receiver antennas are added to the data ( $G$ , Table II). In this sorting operation, it is assumed that the main beam of each antenna is looking down the main beam of the other. This sorting operation assumes the worst interference combination possible. Using the previously determined values, the correction for range and antenna gains is added and all pairs wherein the interference power is less than the minimum discernible signal are dropped from further consideration. Where the interference source is beyond line-of-sight, the correction for tropospheric scatter, or ionospheric scatter is added to the loss factors.

The remaining interference pairs are then subject to detailed calculations. Before conducting the calculations, the additional measured and analytical data that is required is supplied for each of the transmitter and receivers remaining as interference pairs.

The detailed calculations determine whether interference conditions are to be expected, and if expected, to determine their nature, severity and frequency of occurrence. Much more complete information must be sup-

plied for transmitters and receivers subject to detailed calculations.

The result of the detailed calculation is a series of lists showing which receivers are predicted to be subject to interference and which transmitters are responsible. The data will show when interference will be present, if subject to schedule effects. If the interference is intermittent—antenna rotation, for example, could produce intermittent interference—the proportion of the time the interference will be present is given: In the detailed calculation, effects of antenna rotation are included. The following combinations are considered for fixed antennas; side lobe rejection in the direction of the interfering source or receiver; on time of the two items in the interference pairs. For rotating antennas, the combination considered are: interference signal when one antenna points at the other while the second rotates; interference power when one antenna has its first three side lobes in the direction of the other while the other antenna rotates; both antennas look away from each other.

From the rotation rates of the antennas, statistical data is derived giving the percentage of the time that interference will occur in each of these categories: interference unlikely, nuisance interference, interference likely, and interference highly probable.

Tabulated results ( $I$ , Table II) consist of a list of all interference, nuisance interference, interference powers greater than the minimum discernible signal of the receiver. This list gives the



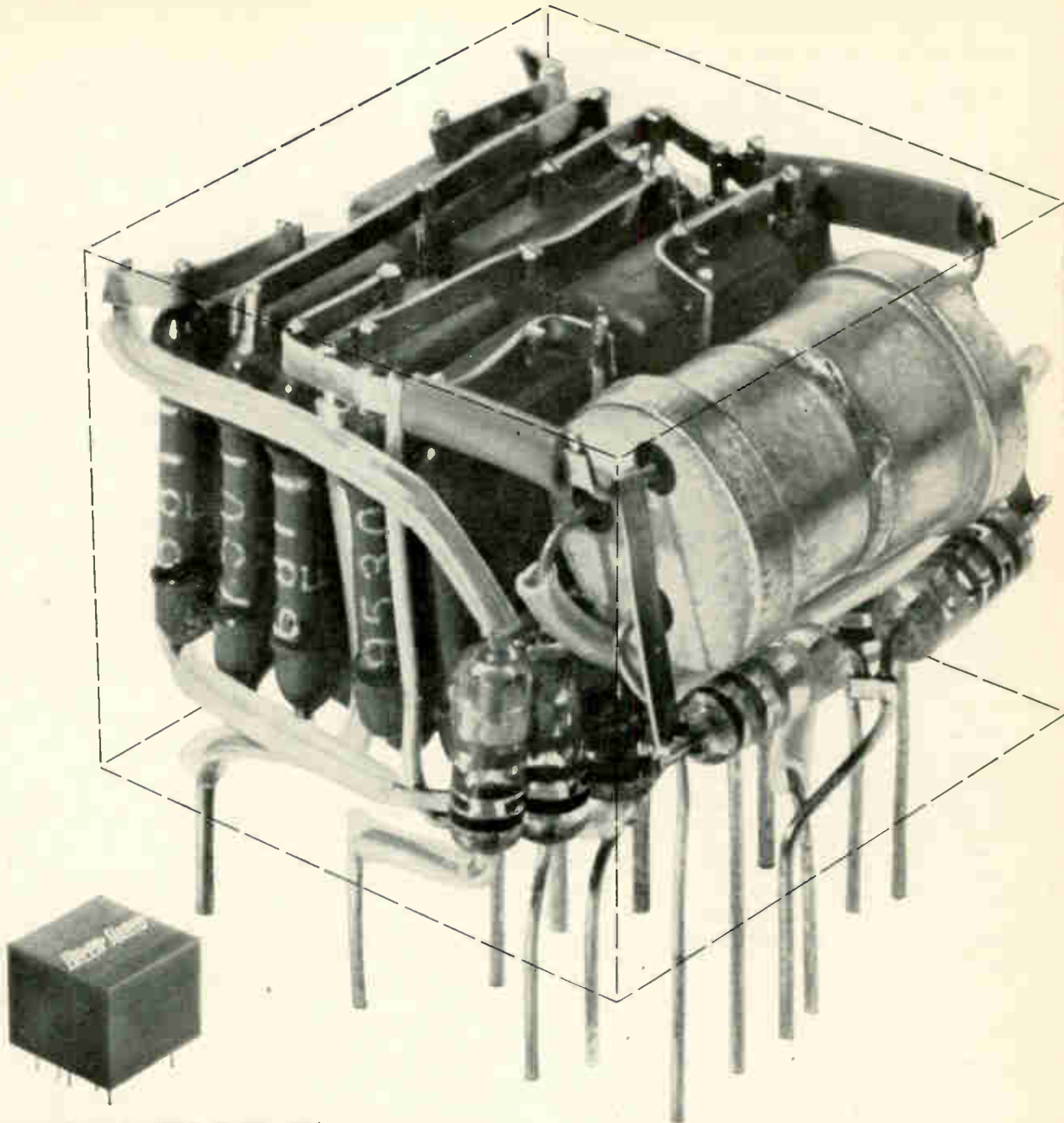

# MINIATURE BUILDING BLOCK MODULES

5 times actual size to better show  
the 28 standard-sized components

Delco Radio's high density packaging of reliable standard components utilizes the unique three-dimensional welded wiring technique. These miniature modules are available off the shelf in 16 basic types. Or with them, Delco Radio can quickly build for you a compact, reliable digital computer for airborne guidance and control or any other military application. Vacuum encapsulated with epoxy resin, the modules perform all the standard logic functions. They meet or exceed all MIL-E-5272D (ASG) environmental requirements, and operate over a temperature range of  $-55^{\circ}\text{C}$  to  $+71^{\circ}\text{C}$ . Too, these same reliable digital circuits are available packaged on plug-in circuit cards. And we can also supply circuits to meet your specific needs. For complete details, just write our Sales Department. *Physicists and electronics engineers: Join Delco Radio's search for new and better products through Solid State Physics.*

PIONEERING ELECTRONIC PRODUCTS THROUGH SOLID STATE PHYSICS

**DELCO  
RADIO**

Division of General Motors • Kokomo, Indiana

GLOSSARY OF EQUATIONS AND TERMS  
PRELIMINARY CALCULATIONS

$$\psi_1 \text{ dbm} = 10 \log_{10} P_T(f_T) + 30 + S'_R(f_T) + 10 \log_{10} B_R - 10 \log_{10} B_I \quad (1)$$

$\psi_{1 \text{ dbm}}$  = interference assuming direct coupling in db related to 1 mw due to receiver spurious response at the transmitter frequency ( $f_T$ );  $P_T(f_T)$  = transmitter total output power in w;  $S'_R(f_T)$  = receiver rejection in db at  $f_T$ ;  $B_R$  = Receiver bandwidth in Mc;  $B_I$  = Transmitter signal bandwidth in Mc; If  $B_R > B_I$  then  $10 \log_{10} B_R - 10 \log_{10} B_I = 0$

$$\psi_2 \text{ dbm} = 10 \log_{10} P_T(f_T) + 30 + S'_T(f_R) + 10 \log_{10} B_R - 10 \log_{10} B_I \quad (2)$$

$\psi_{2 \text{ dbm}}$  = interference assuming direct coupling in db related to 1 mw due to spurious transmitter output at the receiver frequency ( $f_R$ );  $S'_T(f_R)$  = spurious transmitter output at  $f_R$  in db with respect to the transmitter total output power

$$\psi_3 \text{ dbm} = 10 \log_{10} P_T(f_T) + 30 + S'_T(f_S) + S'_R(f_S) + 10 \log_{10} B_R - 10 \log_{10} B_I \quad (3)$$

where  $\psi_{3 \text{ dbm}}$  = interference assuming direct coupling in db related to 1 mw due to spurious transmissions at a harmonic or at the receiver image frequency ( $f_S$ );  $S'_T(f_S)$  = spurious transmitter output at  $f_S$  in db with respect to the transmitter total output power;  $S'_R(f_S)$  = receiver rejection at spurious frequency  $f_S$

following data on each interference pair: noise power due to spurious response of the receiver; noise power due to spurious transmissions from the transmitter; noise power due to spurious response of the receiver to spurious transmissions of the transmitter; total noise power; category of interference with the percentage of time during which it will exist in each category; and additional data appropriate to the situation.

On the basis of the tabulated data, a final prediction is made describing the interference effects and outlining remedies.

The equations used in the sorting operations are listed in the Glossary. Their use in making an interference prediction will

Detailed Calculations

$$I_{1 \text{ dbm}} = \psi_1 \text{ dbm} + G_{TS}(\theta) + G'_{RS}(\theta) - 20 \log_{10} R - 20 \log_{10} f_T + 38 \quad (4)$$

$I_{1 \text{ dbm}}$  = Effective interference power in dbm at receiver input due to spurious receiver response to  $f_T$ ;  $G_{TS}(\theta)$  = Transmitting antenna gain in db at  $f_T$  as a function of angle  $\theta$  off the main beam axis;  $G'_{RS}(\theta)$  = Receiving antenna gain in db at  $f_T$  as a function of angle  $\theta$  off the main beam axis;  $R$  = Distance between antennas in feet;  $f_T$  = Transmitter frequency in Mc

$$I_{2 \text{ dbm}} = \psi_2 \text{ dbm} + G'_{TS}(\theta) + G_{RS}(\theta) - 20 \log_{10} R - 20 \log_{10} f_R + 38 \quad (5)$$

$I_{2 \text{ dbm}}$  = effective interference power in dbm at receiver input due to spurious transmitter power at  $f_R$ ;  $G'_{TS}(\theta)$  = transmitting antenna gain in db at  $f_R$ ;  $G_{RS}(\theta)$  = receiver antenna gain in db at  $f_R$ ;  $f_R$  = receiver operating frequency in Mc

$$I_{3 \text{ dbm}} = \psi_3 \text{ dbm} + G''_{TS}(\theta) + G''_{RS}(\theta) - 20 \log_{10} R - 20 \log_{10} f_S + 38 \quad (6)$$

$I_{3 \text{ dbm}}$  = effective interference power in dbm at rec input due to spurious transmitter output and spurious rec response, particularly at transmitter harmonic or rec image freq;  $G''_{TS}(\theta)$  = transmitting antenna gain in db at spurious freq  $f_S$ ;  $G''_{RS}(\theta)$  = rec antenna gain in db at spurious freq  $f_S$ .

quencies associated with each of the transmitters, and the fundamental and image frequencies associated with each of the receivers.

Use the chart, the interference resulting in radar receiver item 5 will be examined in detail. Placing the transparent matrix over the chart shows that the sources of interference which must be considered are the fundamental and harmonics of transmitter item 4 and the harmonics of transmitter item 6. The data given in Table IV is used for the transmitters and the receiver to be investigated for interference.

Table V lists the terms obtained from the given data. Substituting these terms in the interference equations produces the results given in Tables VI and VII.

The equations listed in Table VI show that in the worst case, that of interference along the path of the main beam axis of transmitting and receiving antennas, the receiver picks up significant interference.

Table VII shows that the tv transmitter will cause interference only when the receiver antenna has its main lobe looking at the transmitter since the receiver's minimum discernible signal is -103 dbm. On the other hand, the radar transmitter will cause interference except when both antennas are looking away from one another. The  $\psi$  calculations for items 5 and 6 assume an effective transmitter bandwidth of 2 Mc.

now be shown in an example involving the equipment listed in Table III.

The frequency data obtained for the equipments are plotted on the frequency chart. Shown are the fundamental, second harmonic and third harmonic fre-

TABLE VI—RECEIVER INTERFERENCE ON MAIN-BEAM AXIS

Symbol	Rec (Item 5) and Radar (Item 4)	Rec (Item 5) and tv (Item 6)
$\psi_1$	60+30-100+0 = -10 dbm	50+30-100 = -20 dbm
$\psi_2$	60+30-120+0 = -30 dbm	50+30-100 = -20 dbm
$\psi_3$	60+30-80-20+0 = -10 dbm	50+30-100-20 = -10 dbm
$I_1$	-10+36+26-60-62+38 = -32 dbm	-20+6+26-76-56+38 = -82 dbm
$I_2$	-30+30+32-60-68+38 = -58 dbm	-20+6+32-76-68+38 = -88 dbm
$I_3$	-10+30+26-60-68+38 = -44 dbm	-10+6+32-76-68+38 = -108 dbm

TABLE VII—RECEIVER INTERFERENCE ON SIDE & BACK LOBES

Symbol	Rec (Item 5) and Radar (Item 4)		Rec (Item 5) and Tv (Item 6)	
	Side Lobe	Back Lobe	Side Lobe	Back Lobe
$I_1$	-51 dbm	-67 dbm	-104 dbm	-117 dbm
$I_2$	-80 dbm	-93 dbm	-110 dbm	-123 dbm
$I_3$	-66 dbm	-79 dbm	-130 dbm	-143 dbm

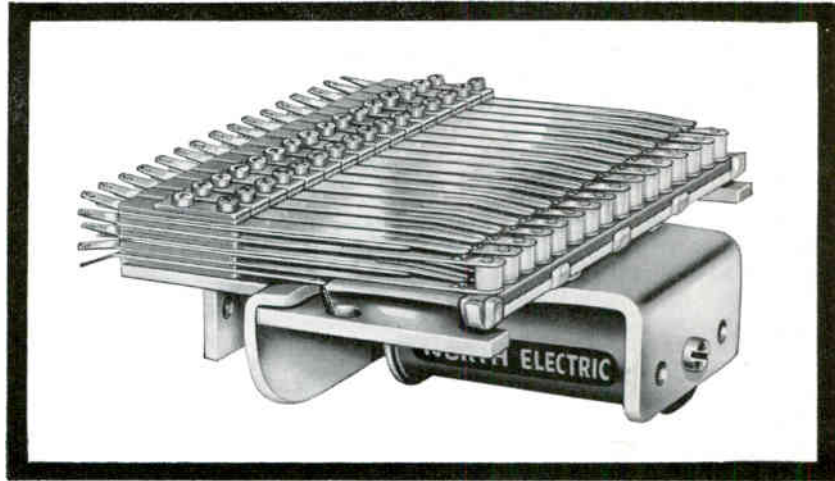

# FOR MULTIPLE CIRCUIT SWITCHING

## NORTH 700 SERIES "GANG" RELAYS

Where reliability is a must—North 700 Series "gang" relays combine fast action multiple circuit switching capabilities with the proven dependability of a telephone type open relay for use in computers, sorting and punching machines and similar applications. North 700 Series relays provide up to 16 pile-ups and are available to 32 form A or to 16 form B or form C contact arrangements.

These relays are also available with double coils for heavy spring loads or extra fast action. Double coil relays are identified as 7200 series and can be supplied with 50 form A or 32 form B or form C contact arrangements.

For applications where the small number of relays in a switching system make a common DC power supply uneconomical, the North 7300 Series is available with AC rectifiers.

North "gang" relays can be supplied with Double Gold Alloy or Solid Silver contacts, with solder type or AMP #78 type contact terminals, and with 12, 24, 48, 75 and 110 volt coils (110 V.A.C. for 7300 Series). Operating speeds range from 30 MS to 70 MS at approximately 2.2 watts. Faster speeds can be obtained with increased power.

For detailed specifications on North "Gang" 700, 7200 and 7300 Series relays, write ...

*ELECTRONETICS DIVISION*

**NORTH ELECTRIC COMPANY**

142 SOUTH MARKET ST., GALION, OHIO



# Magnetic Fields Vary Transistor Gain

By R. W. LADE, D. J. FITZGERALD, A. F. LUCKAS, T. P. LYNCH, Dept. of Electrical Engineering, Marquette Univ., Milwaukee, Wis.

CURRENT density of a carrier frequency signal might be modulated in a transistor amplifier using a built-in field winding in the active element. This possibility is indicated by observations of voltage gain variations when the active element is subjected to strong external magnetic fields.

In recent experiments an increase in common-emitter short-circuit current gain was observed, rather than a decrease.<sup>1</sup> The conventional amplifier in Fig. 1 was used for the measurements. The germanium *pnp* alloyed junction transistor was uncapped and placed in a strong magnetic field. The rest of the circuit was shielded from the field.

With the diffusion current density vector parallel to the magnetic field, voltage gain increased linearly with increasing flux density, as shown in Fig. 2A. When the transistor was rotated 90 degrees with respect to the magnetic field, the opposite effect on gain resulted, as shown in Fig. 2B. With constant flux density, voltage gain as a function of angular rotation of the field was approximately sinusoidal, as shown in Fig. 2C. However, the variations in gain are not centered

about the gain that would exist with no applied field.

When the diffusion current density vector is perpendicular to the field, the vector product of the two is at maximum, which could indicate some variation in the base transport mechanism. However, the greatest gain variations occur with the two vectors parallel, implying that a major contributing factor to the observed results is reaction of the base recombination current to the magnetic field.

Open-circuit voltage gain of a common-emitter amplifier is approximately  $A_v \cong h_{fe} R_L / h_{ie}$ . Thus

$$\frac{dA_v}{d\alpha} = -R_L \frac{d}{d\alpha} \left( \frac{h_{fe}}{h_{ie}} \right) \quad (1)$$

However, since  $h_{fe} = \alpha / (1 - \alpha)$  and  $h_{ie} = h_{ib} / (1 - \alpha)$ , where  $h_{ib}$  is independent of  $\alpha$ , then Eq. 1 can be written

$$d\alpha = - \frac{h_{ib}}{R_L} dA_v \quad (2)$$

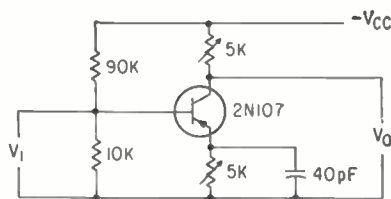
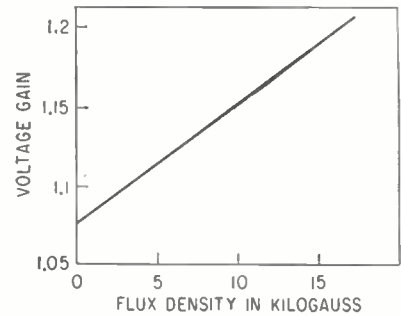
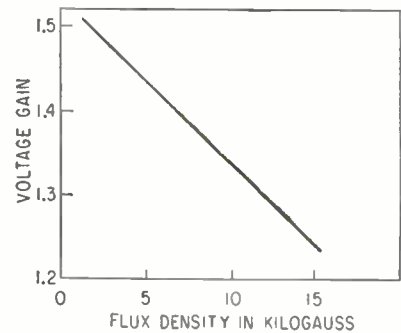

FIG. 1—Uncapped transistor in conventional amplifier was used in experiments



(A)



(B)

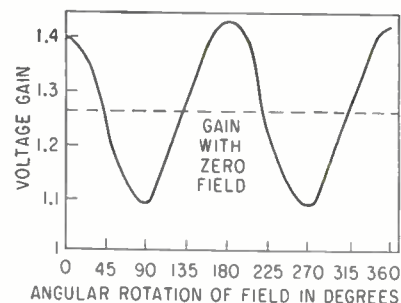

(C)

FIG. 2—Gain increased with increasing flux density with field parallel to diffusion current density vector (A), decreased with field at 90 degrees (B) and varied approximately sinusoidally (C) with rotation of field having constant flux density

## Phase-Comparison Missile Tracker



White radomes enclose precision antennas of Convair Azusa Mark II system which enable USAF to track missiles with accuracy of a few feet at hundreds of miles

In the test circuit,  $\alpha$  is 0.95,  $h_{ib}$  is 32 ohms and  $R_L$  is 100 ohms. Therefore  $d\alpha = -0.32 dA_v$ . The maximum observed variation in voltage gain is 33 percent (Fig. 2C) so that the percentile change in alpha from Eq. 2 is 10.5 percent.

In addition to the gain variations, a slight increase in amplifier bandwidth was noted when an ex-

# Shallcross

precision  
circuit  
news



**Delay-to-Rise-Time Ratio in Only 6 in<sup>3</sup>**

Total Delay	1.5 $\mu$ sec
Rise Time	0.03 $\mu$ sec
Impedance	500 ohms
PRF	2.5 mc
Attenuation	1 db
Distortion	5%
TC	+150 ppm, $\pm 15$ ppm ( $-10^{\circ}\text{C}$ to $+50^{\circ}\text{C}$ )

Some of the toughest performance specs we've seen in 12 years of delay line engineering are crammed into the  $\frac{1}{2}$ " x 2" x 6" case of this lumped constant line. Used by a data processing equipment manufacturer, the unit requires uncommon care in component selection and in circuit layout to achieve the desired 50 to 1 delay-to-rise-time ratio in the space allowed.

Special cores and toroidal winding techniques promote maximum Q, and, when coupled with custom miniature capacitors, desired LC characteristics are obtained within the specified space. An ingenious termination further reduces distortion at tapped outputs and appreciably enhances the pulse time characteristic.

Even if your delay line requirements are not so critical, this same Shallcross ingenuity may pay big dividends in reducing size, cost, or circuit complexity for you. Why not outline your needs to us?

## DELAY LINES



### VARIABLE DELAY

Continuously adjustable delays from 0 to 0.5  $\mu$ sec with 0.005  $\mu$ sec resolution are attainable in this typical Shallcross unit. Maximum rise time is 0.06  $\mu$ sec at maximum delay.



### DISTRIBUTED CONSTANT



### LUMPED CONSTANT

Shallcross' family of distributed constant and lumped constant lines utilize the latest refinements in inductors, capacitors, winding, trimming and packaging techniques.

## STEPPING ACCURATELY



Typical of longer Shallcross delay lines, this variable lumped constant unit provides a total delay of 24.65  $\mu$ sec in 15 steps calibrated to 0.05  $\mu$ sec accuracy. Delay-to-rise-time is 100:1—and in a hermetically-sealed package measuring only 2" x 4" x 7 $\frac{1}{4}$ ".

Of course variations can be made for your requirements—in impedance, taps, rise time, attenuation and so forth. These are regular occurrences with the many hundred designs produced by Shallcross delay line specialists.

**Shallcross Manufacturing Co.** Selma, North Carolina

Precision wirewound resistors, Switches, Instruments, Delay lines, Resistance networks, Audio attenuators.

## PRODUCT APPLICATION

HANSEN  
SYNCHRON  
TIMING MOTORS

synchronous power source for

# ELAPSED TIME INDICATORS

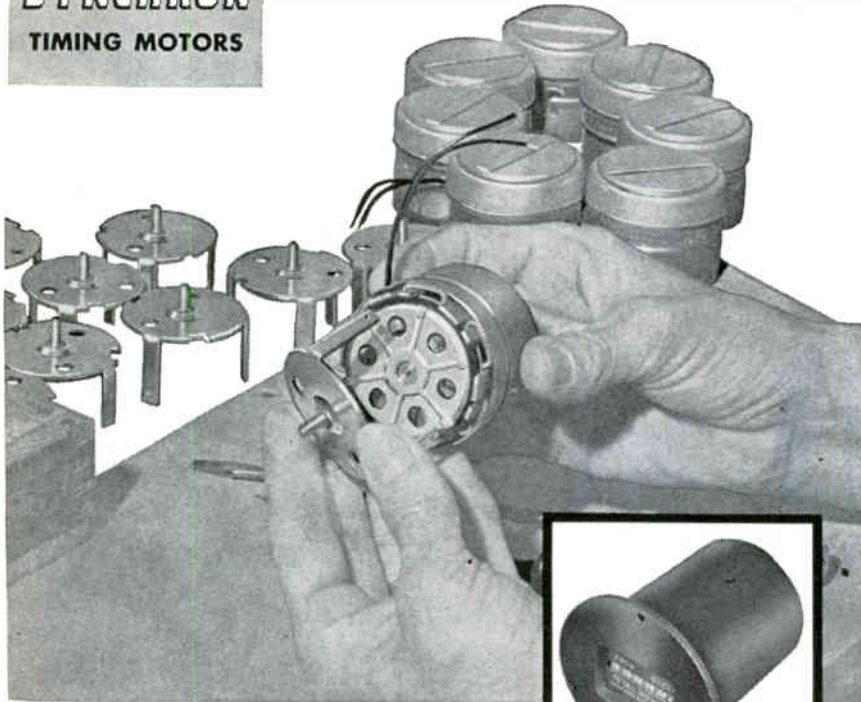
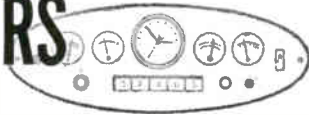

Hansen SYNCHRON motors being assembled into Hobbs engine hour meters



JOHN W. HOBBS CORPORATION, a leading manufacturer of running time meters, uses Hansen SYNCHRON Timing Motors to provide the power for efficient, dependable, long-lasting operation of such devices. The elapsed time indicators measure running time on such typical installations as machine tools, air compressors, motor generator sets, and other equipment run by alternating current.

HANSEN SYNCHRON TIMING MOTORS exceeded the requirements set for the synchronous motor and integral gear train providing the accuracy of time so vital to the operation of Hobbs instruments — including accurate performance over a wide range of ambient temperatures to meet certain military requirements. Hansen SYNCHRON motors are furnished to Hobbs to meet voltage specifications that vary from 120 - 240 - 480 volts, at 25 - 50 and 60 cycles.

The application described demonstrates another way in which Hansen SYNCHRON motors serve as an integral part in product operation. You may be able to profit from such dependable performance applied to your timing application, now being planned or in production. SEND TODAY for informative folder detailing specifications and technical data on all Hansen SYNCHRON Timing Motors and Clock Movements.

#### HANSEN REPRESENTATIVES:

THE FROMM COMPANY  
5150 W. Madison, Chicago, Illinois  
H. C. JOHNSON AGENCIES, INC.  
Rochester, N. Y. — Buffalo, N. Y. — Syracuse, N. Y.  
Binghamton, N. Y. — Schenectady, N. Y.  
ELECTRIC MOTOR ENGINEERING, INC.  
Los Angeles, Calif. — (Olive 1-3220)  
Oakland, California  
WINSLOW ELECTRIC CO.  
New York, N.Y. — Essex, Conn. (SOUTH 7-8229)  
Philadelphia, Penn. — Cleveland, Ohio

Sweet's Product  
Design File



ternal magnetic field was applied parallel to the diffusion current density vector.

Although the percentage change in gain is somewhat limited, it is significant at lower level operating signals. Therefore, a built-in field winding to modulate current density at a carrier frequency seems feasible. Presently a detailed analysis of the effects of magnetic fields is underway at Marquette.

#### REFERENCE

(1) H. A. Kampf, Transistors and Diodes in Strong Magnetic Fields, *Electronic Ind.*, 17, p 71, March 1958.

## Russian People Told of Soviet Research Aims

VIENNA, AUSTRIA—Monitored broadcast from Radio Moscow was aimed at acquainting the home audience with new words. A few statements related to electronics were reported by McGraw-Hill World News.

In discussing cybernetics, broadcasted comments included: Machine builders of the Novokramatorsk works are designing the first automatic rolling-slabbng machine in the world. An immense set of most complex mechanisms will be controlled by an electronic computer.

In the USSR, over 2.5 million people are engaged in calculations and statistics. In a few years electronic computers will help to process a considerable proportion of information and plan the national economy. The electronic computing machine MN-8, created by Soviet scientists, can in one week calculate 100 variations of movement by an airplane whose construction has not even begun.

In relation to polymers and semiconductors, the announcer said that scientists in Irkutsk have created special synthetic substances—polymers with semiconductor properties. Derived directly from atoms and molecules, these semiconductor materials lack the disadvantages common to natural materials.

## Full Time Fuel Cell

CONTINUOUS GENERATION of electric power is promised by a light weight fuel cell for use in satellites and



space vehicles. The cell is charged while exposed to sunlight so that it can continue to supply power when in the shadow of the earth.

Solar cells are used to charge the fuel cell, producing the electric power needed to start a hydrolysis reaction using hydrogen gas, bromine, and water.

Developer of the fuel cell is Ionics, Inc. According to executive vice president and technical director, Dr. Walter Juda, this cell is particularly attractive for space applications because of the high power density obtainable when it discharges and because of the low voltage required from the solar cells for recharging. He indicated that special plastic ion-exchange membranes developed by Ionics are a key part of the cell design.

### Computers Used for Automobile Design

ELECTRONIC COMPUTERS are being used with powerful magnetic vibrators to formulate an analysis that will predict the behavior of cars while they are still on the drawing board. Thus modifications in design can be made without disrupting production schedules and without making costly changes in production tools.

The magnetic vibrators are so powerful they can rock an automobile like a can of paint in an electric mixer. They can also introduce vibrations invisible to the human eye. All points in the car can be exposed to vibration, and the resulting rumbles and twinges are picked up by electronic probes to be fed into the computers. The computers are programmed so that they supply an analysis which can be used to predict the behavior of cars in the design stage. Thus, the whole body structure will be expressed in a mathematical form.

The facility is part of Chrysler Corporations Engineering Division. Manager of the Division, Joseph R. Farnham, says that the key advantage of this center is its ability to duplicate any road or drive-train situation with a mere twisting of dials, and, because there is no test driver, no human variable clouds analysis of different designs.

**NEW**

## twin contact miniature DC-AC choppers



Eleven types, both single and double pole.  
Long life.  
Low noise level.  
Extreme reliability.

**DPDT  
LOW COST  
FULL ISOLATION**

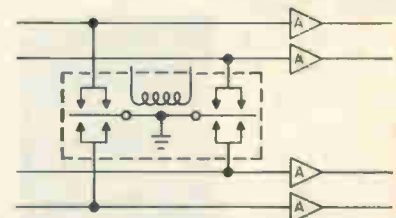

AA



Write for Catalog 515-B

# STEVENS INCORPORATED ARNOLD

QUALITY SINCE 1943

7 ELKINS ST., SOUTH BOSTON 27, MASS.

S/A 16%



Evaporation mask containing amplifier circuit is etched on machine (left). The 0.005-in thin steel sheets containing masks for the passive elements are then mounted on evaporation fixtures (center). After conductance resistance and capacitance elements are deposited on the substrates by high-vacuum techniques, micromanipulator (right) is used to mount the active elements on tiny thumbnail-size circuit (below)

## Keeping Ahead in Practical Microcircuits

By DAVID WILLIAM MOORE,  
 Manager, Lear, Incorporated, Solid State  
 Physics Laboratory, Los Angeles

THE INTEGRATED FORM of microcircuit construction, pioneered by Diamond Ordnance Fuze Laboratory (see Special Report on Microminiaturization, p 92 (ELECTRONICS, Nov. 25, 1960) is Lear's approach for producing accurate, reliable microcircuits in quantity and at reasonable cost.

At Lear, this construction is exemplified by a three-stage voltage amplifier. And the key to circuit accuracy is found in the extreme care taken with each step of fabrication. The DOFL technique obviates extensive post-evaporation tailoring after the original evaporation, and is Lear's basis for preparing microcircuits with no deterioration of circuit stability. This method creates microcircuits for today's market, and readies itself for



Thumbnail array

techniques that may be perfected to deposit active elements directly on the substrate.

Initial art work preparation, and the etching process for the construction of the thin-film circuits require great care and precision. High-vacuum evaporation, used for all phases of circuit deposition, is controllable and economical. All necessary deposition for passive electronic components is carried out in one vacuum chamber.

The cover photograph illustrates the steps in the preparation of microcircuit art work. The original circuit layout is done on Ruby Studnite thin, a commercial stencil-cutting film. This original layout, 25 times the size of the actual circuit, insures accuracy for the deposition of resistors and capacitors having tolerances suitable for most high-performance military electronics circuits. The first reduction, five-to-one, is shown being held by Robert N. Roth and Ken Carter. Finished masks are on the table, and in the hand of Vance K. Cronk on the right. The precision required cannot be obtained without this accurate scaling.

Final retouching is made on the microcircuit art work. All photo reduction is done in two stages using a Robertson Process Camera,

and all final positives are on DuPont Cronar film. The need for careful photography is appreciated when it is realized that openings in the finished mask are often less than 0.005-in wide.

The exposed mask, developed and ready for etching is mounted in the frame of the etching machine shown in the left photo at the top of the page. This machine is a modified standard etcher made by Centre Circuits, Inc., State College, Pennsylvania. Oscillating-spray nozzles spray the work on both sides with the etchant, and produces the uniform etching results which are mandatory.

Masks for the Lear microcircuits are etched in Type-300 series stainless steel, 0.005 or 0.008-in thick. Kodak Photo Resist is applied to both sides of the steel plates using the manufacturer's recommended methods. After mechanical registry, positive films of the front and back sides of the mask are taped together. The coated stainless-steel sheet is then inserted between the positives and exposed one side at a time, in a vacuum-printing frame using a carbon arc light. Developing, drying, and rinsing of the exposed plate are carried out according to the manufacturer's recommendations. Touching up is





## How to use a 4-megacycle instrumentation tape recorder

*Ampex's new AR-300 and FR-700 answer a whole new range of needs*

### For video-bandwidth phenomena

Radar, for instance, can now be tape recorded off receiver and played back repeatedly to scopes, analytical devices or radar guided equipment. Radar testing, reconnaissance and tracking are enormously aided by tape's live-playback capabilities. And for simulation and training, elusive transient phenomena now become repeatable at will.

### For predetection recording and communications monitoring

The recorder's bandwidth catches everything at once — any 4-megacycle band of radio frequencies or the IF stage off a telemetering receiver. This simplifies on-site equipment. One kind of recording serves for all usual types of communications and telemetered data. Later you can play back through detector, discriminator and other equipment as many times as necessary to separate and process the desired channels of information.

### For 5,000,000 binary bits per second

Super-efficient acquisition and reduction systems can be developed around serial pulse-coded data put directly on tape. One reel lasts 60 minutes — holds over seven billion binary bits. Compare this with previous PCM techniques on tape limited to less than 1,000,000 bits per second even at much higher tape speeds and proportionately shorter recording time.

#### The essential data

The Models: AR-300 Mobile or airborne record only, FR-700 single-rack laboratory record/playback. Response: 10 cps to 4 mc ( $\pm 3$  db). Tape speeds: 12½ and 25 ips. Playing time: 60 minutes. Tape: 1.0-mil Mylar, 2-inch width, 10½-inch reels. Data tracks: two wideband plus two auxiliary. Electronics: all solid state. Environmental (AR-300): 10g vibration; 50,000 ft. alt.; -54°C to +55°C. Tape interchangeability: yes, among all AR-300/FR-700 recorders.

Write for full information

AMPEX DATA PRODUCTS COMPANY  
Box 5000 • Redwood City, California • EMerson 9-7111



**AMPEX**

# AIRPAX



## SERIES 500 MINIATURE MAGNETIC CIRCUIT BREAKERS

- RATINGS FROM 50 MA TO 10 AMPS
- DC, 60 CPS and 400 CPS TYPES
- MINIATURE CASE; SIZE ONLY  
1 3/4" x 1 1/8" x 3/8"
- TRIP LEVEL INDEPENDENT  
OF TEMPERATURE

- INSTANTANEOUS OR  
DELAY TYPES
- HERMETICALLY SEALED
- SERIES - SHUNT - RELAY TYPES
- TWO AND THREE GANG  
ASSEMBLIES AVAILABLE

### Positive Protection

Slightly larger than a conventional panel switch, the breaker serves as switch, fuse and relay.

*Bulletin B-97 on request*



CAMBRIDGE DIVISION • CAMBRIDGE, MD.

done under a microscope using lithographer's staging ink.

The developed image on the stainless-steel plates is etched with ferric chloride at 38-deg Baumé and at 120-deg F. After etching, the remaining with benzine and E. T. R. remover. Finished masks are carefully cleaned with Ajax powder.

The completed masks for the resistor and capacitor portions of the three-stage amplifier are deposited onto a one-half by one-half inch soft glass substrate. Other substrates, such as alumina or dense steatite could also be used, as could various single-crystal semiconductor material.



*Touching-up mask patterns*

To insure the evaporation of accurate and stable resistors, a nickel and chromium alloy is evaporated to a thickness of about 100 ohms per square. This assures a predictable post-evaporation aging cycle, stable under extreme environments. A monitoring resistor on the masks insures deposition to the correct total resistance values.

Evaporators are carefully instrumented to provide a record of the time, temperature, voltage, current, pressure and other parameters. Substrate temperature is by far the most important of these parameters, as it, more than any other, controls the character of the deposited film material. All deposition is carried out in vacuum between  $10^{-6}$  mm and  $10^{-7}$  mm of mercury. The higher vacuum is better for the evaporation of the silicon monoxide dielectric used in the Lear-deposited capacitors.

The stainless-steel mask for the capacitance portion of the voltage amplifier is carefully mounted into the evaporation fixtures. This operation is imperative, as is adequate mechanical jiggling to obtain suitable mechanical alignment. The

CB23



*Stainless-steel etched masks*

center photo at the top of p 72 illustrates the loading.

The silicon monoxide dielectric capacitors can be deposited to have a single layer capacity of 0.10 microfarad per sq. in. (0.015 microfarad per sq. cm). It is possible and practical to evaporate capacitors in several layers to increase this value. Breakdown voltage is between 50 and 100 v, and the Q as high as 100.

After deposition of the passive components, uncased transistors and diodes and any large capacitors are inserted into the circuit with the micromanipulator arrangement shown in the right photo at the top of p 72. The micromanipulator simplifies correct placement of the small active elements, and enables the operator to work easily with small parts. If the mechanical advantage of the micromanipulator is set to the magnification of the microscope, the operator has the illusion of working at a one-to-one relationship because he sees his hand out of the corner of his eye moving in step with the work under the microscope. This simple adjustment greatly enhances the ease of operation.

Conducting epoxy is used to bond the transistors and diodes to the deposited circuitry. Uncased transistors and diodes, supplied by several manufacturers, are suitably passivated and protected to provide operational stability.

The microminiaturized version of the voltage amplifier represents a volume saving of more than 10 to 1 over the same three-stage amplifier as it is now being produced for use in Lear flight control equipment, and the two types of amplifiers are completely interchangeable. The small amplifier operates from 28-v d-c, turns out 30 mw, has output impedance of 2,000 ohms and maximum gain of 40.

*MicroMatch*<sup>®</sup>

## RF LOAD RESISTORS COVER THE RANGE:

TO 6000 WATTS AND 3000 MCS.

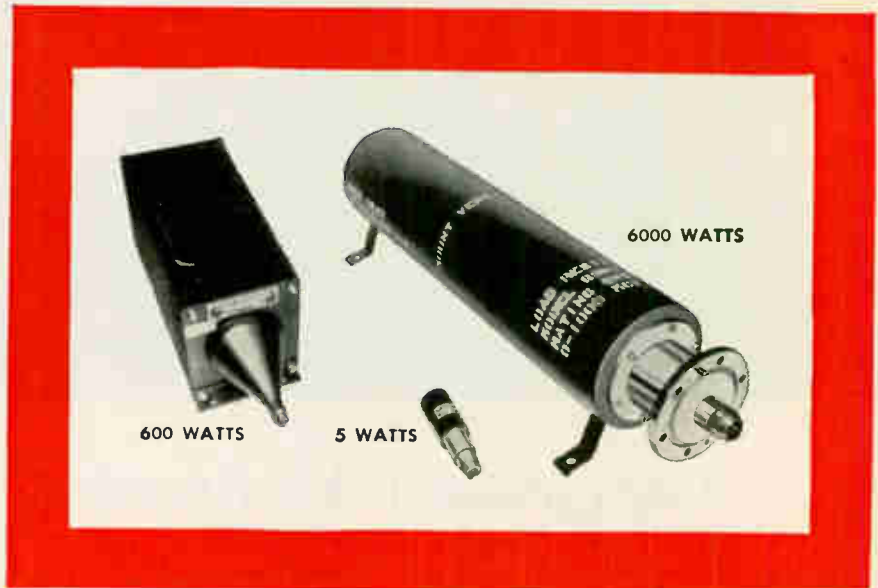

*MicroMatch*

RF Load Resistors provide the virtually reflectionless terminations needed for accurate RF power measurement. They serve many useful purposes as non-radiating RF power absorbers, particularly in lieu of antenna systems during the measurement and alignment phase of transmitter operation.

Other useful functions are in conjunction with feed-through wattmeters to form excellent absorption-type wattmeters, and as a load for side-band elimination filters or high power directional couplers.

SPECIFICATIONS		RF LOAD RESISTORS	
MODEL NO.	FREQUENCY RANGE (mcs)	RF POWER DISSIPATION (watts)	RF CONNECTORS
601	0-3000	5	N, C or BNC
603	0-3000	20	N, C or BNC
633	0-3000	50	N, C or HN
634	0-3000	150	N, C or HN
635	0-3000	200	N, C or HN
636	0-3000	600	N, C or HN
638	0-2000	6000	3/8" flange

Many other special models have been designed and manufactured to meet your particular space and input connection requirements.

For more information on RF Loads, Directional Couplers, Tuners, and RF Wattmeters, write:

**M. C. JONES ELECTRONICS CO., INC.**



185 N. MAIN STREET, BRISTOL, CONN.  
SUBSIDIARY OF





*Trimming end of wire bundle*

*Wiremen start cable makeup by pulling wires from rack to dolly*

## Compressed Air Speeds Cable-Making

COMPRESSED AIR is used by Electronic Associates, Inc., to draw sleeving over long, bulky cables. The technique is especially useful when the sleeving is large diameter spaghetti tubing rolled flat on supply reels. Sleeving up to two inches in diameter has been drawn over 150-foot-long computer system cables.

Cables are prepared in the wire stockroom to minimize materials handling. An area 200 feet long, in the stockroom and in the adjoining harnessing area at the West Long Branch, N. J., plant, is kept clear of obstructions so long cables can be stretched their full length.

Spools of wire frequently used are kept on a large unreeling rack at one end of the area. The spools are racked according to a color code indicating connector row positions: brown for first row, red for second row, and then orange, yellow, green, etc. Special colors are put on the racks as needed.

A strip of masking tape, marked in feet and fractions, is used as a floor ruler. A dolly with a heavy concrete base is moved to the appropriate foot mark and anchored by suction cups. A stanchion on the dolly carries a small work table, a large hook above the work table and

a tube for plastic solvent.

The required wires are pulled from the spools a few feet. The ends are bundled with lacing tape and the tape is wrapped and tied to a hook on the wall near the rack. While one wireman pulls the wires from the rack, another man uses an empty spool on a rod to pull the wire bundle down to the hook

mounted on the dolly stanchion.

Normally, enough wire is pulled for one round trip between the rack, dolly and wall hook. This gives a cable the length pulled or with twice the number of wires pulled and half the length. Wire twist ties are placed at the bundled ends and a few inches from the dolly hook, with the bundle either single or



*Inserting wad into tubing*



*Blowing wad and cord through*

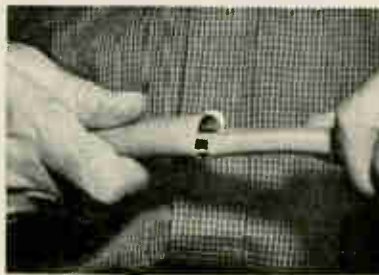

*Splicing with dilated tubing*

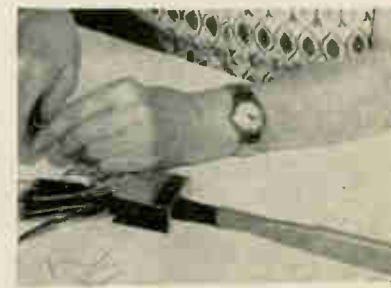

*Extra tubing slips out of way*



## Needed: Engineers to chart the dimensions of 1965 weapons systems

“Too often companies are satisfied with the accomplishments of today and allow schedule pressures to prevent concentration on tomorrow’s business.

“This is not true at Martin-Orlando. We have established a group of high level engineers—the Technical and Research Staff—who have the responsibility for creating and developing the skills and systems that will form the basis for Martin’s business in the time span 1965-1970.

“Finding the men who can staff the 23 technologies necessary is not an easy task. It calls for engineers who are interested in technical rather than administrative accomplishment. It calls for engineers who have the clarity of concept to discard convention. It calls for engineers unhampered by ‘tunnel vision’—who can translate the tactical requirements of the future into engineering reality. It calls for engineers who can do the jobs and meet the qualifications shown on the right.

“Martin-Orlando—prime contractor for Pershing, Bullpup, GAM-83, Lacrosse, Missile Master and BIRDIE—is working on the threshold of the future. If you feel you would like to join us, are qualified, and would enjoy living in Florida, we would very much like to hear from you.”

*James G. Louser*

*Director, Technical and Research Staff*

Martin-Orlando’s Technical and Research Staff has immediate openings for high level engineers and scientists in all 23 technologies being studied. Among these are:

- **OPERATIONS RESEARCH**—Operations Research is of prime importance in the Technical and Research Staff and is conducted primarily on the systems level in such efforts as weapons systems analysis, operational gaming and simulation, and system modeling.
  - **ELECTRONIC SYSTEMS**—conceptual design and evaluation of advanced systems. Of significant interest at this time are high resolution techniques, missile detection and guidance, analytical studies of new communication systems.
  - **COMPUTER TECHNIQUES**—digital systems and logic design for unique weapon systems applications. Concept through prototype experience desired.
  - **INFORMATION THEORY**—as applied to communications, guidance or radar systems with emphasis on information theory, information processing, statistical theory of communications, decision theory, optimum coding and detection.
  - **INERTIAL GUIDANCE**—conceptual and analytical investigation of advanced inertial guidance systems. Experience should be in modern weapons systems with emphasis on systems analysis for employment of inertial guidance techniques, and or conception and design of all or major portions of inertial guidance components.
  - **GROUND SUPPORT EQUIPMENT CONCEPT AND DEVELOPMENT**—emphasis on mobile missile systems analysis. Backgrounds in missile and equipment handling, servicing equipment development, transport and transport vehicle evaluation, soil mechanics, hard based installations, and power generation systems are applicable. Experience with military logistics and tactical military operations highly desirable.
- Other technologies in which immediate openings exist include: Electronic Packaging, Environments Prediction, Structures (Conceptual Analysis and Design), Human Factors, Missile Propulsion.

If you are interested in and qualify for senior level work with this highly select staff, please contact C. H. Lang, Employment Manager, The Martin Company, Orlando 27, Florida.

WORK IN THE CLIMATE OF ACHIEVEMENT

**MARTIN**  
ORLANDO

1 DIGITAL DISPLAY DOES THE WORK OF 15



ACTUAL SIZE

## NEW KEARFOTT DIGISTROBE\* DISPLAY

Kearfott's new, highly compact Digistrobe digital display utilizes the stroboscopic principle to produce an exceptionally high-definition readout in the actual size shown here. Through the use of a unique shutter arrangement, a single diode-encoding matrix is shared by all columns (5 in the standard model), resulting in substantial savings in electronic components and circuitry. The fast response time of the Digistrobe (56 milliseconds transition from one five-digit quantity to a totally different one) permits a single unit to sample several different inputs on command through an input selector switch. Up to 15 individual displays of existing types can thus be replaced by a single Kearfott Digistrobe!

Incorporating only two moving parts and exclusively solid-state switching circuitry, the Digistrobe has extremely long life expectancy and requires minimum maintenance and service. Operation is directly from the output register of a computer, counter or allied equipment, eliminating the cost of intervening circuitry. Two years of extensive laboratory tests assure compliance with Kearfott's rigid standards of quality. For complete data and specifications, write for Digistrobe bulletin.

\*Kearfott Trademark



KEARFOTT DIVISION  
GENERAL PRECISION, INC.

Little Falls, New Jersey

double according to length desired.

A doubled length of lacing cord the length of the cable is prepared. A smaller piece of lacing cord is tied to a wad of cellulose shipping padding the same size as the tubing diameter. Enough tubing for the cable is measured off on the floor ruler.



Piece slides down to cover wire ends

The wad is inserted in the tubing. Then, the nozzle of a compressed air hose is put into the same tubing end. The air blows the wad and the cord through the tubing. To keep air from blowing back out of larger tubing, a washer is placed on the air hose nozzle. A wad need not be used on tubing over one inch in diameter. The lacing will "float" through.

The double end of the lacing is fastened to the wire bundle end with a few half-hitches. The end of the wire bundle, which was bent on the dolly hook, is trimmed clean with a large pair of cable cutters.

Using the cord as a stretcher, the tubing is started over the wire bundle. The air nozzle is put into the tubing end, keeping the sleeving expanded as it is drawn completely over the wire. The wadding and its cord are untied and can be used again.

Available lengths of large diameter tubing are frequently shorter than a long cable, requiring splices. While the first length is being drawn over the scale, one end of the second length of tubing is dipped in lacquer thinner in the tube on the dolly stanchion.

The solvent dilates the tube. The dilated end slides easily over the mating end of the first tube. As the solvent evaporates, the dilated end shrinks to a tight fit. This method is also used with short pieces of tubing for finishing the frayable ends of fiber-covered cables and on splices. Pieces can be kept ready in small jars. However, the plastic

must not be allowed to soak too long or it loses elasticity. Tubing will expand to almost double normal diameter while in solvent.

If a number of short cables of the same makeup are required, the total length of wire is prepared. However, the tubing is drawn on in finished cable lengths and the wires cut at the spaces between the lengths of tubing.

When connectors are assembled to the cables, the tubing usually must extend to the connector. Assemblers have difficulty in pushing back large, tight-fitting tubing to obtain working room. Generally, the sleeving must be tied back. EAI's solution is to cut the main length of tubing a few inches short. A 10-inch length of slightly larger sleeving is then slipped over the main sleeve. This telescopes out of the way while the connections are made and is pulled down to cover the wire ends after the connector is secured.

### Store Miniature Parts In Miniature Stockroom

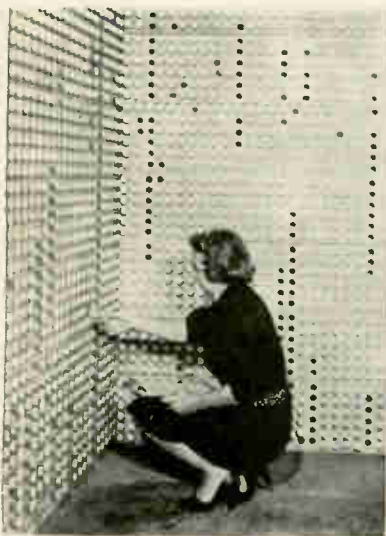

*Tiny stockroom holds inventory of 300,000 chokes*

ONLY WALL SPACE is used at Essex Electronics Division, Nytronics, Inc., Berkeley Heights, N. J., for the storage of subminiature chokes. The chokes, which can be packaged 200,000 to a cubic foot, are stored in their plastic shipping containers in the rear corner of the shipping room. To fill an order, the clerk selects a tube indicating the desired inductance and type, wraps the tube and addresses it.

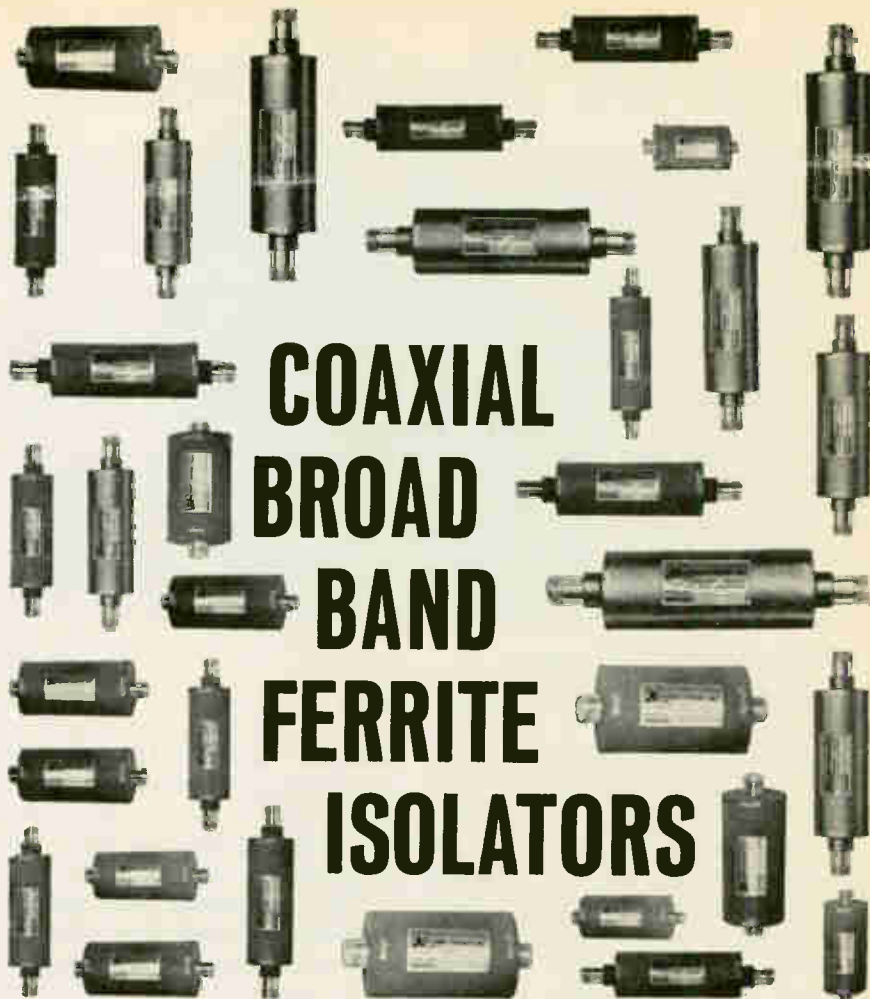

# COAXIAL BROAD BAND FERRITE ISOLATORS

## IN SIZES FOR EVERY APPLICATION

Now—from Kearfott, a new and broader line of Ferrite Isolators to satisfy the most exacting requirements of band width and isolation. Combining low unit loss characteristics with compactness and light weight, this new series of Kearfott Coaxial Isolators is available from present stock. Immediate selection and faster delivery is assured . . . *precision performance proven.*

A FEW OF THE TYPICAL SPECIFICATIONS				
MODEL	FREQUENCY	ISOLATION	INSERTION LOSS	VSWR
C991100-402	1.2—2.6 KMC	10 DB Min.	1.0 DB Max.	1.20
C992100-405	2.0—2.5 KMC	30 DB Min.	.8 DB Max.	1.20
C992100-404	2.0—4.0 KMC	10 DB Min.	1.0 DB Max.	1.20
C992100-407	3.0—3.5 KMC	35 DB Min.	.8 DB Max.	1.20
C993100-401	4.0—8.0 KMC	10 DB Min.	1.0 DB Max.	1.20
C994100-403	7.0—9.0 KMC	25 DB Min.	.8 DB Max.	1.20

Complete information on these or all of the models is available by directing inquiries to: 14844 Oxnard Street, Van Nuys, California, or the sales office in your area.



**KEARFOTT DIVISION  
GENERAL PRECISION, INC.**

*Little Falls, New Jersey*

SALES OFFICES SEATTLE, WASH. VAN NUYS, CALIF. PHOENIX, ARIZ. DAYTON, OHIO CLIFTON, N.J.  
PALO ALTO, CALIF. SAN DIEGO, CALIF. DALLAS, TEX. CHICAGO, ILL. WASHINGTON, D.C.

# New On The Market

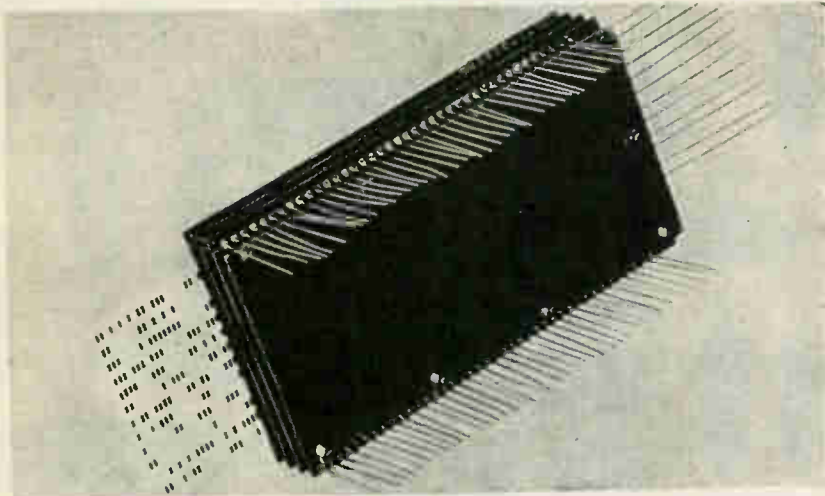

## Experimental Memory

### READOUT FROM PUNCHED CARDS

EXPERIMENTAL punched card memory unit that electronically reads out punched data at high speed from special IBM cards is announced by International Business Machines Corp., 590 Madison Ave., N. Y. 22, N. Y.

The read-only card capacitor memory provides random access to any card or portion of a card. The concept provides an economical substitute in some applications for magnetic core or drum storage.

The experimental unit uses special IBM cards—sandwiches of paper around a layer of aluminum foil. The cards are inserted between pairs of electronic printed circuit boards, which convert the card data into signals directly use-

able in a computer. In conventional memories information is written in electronically. To put information into the punched card unit, a card is inserted or substituted.

The experimental card capacitor memory array consists of several pairs of printed boards facing each other, one with horizontal parallel conductors, the other with vertical parallel conductors. The crossings correspond to the 960 possible hold positions in the IBM card. This amounts to twelve 80-bit words or eighty 12-bit words arranged on the card. When the card is inserted, the presence of a hold at any crossing is detected by capacitance change.

CIRCLE 301 ON READER SERVICE CARD



## Microminiature Relay

### PRINTED CIRCUIT USE

RELAY with dimensions of  $0.8 \times 0.8 \times 0.875$  inch has pin arrange-

ment adaptable to printed circuit boards. Series 4B relay has better

sensitivity per pole than two dpdt microminiature relays and optional terminal arrangement of long or short leads or hook terminals; bracket, stud, or strap mounting is available.

Contact rating for dry circuits is 2 amp resistive; temperature range from  $-65$  to  $+125$  C; dielectric strength 1,000 vrms at sea level; insulation resistance 1,000 megohms min; balanced armature construction protects against vibration and shock; relay will meet all relay military specifications for components of this size. The relay is manufactured by Hi-G, Inc., Bradley Field, Windsor Locks, Conn.

CIRCLE 302 ON READER SERVICE CARD

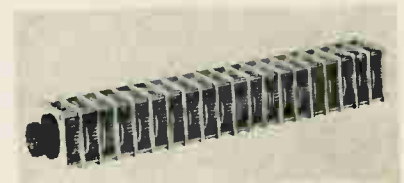

## Precision Switches

### 20-DECK CIRCUITS

FLOATING, stainless steel shaft and a pressure equalizing brush reduce torsion and drag so that up to 20 decks may be used in line of multipole precision instrument switches. The units conform to military specifications and are designed for dry circuit and other applications.

Features include positive action with equal torque in both directions, and a captive rotor that makes all decks self-aligning. Thus any deck can be serviced or replaced with only a socket wrench and without disturbing the wiring of others.

Contacts, collector rings and one piece brushes are all fine-silver, which eliminates effects of oxides and sulphides, and reduces thermal voltages; contact resistance is  $1.3 \pm 0.2$  milliohms. Switches are by Langevin, Div. of Sonotec Inc., 503 South Grand Ave., Santa Ana, Calif.

CIRCLE 303 ON READER SERVICE CARD

## Micro Transistors

### IN ALL GLASS PACKAGE

A LINE of micro-transistors in all glass packages has been introduced by Transitron Electronic Corpora-



# LASER MASER

## RUBY RODS *fabricated to exacting specifications*

VALPEY CRYSTAL CORPORATION is prepared to supply special chromium doped ruby rods fabricated to your specifications with quick delivery.

We can supply rods fabricated from standard growth material and slow grown material oriented at 0° or 90°. We have for quick delivery, .04%, .08% and 1.2% final chromium doped material both in standard and slow growth boules. Other chromium dopings also available. Valpey will also fabricate your material.

Depending on orientation we can supply rods from .080" diameter up to .500" diameter and up to 2½" in length.

We can supply rods to the following specs:

- C axis orientation to within 10 minutes.
- End surfaces optically polished flat to ¼ wave of sodium light.
- Ends parallel to within .000010"
- Tolerance on length ± .005", diameter ± .001".
- Tolerance on 90° angle between end faces and cylindrical surfaces within 1 minute.

Valpey's precision optical department is also prepared to fabricate other materials to your specifications.

Please submit your specifications for a prompt quotation.

**VALPEY CRYSTAL CORPORATION**  
Holliston, Mass. • Tel. GArden 9-4851, 9-4854

CIRCLE 201 ON READER SERVICE CARD



## NYLON works magic with Electronics Fasteners

You may be able to cut assembly costs by reducing the number of components in your product through elimination of insulating bushings, washers, etc. for Nylo-Fast Nylon fasteners have an excellent strength-to-weight ratio with low dielectric constant and high dielectric strength. Resilient Nylon absorbs shocks, adapts itself to mating parts, permitting greater tolerance in manufacturing and reducing risk of loosening by vibration.

Produced in many colors, they have a high resistance to heat, shock, chemical attack and galling. Guaranteed uniform. Will resist continuous temperatures up to 250° F. and remain form stable to 450° F. Nearly zero reflection for radar. Over 400 sizes available for instant delivery. Write for standard samples or send specs for special quotation.



### ANTI-CORROSIVE METAL PRODUCTS Co., Inc.

Office & Factory: Castleton-on-Hudson 14, New York  
Mailing Address: P. O. Box 1894H, Albany 1, N.Y. Phone: PErshing 2-7711  
(direct line from New York City) JUdson 2-7370 Teletype: Castleton 353  
West Coast Warehouse: 2922 East Olympic Blvd., Los Angeles 23, Calif.  
Telephone: ANgelus 8-5131—Teletype: Los Angeles 212

CIRCLE 202 ON READER SERVICE CARD

February 3, 1961

"Doubts are more  
cruel than the worst  
of truths"...*Moliere*



**YOU CAN REST ASSURED WITH STANDARD SILICON RECTIFIERS IN YOUR CIRCUITS!** Designed for critical applications, the 3 newest Standard miniature rectifiers have been subjected to torturous 40 amp surge tests for over 100,000 cycles. Yet these miniatures have been conservatively rated at only 750 milliamps! This is typical of all Standard silicon rectifiers. Available in three packages: Insulated plastic case formed by new molding techniques for superior bonding; hermetically sealed ceramic miniatures in axial lead package and 8AG fuse style "plug-in" case. Performance data: 750 ma average rectified current; 50 to 600 PIV; ambient temperatures -65° to +100°C; (Ceramic -65° to +150°C).

You'll have no doubts with these units in your circuits... Write for technical bulletin or contact your local Standard Rectifier distributor.

7MH Ceramic



7MP Plastic Encapsulated



7MS Ceramic "plug-in" case

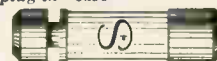

### STANDARD RECTIFIER CORPORATION

620 East Dyer Road  
Santa Ana, California  
Kimberly 5-8241  
TWX: S ANA 8103



CIRCLE 81 ON READER SERVICE CARD

81

tion, 168 Albion St., Wakefield, Mass. The series of 45-volt silicon mesa devices have a current range of 50 $\mu$ a to 20 ma and are for small signal, low level applications. The all-glass hermetic seal provides high reliability by reducing the possibility of leakage; the flat package is compatible with existing circuitry and the devices can be in-

serted into printed boards.

Cutoff frequency is over 50 Mc and betas range from 20 to 80. Package thickness is 0.06 inch, diameter is 0.16 inch; volume is 1/20 of the TO-18 package. The transistors come in amplifier and switching types and have dissipation of 200 mw.

**CIRCLE 304 ON READER SERVICE CARD**

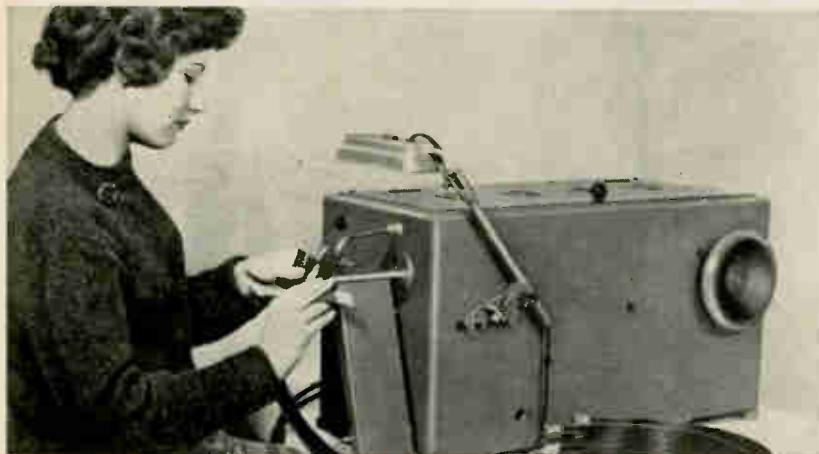

## Shielded Wire Stripper

**SPEEDS PRODUCTION**

MACHINE for stripping shielding from coaxial cable and shielded wire has been announced by Cadre Industries Corp., Box 150, Endicott, New York. On an average, one machine equals the work of twelve persons, resulting in a saving of 184 man hours per machine per day.

Besides the economic advantages, the Shielding Stripper standardizes the length of shielding removed.

The machine is safe, sturdy and easy to operate; no operator training is needed. The wire to be stripped is inserted and the cycle started by depressing a foot switch. Just before the end of the cycle the

scrap shielding is ejected by a short air blast. With normal operating rhythm, cutting action is complete by the time the foot switch is released.

The stripper is available in two models: Model 15 can cut shielding lengths from  $\frac{1}{2}$  to 1 $\frac{1}{2}$  inches; Model 35 cuts lengths from  $\frac{1}{2}$  to 3 $\frac{1}{2}$  inches. Lengths are infinitely variable within the limits. The diameter of the shielding accommodated is fixed, but cutting heads for different diameters are available and are readily changed. The machine is designed to strip only braided wire and any outer sheath or insulation must be removed previously.

**CIRCLE 305 ON READER SERVICE CARD**

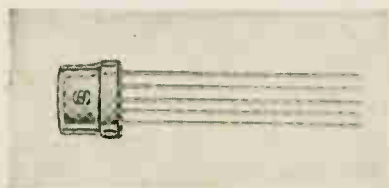

or chopping of voltages can be accomplished from a fraction of a millivolt to  $\pm 10$  volts. The transistorized chopper is inertialess

and can be driven from d-c to 100 Kc.

The switching circuits provide stability and freedom from drift over a wide temperature range. Noise figure of the transistor chopper is competitive with mechanical choppers for many uses, and will not increase with usage.

Applications include low level voltage measurements, d-c amplifier stabilization, high speed servomechanisms, thermocouple instrumentation, and low level switching. The device is made by Solid State Electronics Co., 15321 Rayen Street, Sepulveda, Calif.

**CIRCLE 306 ON READER SERVICE CARD**

## Crystal Cells

**FOR HI-FI SPEAKER**

A SMALL crystal cell for hi-fi speaker systems is now available from Acme Scientific Co., 1450 W. Randolph Street, Chicago, Ill.

The speaker system uses the precision shaped crystal cell as an ionic cloud chamber. When wired into the speaker circuit through inner and outer electrodes, millions of ions are created; movement of the ions is directly proportional to



the output of an oscillator. Amplifier voltage modulates oscillator power to create varying pressures within the ionic cloud chamber, and thus produce sound.

To assure low distortion, the crystal cells are finished to exact size and held square to the ends, without inducing strains into the crystals in the process.

**CIRCLE 307 ON READER SERVICE CARD**

## Transistorized Chopper

**D-C TO 100 KC**

MODEL 20 Microchopper in a metal transistor enclosure provides good electrical shielding and can be plugged into a standard 5-pin transistor socket. Solidly encapsulated, the chopper may also be used as a synchronous demodulator to convert a-c to d-c. Linear switching

## Random Access Memory

**MULTIAPERTURE CORES**

HIGH-SPEED, word-organized, electrically alterable random-access memory uses multiaperture ferrite cores and fully transistorized circuitry. It is capable of non-destructive readout and non-volatile stor-

# Amazing NEW Pencil-Type Epoxy offers almost unlimited applications to industry

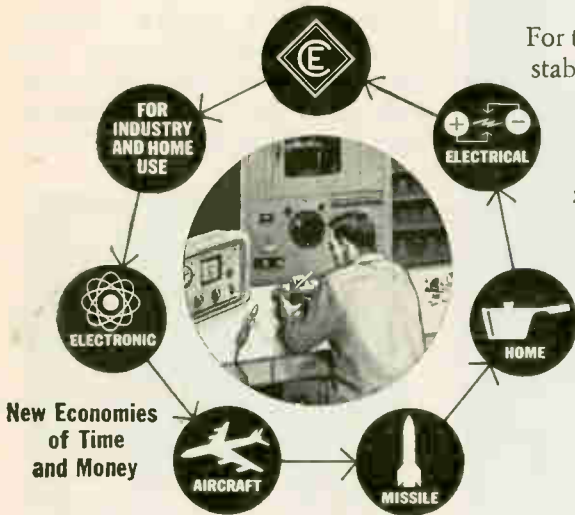

For the first time . . . a single component epoxy in stable stick form. The New Cetron Epoxy Pencil offers a simple solution for most problems involving bonding, cementing, sealing and insulating. In pencil-stick form, the new epoxy is handy to use. In many instances it offers the only practical means of applying epoxy to minute objects and hard-to-get-at places.

The New Cetron Epoxy Pencil is always ready for use . . . requires no refrigeration or special storage . . . nothing to mix. The New Cetron Epoxy Pencil is simple to apply . . . cures fast to a tough, permanent waterproof bond . . . unaffected by most oils and solvents.



WRITE FOR FURTHER INFORMATION  
**CETRON ELECTRONIC CORPORATION**  
 Plastics Division  
 2265 E. Foothill Blvd., Pasadena, California



Supplied in handy pencil-type holder ready to use.

CIRCLE 203 ON READER SERVICE CARD

## DESPATCH *tube* FURNACE

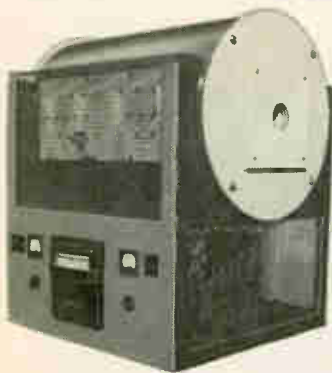

### WITH NEW THERMIONIK POWER SYSTEM

This versatile new tube furnace offers two outstanding advantages—the Thermionik power system, and a greatly reduced heat dissipation.

The Thermionik power system is the first and only to use thyratrons to pulse power to heaters. It allows great savings in cost, space and weight, and temperature control accuracy is limited only by the accuracy of the sensing control system selected.

Heat dissipation is kept to a minimum because body is made of castable refractory with highest insulating qualities.

Automatic or manual control. Muffle type and special models available.

Model SC-32  
 Temperatures to 2600° F.  
 7 KW, 120/1/60 VAC  
 Ceramic Tube 2½" O.D.x36"

For additional information, write today for free bulletin 206-5F3.

**DESPATCH**

OVEN CO.

Laboratory ovens	Burn-off ovens	Sterilizers	Drawer ovens
Pot-type furnaces	Box furnaces	Walk-in batch ovens	

©1960  
 DESPATCH OVEN CO. 619 S.E. 8th St., Minneapolis 14, Minn.

CIRCLE 204 ON READER SERVICE CARD

## ONLY THE LARGE IEE READOUT OFFERS ALL FOUR



Series 80000  
 PRICE COMPLETE  
**\$3300** QUANTITY PRICES ON REQUEST

Write today for complete specifications  
 Representatives in principal cities

Over 1000 firms throughout the world in just a few years prove unprecedented acceptance of IEE digital readouts.

**INDUSTRIAL ELECTRONIC ENGINEERS, Inc.**  
**IEE** 5528 VINELAND AVENUE  
 NORTH HOLLYWOOD, CALIFORNIA

1. ALL DIGITS CAN BE READ FROM ANY ANGLE

2. WORDS  
 May be displayed individually or simultaneously

3. COLOR  
 Colored digits or words and/or color background available

4. DISTANCE  
 Large 3¾" digit can be viewed from over 100 feet away

CIRCLE 83 ON READER SERVICE CARD

83

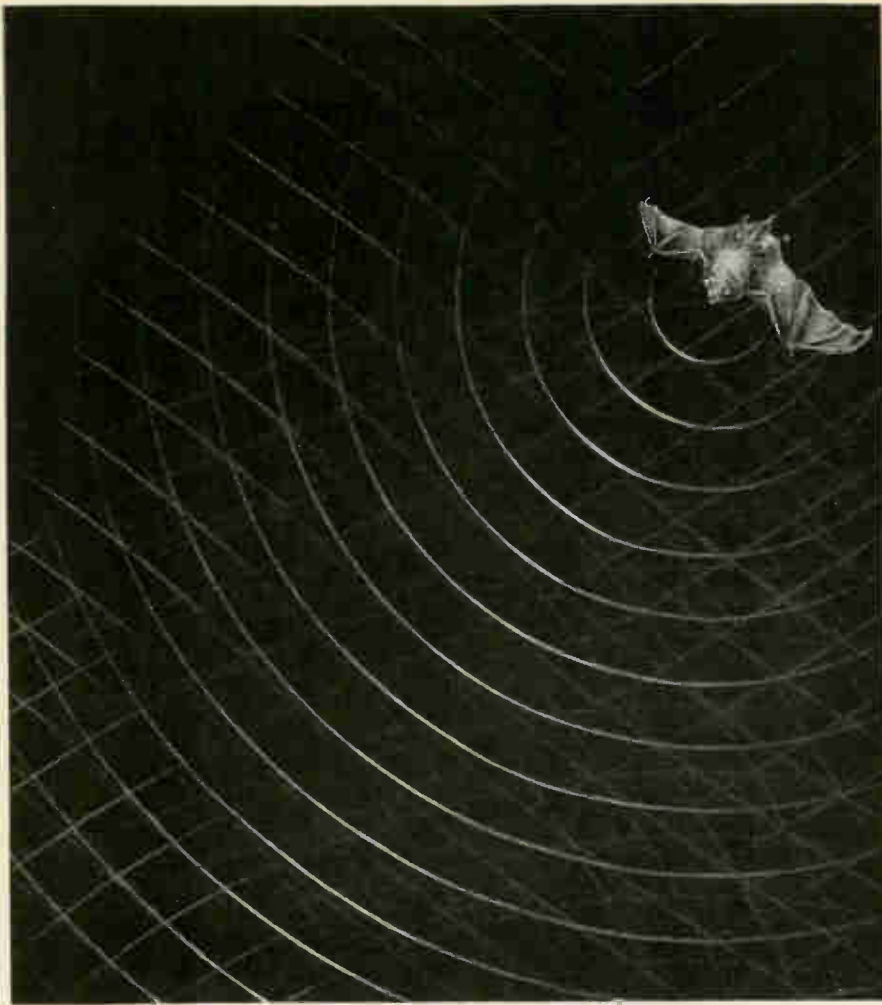

## how to capture a bat - underwater - with a PI tape recorder



To satisfy a yen for sea food, a particularly interesting member of the bat family catches fresh fish by reaching beneath the surface. In studying these bats, Harvard Professor Donald R. Griffin captures the bat's "radar" with a microphone in the air and a hydrophone in the water. The pulses of sound are recorded on alternate channels of a PI tape recorder, and played back at reduced speeds so that the original frequencies, 15 to 200 kilocycles, become audible.

In other studies, Professor Griffin has captured bat sounds in stereo. Using a pair of microphones located at different points, he has recorded and measured the arrival time of sound pulses to determine the bat's changing position with respect to the two microphones.

For capturing bat sounds and other dynamic phenomena for conversion to electrical form, PI recorders offer a number of distinct advantages over conventional instrumentation magnetic tape recorders. A brief note from you will capture the details.



**PRECISION INSTRUMENT COMPANY**  
1011 Commercial Street • San Carlos • California  
Phone LYtell 1-4441 • TWX: SCAR BEL 30

REPRESENTATIVES IN PRINCIPAL CITIES THROUGHOUT THE WORLD

age and does not lose stored information during readout or from power shutdown or failure.

A 1024-word prototype model has been operated at 0.6 microsecond cycle time with access time of 0.2 microsecond. The model and its memory core stack, drivers, switches, timing circuitry, and sense amplifiers have been successfully operated over wide temperature excursions. A 4096-word, 50-



bit tape loading unit is now under development.

A new instruction or an entirely new program can be written into the memory from a tape reader or other input devices. Writing information into the memory cores is by conventional coincident-current technique.

The memory has been developed by Air Arm Div. Westinghouse Electric Corp., P. O. Box 746, Baltimore 3, Md.

**CIRCLE 308 ON READER SERVICE CARD**



## Dual Mode Discriminator FREQUENCY STABILIZER

MICROWAVE dual mode discriminator has been developed for use as a sensing element in klystron frequency stabilization systems.

The discriminator will furnish

an error signal with approximately forty times the stability of the klystron alone. The signal is available over the entire range of the discriminator. Accuracy of the signal frequency depends on the calibration accuracy of the discriminator cavity but accuracies of 0.01 percent can be achieved.

Effect of stabilization in the range of 8,500 to 9,600 Mc is to reduce an inherent klystron signal variation of 0.6 to 0.2 Mc (a function of frequency) to variations of 15 to 30 Kc. The discriminator also provides a substantial reduction in hum and other rapid fluctuations normally present in the klystron signal; it reduces changes due to line voltage fluctuations to a negligible amount. Price range is \$1,200-\$1,400; delivery is 30 days; from Frequency Standards, P. O. Box 504, Asbury Park, N. J.

CIRCLE 309 ON READER SERVICE CARD

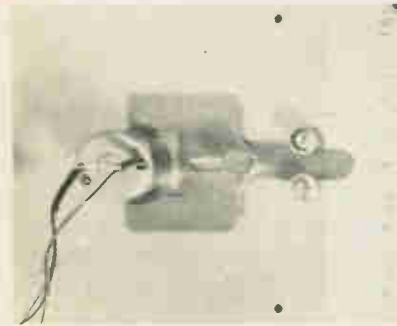

### Clamp Kits GUILLOTINE TYPE

ANGLER INDUSTRIES, Metuchen, N.J., announces a new series of guillotine type clamp kits. The clamp illustrated is made to hold servo-mount synchros, resolvers, potentiometers, etc., in position during test operations. It features all corrosion resistant materials for use under adverse environments. Included in kit are clamp, supports, guides, all necessary hardware and template for drilling mounting holes. Price is \$12.50 per kit.

CIRCLE 310 ON READER SERVICE CARD

### Isolator FIVE INCHES LONG

E&M LABORATORIES, P.O. Box 2427, Van Nuys Station, Van Nuys, Calif. Model X110LI isolator is only 5 in. in overall length. It provides a minimum isolation of 30 db with a

February 3, 1961

## NEW MINIATURE RF FILTERS

$\frac{1}{2}$  Space ..  
 $\frac{1}{2}$  Weight ..

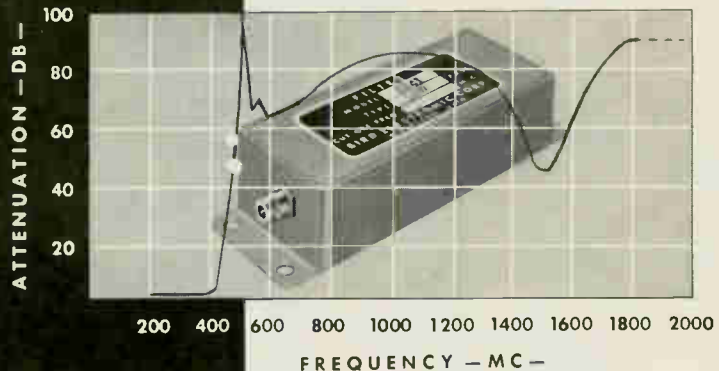
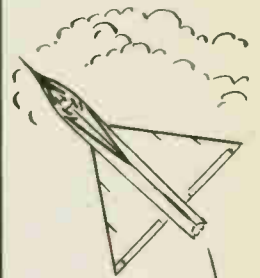

### Model 524

## DESIGNED TO REJECT INTERFERENCE IN "L" BAND

When size and weight are important factors in your rf filter selection, turn to Bird Electronic for your source of supply. Our engineers will design an rf filter to serve your exact requirements with particular attention to component density, accuracy, ease of application and long-life performance.

Our physical facilities to produce and deliver quantity orders dependably can be relied upon to meet your production schedules.

## SPECIFICATIONS

### Model 524I

SIZE: 4- $\frac{3}{4}$ " x  $\frac{3}{4}$ " x 1- $\frac{1}{4}$ "

WEIGHT: 5 ounces

PASS BAND: 225 to 400 mc

CUT-OFF FREQUENCY: 400 mc

POWER RATING: 50 watts

RF INPUT IMPEDANCE: 50-ohm nominal

ATTENUATION: Less than  $\frac{1}{2}$  in pass band; 80 db in stop band

VSWR: Insertion loss and VSWR are very low in pass band

CONNECTORS: Most miniature types



# BIRD

## ELECTRONIC CORP.

Churchill B-1200  
30303 Aurora Road, Cleveland 39, Ohio  
Western Representative:  
VAN GROOS COMPANY, Woodland Hills, Calif.

CIRCLE 85 ON READER SERVICE CARD

85

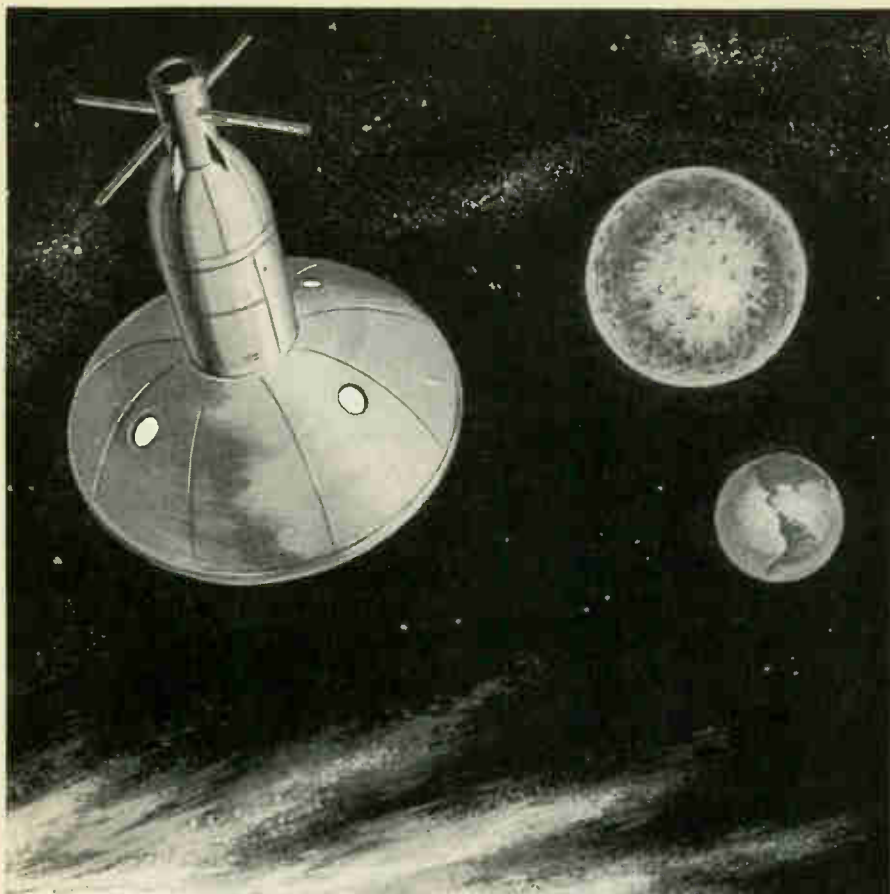

## Predict the sun's effect on space vehicles ... in your lab!

*B&L Optical/Electronic/Mechanical Capabilities  
Bring the Sun Into the Laboratory*

Interplanetary flight will expose our astronauts to direct radiation from the sun, and to direct and reflected radiation from the earth and clouds. To find the effects of this solar radiation on man and vehicles in outer space, Bausch & Lomb has designed a unique Sun Simulator System.

A special combination of lamps, filters, optical system and programmed control accurately simulates the intensity and distribution of these radiation wavelengths duplicating the conditions that exist in actual flight.

The same B&L skills are ready to help on *your* project. Write us for full details. Bausch & Lomb Incorporated,

Military Products Division,  
61414 Bausch Street,  
Rochester 2, New York.

**BAUSCH & LOMB**

SINCE  1853

maximum vswr of 1.10 and a maximum insertion loss of 1.0 db over the entire X-band frequency range, from 8,200 to 12,400 Mc. Price is \$175.

**CIRCLE 311 ON READER SERVICE CARD**



### Power Supply

**50-W MAXIMUM OUTPUT**

MAR-CONE CORP., 44 Winn St., Woburn, Mass. This supply is designed to power thermoelectric cooling modules. It is intended mainly for low-power laboratory experimentation. Output current is manually adjustable, monitored by front-panel meters. No built-in current regulation is included, however a relay switch for activation by an external thermostat is provided to facilitate feedback control. Currents up to 20 amperes can be obtained. Maximum power output is 50 w. Input power is 115 v, 60 cps.

**CIRCLE 312 ON READER SERVICE CARD**

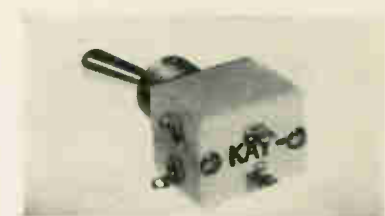

### R-F Switches

**TWO TYPES**

KAY ELECTRIC CO., 14 Maple Ave., Pine Brook, N.J., announces Mega-Switches with Teflon body and solid silver contacts. Their small size (2 in. by 1/2 in. by 1 1/2 in.), low internal resistance, induction and capacities adapt them to critical r-f switching applications. Their high current carrying capacity (in excess of 1,000 w) suggests many other uses in d-c and l-f applications. The switches provide stable operation over a wide range of temperature and humidity conditions,

*Colorado*  
...CENSUS-  
PROVEN  
OUTSTANDING  
NEW  
INDUSTRIAL  
MARKET



Census-proven one of the fastest growing states in the nation ...survey-proven one of the outstanding new industrial markets, Colorado offers new industry Profits with Pleasant Living.



Discover the new markets and opportunities awaiting your company in Colorado. "Site-See" Industrial Colorado now...right at your desk.

**Send for Free Executive Portfolio "INDUSTRIAL COLORADO"**

Newly revised 9-booklet portfolio with up-to-the-minute data on Colorado's industrial sites, assets, opportunities and weekend vacation wonderlands. All inquiries held confidential.

**COLORADO DEPT. OF DEVELOPMENT**  
20 STATE CAPITOL • DENVER 2, COLO  
CIRCLE 205 ON READER SERVICE CARD

## BEEDE-E-25

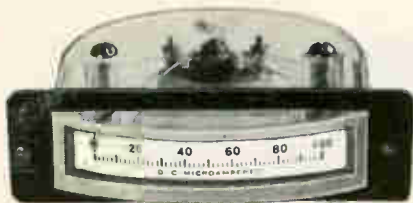

### EDGEWISE METER

... can be used in either Horizontal or Vertical position — may be paired for comparative reading

Conserves space where panel area is limited

**BEEDE**



**ELECTRICAL INSTRUMENT CO., INC.**

PENACOOK, N. H.

CIRCLE 206 ON READER SERVICE CARD  
February 3, 1961

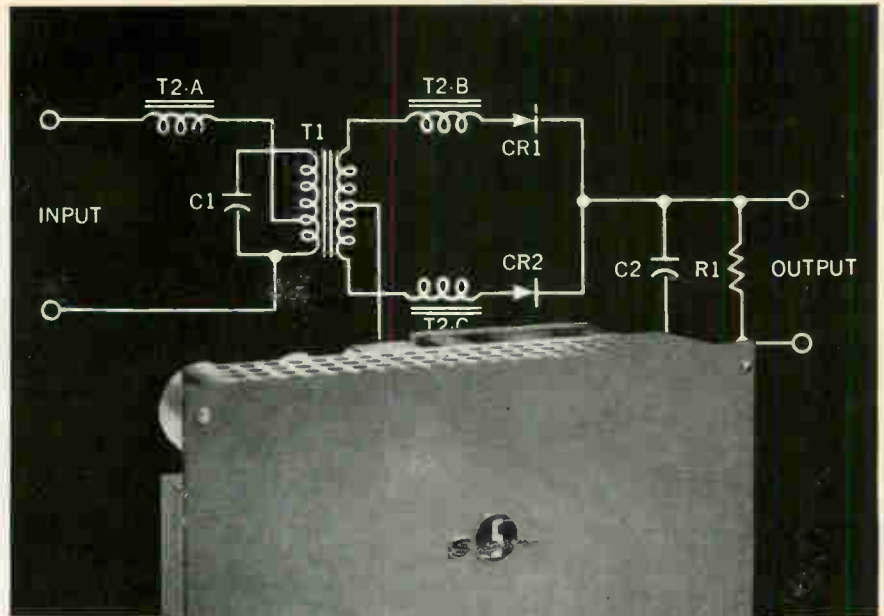

## MD simplicity means savings for you

Here's a line of d-c power supplies you can literally mount in your relay rack and forget . . . the ultimate in simplicity and reliability. It's Sorensen's MD series featuring rugged magnetic regulation, heavy-duty silicon rectifiers, conservative continuous-duty ratings for all components. Output voltage holds to  $\pm 1\%$  for input variations from 100 to 130 vac. 132 stock models from 3 to 1000 vdc output, 50 to 3000 watts (see table for just a few typical ratings). Several units may be used with paralleled outputs for increased capacity up to 9000 watts. Current limiting characteristics particularly suit MD's for battery charging and filament powering . . . can't be damaged by output shorts.

Write for complete MD data . . . Or, better, send for the new Sorensen catalog, listing over 400 power equipment models, plus the name of your Sorensen representative. Sorensen & Company, Richards Ave., South Norwalk, Conn.

### POPULAR MODELS AND PRICES

(Numbers preceding dash in model designation indicate output voltage; those following dash indicate maximum current.)

Model	50 watt	Price	Model	200 watt	Price	Model	750 watt	Price
MD 6.3-8.0		\$159	MD 6.3-31.8		\$257	MD 6.3-120		\$523
MD 12-4.2		145	MD 12-16.7		215	MD 12-62.5		423
MD 28-1.8		137	MD 28-7.2		184	MD 28-26.8		336
MD 48-1.1		131	MD 48-4.2		179	MD 48-15.7		315
100 watt			400 watt			1500 watt		
MD 6.3-15.9		\$194	MD 6.3-63.5		\$348	MD 6.3-239		\$921
MD 12-8.4		171	MD 12-33.3		292	MD 12-125		735
MD 28-3.6		158	MD 28-14.3		247	MD 28-53.6		567
MD 48-2.1		152	MD 48-8.4		231	MD 48-31.3		525

O.33



**CONTROLLED  
POWER  
PRODUCTS**

A SUBSIDIARY OF RAYTHEON COMPANY

... THE WIDEST LINE MEANS THE WISEST CHOICE

CIRCLE 87 ON READER SERVICE CARD 87

# 3-IN-ONE AMCO ENCLOSURE SYSTEM

**Provides Cooling, Mounting and Lighting in Modular Enclosures for Electronic Instruments in Any Installation**

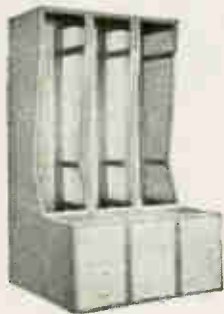

Aluminum



Semi-Custom



Custom

No one type of enclosure meets all environmental and physical demands. AMCO has developed 3 complete systems integrated into 1 system with interchangeable accessories, applicable for both commercial and military use.

**CUSTOM . . . When space and appearance are critical . . .** 16 ga. double-channel steel frames, based on increments of 19<sup>1</sup>/<sub>16</sub>" widths, supports in excess of 3000 lbs. Multi-width panels and cowlings give single-unit appearance with series mounted racks. Meets EIA Standards.

**SEMI-CUSTOM . . . Heavy-duty, more internal clearance . . .** 14 ga. box-channel steel frames, 12 ga. gusseting provides exceptional rigidity both front-to-back and side-to-side. Frames based on 22<sup>1</sup>/<sub>16</sub>" increments provides clearance for recessing 19" wide panels. Meets EIA Standards.

**ALUMINUM . . . Unique! Meets any size . . .** almost any configuration from 6 basic parts . . . 3 castings and 3 extrusions. Any size from 6" to 20 ft.; any slope from 0° to 90° is standard. Mil Specs strength and material (6061-T6 extrusions and 356-T6 castings).

Amco manufactures all necessary blowers, chassis slides, doors and drawers, writing surfaces, cowlings lights and other accessories. **Check the extra savings you get thru Amco's combined-discount system of racks and accessories. PLUS FREE ASSEMBLY.**

Amco is your one complete source of Modular Instrument Enclosure Systems and Accessories. Write today for catalog of complete specifications.



REALISTIC 3 WEEK DELIVERY

Factory trained representatives in principal cities of U.S. and in Canada.



**AMCO ENGINEERING CO.**

7333 West Ainslie Street, Chicago 31, Illinois

with extremely high leakage resistance. Two types are available. The 254-TX is a dpdt unit. Type 254-T is a dpdt unit with coin silver internal shorting strap, designed for attenuator applications.

CIRCLE 316 ON READER SERVICE CARD

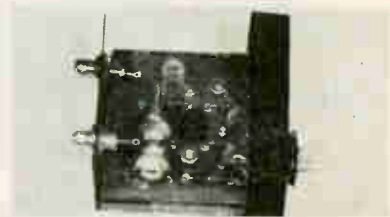

## I-F Amplifiers

MODULAR TYPE

ORION ELECTRONIC CORP., 108 Columbus Ave., Tuckahoe, N.Y. Transistor modular amplifiers have a gain of 10 db at 30, 45, and 60 Mc, and an input and output impedance of 50 ohms. Units can be supplied with 5, 25, 75, or 300 mw capability. The 5 mw modular unit can be age'd over most of its power range. Amplifier has a bandwidth of 6 Mc. The modules operate off a 28 v ± 2 v positive d-c source and have a current requirement of 2 to 40 ma depending upon the output power of the unit.

CIRCLE 317 ON READER SERVICE CARD



## Ventilating Unit

MORE AIR UP FRONT

KOOLTRONIC FAN CO., P. O. Box 504, Princeton, N. J. The KP701 19 in. rack-mounting packaged ventilating unit delivers 350 cfm of filtered air from large twin blowers but uses only 7 in. of panel space. For more effective cooling of hot tubes or assemblies of p-c cards toward the front of a chassis, a new design principle results in air discharge from the top of the unit over almost its entire depth of 8<sup>1</sup>/<sub>2</sub> in. Powered by a ball bearing permanent split capacitor motor with low temperature rise, further insurance of cool operation under continuous duty is secured by a feature of internal

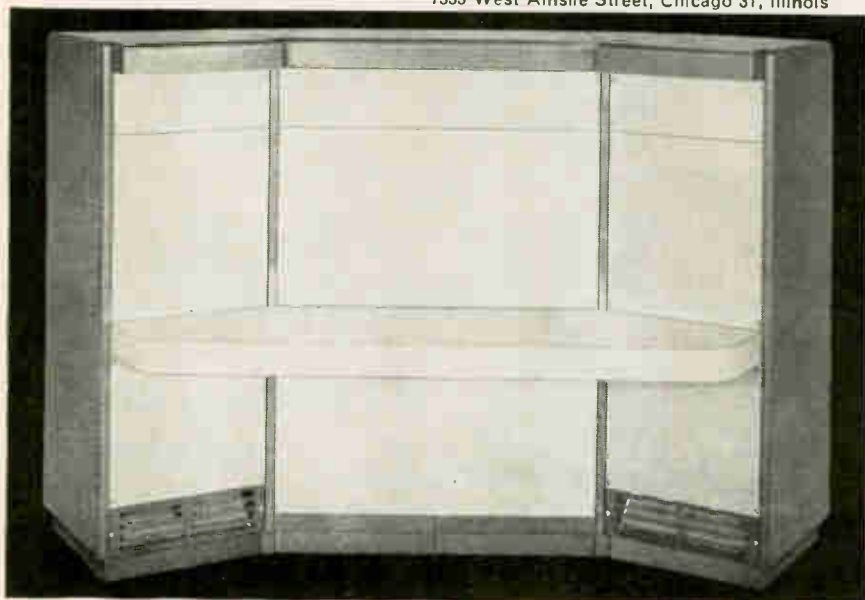



Plot your lumped constant delay line needs  
on these charts!

## TIC DELAY LINES

FEATURE:

- HIGHER RELIABILITY
- LOWER ATTENUATION

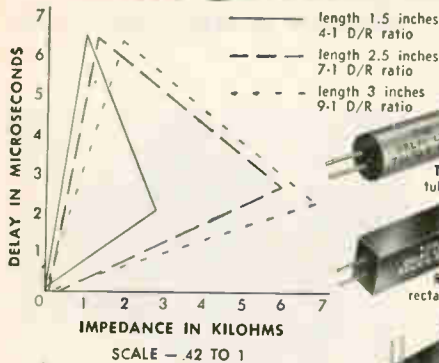

TIC's lumped constant delay lines are available in three standard configurations, TDL (tubular), RDL (rectangular), PCL (printed circuit), PDL series (are made to customer specifications). They feature a higher delay to rise time ratio per cubic inch than is available with conventional techniques. Every TIC Delay Line is hermetically sealed and complies with applicable MIL specs. TIC Delay Lines are M derived, phase and frequency compensated with excellent pulse response characteristics and exceptionally low attenuation. Standard lead lengths of RDL and TDL units is 2". The PCL lead length is 3/4".

If the intersecting lines of your plot are within either of the graphs TIC standard type in any configuration is your answer. For other specifications PDL type provides Delay time to 500 microseconds, Impedance 25 to 10,000 ohms, Delay to Rise ratios to 150-1.

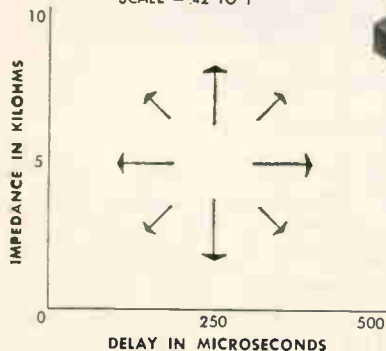

**TECHNOLOGY INSTRUMENT CORP. OF CALIFORNIA**

850 LAWRENCE DRIVE, NEWBURY PARK, CALIFORNIA • HUdson 5-2165

Western Sales Office, Beverly Hills, California, Oleander 5-7661

CIRCLE 207 ON READER SERVICE CARD

## HOW FAST CAN YOU TEST Circuit Design Reliability?

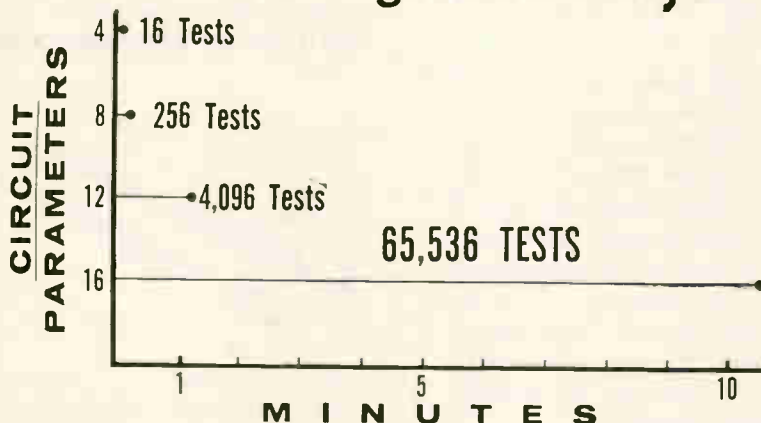

Yes, you can test all combinations of high and low values of as many as 16 circuit parameters in less than 11 minutes!

Write today for informative 8-page Brochure.



**AIRBORNE  
INSTRUMENTS  
LABORATORY**

DEER PARK, LONG ISLAND, NEW YORK  
A DIVISION  
OF CUTLER-HAMMER, INC.



TYPE  
90  
Circuit Design  
Reliability Tester

PRICE:  
\$3600.

CIRCLE 208 ON READER SERVICE CARD

make better parts  
faster, easier, cheaper...  
**FROM TUBING**



A manufacturer of RF connectors was machining contact fingers from Beryllium-copper bar stock on automatic screw machines. This required turning to exact O.D. and drilling to specified I. D. Nature of the material required constant sharpening of cutting tools.

Parts half done to start

Then they switched to Uniform Beryllium-Copper Tubing, drawn to precision I.D. and O.D. specifications—and the "parts were half done to start." Twenty seconds per piece were saved in actual fabrication time, plus the time formerly required for excessive tool maintenance and machine downtime for their replacement.

The Beryllium-copper tubing, costing about 15% less than the bar stock, added further economy to overall part production.

It Pays

Why don't you cut costs by switching to tubing for your precision tubular parts? It pays.

Uniform's fine, seamless tubing is available in many alloys of aluminum, copper, nickel, steel and the precious metals. Sizes range from .010" to .625" O.D. Wall thicknesses down to .001 (.0005 on special order). Tolerances down to .00025.

Write For Catalog

Ask also about our complete fabrication service and the advantages of having your parts produced "at the mill" by tubing specialists.



**UNIFORM TUBES,  
INC.** COLLEGEVILLE 2, PA.

HUxley 9-7276 TWX-CGVL 1044

CIRCLE 91 ON READER SERVICE CARD 91

if  
 all you have  
 for a relay  
 is a sudden  
 impulse...



An impulse relay—one that when pulsed will turn something on and leave it on and when identically pulsed again will turn the load off and leave it off—is nothing new. For years you've been able to buy them, complete with ratchets, pawls, escapements, walking beams, lock-in mechanisms, etc., in a regular commercial quality grade. Sequencing and stepping relays are the more educated relatives in the family.

But in the recent trend of getting more things up in the air, and generally getting more and more out of smaller and smaller relays for practically no power and under unpleasant conditions, the standard commercial impulse relay has often gotten dirty looks. Generally, it wouldn't hold together under the vibration or shock levels, and its size and relatively short life further complicated things.

Naturally, Sigma now has an impulse relay with none of the above drawbacks (mostly because it has none of the above mechanical mechanisms). SPDT contacts will switch 2 amp. resistive loads



(28 VDC/120 VAC) 200,000 times; mechanical life with no contact load is 4 million operations. It works on positive DC pulses as short as 1 millisecond, at speeds up to 10 pps. For the space, weight and power pinchers, this new hermetically sealed relay takes up 1" x 1" x 1 1/4", weighs about 2 1/4 ounces and transfers its contacts on as little as 250 microjoules (e.g., 250 mw. for 1 ms.). Vibration immunity is in the order of 30 g's to 2000 cycles, operating temperature -65° to +125°C. About the only caution is that you've got to feed it pulses of the same polarity.

We're building this little marvel and even have a few anxious customers. People who build telemetering equipment, satellites, and perhaps computers as well, are the Sales Dept's. great white hope. If you like binary counting schemes and such, think of the possibilities if you hooked up several in sequence. And with a small roulette wheel and an acquisitive impulse, one might do handsomely, mightn't one?

# SIGMA

SIGMA INSTRUMENTS, INC.  
 62 Pearl Street, So. Braintree 85, Mass.

AN AFFILIATE OF THE FISHER-PIERCE CO

construction which moves some of the blower air over the motor windings and bearings. Motor is rated at 1.3 amp.

CIRCLE 318 ON READER SERVICE CARD

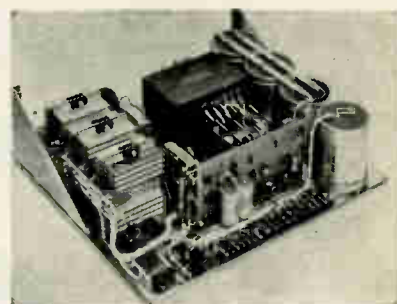

## Power Supplies MODULAR TYPE

INVAR ELECTRONICS CORP., 323 W. Washington Blvd., Pasadena, Calif., has available a line of 45 fully-transistorized, regulated, d-c power supply modules. Units are manufactured in 9 voltage ranges, from 1 to 37 v, and in 5 power ranges, from 0.7 to 15 amperes. All models offer 15 mv maximum line and load regulation, 2 mv maximum ripple, and overload and short-circuit protection. The modules can be operated in series or parallel without modification, and terminals are provided for remote sensing. These units are rated for operation to 50C and are constructed for use as integral modules or for mounting directly on 5 1/2 in. panels.

CIRCLE 319 ON READER SERVICE CARD



## Coaxial Loads PLUG OR JACK STYLE

RADAR DESIGN CORP., Pickard Drive, Syracuse 11, N. Y. Model RDL-6LT (plug or jack style) coaxial load has specified vswr of 1.05 max 1,500 to 6,000 Mc. Typical vswr does not exceed 1.03. The plug type features a slip nut permitting visual inspection of contact with next assemblies. Price and delivery: \$125 each, and stock.

CIRCLE 320 ON READER SERVICE CARD

Complete **LACING CORD** line

designed by

**Electronic  
Specialists**

for

**ELECTRONICS**



Available for immediate delivery from your local Alpha Wire electronic parts distributor. Write for free Catalog I-59.

Who knows better about lacing cord than the leader who has been designing and manufacturing electronic wire and custom cables for 38 years?

- round cords and flat-braided tapes
- nylon, dacron and teflon-fiberglass
- finishes: micro-crystalline wax, synthetic rubber-like resin, teflon resin, synthetic rubber
- meets industrial specifications and MIL-T-713A
- each spool individually packaged in boxes



**ALPHA WIRE CORPORATION** subsidiary of **LORAL Electronics Corporation**  
200 Varick Street, New York 14, N. Y.  
Pacific Division: 1871 So. Orange Dr., Los Angeles 19, Calif.

CIRCLE 209 ON READER SERVICE CARD

**Environmental  
conditioning**

for

**missile**

**guidance**

**systems**



**AiResearch Gyro Conditioners** for the U.S. Army Sergeant missile are the most complete and efficient systems of their type.

The 8 lb. package, consisting of heat exchanger, heater, thermal switches and three fans, maintains a hermetic atmosphere of 85°F. to 160°F. in an outside ambient temperature of -20°F. to 140°F. Even temperature levels throughout the electronic compartment are maintained by an internal fan and low velocity air movement.

AiResearch is the leading designer of such advanced electronic conditioning equipment and systems, and this production unit is but one example of many produced for missile and ground support applications.

When fast attention to your problem, high reliability and small unit size and weight are important, contact AiResearch first.

Environmental conditioning equipment has been produced for the following electronic systems:  
**Detection • Communication • Control • Ground Support • Guidance**

Write for literature today.



**AiResearch Manufacturing Division**

Los Angeles 45, California

CIRCLE 93 ON READER SERVICE CARD 93

Old Fashioned?

See what **Ungar** does to soldering tools next month!

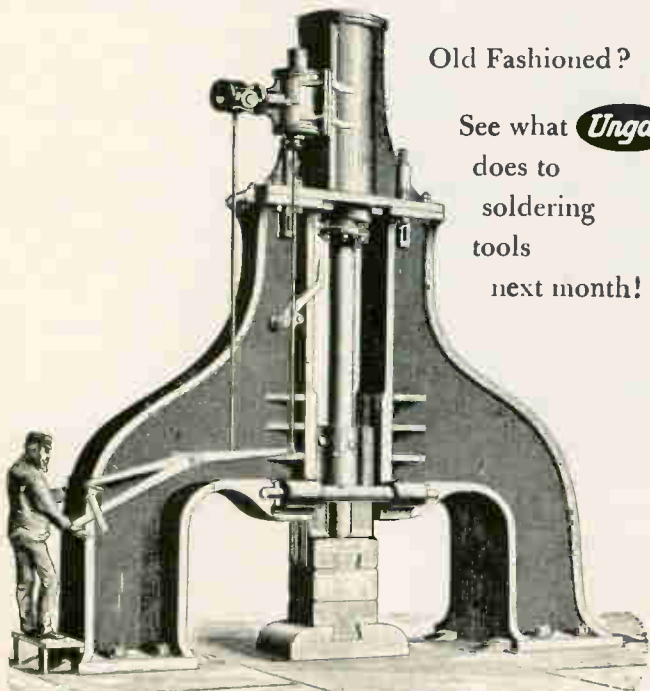

Large-size Steam Hammer • B. & S. Massey  
Manchester, England • Circa 1885

CIRCLE 210 ON READER SERVICE CARD

# IMMEDIATE DELIVERY OF ALL TYPES

BY THE LEADER FOR OVER 10 YEARS

## GEN-PRO®

# NAVY TERMINAL BOARDS

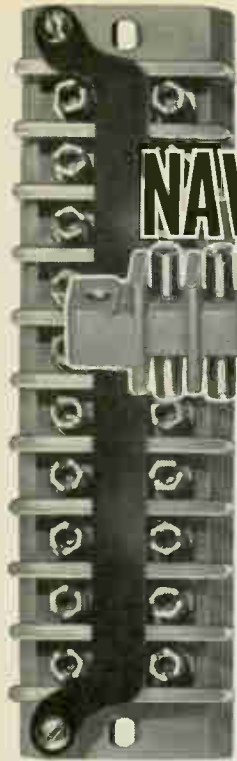

Solid Block 17TB10

Gen-Pro military terminal boards are manufactured and inspected in accordance with latest revision of MIL-T-167B4, BuShips Dwg. 9000-S6505-B-73214 and BuOrd Dwg. 564101. Molding compound, per MIL-M-14E assures low dielectric loss, high insulation resistance, high impact strength.

### NEW MINIATURE TYPES NOW AVAILABLE

Gen-Pro miniature type military terminal boards conform with Bu Ships Dwg 9000-S6505-B-73214 and other applicable specifications.

WRITE today for new catalog with illustrations & specifications

Miniature 26TB10

Feed-Thru Terminal Block 7TB12



## GENERAL PRODUCTS CORPORATION

Over 25 Years of Quality Molding

UNION SPRINGS, NEW YORK TWX No. 169

CIRCLE 211 ON READER SERVICE CARD

## YOURS TODAY—

A frequency standard so accurate that it measures time with a rate of change of less than one second in sixty years!

# 5 x 10<sup>-10</sup>/DAY



Total Dimensions, Standard and Power Supply: 7½" W x 6" H x 12½" D. Shown mounted in 7" x 19" rack panel.

**THE JK-SULZER FS-1100T FREQUENCY STANDARD** is a standard of frequency and time . . . born of and for the age of space. It is fully transistorized. A double proportional control oven houses a 1 mc precision quartz crystal having a Q exceeding 2 million. Each unit is built, aged, and calibrated at Washington, D.C., against groundwave signals of WWV. Simultaneous outputs of 1.0 mc and 100 kc. A companion power supply permits operation from 115 volt AC plus automatic 12 hours minimum of emergency or portable operation from batteries. Today, you can order this 5 x 10<sup>-10</sup>/Day stability, for early delivery, for a wide range of research and test applications. Write for technical literature.

**The James Knights Company, Sandwich, Illinois**

SPECIALISTS IN FREQUENCY MANAGEMENT for space exploration programming, high speed navigation, and spectrum conservation in the growing communications field.

94 CIRCLE 94 ON READER SERVICE CARD

## Literature of

**GOLD ALLOY PREFORMS** Accurate Specialties Co., Inc., 345 Lodi St., Hackensack, N. J. Technical bulletin Z-108 describing gold alloy preforms for use in semiconductor processing is now available.

CIRCLE 321 ON READER SERVICE CARD

**VOLTMETER** Hewlett-Packard Co., 1051 Page Mill Road, Palo Alto, Calif. Catalog gives specifications and technical data on voltmeter 411A.

CIRCLE 322 ON READER SERVICE CARD

**SPECIALTY VACUUM TUBES** Stewart Engineering Corp., Santa Cruz, Calif. Six-page brochure gives a profile of the company's facilities with emphasis on its capabilities in the research, development, and manufacture of specialty vacuum tubes.

CIRCLE 323 ON READER SERVICE CARD

**PRECISION CONNECTORS** Continental Connector Corp., Woodside 77, Long Island, N.Y. Form CC-860 is an 8-page brochure illustrating and describing a line of precision connectors for missile, aircraft, computer and communication applications.

CIRCLE 324 ON READER SERVICE CARD

**POWER INVERTERS** Arnold Magnetics Corp., 6050 W. Jefferson Blvd., Los Angeles 16, Calif. A two-page price sheet gives specifications and pricing information for 100 types of small-size, solid-state power inverters.

CIRCLE 325 ON READER SERVICE CARD

**SOLID STATE CHOPPERS** Solid State Electronics Co., 15321 Rayen St., Sepulveda, Calif., provides a comparative data profile for sixteen microminiature chopper models. Germanium, silicon, high voltage, and d-c driven units are covered.

CIRCLE 326 ON READER SERVICE CARD

**ANTENNA PATTERN MEASUREMENTS** Weinchel Engineering, Kensington, Maryland, has released a 12 page bulletin which describes and illustrates applications of microwave antenna pat-





## Motorola Moves Headquarters

MOTOROLA, INC., Chicago, Ill., recently announced that its move of the company's corporate headquarters to a new administration building in Franklin Park, Ill., is nearing completion.

The new \$7½-million structure (photo) brings together all of the company's corporate executive offices, plus the consumer and automotive products divisions with their respective engineering, developmental and research facilities.

The addition to the existing Franklin Park manufacturing complex completes Motorola's largest single facility in the United States, says Robert W. Galvin, president.

"The new administration building is indicative of the company's planned expansion and growth. It was designed not only to handle our present requirements, but to keep pace with systematic expansion in the future," Galvin said.

The five-story structure encompasses a total area of 327,148 sq ft and has provisions for the addition of a lightweight sixth floor which would increase the usable area 52,000 sq ft.

The building's more than 300 offices are built basically of some 15,000 linear feet of movable metal partitions which can be changed at very little cost to make office arrangements virtually obsolescence proof. Business machines are mounted on a special "floating floor" so their locations can be easily shifted without costly building changes.

Communications are handled by

an expandable five-position telephone switchboard, which is supplemented by Motorola's own "pocket paging" system that supplants the conventional methods of loudspeaker paging.

The system permits private paging of any individual carrying a small pocket receiver, no matter where he is on the premises. A Conelrad Civil Defense system is also available.

The new administration building houses most of the personnel formerly located in the main Chicago building, plus complementary departments from other Motorola plants in the area. The evacuated building will be used to house the company's expanding communications division and Motorola International, S.A.



Name Frank Gunther  
REL President

ELECTION of Frank A. Gunther as president of Radio Engineering Laboratories Inc., Long Island City, N. Y., communications subsidiary

of Dynamics Corp. of America and a leading producer of tropospheric scatter radio equipment, has been announced. He had been executive vice president and general manager of REL since July 1959.

A 35-year veteran with REL, Gunther joined the company in 1925, became a vice president in 1929 and has served in virtually every department and capacity.



General Electric  
Names Wooley

ROBERT L. WOOLEY has been named manager-engineering operation at the General Electric Light Military Electronics Department's armament and control section in Johnson City, N. Y. He was formerly manager of the section's advance engineering component in Schenectady.

## RCA Assigns Toyzer To New Florida Plant

JOSEPH TOYZER, formerly plant manager for RCA facilities at Findlay, O., and Indianapolis, Ind., has been named manager of manufacturing engineering for a new computer production center being completed by the corporation at Palm Beach Gardens, Fla.

The new plant is being constructed for the manufacture of the RCA301, a low-cost electronic data processing system designed for the smaller business firms.

## IMC Magnetics Advances Dale Dowis

DALE DOWIS has been named to fill the newly created position of chief

A BETTER WAY—CREATED BY NCR

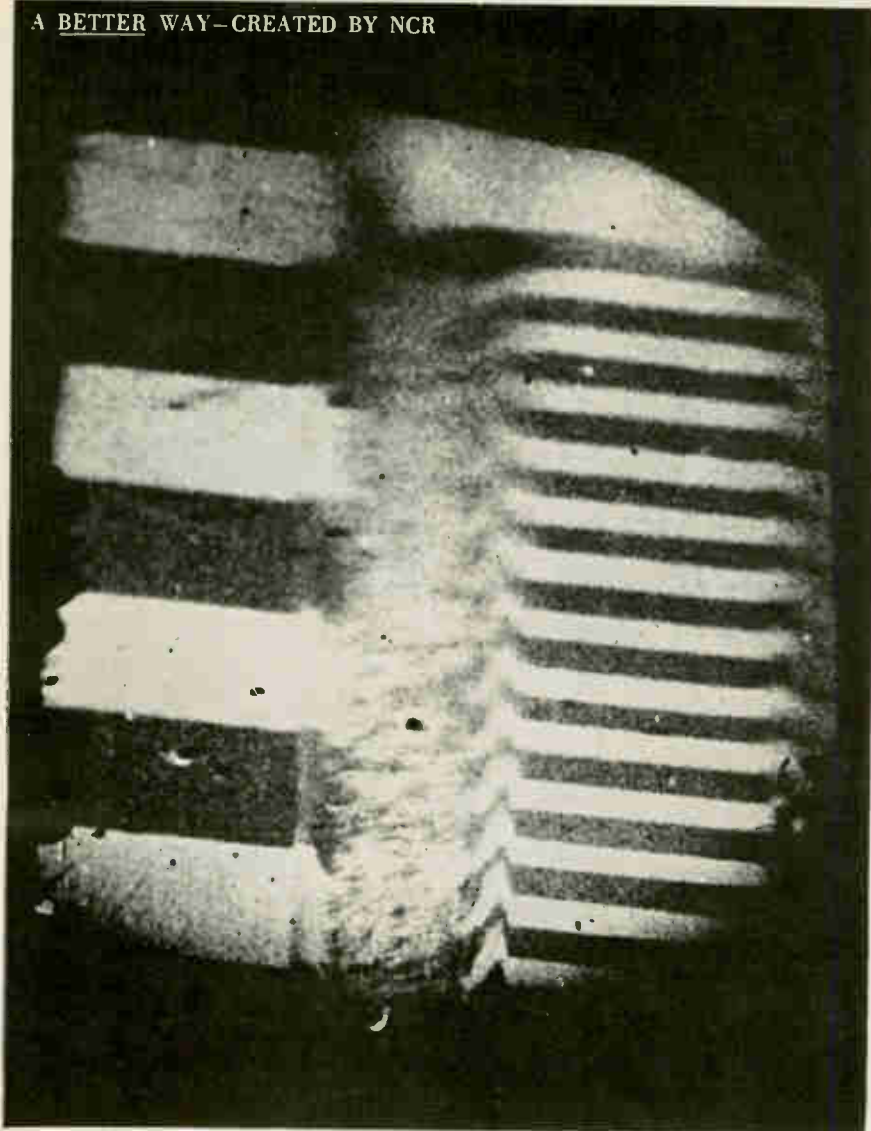

Photomicrograph of magnetically recorded pattern, taken with polarized light, compares readout capability of present systems (left) and NCR MAGOP unit (right).

## Engineering Problem: Increase Digital Readout Capability 2500%

The big problem in achieving higher storage densities in magnetic disc or drum memories is not one of getting information in, but one of reading it out.

Although impressive densities have been attained in the laboratory, present magnetic readout devices are incapable of resolving the recorded data. Separation between the reading head and the data surface results in increased loss, while contact between head and surface usually causes serious wear.

Sidestepping the apparent dilemma, NCR Electronics Division engineers have created MAGOP, a developmental system that reads magnetic data optically. In MAGOP, a beam of plane-polarized light responds to the surface magnetization of the disc or drum,

enabling the system to read out five times as much linear information (25 times as much per area) as present magnetic equipment.

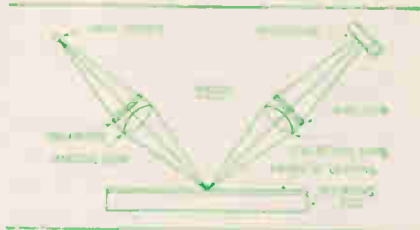

Like most NCR projects, MAGOP involves a combination of scientific disciplines. To the man of extraordinary capabilities—the man who is not content to think in narrow channels—the Electronics Division offers unusual professional and personal rewards.

## DIGITAL COMPUTER ENGINEERS— COMMERCIAL EXPANSION AT NCR CREATES OPENINGS IN LOS ANGELES FOR:

### COMPUTER ENGINEERS

Seniors & Intermediates

Experienced graduate E.E.'s with 3 to 5 years in logic design and transistorized circuit design of digital equipment. Assignments will entail logic and circuit design of buffer storage units and digital peripheral equipment.

### TRANSISTOR CIRCUIT ENGINEERS

Seniors & Intermediates

Highly creative positions are available in circuit analysis and design. Duties include: advanced mathematical studies in transistor circuitry, evaluation of transistor circuitry, component studies and keeping abreast of computer circuit advances. Circuit analysis ability and solid understanding of transistor theory essential. E.E. degree required.

### PRODUCT ENGINEERS

Seniors & Intermediates

Assignments entail design analysis and technical liaison to develop a producible product; establishment of design requirements from a standpoint of cost, product ability and standardization; recommendation of changes for ease of manufacture. Positions require substantial knowledge of manufacturing methods, practices, shop equipment and facilities; solid background in electronic design of digital equipment; E.E. degree.

### SYSTEMS ENGINEER

Experience required in formulating functional design specifications for digital computer systems (buffer storage, punch card, paper tape, magnetic tape, random access devices, system organizations, command structures). Training in logical design, data-handling methods and programming techniques desirable. Assignments entail formulating functional specifications for business computers.

### SYSTEMS TEST ENGINEERS

A responsible position entailing co-ordination of scheduling and utilization of both unit and systems test programs. Originate and analyze test requirements; supervise testing and analysis; recommend changes in design specifications and requirements. Determine validity of test data. Requires E.E. degree plus good knowledge of mechanical engineering, instrumentation, and design engineering.

### TRANSISTOR POWER

SUPPLY ENGINEER

For assignment in specifying power supplies for both large and small digital systems, supervising the design of supplies internally or by vendors, and evaluating supplies to determine conformance to specifications. Requires knowledge and design experience in solid state computer power supplies, their specification, and associated transistor circuitry. Requires experienced graduate E.E. or man with formal training and appreciable practical transistor power supply experience.

Please submit resume to  
Norval E. Powell, Personnel Manager

**National\***

The National Cash Register Company  
ELECTRONICS DIVISION  
1401 E. El Segundo Blvd.  
Hawthorne (Los Angeles), California  
PL. 7-1811

\*TRADEMARKS REG. PAT. OFF.

# HIGHEST PURITY PRECISELY DEFINED

to meet critical  
electronic manufacturing  
needs

## J. T. Baker ELECTRONIC CHEMICALS

'Baker Analyzed' Reagents

SEMI-CONDUCTOR CHEMICALS



FERRITE AND  
THERMISTOR CHEMICALS

EMISSION CHEMICALS

J. T. Baker electronic chemicals offer you the highest standards of purity in the industry—proved by the Actual Lot Analysis and Actual Lot Assay on the label. Your variables are minimized... rejections are fewer... product performance is improved.

IMPORTANT. 'Baker Analyzed' Reagents have consistently met or exceeded the requirements of the electronics industry. Through a continuing program of establishing additional and more stringent specifications, the 'Baker Analyzed' label consistently defines a degree of purity so high that special electronic labeling is unnecessary.

### YOURS FOR THE ASKING—

Important Guide to Electronic Chemicals

Describes J. T. Baker chemicals of exceptional purity for semi-conductors, vacuum tubes, ferrites, thermistors, etc. Also includes specification sheets that define the high standards for 'Baker Analyzed' Reagents. Write for your copy today.



**J. T. Baker Chemical Co.**

Phillipsburg, New Jersey

application engineer at IMC Magnetics Corp., Western Division, Maywood, Calif.

Having joined the company in 1953, Dowis served in various engineering capacities within both the synchro and solenoid departments of the division.



### Radiation Dynamics Appoints Thompson

RADIATION DYNAMICS, INC., Westbury, N. Y., designer and manufacturer of the Dynamitron accelerator, has announced the appointment of Chester C. Thompson as chief electronics engineer. Since 1948 he has been employed in the defense electronics division of the General Electric Co.

### Kollsman Instrument Hires Theodore Boxer

THEODORE BOXER has joined Kollsman Instrument Corp., Elmhurst, N. Y., as manager of special projects in the company's engineering division.

Prior to joining Kollsman, Boxer was director of the ordnance laboratory at W. L. Maxson Co.

### Sylvania Advances Frank Bower

APPOINTMENT of Frank H. Bower to the newly-created post of manager of research and development contracts for the semiconductor division of Sylvania Electric Products Inc., Woburn, Mass., has been announced. In his new position, he is responsible for negotiations, bids and other activities relating to R&D contracts with government agencies and contractors. He continues to coordinate the administrative ac-

# DYNASERT

**COMPONENT  
INSERTING  
for More Uniform  
PW Boards**



You can't beat the quick, precise, feeding, trimming, bending of lead, inserting, and clinching operation in one single stroke of the Dynasert machine. Boards are neater, more dependable, easier to solder tightly. Damage to component body is eliminated. Handle all axial lead components up to 10 times faster. Simplifies operator training. Write for descriptive 12 page booklet.

**United**

UNITED SHOE MACHINERY CORPORATION  
140 Federal Street, Boston, Mass.

CIRCLE 212 ON READER SERVICE CARD

# DYNASERT

**Increase  
Hourly Output  
up to 10 Times Over  
Hand Inserting**



If you insert only a few hundred components a week, Dynasert component inserting machines should be considered. Big or small boards, long or short runs, Dynasert handles all.

Automatically feeds, trims, bends leads, inserts component, and clinches with uniform results. Little operator training. Highly engineered single or multi-stage production machines available. Write for descriptive 12 page booklet.

**United**

UNITED SHOE MACHINERY CORPORATION  
140 Federal Street, Boston, Mass.

CIRCLE 213 ON READER SERVICE CARD



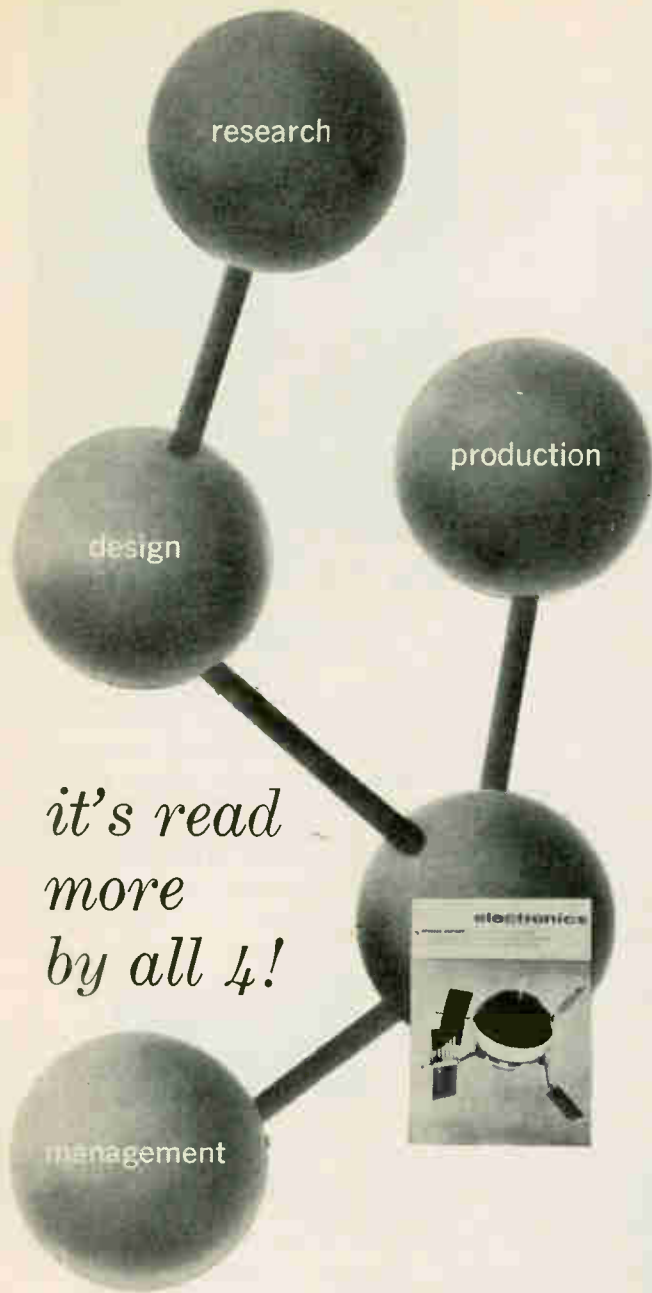

**electronics** is specially edited to keep you informed about the entire industry. With special issues on Electronic Markets, Modern Microwaves, Search and Probe Systems, and other reports you'll want to file and keep

*subscribe today to* **electronics**

Every Friday, **electronics** gives you the latest engineering developments and technically interpreted market trends. So don't wait till everyone on the routing slip has read it. Subscribe now and read **electronics** first. Mail the reader service card (postpaid) to **electronics**, the magazine that helps you to know and to grow! Rates: three years for \$12, one year for \$6; Canadian, one year for \$10; foreign, one year for \$20. Annual **electronics** BUYERS' GUIDE (single issue price \$3.00) included with every subscription.

February 3, 1961

## NEW **M**ethode "FORK" CONTACTS

completely interchangeable with  
available types  
with FULL RADIUSED CONTACTS  
for smoother mating



### IMMEDIATE DELIVERY!

Available in three different styles: for mounting upright printed circuit panel, parallel to printed circuit panel or for 45 angular mating. Fabricated from spring tempered phosphor bronze, finished with gold plating.

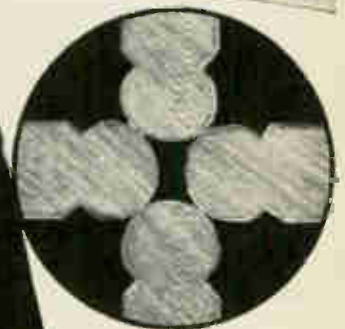

Microphotographic  
view of Methode  
Printed Circuit  
"FORK" CONTACTS

Available in bulk or on disposable plastic strips to users of specified dimensions for easy mounting.



Enlarged view

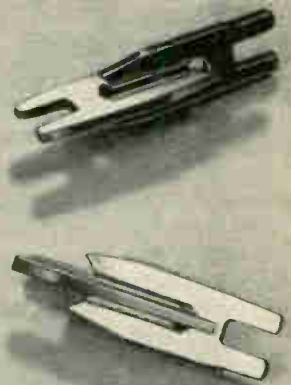

*Applications are limitless as determined  
by your design, ingenuity and needs.  
We invite your inquiry.*

SAMPLES and detailed literature are available.



**M**ethode  
manufacturing corp.

7447 W. Wilson Ave. • Chicago 31, Ill.

Special  
styles  
can be  
too'ed  
upon  
request.

CIRCLE 99 ON READER SERVICE CARD

99

*Here's a simple,  
portable sound  
analyzer*



### THE ALLISON 532 OCTAVE BAND ANALYZER

The Allison 532 is a small, light weight instrument that is exceedingly easy to operate. It separates sound into frequency components for analysis. The 532 is suitable for use with sound level meters, tape recorders, microphone preamplifiers and similar equipment. For complete information, write for Technical Bulletin #532.

#### 532 SPECIFICATIONS

- Five 10 db step attenuator
- Dynamic range of 66 db
- Eight bands with passive network
- Transistorized and battery operated
- Approximate shelf life for battery
- 33 db per octave attenuation rate with flat pass band
- Input level adjustable—nominally 1 volt
- Cutoff frequencies conform to ASA S-1.6-1960 Preferred Frequencies
- Meter circuit meets ASA Standard for S.L.M.S.
- Weight 6.5 lbs; 6<sup>3</sup>/<sub>4</sub>"x6<sup>3</sup>/<sub>4</sub>"x5<sup>1</sup>/<sub>2</sub>"
- Price \$425.00  
F.O.B. factory

Write for new catalog  
of Allison Analyzing  
Instruments



*Proved  
dependable  
in years of service*

**Allison  
Laboratories, Inc.**

11301 OCEAN AVENUE  
LA HABRA, CALIFORNIA

tivities of the division's general engineering department.

Bower has been engineering administrator for the division since joining Sylvania a year ago.



### John Hastings Joins Canoga Staff

JOHN P. HASTINGS has joined the staff of Canoga Electronics Corp., Van Nuys, Calif., as manager, special projects. His principal duties will be in the performance of engineering liaison on major military electronic systems.

Hastings formerly was manager of field operations for American Electronics Corp., instrument division; manager of engineering liaison for Interstate Electronics and a senior project engineer with the Ralph M. Parsons Co.



### Information Systems Advances Ward

CARL D. WARD has been appointed to the position of division manager of the computer division of Information Systems, Inc., Los Angeles, Calif. In this capacity he will have full responsibility for all operations of the division.

Prior to this appointment, Ward was chief engineer of the division and will continue to operate in this capacity as division manager.

# FEEDBACK CONTROL...



## IN ULTRASONIC CLEANING?

Sure! Powertron's Autosonic cleaner uses feedback control the way missile guidance systems do—to ensure maximum reliability and efficiency. Feedback control keeps the Autosonic electronically tuned to peak cleaning efficiency, and makes it genuinely self-tuning. Anyone who can flip a switch can use an Autosonic. What's more—the Autosonic is guaranteed to clean almost anything better, cheaper, and faster than other ultrasonic cleaners.



A complete line of Powertron Autosonic cleaners is available from 2 gals. to 75 gals.—from 100 watts to 3000 watts from \$395 to \$6000.

A ten-minute demonstration in your own plant will show you what feedback control can do for your ultrasonic cleaning problems. Just check your cleaning problems and send in this coupon and Powertron will do the rest.

- |  |  |
|--|--|
| <input type="checkbox"/> Cleaning              | <input type="checkbox"/> Removing                  |
| <input type="checkbox"/> Electrical assemblies | <input type="checkbox"/> Buffing compounds         |
| <input type="checkbox"/> Mechanical assemblies | <input type="checkbox"/> Shop dirt                 |
| <input type="checkbox"/> Circuit boards        | <input type="checkbox"/> Fluxes                    |
| <input type="checkbox"/> Laboratory glassware  | <input type="checkbox"/> Waxes and oils            |
| <input type="checkbox"/> Surgical instruments  | <input type="checkbox"/> Degreasing                |
| <input type="checkbox"/> Engine parts          | <input type="checkbox"/> Brightening               |
| <input type="checkbox"/> Ceramic components    | <input type="checkbox"/> Radioactive contamination |
| <input type="checkbox"/> Metal parts           | <input type="checkbox"/> Other (please describe)   |
| <input type="checkbox"/> Other                 | .....  |

Check here if you'd like a free copy of our technical bulletin, "How to Clean Ultrasonically with Self-tuning."

Name.....  
Title.....  
Company.....  
Address.....

WRITE DEPT. E-2

**POWERTRON  
ULTRASONICS CORP.**  
PATTERSON PLACE • ROOSEVELT FIELD  
GARDEN CITY, L.I., NEW YORK • PIONEER 1-3220

CIRCLE 214 ON READER SERVICE CARD

**GUDELACE  
TAKES THE  
SLIPS  
OUT OF  
LACING**

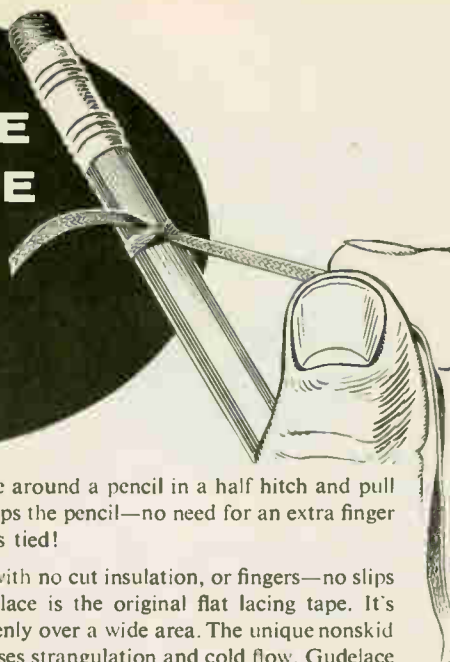

Try this simple test. Tie a piece of Gudalace around a pencil in a half hitch and pull one end. Gudalace's flat, nonskid surface grips the pencil—no need for an extra finger to hold Gudalace in place while the knot is tied!

Gudalace makes lacing easier and faster, with no cut insulation, or fingers—no slips or rejects—and that's *real* economy. Gudalace is the original flat lacing tape. It's engineered to *stay* flat, distributing stress evenly over a wide area. The unique nonskid surface eliminates the too-tight pull that causes strangulation and cold flow. Gudalace is made of sturdy nylon mesh, combined with special microcrystalline wax, for outstanding strength, toughness, and stability.

Write for a free sample and test it yourself. See how Gudalace takes the slips—and the problems—out of lacing.

**GUDEBROD**

Electronic Division  
225 West 34th Street  
New York 1, N.Y.

**BROS. SILK CO., INC.**

Executive Offices  
12 South 12th Street  
Philadelphia 7, Pa.

CIRCLE 215 ON READER SERVICE CARD

For that



**NEW IDEA**

visit the

**IRE SHOW**

March 20-23, 1961

New York

Coliseum and Waldorf-Astoria Hotel

Members \$1.00, Non-members \$3.00

Age limit—over 18

CIRCLE 216 ON READER SERVICE CARD

**Relays  
by  
Stromberg-  
Carlson**

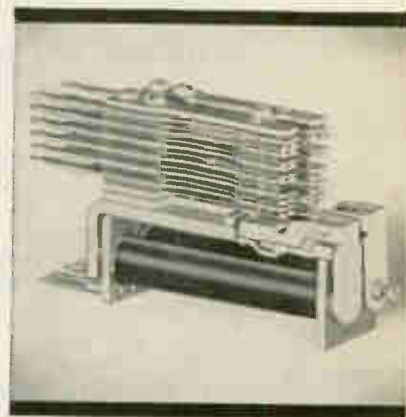

**Telephone-type  
quality • reliability  
durability**

If you require reliable, durable, top quality relays in the equipment you manufacture, you're well advised to consider the relays made by Stromberg-Carlson.

Hundreds of companies have found here the advantages based on our over sixty years of specialization in providing equipment and parts to the independent telephone world.

What's more, we go beyond just the manufacture of relays. If you desire, we can also provide wired mounting assemblies.

Our relays are available in a wide range of types, of which these are representative:

**TYPE A:** general-purpose. Up to 20 Form "A" spring combinations.

**TYPE B:** gang-type. Up to 60 Form "A" spring combinations.

**TYPE BB:** up to 100 Form "A" springs.

**TYPE C:** (illustrated) two on one frame. Ideal where space is tight.

**TYPE E:** characteristics of Type A, plus universal mounting. Interchangeable with other makes.

Types A, B, and E are available in high-voltage models. Our assembly know-how is available to guide you in your specific application.

Details on request from these Stromberg-Carlson offices: Atlanta—750 Ponce de Leon Place N.E.; Chicago—564 W. Adams Street; Kansas City (Mo.)—2017 Grand Avenue; Rochester—1040 University Avenue; San Francisco—1805 Rollins Road.

**STROMBERG-CARLSON**  
A DIVISION OF  
**GENERAL DYNAMICS**

# Electronic Engineers

*for assignments  
on APL's  
satellite program*

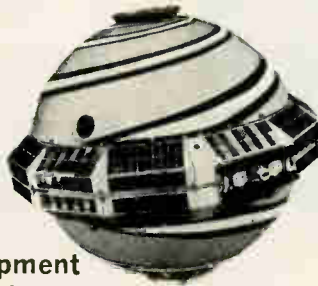

**Research • Development  
Systems Engineering**

You will find association with APL particularly rewarding if you appreciate an atmosphere conducive to original thinking, and if you are capable of making contributions to advance the state-of-the-art.

## Satellite Development Group

The group is responsible for the development of satellites whose function is a major contribution to the national effort. Satellite-borne instruments must continue in operation for at least five years without malfunction in a space environment.

Emphasis is on all phases of effort from conceptual design through hardware fabrication. Within broad limits set by an established program, engineers will enjoy freedom to make creative contributions. Areas open to exploitation are in the field of magnetic memory systems (along with associated transistor switching circuits), other logic devices, and radio frequency transistor circuits to be used in a closed loop, phase and frequency locked, system. An electronic engineering degree is required; two years of experience in the above fields is desired but demonstrated capacity for growth will be given due consideration.

## Satellite Ground System Group

This group is responsible for the design of data handling systems for use in shipboard and air-borne navigational equipment, and for ground tracking equipment. Assignments involve development of novel and highly sophisticated data processing systems, systems coordination, and technical supervision of contractors.

BS or more in physics or electronic engineering plus four to five years of experience in data processing systems required.

**For details about these career  
opportunities, address your inquiry to:  
Professional Staff Appointments**

**The Applied Physics Laboratory  
The Johns Hopkins University**

8633 Georgia Avenue, Silver Spring, Md.  
(Suburb of Washington, D.C.)

*"Put Yourself in the  
Other Fellow's Place"*

**TO EMPLOYERS  
TO EMPLOYEES**

Letters written offering Employment or applying for same are written with the hope of satisfying a current need. An answer, regardless of whether it is favorable or not, is usually expected.

**MR. EMPLOYER**, won't you remove the mystery about the status of an employee's application by acknowledging all applicants and not just the promising candidates.

**MR. EMPLOYEE** you, too, can help by acknowledging applications and job offers. This would encourage more companies to answer position wanted ads in this section.

We make this suggestion in a spirit of helpful cooperation between employers and employees.

This section will be the more useful to all as a result of this consideration.

Classified Advertising Division

**McGRAW-HILL  
PUBLISHING CO., INC.**

330 West 42nd St.,  
New York 36, N. Y.

**SANDERS  
ASSOCIATES INC.**

*Announces*  
the opening of  
**2 NEW FACILITIES**

**ADVANCED  
SYSTEMS  
LABORATORIES**

(on famed "Electronics Row"  
in suburban Boston)

**NEW  
ENGINEERING  
OPERATION**

(on suburban Long Island  
near New York City)

**T**o meet the recent increase to \$53 million in contract commitments, Sanders Associates of Nashua, New Hampshire is rapidly expanding its engineering staff in 3 locations: Nashua Headquarters; Burlington, Massachusetts and Plainview, L.I., New York.

This new expansion follows a 9-year growth from 11 engineers to over 1600 employees — a growth soundly based on technical excellence — inventing new concepts instead of using traditional approaches.

Pioneering programs are being continued in phased arrays, radar, pulse doppler radar systems, space radar and communication systems. Advanced concepts and techniques in a variety of areas provide stimulating assignments involving space technology, missiles and radar systems.

**Positions available at all locations for:**

**SENIOR SYSTEMS ENGINEERS**

To contribute to advanced techniques in the general field of military electronic systems. Applicable experience includes systems analysis, synthesis and integration, with extensive background in circuit design augmented by hardware implementation.

**CIRCUIT DESIGN ENGINEERS**

EE or Physics graduates with 2 to 8 years experience and familiarity with tubes and transistors and their utilization in all types of circuits, as well as the integration of circuits into sub-systems.

**TRANSMITTER DESIGN ENGINEERS**

2 to 8 years experience. For work up to and including microwaves.

**PRODUCT DESIGN ENGINEERS**

ME with heavy experience in feasibility studies coupled with experience in taking developed systems into production, monitoring mechanical design and overall packaging concepts of ECM or other airborne systems.

**Positions in Plainview, L. I.**

**GROUND SUPPORT EQUIPMENT ENGINEERS**

To design and develop system, assembly and sub-assembly electronic test equipment for the military. Should have appreciation for test equipment philosophy, with extensive experience in circuit design and hardware follow-through.

To arrange for a convenient interview at any of the three locations, send resumes to Mr. Richard McCarthy, Employment Manager, in Nashua.



**SANDERS ASSOCIATES, INC.**

NASHUA, NEW HAMPSHIRE

# PROJECT ENGINEERS

Daystrom, Incorporated's Weston Instruments Division, Poughkeepsie, New York is seeking to add two individuals at the Project Engineer level to its industrial line of NON-CONTACT GAUGES engineering group. Project engineers are responsible for the design of gauging systems that are engineered to customer specifications.

Interested individuals should have a B.S. E.E. with a minimum of three years industrial experience that would include electric control circuits, motor control circuits and some experience in tube and transistor circuit design. Experience with X-ray, optics and infra-red techniques is desirable but not necessary. U. S. citizenship is not required.

Poughkeepsie, New York is a highly residential community located 75 miles north of New York City.

For consideration, write in full confidence to:  
Mr. William F. Donahue

**DAYSTROM, INCORPORATED**  
WESTON INSTRUMENTS DIVISION  
229-A Manchester Road Poughkeepsie, N. Y.

CIRCLE 383 ON READER SERVICE CARD

# Security Analyst . . .

Large financial institution seeking a combination of electronics engineer and financial analyst with minimum 5 years experience.

Assignment requires a broad electronics background as well as some knowledge of finance. Salary commensurate with exp. Please submit complete resume to:

P-5992  
ELECTRONICS—Class. Adv. Div.  
P.O. Box 12, New York 36, N. Y.

CIRCLE 384 ON READER SERVICE CARD

ADDRESS BOX NO. REPLIES TO: Box No. Classified Adv. Div. of this publication. Send to office nearest you.  
NEW YORK 36: P. O. Box 12  
CHICAGO 11: 530 N. Michigan Ave.  
SAN FRANCISCO 11: 225 California St.

### SELLING OPPORTUNITIES AVAILABLE

Permanent Magnet, bench type shaker Manufacturer seeks qualified Manufacturer Representatives in the Environmental Test Field for all territories except New England. RW-5968, Electronics.

Competent Representatives desired by mfr. of relays, telephone- and intercomm. systems allied parts. RW-6023, Electronics.

### POSITIONS WANTED

German electronic Engineer 26, bachelor. 2 1/2 years development, construction, end-test at digital computer with vacuum-tube but especially transistors. PW-6046, Electronics.

### DON'T FORGET

the box number when answering advertisements. It is the only way we can identify the advertiser to whom you are writing.



## MANUFACTURERS' REPRESENTATIVES

IN THE ELECTRONIC INDUSTRY

**SAMUEL K. MACDONALD, INC.**  
manufacturers representatives over 25 years  
1531 SPRUCE STREET, PHILA. 2, PA.  
Territory: Pennsylvania • New Jersey  
Delaware • Maryland  
Virginia • West Virginia  
District of Columbia  
Other Offices: Pittsburgh  
Baltimore  
Washington, D. C.

CIRCLE 385 ON READER SERVICE CARD

### Your Inquiries to Advertisers Will Have Special Value . . .

—for you—the advertiser—and the publisher. If you mention this publication. Advertisers value highly this evidence of the publication you read. Satisfied advertisers enable the publishers to secure more advertisers and—more advertisers—mean more information on more products or better service—more value—to YOU.

# Electronic and General Engineers

The U. S. Army Engineer Reactor Group, Nuclear Power Field Office located at Fort Belvoir, Virginia, is currently seeking applicants to fill Electronics and General Engineer vacancies at grade GS-13, \$10,635 per annum. Applicants selected must meet U. S. Civil Service qualification requirements for the position and grade level for which considered.

**ELECTRONIC ENGINEERS:** Permanent positions with broad responsibilities as technical experts and advisors in the field of Electronics (Instrumentation) as it relates to Research and Development activities, installation, operations and maintenance of Nuclear Power Plants.

**GENERAL ENGINEERS:** Permanent positions with broad responsibilities as technical experts and advisors in the field of Nuclear Engineering. Prime experience background in Nuclear Engineering is desired with secondary knowledge and experience in fields of chemistry, health physics, or Electrical Engineering.

Interested persons should submit completed application, SF-57, to the Civilian Personnel Office, Fort Belvoir, Virginia, and make reference to this advertisement. Application forms, SF-57's, may be obtained at your local Post Office, nearest Federal installation, or upon request to the Civilian Personnel Office at Fort Belvoir, Virginia.

CIRCLE 386 ON READER SERVICE CARD

## SEARCHLIGHT SECTION

(Classified Advertising)

### BUSINESS OPPORTUNITIES

EQUIPMENT - USED or RESALE

### DISPLAYED RATE

The advertising rate is \$24.75 per inch for all advertising appearing on other than a contract basis. Contract rates quoted on request. AN ADVERTISING INCH is measured 3/4 inch vertically on one column, 3 columns—30 inches—to a page. EQUIPMENT WANTED or FOR SALE ADVERTISEMENTS acceptable only in Displayed Style.

### UNDISPLAYED RATE

\$2.40 a line, minimum 3 lines. To figure advance payment count 5 average words as a line. PROPOSALS, \$2.10 a line an insertion. BOX NUMBERS count as one line additional in undisplayed ads. DISCOUNT OF 10% if full payment is made in advance for four consecutive insertions of undisplayed ads (not including proposals).

### FOR SALE

Complete 16mm kinescope recording equipment. Unit designed for 16mm Auricon but adaptable to other camera units. (Camera not included.) Has video, audio and r.f. amplifiers, black level and brightness control system.

For details write, Forde Motion Picture Lab, 306 Fairview Avenue North, Seattle 9, Wash.

CIRCLE 460 ON READER SERVICE CARD

## LOOKING FOR USED/SURPLUS ELECTRONIC EQUIPMENT/COMPONENTS?

For an up-to-date listing of such equipment see Searchlight Section of January 13th.

# INDEX TO ADVERTISERS



## Audited Paid Circulation

Aldo-X Inc. . . . .	37	*General Precision Eqpt. Corp. Kearfott (NY) . . . . .	78, 79
*Airborne Instruments Laboratories. . . . .	91	*Green Instrument Co. Inc. . . . .	32
*Airpax Electronics Inc. . . . .	74	*Gudebrod Bros. Silk Co., Inc. . . . .	101
Allison Laboratories, Inc. . . . .	100	Hansen Manufacturing Company, Inc. . . . .	70
*Alpha Wire Corp. . . . .	93	Hathaway Instrument Inc. . . . .	19
Amco Engineering Co. . . . .	88	Heinemann Electric Company. . . . .	33
*American Lava Corporation. . . . .	59	*Industrial Electronic Engineers, Inc. . . . .	83
*Amperex Electronics Corp. . . . .	17	Institute of Radio Engineers. . . . .	101
Ampex Data Products. . . . .	73	*Jones Electronics Co., Inc., M. C. . . . .	75
*Amphenol-Borg Electronics Corp. RF Products Division Danbury. . . . .	28	*Knights Company, James. . . . .	94
Anti-Corrosive Metal Products, Co., Inc. . . . .	81	Litton Systems, Inc. . . . .	38
*Art Wire & Stamping Co. . . . .	34	Magnetic Metals Company. . . . .	8
*Avnet Electronics . . . . .	40	Martin Co. . . . .	77
*Baker Chemical Co., J. T. . . . .	98	Melabs . . . . .	12
Bausch & Lomb Incorporated. . . . .	86	McGraw-Hill Book Co. . . . .	105
Beede Electrical Instrument Co., Inc. . . . .	87	*Methode Manufacturing Corp. . . . .	99
*Burnell & Co., Inc. . . . .	3	Midland Mfg. Co. . . . .	63
*Bussmann Mfg. Co. Div. of McGraw-Edison. . . . .	16	National Cash Register Co. . . . .	97
Cetron Electronic Corporation Plastics Division . . . . .	83	*North Atlantic Industries, Inc. . . . .	27
Colorado Dept. of Development. . . . .	87	North Electric Co. . . . .	67
*Continental-Diamond Fibre Subsidiary of the Budd Company. . . . .	2	Ohmite Mfg. Co. . . . .	13
*Crosby-Teletronics Corporation . . . . .	21	Powertron Ultrasonics Corp. . . . .	100
*Curtiss-Wright Corp. . . . .	95	Precision Instrument Co. . . . .	84
*Dale Products, Inc. . . . .	39	*Philco Corp. . . . .	42
*Daven Company . . . . .	3rd Cover	Powertron Ultrasonics Corp. . . . .	100
Delco Radio . . . . .	65	Precision Instrument Co. . . . .	84
Despatch Oven Co. . . . .	83	* See Advertisement in the July 20, 1960 issue of Electronics Buyers' Guide for complete line of products or services.	
*Electronic Instrument Co., Inc. (EICO) . . . . .	106		
Garrett Corporation, The Airesearch Mfg. Division. . . . .	93		
*General Instrument Co. Semiconductor Div. . . . .	7		
General Products Corp. . . . .	94		

## McGraw-Hill Book News

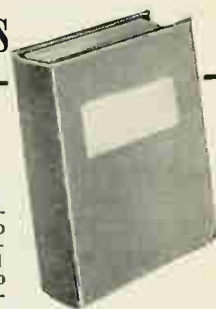

### RADIO TRANSMITTERS

**Just Out.** Gives step-by-step guidance to help you solve problems of operation and maintenance of radio transmitters. Provides a detailed analysis of transmitter components . . . supplies essential design information on amplifiers, coupling circuits, frequency control units, power supplies, cooling equipment and control circuits . . . plus other vital data. By **L. Gray and R. Graham, ITT Laboratories.** 452 pp., 408 illus., \$12.50

### PLASMA PHYSICS

**Just Out.** For scientists, research workers, and technicians—here is clear and detailed coverage of plasma physics ranging from a historical survey of the field—through the basic kinematics of growing waves in plasmas—to important diagnostic experiments for thermo-nuclear research. Covers basic and microwave plasma physics, and magnetohydrodynamics. By **J. Drummond, Boeing Scientific Research Laboratories.** 400 pp., 921 illus., \$12.50

### ELECTRONICS IN ENGINEERING

**Just Out—2nd Ed.** Offers practical, on-the-job help to all concerned with the application of electronic techniques and instruments. Covers vacuum tubes, amplifiers and feedback, oscillators, modulation and transducers, and photoelectric devices. This revised edition contains new material on such areas as semiconductor rectifiers, transistors, semiconductor switching devices, circuit analysis, and analog amplifiers. By **W. R. Hill, Univ. of Washington.** 2nd Ed., 315 pp., 245 illus., \$8.00

### MODERN PHYSICS FOR THE ENGINEER

**Just Out—2nd Series.** Brings you further advanced aspects of today's physics that have application in tomorrow's engineering. Main sections treat the laws of nature, man's physical environment, and technology. Nuclear shell structure, electron scattering, and particle accelerators are among the important topics covered. Edited by **L. Ridenour and W. Nierenberg, Univ. of California, Berkeley.** 400 pp., 190 illus., \$9.50

### 10 DAYS' FREE EXAMINATION

McGraw-Hill Book Co., Inc., Dept. L-2-3  
327 W. 41st St., N. Y. C. 36

Send me book(s) checked below for 10 days' examination on approval. In 10 days I will remit for book(s) I keep, plus few cents for delivery costs, and return unwanted book(s) postpaid. (We pay delivery costs if you remit with this coupon—same return privilege.)

- Gray and Graham—Radio Transmitters, \$12.50  
 Drummond—Plasma Physics, \$12.50  
 Hill—Electronics in Engr., \$8.00  
 Ridenour and Nierenberg—Modern Physics for the Engineer, \$9.50

(PRINT)

Name . . . . .

Address . . . . .

City . . . . . Zone . . . . . State . . . . .

Company . . . . .

Position . . . . .

For price and terms outside U. S.  
Write McGraw-Hill Int'l., N. Y. C.

L-2-3

**EICO 1961**

**KITS AND WIRED**

STEREO  
AND MONO  
HIGH FIDELITY  
TEST INSTRUMENTS  
HAM EQUIPMENT  
CITIZENS TRANSCEIVERS  
RADIOS

LABORATORY PRECISION AT LOWEST COST  
Easy-to-use kits to build

Send for  
**FREE**  
New 1961  
**EICO Electronics Catalog**

EICO, 3300 N. Blvd., L.I.C. 1, N. Y. E-1A  
 Send free 32-page catalog & dealer's name  
 Send new 36-page Guidebook to HI-FI for which I enclose 25¢ for postage & handling.

Name .....  
 Address .....  
 City ..... Zone ..... State .....

**EICO** 3300 N. Blvd., L.I.C. 1, N. Y.  
...praised by the experts  
as **BEST BUYS IN ELECTRONICS**

CIRCLE 217 ON READER SERVICE CARD

# IS YOUR ADVERTISING SELLING THE BIG 4

Tough competition and smart selling demand that the electronics man be reached and sold wherever you find him: *Research, Design, Production, and Management*. Only electronics is edited to interest and influence all four key buyers. Put your advertising where it works *hardest*...

in **electronics**

Radiation Inc. ....	31	Utica Drop Forge & Tool Division Kelsey-Hayes Company .....	15
*Radio Corporation of America... 4th Cover		*Valpey Crystal Corp. ....	81
*Raytheon Company .....	61		
St. Petersburg Chamber of Commerce	18		
Sangamo Electric Co. ....	35		
*Shalleross Mfg. Co. ....	69		
*Sigma Instruments, Inc. ....	92		
Sorensen A Subsidiary of Raytheon..	87		
Sprague Electric Co. .... 5, 14,	20		
Standard Rectifier Corporation. ....	81		
*Stevens-Arnold, Inc. ....	71		
Stromberg-Carlson .....	101		
*Syntronic Instruments, Inc. ....	6		
*Technology Instrument Corp. of California .....	91		
Tokyo Shibaura Electric Co., Ltd. ....	23		
*Transitron Electronic Corp. ....	11		
Ungar Electric Tools Inc. ....	93		
Uniform Tubes, Inc. ....	91		
United Shoe Machinery Corp. Dynasert Division .....	98		
U. S. Components, Inc. ....	36		
*United Transformer Corp. .... 2nd Cover			

## CLASSIFIED ADVERTISING

F. J. Eberle, Business Mgr.

EMPLOYMENT  
OPPORTUNITIES ..... 102-104

EQUIPMENT  
(Used or Surplus New)  
For Sale ..... 104

## ADVERTISERS INDEX

Applied Physics Laboratory, the Johns Hopkins Univ. ....	102
Daystrom Inc., Weston Instruments Div.	104
Forde Motion Picture Lab. ....	104
Sanders Associates Inc. ....	103
U. S. Army Engineer Reactor Group Nuclear Power Field Office. ....	104

This index and our Reader Service Numbers are published as a service. Every precaution is taken to make them accurate, but ELECTRONICS assumes no responsibilities for errors or omissions.

## electronics



Audit Bureau  
of Circulations



Associated Business  
Publications

Audited Paid Circulation

BRUCE A. WINNER,  
Advertising Sales Manager

R. S. QUINT, Assistant Advertising Sales Manager and Buyers' Guide Manager; FRED STEWART, Promotion Manager; RICHARD J. TOMLINSON, Production Manager; GEORGE E. POMEROY, Classified Manager; HUGH J. QUINN, Circulation Manager.

ADVERTISING REPRESENTATIVES: NEW YORK Donald H. Miller, Henry M. Shaw, George F. Werner; BOSTON William S. Hodgkinson, Donald R. Furth; PITTSBURGH David M. Watson; PHILADELPHIA Warren H. Gardner, William J. Boyle; CHICAGO Harvey W. Wernecke, Martin J. Gallay; CLEVELAND P. T. Fegley; SAN FRANCISCO T. H. Carmody, R. C. Alcorn; LOS ANGELES D. A. McMillan, Marshall Freeman; DENVER J. Patten;

ATLANTA M. Miller; DALLAS Robert T. Wood; LONDON Edward E. Schirmer; FRANKFURT Stanley R. Kimes; GENEVA Michael R. Zeynel.

BRANCH OFFICES: National Press Bldg., Washington 4, D.C.; McGraw-Hill Bldg., Copley Square, Boston 16; Four Gateway Center, Pittsburgh 22; Six Penn Center Plaza, Philadelphia 3; 520 North Michigan Avenue, Chicago 11; 55 Public Square, Cleveland 13; 68 Post Street, San Francisco 4; 1125 West Sixth St., Los Angeles 17; 1740 Broadway, Denver 2; 1301 Rhodes-Haverly Bldg., Atlanta 3; 901 Vaughn Bldg., Dallas 1, McGraw-Hill Publishing Co., Ltd., 34 Dover Street, London, England; 85 Westendstrasse, Frankfurt/Main; 2 Place de Port, Geneva.



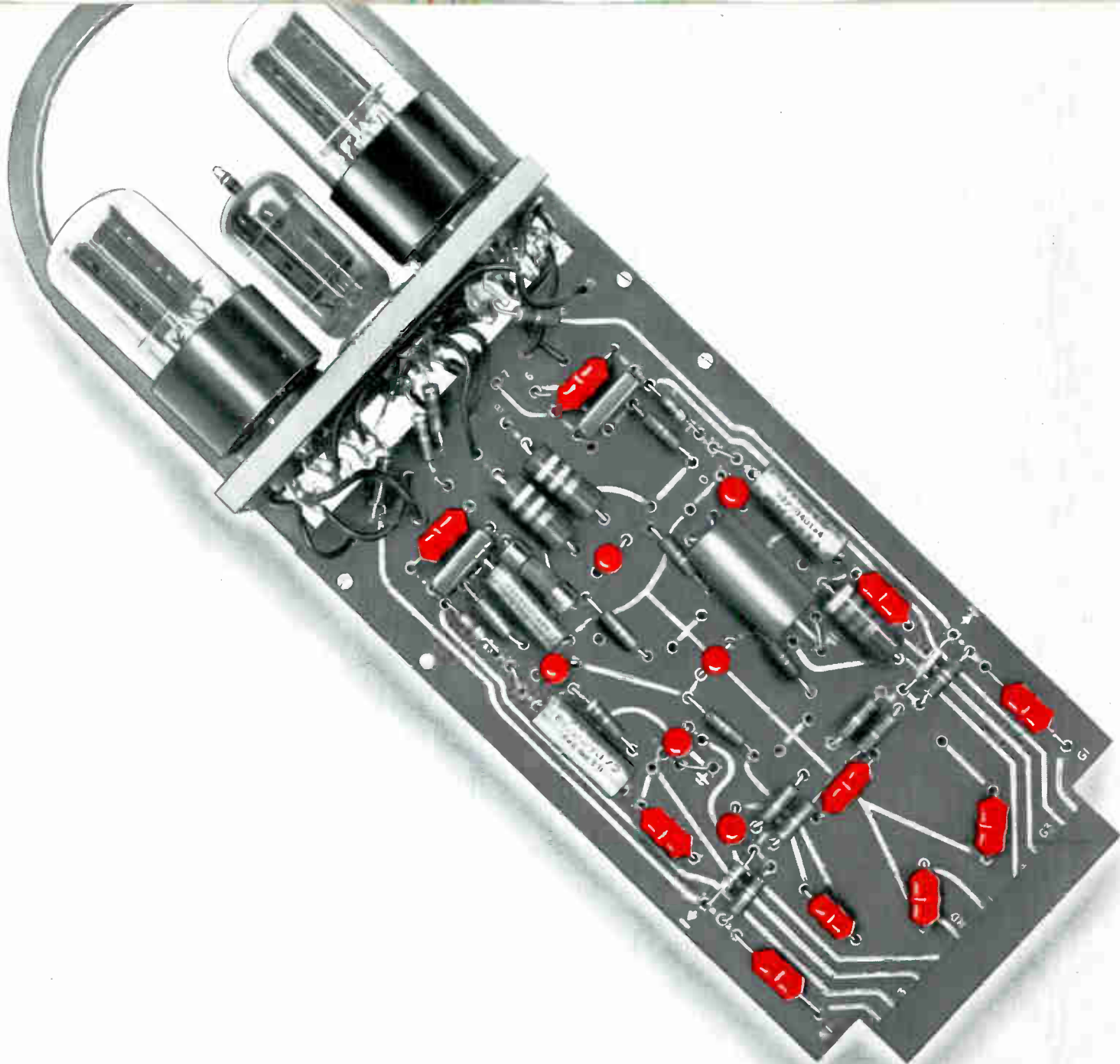

## Top reliability in miniature size...

### *Daven wire wound resistors*

For printed circuit boards, miniature plug-in packages ... any tight place in which you must have a really small wire wound resistor, check Daven for the Super Davohm Miniatures that can solve your problem. For example ...



1273  
"Lollypop"  
Up to 400 K



1274  
Up to 100 K



1250  
Up to 900 K

SHOWN ACTUAL SIZE

These resistors meet and exceed all requirements, except physical size, of MIL-R-93-B, and MIL-R-9444.

The overall stability of Daven Miniature Resistors is possible because of an entirely new approach to subminiature production techniques. A unique spool design permits low-stress winding of fine resistance wire ... obtaining 2 to 3 times the resistance value previously supplied on a miniature bobbin. This is done under the most stringent quality control and inspection.

The industry's widest range of sizes, temperature coefficients, and tolerances is available for your requirements. Write today for further information and a complete resistor catalog.

THE **DAVEN** CO.



LIVINGSTON, NEW JERSEY

Subsidiary of General Mills, Inc.

TODAY, MORE THAN EVER, THE DAVEN © STANDS FOR DEPENDABILITY

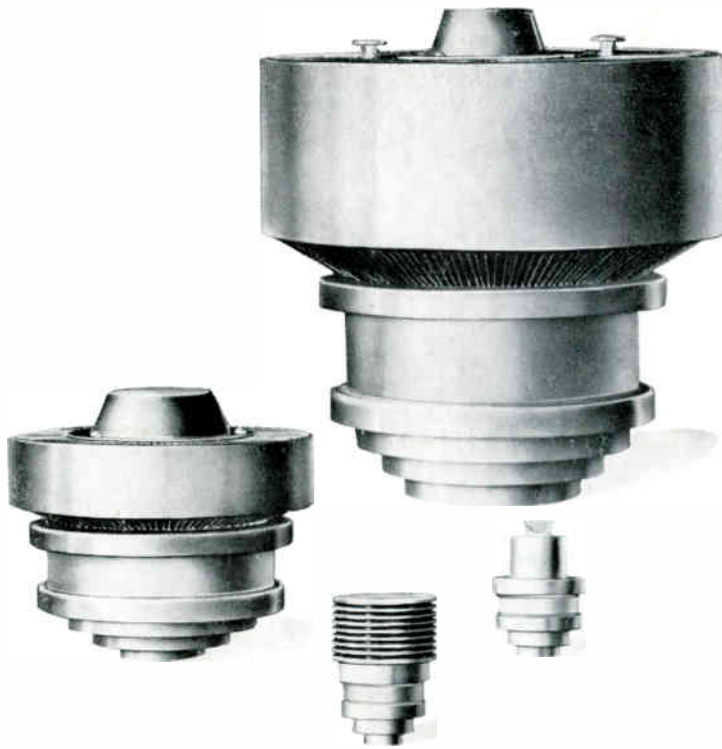

# RCA CERMOLOX TUBES...

## a new concept in Beam Power Tube technology

To meet the increasing demand for dependable UHF power, RCA has developed Cermolox Tubes, a wide line of coaxial, ceramic-metal beam power tubes with precision-aligned grids. These Cermolox tubes are especially well suited to the requirements of aircraft, missile and guidance applications in CW, Pulse, and Hard-Tube-Modulator service.

Already they have set an enviable record of performance in such exacting applications. In Pioneer V, for instance, Cermolox tubes were used in the guidance systems, and in the satellite's high-power transmitter.

Some outstanding features of RCA Cermolox tubes which contribute to long life and reliability are:

- Precise alignment of grids for outstanding efficiency.
- Coaxial-electrode structure adaptable for use either in coaxial-cylinder or parallel-line circuits.
- Exceptionally sturdy structure.
- Low rf-loss ceramic insulation.
- High temperature operation.
- Brazed construction involves no spot welding and assures low rf losses and low internal stresses.
- Compact, ceramic-metal construction.
- Flexibility of cooling techniques: conduction, liquid, and forced air (with RCA's high-efficiency radiator).

The family of RCA Cermolox tubes is shown in the adjacent table. For more information, contact the RCA Field Office nearest you.



The Most Trusted Name in Electronics  
RADIO CORPORATION OF AMERICA

RCA CERMOLOX BEAM POWER TUBES				
Type	Max. Plate Input Watts	Max. Freq. at Max. Ratings	Max. Plate Diss. Watts	Heater Volts/Amperes
<b>CW APPLICATION</b>				
7870 Conduction Cooled	52.5	3,000	25	6.3/1
7801 Conduction Cooled	52.5	3,000	25	12.6/5
6816 Forced-Air Cooled	180	1,215	115	6.3/2.1
7844 Conduction Cooled	180	1,215	115	6.3/2.1
7842 Ruggedized Conduction Cooled	180	1,215	115	6.3/3.0
7457 Ruggedized Forced-Air Cooled	180	1,215	115	6.3/3.0
7843 Conduction Cooled	180	1,215	115	26.5/52
6884 Forced-Air Cooled	180	1,215	115	26.5/52
7650 Ruggedized Forced-Air Cooled	1,250	1,215	600	6.3/7.5
A-2663* Conduction Cooled	1,250	1,215	600	6.3/7.5
7213 Forced-Air Cooled	2,500	1,215	1,500	5.5/17.5
A-2545-A* Forced-Air Cooled	28,000	400	10,000	8/88
<b>PULSED RF APPLICATION</b>				
A-2587-A* Conduction Cooled	3,750	3,000	25	12.6/4.1
7649 Ruggedized Forced-Air Cooled	9,000	1,215	115	6.3/3.0
7651 Ruggedized Forced-Air Cooled	72,000	1,215	600	6.3/7.5
7214 Forced-Air Cooled	180,000	1,215	1,500	5.5/17.5
A-2581-A* Forced-Air Cooled	2,000,000	600	10,000	18/12
<b>HARD-TUBE-MODULATOR APPLICATION</b>				
A-2638* Ruggedized Forced-Air Cooled	8,000	—	115	6.3/3.0
A-2624* Ruggedized Forced-Air Cooled	60,000	—	600	6.3/7.5
A-2627-A* Ruggedized Conduction Cooled	300,000	—	1,500	5.5/17.5
A-2625* Conduction Cooled	1,500,000	—	10,000	18/12

The chart shown above includes all RCA Cermolox Tube types available as of February 4, 1961.

\*Development Type—Available on Sampling Basis

### RCA ELECTRON TUBE DIVISION FIELD OFFICES

INDUSTRIAL TUBE PRODUCTS SALES: NEWARK 2, N. J., 744 Broad St., Humboldt 5-3900 • DETROIT 2, MICHIGAN, 714 New Center Building, TRinity 5-5600 • CHICAGO 54, ILLINOIS, Suite 1154, Merchandise Mart Plaza, Whitehall 4-2900 • BURLINGAME, CALIF., 1838 El Camino Real, Oxford 7-1620 • LOS ANGELES 22, CALIF., 6355 E. Washington Blvd., Raymond 3-8361. GOVERNMENT SALES: NEWARK, N. J., 744 Broad St., Humboldt 5-3900 • DAYTON 2, OHIO, 224 N. Wilkinson St., Baldwin 6-2366 • WASHINGTON 7, D.C., 1725 "K" St., N.W., Federal 7-8500.