

electronics

SPECIAL REPORT *Pioneer V represents one of many probes described in roundup of techniques for studying space, our atmosphere, earth, oceans and living matter*

A McGraw-Hill Publication 75 Cents

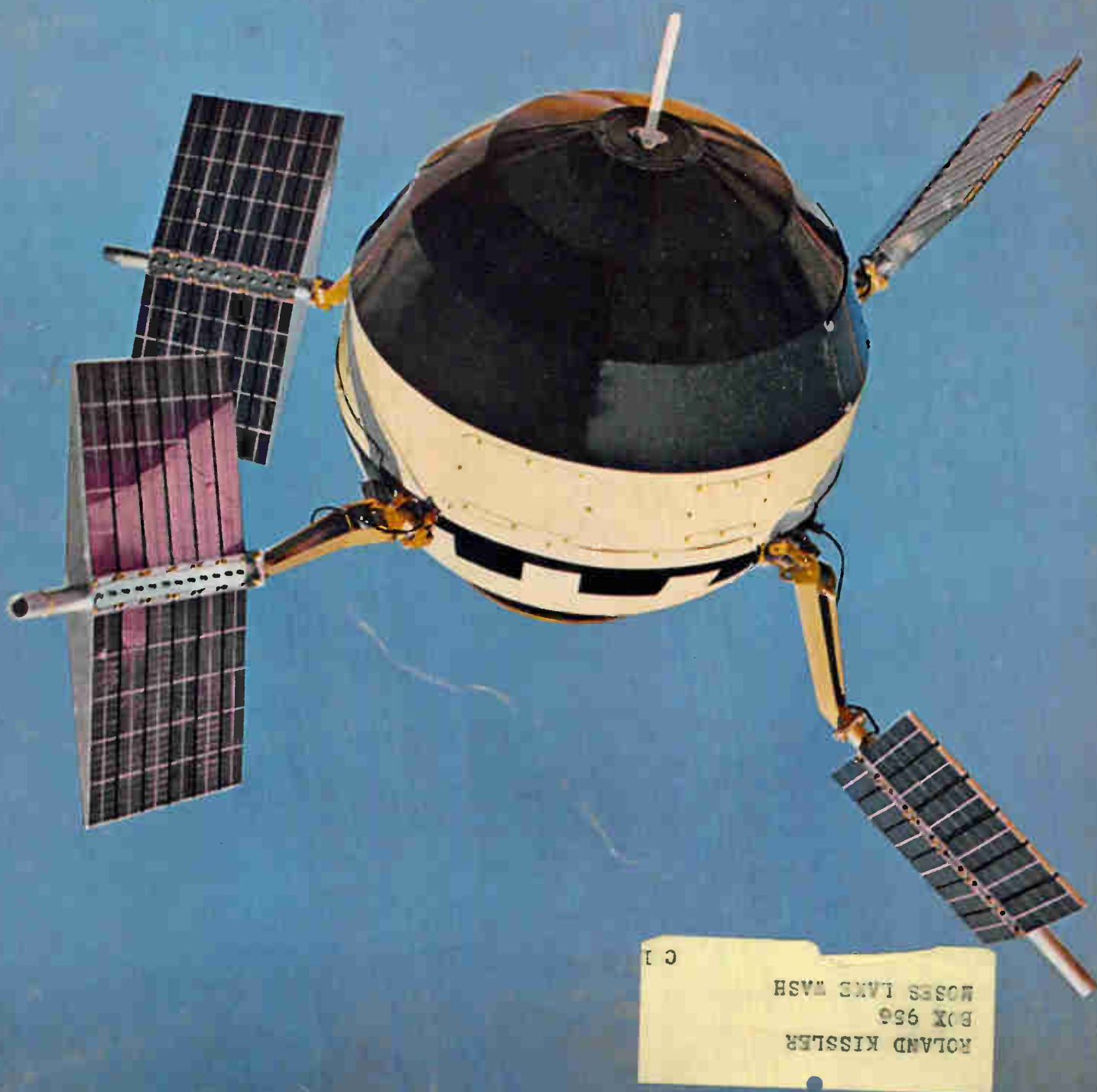

Creative Microwave Technology

Published by MICROWAVE AND POWER TUBE DIVISION, RAYTHEON COMPANY, WALTHAM 54, MASS., Vol. 2, No. 2

A TOTALLY NEW CONCEPT IN "O"-TYPE BWO CONSTRUCTION

--Interdigital-type delay line affords maximum heat dissipation at high power outputs

These broadband voltage tunable backward wave oscillators are the smallest, lightest and most reliable of their kind. They were developed especially for modern airborne and ground-based applications utilizing swept oscillator and frequency diversity techniques. Four compatible types are available. They cover a continuous frequency range of 1 to 12.4 KMC. They are magnetically shielded and are insensitive to the effects of external fields. They exhibit a minimum of fine-grain power output variations. Potted leads permit operation at high altitudes over a wide temperature range. Raytheon-perfected laminating techniques make possible interdigital construction which results in maximum heat dissipation. Under normal operating conditions, no forced-air cooling or protective circuitry is required. Laminate-thickness held to extremely close tolerances assures improved fine-grain frequency characteristics with optimum line matching and consistently reproducible characteristics from tube to tube.

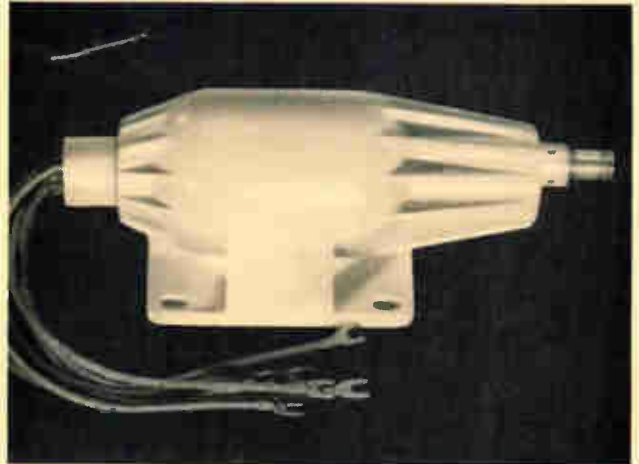

Typical Operating Characteristics

	QKB786	QKB16A	QKB760A	QKB776
Frequency Range	1.0-2.0KMC	2.0-4.0KMC	4.0-8.0KMC	8.0-12.4KMC
Power Output	100 mW Min.	70 mW Min.	30 mW Min.	50 mW Min.
Delay Line (Tuning) Voltage	100-1500 Vdc			
Filament Voltage	6.3 V.			
Cathode Current	45 mA Max.			
Anode Voltage	60-150Vdc	100-200 Vdc	60-130 Vdc	60-130 Vdc
Control Grid Cut-off	-150 Vdc	-100 Vdc	-100 Vdc	-100 Vdc

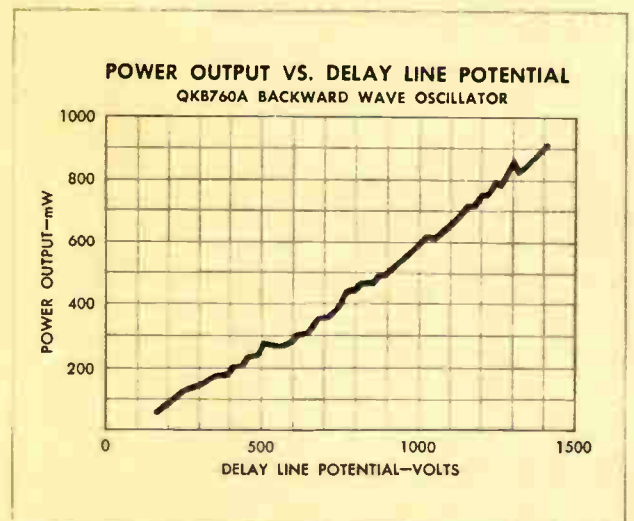
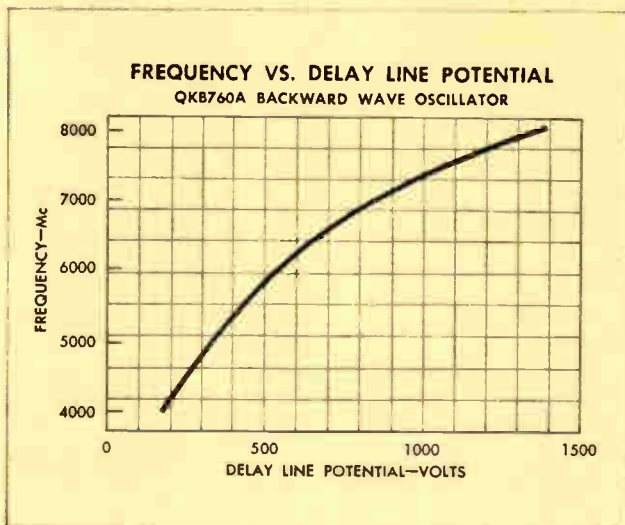

Excellence in Electronics



You can obtain detailed application information and special development services by contacting: Microwave and Power Tube Division, Raytheon Co., Waltham 54, Mass. In Canada: E. Waterloo, Ontario. In Europe: Zurich, Switzerland.

A LEADER IN CREATIVE MICROWAVE TECHNOLOGY
SEE THESE TUBES AT RAYTHEON'S WESCON BOOTH.

electronics

A McGraw-Hill Publication 75 Cents



W. W. MacDONALD, Editor

J. M. CARROLL, Managing Editor
 SENIOR ASSOCIATE EDITORS:
 Samuel Weber, Roland J. Charest.
 ASSOCIATE EDITORS: Frank Leary,
 Michael F. Tamaino, Sylvester P.
 Carter, William P. O'Brien, John
 F. Mason, William E. Bushor,
 Thomas Emma, Sy Vogel, Leslie
 Solomon, M. M. Perugini, George
 J. Flynn. ASSISTANT EDITORS:
 Michael F. Wolf, Nilo Lindgren,
 Stanley Froud, Stephen B.
 Gray. REGIONAL EDITORS: Har-
 old C. Hoad (Pacific Coast, Los
 Angeles), Thomas Maguire (New
 England, Boston). MARKET RE-
 SEARCH EDITOR: Edward DeJongh.
 BUYERS' GUIDE EDITOR: George
 Sideris. ART DIRECTOR: Harry
 Phillips; Howard R. Berry. PRO-
 Duction EDITOR: John C. Wright,
 Jr. EDITORIAL ASSISTANTS: Gloria
 J. Filippone, Arlene Schilp, Bernice
 Duffy, Patricia Martine, Lorraine
 Rossi, Virginia T. Bastian, Ruth
 Ayres, Mildred Scott.

JAMES GIRDWOOD, Publisher

BUSINESS

Soviets Stress Industrial Gear. Major effort is in theory	36
New System Will Measure Missile Trajectories. Means big business	38
Can We Stop the Export Decline? As imports rise, industry ponders	43
Reverberation Units Start Trend. Add depth to stereo	45
Navy Outlines New Research Aims. Hopes for industry action	46
Crosstalk	4
Comment	6
Electronics Newsletter	11
Washington Outlook	14
Financial Roundup	29
25 Most Active Stocks	29
Market Research	32
Current Figures	32
Meetings Ahead	48

ENGINEERING

Pioneer V deep space probe was developed by Space Technology
 Lab for Air Force Ballistic Missile Division and National
 Aeronautics & Space Administration. See p 61 **COVER**

Electronics Probes Nature. Special Report covering space, our
 atmosphere, the earth, the oceans and living matter By W. E.
 Bushor and M. F. Wolf 53

Automatically Controlling Heart-Lung Machine. Reduces hazards of heart surgery By R. Roberts and J. Loeffler	91
Three-Hole Cores for Coincident-Flux Memory. High-speed mem- ory has wide temperature tolerance By H. F. Priebe, Jr.	94
Simulation of Radar Countermeasures. Creating artificial interfer- ence in a radar trainer By J. I. Leskinen	98
Electrical Readout from Thin Ferromagnetic Films. Practical method of high-speed readout By S. Feinstein and H. J. Weber	100
Amplifier Compensates for Speech Level Variations. Unit adjusts for volume difference between talkers and for variations in transmission facilities By L. E. Getgen	103
Delay-Line Controls Tuned Amplifier. Simplifies i-f amplifier tun- ing By I. F. Barditch	108

DEPARTMENTS

Research and Development. Analog-Digital Methods Combined	110
Components and Materials. Transformer Design Reduces Resistance	114
Production Techniques. Plastic Cutouts Help Design P-C Boards	120
New On the Market	124
Literature of the Week	142
People and Plants	144
Index to Advertisers	149

A FAST- STEPPING IONOSPHERE SOUNDER FROM GRANGER ASSOCIATES

STEP FREQUENCY IONOSPHERE SOUNDER MODEL 902

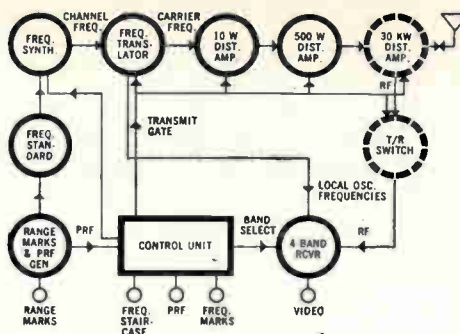

Frequency Range . . . 4.05 Mc to 63.6 Mc
 Number of Channels: Selectable: 160 or 40
 Frequency Increment: 100 kc, 200 kc, 400 kc and 800 kc in four octave bands
 Pulses Per Channel . . . Selectable: 1, 2, 5, or 10
 Pulse Length Selectable: 50, 100, 500, or 1000 μ s
 Pulse Repetition Rate: Selectable: 2, 5, 10, 20, or 50 pps
 Duty Cycle 2% Max.
 Channel Scan Rate . . Channels/Scan x Pulses/Channel
 PRF
 Range Marks Timing comb with markers every 0.2, 1.0, 2.0 and 10.0 milliseconds.
 Frequency Marks . . . Every tenth channel.
 Receiver Bandwidth . . . Selectable: 6 or 16 kc
 Receiver Sensitivity . . 0.5 μ v for 2:1 signal-to-noise
 Receiver Dyn. Range . . Greater than 30 db.
 Power Output 500 watts.
 Operating Controls . . Pulse length, repetition rate, receiver gain and bandwidth, manual or automatic frequency step.
 Frequency Stability . . 5 x 10⁻⁸ parts per week.

Also Available: Model 903 Step-Freq. Receiver, identical to Model 902 without transmitter section; Model 904 Step-Freq. Transmitter, identical to Model 902 without receiver section; 30, 60, or 100 kw Pulse Distributed Amplifiers, and antennas for Sounder.

This fast-frequency-stepping sounder is an extremely flexible tool for ionosphere research and instantaneous optimum frequency measurement for communications. Up to 1600 frequencies from 4 to 64 megacycles are derived from a single ultra stable reference, and are electronically selected at rates up to 50 frequency changes per second.

The complete system can be used for vertical incidence or back-scatter sounding, and two equipments can be remotely synchronized for oblique incidence path-loss recording. Operation is entirely electronic—there are no mechanical switches or tuning devices. The entire system, including a special antenna, was conceived and produced by Granger Associates. Send for data sheets, and for a new brochure describing G/A's unique design and manufacturing experience in pulse systems, wide-band rf components micro-wave tube applications, and other advanced techniques. Inquire about openings on our engineering staff.

Circle 2 on reader service card

Granger Associates / 974 Commercial Street / Palo Alto, California / DAVenport 1-4175

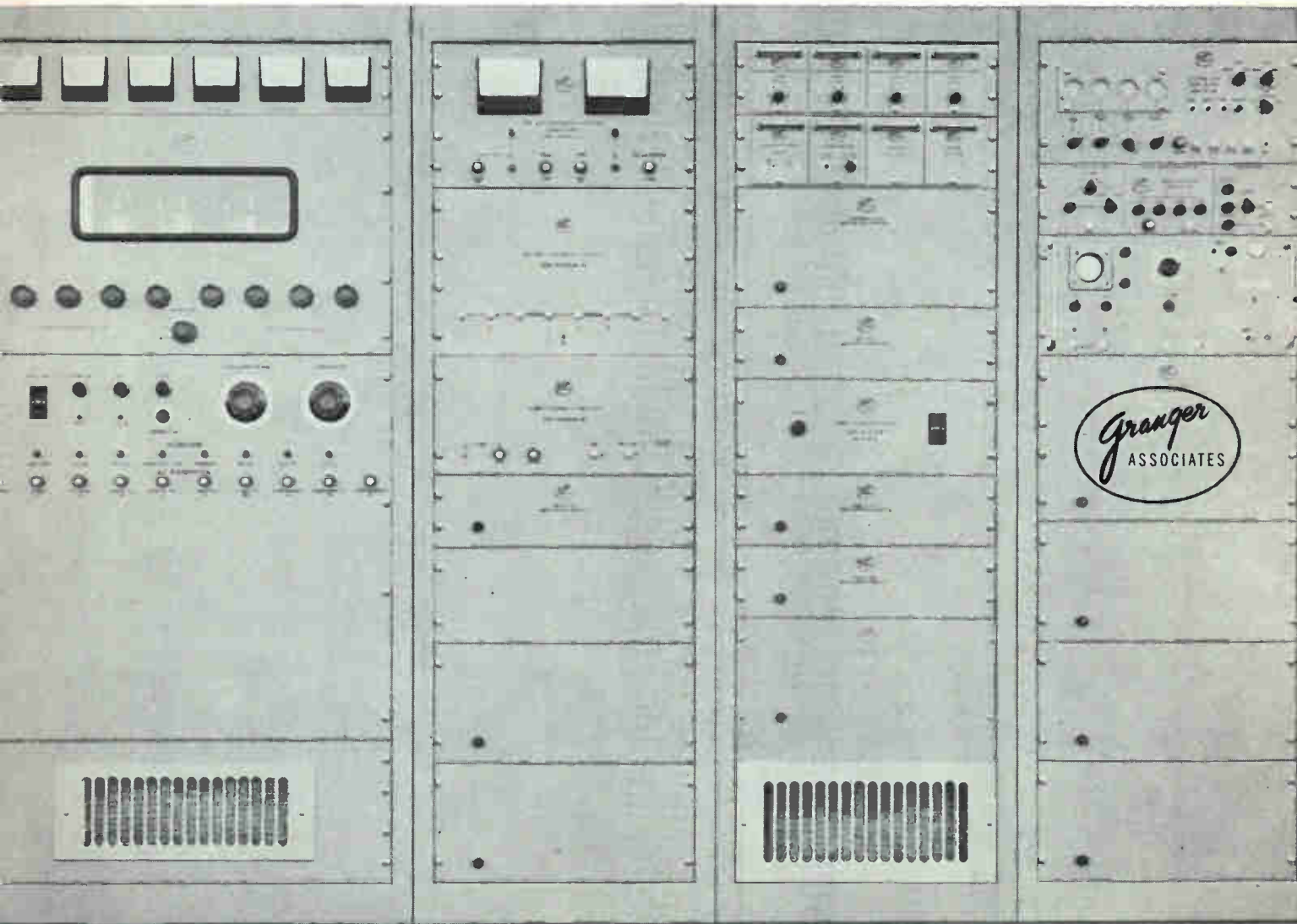



TIROS relies on LAMBDA reliability

Standard Lambda Regulated

Power Supplies have again been selected for a job where reliability and quality are of vital importance. They power the ground equipment in the primary and back-up stations that control and track America's newest missile—TIROS.

In TIROS as in SAGE, Digital Computer Intervention and Display System and other leading electronic projects, Lambda Power Supplies are specified because Lambda equipment has consistently proven its reliability.

This same Lambda quality is the reason Lambda Power Supplies are consistently selected *first* by engineers in independent surveys. To find out more about Lambda Supplies, which are guaranteed for a full five years, send today for the Lambda Catalog. It gives data on Lambda's complete line of tube models ranging up to 525 VDC and transistor models up to 10 Amps.

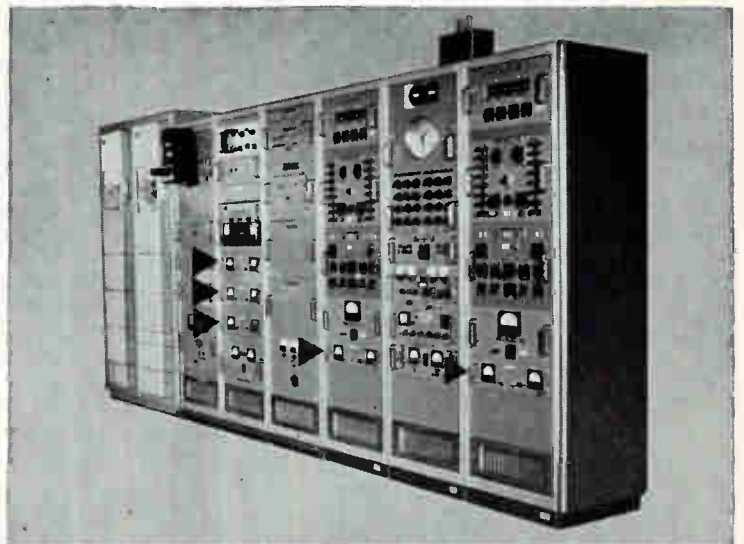

The Tiros System

Sponsored: National Aeronautics and Space Administration
Technical Direction: U. S. Army Signal Research and
Development Laboratory

Developed and Built: Astro- Electronic Products Division,
Radio Corporation of America



LAMBDA ELECTRONICS CORP.

11-11 131 STREET • DEPT. 1 • COLLEGE POINT 56, N. Y. • INDEPENDENCE 1-8500

Published weekly, including the ELECTRONICS BUYERS' GUIDE and REFERENCE Issue in mid-July as part of the subscription, by McGraw-Hill Publishing Company, Inc., James H. McGraw (1860-1948) Founder.

Executive, Editorial, Circulation and Advertising Offices: McGraw-Hill Building, 330 W. 42 St., New York, 36, N. Y. Longacre 4-3000. Publication Office: 99-129 North Broadway, Albany 1, N. Y. See panel below for directions regarding subscriptions or change of address.

OFFICERS OF THE PUBLICATIONS DIVISION: Nelson L. Bond, President; Shelton Fisher, Wallace F. Traendly, Senior Vice Presidents; John R. Callahan, Vice President and Editorial Director; Joseph H. Allen, Vice President and Director of Advertising Sales; A. R. Venezian, Vice President and Circulation Coordinator. **OFFICERS OF THE CORPORATION:** Donald C. McGraw, President; Joseph A. Gerardi, Hugh J. Kelly, Harry L. Waddell, Executive Vice Presidents; L. Keith Goodrich, Vice President and Treasurer; John J. Cooke, Secretary.

Subscriptions are solicited only from persons engaged in theory, research, design, production, management and use of electronic equipment. **POSITION and COMPANY CONNECTION** must be indicated on subscription orders. Subscription rates for individuals within the field of the Publication: United States and United States Possessions, \$6.00 one year; \$9.00 two years; \$12.00 three years. Canada, \$10.00 one year. All other countries \$20.00 one year. Single Copies, United States, United States Possessions and Canada 75¢; Buyers' Guide \$3.00; Single Copies all other countries \$1.50; Buyers' Guide \$10.00.

Our primary aim is to provide subscribers with a useful, valuable publication. Your comments and suggestions for improvement are encouraged and will be most welcome. The publisher, upon written request from any subscriber to our New York Office, agrees to refund the part of the subscription price applying to copies not yet mailed.

Second class postage paid at Albany, N. Y. Printed in U.S.A. Copyright 1960 by McGraw-Hill Publishing Co., Inc.—All Rights Reserved. Title registered in U. S. Patent Office.

BRANCH OFFICES: 520 North Michigan Avenue, Chicago 11; 68 Post Street, San Francisco 4; McGraw-Hill House, London E. C. 4; 85 Westendstrasse, Frankfurt/Main; National Press Bldg., Washington 4, D. C.; Six Penn Center Plaza, Philadelphia 3; Four Gateway Center, Pittsburgh 22; 55 Public Square, Cleveland 13; 856 Penobscot Bldg., Detroit 26; 3615 Olive St., St. Louis 8; 350 Park Square Bldg., Boston 16; 1301 Rhodes-Haverty Bldg., Atlanta 3; 1125 West Sixth St., Los Angeles 17; 1740 Broadway, Denver 2; 901 Vaughn Bldg., Dallas 1. **ELECTRONICS** is indexed semiannually, in July and December, and regularly in The Engineering Index.

Subscriptions: Send subscription correspondence and change of address to Fulfillment Manager, Electronics, 330 West 42nd Street, New York 36, N. Y. Subscribers should notify Fulfillment Manager promptly of any change of address, giving old as well as new address, and including postal zone number, if any. If possible, enclose an address label from a recent issue of the magazine. Since copies are addressed one to two issues in advance, please allow one month for change of address to become effective.

Postmaster: please send form 3579 to Electronics, 330 W. 42nd St., New York 36, N. Y.



Audited Paid Circulation



ELECTRONICS PROBES NATURE. That is the title of a 34-page special report complete in this issue. The report tells how electronic instruments are helping man study the earth, oceans, living matter, our atmosphere and outer space. You will want to save the full-color fold-out.

One type of probe is shown in the photograph. It is a proton precession magnetometer in the torpedo-like structure on the fantail of the oceanographic ship *Vema*. The unit, developed by Lamont Geophysical Laboratory, is towed 500 to 600 ft behind the ship a few feet under the water.

For information on magnetometers and other equipment now helping man to fully understand his environment turn to the special report by Associate Editor Bushor and Assistant Editor Wolff beginning on p 53.

COMPUTERS IN MOSCOW. Soviet computer activity highlighted this year's International Federation of Automatic Control convention held in Moscow. McGraw-Hill Bureau Chief Ernest Conine was on hand for the event as was Derek Barlow of our London Bureau. Together they attended convention sessions, toured exhibits, including one set up by British instrument manufacturers, and buttonholed delegates.

General opinion is that the Soviets are long on theory, short on hardware. Industry applications of many control techniques discussed seem a long way off. For more information on Soviet plans and details on some of their accomplishments, see p 36.

DOING BUSINESS ABROAD. U. S. electronics firms have a big stake in overseas markets. Sales last year topped \$400 million. This market, however, is a declining one getting tighter each year. High tariffs, restrictive standards, currency problems and growing nationalism are only some of the factors working against electronic exports. Nevertheless, U. S. manufacturers feel they can still do business profitably abroad.

Recently in Washington, representatives of 17 electronic companies met with officials of the Department of Commerce to hammer out some of these points. Associate Editor Emma has been speaking with men who were at this meeting as well as with the Washington officials. To learn the shape of the problem and some possible solutions, see p 43.

Coming In Our August 5 Issue

MAGNETOMETERS. As brought out in this issue's special report, one instrument being developed for the next generation of space probes is the optically pumped alkali vapor magnetometer. Slated for a NASA space probe in a Thor-Delta vehicle, a rubidium vapor magnetometer will measure fields as low as 1 gamma, the value believed necessary to learn the nature of lunar, planetary and extraterrestrial magnetic fields.

In our next issue, D. Mansir of Varian Associates in Palo Alto explains the operation of the rubidium vapor magnetometer, as well as the proton precession magnetometer. The proton precession device was used in the Vanguard III satellite and extensively in sounding rockets fired from Fort Churchill, Canada.

ALL UNITS ACTUAL SIZE



HYREL[®] FB
DEPOSITED CARBON RESISTORS
ARE UNMATCHED FOR
PERFORMANCE



HYREL[®] FB DEPOSITED CARBON RESISTORS

are hermetically sealed in ceramic jackets against moisture and vapor... **safely protected** against mechanical abuse.

The Hyrel FB series is intended for applications in military, commercial and telephone equipment where **long life under high humidity, small size, and stability of electrical characteristics** are important.

WRITE FOR ENGINEERING BULLETIN 7010B
SPRAGUE ELECTRIC COMPANY
35 MARSHALL STREET • NORTH ADAMS, MASS.



Made to far exceed MIL-R-10509C Specifications

SPRAGUE COMPONENTS:

CAPACITORS • RESISTORS • MAGNETIC COMPONENTS • TRANSISTORS • INTERFERENCE FILTERS • PULSE NETWORKS
HIGH TEMPERATURE MAGNET WIRE • CERAMIC-BASE PRINTED NETWORKS • PACKAGED COMPONENT ASSEMBLIES

COMMON MODE REJECTION

Low level d-c signals produced by strain gages or thermocouples are best amplified by differential input d-c amplifiers. A differential input d-c amplifier is one which measures the difference between two voltages regardless of the absolute value of the voltages.

The schematic (Fig. 1) shows a differential input amplifier, the difference or differential mode voltage (E_d), and the total voltage common to both input terminals (termed the common mode, E_c).

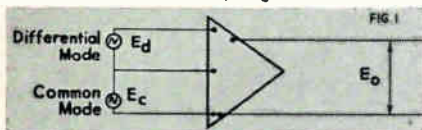

"Common mode rejection" (C.M.R.) refers to a differential input amplifier's ability to measure E_d without errors due to E_c . It is proportional to the ratio of common mode voltage and the equivalent differential input voltage produced by the common mode voltage or

$$\text{C.M.R.} = \frac{E_c}{E_o \text{ due to } E_c} \times \text{gain.}$$

Rejection is generally given for a-c as well as d-c common modes.

Testing amplifiers

for Common Mode Rejection

To determine the C.M.R. of a given differential input d-c amplifier, the input is shorted and connected to a source of common mode voltage as shown. Both d-c and a-c values should be applied and the amplifier output measured with devices of suitable sensitivity (Fig. 2). The C.M.R. is calculated by dividing the product of amplifier gain

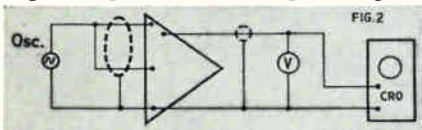

and common mode voltage by the observed output voltage due to the common mode voltage. Since some amplifiers suffer a decrease in gain with a common mode voltage, amplifier gain should be checked with common mode voltage applied. When simulating a differential mode signal, care should be taken to provide an appropriate source of impedance oriented to ground in a manner similar to that of the actual transducer used. For information showing these procedures in detail write for Bulletin BE AN123.

Less than 0.02% error

Honeywell AccuData II Differential Input D-C Amplifier is specified to have common mode rejection of 1,000,000 at d-c, 200,000 at 60 cps, and 5,000 at 400 cps, with full scale differential input of 3 to 30mv. Maximum allowable common mode voltages are 100 v d-c, 15 v pk at 60 cps, and 3 v pk at 400 cps. Adjustment of a C.M.R. balance on the front panel compensates for up to 5 ohms unbalance in either input lead. Thus, either a 1 v 60 cps or 5 v d-c common mode voltage applied to the AccuData II produces only 5 μ v eq. in error signal, or less than 0.02% of the 30 mv full scale input signal.



The AccuData II has single-ended as well as differential input ranges, input impedance of 2 megohms differential (20 megohms single-ended), and power output sufficient to drive the highest frequency galvanometer oscillograph to its maximum deflection. In addition to excellent common mode rejection, the unit offers exceptional zero stability and linearity, very low noise and frequency response to 20 kc. For complete specifications on common mode rejection as well as on other characteristics of the AccuData II, write for Bulletin BS-DISA-1000 to Minneapolis-Honeywell, Boston Division, Dept. 7, 40 Life Street, Boston 35, Mass.

Honeywell



First in Control
SINCE 1885

COMMENT

Back Issues Available

I have on hand a complete file of ELECTRONICS dating from January 1936 through December 1958 which I must dispose of due to the lack of space in our future location.

I would appreciate finding out if there might be an interested party who might wish to acquire such a file for a reasonable offer. All the magazines are in excellent condition.

The files include—besides the regularly issued magazine—all the Buyers Guides and other extra issues that you published . . .

ROBERT G. REED

ROBERT G. REED ASSOCIATES
PITTSBURGH

Japanese Production Workers

Your article on Japanese production workers ("Japanese Production Workers: A Closeup," p 36, Apr. 1) was very interesting to us too.

Mr. R. C. Sprague sensed an error in the cost of the fringe benefits at the Totsuka plant of Hitachi (Comment, p 6, June 17). The 30-million-yen figure may be right; but 30 million yen is not \$833,000.

The misprint seems to be the cause of the misunderstanding.

ANDREW OSAMU IJIMA

MATSUSHITA ELECTRIC
OSAKA, JAPAN

Our article said "30 million yen (\$833,000) a month went toward operating the schools, a hospital, etc., for employees." Our calculator has a floating point; the error is ours. Hitachi budgets \$83,000 a month for those benefits. In the preceding sentence in the article, we mentioned yearly expenditures of 35 million yen for other benefits; this figure was translated as \$972,000, which is also too large by an order of magnitude.

Reader Sprague's intuition—that the fringe benefits were "rather incredible"—was certainly justified.

Manager Kubo of the Hitachi Totsuka plant also wrote us recently:

We were glad to see the description of our plant, and I appreciate the way you described it very much.

It has invited considerable comment throughout Japan.

Since your editor was here, both the Misses Otsu and Noji continue in good health; they are grateful to you inasmuch as it is an honor to be introduced in an internationally famous magazine.

Regarding the recent unrest here, we businessmen, especially those of us directly responsible for industrial activity, look on it as very regrettable.

Some of the intellectuals who are not concerned with business activities, are against the U. S.-Japan security treaty, although they take a different position from that of the Zengakuren and Sohyo. But most of the people consider this incident to be very unpleasant and disgraceful. I am sure this will be proved by the results of the general elections which are supposed to be held in the near future. I believe that the attitude which has been taken so far toward Japan by the editors of ELECTRONICS has been right and correct, and will continue to be the same in the future.

We Japanese are grateful from the bottom of our hearts for the generosity which has been expressed by most Americans in regards to this unfortunate incident.

TOSHIHIKO KUBO

HITACHI TOTSUKA WORKS
YOKOHAMA, JAPAN

Absorber Ceramics

I would like to call your attention to, and to correct, an error contained in a CFI Corporation product release ("Absorber Ceramics for Microwave Applications," New On The Market, p 102, July 1).

The sentence "A typical high-power absorber ceramic. CFI-1003, exhibits exceptionally high losses of 9.05 db per cm at 25 C, and *minimum* attenuation over an extremely wide range of frequencies," should read "... *uniform* attenuation over an extremely wide range of frequencies."

Because the entire significance of our microwave absorber ceramic material is negated due to this error in copy, we would appreciate it greatly if you would permit us to make this correction . . .

E. J. HOFFMAN

CFI CORP.
MINEOLA, N. Y.

July 29, 1960

the first complete line of TRANSISTOR VOLTMETERS . . .



6 ALL-TRANSISTOR MIL TRVMs

- miniature, panel-mounting, for build-in applications
- power supplies included—no battery replacement or checks needed
- isolated inputs • low power consumption
- compact (as small as 2.85" diameter by 6" deep including terminals)
- lightweight • longer life

Model	Meter	Description	Price
301-1 AC TRVM	3½"	zero-left, from 10MV range	\$250.00
302-1 AC TRVM	3½"	zero-center, phase sensitive, from ± 10MV	275.00
303-1 AC TRVM	2½"	50% less panel area than Model 301-1	275.00
304-1 AC TRVM	2½"	zero-center, phase sensitive, from ± 10MV	300.00
305-1 DC TRVM	3½"	zero-center, no zero-set, ± 100MV range	225.00
305-2 DC TRVM	3½"	zero-left version of 305-1, 250MV range	225.00

Note: Due to heavy demand, present delivery of most models is 6-8 weeks. For complete literature, write to Dept. E-7.

... when ordinary instruments are too big or inadequate.



TRIO LABORATORIES, INC.
Plainview, Long Island, New York
Overbrook 1-0400 • TWX HKVL 1166

© 1960, Trio Laboratories, Inc.

CIRCLE 7 ON READER SERVICE CARD

7

These pages from the new **hp** catalog in **WAVE ANALYZERS** in 10 years!

hp 302A WAVE ANALYZER



New, Transistorized — Directly Measures Wave Components

Advantages:

- No calibration or stabilization needed
- Direct readings; accurate
- Measures frequencies 20 cps to 50 KC
- Completely transistorized
- Battery or ac powered; hum free
- Low power consumption; no warm-up needed
- Very sharp acceptance circuits
- AFC; also frequency restorer circuit
- Compact, rugged, versatile

Uses:

Measures and analyzes fundamentals, harmonics, and intermodulation products in telemetering, carrier and vibration systems as well as audio circuits. Speeds analysis of noise and broadcast amplifier characteristics; modulation amplifier, film sound track and recording distortion; hum, network characteristics, etc.

NEW MODEL 302A Wave Analyzer represents a significant improvement in wave analyzer design. Completely transistorized, sophisticated in design, highly selective, free of tedious calibration and stabilization before use—these are but a few of the important convenience and accuracy features in the new 302A.

Other exceptional features are low power consumption (in the order of 3 watts), provision for battery operation (18 to 28 volts) as well as ac line power, and elimination of warmup time.

Simple Operation

In operation the instrument functions as a highly selective tuned voltmeter. A front panel control selects the frequency to be measured and voltage is then read directly on the front panel meter.

Basically, Model 302A functions by separating an input signal into individual components so that each—the fundamental, harmonics and any intermodulation products—may be evaluated separately.

The instrument operates by mixing the input signal with an internal oscillator adjusted to provide a difference frequency of 100 KC. An automatic frequency control circuit maintains a constant difference frequency between the input and oscillator signals. This insures accurate measurements despite frequency drift in the input signal. After modulation by a voltage from the internal oscillator the

announce the first major improvement

signal is passed through a narrow-band crystal filter, amplified and metered.

Frequency Restorer

A frequency restorer circuit makes accurate frequency measurements possible at each component's frequency of the input wave. This circuit supplies a sinusoidal signal at the frequency of the specific component which can be measured on an electronic counter or observed on an oscilloscope. The amplitude of this signal is determined by the level of the selected component. When the mode selector switch is in the normal or AFC position, the signal appears at the output terminals if the meter is indicating.

Model 302A is also particularly useful for measuring small signals on noisy systems or transmission lines. When the mode selector is switched to "BFO" the instrument becomes an oscillator and tuned voltmeter automatically tuned by one control to the same or oscillator frequency. The selective tuned voltmeter then discriminates against the noise and measures the desired signal.

Speed and accuracy of measuring is enhanced by a linearly calibrated tuning control giving the same "tuning feel" throughout range.

Basic Laboratory Instrument

Covering the frequency range of 20 cps to 50 KC, the new 302A is equipped to perform a wide variety of daily measurements. It has broad usefulness not only in audio measurements but in vibration work, telemetry, and carrier applications. The instrument is compact, rugged and features conservative design and high quality throughout.

Specifications

Frequency Range: 20 cps to 50 KC.

Frequency Calibration: Linear graduation 1 division per 10 cycles. Accuracy $\pm(1\% + 5\sim)$.

Voltage Range: 3 μ v to 300 v, full scale readings of:

300 v	300 mv	300 μ v
100 v	100 mv	100 μ v
30 v	30 mv	30 μ v
10 v	10 mv	
3 v	3 mv	
1 v	1 mv	

Ranges provided by an input attenuator switch and a meter range switch in steps of 1:3 or 10 db. Meter range is indicated by a dial mechanically linked to input attenuator. An absolute-relative switch, in conjunction with a variable 10 db control is provided for adjustment of intermediate values.

Warm-Up-Time: None.

Voltage Accuracy: $\pm 5\%$ of full scale value.

Residual Modulation Products and Hum Voltage: Greater than 75 db down.

Intermediate Frequency Rejection: Intermediate frequency present in input signal rejected by at least 75 db.

Selectivity: $\pm 3\frac{1}{2}$ cycle b.w.—at least 3 db down
 ± 25 cycle b.w.—at least 50 db down
 ± 70 cycle b.w.—at least 80 db down
 beyond ± 70 cycle b.w.—at least 80 db down

Input Impedance: Determined by setting of input attenuator: 100,000 ohms on 4 most sensitive ranges, 1 megohm on remaining ranges.

Selected Frequency Output: 1 v open circuit at output terminals for full scale meter deflection. Output level control provided. Frequency response ± 1 db, 20 cycles to 50 KC. Output impedance approximately 600 ohms.

B. F. O. Output: 1 v open circuit at output terminals. Output level control provided. Frequency response ± 1 db, 20 cps to 50 KC. Output impedance approximately 600 ohms.

Automatic Frequency Control: Range of frequency holdin is ± 100 cycles minimum.

Power: 115/230 v $\pm 10\%$, 50/1600 cycles, 3 watts (approximately). Terminals provided for powering instrument from external battery source. Battery supply range 28 v to 18 v.

Weight: Net 43 lbs. Shipping 63 lbs. (cabinet mount).
 Net 35 lbs. Shipping 55 lbs. (rack mount).

Dimensions: Cabinet Mount: 20 $\frac{3}{4}$ " wide; 12 $\frac{1}{2}$ " high; 14 $\frac{1}{2}$ " deep. Rack Mount: 19" wide; 10 $\frac{1}{2}$ " high; 13 $\frac{1}{2}$ " deep.

Price: \$1,750.00 (cabinet); \$1,735.00 (rack mount).

Data subject to change without notice.

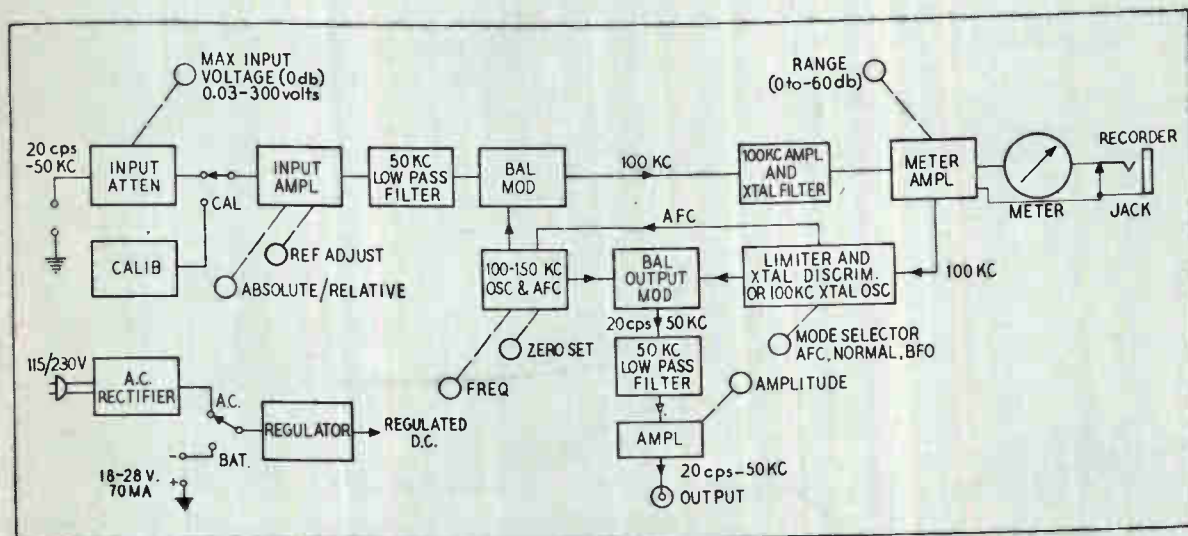

Figure 1. Block diagram, Model 302A Harmonic Wave Analyzer



HEWLETT-PACKARD COMPANY

Dept. 5487A, 275 Page Mill Road, Palo Alto, California, U.S.A.

Cable HEWPACK • Davenport -7000
 Field representatives in all principal areas

CIRCLE 9 ON READER SERVICE CARD

product of the pioneer

DU MONT ANNOUNCES TWO RADICALLY NEW CATHODE-RAY TUBES



The first cathode-ray tubes ever available with this combination of important features

—linear post-accelerator—a spiral resistance winding from tube face to deflection plate for more precise, incremental acceleration; pattern adjustment electrode—to minimize pattern distortion; astigmatism electrode—for optimum spot shape adjustment; new deflection plate construction—minimizing plate splash for more accurate displays. These, plus tighter specifications with higher deflection sensitivity—establish new standards for modern equipment design.

TYPICAL OPERATING CHARACTERISTICS

Parameter	Low-Frequency	High-Frequency
Post Accelerator Voltage	5000	> 10,000
Accelerator Voltage	1400	1400
Pattern Adjustment Electrode Voltage	1400	1400
Astigmatism Electrode Voltage	1400	1400
Focusing Electrode Voltage	180-580	180-580
Spot Size (single layer screen)	0.024	
D ₁ , D ₂ less than	35 V	60 V
D ₃ , D ₄ less than	35 V	22 V
Useful Scan		
D ₁ , D ₂	4½	3.94
D ₃ , D ₄	4½	> 1.96

FEATURES

- ★ Linear (spiral) post accelerator
- ★ Pattern adjustment electrode
- ★ Astigmatism control
- ★ High deflection sensitivity
- ★ Tight tolerances
- ★ Conductive coating for pattern control
- ★ Minimum distortion of pattern
- ★ New deflection plate construction



Write for complete details
ELECTRONIC TUBE SALES.

precision electronics is our business

ELECTRONIC TUBES/INDUSTRIAL TV/MILITARY ELECTRONICS/MOBILE COMMUNICATIONS/SCIENTIFIC INSTRUMENTS/AUTOMOTIVE TEST EQUIPMENT

Allen B. DuMont

ALLEN B. DU MONT LABORATORIES, INC., CLIFTON, N. J., U. S. A.

INTERNATIONAL DIVISION • 515 MADISON AVENUE, NEW YORK 22, N. Y. • CABLES: ALBEEDU, NEW YORK

ELECTRONICS NEWSLETTER

Energy Converters Use Thermionics, Thermocouples

TWO THERMOELECTRIC DEVICES, recently revealed, were developed half-way around the world from each other.

RCA Laboratories announced a new thermionic energy converter with 14-percent efficiency that operates at temperatures produced by combustion of fossil fuels such as kerosene and natural gas. A thermionic cathode heated to 1,100 C and a specially formed anode surrounded by cesium vapor are enclosed in a glass envelope. Earlier models required cathode temperatures in excess of 2,000 C for satisfactory efficiency. New cathode materials and different internal electrode arrangement are credited with the low temperature requirements of the new converter.

A thermoelectric generator using thermocouples and burning fossil fuels was reported by South African engineer Abe Kadish, Johannesburg. Heart of the device is a head made of eight different metals, including antimony, lead, tin, zinc, chromium, nickel and copper. In each generator, several heads are connected in series to produce useable power. Demonstration model produces $8\frac{1}{2}$ v at 300 ma, runs for 98 hours on a gallon of kerosene.

In related research, General Electric recently got a USAF contract for \$697,000 to investigate thermionic converters, another for \$300,000 to develop a thermionic power system, and a \$58,574 Army Signal Corps contract for R&D on a regenerative fuel cell.

Defense Needs Spark R&D Efforts

DEFENSE REQUIREMENTS continue to act as a spur to electronics development efforts.

Airborne Instruments Lab division of Cutler-Hammer is producing a video integrating system which combines coherent moving-target indicator, velocity shaping canceler, and other techniques to eliminate or minimize clutter, accidental interference and jamming. Air Force has bought \$10.3 million worth of

the systems to sort out and filter radar data for presentation to the Sage system.

Navy's Bullpup missile will get a new automatic command-guidance system to be built by Republic Aviation under \$782,576 contract from Grumman. New system uses closed-loop radar command, lines up target and launched missile, closes the missile for the kill by in-flight correction. Up to now, Bullpup has been eyeballed onto target by the pilot, who watched two flares on the missile and controlled the radio-guidance system accordingly.

North American Aviation has copped a \$70,764 Army contract to investigate feasibility of a two-axis inertial guidance system for a short-range ballistic missile.

Stromberg-Carlson will build two engineering test models of an advanced single-sideband tactical radio system. Equipment will be transistorized, is being built under \$1.1-million contract from Army Signal R&D Labs.

Melpar has been commissioned by Air Research & Development Command to determine trends for use in future airborne gear of molecular electronic techniques.

Japanese Push Over-Horizon Systems

GOVERNMENT AID continues to be a significant factor in development of electronics in Japan and in Japanese industry's worldwide market expansion.

Item: Nippon Electric last month completed work on a 50-Kw linear klystron developed under partial government subsidy. The \$170,000 tube, designated LD-247, is 5 ft long by 1.6 ft dia, is a three-cavity type with cathode bombardment, uses a pure tantalum emitter. Maximum beam current is 5 amp, and beam voltage is 30,000 v. The collector is water-cooled and the cavity is forced-air cooled. Efficiency is 38 percent at a gain of 85 db.

Item: Action by the Ministries of Finance and International Trade & Industry have given NEC a favorable position with respect to RCA in competition for a microwave over-horizon system for Egypt. The

two ministries agreed to shuffle fiscal allocations so that NEC can extend a deferred-payment plan that would let the United Arab Republic pay off the cost of the system over a 16 or 17 year period beginning 1 or 2 years from the contract date. The ministries also agreed to let the down payment ride. RCA, also bidding on the \$80-million deal, had reportedly offered a 20-year deferred-payment plan to start two years from the contract date.

Plan Communications Net for Western Hemisphere

INTERAMERICAN telecommunications system to link the nations of the North and South American continents is being planned by the Organization of American States.

Microwave links will form the main trunks of the system, with submarine cables planned for use in the Caribbean basin. Each country will be responsible for the portion of the system on its own territory. Total cost will run \$232 million.

Services under consideration for the system include telephone, telegraph, telex, facsimile, data-transmission, broadcasting, tv, alarm and public order.

Representatives from the nations involved met recently in Mexico City to plan a permanent organization to carry out the project. Charter will be worked out after ratification.

British Firm Cuts Tv Set Production

ONE LEADING British television set-maker is cutting back production. Murphy Radio, in making a 20-to-25-percent cutback in output at its big plant in Wales, said reimposition of government credit controls and restrictions on installment buying had caused a drop in public demand.

Despite softening trend of retail demand (120,900 sets were sold in the United Kingdom in May, compared with 133,900 in April and 165,200 in May 1959), tv set production has remained high and dealers are overstocked. Dealers now profess alarm at the potential impact of credit restrictions, have trimmed their orders to factories.

AB₁

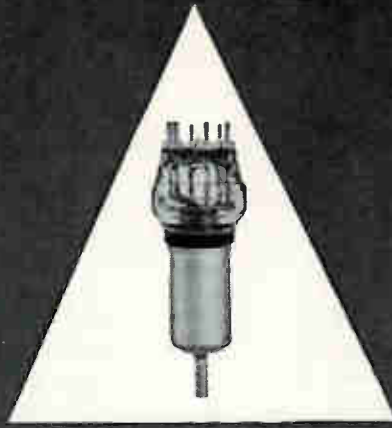

NEED 500 WATTS...OR 75,000 FOR CLASS AB₁ SERVICE?

LOOK WHERE
YOU CAN USE
WESTINGHOUSE
HIGH POWER AB₁
AMPLIFIER
TUBES:

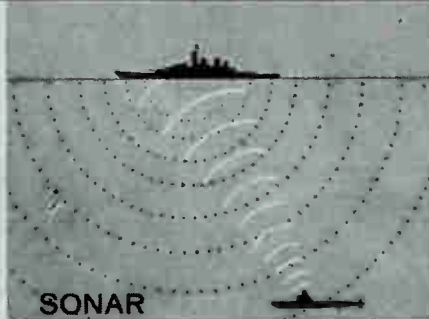

SONAR



MISSILE SHAKER TABLES

Westinghouse high power amplifier tubes in class AB₁ service provide low distortion, high dissipation, high power gain and zero watts drive! For specifications, or information about new applications including **Sonar** and **missile shaker tables**, call or write: Electronic Tube Division, Westinghouse Electric Corporation, Elmira, N. Y.

TYPE	P _o WATTS
WL 7371	100
WL 7685	500
WL 7464	5000
WL 7540	35,000
WL 6379	75,000

YOU CAN BE SURE...IF IT'S **Westinghouse**
Westinghouse Electronic Tube Division, Elmira, N. Y.

NORTH ATLANTIC
industries, inc.



PHASE ANGLE AND RATIO INSTRUMENTS

PHASE ANGLE VOLTMETER MODEL VM-202



FOR DIRECT READING OF...

- Phase angle
- In-phase voltage
- Quadrature voltage
- Fundamental voltage
- Total voltage
- Nulls

A unique, multi-functional instrument that combines in one compact package a phase-sensitive voltmeter, AC vacuum tube voltmeter, phase meter and phase-sensitive null detector. Permits simple laboratory or production line measurement of total, fundamental, in-phase and quadrature voltage components; phase-sensitive nulling of in-phase or quadrature components; direct dial reading of phase angle without ambiguity. Characteristics include high input impedance, high sensitivity and wide voltage range. Optional parallel

rear connectors, built-in reference channel isolation, built-in signal isolation for balanced or single-ended inputs, panel finishes to user specifications. Plug-in modules for reference isolation, signal summing and signal bridging available as optional accessories.

MODEL VM-233 PORTABLE TRANSISTORIZED VOLTMETER. All features of VM-202 in an all-transistor, ruggedized, low power unit for general field use and other applications where small size and light weight are essential.

SPECIFICATIONS

These specifications describe the Model VM-202 Phase Angle Voltmeter only. The wide range of available standard and custom models are shown on this page. Detailed specifications for other models will be supplied promptly on request.

NULLING SENSITIVITY5 microvolts	VOLTAGE RANGE1 mv. to 300V, in 12 ranges
HARMONIC REJECTION55 db (with filters)	VOLTAGE ACCURACY±2% of f.s.
SCALE3-0-3, 10-0-10, linear	PHASE ACCURACYdial: ±1° meter: ±3% of f.s. degrees
PHASE ANGLE DIAL4 scales, 90° (elec.) apart	SIGNAL FREQUENCY1 freq., 30 cps-10 kc.
POWER60 watts, 115V, 60-400 cps.	INPUT IMPEDANCE10 megohms
DIMENSION5¼" h. x 19" w. x 7⅞" d.	REFERENCE INPUT100,000 ohms, 0.25V min.
MOUNTINGbench or rack	OVERLOAD5:1

MODEL VM-204



THREE-FREQUENCY VOLTMETER. For use where signals of known frequencies are encountered repeatedly. Similar to VM-202, but accommodates any three pre-specified signal frequencies, typically 400, 800 and 1000 cps. Choice of frequencies from 60 to 4500 cps in standard models; to 10 kc on special order. Panel size and configuration as VM-202, but 2" deeper case.

AC - to - DC CONVERTER MODEL PSC-410

Transistorized, phase sensitive AC-to-DC converter features high linearity and sensitivity, flat frequency response, high output. Single- or double-ended output proportional to total, fundamental, in-phase or quadrature components. Compact modular, plug-in configuration readily integrates with ground or airborne instrument systems.

BROADBAND VOLTMETER, MODEL VM-301. For laboratory and other applications where a wide range of signal frequencies must be instrumented with highest accuracy. Accommodates signals from 10 cps to 100 kc. Phase shift accuracy 0.2° absolute, 0.01° with special techniques, uniform over full 360°. Phase shift can be read while sweeping frequency in full decade steps. Plug-in rejection filters eliminate harmonic effects. Null indications are insensitive to changes in signal level. Rack or bench mount.

MODEL VM-230B



TRANSISTORIZED VOLTMETER.

Miniature, ruggedized version of VM-202 for modular inclusion in ground support and similar systems requiring small size and dependable performance in severe environments. Range down to 300 microvolts on special order. Input impedance 1 megohm direct; 120h, 0.5 meg. at 400 cps with isolation transformer. Frequency response 20 cps to 20 kc as VTVM.

RATIO BOXES



RATIO BOX		SPECIFICATIONS	
Ratio Range	-0.111111 to +1.111111	Input Volts	0.35f to 1.0f (350V max.)
Frequency Range	25 cps to 10 kc	Series Z	3.5 to 7.5 ohms
Accuracy	from 10 ppm to 1 ppm	Resonant Frequency	400 cps to 10 kc.
Input Z	300 k to 1.0 meg.	Size (typical)	3¼" h. x 19" w. x 8½" d.

Table shows range of available characteristics. Specific combinations of characteristics differ with particular models and will be quoted on request.

Precision inductive AC voltage dividers to meet all range, accuracy and cost requirements. Rack and portable bench models, deviation, binary, automatic stepping types and ratio standards. Maintain rated accuracy over specified frequency range; feature in-line readout, high input and low series impedance.

CVR 550 COMPLEX VOLTAGE RATIO METER

Provides direct reading of in-phase transformation ratio to 0.0001% with phase angles to 0.2 radians, unaffected by quadrature. Combines ratio box and phase angle voltmeter in a single efficient unit. For signals at any three frequencies from 400 to 2000 cps.

Write or call for literature or quotations on your requirements

NORTH ATLANTIC INDUSTRIES, INC.
TERMINAL DRIVE, PLAINVIEW, L. I., N. Y. • Overbrook 1-8600



INSTRUMENTATION AND CONTROL SYSTEMS

SEE US AT WESCON—BOOTH 933-934

WEINSCHEL

COAXIAL TERMINATIONS

DC to 10 KMC
50 ohms

Connectors: N, C, SC, BNC and TNC
Individual VSWR calibrations supplied at seven frequencies: DC, .4, 1, 2, 4, 7.5 and 10 KMC.

Made with Weinschel Film Resistors for maximum stability.



Weinschel Fixed Coaxial Attenuators cover the frequency range of DC to 12.4 KMC. Write for complete catalog.

Weinschel Engineering
KENSINGTON, MARYLAND

WASHINGTON OUTLOOK

LOOK FOR A HEAVIER FLOW of new defense contracts in the three months preceding the Presidential elections.

Normally there is a Summer-Fall slump in military business. From July to October of last year, for instance, contracts averaged less than \$1 billion a month, compared with \$1.9 billion monthly for April-June 1960.

But harking back to the pickup in new orders prior to the 1956 elections, Pentagon insiders anticipate more new orders than usual this season. There were no written orders four years ago; just a few Pentagon phone calls to key procurement agencies in the field. Contracting officers were given the green light on big projects which normally might have bogged down in the Defense Department.

OPERATIONAL READINESS of the first four Atlas ICBM squadrons will be delayed from three to six months. Delays have been caused by tieups in construction of launch facilities and installation of ground support and checkout equipment. Production of the missiles and of electronic sub-systems is not involved.

The first four nine-launcher Atlas squadrons will be soft (unprotected) or semi-hard installations at Warren AFB, Cheyenne, Wyo.; Offutt AFB, Omaha, Nebr.; Fairchild AFB, Spokane, Wash., and Forbes AFB, Topeka, Kans. They will become combat-ready later this year and early in 1961, as construction work now shapes up.

The General Electric-Burroughs radio-command guidance system will be deployed at the first Atlas sites. Arma's all-inertial system will go into six hard sites scheduled for completion in late 1961 or early 1962.

Work on five bases for the Titan is proceeding on schedule. The first one scheduled for completion, at Lowry AFB, Denver, will be ready next summer.

ELECTRONIC INDUSTRIES ASSOCIATION is pushing the claim before Federal Communications Commission that space satellite and earth point-to-point communications systems can share the radio-frequency spectrum without mutual interference. EIA studied the radio-frequency requirements for space communications in the bands above 890 Mc, recommended that FCC use its present frequency allocation system which provides for channel sharing above 830 Mc.

STRATOSCOPE, joint balloon-probe project of National Science Foundation and Office of Naval Research, is serving the communications technology by providing new information on sunspots. Photographs taken last summer by the flight from Lake Elmo, Minn., and released last week, showed bright granulations in the umbra (the dark center) of sunspots.

Granulations in the umbra had been suspected; scientists figure they may be convection cells suppressed by the magnetic field of the spot. More data about magnetic structure of solar disturbances is needed for reliable design of worldwide communications systems.

Telescope and camera system for the Stratoscope flights was designed and manufactured by Perkin-Elmer. Television gear to facilitate ground control was developed by RCA Laboratories.

NAVY'S air-to-surface Corvus missiles—designed to home on and destroy groundbased or shipborne radar—has been killed. Corvus was one of the last of the airbreathers, had cost \$80 million thus far. Navy figured that keeping Corvus going would have cost \$450 million, decided the money could be better spent on another system "offering a wider scope of employment," admits that "much" was learned from the Corvus effort.

Temco was prime contractor; Texas Instruments and W. L. Maxson were responsible for the radar-homing guidance system.

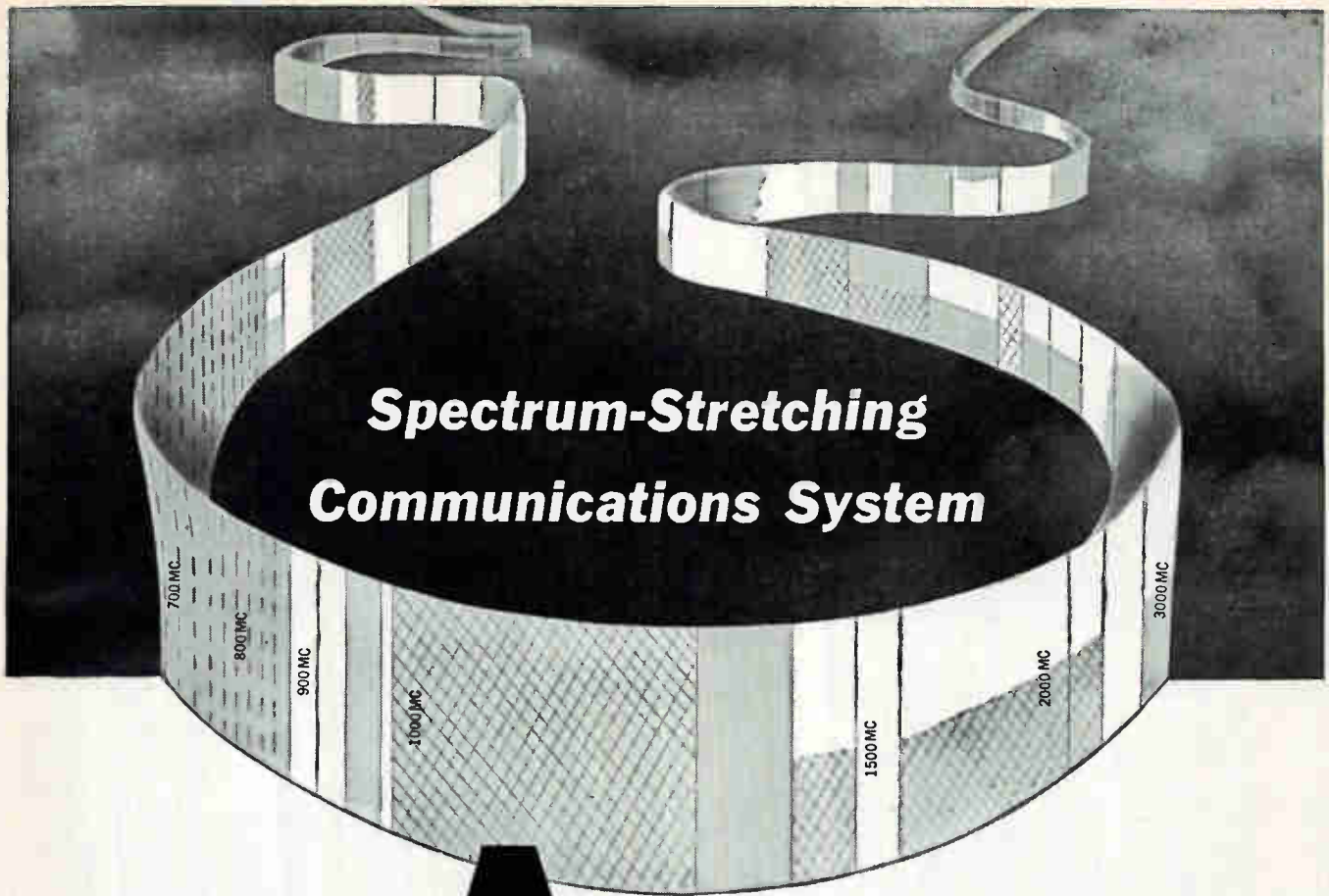

Spectrum-Stretching Communications System

THE BIG **A** LEADS THE WAY TO INTEGRATED COMMUNICATIONS SYSTEMS

ADLER heterodyne repeater techniques have opened a wide range of UHF channels for U. S. Army field communications, and prevented obsoleting of millions of dollars of VHF equipment. Developed and manufactured by ADLER, the "F-Head" converter permits the basic AN/TRC-24 VHF system to be used for UHF relaying in areas where VHF spectrum congestion is a problem. Designed for plug-in use, the compact "F-Head" heterodynes the VHF output of the AN/TRC-24 to the available UHF range. ADLER heterodyne techniques also are employed in advanced TV microwave and repeater systems, and multichannel communications.

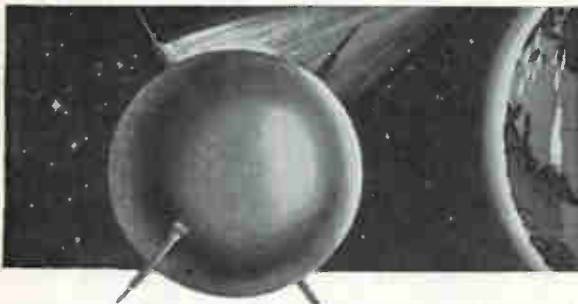

SATELLITE RELAY SYSTEM — A reliable, worldwide network for telegraphy and teletype communications will be realized through PROJECT COURIER of the Advanced Research Projects Agency and U. S. Army Research & Development Laboratories. Each of the Courier's air-ground transportable stations duplex transmit and receive 15 million bits of stored information in the 4-minute contact with the satellite. As subcontractor to ITT Laboratories, ADLER is responsible for design, manufacture and equipment installation of the ground station trailers of this earth-satellite relay system.



TRANSPORTABLE TROPOSPHERIC SCATTER SYSTEM— A new concept in continent-spanning tropospheric scatter communications soon will be available to the U. S. Air Force. For the first time, the full multichannel capability and reliability of a large, fixed installation will be provided in a compact, air-ground transportable package. The all-environment, 10kw, AN/MRC-85 is being designed and manufactured by ADLER under subcontract to Page Communications.

Write for all the facts on how ADLER experience can help solve your communications problems.

A ADLER

ADLER ELECTRONICS, INC. New Rochelle, N. Y.



UNIQUE NEW EIMAC 3CX10,000A3 CERAMIC TRIODE OFFERS VHF POWER - UP TO 20 KW

Eimac expands its ceramic tube line with the introduction of the 3CX10,000A3—the only 10 kilowatt air-cooled ceramic triode in the field. This advanced power tube is intended for use at maximum ratings through 110 megacycles.

An outstanding feature of this clean, efficient ceramic triode is the large reserve of grid dissipation assured by platinum-clad tungsten grid wires. Overload protection has also been built into the 3CX10,000A3 to make it ideal for use in industrial heating—dielectric and induction.

This newly developed triode is also well suited for such applications as broadcast, FM and single-sideband transmitters, ultrasonic generators and sonar pulse amplifiers. It can also be used as a class-AB₂ or class-B linear amplifier in audio or r-f service.

A companion air-system socket and chimney, as shown above, is available with the 3CX10,000A3 to meet your specific requirements. Watch for a low mu version of this high-power triode in the near future.

GENERAL CHARACTERISTICS

EIMAC 3CX10,000A3

CERAMIC TRIODE

	Height	Diameter	Max. Operating Temp.	Filament Voltage	Filament Current	Frequency for Max. Ratings	Max. Plate-Diss. Rating
	8.25"	7.0"	250°C.	7.5	102 amp.	110 Mc.	10,000 watts

EITEL-McCULLOUGH, INC.
San Carlos, California



Silicon Diffusion Computer Diodes

*The Broadest Line in
the Industry...*

PSI has developed these fast recovery silicon diodes for every application in advanced computer design. Choose from military approved, low capacitance, high conductance, low leakage, high voltage types—with assurance of unsurpassed reliability!



ACTUAL SIZE



Fast Recovery Types

MILITARY TYPES

Type Number	Minimum Saturation Voltage * @ 100 μ A (volts)	Minimum Forward Current @ +1.0 volt (mA)	Maximum Reverse Current (μ A)		Reverse Recovery Characteristics	
			25°C	100°C	Reverse Resistance (ohms)	Maximum Recovery Time (μ s)
1N663*	100	100	5 (75v)	50 (75v)	200K	0.5
1N662†	100	10	1 (10v) 20 (50v)	20 (10v) 100 (50v)	100K	0.5
1N658*	120	100	.05 (50v)	**25 (50v)	80K	0.3
1N643†	200	10	.025 (10v) 1 (100v)	5 (10v) 15 (100v)	200K	0.3
1N789	30	10	1 (20v)	30 (20v)	200K	0.5
1N790	30	10	5 (20v)	30 (20v)	200K	0.25
1N791	30	50	5 (20v)	30 (20v)	200K	0.5
1N792	30	100	5 (20v)	30 (20v)	100K	0.5
1N793	60	10	1 (50v)	30 (50v)	200K	0.5
1N794	60	10	5 (50v)	30 (50v)	200K	0.25
1N795	60	50	5 (50v)	30 (50v)	200K	0.5
1N796	60	100	5 (50v)	30 (50v)	100K	0.5
1N797	120	10	1 (100v)	30 (100v)	200K	0.5
1N798	120	10	5 (100v)	30 (100v)	200K	0.25
1N799	120	50	5 (100v)	30 (100v)	200K	0.5
1N800	120	100	5 (100v)	30 (100v)	100K	0.5
1N801	150	10	1 (125v)	30 (125v)	200K	0.5
1N802	150	50	5 (125v)	50 (125v)	200K	0.5
1N803	200	10	5 (175v)	50 (175v)	200K	0.5
1N804	200	50	10 (175v)	50 (175v)	200K	0.5
1N659	60	6	5 (50v)	25 (50v)	400K	0.3
1N660	120	6	5 (100v)	50 (100v)	400K	0.3
1N661	240	6	10 (200v)	100 (200v)	400K	0.3
1N625	30	4 @ 1.5v	1 (20v)	30 (20v)	400K	1 μ sec
1N626	50	4 @ 1.5v	1 (35v)	30 (35v)	400K	1 μ sec
1N627	100	4 @ 1.5v	1 (75v)	30 (75v)	400K	1 μ sec
1N628	150	4 @ 1.5v	1 (125v)	30 (125v)	400K	1 μ sec
1N629	200	4 @ 1.5v	1 (175v)	30 (175v)	400K	1 μ sec

*Maximum DC working inverse voltage is 85% of minimum saturation voltage.

†Mil-E-1/1171 (SigC) †Mil-E-1/1139 (SigC) *Mil-E-1/1140 (SigC) *Mil-E-1/1160 (SigC)

**Max. Reverse Current at 150°C.

OTHER SPECIFICATIONS: Peak Pulse Current, 1 μ sec, 1% duty cycle: 3.0 Amps.

Storage and Operating Temperature Range: -65°C to 200°C.

Fast Switching Low Capacitance Types

TYPE NO.	MIN. SAT. VOLTAGE @ 100 μ A (volts)	MIN. FWD. CUR. @ 1.0 volt (mA)	MAXIMUM REVERSE CURRENT (μ A)		REVERSE RECOVERY CHARACTERISTICS			MAX. CAP. @ ZERO VOLTS (μ mf)
			25°C	100°C	REVERSE RESIST. (Ohms)	MAX. RECOV. TIME* (μ s)	TYPICAL RECOV. TIME** (N μ s)	
1N925	40	5	1.0 (10v)	20 (10v)	20K	0.15	5.0	4.0
1N926	40	5	0.1 (10v)	10 (10v)	20K	0.15	5.0	4.0
1N927	65	10	0.1 (10v) 5.0 (50v)	10 (10v) 25 (50v)	20K	0.15	5.0	4.0
1N928	120	10	0.1 (10v) 5.0 (50v)	10 (10v) 25 (50v)	20K	0.15	5.0	4.0

*Switching from 5mA to -10 volts ($R_L = 1K, C_L = 10\mu$ mf)

**Switching from 5mA to -10 volts ($R_{LOOP} = 100$ ohms, $C_L = 8\mu$ mf including diode capacitance)

PSI

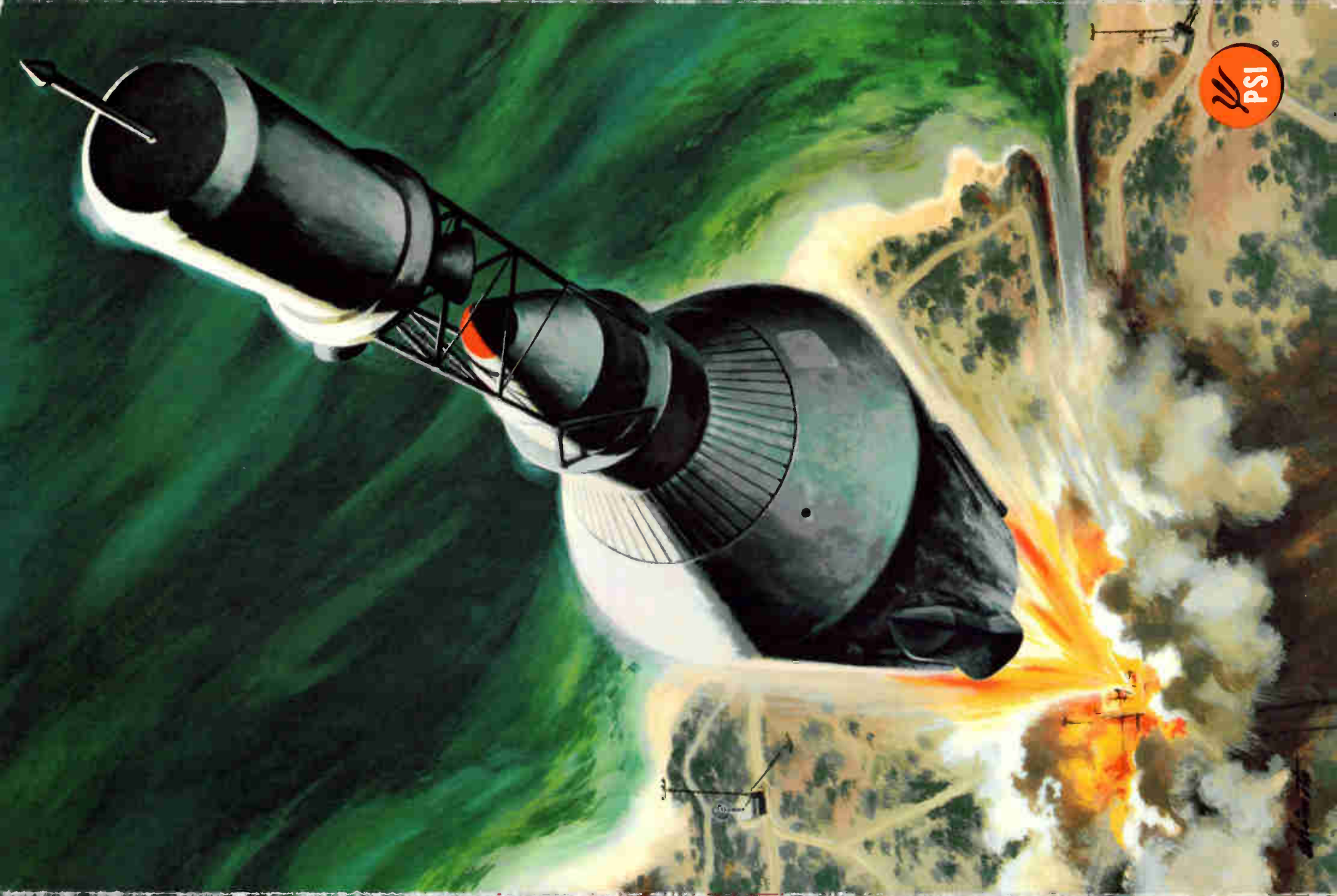

Silicon General Purpose Diodes



ACTUAL SIZE



EIA TYPE NUMBER	Minimum Saturation Voltage @ 100 μ A @ 25°C (volts)	Maximum Forward Voltage DC @ 25°C (volts)		Maximum Inverse Current at Maximum DC Operating Voltage (μ A @ volts)		Maximum Average Rectified Current (mA)	
		@ 100 mA	@ 25°C	@ 150°C	@ 25°C	@ 150°C	
							@ 25°C
1N488A	420	1.0	.100 @ - 380v	25	200	70	
1N488	420	1.1	.250 @ - 380v	50	125	50	
1N487A	330	1.0	.100 @ - 300v	25	200	70	
1N487	330	1.1	.250 @ - 300v	50	125	50	
1N486B	250	1.0	.050 @ - 225v	10	200	70	
1N486A	250	1.0	.050 @ - 225v	25	200	70	
1N486	250	1.1	.250 @ - 225v	50	125	50	
1N485B	200	1.0	.025 @ - 175v	5	200	70	
1N485A	200	1.0	.025 @ - 175v	15	200	70	
1N485	200	1.1	.250 @ - 175v	30	125	50	
1N484B	150	1.0	.025 @ - 125v	5	200	70	
1N484A	150	1.0	.025 @ - 125v	15	200	70	
1N484	150	1.1	.250 @ - 125v	30	125	50	
1N483B	80	1.0	.025 @ - 60v	5	200	70	
1N483A	80	1.0	.025 @ - 60v	15	200	70	
1N483	80	1.1	.250 @ - 60v	30	125	50	
1N482B	40	1.0	.025 @ - 30v	5	200	70	
1N482A	40	1.0	.025 @ - 30v	15	200	70	
1N482	40	1.1	.250 @ - 30v	30	125	50	

EIA TYPE NUMBER	Minimum Saturation Voltage @ 100 μ A @ 25°C (volts)	Minimum Forward Current @ +1.0 VDC @ 25°C (mA)	Maximum Inverse Current at Maximum DC Operating Voltage (μ A @ volts)		Maximum Average Rectified Current (mA)	
			@ 25°C	@ 150°C	@ 25°C	@ 150°C
1N464A	150	100	.5 @ 125	30 @ 125	200	70
1N464	150	3	.5 @ 125	30 @ 125	40	70
1N463A	200	100	.5 @ 175	30 @ 175	200	70
1N463	200	1	.5 @ 175	30 @ 175	30	70
1N462A	70	100	.5 @ 60	30 @ 60	200	70
1N462	70	5	.5 @ 60	30 @ 60	50	70
1N461A	30	100	.5 @ 25	30 @ 25	200	70
1N461	30	15	.5 @ 25	30 @ 25	60	70
1N459A	200	100	.025 @ 175	5 @ 175	200	70
*1N459	200	3	.025 @ 175	5 @ 175	40	70
1N458A	150	100	.025 @ 125	5 @ 125	200	70
*1N458	150	7	.025 @ 125	5 @ 125	55	70
1N457A	70	100	.025 @ 60	5 @ 60	200	70
*1N457	70	20	.025 @ 60	5 @ 60	75	70
1N456A	30	100	.025 @ 25	5 @ 25	200	70
1N456	30	40	.025 @ 25	5 @ 25	90	70

* JAN Types

Zener Diodes 500 mW Power Dissipation

PSI Type Number	Elect. Equiv.	Zener Voltage @ 5 mA @ 25°C		Maximum Dynamic Resistance (ohms) 1	Maximum Inverse Current		At Inverse Voltage (v)
		E Min. (v)	E _z Max. (v)		I _b @ 25°C (μ A)	I _b @ 100°C (μ A)	
PS6465	1N465	2.0	3.2	60	75	100	1
PS6466	1N466	3.0	3.9	55	50	100	1
PS6467	1N467	3.7	4.5	45	5	100	1
PS6468	1N468	4.3	5.4	35	5	100	1.5
PS6469	1N469	5.2	6.4	20	5	100	1.5
PS6470	1N470	6.2	8.0	10	5	50	3.5

1. Measured at 10mA DC Zener current with 1mA RMS signal superposed.

Also Available PS6313-6318 covering
7.5v to 27v Zener Voltages.

EIA TYPES	Zener (Breakdown) Voltage @ 5 mA		Maximum Inverse Current		At Inverse Voltage (v)	Maximum Dynamic Resistance (ohms) 1
	E _z Min. (v)	E _z Max. (v)	I _b @ 25°C (μ A)	I _b @ 100°C (μ A)		
1N702	2.0	3.2	75	100	-1	60
1N703	3.0	3.9	50	100	-1	55
1N704	3.7	4.5	5	100	-1	45
1N705	4.3	5.4	5	100	-1.5	35
1N706	5.2	6.4	5	100	-1.5	20
1N707	6.2	8.0	5	50	-3.5	10

1. Measured at 10 mA DC Zener current with 1 mA RMS signal superposed.

Also Available 1N708-1N723 covering
5.6v to 27v Zener Voltages.

EIA Type ¹	Zener Voltage E _z (Volts) ²	Max. Inverse Current I _s = -1V μ A		Max. Dynamic Resistance I _z = 20mA I _{ac} = 1 mA (Ohms) (Max.)
		25°C	150°C	
1N746	3.3	10	30	28
1N747	3.6	10	30	24
1N748	3.9	10	30	22
1N749	4.3	2	30	23
1N750	4.7	2	30	19
1N751	5.1	1	20	17
1N752	5.6	1	20	11
1N753	6.2	0.1	20	7
1N754	6.8	0.1	20	5
1N755	7.5	0.1	20	6
1N756	8.2	0.1	20	8
1N757	9.1	0.1	20	10
1N758	10.0	0.1	20	17
1N759	12.0	0.1	20	30

1. $\pm 10\%$ Zener Voltage Tolerance

2. E_z measured at Test Current I_z = 20mA

All of the above types can be supplied in $\pm 5\%$ Tolerance of center Zener Voltage Value. (Add suffix "A" for these units.)

ADVANCED SILICON TRANSISTORS WITH UNIQUE CAPABILITIES...

TYPES 2N1505, 2N1506

Available immediately in production quantities

These NPN VHF power amplifiers and oscillators are specially designed for high frequency, high power operation at low supply voltages. They give typical power outputs of 1 w at 70 mc and 500 mw at 200 mc. Highly efficient high frequency operation is assured by combining either with a High-Q Varicap frequency multiplier.

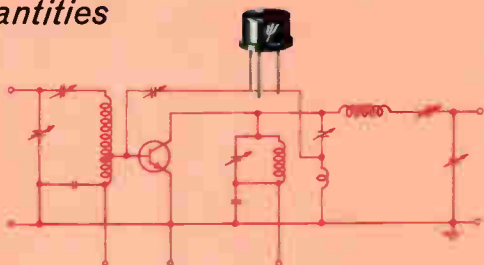

TYPES 2N1409, 2N1410

Available immediately in production quantities

These NPN high speed, high current core drivers and general purpose switches offer fastest switching time at high current ratings with extremely low saturation resistance. This combination makes them ideal for use in transistor-ferrite circuitry and many other computer applications.

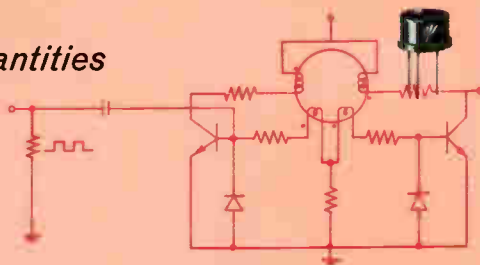

TYPES 2N1335 through 2N1341

Available immediately in production quantities

A unique combination of high voltage, VHF and high power is the outstanding feature of these NPN Mesa transistors, which make it possible for the first time to design video amplifiers with output voltages of 140 v and bandwidth of 10 mc. Other applications are power amplifiers, power oscillators and high voltage switches. *At right: Typical high voltage video amplifier circuit.*

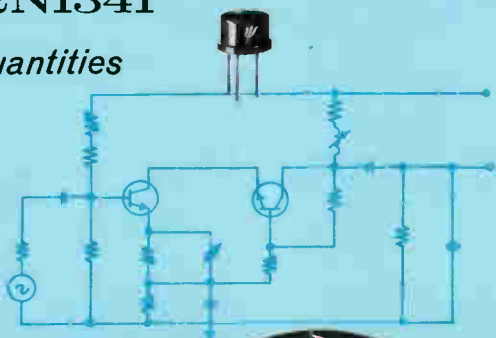

TYPES PT 900, PT 901

Available now for evaluation

10 ampere high frequency, high speed, high power oscillators, amplifiers, switches and converters. These are the only power transistors that offer 100 w at 5 mc plus $m\mu s$ high current switching. *At right: Typical 40 w 10 mc amplifier circuit.*



Now Available! TYPES 2N696, 2N697

LOOK INSIDE FOR LATEST INFORMATION AND SPECIFICATIONS ON PSI SILICON DIODES, ZENERS AND RECTIFIERS

PSI HIGH-RELIABILITY MINIATURIZATIONS

SPECIFICATIONS ON THE WORLD'S SMALLEST EIA SILICON DIODES

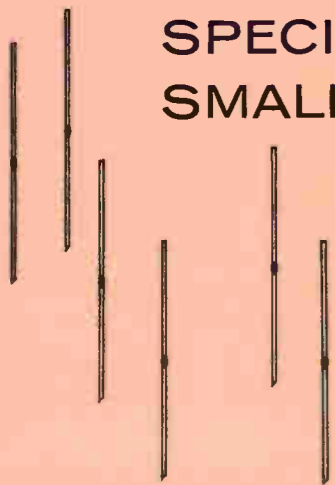

These low leakage EIA types with 250 mW dissipation have been exhaustively tested for reliability and long life. All are available for delivery in production quantities.

Type No.	Min. Sat. Voltage @ 100 μ A (v)	Min. Fwd. Current @ +1.0 V (mA)	Maximum Reverse Current (μ A)		Reverse Recovery Characteristics	
			25°C	100°C	Reverse Res. (Ohms)	Max. Recov. Time (μ S)
1N897	50	5	.025 (10V) .1 (40V)	5 (10V) 20 (40V)	100K	1.0
1N898	50	100	.025 (10V) .5 (40V)	5 (10V) 20 (40V)	100K	0.3
1N899	100	5	.025 (10V) .1 (80V)	5 (10V) 20 (80V)	100K	0.3
1N900	100	50	.025 (10V) .1 (80V)	5 (10V) 20 (80V)	100K	0.3
1N901	100	100	.025 (10V) .5 (80V)	5 (10V) 20 (80V)	100K	0.3
1N902	200	10	.025 (10V) 1.0 (100V)	5 (10V) 15 (100V)	200K	0.3

Phone, wire or write for new low prices and delivery schedules on production quantities.

NEW LOW PRICES ON PD-100 *microdiode*

PSI's super-miniaturized PD-100 silicon diodes are available now at price reductions of as much as 20%! Look at the performance characteristics of these fast-recovery silicon computer types:

- High power dissipation..... 250 milliwatts
- High conductance..... up to 100 mA @ 1 volt
- High voltage..... 200v operating voltage
- Fast recovery..... 200K @ .3 microseconds
- High temperature..... Operating range -65°C. to 150°C.
- High reliability..... Degradation rates of .01 to .1%/1000 hrs. (or .001%/1000 hrs. with special aging)

Type Number	Min. Sat. Voltage @ 100 μ A (v)	Min. Fwd. Current @ +1.0v (mA)	Maximum Reverse Current (μ A)		Reverse Recovery Characteristics	
			25°C	100°C	Reverse Res. (ohms)	Max. Recov. Time (μ s)
PD-101	50	5	1.0 (10v)	25 (10v)	100K	1.0
PD-102	50	20	.5 (10v)	25 (10v)	100K	0.3
PD-103	50	100	.5 (10v)	25 (10v)	100K	0.3
PD-104	100	5	.5 (10v)	25 (10v)	100K	0.3
PD-105	100	20	.5 (10v)	25 (10v)	100K	0.3
PD-106	100	50	.5 (10v)	25 (10v)	100K	0.3
PD-107	100	100	.5 (10v)	25 (10v)	100K	0.3
PD-108	200	10	.5 (10v) 5.0 (100v)	25 (10v)	200K	0.3
PD-109	200	10	.025 (10v) 1.0 (100v)	5 (10v)	200K	0.3



PHYSICAL CHARACTERISTICS:
 HERMETICALLY SEALED—Bonded Surface films.
 TERMINALS—.004x.019 gold plated leads. Lead length 1/2 inch minimum.
 MARKING—Type number designated by color of body and color of stripes on pointed (cathode) lead.
 ALL DIMENSIONS SHOWN IN INCHES.

SPECIFICATIONS NOW AVAILABLE!

*pico*transistor

PSI Type	Equivalent
PMT 011	2N1409
PMT 012	2N1410
PMT 013	2N696
PMT 014	2N697

*micro*transistor

PMT 111	2N1409
PMT 112	2N1410

Write or phone for details on these exciting new Micro components!

ACTUAL SIZE

Please note:

All specifications and information contained herein are current as of

July 15, 1960

HERE'S ONE WAY OF LOOKING AT PRODUCTION CAPABILITY



These silicon transistors are a sample of the production capability housed in the laboratory and manufacturing complex of Pacific Semiconductors, Inc. Each is an advanced type not previously available... each is a PSI origination designed to fill a carefully forecast commercial need.

Because production capability at PSI is based solidly on product origination and product reliability, The Company is carrying on a continuing search for experienced scientists, physicists and engineers of outstanding ability. If you have these talents, you will find unlimited career opportunities at commercially oriented PSI.

Pacific Semiconductors, Inc.

A SUBSIDIARY OF THOMPSON RAMO WOOLDRIDGE, INC.
 CORPORATE HEADQUARTERS: 10451 West Jefferson Boulevard, Culver City, California
 General Sales Offices: 12955 Chadron Avenue, Hawthorne, California

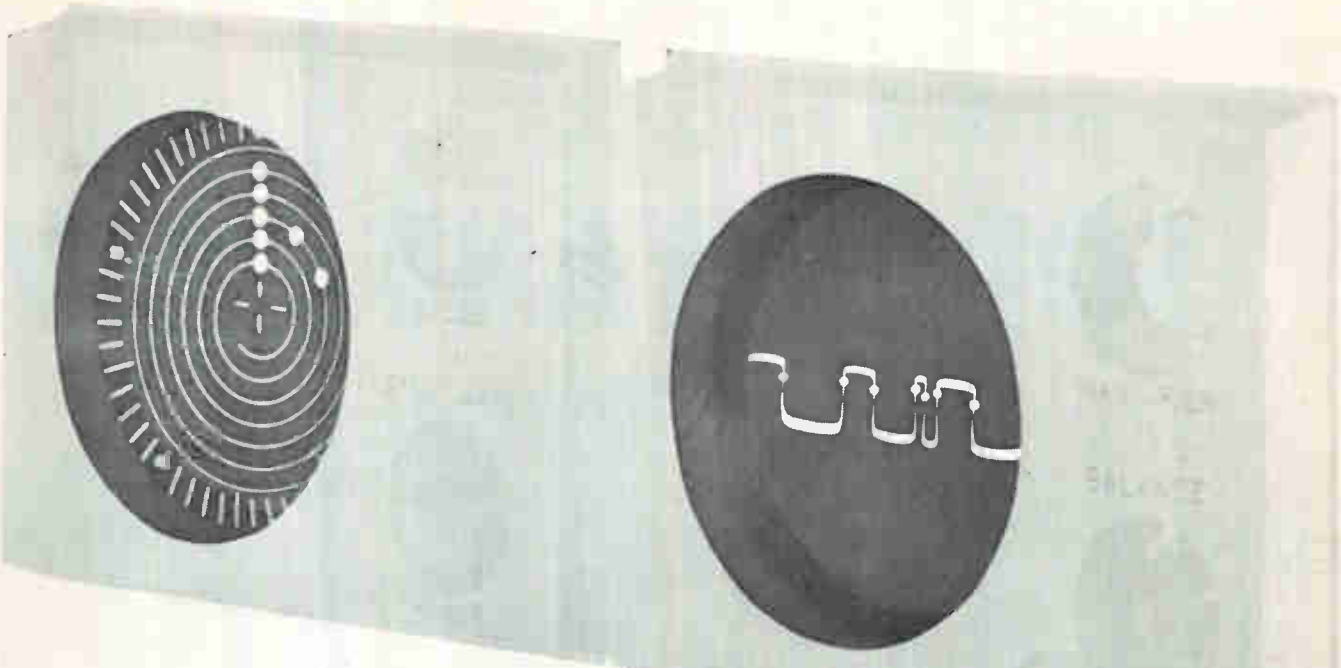

WHAT'S WRONG WITH THIS TELEGRAPH SIGNAL?



...and how do you find out without interrupting traffic?

The answer to the second question is Radiation's TDMS—Telegraph Distortion Measurement System—a compact, self-contained unit for on-line testing, analysis and monitoring of telegraph and data transmission links.

The TDMS detects, measures and analyzes signal distortion on a continuous basis, alerts even a non-technical operator that a circuit is deteriorating. Thus pinpointed, the malfunction (a badly-tuned receiver in a radio link, for example) can often be corrected with little or no circuit downtime.

For detailed information on the TDMS, write for Bulletin RAD EL-7 to Radiation Inc., Melbourne, Fla.

WHAT'S WRONG WITH THE SIGNAL SHOWN ABOVE? Character (letter R) shows a split 4th element, a result of poorly adjusted transmitting equipment. Spiral trace display on Telescan CRT (at left) indicates the presence, and analyzes the nature of characteristic distortion.

THE ELECTRONICS FIELD ALSO RELIES ON RADIATION FOR...

RADIPLEX—50-channel low-level multiplexer with broad data processing applications. Features rugged solid-state circuitry, almost unlimited programming flexibility, unique modular construction for compactness and exceptional ease of operation and maintenance.

RADICORDER—Multistylus recorder provides high-speed instantaneous readout for wide range of data acquisition or processing systems. Eliminates necessity of electronically translating complete data, thereby reduces computer work loads.

TELEMETRY TRANSMITTER—Model 3115 is a ruggedized 215-260 MC unit with extremely linear FM output under the most severe environmental conditions. With its record of outstanding performance in many missile programs, Model 3115 is specified by leading missile manufacturers.



RADIATION
INCORPORATED

See Mallory For **SOLID TANTALUM**

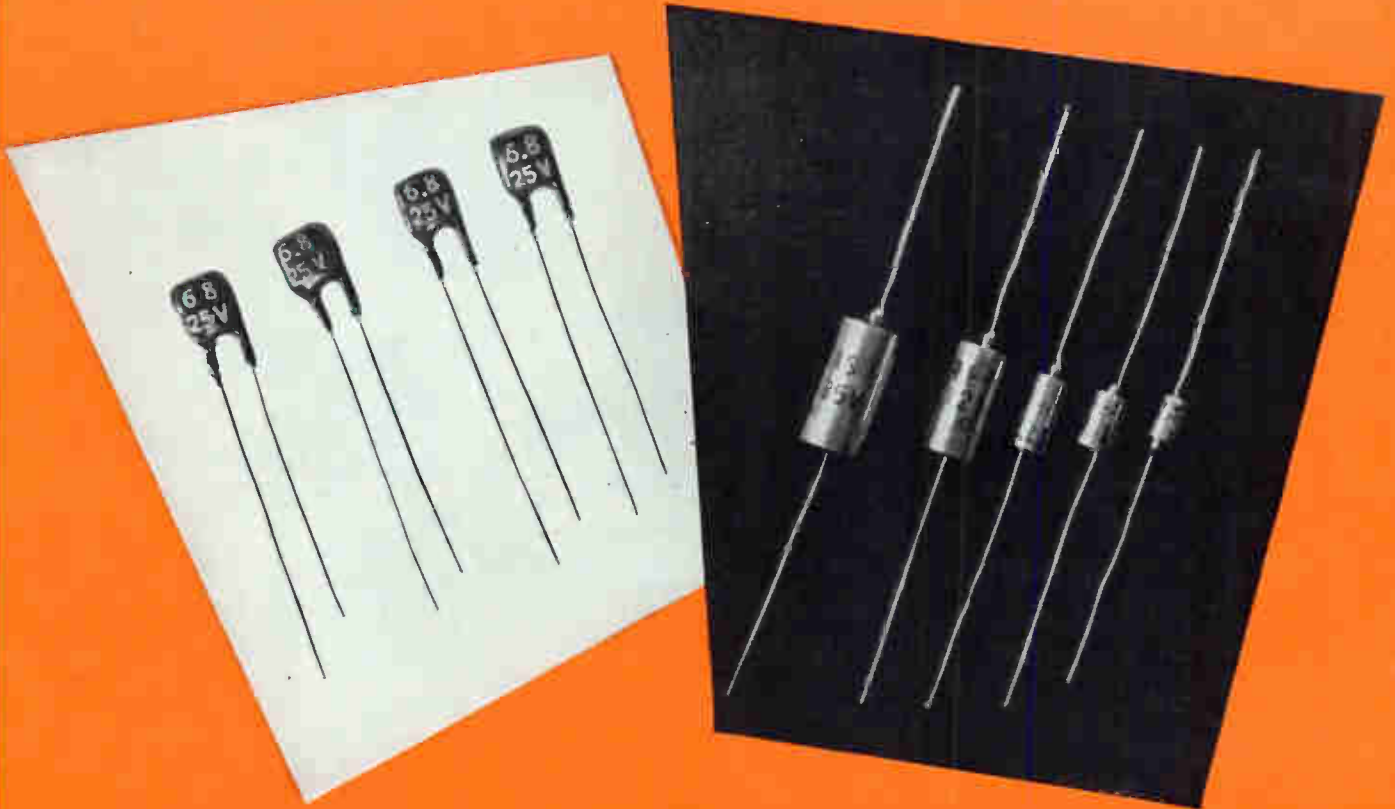

MALLORY SOLID ELECTROLYTE TANTALUM CAPACITORS

Type	Capacity Range	WVDC Rating	Temperature Range	Case Style	Case Size Range
TAM	4.7-56 mfd.	25-6V	-55 to +85°C	Plastic encapsulated, upright mounting	.188" thick, .313" square
TAS	.33-330 mfd.	35-6V	-80 to +85°C	Metal case axial leads	.125" diam. x .250" length to .341" diam. x .750" length

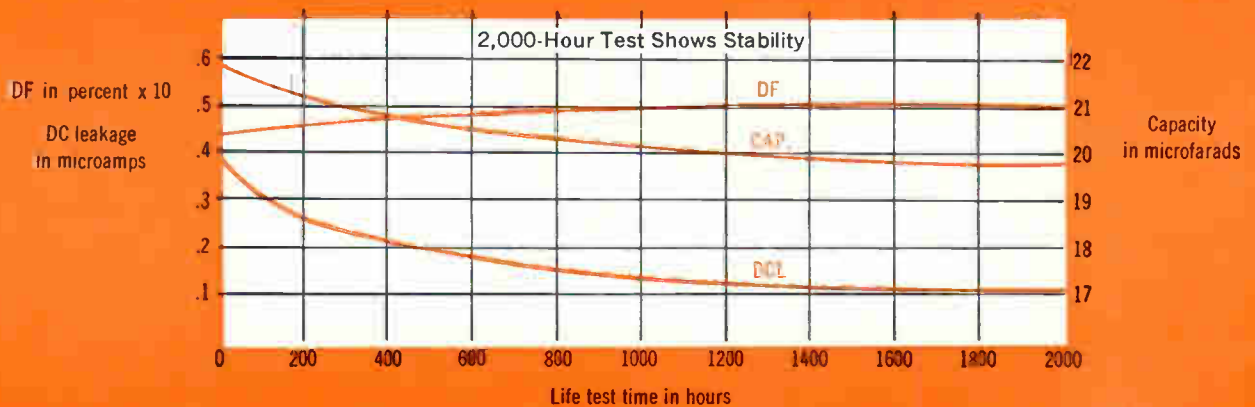

CAPACITORS

... *widest selection*

... *highest reliability*

When you're designing transistorized miniature equipment, you'll find that Mallory solid tantalum capacitors offer new design opportunities because of their stability, freedom from electrolyte leakage, broad temperature range, and high capacitance/volume ratio. Leader in tantalum capacitor development, Mallory gives you extra value in solid types:

Widest selection in the industry. Metal-case subminiature Type TAS, in ratings from .33 to 330 mfd., 35 to 6 volts . . . and the unique, encapsulated Type TAM, especially useful in printed circuits because of its square-case, self-insulated design with grid-spaced parallel leads.

Exceptionally low leakage current . . . key to reliability and high temperature capability . . . obtained by special Mallory processing.

Long Life . . . proved by tests to 10,000 hours.

Broad temperature range . . . rated for 85°C; operable at 125°C at $\frac{3}{4}$ rated voltage, and currently being evaluated for even higher temperatures. Low temperature rating: -55°C for TAM, -80°C for TAS.

Write or call us for a consultation on your solid tantalum capacitor applications. See us, too, for all your tantalum capacitor requirements. Our line of 16 different types is the broadest available . . . covers solid, sintered anode, and foil types, from microminiature to high capacity.

Immediate delivery on 16 Mallory Tantalum Types

HAT: microminiature, metal case	TAP-3: miniature, 30-325 mfd.
TAS: miniature, solid type	M2: miniature, 150°C
TAM: miniature, solid type, plastic encapsulated	XTK: miniature, 175°C
TAF: foil type	XTM: miniature, 175°C
STNT: subminiature, metal case	XTL: miniature, 200°C
TNT: miniature, metal case	XTH: 200°C
TAP-1: miniature, 2-30 mfd.	XTO: 200°C
TAP-2: miniature, 11-140 mfd.	XTV: high capacity, 175°C

Mallory Capacitor Co. • Indianapolis 6, Indiana

a division of

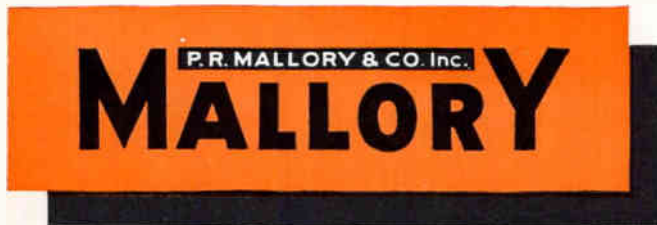

See Mallory Capacitor Company for a complete line of aluminum and tantalum electrolytic capacitors, and motor start and run capacitors.

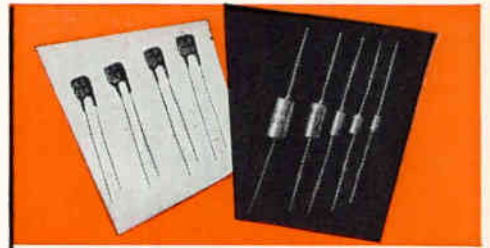

Order Tantalum Capacitors
FROM STOCK

at these

MALLORY
Industrial Distributors

Baltimore, Md.
Radio Electric Service
Binghamton, N.Y.
Stack Electronics
Boston, Mass.
Cramer Electronics, Inc.
DeMambo Radio Supply Co.
Lafayette Radio
Bridgeport, Conn.
Westconn Electronics
Buffalo, N.Y.
Wehle Electronics
Camden, N.J.
General Radio Supply Co.
Chicago, Ill.
Allied Radio Corp.
Newark Electronics Corp.
Cincinnati, Ohio
United Radio
Cleveland, Ohio
Pioneer Electronics
Dallas, Texas
Engineering Supply Co.
Dayton, Ohio
Allied Supply Co.
Denver, Colo.
Denver Electronics
Fords, N.J.
Atlas Electronics
Houston, Texas
Harrison Equipment Co., Inc.
Lenert Company
Indianapolis, Ind.
Graham Electronics
Los Angeles, Calif.
California Electronic Supply
Kierulff Electronics, Inc.
Radio Product Sales
Minneapolis, Minn.
Northwest Radio
Montreal, Que.
Canadian Electrical Supply Co.
Mountainside, N.J.
Federated Purchaser, Inc.
Nashville, Tenn.
Electra Distributing Co.
Newark, N.J.
Lafayette Radio
New York, N.Y.
Harrison Radio Corp.
Harvey Radio Co., Inc.
Hudson Radio & TV Corp.
Lafayette Radio
Terminal Electronics
Oakland, Calif.
Elmar Electronics, Inc.
Ottawa, Ont.
Wackid Radio-TV Lab.
Palo Alto, Calif.
Zack Radio Supply Co.
Pasadena, Calif.
Electronic Supply Corp.
Philadelphia, Pa.
Herbach & Rademan, Inc.
Philadelphia Electronics
Pittsburgh, Pa.
Radio Parts Co.
Seattle, Wash.
F. B. Connelly Co.
St. Louis, Mo.
Olive Electronics
Tampa, Florida
Thurrow Distributors, Inc.
Toronto, Ont.
Alpha Aracon Radio Co.
Electro Sonic Supply
Wholesale Radio & Electronics
Tucson, Ariz.
Standard Radio Parts
Tulsa, Okla.
Engineering Supply Co.
Washington, D.C.
Electronic Industrial Sales
White Plains, N.Y.
Westchester Electronic Supply
Winston-Salem, N.C.
Dalton-Hege Radio Supply



At The Ramo-Wooldridge Laboratories.. integrated programs of research & development of electronic systems and components.

The new Ramo-Wooldridge Laboratories in Canoga Park provide an environment for creative work in an academic setting. Here, scientists and engineers seek solutions to the technological problems of today. The Ramo-Wooldridge research and development philosophy places major emphasis on the imaginative contributions of the members of the technical staff. ■ There are outstanding opportunities for scientists and engineers. *Write* Dr. Richard C. Potter, Head, Technical Staff Development, Department 21-G.



THE RAMO-WOOLDRIDGE LABORATORIES

A DIVISION OF THOMPSON RAMO WOOLDRIDGE INC.
8433 FALLBROOK AVENUE, CANOGA PARK, CALIFORNIA

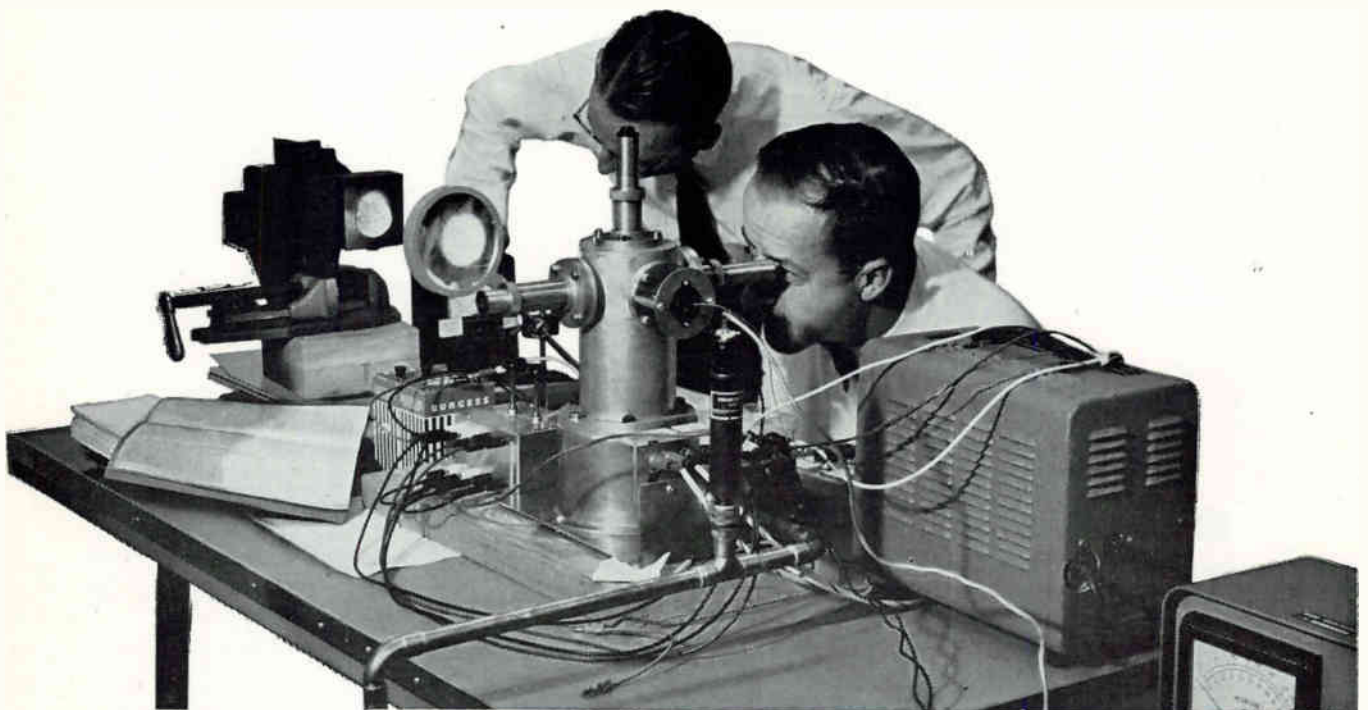

An electron device permits scientists to study the behavior of charged dust particles held in suspension.

IBM Net Tops \$76 Million

FOR THE SIX MONTHS ended June 30 this year, IBM reports a net income of \$76,616,285 after estimated federal income taxes. This is equivalent for the six-month period to \$4.19 a share on the 18,290,649 shares now outstanding. Income for the corresponding period in 1959 was \$64,030,809, equivalent to \$3.51 a share. Net income for the first six months of this year before taxes amounted to \$156,341,285 compared with \$130,706,809 in the corresponding 1959 period. Gross income for this year's first half was \$694,626,974 compared with \$615,371,141 in the first six months of 1959.

Telecomputing Corp., Los Angeles, announces sales of \$27,531,192 for the six-month period ended May 1, 1960. This is an increase of 40 percent over the \$19,634,532 shown in the comparable period of 1959. Sales for the current year's second quarter amount to \$12,722,201, as compared with \$11,069,856 for the second quarter of 1959. Net income for the six-month period ended May 1 was \$624,796 or 18 cents a share on 3,410,322 shares outstanding.

Transistor Electronics Corp., St. Louis Park, Minn., reports sales for the past fiscal year ending Apr. 30 rose from \$129,807 to \$327,631, an increase of 252 percent.

Burnell & Co., Pelham Manor, N. Y., reports net income of \$122,092 for the fiscal year ended Mar. 31. This is equivalent to 25 cents a share on 470,000 shares outstanding and compares with 9 cents a share computed on the same basis a year ago. The company, which manufactures filters for electronic circuits, says sales rose to \$3,223,303 in 1959-60 as compared with the previous year's \$2,686,941.

General Instrument Corp., Newark, N. J., for its first fiscal quarter ended May 30, reports net profits increased 104 percent over

the same period last year, from \$211,129 to \$430,923. Sales increased to a new quarterly record of \$13,010,910 from \$12,728,861 a year ago.

Ling-Temco Electronics, Inc., Dallas, Tex., has been formally approved as the name of the surviving entity in a merger between **Temco Aircraft** and **Ling-Altec**. (ELECTRONICS, Financial Roundup, May 13) Under merger terms Temco has been dissolved and all its assets sold to the new company. It will function as a subsidiary bearing the name of **Temco Electronics & Missiles**. The merger results in a company with combined assets of over \$67 million, according to company spokesmen. Ten million shares of capital stock have been approved with 9 million common shares at a par value of 50 cents and one million preferred shares at \$30 par.

25 MOST ACTIVE STOCKS

	SHARES (IN 100's)	WEEK ENDING JULY 15		
		HIGH	LOW	CLOSE
Gen Tel & Elec	1,226	30 ³ / ₈	28 ⁵ / ₈	28 ³ / ₄
RCA	1,189	66 ¹ / ₄	63 ⁵ / ₈	64
EI-Tron Inc	1,072	1 ⁵ / ₈	1 ¹ / ₄	1 ⁵ / ₈
Ampex	710	38 ⁵ / ₈	35	35 ⁵ / ₈
Gen Electric	693	92 ⁵ / ₈	86 ¹ / ₄	87
Int'l Tel & Tel	653	42 ³ / ₄	40	40 ⁵ / ₈
Sterling Precision	650	3 ⁷ / ₈	3 ¹ / ₈	3 ³ / ₈
Sperry Rand	649	24 ¹ / ₄	23	23 ¹ / ₄
Avco Corp	638	14 ³ / ₈	13 ⁵ / ₈	13 ⁷ / ₈
Collins Radio	518	68 ⁵ / ₈	61 ³ / ₈	64
Westinghouse	513	59 ¹ / ₂	55 ¹ / ₄	57 ¹ / ₄
Gen Inst	499	45 ⁵ / ₈	41	44
Telectro Ind	473	16 ³ / ₄	13 ⁵ / ₈	13 ⁷ / ₈
Univ Controls	460	17 ³ / ₈	15 ⁵ / ₈	15 ³ / ₄
Varian Assoc	400	61	55 ¹ / ₄	57 ¹ / ₄
Lear Inc	386	20 ¹ / ₂	18 ⁵ / ₈	19
Standard Kollsman	380	24 ³ / ₈	22 ⁵ / ₈	23
Gen Dynamics	373	43 ¹ / ₂	41 ¹ / ₂	42 ⁵ / ₈
Beckman Inst	354	91 ¹ / ₄	84	88 ¹ / ₈
Litton Ind	338	87 ⁷ / ₈	81 ¹ / ₈	83 ³ / ₈
Burroughs Corp	327	35 ³ / ₄	33 ¹ / ₂	35 ¹ / ₈
Philco Corp	322	29 ¹ / ₈	27	27 ¹ / ₄
Zenith Radio	312	121 ³ / ₄	115 ¹ / ₄	119 ¹ / ₄
Barnes Engineering	311	48 ³ / ₈	42	45 ¹ / ₂
Dynamics Corp Amer	302	11 ¹ / ₂	9 ³ / ₄	10 ¹ / ₄

The above figures represent sales of electronics stocks on the New York and American Stock Exchanges. Listings are prepared exclusively for ELECTRONICS by Ira Haupt & Co., investment bankers.

NEW ISSUES PLANNED

	No. Shares	Price per Share
Avionics Investing	400,000	\$10.00
Infrared Industries	100,000	*
Vector Mfg.	250,000	13.25
Yardney Electric	254,000	*

*To be announced

DI-ACRO* NOTCHER

Speeds Production,
Saves Extra Operations
on Chassis Work

"I use our Di-Acro Notcher for practically everything," says V. Johnson of Maico Co., Inc., Minneapolis manufacturer of hearing testing equipment. "This machine speeds production—provides one operation notching of cold rolled steel, brass, phosphorous bronze and aluminum up to 16 gauge thick. It's also used for notching fish paper, sponge rubber, 1/16" linen Bakelite and other circuit insulating materials that go into chassis for audio testing equipment."

The 4 ton pressure of this machine has the capacity to cut a 90° notch as large as 6"x6" in 16 gauge steel in one operation. Adjustable gauges mounted on work table are standard. Hardened and ground triangular ram assures years of precision. A clean cut, free from rough edges and burrs, is possible because blade clearance can be easily set. For high speed production,

a power model is available.

Consult the Yellow Pages of your phone book under Machinery, Machine Tools for the name of your nearest Di-Acro distributor or write us for Quick Facts Folder describing this and other Di-Acro machines

Di-Acro Notcher is used on the open end of this .061" aluminum chassis at Maico Co., Inc.



di-acro
PRECISION
METALWORKING
MACHINES

*pronounced
die-ack-ro

O'NEIL-IRWIN MFG. CO.

321 8th Avenue Lake City, Minn.

WHAT HAPPENS WHEN A NATION SPENDS MORE ON GAMBLING THAN IT SPENDS FOR HIGHER EDUCATION?

If you can find any Romans around, ask them. They lived pretty high on the hog in their day. That is, until some serious-minded neighbors from up North moved in. The rest is ancient history.

You'd think their fate would have taught us a lesson.

Yet today we Americans spend twenty billion dollars a year for legalized gambling, while we spend a niggardly four-and-a-half billion for higher education. Think of it! Over four times as much! We also spend six-and-a-half billion dollars a year for tobacco, nine billion dollars for alcoholic beverages, and billions more on other non-essentials.

Can't we read the handwriting on the wall?

Our very survival depends on the ability of our colleges and universities to continue to turn out thinking men and women. Yet today many of these fine institutions are hard put to make ends meet. Faculty salaries, generally, are so low that qualified teachers are leaving the campus in alarming numbers for better-paying jobs elsewhere.

In the face of this frightening trend, experts estimate that by 1970 college applications will have doubled.

If we are to keep our place among the leading nations of the world, we must do something about this grim situation before it is too late. The tuition usually paid by a college student covers less than half the actual cost of his education. The balance must somehow be made up by the institution. To meet this deficit even the most heavily endowed colleges and universities have to depend upon the generosity of alumni and public spirited citizens. In other words, they depend upon *you*.

For the sake of our country and our children, won't you do your part? Support the college of your choice *today*. Help it to prepare to meet the challenge of tomorrow. The rewards will be greater than you think.

It's important for you to know what the impending college crisis means to you. Write for a free booklet to HIGHER EDUCATION, Box 36, Times Square Station, New York 36, New York.



*Sponsored as a public service
in co-operation with The Council for Financial Aid to Education*



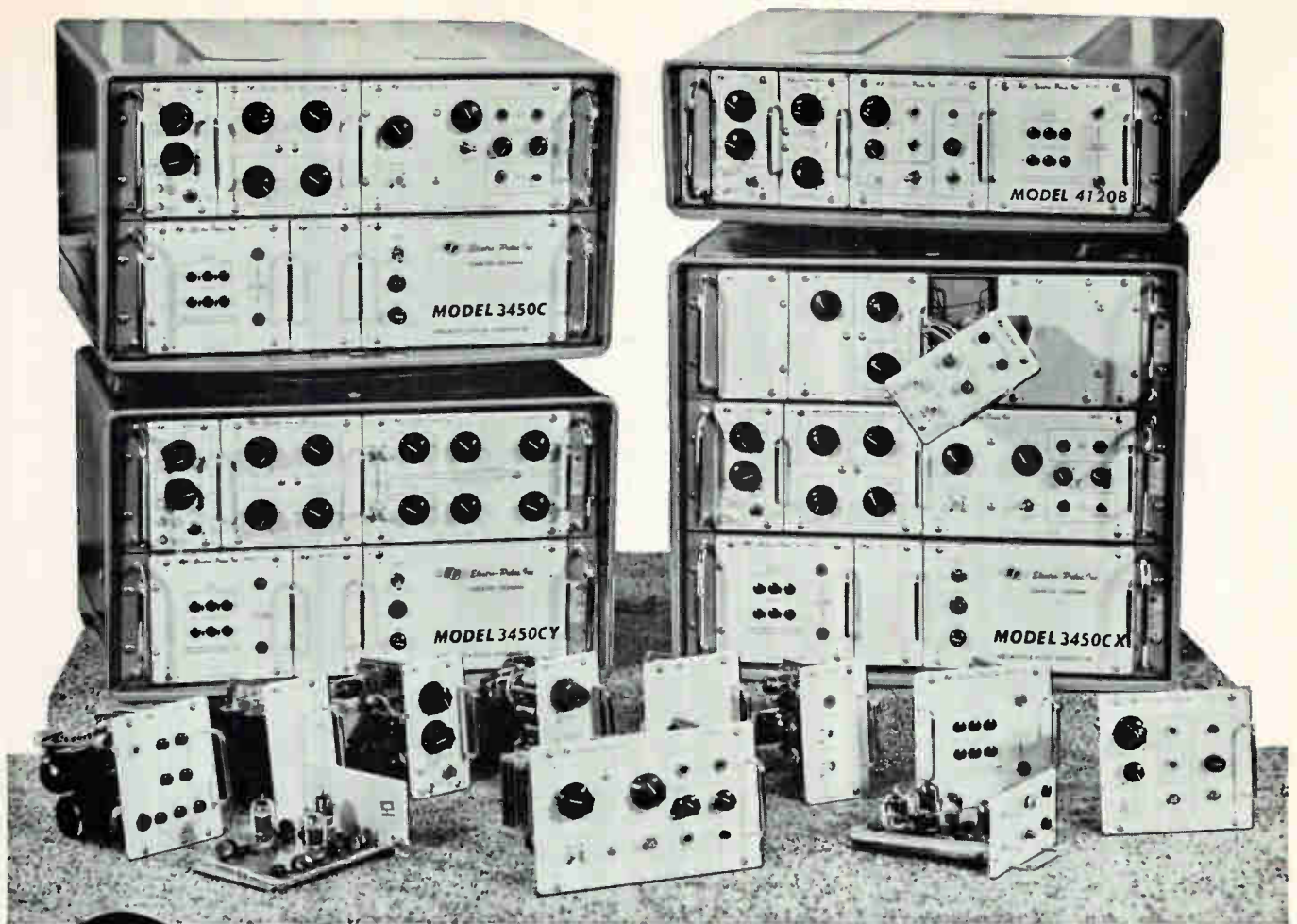

NOW!

FULL coverage in Pulse Instrumentation through MODULAR CONSTRUCTION

Modular plug-in construction adds unparalleled versatility and serviceability to proven EP circuit quality, allows extension of standard instruments to special requirements, and provides the key to rapid, economical fabrication of simple or complex pulse and digital instrumentation systems.

See our
Complete Display
at WESCON
BOOTHS 412-413

Electro-Pulse currently manufactures 137 standard pulse and digital circuit modules (both tube and transistor types). Over 90 catalog instruments are offered to save you time and money in the generation of fast-rise pulses, pulse pairs, pulse trains, gates, time delays, digital words, programmed current pulses, PPM and PCM codes, etc. Our current comprehensive catalog is yours for the asking.

Various combinations of only eleven basic pulse circuit modules,* when plugged into wired rack frames, make up the four standard pulse generators shown above—

- 3450C— $.015 \mu\text{s}$ rise single pulses, 50v into 50 ohms to 2MC, variable durations, delay and waveform.
- 3450C/X—Adds pulse pair and pulse train capabilities to 3450C.
- 3450C/Y—Fast rise, power flip-flop (45v into 470 ohms, Pos. and Neg. outputs), duration to 1 sec., rep rate to 1.7MC.
- 4120B—Economical fast-rise pulses to 500KC, 35v into 100 ohms.

Write for complete data: Bulletins 3450 and 4120

*Basic modules in photo above:

Time Base, Delay and Width Control, Pulse Forming, Flip-flop, Trigger Amplifier, 2 Output Amplifiers, 2 Power Regulators, Rectifier-Filter, and Gating Control, with variations. Also available: Counters, And/Or Gates, Crystal Oscillators, Precision Time Delays, Blocking Oscillators, Mixers, Inverters, Attenuators, Input Amplifiers.

Note, in above photo of 3450CX, the ease with which a single module may be extended on plug-in adapter for service.



Representatives in Major Cities

Electro-Pulse, Inc.

A SUBSIDIARY of SERVO CORPORATION of AMERICA

6711 S. Sepulveda Blvd., Los Angeles 45, Cal.—Phone: ORegon 8-2244

*Pulse and Digital Circuit Engineers:
Rapidly expanding Systems activity and
New Product development at Electro-Pulse
have created several attractive openings
for qualified engineers. Please send resume
to T. C. Ridgway, Personnel Manager.*

2 MEGACYCLE DRY CIRCUIT LATCHING RELAY!

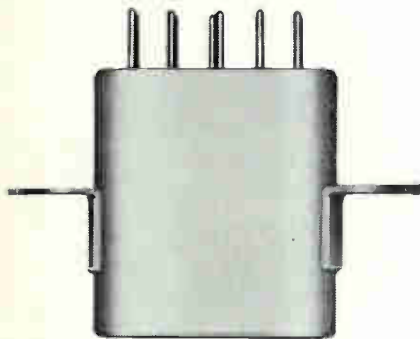

YES! The 101 relay series has operated continuously for over two million cycles without failure.

Only U. S. Relay-Electronics 101 series has unsurpassed sensitivity of 3 milliseconds latching time.

The 101 is a micro-miniature latching relay series that offers **BIG RELAY** performance in crystal can size. Designed for continuous use at -65°C to $+125^{\circ}\text{C}$ temperature range. This relay series has been designed to meet applicable portions of Military Specifications, MIL-R-25018 and MIL-R-5757. Completely adaptable for missile, military, computer and industrial usage where size, weight and environmental extremes are critical. In addition, the 101 series will withstand 100 G shock for a limited duration.

During the WESCON show at Los Angeles, we will have an operating unit on display. Stop by our booth and guess at what cycle this unit will fail. The closest guess will win a valuable citizen band transceiver!

For further information on the 101 Series, and certified test reports, write:



U. S. RELAY-ELECTRONICS
717 No. Coney Ave., Azusa, Calif.
a division of A*S*R Products Co

MARKET RESEARCH

Imports Running 71% Ahead of 1959

ELECTRONICS IMPORT figures for the first quarter are running 71 percent ahead of the first three months last year. Total value of electronic imports for 1960 is expected to top \$135 million, compared with \$80.4 million in 1959 and \$32.6 million in 1958.

These figures are incomplete, since only those items that can be separately detached from Bureau of the Census reports are included. Several large items are missing, lost in huge catchall categories that include both electronic and nonelectronic gear.

Month-by-month reports for 1960 are more detailed, however, and show, for the first time, figures for radar equipment, microphones, loudspeakers, radio-phono combinations, record players and changers, other sound devices and electronic computers. Radios, too, are shown in more detail, and include figures for transistorized and nontransistorized portables, other radio sets, radio tubes and radio parts.

The table shows comparable dollar import figures for 1958 and 1959 for ten product groups.

	1958	1959
	(Thousands of dollars)	
Tv cameras and parts	44	227
Tv tubes and parts	324	387
Tv apparatus & parts	1,037	688
Radio apparatus and parts	28,171	72,724
X-ray tubes	283	397
X-ray apparatus, parts	1,623	1,811
Photocells and electron tubes	529	1,358
Pyrometers, moisture meters and parts	45	40
Phonographs	138	1,813
Phonograph parts and accessories	400	950
	\$32,594	\$80,395

Not included in these figures are United Kingdom exports of record players and record changers, valued at \$9.2 million in 1958 and \$12.4 million in 1959. Missing, too, are West Germany's exports of radio-phonographs and sound equipment. In 1958 West Germany shipped radios, radio-phones and tv sets val-

ued at a total of \$10.2 million to the U. S., and sound recording and reproducing equipment worth \$3.9-million.

Reports for the new commodity groups in the first quarter of this year show imports of radar equipment valued at \$257,000; microphones and parts, \$110,000; loudspeakers, \$206,000; radio-phonographs, \$1.9 million; record players and changers, \$1.8 million; other sound equipment, including amplifiers and hi-fi equipment, \$702,000; and electronic computers and parts, \$713,000.

Other first-quarter figures show radio imports up 61 percent over the first three months of 1959 to \$14.3-million, including transistorized radios worth \$7.8 million. Imports of tv cameras and parts multiplied more than five times, and phonographs multiplied seven times in the same period. Total value of first-quarter imports, including the newly reported groups, is \$22.5-million.

Resistor manufacturers anticipate resistor sales of \$220 million in 1960, about 15 percent above last year's sales of \$194 million. Unit sales should rise from 1.8 billion in 1959 to 2.1 billion this year.

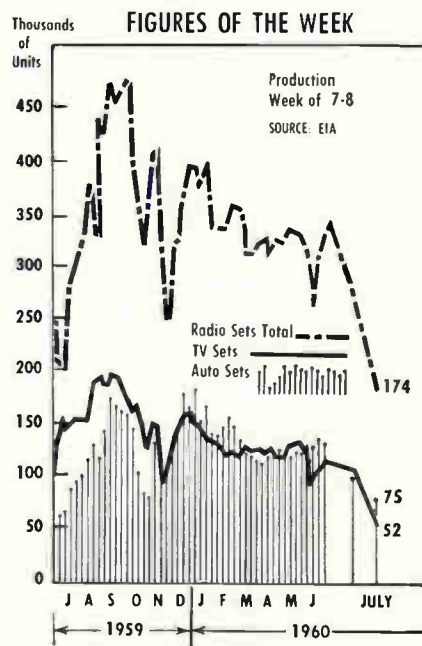

LIKE **WORDS** IN A SENTENCE...

CUBIC DIGITAL SYSTEMS

SPEAK FOR THEMSELVES!



Data Recording



Input Sampling

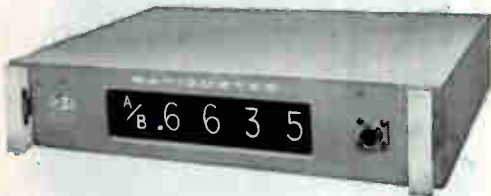

Voltage Ratio Measurement



Resistance Measurement



AC Voltage Measurement



DC Voltage Measurement

Standard-size Cubic Digital Instruments, with modular construction of plug-in units, make for easy development of sophisticated digital systems from standard off-the-shelf instruments. Wiring of systems is between *cases*, and the release of front-panel locking knobs permits the unit to slide out. Simple or complex systems for measurement and recording are quickly, easily available from Cubic, offering "digital systems that design themselves."

And, of course, Cubic quality speaks for itself, too, with such unique features as "controlled drive" stepping switches which swing up and out for ease of routine maintenance. From front panel to rear connector panel, Cubic's is *the superior* digital instrument.

NEW FROM CUBIC . . . the Talking Meter, instrumentation that really *does* speak for itself, with measurements or other parameters reported to the ear by a clear human voice.

Years-ahead engineering, factory production techniques inspired by pride in the end result, careful quality control and reliability testing . . . all these factors make Cubic's the truly fine instrumentation . . . Digital Systems that speak for themselves.



INDUSTRIAL DIVISION

CUBIC CORPORATION

5575 Kearny Villa Road, San Diego 11, California
Electronic Engineering With a Dimension for the Future



RELAX! Just select the
power output, bandwidth.
everything else you need:
and radiation tolerance...

Telephone today! New York, WI 7-4065....Boston, DE 2-7122....Washington, EX 3-3600....Chicago, SP 7-1600....Dallas, RI 7-4296....

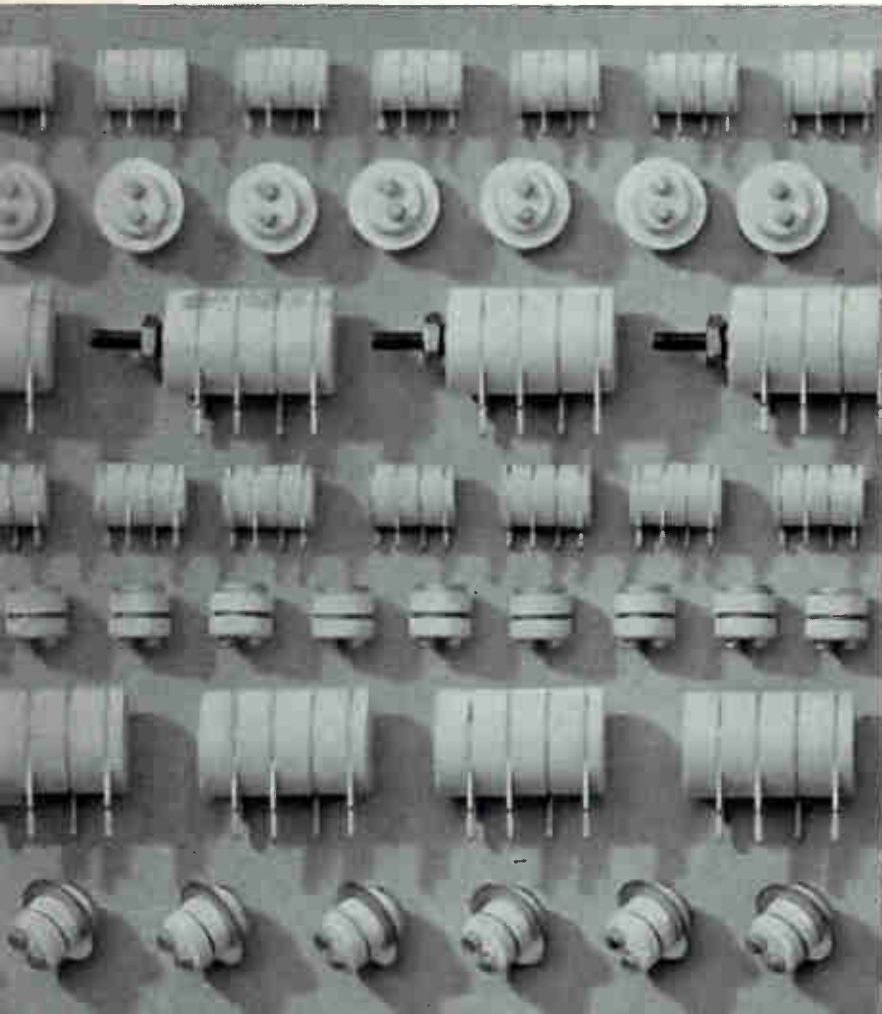

(ACTUAL SIZE)

7462

RF-amplifier triode

7486

RF oscillator-mixer triode

7296

VHF-UHF low-power triode,
shown with mounting bolt

7625

High voltage-gain triode

7266

VHF-UHF detector diode

Developmental, broadband,
40,000-G_m triode

7077

RF-amplifier triode

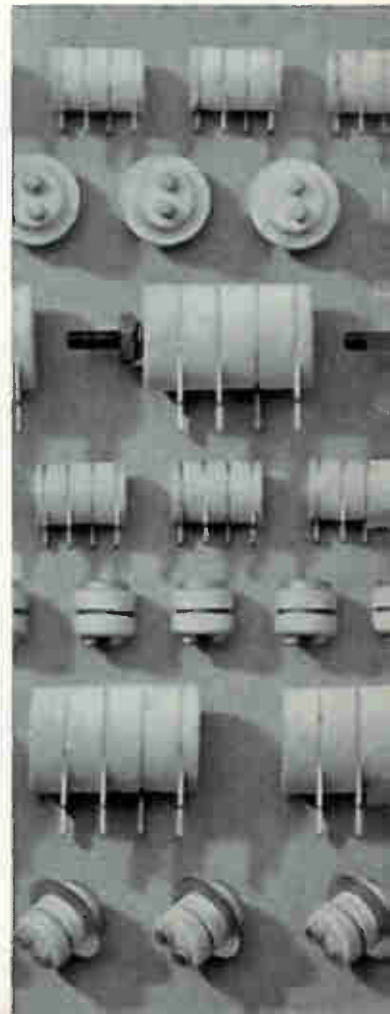

right frequency, function,
G-E Ceramic Tubes have
ruggedness...temperature
high gain...low noise.

Los Angeles, GR 9-7765, BR 2-8566 . . . San Francisco, DI 2-7201 . . . Or call your General Electric Industrial Tube distributor.

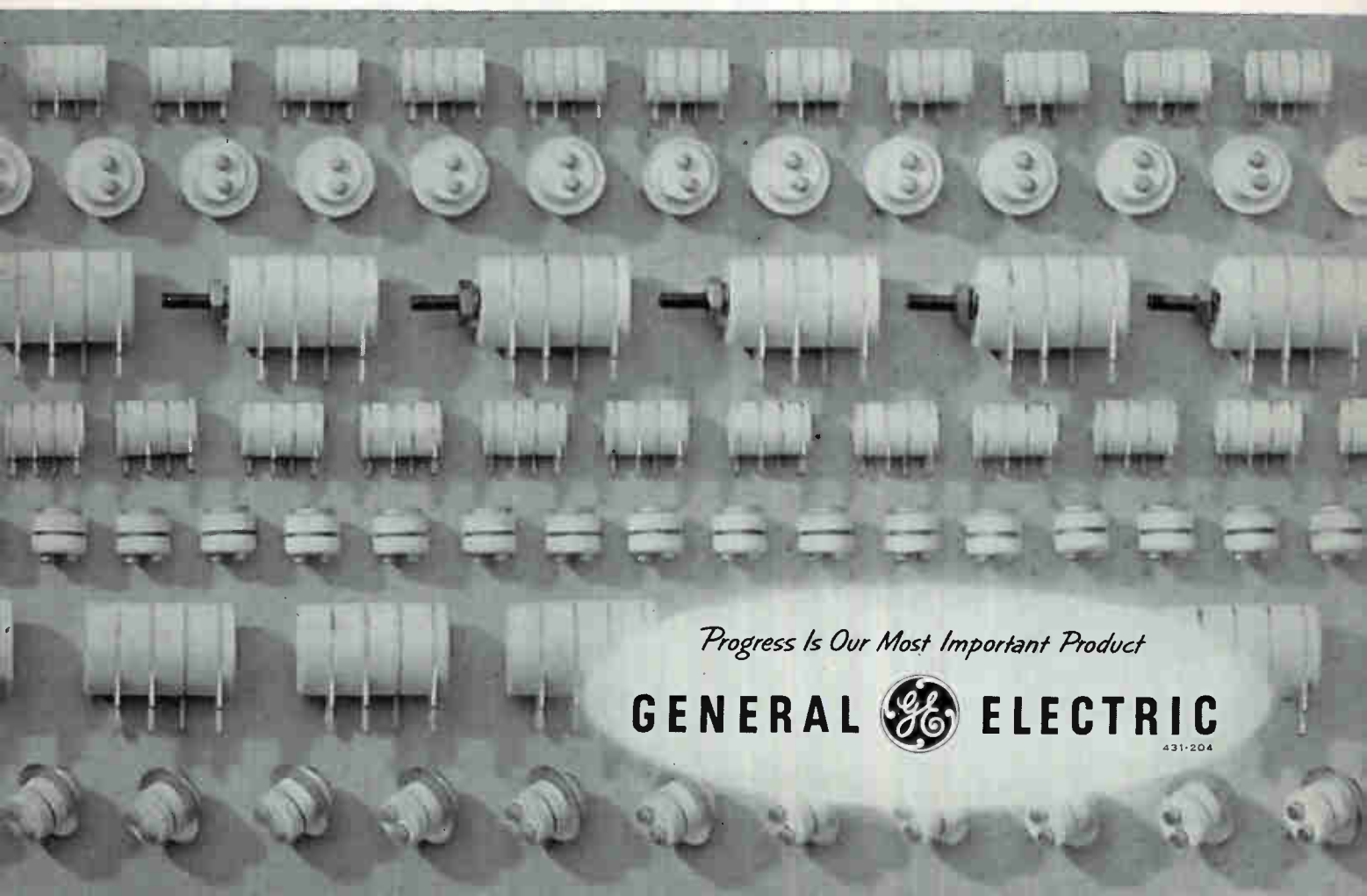

Progress Is Our Most Important Product

GENERAL  ELECTRIC

431-204

Soviets Stress Industrial Electronics

Automatic-control congress provided insights into iron-curtain electronic activity. Here's a roundup

By ERNEST CONINE

McGraw-Hill World News

MOSCOW—FREE-WORLD COMPUTER-MEN attending the recent congress of the International Federation of Automatic Control here were surprised at some Soviet achievements in computers and industrial electronics.

One instrument expert remarked that Soviet scientists are using a leapfrog technique—skipping intermediate steps and developing automatic devices for the long range.

Self-optimizing production controls and computer logic using pneumatic techniques (airjets) were among developments calling forth Western admiration (see *ELECTRONICS*, p 41, March 25). Russian engineers have built self-correcting systems for steel processing control, and to control radio-transmitter output power.

Strong in Theory

"They sat down and thought for

five or six years," says one visitor to the congress; "now this thought is beginning to pay off." The impression lingers, however, that much of the Soviet thought remains just that. Ten of the 29 scheduled tours of Soviet plants were chopped out by the congress host committee; what remained were familiar to many former visitors to the Russian scene. Applications of automatic-control theory in industry still have a distance to go to catch up to the West; although when the theorizing finally takes, progress may come with a rush.

Of the 285 papers presented at the congress, 80 were by Soviet authors and 70 from the U. S. About half of the papers were devoted to theoretical subjects, which dominated the meetings. Keynoter V. A. Trapeznikov of the Soviet Academy of Sciences stressed the importance of theory. He also said that automatic systems to work out comprehensive theories explaining experimentally derived data are "not in the least unlikely;" these systems would fit hypotheses to empiric information. Trapeznikov commented on component reliability, calling it the most important hardware problem, with development of micro-circuitry and standardized building-blocks as additional crucial problems.

State-directed efforts in the instrument and control technology have been aimed—as so much USSR effort is—at beating the West. To accomplish this, the Soviets are applying engineering effort to the problems of a few years hence, meanwhile buying the technology they need today. During the IFAC meeting, 41 members of Britain's Scientific Instrument Manufacturing Association staged an exhibit

of instruments and controls in the Russian capital. Well over 5,000 visitors called, stayed to buy 95 percent of the gear on display, spent some \$600,000 during the SIMA exhibit's 11-day run.

Industrial Electronics

A few sectors of Soviet industry are beginning to sport Western-style production facilities. A closed-circuit tv system to allow engineers to monitor hydroturbine operation remotely was recently put into the Irkutsk hydroelectric station in Eastern Siberia, for example. New steel and other heavy-metals plants feature electronic measuring systems, ultrasonic and X-ray flaw detectors, and other modern trappings familiar to U. S. production managers.

One recent invention is a micro-seismic receiver which can warn miners of coming gas eruptions in shafts and excavations six hours before they happen. Two of the receivers have been tested in the Donets Basin mines. The inventor figures the device can also be used to forecast earthquakes.

Among other recently announced achievements is fine wire 1 to 2 microns in diameter, developed by the Metallurgical Institute of the Soviet Academy of Sciences. The wire is formed from metal placed in a hermetically sealed cask with nitrogen, and heated under high pressure. A tiny hole drilled in the cask allows the molten metal to shoot out in fine filaments.

Medical Electronics

The Soviets created a momentary stir at one technical session of the IFAC congress by presenting a paper on the latest work with bioelectric control, then wheeling in a



During IFAC congress, British instrument makers put on separate exhibit. Russians came, saw, bought



Visitors to automatic-control congress heard 285 papers, visited Moscow sights, saw Soviet engineering accomplishments

youth who laboriously wrote his name on a blackboard using his bioelectric arm.

The Soviet Medical Research Institute and Central Prosthesis Research Institute have been working for several years on artificial limbs actuated by bioelectric signals of the muscles. Earlier models used stepping-switch servo system, electrohydraulic actuators.

In the model demonstrated at the IFAC meeting, the subject was a teenage youth who lost his right arm from gangrene. Electrical impulses from his arm muscle actuate a miniaturized servo system in the artificial arm attached to the living stump. Signals are detected by electrodes strapped over the bending and flexing muscles. Transistors amplify the 25-to-200 microvolt input signals to provide power for the 3-w miniature servo motor in the artificial limb. The whole arm weighs less than three pounds. All four fingers open and close together, with the thumb separately articulated. Power is supplied by batteries.

Consumer Electronics

USSR electronics stresses industrial and military gear at the expense of the consumer sector of the industry. Soviet citizens own 25 million radio sets, less than one for every eight citizens. An additional 30 million subscribers to what the Russians call wire-radio are registered in the USSR; this is a piped-radio service with the subscriber owning merely the loudspeaker.

There are 15 f-m stations in the Russian Federation (largest of the Soviets), and 55 tv stations, many of which merely repeat broadcasts originating elsewhere. Tv subscribers number some 15 million. New tv receivers include 20-in. sets with 110-deg tubes.

Two stations—one in Moscow, the second recently opened in Leningrad—broadcast experimental color twice a week. Soviet experts blame their color problems on "incomplete technology of the color (picture) tubes." Color system in the Soviet Union is compatible with monochrome.

Research

Bright lights in Soviet research continue to be the propaganda-rich space technology and the strategically valuable field of oceanography. Trans-Pacific rocket launches just completed were making test runs on satellite firings scheduled for August. The rocket carrier lofted in June carried a dog named "Plucky" to her fifth successful trip, reached a height of 130 miles, took data on infrared radiation from the earth and its atmosphere, high-altitude ionization, cloud cover, solar ultraviolet radiation, and the muscular tension of animals in the weightless state.

In oceanography, the USSR has put into commission a modern armada of over 100 research vessels, some designed from the keel up for research and scientific investigation. The *Lomonosov*, pride of this armada, is a 6,000-ton vessel; the *Vityaz*, her second finest, is a 5,500-ton ship; also included is at least one research submarine, the *Severnyanka*, of 1,050 tons. Soviet plans to build a bathyscaphe were announced earlier this year, and their own bathyspheres have been in use for several years.

A huge radiotelescope of "Mills Cross" design is now abuilding near Moscow. The cruciform array will be formed by two antennas 3,280 ft long. Soviet scientists claim the system sensitivity will be equal to a dish-type reflector a kilometer (3,280 ft) in diameter.

The big ear will be installed at one of the radioastronomy stations of the Lebedev Institute, which already uses 72-ft-dia computer-controlled dishes. Institute engineers have reported studies in centimeter wavelengths, say the subsurface temperatures on the warm side of the moon are -20 to -30 C, and the surface temperature of Venus is about 100 C.

20-Year Plan

Right at the moment, the Soviet Academy of Sciences is busily formulating a 20-year plan which will lay out tasks for the applied sciences behind the Iron Curtain. Among the more important jobs:

- Research and engineering in the space sciences: rockets and satellites to measure the near-space environment, circumterrestrial radiation belts, earth-sun relationships.

- Atmospheric physics: studies in meteorology and weather prediction; study of methods to dissolve warm clouds, eliminate hail.

- Nuclear physics: controlled thermonuclear fusion.

- Applied mathematics: studies in computer-allied math aimed at development of faster computers for production control, language translation, communications scheduling, traffic control and bank accounting.

- Electronics: work in millimeter and submillimeter wavelengths for communication.

Soviet scientists will also have to increase electric-power production to surpass U. S. generator capacity, drill Mo-holes 15 kilometers or more into the earth's crust to advance geophysical knowledge. Biologists will be doing research in metabolism, malignant cellular growth, heart and cardiovascular diseases, and other common ills.

New System Will Measure Missile Trajectories

Accuracy and capabilities of new missile-trajectory measurement system, Mistram, opens way to technological and business gains

NEW MISSILE TRAJECTORY measurement system (Mistram), now being designed for the Atlantic Missile Range in Florida, will advance both missile and countermissile defense technology, may also open a sizable market for the electronics industry.

Mistram, according to prime contractor General Electric, will be ten to 1,000 times more accurate than existing systems. Missile performance data this precise will contribute to efforts in several areas.

Primary function of the system, which will be installed about 30 miles south-southwest of Cape Canaveral, is to monitor the guidance performance of missiles launched down the Atlantic range. The system will measure position and velocity during the missile's first 1,000 miles of flight, more or less, depending on the objectives of the test, the time the missile stays above the horizon and the size of the airborne antenna. With a 14-inch antenna installed on a missile, GE says, Mistram can track the missile to the moon.

Other programs that can benefit from Mistram data include missile

and nose cone design, propulsion systems, and defense against enemy ballistic missiles. In this latter area, much valuable data on missile characteristics during the initial powered phase of a missile's trajectory can be fed into Project Defender—the Advanced Research Projects Agency's program to come up with a more sophisticated means than Nike Zeus for knocking out enemy missiles. Zeus attempts to hit the approaching missile in its terminal phase before the missile hits its target.

The system can also be useful in precise tracking for recovery of manned or unmanned reentry vehicles and satellite boosters.

Another job Mistram can perform is tracking missiles and satellite boosters as part of a ground-based radio-command guidance system. This task, however, would fall within the province of the Ballistic Missile Division rather than the Air Force Missile Test Center, which is paying for the work.

Business to Industry

The potential business for the

electronics industry from Mistram is big. GE's current contract is for \$15½ million; overall cost of the first site is expected to hit close to \$26 million. Later plans call for adding outlying stations at various downrange island sites for tracking midcourse and terminal phases of missile flight. Other launch sites such as Vandenberg AFB, Calif., and Wallops Island, Va., are also possible customers. For space flight, USAF says, it would be nice to have a Mistram on the moon.

Equipment used in the system, and the subcontractors contributing to this first Mistram, are, according to GE: precision measuring sub-system—GE heavy military electronics department, \$10 million; data transmission/recording subsystem—Lenkurt Electric, \$190,000; analog computer subsystem—Electronics Associates, \$200,000; r-f communications link subsystem—GE communication products department, \$250,000; data multiplex subsystem—Milgo Electronic Corp.; airborne transponder subsystem and transponder test set—GE light military electronics department, \$33,000 a unit; acquisition and tracking subsystem—General Bronze, \$1.4 million.

GE will analyze, design, develop, produce, install and checkout the system. The complete system should be ready for testing by January 1962, should be operational three months later.

How It Works

Mistram is a sophisticated interferometer system consisting of a group of five receiving stations arranged in an L shape. Baselines will be 10,000 ft. and 100,000 ft. The central station will contain a simple tracking antenna. The distance from the central station to the furthest remote station will be approximately 100,000 ft. Antennas at the central station and the four remote stations will follow the flight of a missile and receive signals from its radio beacon. A continuous signal from the missile will permit Mistram to calculate the

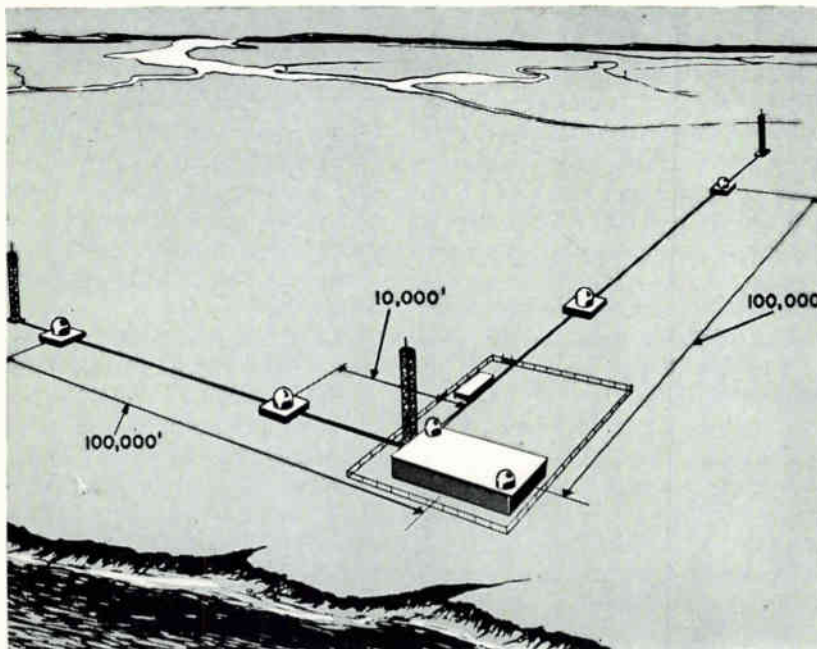

Five receiving stations on 10,000-ft and 100,000-ft baselines receive signals from missile, compute missile's velocity, position and trajectory

missile's position and velocity by precise measurement of phase differences at extremely high modulation frequencies.

Mistram will perform these calculations by measuring the missile's range from the central station, and the difference between this range and the range from each remote station. The measurement of range will describe a sphere to the system and each of the range differences will describe a hyperboloid of revolution. The intersection of these surfaces in space will indicate the missile's position. Mistram will also calculate the missile's velocity from these same signals. The computer used in the system is an IBM 709.

Any error in range measurement at long ranges will be due to the uncertainty in the exact speed of light and in the accuracy of site surveying, says John L. Ford, responsible for systems design and analysis of Mistram. The 10,000-ft baseline is expected to be accurate within $\frac{1}{4}$ inch; the 100,000-ft baseline will be more accurate.

Highly accurate measurement of position across a long baseline utilizing interferometer techniques has been accomplished through the use of a phase-stabilization system. In the past, effects of temperature and equipment changes caused severe deviations in the electrical length of a baseline. The phase-stabilization technique used in Mistram also permits extension of the baseline almost indefinitely, to minimize the effect of atmospheric distortion of the signal path.

Mistram will not require massive and expensive high-precision tracking antennas. Azimuth and elevation information is derived mathematically, by computers, immediately upon receipt by radar of the range-difference data.

Tv Network Formed In Central America

CENTRAL AMERICAN television network with member stations in Costa Rica, El Salvador, Guatemala, Honduras and Nicaragua is now in operation. Said to be the first commercial tv net in the Western Hemisphere outside the U. S., the system serves an area with more than 50,000 tv receivers.

July 29, 1960

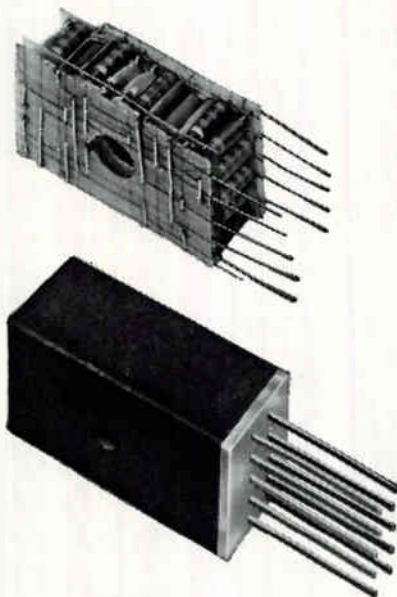

how do you play the numbers game?

The current numbers game consists of seeing how many components you can wedge into a small space. But there's a catch to it.

Some circuit modules may seem small until you string them together and find that interconnections and supporting structure take more space than the modules themselves. That's why it's important, in evaluating miniaturization, not to consider the module size alone, but to be concerned with the over-all size, including module, interconnections, and supporting structure.

New EECO MINIWELD circuit modules are designed with over-all system size in mind. They offer optimum miniaturization not only of modules, but also of interconnections and supporting structure. Add to this the reliability of proven circuits incorporating readily available standard catalog components rather than hard-to-get specials, the superior strength of welded rather than soldered connections, and you have an unbeatable combination of advantages.

We invite you to see for yourself at WESCON, Booth 1017.

Write, wire, or 'phone today for detailed information on the revolutionary new MINIWELD space-saving package.

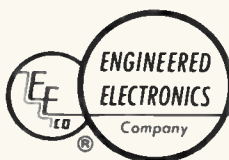

ENGINEERED ELECTRONICS COMPANY

1441 EAST CHESTNUT AVENUE • SANTA ANA, CALIFORNIA
KImberly 7-5651



CHEMICALS

THE RAW MATERIALS OF PROGRESS

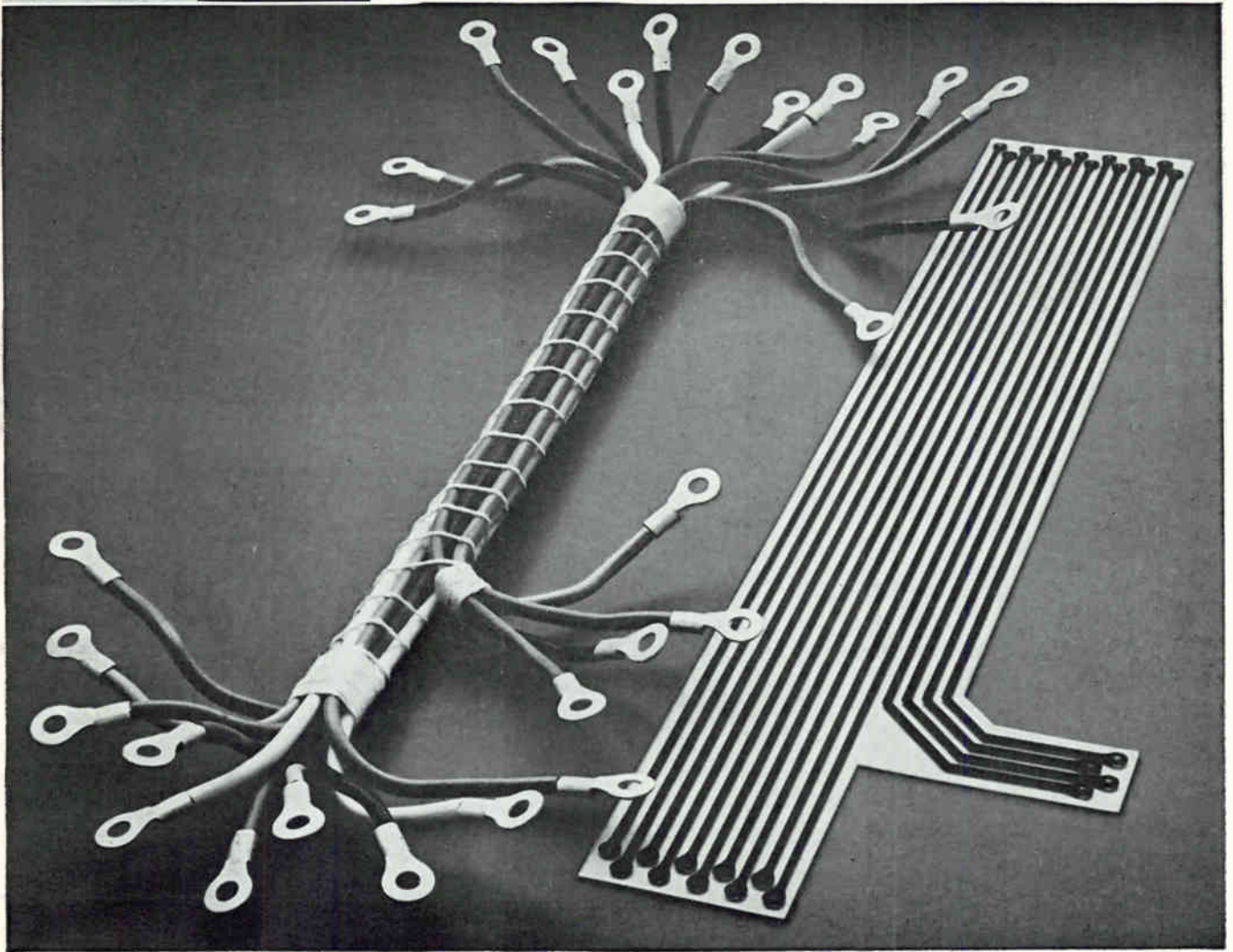

Circuits of **KEL-F**[®] Plastic film cut weight, space, production time

BRAND

Miniaturization is given another step forward through use of KEL-F Plastic laminate on printed circuits, such as that shown above. Manufactured by Sanders Associates, Inc., Nashua, N. H., and sold under the trade name of Flexprint®, these circuits provide optimum dependability in minimum space.

The circuit illustrated, for example, weighs only 2 ounces—its cable counterpart, 14 ounces. All conductors are encapsulated,

thus there is no penetration of moisture or gases. Exact positioning of terminations eliminates wiring errors. And because this circuit is flexible, no short or open circuits will develop due to vibration and shock.

The plastic is extruded and supplied by W. S. Shamban & Company, Los Angeles.

KEL-F Plastic was chosen as the covercoat because of its high dielectric strength, excellent chemical stability, zero moisture

absorption and fine thermal stability. A 3M halofluorocarbon product, it can resist temperatures from -320° F. to 392° F., and remain flexible while providing superior insulation at all frequencies.

Look to KEL-F Polymers to solve your tough insulation jobs. You'll find them readily moldable, while possessing high temperature and good electrical properties. For free literature, write to 3M Chemical Division, Dept. KAX-70, St. Paul 6, Minn.

[®]"KEL-F" is a Reg. T. M. of 3M Co.

CHEMICAL DIVISION

MINNESOTA MINING AND MANUFACTURING COMPANY

... WHERE RESEARCH IS THE KEY TO TOMORROW



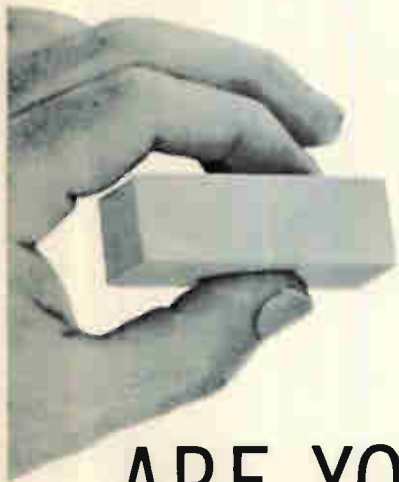

ARE YOUR TALENTS BEING RECOGNIZED?

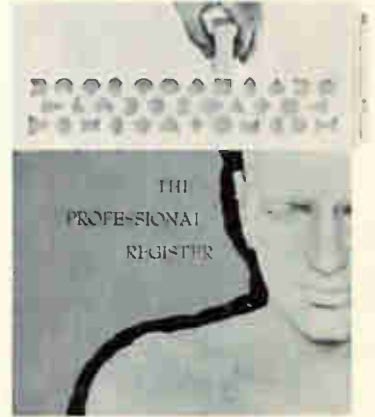
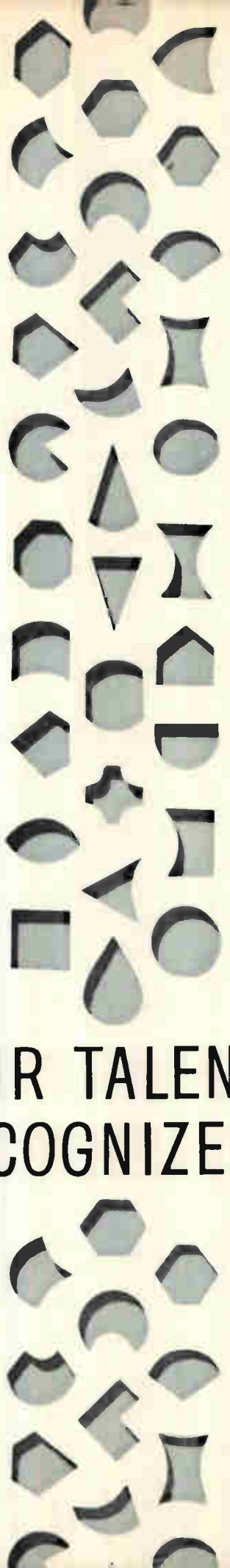

If you would like to know more about Hughes-Fullerton and participate in the new Professional Capabilities Register, please return this post-paid card, today.

First Class
Permit No. 358
Fullerton, Calif.

BUSINESS REPLY MAIL
No postage necessary if mailed in the United States

POSTAGE WILL BE PAID BY

HUGHES-FULLERTON RESEARCH & DEVELOPMENT
Hughes Aircraft Company
Building 600, Room: B-149
Fullerton, Orange County, California

Attention: Manager, Professional Placement E.



PROFESSIONAL REGISTER EMPLOYMENT INQUIRY (Strictly Confidential)

Please complete this card, fold, staple and mail. The information you give constitutes the first phase of the Professional Register Program and will enable our professional staff to make a preliminary evaluation of your abilities. All inquiries will be answered immediately. When you complete the Program, the inventory of your talents and capabilities will be recorded on over 20 electronic data-cards available for instant use in guiding your future progress at HUGHES-FULLERTON.

Name _____
 Address _____
 City _____ State _____ Telephone _____

Education:	BS	MS	PhD	Date (s):	BS	MS	PhD	Date (s):
EE	<input type="checkbox"/>	<input type="checkbox"/>	<input type="checkbox"/>	_____	<input type="checkbox"/>	<input type="checkbox"/>	<input type="checkbox"/>	_____
ME	<input type="checkbox"/>	<input type="checkbox"/>	<input type="checkbox"/>	_____	<input type="checkbox"/>	<input type="checkbox"/>	<input type="checkbox"/>	_____
Mathematics	<input type="checkbox"/>	<input type="checkbox"/>	<input type="checkbox"/>	_____	<input type="checkbox"/>	<input type="checkbox"/>	<input type="checkbox"/>	_____

School (Highest Degree) _____

FOLD

AREAS OF PROFESSIONAL EXPERIENCE:

(please check boxes)

- Computers
- Electron Tubes
- Electronic Circuitry
- Telemetry
- Circuit Theory
- Radar
- Power Generation
- Power Transmission
- Servomechanisms
- Microwaves
- Solid State Physics
- Electromechanical Systems
- Other: _____

FUNCTIONS PERFORMED:

(please check boxes)

- Research
- Development / Design
- Technical Writing
- Project Management / Supervision
- Administrative Staff Support
- Systems Analysis
- Testing / Process Control
- Product Engineering
- Field Engineering
- Operations Research
- General Engineering
- Systems Engineering
- Other: _____

Are your talents being recognized?

Most engineers have had to face an unpleasant fact. Often an employer will hire from outside to fill a supervisory post. Entirely qualified men "inside" are passed over. The problem is generally one of communication. The employer simply does not have adequate knowledge of his employees' abilities and promise.

Hughes-Fullerton's new Professional Capabilities Register reflects the complete engineering-orientation of this fastest-growing Hughes activity. (From 800 to nearly 6,000 people since 1957. Planned, *scheduled* growth.)

The Register makes instantly available a complete record of every individual's abilities, interests and accomplishments. Previously hidden talents can now be put to use. Often these can mean the difference when reassignments or promotions are being made. Your potentials become a very real resource of Hughes-Fullerton Research and Development Staff.

Areas covered in the Register range from language skills through patents to books and articles published. It includes teaching experience, professional affiliations. All data is kept up-to-date and handled by automatic data processing equipment for utmost efficiency.

Hughes-Fullerton's philosophy of giving precedence to the needs of engineers has worked well. Hughes-Fullerton was first with three-dimension radar... a major breakthrough in the state of the art. Other vital areas of interest include advanced data processing and electronic display systems.

These are a few reasons why you should investigate Hughes-Fullerton. Openings exist at several experience levels for a variety of engineering specialties. For full information fill out the post card and mail it today!

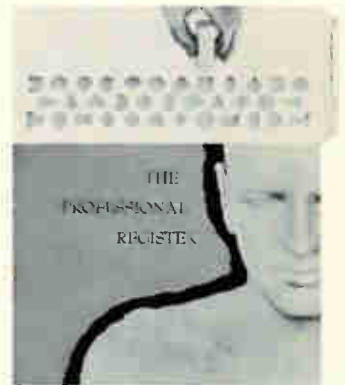

Creating a new world with **ELECTRONICS**

 If reply card is missing, a postcard request will speed another to you. Write: Mr. B. P. Ramstack, P.O. Box 2097, Fullerton, Calif.

HUGHES

**FULLERTON RESEARCH & DEVELOPMENT
 FULLERTON, ORANGE COUNTY, CALIF.**

Can We Stop the Export Decline?

U. S. manufacturers are seeking ways to cope with tariff problems and other aspects of foreign trade as exports continue to drop

U. S. ELECTRONICS FIRMS face mounting difficulties in selling to the export market.

Exports of electronics equipment dropped 3 percent in 1959 from the year before. In 1958 total shipments amounted to more than \$427-million, while in 1959 the figure fell to about \$415 million. Expectations are that the figures for 1960 will continue to slide downward.

Unfavorable Balance

Imports, on the other hand, have quadrupled in two years. Figures from the Foreign Trade Division of the Bureau of the Census show a total of \$19 million in imports of electronics equipment in 1957, \$33 million in 1958, \$80 million in 1959; estimates are that 1960's total will top \$135 million.

In releasing these figures, Census officials add that they do not include such items as United Kingdom shipments of record players and changers which rose from \$7-million in 1957 to \$12.4 million in 1959; West German exports to the U. S. of radios, record players and tv sets which came to \$10.2 million in 1958; and a variety of other imports from other nations as well.

Present unfavorable trend of electronic imports compared with exports was reviewed at a recent meeting between Department of Commerce officials and members of the electronics industry. In the shirtsleeve session, officials explored two general sources of trouble: the lower production costs of foreign electronic equipment and the many trade barriers other nations have erected against U. S. products.

U. S. manufacturers considering these trade barriers say things will get worse before any improvements become evident. The actions of Europe's two main trade groups this month throw some aspects of the problem into sharp focus.

Tariff Walls

Among the so-called Inner Six

member nations of the European Common Market, a 10-percent tariff cut went in effect early this month. The nations are France, West Germany, Italy, Belgium, Netherlands, and Luxembourg. This reduction is the second since January 1959 when a tariff cut of 10 percent was enacted.

In addition, Britain, Sweden, Norway, Denmark, Austria, Switzerland and Portugal—the Outer Seven trade bloc—dropped inter-member tariffs by 20 percent at the beginning of this month.

An 18-member industry panel meeting with Department of Commerce officials in Washington cited some of the foreign trade practices working against the U. S. electronics firm overseas. Besides high tariffs, U. S. exporters have to cope with licensing requirements, restrictive performance standards, high taxes and surcharges. In some countries these range as high as 200 percent of the price of the item before import duties.

Industry spokesmen say these obstacles have been placed in the path of incoming electronic goods to protect local industries. While none of the spokesmen at the Washington meeting found any quarrel with this philosophy, it was pointed out that some practices are extreme. Particularly cited was a case in Mexico where a Mexican factory was established to produce a small line of certain types of radio tubes. As a result tariffs were raised on all tube types entering Mexico. "Each new factory raises a wall," commented one delegate.

Licensing Problems

In the area of licensing requirements, industry spokesmen told government officials that in many countries, specifications for electronic equipment are actually descriptions of domestically produced items. As a result, no equipment manufactured outside the country is able to meet those exact specifica-

tions unless manufacturers enter into licensing agreements with the domestic producer.

One radar manufacturer told of the continued refusal by United Kingdom officials to examine certain U. S. equipment for type acceptance, thereby blocking the entry of any such gear from the U. S.

In the matter of financing incoming shipments of U. S. goods, some Latin American nations were cited as having placed a considerable number of blocks in the way of incoming equipment. Argentina, for example, imposes a 150-percent surcharge on incoming material, and requires that 50 percent of the amount be placed on deposit prior to arrival of the merchandise.

Feelings have been expressed that some of the U. S. firms' difficulties might be solved with the worldwide adoption of specifications for items of electronics equipment. Here, however, new troubles arise.

International Standards

A meeting of the International Electrochemical Commission, an international standard-setting group, will be held this Fall in New Delhi. While U. S. companies have sent delegates to past meetings in Europe, IEC officials fear that the expense of sending people to India will keep many U. S. firms from being represented. From all indications, the U. S. delegations will number about 14, while informed sources say the USSR is planning to send some 200. The only way in which the federal government can help industry defray the expense of attending this conference would require Congressional appropriation.

More favorable tax policies regarding foreign investments, credit guarantee for export transactions, tariff agreements negotiated on a nation-by-nation basis and an upturn in the growing practice of licensing manufacturing facilities abroad are all part of plans now taking form.

ANTENNA TOWERS & STRUCTURES

*Dresser-Ideco Designs, Fabricates, Erects
A Wide Variety of
Large Land-Based Antenna Structures*

Whatever the antenna tower or structural problem, Dresser-Ideco can handle the job. A large technical service staff, more than a quarter-million square feet of well-equipped production area, extensive research and development facilities, and many years experience designing and erecting steel and aluminum structures qualify Dresser-Ideco as a major contractor for any type of antenna tower . . . from 100 to 2000 feet. Below are some of the many types of Dresser-Ideco towers serving the nation's communications and military electronics facilities.

B.



C.



A.



A. Multiple antenna tower. This big 729' tower in Baltimore supports three television antennas on a 105' wide platform at the top.

B. Antenna test range tower for height finding radar.

C. Microwave antenna tower typical of those used in systems built for the Ohio Turnpike and the Illinois Toll Road.

D. Surveillance radar towers on the DEW line. Designed for hurricane force winds and heavy ice and snow loads. These are some of more than 1,000 radar towers built by Dresser-Ideco for the nation's early warning systems.

D.



Dresser-Ideco offers a complete tower and structural service—design, application, field installation. Call or write for consultation on your structural problems at no obligation. Send for booklet "Facilities For Defense Production". Dresser-Ideco Company, A Division of Dresser Industries, Inc., 875 Michigan Avenue, Columbus 15, Ohio.

Branch:

*8909 So. Vermont Avenue,
Los Angeles 44, Calif.*

DRESSER-IDECO COMPANY



Reverberation Units Start Trend

New stereo consoles use electronic reverberation units to add depth as well as width to sound of music. Here's how the units work and other recent trends in consumer electronics

CHICAGO — ARTIFICIAL SOUND reverberation circuits, and more complete home entertainment centers were among consumer products presented at the Music Show here this month.

Reverberation circuits in Zenith, Motorola and Philco stereo consoles are said to add presence and realism to recordings. Conventional left-right two-channel stereo gives the impression of width of the source to the listener, but may be lacking in depth perceived at a live concert. A reverberation unit simulates the fullness of sound of music as played in an acoustic chamber, such as a concert hall, by adding a controlled amount of artificial echo to recorded music.

The Zenith system uses with a sum-and-difference stereo amplifier. Output from the two-channel stereo cartridge is fed into a sum-and-difference matrix. The matrix combines the left and right channels, produces sum and difference signals which are amplified separately. A separation matrix at the amplifier outputs recombines the sum and difference signals to produce conventional stereo, which is fed to the loudspeakers.

The reverberation unit is between the sum-and-difference matrix and the power amplifiers. Part of the sum signal is delayed about 30 milliseconds and passed through a small additional amplifier, then fed into the difference-signal amplifier. Degree of reverberation is controlled by varying the gain of the small amplifier.

Electromechanical Delay

To produce the delay, a portion of the sum signal is fed into a transducer, similar to a moving-coil phonograph pickup. The transducer converts the electrical energy into mechanical energy which drives one end of two coil springs, each about 12 in. long. The other end of each spring is connected to a second transducer, similar to the first, which converts the mechanical energy back into electrical energy. Delay is equivalent to time required

for travel of the mechanical energy along the springs.

Home Centers

Complete home-entertainment centers are being pushed by several manufacturers. These centers combine radio, tv and hi-fi in one large console. Stromberg-Carlson and Capehart demonstrated elaborate systems. One Capehart tv/a-m/f-m/phono sells for \$2,225.

Operating controls on home-en-

tertainment equipment are following a trend toward increased complexity. Some of the more complex controls include rumble and scratch filters, phasing, presence, and variable afc for f-m tuners.

Also seen at the show were several a-m/f-m table-top receivers. Many used 8-in. loudspeakers for improved fidelity. Cabinets for these radios ranged from inexpensive plastic moldings, to elaborate wooden ones.

Army Radar Sees Troop Movement

ARMY COMBAT SURVEILLANCE AGENCY is testing a new mobile radar system that can look 25 miles behind enemy lines, revealing enemy activity on a ppi scope or on quickly-developed 35-mm film for keeping permanent records and making comparisons of movement. Faster but less accurate locating and tracking can also be done by earphones.

The entire radar system, which weighs about 600 lb, can be transported by helicopter to a point overlooking enemy terrain. Three men can set up the three-piece antenna and assemble the equipment, quickly begin plotting movement of enemy

targets.

Movement is detected by the doppler principle. A low-frequency signal is used to provide good brush and foliage penetration.

The system, designated the AN/TPD-2, grew out of Project Michigan, the continuing R&D program being carried out at the University of Michigan's Willow Run Laboratories to increase the Army's capability in combat surveillance and target acquisition. Strand Engineering built the equipment. Engineering cost of four models was \$725,000; total development cost was \$9 million.



Operator studies quickly developed film record of ppi scope for enemy target position changes

NEW *transistorized* PHASE METER



TYPE 328-A

By ACTON LABORATORIES

FREQUENCY RANGE
FROM 10 CPS - 50 KC

PHASE ACCURACY 1°
FROM 10 CPS - 10 KC

LONG-TIME STABILITY

FEATURING... Direct reading from 0° to 360° in 6 ranges of 60° each (on a 5" meter scale).

Type 328-A is designed specifically to measure the phase angle in degrees between two sinusoidal or non-sinusoidal voltages within a frequency range from 10 cps to 50 kc. It is capable of handling a wide variety of applications in the field of audio facilities, supersonics, servo-mechanisms, geophysics, vibrations, acoustics, aerial navigation, electronic power, transformation, signalling, computing amplifiers and resolver systems.

SPECIFICATIONS

Amplitude Range — .25 to 170 volts peak (1 volt min. below 500 cps)

Phase Accuracy — For input signals above 10 volts peak from 10° to 350°; 1° at 10 cps — 10 kc; 2° at 10 kc — 30 kc; 3° at 30 kc — 50 kc

Input Impedance — One megohm shunted by 20 mmf

Recorder Output — Maximum voltage at 360° is —2.0 volts. Internal output impedance is approximately 100,000 ohms

Power Supply — 105-125 volts, 60 cycles A.C. Total power consumption is approximately 20 watts.

Terminals are also provided for operation from an external 45-volt battery.

Accessories available — Pre-amplifiers (10 to 1) and improved ½° accuracy from 10 cps to 10 kc.

Complete technical details on Type 328-A Phase Meter are available on request



**ACTON
LABORATORIES, INC.**

A Subsidiary of

TECHNOLOGY INSTRUMENT CORP.
517 MAIN STREET, ACTON, MASS.
COLonial 3-7756

Navy Outlines New

Research and development clinic highlights specific items including gyros, infrared windows, semiconductors

BUILDING A BETTER MOUSETRAP may not start a stampede these days, but the Navy will beat a path to the door of the engineer who comes up with — among other things — a less accurate gyro, an inexpensive material for infrared windows, a feedback potentiometer for 1,000 F environments, a high-output strain gage that doesn't require amplification, or a transducer with digital rather than analog output.

At a Navy R&D clinic in Boston, industry representatives got a briefing on what the Navy needs — much of it in electronics and much hopefully available from small business and small labs.

When the Navy says it wants a less accurate gyro it quickly adds, of course: reliable, cheaper, lighter. It's needed for short-range missiles, where high drift rate can be tolerated.

The material needed for ir transmission elements must operate in adverse missile environments of

high temperature, rapid heating and cooling, severe vibration. Development of detectors, says the Navy, has outdistanced transmission elements. Sapphire is expensive and silicon becomes opaque in Mach 2 and 3 environments.

To build a reliable feedback control for high-Mach missiles, the Navy urges development of high-temperature feedback pots. Insulation against heat cannot be used since space requirements are critical.

In strain gages, the Navy is looking for a high-output (2 to 5 volts) device that can be coupled directly to a telemetering subcarrier without amplification. This would mean design simplicity and weight reduction.

Digital-output transducers are needed for rocket-engine test stands. Conversion equipment would have to be small enough so as not to interfere with other test hand instruments.

DEW Line Hop Uses New Paramps

NEWEST LEG of the DEW line is the 700-mile jump from Baffin Island's Cape Dyer to Thule in Greenland, according to information released by the U.S. Air Force this week.

New parametric amplifiers designed to cover this distance, which is said to be the longest single hop in any tropscatter system to date, have been designed and installed by General Electric. The company has begun quantity production of models of a parametric upper-side-band converter capable of an overall noise figure of 1.7 db.

The device (see picture) converts a signal in the 350-450 Mc region to 10 Gc and then to an i-f of 16 Mc. A drift cancelled loop is used to minimize the undesired effects of pump-frequency variations.

Company engineers say the parametric units have made possible

noise figure reductions from 4.5 db to less than 2 db and that one observable result is a drop in teleprinter error rate.

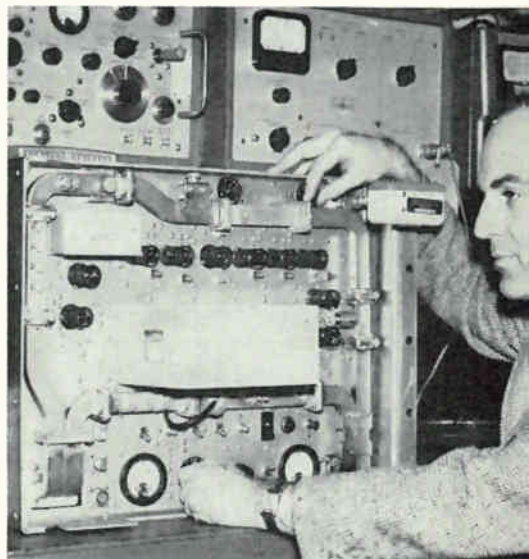

Research Aims

With greater distances being required of radar today, pulse power in megawatts has become common. Only limited exposure can be tolerated by the human body without damage to vital organs. So the Navy is in the market for a simple, reliable, inexpensive, lightweight instrument to warn the wearer when he is in an area of electromagnetic energy of a power level of 0.01 watt per sq cm or greater. Warning would be audible, sub-audible (vibratory) or thermal, depending on the environment in which it is worn. Maximum permissible tolerance of a human to different frequencies is not known, so the instrument would have to respond to an extremely wide band.

For the radar and communications equipment fields, the Navy badly needs inexpensive high-frequency transistors (200 to 500 Mc) that can handle 1 to 10 watts of power, also transistors for frequencies between 50 and 100 Kc that can handle 100 watts.

Silicon transistors are desirable for shipboard and missile use because they are comparatively rugged. However, their present high cost tends to limit their use. The Navy notes that developments are well under way by the Air Force to produce high-power (2-, 5- and 15-amp, 120-volt) silicon transistors, says that will lead to development of equipment such as high-output static inverters.

The Navy advocates new approaches to some problems: a new type of resistor to replace the composition resistor, incorporating low-noise characteristics and increased stability; a totally new type of electrical connector with significantly higher reliability and with a connector configuration that permits two leads to be joined directly; and a new approach to the problem of making switch contacts rugged enough to withstand missile environments. Wiper contacts, according to the Navy, are inadequate when subjected to the accelerations, pressures and temperatures of present systems.

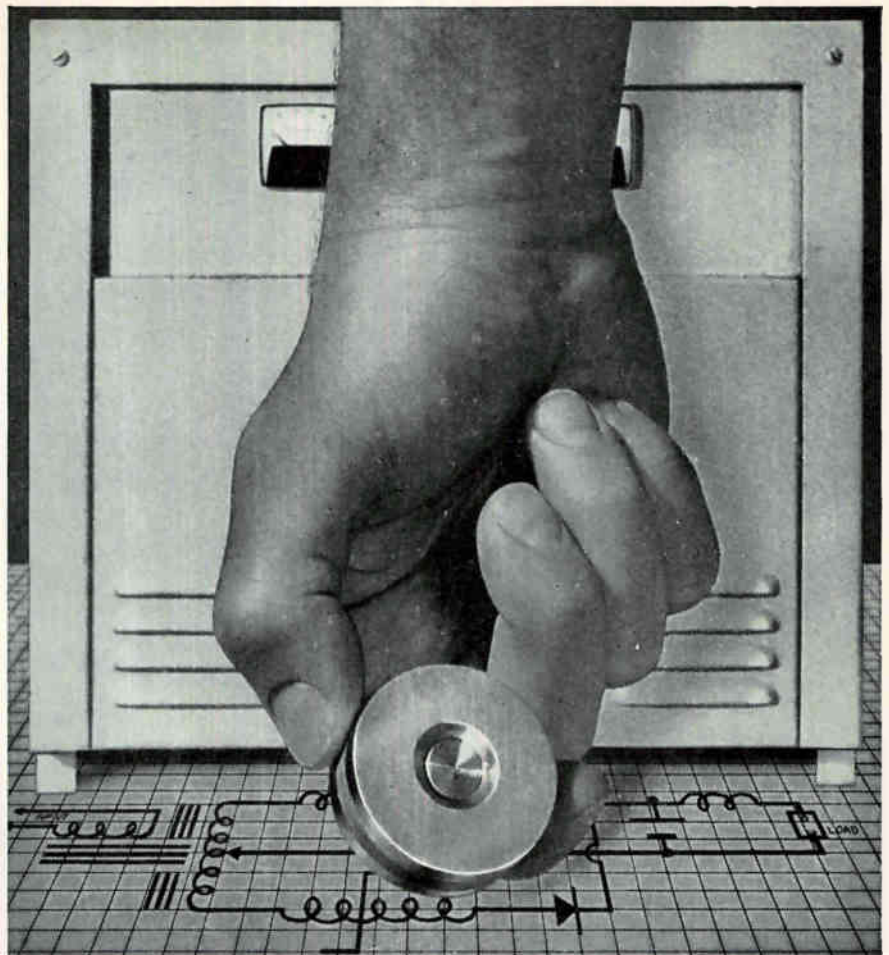

Can a silicon rectifier solve your problem?

It might, if you have a problem in DC power sources. For example, some time ago C & D needed a high efficiency, constant potential, current limiting DC power supply. Output had to be held within $\pm 1\%$ over an AC input variation of $\pm 15\%$. In addition, maintenance would have to be virtually nil.

The answer was found by using a silicon rectifier in combination with simplified components that became the heart of C & D's *AutoReg*® charger. *AutoReg* chargers provide continuous, automatic, unattended charging of industrial storage batteries. With the exception of a timing circuit there are no moving parts. There are no relays to adjust and practically no maintenance is required.

Now, C & D has expanded facilities of the *AutoReg* plant to provide industry with similar DC sources, which incorporate silicon rectifiers and automatic regulation. Final form of these units can supply power in a range from milliwatts to megawatts, depending upon your requirements.

Companies with a problem in DC power sources should write, giving a general outline of their requirements, to: *Vice President in Charge of Engineering*

AutoReg® Power Sources



Manufacturers of *Slyer-Clad*® Industrial Batteries • *PlastiCell*® and *PlastiCal*® Batteries for Communications, Control, and Auxiliary Power • Producers of *AutoReg*® Silicon Chargers and *AutoCal*® Charger-Battery Combinations

*Safe. Easy to operate.
Rate of voltage application conforms
to ASTM standards. Portable
models. Floor mounted models.*

HIGH VOLTAGE

A-C AND A-C/D-C TESTERS

These Sorensen a-c and a-c/d-c testers completely cover the voltage range from 0-150,000 vac and 0-300,000 vdc with current capacities as high as 4000 milliamperes a-c (plus 5 milliamperes d-c for the a-c/d-c units).

All components are conservatively rated to insure maximum life and top performance. Maximum rated current can be drawn continuously over the entire output range and overloads may be supplied for a short time to "burn" faults. Easily reversible d-c polarity of a-c/d-c testers.

New Catalog. Just off the press, Sorensen's new 32-page catalog gives technical data on the complete line of Sorensen a-c and a-c/d-c testers as well as on Sorensen h-v d-c supplies, h-v electrostatic generators, low-voltage d-c power supplies, a-c line-voltage regulators, and frequency changers. Extensive power supply application data is also given. Write for your copy today. Sorensen & Company, Richards Ave., South Norwalk, Conn.

0.4

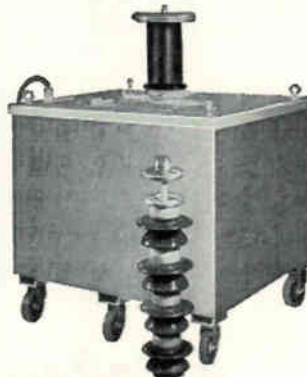
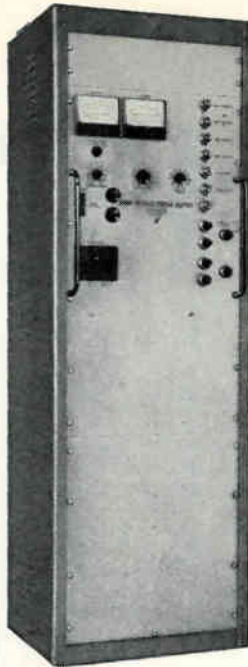

A SUBSIDIARY OF RAYTHEON COMPANY

**CONTROLLED
POWER
PRODUCTS**

...the widest line lets you make the wisest choice

MEETINGS AHEAD

Aug. 1-3: Global Communications Symposium, PGGS of IRE, U. S. Signal Corps; Statler Hilton, Washington, D. C.

Aug. 1-4: Photo-Instrumentation Symp. Soc. of Photo Instr. Engrs., Ambassador Hotel, Los Angeles.

Aug. 8-11: American Astronautical Society, Western National; Olympic Hotel, Seattle, Wash.

Aug. 8-19: Vibration Testing, Sine, Complex and Random Wave, Theory and Practice; Ling Electronics, Anaheim, Calif.

Aug. 9-12: American Institute of Elec. Engrs., Pacific General; San Diego, Calif.

Aug. 15-19: High-Speed Photography; Stroboscopic Light Laboratory, MIT, Cambridge, Mass.

Aug. 18-19: Electronic Circuit Packaging Symp.; Univ. of Colo., Boulder, Colo.

Aug. 22: Scientific Apparatus Makers Assoc. Market Managers; Statler Hilton, Los Angeles.

Aug. 22-26: Thermonuclear Plasma Physics, Symposium, Oak Ridge, U. S. Atomic Energy Comm., Gatlinburg, Tenn.

Aug. 23-26: Western Electronic Show and Convention, WESCON; Memorial Sports Arena, Los Angeles.

Aug. 23-26: Association for Computing Machinery, Nat. Conf.; Marquette Univ., Milwaukee.

Sept. 7-9: Automatic Control, Joint Conf., ASME, IRE, AIEE, ISA; at MIT, Cambridge, Mass.

Oct. 10-12: National Electronics Conf.; Hotel Sherman, Chicago.

The important advances in environmental testing come from MB



NEW MB automatic spectrum equalizer to revolutionize random vibration testing

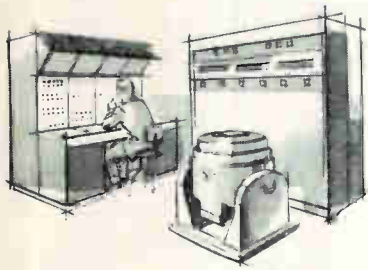

Heart of the MB automatic equalization system is the multi-channel transistorized amplifier which provides amplitude control. The plug-in printed circuit assembly shown above contains four of these channels. Frequency control is provided by the 80-channel filter assembly in the compact metal box.

CONSTITUTING a major breakthrough in applied electronics, MB's new *automatic* spectrum equalizer now means not only more accurate vibration testing . . . but tremendous savings as well in test time and money for missile and aircraft manufacturers.

The reason: set-up time has been completely eliminated. Using solid state magnetostrictive filters with correct phase properties plus servo systems on each of eighty channels in the 15 to 2000 cps spectrum, vibration shaker systems can be completely equalized within 5 seconds.

Savings in time and labor over previous equalization methods can easily mean thousands of dollars per missile tested. Still another advantage is the greatly increased accuracy of accumulated test data. The spectrum is continuously monitored in narrow bandpass channels and compensation automatically made *during* test run.

Automatic spectrum equalization is another of MB's important and continuing contributions in the field of environmental testing.

MB ELECTRONICS

A DIVISION OF TEXTRON ELECTRONICS, INC., 1082 State Street, New Haven 11, Conn.

CIRCLE 49 ON READER SERVICE CARD

New Random Access Memory Package...

uses only 18.75" IN STANDARD 19" RACK

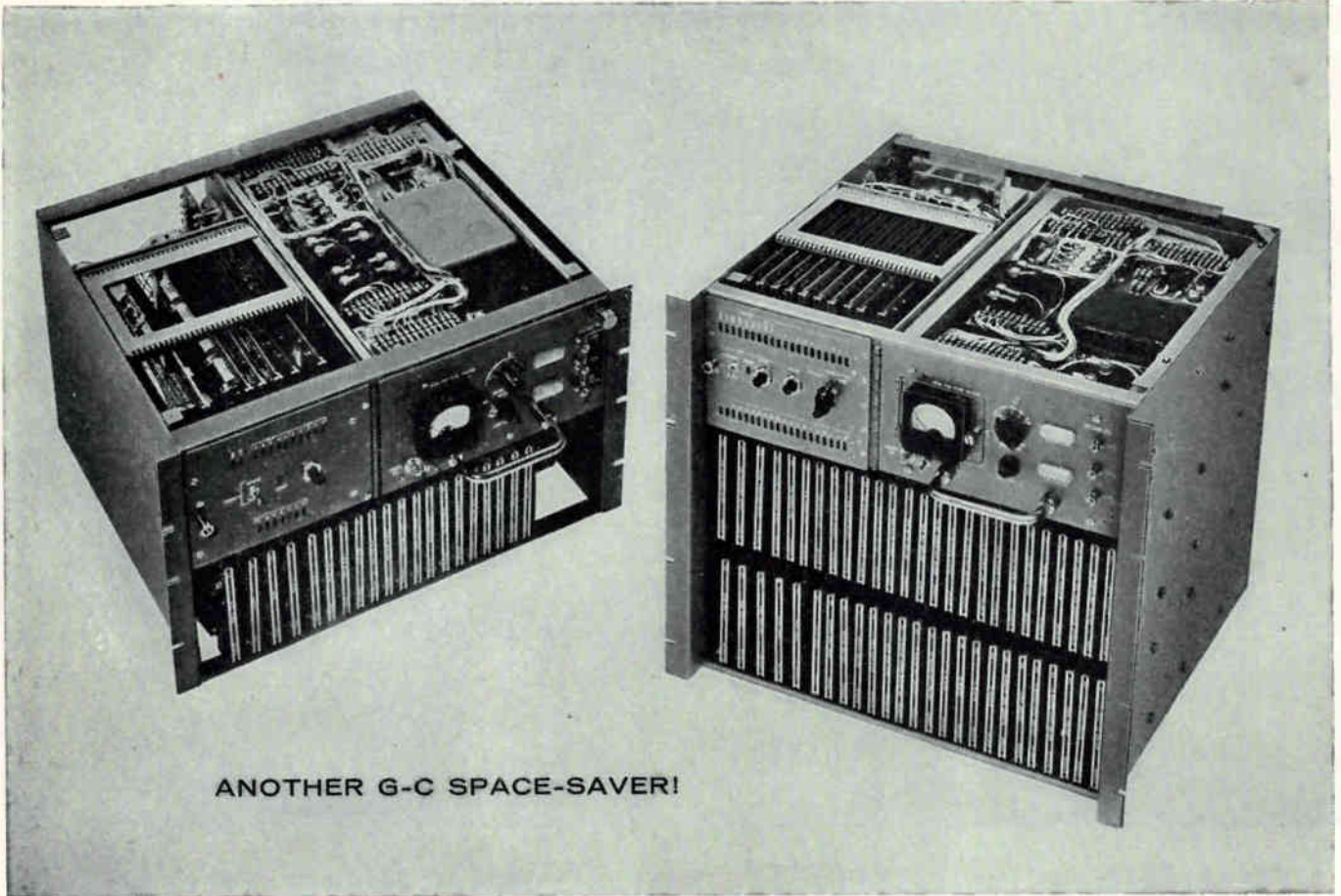

ANOTHER G-C SPACE-SAVER!

GENERAL CERAMICS, continuing its leadership in the memory packaging field, has made available double and triple bay random access memories with up to 4096 characters x 32 bits per character at cycle times up to 6 micro-seconds. Now you can get design economy since the basic G-C package requires only 18.75" of standard rack space—a reduc-

tion of up to 80% over typical units requiring a full six feet.

General Ceramics offers space-saving random access memory designs with varying number of characters, word lengths and logic.

Optional design features include parity checking, test cycles, indicator lights and power supply locations.

*Write on your company letterhead for additional information.
Please mention your requirements; address inquiries to Section E.*



APPLIED LOGIC DEPARTMENT
GENERAL CERAMICS
KEASBEY, NEW JERSEY, U.S.A.

TECHNICAL CERAMICS, FERRITE AND MEMORY PRODUCTS

Conventional Transistorized Full Adder

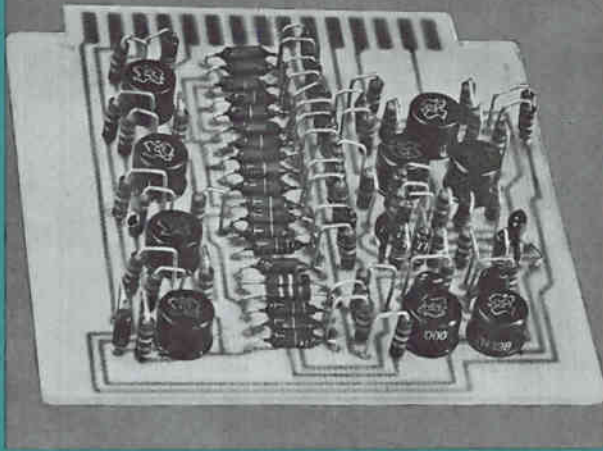

Equivalent **SOLID CIRCUIT*** Semiconductor Networks

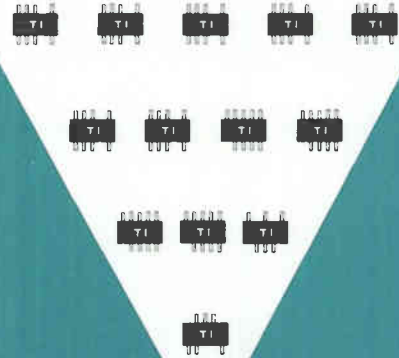

NOW MAKE YOUR OWN EVALUATION

Semiconductor Network
Full Adder



Using one particular interconnection technique for semiconductor networks, this working full adder occupies 1/50th cubic inch.

TI Type 502 silicon **SOLID CIRCUIT** network is intended for binary counter, flip-flop, or shift register applications. Maximum repetition rate of 200 kc. Hermetic sealed package. Write for bulletin TI type 502.

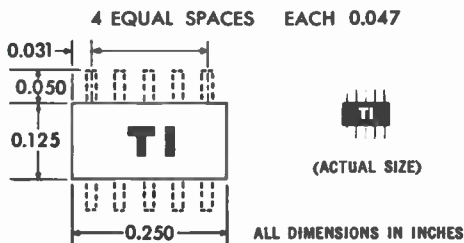
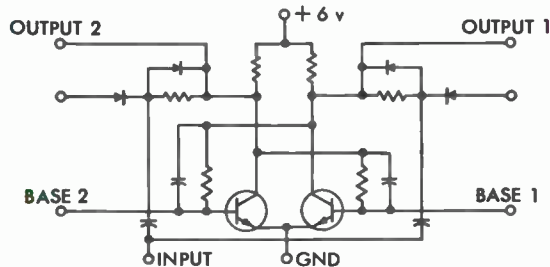

SOLID CIRCUIT* semiconductor networks

Make your own evaluation today of *Solid Circuit* semiconductor networks from Texas Instruments. Available for immediate application, semiconductor networks integrate resistor, capacitor, diode, and transistor functions into single-crystal semiconductor material.

You get improved reliability through the elimination of individual components... element interconnections are reduced as much as 80%... size and weight are drastically reduced and power consumption is minimized.

To design more sophisticated systems in the same space and to increase your system reliability, evaluate the 100:1 miniaturization potential of semiconductor networks. TI Type 502 *Solid Circuit* networks are available now for your evaluation. *TI engineers are ready now to design Solid Circuit networks to meet your missile, satellite, space vehicle, or other micro-electronic specifications.*

Contact your nearest TI Sales Engineer today!

TEXAS  **INSTRUMENTS**
INCORPORATED
POST OFFICE BOX 312 · DALLAS, TEXAS

*Trademark of TEXAS INSTRUMENTS, INCORPORATED

SOLID CIRCUIT* DIFFUSED SILICON BISTABLE MULTIVIBRATOR NETWORK



A MICROELECTRONIC BINARY FLIP-FLOP

for application in

- Counter Circuits
- Shift-Register Circuits
- Reset-Set Flip-Flop Circuits

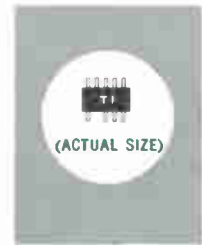

maximum ratings at 25°C ambient

Maximum Supply Voltage	8 v
Maximum Trigger Voltage	8 v
Storage Temperature	- 55° to +125°C

design characteristics:

Design Supply Voltage	6.0 v ± 5%	
Input		
Minimum Pulse Width	1 μsec	
Minimum Trigger Voltage	2.5 volts	
Maximum Trigger Voltage	5.0 volts	
Maximum Trigger Frequency	200 kc	
Maximum Rise Time	1 μsec	
Output Voltages	ON	OFF
With 10K-ohm load to ground	0.7 v max	3.5 v min
With 10K-ohm load to V _s	0.8 v max	4.0 v min
Output Wave Form (typical)		
t _{ON} (90%)	1 μsec	
t _{OFF} (90%)	1 μsec	
Operating Temperature Range	- 40°C to +85°C	

ENGINEERING ASSISTANCE AVAILABLE FOR SOLID CIRCUIT NETWORK APPLICATIONS

TYPE 502 SOLID CIRCUIT* NETWORK CONNECTED AS A BINARY COUNTER

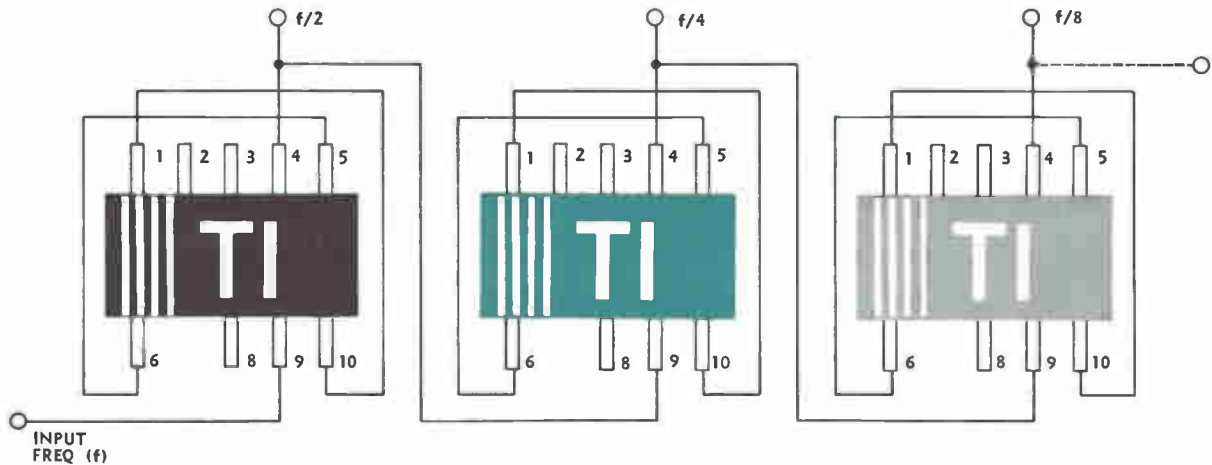

NOTE: SUPPLY VOLTAGE CONNECTIONS NOT INDICATED

* Trademark of TEXAS INSTRUMENTS INCORPORATED

Electronics Probes Nature

By WILLIAM E. BUSHOR, Associate Editor, MICHAEL F. WOLFF, Assistant Editor



SPACE



OUR ATMOSPHERE



THE EARTH



THE OCEANS



LIVING MATTER

University of Manchester's 250-ft radio telescope being used to study the magnetic fields in our galaxy. Located at the Jodrell Bank Experimental Station in England, the telescope has the largest fully steerable paraboloid reflector presently in operation

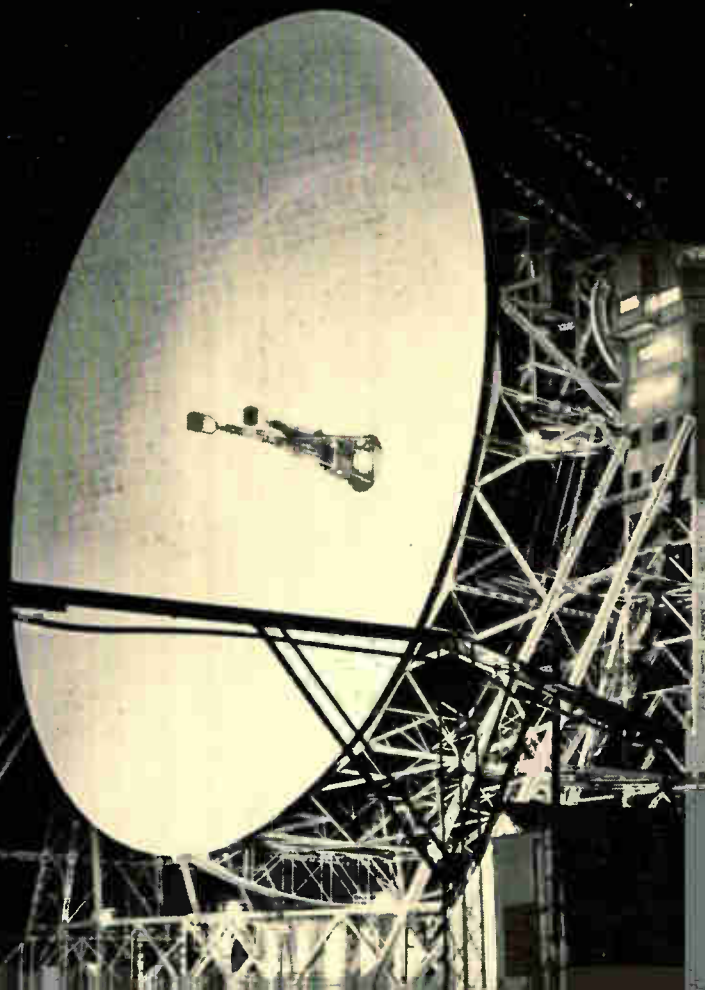

R
REPRINTS
AVAILABLE
SEE
READER SERVICE CARD

© ELECTRONICS, a McGraw-Hill Publication



Research vessel Atlantis, operated by Woods Hole Oceanographic Institution, performs seismic studies of ocean floor configuration, composition and layering. Spout of water is caused by detonation of depth charge

To *probe* means to examine, investigate, search, explore, seek, inquire and scrutinize. This report will attempt to define some of the problems facing science today and describe the electronic probing techniques that have been evolved to help solve them.

We have found there are no fixed boundaries between the numerous disciplines which seek to unravel the secrets of our environment. Also, three problems stand out relative to space, atmosphere, earth, oceans and living matter studies – better component reliability for extreme or unusual environments is required, more adequate instrumentation utilizing electronic techniques is needed, and effective communication, collecting, handling and reducing of data are mandatory.

To understand space, our atmosphere, the earth, the oceans and living matter, they must be treated as a whole – as is done here. The birth of the earth was part of the origin of our galaxy. To follow the evolution of the earth and of life upon it, everything must be considered – from its hot, molten center, out through the mantle of plastic-like material, to the crust we live on, the oceans that surround us, the air we breathe and even space beyond

MANKIND'S BIGGEST PROBE

Project Argus – an experiment consisting of artificial, impulsive injection of known charged particles into the upper atmosphere along known magnetic lines of force at a given time – represented the largest controlled experiment ever attempted by man. His laboratory was space, his subject was a nuclear explosion at the Pacific conjugate points of the earth's magnetic field, his instruments were satellites carrying radiation measuring devices and measuring equipment on the ground for observing optical, radio and magnetic effects. This probe of nature provided valuable information clarifying uncertainties of the dynamics of geomagnetic trapping as well as related geophysical effects

SPACE

From the sensors carried in space vehicles and the techniques of radio and radar astronomy, man is gaining new insight into the nature of the vast frontier called space

ELECTRONIC PROBING OF SPACE is being conducted with methods that are essentially complementary. Satellite, rocket and balloon-borne instruments, radiotelescopes and the active techniques of radar astronomy are providing independent descriptions of the solar system as well as greater insight into phenomena occurring outside.

Vehicular probing offers several sources of data, including the sensors carried, observations of satellite orbits and measurements of the ionospherically refracted radio signals. The instrumentation carried by satellites and space probes, already responsible for such discoveries as the Van Allen radiation belts and the hydro-magnetic ring currents, is listed on the back of the fold-out. An indication of the increasing scope of satellite experiments is provided by the schedule of Table I and the frequency allocations in Table II.

MAGNETOMETERS—Measuring the magnetic fields of the earth, moon and interplanetary space is one of the major experiments in the present space research program.¹ It is hoped this will lead to a better understanding of the origin of the earth's field, the sources of the different variations and the relationships between these variations and other earth-sun phenomena such as ionospheric electric currents and sunspots.

High-altitude satellites are valuable in mapping the earth's magnetic field because the measurements are unaffected by local surface anomalies. Search-coil, flux-gate and proton-precession magnetometers have been used and a more sensitive instrument, the alkali vapor resonance magnetometer, is under development.

Search-coil and flux-gate magnetometers measure the field along a single axis, but they can be used to determine the total magnetic field vector. An example is provided by the experiment designed for Explorer VI.^{2,3} There, the search-coil was mounted so as to measure the field com-

ponent perpendicular to the satellite spin axis and the flux-gate was placed parallel to the spin axis. The third parameter necessary to determine the vector was obtained by placing a photodiode such that sunlight would produce a pulse once each satellite revolution. Time difference between the rising edge of the pulse and the zero voltage out of the coil is a measure of the perpendicular field component relative to the sun. Figure 1 shows a measurement made with the search-coil magnetometer.

The ability of search-coil and flux-gate magnetometers to measure the magnetic field continuously permits observing rapid field fluctuations. While this is not possible with proton-precession magnetometers, which sample the field at 10-sec intervals, the proton-precession device is more accurate and can make total field measurements without calibration or knowledge of vehicle orientation.⁴ Furthermore, telemetry is simplified because the detected signal is a frequency rather than current or voltage.

Two disadvantages of the proton-precession magnetometer, however, make it likely the alkali vapor resonance magnetometer will find more extensive use in space probes. These disadvantages are power dissipation and field dependence of the signal amplitude. The transistorized magnetometer in Vanguard III requires some 200 w-sec for a single measurement and although accurate measurements have been made in fields as low as 0.07 gauss, increased weight and power requirements may make it impractical to build a space probe device for fields below 0.05 gauss. The optically pumped rubidium vapor magnetometer being developed for a NASA space probe by Varian Associates requires approximately 5 w and will be able to measure fluctuations in fields as weak as 10^{-8} gauss.

RADIATION DETECTORS—Transducers such as ion chambers, proportional counters, Geiger counters and

GOLD on Space Research

The great romantic appeal of exploration is not only concerned with past discoveries. Although the earth has been largely explored we are bracing ourselves for a much greater effort of exploration than ever before. The outer atmosphere of the earth, the moon, Mars, Venus, and the other planets, as well as the regions between them are all to come under close investigation soon.

Is all this to be done just because of its romantic appeal? What is there to be discovered in space? Is it going to be worth the enormous effort required? Will the knowledge obtained ever be useful?

The answer, as before any other great exploration, is of course that we don't know what information it will bring. The finding of living organisms on other planets may lead to an understanding of the origin of life. Evidence leading to the understanding of the origin of the solar system and the internal construction of the planets may be obtained. Effects that the sun has on the planets and on the earth may be discovered. The understanding of basic physics may be deepened by experiments that can be carried out

in the unusual laboratory conditions of space. The large-scale construction of the universe and its origin may become clear when detailed observations of distant regions can be made without the intervention of the earth's atmosphere.

It is difficult to imagine that information of this sort would not be immensely useful in a great variety of ways. Previous investigations of astronomy have been most important in shaping all of physics, and with that all of technology. It is sufficient to mention that the laws of motion of matter were formulated by Newton in order to account for the motion of the moon and the planets, or that the idea of nuclear energy sources first arose to account for the light emitted by the sun and the stars. Is it not almost certain that there is an immense store of similarly important discoveries ahead of us?

Electronics is one of the tools for these new discoveries. Electronic devices will be developed for a host of remote operations, for many observing instruments and for the communications systems that are to span the enormous distances. Many technical problems will be solved in the course of this work, many new inventions will be made, many

ENERGETIC PARTICLES

Energetic particle research at high altitudes is concerned with studying cosmic rays, Van Allen radiation and auroral particles. Features of these particles that researchers are trying to determine include their source, composition, spatial distribution, energy spectrum and interrelationship. The best-known spectra of energetic particles are those near relativistic energies and higher; little is known about the range from 0 to 10^7 ev.¹¹

Cosmic rays are high-energy electrically charged particles that apparently originate outside the solar system and bombard the earth continually from all directions. The primary cosmic rays reaching our atmosphere are believed to be 85 percent protons with energies greater than 2 Bev, 14 percent alpha particles and 1 percent heavier nuclei. Their interaction with atmospheric particles creates secondary particles, including secondary protons and nucleons, and various mesons.

Van Allen radiation consists of protons and electrons trapped in the earth's magnetic field in two distinct belts^{12, 13}. The inner belt is centered 3,600 Km above the earth at the magnetic equator and is occupied by a high intensity of protons with energies greater than 40 Mev and electrons in the 40- and 600-Kev range. One theory as to their origin holds that cosmic rays interact with the nitrogen in the earth's atmosphere to produce neutrons which are reflected upwards and decay into protons and electrons. The outer belt, which is centered 16,000 Km above the earth at the magnetic equator, is the belt of greatest density and consists primarily of electrons. The outer region of this belt may have its origin in ionized solar gas, although it has also been suggested that it could be formed by a selective radial diffusion of the trapped radiation.

Auroras¹⁴ are produced by particle streams containing electrons and protons having energies over at least the range from a few hundred to a few thousand electron volts. On striking the atmosphere, these particles ionize and excite the atoms in the air, producing the auroras

scintillation counters have been used extensively for studying energetic particles and electromagnetic radiation.^{8, 9} The detectors are sometimes shielded to admit radiation from a limited solid angle and other times to admit all particles above a threshold energy. Poor threshold definition has been a problem in some experiments. As a result, a scintillation counter was devised for Explorer VI to permit direct observation of low-energy electrons in the Van Allen belts with a detector relatively insensitive to bremsstrahlung (X-ray emission by decelerated electrons).⁸ Advantages of a scintillation counter are that it can be made sensitive to low-energy particles, the resolving time is shorter (on the order of $1\mu\text{sec}$) and the saturation properties are better than a Geiger counter.

Scintillation techniques are also being applied to neutron detection. Researchers at New York University are working on a detector for 5- to 10-Mev neutrons to test theories of the origin of the inner Van Allen belt by measuring the number of reflected neutrons.

Ion chambers have been mostly used such that the total d-c through the chamber and, hence, the total ionization is measured. Another mode of operation is provided by the heavy primary cosmic ray experiment in Explorer VII, devised by the RIAS Division of Martin Co. and the Bartol Research Foundation. This is the only experiment in which an attempt is being made to measure the time and position dependence of the flux of the heavy nuclei in cosmic rays.¹⁰

In this experiment, electrons liberated from the argon atoms in the chamber by incident charged particles are converted to $10\text{-}\mu\text{sec}$ voltage pulses whose size is proportional to the square of the particle's charge. Pulses are

new possibilities will be recognized. Automatic or remotely operating devices will be of use not only in space but also for the automation of industry and for the avoidance of jobs that constitute an inadequate use of human faculties. The realization of extreme reliability will enormously increase the range and the complexity of electronic devices that can be used in other fields. Through the demands that the space field is making on electronics, the subject will be greatly enriched.

These are the indirect benefits for electronics that come from the space effort. There will be some direct ones too, of which the most promising is no doubt the communication satellite. Because of the great bandwidth possible with these systems, the cost per telephone channel may become extremely low. It is difficult to estimate at the present time the economic importance of communication systems that give every person the possibility of an immediate and low-cost communication with any other person on the earth. Such systems will fill a demand we cannot yet see, and their realization will have a profound effect on human society. The communication satellite alone may one day repay a large

fraction of the funds that by then have been invested in the whole of the space effort.

Let us not underestimate the importance of the romantic appeal—it is important in spurring us on, and we may as well admit it. The modern equivalent of the thrill of an explorer landing on a new shore is perhaps that of a scientist having the information of remote sensors on another planet brought to his eyes and ears by electronic devices. Long before any person will step on the surface of the moon, there will be a team in some laboratory who can see and observe what the electronic eyes and sense organs of a vehicle on the lunar surface can observe.

The explorers of the future will often be scientists and electronic engineers, and some of their explorations of remote places will not take them out of their laboratory. Nevertheless their work will be as thrilling, as glamorous and as important as that of the explorers of old.⁶

THOMAS GOLD

Director of Cornell University
Center for Radiophysics and Space Research
Ithaca, N. Y.

sorted in a three-channel pulse height analyzer at atomic number levels corresponding to carbon, fluorine and sulphur, thus permitting the determination of the arrival rate of particles in each category as a function of time and satellite position.

Solar radiation experiments have also utilized ion chambers. A Naval Research Laboratory experiment in Explorer VII has two chambers with lithium fluoride windows to measure Lyman-alpha solar ultraviolet radiation and two argon chambers with beryllium windows sensitive to solar X-rays. Only at perigee, however, has there been a response to solar radiation—at other times the sensitivity to 150-Kev Van Allen belt electrons has masked attempts to measure the radiation, as occurred in the Vanguard III solar X-ray experiment. Thus, the value of both experiments has turned out to be in measuring the lower fringe of the Van Allen belts. More recent experiments incorporate small magnets with field strengths of 3,000 to 4,000 gauss in front of the chambers to deflect the electrons.

ATOMIC CLOCKS—Second-generation space electronics under development includes atomic clocks. While these clocks will probably have application in navigation and communication systems, they may also be used in a NASA satellite to test one prediction of the theory of relativity.

This prediction is that the frequency of any periodic phenomenon will vary with the gravitational potential of the point where the phenomenon occurs. The predicted shift should be detectable by comparing the frequency of an orbiting clock whose frequency stability is reliable to

TABLE I—Planned NASA Satellites and Probes

Year ^a	Vehicle	Missions
SATELLITES		
1961	Juno II	Ionospheric properties, gamma and cosmic rays, ionospheric beacon
	Delta	Solar spectroscopy, radiation belt study
1962	Delta	Atmospheric structure, geodetic flashing light, ionospheric topside sounder
	Scout	International ^b (2), polar ionosphere, polar radiation
	Agna	Polar geophysics
1963	Scout	International, ^b polar atmospheric structure
	Agna	Geophysical observatory, sun-earth relations, astronomical observatory
	Saturn	300-mile orbit (3)
PROBES		
1961	Scout	Ionospheric structure (2), nuclear emulsion recovery
	Atlas-Able	Lunar orbit (2)
	Delta	Interplanetary plasma — magnetic field
	Atlas-Agna	Interplanetary environment — technological development
1962	Scout	Outer atmosphere winds
	Atlas-Agna	Interplanetary environment — technological development, lunar surface properties (3)
1964	Saturn	Lunar orbit, deep space probe

(a) Fiscal (b) Experiments from other nations

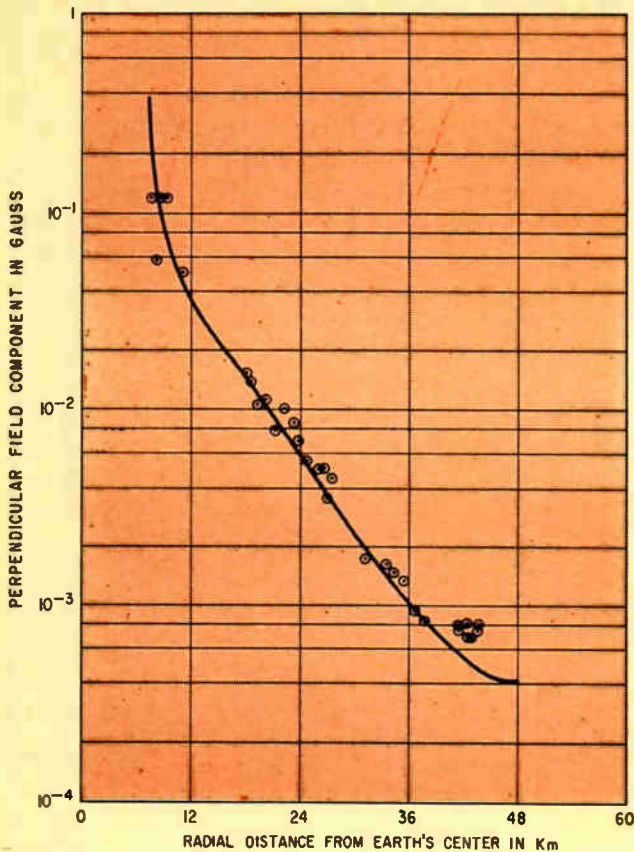

FIG. 1—Explorer VI magnetometer measurements of Aug. 24, 1959 from Space Technology Laboratories show cluster at 42,000 to 45,000 Km altitude, indicating current. Further evidence of 5-million amp current at 7 to 10 earth radii has been obtained with Pioneer V

1 part in 10^{11} over a period of several weeks with the frequency of an identical clock on the ground.²⁵

Various atomic clock systems are being developed, including cesium beam clocks, ammonia masers and gas cell clocks. Accuracies of 1 part in 10^{11} have been obtained with cesium beam clocks but these clocks may be larger than the other types would need to be for comparable accuracies. Masers have the advantage of simplicity, the problem of changes in output frequency with

variations in cavity tuning. Gas cell clocks, still in the early stages of development, employ a sealed-off gas cell in a resonant cavity. They are of relatively simple construction and researchers hope to achieve stabilities comparable to cesium beam standards.

Bureau of Standards under NASA sponsorship is working on a gas cell clock based on detecting the hyperfine transition in the microwave absorption spectrum of rubidium 87 vapor at 6,834.68 Mc. Transmitted light would be measured by a solar cell. With batteries for two weeks operation, the clock might weigh 50 pounds. At ITT Laboratories, the cesium gas cell standard shown in Fig. 2 is being developed under Navy contract BSR 77634.

ORBITING ASTRONOMICAL TELESCOPES — Because of molecular absorption, the earth's atmosphere is transparent to only a small portion of the electromagnetic spectrum. Furthermore, the radiation that does penetrate is distorted by scattering and refraction. Several projects for NASA's observational astronomy and solar physics programs are designed to overcome these problems by placing telescopes in satellite orbits above the tropopause. Besides eliminating effects of atmospheric turbulence, this will open the far ultraviolet spectrum below 3,000 angstroms to observation.

At present, five experiments are being developed for satellites that would be launched into 450- to 500-mile orbits. First launching, a 3,500-lb payload, is scheduled for 1963. Stabilization equipment will be capable of pointing a 36- to 40-in. telescope to within a fraction of a second of arc for periods up to one hour. A starfield acquisition system, possibly consisting of a small telescope and tv, will enable astronomers on earth to move the telescope to the desired star. Coded tv with a scan rate of about one frame per sec will be required. The acquisition system will be designed to detect at least eight light levels approximately equally spaced in logarithmic intensity within the energy range of 10^{-8} to 4×10^{-9} ergs/cm²/sec.¹⁶ Bandwidth on the order of 250 Kc is seen.

As part of this program, Goddard Space Flight Center is developing an ultraviolet stellar spectrograph to get the absolute energy distribution of stars between 1,000 and 4,000 angstroms, and to obtain spectra from nebulas and galaxies. University of Wisconsin is working on an ultra-

TABLE II — Frequencies Allocated to Space and Earth-Space Services for Research Purposes^{7,8}

Primary Service Category (Mc)	Secondary Service Category (Mc)
136–137 ^b	10.003–10.005
400–401 ^c	19.99–20.01
1,427–1,429	39.986–40.002
15,150–15,250	1,700–1,710 ^d
31,500–31,800	2,290–2,300 ^d
	5,250–5,255
	8,400–8,500

(a) 183.6 ± 0.5 Mc also allocated subject to causing no harmful interference (b) Not in Australia and parts of Africa, others only after discontinuation of aeronautical-mobile service (c) Not in Albania, Bulgaria, Hungary, Poland, Roumania, Czechoslovakia, U.S.S.R. (d) Allocated in Region 1 subject to causing no harmful interference

TABLE III — Provisions Made for Radio Astronomy by the Geneva 1959 Radio Regulations⁷

Frequency in Mc			
2.5 ^a	73–74.6 ^b	1,660–1,690 ^e	8,680–8,700 ^e
5 ^a	79.75–80.25 ^c	2,690–2,700	10,680–10,700
10 ^a	150–153 ^d	3,165–3,195 ^e	15,350–15,400
15 ^a	404–410 ^e	4,800–4,810 ^e	19,300–19,400
20 ^a	606–614 ^f	4,990–5,000	31,300–31,500
25 ^a	1,400–1,427	5,800–5,815 ^e	

(a) Standard frequency guard-bands at this frequency (b) In Region 2 (c) In Regions 1 and 3 except Korea, India and Japan (d) In Region 1 (e) In Regions 2 and 3, and 406–410 Mc in Region 1; continuous band within these limits to be designated on national or area basis (f) In Regions 1 and 3 (g) In Albania, Bulgaria, Hungary, Poland, Roumania, Czechoslovakia and U.S.S.R.



Radio interferometer used by the Geophysical Institute at the University of Alaska consists of two 28-ft. telescopes on polar mounts for tracking the circumpolar radio stars in Cassiopeia and Cygnus. Equipment operates simultaneously on 223 and 456 Mc to determine the amplitude and angular scintillation of the stars due to variations in the ionosphere. Increased scintillation has been observed during magnetic storms and auroral displays¹⁷

violet photometer to measure stellar energy distribution and the intensity of emission lines in gaseous nebulas.

The Smithsonian Astrophysical Laboratory is designing a system of five telescopes for ultraviolet sky mapping. A tv system having a resolving power of one minute of arc is being built for this experiment which would take about four months to cover the sky. Princeton University is developing a high-dispersion stellar spectrograph to investigate interstellar gas.

University of Michigan is preparing a satellite package containing three grating spectrometers covering the range from 75 to 3,000 angstroms and a spectroheliometer set on the Lyman-alpha hydrogen line. Each spectrometer will have at least two scan speeds: a two-minute scan and one of 45 to 50 minutes. A step command system permitting the terrestrial control center to move the spectroheliometer in one-minute steps in the east-west and north-south directions is hoped for.

RADIOASTRONOMY—Radiotelescopes measure the frequency, bandwidth and intensity characteristics of the noise-like electromagnetic radiation that penetrates our

atmosphere in the range from approximately 10 to 100,000 Mc. There are many sources of this energy that are especially important to radioastronomers, resulting in the assignment of frequencies as shown in Table III. Radio observatories are world-wide, as indicated on the fold-out.¹⁹⁻²¹

The atomic transition in hydrogen, emitting 1,420-Mc radiation, is of major interest. Also, radioastronomers are trying to detect the deuterium line at 327.4 Mc and the hydroxyl line at 1,667 Mc. Most of the radiation from the Milky Way and point sources, however, arrives over a wide range. At long wavelengths nonthermal radiation (attributed to a synchrotron-like mechanism) is strong; at shorter wavelengths the radiation from thermal emitters is strong.

ANTENNAS—Compared with optical telescopes, radiotelescopes have poor resolving power because of the long wavelengths involved. Thus, telescope design is aimed at obtaining large apertures and using frequencies as high as possible for the particular experiment. Many types of antenna systems are used in radioastronomy; at low fre-

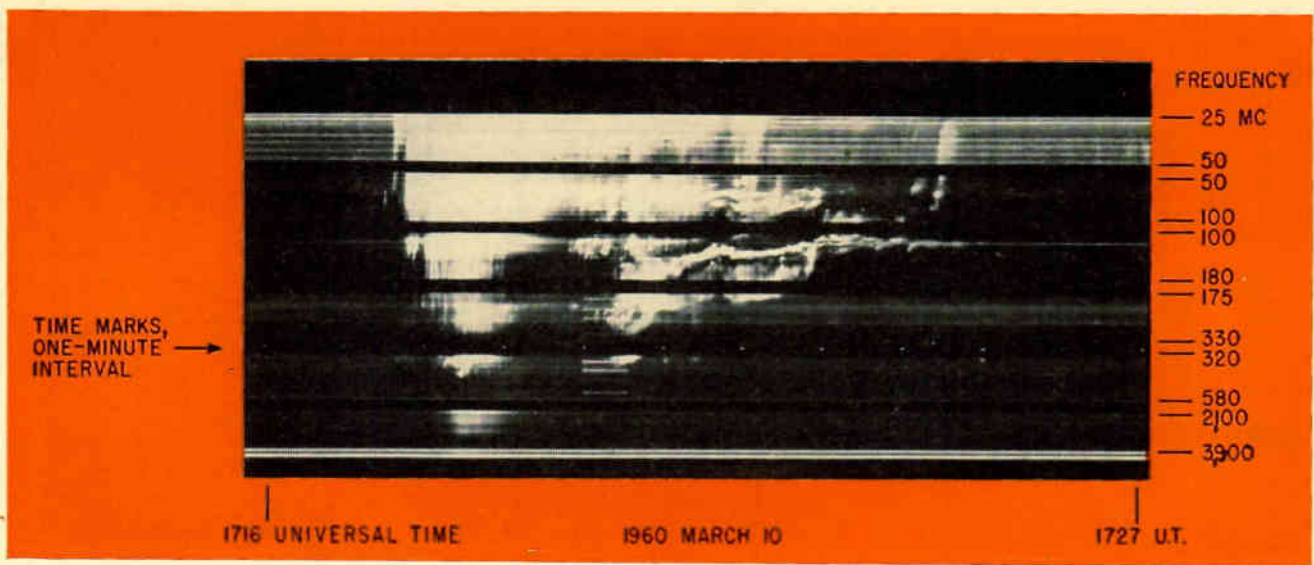

Solar radio bursts are recorded at the Harvard Radio Astronomy Station in Fort Davis, Texas through use of sweep-frequency receivers. This complicated outburst consists of a group of fast-drift bursts which merge into a short-duration continuum burst, followed by a burst of the slow-drift type. Entire outburst was associated with a small solar flare

quencies there are numerous antenna arrays and above 400 Mc the steerable paraboloid is particularly versatile.

The paraboloid is a broadband device limited at one extreme when the aperture is of the same order of magnitude as the longest wavelength to be observed and at the other when the surface irregularities are a significant fraction of the shortest wavelength. Aperture size practical with steerable paraboloids is limited, however, by the cost involved in rotating, stabilizing and pointing large reflectors.

Largest steerable paraboloid being built is the Navy's 600-ft telescope near Sugar Grove, W. Va.²² This telescope, which will be used also as a transmitter, will utilize an inertial guidance system to achieve a pointing accuracy of 30 sec of arc. Individual reflector panels will be adjusted automatically by servos to compensate for distortions caused by wind, temperature and reflector motion. The resolution of 1/12 deg will make it useful for such programs as studying the distribution of un-ionized hydrogen in the arms of our galaxy and mapping the radio images of other galaxies.

One approach to cutting the cost of paraboloid sys-

tems is to build fixed standing reflectors that receive the celestial radio wave from a tiltable flat-sheet reflector and feed it to a horn antenna at the prime focus. Such a system, used essentially as a meridian-transit device, is being built at the Ohio State-Ohio Wesleyan Radio Observatory near Delaware, Ohio.²³ A similar telescope is under construction at Nancay, France, and will have a fixed paraboloid 1,000 ft long.

One method of increasing sky coverage without elaborate steering systems is through the use of fixed spherical reflectors corrected for spherical aberration. National Radio Astronomy Observatory, under National Science Foundation sponsorship, wants a 300-ft aperture telescope with limited sky coverage; a 420-ft spherical section is one solution under consideration. At an aperture of 300 ft, ± 15 -deg coverage is seen.²⁴

RECEIVERS—Although the resolving power of a radio-telescope is determined by the reflector, the ability to detect celestial sources, whose flux intensity will be below 10^{-22} w/m²/cps, is largely controlled by the quality of the radiometric receiver.

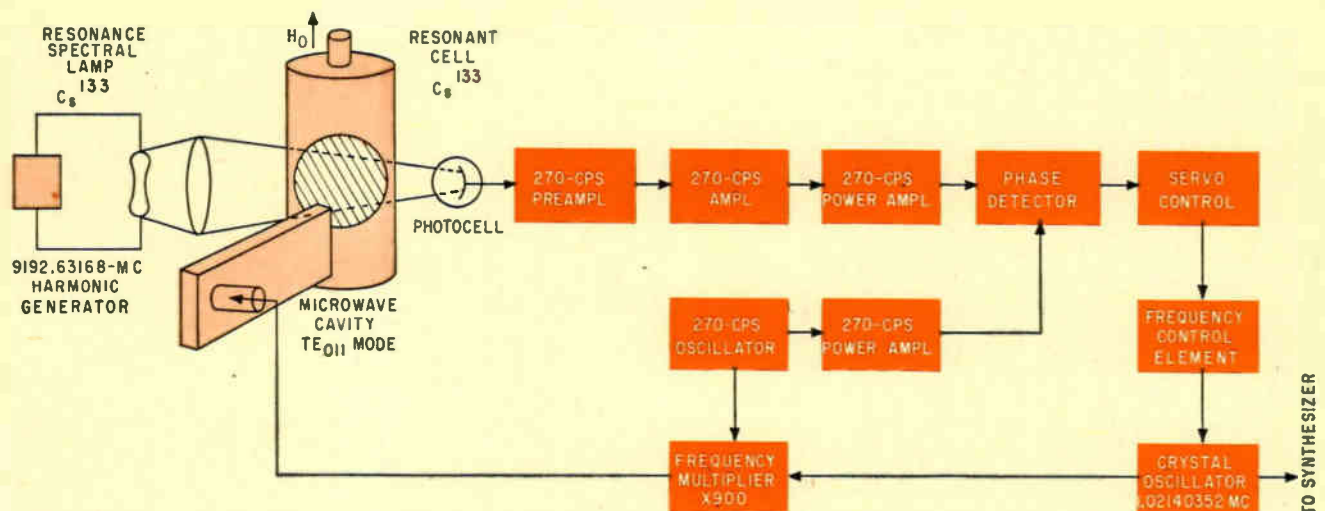
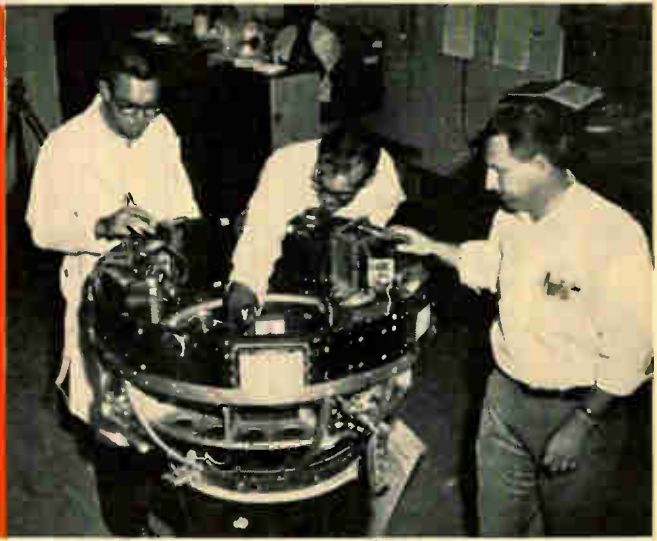
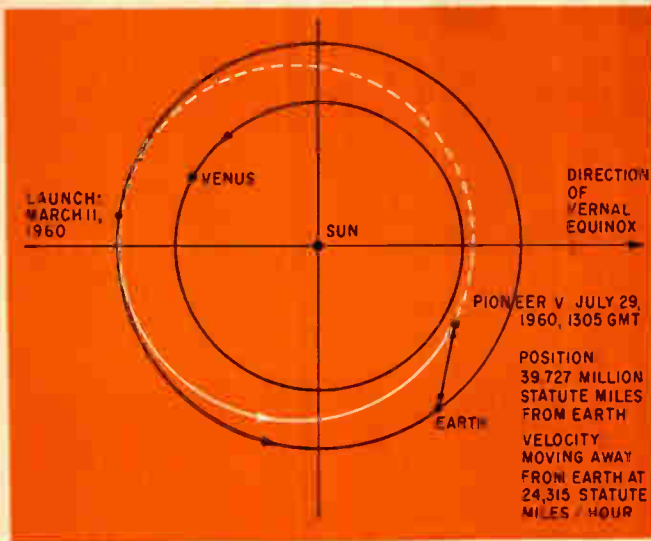

FIG. 2—Cesium gas cell frequency standard in the developmental stage at ITT Laboratories uses optical pumping and detection. Error signal from phase detector controls frequency of quartz oscillator



As Pioneer V travels through space in the solar elliptical orbit shown in the diagram, engineers at Space Technology Laboratories are readying the next Able space probe. Scheduled to be launched later this summer, Able-5 will carry a micrometeorite detector, search-coil and flux-gate magnetometers and five radiation detectors

For each investigation a particular noise in the cosmic field is the subject of investigation. It is the purpose of the receiver to separate this noise from the unwanted cosmic noise and the receiver and man-made noise. Thus, receivers have the major performance requirements of noise, bandwidth and stability, and are generally custom-made for specific experiments.

Most complex of radioastronomy receivers are those for hydrogen-line detection.²⁵ Variable bandwidths of 1 Kc to 6 Mc are required, depending on the source being investigated. Furthermore, galactic rotation produces a differential Doppler shift on the hydrogen line. This requires a precision local oscillator that can scan at varying rates over wide ranges from 1,430 Mc down, with frequency stability of 1 part in 10^7 or better.

Most receivers use crystal mixers as the first stage but masers have been used in the applications of Table IV.²⁶ For higher frequencies the minimum detectable signal capabilities of traveling-wave tube amplifiers for broad band noise signals make them competitive with masers and varactor amplifiers. Between 1 and 10 Gc, rms sensitivities of 0.01 deg K have been achieved on broad-band signals with switched-load type radiometers and traveling-wave amplifiers.

One goal of radioastronomers is to place radiotelescopes on satellites and high-altitude balloons. At these altitudes it will be possible to extend observations beyond the millimeter cutoff produced by molecular absorption in the earth's atmosphere and below the cutoff frequency caused by the ionosphere.

RADAR ASTRONOMY—As a result of the progress in developing more powerful transmitters, large antennas, low-noise receivers and information processing, radar astronomy is becoming an increasingly important method for studying the solar system.^{27, 28} Because it obtains its information by measuring the effect of matter in space on a transmitted signal of known characteristics, radar astronomy will aid in establishing more accurately the

TABLE IV—Solid-State Maser Amplifiers Used in Radio and Radar Astronomy

Frequency (Mc)	Effective System Noise Temp ($^{\circ}$ K)	Aperture Dia (ft)	Organization and Application	Improvement Over Non-Maser
440	200	84	MIT Lincoln Lab; Venus contact from Westford, Mass. (Millstone Hill radar) Feb. 1958	3.5 times
1,420	85	60	Harvard College Obs; hydrogen line studies	5 times
8,500	100	85	Univ of Michigan radio telescope; 8-Mc bandwidth	8 times
8,700 10,000	85	50	Columbia Univ — NRL; first use as passive detector of cosmic noise (April 1958)	12 times

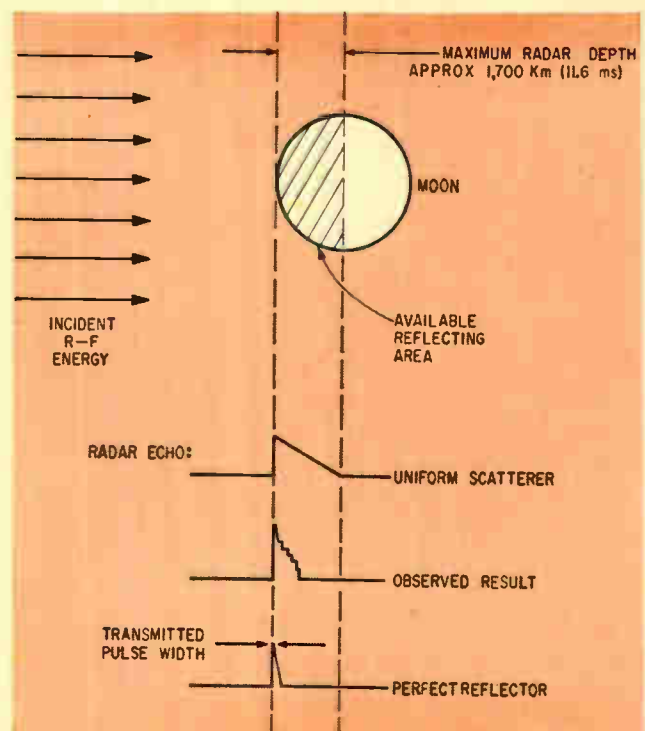

FIG. 3—Moon scattering properties are being studied by Stanford Research Institute radar astronomers²¹

WANTED—Electronics Pioneers

We need a restoration of glamor to electronic pioneering. Because radioastronomy is hard work and must be conducted at remote locations, it has been largely unsuccessful in recent years in attracting first-rate electronics personnel. Too many engineers are more interested in barbecuing steak behind their split levels in suburban Boston and Los Angeles than in performing difficult pioneering work on the frontiers of science in remote regions of the world¹⁸

F. D. DRAKE
National Radio Astronomy Observatory
Green Bank, West Virginia

distance to various solar bodies and the properties of planetary atmospheres. At present radar investigations are confined to the solar system for three reasons: transmitter average power is about 1 Mw, perhaps extending to 10 Mw in a decade or so, echo intensity is reduced by the fourth power of range and total pulse time of flight becomes appreciable (8.6 years for the nearest star).

Radar contacts have already been made with meteors, auroras, the sun, moon and Venus. Future investigations will include improving on the 0.1-percent accuracy to which the Astronomical Unit (mean distance of earth from sun) is known, measuring the rotation, surface features and perhaps composition of the planets, studying the density and dynamics of the ionized gas in cislunar and interplanetary space, and probing to various depths of the sun's corona to study solar disturbances.

Detailed study of the shape and changes with time of the sun's corona is expected to be possible with the radar telescope presently being completed at Stanford University.²⁰ This telescope, built in conjunction with Stanford Research Institute with support by USAF's Cambridge Research Center, will have a 20-60 Mc transmitter and feed 300-Kw c-w into a 142-ft parabolic antenna.

REFERENCES

- (1) NASA, *The NASA Space Sciences Program*, April 16, 1959.
- (2) Applied Physics Dept., Space Technology Laboratories, Inc., Scientific Objectives of the Able-3 Program, *Trans IRE PGMIL, MIL-3*, No. 4, Oct, 1959.
- (3) A. Rosen, Physical Measurements in the Satellite Environment, Paper presented at National Flight Test Instrumentation Symp, May 1960.
- (4) J. P. Heppner, Instrumentation for Space Magnetic Field Studies, Paper presented at American Rocket Soc. 14th Annual Meeting, Washington, D. C., Nov 1959.
- (5) D. Mansir, Magnetometers for Space Vehicles, to be published in *ELECTRONICS*.
- (6) T. Gold, Cornell Univ, private communication, June 24, 1960.
- (7) International Radio Regulations Adopted by Administrative Radio Conference under auspices of ITU, Geneva, 1959.
- (8) A. A. McKenzie and H. A. Manooagian, Telemetering, *ELECTRONICS*, p 153, April 1956.
- (9) R. K. Jurgen, How Transducers Measure and Control, *ELECTRONICS*, p 59, July 4, 1958.
- (10) P. Schwed, RIAS Div. of Martin Co., private communication, May 31, 1960.
- (11) Space Science Board, National Academy of Sciences—National Research Council, *Science in Space*, Chapt. VII, 1960.
- (12) H. A. Manooagian, The Challenge of Space, *ELECTRONICS*, p 65, April 24, 1959.
- (13) J. H. Shaw, A Brief Description of the Natural Environment of Interplanetary Space, *Proc NAECON* Dayton, Ohio, May 1960.
- (14) F. J. Leary, Communications of the Future, *ELECTRONICS*, p 37, July 3, 1959.
- (15) Space Science Board, National Academy of Sciences—National Research Council, *Science in Space*, Chapt. II 1960.
- (16) N. G. Roman, Satellite Astronomical Telescopes, *JrI SMPTE* 69, Jan 1960.
- (17) Photograph taken by V. P. Hessler, Univ. of Alaska, April 1, 1960.
- (18) F. D. Drake, NRAO, private communication, April 19, 1960.
- (19) R. Christensen, General Electric Co. private communication, April 23, 1960.
- (20) G. S. Mumford, Radio Observatories of the World, *Sky and Telescope*, p 300, April 1959.
- (21) World Radio Telescopes—II, *Sky and Telescope*, p 370, May, 1959.
- (22) E. F. McClain, Jr., The 600-Foot Radio Telescope, *Scientific American*, 202, p 45, Jan 1960.
- (23) J. Kraus, Radio Telescopes of Large Aperture, *Proc IRE*, p 92, Jan 1958.
- (24) National Radio Astronomy Observatory Annual Report, July 1, 1959.
- (25) H. I. Ewen, Radio Astronomy Receiver Design Techniques, *Proc NAECON*, Dayton, Ohio, May 1960.
- (26) J. W. Meyer, The Solid State Maser MIT Lincoln Lab Report 4G-0003, April, 1960.
- (27) K. J. Craig, A. Shapiro and B. S. Yaplee, The Role of Radar in Space Research, *Trans IRE PGMIL, MIL-4*, No. 1, Jan 1960.
- (28) P. B. Gallagher and Von R. Eshleman, Radar Approach to Astronomy, *Proc NAECON*, Dayton, Ohio, May, 1960.
- (29) R. B. Dyce, Stanford Research Inst. private communication, May 6, 1960.
- (30) W. E. Gordon, Incoherent Scattering of Radio Waves by Free Electrons with Applications to Space Exploration by Radar, *Proc IRE*, p 1, 824, Nov, 1958.
- (31) R. L. Leadabrand, R. B. Dyce, J. C. Schobohm, A. Fredriksen and R. I. Presnell, Evidence that the Moon is a Rough Scatterer at Radio Frequencies, Stanford Research Inst. Preliminary Report 2, Feb, 1960.
- (32) V. R. Eshleman, Stanford Univ, private communication, May 1, 1960.

For several planets, including Jupiter, it is uncertain as to whether the surface is solid, because of the presence of an opaque atmosphere. These gases would be transparent, however, to sufficiently high radar frequencies. Information about Jupiter's surface is one of the results hoped for from the radar Cornell University is building for ARPA in Puerto Rico. This radar will have a 1,000-ft diameter spherical reflector with beam motion limited to 20 deg in each direction. Frequency will be near 420 Mc and transmitter peak power is 2.5 Mw. On the basis of detecting the incoherent backscatter from the free electrons that exist in and above the ionosphere, the radar will be able to explore the ring currents and measure electron density and temperature as a function of height and time to one or more earth's radii.²⁰

MOON PROBING—Because of its closeness, the moon has been a favorite target for radar astronomers. Stanford Research Institute, under contract with Rome Air Development Center, has been observing radar echoes from the moon at 400 Mc for the purpose of determining its scattering properties. A 60-ft steerable paraboloid at College, Alaska and the 142-ft steerable paraboloid at Fraserburgh, Scotland are being used.

If at radar wavelengths the moon behaves as a rough scatterer, then its radar depth would be 1,750 Km, as shown in Fig. 3. Data obtained with the Fraserburgh telescope show a slow decay with range depth from 400 Km range depth to 1,750 Km range depth, suggesting that while the moon acts as a quasismooth reflector near its visible center, it starts behaving as a rough scatterer as the scattering region departs from this area.

The moon is also being used as a passive reflector in experiments sponsored at Stanford by AFCRC to determine integrated electron densities between the earth and the moon.²² The radar includes a 50-Kw linear amplifier at 23.1 Mc connected to a 2,000-ft broadside array consisting of 48 four-element Yagi antennas. In one technique, three equal-amplitude carriers are transmitted simultaneously. The net shift in phase between the relative position of the carrier phasor and the resultant of the upper and lower sideband phasors before and after reflection is a measure of density; the time variation describes the stability of the medium.

OUR ATMOSPHERE

Meteorological satellites, sounding rockets and weather radars are among the host of probes with which man is learning more about the atmosphere—his earliest scientific laboratory

METEOROLOGICAL EXPERIMENTS have been generally based on sampling small portions of our atmosphere from the ground or with balloons and rockets carrying probes that range from thermometers to radiosondes. Sounding rockets have been valuable in extending balloon measurements vertically into the one percent of our atmosphere above 30 Km. Through a variety of techniques, such as exploding grenades and releasing radar chaff, they have provided data on temperature, pressure, density and winds at high altitudes.

These methods, however, have the inherent limitation that unless the frequency of soundings is high enough or the number of ground stations large enough, small-scale disturbances can be overlooked, resulting in a nonrepresentative measurement. Meteorologists would like to have systems that can determine atmospheric conditions remotely and continuously; for example, a device that could measure temperature as a continuous function of position and time. A step in this direction is provided by meteorological satellites which, by giving area coverage, provide two-dimensional scanning.

TIROS—Nearly 23,000 cloud-cover photographs were read out from the Tiros I weather satellite. These photographs have been used to make actual weather maps and their quality has made meteorologists optimistic about the value of a complete system of satellites.

Tiros, however, is spin-stabilized and can photograph only the sunlit earth during portions of the orbit when the cameras are pointing downward. For this reason, future satellites will be attitude-stabilized. Such satellites would also be able to use more directional antennas.

First stabilized meteorological satellite will be the Nimbus, a 650-lb NASA satellite expected to be launched in mid or late 1961. Nimbus will be launched from the Pacific missile range so that it can be placed into a 600-mile circular polar orbit. Thus, the satellite will have the advantage of being able to view the entire earth twice daily—once as it moves northward and again as it

moves south. This orbit, together with more advanced tv and ir equipment than is now carried, will provide coverage of the worldwide cloud distribution. Nimbus is expected to have a life of six months.

Future versions of Nimbus may carry a radar that could be used for weather search as well as tracking. A satellite weather radar would have the advantage of being able to detect precipitating clouds. For studies of the distribution of precipitation, a 3-cm radar has been suggested as promising for satellites.⁵⁵ At an altitude of 300 miles, the beamwidth should not exceed 1 deg to resolve a 5-mile storm area. Phasing devices in slot antennas could sweep the beam through the 90-deg angle needed to obtain area coverage normal to the path of a

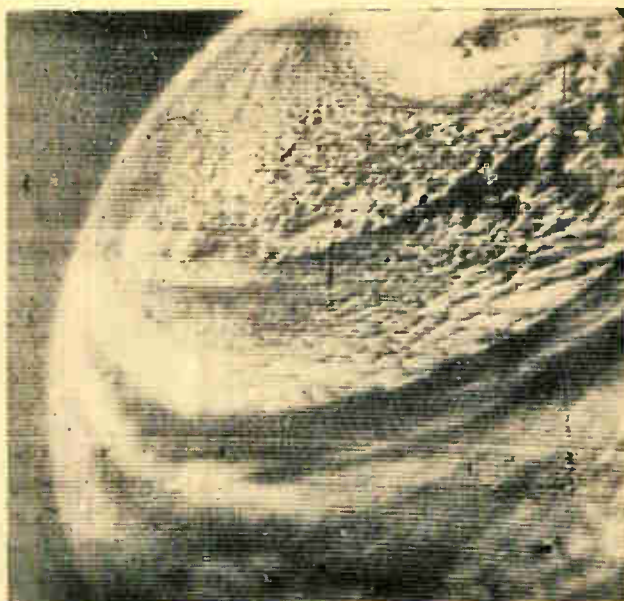

Geophysics Research Directorate photograph from Tiros I on April 4, 1960 shows portion of cyclonic storm over Pacific between Hawaii and United States

SINGER on Atmospheric Studies

Man's motives in studying the atmosphere of the earth take many forms. To some the atmosphere is a scientific laboratory whose study reveals new fundamental knowledge about the operation of natural laws; others study the atmosphere from a very practical point of view in order to predict, improve or change weather conditions. The economic reasons for study of the atmosphere are, of course, obvious. Weather affects not only the farmer, but practically every phase of human existence. Weather control or reliable prediction service could add billions to the national income, according to F. W. Reichelderfer, Chief of U. S. Weather Bureau.

But from the point of view of basic research it is important to note that many new phenomena were first discovered by studying the atmosphere. For example, the discovery of cosmic rays came about through careful studies of the ionization of the atmosphere. The first balloon experiments with ionization chambers showed immediately the existence of penetrating radiation as coming into the earth's atmosphere from outer space. The technology of electronics has been of tremendous importance in practically every phase of atmospheric measurements. However, there are still many properties of

the atmosphere which are not accessible to measurement because of limitations in instrumentation. One important example is an instrument to measure the concentration of atomic oxygen at altitudes above 50 miles. Another important problem in which electronics could play a greater role is the direct measurement of the degree of ionization and of electron concentration in the ionosphere at these altitudes.

In order for the electronics industry to play a greater part in upper atmosphere exploration we need people who combine the talents of an atmospheric physicist and electronics engineer. At the present time the situation is very much that of the upper atmosphere physicist having to do a great deal of electronic design work to develop instruments and techniques for his measurements. One may look forward, however, to the day when the electronics engineer will possess a sufficient background in atmospheric physics to make a greater contribution in the design of equipment. To a large extent this has already come about in ionospheric physics, which is populated largely by electronics engineers who later became interested in the atmosphere.³³

S. F. SINGER
Professor of Physics, University of Maryland,
College Park, Md.

horizontally stabilized satellite with a parabolic antenna.

Another plan for advanced meteorological satellites is to incorporate a sferics detector. Consisting of a receiver and directional antenna, a sferics detector could be combined with cloud-cover photographs to locate thunderstorms, squall lines and, possibly, tornadoes.

HEAT BUDGET—A major study to be undertaken with Tiros II will be the study of the earth's heat budget. This involves measuring the net radiant energy absorbed and emitted by the earth-atmosphere system. For this experiment, Tiros II will carry two irradiometers made by Barnes Engineering Co. One will be a scanning device with a 30- to 40-deg viewing angle for making measure-

ments in five spectral regions. The other will be a non-scanning two-channel radiometer with a 55-deg viewing angle. NASA hopes to launch Tiros II this fall.

Storage of the video data for subsequent playback is an important problem in cloud-cover photography. One technique presently being developed uses electrostatic tape.³⁶ This system utilizes a transducer consisting of a pickup tube and a flexible tape target. The tape has a photoconductive layer under a thin insulator. Recording is achieved by simultaneously exposing the photoconductor to light and the insulator to an electron beam. A charge pattern corresponding to the optical pattern remains on the insulator. When readout is desired, the charge image is read by an electron beam.

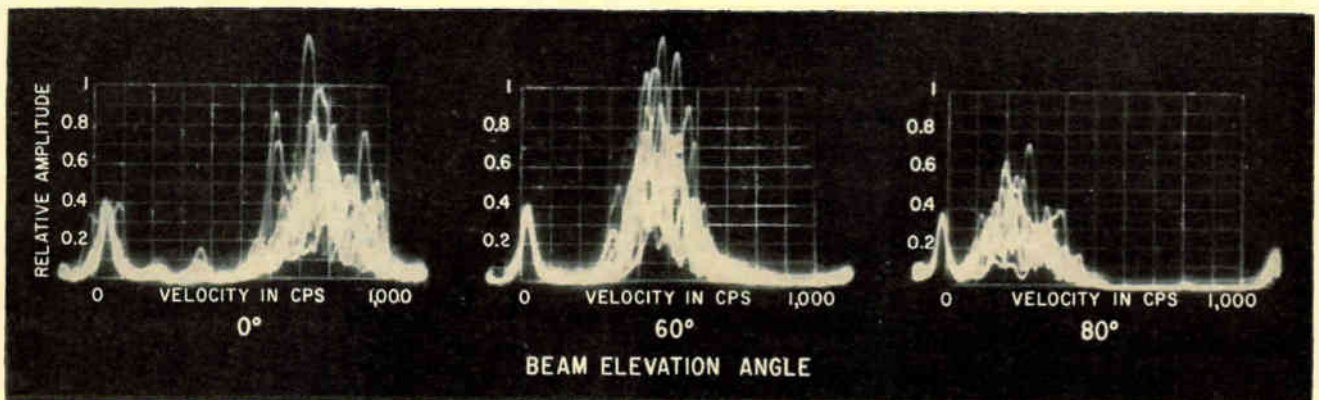

Doppler spectrum from snowstorm for three beam elevation angles gives probability density of velocity within illuminated volume. From this, researchers at Cornell Aeronautical Laboratory obtain data on turbulence and the component of mean wind in direction of beam

DUBIN on Atmospheric Studies

The atmosphere of the earth (and in the future of such planets as Mars and Venus) is being studied to ensure that man's knowledge and understanding of its theories and laws will increase at a pace commensurate with his scientific and technological potential. The earth's atmosphere is the environment in which we live and, accordingly, its comprehension may be used to control the atmosphere or to protect us from dangers associated with it.

Study of the atmosphere involves many direct measurements and related theoretical studies to determine the controlling mechanisms and solar-terrestrial relationships. The atmosphere of a planet may be described as a static spherical shell of gases locked in place by the planet's gravitational field and in a state of near equilibrium reached over the millions of years of formation.

In another sense, a planetary atmosphere is a dynamic, pulsating medium, subjected to a host of effects:

- Variable heating from the sun and the planetary surface.
- Tidal effects from the moon and the sun.
- Chemical effects resulting from chemical reac-

tions activated by the sun and assisted by catalytic minor constituents.

- Electromagnetic forces from charged particles and the planetary magnetic field.
- Special phenomena such as the aurora and corpuscular bombardment by cosmic rays, solar particles and meteoritic dust.

The availability of new technologies of electronics and rocket propulsion has greatly enhanced the exploration of the atmosphere. The great step shown by the Tiros I satellite outlines the complexity of the electronic and technological problems of the next decade. For in this decade man may make great steps in exploring and understanding the atmosphere of the earth and the nearest planets.

It is only through electronic methods in the sensing elements, program controllers, telemetry, and data handling that these advances will occur. Such progress requires many technological and scientific developments from special teams of scientific meteorologists, engineers and physicists.³⁴

M. DUBIN
National Aeronautics
and Space Administration
Washington, D. C.

WEATHER RADAR—Radar plays a major role in the investigation of small-scale atmospheric processes where resolution on the order of a mile and coverage of areas on the order of hundreds of miles are involved.³⁷ Radar primarily observes precipitation, although some clear-air echoes are obtained. For precipitation, radar is a meteorological instrument that can give readings which for frequency of observation and distribution in space cannot be approached by any other instrument. Radar has large potential in hydrological services such as flash-flood forecasting and control of water resources.

A fundamental problem in measuring rainfall rates by radar, however, is that there is no direct correlation between the radar return and the precipitation rate.³⁸ This is because the return is a function of the number of particles of water and their size, and there is no unique water-drop size distribution.

One of the most important uses of weather radars at present is in severe-storm warning systems. The Weather Bureau is installing 31 Raytheon WSR-57 radars along the portion of the coastline vulnerable to hurricanes, through the Midwest tornado belt and in other spots. Most will be installed by Jan. 1961.

The WSR-57 incorporates design characteristics specifically for weather observation. These characteristics are indicated in Table V and include isoecho circuits for delineating the cores of storms. One radar is being installed at Evansville, Ind. for turbulence studies. Operation of the WSR-57 in Florida has shown it capable of detecting light rain at 200 miles and forecasting hail at 220 miles.³⁹

ROCKET EXPERIMENTS—A variety of experiments

have been conducted with rockets. These include measurements of atmospheric pressure, temperature and density, ultraviolet photography, magnetic field and energetic particle studies, and determination of atmospheric composition with mass spectrometers.⁴⁰

Electron density can be measured with electrostatic probes, of which there are many types. Geophysics Research Directorate is developing several probes for altitudes above 38 miles. These include an antenna impedance probe which measures primarily the refractive index, a bipolar probe similar to a Langmuir probe for measuring electron temperatures and ion densities, an ion trap probe and a dual pulse probe.

The ion trap probe consists of a spherical grid across which a fixed saturation voltage is applied. A collecting electrode in series with a logarithmic d-c amplifier forms the inner element and collects positive or negative ions depending upon the polarity of the applied voltage.

The dual probe system utilizes an emitting cathode surrounded by an accelerating screen that measures the rocket potential relative to the plasma. This measurement is used to control the potential on a pulse probe kept near the plasma potential. The pulse probe is simply a cage with an internal collector that periodically collects the electrons. The mean d-c defines the electron density. An 0.5-v sweep of the mean pulse probe potential yields electron velocity distribution and, from this, effective electron temperature.

OZONE—Measurements of ozone distribution in the atmosphere provide clues to atmospheric circulation. Also, ozone is believed responsible for the large annual

TABLE V—Meteorology Characteristics of Weather Surveillance Radars

Type	Wave-Length (cm)	Pulse Width and PRF	Peak Power Output (Kw)	Type of Antenna	Beam-Width (Deg)	Type of Sweep	Presentation	Max Range	Ranging Accuracy (mi)
WSR-1 WSR-1A ^a	10	1 μsec-650 pps, 2 μsec-325 pps	60	6-ft parabola	4	Automatic, 12 rpm, manual control of antenna tilt	PPI, A	180 nautical mi	± 1
WSR-3 WSR-4 ^b	10	1 μsec-650 pps, 2 μsec-325 pps	60	6-ft parabola	4	Automatic, variable speed to 12 rpm, reversible, auto- matic and manual control of ant. tilt	PPI, A, RHI (range- height indicator)	180 n mi	± 1
SCR-615B ^c	10	1.5 μsec-465 pps	750	8-ft parabola	3	Automatic, variable speed to 4 rpm, manual control both forward and reverse. Manual control of ant. tilt	PPI, A	120 statute mi	± 0.1
CPS-9 ^d	3.2	0.5 μsec-931 pps, 5 μsec-186 pps	225	8-ft parabola	1	Manual and auto- matic in horizontal and vertical, either direction. Sector scan in both planes	PPI, off- center PPI, RHI, R, A	400 s mi	± 0.1
SCR-784	10	1.6 μsec-180 pps	250	8-ft parabola	2	Manual and auto- matic in horizontal and vertical	PPI, A, RHI	300 s mi	± 0.1
SP1M SP	10	1 μsec-600 pps, 5 μsec-120 pps	1,000	8-ft parabola	2	Manual and auto- matic in horizontal and vertical	PPI, A, R	250 n mi	± 0.1
APQ-13	3	0.5 μsec-1,350 pps, 0.75 μsec-675 pps, 2 μsec-270 pps	40	30-in. parabola	3	Automatic, 12 rpm, manual control of ant. tilt	PPI, A	75 s mi	± 1
FPS-3	23	3 μsec-400 pps, 6 μsec-200 pps	650	Elliptical half- paraboloid 40 ft wide by 6 ft high	1.3 az lower 0-3 upper 3-15	Automatic, horizontal	PPI	400 n mi	± 1
WSR-57 ^d	10	0.5 μsec-658 pps, 4 μsec-164 pps	500	12-ft parabola	1.8	Automatic and man- ual in hor and vert, either direction	PPI, off- center PPI, RHI, R, A	250 n mi	± 0.5%
Decca-41	3.2	0.2 μsec-250 pps, 2 μsec-250 pps	30	2.6 ft high 14 ft wide	4 vert 0.75 hor	Automatic, 5 rpm manual elevation	PPI	250 n mi	± 1%

(a) Similar to WSR-1 but with RHI ability (b) Similar to WSR-3 but with traveling-wave amplifier added (c) The SCR-615B at the Univ of Fla. has a pulse repetition rate of 400 pps, pulse length of 1.5 μsec and range of 200 s mi (d) Specifically designed for weather search

temperature variations in the stratosphere above the polar regions.

One method of measuring ozone concentration employs two ultraviolet filters, one set to a wavelength where there is attenuation and the other set to one where there is no attenuation. Comparison of the two intensities yields a ratio that is a measure of ozone concentration. So

far, the sun has been used as a light source for this experiment but scientists at U. S. Army Signal Research and Development Laboratory envision using multiplier phototubes with the moon as a light source. This would allow measurements in the polar night at high altitudes. A similar method using the ir portion of the spectrum could be used to determine water vapor concentration.

REFERENCES

(33) S. F. Singer, Univ of Maryland, private communication, May 4, 1960.
 (34) M. Dubin, NASA, private communication, June 27, 1960.
 (35) C. P. Mook and D. S. Johnson, A Proposed Weather Radar and Beacon System for Use with Meteorological Satellites, *Proc 3rd National Convention on Military Electronics*, 1959
 (36) E. C. Hutter, J. A. Inslee and T. H. Moore, Electrostatic Imaging and Recording, *Jri SMPTE*, 69, Jan 1960.
 (37) P. M. Austin, MIT Weather Radar Research, private communication, June 1, 1960.
 (38) H. Foster, U. S. Weather Bureau, private communication, May 3, 1960.
 (39) L. F. Conover, U. S. Weather Bureau, private communication, June 6, 1960.
 (40) J. C. Holmes and C. Y. Johnson, Positive Ions in the Ionosphere, *Astronautics*, July, 1959.

and Probes Successfully Launched by the

Payload Instrumentation	Transmission			Ant. Type
	Freq (Mc)	Pwr (mw)	Life*	
pressure and other data	20.005	"	23	Whip
	40.002	"	23	
ultraviolet and x-radiation; 2 mutually perpendicular scintillation pulse rate, respiration rate and blood pressure of dog; tem-	20.005	"	7	"
	40.002	"	7	
stored bistable multivibrators) for measuring cosmic rays; 12 wire-grid erosion gages); 4 resistance thermometers	108	10	113	Dipole, turnstile
	108.03	60	29	
	108	10	19	Dipole, turnstile
	108.03	5	"	
ometer I but with 1/2-lb tape recorder; micrometeorite erosion stores up to 2 hours of data and plays it back in 5 seconds using system controls return tape speed	108	10	92	Dipole
	108.03	60	81	
sun's corpuscular radiation; ionization and magnetic manomaps; electrostatic fluxmeters to measure charge and strength ter; instruments to measure primary cosmic radiation and mic rays; micrometeorite detectors	20.005*	"	"	Dipoles, trailing rods
to detect electrons, protons and x-rays above several pre-pulse detectors; cesium iodide scintillation counter to radiation	108	10	55	Dipole
	108.03	24	72	
ring radiation in space, micrometeorite detector, search-coil magnetic fields; temperature-measuring instruments; image-scan provided in one direction by payload rotation and in argon-filled ion chamber	108.06	300	"	Dipole
	108.06	1,000	"	
ation in space; a photoelectric sensor to receive reflected	960.05	180	"	Conical payload
ages; radio beacon and control unit	107.97 ^b	20	"	Slot flush with body
	107.94 ^b	20	"	
e and pressure, interplanetary gas, micrometeorites, earth-cosmic radiation and other properties of cosmic rays; radio-d error signals to hydraulics which positioned rudders at release of sodium cloud	19.997	1,000	"	"
	19.995	"	"	
	19.993	"	"	
	183.6	"	"	
sity of sunlight collected by pair of 3-in. parabolic mirrors 15-deg angle from satellite spin axis. Spin, about 50 rpm, ities stored on 75 ft of 1.5-mil recording tape and played on	108	10	23	Metal rods
	108.03	80	27	
30 mev, electrons >10 mev, or hard x- or gamma rays; 2nd 3 mev; sensor to signal passage by moon	960.05	180	4	Conical payload
propulsion, guidance, staging and communications	Classified	"	"	Direct., whip
ining temperature and oxygen sufficient for life; emulsion king beacon plus beacon in recovery capsule	Classified	"	8	Direct., whip
argon-filled ion chamber; Geiger-Mueller tube; proportional :les in strong bremsstrahlung; vlf receiver for whistler-mode meters to map earth's magnetic field; image transmission	108.06	500	56	Dipole
	108.09	500	56	
	378	5,000	56	
ure its performance	"	"	"	"
ure its performance	"	"	"	"
detector; internal temperature and pressure measuring	19.993 ^j	"	"	"
	39.986 ^j	"	"	
etectors (3 erosion gages, 4 microphones, CdS detector, 2 at different pressures connected by differential pressure hambers and electrometer circuit to transmit instantaneous k signal over orbit	108	30	85	Metal rods
	108.03	80	85	
quipment; photo transmission system using low-frequency long distances and fast speeds for short distances)	183.6	5-20w	"	Metal rods
	39.986	"	"	
r radiation balance measurements; ion chamber for measur- f Lyman-alpha ion chambers; photocell; 20-Mc telemetry for ; Geiger-Mueller cosmic ray detector	108	10	"	Loop, turnstile
	20	600	"	
	40, 60	15, 5	"	
ure its performance	"	"	"	"
ure its performance	"	"	"	"
ger-Mueller tube; proportional counter telescope; search-coil ite momentum spectrometer	378	5,000	"	Dipole
	378	150w	"	
espin mechanism; 1/2-in. vidicon wide-angle and narrow-angle r for storing up to 32 pictures per orbit. Pictures are played in./sec	108	30	"	Dipole
	108.03	30	90	
	235(2)	2,000	90	
nath stability of 25 parts in 10 ⁶ transmitting on 54, 324, 162 te rotation	54,324	200	"	Painted silver log spiral
	162	100	"	
	216	100	"	
adio beacon, radar chaff, light in Agena case	"	"	"	"
e and cosmic ray detectors	19.995	"	"	"
i system	"	"	"	"
8-Mc receiver for cosmic noise experiment	"	"	"	Same as Transit I-B
ys below 8 angstroms	108	40	"	Whip

Data obtained mostly from U. S. and Russian press (c) Not disclosed (d) Still in orbit (e) Transmission at 40.01 Mc is harmonic of first (f) Still transmitting (i) Same as Discoverer V (j) Also a 183.6-Mc altimeter in probe and 20.003- and 19.997-Mc transmitters in rocket (k) Lifetime approximate

The United States and Russia

Power Supply	Results of Experiments	Name
Chemical batteries	First successful artificial satellite; recorded internal temperatures and pressures; upper atmosphere densities at higher latitudes obtained from satellite drag	SPUTNIK 1 ^a :
Chemical batteries	Increase in particle counting rate with altitude provided unrecognized hint of radiation belt; satellite acceleration led to discovery of significant solar influence on upper atmosphere densities	SPUTNIK 2 ^b :
Hg batteries	Encountered radiation so intense as to saturate Geiger-Mueller tube, thus discovering Van Allen radiation belt	EXPLORER I:
Hg batteries, solar cells	Provided new measure of earth's oblateness (1/298.3), showed earth to be pear-shaped with 50-ft peak at north pole and 50-ft flattening at south; drag correlated with solar activity	VANGUARD I:
Hg batteries	Provided more comprehensive data on Van Allen belts and micrometeorites	EXPLORER III:
Chemical batteries, solar cells	Measured a high enough flux of low energy electrons in northern regions to account for higher atmospheric temperatures there; made direct measurement of air densities up to 222 mi; found positive atomic oxygen to be predominant ion from 151 to 594 mi; found satellite potential in daytime ionosphere to be as much as -7 v	SPUTNIK III :
Hg batteries	Measured radiation intensity to 1,250 mi, thus providing further data on spatial relationships and properties of Van Allen radiation; measurements of Project Argus radiation indicated geometric form of Argus shells, nature of trapped electrons and characteristics of geomagnetic field	EXPLORER IV;
Hg batteries	Provided first indication of extent of radiation belts, first observation of hydromagnetic oscillations of earth's magnetic field, first measure of interplanetary magnetic field and micrometeorite density; mapped total ionizing flux in radiation belts and discovered departure of magnetic field from theoretical prediction	PIONEER I:
Hg batteries	Discovered that Van Allen radiation belt consists of at least two distinct, widely separated zones of high intensity radiation	PIONEER III:
Chemical batteries	First time a human voice has been beamed from space; satellite accepted and relayed messages from ground stations in Texas, Arizona and Georgia	SCORE:
Chemical batteries	First to reach vicinity of moon; measurements of earth's magnetic field showed marked dip in the field in region of the radiation belt, possibly indicating existence of current ring	LUNIK-MECHTA ^b :
Hg batteries	Furnished data on cloud-cover distribution over daylight portion of orbit; however, interpretation has been difficult because satellite started to precess	VANGUARD II:
Hg batteries	Observed increase in extent of outer radiation belt after high solar activity, thus indicating solar origin of belt; passed too far from moon to trigger photoelectric sensor or sample radiation	PIONEER IV:
Ni-Cd batteries	Difficulty in stabilization caused tumbling, thus hampering consistent tracking acquisition; satellite assumed to have burned upon reentry at unknown point	DISCOVERER I:
Ni-Cd batteries	Temperature-oxygen instruments showed life could be supported; timer difficulty caused capsule containing radiation emulsion packs to be ejected in wrong place and lost	DISCOVERER II:
Ni-Cd batteries, 1,000 solar cells	Took low-resolution tv picture of cloud formations; provided data on vlf propagation, magnetic fields, cosmic radiation as function of time and spatial position, energy spectrum of radiation belts; noted coincidence between increase in radiation level and solar radio noise storms; provided indication of ring current	EXPLORER VI:
"	Reentry capsule not recovered due to malfunction after ejection	DISCOVERER V:
"	Reentry capsule not recovered due to malfunction after ejection	DISCOVERER VI ^a
"	Obtained evidence of a lunar ionosphere; failed to detect a lunar magnetic field greater than 50 gammas	LUNIK II ^b :
Ag-Zn batteries	Obtained extensive magnetic field data so that over large regions of the Western Hemisphere, Australia and South Africa now possible to state absolute value of total field intensity to high accuracy; obtained evidence that magnetic field discontinuity may exist at lower edge of inner radiation belt	VANGUARD III:
Chemical batteries, solar cells	Produced photographs showing 70 percent of far side of moon. Cameras triggered about 40,000 miles from moon	LUNIK III ^b :
Ni-Cd batteries, solar cells	Large scale weather patterns detected; first micrometeorite penetration of a sensor in flight observed; data obtained on heavy primary cosmic rays and radiation belts	EXPLORER VII:
"	Reentry capsule not ejected due to malfunction of electrical system	DISCOVERER VII ^a
"	Reentry capsule ejected but not recovered	DISCOVERER VIII ^a
Ni-Cd batteries, solar cells	Provided further evidence of ring current and indication that outer radiation belt is produced by local acceleration of portion of solar plasma in earth's magnetic field	PIONEER V:
Ni-Cd batteries, solar cells	Cloud-cover pictures of unexpected quality have led to optimism concerning complete system of meteorological satellites; pictures have been used in weather maps and have shown unexpectedly large degree of organization in cloud systems	TIROS I:
Ni-Cd batteries, solar cells	Results so far indicate feasibility of an all-weather global navigational satellite system	TRANSIT I-B:
"	Polar orbit achieved; data capsule ejected but not observed	DISCOVERER XI ^a
Chemical batteries, solar cells	Pressure vessel apparently separated from cabin but because of fault in orientation went into lopsided orbit instead of reentering atmosphere	SPACECRAFT ^b :
Battery-powered	Data returned from several sections of ir spectrum but telemetry failure prevented measuring ir radiation from sodium flares and ICBM firing	MIDAS II:
"	"	TRANSIT II-A ³ :
"	"	RADIATION SATELLITE:
Solar cells, battery	Measuring solar radiation	"

mitting data (g) Life of payload (h) Beacon;
2 weeks (i) Advanced version of Transit I-B

Environmental Cross-Sections

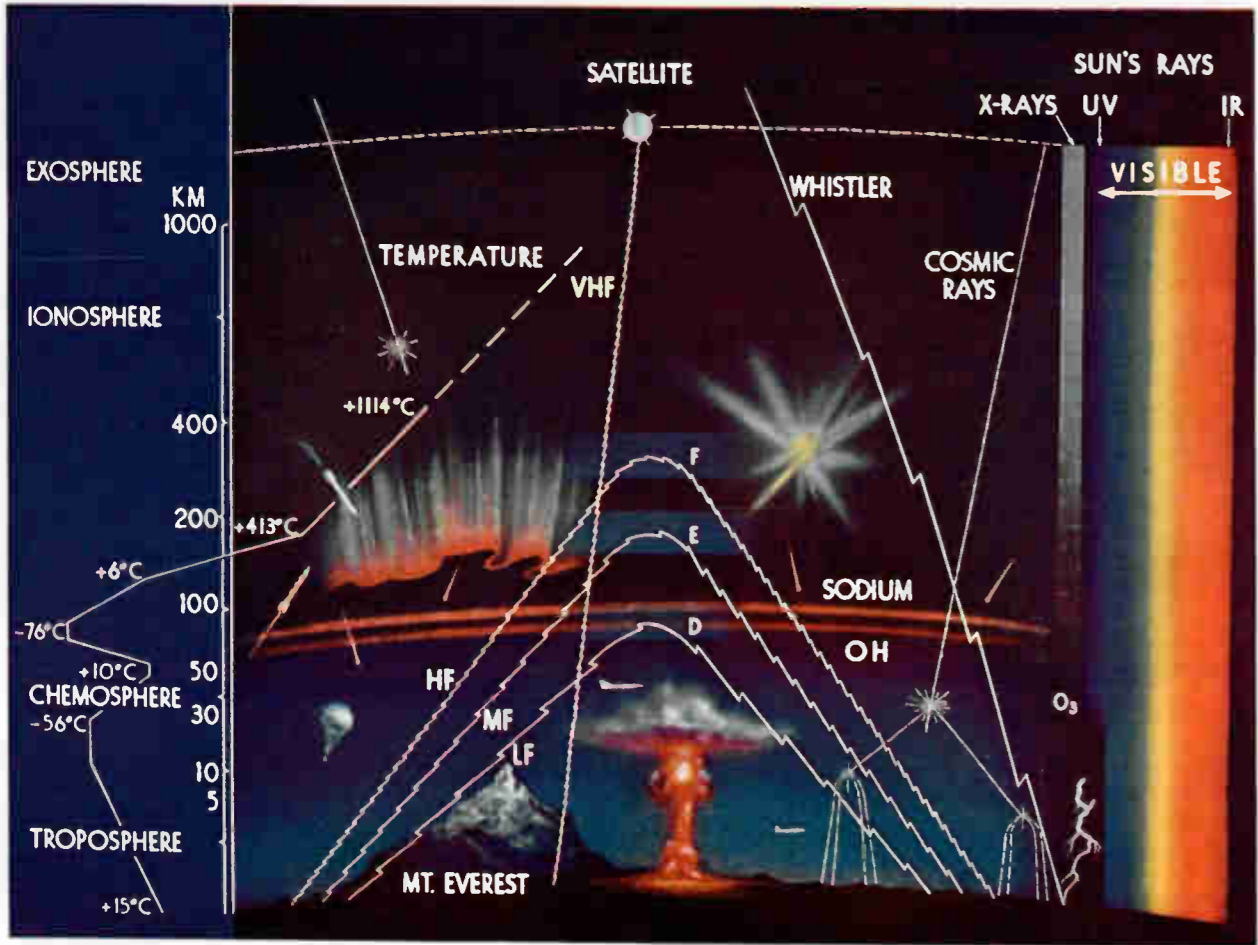

Atmospheric cross-section as defined at Geophysics Research Directorate Ionospheric Physics Laboratory (above) and analogous diagram for strata of earth and ocean

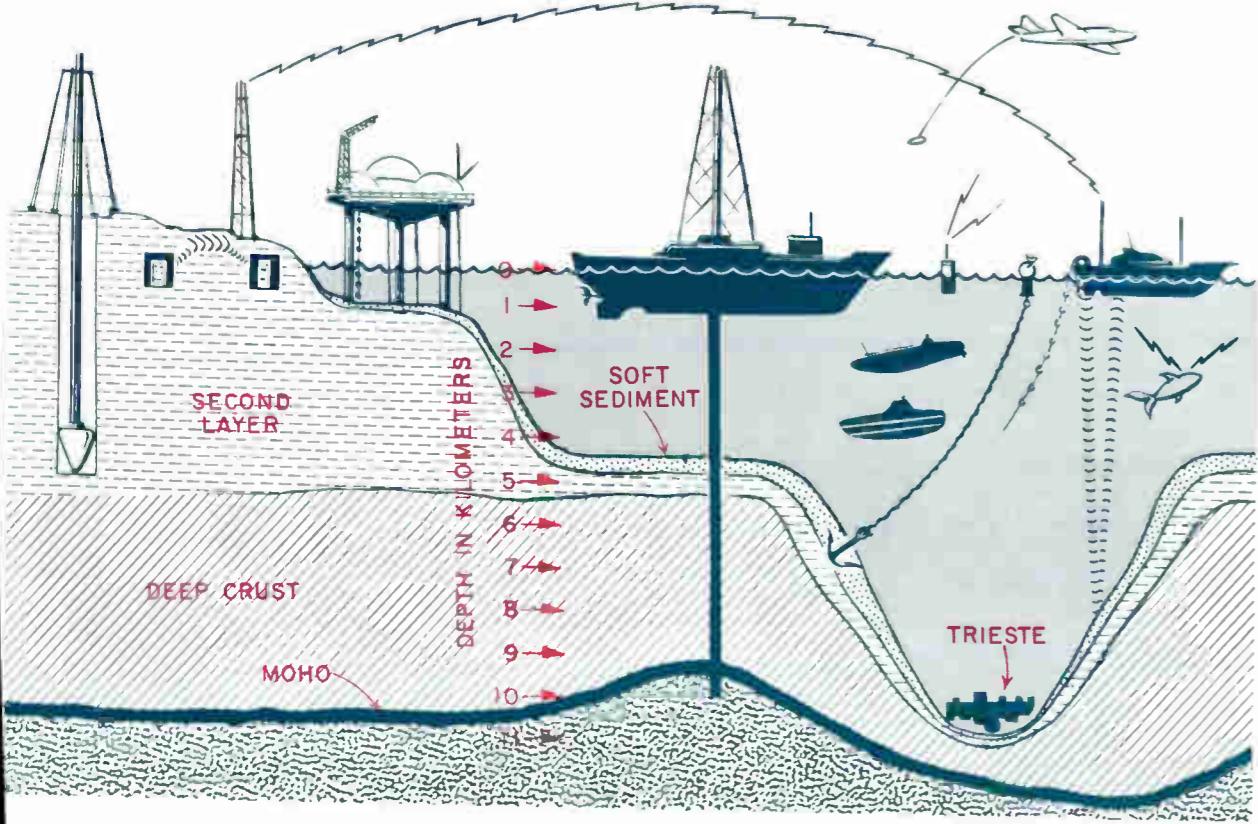

Sites for Probing Nature

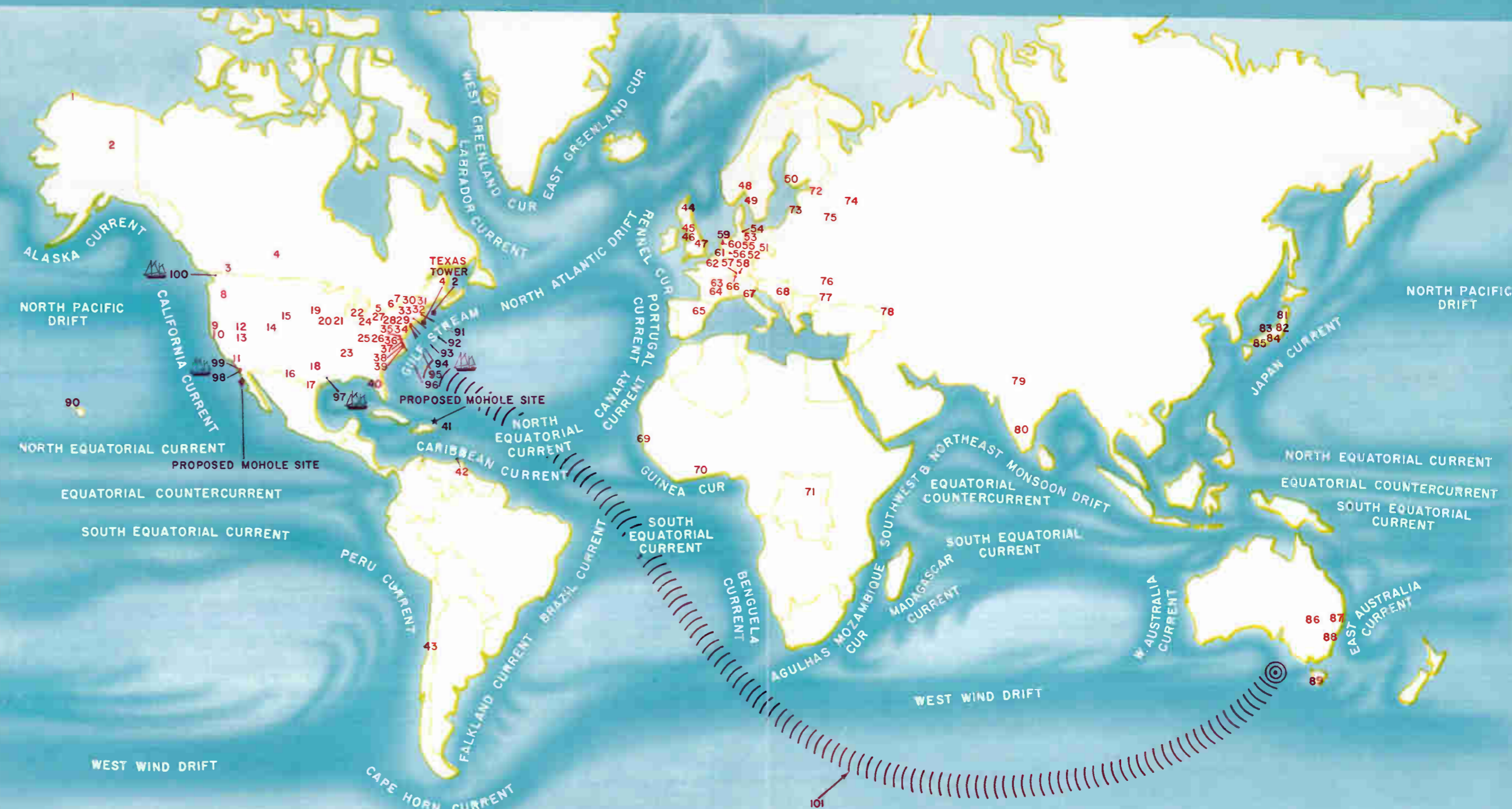

Radio and Radar Astronomy Facilities

- 1 Univ of Alaska, College
- 2 Univ of Alaska, Barrow
- 3 Dominion Obs, Penticton B.C.
- 4 Defense Research Board, Prince Albert, Sask.
- 5 David Dunlap Obs, Toronto, Ont.
- 6 Defense Research Board, Shirley Bay, Ont.
- 7 National Research Council, Ottawa, Ont.
- 8 Univ of California, Hat Creek, Calif.
- 9 Univ of California, Berkeley, Calif.
- 10 Stanford Univ, Palo Alto, Calif.
- 11 NEL, Santa Barbara, Calif.
- 12 Convair, Clark Dry Lake, Calif.
- 13 CIT Owens Valley Obs, Big Pine, Calif.
- 14 Univ of Colorado, NBS: Boulder, Colo.
- 15 NBS Scintillating Observing Sta, Ellsworth, Neb.
- 16 Harvard Radio Astronomy Sta, Fort Davis, Texas
- 17 RADC, Laredo, Texas
- 18 Univ of Texas, Austin, Texas
- 19 Collins Radio Co. Feather Ridge Obs, Cedar Rapids, Iowa
- 20 NBS, Havana, Ill.
- 21 Univ of Illinois, Oanville, Ill.
- 22 Univ of Mich, Peach Tree Mountain Obs, Ann Arbor, Mich.
- 23 Univ of Alabama, Tuscaloosa, Ala.
- 24 OSU-Ohio Wesleyan Radio Obs, Delaware, Ohio
- 25 National Radio Astronomy Obs, Green Bank, W. Va.
- 26 ONR, Sugar Grove, W. Va.
- 27 Cornell Aeronautical Lab, Buffalo, N.Y.
- 28 Cornell Univ, Ithaca, N.Y.
- 29 RPI, Sampson Sta, Troy, N.Y.
- 30 Harvard College Agassiz Sta, Harvard, Mass.
- 31 AFCRC, Ipswich, Mass.
- 32 AFCRC, Hamilton, Mass.
- 33 MIT - AFCRC, Westford, Mass.
- 34 Yale Univ, New Haven, Conn.
- 35 Columbia Univ, N.Y.C.; American Museum-Hayden Planetarium, Huntington, L.I.: N.Y.
- 36 U. S. Army Signal Corps, Ft. Monmouth, N. J.
- 37 ONR moon relay telescopes, Cheltenham, Annapolis, Stump Neck, Md.
- 38 NRL, Washington, D. C.
- 39 NRL, Riverside, Md.
- 40 Univ of Florida, Gainesville, Fla.
- 41 Cornell Univ - ARPA, Puerto Rico
- 42 RADC, Trinidad
- 43 Univ of Chile, Santiago
- 44 RADC, Fraserburgh, Scotland
- 45 Jodrell Bank Experimental Sta, Manchester
- 46 Royal Radar Establishment, Malvern
- 47 Mullard Radio Astronomy Obs, Cambridge
- 48 Oslo Solar Obs, Oslo
- 49 Chalmers Univ of Tech, Gothenburg
- 50 Univ of Helsinki, Helsinki
- 51 Jagellonian Univ, Cracow
- 52 Astronomical Inst, Academy of Science, Prague
- 53 Hertz Inst, East Berlin
- 54 Univ of Kiel, Kiel
- 55 Astrophysical Obs, Potsdam
- 56 Bonn Univ, Bonn
- 57 Fraunhofer Inst, Friburg
- 58 Univ of Tübingen, Tübingen
- 59 Owingeloo Obs, Owingeloo
- 60 Nederhorst den Berg
- 61 Royal Obs, Uccle
- 62 Ecole Normal Supérieure, Marcoussis, Observatoire de Paris, Meudon
- 63 Saint Michel Astrophysics Inst, Saint Michel
- 64 Observatoire de Paris, Nancy
- 65 Observatorio del Ebro, Tortosa
- 66 Swiss Federal Obs, Zurich
- 67 Observatorio Astrofisico, Arcetri
- 68 Inst of Physics, Belgrade
- 69 Ecole Normal Supérieure, Dakar
- 70 Univ of Ghana, Achimota
- 71 Inst pour la Recherche Scientifique en Afrique Centrale, Lwiro
- 72 Pulkovo Obs, Pulkovo
- 73 Inst of Physics, Riga, Latvian S.S.R.
- 74 Gorky Univ, Gorky
- 75 Lebedev Physical Inst, Serpukhov Station
- 76 Mechnikov Obs, Karkov, Ukrainian S.S.R.
- 77 Lebedev Physical Inst Crimean Station; Crimean Astrophysical Obs
- 78 Astrophysical Obs, Bjuran, Armenian S.S.R.
- 79 National Physical Lab, New Delhi
- 80 Astrophysical Obs, Kodaikanal
- 81 Radio Wave Obs, Hirazao
- 82 Univ of Tokyo, Science Museum, Tokyo
- 83 Kyoto Univ, Mt. Koma Obs
- 84 Niigata Univ, Toyokawa City
- 85 Osaka City Univ, Osaka
- 86 Commonwealth Scientific & Industrial Research Org, Parkes
- 87 Commonwealth Scientific & Industrial Research Org, Sydney
- 88 Yale and Columbia Univ, Mt. Stromlo
- 89 G. Reber, Hobart
- 90 ONR moon relay telescope, Wahiawa
- 91 Woods Hole Oceanographic Inst, Woods Hole, Mass. Ships: ATLANTIS, CRAWFORD, BEAR and CHAIN
- 92 Underwater Sound Lab, New London, Conn. Ships: EPCE (RP) 856 and GROUPE (with NRL)
- 93 Lamont Geological Lab, Palisades, N.Y. Ship: VEMA
- 94 Hudson Lab, Dobbs Ferry, N.Y. Ships: GIBBS and ALLEGHENY-ATA
- 95 Bell Telephone Lab, Brooklyn Navy Yard, N.Y. Ship: YAMACRAW (ARC-5)
- 96 NRL, Washington, D.C. Ships: ROCKVILLE, SOMERSWORTH, HUNTING and GROUPE (with Underwater Sound Lab)
- 97 Texas A & M, College Sta. Tex. Ship: HIOALGO
- 98 Scripps Inst of Oceanography, La Jolla, Calif. Ships: SPENCER F. BAIRD, HORIZON, ORCA and STRANGER
- 99 NEL, San Diego, Calif. Ship: EPCE (R) 857
- 100 Univ of Wash., Seattle, Wash. Ship: BROWN BEAR
- 101 Sound waves from depth charge near Australia detected over 12,000-mile span at Bermuda (July 4, 1960)

Oceanographic Facilities

- 91 Woods Hole Oceanographic Inst, Woods Hole, Mass. Ships: ATLANTIS, CRAWFORD, BEAR and CHAIN
- 92 Underwater Sound Lab, New London, Conn. Ships: EPCE (RP) 856 and GROUPE (with NRL)

THE EARTH

Although development is slower than in space technology, electronics is providing the geologist with powerful new tools



Laboratory technician testing a Schlumberger experimental electronic cartridge for use in logging of bore holes

EARTH—THE ORIGINAL MANNED SATELLITE—conceals within it many unexplored areas. Although the time is not far off when man will set foot on other celestial planets, our earth still has not been adequately investigated. Electronics may offer the means for facilitating investigations, achieving better accuracies than heretofore possible and permitting studies not now possible with existing equipment and techniques.

EARTH CURRENTS—Since the sun is a variable star, certain terrestrial electromagnetic phenomena are unquestionably related to solar activity. Among these geophysical phenomena are disruptions of the ionosphere, auroral displays, geomagnetic storms and earth-current disturbances which result from the bombardment of the earth by ion streams emitted by the sun during periods of disturbed solar activity. Invariably, prolonged h-f radio fadeout, large fluctuations in the earth's magnetic field, intensified auroral displays, and severe earth-current disturbances are associated with increased solar activity (flares and prominences) during sunspot maxima.⁴¹

Of particular interest is geoelectric activity, or the flow of electric currents in the earth's crust during an electromagnetic storm. These earth currents are measured as a voltage (earth potential) on wire lines from the cable to earth ground. The earth potential measured on the line increases in direct proportion to the length of line. Thus sufficiently large earth-current fluctuations not only

cause disruption of wire-line network operation, but during severe disturbances permanent damage can also result, especially in regions near the auroral zones.

Intensity of geoelectric activity is strongly dependent upon the geomagnetic latitude where the earth potential is measured. Typical values measured during the electromagnetic storms are: in regions near the geomagnetic equator ($\pm 25^\circ$ geomagnetic latitude)—less than 200 mv per Km; in middle geomagnetic latitudes (25° to 55°)—0.2 to 5.0 volts per Km; in the auroral zones ($60^\circ \pm 5^\circ$ geomagnetic latitude)—3 to 20 volts per Km. Data from Arctic and Antarctic regions indicate geoelectric activity in the polar regions (65° to 90° geomagnetic latitude) to be comparable to that of the auroral zones.

Earth current flow is generally in a N-S direction, except near the geomagnetic equator where it is E-W. Undisturbed diurnal variations show the same general characteristics, but attain smaller values in the range from 5 to 300 mv per Km.

A high degree of correlation has been found between the earth-current and earth-magnetic disturbances, and the observations of ionospheric activity and auroral displays. The simultaneous occurrence of magnetic storms and severe earth-current disturbances is one of the best established facts about geoelectric and geomagnetic activity. The marked parallelism between data of geoelectric activity and that of geomagnetic activity is particularly significant in regard to the solar origin of severe

electromagnetic disturbances that have a world-wide effect. Records of earth-current and magnetic-activity measurements show that the severity and frequency of such disturbances is greatest at high geomagnetic latitudes near the auroral zones, and that these disturbances are usually accompanied by intensified auroral displays and severe disruptions of the ionosphere which adversely affect radio communications.

Recent work at the University of Alaska indicates that rapid fluctuations (period of a few seconds) of earth currents may actually reflect irregularities in the solar ion streams which interact with the earth's main magnetic field, and are the basic cause of disruptions in the ionosphere. Analysis of these data and comparison of earth-current records and magnetograms at College, Alaska,

showed that rapid pulsation of considerable amplitude are much more prevalent in earth-current than in magnetic disturbances.⁴² Thus, refined methods of measuring geoelectric activity may bring to light evidence of geophysical processes which is not resolved by present techniques of ionospheric and geomagnetic measurements.

The Communications Division of Hughes Aircraft Company is engaged in a research program to investigate all available data on terrestrial electromagnetic phenomena. The initial phase of this program is to unravel the geophysical processes involved with the terrestrial electromagnetic disturbances, in particular with regard to the interaction of the earth's main magnetic stream with the solar plasma that is the underlying cause of these disturbances.

DOLL On The Earth

Man has a dual interest in the study of the interior of the earth on which he lives. He naturally has the desire to unearth the buried resources—petroleum, minerals, water—which he can use to improve his living conditions. And being a creature of curiosity, he has the urge to inquire, speculate, and increase his knowledge of the planet on which he will spend most, if not all, of his life. Thus, on one hand we have the exploration geologist and exploration geophysicist whose activities are spurred by the search for buried wealth; on the other hand their more academic counterparts seek, with a purer purpose, primarily to know the history and the nature of the orb.

The science and art of electronics has a prominent part in the activities of both groups. Specialized types of instrumentation have been developed for both surface and borehole investigations. The more modern the instrument, the more complicated it tends to be, and the more electronics it is likely to contain.

To illustrate the special requirements possible for such equipment, consider the instrumentation to be lowered into a borehole for the purpose of measuring a characteristic of the earth strata penetrated. It must be contained in a housing capable of withstanding the hydrostatic pressures in deep, mud-filled holes. Moreover, since drill holes are slim, there is a maximum size limitation for the components. A further practical limitation is the permissible length of the electronic cartridge. Miniaturization is called for to economize on the use of the available space, and also, since logging time is costly to the well operator, to build tools capable of making several measurements on one run in the hole.

In addition, the instrumentation must operate at the elevated temperatures encountered at depth in the earth. The fact that bottom-hole temperatures in excess of 400°F have been recorded in some instances point up the necessity for high-temperature circuit

components. With the continuing trend toward deeper wells, temperature requirements can be expected to be even more severe.

Finally the circuits and construction must be extremely rugged in order to withstand the bumps and jars which may be encountered when the equipment is lowered into the well, and especially when it is transported over rough oil field roads.

Let us turn, now, from problems of equipment to those of the two groups of people: those who are to design the tools, and those who will interpret the results. Earth investigations for the purposes of unraveling the geological make-up of the earth's crust, and discovering and exploiting the earth's riches will no doubt continue, in the main, to require teamwork between instrument designer, and geologist or geophysicist. Hybrids may exist who are specialists neither of circuit design nor of the earth sciences and who will serve the useful function of liaison between the two groups. To some extent, however, each type of specialist must become familiar with the thinking and problems of the other.

The instrument designer must be ever on the alert to new or old physical phenomena which can be adapted for meaningful measurements of earth parameters. On the other hand, the completed exploration instrument measures physical parameters which are almost never quite identical with the parameter the earth scientist would like to measure. The readings must be interpreted, often by empirical rules, in the light of geological or geophysical knowledge. Thus the understanding of the designer must go further than a mere knowledge of circuits. Also, the understanding of the earth scientist must include something of the actual physical phenomena on which the measurements depend to derive the maximum geological or geophysical information from the data.⁴³

HENRI-GEORGES DOLL
Schlumberger Well Surveying Corp.
Ridgefield, Conn.

GEODESY—Geodesy is primarily concerned with measuring the size and shape of the earth and deducing from these parameters some facts about the physical structure of the earth. Investigation of the fine structure of the earth's gravitational field from a highly detailed and precise tracking of a satellite has been carried on. By fine

Airborne magnetometer, electromagnetic detector and scintillation counter are combined in Aero Service's Sikorsky S-55 flying laboratory which is surveying, at tree top height, the Keewatin District in Northern Canada. One of the electromagnetic detector elements is mounted on front boom; magnetometer is suspended from tail



HAPGOOD On The Earth

Man is only beginning his study of the earth. The attention devoted at the present moment to questions of space flight may obscure for the general reader the fact that most of the major problems of the earth we live on are still unsolved. Some of these are practically of much greater importance for us than problems of interstellar space.

Included among them are such questions as: How did the earth begin, as a hot body or as a cold body, and when? How were the continents and ocean basins created? How were the mountains formed? Where did the water of the oceans come from? Where did the heat of the earth come from? What created the great system of submarine canyons, totalling forty thousand miles in length, recently discovered by Professor Ewing and his staff of Lamont Geophysical Laboratory? What causes earthquakes and volcanic eruptions like those that have recently devastated Chile? What is the cause of climatic changes, like the great ice ages, or past warm climates at the poles? One could extend this list indefinitely.

This means that at the present time we have no real science of the earth. If one is to be developed, two things will be required. First, we must begin to place emphasis not on what we know but on what we do not know in this field. Second, we must develop and use new tools of investigation.

Electronics, linked with atomic physics, has recently provided us with important new tools. Two of these have almost revolutionized our ideas about the recent history of the earth. They are the new methods of radiocarbon and ionium dating.

Radiocarbon dating is based on the isotope carbon 14. The "half-life" of this isotope is only about 5,000 years, meaning that in that time it radiates away half its mass. Comparing the remaining amounts of C_{14} in organic material with the amount contained in present living materials enables us to date samples of wood, peat, or animal remains, and

by this means date climatic and other geological changes for the last 40,000 years. Results obtained have basically revised our views of climatic history.

Ionium dating, based on three radioactive elements found in sea water (radium, ionium, uranium) can establish dates for the last million years. Its results agree very well with the results of radiocarbon dating. Other radioactive methods can be used to date geological events hundreds of millions of years in the past. All these methods require an assortment of electronic devices to detect and record radiation and compute the results.

One of the most pressing needs at the present time is a method to detect and measure the constant rather than the changing pressures and stresses in the earth's crust. We can measure the force of earthquake waves, or atomic explosions in the crust, but the steady pressures that may be building up future earthquakes cannot now be detected and measured. This is obviously very important, for upon it will depend our ability to forecast future earthquakes, which occur at intervals of about five years on the average. Here electronics may make a contribution to the future safety of millions of people in that governments will be able to prepare for these upheavals.

Electronics has recently opened a new chapter in archeology: the exploration of submarine ruins with fathometers and with television cameras. Fathometers have made possible detailed surveys of seabottom topography. It has been found possible to lower television cameras and floodlights to the seabottom (even five miles down). Submerged wrecks, and submerged cities located near various coasts may now be studied in detail. Recently Mr. Edward A. Link has used some of these electronic methods to explore the ruins of Port Royal (West Indies) which was swallowed up by the sea long ago.⁴⁴

CHARLES H. HAPGOOD
Keene Teachers College
Keene, New Hampshire

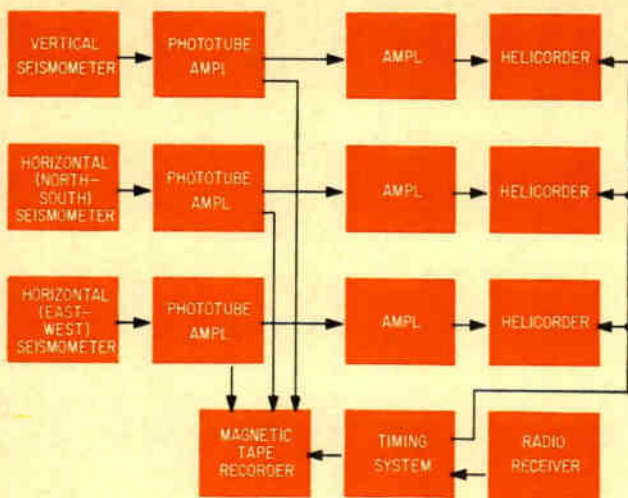

FIG. 4—Advanced instrumentation system for seismological observatories. The phototube amplifier provides gain needed to raise output from submicrovolt level to one suitable for driving magnetic tape recorders and recording amplifiers

structure is meant regions, from the smallest observable up to perhaps several thousand kilometers, in which actual gravity departs from the value predicted. As the satellite passes through these regions of varying gravity, slight deviations from the path predicted on the basis of the smooth potential will result.^{45, 46}

Methods of tracking are: optical-visual (recording theodolites, Moonwatch); optical photographic (Sattrack, Phototrack, Markowitz Moon Camera); infrared (detection of the thermal radiation from the sun reflected from the satellite shell—untried); radio-interferometer (Minitrack, Moonbeam, and the foreign counterparts); radio Doppler shift in which the trajectory is deduced from the line-of-sight component of the satellite's velocity relative to the observer; radio-radar which has been successful for only the biggest antennas and power output; and radio beacon-transponder.

Difficulties associated with the tested radio methods are the magnitude of the errors which arise chiefly from the residual uncertainties in the correction for ionospheric refraction, and also transmitter frequency drift in Doppler measures. While errors are large compared to the smallest theoretically attainable by optical methods, radio methods are indispensable in that they are the only ones that can be used in daylight or bad weather. Furthermore, the comparatively large quantity of radio data makes up to some extent for the lower precision. One obvious disadvantage of all radio methods except radar is that there must be an active transmitter in the satellite.

SEISMOLOGY—Seismology is being advanced rapidly by the use of electronic devices to acquire and process information about earth movements.⁴⁷ Figure 4 shows an advanced instrumentation system that has been made possible by electronic instruments developed during the past several years. This device has a noise level that is predominantly the Johnson noise of its galvanometer, a gain of over 100 db, a dynamic range of over 70 db, and extremely high reliability and stability.

As a result of increasing seismograph sensitivity and improving performance, it has been possible to define better the arrival of different types of seismic waves.

This has, in turn, stiffened the requirements for the timing system from which seismic-wave arrivals are timed.

A new timing system, appropriate for use in the advanced instrumentation system, has been developed by the Geotechnical Corporation. Completely transistorized, it uses a temperature-controlled crystal whose frequency is reduced to 60 cps by divider circuits. It contains an electromechanical programmer that operates from the stabilized 60-cps power and produces contact closures in accordance with a predetermined schedule to make time marks for recorded data. A stroboscope and a manual control permit system time to be adjusted to agree with time as received from WWV.

SUBSURFACE PROPAGATION—The transmission of electromagnetic signals below the surface of the earth is being investigated by Space Electronics Corporation as a long-range communication system.⁴⁸ The system, termed LOREC (Long Range Earth Current), seems feasible and may play an important role in the military communications program.

Because of an energy channeling effect that takes place near the surface of the earth, more effective propagation and guidance of signals to a distant goal can be provided than previously anticipated. In basic terms, the system might work in this fashion. A transmitter, buried a few hundred feet below the earth's surface, sends alternating current through insulated electric cables to a pair of buried electrodes. Signals are of low frequency and confined to a narrow band. These electrodes act as an oscillating dipole antenna and disseminate the signals out into the earth over a wide area and angle. Particularly by benefit of the surface channeling effect, the earth conducts these signals over long distances to a receiver.

Low frequency signals suffer less attenuation in transmission than do high frequency signals. Over long distances, attenuation becomes critical. The narrow bandwidth of the system limits the amount of information sent during a given period, but is necessary to give a good signal-to-noise ratio at the receiver. Conversely, higher frequencies benefit more by the channeling effect. Space Electronics is now calculating the best answer to the frequency-range question.

Despite the relatively narrow bandwidth, advances in coding techniques make possible the communication of considerable information in a short time. Information in many cases also might be restricted to simple alert and execute commands.

MAGNETOMETERS—The proton free precession magnetometer has been used in both outer space and atmosphere studies of the earth's magnetic field.⁴⁹ It also has extensive applications at the earth's surface because of its ability to accurately measure extremely small variations in the earth's magnetic field without the necessity of leveling, calibration, or orientation in azimuth.

Rubidium vapor magnetometers are expected to have a host of applications at the earth's surface in addition to its use for outer space probes. (See Space section.)

WELL LOGGING—Well logging denotes any operation wherein some characteristic data of the formations penetrated by a borehole are recorded in terms of depth.

Electrical logging is one of the important branches of well logging. Essentially, it is the recording of the resis-

tivities (or their reciprocals, the conductivities) of the sub-surface formations, and the spontaneous potentials generated in the boreholes. The technique is used in search of oil and gas.

Other significant varieties of well logs measure the natural radioactivity of the formations (gamma ray logging), and the secondary effects resulting from the bombardment of the formations by neutrons (neutron logging). Radioactivity logging is more recent and, although less universally employed than electrical logging, it has also proved extremely valuable.

Quite recently, a new type of well log has been introduced by Schlumberger Well Surveying Corp. which provides a record of the sound velocity across the formations (sonic logging). With electrical, radioactivity and sonic logging, the corresponding parameters are measured by down-hole instruments called sondes, and are continuously recorded at the surface.⁵⁰

A Nuclear Magnetism Log (NHL) has been developed by Varian Associates which is an adaption of the proton free precession magnetometer which is used to seek out oil and natural gas deposits by measuring the magnetism of the nuclei of atoms. The magnetometer sensing head is housed in a tubular nonmetallic casing and lowered into a well to test the earth's formation.

MOHOLE—Most of what is known about the earth's interior has come about by indirect geological methods—measurement of earthquake waves and studies of volcanic spew, geological surface structure, magnetic fields, meteorites and astronomical observations. The AMSOC (American Miscellaneous Society) Committee of the National Academy of Science is planning by 1963 to drill a hole completely through the crust of the earth beneath the ocean to obtain a complete record of the sediments and volcanic materials laid down since the earth first had a stable surface.

The boundary between the earth's crust and mantle was defined by Professor Andrija Mohorovicic in 1910 as a discontinuity at which the velocity of seismic waves increased sharply. In his honor, this strata is commonly known as the Moho, thus a borehole to the mantle is called a Mohole. Since the oceanic crust is much thinner than the continental crust, the AMSOC Committee believes that the mantle can be reached using the best modern drilling techniques. There are several places where the Moho comes within 31,000 feet of the sea surface—only 20 percent deeper than the deepest oil well.

A feasibility study has indicated sites north of Puerto Rico and between Guadalupe and Mexico are satisfactory.

In addition to taking cores, it is also intended to measure a number of physical and chemical properties during and after drilling. These include density, radioactivity, plastic deformation, magnetism, electrical properties, thermal gradient, porosity and permeability, and seismic velocity and pressure.

REFERENCES

- (41) Hughes Aircraft, private communication, May, 1960.
(42) V. P. Hessler, University of Alaska, private communication, May, 1960.
(43) H. Doll, Schlumberger Well Logging Co., private communication, June, 1960.
(44) C. H. Hapgood, Keene Teachers College, private communication, June, 1960.
(45) National Academy of Sciences—National Research Council, Science in Space—Chapter III: The Earth, a report by the Space Science Board, Washington, D. C., 1960.
(46) Office of Technical Services, U. S. Department of Commerce, The Geodetic Use of Artificial Earth Satellites—Final Report, Aug., 1959.
(47) M. G. Gudzin, The Geotechnical Corp., private communications, June, 1960.
(48) Space Electronics Corp., private communication, May, 1960.
(49) Varian Associates, private communication, June, 1960.
(50) Schlumberger Well Logging Co., Introduction to Well Logging, 1958.
(51) G. Lill and W. Bascom, A Bore Hole to the Earth's Mantle: AMEOC's Mohole, Nature, 184, p 140, July 18, 1959.
(52) W. Bascom, The Mobile, Scientific American, 200, No. 4, April, 1959.

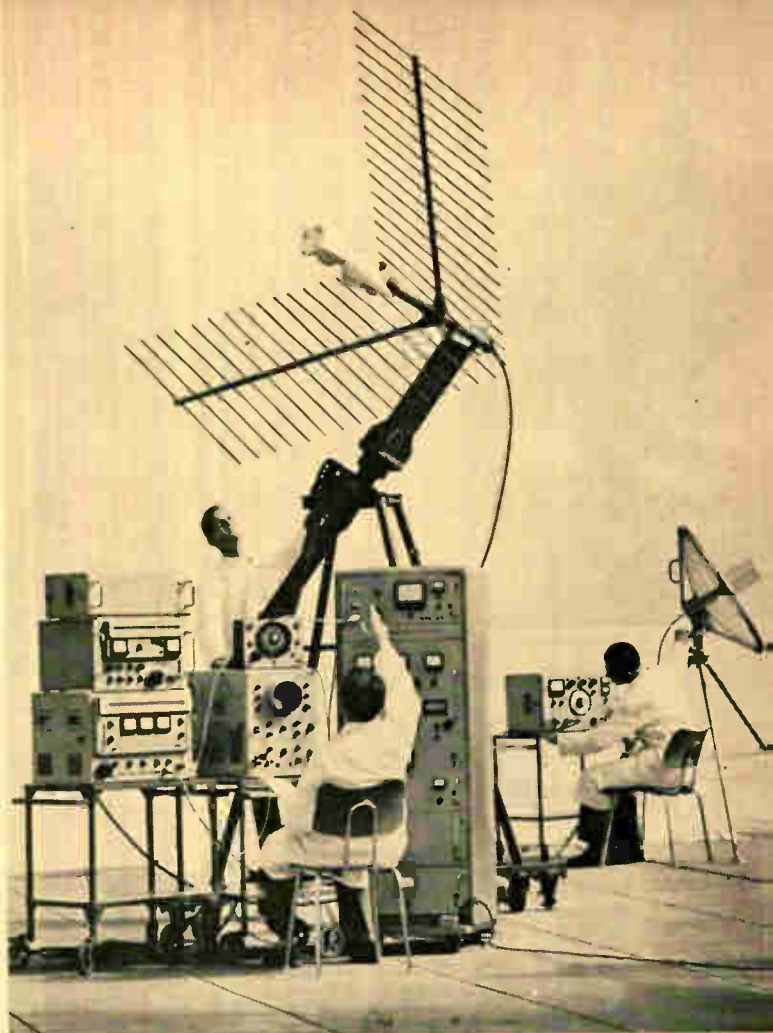

Test assembly for tracking earth satellites developed by Rohde & Schwarz. Decade frequency measuring system measures Doppler shift to determine acceleration and deceleration of satellite for geodetic studies

Measurements of heat flow, thermal conductivity and radioactivity will throw much light on temperatures at great depths, and on the chemical composition of layers in the upper mantle which represents about 85 percent of the volume of the earth and is the principal problem in geophysics today.^{51, 52} Also electromagnetic properties of the mantle will be compared with those at the surface to find out more about the earth's magnetic field. Properties of the rock will be measured by methods similar to those used for oil-well logging.

It is the objective to thoroughly instrument the hole. Some of the instruments already exist; others will have to be developed or miniaturized to fit in the hole (which will be about six inches in diameter at the bottom). A satisfactory low-frequency seismometer is not available at present but steps are being taken to develop a suitable instrument.

THE OCEANS

*To study the 71 percent of earth covered by the seas,
oceanographers will need not only improved
but more reliable instrumentation*

IMPORTANCE of oceanographic probing is just beginning to be discovered generally. Approaches and techniques used to date in accumulating oceanographic data are somewhat antiquated; however, this situation results in part from instrumentation and manpower limitations. This observation applies especially to the more extreme depths of the ocean and the study of the characteristics and phenomena associated with those depths.⁵³

UNDERWATER TRANSMISSION—The only signals which have a transmission power over long range in water are low-frequency pressure waves.⁵⁴ Coding or modulation of these acoustic signals to allow telemetering observations under water is being studied.

A Navy radio facility being constructed at Cutler, Me., will generate at least 1,000,000 kilowatts in the very low frequency radio band (3 to 30 Kc). Although the station is designed primarily for communicating with submarines, the propagation phenomena involved may have interesting oceanographic applications.

SOUND VELOCITY MEASUREMENT—Sound velocity profiles in ocean water can now be measured to depths of 16,000 ft at accuracies of better than 1 in 15,000 by Daystrom's Deep Sea Velocimeter. The basic technique used was developed by NBS. Consisting of immersible and remote units, the instrument is capable of measuring the true velocity of sound in a liquid medium. Under certain conditions, it can also derive the density of the medium. For applications requiring acquisition of both sound velocity and depth continuously, modifications can be made to include a depth sensor.

The immersed unit generates a signal proportional to true sound velocity by using the ring-around principle. This phenomenon depends on a series of supersonic pulses transmitted and received through the liquid over a standard distance. Reception of each pulse initiates the transmission of the next sequential pulse. Thus, the repetition rate of the oscillatory circuits is a function of

the true velocity of sound in the liquid. The output of the device is fed by a cable to a remote amplifier unit which ties in with readout equipment or indicators.

DEPTH MEASUREMENT—The level at which sensing instruments operate, and the topographical features of the sea floor, are of prime importance to the oceanographer. Echo sounding techniques are used extensively for determining the slant distance to a submerged instrument with satisfactory acoustical reflectivity. Also, the vertical distance to the bottom can be found by measuring the travel time of a pulse of sound from the ship to the bottom and back. By placing a sound projector on the instrument, elevation above bottom can be found by measuring the interval between direct- and bottom-reflected arrival times.

A technique developed at Woods Hole Oceanographic

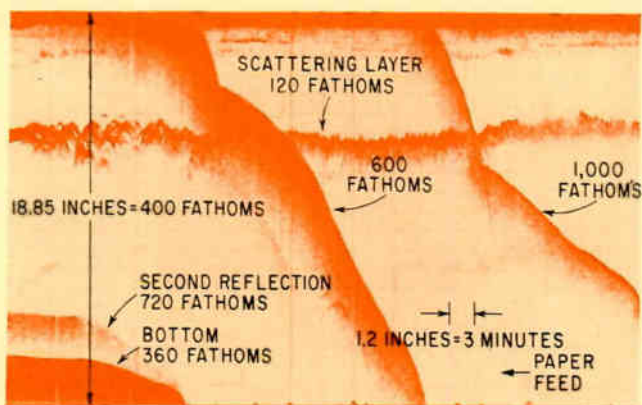

Typical record of ocean bottom made by Lamont Geological Observatory using Westrex Precision Depth Recorder. Presentation is on expanded vertical scale; scale shift is automatic. When sea floor trace rises to 800 fathoms (reading from right to left), the trace begins over again at the bottom and rises to 400 fathoms, and so on. Reflections from different depth ranges can be recorded simultaneously as shown by scattering layer recorded at about 120 fathoms throughout⁵⁵

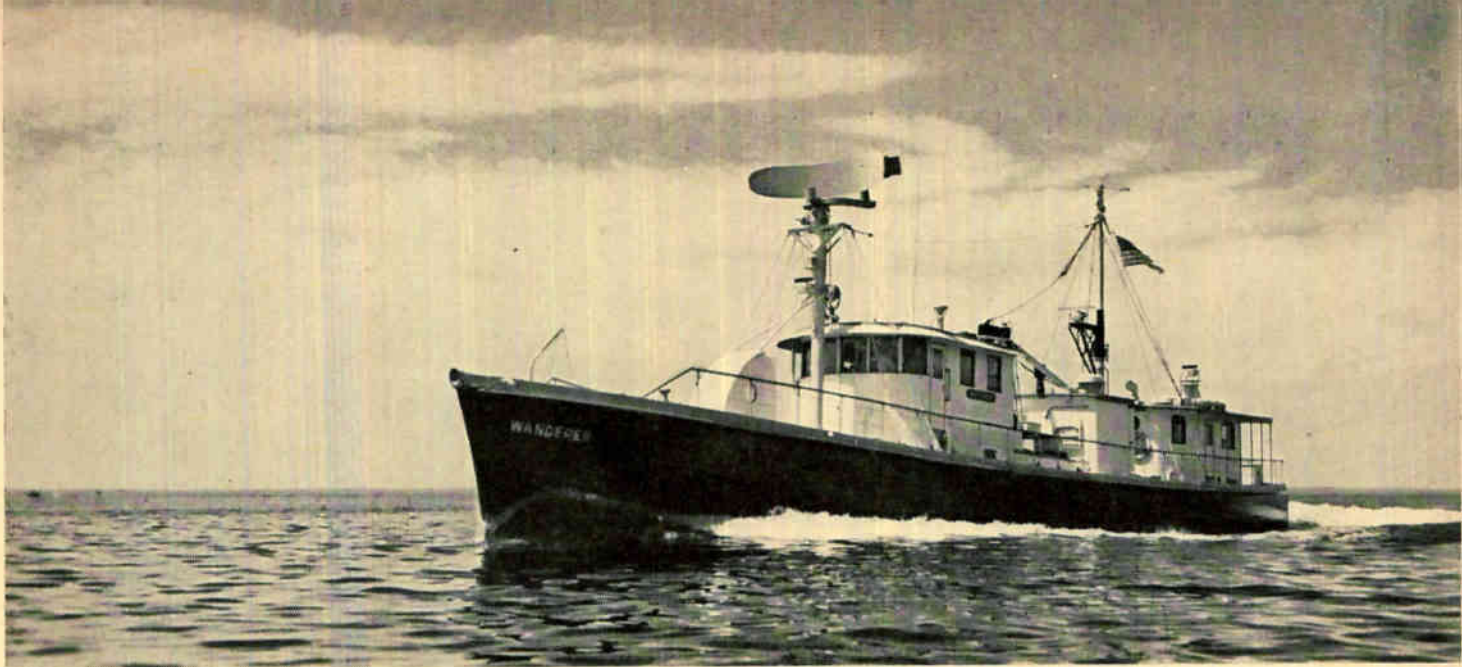

Sperry Marine Division's highly instrumented ship Wanderer is engaged in experimental work leading to remote control of sea probes for increasing accuracy of oceanographic studies

Institution involves use of a sound projector mounted on the instrument package which measures depth by measuring acoustic return of sound waves from the interface between the air and water. Another pressure-sensing device is the Vibrotron developed at Scripps Institute of Oceanography which provides depth information by monitoring the frequency change of a vibrating wire connected to a flexible diaphragm.

TEMPERATURE MEASUREMENTS—Energy content of the oceans has a bearing on ocean currents and weather. Of particular interest is the fine structure in the top hundred meters of water. These readings, for greatest convenience, must be made with the ship underway.

The contour temperature recorder (CTR) developed by Woods Hole is a device which takes data from temperature sensors (thermistors) located in a chain towed

behind a ship, and plots on a continuous record the vertical distribution of isotherms.⁵⁶ The thermistors are electronically scanned in series from top to bottom of the chain and, if it is desired to do so, the scan rate can be adjusted in relation to the speed of the ship so that the information is taken from a vertical column of water. Thermistors are placed in the chain at 25-ft intervals (there are 22 such thermistor stations). The electronic circuits scan these in a time interval that can be adjusted from two seconds to over 20 seconds.

OCEAN CURRENT MEASUREMENT—Direct observation of subsurface currents to determine speed and direction has been made possible by use of neutrally buoyant floats which can be set to any depth and located by the sound they generate.

A technique developed at Woods Hole, called an acoustic theodolite, uses a pinger-hydrophone package. Upon reaching bottom, the pinger is released and the hydrophones, mounted on each corner of a 1½-m-square frame, pick up the continuous transmission as the pinger moves with the current in ascending to the surface. Thus, currents flowing from the sea's surface to the bottom can be shown in a graphic vertical profile made on a strip chart recorder (mounted on the frame). Pinger displacement is a function of the difference in arrival time of the sound waves at the four hydrophones.

Anchored and free-floating surface buoys with radio telemetering links and free-floating submerged buoys carrying acoustic generators have been used to determine drift. The buoys can be triggered from a ship, plane or shore station.

OCEAN-WAVE MEASUREMENTS—A transducer on the sea bottom converts pressure into frequency in a system developed by Scripps.⁵⁷ The oscillations are counted and recorded on shipboard for filtering and spectrum analysis by high-speed digital computers. Oscillation by 1 mm of water pressure in the frequency range 0.2 to 100 cycles per kilosecond (periods of 5,000

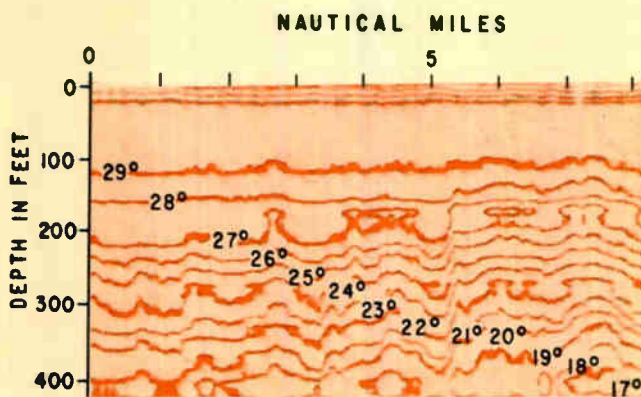

Temperature contour recording of the Gulf Stream east of Jacksonville, Florida, made on Alden's Alfax paper using Richardson Contour Recorder. Thermistor chain towed from ship's stern provides input data. A servo system rotates a disk with slots corresponding to depth. Light passing through these slots illuminates one of three phototransistors which provide signals when isotherms are passed. These signals are amplified and used to mark the record

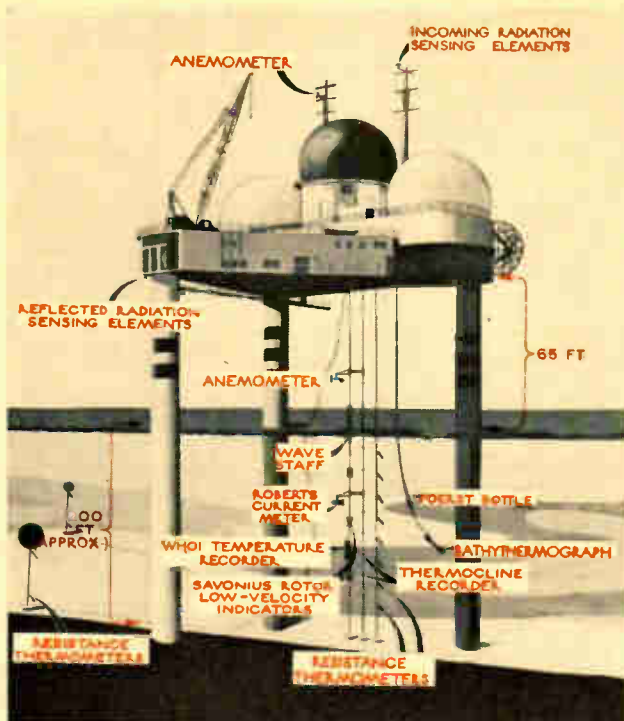

Texas Tower No. 4, shown here, as well as Texas Tower No. 2, are being used as oceanographic platforms by the U. S. Navy Hydrographic Office. All instruments and signal wires are free to be raised or lowered by hand or power

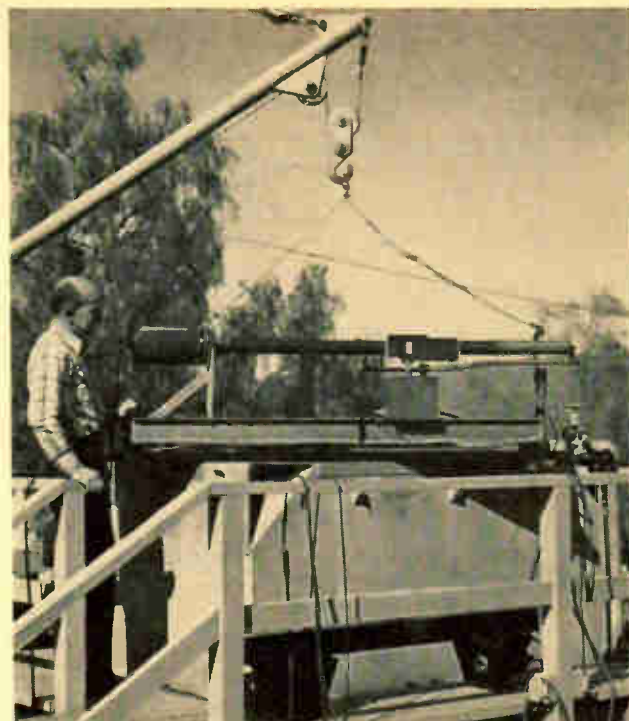

Scientist tests and calibrates nephelometer (across corner of test tank) just before taking data at a field site. Companion instrument on platform floor is called an alpha-meter and is used to measure transmittance of water

to 10 sec) have been recorded at depths exceeding 100 meters. Waves with an amplitude of a few millimeters in the frequency range 0.1 to 10 cycles per kilosecond, at depths exceeding 100 meters can also be measured. The instrument consists of an absolute pressure gage using a vibrating wire pressure transducer which converts pressure to frequency.

MICROMETEOROLOGY—A 30-ft aluminum tower instrumentation mast is part of a complete data sensing, telemetering and recording system under development by scientists of the Engineering Research Division of New York University to gather information on interactions at the air to sea boundary. These processes are important to research on wind-generated waves, storm tides, long-range weather forecasting propagation of electromagnetic waves, and other oceanographic phenomena. Installed in water to a depth of 25 feet, the instruments in the tower are mounted at a specific height above the surface of the water to obtain various measurements.

The encoding and telemetering system consists of eight battery-operated, frequency-modulated, voltage-controlled oscillators that take signals from the sensing instruments. The slowly varying d-c voltage signals from 0 to 5 volts are converted into f-m signals and transmitted back to the boat by a floating cable on eight different carrier frequencies, depending on the characteristics of the signal. Eight signals are recorded on one channel of a high-precision tape recorder along with verbal information about the signals and with a signal from a crystal-controlled oscillator used as primary frequency standard.

OPTICAL MEASUREMENTS—Submarine nephelometers have been built for measuring the volume scattering function of natural waters by Scripps.⁵⁵ This technique is

necessary because great changes take place in ocean and lake waters if brought back in containers. Their balanced aquaria are highly sensitive to environmental factors: gas bubbles collect on the walls of the containers; some species of plankton may die whereas others may undergo accelerated propagation; and detritus settles out or rises to the surface.

The phototube used in this instrument is an end-on multiplier phototube selected for high sensitivity and low noise. Signals from the phototube pass through a logarithmic amplifier to a strip-chart recorder. Also, Scripps has developed underwater photometers to study radiance distribution.⁵⁶

Also, downwelling attenuation functions can be measured with flat-plate Lambert collector for measuring relative values of irradiance. The volume attenuation function is measured with a hydrophotometer which is insensitive to changes in coupling between radiant flux and detector.

SALINITY MEASUREMENT—Aside from the advantage of having the salinity data complete at the conclusion of a cruise, the knowledge of salinity obtained shortly after a hydrographic station has been established can be of help in planning future stations and also makes possible the spotting of a faulty Nansen bottle.

A shipboard salinometer having greater accuracy than could be obtained by the slower chemical titration method and which makes it possible to follow water masses of specific salinity values while underway, has been built at Woods Hole.⁵⁷ The salinometer consists of a constant-temperature bath, a 1,000-cps impedance bridge with glass conductivity cells in two of its arms, a phase detector to convert the 1,000 cps output of the bridge to d-c, and a balancing mechanism to automatically complete

COUSTEAU On The Oceans

The principal motive for studying the oceans seems to me to be sheer inquisitiveness. A couple of years ago at Toulon my colleague, Prof. Harold E. Edgerton of the Massachusetts Institute of Technology, put the idea in plain American. He was diving under the Bathyscaphe FNRS III in the naval dockyard in order to adjust one of the deepsea electronic flash cameras fitted to the gondola. A passerby said, "What do you expect to photograph with that thing?" Edgerton replied, "Brother, if I knew, I wouldn't bother tryin'".

Prof. Harold U. Sverdrup defined oceanography as "the application of all sciences to the study of the sea". Most of the basic disciplines of natural science are now employed in this watery university. Some studies have advanced to the transitional point between pure and applied science, such as the feverish military study of underwater sound waves and diffusion layers. Whatever his program, the sea demands extraordinary capabilities of the scientist. To work efficiently he should learn two essential technologies: seamanship and electronics. They are inter-related, as well. Seagoing research projects have sometimes failed due to the fact that seamanship was wanting. The most elegant exploratory device turned out shoreside may be frustrated in the field if it is unseaworthy or if the experimenters are not adroit in ship-handling, winchwork or launching and recovery.

Today almost every branch of oceanic study depends on electronics. Echo-sounding was the mid-wife of modern oceanography and has delivered a litter of specialized devices. It seems there is a new metering or recording idea every other day. Edgerton has pushed electronic flash photography to the point where we can now place 1600-shot cameras in the greatest abysses and position them by sonar with a depth accuracy of a few feet. We are now producing dynamic bottom reconnaissance films of the choicest interest to geologists and biologists.

Electronics will soon permit us to station robot continuous recording stations for wave, current, temperature, chemical and radiation data. The newest ideas in depth exploring vehicles are a complex of electronic systems.

However adequate the state of the electronic art, we fall far short in its application to oceanography and in the number of applications. This is a symptom of the general malaise in ocean science: not enough money, ships, laboratories and men. The tools exist, the ideas abound, and the need is obvious. Consider the fact that the world oceanographic fleet, including the vaunted giant vessels of the Soviet Union, has not been built for research, but is a hand-me-down collection of freighters, tugs, and naval vessels. Traditional marine architecture cannot serve electronic oceanography. We need radical ships, flouting any classic design precept that stands in the way of using the tools. We do not need ships that look like ships. If the mission of a vessel dictates cockeyed and asymmetrical deck housing and top hamper, she should be "built crazy". Designers must obey mission. Carrier aircraft sliced the top off of battleships and forced the bridge to the rails. Then the British added the logical cater-cornered runway. The new tools of oceanography make a similar demand on marine research architecture.

We require deeper and more agile observation vehicles. A start is being made in manned undersea research stations which give personnel access to the water. The main contemporary challenge in oceanographic electronics is probably to design continuous unmanned recording stations. The fantastic increase in world population demands experimental marine husbandry, or aquaculture, in which electronics will play a part.

We are reaching a point where all research ship personnel, from the mess boy to the senior scientist, should have at least rudimentary electronics. This qualification can only grow in intensity as ocean science moves on. We have found in ten years of Calypso Oceanographic Expeditions that the most rewarding studies involving electronics were carried out by a natural scientist conversant with the art and electronics interested in what he was investigating. The specialist must have general curiosity and wider aptitudes than he needs ashore in order to carry out research at sea.⁶²

JACQUES-YVES COUSTEAU
Director, Musée Oceanographique
Monaco

the fine adjustment in bridge balance. Salinity of an unknown sample is determined by comparing its conductivity with that of a sample of known salinity at the same temperature.

OCEANOGRAPHIC PLATFORMS—Although little mention has been made of using a Texas Tower as an oceanographic platform, the system has presented the oceanographer with a working situation not heretofore attainable in which data can be gathered from a stable platform located in virtual open-ocean environment.⁶¹

The oceanographic laboratory of Tower No. 4 (see

map on foldout) is situated on the lower of three decks midway between two of the three legs or caissons supporting the tower as shown in Fig. 5. Instruments are lowered through deck holes in the laboratory floor, each of which has a steel cable passing through its center.

Winds are measured at several levels with a Navy AN/UNQ-5B anemometer driving a commutator generating a signal voltage proportional to wind speed which is fed to a calibrated indicator. Vane position, through a self-synchronous motor, indicates wind direction in degrees from magnetic north. Waves motion is measured with a calibrated gage which utilizes the principle that

FROSCH On The Oceans

Why is man studying the oceans? What are his motives and goals?

There are a number of reasons. The most important and generally applicable is sheer curiosity, the driving force of most science. Human beings seem to want to understand the universe. In addition the oceans are the last major geographic frontier on earth, the last reservoir of resources: food, water, and fuel (in the fusion sense), available locally. With an increasing population we will have to use the oceans as sources of supply. To do this we must understand them and be at home on and in them. It seems certain that we are going to explore space. For a long time this exploration will be a drain of resources, rather than a gain. It will only be by full exploitation of the earth, including the oceans that we will be able to afford both a high standard of living for the world's population and the fun of exploring space as well as the earth.

Is the state of the electronic art adequate? Where, specifically, are the greatest problems in measurement and observation?

No art is ever adequate for research. We continually struggle to get lighter, simpler, cheaper instrumentation. Telemetry and recording are always major problems. The information must either be recorded in situ, and none of the existing techniques is really adequate, or telemetered to a ship or to shore. Our existing methods have generally had to be developed by oceanographers. We need cheap recorders and telemetry systems with multichannel capability, broader band, higher dynamic range, and lower low-frequency noise than those now available. Broadband high-power electroacoustic transducers are a continuing problem. Quick, easy, really pressure-proof multiple connectors would be very welcome.

We generally have severe environmental problems with standard laboratory equipment at sea, and many

experimental systems fail due to a combination of heat, humidity, and salt. Many useful instruments are simply too finicky to take to sea.

What are some future investigations in which electronics will play a role?

All future investigations will require the assistance of electronic techniques in some form. For example, studies of reflection of audio sound from the sea surface require broadband pulsable audio power sources and transducers, elaborate receiving systems involving hydrophones at various depths, telemetering gear having several channels with broadband high-dynamic-range information to the ship (perhaps by a combination of cable and radio buoy), and sophisticated recording and/or analysis systems, perhaps involving direct extraction from the data of statistical parameters and functions such as auto and cross correlations and higher moments. The example given is a relatively simple one.

Are the right kind of people available to carry out present programs? Are hybrid people required or is it possible for the naturalist to direct the electronics man in such a way that cross-field understanding is not a must?

We need people with broadband training in electronic engineering fundamentals, and an interest in applying their understanding in many ways and fields. They need not have previous knowledge or experience in the field of marine physics. A good scientist and a good engineer can always establish the necessary communication. Too many of the engineers we interview are well trained and experienced in a small specialty without having a broad technical background which alone entitles a man to the designation "engineer." The difficulty is compounded by the fact that there simply are not enough engineers.⁶³

ROBERT A. FROSCH
*Director, Columbia University
Hudson Laboratories
Dobbs Ferry, N. Y.*

utilizes the principle that the resistance of chromel wire varies linearly with the depth of immersion. The signal generated is then amplified and fed to a strip-chart recorder or data-handling system depending on the type of observational program being pursued.

Roberts electromechanical current meters or similar systems for the recording of oceanic currents are used. These instruments employ rotating impellers whose speed is a function of current speed; a system of contacts provide electrical signals against time. Direction values are obtained by a-c signals and are combined in trigger counting circuits which print out on paper tape. Three separate temperature-depth sensing instruments are utilized part time or continuously. A standard bathythermograph is lowered at regular intervals to record the gross temperature structure; resistance thermometers at discrete intervals continuously record and present their

intelligence on strip-chart recorders; and a specially designed underwater cable with a number of thermistor elements open to the water column allows the vertical structure to be scanned every 20 seconds (20 elements at 1 sec per element). All data are recorded on an f-m magnetic tape recorder, putting at the oceanographer's disposal data obtained in the proper time sequence for probing time and space variations in the oceanic structure.

Since it is a stable platform at sea, the tower offers an opportunity to obtain evidence of the rate at which solar energy is absorbed and converted into heat in the upper layers of the ocean. To accomplish this, pyroheliometers (a thermopile consisting of two concentric rings which when exposed to radiation develops an emf whose voltage is applied and recorded against a reference) are installed at selected locations to depict the amount of incident and reflected radiation present. These units are

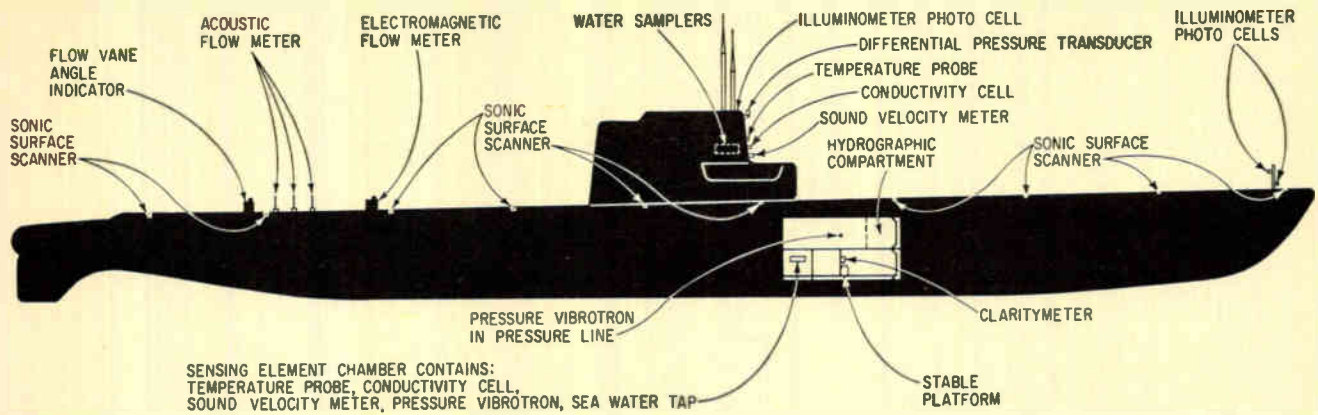

FIG. 6—Experimental, oceanographic submarine developed by U. S. Navy Hydrographic Office. Equipment in hydrographic compartment records, modifies, monitors and calibrates signals; hydraulically raises and lowers the electromagnetic flow meter; pneumatically releases

the tripping mechanism on the water sample bottles; and supplies and regulates required voltages. Also, there are analysis facilities to play back each transducer separately for correlation with flow data, ship motion and pressure fluctuations

sensitive to wave lengths between three thousand and five thousand angstroms.

During special observational periods, a second type of radiometer (which is not hindered by a protective covering as is the pyroheliometer) and sensitive to the entire range of the spectrum, is used to obtain nocturnal as well as diurnal values.

At present, salinity is measured by collecting water samples by mechanical means at the depths of interests and transporting them back to the laboratory for analysis. However, with the recent use of the salinometer (discussed earlier) it may be possible to sample levels of interest directly by pump and obtain salinity profiles on a detailed basis. Also, programs are being conducted to develop a conductivity cell capable of sensing and recording on the spot.

SUBMARINE OCEANOGRAPHY—Potential of the submarine as an oceanographic observation platform has been largely neglected. Its advantages are tremendous and its one outstanding disadvantage—depth limitation—is rapidly being overcome.⁶⁵

Submarines can operate under extreme sea conditions where the need for oceanographic data is most critical and can cruise with complete freedom under the ice-covered water of the Arctic. With sonic devices, it can examine the sea-air interface without distorting the surface by its presence. Moreover, the stability of a submarine permits the use of the most sensitive geophysical instrumentation. Also, it is unencumbered by cables, winches and conventional suspension gear required for oceanographic observation from surface vessels.

About a year ago, the U. S. Navy Hydrographic Office was assigned the task of designing and installing an oceanographic system aboard a submarine. The objective

was the development of an integrated system of instrumentation for collecting, recording and analyzing environmental information important to naval operations.

Oceanographic parameters to be measured include temperature, conductivity, salinity, sound velocity, sea state, water clarity and ambient light. Observation of ship pitch, roll and yaw angles, heave and sway accelerations, and the angular acceleration of pitch and roll will be made since they are essential for careful study of waves and currents. Velocity and direction of water flow across the deck of the submarine are to be measured. Velocity will be measured by both electromagnetic and acoustic flow meters and direction by a freely revolving vane.

Sensing elements for measuring the various parameters are mounted as shown in Fig. 6. Eight racks of electronic gear are required to house the complete experimental control and recording system in the hydrographic compartment. Instrumentation is operated independently of the activities of the submarine except that speed, course and position inputs must come from the ship's controls.

A new concept in measurement of oceanographic variables has been introduced. A tank-like chamber containing sensors requiring contact with the water is installed in the intake of the air conditioning pump. The chamber is 26 by 9 by 5 inches and holds about two gallons of water. A throttle valve system controls the flow of water through the chamber by a bypass and a flow gage to about 7 gallons a minute. Advantage of this chamber is the ease with which sensors may be removed for calibration, repair or replacement. One disadvantage of this system, however, is the time lag caused by the length of traverse from hull to chamber which allows intake water to be warmed before measurement.

REFERENCES

- (53) J. H. Newman, Daystrom Electric, private communication, May, 1960.
 (54) F. K. Koczy, The Marine Laboratory, private communication, June, 1960.
 (55) B. Luskin, Lamont Geological Observatory, private communication, June, 1960.
 (56) C. J. Hubbard and W. S. Richardson, The Contouring Temperature Recorder, Technical report for U. S. Navy, Special Projects Office by Woods Hole

- Oceanographic Institute (unpublished manuscript).
 (57) F. Snodgrass, W. Munk and M. J. Tucker, Offshore Recording of Low-Frequency Ocean Waves, *Trans. Am. Geol. Union*, 39, No. 1, Feb. 1958.
 (58) J. E. Tyler and W. H. Richardson, Nephelometer for the Measurement of Volume Scattering Function in Situ, *J Opt Soc of Am*, 48, p 354, May, 1958.
 (59) R. W. Holmes and J. M. Snodgrass, Scripps Institution of Oceanography, private correspondence, May, 1960.

- (60) K. E. Schleicher and A. Bradshaw, A Conductivity Bridge for Measurements of the Salinity of Sea Water, *Extrait du Journal du Conseil International pour l'Exploration de la Mer*, XXII, No. 1, 1956.
 (61) U. S. Navy Hydrographic Office, private communication, May, 1960.
 (62) J. Cousteau, Musee Oceanographique, private communication, May, 1960.
 (63) R. A. Frosch, Hudson Laboratories, private communication, June, 1960.

LIVING MATTER

Just as electronic probes have helped man

solve problems of the physical world,

so are they helping him study the fundamental processes of life

ZWORYKIN on Living Matter

There are a number of reasons why man studies living matter. The most fundamental of these is that it is a way toward understanding himself and his relation to the remainder of the universe. Next to this philosophic motivation we must rank the humanitarian reason for the study of living matter: the maintenance of health, the prolongation of human life, and the prevention of suffering all demand a familiarity with the physical basis of life. Finally, electronic scientists are becoming increasingly aware of the contribution which the study of living matter can make to their own art: nature has evolved techniques of signal transmission, memory storage, and control which can serve as models in flexibility, reliability, and compactness.

In medical electronics the humanitarian objective stands in the foreground. Electronics is here a handmaiden of the healing arts. Thus, in addition to providing tools for the accumulation of fundamental knowledge, it is concerned with aiding the diagnosis of disease and contributing to preventive medicine and therapy.

To an increasing extent, electronics must provide the tools for observation in the life sciences. The fact that control and communication processes within living systems are largely electrical in nature establishes a continuous demand for suitable low-noise low-frequency amplifiers. The efficient utilization of invisible radiations, such as X-rays and ultraviolet, with minimal injury to the living material observed requires electronic techniques of conversion and intensification. Miniature electronic probes linked by

electromagnetic fields to external recorders constitute an optimal approach for the study of processes within the living body and present a fertile field for the electronics engineer concerned with the advancement of medicine.

The development of electronic computation techniques as an aid to the physician in diagnosis and the prescription of therapy presents a special challenge to electronics: it has the unique promise of making the tremendous expansion of medical knowledge immediately serviceable in the conquest of disease. A simpler application, of great importance for preventive medicine, is the establishment of rapid-access storage centers for standardized health records for the population.

The list of actual and potential contributions of electronics in observation, analysis, and medical practice could be extended indefinitely. Progress is here limited only by the extent of the funds and the manpower available for advancing the application of electronics in medicine and biological research, and the intimate cooperation of the medical scientist and electronic engineer. For greater effectiveness, this cooperation should be on a basis of equality; furthermore, both the medical scientist and the electronic engineer should be sufficiently familiar with the complementary field to facilitate communication and create awareness of fundamental limitations. Men who are adequately trained in both fields are all too rare at the present time. The extension of opportunities for acquiring the needed training remains an important task.

V. K. ZWORYKIN
David Sarnoff Laboratories
Princeton, N. J.

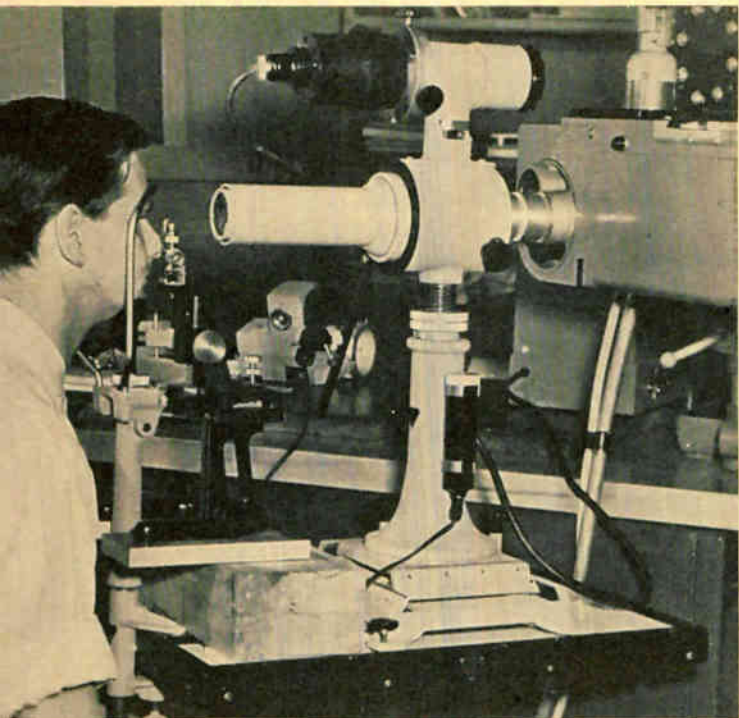

Extremely light-sensitive color tv system developed by CBS Laboratories for research into the vascular system of the eye. Patient finds light tolerable for long periods.

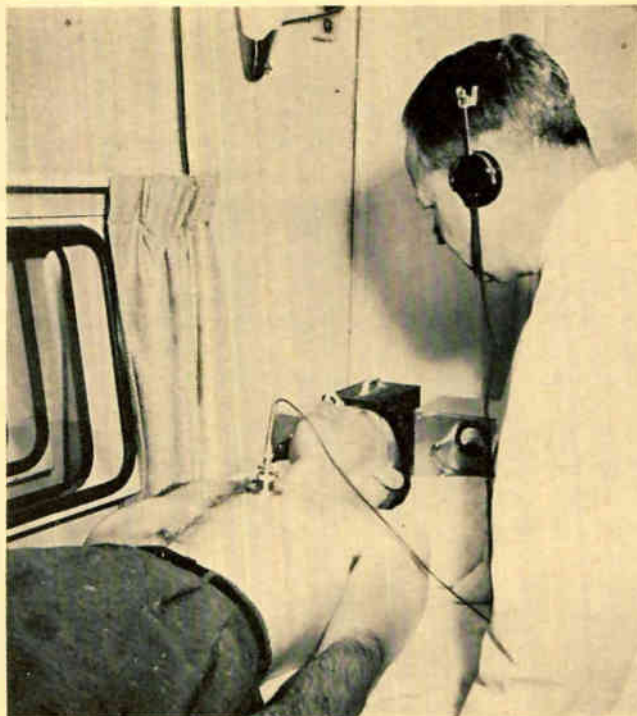

Capacitance pickup built by GM Research Laboratories detects normal murmurs and sounds of blood flow through the heart and large blood vessels

BIOENGINEERING has been defined as the field of applied science which is concerned with the applications of the physical science techniques to problems in medicine and biology.⁶⁴ Electronics has become an effective tool in this comparatively new field.

HEART SOUND MEASUREMENT—To overcome the lack of responsiveness of the ear to low intensity sounds, several types of electronic stethoscopes have been developed. Murmurs of low intensity often are of great importance in early diagnosis of valvular heart disease, but these murmurs may not be audible through acoustical stethoscopes.

A capacitance heart sound pickup capable of detecting chest wall movement as small as one-half billionth of an inch has been developed by General Motors Research Laboratories and the Medical College of South Carolina.⁶⁵ The capacitance device, contained in a small bell-shaped housing similar to the bell of a physician's stethoscope, converts chest wall vibrations directly into electrical signals. These faint signals are amplified and reproduced with a clear trace on an oscilloscope where they can be photographed or recorded on tape.

An electronic stethoscope which enables doctors to listen to the chest noises of a patient in an iron lung while eliminating interference from the pump has been built by Faraday Electronic Instruments, Ltd. Called a Soniscope, the instrument uses a crystal microphone having a special heavy metal diaphragm which transmits only those sounds emanating from a source with which it is in contact. Wanted sounds are separated from the unwanted by high- and low-frequency attenuators.

A transistorized electronic stethoscope developed by

the University of Chicago gives doctors a quick, visual check on pulse rates and patterns at the operating table. A one-millivolt signal is picked up on the chest with two noise-free silver electrodes and fed into a four-stage transistorized amplifier. The output is read on a milliammeter. With a modification in the output, the device can be used to operate a watch strapped to the chest which counts heart beats instead of time.

BLOOD FLOW MEASUREMENTS—An experimental blood flowmeter using nuclear magnetic resonance has been developed by the National Heart Institute.⁶⁶ The system consists of a pair of horseshoe magnets having common pole pieces with 3-inch faces spaced ½-inch apart giving a magnetic field of 3,500 gauss. The resonance signal is detected as a change in plate current when modulating coils wound on the pole caps of the permanent magnet vary the static magnetic field. This in turn varies the intensity at which the oscillator frequency and magnet strength cause the protons to resonate and absorb energy from the oscillator. Plate current change is amplified, filtered free of r-f and evaluated on an oscilloscope. The technique promises to be especially useful for measuring low flow rates.

BLOOD PRESSURE MEASUREMENT—The Visoton produced by Biophysical Electronics, Inc., uses a microphone and amplifier to present pulse rate information on an oscilloscope. With an additional cuff attachment, actual systolic and diastolic pressure can be measured. The device is used on laboratory animals to evaluate drugs, study disease, test experimental surgical techniques and study toxicological effects. Strain-gages fitted into

catheters are also used to measure intercardiac pressure.⁶⁴

TISSUE MEASUREMENT—An ultrasensitive, low-noise transistorized amplifier built by Millivac Instruments detects extremely weak high-frequency electrical signals from muscular tissue. Cardiographs, encephalographs and myographs can detect powerful signals at low frequencies; however, this device detects much weaker signals that occur at frequencies up to 50 Kc. The device has helped find that abnormalities in muscular structure which affect the frequency pattern of voltage generated by the muscle. Thus, important clues in diagnosing muscular diseases are provided.

EYE MEASUREMENTS—Blood vessel and tissue exploration of the eye at low light levels has been made possible by CBS Laboratories' field-sequential color tv system using an image orthicon designed for astronomical observations. Since the color tv camera is more sensitive to the faint light of stars than is the eye, long exposure times are possible. This technique gives sharpness of detail required for making clear motion pictures. The system also permits emphasis of color values for greater contrast so that disease lesions may be made more visible. Early applications show possibility of investigating events in the brain as well as circulatory disturbances related to heart disease and arteriosclerosis.

DIGESTIVE SYSTEM—A pressure sensitive device one inch long and fully equipped with a battery and a radio transmitter is being used to study gastrointestinal problems. Produced by Airborne Instruments Laboratories, the device senses the varying intraluminal pressure in the gastrointestinal tract and transmits the information to a nearby receiver. Originally known as the radiopill (developed by Medical Electronics Center and RCA) it has been further developed and improved. The pressure sensing mechanism is a flexible diaphragm that covers one end of the cylinder. Pressure acting against the diaphragm causes it to change the inductance of an internal battery-powered transistor oscillator which modulates the frequency of oscillation. The f-m signal is transmitted to a remotely located f-m receiver.

ENDOSCOPIC DEVICES—An intraoral probe using flexible fiber optic bundles and a closed-circuit tv system has been developed to permit a dentist to view cavities in a patient's mouth as he works (ELECTRONICS, p 92, Jan. 1).

The Franklin Institute is also experimenting with fiber optic probe for endoscope applications.⁶⁵ Termed Fiberscope, the device is more flexible than present gastroscopes and provides images of good quality. The technique has been extended beyond the optical features of the design to the development of a technique for controlling the configuration of the Fiberscope so that the physician may easily view what would otherwise be an inaccessible place.

REFERENCES

(64) W. E. Frank, Instrumentation for Bioengineering, paper presented at 123rd AAAS meeting, Dec., 1956.
(65) D. Groom and Y. T. Sihvonon, High-Sensitivity Capacitance Pickup for

Heart Sounds and Murmurs, *IRE Trans. on Med. Elect.*, PGME-9, Dec. 1957.
(66) R. L. Bowman and V. Kudravec, Blood Flowmeter Utilizing Nuclear Magnetic Resonance, *IRE Trans. on Med. Elect.*, ME-6, Dec., 1959.

BIOLOGICAL RESEARCH—Currently opening new fields of biochemical and medical research is the electron paramagnetic resonance (EPR) spectrometer.⁶⁶ The importance of the EPR in biological research is now coming to the fore because it provides an accurate and non-destructive analysis of biological systems. Also, it enables the scientist to study reactions while they are in process rather than waiting for completion of the reaction as with other spectroscopic measurements.

The EPR spectrometer is sensitive to free or unpaired electrons in a molecular structure. Each electron of this type has a property, characterized as spin and when the spinning charged particle is placed in a magnetic field it will precess at a frequency dependent on the local magnetic field which the electron experiences in its molecular environment.

During the past few years EPR has made two particularly significant contributions to the understanding of living matter. The first of these—discovered by Professor Calvin of the University of California and Professor Commoner of Washington University of St. Louis—showed that there may be some correlation between the photosynthetic process in plants and the production of unpaired electrons. Since EPR can respond only to unpaired electrons, it was the tool that discovered the existence of unpaired electron formation during photosynthesis.

Professors Calvin and Commoner were able to show that whenever white light is shined on green plants such as spinach chloroplasts or green algae, or upon living bacteria, a signal in the EPR spectrometer was observed which is characteristic of a free radical (molecule containing an unpaired electron). They further have observed that this free radical formation was very fast and existed only when the light was on (active photosynthesis takes place under these same conditions).

Dr. M. B. Allen of Kaiser Research Foundation, Richmond, Calif., and Dr. P. Sogo of the University of California, have shown that the change in the concentration of these free radicals with wavelength follows almost exactly the optical absorption pattern for chlorophyll indicating that chlorophyll is possibly responsible for the generation of the free electron.

Secondly, EPR has contributed to the study of radiation damage of living matter. A group of scientists at Argonne National Laboratories have been able to show that there is a strong correlation between the formation of free radicals in spores produced by high-energy irradiation sources and the inactivity of the spores to germination. This correlation was made by monitoring the free radical level produced with an EPR spectrometer. This group has also shown that further damage takes place when oxygen is allowed to come into contact with the free radical that has been formed.

The authors thanks the government agencies, scientific institutions, colleges and universities, and companies who supplied information for this report.

(67) A. Warnick and E. H. Drake, A New Intracardiac Pressure Measuring System for Infants and Adults, *IRE Nat. Conv. Rec.*, Part 9, 1958.
(68) Varian Associates, private communication, May, 1960.

WHEN YOU NEED FAST SWITCHING specify new Hughes 2N1254-2N1259 P-N-P transistors

Here are the fastest switching p-n-p silicon mesa transistors ever developed. Look at these outstanding features: Typ. f_T of 75MC... thin base region... low stored base charge... low t_d , t_r , t_s , t_f ... β of 1.5 min at 50MC... β of 1.75 typ. at 50MC... low collector capacitance. These transistors have good high-level gain characteristics, exceptional low-level gain characteristics, plus high breakdown voltage. They give excellent performance at low voltages, and they are *outstanding* for high-voltage switching.*

These new high-speed transistors are available in production quantities—right now!

*The series is also available with the same electrical characteristics in a collector-grounded configuration with a free air power dissipation of 750 MW.

There is a Hughes sales office or authorized distributor in your area. Give them a call today. Or, if you prefer, write Hughes Semiconductor Division, Marketing Department, Newport Beach, California.



SWITCHING CIRCUIT

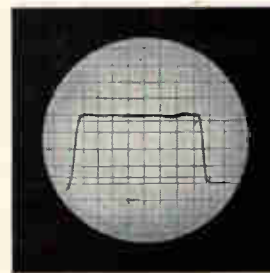
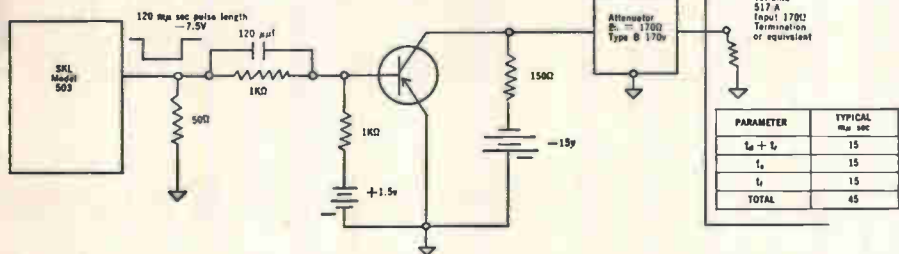

Types—2N1255, 2N1257, 2N1259
D.C. Current gain vs. Collector current
VCE = 1 volt; Temp = 25°C ± 3°C

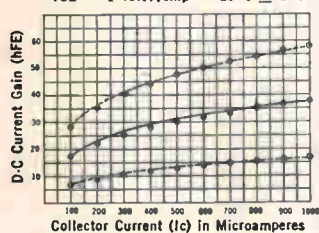

Types—2N1255, 2N1257, 2N1259
D.C. Current gain vs. Collector current
VCE = 1 volt; Temp = 25°C ± 3°C

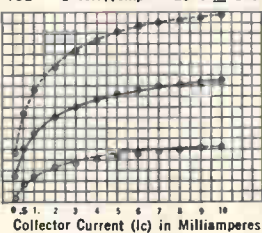

Types—2N1255, 2N1257, 2N1259
D.C. Current gain vs. Collector current
VCE = 2 volts; Temp = 25°C ± 3°C

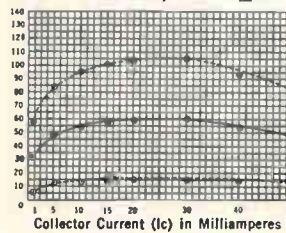

Creating a new world with ELECTRONICS

HUGHES

SEMICONDUCTOR DIVISION
HUGHES AIRCRAFT COMPANY

America's modern way of doing business



Stabilizing rocket — delivered by AIR EXPRESS — gets high-temperature environmental test at California laboratory

Space rocket gets a lift from Air Express

These men aren't on their way to Mars—yet. But the amazing rocket they're perfecting brings that day closer and closer. Right now, they're putting its components through their paces at the North American-Rocketdyne field site in California. The little stabilizing rockets, about to be tested here, have already flown successfully—by AIR EXPRESS . . . the world's fastest, most dependable way to ship. If speed, kid-glove handling and dependable delivery — all at low cost — are vital to your business, always call AIR EXPRESS. And make sure your products, parts and new models are **FIRST TO MARKET... FIRST TO SELL.**

 **AIR EXPRESS** 

 CALL AIR EXPRESS DIVISION OF RAILWAY EXPRESS AGENCY • GETS THERE FIRST VIA U. S. SCHEDULED AIRLINES

CDE Consistently Dependable Capacitors

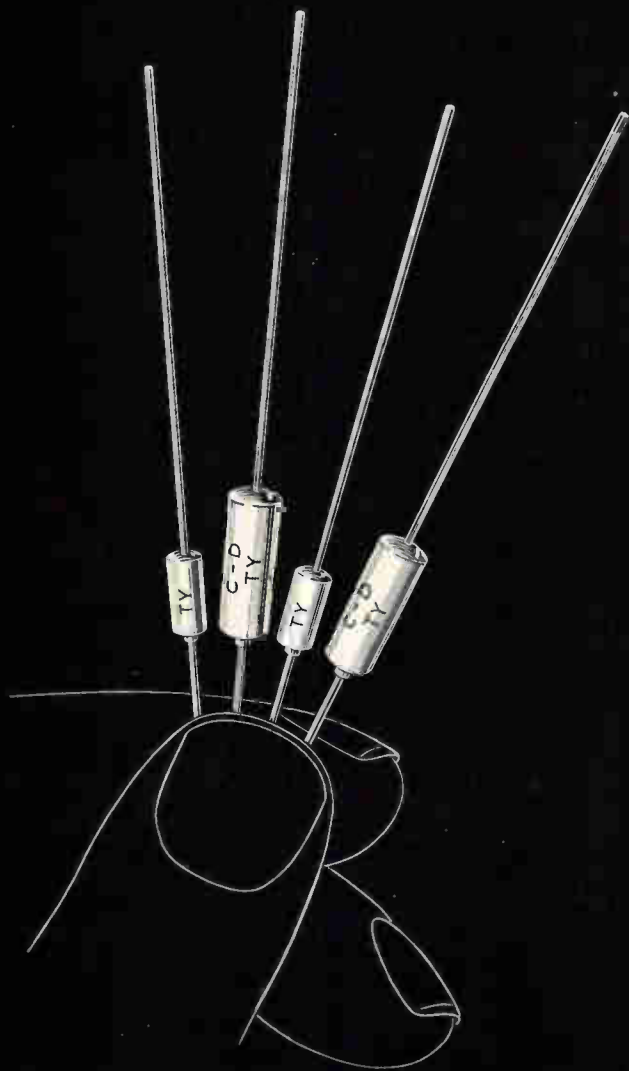

SOLITAN[®]

Cornell-Dubilier's
truly
dry
tantalum
capacitors
for
transistorized
circuits

Subminiature Solitan capacitors — truly dry, solid-state electrolytic capacitors by Cornell-Dubilier — are specifically designed for transistorized applications in computer and military circuits. Immediately available in production quantities, Solitan capacitors offer these outstanding advantages: wide useful temperature characteristics; remarkable stability of capacitance with time and temperature; freedom from corrosion and service aging; unusual resistance to shock and vibration; indefinite shelf life; low dc leakage; low dissipation factor. For engineering assistance and complete data on C-D

Solitan tantalum capacitors, write for Bulletin 537 to Cornell-Dubilier Electric Corporation, South Plainfield, New Jersey. *Manufacturers of consistently dependable capacitors, filters and networks for electronics, thermionics, broadcasting and utility use for 50 years.*

SPECIFICATIONS AND FEATURES

- Ratings up to 47 mfd. at 35 volts DC Working, or 330 mfd. at 6 volts
- Wider useful temperature characteristics within range of -80°C to $+85^{\circ}\text{C}$
- Operate at 125°C at derated voltage
- Freedom from corrosion and leakage
- Extremely small size
- Remarkable stability of capacitance with time and temperature
- Metal cased, hermetically sealed.

CDE

CORNELL-DUBILIER ELECTRONICS DIVISION

FEDERAL PACIFIC ELECTRIC COMPANY

IN RACK AND PANEL CONNECTORS

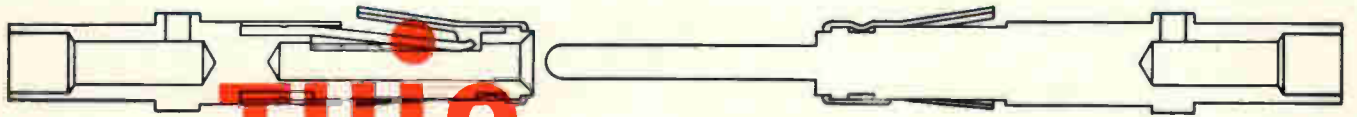

THIS MAKES THE DIFFERENCE!

Right here in the socket contact lies the heart of the **AMPin-cert Connector** line: the AMP cantilever spring. Seated in the slot of the socket to meet the pin shaft, it is your key to top connector reliability.

It provides you with positive wiping action . . . consistently sound electrical contact . . . firm pin grip . . . and stable resistance—yet has an extremely low, uniform insertion and withdrawal force. And, regardless of the metal plating you choose or the thickness you require, all pins and sockets are provided with an underplating of nickel to give long life reliability in all critical applications.

Add to this cantilever construction, many other plus features including AMP's industry proven solderless crimping technique to help you design and manufacture products of the highest reliability and lowest cost.

Take your pick: **AMPin-cert Connectors** in Series D, M and W as well as environmentally sealed or unsealed Series A—all tough enough to soak up heavy punishment while providing the dry circuit sensitivity you need for your most critical applications.

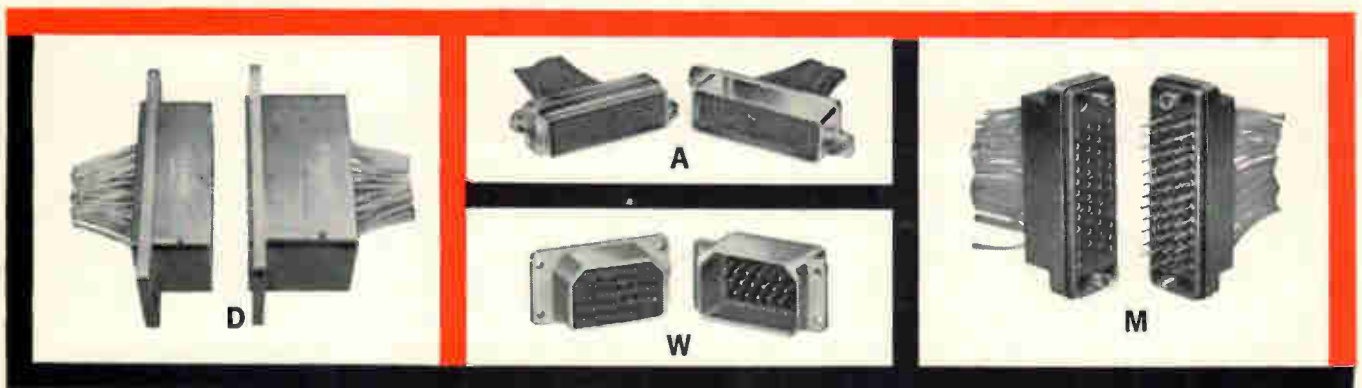

The complete story is available in catalog form. Write today for your copy.

AMP INCORPORATED

GENERAL OFFICES: HARRISBURG, PENNSYLVANIA

AMP products and engineering assistance are available through subsidiary companies in: Australia • Canada • England • France • Holland • Italy • Japan • West Germany

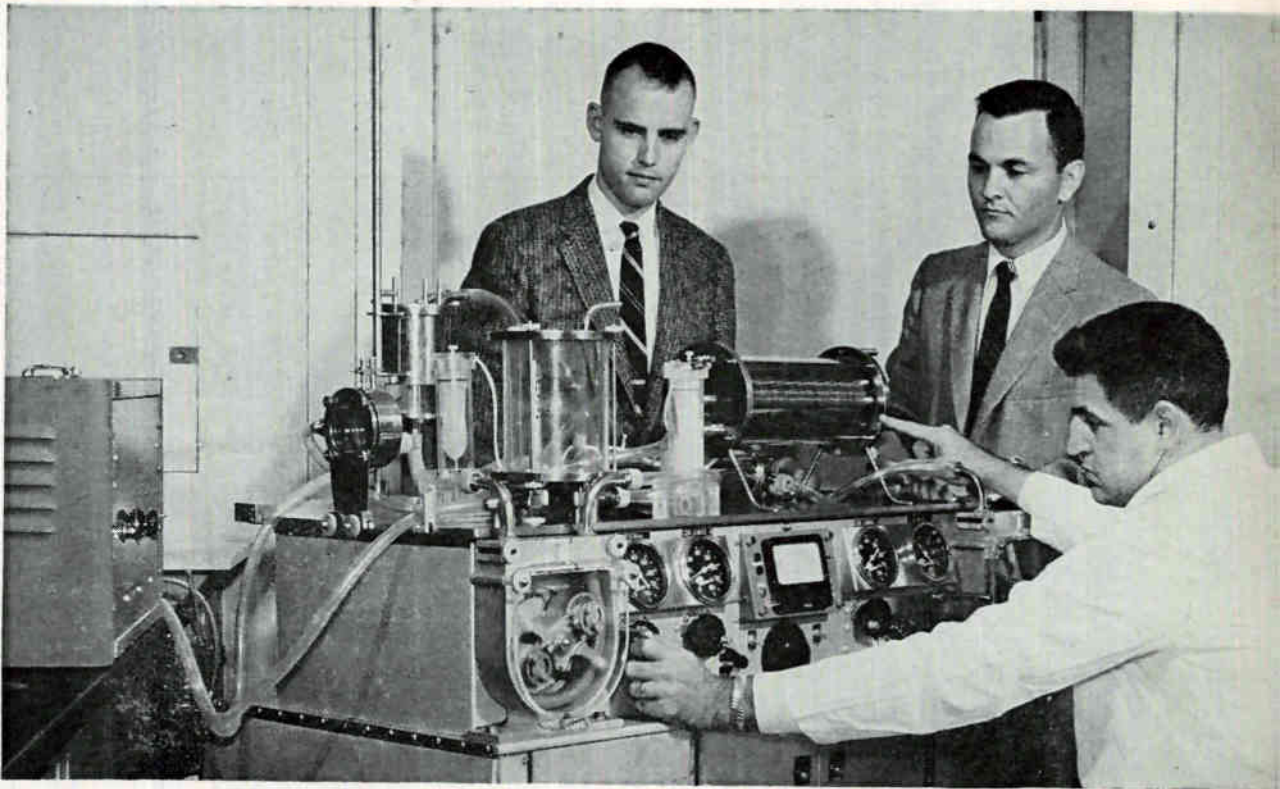

Heart-lung machine. While authors look on, Dr. John Neville controls (left hand) the speed of the venous pump located next to the control. Servo amplifier cabinet is at extreme left

AUTOMATICALLY CONTROLLED HEART-LUNG MACHINE

Automatic controls for heart-lung machines reduce hazards of open-heart surgery.

Liquid level sensors accurately control level of blood in mechanical lung by regulating its flow rate

By RICHARD ROBERTS,
JOHN LOEFFLER,
Development Engineers,
General Electric Co., HME Dept.,
Syracuse, N. Y.

A MAJOR MEDICAL achievement of recent years has been the development of artificial heart-lung machines which perform the normal functions of the heart and lungs during open-heart surgery.

While the machine is in use, the arteries and veins connecting the heart to the circulatory system are clamped, and blood is diverted to the auxiliary heart and lung. Normal beating of the heart is slowed down or stopped for a time which may extend to several hours while repair surgery is performed.

A heart and lung machine, built by Pemco, Inc., in Cleveland, Ohio, is shown. One of four independently variable pumps is at the front left of the machine. The pump op-

erates by trapping a volume of blood in a flexible tube (by pinching the tube between a roller and an outer surface) and then forcing the blood through the tube by rolling the rollers along the surface.

On top of the machine is the oxygenator. It consists of a horizontal cylinder, normally about one-third filled with blood, and a set of rotating disks. The surface of the disks, as they rotate, carry a thin film of blood into an oxygen-enriched atmosphere above the blood level. The blood is oxygenated at a rate which depends upon the disk speeds, the level of the blood, and the amount of oxygen supplied to the lung. In addition to the pumps and oxygenator, the unit also con-

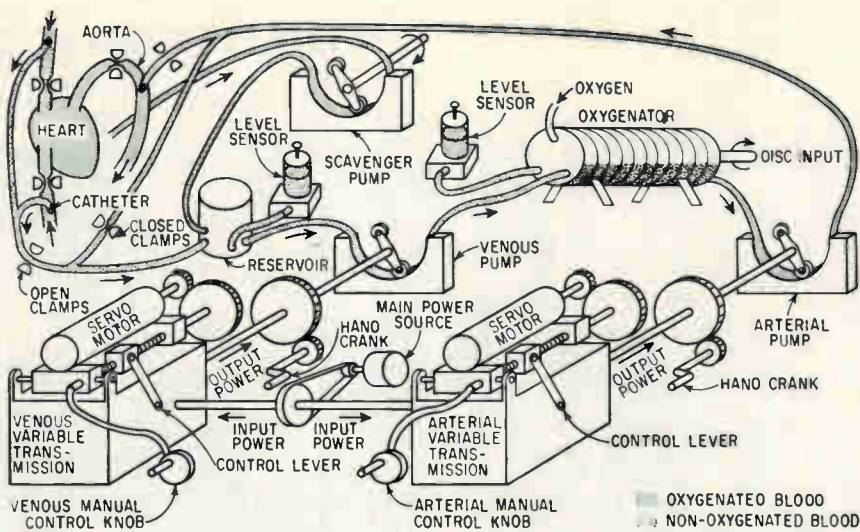
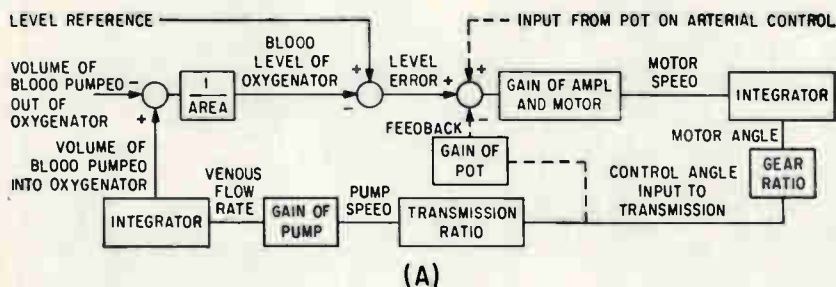
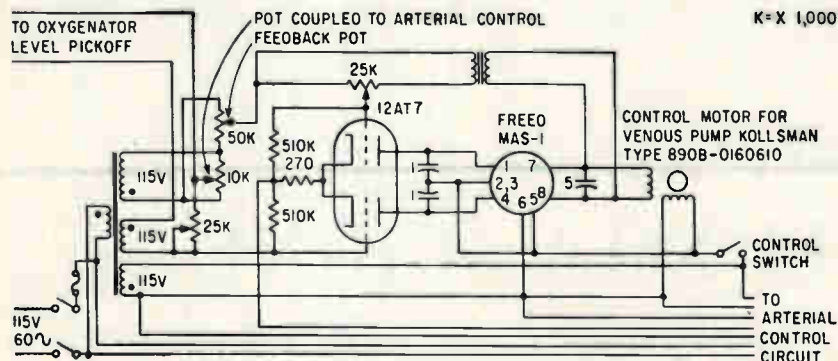

FIG. 1—Heart-lung machine flow schematic shows the functional location of the mechanical components and the connections to the patient



(A)



(B)

FIG. 2—Functional diagram of automatic venous flow control (A), and circuit for venous control (B). Arterial control circuit, not shown, is similar to venous control

tains instrumentation, manual controls and a blood reservoir.

Figure 1 shows a flow schematic of the blood and the function of the components. Just before the patient is switched to the machine, the artificial heart and lung can be adjusted to deliver the correct flow by using the bypass line. After the patient is switched to the machine, this line is clamped. A scavenger pump returns blood lost in the operational field to the reservoir.

Each of the pumps is independently adjustable to any flow rate. A hand control operates a variable-

ratio gear box and an emergency hand crank geared to the pump directly. The operator observes the blood levels in the oxygenator and the reservoir and controls two pumps in accordance with what he observes. With his right hand he controls the arterial pump that delivers blood to the patient, and with his left hand he controls the venous pump that transfers blood from the venous reservoir to the oxygenator.

The arterial flow rate is determined by the bodily needs of the patient and is changed only at the direction of the surgeon as, for ex-

ample, if losses in the operative field are temporarily too high. There is one exception, in which case the operator makes the decision to change the pump speed. This is where the level in the reservoir reaches a low critical point. It is of the utmost importance that the level stay above this point so that bubbles are not introduced into the blood.

The venous flow rate is varied by the operator to maintain a precise level in the oxygenator. This is important since either too high or too low a level will result in improper oxygenation. An attempt is made to hold this level to within one eighth of one inch. Under certain conditions the level may change rapidly, and the operator must pay close attention and respond rapidly to prevent excessive errors.

General Electric Company, at the request of the Upstate Medical Center, State University of New York, substituted automatic controls to replace these manual operations. The controls comprise one control to sense and maintain the correct level in the oxygenator, and one control to sense the reservoir level and prevent it from exceeding a lower limit. The controls had to: be capable of being operated singly or together; not interfere with the normal manual control; be compatible with the operating room power and grounding systems; allow for simple setup and operation, and be reliable.

The equipment before alteration used one constant-speed motor as the power source for all pumps. The variation of speed for each pump was effected by a variable ratio speed transmission. This was controlled by a manual control that made pump speed proportional to the total angular motion of the control knob. The control knob was on the front panel and was connected to the transmission through a flexible shaft.

The mechanical connection of the automatic control was incorporated by mounting a two-phase servo motor on the transmission box such that it could either turn the control shaft and the manual control knob or be turned by them. Thus the servo motor would have control when the servo power was on, and the manual knob would regain control if the servo power were turned off. Two control switches (which

could deactivate either the arterial control motor or the venous control motor or both) were mounted on the front panel.

The most direct way to control the level would be as shown in Fig. 2A. The level would be sensed by a pickoff and compared with a reference. The error would drive the servo motor, the speed of such a device being proportional to error; the motor speed would be time integrated to obtain the control angle input to the transmission, the output speed of which is proportional to the input; and the speed of the pump would cause a proportional flow. This flow would be time integrated to obtain the volume of blood into the oxygenator which, in conjunction with the volume extracted by the arterial pump, would determine the level.

Such a control is inherently unstable because of the two integrations within the control loop. One of these had to be removed for stable operation. It was possible to use a feedback voltage that added to the level error voltage, the feedback voltage being proportional to the control angle input to the transmission. This is shown in Fig. 2A by the dotted circuits and is obtained by a potentiometer fastened to the control lever. Because of the feedback, control angle input is proportional to the level error instead of being proportional to the time integral of the error.

If the venous pump speed is made to match the arterial pump speed, then the only level errors are the long-term cumulative effects of slight variations in pump tube diameters and pump leakages. The venous pump is made to correspond to the arterial pump by feeding-forward a signal derived from a pot fastened to the arterial control lever. This drives the venous motor until the position of the venous control arm as indicated by a feedback voltage from a pot fastened to it corresponds to the arterial control lever position, at which point the feed-forward and feedback voltages cancel. Thus, the pump flow rates are kept in close correspondence and it is necessary only to add a small error voltage from the level sensor to make the correspondence exact.

The amplifier (see Fig. 2B) consists of two channels that are iden-

tical except for the adding of the input signals. The arterial control portion (not shown) has two inputs; a signal derived from the reservoir level, which is nearly constant if the level is deep enough, and a signal from the control knob on the amplifier panel. This control knob selects the arterial flow rate. The feedback is a potentiometer, one of two, connected to the arterial transmission control lever.

The venous control portion of the amplifier has two inputs; a signal derived from the oxygenator level error and an input from a potentiometer connected to the arterial transmission control lever. The feedback potentiometer is connected to the venous transmission control lever. Wherever possible in the amplifier, transformers or saturable reactors have been used for maximum reliability. Circuits used eliminate the need for d-c power supplies.

There was a wide variety of means to sense the blood level. It was decided to use a probe type sensor whereby the depth of a probe into the liquid determines the resistance from it to a totally submerged probe. The liquid was sterilized tap water that was separated from the blood by a thin commercially available rubber membrane. The probes were made of platinum, which is relatively inactive chemically.

The membrane is actually a bag made of osmosis-resistant material, filled with water and suspended in the sensor tube. Probes are inside the membrane. As the blood rises and falls around the membrane,

squeezing and relaxing it, the water level inside rises and falls, thus changing the depth of penetration of the probe in the water, and changing the conductance path.

There were two reasons for using a medium other than blood for the conduction path: first, to isolate all conduction currents from the blood; and second, to preclude the possibility of clogging the probe with coagulated blood. Conductivity of the water was not critical and ordinary tap water gave consistent results. The membrane had to be flexible enough to transmit accurately the changes in blood level but strong enough to resist leakage or rupture.

The control circuit is such that the probes of the oxygenator level sensor and the probes of the reservoir sensor operate at different a-c electrical potentials. The path between the probes is through the two rubber membranes and the water and blood. Although the rubber membranes offer a relatively high electrical resistance it is desirable to ground the blood by grounding the stainless steel connectors at each sensor thus preventing any leakage current from flowing in the circulating blood.

The electrical characteristics of one of the probes is shown in Fig. 3. This probe is used in the reservoir and is a limit. Normal operation is at a depth in excess of 2 cm, therefore the probe normally is insensitive to a change in level. When the depth decreases to approximately 0.5 cm, a further change in level causes a relatively large error signal, which tends to lower the arterial pump rate. The probe in the oxygenator level control is similar except that the top probe does not come as close to the submerged probe. The voltages obtained are lower in value but the shape of the curve is similar to that in Fig. 3. Here, the probe is operated at a depth of about 0.3 cm that is in the high gradient region. A small change in level causes relatively large error voltage.

The authors acknowledge the cooperation and assistance of Doctors J. Neville, D. Enerson and F. Sebening of the Cardiopulmonary Section, Department of Surgery, Upstate Medical Center, State University of New York, Syracuse, New York, and of J. C. Brannan.

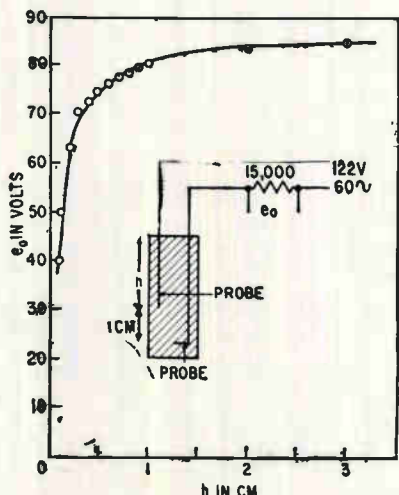
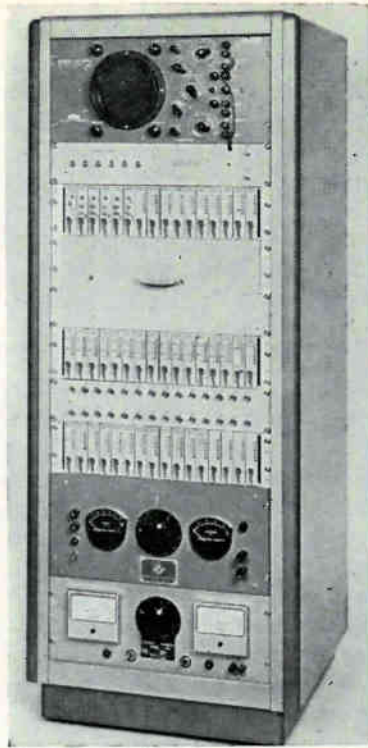

FIG. 3—Performance curve of limit level sensor. Lung level sensor is similar

Three-Hole Cores

By H. F. PRIEBE, JR.,
Bell Telephone Labs, Inc.,
Murray Hill, New Jersey

Complete memory system of 1,120 bits includes power supplies, access circuits, scope and visual monitors



COINCIDENT-CURRENT writing is performed by superposition of the horizontal and vertical write pulses. The two pulses together exceed the coercive force threshold but either one alone must not exceed the threshold. Since the switching time of conventional toroidal cores depends on the pulse current amplitude, the operating speed is also related to the cores' coercive force threshold. These pulse and operating speed limitations have inspired development of other types of memory elements.^{1, 2, 3}

Coincident-flux⁴ operation of a multipath memory element² permits pulse currents that are not limited by the coercive force threshold. Therefore, read and write currents can be larger and shorter cycle times obtained.

Three-hole memory cores operated with a word-organized arrangement—meaning single pulse for the read operation—of coincident-flux selection are being applied to a time-division telephone switching system. The coincident-flux memory system permits a larger memory, with shorter read-write times and with greater tolerance to pulse current variations than is obtained with conventional toroidal cores operated with coincident-current selection.⁴

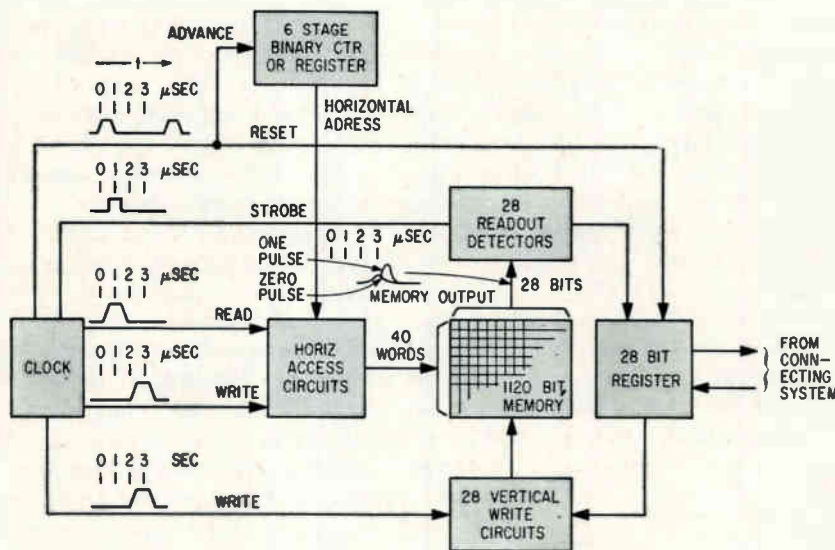

FIG. 1—Destructive read is used in coincident-flux memory system, which has 40 rows or words of 28 bits

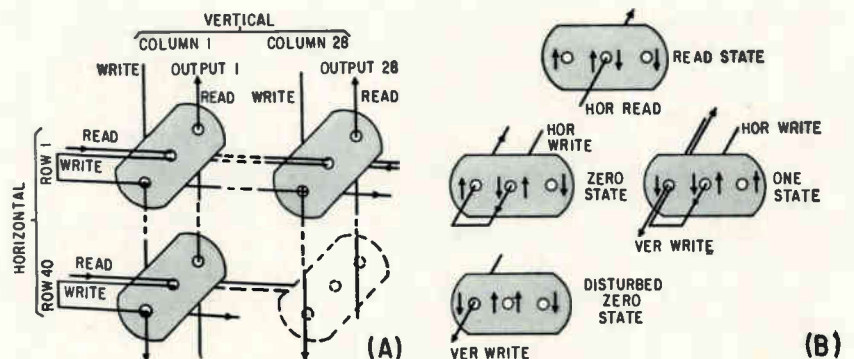

FIG. 2—Wiring of three-hole memory cores is shown in (A) while the flux states for the various conditions are shown in (B)

for Coincident-Flux Memory

High-speed word-organized memory operates over wide temperature and pulse current ranges. Entire 1,120 bit memory can be scanned in 125 microseconds

Basic building blocks of the memory, with approximate pulse times and durations, are shown in Fig. 1. The 1,120-bit memory has 40 rows of 28 bits each. Since destructive read is used, the information in each row of 28 cores is read and written in time sequence. Upon entering a time-slot—the time for a complete read-write cycle—the first operation is to read the row of cores. The output signals from the 28 cores (one word) appear as inputs to 28 read-out detectors where they are strobed by a clock pulse; the ONE signals set their respective flip-flops in the readout register. Updating takes place in the readout register. The word read out of the memory can be erased or a new word written. Following updating, the word in the register is written into the memory row by the combined action of the horizontal and appropriate vertical write pulses. The readout register is then reset and the system is ready to process the next word.

The application requires the memory system to operate sequentially. Consequently, the horizontal address is obtained from a binary counter cycling through 40 intervals (zero through 39). The binary counter is advanced at the same

time the readout register is reset, once for each time-slot of $3.15 \mu\text{sec}$. Random access could be accomplished by replacing the binary counter with a six-stage register and providing an address. With a time-slot duration of $3.15 \mu\text{sec}$, the entire memory content is scanned in approximately $125 \mu\text{sec}$. Read and write pulse durations are approximately $1 \mu\text{sec}$ each, and $1 \mu\text{sec}$ is available between the two pulses for operations of circuits used in updating.

The three-hole memory cores are wired into an array as shown in Fig. 2A. The vertical write wire (bit select) passes through the left-hand or bit select hole in opposite direction to the horizontal write wire.

Flux patterns in the three-hole memory core are shown in Fig. 2B. The read pulse leaves all cells in a horizontal row in the ZERO flux state regardless of previous states. Following the read operation, a ZERO is written in the core by a horizontal write pulse, or a ONE is written by the combined action of a vertical and horizontal write pulse. During the writing of a bit, other cores in the same vertical column will be disturbed by the vertical write pulse appearing on that lead. However, the ONES are

left undisturbed and only the cores in the ZERO state are disturbed. The disturbed ZERO state is also shown in Fig. 2B.

Switching time t and output voltage as a function of pulse current are shown in Fig. 3A. For $1\text{-}\mu\text{sec}$ switching time a typical drive current is approximately 320 ma when the drive pulse rise time is $0.4 \mu\text{sec}$. Output voltage with this drive is approximately 120 mv .

Temperature affects the switching time and output voltage as shown in Fig. 3B when typical drive circuits are used. The drive pulse circuits each consisted of a constant voltage, series resistor and transistor operated as a switch. As shown in the figure, switching time decreases from $0.95 \mu\text{sec}$ to $0.6 \mu\text{sec}$ when the temperature is increased from 0 F to 140 F . However, over this same temperature range, the output voltage changes only a small amount.

Horizontal access, the selection of one memory row out of the 40, is accomplished with a matrix and two translators, binary to one out of eight (four read pulses and four write pulses) and binary to one out of ten. A section of the coincident-voltage matrix that uses high-current diodes in conjunction with transistor drivers is shown in Fig. 4.

Each memory element of the figure represents an entire row of 28 cores or one word of the actual memory. The four by three section of the matrix is capable of selecting one out of 12 horizontal wires which are associated with six time-slots. Connected in the X direction are alternate read and write pulses with suitable logic, and in the Y direction the inputs are such that the circuit is common to both read and write pulses. To achieve the necessary 40 time slots for the entire memory there are eight X

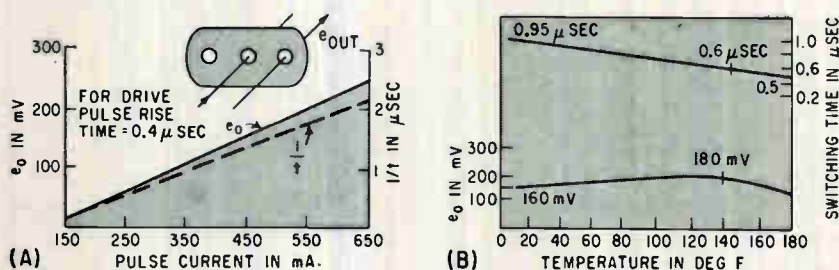

FIG. 3—For a typical drive current of 320 ma , output voltage is approximately 120 mv while switching time for these conditions is $1 \mu\text{sec}$ (A). Temperature effects are shown in (B)

drivers and ten Y drivers.

A coincident voltage matrix is readily implemented with both *npn* and *pnp* transistors in complementary circuits. However, since it was desired to use only *npn* transistors, two types of horizontal pulse amplifiers are used; one has a common-emitter output while the other has a common-collector output. Since it was also desired to avoid the use of transformers, the voltage input to the common collector stage must equal the potential drop across the emitter load, which includes the back voltage of the memory elements. Also, the OFF stage must remain off during the activity of the alternate stage; consequently, the voltage drop across the series resistor plus the saturation voltage drop of the ON transistor must equal or exceed the potential across the memory wires. This results in a pulse voltage input to the X amplifier of slightly greater than twice the memory back voltage. The minimum horizontal pulse currents are approximately 380 ma.

Schematics of the two-stage horizontal pulse amplifiers are shown in Fig. 5A and 5B. Inputs to the AND gate of the X amplifier (Fig. 5A) are a clock read or write pulse and the first two binary digits of the horizontal address. This forms one of the two translations for the horizontal matrix.

Inputs to the translator section of Y amplifier are the last four bits of the address which perform the 1 out of 10 translations for the other side of the horizontal matrix. A composite read-write pulse is also applied to the AND gate of the X amplifier so that the amplifier is ON only when either a read or write pulse is present. Diode D_1 , between the bases of the two transistors, reduces turn-off time of the output stage.

The 28 vertical circuits each consist of a read-out detector, bit register (flip-flop), write gate and a two-stage write amplifier, as shown in Fig. 5C.

During the read interval, a ONE or ZERO will appear on the memory sense wire. The ONE signal exceeds the detector threshold and sets the flip-flop during the strobe interval. The threshold is determined by the diode voltage drop, flip-flop sensitivity, and a d-c bias voltage. The strobe is used to disable the read-

out detector during the write interval when a large noise voltage is present on the sense wire due to the vertical write pulse. If a ONE is stored in the register during a particular time-slot and it is desired to rewrite the ONE, the number is gated (AND circuit) by the vertical clock pulse to its respective vertical write amplifier. Similar to the horizontal drivers, the bit write amplifier delivers a minimum pulse current of 380 ma to the single turn memory wire.

Memory system performance is determined largely by the memory element characteristics. Some of the significant properties are that core output voltage and switching time vary with temperature and pulse current variations. It is convenient to separate the various

noise ratio of 3.33 to 1.

When the temperature is decreased from room temperature to 32 F the core output is reduced approximately 3 percent and switching time is increased 10 percent. At 140 F, output voltage increases 6 percent and switching time is reduced 20 percent. The worst combination results in a net signal-to-noise ratio of 2.77 to 1.

For a typical set of 28 detectors the most sensitive would not respond to a signal of 89 mv (without any d-c bias in the detector threshold), and the most insensitive unit responded to 110 mv. Tolerances on threshold bias and aging add ± 5 percent variation to the above figures. Thus readout detector threshold uncertainty is 30 mv. Signal voltages were measured with a 0.25 μ sec pulse.

The voltage-time area of the ONE outputs that can be sampled for reliable operation is determined from the maximum ZERO and minimum ONE signals as well as the detector threshold. The lower voltage limit of the threshold is set slightly greater than the maximum ZERO. The upper limit on the threshold is set such that the minimum ONE will be detected. The minimum ONE exists with low temperature, low supply voltage and high resistance values. The combined effect of the variations is shown in Fig. 6. The remaining ± 20 percent variation is allotted to the read pulse current.

The write operation requires that both the minimum horizontal write (XW) and the minimum bit select or vertical write (YW) pulses be individually capable of switching the core in the required time. No maximum limit on either pulse is required. However, since the horizontal read and write pulses are derived from similar circuits in a matrix, the variation in the read pulse currents also applies to the horizontal write currents. These are—the slowest core switches in the allotted time, at the lowest temperature and lowest drive—380 ma, 1.1 μ sec. The pulse width is allowed to vary from 1.1 μ sec to 1.2 μ sec. The minimum vertical write should be at least equal to the minimum horizontal write of 380 ma, and the maximum is set by current carrying capacity of other components such as transistors. The outputs

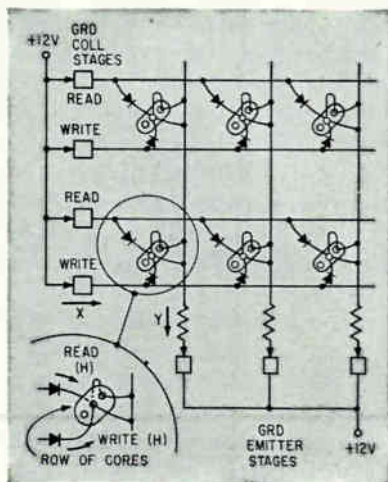

FIG. 4—High current diodes are used with transistor drivers

operating characteristics into two groups—those most pertinent to the detection of output signals and those most relevant to writing information into the memory.

To detect a wanted output from the memory, a threshold is established such that all ONE signals exceed the threshold value and all ZERO's do not, regardless of variations over the range of operation.

The variations relative to ONE outputs come from the initial variation from core-to-core, temperature changes, variations in the readout detector thresholds and variations in drive pulse currents.

Initial variations of the 1,120-bit memory at room temperature range from a minimum ONE of 100 mv to a maximum noise or ZERO of 30 mv, a minimum signal to maximum

from the vertical circuits are allowed to vary from 1.2 to 1.4 μ sec.

With the nominal range of pulse conditions described, the memory system can operate without a failure from 30 to 140 F and the two supply voltage varied ± 20 percent, even at the temperature extremes. (A failure occurs when a ONE is read as a ZERO or ZERO as ONE.)

Photographs of the output signals from one column of the memory after passing through the read-out detector input transformer are shown in Fig. 7. These photographs were taken at room temperature with the positive and negative supply voltages each set at 10 v.

The memory plane is mounted with its diode matrix on a sliding panel or drawer. This arrangement requires less panel space and still

leaves all terminals and connections to the memory accessible but connecting leads are longer than they would otherwise be. The photograph shows the memory, power supplies, scope and visual monitor.

Read and write pulse length can be reduced to 0.5 μ sec when the supply voltages are set at ± 15 volts. Therefore, for a memory system with similar circuits, a microsecond per time-slot could be achieved with somewhat more than 30 volts total supply voltage. The word length (number of bits) that could be accommodated is related to the back voltage. This voltage is approximately equal to twice the ONE output voltage times the number of bits. The number of words permissible depends on the back voltage in a similar manner but,

since a greater tolerance to pulse currents exists in the write condition, 200 words could be accommodated with similar circuits.

Thanks are due many members of the Bell Telephone Laboratories, particularly J. A. Baldwin for supplying the memory plane and J. J. Kleimack and H. E. Talley for providing the transistors.

REFERENCES

- (1) L. P. Hunter and E. W. Bauer, High Speed Coincident-Flux Magnetic Storage Principles, *J App Physics*, 27, p 1257, Nov. 1956.
- (2) H. W. Abbott and J. J. Suran, Multihole Ferrite Core Configurations and Applications, *Proc. IRE*, 45, p 1081, Mar. 1957.
- (3) W. W. Lawrence, Jr., Recent Developments in Very High-Speed Magnetic Storage Techniques, *Eastern Joint Computer Conference*, p 101, Dec. 1956.
- (4) W. L. Shafer, Jr., W. N. Toy and H. F. Priebe, Jr., A Small High-Speed Transistor and Ferrite Core Memory System, *IEEE Trans (Communication and Electronics)*, No. 46, p 763, Jan. 1960.

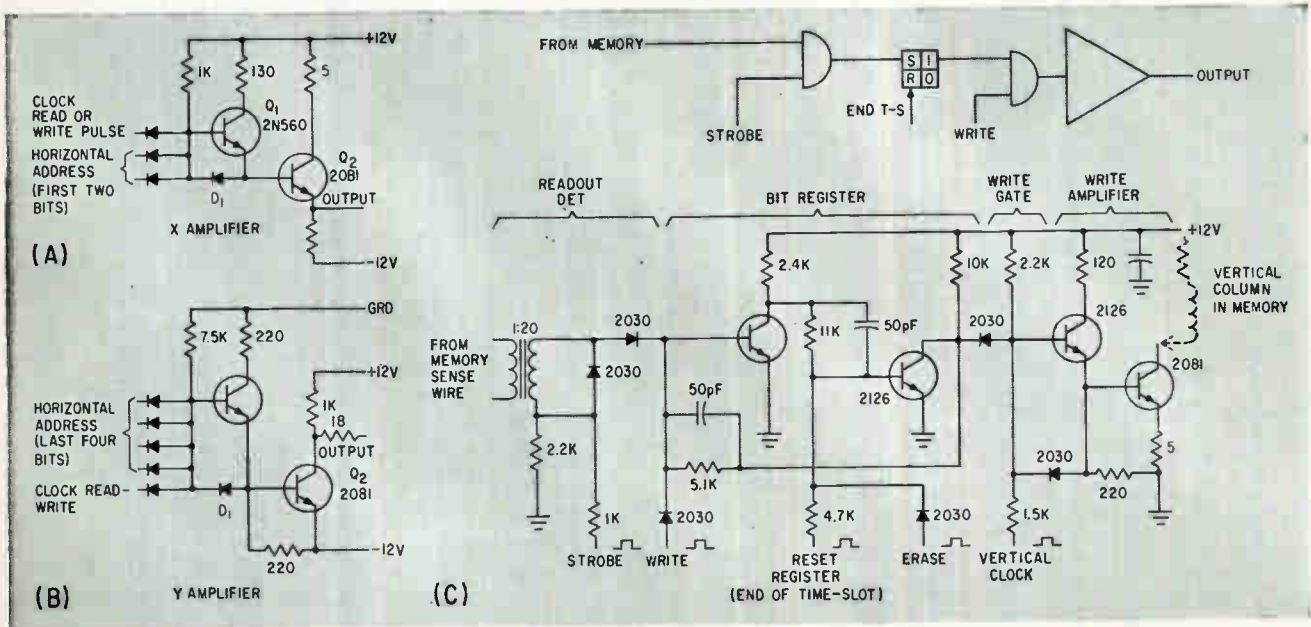

FIG. 5—The X or horizontal pulse amplifiers are shown in (A) and (B). Block diagram and amplifiers of the 28 vertical circuits (C)

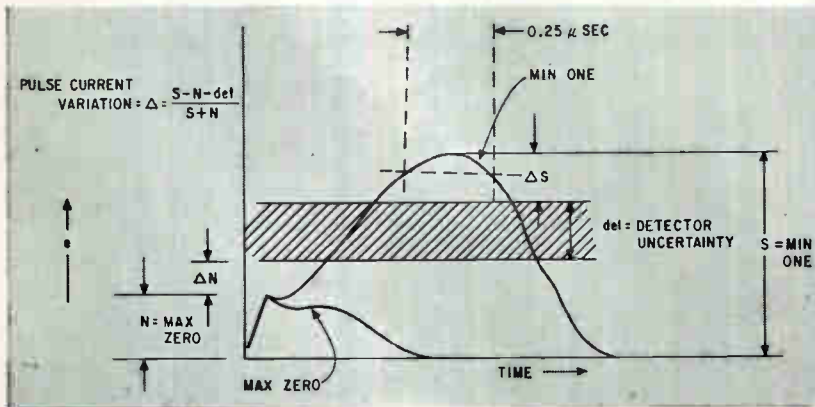

FIG. 6—From the variations of other factors, the allowable pulse-current variation is determined

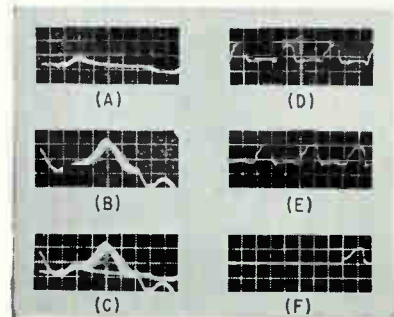

FIG. 7—Pulses of 40 ZEROS are superimposed in (A), 40 ONES in (B), combination of 40 ZEROS and 40 ONES in (C). Horizontal read pulse (D), write pulse (E), and vertical write pulse (F)

Simulation

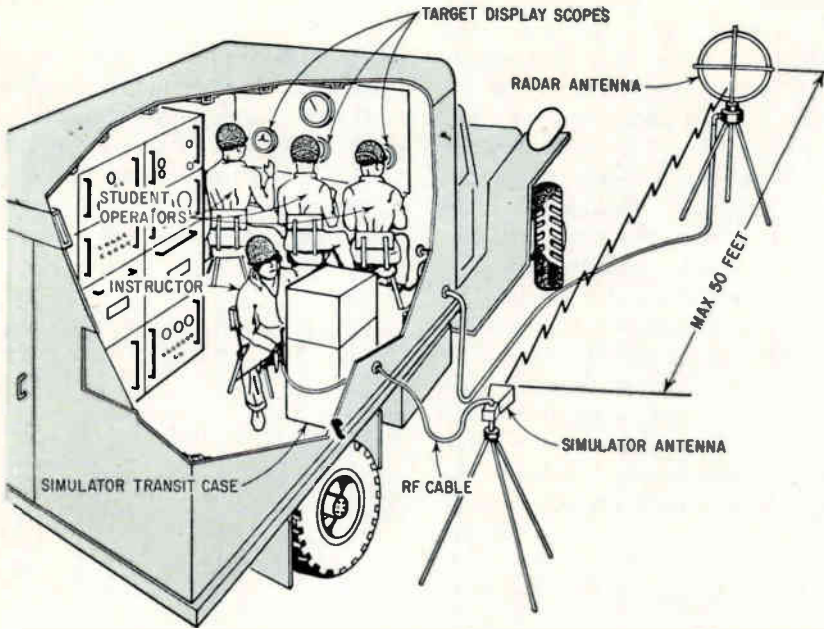

FIG. 1—Instructor beams jamming signals into student's radar antenna

THE X-BAND simulator to be discussed is one of three similar countermeasures simulators that are used to train radar personnel. With the aid of these simulators, each simulator covering a portion of the X, S, or L bands, a student learns how to identify various types of jamming signals and how to use anti-jamming controls which enable him to read through intentional interference.

A typical training arrangement (Fig. 1) constitutes an operational radar plus the countermeasures simulator. The simulator's antenna is directed toward the radar's antenna, which is oriented in the direction of most-favorable target detection. If live targets are not available, synthetic targets may be injected into the radar with auxiliary equipment.

These simulators provide representative types of electronic countermeasures for display on radar scopes, demonstrating the effects of interference upon tracking systems. The most effective counter-countermeasure is determined by the student for each type of countermeasure.

Figure 2 shows a simplified block diagram of the X-band countermeasures simulator. A type 2K45 thermally-tuned internal-cavity reflex klystron is used.

The klystron generates a c-w signal which can be swept over various frequency-sector widths as desired. Tuning and sweeping is achieved by the warping of the cavity grids, which is induced by the heating effect of a current passing through the triode-connected section of the klystron. When the klystron operates at a modulated and/or swept

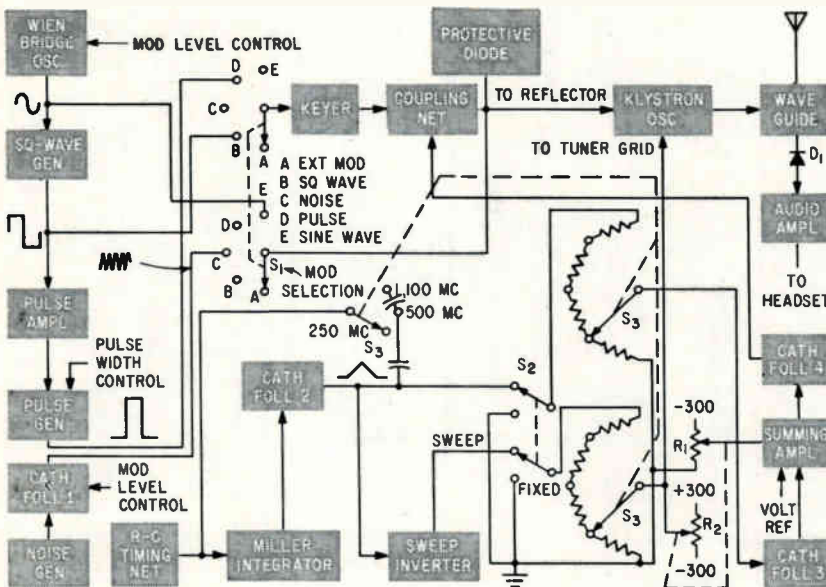

FIG. 2—X-band countermeasures simulator. Switches are set for external modulation and a frequency-sweep of 250 Mc

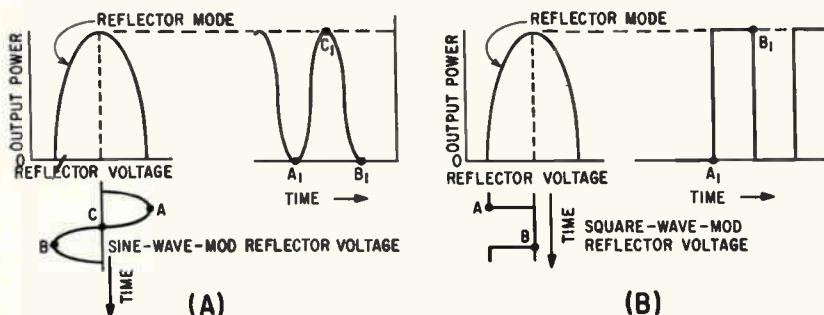

FIG. 3—Klystron modulation with sine wave (A) and square wave (B)

of Radar Countermeasures *This equipment produces*

the sort of radar-jamming tricks a radar operator might expect from an enemy

By J. I. LESKINEN,

Head, Electronics Simulators Branch,
U. S. Naval Training Device Center,
Port Washington, N. Y.

frequency, the modulator waveform voltage is applied to the reflector, and the triangular sweep voltage is applied to the tuner grid.

The carrier signal is modulated by either a sine-wave, square-wave, pulse or noise source, or by an external modulation source, depending on the setting of S_1 . Since output of the klystron varies with reflector voltage, a modulating signal in the reflector voltage modulates the amplitude of the continuous r-f wave.

The r-f output of the klystron is coupled to a waveguide and fed to an antenna which may be vertically or horizontally polarized.

Crystal D_1 detects the student's search-radar signal and a portion of the klystron output from a loop inserted within the waveguide. When the instructor tunes the klystron frequency to the student's radar frequency, the signal level detected by D_1 increases. This signal is amplified by an audio amplifier and passed to the instructor's headset. The increased sound is a positive indication to the instructor that he is creating interference to the student's radar.

The Wien-bridge oscillator, whose output amplitude is stabilized, is of conventional design. An output level control selects the modulation level of the klystron. The square-wave generator is triggered by the sine-wave signal. This generator is a bistable cathode-coupled multivibrator which produces a square-wave output. A pulse amplifier amplifies the square-wave signal and differentiates it, clipping the negative-going pulse. The positive pulse is applied to a monostable-multivibrator pulse generator,

whose pulse width is continuously variable from 1 to 5 μ sec. The noise generator is a gas-filled tube surrounded by a two-pole ring magnet. A bandwidth of 3 Mc of noise is amplified and fed from cathode-follower 1 to the modulation-selector switch, S_1 .

Switch S_2 determines whether the klystron frequency is fixed or swept. During fixed-frequency operation, only steady d-c levels are applied to the tuner grid and the reflector.

The keyer and the outputs of potentiometers R_1 and R_2 set the grid and reflector voltages of the klystron at the levels that produce the desired carrier frequency. For each type of modulation, the bias voltages delivered by these potentiometers is readjusted to permit alignment of the modulating signal with the reflector voltage.

During swept-frequency operation, the triangular wave produced by the timing network and the Miller integrator drives the sweep inverter and cathode follower 3. The inverted wave goes on to the tuner grid, thus sweeping the klystron's frequency. The output of cathode follower 3 goes into a summing amplifier, where the d-c level from potentiometer R_1 and the triangular sweep are added. Cathode follower 4 receives the summed signal, which goes to the coupling network and on to the klystron reflector. Switch S_3 sets the frequency sector that is swept.

A protective diode prevents the reflector from going positive.

Figure 3A illustrates sine-wave modulation of the klystron reflector mode. At instant A, reflector voltage is at a maximum within the

reflector mode and klystron power output A1 is zero. At instant B, reflector voltage is at a minimum within the reflector mode and klystron power output B1 is zero. At instant C, reflector voltage is in the center of the reflector mode and klystron output (C1) is at a maximum. For every sine-wave cycle which modulates the reflector mode, two cycles appear at the klystron output.

Figure 3B illustrates square-wave modulation of the klystron reflector mode. At instant A, reflector voltage is outside of the reflector mode and klystron power output A1 is zero. At instant B, reflector voltage is in the center of the mode and klystron power is at the maximum. Reflector modulation voltage is determined by the modulator and the keyer.

Output of the simulator is low, limiting its range of effectiveness to a maximum distance of 100 feet. Azimuthal coverage is restricted by a directional antenna. Selective frequency control of the modulating signal from 15 cps to 15 Kc is available, as well as fixed frequencies of 50 Kc and 100 Kc. Noise modulation level may be varied from 0 to 100 percent.

The trainers are designed for portability and ease of operation in the field.

A power source of 105 to 120 v. with a frequency from 50 to 440 cps is required. Power supplies are designed to provide good regulation within the limits of voltage and frequency variation. Power consumption is 500 w for the X-band simulator; the S-band simulator requires 50 w and the L-band simulator requires 200 w.

Electrical Readout

By S. FEINSTEIN,
Manager, Applied Research

H. J. WEBER,
Chief Development Engineer,
Servomechanisms, Inc.,
Goleta, California

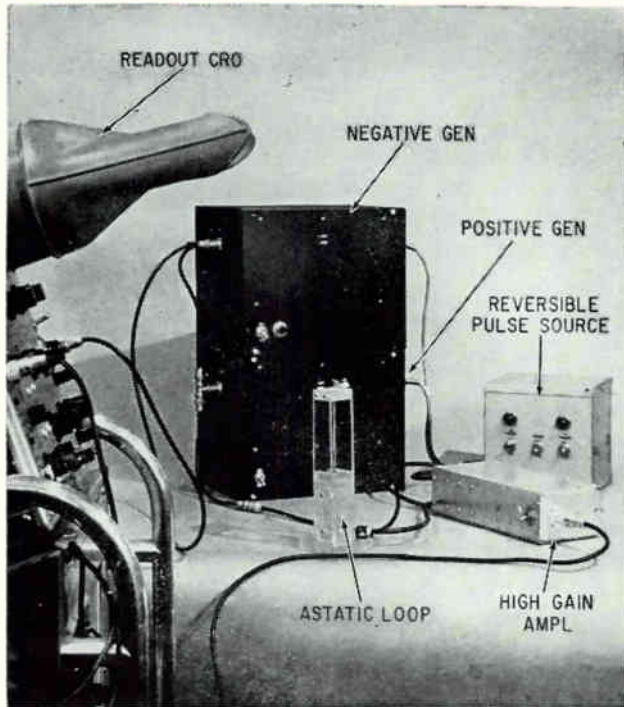

Setup for testing thin magnetic films is shown in top photo. Inset of lower photo shows closeup of the astatic loop

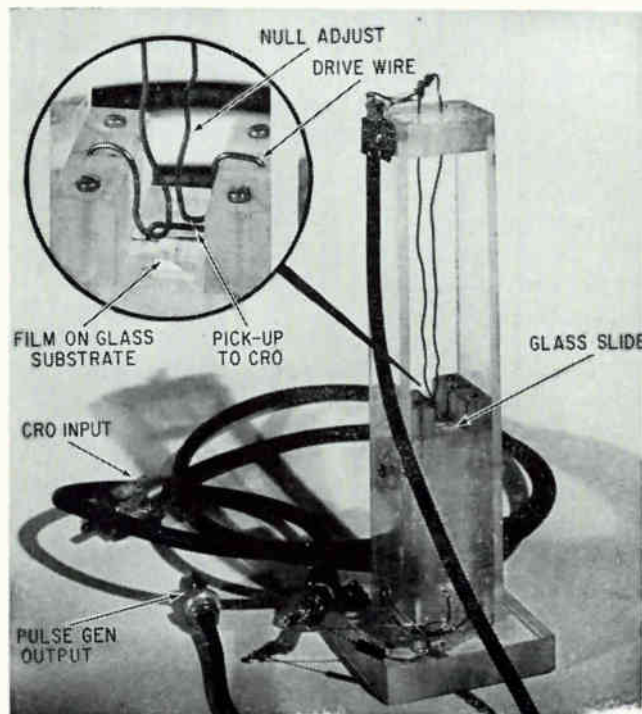

THERE ARE characteristics of thin ferromagnetic films that make them particularly attractive for use in modern computer systems. This performance potential has been recognized by a number of research organizations, both in this country and abroad, and intensive research programs are in process. This article describes one method of interrogating and reading out information in a thin ferromagnetic film.

To fabricate a thin ferromagnetic film, the ferromagnetic material (nickel-iron compound) is vaporized by electron bombardment in a high-vacuum chamber. The vaporized material is collected through a mask on a heated glass substrate in the presence of a local magnetic field.

The film is about 1,000 to 2,000 angstrom units thick and has a square hysteresis loop along the easy axis of magnetization. The magnetic anisotropy results from the crystal orientation due to the local magnetic field that existed during the film formation.

If a conductor is laid across the film, perpendicular to the easy axis of magnetization and current is put through the conductor, the magnetizing force will cause a region of the film under the conductor to change its state of magnetization. Where the magnetizing force is equal to or greater than the coercive force of the film region, the region will be driven from one remanence to the other.

In computer applications it is necessary to determine the state of magnetization that exists in regions under the drive wires. A method of interrogation is to pulse

From Thin Ferromagnetic Films

Applications for thin ferromagnetic films include random access memories, logical elements of computers, storage elements for telemetering and amplifiers.

The requirement for readout is usually a key one. Here is a method of achieving it

the drive wires. If the magnetization of the film region is in the condition of remanence such that the magnetizing force causes no switch (flip) to the other state, it is desired that no electrical signal be read out on a conductor coupled to the film and drive wire.

If a film region were in positive remanence and were caused to flip to negative remanence, then it is desired that the readout wire have induced on it a voltage that may be used in the computer logic circuits. A method of astatic coupling and amplification will be described that permits readout with excellent signal-to-noise ratios.

If a current flows through a conductor a certain magnetizing force results. This will cause a magnetic field expressed in lines of flux per unit area. The density of these lines of flux depends upon the permeability of the medium exposed to the magnetizing force. This is expressed mathematically by $H = B/\mu$ where H is the magnetizing force, B is the magnetic field or flux density and μ is the permeability.

The voltage induced into a pickup loop or coil depends upon the time rate of change of the number of flux lines and the number of turns of the pickup coil

$$E = -N \{(d\phi)/(dt)\}$$

where E is the induced voltage, N is the number of turns and ϕ is the flux (in total number of lines).

The flux lines are actually flux linkages, since flux lines must be closed loops.

In Fig. 1A, if an alternating current generator were applied to an infinitely long conductor in air and the magnetic field at a given instant in time examined, the current might be increasing in the direction shown and produce flux as shown (since the flux density is inversely proportional to the distance from the drive current, only the dominant flux linkages are shown). If a pickup loop were placed to the right of the drive conductor, an induced current as shown would be produced because the flux links the pickup loop to the drive conductor. In Fig. 1B, the pickup loop is placed to the left of the drive conductor and induces a current 180 degrees out of phase with the current shown in Fig. 1A. Thus, a middle position for the pickup loop results in no induced voltage. In Fig. 1C, no net flux linkages exist. An infinitely long drive conductor has been used to simplify the figures. If the drive conductor were a finite loop, the results would be the same except that the degree of overlap for the condition of zero net flux

linkages would be smaller. The reason for this condition is that the flux density inside the drive loop would be greater than the flux density external to the drive loop.

The condition shown in Fig. 1C, where there is no induced current, is the condition of astatic coupling. For the astatic condition to hold, the permeability of the medium about the coils must remain constant during the complete drive cycle; otherwise the distribution of flux would change, upsetting the careful balance. Placing some square hysteresis loop material in the area between the drive conductor and one side of the pickup loop and pulsing the drive conductor with single polarity pulses, the material will be saturated magnetically and exhibit constant permeability. In this condition it is possible to position the output loop for astatic balance. Reversing the polarity of the driving pulse, the material is driven from one remanence to the other. During this switching period, the permeability of the material changes violently.

Figure 1D shows a typical hysteresis curve of a thin magnetic film. The slope of this curve is the permeability. This change of permeability alters the flux distribution and thus upsets the balance in

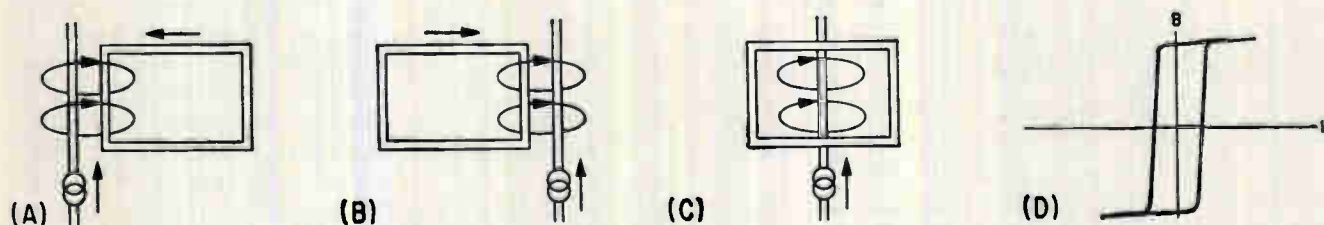

FIG. 1—Current is induced when pickup loop is to right of conductor (A) and to its left (B), no current flows for the condition of astatic coupling (C). Typical thin magnetic-film hysteresis curve shown in (D)

the pickup loop resulting in an output pulse.

The objective of the pulse circuits is to obtain the highest signal-to-noise ratio and to display the output on the tube face of an oscilloscope. The photograph of this equipment shows a reversible pulse source which drives the *pn*p solid-state pulse generator and an *npn* solid-state generator. The output

from these pulse generators is used to drive the magnetic thin films alternately from one remanence to another in the astatic loop. The output from the astatic loop is amplified in a high-gain restrictive-bandwidth amplifier and is displayed on the tube face of the oscilloscope.

The pulse source for recurrent pulses is a pair of mercury relays

used to generate both positive and negative pulses. The pulse generators are capable of single pulse outputs, as well as at a fixed pulse repetition frequency.

Figure 2 is the schematic of the *npn* generator. The first stage, blocking oscillator Q_1 , is triggered by a single positive pulse applied to the input base. The output from the blocking oscillator is shown in Fig. 3A, which indicates an output pulse of almost four volts and only 20 nanoseconds by T_1 measured at the 50-percent point. The blocking oscillator is transformer coupled and amplified in the second stage. The output stage, which consists of a parallel transistor stage to supply the high current pulses required, is transformer coupled to the second stage by T_2 .

The generator is capable of supplying a pulse output of 2 amperes into a 2-ohm load at a pulse width of approximately 70 nanosec, as shown in Fig. 3B.

The negative pulse generator is of almost identical design except for the output stage, which uses a pair of *pn*p transistors in parallel.

These narrow high-current pulses are used to interrogate the magnetic thin films in the astatic loop (as shown in the photograph), which permits nulling the swamping effect of the drive pulses. The films are on a glass slide and the readout is made from a single magnetic domain which has the dimensions of 0.1×0.02 inch.

The output voltage developed from this magnetic domain under the conditions stated is in the order of 0.5 mv. The output signal is affected by the drive current, the distance from the drive wire to the film and the area of the film material.

The pickup loop must be terminated to minimize ringing. A further consideration in design of the pickup amplifier was the bandwidth. If the bandwidth were restricted, the signal-to-noise ratio would be improved since the amplifier would not respond to the residual ringing due to the distributed impedance of the drive circuit. The amplifier shown in Fig. 4 has a gain of 65 db and produces a saturated output. The output as viewed on an oscilloscope is clean and well defined.

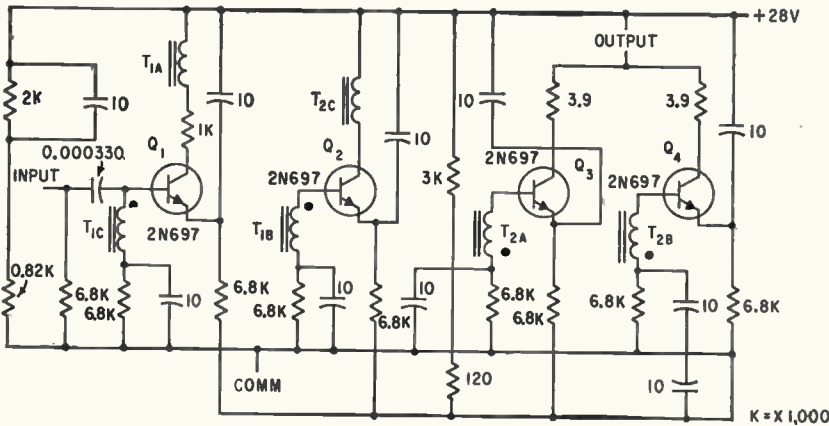

FIG. 2—Pulse generator has single pulse output when input blocking oscillator is triggered by single positive-going pulse

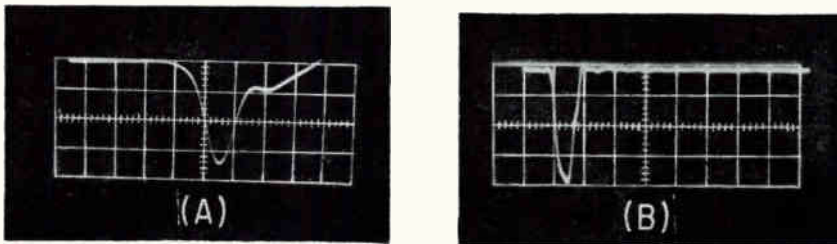

FIG. 3—Blocking oscillator output (A); horizontal axis is 20 ns/cm and generator output (B) is 100 ns/cm. Vertical axis in both is v/cm

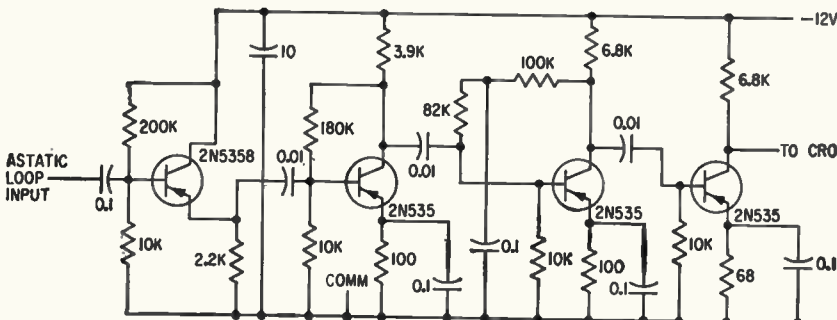
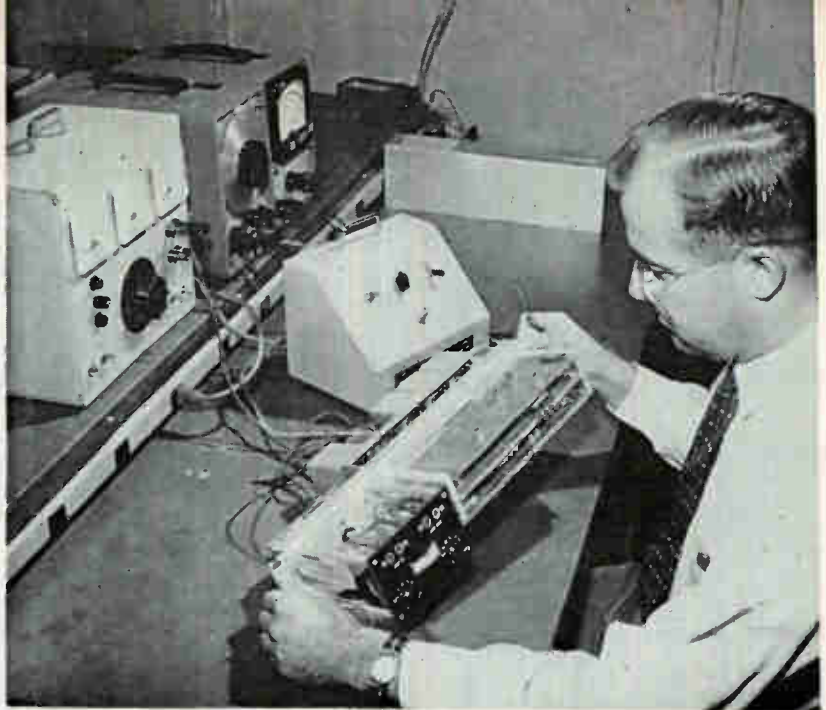

FIG. 4—High-gain amplifier has gain of 65 db and produces a saturated output. The output is applied to the observation cro

Speech adjusting amplifier has built-in meter that is used to check voltage levels



Amplifier Compensates for

Speech-Level Variations

Automatic gain-adjusting amplifier produces constant output for input level variations of 40 db. Intelligibility of speech is ensured by allowing instantaneous peaks to remain

By **LAWRENCE E. GETGEN**

Systems Development Engineer
Lenkurt Electric Co.
San Carlos, Calif.

CIRCUITS used to control speech volume must compensate for two important variables. First, there is the variation in volume between individual talkers. The other variable is the amount of gain or loss of the transmission facility between the microphone or telephone transmitter and the point in the circuit at which controlled volumes are desired.

Statistically, the variation in talker volumes is approximately 5.5 db for a one-sigma deviation. This means that the speech volume variation for 68 percent of the population is 11 db, for 95 percent, 22 db and that virtually all talkers (99.7 percent) fall within a 33-db range. These variations alone often make some sort of regulating amplifier necessary.

In addition to the difference in speech level among people, differences in level due to the system

must be considered in many cases. The difference in net loss between each of several subscribers and a given telephone office would result in different levels at the telephone office even though the same speech level were used in each telephone. Calls made over toll circuits may further increase the range to be handled. Naturally, the magnitude of this type of level difference depends upon the application.

Consideration of both talker level variations and system level differences indicates that a speech regulating amplifier should provide constant output for an input range of approximately 40 db. In addition, it is desirable to maintain the original dynamic range or peak factor of the speech being handled. This latter objective is met by dynamically shifting the entire range encompassed by a typical talker after measuring the average volume of the incoming speech and determining the amount of gain necessary to produce the desired constant output level.

By permitting instantaneous

peaks to pass through, full fidelity and intelligibility of the speech is maintained, avoiding the disadvantages of simple peak-clipping amplifiers which produce considerable distortion. In telephone circuits, which may have many transmission elements in tandem, the amount of distortion introduced by typical peak clipping amplifier is objectionable. The peak clipper has the disadvantage of not providing gain adjustment for low input levels and of distorting high levels. It merely limits the output to a particular maximum value.

Where only speech is handled, it is advantageous to make the gain-increasing action predominantly sensitive to speech and immune to noise and tones. Moreover, the amplifier must not go to full gain during no-signal intervals. To do so would exaggerate line noise. It is desirable to have the device rest at a suitable nominal gain during no-signal intervals, and then increase or decrease gain with the speech input to provide a constant output.

In addition, to protect the trans-

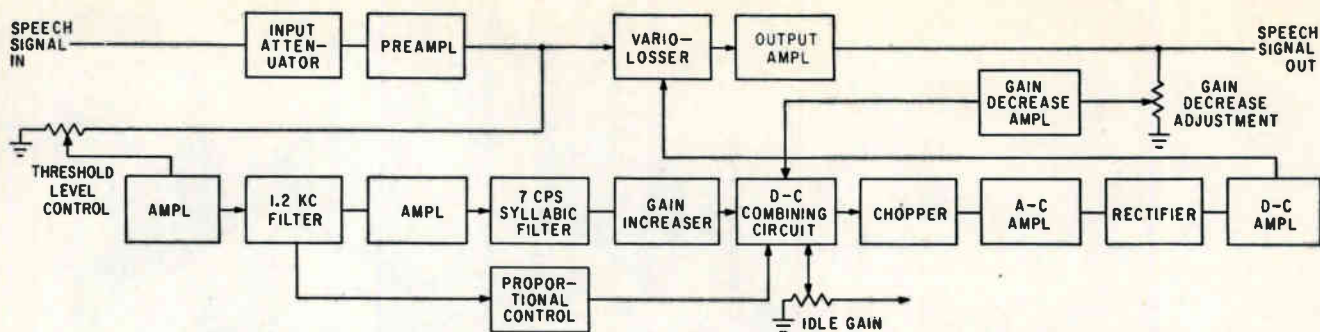

FIG. 1—Combining circuit and Variolosses perform important control functions in system

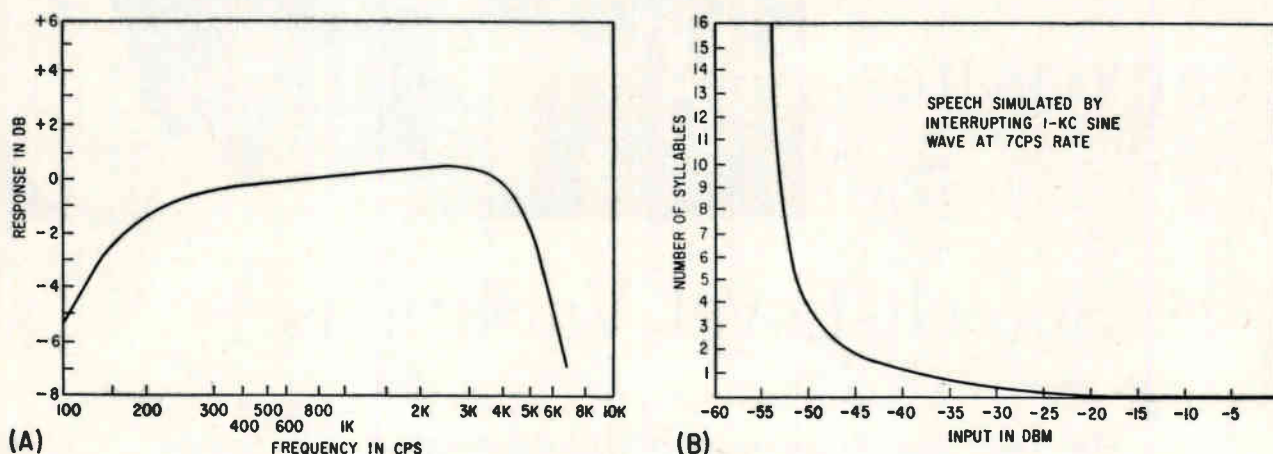

FIG. 2—Frequency response (A) and attack time (B) characteristics show ability of unit to handle speech

mission path from overload, the gain-decreasing action should react instantaneously to any type signal that is too strong. But, where gain increasing is in order, the device should react only to speech, and then the reaction time should be somewhat inverse to the input signal level. Thus, at low levels where noise is most apt to be found, the regulator should be allowed a longer time in which to decide whether the input is speech or noise. As the input level is increased, the possibility of noise decreases and the likelihood of signal increases. Therefore, the attack time can be decreased with increasing input level.

Where the input level is too low to provide an output that has a decent signal-to-noise ratio, gain increasing action should be prevented.

An automatic gain adjusting amplifier that meets these design specifications is shown in Fig. 1. This diagram shows the functional divisions of the circuit as well as the adjustments.

The input attenuator is adjustable in 4-db steps from 0 to 20 db. In the zero-loss position, the unit

accepts inputs within the 40-db range of -54 to -14 vu. In the maximum loss position, the acceptable input range is from -34 to $+6$ vu. Other loss positions allow the input range to be selected between these two limits.

Following the attenuator is a two-stage transistorized preamplifier having 25 db of gain. This amplifier increases the signal level fed to the Variolosses. Otherwise, the Variolosses attenuation will drop the signal into the noise level.

The Variolosses uses a multi-diode arrangement that offers loss to the signal in accordance with the d-c current through it. The loss ranges from 9 to 50 db. The method by which the Variolosses d-c current is derived is the heart of the system. The signal, after attenuation by the Variolosses, is fed to a three-stage transistorized amplifier. This amplifier has 44 db of gain and a break point of $+9$ dbm. It provides a 0-vu signal level to the output terminals.

Overall response of the signal path (input attenuator, preamplifier, Variolosses and amplifier) is shown in Fig. 2A.

Figure 1 shows that the signal is

sampled at the preamplifier output. This sample is fed to the threshold level control. The setting of this control determines the level at which gain increasing action is initiated. For signals or noise below the threshold level, no gain increasing action takes place. Inputs above the threshold level pass through a two-stage amplifier and a 1.2-Kc filter. Because of this filter, the signal sample is taken at a frequency that is representative of speech and is desensitized to frequencies outside the speech range.

There are two outputs from the 1.2-Kc filter. One output passes through a syllabic filter that is tuned to approximately 7 cps. This filter restricts the gain-increase action to syllabic speech only. Therefore, the gain increaser is sensitive primarily to speech inputs and offers a high degree of rejection to random noise and sine wave inputs. The syllabic output is rectified and supplied to the d-c combining network as a source of control current for the Variolosses regulation.

The other output of the 1.2-Kc filter is applied to a proportional control circuit. Output of this cir-

cuit is proportional to the difference between the signal and threshold levels. For a signal level equal to threshold there is no proportional control circuit output. When the signal reaches nominal input level, output of the proportional control circuit equals in magnitude the gain-increaser output. It is however, of the opposite polarity, so when applied to the d-c combining circuit, it completely cancels the gain-increaser output.

In addition to determining the amount of gain-increasing action, the proportional control establishes the time required for the signal to reach full output level. This time is somewhat inverse to the signal level. For example, it requires 16 syllables to reach full output when the signal input is just above threshold. For high signal levels, the time required to reach full output decreases as depicted in Fig. 2B and 3. This reaction time provides considerable protection against going to full gain on noise pulses because at the lower signal levels, where the likelihood of encountering noise is greatest, more time is required to reach full output.

To obtain the waveforms of Fig. 3, a 1-Kc sine wave was interrupted at a 7 cps rate. This waveform approximates syllabic speech and still depicts graphically the gain-increasing action. Although Fig. 3 represents inputs at only threshold, nominal, and maximum input levels, a complete series of waveforms was measured in the laboratory. This series was used to plot Fig. 2B. This graph shows that signals below threshold are entirely ignored by the gain increaser, that the at-

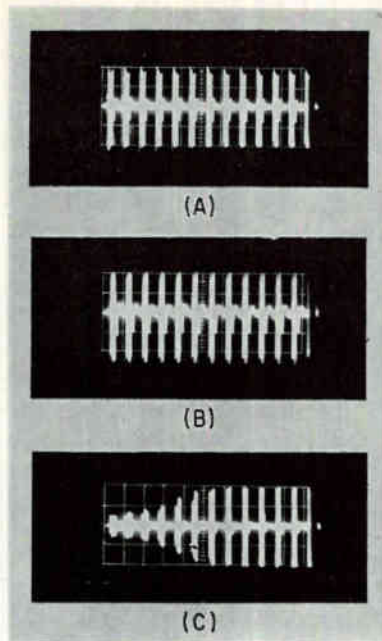

FIG. 3—Response time for inputs of -14 dbm (A), -36 dbm (B) and -53.5 dbm (C)

tack time decreases with increasing signal level, and that the reaction to signals above nominal input level is essentially instantaneous.

In the control circuit, a d-c voltage from a voltage divider (idle gain adjustment) is also fed into the d-c combining circuit (see Fig. 1). It is the function of this adjustment to set the idle (no-signal) gain. The fourth input to the d-c combining circuit provides gain decrease action.

To avoid the instability problems inherent in a transistorized d-c amplifier, the d-c combining circuit output is chopped into a-c by an 18-Kc transistorized chopper. The chopped signal is amplified by a two-stage a-c amplifier, then rectified and applied to the Variolossor.

This Variolossor input controls the overall gain of the signal circuit.

Figure 4A shows the output for both sine wave and speech inputs. There is no gain increase action for either signal for input levels below threshold. In this input range, the output follows the input, db for db, as in any fixed-gain amplifier. At the threshold point, the speech output level jumps to 0 vu with, of course, the time delay depicted in Fig. 2B and 3. The output stays at this level for speech inputs that are more than 40 db above threshold.

Sine waves do not affect the gain increaser. For these the unit acts as a fixed-gain amplifier until the gain-decreasing point is reached. There is a 7 or 8-db difference between the two curves at full output. This difference is based upon a 3-db peak factor for sine waves and an assumed 10-db peak factor for speech as read on a vu meter. On this basis, both signal outputs would have the same peak value and fall below the amplifier distortion break point.

Typical distortion characteristics are shown in Fig. 4B. These were measured for the upper portion of the input level range with the gain increaser disconnected and with the gain decreaser in operation.

The circuit diagram of the system is shown in Figure 5. Transformer T_1 provides for connection to either a balanced or unbalanced 600-ohm line. The internal circuits, except for the Variolossor network, are unbalanced.

Resistors R_1 through R_{12} form a bridged T attenuator having a 20-db loss in 4-db increments. The two-stage preamplifier consists of tran-

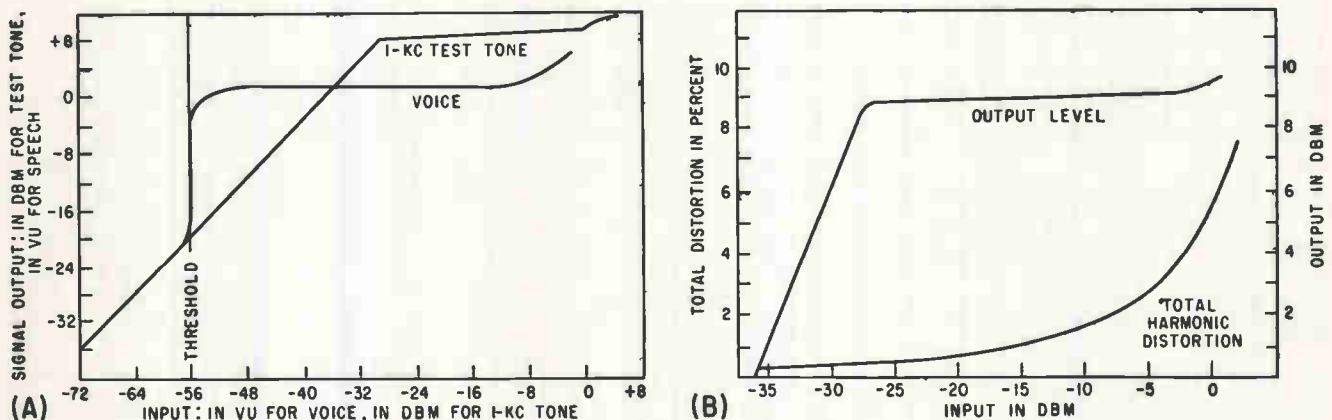

FIG. 4—Tests show gain characteristics for voice and tone (A) and distortion with gain decreaser in operation (B)

sistors Q_1 and Q_2 , the Variollosser is formed by diodes D_1 through D_8 , and the output amplifier is made up of transistors Q_3 , Q_4 , and Q_5 . Transistors Q_6 and Q_7 are the gain decrease.

The transistor amplifiers are conventional R-C coupled stages. The output of Q_2 is the gain increaser input. Input to the gain decrease is from the Q_5 collector through diode D_9 . Control current for the Variollosser flows through D_7 , R_{13} , D_5 and the parallel path D_8 , R_{11} , D_6 to the bridge consisting of D_1 , D_2 , D_3 and D_4 . Variollosser diodes are selected for their a-c impedance. Biasing of these diodes by the control current determines the Variollosser attenuation, within the described range of 9 to 50 db.

The gain-increase input is amplified by transistors Q_9 and Q_{10} , with the threshold level under con-

trol of R_{15} . Bias is such that signals below threshold are ignored and signals larger than threshold are amplified and fed to T_5 . Transformer T_5 is tuned to approximately 1.2 Kc, which is in the center of the speech band. Output of T_5 is fed to amplifier Q_{11} and then thru 7-cycle filter T_6 to Q_{12} . Output of T_6 is also fed to Q_{13} via D_{13} . Transistor Q_{13} provides an output that is of opposite polarity to the gain increaser output. The magnitude of the Q_{13} output varies in proportion to the signal input, so that the net value of the output of Q_{12} and Q_{13} is zero for signals equal or larger than nominal, and for threshold-level signals the output is entirely from the gain increaser.

All control signals are combined in the R-C network consisting of R_{16} through R_{25} and capacitors C_1 and C_2 . One input is the combined

gain increaser-proportional control voltage, another is the gain decrease voltage entering at D_{18} . A third voltage is picked off the d-c voltage divider, consisting of R_{18} and R_{19} , for setting the no-signal or idle gain. The sum of these d-c control voltages is chopped into a-c by transistor chopper Q_{17} and Q_{18} and fed to the base of Q_{14} . After amplification by Q_{14} and Q_{15} , the control signal is converted to d-c by D_{20} and D_{21} and applied through Q_{16} to the Variollosser.

Power requirement is -48 volts d-c at 200 ma. This voltage is used directly by the speech amplifier stages. A regulated -22 volts is derived from the 48-volt supply by Q_8 and D_{10} for the gain increaser and control circuits. Both of these voltages, as well as the Variollosser and the idle gain voltage, can be measured by the meter.

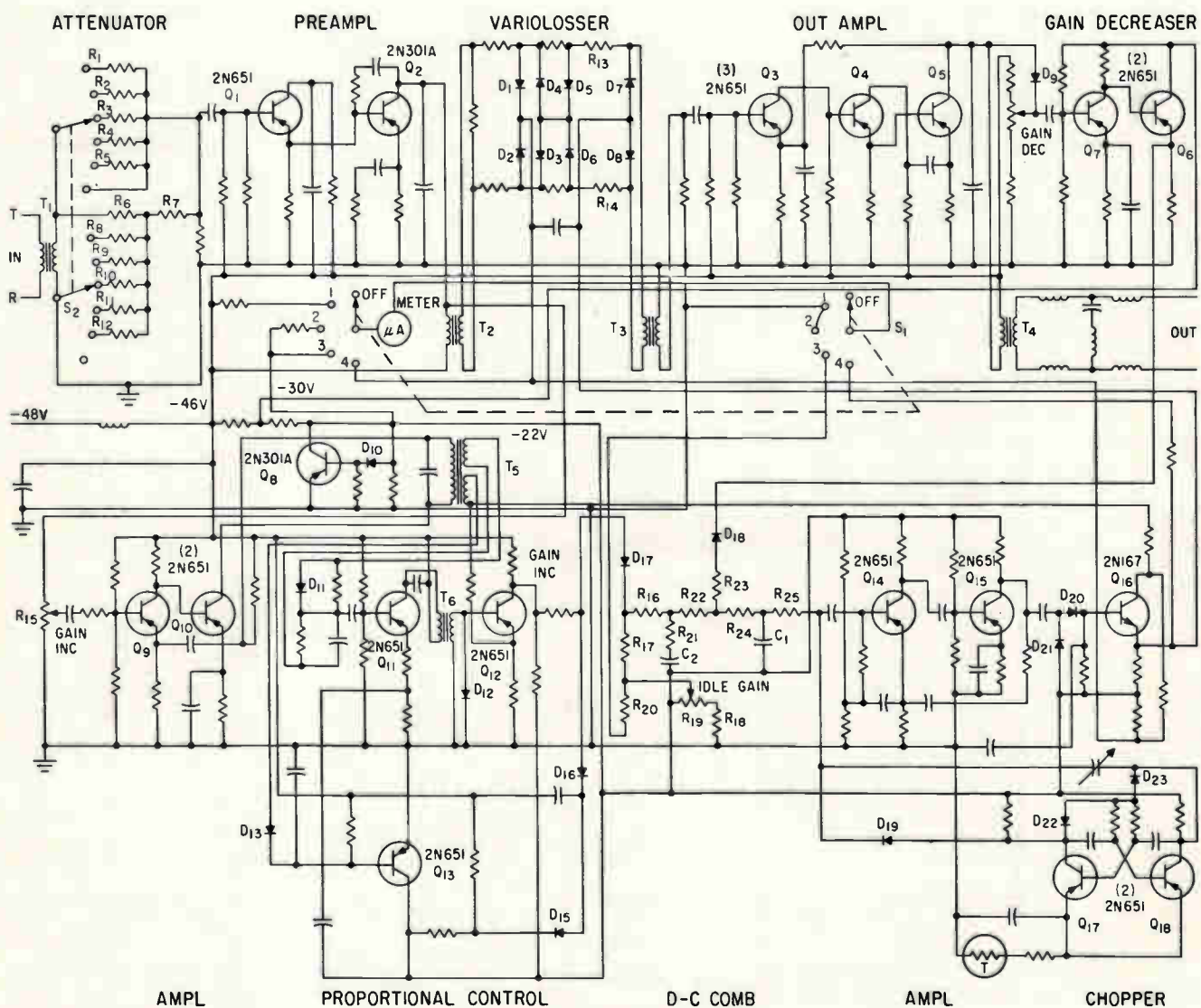

FIG. 5—Circuit provides constant output for input range of 40 db

SUBMINIATURE AND MINIATURE HEAT DISSIPATING SHIELDS

At Booth No. 2605
WESCON SHOW



CINCH

HEAT DISSIPATING

TUBE SHIELDS

for Miniature,
Subminiature,
Octal and Power Tubes.

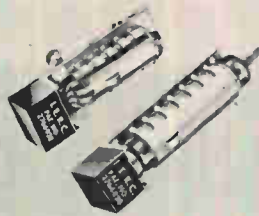

T3-2421



T1-421



T3-321

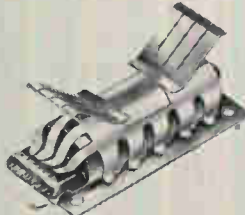

T3-2422-7



T3-1521



T3-322



T5-225015J



T3-1522



T3-421

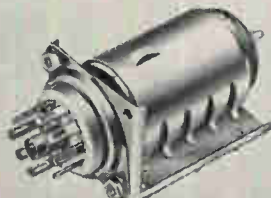

T5P-1415-1

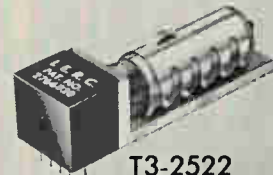

T3-2522



T3-424



T5 and T6



TR5 and TR6



OCTAL and POWER SHIELDS



Manufactured under license agreement with International Electronic Research Corporation

The 7 and 9 pin Miniature Series, T, TR and NW Series are covered by Military Specifications:

- MIL-S-9372B (USAF)
- MIL-STD-242B (Ships)
- MIL-S-19786A (Navy)
- SCL-6307/2 (Signal Corps)

In the Octal and Power Series, the shields are covered by Redstone Arsenal and Signal Corps approval.



Cinch
ELECTRONIC
COMPONENTS



CINCH MANUFACTURING COMPANY

1026 South Homan Ave., Chicago 24, Illinois
Division of United-Carr Fastener Corporation, Boston, Mass.

Centrally located plants at
Chicago, Illinois; Shelbyville,
Indiana; City of Industry,
California; St. Louis, Missouri

CIRCLE 107 ON READER SERVICE CARD

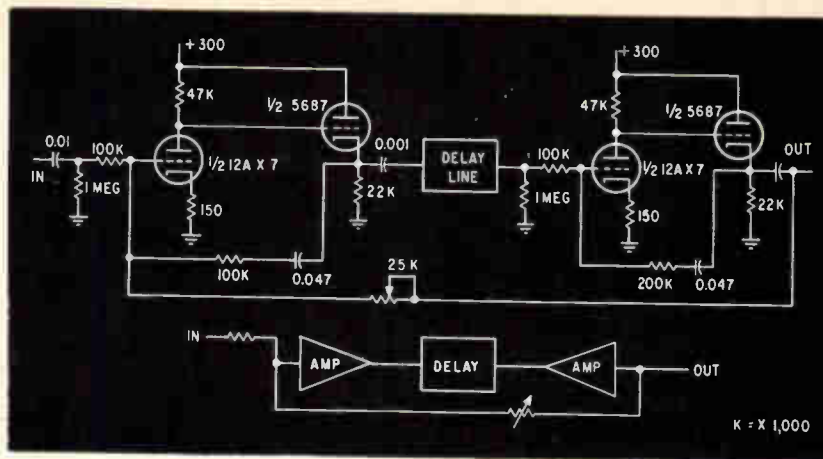

Circuit consists of two amplifiers connected to delay line

Delay-Line Controls Tuned Amplifier

Removes difficulties of tuning conventional i-f transformer, and simplifies equipment. Circuit is used in any system where high gain, high Q and stability are needed

By I. F. BARDITCH,
Air Arm Division,
Westinghouse Electric Corp.,
Baltimore, Md.

IN THE CONVENTIONAL Q Multiplier, which is basically a positive feedback system to reduce the ohmic losses in the circuit, some difficulties occur in stability and adjustment. Although, the circuit described here has features of a Q multiplier, it does not require lumped inductors or capacitors and the unit is simple.

A nonminimum-phase feedback amplifier is connected to give positive summation of signals at certain frequencies and negative summation at others. Two essentially similar operational amplifiers, having internal feedback loops designed to give slightly greater than unity gain, are connected to an electromagnetic, delay line. The line may be fixed or variable in delay length and built of lumped or distributed constant elements.

As seen in Fig 1, the first amplifier, 12AX7, feeds the directly coupled cathode follower, 5687, which drives both the input grid of the first tube through a summing resistor and feeds the signal out to the delay line. The low output impedance makes matching the delay line simple. Feedback loop

of the second amplifier is proportioned for a gain slightly greater than unity. The delayed signal traversing the delay line feeds this second amplifier and the output is fed both to the external load and back to the input of the first amplifier through a pot that allows the Q to be set as desired. Thus, the unit gives summation for frequencies appearing in the proper phase at the input summing resistor. This reinforces the desired input signal. Other signals whose frequency and phase are not correct appear at the input and are cancelled to a greater or lesser extent. At certain values of delay, total cancellation may occur at some frequency. Any residual signal is due to harmonics generated by nonlinearities. As a result one signal frequency is amplified selectively by a frequency-sensitive positive-feedback mechanism. Multiples of this frequency are also reinforced, but if the structure is properly designed the higher frequencies are far from the band of interest and are, as a general rule, attenuated.

Experimental results using the circuit shown, gives a Q of 285 at a frequency of approximately 500 Kc. Much higher values of Q could be realized. The unit could be tuned by adjusting the delay time. The delay line, built either as a mechan-

ically variable line or by using several segments of measured delay line with switching between them, can give a fine tunable unit. Several stages can be cascaded to form a high gain i-f amplifier of controllable gain and bandwidth with those problems usually attendant to inductors and capacitors removed. In addition, delay line stability is put to advantage in reproduction of a stable, high-gain amplifier. Tuning adjustments and Q control can be adjusted by setting a potentiometer to control the gain of the system. The difficulties found in tuning the usual i-f transformer are removed. A simplification in the equipment results where bandwidth switching is desired in a system. The amplifier can be used in communication systems and, moreover, in any system where tuned amplification and high gain, high Q and stability are needed.

The circuit shown can be simplified. However, since a number of delay lines of different impedance levels and design were used, it was felt an operational amplifier capable of driving varying impedance levels would be the best circuit to use. There is no reason why the principle illustrated could not be used with fewer tubes and possibly a transformer to achieve an even smaller and simpler circuit.

IDEAL FOR MINIATURIZATION... WESTON 1/2-WATT VAMISTOR® IN 1/4-WATT SIZE

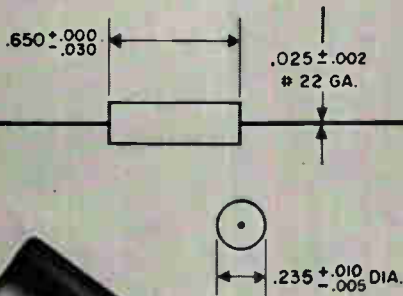
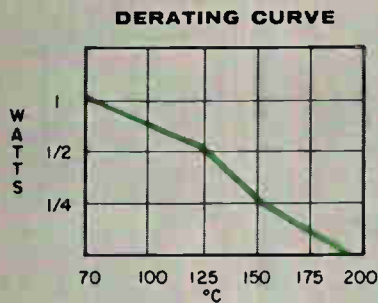

Metal film resistor is supplied in tolerances of ±1%, ±0.5%, ±0.25%, ±0.1%

Exclusive Weston VAMISTORS are especially suited to applications requiring resistors of small size, close tolerances and high reliability. The 1/2-watt "Missile Line" VAMISTOR is no larger than a conventional 1/4-watt, yet has a half-watt rating at 125°C. "Missile Line" VAMISTORS, employing internal inert gas, therefore offer *double* ratings with the same physical size.

Unique Weston design utilizes a special alloy metal film, thermally fused inside a steatite tube. The epoxy-encapsulated unit has higher abrasion resistance, and greater resistance to thermal shock and voltage surges than ordinary film-type resistors.

Many other advantages are provided by the VAMISTOR: Selected units are available with a maximum temperature coefficient of 25 parts per million/°C. Maximum voltage coefficient is only -1 part per million/volt. These resistors offer unusually long shelf life, produce no corona, and are practically non-inductive. Weston VAMISTORS are produced under the most rigid control standards, and meet or surpass all applicable MIL specifications.

Call your Weston representative for more information on the VAMISTOR line, or write for Catalog 04-101.

Daystrom, Incorporated, Weston Instruments Division, Newark 12, New Jersey. *International Sales Division, 100 Empire St., Newark 12, N. J.*

In Canada: Daystrom Ltd., 840 Caledonia Rd., Toronto 19, Ontario.

Model 9855-4 1/2-watt VAMISTOR is supplied in resistances from 100 ohms to 1.5 megohms. Voltage: up to 350. Tolerances: 1%, 0.5%, 0.25% and 0.1%. Overload: withstands 5 times rating for 10 seconds with only 0.012% average deviation from indicated value. Other sizes and ratings also available.

actual size

DAYSTROM, INCORPORATED
WESTON INSTRUMENTS DIVISION
Reliability by Design

Analog-Digital Methods Combined

SEPARATE ADVANTAGES of digital and analog computation may be combined in a project under investigation at the National Bureau of Standards. In a proposed analog-digital differential analyzer, dependent variables are represented by two quantities. A digital number represents the more significant part; a voltage analog represents the less significant part.

The proposed analyzer appears to be suitable for simulating dynamic problems in missile or aircraft design. Adding short digital registers and other digital units to an analog computer increases precision in solving such problems while retaining the higher analog speed.

The analog computer is useful in solving dynamic problems described by differential equations, but it is limited in accuracy and dynamic range. The digital differential analyzer provides higher accuracy and dynamic range. However, operating speed is limited and instability of a solution is possible. Using both techniques can combine high-speed with required precision.

An integrator and a multiplier have been designed so far. In general, they comprise one or more of the following units: input digital register, register for accumulating digital results, digital-to-analog converter, conventional analog integrator, resettable analog integrator, analog summer and comparator. These units can be constructed from common digital and analog circuits. Analog-to-digital converters are not needed.

In the over-all analyzer, the period of time during which the numbers in the digital registers do not change is made as small as possible consistent with component limitations. This approach permits the maximum number of such periods. The greatest speed and precision are realized with the smallest period. However, the period must be long enough to permit full-scale excursions of analog voltages, as well as to fit within bandwidth operational amplifiers.

Improvements in the characteristics of these units will help limit

this period. Even with present components, estimated precision in solving problems can be increased by a factor of 10 to 100 over conventional analog methods.

Under sponsorship of the Bureau of Naval Weapons, construction of breadboard models has been started to evaluate the system. These circuits will contain two integrator and two multiplier units, each capable of receiving input

voltages from other units. Digital registers and digital-to-analog converters will be constructed from transistor digital packages. The analog units will use commercially available wide-band operational amplifiers. These units will have 8-bit plus sign input and accumulating registers, and analog reference voltage will be 10 v. They will operate with a period of 1 millisecond or less.

Zener-Triode Clipper

By RONALD L. IVES,
Palo Alto, Calif.

SQUARING of waves and peak clipping are commonly accomplished by overdriving a triode. Saturation and cutoff of the triode establish upper and lower limits when only moderate precision is required. By using a pair of biased diodes, usually with one or more amplifiers, more precise control can be obtained.

Using Zener diodes for limiting can reduce power requirements and result in a lighter package. In addition, consistencies exceeding 99 percent are obtainable. The Zener diodes are used with a triode.

The basic circuit of a Zener-triode clipper is shown in the figure. Plate load resistor R_1 is chosen so that when there is no input to the grid of the triode, neither Zener diode D_1 nor D_2 conducts. When the grid is driven in the positive direc-

tion, rising plate current causes an increase in the voltage drop across R_1 . When voltage across R_1 reaches breakdown voltage of Zener D_1 , the diode conducts, preventing further drop in voltage at the plate. Thus minimum voltage at the output is established.

When the grid is driven in the negative direction, plate current decreases and plate voltage increases. When voltage at the plate reaches breakdown level of D_2 , that diode conducts. An upper limit is therefore established for output voltage.

Conditions for satisfactory operation are that breakdown voltages of D_1 and D_2 individually are less than plate supply voltage but the sum of their breakdown voltages must exceed plate supply voltage. The range of output voltage is the difference between the sum of the diode breakdown voltages and plate supply voltage.

Output waveform proved to be very near that predicted assuming that all components were perfect. Slight curvature of the tops of the clipped waves is expected as a result of ohmic resistance of the Zener diodes. However, this curvature is barely detectable on a good oscilloscope. It can be reduced if desired by careful selection of R_1 , D_1 and D_2 .

An alternate arrangement is often useful for some types of pulse circuits. If it is certain that the tube will be cut off during most of the negative half cycle, Zener D_2 can be omitted. Output voltage

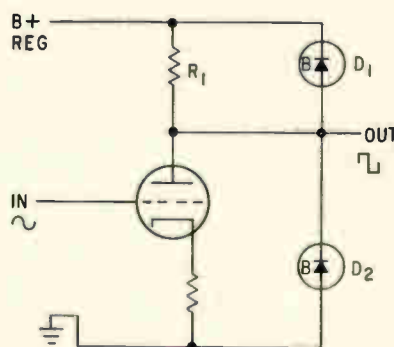

Zener diodes with triode produce square waves with high consistency

Tung-Sol/Chatham CROWBAR Thyratrons

PROTECT HIGH-POWER CIRCUITS AGAINST DESTRUCTIVE ARCS

Any one of a host of causes can trigger internal arcs in high-power tubes with little or no warning . . . even if the tubes are well designed, operate in well-engineered circuits, and have conservative demands placed upon them. Cosmic rays, line-voltage transients, parasitic oscillations, spurious primary and secondary electrons and material whiskers are just a few of the potential sources of these highly destructive arcs.

But by engineering Tung-Sol/Chatham high reliability crowbar hydrogen thyratrons into your design, you can safeguard against costly arc-generated breakdowns. By short-circuiting destructive currents, these zero bias "arc-busters" extinguish the arcs before circuit elements can be damaged.

Instantaneous response and the ability to carry extremely large currents make these rugged thyratrons ideally suited for this purpose. Moreover, they are able to conduct these heavy surge currents even after having been idle for long periods. Each tube contains a hydrogen reservoir which promotes long life and permits optimum gas pressure adjustment for various operating conditions. Write for full technical details. Tung-Sol Electric Inc., Newark 4, N. J. TWX: NK193

Technical assistance is available through the following sales offices: Atlanta, Ga.; Columbus, Ohio; Culver City, Calif.; Dallas, Texas; Denver, Colo.; Detroit, Mich.; Irvington, N. J.; Melrose Park, Ill.; Newark, N. J.; Philadelphia, Pa.; Seattle, Wash. Canada: Toronto, Ont.

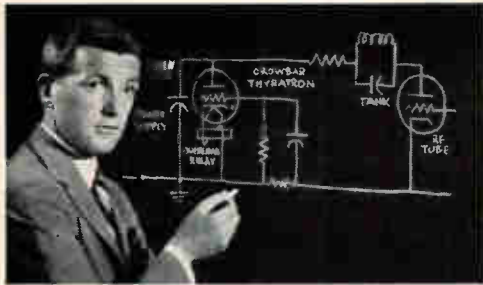

Typical application: A crowbar thyatron is connected in series with a suitable impedance across the filter of the high voltage power supply for a high frequency amplifier tube. Whenever an arc occurs in the power

tube, the rising current is used to deliver a suitable signal to the grid of the thyatron. The thyatron immediately conducts to short circuit the power supply, until the protective circuit breaker opens 0.1 second later.



Type	DC. Anode Forward Voltage	Peak Cathode Current
7559	18KV	1500A
7568	25KV	800A
7605	25KV	2500A

ts TUNG-SOL®

CIRCLE 111 ON READER SERVICE CARD 111

SPECIFY FM SIGNAL GENERATOR

1066A FOR BENCH USE
1066A/1 FOR RACK MOUNTING



Marconi Signal Generator Model 1066A is used in most organizations where FM systems are designed, or maintained. Rack mounting Model 1066A/1 (illustrated) is electrically identical. Engineers appreciate the calibrated Δ frequency controls which enable precise carrier shifts of as little as 1kc in 470 MC. Accurate level and deviation indication, smooth precise controls and functional styling are taken for granted as "typically Marconi".

10-470 MC, all on fundamentals
Deviation to 100kc, meter monitored
Stability .002% per 10 min.
Calibrated Δ freq., meter monitored

BRIEF SPECIFICATION:

Frequency:	10 to 470 MC	Mod. Frequencies:	1 and 5 kc.
Δ Frequency:	0-20 and 0-100kc	Output:	0.1 μ V to 100 mV, 50 Ω .
Stability:	.002% per 10 min.	Accuracy:	Incremental, 0.2 db
Deviation:	0-20 and 0-100kc.	Leakage:	Overall within 2 db
	0-300kc to order.	Amplitude Mod:	Negligible at 0.1 μ V
			Use with Model 1102
			for AM without spurious FM

SOME USERS:

A.E.C. · AVCO MFG. CO · BELL TELEPHONE · BENDIX RADIO · COLLINS RADIO · COLORADO STATE PATROL · CONVAIR · DOUGLAS AIRCRAFT · F.C.C. · GENERAL ELECTRIC · GLENN L. MARTIN CO · HUGHES AIRCRAFT · LOCKHEED AIRCRAFT CO · M.I.T. · MOTOROLA · PACKARD-BELL · PAGE COMMUNICATIONS · PHILCO · RAMO-WOOLRIDGE · R.C.A. · SANDIA CORP · SPERRY-PIEDMONT · STAMFORD UNIVERSITY · STROMBERG-CARLSON · TEXAS INSTRUMENTS · U.S. AIR FORCE · U.S. ARMY · U.S. NAVY · WESTERN ELECTRIC.

MARCONI INSTRUMENTS

111 CEDAR LANE · ENGLEWOOD · NEW JERSEY Telephone LOwell 7-0607
Canada: Canadian Marconi Co · Marconi Building · 2442 Trenton Ave · Montreal 16
Marconi Instruments Ltd · St. Albans · Herts · England

range is then equal to D_1 breakdown voltage.

Single-Test Check for Paramagnetic Crystals

SAPPHIRE AND RUBY CRYSTALS may be characterized by a single measurement, saving time and expense. The new technique was evolved at the Air Force Office of Scientific Research by E. Czerlinsky. It is being evaluated at the Electronic Material Science Laboratory.

Growing paramagnetic crystals with consistent, purity, crystalline perfection and stoichiometry (proper balance of elements) has proved quite difficult. Even with careful control of mixture, temperature and growing time, differences between crystals and even within the same crystal occur.

The properties of each newly grown crystal must be carefully analyzed with several independent measurements required to characterize the crystal properly. These measurements require precise cutting and shaping of the crystal in a special form for testing. After the independent measurements have been completed, a time-consuming and expensive cross-correlation of the data acquired in each measurement must be made.

No precise shaping of the crystal is necessary for testing using the new method. Transmission spectra, luminescence spectra and thermal luminescence are used. The sample is exposed for two minutes to tungsten x-rays, which raise the electrons in the crystal to a higher energy level. When the crystal is heated and the electrons return to ground state, light is emitted; intensity of light output is an index of crystal properties.

Another measure of crystal properties is the luminescence color, which changes as temperature is varied. A photocell is used to detect and plot its intensity. The data can then be used to characterize a particular crystal.

Crystals graded using this method will soon be tested in maser devices to determine if the simplified measurement technique can actually predict characteristics.

The new testing method may prove particularly valuable in the

TC176

maser crystal program at the laboratory. In this project, hundreds of potential maser crystals will be grown and evaluated.

Programmed Control For Blast Furnaces

PROGRAMMED control system developed for blast furnaces will accommodate the wide variety of charging schedules required. It will permit comparison of end product quality with the charging program and give complete material weights and charging times for accounting purposes.

The system will be used by U. S. Steel to draw iron ore, fluxes and coke from hoppers and to weigh, mix and deposit them in the blast furnace. The Westinghouse control system will also record on punched tape the type and quantity of deposited material and the time at which it was charged.

Flexibility in programming is achieved with patchboard leads and switches. Programming or changing the program can be done quickly, which includes sequence of skips, type and quantity of material included in each skip and the bin in which the material is stored. New ore or flux can be stored in any of 14 bins. After filling the hopper, bin number and stored material are related by a patchboard lead connection.

Each of two main conveyors serve seven hoppers. Material from each hopper is deposited on a main conveyor from a weighing conveyor. Weight transducers produce a digital pulse for each 50 pounds of material. Two hoppers can unload on a main conveyor simultaneously, reducing operating time.

After initial programming, the charging cycle is automatic. A replacement bin of the same material is selected for an empty bin, as well as indication of the empty bin. Vibration is initiated to restore material flow in a clogged bin chute. If the condition persists, an alarm is sounded and a light shows which bin is jammed. Simultaneously, a replacement bin is selected and the program continues.

July 29, 1960

NEW!... CONVERTS AC to DC LINEARLY

from 1 mv to 1000 v

Accuracy of conversion

is **BETTER THAN 0.25%**

for frequencies 50 cps to 10 KC



Price \$450

BALLANTINE'S LINEAR AC to DC CONVERTER Model 710

The Model 710 Linear AC to DC Converter converts an AC voltage to a DC voltage which can be measured with an accurate DC device such as Type K Potentiometer, Digital DC Voltmeter, Recorder, etc. With such a combination, a wide range of voltages can be measured with up to 0.25% accuracy, which is considerably better than accuracies of present-day vacuum tube voltmeters. Such a system is more sensitive, covers a wider frequency and voltage range, and is much more rugged and foolproof than a laboratory standard instrument of comparable accuracy. It is also adaptable for use by untrained personnel and on production lines.

The instrument covers an input voltage range of 1 mv to 1000 volts which is divided into six decade ranges. For every decade range the DC output varies from 0.1 volt to 1 volt. The input impedance of the converter has a resistive component of 2 megohms shunted by 15 pf to 25 pf, depending on the range.

The output of the Model 710 Converter is a linear function of the input voltage within each decade. A small error may exist in the decading of the input attenuator or in the frequency response of the amplifier. This error does not exceed $\pm 0.25\%$ over a frequency range of 50 cps to 10 KC and $\pm 0.5\%$ over a range of 30 cps to 50 KC. The upper frequency limit of the instrument is 250 KC, at which point the accuracy is $\pm 1\%$.

The DC output of the converter is single ended and has a maximum output emf of 1 volt with a source impedance of approximately 10,000 ohms. The instrument is the average responding type for distortions as much as 30%, but is calibrated in RMS of a sinewave.

Also available in 19 inch relay rack as Model 710 S/2 Price \$455

Write for brochure giving many more details

— Since 1932 —



BALLANTINE LABORATORIES INC.

Boonton, New Jersey

CHECK WITH BALLANTINE FIRST FOR LABORATORY AC VACUUM TUBE VOLTMETERS, REGARDLESS OF YOUR REQUIREMENTS FOR AMPLITUDE, FREQUENCY, OR WAVEFORM. WE HAVE A LARGE LINE, WITH ADDITIONS EACH YEAR. ALSO AC/DC AND DC/AC INVERTERS, CALIBRATORS, CALIBRATED WIDE BAND AF AMPLIFIER, DIRECT-READING CAPACITANCE METER, OTHER ACCESSORIES.

CIRCLE 113 ON READER SERVICE CARD 113

Transformer Design Reduces Resistance

A NEW TYPE of electrical transformer smaller and lighter than conventional types with identical operating characteristics was introduced by Sylvania Electric Products Inc. The development was described by Sylvania, a subsidiary of General Telephone & Electronics Corporation, as "a fundamental new concept in transformer design."

The new transformer, called the Flexi-core, ranges from 2 to 30 per cent smaller and lighter than types now in use, depending upon the electrical characteristics required.

The heart of the new transformer is a formed core that consists of nests of laminations, or layers, of fabricated steel strips from a continuous roll. Each of these cores consist of two "U"-shaped nests of strips; two nests are fitted together, with the strips at the top of the "U's" interleaved, or meshed. The resulting unit is a hollow rectangle, square, or other shape. A so-called "core" type of transformer utilizes one of these hollow units; in a shell-type transformer, two of these units are placed together so that a center

post is formed. The core of the conventional, more complex "EI" transformer consists of laminations of metal stamped in the shape of the letter "E"; the core is completed by closing in the open side of the "E" with a metal strip stamped in the form of the letter "I".

The use of nested cores allows the magnetic lines of force to flow continually with the grain of the steel used in the core rather than across the grain, as occurs in EI laminations. This reduces the resistance of the magnetic circuit, and therefore permits a Flexi-core transformer to operate as efficiently as a conventional transformer that has a larger and heavier core.

In using nested laminations for cores, the Flexi-core transformer offers engineers flexibility in design never before possible, according to Sylvania. Heretofore, transformer design has been limited by the dies used to make 'EI' laminations.

With Flexi-core, the shape and size of the transformer core can be designed to fit a specific need within broad limits. By being able to design a transformer for the job, rather than having to accept and

adapt a transformer based on 'EI' laminations, designers and engineers will have virtually unlimited freedom.

Can Be Computer-Designed

Pointing out that engineers for the past few years have been using electronic computers to "design" transformers, O. H. Biggs of Sylvania said computer results "could not be followed exactly because of the limitations imposed by 'EI' laminations." Now, he added, the Flexi-core concepts permits "100 per cent application of computer results to design and production."

Flexi-core transformers are now being produced in the company's plant at Ipswich, Mass.

Requests for information on Flexi-core transformers should be addressed to Dept. FT, Sylvania Electric Products Inc., Ipswich, Mass.

New Epoxy Materials Find Electronics Uses

COMMERCIAL-SCALE production of a new family of high-purity, light-stable epoxy compounds is now underway at the Institute, West Virginia, plant of Union Carbide Chemicals Company. This new unit, producing Unox epoxides and Flexol epoxy plasticizers, is now in production. Because of the high success of the operation, Carbide is also announcing reduced prices for several of the epoxides.

The epoxy plasticizers (Flexol EPO, JPO, and EP-8) are effective, low-cost stabilizers and plasticizers for vinyl chloride resins. Their synergistic action with many metallic vinyl stabilizers increases the resistance of vinyls to heat and light degradation.

Flexol EPO, used in vinyl formulations, has excellent long-term compatibility, stabilizing action, and resistance to both color development and rancidity. Flexol JPO differs from Flexol EPO by having a lower

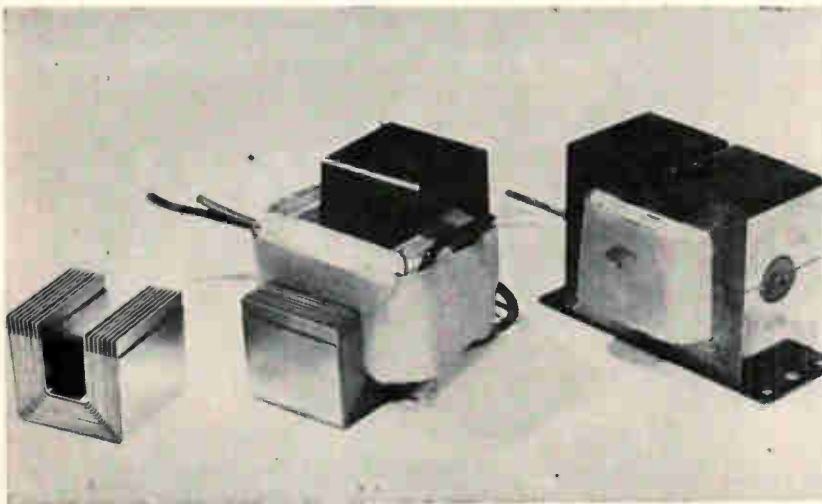

Magnetic lines of force flow continually with the grain of the steel, rather than across the grain as occurs in transformers made with conventional E and I shaped laminations. On the left is one of the four nests of squared U shaped laminations that are used to complete the transformer. In the center, the transformer's coil and leads have been added. On the right, the transformer has been completed with the addition of the nested laminations which have been secured by welds. These Flexi-core transformers were developed by Sylvania

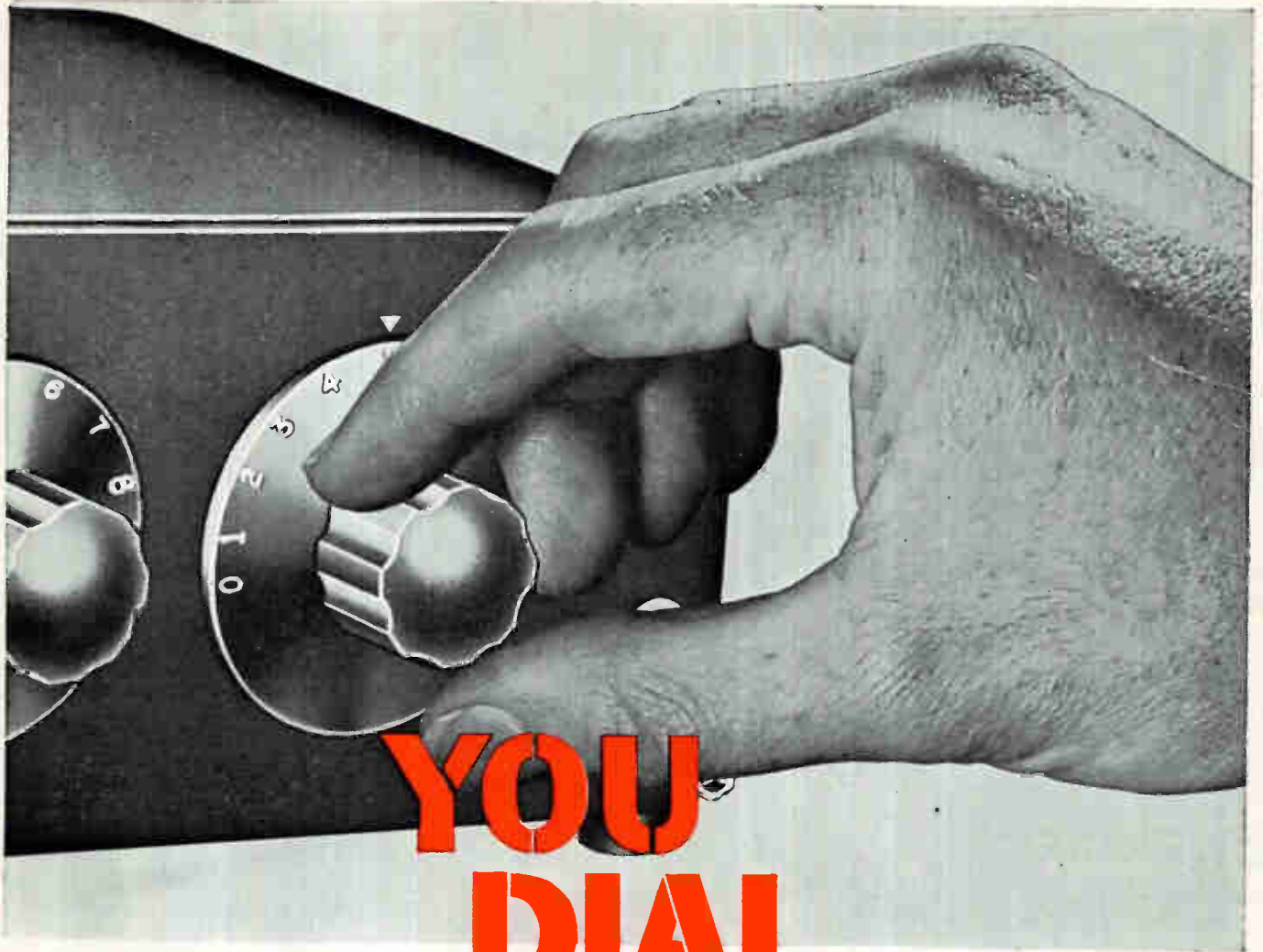

YOU DIAL THE DELAY TIME

with the *New* ESC Direct Readout Variable Decade Delay Line

Now you can make your own rapid selection of desired delay with the new Direct Readout Variable Decade Delay Line — the newest product developed and manufactured by ESC, America's leading manufacturer of custom-built and stock delay lines! Increments of 1/1,000 of the total delay may be selected by the turn of a dial. And there are three models:

Model 101 — a total delay of 9.99 usec.

Model 102 — a total delay of 99.9 usec.

Model 103 — a total delay of 999 usec.

There is a constant impedance of 1,000 ohms between input and output terminals for any delay increment.

Delay/rise time ratio at maximum delay is 33:1. The ESC Direct Readout Variable Decade Delay Line is a passive delay network and will not introduce noise or jitter. Mechanical and electrical modifications available on special order.



ESC

WRITE TODAY FOR COMPLETE TECHNICAL DATA.

exceptional employment opportunities for engineers experienced in computer components...excellent profit-sharing plan.

ELECTRONICS CORP. 534 Bergen Boulevard, Palisades Park, New Jersey

Distributed constant delay lines • Lumped-constant delay lines • Variable delay networks • Continuously variable delay lines • Step variable delay lines • Shift registers • Video transformers • Filters of all Types • Pulse-forming networks • Miniature plug-in encapsulated circuit assemblies

Malco

solderless terminals



**Speed and simplify
wire insertion...
...insure maximum
holding power**

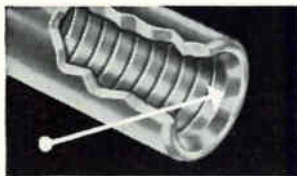

Funnel-edged barrel for fast, easy insertion of wire.

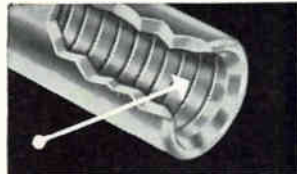

Multiple V-notched internally for better contact and maximum holding power.

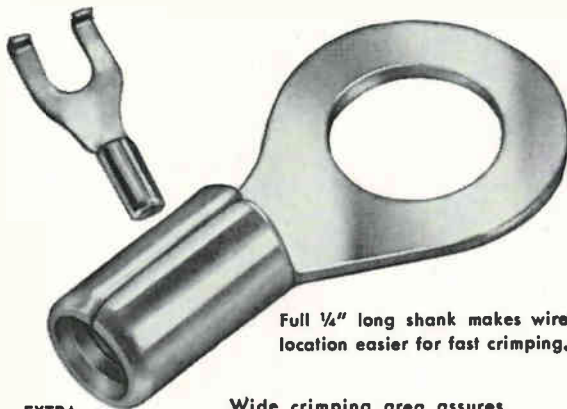

Full 1/4" long shank makes wire location easier for fast crimping.

EXTRA
ADDED
FEATURE
Beveled O.D.

Wide crimping area assures permanent, vibration-free and moisture-proof connections.

other features

- Available in a wide variety of types and styles.
- Made of pure soft copper for high conductivity and electro-tin plated for maximum corrosion resistance.
- Load capacity greater than wire itself.
- Constructed in one piece for economy and strength.
- Quality controlled for dimensional and electrical uniformity.
- Wire ranges clearly marked on all terminals.
- Stocked in 22-16, 16-14, 12-10 wire ranges.

Insulated Solderless Terminals Also Available

Write for new Malco Solderless
Terminals Bulletin No. 601

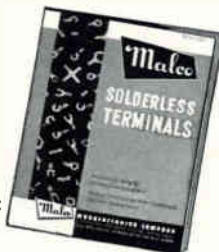

oxirane oxygen and higher iodine number.

Both Flexol EPO and JPO can be used to improve vinyl products such as electrical insulation, calendered film and sheeting, gaskets, foam, and molded articles.

Flexol EP-8 is designed for use in vinyl chloride resins where flexibility as well as heat and light stability are desirable at low temperatures. It also reduces the dilatancy problem of plastisols used in high-speed coating operations. It contributes good hand and drape as the low-temperature plasticizer in vinyl film and sheeting.

The epoxides (Unox epoxide 201, 206, and 207) are the only commercial-scale epoxides with cycloaliphatic structures that eliminate the light-unstable phenolic groups found in conventional epoxies which are based on epichlorhydrin and bisphenol A.

Unox 201 is the most versatile of the diepoxides. It can be formulated to give a wide range of high temperature properties, toughness, cure speeds, and handling characteristics. Its properties — low viscosity, high heat-distortion temperatures, good electrical characteristics, color stability, adhesion, fast reactivity, and compatibility with low-cost hardeners—point to end uses in electrical and electronic components and encapsulation, tooling coatings, laminates, adhesives, and cross-linking applications.

Unox 206 is unique among the epoxides in that it has a viscosity nearly equal to that of water and is a solvent for many solid anhydride hardeners. As a reactive diluent for conventional epoxy resins, it lowers the viscosity without the usual sacrifice in heat-resistance properties of the cured resin. It can be used as a chemical intermediate or as a monomer to make polyglycols containing unreacted epoxy groups. The combination of heat resistance and toughness found in Unox 206 castings is unusual.

Unox 207's compact structure makes possible epoxy plastics with outstanding high-temperature, physical, and electrical properties. Its low combining weight is an advantage when used to cross-link or modify low-cost resins and polymers. Ease of making B-stage

Malco MANUFACTURING COMPANY

4023 WEST LAKE STREET

CHICAGO 24, ILLINOIS

WHAT'S THE BEST WAY TO LEAK-CHECK ELECTRONIC COMPONENTS?

resins make Unox 207 especially attractive for the production of pre-impregnated glass systems. Suggested uses for this diepoxide include: starting material for plasticizers, protective coatings, glass-fiber laminates, grinding-wheel and brake-lining adhesives, and high-temperature encapsulation and tooling. Unox epoxide 207 resins resist stress at temperatures up to 592 F.

Silicone Rubber Filled With Metal Particles

THE DEVELOPMENT of a unique family of silicone rubber which combines a high percentage of heavy metal particles, very finely divided and uniformly dispersed in silicone rubber, was disclosed by the Connecticut Hard Rubber Co. of New Haven.

This new family of materials, designated COHrlastic HG, possesses the familiar properties of silicone rubber. From a series of initial tests conducted thus far, results show the unique properties of this metal-filled silicone rubber to be: its broad temperature range (-85 to +50 F.); extremely good resistance to weather, ozone and ultraviolet light; unusually uniform shielding against X-rays or other high energy radiation; good electrical resistance properties (10^{17} ohm-cm); high specific gravity; a resilient and flexible rubbery material.

COHrlastic HG can be processed in the same manner as normal rubber compounds including molding, extrusion, calendering, and as a coating on fabric.

Because of the unusual combination of metal and silicone rubber, it is suggested that COHrlastic HG might serve as a shielding material against high energy radiation or as an acoustic damping material. It is also likely that this material can be utilized in many other commercial or military applications where it may solve problems unresolved with presently available materials.

A preliminary information sheet which outlines most of the physical properties of this new material, derived from standard tests for rubber products, may be obtained from The Connecticut Hard Rubber Co., Dept. 5137, 407 East Street, New Haven, Connecticut.

CIRCLE 119 ON READER SERVICE CARD→

Test them with CEC's new 24-210B Leak Detector — a highly sensitive, easily portable instrument that detects at least one part helium in 10 million parts of air.

That's a sure way to guarantee component reliability.

The 24-210B can locate leaks as small as 2×10^{-11} atm cc/sec of air, which makes it ideal for leak testing diodes, relays, switches, vacuum tubes and other hermetically sealed electronic components.

This sensitivity is the highest available at the lowest price you can find in a mass spectrometer leak detector ... and you get reproducible readings. Noise level has been reduced to less than 2% of full scale, peak-to-peak.

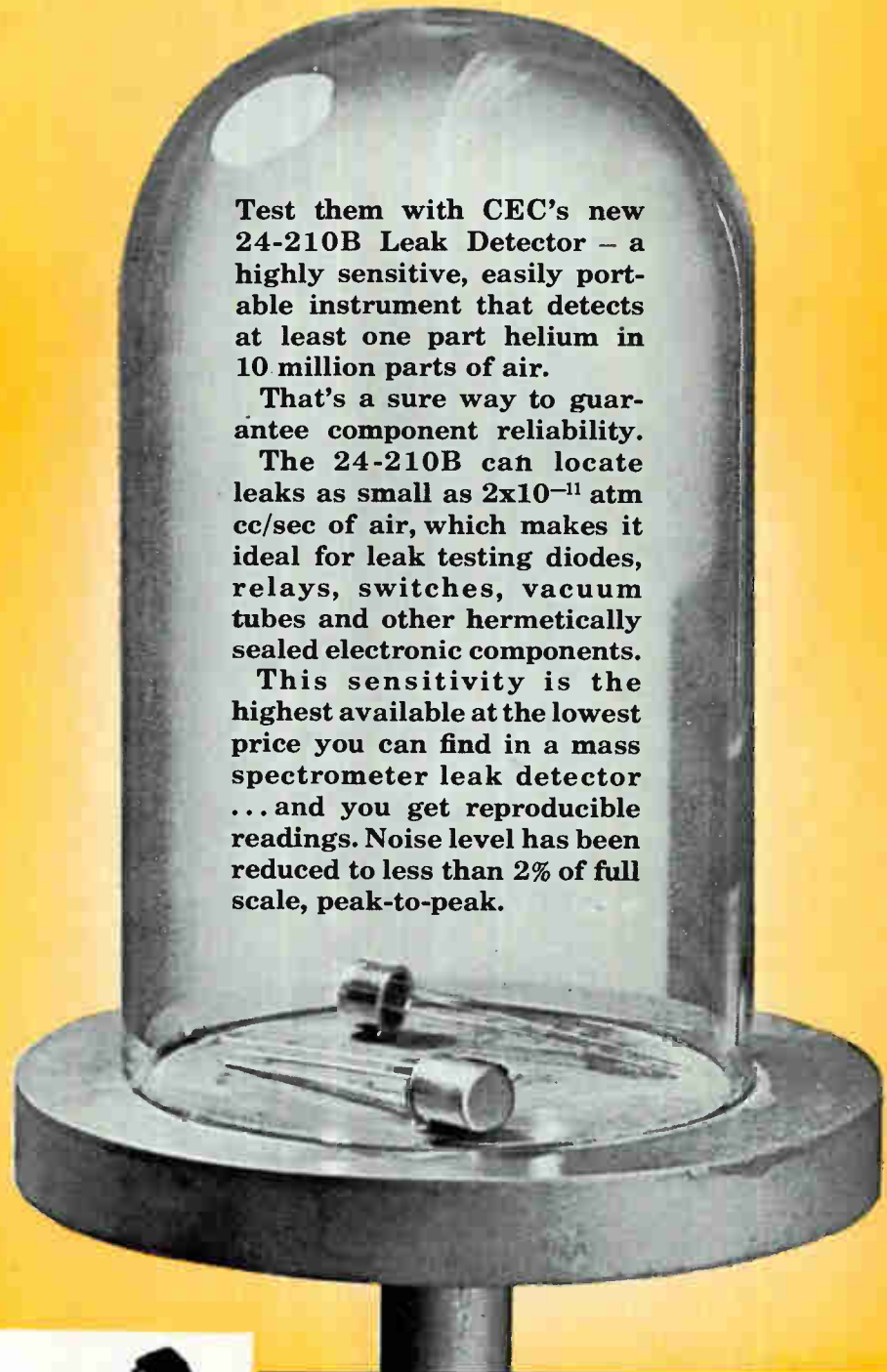

For complete information, write for Bulletin CEC 1830-X5.

The 24-210B, available with mobile workstand, operates without maintenance for as long as six months. CEC provides installation and instructs operators at no extra cost. Instruments and parts are available from stock, delivery two weeks from receipt of order.

Analytical & Control Division

CEC

CONSOLIDATED ELECTRODYNAMICS / pasadena, california

A SUBSIDIARY OF Bell & Howell • FINER PRODUCTS THROUGH IMAGINATION

Plastic Cutouts Help Design C Boards



Cutouts enable engineers to visualize layout and engineering problems

DOUBLE-SIZED PLASTIC cutouts, representing components, help General Radio Co., West Concord, Mass., reduce the time required to design prototype etched wiring boards for instruments. The sample layout becomes the production master if the prototype proves satisfactory.

Board designers use specially-made kits containing about 70 different cutouts, representing some 100 preferred components. The cutouts are colored, with each color representing a class of components. Kits also contain prints giving dimensional details of the components.

A sheet of transparent plastic is

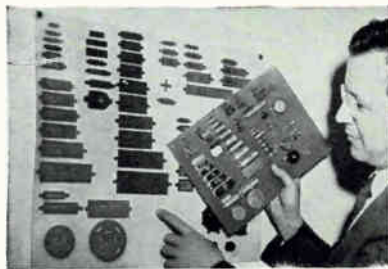

Components and their enlarged counterparts

placed over a grid pattern and the cutouts are arranged on the sheet in a preliminary layout of component positions. At this point, the engi-



Cutouts and specification sheets are boxed in kit

neer can visualize the physical assembly while considering lead lengths, component interactions and other factors which might affect performance of the instrument. Since the plastic cutouts adhere to the plastic sheet without adhesive, they can easily be moved about to adjust the layout.

Audio-visual Training System

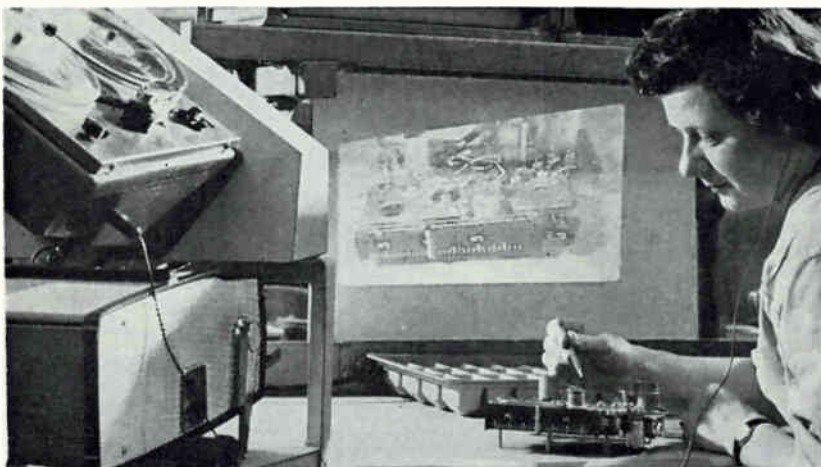

Stereophonic tape recorder-playback unit linked to a slide projector is used by Eclipse-Pioneer Division, Bendix Corp., Teterboro, N. J. to train assemblers. One channel of the tape gives the trainee oral instructions. The second channel carries tone signals which operate the slide changer of the projector. Each time the trainee presses a foot pedal, a new instruction is given and a new slide shown. Bendix says the method frees supervisors from training chores while enabling trainees to produce immediately. Cost of the equipment, assembled from commercially-available recorder, projector and cart, is about \$500

Preparing Master

When the engineer is satisfied with the arrangement, another transparent sheet is placed over the layout. Black tape and patches are used to trace the etched board circuitry on the second sheet. If the board is to be double-sided, a second overlay is prepared for the second side. All layouts are done at twice the size of the actual board.

Composite drafting prints are made from the component and circuitry layouts. A shading effect is obtained by removing the component sheet before exposure is completed. These prints, with component numbers added, can also be used as shop assembly drawings.

A camera which produces a negative the size of the actual board

ANOTHER FAIRCHILD FIRST

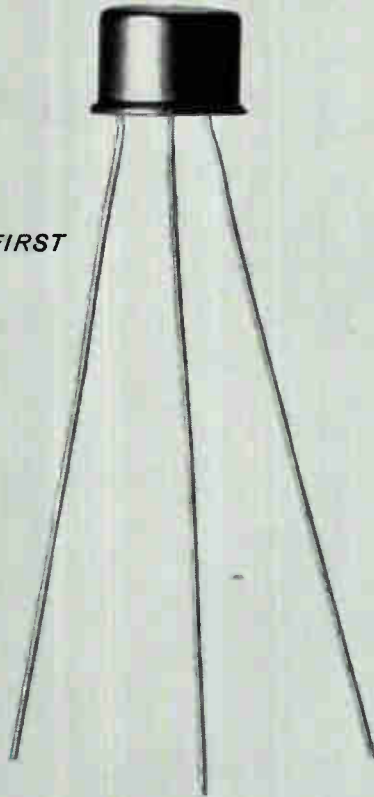

THE UNIVERSAL TRANSISTOR

FAIRCHILD'S 2N1613

DIFFUSED SILICON PLANAR TRANSISTOR

GUARANTEED USEFUL BETAS FROM 100 μ A to 0.5A:

15 @ .1mA 20 @ 1mA 30 @ 150mA 15 @ 500mA

Guaranteed minimum Beta over a 5,000 to 1 range of collector current makes the 2N1613 the most versatile transistor presently on the market.

WIDE RANGE OF APPLICATIONS: in Fast Switching (logic and high current); Amplifiers (low level, low noise, wideband, VHF power).

RELIABILITY IN A NEW DIMENSION: The Planar

Transistor is the most thoroughly proven transistor ever introduced commercially, with over 5,000,000 transistor hours plus 300°C. stabilization on all units.

SOME IMPORTANT PARAMETERS: 7 db—Noise Figure: 100 megacycles—Gain-bandwidth product; 0.0005 μ A I_{CBO} typical at 60V, 25°C.

IMMEDIATE AVAILABILITY: Quantities from 1-999 from franchised Fairchild distributors at factory prices.

TENTATIVE SPECIFICATIONS— FAIRCHILD 2N1613

f _t typical	100 mc
P _C @ 25°C. Case Temperature	3W
h _{FE} (see Beta paragraph above)	Min 30
V _{CER}	40V
V _{CBO}	75V
V _{BE} SAT. (Max.)	1.3V
V _{CE} SAT. (Max.)	1.5V
I _{CBO} @ 25°C. (Max.) measured at 60V	25m μ A



545 WHISMAN ROAD / MOUNTAIN VIEW, CALIF. / Yorkshire 8-8161

For full specifications, write Dept. A.

A WHOLLY OWNED SUBSIDIARY OF
FAIRCHILD CAMERA AND INSTRUMENT COMPANY

TOWER FOOTING
INSULATORS FOR
SELF-SUPPORTING
RADIATORS

LAPP ANTENNA TOWER INSULATORS



We at Lapp are mighty proud of our record in the field of tower insulators. Over 30 years ago, the first insulated broadcasting tower was erected—on Lapp insulators. Since then, most of the large radio towers in the world have been insulated

and supported by Lapp insulators. Single base insulator units for structures of this type have been design-tested to over 3,500,000 pounds.

A thorough knowledge of the properties of porcelain, of insulator mechanics and electrical qualities has been responsible for Lapp's success in becoming such an important source of radio insulators. Write for description and specification data on units for any antenna structure insulating requirement. Lapp Insulator Co., Inc., Radio Specialties Division, 166 Sumner Street, LeRoy, N. Y.

Lapp



Component layout guides preparation of circuitry master



Master is photographically reduced to actual board size

photographs the circuitry layout. The negative is then employed in making the sample etched boards. After design approval, the taped layout is again used to produce photographically Mylar masters, still enlarged. The Mylar masters are sent to etched board suppliers so that production boards will be identical to the prototypes.

Hinges Hold Fragile Parts During Grinding

MAGNETIC TABLES can be used to hold fragile, nonmagnetic workpieces during surface grinding. A Swedish report on the technique is reviewed in European Technical Digest No. 3663, European Productivity Agency, Paris, France. The fixture (Fig. 1) consists of 2 hinged metal flaps with serrated and beveled edges. The undersides of the lower halves of the hinges are precision ground and held flat by the magnetic table. The pull of the electromagnet holds the grip-

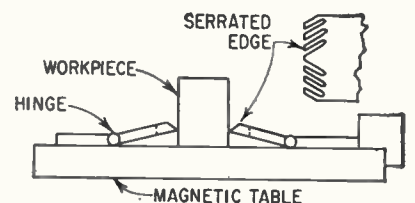

FIG. 1—Fixture grips nonmagnetic materials

ping edges against the workpiece. Strains caused by grinding are absorbed by the serrated edges.

Impregnated Sponge Wipe Tins Metals

Metal surfaces can be tinned before soldering with a sponge impregnated with tinning metals, chemical cleaner and flux. The surface is prepared by first wiping off dirt and grease and then wiped with the sponge. The coating appears at soldering temperatures. According to Wright Manufacturing Co., Cleveland, Ohio, Tin Swipe can be used on galvanized metal, iron, copper, brass, bronze, silver, gold and steel, and has been used to tin printed circuit boards. The coating is normally not much more than a molecule thick, the firm reports, and the tinned surface is noncorrosive.

Dispenser Laminates Adhesive to Tapes

LAMINATOR which makes strip material pressure-sensitive as it is used on the production line has been

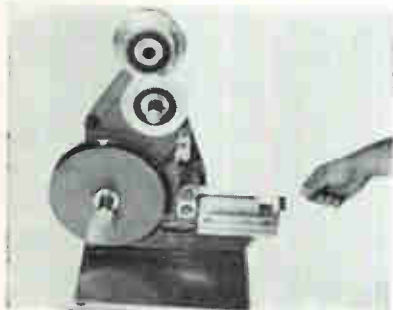

Mica tape is laminated to pressure sensitive film

announced by Minnesota Mining and Manufacturing Co., St. Paul, Minn. It applies 1-mil polyester film, coated on each side with a thermosetting, pressure sensitive adhesive (3M electrical tape X-1115), to such materials as mica tape, metal foil and fish paper. The film is supplied in rolls with a film separation liner. The laminator has feed spools for the strip material and the film, a take-up spool for the separation liner and guide rollers.

July 29, 1960

*lower in density,
more ohms per pound,
less cost per megohm!*

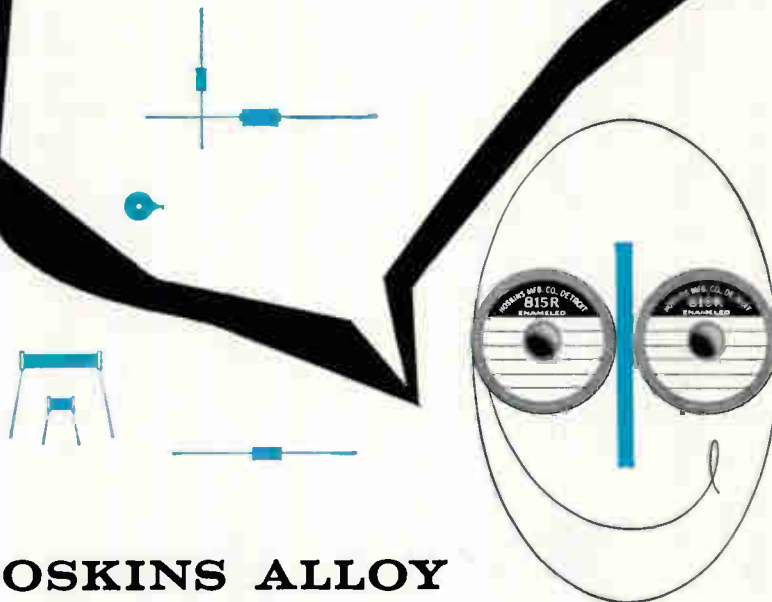

HOSKINS ALLOY

815-R Precision Resistor Wire

12.8 to 14.1% more ohms per pound! 10.8 to 12.7% less cost per megohm! These are worthwhile savings you can realize by using Hoskins Alloy 815-R in your precision wire-wound resistors. It's lower in density, has higher resistivity than standard 800-ohm nickel-chromium alloys. Yet it possesses comparable strength, ductility, resistance to corrosion. Its low temperature coefficient (0 ± 10 ppm per °C. from -65° to $+150^\circ$ C.)* is inherently controlled in the melt, rather than by "aging", to assure optimum uniformity. And it's available now bare or enameled in wire sizes ranging from .0031" down to and including .0004" to meet your particular application requirements.



Yours for the Asking—Handy new Resistor Wire Comparator showing actual savings obtainable for each wire size. 12-page catalog containing complete technical data. Sample spools of wire for testing and evaluation. Send for them today!

*Wire controlled to 0 ± 20 ppm/°C. also available at greater savings—up to 19.6% lower cost/megohm.

HOSKINS MANUFACTURING COMPANY

4451 Lawton Avenue • Detroit 8, Michigan • TYler 5-2860

In Canada: Hoskins Alloys of Canada, Ltd., 45 Racine Rd., Rexdale P.O., Toronto, Ontario

Producers of Custom Quality Resistance, Resistor and Thermocouple Alloy since 1908

CIRCLE 123 ON READER SERVICE CARD 123

New On The Market

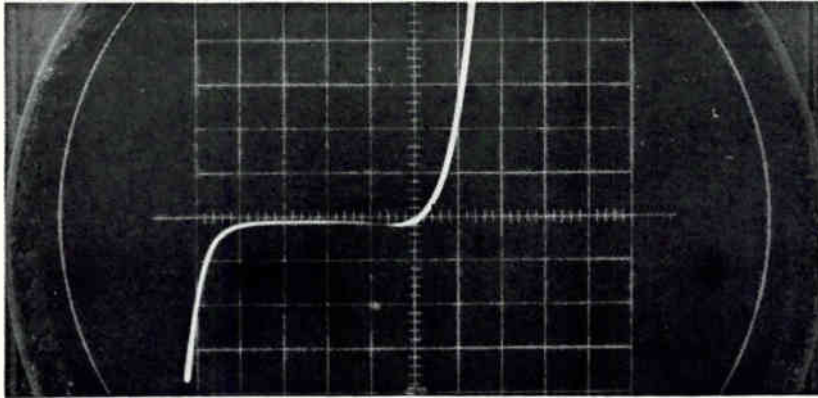

Backward Diode

SMALL-SIGNAL APPLICATIONS

TWO POSSIBLE applications of backward diodes are as a unidirectional coupling element in tunnel-diode circuits and in low-voltage clamping circuits. Backward diodes feature a low forward voltage drop, obtained by using the tunneling effect.

The devices exhibit a maximum peak point current of 100 ma and a maximum forward voltage of 90 mv, at 1 ma. Valley capacitance is

3.5 pf, series inductance is $1 \mu\text{h}$ and series resistance is 3 ohms. The reverse breakdown voltage for 1 ma is 480 mv. The units are hermetically sealed in a TO-18 package and have been designed for low-level switching and small-signal applications in the uhf range. Prototype quantities are available at \$4.00 each from Philco Corp., Lansdale division, Lansdale, Penna.

CIRCLE 301 ON READER SERVICE CARD

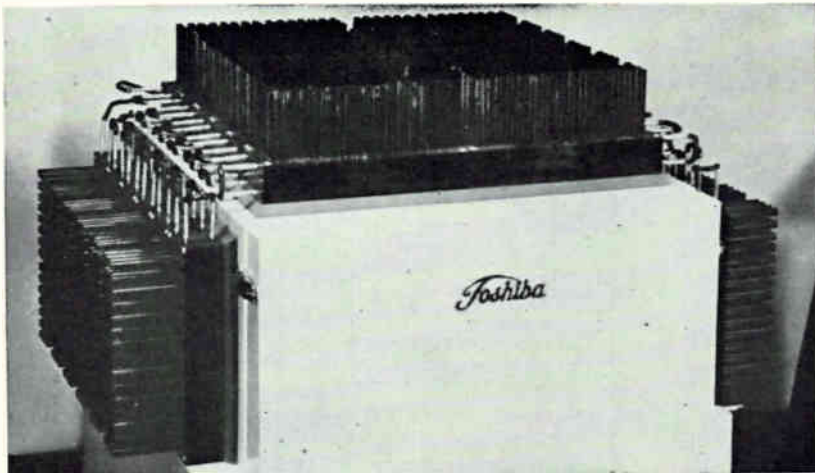

Thermoelectric Refrigerator

COOLS OR HEATS

SEMICONDUCTORS ARE USED in this controlled temperature chamber to give both heating and cooling. Whether the unit heats or cools depends on the direction of the current supplied to it. The chamber is announced by Matsuda Research Institute of Tokyo Shibaura Electric Co., Tokyo.

The thermostatic unit has a capacity of approximately 65 liters. Interior temperatures are controlled with a sensitive thermode-tector that adjusts the current magnitude and direction. The device takes about one hour to reach 20 C when the outside temperature is 40 C. The refrigerator is suit-

able for refrigerating and keeping constant temperatures for transistor appliances, infrared receivers, and equipment for biological and medical use.

CIRCLE 302 ON READER SERVICE CARD

Ferrite Switch

FAST RISE TIME

FAST RISE TIME, low switching speed ferrite switch has been announced by Rantec Corp., Calabasas, Calif. The problem of fast switching time with long dwell time has been solved with the model SXL-141 ferrite switch and the model DS-105 driver. This combination is capable of simultaneous spdt switching and duplexing of received signals.



The unit meets the following specifications: frequency range from 7.75 to 8.35 Gc, isolation of 25 db, insertion loss of 0.3 db, vswr (all ports) 1.3 max., rise time of 175 μsec , switching rate of 1 to 1,000 cps, power-handling ability of 50 watts average, 5 Kw peak. Other units are available in different microwave frequency bands.

CIRCLE 303 ON READER SERVICE CARD

Varactor Diodes

120-GC CUTOFF

LOW-CAPACITANCE varactor diodes have applications in parametric amplifiers and radioastronomy equipment. The silicon mesa units type MA-4293 are hermetically sealed in reversible polarity cartridges similar in size to the MA-450 series. They are manufactured by Microwave Associates, Burlington, Mass.

Shunt capacitance of the diodes is about 0.4 pf, and series lead inductance is about 2×10^{-9} henries.

Low capacitance MA-4297 varactors used in receivers equipped with 5,500-Mc nondegenerate parametric amplifiers have achieved stable overall receiver noise figures of 2.2 db for $\pm 10\text{-Mc}$ bandwidth.

WECKESSER



molded
**BLACK NYLON
SCREWS
and
NUTS**

SEE US
AT
BOOTH
317

WESCON
LOS ANGELES

Acid resistant . . .
Need no insulation . . .
Can't rust . . .
Can't corrode . . .

● **CUT ASSEMBLY TIME**
2-56, 4-40, 6-32, 8-32, 10-32 and
1/4-20 in stock. Actual production
samples will give you the whole
story. Write on your letterhead.

WECKESSER COMPANY

5701 Northwest Hwy. * Chicago 46, Ill.

CIRCLE 200 ON READER SERVICE CARD



**There's
going to be
a meeting**

Who's going to get together and *what* are they going to talk about?

Electronics men are meeting all over the country to talk about everything from ultrasonics to quantum electronics.

electronics tells you where and when "*Meetings Ahead*" . . . gives you the highlights later on.

Another reason why it will pay you to subscribe to *electronics* (or renew your subscription) right now. Fill in the box on Reader Service Card. Easy to use. Postage free.

FIND WHAT YOU NEED IN...

electronics

July 29, 1960

**SIGNALITE
GLOW
LAMPS**

New

FOR

**HIGH
CURRENT**

APPLICATIONS

**IN COMPUTER, COMMUNICATION
AND INDUSTRIAL EQUIPMENT**

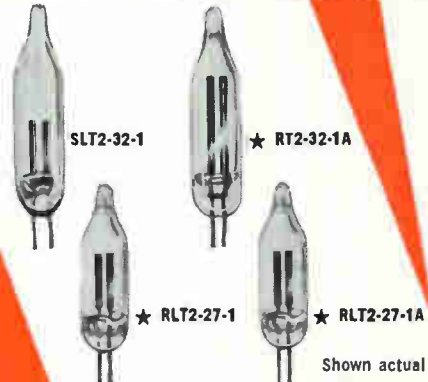

Shown actual size

★ Radioactive additives for reduced dark starting effect

Circuit Components/Indicators

The new line of Glow Lamps offers design engineers increased flexibility in the selection of reliable circuit components for voltage regulation, switching and indicating. As circuit components these lamps can be used in applications requiring up to 20 ma.

For indicating functions these high-light intensity lamps are characterized by brilliance, ruggedness and long life.



**WRITE TODAY FOR
SAMPLES
AND BULLETIN #111**

Signalite INCORPORATED
NEPTUNE, NEW JERSEY Prospect 5-2400

CIRCLE 125 ON READER SERVICE CARD

125

Stable overall receiver noise figure of under 1.8 db is possible for 3,000-Mc radar receivers using nondegenerate parametric amplifiers with ± 10 -Mc bandwidth. Values are for single sideband; ferrite circulator insertion losses are included. Noise

figures of 0.5 db are possible in radio astronomy equipment operating at 1,420 Mc. The diodes are available in experimental quantities.

CIRCLE 304 ON READER SERVICE CARD

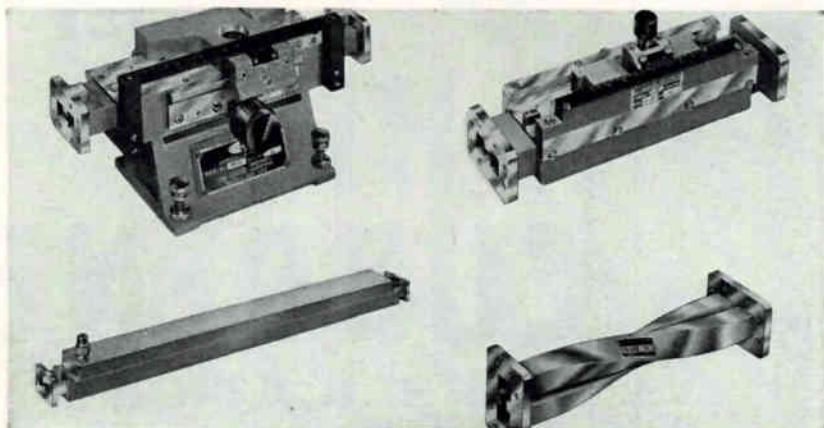

Ridged Waveguide

MEASURING EQUIPMENT

NEW BROADBAND test equipment engineered for the D9 double-ridged waveguide in the 4.75 Gc-to-11 Gc band has been developed by Narda Microwave Corp., 118 Herricks Road, Mineola, N. Y. Ridged waveguides are capable of handling a broader band than ordinary rectangular waveguides at various levels and with a wider range of equipment.

Equipment includes adapters,

tunable detectors, variable attenuators, directional couplers, impedance meters, slide-screw tuners, sliding terminals, high-power terminals, 90-deg axial twists and waveguide tubings. Waveguide cross section and flanges meet the proposed standards now being reviewed by the Electronic Industries Association.

CIRCLE 305 ON READER SERVICE CARD

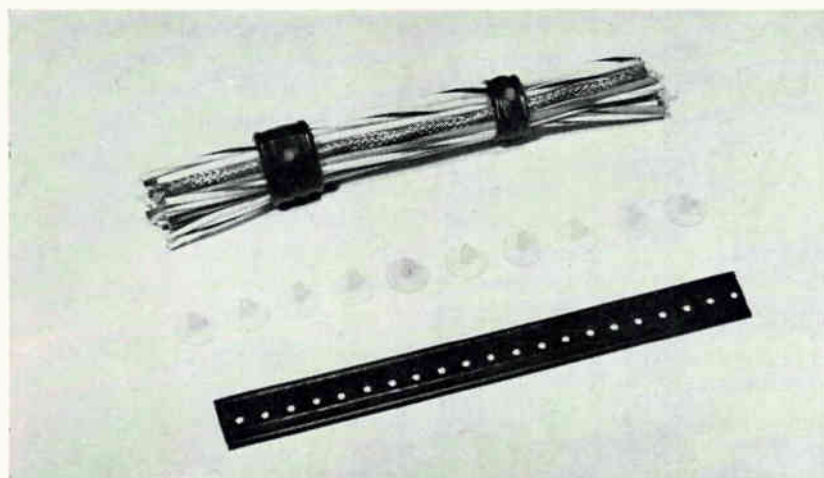

Cabling Device

STRAP AND BUTTON

WIRE AND cable tying system uses a plastic strap with spaced holes and a plastic snap holder. The

method produces low-cost cabling and cuts waste.

The system, called Insuloid strap-

ping, consists of two components, a high-grade polyvinyl chloride plastic belt and a stud-like insert resembling the old-fashioned collar button. Installers wrap the strap around the wire or cable and snap-in a stud. The tying system can be used to secure or group all types of unsupported wire and cable in any diameter or form.

The strapping is available in 75-ft coils in two widths, from Electrovert, Inc., 124 E. 40th St., New York. The $\frac{3}{8}$ -in. width costs \$2.25 a coil and the $\frac{1}{2}$ in. width, \$3.75 a coil. Studs are \$5.00 a thousand.

CIRCLE 306 ON READER SERVICE CARD

Silicon Rectifier

TUBE REPLACEMENT

DESIGNED to replace type 12BW4 and 6BW4 rectifier tubes directly, silicon rectifier unit S-5347 is announced by Sarkes Tarzian Inc., semiconductor division, 415 North College Avenue, Bloomington, Ind. The device may be used in rectifier applications which require 1,600 peak inverse volts at 500 ma d-c.



The silicon rectifier has a 9-pin miniature base, increases equipment efficiency as well as providing increased d-c output from the rectifier. The silicon rectifier provides excellent regulation and high reliability; no filament power is required. User net is \$13.00.

CIRCLE 307 ON READER SERVICE CARD

Uni-Tunnel Diode

LOW-LEVEL DEVICE

SEMICONDUCTOR DEVICE called the Uni-Tunnel diode can be used to simplify the circuits of low-level applications in computers, modulators, detectors and choppers. Twelve types of the diodes are announced by Hoffman Electronics Corp., semiconductor division, 3761 S. Hill St., Los Angeles.

Ability of the Uni-Tunnel diode to operate efficiently at low voltages simplifies circuits and results in

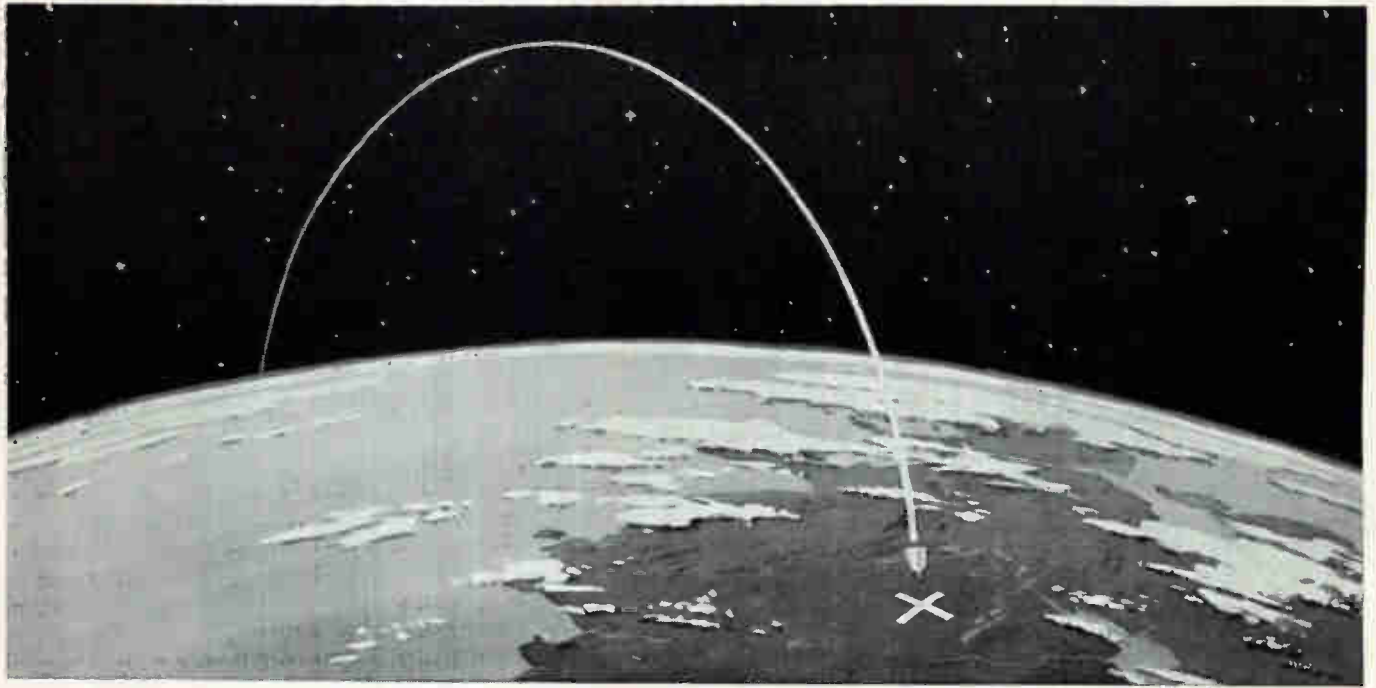

ASSIGNMENT: HIT A TARGET 6000 MILES AWAY

Can you guide a 110-ton Air Force Titan missile far up into the sky, to bring its nuclear warhead down with pinpoint accuracy on a target one-fourth the way around the globe—a target you not only can't see but which continually moves with the spinning earth?

This was the problem in missile guidance the Air Force presented to Bell Telephone Laboratories and its manufacturing partner, Western Electric. The answer was the development of a command guidance system which steers the Titan with high accuracy.

Unlike self-contained systems which demand complex guidance equipment in the missile itself, Bell Laboratories Command Guidance

System keeps its master control equipment on the ground where it can be used over and over again. Thus a minimum of equipment is carried in the missile, and the ground station has full control of the missile during its guided flight. Techniques drawn from the communications art render the system immune to radio jamming.

Bell Laboratories scientists and engineers designed the transmission and switching systems for the world's most versatile telephone network, developed much of our nation's radar, and pioneered in missile systems. From their vast storehouse of knowledge and experience comes the guidance system for the Titan.

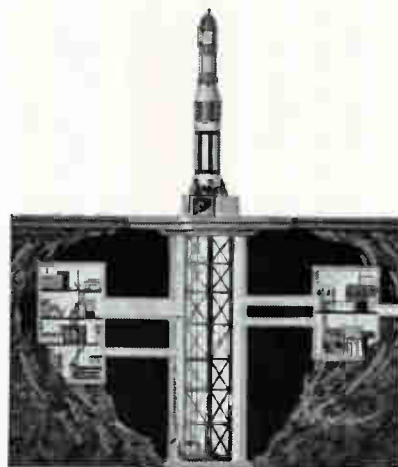

BELL TELEPHONE LABORATORIES

WORLD CENTER OF COMMUNICATIONS RESEARCH AND DEVELOPMENT

USE THE BUYERS' GUIDE AS A MARKETING TOOL

You'll find key information from the marketing viewpoint in the **electronics BUYERS' GUIDE**. It will help you to see the *whole* picture of industry activity clearly.

You'll find facts about the markets... materials... design—available nowhere else.

You'll find *who* makes which products and *where* they are located.

You'll find a reflection of the size, interests and stature of more than 4,000 companies.

Best of all, the **BUYERS' GUIDE** and Reference Issue is accurate, complete and authoritative. You can *act* on the information it gives you. O.S.B

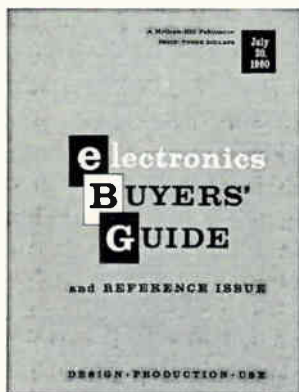

FIND
WHAT
YOU
NEED
IN
THE **electronics**
BUYERS' GUIDE

lower cost, greater reliability and decreased space requirements. The diode uses the tunneling effect to provide high forward conductance at low voltage levels. When biased in the reverse direction, the familiar tunnel-diode current characteristic appears as a leakage current of microamp magnitude. Other features includes extreme radiation resistance and minimum noise and drift. Operating range is from -85 to 200 C.

Minimum forward currents at 0.25 volt range from 0.5 milliampere for the HU-5 to 10 milliamperes for the HU-100; maximum reverse currents (0-0.5 volt) range from 5 to 100 microamperes. Prices are \$10.50 in quantities to 99, and \$7.90 to 999 units for the six standard devices. The six A types (featuring guaranteed maximum capacitance) are priced at \$15 in quantities to 99 and \$11.25 to 999 units.

CIRCLE 308 ON READER SERVICE CARD

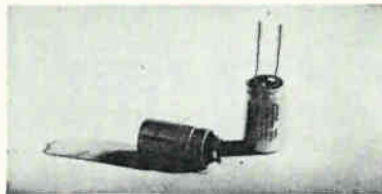

Pre-Expanded Tubing IS TRANSPARENT

CLEAR vinyl tubing that shrinks under heat to provide a tight covering for either symmetrical or gently contoured shapes is now available from the Irvington division of Minnesota Mining & Manufacturing Co., 900 Bush Avenue, St. Paul, Minn.

During manufacturing, the tubing is preexpanded and shrinks upon application to its normal dimensions in 4 to 8 minutes at 300 F. Usable on objects ranging in size from $\frac{3}{4}$ -inch to 5 inches in outside dimension, the fully transparent tubing can be applied where a tight, abrasion- and chemical-resistant electrical insulating cover is required.

Previously available as a standard item only in black and imprinted with an identifying legend, the new material, ScotchTite No. 3025, will also be available in black,

for immediate delivery of

GENERAL INSTRUMENT semiconductors

at factory prices

call your authorized
stocking distributor

CALIFORNIA

Electronic Supply Corp.,
Pasadena
Pacific Wholesale Co.,
San Francisco
San Delco., San Diego
Universal Radio Supply Co.,
Los Angeles
Valley Electronic Supply Co.,
Burbank

COLORADO

Interstate Radio and Supply Co.,
Denver

CONNECTICUT

Sun Radio & Electronics
Co., Inc., Stamford
The Bond Radio Supply, Inc.,
Waterbury

FLORIDA

Electronic Supply, Melbourne;
branches in Miami, Orlando,
St. Petersburg

ILLINOIS

Merquip Co., Chicago

INDIANA

Brown Electronics, Inc.,
Fort Wayne
Graham Electronics Supply,
Inc., Indianapolis

IOWA

Deeco Inc., Cedar Rapids

MARYLAND

Radio Electric Service Co.,
Baltimore

MASSACHUSETTS

The Greene-Shaw Co., Inc.,
Newton

NEW YORK

Delburn Electronics, Inc.,
New York City
Standard Electronics, Inc.,
Buffalo
Sun Radio & Electronics Co., Inc.,
New York City

OHIO

Buckeye Electronics
Distributors, Columbus
The Mytronic Co., Cincinnati
Pioneer Electronic Supply Co.,
Cleveland

OKLAHOMA

Oil Capitol Electronics,
Tulsa

PENNSYLVANIA

D & H Distributing Co.,
Harrisburg
Herbach & Rademan, Inc.,
Philadelphia

TEXAS

Adleta Co., Dallas
A. R. Beyer & Co., Houston
Scooter's Radio & Supply Co.,
Fort Worth

WASHINGTON

Seattle Radio Supply Co.,
Seattle

WISCONSIN

Radio Parts Co., Inc.,
Milwaukee

CANADA

Soule's Magnetics Ltd.,
Willowdale, Ont.



CIRCLE 202 ON READER SERVICE CARD
electronics



GENERAL INSTRUMENT SEMICONDUCTOR REPORT

Design Notes...

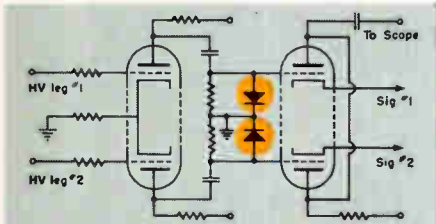

DIODE CLAMPS PREVENT DRIFT IN HIGH SPEED ELECTRONIC SWITCHES
The problem of drift in high speed electronic switches has been solved through the use of clamp diodes. This application is especially useful for stabilizing the operation of go, no-go oscilloscopic testing of dynamic parameters in a variety of electronic components.

In the circuit, General Instrument MP-300 silicon diode/rectifiers may be used because of their superior stability and low reverse leakage (only .05 μa @ 25°C).

Changing from vacuum tube to silicon clamp diodes minimizes problems associated with varying contact potentials. Equipment reliability is improved since total thermal dissipation is reduced. Further, equipment does not have to be reset in case of power line failure.

The small physical size of General Instrument diode/rectifiers is important where a large number of switches are to be used in a single piece of equipment.

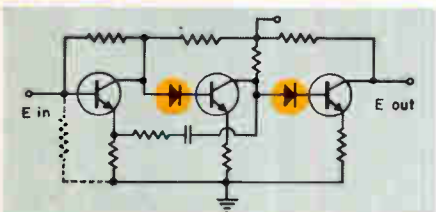

NOVEL CIRCUIT USES DIODES FOR AUDIO COUPLING There are many benefits to be gained through diode coupling of audio amplifiers. The simplified three-stage transistorized audio amplifier shown above uses General Instrument 1N645 subminiature silicon diodes.

Since the diodes are forward biased, ac is virtually direct coupled—resulting in a flat frequency response limited only by transistor parameters. Need for large coupling capacitors is eliminated. Virtually lossless ac coupling is obtained. And, temperature stability is improved because of low external base resistance.

Complete schematics of above circuits are available upon request.

Proved Reliability: ZERO FAILURES after 11,000 hours operation at 150°C!

GI IN 645-IN 649 DIODE/RECTIFIERS AVAILABLE IN PRODUCTION QUANTITIES... EXCEED USAF STANDARDS

General Instrument 1N645 through 1N649 subminiature rectifiers are ideally suited for applications requiring small size and very high reliability. These hermetically sealed glass units are designed to operate over an ambient range from -65° to 150°C... pass MIL-E-1/1143 specifications for breakdown voltage... offer superior life test performance. This series covers the range of 225 to 600 PIV, with maximum average rectified current of 400 ma @ 25°C. Maximum reverse current @ PIV is only 0.2 μa .

These diode/rectifiers are subjected to 100% environmental testing and dynamic oscilloscopic tests to assure high electrical and mechanical uniformity, surpassing the most stringent military specifications.

■ **LIFE TESTS** indicate outstanding stability of the General Instrument 1N645 series subminiature rectifiers under load. Graph shows results of a 1,000-hour test of 231 units from a normal production run. (Conditions: VRMS 160 V ac; Io 400 ma dc.)

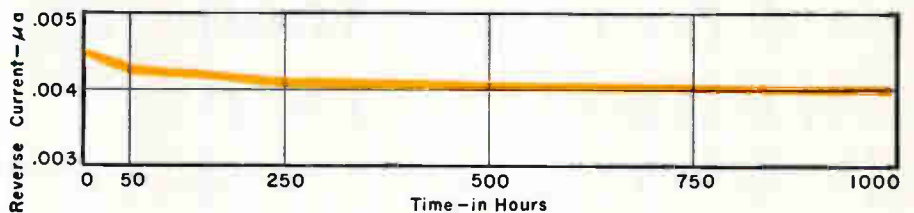

NEW MP SERIES DESIGNED FOR 200°C OPERATION!

General Instrument has achieved an outstanding power-to-size relationship in the high quality MP silicon diode/rectifier series. Parameters for these subminiature glass units are suitable for a wide range of applications under high-temperature conditions:

TYPE	PIV	DC OUTPUT CURRENT (Ma)		REVERSE LEAKAGE (μa) @ PIV		FORWARD DROP @ 400 Ma @ 25°C
		25°C	200°C	25°C	200°C	
MP 100	100	400	50	.05	75	1.0
MP 225	225	400	50	.05	75	1.0
MP 300	300	400	40	.05	75	1.0
MP 400	400	400	35	.05	75	1.0
MP 500	500	400	25	.05	75	1.0
MP 600	600	400	20	.05	75	1.0

CALL ON GENERAL INSTRUMENT for technical data and applications assistance on the complete line of G.I. high reliability silicon diodes.



SEMICONDUCTOR DIVISION GENERAL INSTRUMENT CORPORATION

65 Gouverneur Street, Newark 4, New Jersey

4448



SEES THROUGH WEATHER AND NIGHT

Bausch & Lomb optical-electronic-mechanical capabilities turn radar blips into pictures

Here's new all-day, all-night, all-weather reconnaissance for our Air Force!

Just feed high-resolution radar film through the B&L Cross Correlator—see the meaningful results in a picture that is the equivalent of an aerial photograph.

In war, this system strips the concealment of night and weather from enemy activities. In peace, it can help picture the face of the moon . . . with resolution of five to ten feet!

The same integrated Bausch & Lomb skills that developed this system from design through fabrication are ready to help on your project. Write us for full details.

Bausch & Lomb Incorporated, 99707 Bausch Street, Rochester 2, N. Y.



unimprinted. Special colors are available on special order.

Tubing is furnished in continuous lengths, has an electrical strength of 1,000 volts in 0.016-inch wall thickness, a tensile strength of 3,200 psi, ultimate elongation of 300 percent and a cold brittle point of -20°C .

CIRCLE 309 ON READER SERVICE CARD

Silicon Switch BISTABLE DEVICE

ELECTRONIC COMPUTER CO., 618 Maple St., Conshohocken, Pa. Type 3280 silicon switch is a bistable device of the *pnpn* class transistors featuring 4 terminals. It can be used in circuit designs utilizing 2, 3, or 4 terminals. The switch can be turned on or turned off with gate current to one or both of the control bases. Packaged in the 4 lead TB-4 base, 0.217 deep by 0.340 high, the unit is a fast switching, low holding current conjugate junction switch which is available in a variety of breakover voltages. It is designed for computer devices where low current operation and fast switching time is desirable.

CIRCLE 315 ON READER SERVICE CARD

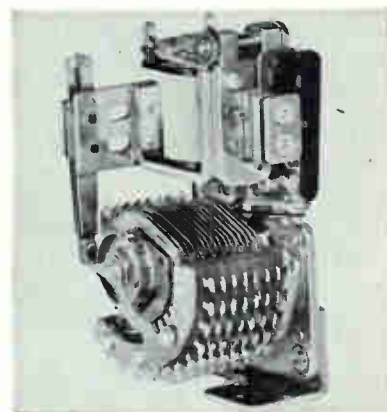

Stepping Switch 10-POINT DEVICE

C. P. CLARE & CO., 3101 Pratt Blvd., Chicago 45, Ill., announces a 10-point stepping switch, type 210, specially designed for digital operation. Switch is small (maximum length $4\frac{1}{8}$ in.), lightweight ($1\frac{1}{2}$ lb with 12 levels) and capable of over 100,000,000 operations with twelve 10-point levels; 300,000,000 with four 30-point levels (properly lubricated and adjusted). It is designed as a dependable component

for such applications as sequence control, totalizing, sampling or single point selection. It transfers from position 10 to position 1 without special circuitry. Available with a wide variety of hermetically-sealed or dust cover enclosures. Terminals or connections to suit application.

CIRCLE 316 ON READER SERVICE CARD

Mixer Diode

FOR K-BAND USE

SYLVANIA ELECTRIC PRODUCTS INC., Woburn, Mass., announces a new K-band mixer (24,000 Mc) micro-wave diode which meets all military environmental tests including shock, temperature cycling, centrifuge, and moisture resistance. Type 1N26C (negative polarity 1N26RC) uses a coaxial package with a hermetic seal and has a temperature rating of 150 C. The overall noise figure has been reduced to 9.5 db maximum. Unit also features a maximum vswr of 1.5, a maximum conversion loss of 7.5 db, and a maximum noise ratio of 1.5 times.

CIRCLE 317 ON READER SERVICE CARD



Speed Control

MINIATURIZED

SPECTROL ELECTRONICS CORP., 1704 South Del Mar Ave., San Gabriel, Calif., has developed a velocity servo, in a package measuring 1½ by 1½ by 3 in., for any system requiring miniaturized, precision speed control. Ready for installation as is, it contains a solid state amplifier, servo motor, gear train and a special potentiometer-switch combination just ½ in. long. The pot has four electrically isolated wipers spaced 90 deg apart, all contacting the same coil. The switch has four wipers riding on an alternately conducting and nonconducting surface. Capable of driving many components, resolvers, ta-

TWELVE IMPORTANT CONTROLS

Uses include such equipment as aircraft instrument panels, shipboard control centers, ground control equipment in either fixed or mobile installations, industrial process control centers, electronic test instruments and computers. Twelve important controls to meet your design problems provide a new standard in reliability of operation.

TP SERIES — Types TP05, TP09, TP11, TP13, TP17 and TP20, in 6 sizes from ½" to 2" diameter. Each is a single-turn, high torque, rotary, wire-wound pot, engineered for peak performance under severe environmental conditions. Threaded bushings, precision register, mounting nut, lock washer and locating pin permit exact positioning for precise control. Available with non-linear functions, including complete series of sine-cosine functions. Accurate, dependable, long-life performance.



high torque panel control.
POTENTIOMETERS

MTF SERIES — Types M3TF, M5TF and M10TF. Housed in corrosion resistant box-like enclosures, all have a lead screw shaft arrangement for driving the wiper transversely from end to end of the resistance element. Encapsulated metallic film resistance element provides infinite resolution, 3, 5 or 10 turns (1080°, 1800°, 3600°) of rotation for accurate setting. Threaded bushing, with concentric locking device supplied to provide simple panel mounting knob for precise manual control.

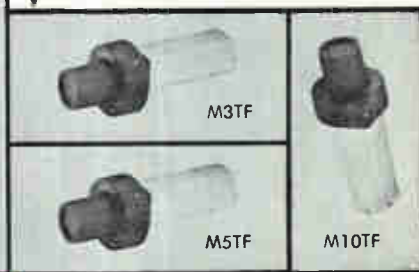

designed
for
precise
setting

P SERIES — Types P1¼, P1⅝ and P3 with numerals designating diameters. Especially designed for low cost commercial applications. These rotary type pots feature low inductance and capacitance. Available in linear or non-linear functions, single or ganged assemblies.

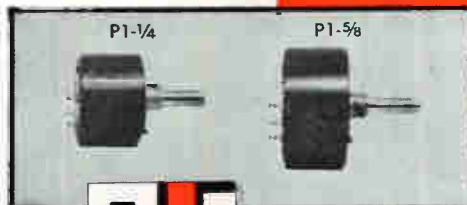

Get this new TIC catalog with complete details on the most complete line of precision potentiometers by calling, writing or wiring.

TECHNOLOGY INSTRUMENT CORP.
569 MAIN STREET, ACTON, MASS.



Subsidiaries:
Technology Instrument Corp. of Calif., North Hollywood, California
Acton Laboratories, Inc., Acton, Mass.
Tucson Instrument Corp., Tucson, Ariz.
Servotrol, Inc., Chicago, Ill.
Altomac Corp., Canton, Mass.

Investigate today's most productive semi-automatic Coil Winder — the Leeson No. 108. Winds up to 30 coils simultaneously on short or long runs. Handles wire from No. 19 to No. 42 (B&S) and finer. Fingertip control . . . quick set-up . . . versatility. Leeson Corporation, P.O. Box 1605, Providence 1, Rhode Island.
(formerly Universal Winding Company)

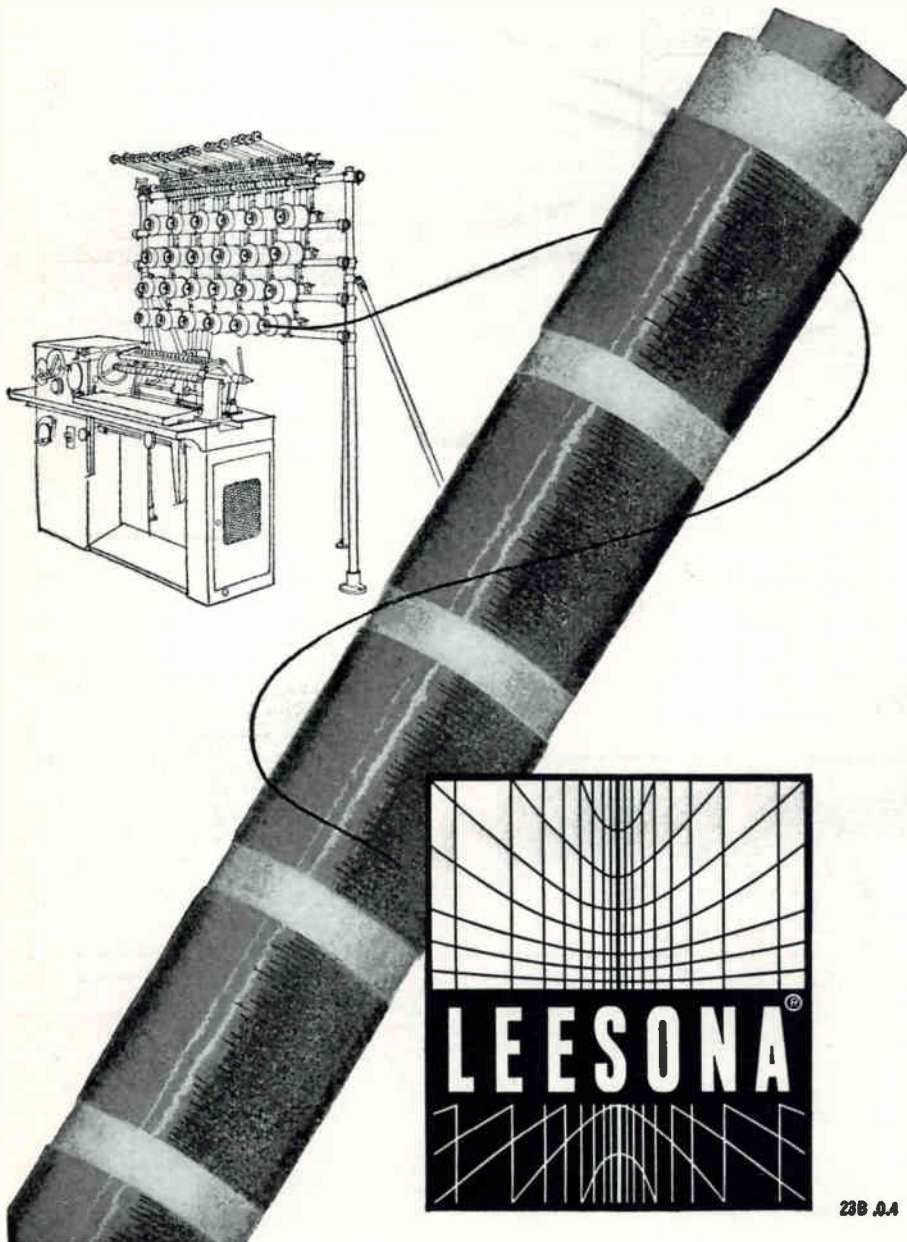

chometers, other pots and switches, the miniature servo accepts d-c signals varying between ± 10 v. The potentiometer is driven so that speed is directly proportional to the d-c signals.

CIRCLE 318 ON READER SERVICE CARD

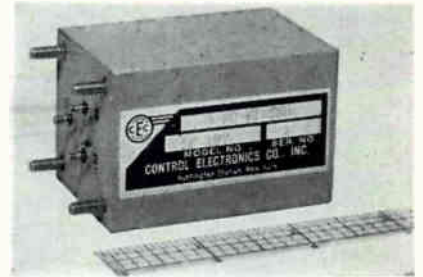

**Low Pass Filter
RUGGED DEVICE**

CONTROL ELECTRONICS CO., INC., 10 Stepar Place, Huntington Station, L. I., N. Y., has developed a miniature low pass filter operating with a cutoff frequency of 3,000 cps. Unit measures only $1\frac{1}{2}$ in. by $1\frac{1}{2}$ in. by $2\frac{3}{4}$ in. high. Model LF-197 has an input and output impedance of 10 K ohms. Attenuation is held to 3 db at 3,000 cps and 40 db at 4,000 cps and above. Specific attenuation at other frequencies are 10 db at 3,120 cps and 20 db at 3,300 cps. Filter meets applicable portions of MIL-F-18327-A with type AJ case is hermetically sealed and potted.

CIRCLE 319 ON READER SERVICE CARD



**Curve Generator
FOR TRANSISTORS**

TRANS-WESTERN ELECTRONICS, P. O. Box 1473, Ventura, Calif. Model 81 is designed to fill the need for a simple inexpensive instrument to generate a collector curve for low and medium power transistors. It generates a single curve in the grounded-emitter configuration for

display on an external oscilloscope. Unit supplies collector voltages continuously variable to 40 v, base currents from 20 μ a to 10 ma and provides collector currents from 200 to 500 ma. It operates from a 117 v a-c source and requires no batteries. Price is \$118.50.

CIRCLE 320 ON READER SERVICE CARD



Digital Printer
SOLID STATE MATRIX

NORTHEASTERN ENGINEERING, INC., 25 South Bedford St., Manchester, N. H., announces model 14-27A digital printer. A hinged door with magnetic catches provides ease of access to the 3-in. paper tape. Top and bottom cabinet panels are completely removable for servicing. The print mechanism is shock mounted. The cabinet is mounted on non-skid glides. Blower cooling is employed. Other specifications are: 115 v a-c, 100 va power input; print rate 1.5 lines/sec; 1-2-2-4 binary code; 8 digit capacity; and dimensions 17 by 17 by 7 in.

CIRCLE 321 ON READER SERVICE CARD

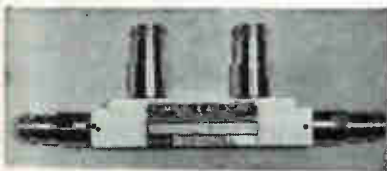

Directional Coupler
FOR BROADBAND USE

MAURY & ASSOCIATES, 10373 Mills Ave., Montclair, Calif. New series of dual directional couplers for broadband applications feature low vswr, high directivity and power handling capacity and can be obtained with either type N or C connectors. Specifications are coupling 30 db at 100 Mc and 12.5 db at 1,000 Mc; vswr is 1.15 max. in the primary arm and 1.20 max. in the secondary arm; directivity above

NEW "SILDISC" 500 mW SILICON DIODE FOR PRINTED CIRCUITS

Only 3/16" dia. x 1/16" thick

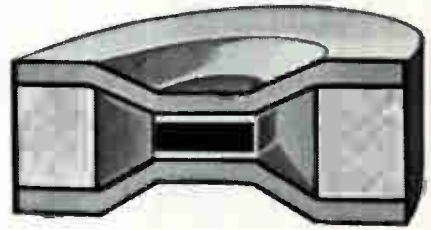

New double-cup design saves space, dissipates heat more efficiently. Plug it in . . . clip it in . . . solder it in or pressfit. Can be mounted many ways.

LOW LEAKAGE "SILDISC" DIODES					
CC Part Number	PIV	Reverse Dc Current at Rated PIV mA	Max. Rectified Dc Output Current mA	Forward Dc Volt. Drop at Rated Dc Current Volts	
CC.5-15	15	.010	500	1	
CC.5-30	30	.010	500	1	
CC.5-50	50	.010	500	1	
CC.5-75	75	.015	500	1	
CC.5-100	100	.020	500	1	
CC.5-150	150	.020	500	1	
CC.5-200	200	.020	500	1	
CC.5-250	250	.025	500	1	
CC.5-300	300	.025	500	1	
CC.5-500	500	.025	500	1	

DOUBLE ANODE TWIN ZENER "SILDISCS"					
CC Part Number	ZENER VOLTAGE RANGE			TYPICAL IMPEDANCE	
	E _z (Min) Volts	E _z (Max) Volts	@ I _z mA	Z _z Ohms	@ I _z mA
CC.5D-1.5	1.35	1.65	50	10	50
CC.5D-1.8	1.63	1.98	50	10	50
CC.5D-2.2	1.97	2.42	50	10	50
CC.5D-2.7	2.42	2.96	50	20	50
CC.5D-3.3	2.96	3.62	30	20	30
CC.5D-3.9	3.51	4.28	30	20	30
CC.5D-4.7	4.23	5.16	30	20	30
CC.5D-5.6	5.04	6.15	20	20	20
CC.5D-6.8	6.12	7.46	20	20	20
CC.5D-8.2	7.38	9.02	10	15	10
CC.5D-10	9.00	11.1	10	15	10
CC.5D-12	11.00	13.5	10	15	10
CC.5D-15	13.4	16.5	10	25	10
CC.5D-18	16.3	19.8	10	35	10
CC.5D-22	19.7	24.2	3	50	3
CC.5D-27	24.1	29.6	3	60	3
CC.5D-33	29.5	36.2	3	80	3

<p>A few mounting possibilities and configurations. Consult us about your special problems.</p>	<p>Offset "Sildisc" allows contact at any angle.</p>
<p>"Sildisc" with one center lead vertical to board.</p>	<p>Double offset "Sildisc" inserted in terminal strip.</p>
<p>Press-fitted into 2-sided board for dip soldering.</p>	<p>Press-fitted into 1-sided board for dip soldering.</p>
<p>Riveted into 2-sided printed circuit board.</p>	<p>2-sided lead terminal "Sildisc" on 1-sided board.</p>

Miniature is the watchword with this new CC silicon diode. The "Sildisc" fits tightest requirements. New double-cup design has maximum heat dissipation.

Ask about CC's complete line of silicon rectifiers and Zener diodes available in low, medium, and high power. Call or write for catalog and engineering data.



Semi-Conductor Component Specialists

CONTROLS COMPANY OF AMERICA

ELECTRON DIVISION

811 W. Broadway, P.O. Box 937, Tempe, Arizona

GUDELACE is engineered for problem-free lacing

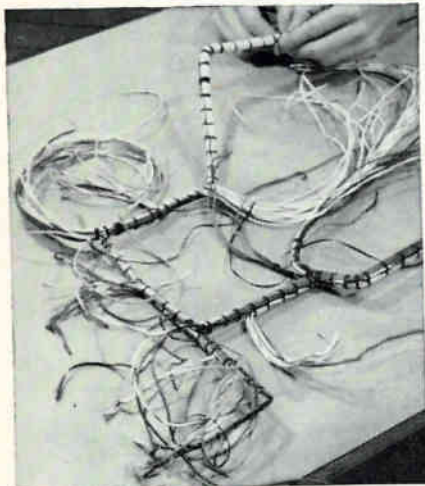

It's no accident that Gudelace is the best lacing tape you can buy. Excellence is *engineered* into Gudelace. A sturdy nylon mesh is meticulously combined with the optimum amount of special microcrystalline wax. Careful selection of raw materials and superior methods of combining them give Gudelace outstanding strength, toughness, and stability. Gudelace is the original *flat* lacing tape which distributes stress evenly over a wide area. It is engineered to stay flat; it will not stretch out of shape when pulled. Gudelace's nonskid surface prevents slipping, eliminating the too-tight pull that causes strangulation and cold flow. Durability and dependability make Gudelace your most economic buy—with no cut insulation, fingers, or feelings.

Write for Data Book with specifications on Gudelace and Gudebrod's complete line of braided lacing tapes and dial cords—Temp-Lace, Stur-D-Lace, and Gude-Glass.

GUDEBROD BROS. SILK CO., INC.

Electronic Division
225 West 34th Street, New York 1, N.Y.

Executive Offices
12 South 12th Street, Philadelphia 7, Pa.

coupling factor is 20 db min. Coupling and directivity accuracy is ± 1.0 db. Nominal impedance of the unit is 50 ohms and they will withstand 500 w c-w. The compact, rugged units are not affected by temperature or humidity changes.

CIRCLE 322 ON READER SERVICE CARD



Silicon Transistors HIGH POWER

TRANSITRON ELECTRONIC CORP., 168 Albion St., Wakefield, Mass., is marketing a series of six new high power diffused mesa type silicon transistors, each with advanced electrical and mechanical characteristics. Series will cover the full current range from 100 μ a to 5 amperes. Applications include regulated power supplies and amplifier output stages. Units feature low saturation resistance (0.80 ohm); good beta linearity; high cut-off frequencies (typically 15 Mc) and voltages up to 100. They come in both 11/16 in. hex stud-mount package and a square flange.

CIRCLE 323 ON READER SERVICE CARD

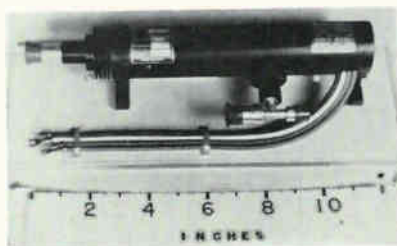

X-Band TWT's PPM-FOCUSED

LITTON INDUSTRIES, 960 Industrial Road, San Carlos, Calif., announces two new metal and ceramic PPM-focused X-band traveling wave tubes. Ideally suited to operate in series as an amplifier chain, the L-3266 and L-3236 cover the frequency band of 7,000 to 11,000 Mc with minimum saturated c-w power of 20 mw and 2 w respectively. Each tube provides small signal

Get the facts together quickly

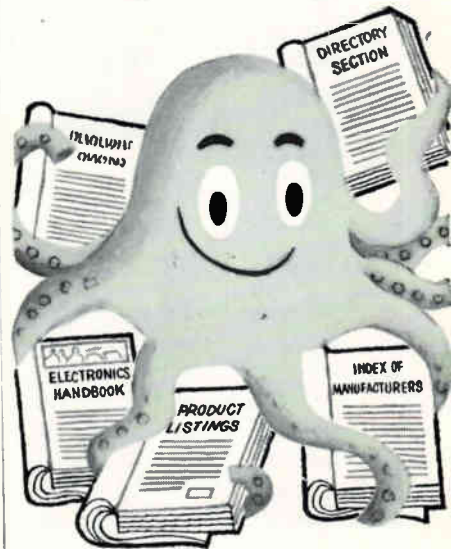

Buying is easier when you've got all the facts in *one* place.

The BUYERS' GUIDE tells who makes it. Gives detailed catalog-type product information and specs. Gives choices in mechanical and electrical characteristics. Gives more choices in terms of materials and design. Also objective and authoritative facts about markets . . . materials . . . design . . . in an exclusive 64-page reference section.

That's why the GUIDE will put you in the *strongest* position to make the best buying choice for yourself and your company.

It's *all* between the covers of one volume. The accurate, complete and authoritative electronics BUYERS' GUIDE and Reference Issue.

O.E.E

FIND
WHAT
YOU
NEED
IN
THE



**electronics
BUYERS' GUIDE**

VERSATILE

Multi-channel—telegraph A1 or telephone A3

STABLE

High stability (.003%) under normal operating conditions

RUGGED

Components conservatively rated. Completely tropicalized



FROM GROUND TO AIR OR POINT TO POINT

Here's the ideal general-purpose high frequency transmitter! Model 446, suitable for point-to-point or ground-to-air communication. Can be remotely located from operating position. Coaxial fittings to accept frequency shift signals.

This transmitter operates on 4 crystal-controlled frequencies (plus 2 closely spaced frequencies) in the band 2.5-24.0 Mcs (1.6-2.5 Mcs available). Operates on one frequency at a time; channeling time 2 seconds. Carrier power 350 watts, A1 or A3. Stability .003%. Nominal 220 volt, 50/60 cycle supply. Conservatively rated, sturdily constructed. Complete technical data on request.

Now! Complete-package, 192 channel, H.F., 75 lb. airborne communications equipment by Aer-O-Com! Write us today for details!

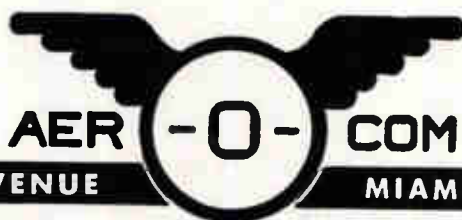

3090 S. W. 37th AVENUE

MIAMI 33, FLORIDA

A-131

$$\Delta E_o = \frac{dE_o}{E_o} = \left[\frac{-1}{1 + \frac{R_1 E_2}{R_2 E_1}} \right] \Delta R_1 + \left[\frac{-1}{1 + \frac{R_2 E_1}{R_1 E_2}} \right] \Delta R_2$$

This equation relates operational amplifier accuracy to the error contribution in each of 2 coefficient resistors. It occurs on page 5 of our technical manual "Networks for Computers".

We manufacture resistors and networks that maintain total ΔE_o accuracy of $\pm 0.005\%$ when required. This performance includes the effects of:

- Initial Tolerance
- Long-term Aging
- Wide Temperature Changes
- Self-heating
- Temperature Retrace Offset
- Voltage Retrace Offset
- Humidity Retrace Offset
- Mechanical Stresses

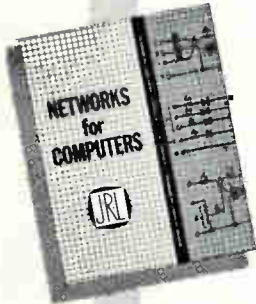

Ordinary "precision" resistors cannot even approach such performance . . . frequently are rated in terms of initial accuracy only. That is why the largest computer manufacturers purchase all critical resistors and networks from us. Prices are surprisingly moderate.

Free to computer design engineers



JULIE RESEARCH LABORATORIES, INC.

556 West 168th Street, New York 32, New York LO. 8-8700

CIRCLE 204 ON READER SERVICE CARD

gain in excess of 33 db. Both weigh less than 4 lb each and are about 12 in. long, including their shielded, temperature-compensated, periodic permanent magnets. They are suitable for use in ECM repeaters, radar-target enhancement systems, frequency diversity radar transmitters, and equipments requiring general purpose microwave amplifiers.

CIRCLE 324 ON READER SERVICE CARD

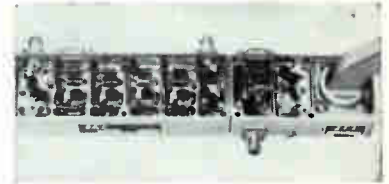

Microwave Receivers SOLID-STATE

LEL, INC., 380 Oak St., Copiague, L. I., N. Y. Designed for incorporation into a satellite, missile guidance system, or microwave link, the TMR-1419 is one of a new series of solid-state microwave receivers. Composed of an orthomode X-band mixer, a low-noise transistorized preamplifier, and a transistorized main amplifier, it combines a set of matched complementary assemblies to provide an overall noise figure of 10 db, a gain of 95 db, and a nominal 9 Mc passband. Less than one-half watt of total input power is required.

CIRCLE 325 ON READER SERVICE CARD



Delay Line ELLIPTIC-CORE

COLUMBIA TECHNICAL CORP., 61-02 Thirty-First Ave., Woodside 77, N. Y., announces a miniaturized, compact delay-line flat No. F840W designed for computer applications. Unit utilizes an elliptical core which makes it possible to obtain a relatively long delay at a high impedance level in a minimum of space. Built around a ceramic core

CONTINUALLY
ADVANCING
Toroidal Windings for All Purposes
COMPONENTS

COMMUNICATION ACCESSORIES COMPANY

306 Lee's Summit, Missouri
CIRCLE 205 ON READER SERVICE CARD

ELECTROMECHANICAL SWITCHES FOR TELEMETERING SYSTEMS!

Specifications, performances, applications for typical electromechanical commutators for long-range sampling, programming. Quick comparisons let you know what's going on . . . see

October 2nd, 1959 issue (did you miss it?). Another reason to subscribe to electronics (or renew your subscription). Fill in Reader Service Card box. Easy to use. Postage free.

FIND WHAT YOU NEED IN...

electronics

with leads embedded, the delay line is $1\frac{1}{8}$ in. long with a cross-section of $\frac{1}{8}$ in. by $11/16$ in. Unit has an impedance level in a minimum of $0.8 \mu\text{sec}$ with a rise time of $0.2 \mu\text{sec}$. Pulse attenuation is 0.2 db. Ripple ratio is less than 5 percent. D-C resistance is under 100 ohms.

CIRCLE 326 ON READER SERVICE CARD

Vibration Meter WIDE APPLICATION

WAYNE KERR CORP., 1633 Race St., Philadelphia 3, Pa. Type B-731A vibration meter has wide application in electronics and aircraft and offers a new method of measuring distance and vibration without physical contact. It avoids hazards and makes remote testing possible. With a range of 50 micro-inches to 0.5 inch (depending upon probe factor) and accuracy of 2 percent, the unit is particularly suited for measuring the dilation and eccentricity of rotating parts, and may be used for vibration tests to meet JAN-MIL specs in electronic components.

CIRCLE 327 ON READER SERVICE CARD

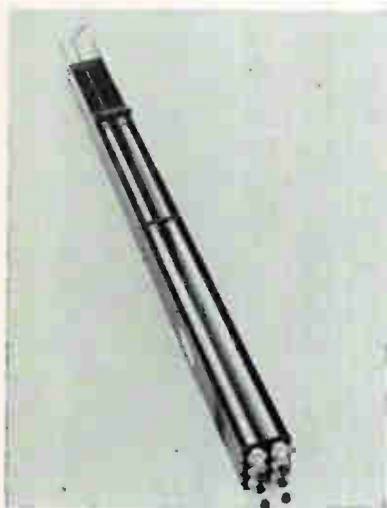

Phase Shifter TRIPLE CHANNEL

RADAR DESIGN CORP., Pickard Drive, Syracuse 11, N. Y. Model 1063 provides 360 deg phase shift for three independent coaxial line channels 215-235 Mc. Trombone construction allows input and output connectors (type N female) to remain stationary. Channels track ± 1 deg and vswr is below 1.20. A

July 29, 1960

Max Schweizer is a Specialist



...at "RACKING UP" RELIABILITY

That incredibly short ($3\frac{1}{2}$ " rack-mounting counter-timer tucked under Max Schweizer's forearm is a tribute to the many years of specialized experience he brings to the position of Chief Mechanical Engineer at TSI. Every one of the 2162 components in the Model 361-R APTI®-METER* is logically located, thermally protected and instantly accessible. No "sardine packing" here!

Incidentally, Max found his job about 800 components easier, because our circuits group has achieved what we call "reliability through sophisticated simplicity" in the 360 Series. His superb packaging job further enhanced that reliability — and the Model 361-R bears a 5-year guarantee.

If you like sharp contrasts, compare this cool, compact, all-solid-state beauty with the hot-as-a-pistol vacuum-tube monsters five times its height and weight, not nearly as versatile or convenient.

Why plod along with old-fashioned counters? Let us send you literature on the newest — Model 361-R APTI®-METER, the only 1 MC solid-state counter!

*APTI®-METER is our registered trade-mark for an ACTIONS-PER-TIME-INTERVAL meter. Model 361-R counts from 0-1MC, has crystal-plus-oven stability of 0.3 ppm/week, IN-LINE NIXIE READ-OUT, and identical-twin, high-impedance, high-sensitivity amplifiers. Features galore, unlimited flexibility, yet the sensible-compromise price is only \$1680.



TRANSISTOR SPECIALTIES INCORPORATED

Sophisticated Digital Instrumentation

TERMINAL DRIVE, PLAINVIEW, NEW YORK • WELLS 5-8700

CIRCLE 139 ON READER SERVICE CARD 139



ELECTRONIC FIELD TEST ENGINEERS

Versatile, practical-minded engineers with a record of accomplishment in the missile, aircraft or related fields will now qualify for a field test position at Convair-Astronautics — creators and testers of the mighty ATLAS ICBM. Positions must be filled immediately at various locations, from Cape Canaveral, Florida to Vandenberg AFB near Santa Maria, California. Field test operations are in two major groups: **ACTIVATION**—coordination of construction and the integration of support systems with facilities; and **OPERATIONS**—the preparation, checkout and launching of the missile itself. Specific requirements are in R. F. communications, instrumentation, missile control and guidance systems.

Write now to R. B. Merwin, Engineering Personnel Administrator, Department 130-90

CONVAIR ASTRONAUTICS

Convair Division of

GENERAL DYNAMICS

5515 Kearny Villa Road,
San Diego, California



16 threads-per-in. lead screw drives all three channels simultaneously. The lead screw crank provided is quickly removed to expose a standard $\frac{1}{4}$ in. shaft for coupling to a drive motor. Total length is 66 in. Delivery is 30 days at \$2,500, in small quantity.

CIRCLE 328 ON READER SERVICE CARD



Phase Meter

DIRECT READING

AD-YU ELECTRONICS LAB., INC., 249 Terhune Ave., Passaic, N. J. New high accuracy direct reading phase meter for measuring a phase angle between two alternating voltages, without either amplitude or frequency adjustment. In addition to its capability of presenting the phase angle directly in degrees on a 7 in. rectangular panel meter with mirror scale, it is also capable of plotting phase-frequency curves on a recorder or oscilloscope. The instrument presents no ambiguity at zero reading, and is perfectly stable for measuring a small fraction of one degree on all ranges including 0-12 deg range. It is particularly suitable for production work, because it is very simple to operate—no amplitude adjustment, no zero adjustment, no frequency adjustment, and direct reading in degrees.

CIRCLE 329 ON READER SERVICE CARD

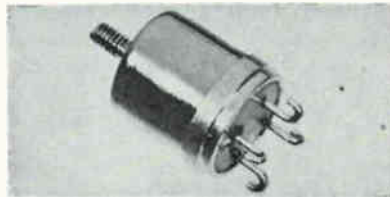

R-F Transformer

WIDEBAND UNIT

NORTH HILLS ELECTRONICS, INC., Glen Cove, Long Island, N. Y. Designed for many applications, the

USE THE BUYERS' GUIDE AS A MARKETING TOOL

You'll find key information from the marketing viewpoint in the **electronics BUYERS' GUIDE**. It will help you to see the *whole* picture of industry activity *clearly*.

You'll find facts about the markets... materials... design—available nowhere else.

You'll find *who* makes which products and *where* they are located.

You'll find a reflection of the size, interests and stature of more than 4,000 companies.

Best of all, the **BUYERS' GUIDE** and Reference Issue is accurate, complete and authoritative. You can *act* on the information it gives you. O.S.B.

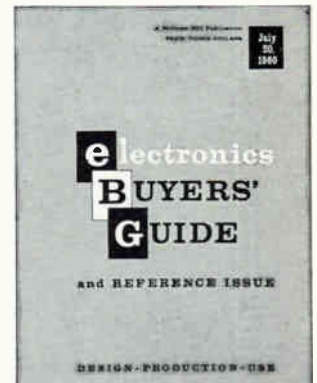

FIND
WHAT
YOU
NEED
IN
THE

electronics BUYERS' GUIDE

1214 wideband r-f transformer covers a frequency range of 1.5 to 130 Mc. Impedance ratio is 75 ohms unbalanced to 600 ohms balanced. Unit will handle 1 w of power. It is hermetically sealed and has a single 4-40 stud mounting. Case is $\frac{3}{8}$ in. o-d by $\frac{3}{8}$ in. long and is nickel-plated. These transformers have been designed for low insertion loss and good matching characteristics over wide frequency ranges. Balanced windings feature extremely low unbalanced voltage. Bandwidth ratings are conservative. Applications include antenna matching interstage coupling, impedance matching, computer drive circuits, pulse applications, voltage step-up and d-c isolation. Units are priced at \$14.95 to \$7.95 depending on quantities.

CIRCLE 330 ON READER SERVICE CARD

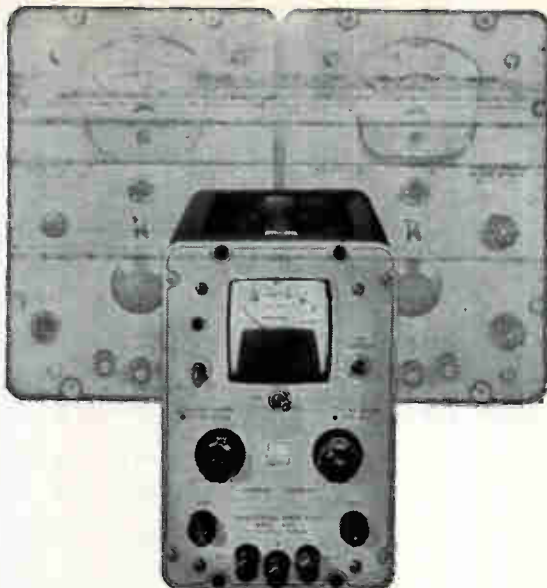

CONSTANT VOLTAGE CONSTANT CURRENT



FROM THE SAME TERMINALS!

The Power Designs Inc. Model 4005 Power Supply adds a new dimension to the application of d-c sources for laboratory instrumentation. Truly universal, the Model 4005 may be operated as a constant voltage source, a constant current source, a constant voltage source with automatic current limiting or a constant current source with automatic voltage limiting.

The Model 4005 employs semiconductor devices exclusively in a new proprietary circuit called.....

AMBITROL* is a dual regulator system permitting continuous control of voltage or current with automatic electronic cross-over to either mode of operation.

The supply also features remote voltage programming, dual concentric controls for both coarse and fine adjustment of voltage or current and the HEATRAN® circuit for electronic control of power transistor dissipation.

*TM applied for.

MODEL 4005 SPECIFICATIONS

INPUT: 105-125 volts, 55-440 cycles single phase.
TEMPERATURE: Continuous duty at full load 0-50° C. ambient
POLARITY: Positive or negative output terminal may be grounded
DIMENSIONS: 5 $\frac{1}{4}$ " W x 8 $\frac{3}{4}$ " H x 11 $\frac{1}{4}$ " D.

CONSTANT VOLTAGE

Range: 1-40 vdc, 0-0.5 amperes.
Regulation: .05% or 10 millivolts max. for line or load variations.
Ripple: .001% or 500 microvolts max.
Response Time: Less than 50 microseconds.
Source Z: 0.1 ohms to 20 kc, 0.5 ohms to 1 mc.

CONSTANT CURRENT

Range: 25 to 500 milliamperes.
Voltage compliance: Output current constant to full rated output voltage of 40 volts.
Regulation: .05% or 250 microamperes max., for line or load variations.
Ripple Content: .01% or 25 microamperes max.
Source Impedance: 100,000 ohms approx.

†Prices subject to change without notice.



†\$143⁵⁰

F.O.B. FACTORY

Frequency Standard

SIMPLE AND PORTABLE

THE HADDAM MFG. CO., INC., Route 9, Haddam, Conn., announces a highly stable secondary frequency standard known as the Bailey ZERO-BEAT. It is particularly useful in the "netting in" of the mobile f-m communication systems, where all the mobile and base stations must be maintained to the exact frequency assigned by the FCC. It features simplified design. A highly stabilized 100 Kc crystal oscillator controls harmonic generators and multivibrators to produce signals in the h-f, vhf and uhf ranges. Output signals of sufficient amplitude are available to saturate the limiter of receivers at all assigned frequencies in the 30-50 Mc, 150-170 Mc, and 460 Mc bands of the new split channel, narrow band mobile communications channels. Accuracy in field service is 2 parts per million (0.0002 percent) from -10 F to + 125 F. Price is \$495.

CIRCLE 331 ON READER SERVICE CARD

July 29, 1960

Power Designs inc.

1700 SHAMES DRIVE WESTBURY, NEW YORK

Edgewood 3-6200 (Long Distance Area Code 516)

CIRCLE 141 ON READER SERVICE CARD 141

wide-range REGATRON® POWER SUPPLIES



... for
laboratories with varied requirements

Wide-range REGATRON Laboratory Power Supplies: available in 0-300, 600, or 1000 volts dc continuously variable, 0-500, 600, 1000, or 1500 ma . . . load regulation to 0.01% or 0.05 V, negligible ripple . . . also 6.3 V ac and regulated dc bias outputs. For all the reasons why leading laboratories prefer REGATRONs send for Bulletin 422.

Model 219B (pictured above)

Main output: 0 to 600 V dc, 0 to 1000 ma.

Load regulation: 0.01% or 0.05 V.

Ripple: 0.0005 V.

Also regulated 0-150 V dc bias supply and 6.3 V ac CT output, ten-turn control, calibrated dial with 3 volt vernier, modulation input. PRICE: \$675 F. O. B. Eatontown, N. J.

© Registered U.S. Pat. Off. Patents issued and pending.

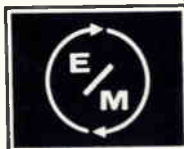

**ELECTRONIC
MEASUREMENTS**
COMPANY, INCORPORATED
EATONTOWN · NEW JERSEY

Telephone: Liberty 2-0300

TWX: EAT 984

CIRCLE 208 ON READER SERVICE CARD

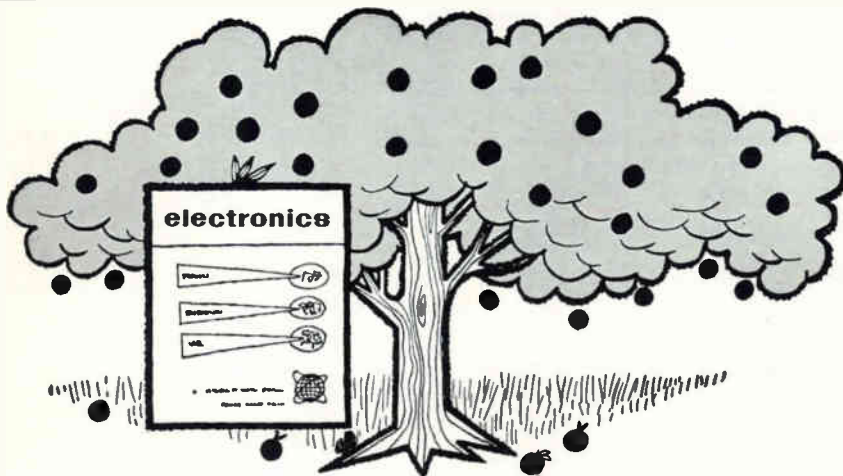

The pick of the crop!

Thumbnail summaries of sales literature on materials, components, equipment, and facilities keep you up-to-date in about 3 minutes of quick, easy reading in "Literature of the Week."

Another reason why it will pay you to subscribe to *electronics* (or renew your subscription) right now. Fill in the box on Reader Service Card. Easy to use. Postage free.

FIND WHAT YOU NEED IN...

electronics

Literature of

RECORDING INSTRUMENTS Hogan Faximile Corp., 155 Perry St., New York 14, N. Y., has available a catalog presenting its line of high-speed recorders which lend themselves to a wide variety of applications.

CIRCLE 350 ON READER SERVICE CARD

MYLAR CAPACITORS Hopkins Engineering Co., 12900 Foothill Blvd., San Fernando, Calif. A 2-color, 8-page brochure describes a complete line of extremely reliable mylar capacitors which feature high insulation resistance, and operating temperatures up to 165 C.

CIRCLE 351 ON READER SERVICE CARD

AUTOMATIC TEST EQUIPMENT Industro Transistor Corp., 35-10 36th Ave., Long Island City 6, N. Y., has released a new brochure describing the ITVAC family of automatic test and classification equipment for semiconductor devices.

CIRCLE 352 ON READER SERVICE CARD

POWER SUPPLIES The Victoreen Instrument Co., 5806 Hough Ave., Cleveland 3, Ohio. Form 3114-9, an 8-page 2-color bulletin, describes a line of high-voltage power supplies. It pictures main components in the broad range of single and dual units for operation up to 5,000 v.

CIRCLE 353 ON READER SERVICE CARD

MICROWAVE ANTENNAS Andrew Corp., 363 E. 75th St., Chicago 19, Ill. The 16-page Catalog M provides detailed engineering data on 60 antennas covering all current commercial and military microwave frequency ranges. Selected cables, waveguides and anti-icing devices are also offered.

CIRCLE 354 ON READER SERVICE CARD

DELAY LINES ESC Corp., 534 Bergen Blvd., Palisades Park, N. J. A recent mailing piece describes miniature modular computer delay lines designed for printed board mounting.

CIRCLE 355 ON READER SERVICE CARD

SELENIUM RECTIFIERS Edal Industries, Inc., 64 Franklin St., New Haven, Conn. An 8-page

the Week

brochure illustrates and describes a wide line of selenium rectifiers covering current ranges from microamperes to thousands of amps and voltage ranges from tenths of a volt to many kilovolts.

CIRCLE 356 ON READER SERVICE CARD

POWER TETRODE General Electric Co., Schenectady 5, N.Y. Bulletin PT-35, 24 pages, contains detailed information on application and operating characteristics of the GL-6283 metal-ceramic tetrode for military and uhf uses.

CIRCLE 357 ON READER SERVICE CARD

MACHINING OF TEFLON Plastic Products Division of Raybestos-Manhattan, Inc., Manheim, Pa. "Basics in the machining of Teflon" is the title of an informative 12-page booklet recently released.

CIRCLE 358 ON READER SERVICE CARD

D-C MOTORS Globe Industries, Inc., 1784 Stanley Ave., Dayton 4, Ohio. Two-page bulletin 121 describes a new line of precision miniature permanent magnet d-c motors that measure $\frac{7}{8}$ in. thick by $\frac{3}{4}$ in. by $1\frac{1}{4}$ in. and develop 0.1 oz in. of continuous duty torque.

CIRCLE 359 ON READER SERVICE CARD

ELECTRONIC SYMBOLS Chart-Pak, Inc., 1 River Road, Leeds, Mass., has available a 40 page booklet dealing with a wide range of Symbtak symbols for electronic drawing and for printed circuitry.

CIRCLE 360 ON READER SERVICE CARD

SILVER-ZINC BATTERIES Yardney Electric Corp., 40-50 Leonard St., New York, N.Y., has issued technical data sheets on two new silver-zinc batteries—the P-1517 and the P/N 5522.

CIRCLE 361 ON READER SERVICE CARD

PACKAGING CAPABILITIES American Electronics, Inc., 9503 W. Jefferson Blvd., Culver City, Calif. A four-page, two-color brochure outlines the capabilities of the Instrument Division in the development and packaging of electronic, electromechanical and mechanical subsystems for control systems in missile, space and aircraft vehicles.

CIRCLE 362 ON READER SERVICE CARD

July 29, 1960

AMCI

LINE STRETCHERS

CONSTANT IMPEDANCE

$$Z_0 = 50 \text{ ohms}$$

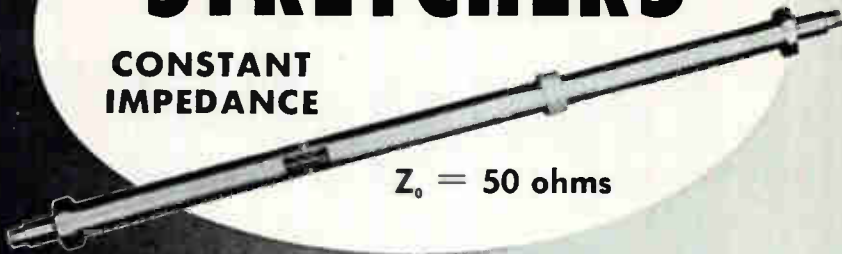

- **Rated at 0.5 kw cw at 1000 mc** except as limited by connectors; constant impedance with low SWR.
- **Rugged and dependable;** electrically active portions are enclosed in and protected by an external case.
- **Intended for long service;** sliding contacts are made between solid coin silver tubes and solid sterling-silver fingers.
- **Provided with a locking device** and with positive stops at both ends of the line-stretcher travel.

TYPE 3701B: 8" extension } available with connectors to $\frac{7}{8}$ " EIA
TYPE 3702B: 14" extension } line, and Types N, HN or LC line.

Write for complete information on AMCI Line Stretchers



CIRCLE 212 ON READER SERVICE CARD

MICO Precision Apparatus

NEW HEAVY DUTY 2 & 3 DIMENSIONAL ENGRAVER

FOR Engraving Nameplates Fine Routing Work Profiling Small Objects Making Small Dies and Molds



UHF COAXIAL WAVEMENTERS

2-75 Centimeter Range

Send for Illustrated Catalogs MICO INSTRUMENT CO.

77 Trowbridge St. Cambridge 38, Mass.

CIRCLE 207 ON READER SERVICE CARD

send for this

FREE

EICO Electronics Catalog



you save 50% on Top-Quality Test Instruments Hi-Fi • Ham Gear

KITS AND WIRED

for professional and home use

- | | |
|-----------------------------|-----------------------|
| TEST INSTRUMENTS | HI-FI |
| battery eliminators | stereo and monaural |
| battery testers | tuners |
| bridges | preamplifiers |
| decade boxes | power amplifiers |
| electronic switch | integrated amplifiers |
| flyback tester | speaker systems |
| oscilloscopes | |
| probes | HAM GEAR |
| signal and sweep generators | cw transmitter |
| tube testers | modulator-driver |
| transistor tester | grid dip meter |
| vacuum tube | |
| voltmeters | OVER 2 MILLION |
| volt-ohm-milliammeters | EICO instruments in |
| | use throughout |
| | the world. |

LIFETIME service and calibration guarantee. IN STOCK at your neighborhood EICO dealer. Send now for FREE catalog E-7A

EICO

33-00 N. Blvd., L. I. C. 1, N. Y.

praised by the experts as BEST BUYS IN ELECTRONICS

© 1960 ELECTRONIC INSTR. CO., INC.

CIRCLE 143 ON READER SERVICE CARD

143



Vector to Open Space Center

NOW UNDER CONSTRUCTION in Trevoze, Bucks County, Pa., is the new space instrumentation center of Vector Mfg. Co., Inc. The building will provide 25,000 sq ft in addition to the 8,000 sq ft in the company's Southampton and Churchville, Pa., facilities.

Vector manufactures telemetry equipment for reporting from as far away as the moon or from a sun-orbit. The equipment consists of transducers, voltage regulators, oscillators, mixers and amplifiers, commutators and transmitters, which, while a missile, rocket or space vehicle is in flight, automatically gather vital flight performance data and transmit it over thousands or millions of miles to equally complex electronic instruments in ground stations.

The company, organized in 1955 by two young engineers, Stanley A. Wulc and Emanuel Wolff, has been producing this equipment about four years.

The new plant, situated on a 24½ acre tract, will be fully equipped for the manufacture, design and development of both components and systems. It will house engineering and manufacturing and will concentrate the company's science library in one spot.

Of special importance will be the environmental testing laboratory, since telemetry components, carried aloft, are subjected to extreme environmental conditions—pressures from sea level to approximate vacuum, temperatures from far below to far above zero, accelerations up to 25,000 g, extreme shocks, sudden loads and strains. Vector's 1959 annual report shows gross sales of over \$2,089,000, an increase

of 302 percent over the 1958 figure. Net profits after taxes were over \$212,000, a 612-percent increase over the 1958 figure. The first quarter of 1960 opened with a backlog of orders of half a million dollars.

The company began 1959 with 19 employees and ended it with 125. A further increase has been taking place, bringing the current total to 150. Vector is undertaking a research and development phase devoted to possible electronics applications in the industrial and commercial fields, but not necessarily connected with telemetry.



Royal McBee Board Elects Ryan

FORTUNE PETER RYAN was recently elected president of Royal McBee Corp., Portchester, N. Y., at a meeting of the company's board of directors. He was formerly executive vice president and vice chairman of the board of directors of Royal McBee.

Ryan is president and director of Royal Typewriter Co., Ltd., and a director of Royal Precision Corp. and RMB Corp., Royal McBee subsidiaries, and is on the board of Kaysam Corp. of America.

Allison To Head Fairchild Section

DAVID F. ALLISON has been named to head the newly formed transistor development section of Fairchild Semiconductor Corporation's R&D Laboratories.

Allison joined Fairchild in February of 1957. He was formerly senior member of the device development section.

Prior to joining Fairchild, Allison was with Shockley Semiconductor Laboratories in Mountain View, Calif.



Lockheed Electronics Appoints Pritchard

EDWARD M. PRITCHARD has been named director of engineering for the Military Systems—Stavid Division of Lockheed Electronics Co., Plainfield, N. J. He will direct the activities of the division's six engineering departments — airborne electronics, electromagnetic systems, shipboard electronics, special projects, advanced techniques, and advanced systems.

Pritchard was formerly employed by RCA, where he held several assignments, the most recent being that of chief systems engineer for the Airborne Systems division of Defense Electronics Products.

Automation Occupies New Facility

THE Magnetics division of Automation Industries, Inc., has occupied a new 12,000 sq ft plant facility in Redwood City, Calif. "The new facility brings the corporation's total factory space to ap-

CONTROL ELECTRONICS' BUYERS' GUIDE

C.E.C. has for years been engaged in the design and production of quality components and systems for both military and industry. A member of our engineering group will be happy to meet with you on any problems you now face.

FILTERS & TOROIDS



BF-139

45 mc band pass filter—3 db bandwidth \approx 2.5% center freq—40 db rejection at $2F_0$ and $0.5F_0$ —input and output impedance 1500 Ω —Hermetically sealed in accordance with applicable MIL specifications—Dimensions: 4 $\frac{1}{4}$ " x 2" x 2 $\frac{1}{2}$ "



LF-197

3000 cps low pass filter—3 db @ 3000 cps—40 db @ 4000 cps—Attenuation at other frequencies specified—Input and output impedance 10,000 Ω —Dimensions: 1 $\frac{1}{2}$ " x 1 $\frac{1}{4}$ " x 2 $\frac{3}{4}$ "



BF-128

45 kc resonant circuit—Max 3 db bandwidth: 4500 cps—Entire package requires only 0.4 cubic inches—Units available from 20 kc to 100 kc—Source impedance 3000 Ω —Dimensions: $\frac{3}{8}$ " x $\frac{1}{16}$ " x 1"

Hundreds of versions of the units shown as well as many other types of filters are offered by C.E.C. Our engineering group will be happy to meet with you and discuss your particular needs.

MICROWAVE COMPONENTS AND INSTRUMENTS

ROTARY VANE FIXED ATTENUATORS



C.E.C. offers resistive attenuators that cover an entire waveguide band. These attenuators maintain a flat attenuation characteristic over their entire waveguide band. ATTENUATION: 3 db, 10 db or 20 db are offered as Standard. Other attenuation values can be preset to your specifications.



VHF-UHF FREQUENCY CALIBRATOR MODEL 121

Range: 50 mc to 11,000 mc in crystal controlled steps of 50 or 100 mc.

Output Level: In excess of -70 dbm minimum for all markers.

Accuracy: $\pm 0.005\%$ at any frequency, unaffected by temperature or power input variations.

HARMONIC MULTIPLIER AMPLIFIER ADAPTER

Output Waveform: CW or Pulse.

Output Level: increases amplitude to -30 dbm in frequency range from 1,000 to 11,200 mc with marker spacing of 1,600 mc. Lower amplitude (-60 dbm) markers are generated with a spacing of 400 mc.

BROADBAND ANTENNA

Designed for use with the Harmonic Adapter, this broadband antenna covers the entire range from 1,000 mc through 11,200 mc.

Used in combination, the three units provide a fast go-no go, remote calibration check on aircraft radar receivers, without the need for connecting cables to the aircraft.

DELAY LINES



ILLUSTRATED: CODING TYPE 20.3 μ sec

LUMPED CONSTANT FIXED & VARIABLE

5 millimicro sec to .1 secs
Impedance to 20,000 Ω
Bandwidth to 250 mc



DISTRIBUTED CONSTANT FIXED & VARIABLE

Delays to 30 μ sec
Impedance to 10,000 Ω
Bandwidth to 20 mc



MAGNETOSTRICTIVE FIXED & VARIABLE

2-10,000 μ sec

Also available as driver & output circuits for the reshaping of pulses.

Numerous versions of the above models as well as a capability to meet all specifications enables C.E.C. to consistently supply the needs of industry. Our engineering staff is always at your service. Write today for complete literature on our product line.



CONTROL *Electronics* CO., INC.

Ten Stepar Place, Huntington Station, N. Y.

HA 7-7961

SPERRY Tunnel Diodes

for engineering test
or application

Any quantities available
for immediate delivery
from any Avnet office.

Call your
Avnet
Applications
Engineer

For dependable service



and immediate delivery*
AVNET

*AVNET-70 State St., Westbury, N.Y. - ED 3-5800
AVNET-45 Winn St., Burlington, Mass. - BR 2-3060
AVNET-4180 Kettering Blvd., Dayton 39, Ohio - AX 8-1458
AVNET-2728 N. Mannheim Rd., Melrose Park, Ill. - GL 5-8160

proximately 110,000 sq ft" Corwin D. Denney, president of the firm, said.

The Magnetics division produces transformers, power supplies, solenoids, focusing coils, and electromagnets in the new Redwood City plant. Sales are principally to organizations engaged in microwave electronics.

Automation, with headquarters in Manhattan Beach, also operates plant facilities in Paramount, Calif., Boulder, Colo., Tulsa, Okla., and Columbus, O.



H-P Promotes Van Rensselaer

HEWLETT-PACKARD COMPANY, Palo Alto, Calif., announces the promotion of Cortlandt Van Rensselaer to the position of general manager of Dymec, an H-P division.

Van Rensselaer joined Hewlett-Packard in 1948 and became sales manager in 1957.



Hal Proppe Joins PCA Electronics

APPOINTMENT of Hal Proppe as sales manager of PCA Electronics, Inc., Sepulveda, Calif., is announced. Company manufactures pulse transformers and delay lines.

Proppe previously was associated

DYNASERT

**Installs Small
or Large Components
up to
10 Times Faster**

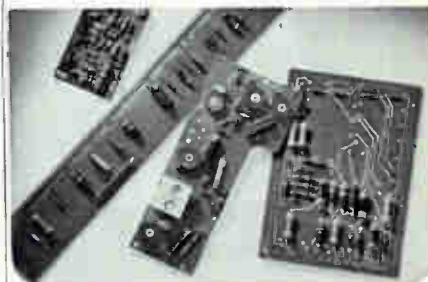

Components in PW boards as small as .032" diameter can be installed with Dynasert machines. If your production is as little as a few hundred insertions a week you should consider Dynasert.

Components can be inserted with leads bent to follow circuit in any direction. Obtain superior quality through precise insertions with Dynasert. Write for descriptive 12 page booklet.

United

UNITED SHOE MACHINERY CORPORATION
140 Federal Street, Boston, Mass.

CIRCLE 209 ON READER SERVICE CARD



WHO DROPPED THE BINOCULARS?

With everybody watching each other along the DEW line and the Iron Curtain these days, electronics has replaced binoculars.

What's happening in the giant markets for missile controls, radar and communications equipment?

electronics tells how things are going, keeps you informed of developments as they occur. This is a good time to subscribe or renew your subscription. Just fill in box on Reader Service Card. Easy to use. Postage free.

**FIND WHAT
YOU NEED IN...
electronics**

with U. S. Electrical Motors, Inc., as Philadelphia district manager, Los Angeles district manager and Western division manager wherein he headed up sales and administration for the 17 western states. In his new post with PCA, he will be responsible for sales nationally.



Salzman Joins R-tronics Inc.

HAL A. SALZMAN recently assumed the duties of executive vice president of R-tronics Inc., Jamaica, N. Y. In this capacity he will be responsible for sales and marketing operations.

Salzman was formerly vice president-sales of the Eastern Precision Resistor Corp. of Brooklyn, N. Y., a position he held since co-founding that company in 1952.

Control Data Names Feng

APPOINTMENT of Tai Nien Feng as associate director of research at Control Data Corp., Minneapolis, Minn., is announced. In his new position he has been assigned initially as a staff consultant to Cedar Division's engineering organization in the fields of servomechanism components and precision electromagnetic devices.

Prior to joining Control Data, Feng held the position of consulting engineer in the Avionics Division of John Oster Mfg. Co., Racine, Wis. He has also had several years experience at the G. M. Laboratories, Chicago, Ill., as head of the new component design department and at Northwestern Electric Co. where he was a senior development engineer.

Powdered Iron Toroids

APPLICATIONS

- High Q circuits for
- Transformers — I.F., etc.
 - Precision filters
 - Delay lines
 - Linear Networks

TOROIDAL FEATURES

- Reduces stray fields and proximity effects to obtain better stability.
- Permits small coil construction
- Higher effective permeability
- Coupling not affected by tuning circuit
- High stability with temperature and time
- Low harmonic distortion
- Improved insulation results in high Q
- Manufacturing methods permit close control of permeability and Q
- Finishes of tough thermosetting resins minimize moisture absorption and provides insulation suitable for winding enameled wire directly on the core.

CORE SIZES

Cores are available in diameters from 9/32 OD to 2" OD

Permeability: From 8 to 45

Recommended frequencies:

Materials are available which will provide good Q from 0.1 to 25 MC

Write for samples and further information.

Radio Cores, Inc.

9540 South Tulley Avenue
Oak Lawn, Illinois

Phone:

GArden 2-3353

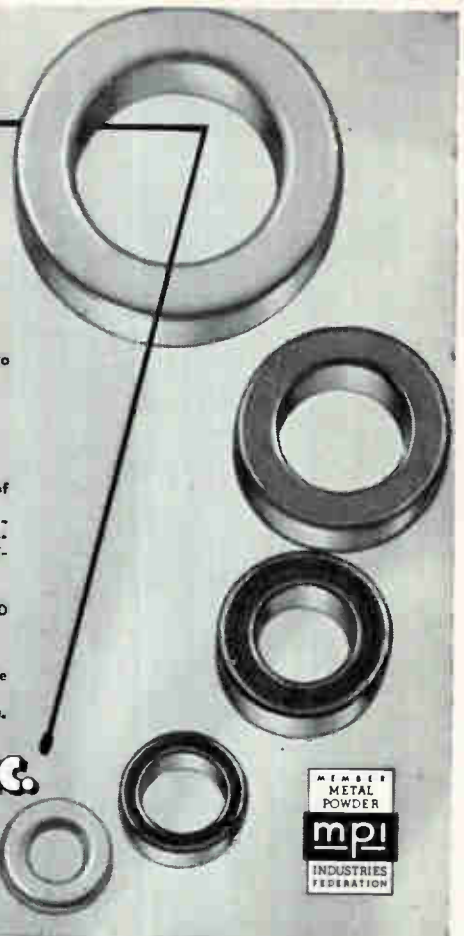

CIRCLE 211 ON READER SERVICE CARD

AINSLIE ANTENNAS

.....for the 100-500 mc BAND



MODEL CF121M — 12 ft. diameter with dipole exciter. Gain 23 db at 500 mc. Minimum side lobes 20 db (or better). Cross Polarization 20 db (or better).

Low VSWR at any frequency in the band. Accomplished through adjustable balun and reflector assembly.

STOCK REFLECTORS—4 in. to 10 ft. diameter solid spun. 4 ft. to 18 ft. diameter mesh. Larger sizes or special shapes on request. Antennas up to 10,000 mc.

Weatherized & corrosion resistant. Rugged, lightweight.

PROMPT DELIVERY
Any type antenna or reflector precision-built to your specifications.

Write for complete performance data sheets.

Ainslie

CORPORATION



MODEL CF141M with 14' diameter reflector available

531 POND STREET, SO. BRAintree 85, MASSACHUSETTS
Designers & Manufacturers of Microwave Antennas & Associated Equipment

EMPLOYMENT OPPORTUNITIES

DISPLAYED RATE

The advertising rate is \$34.33 per inch (Subject to Agency Commission) for all advertising appearing on other than contract basis. Contract rates quoted on request.

UNDISPLAYED RATE

\$2.40 per line, minimum 3 lines. Position Wanted ads in this style, 1/2 the above rate. To figure advance payment count 5 average words to a line.

Electronics Engineers

BSEE, electronics experience, U.S. citizenship required.

For test and evaluation work on highly sophisticated electronic equipment. Creative imagination essential.

Jobs on East coast with considerable overseas travel—non-continuous about 4 months a year.

Salary \$5500 to \$8800 dependent upon experience and ability.

Write giving age, education, experience, address, telephone to:

P-4775, Electronics
Class Adv. Div.,
P. O. Box 12, N. Y. 36, N. Y.

SELLING OPPORTUNITY AVAILABLE

Agent Required to cover entire U.S.A. for the sale of a new universal wiring board, meeting with great success in Europe. For full particulars apply RW-4841, Electronics, Class. Adv. Div., P.O. Box 12, New York 36, N. Y.



MANUFACTURERS' REPRESENTATIVES

IN THE ELECTRONIC INDUSTRY

SAMUEL K. MACDONALD, INC.

manufacturers representatives over 25 years
1531 SPRUCE STREET, PHILA. 2, PA.

Territory: Pennsylvania • New Jersey
Delaware • Maryland
Virginia • West Virginia
District of Columbia

Other Offices:
Pittsburgh
Baltimore
Washington, D.C.

SEARCHLIGHT SECTION

(Classified Advertising)

BUSINESS OPPORTUNITIES

EQUIPMENT - USED or RESALE

DISPLAYED RATE

The advertising rate is \$24-75 per inch for all advertising appearing on other than a contract basis. Contract rates quoted on request. An ADVERTISING INCH is measured 1/2 inch vertically on one column, 3 columns—30 inches—to a page. EQUIPMENT WANTED or FOR SALE ADVERTISEMENTS acceptable only in Displayed Style.

UNDISPLAYED RATE

\$2.40 a line, minimum 3 lines. To figure advance payment count 5 average words as a line. BOX NUMBERS count as one line additional in undisplayed ads.

HARD and SOFT MAGNETRON PULSERS...

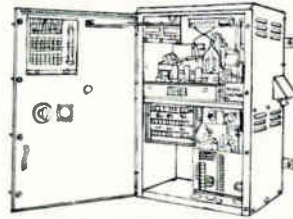

... at bargain basement prices! Will drive dozens of types of Magnetrons up to 250 kw. from \$675.00

Phone: Walker 5-6000



LIBERTY ELECTRONICS, INC.

582 BROADWAY
NEW YORK 12, N. Y.
Cables: TELSERSUP

CIRCLE 460 ON READER SERVICE CARD

LOOKING FOR USED/SURPLUS ELECTRONIC EQUIPMENT/COMPONENTS?

For an up-to-date listing of such equipment see Searchlight Section of July 8th.

SEARCHLIGHT Equipment Locating Service

NO CHARGE OR OBLIGATION

This service is aimed at helping you, the reader of "SEARCHLIGHT", to locate Surplus new and used Electronic equipment and components not currently advertised. (This service is for USER-BUYERS only).

How to use: Check the dealer ads to see if what you want is not currently advertised. If not, send us the specifications of the equipment wanted on the coupon below or on your own company letterhead to:

Searchlight Section Locating Service
c/o ELECTRONICS,
P.O. Box 12, N. Y. 36, N. Y.

Your requirements will be brought promptly to the attention of the equipment dealers advertising in this section. You will receive replies directly from them.

Searchlight Equipment Locating Service
c/o ELECTRONICS, P. O. Box 12, N. Y. 36, N. Y.
Please help us locate the following equipment components.

.....
.....
.....
NAME

TITLE

COMPANY

STREET

CITY 7/29/60

3 steps to using the BUYERS' GUIDE



locate products

In product listings



find product specifications

In the advertising pages



buy products

From local office in manufacturers' listings

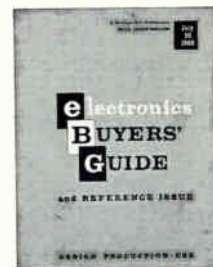

FIND

WHAT

YOU

NEED

IN

THE

electronics BUYERS' GUIDE

INDEX TO ADVERTISERS



Audited Paid Circulation

AMP Incorporated	90	Electronic Instrument Co., Inc. (EICO)	143
Acton Laboratories, Inc.	46	Electronic Measurements Co. Inc.	142
Adler Electronics, Inc.	15	Engineered Electronics Company.	39
Aeronautical Communications Equipment Inc.	137		
Ainslie Corporation	147		
Airborne Instruments Lab.	150		
Air Express	88		
Alford Mfg. Co.	143	Fairchild Semiconductor Corp.	121
Avnet Electronics	146		
		General Ceramics Corporation, Division of Indiana General Corporation.	50
Ballantine Laboratories, Inc.	113	General Electric Co. Industrial Tube Division.	34, 35
Bausch & Lomb Inc.	130	General Instrument Corp. Distributor Div.	128
Bell Telephone Laboratories.	127	Semiconductor Div.	129
		Granger Associates	2
		Gudebrod Bros. Silk Co., Inc.	136
C&D Batteries	47		
Cinch Manufacturing Co.	107	Hewlett-Packard Co.	8, 9
Communication Accessories, Company	138	Hoskins Mfg. Co.	123
Consolidated Electrodynamics Corp.	119	Hughes Aircraft Co.	41, 42, 87
Control Electronics Co., Inc.	145		
Controls Co. of America.	135		
Convair Astronautics, Div of General Dynamics.	140		
Cornell-Dublier	89		
Cubic Corp.	33		
		International Resistance Co.	3rd Cover
Dresser-Ideco Company, A Division of Dresser Industries, Inc.	44		
Dumont Laboratories Inc., Allen B.	10	Julie Research Laboratories, Inc.	138
ESC Corporation	117	Lambda Electronics Corp.	3
Eitel-McCullough, Inc.	16	Lapp Insulator Co., Inc.	122
Electro Pulse, Inc.	31	Leesona Corp.	132

July 29, 1960

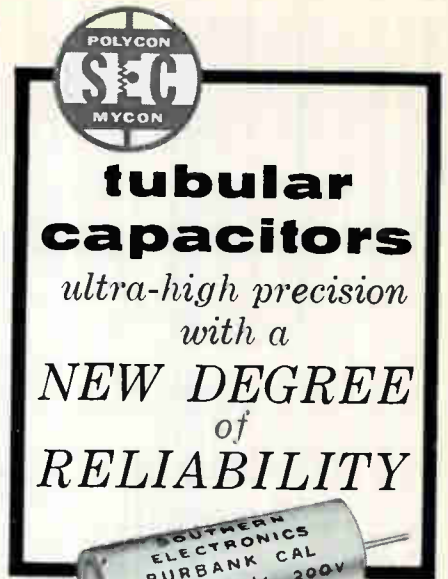

SOUTHERN ELECTRONICS CORP. has long been a leader in the design and manufacture of high-precision tubular capacitors, and has pioneered in supplying them for critical applications in computers, missiles, communications and other high-grade military and commercial equipment. They are made to the same standards as our high-precision polystyrene capacitors so widely accepted for military applications.

SEC tubular capacitors are manufactured under unusually critical quality control standards, resulting in tolerances as low as 0.5% in most values, and hermetic sealing guarantees accuracy over wide environmental changes.

SEC tubulars are available in a wide range of tolerances to meet your needs, from 100 mmfd. to any higher value, in polystyrene, mylar, metallized mylar, teflon and dual-dielectrics.

All SEC tubular capacitors meet or exceed the most rigid MIL-SPECS.

In addition, we manufacture a complete line of tubular capacitors for commercial applications. Let us know your requirements.

Write today for detailed technical data and general catalog.



SEE US AT WESCON
BOOTH 862

SOUTHERN ELECTRONICS Corporation

150 WEST CYPRESS AVENUE
BURBANK, CALIFORNIA

for
Accuracy

in Precision
Test Receivers

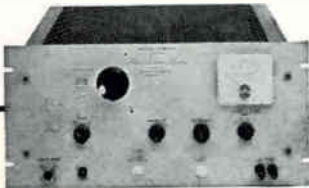

THE AIL TYPE 132

This high precision instrument combines a high gain, low noise figure, intermediate frequency receiver with a secondary standard of attenuation to deliver extremely accurate measurements in a variety of applications:

- Convenient and accurate method for the measurement of **NOISE FIGURE**.
- Ideally suited to high accuracy, quick laboratory calibration of rf attenuators at all frequencies.
- Rapid and accurate in measurement of the selectivity characteristics of rf filters, preselectors and similar devices.
- Valuable for measurement of coupling factors and directivities.

The Type 132 is designed to operate from the i-f output of a wide variety of standard microwave mixers. In combination with these and a suitable local oscillator it becomes a sensitive detector of microwave energy.

Write for descriptive literature.



**AIRBORNE
INSTRUMENTS
LABORATORY**

DEER PARK, LONG ISLAND, NEW YORK
A DIVISION
OF CUTLER-HAMMER, INC.

MB Electronics	49	Weckesser Co.	125
Malco Mfg. Co.	118	Weinschel Engineering	14
Mallory and Co., Inc., P. R.	26, 27	Westinghouse Electric Corp. Electronic Tube Div.	12
Marconi Instruments, Ltd.	112	Weston Instruments Div. of Daystrom, Inc.	109
Mico Instrument Co.	148		
Minneapolis-Honeywell Reg. Co. Boston Div.	6		
Minnesota Mining & Mfg. Co., Chem. Div.	40		

Manufacturers' Representatives

MacDonald Inc, Samuel K.	148
-------------------------------	-----

North Atlantic Industries, Inc.	18
--------------------------------------	----

O'Neill-Irwin Mfg. Co.	29
-----------------------------	----

CLASSIFIED ADVERTISING

F. J. Eberle, Business Mgr.

EMPLOYMENT OPPORTUNITIES	148
-------------------------------------------	-----

EQUIPMENT

(Used or Surplus New)

Pacific Semiconductors, Inc. ...	17, 18, 19
	20, 21, 22, 28, 24
Power Designs, Inc.	141

For Sale	148
Liberty Electronics Inc.	148

Radiation Inc.	25
Radio Cores	147
Radio Corporation of America ...	4th Cover
Ramo-Wooldridge Laboratories, A Div of Thompson Ramo Wooldridge Inc.	28
Raytheon Company	2nd Cover

This index and our Reader Service Numbers are published as a service. Every precaution is taken to make them accurate, but ELECTRONICS assumes no responsibilities for errors or omissions.

Signalite Incorporated	125
Sorenson & Co.	48
Southern Electronics Corp.	149
Sprague Electric Co.	5

BRUCE A. WINNER, Advertising Sales Manager. R. S. Quint, Assistant Advertising Sales Manager and Buyers' Guide Manager. Fred Stewart, Promotion Manager. Richard J. Tomlinson, Production Manager. George E. Pomeroy, Classified Manager. Hugh J. Quinn, Circulation Manager.

Technology Instrument Corp.	181
Texas Instruments, Incorporated Semiconductor-Components Division	51, 52
Transistor Specialties, Inc.	189
Trio Laboratories, Inc.	7
Tung-Sol Electric, Inc.	111

ADVERTISING REPRESENTATIVES

NEW YORK: Donald H. Miller, Henry M. Shaw, George F. Werner.

BOSTON: William S. Hodgkinson.

PITTSBURGH: David M. Watson.

PHILADELPHIA: Warren H. Gardner, William J. Boyle.

CHICAGO: Harvey W. Wernecke, Martin J. Gallay.

CLEVELAND: P. T. Fegley.

SAN FRANCISCO: T. H. Carmody, R. C. Alcorn.

LOS ANGELES: Carl W. Dysinger, D. A. McMillan, Marshall Freeman.

DENVER: J. Patten.

ATLANTA: M. Miller.

DALLAS: Robert T. Wood.

LONDON: Edward E. Schirmer.

FRANKFURT: Stanley R. Kimes.

GENEVA: Michael R. Zeynel.

U. S. Relay-Electronics.	82
United Shoe Machinery Corporation..	14c

In FLAT, FLEXIBLE CABLE

if it's news, expect it first from IRC

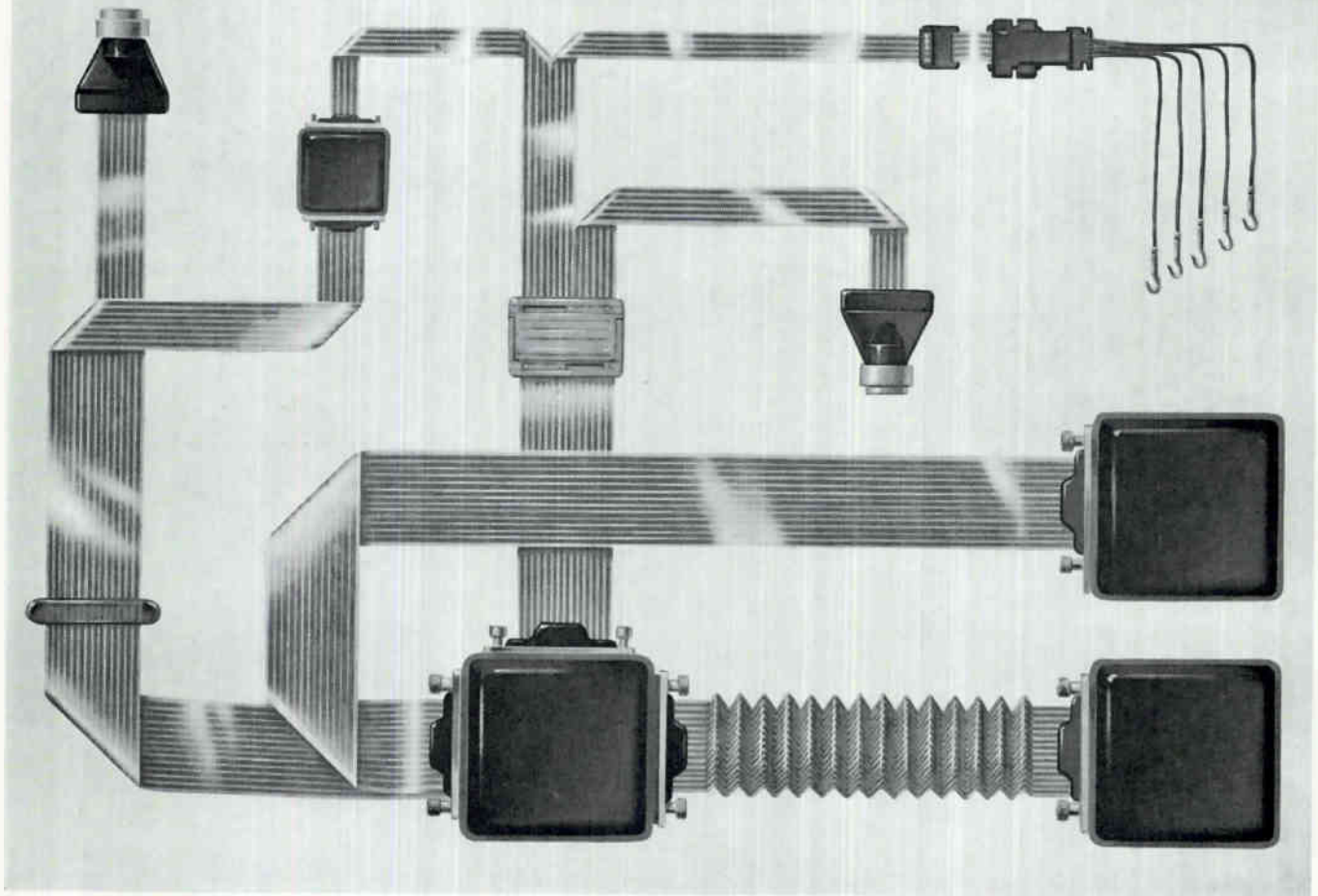

Polystrip® . . . the dynamic approach to reliable miniature and high density wiring packages

IRC Polystrip is a thin, multiple conductor, flexible cable. It consists of a number of parallel, flat copper wires sandwiched between plastic layers. This cable occupies little volume, and is flexible enough to fit into irregular spaces. All conductors are pre-positioned in the same plane permitting simultaneous stripping, terminating or dip soldering to printed wiring boards or connectors.

This new concept of wiring offers many advantages to an electronic circuit engineer:

- Space Savings—7:1 ratio over conventional cable
- Weight Reduction—up to 10:1 depending on insulation and design
- High Strength—inherent in the unitized web construction
- Flexibility—no failure after over a million cycles without tension
- Cost Savings—achieved in installation costs
- Current Carrying Advantages—increases up to 2:1 for given temperature rise
- Chemical and Moisture Resistance—good to excellent
- Reliability—assured by pre-formed cables and sealed insulation

IRC Polystrip is now available in five standard types—from Polyester to Teflon insulations, operational in temperatures up to 200°C, and resistant to most environmental conditions. Additional types possible depending on your application.

For further information on Polystrip, write for Bulletin S-9, International Resistance Co., 401 N. Broad St., Philadelphia 8, Pa.

Teflon is a Reg. T.M.-E.I. du Pont de Nemours & Co.



Leading supplier to manufacturers of electronic equipment

RCA Presents
the Versatile

RCA-6EU7

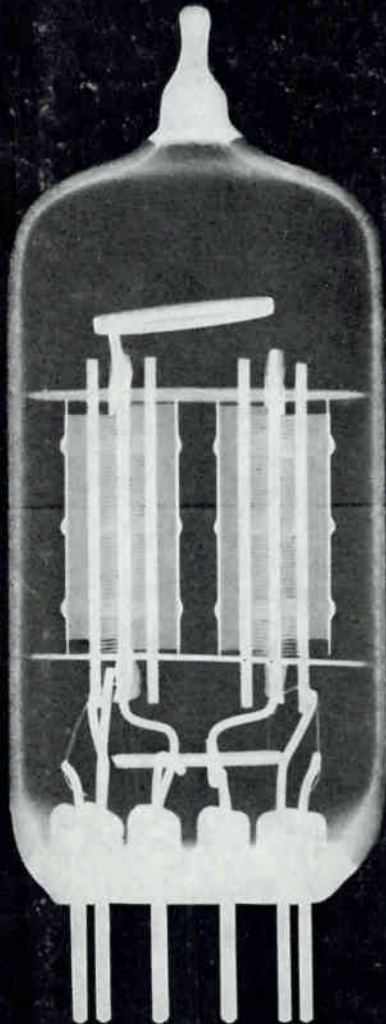

...A NEW LOW-NOISE TWIN TRIODE

to improve performance and simplify the design of Audio Pre-Amplifier Stages

Low noise, high performance, moderate cost—provided by the new RCA-6EU7, a high-mu, nine-pin miniature twin triode designed especially for high-gain, resistance-coupled, audio pre-amplifier stages—in high fidelity amplifiers (monaural or stereo), amplifier kits, tape recorders, juke boxes, and public address systems.

Noise and hum are minimized by the use of double-wound, helical heaters, and a new base layout which keeps heater leads well away from the grid leads.

Low microphonism, high mechanical strength, and reliability are assured by a short, rugged cage which provides sturdy support for the tube electrodes.

New base arrangement also simplifies stereo layouts. The accompanying diagram shows how the basing arrangement facilitates the design of an amplifier using the two triode units for isolated stereo channels.

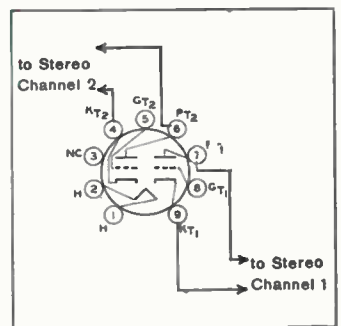

For technical information, contact the RCA Sales Representative at our office nearest you, or write directly to RCA Electron Tube Division, Commercial Engineering, Section G-19-DE-4, Harrison, New Jersey.

EAST: 744 Broad Street, Newark 2, N. J. HUMBOLDT 5-3900. MID-WEST: Suite 1154, Merchandise Mart Plaza, Chicago 54, Ill. WHITEHALL 4-2900. WEST: 6355 E. Washington Blvd., Los Angeles 22, Cal. RAYMOND 3-8361.



The Most Trusted Name in Electronics
RADIO CORPORATION OF AMERICA