

JANUARY 23, 1959

electronics

A MCGRAW-HILL PUBLICATION

VOL. 32, No. 4

PRICE SEVENTY-FIVE CENTS

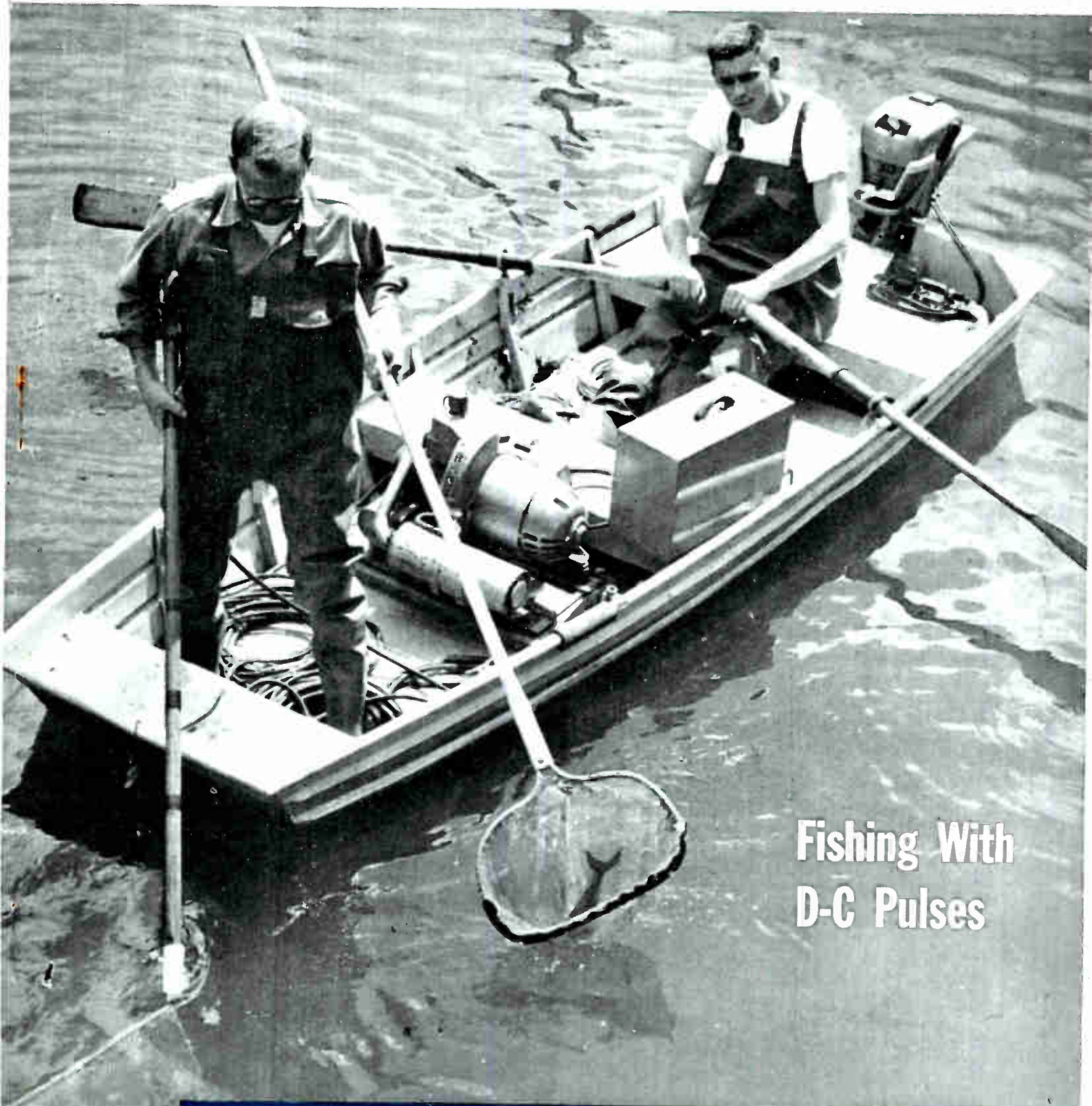

Fishing With
D-C Pulses

New Computer Market Opens in Oil Refining

NEW

Type 1392-A

TIME-DELAY GENERATOR, \$985

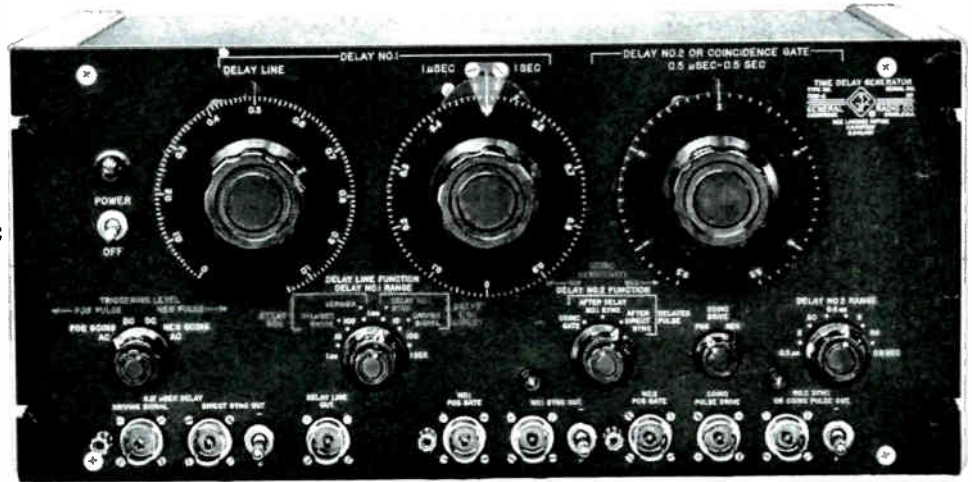

- Continuous delay range from 0 to 1.6 sec
- Two independent delay circuits; 0 to 1.1 sec and 0.5 μ sec to 0.5 sec
- Ten-turn dial calibration is exact everywhere even on 1-10 μ sec range
- Built-in provision for time modulation
- All long delays have associated gate pulse outputs
- Coincidence circuitry for producing exact delays or bursts, and for calibration

- Input circuits accept almost any waveform from dc to 300+ kc to initiate action

- High accuracy, high linearity, high resolution, low jitter

INPUT SYSTEM

- **Input Voltage Required:**
Sine Wave: 0.1v rms
Square Wave: 0.3v, p-p
Pulse (+ or -): 1-volt peak
Input trigger threshold control provided
- **Frequency:** dc to 300+ kc
- **Delay from Input Terminal to Direct Sync Terminal:**
0.12 \pm 0.02 μ sec
- **Direct Sync Pulse:**
Amplitude: \pm 15v
Duration: 0.13 \pm .02 μ sec
Impedance: 93 Ω

The most precise and flexible delay generator available, the 1392-A uses linear sawtooth waveforms and accurate amplitude comparators to produce two variable delays. Gating-on errors encountered in digital equipment are eliminated, yet the accuracy of delay is comparable with digital apparatus when the 1392-A is used with a source of quartz-crystal controlled pulses.

DELAY CIRCUITS

	DELAY NO. 1	DELAY NO. 2
Range	0-1.1 sec in seven ranges	0.5 μ sec-0.5 sec in six ranges
Accuracy	0-1 μ sec range: \pm 0.01 μ sec. Remainder of range: \pm 1% of dial reading	\pm 3% of dial reading
Jitter	1:30,000 at worst	1:20,000
Line Drift	1:10,000 with 20% line change	1:5,000 with 20% line change
Resolution	0-1 μ sec range: 0.004 μ sec. Remainder of range 1:8800	1:2000
Output Sync Pulse		
Duration	0.1 \pm 0.02 μ sec	0.13 μ sec \pm 0.02 μ sec
Amplitude	\pm 25v	\pm 20v
Output Impedance	93 Ω	93 Ω
Max. PRF	for 0-1 μ sec, 300 kc; 1 μ sec to 1.1 sec, 250 kc	300 kc
Duty-Ratio Effects	For duty ratios up to 60%, dial accuracy is 1% as specified; accuracy is 5% at 80% duty ratios	Less than dial accuracy at full scale for duty ratios up to 60% and at bottom end of scale for duty ratios up to 20%

An external signal source establishes within the Time-Delay Generator a 0.1 μ sec synchronizing pulse which serves as the time reference. Two independent variable delay circuits provide delays relative to this reference sync pulse from 0 to 1.1 seconds (Delay No. 1), and from 0.5 μ sec to 0.5 seconds (Delay No. 2). These two delay circuits can be operated "in series," (adding in delay times) or "in parallel," producing two independent delays.

The DELAY NO. 1 circuit includes a passive variable delay line with a precisely calibrated dial to produce incremental delays from 0 to 1 μ sec in 10-m μ sec divisions. This delay line can be used either as the first range (0-1 μ sec) for Delay No. 1, or as a vernier on the 1- μ sec to 1.1-second electronically produced delay. It can also be used to delay the sync pulse produced by Delay No. 2, or to delay an input signal.

DELAY NO. 2 is in principle similar to Delay No. 1, but its associated gate can be used to actuate a coincidence amplifier. In coincidence operation, the gate is opened by the Delay No. 1 sync, and its duration is set by the Delay No. 2 circuits. Delay No. 2 times the gate, and does not produce a sync output. In this way, pulses from a timing comb which are present while the gate is open can be selected. For example, the 0.5- μ sec minimum setting of Delay No. 2 permits the selection of a single 1- μ sec pulse from a 1-Mc train to provide 1- μ sec steps of delay. In addition, the coincidence feature can be used to produce bursts of pulses from a timing comb.

COINCIDENCE CIRCUIT

Input: positive or negative pulse, 5v or over
Input Frequency: 1 cps to 1.7 Mc (for single pulse selection)
Input Rise Time: 0.1 μ sec or less at 5v

GENERAL RADIO COMPANY

275 MASSACHUSETTS AVENUE, CAMBRIDGE 39, MASSACHUSETTS

NEW YORK AREA
Broad Ave. at Linden
Ridgefield, N. J.
N. Y. WORTH 4-2722
N. J. WHIMY 3-3140

CHICAGO
6605 W. North Ave.
Oak Park Ill.
Village 8-9400

PHILADELPHIA
1150 York Rd.
Abington, Pa.
HAncock 4-7419

WASHINGTON, D.C.
8055 Thirteenth St.
Silver Spring, Md.
JUIniper 5-1088

SAN FRANCISCO
1182 Los Altos Ave.
Los Altos, Cal.
WHitecliff 8-8233

LOS ANGELES
1000 N. Seward St.
Los Angeles 38, Cal.
HOllywood 9-6201

IN CANADA
99 Floral Pkwy.
Toronto 15, Ontario
CHerry 6-2171

Issue at a Glance

A McGRAW-HILL PUBLICATION
Vol. 32 No. 4

H. W. MATEER, *Publisher*

JAMES GIRDWOOD, *Associate
Publisher & Advertising Sales Mgr.*

W. W. MacDONALD, *Editor*

John M. Carroll, *Managing Editor*
Feature Editor, John Markus.

Associate Editors: John M. Kinn,
Jr., Frank Leary, Michael F. To-
maino, Howard K. Janis, Sylvester
P. Carter, Haig A. Manoogian,
Roland J. Charest, William P.
O'Brien, George Sideris, John F.
Mason, William E. Bushor, Ronald
K. Jurgen, Thomas Emma, Samuel
Weber.

Pacific Coast Editor (Los Angeles)
Harold C. Hood; *Midwestern Editor*
(Chicago) Harold Harris; *New Eng-
land Editor* (Boston) Thomas Ma-
guire.

Art Director, Harry Phillips, Roy
Thompson.

Production Editor, John C.
Wright, Jr., Bernice Duffy, Jean L.
Matin.

Market Research, Edward De-
Jongh, Marilyn Koren.

Editorial Assistants: Gloria J.
Filippone, Arlene Schilp, Patricia
Landers, Catherine McDermott,
Eleanor Schaefer, Carol Weaver.

R. S. Quint, *Assistant Advertising
Sales Manager and Buyers'
Guide Manager*. Fred Stewart,
Promotion Manager. Frank H.
Ward, *Business Manager*. George
E. Pomeroy, *Classified Manager*,
Hugh J. Quinn, *Circulation Man-
ager*.

New York: Donald H. Miller,
Henry M. Shaw, William J.
Boyle. Boston: Wm. S. Hodgkin-
son. Philadelphia: Warren T.
Gardner. Chicago: Bruce Winner,
Harvey W. Wernecke, Martin J.
Gallay. Cleveland: P. T. Fegley.
San Francisco: T. H. Carmody,
R. C. Alcorn, Los Angeles: Carl W.
Dysinger, D. A. McMillan. Denver:
J. Patten. Atlanta: M. Miller. Dal-
las: Gordon L. Jones, Robert T.
Wood. London: E. E. Schirmer.
Frankfurt: Michael R. Zeynel.

BUSINESS

Digital Computers Strike Oil. More electronics for refineries.....	20
New \$1-Billion Market. Facts on Vandenberg AFB, Pacific Range...	23
Consumer Outlook Bright. Company executives give views.....	24
Stereo Tv Makes Debut. Widescale use three years away?.....	27
Shoptalk	4
Electronics Newsletter	9
Washington Outlook	12
Financial Roundup	15
Over The Counter.....	15
Market Research	16
Current Figures	16
Meetings Ahead	28

ENGINEERING

Fishing With D-C Pulses. Fisherman holds positive electrode which attracts and stuns fish.....	See p 31, COVER
Electronic Fishing with Underwater Pulses. Pulsed d-c attracts fish to positive anode (boat) and stuns them.....	By H. P. Dale 31
New Transistor Works at Cryogenic Temperatures. Grain boundary exhibits properties independent of temperature.....	By S. Weber 34
Microsecond Sampler Handles 126 Channels. Unconventional cir- cuits give high-speed versatility.....	By M. T. Nadir 36
Cathode-Ray Storage Tubes for Direct Viewing. Primary character- istics of common types in tabular form.....	By A. S. Kramer 40
Saturable-Core Oscillator Integrates Gas-Flow Data. Converter varies output frequency with input voltage....	By L. W. Langley 42
Frequency Stepper for Radio Propagation Tests. Pulses study point- to-point propagation..	By E. H. Hugenholtz, A. Seljak and A. Towle 44
D-C to A-C Modulators. Nine types of modulators for d-c to a-c con- version and amplification.....	By G. Sideris 47
Function Generator for Sines or Cosines. Transistorized unit gives 0.1 percent of full-scale accuracy.....	By H. Schmid. 48
Receiver Sensitivity. Chart finds tangential sensitivity from band- width.....	By Charles R. Ammerman and William L. Blair 52

DEPARTMENTS

Research and Development. Dynamic Test of Choke Inductance.....	54
Components and Materials. Modular Design Aids Flexibility.....	58
Production Techniques. Potted Electrodes Speed Testing.....	62
On the Market.....	66
Literature of the Week.....	70
Plants and People.....	78
News of Reps.....	81
Comment	82
Index to Advertisers.....	87

**IMPROVED
CHARACTERISTICS**

**...OF
SPECIAL
INTEREST
TO EVERY
ENGINEER**

**DELCO
HIGH POWER
TRANSISTORS**



UNEXCELLED FOR SWITCHING, POWER HANDLING, EFFICIENCY, RELIABILITY

TYPICAL CHARACTERISTICS AT 25°C.

	2N1100	2N1099	2N174A	2N174	2N173	2N278	2N277	2N443	2N442	2N441
Maximum Collector Current	15	15	15	15	15	15	15	15	15	15 amps
Maximum Collector Voltage (Emitter Open)	100	80	80	80	60	50	40	60	50	40 volts
Saturation Resistance	.02	.02	.02	.02	.03	.03	.03	.03	.03	.03 ohms
Thermal Gradient (Max.) (Junction to Mounting Base)	.8	.8	.8	.8	.8	1.0	1.0	1.0	1.0	1.0 °C/watt
Base Current I_b ($V_{EC}=2$ volts, $I_c=5$ amps)	135	100	135	135	100	100	100	150	150	150 ma
Collector to Emitter Voltage (Min.) Shorted Base ($I_c=.3$ amps)	80	70	70	70	50	45	40	50	45	40 volts
Collector to Emitter Voltage Open Base ($I_c=.3$ amps)	70	60	60	60	50	45	40	55	45	40 volts

*Designed to meet MIL-T-19500/13A (Jan) 8 January 1958 †Formerly DT100 ‡Formerly DT80

Check your requirements against the *new, improved* characteristics of Delco High Power transistors. You will find improved collector-to-emitter voltage . . . higher maximum current ratings—15 amperes, and extremely low saturation resistance. Also, note the new solid pin terminal design.

And of special importance to you is the fact that diode voltage ratings are at the maximum rated temperature (95°C.) and voltage.

Write today for engineering data on the *new, improved* characteristics of *all* Delco High Power transistors.

DELCO RADIO

Division of General Motors • Kokomo, Indiana

BRANCH OFFICES

Newark, New Jersey
1180 Raymond Boulevard
Tel: Mitchell 2-6165

Santa Monica, California
726 Santa Monica Boulevard
Tel: Exbrook 3-1465

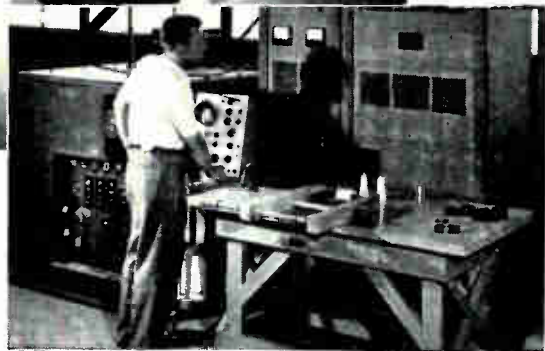

WSW 7372

**Arnold Pulse Transformer
Cores are individually tested
under actual pulse conditions**

**Here's
technical data on
ARNOLD
SILETRON
CORES**

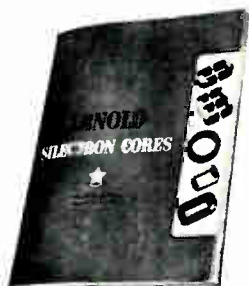

Bulletin SC-107 A
... this newly-reprinted 52-page bulletin contains design information on Arnold Tape Cores wound from Siletron (grain-oriented silicon steel). It includes data on cut C and E cores, and uncut toroids and rectangular shapes. Sizes range from a fraction of an ounce to more than a hundred pounds, in standard tape thicknesses of 1, 2, 4 and 12 mils.

Cores are listed in the order of their power-handling capacity, to permit easier selection to fit your requirements, and curves showing the effect of impregnation on core material properties are included. A valuable addition to your engineering files—write for your copy today.

ADDRESS DEPT. E-91

The inset photograph above illustrates a special Arnold advantage: a 10-megawatt pulse-testing installation which enables us to test-prove pulse cores to an extent unequalled elsewhere in the industry.

For example, Arnold 1 mil Siletron "C" cores—supplied with a guaranteed minimum pulse permeability of 300—are tested at 0.25 microseconds, 1000 pulses per second, at a peak flux density of 2500 gauss. The 2 mil cores, with a guaranteed minimum pulse permeability of 600, receive standard tests at 2 microseconds, 400

pulses per second, at a peak flux density of 10,000 gauss.

The test equipment has a variable range which may enable us to make special tests duplicating the actual operating conditions of the transformer. The pulser permits tests at .05, .25, 2.0 and 10.0 microsecond pulse duration, at repetition rates varying anywhere from 50 to 1000 pulses per second.

This is just another of Arnold's facilities for better service on magnetic materials of all description.

● Let us supply *your* requirements.

THE ARNOLD ENGINEERING COMPANY



Main Office & Plant: Marengo, Illinois

Repath Pacific Division Plant: 641 East 61st Street, Los Angeles, Calif.

District Sales Offices:

Boston: 49 Waltham St., Lexington Los Angeles: 3450 Wilshire Blvd.

New York: 350 Fifth Ave. Washington, D.C.: 1001-15th St., N.W.

SHOPTALK

electronics

Jan. 23, 1959 Vol. 32, No. 4

Published weekly, with a BUYERS' GUIDE and REFERENCE issue in mid-June, by McGraw-Hill Publishing Company, Inc., James H. McGraw (1860-1948) Founder.

Executive, Editorial, Circulation and Advertising Offices: McGraw-Hill Building, 330 W. 42 St., New York 36, N. Y. Longacre 4-3000. Publication Office: 99-129 North Broadway, Albany 1, N. Y.

See panel below for directions regarding subscriptions or change of address. Donald C. McGraw, President; Joseph A. Gerardi, Executive Vice President; L. Keith Goodrich, Vice President and Treasurer; John J. Cooke, Secretary; Nelson L. Bond, President, Publications Division; Shelton Fisher, Senior Vice President; Ralph B. Smith, Vice President and Editorial Director; Joseph H. Allen, Vice President and Director of Advertising Sales; A. R. Venezian, Vice President and Circulation Coordinator.

Single copies 75¢ in the United States and possessions and Canada; \$1.50 for all other foreign countries. Buyers' Guide \$3.00. Subscription rates—United States and possessions, \$6.00 a year; \$9.00 for two years; \$12.00 for three years. Canada, \$10.00 a year; \$16.00 for two years; \$20.00 for three years. All other countries \$20.00 a year; \$30.00 for two years; \$40.00 for three years. Second class postage paid at Albany, N. Y. Printed in U.S.A. Copyright 1959 by McGraw-Hill Publishing Co., Inc.—All Rights Reserved. Title registered in U. S. Patent Office. BRANCH OFFICES: 520 North Michigan Avenue, Chicago 11; 68 Post Street, San Francisco 4; McGraw-Hill House, London E. C. 4; 15 Landgrat-Wilhelm, Frankfurt/Main; National Press Bldg., Washington 4, D. C.; Six Penn Center Plaza, Philadelphia 3; 1111 Henry W. Oliver Bldg., Pittsburgh 22; 55 Public Square, Cleveland 33; 856 Penobscot Bldg., Detroit 26; 3615 Olive St., St. Louis 8; 350 Park Square Bldg., Boston 16; 1321 Rhodes-Haverty Bldg., Atlanta 3; 1125 West Sixth St., Los Angeles 17; 1740 Broadway, Denver 2; 901 Vaughn Bldg., Dallas 1. ELECTRONICS is indexed regularly in The Engineering Index.

Subscription: Address correspondence to: Fulfillment Manager, Electronics, 330 W. 42nd St., New York 36, N. Y. Allow one month for change of address, stating old as well as new address. Subscriptions are solicited only from persons engaged in theory, research, design, production, management, maintenance and use of electronics and industrial control components, parts and products. Position and company connection must be indicated on subscription orders.

Postmaster: please send form 3579 to Electronics, 330 W. 42nd St., New York 36, N. Y.



Member ABP and ABC

COMPUTERS AND THE OIL BUSINESS. Industrial control manufacturers have long looked upon the petroleum refining industry as a prime market for sophisticated computer control applications. Indeed, refineries were being automated long before the word automation was coined.

Although computer sales to the petroleum industry topped 100 units during 1958, the computers sold were used mainly for laboratory and office chores, not on the production line.

Oil men say one reason for slow progress toward computer automation in refinery production is relative inaccuracy of on-line sensing devices used to collect raw data. Instrument manufacturers are getting together with computer people to solve this problem.

Two significant developments in the use of computer automation in oil refineries—one development on the East Coast, the other on the West Coast—triggered our roundup story on p 20. The story involves joint effort by Associate Editor Emma, Pacific Coast Editor Hood and our Washington Bureau.

OVER THE PACIFIC. Last week Associate Editor Leary brought you a closeup of electronic instrumentation inside our Atlantic Missile Range. Now, Pacific Coast Editor Hood brings you a first look at California's new Vandenberg Air Force Base and the Pacific Missile Range over which it fires.

Hood has watched this new electronics complex growing up on scrub pine and sagebrush-dotted hills and sand dunes north of Los Angeles ever since the Air Force moved into the abandoned barracks that used to be the Army's old Camp Cooke.

Now, for his story on what's new electronically on our Pacific Range, and what firms are doing the work, turn to p 23.

Coming In Our January 30 Issue . . .

ANESTHESIA CONTROL. In the usual surgical operation, a trained anesthesiologist administers the proper amount of anesthetic by carefully observing the respiration rate, blood pressure and other responses of the patient.

According to Dr. J. W. Bellville of Sloan-Kettering Institute and G. M. Attura of Industrial Control Co., correlation between the depth of anesthesia and cortical activity in the patient's brain makes automatic anesthesia administration possible. In their servo system, activity and spectral distribution of the patient's encephalogram is monitored, and appropriate shaping networks provide a signal suitable for feedback control.

PANEL DISPLAYS. Solid-state panel display and panel storage devices are receiving great attention for such applications as tv screens, computer storage and amplifying X-ray panels.

Associate Editor Jurgen recently attended the Electron Devices Meeting in Washington and heard a raft of papers on this subject. In his article next week, Jurgen describes a cadmium-sulfide photo-rectifier panel array and an electroluminescent panel with photo-conductive control which show promise for storage, quantizing and character recognition.

MINIATURE RADAR. A short-pulse X-band radar system using a miniature magnetron as the microwave generator is the subject of an article by C. D. Hardin and J. Salerno of the Diamond Ordnance Fuze Labs.

The tiny system has applications in military surveillance, altimetry, miss-distance indicators and scorers, fire control and radar mapping.



Submin Tubes

with
10 SECOND OPERATION TIME

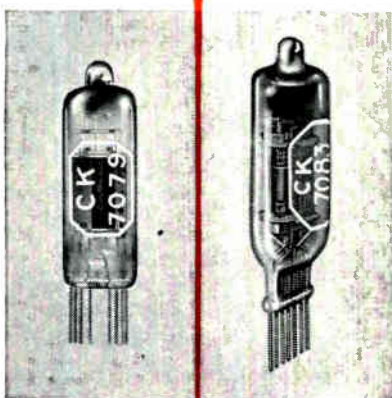
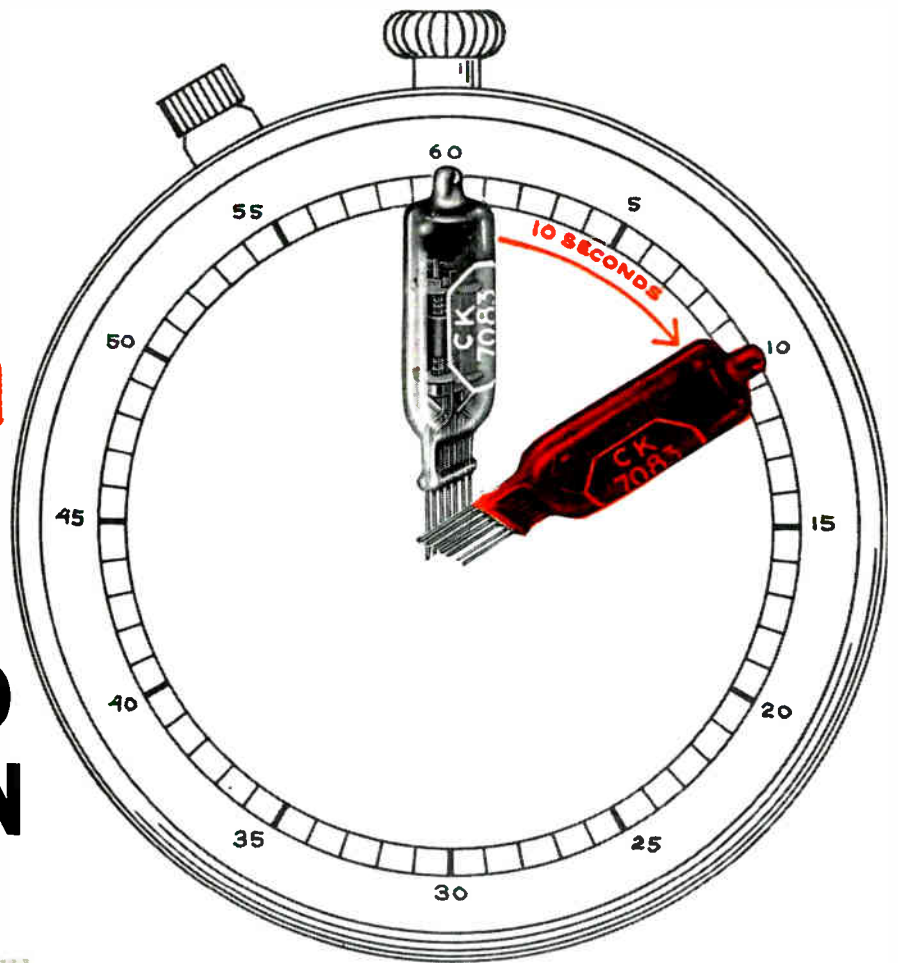

Actual Size

**CK7079
TWIN
TRIODE**

**CK7083
AMPLIFIER
PENTODE**

Gm	5000*	5000
μ	20*	
Heater volts	6.3	6.3
Heater mA	300	200
Plate volts	100	120
Plate mA	8.5*	7.5
	Approximate prototype CK6111	Approximate prototype CK5702WA

*Each section

for critical missile, airborne and other applications

Raytheon CK7079 and CK7083 Reliable Subminiature Tubes operating at rated heater voltage reach 90% of the 3 minute plate current in 10 seconds from a cold start. They meet military specifications for reliable tubes as well as sweep frequency vibration tests to 500 cycles, 10 g.

The Raytheon type CK7079 specification includes a pulse emission test with a minimum limit of 1 ampere peak cathode current per section as well as an 800 ma peak current pulse life test for 200 hours.



INDUSTRIAL TUBE DIVISION

Reliable Miniature and Subminiature Tubes • Voltage Reference Tubes • Voltage Regulator Tubes • Rectifiers • Nucleonic Tubes

Newton, Mass.:.....55 Chapel St., Bigelow 4-7500
New York:.....589 Fifth Ave., Plaza 9-3900
Chicago: 9501 Grand Ave., Franklin Park, National 5-4000
Los Angeles: 5236 Santa Monica Blvd., Normandy 5-4221

The industry that

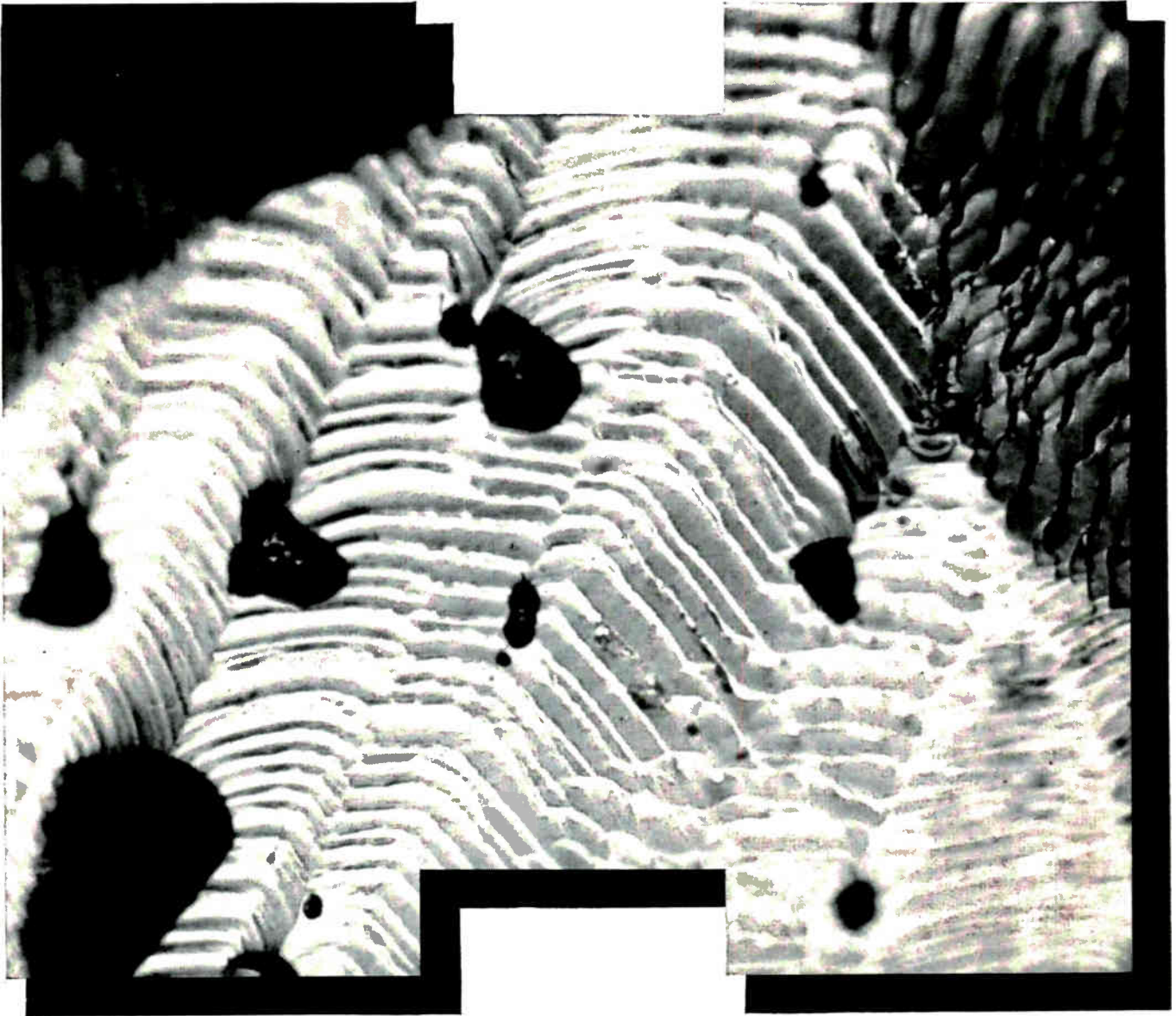

impurity built



Exit cones capable of withstanding temperatures of 6000° F, represent one example of advanced engineering being performed by the Hughes Plastics Laboratory.

This photomicrograph (at left) of an etched silicon crystal is used in the study of semiconductor materials. Impurities introduced into crystals such as this form junctions for semiconductor devices.

In the fast-growing semiconductor industry, Hughes Products, the commercial activity of Hughes, is leading the field. Its programs include basic research on semiconductor surfaces; alloying and diffusion techniques; and materials characterization studies to determine the electrical effects of imperfections and impurities.

In addition, Hughes Products is developing new semiconductor devices such as parametric amplifiers, high frequency performance diodes, and improved types of silicon transistors. New techniques are being devised for casting silicon into various configurations. Also underway is the development of new intermetallic compounds for use in semiconductor devices.

Other activities of Hughes provide similarly stimulating outlets for creative engineering. The Hughes Research & Development Laboratories are conducting

studies in Advanced Airborne Electronics Systems, Space Vehicles, Plastics, Nuclear Electronics, Global and Spatial Communications Systems, Ballistic Missiles... and many more. Hughes in Fullerton is developing radar antennas which position beams in space by electronic rather than mechanical means.

The diversity and advanced nature of Hughes projects provides an ideal environment for the engineer or physicist interested in advancing his professional status.

Newly instituted programs at Hughes have created immediate openings for engineers experienced in the following areas:

Semiconductors	Communications
Microwave & Storage Tubes	Circuit Design
Field Engineering	Systems Analysis
Microwaves	Reliability Engineering
Digital Computer Engr.	Radar

*Write in confidence, to Mr. Phil N. Scheid,
Hughes General Offices, Bldg. 6-D1, Culver City, California.*

© 1958, H. A. C.

The West's leader in advanced ELECTRONICS

HUGHES

HUGHES AIRCRAFT COMPANY
Culver City, El Segundo,
Fullerton and Los Angeles, California
Tucson, Arizona

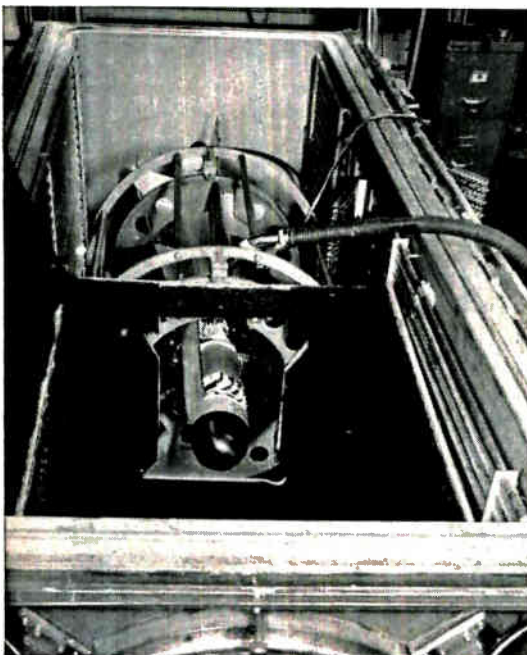

Falcon air-to-air guided missiles, shown in an environmental strato chamber are being developed and manufactured by Hughes engineers in Tucson, Arizona.

AMPLIFY MICROVOLTS WITH STABILITY... measure strain, temperature, other phenomena, to 0.1% with a KIN TEL DC amplifier

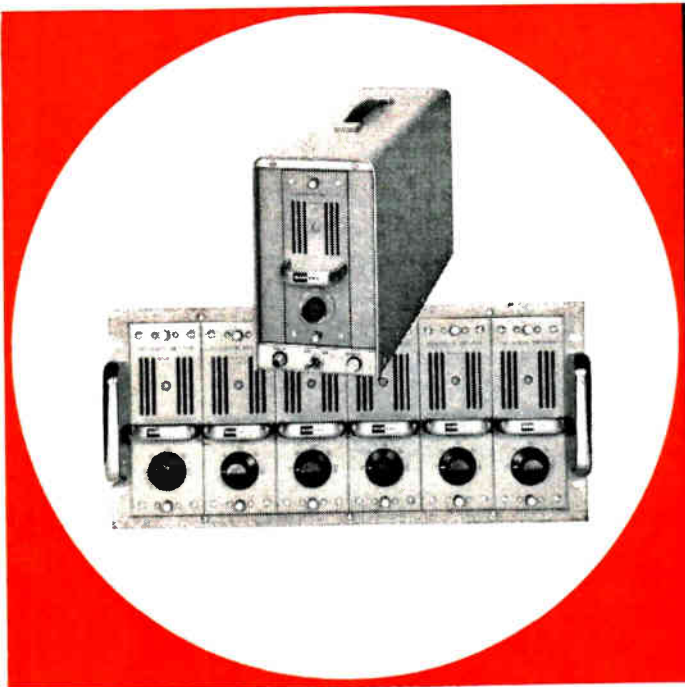

NEW...TRUE DIFFERENTIAL DC AMPLIFIERS ELIMINATE GROUND LOOP PROBLEMS...RESCUE MICROVOLT SIGNALS FROM VOLTS OF NOISE

160 db DC, 120 db 60 cycle common mode rejection with balanced or unbalanced input ■ Input completely isolated from output ■ Input and output differential and floating ■ 5 microvolt stability for thousands of hours ■ 0.05% linearity, 0.1% gain stability ■ Gain of 10 to 1000 in five steps ■ >5 megohms input, <2 ohms output impedance ■ 10 volt at 10 ma output ■ 120 cycle bandwidth ■ Integral power supply

Ideal for thermocouple amplification, the Model 114A differential DC amplifier eliminates ground loops; allows the use of a common transducer power supply; drives grounded, ungrounded or balanced loads; permits longer cable runs; and can be used inverting or non-inverting. The 114A can be mounted in either single amplifier cabinets or six amplifier 19" rack adapter modules. Price: 114A - \$775; six amplifier module - \$200; single amplifier cabinet - \$125.

WIDEBAND, SINGLE ENDED DC AMPLIFIERS AMPLIFY DATA SIGNALS FROM DC TO 40 KC WITH 2 MICROVOLT STABILITY

±2 microvolt stability ■ <5 microvolt noise ■ 40 kc bandwidth ■ 100 K Ω input, <1 ohm output impedance ■ Gain of 20 to 1000 in ten steps with continuous 1 to 2 times variation of each step ■ ±45 V, ±40 ma output ■ 1.0% gain accuracy ■ 0.1% gain stability and linearity ■ Integral power supply

Millions of cumulative hours of operation have proved KIN TEL Model 111 series DC amplifiers to be the basic component for all data transmission, allowing simple, reliable measurement of strain, temperature and other phenomena. DC instrumentation systems - with their inherently greater accuracy, simplicity, and reliability than AC or carrier systems - are made entirely practical by the excellent dynamic performance, stability, and accuracy of KIN TEL DC amplifiers. Price: 111BF-\$575; six amplifier module-\$200; single amplifier cabinet - \$125.

5725 Kearny Villa Road, San Diego 11, California

KIN TEL
A Division of Cohu Electronics Inc.

ELECTRONICS NEWSLETTER

INSTRUMENTATION FOR PROJECT MERCURY man-in-space program will be started by Collins Radio Co. as soon as contract negotiations are completed with McDonnell Aircraft Co., prime contractor. National Aeronautics and Space Administration last week awarded Mercury contract to McDonnell. Collins instrumentation will include: radio voice communications; radio command system for control of the capsule; telemetry system to handle data on capsule conditions and medical information on the occupant; guidance system to put the capsule into orbit and steer it back; tracking system; and a radio beacon system for locating the capsule when it lands.

BANK DATA PROCESSING gets a big push with announcement last week by IBM of its Series 1200 Character Sensing Equipment. System's key is magnetic ink, readable by both men and machines, which is used to print arabic characters on checks. President Thomas J. Watson, Jr., says such character-sensing gear "represents a technological breakthrough in electronic data processing."

Semiconductor diodes are now being made at Chrysler's research laboratory as solid-state physics gets new attention. Firm is expected to make its own diodes to avoid giving away plans to outside suppliers.

AUTOMATIC PRODUCTION of microalloy diffused transistors gets underway at Lansdale, Pa., as Philco aims at entertainment market. Initial production will be high- and middle-frequency MADT's priced roughly equivalent to tubes. New fast automatic transfer line produces 450 units per hour.

STEREOPHONIC BROADCAST STANDARDS will probably be recommended to the FCC before the end of this year by newly-formed National Stereophonic Radio Committee (NSRC). This month W. R. G. Baker, president of Syracuse University's research corporation, is working within the Electronic Industries Association to organize at least four panel groups concerned with various aspects of stereocasting; one has already met.

TRANSISTORIZED five-times-faster version of the IBM 709 computer, the 7090, was announced last week. Company says sophistication permits 210,000 additions or subtractions per second and lowers operating costs. Savings of power and floor-space may range up to 70 and 50 percent, respectively, of the 709's requirements; air conditioning needs will be less. Basic price is reportedly \$2,880,000, with renting price about \$64,000

a month. First unit is slated for classified defense use by Sylvania.

Redstone Arsenal's guided missile school regularly telecasts live courses in missile maintenance via large screen and closed circuit to Ft. Knox, Ky., now plans U. S. missile school network.

MISSILE AND AIRCRAFT ELECTRONICS SALES will gain 30 percent in 1959 and reach nearly \$3 billion, compared with \$2.3 billion for '58. Prediction comes from Stephen F. Keating, vice president and head of military products activities of Minneapolis-Honeywell Regulator Co. "Opportunities for selling electronic 'hardware' may decrease during the coming year," he said, "but the demands for more engineering content and greater reliability will more than offset the decline in the production-line output."

AUTOMATIC AIR APPROACH and landing systems are now "inevitable" for the world's airlines. So says report being circulated by the technical department of the International Air Transport Association. IATA experts believe this objective will be reached by evolution of present systems and devices rather than through revolutionary means. Report says automatic system must permit pilot to take over in emergency. It also calls for long-term studies, including one of cockpit instrumentation.

Electronic music created from electronically-generated or modified sounds is being composed and developed under a five-year \$175,000 Rockefeller Foundation grant to Columbia and Princeton universities.

AUTOMATIC STRIP THICKNESS control system was recently installed on a 30-in.-wide Sendzimir rolling mill at Scovill Manufacturing Co., Waterbury, Conn. System, supplied by Industrial Nuclear Corp., Columbus, O., includes two non-contacting AccuRay measuring units, each containing a radioisotope source and detector, and an AccuRay automatic controller which provides continuous feedback control of the work rolls after translating signals from the gage detectors.

REMOTE CONTROL of machinery by voice is major 1959 program of Acoustics Commission of the USSR Academy of Sciences, says chairman Nikolai Andreyev. Tass scientific review and outlook of 1958-59 quotes him as stating that the problem has been settled theoretically and now presents only technical difficulties. One application foreseen: synchronous translation of spoken word into another language and mechanical shorthand recording.

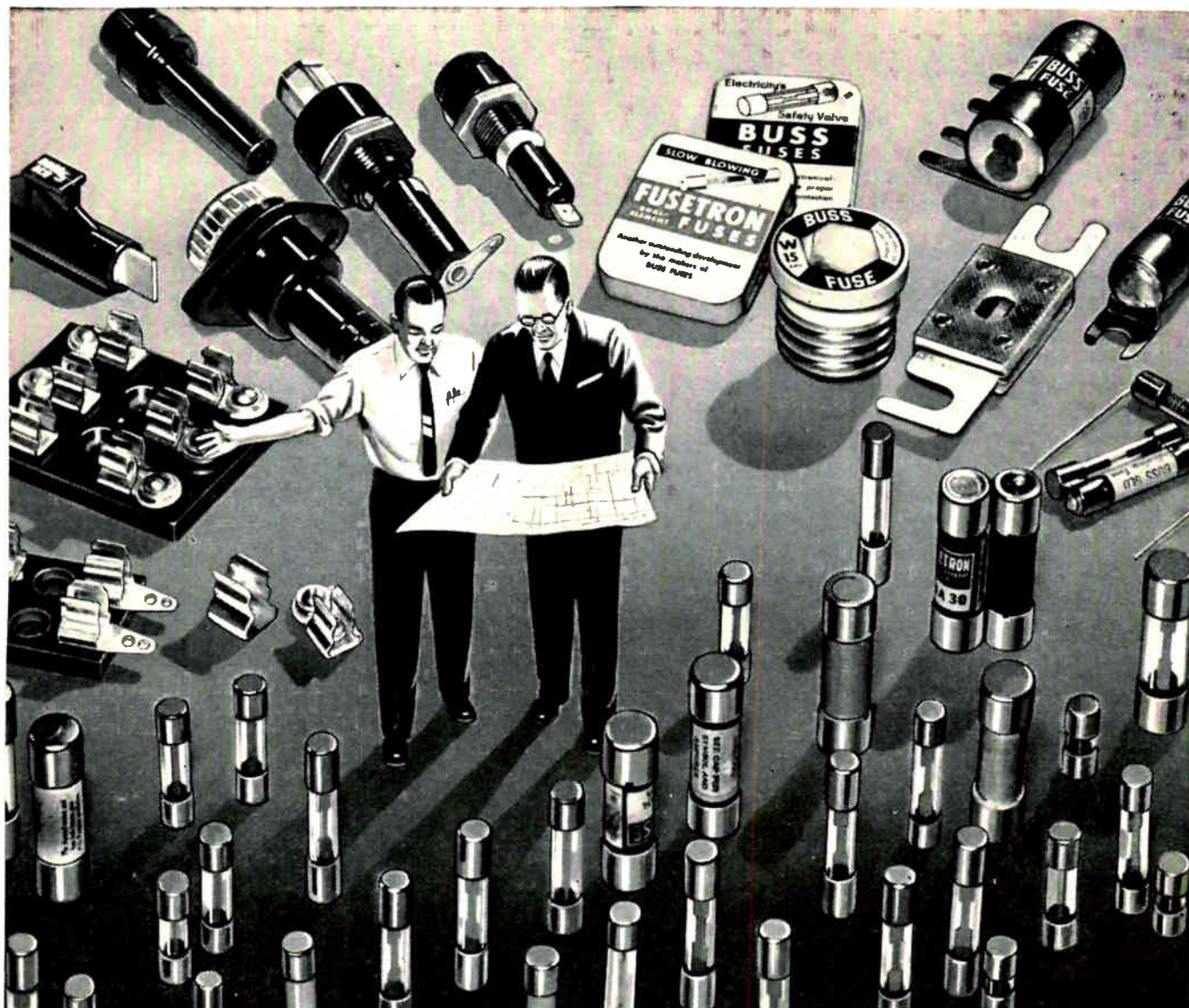

Here's why you get the safest, most dependable electrical protection . . . when you specify *BUSS or Fusetron Fuses*

Each BUSS and FUSETRON fuse is designed and made to meet the highest standard of dependability. Every fuse is then tested in a sensitive electronic device that automatically rejects any fuse not correctly calibrated, properly constructed and right in all physical dimensions.

The dependability of BUSS and FUSETRON fuses provides equipment with maximum protection against damage due to electrical faults and — prevents useless shutdowns caused by faulty fuses blowing needlessly.

By operating as intended, BUSS and FUSETRON fuses help safeguard the reputation of your equipment for service and reliability.

To meet your needs, — there's a complete line of BUSS and FUSETRON fuses in all sizes and types, . . . plus a companion line of fuse clips, blocks and holders.

If you have an unusual or difficult electrical protection problem . . .

. . . the BUSS fuse research laboratory and its staff of engineers are at

your service. In many cases, our engineers can help you save engineering time. Whenever possible, a fuse will be selected that is readily available in local wholesalers' stocks so that your equipment can easily be serviced.

For more information on the complete line of BUSS and FUSETRON Small Dimension Fuses and Fuse-holders, write for bulletin SFB.

BUSSMANN MFG. DIVISION, McGraw-Edison Co., University at Jefferson, St. Louis 7, Mo.

BUSS fuses are made to protect — not to blow needlessly



A COMPLETE LINE OF FUSES FOR HOME, FARM, COMMERCIAL, ELECTRONIC, AUTOMOTIVE AND INDUSTRIAL USE.

159

105 db gain in 60 mc I-F strip

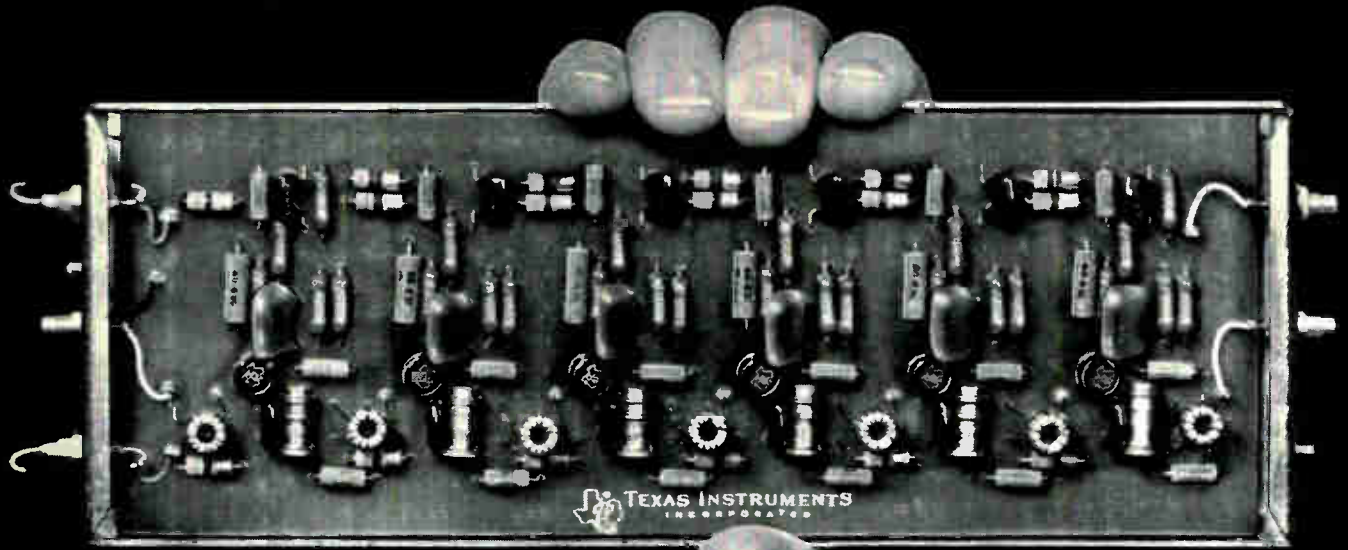

Six-stage, 90 db gain, silicon i-f amplifier designed and built by TI's Apparatus division.

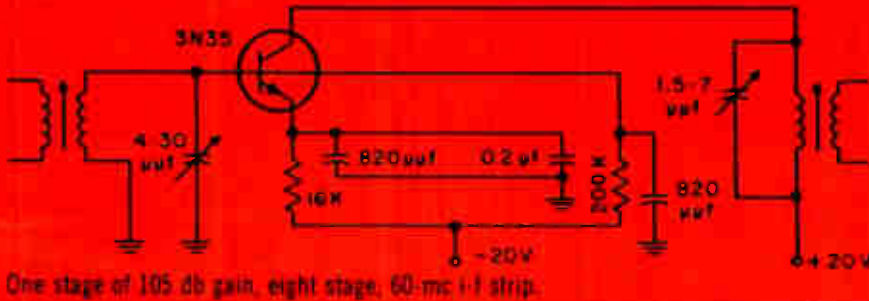

One stage of 105 db gain, eight stage, 60-mc i-f strip.



Write on your company letterhead for 105 db gain, eight stage, 60-mc i-f amplifier applications brochure.

...with TI 3N35 silicon transistors

Actual Size



105 db I-F STRIP CHARACTERISTICS

Bandwidth: 20 mc at 3-db down

Center Frequency: 60 mc

No neutralization required

The high gain of TI 3N35 transistors at high frequencies permits mismatch in the interstage coupling networks to eliminate complicated neutralizing circuitry. You save extra component costs, design with ease and gain added reliability . . . because the mismatch in this application sacrifices only 2.55 db gain per stage!

Designed for your high frequency oscillators, i-f, r-f, and video amplifier circuits, the TI 3N35 features . . . 20-db power gain at 70 mc . . . typical 150-mc alpha cutoff . . . operation to 150°C. These characteristics make transistorization feasible for radar, communications, missile, and other high reliability military applications.

In commercial production at TI for two years, the 3N35 has a product-proved record of high performance and high reliability. These units are in stock now! For immediate delivery, contact your nearby TI distributor for 1-249 quantities at factory prices . . . or call on your nearest TI sales office for production quantities.



from THE WORLD'S LARGEST SEMICONDUCTOR PLANT



TEXAS INSTRUMENTS
INCORPORATED

SEMICONDUCTOR-COMPONENTS DIVISION
POST OFFICE BOX 312 · 13500 N. CENTRAL EXPRESSWAY
DALLAS, TEXAS



What's New in ITV

Many exciting new uses for closed circuit television save time, life, health and money for industry, military, education and business.

- In the Antarctic, the Navy uses CCTV on a helicopter to picture ice conditions to an ice breaker following.
- A utility using ITV to observe water levels saved three salaries.
- In handling freight, ITV inspected cars and gondolas from a distance.
- Watching oil drilling or diving operations on the ocean floor from the surface.
- Checking factory operations for floors above from the main floor saved time and money.
- Guiding bulldozers run automatically in radioactivity areas from a safe distance.
- Stores and markets cut shoplifting and pilferage with ITV.
- Flame patterns in combustion chambers of engines and boilers may now be observed.
- Large organizations reach dealers through ITV in many cities for simultaneous meetings.
- Traffic flow through tunnels or toll bridges is checked and controlled.
- TV camera on factory roof scans large roofs for fires.



ITT makes a complete and versatile line of closed circuit TV for every military, industrial, business and educational requirement. For bulletins, engineering data and other information call our nearest office.

- Los Angeles, Calif. Empire 7-6161
- Detroit, Mich. Jefferson 6-4040
- Fort Myers, Fla. ... WYandotte 5-2151
- Washington, D.C. Empire 5-1515
- Denver, Colo. AMherst 6-2714
- New York City OXford 5-0082
- San Carlos, Calif. LYtell 3-2189
- Ft. Worth, Tex. Jefferson 5-2056

Industrial Products Division

International Telephone and Telegraph Corp.
15191 Bledsoe St., San Fernando, California

Closed Circuit TV • Custom Power Equipment
Infra Red Equipment • Large Screen Oscilloscopes
Electronic Instruments • Autopilots for Aircraft

CIRCLE 9 READERS SERVICE CARD

WASHINGTON OUTLOOK

MILESTONE in the ballistic missile program will be reached shortly when the Air Force awards its first fixed-price type contract to one of the major associate contractors on the Atlas project.

Pentagon won't reveal details on the upcoming contract award, except to cite it as an important step forward for the program. Among the candidates for this contract are the following four firms already active in the field: General Electric, associate contractor for Atlas guidance system and nose cone; North American Aviation, contractor for propulsion; Burroughs Corp., producer of the guidance computer; and Sundstrand Turbo Div., contractor for the airborne accessory power supply system.

The fixed-price type contract would be important evidence that quantity output of Atlas is imminent and that production costs have been more precisely estimated than ever.

Up to now, Atlas contracts—like all research and development projects—have been awarded on a cost-plus fixed fee basis. The fixed fee, which in effect is profit before taxes for the contractor, normally averages 4 percent of costs on development projects. In some cases the fee has run one or two percent higher.

Defense contractors have long grumbled about the low rate of profit allowed on development contracts with cost-plus clauses.

The military services do not ordinarily award fixed-price contracts until the production phase of a project has been reached. On such contracts, the producer's profit usually comes to at least 8 percent before taxes.

If incentive clauses are inserted, the profit can rise to a maximum of 12 percent before taxes. The incentive clause provides a bonus to the contractor for beating delivery dates or for substantially cutting unit costs. In all likelihood, the first Atlas fixed-price type contract will contain an incentive provision.

The contractor normally can hold on to 20 percent of the costs saved on an incentive fixed-price contract—as long as the total gross profit does not exceed 12 percent of the selling price.

- The Federal Communications Commission's annual report, just out, paints an exciting picture of technological progress in electronics, talks about "unbounded horizons" for the industry.

FCC says that tropospheric and ionospheric scatter offer the prospect of international communications, and that the bouncing of radio signals off the moon and the reception of radio emissions from man-launched earth satellites have demonstrated the feasibility of radio communications in space.

The commission forecasts that equipment will be developed to provide for radio communications on the "super high" frequencies. It also cites the use of offset-carrier, single sideband, split channel, and other new techniques permitting expanded radio services. Other highlights of FCC's report:

- Opening of the microwave portion of the spectrum for point-to-point communications is resulting in new voice and telegraph channels, and in teletypewriter, facsimile, relay, and remote-control opportunities for common carriers, broadcasters, public agencies and industry.

- Aural and video educational programming will increase via closed-circuit, educational or commercial stations, or all three.

AT LAST! A Precision 200 KC Scope with Dual Trace Presentation!

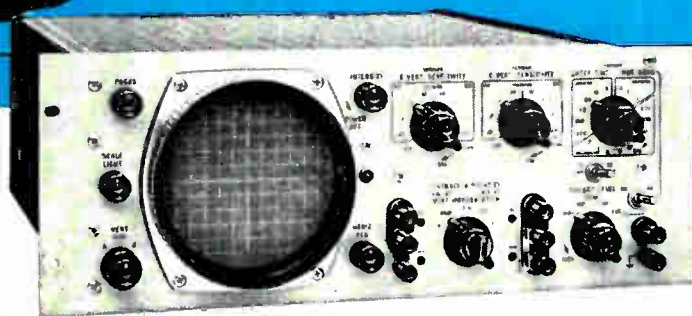
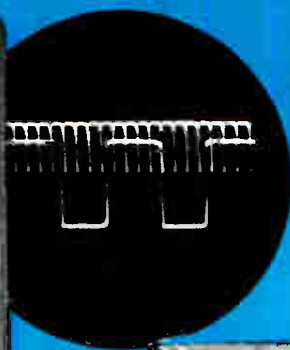

NEW MODEL 122A



Here at last is a 200 KC oscilloscope—priced at just \$625—giving you “big-scope” versatility and the time-saving convenience of simultaneous two-phenomena presentation.

Engineered to speed industrial, mechanical, medical and geophysical measurements in the 200 KC range, the new hp 122A has two identical vertical amplifiers and a vertical function selector.

The amplifiers may be operated independently, differentially on all ranges, alternately on successive sweeps, or chopped at a 40 KC rate.

Other significant features include universal optimum automatic triggering, high maximum sensitivity of 10 mv/cm, 15 calibrated sweeps with vernier, sweep accuracy of $\pm 5\%$ and a “times-5” expansion giving maximum speed of 1 $\mu\text{sec}/\text{cm}$ on the 5 $\mu\text{sec}/\text{cm}$ range. Trace normally runs free, syncing automatically on 0.5 cm vertical deflection, but a knob adjustment eliminates free-run and sets trigger level as desired between -10 and $+10$ volts. Rack or cabinet mount; *rack mount model only 7" high.*

For complete details, write or call your hp representative, or write direct.

HEWLETT-PACKARD COMPANY

5140A PAGE MILL ROAD • PALO ALTO, CALIFORNIA, U.S.A.
CABLE "HEWPACK" • DAVENPORT 5-4451
FIELD REPRESENTATIVES IN ALL PRINCIPAL AREAS

BRIEF SPECIFICATIONS hp 122A

Sweep: 15 calibrated sweeps, 1-2-5 sequence, 5 $\mu\text{sec}/\text{cm}$ to 0.2 sec/cm, accuracy $\pm 5\%$. “Times-5” expander, all ranges. Vernier extends 0.2 sec/cm range to 0.5 sec/cm.

Trigger selector: Internal $+$ or $-$, external or line. Triggers automatically on 0.5 cm internal or 2.5 v peak external. Displays base line in absence of signal. Trigger level selection -10 to $+10$ v available when automatic trigger defeated.

Vertical Amplifiers: Identical A and B amplifiers, 4 calibrated sensitivities of 10 mv/cm, 100 mv/cm, 1 v/cm and 10 v/cm; $\pm 5\%$ accuracy. Vernier 10 to 1. Balanced (differential) input available on all input ranges. With dual trace, balanced input on 10 mv/cm range. Input impedance 1 megohm with less than 60 μmf shunt. Bandwidth DC to 200 KC or 2 cps to 200 KC when AC coupled. Internal amplitude calibrator provided.

Function Selector: A only, B only, B-A, Alternate and Chopped (at approx. 40 KC).

Horizontal Amplifier: 3 calibrated sensitivities, 0.1 v/cm, 1 v/cm, 10 v/cm. Accuracy $\pm 5\%$. Vernier 10 to 1.

Bandwidth DC to 200 KC or 2 cps to 200 KC, AC coupled.

General: 5AQP1 CRT, intensity modulation terminals at rear, power input approximately 150 watts, all DC power supplies regulated.

Price: (Cabinet or rack mount) \$625.00.

Data subject to change without notice. Prices f.o.b. factory.



now offers 8 different precision scopes

DRIVE AND CONTROL IDEAS FOR ENGINEERS

Tips on better designing with FLEXIBLE SHAFTS

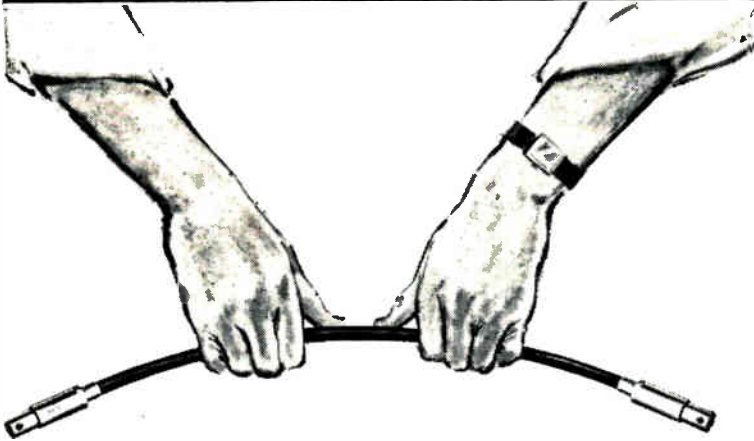

Ready Availability of off-the-shelf standard flexible shafts is a convenience and economy offered engineers by S.S.WHITE. Complete, ready to install, they are ideal for testing experimental designs or for small production runs on remote controls or power drives. Designed for ready attachment to your engaging parts, they come in three-foot lengths in three different diameters. Longer lengths available on request. Write for Bulletin 5801.

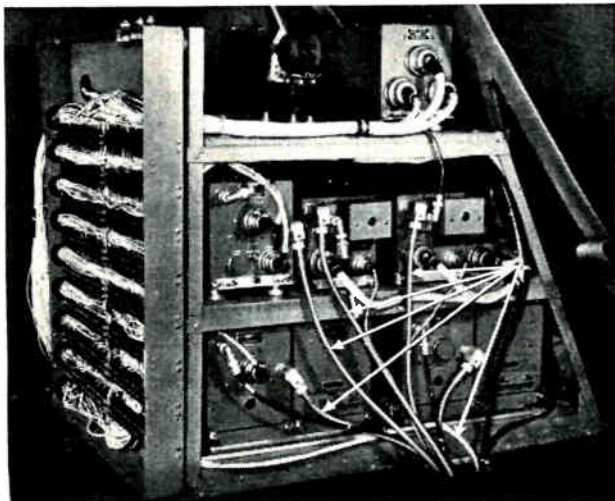

Reliability of Control is essential in the communication and navigation equipment of a small executive type airplane. The equipment, shown here, is operated by the pilot through a remote turning unit connected to the equipment by five S.S.WHITE remote control flexible shafts. Since it is designed for complete instrument flying on the airways, dependability is essential.

S.S.WHITE offers engineering service and a complete selection of flexible shaft sizes and types to meet specialized design requirements. For cost-saving, design-simplifying ideas in flexible drive, coupling and control shafts, write for Bulletin 5601. (Dept. E)

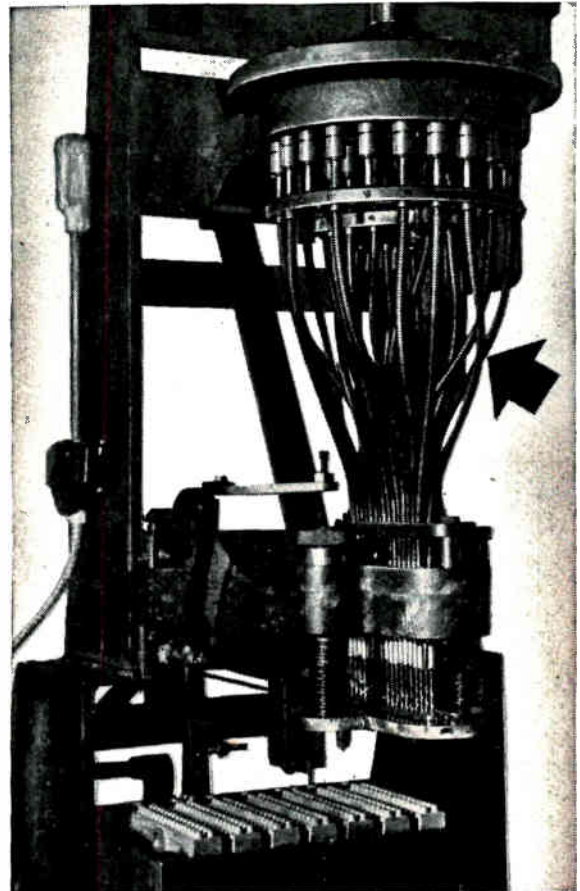

Drilling Patterns can be readily changed in this flexible shaft multiple spindle drill press. There are 38 spindles in this particular machine, any or all of which may be used simultaneously and readily regrouped as desired. The small diameter of the S.S.WHITE flexible drive shafts also permits drills to be set on closer center than on ordinary multiple spindle drilling equipment.

S.S. White

FIRST NAME

IN FLEXIBLE SHAFTS

S.S.WHITE INDUSTRIAL DIVISION
10 East 40th Street, New York 16, New York
Western Office: 1839 West Pico Blvd. Los Angeles 6, Calif.



SEC Rule Aids Small Firms

SECURITIES AND EXCHANGE Commission announces new Regulation E providing for partial exemption from SEC registration of securities offered by small business investment corporations. Offerings of \$300,000 or less by SBI's only require filing of notification with the Commission and preparation of an offering circular.

• **Spencer-Kennedy Labs** of Boston, manufacturer of amplifiers and filters for community tv systems, gives option to buy controlling interest in **Elmira Video, Inc.**, Elmira, N. Y., to **Utilities Industries and Management Corp.** Option holder is a New York venture capital group active in the electronics industry.

• **Automatic Canteen Co.** of America plans merger with **AMI, Inc.**, Grand Rapids, Mich., coin-operated phonograph manufacturer. Terms call for exchange of 5 1/2 shares of AC for each 10 shares of AMI stock. Chairman of AC's board, N. Leverone, says his firm is "carefully planning further expansion in the electronics field."

• **Long-term leasing** of production equipment by electrical-electronics firms rose to an all-time high last year. Total dollar volume of leased equipment and machinery for this group reached \$17 million by December '58, as compared with \$12.5 million a year before. Gain is 36 percent. Electrical equipment and machinery industry ranked among the nation's top ten users of leased equipment. Leases ranged from \$3,000 to \$140,000, covered single units, complete plants.

• **Stockholders** of **Amphenol Electronics Corp.** and **George W. Borg Corp.** approve consolidation of companies into **Amphenol-Borg Electronics Corp.** Borg operates four plants in southeastern Wisconsin. Amphenol, headquartered in Chicago, has 380,000 sq ft, plus near-completion of an additional 160,000-sq-ft plant in Broadview,

a Chicago suburb, and other plants in Connecticut and California.

• **Additional financing** has been obtained by **Pickard and Burns Inc.**, Needham, Mass., radio navigation equipment manufacturer, from **Payson & Trask, N. Y.** P & T has invested \$150,000 in ten-year subordinated notes with warrants to buy common stock. The firm has agreed to finance redemption of some outstanding bonds.

OVER THE COUNTER

1958 LOW	BIDS HIGH	COMMON STOCKS	WEEK ENDING	
			Jan. 2 BID	Jan. 9 BID ASKED
3 3/4	20 1/2	Acoustica Assocs	23 1/4	22 1/4 25 7/8
1 9/8	3	Advance Industries	27 1/8	27 1/8 33 1/8
3 1/8	6 1/8	Aerovox	6 1/8	6 1/8 7
20 1/2	33	Amer Res & Dev	36	36 1/2 39 3/8
16 3/4	24 1/4	AMP Inc	21 1/4	22 25 5/8
17 1/8	69	Ampex	61	62 3/4 66 1/4
5 1/2	15	Appl'd Sci Princet	7 5/8	9 3/4 11 1/2
1 1/8	8 7/8	Avien, A	8 3/4	9 10
6 3/4	24	Baird-Atomic	22 1/2	22 3/4 27 1/4
9 3/4	13 3/8	Burndy	13 3/8	13 3/4 15 1/8
6 3/4	9	Cohu Electronics	6 1/2	6 1/4 8 1/8
11	22 1/2	Collins Radio, A	22 1/2	21 3/4 24 3/8
10 1/4	22 1/4	Collins Radio, B	22 1/2	21 1/2 24 3/8
4	7	Craig Systems	6 3/8	6 1/4 7 1/8
30	50 1/2	Dictaphone	48	47 1/2 50 7/8
17 1/8	25 3/8	Eastern Industries	21 1/4	20 21 3/4
22 3/4	29	Eitel-McCullough	28 1/2	26 3/4 30 3/8
10 1/2	21	Electro Instr	25	23 1/2 27 3/4
34	49	Electronic Assocs	50 1/2	50 1/2 59 1/2
5	11	Electronic Res'rch	11 1/4	11 1/4 15 1/8
8 1/2	12 3/4	Electronic Spec Co	12 3/4	12 1/4 15 1/8
15 1/4	49 1/2	Epsco, Inc	41 1/2	39 48 1/4
5 1/2	9 3/8	Erie Resistor	8 3/4	8 3/4 9 3/4
10	17 1/2	Fischer & Porter	15 1/2	16 1/2 18 3/8
36 3/4	50	Foxboro	50	50 1/2 56 1/2
5 1/2	10 1/2	G-L Electronics	10	10 11 1/4
12	27	Giannini	25	28 31 1/8
30	39 1/2	Hewlett-Packard	39 1/4	39 42 1/8
23 1/4	48	High Voltage Eng	48	50 68 1/2
13 1/4	3	Hycan Mfg	2 7/8	3 3/8 4 1/8
1 1/8	5 1/8	Industro Trans'or	2 7/8	2 7/8 3 3/8
1 1/2	4 3/4	Jerrold	3 3/4	3 7/8 4 1/8
21	30	D. S. Kennedy	26 3/4	26 1/2 29 1/8
3 1/2	29	Lab For El'tronics	26 1/2	27 1/4 30 7/8
19 1/4	28	Leeds & Northrup	27 3/4	27 1/2 30 3/8
2	3 1/8	Leetronics	1 7/8	2 2 3/8
5	18 1/2	Ling Electronics	17 3/8	17 3/8 19
16	20 1/2	Machlett Labs	20 1/2	21 1/2 25 7/8
3 1/4	8 1/4	Magnetic Amplifiers	8 1/4	8 1/4 9
2 7/8	4 1/2	Magnetics, Inc	3 3/4	3 3/8 4 1/4
4 3/8	12	W. L. Maxson	10 3/8	11 3/4 13 1/8
10 3/8	29	Microwave Assocs	30 1/2	32 37 3/4
5 1/4	11 3/4	Midwestern Instr	11 3/4	11 7/8 12 1/8
1 1/8	7	Monogram Prec'is'n	6 3/4	7 1/4 9 1/2
3 1/2	7 1/4	Narda Microwave	7 1/8	9 10
9 3/4	16	National Company	15 3/4	15 17 1/2
14 1/4	56	Nuclear Chicago	31 1/2	29 34 1/8
14 1/2	29 3/4	Oradio Industries	27 3/4	26 1/4 32
4 1/2	7 3/8	Pacific Mercury, A	7 3/8	8 10 3/4
10 3/8	27 1/2	Packard-Bell	27 3/4	28 30 7/8
4 1/4	9 3/8	Panellit, Inc	8 24	8 3/4 9 3/4
21	53 1/4	Perkin-Elmer	52	50 56 1/2
11 3/8	19 1/2	Radiation, A	16 5/8	17 1/4 19 1/8
2 1/8	7 3/8	Reeves Soundcraft	6 1/2	6 5/8 7 3/8
13	32 1/2	Sanders Associates	28 1/2	29 37 3/4
7	12	SoundScriber	16	14 3/4 17 1/4
22 3/4	40	Sprague Electric	39 1/2	40 44
26	35	Taylor Instruments	34 3/4	34 37 1/4
5 1/2	15	Technical Operat'ns	15 1/2	15 3 1/4 18 3/8
5 1/2	15 3/4	Teledrome Mfg	15 1/4	15 1/4 17 1/4
3 1/4	7 3/4	Telecomputing	7 3/4	8 1/4 9 1/8
1 1/8	2 3/4	Tel-Instrument	2 3/4	2 3/4 3 1/2
8 3/4	16 1/4	Topp Industries	13 1/8	13 1/8 14 1/2
3 3/4	10 3/4	Tracerlab	10 1/2	11 14 1/8
1 1/8	3 3/8	Universal Trans'or	3 3/8	2 3/4 3 3/8
14 1/4	40	Varian Associates	39 1/4	43 1/4 49 7/8
12 1/2	18 1/2	Vitro Corp. Amer	14 1/2	15 3/8 16 3/8

The above "bid" and "asked" prices prepared by the NATIONAL ASSOCIATION OF SECURITIES DEALERS, INC., do not represent actual transactions. They are a guide to the range within which these securities could have been sold (the "BID" price) or bought (the "ASKED" price) during preceding week.

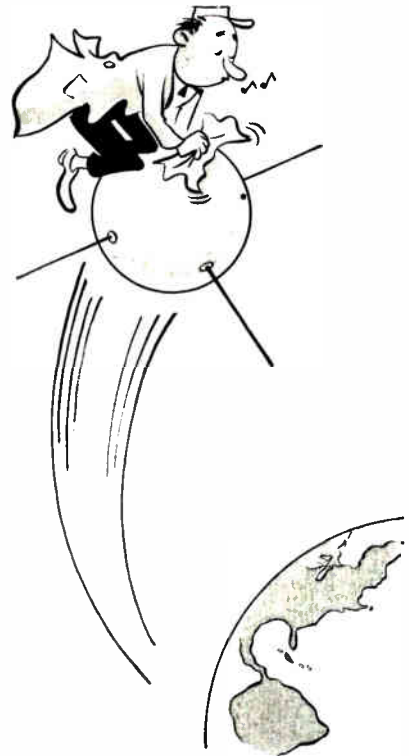

Clean precision parts more safely

New Freon* solvents by Du Pont minimize cleaning hazards

- **Low toxicity**—"Freon" solvents are odorless and much less toxic than ordinary solvents—vapors won't cause nausea or headaches.
- **Won't burn or explode**—Underwriters' Laboratories report "Freon" solvents non-explosive, non-combustible and non-flammable.
- **Non-corrosive**—"Freon" solvents remain neutral through repeated degreasing use without the need of inhibitors.
- **Negligible effects on plastics, elastomers, insulation and color codes**—"Freon" solvents remove oil and grease with minimum swelling of plastics or rubber and without crazing or softening paint, wire coatings or insulation.
- **Leaves no residue**—"Freon" solvents evaporate completely, leave no deposit.

New "Freon" solvents by Du Pont degrease sensitive mechanical and electronic assemblies without damage to delicate parts. Since no inhibitors are needed, no residue is left on the parts, and "Freon" solvents can be recovered and reused without re-inhibiting. Write for free "Freon" solvents booklet. E. I. du Pont de Nemours & Co. (Inc.), "Freon" Products Division 521. Wilmington 98, Delaware.

*Freon is Du Pont's registered trademark for its fluorinated hydrocarbon solvents.



FREE BOOKLET!

No obligation—write for booklet which tells how new "Freon" solvents by Du Pont minimize cleaning hazards.



Better Things for Better Living... through Chemistry

CIRCLE 12 READERS SERVICE CARD

Three different relays with one thing in common...



Sub-Minature Relay Type 95



Miniature Telephone-Type 115



High Voltage Relay Type 134-3468

Sure, these three relays were obviously built for three very different applications—yet they have one common denominator—AEMCO ingenuity. Originally developed to meet rigid electrical and mechanical requirements, these three relays are typical of AEMCO engineering and production facilities.

Although AEMCO manufactures a wide variety of relay types now available as "standards," custom development and manufacture to tight tolerances are AEMCO specialties. Want fast delivery on prototypes? Want outstanding engineering and production facilities at your disposal? Then, send us the specifications on your next relay—we may have an AEMCO "standard" that will save you tooling and valuable time—or if your problem is development, we'll be happy to design a relay to meet your specific requirements.

Need relays?
ask



AEMCO offers a complete line of relays in a wide choice of spring and coil combinations, operating potentials, and contact ratings. If one of hundreds of standard AEMCO relay types does not exactly meet your requirements, we will be happy to design and manufacture a unit to meet or exceed your requirements.

AEMCO also manufactures a complete line of Sequence and Automatic Re-Set Timers, Time Switches and Sign Flashers.

WRITE TODAY

Your inquiries are invited. Ask for your free copy of Relay Catalog describing all standard relays in the AEMCO line.



AEMCO INCORPORATED

15 State St. • Mankato, Minn.

CIRCLE 13 READERS SERVICE CARD

MARKET RESEARCH

CLOSED-CIRCUIT TV SALES

(in millions of dollars)

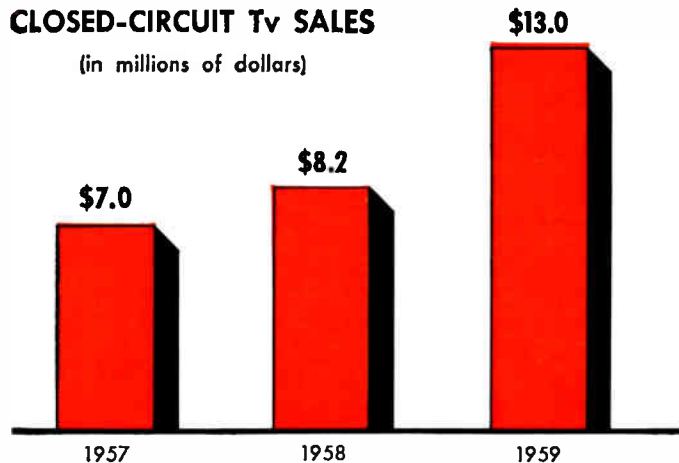

Closed-Circuit Tv Sales Up

THIS should be a big year for closed-circuit tv sales.

ELECTRONICS estimates that closed-circuit sales will amount to \$13 million this year, about 60 percent better than last year. In contrast, sales totaled \$8.2 million in 1958 and \$7 million in 1957.

Current sales figures are already near a \$13-million annual rate. Surveys and studies by several manufacturers also point to this volume for 1959.

Estimates include all industrial-commercial sales and all sales to the military. They also include closed-circuit tv systems using vidicon cameras as well as broadcast type cameras.

Industrial tv sales were recently estimated at \$8 million and \$6 million, respectively, for 1959 and 1958 in "Our Market for 1959", ELECTRONICS, p 41, Jan. 9. Difference stems primarily from fact that our earlier figures include industrial, commercial and only part of military sales.

Present figures include all military sales.

Recession followed by recovery is big factor behind projected sales increase. Less than normal sales growth occurred last year because of recession influence.

Better times this year are expected to bring resumption of normal sales growth, as well as gains to make up some of the sales "lost" in 1958.

Increasing acceptance of closed-circuit equipment by industrial-commercial users is helping to spur sales growth. At present 60 percent of sales are to nonmilitary users and 40 percent to military. In about five years commercial-industrial share is expected to be accounting for about 70 percent of the total.

Most experts guess that annual sales total will top \$30 million by 1964.

Range of opinion is between \$25 and \$50 million.

Optimistic look ahead is partially based on more extensive use of closed-circuit systems in education and trend toward lower prices which will increase number of industrial-commercial users who can afford installations.

Development of transistorized cameras for general use is also expected to be a plus factor because size of equipment is important to many.

FIGURES OF THE WEEK

LATEST WEEKLY PRODUCTION FIGURES

(Source: EIA)	Jan. 2, 1959	Dec. 5, 1958	Change From One Year Ago
Television sets	61,007	103,539	-1.3%
Radio sets (ex. auto)	192,562	358,987	+50.6%
Auto sets	79,228	140,662	+115.3%

STOCK PRICE AVERAGES

(Standard & Poor's)	Jan. 7, 1959	Dec. 10, 1958	Change From One Year Ago
Electronics mfrs.	72.84	58.94	+40.1%
Radio & tv mfrs.	79.79	77.37	+76.9%
Broadcasters	78.22	78.15	+36.1%

New

ALLEN-BRADLEY Power Ferrites for Audio Frequencies (400 to 15,000 cps)

With the development of these two new power ferrites, it is now possible for you to gain the advantages of high-efficiency operation at the lower frequencies. These new ferrites are available in a wide range of shapes and sizes. A-B engineers will be glad to assist you in the application of these new ferrites.



Typical Applications for Allen-Bradley Power Ferrites

W-07



HF Fluorescent Lighting
Ballast

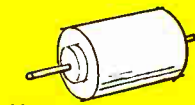

Motor

R-03

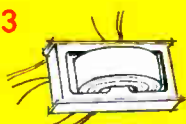

Transistor DC Power
Supply Transformer

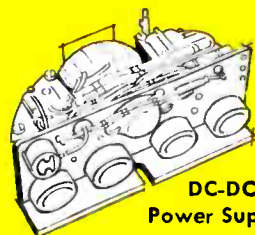

DC-DC
Power Supply

W-07 NEW POWER FERRITE with maximum flux density in excess of 5000 gauss—Here's an A-B ferrite that opens new fields for the use of ferrites in continuous power applications at frequencies between 400 and 15,000 cps—where even special laminated iron alloys are impractical. And its lower material costs bring tremendous savings in high-frequency fluorescent lighting ballasts, power transformers, motors, and high-frequency converters.

R-03 NEW POWER FERRITE has rectangular hysteresis loop—The many unique properties of this R-03 ferrite offer unusual opportunities for designing intermediate frequency magnetic amplifiers, static switching devices, transistorized inverters, and power supplies. At operation above 500 cps, the cost and weight of this new ferrite is less than one half that of square loop, metallic tape wound cores . . . and core losses are much less. In addition, the extreme squareness of the hysteresis loop minimizes transient spikes which can damage transistors.

Allen-Bradley Co., 222 W. Greenfield Ave.
Milwaukee 4, Wis.

In Canada: Allen-Bradley Canada Ltd., Galt, Ont.

ALLEN-BRADLEY Electronic Components

New Allen-Bradley Power Ferrites Open New Design Horizons

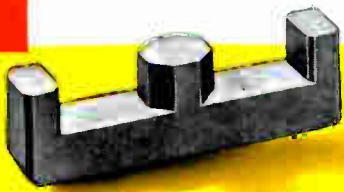

W-07



R-03

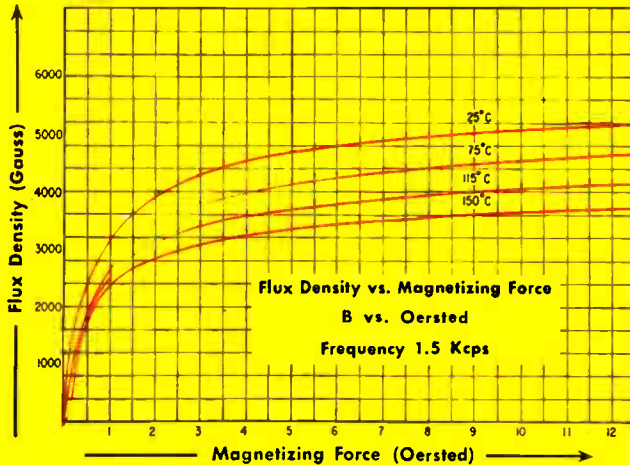

W-07 MAGNETIZATION CURVES show the extremely high flux density available. Also, it reveals that the maximum flux density does not decrease appreciably in increasing temperature. Technical Bulletin 5655 has complete specifications—send for your copy.

TABLE OF MAGNETIC PROPERTIES (TOROIDAL)

Property	Symbol	Unit	Nominal Value	Test Current
Sat. Flux Density @ 10 Oersted	B_s	Gauss	5,200	1.5 Kcps
Residual Mag.	B_r	Gauss	1,000	1.5 Kcps
Coercive Force	H_c	Oersted	.24	1.5 Kcps
Initial Permeability	μ_0	—	1,300	1.5 Kcps
Maximum Permeability	μ_{max}	—	4,000	1.5 Kcps
Curie Point	CP	+ °C	280	—

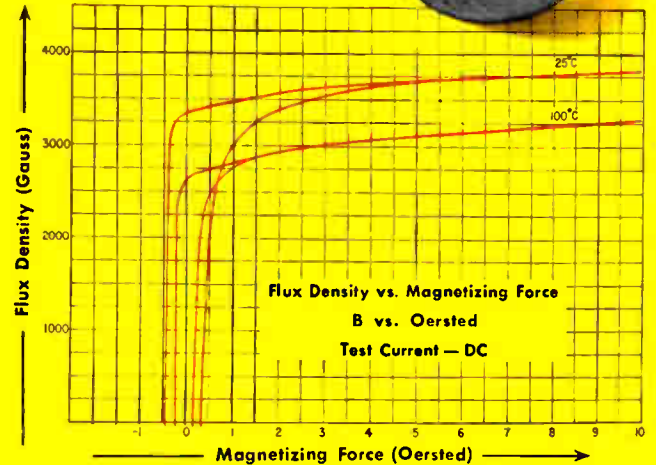

R-03 HYSTERESIS LOOPS show the high flux density provided with low levels of drive. The reduction in area with temperature shows that the loss per cycle is less at higher temperatures. For complete specifications, write for Technical Bulletin 5658.

TABLE OF MAGNETIC PROPERTIES (TOROIDAL)

Property	Symbol	Unit	Nominal Value	Test Current
Sat. Flux Density @ 10 Oersted	B_s	Gauss	3,900	D.C.
Residual Mag.	B_r	Gauss	3,360	D.C.
Coercive Force	H_c	Oersted	.37	D.C.
Initial Permeability	μ_0	—	325	1.5 Kcps
Maximum Permeability	μ_{max}	—	3,500	1.5 Kcps
Maximum Differential Permeability $(\frac{\Delta B}{\Delta H})_{B=0}$	μ_d	—	40,000	D.C.
Switching Time @ 2.5 H_c	t_s	μ sec	2.9	—
Curie Point	CP	+ °C	315	—

Allen-Bradley Co., 222 W. Greenfield Ave., Milwaukee 4, Wis.
In Canada: Allen-Bradley Canada Ltd., Galt, Ont.

1-59-E

ALLEN-BRADLEY
ELECTRONIC COMPONENTS
QUALITY

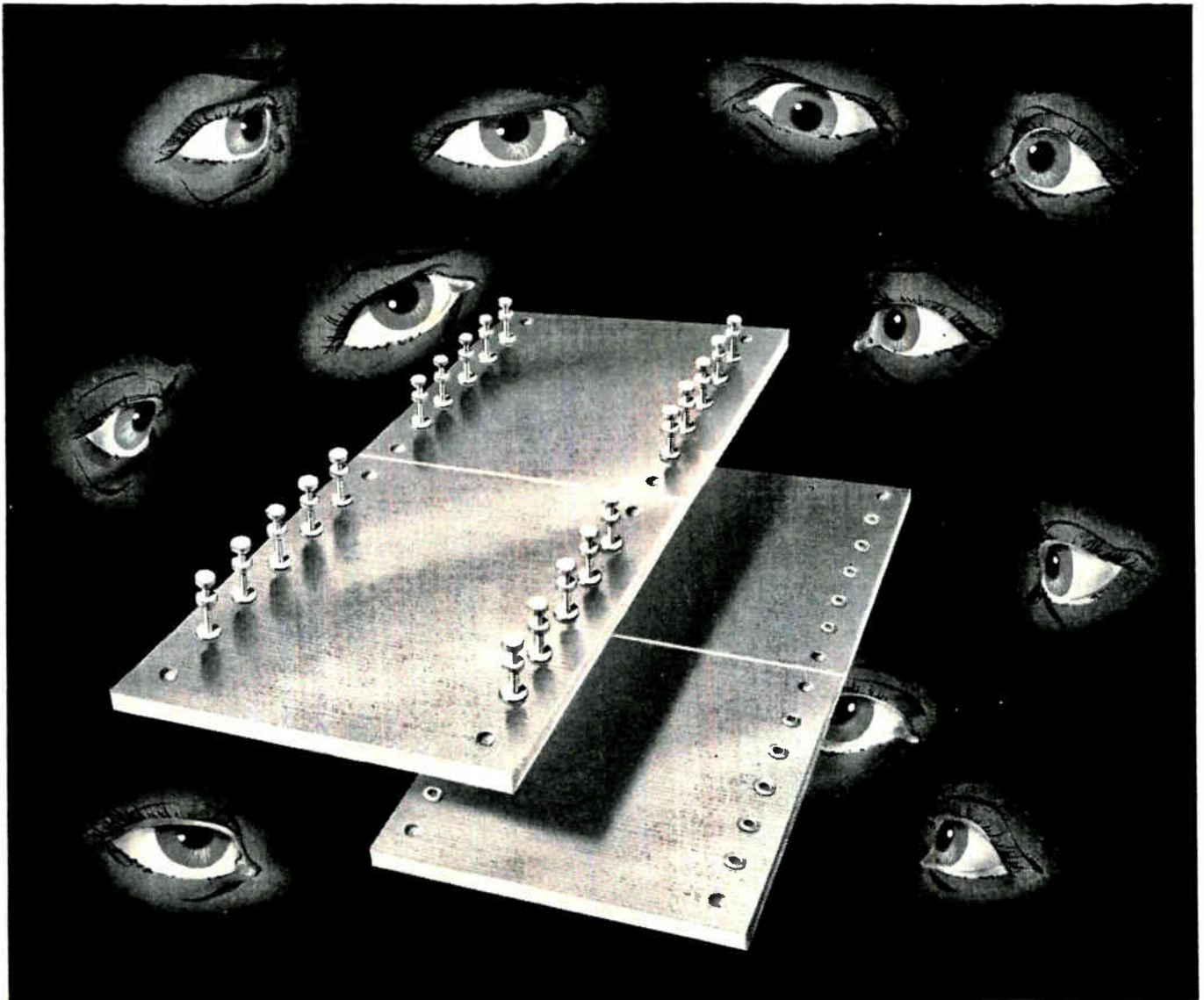

CAMBION terminal boards are available in standard all-set, miniature all-set, standard ceramic and custom-made types. Materials include paper, cloth, nylon or glass laminates, bonded with phenolic, epoxy, melamine or silicone resins. Boards are moisture-proofed and fungus-proofed. Standard or special components are assembled as required.

Our "private eyes" protect you from delinquents

You won't find a single weak spot in any CAMBION® terminal board. We've already made sure there are no cracks in board or terminals; no strain, chips or sunbursts; no insecurely mounted terminals. In fact, such defects are the rarest discoveries, even in our own thorough inspections. That's because the stock used in CAMBION boards is certified top grade . . . CAMBION tooling is specially engineered to prevent product damage . . . and CAMBION workmanship is true craftsmanship.

Quality control like this is standard in every step of CAMBION production — in any quantity. That's why you can count on the complete CAMBION line — terminal boards, solder terminals, insulated terminals, coils, coil forms, capacitors, swagers, hardware — for the trouble-free performance you expect and need. And every CAMBION component is *guaranteed*.

Available locally through authorized CAMBION distributors. Or write to Cambridge Thermionic Corporation, 437 Concord Avenue, Cambridge 38, Massachusetts. On the West Coast: E. V. Roberts and Associates, Inc., 5068 West Washington Blvd., Los Angeles, California. In Canada: Cambridge Thermionic of Canada, Limited, Montreal, P. Q.

CAMBION solder terminals are made of silver plated brass, coated with water dip lacquer. There are 65 different types available in bulk in unlimited quantity or in individual packages of 100. Mounting information and CAMBION tools required are listed on the package.



CAMBRIDGE THERMIONIC CORPORATION
CAMBION®

The guaranteed electronic components





Optimizing control computer (left) by Westinghouse searches out best solution to complex problems. It will soon be at work solving refinery processing puzzles. IBM 704, installed at Esso Research center in Linden, N. J., last month, will be used to design new oil processing equipment

Digital Computers Strike Oil

Collecting and processing data for oil men is keeping a growing number of digital computers and electronic data-handlers busy as electronic control of refineries approaches realization

NEXT FIVE YEARS will find the petroleum industry using more and more digital computers and electronic data-processors. A recent survey predicts the total sales and lease value of such equipment may reach about \$525 million by 1963, as compared with 1958's estimated total of close to \$300 million.

Oil companies first began using digital computers as accounting devices. Within a very short time research and engineering staffs were using them as well.

Operation of an oil refinery is dependent on automatic control to a greater extent perhaps than any other industrial process.

Electronic computers now in use for controlling refinery processes are for the most part analog types although digital gear is beginning to gain importance.

Currently, the basic task of digital computers is one of supplying information rather than controlling operations automatically. The Texas Co., for example, is using computers to determine day-to-day status of crude oil reserves and which available crudes and rates of

operation of various refining units will yield optimum type and volume of products.

Starts World Net

Socony Mobil has begun installation of what will grow to be a worldwide computer net. Initial hookup links the firm's New York headquarters with research and refinery facilities in Paulsboro, N. J., 97 miles away.

Punch-card information transmitted to New York by wire gives data on type of crude oil on hand at the refinery, type of product desired and other information.

The New York computer then provides recommendations on the best use of the refinery's facilities.

In addition to handling the Paulsboro refinery, the New York center also processes similar data prepared by computers in Dallas and Los Angeles by Socony affiliates.

Gulf Oil is using an electronic data-processing system to handle both accounting and engineering at its Philadelphia refinery. The com-

pany has two additional data-processing centers in Texas. One job being done by these computers is taking daily inventory by grades of approximately 700 oil tanks. Information breakdown is by gross barrels, available oil and storage space available.

The computers also perform oil and gas meter calculations from data obtained by flow meters. A Gulf spokesman says the machine handles 25 meter calculations in 50 minutes. It takes ten hours to do the same job manually.

New Developments

Completely automatic control of refinery operations moved a step closer to reality in the light of some developments announced last month.

In Pasadena, Calif., Consolidated Electrodynamics, in conjunction with Esso Research and Engineering, is conducting shakedown tests on a miniature pilot plant controlled by a Royal-McBee LGP-30 computer.

The plant automatically controls processing functions by measuring, recording and adjusting such pa-

rameters as temperatures, pressures and stream compositions.

Because it can explore a new refining process in weeks instead of months, as was previously required, Esso engineers anticipate great savings when the plant goes into commercial operation.

Another machine being readied for work in the petroleum industry is Westinghouse's optimizing control computer (Opcon), which will soon be installed at Sun Oil's Marcus Hook, Pa., refinery. In this unit, controlled variables are set at arbitrary initial values which are rough operator approximations of proper values.

The equipment then computes output figures for observation and next begins making small adjustments in input variables until it finds the set of input values which produce optimum output. It then fixes values at that point. If a new variable is introduced into the process operation, the computer resumes its search and finds a new set of optimum parameters.

This unit is expected to find many applications in the petroleum industry, where successive approximation technique may be used to fill gaps resulting from lack of accurate input data.

Research Goes On

Opinion of some oilmen is that these gaps occur because sensing instruments which collect the data are not precise enough. Instrument precision at the basic level is vital in refinery and research operations because of the many parameters involved in turning crude oil into its many end products.

Instrumentmakers say they are conducting intensive research to improve product accuracy. One manufacturer told *ELECTRONICS* that some criticism tends to be exaggerated because of differing points of view. "Refiners have been thinking in terms of collecting data for use by human operators," he said. "We're working on instruments that provide stable accurate resolving powers to be used by machines."

Sensors built on these principles, claim instrumentmakers, can produce measurements of some functions accurate to one part in 5,000.

0.01%

absolute accuracy

only with EPSCO

VOLTAGE REFERENCE SOURCES

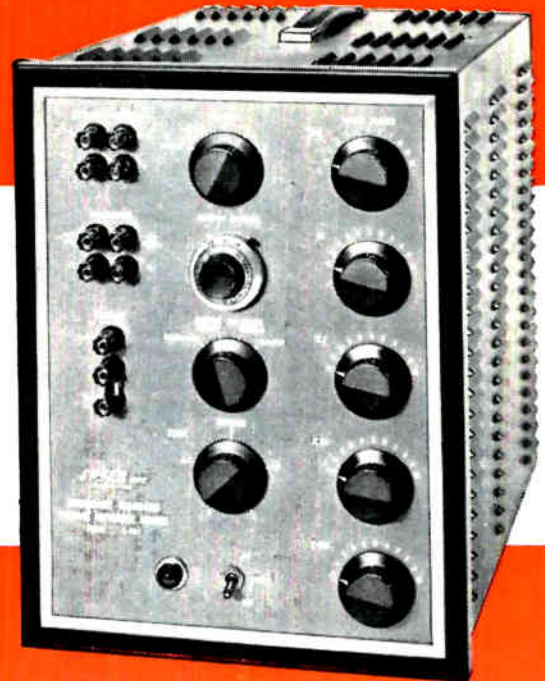

• 0.005% stability

• 1.0 Microvolt resolution down to zero volts

• ± 111.112 volts d-c range

VR-607 (illustrated) — portable, 5 decade switches plus vernier and divider
VR-607B — portable, 17 binary-coded toggles plus vernier and divider
VR-608 — rack-mounting, 5 decade switches plus vernier and divider, and front panel null meter

• Out-perform any other voltage reference source on the market • contain highest quality components: certified standard cells, oil-immersed ultra-stable resistors, high-gain chopper-stabilized amplifiers • being used in the most demanding and critical applications across the country, such as at Convair Astronautics, North American Aviation, Argonne National Laboratory, Massachusetts Institute of Technology, Bell Telephone Laboratories, Goodyear Rubber, Patrick Air Force Base.

Want the full story? Write today for new technical brochure, covering circuit design details, specifications, operating instructions.

EpSCO 
— First in data control

EpSCO, Incorporated, Equipment Division, 588 Commonwealth Ave., Boston 15, Mass.
In the West: EpSCO-West, 125 E. Orangethorpe Ave., Anaheim, California

There is
No Substitute
for
Reliability—

NEW *miniaturized* "MAG MOD" Magnetic Modulators

All Magnetic Modulators strictly conform to MIL-T-27A. Some typical circuit applications for Magnetic Modulators are algebraic addition, subtraction, multiplying, raising to a power, controlling amplifier gains, mechanical chopper replacement in DC to fundamental frequency conversion, filtering and low signal level amplification.

Actual Size



Especially Engineered for Printed Circuit Wafer
Designed Structures and Circuit Assemblies Featuring:

- FASTER RESPONSE TIME
- NEGLIGIBLE HYSTERESIS
- EXTREME STABILITY
(Ambient Temp. Range from -65°C to $+135^{\circ}\text{C}$)
- COMPACT SIZE
- LIGHTWEIGHT
- INFINITE LIFE
- COMPLETE RELIABILITY



Miniaturization of the new Magnetic Modulator makes it possible to incorporate this component into wafer type structures and transistorized printed circuit assemblies without sacrificing ruggedness or reliability.

CONSULT GENERAL MAGNETICS on magnetic amplifier components for automatic flight, fire control, analog computers, guided missiles, nuclear applications, antennas, gun turrets, commercial power amplifiers and complete control systems. Call or write for Catalog B on miniature and standard components.



Magnetic
Input
Modulator



Magnetic
Input
Modulator



Magnetic
Thermocouple
Converter

TYPE NUMBER	IMM - 436 - 2	IMM - 436 - 3	MTC - 435 - 2
Excitations Frequency—Carrier	400 cps	400 cps	400 cps
Signal Winding DC Resistance	1000 ohms $\pm 15\%$ each signal winding	1000 ohms $\pm 15\%$ each signal winding	10 ohms $\pm 15\%$
AC Excitation Volts	5.5 V. @ 400 cps	2.5 V. @ 400 cps	6 V. RMS
Input DC Signal Range	0 to $\pm 100 \mu\text{a.}$	0 to $\pm 80 \mu\text{a.}$	0 to $\pm 10 \text{mv.}$
AC Output Range	0 to 2.2V. @ 400 cps (sine wave)	0 to 1.5V. @ 400 cps (sine wave)	0 to 2.7V. @ 400 cps (sine wave)
Overall Dimensions (Inches)	27/32x27/32x1 5/16	27/32x27/32x1 3/16	1 1/4x7/8x5/8
Null Amplitude (Noise Level)	20 mv. RMS	15 mv. RMS max.	25 mv. RMS max.
Output Impedance	7000 ohms	7000 ohms	10,000 ohms
Null Drift (In terms of input signal) -65°C to $+100^{\circ}\text{C}$	$\pm 0.5 \mu\text{a. max.}$	$\pm 0.5 \mu\text{a. max.}$	$\pm 0.1 \text{mv. max.}$
Hysteresis — % of maximum input signal	0.5% maximum	0.5% maximum	0.5% maximum
Type of Mounting	Male Stud	Female Insert	Male Stud
Maximum % Distortion in Output	25%	15 %	20%
Weight Ounces	1.3 oz.	1.2 oz.	1.5 oz.

GENERAL MAGNETICS • INC.
135 BLOOMFIELD AVE., BLOOMFIELD, NEW JERSEY



CIRCLE 18 READERS SERVICE CARD



Thor (IRBM) rises to vertical position. Training crew member sits at launch control console prior to shot

New \$1½-Billion Market

Here's a report on California's new Vandenberg AFB and the Pacific Missile Range. Buying of electronic gear is well underway

LAST MONTH'S highly-successful first operational Thor shot focused world-wide attention on California's new Vandenberg AFB, and the Pacific Missile Range over which it fires. Reports that upwards of a half-billion dollars in electronic gear will ultimately be used at Vandenberg and PMR have perked up ears of electronics management.

PMR comprises specified areas of the Pacific, certain mainland control and tracking facilities, insular- and ship-based tracking stations down-range, including Hawaii and Midway.

Primary tracking stations are those located at Pt. Arguello, and at heavily-instrumented San Nicolas Island, 55 miles offshore. Lesser installations are at Edwards AFB, at Dugway, Utah, at Tonopah, Nev., and at Pt. Sur and Pt. Cilar, Calif.

Navy spokesman reports three tracking ships are currently in operation, with possibly 12 more to be added later. Tab for each vessel ultimately will be around \$5 million.

First ship, outfitted in October, was civilian-contract vessel *Joe E. Mann*, with Philco largely responsible for the electronic installations. Currently installed gear adds up to \$3 million, with an estimated \$4 million yet to come.

Equipment aboard Navy's *King County* and *Norton Sound* varies somewhat, with tracking radar, telemetry, and Doppler equipment predominating. Most sophisticated tracking ship will ultimately float \$15 million worth of electronics gear.

So-called inland range of PMR, terminating at Dugway, Utah, and Tonopah, Nev., was declared operational in April, 1958. Chance Vought was awarded contract to operate it. Cook Electric Co. provided telemetering, control command equipment, and auxiliary radar vans for inland range.

Overall expenditures to date at Vandenberg top \$50 million, with double that figure slated for additional facilities before 1962. Prime electronics contractors include: Architect-Engineer division of Aerojet-General Corp., with a \$3½ million contract for instrumentation and range safety program; and Kellogg Switchboard and Supply, with a slightly smaller order for base communications system.

Range safety subcontractors, Navy says, include:

- Packard-Bell, providing missile impact prediction system. If missile strays off course and endangers populated areas, range safety officer gets signal to press destruct button. Calculations for this system are

performed by a Bendix G-15 computer.

- Cubic Corp., supplying angle measuring equipment, correlation tracking, and ranging (AME-COTAR) system. Device utilizes radio interferometry principles to gather data from r-f radiation of telemetry transmitter in missile.

- Collins Radio, furnishing command-destruct system designed around standard transmitters, power amplifiers, and antennas. Signal for destruction within 30-mile radius is accomplished by code modulating 500-watt transmitter. For distances up to 700 miles, a 10-kw power amplifier is brought into play.

- Hycon Eastern, supplying timing system used to provide time reference for correlation of events, and to give precision time standard for evaluation of data.

Telemetry system provided by Aerojet is housed in two mobile vans and one fixed station.

One Navy source estimates that total capital value of PMR instrumentation currently under Navy jurisdiction is about \$30 million. Aeronutronic Systems, Inc., has just received a sizable Phase 1 study contract to determine how projected future instrumentation can best be integrated with existing equipment.

TWO OUTSTANDING HIGH-TEMPERATURE MAGNET WIRES

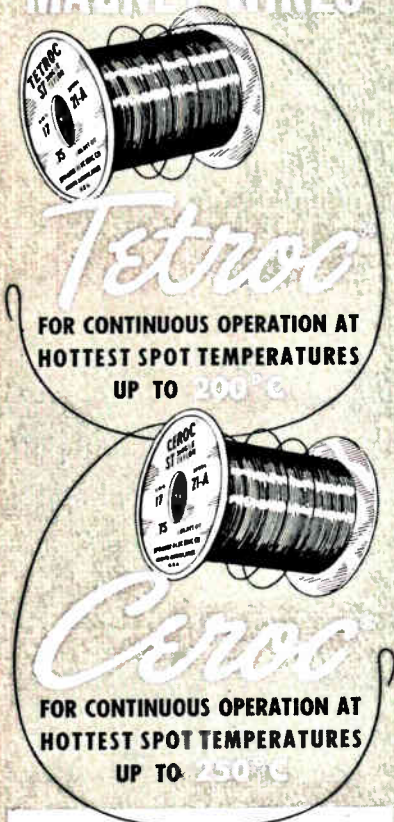

Tetroc
FOR CONTINUOUS OPERATION AT
HOTTEST SPOT TEMPERATURES
UP TO 200°C

Ceroc
FOR CONTINUOUS OPERATION AT
HOTTEST SPOT TEMPERATURES
UP TO 250°C

For continuous operation at hottest spot temperatures up to 200°C (392°F) and up to 250°C (482°F) for short periods of time—depend upon TETROC—an all Teflon-insulated wire available in both single and heavy coatings.

CEROC is Sprague's recommendation for continuous operation at hottest spot temperatures up to 250°C (482°F) and up to 300°C (572°F) for short periods of time. Ceroc has a flexible ceramic base insulation with either single silicone or single or heavy Teflon overlays. The ceramic base stops "cut-through" sometimes found in windings of all-fluorocarbon wire. Both Tetroc and Ceroc magnet wires provide extremely high space factors.

Write for Engineering Bulletins 405 (Tetroc Wires) and 400A (Ceroc Wires).

SPRAGUE ELECTRIC COMPANY
35 Marshall Street, North Adams, Mass.

SPRAGUE[®]
THE MARK OF RELIABILITY

CIRCLE 19 READERS SERVICE CARD

Consumer Outlook

Midwest executives expect higher 1959 sales to be aided by sound design and engineering. Competition looks keen

CHICAGO—CONSUMER electronics manufacturers see 1959 as more profitable than last year.

Top executives in the Midwest expect that much of the good news will be based on solid engineering accomplishments. A check by ELECTRONICS reveals these feelings:

- An expectation that some 6,200,000 tv sets of all types will be sold in '59. That's an estimated increase of 15 percent over the 5,300,000 units sold in 1958.

- Belief that sales of stereophonic high-fidelity units will hit 3,000,000, compared to an estimated 750,000 in 1958. That would probably result in a 63-percent drop in sales of monaural phonographs to 1 million units, from the 1958 volume of 2,700,000 units.

- Predictions that clock radio sales should reach 2,300,000 units, up 2 percent from 1958's 2,250,000, and that portable radio sales should climb to 3,000,000 units, up 7 percent from 2,800,000 in the year past.

Designing to Pay Off

As for setting all-time marks this year, there's this view:

"No record or sensational boom is expected in 1959 in consumer products," Motorola president Robert Galvin told ELECTRONICS. "Competition is keen but is more on a quality-value basis than on a price basis.

"The consumer showed a tenacious interest in upgrading his tastes in 1958. This will continue in '59, with the result that novelty merchandise will go begging while sound design and engineering will prosper."

Galvin believes binaural tape for stereo equipment will be a significant development this year, with adoption of standards for stereophonic radio helping to make stereo "as large a factor as tv today, dollarwise."

Zenith Radio's sales vice president, Leonard Truesdell, is also optimistic, says his company has already sold out to its distributors all of its production of tv, radio and stereo-hi-fi for the first quarter.

Hopeful on Stereo

"Stereo will be very big in '59," he added, "but the last half of the year is hard to foretell." As for tv: "Basic wrong nowadays is the lack of consumer interest in programming the networks are giving us. There's nothing to create a new excitement at the consumer level in tv."

On color tv, Motorola's Galvin says: "Color tv waits on the consumer. They're not buying at today's prices, and there are no engineering developments in view at the moment. Maybe a one-gun tube will help bring prices down to \$300, a more realistic price for a mass market, and a trouble-free set."

Zenith's Truesdell discounts color tv in '59. "Price is too high," he says. "Important advances are needed to help bring the cost to both consumers and producers down."

Zenith is looking at cartridge tapes for stereo "very seriously," he says, "but does not expect to accomplish any mass production of the unit in 1959."

Admiral's president is hopeful about stereo. Ross D. Siragusa believes: "High-fidelity sales for 1958 should show a 25-percent or larger increase over 1957 sales of more than \$200,000,000, and 1959 should produce an even larger percentage increase in this segment."

Color Tv Spending

Siragusa blames the attitude of the major networks for the lack of full public acceptance of color tv. He reports that Admiral is pointing to June 1959, for the introduction of a new color tv chassis and new

Bright

merchandising techniques. "We are going to spend more money on color research than ever before, and have invested heavily to date," he says.

In New York RCA claimed a "significant increase in sales" of color tv sets in 1958 but declined to release figures. The company said its 1959 plans call for "increases in color activities."

FAA Takes Charge of Airways System

THE Federal Aviation Agency has now officially taken over the functions and funds of the Civil Aeronautics Administration.

In doing so Jan. 1, it absorbed the 27,771 people who work for CAA and 36 uniformed officers assigned to coordinate FAA's national defense responsibilities.

It also took on the authority for the money CAA spends: \$471 million for fiscal 1959, of which well over \$100 million goes for electronic equipment.

The fiscal 1959 authorizations for traffic control aids totalled \$142.5 million, up from \$106 million in fiscal 1958.

FAA is now in charge of all buying for the nation's airways system. The agency's Bureau of R&D has complete responsibility over research and engineering for air traffic control.

For Space Photos



The 2½-in. mirror used in Navy tv-type space camera reflects image of Naval Ordnance Test Station electronics specialist working with scanner parts

NEW

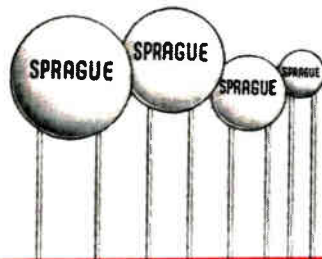

Formulation 40

flattens temperature-stability curve of *Cera-mite*[®] Disc Capacitors

Cera-Mite Ceramic Capacitors are now *smaller, more stable...* thanks to Sprague's new ceramic body Formulation 40. The increased dielectric constant of this newly developed ceramic body gives Cera-Mite Capacitors *three* times the capacitance per unit size than heretofore possible. Capacitance change with temperature over the operating temperature range is negligible.

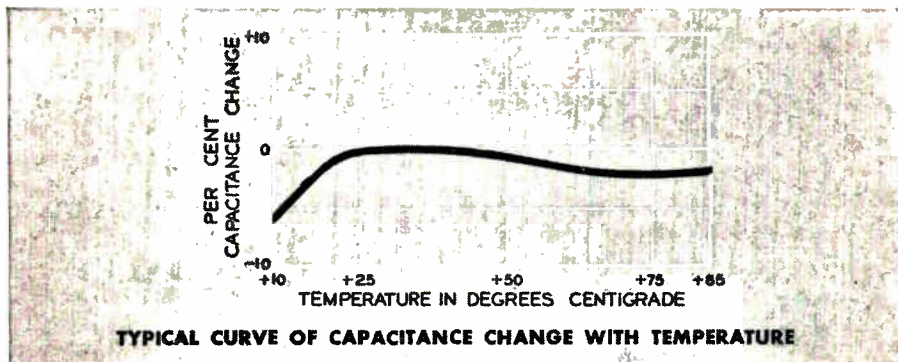

Cera-Mite Capacitors are now available in Formulation 40 from .001 to .02 μ F, 250, 500 and 1000 volts d-c. Engineering Data Sheets 6106 and 6120 list complete ratings and specifications.

Address literature requests to
Technical Literature Section,
Sprague Electric Company, 35
Marshall St., North Adams,
Massachusetts.

SPRAGUE[®]
the mark of reliability

SPRAGUE COMPONENTS:
CAPACITORS • RESISTORS • MAGNETIC COMPONENTS • TRANSISTORS
INTERFERENCE FILTERS • PULSE NETWORKS • HIGH TEMPERATURE MAGNET WIRE
CERAMIC-BASE PRINTED NETWORKS • PACKAGED COMPONENT ASSEMBLIES

NEW HIGH VOLTAGE NPN TRANSISTORS ALLOW TUBE REPLACEMENT AND CIRCUIT COMPATIBILITY

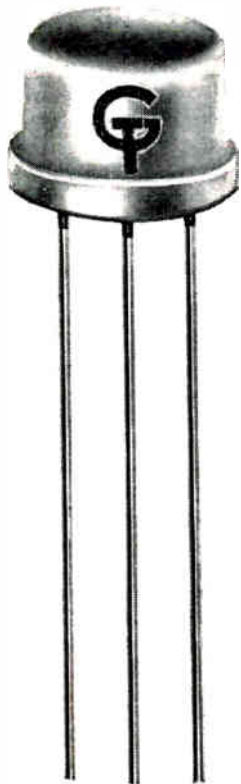

ACTUAL SIZE

GT's new high voltage germanium alloyed junction transistors now allow the same optimization as formerly could be realized only with vacuum tubes. These characteristics plus conventional "transistor" advantages offer new design opportunities in computers, magnetic memory cores, data processing equipment, gas filled indicator tubes and other applications where reduction of space, weight and high reliability are prime requisites.

The GT 1200 is particularly suited to drive gas filled display tubes, such as the Burroughs Nixie® and Pixie®, without changing existing circuitry other than altering voltages so as not to exceed the rating of the transistor.

		GT 1200
Collector to Base Voltage (Emitter Open)	$I_C = 25 \mu A$	90 Volts Min.
Emitter to Base Voltage (Collector Open)	$I_E = 25 \mu A$	20 Volts Min.
Collector to Emitter Voltage (Punch Through)	$I_E = 25 \mu A$	90 Volts Min.

Supplied in T0-9 case

GT 1201 - GT 1202, in addition to driving gas filled display tubes, are ideally suited for driving high inductance loads, driving transformer coupled loads and allow more nearly perfect impedance matching. These transistors are fast devices capable of handling high impedance loads and large signal swings.

	GT 1201	GT 1202
Collector to Base Voltage (Emitter Open)	$I_C = 25 \mu A$ 75 Volts Min.	45 Volts Min.
Emitter to Base Voltage (Collector Open)	$I_E = 25 \mu A$ 20 Volts Min.	20 Volts Min.
Collector to Emitter Voltage (Punch Through)	$I_E = 25 \mu A$ 75 Volts Min.	45 Volts Min.

Supplied in T0-9 case

Write today for Bulletin GT 1200



GENERAL TRANSISTOR

C O R P O R A T I O N

91-27 138TH PLACE

JAMAICA 35,

NEW YORK

IN CANADA: DESSER E-E LTD., 441 ST. FRANCIS XAVIER, MONTREAL 1, QUEBEC. FOR IMMEDIATE DELIVERY FROM STOCK, CONTACT YOUR NEAREST AUTHORIZED TRANSISTOR DISTRIBUTOR OR GENERAL TRANSISTOR DISTRIBUTING CORP., 91-27 138TH PLACE, JAMAICA 35 NEW YORK. FOR EXPORT: GENERAL TRANSISTOR INTERNATIONAL CORP., 91-27 138TH PLACE, JAMAICA 35, NEW YORK.



Stereo Tv Makes Debut

Consumer use of stereo television is seen about three years away. Compatible method assured

CHICAGO—Visitors to the Merchandise Mart during this month's international Home Furnishings Show may count themselves among the first members of the general public to hear stereophonic tv.

Viewers of the prototype tv receiver listened to a dual channel taped program. The first few minutes of the transmission were in monaural sound, and the program was then switched over to stereo.

E. R. Taylor, executive vice president of Motorola, which staged the demonstration, told *ELECTRONICS* that widespread use of stereo tv was about three years away.

Cost Figures

Taylor, director of his firm's advanced tv development, says additional components needed to allow receivers to handle stereocasts would probably cost about \$50 retail on a mass production basis.

An additional \$2,000 worth of transmitting gear would be needed at the broadcast end, he said.

The prototype receiver equipment at the show was integrated into a four-piece modular home entertainment unit. One of the center units housed a phonograph-tape section with f-m radio. The other center unit contained the tv picture tube and chassis. Two outer cabinets each housed speaker groups for tv, phonograph, radio.

Tv stereo sound is transmitted by starting with two microphones (A and B) as in conventional stereo. Compatibility with present monaural tv systems is achieved by using the sum of the two microphone input signals to modulate the sound transmitter of the tv station.

The difference of the two signals is used to frequency modulate a subcarrier having a frequency of 23.6 kc. This frequency was chosen because it is well above the audible frequency range and because it falls between the fundamental and second harmonic of the horizontal

scanning frequency of the tv picture signal.

Composite Signal

The tv receiver not equipped for stereo will receive the audio signal as a composite of the sum and difference of the two sound sources, along with the picture signal. It will be able to detect and reproduce the sum signals of the audio channel, but not the difference signals transmitted by the subcarrier. The signals a conventional set will receive are said to contain the full range of monaural sound.

The stereo tv receiver differs from the monaural receiver only in the audio circuits following the sound detector.

Following the conventional sound detector are the usual monaural amplifiers plus circuitry to recover the signal from the subcarrier. First there is a bandpass filter to separate the sum signals from the difference signals, followed by an f-m detector to recover the difference signals. When this is accomplished the signals are passed through circuits which amplify each channel separately and provide outputs to each of the two speaker systems.

Score Radio Gear

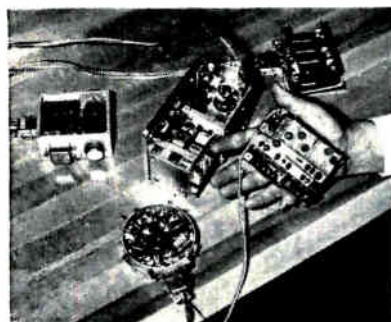

Communications system developed by RCA's Astro-Electronic Products div. and Army Signal Corps for Score satellite included: Held at right: 10-oz transistorized receiver. Behind it: 3/4-lb control unit. Center: 2 1/2-lb 8-w transmitter. Left: Power converter to run transmitter. Foreground: 3/4-lb beacon transmitter

ACCURACIES BETTER THAN 1 PART IN 50 MILLION are free!

WHY NOT USE THEM!

The standard time and frequency transmissions of the National Bureau of Standards radio stations WWV and WWVH provide an invaluable service to laboratories and experimenters throughout the world. Extremely precise (normal transmission stability is within 1 part in 10^9 at WWV and 5 parts in 10^9 at WWVH) audio and radio frequency standards, as well as accurate time intervals and radio frequency propagation warnings, are placed at the disposal of anyone having a receiver capable of tuning to one or more of the transmitting frequencies. Proper use of these facilities can be made to supplement the instrumentation of any laboratory.

The Model WWVC Standard Frequency Comparator is just such an instrument . . . a highly sensitive crystal-controlled radio receiver utilizing WWV and WWVH transmissions.

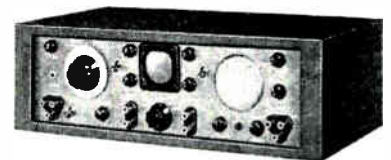

MODEL WWVC
COMPARATOR

A 5-position dial switches *precisely* to any Standard Frequency—2.5, 5, 10, 15, or 20MC. It features built-in oscilloscope and speaker, comparator function selector, Collins plug-in filter for high selectivity, automatic gain and volume controls and adjustable threshold control which eliminates noise and other modulation in tick position.

Send for bulletin #587, "Using Standard Time and Frequency Broadcasts"

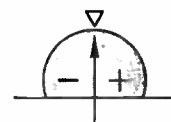

SPECIFIC PRODUCTS

Box 425, 21051 Costanso
Woodland Hills, Calif.

CIRCLE 22 READERS SERVICE CARD

*cold-punch 'em fast
without the cost
of fixed dies!*

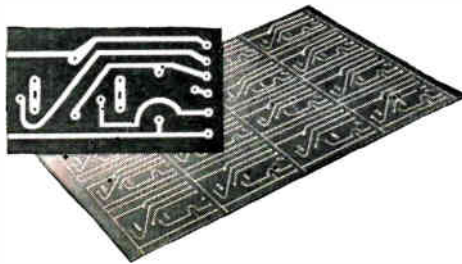

it's easy with the **strippit** **FABRICATOR-DUPLICATOR**

As fast as the operator places the Duplicator stylus in each template pilot hole, the printed circuit board or other work is automatically positioned under the Fabricator punch and the punch tripped. Anyone can learn to operate the Fabricator-Duplicator in a few minutes. Consistently clean holes are produced in laminates from paper base phenolic to glass base epoxy, copper clad one or both sides from .032" to .125" thick — without cracks. Tool changes are made in a few seconds, using Strippit interchangeable standard round, obround, square or special-shape tools.

BUT WHY NOT SEE the Fabricator-Duplicator — and the time-saving new Dupl-O-Scope template-punching attachment — perform on your work at your plant? Write today for complete literature and a demonstration by a Strippit mobile unit! Warehouse stocks in Chicago and Los Angeles for fast deliveries.

WALES **STRIPPIT** INC.

225 Buell Road
Akron, N. Y.

In Canada:
Strippit Tool & Machine Company
Brampton, Ontario

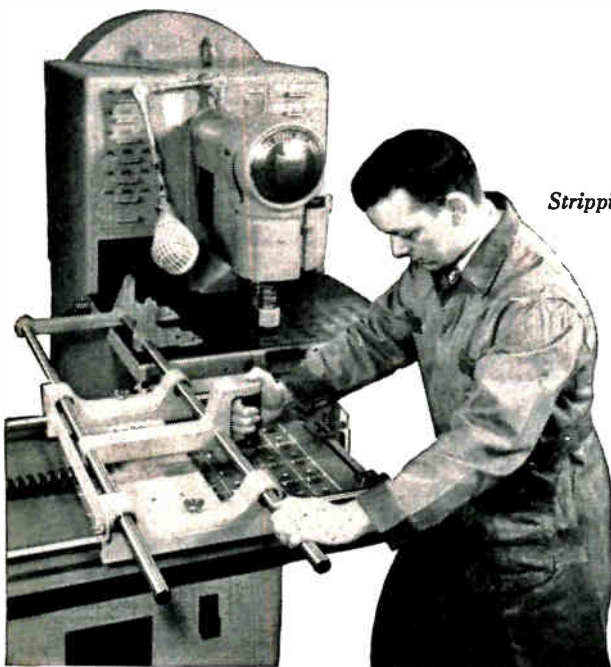

MEETINGS AHEAD

Jan. 29-30: Long Distance Transmission by Waveguides, Institution of Electrical Engineers, London, England.

Feb. 1-6: American Institute of Electrical Engineers, Winter General Meeting, Statler Hotel, N. Y. C.

Feb. 12-13: Transistor & Solid-State Circuit Conf., AIEE, PGCT of IRE, Univ. of Penn., Philadelphia.

Feb. 12-13: Electronics Conference, AIEE, IRE, ISA, OPS, Eng. Soc. Bldg., Cleveland.

Feb. 17-20: Western Audio Convention, Audio Eng. Soc., Biltmore Hotel, Los Angeles.

Mar. 3-5: Western Joint Computer Conf., AIEE, ACM, IRE, Fairmont Hotel, Los Angeles.

Mar. 5-7: Western Space Age Conf. and Exhibit, L. A. Chamber of Commerce, Great Western Exhibit Center, Los Angeles.

Mar. 15-18: National Assoc. of Broadcasters, Annual Convention, Conrad Hilton Hotel, Chicago.

Mar. 23-26: Institute of Radio Engineers, IRE National Convention, Coliseum & Waldorf-Astoria Hotel, New York City.

Mar. 26: Quality Control Clinic, ASQC, Univ. of Rochester, Rochester, New York.

Mar. 31-Apr. 2: Millimeter Waves, Symposium, Polytechnic Inst. of Brooklyn, USAF, ONR, IRE, USA Signal Research, Engineering Societies Bldg., N. Y. C.

Apr. 5-10: Nuclear Congress, sponsored by over 25 major engineering and scientific societies, Public Auditorium, Cleveland.

Apr. 13-15: Protective Relay Conf., A & M College of Texas, College Station, Texas.

Apr. 14-15: Industrial Instrumentation and Control Conf., PGIE of IRE, Armour Research Foundation, Illinois Inst. of Tech., Chicago.

Apr. 16-18: Southwestern IRE Conf. and Electronics Show, SWIRECO, Dallas Memorial Aud. & Baker Hotel, Dallas.

There's more news in ON the MARKET, PLANTS and PEOPLE and other departments beginning on p 66.

Have 310 • Will Travel...

Light!

Burton Browne Advertising

- Hand size, but with the features of a full-size V-O-M.
- 20,000 ohms per volt DC; 5,000 AC.
- EXCLUSIVE SELECTOR SWITCH speeds circuit and range settings. The first miniature V-O-M with this exclusive feature for quick, fool-proof selection of all ranges.
- SELF-SHIELDED Bar-Ring Instrument; permits checking in Strong Magnetic Fields.
- Fitting interchangeable test prod tip into top of tester makes it the common probe, thereby freeing one hand.
- Unbreakable plastic meter window.
- BANANA-TYPE JACKS—positive connection and long life.



MODEL 100

The most comprehensive test set in the Triplet line is Model 100 V-O-M Clamp-On-Ammeter Kit, now available at distributors. The world's most versatile instrument—a complete accurate V-O-M plus a clamp-on-ammeter with which you can take measurements without stripping the wires. Handsome, triple-purpose carton holds and displays all the components: Model 310 miniaturized V-O-M, Model 10 Clamp-On-Ammeter, Model 101 Line Separator, No. 311 extension leads and a Leather Carrying-Case, which neatly accommodates all the components. Model 101 literally makes it possible to separate the two sides of the line when using Model 10. Extension leads permit use of Model 10 at a distance from the V-O-M. Complete Model 100 is only \$59.50.



For full information see your Triplet distributor
or write

TRIPLETT ELECTRICAL INSTRUMENT COMPANY • BLUFFTON, OHIO



PANEL METERS

AND A VOM FOR EVERY PURPOSE AND EVERY PURSE

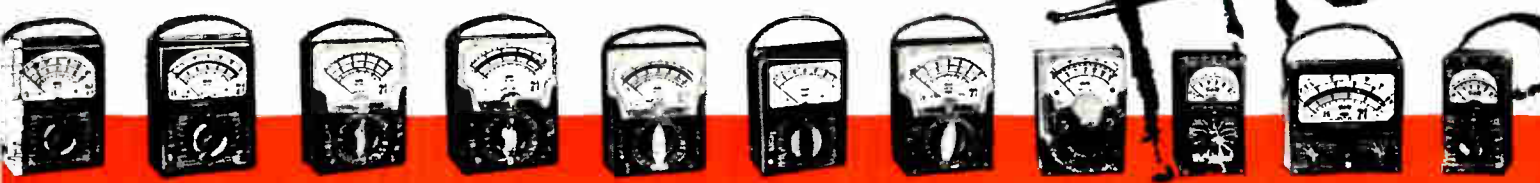

630 630-A 630-PL 630-APL 630-NA 630-T 631 310 656-HH 625-NA 666-R

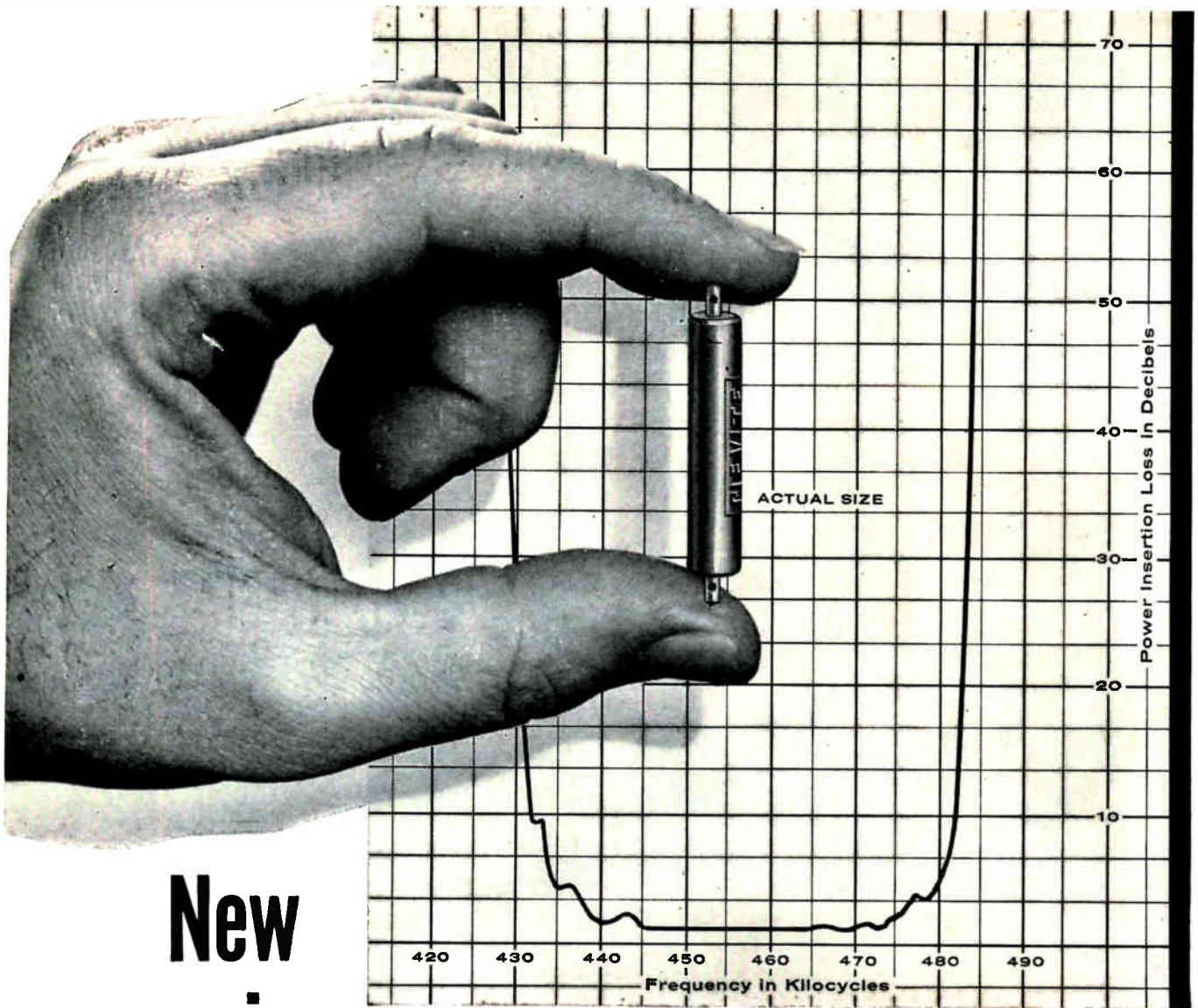

New ceramic ladder filter!

... increased selectivity—stability—1/2 the size!

The new Clevite Ceramic Ladder Filter, using the highly stable "PZT"® ceramic, answers the need of modern communication systems for increased selectivity and frequency stability in a ladder filter—at one-half the conventional size. The curve above shows a specific filter with a 6 db. bandwidth of 46.7 kc and a 60 db. bandwidth of 55.6 kc.

General specifications are:

Bandwidth Range	4 kc to 50 kc
Center Frequencies	100 kc to 1000 kc
Dimensions	1½ in. long— $\frac{5}{16}$ in. OD
Nominal input and output impedance	1500 ohms

Meets Mil-Spec 202A for temperature, humidity, vibration and shock.

WRITE FOR BULLETIN 9405 for complete details. Clevite Ceramic Ladder Filters are available now for your application in production quantities. The Clevite engineering staff will assist you with design problems upon request.

Also write for complete information on the miniature Clevite impedance-matching interstage coupler, and emitter by-pass Transfilters®

CLEVITE ELECTRONIC COMPONENTS

DIVISION OF
CLEVITE
CORPORATION

3311 Perkins Avenue • Cleveland 14, Ohio
MAGNETIC HEADS, PIEZOELECTRIC CRYSTALS,
TRANSDUCERS, CERAMICS AND ELEMENTS



Fish sampling studies are greatly facilitated through the use of this portable electronic fishing device

Electronic Fishing With Underwater Pulses

When electrodes are immersed in a stream and pulsed d-c applied, fish in the area are attracted to the positive electrode where they are electro-narcotized and easily captured by dip nets. Device obtains population data in waters where nets or other collection means are impractical

BY HARRY P. DALE, Electronic Scientist, Fisheries Instrumentation Laboratory,
U. S. Fish and Wildlife Service, Bureau of Commercial Fisheries, Seattle, Wash.

DEVELOPMENT OF A LIGHTWEIGHT portable electric fishing device has provided U.S. Fish and Wildlife Service fishery biologists with a convenient method for obtaining population data in streams and small rivers. Its design and production was prompted by the need for more detailed information in areas where nets and other means of collection could not be used. Electrical methods of fishing in fresh water have been in use for many years' and considerable information regarding the performance

of both a-c and d-c shockers is readily available.

Examination of existing information led to the design of an interrupted d-c shocker. Direct current was selected because of its electrotoxic effect (tendency for fish to move towards the positive electrode). Interrupted d-c was selected because of the considerable economy in physical size and weight accomplished by operating at reduced duty cycles. Further, the addition of a circuit which permits control of pulse frequency and duration allows the

operator to adjust the duty cycle for maximum effectiveness in attraction and capture of fish.

ELECTRODES—The equipment consists of a small portable gasoline-driven generator, a pair of electrodes with connecting cables, and the necessary electronic apparatus for converting the generator output to unidirectional square wave pulses which may be varied in frequency and duration. Energy is coupled into the water by a pair of electrodes placed in the water. The positive electrode consists of an expanded aluminum grid, 15 by 24 in., mounted on a six-foot insulated rod which is connected to the pulsing unit by a waterproof rubber cable. The negative electrode consists of the hull of a 14-foot aluminum boat which transports the generator and pulse gear.

Action of the current in the water may be described as follows: pulsating d-c is passed through the water from one electrode to the other and its presence may be detected at any point between the electrodes. However, as the pulsed current spreads out from the electrodes into the water, its intensity is progressively reduced. The voltage gradient follows the same pattern. Therefore, the effective electrical fishing area is concentrated in the immediate vicinity of the electrodes. When fish enter the electrical field surrounding the electrode, they exhibit a tendency to swim toward the positive electrode. As the distance from the positive electrode decreases, the severity of shock received becomes sufficient to momentarily stun and immobilize the fish. The fish are not injured by this experience and in this condition it is a simple matter to capture them with dip nets.

CIRCUITS—Three basic circuits are required to convert the d-c generator output to unidirectional square waves: a d-c interrupter circuit which functions as a switch to alternately connect and disconnect the generator from the load, a control or timing circuit which determines the number and duration of these connections and a power supply to provide plate, bias and filament voltages for the various hard-tube circuits involved.

Interrupted d-c is supplied to the load terminals by connecting a pair of thyratrons across the gen-

erator output as shown in Fig. 1A.* A negative supply consisting of a transformer and half-wave rectifier provides approximately 90-v bias for the two thyratrons V_1 and V_2 .

Firing of thyatron V_1 by a positive grid impulse causes current flow in the load charging capacitor C_1 to the indicated polarity. Subsequent firing of V_2 connects the positive terminal of capacitor C_1 to the cathode of V_1 , causing its cathode to become positive with respect to its plate. Tube V_1 is extinguished and the generator current is switched to the plate load of V_2 . Arc current in V_2 is extinguished in similar fashion by applying a firing pulse of the grid of V_1 . Frequency and duration of the output pulses appearing across the load terminals is dependent on the timing pulses received from the control unit.

The voltage wave form appearing across the load terminals is a square wave with a rise time of 1 to 3 millisecc and a decay of less than 50 μ sec. Maximum pulsed power produced by this equipment is limited by the generator, duty cycle of V_1 and the conductivity of the water being fished. A single C3J thyatron operating at 50-percent duty cycle will supply a 40-ohm resistive load with a 5-amp current at 200-v d-c.

CURRENT FORMULA—To permit rapid calculation of the maximum pulse current for any pulse duration a formula has been derived from manufacturer's specifications for thyratrons. This expression is $I_p \leq I_a T_a / T_p \leq I_m$, where I_p is the maximum pulse current in amp, T_p is the pulse duration in sec, T_a is the averaging time rating in sec (4.5 sec for type EL-C3J), I_a is the continuous anode current rating in amp (2.5 amp for type EL-C3J) and I_m is the maximum peak instantaneous anode current continuously recurring (300 amp for type EL-C3J).

The device was designed to operate successfully over a wide range of load conditions at relatively high duty cycles, but its use in salt or other low resistance water is not recommended.

CONTROL CIRCUIT—The control circuit produces the timing pulses which determine the frequency and duration of the square waves appearing across the

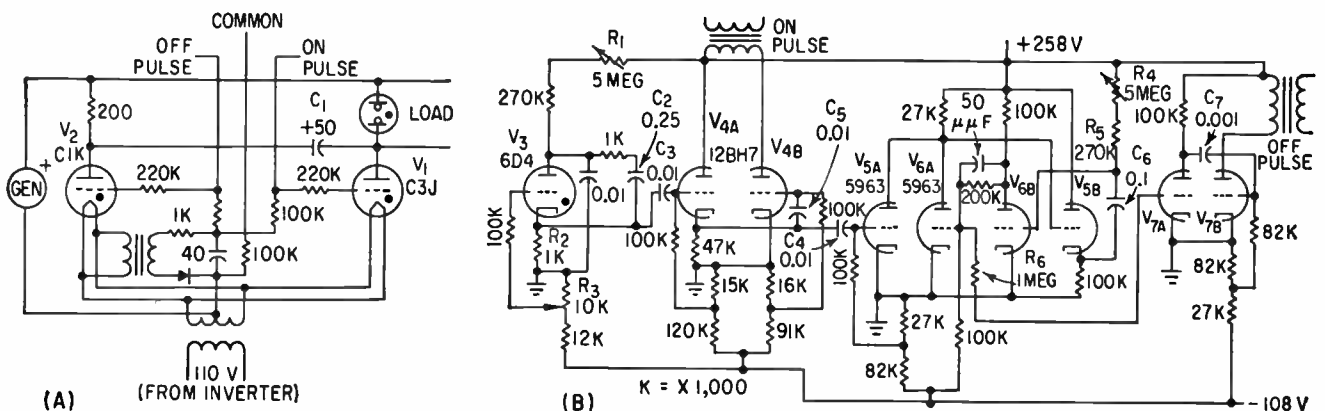
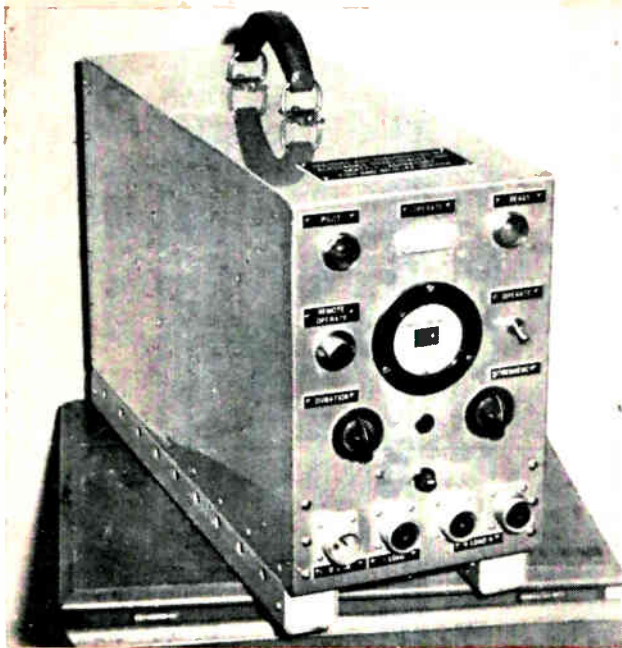

FIG. 1—Schematic of the underwater pulse unit. Frequency and duration of pulses appearing across load terminals of d-c interrupter (A) depend on timing pulses supplied by control unit



Interior view of pulse unit. Control circuit components are assembled in turret cans, permitting rapid replacement and maintenance

Portable pulse unit for electronic fishing. Elapsed time meter is used by biologists in sampling studies

load terminals. This circuit permits variation of frequency from 2 to 30 pps, with durations up to 250 millisecond. A complete schematic of the control circuit is shown in Fig. 1B.

The frequency-determining element is the 6D4 oscillator, V_5 ; its period of oscillation may be adjusted by 5-megohm potentiometer R_1 in the plate circuit. Since the lower side of capacitor C_2 is connected to cathode instead of ground, the trailing edge of the pulse is determined only by the time constant of capacitor C_1 and cathode resistor R_2 and does not vary significantly with changes in frequency. A convenient means for synchronizing the frequency of the oscillator with a standard source is provided by 10,000-ohm potentiometer R_3 which controls the grid bias on V_5 . The output appears as a sharp positive pulse across the cathode resistor of the 6D4.

TRIGGER—The 12BH7 cathode-follower pulse amplifier V_1 is primarily an isolation stage between the oscillator and related trigger circuits. It also performs two additional functions. The output pulse appearing across the cathode resistor of V_{1A} is coupled through a 0.01- μ f capacitor, C_4 , to the grid of V_{5A} which triggers a delay multivibrator. This same output pulse is also coupled through capacitor C_5 to the grid of V_{1B} where it is amplified and inverted to produce a heavy current pulse in the primary of the pulse transformer. The voltage induced across the secondary is the on pulse which fires the C3J in the d-c interrupter circuit.

The delay multivibrator, consisting of V_5 and V_6 , is a one-shot multivibrator with the additional feature that the length of the firing interval can be controlled, making this a convenient means for producing a delayed trigger when used in conjunction with a differentiating circuit. Operation is as fol-

lows: a positive trigger at the grid of V_{5A} is inverted at the plate and directly coupled to the grid of V_{5B} . The negative pulse appearing at the cathode of V_{5B} is coupled through 0.1- μ f capacitor C_6 to the grid of V_{6B} causing its plate voltage to rise. This increase in voltage is coupled to the grid of V_{6A} which begins to conduct. The length of the firing interval of V_{6A} is determined by the combination of C_6 , R_4 and R_5 . The output appears as a square wave across 1-megohm grid resistor R_6 .

Twin triode V_7 converts the square-wave output from V_{6A} to a positive trigger which coincides with the trailing edge of the square wave. When the trailing edge of the square wave appears on the grid of V_{7A} the plate voltage rises suddenly and is coupled through 0.001- μ f capacitor C_7 to the grid of V_{7B} which produces the off trigger in the secondary of the pulse transformer. It is this off pulse which fires the C1K in the interrupter circuit. The time interval between the output pulses of V_{1B} and V_{7B} determines the duration of the square wave present at the load terminals.

POWER—For operating power a 2,500-w d-c generator provides 230 v to a commercially available inverter, which in turn supplies 150 w of 110-v a-c to a rectifier circuit.

The author appreciates the cooperation of R. B. Thompson, Fishery Biologist for technical assistance in preparing this article, and to C. D. Volz and D. L. Thorne for major contributions to the electronic equipment design.

REFERENCES

- (1) Great Britain Ministry of Agriculture, Fisheries and Food, The Elementary Practice of Electrical Fishing in Fresh Water, Fisheries Notice No. 36, 1956.
- (2) H. J. Reich, "Theory and Application of Electron Tubes", p. 477, McGraw-Hill Book Co., New York, 1944.

New Transistor Works At

Where ordinary transistors fail because of immobilization of charge carriers at temperatures in the liquid-helium range, a grain-boundary transistor operates successfully. Device is fabricated from a bicrystal formed by two crystal-lattice structures of different grain orientation. Modulation of sheet conductance at boundary yields amplification

By SAMUEL WEBER, Associate Editor

NOW IN THE LABORATORY stage of development, a new type of transistor has the capability of operation at cryogenic temperatures as low as 2 deg K. Such a transistor would have applications in space electronics where low temperatures could immobilize the carriers in conventional semiconductor devices.

Scientists at Sylvania Electric Products Research Laboratories in Bayside, N. Y., call the device a grain-boundary transistor because it uses the properties exhibited by the boundary formed between the crystal lattice structures of different grain orientation to form structures similar to *npn* or *pnp* junctions.

If two seed crystals are tilted symmetrically about an axis in the 001 direction as shown in Fig. 1, a bicrystal ingot can be grown naturally in which the two portions of the bulk material have lattice structures oriented at the third angle. The transistor is fabricated from slices cut from the ingot perpendicular to the growth direction. If the

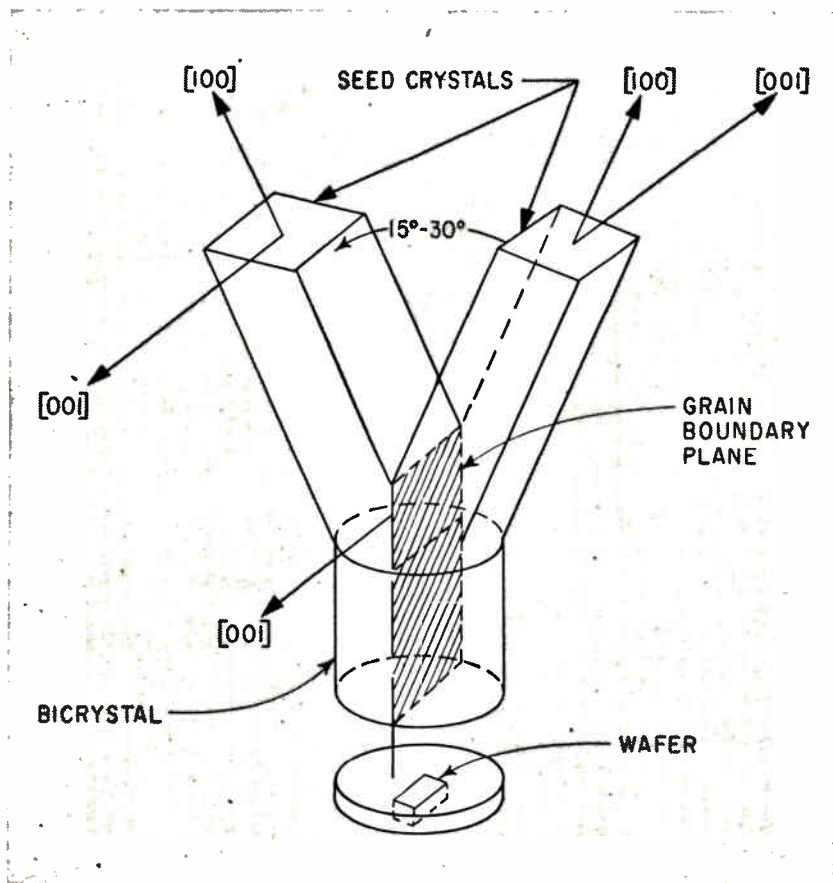

FIG. 1—Diagram shows how bicrystal is grown from precisely oriented seed crystals. Wafer is cut perpendicular to growth direction

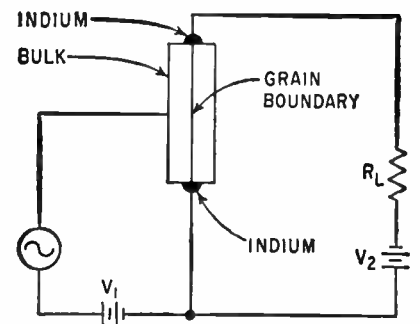

FIG. 2—Simplified circuit shows how modulation is applied to transistor

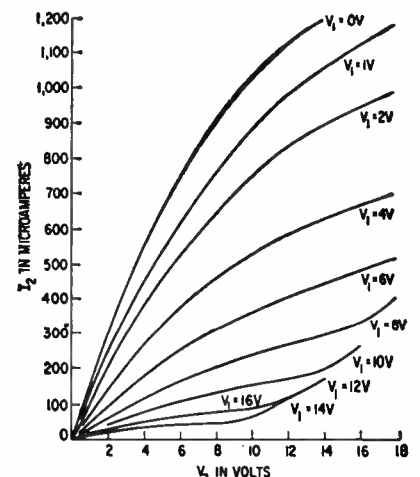
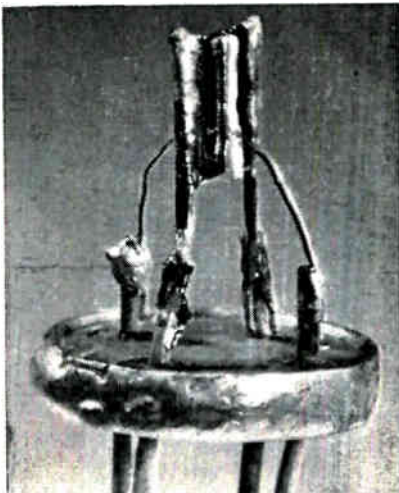

FIG. 3—Typical static characteristics of grain-boundary transistor

Cryogenic Temperatures



Experimental germanium grain-boundary transistor. Ridge along center of wafer is one of pair of rectifying contacts

Germanium ingot and slice showing multiple grain boundaries grow on the same ingot. Similar structures can be grown with silicon

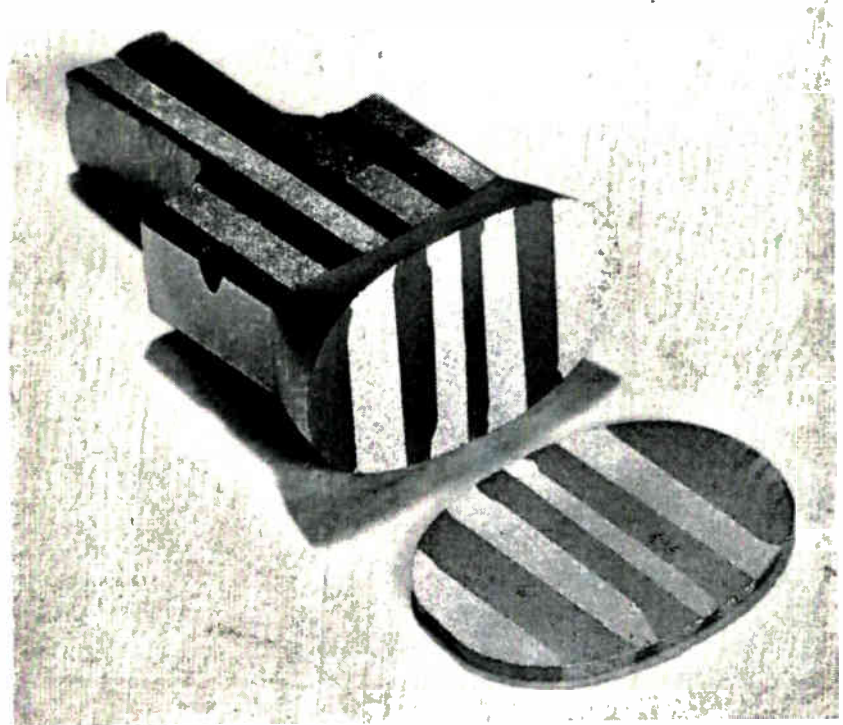

but material used is *n*-type germanium, the grain boundary exhibits *p*-type characteristics. Similarly, if *n*-type silicon is used in the bicrystal, the grain boundary is *p*-type.

Analysis of the properties of the grain-boundary region indicates that a sheet of negative charges due to electrons captured in boundary states is formed within the crystal. The negative charges along the boundary are compensated by a positive space charge composed of ionized donors (in *n*-type germanium). Hence the potential change across the boundary is similar to that of an *npn* structure.

Boundary Characteristics

The grain boundary exhibits two important characteristics; namely the independence of the grain boundary sheet conductance with respect to impurity concentration and the consequent temperature independence of the sheet conductance.

Figure 2 shows how the wafer is connected as a transistor and Fig. 3 shows typical characteristic

curves obtained. Modulation of the sheet current can be obtained by changing the depletion layer width with an applied field, producing amplification.

Photovoltaic Effect

Another interesting characteristic of the grain boundary is a photovoltaic effect in which the photovoltage produced by a small

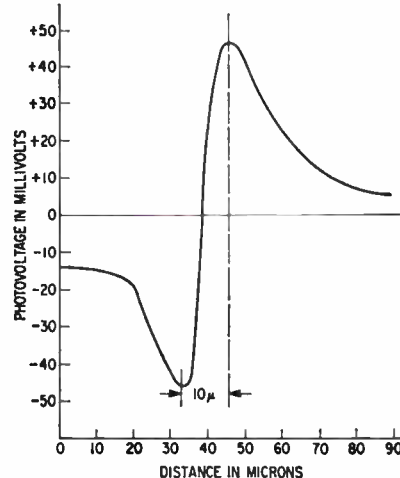

FIG. 4—Distance between peaks of photovoltage characteristic corresponds to width of light beam crossing boundary

light beam, asymmetrically distributed across the boundary experiences a reversal in polarity which goes through zero.

The curve shown in Fig. 4 is a plot of the photovoltage as a function of the distance of the light beam from the boundary. The distance between peaks corresponds to the width of the beam, in this case about 10 microns. This property may have applications as a means of precisely locating the position of a spot of light, such as in missile homing devices. The resolution is limited only by the width of the negatively-charged sheet at the grain boundary.

Future

Optimum impedance and frequency considerations have yet to be determined, but Sylvania scientists express confidence that progress is merely a question of developing the technology. Transistors with transconductances of 3,000 μ mhos have been made in the laboratory, and a method of growing a multiplicity of boundaries on one ingot has been developed, thus facilitating production.

Microsecond Sampler

Electronic switch samples 126 input channels in sequence and at one- μ sec intervals for display on cathode-ray tube. Blocking oscillators, tapped delay lines and diode gates replace multivibrators, gating tubes and sweep generators of conventional circuits

By **MARK T. NADIR**, Consultant, Electronic Div., Globe Industries, Inc., Belleville, N. J.

IN UNDERTAKING development of a microsecond sampling device 126 input channels had to be provided which could be sampled at one- μ sec intervals. And the data display had to be especially linear.

System Operation

The electronic switch as seen in the block diagram of Fig. 1 uses only five types of blocks. The functions performed by the blocks marked ring unit, ring start unit, linear pulse amplifier, and horizontal staircase generator will be described first.

The block diagram of Fig. 2 shows the ring unit in more detail. The blocking oscillator requires a pulse to drive it into operation. When fired, it delivers a 0.6- μ sec pulse into a one- μ sec delay line which, in turn, delivers the pulse into another one- μ sec delay line and so forth. After the sixth delay, the pulse is used as a trigger for the next ring unit. The pulse appearing at the input to each delay line feeds both a sweep pulse

network and a diode-amplifier gate.

The sweep pulse network attenuates the pulse and feeds it into the internal common sweep pulse line. The diode-amplifier gate modulates the pulse amplitude proportionally to the input signal e_{in} . The gate then feeds the modulated pulse ke_{in} into the internal common modulated pulse line. All the ring units are identical.

Figure 3 shows the block diagram of the ring start unit. The blocking oscillator in this unit must be driven into operation from a pulse. When triggered, it fires and delivers a 0.6- μ sec pulse into a three- μ sec delay line. Output from the delay line is used as a trigger for the first ring unit. The blocking oscillator may be triggered either from the last ring unit or from a single pulse generating network which is triggered by closing the ring start switch. Only one ring start unit is required.

The ring start unit and the ring units are connected so that the trigger output of the first unit

feeds into the trigger input of the second unit. The second feeds the third and so on to the last unit. Output of the last unit is used to trigger the first. The ring units and the ring start unit form a closed loop as shown in Fig. 1.

Starting

When power is turned on, the ring start unit and the ring units do not oscillate. When actuated, the ring start switch injects a pulse into the blocking oscillator in the ring start unit. This pulse fires the blocking oscillator. After a three- μ sec delay, this pulse fires the blocking oscillator in the first ring unit. After a six- μ sec delay, the second ring unit is fired. This action is repeated until the pulse arrives from the last ring unit and triggers the ring start unit. The cycles are then repeated. The ring has gone into self-sustaining oscillation.

Ring oscillation has some unusual characteristics. There is only one pulse in the ring at any time. It commutates from oscillator to oscillator in a predetermined manner. The pulse spends most of its time traveling down delay line which control the rate of commutation.

As the pulse enters each successive delay line, it actuates a sweep pulse network which attenuates the pulse and feeds it into a common sweep output line, as shown in Fig. 1. This common line goes to the horizontal staircase generator. Each pulse in the train causes one step of the staircase. Height of the step is determined by the amplitude of the pulse causing it. General shape of the staircase is deter-

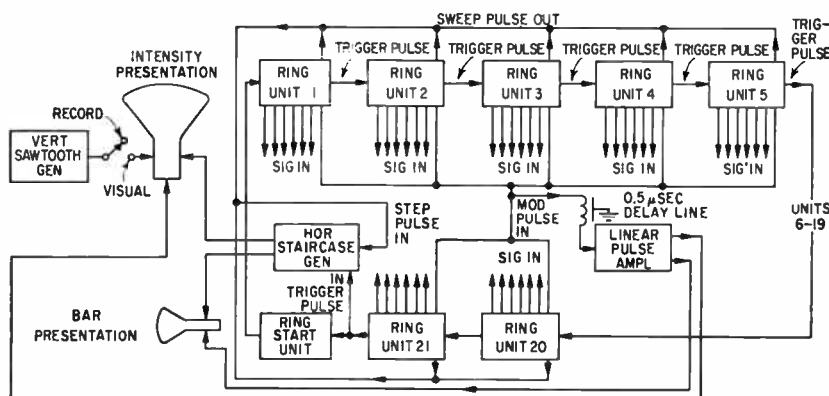

FIG. 1—Overall block diagram of electronic switch

Handles 126 Channels

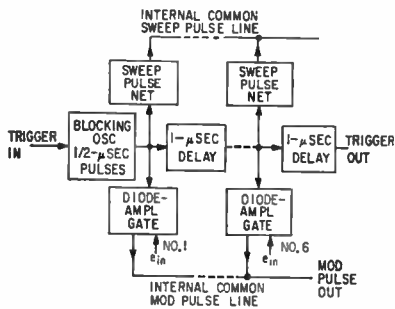

FIG. 2—Basic ring unit block

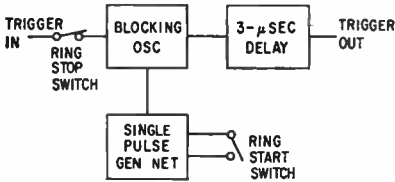
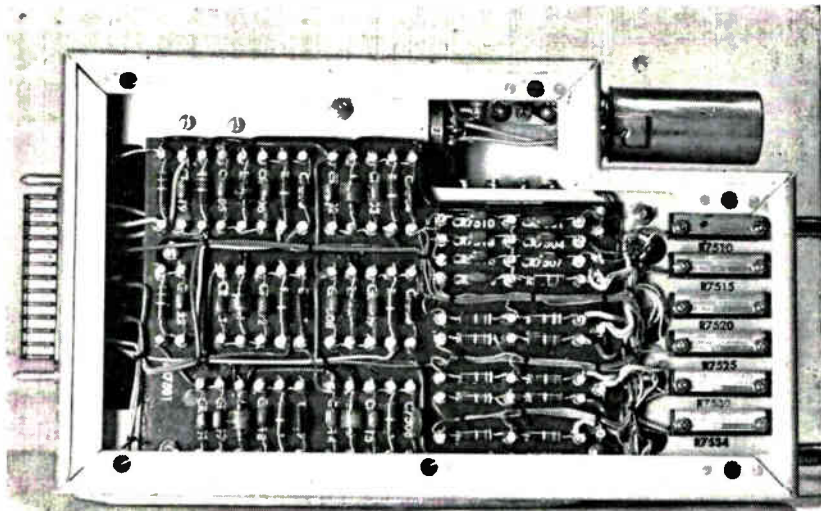

FIG. 3—Ring start unit block



Side view of ring unit with case opened to show component layout

mined by the amplitudes of the pulses on the common sweep line. Output of the last ring unit is used to trigger the flyback of the staircase.

Channels must always be displayed on the crt in their proper sequence for two reasons. First, the n th pulse in the sweep pulse train always causes the n th step of the staircase. Second, the first delay line in the first ring unit always forms the first step in the staircase.

The pulse, on entering a delay line, actuates a diode-amplifier gate. The diode-amplifier has an input terminal to which one of the input channels is connected. This network develops a pulse whose am-

plitude is proportional to the input signal. The network feeds the pulse into the common modulated pulse line. The train of pulses on this line is amplified linearly by the linear pulse amplifier and fed into the crt grid to cause intensity modulation.

The Display

A delay line shown at the input to the linear pulse amplifier is used to delay pulses slightly so that the staircase rise can occur before the pulse is applied to the crt.

Some idea of the appearance of the intensity-modulated crt display can be obtained from Fig. 4A and 4B. Each dot in Fig. 4A represents one input channel. Because data are being displayed as intensity, each dot will vary in brightness according to the signal on that channel. In Fig. 4B, the row of dots is swept down the crt by a slow sweep. Much more detail is visible in Fig. 4B than in Fig. 4A because the eye cannot see individual events which occur more rapidly than 16 to 24 a second.

Spacings between dots are as identical as measurements can make them. This is possible because of the nature of the staircase generator as explained previously.

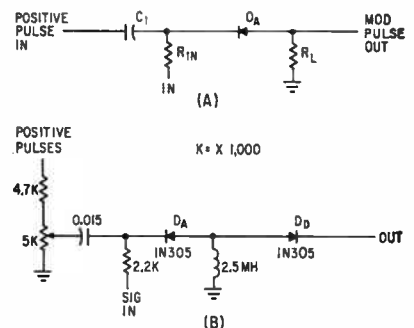

FIG. 5—Basic diode-amplifier gate (A) and actual diode-amplifier used in system (B)

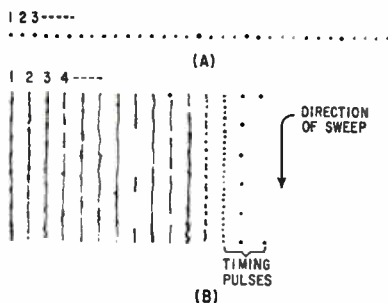

FIG. 4—Appearance of intensity-modulated horizontal sweep with no vertical sweep (A) and intensity-modulated sweep using slow vertical sweep (B)

The dots can neither drift nor jump from their assigned positions because of the method by which they are produced.

Diode-Amplifier Gate

Diode-amplifier gates are networks which use a crystal diode as an amplifying element. They are driven into operation by the pulses obtained from the delay-line inputs. Each ring unit, therefore, has six diode-amplifier gates associated with it. As the delay lines are tapped at one- μ sec intervals and a pulse of 0.6 μ sec travels down the line, only one of these gates can be operative at any one time.

The basic diode-amplifier circuit

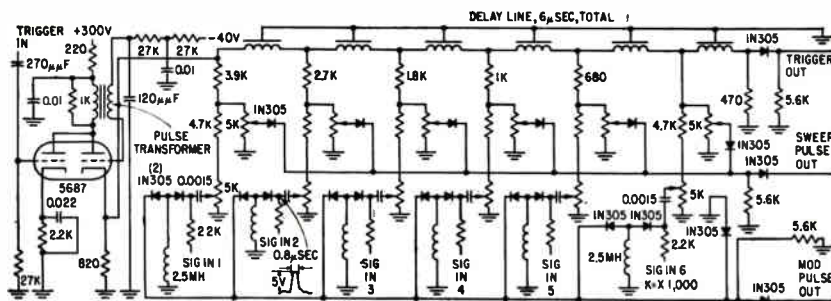

FIG. 6—Schematic diagram for a ring unit

is shown in Fig. 5A. The network consists of capacitor C_1 , resistor R_{in} , amplifying diode D_A and load R_L . A positive pulse applied to C_1 cannot pass through D_A when no signal is present on the input terminal. This is true because no carriers, neither holes nor electrons, are available from the diode electrode to conduct the pulse current. Under this condition, the diode manifests a high back resistance.

If a negative voltage is applied to the input terminal, a current flows through D_A . A short positive pulse applied to C_1 will appear to be transmitted partially by diode D_A . Amplitude of the pulse appearing across R_L will vary linearly with current from the input terminal passing through the diode. Input current appears to act to modulate the output pulse amplitude.

Diode Amplification

The crystal diode is acting as an amplifier when it appears to be acting as a modulator. What actually occurs is as follows: The input voltage causes a current to flow through the diode. Carriers of the current are either holes or electrons. Due to the abundance of carriers, the voltage drop across the diode is low and the accelerating force applied to the carriers is small. Distance between electrodes is large enough so that the carriers take an appreciable time to travel between them.

When a pulse of large amplitude and inverse polarity is applied to the diode, those carriers which have left one electrode but not reached the other are swept back to the electrode from which they came. They are swept back by a relatively large accelerating voltage and re-

turn more rapidly than they were generated. The number of carriers swept back is much greater for a short time than the number which were generated in the same time interval. The current which flows out of the diode during the pulse time is therefore much greater than the current which was applied. Amplification has occurred.

The diode acts as an amplifier only when a pulse is applied. Then a modulated pulse is obtained from the diode-amplifier output. Polarity of the output pulse is inverse to polarity of the input signal when both are observed across the load R_L in Fig. 5A. If the modulated pulse is coupled out of the load by a second diode which will pass the

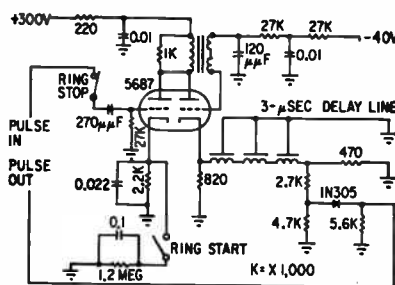

FIG. 7—Circuit diagram for the ring start unit

modulated pulse, no input signal will pass because of the diode's high back resistance to signals of this polarity.

The diode amplifier acts as a gate also since no modulated pulse output can be obtained until a pulse is applied to C_1 in Fig. 5A. Figure 5B shows the diode-amplifier gate network actually used in the ring units of the electronic switch.

The circuit for the ring units is shown in Fig. 6. The blocking oscillator may be seen in the upper left

side of the figure. Bias on the grid of the 5687 keeps the tube cut off until triggered. Component values chosen cause the blocking oscillator to develop a pulse of 0.6- μ sec duration and 105-v amplitude into the delay line.

The delay line is six- μ sec long and tapped at one- μ sec intervals. A sweep pulse network consisting of a 5,000-ohm potentiometer with a diode in its arm and a diode-amplifier gate is driven from each tap through a dropping resistor. Value of the dropping resistors is graded from 3,900 ohms to 0 ohms to compensate for the attenuation of the delay line.

The six- μ sec delay line is terminated in its characteristic impedance to prevent reflections in the line. A trigger is taken from the end of the delay line through a diode to trigger the following stage.

Because the pulse is shorter than the interval between delay-line taps, the pulse can appear on only one tap at any time. Overlapping of channels cannot occur.

There are six diode-amplifier gates and six sweep pulse networks in each ring unit. The six potentiometers associated with the sweep pulse networks can be adjusted individually. Provision is made for connecting six input channels to each ring unit.

Ring Start Unit

The ring start unit is shown in Fig. 7. It consists of a blocking oscillator and a three- μ sec delay line. By actuating the ring start switch, bias on the blocking oscillator is lowered momentarily. This action causes the blocking oscillator to fire once and start the ring. A ring stop switch is provided also. It opens the oscillator input to stop the ring from oscillating.

Linear Pulse Amplifier

Schematic diagram for the linear pulse amplifier is shown in Fig. 8. It is a simple linear amplifier which drives two cathode followers through a delay line.

Pulses to drive the amplifier are obtained from the diode-amplifier gates. Each gate is decoupled from the modulated pulse line in each unit by a diode. Each ring unit is

coupled into the linear pulse amplifier through a diode. Coupling diodes show good forward coupling and little back coupling. Capacitance of the diodes is low.

Outputs of the cathode followers in the linear pulse amplifier go to two crt's. One output is applied to one crt grid for intensity modulation. The other output goes to the horizontal plates of the other crt for bar presentation.

Staircase Generator

The staircase generator is shown in Fig. 9. It can be divided into a positive-going section and a negative-going section. Both sections function alike and differ only in a slight rearrangement of their circuit components. The negative-going staircase is developed from a positive potential; the positive-going staircase from a negative potential.

A pulse from the output of the last ring unit triggers both sections of the staircase generator into flyback. The pulse triggers the 5687 blocking oscillator which in turn drives the 6233 power amplifier.

Pulses appearing on the secondaries of the pulse transformer in the plate circuit of the 6233 charge the 150- μ f capacitors through the 6AX4. Charge on the capacitors has no path to ground except through the 6BF5's and through the leakage resistance. The latter can be neglected.

Sweep pulses are amplified by the 6AH6's and applied to the 6BF5's as shown. Each pulse causes the 6BF5's to draw current using the 150- μ f capacitors as sources. As current is drawn from the capaci-

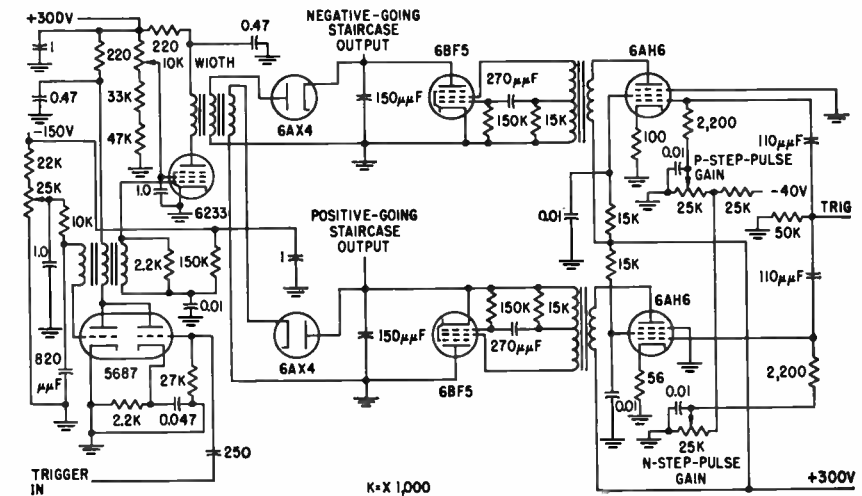

FIG. 9—Schematic diagram of the staircase generator

tors, potential across the capacitors falls and generates a staircase.

As the amplitude of a sweep pulse is increased, more current is drawn by the 6BF5's causing a larger step in the staircase waveform.

The sweep pulses originate in the ring units where provision is made to vary the amplitude of each sweep pulse by adjusting a potentiometer. A staircase of any linearity can be generated.

Output voltage is in excess of 800 v peak-to-peak which is enough to drive the crt's directly. Output signal is taken across the 150- μ f capacitors.

Displays

The instrument has three forms of display presented on two crt's. First, the intensity-modulated pattern with no vertical sweep is used for recording photographically with a continuously moving film

camera. The camera provides the vertical sweep or time axis and the resulting film gives an excellent means for studying the interrelationships of the data on the various channels.

Second, when the intensity-modulated crt is observed directly, using a vertical sweep, it is a good means for observing either coincidence or near coincidence of events. Small changes in brightness, however, are not meaningful because of the nature of the human eye.

Third, if instead of feeding the information to the crt grid, the channel amplitude data are fed to the vertical deflection plates, a bar presentation is obtained. The amplitude of a signal on a channel is shown as the height of the bar above its baseline. Bar presentation has the advantage of displaying the amplitude data in easily discernable form. But the data must be changing at a sufficiently low rate for the eye to be able to follow.

Specifications

The electronic switch described requires 24 in. of a standard rack. This space does not include the crt's. The instrument requires 260 w of power, 160 of which is for heater power. No effort was made to make the device small or to reduce power requirements. Emphasis was upon reliability. The instrument requires 129 μ sec to sample the instrument's 126 input channels.

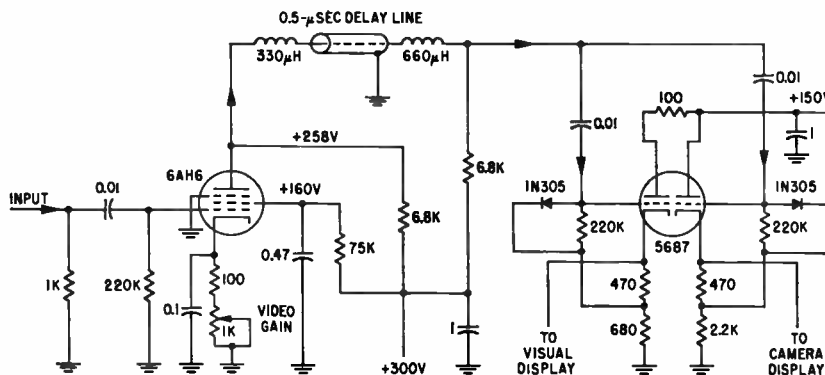

FIG. 8—Linear pulse amplifier has input derived from diode-amplifier gates

Cathode-Ray Storage Tubes

Selection chart lists primary characteristics of seventeen types of direct-view cathode-ray storage tubes representative of those in common use today

By **ARTHUR S. KRAMER**, Senior Technical Specialist, Research Div., A. B. Dumont Laboratories, East Paterson, N. J.

TABLE I—Physical and Electrical Characteristics, Performance Data and Applications for Direct-View Cathode-

Tube Type and Mfr	Description	Deflection/Focus	Defl Factor	Bright-ness, Ft-Lamberts	Writing Speed In./sec
Farnsworth IA-05-P20-2.5 <i>Iatron</i>	2.5-in. dia; 2 guns	Both electrostatic	65 v/in.	2,500 max	300,000
Dumont K-1327	3-in. dia; one gun; charge storage	Both electrostatic	184-248 v/target dia
Hughes H-1009, H-1012 <i>Tonatron</i>	3-in. dia; 2 guns; direct display half-tone storage	Both electrostatic	150 v/in.	500 min	10,000
Vacuum Tube Products 6992	3-in. dia; 2 guns	Both electrostatic	45-90 v/in.	High
Dumont K-1696	4-in. dia; 2 guns	Both magnetic	1,000 min	40,000
Farnsworth 7176,-A, -B <i>Iatron</i>	5-in dia; 2 guns	Both electrostatic	45 v/in.	3,500 max	50,000
Farnsworth IA-10-P20-3 <i>Iatron</i>	5-in dia; 2 guns	Both magnetic	3,000 max	4-40,000
Hughes <i>Memotron</i>	5-in. dia; 2 guns	Both electrostatic	85-115 v/in.	250,000
Hughes H-1010 <i>Tonatron</i>	5-in. dia; 2 guns; half-tone Storage	Both electrostatic	1,500	40,000
Hughes H-1005 <i>Tonatron</i>	5-in dia; 3 guns; half-tone storage	Both electrostatic	125 v/in.	1,500	150,000
RCA 7183	5-in. dia; 2 guns	Write: Mag defl/elec foc	1,500
RCA 6866	5-in. dia; 2 guns	Both electrostatic	28-38 v/in. per E_{c4} kv	2,750	300,000
Vacuum Tube Products 6990, 6991	5-in. dia; 2 guns; tone display	Both electrostatic	28-57 v/in.	High
Westinghouse WX 3912, WL 7228	5-in. dia; 3 guns	Both electrostatic	28-38 v/in. per E_{c4} kv	2,000	WX-300,000 WL-4-40,000
Dumont K-1618	10-in. dia; 3 guns	Both electrostatic	50-70 v/in.	1,000	100,000
Dumont K-1826	10-in. dia; 2 guns	Write: Mag defl/elec foc	700 min	100,000
Dumont K-1810	21-in. dia; 2 guns	Write: Mag defl/elec foc	700 min	50,000

for Direct Viewing

STORAGE TUBES available today may be divided into five general classes: direct-view storage tubes, computer storage tubes, data storage tubes, special scan-converter storage tubes and character-printing types. Table I lists direct-view types.

Advantages these tubes hold over conventional crt's is the fact that non-recurring phenomena can be viewed indefinitely.

Most storage tube devices consist of one to three electron guns, deflection circuits and storage ele-

ments, usually consisting of a dielectric deposit on a mesh or other metallic surface.

Nomenclature for the output gun of multigun direct-view tubes has not been standardized by manufacturers to date. This gun which is neither deflected or focused but is collimated, serves to transfer an image of the stored pattern on the dielectric part of the target to the viewing screen. This tube element is variously referred to as output gun, reading gun, view gun, flood gun and flooding gun.

Ray Storage Tubes

Resolution Lines/in.	Erase Data	Applications and Features
.....	Requires for max persistence 10-v pulse, 0.2 μ sec wide, 90 pps	Handles frequencies in range used by fire control and aircraft cockpit radar. Used for transient studies, data transmission
150/target dia	Takes place immediately after reading	Used for signal conversion, analog and binary storage, improvement of signal-to-noise ratio by integration. Microsecond access to data
45-60	Erase time: 250 millsec max	A and B scan radar presentation, ppi display, weather radar, slow-scan narrow-band tv, map transmission, process monitoring
.....	Requires 10-25-v pulse, 1-10 μ sec wide, 400-3,000 pps	Presents bright visual displays of tv and radar data. Can display tones. Bright enough for viewing in daylight
30	Erase time: 100 millsec max	Handles data in frequency range of fire control and aircraft radar. Transient studies, data transmission, visual communications
30-80	Requires 8-v pulse, 1.5 μ sec wide, 2-5,000 pps	Good resolution in halftone displays. Used in airborne radar, weather radar, transient studies and data transmission
.....	Requires 4-v pulse, 0-500 μ sec wide	Radar plotting, data transmission, oscilloscope transient studies. Bright display permits daylight viewing
50-60	Erase by momentary lowering collector mesh voltage	Displays single or superimposed transients, families of curves, tube or transistor characteristics. Medical electronics
45-60	Requires 0-10-v pulse with duty cycle of 0.5-20 percent	Same as H-1009 and H-1012
50	Requires 0-10-v pulse with duty cycle of 0.5-20 percent	Same as H-1009 and H-1012
50	Requires 2.5-12-v pulse, 10 μ sec wide, 500-2,000 pps	Fire control and aircraft cockpit radar; airport surveillance radar, transient studies, data transmission, visual communications
100	Erase by applying positive pulses to backing electrode	Same as RCA 7183 with higher persistence
.....	Requires 10-25-v pulse, 1-10 μ sec wide, 400-3,000 pps	Same as RCA 7183. Good resolution in half-tone displays. Brightness permits daylight viewing
WX-50 WL-250	Selective erasure accomplished by lowering secondary emission	Fire-control and weather radar, transient studies, data transmission halftone storage; can freeze high-frequency transients
30	High-current, low-velocity erase gun. Local erasure	Large presentation of fire-control and aircraft cockpit radar, airport surveillance radar, transient studies and data transmission
50	Erase time: 100 millsec min	Black face screen improves contrast under high ambient light
30	Erase time: 100 millsec max	Large display for radar data, transient studies, narrow band information transmitted over telephone lines

Saturable-Core Oscillator

Disadvantages of mechanical methods of integrating time-varying electrical functions with respect to time are avoided by using saturable-reactor transistor oscillator whose frequency is related to input voltage. Design refinements permit linearity within 1 percent of full scale on input voltages

By **LAWRENCE W. LANGLEY**

Senior Project Engineer, Automation Div., Southwestern Industrial Electronics Co., Houston, Texas

MEASUREMENT OF GAS QUANTITY for custody transfer and billing purposes often requires integration with respect to time of an electrical signal representative of flow rate.

Such integrations may be performed by a variety of electrical or mechanical methods as well as by time consuming manual planimetry. The saturable-reactor-oscillator integrator, however, does not have the disadvantages presented by many of these techniques.

Operating on the principle that time-base integration of a variable may be performed by counting the cycles of an oscillator whose frequency is proportional to the variable, the saturable-reactor oscillator illustrated in Fig. 1 does not have the instability and power requirements of other voltage-controlled oscillators and is basically a linear device.

Basic Oscillator

Figure 1A shows one type of saturable-reactor oscillator with a high-permeability ferromagnetic tape core.

Assume e_{in} , the function of time to be integrated, is applied and Q_1 is conducting. Winding N_1 acts as both an inductor and the primary of a 2:1 autotransformer, of which N_1 and N_2 comprise the secondary.

Conduction of Q_1 holds point A at ground and cuts off Q_2 by grounding its base through R_1 . An increasing current will flow through N_1 , impeded by inductance, until the core is saturated in the sense of N_1 . Dur-

ing this interval a voltage $2e_{in}$ is induced between the collectors of the two transistors, with the collector of Q_2 positive; R_2 conducts a current $2e_{in}/R_2$ to the base of Q_1 , holding it in conduction.

Saturation

At the instant of saturation, the effective inductance of N_1 is reduced to a small value, and the current

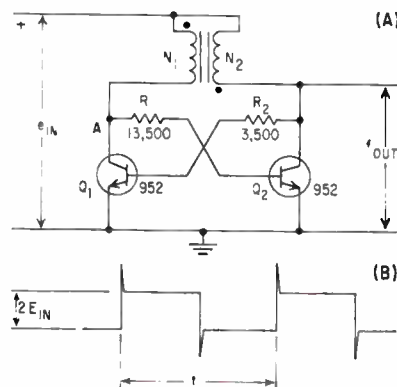

FIG. 1—Basic saturable-reactor oscillator (A) and typical collector waveform (B). Peaks result from stored energy

through it increases rapidly. Since Q_1 has a small saturated resistance between collector and emitter, a small potential will build up at point A, as N_1 current increases.

Since the core is saturated, autotransformer action will cease and the potential across R_2 will decrease rapidly to e_{in} . The combination of the two actions at core saturation causes Q_2 to start conduction, dropping its collector to ground; Q_1 cuts

off when its base drive is removed and winding N_2 starts reset of the core.

The circuit is self starting, self sustaining and highly stable.

The voltage waveform at either collector is as shown in Fig. 1B, each collector being 180 deg out of phase with the other. The voltage peaks at each collector are a result of stored energy in N_1 and N_2 . The energy is small enough to be readily dissipated by the transistors.

If Q_1 and Q_2 are made of silicon, these peaks may be high and it may be necessary to clamp them with Zener diodes. The same diodes will absorb reverse surges across the transistors by conduction in their forward direction.

An average current of $4e_{in}/R_{1,2}$ will be drawn, approximately half through each winding. It consists of d-c with superimposed transients during the switching interval. If these transients are not to affect the signal source, an isolating element must be added to furnish a low impedance source for driving current.

Transfer Function

The first-order expression of the transfer function of a saturable-reactor oscillator is

$$e_{in}/f_{out} = 4BAN10^{-8}$$

where B is core saturation flux density in gauss, A is core cross-sectional area in cm^2 , N is number of turns of each winding, e_{in} is in volts and f_{out} is in cps.

Second-order effects on the transfer function may be ignored for a 1-percent prediction of e/f at an

Integrates Gas-Flow Data

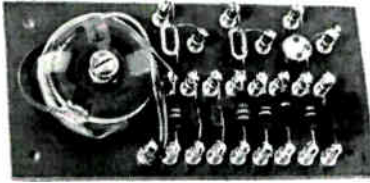

Saturable-core oscillator with clamping diodes and additional transistor stage

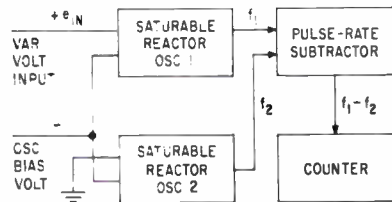

FIG. 2—Time-base integration system for extending input range to zero uses two oscillators

input voltage above 5 v. Oscillators with transfer functions from 0.04 v-sec/cycle to 4 v-sec/cycle have verified the expression given within the limits of error of B and A .

Under continuous operation a well-designed circuit will retain its transfer function consistently within 1 part in 10^4 over periods of a month or more. Measurements of e/f precise enough to detect drift are rather difficult to make.

Of particular interest is the relative temperature insensitivity of this oscillator. Since Q_1 and Q_2 are used as switches, to a first approximation, temperatures within their ratings have no effect on transfer function. Secondary effects of temperature are produced by variation of saturated resistance and change in cutoff leakage.

With germanium transistors, the change in transfer function from 10C to 40C is normally less than 0.1 percent. Changes produced by temperature effects on the core and resistors can be held within the same range by using good quality components.

Linearity Limitations

Oscillators using germanium transistors are linear within 1 percent of full scale down to 1 or 2-v input. Those using silicon transis-

tors become appreciably nonlinear below 5 v. This effect is produced mainly by increased transistor resistance at low base driving currents.

The increase of current through each winding is described by a function of the general form $e^{-Rt/L}$ and when R increases the value of $e^{-Rt/L}$ increases more rapidly. Thus the saturable reactor oscillator will have a transfer function e_{in}/f_{out} that is linear down to an input voltage where transistor resistance become appreciable. The transfer function will rapidly increase as the voltage applied is lowered further.

The only upper limit to applied voltage is the breakdown potential of the transistors. Since an effective potential of $2 e_{in}$ is applied once each cycle to the collector, transistors must be selected which have a maximum V_{ce} of $2.5 e_{in}$ max or greater.

Integration

A time-base integration system using a saturable reactor oscillator driving a counter will accumulate the true time integral if no signal voltage is applied to the oscillator outside its linear range and if frequency components of the input signal are all an order of magnitude below the oscillator frequency. Such an integration system may be used in the measurement of gas flow, where the range of flow rates is restricted to 2 to 1 or at least 5 to 1.

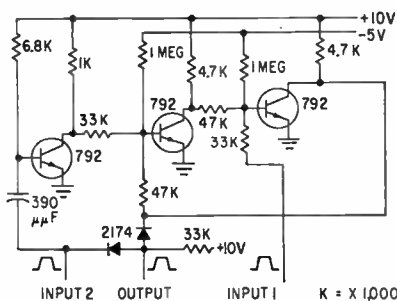

FIG. 3—Subtraction circuit for system of Fig. 2 comprises diode coincidence circuit fed by delay inverter and two-stage subtract trigger

An oscillator which is linear within 1 percent from 2 to 10 v input will in general achieve better than $\pm 1/2$ -percent integral of flow rate, if the rate fluctuates randomly during the measurement period.

Linearity Extension

Integral measurements which involve dynamic ranges greater than 5 to 1 require more sophisticated circuits. To prevent excursion of the oscillator input voltage from its linear range, a bias voltage may be applied to the oscillator sufficient to operate the oscillator near the bottom of its linear range with no signal voltage applied. The effect of such bias will be to add to the integral obtained in any measurement period a number of counts proportional to the measurement period. The bias voltage must be maintained constant or its variations will add error.

The use of a biased oscillator for integration extends the range of the device essentially to zero. This, however, necessitates subtracting the bias integral from each reading.

A device that performs time-base integration over an input range extending to zero and automatically subtracts the bias integral is shown in Fig. 2.

Saturable-reactor oscillator 1 is biased into its linear region by a well-filtered and fairly well-regulated voltage. Oscillator 2 is similar and has the same transfer function. The bias voltage is the only input to oscillator 2. The pulse rate of oscillator 2 is subtracted from the rate of oscillator 1 in a pulse-rate subtraction or anticoincidence circuit.

Since the transfer functions of the two oscillators are equal, any small variation in bias voltage effects both oscillators in the same manner and the pulse rate change cancels. The zero point for integration is fixed at zero input voltage by equality of the two transfer functions.

One possible subtraction circuit is shown in Fig. 3.

Pulse transmitter and receiver at widely separated locations are stepped through frequency range of 25.05 to 48.95 mc in 100-kc increments. Timing and recording equipment at each installation make possible the correlation and observation of mutual propagation conditions between the two points

By E. H. HUGENHOLTZ, A. SELJAK and A. TOWLE, Philips Electronics Industries, Ltd., Toronto, Canada

Frequency Stepper for

OBSERVATION OF MUTUAL propagation conditions between two widely separated locations is made possible by the installation in each of the locations of a pulse transmitter, pulse receiver and a common frequency exciter as well as timing and recording equipment. With the timing devices, which have a high frequency stability, the installations are correlated so that in each case the received pulse from the opposite transmitter is recorded on a film recorder.

Each recording cycle is triggered by the pulse from the local transmitter; hence the timing between both pulse systems must be accurately maintained. This method permits simultaneous observation of propagation phenomena in both directions. During recording, the operating frequency is stepped in 100-kc steps through the range from 25.05 mc to 48.95 mc. In this way a continuous observation of the full frequency range is obtained.

Exciter

A block diagram of the system is shown in Fig. 1. A frequency exciter unit provides a crystal-controlled output frequency which is stepped in 100-kc steps at 1-sec intervals from 31.05 mc to 54.95 mc. Each step corresponds to an odd multiple of 50 kc.

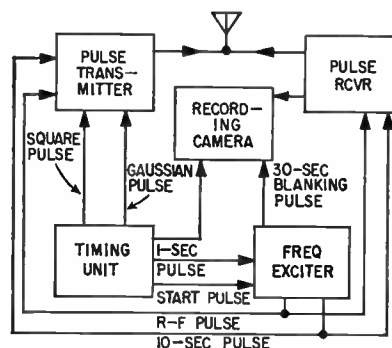

FIG. 1—Block diagram of the complete propagation testing system

At the end of the cycle the exciter goes into a wait position until it is released for another cycle by a start pulse from the timing unit. The

exciter supplies the r-f signal described above to the pulse transmitter and receiver as well as a stepping pulse every 10 sec to switch the tuning in 1-mc steps. It also provides a blanking signal every 30 sec. This signal is used as a frequency marker on the recording.

The pulse transmitter feeds signal pulses with a duration of approximately 25 μ sec and a peak output power of 10 to 20 kw into a rhombic antenna. A pulse receiver is step-tuned with the transmitter and operates from the same antenna. The receiver output signal, consisting of positive pulses of approximately 30-v amplitude, is fed to the recording oscilloscope.

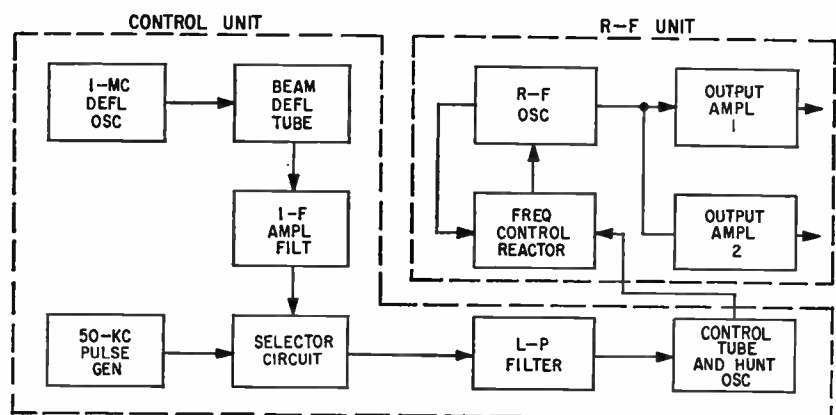

FIG. 2—Block diagram of the frequency exciter unit. This consists of control unit, r-f unit and stepping unit (not shown)

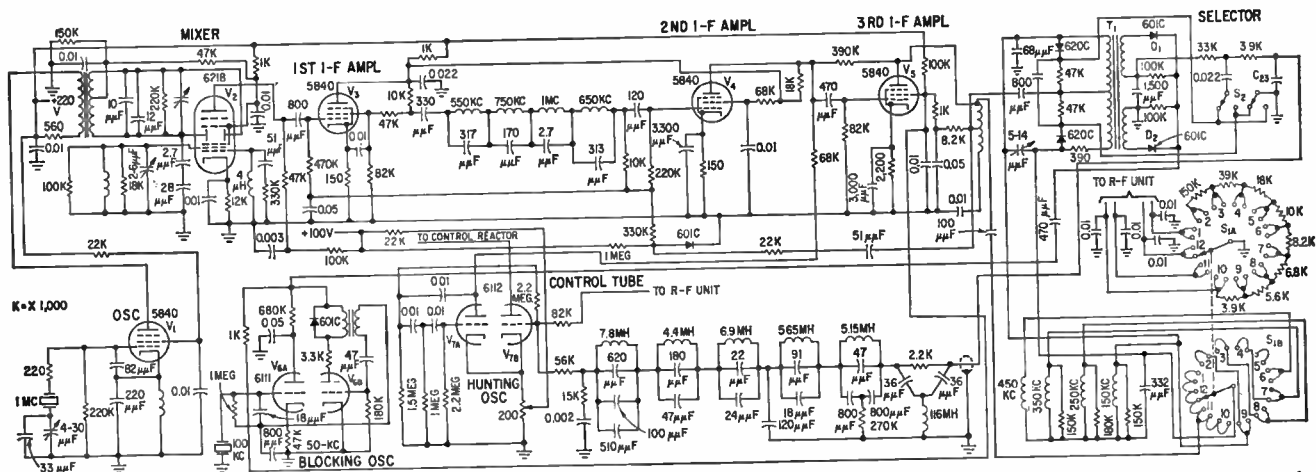

FIG. 3—Schematic of the control unit. Frequency control of the r-f oscillator is obtained by mixing a sample r-f signal with a 1-mc reference spectrum and comparing components of the mixing product with the 50-kc pulse spectrum supplied by pulse generator V_{6a} .

Radio Propagation Tests

The timing unit supplies the 1-sec step pulses and the start pulse as well as Gaussian and square modulation pulses for the transmitter at repetition rates of 30 pps or 15 pps. The unit is controlled by a crystal frequency standard.

Stepping

Figure 2 is a block diagram of the stepped frequency exciter that uses 1-mc and 100-kc crystals as references. Stepping of the output frequency is effected by two switches which are driven by rotary solenoids. One switch operates every second to switch the tuning position of the control circuit in 100-kc intervals from 0.05 mc to 0.95 mc. After completing the 10-step cycle this switch feeds a pulse to the other solenoid which operates a 24-position switch. This steps the controlled oscillator frequency in 1-mc steps. In addition, the 24-position switch is provided with two cam-operated change-over switches that put the installation in the wait position at the end of a cycle and supply the blanking pulse previously mentioned.

Heart of the system is the frequency control circuit. Control is obtained by mixing a sample signal from the controlled oscillator with a 1-mc reference spectrum and by phase-locking a component of the

mixing product with a harmonic of a 50-kc reference spectrum.

Excitation of the 1-mc spectrum and mixing of the sample signal with this spectrum is carried out as a combined function in a type 6218 beam-deflection tube. Since the pulse excitation and pulse-mixing processes are carried out in the electron beam in this tube, no capacitive inertia effects occur and the pulse-mixing process can be accomplished up to several hundred megacycles.

Beam-Deflection Tube

The 6218 beam-deflection tube contains a ribbon-shaped electron beam system. The beam passes through a control grid and a controlling focusing grid. Following the focusing system are two deflection plates and a shield plate with a narrow slot. Behind the slot are a suppressor grid and plate.

A large 1-mc deflection voltage on the deflection plates sweeps the beam past the slot and results in two short plate-current pulses per cycle during the zero passages of the deflection voltage. One of the pulses is suppressed by a gating voltage on the focusing grid, which is derived from the deflection voltage after 90-deg phase shift.

When an r-f signal is impressed on the control grid, the beam is

intensity-modulated and the pulse components reaching the plate represent the mixing product between the signal and the pulse spectrum. This results in the plate current of the tube containing components of the pulse spectrum (harmonics of 1 mc including the d-c component) each with a pair of sidebands at a frequency equal to the difference in frequency between the r-f signal and the nearest pulse harmonic.

For example, for an r-f signal of 51.05 mc, each 1-mc spectrum component has sidebands at ± 50 kc. The lowest frequency components are the frequencies of 50 to 450 kc at odd multiples of 50 kc.

Control

Figure 3 is a schematic of the control unit. Output of the beam deflection tube V_8 is fed to a three-stage i-f amplifier V_4 through V_5 and a filter which suppresses frequencies over 500 kc. The first two stages of i-f are agc controlled. The amplified i-f is then fed to the selector circuit where the signal is compared with a 50-kc pulse spectrum provided by pulse generator V_{6a} . The selector circuit consists basically of a frequency discriminator circuit and a pulse-mixing circuit which provides phase comparison. The function of the selector circuit is to permit the r-f oscil-

lator to lock on a particular frequency and determine whether this frequency is either the upper or lower sideband of the nearest 1-mc harmonic.

Discriminator

In switch S_1 , positions 1 through 5, the frequency discriminator, consisting of transformer T_1 and diodes D_1 and D_2 , is successively step-tuned from 50 to 450 kc in 100-kc steps. The r-f oscillator is thus successively locked to frequencies N , $N + 0.05$, $N + 0.15$, $N + 0.25$, $N + 0.35$ and $N + 0.45$ mc, where N is the lowest frequency of the spectrum being scanned. After switching to position 6, the frequency discriminator selects i-f components from 450 to 50 kc. Reversing switch S_2 causes the oscillator to lock on frequencies of $(N + 1) - 0.45 = N + 0.55$, $(N + 1) - 0.35 = N + 0.65$, etc. Thus the range is scanned over 10 steps of 100 kc each, using only 5 discrete frequencies.

Phase-locking is accomplished by a combination of voltage from hunting oscillator V_{7A} and an output voltage from the pulse-mixer circuit operating on the control circuit. The hunting oscillator supplies a 6-cps signal which sweeps the oscillator frequency through its full control range of approximately ± 450 kc in the absence of phase-locking. When the i-f frequency closely approaches the frequency to which the frequency discriminator is tuned, a beat frequency is developed in the pulse mixer which passes through a low-pass filter network and operates on a reactor control circuit in the r-f section (not shown) to cause a phase lock. As soon as phase-lock is accomplished, the hunting voltage is cancelled by the control signal, except for a residual frequency deviation of approximately 2 cps, which has negligible effect.

The output signal from the selector circuit feeds through appropriate R-C damping networks to a filter which suppresses harmonics of 50 kc up to 250 kc and all frequencies over 250 kc. The signal then feeds control tube V_{7B} .

Plate current from the control tube passes through the windings of a saturable ferrite reactor net-

work which controls the frequency of the r-f oscillator. The network consists of an a-c and d-c reactor in series. The d-c reactor has a high inductance of several henrys and controls the frequency at a rate of approximately 400 kc/ma. The a-c reactor has a much lower sensitivity (approximately 25 kc/ma) and an inductance of about 120 mh. A second winding on the d-c reactor is energized by a fixed d-c current, the value of which is determined by the resistance switched in by switch S_{1A} on the control chassis. This current sets the oscillator to the approximate desired output frequency.

Transmitter

The transmitter consists of a driver unit, a power amplifier stage and a pulse unit. The driver mixes the variable frequency from the ex-

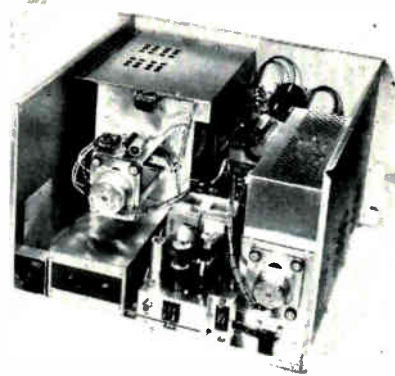

Rear view of transmitter unit shows stepping switches

citer with an internally generated 6-mc signal and amplifies the lower sideband obtained from the mixing process.

The 6-mc fixed oscillator is modulated by the externally supplied Gaussian pulse in conjunction with a feedback pulse for amplitude stabilization. Balanced operation of the mixer is obtained by feeding the variable frequency signal in parallel to the control grids and the fixed frequency in push pull to the suppressor grids.

The use of a balanced mixer automatically suppresses the exciter signal as well as many intermodulation products. An appreciable improvement in efficiency is obtained by using the mixing products from the screen grids as well as the plates of the mixer tubes. These are con-

nected to the load so that components from screen and plate add.

The mixer is keyed by a square pulse from the pulse unit fed to both control grids which are normally cut off. Keying level is maintained by a limiter diode. Later stages use screen keying.

Receiver

The receiver for this system provides positive pulses to the recording unit in response to incoming pulses in the frequency range of 25.05 to 48.95 mc. To assure sufficient amplitude range for the display, the signal output level is maintained within a few db variation by fast-acting agc which restores receiver sensitivity within two or three times the pulse duration.

R-f circuits of the receiver have a flat response over a 1-mc band and are switched in 24 steps by pulses from the exciter unit. The protective antenna input circuit consists of a balanced tuned circuit protected against excessive voltages by a neon-gas gap and coupled to the antenna by a lattice network of high impedance to prevent excessive current in the system.

The antenna is coupled to the mixer through a series amplifier. The mixer operates with low oscillator drive to assure a minimum of spurious response. The first i-f is tuned to 6 mc. A continuous manual gain control with a range of approximately 32 db is incorporated in this stage. A second mixer produces the second i-f frequency of 700 kc which is filtered and feeds into a 40-db step attenuator. Most of the required selectivity of the second i-f section is provided by the fixed filter. The remainder of the five-stage i-f amplifier has low selectivity to present low inertia to the fast action of the agc system.

The output tube following the balanced diode detector has a logarithmic grid characteristic stabilized by a cathode resistor. The tube receives negative pulses on its grid, resulting in further logarithmic compression of the final positive pulses in the plate. The receiver has an input noise figure of better than 8 db and the compression circuit reduces an input signal variation of 60 db to less than 8 db.

D-C to A-C Modulators

Electromechanical, solid-state and other modulators are being increasingly used to take a weak d-c signal and convert it to a-c for amplification. Here are some typical modulators and their characteristics

By **GEORGE SIDERIS**, Associate Editor

MODULATORS are widely used to simplify the amplification of d-c or low-frequency signals. By converting the d-c signal to a-c, modulators enable the designer to side-step many of the drift problems commonly associated with d-c amplification.

The basic mechanism is introduction of an exciting a-c signal as a carrier wave which is modulated by the original d-c signal. Line frequencies are commonly used, but higher frequencies may be employed.

Modulators with dynamic ranges up to 100 db are available, particularly in the electromechanical types.

MODULATOR USES—A common application is amplification of weak signals from transducers. The demodulated output, following the a-c amplification stage, drives indicating and recording devices. Modulators are also used in computer circuits, servomechanism drives, cathode ray tube devices, for comparison of d-c signals, conversion of carrier

frequencies, as well as their familiar use as stabilizers for d-c amplifiers.

Typical characteristics for several classes of modulators are shown in Table 1.

A prime advantage of chopper-type modulators is their low drift. Transistor modulators are especially efficient when a low-power output is desired. Second harmonic magnetic amplifiers are generally considered the most accurate of the magnetic class due to the strength of the second harmonic.

Other modulating systems employ nonlinear resistors and thermistors, voltage-sensitive capacitors, carbon microphones coupled to crystals and vibrating balance beams.

REFERENCES

- (1) B. T. Barber and L. S. Klivans, "Servo Modulators", Control Engineering, McGraw-Hill Pub. Co., Aug., Oct., Nov., Dec., 1957
- (2) J. G. Truxal, "Control Engineers' Handbook," McGraw-Hill Book Co., 1958

TABLE 1—Characteristics of Modulators for D-C Amplification by D-C to A-C Conversion

Modulator	Life (hours)	Max. ^a Exciting Freq.	Temp. Range (°C)	Input Impedance (ohms)	Null (volts)	Drift (volts)	Signal -noise Ratio	Freq. Response @ 400 cps	Remarks on Application
Electromechanical chopper	5,000	600 cps	-65 to 200	1,000,000	1 μ v-1mv	0.1-1mv	100,000	20%	Inexpensive, rugged, high linearity
Crystal diode	>10,000	2.5 mc	-55 to 150	<10,000	100 μ v-1mv	10mv	8,000	10-20%	Good linearity, low power requirements
Transistor	>10,000	100 kc	-50 to 90	<10,000	100 μ v-1mv	1mv	2,000	10-20%	More sensitive than diode, low power
Multigrid tube	varies	>10 kc	-65 to 100	>1,000,000	1-10mv	25 μ v/min	500	—	Fair linearity, temperature sensitive
Vacuum diode	varies	10 kc	-65 to 100	<10,000	>1mv	1 μ v/min	2,000	10-20%	Drift a problem, will take high voltage
Magnetic amplifier	>10,000	10 kc	-75 to 200	3,000	>10mv	5 μ v	500	to 5%	Noise problem at weak signals and low frequencies
Induction galvanometer	—	200 kc	-65 to 100	—	10mv	5 μ v	—	—	Sensitive to vibration and shock
Variable capacitance	—	—	-65 to 100	10 ¹²	10 μ v-1mv	100 μ v	—	—	Measures small currents; expensive
Photoelectric	>10,000	1 kc	-80 to 100	>1,000,000	>200 μ v	<1mv	3,000	—	Temperature-limited by type of photocell

a. Values are generally used limits; exciting frequency of choppers, for example, go as high as 1,800 cps; 60 cps and 400 cps are dominant

Function Generator

Transistorized trigonometric function generator provides an output voltage that is cosine of input voltage. It also performs as a sine function generator. Input voltage is converted into a pulse width which controls an electronic switch. Output from switch is averaged by conventional filtering means.

By H. SCHMID, Link Aviation, Inc., Subsidiary of General Precision Equipment Corp., Binghamton, N. Y.

TRIGONOMETRIC function generators have long been recognized as fundamental computing elements in analog computers. The transistorized cosine-sine function generator to be described works on the theory that the area under the sine curve varies as a cosine function.

In practice, a rectangular pulse is generated with a duration proportional to a direct voltage. The pulse operates an electronic switch which, in turn, cuts off one portion of the sine wave. Since the pulses must be synchronous with the sine wave connected to the switch, the rectangular pulses are generated from the sine wave. This will produce pulses symmetrical with respect to the positive peak of the sine wave. Basic components required for the generator are a linear pulse-width modulator, an ideal switch, an integrator and a sine-wave source.

Since $\sin x = \cos (\pi/2 - x)$, a cosine function generator can always be made into a sine function generator simply by subtracting the argument from the full-scale value.

Circuit Description

The linear pulse-width modulator portion of the complete generator shown in Fig. 1 converts the argument of the cosine/sine function V_x from a direct voltage to a pulse width t . Since the rectangular pulses have to be in synchronism with the sine wave applied to the switch, a closed-loop conversion unit is used to produce the rectangular pulses by driving the squaring amplifier with the same sine wave.

Operation of the closed-loop pulse-width modulator is as follows. The input voltage V_x and a feedback voltage V_f (to be described later) produce an error voltage

which is amplified by the d-c amplifier. Output of the amplifier, V_b , biases the secondary of transformer T_1 . This transformer couples the reference sine wave to the input of the squaring amplifier. The zero level of the sine wave at the input to the squaring amplifier is shifted above ground potential to $A \times (V_x + V_f)$ where A is the gain of the d-c amplifier.

The squaring amplifier has the characteristic of amplifying only a slice of the sine wave (± 10 mv above ground) into a rectangular wave. The squaring amplifier in Fig. 1 is the most straight-forward version of such a circuit. Amplitude of this rectangular wave is determined by the supply voltage of the squaring amplifier. Pulse width of the rectangular wave is determined by the width of the sine wave in the slice to be amplified which, in turn, depends on the bias applied to transformer T_1 . The squaring amplifier provides push-pull output.

Push-pull signals from the squaring amplifier control the bases of the transistor switch outside the conversion unit as well as the bases of the switch in the unit. Purpose of the latter is to limit the amplitude of the rectangular wave accurately to $\pm V_r$, the computer reference voltage. The filter following the switch extracts the average value of the rectangular wave which is proportional to V_r , $(1 - 2t/T)$ identified in Fig. 1 as V_f . This closes the loop of the conversion unit and, by feedback theory, $V_x + V_f = V_b/A$. When the gain of the amplifier is high, V_b/A goes to zero and $V_x \approx -V_f$.

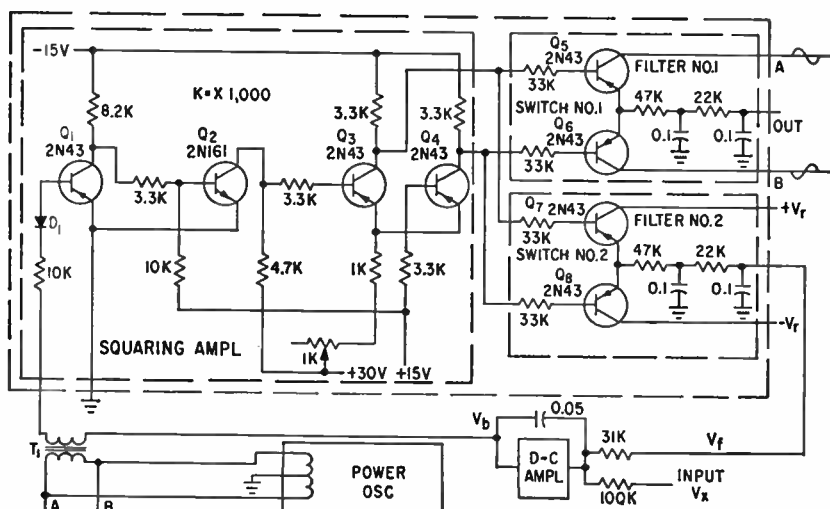
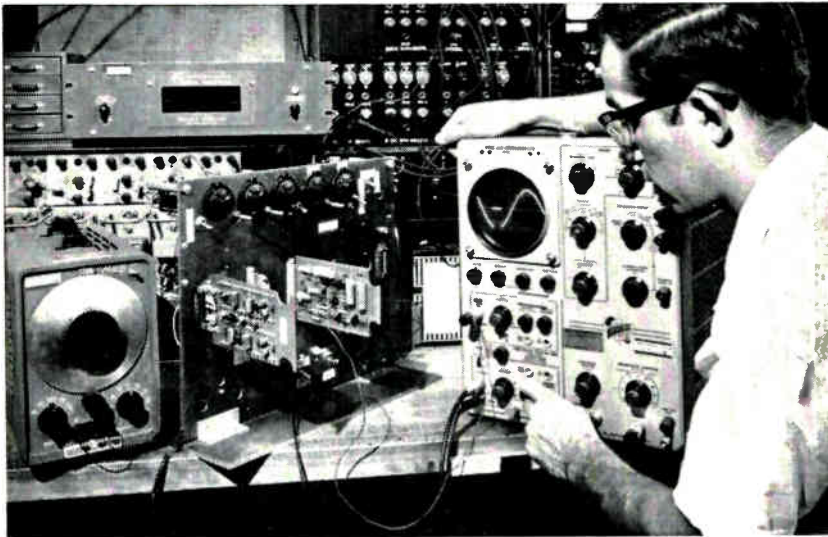

FIG. 1—Schematic diagram of cosine/sine function generator

for Sines or Cosines



Testing of breadboard model of function generator at left center

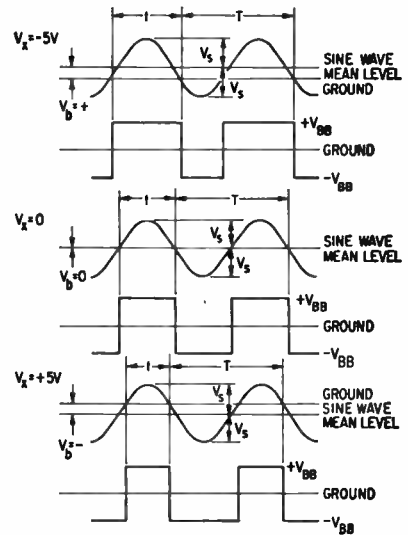

FIG. 2—Variation of pulse width

Figure 2 illustrates the biasing of the sine wave as well as the variation of the pulse width t with respect to V_s . When the input voltage V_s equals zero, the bias voltage V_b equals zero also. There is no d-c bias on the sine wave and the input signal to the squaring amplifier will have positive and negative excursions of equal duration. The pulses at the output of the squaring amplifier will have a pulse width of exactly $T/2$, where T is the total period of the sine wave. As V_s becomes more negative, V_b becomes more positive and pulse width t increases. In a similar manner, t decreases when V_s becomes more positive.

In the analysis of the feedback network it can be shown that the output $(1 - 2t/T)$ is directly proportional to V_s/V_r . When the gain of the d-c amplifier is high, the output is independent of the amplitude, linearity and the frequency of the carrier signal. Only for this reason is it possible to employ a sine wave instead of a linearly varying waveform and still obtain a linear relationship between input and output.

Transistor Voltage Switch

The transistor voltage switch consists of two emitter-to-emitter connected *pnp* transistors. In this

connection, the two transistors operate almost like an ideal switch. But the switch is ideal only with respect to its voltage switching capability and not with respect to its current or impedance switching characteristics.

The control signal for the transistor switch is dependent on the signal to be switched and has to be always more negative and more positive than the most negative and most positive respective signal to be switched. Main purpose of this switch is to limit the amplitude of the rectangular wave to the potentials applied to the collectors.

Switch Output

The transistor voltage switch^{1,2} is responsible for the high accuracy and dynamic range of this generator. It is simpler than its vacuum-tube counterpart and requires no balancing or compensation controls.

If the potential on one collector is a sine wave and the other collector is at ground, output of the switch will have waveforms as illustrated in Fig. 3A. But if push-pull signals are applied to the two collectors, waveforms as shown in Fig. 3B will be seen at the output.

Push-pull signals applied to the transistor switch do not change the principle of operation. They only

improve the accuracy. This occurs because the push-pull signals double the output amplitude for a given sine wave amplitude, compensate for any unbalance in the switch transistor characteristics and compensate the finite rise and fall times of driving pulses.

Filters

The signal connected to the filter inside the feedback loop is a pulse-width-modulated rectangular wave. The signal connected to the filter outside the loop consists of portions of the push-pull sine waves. Width of this signal is equal to the width of the rectangular pulses. Although the frequency spectra of the two signals are different, the design problems for the two filters are similar. For simplicity, they will be considered identical.

When only static or low-frequency performance ($\omega_m < 10^{-4} \omega_c$) is desired, it is relatively simple to design the filters. In fact, a capacitor across the d-c amplifier to make it an integrator is sufficient. When fair frequency response ($\omega_m < 2 \times 10^{-3} \omega_c$) is required and phase shift between the input and output signal of 10 deg or more can be permitted, filters as shown in Fig. 1 may be used. These filters exhibit light weight and compactness which is often re-

quired with transistor circuitry. When optimum frequency response for a specified accuracy and carrier frequency is required, the problem of filtering becomes complicated.

Static Performance

Accuracy of the cosine function generator with push-pull reference sine waves connected to the first transistor switch is ± 0.1 percent of full-scale output over the complete 180-deg range. Total harmonic distortion on the reference sine waves, as measured with a harmonic wave analyzer is about 0.2 percent. As the measured total harmonic distortion increases, the accuracy decreases.

Performance measurements were made with a sine-wave frequency of one kc. Several such measurements have been taken at various other frequencies. Accuracy of the function generator decreases noticeably above four kc. Redesign of the squaring amplifier may permit use of a carrier frequency of 10 kc.

Maximum amplitude of the reference sine wave which can be handled by the transistor voltage switch is determined by the maximum reverse voltage for the particular transistor used. For presently available transistors, this value is 20 v peak-to-peak.

Dynamic range is defined commonly as the ratio between the output for maximum input and the output for minimum input. In the cosine function generator, this definition is not readily applicable because maximum output occurs for zero input and minimum output for maximum input. Minimum output in this device is the integral over a sine wave, which is zero. However, the sine wave will have a d-c component which is the voltage drop across the conducting transistor and the sine-wave source resulting from the base current which flows out of the conducting transistor.

For the breadboard with 27,000-ohm base resistors and five-v maximum output voltage, a voltage drop of about one mv was measured. At the extremes, where the pulse width is zero, the voltage drop across the conducting transistor is the only source of noise. But when the unit operates between these

extremes, additional sources of noise appear in the form of zero offset of the d-c amplifier, rise and fall times of the pulses, and low-frequency ripple at the output of the d-c amplifier.

Since the linear pulse-width-modulator unit is a closed loop and the switch a digital element, the circuit is largely independent of power supply, temperature and component variations. There is only one control in the push-pull stage of the squaring amplifier to vary the amplitudes of the push-pull rectangular waves which drive the switches. This control permits equalizing the amplitudes of the push-pull signal and, at the same time, permits compensating for variations in transistor characteristics.

Summing

The argument of the trigonometric function is fed into a summing amplifier. The impedance is high and the amplitude of the argument can assume practically any value. Although the output impedance of the transistor switch is low—less than 50 ohms—the load to the

percent and come from a source impedance of less than 10 ohms. The sine waves are not required to be frequency stable.

Dynamic Performance

When the input to the cosine function generator varies as a function of time, output from the cosine function generator should be the cosine of this time function. In any carrier system, this function of time can vary only at a frequency which is lower than the carrier frequency. The smaller the ratio between the carrier frequency and the modulating frequency, the more difficult it is to recover the modulating signal from the carrier.

The cosine function generator described thus far operates over a range of 0 to ± 90 deg. Biasing the d-c amplifier in the pulse-width modulator to -9 v or connecting the transistor switch in the pulse-width modulator to 0 and -18 v instead of $+9$ v and -9 v converts the cosine function generator into a sine function generator which operates between 0 and $+180$ deg.

In a similar fashion but inverting the output signal also, a sine function generator operating between 0 and -180 deg can be obtained. The inversion of the output signal is effected by reversing the reference sine waves to the transistor switch, reversing the base drives to the switching transistors or replacing the *pnp* transistors of the switch by *nnp* ones.

If a sine function generator operating between 0 and ± 180 deg (over all four quadrants) is desired, the two sine function generators just described may be connected in parallel. The input voltage is connected directly to both d-c amplifiers and the outputs are summed by another d-c amplifier.

In a similar fashion, range of the cosine function generator can be extended over four quadrants where the first unit operates through the first and fourth quadrant and the second unit through the second and third.

REFERENCES

- (1) H. Schmid, A Transistorized Four Quadrant Time Division Multiplier, p 41, *IRE Trans EC*.
- (2) H. Schmid, A Transistorized, All-Electronic Sine/Cosine Function Generator, p 89, Part 4, 1958 *Wescon Conv Rec*.

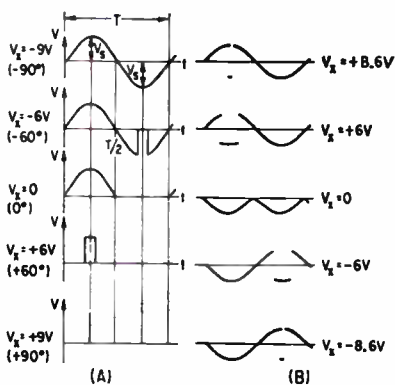
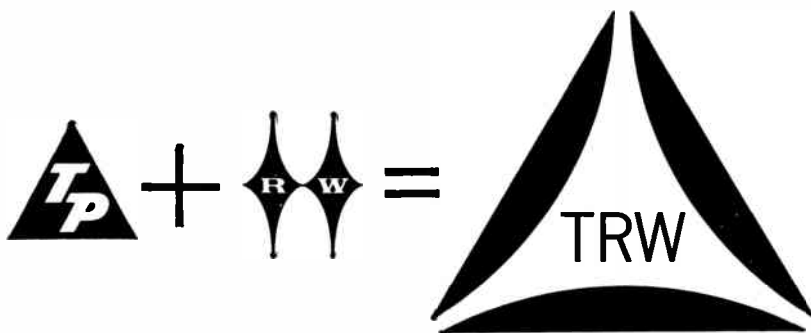

FIG. 3—Waveforms at the output of the transistor switch (A) and at the output of the same switch with push-pull sine waves applied (B)

switch should be larger than 50,000 ohms to avoid any additional current through the conducting transistor. This current would only increase the voltage drop across the conducting transistor and so produce an additional error.

Push-pull sine waves to the transistor switch are required to be amplitude stable to better than 0.1 percent of the sine-wave amplitude. They also must have a total harmonic distortion of less than 0.2



THE MERGER

The legal act of merging two companies into one does not of itself change the sum total of their capabilities. Thus, today the competence of the Ramo-Wooldridge Division for the development of electronic systems for military and commercial applications is indistinguishable from that of its predecessor organization, The Ramo-Wooldridge Corporation, while the skills of the Thompson Products group of divisions in the design and large-scale production of precision devices also remain unchanged. Soon, however, effects of the merger will begin to appear. One early effect will be an important addition of manufacturing strength to Ramo-Wooldridge programs, several of which have passed out of development and are in the prototype or manufacturing phases. Conversely, the special skills of Ramo-Wooldridge scientists and engineers in certain fields can usefully supplement the services that the Thompson Products divisions offer to their customers.

The formation of Thompson Ramo Wooldridge Inc. is intended to provide an unusual capability for the development and production of the complex electronic and mechanical devices and systems required by today's expanding technology.



Thompson Ramo Wooldridge Inc.

Main Offices • Cleveland 17, Ohio
Los Angeles 45, California

DIVISIONS AND PRODUCTS

TAPCO: Missile and aircraft auxiliary power systems, ground support systems, fuel systems, pumps, accessories, hydraulic systems, pneumatic systems; electronic control systems, microwave switches; frame structures, pressure vessels. Jet engine compressor blades, rotors, stators, and impellers; turbine buckets, rotors, and stators; structural and fabricated components. Rocket engine cases, nozzles and pumps. Nuclear reactor control rods, pumps, accessories, and core structures. Precision investment and continuous vacuum cast parts for aircraft, missiles, jet and rocket engines. Vacuum cast super-alloy ingot, billet and mill shapes.

RAMO-WOOLDRIDGE: Electronic reconnaissance and countermeasures systems, infrared systems, analog and digital computers, air navigation and traffic control, anti-submarine warfare, electronic language translation, information processing systems, nuclear energy applications, missile electronics systems, advanced radio and wire line communications.

AUTOMOTIVE and INDUSTRIAL PRODUCTS: Valves and associated parts for all types of internal combustion engines. Steering linkages, front wheel suspension ball joints, hydraulic cylinders and pumps, cylinder sleeves, piston rings. Truck retarders. Diesel engine turbochargers. Rock drill bits and drill rods. Alloy pistons for automotive and aircraft; impact extrusions, permanent mold and die castings. A wide variety of automotive replacement parts distributed nationally and overseas through 7,000 distributors.

CONSUMER PRODUCTS: High fidelity amplifiers; FM-AM radio tuners; magnetic tape recorders; stereophonic sound systems, public address and intercommunication systems. Television cameras for industrial and broadcast purposes; complete low-power television broadcasting stations.

THE THOMPSON-RAMO-WOOLDRIDGE PRODUCTS CO.: Digital control computers and associated equipment for automatic control of industrial processes, data logging and computation, pilot plant operation and process research, test facility operation, and general computational use.

PACIFIC SEMICONDUCTORS, INC.: Germanium and silicon diodes and transistors, high voltage rectifiers, subminiature rectifiers, voltage variable capacitors.

Number of employees: 22,000
Estimated 1958 Sales: \$335,000,000
Plants in Los Angeles, Bell, Culver City and Long Beach, California. Denver, Colorado. Michigan City, Indiana. Cambridge, Massachusetts. Warren and Portland, Michigan. St. Louis, Manchester and Sullivan, Missouri. Cleveland, Euclid, Willoughby, Minerva, and Columbus, Ohio. Danville and Harrisburg, Pennsylvania. Roanoke, Virginia. St. Catherines, Ontario.

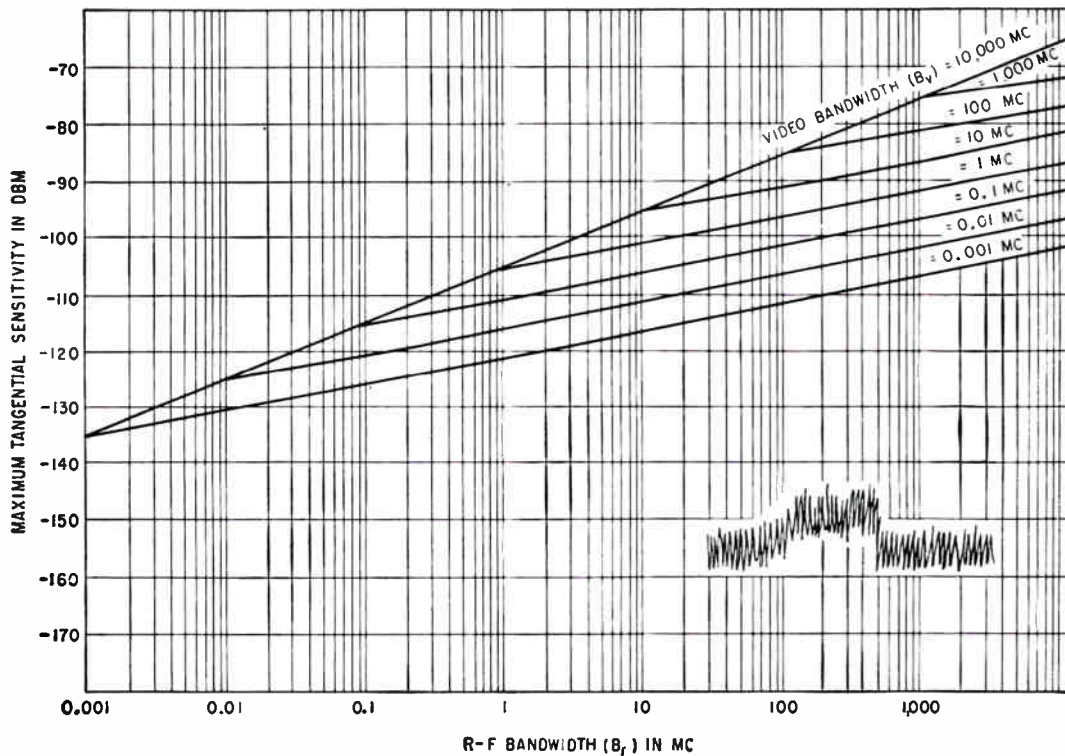

FIG. 1—Tangential sensitivity plotted against r-f bandwidth for various widths. Quadratic detector is assumed

Receiver Sensitivity

Chart relates noise figure to video r-f bandwidth assuming square-law detector. Chart, based on tangential signal level, shows tangential sensitivity when r-f and video bandwidths and noise figure are known

By CHARLES R. AMMERMAN and WILLIAM L. BLAIR

Haller, Raymond and Brown, Inc., Division of Singer Manufacturing Co., University Park, Pa.

RECEIVER SENSITIVITY is related in a convenient chart to noise figure and to video and r-f bandwidth. The chart assumes signal level at the detector is small enough for square-law detection. It also assumes a pulse length great enough to come through the video amplifier without severe distortion.

Frequently an input noise figure can be assumed that is consistent with current developments. However, output signal-

to-noise ratio is dependent not only on noise figure but on bandwidths of the video and r-f (including i-f) amplifiers.

Tangential Sensitivity

A convenient measure of signal-to-noise ratio is a tangential signal in a pulse system. The tangential signal level, shown in the inset in Fig. 1, is that necessary to give an oscilloscope presentation where the bottom of the noise during the pulse is level

with or tangent to the top of the noise between pulses. Over a wide range of conditions, this criterion has been found to be remarkably repeatable.

From the chart, determine tangential sensitivity of a receiver having an r-f bandwidth of 50 mc, a video bandwidth of 2 mc and a noise figure of 5 db. The chart indicates that it is -96 dbm. Adding the 5-db noise figure to the tangential sensitivity, the answer is -91 dbm.

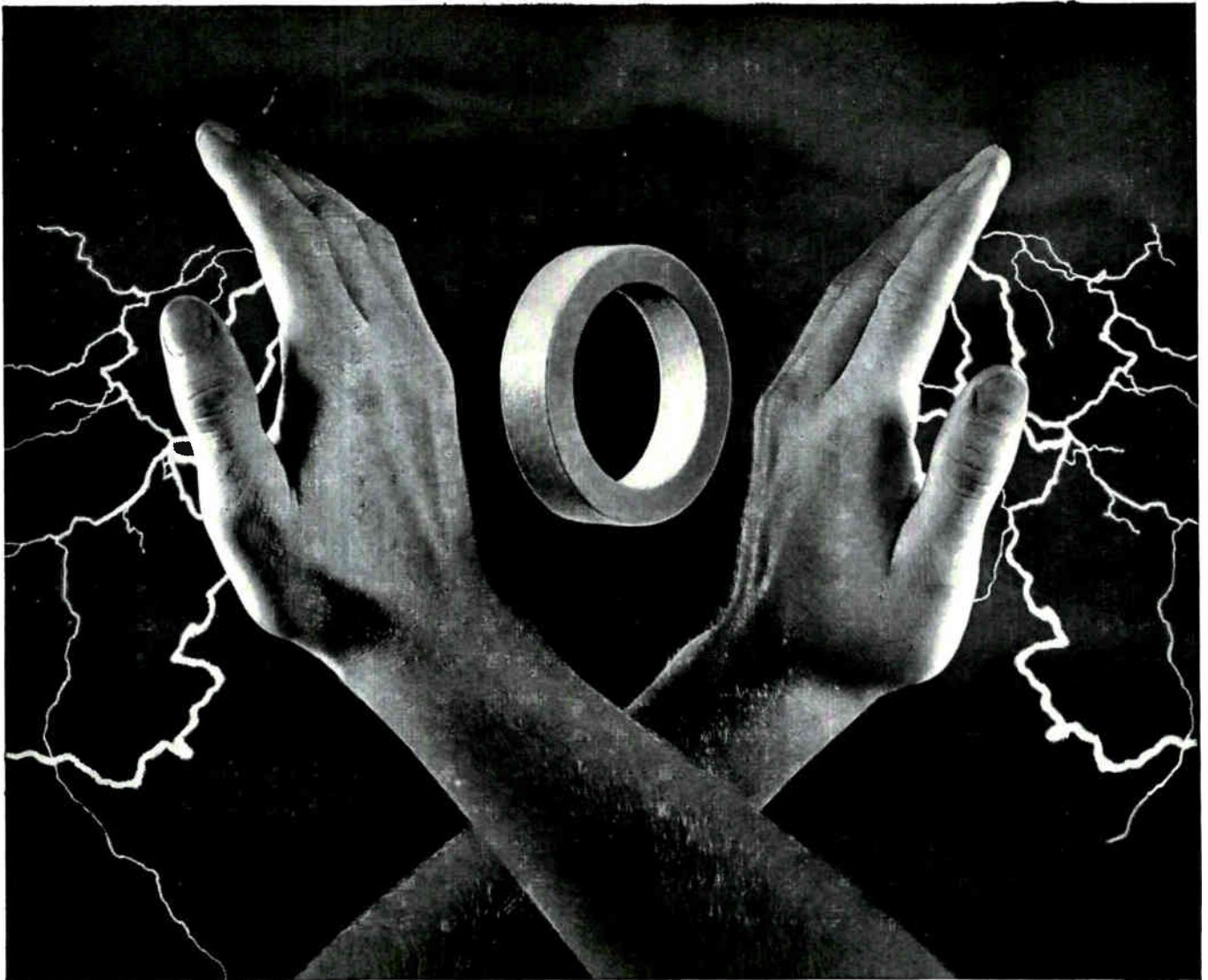

GUARANTEED TO WITHSTAND 1,000 VOLTS!

GVB-finished tape wound core boxes drop your production costs

We have developed a radical new finish for aluminum boxes for tape wound cores. Your production department will glow with delight, for we guarantee this finish to withstand 1,000 volts (at 60 cycles) without taping!

GVB, for Guaranteed Voltage Breakdown (limits), is what we call this new finish. It is perfectly matched to our aluminum core boxes, for it will withstand temperatures from -70°F to 450°F . Potting techniques need not change, for GVB-finish lives happily with standard potting compounds.

By eliminating the need for taping the core box, you also eliminate a time consuming production step. By combining GVB-finish with our aluminum core box, we assure you a core capable of being vacuum impregnated down to 20 mm. of mercury.

And they are Performance-Guaranteed! Like all tape wound cores from Magnetics, Inc., aluminum-boxed or phenolic-boxed, you buy them with performance guaranteed to

published limits. The maximum and minimum limits are for B_m , B_r/B_m , H_l and gain. This data is published for one, two, four and six mil Orthonol[®] and Hy Mu 80 tape cores.

GVB-finished cores are ready for you now. So are the published limits for all Magnetics, Inc. tape wound cores. Write today for more GVB details, and for your copy of the guaranteed performance limits: Dept. E-51, Magnetics, Inc., Butler, Pennsylvania.

MAGNETICS inc.

Dynamic Test of Choke Inductance

By BENJAMIN AGUSTA, Test Equipment Engineering, International Business Machines Corp., Poughkeepsie, N. Y.

INDUCTANCE of filter chokes varies appreciably with the average current flowing through the windings. It is therefore necessary to measure inductance at the rated average current.

A simple method of performing this measurement is shown in Fig. 1. An ordinary full-wave rectifier circuit is used with inductive filtering. By use of a true rms reading a-c voltmeter, an accuracy of approximately 2 percent plus meter error is obtained using the equation

$$L = \frac{R V_L}{754 V_R} \quad (1)$$

where L is inductance in henries, R is resistance in ohms, V_L (true rms) is alternating voltage across L and V_R (true rms) is alternating voltage across R .

Equation (1), relating inductance L to the two alternating voltage readings, is developed below, assuming that the resistance of choke L is negligible. Current flowing through the R - L circuit of Fig. 1 is made up of an average component and an alternating component.

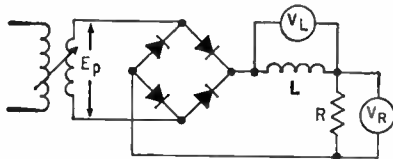

FIG. 1—True rms reading voltmeters provide data to compute choke inductance at rated average current

The alternating component has a fundamental frequency (f) of 120 cps and integral multiples for higher harmonics. From Ohm's law

$$I_1 = \frac{V_{R1}}{R}, I_2 = \frac{V_{R2}}{R}, I_3 = \frac{V_{R3}}{R} \quad (2)$$

and

$$\begin{aligned} V_{L1} &= 2\pi(f)LI_1, & V_{L2} &= 2\pi(2f)LI_2, \\ V_{L3} &= 2\pi(3f)LI_3 \end{aligned} \quad (3)$$

Numeric subscripts represent fundamental and higher harmonics.

Combining equations (2) and (3) and solving for L

$$L = \frac{R V_{L1}}{2\pi f V_{R1}} = \frac{R V_{L2}}{2\pi(2f) V_{R2}} = \frac{R V_{L3}}{2\pi(3f) V_{R3}} \quad (4)$$

If an ideal unity-gain filter that rejects all frequencies above 120 cps precedes the voltmeters, the reading of the voltmeters substituted into equation (1) gives the value of inductance with zero error except for meter inaccuracies.

A filter that rejects frequencies above 120 cps with negligible loading on the R and L elements adds to circuit complexity and introduces inaccuracy. It is more convenient to eliminate the filter and use a-c voltmeters that read the true rms, if appreciable error is not introduced in the inductance measurement.

It can be demonstrated that an error of only 2 percent will be introduced by treating the true rms voltmeter readings as the only component at the fundamental 120-cps frequency.

Example

In practice, assume that a choke of 8 henries at 1 amp is to be measured. Resistance R , supply voltage E_p , and voltmeter scales must be determined.

Voltage E_p should equal supply voltage of the rectifier circuit in which the choke will be used. This value gives the flux density at which the choke will operate. If the value is not given, maximum voltage that the choke can handle must be calculated from the relation

$$E = 4.44 (120) N\Phi$$

where E is magnitude of the 120-cps component of voltage and is related to E_p by

$$E = \frac{4 \sqrt{2} E_p}{3\pi}$$

The value of Φ is the total flux the choke can handle before appreciable change occurs in effective permeability.

Both these methods may require an E_p that results in a resistance

having a very large power rating. Therefore, a compromise is necessary because inductance changes somewhat with a-c voltage swing. For the problem given, an E_p of 23 v rms is assumed, resulting in a resistance of

$$R = \frac{K}{2I_{a-c}} = \frac{2 \sqrt{2}(23)}{1(\pi)} = 20.6 \text{ ohms}$$

The resistor must have a power rating of approximately 25 w.

Magnitude of the 120-cps component of current is

$$I_1 = \frac{K}{3(2\pi f_1 L)} = 22.8 \text{ ma}$$

Therefore, the voltage scale of the meters must be at least $I_1 R \approx 0.46$ v and $K/3 = 14.2$ v for the inductor reading.

Graph Shows Resistor Tolerance for Dividers

By JOHN L. COLLEY, JR., East Haven, Conn.

DESIGNERS of voltage dividers must choose resistors with the widest possible tolerances but which still ensure divider performance within specifications. This selection is necessary because of the premium price of resistors with closer tolerances.

The extreme values of voltage-divider deviations that could result

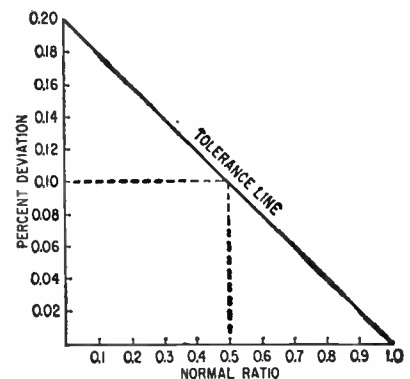

FIG. 1—Percent deviation of voltage divider using 0.1-percent resistors approaches zero as more voltage is taken and approaches 0.2 percent as voltage approaches zero

A NEW PRODUCT

THE REF-AMP*

FOR ULTRA-STABLE POWER SUPPLIES

Transitron's REF-AMP is a voltage reference zener diode and a silicon amplifying transistor, temperature compensated and thermally tied together to provide a total temperature coefficient as low as .002%/°C. This single device, only two inches long, may be used to replace both the reference and the first stage transistor amplifier in regulated power supplies. Thus it actually eliminates four components (resulting in lower cost), and reduces the temperature coefficient.

The REF-AMP gives you these advantages: • Provides temperature coefficient as low as .002%/°C • Affords better tracking over entire temperature range • Produces higher output for given error signal • Reduces number of components and possibility of anomalous drift • Lowers cost

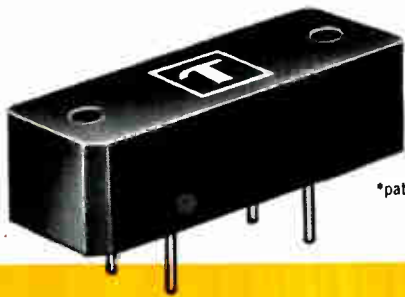

*patent pending

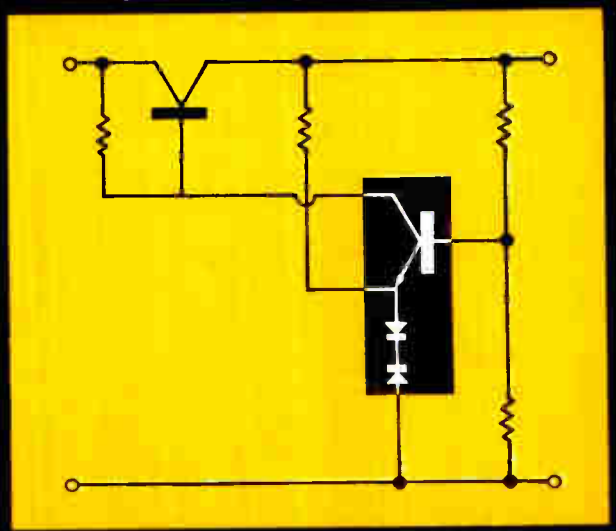

Conventional regulator input stage

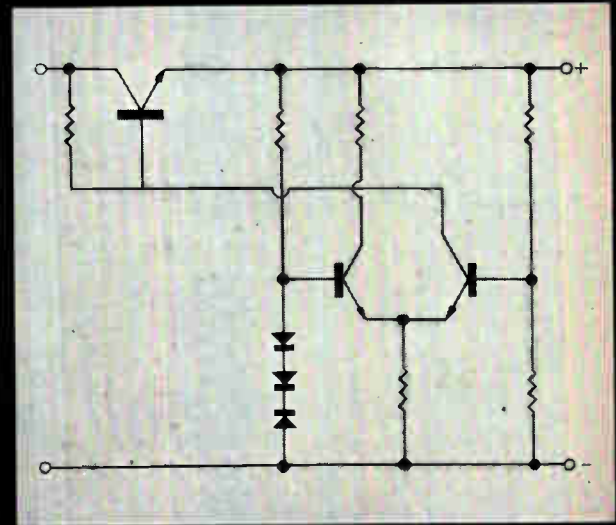

Type	Total Temp. Coeff. (%/°C)	Input Voltage (volts)		Operating Temp. Range (°C)
		Min.	Max.	
3N39	.005	8.3	9.8	-20 to +71
3N40	.003	8.3	9.8	-20 to +71
3N41	.002	8.3	9.8	-20 to +71
3N42	.005	8.3	9.8	-55 to +100
3N43	.003	8.3	9.8	-55 to +100
3N44	.002	8.3	9.8	-55 to +100

TRANSISTORS • RECTIFIERS • DIODES • REGULATORS • VOLTAGE REFERENCES



Transitron

electronic corporation • wakefield, massachusetts



THREE KLEIN PLIERS

to make electrical wiring easier

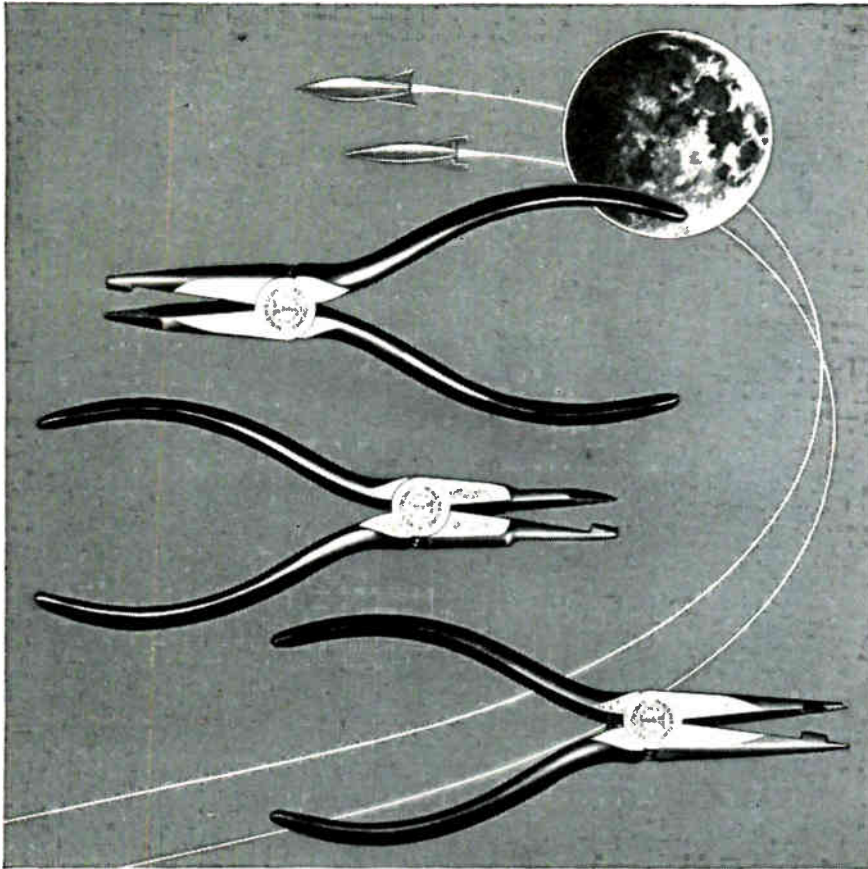

Here are three newly engineered Klein Pliers which will solve difficult problems in the wiring of electronic assemblies. Catalog 101-A describes these and scores of other pliers in the complete Klein line. If you wire electronic assemblies, write for a copy.

ALL-PURPOSE ELECTRONIC PLIER

Patent pending

Shear blade cuts flush and holds clipped end of wire

Requires no sharpening; will cut hard or soft wire. Smooth, continuous action prevents shock which may damage resistors. For bare wire up to 18 gauge.

No. 260-6—length 6 $\frac{3}{8}$ "

No. 260-6C—with coil spring that holds jaws open

NEEDLE-NOSE PLIER

Patent pending

Similar to No. 260-6 but nose has been slimmed down to permit use in confined areas.

No. 261-6—length 6 $\frac{3}{8}$ "

No. 261-6C—with coil spring to hold jaws open

LONG-NOSE PLIER—KNIFE AT TIP

Pat. No. 2,848,724

Jaws behind blade hold clipped wire end firmly

A shear-cutting plier that will cut hard or soft wire. Blade is at the tip of the plier. Supplied with coil spring to keep jaws apart.

No. 208-6PC—length 6 $\frac{3}{8}$ "

Write for Catalog 101-A, which shows the complete line of Klein Pliers, including 20 pliers recently developed.



at different levels of nominal ratio were evaluated assuming resistor tolerances of 0.1 percent. Results are shown in the graph in Fig. 1.

When deviations from nominal ratio were expressed as a percentage of nominal, the deviations were found to be symmetrical about the expected value and to vary linearly with it. The end points of the tolerance line show that tolerance approaches zero as the ratio approaches one. The tolerance approaches 0.20 percent (the sum of the tolerances of the two resistors) as the ratio approaches zero.

Application

This procedure is applicable when tolerances of the two resistors are equal, which is usually the case. Similar graphs may be constructed for tolerance of dividers made with resistors of various tolerances.

Plot percentage tolerances on the ordinate scale versus nominal ratio on the abscissa. Find the sum of the tolerances of the two resistors on the ordinate scale. Draw a line connecting this point to the value of ratio equal one. The tolerance of any nominal ratio from near zero to near one is the ordinate of the tolerance line.

Transistor Voltmeter Is Accurate, Linear

By W. MOSINSKI London, England

GERMANIUM junction transistors are used in a voltmeter providing input impedance of one megohm/volt.

The voltage to be measured is biased against the sum of voltages across R_1 , R_2 and part of R_3 in Fig. 1. To get the corresponding reading on the meter, R_3 is set originally to the correct value against a reference voltage at the input.

Transistors need not be matched, but ought to be the same type. Transistors with small-signal average current gain of about 60 may be used. Transistors T_1 and T_2 should have similar current gains within 20 percent of average. Transistor T_3 may have low current gain.

Overall amplification uses about one percent of the input to provide



Mathias KLEIN & Sons
 Established 1857 Chicago, Ill., U.S.A.
 7200 McCORMICK ROAD • CHICAGO 45, ILLINOIS

the output. Therefore, minor variations in transistor characteristics or small nonlinearities can be tolerated. Final accuracy depends largely on stability of the resistors.

Transistor T_2 functions only to compensate temperature changes, the exact amount being determined by R_5 . Originally, R_5 is set to satisfy the relationship $R_5 + R_0 + R_1 = \alpha_1 R_5$, where α_1 is current gain of T_1 . Each time R_5 is adjusted, R_1 must be adjusted to zero the meter again. Overall amplification is only slightly affected by these adjustments.

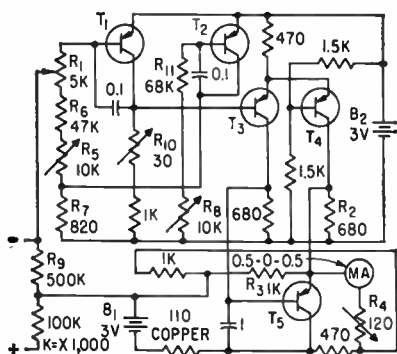

FIG. 1—D-c amplifier for transistor voltmeter has gain of about 100,000

To ensure that no input current flows through R_1 , the terminals are connected together and R_1 is adjusted. Although emitter-to-base voltage of T_1 varies with temperature, voltage across R_2 also varies and cancellation may be almost complete.

Zero Adjustment

Zero adjustment is done with R_{10} , although it could be done with R_{11} .

Transistors T_1 and T_2 and transistors T_3 and T_4 are strapped together with a metal strap to avoid low frequency oscillations, which affect stability. A capacitor was found to be no help.

An increase of 10 ohms in internal battery resistance of B_1 will increase the meter reading one percent. Currents in any part of the circuit are limited to about twice their normal values, and no harm will result when either battery is disconnected.

Resistance variation of the meter coil with temperature changes may be overcome with a copper coil of 110 ohms loosely wound on a form and introduced in the circuit on the negative side of battery B_1 . Compensation covers about $\frac{2}{3}$ of the error.

YOU CAN'T HEAR A 'SPEC' SHEET!

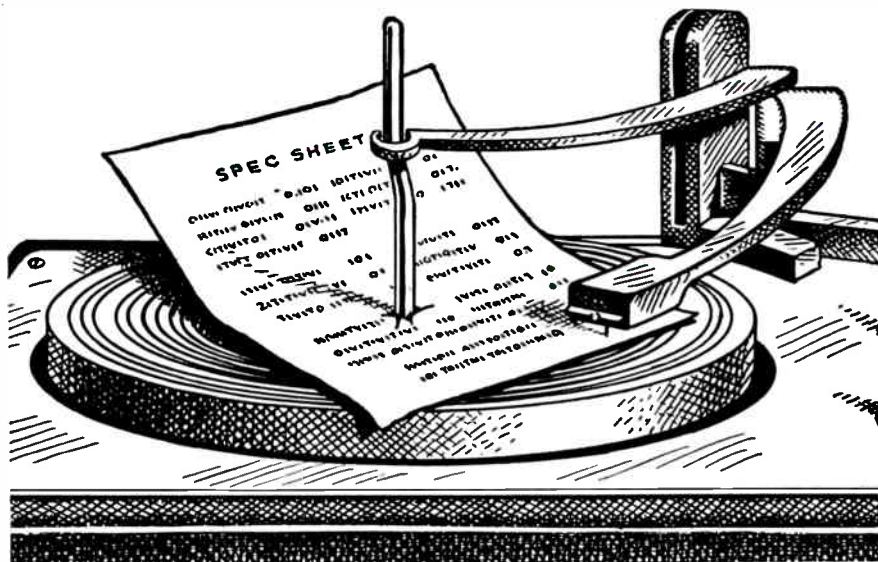

Sonotone's stereo cartridge has more than just good specs... it gives brilliant performance! More phono makers specify Sonotone for the top of their line—here's why:

Only Sonotone gives true sound *without* distortion...high frequency response *without* record cutting! Sonotone stereo gives a performance so superior you can truly *hear* the difference. The secret? Sonotone's four exclusive *operating* features:

1. Extremely high compliance.
2. Amazingly clean wide range frequency response.
3. Wide channel separation, due to Sonotone's pantagraph yoke.
4. Rumble filter to screen out vertical turntable noise.

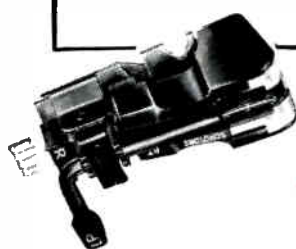

SPECIFY...STOCK...SELL...

Sonotone

Electronic Applications Division, Dept. CRR-19

ELMSFORD, NEW YORK

PROCO

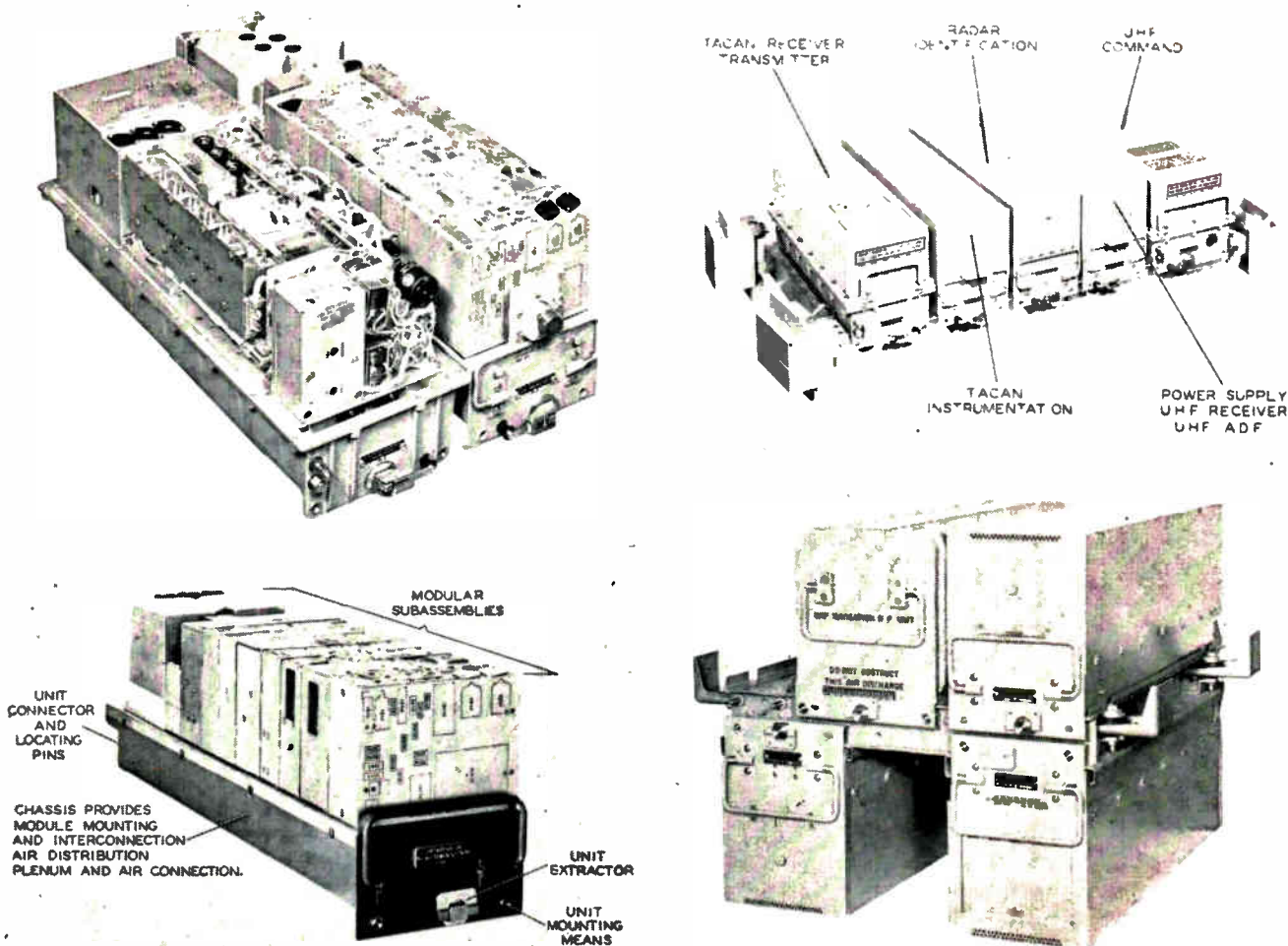

Typical examples of Collins communications equipment incorporating modular design

Modular Design Aids Flexibility

DEVELOPMENT of integrated electronic systems using the modular design concept have saved Collins Radio Company up to 50% in cubic volume as compared to the "standard uncoordinated black-boxes" used before. The packaging techniques say Collins engineers, have given large reduction in space, weight and cooling-air requirements as compared with conventionally designed equipments.

Form Factors

The company's assistant director of research and development, Arthur H. Wulfsberg says the more conventional types of "black-box" electronic components have not lent themselves well to use in integrated electronic systems. Equipment

form factors have resulted in comparatively inefficient use of available air frame space. He reports most equipments do not have capability for integration with aircraft equipment cooling systems and have not been designed for efficient use of cooling air.

Integration with central aircraft power supply systems has been difficult or impractical. Inflexibility of standard equipment types has resulted in a trend toward use of electronic equipment custom-designed for specific air frame types. Examples are those employed in the A4D attack-bomber, the F-104 fighter and the B-58 bomber.

To reduce or eliminate these problems in the use of integrated electronics systems the department

of the Navy's Bureau of Aeronautics has been active in promotion of the modular design concept. The Navy has established MIL-E19600 (AER) general specification for electronic modules. The concept is also being considered for Air Force adoption; specifications covering design and employment of units have been prepared by Wright Air Development Center.

With the concept, equipment is designed in the form of dimensionally standardized plug-in subassemblies. A complete functional equipment consists of a group of modules mounted in a chassis and case system which gives interconnecting wiring, radio interference filtering and other ancillary functions. The system also serves as a plenum

Simplified Cables and Harnesses produced by these new Flexprint[®] Wiring Techniques

FLAT SHIELDED CABLE

Flexprint conductors are laminated between insulated ground planes. Choice of dielectric, spacing and shield configuration provides desired electrical characteristics with good flexibility. This technique also produces exceptionally light weight multi-conductor shielded cables, simulated twisted conductors and simulated coaxial cables.

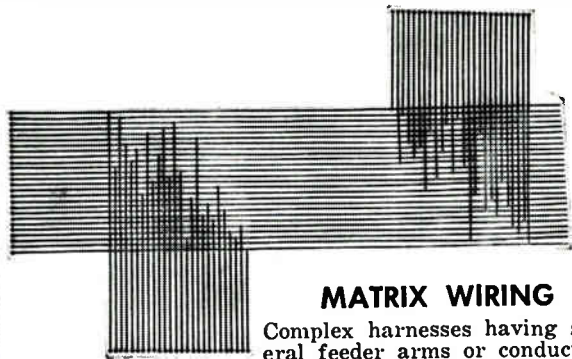

MATRIX WIRING

Complex harnesses having several feeder arms or conductors common to a termination, can be fabricated by the new spot-welded "T" forming technique. Fine conductors can be joined by this method to achieve a high density of interconnections. Crossing conductors are completely insulated.

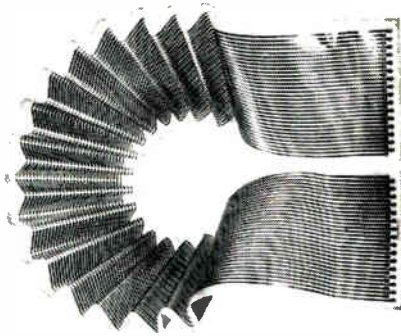

PRE-FORMED CABLES

Flexprint cables can be pre-shaped to resist deformation or return to a desired shape after deformation. For example, this accordion-pleated *sliding drawer* cable for rack-mounted instruments stretches to permit withdrawal of equipment . . . folds neatly out of the way when drawer is closed.

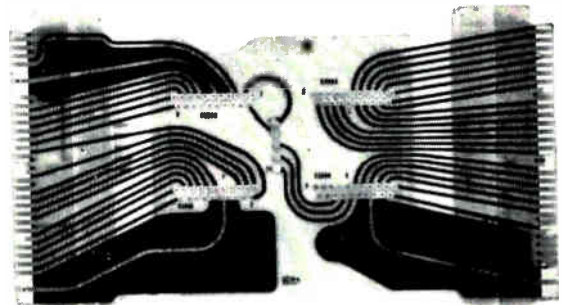

REINFORCED CABLE

Flexprint cables and harnesses can be attached to rigid surfaces for extra strength and stiffness. Here, sections of the cable have been reinforced by bonding to epoxy board. Exposed copper conductors wrapped around the board's edge provide a standard printed circuit plug-in connection.

Can Sanders Flexprint Wiring simplify your complex Cables and Harnesses, too?

It will pay you to investigate! Using the new construction techniques illustrated above, Sanders can produce a wide variety of "3-dimensional" insulated printed flexible cables and harness. They have a combination of characteristics unmatched by ordinary wire and printed circuits.

Flexprint Wiring assemblies save up to 75% in weight . . . 65% in space . . . install in a fraction of the time required for conventional wiring . . .

are available in insulations to meet your environmental requirements . . . have been used and approved in military equipment.

For complete details about capabilities, prices and deliveries, write or call today:

FLEXPRINT[®] PRODUCTS DIVISION



SANDERS ASSOCIATES, INC.

NASHUA, NEW HAMPSHIRE; Dayton, Ohio; Inglewood, California; Washington, D.C.



HIGH DISSIPATION RESISTORS: Space-wound, mica-insulated types for instruments, business machines and other exacting uses. Operate continuously at 175°C dissipating 7½ watts in air or 15 watts against metal.



HEAVY-DUTY PRECISION RESISTORS: Wound with glass-insulated, low-TC wire, "G" Type resistors handle 5-10 times the wattage of standard-size precision types. Available in 1½ to 20-watt types with full-load tolerances to 0.25%

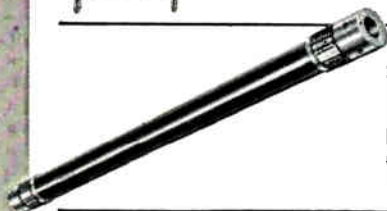

SURGE RESISTORS: Used in high voltage rectifiers, as high current meter multipliers, or as bleeders, these resistors handle 150 watts up to 22½ KV. 100 ohm to 3 megohm types available with 1% tolerances standard.



CORONA-PROTECTED RESISTORS: Ideal for corona control in kilovoltmeters, these Taylor-type high voltage resistors consist of five 0.1% Shallcross resistors mounted in spun aluminum cases. Each unit handles 5 KV (7½ KV max.). Several units may be screwed together for measurements up to 200 KV.



EXTERNAL METER RESISTORS: Sectional wirewound resistors fitted into hermetically-sealed, glazed Steatite tubes with ferrule-type terminals. Resistances up to 6 megohms, ratings from 1¼ to 5 watts at voltages up to 6 KV. Standard tolerances 0.5%; 0.05% on request.

Special Wirewounds for the TOUGH JOBS

When your resistor applications call for the unusual in shape or size . . . the critical in terms of performance and reliability . . . consider Shallcross. Chances are that after 30 years of designing and manufacturing precision wirewound resistors, even the most extraordinary requirements can be met.

Beyond the "specials" shown above, Shallcross regularly produces the widest selection of highly reliable ceramic and encapsulated wirewound resistors available today.

Inquiries for specific types will receive prompt attention. SHALLCROSS MANUFACTURING COMPANY, 2 Preston Street, Selma, N. C.

Shallcross

chamber for proper distribution of cooling air to the modules.

Typical Equipment

As an example of modular sub-assemblies, the equipment employed for use in the North American A3-J-1 Navy attack bomber is illustrative. In this assembly, the RF receiver-transmitter and pulse modulator modules are contained in a pressurized case to permit reliable-full-power operation at high altitude. This case is equipped with a plate-fin-type heat exchange which is cooled by aircraft-supplied cooling air. Internal air is cooled by the heat exchanger and circulated through the modules by means of an internal blower. Modules dealing with the decoding of the received signal and measuring the aircraft heading and distance are contained in a non-pressurized case. The chassis serves as a plenum chamber for distributing the cooling air to the modules.

Chassis openings are proportioned so that air flow to various modules is adjusted to obtain thermal balance in the equipment. The data converter unit also has three indicator coupler modules developed to provide central data source for operation of integrated bearing distance-heading indicators, course indicators and other instruments in single or multiple installations.

Design Pitfalls

The director of a Collins divisional Research & Development group, John McElroy says the design of equipment using the modular concept has not proven to be particularly difficult. But several factors must be considered if full capabilities are realized. (A) Proper functional circuit division is important so modules can be operated with minimum regard to physical location with respect to other modules. (B) Input and output circuits should be designed to be noncritical with respect to wiring capacitance and inductance to permit flexibility of location and satisfactory operation on sub-assembly test cables. (C) Proper performance criteria for each module must be established so that modules can be replaced or interchanged without selection and with

minimum requirements for readjustment. Adjustment controls necessary should be easily accessible at the top of the module.

Test Points

Sufficient test points must be provided to permit rapid localization of trouble to a defective module. A minimum number of test points should be provided to permit monitoring all input and output circuits so that straightforward signal tracing techniques can be employed.

Modules should be thermally designed for most effective use. (Cooling air enters base of module, flows over electrical components and is exhausted through sleeves surrounding electron tubes.)

Most of the problems cited exist in any system using plug-in sub-assemblies and do not relate to the dimensional standardization characteristic of the modular concept. This dimensional standardization has certain problems for the design engineer including the psychological problem of overcoming a certain resistance to regimentation.

Copper-on-Glass Printed Circuits



COPPER PATTERNS are firmly bonded to a glass base in a new type of printed circuit developed by G. V. Planer Ltd., Middlesex, England. Advantages of the construction include suitability for high-temperature operation and inertness due to absence of organic substrate or bonding constituents.

The accompanying illustration shows inductors made from ultrasonically cut glass substrates, each carrying a copper pattern on either side. The plates may be stacked to form multiple-layer inductors with interconnections made across the edges of the glass.

versatile new

PENTA PL-172

external anode

1-KW BEAM POWER PENTODE

new design principle gives extra-high power at low plate voltages

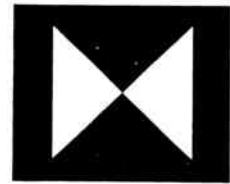
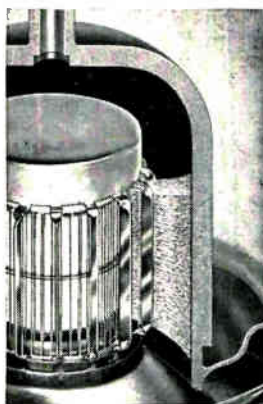

This new pace setter delivers high power at low plate voltage for a variety of r-f and a-f applications. The exceptional performance of the PL-172 is due to the exclusive new suppressor grid vanes which direct electrons to the plate in beams, giving true beam tube characteristics. For critical Class AB₁ linear amplifier applications, for high power audio service, or for high-efficiency, low-drive Class-C use, the PL-172 is a logical choice.

USE IT AS A CLASS-AB₁ LINEAR R-F AMPLIFIER—

Delivers over 1000 watts useful output at only 2000 plate volts, over 1500 watts at maximum ratings.

AS A CLASS-C AMPLIFIER—

Over 2000 watts useful output at high efficiency. Driving power less than 5 watts.

OR AS A CLASS AB₁ AUDIO AMPLIFIER—

Over 1200 watts per pair at 1500 volts. Up to 3000 watts at maximum ratings. Low output impedance simplifies output transformer problems.

RATINGS

Heater Voltage 6.0 volts	Plate current, max. 1.0 amperes
Heater Current 7.5 amperes	Plate dissipation, max. 1000 watts
Plate voltage, max. 3000 volts	Transconductance 21,000 μ mhos

A COMPLETE LINE OF HIGH-EFFICIENCY POWER TUBES

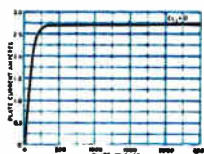
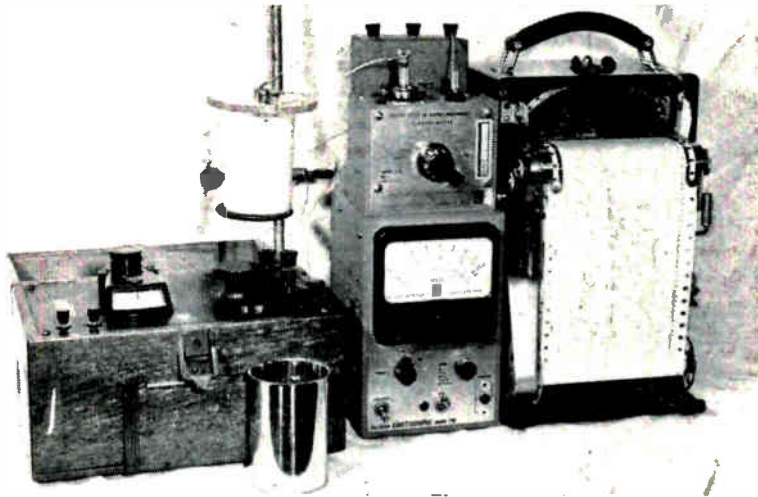

Plate current curve at zero grid voltage shows why the PL-172 gives high power gain and operates efficiently at low voltages. Write for complete technical data and suggested operating conditions. Representatives in principal cities.



PENTA laboratories, inc.

316 N. Nopal St., Santa Barbara, Calif.



Instrumentation for continuous current monitoring device. Electrodes are encapsulated in resin to obtain its resistivity before, during and after polymerization

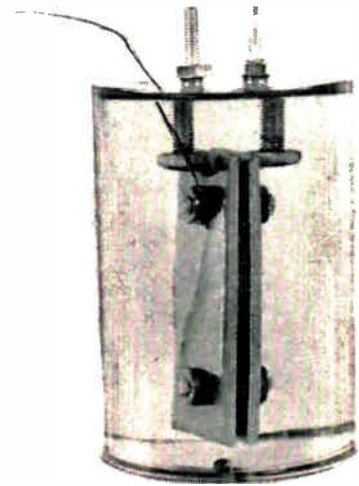

Electrodes encapsulated in sample. Thermocouple is taped to left electrode

Potted Electrodes Speed Testing

ENCAPSULATING RESINS may be readily tested for electrical characteristics and moisture resistance under various operating and manufacturing conditions with a method developed at the U. S. Naval Ordnance Laboratory, Silver Spring, Md.

The continuous current monitoring device (ccdm) can be used to determine a resin's electrical properties before, during and after polymerization. It can determine the effects of fillers, curing agents and curing cycles on resistivity. The latter is particularly important when curing cycles must accommodate temperature-sensitive components.

Instrumentation

CCDM is a sensitive electrometer connected to a set of parallel plate electrodes encapsulated in the resin. Since samples are cast in cans, samples can be cast to the dimensions of the encapsulated circuit or component. Encapsulating the electrodes also avoids machining samples and errors which might arise from moisture and contamination between electrodes and sample. Resistivities ranging from 10^6 to 10^{10} ohm-cm can be obtained.

The instruments used at NOL consist of a Keithley 210 electrom-

eter with a Keithley 2008 decade shunt attachment to monitor the current. Output is fed to a 1-ma Esterline-Angus pen recorder equipped with a timing pen. A thermocouple is taped to one of the electrodes and connected to a Leeds & Northrup potentiometer. This setup permits conductivity of the sample to be plotted against time and temperature.

The recorder and potentiometer may be omitted when measure-

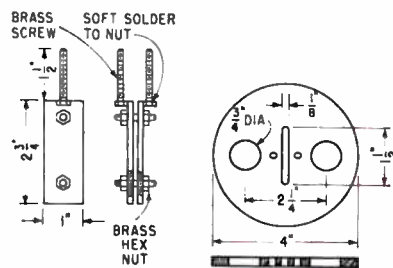

Dimensions of strip electrodes and plastic cover plate used in NOL tests

ments are to be made after the sample is polymerized and has reached an equilibrium temperature. Source of potential is a 45 v battery and a field strength of about 200 v/cm, is used.

Electrodes are brass strips 0.094 inch (0.24 cm) thick, 1 inch (2.54 cm) wide and 2.75 inch (7.0 cm) long. Interelectrode spacing of

0.080 inch (0.2 cm) is maintained by Teflon bushings. The electrodes are bright-dipped and hung before polymerization from a 1/8 inch styrene cover plate with threaded brass rods soldered to each.

Samples, with electrodes are cast in cans. For the electrode size given, a standard No. 1 can (4 by 2.6 inches) is used. Cans and electrodes can be any size, but accuracy decreases with size. Electrodes used in isothermal polymerization measurements consist of 2 concentric cylinders made from nickel-plated copper tubing.

Calculations

Resistance is calculated by Ohm's Law. Voltage drop across the sample is measured and subtracted from the source voltage. The remainder is divided by the current. To obtain resistivity, the surface area of the electrode is divided by the current length path, in centimeters. The result is multiplied by the resistance in ohms. The A L for the strip electrodes cited is 86.

Resistivity over a range of temperatures can be obtained by heating the sample in an oven and recording temperature, time and conductivity. Effects of moisture are measured by placing the oven in a 95 percent relative humidity at-

ANN OUN CING

CONVAIR INSTRUMENTS
designers and builders of:
electromechanical instruments
mechanical instruments
ac & dc measuring instruments
transducers

2900A

DC VOLT METER
 ± 10 MICROVOLTS TO ± 1000 VOLTS



Range: ± 10 microvolts to ± 1000 volts, in 9 decaded steps.

Zero Drift: Less than ± 1 microvolt (referred to the input) over 2-hour period.

Power Sensitivity: 10-14 watts at full scale.

Amplifier Output: Approx. ± 1 volt at 0.1 milliamperes for full scale reading.

Combines direct reading voltmeter with chopper-stabilized DC amplifier ... Accuracy within $\pm 3\%$ (above noise level) of full

scale ... Zero-center meter movement provides polarity indication without switching or lead reversal ... Rugged, all transistor, etched-circuit construction ... Illuminated mirror scale.

A twist of a knob releases chassis from hand carrying case, for insertion in 3-unit modular rack.

Prices:*

Model 2900A DC Voltmeter	\$395.00
Model 2901A Hand Carrying Case	90.00
Model 2902A 3-Unit Rack	175.00

For complete information, write today for CI Bulletin No. 29-2.

* (ALL PRICES FOB SAN DIEGO)

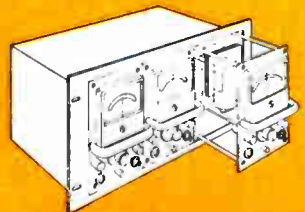

CONVAIR INSTRUMENTS/CONVAIR, A DIVISION OF GENERAL DYNAMICS CORPORATION

3595 FRONTIER STREET,
 SAN DIEGO, CALIFORNIA

Where only the **best**
is good enough . . .



MODEL 440-A

Krohn-Hite oscillators are used

In basic electronic instruments for lab or test work, *less than the best* may be a dangerously bad bargain. Unexpected limitations — of reliability, range, precision — can throw out weeks of work on today's jobs, and can make tomorrow's tougher jobs untouchable.

The *best* instrument of its type is probably a bit more expensive, but it's worth buying . . . because you can believe in it today, and will rely on it tomorrow. An example is the Krohn-Hite Model 440-A wide range push-button oscillator. Here are some facts about it.

FREQUENCY RANGE: 0.001 cps to 100 kc, continuous coverage.

CALIBRATION ACCURACY: $\pm 1\%$ from 1 cps to 10 kc, $\pm 3\%$ from 0.01 to 1 cps and from 10 kc to 100 kc.

RESETABILITY: exact for push-button resetting, subject only to drift of less than 0.05% per hour.

SINE WAVE OUTPUT: 10 volts rms open circuit, 100 milliwatts into 1000 ohms; amplitude constant within ± 0.25 db from 0.1 cps to 10 kc.

SINE WAVE DISTORTION: less than 0.1% from 1 cps to 10 kc, less than 1% from 0.01 to 1 cps and from 10 kc to 100 kc.

SQUARE WAVE OUTPUT: 10 volts peak to peak open circuit, 5 volts peak to peak across 1500 ohms; amplitude constant within $\pm 1\%$ at any frequency; rise time less than 0.5 microsecond.

There's a lot more you should know about the 440-A . . . and about the other Krohn-Hite oscillators, tunable electronic filters, power supplies and amplifiers. In all of them, you'll find the same far-ahead engineering, design and construction. Because K-H instruments *are* good enough even for tomorrow's most critical work, they are increasingly chosen today where reliability and precision are needed.

Write for your free copy of the new Krohn-Hite Catalog.

Krohn-Hite CORPORATION

580 Massachusetts Avenue, Cambridge 39, Mass.

CIRCLE 35 READERS SERVICE CARD

mosphere and removing it for readings at 1 or 2-day intervals. Contacts must be carefully dried. Kel-F coverings are used on 4 to 8-inch leads. The encapsulated electrodes simulate moisture-sensitive components.

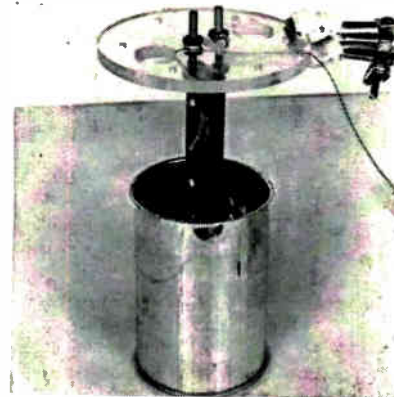

Electrodes hung from plate, ready for encapsulation in can

By using the ccdm to study polymerization under isothermal conditions, optimum curing cycles and the effects of fillers and catalysts can be determined. The ccdm also serves as a quality control tool. Resistivity of a fully-cured sample can be compared with resistivity of a production sample to find out if castings in production are fully cured or require post-curing.

Full details on use and typical results obtained with the ccdm were described by R. W. Warfield, of NOL, at the Second Annual Technical Forum, Baltimore-Washington Section, SPE.

Magnetics and Meters Test Tv Transformers

AUTOMATIC TEST station puts horizontal output transformers (tv flybacks) through a complete test cycle. A good or reject light indicates the test result. An additional 15 lights on the panel indicate any part of the cycle which the flyback may fail to pass.

The tester was built and is used by F. W. Sickles Div., General Instrument Corp., Chicopee, Mass. Its design allows a full test cycle to be made even if a reject condition is found, except that an overload will stop the test.

January 23, 1959 — ELECTRONICS



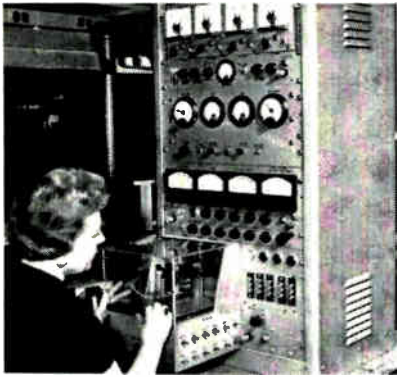

Tester cycles automatically after operator presses start button

The operator is not required to read the meters or make decisions. She inserts the flyback into a fixture with spring-loaded contacts. The machine cycles through 3 series of tests.

Tap test: each connection is checked for continuity and number of turns. Up to 12 taps may be tested. A sine-wave signal is applied to the flyback. Each of the induced tap voltages is fed through a constant-gain amplifier to a magnetic amplifier indicating circuit.

Voltage Tests

Operational voltage test: this test begins upon completion of the tap test. Scan or width, cathode current of the driver tube and recovered high voltage are measured while the flyback is operated under normal conditions. Adjustments for B+ supply voltage are preset.

Overtension test: takes the same measurements as above while the flyback is operated at breakdown voltage. Voltage and time are set to customer requirements. At the conclusion of this test, the equipment shuts off.

The magnetic amplifier indicating circuits employ meter type limit relays to permit selection of any value of a parameter as a nominal value.

Four such circuits are used. One performs all the tap tests. The others are used in the second and third tests of scan, cathode current and recovered high voltage. Indication is delayed for 1 second after the beginning of each test so as not to measure meter lag or switching transients. All voltages are regulated and all critical parts are plug-in. Test tolerances are as close as ± 1 to 3 per cent.

Varflo

sleeving and tubing

**... Will do Class A and Class B jobs!
... For the Price of Class A Insulation!**

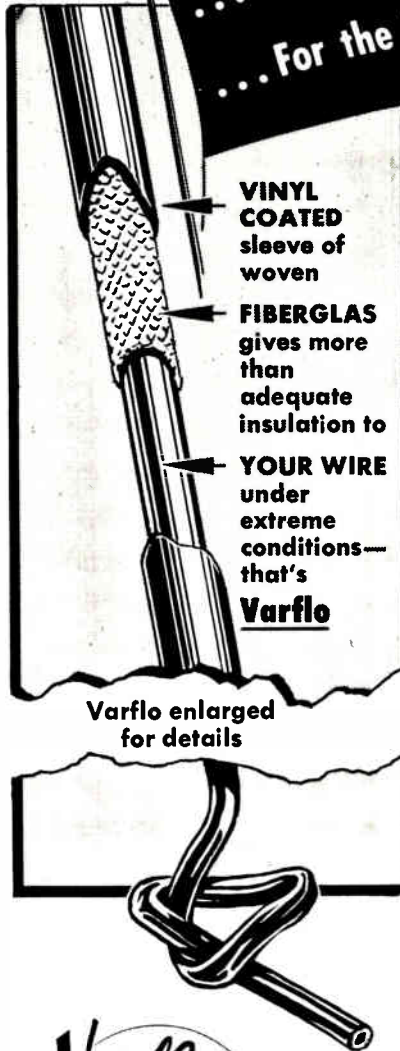

VINYL COATED sleeve of woven

FIBERGLAS gives more than adequate insulation to

YOUR WIRE under extreme conditions—that's Varflo

Wherever you use either—or both—Class A and Class B sleeving and tubing, Varflo will save you money . . . by filling the requirements of both classes at the cost of Class A insulation!

Varflo vinyl-coated Fiberglas Sleeving and Tubing with its superior qualities of flexibility and greater dielectric strength under all conditions make it ideal for both Class A and Class B installations.

- **FLEXIBLE** It can be bent or even tied in knots without cracking or crazing.
- **RESISTANT** to water, alkalis, mild acids, oils and greases.
- **TOUGH** and stands up under vibration. Ideal for "After Treatment" operations.
- **LONGER LASTING** at high temperatures. Withstands hundreds of hours at 300° F. Good shelf life, too.
- **MORE STABLE**, retains dielectric value when pulled back during soldering.
- **AVAILABLE IN 3 NEMA GRADES**, B-A-1, B-B-1, and B-C-2 in 10 colors, in coils, 36" lengths or short pieces.

Varflex
CORPORATION
Makers of
Electrical Insulating
Tubing and Sleeving

Send Today for complete line of samples and recommended uses.



VARFLEX CORPORATION
506 W. Court St., Rome, N. Y.

Please send me free folder containing description and test samples of Varflo Sleeving and Tubing.

Name _____
Company _____
Street _____
City _____ Zone _____ State _____

ON THE MARKET

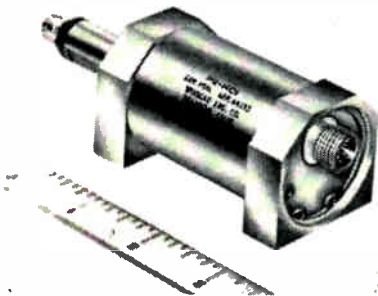

Pressure Transducer varied applications

WIANCKO ENGINEERING, 255 No. Halstead, Pasadena, Calif. In this instrument a solid-state carrier oscillator and demodulator have been combined with a variable-reluctance pickup. The resultant transducer provides all the ad-

vantages of a high-output variable-reluctance pickup, along with the desirability of d-c excitation and 0-5 v d-c output for standard telemetering applications. Advantages offered include continuous resolution, 0-5 v d-c output at constant impedance and low hysteresis. **Circle 200 on Reader Service Card.**

Teflon Terminal double-standoff

SEALLECTRO CORP., 610 Fayette Ave., Mamaroneck, N. Y. A double-standoff Teflon terminal or two standoffs in one unit, and requiring only one hole and one insertion, is presented in type DST-900 Press-Fit. This terminal is actu-

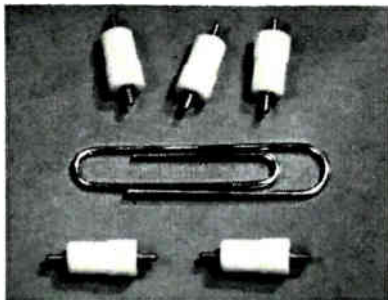

ally two straight shank lugs mounted in a single Teflon body, but electrically and physically separated. Such a terminal provides separate connection points on both sides of a chassis. It combines the double economy of a single unit and a single installation doing the two connection jobs. **Circle 201 on Reader Service Card.**

Spectrum Analyzer high resolution

PROBESCOPE Co., INC., 8 Sagamore Hill Drive, Manorhaven, L. I., N. Y., announces a new low frequency, automatic optimum high resolution spectrum analyzer model SS-5. It will give a fourier

analysis of all signals in the 1 cps to 5.3 kc range and simultaneously measure its frequency and amplitude. Unit is suited for the design and harmonic analysis of servo systems, telemetering systems, power line studies, and tape recorder wow and hum analysis. **Circle 202 on Reader Service Card.**

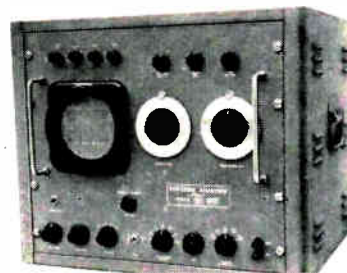

Input Transformers plug-in type

MICROTRAN Co., INC., 145 E. Mineola Ave., Valley Stream, N. Y. A new line of plug-in input transformers are designed to match the



impedance of microphone, pick-up, or line, to a high impedance amplifier. Frequency response is 20 to 20,000 cps \pm 2 db. Size is similar to that of standard octal metal tubes. List price is about \$20. **Circle 203 on Reader Service Card.**

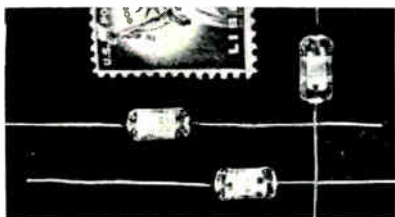

Glass Capacitor fusion-sealed

CORNING GLASS WORKS, Bradford, Pa., has developed a new fusion-sealed glass capacitor designed to give continued peak performance

under moist or corrosive conditions. The CYF capacitor employs two new features to meet military demands for super-high reliability in adverse environments: (1) A new sealing technique provides a strong, air-tight

have you checked this
Remote Actuator for jobs
under Shock and Vibration?

...OAK ROTARY SOLENOIDS

(Mfd. under license from G. H. LELAND, INC.)

MODEL 5E
 SHOWN ACTUAL SIZE

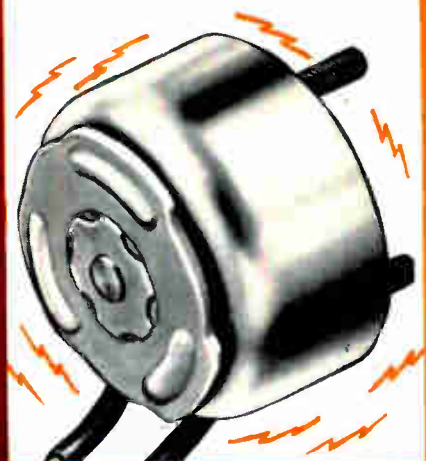

CUSTOM-BUILT FOR—

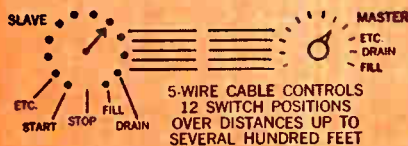

MASTER-SLAVE DEVICES
 (Incremental Positioning)

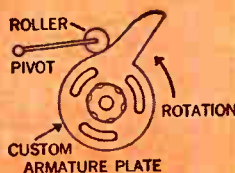

CAM LIFTS

OPERATES IN ANY POSITION

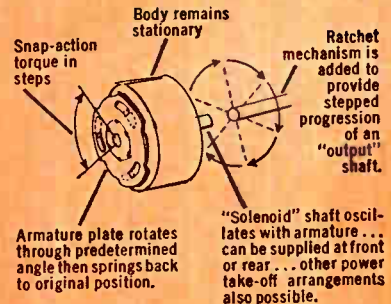

Armature plate rotates through predetermined angle then springs back to original position.

"Solenoid" shaft oscillates with armature... can be supplied at front or rear... other power take-off arrangements also possible.

A, B, C, & D ARE DRIVEN BY SOLENOIDS



4 DECADE COUNTER

ADDED SWITCHING ALLOWS PRESETTING A FUNCTION TO OCCUR AT ANY COUNT SUCH AS SHUT OFF WATER AT 397 COUNT, ETC.

PRESETTABLE COUNTING DEVICES

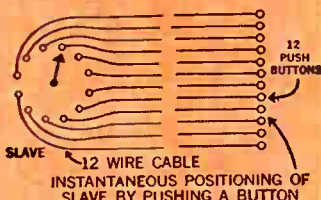

AUTOMATIC SWITCHING

EXTREMELY ADAPTABLE

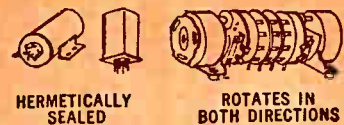

HERMETICALLY SEALED

ROTATES IN BOTH DIRECTIONS



WITH SEALED DUST CAP

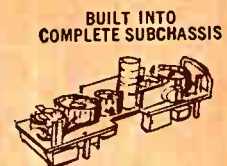

BUILT INTO COMPLETE SUBCHASSIS

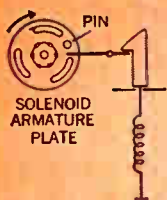

TRIPPING DEVICES

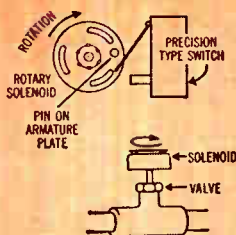

ACTUATORS

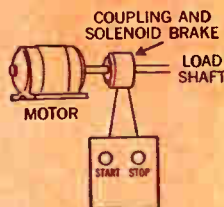

CLUTCHES and BRAKES
 (When Modified for Straight Pull)

stepping torques from 6.4 to 64 inch-ounces

If you've been searching for an actuator that meets such specs as MIL-S-4040A, and is remarkably small for the amount of work it can do, investigate Oak Rotary Solenoids. They operate on DC and are designed for intermittent service. Standard models give steps of 25°, 35°, 45°, 67.5°, or 95° in either a left or right-hand direction. Self-stepping or externally pulsed units are also built. Oak Rotary Solenoids find wide use in both commercial and military equipment. Why not evaluate their unusual capabilities for your next project. We will be glad to help you engineer the job. Just send us a short description and sketch.



1260 Clybourn Ave., Dept. G, Chicago 10, Illinois
 Phone: MOhawk 4-2222

SWITCHES • ROTARY SOLENOIDS • CHOPPERS
 VIBRATORS • TUNERS
 SUBASSEMBLIES

glass-metal seal where the lead joins the body of the capacitor.
(2) A fusion seal around the

perimeter of the capacitor makes it impervious to moisture. The CYF-10 has a capacitance range to 240

$\mu\mu\text{f}$ and a d-c working voltage up to 500 at 125 C. **Circle 204 on Reader Service Card.**



Test Instrument compact package

PANORAMIC RADIO PRODUCTS, INC., 514 S. Fulton Ave., Mt. Vernon, N. Y. In one convenient package that occupies only 19½ in. of panel height the company has incorporated the equipment needed to set up, adjust, monitor and troubleshoot ssb and a-m transmissions. Called the SSB-3, the unit is fast

and exceptionally simple to operate. It consists of a sensitive spectrum analyzer plus a stable tuning head and a two-tone generator. Self calibrating and checking circuitry is also included. Pre-set sweep widths of 150, 500, 2,000, 10,000 and 30,000 cps with automatic optimum resolution eliminate fussing with control settings. **Circle 205 on Reader Service Card.**

Motor-Alternator 420-cps unit

ELECTRIC MOTORS AND SPECIALTIES, King and Hamsher Streets, Garrett, Ind. Series PA-40 motor alternator is designed for all 420 cps output service in the 250 va requirement area. It can be used in end equipment or in laboratory or test applications. It will operate



computers, synchros and servo-mechanisms. Outputs available are: 115 or 230 v, single, two or three phase, at 420 cps. Inputs may be supplied at 230 or 460 v, 50 cps, three phase; 220 or 440 v, 60 cycles, single phase. Polyphase units are in the PA-40 series, and single phase units are designated SA-40. **Circle 206 on Reader Service Card.**

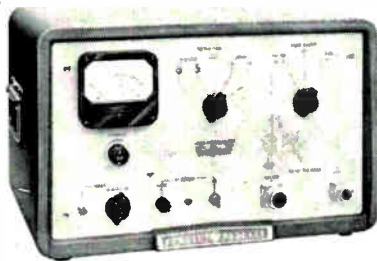

Noise Figure Meter automatic instrument

HEWLETT-PACKARD Co., 275 Page Mill Road, Palo Alto, Calif. Model 340A automatically measures the noise figure of amplifier and microwave receiver systems. It enables semiskilled personnel to

make quick and accurate noise measurements and to adjust receivers and components for optimum performance. Unit provides direct noise figure readings in db, needs no periodic calibration and operates over any frequency range for which there are noise sources. **Circle 207 on Reader Service Card.**

Low Pass Filters sharp cut-off

MAURY & ASSOCIATES, 10373 Mills Ave., Montclair, Calif. Type 4 low pass filters feature low insertion loss, sharp cut-off characteristics and compact size. They cover a frequency range from 100 to 2,000



mc and are supplied with TNC, BNC and N connectors. General

specifications: insertion loss 0.4 to 0.8 db ripple in the pass band, vswr 1.5 max., rejection slope 40 db min. at 1.25 f_c , second harmonic 60 db min., spurious responses 40 db min. greater than 2 f_c , nominal impedance 50 ohm, and power handling 50 w c-w. **Circle 208 on Reader Service Card.**

Power Supplies compact, rugged

NUTRON MFG. Co., INC., 67 Monroe Ave., Staten Island 1, N. Y., announces a new series of compact, rugged, panel mounted power sup-

plies for use where maximum va utilization is required. They feature high quality waveform, voltage and current meters of 2 percent accuracy, output terminals on both front and rear of unit, and are completely self protecting





AVAILABLE NOW

Sperry's new

SRU-216

broad band klystron

has 2,000-mc tuning range combined with frequency stability under severe shock and vibration

- Requires less than 15 watts total power
- Non-axial motion of tuning shaft
- Low tuning torque

This new Sperry Klystron features superior electronic characteristics yet is so rugged it can withstand the severe environments encountered in missile and jet radar applications.

The SRU-216 not only has an extremely wide mechanical tuning range of 2,000 mc but also offers a very wide electronic tuning range from 60 to 100 mc. Frequency remains stable even under severe pressure, vibration and shock environments.

PERFORMANCE

Frequency Range.....	15.0 to 17.0 kmc
Power Output.....	15 mw (min.) from 15.0-15.7 kmc
	20 mw (min.) from 15.7-17.0 kmc
Frequency Stability Under:	
Vibration.....	2.0 mc (max.) at 10 g's, 40-500 cps
Low Pressure.....	-4.0 mc (max.) at 70 mm Hg
Shock.....	±1.0 mc (max.) at 70 g's for 6.5 ms, 3 axes
Temperature Coefficient.....	-.5 mc/°C (max.)

This new tube makes for easier system design. Low power consumption means smaller associated equipment . . . air cooling is not required. Potted base eliminates need for pressurization. Design provides more linear frequency-to-turns ratio over tuning range. The optional four locations of the shaft with respect to waveguide flange gives designers extra flexibility. Write for more information on this new Sperry Klystron.

SPERRY

SPERRY ELECTRONIC TUBE DIVISION, SPERRY RAND CORPORATION, GAINESVILLE, FLORIDA
Address all Inquiries: Gainesville, Florida, or Sperry Gyroscope Offices in Brooklyn · Cleveland · Seattle · San Francisco · Los Angeles · New Orleans · Boston · Baltimore · Philadelphia

Are you SAVING through ENGRAVING?



YOU CAN mark parts, make signs and nameplates, improve your product and cut your costs in 1001 ways with the portable

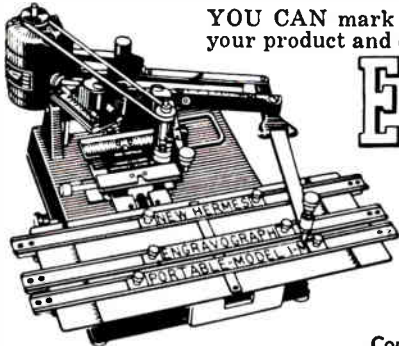

Engravograph

It's tracer-guided for unskilled labor. Every plant needs one, wherever permanent lettering or numbering has to be done. There is a complete line of models to meet your application, from \$298.00 up.

Consult our engineers on how ENGRAVOGRAPH can help your operation, or write on your letterhead for our 28-page fully illustrated catalog ZM-2

new hermes ENGRAVING MACHINE CORP.

13-19 UNIVERSITY PLACE, NEW YORK 3, N. Y.

CIRCLE 48 READERS SERVICE CARD



TRANSISTOR OSCILLATOR

Complete, compact, precise plug-in signal source providing fixed temperature and humidity environment for transistor, crystal, and circuitry elements. Frequency stability: (24-hr. period) 1 part in 10^6 or better. Write for complete data.



THE
JAMES
KNIGHTS
COMPANY

Sandwich 1, Illinois

CIRCLE 49 READERS SERVICE CARD

AN IMPORTANT NEW REFERENCE BOOK

1959 EDITION

INTERNATIONAL RADIO TUBE ENCYCLOPEDIA



768
PAGES

lists over 27,500 tubes of every type Radio, TV, Microwave, Amplifiers, Multipliers, Modulators, Etc. for every commercial, industrial and military application and from every major country of the world.

INCLUDES FULL DETAILS:

base connections, characteristics, electrode structure. Completely cross indexed, with equivalents. Send check or money order. Price—\$15.00 Postpaid.

10 DAY MONEY BACK GUARANTEE

JOSEPH PLASENCIA, INC.
401 BROADWAY • NEW YORK 13, N. Y.

CIRCLE 39 READERS SERVICE CARD

against short circuits. The power supplies are useful in testing diodes, rectifiers, transformers, motors, chokes; for instrument calibration; for a regulated adjustable line source; over and under voltage testing; and as a constant voltage source for critical photometry applications. Circle 209 on Reader Service Card.

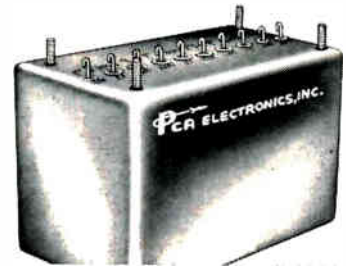

Delay Lines lumped constant

PCA ELECTRONICS, INC., 16799 Schoenborn St., Sepulveda, Calif., has developed a range of lumped constant delay lines custom-built to meet military specifications and delay time tolerances as close as 0.1 percent. Unit illustrated has a delay time of $40 \pm 0.04 \mu\text{sec}$ at 25 C. Temperature coefficient of delay is $<20 \text{ ppm per deg C}$; attenuation, 4 db; rise time, $0.4 \mu\text{sec}$ (10 percent to 90 percent); size, 50 cu. in. Circle 210 on Reader Service Card.

Analytical Balance automatic unit

E-H RESEARCH LABORATORIES, 2161 Shattuck Ave., Berkeley 4, Calif. Model 301A analytical balance features 1-sec measurement time and 0.2 percent accuracy in five automatic ranges from 30 to 3,000 milligrams full scale. On any automatic range the weight of samples placed on the balance is given directly with no mechanical manipulations. Conventional difference methods may be used to extend the range to 200 grams. A valuable operational feature is an electrical mass offset which allows

(Continued on p 74)

PRESENT SUBSCRIBERS

— Please Note!

This subscription coupon is for NEW subscribers. It is not intended as a renewal notice. If you are already personally subscribing, we shall appreciate your passing the form to one of your associates. Thank you.

Mail Reply to: McGraw-Hill Pub. Co., Electronics, 330 W. 42nd St., N. Y. 36, N. Y.



NEW Subscription ORDER FORM

O.K. — put me down for a personal subscription to "electronics" . . . giving me benefit of your weekly editorial service . . .

Check here for 1 year, \$6 for 2 years, \$9 for three years, \$12

- Please One
- Send bill to home address
 - Send bill to Company address
 - Payment Attached

Name _____ Position _____ Dept. _____

Company Name _____

Street _____ City _____ Zone _____ State _____

Products Mfrd. _____ Number of Employees _____
Or Service _____

Street _____ City _____ Zone _____ State _____

Please fill out card completely for best service

Check here if you want Publication sent to your home

Foreign Rates (1 year) Canada \$10, Other Foreign \$20

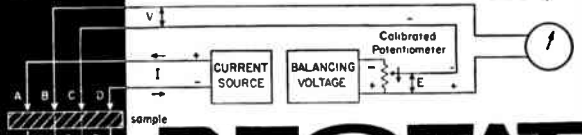
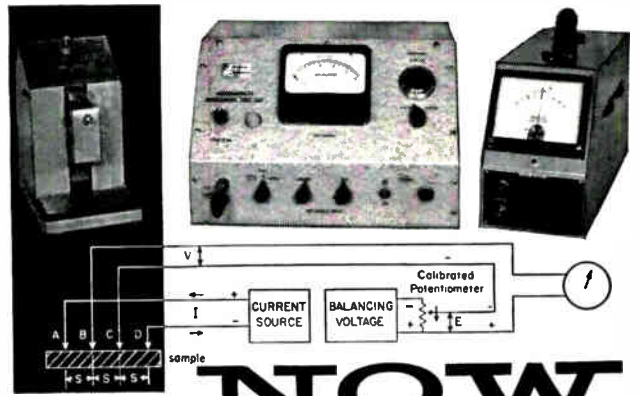

NOW

precise SEMICONDUCTOR RESISTIVITY TEST

The "FOUR-POINT-PROBE" method — an exclusive feature of the BAIRD-ATOMIC Semiconductor Resistivity Test Set, Model JN — for precise resistivity (0.1 to 100 ohm-centimeters) tests, especially designed to measure germanium samples. Measurement Accuracy $\pm 5\%$

Extremely simple to operate. A reliable test set for both production quality control and R&D. The "FOUR-POINT-PROBE" can be adapted for silicon measurement as well.

For complete information, ask for Tech Bul. TP-104

Baird-Atomic, Inc.

33 UNIVERSITY RD., CAMBRIDGE 38 MASS

Baird

Atomic

Instrumentation for Better Analysis

CIRCLE 40 READERS SERVICE CARD

sending a bill?

It'll get there quicker if you give your postal delivery zone number with your address.

The Post Office has divided 106 cities into postal delivery zones to speed mail delivery. Be sure to include zone number when writing to these cities; be sure to include your zone number in your return address — after the city, before the state.

Beattie-Coleman built 100 g's into the MPR-13 Programmer

Resistance to high shock loads is just one of the amazing pluses of the Beattie-Coleman MPR-13 punched Mylar tape Programmer. The MPR-13 is the accepted standard for multi-channel programming because of its compatibility with most missile guidance systems . . . and performs with an accuracy of one part in 50,000 under these high "g" loads! Programs can be initiated or altered in a few minutes with millisecond precision for either repeat cycling or random operations.

The rugged Beattie-Coleman MPR-13 Programmer weighs 3 lbs. 10 ounces, is 2"x 3"x 6". More information is available on request.

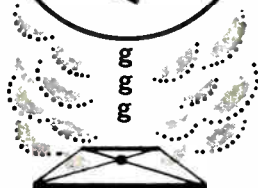
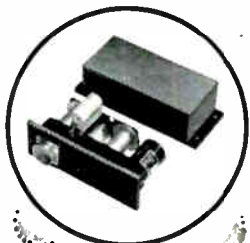

1000 N. Olive St., Anaheim, California
CIRCLE 41 READERS SERVICE CARD

the operator to zero the meter with a container on the balance, thus obtaining the weight of added contents directly. Circle 211 on Reader Service Card.



Instrument Load vswr under 1.02

ALFORD MFG. Co., 299 Atlantic Ave., Boston, Mass. Type 1108B instrument load for type N provides a nearly reflectionless termination on a 50 ohm coaxial transmission line over the frequency range of 0 to 1,100 mc. The rated vswr is under 1.02; the rated maximum input power is 0.5 w. Type 1108 B is designed around a metal film on glass type of resistor. It is unusually stable. Stability plus low reflection makes this load suitable as a secondary standard. Circle 212 on Reader Service Card.



Instrument Clock gas-powered

AMERICAN METER Co., 920 Payne Ave., Erie, Pa., has introduced the Gaslok, a completely self-contained air or gas powered instrument drive and timing unit. It is said to deliver a constant power output of more than 20 times the torque supplied by conventional spring-wound clock mechanisms. Circle 213 on Reader Service Card.

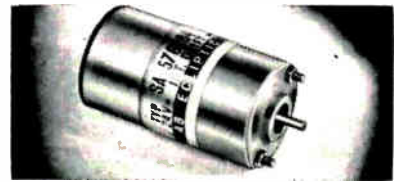

D-C Motors 3,000 to 20,000 rpm

CARTER MOTOR Co., 2762A W. George St., Chicago 18, Ill. A two-lead reversible d-c motor with an air-stabilized Alnico permanent magnet field has been announced. It is available for 6, 12, 24, 28, 32 or 48 v input and is rated at 1/50 h-p for continuous duty or 1/75 h-p in intermittent duty. Speed range is 3,000 to 20,000 rpm. Frame dimensions are 1.3 diameter by 2.4 length, with an overall length of 2 1/2 in. including the shaft extension. Weight is approximately 6 oz. Circle 214 on Reader Service Card.



Cable Test Set automatic unit

OPTIMIZED DEVICES, INC., P. O. Box 38, Gedney Station, White Plains, N. Y. Model 50-A multiconductor cable test set is specifically designed for completely automatic continuity, insulation resistance, and high potential testing of cables or junction boxes with up to 109 conductors. The cable under test is connected by means of patch cords to connectors on the front panel of the test set. Model 50-A is started and proceeds automatically to rapidly check each conductor on a GO, NO-GO basis. Circle 215 on Reader Service Card.

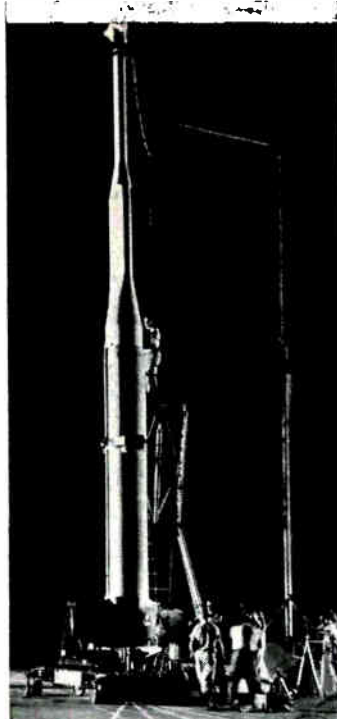
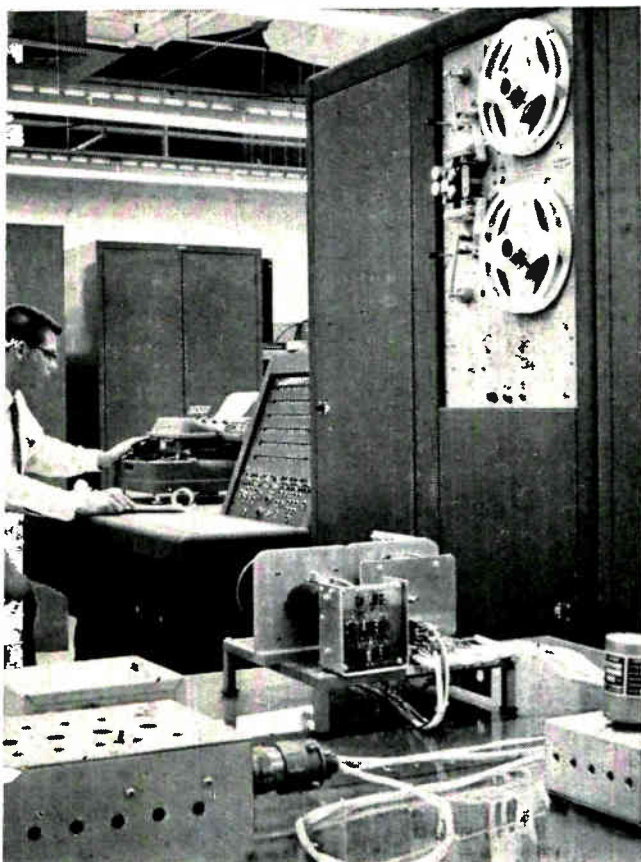

(left) Lockheed X-17. Lockheed-designed checkout computers are already proving their effectiveness in service.

(below) Another Lockheed-designed automatic missile check-out for quick determination of flight readiness.

(left) Automatic Checkout and Readiness Equipment (ACRE) — a Lockheed product — automatically performs pre-program missile checkouts and runs diagnostic routines to localize trouble.

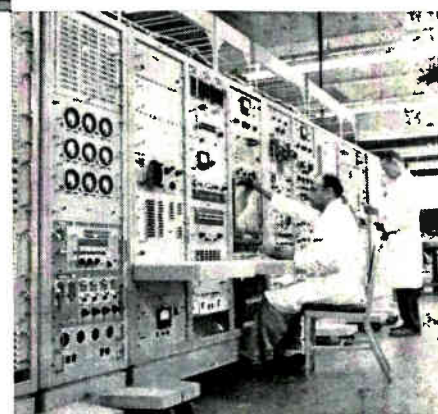

EXPANDING THE FRONTIERS OF SPACE TECHNOLOGY

Lockheed's capability in the design and development of computers is contributing to the advancement of the state of the art. Research is being conducted in the building of machines capable of reading 5,000 characters a minute; in the development of high-speed digital plotters which will operate up to 5,000 points a second from magnetic tape input; in the improvement of library reference systems for the storing and retrieval of information; and in the study of self-organizing machines using variable threshold neurons that will operate essentially without programming.

The ACRE system developed by Lockheed combines outstanding performance at the lowest cost in the industry, and has broad applications to a number of other missile and space projects.

Scientists and engineers of outstanding talent and inquiring mind are invited to join us in the nation's most interesting and challenging basic research and development programs. Write: Research and Development Staff, Dept. AA-22, 962 W. El Camino Real, Sunnyvale, California, or 7701 Woodley Ave., Van Nuys, California. For the convenience of those living in the East and Midwest, offices are maintained at Suite 745, 405 Lexington Ave., New York 17, and Suite 300, 840 No. Michigan Ave., Chicago 11.

"The organization that contributed most in the past year to the advancement of the art of missiles and astronautics."

NATIONAL MISSILE INDUSTRY CONFERENCE AWARD

Lockheed / MISSILE SYSTEMS DIVISION /

SUNNYVALE, PALO ALTO, VAN NUYS,
SANTA CRUZ, SANTA MARIA, CALIFORNIA
CAPE CANAVERAL, FLORIDA
ALAMOGORDO, NEW MEXICO

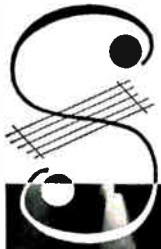

Symphony and Industry



Good living and productive industry go hand in hand. The San Antonio Symphony, one of the nation's finest, is just one of the reasons San Antonio is a wonderful place to live and work. Add an ideal outdoor living climate, good

government, banks that support industry, abundant water, natural gas and electricity, excellent sites, good transportation, to the happiest labor picture in the country, and you have a near-perfect situation for locating your industry.



SAN ANTONIO



For a detailed study of your specific needs
Write Greater San Antonio Development Committee
153 Navarro, P. O. Box 1628, San Antonio, Texas
All communications confidential

CIRCLE 43 READERS SERVICE CARD

NEW Transistorized Relay Combines Fine-Sensitivity with Heavy-Duty Construction

Cutler-Hammer has developed a heavy-duty transistorized A-c relay which will respond to either an A-c or D-c signal between .0028 and .025 amperes. The heart of this compact relay is the plug-in type signal-amplifying module which contains all the electronic parts. This tough module is practically indestructible, and the plug-in design simplifies maintenance . . . cuts downtime to a minimum. The Bulletin 13535 transistorized relay requires no warm up time and it is exceptionally quick in operation. 600 volt model offers a wide selection of contact arrangements . . . rated 15 amperes. 110 volt model rated 10 amperes. Prices unusually low. Cutler-Hammer also offers conductive liquid level probes, and photo-cell units for use with the transistorized relay.



Write today for
Bulletin 13535-A220
CUTLER-HAMMER Inc.,
Milwaukee 1, Wisconsin



CUTLER-HAMMER

Cutler-Hammer Inc., Milwaukee, Wis. • Division: Airborne Instruments Laboratory. • Subsidiary: Cutler-Hammer International, C. A.
Associates: Canadian Cutler-Hammer, Ltd.; Cutler-Hammer Mexicana, S. A.; Intercontinental Electronics Corporation, Inc.

CIRCLE 44 READERS SERVICE CARD

Literature of

MATERIALS

Resists and Inks. Atlas Silk Screen Supply Co., 1733 Milwaukee Ave., Chicago 47, Ill. Included in a recent reference folio is a description of the handling and application of resists and inks used in subtractive and additive methods of printed circuit production. Circle 250 on Reader Service Card.

COMPONENTS

Analog Computation. George A. Philbrick Researches, Inc., 285 Columbus Ave., Boston 16, Mass. Issue No. 6 of *The Lightning Empiricist* contains items of interest and value on applications, techniques, and new or improved components in the field of analog computation. Circle 251 on Reader Service Card.

Choppers. Airpax Electronics Inc., Seminole Division, Fort Lauderdale, Fla., is publishing a series of new pamphlets on choppers entitled "*The Contact Modulator*". Now available is Part I: "Why Use Choppers?" Circle 252 on Reader Service Card.

Retaining Rings. Waldes Kohinoor, Inc., 47-16 Austel Place, Long Island City 1, N. Y. A 24-page catalog, No. RR 10-58, contains descriptions and illustrations of all currently available Waldes Truarc retaining rings, pliers and accessory tools. Circle 253 on Reader Service Card.

EQUIPMENT

Oscilloscope. Hewlett-Packard Co., 275 Page Mill Road, Palo Alto, Calif. Volume 10 No. 1-2 of the Journal contains complete information on a dual-trace automatic base line oscilloscope for the d-c to several hundred kc range. Circle 254 on Reader Service Card.

Microwave Instrumentation, Polytechnic Research & Develop-

January 23, 1959 — ELECTRONICS

the Week

ment Co., Inc., 202 Tillary St., Brooklyn 1, N. Y. A six-page folder illustrates and describes eight samples of the Pacemaker line of microwave instruments and components. Circle 255 on Reader Service Card.

Power Supplies. Opad Electric Co., 69 Murray St., New York 7, N. Y., has issued a two-page catalog sheet illustrating and describing its standard line of zero to 32 v d-c power supplies, with current ratings ranging from 5 to 40 amperes. Circle 256 on Reader Service Card.

Instruments. Ealing Corp., 40 University Road, Cambridge 38, Mass. A new 24-page catalog of Pye Scientific Instruments describes products such as amplifiers and voltmeters; fluxmeters; galvanometers; Kelvin and other type bridges. Circle 257 on Reader Service Card.

Axial Flow Fans. Pesco Products Division, Borg-Warner Corp., 24700 N. Miles Road, Bedford, Ohio. Bulletin 5802 describes the new line of axial flow fans which provide high air displacement and pressure for cooling, heating and ventilating. Circle 258 on Reader Service Card.

Auxiliary Power Supply. Alectra Division, Consolidated Electrodynamics Corp., 325 North Alta-dena Drive, Pasadena 15, Calif. Bulletin 7010 covers the model 60A power supply which features all-transistor circuitry, isolated line voltage, low ripple and low source impedance. Circle 259 on Reader Service Card.

FACILITIES

Instrument Training. The Bristol Co., Waterbury 20, Conn., has issued a new bulletin describing its training school for instrument engineers and technicians. It lists the staff and the five major training courses offered. Circle 260 on Reader Service Card.

BE SURE... BUY E-LITES

engineered especially for computers,
control systems, military applications

You can mount almost any E-lite in a $\frac{3}{8}$ " hole. They'll fit your system application exactly because they're tailor-made for the job by system engineers. Choose from many replaceable-lamp or permanent-



lamp types, with or without built-in resistors, and in a variety of lens styles, colors and data readout capacities. 100% electrical and mechanical inspection assures you of full E-lite quality in every unit.

ACTUAL SIZE—FITS A $\frac{3}{8}$ " DIA. HOLE
THE ORIGINAL MINIATURE INDICATOR LIGHT

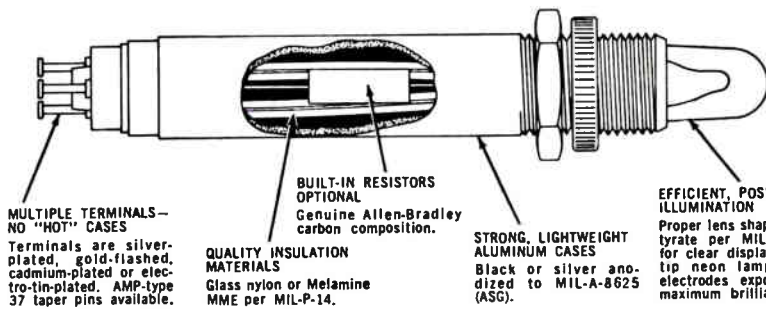

MULTIPLE TERMINALS—NO "HOT" CASES
Terminals are silver-plated, gold-flashed, cadmium-plated or electro-tin-plated. AMP-type 37 taper pins available.

QUALITY INSULATION MATERIALS
Glass nylon or Melamine MME per MIL-P-14.

BUILT-IN RESISTORS OPTIONAL
Genuine Allen-Bradley carbon composition.

STRONG, LIGHTWEIGHT ALUMINUM CASES
Black or silver anodized to MIL-A-8625 (ASC).

EFFICIENT, POSITIVE ILLUMINATION
Proper lens shape in butyrate per MIL-P-10407 for clear display. Form-tip neon lamps with electrodes exposed for maximum brilliance.

TWO-WEEK DELIVERY ON 1560 STANDARD VARIATIONS/SPECIAL PRICES ON VOLUME ORDERS



REPLACEABLE-LAMP TYPES
Single-lamp holders for neon or incandescent lamps. With or without built-in resistors. Variety of replaceable lens types. Up to 3 digits available on flat lenses. 1DH holder shown. Patent applied for (resistor models).

TRANSISTOR CIRCUIT NEON LIGHTS
With built-in diode-resistor network — no adapting needed. Stable, pre-aged lamps fire on minimum voltage. Several models. Round or flat-faced lens, dual-resistor types. Model 1AD (patented) shown.

LOW-COST INDICATORS
Neon and incandescent panel illumination, readout, etc. Round or flat lens. Lens marking available. Push-on retainer for instantaneous installation. Models 1B* (neon) and 1K (incandescent) shown. *Patents applied for.

PERMANENT-LAMP READOUT TYPES
With permanent or changeable lenses, and lenses taking up to 3 digits. Neon or incandescent lamps. Model 1EG (neon) shown.

WRITE FOR COMPLETE TECHNICAL INFORMATION

With photos, descriptions, dimension drawings for the complete line. Submit your special problem for our engineered solution. Information on our neon lamp aging service also sent on request.

Sales representatives in principal cities

Eldema

CORPORATION
1805 Belcroft Avenue,
El Monte, Calif.
A subsidiary of Genisco, Inc.



Geotech Expands Into New Plant

THE Geotechnical Corporation recently moved into a new 40,000 sq ft plant in Garland, Texas.

The move enables Geotech to strengthen and expand its position in the field of research, design, and manufacture of electromechanical instrumentation. In addition to R&D work Geotech produces f-m telemetering, recording, data reduction, and seismograph equipment for commercial and government applications.

Servo Corp. to Consolidate

SERVO CORPORATION OF AMERICA, manufacturer of infrared and automation systems for industrial, railroad and military applications, will build a 120,000 sq ft plant in Hicksville, L. I., N. Y. Ground-breaking ceremonies were recently held for the \$1.5-million structure which will consolidate under one roof the research and development, manufacturing and administrative activities of the firm's six present plants with their complement of 350 people.

The new facilities, to be occupied in August, will permit a 200-percent production increase, firm says. Citing a current backlog of \$5 million in orders, company president Henry Blackstone (shown digging first spadeful of earth) said, "Allowance has been made for a continuing rapid growth in demand for Servo products. Land has been allocated for a 200,000 sq ft addition when required. The number of employees would then be increased to more than 1,000."

Company's products include: infrared detectors, related instruments and their optical components; electronic devices for precision measurement; radio communications and navigation equipment; radio direction finding system; automation gear and servomechanisms; test and analysis equipment; analog and digital computers, and custom-designed machines and instruments.

Government and military sales, which once constituted Servo's whole business, now account for only 40 percent of volume.

The new building's 60,000 sq ft of air-conditioned office and engineering space will include sterile areas for delicate precision assembly work that requires stringent control of dust particles, vibration, temperature, humidity and pressure. Other laboratories will be specially constructed for advanced research in infrared systems, controls and direction finding devices.

Merit Coil Settles In Florida Center

MERIT COIL and Transformer Corp., one of the six firms manufacturing electrical or electronic products in

Hollywood-by-the-Sea, Fla., has completed consolidation of its operation at Merit Plaza there.

Heretofore Merit had been producing its electronic coils, transformers, chokes and flybacks in Chicago as well as in Hollywood.



Narda Appoints Adolph Brenner

NEW project engineer for The Narda Microwave Corp., Mineola, N. Y., is Adolph Brenner. His primary responsibility will be the design and development of microwave components.

Brenner's background in the field of microwave components was obtained at the Electronics and X-Ray Division of F & R Machine Works and Polarad Electronics Corp.

Kester Solder Co. Marks 60th Year

KESTER SOLDER Co., Chicago, completed its 60th year this month. The company, started in 1899, claims to be the first manufacturer of flux-core solder for the then infant electrical industry.

Company now develops and pro-

Production Inspection is Faster and Easier with a J&L Optical Comparator

... and its extreme versatility enables you to perform inspections that used to be "impossible"!

More and more electronics manufacturers throughout the country are using Jones & Lamson Optical Comparators in their quality control operations. Small shops, as well as the giants, have learned that a J&L Comparator pays for itself in very short order.

The Comparator's ability to measure and inspect, through shadow magnification, all sorts of parts and objects

with extreme precision and speed makes it ideally suited for checking electronics components, especially those which are tiny or intricately contoured.

Investigate how the J&L Comparator can help you make your production operations more efficient . . . and more profitable. Write today for a free copy of our new illustrated catalog No. 5700.

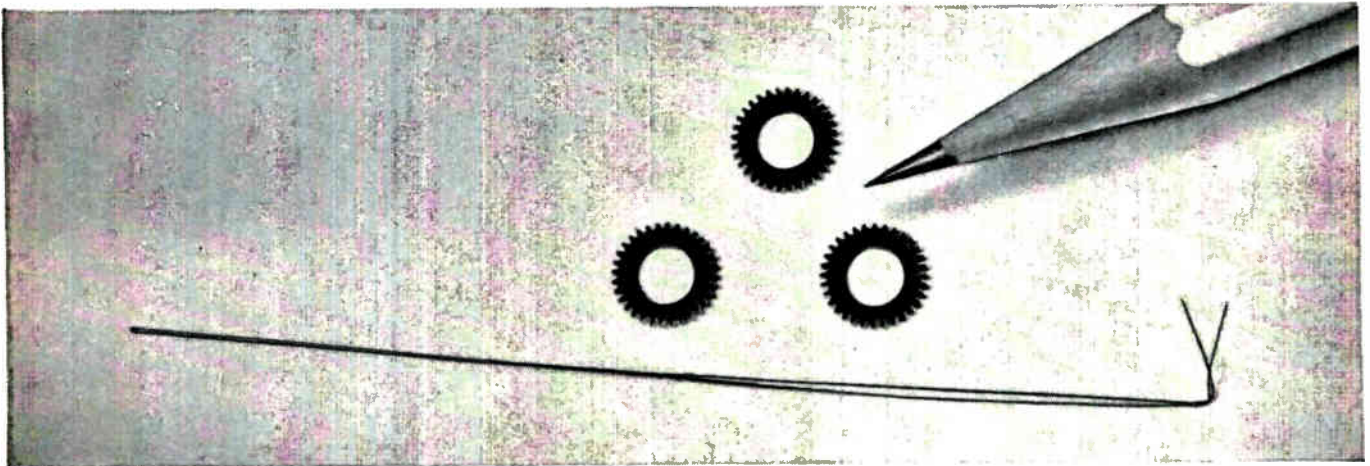

For Instance — A customer writes: "One of our assemblies, containing 32 separate circuits, measures only $\frac{5}{16}$ " dia. by 1" long. The parts which go into this assembly must have perfect shape and tension, which are impossible to check by mechanical

means. Two such parts are these .005" dia. gold wires, and precisely toothed brush spacers. Since using the J&L Optical Comparator in our inspection, assembly failure due to malfunction of either of these two parts has virtually disappeared."

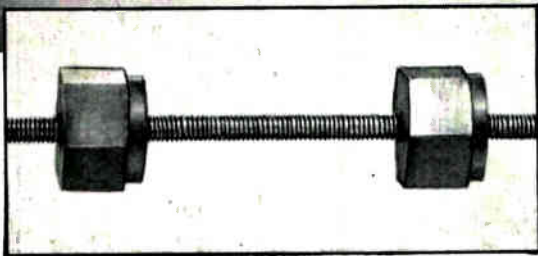
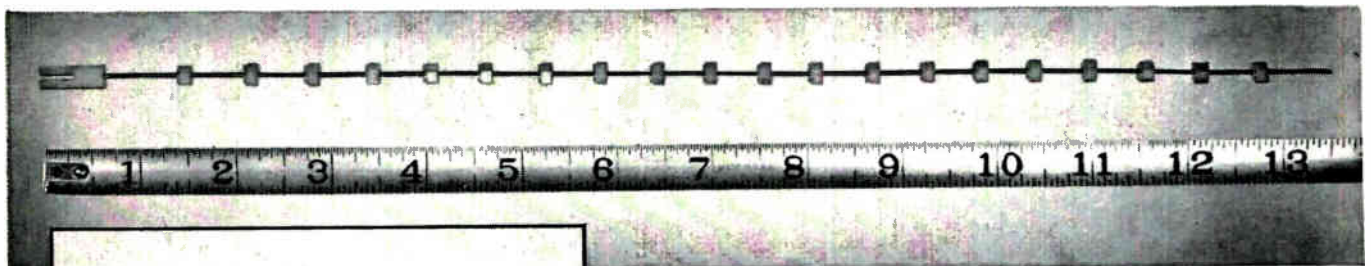

This precisely-threaded rod (used in calculating machines) is of .047" dia. stock, 120 pitch, with continuous threading along its entire 12" length. Threading accuracy and critical dimensions are measured and checked speedily and efficiently with a J&L Comparator.

Model PC-14



JONES & LAMSON

JONES & LAMSON MACHINE COMPANY, Dept. 710, 539 Clinton Street, Springfield, Vermont

American Blower suggests: EASY WAY TO END HEAT FAILURES IN ELECTRONIC UNITS

Problem: End malfunctions from self-generated heat in sensitive electronic equipment. **Solution:** Provide dependable cooling with an American Blower packaged air-moving unit. Numerous sizes and designs to choose from—many can be modified as needed. Or, if necessary, we can start from scratch and design a fan or blower to fit your exact needs. Individual specification bulletins are available: write, detailing your requirements. American-Standard*, American Blower Division, Detroit 32, Michigan. In Canada: Canadian Sirocco products, Windsor, Ontario.

FOR COOLING TRANSMITTERS

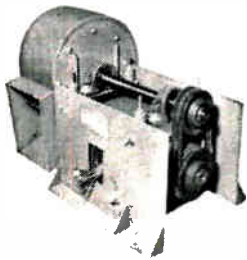

Heavy-duty, V-belt-driven blower. Capacity: 517 cfm @ 0.25" sp @ 640 rpm and 1400 cfm @ 1.5" sp @ 1642 rpm. Bulletin 2712.

FOR COOLING CABINETS



Propeller fan. Capacity: 1325 cfm @ 0" sp to 310 cfm @ 0.62" sp @ 1725 rpm. Write for Bulletin 4812.

* AMERICAN-Standard and Standard are trademarks of American Radiator & Standard Sanitary Corporation.



CIRCLE 47 READERS SERVICE CARD

duces specialized solder for various industries and pioneered development of "solderforms"—pre-formed solder designed to aid the trend toward automation.



TI Elects Dotson

TEXAS Instruments Inc. president P. E. Haggerty recently announced the election of Cecil Dotson of Dallas, Tex., as chairman of the board of directors of Texas Instruments Ltd., wholly-owned British subsidiary of the international electronic manufacturing and geophysical exploration company.

Texas Instruments Limited has headquarters and manufacturing facilities at Bedford, England, and markets its semiconductor devices throughout the United Kingdom and Western Europe.



STL Advances Ruben Mettler

RUBEN F. METTLER was recently appointed executive vice president and general manager of the newly

incorporated Space Technology Laboratories, Los Angeles, Calif.

Until this appointment, Mettler served as vice president and assistant general manager of the Laboratories, formerly a division of the Ramo-Wooldridge Corp. STL is in charge of over-all scientific direction of the Air Force's ballistic missile program which includes the Thor IRBM, Atlas, Titan, and Minuteman ICBM's and the recent Able I space probes.



Tobias Moves To New Post

APPOINTMENT of J. F. Tobias as director of the electronics unit at the Aeronautical and Instrument Division, Robertshaw-Fulton Controls Co., Anaheim, Calif., is announced. He was formerly chief engineer, military electronics, at Hycon Mfg. Co., Pasadena.

In his new post, Tobias will be responsible for the design, development and pilot production of all electronics systems, components and test equipment.

Plant Briefs

Transistor Applications Co. was recently incorporated as Glentronics, Inc., Glendora, Calif. Added plant area has also been obtained, doubling the space available for production.

Tri-Point Plastics, Inc., Albertson, N. Y., pioneers in the extrusion, machining and fabrication of Teflon, have expanded their existing

facilities by another 30 percent. This is the third sizable expansion of the company's plant in as many years.

The recently incorporated Missile Electronics Engineering Co., Van Nuys, Calif., is now open for business. Firm will serve industry and the government in the broad general area of electronics, electro-mechanical and solid state missile components and systems, design, development and manufacture.

Kearfott Co., Inc., Clifton, N. J., recently formed its Components Division, an autonomous operation devoted to the manufacture of servo system components.

News of Reps

The Victoreen Instrument Co., Cleveland, Ohio, announces the appointment of Charles W. Fowler Co. of Berkeley, Calif., as reps for the company's instruments division. Territory covered will include California, Arizona, New Mexico and Nevada.

Digitronics Corp., Albertson, L. I., N. Y., will be represented in the New England area by Ray Perron & Co. of Boston, Mass., for the sale of lumped constant delay lines.

Voak Engineering Co., Upland, Calif., manufacturer of multiturn wire wound potentiometers, names M. W. Riedel & Co. of Alhambra as sales reps for the states of California, Arizona, and Utah.

Chester Cable Corp., Chester, N. Y., has appointed the Martin P. Andrews Co. to handle sales of its electronic wire and cable in upstate New York.

Instrument Development Laboratories, Inc., Attleboro, Mass., appoints John A. Moots & Associates as reps in the greater Dayton, Ohio, area.

Epsco Components Division, Epsco, Inc., Boston, Mass., announces the M. P. Odell Co. as the division rep in Ohio, Michigan and western Pennsylvania.

TELREX LABORATORIES

NEW!

Broad-Band Conical Dipole Corner Reflector Assembly

210 TO 620 MC. WITH 2 ADJUSTMENTS

Model

XCR 210-620

Gain: 8 to 11 db.

F/B ratio: 18 db with no appreciable side lobes.

V/S/W/R: Less than 2 to 1 over the 210 mc. to 620 mc. range. 50 ohm transmission line feed through a special broad-band "Balun" (supplied).

Mounting: Horizontal or vertical onto a 2½" dia. mast. Can be fitted for other diameter masting at extra cost.

Weight: 18 lbs. (approx.). All dural construction with stainless steel fittings.

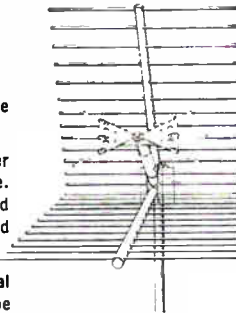

Descriptive literature on request



Telrex LABS.
COMMUNICATION & TV
ANTENNAS SINCE 1921

TELREX ALSO DESIGNS AND MANUFACTURES COMMERCIAL SERVICE "BEAMED-POWER" ARRAYS

ASBURY PARK 25
NEW JERSEY, U.S.A.
Tel. PRospect 5-7252

CIRCLE 50 READERS SERVICE CARD

ONLY KRENGEL'S neoprene DIES MOUNTED ON RADIUS AND SPRING STEEL...give you sharp, even, permanent markings every time on any kind of surface.

Absolutely clog resistant, acid resistant, non-blurring, longer lasting.

Any die or stamp made to order from your blueprint, layout or instructions. Send us your material for quotation today. And remember, Krengel Mfg. Co., Inc. can fill all your marking device, die and ink needs. *Write for FREE catalog.*

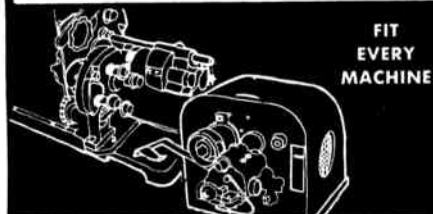
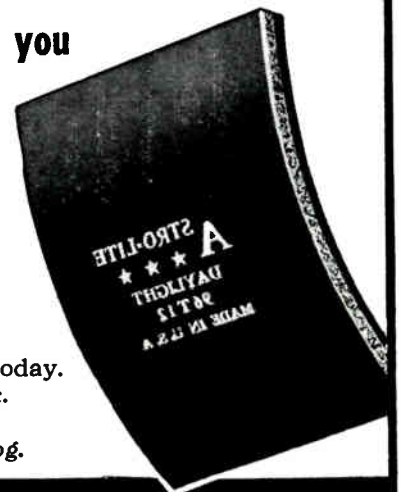

KRENGEL

MANUFACTURING CO., INC.
227 FULTON STREET • NEW YORK 7, N. Y.
COrtlandt 7-5712

CIRCLE 51 READERS SERVICE CARD

HOW ABOUT YOU?

Do you know that many cancers can be cured if detected early? That an annual health checkup is your best protection against cancer?

Are you giving yourself this big advantage? Or are you taking chances with your life because of foolish attitudes about cancer like these?



DON'T EVEN MENTION THAT WORD!

Fear keeps some people from even *learning* cancer facts that can save their lives.

NEVER FELT BETTER!



Checkups help to detect cancer in its "silent" stage before you notice any symptom.



COSTS TOO MUCH!

Dollars you spend for the protection of your health can mean years of life.

Millions of Americans have made an annual checkup a habit... *for life*. How about you?

AMERICAN CANCER SOCIETY

COMMENT

Technological Effects

This thoughtful little summary came to us in our New Year's mail, and we print it here for two reasons. One is that the letter does sum up a double handful of the important effects by which we are all touched in this technology. The other is the thoughtful statement with which reader Rivera apparently starts his new year.

It has been said that engineers and scientists are too pragmatic to be sentimental about anything. This is debatable; the electronics technology progresses with breathtaking speed because the opposite is true.

Men of science are human beings, with dreams and yearnings, and are normally responsive to the esteem of mankind. Inspired by the work of previous investigators, they contribute effort of their own, and become pathfinders for others who take up the torch. This can be verified by history, whose paths are well emblazoned with scientific effects discovered by dedicated men and recorded for posterity as contributions to human understanding of the physical environment.

Some of these important effects are familiar: the *Edison effect*, which started the science of thermionics; the *Oersted effect*, the observation of which started the history of electromagnetism and laid the foundations of electrical engineering; the *Seebeck* and *Peltier effects*, which represent the two complementary approaches to thermoelectricity; the *Doppler effect*, which governs the velocity-dependence of frequency; the *skin effect* in conductors, which even has economic overtones in saving much copper in high-frequency circuits.

Perhaps less well known are such phenomena as the *Joule* (magnetostrictive) *effect*, in which a change in the magnetic field in certain materials causes a change in dimensions, and con-

versely; or the *Hall effect*, in which an electric current passing down the long axis of a flat conductor placed normal to a magnetic field causes a potential difference to appear across the conductor.

Discovery of the *Compton* and *photoelectric effects* shook the foundations of classical wave theory. The Compton effect is the shift to longer wavelengths when X-rays are passed through carbon; the shift is proportional to the scatter angle. The photoelectric effect is the emission of electrons from a clean metal plate held in a vacuum when the plate is struck by a beam of light; the energy imparted to the emitted electrons is independent of light intensity. Observation of these phenomena forced the adoption of a quantum theory for light.

In the semiconductor technology, we have newly observed the *Zener effect* and the *electron-voltaic effect* (in which a *p-n*-silicon junction becomes a voltaic cell when brought near a source of beta radiation). The *Boella effect* is the loss of effective resistance of carbon-composition resistors used in the vhf range due to dielectric losses. In electron-tube circuits, the *Miller effect* demonstrates that input capacitance is dependent on gain and the type of load. In fluorescence, we have the *Raman effect*, for which Prof. Raman won the Nobel Prize in 1930. Because of the *Fechner-Benham effect*, a tv scan can make a red image from 7 frames of which the first three are black, the next three white or transparent, and the last cross-hatched.

The *Zeeman* and *Stark effects* result in a split in the hydrogen line from a sodium flame under the influence of strong magnetic or electric fields respectively.

It is precisely because men of science place high emotional values on prestige and attainment that history records the enrichment of man's fund of knowledge from century to century.

JOHN J. RIVERA

ITT LABORATORIES
NUTLEY, N. J.

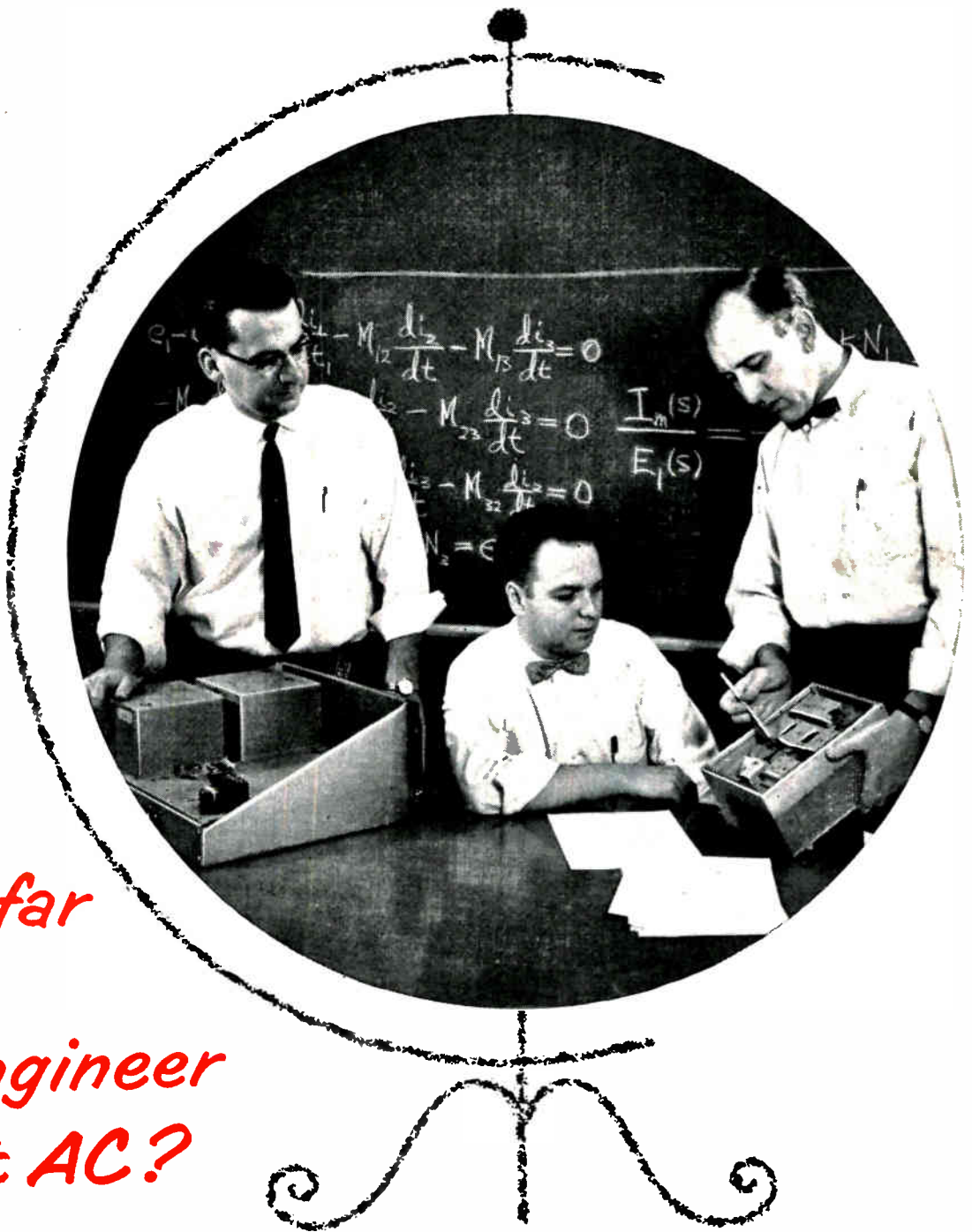

*How far
can
an engineer
go at AC?*

Across the country or around the globe. You will find opportunity in any one of AC's bustling plants or installations.

Your future is bright here. If you are a graduate engineer in the electronics, electrical or mechanical fields—you can go *places* at AC, because AC is going *places*.

Today you can help AC turn out AChiever inertial guidance systems, plus a wide variety of other electro-mechanical, optical and infra-red devices. Tomorrow you can work on instrumentation needs for the "space age".

What's more, at AC you'll enjoy highest professional status, advance in proportion to your ability, and find the long-range security of working for the leader in the field—General Motors.

This merits your attention. For details, just write the Director of Scientific and Professional Employment: Mr. Robert Allen, Dept. A, Oak Creek Plant, Box 746, South Milwaukee, Wisconsin; or Mr. M. Levett, Dept. A, 1300 N. Dort Highway, Flint 2, Michigan.



SPARK PLUG  THE ELECTRONICS DIVISION OF GENERAL MOTORS

Inertial Guidance Systems • Afterburner Fuel Controls • Bombing Navigational Computers • Gun-Bomb-Rocket Sights
Gyro-Accelerometers • Gyroscopes • Speed Sensitive Switches • Speed Sensors • Torquemeters • Vibacall • Skyphone

How a creative engineer can grow with IBM

"Certainly my present assignment on the B-70 offers many growth opportunities," says Project Engineer Edward V. Zaucha. Designed to fly farther, faster and higher than any manned aircraft ever has before, the B-70 requires a completely new radar display system. "My responsibility includes the design of new cathode ray tube circuits plus system studies dealing with specific bomb-nav problems. These studies cover related equipment, such as the search radar and circuit indicator devices. In addition, I coordinate the development of storage tubes, high voltage power supplies and other equipment. A job that covers this much territory is a creative challenge. With IBM I have the opportunity to use all of my training; and in addition, I learn new things every day that will advance my engineering career."

Career opportunities in these areas . . .

- Airborne digital & analog computers
- Ground support equipment
- Inertial guidance & missile systems
- Information and network theory
- Magnetic engineering
- Maintainability engineering
- Optics
- Radar electronics & systems
- Servomechanism design & analysis
- Theoretical design & analysis
- Transistor circuits

Qualifications: B.S., M.S. or Ph.D. in Electrical or Mechanical Engineering, Physics, or Mathematics, and proven ability to assume a high degree of technical responsibility in your sphere of interest.

IBM is a recognized leader in the rapidly expanding electronic computer field. Its products are used for both commercial and military applications. Continuous growth means excellent advancement opportunities. The "small-group" approach assures recognition of individual merit. IBM provides excellent company benefits and salaries are commensurate with your abilities and experience.

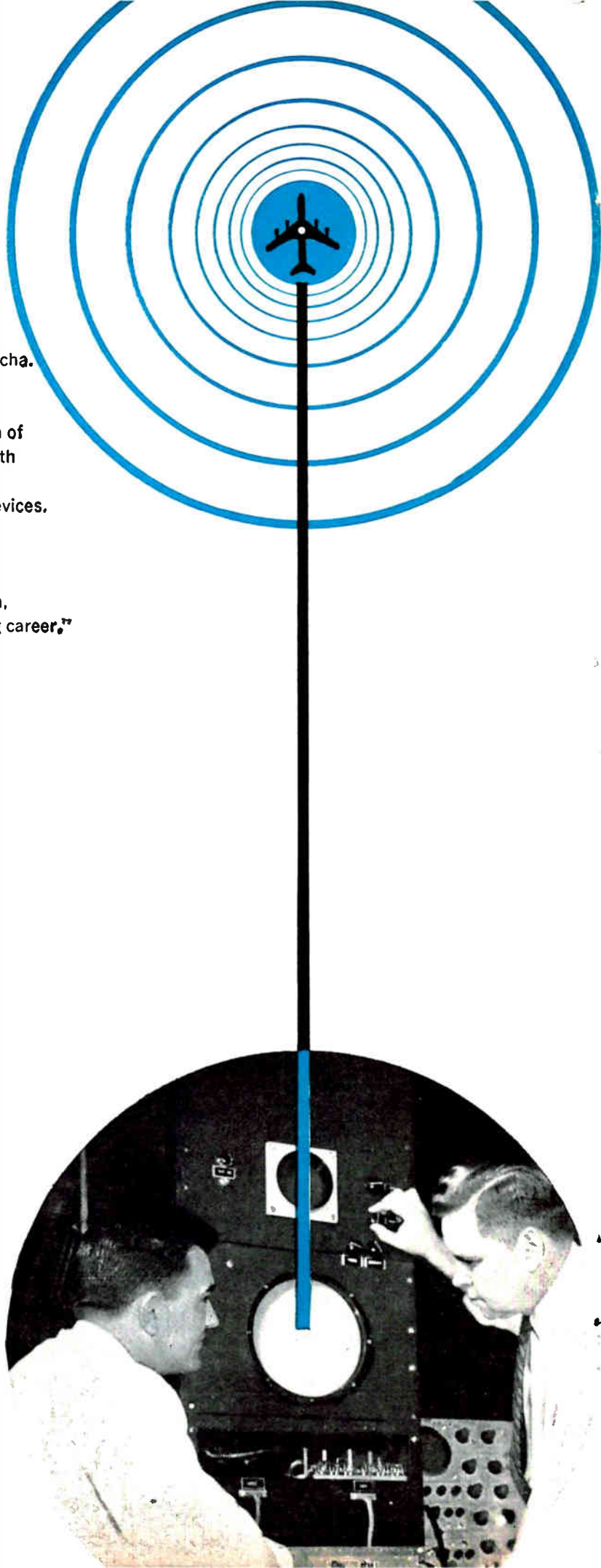

Assignments now open include . . .

RADAR ENGINEER to provide topographical sensors for airborne and space systems. Design airborne radar pulse, microwave and deflection circuitry. Analyze doppler radar systems for theoretical accuracy and performance limitations.

Qualifications: Bachelor's or advanced degree in E.E. with 3 years' experience in radar system development, including display and circuits, control consoles, and radar design.

SYSTEMS ENGINEER to design and analyze closed-loop systems of inertial and radar equipment, display materials, and computers.

Qualifications: Bachelor's or advanced degree in E.E. or Aeronautical. At least 2 years' experience in systems analysis. Additional experience desired in development of military devices—servomechanisms, radar or computers.

704 PROGRAMMER ANALYST to study data flow diagrams and write differential equations of a circuit diagram. To investigate analog and digital real-time control systems using digital and/or analog computer.

Qualifications: M.S. in Physics and 2 years' experience in control systems analysis and/or shielding techniques. Must know transforms, numerical analysis, and be able to construct mathematical model of a reactor.

STATISTICIANS to handle analysis-of-variance and multiple-regression problems. Design experiments for engineering applications and select the optimum form of statistical analysis. Assist engineering in areas such as reliability analysis and human factors engineering by developing statistical programs for the IBM 704.

Qualifications: M.S. in Statistics, with major work in math statistics. Minimum experience, 2 years, preferably with engineering applications.

SENIOR OPERATIONS RESEARCH ANALYST to apply advanced math techniques to weapons systems analysis and evaluation. Entails simulating tactics involving advanced weapons systems then deriving methods for evaluating operational effectiveness of alternate design concepts. Will work extensively with IBM 704 and other digital and analog computers.

Qualifications: M.S. or Ph.D. in Mathematics or Physics and 3 to 5 years' experience.

There are other openings in related fields to broaden your skills and knowledge.

For details, just write, outlining background and interests, to:

Mr. P. E. Strohm, Dept. 554A
International Business Machines Corp.
Owego, New York

IBM

MILITARY PRODUCTS 

ELECTRONIC ENGINEERS

Research & Development

Move ahead with a young, rapidly expanding organization in Hicksville, LI, N. Y.

PROJECT ENGINEERS SENIOR ENGINEERS ENGINEERS

B.S. in E.E. or Physics

We need at once for lifetime careers—additional trained personnel, at all levels, experienced in circuitry and equipment design or applicable exp to work on UHF & VHF systems, wide band knowledge desirable; for challenging assignments on electronic counter-measure systems for military application and electronic instruments for civilian use.

**Salaries commensurate with ability.
Excellent benefits including Profit
Sharing Retirement Trust Plan.**



Call for interview

J. V. Hicks
OVerbrook 1-7100

or send resume
in confidence to

INSTRUMENTS FOR INDUSTRY, INC.

101 New South Rd. Hicksville, LI, N. Y.

TECHNICAL SALES ELECTRONICS

A proven record of sales ability in the electronics industry with strong emphasis on Air Force contracts will qualify for a top sales position in the new West Coast office (Los Angeles) of one of the largest electronic manufacturing and engineering companies. Address:

P-9636, Electronics
1125 W. 6th St., Los Angeles 17, Calif.

ELECTRONIC and ACOUSTICAL ENGINEERS WANTED

By Electro-Voice, Inc.

For research, development and design. Excellent opportunity for advancement and interesting work in rapidly expanding company. Write: Vice President for Engineering, Electro-Voice, Inc., Buchanan, Michigan

A MICROWAVE & TUBE GOLD MINE!

3 Cm RF HEAD
of the APS23
RADAR

Consisting of

Microwave Plumbing
35 TUBES including
4J52 Magnetron 2 Klystrons
also 3 Silicon crystals,
2 Germanium diodes,
7 Relays and countless
other parts.

Motor with blower,
various transformers,
60 Megacycles IF Strip,
10 MC band-width etc.

(Government cost for
tubes alone over 500
dollars.) Your price
with all tubes as above

\$195.00

Complete with 6510
Magnetron and all
other tubes Rugged-
ized type \$245.00.

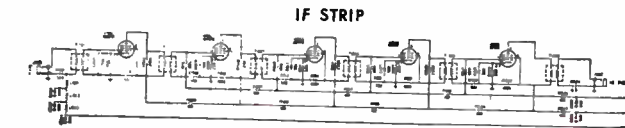

KLYSTRON OSCILLATOR

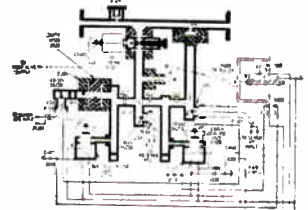

AFC CONTROL

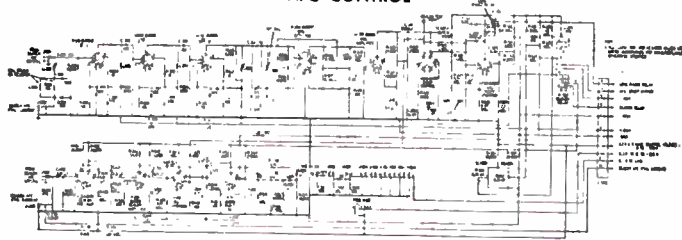

MAGNETRON TRANSMITTER

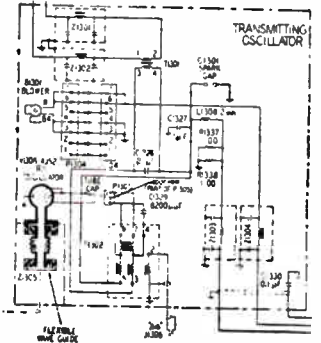

IF RECEIVER

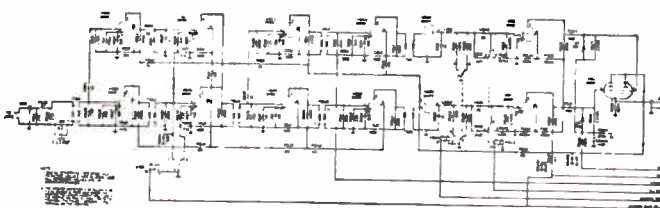

Practically every type of
microwave and radar test
equipment. Also magne-
trons, klystrons, receiving
and transmitting tubes of
every description.

Minimum
Order,
\$25.00



Phone: ORegon 4-7070

LIBERTY ELECTRONICS, INC.

119 PRINCE ST.
NEW YORK 12, N. Y.
Cables: TELSERUP

EMPLOYMENT OPPORTUNITIES

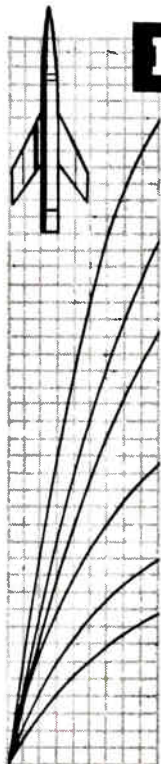

ENGINEERS

JUNIOR • SENIOR • PROJECT

STEP UP TO LEAR

Engineers, if you are experienced in the design and development of air and/or ground based communication and navigation equipment, here is the opportunity you have been looking for.

Lear, for twenty eight years a pioneer in aircraft radio communication, navigation equipment, automatic flight controls and flight indicators, is moving ahead in many new fields.

Lear offers unlimited opportunities for advancement and greater responsibilities to creative minded, electronic engineers.

If you would like to work in sunny Southern California on varied electronic projects, write to:

L. S. PECK, Manager
Industrial Relations

LEAR, INC., 3171 South Bundy Drive • Santa Monica, California

CHIEF DESIGN ENGINEER ELECTRONIC CONNECTORS

Excellent opportunity for experienced engineer with managerial and creative abilities to design, develop and administer a complete line of miniature AN, rack and panel and micro-miniature electrical connectors for commercial and military use. Individual should have specific experience on environmental connectors in cylindrical or rectangular configurations and be capable of assuming full responsibility for all stages of development and manufacture. Salary in five figures with substantial advancement possibilities for the right man. Specify age, education, experience, previous earnings, etc. in first letter.

METHODE MFG. CORP.

7447 W. WILSON AVE., CHICAGO 31, ILL.

ADDRESS BOX NO. REPLIES TO: Box No.
Classified Adv. Div. of this publication.
Send to office nearest you.
NEW YORK 36: P. O. BOX 12
CHICAGO 11: 520 N. Michigan Ave.
SAN FRANCISCO 4: 68 Post St.

POSITIONS WANTED

Wanted—Concern needing top-quality engineering—BME and BEE degrees—10 years experience in industrial, military, and missile fields—prefer Mid-West location. PW-9626, Electronics.

Patent Attorney and Electronic Engineer, age 34, 5 years engineering experience and 8 years experience with large firm in all phases of patent law practice, in connection with wide variety of inventions, primarily in electronics, desires position involving creative engineering work as well as patents, preferably in Chicago area. PW-9655, Electronics.

Need Engineers?

Contact them through this
EMPLOYMENT OPPORTUNITIES section

WE EMPLOY THE HANDICAPPED

WE FIND
IT'S GOOD BUSINESS



A MAJOR
ELECTRONICS MANUFACTURER

TEST YOUR MAGNETIC CIRCUITS



**RAWSON FLUXMETER
TYPE 504**

The only portable fluxmeter available which returns rapidly to zero when a single button is depressed. Simple and fast in operation. Convenient and light in weight.

Not limited to a single type of measurement. Has universal application for laboratories or production. Measures strength of magnets and electromagnets, permeability and hysteresis loops for iron and steel, total flux lines in circuit, flux lines developed in air gap, etc.

Has a mechanical clamp to protect the pivots and jewels when, in transit.

RAWSON ELECTRICAL INSTRUMENT COMPANY

111 POTTER STREET, CAMBRIDGE 42, MASS.

CIRCLE 56 READERS SERVICE CARD
ELECTRONICS — January 23, 1959

INDEX TO ADVERTISERS

*AC Electronics Division	88
Aemco, Inc.	16
*Allen-Bradley	17, 18
American Standard, American Blower Div.	80
*Arnold Engineering Co.	3
*Baird-Atomic, Inc.	73
Bausch & Lomb Optical Co.	88
Beattie-Coleman Inc.	74
Bomac Laboratories, Inc.	3rd Cover
*Bussmann Mfg. Div., McGraw-Edison Co.	10
*Cambridge Thermionic Corp.	19
*Clevite Electronic Components.....	30
Convair Instruments	63
Cutler-Hammer, Inc.	76
Deleo Radio	2
du Pont de Nemours & Co., Inc., E. I. "Freon" Products Div.	15
*Eldema Corporation	77
*Epsco, Inc.	21
*General Magnetics, Inc.	22
*General Radio Company.....	2nd Cover
*General Transistor Corporation	26
*Hewlett-Packard Company	13
*Hughes Aircraft Company	6, 7
*IT&T Industrial Products Div.....	12
Jones & Lamson Machine Co.....	79
*Kintel, a Div. of Colu Electronics Inc... 8	
Klein & Sons, Mathias	56
*Knights Co., James	70
*Krengel Mfg. Co.	81
*Krohn-Hite Corporation	64
Lockheed Missile Systems Division.....	75
*Magnetics, Inc.	58
*New Hermes Engraving Machine Corp..	70
* See advertisement in the June, 1958 Mid-Month ELECTRONICS BUYERS' GUIDE for complete line of products or services.	

If you produce
**FERRITES
ELECTRONIC CORES
MAGNETIC RECORDING
MEDIA**

... then let WILLIAMS
help by supplying you
with latest, authoritative
technical data on

**PURE FERRIC
OXIDES
MAGNETIC IRON
OXIDES
MAGNETIC IRON
POWDERS**

Since final quality of your production of ferrites, electronic cores, and magnetic recording media depends on proper use of 3 specialized groups of magnetic materials ... you'll find it mighty helpful to have all the latest, authoritative technical data describing the physical and chemical characteristics of each. This information is available to you just for the asking. So send today. Meanwhile, here are highlights of each product group.

Pure Ferric Oxides: For the production of ferrite bodies, we manufacture a complete range of high purity ferric oxide powders. These are available in both the spheroidal and acicular shapes, with average particle diameters from 0.2 to 0.8 microns. Impurities such as soluble salts, silica, alumina and calcium are at a minimum.

Magnetic Iron Oxides: For magnetic recording—audio, video, instrumentation etc.—we produce a group of special magnetic oxides with a range of controlled magnetic properties. Both the black ferros-ferric and brown gamma ferric oxides are available.

Magnetic Iron Powders: For the fabrication of magnetic cores in high-frequency, tele-communication, and other magnetic applications, we make a series of high purity iron powders.

These materials are products of Williams research facilities. For your convenience, we maintain fully equipped laboratories for the development of new and better inorganic materials. We also investigate new fields of application. Please write, stating your problem. We'll be glad to cooperate. Address Dept. 25, C. K. Williams & Co., 640 N. 13th St., Easton, Pa.

WILLIAMS

COLORS & PIGMENTS

C. K. WILLIAMS & CO.

East St. Louis, Ill.

Easton, Penna. • Emeryville, Calif.

CIRCLE 57 READERS SERVICE CARD

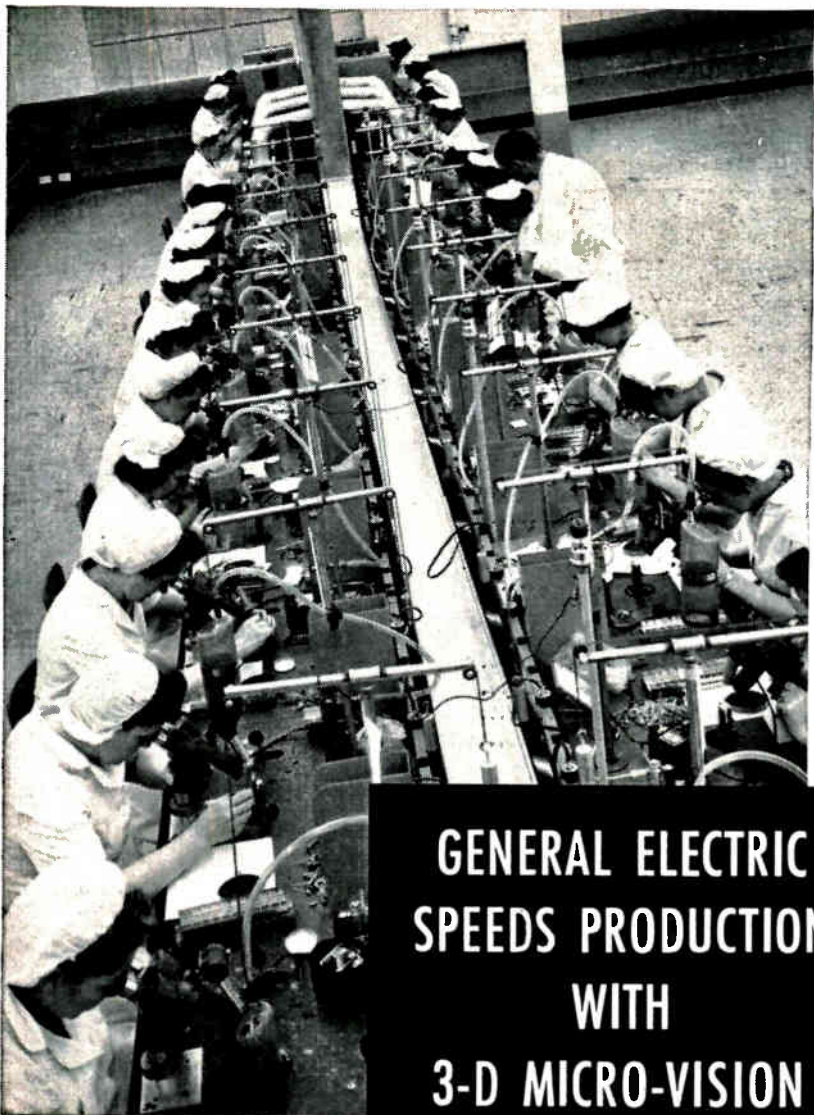

**GENERAL ELECTRIC
SPEEDS PRODUCTION
WITH
3-D MICRO-VISION**

How B & L Stereomicroscopes help in assembly of ultra-precision transistors

These skilled operators are doing a job that "just couldn't be done without stereomicroscopes," according to Norman Spoonley, foreman, Semiconductor Products Dept., General Electric Co., Buffalo. This critical phase of transistor assembly involves soldering a 1-mil nickel wire between a nickel tab and the .6-mil core of a .1" germanium pellet which, in turn, is fused between two 5-mil nickel wires. B&L Stereomicroscopes make it possible by showing enlarged views in natural 3D. Air-tight, dust-free design keeps images sharp, clear, undistorted . . . for full-working-day efficiency without visual fatigue. In assembly, quality control, inspection, some 100 B&L microscopes help G. E. mass-produce to highest precision standards. If you have small-parts assembly and inspection problems, you need B&L Stereomicroscopes.

**SEE FOR YOURSELF!
MAIL COUPON FOR
FREE 15-DAY TRIAL**

BAUSCH & LOMB OPTICAL CO.
70937 St. Paul Street, Rochester 2, N. Y.
 I'd like to borrow a B&L Stereomicroscope for 15-day trial without cost or obligation.
 Send me Stereomicroscope Catalog D-15.

Name

Title

Company

Address

BAUSCH & LOMB



*Oak Mfg. Co.	67
Penta Laboratories, Inc.	61
Plasencia Inc., Joseph	70
*Radio Corporation of America....	4th Cover
*Rawson Electrical Instrument Co.....	87
*Raytheon Mfg. Co.	5
San Antonio Chamber of Commerce....	76
*Sanders Associates, Inc.	59
*Shalleross Mfg. Co.	60
Sonotone	57
*Specific Products	27
*Sperry Electronic Tube Div., Sperry Rand Corp.	69
Sprague Electric Co.	24, 25
*Telrex Laboratories	81
*Texas Instruments Incorporated	11
Thompson Ramo Woodridge, Inc.....	51
*Transitron Electronic Corp.	55
Triplett Electrical Instrument Co.....	29
*Varflex Corporation	65
Wales Stripplit, Inc.	28
White S.S., Industrial Div.	14
*Williams & Co., C. K.....	87

CLASSIFIED ADVERTISING

F. J. Eberle, Business Mgr.

EMPLOYMENT OPPORTUNITIES...84-86
EQUIPMENT

(Used or Surplus New)
For Sale

ADVERTISERS INDEX

Electro-Voice Inc.	85
Instruments for Industry, Inc.....	85
International Business Machines Corp..	84-85
Lear Inc.	86
Liberty Electronics Inc.....	86
Methode Manufacturing Corp.....	86

* See advertisement in the June, 1958 Mid-Month ELECTRONICS BUYER'S GUIDE for complete line of products or services.

This index is published as a service. Every care is taken to make it accurate, but ELECTRONICS assumes no responsibilities for errors or omissions.

The first dual TR tubes came from Bomac.
The first shutter tubes came from Bomac.
The first ceramic window TR's came from Bomac.
The first folded cylinder Pre-TR's came from Bomac.
The first phase control TR tubes (single and dual) came from Bomac.
The first miniaturized crystal protectors came from Bomac.
The first 4.3 mm duplexer, and 4.3 mm magnetron came from Bomac.
The first UHF hybrid duplexer came from Bomac.
The first phase control coaxial balanced duplexer came from Bomac.

**Doesn't it make sense, then — when you have
any problem whatever in microwave tube
engineering, development, production —
To come to Bomac first?**

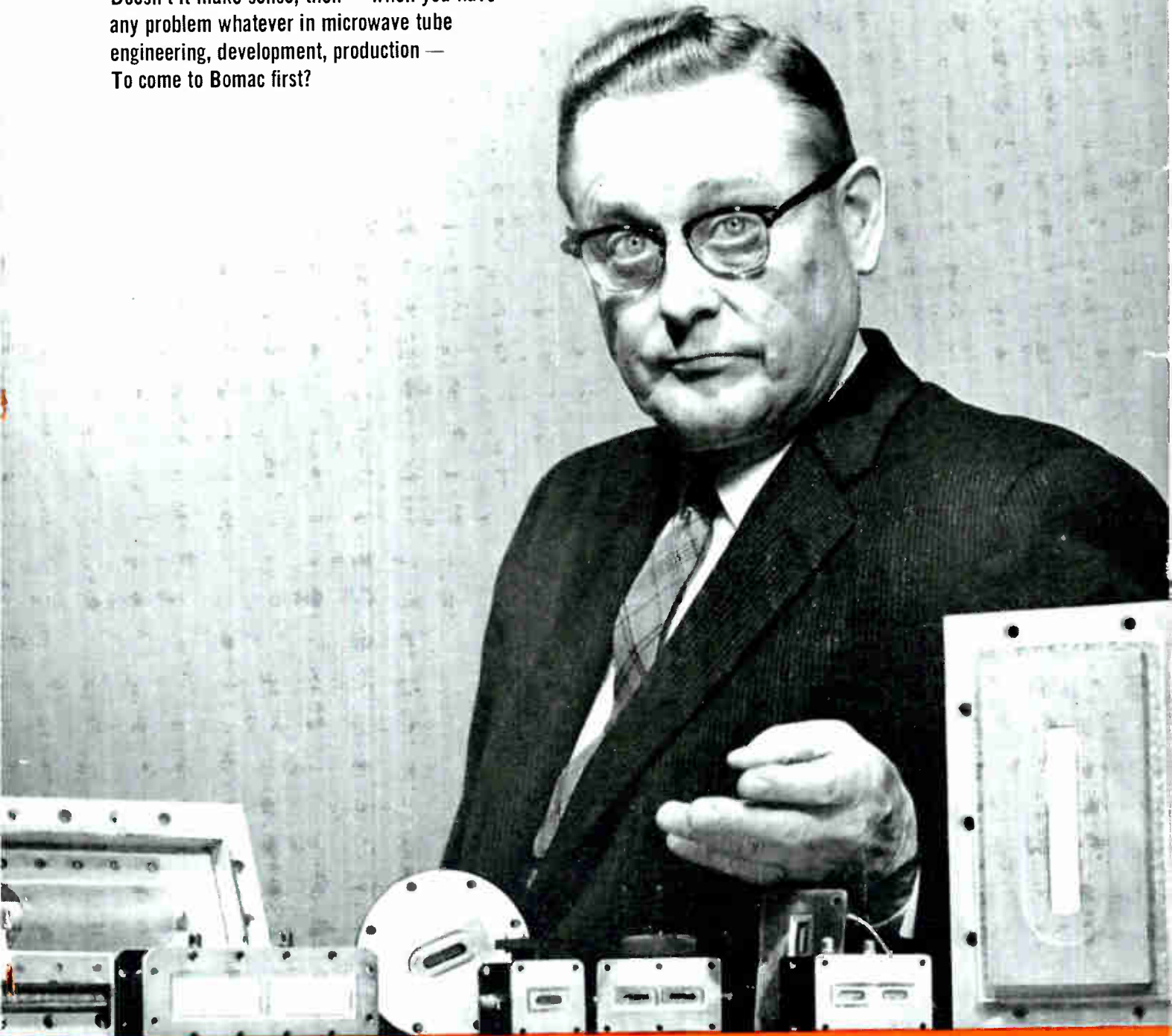

Write for free six page folder.

Leaders in the design, development and manufacture of TR, ATR, Pre-TR tubes, shutters; reference cavities; crystal protectors; silicon diodes; magnetrons; klystrons; duplexers; pressurizing windows; noise source tubes; high frequency triode oscillators; surge protectors

Offices in major cities: Chicago • Kansas City • Los Angeles • Dallas • Dayton • Washington • Seattle • San Francisco • Canada: R-O-R Associates Limited, 1470 Don Mills Road, Don Mills, Ontario • Export: Maurice I. Parriner, 741 745 Washington St., N. Y. C. 14, N. Y.



Bomac LABORATORIES, INC.
Salem Road, Beverly, Massachusetts

RCA

Computer Tubes
Voltage Regulator Tubes
Low-Power Tubes
High-Power Tubes
Super-Power Tubes
Projection Kinescopes
TV Camera Tubes
"Special Red" Tubes
UHF "Pencil-Type" Tubes
Display Storage Tubes
Radechons
Graphechons
Phototubes
Multiplier Phototubes
Photoconductive Cells
Cathode-Ray Tubes
Thyratrons
Rectifier Tubes
Traveling-Wave Tubes
Tunable Magnetrons
"Premium" Type Tubes

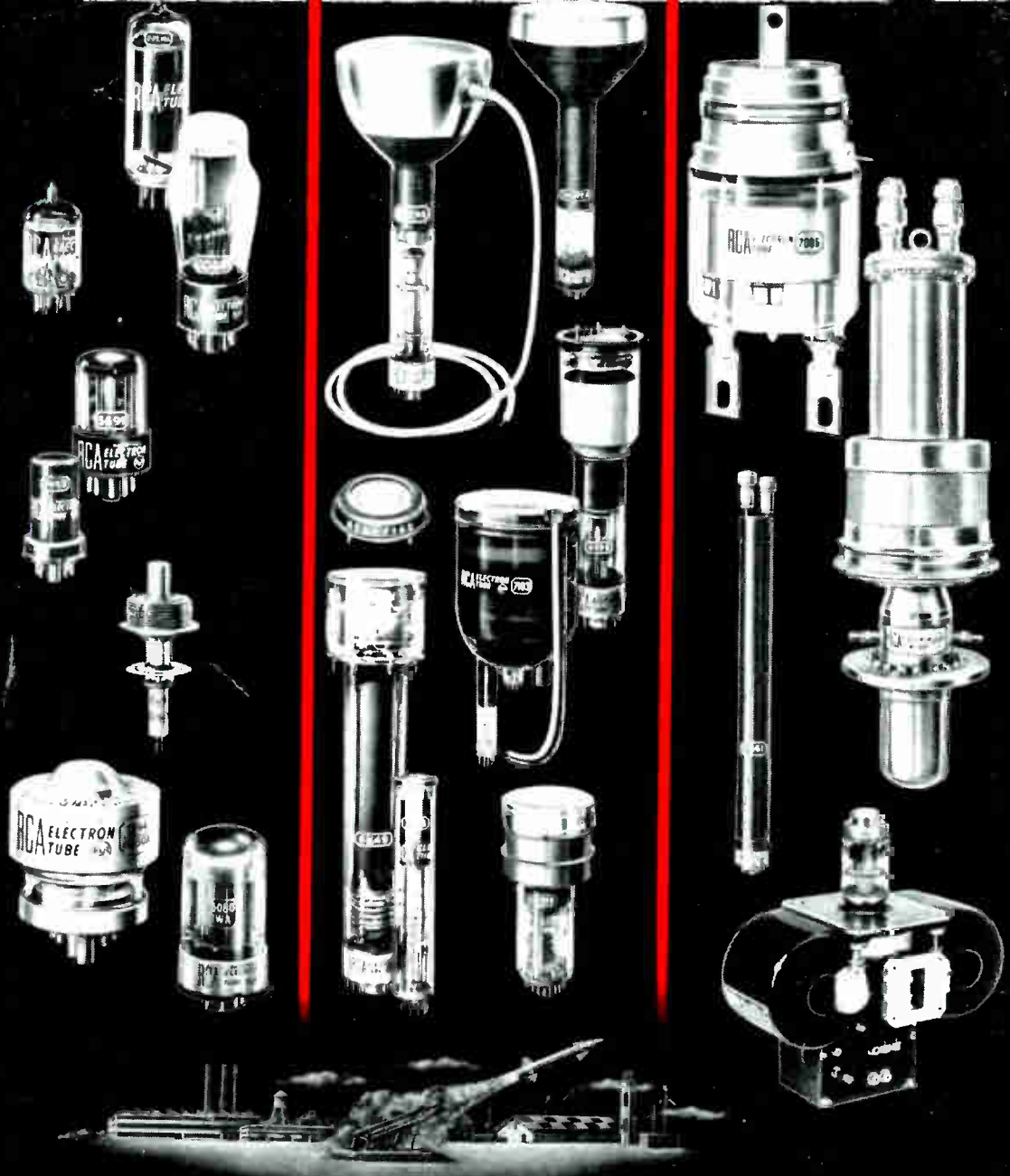

"Across the board"

...FOR INDUSTRY AND THE MILITARY

Regardless of the application areas you are working in—radio-frequency, audio-frequency, video, photoelectronic, oscillographic, power—you can rely on RCA as the one dependable source of quality-engineered tubes *across the board*.

For help in selecting the right tubes for your application—please get in touch with the RCA Field Representative at the RCA office nearest you. For tube technical data on specific tube classes, simply write RCA Commercial Engineering, Section A-19-Q-3, Harrison, N. J.



RADIO CORPORATION OF AMERICA
Electron Tube Division
Harrison, N. J.

Industrial Products Sales

EAST: 744 Broad Street
Newark 2, N. J. • HUmboldt 5-3900

MIDWEST: Suite 1154, Merchandise Mart Plaza
Chicago 54, Ill. • WHitehall 4-2900

WEST: 6355 E. Washington Blvd.
Los Angeles 22, Calif. • RAYmond 3-8361

Government Sales

224 N. Wilkinson Street
Dayton 2, Ohio • BALdwin 6-2366
1625 "K" Street, N. W.
Washington 6, D. C. • DIstrict 7-1260
415 S. Fifth Street
Harrison, N. J. • HUmboldt 5-3900