

electronics

JANUARY 1, 1957

A MCGRAW-HILL PUBLICATION • PRICE 75 CENTS

THYRATRONS CONTROL
SPEAKER-GRILLE CUTTER

**SINGLE-CARRIER
TELEVISION** ..page 151

**Airborne Equipment
Design**page 166

**Reflection
Nomographs** .page 184



OUR MILLIONTH FILTER SHIPPED THIS YEAR...

FILTERS

FOR EVERY APPLICATION



TELEMETERING FILTERS

UTC manufactures a wide variety of band pass filters for multi-channel telemetering. Illustrated are a group of filters supplied for 400 cycle to 40 KC service. Miniaturized units have been made for many applications. For example a group of 4 cubic inch units which provide 50 channels between 4 KC and 100 KC.

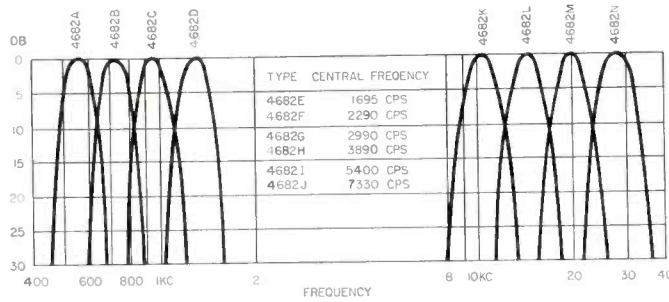

Dimensions:
(4682A) 1½ x 2 x 4"

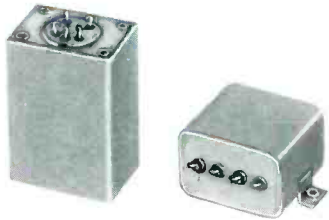

Dimensions:
(3834) 1¼ x 1¼ x 2-3/16"
(2000, 1) 1¼ x 1¼ x 1½"

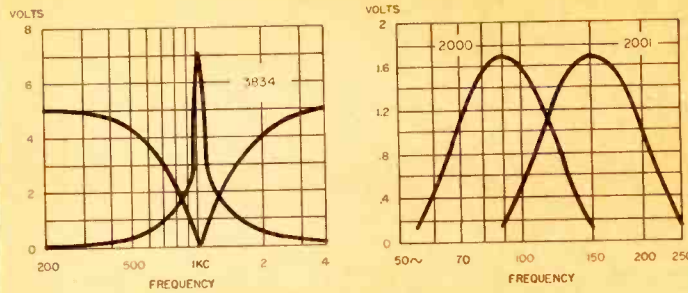

AIRCRAFT FILTERS

UTC has produced the bulk of filters used in aircraft equipment for over a decade. The curve at the left is that of a miniaturized (1020 cycles) range filter providing high attenuation between voice and range frequencies.

Curves at the right are that of our miniaturized 90 and 150 cycle filters for glide path systems.

CARRIER FILTERS

A wide variety of carrier filters are available for specific applications. This type of tone channel filter can be supplied in a varied range of band widths and attenuations. The curves shown are typical units.

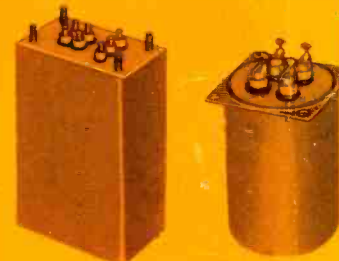
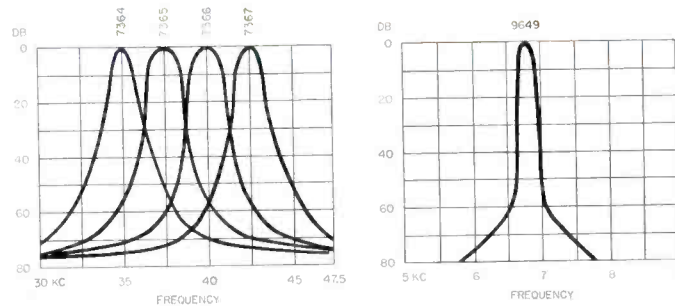

Dimensions:
(7364 series) 1½ x 1½ x 2¼"
(9649) 1½ x 2 x 4"

DISCRIMINATORS

These high Q discriminators provide exceptional amplification and linearity. Typical characteristics available are illustrated by the low and higher frequency curves shown.

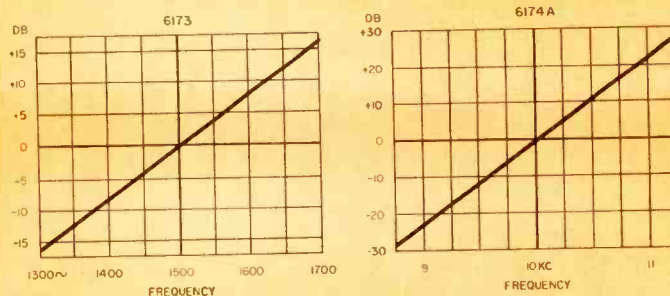

Dimensions:
(6173) 1-1/16 x 1½ x 3"
(6174A) 1 x 1¼ x 2¼"

For full data on stock UTC transformers, reactors, filters, and high Q coils, write for Catalog A

UNITED TRANSFORMER CO

150 Varick Street, New York 13, N. Y. EXPORT DIVISION: 13 E. 40th St., New York 16, N. Y. CABLES: "ARLA"
PACIFIC MFG. DIVISION: 4008 W. Jefferson Blvd., Los Angeles 16, Calif.

electronics

JANUARY 1 • 1957

A McGRAW-HILL PUBLICATION

H. W. MATEER, *Publisher*
W. W. MacDONALD, *Editor*
VIN ZELUFF, *Managing Editor*

Associate Editors

JOHN MARKUS
ALEXANDER A. McKENZIE
JOHN M. CARROLL
JOHN M. KINN, Jr.
FRANK LEARY
MICHAEL F. TOMAINO
HOWARD K. JANIS
SYLVESTER P. CARTER

Assistant Editors

WILLIAM P. O'BRIEN
WILLIAM G. ARNOLD
DAVID A. FINDLAY
HAIG A. MANOOGIAN
GEORGE SIDERIS
LAWRENCE KAMARCK
EDWARD DeJONGH
JOHN F. MASON

Pacific Coast Editor (Los Angeles)

HAROLD C. HOOD

Midwestern Editor (Chicago)

HAROLD HARRIS

New England Editor (Boston)

ROLAND J. CHAREST

HARRY PHILLIPS, Art Director

ROY THOMPSEN
BARBARA ELLWOOD
JOHN C. WRIGHT, Jr., *Production*
JEAN L. MATIN

Editorial Assistants

GLORIA J. FILIPPONE
ARLENE SCHILP
BERNICE DUFFY
BARBARA HEARST
NOREEN HENNESSY
PHYLIS A. CRONIN
BARBARA M. SHAW

WALLACE B. BLOOD, Manager

JAMES GIRDWOOD, *Adv. Sales Mgr.*
R. S. QUINT, *Buyers' Guide Mgr.*
FRANK H. WARD, *Business Mgr.*
G. E. POMEROY, *Classified Mgr.*
JEAN W. HEIGES, *Research*

New York

DONALD H. MILLER
HENRY M. SHAW
MARTIN J. GALLAY

Boston

WM. S. HODGKINSON

Philadelphia

JAMES T. HAUPTLI

Chicago

BRUCE WINNER
WALTER M. LUCE

Cleveland

WARREN H. GARDNER

San Francisco

T. H. CARMODY
R. C. ALCORN

Los Angeles

CARL W. DYSINGER

Atlanta

R. H. POWELL

Dallas

GORDON L. JONES

London

HERBERT LAGLER

KEITH HENNEY, *Consultant*

THYRATRONS CONTROL SPEAKER-GRILLE CUTTER—Press stops at instant die cuts through layers of woven plastic, in installation made by United Shoe Machinery Corp., in high-fidelity loudspeaker plant of Almy, Hayden and Maxwell in Marblehead, Mass. (see p 162).....COVER

SHOPTALK 2

FIGURES OF THE MONTH..... 6

INDUSTRY REPORT 7

Latest Electronigraphs.....	7-26	TV Stocks Begin to Rise.....	20
Industry Boosts Plant.....	7	Transistors Control Tools.....	22
Army Takes Transistor Plunge.....	8	Checks Plugs 10,000 Feet Up.....	24
Printed Wiring Sets Record.....	8	Military Electronics.....	24
SAC Shows B-52 Electronics.....	10	Electronics Ups Stampings.....	26
Business Briefs.....	12	Transceiver Uses Transistors.....	26
British Push Simpler Flat TV.....	14	Financial Roundup.....	28
U. S. Aids Contractors.....	14	Meetings Ahead.....	28
Semiconductor Sales to Triple.....	16	Industry Shorts.....	28
Computer Use Expands.....	20		

CROSSTALK 137

FEATURES

Miniature ITV Camera Uses Drift Transistors.....	138
By L. E. Flory, G. W. Gray, J. M. Morgan and W. S. Pike	
Pulsed F-M Tests Ultrasonic Propagation.....	143
By Robert R. Unterberger	
How to Design Colpitts Crystal Oscillators.....	146
By H. E. Gruen	
Single-Carrier System for Sound and Video.....	151
By Benjamin Wolfe	
Film Reader Measures Recorded Radar Echoes.....	154
By Allan Shapiro	
Ferrite-Rod Antennas Operate in X-Band.....	159
By Frank Reggia, E. G. Spencer, R. D. Hatcher and J. E. Tompkins	
Thyratrons Control Die-Cutting Machine.....	162
By Robert W. Bradley	
Designing Airborne Equipment for Vibration.....	166
By Salvatore P. Mercurio, Jr. and Michael Belby	
Thermistors Compensate Transistor Amplifiers.....	169
By A. J. Wheeler	

CONTINUED ON NEXT PAGE

Metal Detector Finds Ducts and Pipes.....	172
By Carl David Todd	
Operational Bridge Gages High Capacitance.....	175
By R. L. Konigsberg	
Silicon Diode Chopper Stabilizes D-C Amplifier.....	178
By Lawrence Fleming	
Transistors Generate Geometric Scale.....	180
By Euyen Gatt and Jahn H. Park, Jr.	
Reflection Point and Angle Nomographs (Reference Sheet)...	184
By Z. Prihar	
Horsepower Nomograph for Antenna Rotators (Reference Sheet)	188
By Paul W. Peay	

ELECTRONS AT WORK..... 190

Heaterless Tubes	190	Traveling Wave Amplifiers	200
Tower Air Monitor	190	Oscilloscope Amplifier	202
Conelrad Control	190	Clip-On Milliammeter	204
Failure Indicators	192	By E. H. Frei and D. Treves	
White Alice Link Completed	192	Oscillograph Analyzes Cutter	204
Radio Replaces Semaphores	194	Logarithmic Amplifier	214
Remote Visual Control.....	194	By Douglas A. Kohl	
New Radars	196	Egg Candler	218
Level Indicator Uses X-Rays	196	Signal Combiner	220
Defense Inventions	198	Experimental Microwave	224
British Color TV Tests	198	Legal Medium	228
Cordless Audio Receiver	200	Random Numbers	228

PRODUCTION TECHNIQUES..... 230

Phototube-Controlled Drill	230	Drilling Pantograph	242
Assembling Molded Horns	230	Automatic Tinning Machine	244
Calibrating Transducers	232	Thread Insert for Probe Tip	250
Rubber Mat For Bench	234	Rack for Magnetic Cores	254
Detecting Oil On Mica	234	Winder for Miniature Toroids	256
Tape-Controlled Punch Press	236	By J. R. Goodykoontz	
Antenna Support		268	

NEW PRODUCTS..... 270

LITERATURE..... 331

PLANTS AND PEOPLE..... 342

NEW BOOKS..... 361

THUMBNAIL REVIEWS..... 365

BACKTALK..... 368

INDEX TO ADVERTISERS..... 421

SHOP

► **COMMUNICATIONS** . . . For many years every feature article manuscript has been numbered as soon as it is received at the New York office. The 5,000 mark was passed recently and this reminded us that there are two kinds of thought processes, or identification methods, used by people handling feature articles here.

The technical editors find it easier to refer to articles by subject, "that one on pulse counting . . . the servo story" and so on.

The nontechnical people, our secretaries, editorial assistants and others in the layout, illustration and production departments, use only the number of the article. Sometimes an editor is astonished to find out that the nontechnical people handle the numbers with facility equal to that of handling peoples' names.

Occasionally some scrambling occurs, though, when we get a letter from someone in the industry that says:

"Enclosed are some graphs you might like to add to the article by one of our engineers. "No number, no subject, no title, no author's name.

► **BILINGUAL** . . . Some language difficulties in recent months have reminded us of relatively simple differences in our own language that are too often taken for granted.

A few weeks ago we had the opportunity of briefing in New

electronics

JANUARY 1, 1957 Vol. 30, No. 1



Member ABC and ABP

TALK



ELECTRONICS EDITORIAL STAFF: Standing, left to right; Hi Phillips, Jack Kinn, Dave Findlay, Larry Kamarck, John Wright, George Sideris, John Mason, Bill O'Brien, Bill Arnold, Haig Manoogian, Ed DeJongh, Frank Leary, Alex McKenzie. Seated, beginning in foreground; Hal Hood, Sy Carter, Mike Tomaino, John Markus, Bill MacDonald, Vin Zeluff, Jack Carroll, Hap Harris, Rolly Charest, Howard Janis

York Morrie Helitzer, a member of the McGraw-Hill World News Service, just before take-off for his new post in London. Having had some electronics background, he talked our language in what we like to call simple American technical terms.

His first letter back to us after a few weeks in London crystallized the problem. He began:

"Here I am in this strange English-speaking land where a valve is a tube and a tube is a subway. . . ."

► **RAPID FEEDBACK . . .** Editors in the field often run across authors who tell them of things that resulted from publication of an article

a year or two previously.

We heard quickly from the authors of one article in the October issue, Radar Simulator for Laboratory Use, by Henry Bickel and Bob Bernstein. Henry writes:

"The results produced by the publication of our article may be of interest to you, since Bob and I feel that ELECTRONICS has helped us a great deal.

"We have had a large number of inquiries about the equipment since the article appeared, and have gotten the strong impression that a market for a really good search radar simulator exists.

"One result of having the paper appear is that one company con-

tacted us and decided to produce a commercial instrument incorporating all the carefully developed features of our laboratory unit. The simulator is now in production and is being sold at a price of \$25,400.

"We have concluded a consulting agreement with the company which we find quite rewarding."

► **ROCKETS' RED GLARE . . .** A reader reminds us that the July issue appropriately contained the article "Transistors Telemeter Small Missiles."

The basic concepts of rockets as weapons have not changed since they were used early in American history.

Published three times a month, with an additional issue in June, by McGraw-Hill Publishing Company, Inc., James H. McGraw (1860-1948), Founder. Executive, Editorial and Advertising Offices: McGraw-Hill Building, 330 W. 42 St., New York 36, N. Y. Longacre 4-3000. Publication Office, 99-129 North Broadway, Albany 1, N. Y. Donald C. McGraw, President; Paul Montgomery, Executive Vice-President; Joseph A. Gerardi, Executive Vice-President and Treasurer; Hugh J. Kelly, Executive Vice-President; John J. Cooke, Secretary; Nelson Bond, Executive Vice-President, Publications Division; Ralph B. Smith, Vice-President and Editorial Director; Joseph H. Allen, Vice-President and Director of Advertising Sales; J. E. Blackburn, Jr., Vice-President and Circulation Director.

Subscriptions: Address correspondence to Electronics—Subscription Service, 330 W. 42nd St., New York 36, N. Y. Allow one month for change of address. Subscriptions are solicited only from persons engaged in theory, research, design, production, maintenance and use of electronic and industrial control components, parts and products. Position and company connection must be indicated on subscription orders.

Single copies 75¢ for Technical Edition and 50¢ for Business Edition in United States and possessions, and Canada; \$1.50 and \$1 for Latin America; \$2.00 and \$1.50 for all other foreign countries. Buyers' Guide \$3.00. Subscription rates—United States and possessions, \$6.00 a year; \$9.00 for two years. Canada, \$10.00 a year; \$16.00 for two years. Other western hemisphere countries and the Philippines, \$15.00 a year; \$25 for two years. All other countries \$20.00 a year; \$30.00 for two years. Three-year rates accepted on renewals only, are double the one-year rate. Entered as second-class matter August 29, 1936, at the Post Office at Albany, N. Y., under act of Mar. 3, 1879. Printed in U.S.A. Copyright 1956 by McGraw-Hill Publishing Co., Inc.—All Rights Reserved.

BRANCH OFFICES: 520 North Michigan Avenue, Chicago 11, Ill.; 68 Post Street, San Francisco 4; McGraw-Hill House, London E. C. 4; National Press Bldg., Washington, D. C. 4; Architects Bldg., 17th & Sanson Sts., Philadelphia 3; 1510 Hanna Bldg., Cleveland 15; 856 Penobscot Bldg., Detroit 26; 3615 Olive St., St. Louis 8; 350 Park Square Bldg., Boston 16; 1321 Rhodes Hargety Bldg., Atlanta 3, Ga.; 1125 West Sixth St., Los Angeles 17; 919 Oliver Building, Pittsburgh 23. ELECTRONICS is indexed regularly in The Engineering Index.

NOW-PORTABLE 400 cycle power

This new frequency changer makes it possible to provide well regulated 400 cycle power conveniently and quickly. This unit, Model FCR 250, is extremely useful in a wide variety of applications including testing, production, airborne frequency control, computers, missile guidance system testing, and in practically any application where the use of 400 cycle power is advantageous.

Model FCR 250 is only one of a complete line of frequency changers available from Sorensen . . . the authority on controlled power for research and industry. Write for complete information.

ELECTRICAL CHARACTERISTICS

Input	105-125 VAC, 1 phase, 50-65 cycles
Output voltage	115 VAC, adjustable 105-125V
Output Frequency	320-1000 cps in two ranges
Voltage regulation	±1%
Frequency regulation	±1% (±0.01% with auxiliary frequency standard fixed at 400 cycles)
Load range	0-250 VA

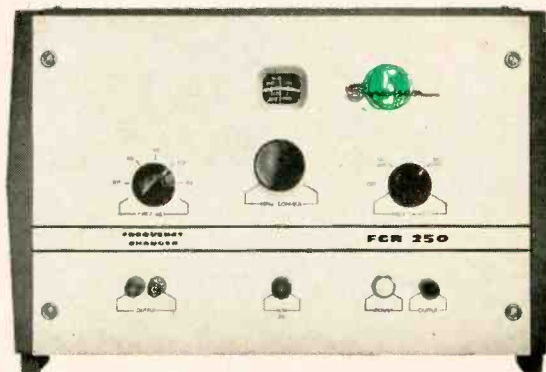
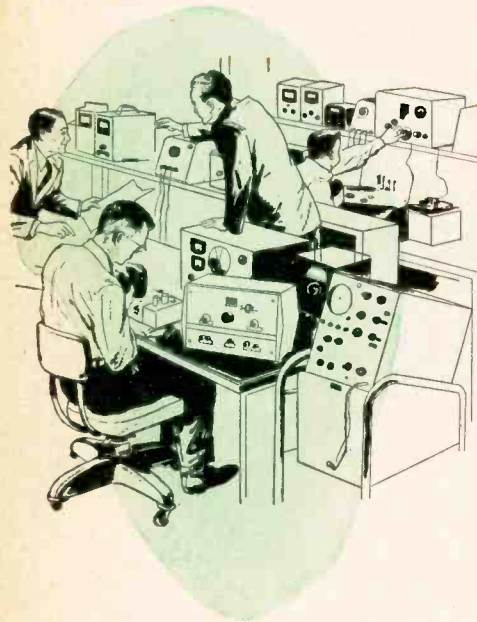

MODEL FCR 250

SORENSEN & COMPANY, INC.



STAMFORD • CONN.

In Europe, contact Sorensen-Ardag, Eichstrasse 29, Zurich, Switzerland, for all products including 50 cycle, 220 volt equipment.

D-695

THE

MUIRHEAD

DECADE OSCILLATOR

with all the best features, prominent among which are:—

- $\pm 0.2\%$ frequency accuracy within 5 minutes of switching on
- Exceptionally low harmonic content
- Output level constant to $\pm 0.5\text{dB}$ (20 c/s-30 kc/s)



See us at the I.R.E. CONVENTION
"Radio Engineering Show"
New York. March 18-21, 1957

SPECIFICATION

THE D-695 MUIRHEAD-WIGAN DECADE OSCILLATOR

FREQUENCY RANGE
10 c/s-31'200 c/s (continuously variable) in two ranges ($\times 1$ and $\times 10$)

FREQUENCY ACCURACY (within 5 minutes of switching on)
 $\pm 0.2\%$ (or better) above 100 c/s, decreasing to ± 0.3 c/s at 10 c/s

HOURLY STABILITY Better than $\pm 0.02\%$

RESETTING ACCURACY 0.1 c/s on $\times 1$ range : 1.0 c/s on $\times 10$ range

HARMONIC CONTENT AT AN OUTPUT LEVEL OF 10 mW
30 c/s-30 kc/s 0.2% into 600 ohm balanced or unbalanced; 0.5% into 10 k ohm unbalanced.
Below 30 c/s Increasing gradually to about 0.6% in the two unbalanced conditions and about 4% in the 600 ohm balanced condition at 10 c/s

HUM LEVEL WITH RESPECT TO 10 mW
-70dB (0.03% of the output voltage at 10 mW)

VARIATION OF OUTPUT LEVEL WITH FREQUENCY
50 c/s-10 kc/s Flat within $\pm 0.1\text{dB}$ 20 c/s-30 kc/s Flat within $\pm 0.5\text{dB}$
Below 30 c/s $\pm 1\text{dB}$

MAXIMUM UNDISTORTED OUTPUT POWER 10 mW

POWER SUPPLY
95-125V, 60 c/s (D-695-A/100) 190-250V, 50 c/s (D-695-A)

OVERALL DIMENSIONS
17½ in. wide \times 12½ in. high \times 8 in. deep (44.5 cm \times 31.8 cm \times 20.3 cm)

WEIGHT 37 lbs (17 kg)

WRITE NOW FOR PUBLICATION 4718

23-1C

MUIRHEAD

MUIRHEAD INSTRUMENTS INC · 677 Fifth Ave · New York 22 · N.Y. · U.S.A.
MUIRHEAD INSTRUMENTS LIMITED · STRATFORD · ONTARIO · CANADA
MUIRHEAD & CO. LIMITED · BECKENHAM · KENT · ENGLAND

PRECISION
ELECTRICAL
INSTRUMENTS

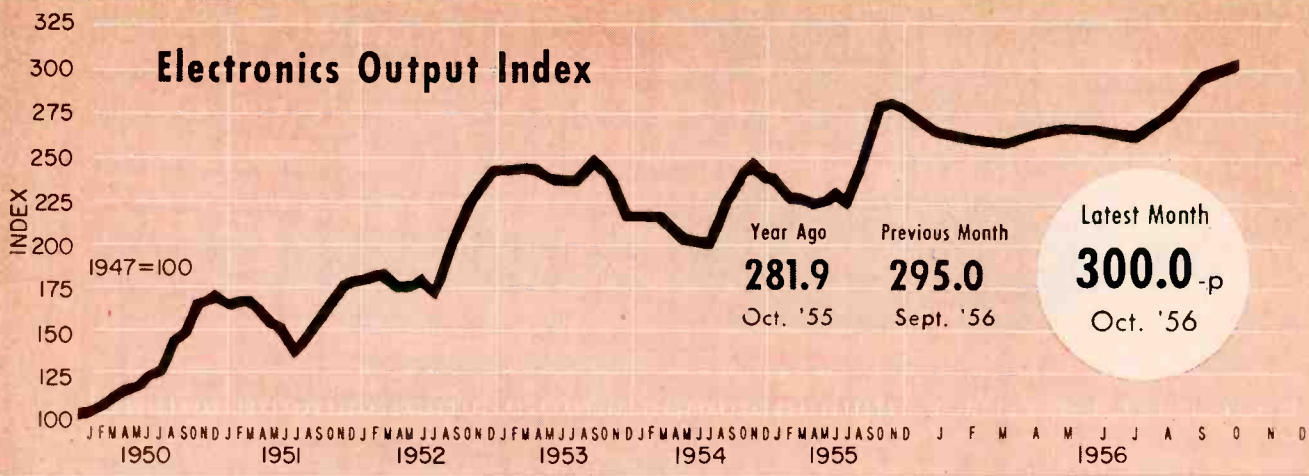

FIGURES OF THE MONTH

	Latest Month	Previous Month	Year Ago
RECEIVER PRODUCTION			
(Source: RETMA)			
	Oct. '56	Sept. '56	Oct. '55
Television sets, total	820,781	894,211	759,735
With UHF	131,243	96,785	109,574
Color sets	nr	nr	nr
Radio sets, total	1,348,864	1,319,189	1,500,206
With F-M	nr	nr	38,920
Auto sets	547,818	349,790	651,017

	Latest Month	Previous Month	Year Ago
RECEIVER SALES			
(Source: RETMA)			
	Oct. '56	Sept. '56	Oct. '55
Television sets, units	683,573	763,881	746,274
Radio sets (except auto)	585,666	756,345	724,305

	Latest Month	Previous Month	Year Ago
RECEIVING TUBE SALES			
(Source: RETMA)			
	Oct. '56	Sept. '56	Oct. '55
Receiv. tubes, total units	42,921,000	44,432,000	48,119,000
Receiv. tubes, value	\$34,362,000	\$35,093,000	\$35,105,000
Picture tubes, total units	1,146,428	1,249,624	1,224,990
Picture tubes, value	\$19,786,764	\$21,709,064	\$23,507,620

	Quarterly Figures		
	Latest Quarter	Previous Quarter	Year Ago
INDUSTRIAL TUBE SALES			
(Source: NEMA)			
	2nd '56	1st '56	2nd '55
Vacuum	\$7,680,250	\$8,754,054	\$9,832,751
Gas or vapor	\$2,983,488	\$3,394,059	\$3,365,008
Magnetrons and velocity modulation tubes	\$16,254,025	\$15,136,522	\$13,193,395
Gaps and T/R boxes	\$1,238,469	\$1,455,558	\$1,677,574

	2nd '56	1st '56	2nd '55
MILITARY PROCUREMENT			
(Source: Defense Dept.)			
Army	\$44,882,000	\$40,490,000	\$32,409,000
Navy	\$34,132,000	\$28,700,000	\$33,741,000
Air Force	\$128,781,000	\$124,828,000	\$136,879,000
Total—Electronics	\$207,795,000	\$194,018,000	\$138,211,000

	Latest Month	Previous Month	Year Ago
BROADCAST STATIONS			
(Source: FCC)			
	Nov. '56	Oct. '56	Nov. '55
TV stations on air	511	509	477
TV stations CPs—not on air	117	114	109
TV stations—new requests	55	56	208
A-M stations on air	2,987	2,969	2,808
A-M stations CPs—not on air	121	121	115
A-M stations—new requests	288	282	217
F-M stations on air	528	528	536
F-M stations CPs—not on air	22	20	20
F-M stations—new requests	7	9	4

	Latest Month	Previous Month	Year Ago
COMMUNICATION AUTHORIZATIONS			
(Source: FCC)			
	Oct. '56	Sept. '56	Oct. '55
Aeronautical	52,389	51,826	43,648
Marine	59,753	59,073	53,426
Police, fire, etc.	21,539	21,346	19,377
Industrial	32,434	31,957	27,091
Land transportation	9,227	9,164	8,216
Amateur	154,311	152,463	140,799
Citizens radio	21,356	20,715	13,862
Disaster	330	330	319
Experimental	744	740	662
Common carrier	2,368	2,418	2,040

	Latest Month	Previous Month	Year Ago
EMPLOYMENT AND PAYROLLS			
(Source: Bur. Labor Statistics)			
	Sept. '56	Aug. '56	Sept. '55
Prod. workers, comm. equip.	404,100-p	397,100-r	389,700
Average weekly earnings, comm.	\$76.92 -p	\$75.76 -r	\$74.34
Average weekly earnings, radio	\$74.15 -p	\$73.75 -r	\$70.30
Average weekly hours, comm.	40.7 -p	40.3 -r	41.3
Average weekly hours, radio	40.3 -p	40.3 -r	40.4

	Latest Month	Previous Month	Year Ago
SEMICONDUCTOR SALES ESTIMATES			
	Sept. '56	Aug. '56	July '56*
Transistors, Units	1,155,000	1,315,000	885,000

	Latest Month	Previous Month	Year Ago
STOCK PRICE AVERAGES			
(Source: Standard and Poor's)			
	Nov. '56	Oct. '56	Nov. '55
Radio-tv & electronics	353.9	370.6	438.4
Radio broadcasters	446.9	457.0	502.7
p—provisional r—revised nr—not reported			
*1955 not available			

FIGURES OF THE YEAR

	TOTALS FOR FIRST TEN MONTHS		
	1956	1955	Percent Change
Television set production	6,050,052	6,520,241	- 7.2
Radio set production	10,884,760	11,527,568	- 5.6
Television set sales	5,287,172	5,896,251	-10.3
Radio set sales (except auto)	5,990,718	4,666,981	+28.4
Receiving tube sales	390,357,000	395,788,000	- 1.4
Cathode-ray tube sales	9,233,780	8,905,771	+ 3.7
		1955 Total	
		7,756,521	
		14,894,695	
		7,421,084	
		6,921,384	
		479,802,000	
		10,874,234	

INDUSTRY REPORT

electronics—January 1 • 1957

Industry Boosts Plant Expansion Plans For 1957

Companies schedule \$100 million increase in spending for new plants and equipment

MANUFACTURERS in the electronics and electrical machinery field plan to spend \$100 million more in 1957 on new plants and equipment than they did in 1956.

Capital spending by the industry will total \$709 million this year, a 17-percent increase over the \$606-million spent in 1956. The figures come from the preliminary survey of Business' Plans for New Plants and Equipment conducted during November and early December by the McGraw-Hill department of economics.

► **Rise**—Although the \$100-million increase is a substantial rise for the

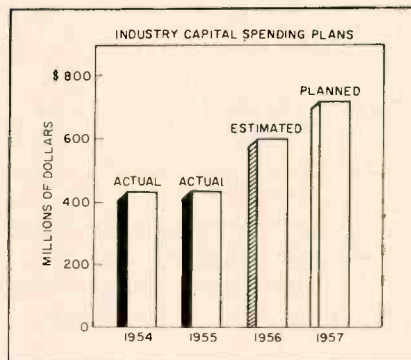

industry in 1957, it represents a leveling in the industry's capital expenditure planning. In 1956, estimated expenditures were nearly 40 percent higher than those of 1955. Thus, 1957 spending represents only half the increase that was planned a year ago. For all manufacturing, the percent change in spending be-

tween 1956 and 1957 is 14 percent so that the industry is still ahead of U. S. manufacturing as a whole.

► **Radio-TV**—The survey shows that despite higher inventories and lower sales in the tv end of the electronics, electrical machinery field, capital spending plans by appliance, radio and tv manufacturers will increase 9 percent in 1957.

► **1958**—About 29 percent of the companies in electronics and electrical machinery expect plant investments to go up in 1958. The same percentage expect spending to decrease. About 42 percent expect expenditures to remain about the same as in 1957.

This is somewhat more optimistic than the expectation of business in

ELECTRONIGRAPHS—A Year-End Glance at Electronics Industry Figures

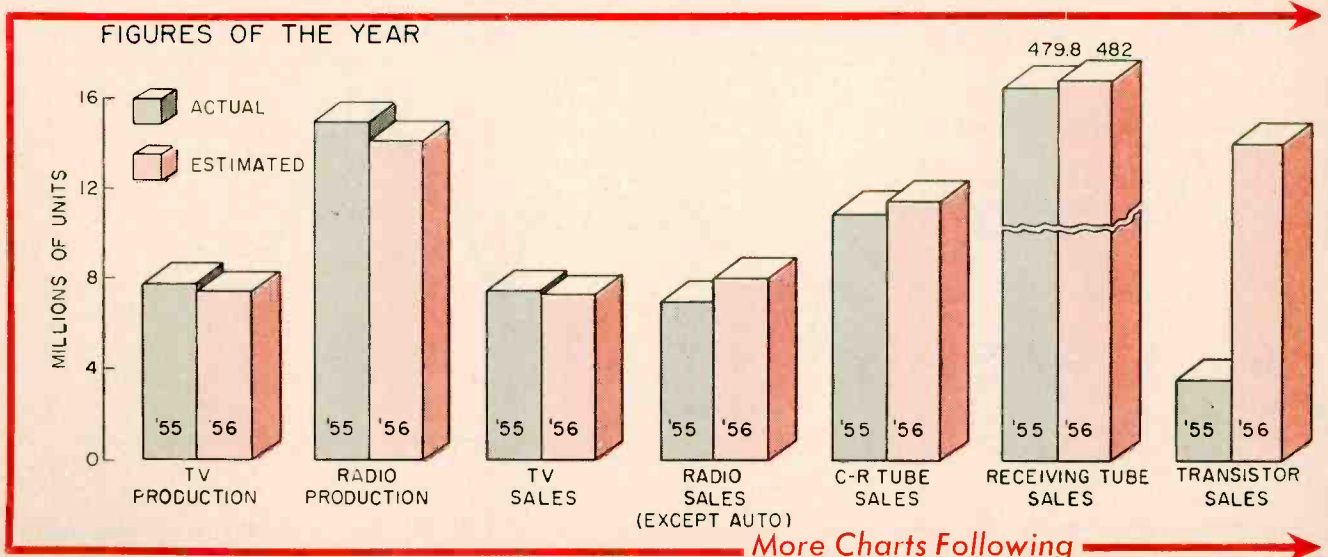

More Charts Following

general as surveyed in the study. For business as a whole, 24 percent of the firms expect plant investment to go up in 1958 compared to 1957 and 30 percent expect it to

go down. Some 46 percent expect it to remain about the same. For all manufacturing the percentages are 22 percent up, 32 percent down and 46 percent about the same.

plies, short-range portable radio sets, portable television cameras, facsimile equipments and beacons.

In addition, the Ordnance Corps is making maximum utilization of transistors in the missile programs now under active development. The transistor will also be one of the principal components for automatic assembly and printed circuit techniques.

Army Takes Transistor Plunge

Using transistors wherever feasible, plan 71 equipments having over 105 million units

FOR receivers and low-power transmitters up to 70 mc for combat area use, Army policy has been not to use vacuum tubes if transistors can do the job.

At present the Army has only one completely transistorized equipment in actual production. There are 12 equipments in pre-production or service test stage. When these models go into production—in about two years—5-million transistors will be used for the initial production. In addition, 59 equipments are now in varying stages of development and will probably be in a production status in three to five years.

In the event of partial mobilization similar to the Korean conflict, the Army would expect to use 10-million transistors just for portable radio equipment.

These are some of the highlights of Col. R. J. Meyer's discussion of the impact of military requirements on electronic development, at the

annual meeting of the American Ordnance Association.

The box shows some of the items currently in Army development.

► **Applications**—The most promising developments for immediate transistor use, according to Col. Meyer, are in the fields of carrier, switching equipments and computers where large quantities of devices will be utilized in single equipments. However, many transistors will be used in power sup-

Army Equipment	No. of Transistors
Multiple Target Coordinate Data Set.....	300
Single Target Coordinate Data Set.....	235
Teletypewriter Set, Electronic....	345
Frequency Meter.....	98
Central Office Switchboard, Automatic	4,300
Converter, Digital Data.....	110
Switching Center, Teletypewriter..	2,000

► **Studies**—In the past fiscal year, about \$15 million was contracted with major transistor manufacturers by the Army Signal Corps for feasibility studies, development of diffusion type transistors, and research in solid state devices.

Printed Wiring Sets New Record in 1956

Radio, tv and computers account for 1,000,000 sq ft increase in yearly production of boards

ESTIMATED total production of printed wiring boards for 1956 approaches 6,500,000 sq ft, based on a sampling of industry usage and available RETMA production figures for the year. This increase of approximately 1,000,000 sq ft over 1955 usage foretells a still greater increase in 1957 and a near-saturation consumption of around

ELECTRONIGRAPHS Continued

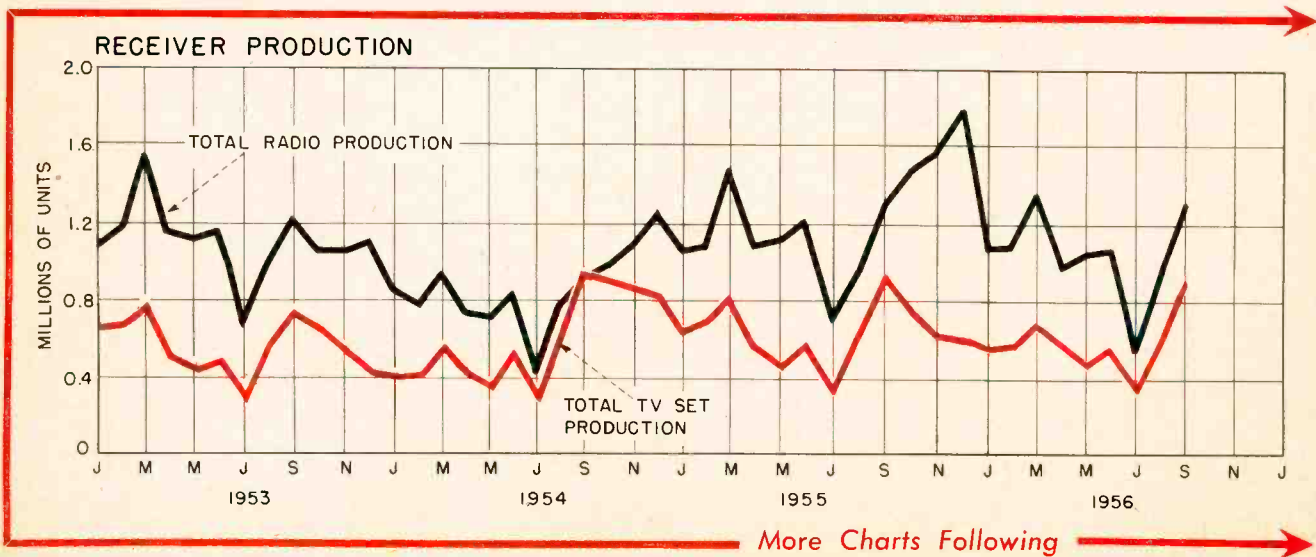

when you're **checked** by network difficulties...

... don't get into an impossible position* for want of specialized advice. Have your toroid and filter problems dealt with by the most advanced engineering in the field — by Burnell.

* Can you see why the "checkmate" below is an impossible position?

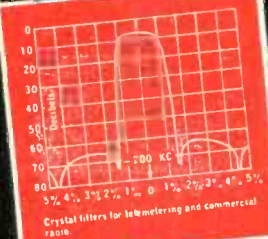
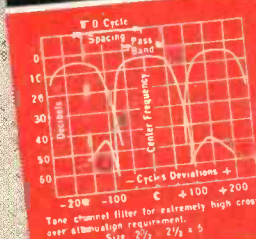
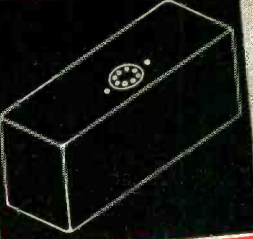
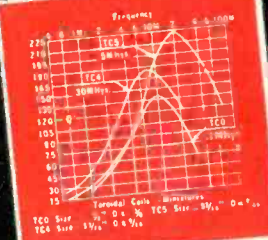
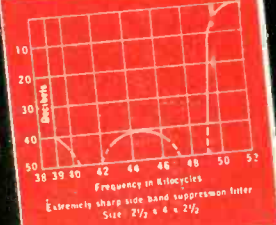
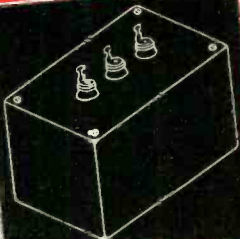
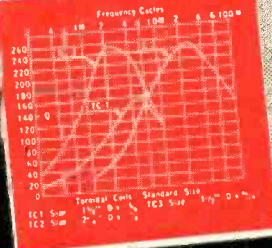
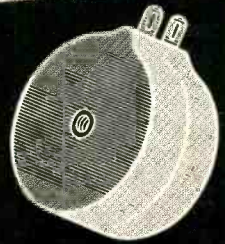
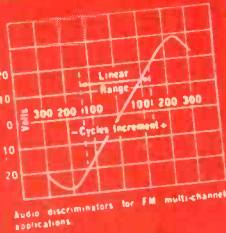

Write for technical information and free catalog. Your inquiries will be handled promptly.

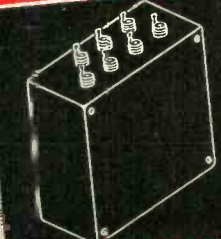
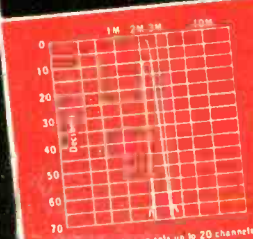

Burnell & Co., Inc.
first in toroids,
filters and related networks



Dept. E-17
45 WARBURTON AVENUE, YONKERS 2, N. Y.
TELEPHONE: Yonkers 5-6800

PACIFIC DIVISION
720 MISSION STREET, SOUTH PASADENA, CALIFORNIA
TELETYPE: PASADENA 7578

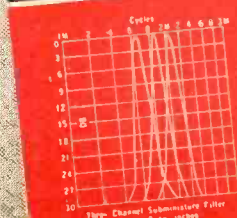

10,000,000 sq ft by 1960.

► **Basis of Estimates**—Television receivers accounted for the greatest use of etched and plated wiring boards in 1956. Although individual sets varied from 46 sq in. for one 9-in. portable to 295 sq in. for one 21-in. color set, the average of 90 sq in. for sets using printed wiring boards was largely determined by usage in the 21-in. black-and-white sets that constituted the great majority of the year's production. Assuming that three out of four sets now use printed wiring and total production is 7,000,000 sets, total tv consumption come to 3,000,000 sq ft.

With about the same percentage of the year's 14,000,000 radios each using around 20 sq in. on the average, combined production for all types of radios for the year accounts for about 1,500,000 sq ft.

The balance of 2,000,000 sq ft for combined military, industrial and computer usage is as accurate as can be determined.

► **Types of Boards**—Phenolic base materials accounted for roughly 5,200,000 sq ft, polyesters 600,000 sq ft, epoxies 400,000 sq ft and other base materials 300,000 sq ft for the year. Etched wiring went on around 4,000,000 sq ft, plated wiring on 2,300,000 sq ft and other types on the balance.



BOMBARDIER and navigator operate two-man station of K-system in B-52. Bombardier, right, takes control for target run as . . .

SAC Shows B-52 Electronics

Bomb-navigation system in use for ten years revealed as Brane system is readied for use

Now, ten years after its first use, the military shows its electronic K-system bombing and navigational control.

Used in Stratofortresses of the Strategic Air Command, SAC, the system automatically measures distance and time to target. It computes ballistics of bomb's curve for existing altitude, temperature and cross-winds, permits final hairline adjustment via radar or optical sight, triggers "bomb away" at the proper instant, then helps the navi-

gator pick the shortest way home.

► **Change**—Sperry Gyroscope, which had engineering responsibility for the system is ending its K-system activity, and turning to development and production of miniaturized, more advanced bomb-navigation gear. Later-model Boeing B-52s will have the K-system replaced with an improved "Brane" (Bombing, Radar, Navigation Equipment) now in production at IBM. As yet, none of the new systems have been installed aboard operational B-52s.

► **Background**—Originally designed, developed and produced by

ELECTRONIGRAPHS Continued

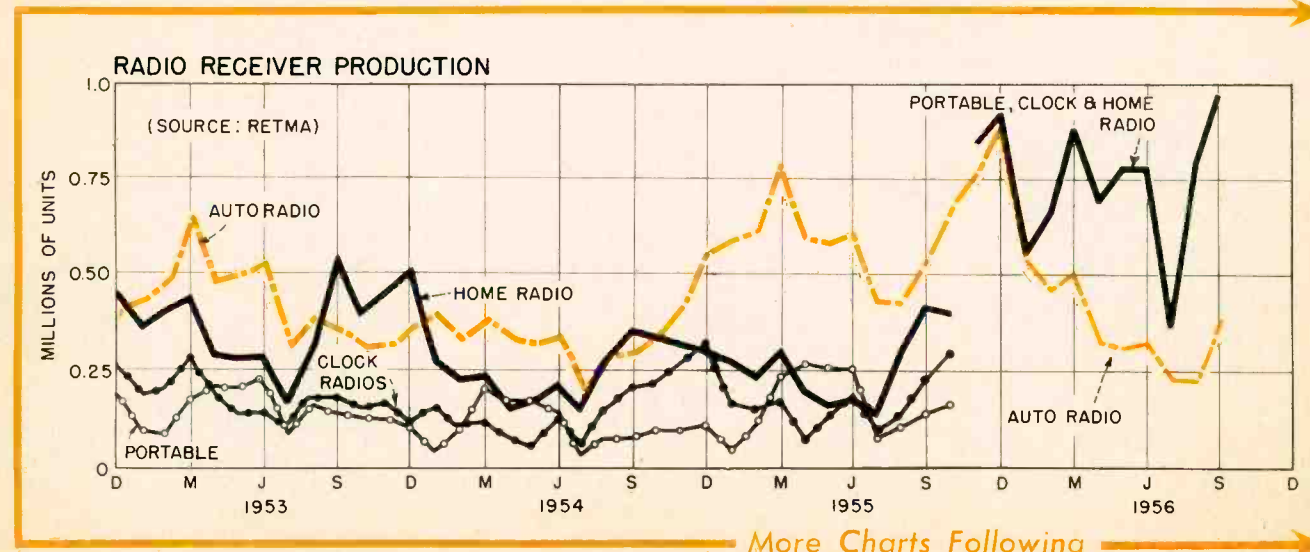



miniaturized **CERA-MITE*** capacitors for transistor radios

TRIED AND PROVEN in thousands of transistor radios, Sprague's miniaturized line of Cera-Mite* disc capacitors is building an enviable record of trouble-free service in the field.

Mass production of a standardized line of the five popular capacitance values in the new smaller 50 volt d-c sizes assures continued high quality.

Two widely separated plants, one at Nashua, New Hampshire, and another at Grafton, Wisconsin, assure our customers of a dependable source of

supply to meet production schedules.

Complete technical data on Cera-Mite capacitors for transistor applications is given in Engineering Data Sheet 6121. Write (on your business letterhead, please) for your copy to the Technical Literature Section, Sprague Electric Company, 35 Marshall Street, North Adams, Mass.

• • •

Sprague on request will provide you with complete application engineering service for optimum results in the use of ceramic capacitors.

*Trademark

the mark of

SPRAGUE[®]

reliability

Export for the Americas: Sprague International Ltd., North Adams, Mass. CABLE: SPREXINT



Officer peers into bombsight of Brane system which will replace K-system

Sperry Gyroscope, manufacture of K-system was dispersed through other firms such as General Motors, National Cash Register, IBM, Eastman Kodak, Western Electric, General Mills, Motorola and Farrand as multiple prime or subsystem sources. Western Electric developed the radar.

About one million factory workers and technicians in 36 states, at 3,050 companies, have been directly engaged to supply various products in K-systems for SAC.

► **Parts**—More than 70,000 individual parts make up the various elements of a single K-system.

Original prototype cost of nearly a half-million dollars was reduced to less than half by manufacturing improvements in volume production.

Business Briefs

► **Business machine manufacturer, National Cash Register, plans to sell \$28.2 million of debentures for working capital to finance sales and carry inventories of electronic data processing equipment and other new products. Net profits for the firm during the first nine months of 1956 were \$12.6 million compared to \$9.7 million for the period in 1955**

► **Hi-fi pick-up manufacturer, Weathers Industries of Barrington, N. J., has been acquired by Ultrasonic Corp. which plans to increase the sound firm's product lines and distribution**

► **Transistor maker, Texas Instruments, plans to sell \$10 million in notes. About \$4 million of the proceeds will be used for a new semiconductor plant and the remainder will be used to refinance the firm's first mortgage bonds and to increase working capital**

► **Sale proceeds of 277,700 shares of AMP \$1 par common stock at \$16.26 per share is to be partly used for general corporate purposes to enable the firm to carry an increased inventory and to finance a larger balance of receivables. Remaining proceeds go to a selling stockholder. Formerly known as Aircraft-Marine Products, AMP produces over 10,000 different types and sizes of solderless terminals**

► **Acquisition of Watts Manufacturing Co., maker of a new continuous-action gas chromatograph, was made by Beckman Instruments. The instrument is said to provide a simple, reliable method for analyzing gas streams in the chemical and petroleum industries**

ELECTRONIGRAPHS Continued

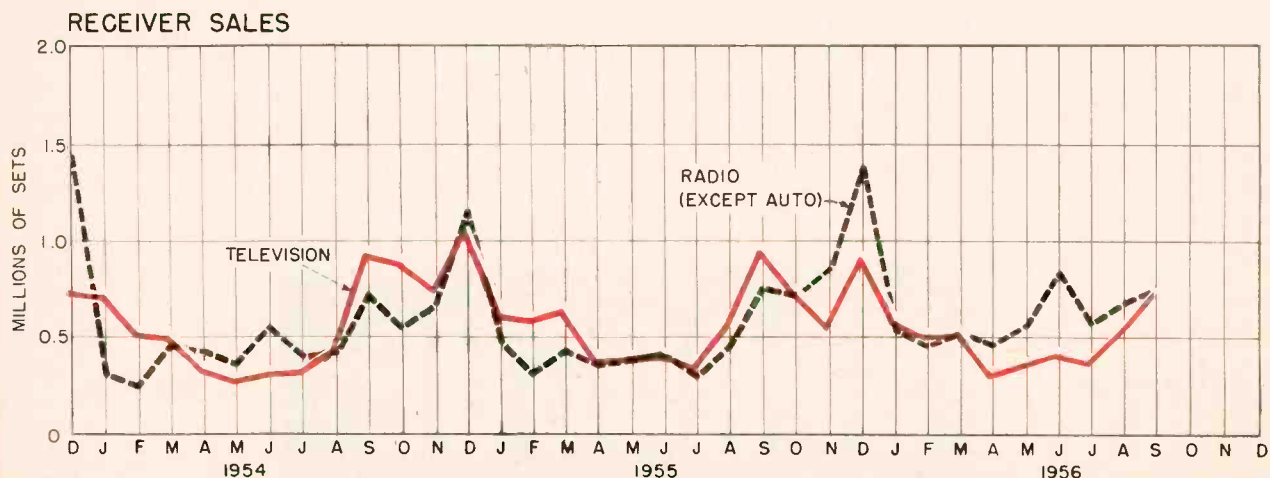

More Charts Following

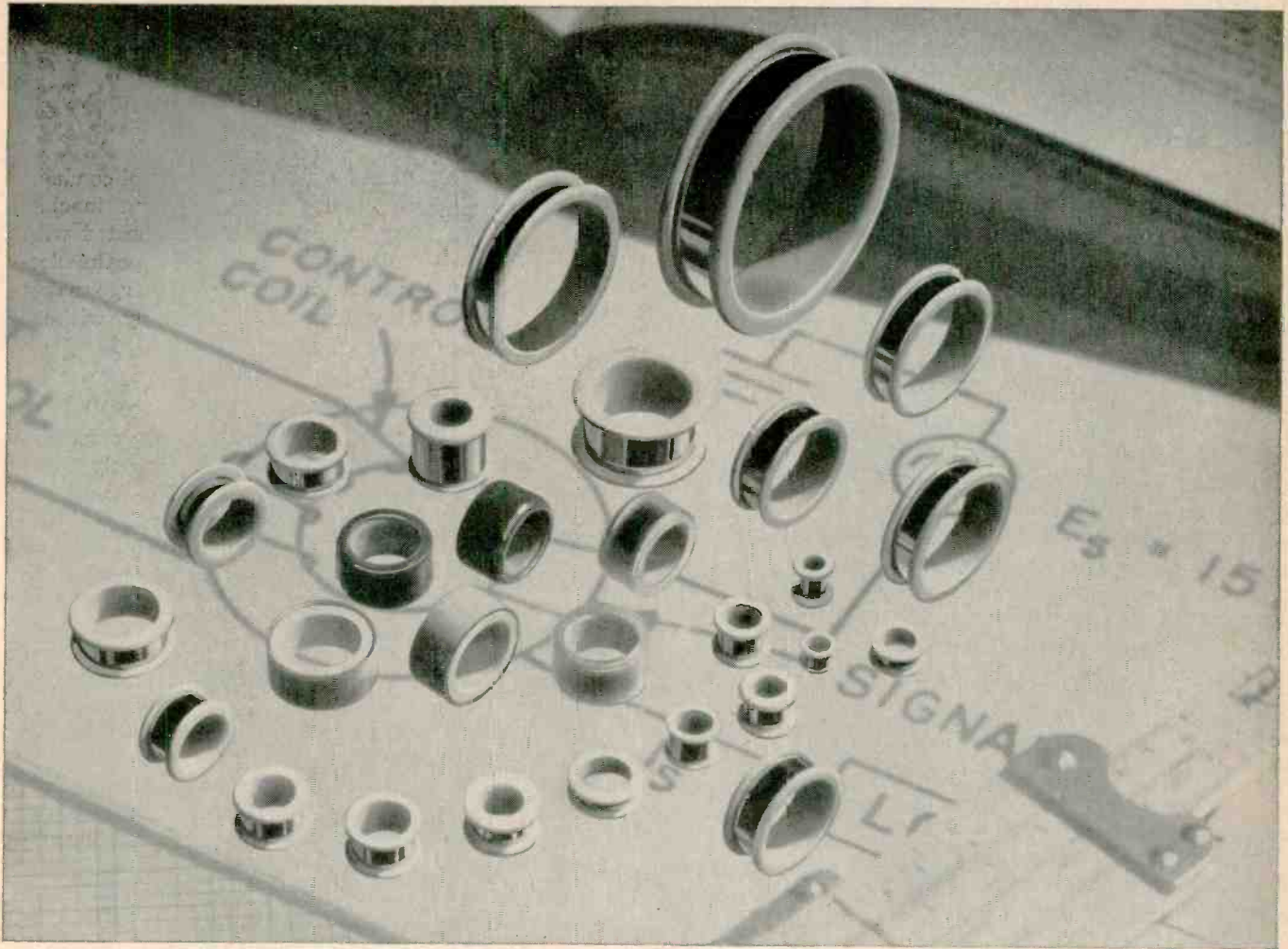

In BOBBIN CORES, you need PRECISION *and precision is the word for ARNOLD*

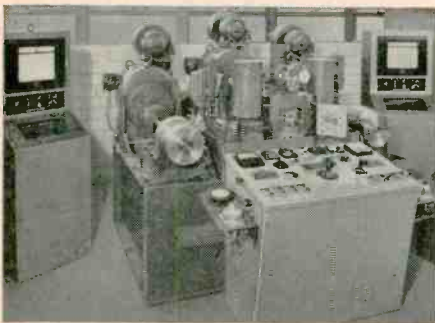

Ultra-thin tape for bobbin cores is rolled to high precision standards for thickness and finish on our own 20-high Sendzimir cold reducing mill, beta-ray controlled.

Write for **BULLETIN TC-108**
"TAPE-WOUND BOBBIN CORES
FOR COMPUTER APPLICATIONS"

Includes essential data on applications and properties, fabrication and testing of Arnold Bobbin Cores; lists standard sizes, etc.

ADDRESS DEPT. E-71

For use in shift registers, coincident current matrix systems, pulse transformers, static magnetic memory elements, harmonic generators and similar equipment, Arnold Bobbin Cores meet the most exacting requirements.

Quality and uniformity? *You'll find them no problem*—because, as a fully integrated producer with highly modern facilities, we're able to maintain close control over every step.

Arnold Bobbin Cores are available in a wide range of sizes, tape thicknesses, widths and number of wraps depending on the ultimate use of the core. Magnetic materials usually em-

ployed are Deltamax, Permalloy and Supermalloy, in standard thicknesses of .001", .0005", and .00025". Core properties include quite rectangular hysteresis loops, relatively low coercive values and high saturation densities, plus the ability to shift in a few microseconds from negative remanence to positive saturation, and vice versa, under conditions of pulse excitation. • Let Arnold supply your requirements for Bobbin Cores—or other tape-wound cores, powder cores, permanent magnets, etc.—from the most complete line of magnetic materials in the industry. WSW 6399

THE ARNOLD ENGINEERING COMPANY



Main Office & Plant: Marengo, Illinois

Regional Pacific Division Plant: 641 East 61st Street, Los Angeles, Calif.

District Sales Offices:

New York: 350 Fifth Ave. Los Angeles: 3450 Wilshire Blvd. Boston: 200 Berkeley St.

British Push Simpler Flat Television Tube

Under development, commercial production expected within year on new color tube

STILL undergoing experiment by inventor Denis Gabor of Imperial College, London, is a flat, shadow-mask color tv tube. Its novel design may obviate some of the manufacturing problems inherent in present color kinescopes. Competition with similar U. S. developments is effectively nullified through patent pooling with Kaiser Aircraft and Electronics Corp. British rights have been assigned to National Research Development Corp. of London.

► **Basic System**—As shown in the artist's drawing, the new tube has the shape of a flat glass box that might be 4½-in. deep for a 21-in. screen. Electrons travel downward from a gun (one for each color) and are deflected horizontally by the scanning plates.

A reversing lens and associated electrodes form a pencil beam that moves, always vertical, from side to side under control of the horizontal circuits. At an appropriate level, the beam is bent horizontally and falls upon the screen carrying lines of colored phosphor.

The vertical scanning array com-

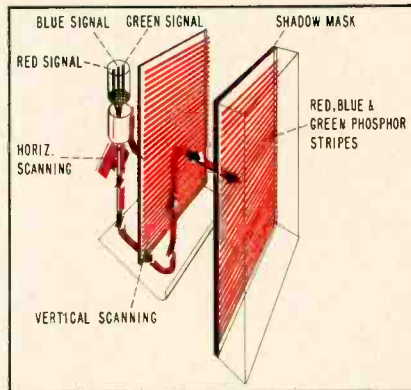

Complex electronic path is traced by beam in new tube

prises a system of parallel conducting strips printed on an insulating base. They are connected with nothing, being charged by the electron beam. Change of charge makes the beam scan vertically without need of sweep circuits.

► **Phosphor Screen** — Although using the shadow-mask principle, the new tube's mask is only 0.025 inch (instead of 0.5) from the phosphor screen, simplifying deposition of the phosphors and improving the effective resolution.

U. S. Aids Contract Financing

MORE LIBERAL policy on progress payments is now in effect as a result of a directive from Defense Secretary Wilson. The new order, in effect, gives contractors more time to pay back money borrowed from the government in the form of progress payments to get a contract going.

► **Method**—Under the previous system, the government immediately charged off on the first deliveries of an item the amount that was lent in progress payments to get production started. This left the contractor with minimum

profits at the beginning of production when the need for money was likely to be greatest.

Under the new directive, less of the progress payments will be deducted from payments for the first items delivered. The contractor gets more money for his early deliveries. The government, on the other hand, has more money tied up in progress payments for a longer period. The new program is expected to raise the estimated \$10 billion a year in defense contracts that are subject to progress payments.

► **Speed**—The new directive reit-

ELECTRONIGRAPHS Continued

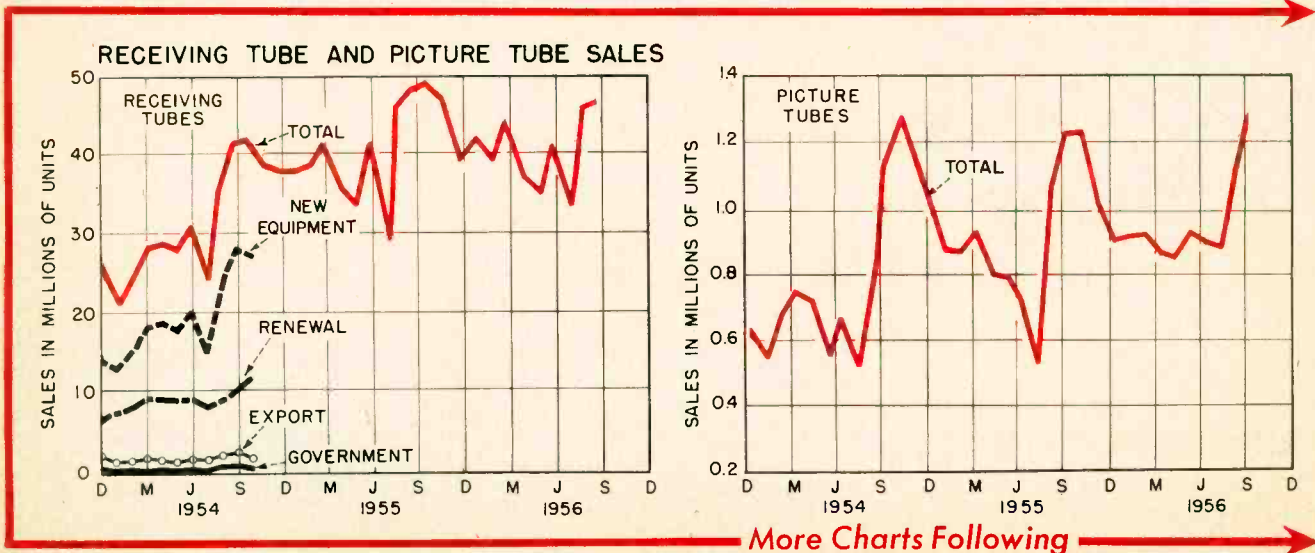

More Charts Following

GROWTH

NEW KAHLE FACILITIES

Kahle paces the growth of electronics . . . anticipating your increasing needs for precision glass, wire and metal working machinery and equipment. New Plant # 2 increases present shop area over 300%.

NEW KAHLE SERVICES

Enlarged services help solve your most difficult machinery and equipment requirements. Faster delivery will be available on all standard types added manufacturing facilities mean greater economy for you . . . increased laboratory and experimental facilities, too!

NEW KAHLE DESIGNS

Kahle's growth places greater emphasis on its engineering capabilities . . . increased numbers of the most modern machine designs are now available to you . . . designs that are shaping tomorrow's electronics.

FAMOUS KAHLE PRECISION

Kahle's exacting precision and meticulous workmanship are progressing, too . . . the cornerstone of a 25-year old reputation, as the world's largest manufacturer of specialized machinery and equipment for the electronic, glass and related industries. Need production equipment? "Call-on-Kahle."

Tell us about your specific requirements and problems.

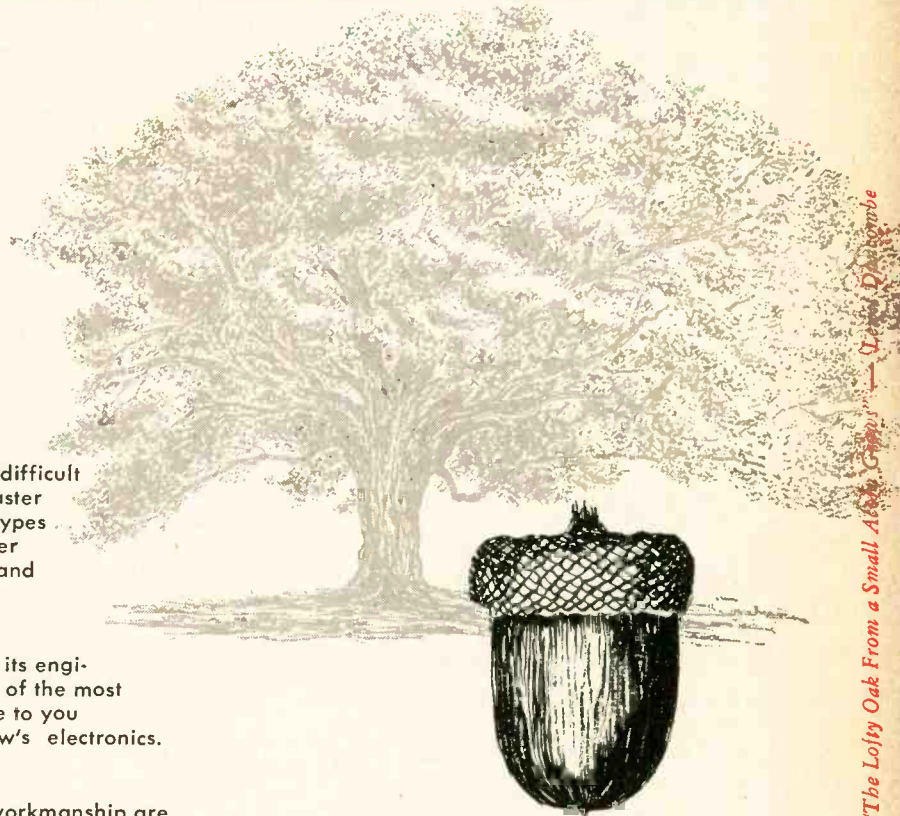

"The Lofly Oak From a Small Acorn" — *John D. Hambro*

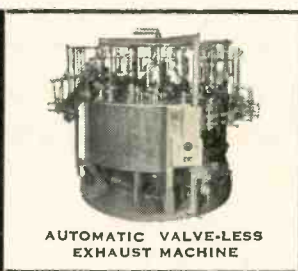
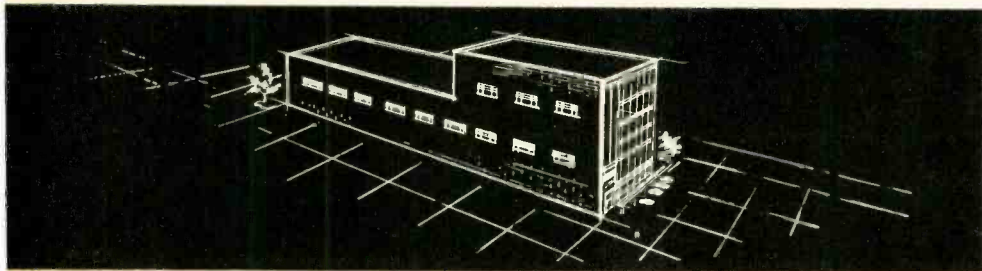

AUTOMATIC VALVE-LESS EXHAUST MACHINE

KÄHLE

ENGINEERING COMPANY

GENERAL OFFICES:

1310 SEVENTH STREET, NORTH BERGEN, N. J.

PLANTS:

SEVENTH STREET, NORTH BERGEN, N. J.

HUDSON AVE., UNION CITY, N. J.

DESIGNERS AND BUILDERS OF SPECIAL AUTOMATIC AND SEMI-AUTOMATIC EQUIPMENT FOR ALL INDUSTRIAL OPERATIONS

erates earlier Defense Department policy that a contractor's need for progress payments or advance payments is not to be treated as a

handicap in awarding contracts. It also directs that progress payments be made promptly when needed and warranted.

Semiconductor Sales To Triple

Aircraft firm sees volume reaching \$300 million by 1960

SEMICONDUCTOR field, comprising transistors, diodes and rectifiers, will be a \$300-million business by 1960, according to Hughes Aircraft.

The firm estimates that the 1957 sales volume of semiconductors will be \$100 million and will be at least three times larger within three years after that.

► **Volume**—Semiconductor production at Hughes in 1956 amounted to about \$12 million which, according to the company, represents about 20 percent of the industry total. In 1955 Hughes says it did \$5.4 million of the industry's estimated total of about \$30 million in semiconductors.

► **Sales**—According to the firm, its silicon product sales are to a point where they now approach in dollar volume the sales of the company's germanium products. Joseph S. O'Flaherty, manager of the company's semiconductor division, said



Unusually long bar of pure germanium converts to pile of 80,000 crystals shown

that technical problems in developing advanced silicon diodes and transistors are rapidly being overcome. He said that Hughes has developed an engineering modification to overcome silicon's slower handling of electric current compared to germanium.

► **Length**—Unusually long germanium ingot shown used by Hughes, is supplied by Eagle Picher Co. of Cincinnati. Most of the ingots supplied to other companies are 12 inches long but those supplied to Hughes are 22 inches long and weigh approximately 1.5 kilograms.

Eagle-Picher purifies these ingots to a high degree and then Hughes adds specific ingredients to them and transforms them into single crystals.

The ingredients are added for the purpose of increasing electrical conductivity. Ingots are transformed into single crystals with no change in weight or shape.

► **Markets**—The firm's forecast of a \$300-million semiconductor industry by 1960 included an estimate that, barring war, 85 percent of the dollar volume will be sold to the civilian industrial and entertainment product industries, and only 15 percent will be sold to the military.

The company estimates that of this year's \$100 million in semiconductor sales, the industrial and military markets will account for about \$75 million and entertainment market about \$25 million. By 1960 Hughes sees semiconductor sales of \$300 million splitting with \$210 million going to industrial and military markets and \$90 million going to the entertainment field.

ELECTRONIGRAPHS Continued

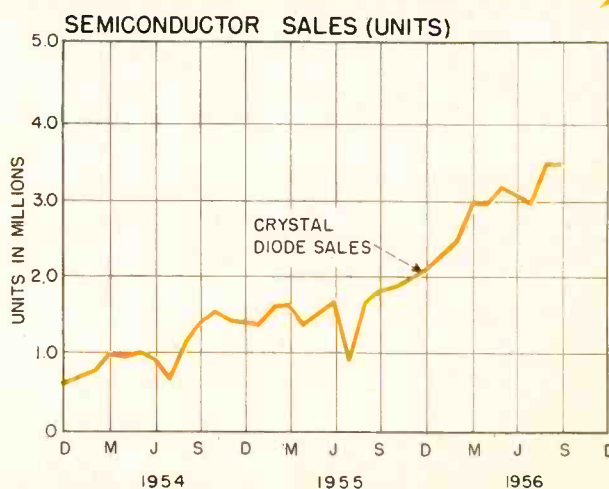
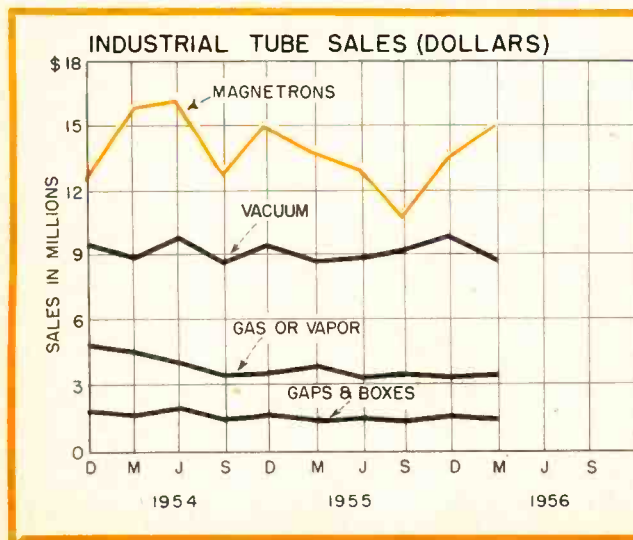

More Charts Following



Not just another salesman... but a skilled engineer at your service

One of these two men is a G-R sales engineer — the other, a customer. You wouldn't know one from the other to hear them talk for there is no high-pressure sales campaign in progress. The General Radio man offers his engineering experience and extensive factory training to the solution of the customer's problem. Our man is on a straight salary; he will lose no commission if the sale of some particular piece of equipment is not made. In fact, he will recommend the equipment only if he finds it is completely suited to the customer's need.

The General Radio sales engineer has a substantial stake in his Company — he is an important member of the professional and management group who administer its operations. He realizes that the type of quality sales service he has to offer produces the lasting customer satisfaction upon which ultimately the future of his Company depends. *This is his basic incentive.*

"We sell direct" is a long established General Radio policy. Our many years of excellent sales engineer-customer relations prove the merit of this method.

General Radio Company, Cambridge, Massachusetts

*You can call the man we have described to aid in your particular problem!
You can reach him at any of the addresses listed at right.*

BOSTON — *TRowbridge 6-4400*
275 Massachusetts Ave.
Cambridge 39, Mass.

NEW YORK — *WHitney 3-3140*
Broad Avenue at Linden
Ridgefield, N. J.

PHILADELPHIA — *HAncock 4-7419*
1150 York Road
Abington, Pa.

WASHINGTON — *JUniper 5-1088*
8055 13th St.
Silver Spring, Md.

CHICAGO — *WAbash 2-3820*
920 S. Michigan Ave.

LOS ANGELES — *Hollywood 9-6201*
1000 N. Seward St.



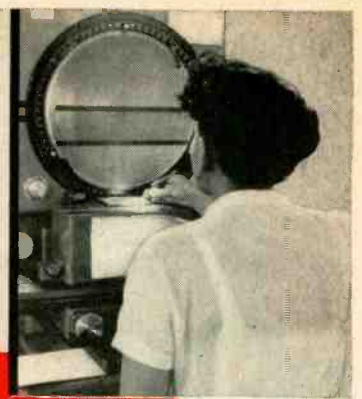
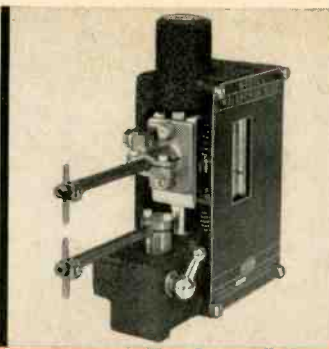
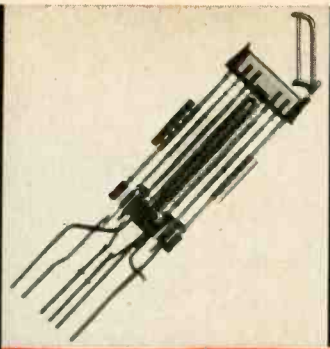

Subminiature Tubes

RELIABILITY +

**Raytheon Subminiature Tubes Give You Reliability Plus
Through Advanced Manufacturing Controls and Techniques
Beyond the Military Requirements**



RELIABILITY + in Environment Control. Raytheon pioneered air conditioned dust and lint controlled manufacturing areas.

RELIABILITY + in Welding Control. Raytheon-developed welding equipments and techniques insure precision welds.

RELIABILITY + in Microscopic Inspection Control. Raytheon provides this control *during manufacture* of parts, sub-assemblies and completed tubes.

These **RELIABILITY +** features and others constantly being developed in Raytheon's unique Pilot Operation guarantee extra equipment protection beyond military specification requirements.

RELIABILITY + in Glass Control. Raytheon-developed flat press construction provides maximum length, strain-free seals and minimizes burned leads and lead corrosion.

RELIABILITY + in X-Ray Control. Raytheon's new microscopic X-ray technique provides non-destructive prevention of latent catastrophic defects.

RELIABILITY + in Quality Control. Engineering supervision of inspection operations throughout the manufacturing cycle.



SPECIAL TUBE DIVISION

RELIABLE MINIATURE AND SUBMINIATURE TUBES • VOLTAGE REFERENCE TUBES
VOLTAGE REGULATOR TUBES • PENCIL TUBES • NUCLEONIC TUBES

NEWTON, MASS.: 55 Chapel St. • B1gelow 4-7500
NEW YORK: 589 Fifth Ave. • PLaza 9-3900
CHICAGO: 9501 Grand Ave., Franklin Park • TUxedo 9-5400
LOS ANGELES: 5236 Santa Monica Blvd. • NOrmandy 5-4221

another **RAYTHEON** first!

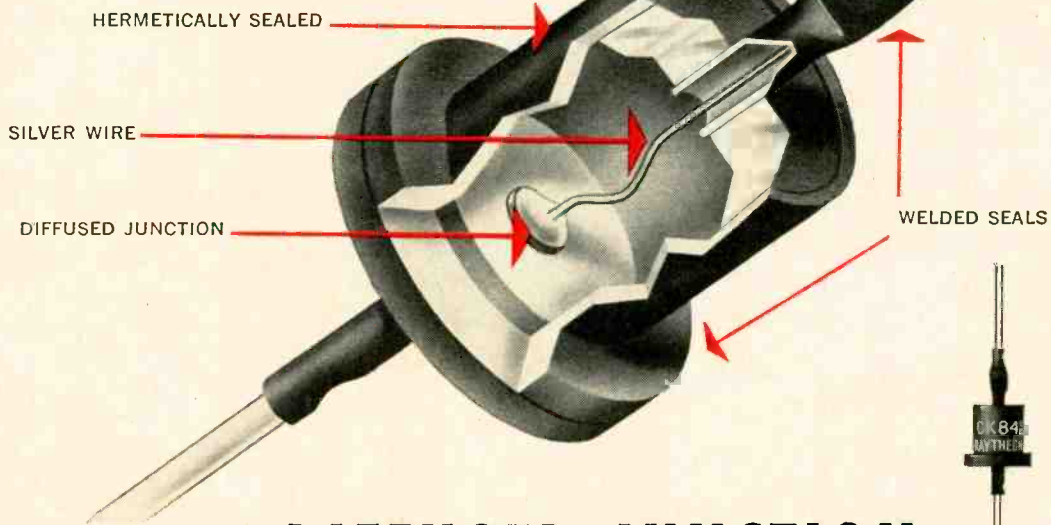

SOLID STATE **DIFFUSED JUNCTION**
SILICON RECTIFIERS
 now in **QUANTITY PRODUCTION**

Uniform Characteristics — Uniformly High Quality

The Solid State Diffusion Process involves the formation of a junction by diffusing suitable gaseous materials into silicon at high temperatures. This process offers many advantages including:

1. Exact control of junction penetration.
2. Precise junction gradient for specific rectifier applications.
3. Flat junctions for uniformity and control of characteristics.

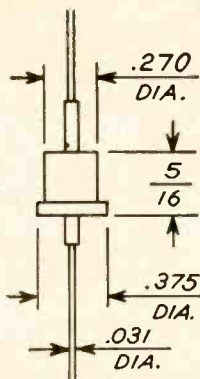

Operating Temperatures — minus 65°C to plus 150°C

Storage Temperature — up to 170°C

Hermetically Sealed — Welded

AVERAGE CHARACTERISTICS

Type	Peak Inverse Volts*	Forward Current** milliamperes 100°C 150°C		Forward Volts*** at 350 mA 100°C	Reverse Current*** (max.) mA at rms volts 100°C
CK840	100	350	100	0.75	0.2 at 70
CK841	200	350	100	0.75	0.2 at 140
CK842	300	350	100	0.75	0.2 at 210
CK843	400	350	100	0.75	0.2 at 280
CK844	500	350	100	0.75	0.2 at 350
CK845	600	350	100	0.75	0.2 at 420

*PIV ratings apply from -65°C to +150°C

**Into inductive or resistive load

***Averaged over one complete cycle



SEMICONDUCTOR DIVISION

Silicon and Germanium Diodes and Transistors • Silicon Power Rectifiers

NEWTON, MASS.: 150 California St. • DEcatur 2-7177
 NEW YORK: 589 Fifth Ave. • PLaza 9-3900
 CHICAGO: 9501 Grand Ave., Franklin Park • TUxedo 9-5400
 LOS ANGELES: 5236 Santa Monica Blvd. • NORmandy 5-4221

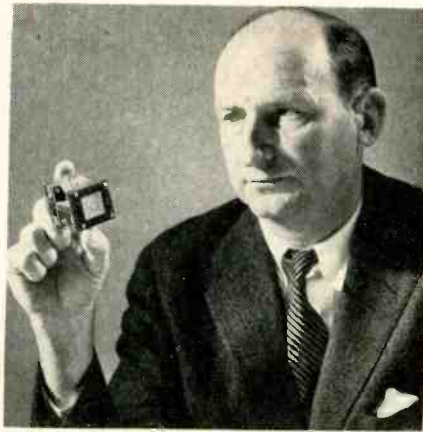
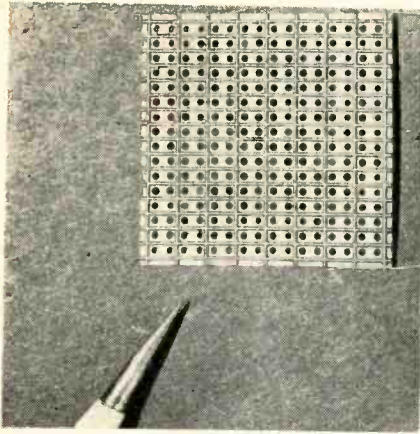

SINGLE ferromagnetic plate (left) capable of storing 256 bits provides compact memory in ten-plate RCA matrix (right) pointing up latest memory technique as . . .

Computer Use in Industry Expands

Developments aid application in all fields. Units control steel, baking and courting

ESTIMATES of the number of data-processing equipment manufacturers in the U. S. range from 100 to 500, indicating the vastness of this field.

► **Latest**—Tiny high-speed memory plate developed at RCA's David Sarnoff Research center in Princeton, N. J. can provide a memory unit with a potential to store 1-million bits. The minute plates store the information as a magnetic field whose direction around a hole determines the memory state. The plates

act as insulators allowing the holes to be joined by conductors formed by printed circuit techniques.

► **Steel**—Production data punched on IBM cards will control production at Jones and Laughlin's new steel roughing mill at Aliquippa, Pa. The \$1.5-million installation, handled by Westinghouse, will be the first card-programmed mill in the industry.

► **Biscuits**—Heart of National Biscuit Company's new \$15-million Philadelphia bakery is an electronic computer which controls the exact amount of sugar, flour and other ingredients fed into 16 mixing machines.

► **Brides**—A new application for Univac was recently demonstrated on a tv show in Los Angeles, Calif. when an ideal couple was selected by the computer after it had sorted answers on 32 questions on the subject of marriage submitted by over 4,000 people. The couple selected by this method were brought together and from all appearances intend to be married this year.

► **Ivan**—Another computer, called MIDAC, has been developed at the University of Michigan to translate Russian literature in theoretical and experimental physics into English. Its magnetic drum memory stores 64,000 Russian words and their English equivalents.

Pipelines Bulge As TV Stocks Begin To Rise

Last quarter sales failing to liquidate high inventories. Price, color, credit blamed

UNLESS tv set sales move very fast in the final weeks of December, the year-end inventory of the industry will be at a record high.

According to RETMA, total tv set inventories at the beginning of the fourth quarter at factory, distributor and retail levels totaled

ELECTRONIGRAPHS Continued

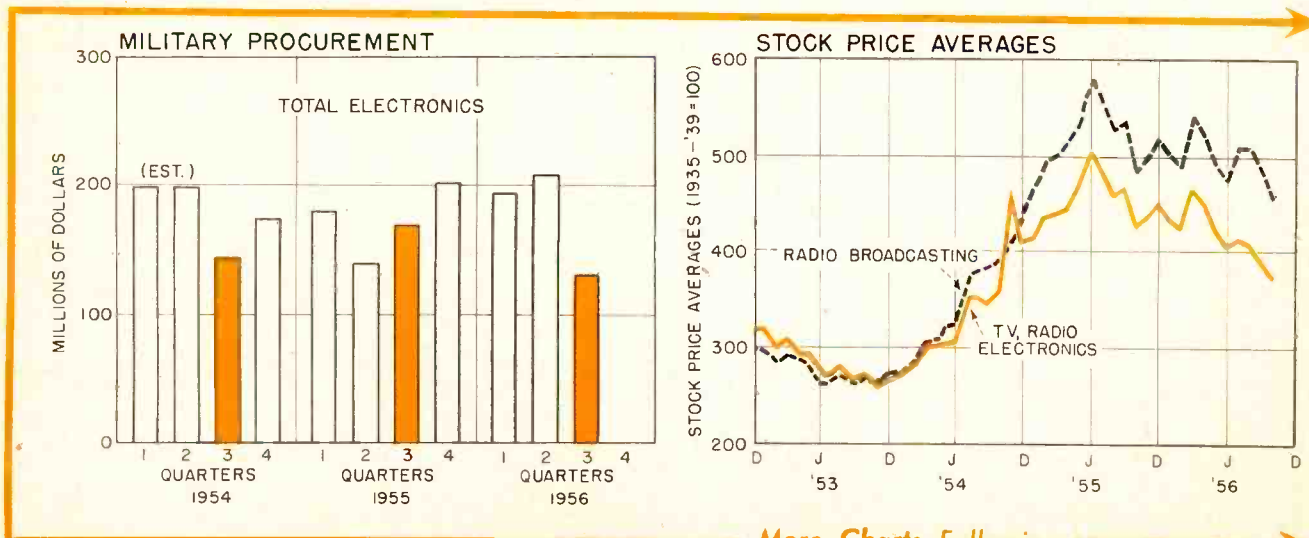

More Charts Following

How to Design for Isolation during Sustained Acceleration

It is becoming increasingly important that vibration isolators continue to provide isolation during sustained acceleration. *This is a requirement in some classes of guided missiles* If the force-deflection characteristic of the isolator is linear, it is easy to calculate the required deflection by multiplying the static deflection of the isolator under the deadweight load by the sustained acceleration expressed as a dimensionless multiple of the gravitational acceleration. Unless it has clearances at least equal to this calculated deflection, the isolator bottoms during the sustained acceleration, and provides no vibration isolation. One way to alleviate this effect is to use an isolator having non-linear force-deflection

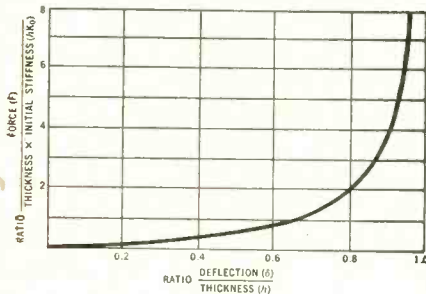

characteristics, as shown by this dimensionless curve and defined by the equation

$$\frac{\delta}{h} = \frac{2}{\pi} \tan^{-1} \left[15.37 \left(\frac{\ddot{x}_s}{f_0^2 h} \right) \right]$$

where δ is the deflection of the isolator under the sustained acceleration \ddot{x}_s , is the natural frequency under normal deadweight load, and h is the "effective thickness" of the load-carrying spring. When sustained acceleration increases the static force on the isolator, deflection increases, but less than if the stiffness of the isolator were linear. This increase in deflection is accompanied by an increase in stiffness; i.e., by an increase in the slope of the force-deflection curve. The effective natural frequency is thus increased because there is no increase in mass, and the transmissibility increases.

To simplify the evaluation of changes in transmissibility, we have prepared a nomograph and set of curves for graphic solution of this problem. Write for your free copy of these useful design data — Bulletin #THO-5 — to BARRY CONTROLS Incorporated, 707 Pleasant St., Watertown 72, Mass

From "Natural Frequency of a Nonlinear System Subjected to a Nonmassive Load", Transactions ASME, January, 1954

PROVED... protection under high-g

SUSTAINED ACCELERATION

of the new **F-10** **CLASSIFIED***

"Only All-Angl Barry Mounts gave effective isolation..."

* One of the newest and hottest fighter aircraft now flying gives its electronic equipment such a terrific slam, when afterburners are turned on or off, that sustained accelerations bottom out MIL-spec mounts — making vibration protection *nil*.

But in this same aircraft, All-Angl Barry Mounts protect the power units of Liquidometer's four fuel-gaging systems, maintaining vibration isolation under sustained accelerations up to 6g vertical and 5g horizontal.

The pilot's life — and the success of his mission — literally depend on the trueness of his fuel-gage readings! And these readings depend on the *protected reliability* of the vacuum tubes and circuitry in the power units.

- In any mounting position
 - Through every attitude of aircraft or missile
 - Under sustained high-g acceleration . . .
- . . . All-Angl Barry Mounts give assured protection of reliability. Write for Data Sheet 956-01 giving details. For specific recommendations, call your Barry Sales Representative.

Barry's new Western Division, in Burbank, California, offers fast, on-the-spot design and prototype service, and production of special systems.

BARRY CONTROLS INCORPORATED

BARRY B MOUNT

SALES REPRESENTATIVES IN ALL PRINCIPAL CITIES

707 PLEASANT STREET, WATERTOWN 72, MASSACHUSETTS

nearly 2.6 million, about 300,000 units higher than a year ago and about 600,000 units higher than in 1954. If total 1956 tv set sales go no higher than 6.7 million units, about 10 percent less than the 1955 volume, year-end inventories will be about 25 percent higher than they were at the end of 1955.

One source already estimates that total inventories will be in the 2.5-million range at the beginning of 1957 and will remain in that area through the first quarter. This could mean that the industry will once again have to cut production back sharply and possibly take the first half of the new year to unload excessive stocks.

► **Why**—Part of the reason behind this year's higher unit inventories is the greater proportion of portable tv sets that are being made. They now account for about 18 percent of total tv set production. Thus, in terms of dollar volume, the inventory situation may not be quite as bad as it seems because of lower cost per set.

Price increases made by many major tv set manufacturers to offset increased costs is another factor behind heavy inventories. Some set makers say the push for color tv sales in 1956 was premature and slowed black and white sales. Others feel that tighter consumer credit has had a limiting effect on sales.

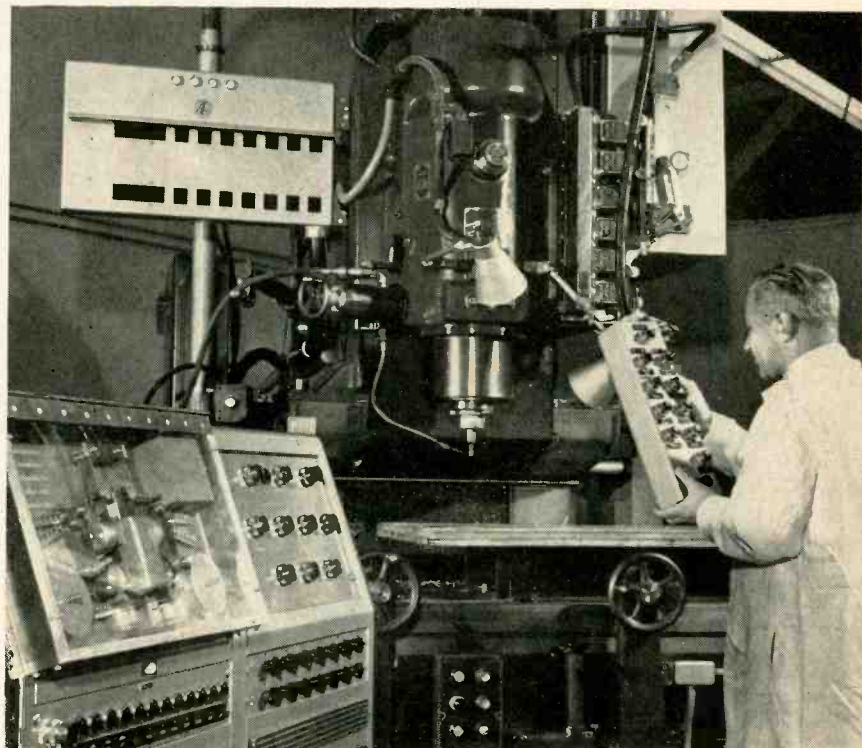

TAPE READER at lower left directs milling machine and controls instruction board at top left when . . .

Transistors Control Machine Tools

RUGGEDNESS and long operating life are two characteristics of transistors that have prompted two manufacturers to introduce machine tool control systems using these devices.

A tracer control system, developed by Minneapolis-Honeywell, uses transistorized circuits to am-

plify and sum the outputs from a two-dimensional pattern follower to control a milling machine or lathe.

In a numerical control system, Autonetics Division of North American Aviation uses transistor circuits to read coordinate data

ELECTRONIGRAPHS Continued

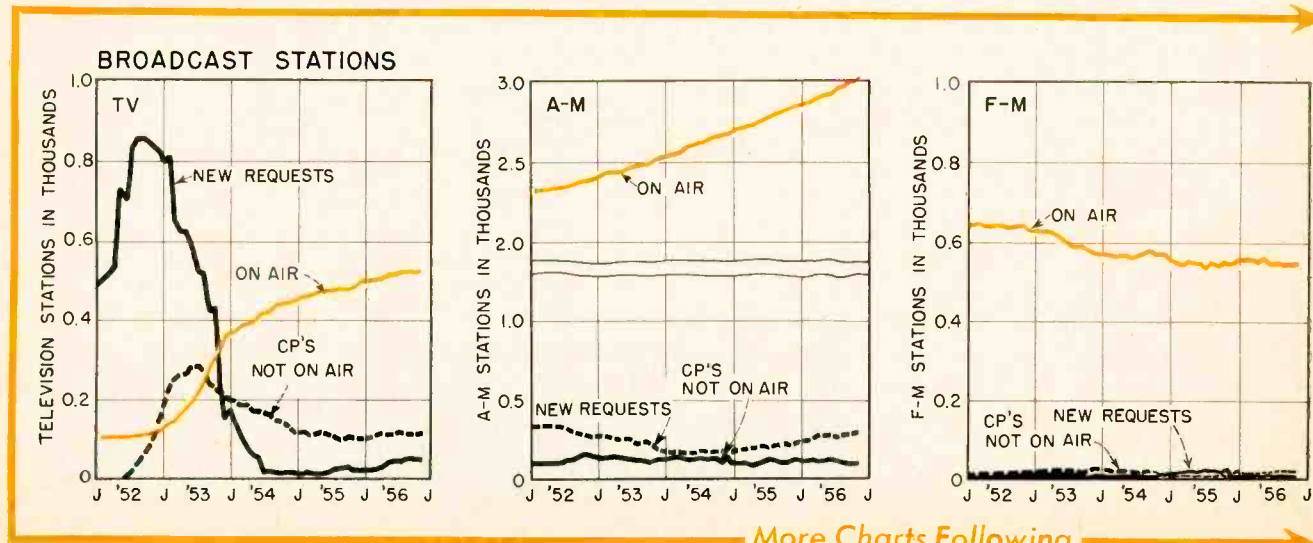



Mobile communication . . . Rock-of-Gibraltar type

The short-wave radio transmitter and receiver illustrated above is known as GRC-19, and we build it for the U. S. Army Signal Corps.

Satisfactory production of such equipment is a matter of more than precise engineering and manufacture. Two other things contribute to the fact that a very large percentage of our facilities is devoted to making products for the military.

First is *environmental testing*. The Stromberg-Carlson Test Center provides 'round-the-clock, seven-days-a-week service in life test areas which range from vibration tests simulating air-borne and vehicular transportation to work in jungle

humidity or stratosphere sub-zero.

Second is *cost-watching*. Under a research and development contract aimed at reducing costs of communication gear, we designed a model of the AN/GRC-19, eliminating some of the automatic features, and costing substantially less than the automatically tuned model. This new set, the AN/GRC-65, will serve in those field applications where manual tuning is satisfactory. Our government is a shrewd buyer. We're proud to have its patronage so often.

There are plenty of career opportunities here for Engineers . . . Why not write us?

STROMBERG-CARLSON COMPANY

A DIVISION OF GENERAL DYNAMICS CORPORATION

General Offices and Factories at Rochester, New York — West Coast plants at San Diego and Los Angeles, California



from magnetic tape prepared on a computer. Plug-in circuit boards reduce down-time for repairs.

► **Operation**—Work requiring a combination of drilling, milling and scribing can be done semiautomatically. Positioning data is obtained from the tape reader which displays appropriate instructions on a board for the operator. These instructions include type of tool, size and spindle rpm of the machine. When these instructions have been carried out by the operator, all operations using that tool are under control of the tape reader.

Checks Spark Plugs 10,000 Feet Up



Waveforms on this Bendix analyzer enable flight engineer to check DC-7 ignition system in flight or on the ground. American Airlines has ordered 125 of the units for a total of \$120,000

Military Electronics

► Six fast tax amortization certificates totaling nearly \$13 million were awarded to five electronics firms in November by the Office of Defense Mobilization. Largest certificate, \$9.9 million, went to Avco's research and advanced development division in Wilmington, Mass.

► Air Force awarded a \$16.5 million contract to GE for radar systems and a \$7.7 million contract to RCA for major subassemblies for airborne radio-receiver sets, power supplies and data

► Magnetic recording firm, Webcor, received a contract of \$2.7 million for airborne radar systems from the Navy Bureau of Aeronautics. The award brings the company's year-end government backlog to \$10.5 million

► New \$8 million testing device that thinks faster than a guided missile flies will be put into operation by the Air Force in 1958. It evaluates data as the missile flies and allows new setting to be put in and evaluated during the same flight. The procedure involves using two high speed Univac computers and careful planning before flight, according to GE

► Contract for improved airborne electronic counter-measure system worth over \$2 million has been let to W. L. Maxon by Navy

► TACAN contract worth \$18.9 million has been awarded to IT&T's Federal Telephone and Radio by Navy's BuAer

► Italian Stacchini Co. plans to supply the Japanese government with 500 radio-controlled missiles of the Airone type

ELECTRONIGRAPHS Continued

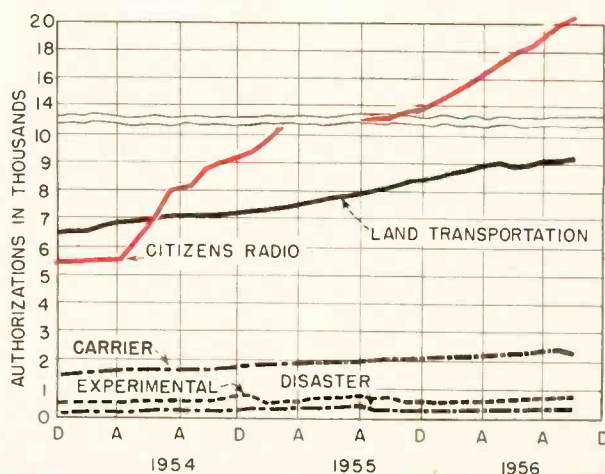
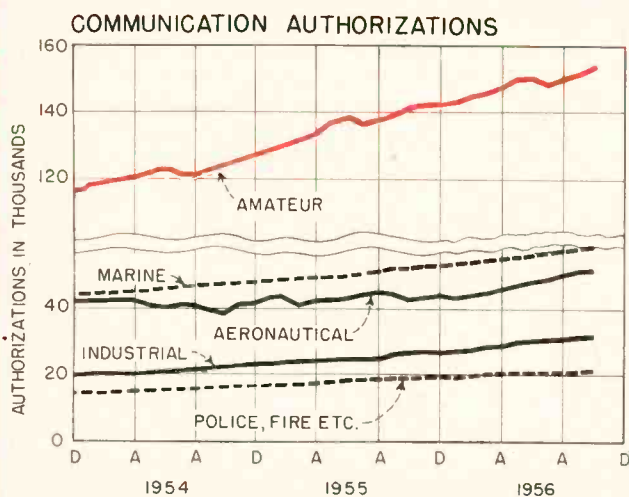

More Charts Following

PERKIN

Tubeless Magnetic Amplifier Regulated DC Power Supplies

PERKIN

Over 15,000 units in operation

PERKIN

WHERE DEPENDABLE PERFORMANCE COUNTS—SPECIFY PERKIN

PERKIN



Typical Standard Unit:
MR532-15A Power Supply
2-36 Volts @ 15 amps



IN POWER SUPPLIES • PERKIN MEANS GREATER RELIABILITY

PERKIN EXPERIENCE

Since 1932, Perkin power supplies have been selected for the nation's most critical projects, such as 1300 Model PR-748 and 680 Model RA-91C units for the Signal Corps, the NAUTILUS, VANGUARD, and in current missile projects. For the AEC, Perkin has provided three units, 0-60V @ 1000 amps ea., 6 units, 0-100V @ 2000 amps ea., 18 units, 0-100V @ 3000 amps ea., etc. This experience is the hidden value built into every Perkin standard DC Power Supply.

PERKIN FACILITIES

Perkin facilities have been doubled in the past year, with additional expansion planned in the near future. Perkin has over 200 people in its organization... manufactures its own transformers... fabricates sheet metal... utilizes the most modern manufacturing equipment... resulting in efficient and economical production techniques which are passed on to you in reasonable prices. In addition, Perkin offers a wider range of units... immediate delivery from stock.

PERKIN ADVANCED DESIGN

Perkin power supplies represent the latest design thinking of the nation's top specialists in the field. Entirely without tubes, vibrating contacts or moving parts, these units have earned for Perkin leadership in the tubeless magnetic amplifier regulated DC Power Supply field, based on technical proficiency.

If you are building a new plant or laboratory, write or wire Perkin or our nearest representative for quotations. Catalog information is also available upon request.

PERKIN ENGINEERING CORPORATION • 345 Kansas St., El Segundo, California • ORegon 8-7215

New York Area: Sales and Warehousing: 1060 Broad St., Newark 2, N.J., Market 3-1454

SALES OFFICES: CHICAGO: BR 4-9135 • LOS ANGELES: RY 1-8810 • PHILADELPHIA: BR 5-2600 • BOSTON: MI 8-0756 • SAN FRANCISCO (PALO ALTO): DA 5-6136
ALBUQUERQUE: 5-9632 • ATLANTA: EL 3020 • CHARLOTTE: ED 2-7356 • DALLAS: FO 8-8306 • DENVER: MA 3-0343 • KANSAS CITY, MO.: VA 1-5330 • MIAMI: MO 5-1563
MINNEAPOLIS: MI 4-7884 • PITTSBURGH: WA 1-2959 • SEATTLE: MO 4895 • ST. LOUIS: PA 5-7701 • WINSTON-SALEM: 4-0750 • CANADA: AGINCOURT, ONTARIO: AX 3-7011



POWER presses at Volkert Stampings produce metal parts for tubes as . . .

Electronics Steps-Up Stampings

Volume climbs to \$100 million in 1956 and may increase 15 percent in 1957

METAL stampings business in the electronics field exceeded \$100 million in 1956 and will go 10 to 15 percent higher this year if present trends hold their course. Growth of color tv should take more metal shadow masks and continued pickup of portable tv with more light-weight metal cabinets and chassis will help boost the volume of the field this year. Several stampers in the electronics field have substantial plant expansions in the works.

► **Figures**—In 1954 there were 2,269 metal stamping plants in the U.S. and only 896 of them had more than 19 employees. Altogether they employed 128,200 people at a payroll of \$569.4 million. An estimated 175 firms have specialized in stampings for electronics.

The East North Central states with 1,036 plants have nearly twice as many stampers as any other region in the U.S. Most electronic stampers are located near New York, Chicago and Los Angeles.

► **Dollars**—Total metal stamping annual business volume exceeds \$1.6 billion in value of shipments. Of this total \$510 million or about

one-third is in the job stampings field and \$474 million or another third is in the automotive field. In the job stampings field, radio and tv stampings accounted for the largest volume for any single category of job stamping. Ten years ago, radio and tv stampings were of such small volume that they were not listed as a separate census category.

► **Expansions**—Sylvania has increased stamping operations in its parts division plant. Superior Tube has completed a new plant in Ohio which triples the floor space of its present leased facilities and boosts its production by 30 percent. At the 63,000 sq ft plant small tubing, nickel cathodes and stamped and deep-drawn parts for electronics are made. The firm also produces shadow-masks for color picture tubes.

Transceiver Uses Eight Transistors

MOBILE radio transmitting and receiving set, designed by Avco engineers for use in the 2 to 4-mc or 4 to 6-mc band, weighs eight pounds and uses eight transistors. It has an operative range of 30 miles.

The receiver and modulator use seven transistors. The three-watt a-m transmitter has two tubes and one transistor.

► **Units**—The case has an upper

ELECTRONIGRAPHS

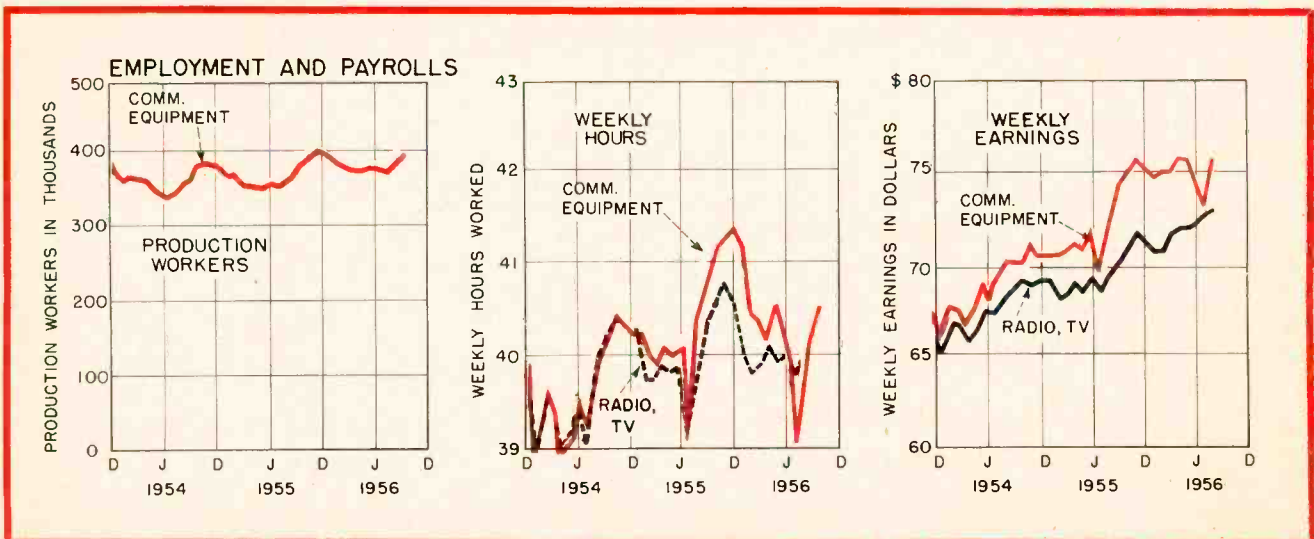

HUGHES PRODUCTS
presents 3 unusual new

STORAGE TUBES

MEMOTRON

The MEMOTRON, a direct-display cathode ray storage tube, retains traces and transients until intentionally erased. Analysis and comparison are possible without photography because MEMOTRON visually displays successive transient writings. All displays occur at uniform brightness, regardless of writing speeds, so are easily photographed for file records. Applications: viewing transients in shock testing, read-out of solutions from analog computers, curve plotting at high and low speeds, electrocardiography, vectorcardiography and heart sounds.

General Specifications:

RESOLUTION...50 to 60 written lines per inch.
WRITING SPEED...0 to at least 100,000 inches/second.
BRIGHTNESS...50 foot-lamberts.
USABLE SCREEN DIAMETER...4 inches.
DIMENSIONS...

Over-all length: 18 1/2 inches \pm 1/2 inch.
Bulb diameter: 5 5/8 inches maximum.
Neck diameter: 2 1/4 inches \pm 3/32 inch.

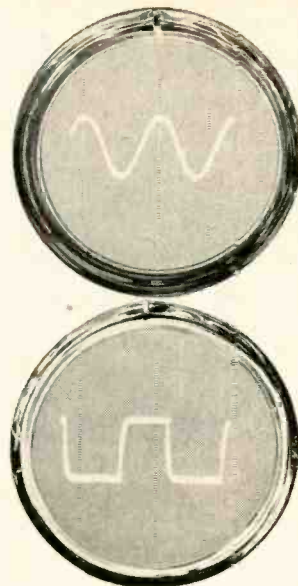

Photos show single transient pulses, 20 microseconds wide with a one microsecond rise time, showing writing capabilities of one million inches per second. These photos were taken in full daylight without a hood.

TONOTRON

The TONOTRON, another exclusive Hughes direct-display cathode ray storage tube with a 5-inch screen, presents a complete spectrum of grey shades. The high light output makes a hood unnecessary, even when viewing in full daylight. TONOTRON's length of persistence and rate of decay are controllable. Superior presentation of the grey scale assures "high fidelity" picture reproduction. Applications: radar, Narrow Band Television, instrumentation, etc.

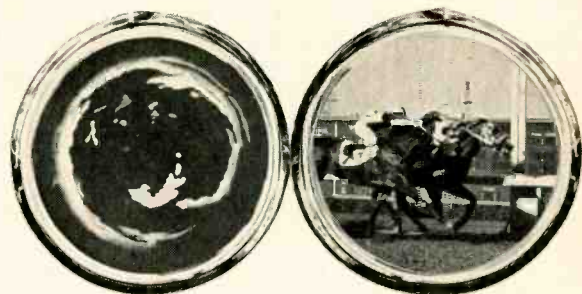

Photos: Left, weather radar with brilliant halftone picture on TONOTRON. Right, TONOTRON freezes action picture until intentionally erased.

TYPOTRON

The TYPOTRON is the first commercially available storage tube for displaying printed data rapidly. A choice of 63 characters is available for the presentation of data in words, numbers or symbols. As a high-speed digital read-out device, the TYPOTRON writes characters 1/8 inch in size at speeds of at least 25,000 characters per second. The written information remains visible indefinitely without fading or blooming, until intentionally erased. This feature makes TYPOTRON an ideal read-out device in many digital computer applications.



Photo: Presentation of all available characters.

HUGHES PRODUCTS

A DIVISION OF THE HUGHES AIRCRAFT COMPANY

ELECTRON TUBES 

Our applications engineers invite your inquiries regarding specific uses of these tubes. For further information and descriptive literature please write to:

HUGHES PRODUCTS • ELECTRON TUBES
International Airport Station
Los Angeles 45, California



Avco transceiver has 8 transistors

and lower section that clip together. The upper unit contains the sending and receiving equipment and the lower unit holds the power supply—a wet-cell battery and generator. A hand crank folds out of the lower unit for generating power in an emergency.

► **Life**—The set operates from the rechargeable battery for ten hours with a duty cycle of five minutes transmitting to each 15 minutes receiving. The receiver will operate 250 continuous hours on one charge of the battery.

► **Operation**—Placing the folding antenna in the top of the case turns the receiver on. The antenna is turned by rotating the outer case of a loading coil built into it.

Financial Roundup

HEALTHY net profits in 1956 compared to 1955 are reported by 13 of the 18 firms listed below.

Of six companies with lower nets than a year ago, five are connected with the tv field to some degree. The other company is mainly in aircraft.

Company	Net Profit	
	1956	1955
Am Elect. 9m.....	\$242,425	\$177,377
Baird Atomic 12m	165,300	*160,674
Beckman 3m.....	378,439	369,712
Clevite 9m.....	2,630,000	3,219,000
Curtiss-Wright 9m	30,912,561	24,012,333
EECO 9m.....	75,796	42,209
Fairchild Camera 9m.....	948,000	800,000
GPE 9m.....	1,768,460	2,375,248
Honeywell 9m.....	14,555,397	11,536,894
Litton 3m.....	401,000	212,000
NCR 9m.....	12,660,792	9,747,523
N. Am Av 12m.....	23,760,962	32,349,176
Servomechanisms 9m.....	482,114	334,671
Standard Coil 3m	*358,706	*215,861
Texas Inst 9m.....	1,506,119	1,099,748
Tung-Sol 9m.....	2,060,810	2,286,511
Varian 12m.....	502,578	432,896
Zenith 9m.....	3,890,765	5,004,069

* Loss

Meetings Ahead

Jan. 14-16: Symposium On Reliability & Quality Control In Electronics, IRE, NBS, ASQC, Statler Hotel, Wash., D. C.

Jan. 23-25: IRE, Symposium On Very Low Frequency Waves, NBS, Boulder Labs, Boulder, Colo.

Jan. 24-25: Digital Computer Symposium, Automatic Coding, Franklin Institute, Phila., Pa.

Jan. 28-29: Symposium On Microwave Ferrite Devices & Applications, IRE, Engineering Societies Bldg., New York, N. Y.

Jan. 30: Electronics In Aviation Day, IRE, IAS, RTCA, Sheraton Astor Hotel, New York, N. Y.

Feb. 7: Annual Mid-Winter Symposium Aircraft Instrumentation, New York ISA, Garden City Hotel, New York.

Feb. 7: IRE Operations Research Symposium, University of Penn. Museum Lecture Hall, Philadelphia, Pa.

Feb. 7-8: 1957 West Coast Convention of the Audio Engineering Society, Ambassador Hotel, Los Angeles, Calif.

Feb. 14: Symposium On Recording Of Heart Sounds, IRE, University Of Buffalo Medical School, Buffalo, N. Y.

Feb. 14-15: 1957 Transistor & Solid State Circuits Conference, IRE, AIEE, U. of Pa., Philadelphia, Pa.

Feb. 15-16: Cleveland Electronics Conference, IRE, Masonic Auditorium, Cleveland, Ohio.

Feb. 26-27: Third Conference on Radio-Interference Reduction, Armour Research Foundation, Chicago, Ill.

Feb. 26-28: Western Joint Computer Conference, IRE, AIEE, ACM, Statler Hotel, Los Angeles, Calif.

Feb. 26-28: Joint Military-Industrial Guided Missile Electronic Test Instrument Symposium, Redstone Arsenal, Huntsville, Ala.

Mar. 18-21: IRE National Convention, Waldorf-Astoria Hotel, New York Coliseum, New York, N. Y.

Apr. 8-11: British Radio And Electronic Component Show, Grosvenor House and Park Lake House, London, England.

Apr. 9-10: Annual Industrial Electronics Educational Conf., IRE, Armour Research, Ill. Institute of Technology, Chicago, Ill.

Apr. 11-13: Southwest IRE Regional Conference & Electronics Show, Shamrock Hilton Hotel, Houston, Texas.

Industry Shorts

► **Force** of about 300 servicemen throughout the country will be trained by GE to install and maintain its closed-circuit tv systems. The servicemen will be employed by independent service stations. The firm is using closed-circuit tv to train two-way radio technicians throughout the country.

► **Individual engines** of enemy aircraft can now be distinguished at distances of up to at least five miles by means of infrared radar, according to F. E. Jones of Mullard, Ltd.

► **Electronic "traffic cop"** that pre-

vents unwanted frequencies from interfering with the operation of radio equipment, developed by IT&T's Federal Labs, is a new version of what is technically known as a magnetostriction filter.

► **Austrian tape recorder exports** reached a total of 24,250 units during the first 10 months of 1956 compared to 18,000 units during all of 1955.

► **Forty color television projection systems** for use in a national closed-circuit tv service were purchased by Closed-Circuit Telecasting System from RCA.

WIDE RANGE WIDE SWEEP— Sweeping OSCILLATOR

The KAY CALIBRATED *Mega-Sweep*



- Continuously Tunable Thru Video VHF and UHF Frequencies, 50KC-950MC Range
- Sweep Widths to 40 MC
- Single Dial Tuning

Used with a standard cathode ray oscilloscope, the Kay Calibrated *Mega-Sweep* will display the response characteristic of wide band circuits over the frequency range of approximately 50 kc to 950 mc. It features a calibrated dial indication of the approximate output frequency. The center frequency of the sweeping output voltage may thus be set to an accuracy of about 10%. The calibrated *Mega-Sweep* is the ideal instrument for use in alignment of amplifiers and filters... also as an FM source of wide range for instructional and lab purposes.

SPECIFICATIONS

- Freq. Range:** 50 kc to 950 mc.
Freq. Sweep: Sawtooth, adjustable to 40 mc. Repetition rate, 50 to 100 c/s.
RF Output: High, approx. 100 mv max. into open circuit. Low, 5 mv into open circuit.
RF Output Control: Microwave attenuator continuously variable to 26 db.
Output Waveform: Less than 5% harmonic distortion at max. output.
Meter: Provides crystal detector current for peak output.
Regulated Power Supply: 105-125 v., 50 to 60 cps. Power Input, 100 watts.

Send for Catalog 110-A

\$495 f.o.b. factory

See us at the IRE Show
Booths 2608 - 09 - 10

KAY ELECTRIC COMPANY Dept.
14 MAPLE AVENUE PINE BROOK, N. J. E-1
CALdwell 6-4000

KAY SWEEPING OSCILLATORS for every application

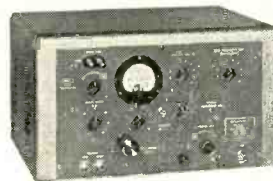

KAY *Mega-Sweep*

Widest range of the Kay line of sweeping oscillators. Provides continuous frequency coverage up through UHF-TV bands—50 kc to 1000 mc. Widely used in radar system development and in alignment and testing of TV and FM systems and components, as well as wide band IF and RF amplifiers and filters. Freq. range, 10 mc to 950 mc. Write for Catalog 100-A. Price, \$465 f.o.b. factory.

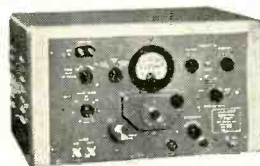

KAY 111-A CALIBRATED *Mega-Sweep*

Higher output model calibrated *Mega-Sweep*, with zero level baseline. Higher output facilitates frequency response testing of UHF converters or tuners. Wider sweep width permits multi-channel response viewing. Zero level baseline is convenient means of measuring gain of test circuit.

Frequency Range	SPECIFICATIONS	
	Output Impedance	Output Voltage (Into Load)
1. 10 mc—950 mc	70 ohms unbalanced	0.15 Volts
2. 450 mc—900 mc	300 ohms balanced	0.3 Volts
Sweep Width: Continuously variable to approx. 40 mc max.		
Write for Catalog 111-A		Price, \$575 f.o.b. factory

KAY 112-A CALIBRATED *Mega-Sweep*

Same as 111-A, except total frequency range is 800 mc to 1200 mc. Catalog 112-A. Price, \$575 f.o.b. factory.

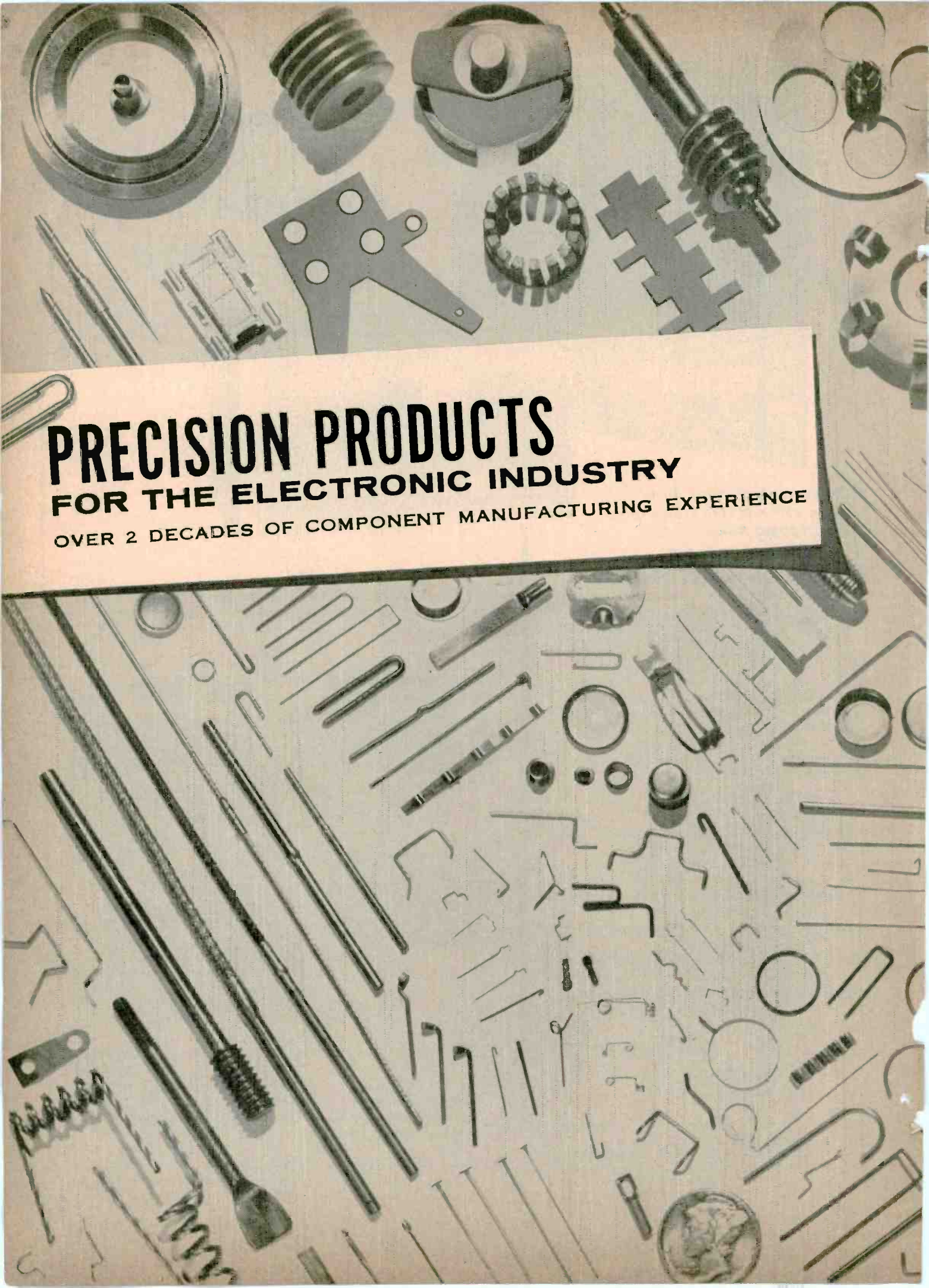

PRECISION PRODUCTS

FOR THE ELECTRONIC INDUSTRY

OVER 2 DECADES OF COMPONENT MANUFACTURING EXPERIENCE

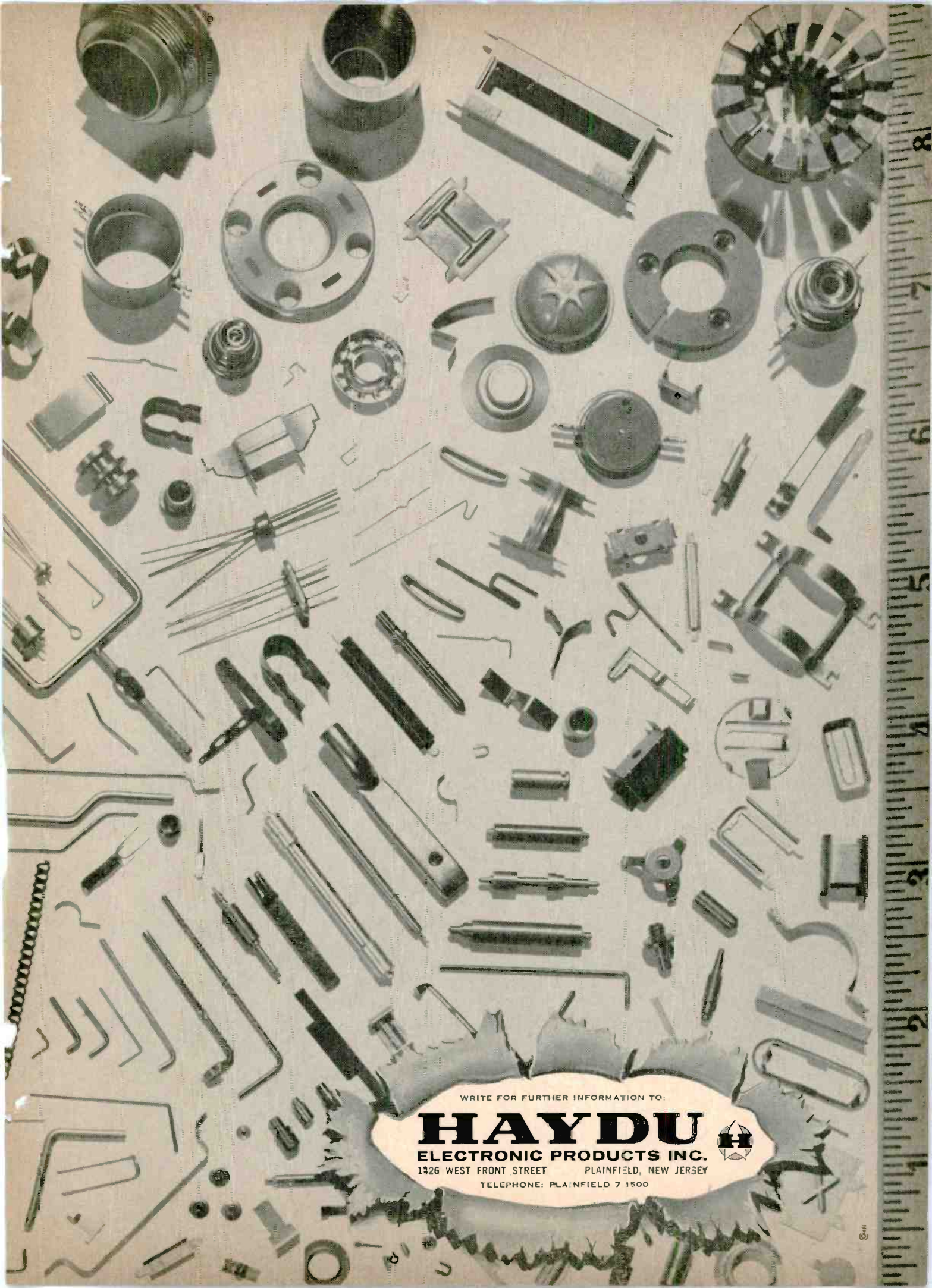

WRITE FOR FURTHER INFORMATION TO:

HAYDU 
ELECTRONIC PRODUCTS INC.

1326 WEST FRONT STREET PLAINFIELD, NEW JERSEY

TELEPHONE: PLAINFIELD 7 1500



for colors that last despite **HEAT**

BH "1151"

SILICONE RUBBER-FIBERGLAS SLEEVING

Silicone rubber insulations are recognized for their resistance to degradation under heat. But when color is introduced, many pigments react with the silicone to destroy the effectiveness of the insulation. With BH "1151" Fiberglas* Silicone Elastomeric Sleeving you have color and positive product protection. Whether you use Natural (Offwhite), Red, Yellow, Blue, Green, Brown, Orange or Violet, the superior insulation benefits are the same. And, with tracer stripes available in all colors, 64 combinations are at your command.

The precisely compounded coating of BH "1151" produces a Class "H" sleeving that easily meets MIL-I-18057 specifications. It offers product protection through a continuous operation range of -90°F. to 400°F., with no adverse effects from high spot soldering temperatures. The resiliency and strength of the sleeving permit expansion to cover irregularities and terminals.

Send for data sheets and production testing samples of BH "1151" . . . testing is believing!

BENTLEY, HARRIS MANUFACTURING COMPANY
1301 Barclay Street
CONSHOHOCKEN, PA. • TELEPHONE: TAYLOR 8-0634

BENTLEY, HARRIS

*Fiberglas**
SLEEVINGS

*BH Non-Fraying Fiberglas Sleeveings are made by an exclusive Bentley, Harris process (U.S. Pat. Nos. 2393530; 2647296 and 2647288). "Fiberglas" is Reg. T.M. of Owens-Corning Fiberglas Corp.

TUBE DESIGN NEWS

GENERAL  ELECTRIC

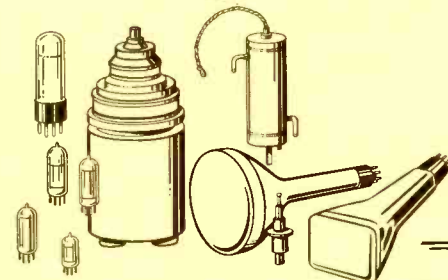

RECEIVING * POWER * CATHODE RAY

Now 54 600-ma, 31 450-ma G-E Series-String Receiving Tubes! Every Circuit Requirement Met

By the steady introduction of new series-string types for television, General Electric, originator of series-string tubes, continues to keep abreast of all circuit requirements of TV manufacturers.

Both in 600-ma and 450-ma ratings, there are G-E tubes with uniform warm-up time to fill virtually every series-string socket. The 54 600-ma types bring economy with reliability to builders of larger-model TV receivers, while the 31 G-E 450-ma tubes offer the same advantages on small second sets and portables.

In handy 8½" by 11" form, General Electric has prepared a complete list of G-E series-string tubes (ETD-1163-D), with all key ratings. Copies on request from any of the G-E offices on the next page.

New, Special General Electric "Sand-Blast" Process Scrubs 5-Star Tube Pins for Better Electrical Contact

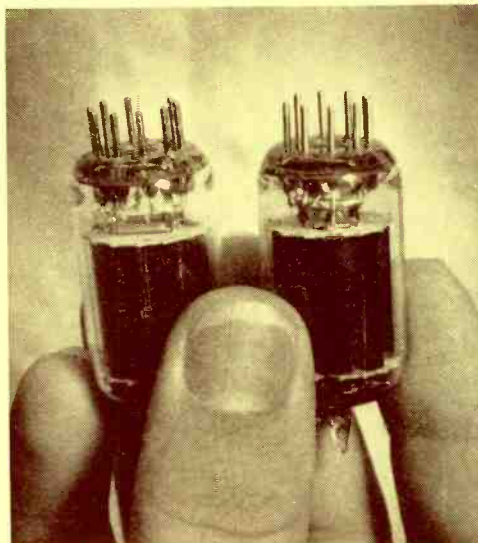

ABOVE: operator holds a 5-Star high-reliability tube while streams of abrasive emulsion scour oxidation off surfaces of pins. LEFT: pins before and after cleaning (unretouched photograph).

New GL-6942 900-mc Power Tetrode Has Heavy-Duty Cathode for Long Tube Life

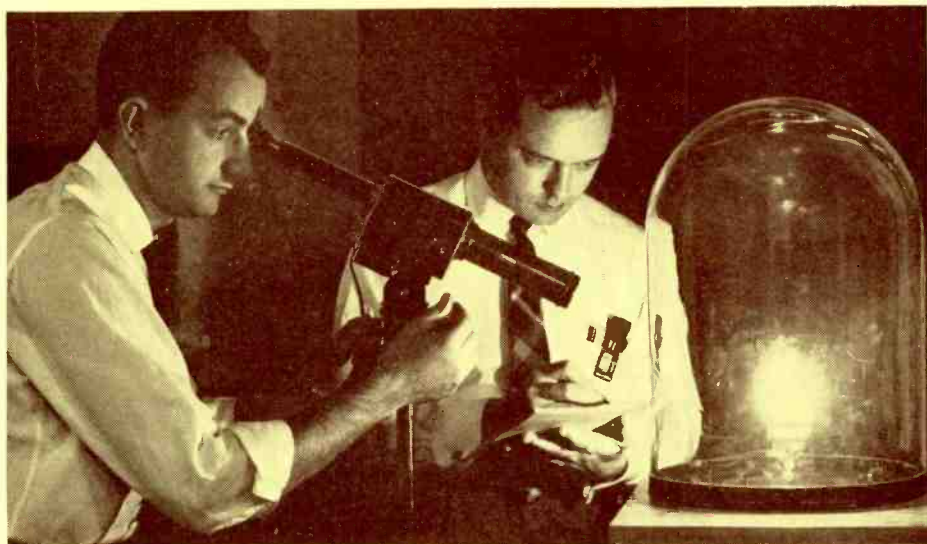

Checking a GL-6942 for operating temperature (optimum relationship between cathode emission and cathode life). Increasing power is fed into tube filament until cathode glow matches color of the element in the optical pyrometer, calibrated for 1950K—the optimum figure. Thoriated tungsten for the cathode permits high-output service with long tube life. See further GL-6942 story on next page, describing tube and its applications.

In order to assure efficient electrical contact of 5-Star high-reliability tube pins from the time the tubes are installed, General Electric has pioneered and developed a new, special process of "sand-blasting", or scouring the pins with a jet-propelled emulsion of abrasive material.

Twin guns that rotate 360° scrub off all oxidation residues and other impurities, so that the cleaned pins have surfaces free from non-conductive substances.

Afterwards the tube pins are rinsed in clear water, then dried by infra-red lamp. When 5-Star Tubes are plugged in, the full surface area of every pin is conductive. Electrical contact is complete.

As one of many processes that contribute to 5-Star Tube high reliability, cleaning pins with abrasive is a link in a long chain of G-E design, manufacturing, and testing steps that make possible dependable tube service in military and industrial applications.

Heavy-duty design protects 5-Star Tubes

(Continued on Page 2, Column 2)

New General Electric 2-Gun 7ALP19 and 7ALP25 Have Space-Saving Rectangular Face-Plates

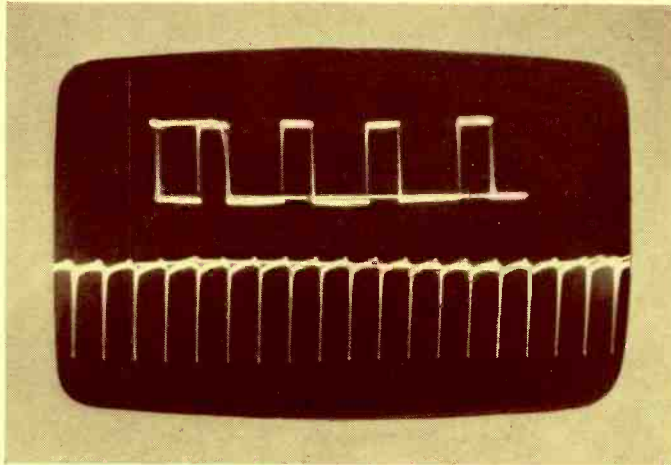

Guns are separately controlled, and share a single face-plate for their independent presentations. These presentations may be alike (for precise comparison) or unlike. Tube deflection and focus are both electrostatic.

General Electric's new cathode-ray tubes for military and industrial service take up minimum space when installed. A single face-plate carries dual images, and the face-plate is rectangular, with virtually no "waste" area. Post-acceleration and gun design with extra-high sensitivity reduce deflection-voltage requirements substantially.

Two types are in production: 7ALP19, with a phosphor that eliminates the initial

blue flash of P7 . . . 7ALP25, with a burn-resistant phosphor that has longer persistence than P19. The tubes can also be obtained with other phosphors if this is desired by the customer.

Face-plate is 4" by 6"—rectangular, spherical. Tight mechanical specifications assure an angle of less than one degree between corresponding traces. Complete tube data will be supplied on request.

1 Kw GL-6942 Meets Power and Frequency Needs in U-h-f "Scatter Propagation"

The new General Electric GL-6942 power tetrode lends itself to "scatter-propagation" techniques, by which a military or commercial u-h-f signal is pushed beyond line-of-sight transmission into distant areas.

Adequate power; dependability; stamina for long periods of max-rating operation—all are power-tube requisites for this work. The GL-6942 has these qualities; and in addition, broad band-width capabilities and high efficiency.

In developing new Type GL-6942 for scatter propagation or for other uses, military and commercial, where high tube output must join with long life, General Electric has introduced design features that make possible 2,000 hours and more operation at full ratings. Extensive G-E factory tests confirm the ability of the tube to operate this length of time at top output.

For example: the GL-6942 cathode is a high-emission-with-long-life thoriated tungsten cylinder. Grid material is strong, dependable platinum-clad tungsten. Ring-seal construction and ceramic insulation are other contributions to tube strength and high-temperature resistance.

Type GL-6942 has many u-h-f applications waiting for it in communications, TV transmission, and data-link systems. Forced-air cooling simplifies installation and maintenance. Complete ratings, characteristics, and performance data on request.

NEW PRODUCT BRIEFS

Receiving Tubes:

4BA6. New G-E 450-ma series-string version of 6BA6 high-gain amplifier pentode.

4BE6. New G-E 450-ma series-string version of 6BE6 pentagrid converter heptode.

5CL8, 6CL8. New G-E triode-pentodes for v-h-f TV tuners. Tubes are identical except for (1) heater ratings, (2) 5CL8 is suited to 600-ma series-string circuits.

12BL6. New G-E remote-cutoff pentode for use as amplifier in auto-radio receivers.

Cathode-ray Tubes:

12SP7-D. New General Electric 12-inch C-R tube for radar and oscillographs. Magnetic focus; 50-degree deflection angle; long-persistence phosphor.

**Ask for
complete information!**

EASTERN REGION

General Electric Company, Tube Sales
200 Main Avenue, Clifton, N. J.
Phones: (Clifton) GRegory 3-6387
(N.Y.C.) Wlconsin 7-4065, 6, 7, 8

CENTRAL REGION

General Electric Company, Tube Sales
3800 North Milwaukee Avenue
Chicago 41, Ill.
Phone: SPring 7-1600

WESTERN REGION

General Electric Company, Tube Sales
11840 West Olympic Boulevard
Los Angeles 64, Calif.
Phones: GRanite 9-7765; BRadshaw 2-8566

General Electric 5-Star "Sand-Blast" Process

(Continued from Page 1)

where shock and vibration are hazards, as in military field and air service. Manufacture is carried out by special trained G-E workers, in surroundings of "Snow White" cleanliness, in order to ward off short circuits that can come from dust or dirt inside a tube. 5-Star life tests are exhaustive, duplicating actual temperature and other operating conditions that will be encountered when tubes are in use.

Airlines, the armed services, industry, all are successfully using 5-Star Tubes to increase the trustworthiness of electronic equipment, cut downtime, and reduce the effort and cost of maintenance.

**NEW
EDITION!**

**G-E Computer
Tubes and Their
Applications**



Includes complete technical data on General Electric computer tubes—standard and 5-Star high-reliability types. Ask for Booklet ETD-1140-A.

Progress Is Our Most Important Product

GENERAL  ELECTRIC

ELECTRONIC COMPONENTS DIVISION, GENERAL ELECTRIC COMPANY, SCHENECTADY, N. Y.

RADAR PULSE PACKAGES

solve
pulse system
problems with

FILTRON

*Balanced
and
Matched*

**PULSE
PACKAGES**

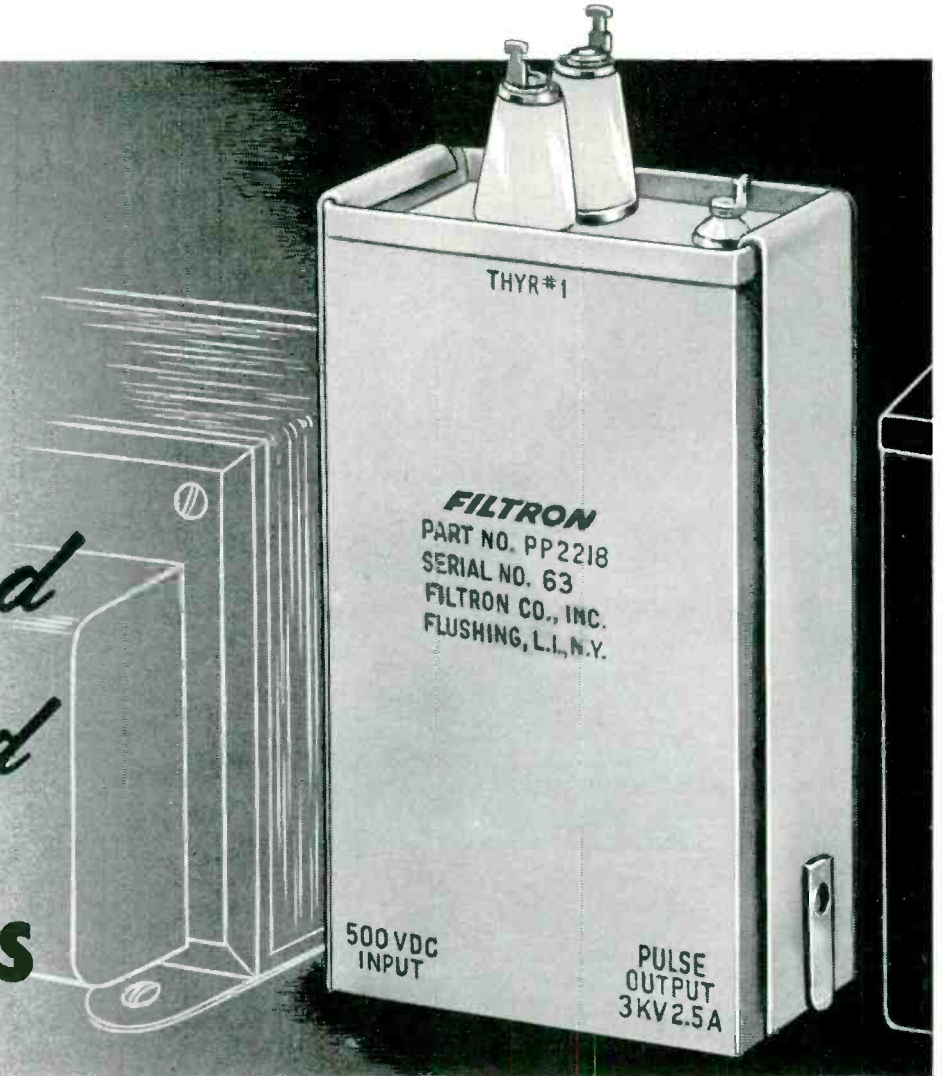

FILTRON DUAL PULSE PACKAGE Part No. PP 2218

CHARACTERISTICS

Input: 500 VDC.

Output Pulse: 3 KV. positive at 2.5 amps.

Pulse Width: 0.8μ sec. at half power points.

Repetition Rate: 410 nominal in each of two channels.

Operating Temperature: -55°C to $+70^{\circ}\text{C}$ ambient.

Altitude: 65,000 ft.

Shock & Vibration: Per MIL Specifications.

Let Filtron engineers design, build and test pre-engineered pulse packages for your radar transmitter system. Saves tedious trial-and-error development work. Eliminates assembly and testing. Reduces inventory.

FILTRON'S TRIGGER-PULSE PACKAGES are designed around a carefully matched and balanced (1) pulse network (2) charging choke and (3) pulse transformer of the line-type modulator. They can be engineered to generate pulses having sufficient power and impedance to trigger any high power hydrogen thyatron.

FILTRON'S HIGH-POWER PULSE PACKAGES are schematically similar, but will generate an optimum required pulse shape for specific radar system transmitted-pulse parameters. Call on Filtron's field engineers . . . they will visit your plant to assure optimum performance of the pulse package in your system.

All Filtron pulse packages are balanced, inspected and 100% tested before leaving the plant. Don't take chances on unmatched components purchased separately. Don't waste valuable engineering man-hours. Find out what Filtron's pre-engineered pulse packages can do for you.

FILTRON

Canadian Representative: Aircraft Appliances & Equipment Ltd., 585 Dixon Side Road, Toronto 15, Ont., Canada

**CO., INC., FLUSHING, LONG ISLAND, NEW YORK
PLANTS IN FLUSHING, NEW YORK, AND CULVER CITY, CALIFORNIA**

RF INTERFERENCE FILTERS • FIXED CAPACITORS • PULSE NETWORKS • DELAY LINES

Completely TRANSISTORIZED AMPLIFIER & SERVO MOTOR

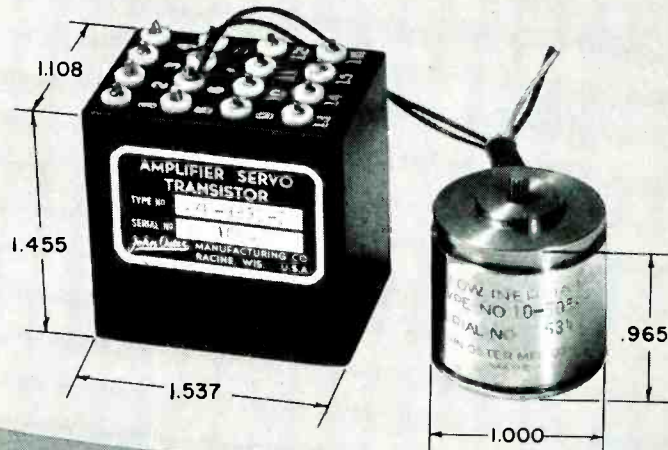

10^5 :1 High Power Gain

*Using Oster
Size 10 Servo Motor*

*Heat rapidly dissipated by unique heat-sink design.
No output transformer needed—amplifier works directly into Oster-
designed size 10 servo motor with center tapped control winding.*

AMPLIFIER DATA

- Input Impedance: 2500 ohms.
- Load Impedance: 250 + j0 ohms. This is the 400 cycle stall impedance of an Oster Type 10-5054-03 servo motor control phase when resonated with 2.0 microfarad capacitor.
- Power Gain (open loop conditions—no negative feedback): 50 D. B. minimum.
- Power Output: 0.5 watt minimum.
- Power Requirements:
 - + 19.5 Vdc—250 ma.
 - + 4.5 Vdc— 20 ma.
 - + 8.5 Vdc— 6 ma. (regulated $\pm 5\%$)
- Amplifier Rating: 0.5 watt min. at 25°C.
- Environment proof operation assured by encapsulation of amplifier assembly.

SERVO MOTOR DATA

- With .015V at 400 cycles applied to amplifier input, motor pinion rotates 5000 RPM minimum under no load conditions.
- With .075V at 400 cycles applied, motor develops .15oz.-in. minimum stall torque. Minimum speed 6200 RPM under no load conditions.
- Up to 0.2 oz.-in. torque can be obtained by energizing the reference phase with 31.0V if motor has an adequate heat sink. This results in a reference phase current of approx. .210 amperes.

Engineers for Advanced Projects:
*Interesting, varied work on designing
transistor circuits and servo mechanisms. Contact
Mr. Zelazo, Director of Research, in confidence.*

Input impedance variations to meet your specific requirements can be made. Write for additional information today.

Other products include actuators, servos, synchros, AC drive motors, servo mechanism assemblies, DC motors, motor-gear-trains, fast response resolvers, servo torque units, reference and tachometer generators, synchro indicators and motor driven blower and fan assemblies.

John Oster

MANUFACTURING CO.
Your Rotating Equipment Specialist

Avionic Division
Racine, Wisconsin

BURTON BROWNE ADVERTISING

Raytheon — World's Largest Manufacturer of Magnetrons and Klystrons

VOLTAGE TUNABLE

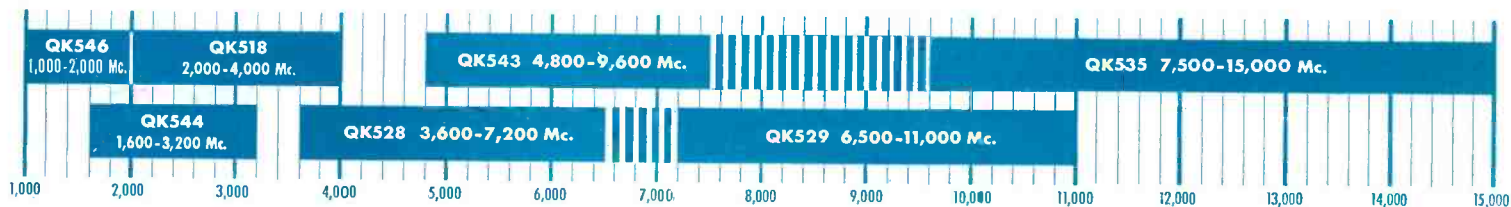

QK518 specifications

Frequency: 2,000-4,000 Mc.
Rapid electronic tuning by varying delay line voltage from 150-1,500 Volts.
Power output: 0.1 to 1 watt.
Complete with compact permanent magnet.
Approximate maximum dimensions: 10" long, 4 $\frac{3}{8}$ " high, 4 $\frac{7}{8}$ " wide.

NEW

Raytheon Backward Wave Oscillator Series

for wide, rapid electronic tuning — 1,000 Mc. to 15,000 Mc.

The tubes in this revolutionary new line of Raytheon Backward Wave Oscillators give you four outstanding performance advantages:

1. Electronically tunable over an *extremely* wide range of frequencies
2. Frequency insensitive to load variations
3. High signal-to-noise ratio
4. Can be operated under conditions of amplitude or pulse modulation

These new tubes are finding fast-growing applications in microwave equipment, including radar and signal generators.

Write today for free Data Sheets on this series of Backward Wave Oscillators. We'll also be happy to answer any questions you may have on this new line.

Excellence in Electronics



RAYTHEON MANUFACTURING COMPANY

Microwave and Power Tube Operations, Section PT-55, Waltham 54, Mass.

Regional Sales Offices: 9501 W. Grand Avenue, Franklin Park, Illinois; 622 S. LaBrea Avenue, Los Angeles 36, California

Raytheon makes: Magnetrons and Klystrons, Backward Wave Oscillators, Traveling Wave Tubes, Storage Tubes, Power Tubes, Receiving Tubes, Picture Tubes, Transistors

Model 630-NA

Volt-Ohm-Milliammeter \$69.50

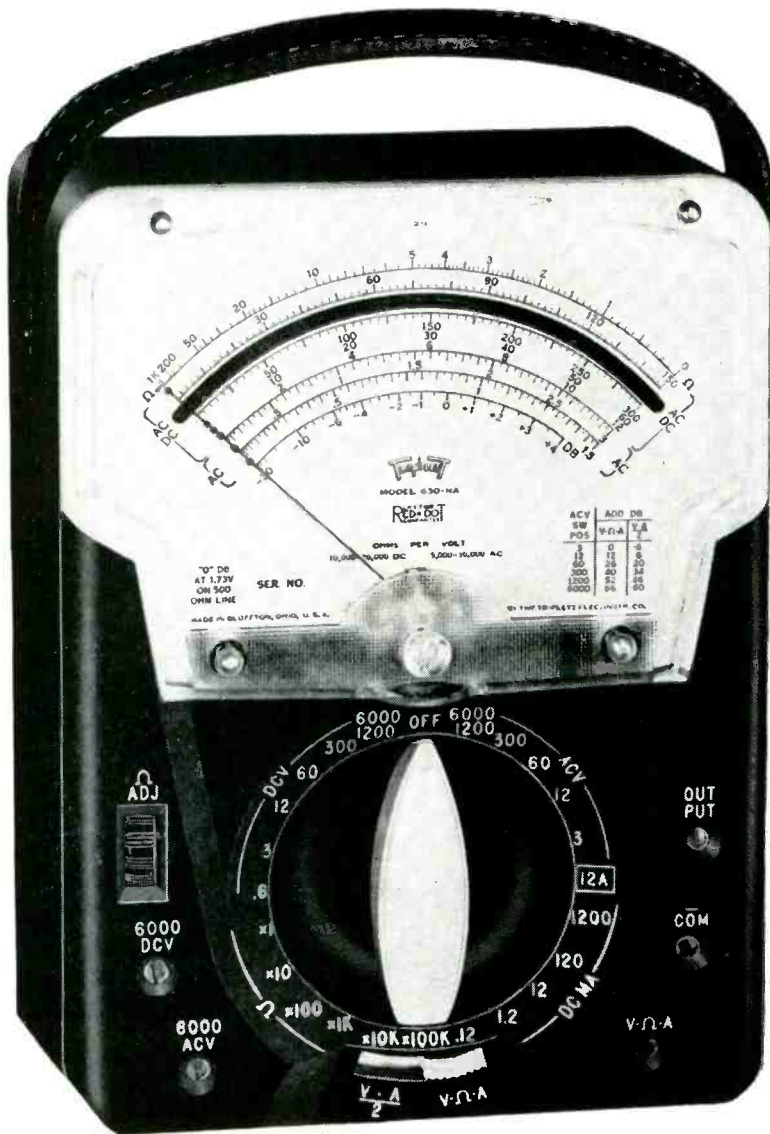

Burton Browne Advertising



All this in one V-O-M
70 Ranges... nearly double those of conventional testers

Meter protection against overloads

Frequency compensated... for accurate readings through 20,000 cps audio.

Highest accuracy—1/2% DC to 1200 volts, 3% AC to 1200 volts; mirror scale and knife-edge pointer to eliminate parallax.

AC-DC on same scale.

Reads 0.1 ohms through 100 megohms.

Incorporating the famous Triplet SINGLE KNOB CONTROL, Model 630-NA comes complete with snap-out batteries (standard D cell for longer life), test leads, alligator clips, non-skid rubber feet and thorough instruction book. OTHER LEADING TRIPLETT FEATURES: Low resistance contacts through banana plugs—completely insulated heavy molded case—clear plastic front with longer easily readable scales—standard sensitivities as used in electronics field.

TRIPLETT

TRIPLETT ELECTRICAL INSTRUMENT COMPANY • Bluffton, Ohio



631
Combination V-O-M-VTVM



630
The Popular All-Purpose V-O-M



630-A
A Good Lab and Production Line V-O-M

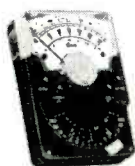

310
The Smallest Complete V-O-M With Switch



630-T
For Telephone Service



666-HH
Medium Size For Field Testing



625-NA
The First V-O-M With 10,000 Ohms/Volt AC



666-R
Medium Size With 630 Features

THE MIGHTY NINE V-O-M LINE

Research for Leadership

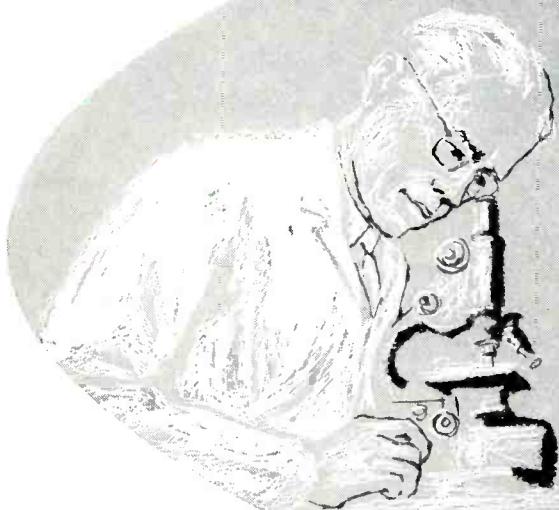

RMC
560

RMC
.01

RMC
300

Specify RMC DISCAPS for
the finest in ceramic capacitors

RMC has steadily increased its leadership in the ceramic capacitor industry as a direct result of a continuing research program. Our modern research laboratory has contributed many innovations in the field and is always at work improving the characteristics of standard DISCAPS. Write on your company letterhead for information on DISCAPS for standard or special applications.

DISCAP
CERAMIC
CAPACITORS

RMC

RADIO MATERIALS CORPORATION
GENERAL OFFICE: 3325 N. California Ave., Chicago 18, Ill.
Two RMC Plants Devoted Exclusively to Ceramic Capacitors
FACTORIES AT CHICAGO, ILL. AND ATTICA, IND.

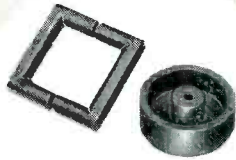

FERRAMIC
CORES

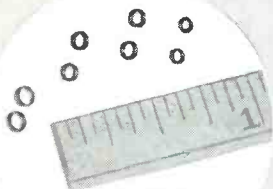

FERRAMIC
MAGNETIC
CORES

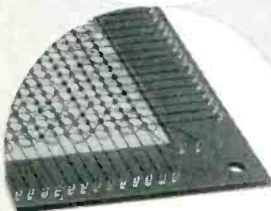

MAGNETIC
MEMORY
PLANES



"ADVAC" HIGH
TEMPERATURE
SEALS



STEATITES

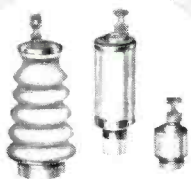

SOLDERSEAL
TERMINALS

Manufacturers of FERRAMIC CORES, MAGNETIC MEMORY CORES, MEMORY PLANES, MICROWAVE FER-
RITES, SOLDERSEAL TERMINALS, HIGH TEMPERATURE SEALS, STEATITE, ALUMINA & CHEMICAL STONWARE

When
you
need

industrial ceramics

consult...

General CERAMICS CORPORATION
General Offices and Plant: KEASBEY, NEW JERSEY
Telephone: VALley 6-5100



General Ceramics design and production facilities are geared to today's electronic and electrical requirements. In many cases, standardized designs and production methods can reduce costs and facilitate delivery. When specifications call for new designs and engineering, General Ceramics' half century of ceramic manufacturing experience is available to help solve your problem quickly, and economically!

*For Complete information,
call or write Department E*

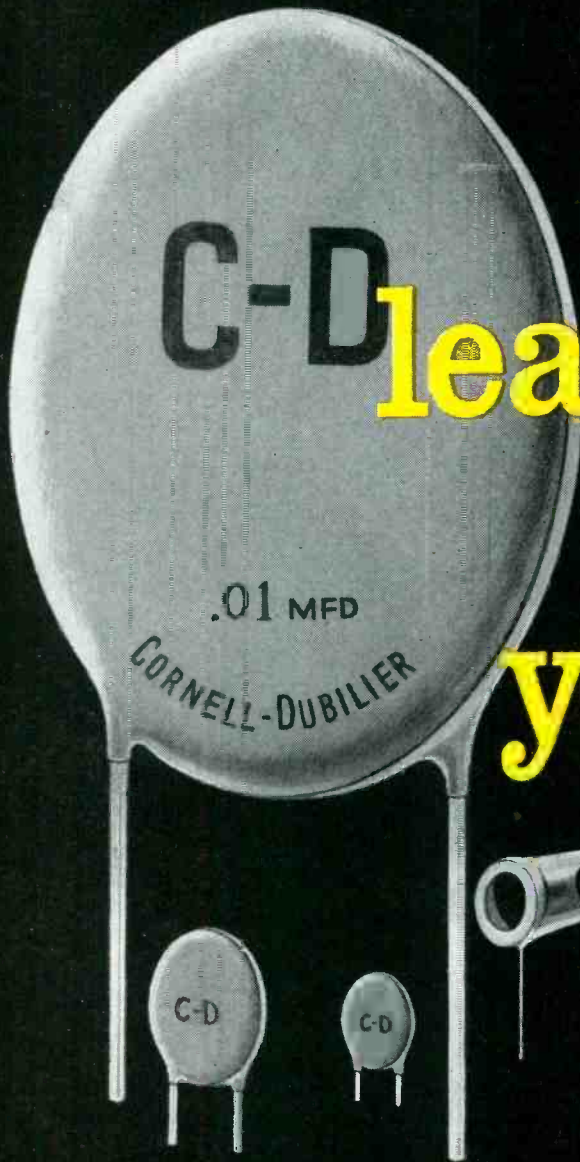

our leadership protects yours...

Because *your* production lines must roll evenly, we've geared *our* production to roll in valleys and peaks, if need be—so that your C-D capacitors will arrive the day you need them. That's why seasonal production peaks are *never* too much for C-D's 16-plant manufacturing capacity.

Typical C-D "Million-Dollar Body" Ceramics:

DISC TYPES: Temperature compensating, stabilized capacity, general purpose bypass, high voltage, A-C line bypass.

AUTOMATION: Plug-in termination available in temperature compensating, stabilized capacity, general purpose bypass, close tolerance disc types.

SPECIAL DESIGN TYPES: Feed-thru, stand-off, spool types are among the many special design ceramic types developed by C-D in accordance with customers' specific requirements, with particular reference to the high frequency field.

Write for catalog to Cornell-Dubilier Electric Corporation, South Plainfield, New Jersey.



CONSISTENT HI-DEPENDABILITY CORNELL-DUBILIER CAPACITORS



SOUTH PLAINFIELD, N. J.; NEW BEDFORD, WORCESTER & CAMBRIDGE, MASS.; PROVIDENCE & HOPE VALLEY, R. I.; INDIANAPOLIS, IND.; SANFORD, FUGUAY SPRINGS & VARINA, N. C.; VENICE, CALIF.; & SUB.: THE RADIART CORP., CLEVELAND, OHIO, CORNELL-DUBILIER ELECTRIC INTERNATIONAL, N. Y.

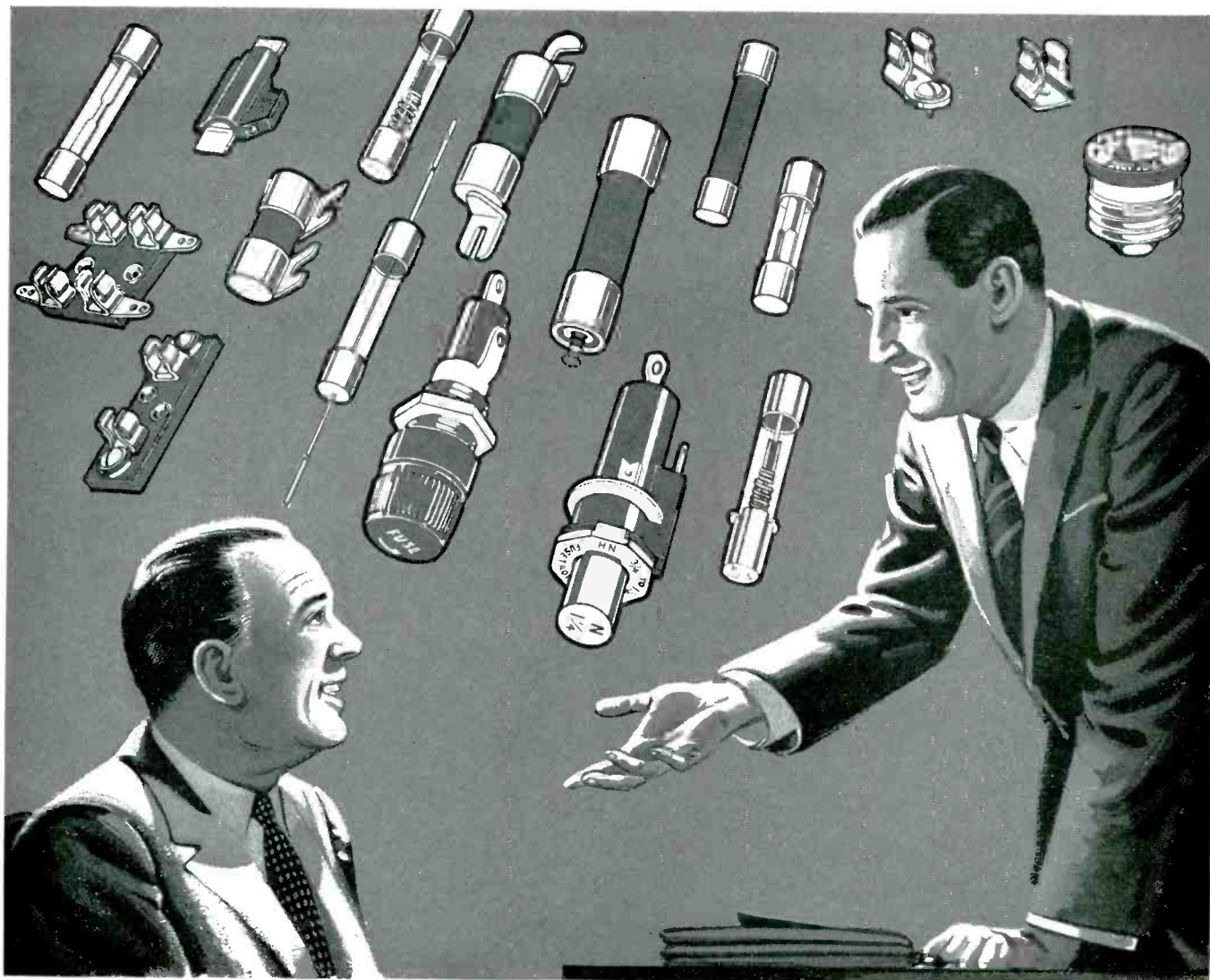

Sizes and Types for every Fuse need

*you'll quickly find the right fuse for the job
—in the complete BUSS fuse line!*

Standard type, dual-element (slow-blowing), renewable and one-time type fuses are all available from one source—BUSS. You'll save time and trouble by turning first to BUSS when you need fuses.

And of great importance, there are no 'kicks' or complaints from your customers about the operation of BUSS fuses—for to assure dependable protection under all service conditions,

BUSS fuses are tested in a sensitive electronic device. Any fuse not correctly calibrated, properly constructed and right in all physical dimensions is automatically rejected.

Save engineering time on special problems in electrical protection. The BUSS fuse engineers are at your service to help you determine the fuse or fuse mounting best suited to your

needs. If possible, they will suggest a fuse or fuse mounting already available in local wholesalers' stocks, so that your device can be easily serviced.

For more information on BUSS and FUSETRON Small Dimension fuses and fuseholders . . . Write for bulletin SFB. Bussmann Mfg. Co. (Div. of McGraw Electric Co.), University at Jefferson, St. Louis 7, Mo.

***BUSS fuses are made to protect
—not to blow, needlessly***



Makers of a complete line of fuses for home, form, commercial, electronic, automotive and industrial use.

Compact power relay— high contact ratings

More relay for your money—that's the big thing you get when you specify Ward Leonard's Bulletin 105 for light power switching jobs.

No delicate, misapplied telephone- or instrument-type relay, the 105. From rigid phenolic base to ample silver-to-silver, self-cleaning contacts, the 105 is built to deal with *power*... just like the larger Ward Leonard relays and contactors. And yet it's extremely compact and low in cost.

You'll find the Bulletin 105 relay—in SPST, SPDT, DPST, and DPDT types—ideal for controlling power to electric heaters, signals, pumps, radio and TV transmitters and public address systems.

Check your catalog file today for Bulletin 105. If it's missing write to: Ward Leonard Electric Co., 31 South Street, Mount Vernon, N. Y. (In Canada: Ward Leonard of Canada Ltd., Toronto.)

7.1

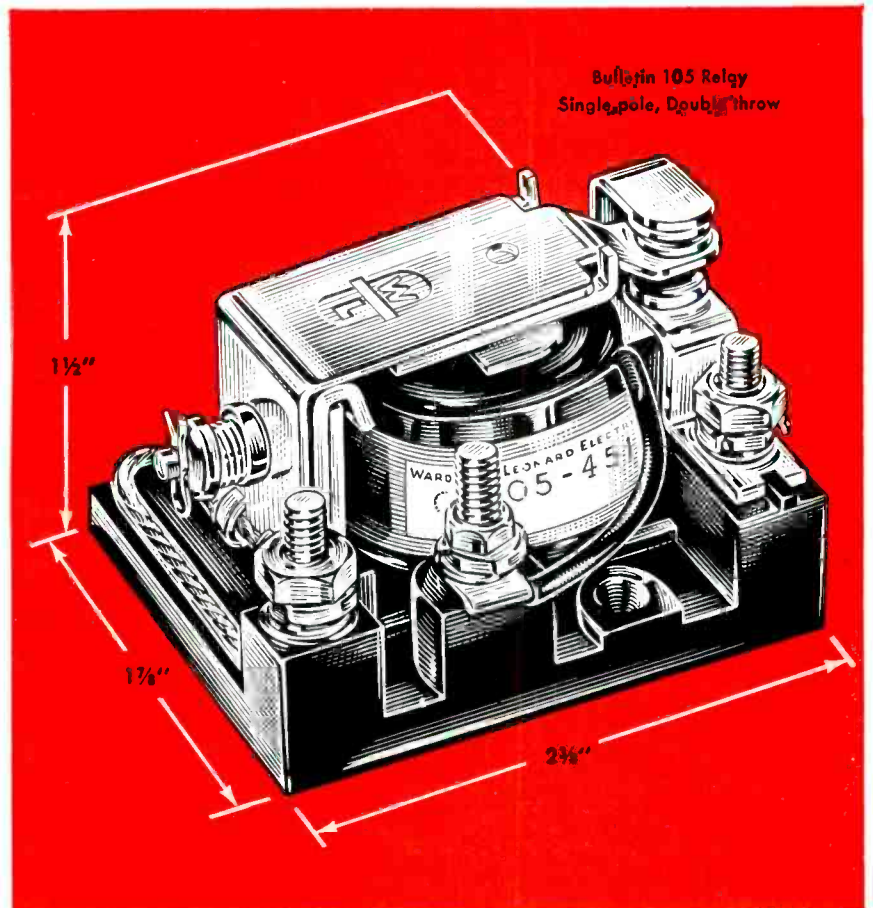

ENGINEERING DATA

SINGLE POLE BULLETIN 105 RELAY

Contact Ratings

Volts	D.C. Amps.*		A.C. Amps.*	
	N.O.	N.C.	N.O.	N.C.
0-24	20	15	20	15
25-125	1/2	1/2	20	15
126-250	—	—	15	10

*Ratings are non-inductive.

COIL VOLTS: 6, 8, 10, 12, 24, 32, 48, 115, 230

AVG. COIL WATTS: 2 D.C., 3.75 A.C.

PICK-UP: 85% or less of rated voltage

WEIGHT: 5 ounces

TERMINALS: Stud type

LIVE BETTER...Electrically



**WARD LEONARD
ELECTRIC COMPANY**
MOUNT VERNON, NEW YORK



RESISTORS



THERMOSTATS



RELAYS



CONTROLS



DIMMERS

Result-**E**ngineered Controls Since 1892



Rugged and Dependable

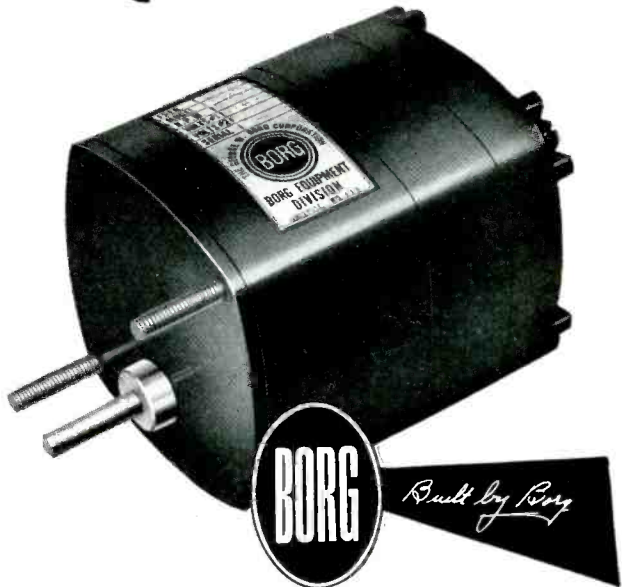

PRECISION INSTRUMENT BORG-MOTORS

Powerful for their size, the Sub-Fractional Horsepower BORG-MOTORS are in every sense rugged and dependable. Designed for quality instrument applications, they today serve the Industrial TV, Recorder, and Instrument field.

BORG-MOTORS are available in synchronous and induction types, with or without gear train. End bells and gear train cases are die-cast alloys . . . precision machined to form a totally enclosed housing. Geared output shafts have two heavy bearing supports to accommodate radial loading. All gears are precision hobbled. Die-cast rotors, mounted on two ball bearings assure long life and continued accuracy.

For many years Borg has made quality precision instrument motors in production quantities. Borg has complete research, engineering, and production facilities to assist you in solving your design and production problems.

**Write for Complete Engineering Data
CATALOG BED-A56**

Reproductions of the Borg Dog, Duke, by artist O. Jack Bond are free upon request. These life-like, lithographed reproductions contain no advertising and are suitable for framing.

BORG EQUIPMENT DIVISION
THE GEORGE W. BORG CORPORATION
JANESVILLE, WISCONSIN



Built by Borg

HOW LONG WILL THEY LAST?

COME BACK IN 1971



These *EL-MENCO* Dur-Mica Capacitors will still be on the job!

In rigid life tests in which the applied voltage was $1\frac{1}{2}$ times rated voltage and the ambient temperature was 125° centigrade, El-Menco DM-15, DM-20 and DM-30 capacitors out-distanced all normal ratings with each lasting over 10,000 hours. Because of the acceleration of these tests, the life of these capacitors may be equivalent to 15 years or more under normal operating conditions.



New, toughened phenolic casing prolongs life, increases stability over wide temperature range. Made to meet environmental and electrical requirements of RETMA and MIL-C-5 specs. Parallel leads simplify use in television, computers, miniature printed circuits, guided missiles, and countless civilian and military applications.

El-Menco Dur-Mica DM15, DM20, and DM30 Capacitors Assure:

1. Longer Life
2. Potent Power
3. Smaller Size
4. Excellent Stability — Silvered Mica
5. Peak Performance

We'll be glad to advise you on your specific needs. Put El-Menco Dur-Mica Capacitors to your own tests. See for yourself.



Write for free samples and catalog on your firm's letterhead.

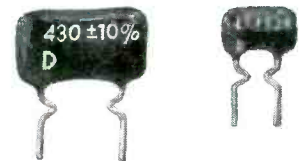

FOR PRINTED CIRCUITS — DM 15 and DM 20 WITH CRIMPED LEADS. Crimped leads specially designed for printed circuits . . . Available for immediate delivery. And lead lengths cut to your specifications.



THE ELECTRO-MOTIVE MFG. CO., INC.

WILLIMANTIC, CONNECTICUT

- molded mica • mica trimmer
- tubular paper • ceramic

Arco Electronics, Inc., 64 White St., New York 13, N. Y.
Exclusive Supplier To Jobbers and Distributors in the U.S. and Canada

A New Analog Multiplying Element



WESTON INDUCTRONIC® PRODUCT RESOLVER

— produces a direct current proportional to the product of two varying electrical signals

- four-quadrant operation
- precise . . . 0.1 per cent
- permanent calibration constant
- speed — 15 millisecond period
- especially suited to a-c/d-c measurements

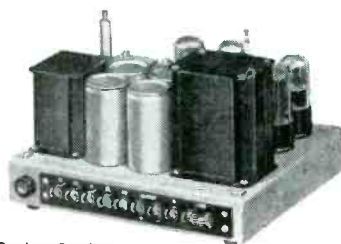

Product Resolver
Amplifying Unit
(cover removed)

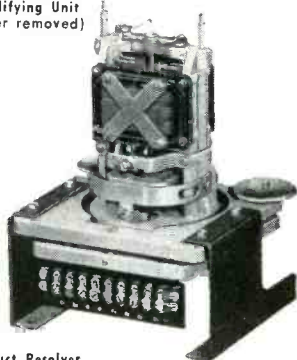

Product Resolver
Converter
(cover removed)

WESTON INSTRUMENTS



This Weston Product Resolver employs an electronically balanced electrodynamic instrument mechanism to develop a product output signal from two input signals by torque multiplication. The Inductronic® balancing system provides precise and rapid response, and an exceptional order of response to displacement. The mechanism is unique to this purpose and stems from Weston's long experience in the design and manufacture of precision dynamometer mechanisms. The complete story on the Model 1482 Inductronic Product Resolver can be obtained from your local representative or by writing Weston Electrical Instrument Corp., Newark 12, N. J., A subsidiary of Daystrom, Inc.



Better Things for Better Living
... Through Chemistry

ELECTRONIC DESIGN

PROPERTY AND APPLICATION DATA
ON THIS VERSATILE ENGINEERING MATERIAL:
TEFLON®

NEWS

No. 1, 1957

Du Pont **TEFLON**® provides new opportunities for miniaturization of electronic equipment

Because of its unusual combination of properties, Du Pont TEFLON tetrafluoroethylene resin provides new opportunities for the miniaturization of electronic components.

TEFLON has a low loss factor, low dielectric constant, and high volume resistivity. It maintains full electrical insulating characteristics, when flexed or bent during assembly and installation.

TEFLON also has good mechanical strength and an exceedingly low coefficient of friction. It is the only insulating material available today that is inert to nearly all chemicals and solvents normally used in commercial practice. An exception to this is metallic sodium and the other alkali metals. At elevated temperatures and pressures, halogens and certain halogenated chemicals and solvents may affect TEFLON.

Use of TEFLON can help cut production costs, too. The soldering iron will not burn or melt insulation of TEFLON. This saves time, labor, and materials.

The following applications are typical of the current uses of TEFLON tetrafluoroethylene resin.

MAGNET WIRE. Such wire, coated with TEFLON, is widely used on high-

temperature components for aircraft and guided missiles, transformers, relays and various types of motors.

HOOKUP WIRE AND LEAD WIRE. Insulation of TEFLON on hookup and lead wire proves advantageous on transformers, motors and harness assemblies for high-temperature applications. The chemical resistance of TEFLON is particularly valuable in gyros and other hermetically sealed components.

COAXIAL CABLE. Used as the dielectric medium of coaxial cable, TEFLON permits the design of miniature constructions which are the equivalent of coaxial cables using much thicker insulation of other materials.

TUBING. Insulation of TEFLON provides excellent protection for tubing used as bus wire and jumpers.

RESISTANCE WIRE. Insulation of TEFLON on small resistance wire facilitates miniaturization of heating equipment.

GLASS-FIBER PRODUCTS. Insulation of TEFLON is being applied currently to such glass-fiber products as lacing, tape and sewing thread. TEFLON provides excellent temperature resistance and withstands cutting action of glass fibers.

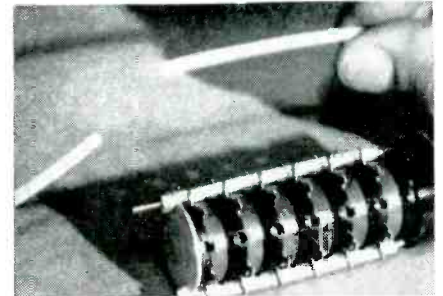

• Tubing of TEFLON serves as an insulator around two stainless-steel studs in miniature rotary tap switches used in military aircraft.

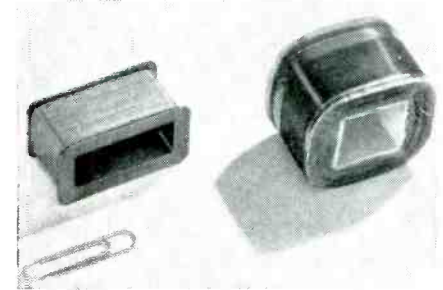

• The paper clip indicates the small size of these coils. The insulation of TEFLON is one important reason why they can be miniaturized.

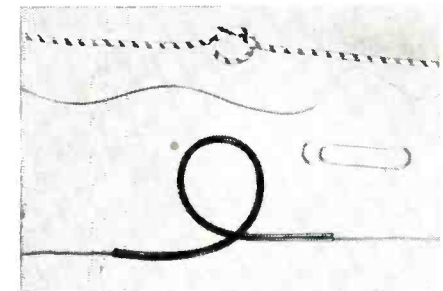

• Here are shown a striped, wrapped lead wire (top) and two samples of miniaturized flexible sleeving — all insulated with TEFLON.

NEED MORE INFORMATION?

Clip the coupon for additional data on the properties and applications of versatile Du Pont TEFLON tetrafluoroethylene resin.

E. I. du Pont de Nemours & Co. (Inc.), Polychemicals Department
Room 171 Du Pont Building, Wilmington 98, Delaware.

In Canada: Du Pont Company of Canada (1956) Limited, P. O. Box 660, Montreal, Quebec

Please send me complete property and application data on Du Pont TEFLON. I am interested in evaluating this material for

Name _____

Firm Name _____

Position _____

Type of Business _____

Street Address _____

City _____ State _____

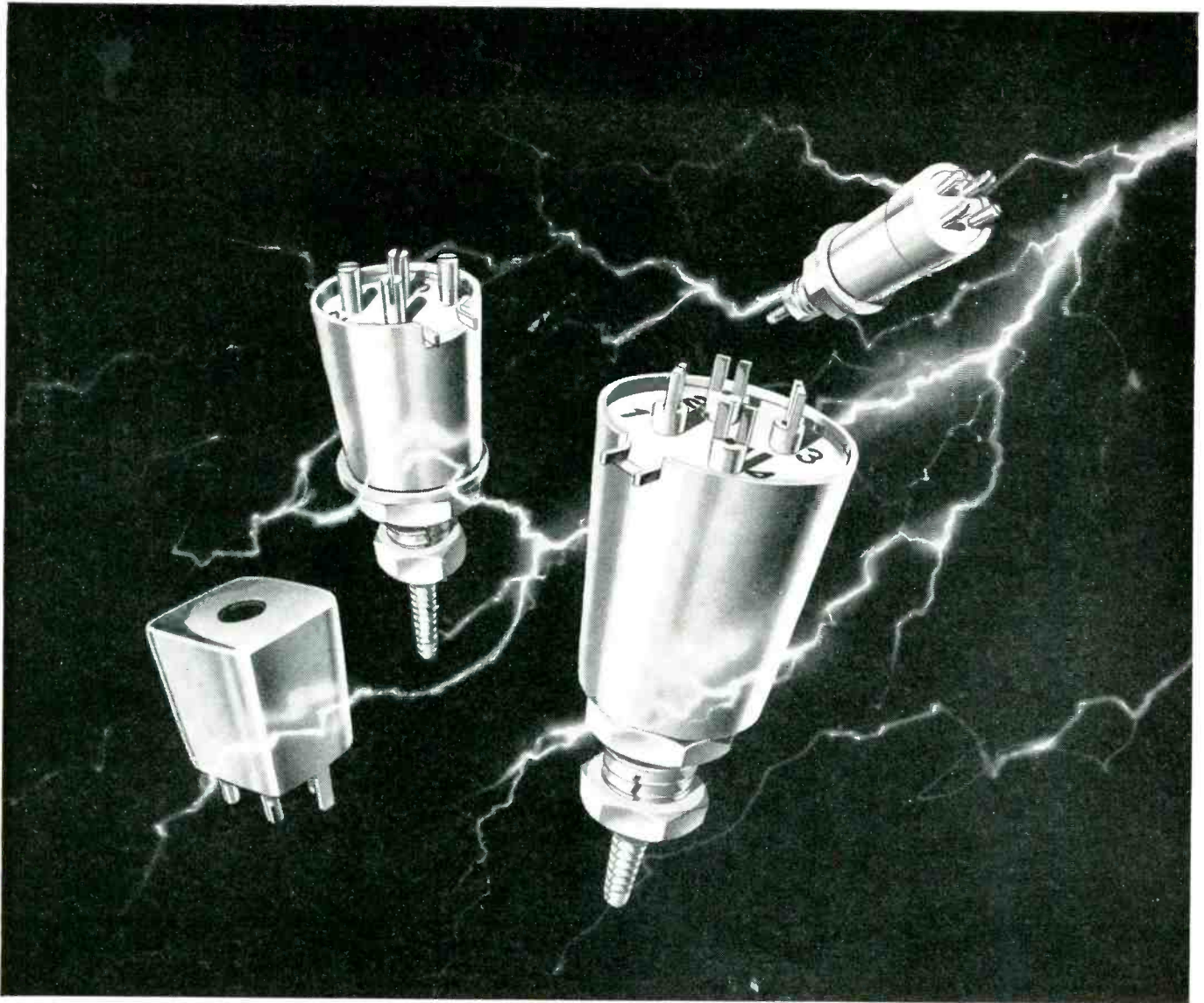

Four sizes of shielded coil forms cover a wide range of design requirements. Dimensions when mounted, including terminals, are: LS-12 (square type for printed circuits), $\frac{1}{2}$ " x $\frac{1}{2}$ " x $\frac{1}{2}$ "; LS-9, $\frac{7}{16}$ " diameter x $\frac{1}{2}$ " high; LS-10, $\frac{5}{8}$ " x $\frac{1}{16}$ "; LS-11, $\frac{1}{16}$ " x $\frac{1}{32}$ ". Each form mounts by a single stud. Windings may be universal or wound to your specifications.

Where shock treatment doesn't work

CTC miniaturized shielded coil forms are highly shock resistant. With mechanically enclosed, completely shielded coil windings, they bring all the ruggedness and dependable performance you require for your "tight spot" applications — IF strips, RF coils, oscillator coils, etc.

CTC combines *quality control* with *quantity production* to supply exactly the components you need, in any amount. CTC *quality control* includes material certification, checking each step of production, and each finished product. And CTC *quantity production* means CTC can fill your orders for any volume, from smallest to largest.

For samples, specifications and prices, write to Sales Engineering Dept., Cambridge Thermionic Corporation, 437 Concord Ave., Cambridge 38, Mass. On the West Coast contact E. V.

Roberts and Associates, Inc., 5068 West Washington Blvd., Los Angeles 16, and 61 Renato Court, Redwood City, Cal.

TYPE SPC phenolic and ceramic printed circuit coil forms can be soldered after mounting. Phenolic forms: $\frac{3}{4}$ " high when mounted, in diameters of .219" and .285". Ceramic forms: $\frac{1}{4}$ " diameter, in mounted heights of $\frac{5}{8}$ " and $\frac{13}{16}$ ", with $\frac{1}{32}$ " powdered iron core, and collars of silicone fibre-glas. Forms come with threaded slug and terminal collar. Units mount through two to four holes, as required. Available as forms alone or wound as specified.

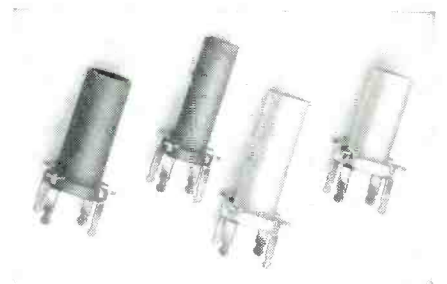

CAMBRIDGE THERMIONIC CORPORATION

*makers of guaranteed electronic components
custom or standard*

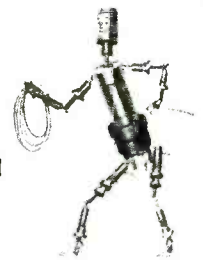

OOPS!

SIGHTS of rockets swooshing heavenward become more and more familiar as we thumb through today's industrial publications. The recalcitrant rocket shown on this page indicates that things *can* go wrong in research, and we don't claim that the absence of a Sanborn oscillographic recording system somewhere along the line was the reason for this disappointing trajectory.

What we do wish to say is that Sanborn equipment is playing an increasingly vital part in rocket development. Used in the laboratory to record flight behavior simulated by analog computers, and in plotting rooms at testing bases to tape down telemetered data, Sanborn "150's" are helping rockets to get and stay where they belong.

You can see Sanborn systems in many other places, too. Oil fields, electronic component production lines, machine tool plants, hydraulic testing laboratories, numerous aircraft manufacturers, computing facilities... are putting single to 8-channel Sanborn systems to work. (Most are housed in vertical mobile cabinets, while those in the "field" are often divided into portable packages for each instrument.) All of them give their users inkless, permanent recordings in true rectangular coordinates, one percent linearity, as many as nine chart speeds, and the efficiency (and economy) inherent in Sanborn unitized design. A dozen different plug-in preamps further extend their value, by making change-over to new recording inputs a quick and easy procedure.



SANBORN COMPANY

CAMBRIDGE 39, MASSACHUSETTS

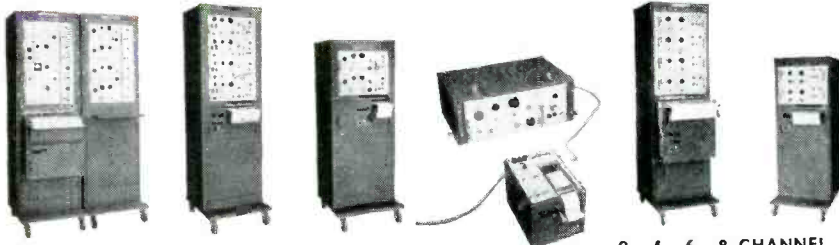

8-, 6-CHANNEL 4-CHANNEL 2-CHANNEL 1-CHANNEL 2-, 4-, 6-, 8-CHANNEL ANALOG COMPUTER SYSTEMS

Which way rockets are going may not be a primary concern of yours. But if recording problems are, you're apt to find some interesting and useful answers in Sanborn's 16 page "150 System" catalog. Write to us for a copy.

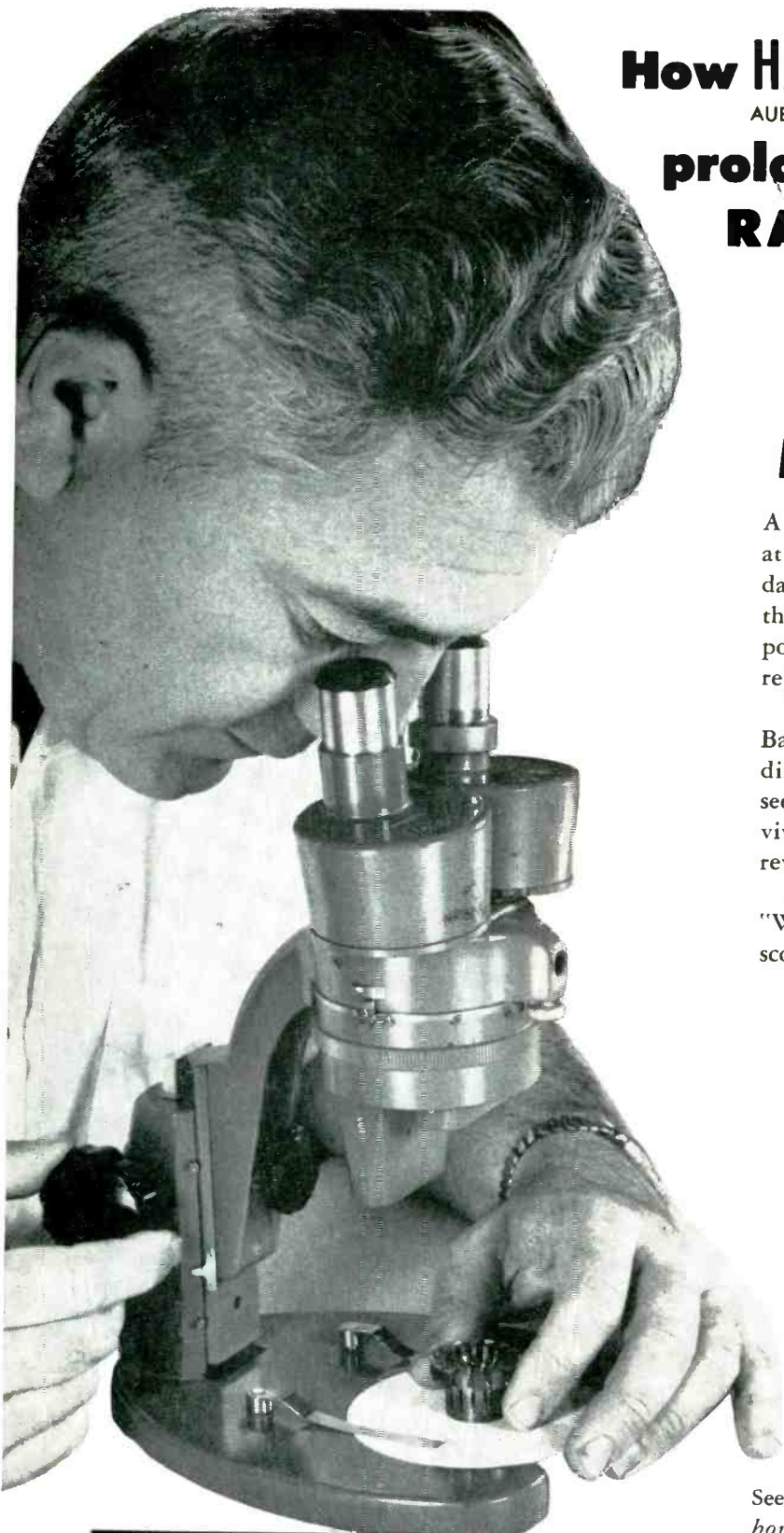

How HARRY WOLFF Co., Inc.,

AUBURNDALE, MASSACHUSETTS

prolongs life of \$5000

RADAR TUBES

with

3-D

MICRO-VISION

A tiny burr on this tuning crown will burn off at normal operating temperatures and cause radar tube failure. Precision components like this are made of metals that cost over \$100 per pound. The tube costs up to \$5000. Obviously, rejects and failures are prohibitively costly.

That's why Harry Wolff Co., Inc., uses Bausch & Lomb Stereomicroscopes to check 368 different edges of each tuning crown. Inspectors see the work right-side-up, clearly magnified in vivid 3-dimensional detail. Burrs are quickly revealed, and easily scraped off.

And that's why Harry Wolff, president, says: "We consider the B&L Wide Field Stereomicroscope as important to us as a precision lathe."



FREE!

**GET THIS EXCLUSIVE 3-D
MICRO-VISION BOOK**

See actual stereo views! Know *how* and *where* to use Stereomicroscopes. Choose exact model for job needs, with unique Selector-Chart. Write today for Manual D-15. Bausch & Lomb Optical Co., 61413 St. Paul St., Rochester 2, N. Y.



BAUSCH & LOMB

SINCE  1853

America's only complete optical source from glass to finished product

Want more information? Use post card on last page.

January 1, 1957 — ELECTRONICS

Square RE-USABLE Metal Pad-Kaging Containers



ELIMINATE majority of handling and storage problems
REDUCE shipping weights and cubic footage

These RE-USABLE Metal Pad-Kaging Containers were developed by PETERS-DALTON for the U.S. Armed Forces. They have been approved and are in use for shipping and storing innumerable items.

P-D Containers eliminate the storing of many cumbersome and highly inflammable materials—they also eliminate the excess labor usually required in packaging such items as delicate radar instruments. Older methods caused finished packages to be heavy and bulky. They were susceptible to breakage and penetration to moisture and fungus. They were wasteful because of their excessive use of man-hours and materials, culminated by the eventual scrapping of the expensive packaging. Also, when reshipping was required, old fashioned containers after having once been opened, were seldom satisfactory for adequate repackaging of the materials — endangering them to damage while in transit. These inadequacies and limitations have been virtually eliminated through P-D RE-USABLE Metal Shipping Containers,

★ ★ ★
Features include: Lightness: Completed packs weigh far less than older style types. Compactness: The P-D RE-USABLE Metal Containers frequently save more than 50% of cubic footage. Economy: Material and man-hour outlays for packaging are reduced 25%.

Special Features: Containers are equipped with air fill valves to eliminate dangers of fungus or moisture and dial type humidity indicators. Drop handles furnished for containers weighing less than 200 lbs.—heavier containers have been designed for fork truck lifting. Extremely simple to close, only ordinary bolts (4 on the smallest container to 14 on the largest) are required; the simplest of hand tools perform the closing or opening operations. Optional: Pressure relief valves to equalize inside to outside pressures.

★ ★ ★
These RE-USABLE Metal Containers were manufactured by PETERS-DALTON for items ranging from aircraft engines, electronic parts, to large A-N containers in all types and sizes for shipping purposes. Complete engineering and manufacturing facilities are at your disposal for design, testing and fabricating. We'll be glad to tell you more—just write, wire or phone.



Materials formerly used in packaging one light military electronic item.

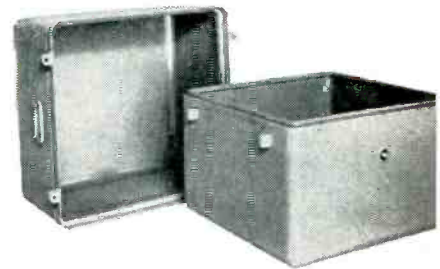

Only two parts to handle.



P-D Re-Usable Container ready to be closed and sealed. Note the simplicity of design.

STEEL SHIPPING CONTAINER DIVISION



Peters-Dalton INC.

A SUBSIDIARY OF DETROIT HARVESTER CO.

17872 Ryan Road • Detroit 12, Michigan

P-D Hydro-Whirl Paint Spray Booths
P-D Industrial Washing Equipment
P-D Drying and Baking Ovens
P-D Hydro-Whirl Dust Collecting Systems

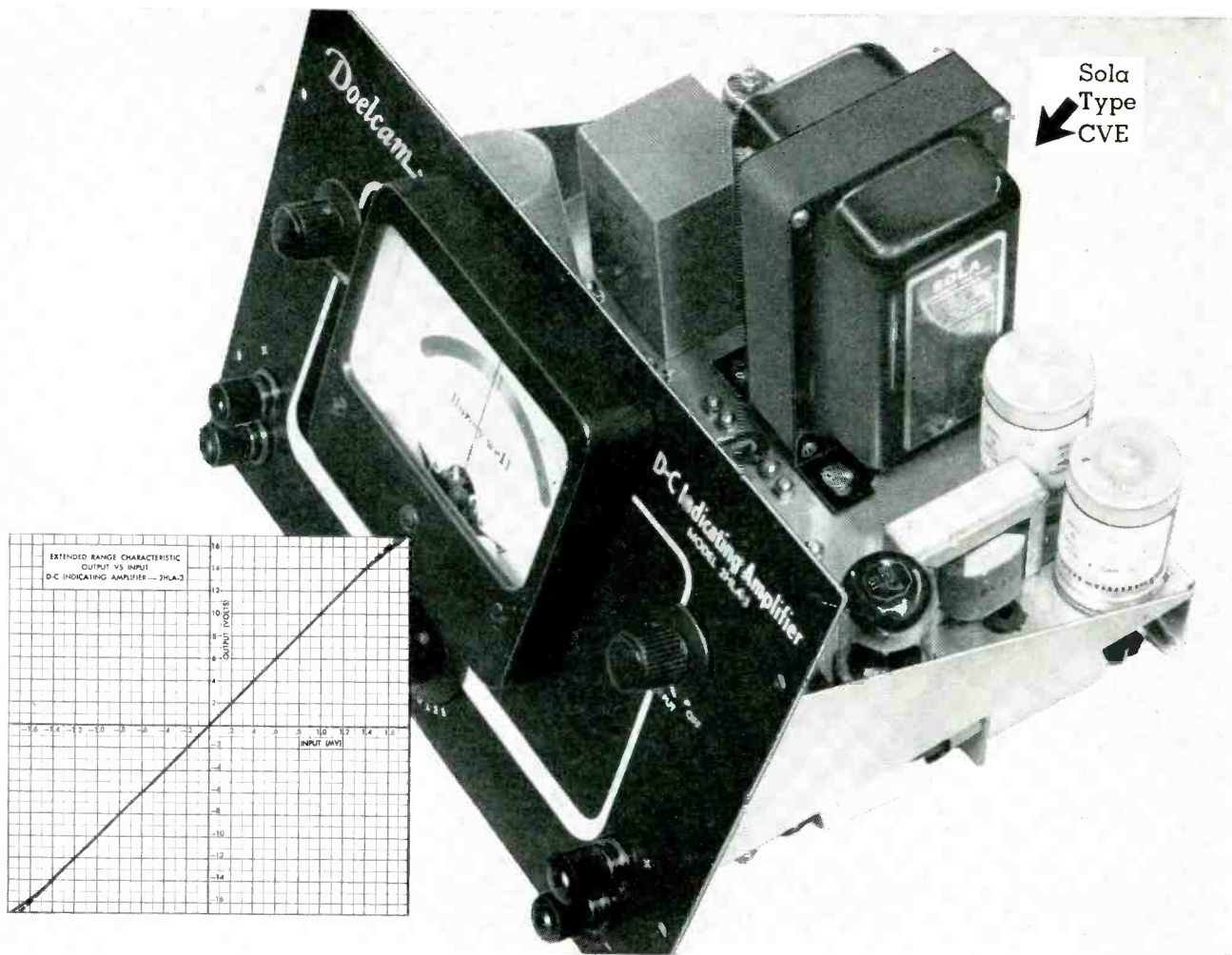

Above is the 2HLA-3 Indicating Amplifier, a product of the Doelcam Division of Minneapolis-Honeywell. Housing is removed to show chassis-mounted Sola

Type CVE Regulated Power Supply Transformer. Inset is an extended-range characteristic showing linear amplifier output.

Sola-Regulated DC Amplifier Provides Reliable Measurement of 2×10^{-15} W Signals

The Doelcam 2HLA-3 DC Indicating Amplifier has introduced a standard of performance heretofore unattainable in the field of amplification and measurement of low level dc signals. This precision instrument measures signals as small as 2×10^{-15} watt. High gain, excellent linearity, and negligible drift of the 2HLA-3 are unaffected by variations in line voltage or tube characteristics.

Contributing to this reliable and stable performance of the Doelcam amplifier is its chassis-mounted Sola Type CVE Regulated Power Supply Transformer. The Sola CVE static-magnetic stabilizer provides a single, compact source of plate and filament supply voltages regulated within $\pm 3\%$, with input voltage variations of 100-130 volts. All windings are on the same core, pro-

viding a moderately-priced unit to replace both voltage-regulating circuit, or component, as well as conventional power transformer.

These Sola transformers are available in three standard models ($\pm 3\%$ regulation); or in special designs with regulation of one winding as close as $\pm 1\%$. They have no moving parts or tubes, and are completely automatic, instantaneous, and continuous in operation. In addition, they provide self-protection against short circuit, and require no maintenance.

Your area representative will be happy to provide you with information on the specific benefits of a Sola Type CVE Regulated Power Supply Transformer as a component in your product.

SOLA *Constant Voltage* TRANSFORMERS



Write for Bulletin 7A-CV-170D
SOLA ELECTRIC CO.
4633 W. 16th St.
Chicago 50, Ill.

CONSTANT VOLTAGE TRANSFORMERS for Regulation of Electronic and Electrical Equipment • LIGHTING TRANSFORMERS for All Types of Fluorescent and Mercury Vapor Lamps. • SOLA ELECTRIC CO., 4633 West 16th Street, Chicago 50, Illinois, Blshop 2-1414 • NEW YORK 35: 103 E. 125th St., Trafalgar 6-6464 • PHILADELPHIA: Commercial Trust Bldg., Rittenhouse 6-4988 • BOSTON: 272 Centre Street, Newton 58, Mass., Bigelow 4-3354 • CLEVELAND 15: 1836 Euclid Ave., Prospect 1-6400 • KANSAS CITY 2, MO.: 406 W. 34th St., Jefferson 4382 • LOS ANGELES 23: 3138 E. Olympic Blvd., ANgelus 9-9431 • TORONTO 17, ONTARIO: 102 Laird Drive, Mayfair 4554 • Representatives in Other Principal Cities

Dual Directional Couplers

for reflectometer measurements on coaxial systems



4 all-new couplers!

**Complete coverage,
216 to 4,000 MC**

Ideal for power measurements

Flat response, high directivity

**Low SWR, wide band
performance**

These new *-hp-* couplers save your time by making possible, for the first time, convenient reflectometer measurements on coaxial antennas, transceivers, counter-measures and TV equipment, etc. Each unit centers on a major band but offers 2:1 frequency coverage. Directivity is high, units handle powers to 50 watts cw, and insertion loss is low for permanent installation. The couplers can be used to measure forward or reverse power or to adjust system flatness.

-hp- 760 series couplers are compact, sturdy, and precision built of highly heat stable materials for long-term accuracy.

SPECIFICATIONS

	<i>-hp-</i> 764D	<i>-hp-</i> 765D	<i>-hp-</i> 766D	<i>-hp-</i> 767D
Frequency Range:	216 to 450 MC	450 to 940 MC	940 to 1,900 MC	1,900 to 4,000 MC
Coupling Attenuation:	20 db	20 db	20 db	20 db
Coupling Accuracy:	±1 db	±1 db	±1 db	±1 db
Max. Prim. Line SWR:	1.10	1.15	1.20	1.25
Max. Second. Line SWR:	1.10	1.20	1.30	1.35
Minimum Directivity:	30 db	30 db	26 db	26 db
Prim. Line. Insert. Loss:	Approx. 0.15 db	Approx. 0.20 db	Approx. 0.25 db	Approx. 0.35 db
Price:	\$125.00	\$125.00	\$125.00	\$125.00

All models: Power handling capacity 50 watts CW or 10 Kw peak. Primary Line Connectors: Type N, Male & Female. Secondary Line Connectors: Type N, Female. Reflectometer Detectors: 764D/765D take *-hp-* 476A; 766D/767D take *-hp-* 420B. Size all units: 9" long; weight 2 lbs. Prices f.o.b. factory. Data subject to change without notice.

HEWLETT-PACKARD COMPANY
3634A PAGE MILL ROAD • PALO ALTO, CALIFORNIA, U.S.A.
Sales engineers in all principal areas
Cable "HEWPACK" • DAVenport 5-4451



highest quality, value, complete coverage



SHIPPED FROM STOCK

Oxygen-free high conductivity copper . . . *in convenient* rod form

Tube manufacturer ends rejects by using PB&B O.F.H.C. copper rod

A major manufacturer of transmitting tubes was getting rejects of approximately 2 per cent in finished tubes, due to microscopic leaks in a copper part made from extruded rod. Each reject meant loss of a tube worth nearly \$100. This source of high vacuum leakage was impossible to detect before assembly. Since switching to O.F.H.C. hot rolled rod, supplied by PB&B, rejects from this cause have completely vanished.

Need *certified grade* O.F.H.C.® copper rod—for use in vacuum tubes or other electrical or electronic equipment?

We can supply you quickly from stock, to highest quality standards. You'll find this material useful and economical in many special applications. It is pre-forged and hot rolled, to produce a dense, homogeneous grain structure free from microscopic porosity. It is not subject to hydrogen embrittlement during hydrogen atmosphere brazing. We certify its conductivity to be at least 98% I.A.C.S.

Cold-straightened rod, in diameters of $\frac{3}{4}$ ", 1", $1\frac{1}{4}$ ", $1\frac{3}{8}$ ", $1\frac{1}{2}$ " and $1\frac{5}{8}$ ", to standard hot rolled tolerances, is regularly stocked in "as rolled" condition. You can order in random lengths, or we can cut to your specifications.

Write today for a quotation on your particular requirements.

® Registered Trade Mark
The American Metal Co. Ltd.

**PHILADELPHIA
BRONZE & BRASS CORP.**

22nd and Master Streets, Philadelphia 21, Pa.

—a subsidiary of

P. R. MALLORY & CO. INC.
MALLORY

for servo amplifiers
... low-speed switches
... control circuits
... power converters

CBS POWER TRANSISTORS

Just as CBS power transistors have earned a fine reputation in "hybrid" auto radio applications, the CBS 2N156 and 2N158 PNP junction power transistors are recognized as "best on the market" for servo amplifiers . . . as well as many switching, control, and power conversion applications.

Check the advanced-engineering features . . . typical characteristics . . . and graph showing the low collector "ON" saturation voltages. They help to explain the growing popularity of these transistors. Important also are two simple facts: The CBS 2N156 and 2N158 uniformly meet their specifications . . . and they are being delivered in production quantities.

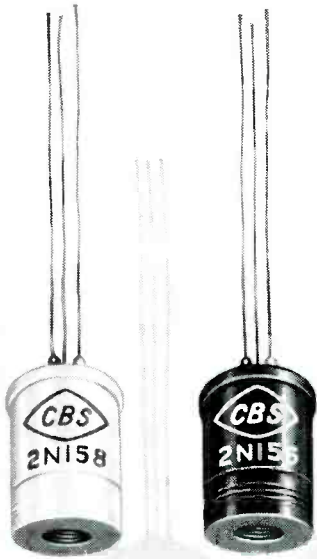

FEATURES

1. High current gain at high current
 2. High current output
 3. High breakdown voltage
 4. High power handling
 5. Low saturation voltage
 6. Low input impedance
 7. Stable, uniform characteristics
- capabilities with suitable heat sink

COLLECTOR CHARACTERISTICS, 2N156 AND 2N158

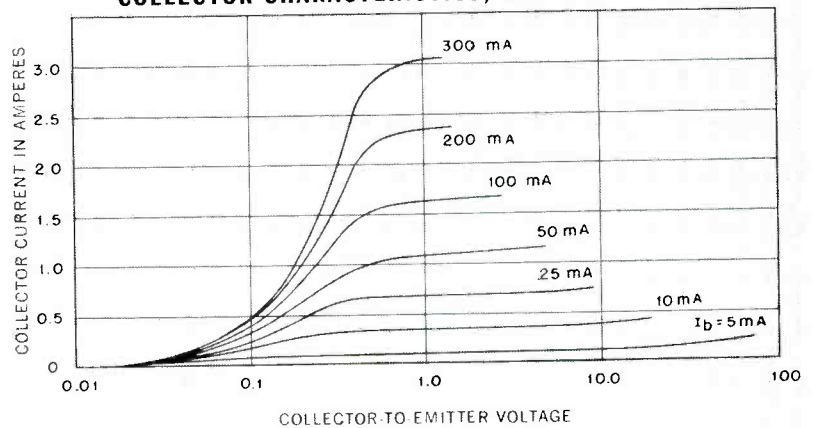

Let our application engineers help you adapt these dependable power transistors to your needs. Write for Bulletin E-259 giving complete data.

TYPICAL CHARACTERISTICS

CHARACTERISTIC	2N156	2N158	
System voltage	12	28	volts
Collector dissipation	5	5	watts
Collector peak inverse voltage	-40	-80	volts
Maximum junction temperature	85°	85°	C
Switching power	26	54	watts
Current amplification (Ic = 2 amp.)	20	13	

*Reliable products
 through Advanced Engineering*



semiconductors

CBS-HYTRON

Semiconductor Operations, Lowell, Massachusetts
 A Division of Columbia Broadcasting System, Inc.

New Stokes

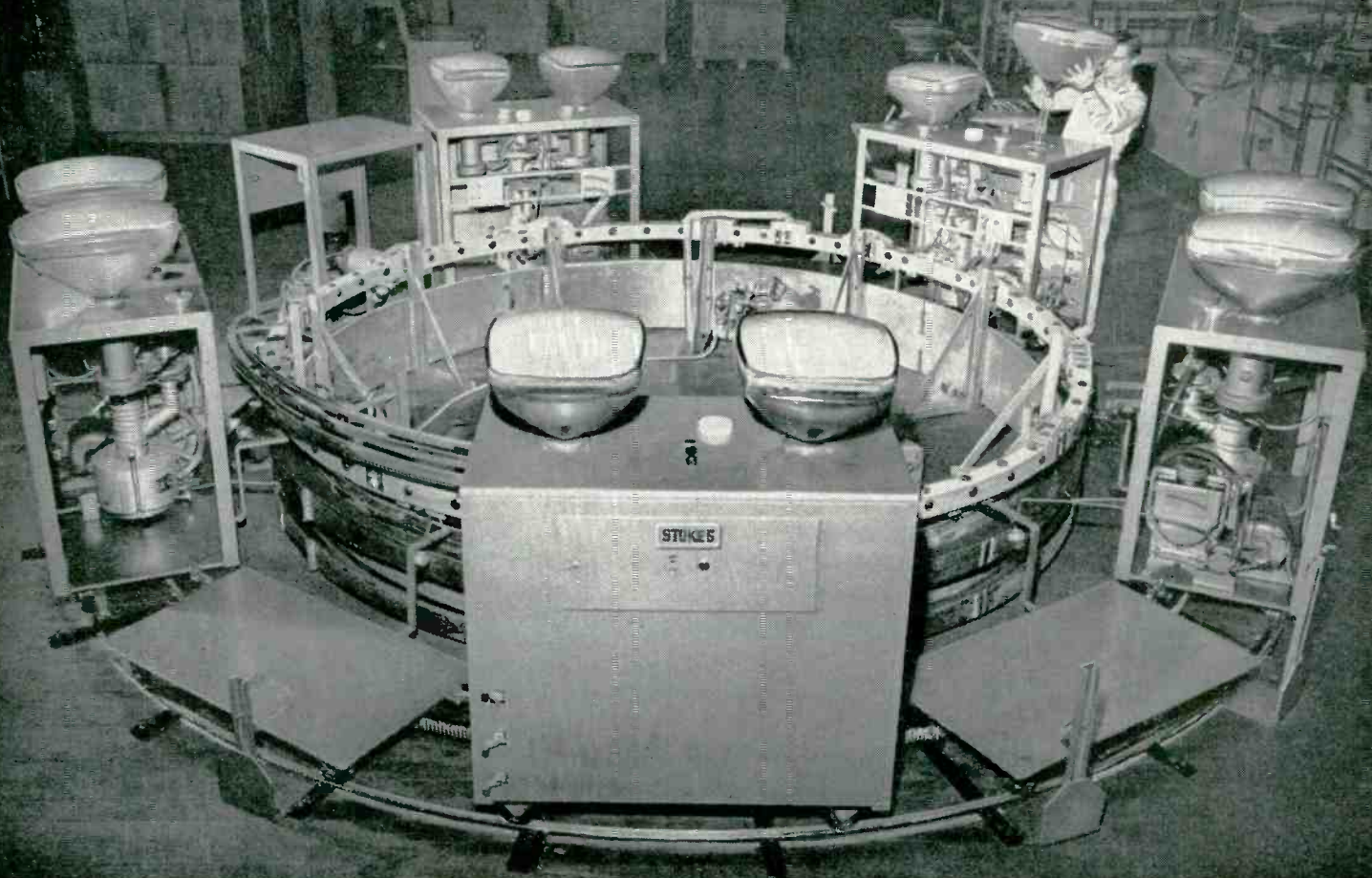

New Stokes dual-tube in-line aluminizing system is setting high standards of economy and productivity at Thomas Electronics, Inc., Passaic, New Jersey.

Electronic equipment manufacturers are profiting from other STOKES Vacuum Equipment...

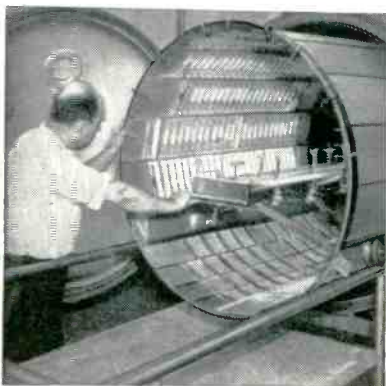

Vacuum Metallizers. Stokes manufactures a complete line of vacuum metallizing equipment to plate selenium rectifiers, printed circuits and other conductive coatings on non-conductive materials.

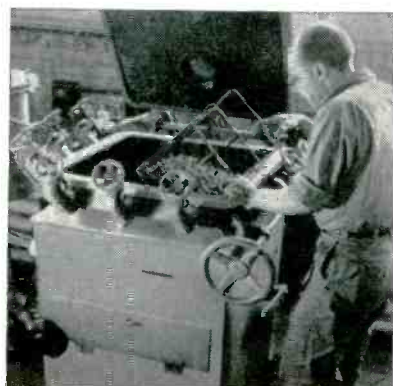

Vacuum Impregnators. Manufacturers of electronic equipment use Stokes vacuum impregnation systems to obtain improved characteristics of coils, condensers, capacitors and other components.



Vacuum Furnaces. Stokes melting and heat-treating furnaces permit electronic manufacturers to pre-process raw and semi-finished materials with less contamination, for increased life and performance.

5 Cart In-line TV Dolly System Aluminizes 96 Tubes Per Hour

New system at Thomas Electronics, Inc.—largest independent manufacturer of cathode ray tubes — affords increased production . . . reduces initial cost . . . requires less floor space and maintenance

TODAY's big news in TV picture tube production is the new Stokes aluminizing system. This high-production equipment evacuates and aluminizes *two tubes per cart* with one pumping system. The new design affords several cost-cutting and production-boosting advantages:

Greater production. Using a mechanical pump and 4-inch high speed "Ring-Jet" booster, overall cycle time is 6½ minutes with 21-inch tubes—96 per hour with the standard five cart system.

Lower first cost. Fewer carts are needed . . . the basic unit, consisting of five carts with ten dollies, costs less than comparable single-tube systems.

Lower maintenance. There is only *one* pumping system for every *two* tubes.

Less floor space. Circular track is only 17 feet in diameter.

Flexibility. Five additional carts can be added to the standard dollies to produce 21-inch tubes at a rate of 192 per hour. Tubes up to 27-inch can be accommodated.

The system is fully automatic. Operator loads . . . and then unloads completely aluminized tubes. Filament replacement is simplified by removable holders. Internal cooling coils provide for rapid cooling of oil in the booster pump before vacuum is released.

A Stokes engineer will be glad to discuss how this new system for black and white or color tubes can be integrated into your production line. He'll also welcome the opportunity to talk over your specialized requirements . . . to apply Stokes' extensive experience in high vacuum engineering and automatic production technology. F. J. STOKES MACHINE COMPANY, 5503 Tabor Road, Philadelphia 20, Pa.

Reference Data:

Microvac Pumps—Catalog 750
Diffusion and Booster Pumps
Specification and performance data
Story of the Ring-Jet Pump
How to Care for Your Vacuum Pump—
Booklet 755
Vacuum Impregnation—Catalog 760
Vacuum Furnaces—Catalog 790
Vacuum Metallizing—Catalog 780
Vacuum Calculator Slide Rule



STOKES

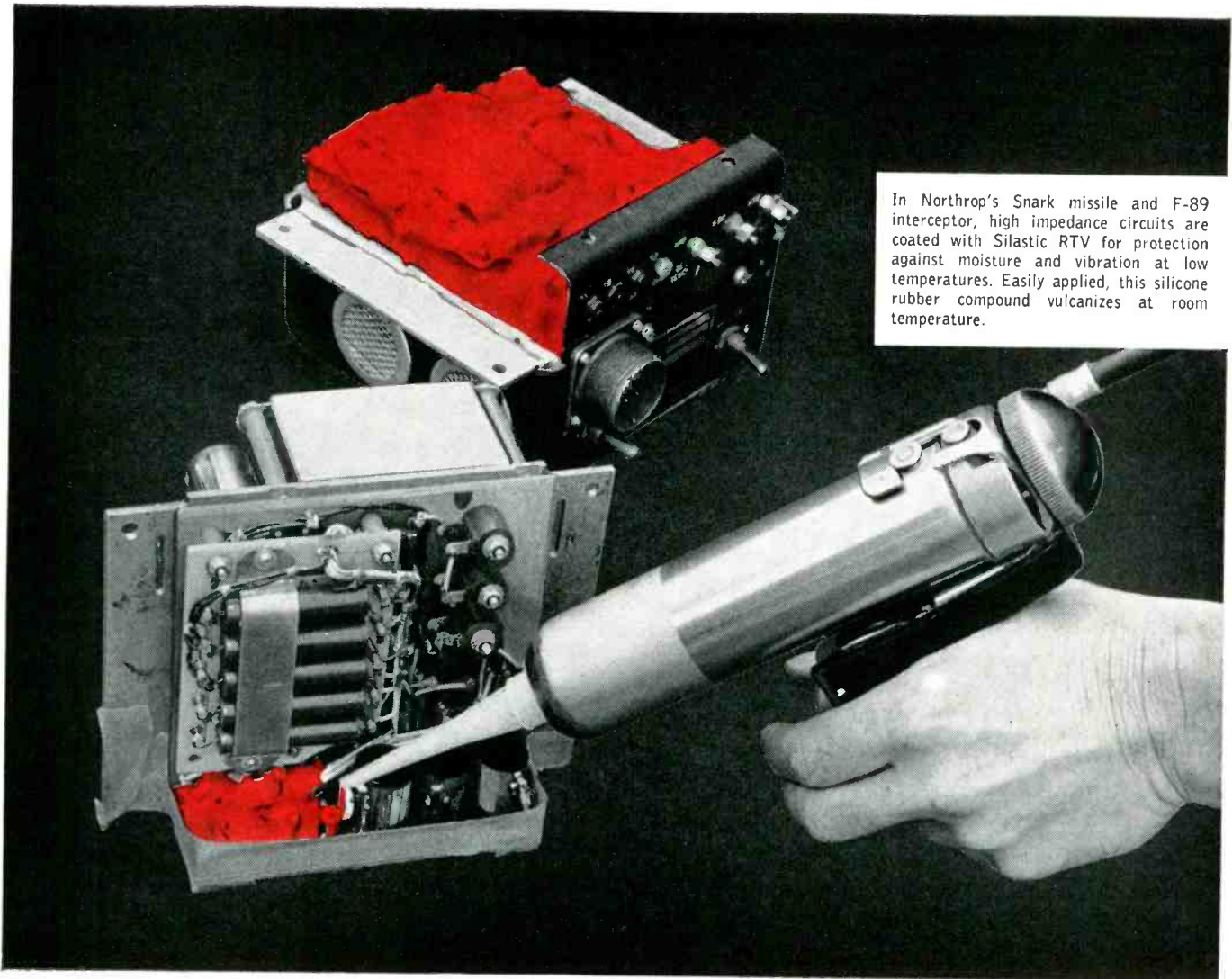

In Northrop's Snark missile and F-89 interceptor, high impedance circuits are coated with Silastic RTV for protection against moisture and vibration at low temperatures. Easily applied, this silicone rubber compound vulcanizes at room temperature.

SILASTIC

SILICONE RUBBER

RTV seals, cushions delicate circuits

Get latest data on Silastic
Mail coupon today

Dow Corning Corporation, Dept. 4813
Midland, Michigan
Please send me latest data on Silastic

NAME _____

COMPANY _____

ADDRESS _____

CITY _____ ZONE _____ STATE _____

* T.M. REG. U.S. PAT. OFF.

Sensitive electronic components can be both cushioned and sealed against moisture by encapsulating with Silastic RTV*, Dow Corning's silicone rubber that vulcanizes at room temperature. A single coating provides protection, and in addition improves electrical properties of the unit, especially surface resistivity. Silastic RTV cures in 24 hours, and remains resilient from -100 F to 350 F. Write for complete data.

Typical Properties of Silastic for Encapsulating and Potting

- Temperature range, °F -100 to 350 F
- Dielectric strength, volts/mil 300 to 500
- Surface resistivity at 50% relative humidity, ohms 2.8×10^{12}
- Dielectric constant, 10^2 cycles per second 2.95 to 3.05
- Dissipation factor, 10^2 cycles per second 0.01
- Moisture absorption after 7 days at room temperature, % +3 to +5

If you consider ALL the properties of a silicone rubber, you'll specify SILASTIC.

first in silicones



DOW CORNING CORPORATION • MIDLAND, MICHIGAN

Generation of Functions of *Two or More* Variables

with the

400 series REAC®

DIODE FUNCTION GENERATOR

- Allows direct generation of slopes up to 12 volts/volt without paralleling diode segments.
- 10-turn potentiometers for both "slope" and "break point" give excellent resolution. Still further improvement in resolution is obtained by splitting slope adjustment into two ranges.
- 1000-division direct read-out 10-turn dials permit logging of function for fast reproduction later.
- Flexible switching system allows number of segments per channel to be varied from 2 to 30.
- Built-in calibration circuit permits functions to be set up quickly and easily without use of external plotting board.

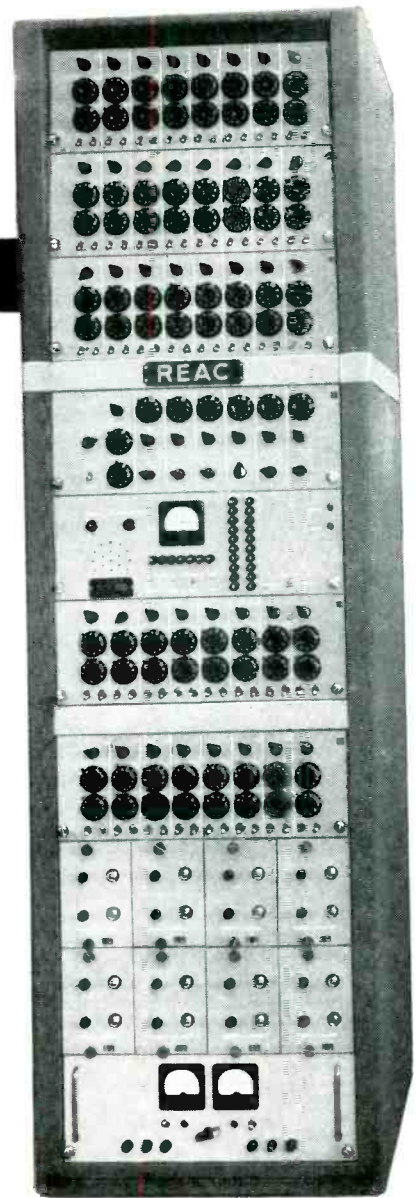
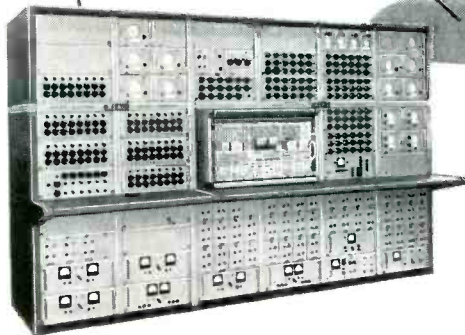

... a complete self-contained unit

The DFG-401 is a completely self-contained unit consisting of 5 channels of function generation, 15 DC amplifiers (with VTVM and all control circuits for monitoring and balancing), and all necessary power supplies (except relay and reference voltages). In the event that any amplifiers supplied are not needed in the problem, they can be made available in groups at the patchbay as inverters with one gain of one.

This unit is ideal for the addition of up-to-date diode function generation equipment to an existing analog computer installation.

Electronic generation of functions of two or more variables is another outstanding Reeves contribution to the flexibility and efficiency of the electronic analog computer. Before installing new equipment, it will pay you to consult us. A comprehensive new REAC "400" series computer technical brochure will be sent upon request.

REEVES INSTRUMENT CORPORATION

A Subsidiary of Dynamics Corp. of America, 201 East 91st St., New York 28, New York

2RV57



REAC Analog Computers



Precision Floated Gyros



Precision Resolvers and Phase Shifters



Servo Mechanical Parts

For the most dependable printed circuits, you need the high bond strength, workability, heat-resistance of **C-D-F DILECTO[®] METAL-CLAD LAMINATES**

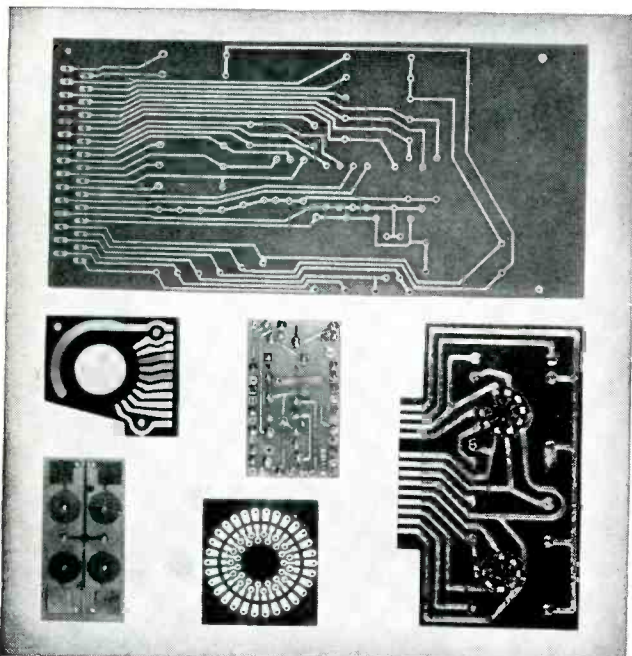

Printed circuits based on C-D-F materials are being used with great success in military electronic equipment, commercial television and radio sets, telephone switchboards—even sub-miniature radiosonde equipment and hearing aids.

Photos courtesy of Photocircuits, Inc., Glen Cove, N. Y.

HIGH BOND STRENGTH—C-D-F's special adhesive for metal-clad Dilecto bonds the copper foil to the plastic without affecting the laminate's superior electrical properties. Heat-resistance, dissipation factor, dielectric constant, dielectric strength, and insulation resistance of the Dilecto base remain unaffected. The closely-bonded foil can be etched cleanly and dipped in hot solder to 450°F. for ten seconds with a guarantee of no blistering or separating. Metal-Clad Dilecto can be punched or machined either before or after etching.

EXCELLENT WORKABILITY—On all four Dilecto metal-clad grades, you can solder, punch, saw, and assemble components either by hand or automatically. Thanks to the inherently superior workability of the plastics laminate over that of ceramic-type materials, Dilecto can be dropped, jammed into tight chassis, and otherwise treated roughly on the assembly line and in service.

HIGH HEAT-RESISTANCE—Metal-Clad Dilecto Laminates are made of phenolic, epoxy, or Teflon* resin for various conditions of service and assembly, and have either cellulosic paper or woven glass-fabric base. All are ideally suited to printed-circuit applications in which heat-dissipation is a major problem. Continuous exposure to high ambient operating temperatures in enclosed electronic equipment has no significant effects on Dilecto's electrical and physical properties.

UNLOAD YOUR HEADACHE HERE! C-D-F, a big, reliable source of supply, can help you get the most for your printed-circuit money by reducing rejects, lowering fabrication costs, assuring dependable quality every time. Send us your print or problem, and we'll gladly supply appropriate test samples free. See our catalog in the Product Design File (Sweet's) or send for the new 20-page Dilecto catalog. Let your nearby C-D-F sales engineer (listed in Sweet's) help you right from the design stage!

TYPICAL PROPERTY VALUES

	Copper-Clad PHENOLIC (Grade XXXP-26)	Copper-Clad PHENOLIC (Grade XXXP-28)	Copper-Clad EPOXY (Grade GB-181E)	Copper-Clad TEFLON* (Grade GB-112T)
BOND STRENGTH—0.0014" foil (Lbs. reqd. to separate 1" width of foil from laminate)	7 to 11	5 to 9	8 to 12	4 to 8
MAXIMUM CONTINUOUS OPERATING TEMP. (Deg. C.)	120	120	150	200
DIELECTRIC STRENGTH (Maximum voltage per mil.)	800	800	650	700
INSULATION RESISTANCE (Megohms) 96 hrs. at 35° C. & 90% RH	50,000	25,000	20,000	Over 10 ⁶ megohms
DIELECTRIC CONSTANT 10 ⁶ Cycles	4.20	4.20	4.54	2.85
DISSIPATION FACTOR 10 ⁶ Cycles	0.026	0.052	0.018	0.0006
ARC-RESISTANCE (Seconds)	10	5	120	180
TENSILE STRENGTH (psi.)	16,000 x 13,000	12,000 x 10,000	48,000 x 44,000	23,000 x 21,000
FLEXURAL STRENGTH (psi.)	21,000 x 18,000	18,000 x 16,000	65,000 x 55,000	13,000 x 11,000
IZOD IMPACT STRENGTH edgewise (ft. lbs. per inch of notch)	0.40 x 0.35	0.40 x 0.35	13.5 x 11.5	6.0 x 5.0
COMPRESSIVE STRENGTH flatwise (psi.)	28,000	22,000	62,000	20,000
BASE MATERIAL OF LAMINATE	Cotton rag paper	Cotton rag paper	Medium-weave, medium-weight glass cloth	Fine-weave, medium-weight glass cloth
COLOR OF UNCLAD LAMINATE	Natural greenish	Natural Brown	Natural	Natural

All these standard grades are available with 0.0014", 0.0028", 0.0042", or thicker electrolytic or rolled copper foil on one or both surfaces. Other metal foils and other resin-and-base combinations can be supplied on special order.

*duPont Trademark



CONTINENTAL DIAMOND FIBRE

CONTINENTAL-DIAMOND FIBRE DIVISION OF THE BUDD COMPANY, INC.

NEWARK 16, DELAWARE

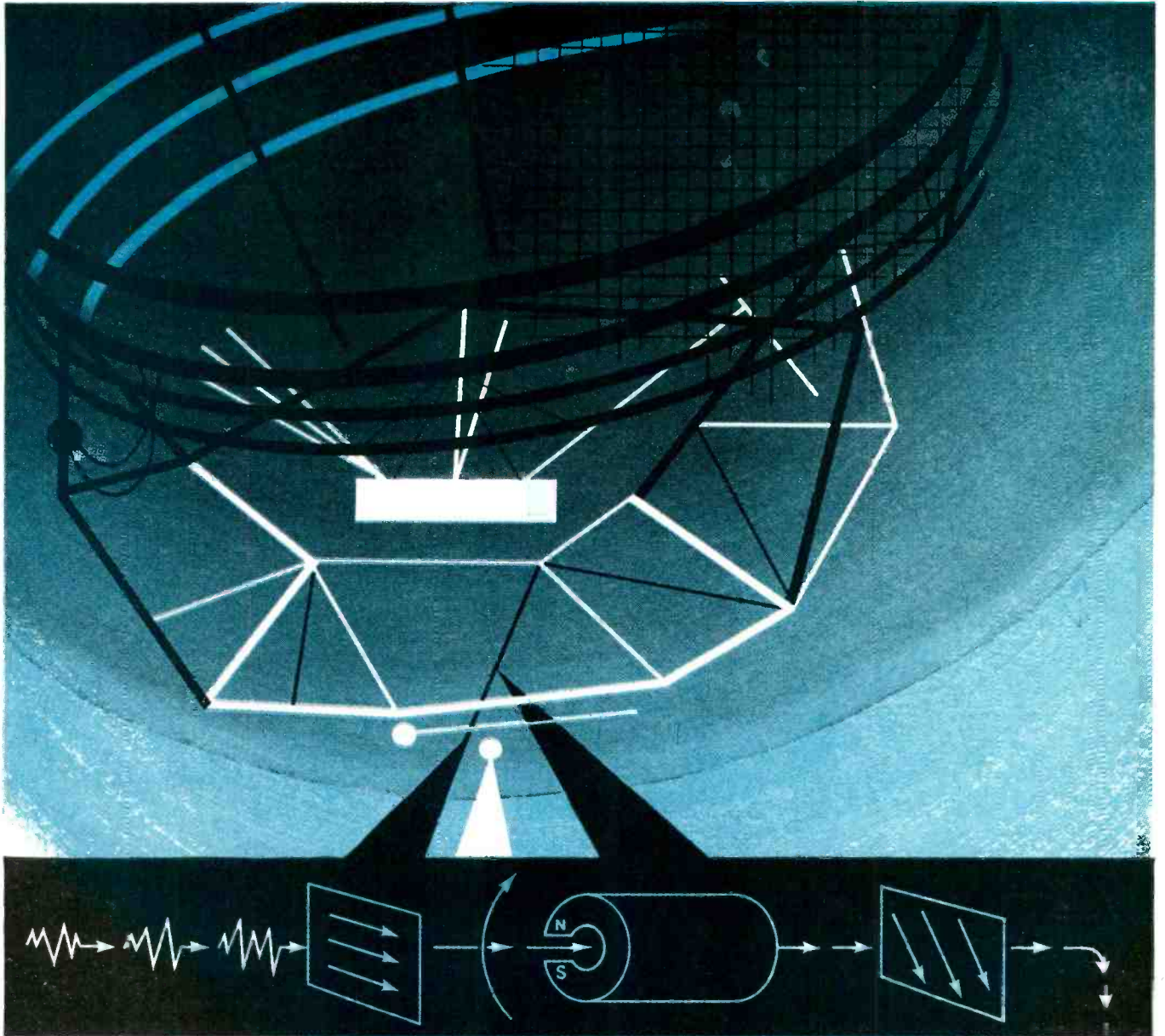

in radar load isolators, too

CRUCIBLE PERMANENT MAGNETS

give maximum energy. . . minimum size

Special applications, such as radar load isolators, demand compact but powerful magnet assemblies. And this is but one of the many places where the *consistently* higher energy product provided in Crucible Alnico magnets pays off.

These Crucible Alnico permanent magnets can be sand cast, shell molded, or investment cast to exact size, shape or tolerance requirements . . . and in any size from a mere fraction of an ounce to hundreds of pounds.

The design and production of permanent magnets has been a Crucible specialty ever since Alnico alloys were discovered. It's one of the good reasons why so many people bring their magnet applications to Crucible. Why don't you? *Crucible Steel Company of America, The Oliver Building, Mellon Square, Pittsburgh 22, Pa.*

CRUCIBLE

first name in special purpose steels

Crucible Steel Company of America

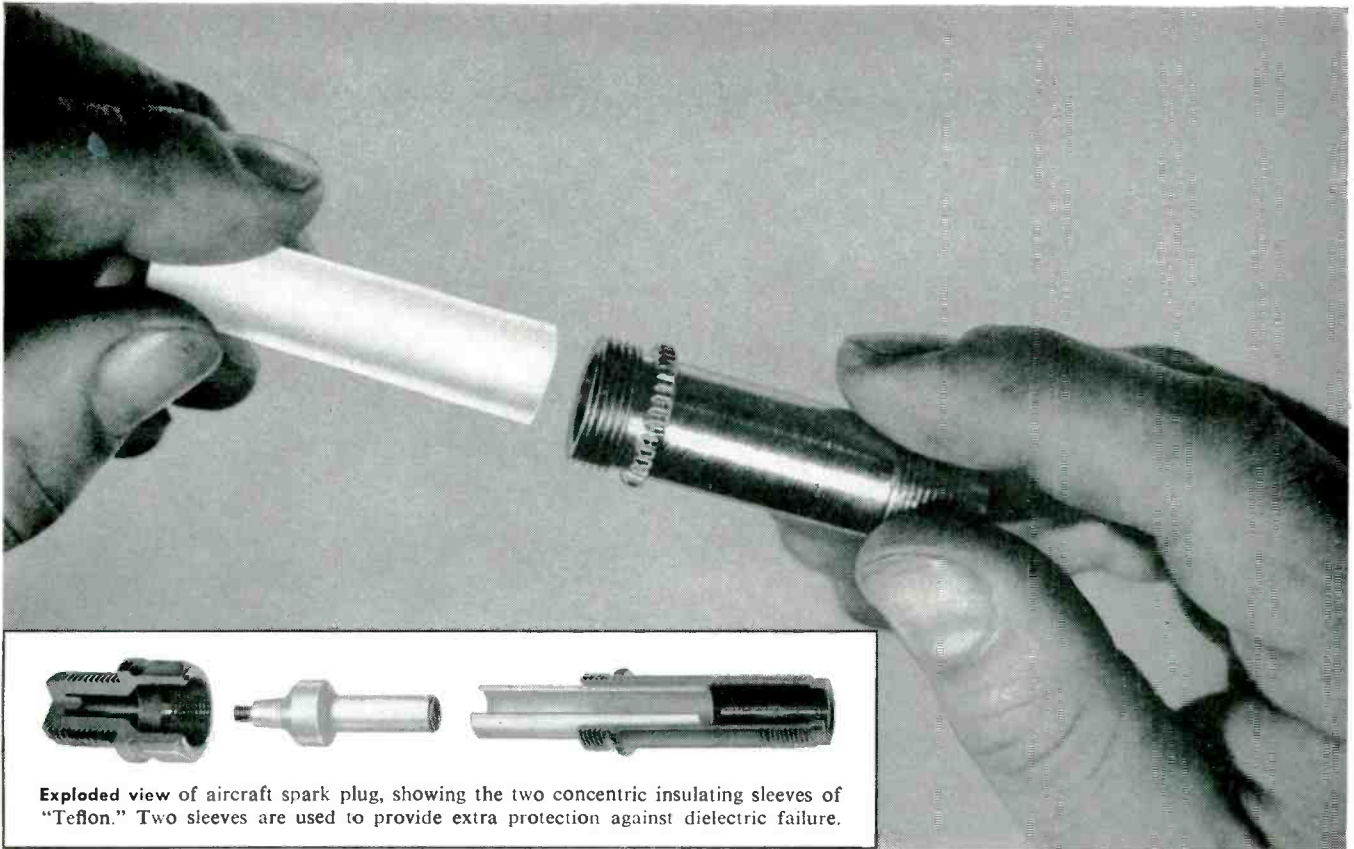

Exploded view of aircraft spark plug, showing the two concentric insulating sleeves of "Teflon." Two sleeves are used to provide extra protection against dielectric failure.

Insure trouble-free design with R/M Teflon* products

For thousands of electrical applications "Teflon" has proved to be the best material because of its combination of properties—electrical, thermal and mechanical. It permits compactness of design, and because of its resiliency and toughness, components made from it often simplify installation. R/M Tape handles easily, conforms well to corners and unusual shapes, can be readily adapted for automatic wrapping.

Here are some of the electrical properties of R/M "Teflon":

1. **Power factor** — less than 0.0003 over entire spectrum from 60 cycles to 30,000 megacycles.
2. **Volume resistivity** — greater than 10^{15} ohm-cm. even after prolonged soaking in water.

3. **Surface resistivity**— 3.6×10^{12} ohms even at 100% humidity.
4. **Good arc-resistance**— on exposure to an arc, the material vaporizes, leaving no carbonized path.
5. **High short-time dielectric strength**— values range from 1000 to 2000 volts per mil, depending on thickness.
6. **Resists high temperatures** — electrical properties are essentially unchanged up to at least 400°F.

Take advantage of R/M's long experience in developing the potentials of "Teflon" for the electrical industry. We fabricate "Teflon" to your specifications or supply it in rods, sheets, tubes, wire and tape in all standard color codings. Send for our bulletin "R/M Teflon Products."

*A Du Pont trademark

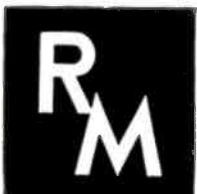
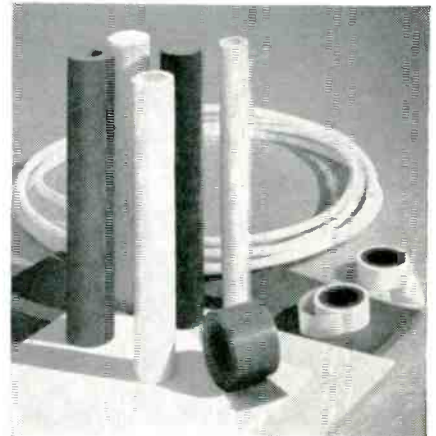

RAYBESTOS-MANHATTAN, INC.

PLASTIC PRODUCTS DIVISION, MANHEIM, PA.

FACTORIES: Bridgeport, Conn.; Manheim, Pa.; No. Charleston, S.C.; Passaic, N.J.; Neenah, Wis.; Crawfordsville, Ind.; Peterborough, Ontario, Canada

RAYBESTOS-MANHATTAN, INC., Engineered Plastics • Asbestos Textiles • Mechanical Packings • Industrial Rubber • Sintered Metal Products • Rubber Covered Equipment
Abrasive and Diamond Wheels • Brake Linings • Brake Blocks • Clutch Facings • Laundry Pads and Covers • Industrial Adhesives • Bowling Balls

having your ups and downs?



... if they involve POTENTIOMETERS

DALOHM has the answer!

All Dalohm components are carefully designed and skillfully made to assure you of supreme quality and dependability, plus the widest versatility of application. These recent additions to the Dalohm line already have met with wide acceptance and enthusiasm.



You can depend on DALOHM



Mil-E-Trized A10-W TRIMMER POTENTIOMETER

Wire Wound, High Temperature, Humidity-Proof, Ruggedized

This Dalohm Trimmer is designed to meet the ever-increasing requirements of such specifications as MIL-E-5272A and MIL-R-12934. It provides precision adjustments in critical electronic circuits under extreme environmental conditions. It has an extended winding surface and assures high precision resolution without sacrificing sub-miniature design. Size is .220 x .310 x 1.250; weight is 2.25 grams.

- Resistance values 10 ohms to 100,000 ohms; standard tolerance 5%; power rating 0.8 watt; temperature coefficient of wire 0.00002/Deg. C. Other resistances, tolerances, leads available on special order.
- Completely sealed; housing of thermo-setting, glass filled material with heat resistance of 200° C continuous. Precious metal plating on all terminals; air evacuated and filled with silicone grease.
- Unique new type sliding contact; unique safety clutch.
- Unit holds set resistance values.
- Mounting flexibility provided for either stacked or multiple arrangements.

Write for Bulletin R-32B

Mil-E-Trized DP-12 POTENTIOMETER

Built to Surpass JAN-R-19

Hermetically Sealed, Moisture-Proof, Ruggedized

Completely protected from arctic cold or tropic damp, from shock, vibration, salt-laden air and ultra-high altitude. Powered at 4 watts, the DP-12 has a power rating of 100% at 40° C, derated to 0 at 125° C. Housing and shaft of black anodized aluminum with back plate of corrosive resistant aluminum. Unit designed for back panel mounting with integral threaded base.

- Operating temperature range—55° C to 125° C Minimum rotational life is 25,000 mechanical cycles.
- Standard resistance range 100 ohms to 40K ohms with standard tolerance of 5%. Other ranges and tolerances available on special order.
- Precision winding gives excellent linearity with 3% maximum deviation.
- Temperature coefficient of wire 0.00002/Deg. C on values of 500 ohms and up; 0.00050/Deg. C on values below 500 ohms.
- Sensitive shaft adjustment.

Write for Bulletin R-31

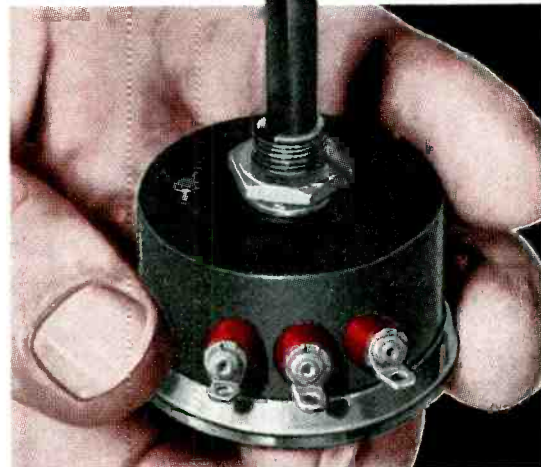

JUST ASK US!

Write for the complete Dalohm catalog of precision resistors, potentiometers, and collet-fitting knobs.

If none of our standard line fills your need, our staff of able engineers and skilled craftsmen, equipped with the most modern facilities, is ready to help you solve your problem in the realm of development, engineering, design and production.

Just outline your specific situation.

DALE
PRODUCTS
INC.

1300 28th Ave.
Columbus, Nebraska, U.S.A.

● In Canada:
Charles W. Pointon, Ltd.,
6 Alcina Ave.,
Toronto, Ont.

● Export Dept:
Pan-Mar Corp.
1270 Broadway,
New York 1, N.Y.

High Purity

Baker ELECTRONIC CHEMICALS

For your electronic tubes and screens—

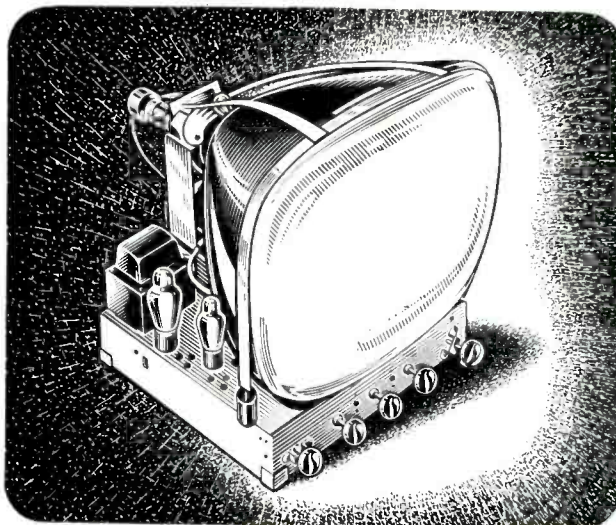

BARIUM ACETATE, C.P. for Electronics

One of many high purity Baker production chemicals for the electronic industry. For use in screen settling, it will pay you to investigate Baker Barium Acetate, C.P. for Electronics. You get double-protection—purity is assured by the high assay and by control of several impurities that are critical.

In the specifications shown below, note that the assay is 99% minimum. Heavy metals, chlorides and insolubles are particularly low. And thorough blending insures that purity is uniform within each lot.

With your need for quick solubility in mind, this material is produced as a fine crystalline powder. Close control of chemical and physical specifications help achieve uniform operating characteristics in your process.

Today, the increasing demands of the electronic industry for closer tolerances present ever-new challenges for higher chemical purity. Baker works closely with chemists and electronic engineers to aid in meeting these challenges. Look over the list of Baker electronic chemicals on this page — write for prices and samples of those which interest you.

BARIUM ACETATE, C.P. For Electronics, Crystal		F.W. 255.452
Ba(C ₂ H ₃ O ₂) ₂		
Assay (Ba(C ₂ H ₃ O ₂) ₂)	99.0	%
Insoluble Matter	0.010	%
pH of 5% Solution at 25°C	7.0-8.5	
Chloride (Cl)	0.003	%
Oxidizing Substances (as NO ₂)	0.005	%
Substances not Precipitated by H ₂ SO ₄	0.10	%
Calcium and Strontium Salts (as SO ₄)	0.50	%
Heavy Metals as (Pb)	0.0005	%
Iron (Fe)	0.001	%

J. T. Baker Chemical Co.

REAGENT • FINE • INDUSTRIAL

Phillipsburg, New Jersey

- Acetic Acid
- Acetone
- Aluminum Nitrate
- Aluminum Sulfate
- Ammonium Carbonate
- Ammonium Chloride
- Ammonium Hydroxide
- Ammonium Phosphate
- Antimony Trioxide
- Barium Acetate
- Barium Carbonate
- Barium Fluoride
- Barium Nitrate
- Benzene
- Boric Acid
- Cadmium Chloride
- Cadmium Nitrate
- Cadmium Sulfate
- Calcium Carbonate
- Calcium Chloride
- Calcium Fluoride
- Calcium Nitrate
- Calcium Phosphate
- Carbon Tetrachloride
- Cobalt Carbonate
- Ether, Anhydrous
- Ether, Petroleum
- Hydrochloric Acid
- Hydrofluoric Acid
- Hydrogen Peroxide
- Lithium Carbonate
- Lithium Chloride
- Lithium Nitrate
- Lithium Sulfate
- Magnesium Carbonate
- Magnesium Chloride
- Magnesium Oxide
- Manganese Dioxide
- Manganous Carbonate
- Methanol
- Nickelous Chloride
- Nickelous Nitrate
- Nickelous Sulfate
- Nitric Acid
- Potassium Dichromate
- Potassium Hydroxide
- iso-Propyl Alcohol
- Radio Mixtures
- Silicic Acid
- Sodium Carbonate
- Sodium Chloride
- Sodium Hydroxide
- Sodium Phosphate Dibasic
- Strontium Nitrate
- Sulfuric Acid
- Toluene
- Triple Carbonate
- Xylene
- Zinc Chloride
- Zinc Nitrate
- Zinc Oxide

PURITY BY THE TON
—for production use

BRANCH OFFICES

NEW YORK
122 E. 42nd St.

CHICAGO
435 N. Michigan Ave.

PHILADELPHIA
6908 Market St., Upper Darby, Pa.

LOS ANGELES
170 E. California St., Pasadena 5, Cal.

Want more information? Use post card on last page.

January 1, 1957 — ELECTRONICS

Transitron

Fast Switching SILICON DIODES

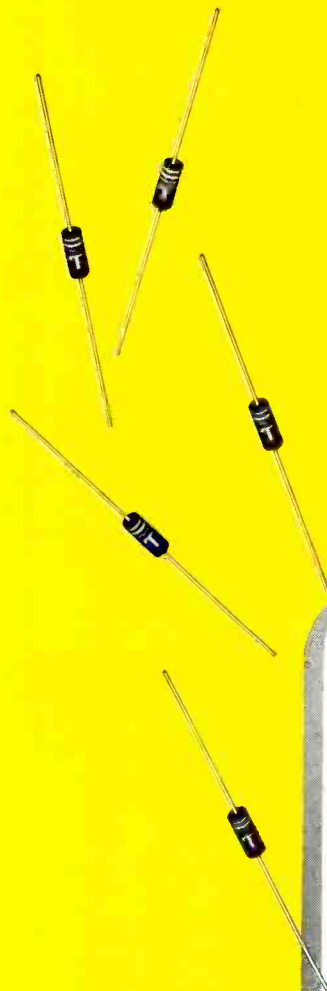

Featuring

- Recovery times under $.3 \mu s$
- High conductance
- High voltage ratings
- Operation to $150^{\circ} C$

Transitron's fast switching silicon diodes are intended for medium and high speed circuits in which diode recovery characteristics are important. These new types are considerably faster in recovery time than other silicon and germanium diodes. They are particularly useful in computer and similar applications.

In addition to excellent static and dynamic properties, reliable performance is assured through close process control and all glass encapsulation.

Type	Minimum Forward Current at 1.5V (ma)	Maximum Inverse Current (μa)	Maximum Inverse Voltage (Volts)	Maximum Recovery Time* (μsec)
SG228	100	.25 @ 175V	200	1
SG226	100	.25 @ 60V	80	1
SG223	30	.25 @ 175V	200	.5
SG221	30	.25 @ 60V	80	.5
SG213	5	.25 @ 175V	200	.3
SG211	5	.25 @ 60V	80	.3
Low Capacitance Types				
1N251	5 @ 1V	.1 @ 10V	30	.15
1N252	10 @ 1V	.1 @ 5V	20	.15

*Measured in the 256 - JAN Recovery Circuit

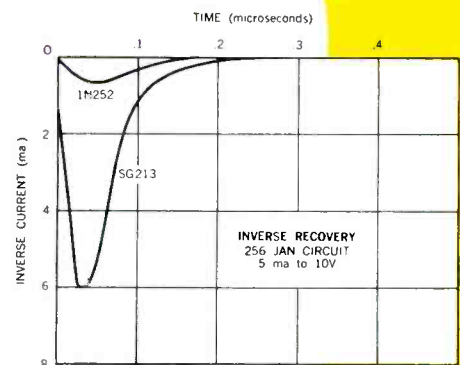

Send for Bulletin TE L350C

Transitron

electronic corporation • wakefield, massachusetts



Germanium Diodes



Transistors



Silicon Diodes



Silicon Rectifiers



Industry's Highest Power Transistors

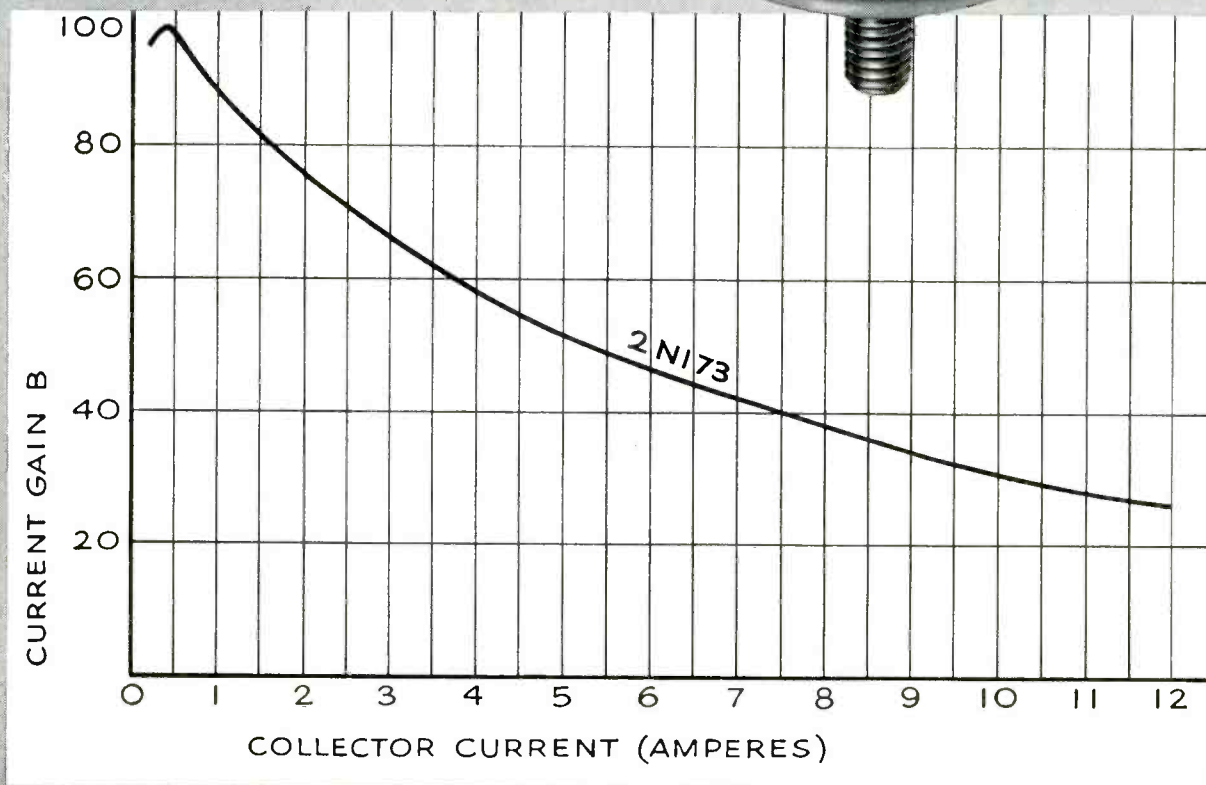

Delco Radio "High-Power" Transistors set a new industry standard of performance—
Produced by the thousands each day!

Delco Radio alloy junction germanium PNP power transistors 2N173 and 2N174, now in volume production, are characterized by high output power, high gain and low distortion. Stabilizing processes eliminate the effect of time on performance characteristics.

The high power handling ability does not exclude applications for low and medium power levels. Performance at low levels exceeds that of many low power transistors and will provide a higher degree of safety and stability to equipment design.

TYPICAL CHARACTERISTICS		
	2N173	2N174
Properties (25°C)	12 Volts	28 Volts
Maximum current	12	12 amps
Maximum collector voltage	60	80 volts
Saturation voltage (12 amp.)	0.7	0.7 volts
Power gain (Class A, 10 watts)	38	38 db
Alpha cutoff frequency	0.4	0.4 Mc
Power dissipation	55	55 watts
Thermal gradient from junction to mounting base	1.2°	1.2° °C/watt
Distortion (Class A, 10 watts)	5%	5%

DELCO RADIO

**DIVISION OF GENERAL MOTORS
KOKOMO, INDIANA**

new...from Raytheon

TEST JACKS

Now the most complete quality line in the industry . . .

All your test jack needs from one reliable source—Raytheon. These brand new components offer a unique combination of highly desired features. Nine colors. Nylon insulators. Beryllium-copper contacts with silver-plated gold-washed solder terminals. Designed for extreme salt spray, humidity, temperature conditions. For standard .080" prods. These jacks conform to military specs. and are competitively priced.

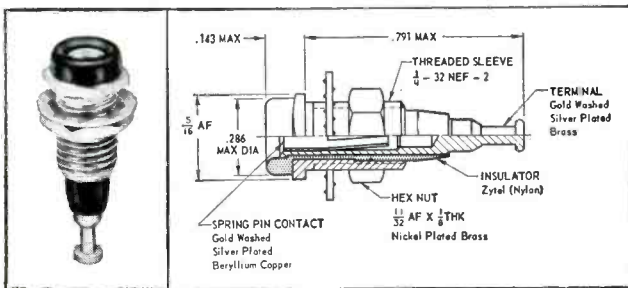

STANDARD TEST JACK

Rugged construction, superior design. Ideal for extreme shock and vibration conditions

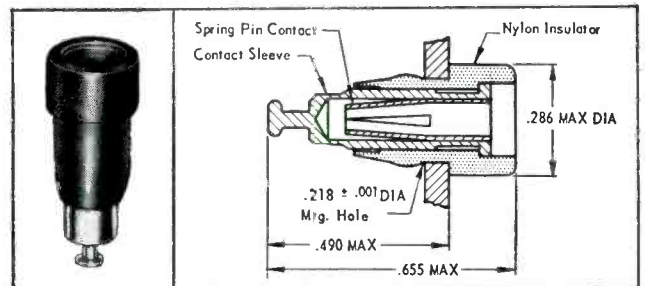

SUBMINIATURE FIXED-CONTACT TEST JACK

Fast, easy, press-fit assembly

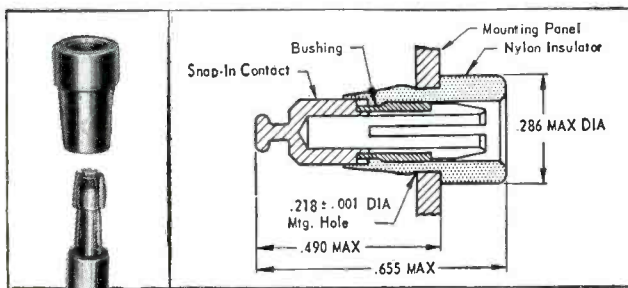

SUBMINIATURE SNAP-IN CONTACT JACKS

Snap-in contact can be soldered to cable before insertion in mounted jack

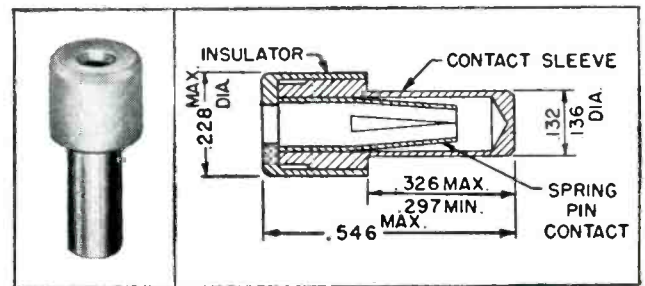

PRINTED CIRCUIT TEST JACKS

Mount on any panel to 1/4" thick

For complete information, please write Dept. 6120



RAYTHEON MANUFACTURING COMPANY
Commercial Equipment Division
Waltham 54, Mass.

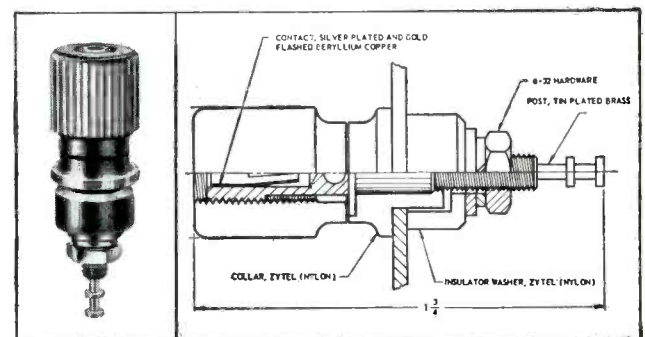

5-WAY BINDING POST

Compact, high strength. Incorporates jack for banana plug or standard .080" prod. Available in black or red

**you
should
know
ED MACDONALD
...he can
save you
money**

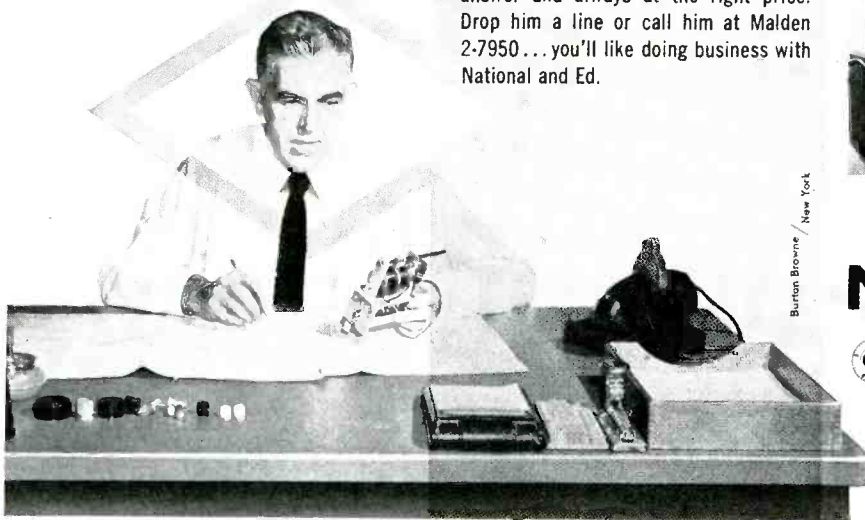

Ed is Product Manager for National Company's Components Division, and one of our busiest men. Through his department pass hundreds of bid requests and special orders from just about every electronics firm in the nation. Ed's job is to provide fast, efficient service that results in substantial customer savings.

While everyone knows National makes a complete line of components — our catalog lists over 300 items — many do not realize that over 60 per cent of our components business is in "other than catalog items."

At their fingertips Ed's group have all the facilities necessary to fulfil your requirements:

1. Fully staffed Engineering Components Department for the design and development of new or special components to your specifications or to meet overall objectives.
2. Complete electrical and mechanical model shop services.
3. Complete facilities, staffed by qualified engineers, for reliability testing of components, sub-assemblies and electronic devices. U.S.A.F. approved environmental test facilities are included.
4. Complete, modern facilities for speedy, economical quantity production of all types of components.
5. A newly expanded order-service department providing fast, reliable handling of bids and special orders.

These National services can save you money! Put National's 42 years of experience and their expanded new facilities to work for you by taking your problems to Ed MacDonald. You can rely on Ed to quickly come up with the right answer and always at the right price. Drop him a line or call him at Malden 2-7950... you'll like doing business with National and Ed.

Burton Browne / New York

Model shop No. 1



Model shop No. 2



Assembly line, components division



Order service and sales, components division



Testing components along assembly lines



Engineer at work in components lab. No. 3

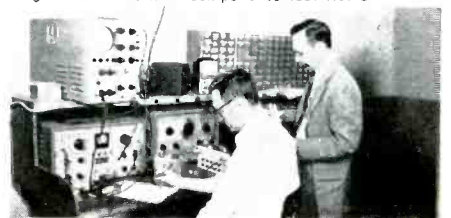

Eight out of every 10 U.S. Navy ships use National Receivers

National 
MALDEN 48, MASS.

tuned to tomorrow

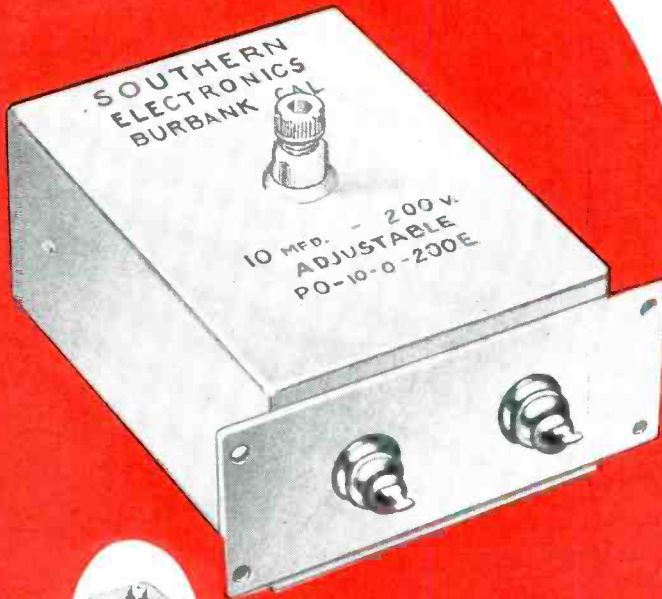
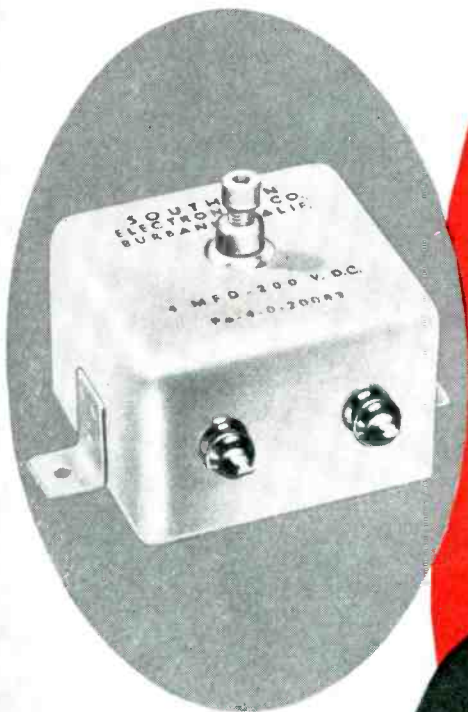

**NOW AVAILABLE FROM
0.1 M.F.D. to 10 M.F.D.**

Check these outstanding features:

- Accuracy in the order of 0.1% or better!
- Long Time stability in the order of 0.03%!
- I.R. — @ 25° C-10¹² OHMS
- Dielectric Absorption — .015%
- Dissipation Factor — .0002
- Temp. Coeff. (—20° to 140° F.) 100 P.P.M. per °C

Excellent for Computer Integration, Test Equipment or Secondary Standards.

America's electronic leaders specify Southern Electronics' polystyrene capacitors for their most exacting requirements. Goodyear Aircraft, Beckman Instruments, Reeves Instrument Corp., Electronic Associates, Inc., Convair, M.I.T., Calif. Inst. of Tech., and many others. Make sure you're getting the finest — always specify S.E.C.!

Wire, write or phone for complete catalog today!

ADJUSTABLE
precision
polystyrene
capacitors

... WITH PERFECT
HERMETIC SEAL TO
INSURE EXTREMELY
LOW LEAKAGE!



SOUTHERN ELECTRONICS
Corporation

239 West Orange Grove Ave., Burbank, California

Never before... Duplexing and Break-In Without Relays

NEW!

Northern Radio

DUPLEX TELEGRAPH SYSTEM

For Multi-Channel Tone Equipment

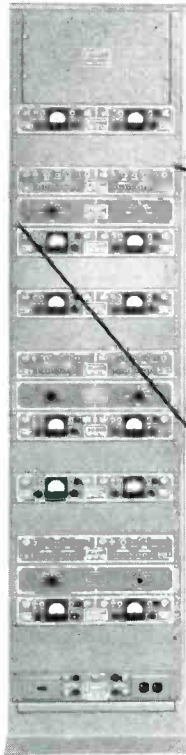

Dual Duplex Selector Panel,
Type 200 Model 1

Dual Loop Switch Panel, Type 200A Model 1

*The use of this unit with the Dual Duplex Selector Panel is optional. The Dual Switch Panel is particularly recommended when rapid switching of various duplex modes of operation is required.

NEW!

Simple 4 position switch selects from 12 possible duplex combinations.

NEW!

Duplex operation between stations connected via carrier telegraph channels.

NEW!

All-electronic, without relays or moving parts to wear.

NEW!

Polar or neutral for either half duplex or full duplex.

NEW!

Break-in now also possible for all half-duplex circuits.

NEW!

Provided with positive feature to prevent space signal lock-out.

NEW!

Includes individual line battery for each channel.

The Northern Radio Duplex Telegraph System consists of one each Dual Frequency Shift Tone Keyer, Type 153 Model 3; Dual Duplex Selector Panel, Type 200 Model 1; Dual Loop Switch Panel, Type 200A Model 1; and Dual Frequency Shift Tone Converter, Type 152 Model 3. The Frequency Shift Tone Keyer and Converter are our latest improved Model 3's, specifically designed for use with this system.

The Dual Duplex Selector Panel and Dual Loop Switch Panel make possible complete duplexing and break-in operation of a Northern Radio or similar multi-channel Frequency Shift tone telegraph system. Such a system meets the requirements of any standard telegraph line or terminal apparatus for either full duplex or half-duplex operation. Because this system is all-electronic, it meets all speed requirements and yet has the flexibility and isolation heretofore possible only with relays.

The Dual Loop Switch Panel rapidly selects half-duplex and/or full duplex mode of operation for any of the 4 standard loop options by front panel switching available from the 12 loop options in the Dual Duplex Selector Panel.

The Dual Duplex Selector Panel provides 12 loop options, patching facilities for monitoring purposes and channel routing, including the possibility of patching-in another teleprinter loop circuit (T-junction). Any of the 12 loop options are available and may be selected for the Dual Loop Switch Panel by simple strapping arrangement. It has an individual line battery for each channel for greatest circuit flexibility. Battery and line fuses are also provided for maximum protection.

The Dual Duplex Selector Panel is provided with positive non-lockout features. An accidental "spacing" of the line, even over prolonged periods of time, such as caused by patching errors, will not lock the system into a permanent space (no loop current) condition. The system will instantly be ready to operate as soon as the fault is removed. This is due to a novel arrangement of the internal batteries which at all times can provide power to the telegraph loops.



Pace-Setters in Quality Communication Equipment

NORTHERN RADIO COMPANY, inc.

147 WEST 22nd ST., NEW YORK 11, NEW YORK

In Canada: Northern Radio Mfg. Co., Ltd., 1950 Bank St., Billings Bridge, Ottawa, Ontario

FOR SPATIAL REFERENCE

Gyros

BY

Greenleaf

QUALITY ABOVE ALL!

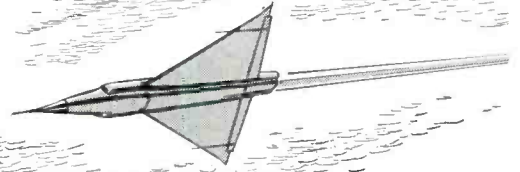

Two Degree of Freedom Gyro Unit

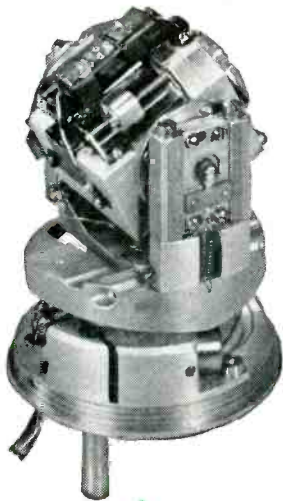

1. GYRO MOTOR DATA

- *a. 115 VAC 400 CPS 1 and 3 Phase
- b. Angular Momentum .6 In. Lbs./Sec. at 24,000 R.P.M.
- c. Warm-up Time 1 Minute at 78° F.
- d. Temperature—From -65°F. to +180°F.

2. GYRO OPERATIONAL DATA

- *a. Can be furnished to detect pitch, yaw and roll or combination of any two.
- *b. Accuracy—Roll Position indicated to a Minimum of $\pm 3^\circ$ over Full Range of 360°.
- c. Drift Rate—1.0° per Minute Maximum.
- *d. Gyro Freedom—Inner Gimble $\pm 70^\circ$. Outer Gimble 360°.

3. PICK OFF DATA

- *a. Type—Potentiometer
- *b. Linearity—0.3%
- *c. Resolution—.25°
- *d. Resistance—5000 ohms
- e. Excitation—5 Volts D.C.
- f. Dead Space—2° Maximum
- g. Synchro Pickoffs also available

4. CAGING MECHANISM

- *a. Electrical Uncaging 28 Volts D.C.
- *b. Mechanical or Electrical Caging

**Can be modified to conform to customer's requirements.*

The Greenleaf Line of Gyros and associated devices is being steadily expanded. It now includes a wide selection of Free and Rate Gyros, and the HIG-3 and HIG-4 Gyros.

ENGINEERING · DEVELOPMENT · PRODUCTION

Write, wire or phone for further information.

THE

Greenleaf

MANUFACTURING COMPANY

A Division of **MANDREL INDUSTRIES, INC.**

7814 Maplewood Industrial Court • Saint Louis 17, Missouri

ENGINEERS WANTED

Greenleaf offers unusual opportunities for mechanical and electrical engineers.

Producers of the HIG-3 and HIG-4 Gyros, Rate and Free Gyros, Differential Pressure Mach Meters, Air Speed Indicators, Computers, Switches and many other precision-built components.

GRE-66



HOW TO BE SURE A VOLT IS A VOLT...



The Weston Standard Cell Comparator Model 1000, made by Weston Electrical Instrument Corp., Newark, N. J., with associated milliammeters, dry cells, main galvanometer, and auxiliary standard cell.*

This H-shaped object, the saturated or "normal" form of the Weston Standard Cell, is the standard reference for electrical measurements. It is essentially a mercury cadmium wet cell hermetically sealed in glass. When kept at 20 degrees C., it maintains its voltage of 1.018636 volts for years. A bank of these cells at the Bureau of Standards in Washington, kept under oil at a constant temperature, is the basic electrical standard of the United States. This, however, is not the cell used by scientists and engineers in their daily work. Since the normal cell must be maintained at a constant temperature for accurate results, the unsaturated or "working" cell, which is portable and is not materially affected by temperature, is ordinarily used.

These working cells must be periodically checked against a bank of normal cells through the use of a comparator system. In the past only a few comparators existed outside the Bureau of Standards. However, the Weston Electrical Instrument Corporation has produced a simplified Standard Cell Comparator which provides the user of working cells, in conjunction with his own bank of temperature controlled normal cells, with an accurate means of standardizing these right in his own plant . . . at a great saving in time, cost and convenience.

THE WESTON COMPARATOR

The Weston Standard Cell Comparator is a specialized

potentiometer wherein the voltage of a working cell under test is opposed to that of a normal cell to produce a voltage difference which, when added algebraically to the normal cell voltage, indicates directly the voltage of the cell under test. With a known normal cell voltage as a reference, the Comparator will measure to well within 5 microvolts the open circuit voltage of any cell in good condition.

With an instrument calibrated to such excellent accuracy as this one, it is worthy of note that Weston uses Driver-Harris Manganin wire for critical resistance networks in its system. Says Weston: "The success of the entire circuit, given accuracy of adjustment, depends upon the permanency of the Manganin, and upon its extremely low temperature coefficient of resistance and its low thermal emf to copper".

Your work may or may not need the extreme degree of accuracy that is a prerequisite here. Either way, Driver-Harris has an alloy that can reliably fill your needs. Manganin is only one of 112 special purpose alloys, produced by Driver-Harris. And each of these was originally custom-made . . . produced exactly to the specifications of someone who needed it. Put your specifications in our hands. You will gain the benefits of the 57 years of experience which has developed the largest variety of alloys ever made by any one company.



Driver-Harris

COMPANY

HARRISON, NEW JERSEY

*A subsidiary of Daystrom, Inc.

BRANCHES: Chicago, Detroit, Cleveland, Louisville, Los Angeles, San Francisco • In Canada: The B. GREENING WIRE COMPANY, Ltd., Hamilton, Ontario

MAKERS OF THE MOST COMPLETE LINE OF ELECTRIC HEATING, RESISTANCE, AND ELECTRONIC ALLOYS IN THE WORLD

DESIGN PROBLEM:

More Rectifier Power per Dollar?

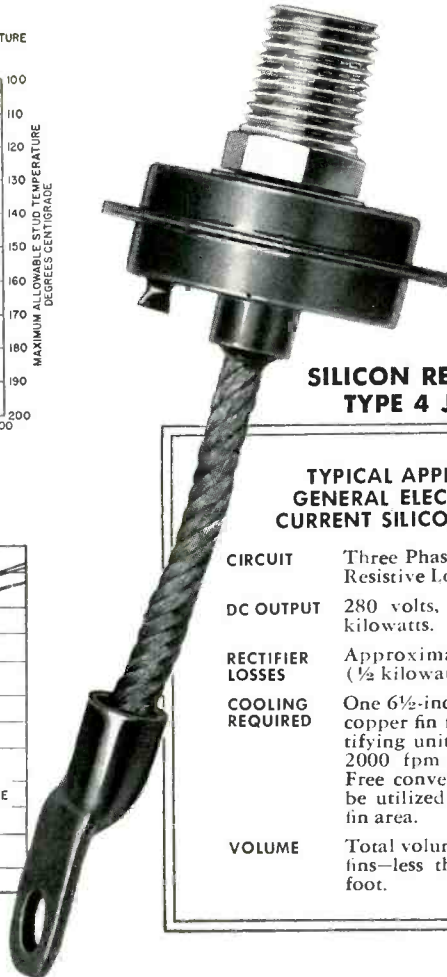
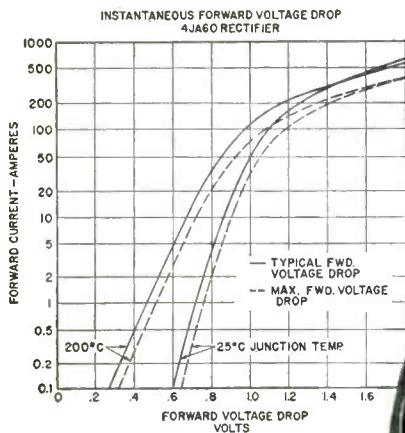
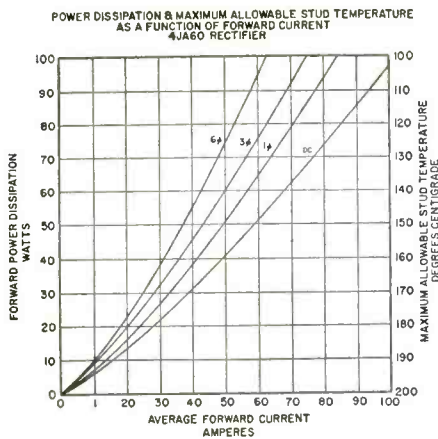

**SILICON RECTIFIER
TYPE 4JA60**

**TYPICAL APPLICATION
GENERAL ELECTRIC HIGH
CURRENT SILICON RECTIFIER**

- | | |
|-------------------------|---|
| CIRCUIT | Three Phase Bridge Rectifier, Resistive Load. |
| DC OUTPUT | 280 volts, 215 amperes, 60 kilowatts. |
| RECTIFIER LOSSES | Approximately one percent ($\frac{1}{2}$ kilowatt). |
| COOLING REQUIRED | One 6½-inch square $\frac{1}{8}$ " thick copper fin for each of six rectifying units when used with 2000 fpm 30°C forced air. Free convection cooling may be utilized by increasing the fin area. |
| VOLUME | Total volume of rectifiers and fins—less than $\frac{1}{3}$ of a cubic foot. |

High Current SILICON RECTIFIERS, available now, cost less than other rectifying devices!



High Capacity Silicon Rectifiers—with rating up to 85 amps at 300 volt operating levels—now cost no more than other junction type rectifiers. These high-efficiency silicon rectifiers are produced using the alloy technique developed by General Electric research. Extended life tests show no deterioration in rectifier characteristics when operated at full rated condition.

All-Welded Seal for Trouble-Free Service. With the large area silicon element hermetically sealed within a steel housing, General Electric Silicon Rectifiers are immune to troubles caused by moisture, vibration, dust, or corrosion. They may be mounted in any position; and have a safe temperature range greater than any of the other junction-type units. Their "plumbing type" stud fitting assures fast cooling through heat sink connections.

Work Anywhere. General Electric Silicon Rectifiers can be

used in *any* rectifier application. They are being installed now in many applications including:

- | | |
|---------------------|-------------------|
| Arc Furnaces | Magnetic Devices |
| Cathodic Protection | Shop DC Supply |
| DC Motor Supply | Welding Equipment |

All General Electric Silicon Rectifiers meet rigid military requirements. They are now available in four voltage ranges. For detailed application engineering information, consult your General Electric representative, or write to *General Electric Company, Semiconductor Products, Section S2517, Electronics Park, Syracuse, New York.*

Progress Is Our Most Important Product

GENERAL  ELECTRIC

PHELPS DODGE THERMALEZE[®]

A PROVEN CLASS "B" FILM WIRE!

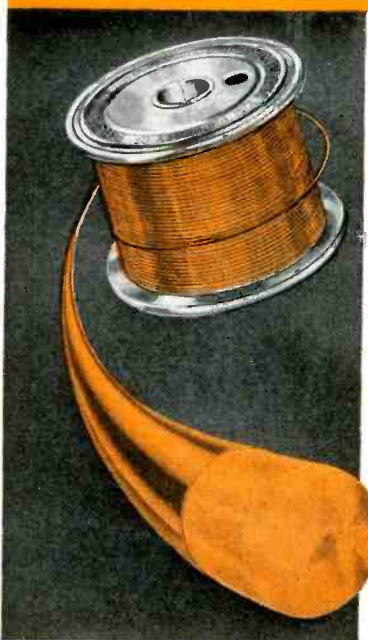

- Dielectric twist performance establishes Thermaleze as Class "B".
- Suitable for Class "B" insulation system designs.
- Over seven years' practical experience in coils, motors, and transformers.
- Essential balance of mechanical, chemical and electrical properties.

Any time magnet wire is your problem, consult Phelps Dodge for the quickest, easiest answer!

FIRST FOR LASTING QUALITY—FROM MINE TO MARKET !

AGED DIELECTRIC TWISTS

Thermaleze vs. Conventional Class "A" Wire
AIEE Procedure

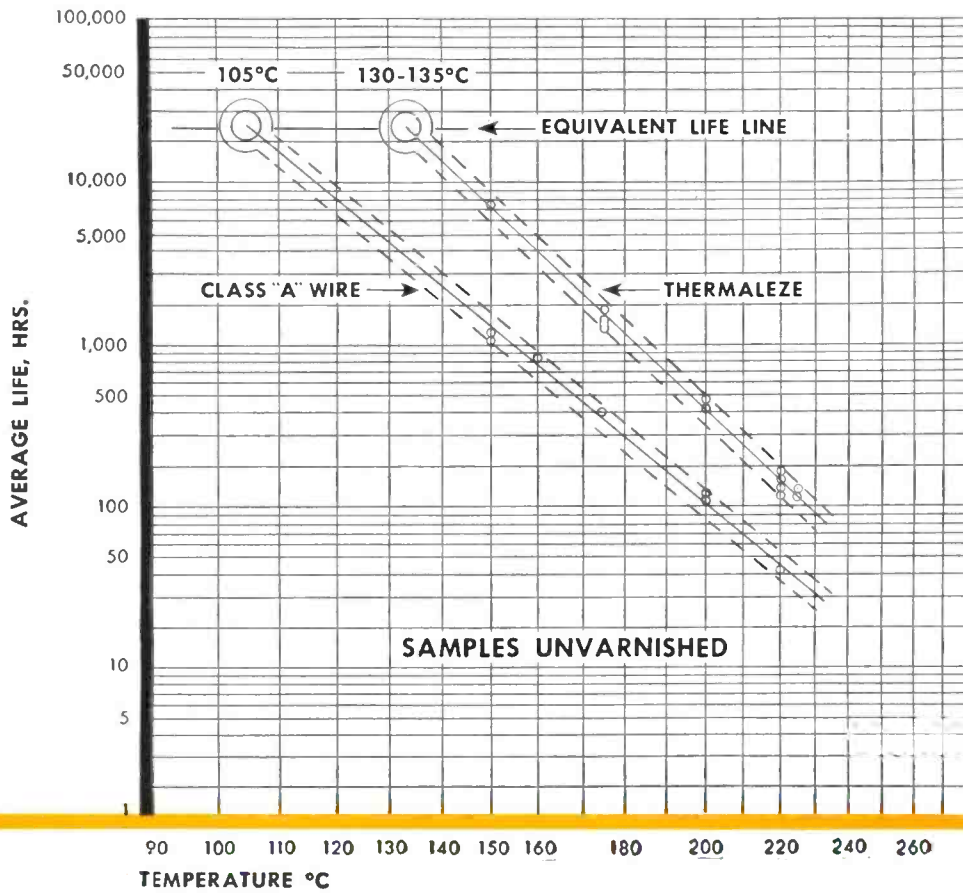

NEMA twist samples aged in oven at various temperatures following AIEE aging procedures



PHELPS DODGE COPPER PRODUCTS
CORPORATION

INCA MANUFACTURING DIVISION

FORT WAYNE, INDIANA

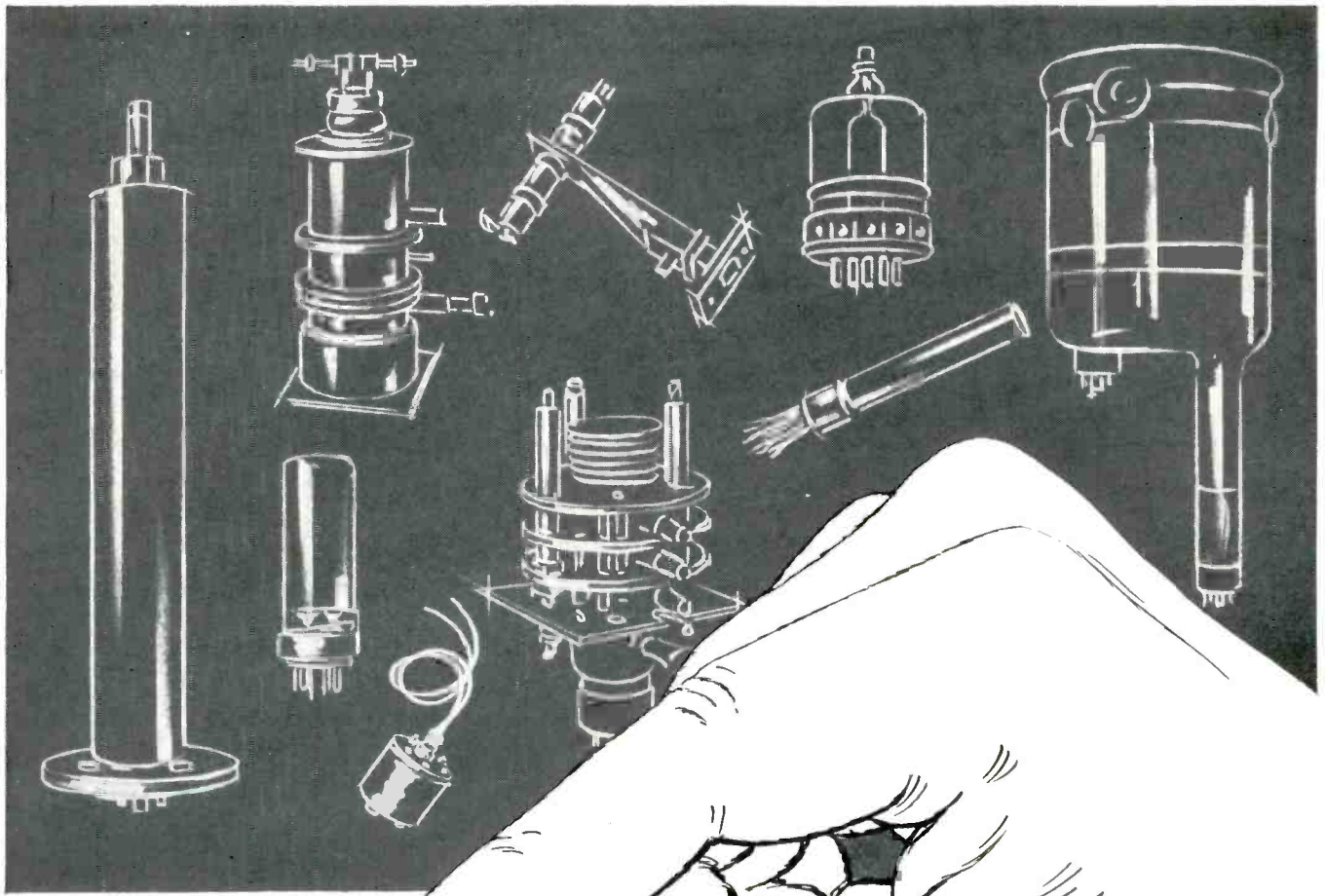

For
critical
applications...

NON-POROUS Tube Element Supports of *Linde* SAPPHIRE

LINDE Industrial Sapphire provides several outstanding advantages when used for tube element supports and spacers in microwave tubes and related equipment. LINDE sapphire is a *single* crystal of 100% aluminum oxide, optically clear, and having zero per cent porosity. There are no outgassing problems. Its dielectric constant is 11.0 at 10,000 megacycles. It has excellent ultra-violet and infra-red transmission characteristics. Seals can be made to metals as well as to glass and ceramics.

Tube supports of LINDE sapphire are particularly suitable for klystrons, magnetrons, backward wave oscillators, electron guns, and similar devices. LINDE sapphire is available in the form of windows, rods, balls, tubes, and special shapes.

Detailed information regarding physical and electrical characteristics of LINDE sapphire is available on your request. LINDE engineers will be glad to discuss your applications with you. Write to "Crystal Products Dept. BD-1."



LINDE AIR PRODUCTS COMPANY

A Division of Union Carbide and Carbon Corporation

30 East 42nd Street  New York 17, New York

In Canada: Linde Air Products Company, Division of Union Carbide Canada Limited, Toronto

The term "Linde" is a registered trade-mark of Union Carbide and Carbon Corporation.

It's New! It's Revolutionary!

AMP's **SHIELDED PATCHCORD PROGRAMMING SYSTEM** is especially designed for programming on Analog Computers, Telemetry, Test Equipment, and all types of sensitive low level circuits.

NEW DESIGN FEATURES INCLUDE:

- Fully insulated as well as shielded removable frontboard and fixed rearboard;
- "Post Patching", without shorting as required in Analog Computers and Telemetry;
- Custom Color-Coded circuit legend provided by a cellular type construction that permits individual hole identification;
- Elimination of signal leakage between circuits;
- Shielded Patchcords, with shield terminated by a contact ferrule, which connects to ground when Patchcord tip is inserted.

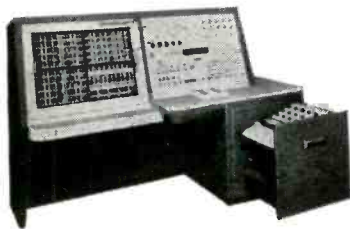

The illustration shows how Berkeley Division of Beckman Instruments, Inc., is using AMP's new Patchcord System in its new EASE* 1200 Analog Computer.

*Trade Mark, Berkeley Division of Beckman Instruments, Inc.

AMP

AMP INCORPORATED

Harrisburg, Pennsylvania

Wholly Owned Subsidiaries:
Aircraft-Marine Products of Canada Ltd., Toronto, Canada • Aircraft-Marine Products (G.B.) Ltd., London, England • Societe AMP de France, Le Pre St. Gervais, Seine, France • AMP—Holland N.V. 's-Hertogenbosch, Holland.
Japanese Distributor:
Oriental Terminal Products Co., Ltd., Tokyo, Japan



TINY *in size* MIGHTY *in performance*

CLAROSTAT* MINIATURIZED CONTROLS

These CLAROSTAT miniaturized controls (U.S. Pat. No. 2,706,760) in both *stabilized* composition-element and wire-wound versions, are mass-produced so that they are now available *when wanted and at the price you can afford to pay.*

Series 48M (*stabilized* composition-element) is smaller than a dime. Series 49M is the size of a penny. Yet either type is mighty in performance. Over half a million of these tiny potentiometers have been put to use in the past eight years.

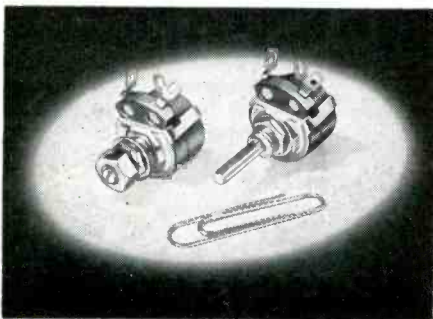

COMPOSITION-ELEMENT

Series 48M. $\frac{5}{8}$ " dia. Featuring Clarostat's stabilized composition element. 500 ohms to 5 megohms. 0.2 watt rating. Choice of tapers. Single or dual. Conforms to Style RV-1 of MIL-R-94A proposed Military Specification.

WIRE-WOUND

Series 49M. $\frac{3}{4}$ " dia. 1 ohm to 20,000 ohms. 1.5 watt rating. Single or dual. Conforms to Style RA-10 of MIL-R-19A proposed Military Specification.

WITH SWITCH

Available in factory-attached S.P.S.T. switch for both Series 48M and 49M. Single or dual. Also with choice of different shafts.

Consult us regarding your control or resistor requirements for miniaturized assemblies. Take full advantage of CLAROSTAT ENGINEERING. Write for engineering data.

*Reg. U. S. Pat. Off.



CONTROLS and RESISTORS

CLAROSTAT MFG. CO., INC.

DOVER, NEW HAMPSHIRE

In Canada: CANADIAN MARCONI CO., LTD., Toronto 17, Ont.

PAYS FOR ITSELF IN SAVINGS

• ELIMINATES DISADVANTAGES OF
MANUAL PRE-WEIGHING ... INCOMPLETE OR
FROTHY MIXING ... PRODUCT LOSS ... INTER-
RUPTED PRODUCTION ... MANUAL POURING

IDEALLY SUITED FOR
PRODUCTION
OR LABORATORY



(Patent Pending)

MIXING-METERING PUMP FOR TWO-PART POURABLE EPOXY RESINS

CHOOSE FROM 8 MODELS FOR
POTTING-CASTING • ENCAPSULATING

Can Be Modified To Meet Many Other Requirements

PRICED FROM \$1985. CALL OR WRITE FOR COMPLETE DETAILS.

accurate

- Maintains ratio of curing agent to resin within $\pm 1.5\%$.

simple

- Easy to operate and calibrate.
- Easy flushing and charging — 40 seconds.
- Single control adjustable volume. Several models with volumes from 0.3 ml to 20 ml per shot.

flexible

- Adjustable ratio, with 40 parts per hundred resin span adjustment. Various models cover range from 1 to 100 parts curing agent per hundred parts resin.
- Thorough mixing on high volume output.
- Up to 100,000 centipoises viscosity of resin, and 60,000 centipoises viscosity of curing agent.
- Down to 300 centipoises viscosity of resin and 0.5 centipoises viscosity of curing agent.
- Individual shots for manual or automatic filling.
- Easily adapted to any production set-up.

economical

- Sharp cut-off after each shot.
- Low volume mixing chamber requires very little material to flush or charge.
- Cuts down rejects — Eliminates production delays and wasted labor. Saves material.

safe

MINIMIZES EXPOSURE WHEN
HANDLING TOXIC MATERIALS



H.V. HARDMAN CO. INC.

BELLEVILLE 9, N.J.

PLYMOUTH 9-1242

Since 1906 . . . Formulating Dependable Potting Compounds

**Measure and plot changes
in variables as they occur...**

with

ElectroniK instruments for research

Here's an exceptional group of instruments to measure and record your research findings swiftly, surely, conveniently. These *ElectroniK* instruments for research can speed completion of your projects, by eliminating many of the tedious, time-consuming details of test work.

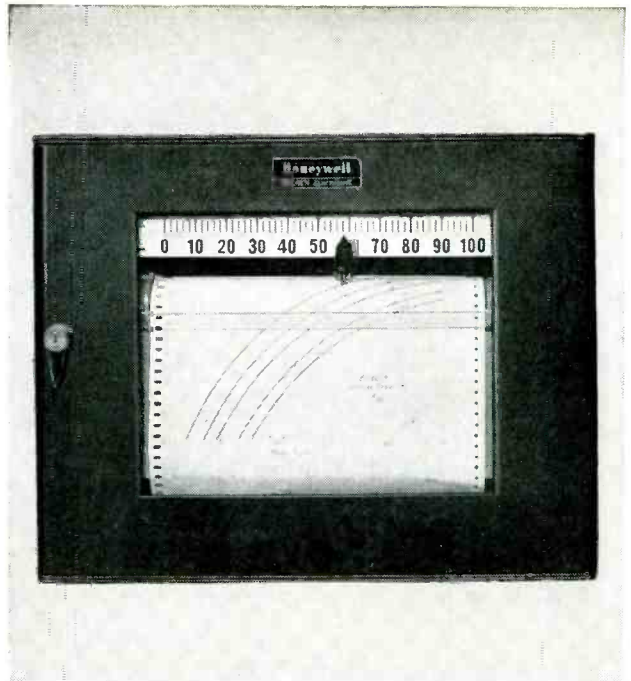

ElectroniK FUNCTION PLOTTER Automatically and continuously plots a curve which shows the relationship of one variable to another. Typical uses: speed versus torque, stress versus strain, temperature versus pressure, plate voltage versus plate current (and other electron tube characteristics), and many other variable relationships. Write for Instrumentation Data Sheet 10.0-5b.

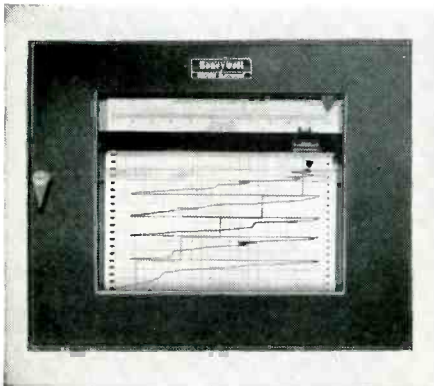

ElectroniK EXTENDED RANGE RECORDER Facilitates measurement of any linear variable whose values change over a wide range, and where precise evaluation and good resolution are important. This instrument is particularly suited to the measurement of forces in conjunction with a strain gage bridge. Write for Instrumentation Data Sheet 10.0-18.

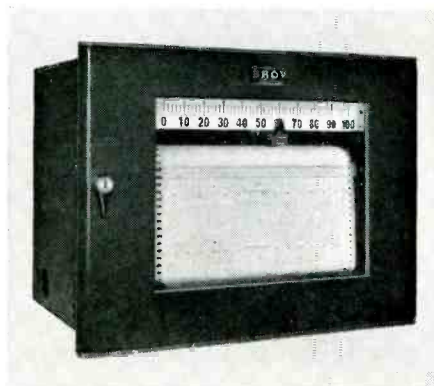

ElectroniK NARROW SPAN RECORDERS Accurately measure d-c potentials as low as 0.1 microvolt and spans as narrow as 100 microvolts. Available as a precision indicator, circular chart recorder, and strip chart recorder. Useful (with appropriate primary measuring elements) for measuring differential temperatures and slight variations in the temperatures of small objects through the use of radiation pyrometry. Write for Instrumentation Data Sheet 10.0-8.

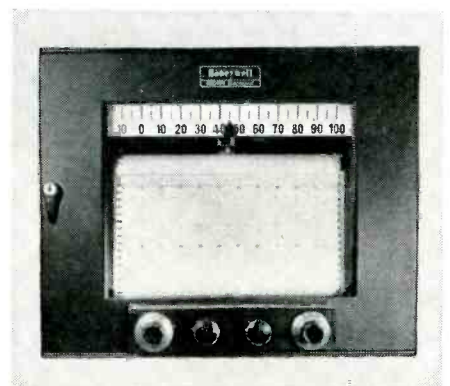

ElectroniK ADJUSTABLE SPAN RECORDER Measures spans and magnitudes of a variety of emf's. Instrument calibration can be in terms of any variable reducible to d-c voltage. Can be used with thermocouples, steam gages, tachometers, and other transducers. Write for Instrumentation Data Sheet 10.0-10a.

Your nearby Honeywell sales engineer can give you complete information about these instruments as they relate to your particular applications. Call him today . . . he's as near

as your phone. MINNEAPOLIS-HONEYWELL REGULATOR Co., Industrial Division, Wayne and Windrim Avenues, Philadelphia 44, Pa. —in Canada, Toronto 17, Ontario.



MINNEAPOLIS
Honeywell
BROWN INSTRUMENTS

First in Controls

7-inch Waldes Truarc retaining rings cut costs, speed assembly-disassembly of 2-high/4-high mill

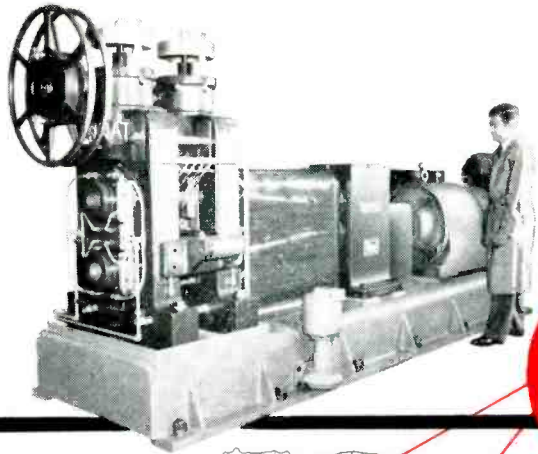

New Model TA-625 2-high/4-high combination rolling mill designed by Stanat Manufacturing Co., Long Island City, N. Y., reduces 2½" ingot to precision-rolled strip as thin as .001".

Waldes Truarc retaining rings help make possible a complete change of work rolls in 20 minutes...solve difficult problems of accuracy control by achieving positive location of bearings to extremely close tolerances. Rings eliminate costly parts and machining, save space, reduce maintenance.

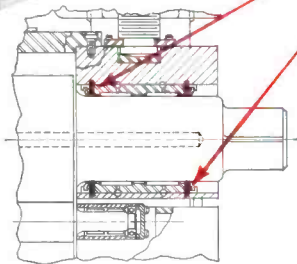

In the assembly illustrated above, 7" Waldes Truarc (Series 5000) retaining rings—three on each roller—are used to position heavy-duty needle bearings in the bearing housing. Smaller rings position bearings in other roller assemblies and retain the shaft of a dual handwheel screwdown. All in all, 18 Waldes Truarc rings are used in the mill. They replace machined shoulders, spacers and lock nuts...eliminate costly threading, other machining operations.

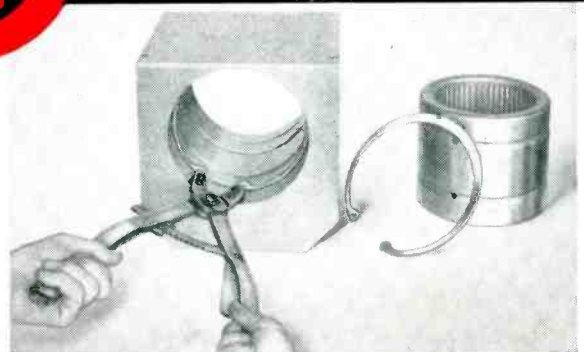

Assembly is simple, even with giant 7" diameter Truarc ring. Special Truarc ratchet pliers grasp the ring securely, ease it into the groove, snap it securely into position. Smaller pliers and various high-speed assembly jigs are available for other rings, permit assembly-disassembly to be performed rapidly even by unskilled labor.

Whatever you make, there's a Waldes Truarc Retaining Ring designed to improve your product... to save you material, machining and labor costs. Quick and easy to assemble and disassemble, they do a better job of holding parts together. Truarc rings are precision-engineered and precision-made, quality controlled from raw material to finished ring.

36 functionally different types... as many as 97 differ-

ent sizes within a type... 5 metal specifications and 14 different finishes. Truarc rings are available from 90 stocking points throughout the U.S.A. and Canada.

More than 30 engineering-minded factory representatives and 700 field men are available to you on call. Send us your blueprints today... let our Truarc engineers help you solve design, assembly and production problems... without obligation.

For precision Internal grooving and undercutting...Waldes Truarc Grooving Tool!

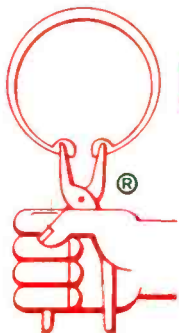

WALDES
TRUARC®
RETAINING RINGS

© 1956 Waldes Kohinoor, Inc., 47-16 Austel Place, L. I. C. 1, N. Y.

Waldes Kohinoor, Inc., 47-16 Austel Place, L. I. C. 1, N. Y.
Please send the new supplement No. 1 which brings Truarc Catalog RR 9-52 up to date.
(Please print)

Name.....
Title.....
Company.....
Business Address.....
City..... Zone..... State.....

E019

WALDES TRUARC Retaining Rings, Grooving Tools, Pliers, Applicators and Dispensers are protected by one or more of the following U. S. Patents: 2,382,948; 2,411,426; 2,411,761; 2,416,852; 2,420,921; 2,428,341; 2,439,785; 2,441,846; 2,455,165; 2,483,379; 2,483,380; 2,483,383; 2,487,802; 2,487,803; 2,491,306; 2,491,310; 2,509,081; 2,544,631; 2,546,616; 2,547,263; 2,558,704; 2,574,034; 2,577,319; 2,595,787, and other U. S. Patents pending. Equal patent protection established in foreign countries.

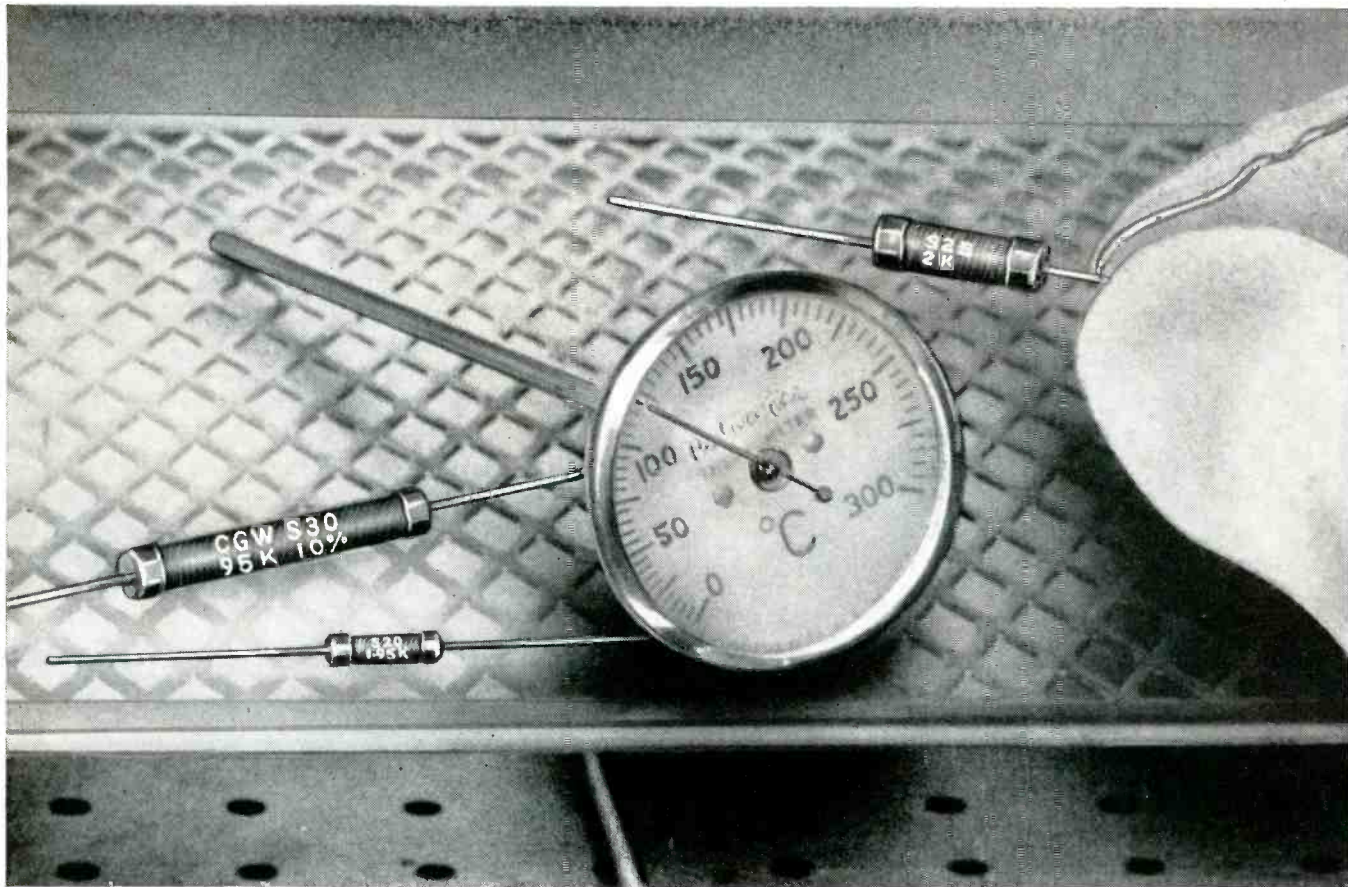

Rugged and stable under high temperature conditions, these Corning S-Type resistors provide savings in space and cost.

Now you can have resistors with all these advantages . . .

1. 120° C. operation with 100% power, derating to 200° C.
2. Same size as deposited carbons
3. Wide resistance range
4. Economical cost

To help you solve the problem of small space and high ambient temperature Corning has developed these Type S resistors.

These are not ordinary film-type resistors. They are integral units made by bonding a metallic oxide to a PYREX glass rod at red heat. They're non-inductive and completely impervious to moisture.

Three sizes are now available in production quantities:

S-20—½-watt at 120° C. (or 1-watt at 40° C.). Range from 10 ohms to 100,000 ohms.

S-25—1-watt at 120° C. (or 2-watts at 40° C.). Resistance range from 10 ohms to 400,000 ohms.

S-30—2-watts at 120° C. (or 4-watts at 40° C.). Resistance range from 30

ohms to 1 megohm.

Corning Type S resistors have an average change in resistance of less than 1.5% after 1,000 hours at rated power.

Tolerances of 1%, 2%, 5% and 10% are available to meet your exact applications.

And how does a volume price of 25¢ each for the S-20 ± 1% tolerance sound to you?

Write for detailed descriptive bulletin.

Ask for information on these other Corning resistors:

Type LP—Low-cost, low-power. In 3-, 4-, 5-, and 7-watt sizes.

Type R—Power resistor to MIL-R-11804B. Tolerances of 2% or 5%, 7 to 115 watts. Range: 10 to 1,000,000 ohms.

Type H—High-frequency 2% or 5% tolerance. Standard ranges from 10 to 1,000,000 ohms and ratings from 7 to 140 watts.

Type HP—High-power resistors. 17, 30, 70, and 150 watts. Tolerances of 2% or 5%. 20 to 500,000 ohms.

Type WC-5—Water-cooled. Range—35 to 300 ohms. Versatile and adaptable.

Type N—Accurate grade. Made to meet all requirements of MIL-R-10509B.

Other products for Electronics by Corning Components Department: Fixed Glass Capacitors*, Transmitting Capacitors, Canned High-Capacitance Capacitors, Subminiature Tab-Lead Capacitors, Special Combination Capacitors, Direct-Traverse and Midget-Rotary Capacitors*, Metallized Glass Inductances, Attenuator Plates.

*Distributed by Erie Resistor Corporation



CORNING GLASS WORKS, 94-1 Crystal Street, CORNING, N.Y.

Corning means research in Glass

International Silicon Diodes

Over 600 types

in full production!

PIV ratings up to 16,000 volts . . .

for high reliability

over a wide temperature range



Write on your letterhead for bulletins on any or all types illustrated. If you have a particular problem, our Application Advisory Group will be happy to submit a prompt evaluation and recommendation.

International Rectifier

C O R P O R A T I O N

EXECUTIVE OFFICES: EL SEGUNDO, CALIFORNIA • PHONE OREGON 8-6281

NEW YORK: 132 E. 70TH ST., TRAFALGAR 9-3330 • CHICAGO, 205 W. WACKER DR., FRANKLIN 2-3889

IN CANADA: ATLAS RADIO CORP., LTD., 50 WINGOLD AVE. W., TORONTO, ONTARIO, RU 1-6174

THE WORLD'S LARGEST SUPPLIER OF INDUSTRIAL METALLIC RECTIFIERS

why companies find it
GOOD BUSINESS
 to specify panel instruments

by **Simpson...**

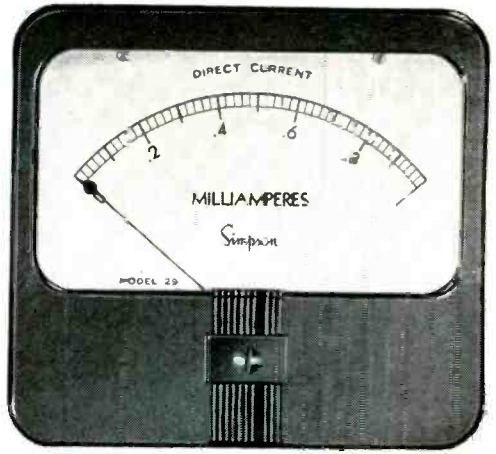

... **QUICK SERVICE** from
HUGE STOCKS!

Over 50,000 stock units, in 800 sizes and types, are available for *immediate delivery* through 1,500 electronic distributors in the United States, Canada, and abroad. This wide distribution can save you time and prevent expensive delays.

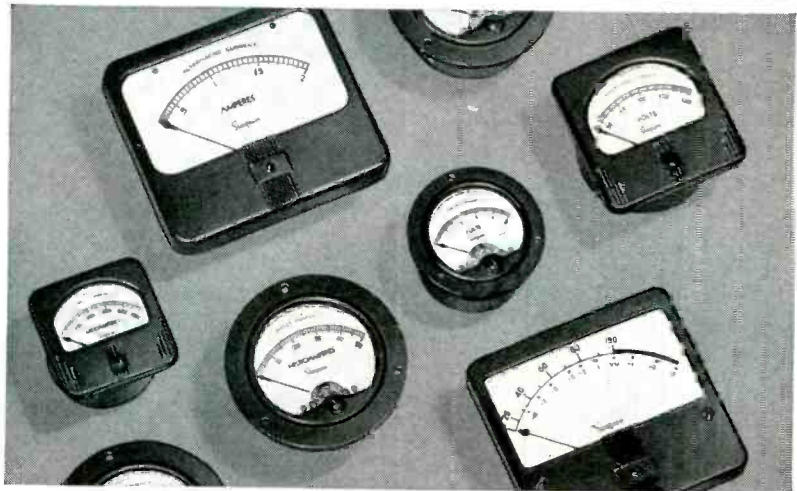

... **EXACT NEEDS**
CUSTOM BUILT!

Many meters quickly built from *standing tools*. Others designed to your specifications. Delivery schedules on which you can rely. Movements include three sizes of Simpson's superb Core Magnet Meter Movement—*self shielded* and exceedingly rugged.

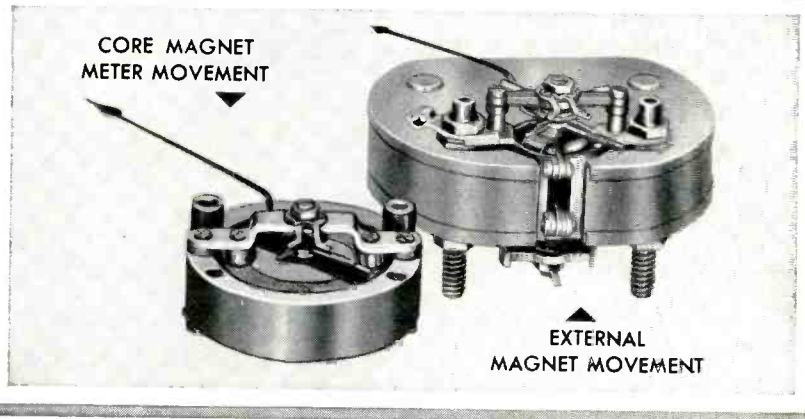

Ask your Simpson representative or write on letterhead for new Catalog now available.

Whatever your needs in panel instruments, you, too, will find it makes good business sense (and design sense) to specify "Simpson." Simpson instruments have established a reputation for laboratory accuracy . . . yet they have the ruggedness to stand up under years of service and severe shocks. Why not send us your panel instrument problems today?

Instruments that stay accurate

SIMPSON ELECTRIC COMPANY

5200 W. Kinzie St., Chicago 44, Illinois • Phone: ESTbrook 9-1121
 In Canada: Bach-Simpson Ltd., London, Ont.

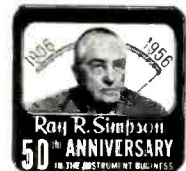

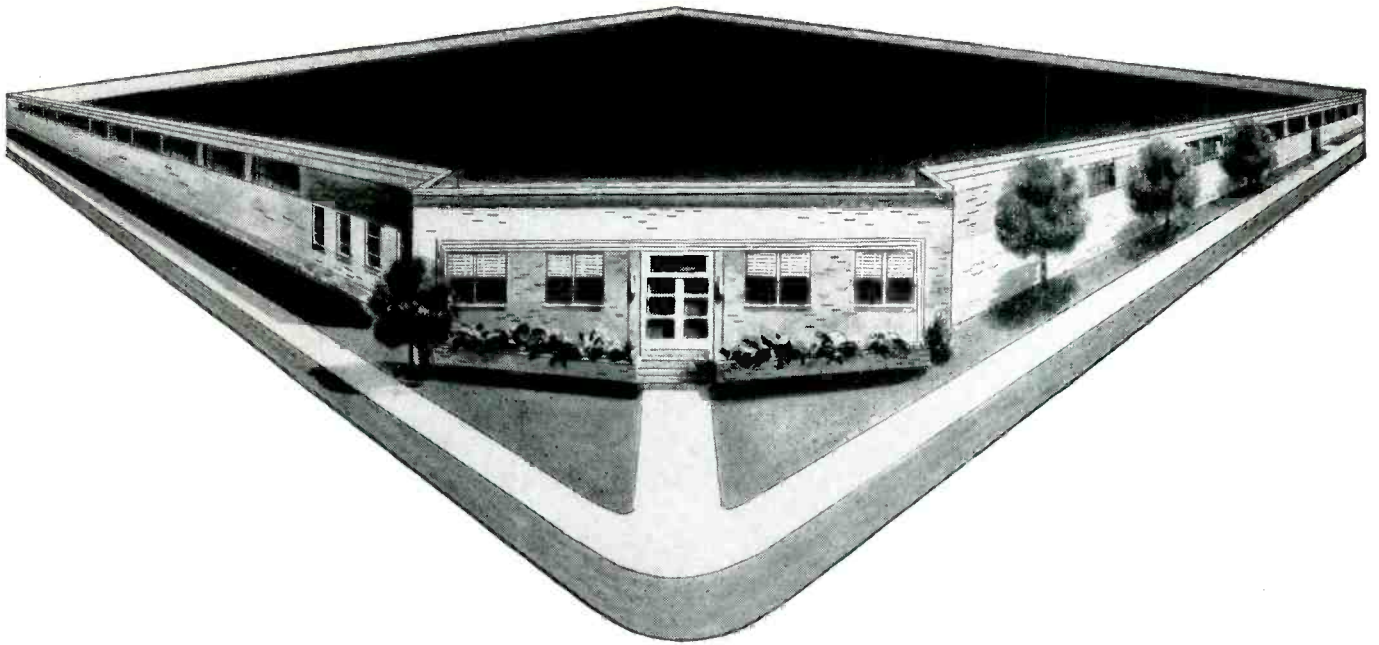

here's what's behind the  crystal that's so far ahead

The Midland Factory shown above is the world's largest plant devoted exclusively to producing crystals for frequency control. It is equipped with the finest and most complete production and testing machinery ever developed for this purpose. Here Midland pioneered development of crystals for color television, and is now ready for full-scale production.

All this is important to you for just one good reason: Every Midland crystal you use has been produced by such advanced techniques and under such rigid quality controls that you can be sure it will prove its completely reliable quality under every operating stress.

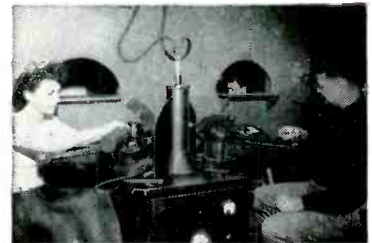

Midland Critical Quality Control extends through every step of crystal production, and includes precise angular control by X-ray. Uniform accuracy is maintained to the millionth part of an inch.

*Whatever your crystal need, conventional or highly specialized,
When it has to be exactly right, contact*



Midland

MANUFACTURING COMPANY, INC.
Fiberglas Road, Kansas City, Kansas

WORLD'S LARGEST PRODUCER OF QUARTZ CRYSTALS

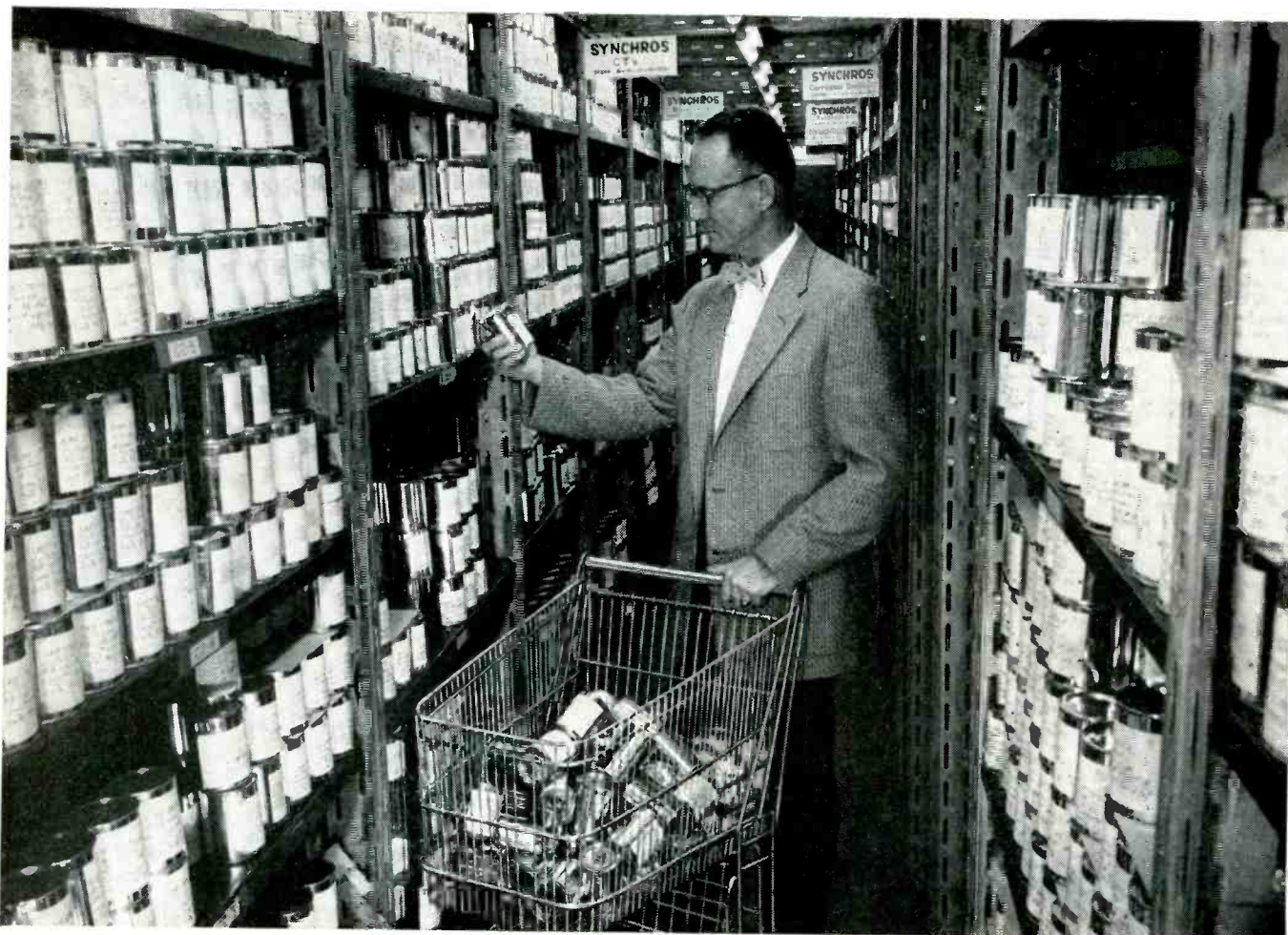

BENDIX SUPERMARKET FOR PRECISION SYNCHROS

If you're in the market for precision synchros, it will pay you to make sure it's the *Bendix* "market" you're in. There you'll get—

FAST DELIVERY: Because of our heavy volume—as the country's largest producer of synchros—we can offer immediate delivery of practically all synchro types.

MINIMUM COST: Again, because of our heavy volume, we can fill even small-quantity synchro orders at production prices.

ALL TYPES—PREMIUM PRECISION: We make just about any type of synchro you could want—all built to the exacting precision standards that long ago made Bendix the "buy-word" for synchros.

So, when you're shopping for precision synchros to use as transmitters, receivers, control transformers, differentials, or resolvers . . . including corrosion-resistant and high-temperature models . . . be sure to find out what we have to offer.

District Offices: Burbank, Calif.; Dayton, Ohio; Seattle, Wash.

Export Sales & Service: Bendix International Division, 205 E. 42nd St., New York 17, N. Y.

**SIZE 8
CORROSION-
RESISTANT**



✓ **MOTOR GENERATORS**
Smallest on market. Linearity
1/2 of 1% to 3000 rpm.



✓ **SYNCHROS**
Outstanding electrical
characteristics.

✓ **LOW-INERTIA
SERVO MOTORS**
High torque-to-inertia ratio.



Eclipse-Pioneer Division

TETERBORO, N. J.



Wafers of ALITE...

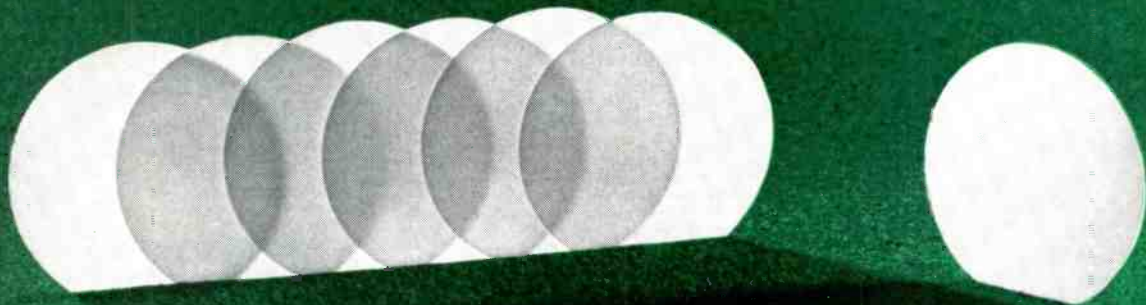

**demonstrate a high degree of
dimensional stability and accuracy**

Here are translucent discs of Alite .010" thin — virtually thin enough to see through! Because Alite possesses unique elastic properties (for instance, it retains elasticity at high temperatures, shows no mechanical hysteresis in the 500° C. range) these pieces were produced for experimental use as diaphragms in high temperature pressure transducers. We show them here to illustrate the outstanding workability of Alite.

The Alites are a series of sintered metallic oxides having a wide range of excellent electrical and physical properties. Alite exhibits low-loss characteristics throughout the en-

tire spectrum, into the microwave range. It maintains high mechanical strength, exceptional hardness and abrasion resistance at working temperatures in the 1300° C. to 1600° C. range.

By use of diamond wheel grinding and lapping, Alite can be finished to any required precision. This is a vital factor in critical applications where a minor error of dimension can produce major errors in dielectric or mechanical behavior.

Standard formulations of Alite are available for electrical or mechanical use, or we can "custom-compound" Alite to meet the design engineer's specific needs.



Is there an idea here for you?

Write for complete data.
Ask for Bulletin A-7.

ALITE DIVISION

U. S. STONEWARE
AKRON 9, OHIO



Subject: BEARING FITS AND FITTING PRACTICES

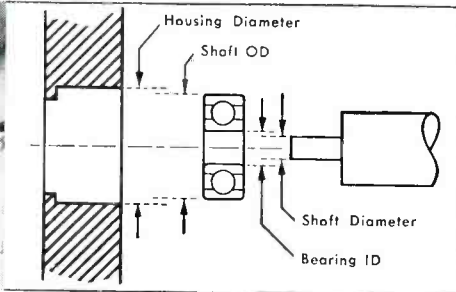

FIG. 1 Principle factors involved in fitting Micro-Bearings. Handling and fitting tools such as furnished by the Baker Co., Maplewood, Maine, enable operators to place or remove Micro-Bearings quickly, easily and help avoid damage.

As shown in Fig. 1, the fitting of Micro-Bearings, like the fitting of larger ball bearings, chiefly involves the clearances between the inside diameter of the housing and the outside diameter of the bearing; the bore of the bearing and the diameter of the shaft. Obviously, proper handling and fitting is an important factor in assembling the bearing to both shaft and housing.

Arriving at workable clearances is the subject of this bulletin.

RECOMMENDED FIT

In view of the absence of standards for shaft and housing fits in assembling instrument bearings, this data sheet is based on experience of users who are heavily involved in fitting problems. For example, the use of interference fitting *tighter than line to line* is not recommended for the majority of applications.

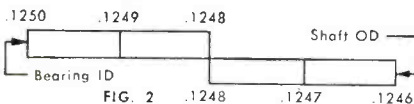

FIG. 2

The achievement of the desired fit by dimensioning is illustrated in Fig. 2. The bearing ID is represented by the top blocks and the shaft OD is represented by the lower blocks. Such a block diagram could also be applied to housings and bearing outside diameters. In this block diagram, it will be noted, the bearing ID is represented by a 0.0002" tolerance with a similar tolerance for the shaft. A resulting fit of line to line to .0004" loose is shown.

An interference fit *not* tighter than line to line is suggested for the following reasons:

1. Difficulty in assembly.
2. Difficulty in disassembly. This is often more hazardous than the assembly operation and may result in total bearing destruction.
3. Reduction in radial play.
4. Danger of bearing ring conforming to possible poor geometry of mating shaft or housing.

TOLERANCE DISTRIBUTION

The maximum 0.0004" loose condition shown in Fig. 1 may be excessive in some applications. The fitting problem then resolves itself to reducing this extreme, and yet maintain the maximum tight fit of line to line. The looseness may be reduced by re-dimensioning the shaft to 0.1249/0.1247 as

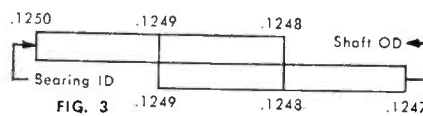

FIG. 3

shown in the block diagram, Fig. 3. If the frequency distributions of shaft and bearing ID sizes were statistically normal, the modal fit of all parts would be 0.0001 loose. Accordingly, an insignificant percentage of parts would be mated to the extreme values, and for practical purposes could be ignored.

With regard to bearings' outside diameters and bores, however, normality of the distribution curve *cannot* be assumed. During the grinding operation, the "most metal tendency" tends to skew the frequency distributions for bearing ID's and OD's in the direction of most metal.

In grinding and finishing shafts and housings, similarly skewed distributions occur.

Operating on a modified probability distribution of tolerance is possible if the volume of parts is sizeable. But the approximate distribution of shaft and housing sizes *must* be verified if this method is to be used.

MATERIALS and SURFACE FINISHES

The ease of assembly is also affected by materials and finishes. The following factors must be considered:

1. The galling characteristics, hardness and ductility of the materials involved.
2. Finish lay patterns produced by various tools and techniques used.
3. RMS surface finish values achieved.
4. Geometry of shafts and housings as regards out-of-roundness, taper, etc.

The possible combinations of these elements in any single application are so numerous that their gross effect can only be ascertained by trial and error, or by a detailed study of operations on individual applications.

SIZING METHODS

Close tolerance fitting may be achieved by performing supplementary sizing operations on housings or shafts by the following methods:

"Bearingizing Tools" manufactured by the Cogsdill Tool Products, Inc., have been used on both housings and shafts, and potentially yield the greatest accuracy in the shortest period of

time (Fig. 4). A — Shaft sizing tool operates by peening oversize shafts to proper diameter. B — Internal Bearingizer enlarges housing holes to proper diameter.

"Ball sizing" has been used with a fair degree of success on through holes. This is essentially a swaging operation utilizing hardened steel or carbide balls.

Whiles shafts may be polished by hand this is an expensive operation and may jeopardize good shaft geometry.



FIG. 4



CODING

Segregation of all parts into .0001 increments has been advanced by some bearing users as a solution to fitting problems. Upon request and for an additional cost, NHBB will code a given shipment to the following table.

DESCRIPTION	CODE	BORE TOLERANCE	O. D. TOLERANCE
LARGE BORE LARGE O. D.	11	+ .0000" - .0001"	+ .0000" - .0001"
LARGE BORE SMALL O. D.	12	+ .0000" - .0001"	- .0001" - .0002"
SMALL BORE LARGE O. D.	21	- .0001" - .0002"	+ .0000" - .0001"
SMALL BORE SMALL O. D.	22	- .0001" - .0002"	- .0001" - .0002"

Coding is not a general solution to the problem of fitting. Experience has shown that unless assembly techniques can cope with the existing distribution of bores and OD's within their .0002 spread, an unbalanced stock situation results in the user's plant.

Manufacturing to closer boundary dimension tolerances is not recommended at the present state of the art. It is not usually feasible to mass produce bearings to a .0001 tolerance spread. It is generally necessary to produce some two to four times the quantity of parts desired to fulfill such requirements on the basis of selection from a standard .0002 tolerance. When a user of bearings relies solely on coding of parts, a procurement and stocking problem is eventually created.

Close collaboration between the bearing manufacturer and user is necessary in planning to meet fitting problems since neither one alone has access to complete knowledge or control over all the variables involved.

DESIGNERS HANDBOOK OFFERED FREE TO ENGINEERS

If you work with miniature bearings, you'll find this new, 70 page authoritative publication a great help in solving problems in designing instruments or small electro-mechanical assemblies.

It will be sent free to engineers, draftsmen and purchasing agents. Write to: New Hampshire Ball Bearings Inc., Peterborough 1, N. H.



AROUND THE WORLD *again and again!*

A fair idea of the extent to which Stackpole fixed composition resistors are used may be gained from this illustration.

Laid end to end, the total number of these tiny components produced to date by Stackpole would extend many times around the world.

Such acceptance is a tribute, both to the high quality of the resistors and to the dependable, personalized service, that Stackpole puts behind each resistor order.

Electronic Components Division
STACKPOLE CARBON COMPANY
St. Marys, Pa.

Type CM-1/32
($\frac{1}{2}$ watt)

PACKAGED FOR YOUR CONVENIENCE!

... in "strip pack"; "stack pack"; or "reel pack" assemblies. Ask your Stackpole field engineer for details.

Type CM-2
(2 watts)

Type CM-1
(1 watt)



STACKPOLE **RESISTORS**

FIXED COMPOSITION

Available for your convenience through leading parts distributors.

modern methods for testing cores

The future of magnetic cores in information handling systems is already well assured. Their high reliability, fast action, small size, and low power consumption stimulate the imagination of more and more engineers working in data processing, weapons systems, and control. And every day finds these new components included in more new designs.

One problem still facing those who want to exploit these exciting properties is the lack of precise uniformity in cores made on a production basis. For as Burroughs has found through 5 years of working with the pioneers in core applications, uncertainties still exist. And before cores become standardized, many changes will probably be made. Those who want to take advantage of the great potential in this new component now must use reliable test procedures which precisely check the tolerances of each core, and are versatile enough to check for the new core specifications of tomorrow.

Burroughs Pulse Control Systems answer this need for leading manufacturers and users of cores by simulating the actual conditions under which each core produced will eventually operate. When conditions require a change in core operating characteristics, the testing system is changed at will, in a matter of minutes, to meet the new requirements.

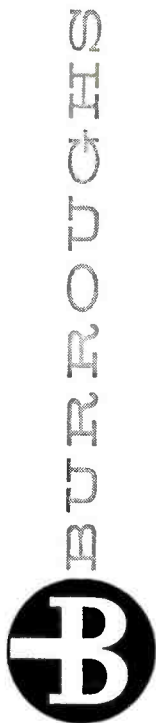
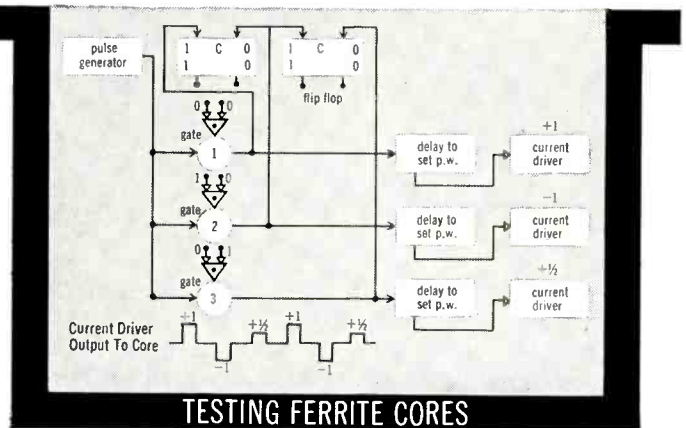
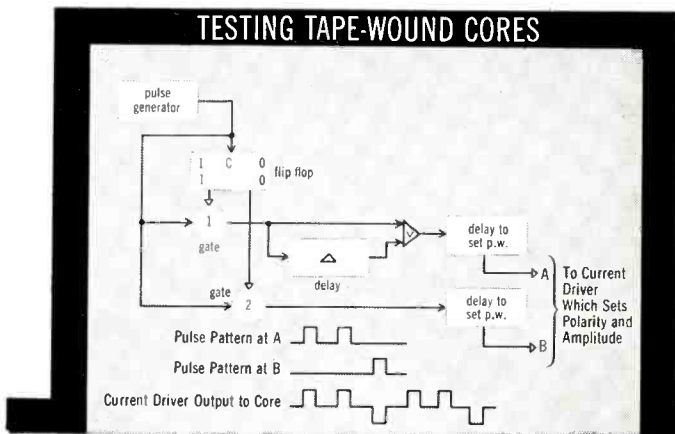

Shown here are typical examples of how these core manufacturers, including Burroughs own core production department, use Burroughs Pulse Control Systems to check tape wound and ferrite cores. An interesting booklet describing core testing in greater detail is yours for the asking. But if you want to test another component by digital techniques, just send us your problem. We'll be glad to work it out, at no cost, and show you how Burroughs Pulse Control Systems can save you hours of engineering time and production headaches.

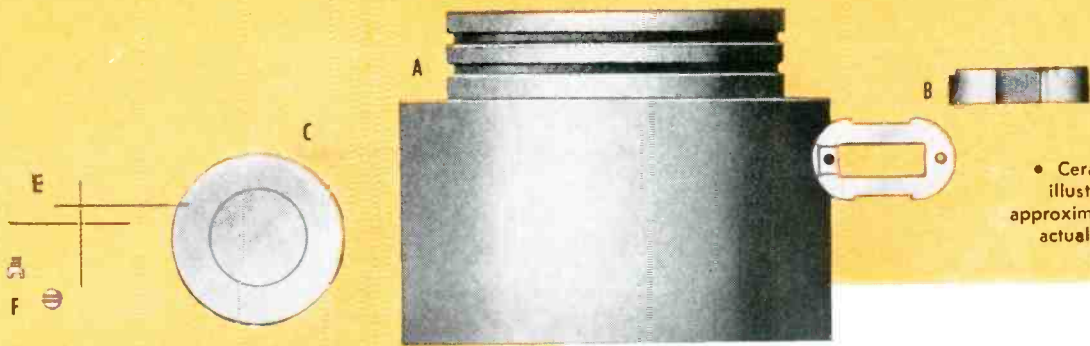

• Ceramics illustrated approximately actual size.

ALSiMAG[®]

PRECISION CERAMICS

produced to precision tolerances

New equipment and techniques are constantly added to improve precision. Few people—few engineers—are aware of the close tolerances which are now possible. There are 3 main reasons for this progress:

COMPOSITIONS. Widest range in the industry. Some AlSiMag materials are hard as sapphire—more wear resistant than tool steel—and are non-magnetic and chemically inert. New Alumina "super ceramics" perform unbelievable feats of strength, thermal and mechanical shock resistance plus excellent electrical characteristics at ultra high frequencies and temperatures. Improved characteristics promote ruggedization, permit miniaturization.

CONTROLS. In preparation of raw materials, designing and building dies, calculating shrinkages . . . at every manufacturing step—forming, firing, inspecting. Over 55 years of experience—where precision in ceramics was pioneered!

FINISHING. Equipment plus skill. Every machine for precision finalizing. Thoroughly trained personnel who consider difficult specifications a personal challenge.



Tell us about your component problems. AlSiMag Precision Ceramics may do a better job for you. Send us a blueprint or sketch with an outline of the operating procedure for complete details.

Do you know

that ceramics can be supplied, in quantity: To tolerances generally associated with precision metal work.

- A. Pistons and cylinders with maximum clearance of as little as .0015".
- B. With faces parallel within .0005".
- C. In flatnesses within light bands.
- D. In thicknesses from .007" up.
- E. In tubular form as small as .015" OD, .008" ID.
- F. Threaded screws as small as 2-56 thread.
- G. With drilled holes as small as .010".

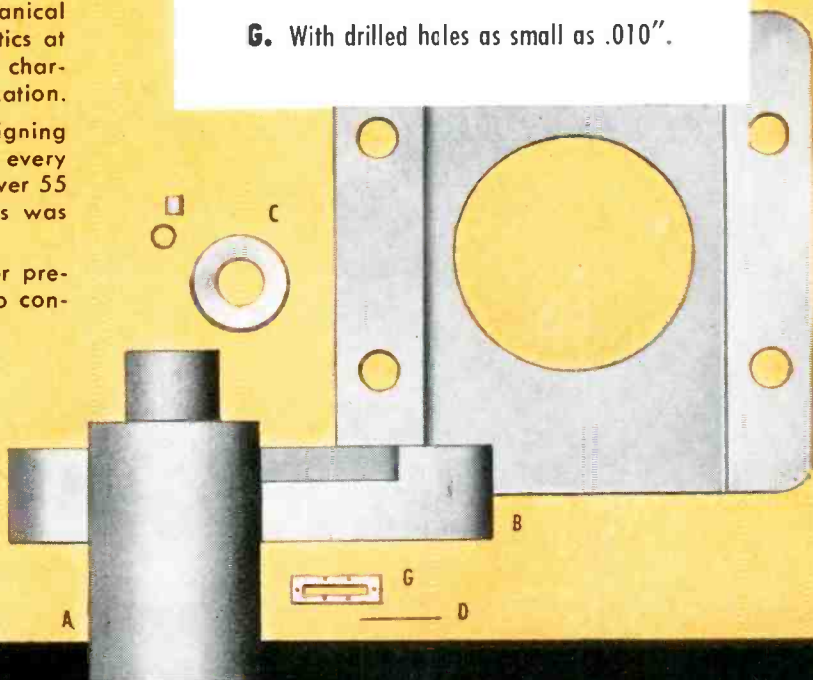

A Subsidiary of
Minnesota Mining and
Manufacturing Company

AMERICAN LAVA CORPORATION

CHATTANOOGA 5, TENN.
35TH YEAR OF CERAMIC LEADERSHIP

For service, contact Minnesota Mining & Manufacturing Co. Offices in these cities (see your local telephone directory): Atlanta, Ga. • Boston: Newton Center, Mass. • Buffalo, N. Y. • Chicago, Ill. • Cincinnati, O. • Cleveland, O. • Dallas, Texas • Detroit, Mich. • High Point, N. C. • Los Angeles, Calif. • New York: Ridgefield, N. J. • Philadelphia, Pa. • Pittsburgh, Pa. • St. Louis, Mo. • St. Paul, Minn. • So. San Francisco, Calif. • Seattle, Wash. Canada: Minnesota Mining & Manufacturing of Canada, Ltd. • O. Box 757, London, Ont. All other export: Minnesota Mining & Manufacturing Co., International Division, 99 Park Ave., New York, N. Y.

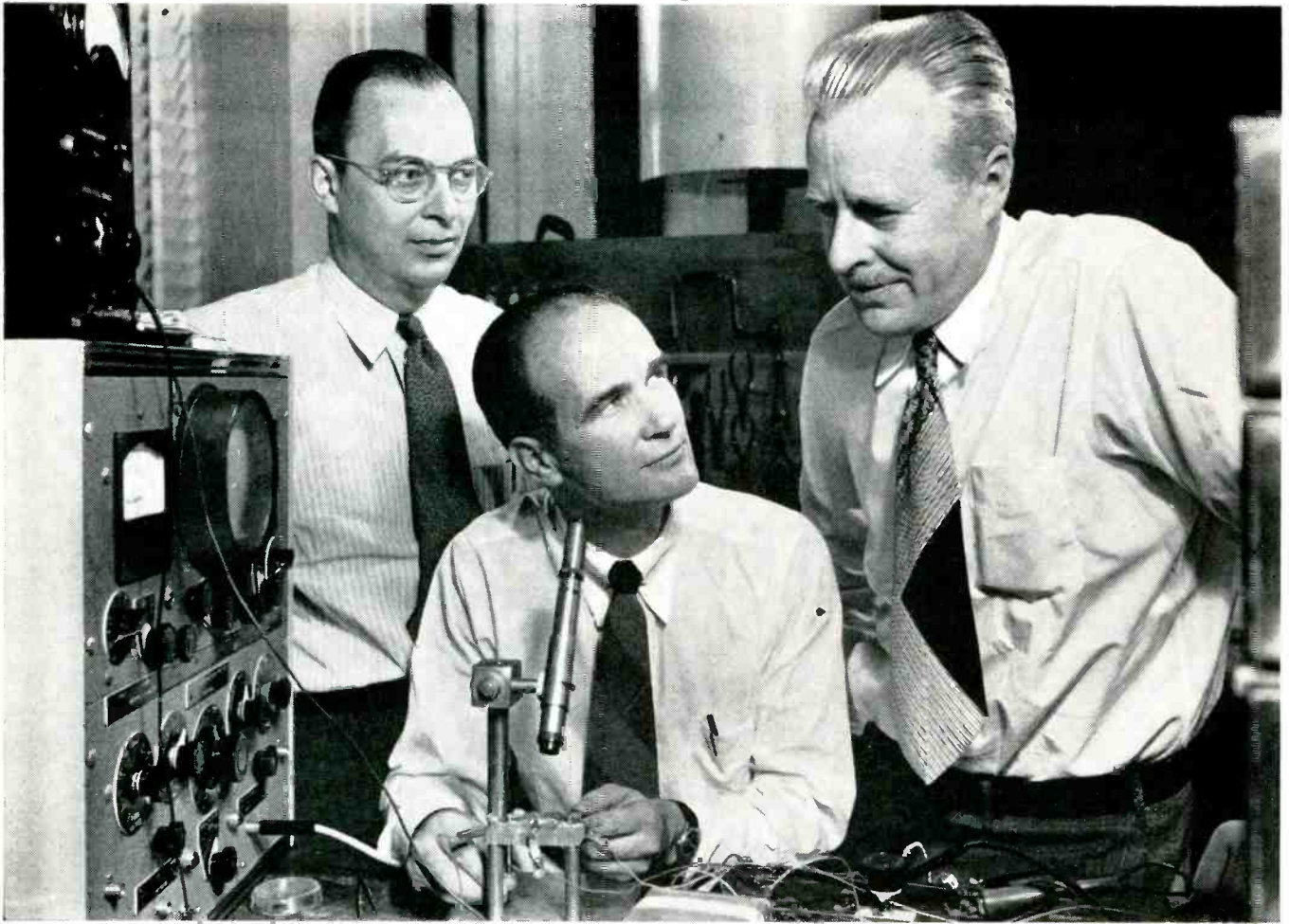

(Left to right) Dr. John Bardeen*, Dr. William Shockley* and Dr. Walter H. Brattain, shown at Bell Telephone Laboratories in 1948 with apparatus used in the early investigations which led to the invention of the transistor.

Bell Telephone Laboratories Salutes Three New Nobel Prize Winners

Drs. John Bardeen, Walter H. Brattain and William Shockley
are honored for accomplishments at the Laboratories

The 1956 Nobel Prize in Physics has been awarded to the three inventors of the transistor, for "investigations on semiconductors and the discovery of the transistor effect."

They made their revolutionary contribution to electronics while working at Bell Telephone Laboratories in Murray Hill, N. J. Discovery of the transistor was announced in 1948. Bell Laboratories is proud to have been able to provide the environment for this great achievement.

This is the second Nobel Prize awarded to Bell Telephone Laboratories scientists. In 1937 Dr. C. J. Davisson shared a Nobel Prize for his discovery of electron diffraction.

Such achievements reflect honor on all the scientists and engineers who work at Bell Telephone Laboratories. These men, doing research and development in a wide variety of fields, are contributing every day to the improvement of communications in America.

**Dr. Bardeen is now with the University of Illinois, and Dr. Shockley is with the Shockley Semiconductor Laboratory of Beckman Instruments, Inc., Calif.*



Bell Telephone Laboratories

WORLD CENTER OF COMMUNICATIONS RESEARCH AND DEVELOPMENT

Want more information? Use post card on last page.

SHIELDING'S *Universal* ENCLOSURE
PROVIDES MAXIMUM SHIELDING EFFECTIVENESS
... FOR COMPLYING WITH ALL APPLICABLE
MILITARY SPECIFICATIONS.

R. F. interference SUPPRESSED

Shielding has the practical solution to all your electro-magnetic suppression problems — the Shielding Universal Enclosure. Multi-Cell® design features either single or double shielding in cell or isolated type enclosure . . . interchangeable standard panels of solid and/or mesh material . . . a wide variety of enclosure sizes both standard and custom-built. A complete test report, performed by independent consulting engineers in accordance with military specifications, has just been completed — evaluating designs and different types of material used. For your copy of this report and the new Shielding folder giving all design details, write today to:



SHIELDING, INC.

11 RESERVE STREET R. VERSIDE, NEW JERSEY

SALES OFFICES:

CHICAGO — R. EDWARD STEHM
DENVER — WILLIAMS & ASSOCIATES
LOS ANGELES — CARL A. STONE ASSOCIATES, INC.
FORT WORTH — MITCHELL SPEARS COMPANY
CANADA — MJB ELECTRONICS SALES LTD., AJAX, ONTARIO

©471

SERVO AMPLIFIER USES AIRPAX CHOPPER

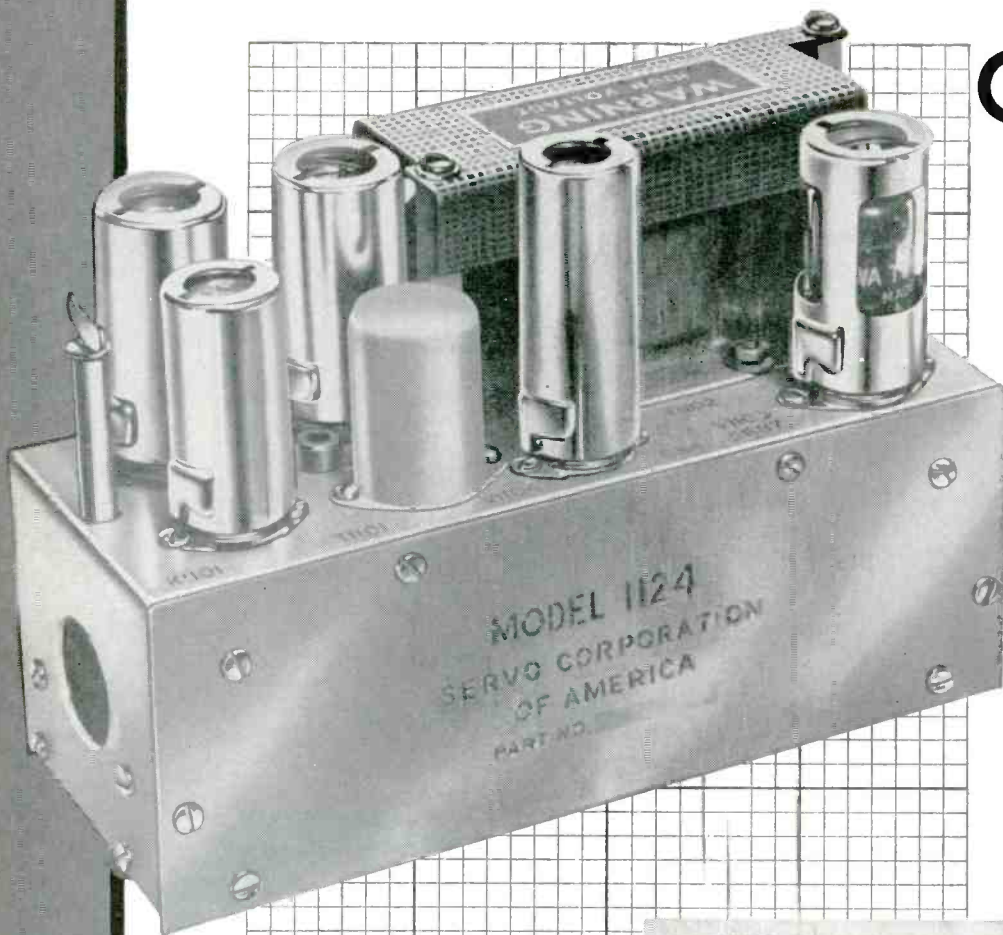

INSTANTANEOUS RESPONSE

This servo amplifier is designed for light-weight, compact, quality performance. It complies with MIL-E-5400.

A miniature 400-CPS chopper modulates a single input or the difference between two inputs. Overall amplifier time lag is negligible compared to a cycle of the supply frequency; signal output is in phase with supply power.

You may be designing a new equipment where a DC input must be amplified. A chopper could help. Why not discuss your problem with us today? Airpax makes the chopper (Servo Corp. of America, New Hyde Park, New York makes the amplifier).

CHOPPER CHARACTERISTICS

CONTACTS: Single-pole double-throw break-before-make contacts are rated for 100 volts and 2 milliamperes.

DRIVE: Drive coil operates from a nominal 6.3 RMS volts at 400 CPS.

TERMINALS: Plugs into conventional 7-pin miniature tube socket, or with solder lugs and flange mount.

DWELL TIME: Nominally 147 electrical degrees, balanced on contacts within 15 electrical degrees.

PHASE ANGLE: Nominally 65 electrical degrees lagging.

INSULATION: 100 MEG between contacts and ground and 10 MEG from drive coil to ground.

NOISE: 200 microvolts average and never greater than 1.5 millivolts peak-to-peak across 1 MEG.

ENVIRONMENT: Hermetically sealed for operation in any atmosphere and at any altitude; operates under 0.06 inch total travel of vibration at 10 to 55 CPS; undamaged by 5 G vibration up to 500 CPS and 100 G shock; operates from -65 to +100 Centigrade. Units also available for operation at +125 degrees Centigrade.



MIDDLE RIVER

BALTIMORE 20, MD.



A major step forward has been achieved by uniting Fairchild precision potentiometers with dynamically balanced and sensitive pressure-sensing elements. The result is a line of superior pressure transducers with potentiometer outputs and featuring all the characteristics of precision, reliability and quality that are identified with Fairchild potentiometers. A specially trained staff of engineers is at your service to consider problems of transducer design and manufacture to meet your specific requirements.

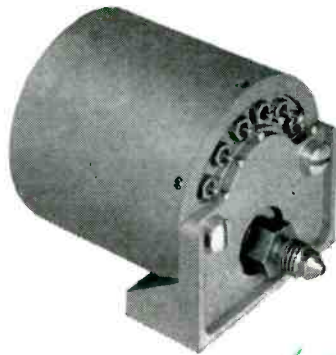

MINIATURE PRESSURE TRANSDUCERS

Featuring Fairchild
accuracy and reliability

The TP-200 illustrated is a new and smaller addition to the line of Fairchild Transducers. These components are now available in a wider range of resistances in either linear or functional, single or dual potentiometer output elements. Measuring only approximately 2" by 2", the TP-200 features a single pressure sensitive diaphragm element which actuates one or two precision potentiometers through dynamically-balanced, stable mechanical linkage. It features unitized construction for easy assembly, field calibration and repair. Variations of size, conformation, and pressure ranges for measurement of differential, absolute, or gauge pressures are available. For complete information write Fairchild Controls Corp., Components Division, Dept. 140-77-A1.

EAST COAST
225 Park Avenue
Hicksville, L. I., N. Y.

WEST COAST
6111 E. Washington Blvd.
Los Angeles, Calif.

FAIRCHILD
PRECISION POTENTIOMETERS
and COMPONENTS

electronics march technical

It's the first IRE Show in New York's Coliseum and attendance will be the biggest ever. Everyone with a stake in the electronic industry will be there March 18th to 21st for the 1957 edition of the Institute of Radio Engineers Show. Engineer or salesman, electronic designer, technician, manufacturer . . . they'll be there to see the latest equipment, circuitry, components and materials.

And before the big show, every important man in the electronic field will be studying the March 1st Technical Edition of **ELECTRONICS** . . . and buying from its advertising pages.

visit your electronics representative at booth . .



edition is the big IRE Show Issue

This pre-show issue is important to the entire industry.

Exhibitors insure wide attendance at your IRE Show booth through the advertising pages of the March Technical Edition of **ELECTRONICS**. Show off your new products and preview your IRE booth in your selling message. Now is the time to make advertising space reservations for this all-important issue which will be referred to before and during attendance at the exhibit and throughout the year.

For non-exhibitors, this carefully-read March Technical Edition of **ELECTRONICS** can describe your products

... for it is a "show in print." This issue of **ELECTRONICS** has firmly established itself as the important convention publication . . . the product show place in conjunction with the IRE Show. Consistent increases in the amount of advertising space in this pre-show issue from year to year prove this is the way for exhibitors and non-exhibitors to reach the entire industry at show time.

You cannot afford to miss this important issue. Closing date for the March 1st Technical Edition of **ELECTRONICS** is February 1st for complete plates; January 25th for copy to set.

• 4308

electronics



A MCGRAW-HILL PUBLICATION, 330 WEST 42ND STREET, NEW YORK 36, N. Y.

CURRENT WL-6198



TOP VIEW



The side appendage will no longer be necessary thanks to advanced Westinghouse design.

NOW! NEW WL-6198A

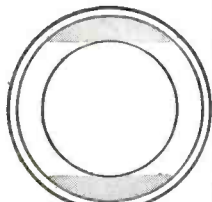
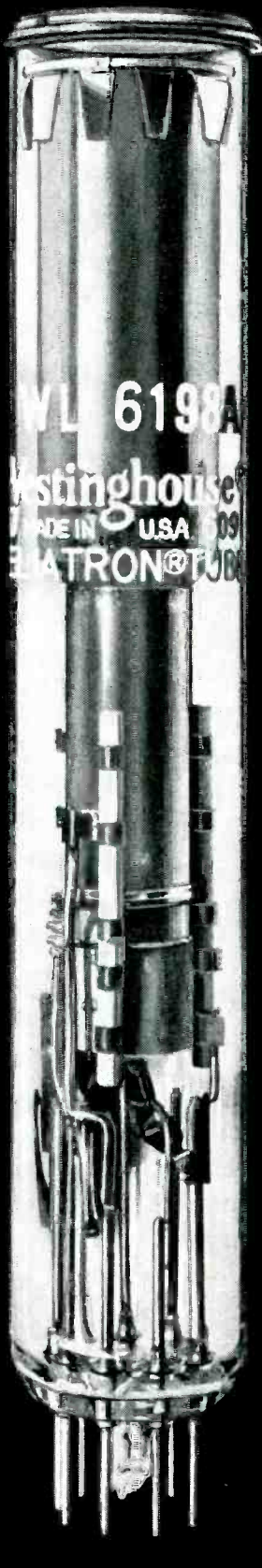

TOP VIEW

New orientation markings on the 6198A permit use of the full photo surface area.

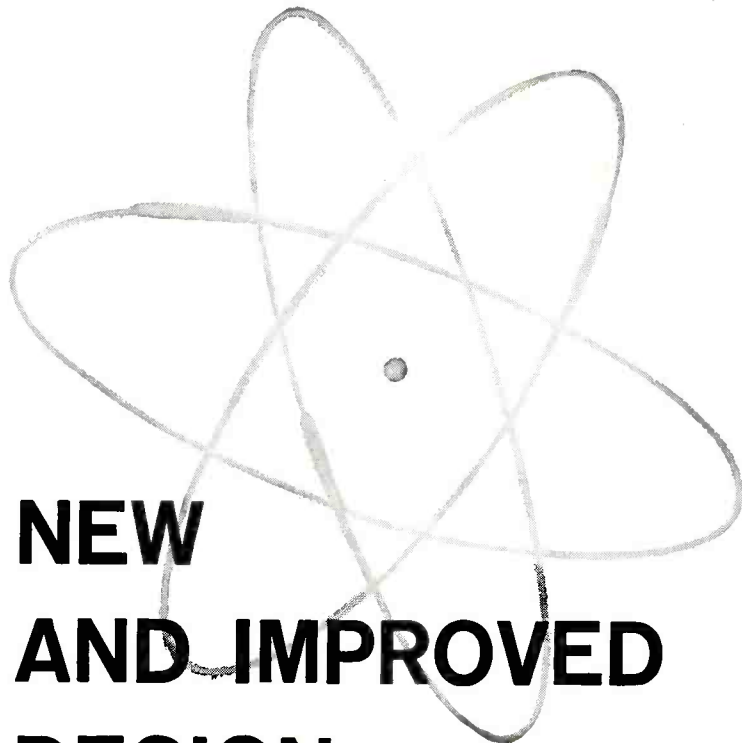

NEW AND IMPROVED DESIGN FROM WESTINGHOUSE

Westinghouse first with redesigned Type 6198 Vidicon Camera Pick-Up Tube . . . first to bring you these important improvements!

IMPROVED MECHANICAL DESIGN. Since the side appendage has been deleted, yoke construction can be greatly simplified because a slot does not have to be provided.

IMPROVED ELECTRICAL DESIGN. This advanced new design permits use of full-length deflection coils in the yoke, and provides focus uniformity to materially improve picture shading. Further, the new WL-6198A permits the introduction of a more uniform photo-sensitive surface to reduce the mottling effects in the picture.

IMPROVED PERFORMANCE FEATURES. Now that mottling is reduced and picture shading improved, the resultant picture is of more uniform clarity . . . with a truer image . . . closer by far to the actual subject being observed and transmitted by the camera.

ENGINEERS! For challenge, security, growth potential, investigate career opportunities now being offered by Westinghouse Electronic Tube Division. Write Technical Placement Director, Westinghouse Electric Corp., Electronic Tube Division, Elmira, N. Y.

You will want full details on this new Westinghouse Vidicon Camera Pick-Up Tube. Get detailed technical data by writing to Commercial Engineering Dept., Westinghouse Electric Corp., Elmira, N. Y.

WATCH WESTINGHOUSE
WHERE BIG THINGS ARE HAPPENING FOR YOU!

6ET-4118

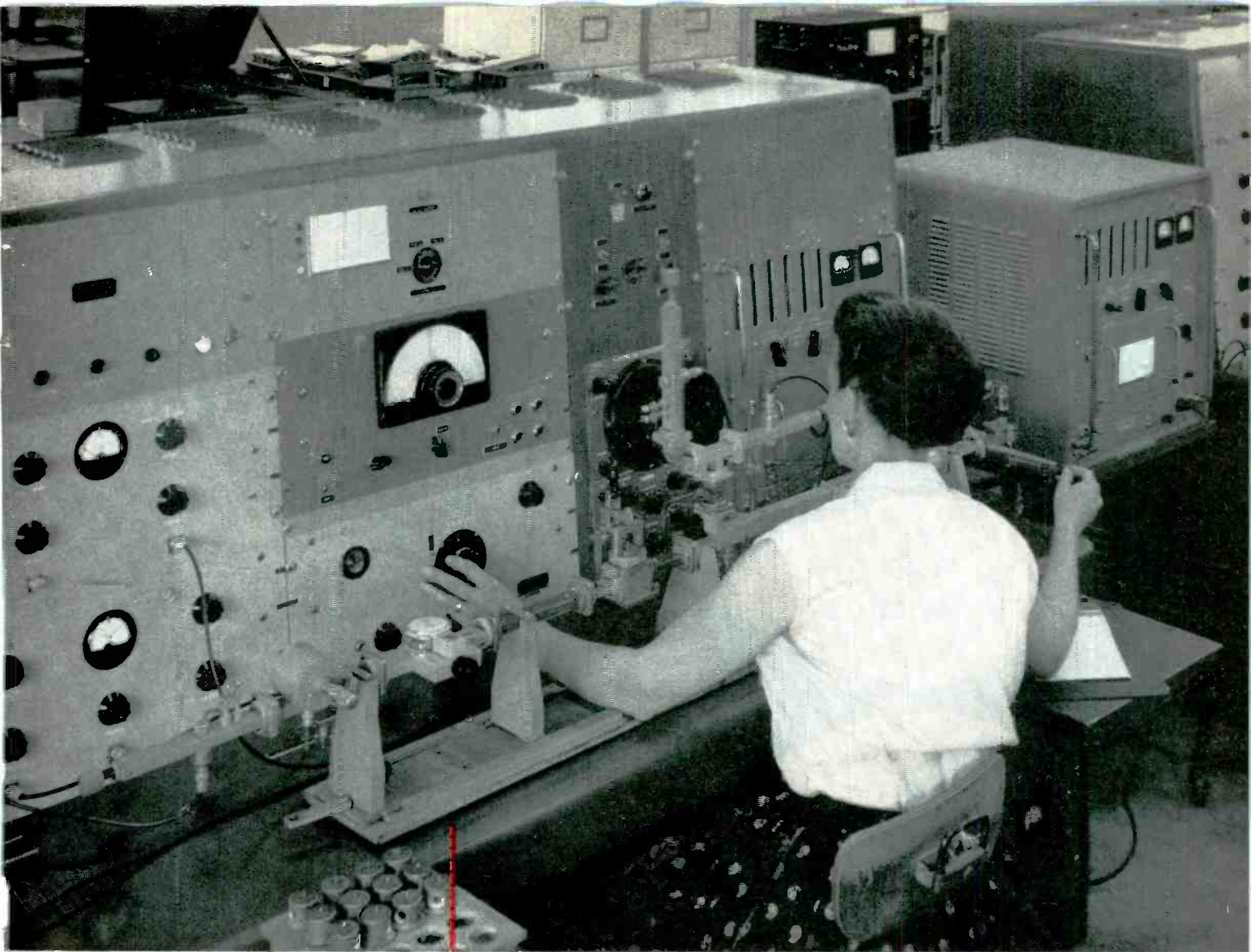

MARGIN FOR ERROR - 1 IN 1,000,000



The special equipment for calibrating and testing radar components used here is precisely accurate to within 1 cycle in 1,000,000.

Designed and built by Bomac test engineers, it typifies Bomac's painstaking emphasis on testing and quality control . . . an emphasis which is largely responsible for the extra measure of dependability in all Bomac microwave products.

***Bomac* LABORATORIES, INC.**
Beverly, Mass.

Positions now open for both junior and senior engineers in microwave tube design and development. The work is challenging, advancement opportunities unlimited, and benefits liberal.

Offices in major cities: — Chicago • Kansas City
Los Angeles • Dallas • Dayton • Washington
Seattle • San Francisco • Toronto

Export: — Maurice I. Parisier, 1860 Broadway, N. Y. C.

**Sylvania is
your source!**

Ge

high purity **GERMANIUM**

for
transistors

for
diodes

Need germanium of critical purity? Sylvania is your source for zone-purified and single crystal germanium of 40-ohm cm resistivity—for your most exacting electronic applications.

Every step in germanium production, from concentrated ore to monocrystalline material, is performed in Sylvania's own plant, under the most rigid quality control checks known to metallurgical science. Starting with spectrographically pure germanium dioxide powder, ingots are produced in a reducing atmosphere. After cleaning and etching, each ingot is repeatedly zone purified. When impurities are reduced to the necessary minimum, undoped crystals are grown by the vertical (Czochralski) method.

Sylvania germanium is available in several forms and degrees of purity, to suit your requirements: as reduced and melted ingots; zone-purified ingots; undoped single crystals. At 25° C, all forms are of the n-type. Also available is high purity germanium dioxide.

You are invited to write us about your specific germanium needs. Standard forms are available promptly. Others, to fulfill special conditions, can be supplied to your order. Write for technical data.

SYLVANIA ELECTRIC PRODUCTS INC.
Tungsten and Chemical Division
Towanda, Penn.

TUNGSTEN • MOLYBDENUM • CHEMICALS • PHOSPHORS • SEMICONDUCTORS



SYLVANIA

LIGHTING • RADIO • ELECTRONICS • TELEVISION • ATOMIC ENERGY

... packaged for efficiency

Hiram Maxim devised the first single-barrel, fully automatic machine gun. It embodied the best features of other fire-arms and Maxim's own refinements. With this automatic, well-packaged gun, one man has the fire power of dozens of individual riflemen.

Hiram Stevens Maxim

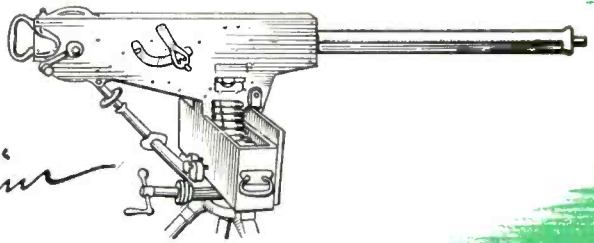

FXR BROAD-BAND MICROWAVE SIGNAL SOURCES



with
direct reading
frequency dial—
one-knob control!

from
950 to 4000 Mc/s

SPECIFICATIONS

Type No. L771A: 950 to 2000 Mc/s.

Type No. S771A: 1900 to 4000 Mc/s.

Direct Reading Frequency Dial Accuracy: $\pm 1\%$ *

Power Output: 50 mw (average) over the band.

Internal Modulation: CW, Square Wave and Pulse (400 to 1800 cps)

External Pulse Modulation and Reflector Modulation (FM) through Front Panel Input Jacks.

Size: 13 1/2" wide x 10" high x 9 1/2" deep.

*When greater accuracy is required, the FXR Type No. N410A Direct Reading Coaxial Frequency Meter will provide $\pm 0.1\%$ accuracy from 1000 to 4000 Mc/s.

Convenience is the "big gun" of the FXR all-in-one Signal Sources. Into one compact package has been built a power supply, klystron, klystron cavity, modulator, variable rf attenuator and an automatic reflector voltage tracking system. These Signal Sources are as easy to use as your home radio. The speed and ease with which broad-band measurements may now be made increases efficiency and allows more time for other tasks. Also, the output power across the band is high enough for most attenuation measurements.

Microwave engineers who use the compact FXR Signal Sources will appreciate the valuable time saved, the convenience, improved stability and simplicity of operation of these units. This represents another example of FXR's leadership in contributing to progress in the Microwave Test Equipment Field.

Write today for a complete catalog of FXR PRECISION MICROWAVE TEST EQUIPMENT.



N410A



FIRST BY FAR

Electronics & X-Ray Division

F-R MACHINE WORKS, Inc.

26-12 BOROUGH PLACE, WOODSIDE 77, N. Y. • ASTORIA 8 2800



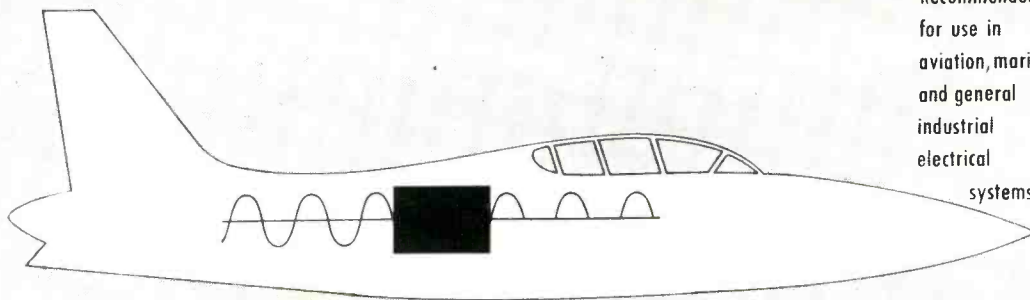
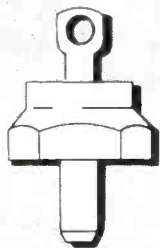

Recommended for use in aviation, marine and general industrial electrical systems.

WN-5051 and WN-5091 with *maximum peak inverse voltage* ratings of 50-350 v. (up to 200 amperes in bridge assemblies).

TYPICAL RECTIFIER CIRCUITS



Single phase full wave (center tap)

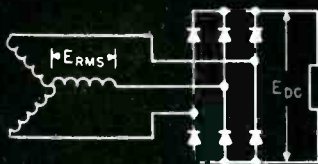

Three phase full wave bridge

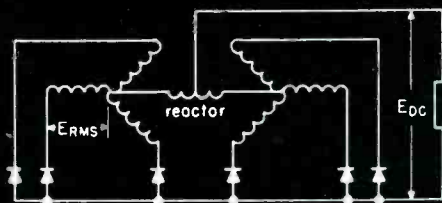

Six phase half wave

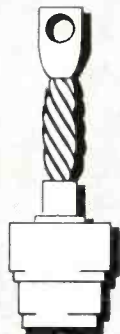

WN-5082 with *maximum peak inverse voltage* ratings of 50-300v. (300 to 5000 amperes in bridge assemblies.)

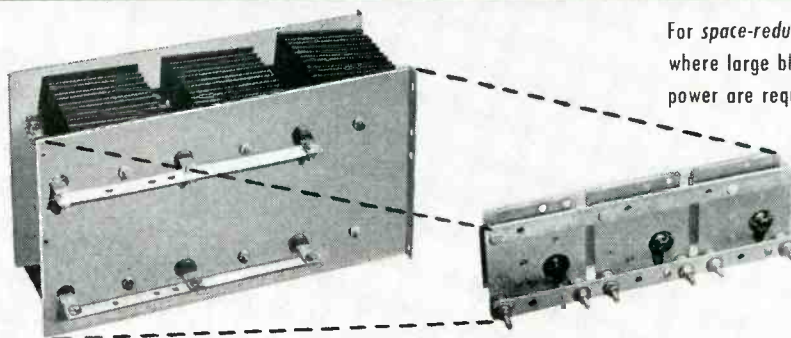

For *space-reducing* design where large blocks of D.C. power are required.

Westinghouse SILICON^(SI) Rectifier cells pack more power in a smaller package!

Recommended for greater reliability, highest efficiency and lowest cost

For the progressive design or application engineer in power, control or electronics . . . for anyone who builds or specifies rectifier assemblies and is constantly seeking equipment design and operational improvement that:

- Provides more power in a smaller space
- Lowers installation cost
- Insures minimum maintenance
- Results in no detectable aging
- Makes possible high ambient temperature operation
- Improves A.C. to D.C. conversion efficiency

Westinghouse Electric Corporation
Semi-Conductor Division, Dept. 00
Youngwood, Pa.

YOU CAN BE SURE...IF IT'S Westinghouse

7ET-4101









Selected **MINIATURES** for **TRANSISTOR** and PRINTED CIRCUIT APPLICATIONS

Design and component engineers are invited to acquaint themselves with the wide variety of miniature low voltage capacitors developed by Good-All Electric. These compact new designs are ideal companion items for use with transistors and other printed circuit components.

Many space-saving Good-All types are as useful for military as for civilian applications. This is particularly true of the molded-in-Epoxy types. It has also proven to be the case with "wrapped" mylar designs which lend themselves to use in potted subassemblies.

Mylar* dielectric is frequently selected for Good-All miniatures because of its superior electrical characteristics — high I.R., low power factor and excellent stability with life. The space-saving it offers in low voltage designs is also an attractive feature.

Good-All offers a wide selection in 50 Volt miniature designs

	REPRESENTATIVE TYPES	TYPICAL SIZE COMPARISONS		
		Cap.	Volts	Diam. Lgth.
AXIAL LEAD 	600UE . . . Mylar dielectric winding molded in dense, moisture-resisting Epoxy.	.01	50	.312 x 15/16
		.1	50	.438 x 1-3/16
		.47	50	.562 x 1-15/16
RADIAL LEAD 	663UW . . . Mylar dielectric winding with tough plastic film case and thermo-setting end seals.	.01	50	.188 x 11/16
		.1	50	.281 x 15/16
		.47	50	.437 x 1-15/16
UPRIGHT MOUNTING 	613G . . . Mylar dielectric winding, extended foil construction, hermetically-sealed metal housing.	.01	50	.173 x 23/32
		.1	50	.313 x 27/32
		.47	50	.50 x 1-3/16
EPOXY COATED CERAMIC DISCS 	600RE . . . This novel design combines features of conventional tubular capacitors and upright mounting types. The mylar dielectric winding is completely encapsulated in Epoxy. In addition to its attractive glossy red appearance the Epoxy formulation developed by Good-All yields a tough, durable coating with excellent dielectric strength.	.01	50	.250 x 11/16
		.1	50	.375 x 15/16
		.47	50	.50 x 1-3/4
UPRIGHT MOUNTING 	600UPE . . . Mylar dielectric winding molded in dense, moisture-resisting Epoxy.	.01	50	.438 x 15/16
		.1	50	.562 x 1-3/16
		.47	50	.688 x 1-15/16
UPRIGHT MOUNTING 	620UPB . . . Mylar dielectric winding with molded bakelite housing and thermo-setting plastic end seal.	.01	50	.375 x 1
		.1	50	.375 x 1-1/4
		.47	50	.625 x 1-7/8
UPRIGHT MOUNTING 	620PM . . . Mylar dielectric winding encapsulated in a plastic impregnated paper tube.	.01	50	.343 x 15/16
		.1	50	.410 x 1
		.47	50	.562 x 1-3/4

These Epoxy coated discs are ideal for use on printed circuit boards that are to be dip soldered, since no wax coating is necessary. The available types of ceramic discs are too numerous to describe in detail. A complete brochure with specifications on each type will be mailed to you upon request.

Dimensional information is contained in the Good-All ceramic disc brochure.

*DuPont's trademark for polyester film.

Write or phone for
consultation on
specific design
problems or to
secure detailed
specifications on the
various capacitor
types shown.



GOOD-ALL ELECTRIC MFG. CO.

OGALLALA, NEBRASKA A leading manufacturer of Tubular and Ceramic Disc Capacitors

DATA FOR



NEW MINIATURE TRIODE-TETRODE

RCA-6CQ8...enables flexibility in circuit design for VHF and combination VHF-UHF TV tuners!

Containing a medium- μ triode and a sharp-cutoff tetrode—with an internal shield to prevent electrical coupling between the two units—RCA-6CQ8 may be used in a combination of applications in color, and black-and-white TV receiver designs. It is especially useful as a combined oscillator and mixer tube in tuners of receivers utilizing an intermediate frequency of 40 Mc. The triode unit is also useful as an rf amplifier, phase splitter, sync clipper and sync separator. The tetrode unit is also useful as a sound or video-if amplifier tube.

The tetrode unit features a plate-current characteristic with a sharp knee. This enables mixer operation with good linearity at relatively low plate voltages. Low grid #1-to-plate capacitance minimizes feedback problems; low output capacitance permits the use of a high-impedance plate circuit with resultant increase in mixer gain.

Additional features of special interest to designers are: separate cathodes—adding to circuit design flexibility, and 450-milliampere heater with controlled warm-up time for series-string circuits. Write for technical data.

17 NEW TUBES FOR SERIES-STRING TV DESIGNS

RCA now offers a comprehensive line of tube types especially useful in TV receivers utilizing 450-milliampere series-heater strings. The heaters all have 11-second warm-up time to minimize voltage unbalance during starting. All types have heater-cathode voltage ratings sufficiently high to insure dependable performance in series-string circuitry.

4AUS	6AM8-A	6CQ8	8CG7
4CB6	6AQ5-A	6CZ5	8CM7
4DT6	6AT8-A	6U8-A	17AX4-GT
5BQ7-A	6AT8-A	8AW8-A	17BQ6-GTB
			17DQ6-A

Chart listing these types, their prototypes, and heater-cathode voltage ratings available on request.

DEFLECTION-AMPLIFIER TUBES FOR 110° SYSTEMS

RCA-6CZ5 for vertical deflection; RCA-6DQ6-A and -12DQ6-A for horizontal deflection...these types are beam-power tubes for service in TV receiver designs utilizing the new short picture tubes having diagonal-deflection angles of 110°. Internal structures are designed to provide for maximum distribution of heat in order to prevent "hot spots" on the plates and to allow "cooler" operation of the grids—resulting in long life. RCA-6CZ5 has a 6.3-volt, 0.45-ampere heater; RCA-6DQ6-A, a 6.3-volt, 1.2-ampere heater; and RCA-12DQ6-A, a 12.6-volt, 0.6-ampere heater. The heaters of these types have the same controlled warm-up time to minimize voltage unbalance during starting in series-string TV applications.



New AF TRANSISTOR PROVIDES HIGH POWER GAIN AT LOW DISTORTION AND WITH HIGH EFFICIENCY



RCA-2N270...an hermetically sealed, alloy-junction transistor of the germanium p-n-p type...is designed especially for use in large-signal audio-frequency circuit applications in home-entertainment radio sets, phonographs, and battery-operated communications equipment. In class A service, one RCA-2N270 can deliver a maximum-signal power output of approximately 60 milliwatts with a power gain of 35 db. In push-pull class B service, two 2N270's can deliver a maximum-signal power output of approximately 500 milliwatts with a power gain of 32 db. Low collector saturation current permits design of af amplifiers which can operate under varying ambient temperature conditions and, at the same time, provides both high efficiency and a high degree of operating stability. Current transfer ratio of 2N270 is nearly constant over the full range of the output-signal swing, even when the peak output-signal current reaches the peak collector current rating. This feature minimizes distortion at high power outputs when low supply voltages are used.

DESIGNERS



NEW HALF-WAVE MERCURY-VAPOR RECTIFIER TUBES FOR HIGH-VOLTAGE HIGH-CURRENT POWER SUPPLIES

RCA-6894 and RCA-6895... specifically for use in high-voltage rectifier circuits designed to supply dc power with good regulation to broadcast transmitters and industrial equipment. Alike except for their bases, these new types are capable of withstanding a maximum peak inverse anode voltage of 20,000 volts. Each type can deliver a maximum peak anode current of 11.5 amperes and a maximum average anode current of 2.5 amperes in quadrature operation. Six of either type in a series, three-phase quadrature circuit can supply up to 143 Kw, at a dc output voltage up to 19,000 volts. Ratings are such as to make them companion tubes to RCA-5563-A mercury-vapor thyatron. RCA-6894 and RCA-6895 are unilaterally interchangeable with RCA-575-A and RCA-673, respectively.



NEW TV CAMERA TUBE OPERATES ON ILLUMINATION AS LOW AS 0.0001 FOOT-CANDLE

RCA-6849... image orthicon designed especially for use in industrial, military, and scientific-research applications... combines extremely high sensitivity with spectral response approaching that of the human eye. RCA-E849 incorporates the new Micro-Mesh 750-line screen which enables increased picture detail and contrast, and eliminates moiré and beat-pattern effects.



PREMIUM TUBES—FOR DESIGNS REQUIRING DEPENDABLE AND UNINTERRUPTED OPERATION

RCA "Premium" Quality tubes are especially designed for use in military and critical industrial applications requiring dependable performance where shock and vibration is a prime consideration. "Premium" tubes are subjected to many special tests during manufacture including those for shock, fatigue, low-frequency vibration, glass strain, and heater cycling to minimize possibilities of early-hour failures. The following tubes have been added to the comprehensive line of "Premium" tubes offered by RCA.

RCA-6J4-WA... designed to meet the military specification Mil-E-1/619-B dated 1/28/55 is a high-mu triode of the 7-pin miniature type with a heater cathode—for use in cathode-drive circuits at frequencies up to about 500 Mc.

RCA-0A2-WA, RCA-0B2-WA... are voltage-regulator tubes of the 7-pin type. The 0A2-WA is designed to meet the military specification Mil-E-1/290A dated 7/16/54; the 0B2-WA, Mil-E-1/291 dated 7/9/53.

RCA-5636, RCA-5636-A... are sharp-cutoff pentodes of the subminiature type having flexible leads for use in gated amplifier circuits, delay circuits, gain-controlled amplifier circuits and particularly in mixer circuits operating at frequencies up to 400 Mc. Small in size, light in weight, and capable of operating at low supply voltages these tubes are especially well suited for use in mobile and in compact portable equipment. May be operated at altitudes up to 60,000 ft. without pressurized chambers. The 5636 conforms to the requirements of the applicable Mil specifications. The 5636-A conforms to the requirements of the applicable USN specification.

For sales information on any of the RCA products shown, please contact the RCA District Office nearest you:

EAST: Humboldt 5-3900
744 Broad Street
Newark 2, N. J.

MIDWEST: Whitehall 4-2900
Suite 1181
Merchandise Mart Plaza
Chicago 54, Ill.

WEST: Raymond 3-8361
6355 East Washington Blvd.
Los Angeles 22, Calif.

Technical bulletins are available for the types shown on the coupon. Circle those types on which you want data and send the coupon to RCA Commercial Engineering, Section A19R-1, Harrison, N. J.

Chart of 450-ma Series-String Tubes

6CQ8	12DQ6-A	6849
6CZ5	6894	5636
6DQ6-A	6895	5636-A

NAME.....

COMPANY.....

ADDRESS.....



RADIO CORPORATION of AMERICA

Tube Division, Harrison, N. J.

Semiconductor Division, Somerville, N. J.

PQ* engineered for

SIMPLER I.F. & VIDEO

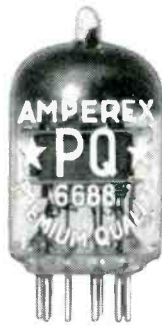

ACTUAL SIZE

*with fewer stages
and lower noise...*

the

Amperex® E180F/6688

Ruggedized

BROADBAND AMPLIFIER PENTODE

With a figure of merit of 1.57 as a broadband amplifier, the AMPEREX E180F/6688 permits the design of simpler, better and more economical IF and video circuits, having 30 to 40 percent fewer stages and improved signal-to-noise ratio, at no sacrifice of either gain or bandwidth. Combining all these superior electrical characteristics with

completely ruggedized construction and extremely long life, the E180F/6688 is ideal for use in unattended communications equipment and instrumentation circuits. It is designed and manufactured in accordance with the special techniques developed for the production of the famous AMPEREX line of 10,000-hour tubes.

***An Amperex 'Premium Quality' Tube**

Comparison of the AMPEREX E180F/6688 with other tubes used in the same applications.

	E180F/6688	TYPE A	TYPE B	TYPE C
Type of Tube	Pentode ¹	Pentode ¹	Tetrode	Pentode ¹
$\frac{G_m}{C_{in} + C_{out}}$ (Figure of Merit as Broadband Amplifier)	1.57	1.25	1.36	0.73
Maximum Power Output at 10% Distortion	0.95 W	0.53 W
Maximum Power Output at 2½% Distortion	0.52 W	0.075 W
Transconductance Phase Angle at 50 Mc	9° ²	12°	12.5°
Input conductance at 100 Mc	500 μmhos ³	665 μmhos
Grid resistance at Maximum Ratings	0.5 Megohm ⁴	0.1 Megohm	0.1 Megohm	0.1 Megohm
Pins	gold-plated ³	not gold-plated	not gold-plated	not gold-plated

¹ inherently more linear

² small angle, achieved by use of special twin cathode lead, ideal for broadband amplifier applications

³ for better high-frequency performance

⁴ higher permissible grid resistance, due to gold-plated grid, makes possible greater overall gain

For the input stages of your I.F. amplifiers, write for information on the AMPEREX E88CC/6922 twin triode—another PQ* tube especially designed for this application.

Detailed data sheets and applications engineering assistance available from:



Special Purpose Tube Division

Amperex ELECTRONIC CORP.

230 Duffy Avenue, Hicksville, L. I., N. Y.

*Relay
Sales*

Telephone
Relays

Midget
Relays

Keying
Relays

Rotary
Relays

Sealed
Relays

Sensitive
Relays

Latching
Relays

Stepping
Relays

Delay
Relays

Timers

Contactors

Motor Starting
Relays

Differential
Relays

Polarized
Relays

AN Approved
Relays

RELAYS

QUICKLY supplied from stock!

ADVANCE
"NEOMITE" RELAYS
in stock . . . Now!

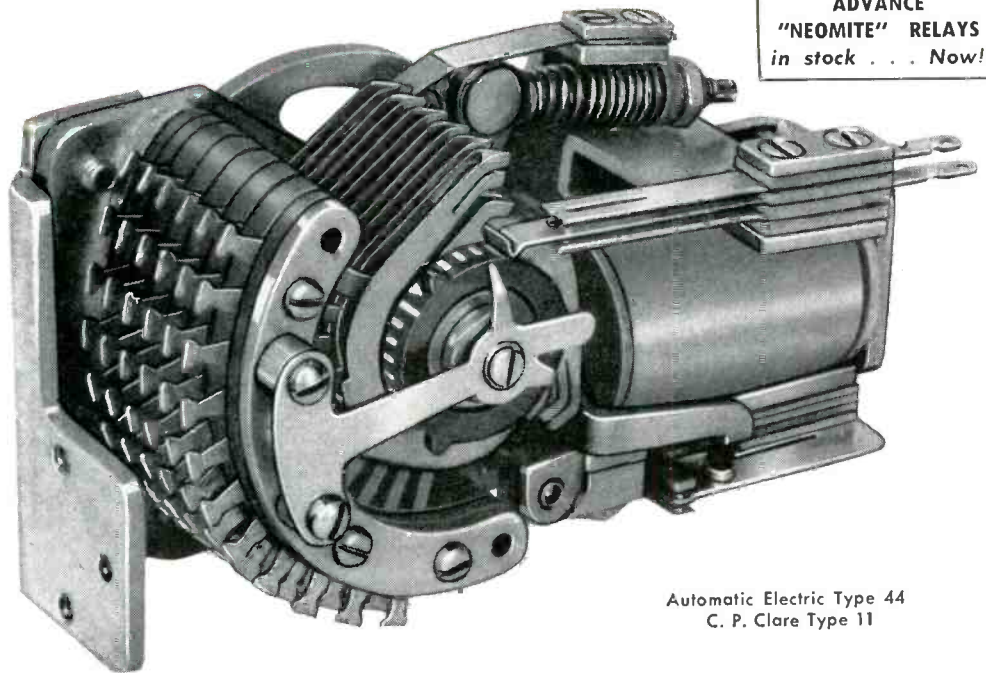

Automatic Electric Type 44
C. P. Clare Type 11

Substantial Quantities of Every Type On Hand

Large or small orders for relays of any type are filled immediately from our comprehensive stock. We save you weeks and months of delivery time. You are relieved of inventory problems and production delays. Call us.

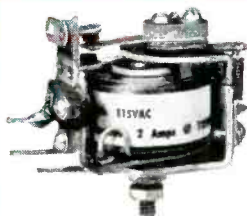

ADVANCE

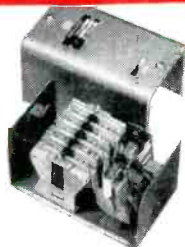

SCHRACK CONTROLS



STRUTHERS-DUNN

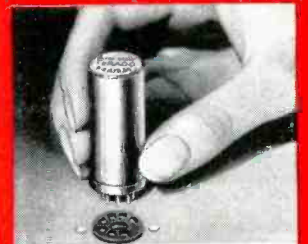

TERADO

Write for new
24 page catalog C-7

*Relay
Sales*

Authorized Distributors for Major Relay Manufacturers.
All relays are new, inspected and guaranteed. Phone
us for same day shipment.

Phone West Chicago 1100

Write for new 24 page catalog C-7

RELAY SALES, INC.

P. O. BOX 186 - A • WEST CHICAGO, ILL.

Let DeMornay-Bonardi build your **COMPLETE MICROWAVE SYSTEMS**

-you'll save design time and testing time.

Cost is 25% to 50% less. Delivery months sooner!

Using "building-block" methods, D-B saves you time and money in special purpose system construction. We manufacture and stock 924 types of reliable components, from 2.60-90.0 KMc/SEC. This wide choice gives us the flexibility to build for any application, and allows better control over the elements in a complex system. It greatly simplifies design, saving weeks of trial-and-error methods.

Each D-B component selected from stock is already tested—hence the assembly needs no proving...

checks out as soon as it's put together... is guaranteed to work. With so many savings in engineering time, D-B can complete a system at a price 25% to 50% lower than your costs. Delivery time is cut by months.

All we need from you to construct a special purpose waveguide system are your electrical requirements and space allowance. We do the rest with building blocks, proved in use since 1941. Talk it over with a D-B representative, or write direct. New D-B catalog now ready—request a copy on your company letterhead.

Heterodyne System Designed for Beckman Instruments, Inc.

This system was designed to measure an unknown frequency anywhere between 10 KMc and 50 KMc by heterodyning it against a set of precisely known frequencies which are generated by multiplication from a low frequency primary standard. The system provides:

- a.** Generation of standard reference frequencies by means of Klystron multiplier, a balanced sideband generator, crystal multipliers and band-pass filters.
- b.** Coarse measurement and filtering of the unknown frequency by means of cavity wavemeters.
- c.** Selection of the proper channel by means of three SPDT switches plus a special 3-way and 5-way switch for transitions from one waveguide size to another.
- d.** Mixing of the unknown frequency with the properly selected reference frequency to provide an unambiguous beat frequency.

Except for the 3- and 5-way switches, all waveguide components used in this system are either stock D-B catalog items, or minor modifications of them—an important factor in quick delivery.

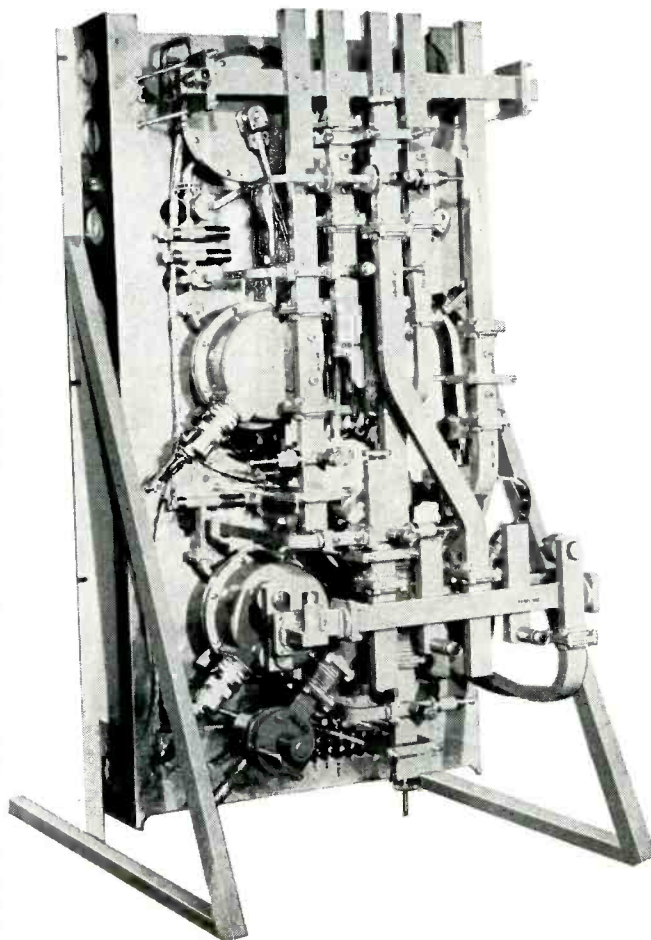

DEMORNAY BONARDI
780 SOUTH ARROYO PARKWAY,
PASADENA, CALIFORNIA

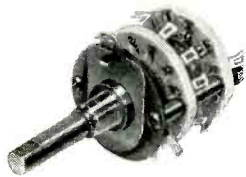

Type F: Miniature 12-position, 30-60° throw, can be mounted in 1-5/16" circle; phenolic, mycalex or steatite.



Type H: Standard 12-position; 1-7/8" diameter; 15-30-60° throw; phenolic, mycalex or steatite.



Types J, K, N: 1-17/64" diameter; provides for flexibility of layout; interchangeable sections, phenolic or steatite.

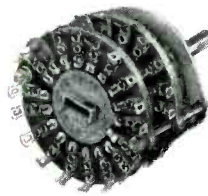

Type L or DL: Using dual eyelet fastening; 18-position; mounts in 2-9/32" circle; phenolic, mycalex.

Special Switches



Multiple Shafts combined to operate snap switches and potentiometers; many different section types.



Type MF: 24-position switch may be mounted in 2-5/16" circle; in phenolic insulation.



Series 20: Simple switch for tone controls, band switching, and talk-listen circuits.



For Printed Circuits: Special lug design for insertion into printed circuit boards.

an INFINITE VARIETY
from standard parts



SWITCHES
CHOPPERS
ROTARY SOLENOIDS*
SPECIAL ASSEMBLIES
VIBRATORS

OAK

MFG. CO.

1256 Clybourn Ave., Chicago 10, Ill.
Telephone: MOhawk 4-2222

*Manufactured under License from G. H. Leland, Inc.

• No matter what you need in low-current switches, you are most sure to find it in an OAK switch design. In the last 25 years, OAK has produced over a quarter billion switches—rotary, slider, pushbutton, plug, and door switches—in thousands of variations. Why not take advantage of OAK's unmatched, switch engineering background . . . production facilities . . . and huge inventory of tooling?

WRITE FOR your copy of the OAK Switch Catalog which covers the most popular of OAK's standard switches.

Type 160 Rotary Slider: 7/8" height allows shallow chassis; leads are readily accessible.



Type 185: New lever-operated version of the standard Oak rotary switches.



Type 130 Pushbutton: Available with from one to 24 buttons, 32 contacts each button.

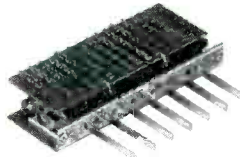

Type 80 Pushbutton: Very adaptable. Used in communication equipment; economical for less complex applications.

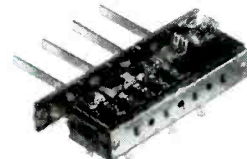



Hughes Quality means Highest Quality in

HIGH-CONDUCTANCE SILICON DIODES

Hughes, long the leader for quality and reliability, has added another new series of Silicon Junction Diodes to the expanding line of Hughes Semiconductors.

Available now: HIGH-CONDUCTANCE SILICON JUNCTION DIODE TYPES HD6571, HD6572, HD6573, HD6574, HD6575 . . . HIGHER VOLTAGES . . . HIGHER CURRENTS . . . EXTREMELY HIGH BACK RESISTANCE . . . BREAKDOWN VOLTAGES TO 400V . . . HIGH FORWARD CURRENT . . . HIGH-TEMPERATURE OPERATION.

The first five types in this new series have been especially established to fill specific applications requiring relatively moderate speed, with high voltage and high current. Examples: high-current clamping; magnetic amplifiers.

The entire series is packaged in the world-famous Hughes subminiature glass envelope, impervious to moisture and to other external contaminants.

ACTUAL SIZE, Diode Glass Body: Length: 0.265-inch, max. Diameter: 0.105-inch, max. Color: Opaque black enamel.

OPERATING TEMPERATURE RANGE: From -75°C to $+150^{\circ}\text{C}$.

Our field sales engineers near you are ready to assist you in selecting the one Hughes germanium or silicon diode type best suited to your specific application. For further information, or for specifications covering the new Hughes High-Conductance Silicon Junction Diodes, please write:

SEMICONDUCTOR DIVISION

HUGHES PRODUCTS

International Airport Station, Los Angeles 45, California

HUGHES PRODUCTS

HUGHES



SEMICONDUCTORS

© 1957. HUGHES AIRCRAFT COMPANY



"BEST IRON WE'VE HAD in the plant," says William Fish, a production supervisor of General Radio, Cambridge, Mass. This company has switched to G-E Midget irons for soldering *both*

delicate and heavy joints in their Type 1862-B Megohmmeters —jobs which formerly required *both* a heavy and a light iron. G-E Midget iron's light weight also helps reduce fatigue.

50 G-E Midget irons do work of 100 former irons at General Radio Co., boost production 25%

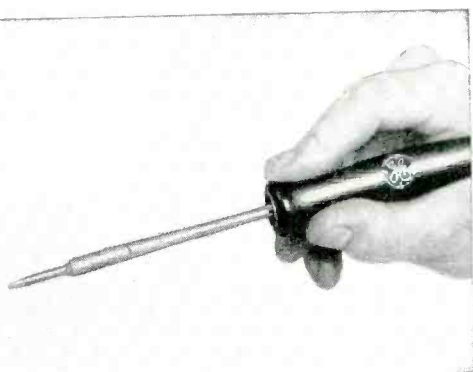

HANDLES LIKE A PENCIL—Weighing less than a package of cigarettes, the General Electric Midget soldering iron speeds production by reducing operator fatigue.

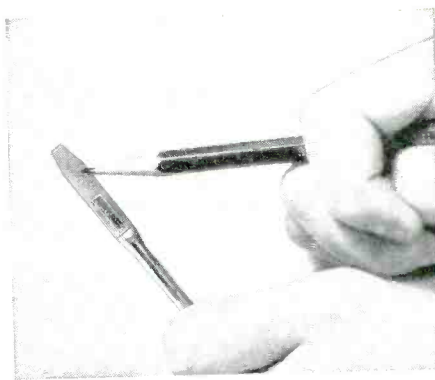

RAPID HEAT TRANSFER is achieved by locating the heater directly in the iron-clad-copper tip. Result—the G-E Midget iron's heat efficiency is 90%.



THREE-IN-ONE IRON with $\frac{1}{8}$ ", $\frac{1}{4}$ ", $\frac{3}{16}$ " tip sizes gives you greater versatility to meet your soldering requirements. Tips can be changed in only 5 seconds.

For more information write for GED-2263, G-E Midget Soldering Iron, Section 724-3, General Electric Co., Schenectady 5, N. Y.

GENERAL  ELECTRIC

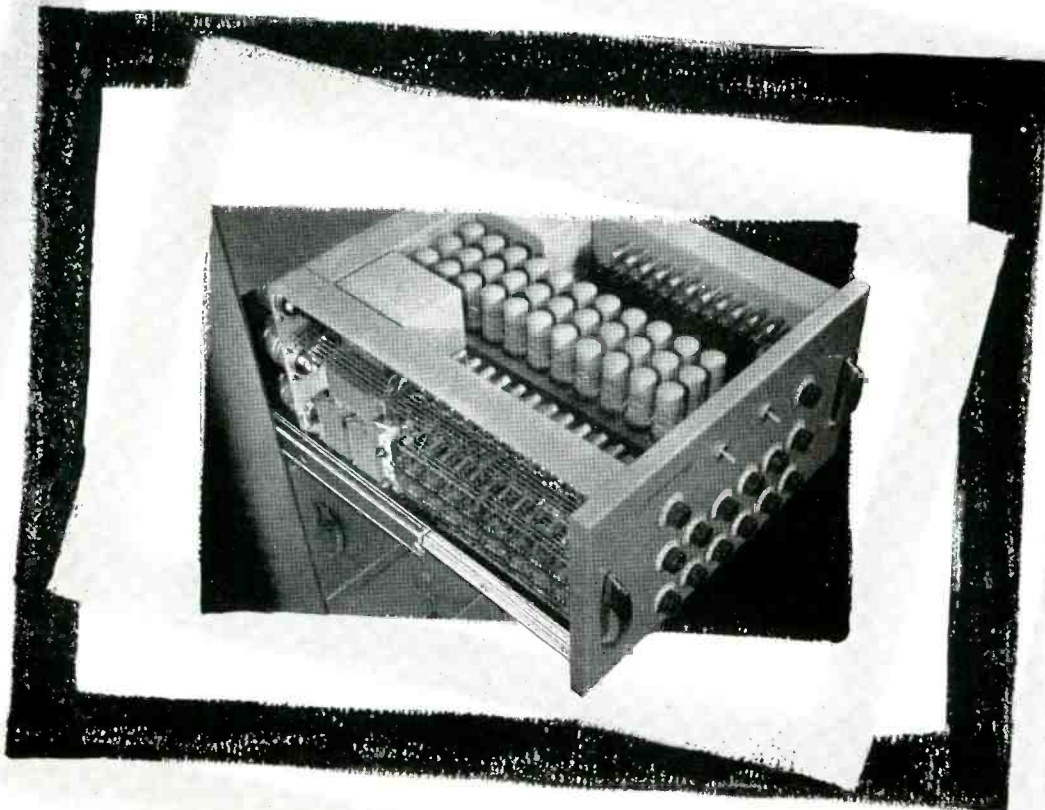

photograph courtesy Consolidated Electrodynamics Corp.

you "build-in" Accessibility with

GRANT INDUSTRIAL SLIDES

IF it's important to keep your electronic equipment functioning with as brief interruptions as possible...**IF** even minor testing and replacement takes undue time because of the nuisance of getting at the equipment mechanically...**IF** certain components *must* be accessible for on-the-spot servicing in seconds...**THEN** you should investigate Grant Industrial Slides.

Grant Industrial Slides provide *built-in* accessibility, without effort or costly loss of operating time. Unlimited varieties of standard and custom types are available and Grant offers complete

engineering services including at-your-plant discussions regarding the development of slides that fit your requirements perfectly.

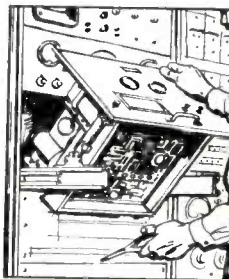

Five seconds to put chassis in testing position. Slides smoothly out of rack, locks. Pivoting mechanism brings under-chassis parts to easiest working angle. Functioning of unit need not be interrupted!

Write for Grant Industrial Slide technical data. Free copy will be mailed on request.

Grant INDUSTRIAL SLIDES

Grant Pulley & Hardware Corporation, 31-73 Whitestone Parkway, Flushing 54, N. Y., 944 Long Beach Avenue, Los Angeles 21, Calif.



NEW SWITCH

*for high-speed
commutating—*

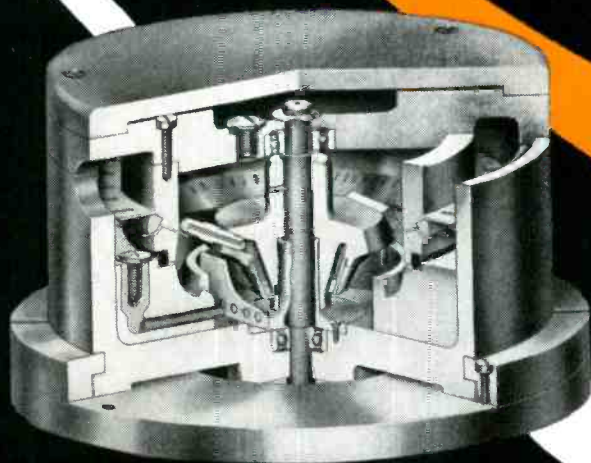

The mercury jet

DELTA SWITCH

• *no contact bounce* • *long life*

Unique multi-position rotary switch for data sampling where application demands high speed (as many as 10,000 samples per second), long life and low noise. Ideal for thermocouple sampling and strain gauge monitoring to a high-speed analog to digital converter or oscilloscope display.

Deltaswitch utilizes rotating jet of mercury to connect sequentially each of many stationary contacts through low-resistance path to a common pole — no brushes or slip rings. Operates satisfactorily from 1,200 to at least 6,000 rpm. Contact resistance approximately .25 ohm. Noise levels of less than 10 microvolts in most applications. Flexible dwell time.

Copyright 1956 by Detroit Controls Corp.



HIGH
reliability
LOW
maintenance

NORWOOD CONTROLS

UNIT OF DETROIT CONTROLS CORPORATION
935 Washington St. • Norwood, Mass.

Complete technical information available upon request.

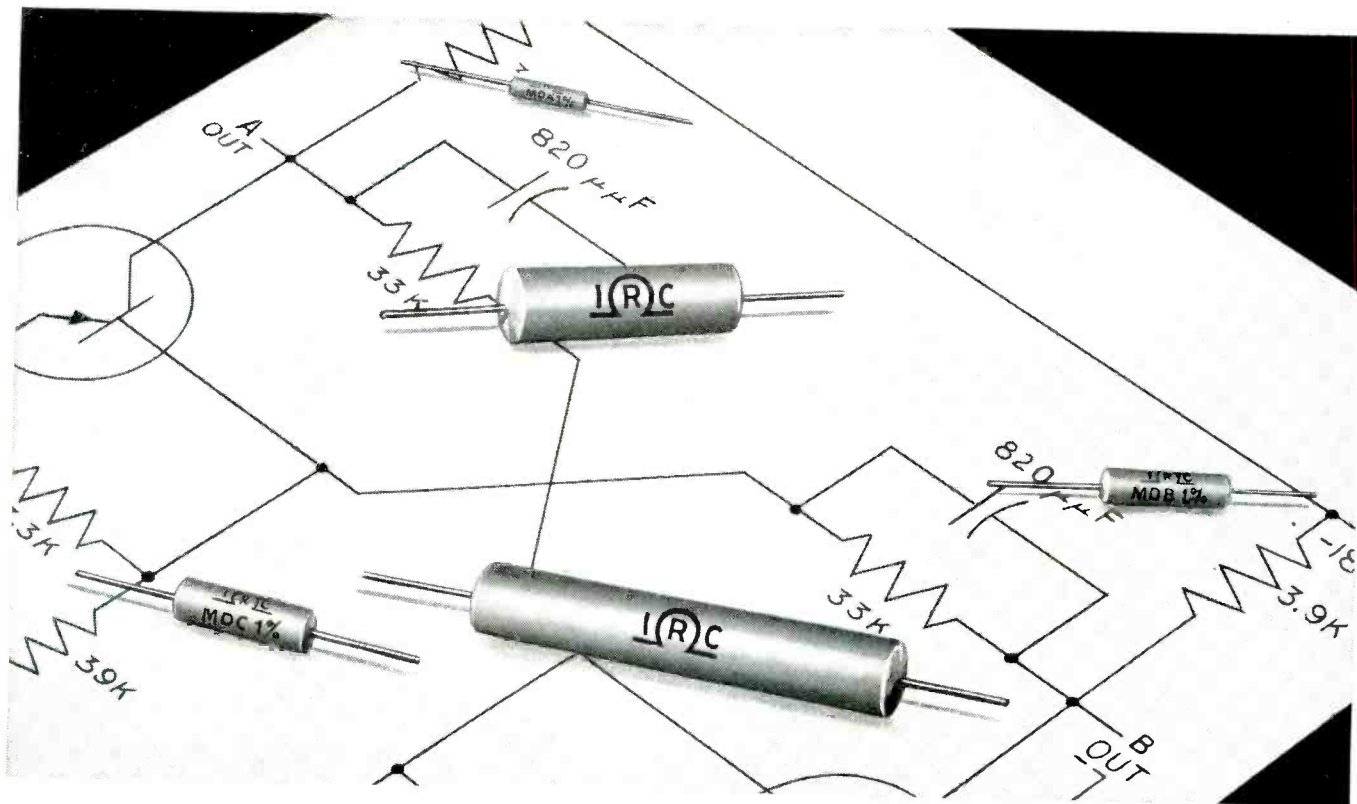

WHY SPECIFY 1 WATT WHEN YOU NEED 1/2 WATT?

Use **IRC**[®] Deposited and Boron Carbon Resistors





Now you can save two ways whenever circuits call for high precision resistors with long term stability and built-in overload protection. IRC Molded Deposited and Boron Carbon Resistors can withstand substantial overloads for considerable periods without exceeding tolerances. This means savings in *space, weight and cost!* The conservative rating of these units assures you of reliability—no need to specify larger resistors.

Announcing a new high-range process featuring stability! With a unit as small as IRC's 1/2 watt Deposited Carbon Resistor, you can cover a resistance range from 10 ohms up to *25 megohms*. With IRC's 2 watt resistor, you can go from 15 ohms as high as *100 megohms*.

If you want the same span of resistance ranges, plus better load life characteristics and greater

resistance to moisture and mechanical damage, you can specify *molded* types in sizes that meet MIL specs for automation equipment. These molded units are now available in 5 ratings—1/8 watt, 1/4 watt, 1/2 watt, 1 watt, and 2 watts. For extremely low temperature coefficients, use IRC Boron Carbon Resistors. Send the coupon today.

RESISTANCES FROM 10 OHMS TO 100 MEGOHMS

Deposited Carbon Resistors	
 Unmolded (1/2, 1 and 2 watts)	 Molded (1/8, 1/4, 1/2, 1 and 2 watts)
Boron Carbon Resistors	
 Unmolded (1/2, 1 and 2 watts)	 Molded (1/8, 1/4, 1/2, 1 and 2 watts)

Insulated Composition Resistors • Deposited and Boron Carbon Resistors • Power Resistors • Voltmeter Multipliers • Ultra HF and Hi-Voltage Resistors.

Wherever the Circuit Says

Low Voltage Wire Wounds • Resistance Strips and Discs • Selenium Rectifiers and Diodes • Hermetic Sealing Terminals • Insulated Chokes • Precision Wire Wounds.



INTERNATIONAL RESISTANCE CO.

Dept. 231, 401 N. Broad St., Phila. 8, Pa.

In Canada: International Resistance Co., Ltd., Toronto, Licensee

Send bulletins describing Deposited Carbons Molded Deposited Carbons Boron Carbons Molded Boron Carbons.

NAME _____

COMPANY _____

ADDRESS _____

CITY _____ STATE _____

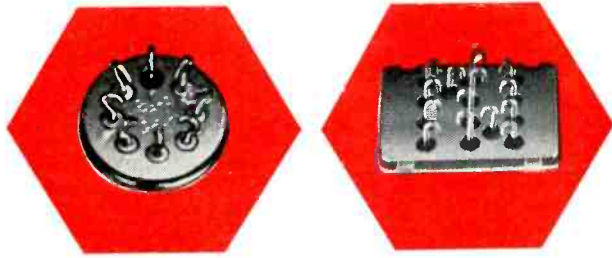

Constantin

**ENGINEERED
GLASS-TO-METAL
SEALS**

seal failure out . . .

seal reliability in

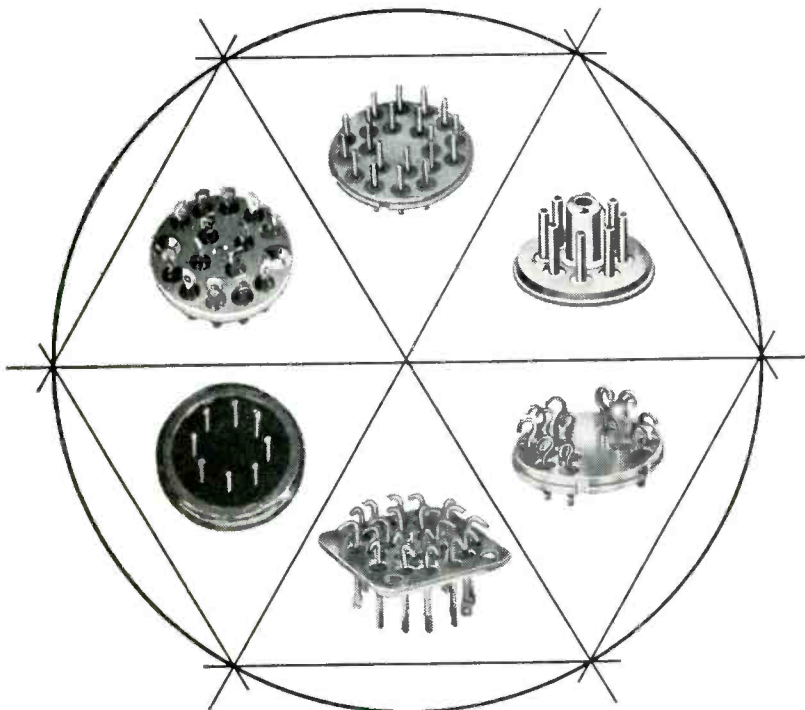

Constantin glass-to-metal seals improve component performance because they are impervious to sub-zero conditions, high pressure, oils, swamp test, compounds, most chemicals, corrosion, salt water immersion, and spray . . . withstand temperature cycling and vibration conditions . . . assure superior performance because of meticulous engineering.

Constantin has available for you a complete, quality line of precision multi-headers — transistor mounts and covers — end seals — single headers — crystal holders — connectors — terminals — electro-mechanical assemblies. Where a standard item cannot be used, Constantin will custom-engineer an exact unit for your particular requirement.

Write today for complete technical data about all Constantin products.

"QUALITY WITH CONFIDENCE"

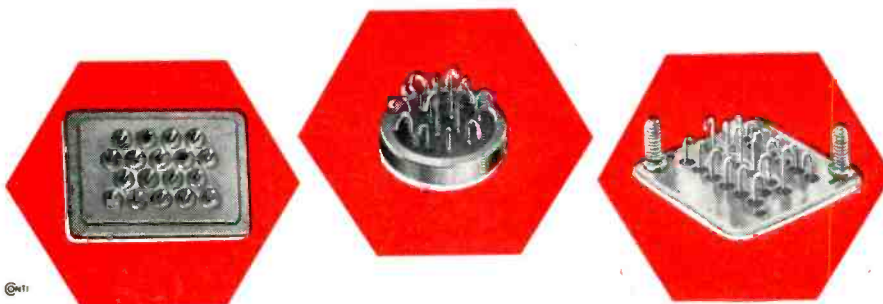

©1957



L.L. Constantin & Co.

**MANUFACTURING
ENGINEERS**

Route 46, Lodi, N. J. • 187 Sargeant Ave., Clifton, N. J.

TRANSISTOR MOUNTS • SINGLE TERMINALS • COMPRESSION HEADERS • END SEALS • CRYSTAL BASES • CONNECTORS • MINIATURIZATION

DYNAMICS OF GROWTH

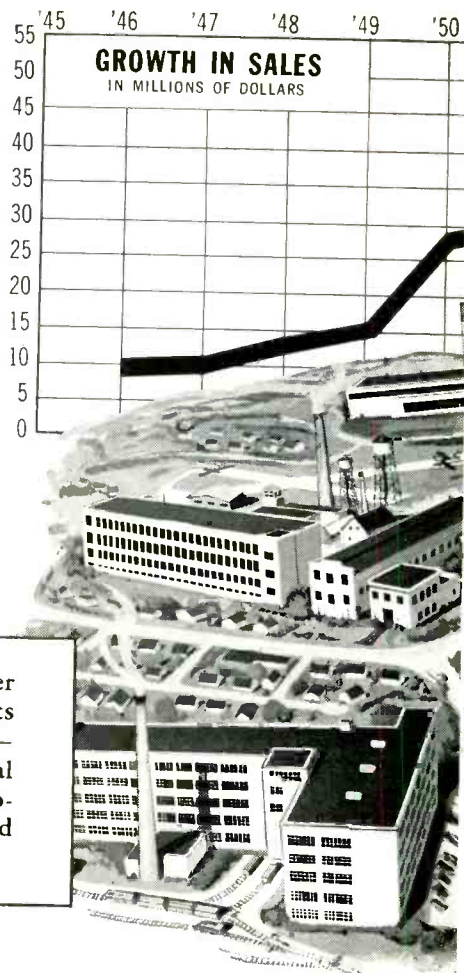

If you want to know the future—of this or any other company—look beyond mere size and tangible assets—into its *background*. Look for accomplishments—experience—reliability—*ability*. These are the real and vital substances that generate the drive and momentum that produce growth in a competitive and changing world.

Resourceful Foot in Big Door

Half a century ago, Tung-Sol people developed the first successful electric automotive headlamp, introduced on the Stoddard-Dayton car of 1907. This was a carbon-filament lamp, crude and fragile by today's standards. But it brought business from other motor car manufacturers as well . . . and it brought *experience*, so that a year or two later, when tungsten first was used for lamp filaments. Tung-Sol was well on its way to a position of leadership among suppliers of components to a growing industry that promised to become a giant.

Find-How and Know-How

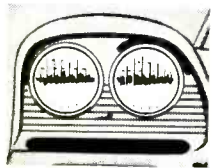

Next, in 1913, Tung-Sol developed a two-filament headlamp, "Tulite", the first to combine high and low beams in a single bulb. With it was won the business of Ford and other prodigiously growing motor car makers.

Growth put increased emphasis on research and development. First, to improve the product . . . to make the lamps themselves better and more dependable. Second, to improve the techniques of manufacturing lamps in ever-increasing quantities, to closer tolerances and more exacting standards of uniformity—and to do these things while constantly improving production economy. And today, these experiences—these assets—have been pooled with the auto lamp industry to perfect the new 4-headlamp lighting system you will see on all cars in the future.

The Capitalized Break

In the mid-1930's, Tung-Sol brought out a flashing tail-light—"Winx"—intended to signal "stop" when a motorist applied his brakes. But its flashing feature soon evolved into the familiar flasher that actuates direction signals and for which Tung-Sol is the industry's major supplier.



Off the Deep End—and Up Swimming

Making lamps involves many technologies—glass—metallurgy—vacuums—skills at which Tung-Sol is master after 53 years of successful doing.

This widely recognized expertness led to Tung-Sol being literally drawn by demand into the manufacture of electron tubes, beginning in the 1920's.

Once in the electronics field, Tung-Sol applied to tubes its basic company policy—"make the best that can be made."



From a primitive electronics engineering nucleus has grown a research-and-development staff of the very first order—still building, both in scientific standing and in numbers, as new accomplishments serve only to present new challenges.

Pioneers in Quality Control

There is a second policy to which Tung-Sol has firmly adhered—that of making components—tubes for set and equipment manufacturers, but not the sets or equipment.

This allowed Tung-Sol to concentrate on *tube* engineering and manufacturing, with emphasis always on quantity production to standards of performance as rigid as those of a research laboratory, yet with absolute uniformity in whatever quantity, and with the reliability demanded by increasingly important uses—particularly those of a nation at war.

Outstandingly important in this responsibility was the development of statistical quality control—a new kind of applied science in which Tung-Sol had early become—and still is—a recognized leader.

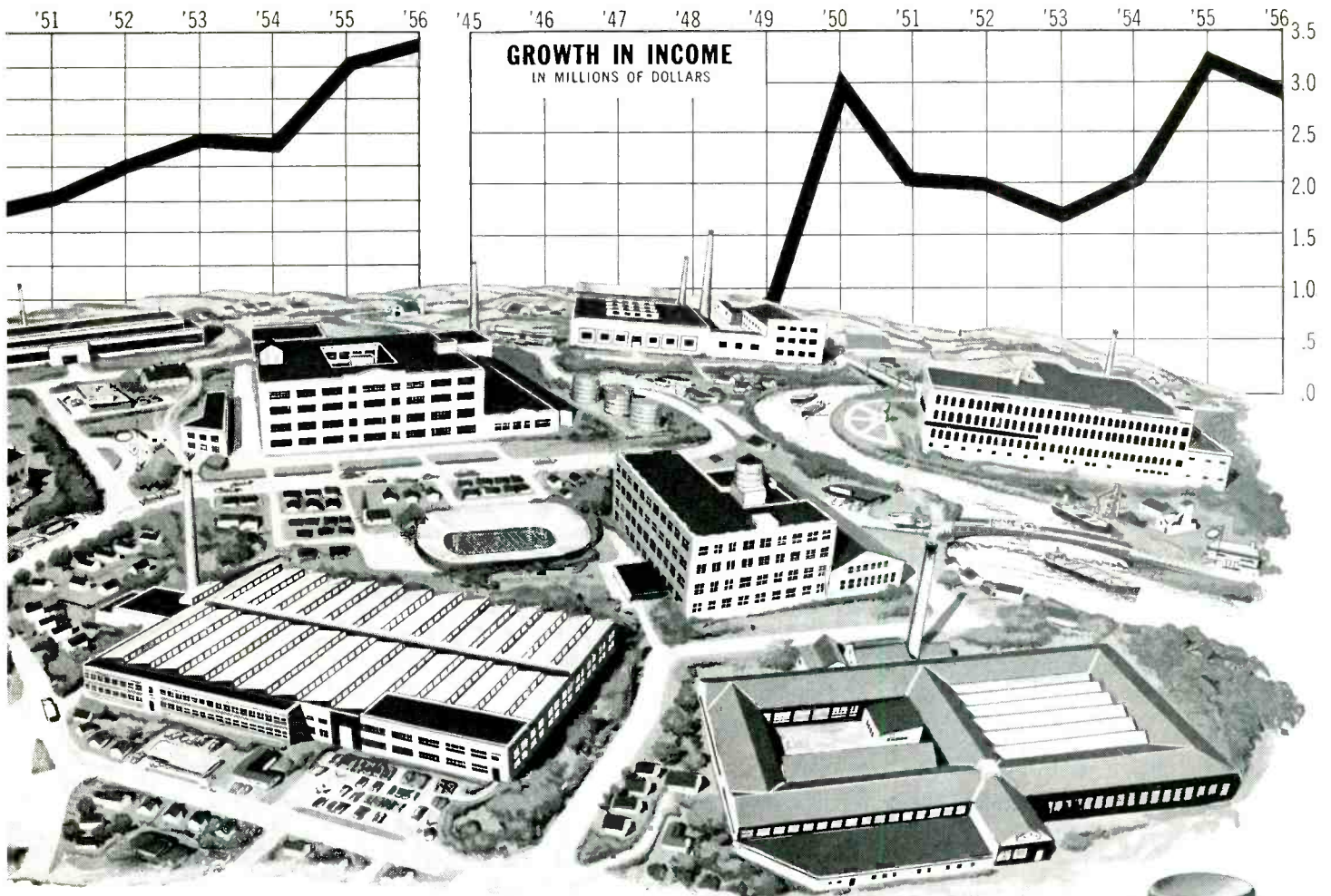

Sharp Sword to Profitable Plowshare

This, among other achievements under pressure, brought its rewards when World War II ended, and the marvels of electronics were turned to everyday uses—as in television and high-fidelity reproduction of music—or to striking new scientific and industrial advances—electronic computers and the automation of production machinery.

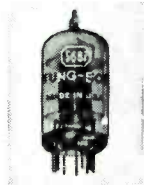

Today, Tung-Sol ranks among the largest suppliers of electron tubes—radio and TV tubes for the makers of receiving sets—for replacement by service dealers—and of many special types required by makers of the elaborate electronic devices that serve manufacturing, transportation, communication and applied science.

Transition to Transistors

Initial steps to the use of semiconductors have been through the development of so-called "hybrid" equipment designed to utilize the best characteristics of both tubes and transistors. Tung-Sol engineering produced the first successful power amplifier tube to operate directly from a 12-volt automobile battery. This tube, the 12K5, filled an enormous gap in the hybrid auto radio design. It is the first practical use of the "space charge grid" principle and has created a new tube classification extremely useful



for many low-voltage driving, switching and control applications.

In the field of "semiconductor" products, Tung-Sol research and development has been working for years, along with the rest of the industry, to perfect the design of these tiny, compact, low-current-consumption units. But more than that, Tung-Sol has been concerned with the perfection of techniques to *manufacture* semiconductors the way it does electron tubes: in large volume, with absolute uniformity, with unsurpassed dependability. You can confidently expect, therefore, that Tung-Sol will be as prominent a factor in the supply of transistors and related semiconductor devices for electronic equipment as it now is in the making of electron tubes.

The Tung-Sol of today is nine busy plants in seven cities, employing 6500 people and covering the nation with five divisional offices and a network of independent wholesale and retail distribution—to serve our nation's two greatest industries—automotive and electronics.

 **TUNG-SOL[®]**

TUNG-SOL ELECTRIC INC., Newark 4 N. J. Sales Offices: Atlanta, Ga.; Columbus, Ohio; Culver City, Calif.; Dallas, Texas; Denver, Colo.; Detroit, Mich.; Irvington, N. J.; Melrose Park, Ill.; Newark, N. J.; Philadelphia, Pa.; Seattle, Wash.; Canada: Montreal, P. Q.

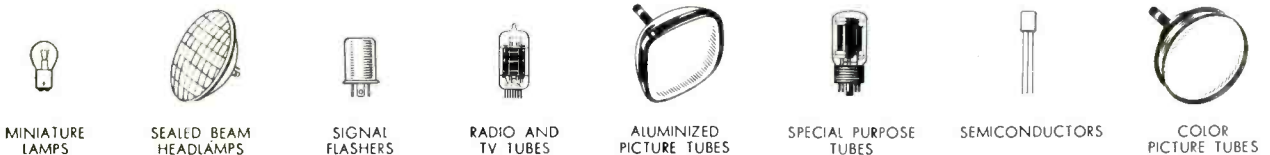

MINIATURE LAMPS

SEALED BEAM HEADLAMPS

SIGNAL FLASHERS

RADIO AND TV TUBES

ALUMINIZED PICTURE TUBES

SPECIAL PURPOSE TUBES

SEMICONDUCTORS

COLOR PICTURE TUBES

Engineers wanted for this assignment:

DESIGN MISSILES FOR MEN

That is the bold objective of the men who engineered and built the Mustangs, Sabres and Super Sabres. Today their mental altimeters are in the stratosphere... their pulse count in Mach numbers. And the airplanes emerging from this new engineering metabolism are veritable missiles in speed and altitude, yet they must house and protect a human pilot in the midst of otherwise fatal phenomena.

Today's aircraft engineer must overcome an atmosphere that ranges from bone-freezing cold to blood-boiling heat... speeds where shock-wave drag and aerodynamic heating demand a bold new approach in design, materials and production techniques.

He is asked to add strength and power—yet cut weight... solve flutter in theory, *and* with a producible design... provide controls that make his vehicle a stable weapons platform even when flying at supersonic speeds.

Finally, his brainchild must graduate from preliminary design and wind tunnel to prove itself both in the air and on the production line. If it fails—*he* has failed.

In this realm of both unknowns and stark reality, engineering is no job for the timid or the easily discouraged or the fellow looking for a soft berth.

A COMPANY WORTHY OF THE GOAL. Engineers have consistently guided the long-range technical advancement of North American Aviation. Newness and progress here are SOP. Some of the longest necks in the industry are on our engineering team. They've been sticking out into the future of aviation for years.

IF YOU'D LIKE TO STICK YOUR NECK OUT... we promise you a management climate that stimulates personal growth—and rewards it with professional and material benefits that are limited only by your own ability.

Write today for full particulars to: Mr. T. J. Wescombe, Engineering Personnel Manager, Dept. 1-E, North American Aviation, Inc., Los Angeles 45, California.

ADVANCEMENT IS RAPID WHERE GROWTH IS RAPID



In 1943, AARON KOLOM graduated from the Illinois Institute of Technology with a B.S.M.E., a scholastic Honor Man in all departments. At North American his first position was in the Structures Section. He was appointed Supervisor of Wing Structures in 1951. With the help of North American's Educational Refund Plan, he received his M.S.A.E. in 1952. And last March, Aaron was promoted to Assistant Project Engineer.



BILL McLEAN obtained his Bachelor of Science degree in Electrical Engineering at Wayne University in 1950. He received his Master's Degree at the University of Southern California in 1951. He began his engineering career at North American Aviation as a Research Analyst in the Servomechanisms Group. Now, five promotions later, Bill is a Group Leader in charge of the Systems Simulation Section.



NORTH AMERICAN AVIATION, INC.

NORTH AMERICAN HAS BUILT MORE AIRPLANES THAN ANY OTHER COMPANY IN THE WORLD



Skilled engineers—plus efficient production methods and modern facilities are available at

DAYSTROM INSTRUMENT

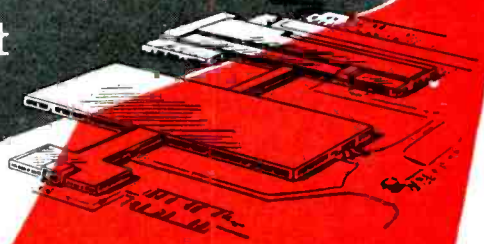

Engineers and production facilities at Daystrom Instrument continue to play an increasingly important role in the needs of the Armed Forces and Industry. Daystrom products contribute sound design and dependable performance to meet today's critical standards. Yes, you can depend on Daystrom for a quality product, on time, at a reasonable cost.



for the NAVY

Fire Control Systems, Mine Detecting Devices, Attack Directors, Catapult Speed Indicators, Servo Control Systems, Torpedo Assemblies, Training Devices.



for the AIR FORCE

Capacitance Testers, All-Attitude Servo Indicators, Transistorized Receivers, RF Switches, Pilot's Dead Reckoning Indicators, Missile Test Equipment, Jet Engine Components and Assemblies.



for the ARMY

Fire Control Systems, Fuzes, Communication Systems.



for INDUSTRY

Test Equipment, Radar Equipment, Nuclear Instrumentation, Electronic and Electro-Mechanical Devices, Sheet Metal Cabinets, Precision Gearing.

DAYSTROM

INSTRUMENT

Division of Daystrom, Inc.
ARCHBALD, PENNA.

OTHER DAYSTROM OPERATING UNITS:

Daystrom Electric Corporation • Daystrom International Division • Daystrom Nuclear Division • Daystrom Pacific Corporation • Daystrom Systems Division • Heath Company • Weston Electrical Instrument Corporation • Daystrom Furniture Division

tally ho...
bogey
sighted!



PHOTO COURTESY: NORTH AMERICAN AVIATION INC.

Three Genisco Accelerometers help the Super Sabre close in

If enemy air infiltration happens, you can be sure that modern knights of the sky powering the swift *Super Sabre* at speeds faster than sound will spearhead America's defense.

Typical of today's supersonic aeronautics, the USAF's *Super Sabre* reflects the finest contemporary engineering skill and scientific creative imagination. But this swept-wing assassin is more than just another jet-powered plane. It is a proven, integrated electro-mechanical system, combining a multitude of precision sub-systems, assemblies, and individual parts.

The automatic flight control system, for example, consists of numerous components, each one vital to the performance of the system. Naturally, component reliability is imperative if the plane is to carry out its

mission. The flight control system of the F100D incorporates three Genisco Model DDL Accelerometers.

The Model DDL is only one of many Genisco Accelerometers now in use on America's air guardians, including our most important operational guided missiles. Like other models, the DDL was designed for a particular application—to function perfectly in the severe vibrational and shock environment of supersonic flight.

Genisco's ability to design for the most stringent applications and to produce precision instruments in large quantities has made the company an important link in our nation's defense chain.

Descriptive technical data on the Model DDL and other Genisco accelerometers will be sent upon request.

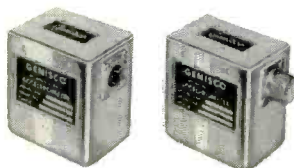

2233 Federal Avenue, Los Angeles 64, California

out of the

e a r t h

— COME THE *new Astron* TYPE AP CAPACITORS IN SUPER-TIGHT STEATITE CONSTRUCTION

Astron enlists a Billion-year-old principle — mechanical fusion — to create a rock-like physical barrier against *all* environmental conditions. New Type AP Paper Tubulars combine a tough Steatite case with cement compound end-seals, forming a completely impregnable shield against heat and moisture — truly impregnable because Steatite is one of nature's *most effective insulators*.

Designed specifically for *economy applications*, Type AP Tubulars fill electronic equipment manufacturers' needs for high performance capacitors at *competitive* prices. These non-inductive, precision-wound paper tubulars operate continuously with exceptionally long life at 85°C, their leads locked securely in place by non-melting end-seals. Special production techniques and meticulously controlled processes assure long shelf life and minimum capacitance change over a wide operating range (-40°C to +85°C) . . . high insulation resistance . . . small size and weight. The dependable operation of Type AP compares favorably with more expensive molded paper capacitors. They exceed RETMA specifications. Type AP Ceramic Cased Tubulars are backed by the famous Astron guarantee. *Ten* separate production tests and 100% final inspection are your absolute protection against costly rejects.

Want greater performance and economy for your capacitor dollar?
Write for full information about Astron AP Tubulars — Today!

ASTRON
CORPORATION
255 GRANT AVE. NEWARK, N.J.

SKOTTIE ELECTRONICS CORPORATION
QUALITY CERAMIC CAPACITORS
A Wholly owned subsidiary
of ASTRON CORPORATION

he's working for you



THIS FELLOW IS TRAINED IN YOUR BUSINESS. His main duty is to travel the country — and world — penetrating the plants, laboratories and management councils . . . reporting back to you every significant innovation in technology, selling tactics, management strategy. He functions as your all-seeing, all-hearing, all-reporting business communications system.

THE MAN WE MEAN IS A COMPOSITE of the editorial staff of this magazine. For, obviously, no one individual could ever accomplish such a vast business news job. It's the result of many qualified men of diversified and specialized talents.

AND, THERE'S ANOTHER SIDE TO THIS "COMPOSITE MAN," another complete news service which complements the editorial section of this magazine — the advertising pages. It's been said that in a business publication the editorial pages tell "how they do it"—"they" being all the industry's front line of innovators and improvers — and the advertising pages tell "with what." Each issue unfolds an industrial exposition before you—giving a ready panorama of up-to-date tools, materials, equipment.

SUCH A "MAN" IS ON YOUR PAYROLL. Be sure to "listen" regularly and carefully to the practical business information he gathers.



McGRAW-HILL PUBLICATIONS

EHF MICROWAVE GENERATORS AND SOURCES

18,000 to 50,000 mc

with

PLUG-IN TUNING UNITS

Now, with the Polarad plug-in interchangeable tuning unit feature you can equip your laboratory with Extremely High Frequency generators and sources covering 18,000 to 50,000 mc permitting wide flexibility of operation at minimum cost. Each of the various tuning units requires no further adjustment after plug-in — all voltages and controls are automatically set for proposed operation.

These new Polarad self-contained instruments operate simply with direct reading, wavemeter dials. They provide cw or modulated signals of known frequency for field, production line and laboratory testing of microwave equipment, components and systems.

Write to Polarad or your nearest representative for complete information.

EHF Microwave Signal GENERATORS

- 7 plug-in r-f tuning units cover the frequency range from 18,000 to 39,700 mc.
- Direct-reading calibrated attenuator output, accuracy ± 2 db.
- Frequency calibration accomplished by a $\pm 0.1\%$ direct-reading wavemeter.
- Internal 1000 cps square-wave modulation.
- Capable of external modulation, both pulse and fm.
- Equipped with integral electronically-regulated power supplies.

EHF Microwave Signal SOURCES

- 9 plug-in r-f tuning units cover the frequency range from 18,000 to 50,000 mc.
- Internal 1000 cps square-wave modulation.
- Capable of external modulation, both pulse and fm.
- Equipped with integral electronically-regulated power supplies.
- Frequency calibration accomplished by a $\pm 0.1\%$ direct-reading wavemeter.



SIGNAL GENERATORS Basic Unit Model HU-2		FREQUENCY RANGE	SIGNAL SOURCES Basic Unit Model HU-1	
Plug-In Tuning Unit Model No.	Power Output Calibrated		Plug-In Tuning Unit Model No.	Power Output Average
G1822	-10 to -90 dbm	18,000 — 22,000 mc	S1822	10 mw
G2225		22,000 — 25,000 mc	S2225	10 mw
G2427		24,700 — 27,500 mc	S2427	10 mw
G2730		27,270 — 30,000 mc	S2730	10 mw
G3033		29,700 — 33,520 mc	S3033	10 mw
G3336		33,520 — 36,250 mc	S3336	9 mw
G3540		35,100 — 39,700 mc	S3540	5 mw
		37,100 — 42,600 mc	S3742	Approx. 3 mw
		41,700 — 50,000 mc	S4150	Approx. 3 mw

Model SG-1218, Signal Generator and Model SS-1218 Signal Source are available to cover the frequency range 12,400 to 17,500 mc.

MODULATION:

Internal modulating:

Frequency 1000 cps square wave.

Requirements for external pulse modulation:

Pulse repetition frequency..... 100 to 10,000 pps.
Pulse width rate..... 0.5 to 10 microseconds.
Pulse amplitude..... 10 volts peak, minimum
Pulse polarity..... Positive.

Requirements for external frequency modulation:

Waveform Sawtooth or sine wave.
Frequency 50 to 10,000 cps.
Amplitude Approx. 10 volts rms, to produce 40 mc deviation.



ELECTRONICS CORPORATION
43-20 34th Street, Long Island City 1, N. Y.

Reliable maintenance service throughout the country is an important part of the Polarad instrument.



REPRESENTATIVES: Albuquerque, Atlanta, Baltimore, Boston, Buffalo, Chicago, Cleveland, Dayton, Denver, Fort Worth, Kansas City, Los Angeles, New York, Philadelphia, Portland, St. Louis, San Francisco, Schenectady, Syracuse, Washington, D. C., Winston-Salem, Canada; Arnprior, Ontario. Resident Representatives in Principal Foreign Cities

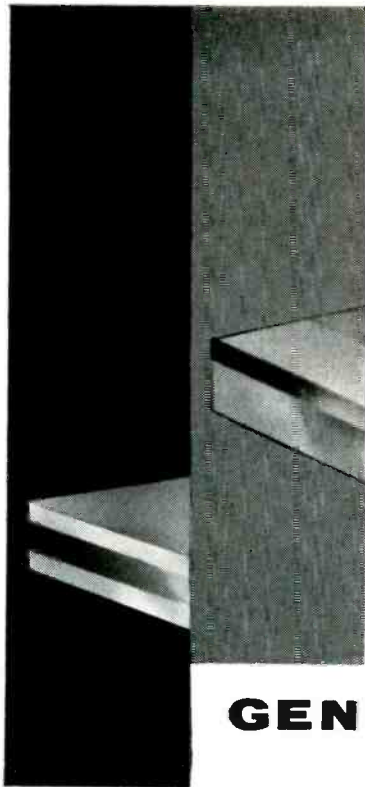

TWO METALS

are often better than one...

and

GENERAL PLATE Clad metals

for electronic uses are a case in point

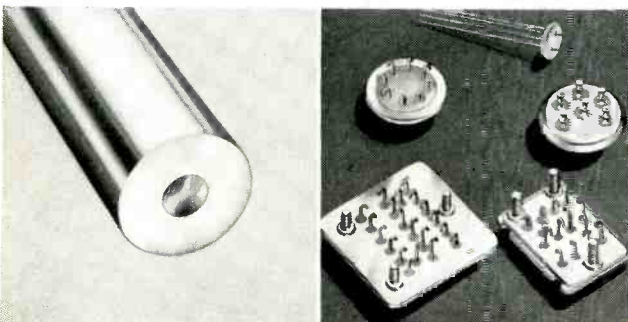
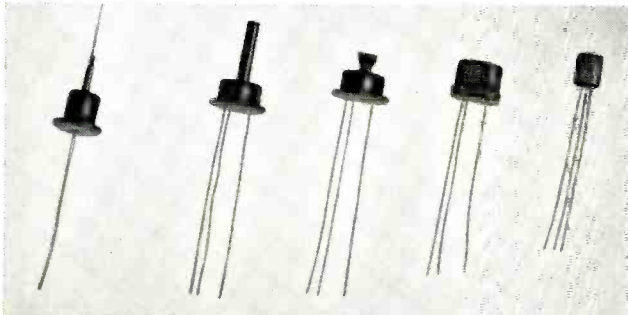
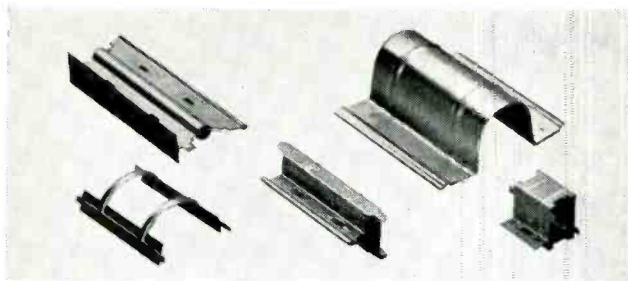

Consider General Plate ALIRON®, ALNIFER®, and NIFER®, all preferred materials for vacuum tube plates. Offering improved performance with attractive cost savings, these General Plate Clad Metals are supplied in annealed coils ready to feed through your production tools. They form beautifully, conserving critical materials and producing more parts per pound. ALIRON and ALNIFER require no carbonizing — the matte finished aluminum blackens evenly during bombardment to provide a highly efficient radiating surface. For full details, write for Technical Data Bulletin 717C.

Or consider General Plate TIN CLAD NICKEL. Here's an improved material for transistor cradle supports. The layer of pure tin is unvarying in thickness and is bonded to a pure electronic grade nickel backing so completely that voids and contaminating inclusions are eliminated. This means perfect wetting during your transistor soldering operations — top transistor performance every time — lower soldering costs too! For full details, write for Technical Data Bulletin 708.

Or look to General Plate COPPER CORED 52 ALLOY WIRE for better glass-to-metal seals. With a 30% copper core you'll get up to three times the electrical and thermal conductivity over solid lead wires of the same size — or you can cut your solid lead wire sizes correspondingly, without reducing electrical ratings by using General Plate Copper Cored 52 Alloy Wire, and take a big step toward miniaturization in sealed terminal blocks and hermetic headers. For full details, write for Technical Data Bulletin 706.

To get the whole General Plate Clad Metal Story, write for our new general catalog, PR-700A, covering many other combinations in both base and precious clad metals — composite electrical contacts — TRUFLEX Thermostat Metals.

Metals & Controls

Corporation

GENERAL PLATE DIVISION

1301 FOREST STREET, ATTLEBORO, MASS.

You can profit by
using General Plate
Clad Metals

AVAILABLE IN PRODUCTION
QUANTITIES



NIXIE

Newest **STAR IN THE
ELECTRONIC GALAXY**

SOME TYPICAL NIXIE APPLICATIONS

1. INDUSTRIAL CONTROL
2. INSTRUMENTATION
3. COUNTERS
4. COMPUTERS
5. MILITARY ELECTRONIC INDICATORS
6. CHANNEL INDICATOR
7. INDICATOR BOARDS
8. DIGITAL VOLTMETERS
9. PAGING SYSTEMS
10. ELEVATORS
11. RADAR

BURROUGHS' 10 DIGIT IN-LINE NUMERICAL INDICATOR!

This small, electronic indicating tube has been human-engineered to give high readability from a wide angle. Direct readout method clearly selects and displays any one of its ten digits electronically . . . reliable, reduces errors, cuts costs in hundreds of diversified applications.

NOTE THESE OUTSTANDING ADVANTAGES:

- 1" x 1"
- Small, simple plug-in tube
- Uses standard sockets
- Vivid numbers for highest visibility
- Lowest power required (¼ watt)
- Uniform Glow
- Operates directly off Beam Switching Tubes or any voltage source
- Radical Simplification of circuitry
- Long life
- Rugged construction

Write to Electronic Tube Division, Burroughs Corporation, Plainfield, N. J. for complete information on your applications.



LOWEST COST INLINE ELECTRONIC INDICATOR

TUBE TYPE 6844 (HB-106)

Electronic Tube Division

BURROUGHS CORPORATION

Plainfield, New Jersey

Microwave Frequency Meters by FREQUENCY STANDARDS



In offering these frequency meters we have endeavored to bring to the electronics industry instruments for frequency measurement which are fairly priced yet without sacrificing a high degree of accuracy resulting from precision manufacture. The frequency determining element of these instruments is a cylindrical resonator with a tuneable choke plunger that provides a smooth and accurate interpolation of frequency. Four models are offered, each model covering a wide frequency range and employing standard waveguide and flanges. Three types, described below, are offered in each frequency range. All models have been designed to use the standard FS Model M-1000 Micrometer Head which has been widely accepted by the electronics industry. Construction is of Invar and accuracy is .01% under laboratory conditions.

Three Types Available

WAVEGUIDE ABSORPTION TYPE I cavity is mounted on the broad face of waveguide. The transmission indication is secured by a crystal loop monitor located opposite the iris input coupling hole. (Type illustrated)

WAVEGUIDE FEED TYPE II cavity is mounted as the termination of a short section of waveguide. The cavity body and output coupling loop are the same as Type I.

WAVEGUIDE TRANSMISSION TYPE III cavity is the same as Types I and II but waveguide is used for input and output coupling.

DESCRIPTIVE LITERATURE AVAILABLE ON REQUEST

TYPE	FREQUENCY RANGE	WAVEGUIDE
Models 8211— 3	8200 to 11500 MC	RG-52/U
Models 7010— 3	7000 to 10000 MC	RG-51/U
Models 5882—1, 2, 3	5800 to 8200 MC	RG-50/U
Models 4458—1, 2, 3	4400 to 5800 MC	RG-49/U

Frequency Standards
General Offices: ASBURY PARK, NEW JERSEY

Address inquiries to
BOX 504



CORES



UNLIMITED



Name it if it's a **Ferrite**, a **Magnetic Iron Core**, a **Molded Coil Form** (Iron and phenolic) or an **E. E. Core**. MOLDITE makes it and MOLDITE is your one consistently dependable source.

MOLDITE continues to pioneer with new methods and techniques closely related to automation in manufacturing stud and studless powdered iron cores. This will enable MOLDITE to produce faster, better and cheaper.

In addition, color TV is finding MOLDITE in the forefront with highly specialized equipment built and designed by MOLDITE engineers for both quality and quantity production.

Truly MOLDITE means Cores Unlimited for unlimited electronic applications today . . . tomorrow!

Send for our Catalog 120

NATIONAL MOLDITE COMPANY

1410
CHESTNUT AVE.,
HILLSIDE 3, N. J.

IRON CORES • FERRITES • MOLDED COIL FORMS • E E CORES

Robert T. Murray Co.
604 Central Avenue
East Orange, N. J.

William A. Franklin
3 Holly Road
North Syracuse, N. Y.

Jerry Gotten Co.
2750 W. North Ave.
Chicago 22, Ill.

Engineering Services Co.
4550 Main St.
Kansas City, Mo.

Perlmuth Electronics Assoc.
2419 South Grand Ave.
Los Angeles, Cal.

John S. Plewes Co.
52 Humbercrest Blvd.
Toronto 9, Ontario

Jose Luis Ponte
Cardoba 1472
Buenos Aires

This **NEW** Magnetic Counter is **EASY** to Reset...

*Except
when it's
Locked!*



Added Evidence
that —

Everyone Can Count on **VEEDER-ROOT**

Designed for panel mounting where remote indication is required, this electrically operated counter is a compact package 5.5" long, 2.1" wide, 2.7" high. Capacity: 1,000 counts per minute. Power consumption, 8 watts. Stocked in 110 and 220 AC and DC. Easy to reset, except when locked . . . then the sturdy tumbler-lock* puts the damper on tampering. Yet one

turn of the key resets all 6 figures to zeros.

This new Magnetic Counter is one of the thousands of Veeder-Root standard and special counters . . . electrically, mechanically and manually operated . . . in daily use throughout the world in industry, business, science and medicine. You, too, can count on Veeder-Root . . . to help you count anything you need.

*National Lock Co. Lock No. 68-4837; Key D-428

Stocked at
Hartford 2, Conn. • New York 19, N. Y.
Greenville, S. C. • Chicago 6, Ill.
Montreal 2, Canada
Offices and Agents in Principal Cities



VEEDER-ROOT
"THE NAME THAT COUNTS"

NOW

2

different methods

FOR

2

different requirements

AEROVOX PRINTED WIRING

You are now offered the choice of TWO different printed-wiring methods: (1) The Aerovox exclusive **Pressed Silver** or (2) The Aerovox **Etched Copper**. Each has its particular field of applications.

Furthermore, Aerovox also offers a choice of different base materials, such as: Phenolic-paper Base, Phenolic Fabric, Epoxy Glass, Melamine Glass, Teflon Glass, Polystyrene and Methacrylite, each with certain characteristics for given usages.

PRESSED SILVER

Produced by a hot die-stamp process in which the conducting pattern is mechanically embossed in one or both sides of the selected base material. Does not rely on any adhesive agent for the bond between conductive and base materials. Pure silver conductors are partially imbedded in base support. Compared with copper, the silver is more resistant to oxidation, solders more readily, and provides superior electrical contact surface with greater resistance to wear, particularly for switching applications.

ETCHED COPPER

Produced by applying an etch-resistant pattern on to a metal foil, usually copper clad. Unprotected metal areas of printed pattern are then etched away leaving desired wiring pattern. The resistant enamels may be applied by (a) Direct photographic means, or (b) Screen printing. The former achieves maximum definition of lines held to close tolerances at relatively modest costs; the latter effects cost savings where extremely fine detail is of secondary importance.

PRINTED WIRING PRIMER . . .

Write on your business stationery for this practical guide on printed wiring. And let our printed wiring specialists collaborate on your particular applications.



AEROVOX CORPORATION

**SPECIAL PRODUCTS DIVISION
NEW BEDFORD, MASSACHUSETTS**

In Canada: **AEROVOX CANADA LTD., Hamilton, Ont.**

they look alike...

and they are alike!

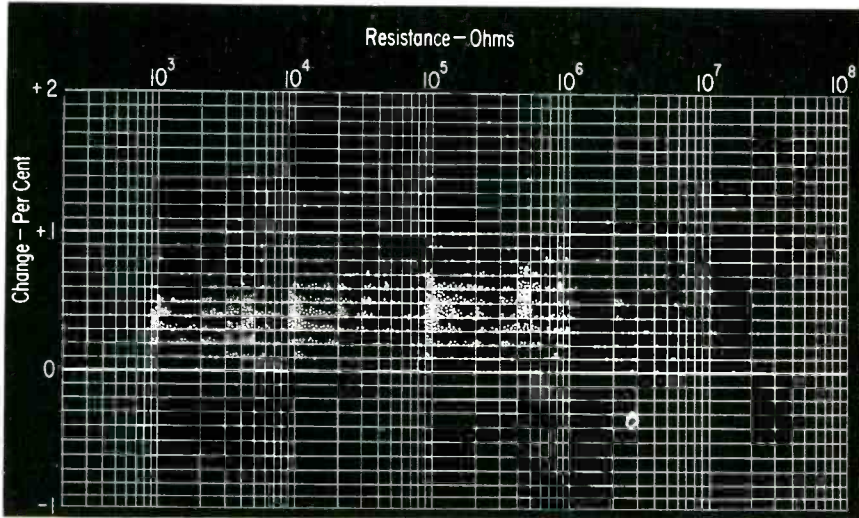

Average resistance change (%) after temperature tests (5 cycles from -55°C to 85°C) on samples from over two billion Allen-Bradley 1/2 watt resistors.

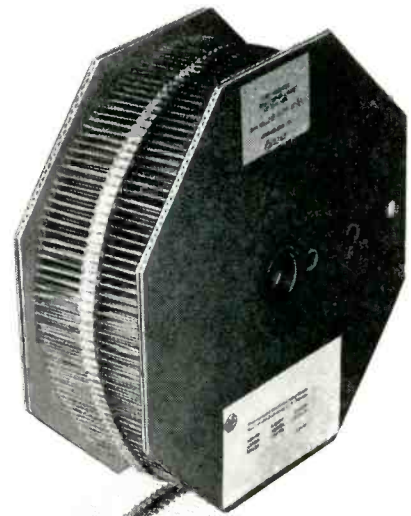

Allen-Bradley fixed resistors are available in 1/10, 1/2, 1, and 2 watt sizes, in all standard RETMA resistance values.

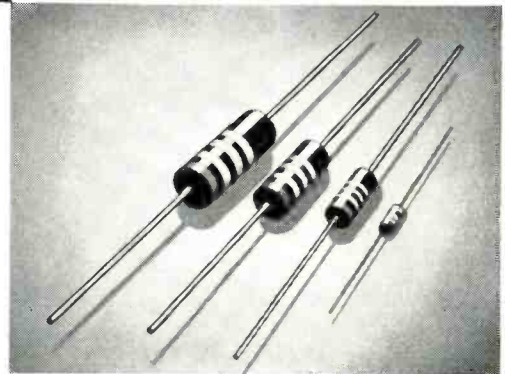

ALLEN-BRADLEY molded composition RESISTORS

They look as alike as peas in a pod—but actually they are far more uniform! Resistance readings taken before and after five complete cycles from -55°C to 85°C showed an average resistance change of about 1/2 of 1%. The maximum resistance change—as indicated on the chart—was below 2%, with the majority of the units registering below 1% change. The chart is a six year record—covering 1248 tests of samples from production runs totaling over two billion resistors. This is only one of many tests to which Allen-Bradley resistors are subjected—to keep "tab" on their quality and uniformity.

This uniformity and stability is the reason that Allen-Bradley fixed resistors are the *quality standard* of the electronics industry.

Allen-Bradley Co., 110 W. Greenfield Ave., Milwaukee 4, Wis.
In Canada—Allen-Bradley Canada Limited, Galt, Ont.

ALLEN-BRADLEY

RADIO, ELECTRONIC, AND TELEVISION COMPONENTS

Here's the big **"PLUS"** for engineers ...

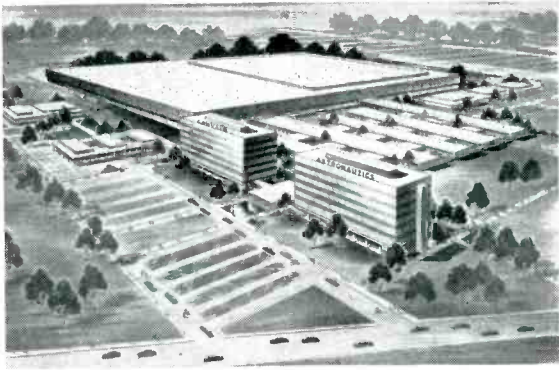

New \$40,000,000 plant for Convair-Astronautics facility, soon to be completed.

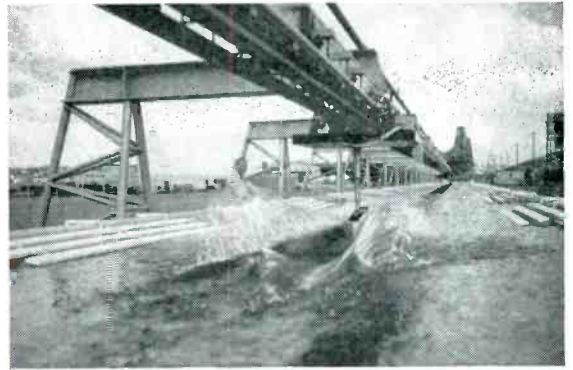

New \$300,000 Convair San Diego seaplane towing tank, first unit of complete hydrodynamics laboratory.

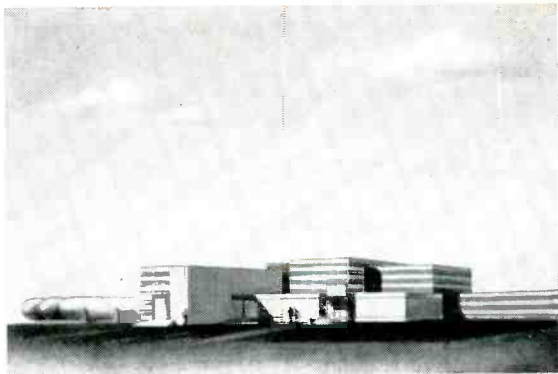

New \$3,500,000 supersonic wind tunnel now under construction at Convair San Diego.



La Jolla Cove, one of many beauty spots within easy reach of San Diego.

the advanced projects and facilities, **PLUS** beautiful, year-round San Diego living

Tremendous projects at Convair San Diego include the F-102A Supersonic Interceptor, the Metropolitan 440 Airliner, the Convair 880 Jet-Liner, and a far-reaching study of nuclear aircraft. To aid engineers in these projects, big new facilities are being added to the already vast Convair San Diego plant. These include a huge installation for research, development, production and testing of the Atlas intercontinental ballistic missile, an elaborate new seaplane towing tank, and a new supersonic wind tunnel.

You'll find an ideal engineering "climate" at Convair San

Diego — excellent salaries, comprehensive personal advantages, engineering policies to stimulate your professional growth, and a rewarding association with men who are outstanding in their engineering fields.

Add to all these the big "plus" of delightful living in sunny San Diego, where America's kindest all-year climate gives you and your family full enjoyment of beaches, mountains, desert resorts, Old Mexico, Hollywood, and many other fun possibilities. For the big "plus" in your future, send full resume to H. T. Brooks, Engineering Personnel, Dept. 925

CONVAIR
C-V **GD**
A DIVISION OF GENERAL DYNAMICS CORPORATION

3302 PACIFIC HIGHWAY • SAN DIEGO, CALIFORNIA

IMPORTANT ACHIEVEMENTS AT JPL



The Analytical Mind and Electronic Computers

The Jet Propulsion Laboratory is a stable research and development center located north of Pasadena in the foothills of the San Gabriel mountains. Covering an 80 acre area and employing 1600 people, it is close to attractive residential areas.

The Laboratory is staffed by the California Institute of Technology and develops its many projects in basic research under contract with the U.S. Government.

Opportunities open to qualified engineers of U.S. citizenship. Inquiries now invited.

The Jet Propulsion Laboratory supports its research and development programs with extensive modern digital and analog computing systems. To this end our computer-equipment staff has made important original contributions in the development of new analog computer components, encoding techniques, and digital data handling equipment including advanced systems for handling the high volume output of supersonic wind tunnels.

Though the computing machines have made dramatic contributions to the Laboratory program, the central figures in this

drama remain the applied mathematicians, engineers, and scientists focusing their analytical minds on the problems of their respective technologies and formulating them for computing machine solutions.

Every technology applying to missile propulsion and guidance is represented on the Laboratory: aerodynamics, guidance, instrumentation, electronics, chemistry of propellants, propulsion systems, design and metallurgy. It is in this setting that applied mathematicians and computer engineers find rich opportunities for growth and achievement in scientific computation.

JOB OPPORTUNITIES
IN THESE FIELDS NOW



COMPUTERS • APPLIED MATHEMATICS • DATA HANDLING • INSTRUMENTATION
APPLIED PHYSICS • TELEMETERING • RADIO AND INERTIAL GUIDANCE
GUIDANCE ANALYSIS • SYSTEMS ANALYSIS • ELECTRO-MECHANICAL
MICROWAVES • PACKAGING • MECHANICAL ENGINEERING

JET PROPULSION LABORATORY

A DIVISION OF CALIFORNIA INSTITUTE OF TECHNOLOGY
PASADENA • CALIFORNIA

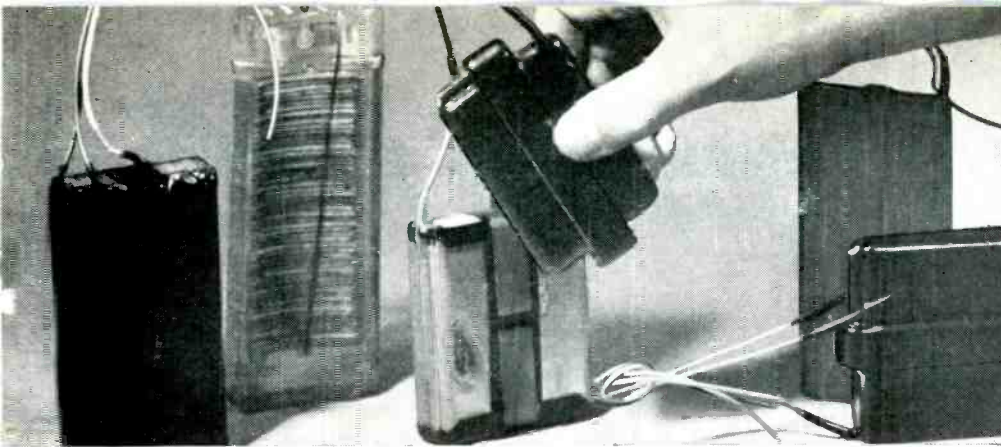

DRY G-E water-activated batteries are made dry, stored dry. Contain no electrolyte to leak or freeze. Demand no maintenance during storage other than normal precaution against moisture.

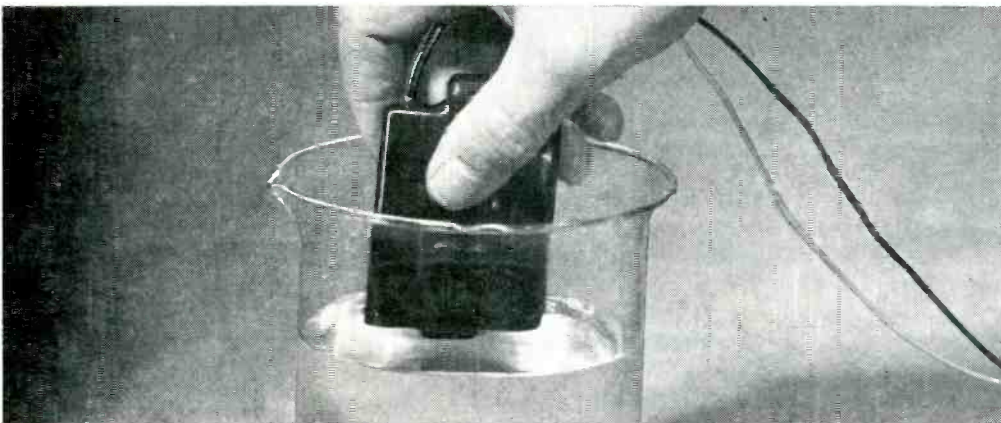

WET To activate, simply immerse in water. Batteries reach operating voltage as fast as 2 seconds . . . operate efficiently in extreme temperatures . . . are unaffected by external hydrostatic pressure.

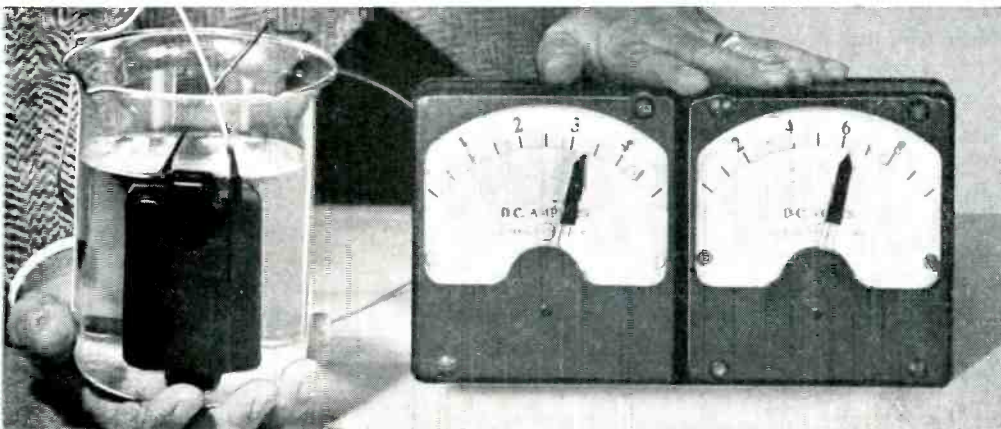

POWER These silver-chloride/magnesium type batteries deliver up to 42 watt hours per pound and 3 watt hours per cubic inch, with nearly level power output over total operating life.

WHERE CAN YOU USE G-E WATER-ACTIVATED BATTERIES? Probably wherever you need a versatile source of d-c power, wrapped inside a small, light-weight package.

Delivering tremendous power for relative size and weight, these primary batteries can be used as "power packs" in any number of series, parallel, or series-parallel combinations you may need.

Though a wide range of ratings and

sizes is available, G-E water-activated batteries can be designed in nearly any combination of sizes, weights, and ratings to fit your specific application.

Examine your power needs now. If space, weight, and exceptional reliability are critical, phone your G-E Apparatus Sales Office, today. A representative will be glad to give you additional information on how G-E water-activated batteries can help solve these problems.

GENERAL  **ELECTRIC**

General Electric's

New

Water-

**Activated
Batteries**

Deliver up to

42 Watt Hours

Per Pound!

For descriptive bulletin GEA-6238A on G-E water-activated batteries, send coupon to:

General Electric Co., Section H223-5
Schenectady 5, N. Y.

for immediate project for reference only

Name

Position

Company

Street

City..... State.....

Electronic Engineers Need

...that's the reason for

electronics'

2 extra editions!

There's a rising tide of interest in the *business* side of the electronic industry.

For instance, the engineer who used to be concerned chiefly with designing a circuit or a product . . . now wants to know where and how it can be *sold*.

His need, increasingly, is for marketing, topical or business information.

This trend could be foreseen . . . *was* foreseen by the editors of **electronics**. For they keep in close and constant touch with its subscribers. Thousands of editorial questionnaires, hundreds of personal interviews all over the country, readership studies by McGraw-Hill's research staff . . . these gave the editors advance knowledge of this growing industry's growing needs in terms of information.

One of the clearest indications was the increasing readership of **electronics'** "Industry Report" and "Plants and People" sections. Letters, comments and requests for information showed that these features of **electronics** should be *expanded* . . . the amount of business information *increased*.

The answer? Two extra editions of **electronics**.

Otherwise, **electronics** remains unchanged.

On the 1st of each month, starting in January, 1957, **electronics** will appear as it always has. This will be the Technical Edition. On the 10th of each month will appear a Business Edition. On the 20th of each month, another Business Edition will appear. The same 46,000 subscribers will receive all three editions.

As for the advertiser, he will have 37 issues to choose from. (This includes the annual BUYERS' GUIDE issue.) He can run all his ads in the original first-of-the-month, Technical Edition, if he wishes. Or in either of the two Business Editions. Or in *both* Business Editions. Or in *all three editions*. He can run a staggered schedule, using any editions.

We would put it this way: "Schedule your ads in **electronics** according to your own good judgment and needs. **electronics** simply provides a wider opportunity with 36 issues, 10 days apart, (plus the mid-June BUYER' GUIDE).



electronics

...of course!

A McGRAW-HILL PUBLICATION • 330 West 42nd St. • New York 36, N. Y.

More Business Information



Published on the

20th

of each month



Published on the

10th

of each month



Published on the

1st

of each month

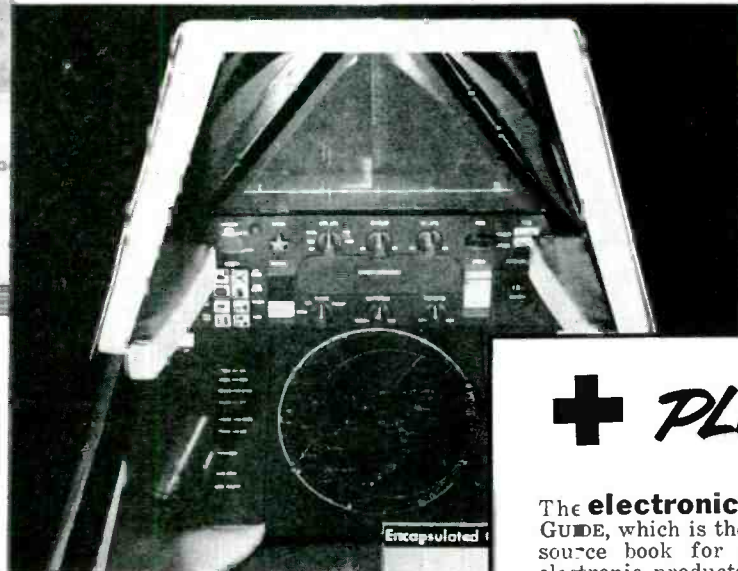

New TV Sound Detector ...page 133
Recognizing Lost Pulses ... 164
Triple-Tuned Circuit Design ... 185

+ PLUS

The **electronics BUYERS' GUIDE**, which is the industry's source book for purchasing electronic products and services. Published each year mid-June, it contains the most accurate, up-to-date listings of what to buy and where.



TAYLOR

Laminated Plastics
Vulcanized Fibre

Shop Talk

TAYLOR FIBRE CO.

Plants in Norristown, Pa. and La Verne, Calif.

PHENOL — MELAMINE — SILICONE — EPOXY LAMINATES

• COMBINATION LAMINATES

• COPPER-CLAD LAMINATES

• VULCANIZED FIBRE

Tips for designers

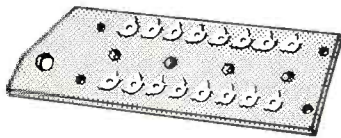

Terminal board for a complex circuit in an electronic spectrophotometer instrument is made of Taylor Grade LE laminate . . . selected for its insulating and mechanical properties.

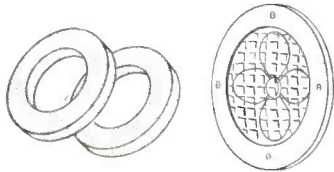

Large exhaust fans use Taylor paper base phenolic washers to help absorb thrust . . . an inexpensive arrangement, with long life.

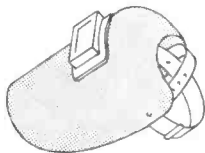

Welders' helmets are fabricated from tough, durable Taylor vulcanized fibre . . . readily formed to many desired contours.

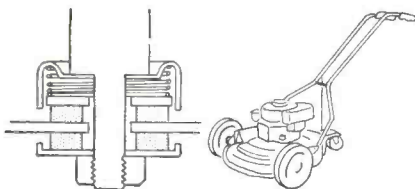

Rotary lawn mower utilizes abrasion resistance of Taylor phenolic laminate washer in slip-clutch attachment of drive shaft to cutting blade.

TAYLOR FABRICATING FACILITIES

Your production problems can often be simplified . . . schedules safeguarded . . . inventory headaches cured . . . and overall costs reduced by having Taylor fabricate finished parts of vulcanized fibre and laminates to your specifications. Efficient, modern facilities are ready to serve you. Write to Taylor about your specific requirements.

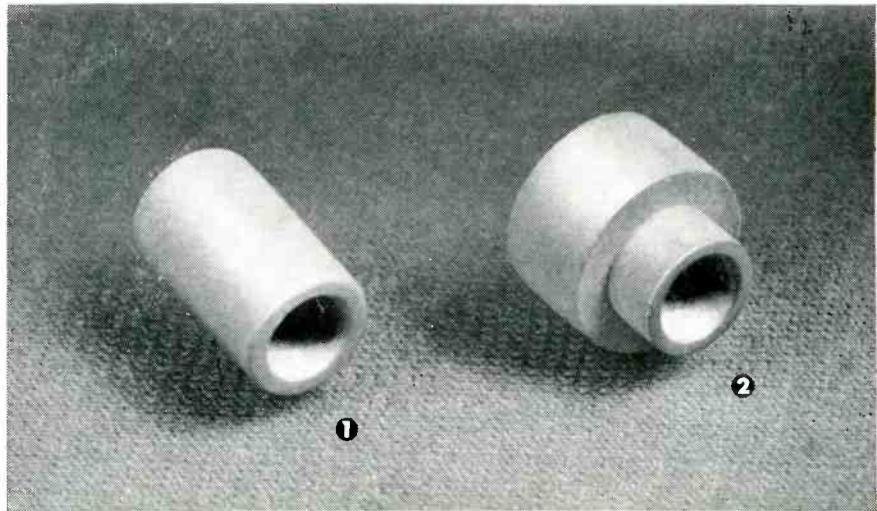

Chosen for its mechanical strength and electrical insulation, this Taylor laminated tubing provides an economical means for making (1) an ignition breaker arm bushing and (2) a distributor terminal bushing.

Strength plus electrical insulation, available in Taylor laminated tubing

Among the most versatile basic materials available to the designer, Taylor laminated plastics are constantly finding new applications . . . in new products for future markets and as replacements for parts in current production.

Widely used in flat sheets for the fabrication of parts for electrical components, Taylor laminates are also available in tube form. This makes them applicable to an even greater number of parts . . . such as bushings, guides, shafts, and housings for resistors, thermistors and fuses. The tubes are supplied with inside diameters as small as $\frac{3}{32}$ ". Standard lengths are 36" or 49", depending on grade, inside diameter and wall thicknesses.

Included in the broad selection of Taylor laminated tubing are a great variety of different grades

. . . paper, fabric and glass bases combined with special formulations of phenol, melamine, silicone and epoxy resins. Each grade offers electrical and physical properties which qualify it for a specific application at a reasonable price.

Of particular interest to economy-minded designers and production managers is the fact that this laminated tubing permits the use of a part for a mechanical application without the need for extra electrical insulation.

Plan to take greater advantage of Taylor laminates . . . in tube, sheet and rod form . . . either in your present products or in those which you are now designing. Call or write for a discussion of your specific requirements.

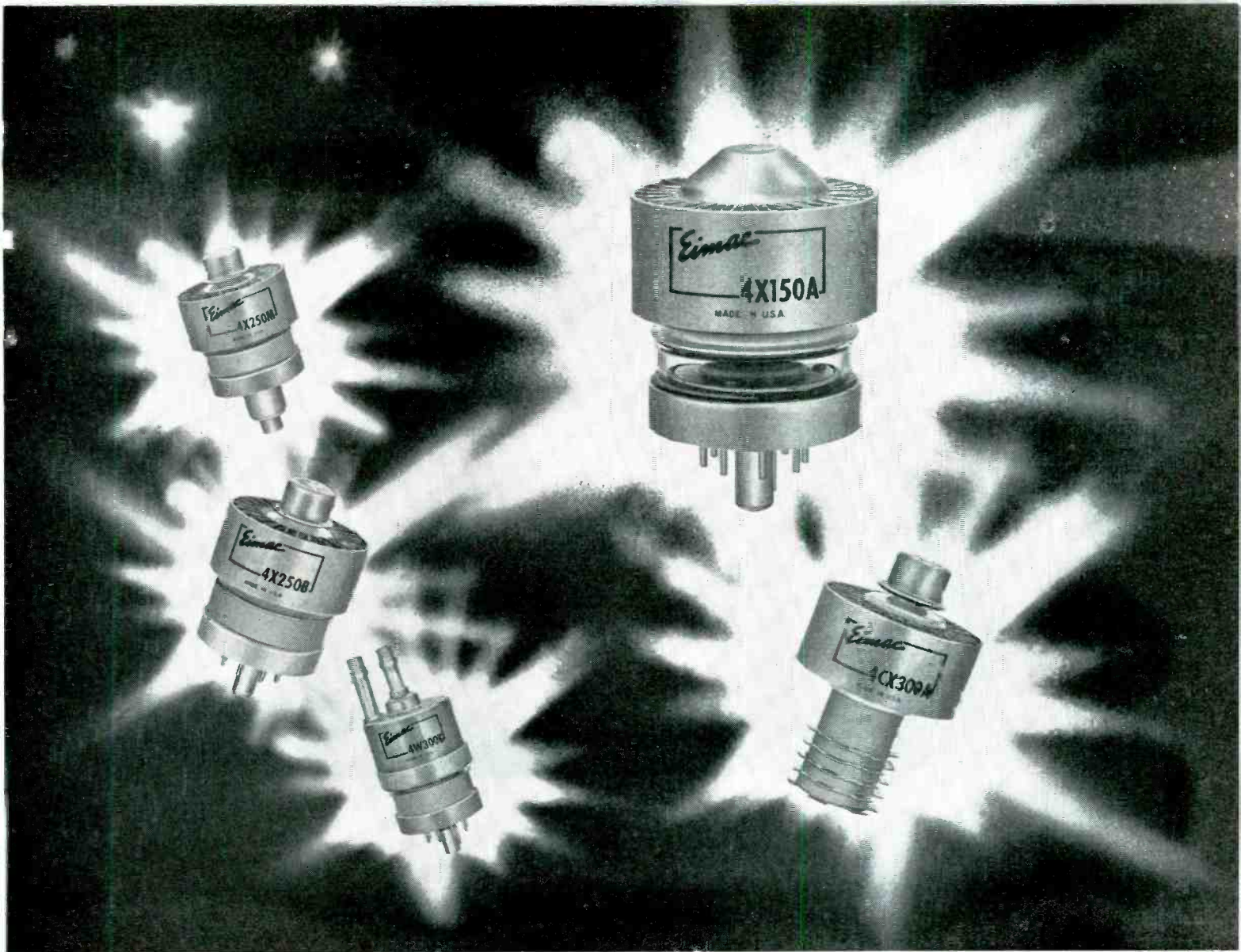

Evolution at Eimac

Back in 1946 Eimac developed and produced the 4X150A—a new concept in power tetrodes. Its immediate acceptance by the industry then, has led to even more popularity now.

But today at Eimac the glass 4X150A is virtually obsolete.

Since 1946 Eimac has constantly improved the 4X150A to the point where it has evolved into a family of superior quality 250w and 300w tubes for operation to 500Mc. Small, compact structure has been retained. In fact, the 4X250 series is interchangeable with 4X150

tubes. Ceramic envelopes make possible greater mechanical strength, better production techniques, and higher temperature processing.

Because "good enough" has never been accepted at Eimac, however, this family of air cooled or water cooled, co-axial or conventional socketed tubes (2.5v, 6v, and 26.5v) is again accelerating the pace in quality, design, and performance, exactly as the 4X150A did a decade ago.

EITEL-McCULLOUGH, INC.
 SAN BRUNO · CALIFORNIA
 The World's Largest Manufacturer of Transmitting Tubes



4X150A

4X150 Series
 4X150A-1946
 4X150G-1949
 4X150D-1952

4W300 Series
 4W300B-1953

4X250 Series
 4X250B-1955
 4X250F-1955
 4X250M-1955
 4CX250K-1956

4CX300 Series
 4CX300A-1956

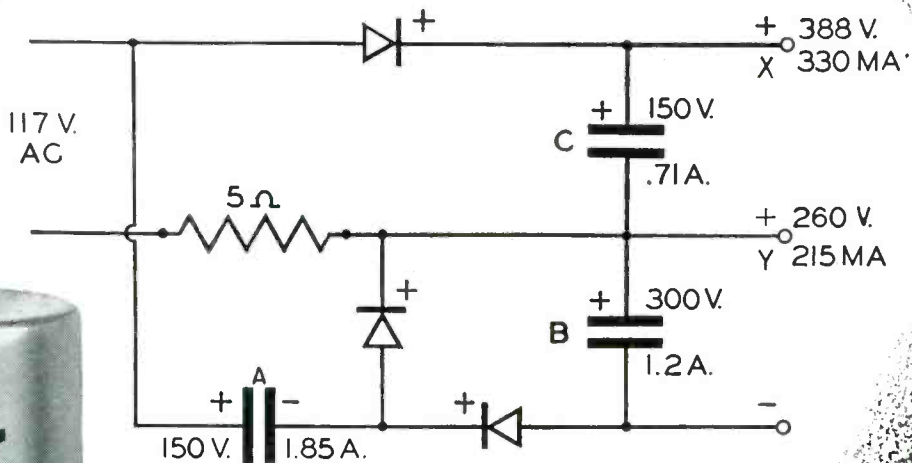

Solve the Voltage Tripler Ripple Current Problem with Mallory FP Capacitors

In the voltage tripler circuit above, the capacitor must handle extremely high ripple currents—and at 60 cycles.

For instance the ripple current in—

Capacitor A is $3\frac{1}{2}$ times the total load current

Capacitor B is $2\frac{1}{4}$ times the total load current

Capacitor C is $1\frac{1}{3}$ times the load at "X"

These ratios are approximate but give some idea for rule of thumb use when selecting capacitor ratings in voltage tripler circuits.

Remember also that silicon rectifiers produce different conditions than those encountered with sele-

nium rectifiers. They are tougher on the capacitors. Large values of capacity are needed to handle such ripple currents and engineering attention is needed here if good field performance is to be expected.

The unique ability of Mallory FP Capacitors to handle these severe ripple current values, even at 85°C ambient temperatures, is due to the use of fabricated anode construction.

If you do not have a copy of the new Mallory FP Technical Information Bulletin showing revised ripple current values—write for a copy—or better still let us help you in the initial design by asking for our engineering service.

Expect more . . . get more from

P. R. MALLORY & CO. Inc.
MALLORY

P. R. MALLORY & CO. Inc., INDIANAPOLIS 6, INDIANA

Serving Industry with These Products:

Electromechanical — Resistors • Switches • Tuning Devices • Vibrators
Electrochemical — Capacitors • Mercury and Zinc-Carbon Batteries
Metallurgical — Contacts • Special Metals • Welding Materials

Parts distributors in all major cities stock Mallory standard components for your convenience.

CROSS TALK

► **1957 LOOKS GOOD . . .** This year will probably see the electronics industry reach its highest peak since the war.

It is an oversimplification, but the primary reason for this prediction is the fact that the military is planning to contract for about 15 percent more electronic equipment than in 1956; the international situation makes this seem desirable. And while military business constitutes less than half our industry's annual take it does represent the number one sparkplug.

Mergers will continue near the '56 pace but, largely because of stepped up direct and indirect military buying, a sufficient number of new companies are again entering the field after a momentary lull to more than keep the total number of manufacturers level.

► **DECENTRALIZATION . . .** One of the most important trends now evident in the industry is the location of new plants in areas heretofore largely devoid of electronics.

Key to the trend is the fact that our industry is now reaching out almost desperately for skilled manpower, not only engineering but also production. It will apparently locate just about anywhere if such manpower is assured, with other plant location criteria considered secondary.

Many a Chamber of Commerce is anxious to encourage us into their local fold; electronics is for the most part light industry and the kind that can operate right on the

fringes of residential areas with a minimum of disturbance to the founding fathers.

► **MEN, MEN, MEN . . .** Scarcely a month goes by but what we see some new evidence of ingenuity on the part of personnel directors looking for engineers.

Dinner was later than eight the other night because when we arrived home Mrs. M was engrossed in a jigsaw puzzle that had arrived that day in the mail. Put together, the puzzle sought to induce her to induce us to investigate the possibilities of a better job in an electronics plant we pass every day about half way between home on Long Island and the office here in midtown Manhattan.

► **SOLID, BROTHER, SOLID . . .** Machine tool builders, along with

many other old-line makers of equipment for industry, have been notoriously cautious about adopting electronic controls. Most of this caution can be attributed to a fundamental feeling over the years that tubes are fragile, which they are when compared with levers, cams and gears.

There is now increasing evidence that all this may soon change. The reason? Reliable or otherwise, the solid-state transistor is already being accepted by these people as the tube never was. It looks to them like their kind of component; sales resistance is knocked way down by the inherent nature of the device.

► **WEIRD WORLD . . .** Field-checking color-tv, a network engineer discovered that the most ghost-free spot in New York City is Woodlawn Cemetery.

LOOKING AHEAD . . .

More tubes without filaments are distinct possibility. Cathode secondary emission started by jolt of external energy can be sustained by inherent internal conditions comparable to ignition-less operation of diesel engines

Further refinement of ferrite loop antennas suitable for mounting beneath automobiles could eventually lead to disappearance of whips

Military emphasis upon airplanes and guided missiles will this year further stimulate interest in miniaturized component parts capable of withstanding higher temperatures and more vibration

Modulation methods are due for additional refinements. "Compatible" single sideband more readily receivable on conventional sets is one possibility

MINIATURE ITV CAMERA

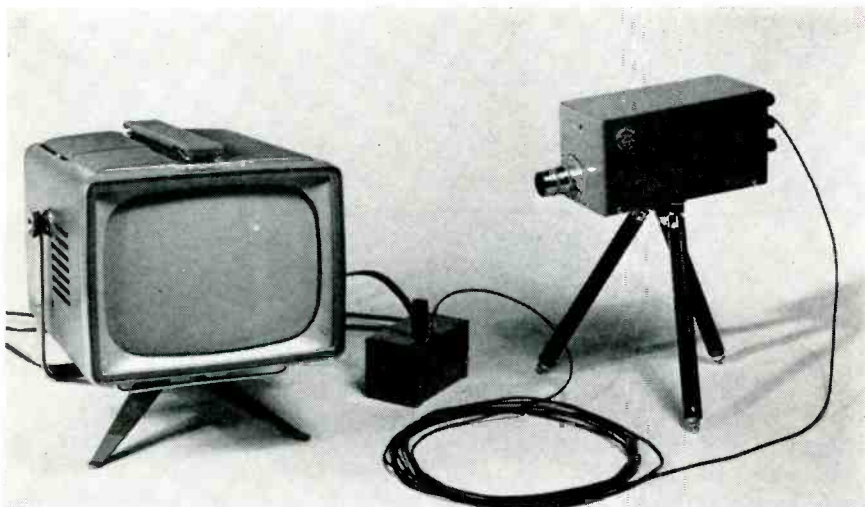

Miniature industrial tv camera with portable home receiver used as monitor

DEVELOPMENT of half-inch-diameter vidicons has made possible the design of transistorized television cameras of small size, low weight, low power consumption and high sensitivity.

The experimental camera to be described is a simple unit which, in connection with any standard television receiver, forms a complete closed-circuit television system. Video information is modulated on a carrier frequency which may be adjusted to channel 2 or channel 3 of the vhf band.

The block and schematic diagrams of the camera are shown in Fig. 1 and 2.

Video Amplifier

For best signal-to-noise ratio, the input impedance is made high, about 50,000 ohms. The vidicon signal current develops about 5 mv across this load at low frequencies.

Since the modulator requires about 200 mv at about 200-ohms impedance, a power gain of approximately 57 db is required. The high-peaker stage requires about 26 db more gain to equalize the falling high-frequency response of the input network; it is advantageous to provide an additional 22 db of high-frequency gain to compensate for the apparent spot size of the camera tube (aperture

correction). Total required high-frequency gain is therefore 105 db.

The first video stage, Q_1 , is connected as an emitter follower to provide the required high input impedance. The output of this stage is direct-coupled to the base of Q_2 .

The first stage of the amplifier is

one of the most critical. During development of the camera, best results were obtained in this stage with experimental RCA drift transistors.

Drift Transistor

The drift transistor utilizes the alloy junction technique but features a base region in which the impurity distribution is carefully controlled to produce a built-in accelerating field. This accelerating field which propels the charge carriers from emitter to collector is a feature not available in conventional transistors.

As a result, the base resistance and the collector transition capacitance of the drift transistor are materially reduced and the high-frequency response consider-

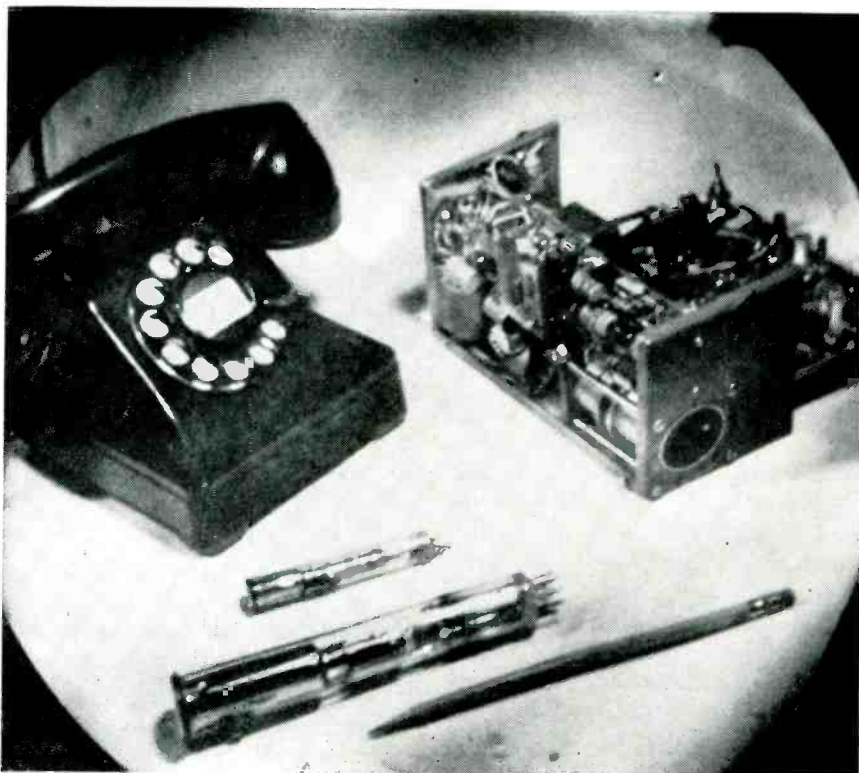

Photo taken from screen of 21-in. home-receiver monitor shows camera resolution

Uses Drift Transistors

By L. E. FLORY, G. W. GRAY, J. M. MORGAN and W. S. PIKE

*RCA Laboratories
Princeton, New Jersey*

SUMMARY — Twelve-transistor industrial-television camera puts out video-modulated r-f signal on either of two vhf channels. Video amplifier stages use drift transistors to achieve 4-mc bandwidth. Pickup tube is only one-half inch in diameter and three inches long. Total camera power consumption is 5.2 watts on a-c line operation

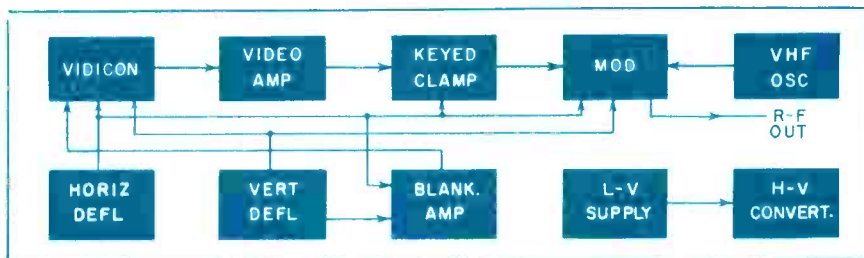

FIG. 1—System block diagram of transistor industrial-television camera

ably improved. In a unilateralized common-emitter circuit, for example, a drift transistor can provide a power gain as high as 45 db at 1.5 mc or 24 db at 10.7 mc.

These units are now commercially available as type 2N247. With present manufacturing tolerances, it may be necessary to select transistors for Q_1 and Q_2 to

obtain satisfactorily high input impedances in these stages.

The second and third stages of the amplifier must be considered together. Neglecting their emitter circuits, they are conventional a-c coupled common-emitter amplifiers. A shunt peaking inductance in the collector circuit of Q_2 maintains the high-frequency response

of the stages to 4 megacycles.

In each emitter circuit, a 470-ohm resistor provides a d-c path of sufficient resistance to obtain adequate d-c stability. Such a high resistance would reduce the stage gain to a low value. Therefore R-C networks comprising R_1C_1 and R_2C_2 are shunted across these emitters. This does not remove all the a-c degeneration. High-frequency positive feedback from the emitter of Q_3 to the emitter of Q_2 , via a capacitive divider, sufficiently increases the high-frequency gain of the circuit to provide the necessary aperture correction.

Transistors Q_1 and Q_3 are biased by common bleeder network R_3R_4 , while Q_2 is biased by its direct connection to Q_1 .

The adjustable high-peaker,

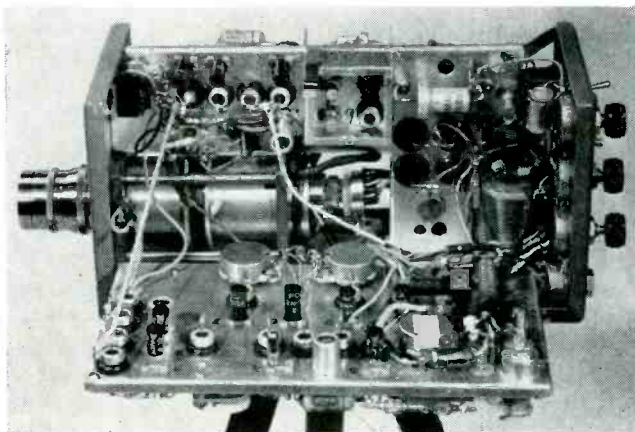

Side views of transistor camera show placement of components.

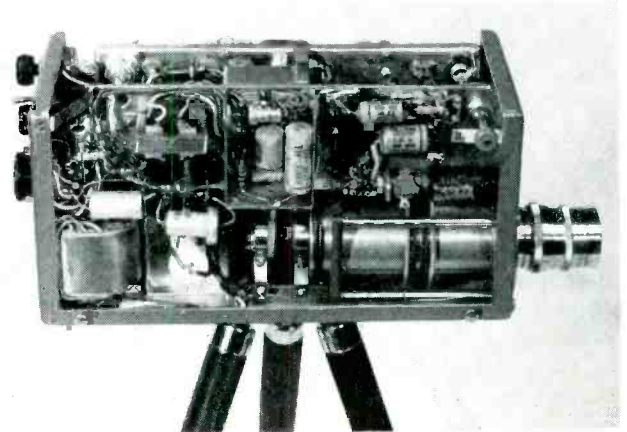

Photodiode is mounted in container at top of front panel

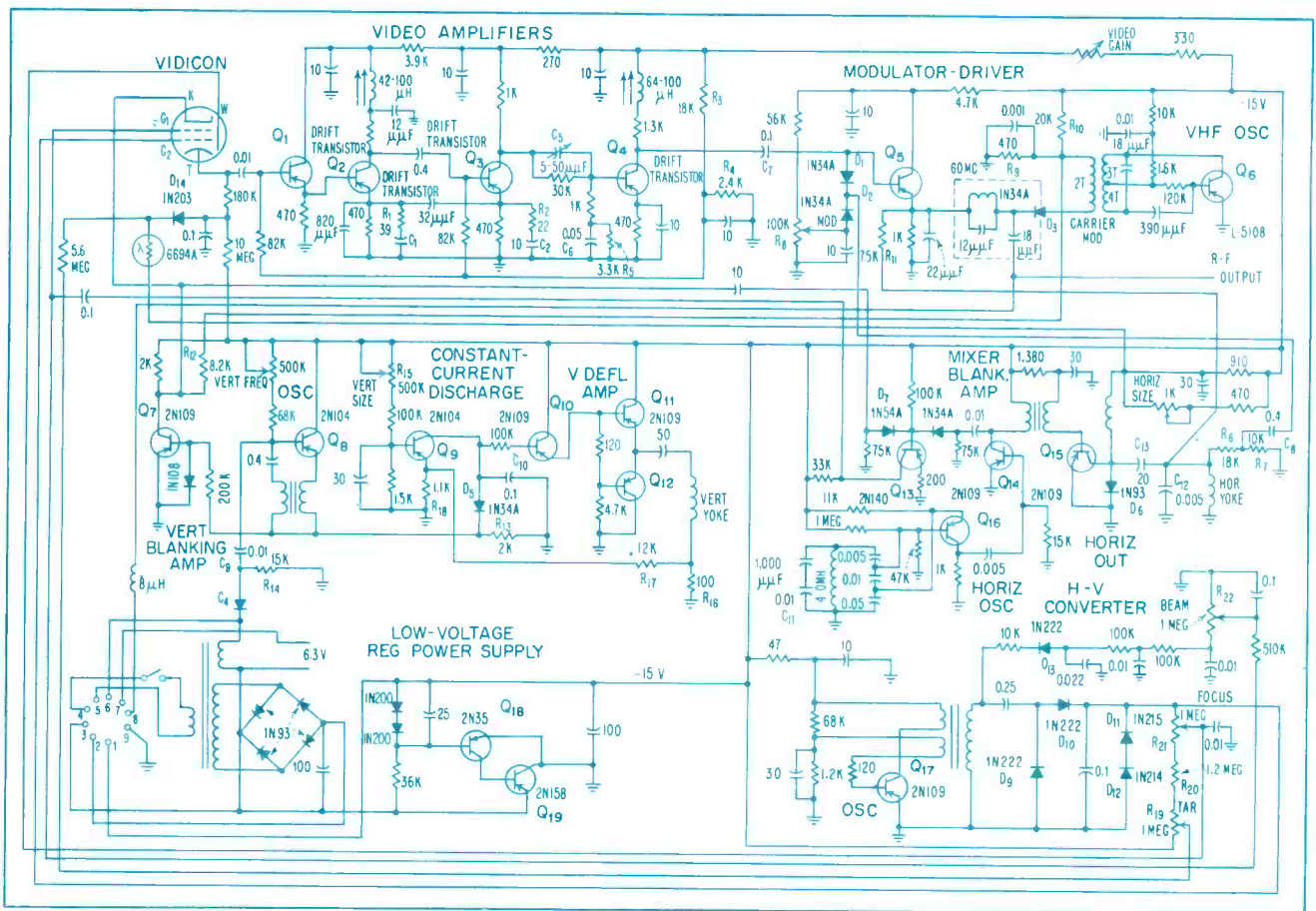

FIG. 2—Camera uses 12 transistors, 20 diodes and one photodiode in addition to vidicon pickup tube

located between the collector of Q_3 and the base of Q_4 , is a simple adjustable high-frequency equalizer. The amount of high-frequency equalization is fixed by the circuit resistances.

Turnover frequency is adjusted by C_5 to match the loss characteristic of the input network. This adjustment is most readily carried out by observing a test pattern and visually adjusting the high-peaker to minimize trailing.

Transistor Q_4 is a conventional common-emitter stage. Its emitter is bypassed and a peaking inductance in its collector maintains its high-frequency gain. Bias is applied via the high-peaker resistors to its base.

Low-Frequency Response

Transmission of a good television picture imposes special requirements on the low-frequency response of the system amplifiers. Making the response good to d-c is usually impractical. A better technique is to adjust the amplifier low-frequency gain and phase re-

sponse to adequately reproduce a square wave at the horizontal scanning frequency and then employ clamping or d-c restoration to reinsert the d-c component. This technique results in smaller coupling and bypass capacitors.

In this equipment, overall low-frequency correction is made by placing capacitor C_5 across R_3 , the resistor being required to bias Q_4 properly. This one capacitor adequately compensates the low-frequency response of the amplifier through Q_4 .

The signal from the collector of Q_4 is a-c coupled to the base of Q_5 via a relatively small capacitor, C_7 . A driven clamp comprising diodes D_1 and D_2 sets the base potential of Q_5 at the start of each horizontal line. Negative drive pulses for the clamp are derived from the horizontal deflection circuit via R_6 , R_7 and C_8 . On each pulse the diodes conduct, clamping the base of Q_5 to a potential which is adjusted for optimum operation of the modulator by R_8 ; d-c information is thus reinserted at this point in

the video amplifier chain.

Modulator D_3 operates as a variable impedance in series with the carrier oscillator output. This impedance is caused to vary in accordance with the video information.

Carrier Oscillator

Transistor oscillator Q_6 is tunable from 54 to 66 mc. Oscillation is maintained by collector-to-base feedback via the tuned transformer. Energy from the oscillator is applied to the anode of D_3 via a two-turn coupling coil on the oscillator transformer. Bias is applied at the same point from a divider comprising R_9 and R_{10} .

The cathode of the modulator diode is connected to the emitter of Q_5 through a trap broadly tuned to the carrier frequency. The modulator diode is adjusted to be conducting with R_8 . The r-f from oscillator Q_6 can then pass through the modulator diode to the output terminal of the camera via capacitor C_7 . Video signals at the emitter of Q_5 vary the diode impedance,

thus modulating the video signal on the carrier.

Synchronizing pulses are also added to the outgoing signal in the modulator. Negative horizontal sync pulses from the deflection circuit are applied via R_{11} , which imposes a negligible load on the video signal.

Positive vertical-sync pulses from vertical blanking amplifier Q_7 are applied to the other electrode of the modulator diode by R_{12} . The resulting composite output signal has both horizontal and vertical synchronizing components of correct polarity with respect to the video information.

Vertical Deflection

Blocking oscillator Q_8 generates negative pulses across R_{13} at vertical frequency. During a-c operation this oscillator is locked to the power line by the circuit comprising D_1 , R_{14} and C_{11} , which injects a suitably shaped line-frequency signal into the base circuit of the oscillator. During battery operation, the blocking oscillator runs free.

The negative pulses across R_{13} are amplified and inverted in vertical blanking amplifier Q_9 and applied to the vidicon cathode to prevent landing of the electron beam during vertical flyback.

Each negative pulse across R_{13} charges C_{10} via diode D_5 . A linear sawtooth voltage is generated across this capacitor by allowing it to discharge between pulses through constant-current transistor Q_{10} .

The magnitude of the discharge current is adjustable with vertical

size control R_{15} . The generated sawtooth voltage waveform has a maximum amplitude of about 10 volts; this limitation being set by the magnitude of the pulse available across R_{13} .

The vertical yoke windings have a resistance of about 200 ohms and an inductance of about 57 mh. The latter is negligible. The sawtooth voltage appearing across C_{10} is coupled into these windings, causing an accurately linear sawtooth current to flow in them. Impedance conversion is performed in the following stages as a first step in accomplishing this purpose.

Emitter follower Q_{10} is direct-coupled to a class B complementary symmetry output amplifier comprising Q_{11} and Q_{12} . Resistor R_{16} limits the voltage which can be applied to this system, swamps out the somewhat nonlinear input impedance characteristics of Q_{10} and raises the load impedance seen by the sawtooth generating circuit.

As a d-c connection to the yoke would cause prohibitive decentering of the vidicon beam, capacitive coupling to the yoke is used.

Capacitor C_{10} is too small to reproduce adequately the sawtooth, but space did not permit a larger unit. Application of negative feedback via R_{16} , R_{17} and R_{18} corrects the resulting nonlinearity in acceptable fashion.

Maximum available peak-to-peak deflection current is about 25 ma.

Horizontal Deflection

The horizontal deflection circuit operates in much the same fashion as its counterpart in contemporary home television receivers; it generates a sawtooth current waveform by periodic interruption of the current flowing in an inductance. Fortunately, transistors make better switches than vacuum tubes in that the impedance of a transistor when conducting is materially lower than that of a vacuum tube.

Transistor Q_{13} an oscillator operating at the horizontal scanning frequency, is similar to an electron-tube Colpitts oscillator. Some temperature compensation is applied for stability by temperature-sensitive capacitor C_{11} which is mounted on Q_{13} .

Although the waveform across the oscillator tuned circuit is a good sine wave, the waveform in its collector circuit is a negative pulse. This keys on transistor Q_{11} . The large positive pulse on the collector of Q_{11} is coupled into the base of horizontal output transistor Q_{15} without inversion by the stepdown transformer. This cuts off Q_{15} , causing a large pulse to appear across the yoke windings during the horizontal retrace period.

Diode D_6 is the usual damper diode, as in a conventional receiver. Capacitor C_{12} adjusts the resonant frequency of the yoke system. It is chosen to lengthen the retrace period to the maximum permissible amount, reducing the peak pulse voltage occurring during the flyback and materially improving the efficiency of the circuit.

To block d-c from the yoke windings, a choke provides a d-c path for the collector current of Q_{15} and capacitor C_{13} couples the collector to the yoke. The horizontal yoke windings have an inductance of about 1 mh and a resistance of about 3 ohms. For good linearity the L/R ratio of the yoke must be as high as possible. The figures given represent about the lowest ratio permissible.

Since a transistor such as Q_{15} really contains a built-in diode in its collector circuit, diode D_6 could be omitted in principle. Due to the relatively high forward impedance of the collector-to-base junction of small transistors, better results can be obtained by adding an additional low-impedance diode as shown.

Blanking

An additional blanking amplifier Q_{13} is associated with the horizontal deflection system. The vidicon requires about 15 to 20 volts of positive blanking signal on its cathode to positively prevent beam landing during the retrace periods under all conditions of beam current and illumination. It is difficult to provide this in a camera in which the maximum supply voltage is 15 volts. For this reason, additional blanking is applied to the vidicon grid to reduce the beam current during retrace.

Diodes D_7 and D_8 , nonlinearly mix positive horizontal pulses from

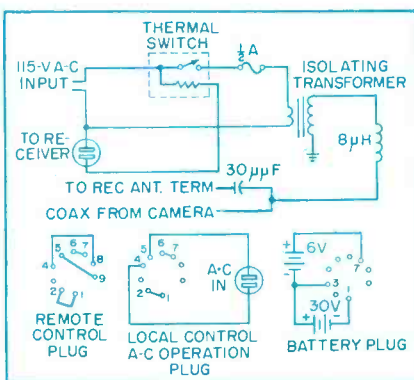

FIG. 3—Adaptor box for remote control of camera (top) and plug wiring diagrams for various types of operation (bottom)

Q_{14} and positive vertical pulses from Q_7 by forming an orgate. The resultant is applied to the base of Q_{13} . Amplified negative blanking pulses at the collector of Q_{13} are applied to the vidicon grid.

This arrangement, in conjunction with Q_7 , results in the application of positive vertical blanking pulses to the vidicon cathode and negative mixed blanking pulses to the vidicon grid. Thus double blanking is supplied during the vertical blanking interval, which is the more critical as it encompasses a number of complete horizontal scans, during the forward scanning portions of which the beam is moving relatively slowly. On the other hand, during the horizontal retrace the beam is always in rapid motion and the resulting current density at the vidicon target is proportionately lower.

High-Voltage Supply

The vidicon requires a positive accelerating potential of about 300 volts, a positive focussing voltage adjustable from 250 to 300 volts and a negative source of bias adjustable from zero to about -100 volts for beam current control. All voltages are referred to the vidicon cathode, which is near ground potential, being returned to the collector of Q_7 .

These voltages are supplied by converter Q_{17} , a square-wave oscillator operating from the -15-volt bus which powers all the transistor circuits of the camera.

As the converter operates at 15 kc, the size and weight of the required filter components is greatly reduced. The operating frequency is controlled by the associated transformer.

The waveform at the collector of Q_{17} is nearly a square wave whose amplitude approaches the supply voltage. The transistor in this circuit is switched rapidly between its fully conducting state in which its current is high but the voltage across it is nearly zero, and its off state in which its current is zero and the voltage across it is considerable. Under these conditions the power dissipated in the transistor is low and overall efficiencies of the order of 70 to 90 percent may be achieved.

The voltage at the transistor collector is stepped up in the transformer and applied to two separate rectifier systems. The first, comprising D_9 and D_{10} is a doubler. Its output is regulated by a pair of silicon zener diodes, D_{11} and D_{12} . Two diodes in series are used to reduce the dissipated power.

The output voltage is adjusted to be from 280 to 300 volts by selection of the regulator diodes, which have fairly wide tolerances as received from the manufacturer.

The bleeder comprising R_{19} , R_{20} and R_{21} provides the wall, focus and target potentials for the vidicon. The maximum current available from this rectifier system is about 800 microamperes. Rectifier D_{13} supplies about 100 volts negative to beam current control R_{22} .

The camera may be operated either from the a-c line or from batteries. During a-c operation, power for the camera may either be taken from an a-c outlet or it may be sent to the camera from the remote viewing point over the same coaxial cable which carries the r-f output of the camera. For either the local or remote a-c mode of operation, the 15-volt bus which operates all the transistor circuits in the camera is energized by the low-voltage regulated supply comprising the power transformer, rectifiers and transistorized voltage regulator Q_{18} , Q_{19} .

Using the remote method of supplying power, the plug shown in Fig. 3 is inserted into the socket to connect the primary of the power transformer across the r-f output connector through the 8-microhenry r-f choke. Power is applied to the end of the output coaxial cable remote from the camera by the adapter box shown in Fig. 3, which interconnects the cable and the remote receiver.

Because of the great frequency separation between the 60-mc camera output and the power-line frequency the simple chokes and capacitors shown adequately isolate the two signals.

The action of the transistor regulator is identical to an electron-tube series regulator. In this case transistor Q_{16} is the series element and Q_{18} is the amplifier. A pair of zener diodes provide the necessary volt-

age reference to the regulator.

The regulator delivers about 150 ma to the 15-volt bus and will hold the output voltage within 0.1 volt of the specified value for any input voltage between 100 and 130 volts. It also reduces the 2-volt ripple content at the output of the bridge rectifier by a factor of approximately 100.

The camera may be operated on batteries by inserting the proper plug, also shown in Fig. 3.

Automatic Sensitivity Control

A novel feature of the camera is an experimental arrangement for automatically varying the camera sensitivity as a function of the ambient illumination of the scene being viewed. A photo-diode is arranged at the proper distance behind a hole of suitable diameter in the front surface of the camera so that it sees a solid angle identical to that of the camera lens.

Increasing light increases the current through the photodiode. This is arranged to reduce the target voltage of the vidicon, thus reducing its sensitivity.

Zener diode D_{14} provides a d-c level shift in this circuit merely for convenience in selecting appropriate operating points for the vidicon and the photodiode. Compensation for ambient illumination changes of the order of 50 to 1 may be provided by this method. Such compensation is useful where the camera operator is unskilled or the camera itself is inaccessible.

The experimental miniature vidicon¹ has the advantage, for use with transistor circuits, of requiring only about 20 ampere turns of deflection field. This is about one-third the amount required by conventional vidicons. The tube may also be made somewhat more sensitive than its predecessor.

The authors wish to acknowledge the direction of V. K. Zworykin in this project and the cooperation of A. D. Cope who supplied the miniature vidicons. The assistance of Lawrence A. Boyer in design and construction contributed materially to the success of the work.

REFERENCE

- (1) A. D. Cope, A Miniature Vidicon of High Sensitivity, *RCA Rev.*, Dec. 1956.

PULSED F-M TESTS

Ultrasonic Propagation

By ROBERT R. UNTERBERGER

*La Habra Laboratory
California Research Corp.
La Habra, California*

SUMMARY — Equipment for experimental study of amplitude and shape of returned ultrasonic wave as a function of frequency has plus and minus 1-db output over range from 165 to 240 kilocycles. Gated receiver provides oscilloscope display and integrates signal for recording and analysis in sonar investigations and in models used for seismic research

INVESTIGATION of ultrasonic signal returns as a function of frequency requires a broadband pulsed ultrasonic system capable of being frequency-modulated. The system response must be flat over the frequency band of operation. Such a flat system response must include not only the frequency responses of both transducers but also the characteristics of the transmission medium between the transducers.

Figure 1 shows a block diagram of the system developed for this purpose. Commercially available components were utilized wherever possible.

The source transducer consists of six cylindrical barium-titanate transducers in parallel in a single two-inch diameter housing. The detector transducer is a single 2.5-mc barium-titanate disk transducer that operates far from resonance. The over-all system response is shown in Fig. 2 for an electrical signal that has been changed into a sound pulse, sent through the transmission medium, detected and reconverted to an electrical signal. The system is flat to ± 1 db from 165 to 240 kc.

Figure 3 shows the input pulses to the source transducer for various frequencies and the output pulses as received from the detector transducer. Up to a fre-

quency of 240 kc, the detected pulses differ little in shape from those at the source transducer. The system response falls off markedly

at 250 kc, however, as shown in Fig. 2 and Fig. 3.

When provided with a negative gate pulse, the sine-wave generator

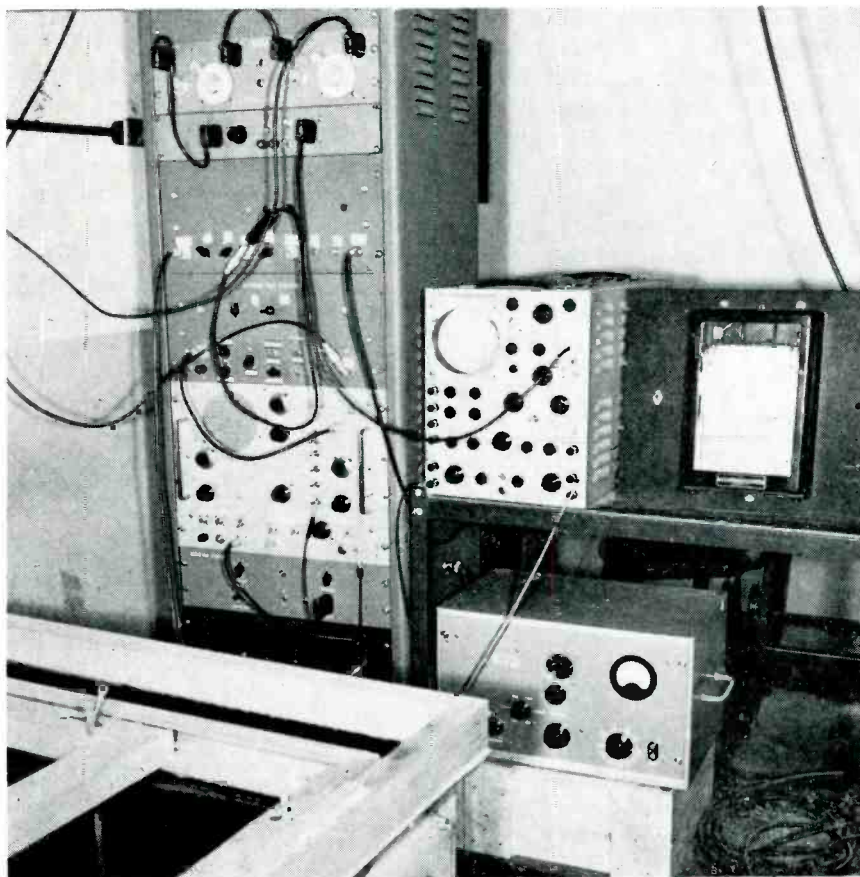

Laboratory setup for ultrasonic investigations uses tank at lower left for transmission medium. Bandpass filter, amplifiers, pulsed sine-wave generator and power supplies are in large cabinet at rear of test tank

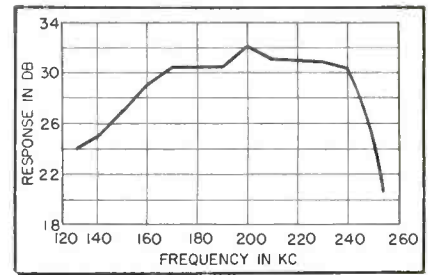
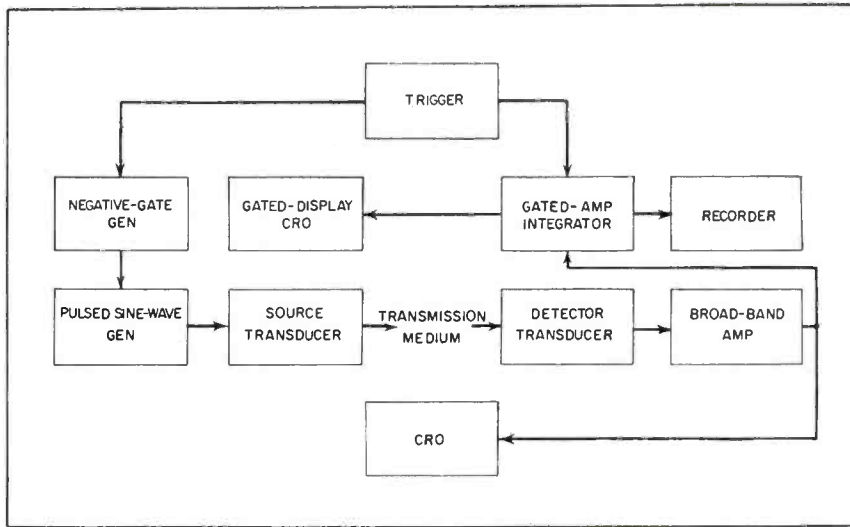

FIG. 2—Overall response of f-m ultrasonic system, including source and detector transducers and transmission medium

FIG. 1—Elements used in pulsed f-m ultrasonic system are commercially available equipments with exception of sine-wave generator, gated amplifier and barium titanate transducers described in text



FIG. 3—Oscillograms showing system response at 170, 200, 220, 240 and 250 kc. Input pulse for each pair is at left.

shown in Fig. 4 produces a train of sine waves at a repetition rate determined by the trigger source, with a pulse duration equal to the width of the negative gate. Pulses of one, two, three or any number of cycles are obtained by changing the input gate width. The sinusoidal wave is generated by a modified Hartley oscillator circuit. A variable capacitor in the tank circuit is motor-driven to provide pulsed f-m signals from 165 kc to 240 kc.

Frequency Response

Peak voltage of oscillations in the tank circuit depends upon the tuning of the circuit because $V = I(L/C)^{1/2}$ and hence $V = 2\pi LIf$, assuming lossless circuit elements. This amplitude dependency upon frequency is not conducive to a flat broadband response.

To eliminate this difficulty, cathode follower V_{2A} feeds amplifier V_{2B} having a resonant circuit in its output. This circuit develops an automatic negative bias which is a function of frequency. To this bias is added a fixed battery bias. The summation of these two biases determines current through the tank circuit between pulses and

thereby the peak sinusoidal voltage of the pulsed sine-wave oscillator.

The pulsed-continuous switch cuts off V_{1A} to monitor or calibrate the frequency of oscillations for given capacitor settings. Tubes V_1 and V_{3B} amplify and invert the pulsed sinusoids to feed the final output stage. An output of 30 v peak-to-peak is obtained when driving a $0.02\text{-}\mu\text{f}$ barium-titanate transducer. The transformer has

a Hypersil core with negative feedback provided from the secondary to aid in damping oscillations resulting from the parallel combination of the transformer inductance and the capacitance of the transducer.

Gated Amplifier-Integrator

The gated amplifier-integrator shown in Fig. 5 is used in the receiver portion of the system to

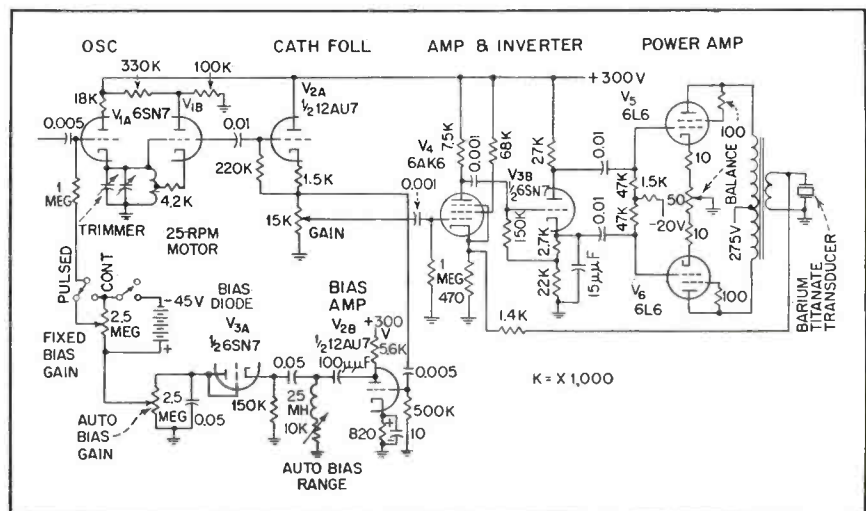

FIG. 4—Pulsed sine-wave generator provides f-m signal through use of 25-rpm motor-driven tank capacitor in modified Hartley circuit

How To Design Colpitts

By H. E. GRUEN

Assoc. Electrical Engineer
Armour Research Foundation
Illinois Institute of Technology
Chicago, Ill.

SUMMARY — Cut-and-try approach characteristic of crystal oscillator development can be avoided by using design method described. Oscillator output voltage can be predicted to better than 25 percent. Performance curves of output and crystal drive level allow performance prediction of circuits having a wide range of parameter values

DESIGN of practical crystal oscillator circuits has always involved a considerable amount of cut and try. Although a complete mathematical analysis is possible when all circuit characteristics are known the result is so complex that its application to a useful circuit is not practical.

Often this mathematical analysis is simplified by various assumptions to the point where little, if any, quantitative information results. The method of design outlined be-

low correlates the two approaches to the problem—a simplified analysis yielding qualitative information, supplemented by circuit performance measurements to provide quantitative information.

The measurements, obtained over a wide range of operating conditions, include such factors as frequency stability, output voltage and power and crystal drive level determined as a function of circuit component values and voltages.

Design data will be developed for

the Colpitts crystal oscillator and for the adaptation of this circuit to electron coupling.

In the circuit of Fig. 1A, the crystal operates at antiresonance with the total grid-to-ground capacitance. Crystal drive level, as well as the available output voltage, is a function of crystal and tube characteristics and operating voltages as well as the capacitance ratio C_3/C_2 .

For this oscillator the equivalent circuit of Fig. 1B is most con-

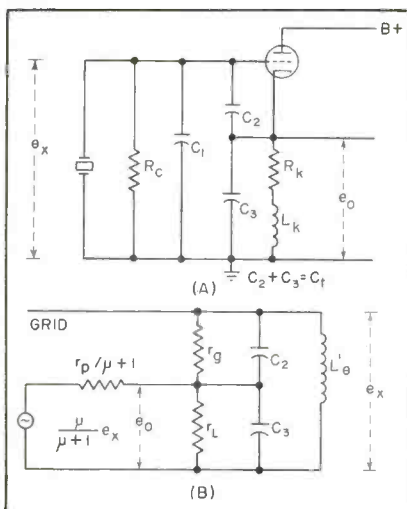
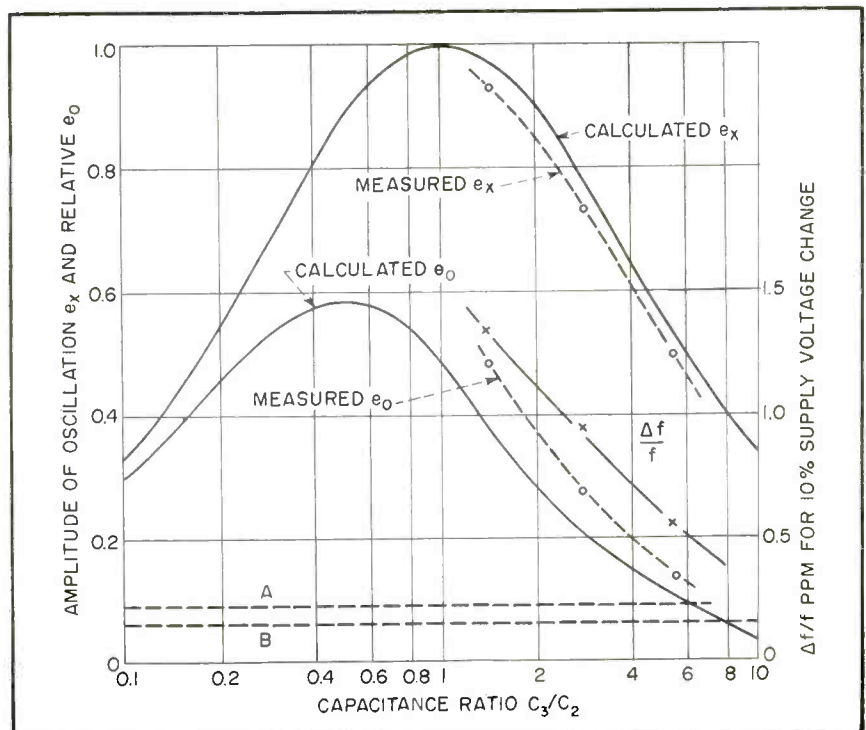

FIG. 1—Colpitts crystal oscillator circuit (A) and equivalent circuit (B) that serve as the basis of the design

FIG. 2—Circuit performance as a function of ratio of the capacitance between cathode and ground to grid and cathode



CRYSTAL OSCILLATORS

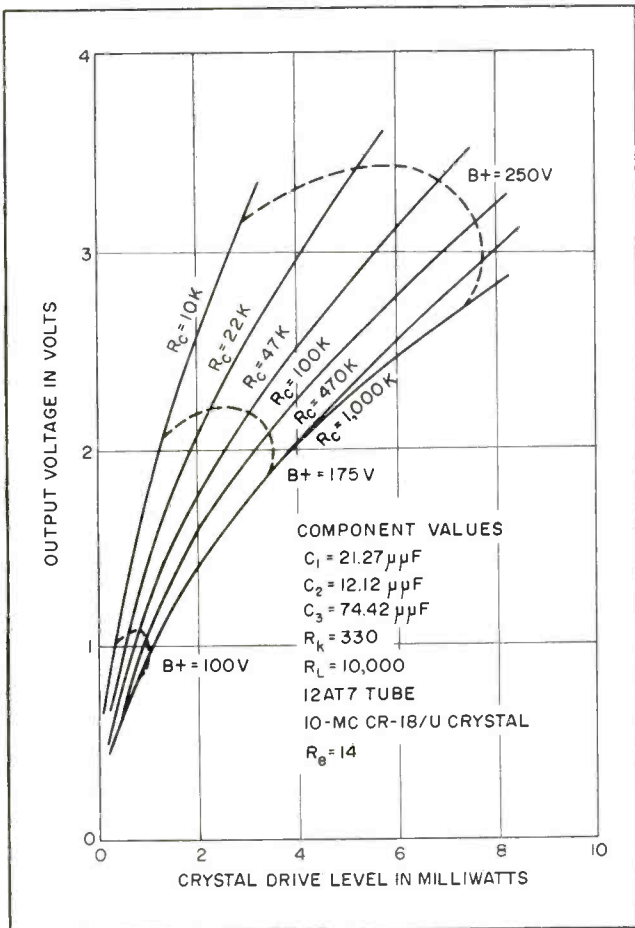

FIG. 3—Crystal oscillator output voltage vs crystal drive as a function of grid bias resistance

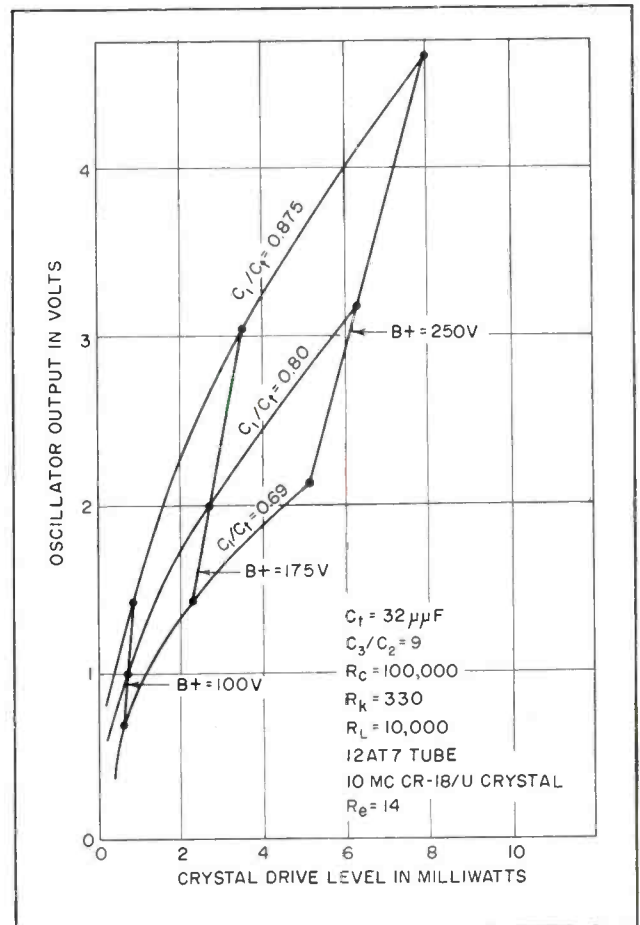

FIG. 4—Output voltage vs crystal drive as a function of C_1 connected between grid and ground

venient since the voltages of interest appear across the crystal and from cathode to ground. The value of L_k is chosen such that its reactance is several times that of C_3 . It thus provides a d-c path from cathode to ground whose a-c impedance is sufficient to be neglected.

The grid circuit losses are represented by r_g and the crystal loss by r_L when C_1 is included as a part of the crystal network. The resistance r_L is the load on the generator when the grid loss r_g is neglected. Using this value of load impedance, the equation of conditions necessary for oscillation can be developed as follows

$$r_p = \frac{\mu P I N f(\omega r_g) f(C_1)}{(1 + N)^2}$$

where $N = C_3/C_2$

$PI = 1/(\omega^2 C_1^2 R_e) =$ performance index of crystal

$$f(\omega r_g) = \frac{r_g \omega C_2}{[1 + (r_g \omega C_2)^2]^{1/2}} \text{ and}$$

$$f(C_1) = \left(1 + \left[\frac{(N + 1) \omega C_1 R_e}{1 - C_1/C_2}\right]^2\right)^{1/2}$$

The equation is satisfied when steady-state oscillations exist. The factors $f(\omega r_g)$ and $f(C_1)$ include the effects of circuit losses. The values of these expressions approach unity as the frequency increases and as R_e of the crystal decreases.

The resultant plot of the loss-free condition is shown in Fig. 2. The upper solid curve represents the amplitude of oscillation, or crystal voltage, and the lower curve the relative output voltage for this condition.

Figure 2 also shows the measured

performance of a 10-mc oscillator as compared to the loss-free condition. For the measurements shown the effective grid-to-ground capacitance of C_2 and C_3 was held constant while their ratio was varied. This maintains a constant crystal load capacity C_L .

Circuit Measurements

Because of the inherently large stray capacitance included in C_3 no measurements were made at ratios less than one. The curve marked $\Delta f/f$ shows the improvement in frequency stability as the capacitance ratio is increased. The horizontal lines A and B are used in the design examples.

The graph of Fig. 3 shows measured output voltage and crystal

drive level as a function of plate voltage for different values of grid bias resistance. This data taken at 10 mc shows increasing values of drive as the resistance increases, indicating the desirability of using small values of resistance if high output at low crystal drive is desired.

However, at lower frequencies oscillation may not start if R_g is too small. The choice of R_g is therefore dependent on the use to which the oscillator is to be put. These results were obtained at 10 mc. At lower frequencies a graph having the same scales would be obtained with larger values of R_g . For example, at 1 mc the line representing R_g equal to 100,000 ohms will be approximated by an R_g of 1 megohm.

In Fig. 4 are shown the results of varying C_1 , the grid-to-ground capacitance, while maintaining a fixed ratio of C_2/C_1 and a constant load capacitance. As C_1/C_2 becomes larger, the output increases greatly for moderate increases in drive level. Within the limits set by stray capacitance in C_2 and C_3 it is advisable to make C_1 as large as possible to obtain large output-to-drive ratios. However, for good stability C_2 should be padded to several times the stray capacitance.

Figure 5 indicates the results obtained by use of different tube types. Both triodes and pentodes of miniature and subminiature construction are included. A type 12AT7 was selected as the reference for obtaining the general circuit performance measurements.

Performance Curves

Circuit performance information is presented in a general form in Fig. 6. The oscillator output in volt-megacycles (rms output voltage times frequency in megacycles) and the crystal drive level are presented as a function of plate supply voltage. For a fixed supply voltage and a given frequency, a range of both output voltage and crystal drive is indicated. The exact values obtained depend on the resistance of the crystal used. The circuit and the range of resistance values used in determining the curve are shown

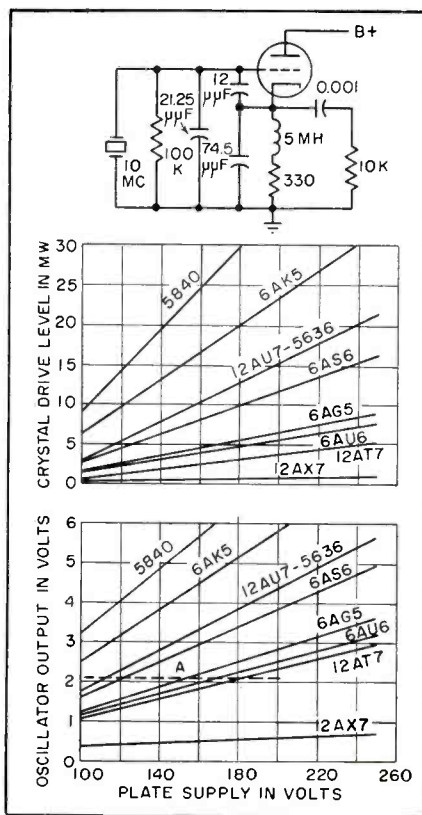

FIG. 5—Output voltage and crystal drive for a number of tubes used in the representative circuit (top)

on the figure.

As an example of the use of this curve, assume that an 8-mc oscillator having an output of 2 volts is required. The volt-megacycle product is 16 and from the curve the required plate voltage can be determined. In this case the required plate voltage will be in the range of 130 to 170 volts. Use of a 150-volt plate supply will yield an output of 2 volts plus or minus 15 percent. The resulting drive level will be from 1.5 to 4 milliwatts depending on crystal resistance.

At frequencies below 3 mc, higher values of grid and cathode bias resistance are required to insure proper starting and drive characteristics. Figure 7 is a generalized performance curve for the low frequency range. The applicable circuit is shown and use of the curve is the same as before.

Electron coupling is used in crystal oscillators as well as in conventional self-excited circuits. Advantages of the electron coupled arrangement include ease of fre-

quency multiplication, high output voltage to crystal drive ratio and frequency stability relatively independent of load variations. This circuit readily adapts itself to electron coupling since the plate operates at a-c ground potential.

The circuit diagram of the electron coupled oscillator appears in Fig. 8. The voltage of interest in determining circuit performance now becomes the screen voltage rather than the supply voltage. Characteristics of triode connected pentodes were determined and circuit performance data for several types are included in Fig. 5 for comparison.

The design of an electron coupled oscillator is taken from the curves just described using the pentode tube connected as a triode. When the performance of the triode circuit has been determined the plate output can be calculated as for a pentode amplifier based on effective values of transconductance and plate circuit impedance.

Excellent isolation of plate impedance variations can be accomplished by using a tube having a separate suppressor lead connected to a bypassed bias potential equal to the cathode bias. Output voltage, crystal voltage and frequency change as a function of plate load impedance for three circuit arrangements are shown in the curves of Fig. 9.

A 6AU6 tube was used, first with suppressor-to-cathode connection, then as a tetrode with suppressor connected to plate and finally with the suppressor connected to a positive bias of five volts. The solid line curves indicate the improved performance of the biased suppressor arrangement.

Design Method

The oscillator circuit shown in Fig. 6 was designed to operate over the frequency range of 2.85 to 16 mc with large output voltage to crystal drive ratios. The corresponding circuit and performance characteristics for the 1 to 2.85 mc frequency range are shown in Fig. 7. These performance characteristics can be used directly in predicting

operation of the standard circuits and can also be used in conjunction with other figures given here to design additional circuits meeting specific performance requirements.

Use of this design method is explained in the example below. The steps necessary if the reference circuit of Fig. 6 meets the given requirements are outlined in detail as shown below.

It is required that the circuit have a frequency of 7 mc; voltage output of 2.25 v rms across a 5,000-ohm load, frequency tolerance of ± 0.006 percent and power supply voltage of 150 v.

The crystal unit to be selected should be a high-quality antiresonant unit of the desired frequency. To obtain proper operation of the crystal the circuit is designed to provide the required load capacitance, which is the total grid-to-ground capacitance of the circuit. The circuits given here are for use with military type crystal units for which a load capacitance of 32 $\mu\mu\text{f}$ is required.

Military type crystal units that can be used in these circuits include the CR-18/U, CR-27/U and CR-36/U. The CR-18/U is a non-temperature-controlled unit, while the CR-27/U and CR-36/U are designed to operate at 75 and 85 C respectively. In this case a CR-18/U crystal unit will meet the requirements provided that frequency changes produced by the oscillator are less than ± 0.001 per cent (the difference between the ± 0.006 -percent frequency tolerance requirement for the circuit and the ± 0.005 -percent tolerance of the CR-18/U over the operating temperature range).

Reference Stability

The stability characteristics of the reference circuit are such that nominal component value changes produce frequency shifts in the order of one or two parts per million. Plate supply changes of ± 10 percent produce corresponding frequency variations of less than two

parts per million. Thus the frequency tolerance of the circuit is well within the ± 0.001 -percent (10 parts per million) requirement.

Having determined that crystal unit CR-18/U is the proper choice, other characteristics of the unit such as recommended drive level (10 milliwatts), effective resistance and other crystal characteristics should be kept in mind. Detailed information on all military type crystal units is contained in military specification MIL-C-3098B.

In this example the output requirement of 2.25 v rms at a frequency of 2 mc yields a volt-megacycle product of 15.75. Plate voltage necessary for obtaining the desired performance from the reference circuit is determined in Fig. 6. From 15.75 on the volt-megacycle scale a horizontal line is projected to intersect the center dotted curve. This is shown as line A of Fig. 6. A plate voltage of nearly 150 v is indicated. Line B projected vertically downward to the drive level scale denotes a drive

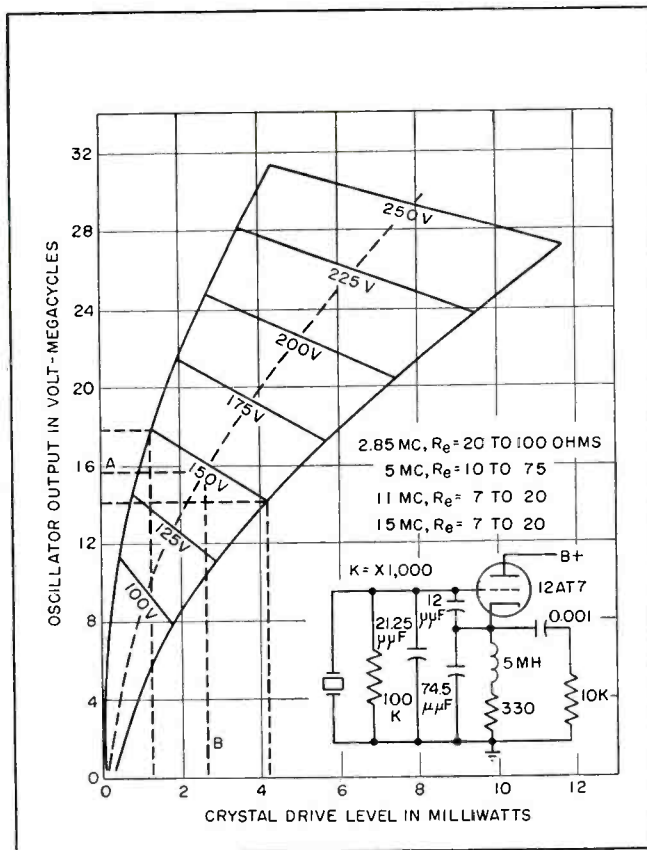

FIG. 6—Performance characteristics for high frequencies

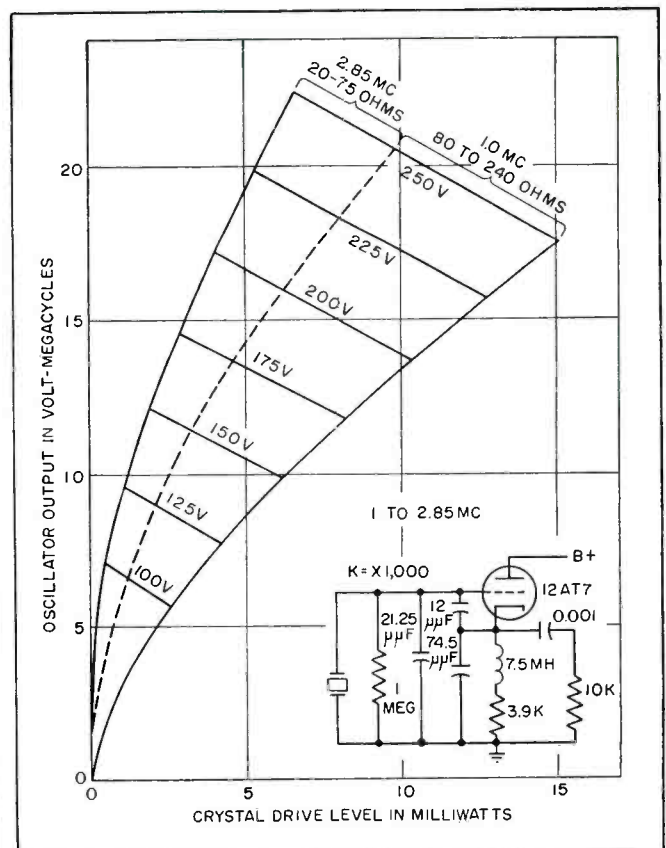

FIG. 7—Performance characteristics for low frequencies

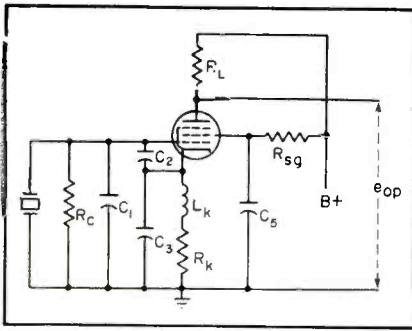

FIG. 8—Typical electron-coupled Colpitts circuit

of 2.6 milliwatts.

Similar projections from the ends of the plate voltage line yield the range of output and drive to be expected from this circuit using typical crystals and a plate supply of 150 volts. In this case at 7 mc, the output will be from 2 to 2.5 volts rms and the drive will be in the range of 1.2 to 4.2 milliwatts.

The reference circuit of Fig. 6 will meet the requirements specified when operated at a plate voltage of 150 volts. Circuit performance with use of other tube types or changes of component values can be determined by the use of Fig. 2 through 5. These modifications may be necessary when the desired output cannot be obtained with the reference circuit or when another tube type is preferred owing to size or power considerations.

The design method can also be used when the oscillator requirements fall outside the performance of the reference circuit. The following example illustrates the use of the method. The case chosen requires a frequency of 7 mc, voltage output of 2.8 v rms across a 5,000-ohm load, frequency tolerance of ± 0.0025 percent and power supply voltage of 150 v.

Crystal Type

According to MIL-C-3098B, a temperature-controlled unit CR-27/U or CR-36/U is necessary to meet the tolerance requirement. These crystals are within 0.002 percent of specified frequency when operated at the recommended temperature. The limit on circuit instability is then 0.0005 percent or five parts per million. This will not be exceeded under normal operating conditions if the recommended

drive level of 5 milliwatts is heeded.

Since the requirement is for 2.8 volts at 7 mc, the volt-megacycle product is $2.8 \times 7 = 19.6$. Plate voltage required to produce the desired output is determined from Fig. 6 as explained in the former example. In the present case a plate voltage of 180 volts is required. Since only 150 volts is available the circuit must be modified to produce the required output at this voltage.

Reference is made to Fig. 5 to determine the operating point for other tube types usable in this circuit. A horizontal line is constructed that passes through the intersection of the 12AT7 output voltage curve and the 180-volt plate supply point. This is shown as dotted line A in the figure and indicates the necessary supply voltage. If, for example a 5636 is chosen the required plate supply is 115 volts.

If the original output of 2.8 volts at a plate voltage of 150 volts is required, various modifications must be made to the circuit. This can be done by a change of the feedback ratio C_3/C_2 , a change in the bias resistance or a change in the value of C_1 the grid-to-ground capacitance.

Figure 2 shows the effects on oscillator performance of varying the ratio C_3/C_2 . The feedback ratio of the reference circuit (Fig. 6) is $74/12 = 6.15$. To determine relative output e , corresponding to this

ratio, a horizontal line (shown as line A on the figure) is constructed through the output voltage curve at point $C_3/C_2 = 6.15$.

A relative output of 0.09 is indicated on the left hand scale. From Fig. 5 it is determined that a circuit using a 5636 tube and having an output of 2.1 volts when the plate supply voltage is 115 volts will provide an output of 3.1 volts when the plate supply is increased to 150 volts. For the desired operation at 150 volts the relative output must then be decreased by the factor $2.1/3.1$, or to $0.09 \times 0.677 = 0.061$. By use of Fig. 2 it can be determined that the required capacitance ratio is 8 (line B). The capacitance values necessary to achieve this ratio are then determined.

Predicting Action

The prediction of electron-coupled performance is based on measured performance of the Colpitts circuit, the design as a Colpitts being the initial step. From the measured bias and signal conditions and known values of plate load impedance, electron-coupled oscillator output^{1,2} can be conveniently determined.

Although a wide range of crystal resistance values is encountered in practice, the use of this design method provides a sufficiently accurate means of performance prediction for the majority of applications. Typical production crystals were used in this study and oscillator output voltage can be predicted to within 20 to 25 percent for these crystals.

The author acknowledges the cooperation and suggestions of the communication and navigation technical personnel of Wright Air Development Center, specifically those of E. H. Borgelt and V. J. Carpanier and thanks his colleagues at Armour Research Foundation, especially Paul Goldsmith and E. A. Roberts, for their helpful suggestions and John Kurinsky who obtained the experimental data.

REFERENCES

- (1) W. A. Edson, "Vacuum-Tube Oscillators," p 177, John Wiley and Sons, New York, 1953.
- (2) H. E. Gruen, Development of a Design Technique for Anti-Resonant Crystal Oscillators, Final Report, Call No. 12, Contract No. AF 33(616)-2125, Oct. 1955.

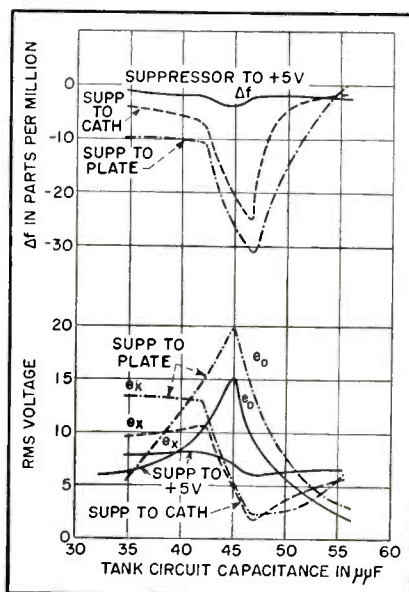

FIG. 9—Output drive and frequency change of electron-coupled Colpitts oscillator as function of plate load impedance



Picture at transmitter console monitor shows multiplexed visual-transmitter signal at modulator input. Lack of 4.5-mc sound trap in monitor causes sound beat pattern



Picture of demodulated video from off-the-air signal is indicative of picture seen on home receivers. Sound beat pattern is filtered out by receiver sound trap

Single-Carrier System for SOUND and VIDEO

SUMMARY — Both aural and visual signals are radiated by visual transmitter during emergencies when aural transmitter of television station is off the air. Multiplexing is accomplished by mixing and rectifying audio and video carriers from miniature vhf transmitter and using demodulated envelope to modulate visual-carrier transmitter

VARIOUS METHODS of tv sound and picture multiplexing are known. However, a simple and economical method is desirable for emergency operation of a tv broadcasting station when the visual portion of the transmitter is operative and the aural portion is not.

This article presents a method for using the visual carrier to transmit both the aural and visual signals. The only investments required are that of a miniature transmitter such as the RCA Monitron, DuMont Dumitter or equivalent and a detector-amplifier unit. The entire equipment cost can be held to less than \$700, including labor and parts for the detector-amplifier unit.

If the main transmitter is con-

By BENJAMIN WOLFE

*Director of Engineering
WAAM-TV, Incorporated
Baltimore, Maryland*

structed so the visual portion can be operated independently of the aural portion, the system requires only the substitution of input signals with a minimum of transmitter adjustment. The entire transfer operation can be accomplished in a matter of seconds.

System

Figure 1 shows the system configuration using either a Dumitter or a Monotran. Figure 2 shows a block diagram of the Monotran transmitter, which is composed of picture-signal circuits and sound-signal circuits. The picture section

includes a crystal oscillator, its associated multipliers and an amplifier-modulator which amplifies the external video signal and impresses it on the picture carrier.

The aural section consists of a variable permeability circuit which frequency modulates a sound crystal oscillator, its multipliers and the amplifier circuit. The sound carrier generated by the crystal oscillator is frequency modulated by an amplified audio signal which may originate from an external audio source.

The modulated outputs of the sound circuits and the picture circuits are fed to a common output level circuit composed of a dual potentiometer and thence to a terminating network for distribution.

Assuming the carrier of this

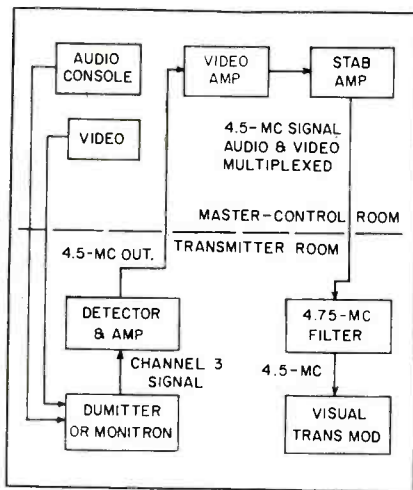

FIG. 1—Block diagram of multiplexing technique used in system

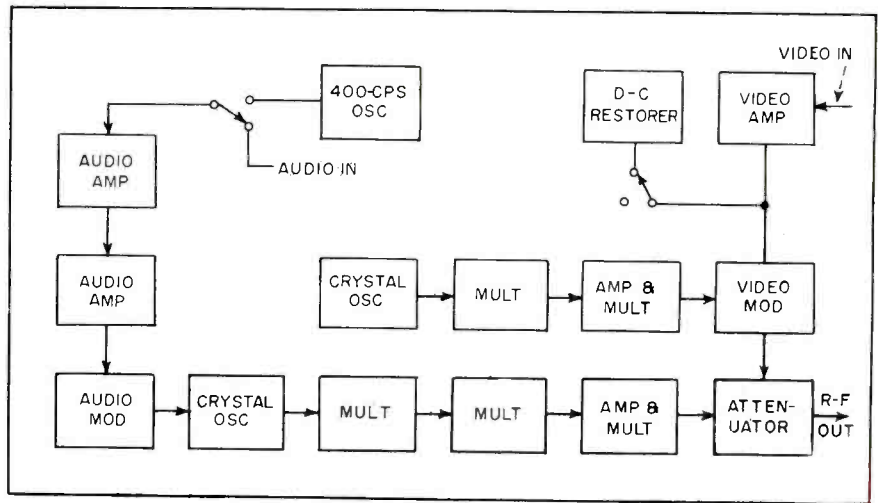

FIG. 2—Monotron or comparable transmitter supplies aural and visual carriers for combined-envelope demodulation

transmitter is on channel 3, the output would be two r-f signals, 61.25 and 65.75 mc, with the sound and picture separated by 4.5 mc.

The output of this transmitter feeds a compensated detector, flat within 1 db to 6 mc, followed by several stages of video amplification as shown in Fig. 3. The audio f-m and video a-m signals delivered by the miniature transmitter are beat against each other and detected to eliminate all r-f to yield the envelope of the original amplitude-modulated video carrier and the difference frequency of the two carriers, a signal frequency modulated about 4.5 mc.

These two signals are fed to the main video transmitter modulator. The video r-f carrier is amplitude modulated by the video signal, amplified and transmitted as the radiated video signal. At the same time, the upper sideband resulting from the video r-f carrier being modulated by the 4.5-mc f-m signal, produces an f-m signal 4.5 mc above the video r-f; it too is passed by the video amplifier and transmitted as the radiated audio signal.

The visual modulator accepts the frequency-shared amplitude-shared signals since its bandwidth is approximately 5-mc wide. Most present day visual modulators employ soft clamping action in conjunction with color broadcasting. This type of clamp circuit provides sufficient impedance at the aural frequency, 4.5 mc above the visual carrier, to nullify clamp action at the aural

carrier signal frequency.

The percentage of visual modulation may be reduced to 60 percent and the aural carrier level adjusted to provide the remaining 40 percent modulation. Thus, the modulated amplifier and any following linear power amplifiers share the aural and visual signal by that amount. While this percentage of visual to aural carrier power provides a good signal-to-noise ratio, it requires some adjustment of the main visual transmitter before the emergency system can be placed in operation.

Power Reduction

Since this signal is amplitude shared and a television transmitter is rated in terms of peak power output, the video power output will have to be reduced accordingly to prevent overloading of the modulator, the modulated amplifier and any succeeding linear power amplifiers.

With the transmitter adjusted to

handle these percentages of aural-to-visual power, the plate currents drawn during black time may be considerably greater than normal. This is so because during black-level with sync only, the synchronizing pulse occurs for 8 percent of the time. However, the aural modulation will still be applied, increasing the average time considerably and causing an increase in average plate current in the modulator, the modulated amplifier and any succeeding linear amplifiers.

Kick-offs

During experimental operation of the system with the 60 to 40 visual-to-aural percentage power ratio, it was found that the final power amplifier circuit breakers had to be set up during black time to prevent kick-offs. The final linear amplifier consists of five 6166 tubes with black-level plate current of 2.5 amperes each.

During black time, this plate current increased to 3.5 amperes per

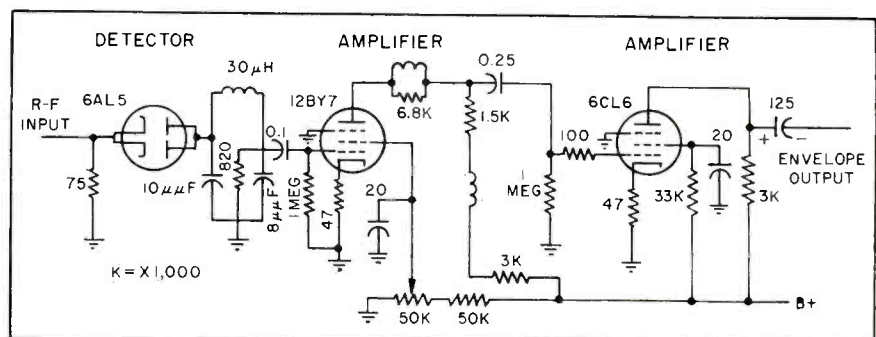

FIG. 3—Detector-amplifier unit costs less than \$100 including parts and labor

tube when the 60 to 40 ratio was used. This ratio permits a high percentage of audio signal through the stabilizing and distribution amplifiers creating sound beat frequencies which are easily discernable on the operating monitors and are objectionable to operating personnel.

To permit placing the system in use with minimum adjustment to the transmitter and minimum monitor cross-talk interference without addition of monitor sound traps, the sound-carrier level is reduced to 9 db below the visual-carrier level at the output of the miniature transmitter. An additional 6-db reduction is imposed on the sound-carrier level by the use of a 6-db low-pass filter employed as standard terminal equipment. The aural-carrier level is then down 15 db relative to the visual-carrier level.

ERP Output

If the erp of the visual transmitter is 316 kw, the aural power output will be approximately 10 kw in this amplitude shared system. For this value of aural carrier, the modulator plate current increases from the normal black level value of 180 ma to about 255 ma.

At black levels, the modulated amplifier plate current as well as the final 50-kw amplifier plate current does not increase sufficiently to be of any concern. While the signal-to-noise ratio is not quite so favorable with the decrease in sound carrier level, the main visual transmitter requires no adjustment other than a slight decrease in the percentage of visual modulation, 10 percent or so; 75 to 80-percent modulation being satisfactory. In addition, the monitors throughout the station are not effected by the objectionable sound beat pattern.

Wherever possible, stabilizing amplifiers should be the type which employ soft clamping. Otherwise, it is preferable to reduce the clamping action slightly, but not to the point where it will be detrimental to the picture signal. This action is helpful in minimizing aural distortion.

Level setup is accomplished with a calibrated oscilloscope. The studio or master control input-video level to the miniature transmitter can be

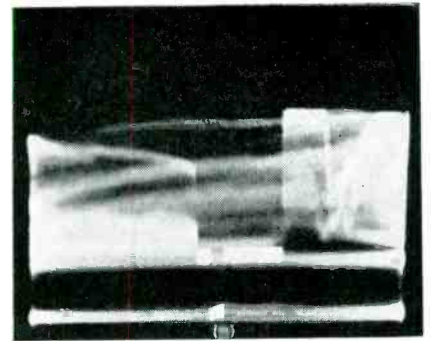
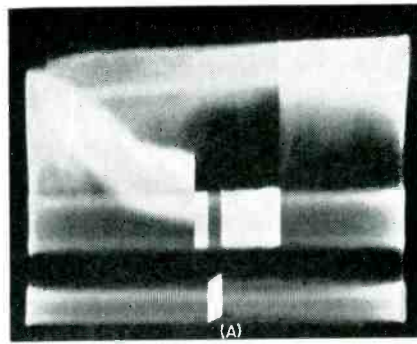

FIG. 4—Output waveform of detector amplifier (A) is 0.2 v p-p; output of station's demodulator unit (B) has large decrease in aural signal

either 1 or 1.4 v peak to peak for the composite signal. The aural level should be 1 mw into a 600-ohm transformer.

If it has been ascertained that the detector-amplifier unit has a flat frequency response to 6 mc, a calibrated oscilloscope should be connected at the output test jack of this unit. The aural power ampli-

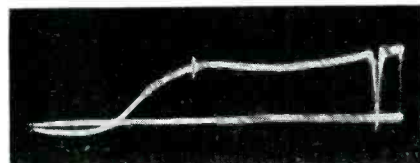

FIG. 5—Response of detector-amplifier with marker at 5.5 mc

fier of the miniature transmitter is adjusted until its output level at the output of the detector-amplifier unit is 0.06 v peak to peak relative to the detected visual carrier of 0.2 v peak to peak.

The stabilizing amplifier output level is adjusted to 1 or 1.4 v peak to peak for the composite visual signal combined with the aural signal.

Figure 4 shows the output at the detector-amplifier and the output of the demodulator. The aural component is reduced considerably at the demodulator unit since it utilizes an overall sound rejection of approximately 40 db.

Figure 5 shows the frequency response curve of the detector-amplifier made by using a sweep generator and a wide-band oscilloscope.

Testing

An audio-frequency run on the system showed the frequency re-

sponse to be ± 3 db from 100 to 15,000 cps. The oscillator was fed to the miniature transmitter at a level of 0 dbm.

The system was tested during normal programming time for a four-day period. A balop card was made and put on the air at the beginning of the test. Appropriate audio announcements informed viewers that the transmission was of an experimental nature and that some adjustment of the fine tuning control might be necessary to receive the audio portion of the transmitted signal.

The visual program material was animated cartoon films. The audio portion of these films was not used because of poor audio quality. Since it was anticipated that there would be some background noise due to the low amplitude of the aural signal, the transmitted audio was made as clean as possible to properly evaluate the system. Accordingly, semiclassical music was prerecorded on tape and used as the audio portion of the cartoons.

A number of viewers reported that the sound was accompanied by some background noise and that there was some distortion of peaks. Careful monitoring of the audio input to the miniature transmitter should minimize this form of distortion.

The system is intended to be used only as an emergency facility when there is no other means of getting a signal on the air.

The author wishes to express his appreciation for the assistance given by Glenn Lahman, chief engineer, and Robert Hankey, transmitter supervisor, during all-night tests of the system.

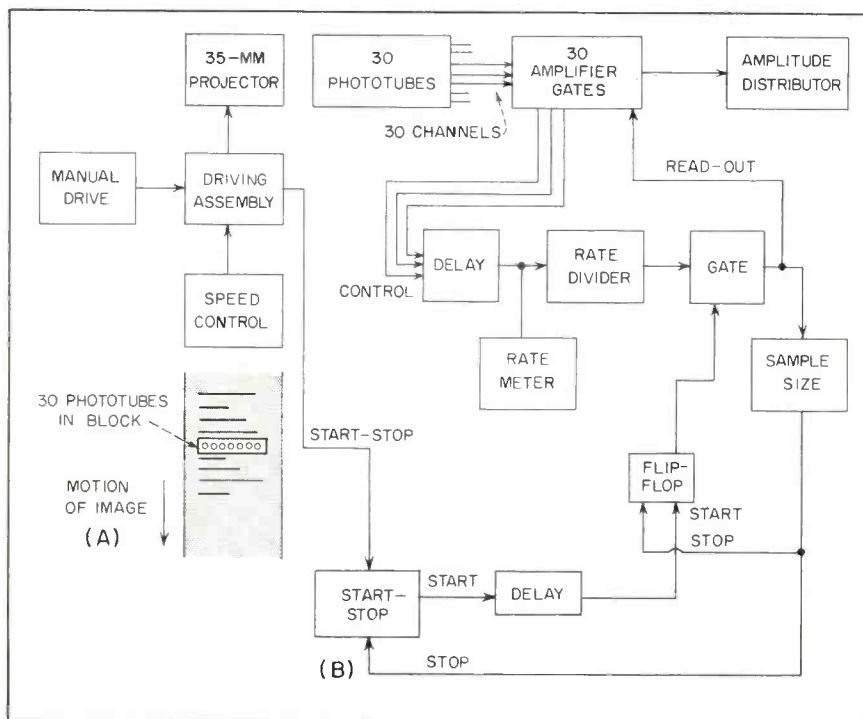
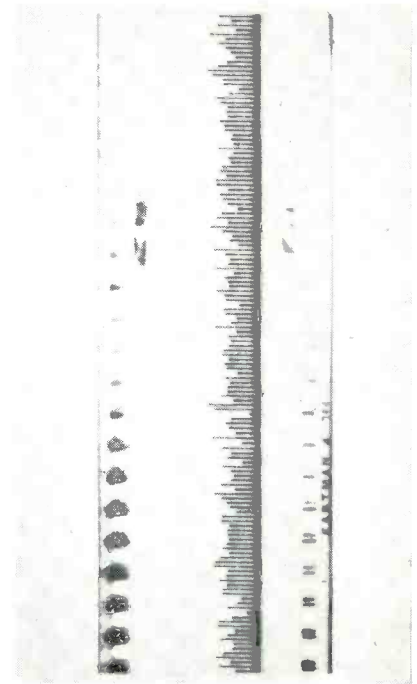

FIG. 1—Major units of film reader and amplitude distributor



Typical data on 35-mm film, in form suitable for analyzing by film reader

FILM READER Measures

By ALLAN SHAPIRO

Wave Propagation Branch, Electronics Division,
Naval Research Laboratory,
Washington, D. C.

SUMMARY — Amplitudes of parallel horizontal lines on 35-mm film are measured in 30 steps by projecting each line in turn onto row of 30 phototubes. Longest line covers all phototubes to give maximum count. Amplitude distributor stores resulting digital output until selected sample size has been read. Cumulative amplitude distribution is then read directly on 30 glow-tube counters, one for each amplitude level

ONE FORM OF data obtained in the investigation of radio wave propagation is the pulse-to-pulse representation of radar echoes. Each radar return is gated at a fixed range and the sampled amplitude, after being stretched, is applied to the X plates of an oscilloscope. The resulting intensified sweep is photographed on continuously moving film. The developed film presents horizontal lines whose length is proportional to the amplitude of the gated echo, as in Fig. 1A.

The first step in an analysis is the reduction of the data into a cumulative amplitude distribution. The accuracy desired will determine the number of levels, which are set equal to the maximum amplitude. Each received pulse will contribute a unit to all levels, which are equal to or less than the corresponding amplitude measured.

After a sample of a prescribed number of pulses has been read, each level will contain the number of pulses in the sample which either exceed or are equal to the level read.

The machine described here performs this analysis automatically from data stored on film.

Theory of Operation

The system includes a 35-mm projector, driving assembly, 30 phototubes, 30 amplifier gates, an amplitude distributor and the control or programming units, arranged as in Fig. 1B.

Thirty levels are used to measure the maximum length of a line. A sample of up to 1,000 lines can be

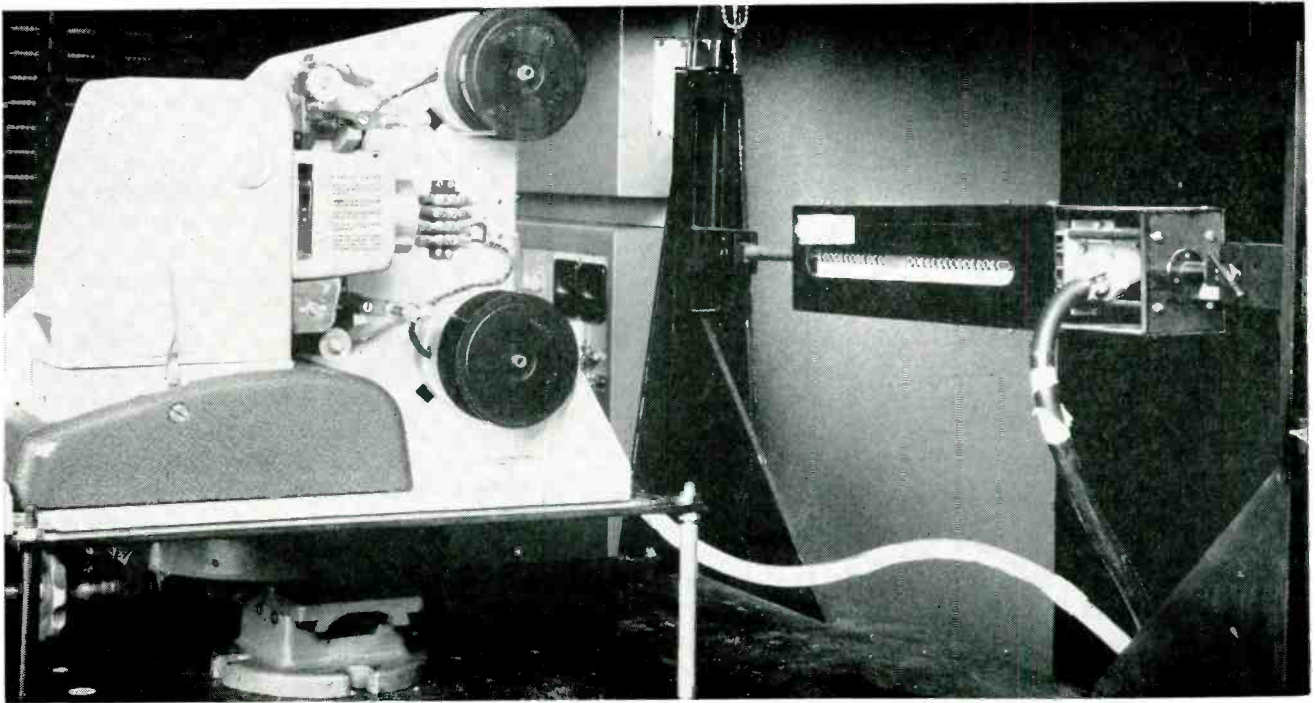

Projector at left throws image of line on horizontal row of 30 phototubes at right

Recorded Radar Echoes

measured in sequence. Each measured line contributes its weighted amplitude to the amplitude distributor. The cumulative amplitude distribution is stored in 30 glow-tube counters from which it can be read off at the end of the sample.

The whole system is controlled by

the start-stop operation on the bottom line. The start switch initiates the driving assembly of the projector and moves the image of the 35-mm film across a row of 30 phototubes. Each line, as it passes over the phototubes, generates an electrical signal in those phototubes

which have been darkened and transmits it to the corresponding amplifier gates. The number of levels which have been actuated is directly proportional to the length of the line. A control pulse, which is generated by the signal of the lowest three levels, interrogates the 30 gates and transmits a pulse through the opened gates to the corresponding glow-tube counters of the amplitude distributor.

Use of a separate control pulse improves and simplifies the overall operation of the system. A great amount of noise due to dust specks or scratches on the film is eliminated, as the levels are read out only in the presence of a data line. Furthermore, having a separate control pulse simplifies the logic of any additional control functions.

To allow all necessary phototubes to be darkened by the line being read, the control pulse is delayed and passed through a pulse rate divider. This provides selective read-out of the amplifier gates by

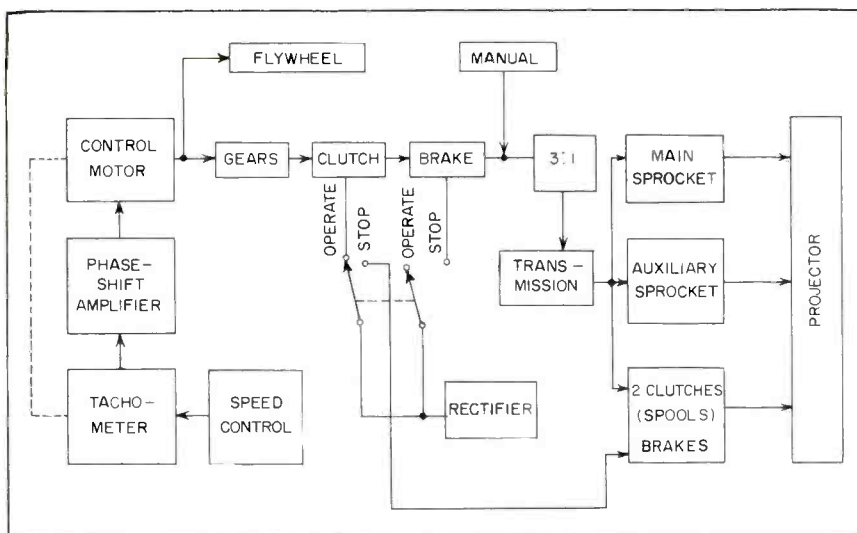

FIG. 2—Relays in film reader circuit control operate-stop switch of projector drive system

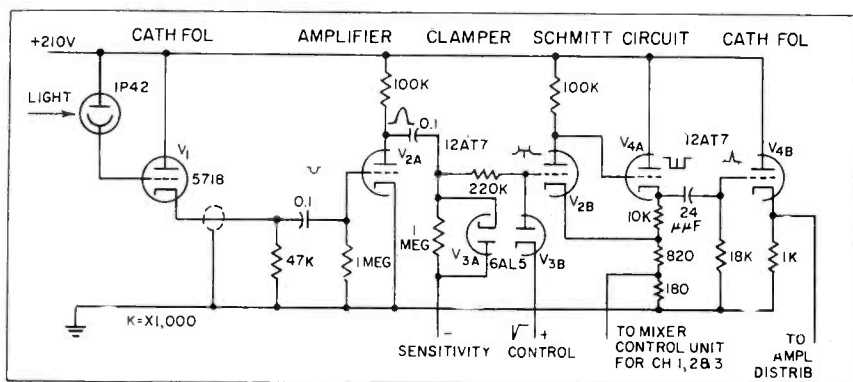

FIG. 3—Phototube circuit, amplifier, gate and output for one channel

reading alternate lines, every fourth line, etc. A time expansion of the sample, without increasing the sample size and the corresponding increase of tubes in the amplitude distributor, is thus accomplished.

The control pulse is also gated by the start-stop flip-flop to permit the projector to come up to full speed before any read-out takes place. Each gated control pulse is counted by the sample size counter, to indicate the number of lines that have been read and stop the system when the desired sample size has been reached. The stop pulse stops the projector and interdicts electronically any further read-out during projector deceleration.

The amplitude distributor consists of 30 three-stage decimal glow-tube counters. Each count is represented by a shift of the glow in a circular path. When the tenth count is accepted a pulse will be transmitted to the next stage. By using bezels with engraved digits of zero to nine around each glow tube, the numbers of the 30 levels in the cumulative amplitude distribution are read out directly.

Projector Drive and Projector

In Fig. 2 is shown a detailed block diagram of the electrical and mechanical system of the projector drive. To obtain constant speed and smooth operation of the film motion, a servo-amplifier is employed to supply voltage to one coil of a two-phase control motor. Any variation of output speed is fed back through a tachometer and compensates for the corresponding variation.

The start-stop switches are controlled by relays triggered by the

start-stop thyatron switch in the control system. In the start position the clutch is engaged and transmits the main drive to the projector. The system is quickly stopped by actuating the brakes in the main drive and on the two film spools.

The projector is a modified Educator 400 slide projector. A wide-angle lens and an additional condensing lens project a 24-inch image at a distance of 1 foot. Smooth operation and small weave have been attained by using a tight gate, two sprocket drives and two guiding rollers.

Film Reader Circuit

A detailed circuit diagram of one of the 30 identical channels of the film reader is shown in Fig. 3. The 1P42 phototube has an extremely high impedance. Maximum sensitivity is obtained by generating the signal across the grid-to-cathode resistance of V_1 formed by the small positive potential of the grid with respect to the cathode.

A dark line passing over the phototube reduces the grid current through V_1 and produces approximately a negative sine wave in the cathode output. This is inverted and amplified in V_{2A} .

The positive clamper consisting of V_{3A} and the related R-C combination compensates for the negative clamping action due to the grid current of V_{2B} . It also helps to discriminate against noise signals. Since noise due to dirt or scratches will occur only once for the most part, while data occur in groups of lines of similar amplitude, the clamping action will increase the sensitivity for sequences of signals while presenting the lowest sensi-

tivity to interfering noise signals.

The Schmitt trigger circuit containing V_{2B} and V_{4A} converts the positive sine wave into a pulse whose width is slightly less than that of the sine wave, as indicated in Fig. 4. In the quiescent state V_{4A} is conducting and cuts V_{2B} off by supplying a positive cathode potential. The line-generated sine wave fires V_{2B} , reducing the plate current of V_{4A} . The cathode voltage of V_{4A} remains close to zero until the grid voltage of V_{2B} reaches cut-off again. During conduction of V_{2B} , the negative control pulse appears through V_{3B} and cuts V_{2B} off momentarily, generating a positive pulse at the cathode output.

The output of V_{4A} is fed to a sharply differentiating network which eliminates the slow edges of the gate and transmits only the narrow control pulse to the final cathode follower.

The length of the line determines the number of phototubes darkened. The phototubes above the end of

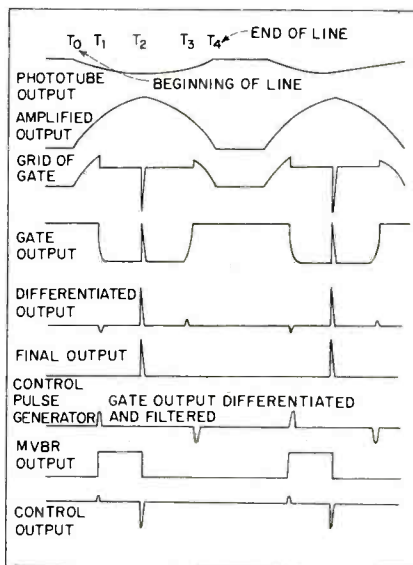

FIG. 4—Timing for channel operation

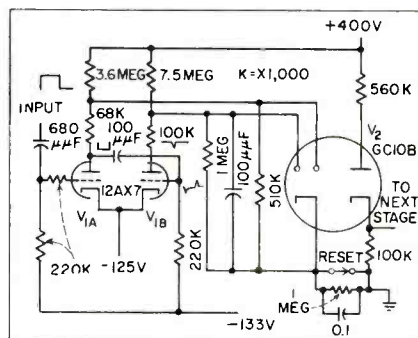

FIG. 5—Trigger circuit and decimal-indicating glow-tube

the line will not generate any signal and V_{2B} in the corresponding channels remains cut off. The control pulse appearing at the grid will cut the tube off further and no signal will be transmitted.

Only those channels which have been actuated by the data line will transmit the control pulse. These output pulses are used to add a unit count to the corresponding glow-tube counters in the amplitude distributor.

Amplitude Distributor

The amplitude distributor consists of 30 glow-tube counters and 30 associated pulse shapers at the input. Each glow-tube counter consists of three glow tubes and their three trigger tubes. One glow tube and its associated trigger tube is shown in Fig. 5. The properly shaped input pulse generates negative pulses on the two plates of the trigger tube which are delayed with respect to each other.

In the d-c condition, both guides of the glow tube are positive with respect to the cathode. The first negative pulse transfers the glow to the first guide. As soon as the negative potential on the first guide has decayed, the second negative pulse transfers glow to the second guide. The decay of the second pulse generates the final transfer to the next cathode. Two guides are needed to insure forward transfer.

Control Pulse

The generation and use of the control pulse is shown in Fig. 6. A control pulse is generated by the beginning of each line. To eliminate any loss of the control function due to weave of the base line, the three lowest channels are used to supply the initiating waveform. A low-pass filter in the input prevents the generated control pulse from feeding back and starting oscillation. The first gating waveform of the three channels, after being amplified and differentiated, triggers delay multivibrator V_2 through trigger tube V_{1B} .

The delay is controlled by potentiometer R_1 and is set to center the control pulse inside the gating waveform of each channel. The delayed pulse is then fed through the

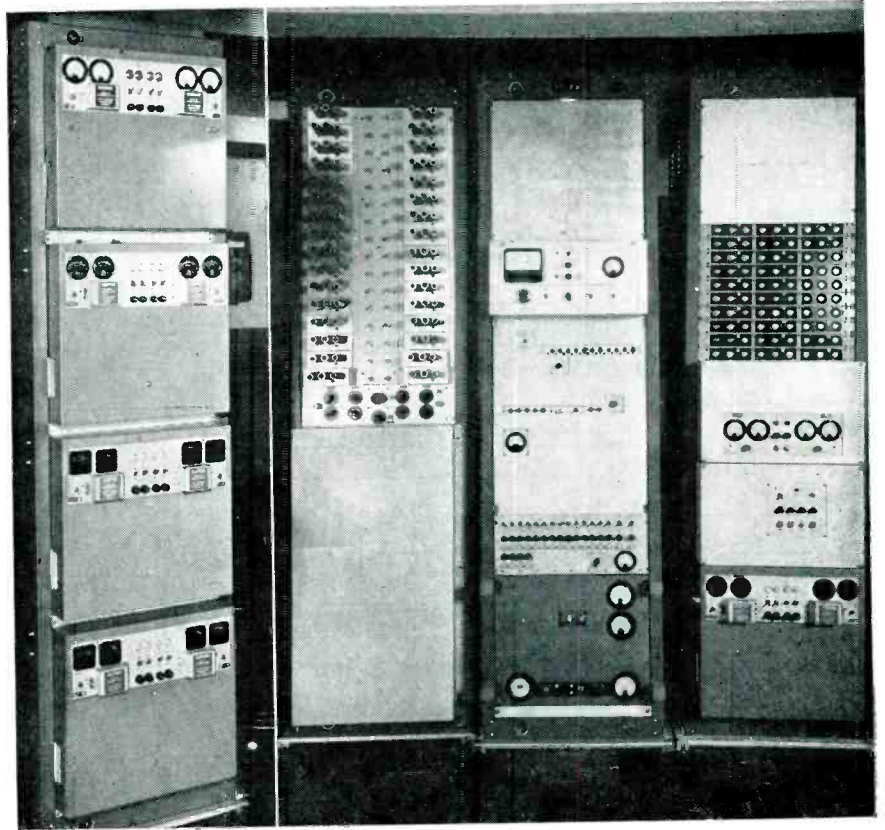

Equipment racks associated with film reader

rate selector switch to the start-stop gate. The rate selector switch selects the desired division from the row of cathode followers, which transmit the output of the divider flip-flops.

Start-stop gate V_4 in Fig. 7 is controlled by the grid of V_{1B} . When the start-stop flip-flop is on the off or stop condition, a positive potential on the grid of V_{1B} raises the cathode potential of V_4 , biasing V_{4A} to a value far below cutoff.

If a control pulse appears at the gate of V_{4A} , it will not be transmitted. The start command turns on the flip-flop after a fixed delay. This lowers the grid potential of V_{1B} and opens the gate. All control pulses will now be passed, until the flip-flop is turned off by the stop command from the sample size counter.

The normally closed start switch in the cathode of thyatron V_6 starts the system by interrupting the plate current of V_6 , de-energizing the relay and thereby engaging the clutch in the main projector drive. Also, the pulse on the plate of V_6 triggers delay multivibrator V_7 , which opens gate V_4 after a pre-

scribed delay. The crystal diode in the input circuit of V_6 prevents feedback to the flip-flop from the start-pulse transient.

When the full sample size has been reached, the stop pulse from the sample size counter fires the thyatron. This energizes the relays which in turn energize the brakes of the drive system. It also closes gate V_4 by triggering the start-stop flip-flop to the off condition.

Sample Size Counter

The sample size counter consists of a trigger stage, nine flip-flops and an output cathode follower. Each flip-flop has a switch associated with it which can preset the flip-flop to either one or zero.

All control pulses which interrogate the 30 channels are accumulated in the counter. When the full counter capacity of 1,024 is reached, the last flip-flop produces the output pulse which stops the system. By presetting the counter to the complement of the sample size to 1,024, any sample size from 1 to 1,024 can be obtained.

Each film has its own calibration,

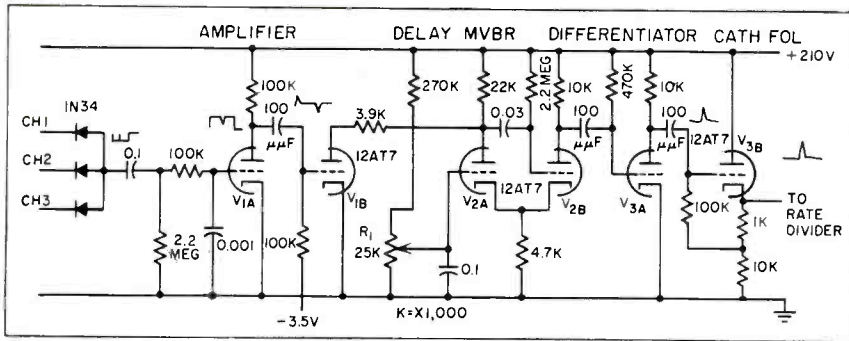

FIG. 6—Generation and delay circuit for control pulse

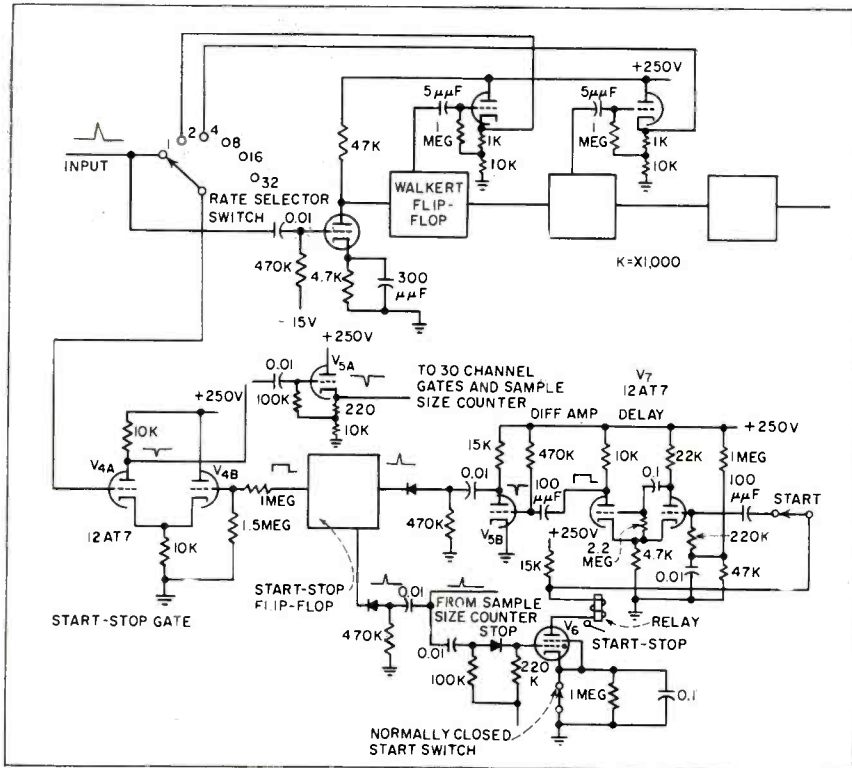

FIG. 7—Rate divider and start-stop gate circuits

which is recorded as 16 distinct groups of lines whose length varies in steps from the minimum detectable signal to the maximum amplitude. These calibrations are used to align the system. Since most of the calibrations are identical, the alignment does not have to be repeated for each film.

For visual alignment, the longest line of the calibration is projected onto the row of phototubes. The projector is positioned by a rotary table to place the projected line over about $29\frac{1}{2}$ phototubes. The phototube block is then tilted by two adjusting screws to align the row of phototubes as exactly as possible with the projected line. This assures simultaneous triggering of all phototubes.

For electronic alignment, the analysis is started by taking small samples of the calibration steps, starting with the smallest line, and monitoring the gated output for the first few channels. Delay potentiometer R_1 in Fig. 6 is adjusted to center the control pulse in the channel gate. This can be checked for several calibration steps, to obtain optimum position due to slight variation in placing of phototubes.

When steps of longer length are reached, the visual adjustment is checked electronically by noting the shift of the control pulse inside the gate. A slight adjustment of the phototube block may be necessary to recenter the control pulse. This completes the alignment of the system and the calibration.

To operate the system, the sample size counter is preset for the desired sample size. The system is reset and started. When the full sample size is reached, the system stops. The 30 levels in the amplitude distributor are read out and after resetting the system a new sample is started.

The system has been wired for easy maintenance and quick location of failure to keep dead time to a minimum. The 30 amplifier gates are plug-in units and can be individually monitored at both the phototube output and gate output. Neon lights have been used freely to monitor points in the amplifier and control circuits to indicate any failure.

Conclusions

The use of the equipment has greatly reduced the time of analysis compared to the time of data taking. It is intended to increase the accuracy to about 1.5 percent by increasing the number of levels to 60. However, it is not deemed practical to go beyond this because of the corresponding increase in the size of the equipment.

The operating speed is limited by the high impedance of the phototubes and could be increased by using some of the newly produced phototransistors. The system appears reliable for intermediate speeds.

Due to a separate control pulse it shows good noise discrimination and allows flexibility of programming. The time of alignment becomes insignificant for standardized film recording. It is planned to read out the glow-tube counters automatically and print the results on an electronic typewriter to give a permanent record immediately.

Help and guidance received from D. L. Ringwalt, both in the theory and construction, is acknowledged. P. L. Watkins designed the projector drive and helped in the modifications of the projector. The Atomic Instrument Co. designed and assembled the 30-level amplitude distributor. The assistance of J. Capp and E. G. Hardison in solving the many mechanical and constructional problems contributed to the success of the project as it approached completion.

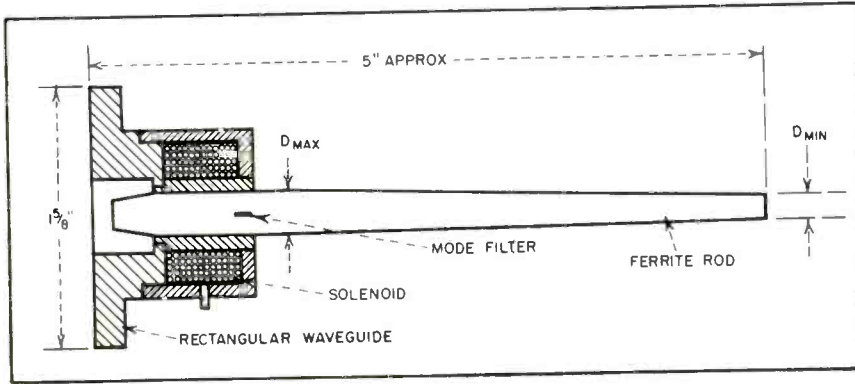

FIG. 1—Basic ferrite-rod antenna system for coupling to end of standard waveguide. Tapered end in waveguide aids impedance matching

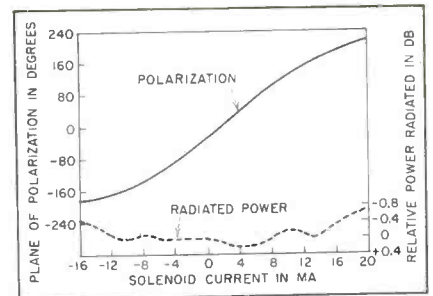

FIG. 2—Polarization and radiated power of ferrod antenna in relation to mode-switch solenoid current at 9,430 mc

By FRANK REGGIA,
E. G. SPENCER,
R. D. HATCHER,
and J. E. TOMPKINS

*Diamond Ordnance Fuze Laboratories
Washington, D. C.*

FERRITE-ROD ANTENNAS OPERATE IN X-BAND

SUMMARY — Dielectric radiators use ferrite-rod elements and ferrite switching devices for mode switching, array scanning and beam lobing. Radiation patterns show optimum design configuration of rod radiators for operation in the 9,000-mc band. Gain of a single radiating element is about 20 with vswr of less than 1.2

MICROWAVE antenna systems have been developed for X-band use, which employ rods of commercially available ferrites (ferrods) as dielectric radiating elements. Application of a magnetic field to a section of the ferrite radiator is used to obtain beam scanning, beam lobing, switching, modulation or rotation of the plane of polarization.

A typical X-band ferrite has a dielectric constant of 13.6 and an

initial permeability of 0.78. Its field-dependent permeability has a tensor characteristic which gives rise to the Faraday effect and the development of many useful devices.

The basic ferrite-rod antenna system is shown in Fig. 1. The radiator may be considered a dielectric-rod radiator, excited by a ferrite-filled section of cylindrical waveguide with a longitudinal applied magnetic field. The rod protrudes into the rectangular wave-

guide section and is magnetically coupled to the r-f fields. The short taper at the input end is used for impedance matching. The radiating portion of the ferrite rod is tapered to give maximum radiation along its axis and minimum radiation in the side lobes. The overall length of the system is about 5 inches. The ferrite-rod is $\frac{1}{4}$ -in. in diameter and about $4\frac{1}{2}$ -in. long.

The ferrite-filled waveguide section is $\frac{3}{4}$ -in. long and is surrounded

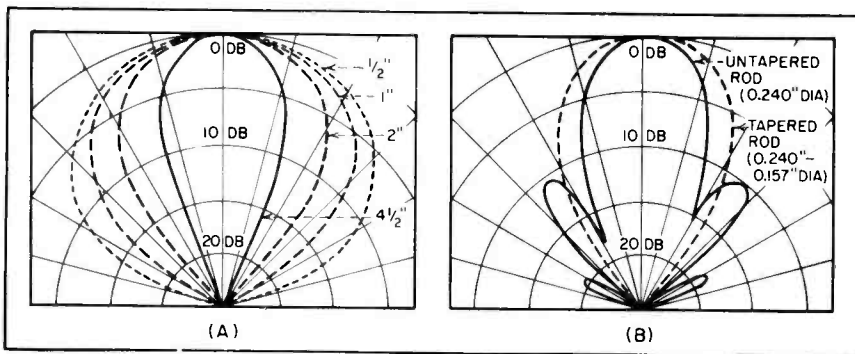

FIG. 3—Effect of ferrite length on radiated pattern at 9,500 mc (A) and effect of tapering rod (B) at 9,600 mc. Note reduction in side lobes obtained by tapering

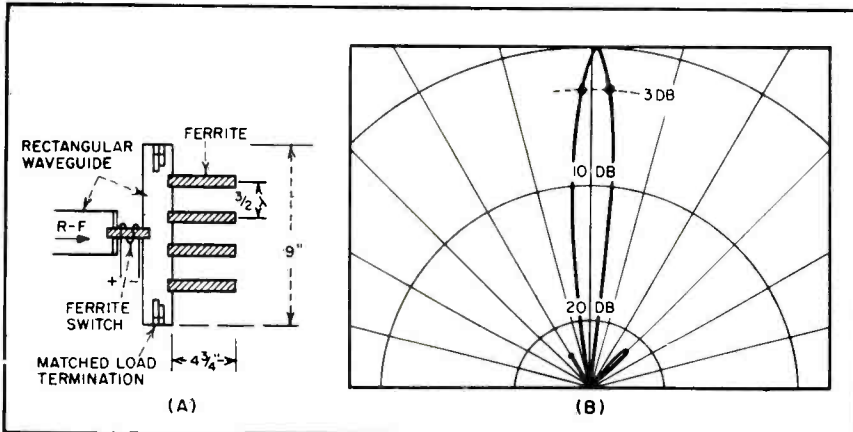

FIG. 4—Four-element radiator (A) has fan-shaped pattern in the plane of the rods as shown at (B). Vertical pattern of array is same as that of one rod

by a low-current solenoid. The mode filter, 0.02-in. thick and 0.06-in. wide, goes through the ferrite and makes electrical contact to both sides of the circular guide. These three components make up the ferrite mode switch or modulating section of the system.

Mode Switch Action

Operation of the mode switch depends on Faraday effect in the ferrite. This causes a rotation of the plane of polarization of the microwave energy incident upon the mode filter when a longitudinal magnetic field is applied as shown in Fig. 2. When the polarization of the incident wave is perpendicular

to the length of the mode filter, the wave propagates across essentially unchanged.

Rotating the polarization parallel to the length of the mode filter short-circuits the electric field, rejecting the microwave energy incident upon it. Greater than 20-db switching can be obtained with this modulating section with control currents of approximately 10 ma.

Modulating frequencies in the kilocycle range have been used with this system. Where required, it is possible to extend this frequency range up to a few megacycles by high-speed pulsing techniques.

Impedance matching between rod and waveguide is accomplished by

adjusting the length of the rod extending inside the guide. This adjustment is made less critical by a short taper at the input end of the rod. Input vswi's less than 1.2 and half-power beam widths of less than 28 degrees are not difficult to obtain with this single radiator.

Directivity in relation to length of a single untapered ferrite radiator, 0.240 in. in diameter, is shown in Fig. 3A. The rod is fed from the end of a rectangular waveguide at 9,500 mc. Beam width decreases with increasing length of the ferrite. Gain of a single untapered radiator 4 1/2 in. long was found to be approximately 20 at this frequency.

A comparison between the radiation patterns of a tapered and an untapered ferrite radiator, 3 1/2 in. long, at 9,600 mc is shown in Fig. 3B. Although the untapered rod gives a narrower beam, the power radiated in side lobes is excessive. This side-lobe radiation is almost completely eliminated by the tapered ferrite but produces an increase in the width of the main beam. By increasing the length of the tapered ferrite, the original value of the beam width is restored.

A simplified drawing of a 4-ferrite rod linear array and its radiation characteristics in the plane of the rods are shown in Fig. 4. The half-power beam width in this plane is approximately 6 degrees. In the vertical plane, beam width is that of a single rod, resulting in a narrow fan-shaped beam. The individual radiating elements are spaced λ_r apart, providing maximum radiation along the axis of the rods.

Cavity-Fed Arrays

Another type of antenna array has been designed with ferrite-rod radiators magnetically coupled from resonant cavities. These cavity arrays are simple to construct and, in general, give higher gains than those previously described.

The field distribution and position of the rods inside a TE_{304} mode cavity, exciting a square array of ferroids, are shown in Fig. 5. The magnitudes, directions and positions of the electric and magnetic fields can be seen with the rods at positions of maximum magnetic field.

There are six positions away

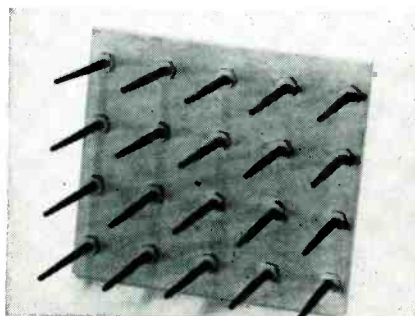
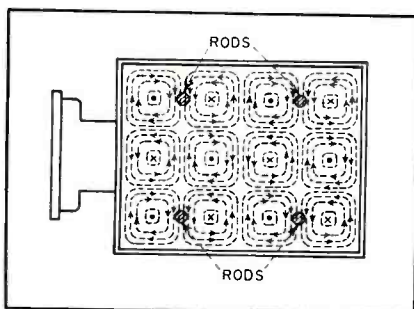

FIG. 5—Cavity array has rods positioned at points of maximum magnetic field intensity

from the walls at which there are zero electric and magnetic fields and zero r-f wall currents. At all such positions, shorting posts are placed to insure the proper mode of oscillation of the cavity and to insure in-phase excitation of the ferrid radiators.

An extension of this technique using 20 ferrite rods is shown in a photograph. The dimensions of this TE_{800} cavity array are 7 in. by $7\frac{3}{4}$ in. by $\frac{1}{2}$ in. and the cavity is excited by a waveguide coupling in the back. The beam width produced is 6 degrees by 7 degrees.

Array Switching and Lobing

To utilize the small size of the ferrite-rod antenna system, compact microwave switches, circulators, and phase shifters were designed to obtain beam scanning, lobing and switching.

Operation depends upon the variable magnetic properties of the ferrite as shown in Fig. 6. These curves show the components of the dispersive scalar permeability, $(\mu' + K')$ and $(\mu' - K')$, of the ferrite below magnetic saturation for positive and negative circularly-polarized waves, respectively. Since a linear wave may be considered to be composed of these two circularly-polarized waves, the effective permeability (μ'_{eff}) for a linear wave is included in the figure.

The small microwave switch consists of a $\frac{1}{4}$ inch ferrite-filled cylindrical waveguide section inside a low-field solenoid. The ferrite protrudes approximately $\frac{1}{8}$ -in. into a rectangular waveguide. The switch is on when no current flows through the solenoid. With approximately 10-ma solenoid current, the plane of polarization of the microwave energy is rotated 90-deg in the cir-

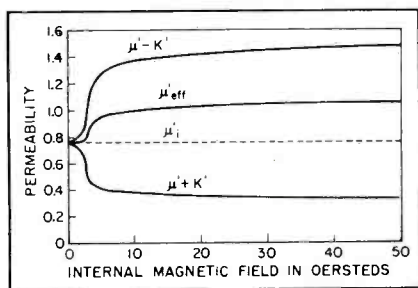
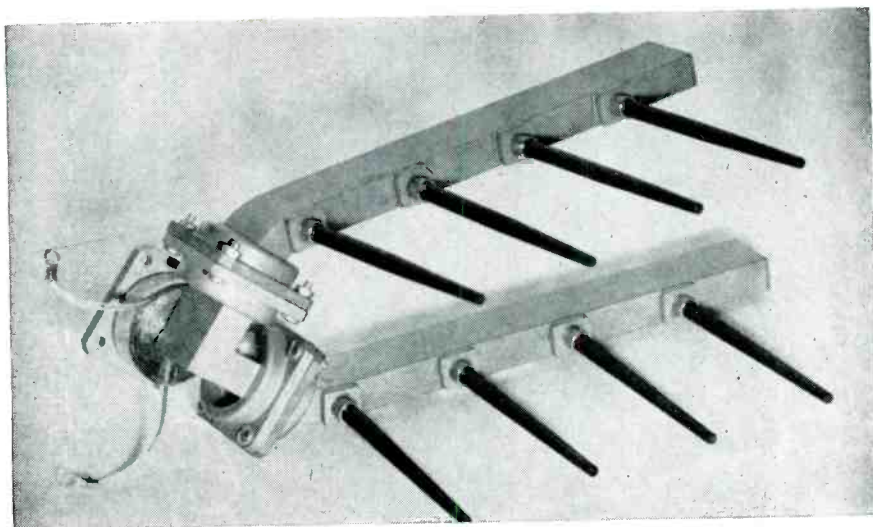

FIG. 6—Circularly polarized permeabilities of ferrite material plotted against internal magnetic field



Beam lobing ferrite-rod antenna system using ferrite magnetic switch

cular waveguide section. This rotated r-f field is now cross-polarized with respect to the output waveguide and the energy is reflected back toward the source. Up to 30-db switching has been obtained with this device.

By employing a slightly smaller ferrite-filled cylindrical waveguide section, the same form of switch is made to operate on the waveguide-below-cutoff principle. When current flows in the solenoid, effective permeability of the ferrite is increased sufficiently to allow the ferrite-filled section of waveguide to be near, but above, cutoff. With no current in the solenoid, the effective permeability is decreased and the waveguide is operating below cutoff. Up to 50-db switching has been obtained with this device.

Circulator-Type Switch

Another ferrite unit using the Faraday effect is a circulator-type switch. The microwave energy enters a ferrite-filled section of waveguide where its plane of polarization is changed by an external magnetic field. By rotating the plane of polarization, energy can be made to propagate through either arm. At least 20-db switching can be obtained with less than 20-ma solenoid current.

This switch has been used effectively in beam-lobing systems as shown in one of the photographs.

Array Scanning

Application of a longitudinal magnetic field to the feed section of

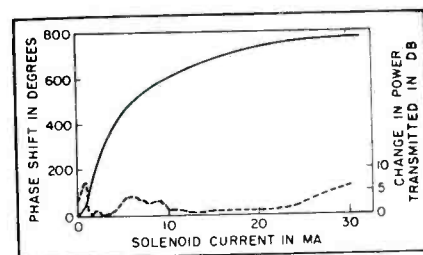
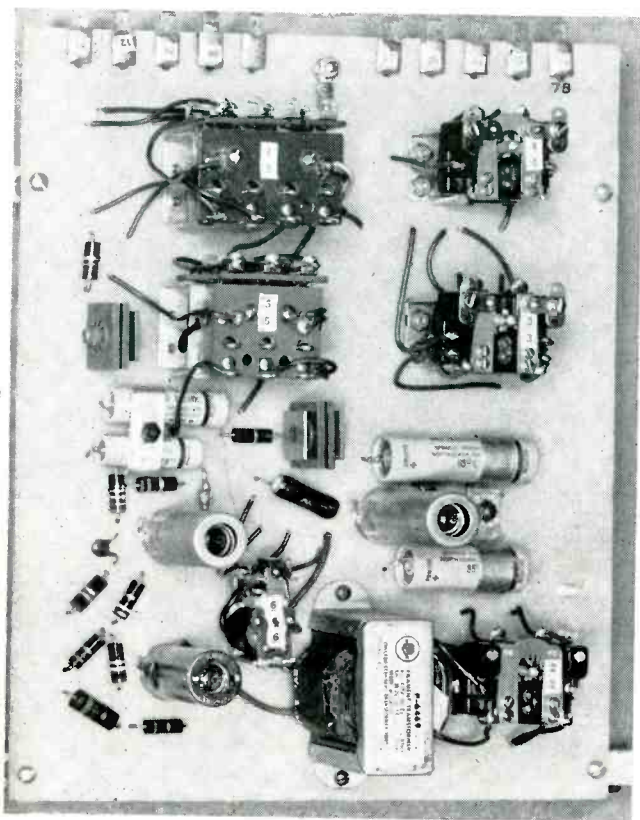

FIG. 7—Phase shift and power output as solenoid current is changed

a ferrite radiator results in a change of the phase of the radiated energy with respect to its neighbor. By phase shifting between rods the radiated beam can be made to scan back and forth by an amount equal to its beam width. In a particular application, beam shifting of ± 5 degrees was obtained using this technique without causing a deterioration of the beam characteristics.

Another method for obtaining the same results is to use a closed form of ferrite phase shifter having the properties shown in Fig. 7. Reciprocal phase shifts greater than 600 degrees have been obtained with variations in transmitted power as shown in the lower curve.

This ferrite device, similar to the microwave switch is used between the radiating elements. A phase shift of 90 degrees between radiating elements spaced λ , apart will give a 10-deg beam scan. In the laboratory a ± 10 -deg scan was obtained at a 20-kc scanning rate with only moderate broadening of the beam.



Component lay-out on printed-circuit wiring board. Solder-in-type relays were used for minimum unit cost

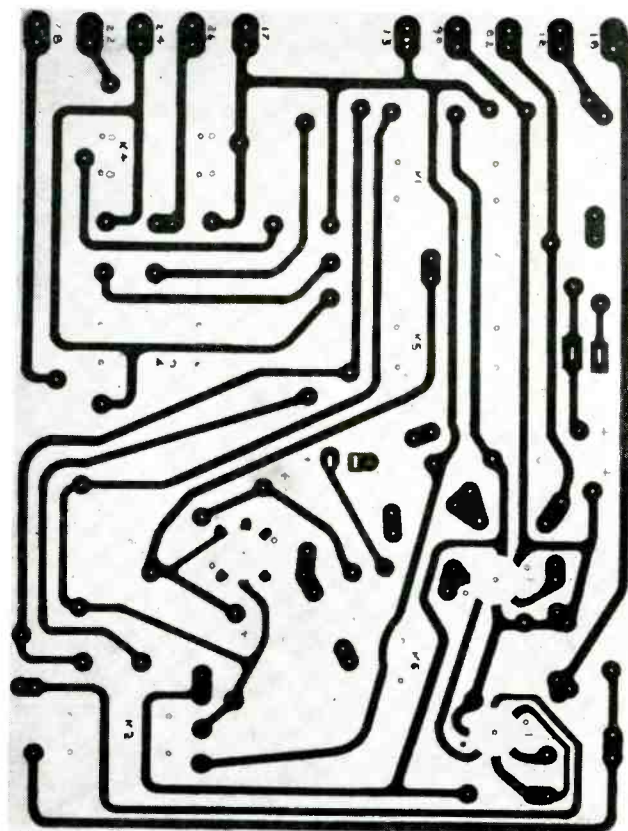

Rear of printed circuit board. Material is 3/32-in. epoxy-glass

THYRATRONS CONTROL

SUMMARY — Time delay and two-thyratron control circuits stop hydraulically actuated cutting die as it completes circuit between conductive surface of cutting pod and beam striking plate. Stopping press short results in longer die and cutting pod life and reduced floor vibration when cutting leather, cloth and sheet plastic as in the manufacture of escutcheons. Operator's hand-to-hand resistance is made part of control circuit to stop press for safety

MECCHANICAL SWINGING-BEAM die-cutting machines have been in existence for over 40 years. Their work varies from cutting leather, plastic cloth and fish to cutting escutcheon rims for tv picture tubes. About 28,000 machines are in industrial use.

The beam motion is a fixed stroke from a flywheel crank. The operator sets the beam height to drive a cutting die through the work into

the cutting surface to obtain a clean cut. Die sets must be of the same height, otherwise die sticking or insufficient cutting results. Resharpener one die of a set requires changing the beam-height setting.

The moving masses which produce cutting forces of 20,000 pounds create considerable impact floor loading. Thicker gage material required multiple cutting.

While the mechanical cutting

machines have done creditable work, electronic control results in safer and more efficient operation.

Cutter

The electronic stroke-controlled cutter consists of a hydraulically operated cantilever beam which strikes downward pressing a cutting die through the work onto a conductive cutting surface. The machine has a one-horsepower

The Front Cover

By **ROBERT W. BRADLEY**

*Senior Electronic Engineer, Research
Division United Shoe Machinery Corp.,
Beverly, Mass.*

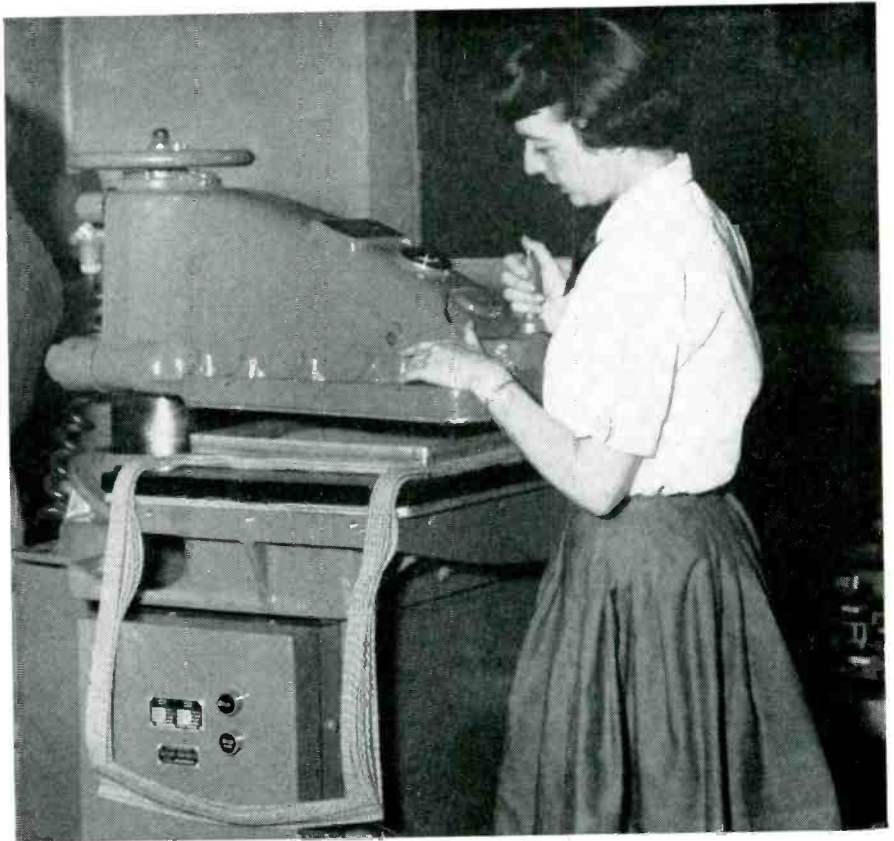

Operator safety is provided by including hand-to-hand resistance in control circuit

DIE-CUTTING MACHINE

motor and flywheel which drives a six-piston hydraulic pump, producing up to 5,100 psi working pressure as needed. This drives the beam-spindle, piston developing up to 30,000 pounds total force.

The electronic control limits this force to a value necessary only to cut the work, preventing high-pressure build-up and minimizing floor reaction. Hydraulic operation dampens the release of the machine deflection which further minimizes floor reaction. A solenoid-operated hydraulic valve provides sharp fluid cutoff.

The cantilever striking beam has a falling velocity of approximately 4 ips and a pressing downward velocity of 1 ips. It is possible to set the beam height mechanically by a position wheel thus minimizing the free stroke.

A $\frac{1}{4}$ -in. aluminum striking plate is attached to the bottom of the

beam, but electrically insulated from it. The remainder of the machine, including the cutting surface, is at machine ground potential.

Two cutting surfaces may be used. A carbon-rubber-resin type is useful for overall cutting. This pad has an average resistance of 5,000 ohms per cm.² Another cutting surface constructed of an insulating coating over sheet aluminum is useful for cutting materials having high conductivity such as metallic cloth.

Stroke

The cutting stroke is terminated electronically when the cutting die completes the circuit between the beam-striking plate and the conductive cutting surface. Because of this electronic control, beam-height position is relatively unimportant.

It is possible to use several dies of different heights in sequence without readjusting the machine and with consistent cutting control, provided the machine is set to the highest die.

Controlled die penetration eliminates die sticking and die damage. A longer life of cutting surface is maintained. Improved cutting performance with less operator fatigue has also been noted.

Stroke Control

The automatic stroke limiting control must stop the beam travel for controlled die penetration into the conductive cutting surface to assure accurate cutting; pre-trigger the control with high values of hand-to-hand body resistance to stop the beam travel and prevent body injury; and must have an accurately repetitive time delay for pressure build-up to make it useful

This resulted in good timing, providing a ± 1 -millisecond variation from 140 v a-c to 90 v a-c. Fifty-cycle operation was satisfactory to 95 v a-c with possible operation down to 85 v a-c.

Shock and Vibration

A test apparatus was developed for accelerated testing of the cutting machine electronic control and associated beam time-delay block. The maximum acceleration of the cutting machine base is 1 to 2 g.

The testing apparatus subjected the control unit mounting bed to 13.4-g maximum acceleration. Acceleration values were checked by a linear velocimeter developed here. Round sponge-neoprene-rubber shock mounts reduced the printed-circuit-board acceleration to 4.9 g hence they were incorporated in the final design. Acceleration of the potted capacitor time-delay block was 8.5 g.

The units were found to stand up well after extraordinarily long testing. The control unit was supplied with electric power and triggered during each stroke of the accelerated test. One sample unit was subjected to seven million cycles or seven years of normal machine cycle use. One 2D21 thyatron failed at one million cycles, another at 0.7 million cycles and a third at 1.5 million cycles. The industrial type 2D21's (5727) showed no improvement over the regular. Broken tube glass tips, fractured heater wire and open heater welds constituted the failures.

Components

Thytrons were chosen over vacuum tubes because of their longer life, sturdier construction, greater grid-cathode distance and satisfactory operation at reduced heater voltages.

A 0.001- μ f, 9/16-in. diameter ceramic capacitor, used to stop pre-firing of the first stage on application of B+, broke off on one vibration test. A $\frac{1}{8}$ -in. diameter capacitor passed all other tests.

Electrolytic capacitors when mounted horizontally, would break their leads. When placed vertically the internal bulk of the capacitor would slide up and down inside the capacitor can until the internal

wire connection broke. Horizontal position with a mounting clamp, plus a 250-v working voltage rating gave no failures.

Horizontal mounting of the control-relay armature-shaft was a must for in a vertical position the acceleration shocks wore notches in the shaft supports, preventing relay operation.

Studies of shock and vibration in the field showed that in concrete buildings of recent design, there was more shock on the electronic control unit from mechanical cutting machines nearby than from operation of its own machine.

Sequential Operation

Closing the start switch energizes the control transformer which supplies 110 v a-c to the control thyatron filament and control power supplies and starts the pump motor.

Lock-out relay RE_1 is immediately energized opening contacts RE_{1A} and RE_{1B} so that the machine cannot be operated.

The control grid of the first thyatron is grounded through RE_{1B} contacts. As soon as the thytrons are heated sufficiently, the first and

second thytrons will fire energizing relay RE_2 , opening contacts RE_{2A} and RE_{2B} . Relay RE_1 is now deenergized closing RE_{1A} and RE_{1B} .

Pushing the trip switch on the beam now operates the machine. However, if some part of the control had failed to operate, then relay RE_2 would not have operated and relay RE_1 would have remained energized, its open contacts preventing trip-switch circuit completion.

Trip Switch

Pushing the trip switch energizes relay RE_1 which is locked in by contacts RE_{1C} and RE_{2A} . Relay RE_5 is energized through RE_{1A} . Rectifier No. 3 and R_1 . It was necessary to delay operation of relay RE_1 approximately 40 milliseconds after energizing RE_1 to provide sufficient time between the opening of the fired thyatron's plate circuit by contacts RE_{1C} and the closing of contacts RE_{1A} to extinguish the thytrons. Before RE_{1A} can restore plate voltage to the thytrons, the fired thyatron grid is still tied to the beam striking plate and has 18-v negative bias to prevent it from firing.

On closing of RE_{1A} the beam solenoid is energized starting the beam downward. Shorting of the beam striking plate to the conductive cutting surface by the cutting die fires the first thyatron energizing relay RE_2 . Contacts RE_{2A} and RE_{2B} open, removing beam solenoid power and the beam returns to its original position. Relay RE_1 is unlocked by opening of contact RE_{2A} . The machine is now ready for the next cut.

The high pressure overload switch—relay system RE_3 is set for release at 5,100-psi hydraulic line pressure. Operation of RE_3 returns the beam to its original upward position.

Hand-to-foot body resistance measurements and experiments show that this is entirely feasible and practical. To complete the operator's circuit to ground for these cases conductive shoes made to the U.S. Bureau of Mines specifications for conductive shoes may be worn. A machine grounded sheet of metal could serve as the floor area for the operator.

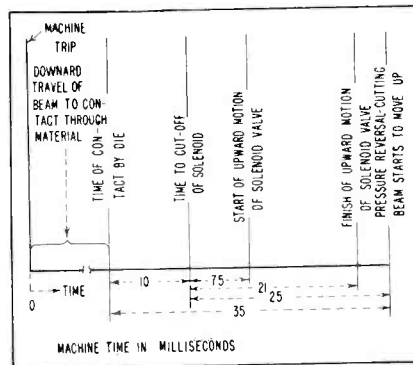

FIG. 2—Time diagram shows operating sequence

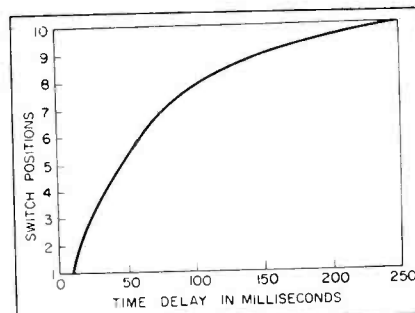
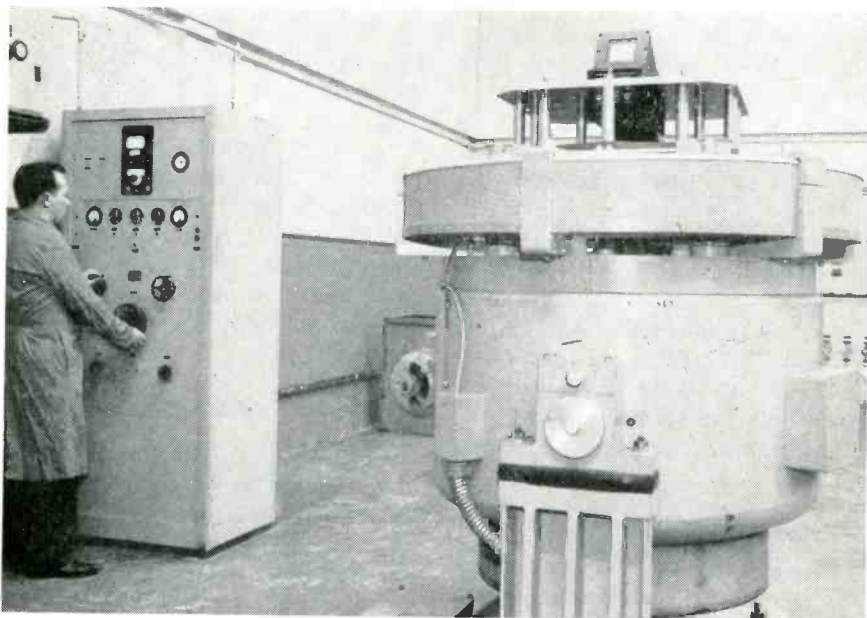

FIG. 3—Stroke control unit time delay for various switch positions



Vibration testing table in vertical position with electronic gear under test mounted on top

CHECKLIST FOR HIGH VIBRATION

- Chassis—
 - Low center of gravity
 - Rigid construction
 - Ductile material where possible
- Capacitors—
 - Use axial lead types
- Resistors—
 - Ferrule clips for larger sizes
- Transformers—
 - Mounting studs attached to core
- Meters—
 - Rubber grommet mounting
 - Leads slack
- Wires—
 - Flexible mounted components:
 - leads slack
 - Rigid mounted components:
 - leads tight

DESIGNING AIRBORNE

SUMMARY — Techniques of chassis design, component placement and testing methods to help electronic equipment attain maximum reliability in aircraft and missile applications. Proper selection and design of components contributes to reliability under high vibration conditions

ONE most important consideration for airborne electronic equipment is the design of the mechanical chassis or supporting structure. It has to be light in weight, minimum in size, yet able to maintain good mechanical strength.

A good design should have a center of gravity as close to the mounting surface as possible to help reduce vibration amplification caused by coupling modes of vibration.

The chassis must be rigid to maintain the natural frequencies of vibration above the testing frequency range as resonant points subject the structure to high repeated loadings. Supporting members can be made rigid by increasing thickness, flanging the ends, changing the geometry of the

structure or by ribbing the surfaces as shown in one of the photographs. Use of gussets and the proper location of stiffening members also aid in reducing flexibility.

Figure 1 shows an amplification curve obtained on an existing unit. High transmissibility was experienced at the resonant point.

Component Selection

Capacitors should be mounted to prevent relative motion between the leads and body. As an example, use of a 0.02- μ f disk type capacitor in one application resulted in broken leads during vibration. By the nature of its design, as shown in Fig. 2A, this capacitor caused a cantilever action. This action was eliminated by changing the leads so they were mounted axially

as in Fig. 2B, thus removing the cantilever effect and eliminating the large relative motion that existed during vibration.

Transformers that have mounting studs attached directly to the iron core are generally preferable. Studs mounted to a relatively weak housing can be pulled away by high vibration forces. If the mounting bolts are secured to the core, the large internal forces are removed from the housing.

Ruggedized meters are desirable to withstand vibration forces. Use of rubber grommets at the meter mounting studs will result in a low resonant frequency of the meter. Care should be taken to attach leads to the terminals with sufficient slack to avoid wire breakage.

Large resistors mounted in fer-

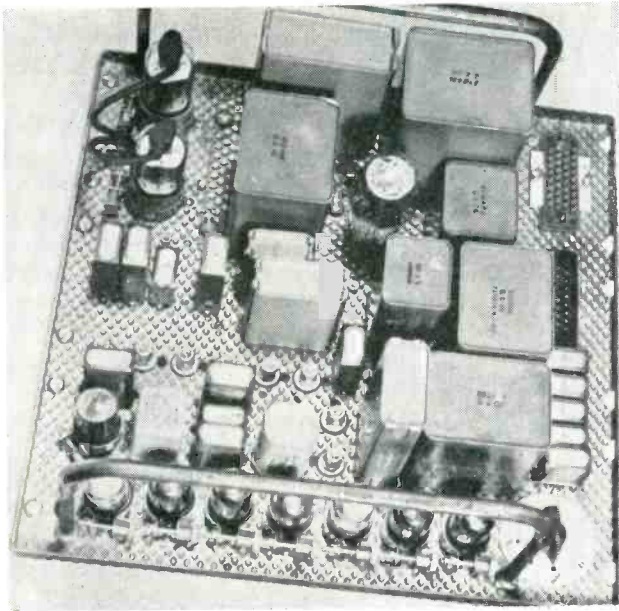

Chassis rigidity is increased by use of dimpled surface

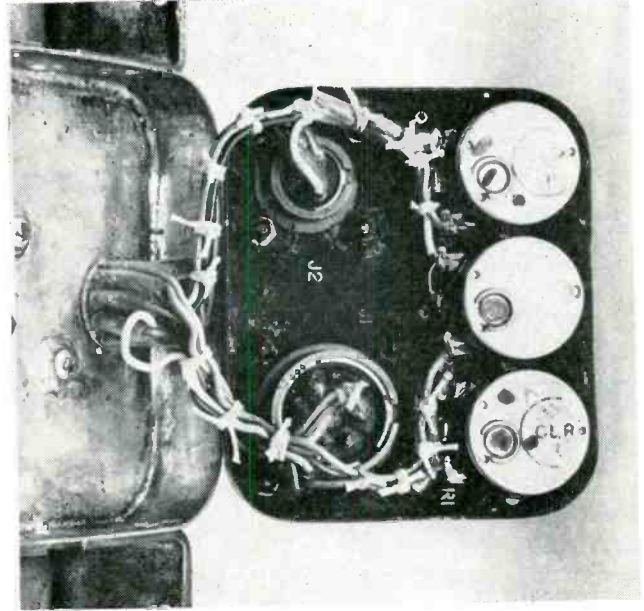

Tieing wires prevents build-up of vibrations in any one lead

EQUIPMENT for Vibration

By SALVATORE P. MERCURIO, Jr. and MICHAEL BELBY

*Light Military Electronic Equipment Department
General Electric Co.
Utica, New York*

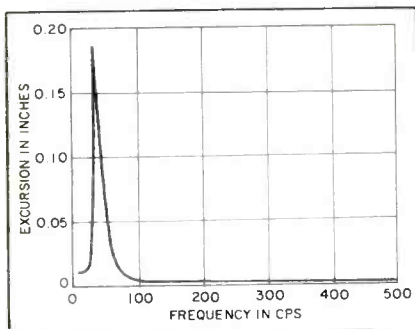

FIG. 1—High transmission of vibration in the 31-cps region as measured on chassis under test on vibration table

soldering should be avoided. Heat causes brittleness and produces low fatigue life.

Crystals

Crystals have been mechanically redesigned to meet vibration requirements.

For example, crystals in the range of 244 to 428 kc were selected at random and subjected to a vibration cycle of five to 500 cps at 2 g maximum. The exterior crystal cans were removed so the internal parts could be examined under vibration with a stroboscope.

All crystals had severe resonant points. The lower rated crystals experienced mechanical failure at the joining point of the crystal quartz leads and the supporting wire mounting.

The failures were remedied by increasing the wire size, for greater support, and eliminating several sharp bends. Figure 3 illustrates the change that was incorporated. The ruggedized crystals had no resonant point within the 500-cycle range.

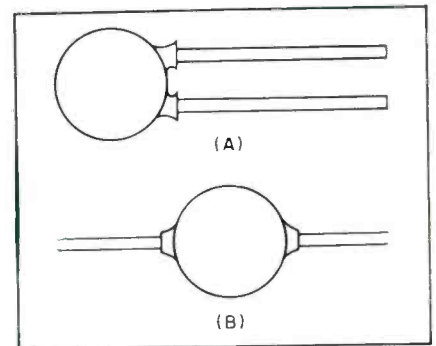

FIG. 2—Side-mounting of disk capacitor (A) permits high vibration. Axial mounting (B) provides more rigid support

rule clips should be provided with spring locks to ensure stability during vibration.

Wire breakage creates a major problem in design. When the component is mounted so motion can take place because of isolation, sufficient wire slack should be provided. One of the photographs shows use of cord to secure a group of wires to prevent build-up of vibration in any one of them. If the component is mounted solidly, so motion cannot take place, leads should not have slack.

Excessive heating of wire during

Ruggedized tubes are being made that are capable of meeting higher vibration requirements. However, it is of little value to ruggedize a tube based on general vibration requirements if the vibration conditions are not controlled in the structure. A tube may be designed for a maximum excursion of 0.010 inch at five to 500 cps. If this tube is placed on a flexible member, the resulting excursion at resonance may be two to four times as great.

Tube failure seldom occurs be-

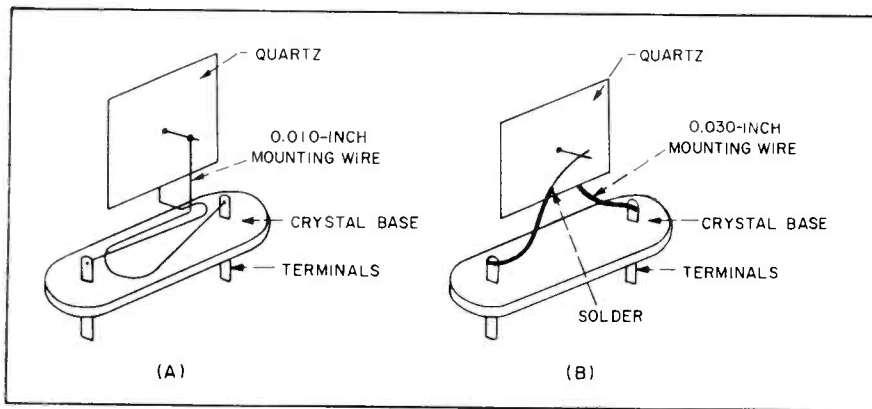

FIG. 3—Conventional crystal mounting (A) has lower tolerance to vibration than more rigid mount (B) designed for vibration up to 500 cps

cause the tube is inadequate. If ruggedized tubes are used with a good choice of tube location, a firm clamping system and a good chassis and supporting structure, failures can be reduced sharply.

Fastening Devices

Components and subassemblies must be made accessible for ease in repair and maintenance and must be firmly attached to prevent imposing any great amplification of vibration forces.

Proper fasteners must be selected to obtain maximum use. Where subassemblies are attached permanently and removal is not a design requirement, rivets are useful. Rivets fastened by machine provide a more uniform tension than screws or bolts fastened by an individual assembler.

Where assemblies or components are to be mounted so they may be removed, screws are often used. Lock washers should always be used in conjunction with screws. The split ring-lock washer, in particular, was found to be satisfactory because impact loading during vibration does not cause the adjacent soft metal, such as aluminum, to deform washer.

Use of quick disconnects has the advantage that a faulty component can quickly be removed and a new one replaced. However, much care must be taken so the unit does not become overloaded by the use of improper quick-disconnect fasteners.

It is advisable to use ductile materials when possible. When design demands the use of brittle materials proper isolation should be

provided to prevent failures under impact loadings.

Vibration Evaluation Testing

There are a number of points to be considered when conducting vibration evaluation tests on airborne equipment.

Testing facilities should be checked to determine their accuracy. This includes checking the vibration machine for levelness and resonance in the supporting table and calibrating the velocity pickups, accelerometers and other testing meters. The vibration machine shown in the photograph can be swung through 90 degrees. It has a frequency range from five to 500 cps.

Fixtures used to mount the equipment should have a center of gravity coinciding with the center line of the table. If this is not done, the equipment mounted on the fixture may be subjected to additional forces beyond the original test requirements and invalid data will result.

Weight added underneath the fixture, as in Fig. 4, brings the center of gravity of the supporting fixture and mounted unit in line with the center line of the table. Thick aluminum plates are useful in making fixtures, since aluminum has a great relative damping capacity and little elasticity.

Before making a vibration test, each unit should be inspected for electrical and mechanical accuracy and critical components tested to determine ability to withstand the vibration requirements. Wiring is then attached to the unit being tested and the vibration machine

is set up for initial vibration conditions. The vibration amplitude is checked by a vibrometer as the test proceeds.

Initial vibration of the assembly should be made at reduced amplitude to locate critical resonance points. From this test the transmissibility ratio of the equipment can be determined. In many cases, due to damping in the system, these resonance points may not be objectionable. However, if the transmissibility is excessive, corrective action must be taken. Usually supporting members are made more rigid by ribbing the surfaces, flanging the members or increasing thickness so unwanted resonance is above the testing frequency range.

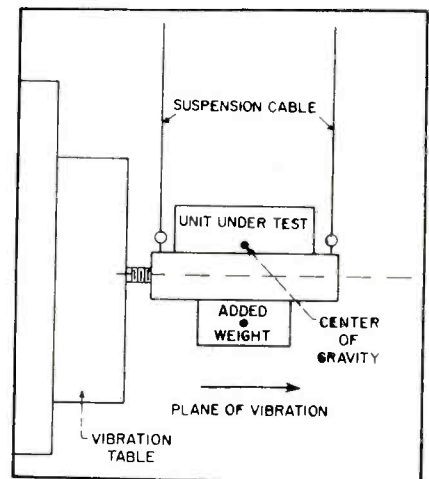

FIG. 4—Adding weight under vibration test mounting will bring center of gravity in line with table center line

A monitoring device which will define the satisfactory electrical operation of the equipment is required. If at all possible, this monitoring device should encompass the complete electrical function on one indicator, such as an oscilloscope.

Recording instruments should be used if adaptable to the particular test. It is also necessary to observe the equipment being tested for any mechanical failures, which might show up in a number of ways. A slight buzzing or an abrupt change in the magnitude or quality of the vibration noise being generated by the equipment in test are common examples of failure symptoms.

Thermistors Compensate Transistor Amplifiers

By A. J. WHEELER

Semiconductor Division
Radio Corp. of America
Somerville, New Jersey

SUMMARY — Temperature compensation of class-B push-pull transistor amplifiers is necessary to minimize distortion and prevent runaway. Typical compensating circuits using thermistors are described and equations for calculating component values and restrictions on use of two types of thermistor materials are given. Design technique gives an approximation to the desired linear decrease in bias with increase in ambient temperature

TRANSISTOR CLASS-B push-pull output stages usually use the common-emitter configuration because it permits high power gain and conserves battery power.

Design Method Development

A transistor circuit using thermistor compensation is shown in Fig. 1. Series and parallel resistances are used to shape the bias curve to a desired temperature function.

The thermistor bias circuit must provide an approximation to the desired change of 2.5 mv per degree C for alloy-junction transistors. Because the variation of thermistor resistance with temperature is approximately exponential, a shaping network must be used to obtain this variation.

Figure 2 shows a comparison between thermistor resistance as a function of temperature and the resistance of a thermistor circuit in which the parallel and series resistances were chosen to give an approximation to a linear change with temperature.

Tracking Conditions

In the circuit shown in Fig. 3A, the bias voltage is a constant ratio of the voltage between m and n , V_{mn} , which decreases with increasing temperature due to the drop in thermistor resistance R_T . Resistor

R_2 must equal a certain fraction of the thermistor resistance at room temperature (25 C) for tracking to occur at selected temperature points.

Three points are used: 0 C, 25 C and 50 C. The relative value of R_2 with respect to the thermistor resistance at 25 C is dependent on the type of thermistor material

used, and may be determined from calculations based on Fig. 4.

The nonlinear curves of Fig. 4 show the conditions for tracking at the selected temperature points for several values of room-temperature bias. The factors f_0 and f_{50} represent the relative change in resistance of the thermistor branch of the bias circuit shown in Fig. 3A. The factor f_{50} is equal to the ratio of the resistance of the branch at 50 C to its resistance at 25 C; f_0 equals the ratio of its resistance at 0 C to its resistance at 25 C. For a particular room-temperature bias, any point f_{50} , f_0 falling on the appropriate curve will allow tracking at the selected points.

The relation from which these curves are calculated may be derived in the form of

$$f_0 = \frac{f_{50}(k_1 - 1)}{(k_2 - 1) + f_{50}(k_1 - k_2)}$$

where k_1 is the ratio of the bias voltage desired at 25 C to that desired at 50 C, and k_2 is the ratio of the bias voltage desired at 25 C to that desired at 0 C.

Restrictions on Material

The dashed lines in Fig. 4 show the variation obtainable in f_{50} , f_0 as the value of R_2 is increased from zero to some higher value for two types of thermistor material. The

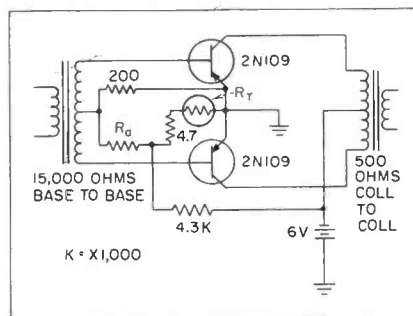

FIG. 1—Class-B push-pull amplifier

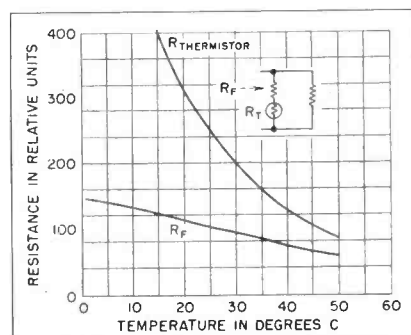

FIG. 2—Modified thermistor characteristic

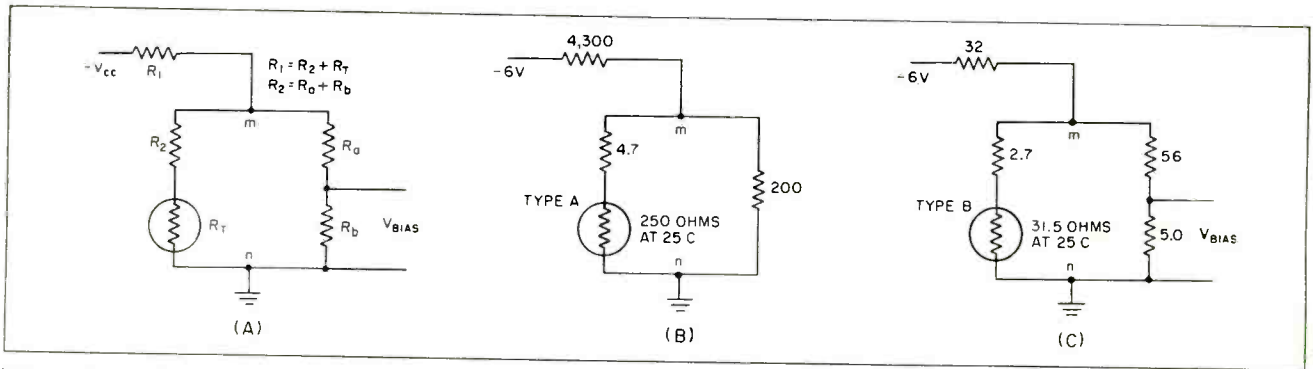

FIG. 3—Generalized bias circuit (A), bias circuit when R_a is zero (B) and bias circuit when R_a does not equal zero (C)

point for R_2 equals zero, designated f'_{50} , f'_0 , is dependent on the temperature coefficient of the particular type of thermistor material selected. The slope of the dashed line is determined by the relation

$$m = (f'_0 - 1)/(1 - f'_{50}) \quad (1)$$

The ratio of R_2 to the thermistor resistance at 25 C as the resistance of R_2 is increased may be expressed as p . As an example, values of p are marked off on the dashed line for type A material. The intersection of the dashed line with the solid curves in Fig. 4 determines the proper value of R_2 expressed in terms of p . The value of p at the intersection may be calculated from the equation

$$p = (f'_{50} - f_{50})/(f_{50} - 1) \quad (2)$$

The choice of thermistor material is subject to restrictions based on the curves shown in Fig. 4. If the point f'_0 , f'_{50} lies to the right of a desired bias curve, negative values of R_2 are required. Consequently, the choice of a thermistor material which provides a point f'_0 , f'_{50} to the left of or coincident with the desired bias curve is necessary to obtain a realizable value for R_2 .

Restriction on R_a and R_o

When R_a in the circuit of Fig. 3A is equal to zero

$$R_b = \frac{V_{cc} \times R_3}{(V_{cc} \times K_1) - [V_{B25} \times (K_1 + 1)]} \quad (3)$$

where V_{cc} = collector supply voltage, V_{B25} = bias voltage at 25 C, R_3 = resistance of $(R_2 + R_T)$ at 25 C and

$$K_1 = \frac{1 - (k_1 \times f_{50})}{f_{50} \times (k_1 - 1)} \quad (4)$$

where k_1 = ratio of desired 25 C bias voltage to that desired at 50 C and f_{50} = ratio of R_3 at 50 C to R_3 at 25 C.

Because the equation for R_b is independent of R_1 , R_b may be determined as soon as a thermistor has been chosen and R_2 has been calculated. As a first approximation, the value of thermistor resistance at 25 C should be about twice the desired bias-circuit resistance between base and emitter at 25 C.

Calculation

The value of R_1 may be calculated from

$$R_1 = \left(\frac{V_{cc}}{V_{B25}} - 1 \right) \left(\frac{R_3 \times R_b}{R_3 + R_b} \right) \quad (5)$$

This calculation is the final step in determining the bias network when R_a is equal to zero.

When R_a is not equal to zero, the following inequality must exist so R_a is a realizable value.

$$R_1 \leq \frac{1}{4} \times \frac{K_1^2}{K_1 + 1} \times \frac{V_{cc}}{V_{B25}} \times R_b \quad (6)$$

Provided this inequality is met

by the choice of suitable values for thermistor resistance, R_2 and R_b , the value of R_a may be determined from the relation

$$R_2 = \frac{1}{2} \left[R_b (NK_1 - 2) + \sqrt{(NK_1 R_b)^2 - (4NR_b R_3)} \right] \quad (7)$$

where $N = V_{cc}/V_{B25} (1 + K_1)$ (8)

The value of R_1 is determined by

$$R_1 = \left(\frac{R_3 \times R_4}{R_3 + R_4} \right) \left[\left(\frac{V_{cc}}{V_{B25}} \times \frac{R_b}{R_4} \right) - 1 \right] \quad (9)$$

where $R_4 = R_a + R_b$ (10)

Selection of Thermistors

When R_a is equal to zero, the thermistor resistance at 25 C is chosen so that the resistance of R_3 and R_b in parallel is low enough to avoid excessive loss of input power but high enough so that battery life is not appreciably shortened.

As a first approximation, the thermistor resistance at 25 C is

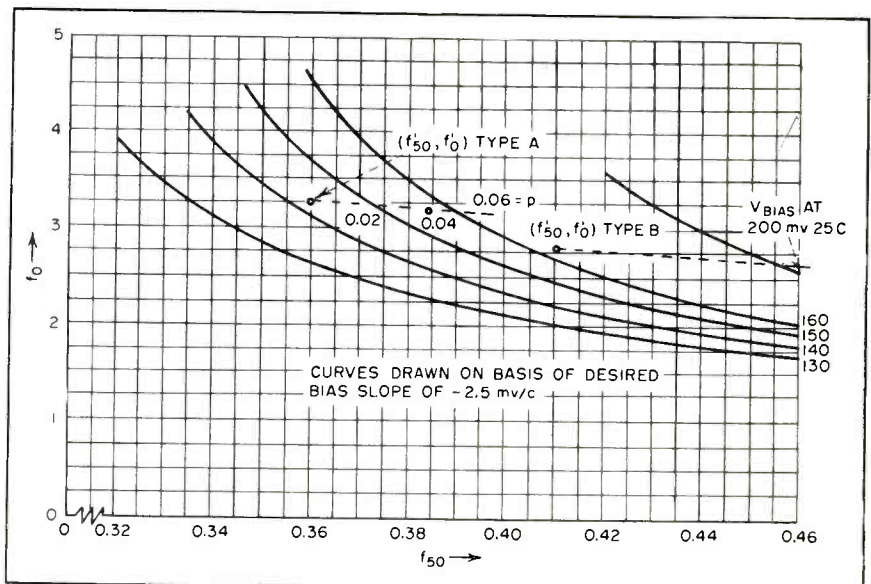

FIG. 4—Conditions necessary for three-point tracking at 0, 25, and 50 C

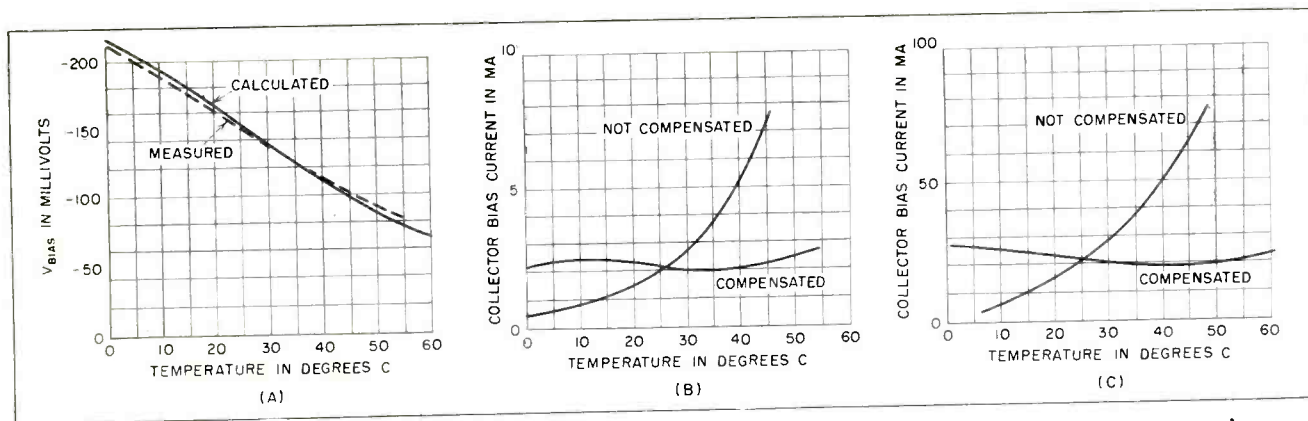

FIG. 5—Bias (A) collector current-temperature characteristic (B) when R_a is zero and characteristic (C) when R_a does not equal zero

chosen to be about twice the desired base-to-emitter bias-circuit resistance.

When R_a is not equal to zero, the resistance presented to the base-emitter terminals is nearly equal to R_b if R_a is sufficiently large. Thermistor resistance then depends on the inequality, Eq. 6.

In either case, the type of thermistor material used will depend on the magnitude of the desired base-emitter voltage at 25 C. Various types of thermistor material differ in resistance-temperature characteristics and, therefore, have different points on Fig. 4 for corresponding values of f'_{50} , f'_0 . The types A and B thermistor material used as examples possess typical resistance-temperature characteristics.

Thermistor current in the final circuit design should not be high enough to produce self-heating. Otherwise the obtained bias will be lower than calculated, and tracking points will be changed.

Application

Figure 3B shows the application of this biasing method using 2N109 transistors with a supply voltage of 6 volts when R_a equals zero. The 2N109 transistors require a base-emitter bias voltage of 150 mv for an idling current of 2 ma. From consideration of input power loss and battery drain, the bias resistance between base and emitter should be about 100 ohms.

Because the point f'_0 , f'_{50} (3.3, 0.36) for type-A thermistor materials lies to the left of the 150 mv bias curve as shown in Fig 4, a straight dashed line having a slope

m is drawn from this point to intersect the 150 mv curve. From Eq. 1 slope m is -3.59 . Values of f'_{50} and f'_0 may be obtained from published data on thermistors. The intersection for type-A material occurs at point $f_0 = 3.25$, $f_{50} = 0.3725$. From Eq. 2 the value of p is 0.02.

Example

If a thermistor having a resistance of 250 ohms at 25 C is chosen, resistor $R_2 = 0.02 \times 250 = 5$ ohms. A value of 4.7 ohms may be chosen as the nearest value. The value of f_{50} for this combination is then

$$f_{50} = \frac{R_{t25} + R_2}{R_{t25} + R_2} = 0.371$$

The value of k_1 is determined by $k_1 = V_{B25}/V_{B50} = 1.714$, hence from Eq. 4, $K_1 = 1.37$. The value of R_b , as determined from Eq. 3 is then 194. Note that V_B at $tC = V_B$ at $25 C - \Delta t$ (2.5 mv/C), where $\Delta t = -25 C + t$.

Choosing a value of 200 ohms for R_b , R_1 may be calculated from Eq. 5 and becomes 4,370 ohms. A value of 4,300 ohms is chosen for R_1 .

Figure 5A shows both calculated and measured bias as a function of temperature. Figure 5B shows experimental data on collector current-temperature characteristics for 2N109 transistors.

Method

Figure 3C shows this design method used when R_a does not equal zero. A bias voltage of 200 mv is required to minimize cross-over distortion. Because the transistors used in this application have low input impedance, the bias resist-

ance between base and emitter should be approximately 5 ohms.

Figure 4 shows that either type-A or type-B material may be used because the curves for both types begin at points to the left of the 200 mv bias curve. Type-B material will be used because it permits the use of lower resistance values. The dashed line drawn from the point f'_{50} , f'_0 for type-B material has a slope $m = -3.085$ (from Eq. 1).

At the intersection of this line with the 200 mv bias curve, f_{50} equals 0.4556 and f_0 equals 2.68. The value of p is then calculated from Eq. 2 and is 0.0847.

The factor k_1 is 1.4546, therefore, K_1 equals 1.62. The resistor R_2 can then be selected to satisfy the inequality, expression 6, and equals $7.52 R_b$.

If a value of 5 ohms is used for R_b , then $R_2 \leq 37.6$ ohms.

Available Values

An available thermistor value is 31.5 ohms at 25C. Although lower values are available, they would entail higher and undesirable values of bias-circuit current.

The value of R_2 is calculated from $R_2 = p \times R_{T25} = 2.7$ ohms.

Then $R_2 = R_2 + R_{T25} = 2.7 + 31.5 = 34.2$ ohms.

The value of N given by Eq. 8 is 11.46 and the value of R_a given by Eq. 7 is 56 ohms.

The value of R_1 is calculated from Eq. 10 and is 61 ohms. Therefore the value of R_1 as calculated from Eq. 9 is 32 ohms.

The compensation effected by the bias circuit shown in Fig. 3C is shown in Fig. 5C for an experimental high-power transistor.

METAL DETECTOR FINDS DUCTS and PIPES

SUMMARY — Search coil encased in Faraday shield is used as tank coil of transistor oscillator whose frequency shifts when coil comes near metal. Oscillator output is fed through selective amplifier to meter with deflection proportional to frequency shift. Inexpensive unit can speed defense production by aiding in locating ducts and piping when converting plants for production of missile and navigational devices

By **CARL DAVID TODD**

*Design Engineer
Semiconductor Products Department
General Electric Company
Syracuse, New York*

LOCATING OBJECTS such as conduits, gas and water pipes or heating or ventilating ducts when their exact position is not known requires some method to obtain approximate location before any work may be done. A metal detector is of great assistance in such situations, but the cost of commercial detectors make the purchase of a device of this type impractical except when it is used extensively.

One solution is to build a detector such as described in this article.

This metal detector is simple in construction and operation, is completely portable yet performs well. Total cost of the device runs approximately \$15.

Principle

If a sheet of conducting material is brought near the tank coil of an oscillator, its frequency increases or decreases slightly because of electromagnetic coupling between coil and sheet. This action exists in the use of a tuning wand for the alignment of tuned circuits.

In the metal detector, the search coil is the tank coil of an oscillator. Thus the presence of any metal will cause a shift in the oscillator frequency.

Theory

If the signal from the variable frequency oscillator feeds a selective amplifier, the amplifier output amplitude will be a function of the oscillator frequency. A typical response curve of a selective r-f amplifier is shown in Fig. 1.

If the presence of metal causes a shift in the oscillator frequency by the amount Δf , then the amplifier

output will vary by ΔA , or ΔA , depending on the operating point on the response curve. If the fixed operating point—that is, the frequency of oscillation when no metal is near the search coil—were at point *a* the shaft in output would be small depending on the amplifier bandwidth in comparison with the shift in frequency, Δf .

However, if the operating point is at either *b* or *c* then the change in output for the same frequency shift is much greater. The metal detector may be operated at any of the points *a*, *b* or *c* at the discretion of the operator.

To indicate the output level of the selective amplifier a rectifier-amplifier circuit such as shown in Fig. 2 may be used. The r-f signal from the amplifier feeds the base of a transistor. With no signal, the d-c collector current is small. However, when an a-c signal is applied to the base, the transistor will be biased on for the half-cycle in which the base is negative with respect to the emitter.

This causes a collector current to flow that is a function of the amount of a-c signal input.

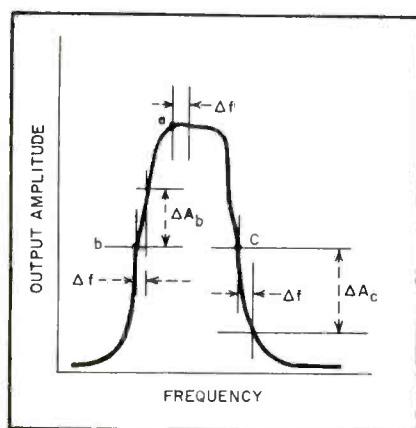
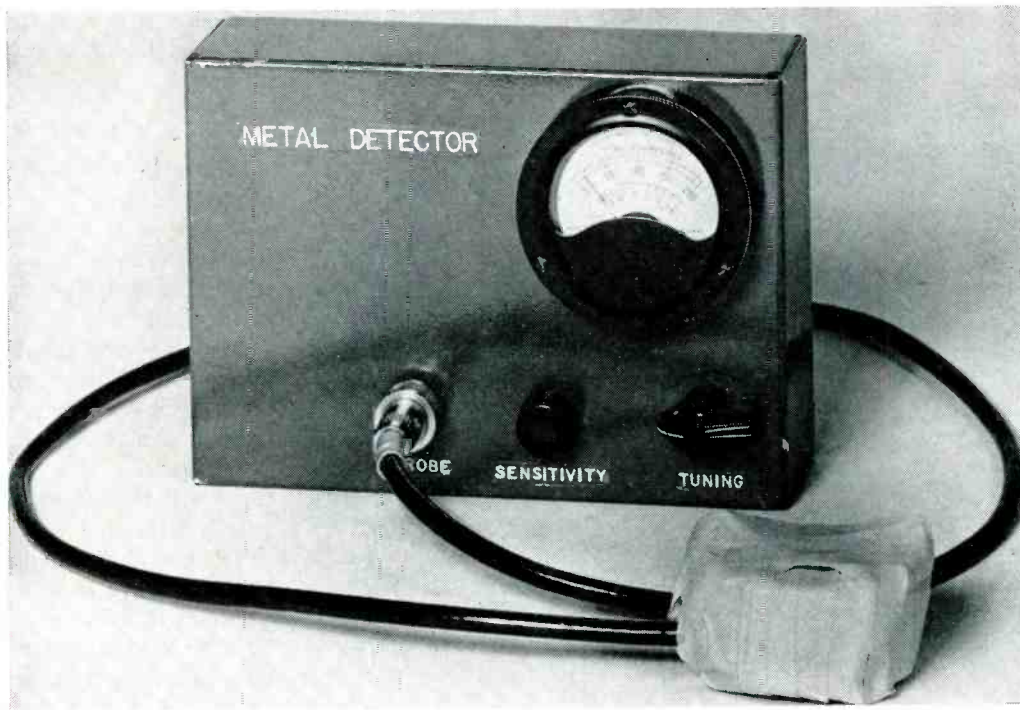

FIG. 1—Selective amplifier response curve shows various possible operating points for amplifier operation



Simple metal detector gives noticeable deflection when placed 8 inches from 2-sq ft metal sheet

The meter reads the average of the semisine wave of the collector current, since the meter movement cannot follow the individual r-f pulsation.

Circuit

The complete schematic is given in Fig. 3. The oscillator is a Colpitts type to allow the tank coil to be of the untapped variety, thus simplifying the search coil connections. The tank coil comprises the

search coil and is connected to the detector chassis by a shielded coaxial cable to eliminate external capacitance effects.

The output of the oscillator is taken from the emitter and fed into the selective amplifier by isolating resistor, R_1 . This resistor serves to keep the resonant circuit of the input transformer, T_1 , from affecting the frequency of oscillation and also decreases the loading effect on the resonant circuit of T_1 , thus in-

creasing Q and selectivity.

Only one stage of amplification was used in the model, although a second stage could be used to give greater selectivity and thus greater overall sensitivity of the instrument. If a second amplifying stage were added, the overall gain of the system should not be much more than with one stage so as not to overdrive the meter.

The gain of the amplifiers can be decreased by inserting an unby-

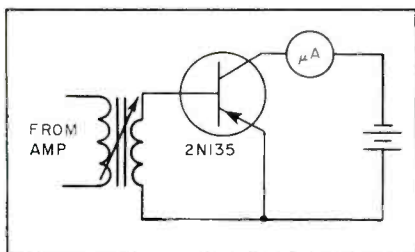

FIG. 2—Circuit indicates r-f output level since collector current is a function of a-c signal input

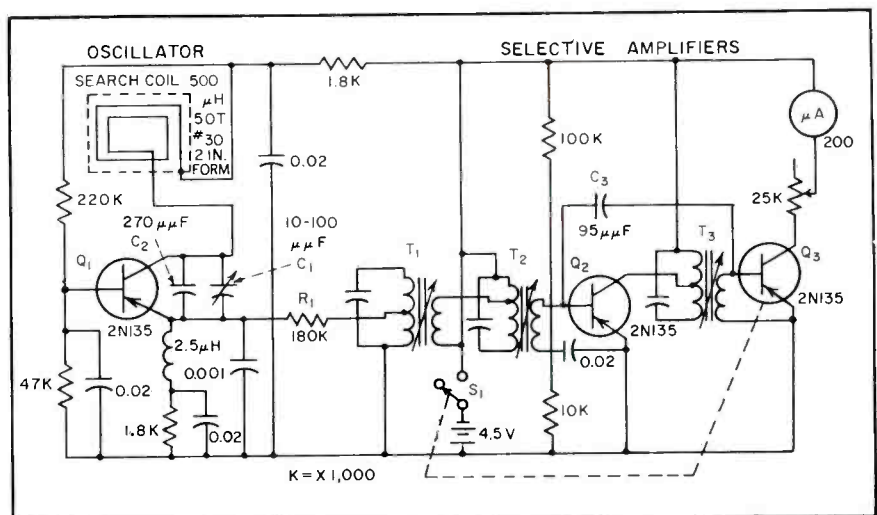
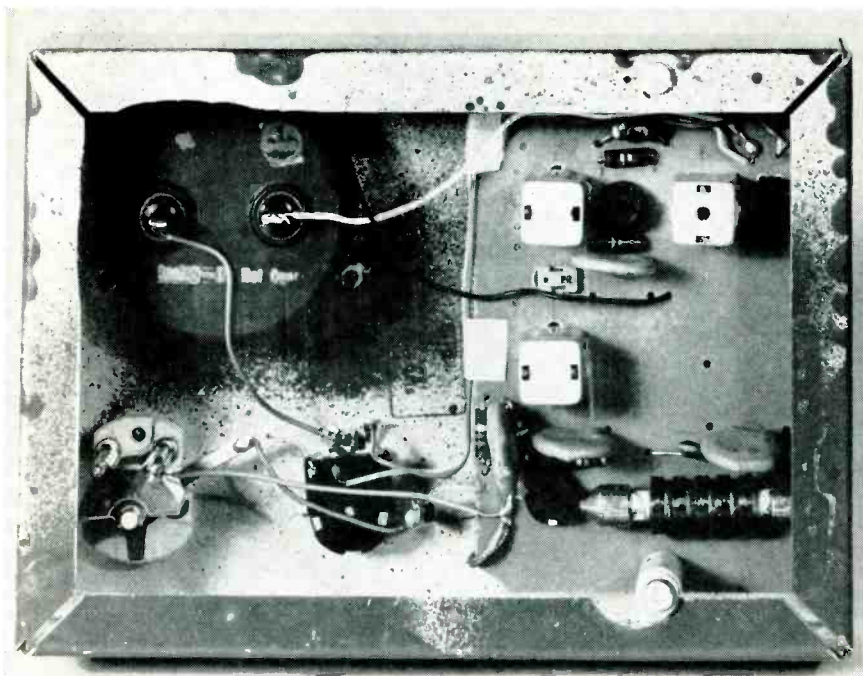

FIG. 3—Circuit of metal detector uses cascade i-f transformers to improve selectivity



Internal view of detector. Components are mounted on plastic laminate chassis

passed resistor in the emitter lead thus causing degeneration.

The combination of transformers T_1 and T_2 in cascade serve to increase the selectivity of the selective amplifier. If more transformers are used, it may be necessary to increase the overall gain because of the additional transformer losses.

The value of the supply voltage is not critical, but once set, should not be changed. Collector capacitance is a function of voltage and thus a change in supply voltage would detune the amplifier. There is also the possibility that a change in supply voltage could cause oscillation owing to the shift in value of feedback capacitance required for stable operation.

Construction

The metal detector was constructed in a 5 by 7 by 2 in. aluminum chassis. The oscillator and selective amplifier were built on a small plastic laminate subchassis as may be seen in the photograph. The additional socket, also visible in the photograph, was not used.

The transformers were a type designed as i-f transformers in transistorized receivers. The frequency was chosen at about 435 kc, a frequency low enough to prevent interference in radio receivers us-

ing 455-kc i-f amplifiers.

The amplifier is aligned using the level indicator as an output indicator. If a signal generator is not available, the oscillator may be used to align the amplifier. To do this the search coil is brought near a standard a-m radio receiver tuned to any station. The oscillator is tuned until a zero beat is obtained in the radio causing the detector oscillator to operate near 455 kc.

The i-f transformers will usually be tuned to this frequency and some output should be visible on the meter. If not, the oscillator should be tuned back and forth slightly until some output is visible. The i-f transformers are then tuned until the output meter reads a maximum.

To decrease the center frequency of the amplifier, decrease the oscillator frequency a small amount by increasing the tuning capacitance. The i-f transformers should be adjusted to give a maximum output at this frequency thus completing the alignment.

To insure that variable capacitor C_1 is at midrange at the aligned frequency capacitor C_2 may be changed slightly. This insures that the operating point on the frequency response curve may be selected on the desired slope.

If the output level is insufficient to give greater than full-scale de-

flexion at the resonant frequency, then resistor R_1 may be decreased slightly.

Neutralizing

While the value of the neutralizing capacitor, C_3 , is shown as 95 $\mu\mu\text{F}$, the exact value may be somewhat different. This capacitor prevents the amplifying stage from oscillating.

In some configurations, slightly higher or slightly lower values of neutralization capacitance may be needed, depending on the transformers used, the collector capacitance of the transistor, and the supply voltage.

The search coil is an air coil with an inductance of roughly 500 μH . The coil consists of approximately 50 turns of number 30 enameled wire around a 2-in. cardboard tube. A larger diameter coil with the same inductance would give greater sensitivity.

Shield

If precautions to prevent external capacitance effects were not used, the oscillator frequency would be shifted whenever the coil came close to any object, metallic or not. To eliminate this problem, the entire coil is enclosed in a Faraday shield, which allows a magnetic field to pass through without interference, but blocks any electric field.

It is important that no closed loops are produced by the shield since they would load the coil and decrease Q . Therefore the shield cloth should be sprayed with plastic before forming to prevent adjacent wires from shorting to each other.

To operate the completed metal detector the oscillator is tuned by the variable capacitor until a deflection is noted on the meter. For maximum sensitivity the oscillator is not tuned from maximum meter deflection but is tuned to either a slightly higher or slightly lower frequency point.

If the search coil is brought near any metallic conductor, the meter deflection will either increase or decrease a slight amount. The direction of the change in meter deflection depends on the choice of points b or c for an operating point on the frequency response curve.

OPERATIONAL BRIDGE Gages High Capacitance

SUMMARY — Low-frequency bridge uses high-gain d-c chopper-stabilized operational amplifiers in shunt with two passive ratio arms to measure capacitances up to 30 μf , with dissipation factors of 0.002 or greater, over a 0.05 to 10-cps frequency range. Bridge is used to accurately evaluate integrating-network capacitors for missile control systems. Range can be extended to 100 μf and modified circuit measures inductances from 100 to 1,000 H

By R. L. KONIGSBERG

Applied Physics Laboratory
Johns Hopkins University
Silver Spring, Maryland

IN MISSILE CONTROL SYSTEMS, operational amplifiers are frequently employed in integrating circuits at low frequencies. The integrating network generally consists of a resistance in series with the amplifier input and a capacitance connected between amplifier output and input. Capacitance values may range up to 30- μf depending on the application. For accurate work it is desirable to know the low-frequency performance and the temperature characteristics of this capacitance. This article describes a bridge, called an operational bridge because of its nature, designed to measure capacitance in the range 1 to 30 μf and dissipation factors of the order of 0.002 or greater at frequencies from 0.05 to 10 cps.

Design

Accuracy is established by proper design. Capacitance and dissipation accuracies of the order of several tenths of 1 percent and several percent, respectively, can be expected. With care, the bridge capacitance and frequency range may be extended without sacrifice in accuracy.

High values of inductances may also be measured by simple modi-

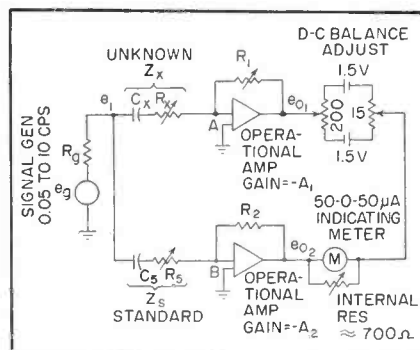

FIG. 1—Operational bridge circuit. Meter is connected between amplifier outputs instead of conventional A-B points

fications of the circuit.

Figure 1 shows a schematic of the operational bridge. It differs from the ordinary four-arm passive type in that the two passive ratio arms, R_1 and R_2 , are shunted by high-gain d-c chopper-stabilized operational amplifiers. The unknown Z_x , consisting of C_x in series with R_x , is compared with a standard Z_s , consisting of C_s and R_s in series.

In the ordinary bridge, balance is indicated by a meter connected between junction points A and B. In the operational bridge, the indicating meter is connected between operational amplifier outputs to indicate balance.

Initial d-c unbalance between amplifier outputs, generally in the millivolt region, may be compensated for by the d-c balance controls.

Bridge a-c balance is obtained by varying R_1 and R_2 .

Bridge Balance

For bridge balance, it can be shown that:

$$\frac{e_{o1}}{e_i} = - \left(\frac{R_1}{Z_x} \right) \frac{\left(A_1 - \frac{Z_{o1}}{R_1} \right)}{(1+A_1) + \left(\frac{R_1+Z_{o1}}{Z_x} \right) + \left(\frac{R_1+Z_{o1}}{Z_{o1}} \right)} \quad (1)$$

$$\frac{e_{o2}}{e_i} = - \left(\frac{R_2}{Z_s} \right) \frac{\left(A_2 - \frac{Z_{o2}}{R_2} \right)}{(1+A_2) + \left(\frac{R_2+Z_{o2}}{Z_s} \right) + \left(\frac{R_2+Z_{o2}}{Z_{o2}} \right)} \quad (2)$$

where subscripts 1 and 2 refer to respective bridge branches, R_1 and R_2 are bridge ratio arms, $Z_x = R_x + 1/j\omega C_x$ is the unknown impedance, $Z_s = R_s + 1/j\omega C_s$ is the standard impedance and R_i includes any known loss of the standard capacitor C_s , Z_{oi} is the output

impedance of the operational amplifier without feedback, Z_o is the input impedance of the operational amplifier without feedback and A is the complex open-circuit gain of the operational amplifier.

At bridge a-c balance, as indicated by zero deflection of the output meter,

$$\frac{e_{o1}}{e_1} = \frac{e_{o2}}{e_1} \quad (3)$$

Substituting Eq. 1 and 2 in Eq. 3, equating real and imaginary terms, solving for R_x and C_x and making simplifying assumptions:

$$R_x = R_o(R_1/R_2) \quad (4)$$

$$C_x = C_o(R_2/R_1) \quad (5)$$

The dissipation factor d_x is determined as

$$d_x = \omega R_x C_x = \omega R_o C_o = d_o \quad (6)$$

where d_o is the dissipation factor of the standard bridge arm.

Accuracy

In general the accuracy of Eq. 4 and 5 will improve as A_1 and A_2 increase, Z_{o1} and Z_{o2} decrease and Z_{o1} and Z_{o2} increase. In the experiment A_1 and A_2 were about 100,000 at 0.05 cps and fell off to about 1,000 at 10 cps. This loss in gain has a second-order effect on capacitance accuracy and a first-order effect on dissipation factor accuracy.

As a consequence the dissipation factor accuracy deteriorates at 10 cps and may become as high as 50 percent. An overall capacitance accuracy of ± 0.25 percent is readily achievable in the 0.05 to 10 cps range, while accuracies of 5 percent can be realized in the 0.05 to 2 cps range.

With careful bridge design, higher accuracies are within reach. These accuracies are necessarily referred to the capacitance standard accuracy and based on assumed capacitance and dissipation factor values for the standard C_o . A high-quality low-loss 1- μ f polystyrene capacitor was employed as the standard.

Standard

This capacitance is measured around 100 cps on a capacitance bridge and is assumed to remain constant down to 0.05 cps. Its dissipation factor, unknown in the 0.05 to 10-cps range, is assumed to be constant at 0.001.

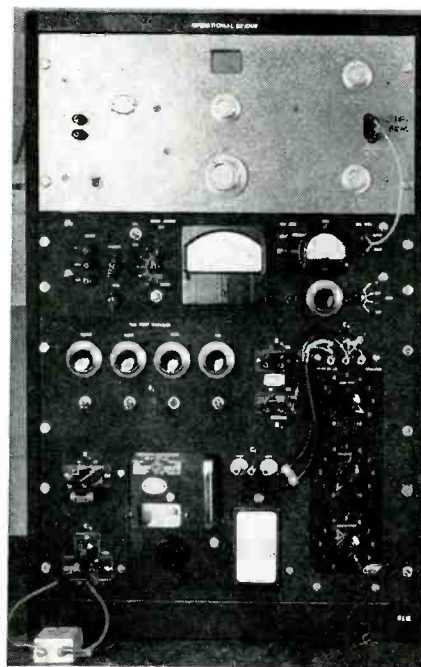

Unknown capacitor at lower left is connected to operational bridge for test. Operational amplifiers are located behind rack in center of unit

The operational bridge affords high output current sensitivity at bridge balance, especially at low frequencies, because of the low output impedances offered by each operational amplifier when the gains A_1 and A_2 are sufficiently high. The current sensitivity is mainly a function of the metering circuit impedance, which can be made as low as practical.

Stability

The stability of the bridge d-c balance is especially good at low frequencies. The chopper-stabilized operational amplifiers suppress significant d-c drifts normally occurring at 0.05 cps where observations must be made for a minimum of 20 seconds. Maximum d-c stabilization is obtained by feed-

back connections through R_1 and R_2 since Z_o and Z_i effectively block d-c flow through the signal generator.

Assuming the known accuracy of the standard Z_o , exact bridge readings depend upon several factors and precision is obtained by efficient use of their effects.

Finite gains without feedback, of the operational amplifiers, provide greater accuracy as gain increases. These gains ranged from over 100,000 at d-c to better than 1,000 at 10 cps.

Impedance

Finite input impedances, without feedback, produce greater accuracy at higher impedances. Non-zero output impedance, without feedback, produce greater accuracy at lower output impedances. A cathode follower output stage, added to each amplifier, reduces the effective output impedance from 50,000 ohms to about 200 ohms.

The impedances to ground at points A and B of Fig. 1, which may be due to the unknown Z_o and standard Z_o , form part of the input impedance of the operational amplifier and affect the accuracy indicated above.

The relative magnitudes of stray impedances across the amplifiers, compared to respective bridge arms R_1 and R_2 affect accuracy. The larger these impedances which shunt R_1 and R_2 , the greater the accuracy.

Sensitivity

The sensitivity of the bridge—that is, the ratio of respective changes in metered output current to changes in the parameters being varied (R_1 and R_2) about the bridge balance point—also affect

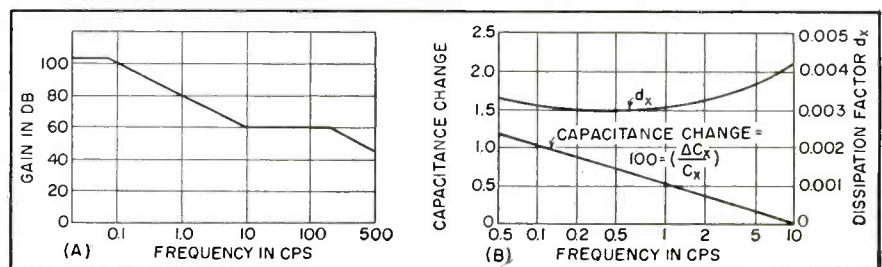

FIG. 2—Open-circuit gain-frequency characteristic of typical chopper-stabilized amplifier (A) and variation of capacitance change and d_x with frequency (B)

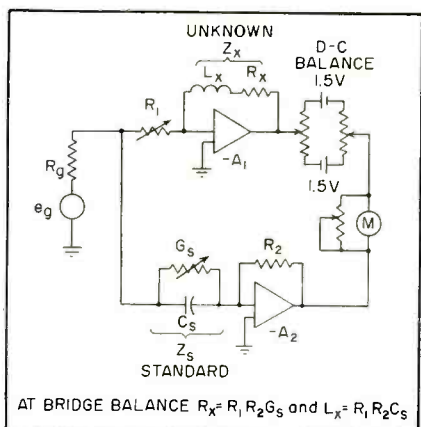

FIG. 3—Modification of bridge to measure inductance

accuracy. Sufficiently high sensitivity is obtained for changes in R_1 .

The accuracy in the determination of C_s is not appreciably affected by this factor. However, the sensitivity to changes in R_s is not as great as that for changes in R_1 and this factor affects the accuracy of the R_x or d_x measurement. Better results, however, can be obtained by using a more sensitive a-c balance indicating meter. The stability and noise of the system permit this change.

Noise

In actual operation the inherent noise introduced in the metering circuit by the active bridge arms is low and does not affect the settings for bridge balance.

Distortion terms arising from the waveform of the signal generator and the linearity of the amplifiers may influence the bridge balance. However, the effects of these factors were found to be insignificant.

The d-c stability of the amplifier, especially for low-frequency measurements, around 0.05 cps, affects accuracy. Drift is insignificant primarily because chopper-stabilized amplifiers are used.

Stray impedances from each amplifier output to ground are minimized by using amplifiers with low output impedances, without feedback. However, this effect is insignificant since cathode follower output stages are used.

Impure ratio arms R_1 and R_2 , (whether or not R_1 and R_2 are entirely real or contain reactive com-

ponents) is usually of no concern in the low frequency region because the reactance due to either shunt capacitance or series inductance is large or small, respectively, compared to the values of R_1 and R_2 employed.

A disadvantage of this type of bridge lies in the possibility that the combination of Z_x , feedback resistance R_1 and gain $-A_1$, and/or the combination of Z_s , feedback resistance R_2 and gain $-A_2$ ($-A_1$ and $-A_2$ may be complex numbers), may result in oscillation. This depends on the open-loop gain and phase characteristics of each amplifier in conjunction with the transfer characteristics of the as-

stance does not vary down to frequencies as low as 0.05 cps and that the dissipation factor is 0.0001 in the 0.05 to 10-cps range.

The values of C_s , measured with a specially constructed parallel- T bridge employing two 1- μ f polystyrene standards, are within 0.5 percent of the values obtained by the operational bridge method. Since the accuracy of the parallel- T bridge measurement is estimated to ± 0.5 percent, the capacitance measurements are confirmed.

No check on the dissipation factor d_x was made owing to the inherently large errors involved in calculating d_x from the parallel- T bridge-balance equation.

Table I—Amplifier Characteristics

Freq	Gain
D-C to 0.072 cps	Over 100 db
0.072 to 10 cps	20 db/decade slope
10 to 200 cps	60 db minimum
above 200 cps	20 db/decade slope
Input Z	200,000 ohms
Output Z	50,000 ohms
Output Voltage	-50 to +50 volts
Gain and impedances are open-circuit	

Table II—Bridge Ratio Arms

Freq cps	R_1 Ohms	R_2 Ohms
0.05 0.10	65,000	2,000,000
0.20 0.50	16,000	500,000
1.0 2.0	3,200	100,000
5.0 10.0	800	25,000

sociated feedback networks, assuming the signal generator output impedance R_g is negligible. Hence, care must be exercised in the choice of the amplifiers, since R_1 and Z_x and/or R_2 and Z_s are usually fixed by other considerations.

In any particular application, an oscilloscope is connected to either amplifier output to eliminate oscillations. Required characteristics of the amplifier are given in Table I and Fig. 2A.

Experimental Results

Figure 2B shows the variations in C_s and d_x with frequency for a special metallized paper capacitor with a nominal capacitance of 30 μ f. The standard capacitance used in all tests is a high-quality polystyrene capacitor with a measured capacitance of 1.004 μ f at 100 cps. Calculations are based on the assumption that the latter capaci-

Bridge ratio arms R_1 and R_2 , employed at the various test frequencies, are shown in Table II. They were selected for accuracy and sensitivity.

Applications

Careful design should extend the range of application of the operational bridge. The frequency of measurement could be extended down to 0.01 cps with some possible sacrifice in bridge accuracy. Using a suitable standard, it is possible to extend capacitance mensuration up to 100 μ f.

The circuit modification shown in Fig. 3 could measure 100 to 1,000 henrys inductance at frequencies around 1 cps. In this form the circuit resembles a Maxwell bridge.

The writer acknowledges the assistance of A. Bush, R. Doud and B. Amsler of this Laboratory.

SILICON DIODE Chopper

By LAWRENCE FLEMING
Falls Church, Va.

SUMMARY— Stability of 100 microvolts per hour is possible with high-back-resistance silicon diodes in contrast with 2 millivolts an hour using direct-coupled thermionic amplifiers. Input impedance is 100 times greater than with germanium crystals. Practical biological amplifier also uses phase detector that cuts rectified d-c requirement

SILICON junction diodes in an a-c excited bridge afford a compact and long-lived means of chopping d-c signals at millivolt levels, for further amplification as a-c. Because of the high back resistance of such diodes, input impedances of around 1 megohm are readily realized, in contrast to maximum impedance of about 10,000 ohms obtainable from bridges made with germanium crystal diodes.

Zero stability is in the order of 100 microvolts per hour or better, compared to a minimum drift rate of some 2 millivolts per hour realizable with direct-coupled thermionic amplifiers.

Where portability and reliability are important, a leading advantage of the chopper class of amplifiers is the simplicity of its power-supply requirements, since no regulation or auxiliary bias voltages are needed.

Basic Chopper

The amplifier described was developed for a biological application. Figure 1 shows the basic half-wave diode chopper circuit. The applied a-c excitation is large compared to the extent of the curved region of the diode characteristic. Action is that of a shunt spst switch. Both diodes CR conduct on the forward half-cycle; both are nonconducting on the reverse half-cycle.

Resistance R is normally in-

serted in series with the input to reduce loading on the input source. So long as R is low compared to the back resistance of the diodes, there is negligible conversion loss. Values of 1 megohm for R are practicable. The effective resistance R' looking into the input terminals will be higher than the resistance R , since the diodes are conducting only part of the time. For a 50-percent duty cycle, $R' = 2R$.

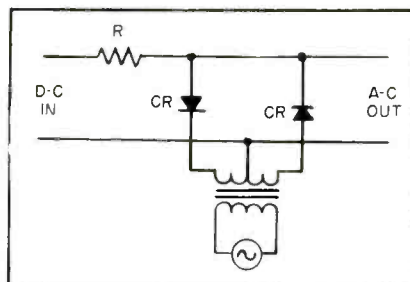

FIG. 1—Basic diode chopper

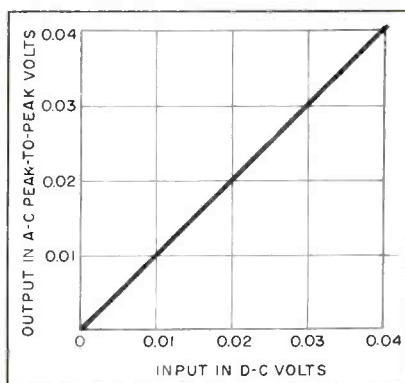

FIG. 2—Typical amplitude conversion characteristic of silicon-diode chopper

Figure 2 shows an experimental transfer characteristic for such a chopper. Residual a-c output at the best balance adjustment was around 200 microvolts, with 6 volts a-c applied and linearity was within 1 percent up to 40 millivolts input.

Practical Amplifier

The circuit of a practical amplifier designed to drive a pen recorder is shown in Fig. 3 complete with power supply. Output of 10 milliamperes each side of center is required as response to an input of ± 20 millivolts d-c. Input impedance is 500,000 ohms and frequency response 0 to 10 cps.

Since higher frequency response was not needed, advantage was taken of the simplicity inherent in 60-cps excitation. An overall transfer characteristic is shown in Fig. 4.

In the circuit of Fig. 3, the d-c input signal is chopped by the silicon-junction diodes CR_1 and CR_2 , excited from the regular 6.3-volt heater supply. Balance is adjusted by potentiometer R_0 . Resistors R_2 and R_3 are included to limit the diode current during the conducting half-cycles and also to improve balance stability in a manner described later. The chopped input signal is fed through a conventional two-stage a-c amplifier employing the dual triode V_1 . The output of this amplifier feeds a

Stabilizes D-C Amplifier

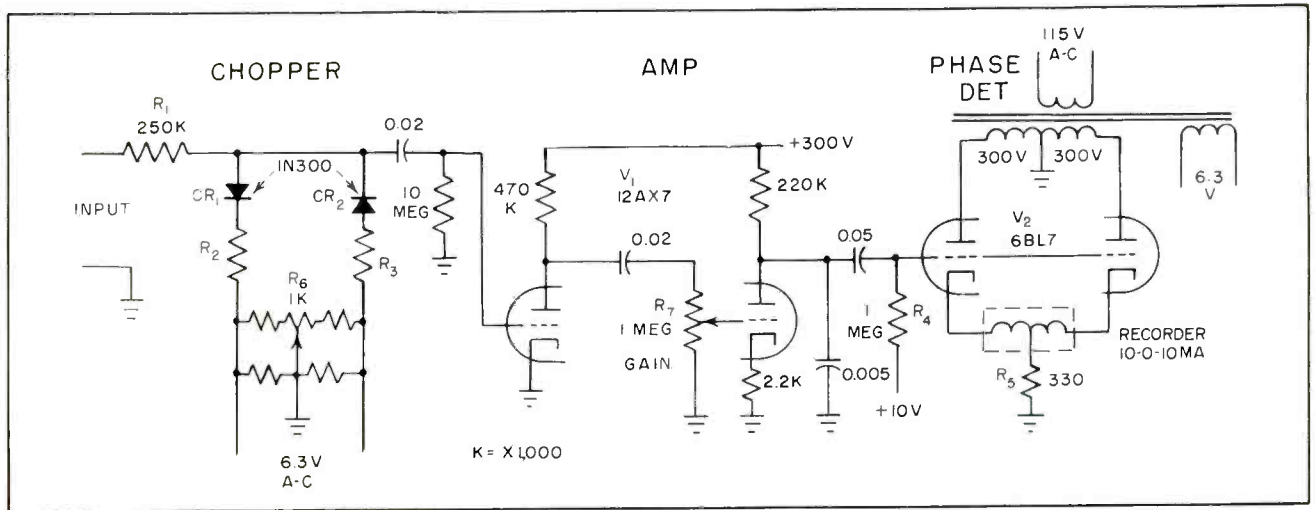

FIG. 3—Amplifier used in biological studies employs silicon-diode converter and phase detector

phase detector using another dual triode V_2 .

This last stage operates at a high enough power level to drive directly the recording galvanometer. Since the plates of the two sections of V_2 are supplied with a-c in opposite phase, the phase of the common grid signal will determine which tube conducts.

Phase Detector

This particular type of phase detector simplifies the power supply, since the only rectified d-c plate power needed is a couple of milliamperes for the voltage amplifier for V_1 , the heavier current to V_2 being a-c. The d-c supply for V_1 is a small rectifier (not shown) fed from one side of the high-voltage winding of the power transformer.

The positive grid return voltage supplied to grid resistor R_4 and the value chosen for R_5 will depend on the resistance and sensitivity of the galvanometer. Capacitors across the galvanometer coil may be required to smooth out the effects of the 60-cps pulsation in the driving current, but are not always needed.

Provision is sometimes desirable for a few volts differential in the d-c bias applied to the grids of V_2 , to make up for zero-

offset resulting from poor matching of the triode sections.

It is of interest that a phase-sensitive detector must be used in an amplifier of this general type if the gain control (for example R_7) in the a-c amplifier chain is to operate without shifting the zero. With a simple amplitude detector, the output of the system is a two-valued function of the input, the chopper has to be operated off-balance and the gain control inevitably moves the zero position as well as the gain.

The balance control R_5 is associated with a set of fixed padding resistors, to ease the strain on the potentiometer's resolution and stability.

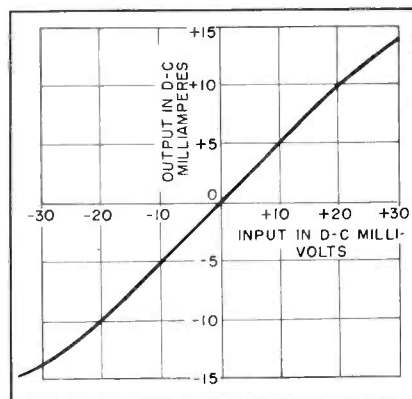

FIG. 4—Overall transfer characteristic of amplifier in Fig. 3

The effect of diode characteristics on the null output is mainly a second-order one. The diodes are swept rapidly through the region of curvature during a relatively small portion of the cycle. During conduction, balance depends primarily on the equality of the series resistors R_2 and R_3 since the voltage drop across them is much larger than across the diodes.

Differential Bias

During the reverse half-cycle the balance is a function of diode back current and source resistance, but is not a problem if the source resistance is reasonably low, such as 1 megohm. Exploration of the ultimate capabilities of such circuits would involve selection of diodes and auxiliary differential biasing arrangements.

Temperature effects upon balance are very small in the ordinary ambient range.

REFERENCES

- (1) C. M. Verhagen, A Survey of the Limits of D-C Amplification, *Proc IRE*, **41**, p 615, May 1953.
- (2) M. D. Liston, High Sensitivity D-C Breaker Amplifier, *ELECTRONICS*, p 206, Jan. 1954.
- (3) O. H. Schmitt and C. H. MacPherson, An A-C Operated Portable Electrometer Type Millivoltmeter, *Rev Sci Instr*, **25**, p 310, Sept. 1954.
- (4) T. M. Dauphinee and S. B. Woods, Low Level Thermocouple Amplifier and a Temperature Regulating System, *Rev Sci Instr*, **26**, p 693, July 1955.
- (5) Britton Chance et al, "Waveforms," McGraw-Hill Book Co., New York, N. Y., 1949.

TRANSISTORS GENERATE

SUMMARY — Use of geometric rather than arithmetic scales provides greater accuracy when measuring quantities varying over wide ranges. Step inputs to transistorized computing circuit trigger two integrators to furnish fast and slow ramp functions. Ramp voltages are compared at discriminator and, when equal, cause fast integrator to recycle producing a chain of pulses spaced geometrically. Applications include study of pulse amplitude, pulse-width and pulse-position-modulation systems as well as logarithmic operations in electronic computing

By **EUYEN GOTT** and **JOHN H. PARK Jr.**

*The Johns Hopkins University
Radiation Laboratory
Baltimore, Maryland*

SUCCESSIVE READINGS of a uniformly divided scale form an arithmetic progression called an arithmetic scale. This kind of scale is satisfactory as long as the variation of the measured quantities is small. In practice however, quantities varying over a ratio of 10:1 or more are not uncommon. In such cases, the relative accuracy of the measurement varies considerably.

To obtain a constant minimum relative accuracy a scale whose successive readings form a geometric progression is proposed and tran-

sistor circuits for producing such a scale are described.

Constant Accuracy

The word accuracy is used to denote relative accuracy hereafter for the sake of simplicity. It is defined as

$$A(x) = 1 - |m - x|/m \quad (1)$$

where $A(x)$ is the accuracy, x is the actual magnitude of the quantity and m is its measured value. Although x is a continuous variable, m is restricted to a particular set of values $m_0, m_1, m_2, m_3, \dots$ rendered by the scale used.

For an arithmetic scale, the m 's are usually integers. A geometric scale requires $m_n = km_{n-1}$ with $k > 1$.

In either scale, the particular points where readings are taken can be so arranged that one of the three possible cases [$m \leq x$, $m \geq x$ and $m > \text{or} < x$] is true. This is shown in Fig. 1.

For simplicity, only $m \geq x$ will be discussed although the same reasoning can be applied to the other cases. In practice, the case of $m > \text{or} < x$ with m_i occurring at the midpoint of the i th interval

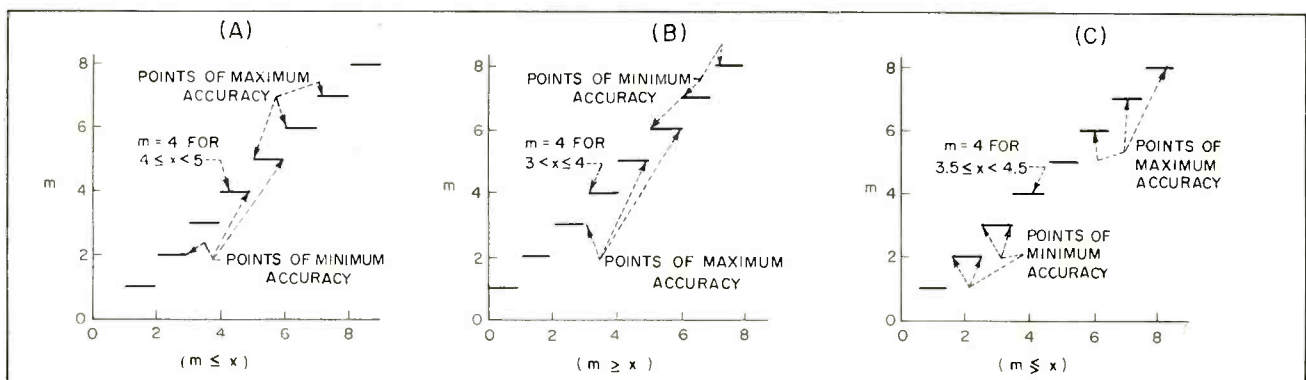
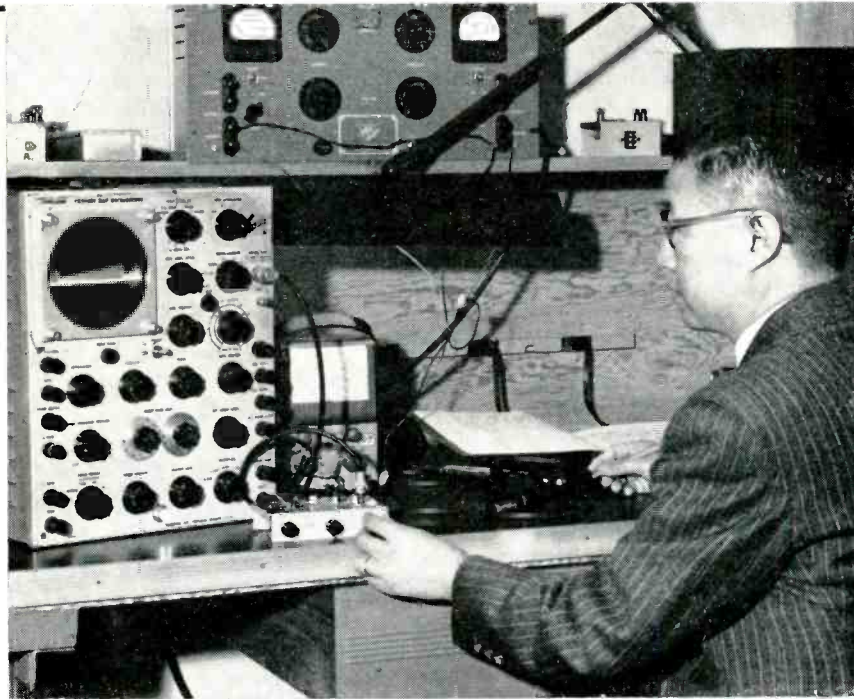

FIG. 1—Graphical representation of ways of setting the reading points of a scale. Method works equally well for both arithmetic and geometric scales

GEOMETRIC SCALE



Compact transistorized unit produces geometric progression display on cro

reduces the possible difference between m and x to a minimum.

Applying the condition of $m \geq x$, Eq. 1 becomes

$$A(x) = x/m \quad (2)$$

From Eq. 2, $A(x)$ can be represented by a broken curve consisting of an infinite number of straight lines as shown in Fig. 2A. These straight lines start and end at the points where readings are taken—points of minimum and maximum accuracy. A closer look at the points of minimum accuracy for the two kinds of scales reveals that for the arithmetic scale, minimum ac-

curacy occurs when $m - x$ is almost equal to unity. Substituting $m = x + 1$ into Eq. 2 gives

$$\min A_a(x) = x/(x + 1) \quad (3)$$

This is shown in Fig. 2A by the dotted hyperbola which indicates that the minimum accuracy is poor when x is small. It gradually improves when x increases. The actual accuracy also ranges between zero and unity when x varies.

For a geometric scale the measurement is least accurate when x differs from m by almost one division. For example, if $m = m_n$, then $x = m_n$. Hence Eq. 2 becomes

$$\min A_g(x) = m_7/m_8 = m_n/m_{n+1} = 1/k \quad (4)$$

Thus a constant minimum accuracy can be obtained with the geometric scale. By choosing k nearly equal to unity, $\min A_g(x)$ will also be close to unity and the range of variation of the actual accuracy will be small.

Double-Sweep Method

To produce a geometric scale, two linear ramps are employed, as shown in Fig. 2B. The slow ramp starts at $x = 0$ and the fast ramp starts at $x = m_0$. The slopes of the two ramps are functions of k . For

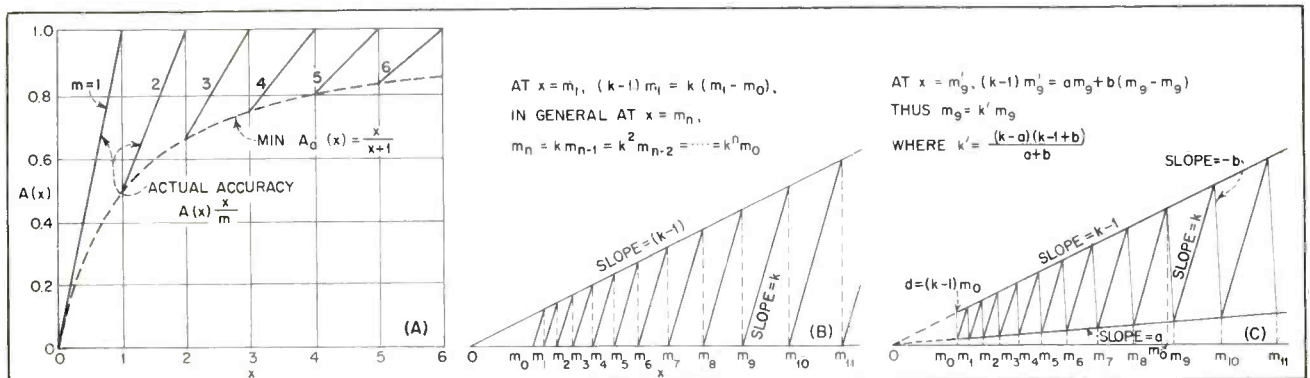

FIG. 2—Dotted hyperbola in (A) indicates minimum accuracy is poor when x is small. Ramps required to produce geometric scale (B) are modified so low ramp starts at same time as fast ramp (C)

example if $k - 1$ is the slope of the slow ramp, then k will be that of the fast ramp.

The two ramps meet when $x = m_1 = km_0$. At this time the fast ramp is cut off and restarted from the initial zero level. It meets the slow ramp again at $x = m_2 = k^2m_0$. By starting and stopping the fast ramp repeatedly a geometric scale is obtained.

This is an ideal situation. In practice, since ramp functions are usually produced by charging capacitors, it is not possible to restart the fast ramp as soon as it meets the slow ramp. An increasingly longer waiting period is necessary each time. It is also found that under certain circumstances the starting level increases gradually. Taking these two factors into account, a slightly different value for the ratio m_n/m_{n+1} is obtained. The details are shown in Fig. 2C.

A further modification in Fig. 2C allows the slow ramp to start at $x = m_0$ but with an initial level of $d = (k - 1)m_0$. This means that the two ramps can be started simultaneously after m_0 seconds from the beginning of the measurement. At the end of the measurement the same control can be used to stop the two ramps together.

Block Diagram

Figure 3 is a functional block diagram of the transistor circuit for producing a geometric scale.

The input consists of controlling step functions. A positive step comes at m_0 seconds after the beginning of the measuring period and puts the circuit into operation. At

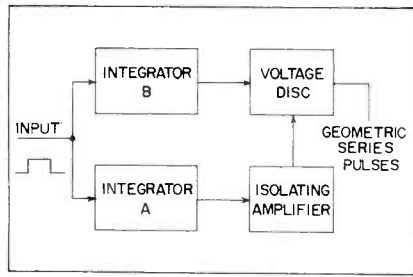

FIG. 3—Block diagram of transistor geometric-series pulse generator

the end of the period a negative step rests the circuit.

Ramps

The slow ramp is produced by integrator A and the fast ramp by integrator B. The voltage discriminator constantly compares the outputs of these two integrators. As soon as their instantaneous magnitudes become equal, a pulse is generated by the discriminator which discharges integrator B. At the end of the pulse, integrator B restarts the fast ramp again and the whole process is repeated. Thus a series of pulses whose consecutive spacings increase at a constant rate is produced continually until the two integrators are stopped by the controlling input signal.

The isolating amplifier is inserted between integrator A and the voltage discriminator so the discriminator will not disturb the slow ramp.

Circuit Description

A circuit employing both point-contact and junction transistors is shown in Fig. 4. Type npn transistors in the grounded-collector con-

nection are used for the integrators and amplifier. For good results, high- α and high-collector-resistance junction transistors must be specified. The discriminator uses one point-contact transistor.

A transistor version of the compensated bootstrap circuit is employed for the integrators. Compensating resistors R_4 and R_7 should be so chosen that linear outputs are obtained at the base of Q_1 and at the emitter of Q_2 . The use of the emitter of Q_2 as the output terminal for driving the isolating amplifier, Q_3 , makes it easier for Q_3 to isolate the slow ramp from the sudden disturbances at the voltage discriminator.

Linearity

When other circuits are connected to the integrators their effects on the linearity of the ramps should be as small as possible, thus high back-resistance silicon junction diodes are used for D_1 , D_2 and D_3 .

The designed initial amplitude of the slow ramp can be obtained by choosing proper values for the resistors R_1 and R_2 .

The grounded-collector isolating amplifier has as its load the base-collector loop of the voltage discriminator. Thus, R_6 must be high enough to make the isolating amplifier see a positive load at all times.

The discriminator uses an emitter-input, negative-resistance point-contact transistor multivibrator. The slow ramp is fed by the isolating amplifier to its base through resistor R_6 and the fast ramp is fed to its emitter through diode D_3 .

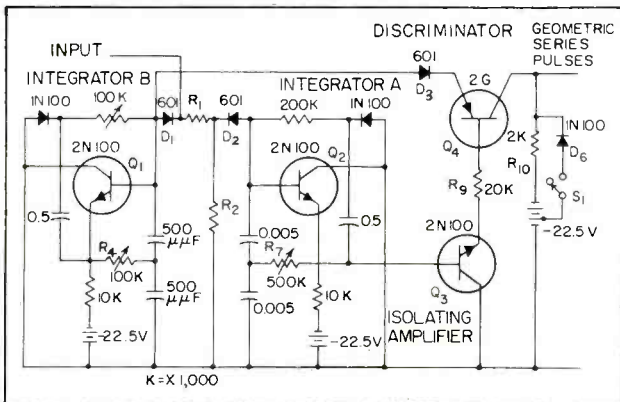

FIG. 4—Circuit uses npn junction transistors in integrators and amplifier, point-contact transistor in discriminator

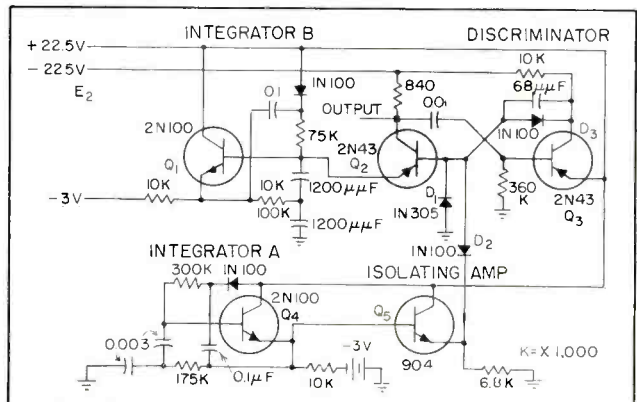

FIG. 5—Change in discriminator circuit allows use of junction transistors throughout

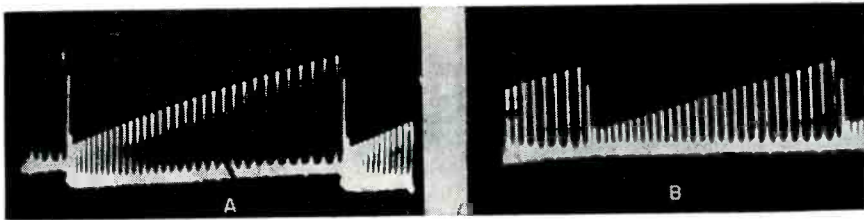

FIG. 6—Uneven base line caused by gradual rise of valley point and collector cut-off current (A) is eliminated by compensating R_{10} with diode D_6 (B)

A circuit using only junction transistors is shown in Fig. 5. It differs from Fig. 4 mainly in the voltage discriminator circuit (Q_2 and Q_3). Here the two ramp functions are compared between the emitter and the base of Q_2 . The emitter is always at the potential of the fast ramp while the base is at the potential of the slow ramp as long as D_2 is conducting. Normally Q_3 is conducting in the transition region, D_2 is biased in the forward direction and D_1 , D_3 are biased in the reverse direction.

When the magnitude of the fast ramp just surpasses that of the slow ramp, Q_2 starts to conduct, cutting off Q_3 . The base of Q_2 is thus forced toward E_2 , and D_2 and D_3 become reverse and forward biased respectively. Q_2 continues to conduct until the potential at the base reaches ground (integrator B is therefore returned to ground) and D_1 conducts cutting off Q_2 . The circuit then returns to normal.

Even Base Line

The output pulses of the circuit of Fig. 4 are shown in the two photographs of Fig. 6. Delay time m_0 was omitted in taking the two pictures.

The rising base line of Fig. 6A is caused by the fact that the slow ramp acts as a part of the supply voltage in the base-collector loop of the voltage discriminator. This causes both the collector cut-off current I_{co} and the valley point of the negative-resistance curve to increase linearly with time. The increasing valley point makes each pulse stop at a higher level than the preceding one and the increasing I_{co} flows through load R_{10} when there is no pulse.

If an even base line as shown in Fig. 6B is desired, the effect of both I_{co} and the valley point can be re-

duced by making R_{10} small. However, this has the disadvantage of reducing the amplitude of the output pulses as well.

A better method to obtain an even base line without sacrificing pulse amplitude is to put a biased diode, D_6 in parallel with R_{10} . This reduces the effect of I_{co} to a negligible degree. Diode D_6 conducts in the absence of a pulse and stops conducting when a pulse comes. The design criterion is that the original current flowing through D_6 before the start of the first pulse must be at least equal to the highest I_{co} anticipated at the peak of the slow ramp.

Figure 7 shows the waveforms of the fast ramp and the output pulses at the emitter and the collector respectively of Q_2 in the circuit of Fig. 5.

Further Advantage

A constant minimum accuracy is not the only advantage of a geometric scale. Compared with an arithmetic scale of the same minimum accuracy when measuring a certain range of values, the geometric scale gives a much smaller digital number at the output. When the variation of the quantity to be measured is large, the simplification in equipment necessary to handle the data is tremendous.

For example, if a number varies from 20 to 20,000, an arithmetic scale will have a minimum accuracy of 95 percent and a fifteen-stage binary counter or a five-stage decimal counter will be necessary to handle the data. Using a geometric scale with a constant minimum accuracy of 95 percent, the highest output number is only 142 instead of 20,000 and an eight-stage binary counter or a three-stage decimal counter is enough.

Owing to the linear relationship between voltage and time of a ramp

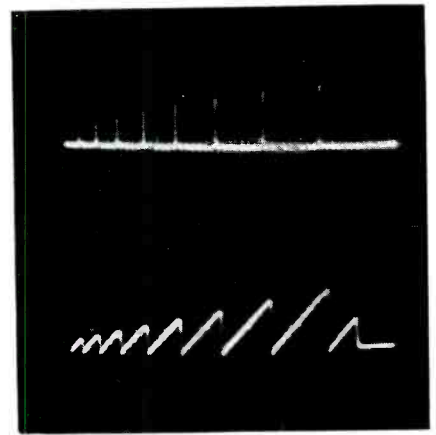

FIG. 7—Output pulses at collector of Q_2 in circuit of Fig. 6

function the geometric scale can be used to measure either time or voltage. In either case, the circuit operation starts m_0 seconds after the reception of the quantity to be measured. If the quantity is time, the end of the measurement coincides with that of the quantity and no delay is involved.

If the quantity is voltage, the measurement ends when the instantaneous magnitude of the slow ramp equals that of the quantity. The time delay in this case depends on the slope of the slow ramp and the voltage to be measured. Another voltage discriminator should compare the slow ramp with the received voltage, which can be stored in a holding capacitor. This voltage discriminator signals the equality of the two voltages and discharges the holding capacitor simultaneously.

Applications

The geometric scale can be employed for the analysis and coding of pulse amplitude, duration or position modulation. In addition, the geometric scale can also be used in computers to reduce multiplication and division to addition and subtraction respectively, to find the logarithm of a number, or to obtain the n th root of a given quantity.

The authors acknowledge the help of M. I. Aissen and H. Blasbalg in ideas and S. Edelson and F. W. Schaar in bench work.

This research was supported by the U. S. Air Force through the Office of Scientific Research of the ARDC.

Reflection Point and

By Z. PRIHAR

Consultant
RCA International Div.
New York, N. Y.

SUMMARY — Determination of propagation losses over complex paths requires a knowledge of the reflection point that is seldom midway between antenna and an obstruction contributing to knife-edge diffraction. Nomograms give distance and angle with little additional computation

ANGLE and point of reflection of radio waves are required information when calculating propagation losses in four-path propagation, as by knife-edge diffraction.

If no logical reflection point is apparent, it is found by choosing a distance at which the angles of incidence and reflection from the tangent plane are equal. This is done by a trial and error method that is sometimes laborious and time-consuming.

A direct analytical method is suggested below. Nomograms give a direct reading of the distance and angle with little additional computation.

Referring to Fig. 1, the following particulars are usually known: antenna height h_1 in feet; obstruction height h_2 in feet; and distance d from h_1 to h_2 in miles.

From Fig. 1,

$$\begin{aligned} \text{effective height } h_1' &= h_1 - p_1 \\ \text{effective height } h_2' &= h_2 - p_2 \end{aligned}$$

If a = earth's radius (3,963 miles)

$$(a + p_1)^2 - a^2 = d_1^2$$

since

$$p_1 \ll 2a, \quad p_1 = d_1^2/2a \quad (1)$$

Denoting $R = Ka$ = effective earth radius, for $K = 4/3$,

$$\begin{aligned} p_1 &= d_1^2/2R = \\ 5,280d_1^2/(2.4/3.3963) &= d_1^2/2 \quad (2) \end{aligned}$$

where p_1 is expressed in feet and d_1 in miles.

If d_1 is known, the effective height h_1' will be given by

$$h_1' = h_1 - d_1^2/2 \quad (3)$$

and

$$h_2' = h_2 - d_2^2/2 \quad (4)$$

where

$$d_2 = d - d_1$$

At the point of reflection, since angle of incidence must

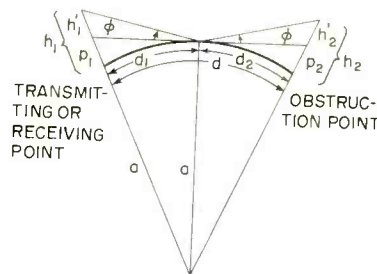

FIG. 1—Geometry of path between station and obstruction

be equal to the angle of reflection,

$$h_1'/d_1 = h_2'/d_2 \quad (5)$$

Substituting Eq. 3 and 4 in Eq. 5 and rearranging results in the following implicit expression for d_1 for any value of K

$$\begin{aligned} d_1^3 - 3dd_1^2/2 + \\ d_1(d^2/2 - h_1Ka - h_2Ka) + dh_1Ka = 0 \quad (6) \end{aligned}$$

and for d and d_1 in miles, h_1 and h_2 in feet and for any K , Eq. 6 becomes

$$\begin{aligned} d_1^3 - 3dd_1^2/2 + d_1(d^2/2 - \\ 3h_1K/4 - 3h_2K/4) + 3dh_1K/4 = 0 \quad (7) \end{aligned}$$

and for $K = 4/3$

$$d_1^3 - 3dd_1^2/2 + d_1(d^2/2 - h_1 - h_2) + dh_1 = 0 \quad (8)$$

It will be found that Newton's approximation method will offer the simplest and quickest way of finding the value of d_1 . If d_1 is chosen arbitrarily for which Eq. 8 is $f(d_1) \neq 0$, an approximate solution will be obtained with d_1' when

$$d_1' = d_1 - f(d_1)/f'(d_1) \quad (9)$$

d_1 is the arbitrarily chosen value and $f'(d_1)$ the first derivative of Eq. 8

$$f'(d_1) = 3d_1^2 - 3dd_1 + (d^2/2 - h_1 - h_2) \quad (10)$$

A still better approximation will be obtained by repeating the calculation of Eq. 9 with the newly found value d_1' when

$$d_1'' = d_1' - f(d_1')/f'(d_1')$$

The following example illustrates the application of the above method. Let $h_1 = 100$ feet, $h_2 = 2,000$ feet, $d = 60$ miles and $K = 4/3$. Assuming an arbitrary value of $d_1 = 10$ miles, Eq. 8 yields for $d_1 = 10$ miles

$$f(d_1) = f(10) = -5,000$$

and according to Eq. 10

$$f'(d_1) = f'(10) = -1,800$$

$$f(d_1)/f'(d_1) = 5,000/1,800 = 2.783$$

hence

$$\begin{aligned} d_1' &= 10 - 2.783 \\ &= 7.217 \quad (\text{say } 7.22) \end{aligned}$$

(continued on page 186)

Angle Nomographs

$$t' = (d^2/4 + h_1 + h_2) / s^2$$

$$q' = (h_2 - h_1) / ds^{3/2}$$

$$d_1 = w + d/2$$

$$w = sw'$$

$$s = 20(\text{SCALE})$$

ALL d's IN MILES AND

ALL h's IN FEET

STEPS

1. DETERMINE t' AND q'
2. READ OFF CORRESPONDING w' ON HORIZONTAL LINE
3. DETERMINE $w = 20w'$ AND d_1
4. DETERMINE $d_2 = d - d_1$
5. DETERMINE

$$h_1' = h_1 - d_1^2/2$$

$$h_2' = h_2 - d_2^2/2$$
6. CHECK FOR

$$h_1'/d_1 = h_2'/d_2$$
7. READ OFF ANGLE OF REFLECTION FROM FIG. 3

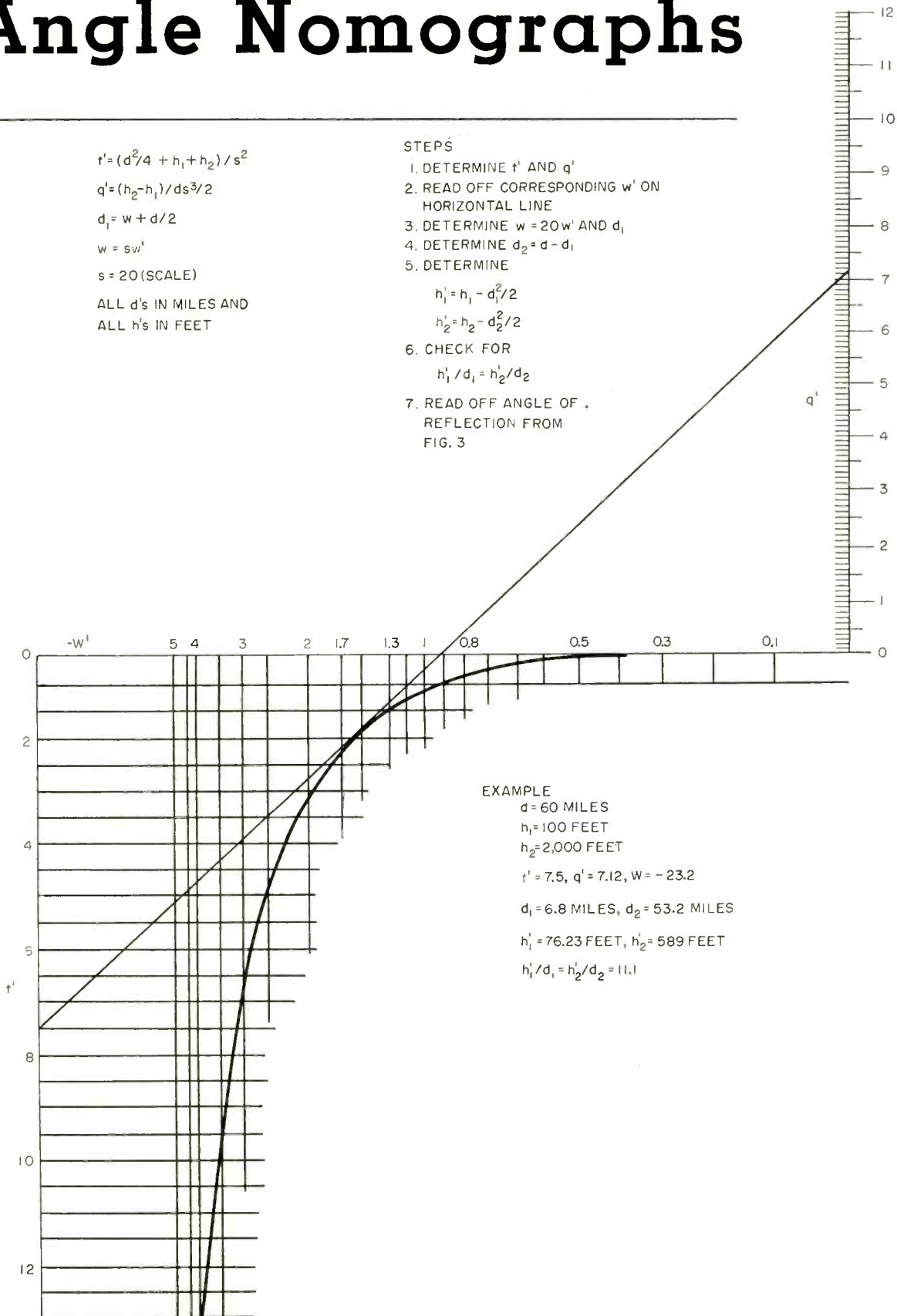

Fig. 2—Intermediate nomogram gives distance data and tangent value

Repeating the same process for $d_1' = 7.22$

$$f(d_1') = f(7.22) = -481.3$$

$$f'(d_1') = f'(7.22) = -1,443.2$$

$$f(d_1')/f'(d_1') = 481.3/1,443.2 = 0.334$$

$$d_1'' = 7.22 - 0.334 = 6.886 \text{ miles}$$

The actual value for d_1 in the above example was 6.88 miles.

Having determined d_1 all the other values can now be deduced.

$$d_2 = d - d_1 = 60 - 6.886 = 53.114 \text{ miles}$$

$$h_1' = h_1 - d_1^2/2 = 76.234 \text{ feet}$$

$$h_2' = h_2 - d_2^2/2 = 589.8 \text{ feet}$$

reflection angle = incident angle = $\phi = \tan^{-1}h_1'/d_1 = \tan^{-1}h_2'/d_2$
From above,

$$h_1'/d_1 = 11.069; \quad h_2'/d_2 = 11.05$$

The numerical value of $f(d_1)/f'(d_1)$ for any arbitrarily chosen value of d_1 will offer some indication how far d_1 is off its correct value.

for $f(d_1)/f'(d_1) > 1$ the difference is substantial

for $f(d_1)/f'(d_1) < 1$ the difference is small

A reasonably approximate value of d_1 is given by

$$d_1 = d/2(h_2/h_1)^{1/2}$$

For instance, for the above numerical example, with $d = 60$ miles, $h_2 = 2,000$ feet, $h_1 = 100$ feet

$$d_1 = 60/2 \times 4.472 = 6.75$$

The actual value, as found above, was 6.886.

$$\text{Let } d_1 = w + d/2$$

then Eq. 8 will have the form

$$-w^2 - tw - q = 0$$

where

$$t = (d^2/4 + h_1 + h_2)$$

and

$$q = (h_2 - h_1)d/2$$

where d is expressed in miles and h in feet. Figure 2 will give the value of w for any given values of t and q . To keep the values of q and t within the limits of the nomogram a reducing scale $s = 20$ was used. With this scale, the relationships shown on Fig. 2 hold true.

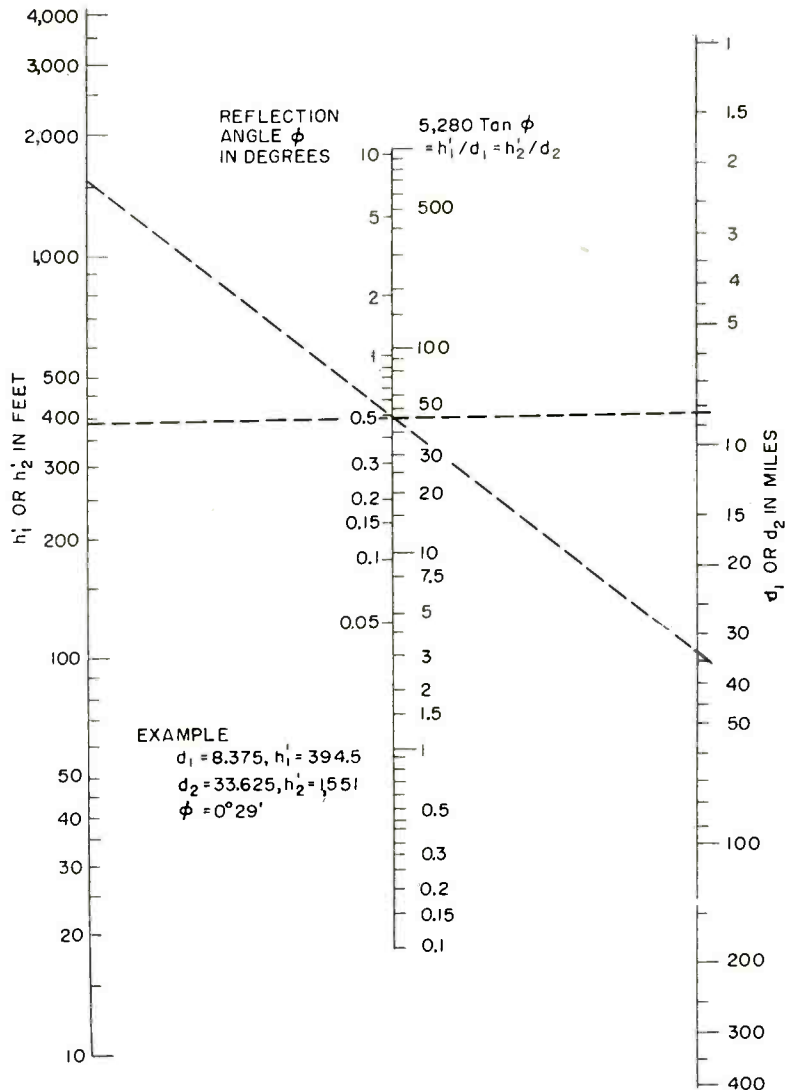

FIG. 3—Chart shows tangent value for four-thirds earth and reflection angle

where d and h are expressed in miles and feet respectively.

Having determined the value of d_1 from Fig. 2, the value of d_2 can then be deduced from $d_2 = d - d_1$ and h_1' and h_2' from the relations given by Eq. 3 and 4 respectively.

Given d_1 and h_1' and d_2 and h_2' , the angle of reflection corresponding to

$$h_1'/d_1 = h_2'/d_2$$

can then be obtained from Fig. 3 as illustrated by the example given.

$$l' = (d^2/4 + h_1 + h_2)s^2$$

$$q' = (h_2 - h_1)s^2d/2$$

and

$$w' = sw$$

For the numerical example, $d = 60$ miles, $h_1 = 100$ feet and $h_2 = 2,000$ feet,

$$t = 3,000, \quad l' = 7.5$$

$$q = 57,000, \quad q' = 7.12$$

$$w = -1.16, \quad w' = -23.2$$

and

$$d_1 = -23.2 + 30 = 6.8$$

For any K value, other than $K = 4/3$,

$$l' = (d^2/4 + 0.75Kh_1 + 0.75Kh_2)s^2$$

$$\text{and}$$

$$q' = (h_2 - h_1)0.75Kds^2$$

CINCH SOCKETS

FOR TRANSISTORS AND PRINTED CIRCUITS

**CINCH SOCKETS
FOR PRINTED CIRCUITS
MEET EVERY
REQUIREMENT**



22698



20684



22661



22743



22352



22470



22473



20683

The CINCH sub-miniature and miniature sockets insure positive electrical contact, hold transistors and tubes securely in place, permit easy maintenance and replacement, provide maximum insulation resistance and minimum high frequency loss.

Utilizing the latest manufacturing procedures with unlimited capacity, CINCH assures you of a dependable source of supply of a quality product.

YOU CAN DEPEND ON CINCH

QUICK EASY ASSEMBLY WITH CINCH TRANSISTOR SOCKETS



22468



22452



14148



22455



20928



16995



22317



22555



20248



14273



22674



22384



22485



17431



20782

Sockets Shown Actual Size.

Centrally located plants at Chicago, Illinois; Shelbyville, Indiana; LaPuente, California; St. Louis, Missouri.



**Cinch
ELECTRONIC
COMPONENTS**

CINCH will design, or redesign, components to fit specific needs, and will assist in the assembly of components through proven automation technique.

CINCH MANUFACTURING CORPORATION

1026 South Homan Ave., Chicago 24, Illinois

Subsidiary of United-Carr Fastener Corporation, Cambridge, Mass.

HORSEPOWER NOMOGRAPH for Radar Antenna Rotators

SUMMARY — Chart assists designers in making rapid preliminary calculations of the horsepower necessary to rotate shipboard radar-antenna reflectors which are not enclosed by radomes. Chart is applicable to elliptical as well as rectangular reflectors

By **PAUL W. PEAY**

*Project Engineer
Radar Equipment Engineering, Electronics Division
Westinghouse Electric Corporation
Baltimore, Maryland*

KNOWING THE DIMENSIONS and desired speed of rotation of a radar antenna, this chart permits a rapid determination of the horsepower required to power the drive mechanism.

The total torque necessary to rotate the antenna was calculated from $T = \sqrt{T_d^2 + T_v^2} + T_M$, where T_d is torque for a balanced antenna in moving air, T_v is torque for an aerodynamically unbalanced antenna rotating in moving air and T_M is torque for a mechanically unbalanced antenna due to roll of a ship. In utilizing these torques, the following assumptions were made: wind velocity = 80 mph; aerodynamic unbalance factor = 0.25 ft; streamline or drag coefficient = 1.0; center of gravity displacement = 1 ft; antenna height above ship's roll center = 100 ft; period of ship's roll = 5 sec; ship's roll = 30 deg.

The horsepower was then found from the relationship $hp = (\text{torque} \times \text{rotational speed}) / 5,250$.

Examples

(1) Find the hp per ft of antenna height to drive a 20-ft wide by 12-ft high antenna revolving at 10 rpm.

Draw a vertical line from 20

on the reflector width scale to intersect the 10-rpm curve; from this draw a horizontal line to the hp/ft scale where the answer is 1.05. Multiplying this by 12 gives 12.6 as total horsepower.

(2) Find the total horsepower to drive a 28-ft wide by 15-ft high antenna revolving at 16 rpm. From 28 on the width scale, draw a vertical line to the

16-rpm curve. From this intersection draw a horizontal line to the base line, from there to 15 ft on the height scale. Horsepower is read as 60 from the total horsepower scale.

Horsepower values shown on this chart are for rectangular antennas; for elliptical antennas, use 59 percent of the rectangular antenna horsepower.

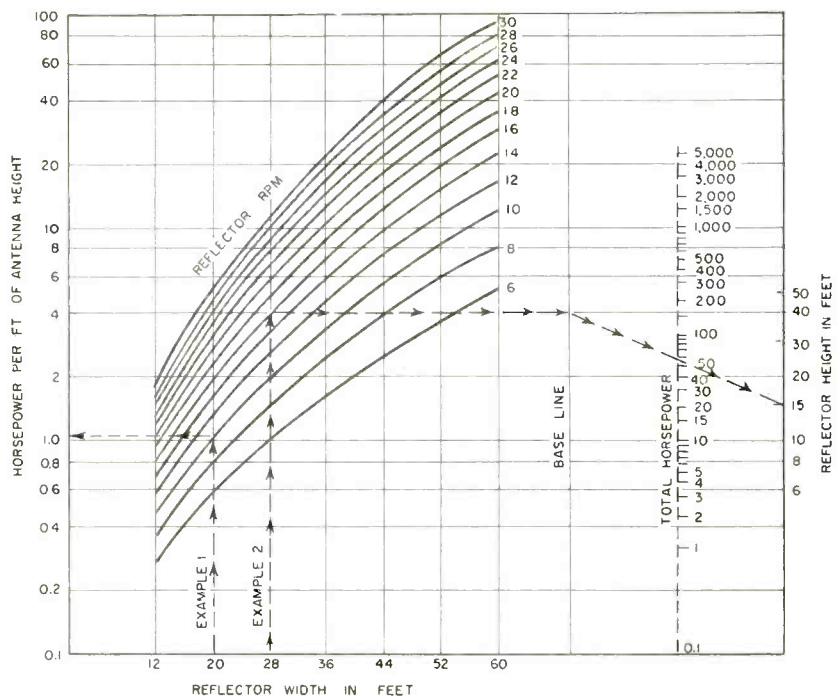

Chart gives horsepower in terms of radar antenna size and rotational speed

Mallory Contact Design Service Saved 40%

for an automotive relay manufacturer

A manufacturer of automotive-type relays required a contact disc for a new component. The original design called for a screw-machined blank one-half inch in diameter, with a silver alloy disc brazed to the base.

Investigation revealed the cost of the contact made in that manner would be beyond budget. Mallory contact engineers redesigned the contact to allow the assembly of a thin silver alloy facing on the base by

crimping instead of brazing. A locating projection on the blank holds the contact disc in place.

Prices based on the Mallory method of contact assembly were submitted to the manufacturer. Evaluation proved the design acceptable—the cost analysis proved a 40% saving over the original design—the manufacturer was able to develop the relay product within its acceptable cost limits.

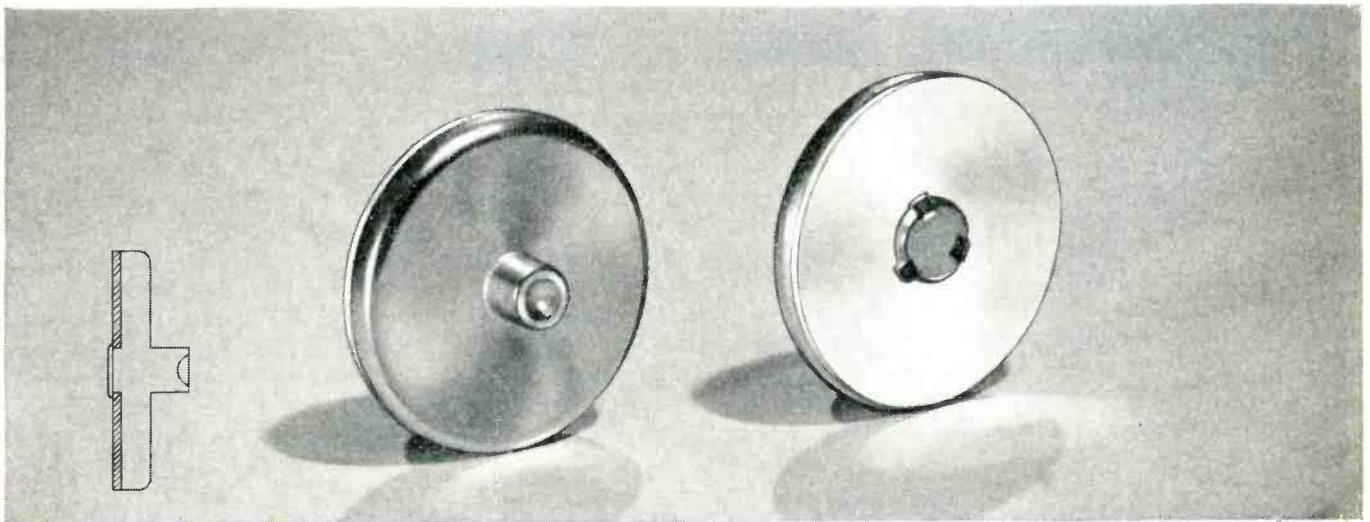

Five MALLORY keys to economy through contact engineering

1. **The most effective** contact material from the extensive line developed by Mallory. More economical alloys often can satisfy *actual* service conditions.
2. **The most economical** contact design . . . for your purchasing, production and product needs.
3. **The most economical** backing material . . . from a group of Mallory alloys developed for this use.
4. **The most economical** backing member design in relation to contact and product design requirements.
5. **The most economical** method of assembling contact and backing member.

By coordinating *all* these important elements of contact design, Mallory can help you put into effect a long-range plan for cutting contact cost and assuring peak performance.

Write or call Mallory for consultation

Serving Industry with These Products:

Electromechanical—Resistors • Switches • Tuning Devices • Vibrators
Electrochemical—Capacitors • Mercury and Zinc-Carbon Batteries
Metallurgical—Contacts • Special Metals • Welding Materials



Electrons At Work

Edited by ALEXANDER A. MCKENZIE

Heaterless Tubes Use Secondary Emission

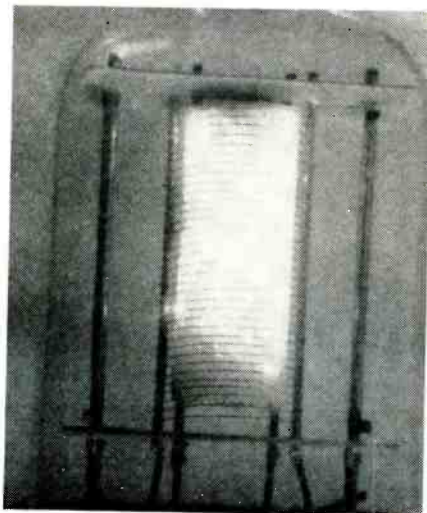

Self-sustained secondary emission developmental tube has plate in the form of a grid. Two different cathodes show effects of surface material on emission pattern

COLD CATHODE self-sustained field emission tubes, called sse tubes, are presently under development at the laboratories of Tung-Sol Electric Inc., Bloomfield, New Jersey. These tubes are characterized by their ability to provide plate currents of 25 to 50 ma per sq cm of cathode surface at plate voltages ranging between 100 and 300 v as differen-

tiated from tubes requiring either gas or high plate voltage to obtain current.

Main emphasis is being placed on determining the structure of the cathode coating. The coatings, usually some form of magnesium oxide, may be applied to the cathode base by either spray or cataphoretic techniques. For the

moment, porous surfaces seem to give a more uniform distribution of current over the total surface.

Starting the emission presents a problem. A Tesla coil is now used, although ultraviolet light and radioactive materials could also be employed. One direction of present research is to determine ways of establishing easy starting conditions.

Emission in these tubes is always combined with electroluminescent effects that give the cathode a blue light. So far, high local or spot temperatures ranging from 30,000 to 150,000 C and wide velocity distribution are the main deterrents to their application in devices.

As seen in the photographs, the emission patterns are spotty, originating from the cracks in the coating, which seem more active. As emission becomes more uniform, it is expected that higher transconductance values for control grid structures will result, making them feasible as replacements for some present tube types.

Tower Air Monitor For Broadcasters

IN BROADCAST stations where one or more of the antenna towers is located at a distance from the transmitter, it is sometimes necessary for personnel to inspect coupling equipment while keeping aware of the progress of a program.

At WNEW, New York, transmitter supervisor Karl Neuwirth uses

a simple monitor that plugs into a convenience outlet. The circuit shown comprises a tuned coil and capacitor, with short antenna wire attached, feeding a diode rectifier.

► **Signal Strength**—A rough indication of the field strength is given by the meter that is followed by a

filter, volume control and loudspeaker. In practice, the device is fastened to the wall and is thus immediately available as soon as the door to the doghouse is opened.

Its advantage is that program and operation can both be monitored without the expense and complication of wire lines between transmitter house and tower.

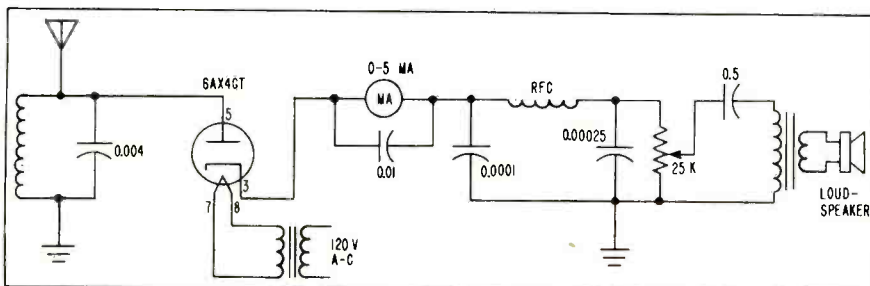

Circuit of the simple broadcast transmitter monitor

Conelrad Control

OPERATING procedures for television and f-m stations require that they go off the air during periods of Conelrad alerts. Conelrad is the technique by which some stations are taken off the air and radio broadcast stations continue with



VOLTAGE REGULATED POWER SUPPLIES

*for Transistors • Strain Gages
Relays • Filament Power*

MODEL	Volts	Current	Regulation		Ripple	Recovery Time*	Stability For 8 Hours	Output Impedance		Dimensions			Price
			Line 105-125	Load 0-Max.				DC-20	20 ~ -100 KC	W	H	D	
2600	0-60	0-2 Amp.	5 Mv.	5 Mv.	1 Mv.	50 μ sec.	10 Mv.	0.002 Ω	0.0005 Ω	19"	10½"	17"	\$690
2650	0-60	0-5 Amp.	5 Mv.	5 Mv.	1 Mv.	50 μ sec.	10 Mv.	0.001 Ω	0.0002 Ω	22½"	28"	19"	\$1190

Good stability
Fast recovery time
Low output impedance
Excellent regulation
Low ripple

POWER REQUIREMENTS: 105-125 volts, 60 cycles.
FUSE PROTECTION: Input and output fuses on front panel. Time delay relay is included to prevent unregulated voltage from appearing at the output terminations.

OUTPUT TERMINATIONS: DC terminals are clearly marked on the front panel. Either positive or negative terminal of the supply may be grounded. DC terminals are isolated from the chassis. A binding post is available for connecting to the chassis. All terminals are also brought out at the rear of the unit. Two terminals are mounted at the rear of the chassis to provide for picking up the error signal directly at the load. This connection compensates for the voltage drop in the wires (and ammeter) connecting the power supply to the load.

METERS: Ammeter: 0-2 amperes, 4" rectangular for Model 2600
0-5 amperes, 4" rectangular for Model 2650

Voltmeter: 0-60 volts. 4" rectangular

CONTROLS: Power on-off switch, DC on-off switch, remote error signal on-off switch, coarse and fine voltage controls. The coarse voltage control is a ten turn potentiometer which varies the voltage from 0-60 volts. The fine voltage control is a ten turn potentiometer which varies the voltage 1 volt. The voltage divider network allows a 61 volt variation in output voltage.

*Recovery time is less than 50 microseconds. The excursion in the output voltage during the recovery period is less than 50 millivolts for line fluctuations from 105-125 volts or load variations from 0-to maximum current.



FOR COMPLETE LINE
WRITE FOR CAT. B-568

KEPCO LABORATORIES, INC.
131-38 SANFORD AVENUE • FLUSHING 55, N. Y. • INDEPENDENCE 1-7000

messages to the general public while simultaneously operating so as to deny navigational information to enemy aircraft.

Depending upon circumstances, television stations in some cities may be designated to cut off transmission of either sound or picture carrier or both according to a pre-determined pattern.

► **Sound Cutoff**—One television station provides a pushbutton in the output of the crystal-driver chassis of the sound transmitter to cut off excitation to following stages. This pushbutton or key is immediately accessible to station operating engineers, but in a location in which it is not likely to be accidentally operated.

The picture carrier is similarly keyed off using the middle position

of a three-point switch. In this equipment, two crystals are available, and the selecting switch had the midposition contacts added.

Failure Indicators

INTERLOCK circuits probably cause broadcasters more grief than any other type of failure. Often, there is no clear indication as to which of a long series of door switches has failed to make contact.

One station has overcome this problem by operating a multicontact relay from each interlock switch. A set of contacts is connected in the conventional interlock chain circuit. Another pair lights a neon indicator when the door or enclosure switch is properly closed. Interlock failure is immediately

pinpointed by observation of the central indicator panel.

► **Temporary Lockout**—In case of damage to an interlock switch, station engineers are likely to jumper out the defective circuit to keep program on the air. Such dangerous practice is avoided in the station mentioned by providing a separate switch on the indicator panel.

When this emergency switch is thrown on, it closes the operating contacts of the relay in the defective circuit without affecting the relay coil circuit. Thus, the indicator still shows trouble by remaining unlighted and the engineer on watch has this visual reminder continually before him.

Bias-failure relays are similarly equipped with indicator lights to give a quick analysis of failure.

White Alice Link Completed In Alaska

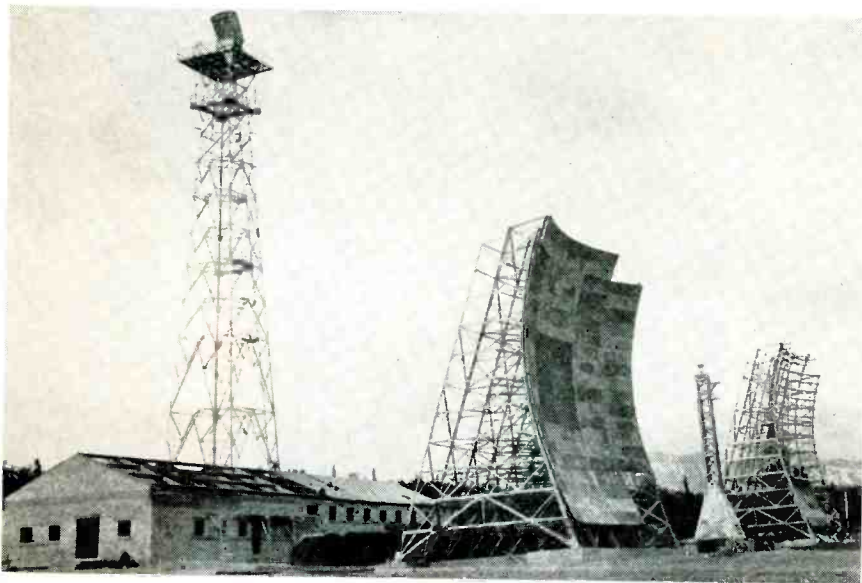

Typical White Alice relay station. Transhorizon antennas at right (one is under construction) weigh 100 tons. Microwave relay for short hops at left. Eventually range of such stations may be increased to 200 miles

EXTENSION of the Alaska Communications System providing telephone and telegraph service in the Territory for Army, Navy, CAA and the general public has recently been made possible by construction of a new 176-mile radio link.

The first completed section of the White Alice system connects Anchorage with a military installation on Middleton Island (see map). Western Electric officials turned the

circuit over to Alaskan Air Command at the end of November.

Major purpose of the White Alice system is to provide defense communications among radar outposts, including the DEW Line, and combat centers. However, commercial telephone and telegraph service now becomes available to Cordova, an important fishing center. Operation of the circuits will be assumed for Air Force by Federal Electric

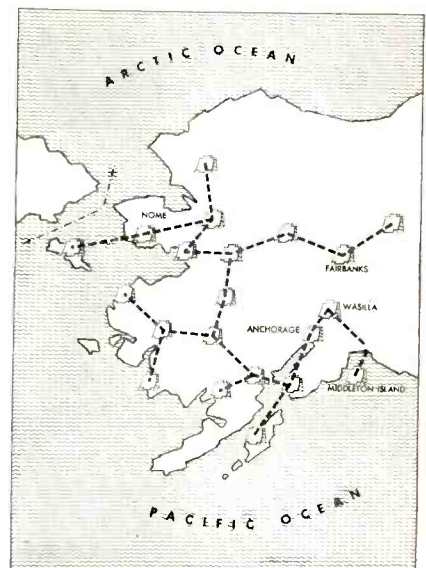

Approximate routes of the White Alice circuits constructed under contract with Western Electric for the Air Force

Corp., a division of International Telephone and Telegraph Corp.

► **Multichannel System**—The broad-band communications system operates with relays approximately 170 miles apart using forward propagation tropospheric scatter. Signals are refracted in the troposphere, a layer of air extending about five miles above the earth's surface. Only a small part

Another product *surprise* from Helipot!



Fire burn and cauldron bubble! Cook our new **HELIPOT**® Model 50 trimming-type potentiometer to a fare-thee well. Fish it out . . . shake it . . . kick it over the goalposts. And it works as good as new.

Question:

How come this amphibious trim-type miracle?

Answer:

Fusing and housing. The resistance element "slip ring" and terminals are fused to the Steatite (high-grade, mechanically stable porcelain) frame . . . enclosed in a one-piece stainless-steel seamless-

tubing housing . . . to form an indefatigable unit that laughs off heat and moisture, sneers at shock and vibration.

For a trimming-type potentiometer with nominal resistance values from 1,000 to 25,000 ohms . . . that remains stubbornly stable after being set . . . for airborne applications, where weight and space are critical, stability and resistance to vibration vital . . . there's only one answer: Model 50.

Model 50 and the encapsulated Model 51 are both fully described in data file 121.

Beckman®

Helipot Corporation: Newport Beach, California
a division of Beckman Instruments, Inc.
Engineering representatives in principal cities

of the original energy is scattered towards the receiver.

On this account high-gain transmitting and receiving antennas are

required as shown in the photograph. There are 33 transmitting and receiving sites providing 3,100 route miles and 170,000 telephone

circuit miles. A total of 50,000 telegraph circuit miles will be available when the project is completed in 1958. Work began early in 1955.

Radio Replaces German Railway Semaphores



Motorman of passenger car has telephone (at right hand) and illuminated signal box (above his head). Signals from passing



train actuate lamps at central control board (right) that shows track occupancy and progress of trains

RAILWAY trains on the 41-km line between Malsfeld and Treysa, Hesse, Germany are controlled by signals in the cab received by radio. Although the system is essentially for signaling, voice communications are also possible when desired.

Orders from the switching center

at Homburg are relayed to stations along the line and when confirmation is received the centrally operated signal system is appropriately set.

Rail magnets at numerous points along the route automatically indicate the position of the train at the central switchboard by means

of lamps on a miniature route board.

Colored lights in the cab show orders for stop, go and slow. Warning signals show that a change will take place and a horn gives audible indication of a change in signals.

(continued on p 196)

Remote Visual Control Of Proton Beam

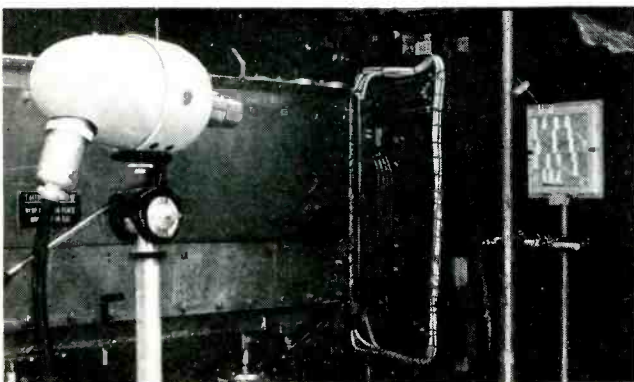

Physicists at Brookhaven National Laboratory can study the shape of the 3-bev proton beam from the cosmotron using the GPL camera and monitor shown above. Visual observation of the



pattern produced on a sodium iodide mosaic (left) facilitates accurate adjustment of the focusing magnets. Remote control of the closed circuit tv system reduces exposure of personnel

DESCRIPTIVE DATA

- **SIZE:** 1 inch diameter x 2¼ inches long
- **WEIGHT:** 3.8 ozs.
- **FULL SCALE RANGE:** 40 to 400 degrees/second
- **LINEARITY:** 0.1% of full scale to ½ range, within 2% to full range
- **RESOLUTION:** 0.01% full scale
- **DAMPING:** Fluid damped, temperature compensated
- **PICKOFF:** Variable Reluctance type, 400 - 6,000 cps
- **MOTOR EXCITATION:** 6.3 volts - 400 cps, 26 volts - 400 cps, 9 volts - 1,000 cps

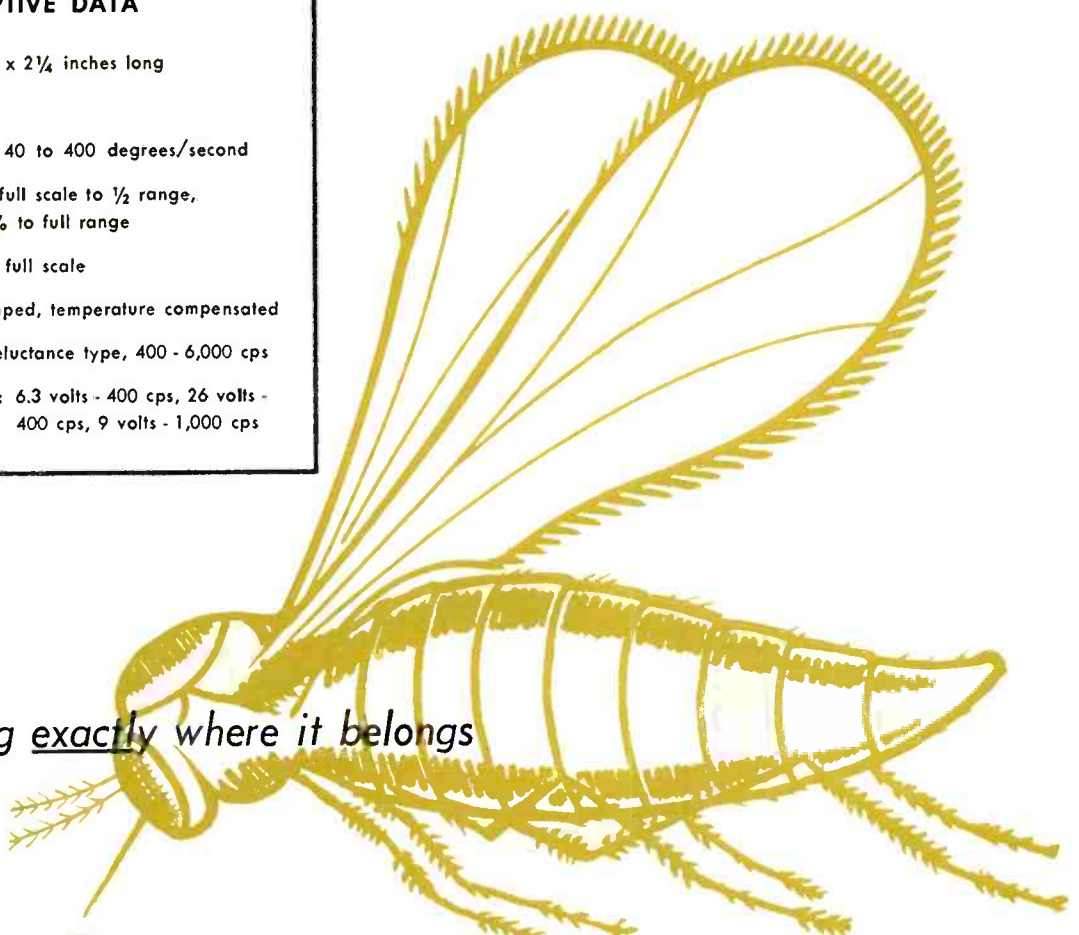

Putting the sting exactly where it belongs



Gnat Rate Gyro
Shown actual size

GOLDEN GNAT

Miniature Rate Gyros for Missiles and Aircraft

Here is a precision, miniature rate gyro. It's tiny . . . measures only 1 inch in diameter and 2¼ inches in length. It's rugged . . . withstands 100G shock and 10G vibration to 2,000 cps. It has a record of proven performance.

Even under the most severe environmental conditions the Golden Gnat will perform as required. To make this possible many unique design details have been incorporated. One such detail is the Gnat's *gold plated* steel housing for improved corrosion resistance and positive hermetic sealing.

Wherever the need exists for high performance miniature rate gyros such as for autopilot stabilization in missiles and aircraft, antenna stabilization and fire control applications, the Golden Gnat is ideally suited. Write for Bulletin GN . . . Minneapolis-Honeywell, Boston Division, Dept. 7, 1400 Soldiers Field Road, Boston 35, Mass.

MINNEAPOLIS
Honeywell 
B O S T O N D I V I S I O N

New Radars Speed Traffic Control

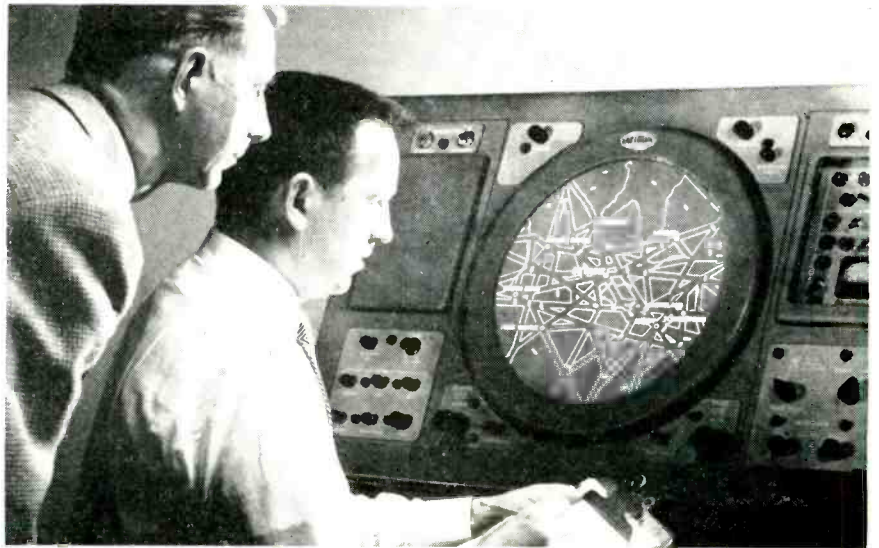

Long-range radars that can track aircraft from 130 to 200 miles, depending upon size and altitude, will be turned over to CAA by Raytheon beginning next summer. Map can be projected on screen electronically for quick identification

FEATURES of the 23 long-range radars to be used at strategic airports throughout the country include linear or circular polarization and moving target indication. Linearly polarized waves are reflected uniformly by the desired target and by storm clouds and are therefore useful in spotting storms.

When the waves are circularly polarized, the millions of spherical raindrops reflect them in reverse and the return is filtered out. However, aircraft tend to reflect a large portion of the wave with

the original twist and can therefore be spotted through storm clouds.

Moving-target indication circuits built into the radar equipment discriminate between fixed obstacles, such as buildings and mountains, and show only moving objects.

Trouble circuits show continuously the operational state of the equipment and allow operators to switch to alternate channels while maintenance is carried on.

Each radar employs a 40-foot antenna that effectively covers about 125,000 square miles of area.

Level Indicator Uses X-Rays



Liquid detergent packaged in tin cans is measured by GE x-ray device for level

CONTENTS of cans moving off a high-speed filling line can be accurately checked for underfill, overfill or both using x-rays with electronic gating and control circuits to divert off-standard containers.

Equipment used in General Electric's Hytafill system is shown in the block diagram. Variations in level as little as 1/32 inch can be detected at speeds of 900 cans a minute.

In operation, a narrow x-ray beam traverses the conveyor immediately after the photoelectric

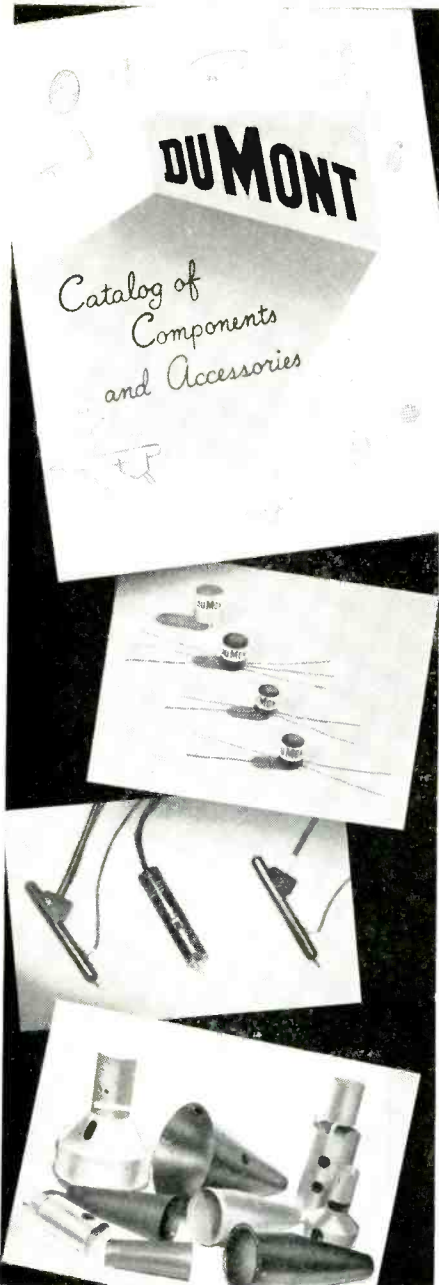

New— and Complete

Illustrated listings of components and accessories for oscilloscopes including specifications on such items as knobs, pulse transformers, probes, magnetic shields, photographic recording equipment, racks and carrying tables. Many more miscellaneous items listed in easy to read form.

• Write for your copy

DU MONT

ALLEN B. DU MONT LABORATORIES, INC.
Technical Sales Dept. • Clifton, N. J.
Want more information? Use post card on last page.

FIRST silicon transistors meeting NAVY SPECS



For *reliability* under *extreme* conditions . . . design with TI's military silicon transistors . . . built to give you high gain in small signal applications at temperatures up to 150°C. Made to the stringent requirements of MIL-T-19112A (SHIPS) and MIL-T-19502 (SHIPS), these welded case, grown junction devices furnish the tremendous savings in weight, space and power you expect from transistorization . . . *plus* close parameter control

that permits you to design your circuits with confidence.

All 19 Texas Instruments silicon transistor types have proved themselves in military use. First and largest producer of silicon transistors, TI is the country's major supplier of high temperature transistors to industry for use in military and commercial equipment.

degradation rate tests for TI's USN-2N117 and USN-2N118 silicon transistors

test	condition	duration	end point at 25°C
lead fatigue	three 90-degree arcs	—	no broken leads $I_{CO} = 2\mu A$ maximum at 5V $h_{ob} = 2\mu mhos$ maximum $h_{fb} = -0.88$ minimum for 2N117 $h_{fb} = -0.94$ minimum for 2N118
vibration	100 to 1000 cps at 10 G	3 cycles, each x, y, and z plane	
vibration fatigue	60 cps at 10 G	32 hours, each x, y, and z plane	
shock	40 G, 11 milliseconds	3 shocks, each x, y, and z plane	
temperature cycle	-55°C to +150°C	10 cycles	
moisture resistance	MIL-STD-202	240 hours	
life, intermittent operation	$P_c = 150$ mW, $V_c = 30$ V	1000 hours, accumulated operating time	
life, storage	150° C, ambient	1000 hours	no mechanical defects interfering with operation
salt spray	MIL-STD-202	50 hours	

**LOOK TO TI FOR: SILICON HF, MEDIUM POWER, POWER, AND SMALL SIGNAL TRANSISTORS
SILICON DIODES AND RECTIFIERS • GERMANIUM VHF, POWER, RADIO, AND GENERAL PURPOSE TRANSISTORS**

**pioneer producer of
silicon transistors**



**TEXAS INSTRUMENTS
INCORPORATED**
6000 LEMMON AVENUE DALLAS 9, TEXAS

by every test



is BEST!



ATR AUTO RADIO VIBRATORS

Have Ceramic Stack Spacers

A COMPLETE LINE OF VIBRATORS

Designed for Use in Standard Vibrator-Operated Auto Radio Receivers. Built with Precision Construction, featuring Ceramic Stack Spacers for longer lasting life. Backed by more than 22 years of experience in Vibrator Design, Development, and Manufacturing.

Free



"A" Battery Eliminators, DC-AC Inverters, Auto Radio Vibrators



NEW MODELS

NEW DESIGNS

NEW LITERATURE

See your jobber or write factory

AMERICAN TELEVISION & RADIO CO.

Quality Products Since 1931

SAINT PAUL 1, MINNESOTA—U. S. A.

Want more information? Use post card on last page.

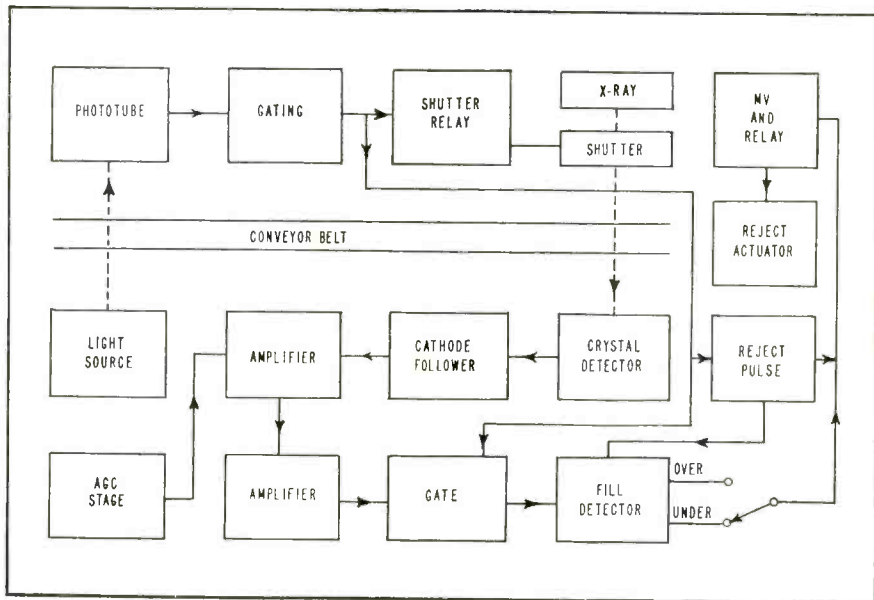

Block diagram of a liquid level fill detector that will reject either over or underfilled cans depending upon the setting of the controls

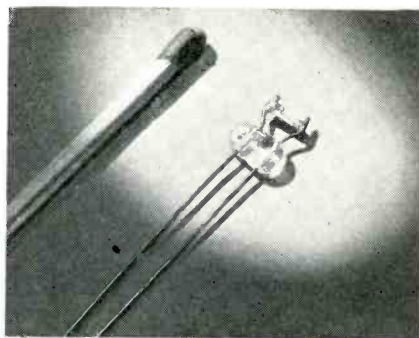

Sensitive cadmium sulfide crystal is used as x-ray detector

circuit is interrupted by passage of a can. The x-ray beam is adjusted to desired height. When fill is incorrect, receipt of the beam is altered by the can's content to register on the detector. The amplified signal from the detector triggers the rejecting device.

Defense Inventions

SUPPLEMENTARY listing of technical problems affecting the national defense has been issued by

British Color TV Tests

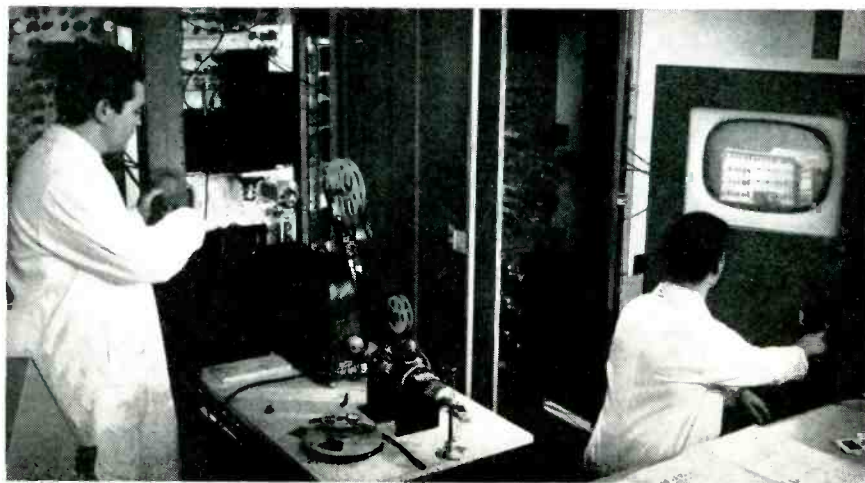

Experimental equipment is being used at Sylvania-Thorn color television laboratories at Enfield, England. Work in progress employs equipment and techniques required under U. S. NTSC color standards

Quickly... economically...

SOLVE CLOSURE PROBLEMS

with
HUDSON
Precision Drawn
CASES-COVERS



Thousands of Standard Designs available for fast delivery! Hudson offers a wide range of sizes from miniature to large in a variety of shapes that meet all but the most unusual closure requirements. Hundreds of optional features are available on most HUDSON standard cases and covers.

Complete Service on quality metal stampings and sheet metal work. Expert fabrication of simple or complex sub-assemblies to exact specifications.

SPECIFY HUDSON-

for precision components of:

- STEEL
- BRASS
- ALUMINUM
- COPPER
- MU METAL

including:

certified alloy welding, certified spot welding, silver soldering and brazing. For complete information on standard closures write for the new Hudson catalog; for quotations on custom parts and sub-assemblies send drawings and specifications. HUDSON offers designers and engineers fast delivery of precision closures at commercial prices! Ask for quotations on your requirements today!



HUDSON STANDARD CLOSURES MEET PRACTICALLY EVERY DESIGN REQUIREMENT!

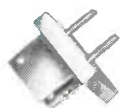
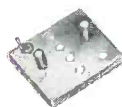
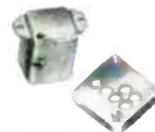
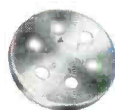

THREE
PLANTS TO
SERVE YOU



HUDSON TOOL & DIE COMPANY · INC

18 MALVERN ST., NEWARK 5, N. J.
TELEPHONE: Market 3-7584

TRANSCO COAXIAL SWITCHES

-the complete line
for **broad-band,**
high efficiency
RF switching

You'll find TRANSCO switches reliable under all conditions described in existing military specifications. Reliability—plus minimum insertion loss, low V S W R, and high isolation between channels—make TRANSCO the most specified coaxial switches in the industry.

Send your coaxial switching problems to TRANSCO. Technical data on any unit or the complete line sent on request.



1460
series

MOTOR OPERATED

—SP2T to SP6T; also DP transfer and DPDT Frequencies to 11,000 MC.



M1460
series

MANUALLY OPERATED

— same contact arrangement and RF head as the 1460 Series.

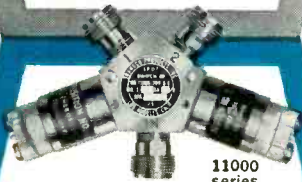

11000
series

MINIATURE—SPDT

— remote-control unit, excellent RF characteristics over wide frequency range.



14000
series

MINIATURE—SP4T

— for wide application flexibility. Weight only 0.75 lbs. Frequencies to 10,000 MC.

TRANSCO

PRODUCTS, INC.

Always the Finest in Avionics
12210 NEBRASKA AVE.,
LOS ANGELES 25, CALIF.

REPRESENTATIVES IN MAJOR AREAS

the National Inventors Council. Two listings were published in 1954.

Among the problems for which solutions are sought are counter-countermeasures (how to combat radar jamming) three-dimensional radar (to give accurate height as well as azimuth and range information) and a quick-heating

cathode (an efficient, indirectly heated, unipotential, thermionic cathode capable of operation in less than one second).

Further information on these and other subjects can be obtained by addressing inquiries to The National Inventors Council, U. S. Department of Commerce, Washington 25, D. C.

Cordless Audio Receiving Device



The Eareceiver clamps over the left ear as shown and contains its own battery

INDUCTION pickup from an audio loop placed in the region for listening provides headphone audibility with a self-contained receiver. For home use, a loop is connected in series with the speaker voice coil and the receiver volume is turned up.

The amplifier driving the loop must have an output impedance of 4 to 8 ohms. The amplifier should have an output rating of about 2 watts for normal listening. Low-frequency boost of about 15 db near 150 cycles improves fidelity.

If a loop comprising 6 turns of

Traveling Wave Amplifiers Under Test

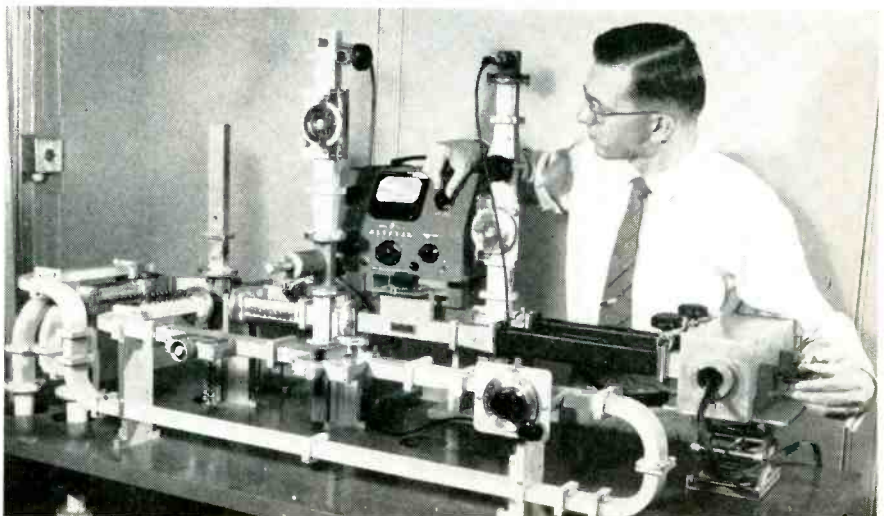

Tests on the t-w amplifier tube at Bell Labs are directed towards applying these broad-band transmission devices to practical communications circuits. This tube gives 5 watts output with a bandwidth of 500 mc in the 6,000-mc band. Nonlinearity is checked by feeding an a-m signal into the tube. If nonlinearity exists, some of the a-m is converted to phase modulation, which can then be detected in the amplified signal at the output of the t-w tube

Want more information? Use post card on last page.

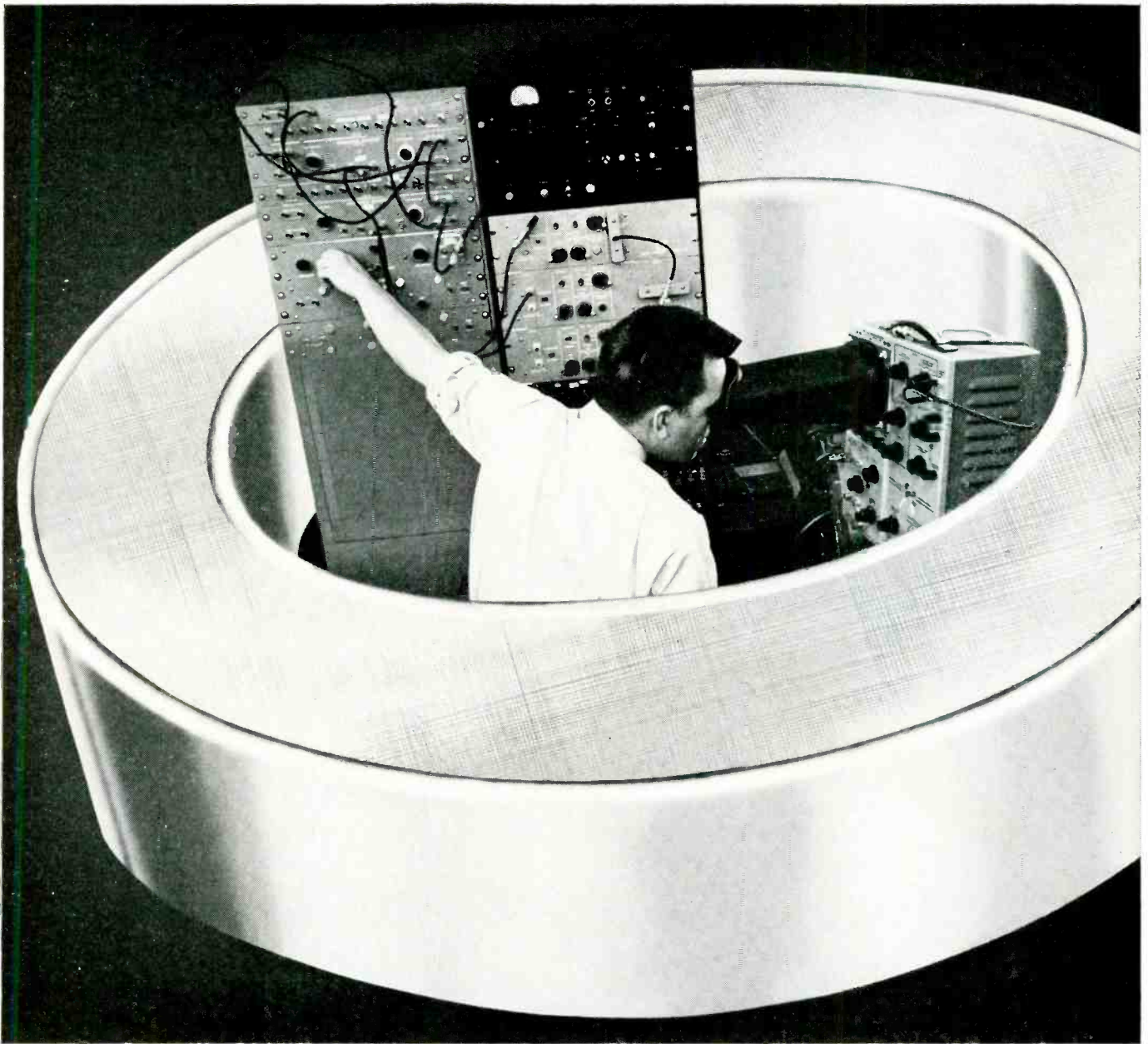

what makes tape wound cores reliable?

Reliability demands physical protection. Magnetic alloys which provide square hysteresis loop characteristics are strain sensitive. Distortion caused by coil winding will disturb precise magnetic characteristics, alter performance. So Magnetics, Inc. has devised a rigid, extra-strong aluminum core box to protect the magnetic core within from winding stresses, thus eliminating distortion.

Reliability demands electrical stability through the years. Suppose guided missiles failed to function in a future emergency because the magnetic properties of tape wound cores had changed. Cores must operate just as effectively years from now as they do today, whether or not they have been in use. Vibration, shock, and temperature changes can endanger such performance. That's why Magnetics, Inc. cushions tape windings with a special inert material in the extra-strong aluminum core box. And that's why it is especially important that our tape wound cores enclosed in aluminum boxes will withstand temperatures up to 450°F.

Reliability demands exacting standards on the part of the manufacturer. Judge a product by the company that makes it. Take a company that has pioneered a core box so advanced that it even permits vacuum impregnation. Take a company whose attention to design detail permits the offer of the *only* Performance-Guarantee in the industry. That's a real definition of reliability. Why not ask us how it will work for you? *Magnetics, Inc., Dept. E-32, Butler, Pennsylvania.*

*For Full Details, Write For
Catalog TWC-100A*

MAGNETICS inc.

CABLE: MAGNETICS

actual size

**MORE
"MUSCLE"
FOR CRITICAL
CONTROLS**



Disassembled induction receiver. Parts of receiver proper are duplicated to show obverse (right)

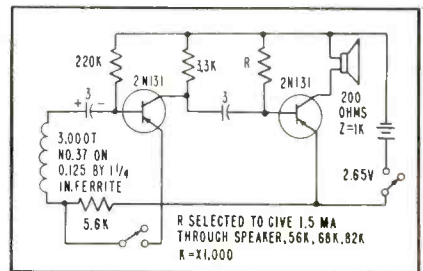

Circuit diagram of induction receiver

No. 18 wire is made to encircle an area 10 by 40 feet adequate field will be created using the 2-watt amplifier.

The circuit diagram of the induction-pickup device and the photograph show the nature of the equipment employed. The antenna coil is encapsulated in the clamp that fits behind the ear. The receiver proper contains the miniature loudspeaker behind a punched grill and, on the other side, an off-on switch.

Information about the equipment was furnished by Norris Electronics Corp., Scottsdale, Arizona.

Oscilloscope Amplifier

PREAMPLIFICATION of signals into an oscilloscope is often necessary but frequently awkward when conventional amplifier units must be employed. A commercial amplifier

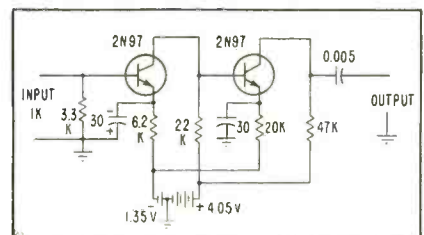

Circuit of Du Mont preamplifier



GLOBE'S NEW PRECISION PLANETARY GEARMOTOR. This new a.c. power unit, custom-engineered to your applications, mates Globe's advanced design hysteresis-synchronous motor with a built-in planetary gearing system . . . all in one, compact, lightweight, environment-proof package. Units are inherently accurate for precise timing and control. Motors supplied for normal frequency ranges and speeds, provide absolute synchronous rotation, extremely smooth operation, and high starting and running torque. High efficiency planetary gearing features low backlash and low composite error. Broad selection of gear ratios includes odd and even speed reductions, and torques up to 1500 oz. in. Dimensions, 1.675" dia. x 3.186" to 4.095" long; and weight, 16 to 20 ounces, depend on ratio. Induction and variable frequency types also available. Units meet military specifications. Prompt delivery on prototype and production orders. Write for bulletin 1270.



INDUSTRIES, inc.

dayton 4, ohio

"dedicated to the best in product and in service"

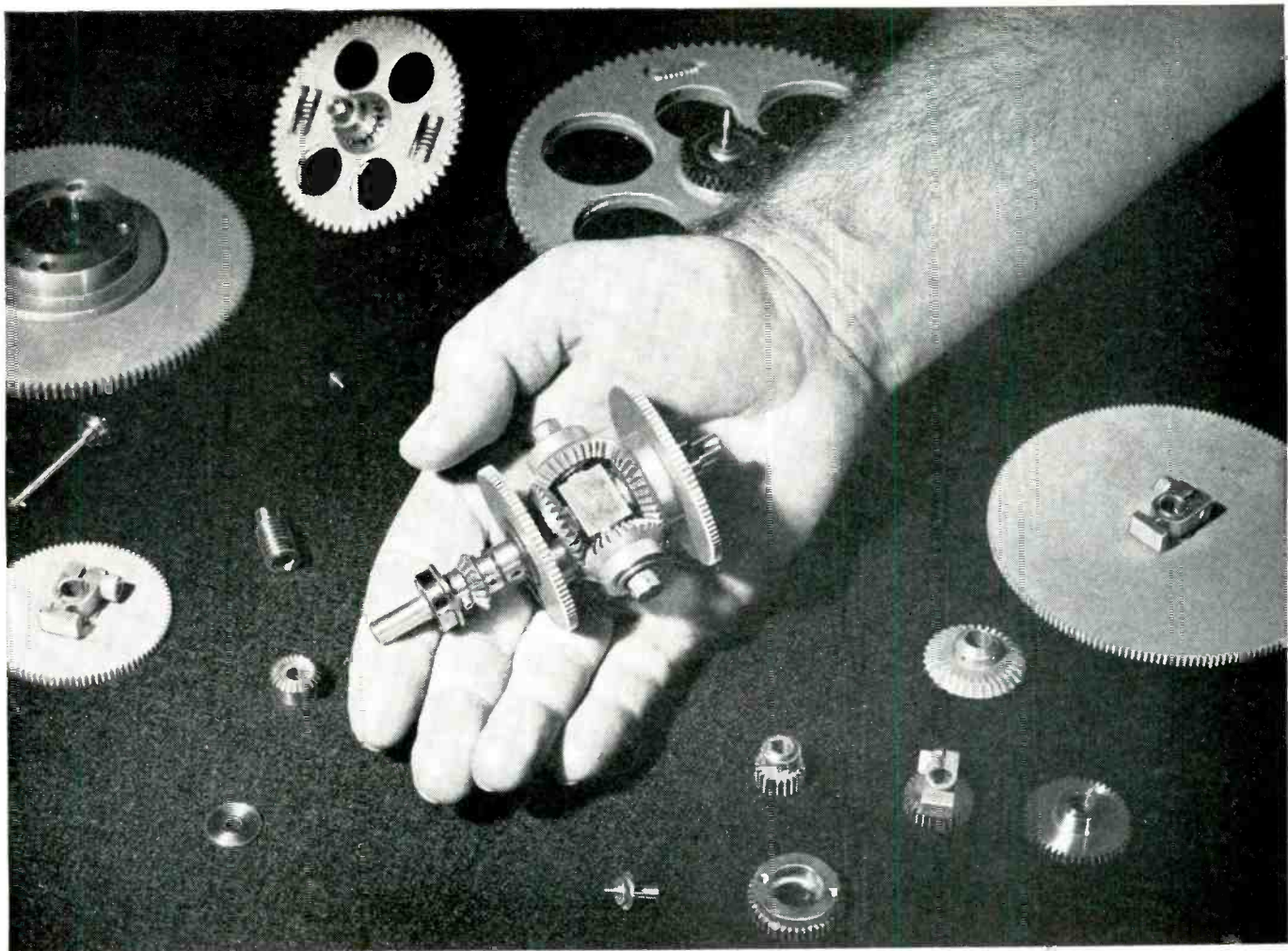

Geared To The "Go"

OF THE MOST PRECISE EQUIPMENT

Spur, bevel, spiral, hypoid, zerol, helical, worm gears . . . anti-backlash gears . . . differentials . . . gear trains . . . complete computers, Atlas "precisioners" them all to the most exacting specifications of electro-mechanical equipment.

Fine gears of all types and the modern equipment to make them are just one phase of the complete facilities of Atlas. Whether your product is a specialized part for electronic equipment or a complete electro-mechanical assembly Atlas will engineer precision assemblies and components to your requirements.

Atlas design, production and methods engineers, toolmakers and skilled mechanics work right along with you on a job basis. Every modern cost-cutting tool and technique is at your service . . . plus quality control, functional testing and modern electronic recording gear checking equipment.

From idea stage to production efficiency Atlas "creative engineering" can help you get your product *underway* quicker and at lower costs. Write today for booklet "Precisionering Electro Mechanical Equipment." Atlas Precision Products Co., Philadelphia 24, Pa., (Division of Prudential Industries).

"From Drawing Board . . . to Production Line"



ATLAS

Precision Products



AMPHENOL RF CONNECTORS

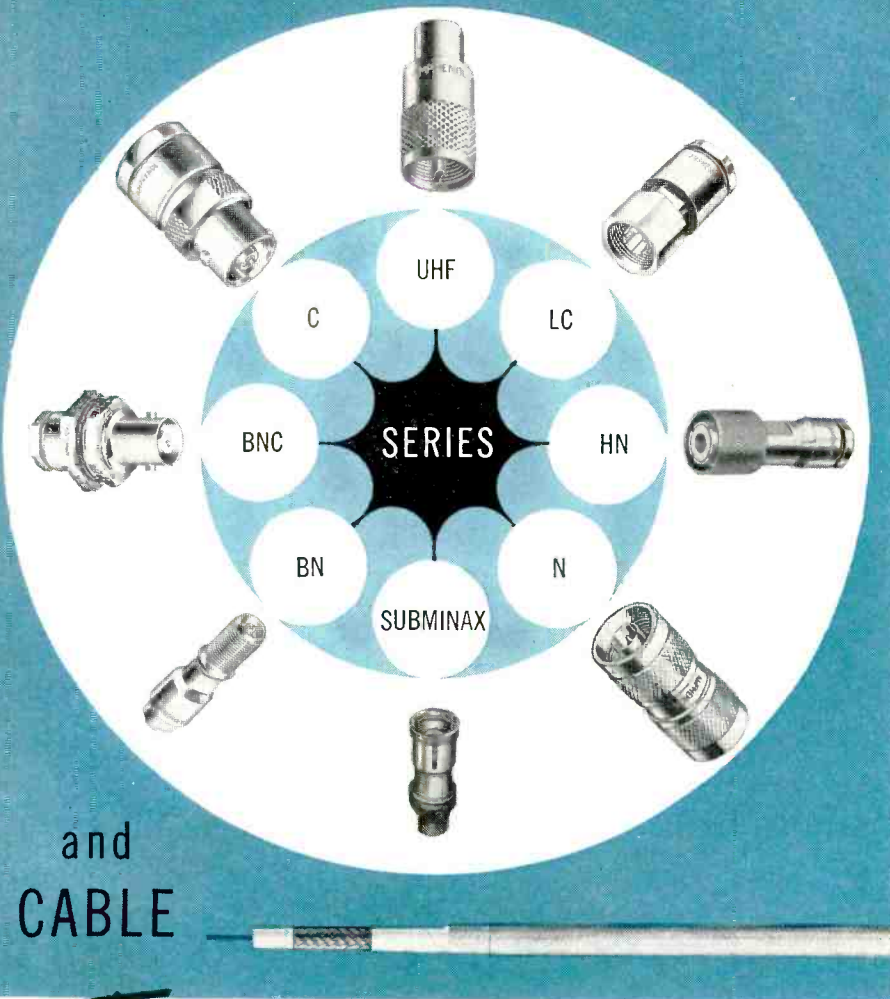

Engineers

turn to AMPHENOL for the RF components they need for these important reasons:

- 1 AMPHENOL manufactures all popular Series, offering a large availability listing of standard connectors.
- 2 AMPHENOL manufactures the coaxial cable to match its connectors. Only AMPHENOL has assumed this engineering responsibility for proper cable/connector fit.
- 3 AMPHENOL works with you on "specials" and adaptations of standards that point the way to engineering advances in this critically important field.

Recent AMPHENOL "firsts" in RF connectors and cables include Captivated Contact* and Subminax connectors, Teflon tape coaxial cable, Subminax Teflon coaxial cable and Teflon cable with non-magnetic conductors. AMPHENOL leads in the manufacture of approved RG-/U Teflon dielectric coaxial cables.

*PATENT PENDING

✻ Are you on our mailing list for catalogs, technical data or our monthly publication "Engineering News"? Write us on your letterhead for this valuable service.

AMPHENOL ELECTRONICS CORPORATION
1830 S. 54th Avenue, Chicago 50, Illinois



employing transistors uses the circuit shown.

Voltage gain is 1,000. Noise is 1 μ v rms referred to input and the response is 3-db down in the range from 20 cps to 30 kc. The unit is powered with mercury cells that have a life of 1,000 hours in this type of service. Input resistance is approximately 1,000 ohms.

Clip-On Milliammeter Uses Magnetic Amplifier

By E. H. FREI
and
D. TREVES

Weizmann Institute of Science
Rehovoth, Israel

CURRENT measurement usually requires that the circuit be interrupted. For larger currents, clip-on instruments have been used for many years. With these instruments and with the instrument described here the tested wire is surrounded by a magnetic material and the magnetic flux generated in this material is measured.

The most commonly used clip-on instrument is an a-c meter with ranges of several amperes. Its main part is a current transformer that is clipped around the wire to

Oscillograph Analyzes Cutter

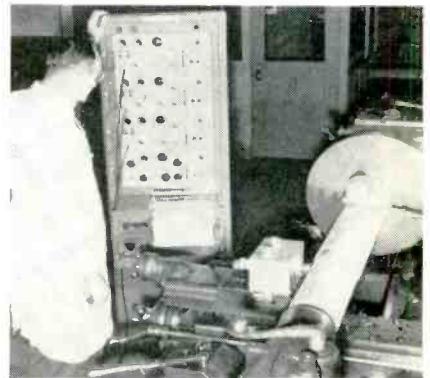

Test lathe used to evaluate carbide cutting tools is equipped with transducers feeding into four-channel electronic oscillograph that indicates three components of force acting upon the tool. Engineers at GE's metallurgical department in Detroit can also measure speed, temperature and machine-tool horsepower



Can you help add to these achievements?

These accomplishments in pure and applied science are widely known. To this impressive list, scientists and engineers at the Laboratory's Livermore site are making equally important contributions in the fields of nuclear weapons design, nuclear rocket propulsion, controlled thermonuclear energy (Project Sherwood) and high current accelerators.

What you can do to help add to these accomplishments is limited only by yourself—your *ability* and your *interest*.

For the University of California Radiation Laboratory is managed and directed by outstanding scientists and engineers.

These men are your "team-mates"... offering pioneering knowledge of the nuclear field and the newest, most expansive laboratory facilities. Here—where new ideas and techniques are traditional—initiative is constantly encouraged and developed.

IF YOU are a **MECHANICAL** or **ELECTRONICS ENGINEER**, you may be involved in a project in any one of many interesting fields, as a basic member of the task force assigned each research problem. Your major contribution will be to design and test the necessary equipment, which calls for skill at improvising and the requisite imaginativeness to solve a broad scope of consistently unfamiliar and novel problems.

If you are a **CHEMIST** or **CHEMICAL ENGINEER**, you will work on investigations in radiochemistry, physical and inorganic chemistry and analytical chemistry. The chemical engineer is particularly concerned with the problems of nuclear rocket propulsion, weapons and reactors.

If you are a **PHYSICIST** or **MATHEMATICIAN** you may be involved in such fields of theoretical and experimental physics as weapons design, nuclear rockets, nuclear emulsions, scientific

photography (including work in the new field of shock hydrodynamics), reaction history, critical assembly, nuclear physics, high current linear accelerator research, and the controlled release of thermonuclear energy.

In addition, you will be encouraged to explore fundamental problems of your own choosing and to publish your

findings in the open literature.

And for your family—there's pleasant living to be had in Northern California's sunny, smog-free Livermore Valley, near excellent shopping centers, schools and the many cultural attractions of the San Francisco Bay Area.

You can help develop tomorrow—at UCRL today

Send for complete information on the facilities, work, personnel plans and benefits and the good living your family can enjoy.

© UCRL

The cyclotron

The synchrotron

The proton linear accelerator

The Bevatron

Electromagnetic separation of uranium-235

Discovery of plutonium and many other transuranium elements

Discovery of

URANIUM-233

TRITIUM

CARBON-14

IRON-59

IODINE-131

Discovery of the antiproton and antineutron

Artificial production of mesons



DIRECTOR OF PROFESSIONAL PERSONNEL
UNIVERSITY OF CALIFORNIA RADIATION LABORATORY
LIVERMORE, CALIFORNIA

64-3-3

Please send me complete information describing UCRL facilities, projects and opportunities.

My specialty is _____

My degree(s) are _____

Name _____

Address _____

City _____ Zone _____ State _____

pulse-forming networks and pulse capacitors

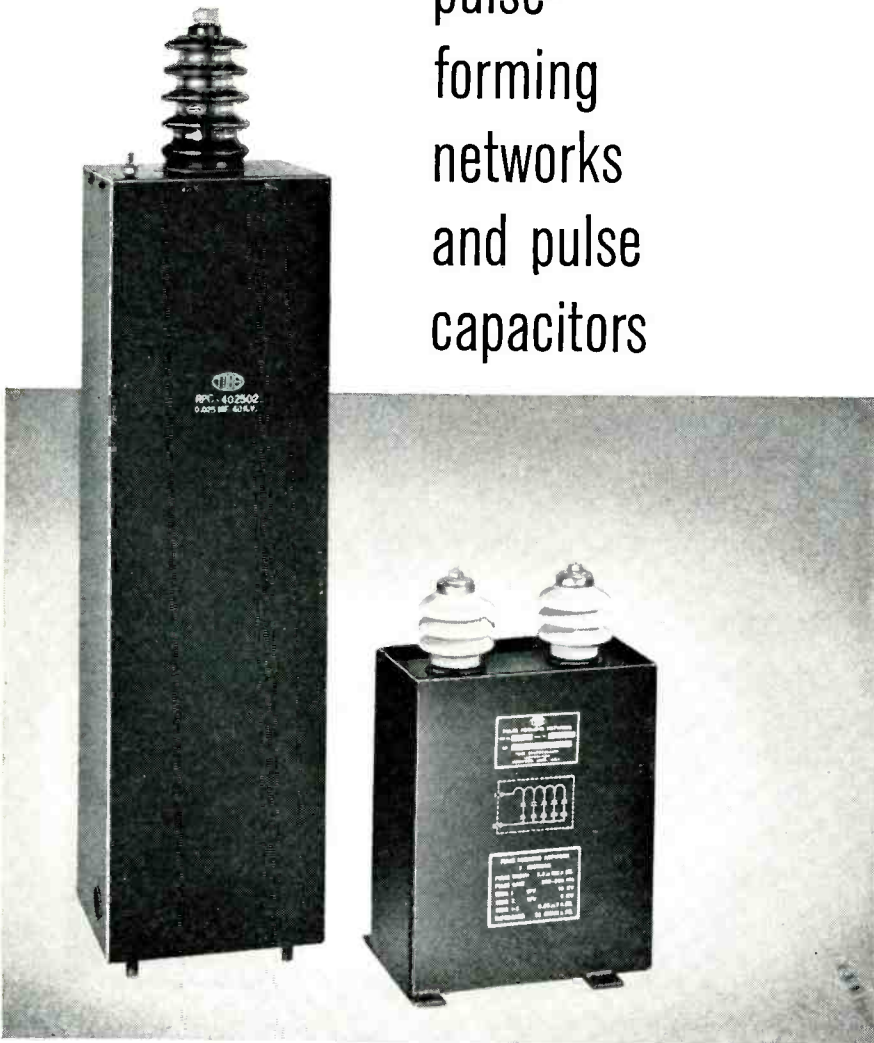

TOBE pulse-forming networks have an excellent record of performance, in radar, and in seasoning and test equipment for magnetrons and hydrogen thyatrons. Our design experience and production facilities assure deliveries to your schedule requirements.

We invite inquiries on specific applications. The services of our engineers are always available. Write TOBE Deutschmann Corporation, Norwood, Massachusetts.

Tobe Exclusives:

All Tobe pulse forming networks and pulse capacitors are operated in our modulators under actual working conditions. At conclusion of these tests every unit is checked to assure complete conformance to customer specifications. This guarantees higher reliability and dependability of Tobe products.

Excellent thermal-stability and minimum loss characteristics.

TOBE pulse-forming networks are available in a wide range of ratings and sizes . . . TOBE pulse capacitors are recommended for network applications above 25KV.



TOBE DEUTSCHMANN • CAPACITOR PIONEERS SINCE 1929

be tested. In the d-c meter, the core of a moving-iron-type instrument is clipped around the current-carrying conductor.

In all these, the magnetic flux of the current to be measured energizes the instrument.

In the instrument described here only a probe containing a magnetic amplifier is clipped around the wire. The indicating meter itself is connected to the probe by appropriate circuits. It is not much

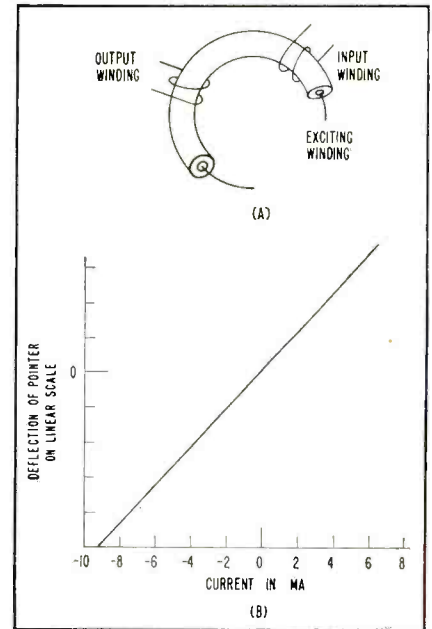

FIG. 1—Basic form of the crossed-field transducer coil and windings (A) and current scale showing range and linearity (B)

more complicated than a vtvm. This system possesses high sensitivity and can be designed to give a linear response over a large range of currents.

The magnetic amplifier or transducer works on the second-harmonic principle. It is usually designed with two cores so connected that in the common output the signals combine and the exciting currents compensate each other¹. Using this amplifier for the clip-on instrument would mean that two cores must be used. This would be cumbersome.

As small air gaps may remain in the cores at the points where they open and close, errors might result if these gaps are not equal. A new type of second-harmonic amplifier has been designed, in which only a single core is used but the

THE WORLD'S LARGEST ANTENNAS *are coming from* KENNEDY



TRACKING ANTENNAS

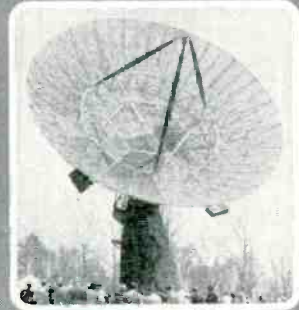

RADIO TELESCOPES

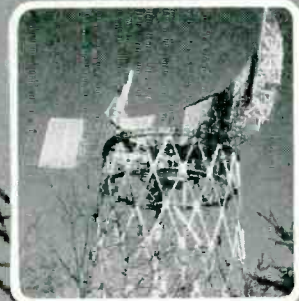

RADAR ANTENNAS



TROPOSPHERIC SCATTER

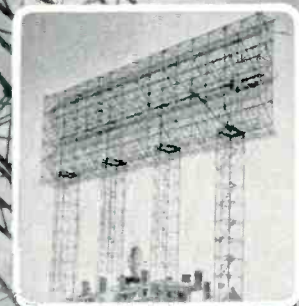

IONOSPHERIC SCATTER

ALL round the globe, mighty antennas like these are serving as electronic eyes and ears for the free world . . . ample proof that Kennedy has the know-how and the facilities to solve your antenna problems, large or small — all the way from design through installation.



ANTENNA EQUIPMENT

D. S. KENNEDY & CO.

COHASSET, MASS. — TEL: CO4-1200

DESIGNER'S FAVORITE SENSITIVE, VERY RESPONSIVE

Thermoswitch[®] Is Rugged, Adaptable, Heat Controller

ASHLAND, MASS. — Word emanating from here is that Fenwal Incorporated's THERMOSWITCH units are usually the best solution for a design engineer with temperature-control problems.

THERMOSWITCH thermal controls are adaptable, sensitive, responsive, small, tough, and accurate — and their price is right. They frequently replace controllers costing much more, and do a better job.

Their principle of operation is unique — and highly competitive in terms of every quality most design engineers would require. The unique principle is this: *the activating control element is a single-metal shell that expands or contracts instantaneously with temperature changes, making or breaking the totally-enclosed electrical contacts.*

Design engineers have put THERMOSWITCH units to work everywhere that temperature control is vital — in planes . . . factories . . . ships . . . hospitals . . . food-processing plants . . . homes . . . laboratories. The list of THERMOSWITCH applications is virtually endless. So is the list of physical ordeals the units have survived and the high performance standards they've met.

When tested alongside bulb-type and enclosed bi-metallic thermostats under identical conditions, THERMOSWITCH units have overwhelmed both with performances like these:

- reaction speed, four to nine times as fast;
- heat-responsive area, three to six times as large;
- heat-transfer path, only one-third to one-sixth as long;
- temperature differential, only one-tenth to one-nineteenth as great;
- vibration-sensitivity, only one-twelfth to one-eighteenth as great;
- shock-sensitivity, only one-tenth to one-eighteenth as great;

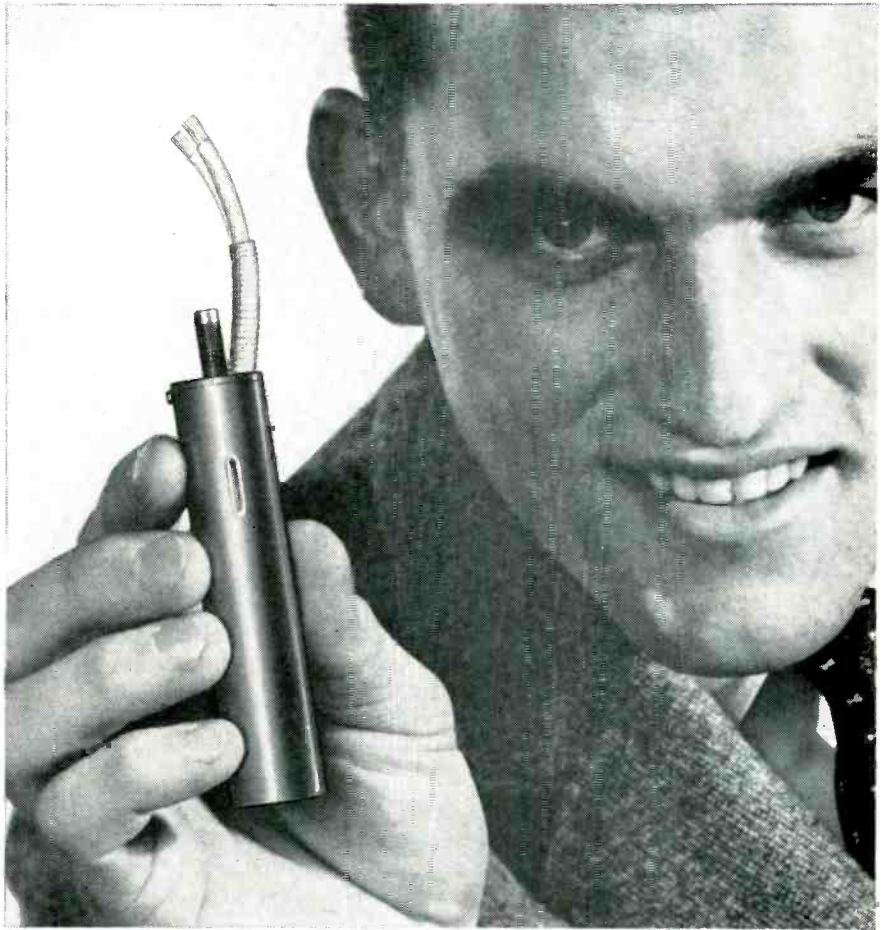

FENWAL THERMOSWITCH UNITS may solve your temperature control problems, too. Sensitive, tough, and accurate — they have been put to work by designers wherever temperature control is vital. Over 25,000 variations of the THERMOSWITCH unit are available. Write for THERMOSWITCH folder.

Added to these points of superiority are such demonstrable features as uniformity of sensitivity throughout the operating range, built-in temperature anticipation, enclosed tamper-proof assembly, direct radiant heat reception, and an operating range from -100°F. to 600°F.

Other ranges are available, too. The point at which a unit makes or breaks a circuit is determined by a set screw easily adjusted in the field.

There's a Fenwal sales engineer ready to help you apply THERMO-

SWITCH units to your particular heat control problems — ready with over 25,000 variations. Write Fenwal for his name and for complete specifications. Fenwal Incorporated, 201 Pleasant Street, Ashland, Mass.

Fenwal

**CONTROLS TEMPERATURE
...PRECISELY**

COMAR

is your best source for TELEPHONE TYPE
RELAYS

Standards
and
Specials

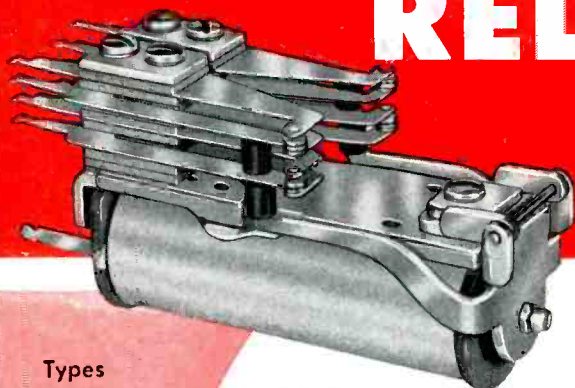

Types
To Fit
Every
Need

TYPE TL—Fast-acting, sensitive, long-life, multi-pole relay. Max. voltage, 220 VDC. Max. contact combination, 8 PDT. Max. contact load, 5 amperes. Coils available for up to 0.1 second delay on operate and up to 0.4 second delay on release. Single or double switch stacks. 4" long, 1½" wide, ¼" high, plus stack.

TYPE T—Voltages up to 125 volts DC, or up to 20,000 ohm coil. Contact combinations up to 6PDT; ratings up to 10 amperes at 115 v. AC. (SPST.), can be supplied with time delay. Size 2⁷/₃₂" long, 1¼" wide, 1⁵/₁₆" high, depending on stack.

TYPE TJB—Fast-action. Long core provides greater sensitivity. Voltages up to 125 volts DC, or up to 15,000 ohm coil, std. Contact combinations to 6PDT; ratings to 10 amperes at 115 v. AC on SPST. Size: 2" x 1³/₁₆" x 1¼". Bifurcated blades available.

TYPE TMB—Sensitive type. Voltages up to 125 v. DC, or up to 10,000 ohm coil, std. Contacts up to 6PDT. Ratings to 10 amp. at 115 v. AC on SPST.

Vibr.: 10G at 5 to 300 cps, or 5G at 300 to 500 cps. 1½" x 2³/₃₂" x 1½". Bifurcated blades available.

TYPE TS—Miniature telephone type. Size: 1⁵/₃₂" x 2³/₃₂" x 1³/₆₄", for 4PDT. Voltages up to 125 v. DC, or up to 6500 ohm coil. Vibration: 10G at 5 to 500 cps depending on contacts and combinations.

Send for
Complete
Details



3349 ADDISON STREET
CHICAGO 18, ILLINOIS

RELAYS • SOLENOIDS • COILS • SWITCHES • HERMETIC SEALING

lessens the influence of an external magnetic field, since it splits into equal and compensating fields within a symmetrical probe. The voltages directly induced in the output coil by the exciting currents will also tend to be lower.

A mumetal shield further protects the probe from the influence of external magnetic fields. A rubber cushion is used between the shield and the ferrite. This allows the ferrite to align itself properly at the connecting faces and magnetically insulates the ferrite from the metal shield.

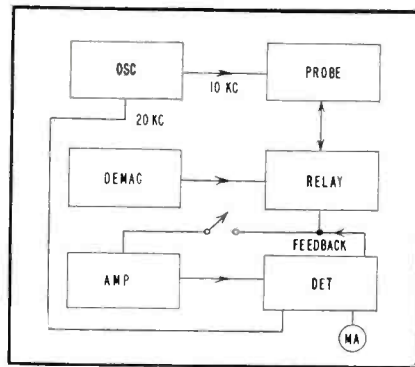

FIG. 3—Mechanical detail of the current probe

A cable containing the leads to the exciting winding and output winding connects the probe to the associated circuits.

As shown in block diagram Fig. 3 and circuit of Fig. 4, a push-pull oscillator supplies the 10-kc exciting current. At the cathode-resistor, the second harmonic is available. It was considered more economical to build a simple oscillator that may drift slightly, and to make the other circuits insensitive to such a drift.

The voltage from the output coil of the probe is fed into a two-stage amplifier tuned to 20 kc. The frequency response of this amplifier is so designed that it allows for the frequency drift of the oscillator without shifting the phase and is selective enough to reject most of the first and third harmonic components that might be present.

A synchronous detector is used for demodulation. Its output is fed to a zero-center milliammeter. If the current changes direction, or if the probe is reversed, the phase of

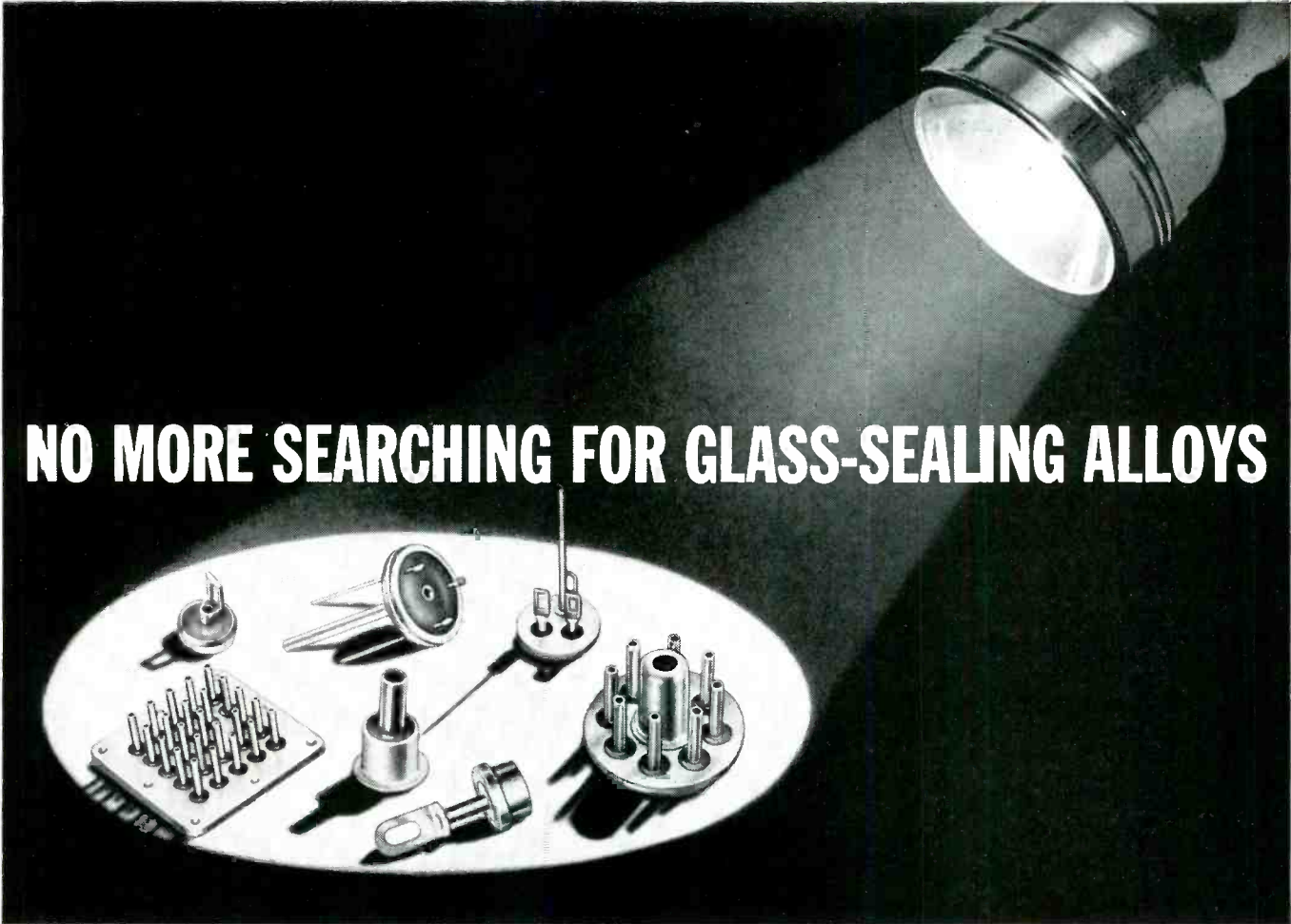

NO MORE SEARCHING FOR GLASS-SEALING ALLOYS

Photos of parts using glass-sealing alloys, courtesy Electrical Industries, Newark, N.J.

Superior Tube offers widest selection

EASY-TO-USE SELECTION CHART FOR GLASS-SEALING ALLOYS				
Kind of glass used	Superior Tube alloys to be specified	Condensed Physical Properties		
		Thermal Exp. Coeff.	Density	Temper
Corning Glass Nos. 704, 706, 708, 708AJ	# 42	5.3	0.29	All alloys available in Tempers 1, 2 and 3
Corning Glass Nos. 001, 012, G12	# 52	9.5	0.298	
Corning Glass Nos. 001, 012, 8160	# 4 (Sylvania)	8.5	0.292	
Corning Glass Nos., External 008, 001, 012, 024, 8160	446	10.5	0.273	
Theoretically any glass. Use with feathered edge seal.	OFHC Copper	16.5	0.323	
Corning Glass Nos., Internal 1990, 1991; External, any soft glass	MT-1010	12.5	0.283	

Best place to look first for the glass sealing alloys you need is Superior Tube Company. Wide selection available for virtually all application requirements. Quantities as small as 50 ft. in any size and analysis. Superior Tube Glass Sealing alloys are cold drawn to close tolerances in Seamless or Weldrawn* form. Sizes from .012 in. to 5/8 in. OD, with walls ranging from .0015 in. to .083 in. maximum. Supplied in random and coiled lengths—8 in. diameter coils up to .075 in. OD, 18 in. diameter coils for larger sizes. 90% of coils are 30 ft. minimum, 10% are 10 ft. minimum. In addition to the standard alloys listed in table, many special alloys are available on special order.

*T.M. Reg. U.S. Pat. Off., Superior Tube Co.



SUPERIOR TUBE CO.
2500 GERMANTOWN AVE., NORRISTOWN, PA.
Please send detailed information on Glass Sealing Alloys.

Name

Company

Street

City Zone State

Superior Tube

The big name in small tubing
NORRISTOWN, PA.

Johnson & Hoffman Mfg. Corp., Mineola, N.Y.—
an affiliated company making precision metal stampings and deep-drawn parts

BALLANTINE Model 300

STILL THE FINEST IN
ELECTRONIC VOLTMETERS

Featuring a Logarithmic
Voltage Scale and
Uniform Decibel Scale



PRICE \$210.

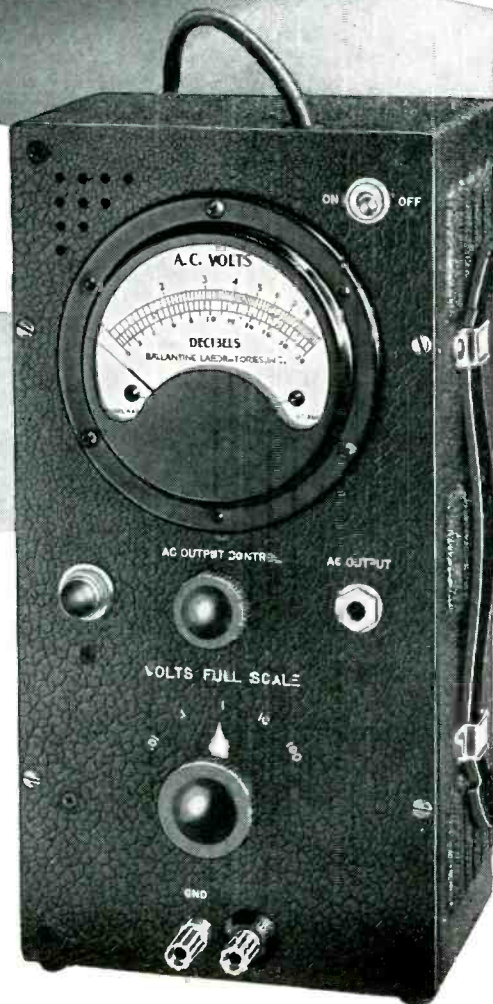

VOLTAGE RANGE001v to 100v
FREQUENCY RANGE 10 cps to 150 kc
ACCURACY 2% ENTIRE RANGE
INPUT IMPEDANCE ½ meg shunted by 30 µf

- Stability insured by the exclusive use of wire-wound resistors in the attenuator and feedback network.
- Same accuracy of reading at ALL points on the logarithmic voltage scale and linear decibel scale.
- Only ONE voltage scale to read with decade range switching.
- No "turn-over" discrepancy on unsymmetrical waves.
- Accessories available to extend the range to 20 µv and to 42,500 volts.
- Available Precision Shunt Resistors convert voltmeter to microammeter covering range from 1 microampere to 10 amperes.
- Provides 70 DB amplifier flat within 1 DB from 10 cps to 150 kc.

For further information on this and other Ballantine instruments
write for our new catalog.

BALLANTINE LABORATORIES, INC.



100 FANNY ROAD, BOONTON, NEW JERSEY

the second harmonic will change by π and the indicator on the milliammeter will also change direction.

Negative feedback is used. The output of the synchronous detector is fed into the probe through the pick-up coil. This greatly increases the instrument's range of linear operation and adds to the general stability of the system. It would be possible to switch ranges by changing the amount of the negative feedback.

Too-high currents might permanently magnetize the probe. To de-

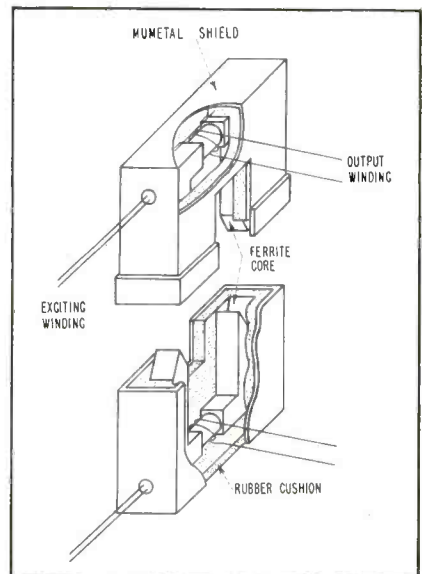

FIG. 4—Circuit diagram shows the demagnetizing circuit and timing method employed to insure nonuse during demagnetizing

magnetize it, a demagnetizing circuit is connected to the pick-up coil through a relay. This circuit produces a slowly decaying current of power-line frequency. After the current has decayed sufficiently, the relay automatically reconnects the probe to its normal circuits. A pilot lamp on the panel lights automatically during the three seconds that the demagnetizing circuit is in operation and the instrument cannot be used.

Figure 1B shows measurements made with the instrument. The accuracy and reproducibility are about ½ ma.

Any measuring instrument must be designed in accordance with a specific range of impedances of the circuits to be tested. The instru-

engineers

SPERRY offers you a rewarding future
in a beautiful Long Island setting

... Where you'll
grow professionally
as Sperry
continues to
grow

... Where you'll
live, relaxed, in
the lovely Long
Island countryside

... Where you'll
enjoy a world of
recreational
and cultural
outlets

You should consider your career at Sperry in two different, but equally advantageous lights.

Professionally, you will be joining an organization whose technical prestige and prowess are world-famous. You will be associating with outstanding Engineers and Scientists. You will be expected to help carry on the tradition of Sperry achievement... to contribute to the long line of Sperry "firsts" which have marked the past fifty years. In this connection, because Sperry activities are so diversified, your work will be on diverse and fascinating projects. Your rewards, of course, will be substantial. You will gain recognition, promotion and remuneration in direct proportion to your talent. Of prime importance is the fact that you will be with a company which is continuously expanding. And, certainly, as Sperry progresses, you will progress.

Personally, you will be discovering a new and very pleasant way of life. If ever a place can justifiably claim to "have everything," that place is Long Island. Like country? You'll thrill to the fields and flowers, the woodlands and lakes and quaint villages that abound on Long Island. Beaches? Take your choice of countless bay and ocean bathing parks, all clean and inviting. Homes? You may rent or buy on any scale you wish, from a modest suburban apartment to a sizeable country home. Wherever you live, you'll find schools, shops, churches, libraries nearby. And yet this whole wonderful environment lies not too far from New York's skyscrapers... close enough for you to enjoy dinner, the theater or a concert any evening the mood strikes you. Near at hand, too, are five universities at which you may study under Sperry's full tuition refund plan.

Make a date today to investigate the well-rounded life awaiting you at Sperry

Openings for development, research and production engineers in practically every specialized field, including the following:

- Automatic Pilots • Valves • Controls • Electronic Amplifiers • Servo Systems • Digital Computers • Jet Engine Fuel Controls • Precision Radars • Microwave Systems • Delay Lines • Motors • Electrical Measurements • Ballistic & Satellite Missiles • Anti-Aircraft Fire Control Systems • Guidance Systems • Flight Control Systems • Instrumentation • Display Equipment • Antennas • Microwave Tubes • R. F. Coils • Magnetic Amplifiers

APPLY IN PERSON

daily (including Sat.) Also Wed. eves.

OR SUBMIT RESUME

to Mr. J. W. Dwyer
Employment Manager

OR PHONE FOR APPOINTMENT

Fieldstone 7-3600, Ext. 2605 or 8238

SPERRY

GYROSCOPE COMPANY

DIVISION OF SPERRY RAND CORP.

GREAT NECK, LONG ISLAND, N. Y.

ERIE

DISC CERAMICONS[®]

FOR

Radios

TV's

Computer Assemblies

Instruments

Record Players

Military Equipment

Communication Equipment

Test Devices

Business Machines

Electronic Organs

Automatic Industrial Controls

The three types in which ERIE Disc Ceramicon are available are offered in a wide range of values. The capacitors have flat ceramic dielectrics with fired silver electrodes to which lead wires are firmly soldered. The completed units are given a protective coating of phenolic which is vacuum wax impregnated for excellent moisture seal. Disc Ceramicon are made in six sizes ranging from 5/16" max. to 3/4" max. diameter. Write for complete description and specifications.

AVAILABLE IN 3 TYPES

TEMPERATURE COMPENSATING

Disc Ceramicon offer a wide combination of temperature coefficient and capacitance values. They meet all requirements for RETMA REC-107A Class 1 ceramic capacitors. Available in capacity ranges from 1.5 to 2810 mmf at 500 V.D.C.W. and temperature coefficients ranging from P120 through N5600.

GENERAL PURPOSE Disc Ceramicon have low series inductance which assures efficient high frequency operation. Values from 1.5 mmf to .02 mfd. Rated at 500 Volts D.C. Working.

HIGH VOLTAGE Disc Ceramicon employ the same basic diameters and design that have been standardized in 500 volt ceramic capacitors. Conservative voltage rating beginning at 1 KV D.C.W. are based on extensive life test data.



ment described will not show measurable error if the impedance of the tested circuit is 0.5 ohm (at 20 kc) or more. It should be noted that there is no upper boundary to the impedance of the tested circuit.

On the other hand, such an instrument slightly influences the tested circuit. Its influence on the direct current is zero but it adds

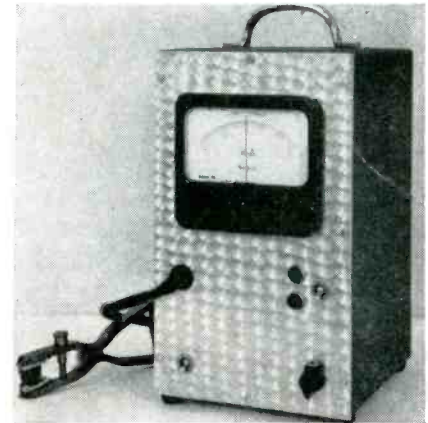

Complete instrument with probe at left

some inductance to the tested wire. With the design described the inductance is less than $0.2 \mu\text{h}$. Some voltage is also induced into the tested wire; in the instrument described it is less than $20 \mu\text{v}$ rms total (10 kc and its harmonics).

REFERENCES

- (1) H. F. Storm and others, "Magnetic Amplifiers", J. Wiley and Son, New York, 1955.
- (2) E. H. Frei, S. Shtrikman and D. Treves, A Transducer Using Crossed Magnetic Fields, *Bull. Res. Council of Israel* 3, p 443, 1953.
- (3) D. M. Grimes and D. W. Martin, Reversible Susceptibility of Ferromagnetics, *Phys. Rev.* 96, p 889, 1954.
- (4) E. H. Frei, S. Shtrikman and D. Treves, Transverse Susceptibility in Ferromagnetics, *Bull. Res. Council of Israel*, 1955, in press.

Logarithmic Amplifier Has 50-db Range

BY DOUGLAS A. KOHL

Senior Engineer
Engineering Research and Development
Mechanical Division
General Mills, Inc.
Minneapolis, Minn.

IT HAS BEEN difficult to achieve satisfactory stability as well as accuracy in most all-vacuum tube logarithmic amplifier circuits without

TRADE MARK
ERIE
electronics

ERIE ELECTRONICS DIVISION

ERIE RESISTOR CORPORATION

Main Offices and Factories: ERIE, PA.
Manufacturing Subsidiaries

HOLLY SPRINGS, MISSISSIPPI • LONDON, ENGLAND • T. ENTON, ONTARIO

Splitting Split Seconds

FOR ACCURATE MEASUREMENT
OF ELAPSED TIME...
AS CLOSE AS 0.001
OF A SECOND

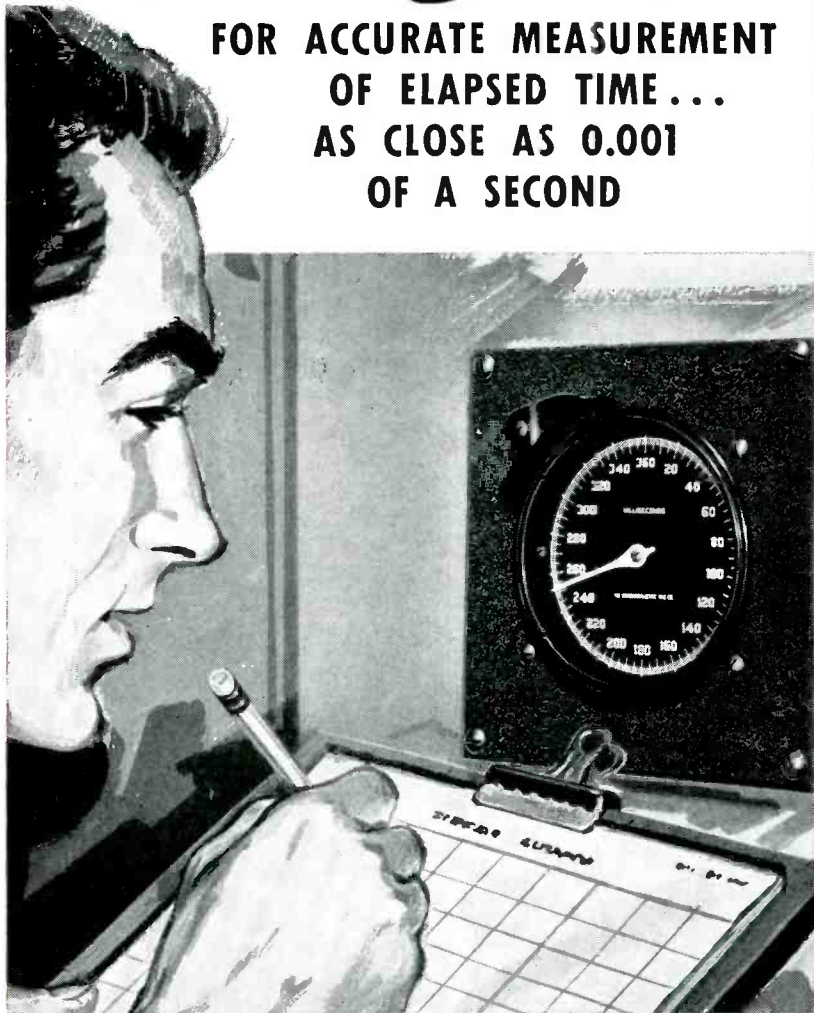

THE STANDARD PRECISION TIMER

is the indispensable STOP watch in laboratory and test cell, on experimental nuclear projects, precision production, check and final inspection. Many important applications in almost every industrial plant and research laboratory.

Built in many different advanced designs — both panel mounted and portable case — to meet almost every conceivable need for the precise measurement of time. Synchronous motor drive. Electric clutch controlled by manual switch, automatic switch or output of electronic tubes. Manual or electric zero reset.

Model	Scale Divisions	Totalizes	Accuracy
S-100	1/5 sec.	6000 sec.	±.1 sec.
S-60	1/5 sec.	60 min.	±.1 sec.
SM-60	1/100 min.	60 min.	±.002 min.
S-10	1/10 sec.	1000 sec.	±.02 sec.
S-6	1/1000 min.	10 min.	±.0002 min.
S-1	1/100 sec.	60 sec.	±.01 sec.
MST	1/1000 sec.	.360 sec.	±.001 sec.
MST-500	1/1000 sec.	30 sec.	±.002 sec.

THE WORLD'S MOST ACCURATE and RUGGED
time measuring instrument...
THE STANDARD PRECISION TIMER



◀ Timing photo-cell controlled exposures in automatic photo printing machine at Eastman Kodak Co.



▲ Timing test action in automatic transmission research at one of world's largest automotive manufacturers.

For Glenn L. Martin's ▶ Gunnery Trainer — in 12-channel Playback System designed by Cook Research Laboratories.



At Bendix — Westinghouse Research Dept. laboratories — measuring brake application and release time to 1/100th second.

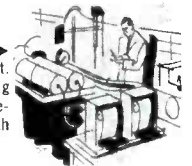

◀ At American Brass Co. — indicating metallurgical analysis in Direct Reading Spectroscope by Baird Associates.



▲ At General Electric Co. — Trumbull Division — measuring operating time of circuit breakers.

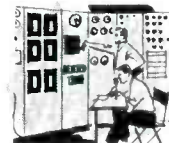

At Yucca Pass, Nevada ▶ Proving Grounds — helping maintain split-second control of atomic bomb tests.



▲ Timing elements required to complete telephone connections in Bell Telephone offices across the United States.

Send Today for Bulletin No. 198

**THE
STANDARD
ELECTRIC
TIME COMPANY**
Springfield 2,
Massachusetts

THE STANDARD ELECTRIC TIME Co.
97 Logan St., Springfield 2, Mass.

Please send Bulletin 198.

Name.....Title.....

Firm.....

Address.....

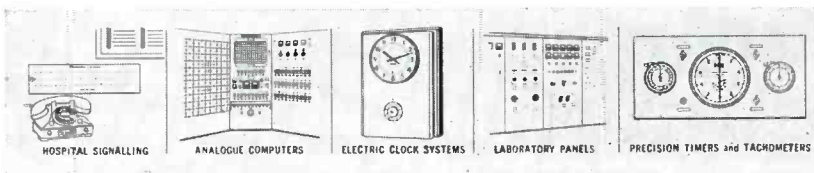

Celco TOROIDS

... Offered in a
wide range of sizes

#50 wire on .062" ID
#15 wire on 9" OD



Whether it's a complex 10 winding magnetic amplifier or a simple choke . . . at Celco each toroid is precision-made. New core materials are used in Toroidal magnetic amplifiers, reactors and transformers to achieve maximum performance.

At Celco, the proper matching of cores, winding, handling, impregnation, encapsulation and electrical history of the final assembly is carefully controlled to maintain the original design characteristics.

Our years of design, development, and production know-how are available for application to your specific **TOROIDAL** problems.

For immediate attention, call **RAMsey**
9-1123 — or write today.



Celco

Constantine
Engineering Laboratories Co.

MAHWAH, N. J.
RAMsey 9-1123



Your plant is only hours away by the **Celco Air Fleet**

involving considerable complexity. The basis for the circuit described here, and shown in Fig. 1, is that of the exponential relationship between the terminal voltage and time of discharge in an R-C network.

The fundamental stability of the circuit is derived from the passive resistance and capacitance of the R-C circuit as well as the use of vacuum tubes as bistable elements only. Circuits designed to use the R-C discharge to provide logarithmic response to nonperiodic phenomena have been described,¹ however, the generation of a series of R-C type waveforms as a kind of operational carrier described here

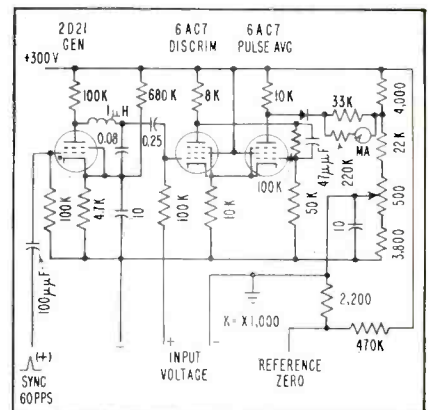

FIG. 1—Logarithmic amplifier uses sawtooth waveform as operational carrier

provides a logarithmic function that is an average of a large number of R-C discharges, thereby improving the accuracy and stability.

The operational carrier is a series of R-C charging waveforms similar to those of a thyatron sweep generator in an oscilloscope. The repetition rate of the waveforms may be chosen with deference to the desired time response of the output circuit. The circuit based on synchronizing to line frequency will match the time response of most fast potentiometer type recorders or servos.

The input signal voltage is isolated by means of a resistor from the input grid of the trigger circuit. A circuit such as a Schmitt trigger pair will generate an output pulse of duration equal to the time the input waveform exceeds the trigger amplitude level.

A simple averaging circuit cou-



DU MONT SPACE-SAVER RADAR TUBES

CONVENTIONAL DESIGN



Miniaturized in everything but screen size and performance, DuMont space-saver radar tubes meet modern air-borne radar requirements. *Available in 3 to 12-inch sizes.*

HIGH LIGHT OUTPUT AND RESOLUTION • LOW HEATER CURRENT • DESIGNED FOR FACE-PLATE MOUNTING • SMALL NECK WITH 9-PIN MINIATURE BASE • ELECTROSTATIC OR MAGNETIC FOCUS AND DEFLECTION.

DU MONT[®]

Industrial Tube Sales, ALLEN B. DU MONT LABORATORIES, INC., 2 Main Ave., Passaic, N. J.



ALLIED RADIO
100 N. WESTERN AVENUE - CHICAGO 80, ILL.
Telephone HY 4700

Everything in Electronics - OUR 36TH YEAR

THE EARTH SATELLITE

CATALOG NO. 160
1957
INDEX ON PAGE 947

Send for the
most widely used
Electronic
Supply
Guide

Free
ON REQUEST

ALLIED'S 1957 356-PAGE CATALOG

World's largest Stocks OF

ELECTRONIC SUPPLIES FOR INDUSTRY

Simplify and speed your purchasing of electronic supplies and equipment: send your orders to ALLIED—the reliable one-supply-source for *all* your electronic needs. We make fastest shipment from the world's largest stocks of electron tubes (all types and makes), transistors, test instruments, audio equipment, electronic parts (transformers, capacitors, controls, etc.), and accessories—*everything* for industrial and communications application, for research, development, maintenance and production. Our expert Industrial supply service saves you time, money and effort. Send today for your FREE copy of the 1957 ALLIED Catalog—your *complete* Buying Guide to the world's largest stocks of Electronic Supplies for Industrial and Broadcast use.

ultra-modern facilities for the
fastest service in Electronic Supply

Our 36th Year



100 N. WESTERN AVE., DEPT. 11-A-7, CHICAGO 80, ILLINOIS

ONE COMPLETE DEPENDABLE
SOURCE FOR EVERYTHING IN ELECTRONICS

ALLIED RADIO

pled to the output plate of the trigger circuit converts the pulse length into a linear meter deflection or voltage output.

In Fig. 2A the voltage $e(t)$ at the plate of the generating thyatron is shown. Typical values for the

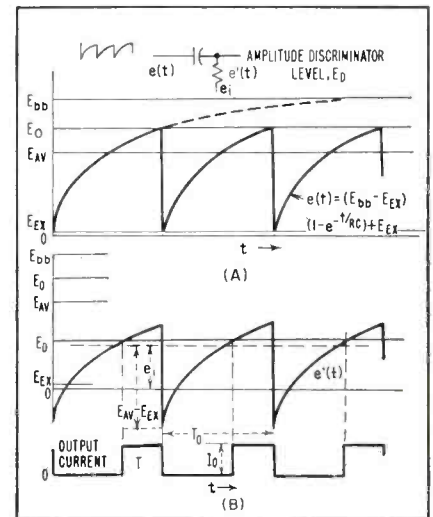
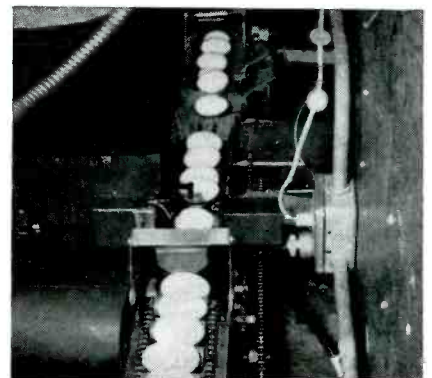

FIG. 2—Output of thyatron generator (A) has voltage relationship (B) at grid of trigger circuit

indicated voltages corresponding to the schematic circuit shown later might be as follows: $E_{bb} = 300$ v, $E_{c} = 238$ v, $E_{av} = 188$ v and $E_{ex} = 18$ v, $T_0 = 0.0167$ sec.

When this waveform is coupled to the grid of the trigger circuit by means of a capacitor a new set of voltage relationships $e'(t)$, Fig. 2B, exist. The two descriptions are

Egg Candler



The Librascope machine shown used at the Hofman-Jackson Egg Co. in Anaheim, Calif. scans 7,200 eggs an hour. Manual candlers can maintain a speed of one egg a second for a short time. Eggs containing blood spots are automatically rejected by the photoelectric device

Potter & Brumfield engineering is in this picture

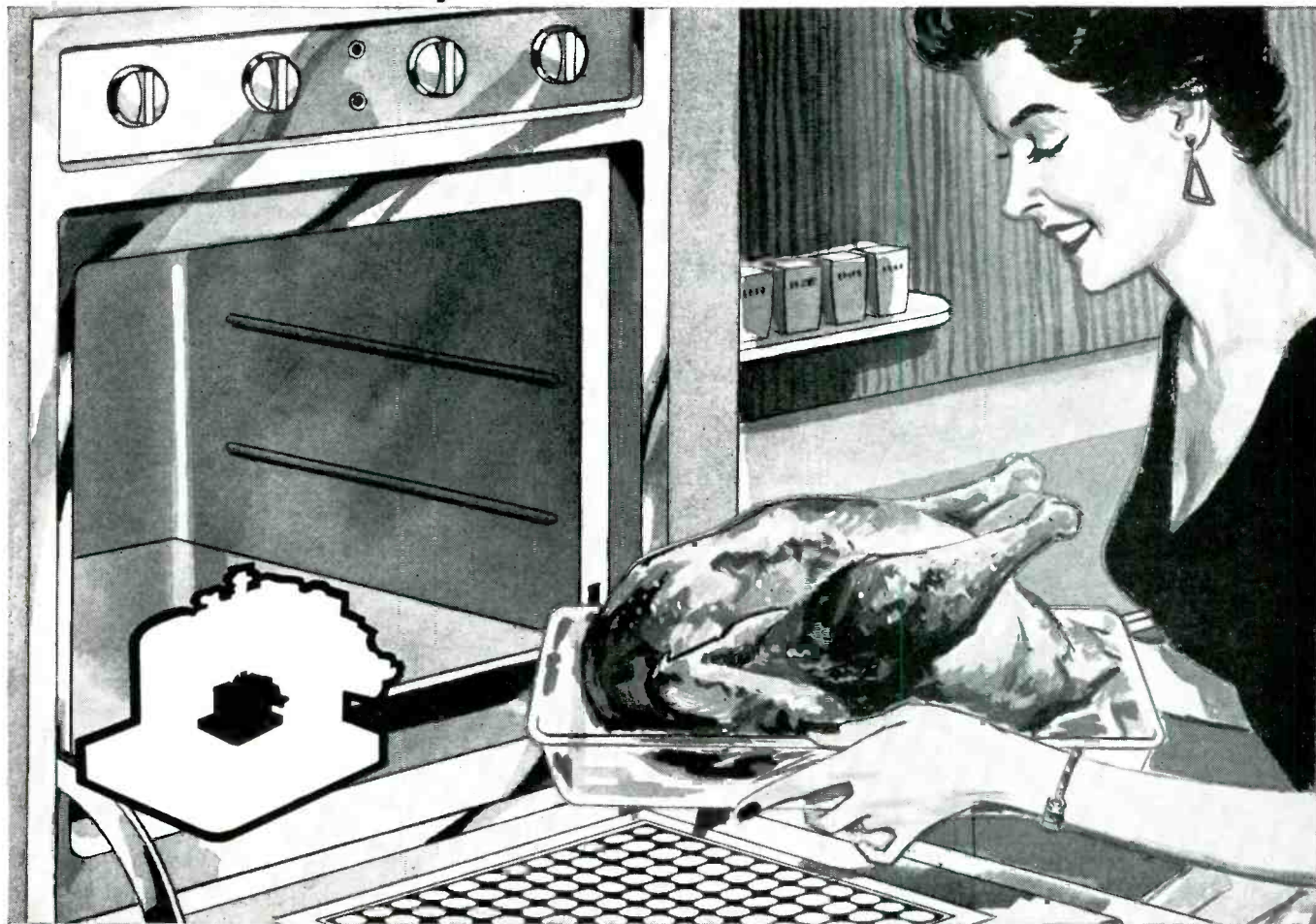

Which P&B relay would you specify to **CONTROL AN ELECTRONIC OVEN?**



PR Series



MS Series



MR Series

New electronic ovens—the kind which cook an 18-pound turkey in an hour and a half, a large beef roast in 30 minutes, or bake potatoes in 4 minutes—require heavy duty, fast-acting relays designed for high voltage switching. Long, trouble-free service is essential and U/L approval is a must.

The relay specified by one top manufacturer to fill this bill is P&B's PR 11, specially adapted to our customer's specifications. P&B engineers are old hands at adapting basic relay types to highly specialized uses. Twenty-five busy years of relay designing, engineering and manufacturing at P&B have built an unrivaled backlog of information and skill which is yours to command.

ENGINEERING DATA

SERIES: PR Heavy Duty.

CONTACTS: Max. DPDT. 5/16" dia. silver, 13 amps. at 115 V., 60 cycle, non-inductive. 6.5 amps. at 230 V. 60 cycle, non-inductive.

VOLTAGE RANGE: 6 to 110 V. DC. 6 to 230 V. AC.

COIL RESISTANCE: 63800 ohm max. DC.

TEMPERATURE RANGE: DC, -45° to 85° C. AC, -45° to 55° C.

PULL-IN: DC, 75% nominal. AC, 78% nominal.

TERMINALS: Heavy duty screw type. Adaptable for printed circuits or plug-in.

BASE: Molded phenolic or metal.

MOUNTING: (2) 3/16" dia. holes on 1/8" centers.

DIMENSIONS: 2 1/2" W. x 3 3/8" L. x 2 1/2" H.

P&B RELAYS AVAILABLE AT MORE THAN 500 DISTRIBUTORS IN ALL PRINCIPAL CITIES

Potter & Brumfield, inc. PRINCETON, INDIANA
Subsidiary of AMERICAN MACHINE & FOUNDRY COMPANY

Manufacturing Divisions also in Franklin, Ky. and Laconia, N. H.



LAPP...

FOR 38 YEARS

— SPECIALISTS IN

ELECTRICAL PORCELAIN

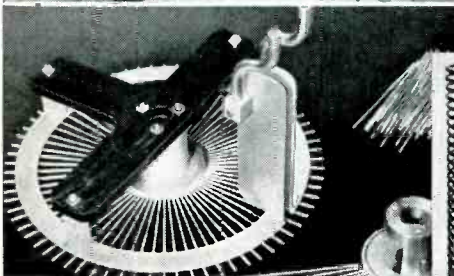
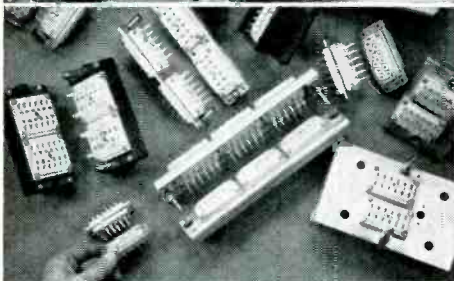
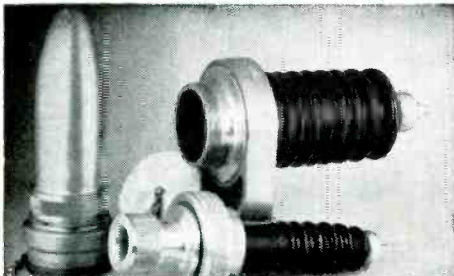

From the earliest day of radio and radio-frequency circuits, Lapp has pioneered the application of electrical porcelain and seatite to the special requirements of this industry. Today, "Radio Specialties" identifies a large and efficient department at Lapp where hundreds of parts for hundreds of specialized requirements have been designed and built. We welcome the opportunity to help you—in design and production—with your requirements for insulating parts and associated sub-assemblies. Write Lapp Insulator Co., Inc., Radio Specialties Division, 908 Sumner Street, Le Roy, N. Y.

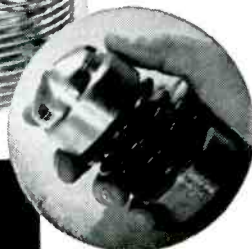
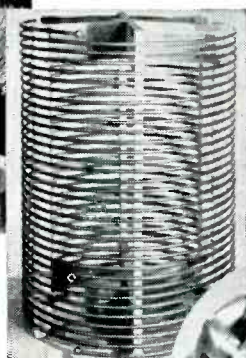

Lapp

related by the average value of the generated waveform as shown below.

$$e'(t) = [e_i - (E_{av} - E_{ex})] + e(t) \\ = e_i - (E_{av} - E_{ex}) + (E_{bb} - E_{ex})(1 - e^{-t/RC}) + E_{ex}$$

Where: e_i is the input voltage
 E_{bb} is the plate supply voltage
 E_o is the waveform zero
 E_{av} is the voltage of the average of the waveform
 E_{ex} is the thyatron extinction voltage
 $e = 2.718$
 t = time in seconds
 R is thyatron plate resistor
 C is the effective shunt capacitance to ground

The output pulse duration T is proportional to the time that $e'(t) \geq E_D$, the discrimination level. Thus, when the pulse is initiated

$$e_i - E_D - (E_{av} - E_{ex}) + (E_{bb} - E_{ex}) \\ = (E_{bb} - E_{ex})e^{-t/RC}$$

Solving for an explicit equation in t yields

$$t = \lambda [\log_e \beta - \log_e (e_i + \alpha)] \\ \text{Where } \lambda = RC \\ \beta = E_{bb} - E_{ex} \\ \alpha = \beta + E_D - (E_{av} - E_{ex})$$

Note that the α term originates from the average component of the waveform and that when a fixed bias equal to α is applied to the input voltage the term disappears. The time interval t is then related

Signal Combiner



Undergoing final test in GE broadcast equipment plant at Electronics Park is a plumber's nightmare, technically known as a filterexer, used at television stations to combine sound and picture signals from separate transmitters to feed a single antenna

Get unprecedented performance—

**See for yourself why the new
LEACH BALANCED-ARMATURE RELAYS
outperform all other types in resistance
to shock, acceleration and vibration**

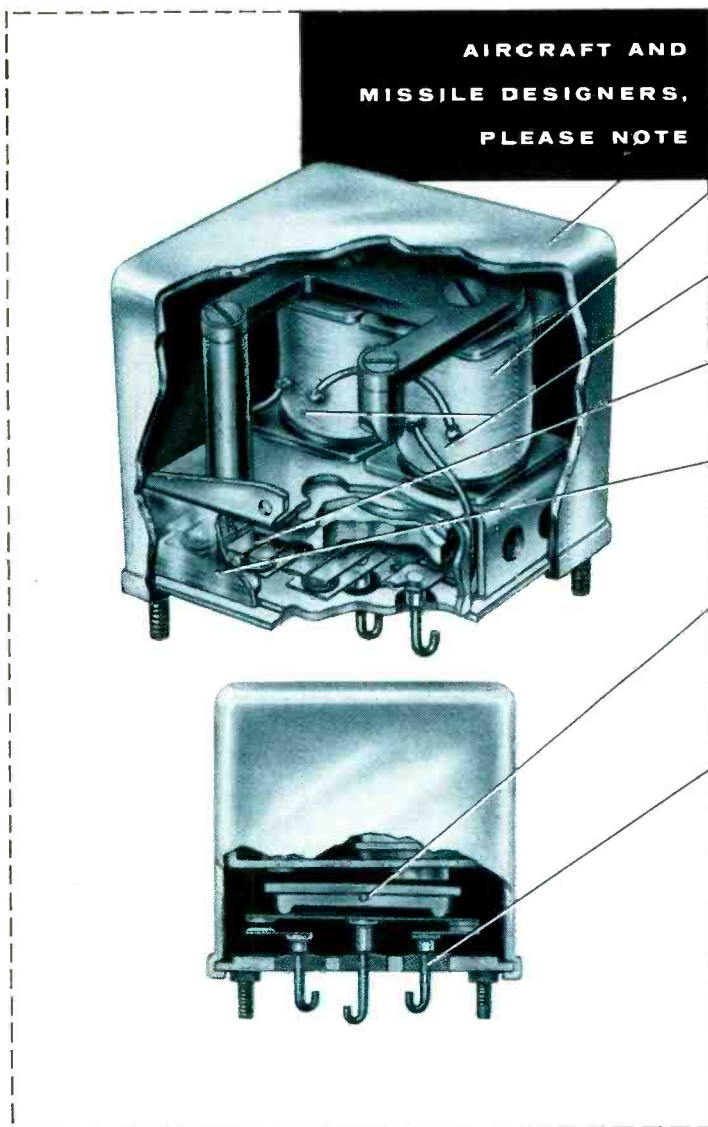

**AIRCRAFT AND
MISSILE DESIGNERS,
PLEASE NOTE**

ONE-PIECE DIE CAST ALUMINUM HOUSING for maximum strength and vibration resistance with minimum weight.

MAGNET COIL wound with Teflon insulated magnet wire on one-piece Kel F bobbin assures reliability at elevated ambients.

DUAL COIL construction is the most efficient magnetic circuit for minimum height and maximum resistance to vibration and shock.

BIFURCATED CONTACTS assure high reliability in contact making circuits. Overtravel and high contact pressures produced by the pivoted armature result in immunity to shock and vibration.

ARC BARRIER of Kel F molded construction provides long arc path for use on 3 phase ac circuits, prevents phase-to-phase flashover.

BALANCED-ARMATURE DESIGN. In a *Balanced-Armature* construction, shock and vibration forces cannot cause the relay armature to move. This eliminates faulty operation of contacts due to vibration and shock forces.

HEADER AND CONTACT ASSEMBLY features simplified construction which eliminates internal wiring, lowers lead resistance, provides maximum resistance to vibration. Contacts and working parts are readily accessible through-out assembly, so that Leach is able to measure contact gap, contact pressure and overtravel, prior to sealing, on 100 per cent of production. Customers are assured of maximum performance from every production relay. Patent Pending.

MEETS ALL REQUIREMENTS OF THE MOST EXACTING OPERATING ENVIRONMENTS

The Leach Balanced-Armature Relays meet or exceed requirements of MIL-R-5757, MIL-R-6106, MIL-E-5272. Typical ratings include: vibration, 20 G's to 500 cps (higher ratings available); shock and acceleration, more than 50 G's; temperature, -50° to $+125^{\circ}$ C; life, 50,000 continuous operations minimum at rated load; coils, any resistance to 10,000 ohms—also available for 115 vac, 400 cps operation.

Write today for your copy of the *Leach Balanced-Armature Relay Catalog*.

LEACH

CORPORATION

LEACH RELAY DIVISION

5915 AVALON BOULEVARD, LOS ANGELES 3, CALIFORNIA

DISTRICT OFFICES AND REPRESENTATIVES IN PRINCIPAL CITIES OF U. S. AND CANADA

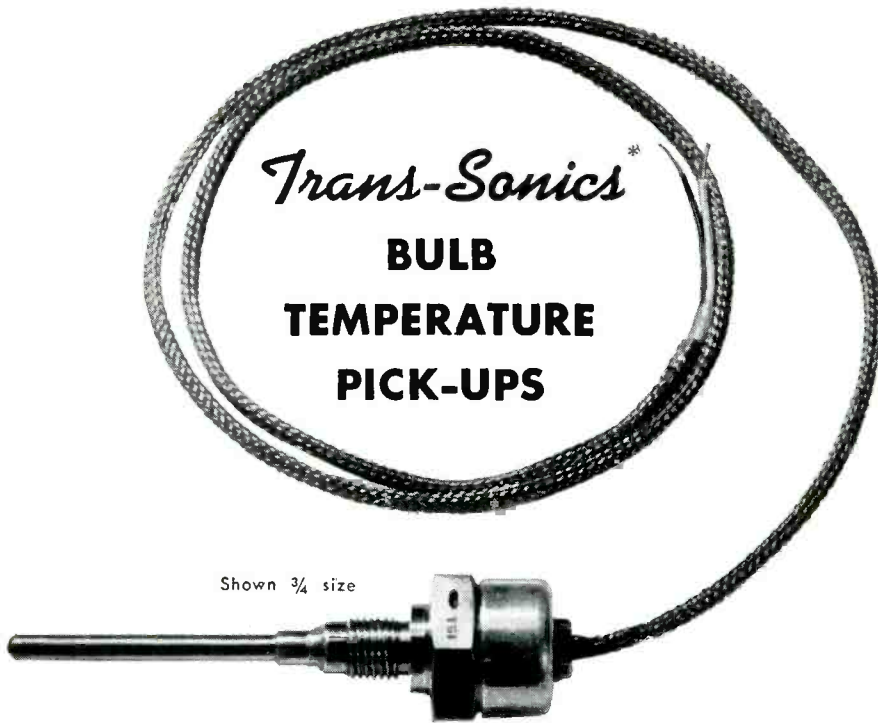

Shown $\frac{3}{4}$ size

- OUTPUT UP TO 5 VOLTS WITHOUT AMPLIFICATION
- ACCURATE UNDER 25G TO 2,000 CPS VIBRATION
- AVAILABLE IN VARIOUS RANGES FROM -300°F. TO 1500°F.
- RESISTANCE CHANGE OF 100 OHMS OVER SPECIFIED RANGE

Trans-Sonics Type 1300 Bulb Temperature Pick-ups are precision high-speed resistance thermometers with a platinum resistance winding as the sensing element. Each Type 1300 Bulb Temperature Pick-up is individually calibrated and supplied with its own calibration sheet. The temperature interval over which the 100 ohm resistance change will occur may be as low as 100°F. These pick-ups are designed to withstand pressures up to 3,000 psia. When specified they can be furnished for installations in *corrosive* liquids or gases. Their leads can be exposed to temperatures up to 600°F. and may be detached from the instrument proper for shortening or easy replacement. Write for Bulletin 1300 to Trans-Sonics, Inc., Dept. 5.

* Reg. Trademark

SPECIFICATIONS

- CASE CONSTRUCTION:** Stainless Steel
ACCURACY: $\pm 1\%$ of full scale range
PRECISION: $\pm 2\%$ of full scale range
MAXIMUM CONTINUOUS CURRENT: 20 ma rms
 (averaged over 1 second)
TIME CONSTANT: Less than 2.5 seconds in agitated water
ENVIRONMENTAL OPERATION CONDITIONS
PRESSURE: 3000 psia (at room temperature)
VIBRATION: 1" double amplitude, 0 to 22 cps
 $\pm 25g$, 22 to 2000 cps
SHOCK: 60 g in any direction, per para. 4.15.1
 of MIL-E-5272A (10 milliseconds shock)

For Transducers, See Trans-Sonics

Trans-Sonics, Inc.

P. O. BOX 328

LEXINGTON 73, MASSACHUSETTS

to the logarithm of the input voltage e_i .

The pulse always ends at the end of the cycle: $t = 0$ and $T = T_o - t$ so that when a is inserted for the proper zero condition

$$T = T_o - \lambda \log_e \beta + \lambda \log_e e_i$$

or

$$T = K + \lambda \log_e e_i$$

where K is the constant replacing zero when transformed to a logarithmic scale.

Considering the output current
 The average output current =

$$\frac{\int_0^{T_o} i(t) dt}{T_o}$$

and the meter deflection will be

$$D = F \int_l^{T_o} I_o dt \times F I_o (T_o - t) = F I_o T$$

so that deflection = $K' + \lambda' \log_e e_i$

where F = meter constant
 I_o = output pulse height

In practice a diode is used to assure that I_o is constant.

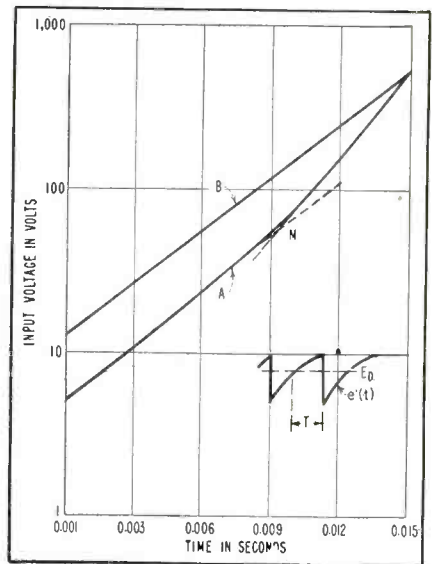

FIG. 3—Width of output pulse varies linearly with logarithm of input voltage

As shown in Fig. 3 the pulse width of the output pulse train varies linearly with the logarithm of the input voltage. For curve A the zero pulse width was obtained with an a voltage of 17 volts in this case. The discrimination level, E_p , was deliberately set low to illustrate how the full range of 50 db is the combination of two curves each with a separate slope.

The lower portion of the curve

THE RADIO ENGINEERING SHOW

moves to the COLISEUM!

MARCH 18-21 • NEW YORK CITY

SO BIG it takes all 4 floors of New York City's Coliseum to hold this year's great annual IRE Radio Engineering Show. For 4 phenomenal days the largest show ever assembled will open its doors to more than 41,000 engineers just 4 minutes from Times Square.*

IS IT TOO BIG—not for a 12 billion dollar and still growing industry! More than 200 papers presented by 22 professional groups at the Convention's 55 technical sessions will summarize all that's new in radio-electronics research and development... the 834 exhibitors will also represent over 80% of the productive capacity of the industry. Not by a long shot is this show too big for what will soon be our nation's largest industry. Plan now to be at this vitally important radio-electronics show!

*41,017 engineers and businessmen from coast to coast and in every field of radio-electronics attended the 1956 Radio Show... the forecast for 1957 is even higher!

**OVER 800 NEW IDEAS
IN RADIO-ELECTRONICS
ENGINEERING
PRESENTED BY MORE THAN
800 EXHIBITORS!**

**1st floor: EQUIPMENT
2nd floor: COMPONENT PARTS
3rd floor: INSTRUMENTS &
COMPONENTS
4th floor: PRODUCTION &
3 lecture halls**



The
Institute of
Radio
Engineers

1 East 79th Street, New York 21, N.Y.



for special applications...
CENTRICORES

SPIRALLY WRAPPED

Hymu-Squaremu-Microsil



Centricores having **UNIFORM** magnetic properties
in metallic or phenolic encasements

CENTRICORES are processed from thinner gauge materials including Hymu, Squaremu "79", Squaremu "49", Microsil and "49" Alloy for magnetic amplifier and special transformer applications. New sizes are being constantly added to standard sizes available from stock for prompt delivery. Write for Bulletin C-1 covering magnetic properties. Also indicate where Magnetic Amplifier test procedure data is desired.

MAGNETIC METALS

COMPANY

Electromagnetic Cores
and Shields

Hayes Avenue at 21st Street, Camden, N.J.

ranging over a decade up to the region near M is generated under conditions whereby the instantaneous grid voltage on the input grid of the trigger circuit never exceeds the level at which grid current will be drawn. Above the M region the grid draws current that is effectively adding a bias value to the input voltage. The change in grid current with input voltage in this region is such that the slope of the curve is changed but retains the logarithmic relationship because of the exponential shape of the waveform carrier.

If the value of E_b is chosen to match the amplitude of the carrier it is possible to make the function conformity good over the entire 50-db range. If E_b plus the absolute average voltage of the carrier $E_a - E_{av}$ is made to equal the voltage at which grid current commences in the input to the trigger circuit, then curve B will result. In this case a equals 42 volts and is typical of the schematic circuit shown later.

The maximum overall range of the log function is thus determined by summing the following values

maximum input voltage = initial grid current voltage + maximum carrier pulse height + maximum d-c component of carrier

Representative of the schematic

Experimental Microwave

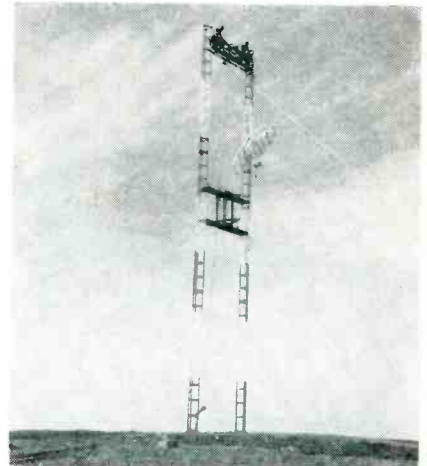

Parabolic antenna is being hoisted to the top of a 60-foot tower at relay point in Stromberg-Carlson experimental 60-mile loop to test multiplex telephone and signal circuits operated on microwave carrier frequencies

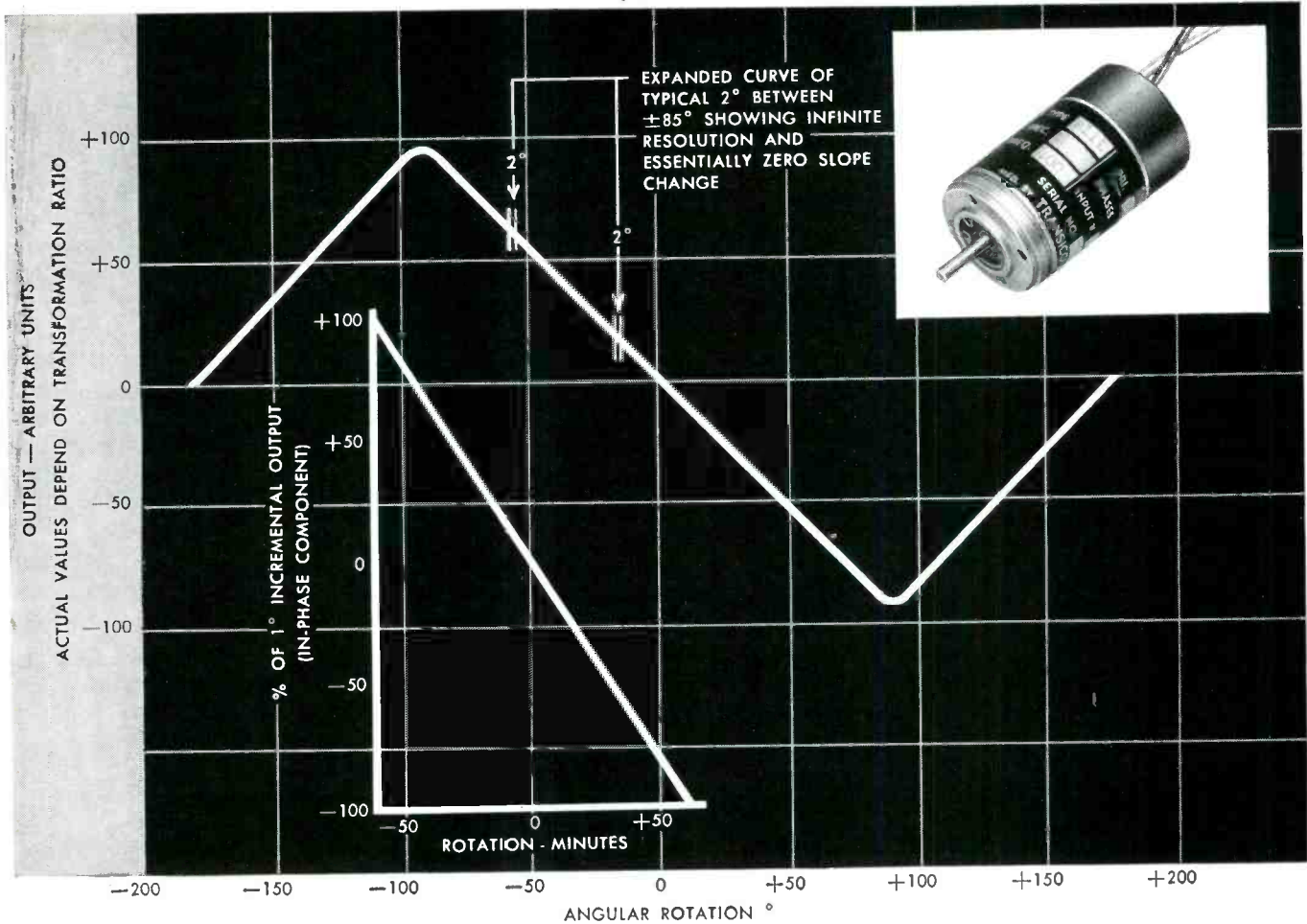

Inductive pot gives accurate noiseless output with infinite resolution

Weapons systems . . . analog computers . . . proportioning circuits — wherever the limitations of linear resistance potentiometers cannot be tolerated, this precision pot is the answer.

The Transicoil Type 11-L Linear Inductive Potentiometer provides extreme angular accuracy for applications requiring high gain amplification, low friction linear output with infinite resolution. Hairspring connectors give low torque, yet completely eliminate slider and contact noise. When operated into the proper load resistor, output is linear to within 1/4% through an angular rotation of ±85°. Output voltage is proportional to shaft displacement from null.

If you are faced with a synchro or servo problem, be sure to get in touch with Transicoil.

Although Transicoil manufactures precision rotating components like this inductive pot, you will benefit most by letting Transicoil design and supply your complete servo package. You will be under no obligation — you pay only for results, on a fixed fee basis, for equipment delivered and operating properly.

TYPE 11-L INDUCTIVE POTENTIOMETER CHARACTERISTICS

INPUT VOLTS	INPUT AMPS	INPUT WATTS	OUTPUT VOLTS (MIN.)	NULL VOLTS	PHASE SHIFT INPUT TO OUTPUT MAX.
10.0	0.082	0.15	0.1 v/°	.007	5° LEAD
			0.33 v/°	.020	
26.0	0.031	0.15	0.1 v/°	.007	5° LEAD
			0.33 v/°	.020	
115.0	0.023	0.45	0.60 v/°	.040	5° LEAD

Frequency 400 cps



TRANSICOIL CORPORATION
Worcester • Montgomery County • Pennsylvania

Lightweight!

SERVO

Magnetic Amplifiers

The servo amplifiers illustrated are typical standard types. Other models, including higher power types, are available for systems engineering. The complete MA line offers the designer a choice of compact, low cost types, amplifiers featuring fast response at high gain and all-magnetic models providing highest performance.

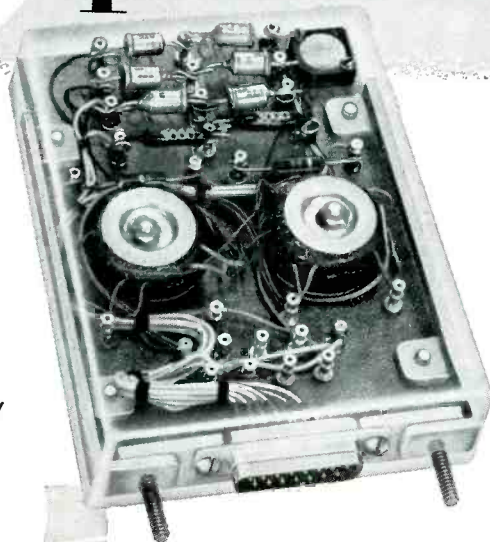

In addition to standard types, custom designs can be produced for special applications, or complete servo and automatic control systems can be engineered to your requirements.

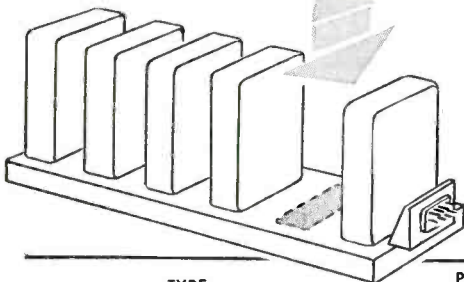

TYPE	SUPPLY	POWER OUTPUT	SENSI-TIVITY	RESPONSE TIME-SEC.
LIGHTWEIGHT SUB-MINIATURE MAGNETIC AMPLIFIER	115 volts 400 cps.	½, 3, 5, 10 watts	.02 volts	.003
MAGNETIC PRE-AMP + SATURABLE TRANSFORMERS	115 volts 400 cps.	3, 5, 6, 10, 18 watts	1 volt AC	.03
MAGNETIC PRE-AMP + HIGH GAIN MAGNETIC AMPLIFIER	115 volts 400 cps.	5, 10, 15, 20 watts	0.1 volt AC	.008 to .1
TRANSI-MAG*: TRANSISTOR + HIGH GAIN MAGNETIC AMPLIFIER	115 volts 400 or 60 cps.	2, 5, 10, 15, 20 watts	.08 volt AC into 10,000 ohms	.01

Call or write for new illustrated bulletins.

Magnetic Amplifiers • Inc

632 TINTON AVE., NEW YORK 55, N. Y.—CYpress 2-6610

West Coast Division

136 WASHINGTON ST., EL SEGUNDO, CALIF.—EAsgate 2-2056



circuit is a total of 640 volts. When the a bias is added this becomes approximately 600 volts. It should be noted also that the drawing of grid current does distort the R-C waveform but this takes place after the trigger circuit has already switched states.

Figure 4 is the output versus input curve of the circuit. The function conformity as expressed by the maximum deviation from the best-fitting true curve in terms of percent of the maximum input voltage is 0.6 percent or less and occurs only in the M region.

The input resistance is nonlinear presenting an effective resistance

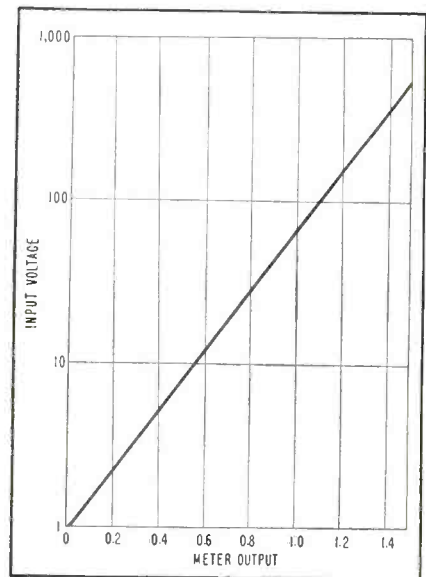
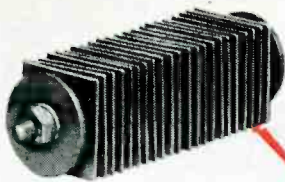
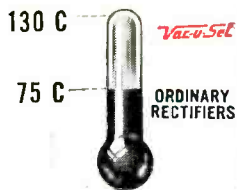

FIG. 4—Meter indication for various values of input voltage

no less than 400,000 ohms at an input of 500 volts where the grid current is a maximum.

Long time stability of this circuit is primarily dependent upon the stability of the $B+$ supply. It is not necessary to regulate the a-c heater supply. However, $B+$ supply regulation of better than 0.5 percent is recommended. In addition, the thyatron plate resistor and capacitor should be of good quality with respect to ambient temperature conditions.

The time response of the circuit itself (10 to 90 percent) is a function of the input isolation resistor and the coupling capacitor. Response time is less than 0.3 sec for



FOR HIGH TEMPERATURE APPLICATIONS such as mobile radios, G-E Vac-u-Sel rectifiers have given outstanding service. Unlike ordinary rectifiers limited to 75C, the G-E Vac-u-Sel rectifier will operate dependably at full rating up to 130C ambient . . . and at no price premium.



DESIGNED FOR HIGH-TEMPERATURE OPERATION . . .

G-E *Vac-u-Sel** Stacks Rectify at 130C; Cost No More Than Ordinary Rectifiers

Where temperatures are soaring and conditions rugged, General Electric Vac-u-Sel rectifiers continue to deliver dependable operation.

DEPENDABLE OPERATION IN HIGH AMBIENTS is a characteristic of Vac-u-Sel rectifiers made possible by the exclusive manufacturing process described below. This process results in a rectifier that operates successfully at 130C ambient at full voltage and current . . . **without derating**. To operate under these conditions, ordinary selenium rectifiers must be derated. This high-temperature characteristic is available in Vac-u-Sel rectifiers at no extra cost.

WHEN DESIGN SPACE IS AT A PREMIUM, the high-temperature 45-volt Vac-u-Sel stack is your best buy. Its higher voltage rating means that fewer cells can be used than with lower-rated cells. The 45-volt stack will operate at 110C ambient at full voltage and current with a life expectancy of over 1000 hours.

For further information, contact your nearest G-E Apparatus Sales Office, or write for bulletin GEA-6273 to: Section 461-43, General Electric Co., Schenectady 5, N. Y.

Vac-u-Sel is the trade-mark of the General Electric Co. It designates top-quality selenium rectifiers manufactured by an exclusive sphere-type vacuum-evaporation process by

the Rectifier Department, headquarters for silicon, germanium, selenium, and copper-oxide component rectifiers.

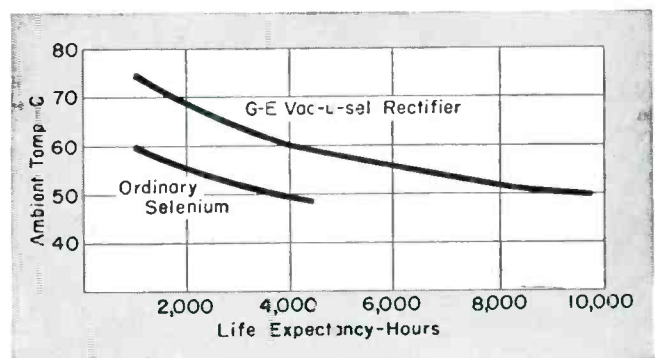

These curves show how a G-E Vac-u-Sel rectifier which is operating at twice normal current, will outlast an ordinary selenium stack operating at only normal current. This explains how a smaller, less expensive G-E rectifier can be used to match performance of ordinary rectifiers.

Progress Is Our Most Important Product

GENERAL  ELECTRIC

IT'S TRUE

You Can Have Precision Parts with

10,000,000,000,000
MEGOHMS
per cm³
VOLUME RESISTIVITY

by specifying
DIAMONITE
high alumina ceramics

with all these highly-developed properties, too!

The ultra-high volume resistivity of Diamonite, even at very high temperatures, together with its other highly developed dielectric properties as shown at the right, offer many opportunities for improved electronic design and performance.

Its absolute zero water absorption factor insures uniform performance under all atmospheric conditions and its highly developed physical and thermal characteristics often solve vexing problems.

PROPERTIES AVAILABLE IN DIAMONITE	
Composition	to 97% Al ₂ O ₃
Tensile Strength	to 28,500 p.s.i.
Modulus of Rupture	to 49,500 p.s.i.
Compression Strength	to 500,000 p.s.i.
Impact Resistance	23 / 25 foot
Specific Gravity	to 3.82
Pore Volume	less than 1%
Softening Temperature	1850°C
Thermal Conductivity	0.2-cal/sec/cm ² /cm ² /C
Average Coefficient of Thermal Expansion	cm/cm ³ /C
Volume Resistivity	25°/200°C 7.3x10 ¹⁴ ohms per cm ³
Dielectric Constant	2500°C 2.6x10 ¹⁴
Dielectric Loss	10 ¹⁴ ~ 877
Factors	20°C 10 ¹⁴ ~ 0009
Hardness	Mohs 9+
Water Absorption	Absolute Zero
Thermal Shock Resistance	Determined Electrically after 1,000°C in water
Thermal Shock Resistance	Determined Electrically after 48 hours immersion and air quenching without loss of strength

If you require precision parts, specify Diamonite in design.

Recent publication of the Diamonite advertisement reproduced above raised questions in some quarters as to the accuracy of the figures quoted.

For purposes of clarification, we offer the following explanation:

The ten trillion megohms/cm³ volume resistivity of Diamonite given in the headline is, although not specifically stated, in air at room temperature (20°C).

Volume Resistivity values shown in bold face type in the table of Properties Available in Diamonite are given in ohms and are elevated temperatures, 250°C and 500°C respectively.

(Volume resistivity of non-metallic substances such as Diamonite drops off as temperature increases, which is the reverse of what happens in most metals.)

The figures above were determined by Horizons Incorporated Research Laboratories, Cleveland, Ohio.

So, IT'S TRUE . . . you can safely specify Diamonite wherever ultra-high insulating qualities, even at very high temperatures, are required.

For complete data on Diamonite for electronics applications, write for special electronics brochure.



products
manufacturing
company
Canton 2, Ohio

the circuit shown. The output averaging circuit is the essential limitation of this factor because the repetition rate of the carrier waveform and thus the size of the coupling capacitor, may be altered to achieve any desired response. The constancy of the sync impulse is also a factor in stability and should be reasonably free of jitter.

The zero is established by applying a standard input voltage and adjusting the zero control to achieve a certain deflection near the zero-current end of the meter or recorder. This avoids possible ambiguity owing to the diode in the output circuit.

REFERENCE

(1) D. Maeder, Gamma Ray Scintillation Spectrometer with Logarithmic Pulse Height Response, *Rev Sci Inst*, p 805, Sept. 1955.

Legal Medium

FEDERAL Revenue Service is encouraging employers to submit quarterly reports of wages taxable under FICA on tape. Only those companies with IBM 705 or Univac machines would be able to comply. Form 941 data has already been sent on magnetic tape from GE.

Random Numbers

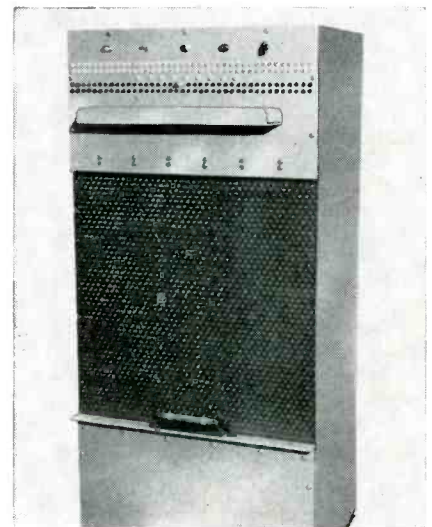

Using the stochastic generator illustrated, truly random numbers can be obtained without the necessity of transcribing by hand from tables or drawing numbers from a bowl. In the equipment, built by Loyola Labs in Los Angeles, numbers are generated continuously at a rate of ten a second

GENERAL TRANSISTOR TESTING ASSURES COMPUTER RELIABILITY

Precision manufacturing is not enough! says GT. So General Transistor constantly tests. Along every production step keen eyes, highly skilled technicians, and special instruments check and recheck each transistor. These tests, developed by GT for every specific purpose and characteristic vital to computer reliability assures accuracy and dependability throughout. Whatever your circuit needs, call in General Transistor —one of the largest suppliers of transistors for computers.

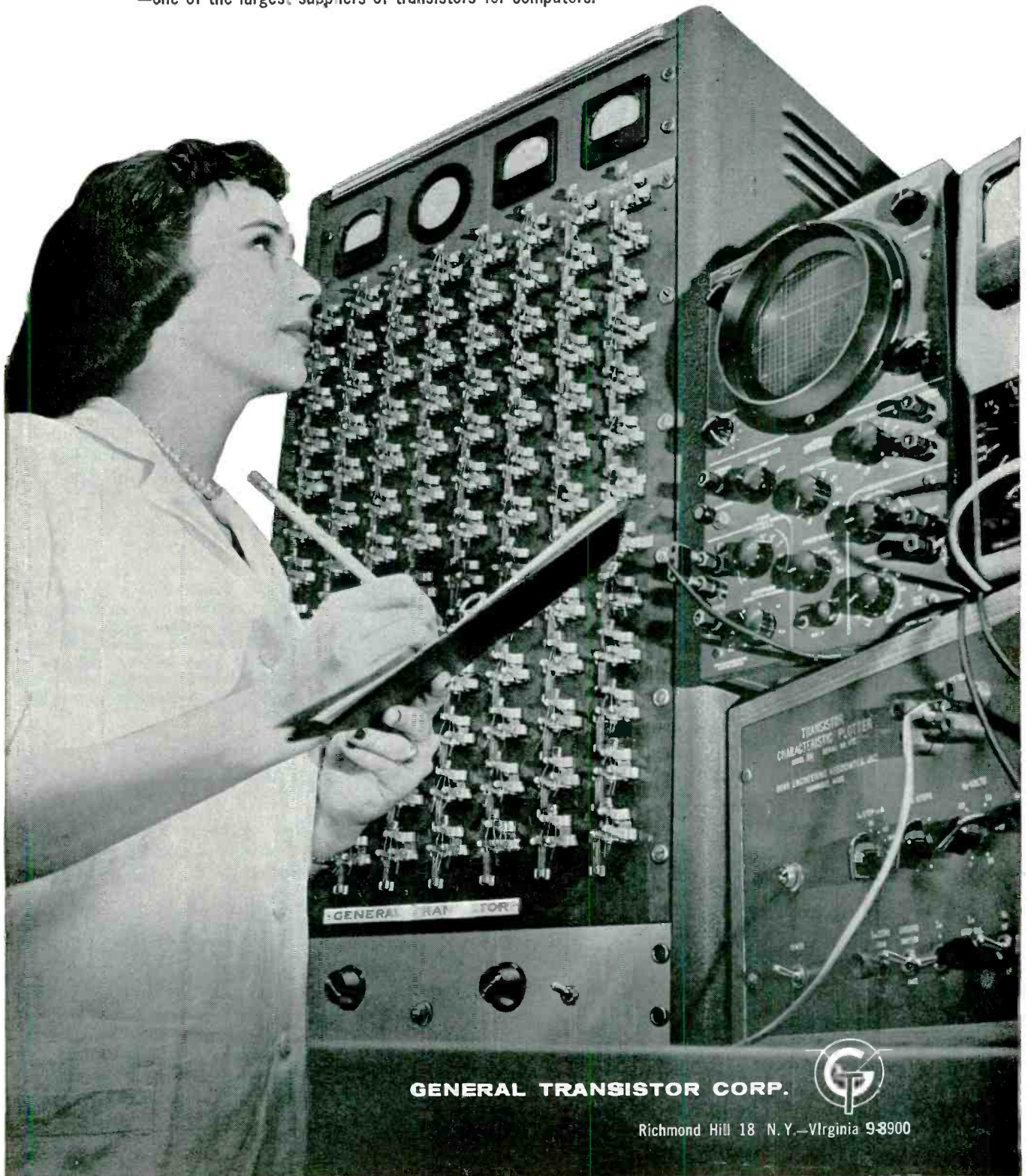

GENERAL TRANSISTOR CORP.



Richmond Hill 18 N. Y.—Virginia 9-3900

Phototube-Controlled Drilling Machine for Printed-Wiring Boards

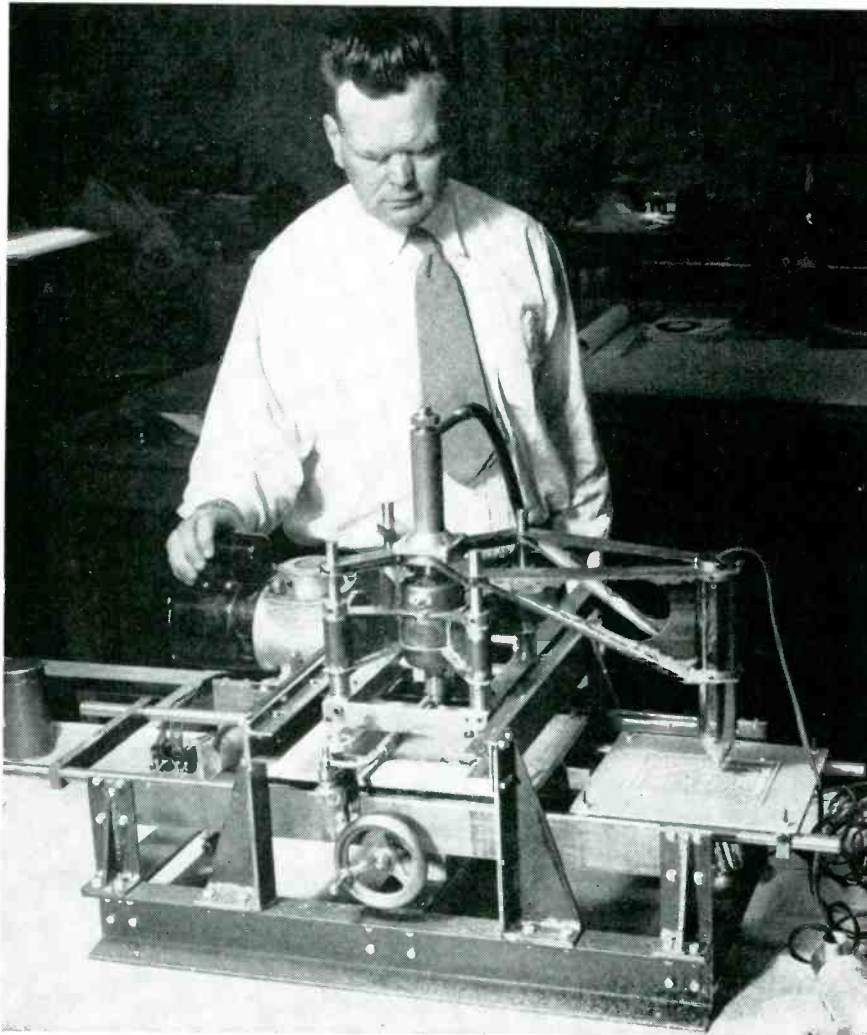

A SELF-PROGRAMMED automatic drilling machine under development at Federal Telecommunication Laboratories, Nutley, N. J., a division of International Telephone and Telegraph Corp., is designed for use on small production runs of printed-circuit boards. A hand-drilled facsimile of the desired board is scanned by a photoelectric system which activates the stationary drill as an electromechanical control system moves in X and Y directions the table holding the facsimile or template and the board to be drilled. All dimensions are controlled to within 0.003 percent accuracy.

The apparatus cuts drilling time for an average 100-hole circuit board from 20 minutes to about one minute, effecting considerable savings in time and operating costs.

Facsimile board moves back and forth under phototube at right as blank board at other end of table moves correspondingly under stationary electric drill which is brought down for each hole by air cylinder. Electric motor and gear system make table of machine move to give scanning pattern

Assembling Two-Piece Vacuum-Molded High-Fidelity Horns

VACUUM MOLDING of sheet polystyrene is used to produce highly critical mid-range horns for a three-way exponential high-fidelity horn system in the Grand Rapids, Mich. plant of AMI Inc.

In this process, 30-inch by 40-inch sheets of high-impact polystyrene $\frac{1}{8}$ inch thick—the thickest available commercially—are placed individually in a vacuum mold with a magnesium-aluminum alloy male die. The die is shaped to provide two horn half-sections from one sheet, that can later be combined to form one complete horn.

The sheet is heated at 700 F for 2 $\frac{3}{4}$ minutes until pliable, when 65 to 70 lb of vacuum pressure per square inch is applied through die vents to shape the polystyrene to the male die. The formed sheet is then cooled with a water spray to enable the operator to remove it from the mold.

While in the complete sheet stage, the horn halves are scribed to insure that the two parts will match perfectly when assembled. The excess material is then cut from the sheet with a band saw and the two halves are roughed out to shape. A solvent is applied to the flanged

edges of the horn halves, and they are stapled together to preclude shifting as the chemical reaction

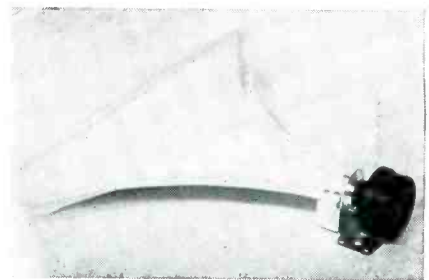

Completed 550-4,000-cps mid-range horn with attached driver, made by cementing together vacuum-molded half-sections



FROM "GIANT" 10-INCHERS TO "SUPER-COLOSSAL" 27'S . . . early black-and-white to the latest rainbow colors . . .

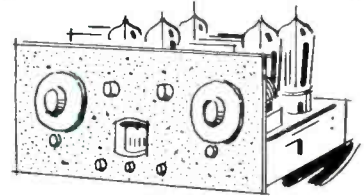
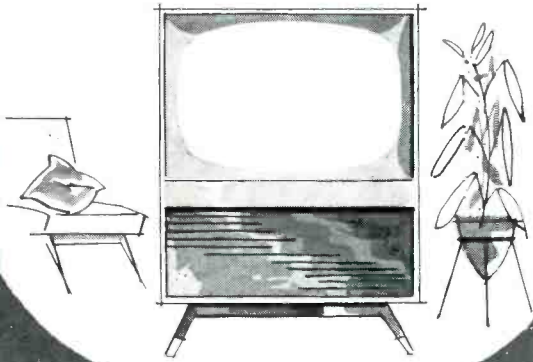

FROM PRIMITIVE "TRF'S" TO THE HIGHEST OF THE "FI" . . . the earphone era to the most modern of radios.

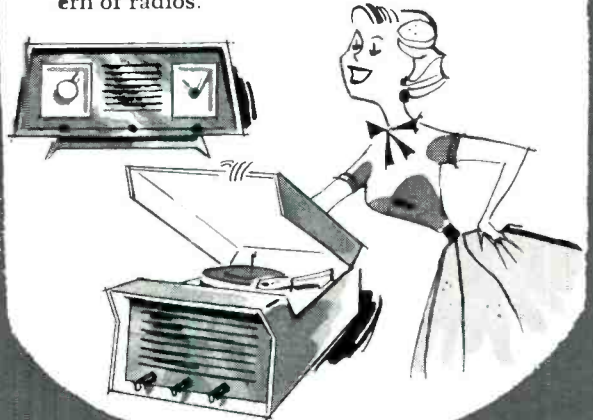

KESTER SOLDER

COMPANY • 4204 WRIGHTWOOD AVENUE • CHICAGO 39, ILLINOIS
NEWARK 5, NEW JERSEY • BRANTFORD, CANADA

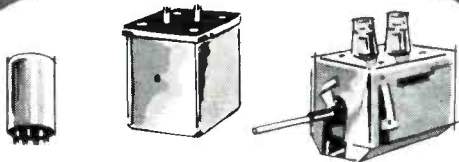

FOR MORE THAN HALF A CENTURY, one of the "constants" of the ever-expanding electronics industry has been Kester Solder. Equipment and components originally soldered with Kester continue to give excellent service; regardless of their age, the soldered joints stay in perfect condition for the life of the unit. That's why Kester Flux-Core Solder has the greatest acceptance in the industry . . . why you should always insist on Kester.

WRITE TODAY for the KESTER 78 page text-book "Solder . . . Its Fundamentals and Usage." Free!



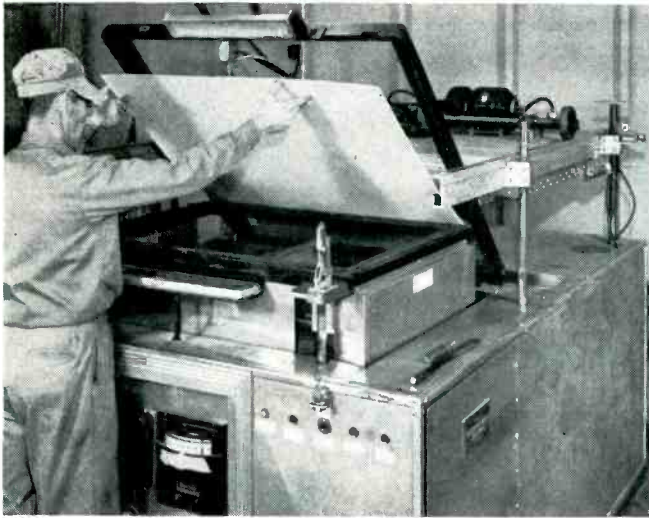

Placing polystyrene sheet over male die in molding machine

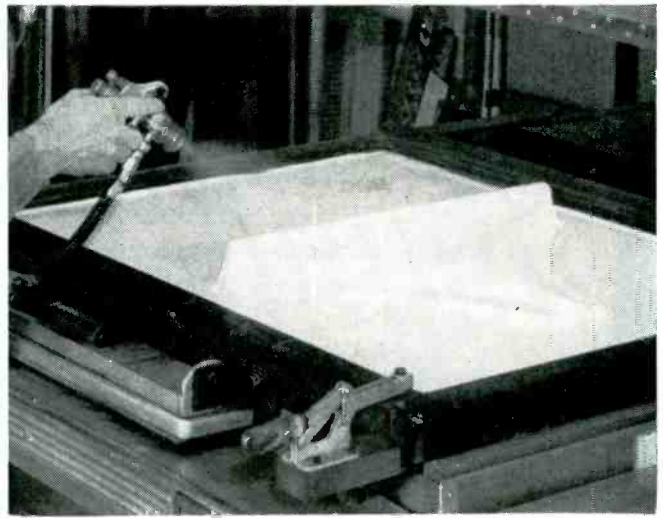

Cooling formed sheet with water spray



Roughing out sheet on band saw before cutting apart the two horn halves

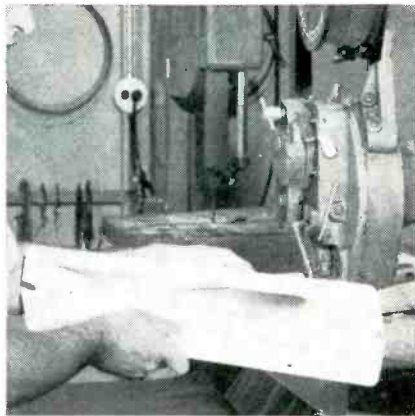

Fastening horn halves together on power stapler after applying cement to flanges



Trimming flanges of cemented horn with router running against steel template

bonds them together to form an absolutely air-tight joint. The process insures a rigid one-piece assembly and smooth finish that is necessary for acoustic efficiency and desirable for appearance and easy handling.

The horn is then placed in a jig that holds it for operations in which the face of the opening is routed to insure precise fit in the cabinet. Pilot holes are drilled for attaching the horn to the horn inclosure and

the entire horn is deburred to remove sharp edges. The flanges at the small end of the horn are drilled for attaching the metal bracket on which is mounted the mid-range driver.

Portable Voltage Ratio Calibrator for Aircraft Transducers

A VOLTAGE RATIO CALIBRATOR, developed by the Flight Test Laboratory at Martin, provides a more rapid and accurate method of calibrating potentiometric-type transducers in aircraft. This unit consists of a precision multi-turn potentiometer with a digital-type 0-999 dial driven by a two-phase motor and a chopper-input high-gain amplifier.

The transducer to be calibrated is connected to the unit by means of jacks on the front panel. The transducer and the potentiometer

are both supplied by power from an internal battery, or by the aircraft power supply, as desired. The difference in the relative positions of the two wiper arms appears as an error voltage at the input to the amplifier, where it is amplified and used to drive the motor, thereby repositioning the

Voltage ratio calibrator, at right, with convenient carrying handle, is here connected to programming board behind pilot's seat in a plane

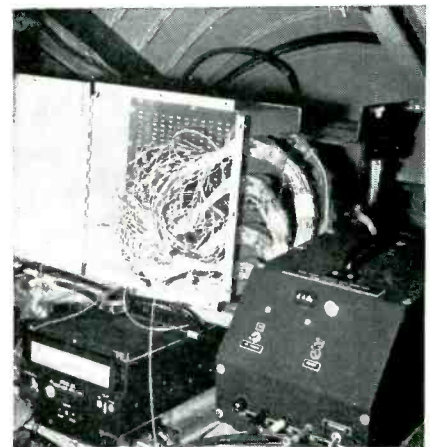



GUIDED MISSILE RESEARCH and DEVELOPMENT

A major guided missile research and development program has several significant characteristics that are of particular interest to the scientist and engineer.

First, it requires concurrent development work in a number of different technical areas such as guidance and control, aerodynamics, structures, propulsion and warhead. Each of these large areas in turn contains a wide variety of specialized technical activities. As an example, digital computer projects in the guidance and control area involve logical design, circuit design, programming, data conversion and handling, component and system reliability, input-output design, and environmental and mechanical design.

A second characteristic is frequently the requirement for important state-of-the-art advances in several of the technical areas. For instance, the supersonic airframe needed for a new missile may necessitate not only novel theoretical calculations, but also the design and performance of new kinds of experiments.

A third characteristic of missile development work is that such close interrelationships exist among the various technical areas that the entire project must be treated as a single, indivisible entity. For example, what is done in the guidance portion of the system can affect directly what must be done in the propulsion and airframe portions of the system, and vice versa.

These characteristics make it clear why such work must be organized around strong teams of scientists and engineers. Further, for such teams to realize their full potential, they must be headed by competent scientists and engineers to provide the proper technical management. And finally, all aspects of the organization and its procedures must be tailored carefully to maximize the effectiveness of the technical people.

Principles such as these have guided The Ramo-Wooldridge Corporation in carrying out its responsibility for overall systems engineering and technical direction for the Air Force Intercontinental and Intermediate Range Ballistic Missiles. These major programs are characterized by their importance to the national welfare and by the high degree of challenge they offer to the qualified engineer and scientist.

*Openings exist for
scientists and engineers
in these fields of
current activity:*

Guided Missile Research and Development
Aerodynamics and Propulsion Systems
Communications Systems
Automation and Data Processing
Digital Computers and Control Systems
Airborne Electronic and Control Systems

The Ramo-Wooldridge Corporation

5730 ARBOR VITAE STREET • LOS ANGELES 45, CALIFORNIA

Couch Rugged



RELAYS

Specify the COUCH MODEL 2A or 4A relay whenever HIGH SHOCK-HIGH VIBRATION capabilities are required and for DRY-CIRCUIT applications.

VIBRATION . . . 5 to 25 cps @ 0.4" peak to peak excursion; 25 to 2000 cps @ 20G acceleration; No contact opening, relay energized or de-energized.

SHOCK ELECTRICAL . . . 75G for 10 milliseconds minimum. No contact opening, relay energized or de-energized.

SHOCK MECHANICAL . . . 200G minimum . . . no physical damage to relay or change in electrical characteristics.

Models 2A and 4A are subminiature, hermetically sealed, D.C. relays which meet and in several respects exceed the requirements of MIL-R-5757B. They are actuated by a "balanced-armature" rotary motor. Both models are particularly suited to dry-circuit switching applications.

LEADING PARTICULARS

Ambient Temp.:	-65°C to +125°C
Weight:	3.2 oz. maximum
Height of Case:	1½" maximum
Diameter of Case:	1¾" maximum
Terminals:	Flattened & pierced
Contact	DPDT — Model 2A
Arrangement:	4PDT — Model 4A
Contact Material:	Fine silver to molybdenum
Operation:	Simultaneous operation, simultaneous release, no contact bounce
Pull-in-power (Coil):	¾ watt — Model 2A ½ watt — Model 4A

Test Data and Literature on Request

Built-in Dependability

S. H. Couch Company, Inc.

NORTH QUINCY 71, MASSACHUSETTS

Want more information? Use post card on last page.

potentiometer wiper arm until the error signal disappears. As the motor turns the potentiometer, it also turns the counter which is positioned in relation to the wiper arm to read directly in volts-ratio.

The precision potentiometer used in the unit is accurate to 0.1 percent and the dial can be

read easily to a voltage ratio of 0.0005. To check accuracy, a switch is provided for correcting precision resistors designed to give a 0.500 volts-ratio reading.

These units, built at low cost, have saved an average of 10 minutes on each calibration and eliminated the need for having two men working together.

Rubber Mat For Bench Protects Assemblies

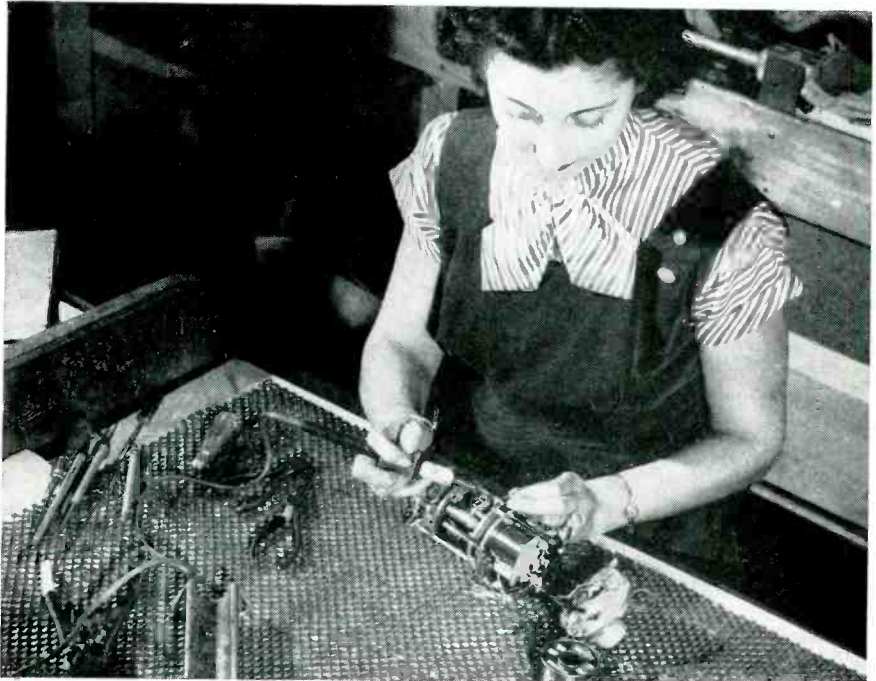

Rubber mat with large holes minimizes rolling of circular frame for airborne electronic unit

PERFORATED RUBBER matting is used at work positions on assembly benches in the Long Island City plant of Ford Instrument Co. to protect delicate ground position indicator units during soldering and other assembly work. The matting also serves to prevent small round tubes and parts from

rolling off the bench.

At inspection and test positions, the perforations in the matting serve to receive abrasive particles, preventing them from grinding into the finish of the chassis or housing when it is slid along the bench or rotated for the various inspection and test operations.

Detecting Oil On Punched Mica Parts

MANUFACTURERS AND fabricators of mica spacers for tubes find that cool-burning, high-intensity fluorescent ultraviolet lamps are the new time-saving quality control tools for detecting oil contamination.

Natural mica, being a mineral composed of very thin leaves or layers, readily absorbs any oil which may be deposited upon it

during a stamping operation. The raw mica itself is not contaminated with oil, but in the process of blanking mica in a power press, oil from the dies often contaminates a tremendous number of stamped parts. Mica spacers and other fabricated mica products which are used as components of vacuum tubes must be free from oil. If not, the heat generated

PULSE JITTER TESTER

FEATURES

- Self-contained cathode ray tube with continuously adjustable horizontal sweep from 40 to 2,000 cps. Can be synchronized with signal.
- Printed circuit construction
- Self-contained calibration in three ranges: 100 milli u sec., 10 milli u sec., 5 milli u sec.
- Power frequency range from 50 to 420 cps.
- Provision for measurement of jitter frequency by Lissajous figures.

MEASURES

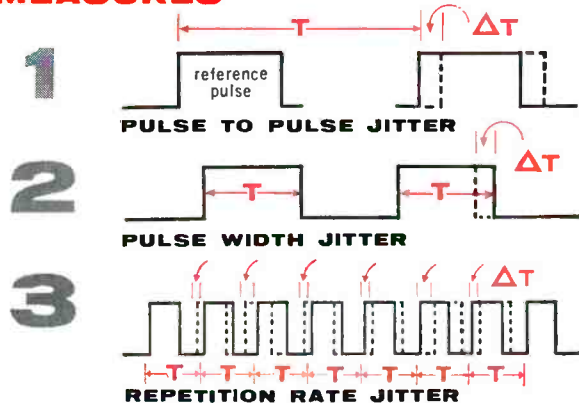

DISPLAYS

- JITTER MAGNITUDE
- JITTER WAVEFORM

A new Polarad instrument to show the magnitude and waveform of jitter modulation in rate generators, pulse width modulators encoding devices, precision time generators.

Here is how it measures:

1. pulse to pulse jitter. Two 5 mc oscillators are pulsed—one with the leading edge of each pulse. The outputs of the oscillators are compared in the phase detector and displayed on the CRT.
2. pulse width jitter. The leading and trailing edges of a pulse gate the 5 mc oscillators and are compared.
3. repetition rate jitter. The leading edge of the pulse gates a 5 mc oscillator which is compared with a stable 5 mc crystal controlled oscillator in a phase detector. The output of the phase detector is divided by a calibrated attenuator in factors of ten and two and displayed on a CRT.
4. waveform of jitter. Obtained by rectifying the output of the phase detector.

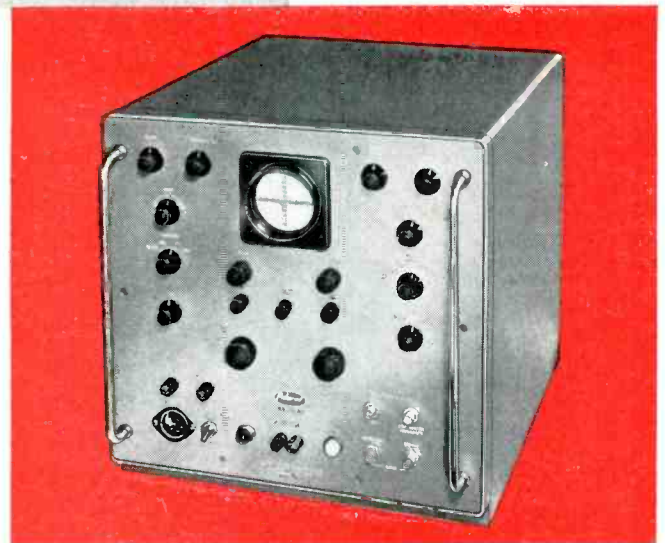

MODEL PJ-1

SPECIFICATIONS

Input Requirements:

Pulse Width	0.2 to 10.0 microseconds.
Repetition Rate	50 to 6,000 pps.
Amplitude	5 to 50 volts, peak-to-peak.
Polarity	Positive or negative.
Input Impedance	82,000 ohms shunted by 25 micromicrofarads.
Measuring Level	50% point of input pulse, nominal.

Jitter Measurements:

Repetition Rate Jitter	.5, 10, 100 millimicroseconds and 1, 10, 100 microseconds full scale.
Width or Relative Jitter	.5, 10, 100 millimicroseconds full scale.
Residual Jitter	Less than 0.5 millimicroseconds on 5, 10, and 100 millimicrosecond ranges.
Useable Horizontal Frequency Range	15 cycles to 25 kc.
Power Input	115 v \pm 10%, 50 to 420 cps, 400 watts.
Dimensions	19 wide by 17½ high by 12 inches deep.
Weight	60 lbs.
Outputs Provided For	(1) External oscilloscope; (2) Recorder (\pm 5 ma. into 1,000 ohms) for disturbance frequency.

AVAILABLE ON EQUIPMENT LEASE PLAN



ELECTRONICS CORPORATION
43-20 34th Street • Long Island City 1, N. Y.

Maintenance Available by
Field Service Specialists



REPRESENTATIVES: Albuquerque, Atlanta, Baltimore, Boston, Buffalo, Chicago, Cleveland, Dayton, Denver, Fort Worth, Kansas City, Los Angeles, New York, Philadelphia, Portland, St. Louis, San Francisco, Schenectady, Syracuse, Washington, D. C., Winston-Salem, Canada; Arnprior, Ontario. Resident Representatives in Principal Foreign Cities

For PILOT LIGHTS

CONSULT

DIALCO

Your product benefits 3 ways from the use of a DIALCO Pilot Light:

Enhanced appearance: The glow of light and sparkle of a lens add colorful visual attraction.

Greater safety: A timely warning flashed by a pilot light can prevent damage to equipment.

Added service: Discs inserted behind lenses can be used to deliver specific messages, such as "FUEL LOW", "ON", "OFF", etc.

Let the Dialco engineering department assist you in selecting the right lamp and the most suitable pilot light for your needs.

Dialco offers the complete line of pilot lights, from sub-miniature types to giant units with 1½" lenses.

Every assembly is available complete with lamp.

SAMPLES ON REQUEST AT ONCE — NO CHARGE

Illustrations are approx. 70% actual size . . . (A) No. 8-1930-111 sub-miniature pilot light . . . (B) No. 521308-991, with multivue cap . . . (C) No. 922210-111, dimmer type . . . (D) No. 47901 with light shield cap.

Write for latest catalogues and Design Brochure.

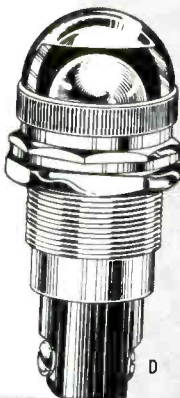
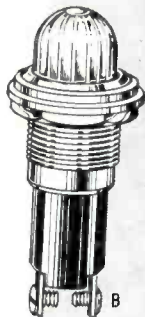

Foremost Manufacturer of Pilot Lights

DIALIGHT CORPORATION

60 STEWART AVE. • BROOKLYN 37, N. Y.

HYACINTH 7-7600

PLANT AT
BROOKLYN, N. Y.

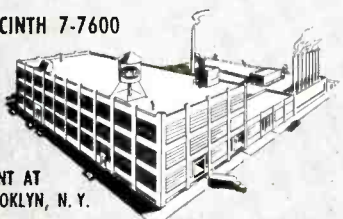

Want more information? Use post card on last page.



Inspecting mica spacers for tubes under overhead long-wave lamp. White fluorescence on punched edges indicates oil contamination from dies of punch press



Using portable long-wave lamp to spot-check incoming mica parts for oil contamination

causes the oil to gas, rendering the tube useless.

► **Example**—American Mica Insulation Co., Manasquan, N. J. manufacturers of mica supports for the grid, filament and cathode of vacuum tubes, now inspects mica punchings under Blak-Ray long-wave model XX-40 lamps distributed by Black Light Eastern Corp., Long Island City, N. Y. This overhead unit was designed to give even radiation over a broad area.

The inspection can be done under normal lighting conditions, although the fluorescence of the oil is more obvious when there is less visible light present. Uncontaminated mica does not fluoresce and will reflect a dull purplish glow under the lamp, whereas oil on mica will fluoresce and emit an easily distinguished white glow.

For spot-checking mica shipments, a portable long-wave Mineralight SL-3660 lamp is also available.

Wiring Board Press Uses Tape Control

A COMPLETELY PUNCHED wiring board can be reproduced in less than 5 minutes after receipt of the drawing by using a new automatic tape-programmed punch press developed by GE's Light Military

Electronic Equipment Department in Utica, N. Y. The 5-minute time includes conversion of the master drawing to punched tape, loading of the tape into the incremental positioner control for the press and

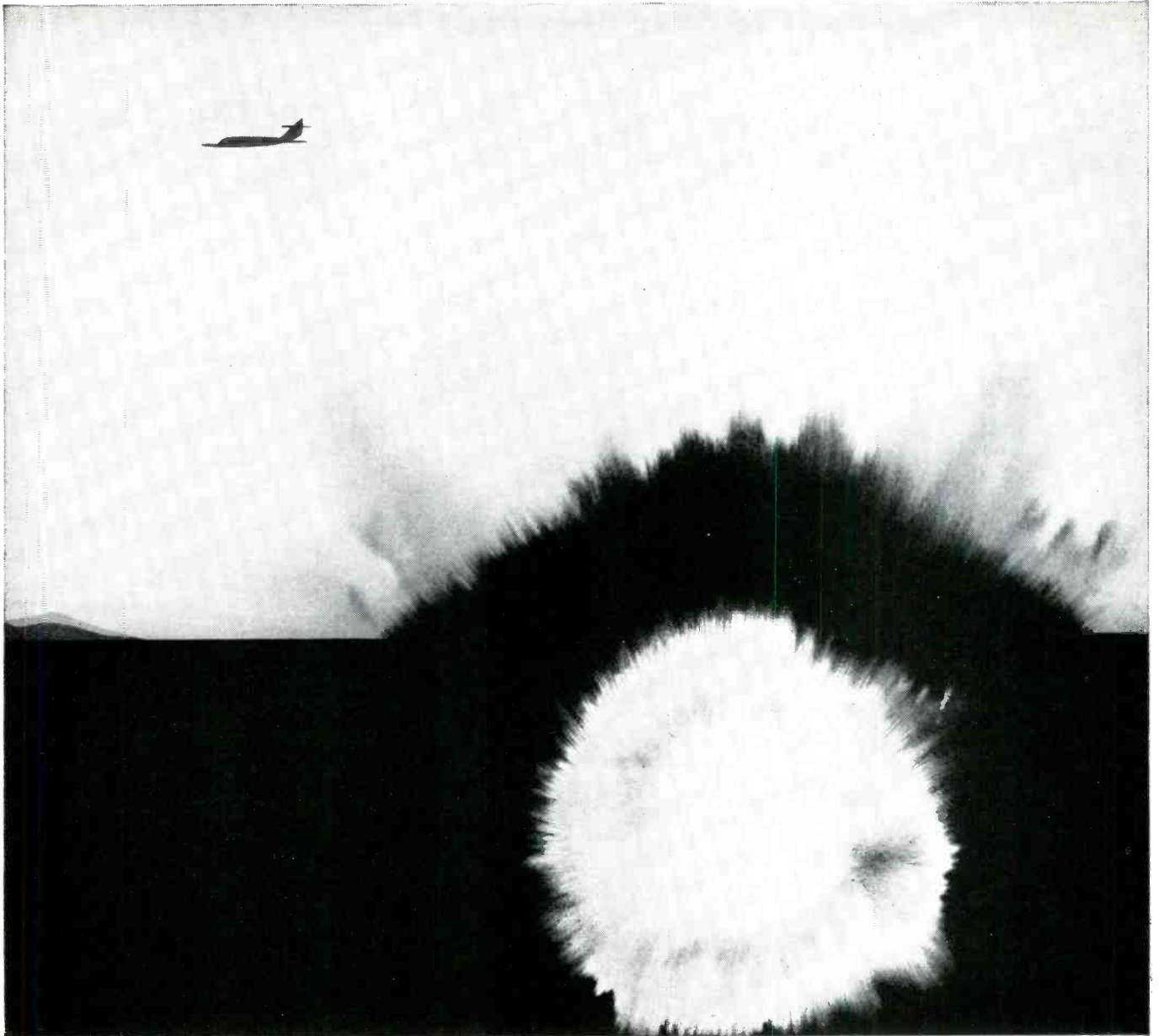

In underwater ordnance, too

AMF has experience you can use

● From the development and production of complete underwater ordnance systems, both conventional and atomic—to the design and manufacture of underwater vessels to withstand crushing hydrostatic pressures at great depths—AMF is daily engaged in hundreds of complex engineering tasks. ● The highly specialized, yet widely diversified activities of some 35 engineering and production facilities provide AMF with a wealth of experience that covers nearly every field of industry. And it is immediately available to you. ● Call upon AMF with your problem. See for yourself why this all-around experience in answering the needs of government and industry alike has made AMF the “can do” company.

Research, Development,
Production in these fields:

- Armament
- Ballistics
- Radar Antennae
- Guided Missile Support Equipment
- Auxiliary Power Supplies
- Control Systems



Defense Products Group

AMERICAN MACHINE & FOUNDRY COMPANY

1101 North Royal Street, Alexandria, Va.

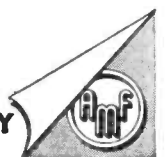

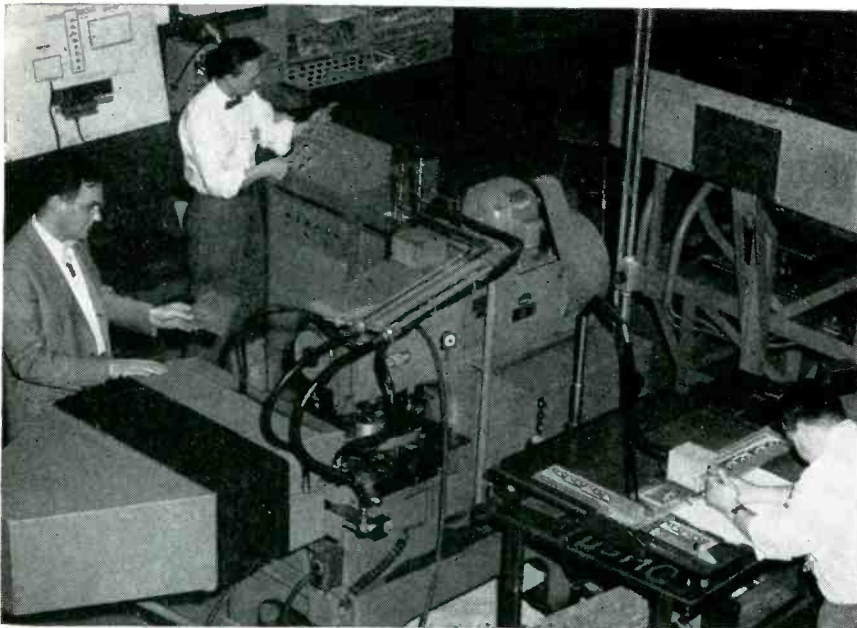

Automatic tape-programmed punch press installation for 0.1-inch dimensional system. Drawing-to-tape programmer is at front right. Man holding board is at press loading position, directly behind binary-code incremental positioner covered by hood. Man at rear is loading tape into reader for press

loading of a blank board into the press.

Subsequent boards can be reproduced from that tape in less than a minute each, with the exact time depending on the number of holes. The machine is designed around a basic Weidemann press, so that up to 12 different sizes of holes may be punched.

► **Tape Puncher**—Hole layout is based on a 100-mil grid. The table of the drawing-to-tape programmer

is drilled with a grid of holes in an enlargement ratio of 2 to 1. The drafting department uses this same ratio for its transparent drawing. This drawing is fastened into position on the table with pieces of masking tape, after aligning it with grid holes underneath.

The operator moves the stylus of the programmer over the first hole to be punched and pushes it through the paper into the corresponding drill hole in the table. The stylus is mounted on a carriage

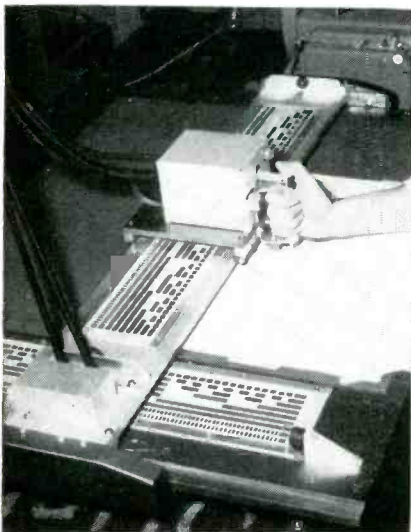

Drawing-to-tape programmer, showing thumb-operated stylus that is moved over binary-coded carriages. Tape puncher is at rear of drawing table



Removing punched tape. Control box on top of puncher gives choice of twelve different hole sizes, producing corresponding code markings on tape

To the ENGINEER of high ability

Through the efforts of engineers The Garrett Corporation has become a leader in many outstanding aircraft component and system fields.

Among them are:

- air-conditioning
- pressurization
- heat transfer
- pneumatic valves and controls
- electronic computers and controls
- turbomachinery

The Garrett Corporation is also applying this engineering skill to the vitally important missile system fields, and has made important advances in prime engine development and in design of turbochargers and other industrial products.

Our engineers work on the very frontiers of present day scientific knowledge. We need your creative talents and offer you the opportunity to progress by making full use of your scientific ability. Positions are now open for aerodynamicists

- ... mechanical engineers
- ... mathematicians ... specialists in engineering mechanics ... electrical engineers ... electronics engineers.

For further information regarding opportunities in the Los Angeles, Phoenix and New York areas, write today, including a resume of your education and experience.

Address Mr. G. D. Bradley



9851 So. Sepulveda Blvd.
Los Angeles 45, Calif.

DIVISIONS
AiResearch Manufacturing,
Los Angeles
AiResearch Manufacturing,
Phoenix

AiResearch Industrial
Rex — Aero Engineering
Airsupply — Air Cruisers
AiResearch Aviation
Service

Want more information? Use post card on last page.

January 1, 1957 — ELECTRONICS

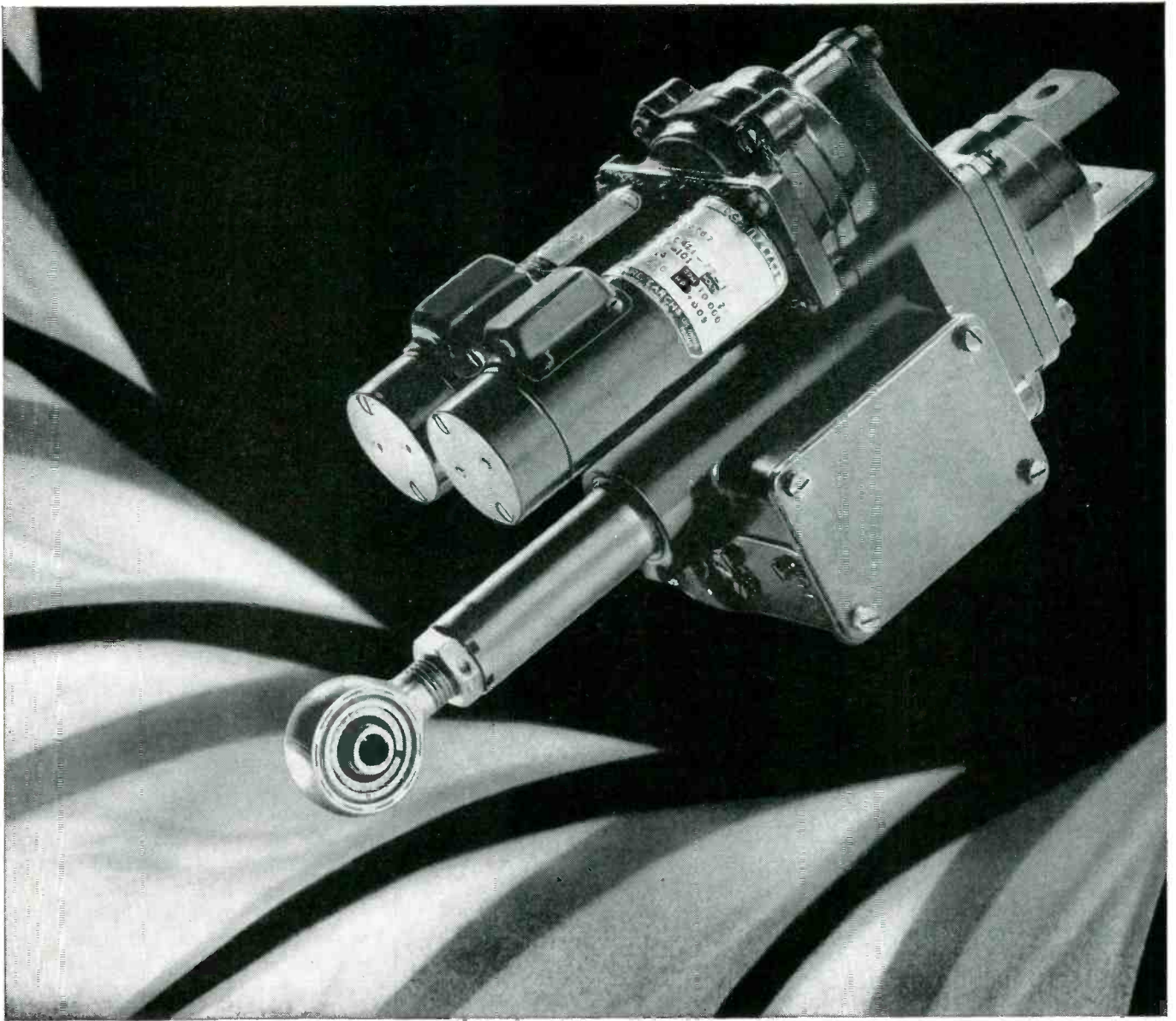

Four-speed actuator

AiResearch two-motored unit provides automatic control plus an instantaneous manual override at the work end of its Air Data System

During high-speed flight, where control is so delicate it is often by trim surfaces alone, immediate response under emergency conditions is of critical importance. The actuator shown allows immediate pilot override of the automatic system without any disconnect activity or mechanical clutching device. If necessary any one of four speeds may be instantaneously selected.

The unit operates with complete dependability at ambient temperatures up to 300°F.

AiResearch actuators operate on split-field or permanent magnet DC motors, on AC servo motors or on single-phase, two-phase or three-phase AC motors. They can supply feedback signals to the control and be provided with neutral positioning and light-switches.

We are now engaged in the development of Air Data Systems of all types, assuming full system responsibility. Because we manufacture the entire system, including transducers, computers and actuators, you are assured of the utmost in system compatibility.

Outstanding opportunities for qualified engineers. Write for information.

THE GARRETT CORPORATION
AiResearch Manufacturing Divisions

Los Angeles 45, California • Phoenix, Arizona

Designers and manufacturers of aircraft systems and components: REFRIGERATION SYSTEMS • PNEUMATIC VALVES AND CONTROLS • TEMPERATURE CONTROLS
 CABIN AIR COMPRESSORS • TURBINE MOTORS • GAS TURBINE ENGINES • CABIN PRESSURE CONTROLS • HEAT TRANSFER EQUIPMENT • ELECTRO-MECHANICAL EQUIPMENT • ELECTRONIC COMPUTERS AND CONTROLS

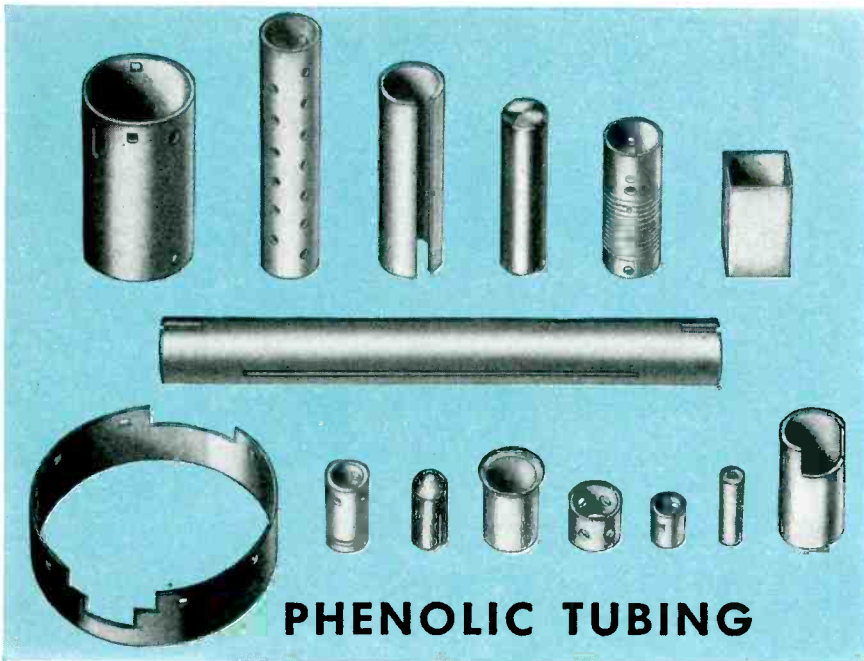

PHENOLIC TUBING

**SPECIFY... CLEVELITE *
BECAUSE**

It has high insulation advantages, uniformity and inherent ability to hold close tolerances which give you dependability.

CLEVELITE dependability is the answer for product performance at its best.

Also, ensure over-all economy by adding Clevelite reliability to your product.

Write for folder showing the various grades in which Clevelite is produced. Your inquiry will receive prompt attention.

*Reg. U. S. Pat. Off.

THE CLEVELAND CONTAINER COMPANY
 6201 BARBERTON AVE. CLEVELAND 2, OHIO
PLANTS AND SALES OFFICES:
 CHICAGO • DETROIT • MEMPHIS • PLYMOUTH, WIS. • OGDENSBURG, N.Y. • JAMESBURG, N.J. • LOS ANGELES

ABRASIVE DIVISION at CLEVELAND, OHIO
 Cleveland Container Canada, Ltd., Prescott and Toronto, Ont.

Representatives:

NEW YORK AREA: R. T. MURRAY, 604 CENTRAL AVE., EAST ORANGE, N. J.
 NEW ENGLAND: R. S. PETTIGREW & CO., 62 LA SALLE RD., WEST HARTFORD, CONN.
 CHICAGO AREA: PLASTIC TUBING SALES, 5215 N. RAVENSWOOD AVE., CHICAGO
 WEST COAST: IRV. M. COCHRANE CO., 408 S. ALVARADO ST., LOS ANGELES



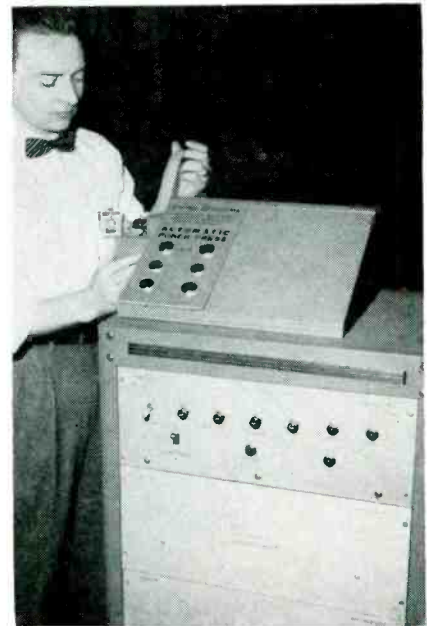

Loading punched tape into control head for automatic punch press

that moves over a silver-plated array of binary code blocks produced by etching. This horizontal carriage in turn moves over a similar vertical binary code strip. Each movement of the stylus is thus translated into the binary code called for by a standard Flexo-writer paper-tape puncher.

The grid of drilled holes eliminates the need for dimensioning the master drawing, yet gives the required high accuracy of hole placement even when the drawing is made free-hand.

► **Operation**—The punched tape is loaded into the control head of the automatic punch press. Where only a single sample board is desired, the tape is run through once. For more than one board, the ends of the tape are cemented together to form a loop. A blank board, previously punched with two positioning holes, is slipped into position on the holding pegs of the incremental positioner and the start button is pushed. Holes are punched one after another automatically. High accuracy of position is achieved by using the binary code strips in reverse on the positioner. The table cycles automatically to the unloading position when punching is completed.

► **Corrections**—A tape proofer and corrector serve for reading each

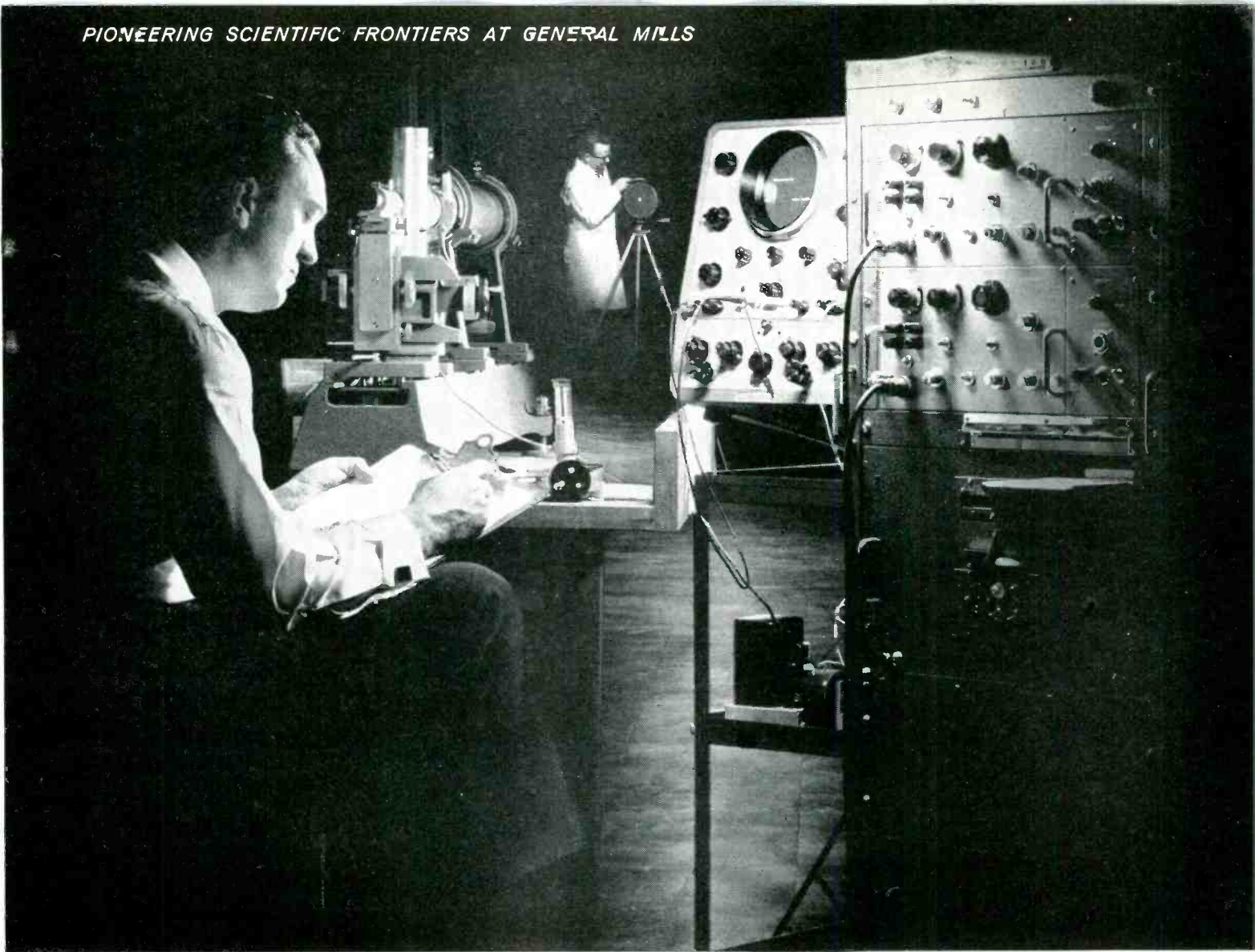

Dr. J. E. Barkley, director of research, takes a reading in the dark tunnel during study of new infrared techniques being conducted by the Mechanical Division of General Mills.

What else can infrared do?

Infrared detection devices have become almost commonplace. These invisible rays are now used in photography and several other industrial and military applications. But the full capabilities of infrared have not yet been determined. Dr. Barkley and his staff, working from an extensive background in current uses of infrared, are researching several possible applications right now.

These studies in basic infrared tech-

nology represent but a single phase of General Mills' over-all program of advanced exploration in theoretical and developmental physics, electronics and mechanical design.

Findings in this "research for tomorrow" are being translated regularly into practical applications for industrial and military use today. If you have product or production problems, you can profit from these applications, and from our high-level production facilities.



CAN YOU BENEFIT FROM HIS SKILL AND EXPERIENCE?

Skilled craftsmen, who are as proud of the precision products they produce as they are of the highly specialized machines they use, work with exacting care which comes only from many years of experience. Mass production and on time delivery of electro-mechanical and mechanical devices is routine at General Mills.



Send for Production Facts New booklet shows our facilities, names our customers—introduces you to on time, precision manufacturing. Write Mechanical Division, Dept. EL-1, General Mills, 1620 Central Ave. N. E., Minneapolis, Minn.

MECHANICAL DIVISION

CREATIVE RESEARCH AND DEVELOPMENT + PRECISION ENGINEERING AND PRODUCTION



It's a mighty thin line...

... between optimum efficiency and chaos, when you're working with multi-component electronic assemblies. You want components on time ... dependably produced ... and you want to see your *own* production lines busy first, before farming out work.

But ... is it sensible to try to make *all* your own components? Can you afford setting up new lines ... hiring new people ... fussing for hours with dozens of different parts sources for just *one* component?

And what about those inevitable "end of run" slumps, when hands are idle, space goes wasting and costs pile up out of all proportion?

that's when
you need

a "balancer"

EED, an expert sub-contractor of electronic components for radio-TV and commercial-military manufacturers, enables you to plan a balanced production ... to put your own facilities to the fullest use, yet stay clear of the risks and harassments of sub-assembly production.

Our staff, trained up to the minute in time-saving, cost-saving methods, is experienced in every type of component assembly from amplifiers to zero adjusters.

Our facilities, modern and centralized, are geared to handle either limited quantity—high quality assemblies or volume—economy runs.

And of course, as a division of I.D.E.A., Inc. (where the world famous pocket-size Regency Radio is made) we're particularly adept in miniature production, including transistorized, etched circuit, dip soldered assemblies.

Unequaled, specialized staff, facilities and experience—they're ready to work for you. Just send us your drawings and full details and we'll be glad to submit complete cost and delivery estimates. For *Facilities Brochure*, write direct to:

ELECTRONIC EQUIPMENT DIVISION

I.D.E.A., Inc., 7900 Pendleton Pike
INDIANAPOLIS 26, INDIANA

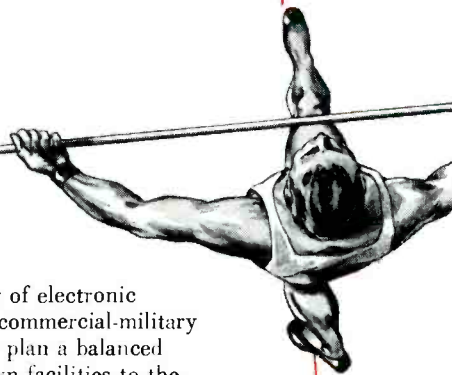

Tape proofing and correcting machine. Tape reader is at front left of machine and duplicating tape punch is at rear

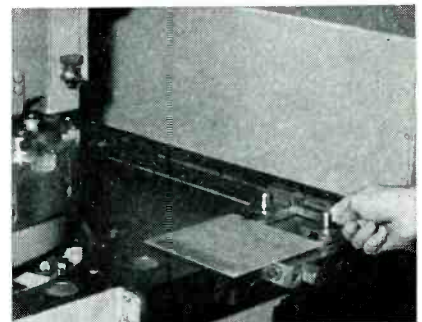

Method of loading wiring board on servo positioner of press

finished tape and checking it against a master drawing. As the tape is run through this machine, pilot lamps light up to indicate the punched positions.

To make corrections, a duplicate tape is produced from the master. The operator watches this operation until the point is reached where a correction is desired, then depresses the cancel bar and punches in the new number manually by pressing numbered buttons provided for that purpose. These buttons can also be used for punching an entire new tape manually, directly from a dimensioned master drawing. This tape proofer uses a standard Flexowriter reader and tape punch mechanisms.

Drilling Pantograph

A NEW TRACER-GUIDED pantograph machine for etched or plated wiring boards, brought out by Hermes Engraving Machine Corp. of New

The British Electronics Industry is making giant strides with new developments in a variety of fields. Mullard tubes are an important contribution to this progress.

ELECTRONICS IN BRITAIN

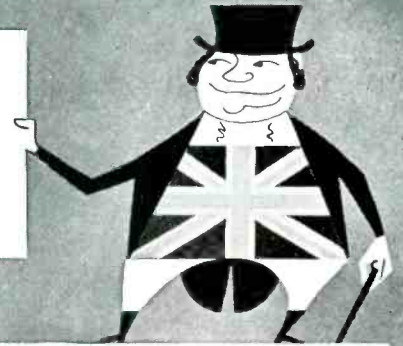

Principal Characteristics

	61SV	61RV
Peak spectral response	2.5 μ	2.5 μ
Spectral range	0.3 to 3.5 μ	0.7 to 4.5 μ
Cell resistance (average)	4M Ω	100K Ω
Max. applied voltage	250V	100V

Sensitivity

a. Tungsten light source at 2700°K	3.0mA/lumen	300 μ A/lumen
b. Black body at 200°C (radiation) energy 5.82 μ W; chopper frequency 800c/s; amplifier bandwidth 50c/s	180V r.m.s./W peak to peak	1.66V r.m.s./W peak to peak



61SV/61RV

extra-sensitive infra-red photoconductive cells

Important among recent British achievements is the introduction by Mullard of two new photoconductive cells, the 61SV and the 61RV. These cells, specially designed for detecting infra-red radiations, combine an unusually high order of sensitivity with an extremely fast response, peaked at a wavelength of 2.5 microns. Their spectral range extends beyond the usual limits of infra-red detectors down to the red end of the visible spectrum.

The high signal-to-noise ratios of the 61SV and the 61RV make them ideal for measuring small temperature variations of relatively low heat sources down to 100°C. Additionally, their small size and rugged construction qualify them for the majority of infra-red applications in industry.

For further technical information and advice on the use of these outstanding photocells please write to either of the companies listed here.

Supplies available from:—

in the U.S.A.

International Electronics Corporation,
Dept. E1, 81 Spring Street, N.Y. 12,
New York, U.S.A.

in Canada

Rogers Majestic Electronics Limited,
Dept. IP, 11-19 Brentcliffe Road,
Toronto 17, Ontario, Canada.

Mullard

ELECTRONIC TUBES *used throughout the world*

MULLARD OVERSEAS LTD., MULLARD HOUSE, TORRINGTON PLACE, LONDON, ENGLAND

Mullard is the trade mark of Mullard Ltd., and is registered in most of the principal countries of the world.



PANELSCOPE

by

Waterman

FOR AUTOMATIC
PORTRAYAL

5 POUNDS

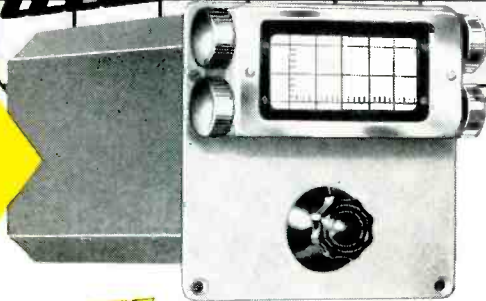

ANOTHER EXAMPLE OF **Waterman** PIONEERING...

The Waterman **PANELSCOPE** is a custom-built cathode ray tube oscilloscope, with simplified operation, and yet available at a low price. The **PANELSCOPE** concept provides for the following:

- **MINIATURIZATION** — Panel space required is only 5¼" x 5-3/16" — depth is 10" and the weight is less than 5 lbs. The **PANELSCOPE** can be installed in practically any equipment — mobile or stationary air, sea, or land — military or commercial.
- **SIMPLICITY OF OPERATION** — Twist of a single rotary switch provides a synchronized pattern of desired incoming signal (up to 11 circuits) against proper linear time base. This is ideal for monitoring and trouble shooting, as it removes the need of fiddling with knobs as it is done now on general purpose oscilloscopes. The static controls, such as beam, focus, positioning, and graticule brightness are located in tube escutcheon.
- **CUSTOM DESIGN** — A wide variety of — signal amplifiers with response from dc to megacycles and sensitivities from 5 millivolts — synchronized or triggered linear time base generators from ½-cycle (and lower if need be) to 2 microseconds — can be specified by you to fit your needs for particular equipment.
- **PARTIAL KIT FORM** — The **PANELSCOPE** comes fully wired and tested with chosen signal amplifier, linear time base generator and attendant sync. amplifier. The desired signal attenuators, frequency and amplitude determining components, and method of synchronization can be installed either by us or by you.
- **POWER REQUIREMENT** — Less than 10 watts of line power for built-in high voltage supply — The required B+ and heater current as selected by your requirements. For those cases where B+ and heater power is not available, auxiliary power pack can be supplied.

There is a place in your equipment for Waterman **PANELSCOPE**, a custom built oscilloscope at production prices, although your needs may be but one or two. May we have your requirements?

WATERMAN PRODUCTS CO., INC.

PHILADELPHIA 25, PA.
CABLE ADDRESS: POKETSCOPE

MANUFACTURERS OF

PANELSCOPE*
S-4-C SAR PULSESCOPE*
S-5-C LAB PULSESCOPE*
S-11-A INDUSTRIAL POKETSCOPE*
S-12-B JANIZED RAKSCOPE*
S-12-C SYSTEMS RAKSCOPE*
S-14-A HIGH GAIN POKETSCOPE*
S-14-B WIDE BAND POKETSCOPE*
S-14-C COMPUTER POKETSCOPE*
S-15-A TWIN TUBE POKETSCOPE*
RAYONIC* Cathode Ray Tubes
and Other Associated Equipment

*T. M. REG.

York City, combines adjustable ratio setting with pneumatic drill feed so that an unskilled operator can easily drill over 100 holes per minute.

A master template has a drilled dot for each hole to be drilled. The dots are connected with grooved lines so that the operator can quickly glide the tracing stylus of

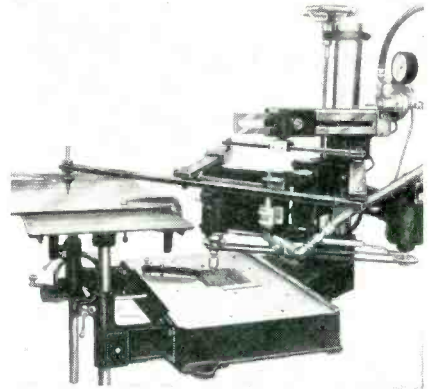

Operator moves stylus over template clamped to table at left, to control drilling of etched wiring board on lower table

the pantograph from dot to dot. A heavy-duty ball-bearing spindle, operating at a speed up to 15,000 rpm, is air-actuated for up and down movement of the drill at the other end of the pantograph.

The pneumatic attachment which controls the feed is easily adjustable. Drilling is initiated by a sensitive solenoid unit which can be operated by either hand, knee or foot, or automatically when the tracing stylus is placed in the dot of the master template.

The multi-ratio pantograph is adjustable and allows the use of an enlarged master template laid out in any ratio from 1:2 up to 1:12. Any slight error in the template is reduced on the finished product in relation to the ratio used.

Automatic Tinning Of Relay Springs

TERMINALS OF relay springs are automatically fluxed, tinned and ejected in groups of six by a soldering machine developed in the Clifton, N. J. plant of Federal Telephone and Radio Co., a division of IT&T. The operator merely has to load the contacts on to the



WATERMAN PRODUCTS



Fast-accurate automatic data processing!

THE RADIATION, INC. DIGITAL DATA HANDLING SYSTEM

**PROCESS DATA
IN MINUTES
INSTEAD OF DAYS**

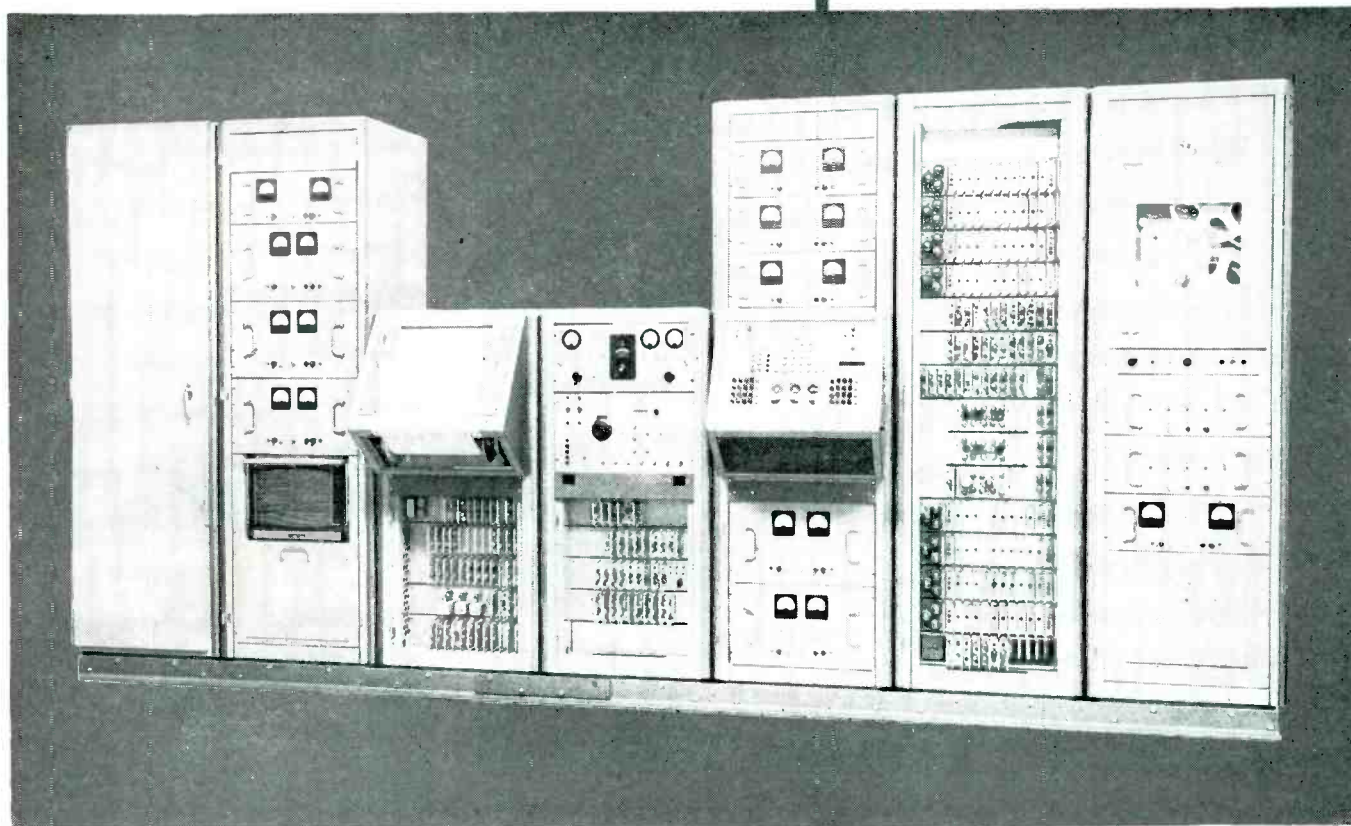

WHATEVER FORM YOUR ORIGINAL DATA IS IN —

- direct analog voltages
- output from any telemetry system
- output from most data collection systems

this equipment converts the raw data, either analog or digital, to digital information acceptable by high-speed computers.

Write for complete information on how this system can fit your data handling problem.

FEATURES:

- High-speed operation
- Automatic programming
- Digital operation throughout
- Extreme accuracy
- Flexibility
- Instantaneous Quick-Look analog plots
- Integral zero-shift, scale factor, and linearization

Address inquiries to Dept. K
P.O. Box 37
Melbourne, Fla.



RADIATION Inc.

Melbourne, Fla.
Orlando, Fla.

Electronics • Avionics • Instrumentation



Personnel inquiries invited.

demonstration in reliability



self-healing metallized film capacitors

The principle of self-healing in Dearborn metallized film capacitors depends, not on renewal of the dielectric, but on the thinly deposited plate flashing away from punctures without carbonization, leaving a clean, insulating film area surrounding the puncture.

Compensation for loss of plate area is carefully controlled; forced breakdown and healing through overvoltages applied to each unit, in manufacture, results in stable rated capacitance and unprecedented reliability at working voltages.

Dearborn engineering delivers other benefits, too . . . greatest range of values, smallest size. Sizes like these, for example, one end insulated:

.018 mfd 200 WVDC, .174" OD x $\frac{9}{16}$ " long
.047 mfd 200 WVDC, .235" OD x $\frac{9}{16}$ " long
10.0 mfd 200 WVDC, 1" OD x $2\frac{1}{4}$ " long

047-200V.D.C.

ASK FOR ENGINEERING BULLETIN DC-15

- Operating temperature range -65°C to $+125^{\circ}\text{C}$
- 50,000 megohm-mfds at 25°C
- Low RF impedance and higher self resonant frequencies not previously available in similar design
- Furnished in hermetically sealed tinned brass cases, glass to metal seals, bath tub or rectangular cases, single or multiple sections

Dearborn

**electronic
laboratories, Inc.**

231 SOUTH LA SALLE STREET
CHICAGO 4, ILLINOIS

OPERATING EXCLUSIVELY UNDER MIL Q5923B

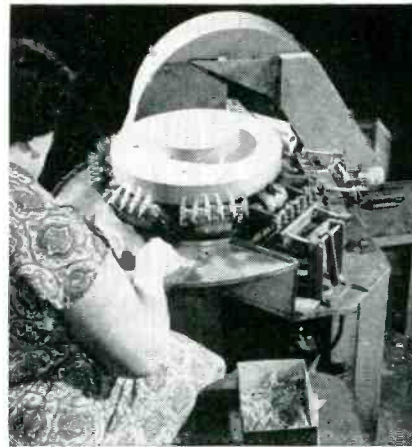

Automatic terminal-tinning machine for relay springs. All actions are produced by a central cam underneath, driven by an electric motor through a gear box. Tinned springs drop into tote pan at right after rinsing of flux and drying by covered water wheel at rear

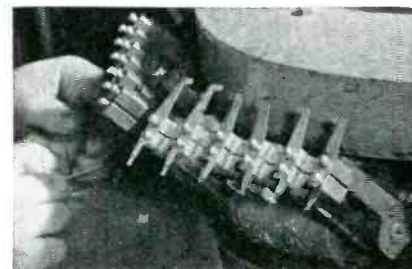

Loading position on machine



Fluxing position, with long narrow pan ready to bring flux out of main flux bath up to terminals of the six contacts on the holding pins

holding pins at the turntable-loading position.

At the loading position, a cam brings the spring-holding arms up at an angle to simplify loading and prevent the spring from falling out. As the turntable indexes past the loading position, the pins are forced apart by a spring as the arms are lowered into position for

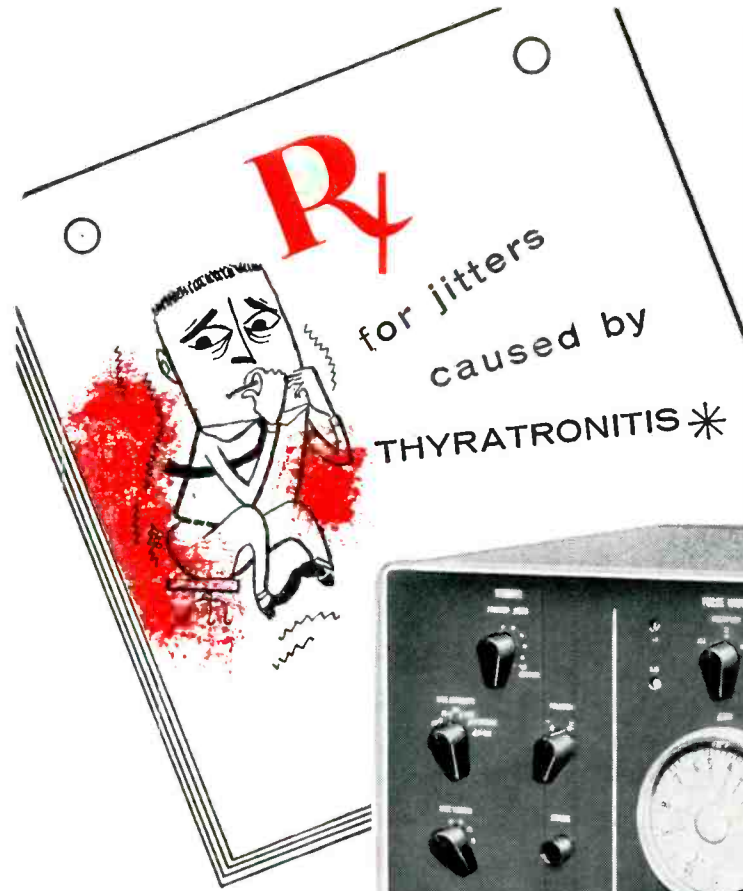

one of the **400** series

Hard Tube Circuitry: Hard tube circuits assure jitter-free relationship between pulse and synchronizing triggers.

Repetition Rate: 100,000 PPS to single pulse with either positive or negative polarity.



Du MONT 404 PULSE GENERATOR

SPECIFICATIONS

*** DEFINITION :** A common ailment of an hereditary nature, common to certain species of pulse generators. **Symptoms:** bumps, squiggles, and twitches in pulse. **Cause:** nervous triggering of pulse due to too much hydrogen in thyratron (or something like that).

PRESCRIPTION: Hard tube circuitry for pulse generation.

Du Mont's done it! Here is a pulse generator that you can depend on for high-speed pulses that are clean and accurate every time. A completely new hard-tube circuit provides pulses with a broad range of widths, amplitudes and repetition rates, resulting in an instrument that can simulate virtually any test condition.

There is no other pulse generator that approaches the 404 in performance, operating ease, or value. Write for complete details...

Pulse Output: Nominally 50 volts across 50 ohms; Attenuator provides up to 60 db attenuation in 1/2 db increments; Attenuator accuracy: ± 3%; Overshoot less than 3%; positive or negative pulse polarity.

Pulse Duration: Width, 0.05 usec to 100 usec continuously variable; Rise or fall time less than 0.018 usec; duty cycle, 10%. Automatic, built-in overload protection.

Repetition Rate: Internal, external or manual. Internal 10 pps to 100,000 pps, continuously variable. Facilities for external trigger up to 100 kc. Manual push button for single pulse operation.

Trigger Output: 25 volts across 50 ohms, positive or negative. Rise time less than 0.05 usec; width, 0.1 usec.

Pulse Delay: -2 to +E usec with respect to internal or manual trigger; continuously variable.

\$675* *Slightly higher for 50 cycle areas.

Cat. No. 4013-K Description 115-V; 50/60 cps

DU MONT®

TECHNICAL SALES DEPARTMENT, ALLEN B. DU MONT LABORATORIES, INC., CLIFTON, N. J.

Electronic Designers:

OVER 240 MODELS OF JOY FANS...

... Designed especially for your applications



LIGHTWEIGHT because they are made of aluminum or magnesium castings produced in Joy's own foundries.

COMPACT design—with motor mounted inside the fan—permits installation anywhere... even inside a duct.

EFFICIENT vaneaxial design provides more air per given size than any other type fan.

Joy's vaneaxial design is rugged and simple. The outer casing, the vanes, and motor mounts are cast in one piece... vibration free. Experience as the world's largest manufacturer and supplier of vaneaxial fans to G. E., Hallicrafters, Lear, Motorola, R.C.A., Raytheon, Sylvania, means Joy has the background to help you with your problems.

Joy has a complete line of fans... over 240 standard models with custom designs available to your specifications... fans from 1/500th hp up. Let us help... Write Joy Manufacturing Company, Oliver Building, Pittsburgh 22, Pa. In Canada: Joy Manufacturing Company (Canada) Limited, Galt, Ontario.

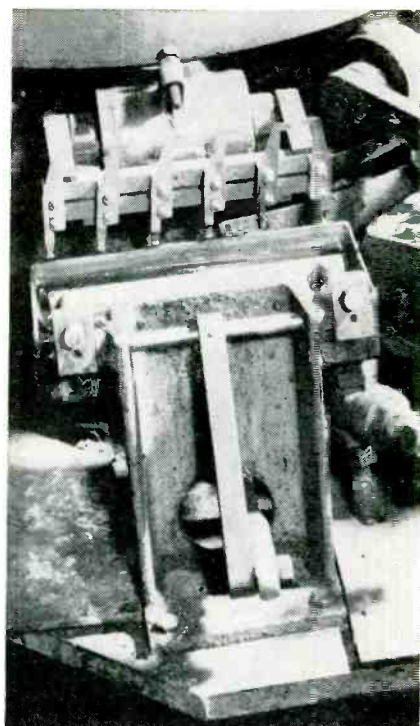
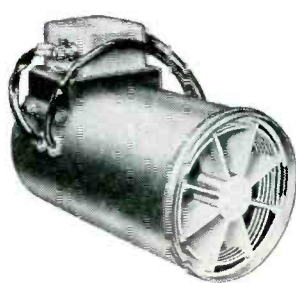

Soldering position, with contacts immersed in narrow inner pan that has been brought up out of solder bath by cam action

fluxing and soldering. This spring tension prevents the springs from sliding off the horizontal pins.

► **Tinning**—At the fluxing station, cam action brings a long, narrow pan out of the flux container and up to the downward-projecting terminals. The pan then retracts, the turntable indexes to the solder position and a similar long, narrow pan rises up to the terminals from

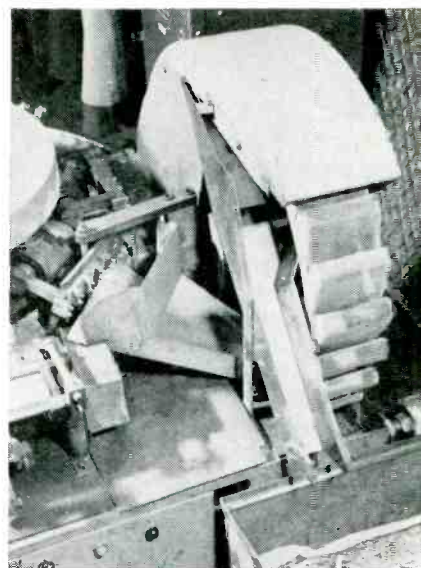

Output end of machine, showing screen-bucket water wheel that brings springs up out of rinse water bath and through hot air blast for drying



Write for FREE Bulletin 135-39

WSW 16348-135

JOY

WORLD'S LARGEST MANUFACTURER OF VANEAXIAL-TYPE FANS



Yes, MARCONI'S
have just what
is needed!

Marconi instruments include a range of Signal Generators designed to meet practically every requirement.

As the Signal Generator is the basic tool in radio research, it is not surprising that Marconi Instruments have had long and unrivalled experience in this fundamental field. Generators are available which will fulfil practically every requirement, and new types are continually being added to the already large range at present available.



F.M./A.M. SIGNAL GENERATOR
TYPE TF 1066

For particulars of other Generators please see the Complete Catalogue of Marconi Instruments

Carrier Frequency Range: 10 to 470 Mc. • No spurious sub-multiple outputs; r.f. oscillator generates direct at carrier frequency on all bands. • F.M. monitored and variable up to 100 kc deviation. • A.M. monitored and variable up to at least 40% depth. • Output Level variable from 0.2 microvolt to 200 millivolts. • Precision Incremental Tuning with frequency change indicated on a directly-calibrated meter.



VACUUM TUBE VOLTMETERS · FREQUENCY STANDARDS · OUTPUT METERS
F.M. & A.M. SIGNAL GENERATORS · DEVIATION METERS · WAVEMETERS
WAVE ANALYSERS · Q METERS · AUDIO AND VIDEO OSCILLATORS

Full data and prices will be mailed immediately on request

44 NEW STREET · NEW YORK 4

**CANADIAN MARCONI COMPANY,
6035, COTE DE LIESSE.
MONTREAL 9, CANADA.**

HEAD OFFICE: MARCONI INSTRUMENTS LTD., ST. ALBANS, HERTS., ENGLAND



FILTERS BY TRIAD



The same brilliant design, expert workmanship and extensive facilities that make TRIAD transformers the "Symbol of Quality" is available to develop special wave filters for your particular requirements.

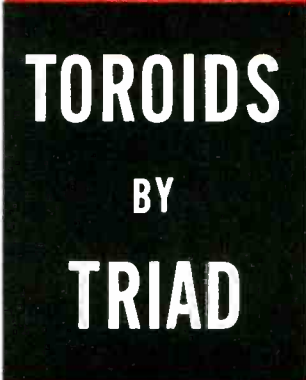
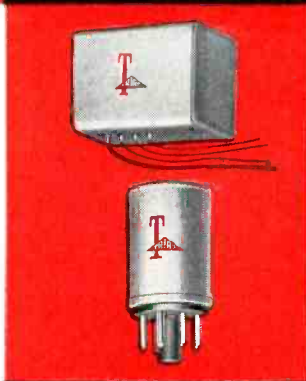
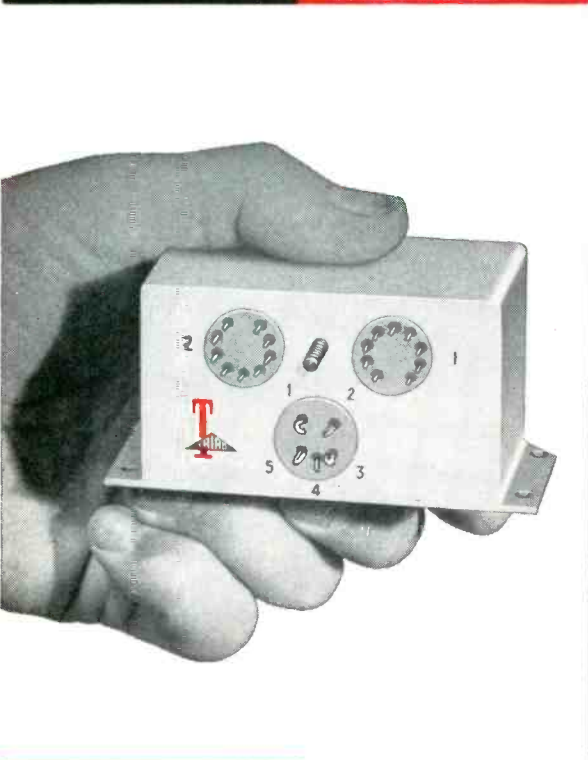
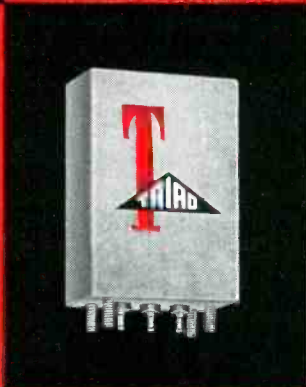

TOROIDS BY TRIAD

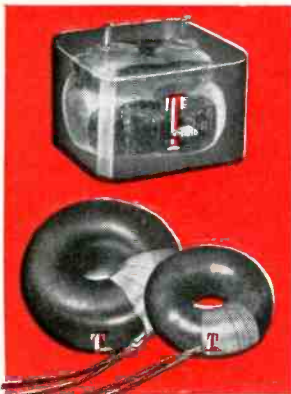

T
TRIAD
TRANSFORMER CORP.
4055 REDWOOD AVE.
VENICE, CALIFORNIA

If your requirements are Reliability, Accuracy, Stability, with even temperature and humidity, specify TRIAD quality Toroids for your products. Special inductors, to your specifications, available from the factory.

out of the pot of molten solder. Dwell time here is ample to give good tinning. The pan then retracts, the head indexes to the ejection position and a cam-operated blade knocks the tinned springs off the pins into a water-cooling wheel.

The technique used for bringing the solder up to the terminals minimizes dross problems, so only an occasional wiping of the solder surface is needed. A fresh film of beeswax is placed on top of the solder about four times a day.

► **Cooling**—A series of cups made from brass screen are mounted on a motor-driven wheel that brings the springs out of the rinsing water and through a blast of hot air before allowing them to drop down a chute into a tote pan. The rinsing removes any residual flux. The heater and fan for drying the springs are located under the machine and the hot air is brought up to the screen wheel by a stove pipe.

Thread Insert Speeds Probe Tip Assembly

A WIRE THREAD INSERT made by Heli-Coil Corp., Danbury, Conn., solves three assembly problems simultaneously on molded nylon probe tips made by Tektronix for use with oscilloscopes. The insert protects the relatively soft molded nylon threads from wear when changing tips on the probe, forms part of the electrical circuit and holds in place a thin copper disk.

Because the probe tip is less than an inch long, the inserting

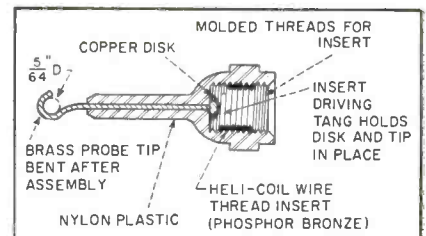

Wire thread insert provides strong, wear-resistant threads in nylon plastic, holds copper disk in place and provides good electrical contact between probe tip and probe

expand your
oscillograph capacity as your
needs demand...

with the
HEILAND
Series 700C
Recording
Oscillograph

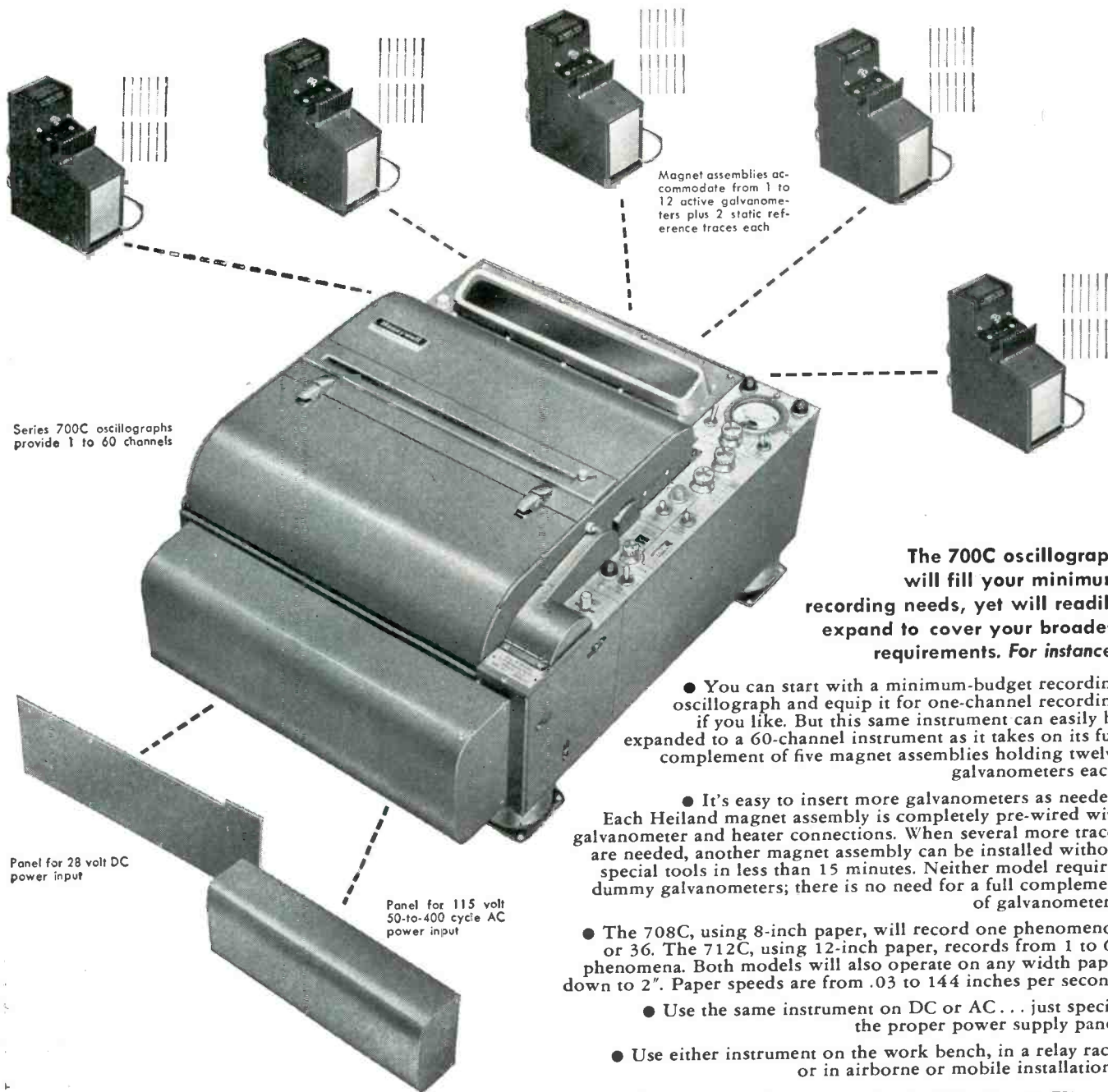

Series 700C oscillographs provide 1 to 60 channels

Magnet assemblies accommodate from 1 to 12 active galvanometers plus 2 static reference traces each

Panel for 28 volt DC power input

Panel for 115 volt 50-to-400 cycle AC power input

The 700C oscillograph will fill your minimum recording needs, yet will readily expand to cover your broadest requirements. For instance:

- You can start with a minimum-budget recording oscillograph and equip it for one-channel recording if you like. But this same instrument can easily be expanded to a 60-channel instrument as it takes on its full complement of five magnet assemblies holding twelve galvanometers each.
- It's easy to insert more galvanometers as needed. Each Heiland magnet assembly is completely pre-wired with galvanometer and heater connections. When several more traces are needed, another magnet assembly can be installed without special tools in less than 15 minutes. Neither model requires dummy galvanometers; there is no need for a full complement of galvanometers.
- The 708C, using 8-inch paper, will record one phenomenon or 36. The 712C, using 12-inch paper, records from 1 to 60 phenomena. Both models will also operate on any width paper down to 2". Paper speeds are from .03 to 144 inches per second.
- Use the same instrument on DC or AC... just specify the proper power supply panel.
- Use either instrument on the work bench, in a relay rack, or in airborne or mobile installations.

For complete details, write for Bulletin No. 700-EK

MINNEAPOLIS
Honeywell

Heiland INSTRUMENTS

5200 E. EVANS AVE., DENVER 22, COLORADO

SALES—SERVICE FACILITIES AROUND THE WORLD

***Fastest
fully automatic
toroidal
coil winder!***

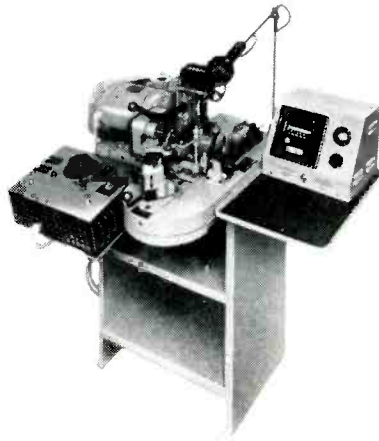

***World's fastest winding machine with
automatic core rotation . . .***

***. . . produces uniform coils
automatically***

Winding compact, uniform toroids quickly is no problem with this machine. Boesch TW 200 has an automatic core holder and rotating assembly that eliminates any manual coil handling during winding. The result? Every coil is wound evenly; each toroid is an exact duplicate of the previous design. What's more, this easily-operated machine winds all types of magnet and filar wire including silk, cotton and Teflon or sleeve covered wire . . . operates at fixed or variable speeds . . . produces toroids with .218" ID through 5" OD in AWG #20 through #42. Get full details on the Boesch Automatic Coil Winder and all Boesch machines today. Write for Catalog 57A now.

Boesch Automatic and Semi-Automatic machines feature interchangeable shuttle equipment, easily adapting them to all your winding needs . . . one of many advances pioneered by Boesch.

B **BOESCH MANUFACTURING
COMPANY, INCORPORATED**
BOESCH DANBURY, CONNECTICUT

Comparison is the best test of excellence. See for yourself why Boesch manufactures the world's most superior winding machines.

tool is held in a bench vise and the tip is brought to the inserting tool, instead of the conventional method of bringing the tool to the part. The insert is placed in the tool and prewound. With the brass

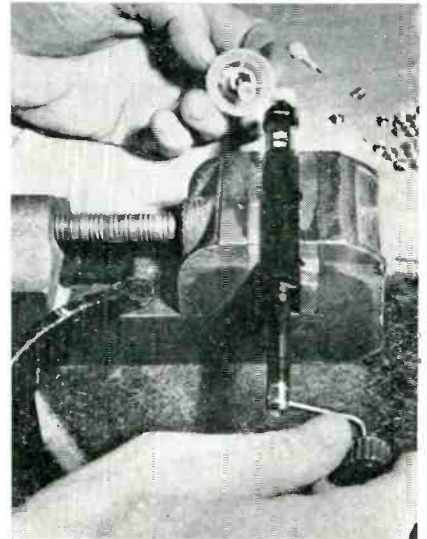

Inserting tool is held in vise. Insert is placed in tool and prewound

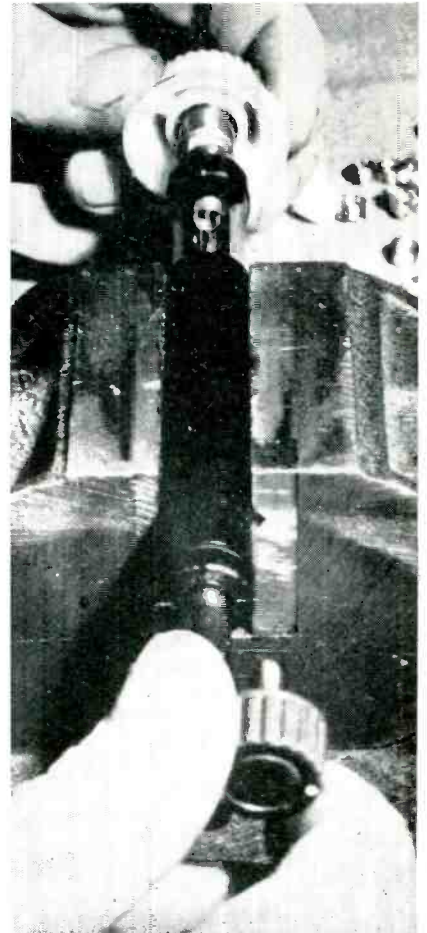

With brass tip and copper disk assembled, plastic body is placed in a hand-held jig while insert is turned into body

**FAST...PRECISE...AUTOMATIC
RESISTANCE MEASUREMENTS
FOR LABORATORY OR INDUSTRY**

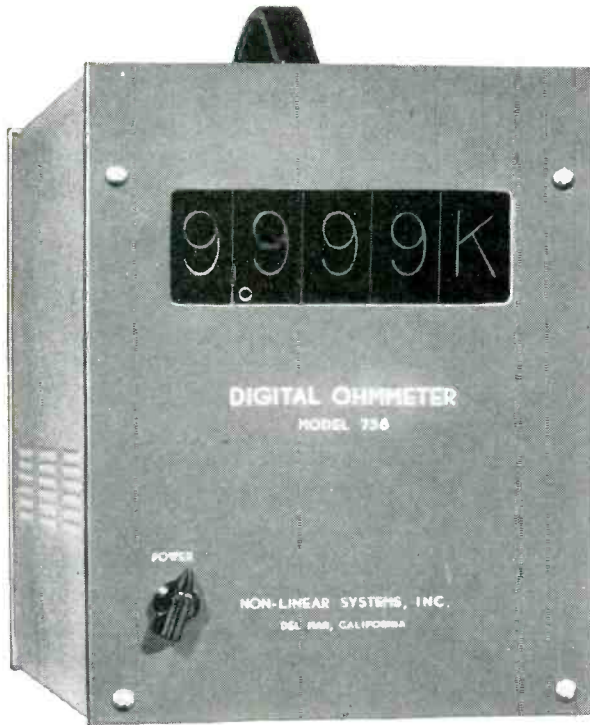

Models 758 and 759 available in either rack mount or portable. Portable model is pictured above.



FAST, AUTOMATIC MEASUREMENT of a wide range of resistance values, with an exceptionally high degree of accuracy, now is available in Non-Linear Systems Digital Ohmmeters. Resistance values are displayed in a horizontal line on one-inch-high luminous numerals clearly legible at distances to 30 feet. The readout decimal point location and range selection are automatic. And these instruments feature the exclusive NLS *oil-sealed stepping switches*, specifically re-designed for NLS digital equipment. This feature has been time-tested in the widely accepted NLS Model 451 Digital Voltmeter; it guarantees maximum maintenance-free life of stepping switches even in the presence of dust and humidity. Accuracy, ruggedness, high-speed automatic operation, reliability and economy adapt NLS Digital Ohmmeters to a wide variety of applications in laboratory, production, inspection and field testing...even with unskilled personnel. Ask your nearest NLS representative about these instruments...or mail the coupon below for full details.

CHARACTERISTICS

Model 758 (4-Digit Display)

RANGES: .0001K to .9999K 100.0K to 999.9K
1.000K to 9.999K 1000K to 9999K
10.00K to 99.99K

ACCURACY: $\pm 0.1\%$ of value read or 1 digit, whichever quantity is greater.

Model 759 (5-Digit Display)

RANGES: ACCURACY: *

0.0001K to 9.9999K $\pm (0.01\% + 1 \text{ digit})$
10.000K to 99.999K $\pm (0.01\% + 1 \text{ digit})$
100.00K to 999.99K $\pm (0.03\% + 1 \text{ digit})$
1000.0K to 9999.9K $\pm (0.05\% + 1 \text{ digit})$ to 5 meg.
 $\pm (0.1\% + 1 \text{ digit})$ to 10 meg.

*Percentages are expressed as % of value measured

BOTH MODELS

RANGE SELECTION & DECIMAL LOCATION: *Automatic*
SIZES: *Rack Mount*—5 1/4" H, 19" W, 15 1/4" D.
Bench Top (Portable)—11" H, 8 1/4" W, 15 1/4" D.
WEIGHT: 33 lbs

PRIMARY POWER: 115 \pm 10v, 60 cycles, 75 watts.

ACCESSORIES: *Data printing provision with automatic print control and Clary Printer or Electric Typewriter.*

*Connection and automatic control for card or paper tape punching equipment.
Multi-channel input scanners.*



non-linear systems, inc.
Del Mar, Calif. • Phone: SKyline 5-1134

ORIGINATORS OF THE
DIGITAL VOLTMETER

Digital Ohmmeters • AC-DC Converters • Data
Reduction Systems • Digital Readouts • Peak
Reader Systems • Binary Decimal Converters
Digital Recording Systems

NON-LINEAR SYSTEMS, INC.
Dept. B-157, Del Mar Airport, Del Mar, Calif.

Send new *Technical Bulletin 1256* with full information on *NLS Digital Ohmmeters—Models 758 and 759.*

NAME _____
COMPANY _____
ADDRESS _____
CITY _____ STATE _____

DECADE RESISTANCES & VOLTAGE DIVIDERS

delivered from stock

Accuracy: 10 ohms and above: $\pm 0.1\%$
 1 ohm: $\pm 0.25\%$
 0.1 ohm: $\pm 1\%$
 0.01 ohm: $\pm 5\%$

Temp. Coeff.: $\pm 0.002\%$ per degree C.
 Maximum Load: $\frac{1}{2}$ -watt per step
 Frequency Limit: Non-inductive to 20KC

DECADE RESISTANCE BOXES

Type	Dials	Ohm Steps	Total Resistance—Ohms	Price
817	3	0.01	11.1	\$60.00
818	3	0.1	111	51.00
820	3	1	1,110	56.00
821	3	10	11,100	60.00
822	3	100	111,000	63.00
823	3	1,000	1,110,000	77.00
824	3	10,000	11,100,000	120.00
817-A	4	0.01	111.1	75.00
819	4	0.1	1,111	71.00
825	4	1	11,110	77.00
826	4	10	111,100	79.00
827	4	100	1,111,000	92.00
828	4	1,000	11,110,000	139.00
8285	5	0.1	11,111	94.00
829	5	1	111,110	101.00
830	5	10	1,111,100	113.00
831	5	100	11,111,000	155.00
817-C	6	0.01	11,111.1	105.00
8315	6	0.1	111,111	109.00
832	6	1	1,111,110	121.00
833	6	10	11,111,100	169.00



UNMOUNTED DECADE RESISTANCES

Type	Dials	Ohm Steps	Total Resistance—Ohms	Price
435	1	0.1	1	\$12.00
436	1	1	10	13.25
437	1	10	100	13.25
438	1	100	1,000	15.00
439	1	1,000	10,000	16.00
440	1	10,000	100,000	18.50
441	1	100,000	1,000,000	32.50
442	1	1,000,000	10,000,000	60.00



DECADE VOLTAGE DIVIDERS (Potentiometers)

Type	Dials	Ohm Steps	Total Resistance—Ohms	Price
845	3	1	1,000	98.00
837	4	0.1	1,000	126.00
835	4	1	10,000	132.00
836	4	10	100,000	146.00

SHALLCROSS MANUFACTURING COMPANY

522 Pusey Ave., Collingdale, Pa.

Shallcross

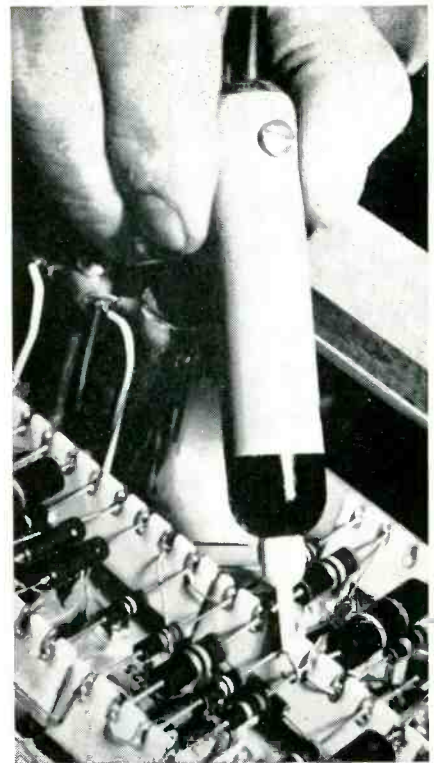

Method of using hook at end of probe tip

probe tip and copper disk in place, the assembly is placed in a special hand-held jig developed by Tektronix and the insert is wound into the plastic body. It is now ready to receive the 10-32 threads of the probe. Inserts are installed at the rate of about 120 per hour.

Handling Rack for Magnetic Cores

ORDINARY drinking straws facilitate handling of small wound tape magnetic cores during manufacture and testing in the Butler, Pa., plant of Magnetics, Inc. A drilled block of wood holds straws vertically while

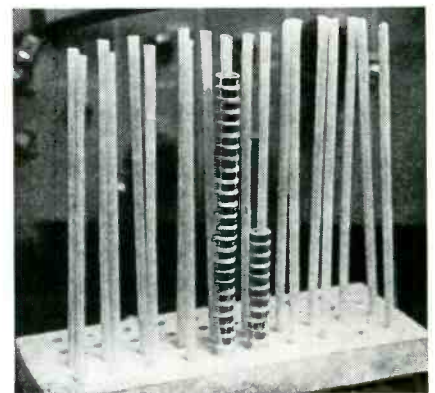

Drinking straw rack for handling small wound tape magnetic cores

population -



Even in the most remote areas, wings aloft are guided on their way by AeroCom's new medium range Aerophare Transmitter. This transmitter was designed and built to provide long, trouble-free service with no attendants...even where the total population is Zero.

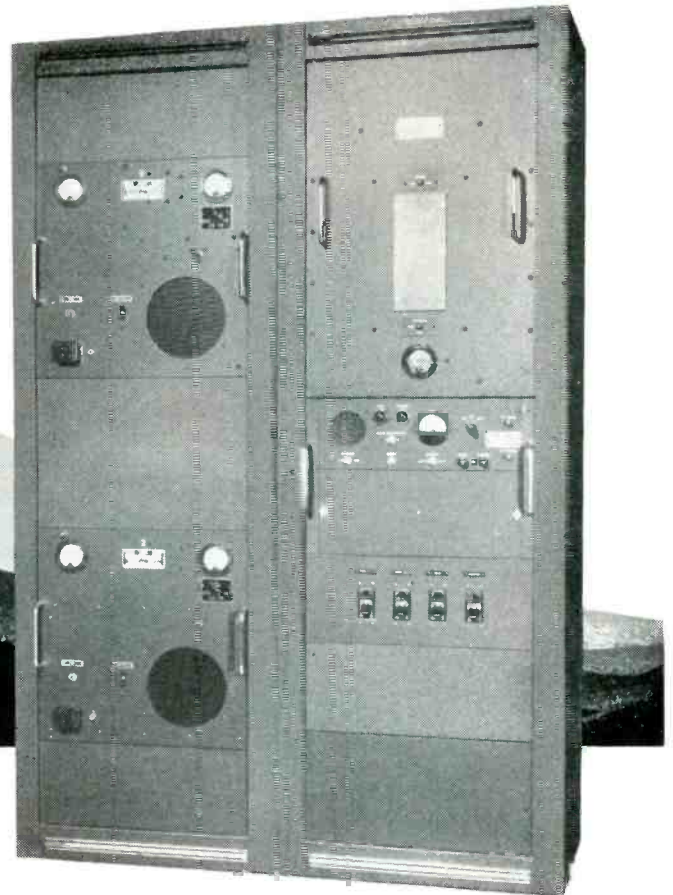
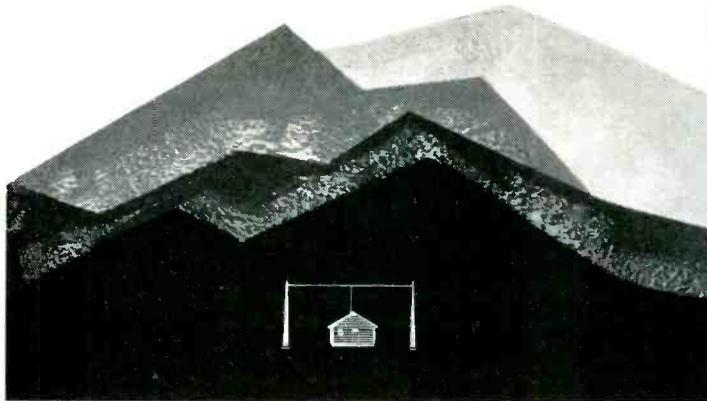

AEROCOM'S **Dual Automatic** **Package-Type Radio Beacon**

for completely unattended service. This aerophare (illustrated) consists of two 100 watt (or 50 watt) transmitters with keyer, automatic transfer and antenna tuner. (Power needed 110 or 220 volts 50/60 cycles, 520 V. A. for 50 watt, 630 V. A. for 100 watt.)

Frequency range 200-415 kcs.: available with either crystal or self excited oscillator coil. High level plate modulation of final amplifier is used, giving 40% tone modulation in 100 watt transmitter and 60% in 50 watt model. Microphone P-T switch interrupts tone, permitting voice operation.

The "stand-by" transmitter is selected when main transmitter suffers loss (or low level) of carrier power or modulation. Audible indication in monitoring receiver tells which transmitter is in operation.

Unit is ruggedly constructed and conservatively rated, providing low operating and maintenance costs.

Also available in 1 K.W. and 4 K.W. Models

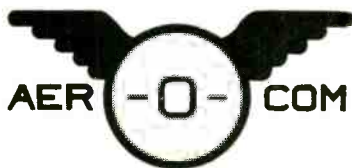

3090 S. W. 37th AVENUE • MIAMI 33, FLORIDA

A-134

There's a dependable

Bendix* **AN** **SCINFLEX CONNECTOR**

for every electrical circuit



These electrical connectors are designed and built to provide maximum performance under the most rugged operating conditions.

Well recognized for outstanding characteristics of resistance to moisture and vibration, these connectors are provided in a variety of AN types.

Our Sales Department will be glad to furnish complete information on request.

*Trademark

Bendix **SCINTILLA DIVISION OF** **Bendix**
SIDNEY, NEW YORK AVIATION CORPORATION

Export Sales and Service: Bendix International Division,
205 East 42nd St., New York 17, N.Y.

Canadian Representatives: Aviation Electric Ltd.,
200 Laurentien Blvd., St. Laurent, Montreal 9, Quebec

FACTORY BRANCH OFFICES:

117 E. Providencia Avenue, Burbank, California • 512 West Avenue, Jenkintown, Pennsylvania • Stephenson Building, 6560 Cass Avenue, Detroit 2, Michigan • 5906 North Port Washington Road, Milwaukee 17, Wisconsin • American Building, 4 S. Main Street, Dayton 2, Ohio • 8401 Cedar Springs Road, Dallas 19, Texas • Boeing Field, Seattle 8, Washington • 1701 "K" Street, N. W., Washington 6, D. C.

cores are dropped over the end. During testing, untested cores are removed from one straw, tested and then placed on another straw according to the core's characteristics. The shipping department packs the straws with the cores to provide easy handling during wrapping.

Coil Winder for Miniature Toroids

By J. R. GOODYKOONTZ

*Miniaturization Section
Hughes Aircraft Co.
Culver City, Calif.*

TEDIOUS HAND WINDING of miniature toroidal coils is eliminated completely by an automatic coil-winding machine produced by the Weapons System Development Laboratories of Hughes Aircraft Co.

An ordinary needle, threaded with a length of magnet wire, is



Coil-winding machine for miniature toroidal cores uses sewing action. Rotating magnet moves needle in circular path

passed through the toroidal core in a simple sewing action. A motor-driven permanent magnet moves the needle in a circular path, as shown in Fig. 1. Each time the magnetically controlled needle passes through the toroid, a turn of wire is placed directly around the surface of the core. As the toroid is wound, it rotates so that the turns of wire are evenly distributed. The size of the toroid to be wound in this manner is limited essentially by the size of the needle that can pass through its center.

► **Older Methods**—Prior to this development, the only winding machine available to the industry was

FOR THE THIRD CONSECUTIVE YEAR

ENGINEERS RATE LAMBDA FIRST

in all
Power Supply
Surveys

Every independent study of power supply preferences has shown an overwhelming vote for Lambda. In the most recent survey, made by a leading electronics publication, engineers who specify power supplies choose Lambda by more than 2½ times over the next identified manufacturer. This is the greatest margin of preference yet. Here is additional proof that the more opportunities users of power supplies have to try Lambda equipment for themselves, the more they recognize the superiority of these outstanding units.

We suggest that you inspect Lambda power supplies in use in your own area. We will be happy to provide names of nearby users. Ask the candid opinion of the men who work with this precision-engineered equipment daily.

L A M B D A

MANUFACTURER "B"

MANUFACTURER "C"

MANUFACTURER "D"

MANUFACTURER "E"



QUALITY CONTROL assures you of long, dependable service from these assembly-line-produced power supplies



HERMETIC SEALING PROCESS provides for complete quality control. Lambda makes all its own transformers.

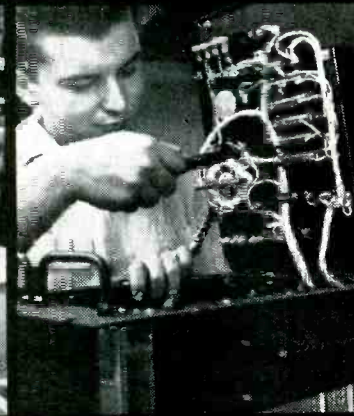

MECHANICAL INSPECTION at every relevant point means trouble-free operation for you.

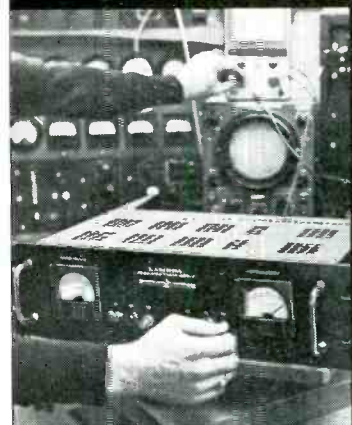

ELECTRONIC INSPECTION is designed to provide consistent quality and eliminate in-service down-time.

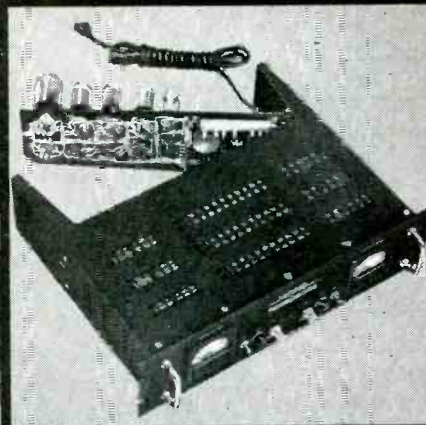

TYPICAL NEW LAMBDA "COM-FAE" MODEL (200-400-800 MA units) occupies a minimum amount of space, delivers maximum performance, is easy to service and maintain.



LAMBDA ELECTRONICS CORP.

The first name in power supplies

11-11 131 STREET • COLLEGE POINT 56, NEW YORK



SEND FOR NEW CATALOG 57

Just off the presses. Illustrations and specifications for the complete line of Lambda Regulated D.C. Power Supplies.

NEW

**AMPLI-VISION-TELCON
HELICAL MEMBRANE CABLES**

FOR EVERY HIGH FREQUENCY APPLICATION



Combining low attenuation with minimum VSWR, Ampli-Vision Telcon Helical Membrane Cables have perfect characteristics for RF use . . . uniform frequency response . . . low temperature coefficient for all electrical characteristics . . . low noise level . . . high signal handling capacity . . . utmost flexibility permitting ease of installation . . . perfectly matched fittings and terminations . . . ALL THIS AT LOW COMPETITIVE PRICES.

Ampli-Vision-Telcon HM series cables consist of an inner copper conductor separated from an aluminum outer sheath by a helical polyethylene membrane. This cable is furnished either with a bare aluminum sheath or a vinyl protective sheath extruded over the aluminum.

CHARACTERISTICS OF AMPLI-VISION-TELCON HM CABLES							
Cable Code	AV6	AV4	AV7	AV8	AV9	AV11	AV10
Characteristic Impedance (Ohms)	75	75	75	50	50	50	50
Nominal Diameter	½"	¾"	1½"	½"	¾"	1½"	3⅛"
Attenuation (db/100 ft.)							
1 Mc/s	0.073	0.048	0.024	0.083	0.054	0.026	0.0115
1000 Mc/s	0.7	1.8	1.05	2.9	2.0	1.15	0.67
Power Rating (Kw)							
1 Mc/s	12	21	59	13	24	66	230
1000 Mc/s	0.33	0.57	1.35	0.37	0.66	1.5	4.3
Max. R.F. Voltage Kv.	1.3	2.2	4.5	1.3	3.0	5.5	12
Weight Lbs./1000 ft.:	96	233	575	150	240	630	2360

A complete line of other types of coaxial cables is also available from Ampli-Vision. For complete information write to Dept. K.

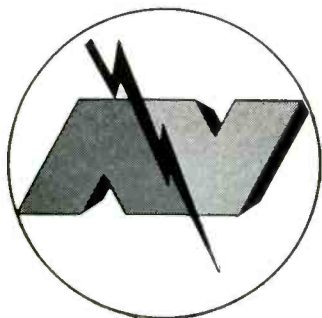

ampli-vision

Products of

International Telemeter Corporation

2000 Stoner Avenue, Los Angeles 25, California

a subsidiary of

Paramount Pictures Corporation

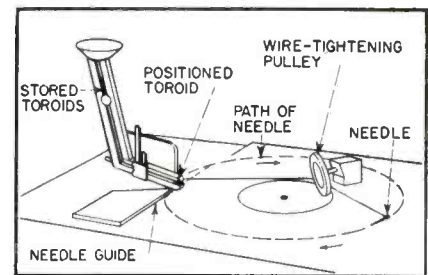

FIG. 1—Magnetically controlled needle follows circular path and passes through toroid once per revolution

the conventional split-bobbin type. While this is satisfactory for many applications, the minimum inside diameter of the finished coil is limited by the dimensions of the bobbin that must pass through the toroid during winding. Thus, it is difficult if not impossible for the conventional machine to wind wire on cores which may have initial inside diameters of 1/16 inch or less. These small cores heretofore had to be wound by hand—a method which was tedious, slow and often prohibitively expensive.

► **New Machine**—Besides the basic device of the magnetically controlled needle, the winding machine employs auxiliary mechanisms for accurately guiding the needle during its entry into the toroid, dispensing and holding the toroids, tightening the turns and preventing wire kinking.

► **Needle Control**—The winding machine has a smooth horizontal working surface made of a non-magnetic material. The rotating permanent magnet is situated just beneath the working surface. The threaded steel needle is placed on the working surface so that it lies in the field of the magnet. As the magnet rotates, the needle follows it, describing a circular path.

Since the radial position of the magnet might change slightly with use or the position of the needle might change with respect to the magnet, it is desirable to guide the needle in a positive manner just preceding its entry into the toroid. A flat metal nonmagnetic needle guide piece is installed immediately in front of the toroid. The guide deflects the needle and causes it to

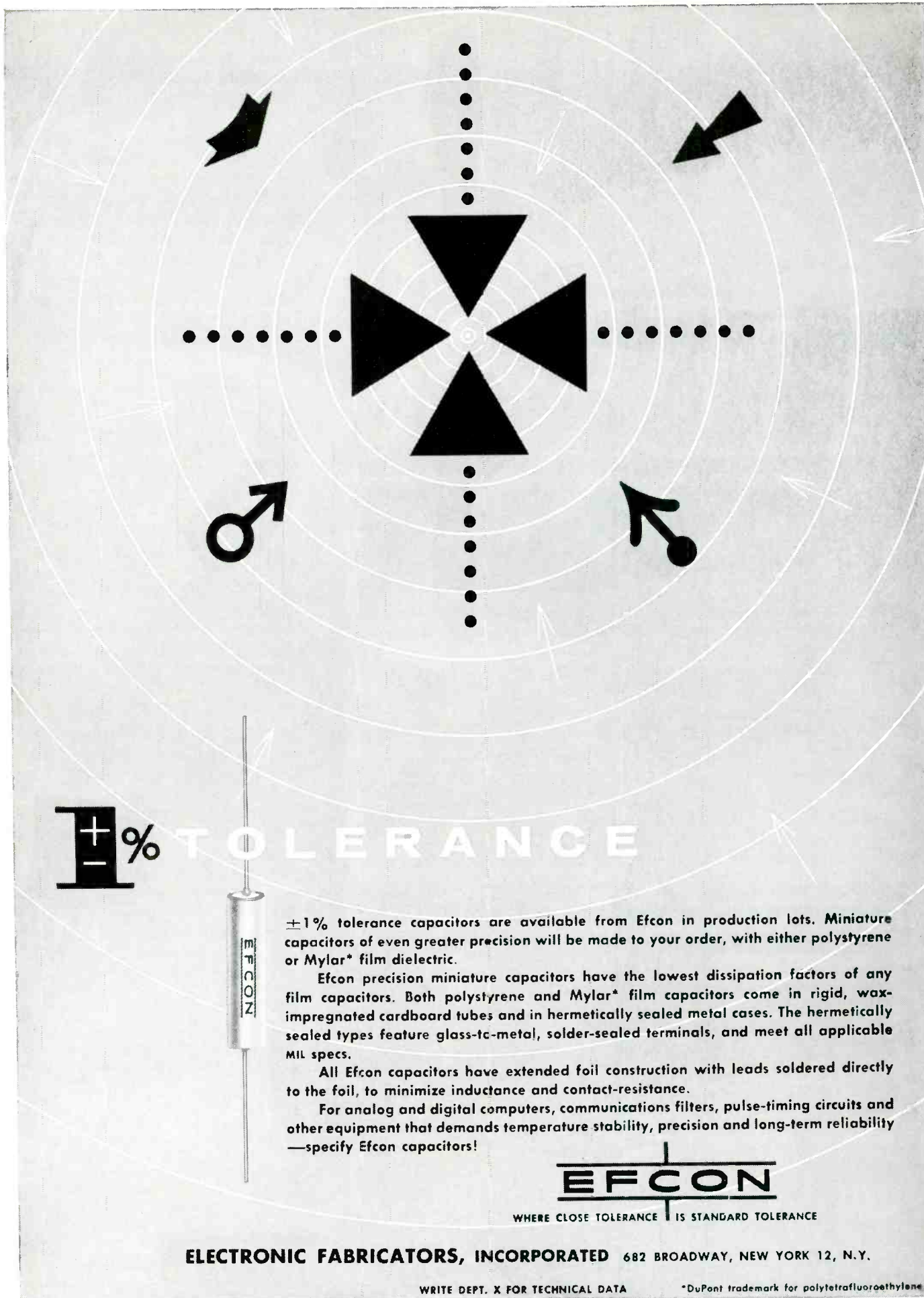

±1%

TOLERANCE



±1% tolerance capacitors are available from Efcron in production lots. Miniature capacitors of even greater precision will be made to your order, with either polystyrene or Mylar* film dielectric.

Efcron precision miniature capacitors have the lowest dissipation factors of any film capacitors. Both polystyrene and Mylar* film capacitors come in rigid, wax-impregnated cardboard tubes and in hermetically sealed metal cases. The hermetically sealed types feature glass-to-metal, solder-sealed terminals, and meet all applicable MIL specs.

All Efcron capacitors have extended foil construction with leads soldered directly to the foil, to minimize inductance and contact-resistance.

For analog and digital computers, communications filters, pulse-timing circuits and other equipment that demands temperature stability, precision and long-term reliability—specify Efcron capacitors!

EFCON

WHERE CLOSE TOLERANCE IS STANDARD TOLERANCE

ELECTRONIC FABRICATORS, INCORPORATED 682 BROADWAY, NEW YORK 12, N.Y.

WRITE DEPT. X FOR TECHNICAL DATA

*DuPont trademark for polytetrafluoroethylene

BOURNS

announces new **TRIMPOTS**[®] for quick assembly

130 **TRIMPOT**[®] solder-lug type



You can solder your hook-up wire direct to this instrument, and eliminate splicing. Terminals are standard flat, slotted lugs to provide fast, secure connections.

The silver-plated solder lugs are extremely rugged. Instrument is not affected by soldering iron temperatures.

205 **TRIMPOT**[®] for printed circuits



Round pin terminals on this unit may be plugged into holes in your printed circuit boards for dip soldering. Terminals are gold-plated copper, $\frac{1}{2}$ " long, .028" diameter, and spaced in multiples of 0.1". Mounting is accomplished by 2-56 screws through body eyelets, or by pins only.

BOTH UNITS PROVIDE a usable potentiometer range of 98%, and low residual resistance either end, 0 to 1%. Low temperature coefficient wire is utilized in the precision wirewound resistance elements.

In all other design features, these instruments are similar to the original Model 120 TRIMPOT. Each is subminiature in size ($1\frac{1}{4}$ " x $\frac{5}{8}$ " x $\frac{1}{4}$ "), and weighs only 0.1 oz. Other characteristics include 25-turn screwdriver adjustment, self-locking shaft, and excellent performance under extreme shock, vibration and acceleration. Units meet or exceed most government specifications. Delivery from stock on standard resistances. Send for Bulletins 130 and 205.



BOURNS LABORATORIES, INC.

General Offices: 6135 Magnolia Ave., Riverside, Calif.
Plants: Riverside, California—Ames, Iowa

COPR. BL

TRIMPOTS • LINEAR MOTION POTENTIOMETERS • PRESSURE TRANSDUCERS AND ACCELEROMETERS

travel in a straight line immediately prior to and during its entry into the toroid, as indicated in Fig. 2.

Thus, if the toroid is positioned with respect to the guide, no great attention need be paid to the path which the needle would take without the guide. Tolerance requirements on the magnet driving and positioning mechanism and the field configuration of the magnet are thereby reduced, with the result that the machine is easier to build and less likely to get out of alignment during operation.

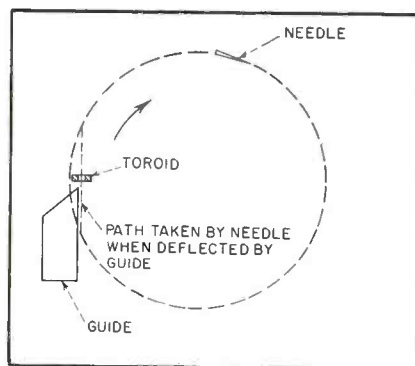

FIG. 2—Guidepiece causes needle to travel in straight path preceding entry into toroid

► **Toroid Feed**—A device capable of dispensing a torodial core, holding it in the proper position with respect to the path of the needle, and rotating it during winding so the turns of wire are evenly distributed is shown in Fig. 3. Here the toroids are stored in a groove formed by the two vertical members. By rotating the dispensing wheel, a single toroid is caused to drop down the groove. The toroid is advanced to the winding position by

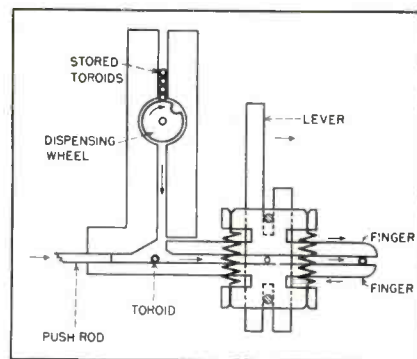
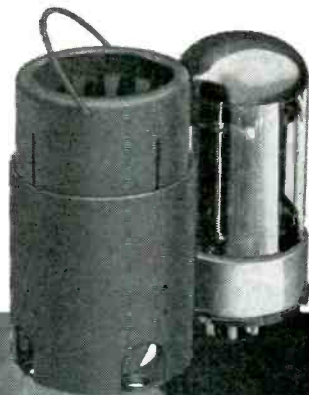

FIG. 3—Device for automatically dispensing, holding and rotating toroid eliminates prohibitively expensive hand operations

-the heat's off!



This Electronic Reliability Engineer just discovered the IERC way to insure his chances of meeting equipment reliability specifications and military acceptance schedules.

Tubes failures (too often and too soon) caused by heat and vibration, the major causes of electron tube failures, were his problem.

With IERC Heat-dissipating Tube Shields, the "heat was off" both the suffering tubes and our man with the problem! Tube operating temperatures were lowered as much as 150°C and tubes are lasting 5 times longer. Schedules were met—time and money saved—highest tube reliability achieved!

Suspect and investigate the heat and vibration menace when tube failures plague you. Eliminate it with IERC Heat-dissipating Tube Shields—available in sizes for Miniature, Subminiature, Octal and Power types of electron tubes.

PATENTED OR PATS. PEND. IERC T-12 SHIELD AND BASE WITH 6080 TUBE ILLUSTRATED. CROSS-LICENSED WITH NORTH AMERICAN AVIATION, INC.

IERC literature and latest Octal and Power tube shield Technical Bulletin available now—FREE!

International



electronic research corporation

145 West Magnolia Boulevard, Burbank, Calif.



PINPOINTED

By... **BIG D** COMPONENTS

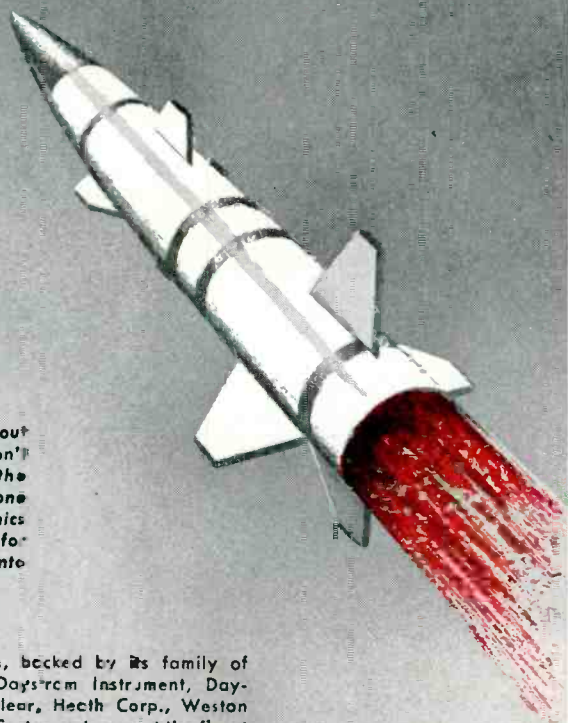
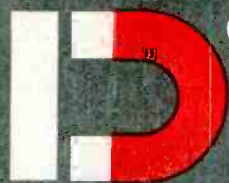

You may know your abc's about control components—but, don't stop there—learn about the "BIG D"—D for Daystrom, one of the big names in electronics and control components—D for dependability that is built into each Daystrom product.

Daystrom Pacific Corporation, backed by its family of Daystrom operating units (Daystrom Instrument, Daystrom Electric, Daystrom Nuclear, Heath Corp., Weston Electrical Inst. Co., Daystrom Systems) turns out the finest Gyros, Accelerometers, Intervalometers, Potentiometers and allied components—components whose accuracy and dependability help "pin point" the target for many of today's and the future's guided missiles.

Interesting, well-paid positions with an exceptional future are available to qualified engineers.

GYEOS, POTENTIOMETERS, ACCELEROMETERS, INTERVALOMETERS AND ALLIED COMPONENTS

Write now... for free facilities brochure
and product catalogue sheet



DAYSTROM PACIFIC CORPORATION

A subsidiary of Daystrom, Inc.

3030 NEBRASKA AVENUE
SANTA MONICA, CALIFORNIA

D for DAYSTROM — DEPENDABILITY

a push rod. When a toroid is in working position, it is held tightly between two spring fingers.

A pivoted lever engages the two fingers at two pins. When the lever is moved to the right (clockwise), the top finger moves to the right and the bottom finger moves to the left by an equal amount. This motion of the fingers causes the positioned toroid to rotate. Since the motions of the two fingers are always equal and opposite, the toroid does not change position; it rotates only.

By positioning the entire device properly with respect to the fixed needle path and by calibrating the push rod so the working position is uniformly chosen each time a toroid is inserted, it is possible to place a toroid in the path of the needle with accuracy and rotate it during winding without disturbing its alignment. To eject a toroid from the device, the rod is advanced to the right until the toroid is released from the ends of the fingers.

► **Continuous Threading** — After the first turn of wire is placed on the toroid, no additional wire need be supplied to the needle. The total length of wire in motion on the machine after the first turn is wrapped is equal to the diameter of the circle traversed by the needle. As each successive turn is applied, the length of wire in motion becomes less, with the result that the orbit of the needle is shortened on the side opposite the toroid position.

This decreasing of wire length is not detrimental to the winding operation since the needle will follow the magnet even though it is restrained by the wire to move in a

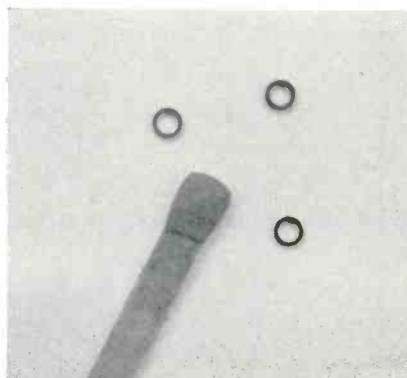

Examples of machine-wound toroids

*The 20th Century's most challenging
opportunity for the creative engineer...*

Automatic Control Systems

for tomorrow's needs and hypersonic speeds

Ten years ago—when AUTONETICS began its work—miles-per-hour thinking had to be abandoned. The task of developing guidance and control systems for the Air Force SM-64 NAVAHO Intercontinental Missile demanded engineers who could design, manufacture, test and *produce in quantity* automatic controls that would operate in environments and at speeds never before experienced.

Today—because of its proved ability to convert ideas into engineering fact—AUTONETICS is one of the few organizations in the world with a unique stockpile of experience in information processing, inertial navigation, flight controls, armament control systems, computers and other automatic control systems.

MINDPOWER AND FACILITIES

The projects we are pursuing at AUTONETICS call for extremes in mindpower and environmental facilities.

We have the facilities... among them a new Autonavigation building where each cubic inch of air contains fewer than 6 dust particles... where temperature variation is held to plus or minus 1°.

And we have a Flight Test Section second to none.

The mindpower—frankly, we'd like to find more of it.

IF YOU'RE THE MAN WE'RE LOOKING FOR...

you have knowledge, enthusiasm and imagination—tempered with judgment. You're both research and production-minded—a dreamer and a doer at the same time. At every level of experience, you'll have an opportunity to conceive and activate an idea. Then prove it—a better way!

And you'll do it in a management climate that stimulates personal growth—and rewards it with the responsibility, professional recognition and material benefits limited only by your own ability. Your own academic stature can be constantly enlarged by our Educational Refund Plan... and some of the nation's finest universities are nearby.

Write today for full particulars. If you're the man we're seeking we'll be glad to arrange a personal interview where you are now residing.

Write: Mr. A. Brunetti, Autonetics Engineering Personnel, Dept. 911, 1-E, Box AN, Bellflower, California.

ADVANCEMENT IS RAPID WHERE GROWTH IS RAPID



Chief Engineer Robert Ashby, 44, is one of our nation's top electronics scientists. He holds AB and MA degrees in Physics from Brigham Young, a Ph.D. in Physics from the University of Wisconsin. His hobbies are Southern California year-round "naturals"—golf and swimming.



Lester Kilpatrick received his BSEE from Texas Tech in 1946, his MSEE from M.I.T. two years later. During 8 years at North American, he has earned a national reputation as an authority on digital computers. With his wife and 4 year old son, he likes to spend week ends "at the beach."



Navy vet E. A. O'Hern joined Autonetics in 1951 after earning his BS, MS and Ph.D. from Purdue University. A Research Supervisor, he has developed advanced techniques for analysis of autopilot-controlled flexible airborne vehicles. His hobbies include baseball, basketball and music.

Autonetics

A Division of North American Aviation, Inc.



AUTOMATIC CONTROLS MAN HAS NEVER BUILT BEFORE

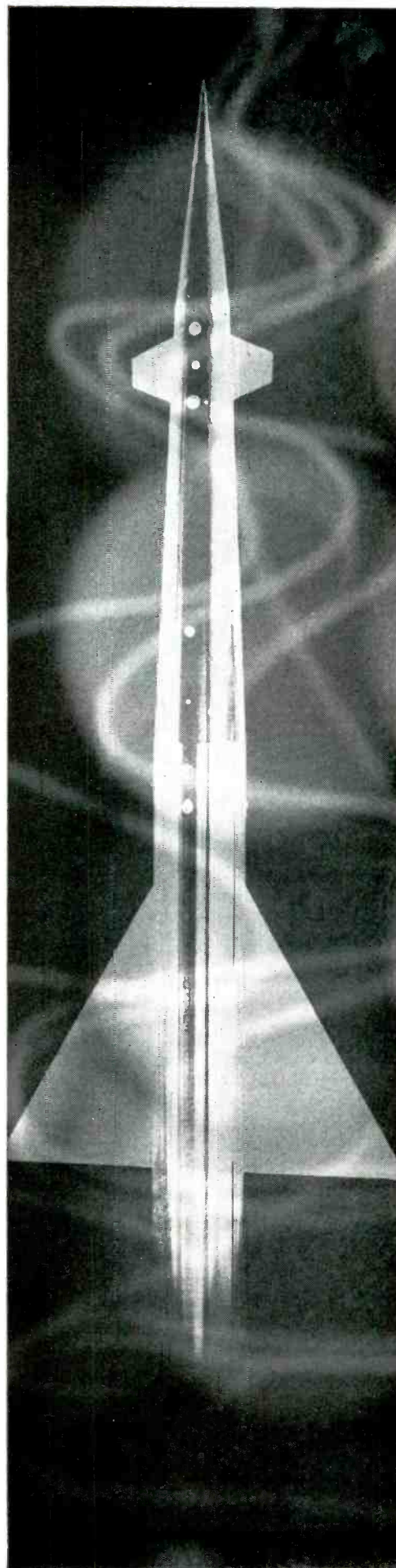

New Bi-Directional Power Monitor



25 to 1,000 mc

10 to 500 watts

Only 2 plug-in elements

MODEL 164

Quickly measures incident or reflected power, simplifies matching loads to lines

New Sierra Model 164 is a compact, versatile, bi-directional monitor for intermittent or continuous measuring of incident or reflected power, or convenient and precise matching of loads to lines. The instrument offers unequalled measuring ease and economy, since only two plug-in elements are required for coverage of all frequencies 25 to 1,000 mc and wattages 10 to 500 watts. Two plug-in elements cover, respectively, 25 to 250 mc and 200 to 1,000 mc. Both have 4 power ranges: 10, 50, 100 and 500 watts. Accuracy is $\pm 5\%$ full scale. No auxiliary power is required to operate the instrument.

Because of its compact size and wide range, Model 164 is ideal for portable applications (mobile, aircraft, etc.) as well as laboratory use. It is supplied in a sturdy carrying case (one or both plug-in elements supplied as ordered) and both meter and directional coupler may be removed from the case for remote monitoring. The monitor may be equipped for most connectors normally employed with 50 ohm lines. A twist of the wrist selects incident or reflected power, or any power range, without requiring removal of power. No exchange of plug-in elements is necessary to read low levels of reflected power.

TENTATIVE SPECIFICATIONS

Power Ranges: 10, 50, 100 and 500 watts full scale direct reading.

Accuracy: $\pm 5\%$ of full scale.

Insertion VSWR: Less than 1.08.

Impedance: 50 ohm coaxial line.

Frequency Ranges: 25 to 1,000 mc. Two plug-in elements.

Low Frequency Element: 25 to 250 mc.

High Frequency Element: 200 to 1,000 mc.

Data subject to change without notice.

sierra



Sierra Electronic Corporation

San Carlos 2, California, U. S. A.

Canada: Atlas Radio Corporation, Ltd.

Toronto, Ontario

Manufacturers of Carrier Frequency Voltmeters, Directional Couplers, Wave Analyzers, Line Fault Analyzers, Wideband RF Transformers, Custom Radio Transmitters, VHF-UHF Detectors, Variable Impedance Wattmeters, Reflection Coefficient Meters, Calorimeters, Water Loads, Thermopiles, Ion Gauge and Ion Gauge Amplifiers, Phase Changers.

3317

Sales representatives in major cities

shorter path each revolution. Of course, this process cannot continue indefinitely. A point will eventually be reached where the magnet will lose the needle and the needle will stop. With the machine in its present state, as many as 20 turns have been wound before losing magnetic control of the needle. As many as nine windings of 15 turns each have been put on a single core.

The restricted number of turns per winding does constitute a limitation, though not a serious one because this is a greater number than is required for most applications. The number could be increased by increasing the strength of the magnet, by increasing the permeability of the needle, or by moving the magnet along a continuously adjustable track.

► **Turn Tightening**—The only force available for pulling the turns tight about the core is the force exerted on the needle by the magnet. While this magnetic force is sufficient to move the needle and the wire, it is not enough to pull the individual turns to the degree of tightness desired.

Turn tightening is achieved by the mechanism shown in Fig. 4. Here, a small turntable is mounted in the center and flush with the working surface of the winding machine. This turntable is driven clockwise by connecting it directly to the shaft of the motor which turns the magnet. A rubber-rimmed wheel is positioned so that it engages the turntable. When the turntable rotates, it causes the wheel to rotate since the latter is free to turn on its shaft. The wheel is canted so that its outer edge is lifted above the turntable surface, facilitating the passage of the wire under the wheel.

When the needle and the wire are in the position indicated, the wire is in a relatively taut condition. At this point the wire passes between the turntable and the wheel. During the time the wire is engaged between the turntable and the wheel, it is moved slightly to the right. This slight tug pulls the wire tight about the core. By changing the position of the wheel with respect to the turntable, the amount of tug



For your Magnetic Shielding Problems . . .

MUMETAL is the answer!



Write for your copy
"MAGNETIC MATERIALS"

This 32-page book contains valuable data on all Allegheny Ludlum magnetic materials, silicon steels and special electrical alloys. Illustrated in full color, includes essential information on properties, characteristics, applications, etc. Your copy gladly sent free on request.

ADDRESS DEPT. E-85

Mumetal shields will give instant relief to interference caused by extraneous magnetic fields. This material can cure many troubles—solve many a problem for you.

Use it where high permeability is required at low flux densities, such as in input and microphone transformers, hearing aid diaphragms, instruments, wire and tape recorders, etc. For properly heat treating Mumetal, we can also offer commercial hydrogen annealing facilities.

A fund of technical data on shields

and other applications for Allegheny Ludlum Mumetal is available—let us help with your problems.

In addition to Mumetal and other high-permeability alloys, we offer a range of magnetic and electrical alloys and steels that is unmatched in its completeness. Our services also include the most modern facilities for lamination fabrication and heat treatment. • Let us supply your requirements. *Allegheny Ludlum Steel Corporation, Oliver Building, Pittsburgh 22, Pa.*

STEELMAKERS to the Electrical Industry

Allegheny Ludlum

Warehouse stocks of AL Stainless Steels carried by all Ryerson plants



WSW 6094

can be adjusted through a considerable range.

► **Antikinking**—During the development of the machine, the wire frequently became kinked during the winding operation because for half of each cycle the wire was in a slack condition and essentially uncontrolled. The kinking difficulty was overcome by placing a plate of nonmagnetic material parallel to and 1/16 inch above the working surface. This left room for the

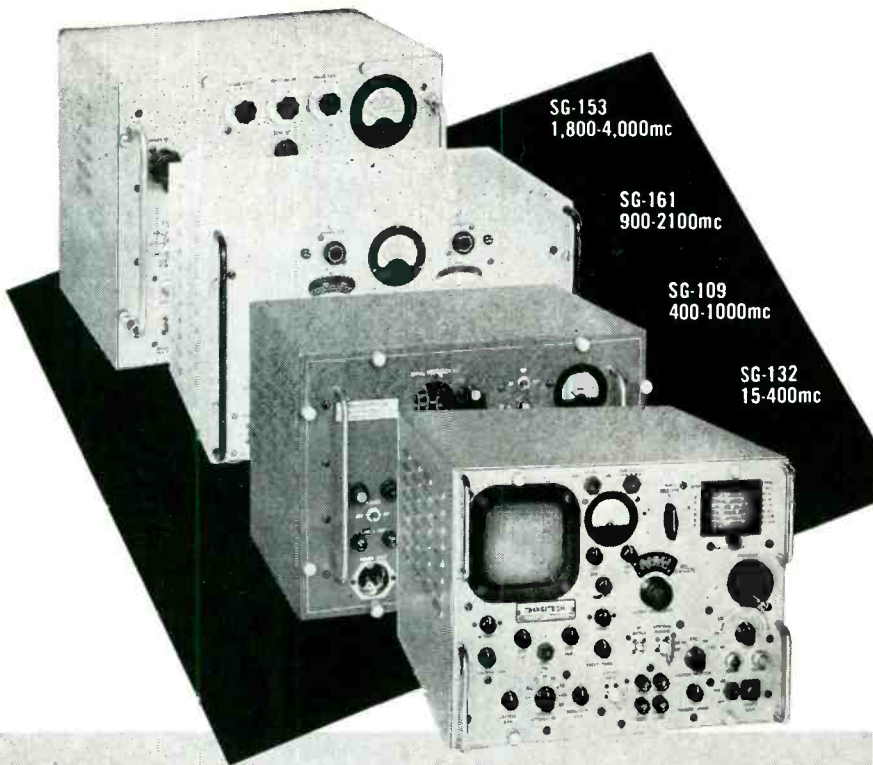

SG-153
1,800-4,000mc

SG-161
900-2100mc

SG-109
400-1000mc

SG-132
15-400mc

ADVANCED ENGINEERING IN PRECISION R.F.

SIGNAL and SWEEP GENERATORS



TRANSITRON, INC.

186 GRANITE ST., MANCHESTER, N.H.
Subsidiary of Van Norman Industries

Transitron offers a complete line of precision VHF, UHF and SHF Signal and Sweep Generators for laboratory and production use. The exceptional accuracy of these generators allows precise measurements for standing wave ratio, receiver sensitivity, noise figure, image rejection, antenna characteristics and many others.

The latest Transitron development, the SG-132 Precision Sweep Generator, is unmatched in versatility by any other on the market. It offers extremely wide sweep width — 40% of the center frequency, from 15 to 400 mc — with an accuracy of $\pm 0.5\%$. There is an almost complete absence of frequency drift, plus extreme flatness of output over the entire sweep band. A built-in crystal calibrator provides frequency checks within 0.01% throughout the frequency coverage.

SIGNAL GENERATORS

- Mod. SG-109.....400-1000mc
- Mod. SG-161.....900-2100mc
- Mod. SG-153....1800-4000mc
- Frequency Accuracy $\pm 1\%$
- Power Output ...1mw(0dbm)
- Attenuation120db(± 2)
- Output Imped.50 ohms
- Provisions for internal pulse modulation, external modulation and synchronization

SWEEP GENERATORS

- Mod. SG-132 15-400mc
- Frequency Accuracy $\pm 0.5\%$ (with internal markers $\pm 0.01\%$)
- CW, AM and FM Output
- FM Deviation $\pm 1\%$ to $\pm 20\%$ at any frequency setting
- Constant output under all conditions $\pm 0.25\text{db}$
- Power Output 0.1 to 150,000 microvolts
- Output Imped.50 ohms
- Built in Oscilloscope with DC coupled amplifiers

POSITIONS AVAILABLE FOR QUALIFIED ENGINEERS

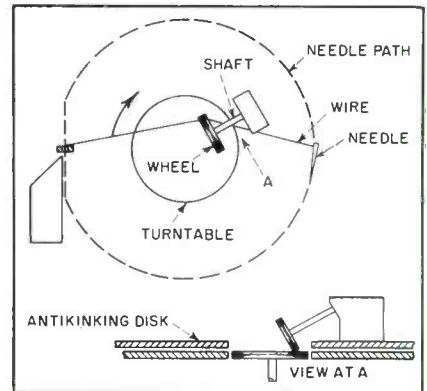

FIG. 4—Threading mechanism, showing wheel-engaging turntable

needle and wire to move freely within the 1/16-inch space, but constrained the wire to lie essentially in a plane at all times. This arrangement can be seen in Fig. 4.

► **Improved Production**—It is not necessary to thread the needle each time a new winding is applied. The operator is continuously supplied with needles which have been threaded at a preceding station; thus, a new needle is used for each winding.

With such a production scheme, a fairly rapid production rate should be possible even with the machine in its present form. To improve production, certain modifications are possible. A counter, clutch and brake mechanism could be added which would automatically stop the machine when the required number of turns have been wound. Winding speed could be increased. The toroid-dispensing mechanism could be further mechanized so that a toroid is put into position by pressing a button. The toroid-rotating mechanism could be made automatic by driving

Wanted!

Engineers who will accept the challenge of the most urgent program in the free world today...

Long Range Guided Missiles

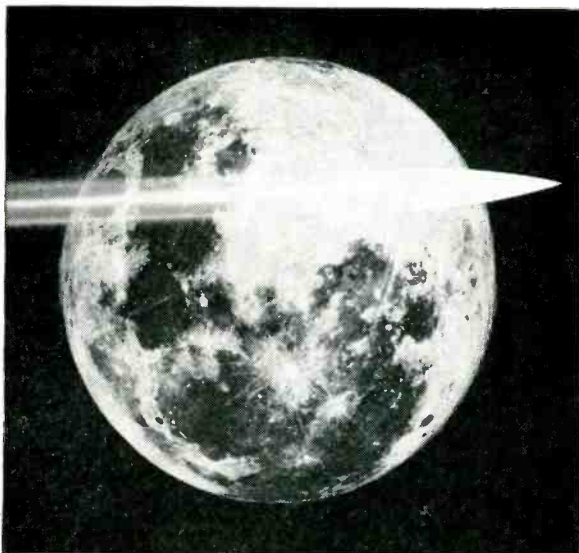

Ten years ago there was only a handful of men in the country who said it could be done. Today, more and more engineers—their technological noses scenting the fact that engineering history is in the making—are picking up the gauntlet of the greatest engineering challenge American ingenuity has ever faced—the race against time and the phenomena of long range guided missiles.

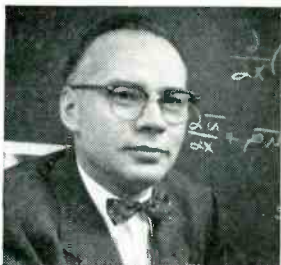

Dr. E. R. van DRIEST, Chief Scientist, is nationally recognized for his work in aerothermodynamics. He has a BS, Case Institute of Technology; MS, University of Iowa; Ph.D., Cal Tech; and Sc.D, Technisch Hochschule, Zurich, Switzerland. Around his home, in Whittier, he finds ideal opportunities for the pursuits he and his family like best—horseback-riding, archery and other outdoor activities—perfect complement to the absorbing mysteries of his work.

Research and development that would ordinarily take years is today—of necessity—being telescoped into months. Problems of aerodynamics, thermodynamics, high temperature materials, aeroelasticity—that a decade ago were only theory in textbooks are today being solved. What's more, the production techniques necessary to turn these solutions into hardware have been evolved.

Major Missile Center

One of the major centers of this activity is North American Aviation's Missile Development Di-

vision. In 1945 North American started a program of research and development in this field. As far back as 1948, the first NATIV—North American Test Instrument Vehicle—streaked to trajectory altitude of 10 miles. One result of this type of pioneering was complete weapons system responsibility for the Air Force SM-64 Navaho Intercontinental Guided Missile—a gigantic task embracing almost every field of engineering.

Progress Grows Apace

We can't give details here, or describe facilities, solutions, flight tests. But we *can* tell you this: a new engineering chapter is being written. It is reaching its climactic phase. There will never be a better time for you to become a Missile Engineer.

Are You This Kind of Man?

Can you break with tradition...leave conventional methods behind...and explore the unknown with the faith that in every obstacle lies the seeds of new successes?



MANUEL C. SANZ, Chief of Materials Research, found unique scope for his special talents at North American. This Chemical Engineer, with a Masters in Physics and Chemistry, is named as the inventor in a patent on the famous Chem-Mill Process. His son leads a Los Angeles school band—with a chem-milled baton!

Write today for full particulars. If you're the man we're seeking, we'll be glad to arrange a personal interview *where you are now residing*.



JIM THOMPSON's career in missile engineering at North American began in 1951. Today, Jim is Group Leader of Flight Instrumentation at the Missile Test Facility, Patrick Air Force Base, Florida. The tropical climate there is ideal for his favorite sports—fishing and golf.

If You Join These Men, We Promise You

a management climate which stimulates personal growth—and rewards it with responsibility, professional recognition and material benefits limited only by your own abilities. Your own academic stature can be constantly enlarged with our Educational Refund Plan—and some of the nation's finest universities are close at hand.

Contact: Mr. M. Brunetti, Engineering Personnel Dept. 1E
Missile Development Division, 12214 Lakewood Blvd., Downey, California.

NORTH AMERICAN AVIATION, INC.



He's playing golf with the man

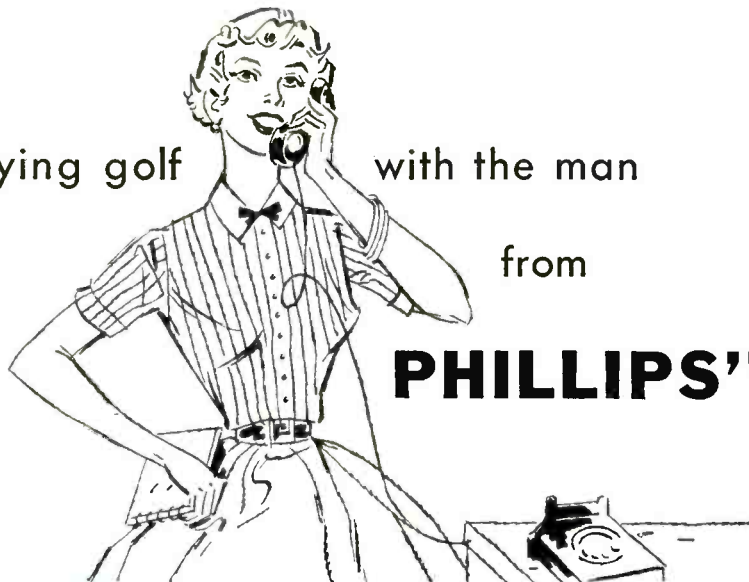

from

PHILLIPS"

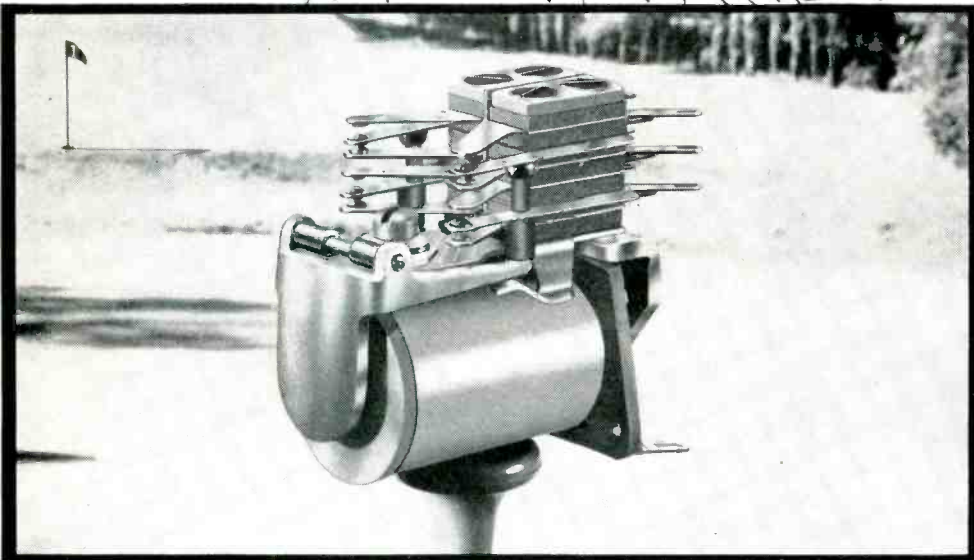

COIL CHARACTERISTICS:

Operating Voltage:
up to 230 volts D.C.
Resistance: up to 14,000 ohms.
Single or double wound.
Operating Current:
0.004 Amps., minimum
Operating Time:
0.003 Secs., minimum

CONTACT ASSEMBLY:

All forms A, B, or C.
Single or double
pile-up. Code # 4 Palladium
contacts, standard.
Other contacts available.

MOUNTING:

Two 4-40 tapped
holes on 3/8" centers

**what's
your
handicap**

For lightning calculations of high speed computers and data processing equipment — for lightning responses of guided missiles and modern aircraft, the new Type 9 relay meets all the critical requirements. A miniature telephone-type multi-contact relay, the Type 9 combines speed of action, reliability and high resistance to shock and vibration. It is available in a wide choice of contact materials and with a maximum of 18 springs (9 per pile-up). Springs are phosphor bronze for long life. Each unit is individually adjusted to insure conformance with rigid operating specifications. Type 9 is available as a hermetically sealed unit, measuring 1" x 1 5/8" x 2", only slightly larger than the regular relays.

Work with your man from PHILLIPS on any relay problem — multi-contact, power, hermetically sealed, A.C. or D.C.

HERMETIC SEALS, MULTI-CONTACT, POWER, HERMETICALLY SEALED RELAYS, ACTUATORS

PHILLIPS

PHILLIPS CONTROL CORPORATION . . . JOLIET, ILLINOIS

AN ALLIED PAPER CORPORATION SUBSIDIARY

SALES OFFICES: NEW YORK - PHILADELPHIA - BOSTON - SAN FRANCISCO - DENVER - SANTA MONICA
WASHINGTON - WINSTON SALEM - CLEVELAND - DALLAS - SEATTLE - KANSAS CITY - ST. LOUIS - DETROIT

it, through suitable gearing, from the magnet motor.

Even without such refinements, the present laboratory model demonstrates that the general technique is a practical one. Miniature toroids can be wound now in sufficient quantities to fill any industrial requirement.

This winder description is abstracted from a paper presented at the 12th Annual National Electronics Conference, and is scheduled to be published in its entirety in Vol. 12 of the Proceedings of the National Electronics Conference, Inc., 1956.

Antenna Support

A NEW TUBULAR plastic support for ferrite-core antennas has been developed by Pilot Radio Corp., in cooperation with Anchor Plastics Co. These antennas should be as far away from the chassis as possible, to avoid r-f interference, and the supporting structure should preferably be nonconductive and nonmagnetic.

The antenna holder developed for this purpose is an Ancorene rigid high-impact plastic extrusion consisting of a split tube to which a long flange is integrally attached. Two holes in the flange are used for mounting the assembly to the chassis. The tubular part holds the antenna element.

The strong plastic tubular enclosure protects the wire from damage and prevents breakage of the core.



Plastic extrusion bolted to rear of high-fidelity tuner supports and protects fragile ferrite-core antenna



Variable-resistor trouble caused by failure of spring to resist corrosion and heat. Or by failure to permit sound weld on collar. SOLVED WITH INCONEL* NICKEL-CHROMIUM ALLOY. Resistor shown is used in power field, also in welding equipment. Sliding Inconel spring clip, silver contact rivet, assure corrosion resistance, weldability, and constant pressure. Despite 570°F temperatures at times, Inconel spring takes overloads. Replaced plated-steel springs. Used last 5 years by International Resistance Co., Philadelphia, Pa.

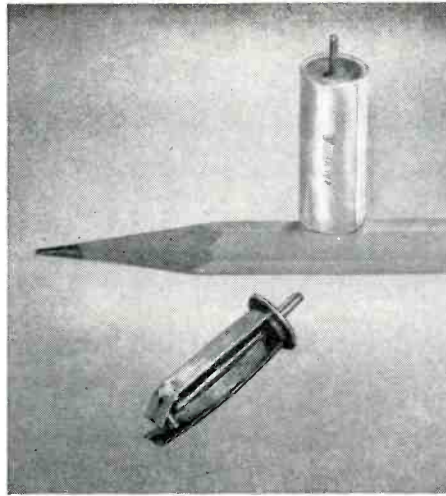

Sticking, fouling, commutation trouble on conductive actuating contact springs. Encountered in miniature thermostats. SOLVED WITH DURA-NICKEL* AGE-HARDENABLE NICKEL STRIP. Constant elasticity gives true snap action. In $\frac{3}{8}$ " x $\frac{15}{16}$ " unit shown, temperature control is held to within 2°F up to 350°F. No drift, no sticking, no fouling in this "Val 90" miniature thermostat. Resists fatigue and relaxation. Made by Valverde Laboratories, 252 Lafayette St., New York 12, N. Y.

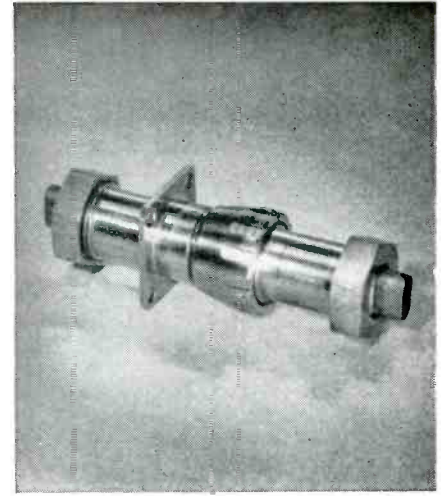

Vibration and heat trouble often pose problems to designers of electrical connectors used, for example, continuously at 800°F in aircraft. SOLVED WITH "R"* MONEL FREE-MACHINING NICKEL-COPPER ALLOY . . . OR CAST MONEL. Units fabricated from these nickel-copper alloys never rust or freeze together. Show no carbide precipitation at 800°F. Permit quick make-break connection of watertight, gas-tight joint such as above "Hot Zone" Electrical Connector that defies vibration. Produced by American Phenolic Corp., 1830 South 54th Ave., Chicago 50, Ill.

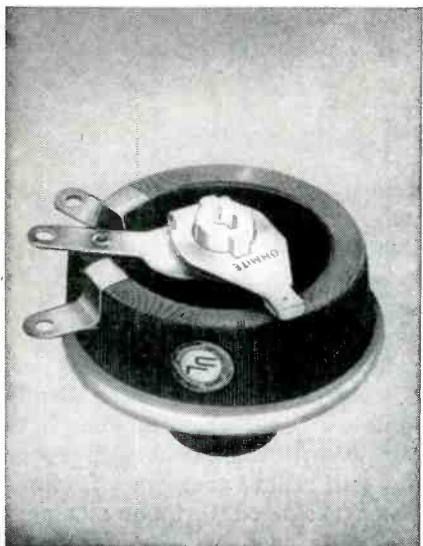

Electrical-resistance trouble from oxide on terminal lug of rheostat. A problem when contact brush is moved from resistance wire to terminal lug very infrequently. SOLVED WITH MONEL* NICKEL-COPPER ALLOY. Monel lug allows excellent electrical contact. Used on rheostats for 22 years by Ohmite Manufacturing Co., 3601 Howard St., Skokie, Illinois.

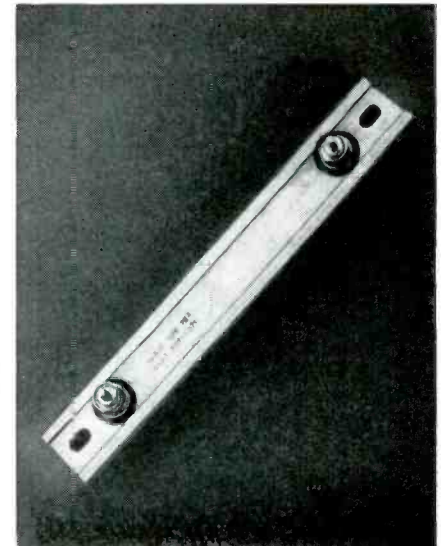

Liquid-corrosion trouble due to attacks by chemicals, brine and the like. On sheathing of strip heaters, for example. SOLVED WITH MONEL* NICKEL-COPPER ALLOY. This Monel sheath resists deterioration from heat as well as corrosives, yet permits delivery of heat up to 750°F. Unit shown is product of Waage Electric, Inc., Kenilworth, N. J.

Trouble-spots . . .

removed by designers using Inco Nickel Alloys

Take no chances. Use components that will back up your designs.

Those illustrated give trouble-free performance, thanks to vital parts made from Inco Nickel Alloys.

Component manufacturers use Inco Nickel Alloys where parts require combinations of properties. High mechanical properties, specific electrical properties, corrosion resistance, resistance to high or low temperatures, good work-

ability and machinability.

Inco's research staff can recommend the right alloy for your trouble. So whenever you have a component problem, check with us.

*Registered Trademark

The INTERNATIONAL NICKEL COMPANY, Inc.
67 Wall Street

New York 5, N. Y.



New Products

Edited by WILLIAM P. O'BRIEN

77 New Products and 49 Manufacturers' Bulletins Are Reviewed
. . . Control, Testing and Measuring Equipment Described and
Illustrated . . . Recent Tubes and Components Are Covered

SILICON RECTIFIERS

in welded cases

TEXAS INSTRUMENTS INC., 6000 Lemmon Ave., Dallas 9, Texas, has announced four new production types of 1,500-v single element grown junction rectifiers featuring welded case construction. Ideal for use in series in crt power supplies and similar h-v circuits, these miniature silicon rectifiers operate stably to 150 C, have forward current ratings to 125 ma. They are immediately available

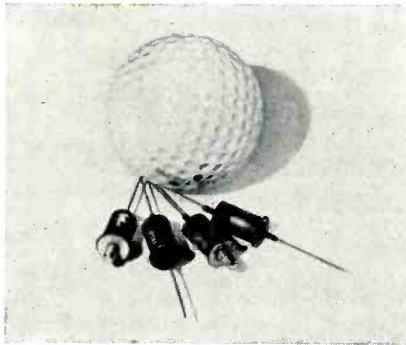

in two types of axial and stud half-wave models. The axial models 1N588 and 1N589, allow point-to-point wiring; stud models, 1N590 and 1N591 are designed to provide maximum heat dissipation.

All units are temperature cycled from -55 C to $+150\text{ C}$ for four cycles . . . then 100 percent tested to assure operation in accordance with specified design characteristics. Bulletins DL-S 649 and DL-S 650 contain complete design data including characteristic curves. **Circle P1 inside back cover.**

THYRATRON

saves circuit components

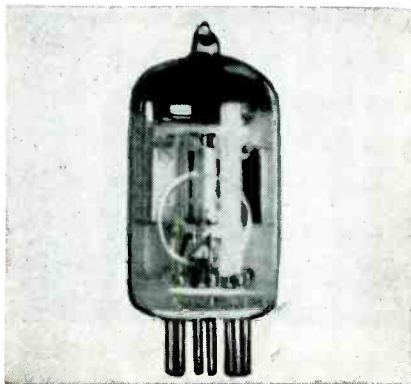

KIP ELECTRONICS CORP., 29 Holly Place, Stamford, Conn. Type KP-80 coincidence thyatron may be used in circuits where the coincidence of two or three signals should fire the tube.

Operating on the principle of ion deflection, the KP-80 may find application in computers, automation control apparatus, coding or programming devices, counters, or wherever coincidence function is to be performed.

The KP-80 has three control grids and is designed for use where the coincidence of either two or three events (signals received) causes some operation (tube conduction). In circuits where coincidence functions are now accomplished with as many as 14 components (performing merely double coincidence) the use of the KP-80 will save time and space and will reduce cost, since it eliminates the need for many components as well as the time and labor required to assemble them. **Circle P2 inside back cover.**

F-M RECEIVER

for multiplex operation

BROWNING LABORATORIES, INC., 752 Main St., Winchester, Mass., announces a new monitor and relay crystal-controlled receiver for the f-m broadcast band, 80 to 108 mc. The new receiver is expected to find widespread use in relay work also.

Standard rack panel mounting, simplex-multiplex switch, signal



strength meter and 600/150 ohms output are some of the features. Complete technical information and prices are supplied on request. **Circle P3 inside back cover.**

PUSHBUTTON SWITCH

for electronic calculators

HETHERINGTON, INC., 1200 Elmwood Ave., Sharon Hill, Pa., has

About a Sawtooth, Clamping and your Efficiency...

Let's look at it this way—What features should an instrument incorporate to make your job easier, help prevent costly mistakes? Take the case of the new PRD Klystron Power Supply. Should we incorporate a sawtooth rather than a sine wave modulation? It's easier to put in a sine wave. However, a sawtooth has the definite advantage of eliminating phasing and blanking problems when the frequency response of a transmission device is to be studied. So, in goes the sawtooth. It's easy enough to get hold of some sine wave modulation which can be applied through the external modulation input.

As for preventing mistakes—consider switching from cw to square wave modulation. Suppose you forget to readjust the reflector voltage . . . Sure, you'll catch the mistake later, but time is lost. The new PRD Klystron Power Supply has an electronic clamping circuit which locks the top of the square wave to the previously chosen reflector voltage. No readjustments to think about, no mistakes.

Want to modulate with pulses—use the external input. The rise time degradation of your pulses will be less than .1 microsecond!

Another point, good regulation! Here's an example: a $\pm 10\%$ line change or *any* load change will cause a reflector voltage change of only $\pm 0.1\%$.

Compare . . . chances are that you'll send in your order for the PRD Type 809, too.

**PolYTECHNIC RESEARCH
& DEVELOPMENT CO., INC.**
202 TILLARY STREET, BROOKLYN 1, NEW YORK
Telephone: ULster 2-6800



The New PRD KLYSTRON POWER SUPPLY



HERE'S WHAT THE TYPE 809
CAN DO FOR YOU —

- Powers most low and medium voltage klystrons — up to 600 V., at 65 ma being supplied and reflector voltages up to -900 V.
- Has electronic readjustment of reflector voltage when changing from cw to square wave modulation — no errors due to forgetfulness
- Has variable square wave, sawtooth and provision for external modulation for pulses
- Affords exceptional stability and regulation at modest cost
- Price \$350.00 F.O.B. New York

(Available from stock. Call or write for new Bulletin.)

Midwest Sales Office:
1 SOUTH NORTHWEST HIGHWAY,
PARK RIDGE, ILL. — TAlcot 3-3174
Western Sales Office:
737-41, SUITE 7, NO. SEWARD ST.
HOLLYWOOD 38, CAL. — HO-5-5287

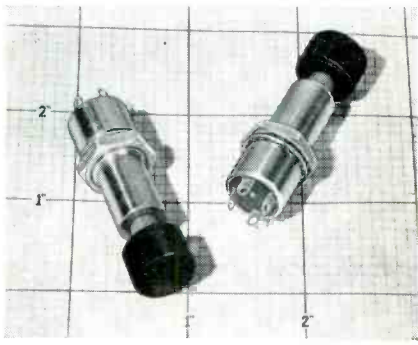

announced a slim new pushbutton switch for computers, calculators and similar devices using whole banks of adding machine-type key switches. Type B5023 momentary-contact switch has a smooth, precise non-snap action that closely approaches the speed of operation, convenience and general "feel" of mechanical-type pushbuttons long used on calculating machines.

The switch responds to an operating pressure of only $\frac{1}{2}$ lb and has a total button travel of $\frac{1}{4}$ in. Contact arrangement is two-circuit, break-before-make.

The switches are designed for a life of over 100,000 cycles at rated load of 28 v, 3 amperes. Complete specifications are available on request. Circle P4 inside back cover.

TEN-TURN POT

with choice of windings

HELIPOT CORP., Newport Beach, Calif. Series 7700 precision potentiometer is a new 10-turn unit, $1\frac{1}{8}$ in. in diameter for servo or three-hole pilot mounting. A distinctive feature is the choice of windings—air-core winding with a range of total resistance from 200 to 5,000 ohms; copper-mandrel winding from 5,000 to 200,000 ohms.

In air-core windings, linearity approaches the resolution of the unit without padding or shunting.

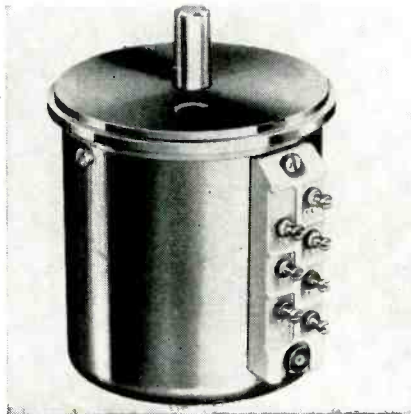

This is because the resistance element is servo-wound directly on the potentiometer drum. The winding process corrects for errors in the unit resistivity of the wire and for mechanical-tolerance deviations in the drum. Also, air-core wound units of the 7700 series have negligible phase shift in a-c circuitry . . . less than 0.1 deg.

By incorporating 11 mechanical coil turns, the series 7700 provides 180 deg overtravel at each end. Mechanical stops are standard, with stop-load strength of 50 in.-lb. Circle P5 inside back cover.

PULSE TRANSFORMERS

high-voltage type

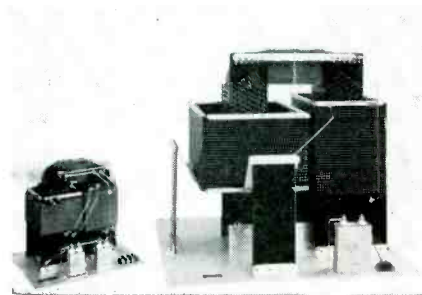

PEARSON ELECTRONICS, 1200 Bryant St., Palo Alto, Calif. This line of pulse transformers is designed for very high voltage, peak power, and average power operation. They are for use with klystrons, twt's, particle-accelerator injection guns, and other h-v high power pulse devices. Standard models cover a wide range of volt-

ages, pulse lengths, impedances, rise and fall times and repetition rates.

Illustrated are two typical units. One is a 120-kv, 2- μ sec, 10-mega-watt unit. They are for immersion, without impregnation, in insulating transformer oil.

For applications where the output voltage is to be exposed to air, tanked and hermetically sealed units are available. Circle P6 inside back cover.

FREQUENCY METER

wide-range type

POLYTECHNIC RESEARCH & DEVELOPMENT Co., INC., 202 Tillary St., Brooklyn 1, N. Y. Type 504 heterodyne frequency meter is now equipped with a new interpolation dial which saves time and avoids ambiguity. Visual presentation is facilitated by a 2-in. crt. Headphones can be used to de-



termine zero beat. The instrument measures frequencies from 100 to over 10,000 mc. It can also be used as a calibration instrument because it generates frequencies from 500 mc to over 10,000 mc. Accuracy is better than 0.03 percent over the whole range and 0.002 percent at 5-mc crystal check points. Price is \$695.

Since the instrument is portable, it is used for field testing of



pioneers in tubeless and transistor designs

- Tubeless — Semi Conductor Design
- For High Current and Transistor Applications

- Continuously Adjustable Zero Max
- High Conversion Efficiency



- Low Heat Dissipation
- Dual AC or DC Output
- Instant Warm-Up

- Automatic Overhead Protection
- Stable Trouble-Free Operation

**tubeless
DUAL TRANSISTOR SUPPLY**

ERA's MODEL 310 is a regulated dual output, high current tubeless power supply, specially designed to power both high and low current transistors and similar devices. Other applications include solenoid and magnetic clutch operation, motor control, computer magnetic memory devices, DC filament supply, and all types of regulated DC high current laboratory and industrial power requirements.

ERA's MODEL 310 features low passive internal DC impedance, yielding exceptionally good load transient response. Outputs are insulated, continuously adjustable and provide any polarity combination for both emitter and collector biases.

SPECIFICATIONS

Input — 100-125V AC, 60 cps.
 Dual Voltage Outputs — #1 0-30V DC or 0-130V AC
 #2 0-30V DC or 0-130V AC
 Output Current — either output 1.5 AMPS MAX. or 30 VA
 Line Regulation — $\pm 1\%$ for 100-125V AC input
 Load Regulation — Internal DC resistance less than 3 ohms
 Ripple — less than 0.05%
 Shunt Impedance (AC) — less than 0.2 ohms at 60 cps.
 Size — 19" bench and rack mounting 8 $\frac{3}{4}$ " panel

Model 310 Price \$295.00

Metered Model 310M Price \$335.00

Send for Catalogue E-157 for further details, and data ERA's transistor test equipment, tubeless power supplies, transistor packaged circuits.

Electronic Research Associates, Inc.

67 East Centre Street, Nutley 10, N.J.

Nutley 2-5410

transmitters, receivers and signal generators. Circle P7 inside back cover.

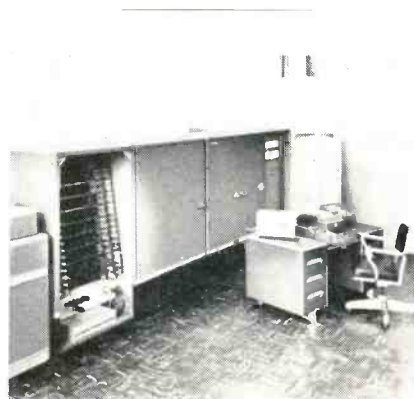

CARD CONVERTER adds to computer's uses

LOGISTICS RESEARCH INC., 141 South Pacific Ave., Redondo Beach, Calif. A new card converter automatically translates alphabetically and decimally coded data recorded on cards into binary "language" understood by the ALWAC electronic digital computer. It makes possible the direct and automatic transfer of data from cards to computer for processing. The processed data can then be recorded on cards or tape for storage.

Addition of this card converter greatly increases the ALWAC III-3 computer system's range of application which now includes processing payroll, personnel, sales, inventory, production and accounting records, alphabetically and decimally coded on cards. Circle P8 inside back cover.

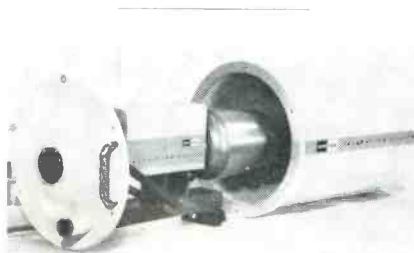

CAMERA AND HOUSING for high noise environments

KAY LAB, 5725 Kearny Villa Road, San Diego 11, Calif., announces a new ruggedized tv camera and a new acoustical housing. They are ideally suited for rocket and jet engine test facilities, rocket launching sites and similar appli-

another example of exciting work at los alamos...

OMEGA WEST

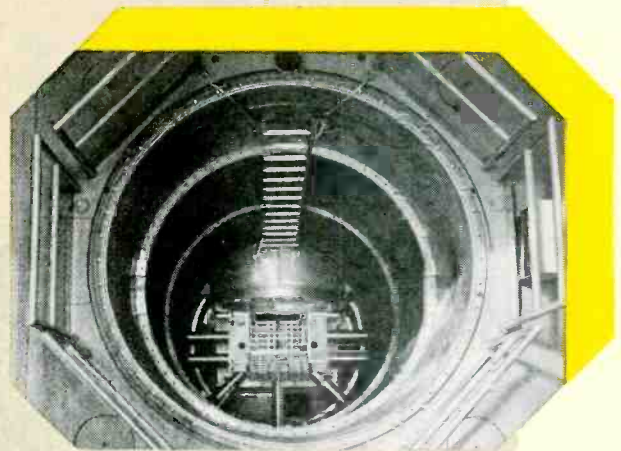

Los Alamos Scientific Laboratory is a non-civil service operation of the University of California for the U. S. Atomic Energy Commission.

Omega West, newest of the research reactors at Omega site in Los Alamos, is one of several reactors in operation or under development at the Laboratory. The OWR is designed for high flux at low cost, flexible operation, and has extremely versatile port facilities. This installation is an important addition to the impressive array of research facilities available to Los Alamos scientists.

The Laboratory is interested in receiving employment applications from engineers and scientists of superior qualifications. Direct your inquiry to:

Department of Scientific Personnel
Division 1603

los alamos
scientific laboratory

OF THE UNIVERSITY OF CALIFORNIA

LOS ALAMOS, NEW MEXICO

Ace can meet your requirements in quality and delivery of **NONLINEAR POTENTIOMETERS**

Nonlinear precision wire-wound potentiometers in standard and sub-miniature sizes are now available in prototype or production quantities from Ace Electronics Associates . . . and you can be sure of delivery.

These new Ace nonlinear units incorporate the same advanced engineering, precision craftsmanship, and controlled quality which have made ACEPOT linear potentiometers standards of excellence.

A new Division directed by highly qualified engineers, special prototype section, and mass production facilities are at your service to meet your requirements for quality and delivery of nonlinear precision potentiometers.

For complete information . . .

Call or write William Lyon or Abraham Osborn, Nonlinear Division, outlining your requirements. Your inquiry will receive prompt attention . . . and you will get delivery as specified.

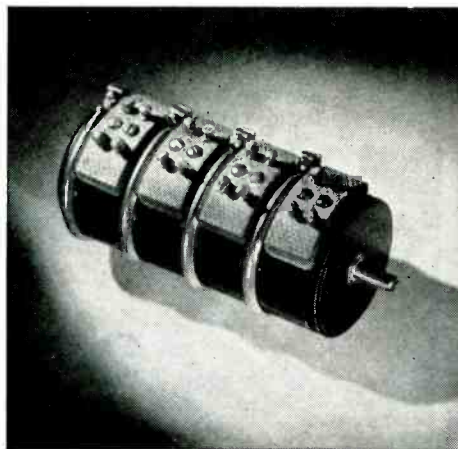

Featuring!

Highly developed design techniques achieve high resolution and close conformity for your unique nonlinear requirements.

* trademarks applied for

ACEPOT*
ACETRIM*

ACE ELECTRONICS ASSOCIATES, INC.

Dept. E, 101 Dover St. • Somerville 44, Massachusetts

Telephone: MOnument 6-4801

Engineering Representatives in Principal Cities

NEW PRODUCTS

(continued)

cations where noise conditions prohibit the use of ordinary equipment. The acoustical housing provides approximately 45 db of isolation. It will accept the remote iris-focus, auto-zoom lens, and three-lens turret accessories for the camera. A heavy duty pan-tilt unit is also available for the acoustical housing.

The new units will permit use of tv equipment in a considerable number of applications where such equipment was previously prohibited by high-noise conditions. Circle P9 inside back cover.

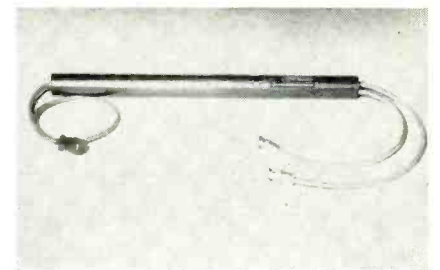

TWT AMPLIFIER operates from 8.2 to 11 kmc

HUGGINS LABORATORIES, INC., 711 Hamilton Ave., Menlo Park, Calif. The HA-9 X-band traveling wave amplifier tube operates from 8.2 to 11.0 kmc without the necessity of any electrical or mechanical operating adjustments. A high-gain, medium power broadband device suitable for many microwave applications, it includes provisions for grid modulation with which any electrode may be operated at ground potential.

► Specifications — Small signal gain is 36 db minimum; saturation gain, 30 db minimum; power output, 30 dbm; magnetic field, 650 gauss; capsule length, 15½ in.; capsule diameter, 1.0 in. and net weight, 2 lb. Circle P10 inside back cover.

SENSITIVE RELAY in miniature size

ELGIN NATIONAL WATCH CO., Elgin, Ill., has developed a new sensitive relay in minimum size. Designed to perform with low drain, the relay operates on as little as 10 mw of power.

In its primary application, the

Need accurately controlled

POWER?

USE KAY LAB ABSOLUTE DC POWER SUPPLIES AND METER CALIBRATORS

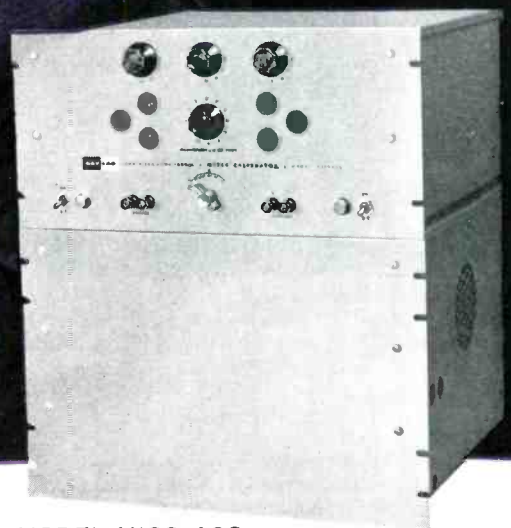

MODEL M100-A20

- STANDARD CELL ACCURACY
- 0.01% STABILITY
- <0.5 MILLIVOLT RIPPLE
- 0.002% REGULATION
- <0.2 MILLISEC RESPONSE TIME
- 21 MODELS: 0-2000V, 0-2 AMP

SPECIFICATIONS

POWER SUPPLY: Short Time Stability (several hours), $\pm 0.005\%$ —Long Time Stability, $\pm 0.01\%$ —Output Voltage Calibration, $\pm 0.02\%$ —Output Impedance, $< 0.01\Omega$ at DC, $< 0.05\Omega$ to 200 kc—Output Hum and Noise, < 0.5 millivolt—Load Regulation Factor, $\pm 0.01\%$ —Line Regulation Factor, $\pm 0.002\%$.

METER CALIBRATOR: Same as Power Supplies with following exceptions for models which go to zero volts: Calibration Tolerance, $\pm 0.05\%$ —Hum and Noise, < 2 millivolts—Line Regulation Factor, $\pm 0.01\%$ of full scale.

KAY LAB's unique chopper stabilized circuit constantly compares the output with an internal standard cell, providing stability, accuracy, and dynamic characteristics without equal. Direct reading calibrated dials provide instant voltage selection. Both current and voltage regulated models available. Ideal wherever a general purpose precision voltage or current source independent of line or load is required... for laboratory and production meter calibration, computer reference, secondary standard, DC bridge supply, transistor testing, circuit design, nucleonics instrumentation, null voltmeter...

KAY LAB

Representatives in all major cities

Write, wire, phone today for demonstration

5725 KEARNY VILLA ROAD • SAN DIEGO 11, CALIFORNIA • BROWNING 7-6700

PUREST WATER

(HOH ABSOLUTE)

10,000,000* OHM Water, Free of Bacteria and other submicroscopic Particles, Organics and Silica.

Closest thing to HOH ABSOLUTE . . . an entirely new standard of water purification by Barnstead now makes new advances possible in Chemical, Electronic, and Nuclear fields.

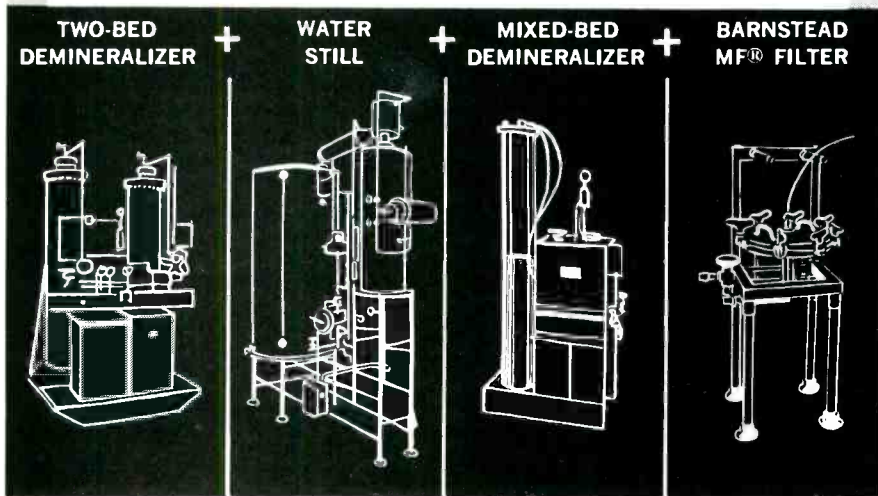

The purification of water often requires special engineering, and a broad consideration of accessory equipment. The above combination of Water Demineralizers, Water Still, and Barnstead MF Filter, operated in series, will produce 10,000,000 OHMS water in production quantities . . . free of bacteria, organics and silica.

Whatever your water purification problem, Barnstead engineering coupled with Barnstead's extensive line of Pure Water equipment has the authoritative answer. Write today!



Catalog "G"
Describes line of water stills from 1/2 to 1000 gph.



Catalog 127
Mixed-Bed, Two-Bed, and Four-Bed Demineralizers



Bulletin 141
MF Filter, filters out particles to 0.45 micron

BOSTON Jamaica 4-3100		NEW YORK Kingsbridge 8-1557
PHILADELPHIA LOcust 8-1796	CLEVELAND ACademy 6-2266	CHICAGO FInancial 6-0588
LOS ANGELES RYan 1-9373	SAN FRANCISCO TEmplebar 2-5391	

*Corrected to 18°C.

TRADE MARK REG. U.S. PAT. OFF.
Barnstead
STILL & DEMINERALIZER CO.
(BARNSTEAD STILL AND STERILIZER CO.)

84 Lanesville Terrace, Boston 31, Mass.

SN relay will be used in aircraft navigational control systems, but has equal application in power-premium communications equipment.

The relay measures 1 1/4 in. in height, is 0.968 in. sq and weighs 3 oz. It operates over a temperature range of from -65 C to +105 C with high vibration resistance in both spdt and dpdt models. At the 10-mw power rating the relay has coil resistances of 8,000 and 10,000 ohms; at 40-mw it has ratings of 500, 2,500, 8,000 and 10,000 ohms with others available upon request. Circle P11 inside back cover.

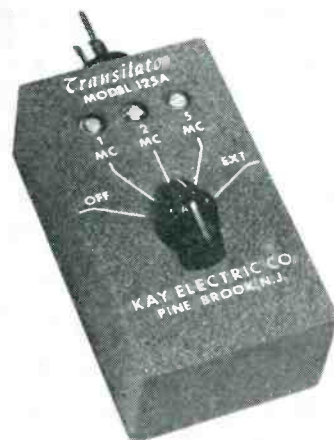

TRANSISTOR OSCILLATOR is crystal-controlled

KAY ELECTRIC Co., 14 Maple Ave., Pine Brook, N. J. Model 125A Transilator is a new portable, crystal-controlled transistor oscillator. It employs a pair of transistors and a unique diode feedback system in a battery-operated unit. Output frequencies of 1, 2 and 5 mc are available by rotating a selection switch. An external crystal jack is provided to furnish other frequencies falling between 1 and 5 mc (such as the 3.58-mc color carrier frequency).

Because of its excellent frequency and amplitude stability, the Transilator may be used to calibrate oscilloscope sweep speeds and repetition rates, radar range units and chroma circuits. This unit may also be used to calibrate oscillators by inspecting Lissajous figures. Three frequency adjustments are provided.

Output is 0.25 v at 1,000 ohms

Federal's NEW "V-M-D" PROCESS

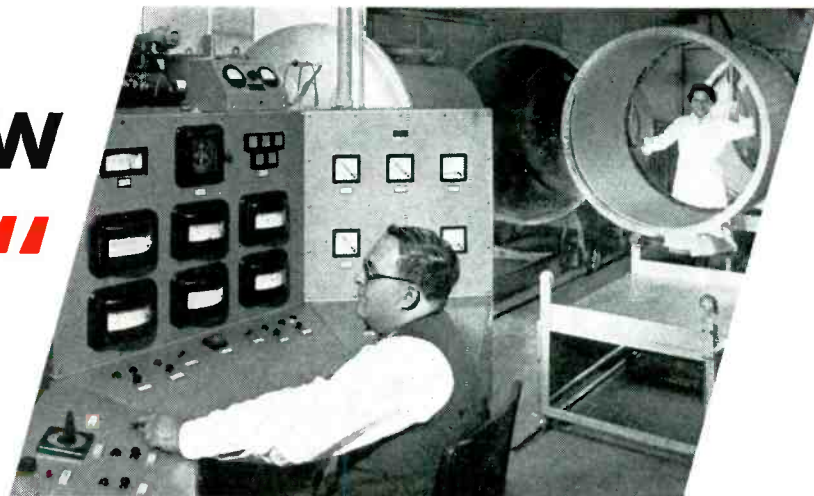

produces **HI-DENSITY Selenium Rectifiers**
with **3 MAJOR SAVINGS...**

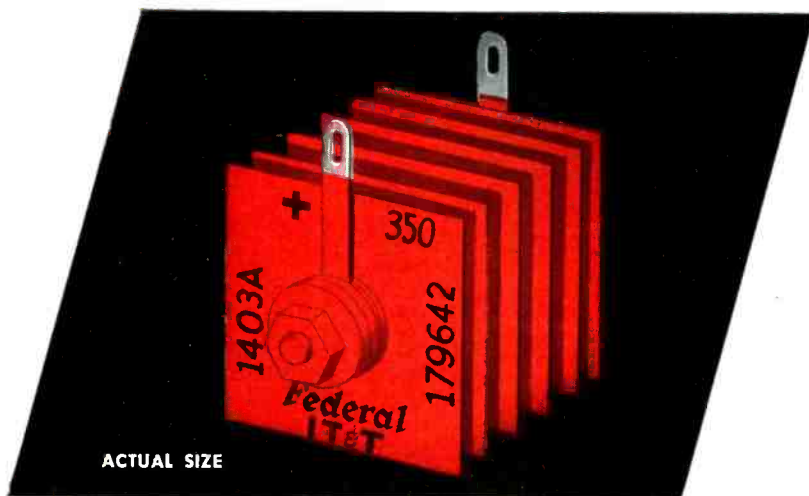

SPACE
... more than **42%**
WEIGHT
... averaging **23%**
COST
... as much as **24%**

"V-M-D" (Vacuum Multiple Deposition) is the unique process developed by Federal for the controlled application of the selenium and counterelectrode to the aluminum base plate. "V-M-D" cells are remarkable for their lower voltage drop, longer life, greater uniformity and higher temperature and voltage ratings.

One of the many new products made possible by this exclusive process is the Federal *Hi-Density* Radio-TV Rectifier. These miniature, low cost Hi-Density Seleniums rectify *twice* as much power as equivalent-sized rectifiers of other make. They are being produced in ratings of 150 to 500 ma. and are backed by two years of laboratory testing and more than a year's success in the replacement field. They are now available in volume to the electronics industry. Other products also possible with the "V-M-D" process are:

45-Volt-Cell Rectifiers • 150° C. Hi-Temperature Rectifiers
40,000-Hour Rectifiers • Hi-Density Industrial Rectifiers

For more information about any of these new products write to Dept. F-213

Federal Telephone and Radio Company
A Division of INTERNATIONAL TELEPHONE AND TELEGRAPH CORPORATION
COMPONENTS DIVISION • 100 KINGSLAND ROAD • CLIFTON, N. J.

In Canada: Standard Telephones and Cables Mfg. Co. (Canada) Ltd., Montreal, P. Q.
Export Distributors: International Standard Electric Corp., 67 Broad St., New York

FEDERAL'S NEW "V-M-D" CELLS HAVE 4 EXCEPTIONAL CHARACTERISTICS ...

- Longer life ... 40,000 hours and more.
- Higher temperature ratings ... up to 150° C. ambient.
- Higher voltage ratings ... up to 45V RMS.
- Higher efficiency ...
25% lower forward losses.

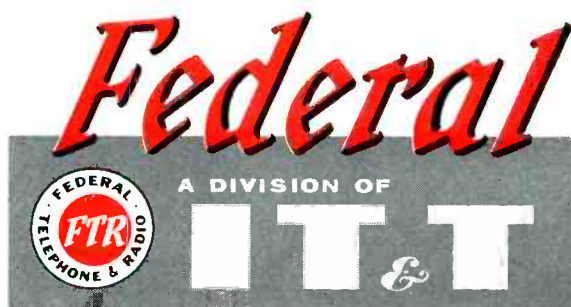

We'll Help You Put More "Automatic" In Your Automation!

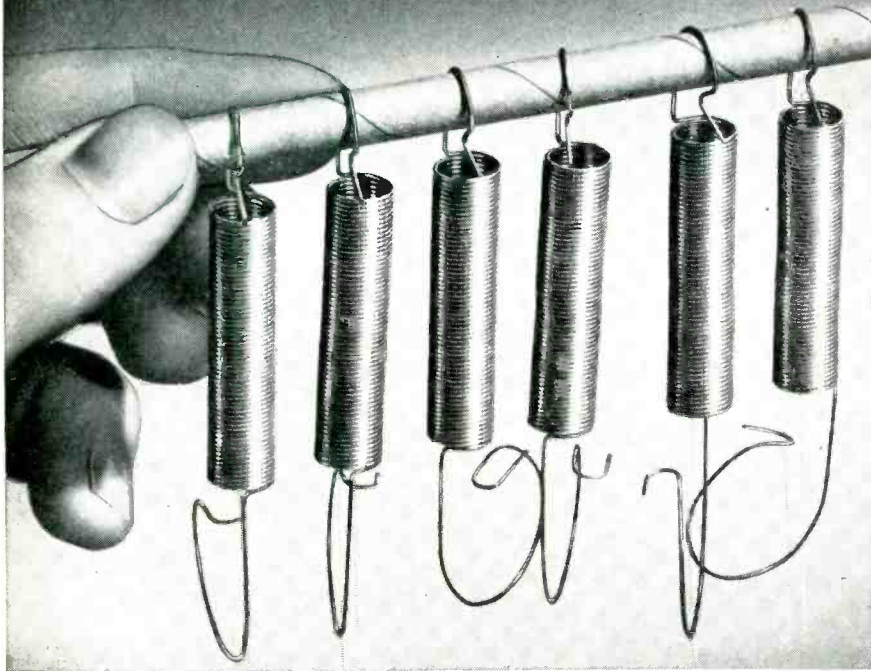

● There is an "extra" Lewis Service many spring users don't know about... it might be called: "packing for production" or "arranged for automation." It's simply the way in which Lewis Springs and Wireforms may be shipped to reach the production line ready for quick, time-saving handling and the most efficient assembly operation... by hand or automatic equipment.

Working with customer's production men, Lewis Engineers devise the packing method best suited to the job: Perhaps threaded on a rod... on special holders... in envelopes... tied or grouped in bundles... and in many other different ways.

If you use springs and wireforms, and have plans to further "automate" production we'd like to help you with our "extras" in Lewis Service. And, of course, top quality springs and wireforms are our business. Send us your problem.

LEWIS SPRING & MANUFACTURING COMPANY
2656 W. NORTH AVE. CHICAGO 47, ILL.

Lewis  **PRECISION
SPRINGS**

The Finest Light Springs and Wireforms of Every Type and Material

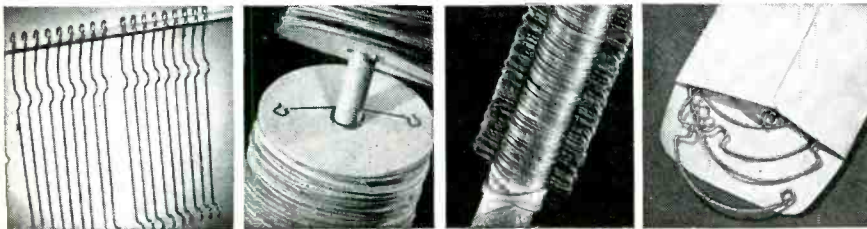

impedance level. Dimensions are 2 in. by 1½ in. by 4½ in. Weight is 12 oz. Complete information and detailed specifications are available. Circle P12 inside back cover.



DATA RECORDER fourteen-channel type

TELECTRO INDUSTRIES CORP., 35-18 37th St., Long Island City 1, N. Y. Model TR-150-14 magnetic tape recorder-reproducer is designed specifically for recording and reproducing data from telemetering channels. It is a 14-channel three-speed unit. Data are recorded on and reproduced from a 2,400-ft magnetic tape moving at 15 ips, 30 ips or 60 ips. Frequency response is 200 to 20 kc ±3 db at 15 ips; 200 to 40 kc ±3db at 30 ips and 200 to 80 kc ±3db at 60 ips. Rewind time is less than a minute for a full reel of tape.

The TR-150-14 is supplied as five separate units, each suitable for mounting in a standard relay rack. The separate units comprise a low and high voltage power supply; filament and bias supply; recording amplifiers; playback and amplifiers and tape-transport mechanism. Circle P13 inside back cover.

SPIRAL WHIP ANTENNAS for the 30-50 mc region

MARK PRODUCTS Co., 6412 W. Lincoln Ave., Morton Grove, Ill., announces new spiral whip antennas for the '30 to 50-mc region. The SW-44 series are continuously loaded vertical whip antennas for

Henry Rempt (second from left), head of the Electronics and Armament Systems Division, discusses problems inherent in the application of large electronic sensing devices to aircraft with David Morrissey, A.E.W. Systems Specialist, Harold Held, Data Links Specialist in the Advanced Techniques Group, and Nelson Harnois, head of the Electronics and Armament Systems Engineering Department.



Lockheed expands electronics division

■ To keep pace with its ever-increasing emphasis on electronics, Lockheed has expanded and centralized research and development activities under the Electronics and Armament Systems Division. The Division is under the direction of Henry Rempt.

Responsibilities of the Division include originating and developing complex electronics and armament systems for all new Lockheed aircraft.

A number of technical management positions for Electronics Systems Engineers has been created. The positions will appeal particularly to those who seek an extremely wide range of assignments.

Electronics Engineers possessing experience or keen interest in systems activities are invited to write E. W. Des Lauriers, Dept. ED-9-1.

Technical management positions are open in fields of:

Fire control, countermeasures, inertial systems, weapons, communications, infra-red, optics, sonics, magnetics, antennas and micro-waves.

Under Lockheed's philosophy of operation, Electronics Systems Engineers supervise and participate in conceiving advanced systems and then performing research, development and evaluation up to production stages on all Lockheed aircraft — radar search planes, high-speed fighters, cargo and passenger transports, bombers, jet trainers.

California Division

LOCKHEED

AIRCRAFT CORPORATION • BURBANK

CALIFORNIA

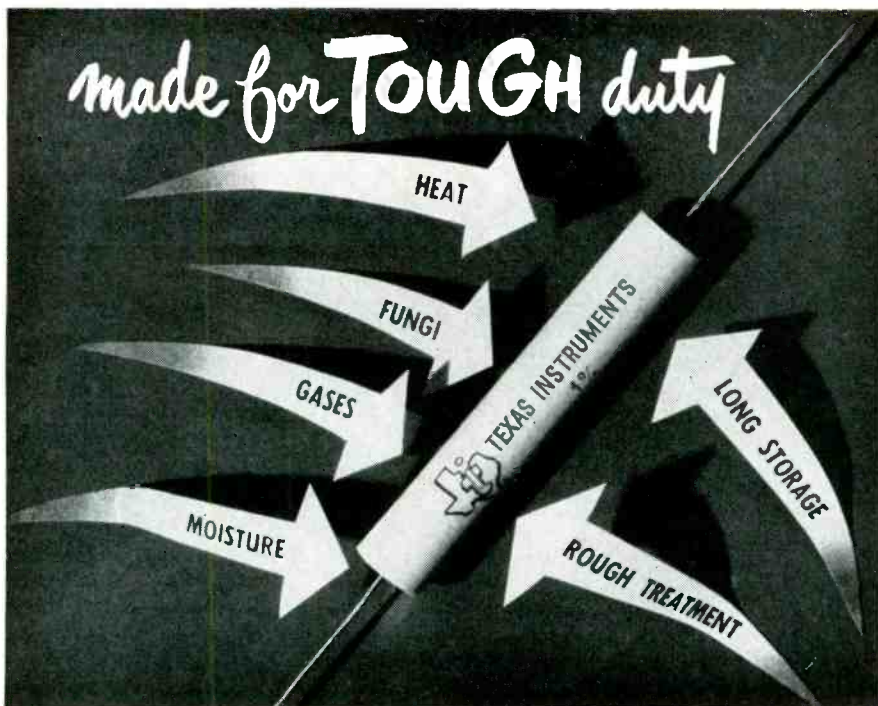

TEXAS INSTRUMENTS

HERMETICALLY SEALED RESISTORS

PRECISION DEPOSITED CARBON TYPE

Built for hard service far exceeding MIL-R-10509A specifications . . . with $\pm 1\%$ resistance tolerance . . . high stability over temperature range and under overload, these ruggedized resistors give top performance in extreme environmental conditions. Texas Instruments hermetically sealed resistors are leakproof, trouble-free, and fully insulated.

Featuring low negative temperature coefficients, TI hermetically sealed resistors are precision manufactured, ideally suited for automatic assembly applications. Under operating conditions, these superior units show negligible voltage coefficient and noise level.

Mass-produced to the same exacting tolerance and quality standards, Texas Instruments Industrial Line and MIL-Line deposited carbon resistors provide exceptional accuracy and reliability throughout a wide range of applications. For *increased* reliability — at economical prices — design with TI precision resistors. All three types are available in five sizes from $\frac{1}{2}$ watt to 2 watts . . . with resistance values from 25 ohms to 30 megohms.

FOR COMPLETE DATA, WRITE
FOR BULLETIN DL-C 539

RECOMMENDED DERATING CURVES OF TI
HERMETICALLY SEALED LINE
DEPOSITED CARBON RESISTORS

Curve A — Conservative rating equivalent
to MIL-R-10509A.

Curve B — High rating can be applied
where a 3% permanent change
in resistance can be tolerated.

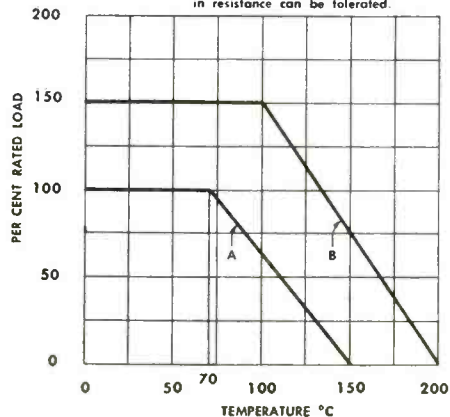

TEXAS INSTRUMENTS
INCORPORATED
6000 LEMMON AVENUE DALLAS 9, TEXAS



vehicular applications. The units are approximately 0.1 wavelength long at the operating frequency with maximum length running about 4 ft at 30 mc.

These units are molded in Fiberglass, have good strength and abrasion characteristics. They perform electrically equivalent to the full quarter wave stainless steel whips at these frequencies.

Because of their short physical lengths, the SW-44 series of uniformly loaded whip antennas can be mounted on the top of the cab roof in truck applications or on top of the car roof in vehicular applications. This position gives much more uniform pattern coverage and better transmitter loading. **Circle P14** inside back cover.



EDGE CONTROL SYSTEM eliminates waste

INTERCONTINENTAL DYNAMICS
CORP., 170 Coolidge Ave., Englewood, N. J. The Linar Edgetrol photoelectronic edge guidance system offers the answer to run-out of continuously processed



HOW ARE YOUR COMMUNICATIONS ?

Do the booklets, pamphlets, and manuals you use really *work* for you? Are these vital publications, that tell the story of your products and your company, as effective, readable, well designed and illustrated as they can be? Today more than ever, your entire operation is judged by each annual report, employee manual, and public relations piece that you produce. Have you examined your communications lately? If you have any doubt as to the impact of your instructional and promotional literature, remember . . .

COMMUNICATION IS OUR BUSINESS

For a good many decades McGraw-Hill has stood for complete coverage in the business literature field. Now the McGraw-Hill TECHNICAL WRITING SERVICE offers a new approach to your publication problems — an *integrated* writing, editing, illustrating, and printing service for the *custom* production of: INSTRUCTION MANUALS, PRODUCT BULLETINS, TRAINING AIDS, INDUSTRIAL RELATIONS LITERATURE, ANNUAL REPORTS, COMPANY HISTORIES, PROCEDURAL GUIDES and other collateral literature. More than 150 editorial and graphic experts are at your disposal, ready to prepare high-quality material to your own or government specifications. Save time, save money . . . and make your communications work! Let *our* staff be your staff for technical and business publications.

McGraw-Hill Book Co. TECHNICAL WRITING SERVICE

Write or phone Technical Writing Service, McGraw-Hill Book Co., Inc.
330 West 42nd Street, New York 36, N. Y. • LOngrave 4-3000

This service is available through ad agencies.

EIMAC Vacuum Switches for high-voltage switching in severe environments.

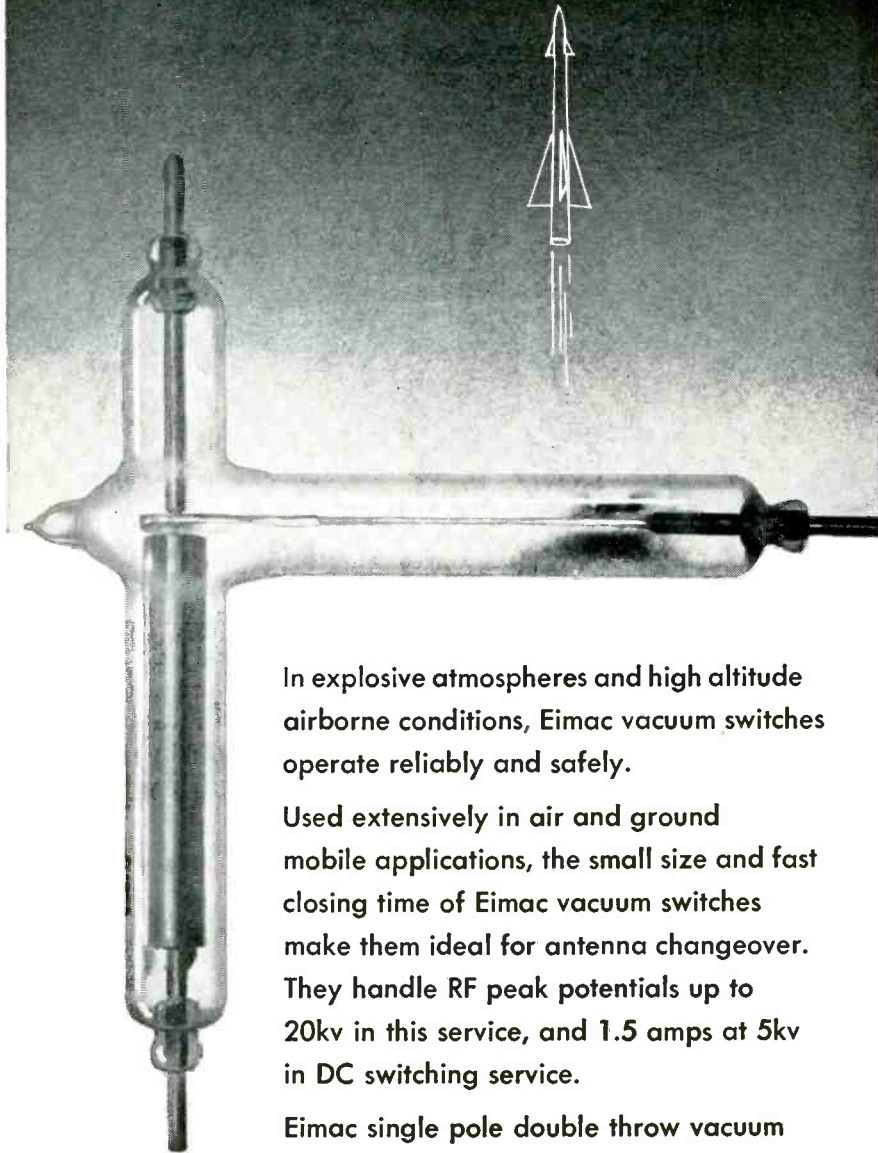

In explosive atmospheres and high altitude airborne conditions, Eimac vacuum switches operate reliably and safely.

Used extensively in air and ground mobile applications, the small size and fast closing time of Eimac vacuum switches make them ideal for antenna changeover. They handle RF peak potentials up to 20kv in this service, and 1.5 amps at 5kv in DC switching service.

Eimac single pole double throw vacuum switches are available in four types, including one for pulse service.

If you have a switching problem, write our Application Engineering Department for further information.

material and elimination of edge waste. The equipment is fully automatic. Seven versatile sensing heads provide a variety of models enabling complete system operation with any material under any conditions. Since edge detection is by photoelectric means, no force or pressure is applied to the material under control. This solves the problem of errors which might occur due to side motion of light or loose material.

Used for accurate printing, coating, tubing and rerolling, slitting and punching, tenting, intersheeting and manifolding, the system controls edge registration and web position of all opaque materials, porous materials, single thickness films and laminates. It is capable of maintaining control accuracies within $\frac{1}{32}$ in. at any speed. Circle P15 inside back cover.



ELECTRONIC TIMER with improved design

GENERAL CONTROL CO., 1212 Soldiers Field Rd., Boston, Mass., has converted production to an improved design of its type ET electronic timer. Recent changes include an improved line of matched industrial housings for various mounting conditions. In the case of the boxed, sheet-metal housing, the type ETH, the front of the enclosure has been split to permit access to the terminals for fast wiring changes. Other changes have been the slide-out chassis with plug-in tube and capacitor and a complete up-grading of components. Type ET electronic timer will control timed opera-

Eimac

EITEL-McCULLOUGH, INC.
SAN BRUNO CALIFORNIA
The World's Largest Manufacturer of Transmitting Tubes

UNIVAC talks your language



The man of science speaks a language of his own . . . a specialized language. He is a special kind of person and needs a special kind of atmosphere in order to do his best work. The working conditions, facilities, incentives, satisfactions to be found at Univac create this kind of atmosphere. Univac is an organization founded by engineers, built by engineers, with a staff that is predominantly professional, with a program specifically designed to meet your special needs . . . to help you achieve your full stature, professionally and financially. Univac talks your language. Talk to Univac about your future soon.

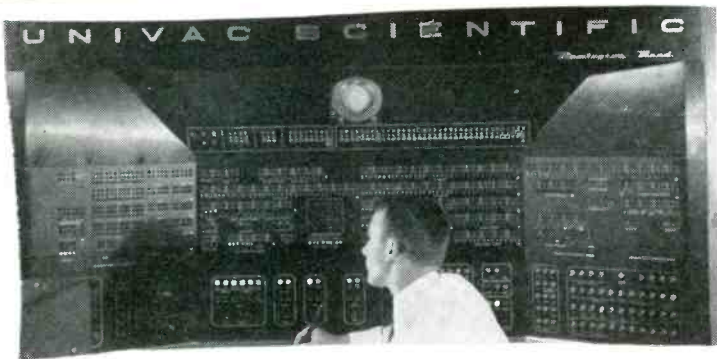

IMMEDIATE OPENINGS FOR

Electronic Engineers
Logical Designers
Mechanical Engineers
Physicists
Programmers
Mathematicians

Send Complete Resumé to

Remington Rand Univac

DIVISION OF SPERRY RAND CORPORATION

Dept. PJ-2

2300 W. ALLEGHANY AVENUE • PHILADELPHIA, PA.

MEASURE NOISE AND FIELD INTENSITY FROM 150 KC TO 1000 MC— WITH ONE METER!

Quickly • Accurately • Reliably

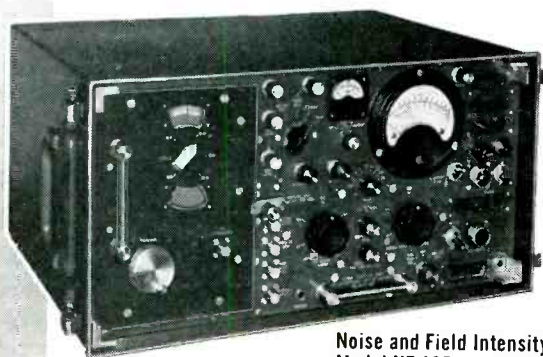

Noise and Field Intensity Meter
Model NF-105
(Commercial Equivalent of AN/URM-7)

Empire Devices Noise and Field Intensity Meter Model NF-105 permits measurements of RF interference and field intensity over the entire frequency range from 150 kilocycles to 1000 megacycles. It is merely necessary to select one of four individual plug-in tuning units, depending on the frequency range desired. Tuning units are readily interchangeable... can be used with all Empire Devices Noise and Field Intensity Meters Model NF-105 now in the field.

Each of the four separate tuning units employs at least one RF amplifier stage with tuned input. Calibration for noise measurements is easily accomplished by means of the built-in impulse noise calibrator. With this instrument costly repetition of components common to all frequency ranges is eliminated because only the tuners need be changed. The same components... indicating circuits, calibrators, RF attenuators, detectors and audio amplifier... and power supplies... are used at all times.

Noise and Field Intensity Meter Model NF-105 is accurate and versatile, it may be used for measuring field intensity, RF interference, or as an ultra-sensitive VTVM. A complete line of accessories is available.

For complete performance data, send for Catalog No. N-356

NEW YORK—Dlghy 9-1240 • SYRACUSE—Syracuse 2-6253 • PHILADELPHIA—SHerwood 7-9080 • PITTSBURGH—ATlantic 1-9248 • BOSTON—TWInbrook 4-1955 • WASHINGTON, D. C.—DEcatur 2-8000 • ATLANTA—EXchange 7801 • VALPARAISO, FLA.—3937 • DETROIT—BRoadway 3-2900 • CLEVELAND—EVERgreen 2-4114 • DAYTON—FUItton 8794 • CHICAGO—ESTelbrook 9-2700 • ST. LOUIS—EVERgreen 5-7728 • DENVER—MAIn 3-0343 • FORT WORTH—WAlnut 3-8811 • ALBUQUERQUE—ALbuquerque 5-9632 • LOS ANGELES—REpublic 2-8103 • PALO ALTO—DAvenport 3-4455 • PORTLAND—CAPital 7-3830 • STITTSVILLE, ONT., CAN.—HAzeldean-56 • EXPORT: NEW YORK—MURray Hill 2-3750

EMPIRE DEVICES PRODUCTS CORPORATION

38-15 BELL BOULEVARD • BAYSIDE 61 • NEW YORK

manufacturers of

FIELD INTENSITY METERS • DISTORTION ANALYZERS • IMPULSE GENERATORS • COAXIAL ATTENUATORS • CRYSTAL MIXERS

tions between 60 millisecc and 60 sec and is adjustable to any fraction of this range. It is available in 115 v a-c, 60 cps; 220 v a-c, 60 cps. Bulletin ET-600 gives further data. Circle P16 inside back cover.



THICKNESS TESTER for the finishing industry

UNIT PROCESS ASSEMBLIES, INC., 61 E. 4th St., New York 3, N. Y. The Dermitron nondestructive thickness tester makes possible 100-percent inspection of production of nearly any possible coating on almost any base. It gives fast, accurate and direct readings of thickness of such combinations as silver on brass, copper on zinc die-castings, nickel on brass, metallizing on plastic, anodizing on aluminum and plating on ceramics—all without the use of chemicals. Circle P17 inside back cover.

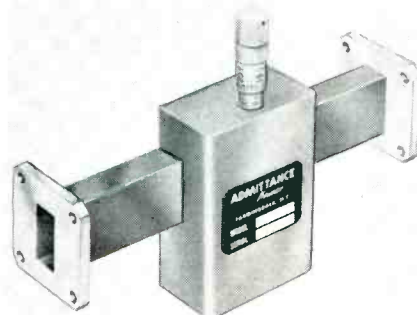

ATTENUATOR features rugged design

ADMITTANCE-NAMCO CORP., 9 Alan Court, Farmingdale, L. I., N. Y., has announced a new precision calibrated attenuator. Featuring a simple and rugged design, it is not affected by changes in humidity or temperature variations. The accuracy at calibration frequency

eap

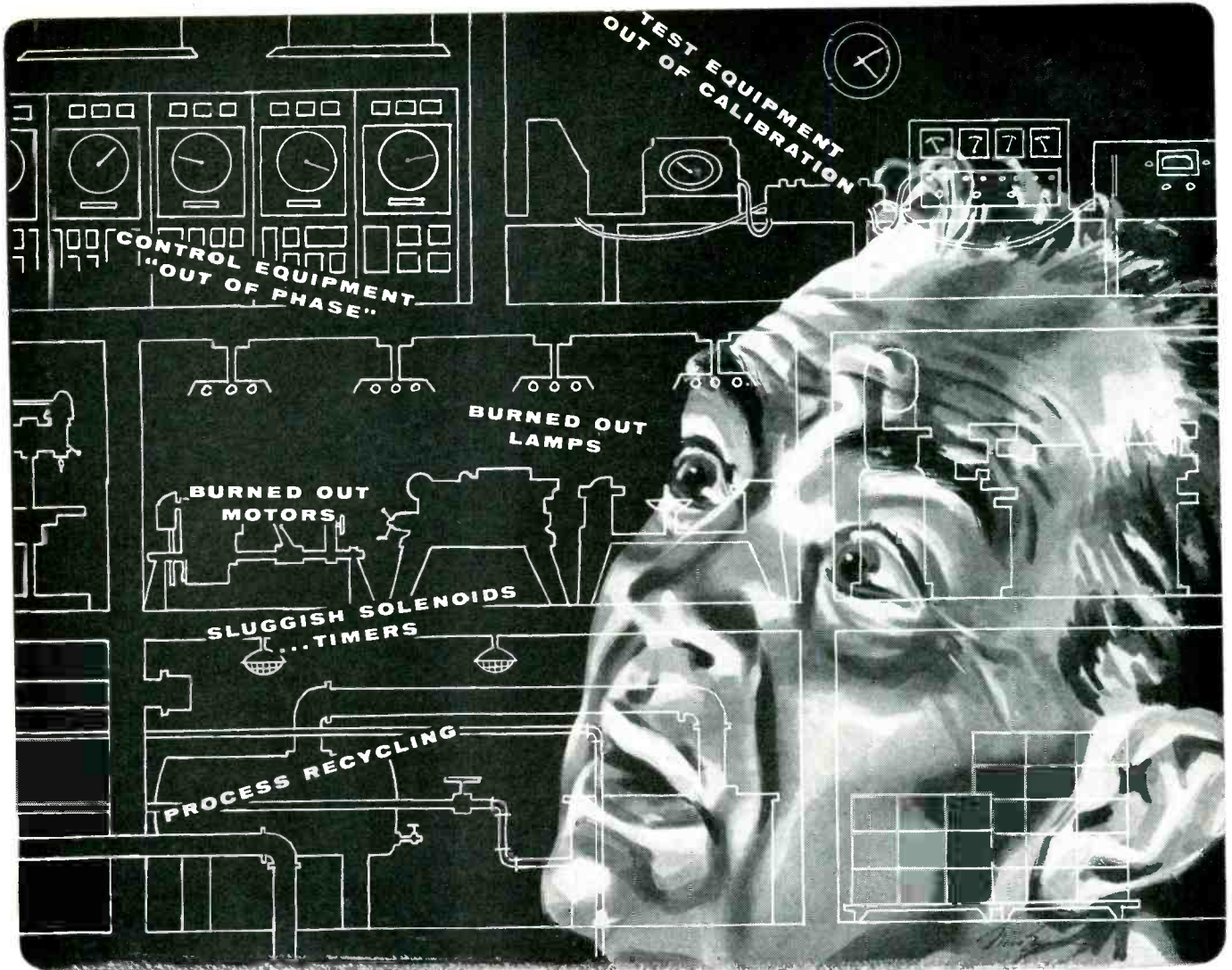

TAKE A HARD LOOK

at how **V.V.T.*** can be causing trouble

*Varying Voltage Troubles masquerade under many names — and some you will never hear about because they are so common they become "standard operating procedure".

You'll find that a STABILINE® Automatic Voltage Regulator can end many of your production, maintenance and inspection "bugs". STABILINES maintain constant voltage to voltage-sensitive equipment. They are a sure cure for costly varying voltage troubles that can cause burned out motors and lamps . . . production rejects due to sluggish solenoids . . . process recycling caused by out-of-phase control equipment . . . electronic tube failure — just to name a few.

There is a STABILINE to meet your automatic voltage regulation requirements. Three types are offered: Type EM (Electro-Mechanical), Type IE (Instantaneous-Electronic) and Type TM (Tubeless Magnetic). Numerous standard models are available in capacities from ¼ to 100 KVA.



STABILINE TYPE EM6220Y. Holds output voltage constant . . . ends the troubles caused by voltage variations.

Be sure to see SUPERIOR ELECTRIC'S Mobile Display when it is in your area
 Branch Offices: Los Angeles, California • San Francisco, California • Toronto, Ontario, Canada • Miami, Florida • Chicago, Illinois • Baltimore, Maryland
 Detroit, Michigan • New York, New York • Cleveland, Ohio • Dallas, Texas
 Seattle, Washington



**THE
 SUPERIOR ELECTRIC
 COMPANY**

BRISTOL, CONNECTICUT

THE SUPERIOR ELECTRIC COMPANY
 201 MIDDLE STREET, BRISTOL, CONNECTICUT

Please have your representative call
 Please send me STABILINE Bulletin S157

Name

Address

City Zone State

5

**IMPORTANT
REASONS
WHY YOU
SHOULD
SPECIFY**

**RESINITE
COIL FORMS**

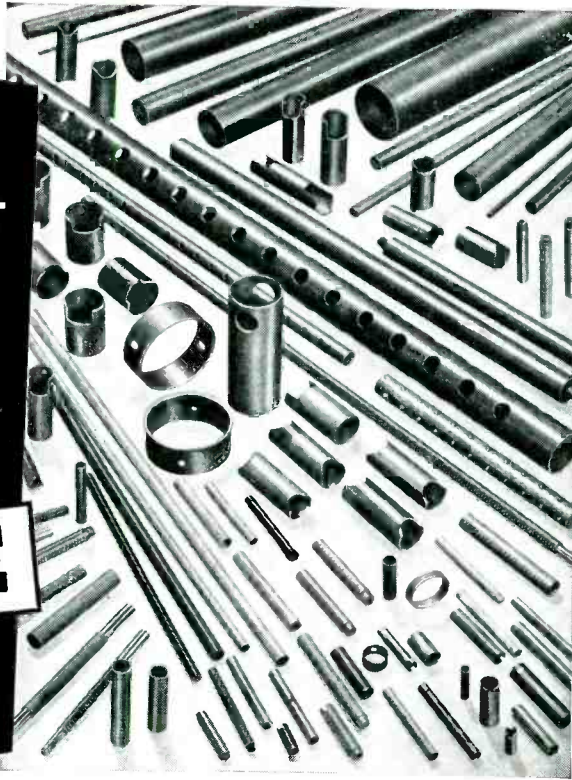

1. **RESINITE AC** combines all the mechanical and dielectric advantages of phenolics with the high dielectric strength, moisture resistant and non-corrosive properties of cellulose acetate.
2. **RESINITE 104** is a tough material suitable for stapling, severe forming and fabricating.
3. **RESINITE 8104** minimizes the effects of electrical property degradation characteristic of laminated phenolics when subjected to high humidity and temperature.
4. **RESINITE TruTork** provides an internally threaded or embossed form to fit any threaded core, regardless of diameter or threads per inch.
5. **RESINITE** gives torque control of plus or minus 1 inch ounce—axial pressure in excess of 25 pounds.

Ask us how you can save money by replacing expensive plastics with low-cost Resinite tubes for many applications involving high chemical or moisture conditions.

Get full information on Resinite Coil Forms. Request detailed technical literature.

RESINITE CORPORATION

Sales Representatives in:

California, Oregon, Washington: Covina, California, Edgewood 2-4693
 Illinois, Indiana, Iowa, Wisconsin, Missouri, Minnesota: Chicago, Illinois, ARmitage 6-5200
 Indiana, Ohio: Logansport, Indiana, Logansport 2555
 Northern Ohio: Cleveland, Ohio, Atlantic 1-1060
 New England: Framingham, Massachusetts, Trinity 3-7091
 New Jersey, Delaware, Washington, D.C., Maryland, Eastern Pennsylvania, Virginia, Metropolitan New York: Jersey City, New Jersey, Swathmore 5-2480
 Upper New York: Syracuse, New York, Syracuse 4-2141
 CANADA: Montreal, Quebec, Canada, Walnut 0337
 MEXICO: Mexico 6, D.F., Telephone 35-06-18

Division of

PRECISION PAPER TUBE COMPANY

2035E W. CHARLESTON ST. • CHICAGO 47, ILLINOIS

NEW PRODUCTS

(continued)

is 0.2 db. The vswr at the maximum 40-db attenuation is 1.15. In the range of 0.20-db insertion it is less than 1.1 vswr. This attenuator is micrometer driven, with the driving mechanism entirely free of backlash. Its dissipative element is an evaporated nichrome film on a glass plate.

A calibration chart is supplied with each instrument and it can be calibrated at any frequency upon request. The model WX-510 illustrated operates from 8.2 to 12.4 kmc. Circle P18 inside back cover.



TESTER

connects to all fuel gages

TELECTRO INDUSTRIES CORP., 35-18 37th St., Long Island City 1, N. Y. The MD-2 capacitor type fuel quantity gage tank unit tester meets all requirements of AF Spec MIL-T-4687. It combines a servo operated self-balancing three terminal capacitance bridge and an extremely accurate megohm meter. The capacitance bridge is designed specifically to measure capacitances to values of 5,000 $\mu\mu\text{f}$ in three ranges in increments as low as 0.1 $\mu\mu\text{f}$. Accuracy is better than 0.5 percent of full scale and measurements are read directly through the use of a main and vernier dial.

The megohm meter measures resistances to values of 10,000 megohms, in one range. This section of the unit features a log scale for higher accuracy. The MD-2 will find wide use in the measurements of leakage resist-

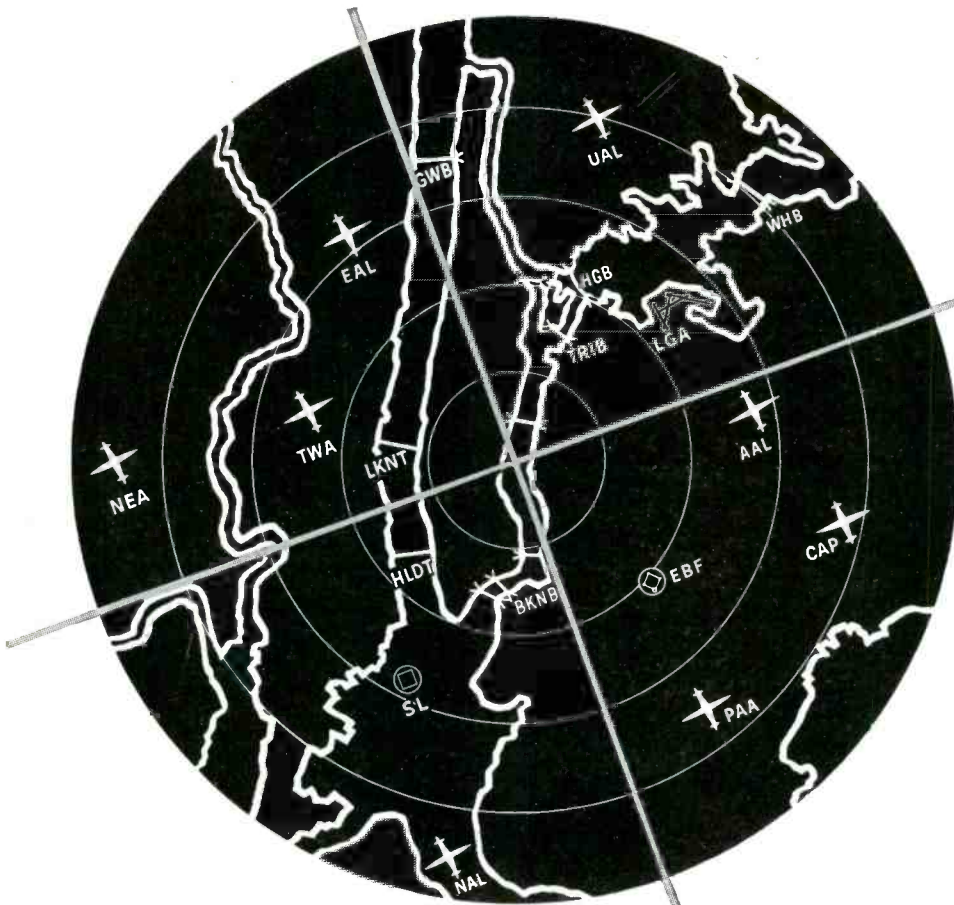

DESTINY ON DISPLAY
 IBM computer generated display presents moving "situation map" of the skies over New York City. Symbols represent commercial airliners and ground reference.

"INSTRUCTIONS" for a nation's safety!

Heart of America's air defense warning and control system—SAGE—is an IBM electronic computer. In split seconds, if the need should ever arise, the computer will be able to digest huge volumes of data on any invasion of hostile aircraft—report its findings *visually* on a scope! This display of computed data will enable watching airmen to issue "instructions" to defensive weapons with unprecedented speed and certainty.

Computers for SAGE are being produced and installed by IBM to help assure the Air Force of swift, fact-based tactical decisions. Thus IBM's systems engineering skill assists the military in bringing electronic exactness to the task of keeping America alert.

Engineers! Technicians! IBM offers exciting opportunities to work on computers, control systems, inertial guidance, microwave circuitry—the most wide-open field in the electronics industry.

IBM Laboratories and Manufacturing Plants are located in: Poughkeepsie, Owego, Endicott, Kingston, N. Y.; Rochester, Minn.; Lexington, Ky.; and San Jose, Calif.

Write: R. A. Whitehorne, International Business Machines Corporation, Room 401, 590 Madison Avenue, New York 22, N. Y.

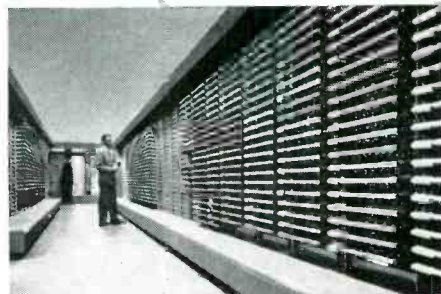

DATA PROCESSING
 MILITARY PRODUCTS

TIME EQUIPMENT
 ELECTRIC TYPEWRITERS

new

"Complete Protection"

miniature and sub-miniature

Continental Connectors

for external applications

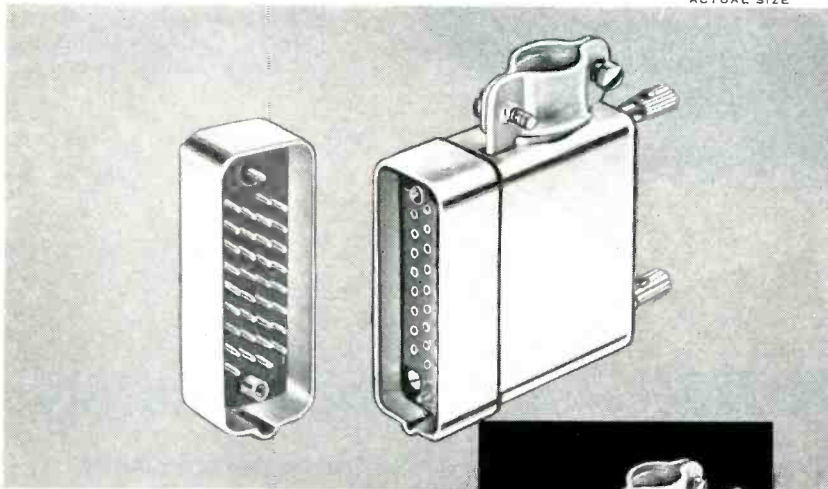

SM 34-20PSP

SM 34-20SSKH-1C

Aluminum shells now give complete protection on Miniature Series 20 and Sub-Miniature Series SM-20 with or without polarizing screwlocks.

These are the smallest and most reliable connectors available—ideal for both internal and external applications.

Complete enclosure except for mating surfaces is provided by the protective shells.

Available in 5, 7, 9, 11, 14, 20, 26, 34, 50, 55, 75, and 104 contacts, Series 20; and in 5, 7, 11, 14, 20, 26, 34, 50 contacts, Series SM-20 Sub-Miniature.

Connectors may be used without hoods and with protective shells only. Write for outline drawings showing shell and hood arrangements. ELECTRONIC SALES DIVISION, DeJUR-Amsco Corp., 45-01 Northern Blvd., Long Island City 1, N. Y.

* PAT. NO. 2746022

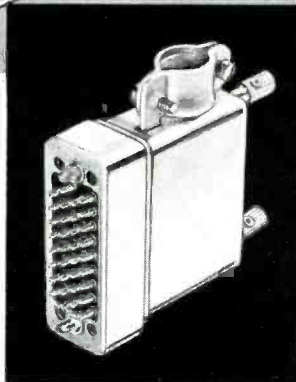

ELECTRICAL RATINGS:

Voltage Breakdown

At Sea Level 2100 Volts RMS
At 60,000 Ft. 750 Volts RMS

Contact Rating 5 Amps

Solder Cup #20 AWG wire max.

Meets requirements of MIL-C-8384

NEW PRODUCTS

(continued)

ance of cables and capacitances.

The tester is supplied with nine accessory cables for connecting to all types of fuel gages. Circle P19 inside back cover.



FERRITE ISOLATOR handles 200 kw peak power

KEARFOTT Co., INC., Western Division, 253 North Vinedo Ave., Pasadena, Calif., has available a new high power displacement absorption ferrite isolator, model W-167-1A. It is rated at 200 kw peak and 300 w average. Isolation is 17 db minimum and insertion loss is 0.5 db maximum. The vswr is approximately 1.1; unit weight, 18 oz; insertion length, 1.75 in. Circle P20 inside back cover.

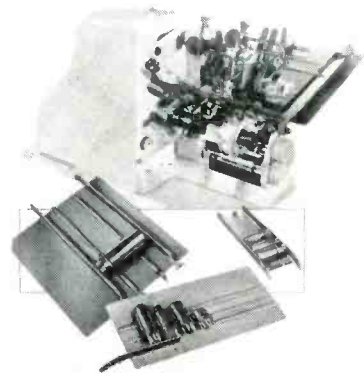

MARKING MACHINE for branding vacuum tubes

MARKEM MACHINE Co., Keene 59, N. H. Tube manufacturers can imprint trademark, company name, tube type designation and other details on vacuum tubes at rates as high as 7,000 per hour, on a cylindrical object-marking ma-

you're
always
sure
with

DeJUR

electronic
components

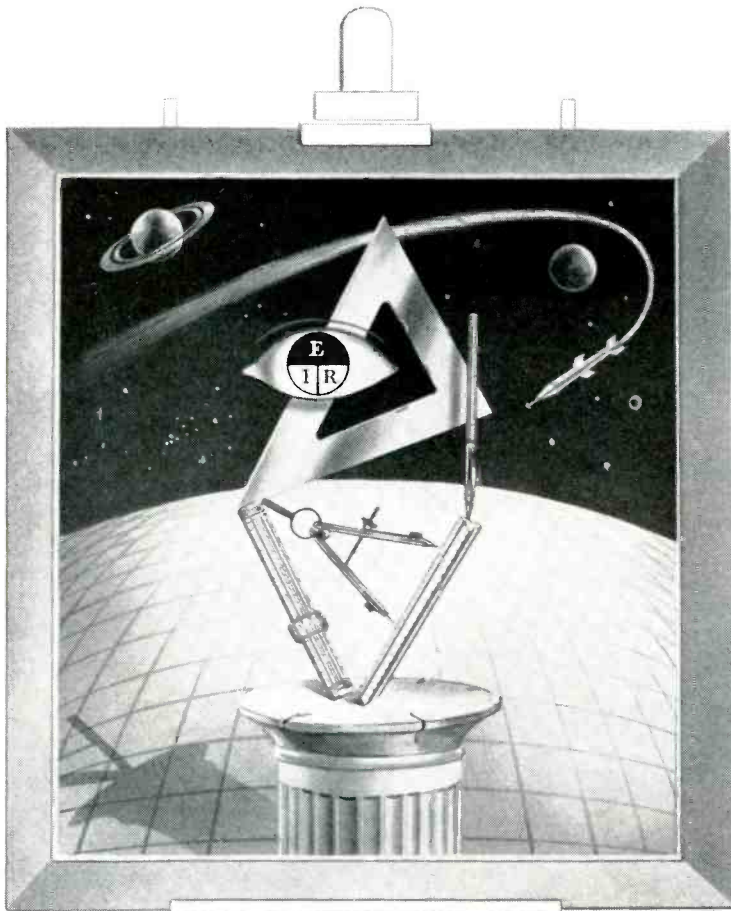

portrait: a modern electronics engineer

He is alert — scientific —
instinctively interested in progress.
He is a combination of science
and vision, of tools and thoughts.
But — above all — he is a man
seeking a secure professional
future and working toward
building that security.

He is the sort of man you'll find at LFE —
the sort of man LFE is seeking.

experienced
in the
following
fields:

AIRBORNE RADAR	AIRBORNE DOPPLER NAVIGATION
TRANSFORMER DESIGN	BLIND LANDING SYSTEMS
TRANSISTOR CIRCUITS	MACHINE TOOL CONTROL
MAGNETIC COMPONENTS	MAGNETIC RECORDING
MOVING TARGET INDICATORS	VIDEO INTEGRATORS
ELECTRONIC EQUIPMENT PACKAGING	DATA PROCESSING
COMMERCIAL AND MILITARY TEST EQUIPMENT	

WE OFFER: ▼

- Top starting salaries
- Unique educational advantages (100% of tuition — day and evening courses)
- Challenging and diversified projects
- Liberal employee benefits
- Excellent opportunity for advancement.

SEND RESUME or request for further information to:
DR. M. A. MEYER, CHIEF ENGINEER,

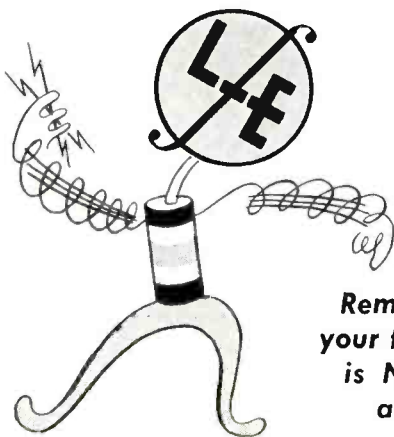

Remember
your future
is NOW—
at

LABORATORY FOR ELECTRONICS, INC.



BOSTON 14, MASSACHUSETTS

DeJUR high precision panel instruments

SERIES 100 Actual Size



1" Sealed Sub-Miniature—Meets smallest weight and space requirements. 9 meters can be mounted in only 3 3/4" square! Accuracy $\pm 3\%$ of full scale.

MODEL 131 3/4 Actual Size



1 1/2" Ruggedized Miniature—Special ruggedized features to withstand heavy duty operation. Sealed windows and terminals.

SERIES 647 1/2 Actual Size

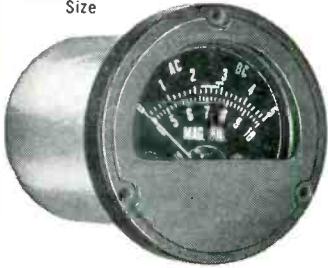

2 1/2" Multiple-Scale—Unique space saver. Provides up to 5 scales in all sensitivities. Sealed housing.

MODEL 150 3/4 Actual Size



1 1/2" Sealed Miniature—Easy one hole mounting. Sealed windows and terminals. Square model available on order.

Precision instruments by DeJUR provide a combination of compact design, accuracy and high quality. All DC models use external pivot D'Arsonval movements, and are housed in metal cases.

Our engineering department will be glad to help you with special scales, ranges or specifications. For the complete technical data sheets write to Electronic Sales Division, DeJUR-Amsco Corporation, 45-01 Northern Blvd., Long Island City 1, N. Y.

MODEL R-230 1/2 Actual Size



2 1/2" Ruggedized or Sealed—Withstands shock, vibration and temperature extremes. Sealed windows and terminals. Also available in 3 1/2" size.

SERIES HD-654 3/4 Actual Size



3 1/2" Elapsed Time Indicator—Easy to read 5 digit counters can be provided to register tenths of minutes or hours.

you're
always
sure with
DeJUR

chine recently developed.

The model 20A machine handles tubes ranging from miniature glass types to bulgy or pear-shape types, by means of five different interchangeable chutes. Chutes are marked according to the tube types they will accept, together with calibrated adjustment scales. Precision molded rubber printing elements and specially formulated marking compounds assure clear, attractive imprints. Chute feed and automatic ejection provide production speeds from 3,000 to 7,000 tubes per hour.

Specifications include dimensions of 26 by 13 by 18 in.; bench mounting; 1/4-hp motor drive; maximum imprint size 2 1/4 by 6 in. Circle P21 inside back cover.

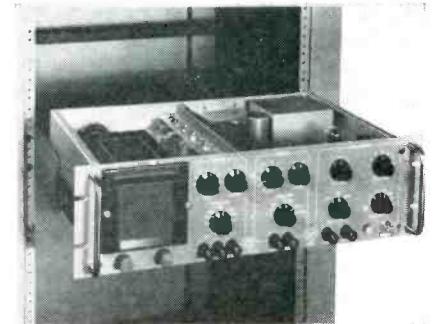

RACK PANEL SCOPE uses printed circuits

ELECTRONIC TUBE CORP., Philadelphia, Pa. Model K-10-R rack panel oscilloscope provides the equivalent of a 5-in. diameter viewing tube on its 3 1/2 in. sq crt. Overall size of the instrument is 5.25-in. high, 19-in. wide and 11.375-in. deep. Weight is approximately 22 lb. It uses printed circuits throughout.

► **Specifications**—The crt is type 41HAP1, square face plate, over-all voltage 1,500. Power requirements are 115 v a-c, 60 to 400 cps, ± 10 percent. Vertical amplifier sensitivity is 0.028 v p-p per in., and 0.3 v p-p per in., horizontal. The Z-axis intensity modulation is 2 to 56 v peak (negative) depending on intensity setting required to blank the beam.

Input impedance of the vertical amplifier is 2 megohms across 40 μf single ended and 4 megohms across 40 μf balanced; horizontal

McGraw-Hill Mailing List Will Help You

- Merchandise your advertising
- Conduct Surveys
- Get leads for your salesmen
- Get inquiries about your product or service
- Pin-point geographical or functional groups
- Sell Direct
- Build up weak territories
- Aid Dealer Relations

Direct Mail is a necessary supplement to a well rounded Business Paper advertising program.

600,000 actual names of the top buying influences in all the fields covered by the McGraw-Hill publications make up our 150 mailing lists. These lists are built and maintained primarily for our own use, but they are available to you for Direct Mail purposes. Pick out a list of YOUR prospects from our Industrial Direct Mail Catalogue.

More and more, progressive companies are using Industrial Direct Mail regularly as an advertising medium. They effectively allocate a portion of their ad budgets to this second medium at the same time as they concentrate on the best business publications.

For complete, detailed information about our service, fill in the coupon or write for your copy of our free Business and Industrial Direct Mail catalogue.

for Results



Mc GRAW-HILL
DIRECT MAIL LIST SERVICE

Direct Mail Division

McGraw-Hill Publishing Co., Inc.
330 West 42nd St., N. Y. 36, N. Y.

Please forward my free copy of the
McGraw-Hill "Industrial Direct Mail Catalogue."

NAME _____

COMPANY _____

ADDRESS _____

CITY _____ STATE _____

GET THEM NOW!

Prototype units and initial production requirements from
Guardian Franchised Distributors in U.S. and Canada.

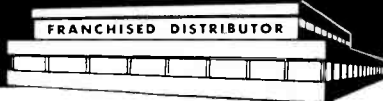

IMMEDIATELY AVAILABLE GUARDIAN POWER CONTROLS

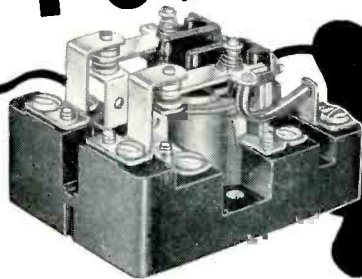

GUARDIAN
25 AMPERE
Interchangeable Coil
POWER RELAY
Built to Meet U/L Specifications

Control more power in less space with this new Guardian 25 AMPERE A.C. Power Relay for motor starting, heater loads and other heavy duty applications. Standard unit has double pole, double throw contacts rated at 25 amperes continuous duty, 230 volts A.C., with 75% power factor. Operating power requirement is 9.5 VA.; coil drain approximately .080 amperes at 115 volts, 60 cycles. Two easily accessible screws permit removal and replacement of completely interchangeable coil assemblies rated at 6 V.-24 V.-115 V.-or 230 V., A.C. Relay measures $3\frac{3}{8}$ " x $2\frac{1}{2}$ " x $2\frac{3}{16}$ ", weighs 11 oz.

Mounting: 2 holes for $\frac{3}{32}$ screws on $1\frac{1}{8}$ centers.

NEW! The GUARDIAN POWERLOID*

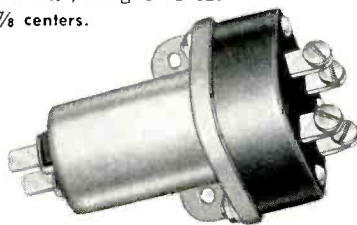

Designed and Tested for 230 V., A.C. Loads up to 3 H.P. Motors and 8400 Watt Heater Loads

A Guardian original—this new POWERLOID offers definite advantages which are far ahead of anything being offered for the electromagnetic control of motors

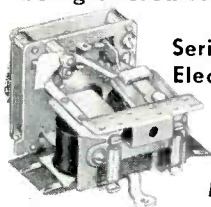

Series M. E. R.
Electrical Reset
Stepper

Write for
Stepper
Bulletin—P-84

and heater units. Available in a variety of contact combinations. Rugged, totally enclosed . . . low priced!

*An electromagnetic switch actuated by a solenoid plunger.

write — Arrange for delivery of Production Samples of Guardian's Power Relay and Powerloid. Send for Name of Nearest Franchised Distributor Who Carries IN STOCK a Complete Line of Guardian Industrial Relays—Power Relays—Powerloids—Reloids—Solenoids—Steppers—Switch Kits.

GUARDIAN  **ELECTRIC**
1625-A W. WALNUT STREET CHICAGO 12, ILLINOIS
"Everything Under Control"

amplifier, 2 megohms across 40 μf ; Z-axis, 0.2 megohm across 30 μf .

Frequency response, attenuation, linear sweep time and other technical data are available on request. Circle P22 inside back cover.

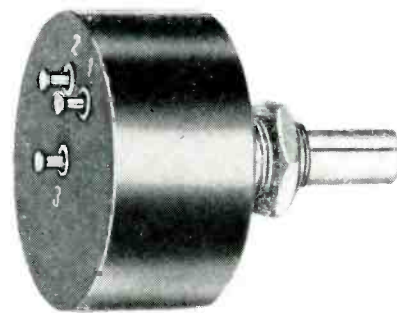

SINGLE TURN POT for instrumentation uses

ELECTROMATH CORP., 190 Henry St., Stamford, Conn. A new single turn potentiometer (13-100-1) with an operating temperature range of from -55 C to $+100$ C has wide application possibilities in instrumentation and general servo-mechanism uses. Weighing approximately $1\frac{1}{2}$ oz. it has a diameter of $1\frac{1}{8}$ in. and a length of $57/64$ in. beyond bushing. It has a total resistance range of 50 to 40,000 ohms, with linearity as close as ± 0.25 percent. Maximum dimensional stability, impact strength and heat dissipation are provided through one piece anodized aluminum alloy housing. A low torque of 0.5 oz.-in. permits use of smaller servos.

The unit has electrical rotation of 356 deg ± 2 deg continuous mechanical rotation, low noise level and long life. Up to eight taps can be added during manufacture with each tap welded to a single turn of resistance wire. Circle P23 inside back cover.

FUNCTION GENERATOR sine or square wave output

ENGINEERING SPECIALTY Co., 3100 Eldredge St., Salt Lake City, Utah. Model FG113 is a compact source of sine and square waves, with a frequency range of 0.1 to



120 cps. Maximum output is 24 v peak-to-peak for the sine wave and 16 v peak-to-peak for the square wave. Because the unit has a low frequency range, it is well adapted to servomechanisms work and transient studies as well as laboratory work, demonstrations and research. The generator also finds wide application in medical research and testing. A separate attenuator and monitor can be supplied with the generator to provide constant amplitude signals in the microvolt and millivolt region.

Weight of the model FG113 is 19 lb. Price is \$200. Circle P24 inside back cover.



UNIVERSAL ADAPTER can be used as a-c bridge

MILLIVAC INSTRUMENT CORP., 444 Second St., Schenectady 6, N. Y. The CM-21A Poly-Functionist is a combined shunt box and Wheatstone bridge which facilitates electrical measurements in chemistry and physics. It uses a 10,000-ohm,

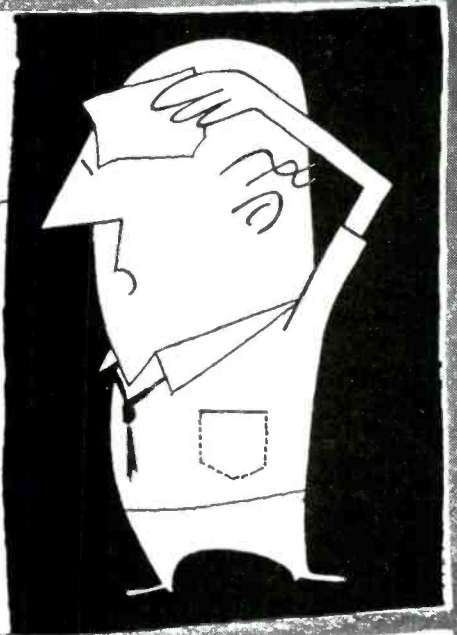
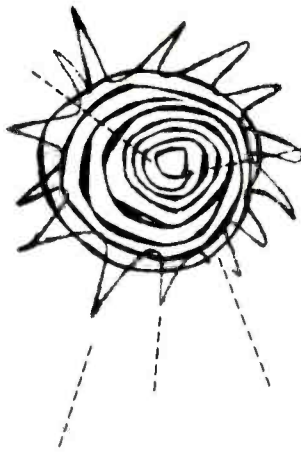

wherever

HIGH OPERATING TEMPERATURES
are a matter of fact

Then it's time to face the facts. Just any insulated wire or cable won't meet the test. But you can be sure that there's a Continental heat-resistant wire or cable that will. And when you meet high operating temperatures combined with moisture and corrosive vapor problems, the fact of the matter is ONE Continental wire that offers insulated advantages to meet your requirements all ways.

ELECTRONIC INSTRUMENT INSULATED WIRE

600-3000 volt service. Sizes: 32 AWG to 6 AWG inclusive. CONSTRUCTION: stranded tinned copper, polyvinyl insulation with or without nylon jacket. Maximum operating temperature: 100°C.

CONFORMS TO: MIL-W-16878B

COLOR CODED: 1, 2, or 3 spiral stripes over polyvinyl insulation.

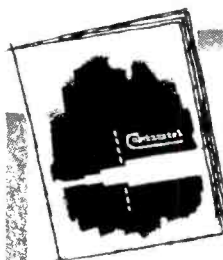

FACT-FILLED CATALOG

NEW, COMPLETE CATALOG OF CONTINENTAL INSULATED WIRE AND CABLE AVAILABLE ON REQUEST. WRITE TODAY.

Continental

WIRE CORPORATION

WALLINGFORD, CONNECTICUT • YORK, PENNSYLVANIA

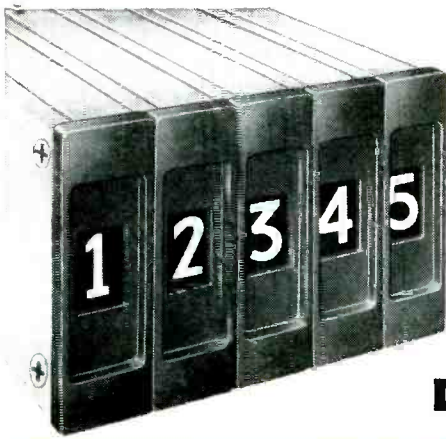

New

UNION

Digital Indicator

**combines data readout
and storage facilities**

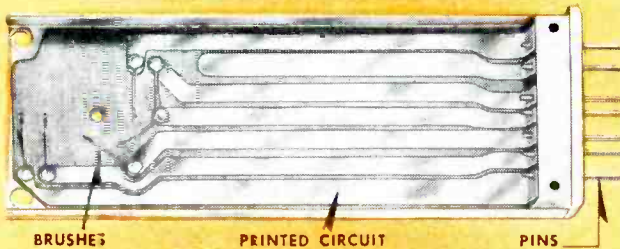

BRUSHES

PRINTED CIRCUIT

PINS

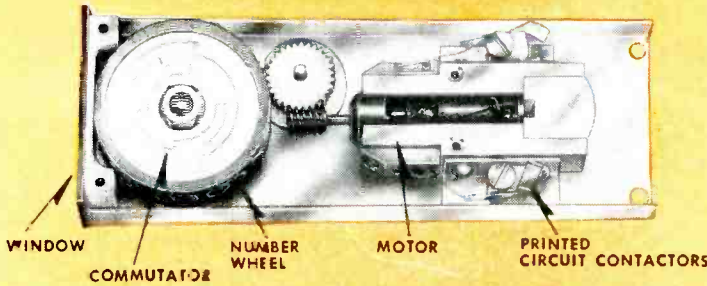

WINDOW

COMMUTATOR

NUMBER WHEEL

MOTOR

PRINTED CIRCUIT CONTACTORS

Physical characteristics: Over-all length... $5\frac{1}{8}$ "", width... $\frac{3}{32}$ "", height... $1\frac{1}{4}$ "", weight... .7 oz., operating time at 24 volts... .0.8 sec., life expectancy... 1,000,000 operations. Character size... $\frac{3}{8}$ " \times $\frac{1}{4}$ ".

The new UNION Digital Indicator will satisfy most requirements for data display, either local or remote. It is a companion product to our Alpha-Numerical Data Display Indicator, but occupies only one-half the volume and requires under three watts power.

The ability of the indicator to operate as a storage facility, a readout device, and its inherent non-dissipating storage give it characteristics not to be found in any other indicator of this type.

The indicator is motor-driven and operates on a direct wire basis in response to binary code. The coded

decimal notation was chosen for prototype to demonstrate more familiar uses, but other notations can be used.

A typical application in a pipeline remote control system works like this: Telemetered digital data on temperature and pressure is received at a central station and entered into an intermediate storage. From there it is routed to the appropriate digital indicators for visual display and electrical storage for time programmed input to a telelog printer. Each indicator can store four binary bits and eliminates the use of relays for this purpose. Write for our new Bulletin 1011.

NEW PRODUCTS

(continued)

10-turn Helipot control alternatively as a calibrated shunt for the measurement and recording of d-c currents or as the measuring arm of an a-c or d-c Wheatstone bridge.

When used as an a-c bridge, the Poly-Functionist delivers a polarized d-c output signal; it is positive if the resistance being measured is lower than the balancing value and negative if it is higher. Thus the CM-21A provides the possibility of making measurements in a calibrated unbalanced bridge condition with proper discrimination between above-par and below-par a-c resistances in the same manner in which a d-c bridge indicates a deviation of a resistance beyond and below the balance point. Circle P25 inside back cover.



TRANSFORMERS constant voltage type

THE JENSEN MFG. Co., 6601 S. Laramie Ave., Chicago, Ill., is now manufacturing a group of type ZC constant voltage transformers. They are designed expressly for the distribution systems commonly referred to as 70-v constant voltage systems.

The units are engineered to draw a predetermined amount of power from a 70-v line. All are mountable in W-1 weatherproof transformer cases with the exception of the ZC-3514.

Types ZC-100, ZC-200, ZCO-300 and ZC-400 are equipped with terminal board with a handy pin jack adjustment for the desired input power. Heavy duty screw terminals are provided for speaker and line connection. The transformers are completely impregnated and dip processed for

GENERAL APPARATUS SALES
UNION SWITCH & SIGNAL
DIVISION OF WESTINGHOUSE AIR BRAKE COMPANY
PITTSBURGH 18, PENNSYLVANIA

operation in outdoor and industrial atmospheres. Circle P26 inside back cover.

I-F CRYSTAL FILTER subminiature type

BURNELL & CO., INC., 45 Warburton Ave., Yonkers 2, N. Y., announces a subminiature i-f crystal filter for 455 kc designed to operate from a high- μ pentode (220 k ohms) to grid. The 9-kc wide pass band permits use of the filter in practically any communications or highly selective receiver with good fidelity of operation. The pass band is smooth and monotonic with no spurious responses that could permit the passage of other channels, images or harmonics. The insertion loss of 12 db is considerably less than most other i-f filters on the market and the attenuation is 50 db at a band width of less than 20 kc.

Size is $\frac{1}{8}$ by $1\frac{1}{16}$ by $2\frac{1}{4}$ in. high. Weight is $4\frac{1}{4}$ oz. It is designed to meet applicable portion of MIL-T-27 and other government specifications. Known as part No. S-17976, this filter is easily inserted in any interstage circuit with no other circuit modification necessary. Circle P27 inside back cover.



ELECTROLYTICS for computer power supplies

SPRAGUE ELECTRIC Co., 125 Marshall St., North Adams, Mass., has available a new series of high-capacitance electrolytic capacitors designed especially for filtering power supplies in digital computers and other applications, which require an unusual degree

UNION

Reliable Relays - AC & DC in stock for quick shipment

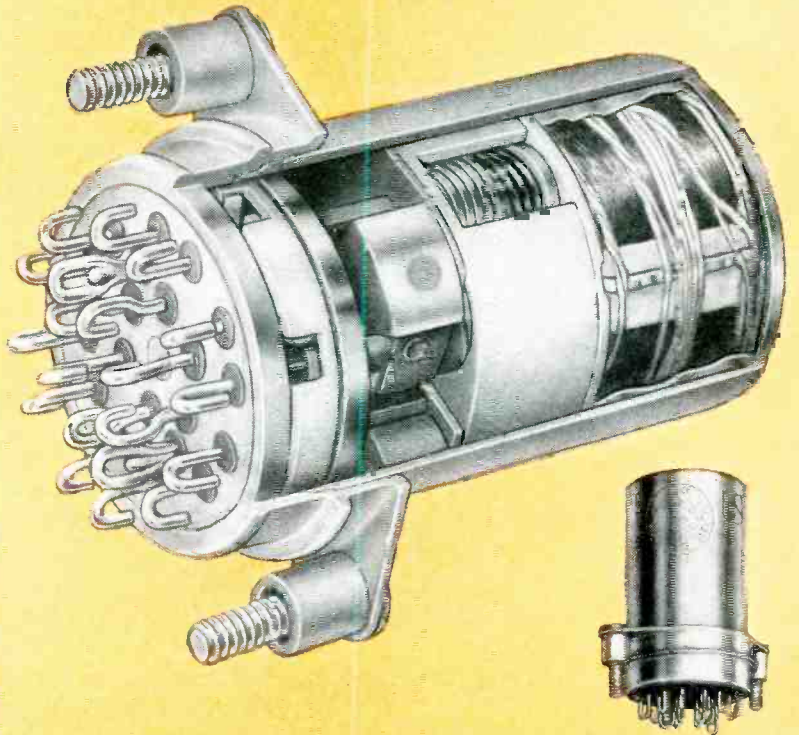

Cutaway view of AC Miniature Relay which includes a selenium rectifier of our own manufacture for highest reliability. Suitable for airborne circuits.

When you need miniature relays of utmost reliability, come to Union Switch & Signal. Our relays with gold alloy contacts have established a record for dependability unsurpassed in the industry.

And if you need relays in a hurry, you can get them. Any of the standard UNION DC or AC miniature relays can be shipped from stock. These include: (1) Plug-in mount, (2) Single screw mount, (3) Center of gravity flange mount, (4) Double screw mount, (5) Top flange mount, (6) Clamp mount, (7) Bottom flange

mount, (8) Flange mount.

Contacts can be gold alloy, which are especially fitted for dry-circuitry use, or palladium for general use.

Coil resistances up to 13,500 ohms.

Vibration resistance up to 2000 cycles at 30 G's and shock resistance in excess of 50 G's.

High life expectancy. Tested through 1,000,000 operations.

ALL UNION Miniature Relays meet or exceed the requirements of MIL-R-5757-C. Write for a copy of Bulletin 1010.

GENERAL APPARATUS SALES

 **UNION SWITCH & SIGNAL**

DIVISION OF WESTINGHOUSE AIR BRAKE COMPANY

PITTSBURGH 18, PENNSYLVANIA

20
TO
200 D.P.

SEND YOUR
PRINTS FOR
QUOTATION

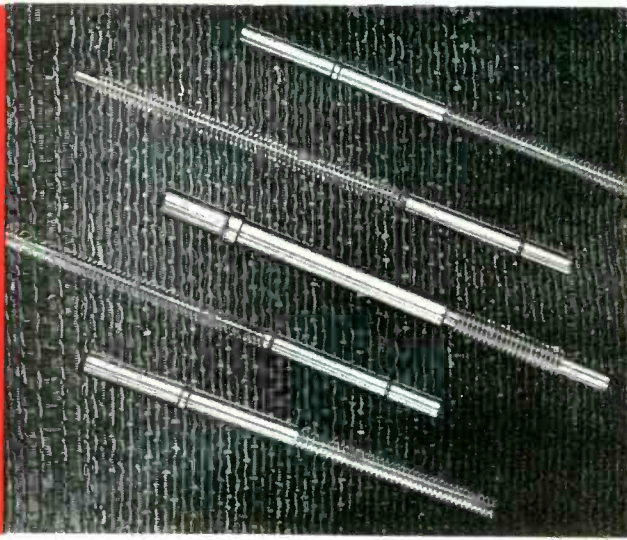

SPURS • HELICALS • WORM AND WORM GEARS • STRAIGHT BEVELS
LEAD SCREWS • RATCHETS • CLUSTER GEARS • RACKS • INTERNALS • ODD SHAPES

THE *Finest*

IN GEARS



Beaver Gear Works Inc.

1021 PARMELE STREET, ROCKFORD, ILLINOIS

Engineers who know
—SPECIFY

Q-max*

A-27 SUPERFINE
LOW-LOSS RF LACQUER

*Registered
Trademark

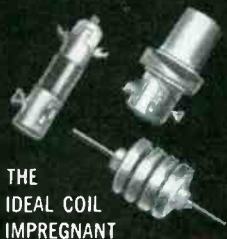

THE
IDEAL COIL
IMPREGNANT

• Q-Max, an extremely low loss dielectric impregnating and coating composition, is formulated specifically for application to VHF and UHF components. It penetrates deeply, seals out moisture, provides a surface finish, imparts rigidity, and promotes stability of the electrical constants of high frequency circuits. Its effect upon the "Q" of RF windings is practically negligible.

• Q-Max applies easily by dipping or brushing, dries quickly, adheres well; meets most temperature requirements. Q-Max is industry's standard RF lacquer. Engineers who now specify Q-Max! Write for new illustrated catalog.

COMMUNICATION PRODUCTS COMPANY • INC
MARLBORO, NEW JERSEY—Telephone: FReehold 8-1880



Pacific Coast Branch: 120 SANTA BARBARA ST., SANTA BARBARA, CAL.—Woodland 2-1712-4

of long and trouble-free service life.

Type 32D capacitors may be obtained in a complete line of ratings ranging from capacitances as high as 3,600 μf at 5 v to 700 μf at 350 v d-c working. They are listed in engineering bulletin 3441. The bulletin also describes the severe performance requirements which these capacitors will withstand. Copies are available on letterhead request. Circle P28 inside back cover.

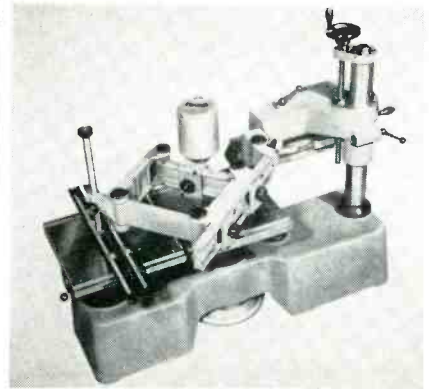

ENGRAVING MACHINE
versatile, precise, simple

SCRIPTA MACHINE A GRAVER, 7, Passage Turquetil, Paris 11, France, (with U. S. agents—George Scherr Co., 200 Lafayette St., New York, N. Y.). The Scripta model SR-3D is a three-dimensional pantographic machine tool of high precision and extreme versatility. It is designed to do engravings in relief or intaglio, as well as to reproduce diecasting moulds and embossing punches. No special skill or training is required to operate the machine.

Its principal feature is the pantograph, in the form of a parallelogram, one of the arms being extended to carry the stylus which traces the master and which produces corresponding movements, at a reduced scale, of the rotating engraving cutter. Ratios reduction on the pantograph (controlled by means of two screws) are from 2-to-1 to 6-to-1, enabling 23 different dimensions to be obtained from one guide. Maximum height of work accommodated under the pantograph is 5.3 in.; with an extra-long column, this is in-

creased to over 16 in. Surface covered at one setting with pantograph set for a 2-to-1 ratio is about 15½ in. by 9½ in.

Applications include engraving of nameplates, dials, panels and tools. Literature is available. Circle P29 inside back cover.



ETCHING SOLUTION in polyethylene bottles

TECHNIQUES, INC., P. O. Box 85, Hackensack, N. J., now offers its copper etching solution in convenient sized unbreakable polyethylene bottles, for engineers making prototypes of etched wiring boards. The quart size will etch 500 sq in. and the pint size will etch 250 sq in. of one ounce copper before exhaustion is reached. Circle P30 inside back cover.

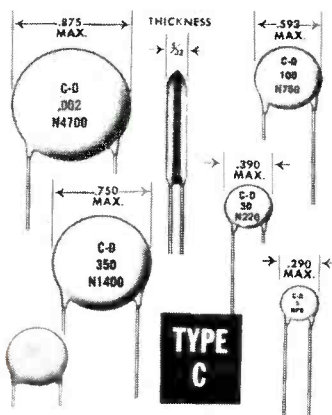

CERAMIC CAPACITORS temperature-compensating

CORNELL-DUBILIER ELECTRIC CORP., South Plainfield, N. J. The type C TinyMike disk capacitors are designed to provide linear capacitance change to correct for temperature drift of other circuit

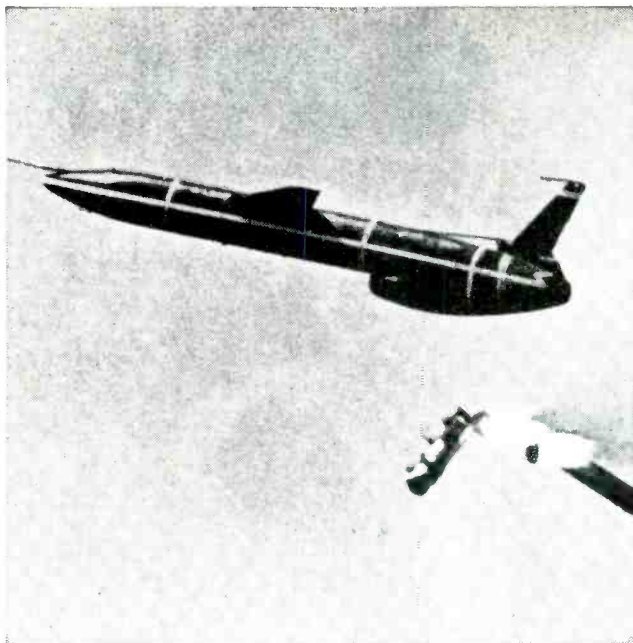

Photo courtesy of Northrop Aircraft, Inc.

High-speed control for high-speed missiles

Nowadays, target, aircraft, and missile speeds are too fast for human reactions. Automatic equipment makes ready, radar eyes take aim and a computer pulls the trigger.

Replacing men with machines on the firing line gives us a better chance for an interceptor kill or successful missile shot. And, today, we can't afford to miss. That's why reliability of every component is so important in modern fire control gear. And reliability is the main reason engineers—like those designing Northrop Aircraft's Snark missile (above)—so often pick Bristol's® Syncroverter® High-Speed relays (or the very similar Syncroverter chopper).

These high-speed relays have a normal life of billions of operations in dry circuit applications. They're available in SPDT and DPDT models with the typical characteristics listed below and in many variations.

And, of course, many critical applications other than fire control—such as air-to-ground telemetering, analog and digital computers, aircraft or missile navigation equipment, carrier current switching—can benefit from the outstanding reliability of Bristol's Syncroverter line. Write for complete technical data today. The Bristol Company 152 Bristol Road, Waterbury 20, Conn.

6.61

TYPICAL CHARACTERISTICS

Temperature range: -55°C to 100°C
 Operating shock: 30G; 11 milliseconds duration
 Vibration: 10-55 cps (see below, Mounting); 10 G
 Contact ratings: up to 35v, 45 microamperes
 Stray contact capacitance: less than 15 mmfd
 Pull-in time (including bounce):
 as low as 200 microseconds
 Drop-out time: 300 microseconds
 Life: Billions of operations
 Mounting: Octal tube socket; others available, including types for vibration to 2000 cps.

BRISTOL FINE PRECISION INSTRUMENTS
FOR OVER 67 YEARS

FANSTEEL

S.T.A. Capacitors

SOLID TANTALUM

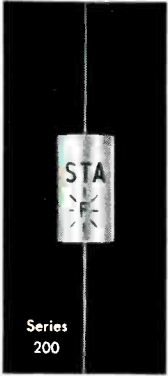

Small*

Stable**

Large Capacity***

*** How Small?.....**

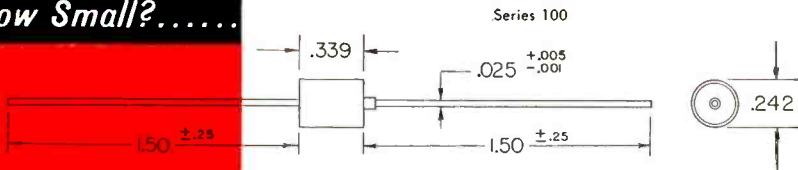

**** How Stable?.....**

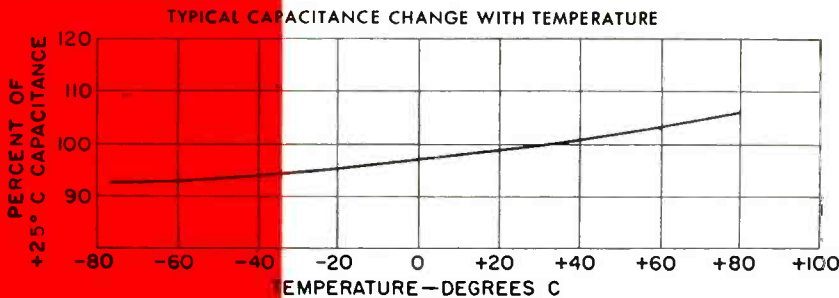

***** How Large?....**

Series 100	1 mfd at 35 volts
Series 200	5 mfd at 35 volts
Series 300	20 mfd at 35 volts

NOW AVAILABLE IN PRODUCTION QUANTITIES

(Write for bulletin 6.112)

FANSTEEL METALLURGICAL CORPORATION
North Chicago, Illinois, U.S.A.



TANTALUM CAPACITORS... DEPENDABLE SINCE 1930

elements, as in critical r-f tuning and resonant circuit applications. They are $\frac{5}{8}$ in. thick, insulated with a phenolic and high-temperature wax impregnated coating and are available in 13 standard temperature coefficients from P100 to N4700 in each of five sizes from 0.290 to 0.875 in. in diameter.

► **Ratings**—Working voltage is 600 v d-c, with higher ratings on special order. Capacitance tolerances available are ± 5 percent, 10 percent or 20 percent at 25 C in all temperature coefficient values—but not less than $\pm 0.25 \mu\text{mf}$ (P100 to N900). Maximum capacitance drift for P100 to P900 is 0.2 percent or $0.05 \mu\text{mf}$, whichever is greater; for N1400 to N4700, it is 2 percent or $0.25 \mu\text{mf}$, whichever is greater. Power factor is 0.1 percent maximum at 1 mc to N750; 0.5 percent maximum from N900 to N4700. These type C units meet the electrical specifications of RETMA Standard REC-107-A and JAN-C-20A. Circle P31 inside back cover.

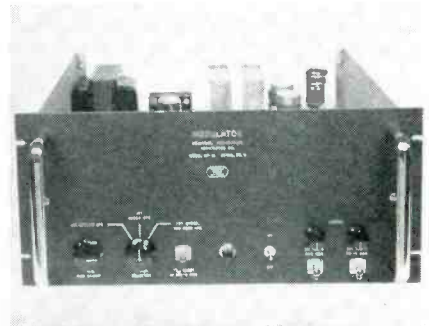

MODULATOR
for r-f signal sources

WEINSCHEL ENGINEERING, 10503 Metropolitan Ave., Kensington, Md. Model MO-1A is used to square wave modulate r-f signal sources including klystrons. It is used where high stability is required for the audio frequency of the modulated r-f signal. This is usually necessary in test set-ups utilizing narrow-band audio amplifiers.

A 1,000-cps tuning fork maintains the 1,000-cps square wave within 0.01 percent of this frequency.

The square wave output voltage is sufficient to modulate most com-

mercial medium-power klystrons.
 Circle P32 inside back cover.

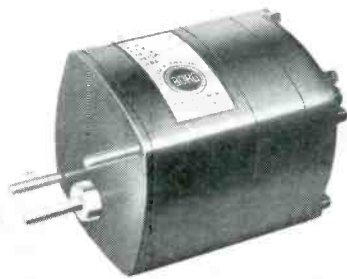

SMALL MOTORS
 subfractional h-p type

GEORGE W. BORG CORP., Janesville, Wisc., has announced an improved line of subfractional h-p motors for precision instruments. They are offered in a range of 1/2,000 to 1/750 h-p and are available in both synchronous and induction types, with or without gear trains.

Featuring ruggedness and dependability, the motors are designed for quality instrument application and find wide use in the industrial tv, recorder and instrument fields. End bells and gear train cases are die-cast alloys, precision machined to form a totally enclosed housing. Geared output shafts have two heavy bearing supports to accommodate radial loading. All gears are precision hobbled. The die-cast rotors are mounted on ball bearings for longer life and continued accuracy.

The company offers complete research, engineering and production facilities to help users solve design and production problems. Literature and complete engineering data are available. Circle P33 inside back cover.

HEAVY DUTY VIBRATOR
 runs 8-10 C cooler

JAMES VIBRAPOWR CO., 4050 N. Rockwell St., Chicago, Ill. Model J-28 heavy duty vibrator runs 8 to 10 C cooler than others. It is specifically designed for the two-way radio communications field where ambient heat problems require cool running components. This 6/12-v, seven prong, split

FANSTEEL SILICON RECTIFIERS



Small*

Wide Range**

High Performance***

* How Small?.....

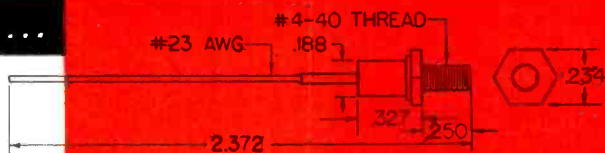

** How Wide?.....

Available in peak
 inverse voltage ratings from
 50 through 250 volts

*** How High?.....

Rated at 500 milliamperes
 without heat sink

Write us about your application



FANSTEEL METALLURGICAL CORPORATION

North Chicago, Illinois, U. S. A.

DEPENDABLE RECTIFIERS SINCE 1924

IBM needs

SEMI-CONDUCTOR ENGINEERS

Would you like to play a major role in the design, development and manufacture of transistors?

IBM now has challenging openings in the product development of semi-conductor devices for commercial data processing and airborne computers. There are unlimited opportunities for professional achievement and advancement in our new Semi-Conductor Engineering Laboratory and Manufacturing facility at Poughkeepsie, New York, and at our Airborne Computer Laboratories at Owego, New York.

If you are an electrical, mechanical or chemical engineer, physicist, metallurgist, or chemist with a B.S. or advanced degree and at least 2 years' experience in the design, development or manufacture of semi-conductor devices and materials, consider IBM's advantages:

Your advancement is based solely on merit.

IBM's growth is creating many unusually responsible career positions.

IBM serves large and small businesses, science, education, government and the military, assuring stability and continued growth.

Liberal company benefits and excellent salaries.

Family educational and country club facilities.

Moving and travel expenses paid.

Write, giving details of education and experience, to:
R. A. Whitehorn, IBM, Dept. 401, 590 Madison Avenue,
New York 22, New York.

IBM

INTERNATIONAL
BUSINESS MACHINES
CORPORATION

DATA PROCESSING • ELECTRIC TYPEWRITERS • TIME EQUIPMENT • MILITARY PRODUCTS

NEW PRODUCTS

(continued)

reed vibrator performs better and lasts longer because of its intrinsic cool operating characteristics. **Circle P34 inside back cover.**

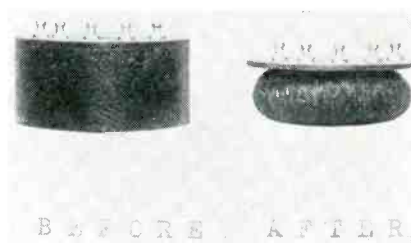

RESIN SOLVENT reclaims electronic parts

RAM CHEMICALS, P. O. Box 192, Gardena, Calif. Labeled De-Solv 292, a new liquid chemical compound disintegrates epoxy or polyester resins in which electronic components and electronic systems have been imbedded, simply by immersing the electronic units in the solution. Then the usable parts may be salvaged or the defective parts can be replaced before reencapsulating.

The cost of reclaiming electronic components with De-Solv 292 is negligible since labor is virtually eliminated and the solution can be reused again and again. It will not harm phenolic base systems such as printed circuits. The solution is available in 1, 5 and 50-gallon containers. Complete information and prices may be had on request. **Circle P35 inside back cover.**



CURVE TRACER for all triode transistors

SONEX, INC., 245 Sansom St., Upper Darby, Pa. Model CT-103 transistor curve tracer, when used with an oscilloscope, presents one curve at a time of the collector family, with I_b held constant. This

may be done on all *npn*, *pnp*, surface barrier, grown or diffused junction transistors. The base current is indicated at all times on a 4-in. panel meter and can be varied from 0 to 500 μ a. The collector current can sweep out to 10 ma while the limits of collector voltage being swept are controlled. Calibrated coordinate axes are displayed at all times.

Another use for the curve tracer is the presentation of the forward and reverse characteristics of crystal diodes with the calibrated axes. The voltage versus current characteristic of thermistors and varistors can also be displayed simultaneously with calibrated axes. Circle P36 inside back cover.



ATTENUATORS

Beer's type units

ARENBERG ULTRASONIC LABORATORY, INC., 94 Green St., Jamaica Plains 30, Mass. Model AT693 precision attenuators have a range of 0 to 121 db in 1 db steps. Impedance is 93 ohms. Accuracy is 1 db maximum, absolute error; $\frac{1}{2}$ db, relative error. Frequency range is 0 to 100 mc; power level, 1 watt maximum. Circle P37 inside back cover.



A-C RATIOMETER with five-digit read-out

ELECTRO INSTRUMENTS, INC., 3794 Rosecrans St., San Diego 10, Calif., has announced a completely auto-

NEW PACKAGE
CRYSTAL and OVEN

HIGHER STABILITY

BETTER AGEING FACTOR

HERMETICALLY SEALED



BTC-2

The plug-in BTC-2 incorporates an all-glass vacuum mounted crystal plus integral temperature stabilization for high precision frequency control at 75°C. or 85°C.

For example, this hermetically sealed package will stabilize within .00004% at 5 mc at -55°C. ambient. In this instance, frequency shift due to ageing will not exceed .0002% during first year of service.

Available at specified frequencies from 4 kc to 125 mc. Write for Bulletin #497.

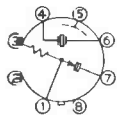
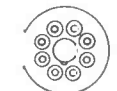
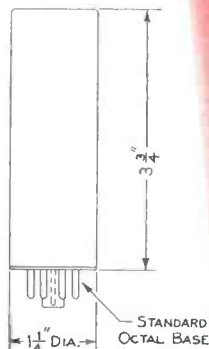

WIRING DIAGRAM



BLILEY ELECTRIC COMPANY
UNION STATION BUILDING • ERIE, PENNSYLVANIA

Electro-Pulse presents a New

FAST PULSE GENERATOR

- Output Flexibility
- Advanced/Delayed Operation
- Direct Coupled Pos. or Neg. Pulses

ECONOMICAL ...

... FAST RISE TIME

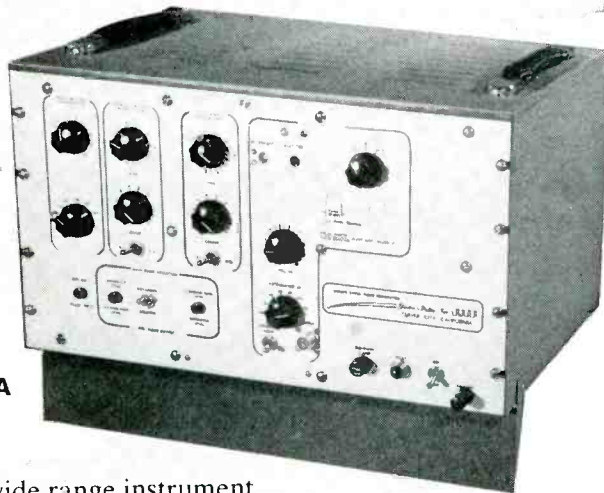

Model 2125A

A wide range instrument designed for the economical generation of fast rise time pulses at low impedance. Direct coupled output at ground potential minimizes waveform problems, and optional use of internal load allows provision of full power to low impedance loads and optimum waveform to higher loads.

- 90 V Amplitude Open Circuit, 50 V into 50 Ohm Load
- .02 μ s Rise Time
- 10 CPS to 100 KC Rep. Rate
- 0 to 100 μ s Delay or Advance
- .1 to 100 μ s Pulse Width
- 60 DB Attenuator.

Write for Complete Data: Our Bulletin 2125A/E

The Model 2125A Pulse Generator is the latest addition to the Electro-Pulse line of electronic instrumentation which includes Precision, Variable, and Megacycle Pulse Generators, Pulse Code Generators, Pulse Oscillators, Time Delay Generators, and Electronic Counting Equipment.

Model 2120A PRECISION PULSE GENERATOR

Representatives in Major Cities

EP Electro-Pulse, Inc.

11861 TEALE STREET, CULVER CITY, CALIFORNIA
Telephones: EXmont 8-6764 and TEXas 0-8006

matic a-c ratiometer for measuring, with no phase shift error, the ratio of two a-c voltages, E_1 and E_2 , where E_1 is derived from E_2 and E_2 drives both the bridge of the ratiometer and the test unit.

Measurements are displayed digitally on the in-line five-digit read-out. In operation, a-c voltages are converted to d-c and the d-c voltages presented. The instrument is particularly suited for transformer testing, precision tachometer and resolver testing and for checking a-c computing networks.

► **Partial Specifications** — Ratio range is 0.0000 to 1.0999. Sensitivity is 0.1 mv. Accuracy is ± 2 digits. Read-out time is 1 second. Complete specifications and price information are available from the manufacturer. **Circle P38 inside back cover.**



METAL FILM RESISTANCE CARD

RESISTANCE CARDS for microwave attenuation

FILMOHM CORP., 48 W. 25th St., New York 10, N. Y. The new metal film fibre glass plastic resistance card is highly stable microwave attenuator material. The base is a fine weave glass cloth impregnated with high temperature thermosetting resin. Resistance is a thin film of pure metals, approximately 50 millionths of an inch thick, uniformly deposited on one or both surfaces of the plastic. A protective coating is provided over the metal film.

► **Specifications**—Resistance range is 25 ohms per square to 750 ohms

per square. Standard tolerance is +10 percent. The standard card is 5 in. wide by 12 in. long, exclusive of colloidal silver terminals. Thickness is 0.025 ± 0.003 or 0.032 ± 0.003 . Maximum surface temperature should be limited to 130 C. Circle P39 inside back cover.

ANTENNA FEED used in scatter systems

GENERAL BRONZE CORP., Brach Div., 711 Stewart Ave., Garden City, N. Y., has developed an antenna feed for use with parabolas in scatter communication systems. It has a gain of approximately 35 db at 755 mc with a 30-ft parabola and covers a bandwidth of 755 to 985 mc with a vswr of less than 1.2 with the majority of the frequency range running less than 1.1 or better. Circle P40 inside back cover.

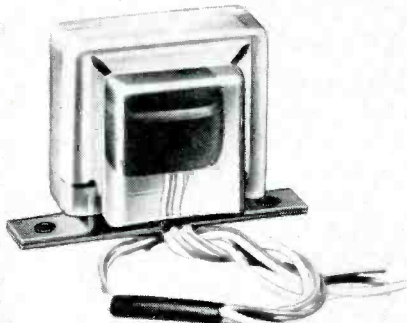

NEW COMPOUNDS for encapsulating purposes

TELECTRO INDUSTRIES CORP., 35-18 37th St., Long Island City 1, N. Y., has available new encapsulating compounds for all industrial and commercial applications. They are available in three distinct types and formulas—transparent, flexible and foam.

The transparent compound is quick setting in 15 minutes at 180 F, is inexpensive, consists of only two components and is easily released from the molds. The flexible type is an epoxy formulation that features variable flexibility, is considerably less expensive than other epoxy formulations and consists of only two components. The foam com-

Lest confusion reign

Once there was a Prospect who wanted a small, fast relay that would respond to the direction of flow of current, and which would do it at least a few million times. He journeyed from Source to Source, asking his questions with straightforward hopefulness. But everywhere the answers were equivocal, with nary a single "Yes" or "No." There were moments when he *thought* a center off type for differential operation was just what he wanted, but he became uncertain after losing the ability to distinguish between spring bias and the everyday human variety. At other times, also, in the company of other Sources, his hopes rose when answers about "speed" began "will handle 750 pulses per second..." (here was the way *he* liked to hear people talk), only to sink again when followed by such words as "... depending, of course, on the amount of excitation expressed as a net pulse level." Long before, he had abandoned Pinning Down, and had begun a desperate attempt at Keeping Up. But finally he realized he sought in vain; a relay to meet his requirements could not possibly be described simply. He wandered away, head bowed — crumpled fragments of data sheets fluttering after him.

Series 72 HIGH SPEED RELAY

With what may seem like undue pride, we only wish this wretched soul had stumbled on one of our devices, namely the Sigma 72 relay. Not that the language of our literature is so pristine, wholly untouched by the jargon of the Trade, but we could have told him that our 72

is an SPDT relay which responds to direction of current flow.

In correctly designed circuits, takes about 0.2 milliseconds for transferring its contacts and is intended for high speed switching up to 500 pulses per second.

Gives practical value to its high operating speed by switching a 60 ma. 110VDC inductive load half a billion times on the average without maintenance.

Allows repair and adjustment by the user (detailed manual and test set available).

By comparison, takes up little space ($1\frac{7}{16}$ " dia. x $2\frac{5}{8}$ " high) and is lightweight.

Bulletin on request.

SIGMA

SIGMA INSTRUMENTS, INC.,
62 Pearl Street, So. Braintree, Boston 85, Massachusetts

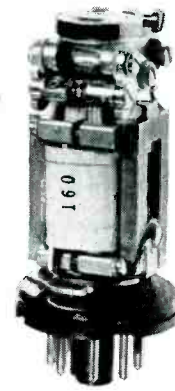

POLARIZED
TRADE & MARK
ANODIZED
TRIPPING POINTS
MAGNETIC LATCH-IN

ELECTRICAL SYMMETRY
LOAD CIRCUIT PARAMETERS

PERSONAL BIAS

DIFFERENTIAL OPERATION

CENTER-STABLE, SIDE SADDLE

PERCENT-BREAK

NIP AND TUCK

75% CONTACT EFFICIENCY



0 CPS to 1 MC!
DIRECT READING

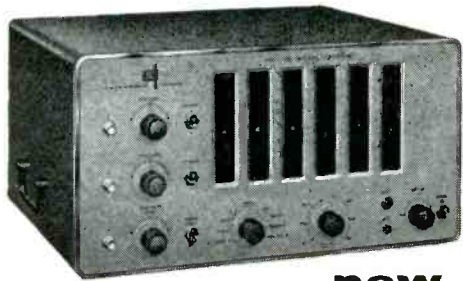

new
Computer-Measurements Model 226A

UNIVERSAL COUNTER-TIMER

OUTSTANDING FEATURES:

- ★ Three independent, adjustable trigger level controls permitting full rated sensitivity at any voltage level between -300 and +300 volts.
- ★ Small voltage increments ordinarily masked by attenuators are easily selected.
- ★ Simplified color-coded controls and direct read-out in kc, mc, sec, or millise, with automatic decimal point indication.
- ★ Oscilloscope marker signals facilitate start and stop trigger level adjustment for time interval measurement of complex waveforms.

A brand new, multi-purpose instrument provides precision measurement of frequency, frequency ratio, period (1/frequency) and time interval. Pressure, velocity, acceleration displacement, flow, RPS, RPM, etc., may also be measured with suitable transducers. The 226A may be used as a secondary frequency standard.

price: **\$1,100.00**

Long Term: 3 parts per million per week
 Display Time: Automatic: Continuously variable 0.1 to 10 seconds
 Manual: Until reset
 Input Impedance: 1 megohm and 50 mmf
 Trigger Level: Continuously adjustable from -300 to +300 volts
 Accuracy: ± 1 count \pm stability
 Secondary Frequency Standard: 1 mc; 100, 10, 1 kc; 100, 10, and 1 cps
 Dimensions: 17" W x 8 $\frac{3}{4}$ " H x 13 $\frac{1}{2}$ " D approx.
 Weight: 50 lbs. approx.

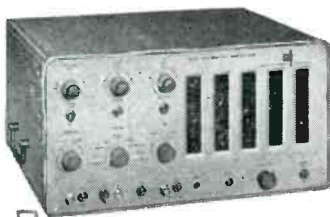

MODEL 225A 0 cps-100 kc
UNIVERSAL COUNTER-TIMER

Similar to the 226A in design. Featuring Oscilloscope Trigger Level Marker Signals; Three Direct-Coupled Inputs of 70 mv sensitivity; Direct Reading, Automatic Illuminated Decimal Point. Easily portable. Price: \$840.00

Data Subject to Change Without Notice - Prices F.O.B. Factory

Write for complete specifications on the new 226A and the 225A models and the complete CMC line of electronic counting and controlling equipment.

Computer-Measurements Corporation

5528 Vineland Avenue, North Hollywood, Calif. Dept. 78A

FREQUENCY

SPECIFICATIONS:

FREQUENCY MEASUREMENT

Frequency Range:
0-1,000,000 cycles per second
Input Sensitivity:
0.2 volt rms.
Direct-coupled input
Time Bases:
0.00001, 0.0001, 0.001, 0.01, 0.1, 1 and 10 seconds. Also can use external 0-1 mc standard

PERIOD MEASUREMENT

Period Range:
10 microseconds to 1,000,000 seconds
Frequency Range:
0.000001 cps to 100 kc
Input Sensitivity:
0.2 volts rms.
Direct-coupled input

Gate Times:

1 and 10 cycles of unknown frequency
Standard Frequency Counted:
1 mc; 100, 10, 1 kc; 100, 10, 1 cps; external 0-1 mc.

TIME INTERVAL MEASUREMENT

Range:
3 microseconds to 1,000,000 seconds
Start and Stop:
Two independent or common channels
Positive or negative slope
Input Sensitivity:
0.2 volts rms.
Direct-coupled input
Standard Frequency Counted:
1 mc; 100, 10, 1 kc; 100, 10, 1 cps; external 0-1 mc.

GENERAL

Stability:
Short Term: 1 part in 1,000,000 (temperature-regulated crystal)

NEW PRODUCTS

(continued)

pounds are available in various densities and require low temperatures up to 150 F for curing. They readily flush air when expanding and the finished casting is easily removed from the mold.

The company will supply these compounds in any quantities or will encapsulate your products at a reasonably low price. Circle P41 inside back cover.

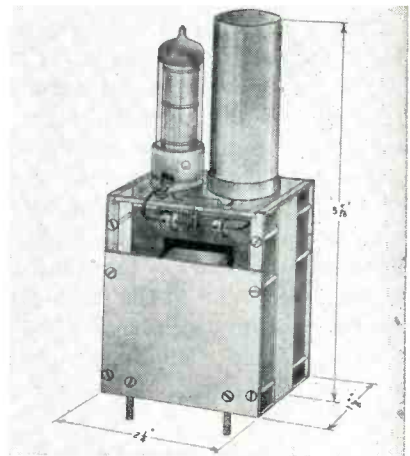

POWER SUPPLY
low-capacitance unit

ELCOR INC., P. O. Box 354, McLean, Va. Model A105-15 Isoply is the first of a series of isolated power supplies, featuring low shunt capacitance. A special transformer construction and mounting of the rectifiers and filtering circuit allows the entire secondary circuit to be capacitively as well as conductively isolated from ground.

The low value of shunt capacitance (20 μ mf) makes the supply suitable for use in a wide variety of high-speed, direct-coupled circuits that require an ungrounded power supply.

This Isoply features a regulated 105-v output conservatively rated at 15 ma maximum current. The unit operates directly from 110 to 125 v, 60-cycle a-c. Price is \$49.50. Circle P42 inside back cover.

MEGOHM DECADE BOX
for calibration purposes

EASTERN PRECISION RESISTOR CORP., 675 Barbey St., Brooklyn, N. Y., has announced a new standard megohm decade box. The ten re-

FREQUENCY • TIME INTERVAL • PERIOD • FREQUENCY • TIME INTERVAL • PERIOD • FREQUENCY • TIME INTERVAL • PERIOD • FREQUENCY



cc-30

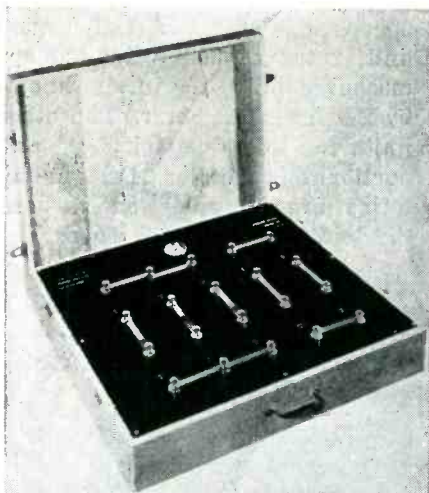

sistors in the unit are 100,000-ohm precision wire wound; accurate to ± 0.005 percent absolute; matched to within 0.002 percent absolute. The temperature coefficient of resistance wire is 0.000005 per deg C. Resistors are calibrated at 25 C.

By use of the gold plated links provided, it is possible to select any resistance value from 10,000 ohms to 1,000,000 ohms in intermediate steps. This is accomplished by placing the resistors in series or parallel circuits. Since each resistor is terminated to individual terminal posts, it is possible to employ a single resistor as an arm of a resistance bridge or as many as 10 individual resistors in as many circuits.

This megohm decade box is 26 by 22 by 6 in. Circle P43 inside back cover.

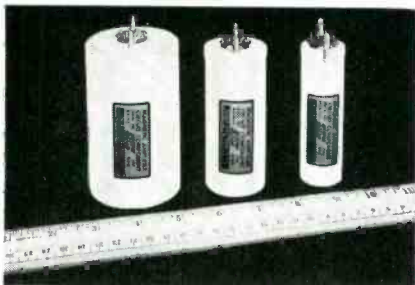

CIRCUIT COMPONENTS
magnetic amplifier type

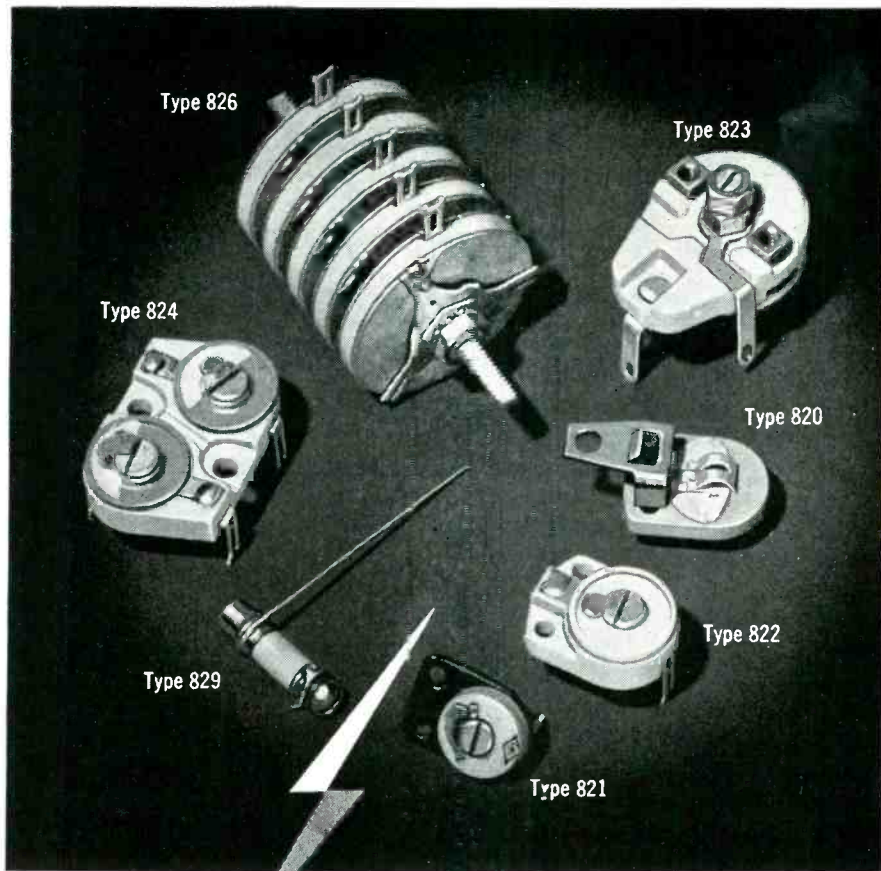

ADLER ELECTRONICS, INC., One Le-Fevre Lane, New Rochelle, N. Y. Maximag magnetic amplifier circuit components are a new line designed as building blocks which can be used to assemble any of the well-known basic circuits for fast response and high gain.

Three basic sizes are available



cRL The most complete line of Ceramic Trimmer Capacitors

Eight standard types. Special designs engineered to specifications.

-  Rotors and stators ground optically flat, to insure dependability and accurate retrace.
-  Lightweight rotors always in balance and under heavy spring pressure. Provide excellent stability under vibration without special locking device.
-  All units easily adjusted. Full capacity range is obtained with 180° rotation. Equal stability is maintained at any position from minimum to maximum.

All units rated
600 V. D. C. W.,
1500 V. D. C. test
Capacity range from
.5 to 125 mmf.
Small size—light weight
Power factor less than
0.2% at one megacycle

For further information,
write for Technical Bulletin 42-101R1.

Centralab

A DIVISION OF GLOBE-UNION INC.

914A East Keefe Avenue • Milwaukee 1, Wisconsin
In Canada: 804 Mt. Pleasant Road, Toronto, Ontario

D-2356

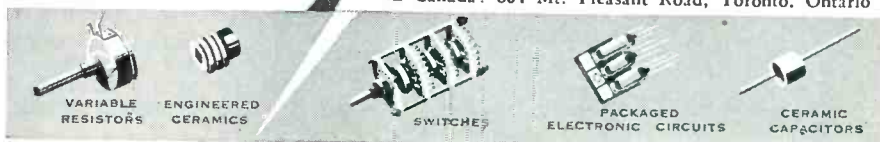

**True Hermetic Sealing
assures Maximum Stability**

in **AMPERITE** **RELAYS and REGULATORS**

Simplest • Most Compact • Most Economical



STANDARD



MINIATURE

Thermostatic **DELAY RELAYS** **2 to 180 Seconds**

- Actuated by a heater, they operate on A.C., D.C., or Pulsating Current.
- *Hermetically sealed.* Not affected by altitude, moisture, or other climate changes.
- *SPST only* — normally open or normally closed.

Amperite Thermostatic Delay Relays are compensated for ambient temperature changes from -55° to $+70^{\circ}$ C. Heaters consume approximately 2 W. and may be operated continuously. The units are most compact, rugged, explosion-proof, long-lived, and — *inexpensive!*

TYPES: Standard Radio Octal, and 9-Pin Miniature

Also — **Amperite Differential Relays:** Used for automatic overload, under-voltage or under-current protection.

**PROBLEM? Send for
Bulletin No. TR-81**



POWER SUPPLY for h-v applications

TELECTRO INDUSTRIES CORP., 35-18 37th St., Long Island City 1, N. Y. Model 922 30-kv regulated power supply is designed specifically as a laboratory instrument or as a production tool. It can be used for all h-v applications such as power supply for kinescope, testing capacitors, testing cables, testing transformers and other dielectric materials, electrostatic painting and precipitrons. It is supplied on a single chassis $19\frac{1}{4}$ by 18 by $14\frac{1}{4}$ in. high suitable for mounting in a standard relay rack.

► **Specifications** — Model 922 requires a 105 to 125 v, 60-cps source, consumes 300 va and delivers from 0 to 30 kv d-c at 0 to 0.5 ma. Regulation is better than 0.1 percent and ripple is less than 0.1 percent rms. Output voltage and current are read on $4\frac{1}{2}$ -in. panel-mounted meters and all controls are easily accessible on the front panel. **Circle P44 inside back cover.**

BALLAST REGULATORS

Amperite Regulators are designed to keep the current in a circuit *automatically regulated* at a definite value (for example, 0.5 amp.) . . . For currents of 60 ma. to 5 amps. Operate on A.C., D.C., Pulsating Current.

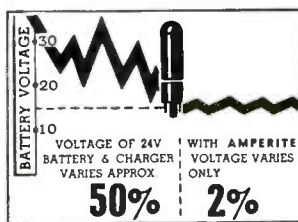
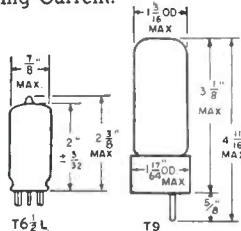

T9 BULB



Hermetically sealed, they are not affected by changes in altitude, ambient temperature (-55° to $+90^{\circ}$ C.), or humidity . . . Rugged, light, compact, most inexpensive.

Write for 4-page Technical Bulletin No. AB-51

AMPERITE CO., Inc.
561 Broadway, New York 12, N. Y.
Telephone: CAnal 6-1446

In Canada: Atlas Radio Corp., Ltd.
50 Wingold Ave., Toronto 10, Ontario.



Individual inspection and double-checking assures top quality of Amperite products.

CONVERTER

uses seven transistors

WAUGH ENGINEERING Co., 7842 Burnet Ave., Van Nuys, Calif. Model FR-301 transistorized converter accepts variable frequency input signals from turbine flowmeters or a-c tachometer gener-

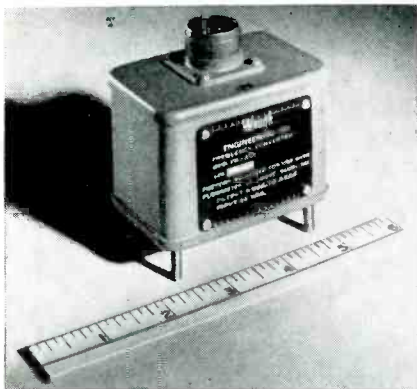

ators and converts them to a 0 to 5-v signal suitable for telemetering. The converter is intended for use in guided missiles and piloted aircraft where fluid flow rates must be telemetered to the ground. It is housed in a 3 by 2 by 2½ in. box with a single aircraft-type electrical connector. Span adjustment is included to give 5-v output for a wide range of input frequencies. Output voltage is linear with frequency within 0.2 percent of full scale and varies less than 0.2 percent for a 5-percent variation in the 28-v supply. Usable temperature range is -60 F to +170 F. Circle P46 inside back cover.

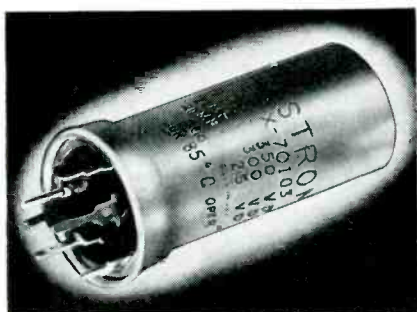

ELECTROLYTIC
for printed circuits

ASTRON CORP., 255 Grant Ave., East Newark, N. J., has manufactured an electrolytic specifically designed for printed circuits and automatic assemblies.

Style EY electrolytic features the SM safety margin construction which will withstand surge voltage and momentary overloads, without permanent damage. Hermetically sealed, the EY is extremely reliable in tropical, hot and humid climates.

Available in a wide range of values, this electrolytic utilizes pure foil and a special high-gain

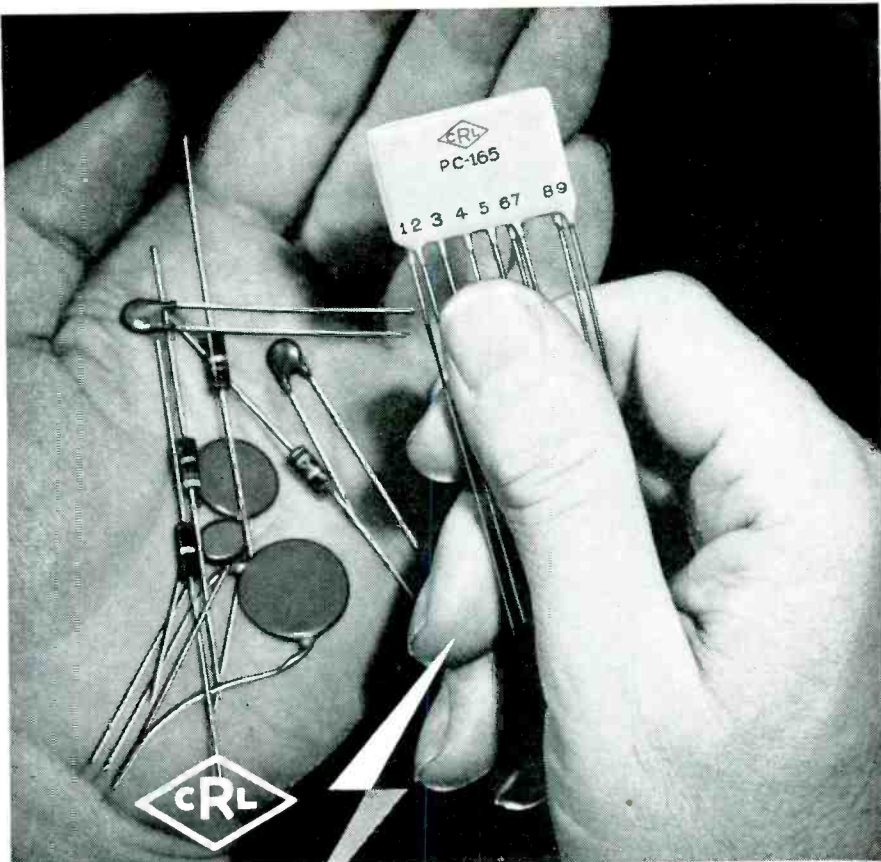

1 packaged electronic circuit
replaces 9 separate components!

60,000,000 Centralab P.E.C.'s like this — in various component values — are being used by leading manufacturers

A Centralab Packaged Electronic Circuit is a *complete circuit* which includes capacitance, resistance, and often inductance — in addition to wiring.

Design one compact package into your equipment, instead of several individual parts, to . . .

- . . . reduce inventory
- . . . reduce size
- . . . reduce weight
- . . . eliminate wiring errors
- . . . reduce assembly cost
- . . . improve circuit stability

Centralab P.E.C.'s pass all Mil-R-11A and Mil-C-11015A requirements within their range.

Over 160 standard P.E.C. designs are available for your immediate use. For special requirements, call on Centralab engineers — but *early* in the planning stage, *before* you've "frozen" your design.

Write for Centralab
Printed Electronic
Circuit Guide No. 3 —
and Technical Bulletin
42-227.

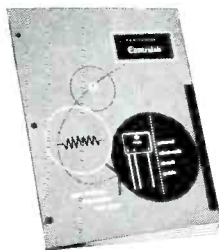

*Trademark

Centralab

A DIVISION OF GLOBE-UNION INC.

914A East Keefe Avenue • Milwaukee 1, Wisconsin
In Canada: 804 Mt. Pleasant Road, Toronto, Ontario



Build into your transmitter



this handful of assurance

MicroMatch Directional Couplers* measure RF Power and VSWR—giving you, the designer, positive confirmation of your transmitter's performance and providing your customer with a monitor that constantly watches his transmission line and antenna.

Built into major military communications and ballistic missile programs, these compact, rugged—and low cost—couplers produce an output essentially independent of frequency over the range of 3 to 4000 megacycles. They are adjusted for full scale meter deflection at power levels of 1.2 watts to 120 KW. Accuracy of power measurement is plus or minus 5% of full scale.

WRITE FOR OUR 50-PAGE CATALOG ... OR SEE PAGE 323 OF ELECTRONICS BUYERS GUIDE FOR MORE INFORMATION



**WHEN MICROMATCH® IS BUILT IN—
YOU KNOW WHAT'S GOING OUT**

*U. S. Letters Patent No. 2,588,390



M. C. JONES ELECTRONICS CO., Inc.
BRISTOL, CONNECTICUT

NEW PRODUCTS

(continued)

etch process to assure dependable operation. Clearly marked for easy installation, the EY is designed to save costs and assembly time. Circle P47 inside back cover.

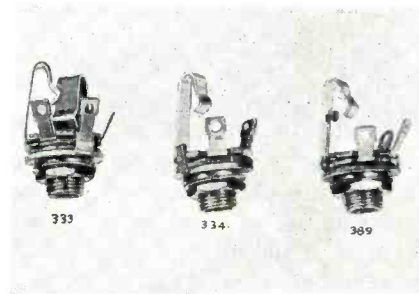

PHONE JACKS
to military specifications

RICHARDS ELECTRORAFT, 3741 North Kedzie Ave., Chicago 18, Ill., are now producing jacks that meet exacting military specifications. These Han-D jacks require a minimum of panel space and depth behind panel. Assured electrical contact is provided by positive pressure from nickel silver springs. Notched insulating washers that engage both spring blades and terminals provide a positive locking arrangement that restricts shifting of electrical connections or changes in adjustment.

Currently supplied in three models, No. 334 (JAN type JJ-034) is a 2-conductor open circuit jack, No. 389 (JAN type JJ-089) provides a 2-conductor closed circuit and No. 333 (JAN type JJ033) is a 3-conductor open-circuit type. All have heavy brass nickel plated frames and fit any standard mating plug. Circle P48 inside back cover.

PRODUCTION TEST SET
for tv tubes

RESEARCH ELECTRONICS LABORATORIES, Roslyn, Pa. Model 303 automatic push button production test set for tv tubes has been announced. Provision for complete testing include: regulated power supplies, automatic current regulated gas ratio meter, protected meter circuitry, autoadjusting yoke assembly, chain drive rotary ion trap, individual circuit break-

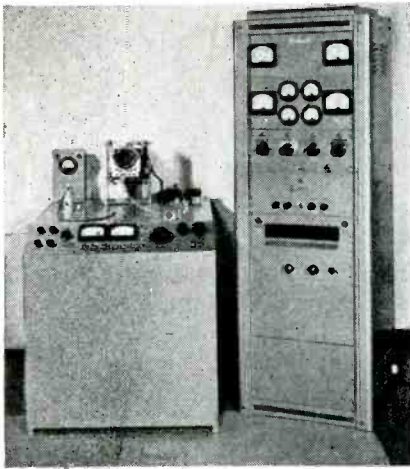

ers for each power supply, functionally placed control knobs, zero centered leakage meters reading either polarity, built-in preheater and short checker, high voltage protective series resistors, plug-in relays and a pin point dot pattern video generator. Price is \$3,530. Circle P49 inside back cover.

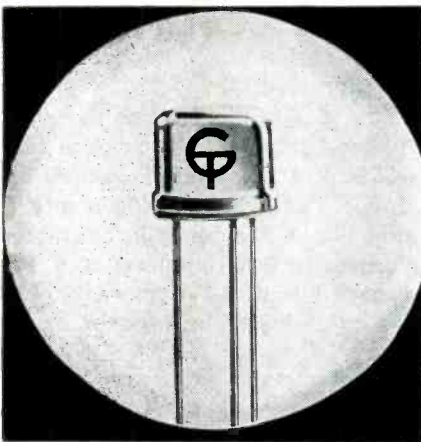

JUNCTION TRANSISTOR
germanium *pn*p type

GENERAL TRANSISTOR CORP., Richmond Hill, N. Y., has announced the production of a new germanium *pn*p alloyed junction three-lead transistor. Known as type GT-109, it is designed primarily for use in l-f push-pull stages such as audio amplifiers, portable radio receiver output stages and l-f r-f amplifiers. Used in class B circuitry, the GT-109 offers high efficiency and low battery drain.

The entire unit is hermetically sealed in a metal case with glass headers. The tinned flexible leads may be soldered into the circuit or used with standard plug-in sockets. They may also be mounted in



(Shown Actual Size)

Here's the famous Revere glaswitch *in a relay* . . . individual contact pairs hermetically sealed . . . immune to contact contamination and mechanical "bugs" . . . operating time less than 2 milliseconds. Tamper proof . . . small . . . easily stacked. Used for telemetering read-out and many other applications. Suitable for explosive atmospheres.

The Revere glaswitch relay shown consists of an actuating coil and four SPST magnetically operated, hermetically-sealed glaswitches. Assembly is mounted in shock-resistant rubber and enclosed in a steel housing for magnetic shielding and protection. Relays can be stacked in any combination without interaction; number of contacts can be varied; 6, 12, 24 or 48 V.D.C. coils, mounting and plug-in provisions to suit specific applications.

CHARACTERISTICS (24-Volt Coil):

- Contact Rating: At 28 V.D.C.: 0.5 amp inductive (L/R = 0.026) or resistive.
- Contact Form: Normally open or normally closed.
- Contact Surface: Electro-plated rhodium.
- Sensitivity: Approximately 500 milliwatts.
- Operating Time: 4.5 milliseconds at 24 volts D.C.
1.9 milliseconds at 50 volts D.C.
- Temperature Rise: 10°C. at 24 volts D.C.
(Continuous) 30°C. at 50 volts D.C.
- Contact Life: 100,000 cycles guaranteed at rating specified above; increases rapidly as load decreases.
- Small Size: 0.88" x 0.88" x 3.25"

* Revere trademark



glaswitch* relay
... hermetically sealed contacts

LIGHTNING RESPONSE . . . LOW CAPACITANCE

How would you apply it?

- HIGH SPEED SWITCHING
- LOW CAPACITANCE REQUIREMENTS
- DRY CIRCUIT SWITCHING
- EXPLOSIVE ATMOSPHERES
- HIGH CYCLING REQUIREMENTS
- PULSE CIRCUITS

Send for Engineering Bulletin 1061

Revere CORPORATION OF AMERICA

WALLINGFORD, CONNECTICUT, A Subsidiary of Neptune Meter Company

*Ah
precision!*

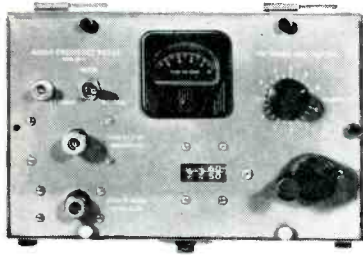

FREQUENCY METER MODEL 802B

Range of 2350 to 10,500 megacycles covers the most used frequencies. Veeder-root digital counter provides accurate, legible readings which are referred to calibration charts for frequency in megacycles to rated accuracy of 0.2% without calculation. Completely self-contained with built-in detector and indicating meter.

SLOTTED LINES MODELS 319 THROUGH 324

Six portable models, incorporating carriage drive mechanism integral with wave guide assembly measures VSWRs and impedances from 2600 to 18,000 megacycles per second, covering wave guide sizes from 3 X 1½ inches to .702 X .391 inches. Can be used with all standard military and commercial RF probes and detectors.

COMPLETE LINE OF COAXIAL AND WAVEGUIDE INSTRUMENTS INCLUDES:

DIRECTIONAL COUPLERS	SLOTTED LINES
TERMINATIONS	BENDS
FREQUENCY METERS	ATTENUATORS
HORNS	STANDARD REFLECTIONS
TUNERS	BOLOMETERS
ECHO BOXES	THERMISTORS

FREE ILLUSTRATED CATALOG

contains much valuable data



any position. Circle P50 inside back cover.

DUO-TRIODES three new types

STATE LABS INC., 649 Broadway, New York 12, N. Y. Ericsson of Sweden announces 3 new types in their ruggedized-longlife series of electronic tubes, the 2C51/2C51L, 18C51 and 407A. Each tube is a duotriode, medium-mu, 9-pin miniature, suitable for a variety of applications in amplifiers, mixers and oscillators. The triode sections are internally shielded and independent of each other except for the common heater, making the tubes useful in cascode amplifiers.

All tubes are constructed for maximum service, life expectancy being well above 10,000 hours. Extreme care in processing and use of pure nickel cathode sleeves insure freedom from interface formation and suitability for on-off application. The tubes are highly resistant to impact shock and vibration.

The 2C51/2C51L has a 0.3-ampere heater at 6.3 v, while the 18C51 is rated at 0.105 ampere at 18 v. The 407A has a center-tapped heater and may be operated in series at 0.050 ampere, 40 v, or in parallel at 0.1 ampere, 20 v. Circle P51 inside back cover.

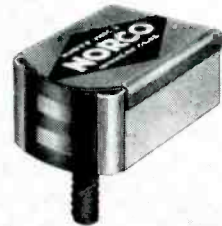

MAGNETIC HEAD for recording and playback

THE NORTRONICS Co., 1015 S. Sixth St., Minneapolis 4, Minn., has announced the model TLD in-line magnetic head for low-cost, high quality recording and reproduction in stereophonic sound applications. The head can be compensated for flat response between 30 and 10,000 cps at 7.5 ips. It is



the **narda**
corporation

160 HERRICKS ROAD, MINEOLA, N. Y. • PIONEER 6-4650

COMPLETE INSTRUMENTATION FOR MICROWAVE AND UHF

compact and will provide long wear, negligible oxide accumulation, excellent rejection of surrounding fields and uniformity of frequency and amplitude response.

This new head features precision ground and lapped gap, balanced electric and magnetic structure, high output and precise colinear alignment. The active tape surfaces do not pass over any epoxy resin or plastic surfaces, thereby eliminating the need for frequent cleaning even under humid conditions. The head is suited for use in new equipment, design, replacement and for conversion of existing tape recorders to stereophonic tape phonograph equipment. Detailed dimensional drawings, specifications and prices are available. Circle P52 inside back cover.

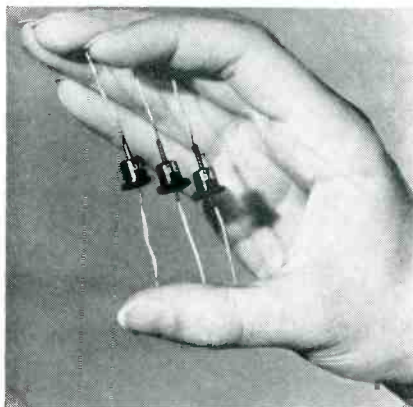

SILICON RECTIFIERS low-current type

GENERAL ELECTRIC Co., Syracuse, N. Y., announces three new types of low-current silicon rectifiers. They are designed for use in aircraft and other airborne computers, guided missiles, magnetic amplifiers, and electronic and electrical equipment operating at high temperature.

► **Ratings**—The rectifiers, RETMA type designated 1N536, 1N539 and 1N540, are rated respectively at maximum peak inverse voltages of 50, 300 and 400 v. Maximum allowable rms voltages are 50, 300 and 400 v; maximum allowable rms voltages are rated at 35, 210 and 280 v respectively.

Ambient operating temperature for the series is from -65 to 165 C

potter

Standard Radio Noise Filters

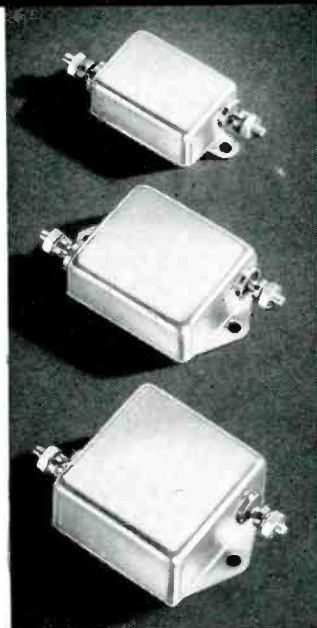

SMALL SIZE

LIGHT WEIGHT

HIGH TEMPERATURE
OPERATION

SPECIFIC PERFORMANCE
CURVES FURNISHED
ON EACH UNIT

SCREW TYPE
COMPRESSION GLASS SEALS

VIBRATION RESISTANT

SMALL SIZE: Can for 5 to 25 ampere unit measures only 1 3/4" x 1 1/4" x 3/4". Other sizes in proportion. Tolerance: (general) ± 1/32" (mounting centers) ± 1/64".

LIGHT WEIGHT: 5 to 25 ampere unit weighs only 72 grams; 10 to 50 ampere unit 135 grams; 20 to 100 ampere unit 202 grams.

HIGH TEMPERATURE OPERATION: Continuous duty operation at full rated amperage up to 125°C. Up to 5 times rated amperage at low temperatures and intermittent duty.

SPECIFIC PERFORMANCE CURVES ON EACH UNIT: Graphs* show exact performance to be expected for each unit under outlined condition of load current and ambient temperature. Current ratings from 2 1/2 to 100 amperes.

SCREW TYPE COMPRESSION GLASS SEALS: (1) provide a hermetically sealed unit (2) withstand torque up to 14 pound inches and (3) are 100% fungus resistant.

VIBRATION RESISTANT: Internal components "locked" in place by thermo setting resin fill. New triangular mounting ears on both the 10 and the 20 ampere units.

* Request informative bulletin.

THE **potter** COMPANY
Specialists in Layer Wound Capacitors Since 1925
1930 SHERIDAN ROAD, NORTH CHICAGO, ILL.

ENGINEERS & PHYSICISTS

Electronics

APL-An Organization Of And For Technical Men And Scientists

The applied Physics Laboratory (APL) of the Johns Hopkins University is an organization of and for technical men and scientists. Several factors allow for more effective utilization of "mind power" at APL. They lead to tangible and intangible satisfactions for staff members that could not be gained elsewhere.

Among them are:

1. Individual staff members are given a measure of responsibility and initiative much greater than in many comparable establishments. Decision-making, on all levels, is placed in the hands of scientists and technical men.
2. Staff members do not restrict their efforts to limited technical problems. Instead they are asked to assess and solve problems of a systems nature, including analyses of complete tactical problems.
3. APL handles technical direction of the work of many associate and sub contractors, including 21 universities and leading industrial organizations. As a result, APL staff members enjoy a rewarding exchange of ideas and techniques with other leaders in R & D.
4. The combined facilities of APL, its associate and sub contractors, and Government test stations provide opportunities for members of its technical staff to develop and exploit their varied capabilities in a unique environment where teamwork and individual initiative are fused.
5. This esprit and freedom to look into new concepts has resulted in a number of "quantum jumps" in defense capability, including the proximity fuze, the first supersonic ramjet engine, and the Navy's Bumblebee family of missiles which includes TERRIER, TALOS and TARTAR. APL is presently attempting breakthroughs on several important fronts.

APL'S expansion program recently witnessed the completion of new laboratories covering 350,000 sq. ft. in Howard County, Maryland, equidistant from Washington, D. C. and Baltimore. Men of originality are invited to inquire about staff opportunities. Salaries compare favorably with those of other R & D organizations.

OPENINGS EXIST IN:

ANALYSIS: Dynamic analysis of closed-loop control systems; analysis and synthesis of guidance systems; counter-countermeasures systems; electrical noise and interference.

DESIGN: Control and guidance circuitry; telemetering and data-processing equipment; microwave components, antennas, and radomes; transistor and magamp applications; external missile systems.

TEST: Prototype engineering and field test evaluation.

For Additional information write: Professional Staff Appointments

The Johns Hopkins University Applied Physics Laboratory

8609 GEORGIA AVENUE,

SILVER SPRING, MD.

NEW PRODUCTS

(continued)

with storage temperature rated at -65 to 175°C . Maximum rated output current for the series is 750 ma at an ambient temperature of 50°C . At an ambient temperature of 150°C , all the rectifiers have a maximum rated output current of 250 ma. The full load forward voltage drop is a maximum of 0.5 v at 150°C .

As many rectifiers can be used in series as needed to obtain the desired voltage rating. The new types are hermetically sealed in metal cases, having glass-to-metal seals for maximum reliability. **Circle P53 inside back cover.**

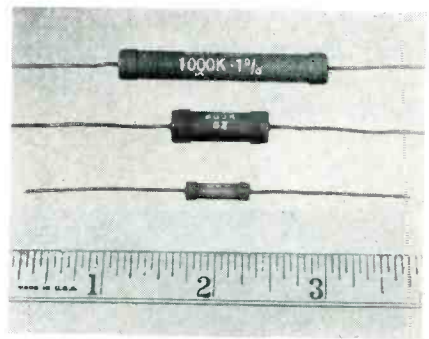

GLASS RESISTORS high-temperature, film-type

CORNING GLASS WORKS, Corning, N. Y. High-temperature, precision, film-type glass resistors with widely increased resistance ranges are available. Resistance ranges of the type S resistors have been increased by a factor of 10. Maximum resistance has been increased in the $\frac{1}{2}$ -w resistor to 100 K ohms; in the 1-w resistor to 400 K and in the 2-w to 1 megohm.

The resistors are capable of operating at temperatures up to 200°C . Even at 120°C this resistor can carry the full room-temperature wattage of any standard precision film resistor of the same size. They meet all the requirements of military specifications MIL-R-11804B.

These resistors are recommended particularly for missile systems and other high-temperature circuitry. Temperature coefficients on the improved resistors have been reduced to ± 300 ppm per deg C. The new glass resistors are manufactured by permanently bonding a metallic oxide to Pyrex brand glass rod at red heat. Both core

and film are impervious to moisture. Circle P54 inside back cover.

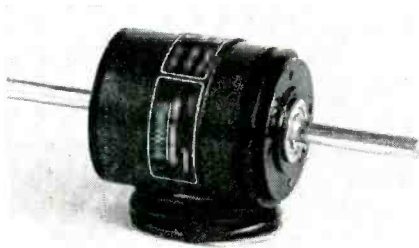

FRICITION CLUTCH
magnetic type

DYNAMIC INSTRUMENT CORP., 59 New York Ave., Westbury, L. I., N. Y., announces a magnetic clutch for application in low power servo-mechanisms. The unit has successfully met stringent military, environmental and performance specifications. Standard models are designed to operate on 24 v d-c, delivering a minimum of 50 oz in. of torque. Response time is within 3 milliseconds. Endurance tests reveal no reduction in performance when tested at rated load, and high speed for one million cycles. The unit introduces a maximum of two minutes angular displacement error into the system upon engagement. Power consumption is 3 w. Circle P55 inside back cover.

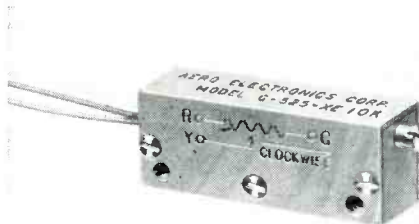

POTENTIOMETER
miniature trimming type

AERO ELECTRONICS CORP., 2311 West Burbank Blvd., Burbank, Calif. A new miniature trimming potentiometer features unusual ruggedness, stability and long life. For maximum rigidity, body and cover are made of aluminum. Both are U shaped, the cover being precision-fitted to the body—a construction which resists warping and twisting under extreme

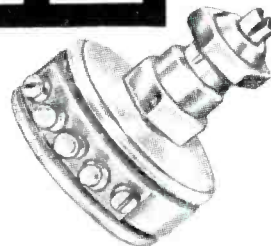
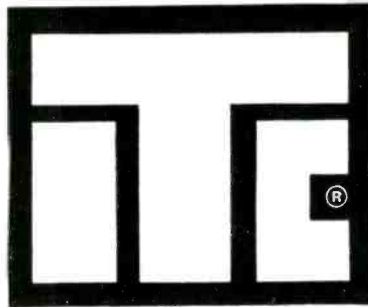
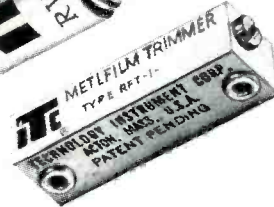
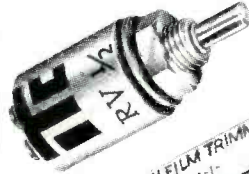
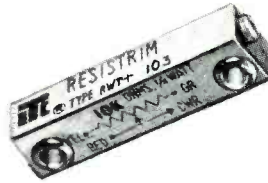

The TIC Trimmer Potentiometer Line includes units from 1/2 inch to 1 inch in size . . . 50 to 100K ohms in resistance . . . -55° C to +145° C temperature range . . . power ratings up to 4 watts. Advanced mechanical design provides extremely precise, stable adjustments under all forms of adverse environmental conditions.

TIC was the originator of the high stability subminiature trimmer pots. For example the original metal-film potentiometer, the TIC RFT Metfilm, represents the outstanding advance high stability trimmer potentiometer design. The RFT contains a resistance element of metallic film that provides infinite resolution for ultra-fine trimming. Compactness of the RFT permits stacking 7 to the square inch. Latest addition to the TIC Trimmer Line is the new low cost RWT which, like the RFT, provides adjustment by use of a 25-turn lead screw.

Complete information on the TIC Trimmer Potentiometer Line is available upon request.

- Threshold voltage adjustment
- Fixed gain adjustments
- Critical magnetic and electric bias
- Balancing adjustments
- Padding
- Adjusting scale factors
- Parameter compensation
- Fixed reference circuits

THERE'S A
TIC TRIMMER POT
for every application

TIC manufactures in production quantities the most complete line of precision trimmer potentiometers in the industry. Common to all TIC trimmers is the unexcelled TIC quality construction and advanced design. The wide selection of sizes and shapes, in addition to the wide range of power and temperature capabilities, permit selection of units of maximum compatibility with a specific application.



TECHNOLOGY INSTRUMENT CORP.
569 Main Street, Acton, Mass., COLonial 3-7711.
West Coast Mail Address, Box 3941, No. Hollywood, Calif., POplar 5-8620

Standard types of COMMUNICATION EQUIPMENT

Radio Engineering Products is currently producing a number of types of equipment, electrically and mechanically interchangeable with standard Bell System apparatus. Complete equipments of the following types, and components for these equipments are available for early delivery.

CARRIER-TELEPHONE EQUIPMENT

- C5 Carrier-Telephone Terminal (J68756). A kit for adding a fourth standard toll-grade channel to existing C systems is available.
- C1 Carrier-Telephone Repeater (J68757)
- 121A C Carrier Line Filter and Balancing Panel
- H Carrier Line Filter and Balancing Panel (X66217C)

CARRIER-TELEGRAPH EQUIPMENT

- 40C1 Carrier-Telegraph Channel Terminal (J70047C)
- 140A1 Carrier Supply (J70036A1, etc.)
- 40AC1 Carrier-Telegraph Terminal
- Grid Emission Test Set (J70047D1)

VOICE-FREQUENCY EQUIPMENT

- V1 Telephone Repeater (J68368F)
- Power Supply (J68638A1)
- V1 Amplifiers (J68635E2 and J68635A2)
- V3 Amplifier (J68649A)
- V-F Ringers (J68602, etc.)
- Four Wire Terminating Set (J68625G1)
- 1C Volume Limiter (J68736C)

D-C TELEGRAPH EQUIPMENT

- 16B1 Telegraph Repeater (J70037B)
- 10E1 Telegraph Repeater (J70021A)
- 128B2 Teletypewriter Subscriber Set (J70027A)
- Composite Sets, several types

TEST EQUIPMENT

- 2A Toll Test Unit (X63699A)
- 12B, 13A, 30A (J64030A), and 32A (J64032A) Transmission Measuring Sets
- 111A2 Relay Test Panel (J66118E)
- 118C2 Telegraph Transmission Measuring Set (J70069K)
- 163A2 Test Unit (J70045B)
- 163C1 Test Unit (J70045D)

COMPONENTS AND ACCESSORIES

- 255A and 209FG Polar Relays
- Repeating Coils, several types
- Retard Coils, several types
- 184, 185, 230A and 230B Jack Mountings

VACUUM TUBES

101D, F & L	323A & B	396A
102D, F & L	328A	398A
104D	329A	399B
205D	336A	400A
274A & B	350A & B	408A
281A	355A	120A Ballast Lamp
305A	393A	121A Ballast Lamp
310A & B	394A	

RADIO ENGINEERING PRODUCTS
1080 UNIVERSITY ST., MONTREAL 3, CANADA
TELEPHONE
UNiversity 6-6887
CABLES
RADENPRO, MONTREAL

torsional stress and protects against humidity, splashing and dust.

The Aero-Pots are adjustable throughout 32 turns by a screwdriver in a slotted shaft. The shaft is precision threaded and operates under controlled torque derived from inherent frictional properties of special plastics. Accurate adjustments are obtained with precise increments and torque is constant throughout the adjustable range. With the wiper supported on two sides, settings are stable under extreme vibration, acceleration and shock. Temperature characteristics also are stable due to use of resistance wire having a low temperature coefficient.

► **Specifications**—Case dimensions are 1¼ in. long, ½ in. high, ⅜ in. wide. Weight is ¼ oz. Resistances range from 100 ohms to 50,000 ohms in one case size. Resolution depending on resistance is 0.2 to 2 percent. Linearity is 1 percent. Temperature range is -55 C to +125 C. Units are available with Teflon insulated wire leads, plug-in terminals or solder terminals. **Circle P56 inside back cover.**

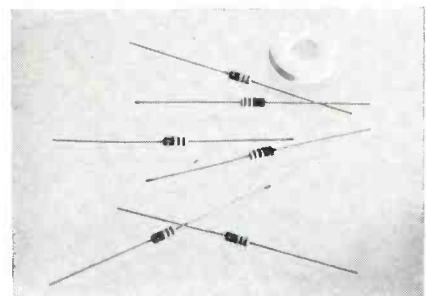

SILICON DIODES

for pulse circuitry design

HUGHES PRODUCTS, A Division of the Hughes Aircraft Co., Los Angeles 45, Calif., has added to its line a group of new quick-recovery silicon junction diodes. Types now available in this new series are: 1N625, 1N626, 1N627, 1N628 and 1N629.

► **Characteristics**—These diodes afford high speed, high voltage and high temperatures. They can be used instead of vacuum or germanium diodes in most h-f or fast-

switching circuits. Examples are: flip-flop circuits, modulators and demodulators, discriminator circuits, clamping and gating circuits and detectors.

All types are packaged in a one-piece, fusion-sealed glass envelope, impervious to moisture and to other contaminants. The diode glass body measures 0.105-in. by 0.265-in. maximum. Ambient operating temperature range is from -55 C to $+135\text{ C}$. Maximum power dissipation is 200 mw at 25 C . All types recover to a minimum of 400K ohms in $1\ \mu\text{sec}$ when switched from 30 ma forward to 35 v reverse. Circle P57 inside back cover.

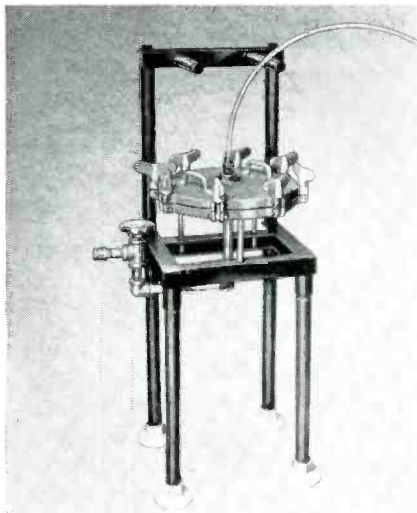

SUBMICRON FILTER has wide applications

BARNSTEAD STILL & DEMINERALIZER Co., Lanesville Terrace, Jamaica Plain, Boston 31, Mass. Using a new ultrafine method of water filtration, the MF submicron filter is effective in filtering out particles as small as 0.000016 in., thus making it possible to eliminate production problems in the manufacture of transistors, Charactron tubes and the like.

The filtering element consists of a cellulose-ester disk, approximately 150 microns thick, with total pore volume of 80 to 85 percent. The operating pressure drop across a clean filter disk is less than 0.3 lb per sq in. at flow rate of 100 gallons per hr. This filter element provides quantitative retention of all particles larger than



CUSTOM BUILT TRANSFORMERS

for

LONG LIFE and HIGH EFFICIENCY

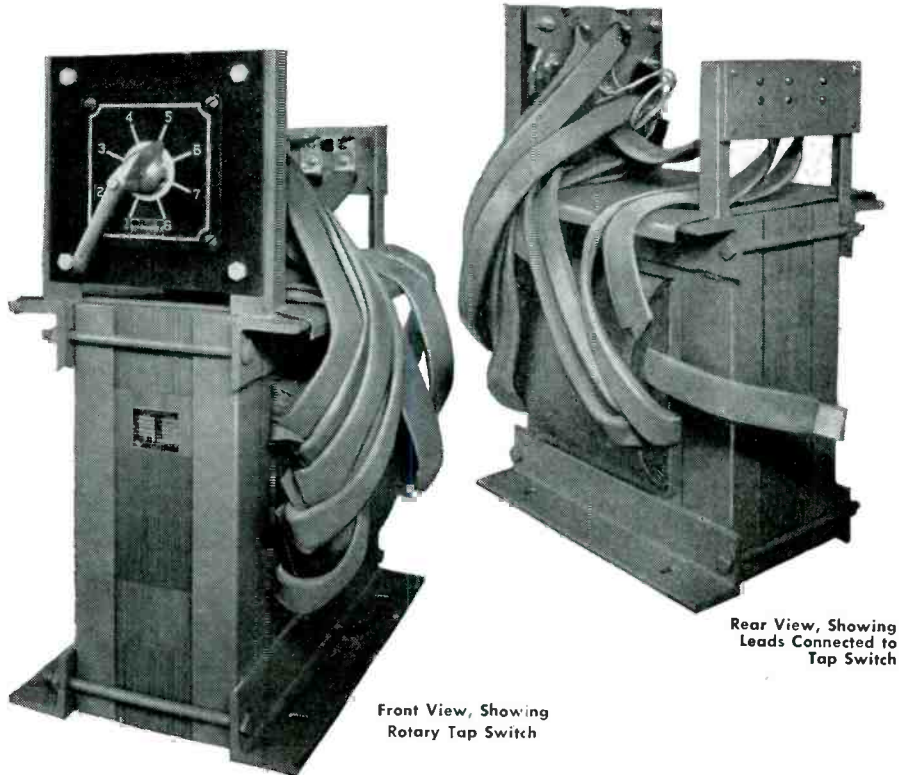

Front View, Showing
Rotary Tap Switch

Rear View, Showing
Leads Connected to
Tap Switch

The transformer shown above is a 50 KVA 440/225-400 in 25 volt steps with rotary tap switch mounted in place. The entire transformer is designed to fit into the customer's cubicle. The tap changer can be equipped with an auxiliary 5 ampere switch to open contactor if the tap changer is rotated under load.

The important features of NWL construction are vacuum pressure impregnation with high temperature synthetic varnishes, plastic and inorganic insulations. The use of grain oriented steels, carefully fabricated, annealed, and assembled and conservative design make for long life and high efficiency. Every transformer has "built-in" 36 years experience.



Established 1920



WINDING LABORATORIES, INC.

P. O. Box 455, Dept. 102, Trenton, N. J.

CHALLENGE!

This is it. The call to make history. The challenge of the ICBM, Titan.

Accept it—lay your skill, courage and tough-minded determination on the line—and you'll join an engineering team dedicated to reaching another plateau in man's conquest of space.

In return, we offer you unbounded opportunities as promising as the growth of our company. We offer the deep-down satisfaction of working with top engineers. We offer the modern facilities of our plant, located in the foothills of the Colorado Rockies.

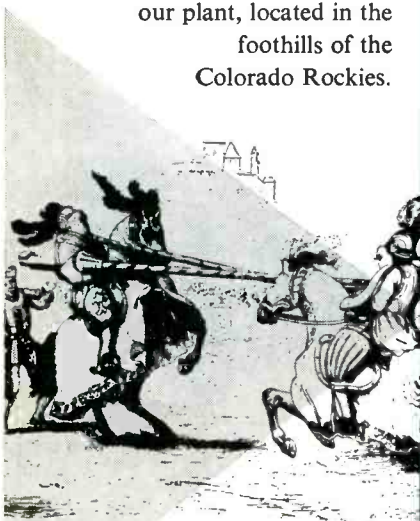

CHALLENGE

If this challenge calls you, write today to: Emmett E. Hearn, Employment Director, Dept. E-1, P.O. Box 179, Denver 1, Colorado.

MARTIN
DENVER



0.45 micron suspended in water at temperature under 200 F.

Further information and specifications are available. Circle P58 inside back cover.

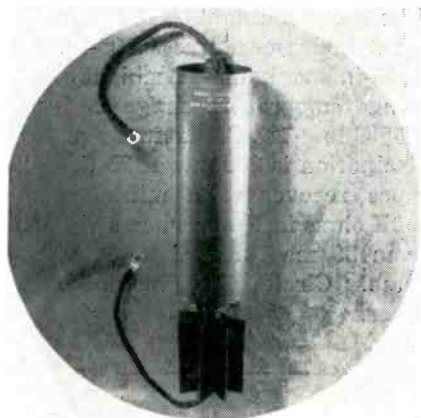

THYRATRON

for design engineer use

NATIONAL ELECTRONICS, INC., Geneva, Ill. A new 30-ampere thyatron, the NL-732, is gas and mercury-vapor filled for long life, quick-starting and use without gas cleanup cushioning circuits. It is especially designed for motor speed control and a-c control applications.

► **Ratings**—Filament voltage is 2.5 v; filament current, 55 amperes; peak inverse and forward volts, 1,500 v; anode current, 30 amperes; peak anode current, 160 amperes; anode current averaging time, 30 sec; filament heating time, 180 sec. Circle P59 inside back cover.



PULSE OSCILLATOR

a clock pulse generator

ELECTRO-PULSE, INC., 11861 Teale St., Culver City, Calif. Model 3420B pulse oscillator is a wide range

trigger generator producing pulses at repetition rates from 100 cps to 3.3 mc. The instrument is particularly useful as a clock pulse generator, for flip-flop resolving time studies and for general use in high speed pulse circuitry development.

Two separate blocking oscillator output pulse—each available with positive or negative polarity—are provided in a half-period relationship enabling, by mixing, such waveforms as alternate positive and negative pulses.

Output pulses are approximately 0.1 μ sec wide from an impedance level of less than 250 ohms, with amplitude variable to 25 v open circuit. The unit weighs approximately 29 lb.

An integral power supply, operating on 115 or 230 v, 50 to 400 cycle a-c (175 w), is furnished. Circle P60 inside back cover.

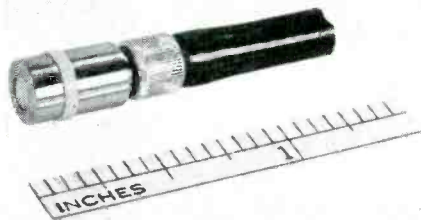

PRESSURE TRANSDUCER subminiature type

KISTLER INSTRUMENT CO., 15 Webster St., North Tonawanda, N. Y. The New SLM pressure transducers, only $\frac{1}{4}$ in. diameter by $\frac{1}{2}$ in. long, exhibit characteristics superior to larger instruments. The fast response time is in the order of 1 μ sec. The signals are exceptionally sharp and free from electrical and mechanical noise.

► **Measurements**—Successful measurements have been made as low as 0.01 psi on shock tubes. These gages will also measure steady and slowly varying pressures as well as very fast pressure transients. The instruments are calibrated by simple conventional static methods.

Available in 4 models, the transducers cover a range of applica-

RCA INSTRUMENTS OF LABORATORY PRECISION

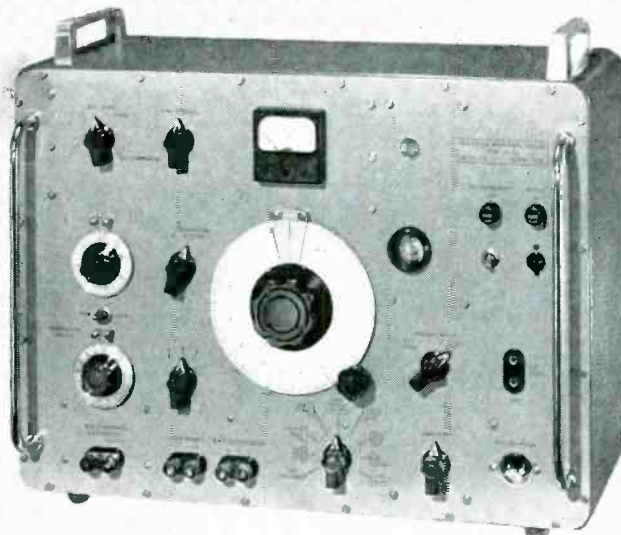

Precision
engineered
to do
a more
versatile
job

RCA PRECISION IMPEDANCE BRIDGE
TYPE LB-52 \$585.*
Also ask about a utility bridge.

IMMEDIATE
AVAILABILITY

THIS PRECISION IMPEDANCE BRIDGE has a combination of advanced features which you'll respect more and more as you put it to work! Most versatile bridge in its price class, it provides an internal metered source of voltage and current; AC detection for all measurements, including DC, via "magic eye" null indicator; provision for use of external standards. It measures resistance, capacity, inductance, dissipation factor and "Q"... facilitates measurement of incremental inductance and electrolytic capacitors.

RESISTANCE:
0.01 ohm to 10 megohms.
Accuracy:
 $\pm 1\%$ from 0.1 ohms to
1 megohm.
 $\pm 2\%$ outside these limits.

CAPACITANCE:
1 μ mf to 100 μ f.
Accuracy:
 $\pm 1\%$ from 100 μ mf to 10 μ f
 $\pm 2\%$ or ± 0.2 μ mf, which-
ever is greater, outside
these limits.

INDUCTANCE:
10 μ H to 1,000 H.
Accuracy:
 $\pm 2\%$ from 100 μ H to 50 H.
 $\pm 3\%$ from 50 H to 1,000
H, somewhat less accurate
from 10 μ H to 100 μ H.
Q:
0 to 12.
Accuracy: $\pm 5\%$ of
reading or ± 0.005 for
values less than 0.1.

DISSIPATION FACTOR:
0 to 0.12.
Accuracy: $\pm 5\%$.
DC COMPONENT:
Adjustable between the
following limits:
Current: 0 to 100 ma. $\pm 3\%$.
Voltage: 0 to 50 V,
0 to 500 V.
BRIDGE EXCITATION:
Internal: 1,000 cps $\pm 2\%$,
power line frequency or DC.
External: 50 to 10,000 cps.

For complete information on the above and other instruments in the
RCA line write to RCA, Dept. N-46, Building 15-1, Camden, N.J.

Instrument Engineering Representatives in Principal Cities

*Price in U.S.A., f.o.b. Camden, N.J. Subject to change without notice.

Tmk(s) ®



RADIO CORPORATION
OF AMERICA
CAMDEN, N.J.

COMMERCIAL
ELECTRONIC
PRODUCTS

In Canada: RCA VICTOR Company Ltd., Montreal



announces
an unusually precise

SERVOMOTOR- TACHOMETER GENERATOR

HIGHER
AMBIENTS

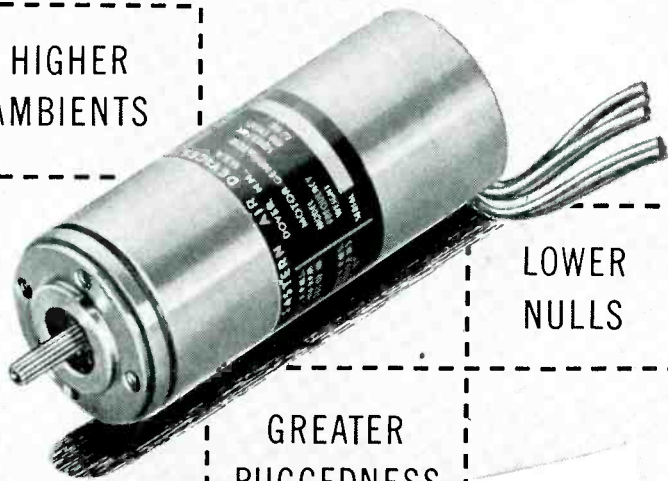

LOWER
NULLS

GREATER
RUGGEDNESS

SIZE 11
SJ1HLX7
(Actual size)

for
**INSTRUMENTATION
FIRE CONTROL
AUTOPILOTS
MISSILES
COMPUTERS**

FEATURES:

Zero Speed Voltage (RMS)

8.0 mv in phase
15.0 mv quadrature
19.0 mv total

Max Ambient Temp.

150°C

Linearity

0.5% to 3600 rpm

Output Gradient Phase Shift

0.5V/1000 rpm (min.) $\pm 10\%$

Servo motor meets Bu. Ord. MK-14 specifications.

Equipped with precision gearhead for lower backlash.

Rugged, one-piece assembly.

WRITE for complete detailed information

EASTERN AIR DEVICES, INC.

SOLVING SPECIAL PROBLEMS IS ROUTINE AT EAD

387 CENTRAL AVENUE • DOVER, NEW HAMPSHIRE

tions for which precision pressure instrumentation previously was not available. The 4 models are the blast gage, the shock-tube gage, the ballistics gage and the hyperballistics gage. These instruments cover a range of pressures from 0.01 to 100,000 psi. Circle P61 inside back cover.



FERRITE LOAD ISOLATOR for S-band applications

LITTON INDUSTRIES, 5873 Rodeo Road, Los Angeles 16, Calif. Model S10/S18 ferrite load isolator provides higher isolation with one-third less space and weight than previously available isolators. Engineered for minimum size and weight, it provides 18-db isolation over a 300-mc bandwidth from 2,500 mc to 3,000 mc. With waveguide flanges, maximum insertion loss is 1.0 db. Maximum input vswr is 1.5. The isolator can handle up to 500 kw peak power and 250 w average without external cooling. With air or liquid cooling, power handling capacity is increased.

Both coax and waveguide adapters are available to permit easy adaptation to system requirements. Electrical characteristics and mechanical configuration can be easily modified to meet exacting customer specifications in new search, early warning and other S-band radar. Circle P62 inside back cover.

BUTTON STEM MACHINE a high speed unit

KAHLE ENGINEERING Co., 1400 Seventh St., North Bergen, N. J., has designed and put into production a new series of specialized button stem making machinery. They were developed to produce a

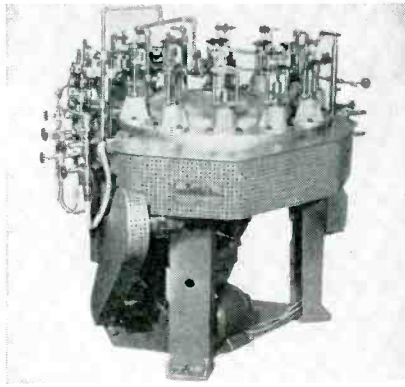

variety of quality, metal-flanged, subminiature button stems for transistors, subminiature tubes and similar applications. Production speeds of up to 600 units per hour are easily attained. Machine No. 2707, which is typical of the series, utilizes 12 heads, each of which has an individual upper and lower mold. An exclusive feature is that each head position incorporates a very precise die to correctly position and hold the metal flange, ferrule or eyelet. Also incorporated at each head is an accurate, automatic bead loading device. Further technical information is given in data sheet No. 2707. **Circle P63 inside back cover.**

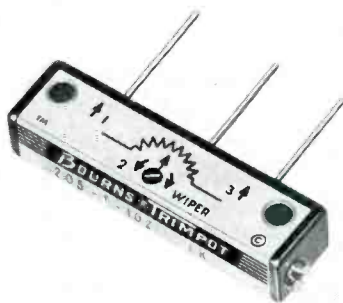

SUBMINIATURE POT for printed circuits

BOURNS LABORATORIES, INC., 6135 Magnolia Ave., Riverside, Calif., has added to its line of Trimpots, the model 205, a subminiature unit with round-pin terminals for printed circuit applications. Terminals, which can be inserted into punched holes in printed circuit boards, are gold-plated copper, 1/2 in. long, 0.028 in. in diameter and spaced in 0.1-in. multiples. Mounting is accomplished by use

a proven performer always in control

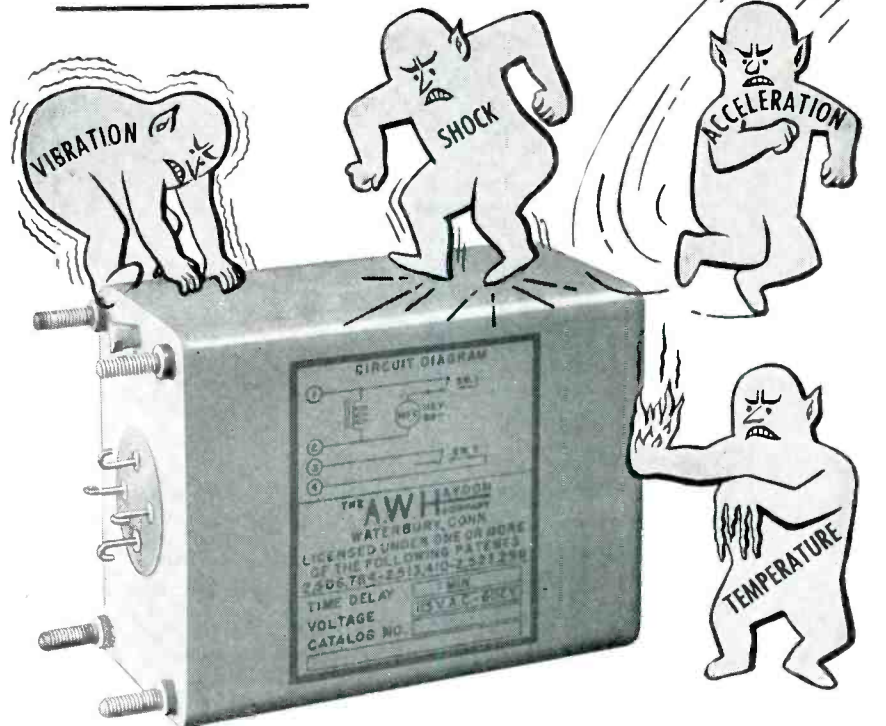

the A. W. HAYDON CO. delayed reset time delay relays

Protect power tubes in expensive transmitting, receiving or control equipment two ways:

1. On initial application of line voltage, the timer operates as a standard Time Delay Relay providing the delay equipment required to get up to correct operating temperature. Therefore, you can throw your load right across the line, and plate voltage will not be applied until filaments or heaters warm up. This eliminates the need for estimating warm-up time, preventing premature tube failures.

2. If line voltage fails, an escapement in the timer operates to provide a Reset Rate which can be calibrated to the cooling characteristic of the equipment. "Down time" is kept to a minimum, and equipment is back in operation as soon as practical after line voltage is restored. This automatic system takes all the "guess" out of operation. You know that no time is wasted — no tube life sacrificed by operator error.

Do you have another application where a Delayed Reset is necessary? These timers will undoubtedly solve your problems too!

PREFERRED WHERE PERFORMANCE IS PARAMOUNT.

Shown in the chart is a typical characteristic. In this case the Reset Rate is equal to the Time Delay.

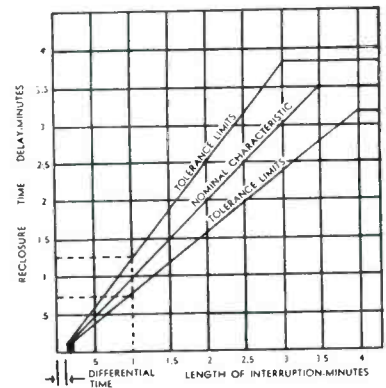

SPECIFICATIONS

- 1. Operating temperature range: -65°F to 160°F.
- 2. Vibration: 5-55 CPS with 10g maximum acceleration.
- 3. Shock: 30g (11ms duration)
- 4. Hermetically sealed units meet military requirements for fungus, humidity, and salt spray.

Write for Bulletin AWH TD402 describing 6400 Series DC, 11400 Series AC, 24300 Series 400 Cycle



The **A.W. HAYDON Company**

235 NORTH ELM STREET, WATERBURY 20, CONNECTICUT
Design and Manufacture of Electro-Mechanical Timing Devices

Technical assistants for...

Electron Tubes

The Electron Tube Laboratory is engaged in research and development in the fields of direct-viewing storage tubes and microwave tubes. The personnel comprises men with many years' experience in the field of electron tubes and their applications.

Very new developments in microwave and display tubes have created a number of openings at the research and development level for Laboratory Assistants. At Hughes, engineers, scientists and technicians develop their ideas from inception to quantity production. Thus, assistants working with electron tube products have unlimited scope for applying their talents and skills to a wide range of military and commercial uses.

You should qualify in any 3 of the following areas:

- Electron Circuitry and Test Equipment Construction
- Mechanics and Benchwork Skills
- Tube Fabrication Techniques
- High Vacuum Techniques
- Microwave Testing
- Tube Chemistry
- Precision Assembly

HUGHES

RESEARCH AND DEVELOPMENT LABORATORIES
 SCIENTIFIC STAFF RELATIONS
 Hughes Aircraft Company, Culver City, California

of 2-56 screws through body eyelets, or by pins only. Unit will dissipate 0.25 w at 50 C, and has a maximum operating temperature of 105 C.

In all other design features the model 205 is similar to the model 130 Trimpot. It meets or exceeds most government specifications. Literature is available on request. Circle P64 inside back cover.

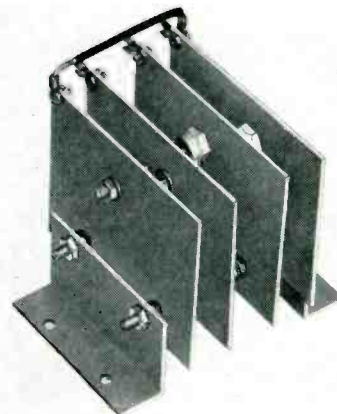

SILICON RECTIFIER is hermetically sealed

SANFORD MILLER Co., 691 Bedford Ave., Brooklyn, N. Y., has announced a new type of silicon power rectifier with many advantages over the selenium rectifier. It features 99-percent efficiency and 4-percent regulation. It has a high forward current with a low voltage drop and a low reverse current which gives it magnetic amplifier quality. Its high operating temperature (190 C up to 120 C ambient) and high operating voltage (up to 600 piv) are other advanced features.

Small in size and easy to fan cool, this silicon rectifier is hermetically sealed and shows no noticeable aging after long use. Circle P65 inside back cover.

C-R TUBE for display applications

SYLVANIA ELECTRIC PRODUCTS INC., 1740 Broadway, New York 19, N. Y., has announced the Wamoscope, a new type of crt for radar, tv and other electronic display applications. It combines most of the essential functions of a micro-

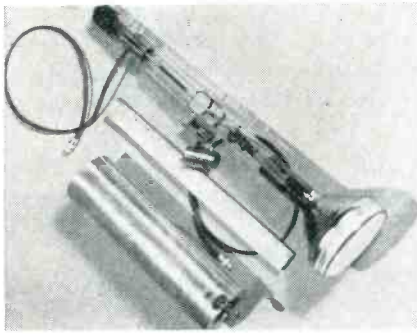

wave receiving set for tv or radar in a single tube envelope, eliminating many of the tubes and components required by conventional receivers. Microwave signals go directly from the antenna into the tube, where they are amplified, detected and displayed on the tube's fluorescent screen. The tube, a 5-in. diameter fluorescent screen. Illustrated is the solenoid which fits over the twt section to focus it, and the tube's r-f transducers. Wamoscope operates in the microwave frequency range of 2,000 to 4,000 mc. Circle P66 inside back cover.



STORAGE BATTERIES
nickel cadmium type

NICKEL CADMIUM BATTERY CORP., 68 Pleasant St., Easthampton, Mass. Ranging in sizes smaller than a cigarette lighter and from ½ to over 150 ampere hours capacity, NICAD's complete new line of miniaturized nickel-cadmium sintered-plate storage batteries has been released. They are well adapted for use in airborne or portable, electronic instruments and communications equipment.

Capable of repeated cycle service, they have useful capacity in temperatures ranging from -40 F to +165 F. They require little maintenance and can be stored indefinitely in any state of charge without deterioration or fear of

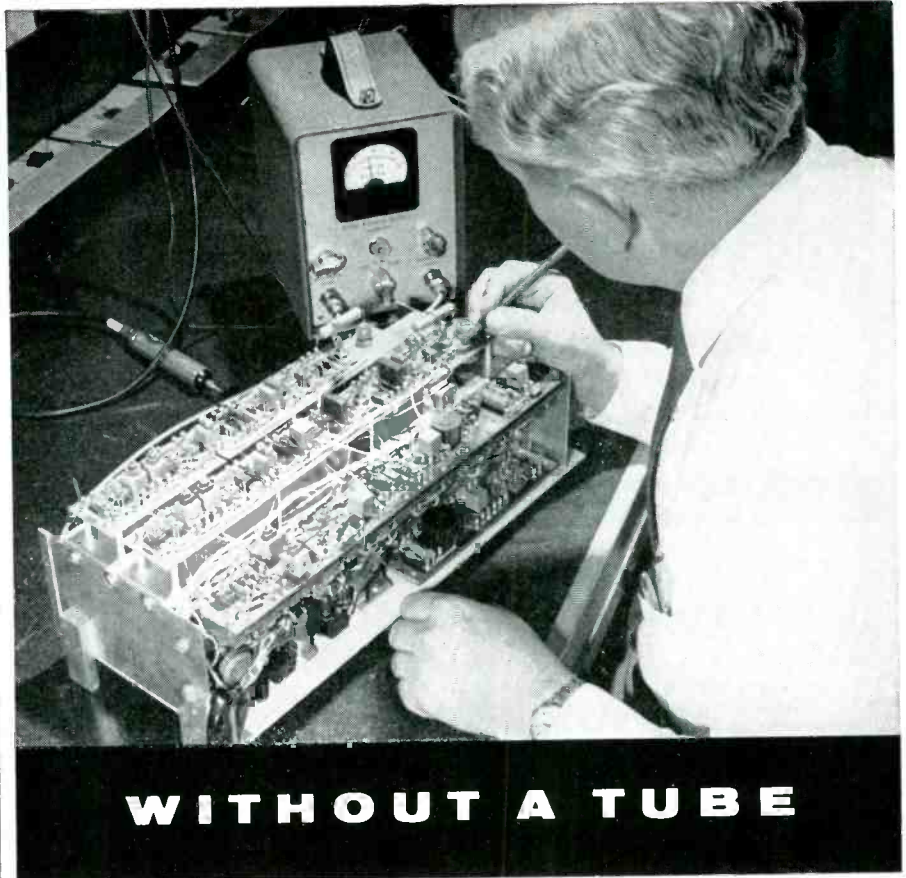

Here's the first step toward lifetime reliability in electronic gear — the conversion from vacuum tubes to rugged, lightweight, small size Berkeley FERRISTORS*.

Berkeley FERRISTORS* consist of simple wire-wound coils on a ferro-magnetic core, encapsulated in epoxy resin. Costing less than comparable vacuum tubes, they offer these advantages:



1. Continuous-duty reliability
2. Unaffected by vibration, shock, high overloads, humidity changes, temperature extremes
3. Total weight only ½ ounce; small as a cube of sugar

..... TYPICAL APPLICATIONS

FERRISTORS* are now used as oscillators, multi-vibrators, bi-stable elements, one-shots and various linear amplifiers including coincidence amplifiers, balanced amplifiers and differential amplifiers.

Why wait for your competitor to use FERRISTORS* and offer electronic gear with lifetime reliability? Investigate now and beat him to the punch — write for Data File 110, "Electronic Design with FERRISTORS*." Please address Dept. G1



Model 470 RF Power Supply has dual outputs to supply 1.7 mc to drive up to 4 ring-of-10 bi-stable elements and to supply 10 mc to power at least 10 linear amplifiers. Ideal for preliminary investigations of circuits using the Berkeley FERRISTOR*. Price \$95.00 f.o.b. factory.

Beckman* / **Berkeley Division**
Richmond 3, California
a division of Beckman Instruments, Inc.

*Trademark

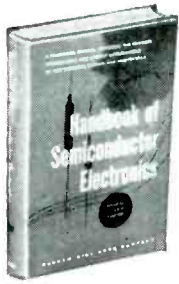

How to design transistor circuits

Here is a thorough, comprehensive guide and reference work for all concerned with the design and application of semiconductor devices. In it you get authoritative coverage of the entire field, by 13 specialists. You will be able to understand the basic physical methods for semiconductor device action, you will be able to assemble the necessary equipment and fabricate typical semiconductor devices by laboratory methods; and you will learn how to design a large variety of transistor circuits for use in various frequency ranges.

HANDBOOK OF SEMICONDUCTOR ELECTRONICS

Edited by LLOYD P. HUNTER
Senior Physicist, International
Business Machines Corporation

604 pages, 484 illustrations,
\$12.00

RECENT MCGRAW-HILL BOOKS

ELECTRONIC ANALOG COMPUTERS

A practical and comprehensive treatment of d-c analog computers, used as differential analyzers, equation solvers, simulators, and control system components. Shows how to set up problems for computation and gives examples of practical applications in typical problems of applied mathematics and engineering design. By G. A. and T. M. Korn. 2nd ed. 464 pages, 223 illustrations, \$7.50.

ANALOG COMPUTER TECHNIQUES

Gives specific techniques for the solution of difficult or unusual problems. The use of diodes and differential relays in analog computation is explained; and sections describe repetitive computers and the principles of operation of digital differential analyzer equipment. By C. L. Johnson, USAF Institute of Technology. 264 pages, 148 illustrations, \$6.00.

ESSENTIALS OF TELEVISION

Here is a valuable source of essential information on the theory of electronic circuits and vacuum tubes and their applications in television receivers. The operation of three monochrome receivers is described in detail from antenna to

picture tube and loudspeaker. Table lists name, function, and value of each resistor, capacitor, inductor and tube in a typical receiver. By Slurzberg, Osterheld and Voegtlin. 687 pages, 462 illustrations, \$8.50.

MATHEMATICS FOR ELECTRONICS WITH APPLICATIONS

This book is designed to correlate engineering practice and the mathematical topics which are of prime importance to the electronics and communications fields.

Covers transistors, the matrix method of network analysis, dimensional analysis of electronic problems including a discussion of the mks systems of units, intermodulation testing, and certain aspects of color television. By Nodelman and Smith. 391 pages, 166 illustrations, \$7.00.

MODERN MATHEMATICS FOR THE ENGINEER

Gives you concrete help in three vital areas: 1) in formulating and solving design problems by using mathematical models; 2) in applying mathematics of chance and probability; and 3) in obtaining numerical solutions and working with high-speed computing equipment. Each chapter prepared by a top authority. Edited by Edwin F. Beckenbach. U. of Cal., 516 pages, 97 illustrations, \$7.50.

freezing. Corrosive fumes are not given off and pressure release plugs prevent electrolyte spillage. Circle P67 inside back cover.



TUBE SHIELD for photomultiplier type

JAMES MILLEN MFG. CO., INC., 150 Exchange St., Malden 48, Mass., announces the availability of the 80802E tube shield for the new RCA 6810 photomultiplier tube. This shield is designed to provide optimum shielding for magnetic fields. Particular care has been taken in the selection of material (mu-metal) and in the fabrication and processing. Circle P68 inside back cover.

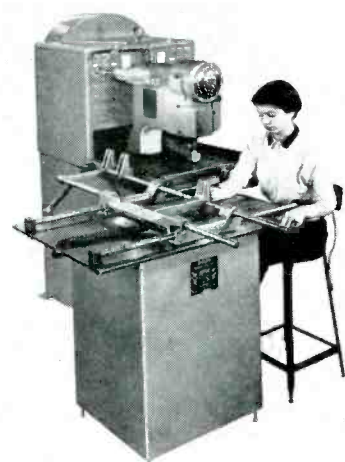

PUNCHING MACHINE for printed circuits

WALES-STRIPIIT CORP., 345 Payne Ave., North Tonawanda, N. Y. A specialized press, model 10-AA fabricator, has been redesigned specifically for punching printed circuit boards. Employing a pantograph-principle accessory called the positive duplicator, the press

EXAMINE ANY BOOK 10 DAYS FREE

McGraw-Hill Book Co., Dept. L-1, 327 W. 41st St., N.Y.C. 36

Send me book(s) checked below for 10 days' examination on approval. In 10 days I will remit for book(s) I keep plus few cents for delivery costs, and return unwanted book(s) postpaid. (We pay delivery costs if you remit with this coupon—same return privilege.)

- Hunter—Hdbk of Semiconductor Elect., \$12.00
- Korn & Korn—Elect Analog Computers, \$7.50
- Johnson—Analog Computer Techniques, \$6.00

- Slurzberg—Essentials of Television, \$8.50
- Nodelman & Smith—Math for Electron, \$7.00
- Beckenbach—Modern Math. for the Eng., \$7.50

(PRINT)

Name City Zone State

Address Company

Position

For price and terms outside U. S., write McGraw-Hill Int'l., N.Y.C.

L-1

reproduces any pattern of holes up to 15 in. by 25 in. area from a master template. Holes of any shape from 0.030 in. to 3½ in. diameter can be punched cold in most dielectric materials. Superior hole quality is assured by close-fitting guides which accurately align the punch tip with the die.

Pilot-pin accuracy is maintained between the template and work piece since both are located by precision ground locator pins. By reversing the ordinary process and using a pointed stylus in a pilot printed circuit located in the duplicator, the master template can be punched out in the desired pattern and standard pilot hole size of ⅜ in. diameter. Other pilot hole sizes can be produced. Since the fabricator is a 20-ton press, steel templates up to ¼ in. thick are easily punched. Further information is available from the company. Circle P69 inside back cover.

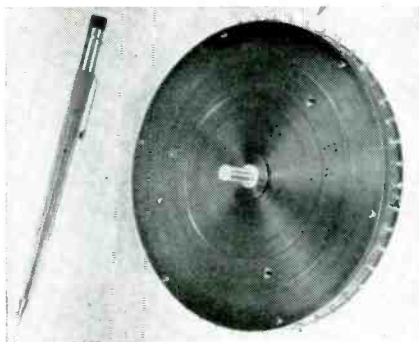

PRECISION POT
a multitap unit

THE GAMEWELL Co., Newton Upper Falls 64, Mass. A special 48-tap version of the newly developed RL-270A-5 precision potentiometer has been produced for use in the seismograph department of a large oil company.

► **Specifications**—This 5 in. diameter potentiometer has 48 taps around the perimeter, spaced to give 47 equal resistance sections, while maintaining the guaranteed linearity of ±0.1 percent. There is a total resistance of 500,000 ohms which affords a resolution of 0.0075 percent (13,000 turns).

Positive precious-metal spring contacts with extremely high unit

now available from STANCOR

STOCK SELENIUM RECTIFIER TRANSFORMERS

for use with

popular brands of **STOCK** selenium rectifiers

These new Stancor Transformers were specifically designed to operate in Full-Wave Center-Tapped or Bridge Type power supply circuits, with the most popular size stock selenium rectifiers.

Designed for 117V 50-60 cycle operation, the transformers may be satisfactorily operated at 400 cycles.

They are recommended for all high current—low voltage applications: Variable tap arrangements permit an almost unlimited choice of voltages from 3.3V DC to 63.0V DC, up to 22.5 Amperes, DC, depending on the particular transformer the user selects.

These transformers may be used to heat tube filaments where filaments are not subject to any high voltage stresses.

Stancor selenium rectifier transformers are in stock for immediate delivery from your Stancor distributor.

WRITE FOR FREE BULLETIN 518 listing detailed information on the complete line of Selenium Rectifier Transformers.

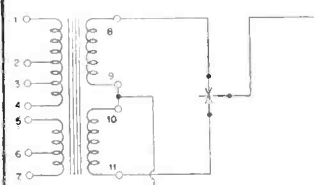
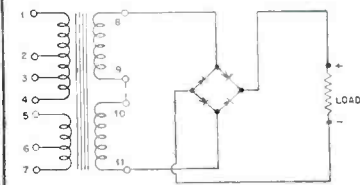
TYPICAL OUTPUT VOLTAGES (Stancor Transformer RT-201)		 FULL-WAVE C.T.				 FULL-WAVE BRIDGE			
RT-201		Output 2.0 A. D.C.				Output 1.25 A. D.C.			
Input 117vac Term. No.	Connect Term. No.	Resistive Load		Capacitive Load*		Resistive Load		Capacitive Load**	
		Secondary Volts AC	Output Volts DC	Secondary Volts AC	Output Volts DC	Secondary Volts AC	Output Volts DC	Secondary Volts AC	Output Volts DC
1-2	—	29.4	11.2	28.8	13.8	28.5	23.0	27.9	30.0
1-7	2-6	26.0	9.8	25.7	11.7	25.4	20.0	25.1	26.4
1-6	2-5	23.0	8.4	22.7	9.9	22.3	17.3	21.8	22.2
1-7	2-5	20.9	7.4	20.8	8.6	20.2	15.4	19.8	19.7
1-3	—	19.4	6.7	19.1	7.6	18.6	13.9	18.2	17.6
1-7	3-6	17.8	6.1	17.6	6.7	17.2	12.8	16.8	15.7
1-6	3-5	16.3	5.3	16.1	6.0	15.7	11.2	15.2	13.8
1-7	3-5	14.9	4.7	14.8	5.3	14.3	10.3	14.1	12.4
1-4	—	14.2	4.4	14.2	5.0	13.7	9.7	13.5	11.6
1-7	4-6	13.4	4.0	13.3	4.4	12.7	8.8	12.5	10.4
1-6	4-5	12.4	3.6	12.4	3.9	11.7	7.9	11.7	9.5
1-7	4-5	11.7	3.3	11.7	3.5	11.1	7.4	11.1	8.7

*1000 MFD. ** 500 MFD.

Export Sales:
Roburn Agencies, Inc.
431 Greenwich Street,
New York 13, N. Y.

CHICAGO STANDARD TRANSFORMER CORPORATION

3501 WEST ADDISON STREET CHICAGO 18, ILLINOIS



ENGINEERS: *Electronic & Mechanical* Physicists:

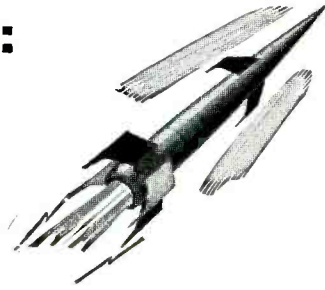

Work where PERFORMANCE pays off

Men of talent and drive can move ahead without delay or red tape at Melpar because skill, ability and performance are the *primary* factors governing advancement. Due to the fact that we've doubled in size every 18 months since our beginnings in 1945, middle and top level positions open up constantly.



Melpar believes that the engineer deserves an organization and facilities that can enhance his creative abilities. For this reason our laboratories were designed and built to specifications prepared by Melpar engineers. A wealth of equipment is available. Our project group system enables the engineer to participate in all phases of development problems and thus quickly acquire greater technical and administrative know-how, essential to eventual managerial responsibility. The system also enables us to more accurately evaluate the individual's contribution and more rapidly justify promotions.

Live Where You LIKE It

Living—for the whole family—is immensely rich in the two locales where Melpar's R & D activities are centered. Our 265,000 sq. ft. main laboratory near Washington, D. C., enables you to live in an area enjoying incomparable cultural and recreational advantages. The climate allows outdoor recreation 215 days of the year. Fine homes and apartments are available in all price ranges. Our Watertown and Boston, Mass. laboratories offer the unique advantages of cosmopolitan Boston with its theatres, concerts, art galleries, museums, universities and schools which are second to none. Nearby are seaside and mountain resorts offering a variety of winter and summer sports.

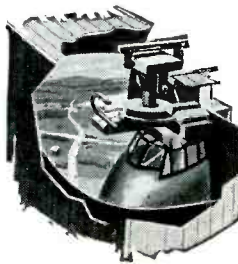

Openings Exist in These Fields:

Flight Simulators • Radar and Countermeasures • Network Theory • Systems Evaluation • Microwave Techniques • Analog & Digital Computers • Magnetic Tape Handling • UHF, VHF, or SHF Receivers • Packaging Electronic Equipment • Pulse Circuitry • Microwave Filters • Servomechanisms • Subminiaturization • Electro-Mechanical Design • Small Mechanisms • Quality Control & Test Engineering

Write for complete information. Qualified candidates will be invited to visit Melpar at Company expense.

Write: Technical Personnel Representative

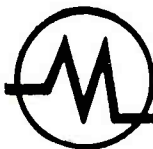

MELPAR, Inc.

A Subsidiary of Westinghouse
Air Brake Company

3615 Arlington Blvd., Falls Church, Va.
10 miles from Washington D. C.

Openings also available at our laboratories in Watertown and Boston, Mass.

NEW PRODUCTS

(continued)

pressures insure permanent vibration-proof contact having low resistance without linearity distortion at the tap. Circle P70 inside back cover.

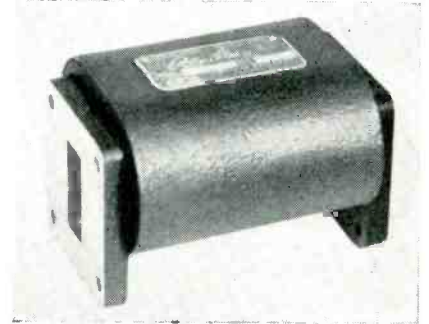

LOAD ISOLATOR features minimum size

CASCADE RESEARCH CORP., 53 Victory Lane, Los Gatos, Calif., announces the model X-146 Uni-line X-band load isolator which offers many advantages in applications where minimum size and weight are important considerations. The new isolator is 2 7/8 in. long by 1 1/8 in. high and weighs only 25 oz.

Frequency range is 8.6 to 9.6 kmc with vswr less than 1.1, (typically 1.04). Forward attenuation is 0.5 db. Load isolation is 9 db at band edges and 12 db at band center. Power rating, (into load with vswr of 2 to 1) is 125 w average and 150 kw peak. Circle P71 inside back cover.

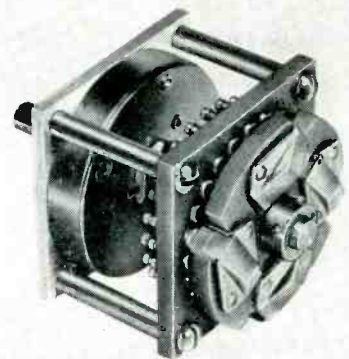

ROTARY SWITCH knee-action type

THE DAVEN CO., 530 W. Mt. Pleasant Ave., Livingston, N. J. Type 142-CM knee-action rotary switch is 1 1/4 in. square and is available with as many as 4 poles on a single

deck. In addition, as many as 7 positions per pole, with shorting action, and 4 positions per pole, with nonshorting action, can be obtained with the new units.

The 142-CM employs rotors, slip rings and contacts of solid silver alloy. Turret-type terminals, gold plated to facilitate soldering, are supplied for easy wiring. The new switch can be supplied in multi-deck arrangements, with as many decks as required. In the single deck version, the switch can be furnished as a round unit. This variation is designated as type 42-CM.

Phenolic parts of the new switch are XXXP in accordance with MIL-P-3115B. All metal parts are plated to withstand 200-hr salt spray tests.

The 142-CM switch is capable of several-million cycles of operation. A roller-type detent is used for accurate contact positioning. Circle P72 inside back cover.



TIME DELAY RELAYS have dial head adjustment

ELASTIC STOP NUT CORP. OF AMERICA, Elizabeth, N. J., has developed a new line of dial head Agastat time delay relays for applications requiring frequent time adjustments. Dial markings permit easy calibration for accurate adjustment and each dial is color coded to identify the timing range.

There are four timing ranges available in the dial head model. Ranges run from 1/10 to 3 sec and 30 sec to 15 minutes. Each unit is adjustable within these timing ranges, and the complete adjust-

SAVE PANEL SPACE

with these
CONCENTRIC-SHAFT

PRECISION POTS

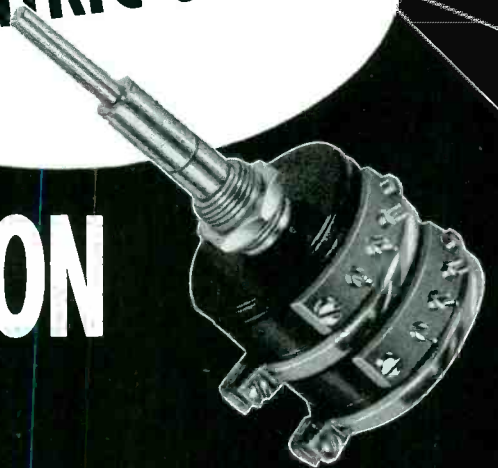

You can put twice as many precision controls
in the same panel space
with Waters' new concentric-shaft potentiometers.

Two precision pots • in 7/8" or 1 1/8" size • assembled in tandem • for single-hole or servo mounting • and control by one dual knob • with stops, or for continuous rotation of either or both elements • save vital space • and simplify your designs.

Concentric-shaft, tandem precision potentiometers can be furnished to meet substantially the same specifications as the standard line of Waters RTS 7/8 and AP1 1/8 pots.

Write today for further information, or see your Waters representative.

New Idea in Control Mounting

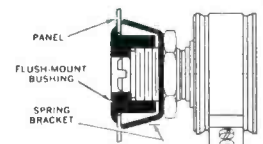

Now you can easily make any single-hole-mounting pot or trimmer into a flush-mounted or recessed control. Just use the Waters "Pot-Hook"®. Fits any panel up to 1/8" thick; available for 1/8" or 1/4" shaft; can be furnished with "O" ring and gasket for panel seal. Write for data sheet.

Waters
MANUFACTURING, inc

APPLICATION ENGINEERING OFFICES
IN PRINCIPAL CITIES

Wayland, Massachusetts
P. O. Box 368, So. Sudbury, Mass.



Why "CHOKER" your soldering iron?

— just "CRADLE" it with a
HEXACON
HATCHET SOLDERING IRON

The operator has to "choke" the conventional straight iron to hold it, whereas the HEXACON HATCHET IRON "cradles" in the hand with no perceptible grip whatsoever — thus relieving hand strain and eliminating the "heavy hand", the cause of poorly soldered joints. Because HEXACON HATCHET IRONS are perfectly balanced in weight, they enable the operator to solder in a natural position and relieve fatigue of arm and back.

Send for new circular No. 70H giving more details and comparative competitive performance data.

HEXACON ELECTRIC COMPANY
130 West Clay Ave., Roselle Park, New Jersey



A COMPLETE LINE
OF HATCHET IRONS
BY HEXACON
— Originator
and Pioneer

CAT. NO.	WATTS	TIP DIA.	PRICE
25H	25	1/8"	\$ 6.50
26H	30	3/16"	6.50
30H	60	1/4"	6.75
70H	80	3/8"	11.00
100H	100	3/8"	12.00
150H	150	3/8"	12.75
151H	175	1/2"	13.50
200H	200	5/8"	14.00
300H	300	7/8"	18.25

ment is attained by one revolution of the dial. The new dial head models consist of a pneumatic timing head, a solenoid assembly, a switch, a coil and terminals.

Agastat relays are relatively unaffected by wide temperature changes from -65 to +160 F. They can be supplied for continuous a-c duty and for continuous or intermittent d-c service. They are available for a-c operation at all standard voltages from 6 to 550 v, 60 cps and 25 cps. For d-c operation, they are made for all standard voltages from 6 to 230 v. Circle P73 inside back cover.

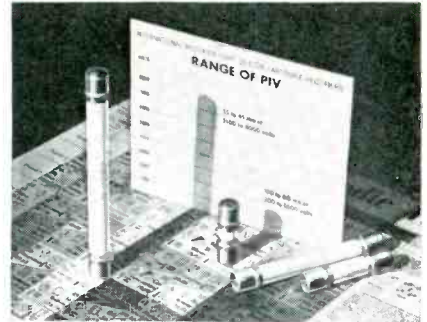

SILICON DIODES

high-voltage type

INTERNATIONAL RECTIFIER CORP., 1521 E. Grand Ave., El Segundo, Calif., has developed 16,000-v silicon diodes. They are a series of h-v silicon rectifiers especially designed for power applications where high ambient temperature, reliability, high efficiency and miniaturization are prime requirements.

Ratings range from 600 v at 100-ma half-wave d-c output to 16,000 v piv at 45 ma. They offer high rectification efficiency over an operating ambient temperature range of -55 C to +150 C. To assure reliability, stability and freedom from contamination, matched and selected p-n junctions are assembled in series into a metallized ceramic housing with ferrule type terminals, thus providing hermetic seal.

The silicon diodes are ideal components for all types of h-v. low-current power supplies, that is, computing machines, magnetic amplifiers, crt and radar h-v supplies, electrostatic precipitators,

WIRE CLOTH

SAVE
on Quality Cloth

IMMEDIATE DELIVERY
Wide range of meshes from
large Pittsburgh stock

SPECIALIZING IN
Extra fine precision-
woven meshes used
in electronics industry.

VARIOUS MESHES

Brass, copper, monel and pure nickel etc. Available in a variety of weaves, with stainless steel and phosphor-bronze regularly woven up to 400 X 400 mesh.

FOR FAST SERVICE CALL OR WRITE . . .

FACTORY ENTERPRISES, INC.

3431 BUTLER STREET, PITTSBURGH 1, PA.

TELEPHONE

MU. 1 1199

guided-missile circuits and many special military applications. Bulletin SR-139A is available. Circle P74 inside back cover.



HIGH-VACUUM DIODE
for horizontal deflection

WESTINGHOUSE ELECTRIC CORP., Electronic Tube Division, Box 284, Elmira, N. Y., has available a new half-wave high-vacuum diode, type 12D4, designed for service as a damping diode in horizontal deflection circuits of tv receivers. The tube, having a heater voltage and current of 12.6 v and 0.6 ampere respectively, is designed for use in receivers which employ series-connected heaters. When employed in this type of circuit, with other tubes having a heater rating of 600 ma, heater voltage surges across individual tubes are minimized because the heater warmup characteristic is controlled. Circle P75 inside back cover.



CONNECTORS
subminiature type

CANNON ELECTRIC Co., 3208 Humboldt St., Los Angeles 31, Calif., has announced a new line of subminiature connectors coded MC, for use with miniature equipment

CO-AX
4 mmf/ft

capacitance
& attenuation

★
ULTRA LOW

WE ARE SPECIALLY ORGANIZED
TO HANDLE DIRECT ORDERS OR
ENQUIRIES FROM OVERSEAS
SPOT DELIVERIES FOR U.S.
BILLED IN DOLLARS —
SETTLEMENT BY YOUR CHECK
CABLE OR AIRMAIL TODAY

TYPE	μμ F/ft	IMPED. Ω	O.D.
C1	7.3	150	.36
C11	6.3	173	.36
C2	6.3	171	.44
C22	5.5	184	.44
C3	5.4	197	.64
C33	4.8	220	.64
C4	4.6	229	1.03
C44	4.1	252	1.03

NEW 'MX and SM' SUBMINIATURE CONNECTORS
Constant 50Ω-63Ω-70Ω impedances

TRANSRADIO LTD. 138A Cromwell Rd. London SW7 ENGLAND CABLES: TRANSRAD, LONDON

NOW... A RELAY
15 G UP TO 2000 CPS

ACTUAL SIZE

DIMENSIONS:
15/32" dia. x 1 3/4" long

WEIGHT:
7/8 oz.

OPERATING POWER:
500 MW Max. (This relay is available for power requirements as low as 100 MW but with slightly less vibration resistance.)

VIBRATION RESISTANCE:
15G up to 2000 CPS

PHOTO
Martin Malader, courtesy
The Glenn L. Martin Company

Wheelock **SIGNALS**
INC.

RELAYS **LONG BRANCH, N. J.**

Limited quantity of model shop samples available — submit your specifications and requirements with your inquiry.

Little Mag says:

TWO GREAT NAMES!**REL****RADIO ENGINEERING
LABORATORIES, INC.**

(Top Name in Tropo Scatter).

MAGNATRAN®**MAGNATRAN, INCORPORATED**
(Top Name in Magnetic Components for Tropo Scatter Power Supplies).**HELP PROVIDE WORLD LEADERSHIP**

More Kilowatt miles of Tropo equipment by (REL) are in use and in production than those of all other companies combined . . .

More Kilowatt miles of (Magnatran) Components and equipment are in use and in production than those of all other companies combined.

MAGNATRAN has provided the following equipment for these major projects:

THE FIRST: POLEVAULT
THE LARGEST: WHITE ALICE
THE NEWEST: AN/FRC—39

MAGNATRAN incorporated
P.O. Box 211 KEARNY, NEW JERSEY, U.S.A.

using 5-amperes current per contact, to supply compactness and sturdy construction for various instrumentation in aircraft and electronics.

Interfacial sealing provides vibration and moisture resistance. There are 2 insert sizes in resilient material and 8 receptacles and plugs, with 84 different possible connector combinations. Minimum flashover at sea level of the resilient insulator type is 1,900 v rms, 60 cps.

Four hermetically sealed receptacles are available. Flashover of the hermetic seals is 1,352 v. Further information and dimensional data are available. Circle P76 inside back cover.



A-C DECADE AMPLIFIER
uses transistor circuitry

BURR-BROWN RESEARCH CORP., Route 4, Box 139, Tucson, Arizona. Model 100 a-c decade amplifier utilizes transistor circuitry exclusively. It is the first of a series of the firm's miniaturized building block laboratory test equipment. It features selectable gains of X10 and X100, 2-percent accuracy, 1 to 800,000-cycle bandwidth, 1.2-percent distortion, 100 K input impedance, low noise and no hum. Self-powered from 9 standard "C" size flashlight batteries, battery life of 1,000-hours continuous operation may be expected. The amplifier may be used in a wide variety of preamplifier applications and will increase the sensitivity of other measuring equipment such as voltmeters and oscilloscopes. Price is \$127. Circle P77 inside back cover.

*An Unusual
Opportunity At
Ramo-Wooldridge*

**ELECTRONIC
COUNTERMEASURES**

A significant electronic countermeasures project is in progress at Ramo-Wooldridge. Circuit engineering responsibility for this project includes directing engineers in the translation of system functions into circuitry. New and unusual circuitry applications are an important aspect of the work. Applicable areas of experience are circuitry design for video, radar, or communication systems.

Scientists and engineers experienced in these fields are invited to explore this opening. Please address inquiries to: Mr. W. J. Coster.

The Ramo-Wooldridge Corporation

5730 ARBOR VITAE STREET • LOS ANGELES 45, CALIFORNIA

New Literature

Research and Engineering. Servo Corp. of America, 20-20 Jericho Turnpike, L. I., N. Y. A new four-page brochure describes the company's facilities for electronic research and development. Listed are the company's capabilities in infrared, electromechanical, optical, electronic, communication and navigation, control and data systems engineering. Fields of interest and completed contracts are listed. Circle L1 inside back cover.

Force Transducers. Daytronic Corp., 216 S. Main St., Dayton 2, Ohio. A two-page bulletin describing the series 140 force transducers is available on request. Included are theory of operation, applications information, photographs and complete electrical and physical specifications for the transducers which are based on a combination of the proving ring and differential transformer principles and which are useful for dynamic or static measurement and control involving force, stress, weight, torque and similar quantities. Circle L2 inside back cover.

Integrated Data Processing. Ditto, Inc., 6800 N. McCormick Rd., Chicago 45, Ill. How businesses of any size can select the correct integrated data processing system for their specific needs is explained in a new booklet. The 24-page booklet discusses one-writing systems, punched cards, magnetic and punched tapes, telegraphic transmission and electronic computers.

A major point stressed is that integrated data processing equipment should be carefully chosen for the needs of a particular business. Larger firms can make profitable use of elaborate electronic equipment. Other firms may find such equipment wasteful of time and money. For many firms, a one-writing direct process or offset duplicating system is recommended.

The booklet also points out that

practically all equipment involved in office automation can be linked to one another. This makes it possible for a growing business to add and adapt IDP to meet its needs. Circle L3 inside back cover.

Small Silicon Rectifiers. General Electric Co., Syracuse, N. Y., has announced a new brochure of application notes on the 4JA60 series of small high-current silicon rectifiers. The rectifiers described can handle 10 kw in a 3-phase bridge circuit.

Brochure ECG-148A should prove of assistance to designers of aircraft electronic equipment, locomotive propulsion motors, automation equipment, computers, and the like. Included are characteristic curves for power dissipation, instantaneous forward voltage drop, and maximum allowable surge current at maximum rated load conditions.

Information to help the engineer design for fault currents, to determine maximum forward current under various conditions, to evaluate methods of cooling, and to make thermocouple measurements is presented. Circle L4 inside back cover.

Telesyn Synchronos. Ford Instrument Co., Division of Sperry Rand Corp., 31-10 Thomson Ave., Long Island City 1, N. Y. A 12-page, 2-color brochure describes and illustrates this firm's standard line of sizes 1, 3 and 5 Telesyn synchronos. Engineered to high military and commercial standards, the units discussed are available as transmitters, receivers, control transformers, and differential units. The brochure provides much application information as well as detailed specifications and performance data. Circle L5 inside back cover.

Voltmeter Data. International Instruments Inc., P. O. Box 2954 New Haven 15, Conn., has published a new engineering data sheet covering its line of minia-

the specs are the proof...
the BEST BUYS are **EICO**
for COLOR & Monochrome TV servicing

NEW COLOR and Monochrome DC to 5 MC LAB & TV 5" OSCILLOSCOPE



= 460
Factory-wired and tested \$129⁵⁰
Also available as kit \$79⁹⁵

• Features DC Amplifiers!

Flat from DC-4.5 mc, usable to 10 mc. VERT. AMPL.: sens. 25 rms mv/in; input Z 3 megs; direct-coupled & push-pull thruout; K-follower coupling bet. stages; 4-step freq-compensated attenuator up to 1000:1. SWEEP: perfectly linear 10 cps-100 kc (ext. cap. for range to 1 cps); pre-set TV V & H positions (30 & 7875 cps); auto. sync. ampl. & lim. PLUS: direct or cap. coupling; bal. or unbal. inputs; edge-lit engraved lucite graph screen; dimmer; filter; bezel fits std photo equip. High intensity trace CRT. 0.06 usec rise time. Push-pull hor. ampl., flat to 400 kc, sens. 0.6 rms mv/in. Built-in volt. calib. Z-axis mod. Sawtooth & 60 cps outputs. Astig. control. Retrace blanking. Phasing control.

NEW TV-FM SWEEP GENERATOR & MARKER



= 368
Factory-wired and tested \$119⁹⁵
Also available as kit \$69⁹⁵

Entirely electronic sweep circuit (no mechanical devices) with accurately-biased inductor for excellent linearity. Extremely flat RF output: new AGC circuit automatically adjusts osc. for max. output on each band with min. ampl. variations. Exceptional tuning accuracy: edge-lit hairlines, 6:1 vernier. Swept Osc. Range 3-216 mc in 5 fund. bands. Variable Marker Range 2-75 mc in 3 fund. bands; 60-225 mc on harmonic band. 4.5 mc Xtal Marker Osc., xtal supplied. Ext. Marker provision. Sweep Width 0-3 mc lowest max. deviation to 0-30 mc highest max. dev. 2-way blanking. Narrow range phasing. Attenuators: Marker Size, RF Fine, RF Coarse (4-step decade). Cables: output, 'scope horiz., 'scope vertical.

NEW DYNAMIC CONDUCTANCE Tube & Transistor Tester

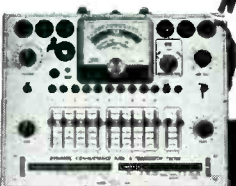

= 666
Factory-wired and tested \$109⁹⁵
Also available as kit \$69⁹⁵

COMPLETE with steel cover and handle.

SPEED, ease, unexcelled accuracy & thoroughness. Tests all receiving tubes (and picture tubes with adapter). Composite indication of Gm, Gp & peak emission. Simultaneous sel of any 1 of 4 combinations of 3 plate voltages, 3 screen voltages, 3 ranges of continuously variable grid voltage (with 5% accurate pot). New series-string voltages: for 600, 450, 300 ma types. Sensitive 200 ua meter. 5 ranges meter sensitivity (1% shunts & 5% pot). 10 SIX-position lever switches: free-point connection of each tube pin. 10 push-buttons: rapid insert of any tube element in leakage test circuit & speedy sel. of individual sections of multi-section tubes in merit tests. Direct-reading of inter-element leakage in ohms. New gear-driven rollechart. Checks n-p-n & p-n-p transistors: separate meter readings of collector leakage current & Beta using internal dc power supply.

See the 50 EICO models IN STOCK at your neighborhood distributor. Write for FREE Catalog E-1
Prices 5% higher on West Coast
EICO BROOKLYN 11, N. Y.

HIGH POWER at TRANSISTOR VOLTAGES

Model DV 60-2 Transistor POWER SUPPLY

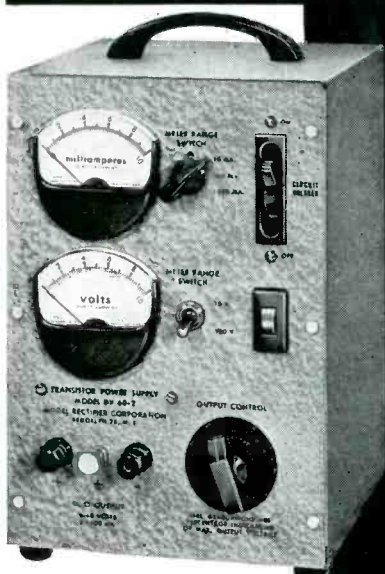

\$110



Thorough and versatile! Efficiently powers all transistor circuits. Unparalleled performance and price.

- **AC OPERATED**, delivers 0-60 volts DC at currents up to 1000 milliamperes.

- **SUPERIOR** to conventional DC power supplies specified for vacuum tube high voltage range and offering erratic reactions when used at low transistor voltages.

- **CONTINUOUSLY VARIABLE**, equivalent to a battery. High power.

- **RIPPLE SUPPRESSION** below 0.2% at rated current, by two section choke input filter.

- **COMPLETE CONTROLS**, front panel switch-type magnetic circuit breaker, neon pilot light, Powerstat output control, multirange voltmeter and milliammeter and output binding posts. Meters accurate to 2%, readable at distance. Height 10 3/4", Width 7", Depth 9 1/4", 21 lbs.

WRITE FOR CATALOG
OF ENTIRE LINE
**MODEL RECTIFIER
CORPORATION**
1065 Utica Ave.
Brooklyn, New York

ture, expanded scale a-c voltmeters. Supplementary information such as mounting dimensions, case descriptions, standard and special resistances and so forth, is contained in additional data sheets covering each specific model. Free copies of any of these are available. **Circle L6 inside back cover.**

Electronic Facts Handbook. American Machine & Foundry Co., 261 Madison Ave., New York 16, N. Y., has published a 20-page booklet entitled "Electronic Facts Handbook." The pocket-size booklet is a collection of carefully selected reference data useful to people concerned with government and industrial R&D activities.

Typical among the many subjects covered are Army and Navy synchros, AN nomenclature for communication equipment, radar terms, frequency bands and wavelength, analog and digital computers, and conversions of wind pressures to pressures. **Circle L7 inside back cover.**

Solderless Wiring Devices. Electric Terminals Corp., 2021 Center St., Cleveland 13, Ohio. A new eight-page technical bulletin entitled "Solderless Wiring Devices" illustrates, describes and furnishes sizes and specification data on new time-saving solderless terminals and connectors for crimping to wire extremities. **Circle L8 inside back cover.**

Arithmetic Control Unit. Philco Corp., 4700 Wissahickon Ave., Philadelphia 44, Pa., recently published a four-page folder on the Transac arithmetic control unit which occupies only 1/3 cu ft, weighs less than 12 lb, operates on only 3-v potential and employs direct-coupled circuitry.

Other information contained in the bulletin includes the following:

The unit contains nearly 1,000 tiny transistors, 300 resistors and 12 capacitors permanently dip-soldered into compact, plug-in, printed-circuit cards. Each card contains all the necessary functions for one binary digit. Transac math-control units with larger

digital capacities can be built in building-block fashion by simply increasing the number of plug-in cards. **Circle L9 inside back cover.**

Fabricated Precision Parts. Mica Insulator Co., Schenectady, N. Y., has available an eight-page booklet on precision parts fabricated from Lamicoid plastic laminates. The illustrated booklet describes the range of parts produced by punching, turning, milling, automatic screw machining and other processes. Also shown are examples of molded, molded-macerated and postformed parts, as well as dials, charts and signs made from decorative grades of Lamicoid.

The advantages of having precision parts fabricated by the producer of the base material are listed. **Circle L10 inside back cover.**

Temperature-Compensating Disk Capacitors. Cornell-Dublier Electric Corp., South Plainfield, N. J. Catalog No. 616 gives full details on new TinyMike ceramic capacitors. Included are illustrations, types and their characteristics and specifications. **Circle L11 inside back cover.**

Magnetic Industrial Counters. Berkeley Division of Beckman Instruments, Inc., 2200 Wright Ave., Richmond, Calif. Theory and circuitry underlying substitution of magnetic devices for vacuum tubes in industrial high-speed counting equipment is explained in data file 109.

It explains how a miniature saturable reactor device, the Ferristor, replaces most of the short-lived vacuum tubes to produce a far more rugged and reliable events-per-unit-time instrument for countless industrial uses.

Besides describing the Ferristor itself, the data file includes a detailed study of circuitry, time base and other electronic components. Complete diagrams illustrate the text. **Circle L12 inside back cover.**

Precision Wirewound Resistors. Bradford Components, Inc., 33-35

Bishop St., Bradford, Pa. Type BPW precision wirewound resistors are illustrated and described in a recent four-page folder, catalog 564. Electrical and physical characteristics, a derating curve and tabular specifications are included. Applications and ordering information are given. Circle L13 inside back cover.

Variable Delay Line. General Radio Co., 275 Massachusetts Ave., Cambridge 39, Mass. Volume 31, No. 5 of the *Experimenter* covers a new type of variable delay line. The variable delay lines described find application wherever it is desired to delay wide-band signal without introducing phase distortion. Design features, methods of application, specifications and price are included. Circle L14 inside back cover.

Time Delay Relay and Thermostat. Curtiss-Wright Corp., Electronics Division, 631 Central Ave., Carlstadt, N. J. New data sheets have just been printed on the Snapper thermal time delay relay and thermostat. Description, technical specifications, adjustment information and features are given. Circle L15 inside back cover.

D-C Amplifier. Jarrell-Ash Co., 26 Farwell St., Newtonville 60, Mass. A new four-page bulletin designated CH374 describes the Hilger-Negretti d-c amplifier, an ultra-sensitive, zero-drift galvanometer amplifier for use in measurement of extremely low currents and potentials. Suitable for a wide variety of measurement and thermometry applications in the fields of physics and chemistry, as well as electronics, the amplifier discussed features a continuously variable sensitivity giving a full 5-ma output for any input from 5 to 50 mv. Circle L16 inside back cover.

Closed-Circuit Television. General Precision Laboratory Inc., 63 Bedford Road, Pleasantville, N. Y., has published a four-page general application brochure on its ii-TV—industrial and institutional television. The equipment illustrated and described is designed

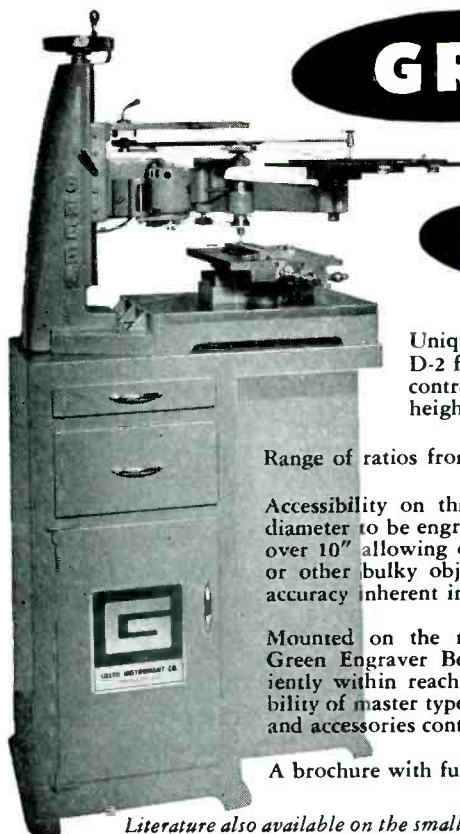

GREEN

Model D-2

Pantograph Engraver

Unique design of the two-dimensional Model D-2 features — Single micrometer adjustment controls vertical depth of cut, and adjusts height of copy table and pantograph.

Range of ratios from 2 to 1 to infinity!

Accessibility on three sides permitting panels up to 30" diameter to be engraved, milled or profiled. Vertical range over 10" allowing operations on complete chassis, cabinets or other bulky objects. Ruggedness, stability and precise accuracy inherent in construction.

Mounted on the ruggedly constructed heavy duty steel Green Engraver Bench. All functional parts are conveniently within reach of the operator while seated. Accessibility of master type sets stored in lower cabinet trays, tools and accessories contribute to productive capacity.

A brochure with full details is yours upon request.

Literature also available on the smaller Model 106 three-dimensional engraver.

GREEN INSTRUMENT COMPANY

363 Putnam Ave., Cambridge, Mass.



- Extended low frequency response to 1000 cps
- High frequency response to 210 Mc with linear phase shift and rise time less than .0026 μ sec
- Gain flat to within $\pm 1\frac{1}{2}$ db and stabilized to ± 0.2 db
- Voltage and current regulation minimize effect of fluctuations in line voltage and tube characteristics
- Ideal for distortionless pulse and transient amplification as in radar, nuclear and television research

Write for data sheet on SKL Model 202D

SKL

SPENCER-KENNEDY LABORATORIES, INC.

1320 SOLDIERS FIELD ROAD, BOSTON 35, MASS.

PRECISION ATTENUATION to 3000 mc!

SINGLE "in-the-line" ATTENUATOR PADS and 50 ohm COAXIAL TERMINATIONS



PROTECTED UNDER STODDART PATENTS

This new group of pads and terminations features the popular Types C and N connectors, and permits any conceivable combination of the two styles.

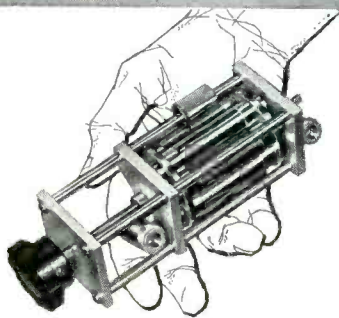

PROTECTED UNDER STODDART PATENTS

six-position

TURRET ATTENUATOR

- Frequency Range: dc to 3000 mc.
- Characteristic Impedance: 50 ohms.
- Available Attenuation: Any value from 1 db to 60 db.
- Accuracy: ± 0.5 db.
- Power Rating: One watt sine wave power dissipation.

STODDART

Aircraft Radio Co., Inc.
6644-A SANTA MONICA BLVD.
HOLLYWOOD 38, CALIF. • HO 4-9294

for any task requiring instantaneous visual communication—observation, magnification, instruction and control. Camera specifications are listed. Circle L17 inside backcover.

Pneumatic-Balance Camera Dolly. Studio Television Products Sales Corp., 11 West 42nd St., New York, N. Y. A four-page illustrated brochure covers the PN6 series pneumatic-balance camera dolly which provides smooth, jerkless motion in both the vertical and horizontal planes. Features, description, specifications and prices are given. Circle L18 inside back cover.

Insulating Materials. Westinghouse Electric Corp., Micarta Division, Trafford, Pa. Booklet B-1050, entitled "Insulating Tapes and Fabrics Facts," is available. It describes properties of treated papers, organic varnished fabrics and combination insulations, organic varnished glass fabric insulation and silicone treated and special insulations. Circle L19 inside back cover.

Toggle Switch Seals. Automatic & Precision Mfg. Co., 252 Hawthorne Ave., Yonkers, N. Y. A one-page engineering bulletin, No. Hex-7, describing series N-1000 Hexseals is available from the manufacturer. It features a high pressure switch boot which contains an internal hexagonal nut. Used to replace standard panel mounting hardware on toggle switches, the boot serves as both sealing device and locknut.

Construction of the hermetic unit is shown by a cross-section drawing and descriptive text. Applicable military specifications met by the unit are listed, sealing materials and their properties are presented and operating characteristics discussed. Color, sizes and special modifications are also described. A price schedule is available. Circle L20 inside back cover.

Digital Differential Analyzer. Litton Industries, 336 North Foothill Road, Beverly Hills, Calif. The second issue of the *DDA Summa-*

tion shows a few ways in which the company's digital differential analyzer can be applied in one's work. The computer described will provide digital accuracy in solutions to many problems being solved on analog computers. The DDA discussed is programmed easily and provides solutions to different equations not readily adaptable to other computers. Circle L21 inside back cover.

Vibration Pickups. Brush Electronics Co., 3405 Perkins Ave., Cleveland 14, Ohio, has published a four-page folder illustrating and describing its vibration pickup preamplifier model BL-1606, and its vibration pickup model BL-4305. The preamplifier described is designed as a link between the Brush accelerometers models BL-4305, BL-4306, BL-4307 or any type of vibration pickup and one of the Brush AF analyzers models BL-2105, BL-2109 or amplifier model BL-2601 or BL-2602. Thus, users are provided with the absolute measurement or recording of acceleration, velocity or displacement.

The literature is divided into two parts. The first covers the preamplifier and gives complete data on product design, operation and application. Also included is detailed specification information. The second part illustrates and describes the design and use of Brush vibration pickups and also lists complete specifications. Circle L22 inside back cover.

Pulse Generator. Rutherford Electronics Co., 3707 S. Robertson Blvd., Culver City, Calif. A recent four-page bulletin contains an illustrated description of model B-3 pulse generator, a general-purpose instrument designed for applications involving repetition rates through 1 mc, delays from 0 to 10,000 μ sec and fast rise time pulse outputs of positive or negative polarity and widths to 10,000 μ sec. Features, specifications and prices are given. Circle L23 inside back cover.

Millivolt Recorders. Leeds & Northrup Co., 4934 Stenton Ave., Philadelphia 44, Pa. A four-page

data sheet E-ND46(6) describes the complete line of Speedomax G millivolt recorders. Specifications are given, features are tabulated and ordering instructions are included.

The instruments described are stocked 0 to 10 mv recorders; one, two and three-cycle d-c logarithmic recorders; instruments with zero suppressed or zero elevated ranges; a medium high impedance recorder operating with a source resistance as high as one megohm and a low level d-c microvolt recorder with a minimum span of 400 microvolts. **Circle L24 inside back cover.**

Ceramic Capacitors. Centralab, a division of Globe-Union Inc., 900 E. Keefe Ave., Milwaukee 1, Wisc. An eight-page technical bulletin gives basic data on ceramic capacitors. Included are background material, illustrations, advantages and characteristics and specifications for various types. Data to furnish on enquiries are also given. **Circle L25 inside back cover.**

Subminiature Meter. International Instruments Inc., P. O. Box 2954, New Haven 15, Conn., has available an engineering data sheet completely describing the model 104, a 1-in. round flush mounting panel meter particularly adapted to portable, airborne and other similar equipment where high accuracy must be combined with minimum size and weight. Information given includes specifications, standard ranges and maximum resistances, and dimensional data. **Circle L26 inside back cover.**

Static Control Logic Elements. General Electric Co., Schenectady 5, N. Y. The eight-page booklet, GEA-6578, defines static control, lists advantages and describes components of the company's general-purpose static control system. The two-color publication explains how static control operates without moving parts and covers the logic function concept, logic functions and conventional control, basic principles of static control, circuit characteristics,

**Reduce pumpdown time with VENTED-EXHAUST
NOW AVAILABLE ON ALL TWO-STAGE DUO-SEAL PUMPS
TWO-STAGE CONSTRUCTION • LARGE CAPACITY • HIGH VACUUM**

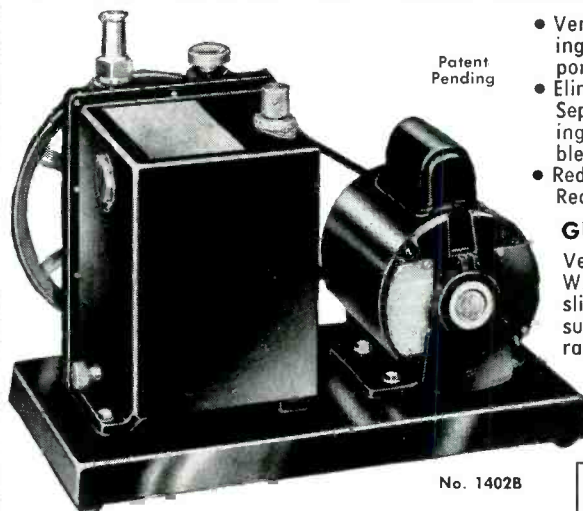

Patent Pending

- Vented Exhaust Permits Pumping of Most Condensable Vapors
- Eliminates Use of Traps or Oil Separators in Systems Containing Water or Other Condensables
- Reduces Number of Oil Changes Required

GUARANTEED VACUUM

Vent closed, 0.1 micron. When the vent is open, only slightly higher ultimate pressures result—usually in the range of 1 micron.

FREE AIR CAPACITY

140 liters/minute
(5 cubic feet)

Illustration shows the 1402B Duo-Seal Pump equipped with Vented Exhaust.

No. 1402B



- PAT. NO. 2,337,849**
- 1402B. DUO-SEAL VACUUM PUMP, Motor Driven. For 115 Volts, 60 Cycles, A.C. Each \$310.00
- 1402C. DUO-SEAL VACUUM PUMP, Motor Driven. For 230 Volts, 60 Cycles, A.C. Each, \$310.00

- 1402D. DUO-SEAL VACUUM PUMP, Motor Driven. For 115 Volts, D.C. Each, \$380.00 For attached Belt Guard, add \$17.50 to above price.
1402. DUO-SEAL VACUUM PUMP, Unmounted. With pulley, but without motor, belt, or base. Each, \$240.00

W. M. WELCH SCIENTIFIC COMPANY
DIVISION OF W. M. WELCH MANUFACTURING COMPANY
ESTABLISHED 1880

1515 Sedgwick St., Dept. H, Chicago 10, Illinois, U.S.A.

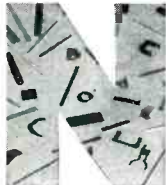
NEY'S SMALL PARTS PLAY A BIG PART IN PRECISION INSTRUMENTS • NEY'S SMALL PARTS

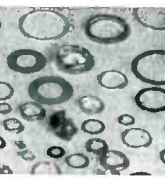





PRECIOUS METAL

ENGINEERED CONTACTS, SLIP RINGS & ALLOYS

Ney designs and makes to customers' specifications sliding contacts, slip rings and assemblies, commutator segments and assemblies, brush and brush holder assemblies, and precious metal resistance wire. Consult Ney's Engineering Dept. and find out how precious metals can improve your products.

THE J. M. NEY COMPANY, P.O. BOX 990, DEPT. E HARTFORD 1, CONN.
Specialists in Precious Metal Metallurgy since 1812



Ney has just built this modern new plant to give you even better products and better service.

NEY'S SMALL PARTS PLAY A BIG PART IN PRECISION INSTRUMENTS • NEY'S SMALL PARTS

monitor lights and amplifiers. Circle L27 inside back cover.

Speed Recorders. Leeds & Northrup Co., 4934 Stenton Ave., Philadelphia 44, Pa. Concise information about the compact, electronic Speedomax H indicators and recorders now available for precise measurement of rotational or linear speeds, and about the tachometer generators used with them, is presented in an illustrated two-page data sheet.

Data sheet ND46-27(100) completely lists the features and specifications of the indicators and round-and strip-chart recorders, and tabulates the characteristics and speed ranges of both standard and explosion-resistant tachometers. Circle L28 inside back cover.

Accessories and Components. Allen B. DuMont Laboratories, Inc., 750 Bloomfield Ave., Clifton, N. J. A compilation of the company's complete line of accessories for electronic test equipment and components for electronic circuitry appears in a recent catalog. More than 200 items associated with cro's, oscillograph record cameras and other electronic test equipment are described in the 20-page catalog. Among these accessories are knobs, test probes, magnetic shields, viewing hoods, photographic developing equipment, crt and multiplier phototube base clamps, base sockets and connectors, movable tables and rack mounting adapters.

Also included in the listing are electronic circuit components such as pulse transformers and wide-band toroids. The listings include photographic and written descriptions, catalog numbers and prices for each item. Requests for this catalog should be on company letterhead.

Ferrite Flyback Transformer Core Standard. Metal Powder Association, 130 W. 42 St., New York 36, N. Y. Standard 20-56 sets forth a method of testing ferrite flyback transformer cores. It does not attempt to provide a complete evaluation of the core material, but rather provides a means of unifying the methods of measure-

TERMALINE COAXIAL LOAD RESISTORS

50 ohms DC to 4000 mc—5 watts to 2500 watts

The constant resistance (Low VSWR) of the TERMALINE resistor make it the ideal dummy load and standard resistor at UHF and VHF Design is such that normal reactance is put to work producing a pure resistance over an extremely wide frequency range. Acting as a "bottomless pit" for RF energy, thousands of TERMALINE units are in daily use in high frequency applications.

Model	Cont. Power Rating	Input Connector
80F	5 watts	UG-23B/U
80M	5 watts	UG-21B/U
80A	20 watts	UG-23B/U
81	50 watts	UG-23B/U
81B	80 watts	UG-23B/U
82	500 watts	Adaptor to fit UG-21B/U supplied
82A	500 watts	
82C	2500 watts	

Adapters or cable assemblies for standard coaxial line available.

ALL TERMALINE units, except Model 82C, are self-cooled. Substantial quantity discounts.

LITERATURE UPON REQUEST

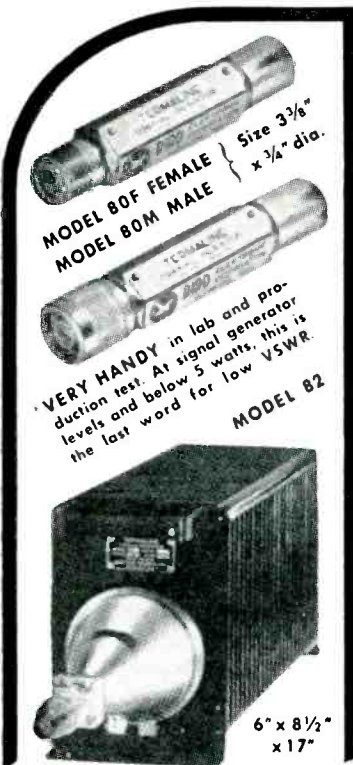

BIRD ELECTRONIC CORP.

1800 EAST 38TH ST., CLEVELAND 14, OHIO

TERMALINE Coaxial Line Instruments

VAN GROOS COMPANY
Sherman Oaks, Cal.

TRANSFORMERS FOR ELECTRONICALLY REGULATED POWER SUPPLIES

Now... over the counter

Avoid delay in making your breadboards, no waiting for a special when a

STERLING 2K SERIES

transformer will meet your requirements exactly. Stack STERLING 2K units are available for supplies from 100 milliamperes of 100 volts to 400 milliamperes at 300 volts

Each 2K transformer provides:

- PLATE VOLTAGE ALLOWANCE FOR PASS TUBE.....
- RECTIFIER FILAMENT POWER.....
- PASS TUBE FILAMENT POWER.....
- REGULATOR CIRCUIT FILAMENT POWER.....
- AUXILIARY FILAMENT POWER FOR OTHER CIRCUIT REQUIREMENTS.....
- REGULATOR CIRCUIT PLATE POWER.....
- APPLICATION BULLETIN WITH EACH UNIT

Military versions of each of these units is also available. Technical data on the complete line is available on request.

SAMPLES? SPECIALS? SHORT RUNS?

The 2K series is only one of the many types we make. We specialize in custom-built transformers to your specifications. Let our engineering staff help solve all your transformer problems.

Samples delivered in 1 to 3 weeks.



Technical specifications on a typical unit of this family of transformers for use in a 300 volt 200 milliampere dc regulated power supply with 90 to 130 V AC input:

ST2010

Primary: 115 Volts AC, 50 to 1000 cps

Secondaries:	
570-0-570V	240 mac*
5.0V	3 A
6.3V	3 A
6.3V	1.2A
6.3VCT	6 A

*Note 40 ma provided

Size: 5/8 x 4 5/8 x 5 1/2 H
Mtg. Centers: 3 1/2 x 3 1/2
Weight 15 lbs.
Associated Choke: ST2009
4 Henries at 240 mac.



299 North 7th St., Brooklyn 11, N. Y.
STagg 2-4200

NOW...ANY MICROWAVE COMPONENT CAN BE BUILT AND ENGINEERED TO YOUR PARTICULAR APPLICATION

Regardless of complexity, design or tolerance problems—you can get UHF or microwave components that are job-engineered to your application. All units are delivered, *electrically tested and proven*, ready for immediate operation.

Components can be built from your prints or can be designed and built to integrate with the application. Close and confidential coordination is maintained from drawing board stage to installation.

Range of assemblies is practically unlimited—from dc. to over 40,000 mc., military or industrial. Typical examples are these components, delivered ready for field use:

Telemetering . . .

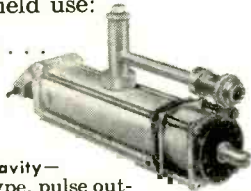

Tunable S-Band Transmitter Cavity—re-entrant type, pulse output 150 w., operates at extreme altitudes and under extreme conditions of temperature, humidity and salt spray.

Improving signal-to-noise ratio . . . selectivity . . .



Tunable UHF Pre-Selector—relatively low frequency coaxial resonator with very low insertion loss, extreme selectivity and very high signal-to-noise ratio. Especially adapted to use in aircraft or in crowded communication bands.

Calibrating . . . designing S-Band components . . .

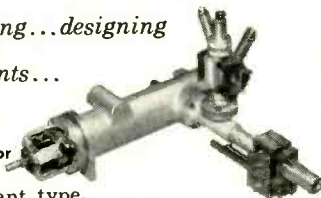

S-Band Signal Generator Cavity—re-entrant type, complete with thermistor mount and calibrated variable attenuator. Frequency range 2700 to 3400 mc.

Get the facts on our complete design, engineering and mechanical fabrication facilities. Have us quote on your needs—cavities, mixers, duplexers, multipliers, rotary joints, twists, bends and other components or assemblies.

Contact us today. Request catalog.



J-V-M ENGINEERING COMPANY
4631 LAWNDALE AVENUE, LYONS, ILLINOIS
(Chicago Suburb)

NEW LITERATURE

(continued)

ment and inspection throughout the ferrite core consuming industry. Test conditions are specified for nickel-zinc ferrites and manganese-zinc ferrites.

The method described employs a signal generator audio power amplifier and Fluke volt ammeter wattmeter. Copies of the Standard are available at 25 cents apiece. **Circle L29 inside back cover.**

Integrated Field Coil. Allis-Chalmers Mfg. Co., 935 South 70th St., Milwaukee 1, Wisc. Leaflet 05R8525 describes an integrated field coil with a newly developed insulating system designed to protect electric motors and generators against atmospheric contaminants and destructive mechanical forces. The unit discussed is currently available for synchronous and d-c machines subject to severe duty cycling in Class A and B temperature classifications. **Circle L30 inside back cover.**

Subminiature Lever Switches. International Instruments Inc., P. O. Box 2954, New Haven 15, Conn., has announced an engineering data sheet completely describing two new subminiature lever switches—the series L-7000 (without spring return) and the series SRL-7000 (with spring return). It includes all electrical characteristics, details of construction, listings of available models specifications and mounting dimensions. **Circle L31 inside back cover.**

Thermistor Overheat Detectors. Fenwal Inc., Ashland, Mass. A four-page brochure covers the new thermistor-actuated overheat detectors developed for temperature control and overheat detection in aircraft. Brochure MC134 describes the unique advantages of sensing temperature with thermistor elements, suggests applications and installation techniques, and lists all physical, performance and military specification data. **Circle L32 inside back cover.**

Components for Transistor Circuits. Thordarson-Meissner, Seventh and Belmont, Mt. Carmel, Ill. Catalog No. J-780

New Rhodium Plate Won't Curl, Crack or Peel!



RHODEX

A rhodium plating process that produces *Compressively Stressed deposits . . . developed specifically for industrial applications. RHODEX will materially increase the fatigue resistance of the metal over which it is deposited.

*Patent Pending

SEL-REX CORPORATION
Precious Metals Division
155 Manchester Place • Newark 4, N. J.

Please rush descriptive literature and technical data on Sel-Rex RHODEX (Compressively Stressed Rhodium.)

NAME _____
COMPANY _____
ADDRESS _____
CITY _____
ZONE _____ STATE _____

a complete line of
Printed Circuit Hardware
and
Terminal Inserting Equipment

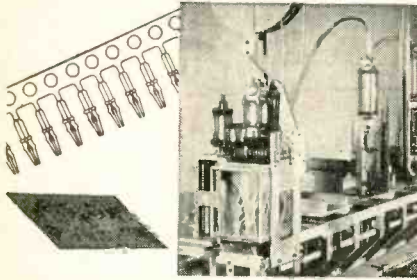

Tubular Pin Terminals—Insert automatically into printed circuit board at huge production savings. Snap into position with positive locking action by means of self-retaining snap-in feature. Double ends permit wrapping or inserting leads at either end. Ask for Bulletins 550 and 551.

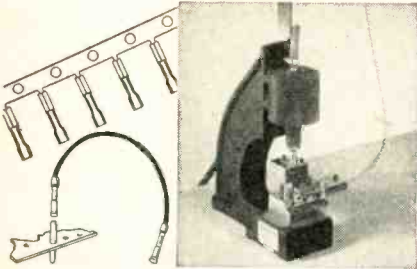

Solderless Wire Disconnect Female Terminals—Speedily applied to leads by means of cost-saving automatic equipment. Fits quickly and firmly to tubular pin terminals. Solderless wire crimp can be varied to fit various size insulated wires. Ask for Bulletin 553.

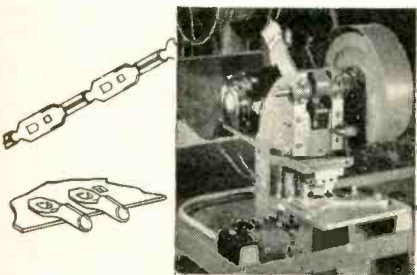

Line Cord Interlock Terminals—For single or multiple lead connections. Another Malco automation development to provide production short cuts and assembly economy. Terminals are staked quickly and firmly into printed circuit boards. Ask for Bulletin 554.

Malco printed circuit hardware can be engineered to your specific requirements. Give us the facts about your operation. We'll show you how your costs can be lowered and your production increased. Ask for Bulletin 551.

Malco TOOL and MANUFACTURING CO.

4023 W. Lake St., Chicago 24, Ill.

NEW LITERATURE

(continued)

presents a complete line of components for transistor circuits. Included are 36 audio transformers, 10 i-f transformers, seven ferrite antenna coils, five oscillator coils and four midget variable capacitors. List prices are given. **Circle L33 inside back cover.**

Microwave Ferrite. Raytheon Mfg. Co., Foundry Ave., Waltham 54, Mass. A recent data sheet covers type R-151, a new ferrite material recommended for use at X- and K-band frequencies in Faraday rotation devices such as isolators, modulators, switches and circulators. A digest of approximate properties is given. **Circle L34 inside back cover.**

Electrical Insulations. Insulation Manufacturers Corp., 565 W. Washington Blvd., Chicago 6, Ill., has available an alphabetical guide to electrical insulating materials. The listing will enable engineers and manufacturers to locate any of the electrical insulations needed in their work. Common names and trade names of products are cross-indexed for ready identification. Trade marks are also shown. The last two pages identify the insulations with their makers. **Circle L35 inside back cover.**

Silicon Rectifier Stacks. Transition Electronic Corp., Wakefield, Mass. A six-page folder covers the TD series silicon rectifier stacks which feature reliability at high temperatures, high voltage operation, high current output, excellent regulation and negligible leakage current. General specifications, mechanical drawings and information on selecting a stack for a given application are included. **Circle L36 inside back cover.**

Pocket Reference Book. Radio Corp. of America, Harrison, N. J. The 1957 issue of the Tube Division reference book is now available. The pocket-size book contains 200 pages of information on tubes, semiconductor devices and electronic components. The section on tubes includes a quick selection guide of RCA power, c-r, phototubes and special tubes for radio and industry, an inter-



The
Curtiss-Wright
"SNAPPER"

**NEW CONCEPT... ADVANCED DESIGN
IN THERMAL TIME DELAY RELAYS**

- Eliminates chatter with snap action
- Single-pole, double throw contacts
- Wide ambient range (-65°C $+100^{\circ}\text{C}$)
- For military, commercial and industrial applications
- Metal envelope (7 or 9 pin) miniature or (8 pin) octal
- Glass envelope in 9 pin miniature
- Preset time delays in metal from 3 to 90 seconds, glass from 5 to 60 seconds

Write to Thermal Devices Department
for latest data sheets



Curtiss-Wright has career positions open for qualified engineers and technicians.

changeability directory of tubes for communications and industry and 37 pages of receiving tube characteristics, with base and envelope connection diagrams. Picture tube characteristics and socket connections occupy 12 pages.

Also included are reference data on test instruments, speakers, tv components, selenium rectifiers, lightning arresters, miniature lamps and radio batteries. **Circle L37 inside back cover.**

Switches and Relays. Jaidinger Mfg. Co., Inc., 1921 W. Hubbard St., Chicago 22, Ill. A catalog is now available showing approximately 40 different switches and relays, ranging in size from standard size units to the miniature and describing the operation and characteristics of each. It also shows many of the new developments in switches and relays and gives complete specifications, size and other information of importance to engineers, designers and manufacturers. **Circle L38 inside back cover.**

Phosphor-Bronze Data. American Silver Co., 36-07 Prince St., Flushing 54, N. Y. A four-page data sheet contains pertinent information on the physical characteristics, processing and applications of phosphor-bronze in thicknesses as low as 0.0005 in. ± 0.0001 in. The relatively inexpensive spring material described exhibits high strength, long fatigue life, good electrical conductivity and excellent resistance to corrosion. Applications listed range from shims to electronic computer tape. **Circle L39 inside back cover.**

Miniature Magnetic Shift Registers. Magnetics Research Co., 255 Grove St., White Plains, N. Y. Technical bulletins No. 127 and 128 cover a line of seven miniature magnetic shift registers. The devices described are designed for operation where physical size and ease of interchangeability is at a premium. Complete specifications and price schedules are shown. **Circle L40 inside back cover.**

Products Catalog. Gulton Industries, Inc., 212 Durham Ave., Metuchen, N. J. The company's

how to get more volts per pound at high altitudes

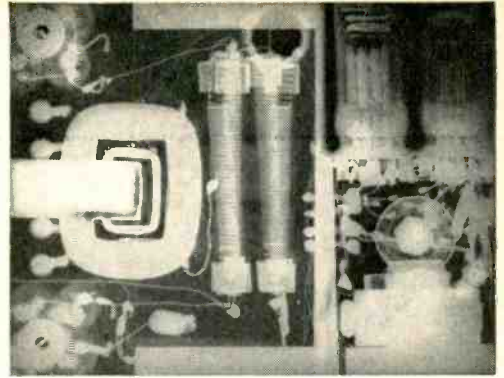

PROBLEM: Design a *regulated* high-voltage dc power supply for operation at high altitudes. Specifications:

- Input voltage—400 cps $\pm 10\%$ • Output—dual: 4 KV at 2.5 ma; 8 KV at .3 ma • Regulation—no load to full load within 1% • 105 cubic inches maximum • Light as possible.

SOLUTION: We designed a vacuum tube regulator circuit, with the regulator tubes kept at low voltage. Result: The tubes could be mounted externally—for easy replacement.

For compactness and to protect high-voltage components against the hazards of moisture or rarefied air, we cast the rest of the unit in epoxy resin.

The assembly weighs only 6 $\frac{3}{4}$ lbs., occupies 96 cu. in., plus terminals.

This sort of engineering can be at your service too. When *you* need electronic assemblies—by hundreds or thousands—straightforward or special design—make use of our production and design experience and facilities.

CALEDONIA ELECTRONICS AND TRANSFORMER CORP.

Dept. E-1, CALEDONIA, NEW YORK

In Canada: Hackbusch Electronics, Ltd., 23 Primrose Ave., Toronto 4

Now... Modernize
high power electrical and electronic
equipment with

NEW ELECTROSEAL TRANSFORMERS



Unique sealed construction exclusive with Electro Seal transformers allows new applications for an open-type unit. Whether you want 1 or 100 KVA, Electro Seal gives drastic size reduction along with a neat and clean appearance. Actual weight per KVA as much as two-thirds less, dimensions as much as one-half competitive transformers. New sealing compound protects coils against dirt and moisture, and permits high temperature operation (Class B or C). Electro builds in the reliability you need... plus high overload capacity. Electro Seal transformers are built to your specifications. Write for literature.

ELECTRO ENGINEERING WORKS, INC.

401 Preda Street, San Leandro, California / In the Metropolitan Oakland area

MARKEM[®] MACHINES

Solve "IN-PLANT" PRINTING PROBLEMS
- FASTER - NEATER - AT LOWER COST

COLOR BANDING WIRE LEAD COMPONENTS

The Markem 69A Machine semi-automatically applies up to six color bands to wire lead components such as resistors and condensers. Band width and color changes are easily made. Automatically feeds and ejects; bands about 50 objects per minute. The 69A will also mark cylindrical objects with complete label detail, in one or two colors.

Other Markem machines available for marking electrical parts and products of all sizes and shapes. Write for detailed information.

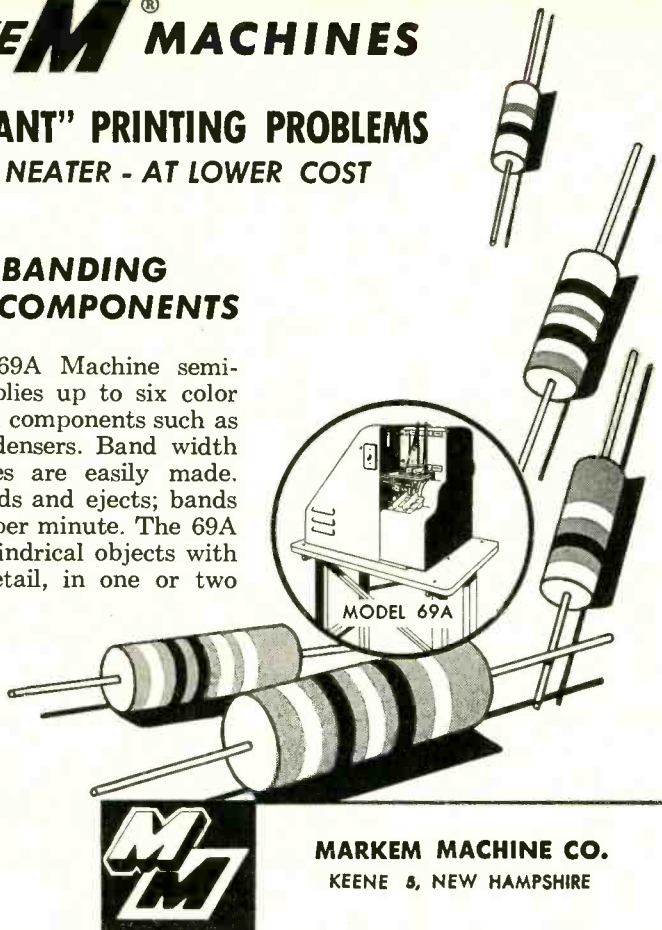

MARKEM MACHINE CO.
KEENE 5, NEW HAMPSHIRE

U A C completely electronic power supplies

Deliver up to 100 Watts
with 98% Efficiency
in a 3" x 4" x 6" Package

INPUT—28v DC
—110 vac, 60 cps
OUTPUT—To 100 watts at voltages from 300 to 500 DC
MAXIMUM WEIGHT—5 lbs.
MAXIMUM SIZE—3" x 4" x 6"
± 2% inherent regulation
Operation to a temperature of 100°C with no derating.
Operation to a temperature of 150°C available.
Can meet existing environmental specifications.

UAC 1—500 watt semi-conductor power supplies save weight and space, increase efficiency for CLOSED CIRCUIT, AIRBORNE, TV-RADAR, RADIOSONDE, AIRCRAFT RADIO RECEIVERS, TRANSMITTERS, COMPUTERS, SERVOS, RADAR, TELEMETERING and many other applications.

Write, wire, phone your requirements. Ask for information on our DC to DC and AC to DC

UAC[®] electronics a division of Universal Atomics Corp.
Dept. E1 50 Bond Street, Westbury, L. I., N. Y. EDgewood 3-3304

NEW LITERATURE

(continued)

products and achievements are discussed and illustrated in a new revised 16-page catalog. The brochure breaks down the divisions and associates and describes the products with photographs of each. Among the products included from seven different divisions are: electromechanical, electroacoustical and electronic devices, instruments, transducers and complete systems; thermistors; precision-built magnetically regulated power supplies; ultrasonic components, systems and consultation service; piezoelectric ceramic materials and ceramic-based electronic components; meters featuring the Greibach bifilar suspension and automatic controls. **Circle L41 inside back cover.**

Aircraft Switches. Micro Switch, a division of Minneapolis-Honeywell Regulator Co., Freeport, Ill. The 24-page Catalog 77 covers 12 different groups of precision snap-action switches. In all, over 70 different enclosed switches for airborne equipment are described. The literature is complete with photos, dimensional drawings, electrical ratings and technical information. **Circle L42 inside back cover.**

Two-Way Radio. General Electric Co., Syracuse, N. Y., has published bulletin ECR-380-A on the company's new Progress line 450-mc two-way radio. It gives details on printed circuitry, interchangeable components, cabinets and mounting. **Circle L43 inside back cover.**

Microwave Resistors. Filmohm Corp., 48 W. 25th St., New York 10, N. Y. Bulletin M-1 covers a line of evaporated metal film microwave resistors. Included is information on terminals, resistance range, tolerance, frequency characteristics, power rating and dimensions. **Circle L44 inside back cover.**

D-C Power Supply. Electro Products Laboratories, 4500 N. Ravenswood Ave., Chicago 40, Ill. New literature explaining the construction and operating principles of a specially filtered d-c power supply has been announced. The illustrated catalog sheet shows that

Cylindrical BOBBINS UNLIMITED

OF EPOXY RESIN, NYLON,
TEFLON AND OTHER PLASTICS

CUSTOM-FORMED TO ANY
CYLINDRICAL SHAPE IN
DIAMETERS OF 1/8" TO 7/8"
AND LENGTHS UP TO 7"

NO MOLDS NECESSARY



Illustrated are but a small fraction of the countless possible variations of cylindrically shaped bobbins we can custom form of plastic materials.

Whatever your particular individual requirements in cylindrical bobbins in above size ranges, it will be in your best interests to consult with our engineering staff. This service is offered without cost or obligation, of course. Any quantity promptly supplied—and remember . . . no molds necessary.

Send blueprint or samples for prompt quotation.

ORANGE PRODUCTS INC.

554 Mitchell St., Orange, N. J.

NEW LITERATURE

(continued)

the model NFA power supply has less than a 1-percent ripple at top load and is used for design testing and servicing radios and electronic equipment in aircraft, autos, tanks, marine craft; transistor circuits; relays and solenoids; telephone circuits; laboratory and research instruments; plating operation and low voltage devices. Circle L45 inside back cover.

I-F Amplifiers. LEL, Inc., 380 Oak St., Copiague, L. I., N. Y. A broad line of i-f amplifiers and preamplifiers using miniature and sub-miniature tubes is illustrated and described in a four-page brochure. Units described include laboratory types for noise figure measurement, subminiature preamplifier and afc units, and general purpose amplifiers for radar and guided missile applications. Circle L46 inside back cover.

Indicator For Digital Systems. Leeds & Northrup Co., 4934 Stenton Ave., Philadelphia 44, Pa., has available a new two-page preliminary data sheet E-ND46(101) describing the Speedomax H model R indicator for digital systems.

Examples of applications involving simultaneous or sequential readout with this equipment are given. A picture of the digital conversion unit mounted in the Speedomax H indicator is included. Complete specifications are given as well as operating ranges. Circle L47 inside back cover.

Radio and Electronic Components. Amphenol Electronics Corp., 1830 South 54th Ave., Chicago 50, Ill. Catalog B5 is a general catalog providing a condensed yet comprehensive listing of the company's extensive line of radio-electronic products. This easy and informative reference includes accurate descriptions of each part or component listed as well as helpful engineering and electrical data. It features a complete index, logical grouping of parts by their uses, proximity of related items, dimension drawings, mounting diagrams and many photographs. Circle L48 inside back cover.



Complete technical details are contained in our key catalog, available without charge. Just write.

Form A, C or D contacts. Or you may order special strips with intermixed contacts.

STROMBERG-CARLSON S-C
A DIVISION OF GENERAL DYNAMICS CORPORATION
1000 Communication Industrial Bldg., 110 Carlton Rd., Rochester 3, N.Y.

For automation programming... Stromberg-Carlson push-type keys

Constructed around a rigid steel framework, our multiple push buttons are available in white or colors. Push buttons may be furnished blank or with letter or numerical designations as desired. Standard spring combinations are furnished with

In addition to strips of 20 keys, as illustrated, you may order combinations of 7, 10 or 12 strip-mounted keys. "Make," "break," "break-make" and "make-before-break" combinations may be applied as the program requires.



Plants and People

Edited by WILLIAM G. ARNOLD

Electronics industry technical societies and trade associations name officers and directors for 1957. Manufacturers continue plant and facility expansions with new construction. Engineers and executives are promoted, move to new jobs

IRE Elects 1957 Officers, Honors Three Engineers



John T. Henderson

JOHN T. HENDERSON, principal research officer of the National Research Council, Ottawa, Canada has been elected president of the Institute of Radio Engineers for 1957. He succeeds Arthur V.



Yasujiro Niwa

Loughren, color television consultant, as head of the international society of 53,000 people

Yasujiro Niwa, president of Tokyo Electrical Engineering College, Tokyo, Japan will succeed

Herre Rinia, director of research of the Philips Research Laboratories in Eindhoven, Holland as IRE vice-president.

Elected as directors for the 1957-1958 term are D. E. Nobel, executive v-p of the communications and electronics division of Motorola, and Samuel Seely, professor and head of the department of electrical engineering at Case Institute.

Regional directors elected for 1957-1958 are as follows: Region 2, F. A. Polkinghorn, Bell Telephone Laboratories, Whippany, N. J.; Region 6, Kenneth Newton, Bendix Aviation Corp., Kansas City, Mo.; Region 8, A. B. Oxley, RCA Victor Company, Ltd., Montreal, Canada.

► Awards—The Morris Liebmann Memorial Prize Award will go to

RETMA Board of Directors and Officers For 1956-57

Paul V. Gelvin	Ewen C. Anderson	B. W. Cooper	Herbert W. Clough Vice President	H. J. Hoffman Vice President	F. R. Lack Vice President	R. E. Carlson Vice President	Robert S. Bell Vice President	Max F. Balcom	Benjamin Abrams	R. G. Zender
L. C. Truesdell	W. J. Holligon	T. M. Douglas	H. Leslie Hoffman	Leslie F. Muter Treasurer	James D. Secrest Executive Vice President and Secretary	Robert C. Sprague	A. D. Plamondon, Jr.	Frank Frelmann	Robert C. Tait	
R. S. Gafes	David T. Schultz	E. K. Foster	Roy F. Sparrow	Glen McDaniel General Counsel	W. R. G. Baker President	Harry A. Ehle	Larry F. Hardy	R. J. Shank	W. Myron Owen	A. Blumenkrantz
J. A. McCullough	D. R. Hull	Roy S. Laird	Joseph N. Benjamin	Charles F. Strameyer	John W. Van Allen General Counsel Emeritus	C. Russell Cox	Roland M. Bixler	Chester G. Gifford	R. E. Cramer, Jr.	W. S. Parsons

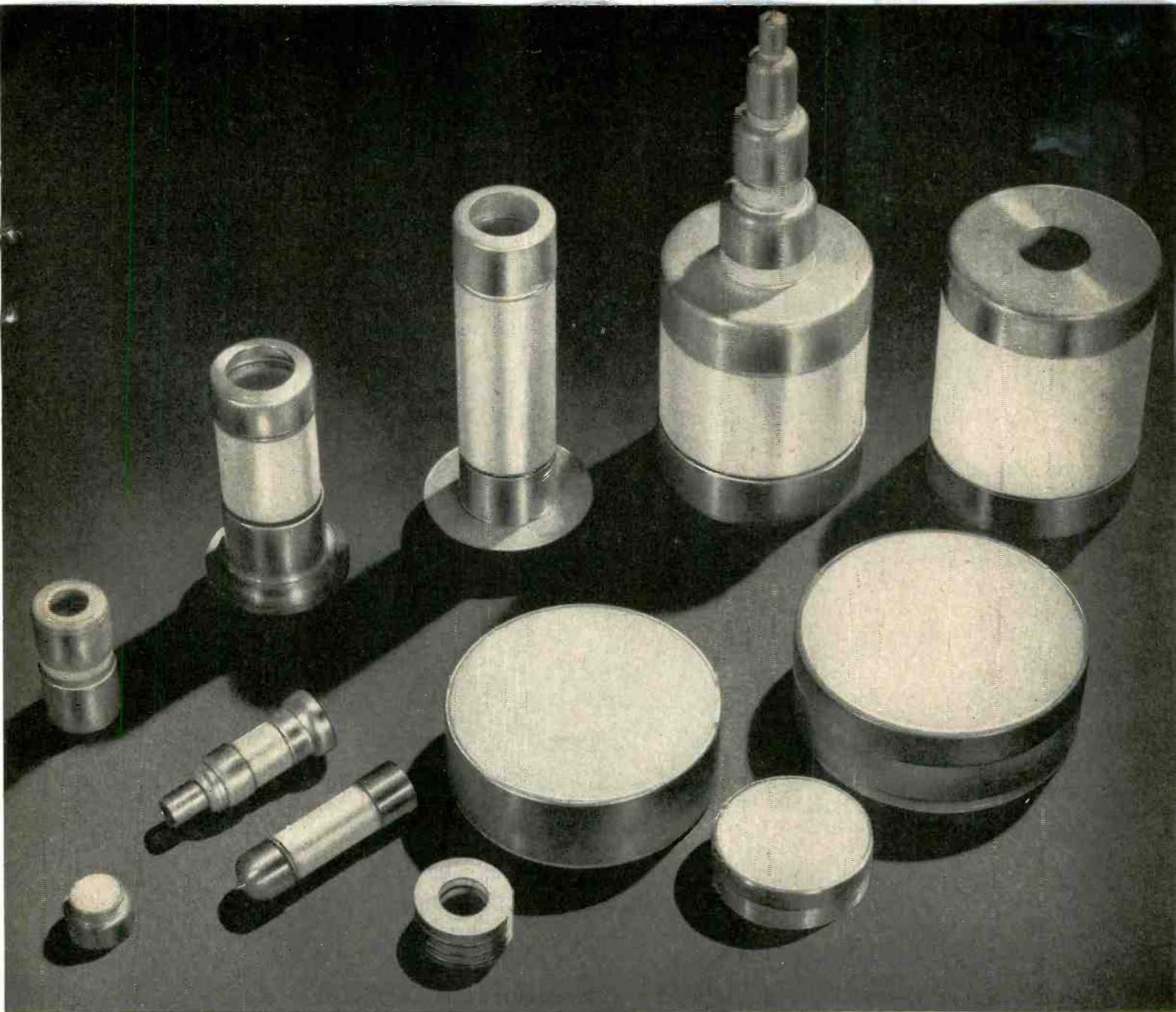

Why your ceramic-to-metal seals need **RAYTHEON R-95 HIGH-ALUMINA CERAMIC**

Fundamental to the problem of reliable seals is a reproducible ceramic body. And equally basic to the quality of the ceramic body are these essential characteristics:

1. Vacuum tightness
2. Sure thermal shock resistance
3. Reliable mechanical properties
4. Dependable electrical properties
5. High temperature characteristics
6. Economical fabrication
7. Uniformity—from lot to lot—in each of the above

Raytheon's R-95 ceramic meets every one of these exacting demands, consistently!

Ceramic parts manufactured from Raytheon's R-95 high-alumina are available, either alone or as hermetic ceramic-to-metal assemblies, in accordance with your specifications. The assemblies can be soldered into your production in your own plant.

Send sketches or drawings outlining dimensions and tolerances, together with operational conditions. We will be pleased to supply information and help on any of your ceramic needs.

Write for complete specification sheet. No cost or obligation, of course.

RAYTHEON MANUFACTURING COMPANY

Ceramic Sales

Waltham 54, Massachusetts



*Excellence
in Electronics*

O. G. Villard, Jr., professor at Stanford University, Stanford, Calif. "for his contributions in the field of meteor astronomy and ionosphere physics which led to the solution of outstanding problems in radio propagation." The award is made annually to a member of the IRE for a recent important contribution to the radio art.

Donald Richman, supervising engineer at Hazeltine Corp., Little Neck, N. Y. will be the recipient of

the Vladimir K. Zworykin Prize Award "for contributions to the theory of synchronization, particularly that of color subcarrier reference oscillator synchronization in color television." This award is made annually for outstanding contributions to electronic television.

The Harry Diamond Memorial Prize Award will be given to Georg Goubau, physicist at the Signal Corps Engineering Labs., Ft. Monmouth, N. J. "for his many con-

tributions in ionospheric research and circuit theory and for his discovery of the surface wave transmission principle." The Diamond award is given annually to a person in government service for outstanding contributions in the field of radio or electronics as evidenced by publication in journals.

All three of the awards will be made during the IRE National Convention, Mar. 18-21 in New York City.

Loughren Joins Airborne Instruments As Research V-P

ARTHUR V. LOUGHREN has been appointed vice-president of the new research division of Airborne Instruments Laboratory in Mineola, N. Y.

For the past 20 years he was associated with the Hazeltine Corp. as design engineer; consultant and vice-president in charge of research.

His honors and awards in the field of electronics include the U. S. Navy Certificate of Commendation for "outstanding service to the Navy for contributions to elec-



Arthur V. Loughren

tronic development during World War II"; the David Sarnoff Gold Medal in 1953 by the Society of Motion Picture and Television Engineers for "meritorious achievement in television engineering"; the 1954 Plaque of the RETMA-IRE Radio Fall Meeting with the citation "for his contributions to color television"; the IRE Morris Liebman Memorial Prize in 1955 for his "contributions in the formulation of the signal specifications for compatible color television"; and presidency of IRE.

Avco To Build Research Center In Massachusetts



Arthur Kantronitz, left, and Lloyd P. Smith of Avco view model of research center

ment center for basic and applied science in Wilmington, Mass. The center will be in operation by mid-1958.

The research and advanced development division of Avco will be housed in the center. The division was organized 14 months ago. At present it is concerned largely with research and development of advanced missile systems for the Department of Defense.

Temporarily, the division has headquarters in Lawrence, Mass. and its research laboratory is in Everett, Mass. Both these facilities and the research departments of several other Avco divisions will be housed permanently in the new center.

The four buildings in the center for research, administration, development and fabrication will provide over 400,000 sq ft of floor area.

Total area of the site for the center is 100 acres.

AVCO MANUFACTURING CORP. which recently sold its Bendix home laun-

dry division to Philco, will build a \$15 million research and develop-

Continued on page 346

Type 525 TV Waveform Monitor For QUALITY CONTROL



in Telecasting

The Tektronix Type 525 displays the television-signal waveform with the precision required for high-quality monochrome and color telecasting. Excellent linearity and gain stability, four separate vertical-amplifier response characteristics, keyed clamp-type dc restorer, high accelerating potential, and automatically-synchronized sweeps are features contributing to an accurate, useful waveform presentation. With this accurate monitor on the line you can easily check the quality of your incoming and modulating signals.

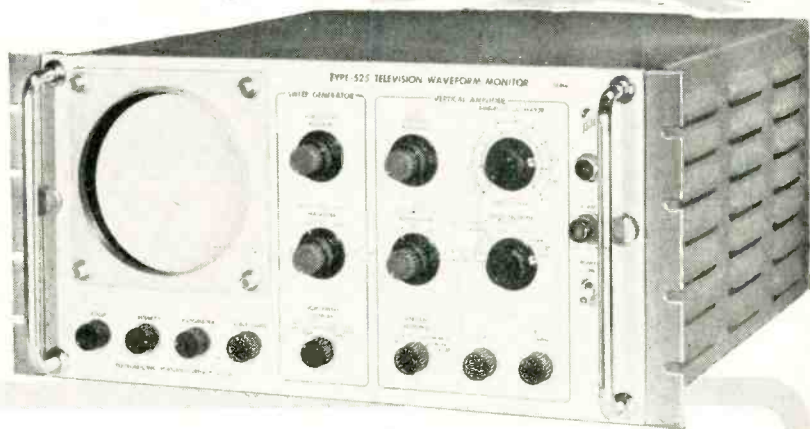

TYPE 525 CHARACTERISTICS

Frequency-Response Settings

FLAT—within 1% from 60 cycles to 5 mc.

LOW PASS—passes stairstep, blocks high frequencies.

HIGH PASS—passes 3.6 mc test signal, blocks stairstep.

IRE—meets IRE standards for level measurements.

Vertical Linearity. Signal can be expanded to equivalent of 35 cm, with any 7 cm accurately displayed on the screen.

Stability. All dc voltages electronically regulated. Vertical-amplifier gain stability within 1% over a ten-hour period.

Sensitivity. Basic sensitivity 0.015 v/cm. 1x, 2x and 5x step attenuator and variable gain control.

Sweeps. Automatically synchronized to display 1½ to 5 lines or fields. 1x, 5x, or 25x sweep magnification.

DC Restorer. Keyed clamp-type—restores dc level to tip of sync pulse. Can be switched in or out as desired.

Amplitude Calibrator. Pulse type, duty cycle about 75%. Four ranges—0.05, 0.15, 0.5, and 1.5 volts, accurate within 2% of full scale. Variable control linear within 1%.

Paralleled Input Connectors. Two pairs of input connectors for differential or single-ended input. Video line can be bridged or terminated at monitor.

4-KV Accelerating Potential. Tektronix precision cathode-ray tube provides 8 cm vertical deflection, bright trace.

Mounting. Slide-out mounting in standard 19" rack. 8¾" high, 19" wide, 20¾" rack depth, 22¼" overall.

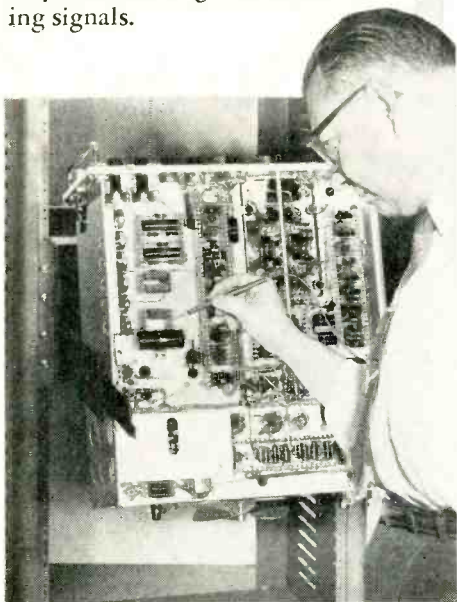

SLIDE-OUT MOUNTING

The Type 525 chassis slides forward out of its rack-mounting cabinet and tilts up for convenience in servicing.

Type 525—\$1050 f.o.b. Portland, Oregon

Please call your Tektronix Field Engineer or Representative for complete specifications, or write to:

ENGINEERS—interested in furthering the advancement of the oscilloscope? We have openings for men with creative design ability. Please write to Richard Ropiequet, Vice President, Engineering.

Tektronix, Inc.

P. O. Box 831 • Portland 7, Oregon

Phone CYpress 2-2611 • TWX-PD 265 • Cable: TEKTRONIX

TI Subsidiary Opens New Plant



Production lines at Houston Technical Laboratories

HOUSTON TECHNICAL LABORATORIES, instrumentation subsidiary of Texas Instruments, formally dedicated its new plant in Houston, Texas. HTL develops and manufactures geophysical and industrial instruments.

The HTL new main plant has 40,000 sq ft of space on the first floor for offices, laboratories, and manufacturing. There is a 40,000 sq ft area under the plant for stor-

age and parking. It is situated on a five-acre tract.

The new plant is larger than the entire TI company plant of ten years ago. Total Texas Instruments office and manufacturing space is now over 400,000 sq ft—a tenfold growth—and the \$40 million-plus sales volume predicted for this year represents a fifteen-fold growth in ten years. The company now employs over 4,000 people.

Wescon Elects Officers for 1957

DONALD B. HARRIS was elected chairman of the 1957 Western Electronic Show and Convention board of directors. The show will be held in San Francisco's huge Cow Palace, Aug. 20-23, 1957.

Harris, manager of electron tube research at the GE microwave laboratory in Palo Alto, succeeds 1956 chairman, C. Frederick Wolcott.

Vice-chairman in charge of exhibit operations for the 1957 WESCON is Norman H. Moore, vice-president of Litton Industries and managing director of its electron tube division in San Carlos, Calif. He has served on the WESCON board for the past two years.

The vice-chairman in charge of convention activities for the 1957 show is B. M. Oliver, director of research and development at Hewlett-Packard in Palo Alto. This is his first year on the board of directors. He was named by the IRE



D. B. Harris, right, and C. F. Wolcott

to the four-year term beginning in 1957.

H. Myrl Stearns, vice-president and general manager of Varian Assoc. in Palo Alto, was elected secretary-treasurer for the next WESCON. Stearns was named to the board by the West Coast Elec-

Designed for



Application



The No. 90901
One Inch
Instrumentation Oscilloscope

Miniaturized, packaged panel mounting cathode ray oscilloscope designed for use in instrumentation in place of the conventional "pointer type" moving coil meters uses the 1" 1CP1 tube. Panel bezel matches in size and type the standard 2" square meters. Magnitude, phase displacement, wave shape, etc. are constantly visible on scope screen.

JAMES MILLEN MFG. CO., INC.

MAIN OFFICE AND FACTORY
MALDEN
MASSACHUSETTS



New!

**MEASUREMENTS'
FM**

Standard

Signal

Generators



MODEL 210 SERIES

Measurements' Model 210 Series of Standard FM Signal Generators is designed for FM receiver measurements in the standard FM band; for measurements on railroad and automobile FM radio systems, research on FM, multiplexing and telemetering equipment. Models are available for use within the limits of 30 to 200 Mc each with a tuning range of approx. 1.2; for example, Model 210-A, 86 to 108 Mc.

FEATURES:

- Wide deviation with low distortion.
- Low spurious residual FM.
- Models coverings 30 to 200 Mc.
- Accurate output voltage calibration — low VSWR.
- Operates at fundamental carrier frequencies.
- Vernier electronic tuning.

SPECIFICATIONS:

FREQUENCY RANGE: Five different models, each with tuning ratio of approx. 1.2, cover range from 30 to 200 Mc.

TUNING: Vernier frequency dial, and electronic tuning for frequency deviation.

OUTPUT VOLTAGE: 0.1 to 100,000 μ v.

OUTPUT SYSTEM: Mutual-inductance attenuator with 50-ohm source impedance with a low VSWR.

MODULATION: Selectable 400 and 1000 cycle internal audio oscillator. Other modulation frequencies available.

MODULATION FIDELITY: Frequency deviation response within ± 0.5 db from d.c. to 15,000 cycles, within 3 db to 70 Kc.

RESIDUAL FM: Spurious residual FM 60 db below 75 Kc. deviation.

POWER SUPPLY: 117 v., 50-60 cycles, 45 watts.

(complete data on request)

Laboratory Standards

MEASUREMENTS CORPORATION
BOONTON • NEW JERSEY

Want more information? Use post card on last page.

ELECTRONICS — January 1, 1957

tronic Manufacturers Association. The additional four WESCON directors are Bruce S. Angwin of General Electric tube division, E. P. Gertsch of Gertsch Products, C. Frederick Wolcott of Gilfillan Brothers, and Gramer Yarbrough of Elgin electronics division.

WESCON is the joint activity of the San Francisco and Los Angeles sections representing the 7th Region of the IRE and the West Coast Electronic Manufacturers Association.

Hoover Expands In Electronics

HOOPER ELECTRONICS plans to build the first section of a \$1.5 million office and factory building at Timonium, Md.

Hoover Electronics is a subsidiary of the Hoover Co. of North Canton, Ohio.

John M. Pearce, vice-president and general manager of the electronics firm, said the company's administrative, engineering, manufacturing and printed circuit departments, now scattered in four buildings in the Baltimore area, will be consolidated within the new Baltimore county plant.

Located on an 8-acre tract the building will be constructed in three stages.

Construction of the first stage, costing \$540,000 and providing 30,800 sq ft, began in December.

The second and third stages of the construction program, plans for which have not yet been completed, will follow at a later date. When completed, the building will provide 110,000 sq ft, or more than four times the space now available to the electronics company at its present locations.

The first stage should be ready for occupancy late this summer.

A major expansion program, which has seen the electronics company grow from 40 to nearly 200 employees in less than a year, and a substantial backlog of contracts necessitated construction of a modern building to consolidate all activities.

The expansion program began last October when the Hoover Company, manufacturers of electric

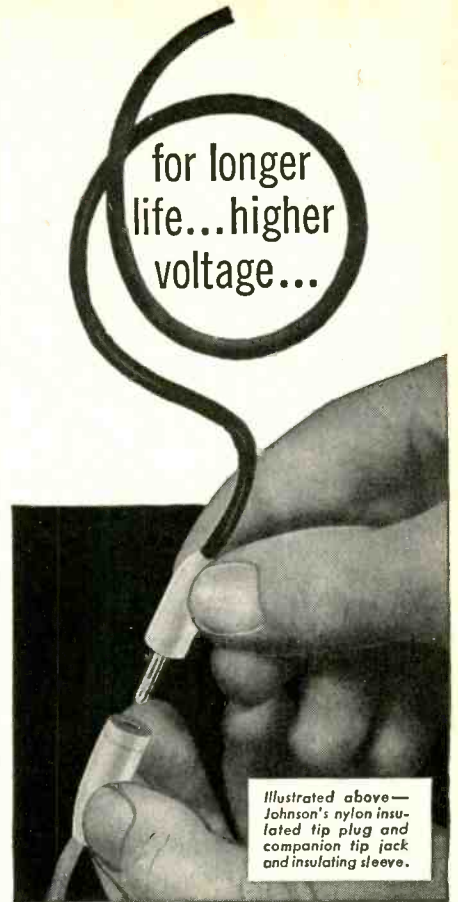

Solderless Nylon Connectors

(Available in 11 bright colors)

- Shock-proof nylon sleeves—won't chip or crack with the hardest usage.
- Excellent for high voltage applications.
- Highly resistant to extremes of heat, cold and moisture.
- Tip and banana plugs designed for simplified solderless connection of up to 16 gauge stranded wire. Jacks require soldered connection.
- Economical—simple, functional design gives you top quality at low cost.

SPECIFICATIONS

BANANA PLUG—Nickel-plated brass construction with nickel-silver springs. Spring plug is .175" diameter, fits all standard banana jacks.

TIP PLUG—Recessed metal head is fully insulated. Metal parts are brass, nickel-plated. Pin is .081" diameter—fits all standard tip jacks.

NYLON TIP JACK AND INSULATING SLEEVE—Complete assembly includes standard nylon tip jack with threaded nylon insulating sleeve. Ideal for patch cords or for panel mounting where an insulated rear connection is desired.

Write for samples, prices and further information.

Pilot Lights

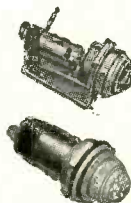

Available in a wide variety of types; Johnson Pilot Lights are stocked by parts distributors throughout the country. Available types include: continuous indication neon types; models for high and low voltage incandescent bulbs; standard or wide angle glass and lucite jewels in clear, red, green, amber, blue, or opal lenses. Specials, including those meeting military specifications are also available in production quantities. For full information, write to:



E. F. Johnson Company

2708 SECOND AVE. S.W. • WASECA, MINN.

Want more information? Use post card on last page.



another
product
surprise

from
Helipot...

Beckman® Servomotor- Rate Generator

Snug as two bugs in their unitized stainless steel housing, motor and generator work hand-in-hand on the same shaft... to improve response characteristics of suffering servo systems.

Where the trouble is in the dynamics of your system components, watch this purposeful pair roll up their sleeves and go to work. The high torque-to-inertia motor, for instance, responds quickly and accurately to error signals... with acceleration at stall up to 100,000 radians/sec.². Signal-to-noise ratio of the linear generator is 25:1 or better. Aiding and abetting each other in their dedicated mission, they'll operate continuously at stall and at total unit temperature from -55°C to 200°C.

Right now, our corrosion-resistant, completely encapsulated Servomotor-Rate Generators are available in sizes 11, 15 and 18. (We'll soon add size 8; eventually, other sizes.) We've got descriptive literature available too. It's data file 131.

Beckman®
Helipot
Corporation
Newport Beach, California
a division of Beckman Instruments, Inc.
Engineering representatives
in principal cities

889

Want more information? Use post card on last page.

cleaners and appliances, purchased a controlling interest in Phecco, Inc., a three-year-old Baltimore firm, and changed its name to Hoover Electronics Company.

David P. Coffin, Jr., a senior engineer, has been appointed chief of the defense projects section of the firm. He joined Hoover Electronics in 1952.

Named to head the mechanical engineering section is John P. Gobetti. He was an advisory engineer (mechanical) at the Westinghouse Air Arm in Baltimore before joining the Hoover firm recently.

Kevin Lynch, a former supervisor of inspection at the Martin Company, has been appointed chief of the quality control section.

Raymond P. Moore, Jr., has assumed the duties of manager of engineering services. He formerly was an electronics engineer with RCA.

Robert P. Wehrmann heads the telemetering section. He formerly was a unit leader in the r-f systems group at Convair.

Frank Parish has been made administrative assistant.

Thomas B. Schillo has joined the Hoover Electronics Co. as operations manager. He was formerly a principal engineer at the Bendix Radio division of the Bendix Aviation Corp.

As operations manager for Hoover he will co-ordinate all phases of company projects.

Dalmo Victor Unveils New Plant



Dalmo Victor's new electronics plant in California

THE NEW two million dollar, 180,000 sq ft plant of Dalmo Victor was officially opened in Belmont, Calif. Previously, operations were spread among six different buildings in San Carlos and Belmont. The new plant consolidates all offices and manufacturing processes under one roof and houses 1,100 employees.

Dalmo Victor was founded in 1921 by T. I. Moseley who still serves as president. It operated first as a job shop in San Francisco employing about 20 persons and their early products were phonograph needles, permanent wave equipment, electric razors, and thermostats.

In January of 1954 the entire stock of Dalmo Victor was purchased by Textron Inc. of Provi-

dence, Rhode Island. While local management continued to operate the company as an autonomous division, Textron ownership has provided capital for expansion leading to the construction of the new Belmont plant.

Bahr Heads Engineer Week Committee

THE NATIONAL SOCIETY OF PROFESSIONAL ENGINEERS has named John L. Bahr, chief engineer of National Vulcanized Fibre Co. as national chairman of the committee to plan and promote National Engineers' Week, February 17-23, 1957.

The theme for the 1957 observance is "Engineering... America's



John L. Bahr

Great Resource." The purpose of the event is to bring before the public the contributions which the engineering profession has made to our modern way of life. It is hoped the promotion will encourage more young people to enter the engineering profession.

National Engineers' Week committee sponsors are: Vannevar Bush, former president of Carnegie Institution of Washington; Allen B. DuMont, chairman of the board of Allen B. DuMont Laboratories; Charles F. Kettering of General Motors Corp.; James R. Killian, Jr., president of Massachusetts Institute of Technology; Clarence H. Linder, vice-president of General Electric Co.; Thomas E. Murray, commissioner of United States Atomic Energy Commission; Royal W. Sorensen of California Institute of Technology; Philip Sporn, president of American Gas and Electric Co.; David B. Steinman, consulting engineer; Charles Allen Thomas, president of Monsanto Chemical Co. and Robert E. Wilson, chairman of the board of Standard Oil Company of Indiana.

CEC Dedicates Plant, Plans Two More

CONSOLIDATED ELECTRODYNAMICS CORP. in Pasadena, Calif. dedicated its new \$1.5 million 130,000-sq ft engineering and research center. Dr. Alan T. Waterman, director of the National Science Foundation, was principal speaker at the dedication.

Since its establishment in 1937, Consolidated's employees have

Dress Up Your Products with these NEW KNOBS

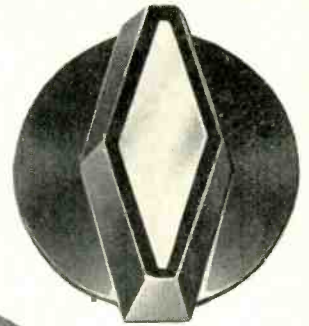
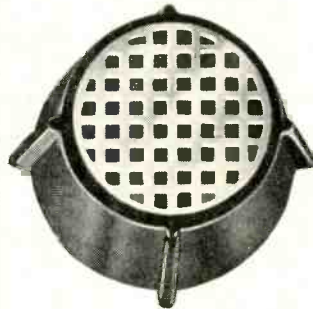

Designed by
Robert Podall

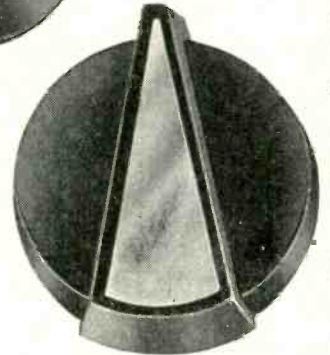

These new knobs feature decorative metal inserts, in a choice of chrome, copper, satin brass and gold. Available in a variety of thermosetting materials, both phenolic and urea. Send for details.

ROGAN BROTHERS

8031 N. Monticello Ave., Skokie, Illinois

Precision - Produced MATERIALS for TRANSISTORS and DIODES

★ **GOLD** doped with N-type or P-type elements — supplied in the form of wire, sheet or ribbon and cut or stamped pieces.

★ **INDIUM** electroplated base or precious metal wires.

★ **WELDED RIBBONS**—Dissimilar metal ribbons of the same width can be continuously welded together, within close overlap tolerances.

Specialists in
the Unusual

Write for List of Products



SIGMUND COHN CORP.
121 SOUTH COLUMBUS AVE., MOUNT VERNON, N. Y.



THE
INEVITABLE CHOICE
FOR
CRITICAL CIRCUITRY
IN
Computers

HIGHEST
INSULATION
RESISTANCE

LOWEST ERROR
DUE TO DIELECTRIC
ABSORPTION



fci
TEFLON^{*}
CAPACITORS

fci Teflon dielectric capacitors represent today's ultimate achievement in low dielectric absorption and high insulation resistance. Their extremely low values of dielectric absorption can reduce errors in computers due to false threshold voltages by a factor of at least 5 when substituted for other types of capacitors. Furthermore, their ultra-high insulation resistance contributes significantly to the reduction of errors due to loss of charge during storage periods.

**ELECTRICAL CHARACTERISTICS
OF fci TEFLON CAPACITORS**

Operating Temp. Range.....	-55°C. to +200°C.
Voltage Range, DC.....	100 to 30,000
Capacitance Range.....	.001 to 20 mf
Power Factor.....	.02% @ 1 kc
Dielectric Absorption.....	.01%
Voltage Derating at 85°C.....	none
Voltage Derating at 125°C.....	none
Voltage Derating at 150°C.....	none
Voltage Derating at 200°C.....	33%
Temperature Coefficient.....	-50 ppm/°C.
I.R. at Room Temperature.....	10 ⁷ megohms/mf
Capacitance Stability.....	0.1%

fci

*Reg. DuPont T.M.

film capacitors, inc.

3400 Park Avenue, New York 56, N. Y. • CYPRESS 2-5180

Want more information? Use post card on last page.

PLANTS AND PEOPLE

(continued)



New CEC engineering and research center

grown from 10 to more than 2,500; facilities have increased from a small store building in Pasadena to six structures totalling 400,000 sq ft; and proprietary products have increased from a handful, used only in geophysical exploration, to more than 200.

Consolidated built its main Hastings Ranch plant on a 13-acre site in East Pasadena in 1951. In addition to the new engineering and research center and a two-story annex to the main building, the company has four other plants, three in Pasadena and one in Rochester, New York. It will begin construction in 1957 on two additional 130,000-sq ft buildings on its Monrovia Airport property.

Company sales increased from \$832,000 in 1945 to more than \$17-million in 1955. They are expected to exceed \$23-million in 1956.

**New Company Starts
In San Diego**

A NEW ELECTRONICS COMPANY, Nacimco Products, has been formed in San Diego, Calif.

Facilities and production management of National City Machine Co. and San Diego Machine Co. have been combined in the new firm which initially is using plants of both concerns. Operations later will be consolidated in the National City plant where more than 3,000 sq ft of new engineering production space has been constructed. More expansion is planned.

Fields of interest of the new concern include precision parts and tooling for aircraft producers, ground and airborne technical in-

for compactness
and light weight . . .

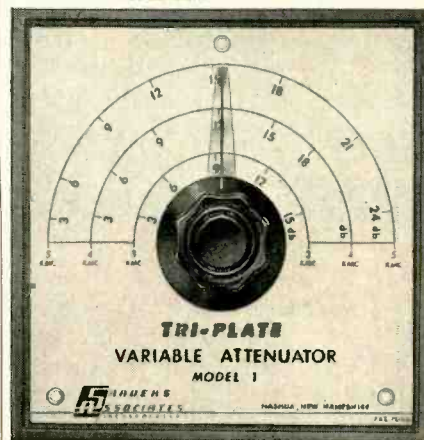

SANDERS
TRI-PLATE[®]
VARIABLE
ATTENUATOR

with a new type of printed
circuit transmission line

developed by Sanders Associates, Inc.

This small, compact attenuator is used in the frequency range of 1000 to 6000 mc. Designed for use with a coaxial cable connection, it has low external leakage and gives broad-band performance.

Maximum Attenuation — linear function of frequency (20 db at 4,000 mc)

Insertion Loss — less than 1.5 db

Maximum VSWR — less than 1.25 at 4,000 mc.

Characteristic Impedance — 50 ohms

Average Power Rating — 2 watts

Dimensions — 5" x 5" x 1/4"

Weight — 8 ounces

Other Tri-Plate products such as transitions, directional couplers, hybrid rings and special antennae can also be supplied.

Microwave systems will be engineered for conversion to TRI-PLATE and produced to your requirements.

For detailed specifications,
write to Dept. E-1

© Sanders Associates



Want more information? Use post card on last page.

January 1, 1957 — ELECTRONICS

strumentation systems for aircraft and missiles, and consultation and research on specialized engineering and instrumentation data.

C. L. Rubesh has been elected president of Nacimco Products. He has been owner and operator of National City Machine since 1947. R. G. Greenbaum, formerly a senior electronics engineer at the Convair division of General Dynamics, is Nacimco's chief engineer. General manager is W. Don Howell, formerly senior buyer for Atlas research and development at Convair. Design engineer is James E. Elliott, formerly a Convair flight test engineer directing engineering of instrumentation for the Atlas intercontinental ballistics missile program. Another Convair flight test engineer, J. L. Shumway, has become Nacimco Products' research physicist.

Honeywell Expands Electronics in Wabash

A NEW, half-million-dollar manufacturing facility will be constructed in Wabash, Ind. by Minneapolis-Honeywell Regulator Co.

The 58,000-sq ft, one-story building will be used for the production of electronic air cleaning equipment and other specialized metal products for residential and commercial temperature controls.

General Ceramics Promotes Bouwmeester



John H. Bouwmeester

JOHN H. BOUWMEESTER has been appointed executive vice-president

GET the FACTS



GRC tiny molded PLASTIC PARTS

specializing in NYLON

SEND FOR YOUR COPY OF THE NEW GRIES PLASTICS BULLETIN

Find out how Gries' exclusive techniques make possible product designs using tiny components that might be production problems by ordinary means. How Gries uses special machines which mean extremely low tooling costs, high speed production for volume requirements. Bulletin is packed with examples, charts, engineers' check list.

Write today for new Bulletin and Samples.

Send prints for quotation.

- Completely automatic injection molding.
 - Continuous or individual insert molding.
 - GRC molds ALL thermoplastics nylon a specialty.
- Quick deliveries on quantities of 25,000 to millions

NO MINIMUM SIZE!

Maximum size: .03 oz.—1/4" long



GRIES REPRODUCER CORP.

151 Beechwood Ave., New Rochelle, N. Y. New Rochelle 3-8600

for service and lab. work

Heathkit PRINTED CIRCUIT OSCILLOSCOPE KIT FOR COLOR TV!

① Check the outstanding engineering design of this modern printed circuit Scope. Designed for color TV work, ideal for critical Laboratory applications. Frequency response essentially flat from 5 cycles to 5 Mc down only 1 1/2 db at 3.58 Mc (TV color burst sync frequency). Down only 5 db at 5 Mc. New sweep generator 20-500,000 cycles, 5 times the range usually offered. Will sync wave form display up to 5 Mc and better. Printed circuit boards stabilize performance specifications and cut assembly time in half. Formerly available only in costly Lab type Scope. Features horizontal trace expansion for observation of pulse detail — retrace blanking amplifier — voltage regulated power supply — 3 step frequency compensated vertical input — low capacity nylon bushings on panel terminals — plus a host of other fine features. Combines peak performance and fine engineering features with low kit cost!



MODEL 0-10 \$69.50 Shpg. Wt. 27 lbs.



MODEL TS-4 \$49.50 Shpg. Wt. 16 lbs.

Heathkit TV SWEEP GENERATOR KIT ELECTRONIC SWEEP SYSTEM

② A new Heathkit sweep generator covering all frequencies encountered in TV service work (color or monochrome). FM frequencies too! 4 Mc — 220 Mc on fundamentals, harmonics up to 880 Mc. Smoothly controllable all-electronic sweep system. Nothing mechanical to vibrate or wear out. Crystal controlled 4.5 Mc fixed marker and separate variable marker 19-60 Mc on fundamentals and 57-180 Mc on calibrated harmonics. Plug-in crystal included. Blanking and phasing controls — automatic constant amplitude output circuit — efficient attenuation — maximum RF output well over .1 volt — vastly improved linearity. Easily your best buy in sweep generators.



Heath COMPANY A SUBSIDIARY OF DAYSTROM, INC. BENTON HARBOR 14, MICH. WRITE FOR FREE CATALOG ...COMPLETE INFORMATION



**DC-AC
CHOPPERS**

For 60 Cycle Use

Built to rigid commercial specifications.

Twenty-two types, both single and double pole.

Long life.

Low noise level.

Extreme reliability.

Write for Catalog 370.

STEVEN ARNOLD INC.
SOUTH BOSTON, MASS.

STEVEN ARNOLD INCORPORATED
ARNOLD

22 ELKINS STREET
SOUTH BOSTON 27, MASS.

S/A-10

of General Ceramics. Before assuming his present duties he served the firm as vice-president in charge of manufacturing. He is a member of the company board of directors and president of the Advanced Vacuum Products division in Stamford, Connecticut.

Prior to joining the company he was vice-president in charge of manufacturing and director of the Indiana Steel Products Co. in Valpariso, Ind.

Speer Carbon Enlarges Research

A NEW RESEARCH and development laboratory for Speer Carbon Co. is under construction in Niagara Falls, N. Y. The new 23,000 sq ft research facility is scheduled for completion in the fall of 1957.

Research activities of all Speer divisions are to be concentrated in the new laboratory. It will permit a broadening of research operations to almost double the present scope within the next few years.

Speer's electronics division produces fixed composition resistors, ceramic and molded capacitors and specialty coils. The division has announced that it will also produce a new device incorporating combinations of resistors and capacitors into a single unit.

Sylvania Builds New Electronics Plants

SYLVANIA ELECTRIC plans to build a multimillion-dollar research and development center in Amherst, N. Y. for the company's electronic systems division.

Construction of the new 100,000 sq ft Amherst center will begin early this year on an 18-acre site, near the Buffalo Municipal Airport. The site was purchased late in 1955 by the company.

On its completion, the Amherst building will be occupied by the division's Buffalo Engineering Laboratory. M. C. Scott is laboratory manager. The division's manufacturing operations will continue in the present location, where nearly 170,000 sq ft are leased by the company. There is a strong possibility that additional production facili-

THESE . . .

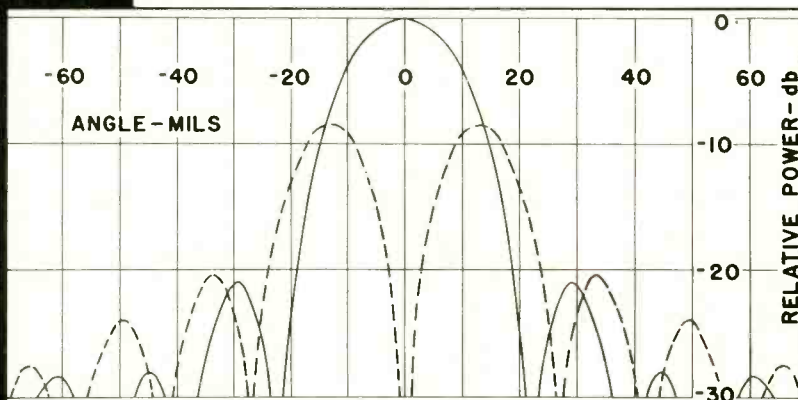

Patterns of precision microwave antennas will be measured accurately and rapidly at the new microwave facility now being readied by Wheeler Laboratories near Smithtown, Long Island. Early in 1957, these new quarters will be equipped and staffed to solve unusual antenna problems.

Inquiries are invited; a brochure describing our services is available.

WHEELER LABORATORIES, INC.
122 Cutter Mill Road • Great Neck, N. Y.

HUNter 2-7876



GET THE EXACT TERMINAL YOU NEED AT NEW LOW PRICES!

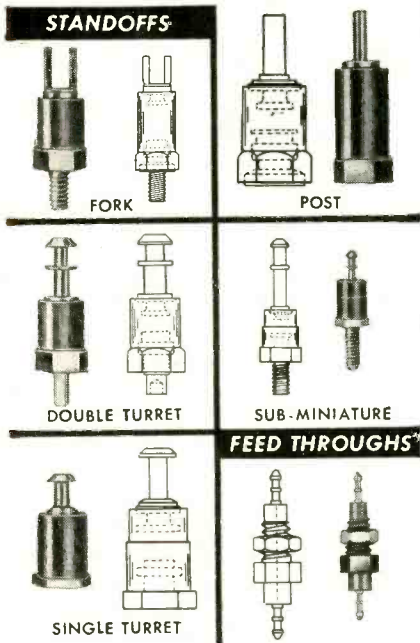

FROM THE LARGEST STANDARD and CUSTOM LINE AVAILABLE...

Over 100 varieties are furnished as standard. This includes a full range of types, sizes, body materials and plating combinations. Specials can be supplied to any specification. The Whitso line is complete to the fullest extent of every industrial, military and commercial requirement.

Standoff terminals include fork, single and double turret, post, standard, miniature and sub-miniature body types—male, female or rivet mountings—molded or metal base. Feed through terminals are furnished standard or to specification.

Whitso terminals are molded from melamine thermosetting materials to provide optimum electrical properties.

Body Materials: Standard as follows—melamine, electrical grade (Mil-P-14, Type MME); melamine impact grade (Mil-P-14, Type MMI); and phenolic, electrical grade (Mil-P-14, Type MFE).

Plating Combinations: Twelve terminal and mounting combinations, depending on electrical conditions, furnished as standard.

Specials: Body materials and plating combinations, also dimensions, can be supplied to any custom specifications.

PROMPT DELIVERY IN ECONOMICAL QUANTITY RUNS

Get facts on the most complete, most dependable source for terminals and custom molded parts. Request catalog.



9328 Byron Street, Schiller Park, Illinois
(Chicago Suburb)

Want more information? Use post card on last page.

ELECTRONICS — January 1, 1957

PLANTS AND PEOPLE

(continued)

ties will be built on the Amherst site in the future.

When the laboratory at Amherst goes into operation full time, nearly 500 persons are expected to be employed there, approximately half of whom will be engineers. This total will be about double the current employment of 260 at the Buffalo Engineering Laboratory.

Sylvania Electric also announced that it will construct a 50,000-sq ft addition to the electronics division headquarters plant in Woburn, Mass.

The addition will bring the total floor area of the Woburn facility to over 200,000 sq ft. It will be used to house sales and purchasing activities, equipment development functions, and machine and parts shops.

Construction will start in January, with completion scheduled for July, 1957.

The addition, which enlarges the Woburn facility by about one-third, was made necessary by the expansion of manufacturing and developmental activities in transistors, diodes, and special-purpose electron tubes.

Mallory Appoints Research Director



C. H. Moore

P. R. MALLORY & Co. appointed C. H. Moore as executive director of corporate research and development. Dr. Moore previously was the director of engineering for the



Fight production fatigue—at machines or assembly tables, in the laboratory, drafting room, anywhere—with scientifically comfortable Royal chairs and stools developed by correct-posture specialists. Royal Industrial Seating keeps workers aggressive, alert—stands up under toughest usage. There's a type and size for every need, each combining beauty, utility, function.

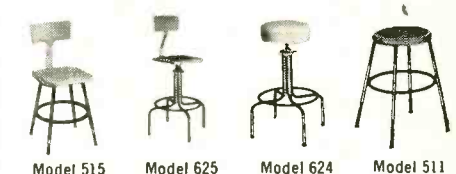

TIME-SAVING Royal CABINETS AND SHELVING

Royal advanced engineering and versatility can also be yours in good-looking, low-maintenance shelving and cabinets Royal-built from fine furniture steel—items such as foreman's desks, machine stands, counter storage units, wardrobes, open and closed-type shelving. Finished in oven-baked Plastelle enamel with high resistance to marring and chipping. Royal dealers from coast to coast can assist you in your planning.



Storage Cabinets



Foreman's Desks



Sectional Steel Shelving

GET THIS FREE BOOKLET NOW

Royal Metal Manufacturing Company
175 N. Michigan Ave., Chicago 1, Ill., Dept. 30B
Please send me free 24-page Catalog No. 7001.

Individual _____
Company _____
Street _____
City & State _____

Want more information? Use post card on last page.

Protect Your Printed Circuits

against corrosion

BEFORE SOLDERING

DURING SOLDERING

AFTER SOLDERING

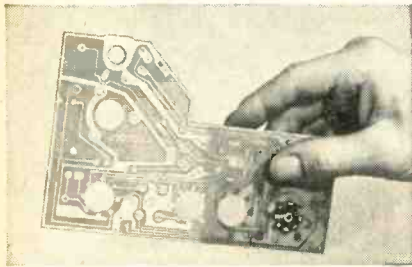

FLUXCOTE 21-XR

The liquid soldering flux with protective coating characteristics . . .

plus:

- Smooth, fast action
- High insulation resistance
- Light, tack-free, varnish-like protective film after soldering

Whatever your printed circuit production, dip . . . spot . . . or area soldering you get full three-way protection against corrosion with Lonco Fluxcote 21-XR.



REQUEST FREE TECHNICAL BULLETIN

"The Soldering of Printed Circuits"

Also request free samples and data on other Lonco Products used in printed circuit manufacture: INSULATING ROSIN FLUXES

SEALBRITE COATINGS • SOLDER RESIST • FLUX REMOVERS
FLUX THINNERS • OXIDE REMOVERS



LONDON CHEMICAL COMPANY, Inc.

1535 North 31st Avenue
Melrose Park, Illinois

PLANTS AND PEOPLE

(continued)

Mallory metallurgical divisions.

He has been with the company since 1951. In his new assignment he will coordinate the efforts of three laboratory directors, J. M. Booe, director of the chemical and metallurgical laboratories; Clarence Huetten, director of the electrical & electronic laboratories and A. E. Middleton, director of the physics and physical chemistry laboratories.

Dr. Moore will also be responsible for Mallory's research efforts in Europe and on the West Coast.

Mallory plans to continue active participation in government sponsored research in such fields as metals, semi-conductors, electronic components and circuits, electrochemical devices.

Bendix Sets Up Systems Division

THE Bendix systems division has been formed at Ann Arbor, Mich. as a new operating division of Bendix Aviation Corp.

The new division will concentrate on weapons systems requirements of the Department of Defense. Bendix will construct a large laboratory and engineering building near the University of Michigan's north campus. In that same area are the U. of M. aeronautical and automotive engineering laboratories, the Phoenix Memorial laboratory with its new atomic reactor, and the research laboratories of Parke Davis & Co.

Russell D. O'Neal, formerly director of the systems planning group of Bendix, has been named general manager of the new division, reporting to A. P. Fontaine, engineering vice-president. The division, which will occupy leased space in Ann Arbor pending completion of its first building in August, 1958, will be staffed initially with top scientists and engineers from the systems group of Bendix. They will move to Ann Arbor from Detroit within the next month.

Within three to five years the new division will have about 1,000 engineers, scientists and supporting staff personnel. The systems division will not be a manufactur-

NEWS FOR IMMEDIATE RELEASE!



NEW ALPHA Q METER Model 162

noteworthy features:

NO THERMOCOUPLE TO BURN OUT. NO SPECIAL TUBES. Almost impossible for overloads to damage meter. Wide frequency range — 50 kc/s to 75 mc/s. Internal regulation in both 110 and 220 volt operation. Easily operated by inexperienced personnel. Injection voltage (always 20 millivolts) easy to monitor; meter easy to read. Dust cover protects all controls.

For complete specifications write to

ALPHA INSTRUMENT CO.

Dept. E.

43 Hempstead St., New London, Connecticut
Reps: Some territories still open

Soon to be released!

FM Signal Generators • Circuit Analyzers

CABLE CLIPS

of all Nylon
for severe conditions

of Ethyl Cellulose
for maximum economy



WECKESSER



molded
Black Nylon
SCREWS
and NUTS

- ★ Acid resistant
- ★ Need no insulation
- ★ Can't rust
- ★ Can't corrode

WECKESSER COMPANY

5701 Northwest Highway • Chicago 30, Ill.

Want more information? Use post card on last page.

Want more information? Use post card on last page.

ing plant. Production will be handled by existing manufacturing divisions of Bendix, but if these prove insufficient a new facility will be established similar to the corporation's Talos missile plant at Mishawaka, Ind.

Ford Instrument Names Despres



Joseph A. Despres

JOSEPH A. DESPRES has been appointed administrative assistant to the vice-president for engineering at Sperry Rand's Ford Instrument Co.

Ford specializes in research and manufacture of missile and weapon controls, air and sea navigational equipment and computing devices.

For four years Despres was associated with Airborne Instruments Laboratory, serving as administrative assistant to the director of the engineering and production division. In 1950 he was appointed industry officer with the Economic Cooperation Administration at The Hague.

From 1930 until the business was sold in 1950, Despres was associated with Bernard Rice's Sons, Inc. He had served as president and chief engineer since 1937.

Hoffman to Build New Engineering Building

A NEW electronic research and development building, with nearly a full acre of floor space, will be constructed by Hoffman Laboratories.

The 40,000-square foot engineering facility will be located opposite the present Hoffman Laboratories

TRACER-GUIDED DRILLING 100 HOLES P. M.

WITH NEW HERMES *Engravo*

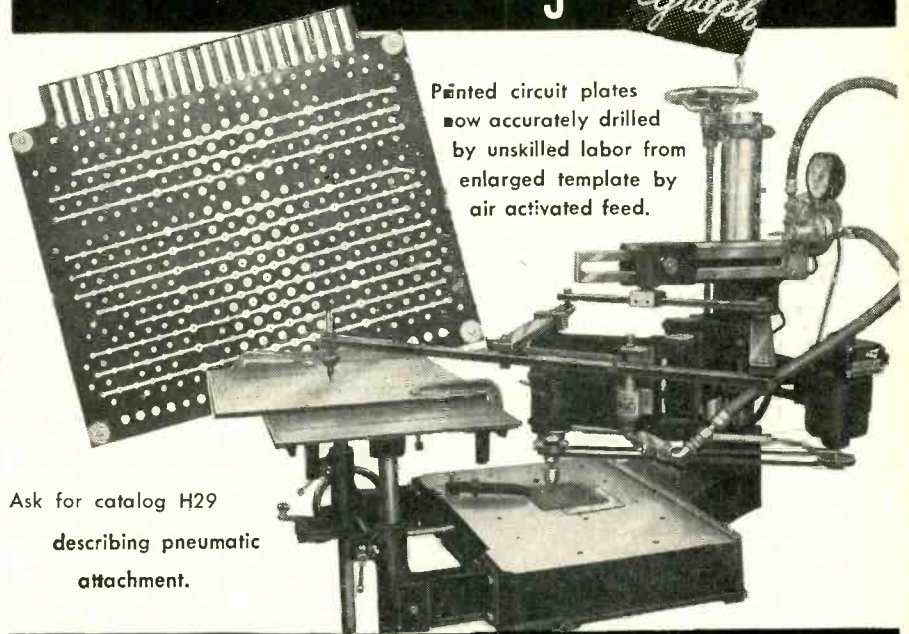

Printed circuit plates
now accurately drilled
by unskilled labor from
enlarged template by
air activated feed.

Ask for catalog H29
describing pneumatic
attachment.

new hermes ENGRAVING MACHINE CORP.
13-19 University Place, New York 3, N.Y.

ULTRA-LOW DISTORTION AMPLIFIER

0.005% Distortion At 50 Watts

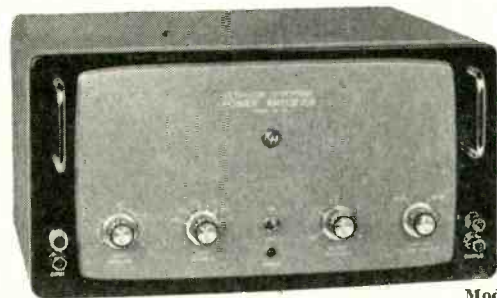

Model UF-101

Krohn-Hite ULTRA-LOW DISTORTION 50 WATT POWER AMPLIFIER incorporates 80 db of negative feedback with harmonic and intermodulation distortion of less than 0.005%. The response is flat ± 0.5 db from 0.5 cps to 30 kc. Excellent transient response is maintained at all output impedances from 2 to 450 ohms by switching the feedback to the output transformer secondary winding being used. A dynamic range of 110 db is obtained by careful shielding and the use of d-c on the heaters of the first two stages. Four type 6550 output tubes are operated in class AB₁ to deliver 50 watts conservatively. This amplifier provides a lower distortion laboratory signal source and is useful in the development and testing of high quality audio equipment. Price \$425.00 f.o.b. factory.



For Further Details Write Dept. E

Krohn-Hite Instrument Co.

580 Massachusetts Avenue • Cambridge 39, Massachusetts

TYPE
120-D

NEMS-
CLARKE

FIELD
INTENSITY METER

LIGHT WEIGHT
DIRECT READING
SELF-CONTAINED

A portable instrument for measuring the wide range of radio signal intensities from 540 to 1600 kc. Its range is from 10 microvolts to 10 volts per meter, making it equally effective for interference studies at low signal strengths and close-in measurements on high-power directional arrays.

Accuracy is assured by a calibration method that compensates for variations in tube characteristics and for voltage variations in the self-contained battery power supply. Operation is simple—measurements made rapidly—direct reading on all ranges—requires no charts or multiplication factors—no warm-up period necessary.



NEMS-CLARKE

Incorporated

919 JESUP-BLAIR DRIVE
SILVER SPRING, MARYLAND

For further
information
write Dept. K-2

DEFLECTION YOKES

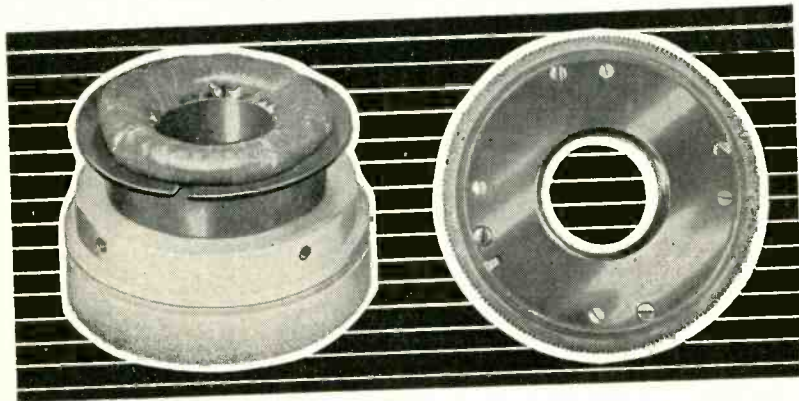

We specialize in the design and manufacture of precision deflection yokes for military and commercial applications. Phone or write for immediate engineering evaluation of your critical display problems.

Celco

Phone: RAMsey 9-1123

Constantine Engineering Laboratories Co.

Island Avenue

Mahwah, N. J.

building. It is designed to handle the expanded activity of Hoffman's engineering department and will provide for additional future growth. This is part of a program aimed at doubling Hoffman's engineering force within the next two years. The new building will also house the new products engineering group and will contain facilities for advanced research and application of solar energy and other semiconductor devices.

In addition to the new engineering building, ground is also being broken for a new administrative building immediately adjacent to the present facilities which will consist of a 10,000 sq ft building to house some of the administrative offices of the Hoffman Laboratories operation.

Lockheed Appoints
Missile Heads



L. Eugene Root

L. EUGENE ROOT was appointed vice-president of Lockheed Aircraft Corp. and general manager of its missile systems division.

A former top executive in the Rand Corp. and chairman of the Aerodynamics Advisory Panel of AEC at Los Alamos, Root will succeed Lockheed senior vice-president Hall L. Hibbard who has been pro tem director of the division during this year.

Hershel J. Brown, who has been acting assistant general manager of the missile division, has been appointed permanently to that position.

Lockheed also announced that Richard J. Burke has been ap-

Under one roof . . .

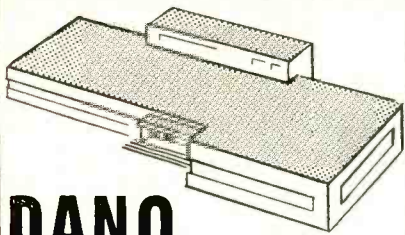

DANO

makes all these coils to exact specifications:

- ✓ Encapsulated Coils — in either Polyester or Epoxy Resins
- ✓ Coils for High Temperature Applications
- ✓ Bobbin Coils
- ✓ Form Wound Coils
- ✓ Paper Section Coils
- ✓ Acetate Bobbin Coils
- ✓ Cotton Interweave Coils

Analyse YOUR coil problems carefully. If your products require any of these coils you'll do well if you "deal with Dano", leaders in electrical coil windings to customer specification.

TRANSFORMERS MADE TO ORDER



THE DANO ELECTRIC CO.
MAIN ST., WINSTED, CONN.

STAVOLT POWER RECTIFIERS

30
Standard
U.L. Approved
Models

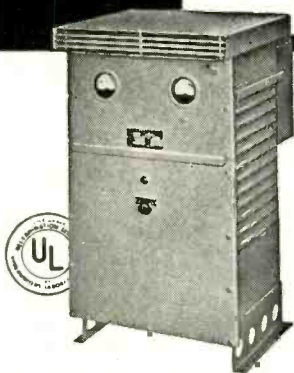

- Stationary or Mobile Types
- For Hangars, Air Fields, Missiles
- For Factories and Labs

Mag-Amp Control, Stable, Fast
15 to 1500 amps

Write for interesting
information to

CHRISTIE ELECTRIC CORP.
Formerly McCOLPIN-CHRISTIE CORP.
27th Year of Rectifier Manufacturing
3410 W. 67th St., Los Angeles 43, Calif.

Want more information? Use post card on last page.

ELECTRONICS — January 1, 1957

PLANTS AND PEOPLE

(continued)

pointed head of the missile systems division's telemetering department, at the company's Palo Alto research laboratory.

Before joining the firm he had been with the U. S. Naval Ordnance laboratory at White Oak, Md., where he was deputy chief of the underwater ordnance department.

Air Associates Names Research Head



Donald D. King

DONALD D. KING, formerly director of the radiation laboratory at Johns Hopkins University, has been elected vice-president in charge of research for Electronic Communications, a wholly-owned subsidiary of Air Associates. In his new capacity, Dr. King will be director of the new research laboratory, recently established in Baltimore, Md.

At the new research laboratory, Dr. King and his staff will concentrate on electronic counter measures research, systems studies, infra-red work and related military electronics.

GE Selects Computer Site, Opens Addition

PHOENIX, ARIZ. has been selected as site for headquarters of GE's computer department. Temporary headquarters have been at Syracuse, N. Y.

Initially the Phoenix facility will consist of administrative, engineering and research activities. Eventually computers will be manufactured there.

Key personnel will be moved

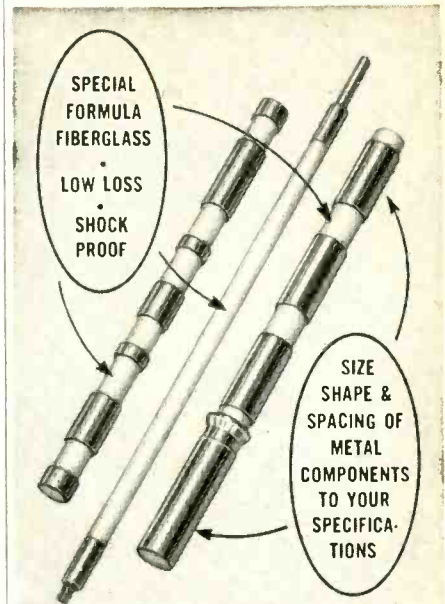

STOP BREAKAGE!
Get Automatic's New
"HIGH-STRENGTH" Rotor
Shafts, Plunger Rods
& Connecting Rods!

Stop worrying about the breakage problem of ceramics and steatite. Automatic's "Hi-Strength" rods and shafts are the revolutionary answer to the problem of transmitting mechanical motion to electrical components without electrical loss.

SHOCK PROOF . . .

"Hi-Strength" rods have 5 times the tensile, 4 times the flexural and 12 times the impact strength of steatite.

LOW LOSS . . .

Special formula fiberglass insures excellent electrical characteristics under most operating conditions.

Compare the physical and electrical properties of Automatic's "Hi-Strength" with steatite as tested and certified by the United States Testing Laboratories, then specify . . . "Hi-Strength."

WRITE, WIRE OR PHONE FOR FURTHER INFORMATION AND TECHNICAL DATA.

Automatic
METAL PRODUCTS CORP.

321 Berry Street, Brooklyn 11, N. Y. • EVERgreen 8-0364
Want more information? Use post card on last page.

ADVANCED DESIGN

new...PRECISION "POT" by GENERAL CONTROLS

PRM 123

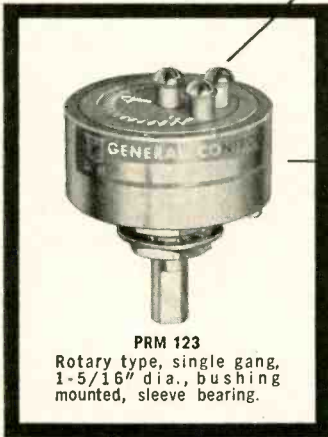

PRM 123
Rotary type, single gang,
1-5/16" dia., bushing
mounted, sleeve bearing.

General Controls, famous for 25 years as a supplier of mechanical and electro-mechanical controls for home, industry and the military... proudly announces a new product of its Potentiometer Division...

FEATURES...

- Variations from 100 to 50,000 ohms resistance.
- Standard tolerances $\pm 3\%$ resistance, $\pm 0.3\%$ independent linearity.
- Exceeds MIL-R-12934, -E-5272A Specs.
- Explosion-proof, or dust-tight seals.
- Operating temperatures are -65°F. to 275°F.
- Special Spec. Models Available.

Write for 1956 Catalog!



GENERAL CONTROLS

POTENTIOMETER DIVISION

Glendale 1, California

Factory branch offices serving all principal cities of the United States and Canada

—they're dependable!

like

precision, deep drawn
KOVAR*
PARTS

← from 1/4" dia. and 3/4" deep, .025" thickness

Consult the Engineering Company for quality parts or sub-assemblies of steel, aluminum, copper, brass, kovar, nickel and monel. Fast, economical service on long or short runs. The most modern machines and micro-precision tools assure highest accuracy.

*Registered trademark of the Westinghouse Electric Corp.

WRITE TODAY for quotations, sending your sketches or blueprints; no obligation.

THE engineering CO., 27 WRIGHT ST., NEWARK 5, N. J.

from Syracuse to leased quarters at Phoenix early next year.

The department will develop computers for business, industrial and military use.

The computer department's laboratory at Menlo Park, Calif., will not join the move to Phoenix. It is devoted entirely to development of the ERMA (electronic recording machine-accounting) computer system for the Bank of America.

The computer department is the second GE national department to move its headquarters to the West. The atomic products equipment department moved to San Jose, Calif. in September.

GE announced the creation of a new operating department geared to meet the demands of a constantly expanding communications market.

The new department will be known as the communication products department and will absorb functions previously handled by the company's communication equipment section. Products of the new department will include mobile radio, microwave radio relay, radio traffic coordination units, power line carrier equipment, terminal equipment and other communication systems.

Harrison Van Aken, Jr., has been promoted to the position of general manager of the new organization. Van Aken previously headed the communication equipment section

AMF Appoints Electronics Head

ROBERT W. PEARSON, formerly manager of reliability control in the missile and surface radar department of R. C. A. has been appointed to the newly-created position of deputy general manager for operations at AMF's electronics division in Boston, Mass.

He will be responsible for the operation of the engineering, manufacturing, material and quality control departments.

Pearson joined R C A in 1948 as senior staff engineer in the production department, and later was administrator of mechanical design and manager, engineering standards and services. He was subse-

You Get Things Done With Boardmaster Visual Control

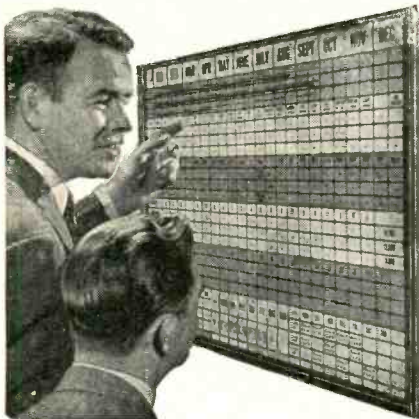

- ☆ Gives Graphic Picture of Your Operations—Spotlighted by Color
- ☆ Facts at a glance — Saves Time, Saves Money, Prevents Errors
- ☆ Simple to operate — Type or Write on Cards, Snap in Grooves
- ☆ Ideal for Production, Traffic, Inventory, Scheduling, Sales, Etc.
- ☆ Made of Metal, Compact and Attractive. Over 100,000 in Use

Complete price **\$4950** including cards

FREE

24-PAGE BOOKLET NO. C-20
Without Obligation

Write for Your Copy Today
GRAPHIC SYSTEMS

55 West 42nd Street • New York 36, N. Y.

I'm Building a College Fund for My Kids with the EXTRA MONEY



I'm earning in Mobile-Radio Maintenance!

I couldn't set aside from my engineer's salary enough money to send the kids through college. So when I learned of the boom in mobile-radio I decided to start my own part-time business. Now my income from mobile-radio maintenance goes into a "college bank account."

This can be your story, too. Send coupon for your free copy of "HOW TO MAKE MONEY IN MOBILE-RADIO MAINTENANCE." Published by Lampkin Laboratories, Inc., manufacturers of the 105-B Micrometer Frequency Meter and 205-A FM Modulation Meter.



LAMPKIN LABORATORIES, INC.
Instruments Div., Bradenton, Fla.

At no obligation to me please send "HOW TO MAKE MONEY IN MOBILE-RADIO MAINTENANCE."

Name _____
Address _____
City _____ State _____

Want more information? Use post card on last page.

ELECTRONICS — January 1, 1957

PLANTS AND PEOPLE

(continued)



Robert W. Pearson

quently named manager of product planning.

Prior to that he was superintendent of the radio division of Federal Television and Radio Corp. from 1946 to 1948. From 1937 to 1942 he was an industrial electronic control engineer with Westinghouse.

Daystrom Buys Multipot Firm

DAYSTROM has negotiated an agreement for the purchase of Ford Engineering Co. of Upland, Calif., manufacturers of potentiometers for the electronic trade under the name Multipot.

Upon completion of the sale, Ford would continue its operations and production at its two plants in Upland and receive technical assistance from Daystrom Pacific Corp., Santa Monica, Calif.

Ford Engineering was organized in 1948 to succeed a partnership formed in 1947 to manufacture electronic components. The company has approximately 50 engineers and technicians. Alfred S. Voak, president of Ford and sole stockholder, will continue with the company as a consultant.

Norris-Thermador Acquires North Am.

NORRIS-THERMADOR CORP. has acquired North American Instruments of Altadena, Calif., a developer and manufacturer of precision instrument components for automation.

In the four years since its founding, North American Instruments'

NEW

magnetically
-controlled

COUNTER -DIVIDER

Magnivider



Using a "ladle-bucket" principle, magnetic cores in the unique Magnivider circuit set a new high of reliability and ruggedness wherever counting, scaling or frequency division is required.

Self-contained Magnivider plug-ins are ideal for your new equipment designs. Compared to conventional four-tube counters, one-tube Magnividors offer

- one-third the size
- 50% less power drain
- twice the reliability
- compatible scales of 9-10-11
- counting rates from 0 to 50 Kc.
- both low and high impedance outputs
- direct cascading without buffers

Magnividors have a wide range of applications

- Random counting
- Preset counting
- Cycle counting
- Frequency division
- Timing chains
- Synchronizing circuits
- Accumulators

Write for our Technical Bulletin 145 to obtain complete information and specifications.



Dept. E12

**MAGNETICS
RESEARCH
COMPANY**

255 GROVE STREET
WHITE PLAINS, N. Y.

Want more information? Use post card on last page.

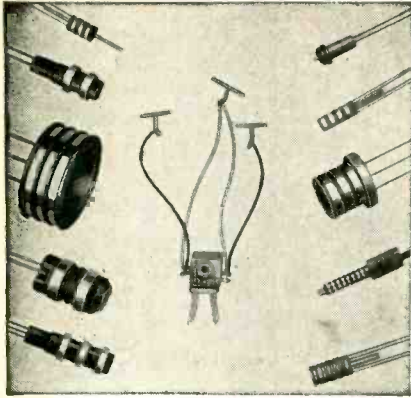

Miniature and Sub-Miniature
SLIP RING ASSEMBLIES
BRUSH BLOCK ASSEMBLIES
COMMUTATORS

and other
 Electro-Mechanical Components

PRECISION MADE
TO YOUR OWN SPECIFICATIONS

Precision molded products with exacting tolerances in precious and non-precious solid metals of all alloys. All types of Thermo-Plastic and Thermo-Setting materials.

Slip Ring Assemblies fabricated or one-piece precision molded to your specifications in Nylon, Kel-F, Mineral filled Mellamine, Phenolic, and other materials. Rings and leads spot welded or brazed together for positive electrical circuit.

Our Swiss methods and techniques are geared to meet exacting requirements. We invite your inquiries.

COLLECTRON CORPORATION

MUrray Hill 2-8975 • 216 East 45th Street • New York 17, N. Y.

sales have grown to \$1,000,000 annually. Most of its principal customers—including 44 manufacturers and laboratories—are in the aircraft, missile and petroleum industries.

Eugene Bollay, meteorologist and engineer, remains as president of the firm.

GPL Selects Engineers, Expands Plant



R. L. Garman

RAYMOND L. GARMAN, formerly vice-president of GPL, has been elected to the new position of executive vice-president and technical director, and James W. Murray, formerly vice-president, was elected executive vice-president and general manager, another new post. Dr. Garman will be responsible for technical administration of the company, including research and development and Murray for all phases of manufacturing and administration.

Richard W. Lee, director of GPL's avionic engineering division and William J. Tull, director of the avionic sales division, were both elected vice-presidents.

Other elections announced at the same time include: William P. Hilliard, formerly a vice-president of Pleasantville Instrument Corp., GPL's manufacturing subsidiary, to president of PIC; and Raymond G. Johnson, controller, to the additional office of assistant treasurer.

General Precision Laboratory has broken ground for a second engineering building at Pleasantville, N. Y. of approximately 21,000 sq ft to complement the 28,500 sq ft engineering building completed last year.

MICRO-MINIATURE Metallized Paper CAPACITORS

NEW!

Contain all of the outstanding Hopkins quality characteristics so well recognized throughout the world. Super-small for transistorized circuits and other compact circuitry requirements. Only $\frac{3}{8}$ " max. length in values from .005 to .05. Standard tolerances in voltage ratings from 100 to 400 VDC. Operating temperature range from -55°C to $+100^{\circ}\text{C}$, without voltage derating. Hermetically sealed in metal cans or phenolic encased. Prompt delivery.



Send for catalog!

Phone, write or wire, TODAY!

HOPKINS
 Engineering Co.

12900 Foothill Blvd.
 San Fernando, Calif. • EMpire 1-8693
 Offices in Washington, D.C. and San Francisco

New Books

Vacuum Tube Circuits and Transistors

BY LAWRENCE BAKER ARGUMBAU.

John Wiley & Sons, Inc., New York, 1956, 646 p, \$10.25.

IN this book, as in his first, "Vacuum Tube Circuits", in 1948, Mr. Argumbau maintains the marvelous simplicity of approach and emphasis of fundamental principles in presenting basic circuit concepts. The book is written in such a fashion that it would appeal not only to the engineering student, but would also serve as an invaluable guide to the professional engineer on the fundamental processes and techniques as well as a basis for advanced ideas. The inclusion of such topics as transistors, frequency modulation, color television, inverse feedback and noise are indications of the up-to-date aspect of the subject matter.

The transistor section, written by one of the well-known authorities in the field, Professor Richard Brooks Adler, is an excellent representation of the physics involved in transistor operations. Professor Adler has supplied a wealth of material covering the basic characteristics of the transistor and its uses in a clear, yet compact manner.

► **Salient Features**—Some of the other salient features of the book are: the originality and plentifulness of problems throughout the book; the minimum use of formalized mathematics; the incidental use of historical background and its effect on technological advances; enjoyable sense of humor and philosophy interspersed with the technical material and above all, a presentation of material in a well organized manner.

The first three chapters—Radio Communications; Diodes and Rectifiers; Triodes, Pentodes, and Linear Amplifiers—cover the usual introductory material found in most communication or electronic engineering text books, but are enhanced by clarity of presentation and the abundance of well thought-out sets of problems.

The author's sense of humor is illustrated by the title. "Direct-

Voltage Amplifiers—Why to Avoid Building Them" and in his concluding remarks on the subject where he philosophizes, "It is usually possible to solve a difficult problem in a difficult manner by brute force and ignorance. However, real advances are made by recognizing difficulties and avoiding them."

► **Semiconductor Physics** — In Chapter IV, Dr. Adler covers the physics involved in understanding of the operation of the semiconductor diode and the transistor by the circuit engineer. No use is made of quantum mechanics, but its importance is pointed out where necessary. The chapter starts with the subject of atoms and their arrangement in matter and covers such items as the basic distinction between conductors, insulators and semiconductors; intrinsic semiconductors; extrinsic semiconductors; physical and electrical properties of *p-n* junction diodes and junction transistors. For completeness, a discussion of point contact diodes and transistors is included.

Chapter V, also by Dr. Adler, entitled Transistors (Linear Amplifiers) is, as the author states, to discuss those aspects of simple transistor circuits which seem to be of lasting significance. Such basic subjects as low frequency equivalent circuits for transistors; common-base, emitter and collector connections, effect of bias conditions on the incremental parameters; d-c bias conditions and temperature dependence, also high frequency response considerations are covered, providing the engineer with all the material sufficient to gain a complete and comprehensive background of the vital circuit fundamentals needed for use in advance transistor circuit design.

Chapter VI, Transient Response of Video Amplifiers; Chapter VII, Amplitude Modulation and Tuned Amplifiers; Chapter VIII, Power Amplifiers, and Chapter IX, Oscillators, contain the standard subject material usually found under such titles, but they are distinguished

**SWITCH TO
AUTOMATIC
CONTROL!**

With 

**the complete line of
relays, timers and
time switches**

Specialists in the control field for more than 30 years, AEMCO offers you fresh, new ideas . . . ideas that save you money in automatic control . . . ideas that save you valuable time. Your inquiries are invited write for complete information.

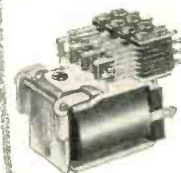

RELAYS



INDUSTRIAL
TIME CONTROLS

At AEMCO we specialize in both the design and manufacture of relays to your mechanical and electrical specifications. Should one of hundreds of stock AEMCO relays fail to meet your specialized requirements exactly, we will be happy to build a unit not only to meet, but to exceed those specifications.

Now control that vital operation automatically! Available in many different models with automatic or manual re-set, AEMCO industrial time controls help eliminate waste . . . help speed up production. Variations are available on standard cycling models . . . dials are easy to read, easy to set.

Write Today

For detailed information on AEMCO Relays or the complete AEMCO Industrial Time Control line.



INCORPORATED

12 State Street • Mankato, Minn.

Want more information? Use post card on last page.

Reliable Sensitive Relays

Now available for quick delivery



the electronics division of IRON FIREMAN

is now mass-producing its new 400 series sensitive relay. This new relay possesses high sensitivity and reliability even under extremely severe environmental conditions. Many leading manufacturers with prime military contracts for electronic systems are using these 400 series Iron Fireman sensitive relays.

A 60-page Certified Qualification Report*

showing compliance of this relay to military specifications is now in the hands of the Iron Fireman Electronics representatives listed here. They will be pleased to go over this report with you.

M. B. Gilbert Co.
6214 W. Manchester Ave.
Los Angeles 45, California

Jules J. Bressler Co.
4808 Bergenline Ave.
Union City, New Jersey

Massey Associates
529 Brookhurst Ave.
Narbeth, Pennsylvania

Massey Associates
1 Thomas Circle N. W.
Washington, D. C.

Seatronics, Inc.
911 Western Ave.
Seattle 4, Washington

*Qualified to MIL-R-5757B.



Send today for "Sensitive Relay Data File" Contains specification sheets, operational charts, temperature conversion charts, and other helpful information.

IRON FIREMAN Sensitive Relays

2810 S. E. Ninth Avenue, Portland 2, Oregon

Want more information? Use post card on last page.

by the general style found throughout the book of an explanatory technique, rather than the descriptive approach. Some of the advance sections which would appeal to the engineer in these chapters are the subjects in Chapter VI, Transient Response of Video Amplifiers: computation of response to an arbitrary signal from unit function response; superpositional integral in impulse form; multi-stage video amplifiers—uniform-stretch function; in Chapter VIII, power series treatment of nonlinearities and in Chapter IX, self-modulated oscillations. Included in these chapters are short discussions of transistor power amplifiers, r-f amplifiers and oscillators.

► **Receiver Circuitry**—The remainder of the book is devoted to receiver circuit design with concentration on Mr. Arguimbau's chief specialty, f-m receiver design, where he points out that for f-m receiver design capable of suppressing high percentage of interference, the following precautions are necessary: the linear portions must have flat frequency response over the modulation band, the response must be independent of amplitude over the interfering beat frequency cycle, the variation of rectified output with frequency should be linear over a wide frequency range, the detector should be quick acting, the linear front end of the receiver should have adequate selectivity and that there should be good selectivity ahead of the mixer.

Other subjects are inverse feedback, color television, transient time and noise. The chapter on television provides the author with a chance to present the basic types of switching circuits pertaining to most nonlinear fields of application, covering most of the basic tv circuit theory, along with an introduction to the concepts of color tv.

► **Transit Time**—The chapter on transit time uses the operation of the klystron tube to illustrate the way which transit time effects can be put to use at high frequencies. This chapter should be enjoyed by the engineer who desires a clear approach to the introduction of high frequency techniques. The

chapter on noise presents both vacuum tube and transistor noise conditions in a manner understandable to the average engineer. In the author's words, concerning the simplicity of scientific presentation, "Many topics present no fundamental difficulty. With a little practice, they can be handled easily and on the other hand, some topics require, for a true fundamental understanding, a prolonged study of physical processes which are still matters of controversy and surmise. The problem is likely to be complicated by unnecessarily powerful mathematical artillery which nearly always is brought into action in the study of a new development before simple rules are appreciated." — *Seymour Schwartz, General Manager, Transistor Applications Co., Boston, Mass.*

Electronics in Industry

BY GEORGE M. CHUTE

Second Edition, McGraw-Hill Book Co., Inc., New York, 1956, 431 p, \$7.50.

THE goal of this book is to present the basic fundamentals of industrial electronics for the civil, aeronautical and mechanical engineer. The material is well organized and even the electronics engineer who specializes in one phase of electronics should find it a valuable addition to his book shelf as a reference source for material falling outside of his specialty.

The author has succeeded in presenting several difficult concepts in easy-to-understand form. For example, in a relatively few pages, he has managed to convey a clear picture of the Nyquist-analysis approach to servomechanisms.

If any one subject is treated out of proportion to the others, it is resistance welding where the material presented is in considerable detail. Communications techniques and circuits are not covered.

The self-study questions at the end of each chapter are well chosen to stimulate further thinking on the various subjects discussed and

to serve as a check to see that the important features of each chapter have been absorbed.

► **Transistors**—Some electronics engineers will take issue with the author in his description of transistors as nonelectronic devices. The discussion is clearly written and easy to understand. Although the material presented would hardly qualify an engineer to design transistor circuits, he would be familiar with what they can and can't do and he would retain enough basic information to avoid making serious errors in setting up experiments.

The author is unusually successful in clarifying the reasons for observing polarity requirements in transistor circuits. Unfortunately three of the diagrams showing various methods of connecting transistors fail to follow convention; Fig. 27-9 on page 395 shows *pnp* transistors with their collectors connected to the positive side of the voltage source.—JAMES D. FAHNESTOCK, *Potter Instrument Co., Great Neck, N. Y.*

Mechanical Design for Electronic Engineers

BY R. H. GARNER.

D. Van Nostrand Co., Inc., Princeton, N. J., 1956, 223 p., \$15.00.

THE constantly increasing need for mechanical design information in the development of electronic gear has magnified the lack of texts and other information available in this field. Mr. Garner's book is an attempt to fill this void and to give the electronic engineer some basic understanding of how to approach his mechanical engineering problems.

Unfortunately, Mr. Garner falls very short of the mark he has set. His book is an accumulation of technical data and commercial devices gleaned from manufacturers' catalogues and manuals. There is little, if any, discussion on the application of this information to the problems of the electronics engineer.

Typical of this lack of information is a section under "Finishing

A MESSAGE FOR *Scientists*
from
UNION CARBIDE
AND CARBON CORPORATION

**Is YOUR FUTURE
in this CRYSTAL?**

At Linde Air Products Company, a Division of Union Carbide and Carbon Corporation, scientists investigate new crystals . . . explore exciting possibilities for crystal products . . . help market crystals for scientific and industrial applications.

At LINDE scientific initiative is encouraged; research is done individually or by teams of two or three. LINDE's expanding Crystals Laboratory and sales staff require the creative talents of scientists and physicists—recently graduated as well as seasoned engineers—for responsible positions.

Many a scientific "barrier" has been broken through by the imaginative and creative thinking of the men and women in LINDE laboratories. Some examples of LINDE "firsts" are: sapphire rod, windows, and hemispheres . . . single crystal ferrites . . . light pipes for radiation pyrometers, with practical applications in the research, electronics, communications, jet aircraft, and rocket fields. Working with the people who accomplished this, you will create and develop new products and applications for the future.



Look into the crystal—the LINDE sapphire crystal—for your own future. Write now—today—to Arthur K. Seemann, Manager, Crystals Department BD-1.



LINDE AIR PRODUCTS COMPANY

A Division of Union Carbide and Carbon Corporation
30 East 42nd Street **NY** New York 17, N. Y.

The term "Linde" is a registered trade-mark of Union Carbide and Carbon Corporation.

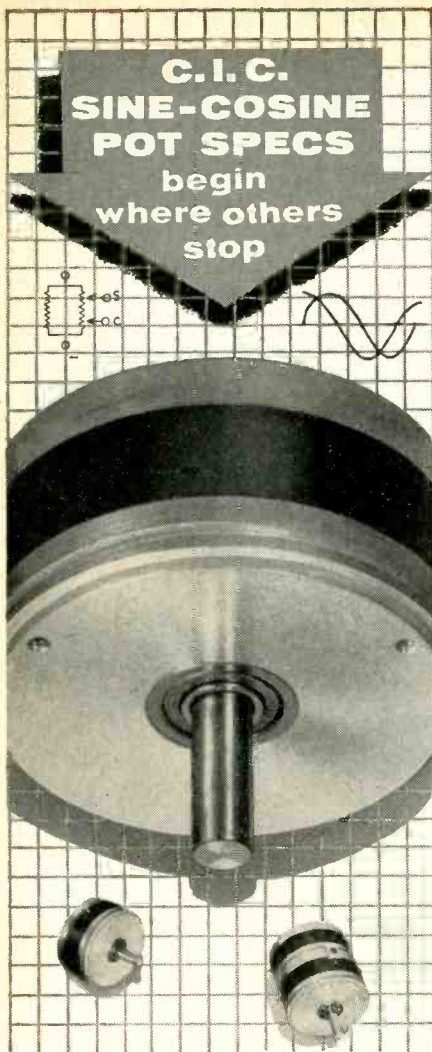

Infinite resolution and absolute dependability distinguish CIC ultra-precise Potentiometers. In the generation of the sine wave CIC Pots provide smooth, reliable performance, distortion free at all angles of rotation.

CIC carbon film Sine-Cosine Pots, the proven product of a unique research program, provide greater accuracy in smaller case sizes. Sizes range from 1" to 5" diameter with corresponding best conformities from .3% to .03%. Compensation for loading can be provided with no loss of performance.

At speeds in excess of 1,000 r.p.m. CIC guarantees life in excess of two million revolutions.

Many firms with critical specifications for industrial instrumentation, military fire control and flight guidance equipment rely only on CIC Potentiometers.

Our highly qualified engineers are ready to discuss your specific requirements with you. Call us today.

"For Precision Performance ... specify CIC"

Detailed Technical Data Sheets available on request.

cic
COMPUTER INSTRUMENTS CORPORATION
 IVanhook 3-8200
 92 Madison Ave. • Hempstead, Long Island, N. Y.

Want more information? Use post card on last page.

Processes", in which Mr. Garner outlines numerous commercial cleaning processes such as Parkerizing, Bonderizing, aluminum surfacing and Electro finishing. In his discussions he outlines the manner in which these finishes are applied, but does not discuss in any detail the whys and whens these finishes should be utilized. Further, Mr. Garner has a paragraph on colors in which he advises that white should be used for hospital and hygienic applications and that black for reduced light reflection trol desks and panels in fashionable locations. Mr. Garner could have discussed the application of black for reduced light reflections and heat absorption, the use of white or aluminum for better light and heat reflection.

It seemed that Mr. Garner's discussions were either so elementary as to be useless, or the subject was completely glossed over. The subject of welding has been completely omitted from the discussion on sheet metal working and in short, this reviewer found Mr. Garner's book nothing but a glorified index and another publication on a subject which does need information made available but to which this book adds very little.—DANIEL S. KARP, *Karp, Lesser & Co., Inc., New York, N. Y.*

Musical Acoustics

BY CHARLES A. CULVER. *McGraw-Hill Book Co., Inc., New York, 1956, 365 p. \$6.00.*

THIS book has outstanding illustrations and fine descriptions of the many types of musical instruments. It is well suited to, and intended for, a textbook for music majors in colleges and universities. It is also likely to be of interest to high-fidelity enthusiasts and professional musicians.

Both chapter subheadings and figures are keyed to the chapter numbers, which makes it easy to refer to any particular item.

► **New Features**—New for this edition are chapters on basic concepts and simple harmonic motion. Black-faced type indicates

important concepts, standing out for quick reference. Equations used are not derived and for the most part are explained adequately. Also new are the questions which accompany the first twelve chapters. Some are quite interesting; for example on p 36, "A boy claps his hands in front of a public library building, and hears a momentary musical sound reflected from the steps leading to the building. What is the frequency of the sound if the steps are 1 ft wide, and the temperature is 68°F?"

Highlights of the book are the oscilloscope pictures of typical sounds of the various instruments and their spectrum charts. An audio engineer could learn a great deal from these. For example Chapter 13, Wind Instruments, has 32 cathode-ray pictures. Some of these are in groups; for instance Fig. 13-7 shows four pictures, each of a musical A, 220-cps tone, from a clarinet, viola, harmonic flute and diapason. Line drawings show the spectra of these tones in Fig. 13-8.

Chapter 9, Musical Instruments and Temperament, is particularly well done. In 18 pages the author combines physics, music, and elementary mathematics. He even works in a little history, mentioning (p 132) the scales used by the Chinese, Arabs, Hindus and Persians. The latter divided the octave (frequency range 2:1) into twenty-four steps, i.e., quarter-tone steps. In this chapter are good explanations of musical interval, dissonance, consonance, major chords, minor chords, major tone, minor tone and equally tempered scale.

The chapters Electronic Musical Instruments and Recording and Reproduction of Music, 12 and 20 pages respectively, give brief summaries.

► **Quotes and Comments**—Subjective tones are referred to as "aural harmonics," p 92. The difference tones are ascribed to Tartani, an Italian violinist (1,754), and the sumtones to Helmholtz. Helmholtz is also quoted, p 104, "differences in musical quality of tone depend

solely on the presence and strength of partial tones, and in no respect on the differences in phase under which these partial tones enter into the composition." Further mention is made of later work (1,934-1,937) by Firestone and his coworkers who show that phase does matter.

Concerning seventeenth and eighteenth-century violins, several items of recent research are mentioned, p 195.

Speaking of a percussive tone, p 107, "in such instances the vibratile member is excited by being struck a more or less sharp blow at a definite point in its structure. Under such circumstances, immediately after the stroke, the upper partials, in general, are found to be relatively strong. But owing to the natural damping of the vibrating member or to the damping caused by the hammer while it is in momentary contact with the string or bar, these higher partials tend to decrease rapidly in amplitude, the most pronounced change occurring in less than one-tenth of a second after the initiation of the sound. Partial which diminish in intensity in this manner are often referred to as transients."

As an instance where improvement might be considered it is stated on p 83 that "pitch is that subjective characteristic of a sound that enables us to classify a sound as being acute or grave." "Acute" and "grave" are not explained. The unit "cps" should be added to p 93 for the absorption coefficient table.

The author has at his disposal the field of electronics which was not available when the early classic was printed (D. C. Miller, "Science of Musical Sounds," 1916). Professor Culver has done an excellent job. His book should be on the shelf of anyone who wants to know about the fundamentals of musical tones.—RICHARD C. HITCHCOCK, *Syntron Company, Homer City, Pa.*

Thumbnail Reviews

National Simulation Conference. Southern Methodist University, Dallas, Texas, 1956, \$5.00 (paper). Procedures

DI-FORMED PAPER TUBES IMPROVE YOUR COILS ...SAVE MONEY AND PRODUCTION HEADACHES

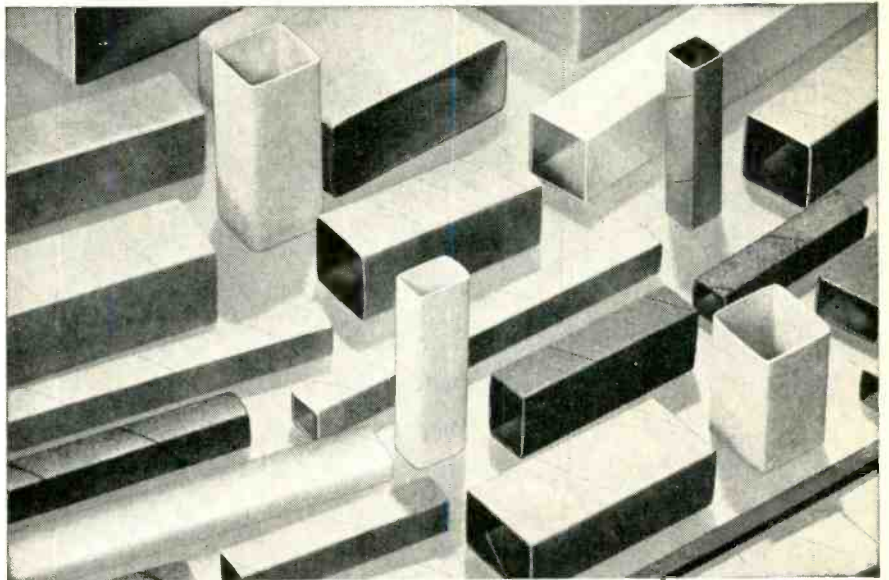

HERE ARE THE FACTS

Di-Formed Tubes feature a special patented Precision Paper Tube construction which produces a completely ridgeless surface, thus eliminating wire pile up and resultant coil shorts.

Side walls are straightened under pressure during the winding operation. The bow being thus controlled permits a perfect fit between mandril and tube as provided by Precision's low-cost Related Mandril Service.

Under the Related Mandril Service, Precision supplies the coil manufacturer with accurately ground steel or aluminum mandrils at a price comparable to commonly used unsatisfactory wood or undersized steel mandrils. *This is not a profit-making service. Its sole purpose is to give the coil manufacturer these advantages:*

1. Provide proper tube support.
2. Facilitate stacking operations.
3. Prevent coil collapse.
4. Save machine and operator fatigue.
5. Permit smaller core, thus decreasing coil size and eliminating pressing.

Get full details on Precision Di-Formed Tubes and Related Mandril Service. Write, wire or phone today.

Sales Representatives in:

California, Oregon, Washington: Covina, California, Edgewood 2-4693
 Illinois, Indiana, Iowa, Wisconsin, Missouri, Minnesota: Chicago, Illinois, ARmitoge 6-5200
 Indiana, Ohio: Logansport, Indiana, Logansport 2555
 Northern Ohio: Cleveland, Ohio, Atlantic 1-1060
 New England: Framingham, Massachusetts, Trinity 3-7091
 New Jersey, Delaware, Washington, D.C., Maryland, Eastern Pennsylvania, Virginia, Metropolitan New York: Jersey City, New Jersey, Swathmore 5-2480
 Upper New York: Syracuse, New York, Syracuse 4-2141
 CANADA: Montreal, Quebec, Canada, Walnut 0337
 MEXICO: Mexico 6, D.F., Telephone 35-06-18



PRECISION PAPER TUBE CO.

2041 W. CHARLESTON ST.

CHICAGO 47, ILL.

Plant No. 2: 1 Flower St., Hartford, Conn.

of a conference held January 19, 20, 21, 1956 in Dallas, Texas. Thirty-five pages describe application of analog and digital computers in solving engineering and scientific problems mostly of a dynamic nature.

Evaluation of Insulating Oils—European Developments. American Society for Testing Materials, Philadelphia, Pennsylvania, 1956, 78 p, \$1.75 (paper). Developments in testing transformer oils discussed in three papers and discussion minutes.

Electron Physics Tables. L. Marton, C. Marton, and W. G. Hall, National Bureau of Standards Circular 571, Government Printing Office, Washington D. C., 1956, 83 p, \$.50. Facilitates computations in field of electron physics. Calculations were done on NBS automatic digital computer, SEAC.

Television Servicing. Matthew Mandl, MacMillan Co., New York, 1956, 460 p, \$6.50. Servicing instructions for home television receivers. Covers uhf circuits. Touches upon color tv receivers, printed circuits and projection television. Anticipates the home tv receiver field by including a chapter on transistors.

Inverse Feedback. Alexander Schure, John F. Rider Publisher, New York, 1956, 56 p, 90¢ (paper). Stability of performance, automatic control and control of frequency response are a few accomplishments of inverse feedback in electronic circuits. Book describes principles and applications.

TV Manufacturers' Receiver Trouble Cures, Vol. 8. M. Snitzer, John F. Rider Publisher, New York, 1956, 128 p, \$1.80 (paper). Troubles and cures associated with specific tv home receiver chassis. Covers manufacturers alphabetically from RCA to Zenith.

TV Servicing Guide. Leslie D. Deane and Calvin C. Young, Jr. Howard W. Sams & Co., Indianapolis, Ind., 1956, \$2.00 (paper). Troubles and their cures arranged by symptom which in many cases is picture of distorted test pattern on tv screen.

Basics of Phototubes & Photocells. David Mark. John F. Rider Publisher, New York, 1956, 136 p, \$2.90 (paper). Elementary course in theory and application of phototubes and photocells as used in electronic equipment.

Automation. R. H. MacMillan, Cambridge University, New York, 1956, 100 p, \$1.95. Economic and sociological impact of mechanized production equipment and computers. Book is written largely from a British point of view. Author views automation as a force for potential solution of many social and economic problems.

NEL Reliability Bibliography. W. E. Jorgensen, I. G. Carlson, and C. G. Gros. U. S. Navy Electronics Laboratory, San Diego, California, 1956 (looseleaf). Covered circuit design, components, electron tubes, failure analysis, human engineering, maintenance, mechanical design, systems and



Zell

**Specialists
IN STAMPING AND DRAWING**

- KOVAR • RODAR
- THERLO • FERNICO
- Other IRON-NICKEL-COBALT Alloys

CUT TOOLING COSTS!
Over 3,000 high precision tools and dies available to reduce your initial tooling time and costs.

COMPLETE FACILITIES FOR PRECISION PRODUCTION OF ELECTRONIC COMPONENTS

Our facilities are geared to meet your production and engineering needs for components of any description. Unusually Complete Tool Room • Press Shop • Hydrogen Annealing, Machining and Polishing Operations • Glass-to-Metal Hermetic Sealing. Production of completed parts ready for assembly in your own plant.

A complete service in our plant means prompt service to your plant.

Call on us for free consultation and quotations.

ZELL PRODUCTS CORP.
276 Main Street, Norwalk, Conn.

DIGITAL COMPUTERS

for ICBM and IRBM

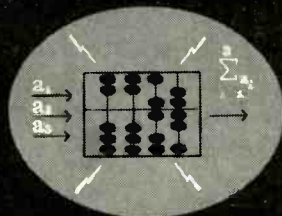

The field of Digital Computers is an important one in guided missile research at Ramo-Wooldridge, where engineers and scientists are providing systems engineering and technical direction for the Air Force Ballistic Missile Programs.

The systems team concerned with digital computers represents many technical specialties. Among them are logical design... circuit design... programming... data conversion and handling... component and system reliability... input-output design... and environmental and mechanical design.

The essential function of Project Engineering supplements these technical specialties. Project Engineers are responsible for technical management liaison with other organizations participating in these missile programs.

R-W's broad systems responsibility for ICBM and IRBM has created unusual technical and project opportunities in the field of digital computers. Positions are open in Los Angeles and at Patrick Air Force Base, Florida.

Please address inquiries to: Mr. W. J. Coster

The Ramo-Wooldridge Corporation

5730 ARBOR VITAE STREET • LOS ANGELES 45, CALIFORNIA

ZOPHAR

---WAXES
---COMPOUNDS

Zophar Waxes, resins and compounds to impregnate, dip, seal, embed, or pot electronic and electrical equipment or components of all types; radio, television, etc. Cold flows from 100°F. to 285°F. Special waxes non-cracking at -76°F. plain or fungicidal. Let us help you with your engineering problems.

For immediate service contact:

L. E. Mayer, Sales Manager
A. Saunders, Technical Director
H. Saunders, Chemical Laboratory
Phone SOuth 8-0907



ZOPHAR MILLS, INC.
112-130, 26th Street,
Brooklyn 32, N. Y.

**YOU CAN SAVE
UP TO 50% ON**

SMALL PARTS LIKE THESE

by using
TRADEMARK

BEAD CHAIN Multi-Swage PRODUCTS

Every year Bead Chain produces billions of tubular metal parts for electronic and mechanical applications. Multi-Swage eliminates costly turning, drilling, stamping and forming—automatically swages from flat stock into strong precision forms with positive, tight seams. If you're a volume user of such parts, in any metal, up to 1/4" diam. x 1 1/2" long, find out how much Multi-Swage can save you. Send sketch or standard parts for prompt estimate. Write for catalog today.

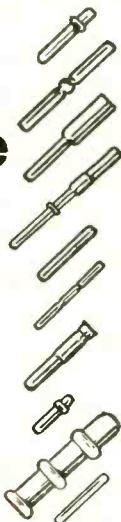

THE BEAD CHAIN MANUFACTURING CO.
88 Mountain Grove St., Bridgeport, Conn.

Want more information? Use post card on last page.

ELECTRONICS — January 1, 1957

NEW BOOKS

(continued)

testing. Available to government contractors upon request to Commanding Officer USNEL, San Diego.

Digital Differential Analyzer. George F. Forbes, Pacoima, California, 1956, 154 p, \$7.50 (paper). Applications manual for digital and analog-type differential analyzers. Provides starting point in the approach to actual problem solutions.

Superheterodyne Converters. Alexander Schure. John F. Rider Publisher, New York, 1956, 56 p, \$0.90 (paper). Explanation of various circuit configurations explained on the technician level.

ASTM Standards on Metallic Electrical Conductors. American Society for Testing Materials, Philadelphia, Pennsylvania, 1956, 300 p, \$3.50 (paper). Standards cover copper, copper alloy, aluminum, and galvanized steel core wire. Includes 52 ASTM standards, 43 specifications, and 7 test methods.

ASTM Standards On Electrical Insulating Materials. American Society for Testing Materials, Philadelphia, Pa., 1956, 636 p, \$6.00 (paper). Specifications and test methods for insulating varnishes, molded materials, mineral oils, ceramics, insulating board and mica. Includes 83 test methods. Changes include testing silicone varnishes and how to clean plastic for insulation resistance test.

Power System Stability, Volume III—Synchronous Machines. By Edward Wilson Kimbark, John Wiley & Sons, Inc., New York, 1956, 322 p, \$10.00. Characteristics and theory of synchronous machines, their excitation systems and effects such as saliency, damping, saturation and high-speed excitation. Steady-state stability, which was touched upon in Volume I, is covered in some detail.

Nachrichtenübertragung mittels sehr hoher Frequenzen (Communications at Very-High Frequencies). By Gerhard Megla, Fachbuchverlag, Leipzig, 272 p, 1954. Survey for the communication engineers on the use of high-frequency (100 mc and above) techniques. Numerous numerical examples and specific illustrations are given. Main subjects are propagation and modulation techniques. Most applications are made with telephone or television transmission in mind, with essentially no treatment of microwave tubes or circuits.

Neutral Grounding in High-Voltage Transmission. By R. Willheim and M. Waters, D. Van Nostrand Co., Inc., New York, 1956, 669 p, \$15.00. Good and bad features of various methods of neutral grounding and conditions under which they can be employed. Large portion of volume is devoted to resonant grounding, including roundup of its practice around the world.

Precision

PHASE METERS



NOW

**DIRECT READING
WITH NO ADJUSTMENT
FROM 1 CPS TO 500 KC**

FEATURES

0.3 volt sensitivity, 1/4° relative accuracy. Measures a small fraction of 1° from 1 cps to 500 kc.

Meter reading independent of signal amplitudes.

No ambiguity at zero degree.

Provision for self-calibration and self-adjustment.

6.5" long mirror scale on panel meter.

New cathode-coupled limiter stages with plate-to-grid degeneration.

SPECIFICATIONS

Frequency Response: Type 405—10 cps to 100 kc; Type 405H—10 cps to 500 kc; Type 405L—1 cps to 20 kc.

Phase Range: 0-12, 0-36, 0-90, 0-180 and 180-192, 180-216, 180-270, 180-360 degrees.

Accuracy: ± 0.25° relative, ± 2% absolute.

Input Voltage: 0.3 volt to 70 volts for Type 405 and 405L; 2 volts to 40 volts for Type 405H.

Price: Type 405—\$485.00;

Type 405H—\$524.00;

Type 405L—

\$546.00

ADVANCE

Electronics Lab., Inc.
249-259 Terhune Ave.,
Passaic, N. J.



Want more information? Use post card on last page.

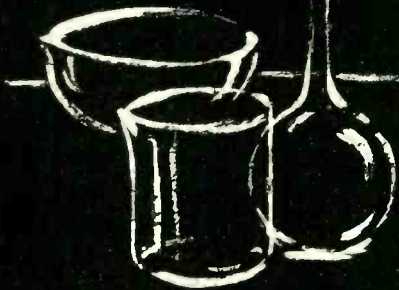

Look no further—
If you're looking for
"BORON-FREE"
fused quartz
LABORATORY WARE

The world's largest producer of fused quartz products can help you with your most critical and exacting needs for your laboratory ware.

Vitreosil® products can be supplied in an unusually large variety of types and sizes. Also fabricated to specification to meet individual requirements.

TRANSPARENT VITREOSIL

For ultra-violet applications, metallurgical investigations, chemical research and analysis, photochemistry, spectroscopy and physical, optical and electrical research.

Send specifications for your requirements. Please use coupon below.

**THERMAL AMERICAN
 FUSED QUARTZ CO., INC.**
 18-20 Salem Street, Dover, New Jersey

Please send technical data on

Company _____

Name & Title _____

Street _____

City _____ Zone _____ State _____

Want more information? Use post card on last page.

Backtalk

Phasor Poesy

DEAR SIRs:

THE gradually increasing use of the word "phasor", rather than "vector", in a-c circuit work has suggested the following lines. My only claim is that they are original with me.

With the increasing em pha' sis
 On vector a nal' ysis
 Confusion is created,
 Of things unrelated,
 When "vector" is used
 (A word much abused)
 To describe phase relations
 Of a-c perturbations.
 Let's use the term "phasor"
 And be sharp like a razor.

Possibly you could use this to explain some article in which the newer term is used. If so, you are welcome to publish it, providing your worthy publication absorbs the inevitable criticism of the rhyme and meter.

HAROLD E. FELLHAUER
Cedar Rapids, Iowa

Editor's Note: We like it and invite readers to comment or use it in manuscripts submitted to ELECTRONICS.

Gravity Sinks

DEAR SIRs:

YOUR invitation to gravity hypothesizers has evoked some interesting comments but has far from exhausted the subject, (*Electronics*, 1956: Jan. p 121; March, p 500; July p 372; Oct. p 465, 468).

Consider, for example, the long-forgotten ether-sink theory of Karl Pearson (*Am J Math* 13:309, 1891). The basic idea is that two sinks in an ether will be attracted inversely as the square of the distance, just like two sinks in water. The difficulty was that no ether sinks were available; classical physics was built on the respectable, law-abiding, closed system. Today, however, the closed system is gone, and all forms of matter down to the electron are apparently open systems (*Stern, Sci.* 116:493 1952). Since a sink is basically an open system, is it not possible that the elementary particles may arise

from sub-electrical sinks, an incidental result of which is gravity?

To illustrate with a crude analogy, living things are sinks: they absorb chemical energy and convert it to another form—biological. The latter eventually appears as a different form of matter, a community of living things, which may be termed social mass. A social mass, as a city, requires a constant flow of food energy to exist. The density of this incoming energy increases inversely as the distance from the city. For a hypothetical city that exists in a volume, the density of the incoming energy would increase inversely as the square of the distance. It is this geometrical property of an aggregate of sinks which allows a gravity model.

This concept may be expressed in the analogy, gravitational sink : electrical particles :: living thing : social mass. Since living things may exist only in an appropriate environment of matter, we also have the analogy, living things : chemical matter :: gravitational sink : an ether. If the idea of an ether is appalling, modern physics offers no basic objection provided an ether does not sensibly affect motion of electrical matter. Dirac, for instance, hypothesizes an ether (*Sci. Mo.* 78:142, 1954) invoking relativity, which as is commonly believed, specifically forbids it. Also, the Lorentz ether theory is still as satisfactory, experimentally, as the Special Theory of Relativity (Ives, *J. Opt. Soc. Am.*, 1939, 1941-4; *Phil. Mag.*, London, 36:292, 1945).

A more literal interpretation of these analogies endows the gravitational sink with properties akin to those of living things, such as reproducibility. This vitalistic interpretation of the microcosm has been suggested elsewhere (Rudfer, *Proc. IRE* 40:1734, 1952) in connection with psi (telepathy). Now, the properties of psi, if they are veridical, are related to those of the mind, so that the two must be bracketed. The origin of mind is presently considered to be outside the scope of physics.

Although there are attempts be-

ing made, through the related disciplines of chemistry and biophysics, to account for biological phenomena in terms of electrical matter, there are serious difficulties when the subtle properties of the mind are involved. Why not start from a sub-electrical vital process and derive therefrom both physical and biological properties? On the basis of Mach's Principle of Intellectual Economy, this is a more general approach.

Recent advances on the mechanism of nerve processes support this view (Eccles, *Nature* 168:53, 1951). The action required to transfer a nerve impulse is shown to occur within the magnitude of Planck's constant of action, *h*. This supports a sub-electrical origin of mind.

Microcosm

To carry the analogy still further, quantum mechanics requires that each fundamental particle should interact with all others. The process is inexplicable in terms of inert matter except in an abstruse statistical manner. In terms of vital matter, the process is self-evident. A social mass, such as the United States, has a definite boundary in space and time. However, Americans are found everywhere outside these boundaries, and the U. S. interacts with all other social masses, however remote. A vitalistic interpretation of the microcosm can account in a like manner for the dilemma posed by quantum mechanics.

An observer on the moon who could observe our cities in detail, but with not quite enough resolving power to see living things, would come to conclusions similar to those we now have about the microcosm. The growth and decay of cities, the daily variations in night-lighting, seasonal changes in farm areas, traffic flow—all these he could describe in a statistical manner resembling our present statistical interpretation of microcosmic events. Unless he guessed at the existence of life, the moon observer would be forced into an artificial mathematical interpretation of our world. Quantum mechanics may presently be in a similar predicament with



PHAZOR PHASE METER
Pat. Pend.

MODEL 200 A

PRICE **\$349.50**
F.O.B. NEW YORK

- HIGH ACCURACY
- MEASURES FROM 0 TO 360 DEGREES
- READINGS NOT AFFECTED BY NOISE AND HARMONICS
- PHASE SHIFTS OF THE ORDER OF .01° CAN BE MEASURED EMPLOYING SPECIAL CIRCUIT TECHNIQUES
- MEASURES IN-PHASE AND QUADRATURE COMPONENTS SEPARATELY

For further information contact your nearest representative or write for brochure

INDUSTRIAL TEST EQUIPMENT CO.
55 E. 11th ST. · NEW YORK 3 · GR. 3-4684

Manufacturers of

- PHASE METERS
-
- NULL DETECTORS
-
- IMPEDANCE COMPARATORS
-
- POWER OSCILLATORS
-
- FREQUENCY STANDARDS
-
- AUTOMATIC HI-POT
-

Other Electronic Test Equipment

IMPREGNATING
SEALING
DIPPING
INSULATING
BLENDING

POTTING
HEAT CONDUCTING
MOISTURE PROOFING
FUNGUS PROOFING
ENCAPSULATING



WAXES BIWAX COMPOUNDS

Standard compounds available from stock.
Samples and specifications on request.
Modifications developed and produced to meet specific requirements.
Information relating to your problem will enable us to make recommendations. Write to

BIWAX CORPORATION

3445 HOWARD ST.
SKOKIE ILLINOIS

MAGNETS

HIGH ENERGY
PRECISION
ALNICO
PERMANENT
MAGNETS

WE CARRY
IN STOCK
ALL SIZES,
ALL SHAPES,
ALL ALNICO
GRADES

When you need them — as you need them. Experimental or production quantities.

PERMAG
services include:

- ENGINEERING
- PRECISION CUTTING
- PRECISION GRINDING
- MAGNETIZING

24 HOUR DELIVERY

Send for Catalog

PERMAG CORP.
210 TAAFFE PLACE, BROOKLYN 5, N. Y.
Phone: MAin 2-0114

RIBBONS • STRIPS

★ PURE TUNGSTEN ★ THORIATED TUNGSTEN
★ MOLYBDENUM ★ SPECIAL ALLOYS

and OTHER METALS

IN
ULTRA THIN SIZES

to
TOLERANCES CLOSER THAN COMMERCIAL STANDARDS
by

OUR SPECIAL ROLLING TECHNIQUE

Note: for highly engineered applications—strips of TUNGSTEN and some other metals can be supplied

ROLLED DOWN TO .0003 THICKNESS

- Finish: Roll Finish—Black or Cleaned
- Ribbons may be supplied in Mg. weights if required

For HIGHLY ENGINEERED APPLICATIONS

DEVELOPED AND MANUFACTURED BY

H. CROSS CO.

15 BEEKMAN ST., N. Y. 38, N. Y.
WOrth 2-2044
TELEPHONE: COrtlandt 7-0470



**when you need
small parts like these . . .**

The fabrication of precision parts of industrial ceramics is a specialized job . . . and STAR specializes in it!

There is practically no limit to the variety of shapes we can turn out to meet your simple or intricate specifications precisely . . . economically.

More than 25 automatic presses, operating 24 hours a day are available to turn out ferrules, grommets, eyelets, rings, cups, shells, and millions of other close tolerance parts made from Star Ceramics. This means lower cost to you . . . faster service to meet busy production schedules.

Write for complete details, a generous assortment of samples and our NEW 20-page catalog.

the **★ STAR**
porcelain company
42 Muirhead Avenue, Trenton 9, N. J.

SIMPLYTROL AUTOMATIC PYROMETERS

For Control of Temperature



10 standard ranges from -200° to +3000° F.
Accuracy 2% (limit of calibration error).
Sensitivity 4 ohms per millivolt.

Cat. No. 4535, size 10" x 6" x 7".
Range 0/1000°F, 0/500°C. \$135.00

Thermocouple-type automatic pyrometer for controlling temperature in furnaces or ovens and manufacturing processes. Leads between Simplytrol and its thermocouple sensing element may be up to 100 feet or more depending on temperature range and lead wire resistance. Load relay, 5 amperes S.P.D.T. Optional heavy duty relays to 40 A. Either AUTOMATIC control or LIMIT shutoff. An automatic Simplytrol turns heat on and off to hold required temperature. Proportioning effect can be increased or decreased by changing cam on the sensing cycle. With shorter cycles, control more nearly approaches straight line. A limit Simplytrol locks up when the trip point is reached and remains locked until reset. Use limit Simplytrols for monitoring and safety shutoff or alarm.

Cabinet model for wall mounting or portable shown above. To the right is an MFP Simplytrol for flush mounting in a cabinet or control panel. Several other mountings are shown in Catalog 4-A. Send for your copy. Assembly Products, Inc., Chesterland 4, Ohio. Phone (Cleveland, O.) HAmilton 3-4436. (West Coast: Desert Hot Springs 4, Calif. Phone 4-3133 or 4-2453).
Cleveland Electronics Show, Feb 16-17, Masonic Auditorium



Cat. No. 4532-MFP, size 5" x 5 1/2" x 8" deep.
Range 0/1500°F, 0/800°C. \$127.00

BACKTALK

(continued)

matter originated in about a half hour some several billion years ago, from a dense substance termed ylem. But the source and nature of the ylem is obscure. A vitalistic origin of matter, however, offers a very simple explanation. This may be succinctly stated in the analogy, social mass : evolution :: matter : the creation. An evolutionary origin of a sub-electrical reproducing open system from the ether is sufficient to initiate the creation. There is nothing as proliferous as the reproducing system when multiplication is unimpeded by nature. The expansion potential of flies is a suitable example.

In sum, the existence of a vital process in the microcosm, chimeric as it many sound, has interesting possibilities.

MARTIN RUDERFER
Airborne Instruments Laboratory
Mineola, New York

Professionalism

DEAR SIRS:
SINCE WORLD WAR II, engineering organizations everywhere have been attempting to bring about an atmosphere of professionalism in engineering. They have set up codes of ethics. They have issued proclamations and have set up qualifications for acceptance into the "fraternity".

These are all important moves, but the surface has barely been scratched, and progress has been limited. To be really effective, a grass-roots movement must take place. Professional men and women are not commodities to be traded on the industrial market. But engineers have largely been considered as such, mere factors in the national equation, who can be attracted or pirated from one interest to another by the offer of \$.20 more per hour, or by other material considerations.

Professionalism is a frame of mind. Naturally, every man wishes to elevate his economic and intellectual position; but national arguments and sales points which quote futures on starting pay for engineers and on other material issues

Ideal for
ANTENNA CONNECTIONS
PHOTO-CELL WORK
MICROPHONE CONNECTIONS

JONES SHIELDED TYPE PLUGS & SOCKETS



LOW LOSS PLUGS AND SOCKETS FOR HIGH FREQUENCY CONNECTIONS. SUPPLIED IN 1 AND 2 CONTACT TYPES:

101 Series can be furnished with 1/4", .290", 5/16", 3/8" or 1/2" ferrule or cable entrance. Knurled nut securely fastens unit together. Plugs have ceramic insulation and sockets have bakelite. Quality construction. Fine finish. Assembly meets Navy specifications.

For full details and engineering data ask for Jones Catalog No. CS-21

JONES MEANS Proven QUALITY

HOWARD B. JONES DIVISION
CINCH MANUFACTURING CORPORATION
CHICAGO 24, ILLINOIS
SUBSIDIARY OF UNITED-CARR FASTENER CORP.

WANTED

Unusual Executive Electronics Engineer for an Unusual Opportunity

A progressive rapidly-growing New York Electronics Corporation which owns basic patents that are of major importance in the communications field and are worldwide in scope, seeks Engineer with broad successful experience in development of complex electronic apparatus. Must possess executive ability to tactfully handle group of engineers to expedite important R and D contracts and work smoothly with Chief Engineer and management. Excellent opportunity for advancement to top position. This company has tremendous potential for growth on worldwide basis. All replies will be strictly confidential. Send complete resume including salary requirements to

P-3689, Electronics,
Class. Adv. Div., P. O. Box 12,
New York 36, N. Y.

Want more information? Use post card on last page.

ELECTRONICS — January 1, 1957

BACKTALK

(continued)

the idea of professionalism, as this writer sees it.

An engineer, to be worthy of the term "professional", must enter his field with service in mind. His prime motivation and self query must be: "What can I do to aid man or to contribute to the sum of his knowledge by entering engineering as a life work?" The serious doctor, lawyer, minister, statesman, teacher, writer, artist and composer must and does ask himself that question before he examines the item of monetary returns.

The engineer who allows himself to be swayed in or out of his technical career by his prospects of money income and its implications alone is not and can never be, a professional.

A professional with genuine ability more often than not will in time earn a considerable amount of money, but this is never his prime motivation. The "technician" who measures his success by his income, rarely becomes a "five-figure" man. Strangely, the latter frame of mind is also usually the one most responsible for the loud clamor for "professional recognition".

Professionalism is an atmosphere, an intangible, an attitude; and all the shingles, diplomas, sheepskins and degrees produced in the nation's shingle-diploma-sheepskin-and-degree factories can not make a "professional" out of a man who is motivated alone by the thought of personal benefit and public awe for his work.

THOMAS E. DUSTIN
Fort Wayne, Indiana

Editor's Note: Mr. Dustin's letter also appears in the Fort Wayne Engineers' Club *Engineers' News*.

Storage Tube Elements

DEAR SIRS:

IN THE article entitled "Designing Storage-Tube Equipment" in the July ELECTRONICS, page 126, a wiring error was made in redrawing Fig. 1.

In the rough of this drawing as submitted, the connections to the three tube elements at the face end

HIGH DIRECTIVITY BROADBAND MICROWAVE COUPLERS



HIGH POWER COAXIAL DIRECTIONAL COUPLERS

with MINIMUM DIRECTIVITY of 23 db.

for the FREQUENCY RANGE 100 through 3,000 mcs.

Available in line sizes from Type N to 3 1/8", will handle full power rating.

These high power, high directivity, broadband couplers can be furnished either Uni-Directional or Bi-Directional, with choice of input and output flanges.

Normally supplied for 30 db. coupling. Coupling varies 3 db. over a 2-1 frequency range. Directivity is independent of frequency. The V.S.W.R. is less than 1.15 to 1, for main line. No external DC return is required for use with Crystal Detector or Bolometer. The accuracy is within .25 db. at center frequency.

Write for our Component catalogue, it is the most complete and comprehensive in the field . . . available on request.



Manufactured by



252 E. Third St. • Dept. E-J • Mt. Vernon, N.Y.
Want more information? Use post card on last page.



PIX

DEPENDABLE, PRECISION WIRE FORMING AND STAMPING SPECIALISTS

PIX Manufacturing Co., Inc.
81-A Hudson St.
Newark 3, New Jersey

Precision parts from PIX to meet your production and engineering needs—from .002" dia. to .125" dia. Modern facilities, high-production equipment. Radio tube parts, drawings, piercing, wire straightening, cutting and forming, relay components, transistor bases, terminal lugs, multislide stampings, beryllium copper contacts and printed circuit connectors. Send sketch or print for quotation.

of the tube were not shown individually. This left the way open for a wrong guess when the diagram was redrawn.

The three elements shown at the face end of the tube are, from left to right, the decelerator, the storage screen, and the signal electrode. The storage screen is shown connected to the load resistor R_L but should be connected directly to the mode switch box. The signal electrode (the element nearest the screen end of the tube) develops the stored output and should be connected to R_L .

ALVIN S. LUFTMAN
Senior Project Engineer
Raytheon Manufacturing Co.
Waltham, Massachusetts

Credit Clarified

DEAR SIRs:

IN the October 1956 issue of ELECTRONICS (p 182) there appears an article entitled "Carrier Telephone Expands Rural Service".

There are four inferences reflected in the published article which we feel should be corrected in the minds of your readers.

The company credit line of the article should have indicated that James E. MacDowell was an employee of the North Electric Company, Galion, Ohio, at the time the article was submitted.

The photographs used in the article were of North Electric Company's equipment, manufactured and sold exclusively by the North Electric Company.

The basic engineering and technical information used in the article was the result of large investments of money in personnel, equipment and development time by the North Electric Company. The personnel included James E. MacDowell.

The article, as published, suggested a sales price of approximately \$500.00 per channel. This price was considerably under the sales price of the equipment of the North Electric Company which has the lowest price of the competitive equipment in this field.

H. D. BURNS
North Electric Co.
Galion, Ohio

... Electrical Coil Windings

For 40 years . . . specializing in all types of coils to customers' specifications. Design or engineering assistance available on request.

COTO-COIL CO., INC.
SINCE 1917
65 Pavilion Avenue Providence 5, Rhode Island

PRECISION PLASTIC CAPACITORS AT COMPETITIVE PRICES!

POLYSTYRENE and MYLAR*

Capacitance	From .001 mfd to any value
Voltage	From 50 V.D.C. to 30 KV
Tolerance	Polystyrene From $\pm 0.1\%$ to $\pm 5\%$ Mylar* From $\pm 1\%$ to $\pm 10\%$

SMALLEST CASE SIZES
TUBULAR—BATHTUB—RECTANGULAR

Very Good Deliveries *DuPont T.M.

PRECISION CAPACITORS, INC.
150 W. Cypress Ave. Burbank, Calif.

PROFESSIONAL SERVICES

Consulting—Patents—Design—Development—Measurement

in

Radio, Audio, Industrial, Electronic Appliances

•CONTACTS•

FOR THE FIELD OF
ELECTRONICS

BRIGGS ASSOCIATES, INC.

Engineering Services

ELECTRONICS MECHANICAL

Development — Manufacturing — Consulting
Special Machines — Instrumentation — Automation
Electron Tube Design, Materials, Reliability

10 DeKalb St. Broadway 9-2120 Norristown, Pa.

NIAGARA ELECTRON LABORATORIES

CONSULTATION - DESIGN - CONSTRUCTION
MFG. THE THERMOCAP RELAY

Specializing in solution of problems of electronic and electro-physical instrumentation for the research or analytical laboratory. Industrial plant problems also invited.

Andover, New York Cable Address: NITRONLAB

CROSBY LABORATORIES, INC.

Murray G. Crosby & Staff

Radio - Electronics
Research Development & Manufacturing
Communication, FM & TV

Robbins Lane, Hicksville, N. Y.
WElls 1-3191

PICARD & BURNS, INC.

Consulting Electronic Engineers

Analysis and Evaluation
of Radio Systems

Research Development and Production
of Special Electronic Equipment

210 Highland Ave. Needham 94, Mass.

DELAWARE PRODUCTS CO.

Analog Voltage to Digital Conversion
Digital Voltage Recording Systems

Design-Development-Manufacturing

300 Broadway Camden 3, N. J.

ALBERT PREISMAN

Consulting Engineer

Television, Pulse Techniques, Video
Amplifiers, Patent technical consultation.

616 St. Andrews Lane, Silver Spring, Maryland.
JUUniper 5-6307

ELECTRONIC RESEARCH ASSOCIATES, INC.

"TRANSISTORIZE" YOUR PRODUCT!
Complete Service in consulting, research, develop-
ment, and production on Transistor circuitry, prod-
ucts and instrumentation.

67 East Centre Street Nutley, N. J.
NUTley 2-5410

TELECHROME MFG. CORP.

Electronic Design Specialists

COLOR TELEVISION EQUIPMENT
Flying Spot Scanners, Color Synthesizers, Keyers,
Monitors, Oscilloscopes and Related Apparatus,
Telemetering for Guided Missiles.

J. R. Popkin-Churman Pres. & Dir. of Eng.
28 Ranick Dr. Amityville, L. I., N. Y.

ERCO RADIO LABORATORIES, INC.

Radio Communications Equipment

Engineering - Design - Development - Production
Our 27th Year in Air to Ground
Communications and Radio Beacons

Garden City • Long Island • New York

TRANSISTOR CONSULTANTS, INC.

TRANSISTOR ENGINEERING

Consultation; cost analysis; training programs.
Engineering systems and Design Studies.
Instrumentation; Prototype Construction.
New Processes and Component Designs for Transis-
torized Computers; Servos; Radios.
Laboratory Investigations; "Life-Test"; "Fringe
Area" Evaluations.

P. O. Box 333 Morris Plains, N. J.

WHEELER LABORATORIES, INC.

Radio and Electronics

Consulting — Research — Development

R-F Circuits — Lines — Antennas

Microwave Components—Test Equipment

Harold A. Wheeler and Engineering Staff
Great Neck, N. Y. HUunter 2-7876

General Atronics Corporation

David E. Sunstein George J. Laurent
Dr. Robert W. Roop Bernard D. Steinberg

Consulting Services—Electronics, Acoustics, Techni-
cal Planning Operations Research for Industrial
Consumer and Government Products.

125 City Line Av. Bala-Cynwyd, Pa. (Phila. suburb)
MOHawk 4-8090

THE KULJIAN CORPORATION

ELECTRONICS DIVISION

Consulting Electronic Engineers

Research Development, Production of
Automatic Controls — Special Instrumentation
1200 No. Broad St., Philadelphia 21, Pa.
Stevenson 2-9000

YARDNEY LABORATORIES

Research-Design-Development

Electro-Chemical Generators of Energy

40-48 Leonard Street WOrth 6-3100
New York 13, N. Y.

Measurements Corporation

Research & Manufacturing Engineers

HARRY W. HOUCK MARTIAL A. HONNELL
G. ROBT. MEZGER

Specialists in the Design and
Development of Electronic Test Instruments
Boonton, New Jersey

Consult

these SPECIALISTS

Let them save your time by bringing
their broad experience in their specialty
to bear on your problems.

THE RIGHT LOCATION for your operation

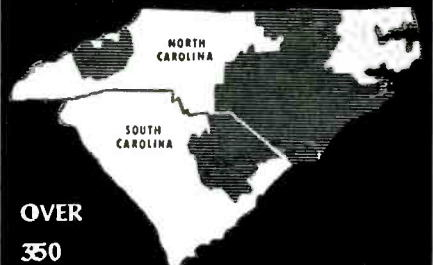

OVER
350

COMMUNITIES TO CHOOSE FROM

(Address
S. P. Vecker, Vice President
Area Development Dept.)

CAROLINA POWER & LIGHT COMPANY

RALEIGH / NORTH CAROLINA



MANUFACTURERS' REPRESENTATIVES

IN THE ELECTRONIC INDUSTRY

As a service to readers, ELECTRON-
ICS presents the advertisements for
some of the leading manufacturers'
representatives in the electronic in-
dustry. These firms are qualified to
help the *Manufacturer* with his dis-
tribution problems; the *Buyer* with
his product needs.

PENNSYLVANIA

SAMUEL K. MACDONALD, INC.

manufacturers representatives over 25 years
1531 SPRUCE STREET, PHILA. 2, PA.

Territory:
Pennsylvania • New Jersey
Delaware • Maryland
Virginia • West Virginia
District of Columbia

Other Offices:
Pittsburgh
Baltimore
Washington, D.C.

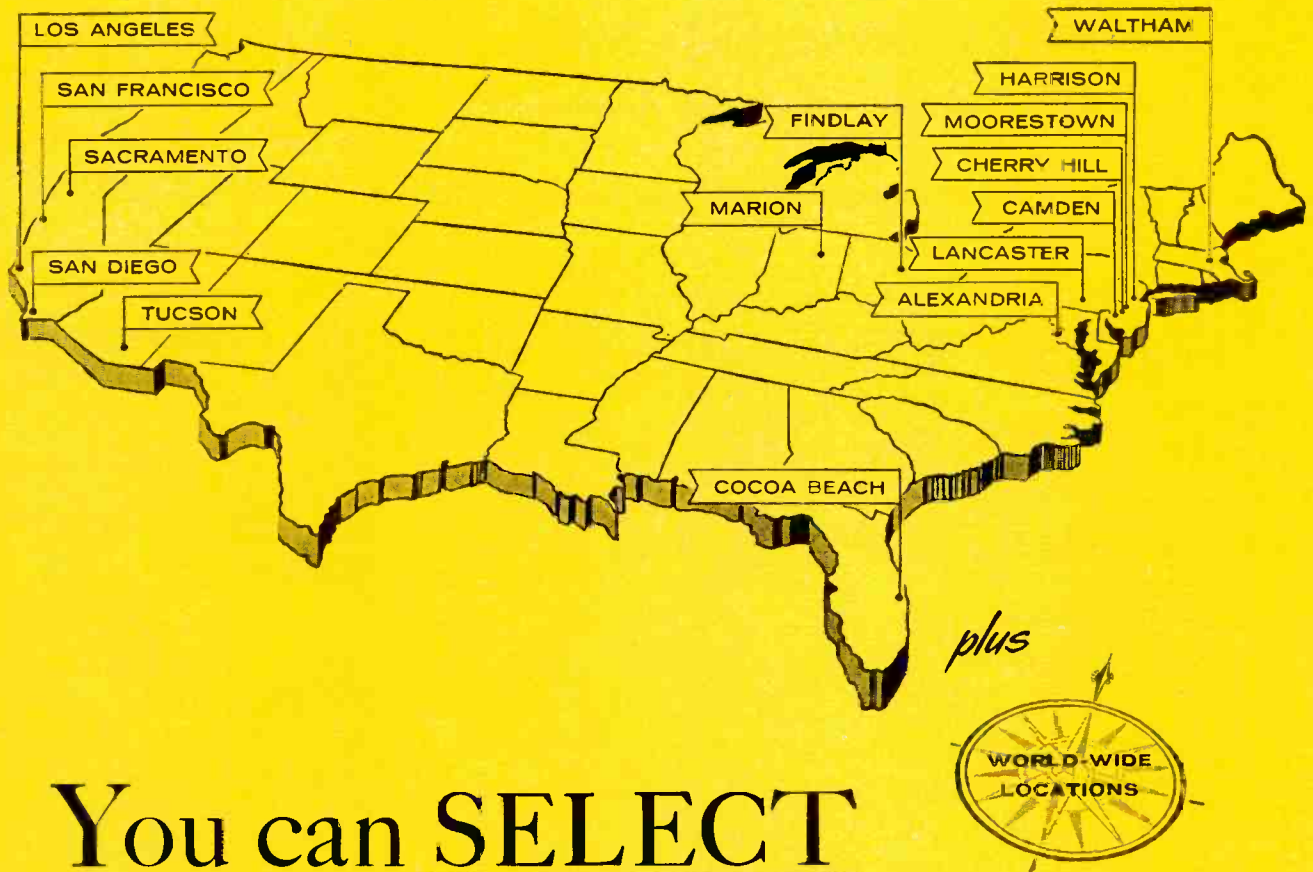

You can SELECT at RCA!

... New Opportunities ... 17 + Locations ... One Best For You And Your Family

Can anyone but RCA offer you a choice of locations like this?

At Camden, Moorestown or Cherry Hill, you enjoy cultural advantages of Greater Philadelphia, live at moderate cost in pleasant suburban communities. Waltham offers at-home opportunities for New England engineers. Four ideal West Coast locations. Harrison borders on Greater New York. Lancaster, Marion and Findlay have small-town advantages. There's pleasant year-round outdoor living in Cocoa Beach, on Florida's central east coast. RCA Service Company and International Division assignments include ideal locations in the United States, and wherever RCA electronic equipments are installed and serviced throughout the world.

Individual Recognition—

RCA organizes engineering activities into groups small enough to allow broadest scope for your individual accomplishment. The average group has just 11 engineers. Yet, in all activities, you are supported by the entire facilities and engineering resources of RCA.

Salaries—

RCA engineering salaries average measurably higher than other companies' in the field. Intermediate engineers, \$5000-\$8500; senior engineers, \$8500-\$15,000; staff and supervisory salaries open.

Advancement—

Scheduled, objective appraisal of your work speeds promotion. Professional and financial progress is just as sure as your achievements make it.

Professional Status—

RCA bases world leadership in electronics on the abilities of exceptional men at every organizational level. Many have notable engineering and scientific reputations. You work in day-by-day association with men of this caliber.

Benefits—

There's a complete program at RCA. A very liberal Tuition Refund Plan. Company-paid life, sickness and accident, hospital-surgical insurance for you and your family. Modern retirement plan. Relocation expenses paid. Suggestion and patent awards.

Now, Pinpoint Your Future

...Here are the Opportunities!
...Here are the Locations!

FIELDS OF ENGINEERING ACTIVITY		MANAGERIAL	TYPE OF DEGREE AND YEARS OF EXPERIENCE PREFERRED															
			Electrical Engineers				Mechanical Engineers			Physical Science			Ceramics Glass Technology Metallurgy					
			0-2	2-3	4-15		0-2	2-3	4-15	1-2	2-3	4-15	1-2	2-3	4-15			
• SYSTEMS (Integration of theory, equipment and environment to create and optimize major electronic concepts.)	AVIATION ELECTRONICS • CONTROLS		W	W	W	C	W	W	W	W	W	W	W	W	C			
	DIGITAL DATA HANDLING DEVICES	M		M	M			C	C			C	C					
	MISSILE ELECTRONICS • RADAR	M	W	M	M	W	M	M	W	W	W	W	W	W	X	X		
	INERTIAL NAVIGATION			W	W		W	W			W	W						
	COMMUNICATIONS			C	C										C	N		
• DESIGN • DEVELOPMENT																		
MISSILE WEAPONS SYSTEMS —Planning and Design—Radar—Fire Control—Servo Mechanisms—Computers		M	M	M	M	M	M	M	M	M	M	M	M	M	M	M		
AVIATION ELECTRONICS —Radar—Computers—Servo Mechanisms—Shock and Vibration—Circuitry—Remote Control—Heat Transfer—Sub-Miniaturization—Automatic Flight—Automation—Transistorization		W	W	W	W	W	W	W	W	W	W	W	W	W	W	W		
RADAR —Circuitry—Antenna Design—Servo Systems—Gear Trains—Intricate Mechanisms—Fire Control—Information Handling—Displays		M	M	M	M	M	M	M	M	M	M	M	M	M	M	M		
COMPUTERS —Systems—Advanced Development—Circuitry—Assembly Design—Mechanisms—Programming—Digital Data Handling Devices			C	C	C	C	C	C	C	C	C	C	C	C	C	C		
KINESCOPES (B & W and Color), OSCILLOSCOPES —Electron Optics—Instrumental Analysis—Solid States (Phosphors, High Temperature Phenomena, Photosensitive Materials and Glass to Metal Sealing)			L	L	L	L	L	L	L	L	L	L	L	L	L	L	L	L
RECEIVING TUBES —Tube Design—Test and Application Engineering—Chemical and Physical Development—Methods and Process Engineering—Advanced Development			H	H	H		H	H		H	H		H	H		H	H	
SEMICONDUCTORS —Transistors—Semiconductor Devices—Materials			V	V	V	V	V	V	V	V	V	V	V	V	V	V	V	V
MICROWAVE TUBES —Tube Development and Manufacture (Traveling Wave—Backward Wave—Magnetron)		M		H	H		H	H		H	H		H	H		H	H	
GAS, POWER AND PHOTO TUBES —Photosensitive Devices—Glass to Metal Sealing—UHF and VHF—Power			L	L	L	L	L	L	L	L	L	L	L	L	L	L	L	
COMMUNICATIONS —Specialized Systems—Microwave—Mobile—Aviation—Audio—Propagation Studies—Acoustics—Transducers			C	C	C		C	C	C	C	C	C	C	C	C	C		
BROADCAST AND TV —Monochrome and Color Studio Equipment—Cameras—Monitor—High Power Transmitters			C	C	C	C	C	C	C	C	C	C	C	C	C	C		
• SYSTEMS APPLICATION (Evaluation and Planning—Design and Development—Modification—Specification)																		
MISSILE TEST INSTRUMENTATION (Data Acquisition and Processing)—Radar—Telemetry—Timing—Communications—Optics—Computers		F	F	F	F	F	F	F	F	F	F	F	F	F	F	F		
RADAR —Airborne—Surface—Shipboard—Sonar—Fire Control		F	F	F	F	F	F	F	F	F	F	F	F	F	F	F		
COMMUNICATIONS —Radio—HF—VHF—UHF—Microwave—Telephone—Teletype—Telegraph Terminal Equipment—Wave Propagation		F	F	F	F	F	F	F	F	F	F	F	F	F	F	F		
• MACHINE DESIGN Mechanical and Electrical—Automatic or Semi-Automatic Machines			L	L		L	L	H	H		L	L						

Locations: C—Camden, N.J. F—Cocoa Beach, Fla. H—Harrison, N.J. I—Clark, N.J. (periodic foreign assignments). L—Lancaster, Pa. M—Moorestown, N.J. N—New York, N.Y. S—RCA Service Co. (Cherry Hill, N.J.; Alexandria, Va.; Tucson, Ariz.; San Diego, Sacramento, San Francisco, Calif., Foreign Assignments). V—Somerville, N.J. W—Waltham, Mass. X—West Los Angeles, Calif. Y—Marion, Ind.

Please send resume of education and experience, with location preferred, to:

Mr. John R. Weld, Employment Manager
Dept. A-15A, Radio Corporation of America
30 Rockefeller Plaza, New York 20, N.Y.



RADIO CORPORATION of AMERICA

Copyright 1956 Radio Corporation of America

EMPLOYMENT OPPORTUNITIES

The Advertisements in this section include all employment opportunities—executive, management, technical, selling, office, skilled, manual, etc.



Positions Vacant
Positions Wanted
Part Time Work

Civil Service Opportunities
Selling Opportunities Wanted
Selling Opportunities Offered

Employment Agencies
Employment Services
Labor Bureaus

DISPLAYED

The advertising rate is \$25.25 per inch for all advertising appearing on other than a contract basis. Contract rates quoted on request.

An advertising inch is measured $\frac{3}{8}$ " vertically on a column—3 columns—30 inches to a page.

Subject to Agency Commission.

---RATES---

\$2.40 per line, minimum 3 lines. To figure advance payment count 5 average words as a line.

Box Numbers—counts as 1 line.

Position Wanted ads are $\frac{1}{2}$ of above rate.

Discount of 10% if full payment is made in advance for 4 consecutive insertions.

Not subject to Agency Commission.

UNDISPLAYED

Send NEW ADS or inquiries to Classified Advertising Division of ELECTRONICS, P. O. Box 12, N. Y. 36, N. Y., for February 1st issue closing January 2nd.

ENGINEERING MANAGER

Top executive position leading to vice president assignment with nationally known company long established in research, development, and manufacture in field of miniature electronics, recording, instrumentation, and related products, both commercial and military.

Variety of projects—large and expanding staff of engineers and technicians—excellent facilities and location.

Requires man of broad engineering background, outstanding technical abilities in electronic field, creative imagination, and successful record of administration and leadership. Age preference 38 to 50. Substantial salary plus participation in company progress.

Give full personal history and complete detail on fields of experience. Replies confidential.

P-3616, Electronics,
520 N. Michigan Ave., Chicago 11, Ill.

opportunities in NEW HAMPSHIRE for a few ambitious, graduate ENGINEERS

Electronics—general
circuit design
Sales—electronics test
equipment

ESTABLISHED mfr. needs competent men who seek challenging broad-gauge work in small but progressive company. No specialists—only well rounded men acceptable.

Northeastern Engineering, Inc.

Manchester, N. H.

EDWARDS

EMPLOYMENT AGENCIES, INC.

EXECUTIVES—ENGINEERS

73 Warren St., N.Y. 17, N.Y. • BA 7-3672

ELECTRONIC AND MECHANICAL ENGINEERS for positions as directors, scientists, physicists, staff, project, departmental heads, designers

for: guided missiles • radar
analog computers • tubes
field engineering • pulse
servomechanism • antennas
communications • packaging
transformers • TV and radio
transistors • audio systems
• instrumentation •
microwave research & development

Discreet service. Hundreds of client companies from coast to coast. Mostly fee-paid positions. Send resumes. Confidential.

REPLIES (Box No.): Address to office nearest you
c/o This publication Classified Adv. Div.

NEW YORK: P. O. Box 12 (36)

CHICAGO: 520 N. Michigan Ave. (11)

SAN FRANCISCO: 68 Post St. (1)

LOS ANGELES: 1125 W. 6th St. (17)

POSITIONS WANTED

Chicago Representative. Electronic engineer, self-employed will serve as branch for mfr. PW-3639, Electronics.

Senior electronics engineer, views with enthusiasm the future of the data processing, computer field, feels insufficiently exploited in present capacity. Experienced digital techniques, transistorized circuitry; MSEE. 34 yrs. old, single, can relocate or travel. Looking for growing company willing to devote equivalent measure of zeal and about \$10,000/yr. to common cause. PW-3643, Electronics.

CHIEF MECHANICAL ENGINEER

\$12,000-\$14,000

Florida. One of the nation's leading manufacturers of electro-mechanical equipment is seeking a Chief Mechanical Development Engineer for its new Florida Division. Company client assumes agency fee and relocation expense. Contact in strict confidence.

28 E Jackson Blvd. Chicago 4, Ill.
MONARCH PERSONNEL

YOUR ORGANIZATION

Is it complete?

Are you expanding it?

Making Replacements?

Naturally, you are anxious to secure the most suitable man or men available. You want men with the special training that will make them an asset to your organization. You can contact such men through an advertisement in this Employment Opportunities Section of ELECTRONICS.

ELECTRONICS

Box 12

New York 36, N. Y.

PARADISE REGAINED

by dahl



For information regarding
Engineering Positions
in the
Microwave and Power Tube Operations
Write D. Hamant

RAYTHEON MANUFACTURING COMPANY

Waltham 54, Massachusetts



Excellence in Electronics

This coupon mailed TODAY

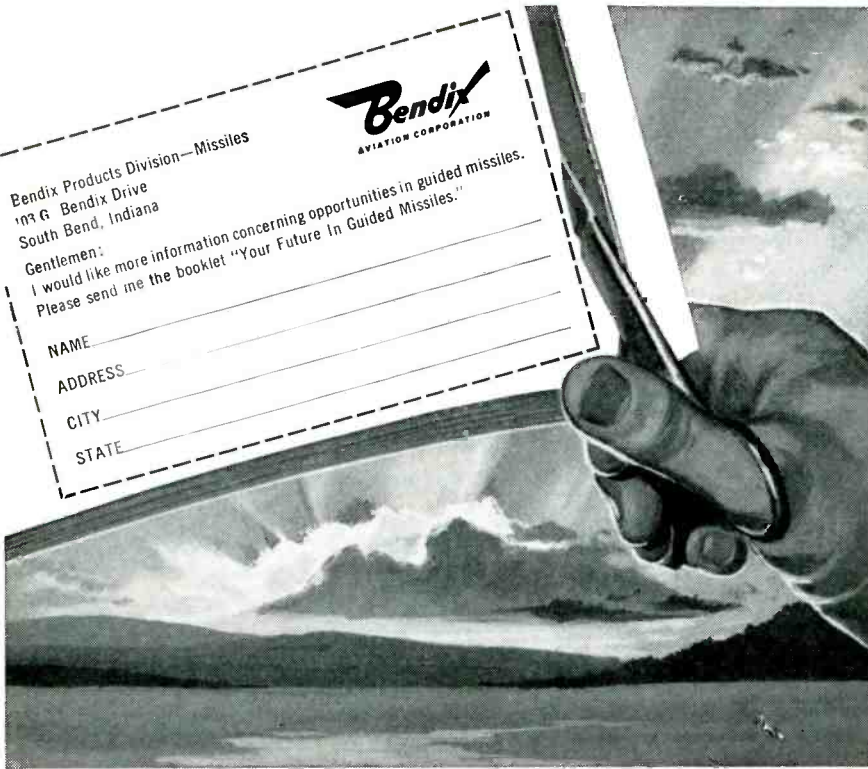

... may bring you a brighter TOMORROW!

There just isn't any question about it—the trained engineer of today has more opportunity than ever before.

However, and this is vitally important, the possibility for individual progress is far greater in certain organizations than in others. That's why every engineer concerned with his future should look into the job opportunities offered in the guided missile field.

Here at Bendix Products Division—Missiles, you can get in on the ground floor of a new, but proven, dynamic business with long-term potentials in the

development, engineering and manufacturing of the nation's most important weapons system. It is truly the business of the future with many commercial as well as military applications.

Then, too, at Bendix Products Division—Missiles, you have all the advancement possibilities of a compact, hard-hitting organization backed by the resources of the entire nation-wide Bendix Aviation Corporation.

So that you may analyze for yourself the various job opportunities and the possibilities of rapid advancement, we have prepared a thirty-six-page book which gives detailed background of the functions of the various engineering groups.

Any ambitious engineer looks forward to a brighter tomorrow. May we suggest that the first step toward this goal is the mailing of the coupon for your copy of "Your Future in Guided Missiles".

**Prime Contractor for
TALOS MISSILE**

ELECTRONIC ENGINEERS

RESEARCH DEVELOPMENT

Expansion of our engineering department requires electronic engineers with radar, servo, sonar or transistor circuit experience. Excellent opportunity for advancement with top-calibre associates. New modern plant in the suburbs with ideal laboratory facilities and well-trained technical assistants.

Other Opportunities in the following areas:

- TECHNICAL WRITERS
- DRAFTING Electrical Layout
- DETAILING Electrical - Mechanical

DESIGN ENGINEERS

Must have EE degree or equivalent, with 3-5 years experience in one of the following:

- Flight Simulators
- Analog Computers
- Radar & Sonar Trainers
- Radar Guidance & Fire Control Systems
- Redesign, Modification & Testing of Radar & Electronic Systems
- Electronic Installation & Maintenance
- Coil & Transformer Design
- Packaged Power Supplies

Other Openings For:

COMMUNICATIONS EQUIPMENT DESIGNERS

COMPUTER DESIGNERS

FIELD ENGINEERS

(*) Must have E.E. degree or equivalent with 5-10 yrs. experience.

*Positions located throughout USA

LOCATION:

On U. S. Highway 22, thirty miles (45 minutes) from New York City.

ENVIRONMENT:

One of the finest plants of its kind . . . spacious, modern, air-conditioned. Conducive to bringing out the best of your abilities!

ABOUT THE COMPANY:

Organized in 1945. Engaged in research, design and development for the Armed Services.

ITS BENEFITS:

- Pension Plan
- Group Life Insurance
- Paid Holidays
- Paid Sick Leave
- Paid Vacations
- Education & Tuition Assistance
- Other Group Insurances

**Interviews in Your
Community by Appointment**

*Send complete resume, write or call
personnel director.*

STAVID Engineering, Inc.

U.S. Highway 22,
Watchung, P.O.
Plainfield, N. J.
Plainfield 7-1600



ENGINEERS

Be certain *you*
MAKE THE RIGHT CHOICE!
HAVE THE RIGHT JOB!



ASK YOURSELF THESE QUESTIONS —IT WILL PAY YOU.

CHALLENGING
 OPPORTUNITIES IN

•
 AVIONICS
 •
 INERTIAL SYSTEMS
 •
 COMPUTERS
 (Digital and Analog)
 •
 MISSILE GUIDANCE
 •
 JET ENGINE
 FUEL CONTROLS

with
 AC ELECTRONICS
 DIVISION
 OF

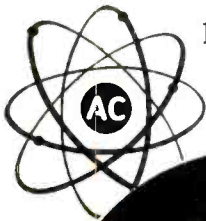

**GENERAL
 MOTORS
 Corporation**

Flint 2, Mich.
 and
 Milwaukee 2, Wis.

Whether a Recent Graduate making his first choice or a veteran Engineer seeking that permanently RIGHT position, ask yourself the following questions:

MY TALENTS ARE BEST SUITED FOR?

Engineers come all sizes, shapes and potentials. G.M.'s policy of decentralization creates individual opportunity for development and advancement.

STARTING WAGE? POTENTIAL EARNINGS?

At G.M. these two questions are best answered by another question—"How high is up?" Earnings both present and future are entirely dependent upon you. At AC you determine your earnings.

PERMANENCY OF POSITION WITH AC?

AC has been designated the official ELECTRONICS DIVISION for all General Motors Divisions. We are permanently dedicated to the research, development and manufacture of things Electronic . . . making America so it's safer and better.

RESEARCH FACILITIES?

At AC you enjoy working with the latest and the finest of equipment and with the top men in the field.

LIVING CONDITIONS?

Are the finest possible in Milwaukee, America's most progressive town combining big town cultural and civic advantages with small town hospitality. "An ideal town for ideal family living."

WHAT CAN AC DO FOR ME?

Write us in strictest confidence . . . you will hear from us by return mail. Send us the coupon below . . . YOUR FUTURE DEPENDS UPON IT.

AC The Electronics Division
 General Motors Corporation, Milwaukee 2, Wis.

Send me full particulars about AC ENGINEERING OPPORTUNITIES

- So you can better "tailor make" your offer to me I have attached a resume of my education and/or work experience.
- I will send it at a later date.

Name _____

Address _____

City _____ Zone _____ State _____

engineers
and
physicists
seeking
stability

... find it at Farnsworth,
the newest electronics division
of International Telephone
and Telegraph Corporation
... the world's most
extensive combined research,
development,
manufacturing and
operating organization in
telecommunications
and electronics.
Combine the advantages of
"large company"
stability and technical
perspective with Farnsworth's
"small company"
flexibility, growth,
and recognition of the individual
and you have
the ideal situation that
warrants investigation.
Your resume
will receive prompt,
confidential attention.

Address:
Technical Employment Director
FARNSWORTH ELECTRONICS COMPANY
FORT WAYNE, INDIANA

Farnsworth

A DIVISION
OF INTERNATIONAL
TELEPHONE AND TELEGRAPH
CORPORATION



A DIVISION OF



ENGINEERS
AND
SCIENTISTS

with degrees in
E.E., M.E., Ch.E. or PHYSICS

Honeywell

BROWN INSTRUMENTS

First in Controls

**LEADS THE WAY IN
A WORLD OF
OPPORTUNITIES**

■ **THE COMPANY**—Judging a company on its past performance constitutes sound logical thinking. Looking over BROWN INSTRUMENTS record of accomplishment tells a reassuring story of continuous growth during nearly a century of pioneering in the industrial instruments and control field.

■ **ASSIGNMENTS**—Diversified . . . permanent, non-routine, in the newest scientific field of NUCLEAR INSTRUMENTATION and AUTOMATION. The bulk of our work is for industrial use.

■ **COMPENSATION**—Rewarding . . . salaries are competitive with those offered in other industries. Our benefits include free group health insurance, hospitalization and surgical benefits, as well as an excellent retirement plan. Relocation assistance.

■ **GROWTH**—Unlimited . . . your performance and salary is re-evaluated twice yearly. Our policy to promote from within is responsible for present management.

■ **EDUCATION**—Excellent . . . financial assistance for those desirous of furthering their education at one of several renowned Philadelphia colleges or universities.

Men with the vision to create and the will to act can find an abundant outlet for their creative talent in either RESEARCH, DESIGN and DEVELOPMENT APPLICATION or SYSTEMS ENGINEERING. Whatever the choice, you and only you will be able to control and measure your progress with this company which leads the way in a world of opportunities . . .

Write to D. R. GARVEY
Manager Employment,
Dept. E

Honeywell

BROWN INSTRUMENTS DIV.

Wayne & Windrim Aves.
Philadelphia 44, Pa.

FORMATION D'EAU OXYGÉNÉE PAR ACTION
DES RAYONS GAMMA SUR DES SOLUTIONS AQUEUSES
 $^{16}\text{O} \ ^{18}\text{O} - \text{H}_2 \ ^{16}\text{O}$

QUANTUM THEORY OF LINE BROADENING
BY AN IONIC PLASMA

Reduction of NaI Background

Discontinuous Servo for Control of Power Reactors

THE PLASTIC DEFORMATION OF URANIUM
ON THERMAL CYCLING

**Deformation Mechanisms of
Alpha-Uranium Single Crystals**

FACTORS IN THE RADIOSENSITIVITY OF MAMMALIAN CELLS

Fission Product Kilocurie Source:
Preparation, Radiation Intensity

On the Consequences of
the Possible Existence
of the Hyperdeuteron

**Allotropic Transformations
In Titanium, Zirconium,
and Uranium Alloys**

Using Intermediate Experiments
for Reactor Nuclear Design

Spontaneous Fission Systematics

THE QUANTITATIVE DETERMINATION OF
GAMMA-RAY EMITTING ELEMENTS
IN LIVING PERSONS

A Preliminary Study
of Superheating
Boiling Reactors

Ionization of Air by Beta Rays
from Point Sources

Mechanical Master-
Slave Manipulator

**Chromatography and
Electrochromatography**

Continual Injection into
Circular Ion Accelerators

Organic Coolant-Moderators
for Power Reactors

Recoil Type Neutron Spectrometer for 0.05 to 1 Mev

Gaseous Scintillation Counting Consistent Biochemical Pattern
in Malignant Tumors

**Einige neue Beobachtungen
an photochemisch verfarbten Lithiumfluorid.**

SURVEY OF SEPARATION PROCESSES
FOR IRRADIATED FUELS Nuclear Reactor Control

**Thermodynamic Properties
of Liquid He^3 between 0.23° and 2° K.**

The Condensed System Bromide Trifluoride-
Antimony Pentafluoride

Theories of the Earth's Magnetism

Radiation as a Carcinogenic Agent

(SOME RECENT PUBLICATIONS)

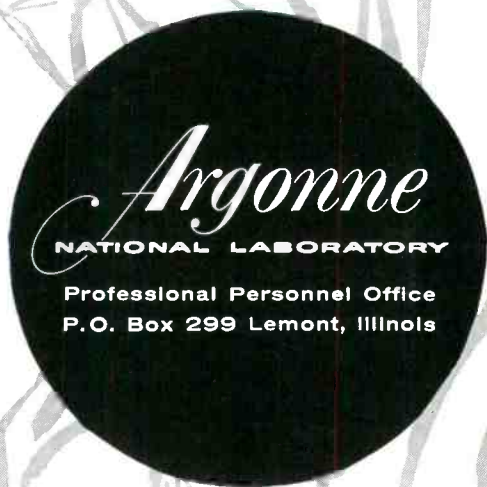
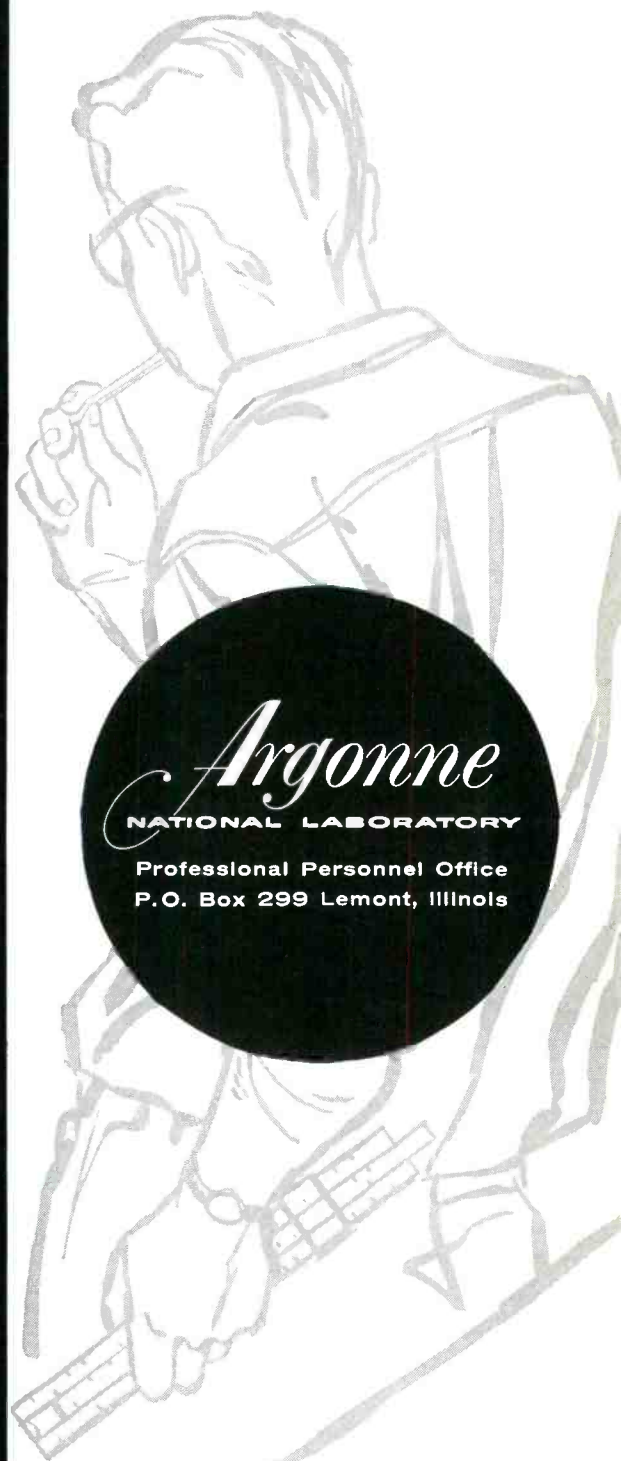

Argonne
NATIONAL LABORATORY

Professional Personnel Office
P.O. Box 299 Lemont, Illinois

INQUIRIES INVITED

MATHEMATICIANS
PHYSICISTS
CHEMISTS
METALLURGISTS
CHEMICAL ENGINEERS
METALLURGICAL ENGINEERS
MECHANICAL ENGINEERS
ELECTRICAL ENGINEERS
PHYSICIANS

Engineering for Tomorrow...

... at Convair-Pomona the country's first exclusive guided missile plant. Here in the heart of America's tremendously fast growing Electronics industry, we at Convair are engineering for tomorrow today! The engineering miracles now being developed for America's defense in the design and manufacture of guided missiles is the groundwork for the fantastic future in store for America tomorrow through electronic engineering. Join the Convair team now, work in America's finest engineering facility. Completely modern... Completely air conditioned.

*Excellent opportunities
now available in:*

- ELECTRONICS**
- AERODYNAMICS**
- DYNAMICS**
- THERMODYNAMICS**
- OPERATIONS RESEARCH**
- HYDRAULICS**
- MECHANICAL DESIGN**
- LABORATORY TEST**
- ENGINEERING**

Generous travel allowance to Engineers who are accepted. Write now enclosing a complete resume to:

Employment Department 3-G

CONVAIR

A DIVISION OF
GENERAL DYNAMICS
CORPORATION

POMONA
CALIFORNIA

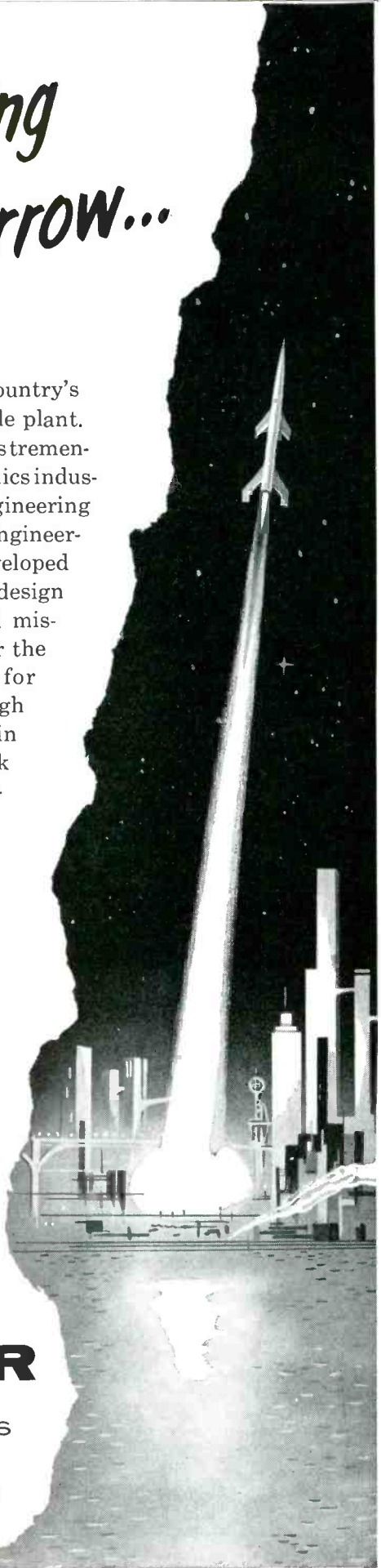

Something
of
highly unusual
interest
is happening
in
**COMMERCIAL
ADVANCED
DEVELOPMENT
ENGINEERING**
Up to \$15,000

To build a commercial advanced development section, we offer extremely interesting positions to creative engineers and physicists. Diversified work in industrial controls, scientific and electronic instruments, bandwidth compression, computers, applied physics, new communication systems. We can fit your special interests. Senior and Junior engineers are needed.

Join the imaginative, creative men already probing deeply into this field with an electronics pioneer and leader!

***To arrange confidential
interview, send resume to**

P-3776, Electronics,
Class. Adv. Div. P.O. Box 12, N.Y. 36, N.Y.

GETTING NOWHERE ?
.....



**RAYTHEON
FIELD ENGINEERING
HAS A FUTURE!**

Ready to go ahead? Field engineering at Raytheon is an open door to advancement. We recognize ability just as quickly as seniority. Many of our executives were formerly field engineers. And Raytheon's Field Engineering Section is continually expanding to meet the need for laboratory and field support of new electronic equipment.

Engineers with suitable experience are assigned highly responsible project engineering positions. In this capacity they provide liaison with company engineering laboratories and our military and industrial customers.

Our primary interest is in men who have field experience and a degree in Electrical Engineering. However, an extensive electronics background, which includes applicable missile, radar or sonar experience, will be given full consideration. We also have a few positions for men familiar with mechanical and hydraulic technics.

Your future at Raytheon includes attractive salaries — regularly reviewed for merit increases; assistance in relocating; life and accident insurance; company-sponsored educational opportunities—other benefits and allowances. Write to E. K. Doherr for information.

Excellence in Electronics



RAYTHEON MANUFACTURING COMPANY

Government Service Department

100 River Street, Waltham 54, Massachusetts

Mr. ENGINEER
Why Not Consider
FIELD ENGINEERING

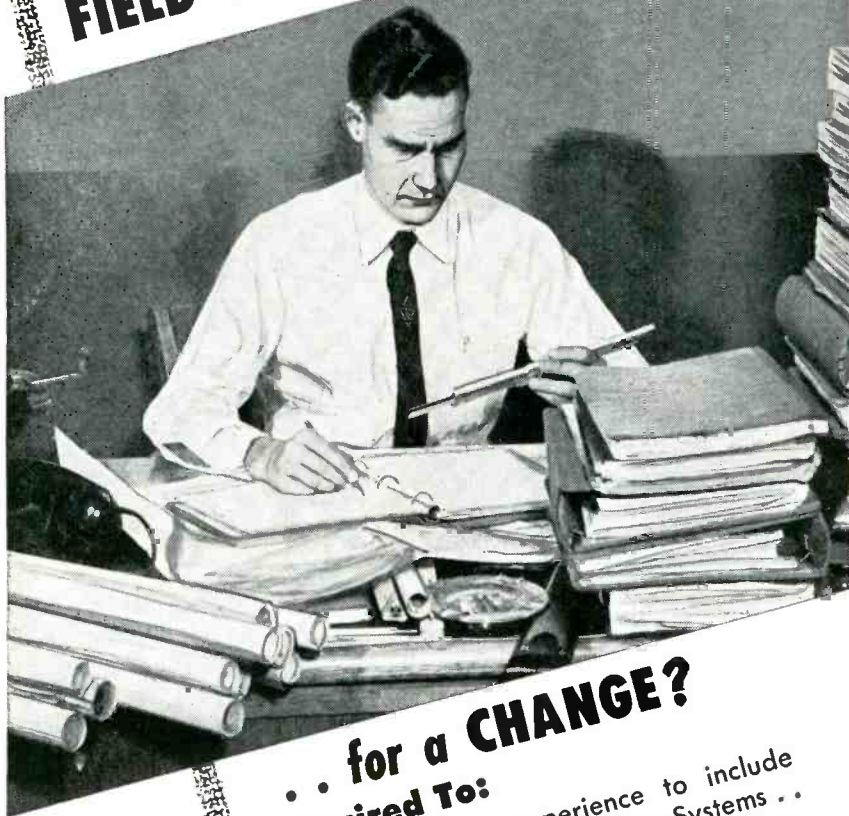

Have YOU Ever Desired To:

- **EXPAND** your experience to include World Wide Communications Systems . .
- **BECOME** fully experienced in the world's most advanced electronic systems and equipment . .
- **ENJOY** the freedom of locating anywhere in the world . .
- **INCREASE** your earning potential and provide greater security for your family . .

• If you find yourself answering yes to any of these questions, let us send you our new, full color, illustrated employment brochure which explains the challenge as well as the positions now open for PHILCO Field Engineers. Write NOW . . . get the facts on . . .

"PHILCO . . . First IN EMPLOYMENT OPPORTUNITIES"

PHILCO TECHREP DIVISION

DEPT. 19, 22nd & Lehigh Avenue,
 Philadelphia, Pa.

ENGINEERS

PARTS APPLICATION

(Reliability)

ME or EE degree with design experience and/or application experience. Job will be to recommend types of parts to be used and how these parts shall be used.

Qualified men will become a vital part of a Reliability Group.

GM

INERTIAL GUIDANCE SYSTEM PROGRAM

• ELECTRONICS DIV.,

Milwaukee 2, Wis.
 Flint 2, Mich.

Enjoy Challenging Opportunities in the most versatile Laboratories in the country. Work with the top men in the field and with the finest test, research and development facilities. We are in the process of a Major, Permanent, Expansion Program. New Plant facilities being added in suburban Milwaukee area.

To aid you in your professional advancement AC will provide financial assistance toward your Master's degree. A Graduate Program is available evenings at the University of Wisconsin, Milwaukee.

GM's Electronics Division aggressive position in the field of manufacture and GM's long-standing policy of decentralization creates individual opportunity and recognition for each Engineer hired.

Recent EE,ME Graduate Inquiries Also Invited

Milwaukee offers ideal family living in a progressive neighborly community in cool, southern Wisconsin where swimming, boating, big league baseball and every shopping and cultural advantage is yours for the taking.

To arrange personal, confidential interview in your locality send full facts about yourself today to

Mr. John F. Heffinger
 Supervisor of Technical Employment

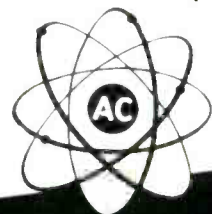

Electronics Div.
General Motors Corp.
 FLINT 2, MICHIGAN
 MILWAUKEE 2, WISCONSIN

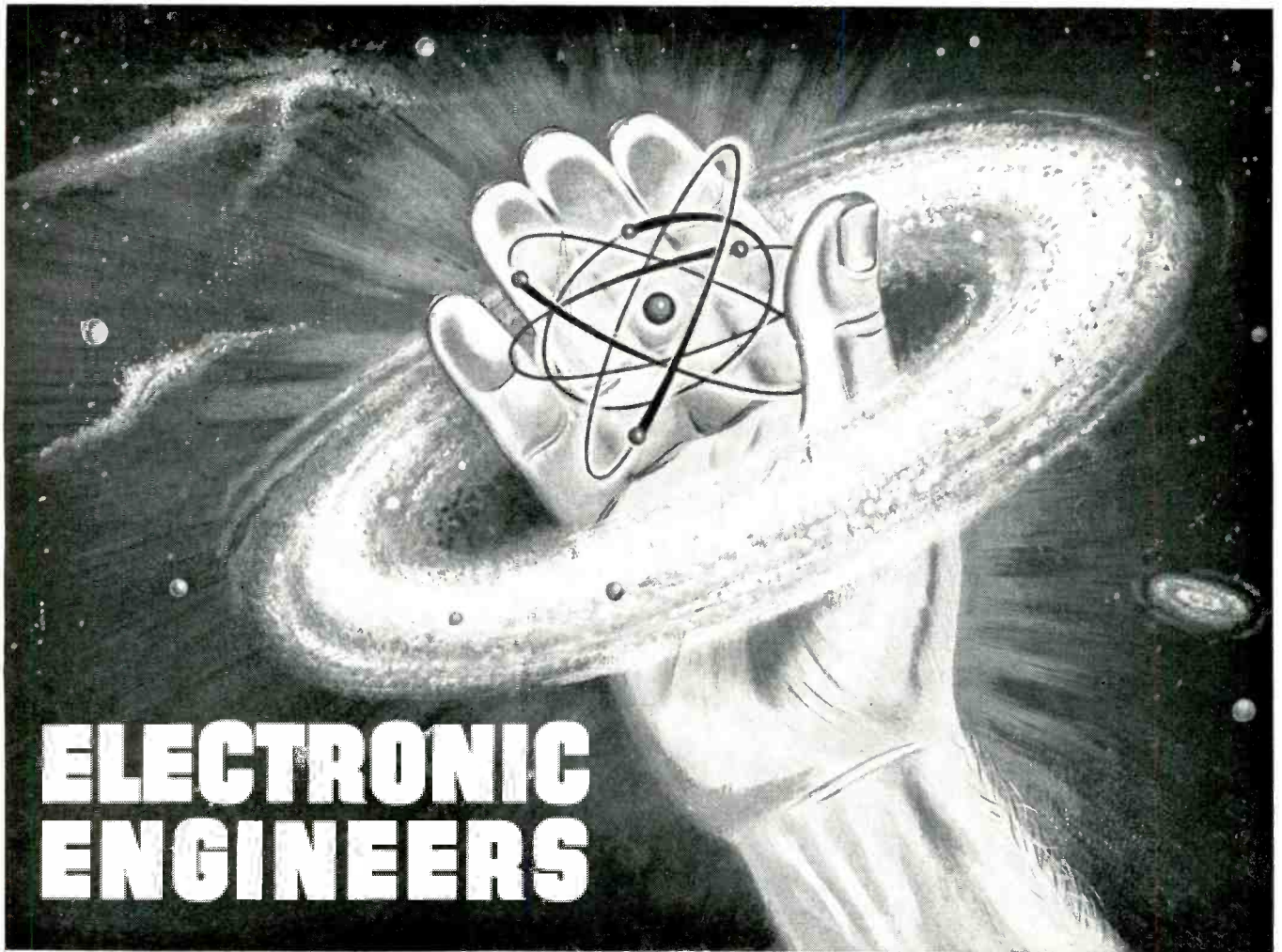

True professional accomplishment within your grasp!

Everything and everyone at Bendix Radio is attuned to the task of producing significant accomplishments in the field of advanced electronics. We have the vision of leading, creative engineers. We have the skilled sub-professional people who are resolute in their dedication to the job of producing the BEST. We have the most modern facilities and equipment to encourage an engineer's finest efforts. We have company policies which recognize to the fullest extent the professional aspects of the engineer's career. At Bendix Radio, engineers are kept well-informed as to the status of company work and project developments.

As a Bendix Radio engineer, you will receive an excellent salary, periodic merit reviews and complete company benefits—including assistance in graduate education. You will live the good life with many cultural and recreational advantages in a beautiful suburban area amidst friendly people.

We invite you to set your goals high and to move upward toward their accomplishment *fast* at Bendix Radio. Act now!

Simply drop us a postal card briefly stating your education and experience. We'll act fast . . . and confidentially!

THERE ARE OPENINGS WITH BENDIX RADIO TO WORK IN THESE FIELDS:

- MISSILE GUIDANCE & TRACKING SYSTEMS
- RADAR WARNING SYSTEMS
- MILITARY ELECTRONICS RESEARCH & DEVELOPMENT
- AUTOMOTIVE ELECTRONIC RESEARCH
- AIRBORNE ELECTRONICS SYSTEMS
- MOBILE COMMUNICATIONS SYSTEMS

ADDRESS: Employment Supervisor, Dept. J-1



Bendix

DIVISION OF BENDIX AVIATION CORP., BALTIMORE 4, MD.

Radio

ENGINEERS...PHYSICISTS NEW opportunities at MOTOROLA

YOUR CHOICE OF 3 LOCATIONS

New Motorola research laboratories are expanding, creating outstanding career advantages—your opportunity to get in on the ground floor of a swiftly expanding company. You'll enjoy working in these modern laboratories . . . with liberal employee benefits, including an attractive profit sharing plan. Salary levels are open and commensurate with ability.

POSITIONS AVAILABLE IN: two-way communications • missile electronics • radio & TV (color) • weapons systems • computer application & design • transistor research & production • microwave systems • servo-mechanisms • physical chemistry • metallurgical eng. • field eng. • electronic sales eng. • drafting, design, & layout • aerophysics • radar & military electronics

PHOENIX, ARIZONA



Outdoor, relaxed living the year-round, with lots of room to grow (on the job and off) in this land of sunshine.

RESEARCH LABORATORY

write to: Mr. R. Coulter, Dept. A 3102 N. 56th St., Phoenix, Ariz.

SEMI-CONDUCTOR LABORATORY

write to: Mr. V. Sorenson, Dept. A
5005 E. McDowell Rd., Phoenix, Ariz.

RIVERSIDE, CALIFORNIA



Planned communities, modern shopping centers, advanced schools, fine buys in homes. There's room to grow and more fun in Riverside.

write to: Mr. C. Koziol, Dept. A Box 2072, Riverside, Calif.

CHICAGO, ILLINOIS

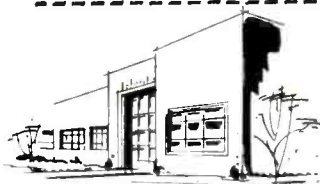

Live a relaxed midwest life in one of the beautiful suburbs, yet have all the "big city" advantages—cultural, social, and educational.

write to: Mr. L. B. Wrenn, Dept. A
4501 Augusta Blvd., Chicago, Ill.



MOTOROLA

ELECTRONIC ENGINEERS!

HERE'S THE OPPORTUNITY OF YOUR LIFETIME!

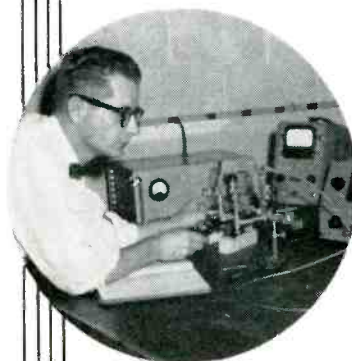

For Just Three Cents!



That's right! The stamp on your letter asking for more information about MEMCO opens the door of opportunity . . .

- to use your creative engineering talents.
- to work on all phases of your projects.
- to be appreciated as an engineer, not as a replaceable cog in a big machine.
- to get top pay and many benefits.
- to build a sound, worthwhile future.

So, if you are tied up in red tape . . . if the scope of your work is limited . . . if you can't use your creative engineering talents . . . then MEMCO offers you a welcome escape from stagnation and monotony.

For full details please write to:
Mr. J. E. Richardson,
Personnel Director

MARYLAND ELECTRONIC

MANUFACTURING CORPORATION
5009 Colvert Road
College Park, Maryland
(A suburb of Washington, D. C.)

biggest
opportunities
in
electronics
today...

MICROWAVE ENGINEERS

NEW OPPORTUNITIES

—at Sylvania's
Electronics Division

A new plant at Williamsport, Pa.—
just opened, and offering
ground-floor opportunities
in advanced electronics.

A new wing at Woburn, Mass.—
to be added soon to the
already-extensive facilities
of this division.

These are only two examples of
expansion at Sylvania in the field
of electronics. As we continue
to branch out in new directions
— we offer more and more
opportunities for talented engineers
to join a dynamic, forward-looking
company, an acknowledged leader
in a growing young industry.

IMMEDIATE OPENINGS FOR ABLE MEN AT ALL LEVELS

... If you have a pioneering type
of mind, and if you can picture
yourself as an integral part of the
group of top-calibre engineers
now working on backward
wave magnetrons... we'd like
to hear from you.

Fill out the coupon below
for immediate action:

R & D PROJECTS ON BACKWARD WAVE MAGNETRONS AT SYLVANIA

Right now, after more than 2½ years of research and
development, Sylvania engineers are moving into the
application stage on the amazing backward wave
magnetrons.

Combining the high power capabilities of magnetrons
with voltage tunability of traveling wave oscillators —
these present power-producing components with
tremendous potential. The immediate outlook in the
countermeasures field is very bright, far exceeding
present capacity to manufacture. And as for the
long-range picture — with increasing knowledge
we can expect these new tubes to strongly affect
the magnetron market.

More professional men are needed at Sylvania to
carry on this highly advanced work, to help solve
problems involving:

- a. Crossed field electron optics to design guns
giving proper high power beams and to give insight
into interaction mechanism.
- b. Precision methods of assembly of extremely
complex devices.
- c. High voltage design. Voltages involved are
comparable to magnetron voltages but must be
capable of being applied continuously — thus problem
in order of magnitude is more severe than in magnetron.

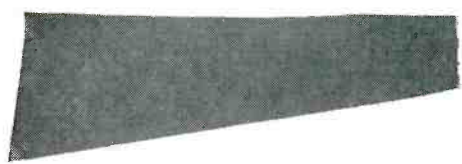

Mr. Roland W. Coates
Sylvania Electric Products Inc.
Electronics Division
100 Sylvan Road, Woburn, Mass.

Name _____

Age _____ Degree _____ Degree Date _____

Address _____

Interest in: RESEARCH DEVELOPMENT PRODUCTION

Years related experience _____ Years total experience _____

Types of products _____ salary expected _____

Resume enclosed YES NO

BURROUGHS RESEARCH CENTER NEEDS *Good* ENGINEERS

Engineers WHO WANT AN IVORY TOWER

We don't specialize in real ivory towers, but we do take pride in giving GOOD engineers a place to dream.

At the Burroughs Research Center, the creative engineer is given full reign in utilizing his initiative, abilities and other talents. He is encouraged to try out his own ideas and to develop new ones because, here at Burroughs where research is king, ideas are an important product.

And, a man in an 'ivory tower' needs lots of peace and quiet to do his best work . . . that's why our Research Center has been conveniently located in a beautiful suburban area so our engineers can work, live and enjoy their leisure time with their families in the relaxed aura of suburban community life far from the clatter and clang of the city.

If you're looking for our type of 'ivory tower', plus good pay and a top-flight benefit program, why not look into the Burroughs story today?

Inquiries are invited from those qualified as

- ELECTRICAL ENGINEERS
- ELECTROMECHANICAL ENGINEERS
- PHYSICISTS • MATHEMATICIANS
- MECHANICAL DESIGN ENGINEERS
- MECHANICAL ENGINEERS



Write or Telephone

M. E. JENKINS, PLACEMENT MANAGER • PAOLI 4700

For Interview at Your Convenience

BURROUGHS CORPORATION
Research Center

PAOLI, PA. • On Philadelphia's Main Line Near Historic Valley Forge

ARIZONA

Famous for its Climate
and for Western Living

GOODYEAR AIRCRAFT CORPORATION

ELECTRONIC LABORATORY

Arizona Division
Litchfield Park, Arizona

Modern schools.

Outdoor recreation the year 'round.

This modern laboratory is the Western Division of the well-established Aerophysics Department of the Goodyear Aircraft Corporation of Akron, Ohio.

A Subsidiary of the
GOODYEAR TIRE & RUBBER CO

INTERVIEWS IN EASTERN AND MID WESTERN CITIES ARE NOW BEING ARRANGED FOR EARLY JANUARY. WESTERN INTERVIEWS WILL BE ARRANGED THE LATTER PART OF THE MONTH.

OPENINGS AT ALL LEVELS OF EXPERIENCE IN THE BRANCHES OF ENGINEERING LISTED BELOW AND OTHER RELATED FIELDS.

Complete Missile and Electronic Systems
Microwaves, Servomechanisms,
Radars and Stabilized Antennas
Transistor Application, Electronic Packaging,
Electronic Ground Support Equipment

Long range research and
development projects

University of Arizona graduate studies available under the Goodyear Fellowship Program, or company financed evening courses.

WESTERN LIVING AT ITS BEST
"IN THE VALLEY OF THE SUN"

Modern Inexpensive Housing

Send resume to: A. E. Manning

Engineering and Scientific Personnel

GOODYEAR AIRCRAFT

LITCHFIELD PARK
PHOENIX, ARIZONA

Similar opportunities available in our
Akron, Ohio Laboratory



A NEW FRONTIER FOR TECHNICIANS

RCA offers an opportunity for you to apply your technical skill to its Missile Test Project at Patrick Air Force Base, Florida—"Launching Site of the Satellite."

Here at the world's longest missile testing range, extending from Florida far across the South Atlantic, you can enjoy improved status with the recognized leader in Electronics. Unprecedented growth opportunities are offered in various phases of data acquisition, transmission and processing, including Radar—Communications—Optics—Computers—Timing—Telemetry.

At RCA's Missile Test Project you will enjoy technical advancement

combined with famous Florida living. Your family will appreciate the ideal climate—allowing year 'round outdoor activities—and pleasant social surroundings.

Immediate assignments are available in Florida, the Bahama Islands, and aboard tracking ships in the South Atlantic. Attractive home leave policy and salary differential make the Bahama Islands and tracking ship assignments especially attractive for single men.

Let the Missile Test Project become *your* symbol of the future. Join in our assault on the frontier of space!

For complete information about this new and challenging field, write to:

Personnel Manager, Dept. N-10A
RCA Service Company, Inc.
Missile Test Project
P. O. Box 1226
Melbourne, Florida



RADIO CORPORATION of AMERICA

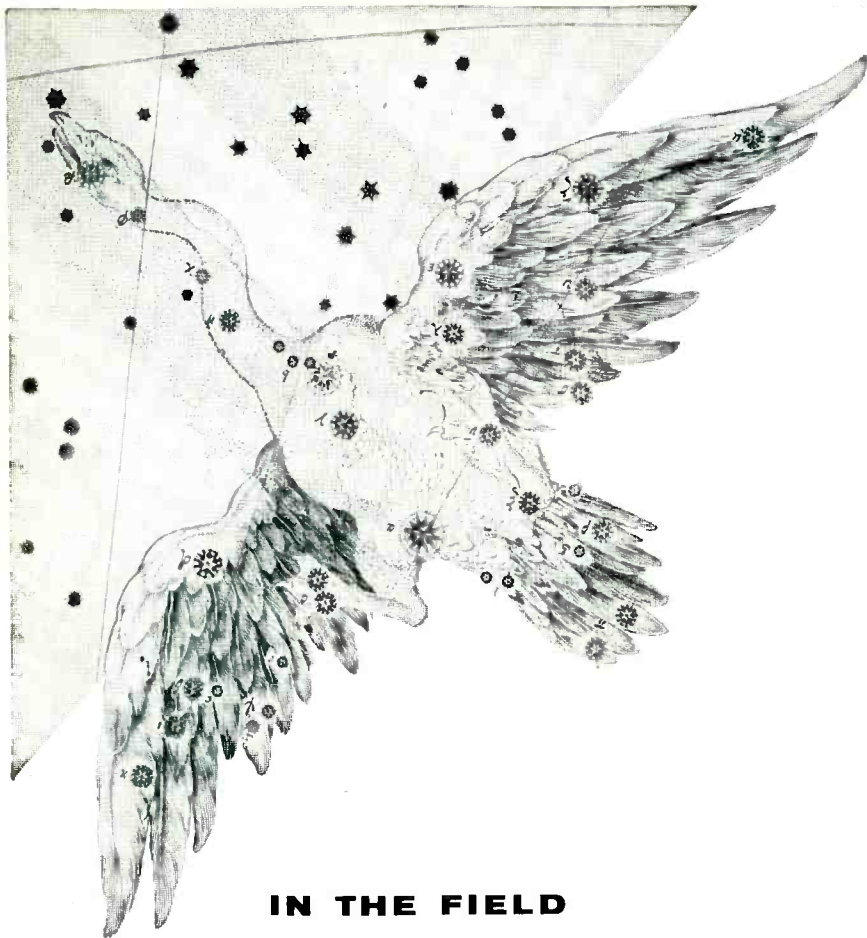

**IN THE FIELD
OF ELECTRONICS
THE GOOSE HANGS HIGH!**

In the development of guidance and telemetering systems for the research vehicles of outer space, the challenge is great and the ceiling is infinity.

Today, Martin has more exciting opportunities to offer the electronics engineer than any other company in the world of flight systems development.

From the Martin P6M to the VANGUARD series of satellite launching vehicles to the first Moon rocket (already beyond the talking stage), the goose hangs high.

If you're "hunting," contact J. M. Hollyday, Dept. E-1, The Glenn L. Martin Company, Baltimore 3, Maryland.



Admiral.
has a future for
Engineers—Physicists in
**NUCLEAR RADIATION
DAMAGE CONTROL**

SENIOR PHYSICIST

Ph.D. with nuclear engineering background, to evaluate nuclear radiation damage to electronic components, to develop techniques in radiation instrumentation and to develop methods and materials suitable for use in components subjected to high level nuclear environments. Work involves experimentation with reactors and multikilocurie cobalt source.

NUCLEAR INSTRUMENTATION

Engineer familiar with Geiger counters and ionization chamber radiac instruments, to assist group leader in developing contract and proprietary items in the nuclear instrument field.

Career-minded men with several years specialized experience are invited to join our rapidly expanding program. Current openings offer excellent income and employee benefits including retirement plan, paid group insurance and college tuition refund plan plus ideal working conditions. On-the-job training for junior and intermediate engineers.

If you are qualified in either of these fields, explore *your* opportunity with Admiral today. Write Mr. Walter Wecker, Personnel Manager.

Admiral Corporation

3800 W. Cortland Street
Chicago 47, Illinois

STRAIGHT TALK

About an

ENGINEERING CAREER

at

OTIS ELECTRONIC DIVISION

The full resources of the century-old Otis Elevator Company are available for expansion of its new Electronic Division.

Under prime contract, this division is conducting basic development work in the most advanced areas of bombing navigation systems, radar systems and missile launching test equipment. Current openings are for engineers with knowledge of servomechanisms, analog computers, digital techniques, sweep circuits, or pulse techniques.

Otis' Electronic Division expects to explore commercial applications in the future . . . assuring job stability as well as a full measure of liberal benefits for which Otis is well known.

Send resumes to
WILLIAM B. DeFRANCIS
for confidential interview.

ELECTRONIC DIVISION



OTIS ELEVATOR Co.

35 Ryerson St.,
Brooklyn 5, N. Y.

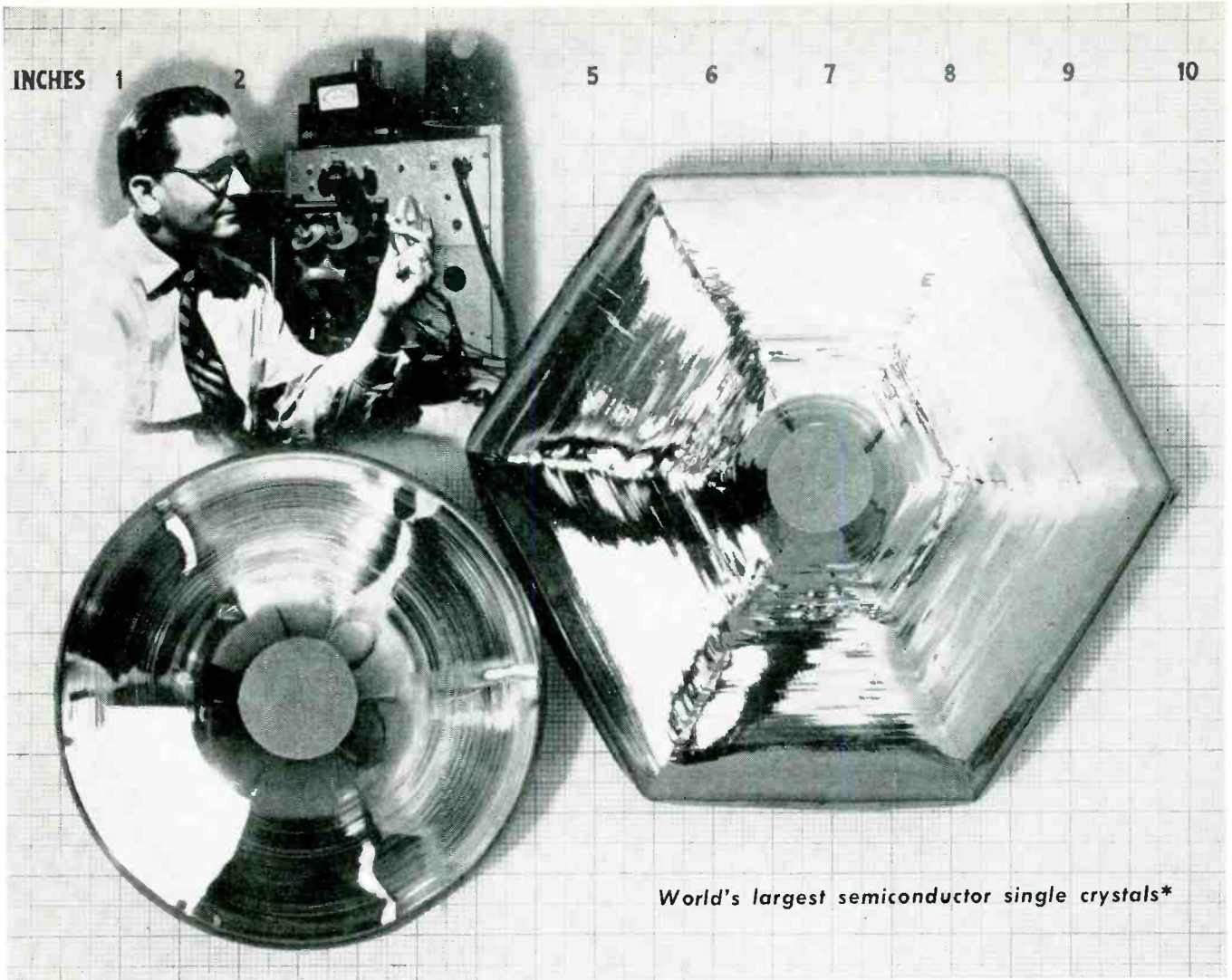

*World's largest semiconductor single crystals**

ENGINEERS / PHYSICISTS

You are invited to join one of these expanding programs at Texas Instruments — where recognition of individual achievement has contributed to its fifteenfold growth in the last ten years. Advanced personnel policies include company-sponsored educational assistance, profit sharing, insurance and pension plans.

The TI plant is within Dallas, yet away from downtown traffic... within 5 minutes of fine residential areas, churches, and public and private schools. Your home will be within 15 minutes of year-around recreational, amusement, and cultural facilities.

* Produced in connection with the many investigations into solid state physics and electrical phenomena being carried on by Texas Instruments Incorporated... leading manufacturer of semiconductor products... 26-year-old pioneer and leading supplier of geophysical exploration services... currently engaged in design, development, and manufacture of electronic components, instruments, optics, and military apparatus — at a \$44 million volume.

SEMICONDUCTOR DEVICES AND OTHER COMPONENTS

transistors • transistor circuits
diodes • rectifiers
transformers • resistors
panel meters
test equipment

Address
SEMICONDUCTOR-COMPONENTS
replies to:
Mr. William C. Spaller

ELECTRONIC AND ELECTRO-MECHANICAL APPARATUS

radar • sonar • infrared
navigation • magnetics
telemetering
communications
computers

Address
APPARATUS replies to:
Mr. Robert E. Houston



TEXAS INSTRUMENTS
INCORPORATED

6000 LEMMON AVENUE DALLAS 9, TEXAS

electronic engineers

SENIOR and JUNIOR

Continued Expansion
Opens Up New Opportunities with



Greenwich, Connecticut

Excellent positions are available with the General Engineering Laboratories of American Machine & Foundry Company, a recognized leader in the design, development and manufacture of atomic, electronic and mechanical equipment for the consumer, industry and defense.

If you qualify in any of the fields listed below, investigate these opportunities now:

- High power radar system development
- Tropospheric scatter systems
- Microwave theory & component design
- Electronic packaging
- Missile control and handling systems
- Antenna design
- Electronic countermeasures
- Telemetry
- Data handling
- Circuit theory
- Navigation systems
- Instruments

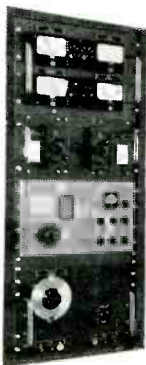

Good opportunities for advancement through advanced education on the premises as well as at nearby graduate schools in addition to a liberal tuition reimbursement plan, excellent employee benefits and an ideal location in Connecticut, surrounded by fine suburban communities. Relocation expenses paid.

Advanced electronic equipment recently designed by **AMF**

Please send your resume to Mr. J. F. Weigandt
OR for additional technical information,
contact Mr. D. R. Barker or Mr. H. R. Holloway
NOrmandy 1-7400

General Engineering Laboratories
American Machine & Foundry Company

Fawcett Bldg. • Fawcett Place
Greenwich, Connecticut

Electronic Engineers
Mechanical Engineers
Advancement... Security
... Responsibility

Professional personnel needed at all levels to fill responsible openings at this steadily expanding Division of Bendix Aviation Corporation. It's your chance to get specific assignments at the peak of the art in ELECTRONICS and MICRO-WAVE DEVELOPMENT and DESIGN. Good salaries, all employee benefits, ideal suburban living conditions. Whether you be a Department Chief or a Junior Engineer with less than one year's experience, we have the opening and the shoes for you to fill.

Address: Chief Engineer Dept. H

Bendix
AVIATION CORPORATION
York
DIVISION
York, Penna. York 47-2611

electronic
research engineers

for **SYLVANIA'S**
APPLIED RESEARCH LABORATORY

If you are an electronic research engineer qualified to assume major project responsibility, there are excellent opportunities at Sylvania's new Applied Research Laboratory. We are presently forming groups to carry out theoretical and experimental research to establish system requirements for future aircraft ECM systems and airborne radars; devise and evaluate counter-countermeasures techniques; study low altitude clutter rejection problems; and investigate passive detection system requirements. If your interest is in one of these fields, you will find stimulating associates and unlimited opportunities to contribute and gain recognition at Sylvania.

For further information send resume to:
Dr. L. S. Sheingold, Manager
APPLIED RESEARCH LABORATORY



Waltham Laboratories
100-J5 First Avenue
Waltham, Massachusetts

ENGINEERS-SCIENTISTS: ANNOUNCING A VAST PROGRAM IN MISSILES RESEARCH AND DEVELOPMENT IN PHILADELPHIA WITH MANY ATTRACTIVE PROFESSIONAL OPPORTUNITIES

The Missile & Ordnance Systems Department of General Electric

Where We Are...

In PHILADELPHIA near 30th St. PRR Station...until our new 110 acre facilities are ready in Valley Forge—17 miles by Schuylkill Expressway from Downtown Philadelphia.

What We're Doing...

A PRIME CONTRACTOR—developing the ICBM and IRBM Nose Cones complete with nuclear arming and fuzing devices, gyros, accelerometers, resolvers, induction generators, amplifiers, servos. This G-E Department is the center of company-wide studies in viscosity, diffusion, thermal conductivity, radiation, laminar and turbulent shock layers, etc., for a vast missile system program.

How We're Doing It...

The Department's primary objective is to create the country's TOP TEAM on Guided Missile Research and Development and with this team assume FULL MISSILE SYSTEM RESPONSIBILITY for the entire General Electric Company. This will involve making use of the tremendous potential in the company's more

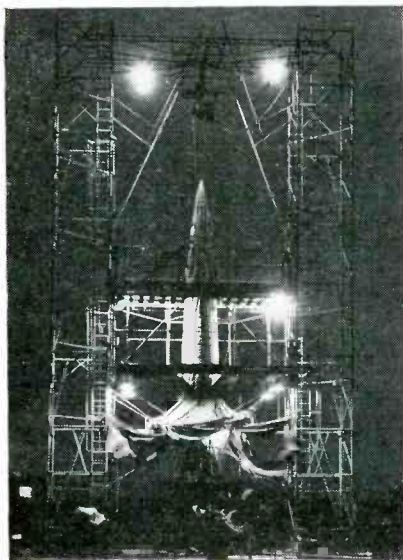

ZERO minus 4 hours! A G-E test missile, still shrouded in the early morning dampness before launching, represents more than a decade of research and development.

than 100 operating departments and its many research laboratories.

Where We're Headed...

INTO EVERY PHASE OF MISSILE RESEARCH & DEVELOPMENT including:

...MISSILE WEAPONS SYSTEMS—target and missile tracking—radars—computers—handling equipment—launching equipment—logistics equipment—and others, all designed FROM THE GROUND UP as one system!

...SPECIFIC MISSILES—also Satellites including propulsion, guidance, airframes, and warhead arming and fuzing devices.

...SPECIAL COMPONENTS OF MISSILES—such as inertial guidance systems.

What We're Using...

HYPERSONIC WIND, SHOCK, HELIUM TUNNELS—mass accelerators—linear accelerators—electric arc mass accelerators—hyper-velocity shock tunnels. UNDER DEVELOPMENT: the LARGEST GAS SHOCK TUNNEL in the country...PLUS laboratories and equipment second to none. AND WHEN NEEDED—the resources of over 100 other G-E departments!

What All This Means to You...

Stable career growth, full use of your abilities, creative experience and rapid advancement either into management or further specialization, with a professional staff that is expanding rapidly.

Scientists with advanced degrees will have a particularly attractive opportunity to engage in high levels of basic and applied research in such advanced fields as Astrophysics,

High Temperature Phenomena, Advanced Mathematical Concepts, Aerodynamics, Classical Physics, Materials Development, and Communications Theory.

...Engineers and Scientists with education and experience in any of the fields listed below are invited to correspond with us...

DEGREE: *Electrical Engineer, Aeronautical Engineer, Aerodynamics, Mechanical Engineer, Physics, Mathematics.*

EXPERIENCE: SYSTEMS—*Development, Synthesis, Operations Analysis* • AEROPHYSICS • COMPUTER DESIGN—*Analogue, Digital* • MATERIALS & PROCESSES • INSTRUMENTATION—*Telemetry, Transducers, Recording, Recovery* • DATA PROCESSING—*Systems Design, Analysis, Programming* • GUIDANCE—*Inertial Guidance, Component Development* • TECHNICAL WRITING • FIRE CONTROL • STRUCTURES—*Thermodynamics, Electrical Design, Stress Analysis, Structure Design, Vibration, Aerodynamics* • ARMING AND FUZING—*Component Development, Test Equipment* • FIELD TEST • SYSTEMS TEST • GROUND SUPPORT EQUIPMENT DESIGN—*Controls, Handling Equipment, Launching Equipment.*

Missile & Ordnance Systems Department would be pleased to receive a resume of your education and experience.

All resumes will be carefully reviewed by the MANAGERS of our various technical components. You will be invited to visit our offices and discuss the work we are doing directly with the manager with whom you would be working. All communications will be entirely confidential. (You need not reveal the name of your present employer.)

Please send resume to Mr. John Watt, Room 510-14
MISSILE & ORDNANCE SYSTEMS DEPARTMENT

GENERAL  ELECTRIC

3198 Chestnut Street • Philadelphia, Pennsylvania



AVCO MANUFACTURING CORPORATION
Crosley Division

Foremost in Electronics

Offers Engineers Many Advantages!

**WHEN THE PILOT CAN'T SEE
"Volscan" BRINGS**

Him Down . . . SAFELY! SURELY!

One of the major advances in aviation history is "Volscan". This remarkable electronic device enables the pilot to come in even though he can't see where he is or where he is going. Wouldn't you like to play a part in important achievements such as this? If so, we have top openings for engineers in many different categories.

- | | |
|--|---|
| <p>1. Guided Missiles</p> <p>2. Computer and Analytical Services
(Design and Development)
(Programming and Application)</p> <p>3. Ground Radar</p> <p>4. Air Traffic Control</p> <p>5. Antennas & Micro-Waves</p> | <p>6. Communications
(Airborne Transmitters and Receivers)</p> <p>7. Airborne Fire Control</p> <p>8. Airborne Defense</p> <p>9. Servo Mechanisms</p> <p>10. Transistorized Equipment</p> |
|--|---|

Contact us and find out where you can fit into the major programs now being started. There are numerous company benefits and you will be paid generous relocation expenses.

SEND A RESUME TO:

Mr. Nick M. Pagan,
Employment Manager

AVCO Manufacturing Corp.

Crosley Division

2630 Glendale-Milford Road
Evdendale, Cincinnati 15, Ohio

Admiral

has specific openings
for experienced engineers in:

RADAR

L BAND

Project level work on L band radar and beacon coding, decoding, and pulse train generating and processing circuits.

AIRBORNE RADAR

In X band range. An experienced man at project level to improve and modify existing systems and to contribute ideas for proprietary systems.

RADAR DESIGN—ECM

To analyze, develop and design advance radar techniques and electronic countermeasures.

Career-minded men with several years specialized experience are invited to join our rapidly expanding programs in communications projects. On-the-job training for junior and intermediate engineers.

Current openings offer excellent income and employee benefits including retirement plan, paid group insurance and college tuition refund plan plus ideal working conditions.

If you are an engineer with qualifications in any of these fields explore your opportunity with Admiral today. Write Mr. Walter Wecker, Personnel Manager.

Admiral Corporation

3800 W. Cortland Street
Chicago 47, Illinois

HRB

**graduate
work?**

HRB offers the young engineer and physicist a sound beginning in the electronic field. The company offices are located just a few minutes walk from the campus of the Pennsylvania State University where you may join many others of the HRB staff in doing graduate work in your specialized field. The University, ranking in the top ten of engineering training, boasts a swimming-pool-type Nuclear Reactor, one of the few in the country. Along with the proximity of the University, HRB offers excellent salaries and generous benefits.

For application form, write:

Technical Personnel Officer
Haller, Raymond & Brown, Inc.
State College, Pennsylvania

**HOW TO BE THE HAPPIEST CREATIVE
ENGINEER IN CALIFORNIA**

Engineers (E.E., M.E., Mfg., Sales) can have the kinds of jobs that creative men dream about. Top salaries and benefits. Suburban locations in Fullerton, Newport Beach, Richmond, or Palo Alto.

Write Beckman Instruments, Inc., 2999 W. 6th Street
Los Angeles 5, California. Ask for Career File 52-1

Here we go!

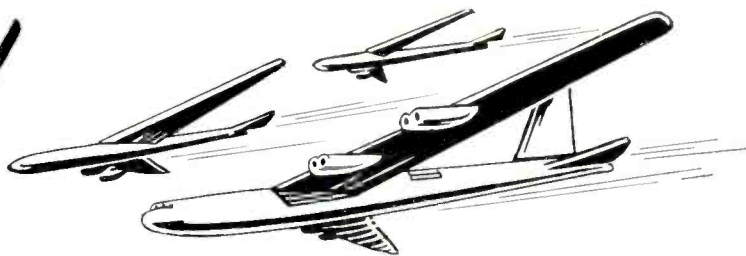

PRIME CONTRACTORS

. . . to the ARMY for HAWK I

. . . to the NAVY for SPARROW III

Raytheon's reputation for outstanding engineering and its ability to deliver has brought many major defense contracts. An already expanding Missile Systems Division needs junior and senior engineers to speed up the vital work being carried on here.

The progress of these engineers will be limited only by their ability. Raytheon pays well to start, and as a youthful, dynamic company it provides excellent opportunity for growth. You will be associated with leading scientists and engineers in an informal atmosphere that encourages and stimulates creative ability. Financial assistance is offered for engineering courses.

Our plants are located in suburban Boston allowing a choice of urban or rural living. The area is famous for climate, recreation, education, culture, research and medicine.

If you have experience and are interested in guided missile systems, we have openings in:

Circuit Design	Electronic Packaging
Microwave	Test Equipment Design
Antenna Design	Specifications
Systems Engineering	Tube Applications
	Infra Red

Call or send brief resume to:

G. P. O'Neil

RAYTHEON

**MISSILE
SYSTEMS
DIVISION**

B E D F O R D , M A S S .

engineers

scientists

there are **LEADERS OF MEN** and **LEADERS OF IDEAS**

Advanced Circuits •
 Communications •
 Computers • Data
 Processing • Dielectric
 and Magnetic Materials •
 Dielectric and Magnetic
 Devices • Microwave
 Techniques • Radar •
 Semiconductors • Solid
 State • Systems
 Analysis • Thermionics •
 TV Systems •
 Underseas Warfare •
 Video Displays

... and a satisfaction in them both. In an organization as diversified as General Electric, one would be unthinkable without the other.

From its inception, the purpose of General Electric's Electronics Laboratory has been to gather these leaders of ideas, over two-thirds of whom possess advanced degrees. We've given them all the resources and research facilities they would need ... and then, left them alone.

Currently we are working on some of the most interesting and advanced concepts in electronics — military systems, advanced circuits, communications, computers, radar, to name just a few.

You will like the environment, the level of work, the opportunity for technical growth (including Laboratory sponsorship of advanced study at local universities) and the professional caliber of your associates.

Beautiful campus-like Electronics Park is located in the heart of upstate New York which provides splendid living conditions.

Opportunities in applied research and advance development are available for qualified **Electronics Engineers, Physicists and Mathematicians** with MS or PhD degree or equivalent.

Apply in confidence to General Electric. Please include your age, training, experience and professional references.

Write to Mr. Roy R. Solaski, Electronics Laboratory

GENERAL ELECTRIC
 Syracuse, New York

TEST ENGINEERS

WILL YOU REACH YOUR MAXIMUM POTENTIAL?

No matter what your ability, you **MUST HAVE** the job opportunity and the **BEST** of **TOOLS** and **FACILITIES** to develop your talents to the fullest.

Investigate the Environment created at AC for its Advanced Development Programs on Missile Guidance and Aircraft Fire Control Systems.

OUR ENVIRONMENTAL LABORATORY

is one of the most versatile laboratories in the country and we are in the process of a Major, Permanent Expansion. 225,000 square feet plant being added in suburban Milwaukee.

Our men enjoy working with the finest of test equipment and lab facilities and with the top men in the field.

We are currently engaged in the following types of Test Activities.

- **VIBRATION TESTING**
- **COMPLEX WAVE ANALYSIS**
- **LOW TEMPERATURE-ALTITUDE**
- **HIGH TEMPERATURE**
- **RELIABILITY EVALUATION**
- **INSTRUMENTATION**

Mr. John F. Heffinger, Supervisor of Technical Employment

THE ELECTRONICS DIVISION

GENERAL MOTORS Corporation

FLINT 2, MICH.

MILWAUKEE 2, WIS.

ELECTRONIC DESIGNER

Development and design of industrial measurement and control equipment for the continual process industries. Unusual opportunities in a rapidly expanding firm and industry for personal growth through technical "know how" and hard work. BSEE or MSEE required. 1 to 10 years experience. Servo and feedback experience helpful. Send resume to: 1205 Chesapeake Ave., Columbus 12, Ohio.



**ELECTRONIC ENGINEERS
 PHYSICISTS and related
 TECHNICAL PERSONNEL**

B.S. M.S. Ph.D.
Salaries \$5,000 to \$15,000+

Many openings listed here with private Industry, universities and government divisions. Apply in person or send resume. No placement fee.

ENGINEERING & SCIENCE UNIT
 A highly specialized placement service.

NEW YORK STATE EMPLOYMENT SERVICE
 119 Fifth Ave. New York 3, N. Y.

New Advertisements

received by January 2nd will appear in the February issue subject to space limitations.

**Classified Advertising Division
 ELECTRONICS**

P. O. Box 12 New York 36, N. Y.

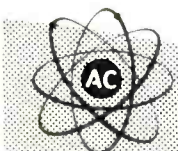

BE HAPPY... ...GO BERKELEY!

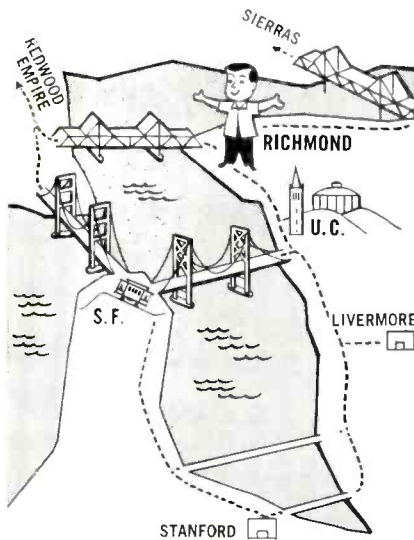

If you've looked around much for a new job, you know some companies solemnly offer you the moon on a silver platter. At Berkeley, we're fresh out of moons. But we can deliver something you won't find everywhere—a first-rate place to work and live. You can relax here and find satisfaction in your work. Nobody breathes down your neck—all the stuffed shirts were kicked out long ago. This is a fast-growing company, and you'll have plenty of responsibility and a chance to move ahead rapidly. Our engineers work in new, comfortable quarters, completely equipped for research and development. You'll be paid well, share in the profits, and receive many other benefits. Most of all, though, you'll be happy you made the change.

We shouldn't have to say much about the San Francisco Bay area. If you like living, you ought to try it here. Our plant in Richmond is just 22 minutes from the nearest cable car.

Basically, we're looking for effective electronic circuit designers. We need analog computer design engineers, computer applications engineers, field engineers with troubleshooting experience, industrial systems engineers, and electronic technicians. We also need men with experience in new techniques, such as transistors or magnetics, and in such specialties as microwave, uhf, nuclear radiation detection.

For details, write or phone:
HARRY MCELROY,
Personnel Director

Berkeley *division*
BECKMAN INSTRUMENTS INC
RICHMOND 3, CALIF. • LANDSCAPE 6-7730



"I chose Stromberg-Carlson for opportunity... maybe you should, too"

Stromberg-Carlson offered me and my family so much more than a good salary, plus bonus and a flock of fringe benefits, that I couldn't say anything but "When do I start?"

There's the Company itself—sixteen times bigger today than in 1940—and now a division of the headline-making General Dynamics Corporation. One look at its Electronic Engineering alone convinced me that here is probably the "hottest" electronics industry in America today.

Of course, there's Rochester, and its surroundings. Right in the heart of the Finger Lakes; only four hours from the Adirondacks. Home of the Eastman School of Music and Eastman Theatre; of world-famous parks; of no less than thirteen golf courses; of schools and shopping centers unrivalled in the East; of scientific industries whose engineers turn up as your next-door neighbors.

But above all there's opportunity. As the chap who hired me put it, "This is the spot for men who are either stymied in a little company, or buried in a giant." Opportunity, that's it—no limits to individual initiative and accomplishment—and with all that expansion there sure is going to be a lot of promoting! Brother, here's a place where I can develop! Why not check my conclusions? Start with a brief note to

- Countermeasures
- Data Systems
- Digital Techniques
- Electro-Mechanical Design
- Infrared
- Laboratory and Test Engineering
- Microwave Circuits
- Navigational Systems
- Radar
- Transistor Engineering
- Communication Systems
- Missile Guidance Systems
- Systems Test Equipment
- Writers—Technical
- Components and Specifications

R. W. Holmes, Electronic Engineering

STROMBERG-CARLSON COMPANY
A DIVISION OF GENERAL DYNAMICS CORPORATION

16 Carlson Road, Rochester 3, N.Y.



*To the electronics
engineer who
can write...*

here
is
your
IVORY TOWER

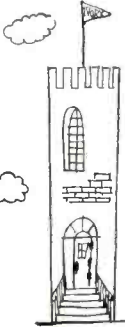

You'll live in a clean, progressive, thriving community . . . a city of beautiful homes and broad tree-lined streets . . . a cultural and recreational center of the Midwest. The way of life is pleasant and relaxed. It's the kind of town you like to raise a family in.

You'll write for the creative leader in electronics. There'll be a sense of accomplishment and satisfaction in your work. A feeling of contributing in a major way to the advancement of the science of electronics. And, at the same time, you'll have the opportunity to learn and advance yourself technically in electronics.

The place — Cedar Rapids, Iowa

The job — technical writing.

Check into the opportunities Collins offers technical writers, in the fields of:

Microwave Relay	SSB Systems	Guided Missiles
Navigation Systems	Computers	Radio Astronomy
Communication Systems	Flight Control	Amateur Radar Systems
		Equipment

Collins offers you top salary, rapid advancement, company benefits, liberal moving expense. Electrical Engineers or Physicists are desired. Actual writing experience is not necessary. U.S.A. citizenship is required.

Positions also open in Dallas and Burbank.

Send resume to:
Industrial Relations Director
COLLINS RADIO COMPANY
Cedar Rapids, Iowa

ENGINEERING OPPORTUNITIES

Aircraft Radio Corp., the industry's leader in avionics for over 30 years, has openings on its staff for forward thinking engineers in the following fields:

- TRANSISTOR CIRCUIT PROJECT ENGINEER
- SERVO AND INSTRUMENT ENGINEER
- ENVIRONMENT—TEST ENGINEER
- COMPONENTS ENGINEER
- CHIEF ENGINEER TO HEAD SERVO AND INSTRUMENT DEPT.
- ADVANCED TECHNICIANS

WRITE OR CALL COLLECT: *Personnel Manager*



AIRCRAFT RADIO CORPORATION

BOONTON, NEW JERSEY

Deerfield 4-1800 Ext. 238

**ARE YOU IN NEED
OF ENGINEERS
or of
HIGHLY TRAINED TECHNICIANS
for your Personnel Program?**

We offer a free booklet especially prepared to help you solve this problem. It is called the "RESERVOIR OF ENGINEERS and TECHNICAL MEN."

This booklet shows, through a listing of the major job titles held by readers of McGraw-Hill Publications, how these men are gathered in convenient, compact groups that you can economically reach with your advertising. Here are no huge, swollen circulations, with expensive price tags where maybe not one reader in a thousand would have the necessary job qualifications.

In a recent advertisement one of the leading aircraft manufacturers restated a well known, but seldom practiced principle:

A trained, experienced engineer in one specialty can be retrained in almost any other engineering specialty with a minimum of time and effort expanded.

It is one of the purposes of this booklet to show how you can best reach men specifically trained for your needs or technicians who can be easily and quickly retrained.

For your free copy of this booklet write us on your letterhead. You are under no obligation whatsoever. There is a limited supply so write us now.

**McGraw-Hill
Publishing Co., Inc.**

*Classified
Advertising* *Box 12
Division*

330 West 42nd St.,
New York 36, N. Y.

opportunities in

**OPERATIONS
RESEARCH**

The Operations Research Office of The Johns Hopkins University offers exceptional opportunities for scientists who prefer the challenge of operational problems of unusual scope and diversity to routine design and development work.

Our current research program has openings for men qualified in electronics and physics who are particularly interested in:

- Mathematical Analysis
- Determining applications of known photographic, acoustic, infrared and radar techniques to military problems
- Military communications systems planning, analysis and evaluation
- Electronic Countermeasures Analysis

Please send your resume to
Research Personnel Officer

THE OPERATIONS RESEARCH OFFICE

**THE
JOHNS HOPKINS
UNIVERSITY**

7100 Connecticut Avenue
Chevy Chase, Md.

**Electronic Electrical
ENGINEERS**

If you are interested in gaining diversified experience as well as utilizing your creative ability, our expanding Research and Development projects in ELECTRONIC COMPONENTS offers you this opportunity.

The COMPONENTS field is one of rapidly growing importance, and our staff is currently engaged in projects involving Materials, Fundamental Design, Measurements, High Temperature Application, and Reliability Problems. Positions are available at all levels of professional attainment and participation in these and other projects should be particularly interesting to engineers who desire breadth and variety in their profession.

Advantages of employment at Armour Research Foundation include tuition free graduate study, generous re-location allowance, as well as competitive pay and excellent working conditions.

If you are interested in this excellent opportunity to advance professionally, please write:

J. A. Metzger

ARMOUR RESEARCH FOUNDATION

of Illinois Institute of Technology

10 West 35th St. Chicago 16, Illinois

OPPORTUNITIES ALSO AVAILABLE
IN TUCSON, ARIZONA

If you're seeking a top career
in a **UNIQUE** location—

Look to FTL . . . where you work, live and relax
in beautiful suburban New Jersey . . . only minutes
away from New York City's wealth of scientific,
cultural and entertainment facilities

Mountains, lakes, ocean beaches, fishing, boating, golf—
all the things a man and his family enjoy—are within easy
reach of the "FTL Community."

At FTL you work in country-like atmosphere . . . in one
of America's great research and development centers . . .
with leaders in electronics . . . with every opportunity to
build a stable and rewarding career . . . as a member of
the world-wide IT&T Engineering Team.

FTL provides group insurance, company-paid medical
and pension plans, tuition refund and many other em-
ployee benefits.

Write today for information on any of the following
interesting assignments now open at Federal Telecommu-
nication Laboratories, Nutley, New Jersey:

- Radio Communication Systems • Traveling Wave Tubes
- Electronic Countermeasures • Air Navigation Systems
- Antennas • Missile Guidance • Computers
- Transistors and other Semiconductor Devices
- Telephone and Wire Transmission Systems

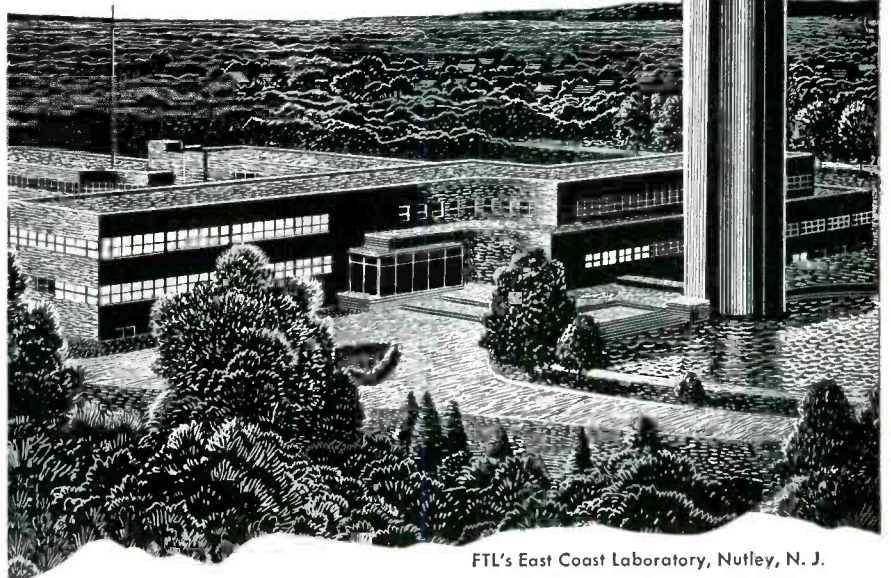

FTL's East Coast Laboratory, Nutley, N. J.
—only 28 minutes from New York City

If you prefer
CALIFORNIA—

• Opportunities for relaxed living
and career-building also available at
FTL's West Coast Laboratory . . . with
openings in Digital Computers, Iner-
tial Navigation Systems and Infra
Red Systems. Write to 15191 Bledsoe
St., San Fernando, Cal.

FTL



MAIL THIS COUPON TODAY

Federal Telecommunication Laboratories
500 Washington Avenue, Nutley, N. J.
Please send literature describing opportunities
and benefits at FTL, in Nutley, New Jersey.

Name _____
Address _____
City _____ Zone _____ State _____

Federal Telecommunication Laboratories
A Division of INTERNATIONAL TELEPHONE
AND TELEGRAPH CORPORATION

UNUSUAL OPPORTUNITIES AT ARMA

New long range projects assure not only challenging, high-level creative work, but security and job stability as well. Excellent starting salaries plus all the resort and cultural advantages of suburban Long Island living.

- (A) **DIGITAL COMPUTER ENGINEERS** for application of transistorized digital computers to Fire Control, Navigation and Missile Guidance Systems. Openings in Computer Applications, Logical Design, Dynamic Analysis, Circuit Development, Component Development, Packaging Design and Field Evaluation.
- (B) **TRANSISTOR CIRCUIT ENGINEERS** for applications in Fire Control, Navigation and Guidance Systems, utilizing analog and digital computing techniques.
- (C) **SYSTEMS EVALUATION.** Experience necessary in the following areas: Systems Analysis—Evaluation methods and techniques, data requirements, error analysis. Project Engineering—Planning functions, program scheduling, facility requirements. Instrumentation—Electrical and mechanical design of ground and airborne instrumentation. Telemetry—Ground and airborne telemetry systems and telemetry checkout equipment.
- (D) **DATA REDUCTION & ANALYSIS ENGINEERS.** Experience required: General Planning for Data Processing, including estimating and scheduling; specification of data transcription equipment and techniques; preparation of computational requirements; procedures, and knowledge of machine programming; mathematical studies, equation formulation, digital smoothing and filtering techniques; data reduction equipment, functional design and project engineering.
- (E) **MISSILE GUIDANCE SYSTEMS ENGINEERS** to work in the areas of System Synthesis (mathematical & functional); System Analysis and Evaluation (dynamic & error); System Instrumentation, System Integration (electrical & mechanical compatibility); System In-Plant Test. Degree in E.E., Physics or Mathematics necessary, with active participation in any of the following fields: Advanced mathematics; guidance and control systems; statistical error analysis; inertial navigation systems; stable platform; analog or digital computing systems; optical systems.
- (F) **ELECTRONIC SYSTEMS.** Advanced systems analysis and research in the fields of: Radar, Counter-measures, Guidance, Navigation, Communication, Propagation. B.S., M.S., or Ph.D., with heavy experience in military airborne and ground systems.

Fill out and mail the coupon to indicate your interest in any of these jobs. Or, simply check the second box if you would like to receive a free copy of "AN ANSWER RE: GUIDANCE", containing five technical papers discussing important questions relating to Inertial Navigation.

ARMA

Division American Bosch Arma Corp.
Roosevelt Field, Garden City, L. I., N. Y.
Technical Employment Dept. E-674

Gentlemen:

() Please send me additional information concerning the job coded _____

() Please send me a copy of AN ANSWER RE: GUIDANCE. I understand I am under no obligation.

NAME

ADDRESS

CITY..... ZONE.... STATE.....

Engineers Needed for Research and Development Positions in the

Design of electronic instrumentation for underwater ordnance, including high gain amplifiers, conventional filters, power amplifiers, oscillators and detectors in the ultrasonic range.

Analytical and experimental treatment of scientific research problems in the fields of hydrodynamics, acoustics, electronics, network theory, servomechanisms, mechanics, information theory and noise analysis including analogue and digital computations.

Design of transducers, fundamental problems in underwater acoustics involving transmission, attenuation, reflection, etc. Problems in sound control and noise reduction. Acoustical aspects of systems research including operations research and feasibility studies.

**EXCELLENT WORKING CONDITIONS
LIBERAL VACATION POLICIES
OPPORTUNITIES FOR GRADUATE STUDY
UNIVERSITY FACULTY APPOINTMENTS**

Send Resume to ARNOLD ADDISON, Personnel Director

**THE PENNSYLVANIA STATE UNIVERSITY
ORDNANCE RESEARCH LABORATORY**

UNIVERSITY PARK

PENNSYLVANIA

Man Hunters

.... ATTENTION!

When you are in need of specialized men for specialized jobs—from general managers to supervisors—contact them through the EMPLOYMENT OPPORTUNITIES SECTION of McGraw-Hill publications.

The EMPLOYMENT OPPORTUNITIES SECTION is the national market place for those wanting the services of men in technical, engineering and operating capacities in the fields served by these publications.

AMERICAN MACHINIST
AVIATION WEEK
BUSINESS WEEK
CHEMICAL ENGINEERING
CHEMICAL WEEK
COAL AGE
CONSTRUCTION METHODS AND EQUIPMENT
ELECTRICAL CONSTRUCTION AND MAINTENANCE
ELECTRICAL MERCHANDISING
ELECTRICAL WHOLESALING
ELECTRICAL WORLD
ELECTRONICS

ENGINEERING AND MINING JOURNAL
ENGINEERING NEWS-RECORD
FACTORY MANAGEMENT AND MAINTENANCE
FLEET OWNER
FOOD ENGINEERING
NATIONAL PETROLEUM NEWS
NUCLEONICS
PETROLEUM PROCESSING
PETROLEUM WEEK
POWER
PRODUCT ENGINEERING
TEXTILE WORLD

The men you need are the men who read the
EMPLOYMENT OPPORTUNITIES SECTION of

McGraw-Hill Publications

P. O. BOX 12, NEW YORK 36, N. Y.

Admiral®

has specific openings
for experienced
engineers in:

Television Military and and Civilian

UHF RECEIVER DESIGN

With experience in low noise wide band front ends and I F circuits for military television systems.

TUNER ENGINEER

To design tuners for UHF and VHF systems—military and civilian. To pursue a program of original ideas in this field at the developmental level.

DEFLECTION CIRCUITRY

With experience in designing horizontal and vertical oscillators, control circuits and associated components.

EXPORT TELEVISION

TV receiver engineer for work on a line of export receivers. Familiarity with tuners and I.F. systems for European standards and conditions useful in this work. Will consider a non-citizen with practical TV experience.

MILITARY TV

Airborne and ground systems including receivers, transmitters, cameras, antennas, sync generating systems, and displays, as well as printed circuit and transistor applications.

Career-minded men with several years specialized experience are invited to join our rapidly expanding programs in communications projects.

Current openings offer excellent income and employee benefits including retirement plan, paid group insurance and college tuition refund plan plus ideal working conditions.

If you are an engineer with qualifications in any of these fields explore *your* opportunity with Admiral today. Write Mr. Walter Wecker, Personnel Manager.

Admiral Corporation

3800 W. Cortland Street
Chicago 47, Illinois

A HAPPY COMBINATION at

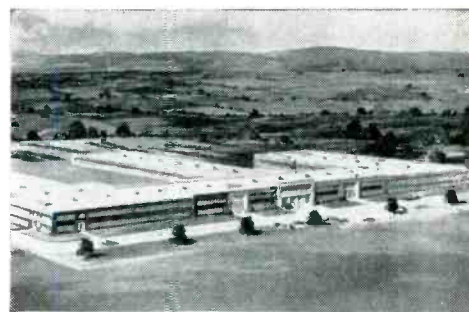

RAYTHEON'S WAYLAND LAB

—CHALLENGING WORK—

Our success in obtaining prime, long-range contracts for Aircraft Weapons Systems, major Defense Radars, Fire Control Systems and many others provides lasting and challenging opportunities for good Systems and Design Engineers who are ready, willing and able to work on some of the most advanced radar and weapons systems being designed today.

—PLEASANT LIVING—

Wayland and the surrounding territory constitute a select residential area where an acre-per-house is the rule. History records these towns—Lexington, Concord, Sudbury, etc. — as having famous beginnings; just the right amount of modern progress blended with this background renders them ideal for relaxed and pleasant New England living.



WAYLAND LAB

Send resume to:

Radar Professional Personnel
Box 242-F
Raytheon Manufacturing Company
Wayland, Massachusetts



TIME FOR A CHANGE
TO A BIGGER POSITION.
BAIRD-ATOMIC WANTS
PROJECT ENGINEERS.

Emission Spectroscopy • Infrared Absorption Spectroscopy • Radioactivity Detection & Measurement • Electronic Industrial Counting • Transistor Circuitry

If you prefer this responsibility, enjoy the satisfaction of following the development of a project from start to finish, can meet the diverse requirements of project work, can handle public contacts and will travel as necessary—

If you would like to work in Cambridge, Mass., leading electronic center of New England, offering community advantages and opportunity for advanced study at Harvard and MIT, just a 20 minute drive from Boston—

Apply to the Personnel Director Baird-Atomic Inc., 33 University Rd., Cambridge, Mass. All replies will be held in strict confidence. Your inquiry is invited.

Baird — Atomic Inc.

33 UNIVERSITY ROAD, CAMBRIDGE 38, MASS.

GOODYEAR ATOMIC CORPORATION
POSITIONS NOW OPEN
IN
PLANT ENGINEERING
PRODUCTION
DEVELOPMENT
FOR
ENGINEERS
CHEMISTS
TECHNICAL WRITERS
METALLURGISTS
STATISTICIANS
PHYSICISTS
POSITIONS OPEN ON SEVERAL
LEVELS OF RESPONSIBILITY
FORWARD COMPREHENSIVE
RESUME TO:
EMPLOYMENT DEPARTMENT LL
GOODYEAR ATOMIC CORPORATION
BOX 628, PORTSMOUTH, OHIO

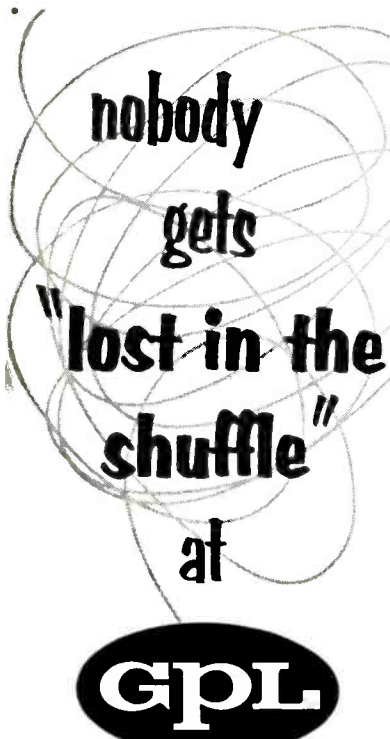

GENERAL PRECISION LABORATORY is organized in small engineering groups where everyone has a chance to use initiative, assume responsibility, show what he can do.

Results tell the story. Just one example: GPL engineers harnessed Doppler and developed the AN/APN-66 air navigation systems that are the most accurate airborne systems in operation today.

At GPL you'll have freedom from administrative routine, and enjoy the satisfaction that comes with using facilities as up-to-date as they come. Because GPL is a member of the nationwide General Precision Equipment Group, you'll share in numerous added employment and professional benefits. And remember—you and your future will never be lost in the shuffle.

If you have the skill and imagination we need—and if you want personal recognition and opportunities to grow in your profession—send your resumé to Richard E. Hoffman, Employment Manager. Interviews can be arranged in advance at any time, including weekends. Security limits us to U. S. citizens only. We will pay the expenses of qualified applicants to come for an interview.

RADAR NAVIGATION AND BOMBING SYSTEMS
(Doppler & Inertial)

Research • Development • Applications
Systems Analysis • Systems Test
Administrative Engineering • Mechanical Packaging
Field Engineering • Technical Writing
Production Follow-up

Computers • Servos • Microwave Techniques
Pulse Circuitry • Transistorization

General Precision Laboratory Incorporated

63 Bedford Road, Pleasantville, New York

In the heart of Westchester County

A SUBSIDIARY OF



NEW Staco

AIRCRAFT COMPONENTS DIVISION

We require several qualified electro-mechanical and electronic engineers, and electronic technicians to form the nucleus of our engineering department of this new division in our fast-growing, progressive firm. Salary commensurate with ability.

STANDARD ELECTRICAL PRODUCTS CO.

2240 E. Third St., Dayton 3, Ohio
Call Collect KENmore 1191

NEED ENGINEERS

Place an "Engineers Wanted" advertisement in this EMPLOYMENT OPPORTUNITIES section. It's an inexpensive, time saving method of selecting competent personnel for every engineering job in the Electronics industry. The selective circulation of ELECTRONICS offers you an opportunity to choose the best qualified men available throughout the industry.

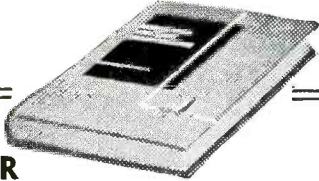

COLOR TELEVISION STANDARDS

States the underlying factors relating to the choice of color television standards, and the effect of the standards on practical broadcasting and receiving equipment. Covers NTSC color TV standards and terminology, compatibility, performance, and FCC rules and regulations. Selected Papers and Records of the National Television System Committee. Edited by Donald G. Fink, Vice-chairman, NTSC (1950-52), Director of Research, Philco Corporation. 520 pp., 290 illus., \$8.50.

INTRODUCTION TO ELECTRONIC ANALOGUE COMPUTERS

Covers principles, operation, and design of analog computers. Gives descriptions of components, computing elements, and procedures for arranging problems for analog computation. Emphasizes the effects of imperfections in computing elements, and means for reducing these factors. By C. A. A. Wass, Supt. of the Dynamic Analysis Division, Royal Aircraft Establishment, Farnborough, England. 237 pp. 149 illus., \$6.50.

TRANSMISSION-LINE THEORY

Systematic, rigorous, and thorough treatment of theory of transmission lines of various types. Proceeds from basic electromagnetic principles and derives the conventional transmission-line equations together with the formulas for line constants and all approximations involved. Formulation is sufficiently general to permit analysis of end effects and discontinuities as well as the more usually treated properties. By R. W. P. King, Gordon McKay Prof. of Applied Physics, Harvard Univ. 525 pp., 629 illus., \$12.00

PROFESSIONAL ENGINEER'S EXAMINATION QUESTIONS AND ANSWERS

Over 500 questions and complete answers to help engineers pass state license examinations. Covers mechanical, electrical, civil, and chemical engineering, and includes engineering economics and land surveying. Latest questions—suitable for all states. Author has worked on New Jersey examination preparation for 19 years. By William S. LaLonde, Jr., 462 pp., 234 illus., \$6.50.

10 DAYS' FREE TRIAL

McGraw-Hill Book Co., Inc. Dept. FL-1
327 West 41st St., New York 36, N. Y.

Send me book(s) checked below for 10 days' examination on approval. In 10 days I will remit for book(s) I keep, plus few cents for delivery costs, and return unwanted book(s) postpaid. (We pay delivery costs if you remit with this coupon—same return privilege.)

Fink—Color TV Standards—\$8.50
 Wass—Elec. Analogue Computers—\$6.50
 King—Transmission-Line Theory—\$12.00
 LaLonde—Prof. Engr. Ques. & Ans.—\$6.50

(Print)
 Name
 Address
 City Zone State
 Company
 Position

For price and terms outside U. S. FL-1
 Write McGraw-Hill Int'l., N. Y. C.

Career opportunities
 in BOSTON
 are better
 than ever!



Long range research, engineering and production programs at Honeywell in Boston have created new and unusual career opportunities in the instrument and semiconductor fields. In addition to professional and financial advancement, these career opportunities offer the *recognition* that goes with working in a small compact engineering group of an autonomous division and *advancement* through association with the world's largest producers of automatic controls.

Gyro and Accelerometer Design Engineers

Data Handling Amplifier Design Engineers

Electrical Design Engineer for Automation Equipment

Semi-Conductor Engineers for R & D and Production

Chemical, Mechanical, Metallurgical Process Engineers

Write Mr. F. L. Mannix, Personnel Director, Minneapolis-Honeywell, Boston Division, 1400 Soldiers Field Road, Boston 35, Mass., or call ALgonquin 4-5202.

MINNEAPOLIS
Honeywell



BOSTON DIVISION

*Servo
Engineers*

**ELECTRICAL
MECHANICAL**
Inertial
Guidance
System
Program

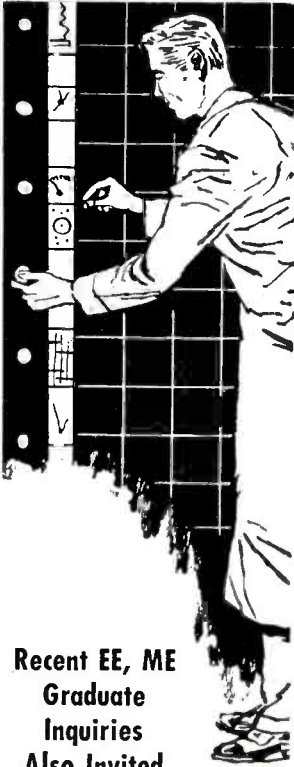

**Recent EE, ME
Graduate
Inquiries
Also Invited**

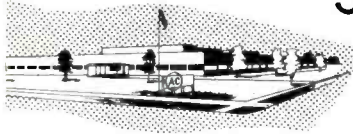

Enjoy Challenging Opportunities in the further development and systems testing of Inertial Guidance Systems and their Servo Loops in the most versatile laboratories in the country.

Work with the top men in the field and with the finest test, research and development facilities. New plant being added in suburban Milwaukee as a part of Major, Permanent, Expansion Program.

AC will provide financial assistance towards your Master's Degree. A Graduate Program is available evenings at the University of Wisconsin, Milwaukee.

GM's long-standing policy of decentralization creates individual opportunity and recognition for each Engineer hired.

Milwaukee offers ideal family living combining small town hospitality with every metropolitan shopping and cultural advantage.

For personal, confidential interview in your locality send complete resume to

Mr. John F. Heffinger
Supervisor of Technical Employment



THE ELECTRONICS DIVISION

GENERAL MOTORS CORPORATION
FLINT 2, MICH. • MILWAUKEE 2, WIS.

Electronic Engineers

DIGITAL COMPUTER
DESIGN
PROCESS CONTROL
AUTOMATION
SPECIALIZED
INSTRUMENTATION
TECHNICAL PROBLEM
CONSULTATION

If your abilities & ambitions are stymied,
your time is valuable in research at

CONTINENTAL OIL COMPANY
PONCA CITY, OKLAHOMA

SEND DETAILED RESUMÉ TO PERSONNEL DIVISION

*Electronic
Engineers*

Excellent growth
opportunity with
expanding division of
AAA-1 company serving
Industry and Government with
custom-built Automation Systems

**SUPERVISORY & PROJECT LEVEL ENGINEERS
ALSO, SENIOR TECHNICIANS**

3 to 5 years' Solid Experience Background in:

- DIGITAL SYSTEMS
- PULSE TECHNIQUES
- CIRCUIT DESIGN

TOP SALARIES plus OVERTIME

Convenient Location Near
8th Ave. Subway (15th St.)

Send resume or
Call: **WATkins 4-3630**



**THE
AUSTIN
COMPANY**

76 Ninth Avenue, N. Y. C.

FOR RATES OR INFORMATION

About Classified
Advertising,

Contact
The McGraw-Hill
Office Nearest You.

ATLANTA, 3
803 Rhodes-Haverty Bldg.
R. POWELL
WAlnut-5778

BOSTON, 16
350 Park Square Bldg.
H. J. SWEGER
HUBbard 2-7160

CHICAGO, 11
530 No. Michigan Ave.
W. HIGGINS
J. BRENNAN
MOhawk 4-5800

CINCINNATI, 37
1825 Yorktown Rd.
Swifton Village, Apt. 2
G. MILLER
REdwood 1-3238

CLEVELAND, 15
1510 Hanna Bldg.
W. SULLIVAN
SUperior 1-7000

DALLAS, 2
Adolphus Tower Bldg., Main
& Akard Sts.
G. JONES
Riverside 7-5064

DETROIT, 26
856 Penobscot Bldg.
W. STONE
WOodward 2-1793

LOS ANGELES, 17
1125 W. 6th St.
C. DYSINGER
D. McMILLAN
MAdison 6-9351

NEW YORK, 36
330 West 42 St.
S. HENRY
D. COSTER
R. LAWLESS
R. HATHAWAY
LOngacre 4-3000

PHILADELPHIA, 3
17th & Sansom St.
E. MINGLE
H. BOZARTH
Riffenhouse 6-0670

ST. LOUIS, 8
3615 Olive St.
W. HIGGINS
JEfferson 5-4867

SAN FRANCISCO, 4
68 Post St.
R. ALCORN
DOuglas 2-4600

RESEARCH AND DEVELOPMENT ENGINEERS

Career opportunities in Central Research Laboratory of stable, growing company. Electronic engineers with B.S. or M.S. for advanced circuit design on audio systems, magnetic recording, transistor control circuits for aircraft instrumentation and high frequency instruments. Positions offer opportunity for creative work in stimulating environment. Send resume to: Frank V. Paley, Professional and Technical Employment Manager,

THOMAS A. EDISON, Inc.
WEST ORANGE, N. J.

COMMUNICATIONS ENGINEERS and TECHNICIANS

EXCELLENT SALARIES
MINIMUM PREREQUISITES

ENGINEER EE Graduates with 3 years experience
TECHNICIAN 2 years technical school in communications and 3 years experience.

Require installation adjustment and maintenance experience with communication receivers and associated terminal equipment. Also, men with similar experience with high-powered transmitters, antennas, transmission lines.

Must be willing to travel in United States and Overseas.

Page Communication Engineers, Inc.
710 Fourteenth St., N.W., Washington 5, D.C.

RESEARCH AND DEVELOPMENT ENGINEERS

For creative engineers with imaginative and analytical minds, The RAND Corporation offers positions demanding the highest levels of initiative and ability. Individual responsibility includes Equipment Integration, Theoretical Evaluation, Equipment Improvement, and Theoretical Implementation in complex Digital Computer Controlled Systems. RAND engineers are fully oriented in the requirements, limitations and scope of the entire system and they assume the responsibility for improving, revising, broadening and perfecting the complete project.

Academic degrees in the engineering sciences are desirable but no more important than a sound background, practical experience and a demonstrated aptitude. Salaries offered are commensurate with ability and experience.

Orientation for successful applicants will begin in Eastern Massachusetts, and subsequent permanent relocation to Santa Monica, California, will be required. For further information or confidential interview, write, enclosing your detailed resume, to:

John Creighton

The **RAND** Corporation

Box 98, Lexington 73, Massachusetts

WHAT "CAREER OPPORTUNITY"

Means to an Electronic Engineer at General Electric

"CAREER OPPORTUNITY"...two words you see used everywhere.

WE USE THEM a lot at Electronics Park. But with this difference. To every man who comes to work with us, "career opportunity" has a specific meaning.

And for a very good reason.

ELECTRONICS PARK is where many new concepts in electronics are born. The G-E organization here is primarily in the business of designing and developing *new* things—components, systems, equipments. Often a whole new product line results from applied research activities here—and after preliminary

production and sales in this area, a new department is organized to handle it—a new plant built in another area—and a new management staff appointed to direct it.

AND MANY of the supervisory and specialist positions in such a new G-E department are drawn from the experienced development staff at Electronics Park.

JOIN US NOW... if you have a BS, MS or PhD degree in Electrical or Mechanical Engineering or Physics AND/OR electronic experience. Send the coupon below... or if you prefer, write us personally in complete confidence.

TO: GENERAL ELECTRIC
Electronics Pk.,
Syracuse, N. Y.
ATT: Dept. 1-7-E
Technical Personnel

I am interested in ...
... Advanced Development
... Design
... Field Service
... Technical Writing
... Sales

In the field of ...
... Military Radio & Radar
... Multiple Microwave
... Mobile Communications
... Semiconductors
... Electronic Components
... Computers
... Tubes & Antennas
... Television Receivers
... Industrial Television

FROM:

NAME _____

ADDRESS _____

DEGREE _____

GENERAL  ELECTRIC

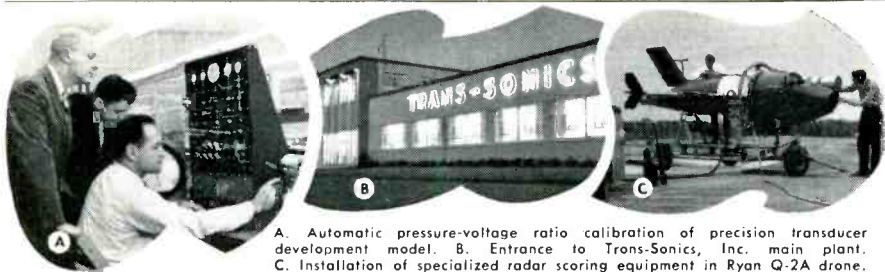

A. Automatic pressure-voltage ratio calibration of precision transducer development model. B. Entrance to Trans-Sonics, Inc. main plant. C. Installation of specialized radar scoring equipment in Ryan Q-2A drone.

Do these pictures fit into your future?

The experience of Trans-Sonics, Inc. in the development of airborne microwave electronic systems and the design and manufacture of precision temperature and pressure transducers has made it one of America's fastest growing electronic firms. The rapid expansion necessary to keep pace with this progress has created a number of long-term opportunities in key engineering positions.

If you are a career-conscious engi-

neer who seeks to improve his future by becoming associated with a company where:—

you will have greater responsibility working with a small, flexible integrated group . . . you will enjoy recognition and promotion that are not tied to seniority

then you should investigate one of the following positions.

**RESEARCH & DEVELOPMENT DEPT.
AIRBORNE RADAR EQUIPMENT**

ELECTRONIC ENGINEER

Overall responsibility for Field Test Program.

ELECTRONIC DESIGN ENGINEER

Group leader for advanced designs.

**ENGINEERING DEPT.—PRECISION
TEMPERATURE & PRESSURE TRANSDUCERS**

ELECTRICAL OR MECHANICAL ENGINEER

Technical direction, programming and supervision of qualification and environmental tests.

Write to Mr. Elmer G. Guilmartin or call collect BUrlington 7-2011.

Trans-Sonics, Inc.

LEXINGTON 73, MASSACHUSETTS

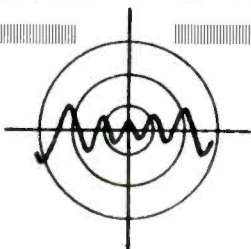

LOUDSPEAKER ENGINEERS

for research, development & design of

Public Address & Hi Fi • Loudspeakers & Enclosures

UNIQUE OPPORTUNITY

for creative men. Excellent future with progressive, long established, leading firm in loudspeaker industry
Salary commensurate with ability

Please send resume or telephone
Personnel Director, WHITE PLAINS 6-7700

UNIVERSITY LOUDSPEAKERS, Inc.

80 South Kensico Avenue
White Plains, New York

DO YOU NEED ENGINEERS WITH EXPERIENCE IN:

- Research
- Development
- Design
- Instrumentation
- Servomechanisms
- Missiles
- Audio Systems
- Control Systems
- Radar
- Computers
- Transistors
- Other Fields

Place an "ENGINEERS WANTED" advertisement in this SEARCHLIGHT SECTION of ELECTRONICS. It's an inexpensive, time saving method of selecting competent personnel for every engineering job in the electronics industry. The selective circulation of ELECTRONICS offers you an opportunity to choose the best qualified men available throughout the industry.

For Rates and Information

Write:

CLASSIFIED ADVERTISING DIVISION

Box 12

McGraw-Hill Publications

New York 36, N. Y.

BUSINESS OPPORTUNITIES

EQUIPMENT - USED or RESALE

UNDISPLAYED RATE

\$2.40 a line, minimum 3 lines. To figure advance payment count 5 average words as a line.

BOX NUMBERS count as one line additional in undisplayed ads.

DISCOUNT of 10% if full payment is made in advance for four consecutive insertions of undisplayed ads (not including proposals.)

Send NEW ADS or Inquiries to Classified Adv. Div. of Electronics, P. O. Box 12, N. Y. 36, N. Y., for February 1st issue closing January 22nd

The publisher cannot accept advertising in the Searchlight Section, which lists the names of the manufacturers of resistors, capacitors, rheostats, and potentiometers or other names designed to describe such products.

DISPLAYED RATE

The advertising rate is \$21.75 per inch for all advertising appearing on other than a contract basis. Contract rates quoted on request.

AN ADVERTISING INCH is measured 7/8 inch vertically on one column, 3 columns—30 inches—to a page.

EQUIPMENT WANTED or FOR SALE ADVERTISEMENTS acceptable only in Displayed Style.

**BC-221 HETERODYNE
FREQUENCY METERS**

The most widely used frequency calibrating device. Over 500,000 have been made. Provides an accurate (.01% or 25 cycles of indicated frequency when within -30°C to +50°C temperature range) reference source of frequency for calibrating oscillators, receivers, transmitters, etc. Operates over fundamental range 125-250 KC and 2-4MC with over 1500 calibration points supplied. Harmonics useful to 6th order. Indication by audible zero beat, RF output 2 milliwatts. Can be operated from either internal batteries (not supplied) or through AC supply; 2 of which are available. Bolton has reworked these surplus units to meet Military Specifications 71-811E and furnishes a certification of accuracy with each instrument issued in addition to calibration book and 176 page instruction manual. Packed, each unit measures 19 1/2" x 13 1/2" x 14" and weighs 21 lbs.

Prices for non modulated type... \$135.00
(Our choice of model)

Prices for modulated type... \$165.00
(Our choice of model)

Set of Batteries... \$11.50
Our commercial power supply... \$35.00
(BL16—weight: 6 lbs.)

Military Supply... \$95.00
(RA133A—weight: 10 lbs.)

**FM SIGNAL GENERATOR
I-208**

Built like the proverbial "brick battleship" the I-208 is the principle component of Signal Generator SG-6. This instrument is used in the calibration and alignment of frequency and sensitivity of frequency modulated radio equipment. The device has built into it, circuitry for the accurate determination of power output and frequency deviation. The I-208 operates from either a 115 volt 60 cycle source or 12 volt storage battery. The RF output at the end of the 30 ohm line is .333 milliwatts. Up to 7 milliwatts is available at a high output terminal. The frequency range is 1.9 to 4.5 megacycles and 19-45 megacycles with the accuracy of .03% of dial indication. These instruments are like new and furnished with instruction books. Packed for export, each instrument measures 14" x 20" x 14" and weighs 125 lbs.

PRICE: \$1050.00 including instruction book.

BOLTON 
Laboratories, inc.
BOLTON, MASSACHUSETTS, U. S. A.

BRITISH PUBLIC COMPANY

With wide production facilities in light engineering, electrical and electronic fields requires to tie up with an American Company with a view to manufacturing new products in the United Kingdom.

BO-3504, Electronics
Class. Adv. Div., P. O. Box 12, New York 36, N. Y.

**If there is anything you want
that other readers can supply
OR ... something you don't want—
that other readers can use—
Advertise it in the
SEARCHLIGHT SECTION**

WANTED

**We will buy the equipment listed below
REGARDLESS of CONDITION!**

Special Price Paid For R.C. 286 Antenna

JUNCTION BOXES

CBY-62018—CW-22081—CBY-62008A—CBY-23049

RELAYS

5059R—5058—5055—5053M—5053—Price Bros. Relay #10
A-18259—Antenna Switching Relay Box—BG-AN-198—BC-408

TUBES

35T—Eimac—53A—VT-127A—WL-530—100TH—250TH
450TL—750TH—15E

TRANSFORMERS

D 163248—RET. D 163250—D 163254—D 162899—D 183254
D 165964—KS 9273—KS 9012—KS 9536—KS 9336
KS 9608—KS 9602—KS 9605—KS 9117—KS 9607
KS 8984—KS 9153—KS 8983—X 330005—A 14987

AIRCRAFT SPARK PLUGS

RB-19R—RB-48552—590 S2—613 S2—RB 5/2—RD 5/3—RB 5/4
RB 5/5—RB 23-R—RP-43-S—63-S*—64-S—LE-44—LE-45—LS-48
AC-181—AC-281—RB-212 S2—RB-312 S2—RC-9R—RS-14-1R
RZ-14-R—R-214—RB 27-R—RB-23—RS 19-2R—RN-5/3

Will also purchase new or used magneto points.

RADIO and ELECTRONIC SURPLUS

14000 Brush Street • Detroit 3, Michigan

Phone: TOWnsend 9-3403

Superior Vacuum Tube Patents

Eleven U. S. Patents for sale or license. Cover superior, practical, standard vacuum tubes for UHF, VHF, FM, TV, Radio, Power, Transmitting, Industrial Applications.

BINNEWEG TELEVISION 5330 College Ave.
Oakland 18, Calif.

ENGINEERING DEGREES

(Under and Postgraduate)

E. E. Option Electronics
Earned Through Home Study
Residential Courses Also Available

PACIFIC INTERNATIONAL UNIVERSITY
American College of Engineering
Box 27724 Hollywood 27, Calif.

ASSEMBLING

Plant in the Netherlands, equipped with modern machinery and test instruments has capacity over for the assembling of small and medium sized apparatus in the electronic field. The plant is 4,000 sq. feet big, and 1 year new.

CWW-3706, Electronics
Class. Adv. Div. P. O. Box 12, N. Y. 36, N. Y.

Additional Wanted Advertising on page 414

RADAR

P.P.I. REMOTE REPEATERS

VD-7" Upright
VE-7" Table Type
VF-5" "B" Scope "5" P.P.I.
VG-"24" Plotting Table
VJ-12" Upright
VK-12" Upright
VL-12" Upright R.H.I. IND.
All indicators are 110v 60 cyc.

SHORAN

AN/APN-3-AN/CPN-2

The AN/APN-3 and AN-CPN-2 are Precision distance measuring installations. This equipment operates on 225 mc. The range is 250 miles with an accuracy of 25 feet. This equipment is widely used by geological companies for prospecting and mapping. Power input is 110v 400cyc and 28v DC.

AN/GSQ-1 NAVY TYPE PF SPEECH SCRAMBLER

This is a unit designed to be attached to either a radio or telephone circuit to scramble speech or code. This equipment utilizes coded cards in each terminal equipment. Unless the properly numbered card is inserted on the receiving end the speech can not be unscrambled. This provides an excellent privacy system. 24 VDC input. Mfg. Western Electric.



SCR-536 HANDI-TALKIE

Freq. range 3.7.5.5mc crystal controlled battery operated handi-talkie. The range of this equipment is approximately 2 miles. We can supply these sets to your specified freq. Completely reconditioned and guaranteed. **WE CAN SUPPLY OVER 1500 OF THESE SETS**

AN/ARC-12

AIRBORNE 225-350 MC TRANSCEIVER

These sets provide 10 chan channel communication from 225 350 mc. A guard channel is also provided. The AN/ARC-12 is a late set and is the V.H.F. version of the AN/ARC-1, and can communicate with the ARC-19, ARC-27, ARC-33 etc. Output is 8 watts. Input is 28 VDC.



RADALAB INC.

87-17 124th St., Richmond Hill 18, New York, N. Y.

Phone Virginia 9-8181-2-3

OVERSEAS CUSTOMERS CALL US DIRECTLY BY TELEX OVERSEAS TELETYPE TWX N. Y. *4-4361

AN/ASQ-1 AIRBORNE MAGNETOMETER

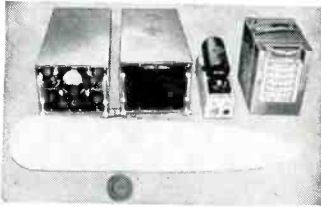

This is an airborne chart recording magnetometer. The set consists of an amplifier, oscillator, detector head, chart profile recorder, power supply. The equipment has a sensitivity of 2 gamma. The AN/ASQ-1 records on an Esterline angus recorder disturbance in the earth's magnetic field. An indicator is provided that gives a bearing on a magnetic disturbance. Input is 28v DC. Weight about 130 lbs.

AN/APR-4 Search Receiver

The AN/APR-4 receiver is a precision laboratory instrument covering 38-4000 MC in 5 plug-in tuning units. The tuning units are calibrated directly in megacycles. A wide or narrow band width I.F. may be selected in the receiver enabling pulsed signals to be observed. Outputs for a pulse analyzer; pan-adaptor, etc. are provided. A tuning meter is also provided. Input 110v 60 cyc.



MN-5

F.M. 30-42 MC MOBILE RADIO SETS

This set is ideal. For police, military or anywhere a compact reliable system of communication is desired. Power output is 5 watts. Set is completely remote controlled. Input is 12 VDC.

CARRIER EQUIPMENT

CF-1 4 CHAN. VOICE AND TELEG. TERMINAL 115v 230v A.C. 12v D.C.
CF-2 4 CHAN. TELEGRAPH AND TELETYPE TERMINAL 115v 230v A.C. 12v D.C.
CF-3 4 CHAN. INTERMEDIATE REPEATER 115v 230 A.C. 12v D.C.
CF-4 CARRIER CONVERTER. Used to adapt the CF-1 and 2 for operation on a simple 2 wire trans. line instead of using spiral 4. 115v, 230v A.C. 12v D.C.
TH-1 TELEGRAPH TERMINAL

EQUIPMENT

AN/CPN-6 3 CM Beacon
AN/UPN-4 3 CM Beacon
AN/URC-4 VHF Rescue Set
AN/TRC-1, 2, 3, 4, 6, 7.
AN/GRC-9 Field Radio, many other AN equipments.
SCR-191, 300, 399, 499, 508, 608, 808, and others.
TEST SETS from TS-1 to TS-700 many late types
PARTS SPARE and sets of equip. mfg. after 1948, radar, radio and special types write NOISE MEASURING UNITS.

RDO

NAVY SEARCH RECEIVER

The RDO is a very elaborate radar search receiver greatly improved over the APR-4. The set uses APR-4 tuning units, but is much more versatile, having input metering, D.B. output meter, automatic noise limiter, and greater selectivity and sensitivity. The RDO is recommended when only the very best will do. Input 110v 60 cyc.



RC-115B GROUND 75 MC MARKER BEACON TRANS.

This is a 75 C Marker Beacon Ground Station. This equipment comes mounted in a transporting trunk. The set can emit either inner, outer, or airways signals. The transmitter is crystal controlled. 110 Volts 60 cyc. Late USAF equip.

INFRARED SNOOPERSCOPE TUBE

TYPE 6032—Infrared Image Converter Tube. Electrostatic focusing. Size 2x4 1/2". List \$150.00. Requires 20,000 volt, 0.05 milliamper supply. This tube is in current use in all U. S. military infrared equipment & is 2 to 3 times superior to the old 1P25 in definition and performance. Diagram for simple power-supply included. A \$120.00 saving—NEW SURPLUS. Guaranteed. ONLY \$29.95 postpaid.

INFRARED LIGHT SOURCE

Snooperscope Part #1361A.—Input 6 volts, 5 amps. Has special 5/8" dia. A-1529 glass filter & goldplated reflector. Projects a powerful beam of invisible infrared radiation (free of all visible light) that illuminates objects for infrared viewing up to 400 feet. For any infrared system. Complete with bulb.

STK. #L-5459.—NEW, ONLY.....\$7.95 Ppd.

STK. #L-5462.—Used, New Condition \$5.95 Ppd.

IMAGE TUBE POWER SUPPLY

Part #1450A.—Power-pack for 1P25 Tube (will also supply CV-147 Tube) Input 6 V.D.C., output 4,250 V.D.C. and additional focusing voltages. Checked-out, complete & operating with 1654 tube. Gov't cost \$68.00. Used. NEW CONDITION \$7.95 Ppd.

McNEAL ELECTRIC & EQUIPMENT CO.
4736 Olive St. Dept. E-1 St. Louis 8, Mo.
Terms: Prices Include Postage. Cash With Orders. Well Rated Concerns (D & B) Net 10 Days Cash.

MINIATURE

Type - **5687**

Twin Triode Tube

Brand New—Purchased from Original Manufacturer.

Laboratory Checked—Fully Guaranteed by us. Production Quantities available. Immediate Delivery.

Priced much lower than your present equipment cost.

KLEIN & SCHWAB

74 Cortlandt St. N. Y. 7 N. Y.
Beekman 3-5690

Your inquiry will have Special value . . .

If you mention this magazine, when writing advertisers. Naturally, the publisher will appreciate it . . . but, more important, it will identify you as one of the men the advertisers wants to each with this message . . . and help to make possible enlarged future service to you as a reader.

A N C O N N E C T O R S

FAST DELIVERY

FROM STOCK

LOW PRICES

Let us quote on your requirements.

All comply with government specifications

Wilgreen Industries
99 MURRAY ST., NEW YORK 7, N. Y.
WOrth 4-2490-1-2

Cadmium or olive drab finish.

SAVE ON TUBES BRAND NEW TUBES GUARANTEED TUBES

OA2	\$.90	2K34	85.00	6J4WA	2.50	WF-274B	.90	464A	1.95	842	1.50	5725/6A56W/	4.00
OA2WA	3.00	2K35	175.00	6J6W	1.00	FG280	27.50	X-481D	50.00	845	3.00	6187	4.00
OA5	3.50	2K39	100.00	6K4	2.25	WE-282A	2.74	CK501AX	1.00	849	17.50	5726/6AL5W	.60
OB2	.60	2K41	100.00	6L6Y	2.00	WE-282B	5.00	RH-507	20.00	851	7.50	5727/2D21W	1.50
OB2WA	3.00	2K42	110.00	6L6WGB	3.75	WE-283A	3.50	508/6246	150.00	852	4.00	5726/6AL5W/	
OB3VR90	.85	2K43	110.00	6SK7W	1.00	QK283A	150.00	527	20.00	861	15.00	6097	3.25
OD3	.60	2K44	110.00	6SL7W	1.25	QK284A	150.00	WL-530	17.50	865	.90	5744	1.00
1AD4	1.00	2K45	35.00	6X4W	1.00	WE-285A	5.00	559	4.00	872A	1.35	5749/6BA6W	1.25
ELC1B	1.00	2K46	200.00	6X4WA	2.25	WE-286A	5.00	583	2.00	884	1.00	5750	3.00
1B22	1.10	2K47	75.00	6X5WGT	1.25	287-A	2.20	KU-610	3.50	GL-889	35.00	5751	3.00
1B23	2.75	2K48	55.00	SRC-12	150.00	WE-290A	7.00	KU-627	7.50	GL-889A	50.00	5751WA	3.50
1B24	5.00	2K50	150.00	7YP2	150.00	GB-302	5.00	KU-628	7.50	902A	2.00	5755/420A	Q
1B24A	12.50	2K54	5.00	12AY7	1.70	304TL	12.50	WL-652	20.00	902P1	2.00	5763	1.20
1B26	1.25	2K56	50.00	12DP7	15.00	WE-305A	2.85	HK-654	18.50	905	3.00	5784WA	7.00
1B27	10.00	2X2A	.90							917	1.50	CK-5787	4.75
1B29	2.50	3AP1	1.50							919	1.50	5814	.65
1B32	1.00	VR-33	99.50							922	1.75	5814WA	3.00
1B35	3.50	3B22	1.45							927	.75	5819	35.00
1B36	4.00	3B24	1.00							935	4.00	5825	7.95
1B40	2.00	3B24W	4.75							957	.35	5829	1.00
1B42	5.00	3B26	3.00							958A	.35	5837	50.00
1B44	15.00	3B29	6.00							959	1.25	5840	4.00
1B45	25.00	3C22	60.00							991	.75	5840A	5.00
1B47	4.00	3C23	3.75							CK-1005	.35	5841	5.00
1B51	6.75	3C24	2.50							CK-1006	2.50	5844	1.50
1B62	4.00	3C31	1.00							CK-1007	.45	5851	4.00
1B63A	19.50	3C33	6.50							1229	2.75	5852 TE-5	6.00
1N21B	1.25	3C45	7.00							1500T	75.00	5876	8.00
1N21C	3.00	3DP11A	6.00							1603	3.50	5879	1.25
1N23B	.90	3D21A	3.00	12GP7	15.00	307A/RK75	.75	GL-672	20.00	1614	1.50	5881	2.50
1N23BM	3.00	3E29	8.50	FG-17	3.95	WE-308B	12.50	WE-701A	2.50	1620	3.00	5893	9.00
1N25	2.20	3FP7A	2.50	RX-21	3.50	WE-310A	4.00	702A	.50	1622	2.00	5894	15.50
1N26	3.50	3JP1	7.50	PJ22	Q	WE-311B	4.00	WE-703A	1.25	1623	1.25	5896	4.00
1N28	6.00	3J30	35.00	HK24	3.00	WE-312A	1.50	WE-704A	.60	1624	1.15	5899	4.00
1N31	1.90	3J31	35.00	26E6WG	2.50	WE-315A	10.00	WE-705A	.75	1625	.70	5902	5.50
1N32	9.00	3K22	150.00	RK-28A	2.50	WE-316A	.50	706AY-GY	10.00	1626	.25	5902A	5.50
1N38A	.60	3K23	150.00	BK29D	Q	WE-323A	10.00	707B	2.50	1631	1.00	5902A(CL)	2.50
1N40	4.75	3K30	100.00	5T	.70	WE-326A	5.00	WE-708A	.75	1636	.75	5904	Q
1N42	8.00	4-65A	14.50	D-42	40.00	WE-337A	5.50	WE-709A	1.50	1641	1.35	5926	11.00
1N46	.60	4-125A	19.50	RK47	3.00	WE-338A	5.00	714A	7.50	1945	65.00	5910	.60
1N52	.65	4B23	3.50	V-50	75.00	WE-348A	6.00	715A	1.75	2000T	150.00	5915	.80
1N63	1.40	4B26	7.50	V-50XR	75.00	WE-349A	5.00	715B	3.00	2050	1.00	5922	3.50
1N69	.40	4B31	20.00	HK-54	2.00	WE-50A	2.50	715C	10.00	2051	.65	5933/807W	5.00
1P21	40.00	4C27	7.50	QK-57	Q	50B	2.00	717A	.50	HK3054	100.00	5956	3.00
1P24	1.50	4C28	25.00	QK-59	20.00	54C	7.00	720AY-EY	35.00	ZB*200	99.50	5965	1.00
1P25C	Q	4C35	13.50	QK-60	20.00	WE-355A	9.95	721A	.75	4210	Q	5977	3.00
1P28	7.50	4D21	19.50	RK-60/1641	1.25					R-4330	9.00	5977A	3.00
1P30	1.35	4E27	7.50	RK-61	2.50					R-4340	9.00	5981	70.00
1V5	.90	4J22	100.00	QK-62	20.00					5516	5.50	5962	149.50
1W5	.90	4J26	100.00	HY-65	1.00					5517	1.00	5987	9.50
1Z2	2.50	4J27	100.00	RK-65/5D23	7.50					5544	15.00	5997 TE-10	9.00
2A1P	4.00	4J28	100.00	FG-67	9.00					5551 FG271	25.00	6005/6AQ5W	1.75
2A1P1A	6.00	4J29	100.00	HY-69	2.25					5553		6021-A	4.50
2A515	4.75	4J30	100.00	RKR-72	.50					FG258A	80.00	6028/408A	2.00
2B24	.80	4J32	45.00	RKR-73	.50					5559 FG57	10.00	6037/OK243	75.00
2C33	.75	4J34	25.00	FG-95	16.50					5560	16.50	6038	9.50
2C35	2.50	4J42	25.00	ML-100	50.00					5561	29.50	6044	15.00
2C39A	9.50	4J50	99.50	100TH	6.50					5586	110.00	6046	.75
2C39A sealed	11.00	4J52	50.00	WE101D	3.00					5588	80.00	CK-6050	2.00
2C40	8.50	4J63	49.50	FG-104	29.50					5591/403B	2.75	6073	2.25
2C42	8.50	4J64	49.50	FG-105	11.00					5606	125.00	6074	2.50
2C43	8.75	4PR60A	45.00	F-123A	2.50					5611	45.00	6080WA	6.75
2C44	.30	4X150A	20.00	F-128A	10.00					5634	6.50	6080	4.00
2C46	5.00	4X150D	25.00	FG-154	10.00					5636	2.95	6081/ATR407	22.50
2C50	6.00	4X150G	30.00	VT158	9.75					5639	6.50	6082	3.25
2C51	3.95	4X250M	35.00	FG-166	6.75					5639A	7.00	6088	1.50
2C52	2.75	5ABP1	20.00	FG-172	17.50					5643	5.00	6095	2.00
2C53	10.00	5ADP1	20.00	QK-181	12.50					5644	6.50	6096	1.30
2D21	.75	CSB	1.00	HF-200	10.00					5645	6.00	6099	1.40
2D21W	1.00	5BP2A	2.95	WL-200	75.00					5646	4.50	6100/6C4WA	2.25
2D29	.80	5CP1	1.95	CE-203	2.50					5647	5.00	6101/6J6WA	2.25
2E24	2.50	5CP1A	7.50	203A	3.50					5650/5981	70.00	6110	6.90
2E25	3.75	5CP7	8.00	204A	25.00	WE-356B	3.50	721B	7.00	5651	1.40	6111	5.00
2E26	3.25	5CP7A	8.00	205F	7.50	WE-359A	2.00	722A	.75	5654	1.50	6112	6.50
2E27	.60	5CP11A	9.50	207	75.00	368AS	1.00	723A B	7.50	5654/6AK5W/		6116	150.00
2E32	1.00	5C22	27.50	211/VT4C	.60	385A	Q4	725A	3.00	6096	3.25	6117	60.00
2E41	2.25	5JP1	10.00	212E	15.00	WE-388A	1.20	726A	5.00	5656	7.00	6130	7.50
2H21	60.00	5JP2	5.00	WL-218	15.00	WE-393A	4.50	726B	15.00	5657	100.00	6136	2.50
2J31	10.00	5JP4	5.00	QK221	150.00	WE-396A	3.25	726C	15.00	5663	1.25	6147	3.00
2J32	10.00	5JP5	6.50	QK235	Q	FP-400	20.00	730A	7.50	5665	35.00	6153	5.00
2J33	29.50	5JP11A	7.50	QK-243	50.00	WE-403A	1.50	750TL	35.00	5667	125.00	6159	3.00
2J34	10.00	5MP1	2.95	QK-249	150.00	WE-407B/5591	2.75	801A	.35	5670	2.00	6177	75.00
2J36	29.50	5NP1	2.00	WE245A	6.45	WE-404A	12.00	802	2.00	5670WA	4.25	6189	
2J48	10.00	5R4GY	1.25	WE-2493	2.50	WE-40-A	2.00	803	8.00	5675	7.00	12AU7WA	3.00
2J49	35.00	5R4WGA	4.00	249C	3.00	WE-407A	4.00	804	2.00	5676	1.15	6201/12AT7WA	3.00
2J50	35.00	5R4WGY	2.50	250-R	4.50	WE-408A	2.25	807	1.20	5683	5.75	6203	2.75
2J51	200.00	5Y3WGT	1.75	250TH	21.00	WE-412A	4.50	807W	2.00	5687	1.85	6205	6.00
2J54	25.00	6AC7A	1.00	250-TL	12.50	GL-414	63.00	808	1.00	5687	3.00	6211	1.25
2J55	32.50	6AC7W	1.00	WE-251A	49.50	WE-416B	37.50	809	2.25	5697	5.00	6211	1.25
2J56	40.00	6AK5W	1.00	WE-252A	7.50	417A	2.50	811	2.90	5692	5.00	6246/508	200.00
2J61	15.00	6AN5	2.25	QK252	Q	WE-417A	12.50	812A	3.50	5693	4.50	VA-6310/	11.50
2J61A	50.00	6AR6	1.50	WE-254A	2.50	WE-418A	16.00	813	9.50	5696A	1.25	V260	75.00
2J62	5.00	6AS6W/5725	2.70	FG-258A	80.00	WE-421A	7.00	814	1.35	5702	1.50	6363	75.00
2J62A	50.00	6AS7G	2.50	WE-258B	5.00	WE-422A	10.00	815	1.50	5702WA	6.00	8002R	15.00
2K22	13.50	6AU6WA	2.50	V-260	Q	WE-423A	5.75	828	8.00	5703	9.00	8012	1.00
2K23	12.50	6BL6	30.00	VA-6310	75.00	WE-428A	40.00	829	5.00	5703WA	4.00	8025A	2.85</

BARRY BARGAINS

LABORATORY TEST EQUIPMENT

5" DUMONT SCOPE MODEL 274A
regularly sold for \$150 now available for **LESS THAN HALF PRICE**. Portable, light weight. Ship wt. only 35 lb. Used, clean, checked out and guaranteed F.O.B. N.Y.C.
SPECIAL! \$65.00

UHF SIGNAL GENERATOR GEN'L RADIO TYPE 804

7.5 to 330 mcs. Made by G.R. & Federal Engineering. Used, clean, checked out and guaranteed. Special! (Worth Over \$800.00)
F.O.B. N.Y.C. \$99.50

5" DUMONT model 208H. A REAL BUY \$95.00
5" RCA model WO 88A. (Worth \$170). Vy good ABSORPTION WAVEMETER. General Radio type 758A New orig. ctng. w/instructions. 85.00
Some made by Hewlett-Packard (Orig. \$40)
MEGA-MARKER SR. 13 char. stat. marker. Very good cond. stat. included. 512.50
FM SIGNAL GENERATOR. Measurements mod. 78FM. Very good condition. 549.50
UHF SWEEP GENERATOR. RCA WR-41B. Very good. 5175.00
TV SWEEP GENERATOR. RCA WR-59A. Very good. 5225.00
TV SWEEP GENERATOR. RCA WR-59B. Very good. 575.00
TV SWEEP GENERATOR. RCA WR-59C. Very good. 5125.00
TV SWEEP GENERATOR. RCA WR-59D. Very good. \$150.00

EXTRA SPECIALS

TRANSFORMER. 3100-0-3100 volts @ 1/2 amp! A real brutal! PRIMARY: 98-104-110-118-122 volts. 60 cycles AC. SECONDARY: 3100-0-3100 @ 500 ma. 15 KV impregnated mica insulation. Conservatively rated. 9" x 8" x 7 1/2". New in original mfg's. wood boxes. 60 lbs.
POB, N.Y.C. \$34.50

10KV oil FILLED POWER XFMR. New Orig. erated Gen'l Electric. For radio station or industry. PRIMARY: 220 volts 3 phase 60 cycles. SECONDARY: 10KV @ 3.2 A. OR 9850 @ 1.4A. PLUS 4925 @ 3A. Mean. (Unrated) abt. 4 1/2" high x 3 1/2" x 2 1/2" deep. Wt. 1600 lbs. New F.O.B. Phila. (worth \$4,200) our Price Only...
\$250.00

RING DOWN PANEL. W.E. RD-101. Switchboard in compact form. Rack mtd. For 12 order wire lines. 1 New orig. erated.
\$150.00

Terms: F O B—N Y C—25% Deposit with order—or send full remittance to save C O D charges—D & B Rated Firms (F2 1/2 or Better) Net 10 days. CABLE: BARRYLECT. N. Y. TELEGRAPH: BARRY ELECTRONICS, FAX, N. Y. C.

BARRY ELECTRONICS CORP.
Dept 1-E
512 Broadway, N. Y. 12, N. Y.
Phone: Walker 5-7000

CONSISTENTLY HIGH QUALITY ELECTRONIC TUBES

Guaranteed • Unused • Boxed

Critical Types Lab Tested for Your Protection

0A3/VRT5 .95	VXR-130. 1.75	5636A. 2.95
0B2 .75	VT-165. .60	5638. 3.10
0C3 .75	371B. .90	5639. 9.50
0D3 .75	FG-172. 19.90	5640. 3.00
1B35 3.50	NU200. 15.50	5643(JAN). 5.00
1B63A 20.00	211/VY4C. 5.00	5651. 1.40
1N21 1.50	253A. 3.00	5654. 2.40
1N23 .50	GL-299. 2.00	5656. 4.50
1N70 1.60	3047L. .60	5696. .90
1P24 1.50	(Surp) 14.00	5703. .55
1U4(surp). .38	307A. .60	5704. 1.90
NE-2 .25	316A. .40	5718. 2.00
2C44 1.00	339A. 10.00	5719. 2.00
2C40 8.50	350A. 2.75	5726/. 2.00
2C43 8.50	350B. 2.75	6AL5W .90
2C46 6.00	357A. 15.00	5751. 4.50
2C51 2.25	359A. 1.75	5794. 5.00
2C53 9.95	396A/2C51. 3.00	5802. 4.75
2D21W .85	412A. 3.75	5812. 1.00
2D21W/5727 .95	416B/6280. 29.50	5814. 1.00
2J32 12.50	421A/5998. 3.00	5829. 1.00
2K25A 19.75	4507H. 4.00	5840. 4.50
RK-2K28 25.00	(Surp) 47.50	5896. 4.50
2K55 15.00	GL451/8020. 2.00	5910. .45
3B25 1.50	ME578. 15.00	5953. 4.50
3B24W 5.00	2666/5J30. 5.00	5933/807W 1.50
3B25 5.00	GL673. 13.00	GL6046. 3.00
3B26 5.00	703A(T-S). 4.75	6095. .75
EL3C/4B24. 4.50	725A. 4.00	6097. 1.50
3C23 4.50	7507L. 35.00	6100. 2.00
3C46 1.40	(Surp) 7.50	6113. 1.25
3D23/TB35. 4.75	806. 1.00	6134. 1.75
3K2000LK 807. 1.00	807W/5933. 1.50	6135. 1.75
write 807. 1.00	814. 2.75	6183(GE). 400.00
4-400A 58.50	808. 1.00	6263. 10.00
4B22/EL5B. 5.50	814. 2.75	6267. 6.50
4PR60A (Surp). 40.00	833A. 36.00	6278. 6.50
4X500A (Surp). 65.00	837. 1.25	6263. 10.00
4X500F (Surp). 45.00	845. 1.00	6263. 10.00
5D10 6.25	866A. 4.00	CSF14. 15.50
5JF5 6.00	866J/2B26. 1.40	6292. 37.50
6BL6 29.00	869B (Surp). 25.00	7193. 1.30
6C21/4507L 15.00	869B(RCA com'l). 45.00	8002R. 15.00
6J6W 50.00	872A. 1.25	8008/872A. 3.25
10K9PT 18.50	885. 1.00	8011. 2.50
12DP7A. 29.50	902P1. 2.75	8020. 2.00
15E 1.25	917. 2.00	9002. .65
QK60 40.95	918. 1.50	9004. .85
FG-32 4.50	927. 1.50	VX5005/. 55.00
35T G(Surp) 2.45	CK1007. 75	VX5027. 55.00
CRP-72 40	1616 .50	9006. .20
FG81A 3.25	1629 .55	9006. .20
	1636 .80	9006. .20
	1960 .60	9006. .20

SAVE dough! / HARJO!

RCA TV CAMERA



NEW Surplus 100's SOLD!
Only few left at this price!

Ideal for labs, industry, prisons, TV technicians, swim pools, medical "mechanical eye" for closed circuit TV. 1846 Iconoscope, 6-stage video amplifier and clipper. THE REAL THING! Send for new, free, complete technical data. SOLD AT FRACTION OF REAL VALUE!

\$197.50

TEST EQUIPMENT

- AN/GPM-14
- LAG TS-125
- TS-10C TS-143
- TS-13 TS-182
- TS-15 TS-184
- TS-16 TS-204
- TS-19 TS-251
- TS-24 TS-261
- TS-32 TS-268
- TS-33 TS-294C
- TS-34 TSX-45E
- TS-35 I-56
- TS-36 I-122
- TS-45 I-166
- TS-47 I-177
- TS-59 I-222
- TS-89 IE-12
- TS-92 IE-19
- TS-110 IE-36

GROUND ELECTRONICS

- ARB BC-342
- ART-13 BC-344
- BC-191 BC-348
- BC-222 BC-375
- BC-224 CRT-3
- BC-312 TCS-12
- BC-314

AIRCRAFT ELECTRONICS

- ARC-1 ARC-27
- ARC-3 MN-62
- ARC-4 MN-53
- ARC-5 LP-21
- ARC-12 LP-31
- ARN-6 AS313-B

POWER ELECTRONICS

- DY-11 PE-206
- DY-12 5D21NJ3A
- DY-17
- Pioneer 12117
- Pioneer 12123
- Pioneer 12133
- Pioneer 12142

1,000's of other items
Tell us your needs!

RADAR EQUIP.

- APA
- APS-4-.6
- APS-15
- SCR-717-.720
- SL
- APQ-13
- T-116/APT-5A

1-222 SIGNAL GENERATOR-MICROVOLTER
Freq. range: 8-15 Mc. & 150-230 MC. Complete with all tubes and 5 MC Calibrating Crystals. Self-contained 110 V. and 60 cycle power supply. With Schematic. Cost the Govt. approx. \$700.00 Brand New...
\$49.95

WANT TO BUY! BC-224, BC-348 RECEIVERS

ARC-3 BC-788 R5/ARN-7
Cash or trade. Immediate action.

IMPORTERS-EXPORTERS!

Write us in fullest confidence. Lowest prices. Dependable merchandise, certified by CAA if desired, quick delivery and prompt action on foreign inquiries in all languages!

Harjo Sales Co.
Office-Warehouse: 503 N. VICTORY BLVD. BURBANK, CALIF. Phone: Thornwall 5-2613

SPECIAL TUBE OFFER

Recent production according to latest Military specs. Brand New factory sealed.

- 2J34 — \$12.50
- 2J48 — \$30.00
- 730A — \$ 7.50

Also

2K50-\$150.00
10,000 6F5 Brand new RCA & GE .35
20,000 3A5 Brand new RCA & Raytheon .50
10,000 0B2 Brand new Raytheon & Hytron .60

EMELTONE ELECTRONICS

71 West Broadway, New York 7, N.Y. Rector 2-1696

A BARGAIN FOR YOU in a...

SOLA Constant Voltage TRANSFORMER

End Fluctuating Line Voltage

OVER 60% OFF the factory price of a 1-input 2,000 VA unit! And here's another bonus! This Air Forces 2,000 VA overstock, Sola Cat. No. 30768, has 4 inputs! 90-125 V., 190-250 V., 60 cy. or 50 cy. Isolated secondary is constant 115.0 V. ± 1% from no-load to full-load of 17.4 amp. So, if you choose, use it as a 220:115 V. step-down. And slash \$147.50 off the factory 1-input price!

Brand new in original wood box. 4 cu. ft. Ship. wt. 254 lbs. F.O.B. Pasco, Wash. Only **\$97.50**

(EXPORTERS: Note choice of 50 cycles.)

THE M. R. COMPANY
P. O. Box 1220-B Beverly Hills, Calif.

NEW CATALOG

WAVEGUIDE and COAXIAL Test Equipment & Components
write on company letterhead

ADMITTANCE-NAMCO CORP.
Farmingdale, L. I., N. Y.

FOR SALE

New and unused component electronic parts. Including resistors, condensers, switches, tubes, photomultipliers, crystals, etc. Photomultipliers are REA #6199 in original cartons, crystals are sodium iodide thallium activated 1" cylindrical in original sealed containers. Very favorable prices. Write to

Electronic Parts
P. O. Box 3164 Glendale 1, California

PLATE CIRCUIT RELAYS



SIGMA 4F8000S; 8000 ohm; 1.6 ma to operate, 0.5 ma to release; SPDT (1C); #R425 4.95*

SIGMA 5F10000CDW; 10000 ohm; 3.0 ma to operate 2.0 ma to release; SPDT (1C); #R674.....6.95*

SIGMA 5F16000S; 16000 ohm; 0.55 ma to operate 0.2 ma to release; SPDT (1C); #R627 6.95*

SIGMA 5F16000CDW; 16000 ohm; 2.5 ma to operate 1.5 ma to release; SPDT (1C); #R675 6.95*

POTTER-BRUMFIELD LB1D; 5000 ohm; 7 ma; SPST (1A); #R2301.25*

POTTER-BRUMFIELD LB5D; 5000 ohm; 7 ma; SPDT (1D); #R6071.50*



ADVANCE TD/1C/10,000 P3B (E8928-1); 5 ma; SPDT (1A), 8 amp contacts; 10,000 ohm; 9 pin RTMA miniature plug base. Hermetically Sealed; #R10456.00*

ADVANCE TD/1A,3B/10,000 P3B (E8929-1); 6 ma; SPDT (1A,3B), 8 amp contacts, 10,000 ohm; 9 pin RTMA miniature plug base; Hermetically Sealed; #R10466.00*

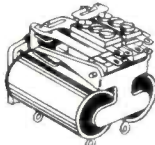

ADVANCE SH/6C/10800; 4 ma; 6PDT (6C); Dual Coil, 10,800 ohm; #R1308 8.50*

ADVANCE SH/1A,1C/16,000; 1 ma; 1A, 1C; Dual Coil, 16,000 ohm; #R13096.00*

KURMAN SUPER SENSITIVE RELAYS



Our Stk#	Kurman Stk #	Oper Ma	DC Ohm	Price Ea
R1032	220C18	280	0 19	4.00
R1030	220C38	3	2000	4.50*
R1031	220C40	1.8	4700	4.75*
R277	220C42	0.5	11400	5.95*
R1033	220C44	0.5	29000	7.50

KURMAN GENERAL ELECTRIC NORTH ELECTRIC GUARDIAN
PRICE ELECTRIC CLARE WESTERN ELECTRIC
LARGEST STOCK OF RELAYS IN THE WORLD!
STRUTHERS DUNN ADVANCE AUTOMATIC ELECTRIC
SIGMA POTTER BRUMFIELD LEACH

MISCELLANEOUS PLATE RELAYS

SIGMA 41FS7; 25 ma; SPDT (1C); 10,000 ohm; #R9142.25*

G. E.; 3 ma; SPST (1A); 10,000 ohm; #R6081.50*

KURMAN 23CE42; 1.5 ma; SPDT (1C); 5000 ohm; #R6094.00

KURMAN 23CF42; 1.25 ma; SPDT (1C); 5000 ohm; Adjustable; #R5524.25

KURMAN MIDGET; 12 ma; SPDT (1C); 1200 ohm; #R3151.25*

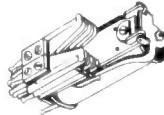

CLARE G (K102); 6 ma; SPDT (1C); 3500 ohm; #R30 1.80*

CLARE C (K101); 2 ma; SPDT (1C); 6500 ohm; #R5884.00*

RBM 452-1041 TELEPHONE TYPE; 4 ma; DPDT (2C); 12000 ohm; #R6853.00



NORTH ELECTRIC MULTIPLE CIRCUIT

An extra fast relay in which moving contact points are mounted on small bars at end of spring-wire reeds. Fixed contacts of the cross-bar type are on terminal-mounted pieces.



Reeds are mounted parallel to the coils so that each contact-bearing weight is positioned across ends of two pole pieces of a coil. "Double-action" flux pulls the movable points in firm contact with the cross bars when the coils are energized. The wire springs return them to unoperated position when the coils de-energize.

Overall dimensions 3 3/8" x 1 1/4" x 2". depth of frame only, or 4 1/4" including all reeds and terminals. Weight: 14.3 oz.

Type N13C; Three 900 ohm coils; (Two coils operate DPDT; one coil operates 4PDT) 8PDT Total. #R12059.75*

Type N24L; Four coils (two—900 ohm and two—1300 ohm); each coil actuates 4PDT contacts individually (Total 16PDT). Coils can be connected individually or in parallel for 16PDT. #R120212.75

Type N14W; Same as N24L. #R1206. 12.75

Type N24F; Four 1300 ohm coils. Same contact grouping as above. #R1207.....12.75

Type N24P; Four coils (three—1300 ohm and one—900 ohm); same contact grouping as above. #R120912.75

Type N25L; Five 1300 ohm coils; each coil actuates 6A contacts individually (30A total). Coils can be connected individually or in parallel for 30A. #R1208.....12.75

CHRONOMETRICALLY GOVERNED D-C TIMING MOTOR BORG-WARNER:



6—24VDC; IRPH pulses are applied to a dc actuator at regular intervals controlled by a cam and a set of contacts on the mechanism. A chronometric governor and balance wheel assure accurate speed regardless of applied voltage or reaction torque. #TDM103. 4.95 ea.

PHASE SHIFT CAPACITORS



W.E. #D150734 S.C. Stock No. 2C6886-1053/C2. As used in BC1053A. SCR-545.

Mark 34 and other Radar equipment. New, in original boxes. \$25.00 each*

AGASTAT TIME DELAY RELAY

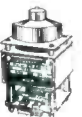

Light, versatile, unaffected by voltage variations, instantaneous recycling. When automatic machinery and circuits must be timed with repetitive accuracy (from 0.1 second to ten minutes or more) you'll find a sure, reliable answer in AGASTAT electrically actuated pneumatically-timed delay relays.

TYPE ND-21; 240VDC, SPDT, Double Break (Form W); Adjustable Time Delay, Min. Delay: 0.5 sec.; Time delay starts when call is de-energized (instantaneous make, slow break); #R1151\$6.95 ea.

For A-C operation use #R1151 with power supply kit PS103.....\$3.95 ea.*

Prices listed with asterisk (*) are subject to QUANTITY DISCOUNTS

1-9	as quoted	50-99	15%
10-49	10%	over 100	20%

MINIATURE AIRCRAFT RELAYS

AUTOMATIC CLARE TYPE "K" ELECTRIC CLASS "S"

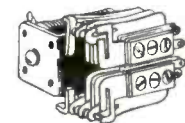

Use a Class "S" relay in aircraft and similar applications where lightweight, small size, and resistance to shock and vibration are important requirements, or where minimum inductance and maximum speed of operation are essential.

Listed below are Automatic Class "S" frames and coils from our stock. They may be purchased separately. However, a complete relay consists of coil and frame. In ordering complete relays, specify which coil with which frame, i.e., F508 with K507.

Stk#	Contacts	Price Ea*	Stk#	Ohms	Price Ea*
F508	1A	.70	K511	500	.90
F509	1C	.90	K507	600	.95
F510	2A	.90	K508	640	.95
F511	1A, 1C	1.10	K509	5000	1.75
F512	1B, 1C	1.10	K510	8000	2.25
F513	1A, 1B, 1C	1.30			
F514	5A	1.50			

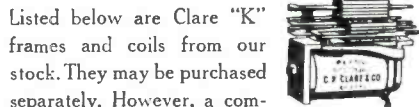

Listed below are Clare "K" frames and coils from our stock. They may be purchased separately. However, a complete relay consists of coil and frame. In ordering complete relays, specify which coil and which frame. i.e.: F501 with K506.

Stk#	Contacts	Price Ea.	Stk#	Ohms	Rated Volts	Price Ea
F501	1A	.65	K501	17	4	.60
F502	1B	.65	K502	30	6	.65
F503	1C	.80	K503	120	12	.75
F504	1A, 1B, 1C	1.10	K504	250	24	.85
F505	2C	1.10	K505	300	24	.85
F506	2C, 1B	1.25	K506	1300	60	1.25
F507	4C	1.70	K512	3000	100	1.50

ALL MERCHANDISE IS GUARANTEED AND MAY BE RETURNED FOR FULL CREDIT

SEND FOR LATEST CIRCULAR. TERMS:—All Prices F.O.B. Our Plant. Rated Firms Net 10 Days; All Others Remittance with Order. Orders Under \$10.00 Remittance with Order. Plus Approximate Shipping Charges (Overage Will be Returned). Cable address: UNIGENCOR, N. Y.

324 CANAL ST., N.Y.C., 13, N. Y. WALKER 5-9642

Universal general corp.

TUBES • ALL FAMOUS ADVERTISED BRANDS ONLY • TUBES

RMA GUARANTEE—From 10% to 95% Below Manufacturers Price—Look and Compare

Special Prices to Quantity Buyers. Most of Our Tubes are Jan.—95% are Original boxed — Brands such as R.C.A., G.E., Ken-Rad., Sylvania, Tung-Sol and Raytheon.

Type	Price	Type	Price	Type	Price	Type	Price	Type	Price	Type	Price	Type	Price	Type	Price	Type	Price	Type	Price
AB-150	51.99	VR-150	.79	2K22	14.50	5BP1	2.49	12AU7	.76	271A	12.99	706A	6.75	815	1.99	1616	.59		
CF31	6.35	OA2	.74	2K23	16.50	5BP1A	8.99	12GP7	12.95	274A	5.95	706B	14.50	816	1.05	1619	.92		
CSB	7.99	OB2	1.99	2K24	18.99	5BP4	2.99	15E	1.25			706C	17.50	826	1.75	1625	.29		
CS6	7.99	1B22	1.69	2K28	29.50	SC22	25.00	15R	.39	274B	1.79	706D	35.00	829B	9.95	1629	.29		
CK-551AX		1B24	5.99	2K33A	59.95	SCP1	3.99	26AT/GT	2.99	276A	7.25	707A	3.55	830B	2.99	1630	.79		
2E41	1.79	1B29	9.95	2K41	72.50	SCP1A	12.49	26C6	1.19	282A	6.49	707B	3.95	830C	7.49	1632	.59		
CRP RK-		1P30	3.99	2K45	32.50	SCP7	9.99	28D7	.89	282	7.50	707C	3.95	830E	2.99	1641	1.88		
72	.49	2A/G	1.10	2K54	8.95	SCP11A	14.99	7BP7	6.25	286A	5.00	708A	2.99	833A	31.50	1642	.39		
EC1	1.99	2A1	3.99	2K55	9.50	SFP7	3.99	10Y	5.00	304TH	7.95	708A	1.69	836	1.99	1642	.39		
EF-50	.29	2AP1A	6.44	2V3/G	1.39	SHP4	2.49	12X3	1.59	304TL	1.85	713A	24.95	838	3.50	1806P1	4.99		
E1148	.29	2B11	1.99	2X2	.34	SJP4	16.99	24R	1.89	307A	3.99	715A	2.65	841	.59	2050	.95		
EM-3GA	39.50	3A5	.89	3A5	.69	SJ32	65.00	35T	4.29	310A	3.99	715B	6.45	845	6.49	2051	.76		
F123A	5.99	3AP1	5.95	3AP11A	4.95	SLP1	13.99	53A	2.29	347A	4.89	715C	14.50	845	6.49	2051	.76		
FG17	4.50	3B22	1.99	3B22	1.49	SNP1	6.99	QK-62	24.50	347A	2.99	717A	4.99	851	16.50	5651	1.39		
FG-105	14.99	3C26	.39	3B22	1.49	SR4WGY	6.99	53A	2.29	350B	2.99	718A/CY	29.75	861	19.00	5656	1.40		
FG-154	14.99	3C26A	.49	3B23	3.25	6C21	19.95	53A	2.29	350B	2.99	719A	14.65	864	.69	5670	2.20		
FG172	24.95	3C39	4.99	3B24	2.99	6AC7	.64	53A	2.29	350B	2.99	720CY/DY	29.75	865	.45	5686	1.79		
HF-100	7.49	3C40	10.99	3B24W	4.99							721A	1.49	866A	1.19	5687	2.69		
HK-24	3.99	3C42	9.75									721B	8.45	866A	1.19	5687	2.69		
HK-54	7.49	3C43	10.99									722	1.99	869B	30.00	5725	1.99		
HY-65	1.20	3C44	1.15	3BP1	2.99							723A/B	8.99	GL-872A	2.49	5726	1.00		
HY-114B	.69	3C46	1.49	3BP1A	6.35							724A	1.15	872A	1.29	5744	.91		
KU-610	3.49											724B	1.45						

CRYSTAL DIODES	1N21	1N21A	1N21B	1N21C	1N21D	1N21E	1N21F	1N21G	1N21H	1N21I	1N21J	1N21K	1N21L	1N21M	1N21N	1N21O	1N21P	1N21Q	1N21R	1N21S	1N21T	1N21U	1N21V	1N21W	1N21X	1N21Y	1N21Z
	.15	.15	.15	.15	.15	.15	.15	.15	.15	.15	.15	.15	.15	.15	.15	.15	.15	.15	.15	.15	.15	.15	.15	.15	.15	.15	.15

Manufacturers, exporters, and large quantity users—Inquire on your letterhead for our inventory listing of receiving tubes, special purpose tubes, resistors, condensers, and other radio and television parts.

HY-65	1.70	2C51	2.75	3C21	1.29	6AC7W	1.50	89Y	.15	WL-417A	2.74	725A	3.99	874	1.25	5751	2.15		
REL-21	1.00	2C53	9.90	3C22	64.95	6AG7	.79	100TH	6.95	GL-434A	6.66	726A	9.50	876	.99	5760	2.95		
RM-34	.39	2E24	2.49	5C23	5.99	6AJ5	1.19	203A	5.99	446A	1.49	726B	9.50	878	.99	5763	1.79		
RK-59	1.88	2E27	1.64	6AK5	5.95	6AK5W	1.64	208B	3.99	446B	1.79	726C	24.50	884	1.00	5814	1.35		
RK-60	1.99	2D21	.79	3C28	5.95	6AN5	2.12	207	49.50	728A/B/Y	7.95	728A/B/Y	35.00	885	1.10	5851	3.20		
RK-61	3.50	2D21W	1.39	3C33	8.99	6ARR	1.49	213	3.72	730A	7.95	802P1	2.99	912	2.99	5933	1.19		
RK-65/SD23	14.99	2J21	2.99	3C45	6.25	6AS6	1.19	215A	4.99	471A	1.25	800	1.29	917A	2.99	5937	3.89		
RM-73	.69	2J21A	4.95	3CP1	2.25	6AS7/G	2.49	217A	2.99	CK-508A X	1.10	801A	1.42	921A	1.99	5963	1.19		
RK-283A	6.99	2J27	1.99	3E29	10.25	6B6	39.50	217C	3.99	CK-521A X	1.40	802	2.89	955	.19	6080	2.99		
VT25/10	.49	2J26	2.50	3DP1	1.88	6C1	4.99	217A	3.99	527	14.50	804	2.69	956	.25	8002R	18.50		
VT25A/10Y	.39	2J27	5.99	3E29	10.25	6D4	2.99	233A	8.00	WL-530	19.50	805	9.99	957	.29	6080W	3.99		
VT25A/10Y Spec	.26	2J30	14.50	3EP1	1.88	6F4	2.99	249B	2.99	WL-531	6.25	805	4.90	958A	.33	8005	4.50		
VT-158	17.50	2J31	14.50	3FP7	2.95	6J4	2.99	249C	3.99	532A	.99	807W	1.25	959	1.40	8013	2.50		
VU-111	.19	2J32	13.50	3GP1	3.95	6J4W	3.75	250TH	24.95	700A/B/C/D	.99	808	1.79	CK1005	.39	8013A	3.49		
1B37/532A	.95	2J33	13.50	3HP7	2.95	6K4	3.99	250TL	4.99	E	10.99	809	3.15	CK1006	1.97	8025	1.99		
QK-59	29.50	2J34	13.50	3J21	49.84	6L4	3.99	250R	3.99	703A	4.99	809	12.95	7000T	94.50	9001	.79		
QK-61	32.00	2J38	14.00	4A-11	.49	6X4W	1.49	251A	5.99	703A	1.90	811	3.19	1608	.95	9004	1.19		
QK-185	99.00	2J49	39.50	4C27	8.95	7BP1	9.95	258A	5.99	704A	1.59	813	1.59	1614	1.49	9006	.19		
VR-78	.89	2J61	16.40	4C28	35.50	12A6	.39	259A	5.99	705A	1.25	814	2.49	1614	1.49	9006	.19		
VR-90	.89	2J62	9.60	5AP1	3.95	12AT7	.85	264C	3.90										
VR-105	.79					12DP7A	18.35	269A	13.50										

FAY-BILL DISTRIBUTING CO. DEPT. E1
418 Broome St., N. Y. 13, N. Y.
Telephone CAnal 6-8404

All boxed and fully guaranteed. Special quantity discount—10% on 100 or more of same type. Minimum order \$10.00. Thousands of other types in stock. . . . Send us your requirements. F.O.B. New York 25% deposit with order or if paid in advance save C.O.D. charges. Rated firms net 10 days. Prices subject to change without notice. For fast service ask for Sy.

COAX CONNECTORS

SO239	M359A
24¢	15¢
831R	831AD

FOR MORE QUALITY-PER-DOLLAR, BUY RECONDITIONED

TEST EQUIPMENT

WE WILL QUOTE ON NEW AND USED TOP-QUALITY COMMERCIAL BRANDS AND SELECT MILITARY SURPLUS ITEMS IN OUR CHOICE STOCK, TO YOUR NEEDS.



AN/APR-4 LABORATORY RECEIVERS

Complete with all five Tuning Units, covering the range 38 to 4,000 Mc; wideband discone and other antennas, wavetraps, mobile accessories, 100 page technical manual, etc. Versatile, accurate, compact—the aristocrat of lab receivers in this range. Write for data sheet and quotations.

We have a large variety of other hard-to-get equipment, including microwave, aircraft, communications, radar; and laboratory electronics of all kinds. Quality standards maintained. New Reduced Prices On: LARGE POWER UNITS, DYNAMOMETERS.

ENGINEERING ASSOCIATES

434 PATTERSON ROAD

DAYTON 9, OHIO

★ RCA ★ TUNG SOL ★ GE ★ ALL FAMOUS MAKES ★ TUBES ★ GUARANTEED ★ SAVE \$\$\$ ★

1LD5	.58	12BH7	.80	EL-6B	6.05	5751	1.50
1H6GT	.83	12SN7	.72	ELC1K/B	7.00	5687	2.75
6AG5	.65	25L6GT	.50	ELC16/J	28.90	5844	1.00
6AK5	1.25	83	.52	1B26	1.25	5881	2.60
6AS5	.72	HY-69	2.00	3C24	2.50	5815A	.60
6CS6	.69	HY-75	1.00	2D21	7.5	5998	4.95
6SH7	.55	HY615	1.00	2050	1.00	5965	1.50
6SJ7	.59	HY114	2.00	284D	7.50	6136	2.50
12AY7	11.95	EL1-C	4.20	5725	2.00	6197	1.95
12AT7	.85	EL3-C	4.50	5727	1.40	6350	1.35

★ TYPE UG-BNC-UHF ★ CONNECTORS ★ HUGE STOCK ★

We Purchase Tubes, Inventories, Contract Terminations

Amphenol Distributors

★ DUTCHESS LABS ★

38 Catskill Ave. Tel Pok-5944 Poughkeepsie, N. Y.

COMMUNICATIONS & TEST EQUIPMENT

Top quality communications and test equipment at low prices.

Here are a few leaders

- ARC-1,-3,-27 etc.—Airborne Transmitter-Receiver.
- BC-375—Complete two cases, export, packed, unused ground transmitting equipment.
- AN/ARN-6 & -14—Radio compass equipment.
- ART-13—Transmitter 100 W Airborne or ground.
- AN/APR-4 — Laboratory receiver with tuning units.
- TS-147D/UP—X band test equipment Signal generators.
- TS-323/UR—Frequency meter.
- 334-E—Control box.

Prices on request only
Immediate Delivery

We buy clean communications and test equipment unmodified. Top prices.

MONTGOMERY EQUIPMENT CO.

14315 Bessemer St.
Van Nuys, California
Telephone: STate 6-4657
Telegraph Station YHV
Cable Address MONTEQUIP

ELECTRONIC

WAR TERMINATION INVENTORIES

WRITE OR WIRE FOR INFORMATION ON OUR COMPLETE LINE OF SURPLUS ELECTRONIC COMPONENTS. ALL PRICES NET F.O.B. PASADENA, CALIFORNIA

C&H SALES CO.

2176-E East Colorado St.
Pasadena 8, California
RYan 1-7393

INVERTERS

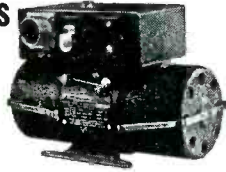

- 10042-1-A Bendix
DC Input 14 volts; output: 115 volts; 400 cycles. 1-phase; 50 watt **\$35.00**
- 12116-2-A Bendix
Output: 115 VAC; 400 cyc; single phase; 45 amp. Input: 24 VDC, 5 amps. **\$35.00**
- 12117 Bendix
Output: 26 volts; 400 cycles, 6 volt amperes, 1 phase. Input: 24 VDC; 1 amp. **\$15.00**
- 12121 Bendix
Input: 24 volt D.C. 18 amp. 12000 r.p.m.
Output: 115 volts, 400 cycle, 3-phase, 250 volt amp, 7 pf. **\$49.50**
- 12123 Bendix
Output: 115 V; 3 phase; 400 cycle; amps. .5 Input: 24 VDC; 12 amp. **\$49.50**
- 12126-2-A Bendix
Output: 26 volts; 3 phase; 400 cycle; 10 VA; 6 PF. Input: 27.5 volts DC; 1.25 amps. **\$24.50**
- 12130-3-B Bendix
Output: 125.5 VAC; 1.5 amps. 400 cycles single phase, 141 Va. Input: 20-30 VDC. 18-12 amps. Voltage and frequency regulated. **\$49.50**
- 12137 Bendix
Output 250 VA, 115 volts, 3 phase, 400 cycle, 1.25 amp., 0.8 pf. Input 27.5 volt DC, 20 amp. **\$59.50**
- 12147-1 Pioneer
Output: 115 VAC 400 cycles; single phase. Input: 24-30 VDC; 8 amps. **Price \$39.50 each**
- 778 Bendix
Output: 115 volt 400 cycle; 190 VA; single phase and 26 volt, 400 cycle, 60 VA, single phase. Input: 24 VDC. **\$37.50**
- 10285 Leland
Output: 115 volts AC; 750 VA, 3 phase, 400 cycle, .90 pf and 26 volts, 50 VA single phase, 400 cycle, .40 pf. Input: 27.5 VDC 60 amps. cont. duty, 6000 rpm. Voltage and frequency regulated. **\$59.50**
- 10339 Leland
Output: 115 volts; 190 VA; single phase; 400 cycle, .90 pf. and 26 volts; 60 VA; 400 cycle, .40 pf. Input: 27.5 volts DC, 18 amps. cont. duty, voltage and freq. regulated. **\$49.50**
- 10486 Leland
Output: 115 VAC; 400 cycles; 3-phase; 175 VA; .80 pf. Input: 27.5 DC; 12.5 amps.; cont. duty. **\$70.00**
- 10563 Leland
Output: 115 VAC; 400 cycle; 3-phase; 115 VA; 75 pf. Input: 28.5 VAC; 12 amps. **\$35.00**
- PE109 Leland
Output: 115 VAC, 400 cyc.; single phase; 1.53 amp.; 8000 rpm. Input: 13.5 VDC; 29 amp. **\$50.00**
- PE218 Leland
Output: 115 VAC; single phase pf. 90; 380/500 cycle; 1500 VA. Input: 25-28 VDC; 92 amps.; 8000 rpms.; Exc. Volts 27.5. BRAND NEW **\$30.00**
- MG149F Holtzer-Cabot
Output: 26 VAC @ 250 VA; 115 V. @ 500 VA; single phase; 400 cycle. Input: 24 VDC @ 36 amps. **\$40.00**
- MG153 Holtzer-Cabot
Input: 24 VDC; 52 amps. Output: 115 volts —400 cycles, 3-phase, 750 VA. Voltage and frequency regulated. **\$95.00**
- DMF2506M Continental Electric
24-30 volts input; 5.5-45 amps.; cont. duty. Output: 115 volts; .44 amps.; 400 cyc.; 1 phase; pf. 1.0; 50 watts. **\$39.50**
- 940702-1 Eicor, Class "A"
Input: 27.5 volts at 9.2 amps. AC. Output: 115 volts 400 cycles; 3 phase 100 voltamp; continuous duty. **Price \$39.50 each**

WESTINGHOUSE TYPE FP Inerteen CAPACITOR



125 mfg, 3,000 volts style no. 1196282 approx. size 14"x13"x5" approx. weight 62 lbs. **\$69.50 ea.**

SELSYNS-SYNCHROS



- | | |
|---|--------------------|
| 1CT Cont. Trans. 90/55V 60 cy. | \$37.50 |
| 1DG Diff. Gen. 90/90V 60 cy. | 37.50 |
| 1F Syn. Mtr. 115/90V 60 cy. | 37.50 |
| 1G Gen. 115V 60 cy. | 37.50 |
| 1SF Syn. Mtr. 115/90V 400 cy. | 12.50 |
| 2J1F1 Gen. 115/57.5V 400 cy. | 7.50 |
| 2J1F3 Gen. 115/57.5V 400 cy. | 10.00 |
| 2J1FA1 Gen. 115/57.5V 400 cy. | 7.50 |
| 2J1G1 57.5/57.5V 400 cy. | 5.00 |
| 2J1H1 Diff. Gen. 57.5V 400 cy. | 7.50 |
| 2J5D1 Cont. Trans. 105/55V 60 cy. | 17.50 |
| 2J5F1 Cont. Trans. 105/55V 60 cy. | 17.50 |
| 2J5H1 Gen. 115/105V 60 cy. | 17.50 |
| 2J15M1 Gen. 115/57.5V 400 cy. | 17.50 |
| 5CT Cont. Trans. 90/55V 60 cy. | 34.50 |
| 5D Diff. Mtr. 90/90V 60 cy. | 34.50 |
| 5CDG Diff. Gen. 90/90V 60 cy. | 34.50 |
| 5F Syn. Mtr. 115/90VAC 60 cy. | 34.50 |
| 5G Syn. Gen. 115/90VAC 60 cy. | 34.50 |
| 5HCT Cont. Trans. 90/55V 60 cy. | 42.50 |
| 55DG Diff. Gen. 90/90V 400 cy. | 12.50 |
| 6DG Diff. Gen. 90/90V 60 cy. | 25.00 |
| 6G Syn. Gen. 115/90VAC 60 cy. | 34.50 |
| 7G Syn. Gen. 115/90VAC 60 cy. | 42.50 |
| R 10-2A Kearfott Cont. Mtr. 115V 400 cy. | 17.50 |
| R200-1-A Kearfott Cont. Trans. 26/11.8V 400 cy. | 15.00 |
| R210-1-A Kearfott Trans. 26/11 8V 400 cy. | 15.00 |
| R220-T-A Kearfott Receiver 26/11.8V 400 cy. | 20.00 |
| R235-1A Kearfott Resolver 26/11 8V 400 cy. | 22.50 |
| C56701 Type 11-4 Rep. 115V 60 cy. 115V 60 cy. | 20.00 |
| C69405-2 Type 1-1 Transm. 115V 60 cy. | 20.00 |
| C69406 Syn. Transm. 115V 60 cy. | 20.00 |
| C69406-1 Type 11-2 Rep. 115V 60 cy. | 20.00 |
| C76166 Volt. Rec. 115V 60 cy. | 10.00 |
| C78248 Syn. Transm. 115V 60 cy. | 12.50 |
| C78249 Syn. Diff. 115V 60 cy. | 5.00 |
| C78863 Repeater 115V 60 cy. | 7.50 |
| C79331 Transm. Type 1-4 115V 60 cy. | 20.00 |
| 851 Bendix Autosyn Mtr. 22V 60 cy. | 7.50 |
| 403 Kollsman Autosyn. Mtr. 32V 60 cy. | 7.50 |
| FPE-25-11 Diehl Servo Mfr. 75/115V 60 cy. | 22.50 |
| FPE-43-1 Resolver 400 cy. | 25.00 |
| FJE-43-9 Resolver 115 V 400 cy. | 25.00 |
| 999-0411 Kollsman 26V 400 cy. | 15.00 |
| 13770410 Kollsman 26V 400 cy. | 10.00 |
| 1515B-0410 Kollsman 26V 400 cy. | 20.00 |
| 13047-2-A Bendix 26V 400 cy. | 12.50 |
| 2900 Transicoil 115 V 400 cy. | 15.00 |
| 15CX4a Synchro Transmitter MK 22 MOD 1 | \$15.00 ea. |

SIMPLE DIFFERENTIAL



Stock No. 101

Size: 2-5/32" long x 1 1/4" dia.; bearing one end 1/2" O.D.; Shaft Size: 1" long, threads 8-32-3/4" long, with bearing shaft 1/8" dia. x 1/4" long. Gear on shaft end 1-7/16" dia., gear on bearing end 1 1/4" dia. Drive gear 25/32" dia.

\$3.95 ea.

SIMPLE DIFFERENTIAL



Stock No. 106

1:1 reverse ratio, 60 teeth on large gear; 1/4" shaft. Size: 3" long with 1-15/16" dia.

\$3.95 ea.

SIMPLE DIFFERENTIAL



Stock No. 149

size 2-3/8" long, 1-1/8" diameter, 1/4" shaft each end 1-1 reverse ratio 32 teeth on input and output gear price **\$3.50 ea.**

Dual Simple Differential



Stock No. 110

1:1 reverse ratio or both. Size: 3/4" long x 1-7/16" dia. Shaft size 1/8" and 5/32".

\$7.50 ea.

SMALL DC MOTORS



- (approx. size overall 3/4" x 1 1/4" dia.):
- | | |
|---|--------------------|
| 5067126 Delco PM, 27 VDC, 125 RPM, Governor Controlled | \$15.00 ea. |
| 6069600 Delco PM 27.5 VDC 250 rpm | 12.50 |
| 5069230 Delco PM 27.5 VDC 145 rpm. | 15.00 |
| 5068750 Delco 27.5 VDC 160 rpm w. brake 6.50 | |
| 5068571 Delco PM 27.5 VDC 10,000 rpm (1x1x2") | 5.00 |
| 5069625 Delco 27.5 VDC 120 rpm w/governor | 15.00 |
| 5069790 Delco PM, 27 VDC, 100 RPM, Governor Controlled | 15.00 ea. |
| 5BA10A118 GE 24 VDC 110 rpm | 10.00 |
| 5BA10A137 GE 27 VDC 250 rpm reversible | 10.00 |
| 5BA10A152 27 VDC 145 rpm reversible | 12.50 |
| 5BA10A150, G.E., 12 VDC, 140 R.P.M., | 15.00 |
| 5BA10F132, G.E., 12 VDC, 9.5 R.P.M., | 15.00 |
| 5BA10F133, G.E., 12 VDC, 56 R.P.M., reversible | 15.00 |
| 806069 Oster series reversible 1/50 h.p. 0,000 rpm 27.5 VDC 1 5/8" x 3/2" | 5.00 |
| C-29P-1A 27 VDC 1/100 h.p. 7,000 rpm | 3.00 |
| 7100-B-PM Hansen 24 VDC 160 rpm | 7.50 |
| SSFD-6-1 Diehl PM 27.5 VDC 10,000 rpm | 4.00 |

NEW YORK TUBE & MICROWAVE TEST EQUIPMENT EXCHANGE

Special! TS45 X BAND GENERATOR—\$99.00

NEW UNUSED SURPLUS TS 259 K BAND
23400-24500 MEGACYCLES SIGNAL GENERATOR

SPECIAL! 5,000 V. POWER SUPPLY

For IP25 Infrared Image Converter from 3 V. Battery Source. **\$990**
NEW, Complete with RCA 1654 Tube

NEW MICROWAVE TEST EQUIPMENT
TS148/UP SPECTRUM ANALYZER
TS147D SIGNAL GENERATOR

Field Type X Band Spectrum Analyzer. Band 8430-9580 Megacycles.

Will Check Frequency and Operation of various X Band equipment such as Radar Magnetrons, Klystrons, TR Boxes. It will also measure pulse width, c-w spectrum width and Q, or resonant cavities. Will also check frequency of signal generators in the X band. Can also be used as frequency modulated Signal Generator etc. Available new complete with all accessories, in carrying case.

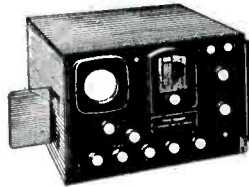

OTHER TEST EQUIPMENT USED CHECKED OUT SURPLUS

TSK1/SE	T35/AP	TS108	TS226	SURPLUS EQUIP.
TS3A/AP	TS36/AP	TS110/AP	TS239A-TS239C	APA10
RF4/AP	1-96A	TS125/AP	TS251	APA38
TS12/AP	TS-45	TS126/AP	TS258	APS3 APS4
TA13/AP	TS47/APR	TS147	TS270	APR4
TS14/AP	TS69/APR	TS174/AP	TS418	APR5A
TS33/AP	TS100	TS175/AP	TF890/1	APT2-APT5
TS34/AP	TS102A/AP	TS182	834	and many others

SPECIAL

Thousands of tubes available at special prices

PARTIAL LIST			
2AP1	6H6	307A	5691
4C27	6K8G	274A	5692
4C28	6AR6	274B	5693
5A6	5RAWGY	262S	5639
5BP4	5W4GT	328A	5814
4J52	OZ4A	357A	9001
2A4G	6AC7	450TH	9002
6C21	28D7	450TL	9003
6J5GT	VT52	957	9006
	89	MANY OTHER TYPES	

WHOLESALE and EXPORT ONLY
Minimum tube order \$25



Phone: ORegon 4-7070

LIBERTY ELECTRONICS, INC.

119 PRINCE ST.
NEW YORK 12, N. Y.
Cable: TELESERP

MOTOR GENERATORS AND CONVERTERS

50, 60, 400 and 800 cycle and DC Power Supplies

Dual output generator:

115/1/400 @ 39 Amps; 28 V DC @ 17.9 Amps, NEW, MOUNTED OR UNMOUNTED	Write
28dc to 110/1/800 @ 1kva	\$49.50
(Overall length: 12 inches)	
110dc to 110/1/800 @ 350va	150.00
110ac to 110/1/800 @ 350va	235.00
220-440/3/60 to 110/1/400 @ 2kva	435.00
329dc to 110/1/60 @ 350va	100.00
110dc to 110/1/60 @ 350va	59.50
110dc to 28dc @ 250va	49.50
110/1/60 to 28dc @ 250va	97.50
220/1, 3/60 to 28dc @ 250va	97.50
110dc to 110/1/60 @ 1.25kva	135.00
220dc to 110/1/60 @ 1.25kva	145.00
110dc to 110/1/60 @ 350va	85.00
110dc to 110/1/60 @ 500va	95.00
110dc to 110/1/60 @ 5kva	285.00

SYNCHROS & SELSYNS

1F	\$55.00	6DG	\$34.50
1SF	55.00	6G	49.50
1C	55.00	7C	49.50
1DG	42.50	2J1F1	10.00
5F	39.50	2J1G1	10.00
5C	39.50	2J1H1	10.00
5CT	45.00	AY-43 autosyn.	
SSDG	27.50		

VARIABLE SPEED MOTOR—AC OR DC

Excellent Laboratory Item

110 or 220 volts, 1ϕ, 60~,—or 110 volts dc]
1/4hp @ 800-1800rpm, with movable brush speed control. **\$39.50**

COMPASS ELECTRONICS SUPPLY

A Division of Compass Communications Corp.



75 Varick St. New York 13, N. Y.
CANAL 6-7455
Cable Address: COMPRADIO, N. Y.

AIRBORNE ELECTRONICS Inc.

155 FIRST STREET, MINEOLA, N. Y.

Communication & Navigation Equipment & Accessories

TELEPHONE: PIONEER 6-6410 CABLE: AIRLECTRON MINEOLANY

WANT TO BUY!

BC-224, BC-348 RECEIVERS

ARC-3 BC-788 R5/ARN-7
Cash or trade. Immediate action.
HARJO SALES CO. Dept. B
503 N. Victory Blvd. Burbank, Calif.

— WANTED — GERMANIUM

Metal Scrap, Oxide Scrap Residues, Etc.
Highest Prices Paid

W-3596, Electronics Classified Adv., Div., PO Box 12, N.Y. 36, N.Y.

WANTED	
ART-13/T47A Transmitters	BC-348 Rec'r Modified mlters\$175.00
ART-13/T47 Transmitters	BC-348 Rec'r Unmodified\$ 50.00
BC-788C Alt. Transceiver	A R C - I Transceiver
A R C - 3 Transceiver	BC-342 Rec'r ..\$ 50.00
Complete\$325.00	BC-312 Rec'r ..\$ 40.00
R5/ARN-7 Radio Com. pass\$175.00	1-152C Ind.\$ 50.00
Ship via Express C.O.D. Subject to Inspection to H. FINNEGAN, 49 Washington Ave. Little Ferry, N.J.	

CASH PAID! Sell your surplus electronic tubes. Want unused, clean transmitting, special purpose, receiving, TV types, magnetrons, Klystrons, Broadcast, etc. Also want military & commercial lab test and communications gear. We swap too, for tubes or choice equipment. Send specific details in first letter. For a fair deal write, wire or telephone: WAikor 5-7000
Barry, 512 Broadway, New York 12, N. Y.

we will pay you **TOP \$\$\$.** ☹☹
for an AN/ARC-3!

Also pay fabulous prices for R-77/ARC-3 & T-67/ARC-3
Phone us collect on ARC-3 components •

Stanley 7-0406

What else do YOU have?

BC-788? I-152?
R5/ARN-7? RT-18/ARC-1?
TEST SETS TS? ETC.?

ARROW SALES, INC. Dept. E.
7460 VARNA AVE., NO. HOLLYWOOD, CAL.

NEED METERS?

STANDARD or SPECIALS

ANY QUANTITY—NEW—MILITARY

FOR ELECTRONIC—MILITARY AIRCRAFT—HAMS

ALL MAKES—MODELS RANGES—SIZES

METERS REPAIRED RESCALED RECALIBRATED

WRITE - PHONE - WIRE

INSTRUMENT SERVICE

76-14 Woodside Ave.
Elmhurst 73, N. Y.

CAA No. 4264 Ltd. HA 9-2925

COMMUNICATIONS EQUIPMENT CO.

EE-89 REPEATER

Extends range of EE-8 field phone up to 20 miles of dry or wet wire operation. Extremely rugged, portable and lightweight. Uses hybrid coils and V. T. Amplifier, with extreme long-life characteristics. Brand New. Complete With Tube \$12.75 each & Tech. Manual, only.

HELMHOLTZ PHASE-SHIFTER

Stator consists of 4 loops oriented at 90 degrees to each other. Total stator inductance is 40 MH. rotor: 10MH. total phase shift 0-360 deg. Designed for range unit of SCR-268 \$3.95 each

PULSE TRANSFORMERS



352-7150. Primary 50 ohms. Secondary 1000 ohms. 12,000v. 12.0 Amp. Pulse: 1 or 2 usec. at 001 duty ratio. Fitted with magnetron well and bifilar winding for filament supply. \$32.50
MAGNETRON PULSE TRANS. #964: Prim. imp. 30 ohms. 1600 v. pulse. Secondary imp. is 1250 ohms. 12 is 0.001 at 1.2 usec. Bifilar winding 1.2A. \$8.50

RAYTHEON WX 4298E. Primary 4KV. 1.0 USEC. SEC. 16K-16 AMP DUTY RATIO: 001 400 CYCLE FIL. TRANS. "BUILT-IN" \$22.50
GE #K-2449A Primary: 9.33 KV. 50 ohms Imp. Secondary: 28 KV. 450 ohms. Pulse length: 1.05/5 usec @ 635/120 PPS. PK Power Out: 1.740 KW. Bifilar: 1.5 amps. \$62.50
GE #K-2748-A. 0.5 usec @ 2000 Pps. Pk. Pwr. out is 32 KW impedance 40:100 ohm output. Pri. volts 2.3 KV Pk. Sec. volts 11.5 KV Pk. Bifilar rated at 1.3 Amp. Fitted with magnetron well. \$24.50
K-2745 Primary: 3 1/2 KV. 50 ohms Z. Secondary: 14/12.0 KV 1025 ohms Z. Pulse length: 0.25/1.0 usec @ 600/600 PPS. Pk. Power 200/150 KW. Bifilar: 1.3 Amp. Has "built-in" magnetron well. \$32.50
K-2461-A Primary: 3.1/2.6 KV-50 ohms (line). Secondary 14/11.5 KV-1000 ohms Z. Pulse Length: 1 usec @ 600 PPS Pk. Power Out: 200/130 KW. Bifilar: 1.3 Amp. Fitted with magnetron well. \$29.50
K35145-Pulse Inverter. Pri: 6 KV Pk. Pulse Negative. Sec. Pos. Pulse. 4 KV; 1 usec. and 001 DUTY RATIO. \$6.50
UTAH X-1511T-1: Dual Transformer, 2 Wdgs. per section 1:1 Ratio per sec 13 MH inductance 30 ohms DCR \$5.00
UTAH X-1501T-1: Two sections. 3 Wdgs. per section 1:1:1 Ratio. 3MH. 6 ohms DCR per Wdg. \$5.00
68G711: Ratio: 4:1 Pri: 200V. Sec. 53V. 1.0 usec Pulse @ 2000 PPS. 0.016 kVA \$4.50
TR1049 Ratio 2:1 Pri 220 MII. 50 Ohms. sec 0.75 1H. DCR 100 Ohms \$6.75
K-994695-501: Ratio 1:1 Pri. Imp. 40 Ohm. Sec. Imp. 40 Ohms. Passes pulse 0.6 usec with 0.05 usec rise \$8.95

MICROWAVE ANTENNAS

3 CM ANTENNA ASSEMBLY: Uses 17" paraboloid dish, operating from 24 vdc motor. Beam pattern: 5 deg. in both Azimuth and elevation. Sector Scan: over 160 deg. at 35 scans per minute. Elevation Scan: over 2 deg. Tilt: Over 24 deg. \$35.00
3cm. Horn. 1" x 1/2", with twist and 180 deg. bend. With dielectric window \$22.50
AT49/APR-Broadband Conical. 300-3300 MC. Type N Feed. \$8.95
Discon. Antenna AS 125 APR. 1000-3200 mc. Stub supported with type "N" Connector. \$14.50
AS14A/AP. 10 CM pick up dipole assy. complete w/ length of coax and "N" connectors. \$4.50
AS46A/APG-4 Yagi Antenna. 5 element array. \$22.50
30" Parabolic Reflector Spun Aluminum dish 10 1/2" Focus \$4.85
AN/APA-12-Sector Scan adaptor for APS-2 radar-Complete Kit \$37.50
LP-24 Alford loop, for use with glide-path transmitters (MTRN 1), etc 100-108 mc \$32.50
18" PARABOLIC DISHES, spun aluminum. Focus approx. 8 inches \$4.95

VHF BUTTERFLY TANK

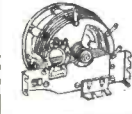

Butterfly tank unit: Tunes 60-300 mc. Ideal for frequency meter, grid-dipper, signal source, etc. New, complete with acorn tube socket. \$5.75

SPARES FOR APN-9

Power Trans. Pt. No. 352-7295-2 \$4.95 each
Counter Trans. T111, T112, T117, Pt. No. 352-7251-2 \$2.50 each
Counter Trans. T113, T114, T115, T116, T118, T119, T120, Pt. No. 352-7250-2 \$2.50 each
I. F. Trans. T107-T110 Pt. #352-155HS \$1.00 each
Resistor: R150, R157, R162 84,000 OHMS .50 each
Resistor: R130, 220,000 ohms .50 each
Resistor: R159 120,000 ohms .50 each
Resistor: R152, R164, 17,000 ohms .35 each

DYNAMOTORS

TYPE	INPUT		OUTPUT		Price
	VOLTS	AMPS	VOLTS	AMPS	
BD R83	14		275	.150	\$6.50
POSX 75	14	2.8	220	.08	8.95
DM33A	28	7	240	.250	3.95
B-19	12	9.4	575	.110	6.95
			500	.050	
			300	.260	3.95
			150	.010	
			14.5	5.	
PE 73 CM	28	19	1000	.350	17.50
BD 601	14	2.8	220	.08	8.95
DAG-33A	18	3.2	450	.06	2.50
BDAR 93	28	3.25	375	.150	6.95
					14.5
					5.
					17.50
					8.95
					2.50
					6.95
					14.5
					5.
					17.50
					8.95
					2.50
					6.95
					14.5
					5.
					17.50
					8.95
					2.50
					6.95
					14.5
					5.
					17.50
					8.95
					2.50
					6.95
					14.5
					5.
					17.50
					8.95
					2.50
					6.95
					14.5
					5.
					17.50
					8.95
					2.50
					6.95
					14.5
					5.
					17.50
					8.95
					2.50
					6.95
					14.5
					5.
					17.50
					8.95
					2.50
					6.95
					14.5
					5.
					17.50
					8.95
					2.50
					6.95
					14.5
					5.
					17.50
					8.95
					2.50
					6.95
					14.5
					5.
					17.50
					8.95
					2.50
					6.95
					14.5
					5.
					17.50
					8.95
					2.50
					6.95
					14.5
					5.
					17.50
					8.95
					2.50
					6.95
					14.5
					5.
					17.50
					8.95
					2.50
					6.95
					14.5
					5.
					17.50
					8.95
					2.50
					6.95
					14.5
					5.
					17.50
					8.95
					2.50
					6.95
					14.5
					5.
					17.50
					8.95
					2.50
					6.95
					14.5
					5.
					17.50
					8.95
					2.50
					6.95
					14.5
					5.
					17.50
					8.95
					2.50
					6.95
					14.5
					5.
					17.50
					8.95
					2.50
					6.95
					14.5
					5.
					17.50
					8.95
					2.50
					6.95
					14.5
					5.
					17.50
					8.95
					2.50
					6.95
					14.5
					5.
					17.50
					8.95
					2.50
					6.95
					14.5
					5.
					17.50
					8.95
					2.50
					6.95
					14.5
					5.
					17.50
					8.95
					2.50
					6.95
					14.5
					5.
					17.50
					8.95
					2.50
					6.95
					14.5
					5.
					17.50
					8.95
					2.50
					6.95
					14.5
					5.
					17.50
					8.95
					2.50
					6.95
					14.5
					5.
					17.50
					8.95
					2.50
					6.95
					14.5
					5.
					17.50
					8.95
					2.50
					6.95
					14.5
					5.
					17.50
					8.95
					2.50
					6.95
					14.5
					5.
					17.50
					8.95
					2.50
					6.95
					14.5
					5.
					17.50
					8.95
					2.50
					6.95
					14.5
					5.
					17.50
					8.95
					2.50
					6.95
					14.5
					5.
					17.50
					8.95
					2.50
					6.95
					14.5
					5.
					17.50
					8.95
					2.50
					6.95
					1

Gear Reduction MOTORS:



DELCO 5069370 (Shown at left) 27 VDC Reversible PM Motor and Gear Assy. in an aluminum case. Output speed is 80 RPM through a friction clutch to a double shaft, 1/4" x 3/8" on one side, 1/4" x 1 1/2" on the other. Size complete Assy. 3 3/4" x 2" x 1 1/2" excluding shaft. Has built-in noise filter system. Wt. 1 lb. \$5.95

Same Motor as used in above Assy. Size: 1 3/4" x 1 1/2" x 2 1/4". Wt. 4 oz. \$3.95

REVERSIBLE SHAUNT MOTOR—Oster Type KU-IL-IR, 28 VDC @ 8 A. Heavy duty gear reduction motor, 2 1/2 lb. ft. torque, to 100-200 RPM. Size: 10" L x 7" W x 4 1/4" H. Shaft size: 7/16" D x 3/4" L. Wt. 11 3/4 lbs. \$7.95

PHILCO Gear Reduction No. 441-1008 24-VDC—Output speed 37 RPM 40 lb. inch torque. Size 4" x 3 3/4" x 5 1/2". Shaft size: 5/16" x 3/8". Wt. 3 lb. 12 oz. \$5.95

WINDSHIELD WIPER MOTOR—24 VDC. Very powerful. Maybe be used wherever an oscillation motion is desired, such a stirring or agitation. Size: 2" x 3 1/4" x 3 3/8". Shaft extends out 1 1/2" from motor. Wt. 1 lb. 10 oz. Stock No. 101924. \$2.95

EMC 41314 110 VAC 60 Cy. Induction Motor with mounting feet. 1550 RPM through a gear reduction to 24 RPM. Right angle drive. Size: 4" x 3 3/4" x 7 3/4". Shaft size: 5/16" x 3/8" with removable Gear. Wt. 5 lb. 13 oz. \$9.95

WESTERN ELECTRIC RWC 2505 1/2-Holzer Cabot No. KS5978-01. 115 VAC 60 Cy. 11 Watt 65 RPM 75 oz. inch torque—Reversible. Size: 2 1/4" x 2 1/4" x 2 3/4". Shaft size: 3/16" x 1/4". Wt. 2 lb. \$9.95

GENERAL ELECTRIC 5BA10AJ52—27 V @ 65 A. Gear reduction 145 RPM Output on a 1/4" x 3/8" Splined shaft, 14 oz. inch torque. Motor size: 1 3/8" x 3 1/4". Wt. 8 oz. (Pictured at right) \$4.95



G E 5BA10AJ370 \$4.95—250 RPM.

DELCO APPLIANCE 5069825—27 VDC—Gear reduction to 120 RPM output. Governor controlled speed. Size: 1 3/8" x 4 1/4". Shaft size: 1/4" x 3/8". Wt. 8 oz. \$10.00

HOLTZER CABOT Type 2505—115 VAC 60 Cy. 9 Watt 1.9 RPM Reversible 75 oz. torque. Has multiple disc cover wheel with micro switch mounted on bracket assy. Overall size: 3 3/8" x 4 3/8" x 4". Wt. 3 lb. 2 oz. \$9.95

AIR ASSOCIATES EE1530—Gear reduction, 24 VDC @ 8 A. 25 lb. inch torque, 5 RPM Reversible. Size: 4 1/2" x 3 1/2" x 5 1/2". Keved shaft: 1/2" x 1 1/4" with a 4" arm attached. Wt. 5 lb. \$7.95

JOHN OSTER Shunt Motor B-9-1—27 1/2 VDC @ 7 A. 5600 RPM. Aluminum cased motor and gear assy. Motor is flange mounted to gear case. Two gear reductions 22 and 5 1/2 RPM on 1/4" x 1 1/4" shafts. Size: 2 3/8" x 3" x 7". Wt. 1 lb. 14 oz. \$3.95

BENDIX LM1081—24 VDC 1/25 HP—15000 RPM Series Motor Geneva Loc. Actuator. Shaft rotates 1/4 revolution and stops, is locked in place until next contact is made, then the cycle is repeated. Time per cycle: approx. 3 seconds. Size: 4" x 2 1/4" x 5 1/4". Shaft size: 1/4" x 1/2". Wt. 1 lb. 14 oz. \$7.95

24 VAC Gear Motor No. 14-343—3 RPM output. Size: 5" x 2 1/2" x 1 1/4". Shaft size: 5/32" x 3/8". Wt. 1 lb. 2 oz. \$1.95

New List—Including many other Motors, Blowers, Dynamotors, etc. Free—Write for copy today!

HIGH SPEED MOTORS:

JOHN OSTER TYPE C 24A-1B—KS-5829-01—27 VDC 1/100 HP, 7000 RPM DC Series Motor \$2.95

2" D x 3" L. Shaft Size: 1/4" x 1". Wt. 1 lb. GENERAL ELECTRIC 5BA25AJ32B—Flange type mount, 24 VDC @ 2.9 A, 7000 RPM, 3 wire reversible with Magnetic brake. Size 2 1/2" x 4 1/4" L. Shaft size: 3/16" x 3/8". Splined. Wt. 2 1/4 lbs. Price \$3.95—Motor only.

GENERAL ELECTRIC 5BA25D2300—Flange type mount 24 VDC @ 2 A, 4600 RPM Governor controlled with Magnetic brake. Size 2 1/2" D x 5 3/8" L. Shaft size: 3/16" x 7/8". Splined. Wt. 2 1/2 lbs. Price—Motor only \$3.95

AIR ASSOCIATES EE1430M2 SPEC. No. KS-5875L01—Flange mount 27 VDC @ 20 A, 7000 RPM 3800 RPM Size: 4 1/4" x 4 1/4" x 6 3/4" L. Keved shafts, 1/2" x 1 1/2" with gear attached. Wt. 9 3/4 lbs. \$7.95

GENERAL ELECTRIC 58A25MJ424—Type BA—24 V @ 1.2 A, 7100 RPM 1/20 HP. Flange mount. Motor size: 2 1/2" x 5". Shaft size: 1/4" x 1". Wt. 3 1/2 lbs. \$3.95

MINIATURE BLOWERS:

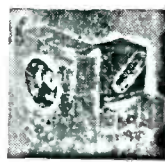

MOTOR and BLOWER—DELCO 5069371 27 VDC Reversible PM Motor, 6000 RPM, with Blower. Overall size, including Blower: 2 1/2" x 2 1/4" x 3". Wt. 9 oz. As pictured to left. Price, \$4.50

GE CO 5069267—27 VDC, 6000 RPM, 1.5 oz. in torque. Reversible Shunt Motor, Flange Mounted. Size: 1 3/4" x 2 1/2" L. Flange 2 1/4" D. Shaft: 1/4" x 1". Blower Fan attached. No. 101267 \$2.95

24 VOLT 10 CFM BLOWER—Housed in a cast aluminum case. Shunt Type Motor: 24 VDC @ .6 A 5000 RPM with motor noise Filter. Size: 3 3/4" D x 4 1/2" L x 4 1/2" H. Wt. 1 lb. 10 oz. No. SS2345 \$5.95

115 VAC 400 CY. 10 CFM BLOWER—7200 RPM 1100 HP. Bakelite blower Housing. Overall size: 3 1/2" x 3 1/2" x 4 1/2". Wt. 1 lb. 7 oz. East-ern Air Devices No. 21A \$5.95

10 CFM BLOWER—OSTER MOTOR C2BP-1A—27.5 VDC 1/100 HP, 7000 RPM. Bakelite blower Housing. Overall size: 3 1/2" x 3 1/2" x 4 1/2". Wt. 1 lb. 4 oz. Price \$5.95

115 V. 60 CYCLE BLOWERS:

115 VAC 60 Cycle SINGLE TYPE—100 CFM—2 1/4" intake; 2" outlet. Complete size: 5" x 6". No. 1C939 \$8.95

115 VAC 60 Cycle DUAL TYPE—100 CFM—4" Intake—Dis. Each Side. Complete size: \$13.95

115 VAC 60 cycle COMPACT TYPE—100 CFM; Motor built inside squirrel cage; 4 1/2" intake; 3 3/8" Dis. Complete size: 4 1/2" W x 8 3/8" H x 8 3/8" D—No. 2C067 \$14.95

115 VAC 60 cycle FLANGE TYPE—140 CFM; 3 1/2" intake; 2 3/8" Dis. Complete size: 7 1/2" W x 7 1/2" H x 8 3/8" D—No. 1C907 \$13.95

115 VAC 60 cycle FLANGE TWIN—275 CFM; 4 1/2" intake; 3 1/2" x 3" Dis. Complete size: 11 3/4" W x 2 3/8" H x 8 1/16" D—No. 2C069 \$21.95

DYNAMOTORS

INPUT VOLTS	OUTPUT VOLTS	MA	STOCK No.	PRICES USED	NEW
12 VDC	220	30	DM-24	\$2.95	\$4.95
12	625	225	DM-35	9.95	
12	230	90	PE-133	4.95	6.95
12 or 24	540	450	DA-12		14.95
12 or 24	230	100	DA-14		8.95
14	220	70	DM-24	4.95	7.95
14	375	150	BD-87	3.95	4.95
14 VDC	330	150	BD-87	3.95	5.95
14	250	50	DM-25	6.95	8.95
24	250	60	PE-86		8.95
28	1000	350	PE-73	8.95	

FAIR RADIO SALES • 132 SOUTH MAIN ST. LIMA, OHIO



KOILED KORDS 3 wires \$1.26
22 inches long stretches to 9 ft.

1 Amp G.E. Mercury Switches, 2 for \$1.00, 12 for \$5.00
5 Amp Durakool Mercury Switches, 2 for \$1.50, 8 for \$5.00

G.E. Switchettes All Types—75c ea 10 for \$6.00 100 for \$50

115 V. AC RELAYS DPDT.....\$2.90

TELECHRON Motors
2 RPM...\$2.90 1 RPM...3.95
3 RPM...3.90 3 R.P. Hr...2.85
4 RPM...2.90 1 R.P. 2Hr...2.80
3.6 RPM...3.15 60 RPM...4.85
1 RPM—50 Cycles, \$1.85
Laboratory Special 1 of Each Motor \$25

GONIOMETER
TYPE CFT-47372 — 250 to 1500 K.C.

PLEASE INCLUDE POSTAGE

BLAN EST. 1923
64 J Dey St. New York 7, N. Y.

General Radio VARIACS in stock. Special Sale on a few 200-B (1 amp.) removed from equipmt.....\$8.95

HAND WOUND 10 Sec. to 24 Min. TIMER SWITCH...\$1.35

6 Watt Most POWERFUL TELECHRON MOTOR 110V 60 Cy
6 RPM reversible...\$10.00
1 RPM...\$6.50

HAYDON TIMING MOTORS
110v 60 cycle 30 RPM...\$2.60
110v 60 cycle 1 RPM...2.60
230v 52 RPM...1.00
60 cy 1 RPM...1.00

HANSEN Synchron 4 rpm \$4.24
CRAMER 4 rpm \$4.65

DIEHL-DELCO
P.M. motors. Made for 24 volts. Will work at lower speed at 12v. or 6v. Battery or Rectifier. Size 1"x1"x2". \$3.75

Over 400 electronic control circuits

now available for quick, easy reference



Here are the circuits you need for sorting, timing, measuring, and counting; for sweep control, triggering, temperature and motor control, and hundreds of other industrial uses—each with concise description, performance characteristics, component values, and practical applications. Save hours, even days, of search and preliminary work to find basic circuit ideas for a particular application—consult this big, handy collection of tested circuits—selected from recent issues of *Electronics* and classified and indexed for quick use.

Just Out!

Handbook of INDUSTRIAL ELECTRONIC CONTROL CIRCUITS

By John MARKUS and Vin ZELUFF
Electronics Magazine
352 pages, 412 diagrams, \$8.75

Following each description is a reference to the original source where you can get more details on related mechanical problems or study graphs of performance characteristics. In the index, each circuit is cross-indexed as many as a dozen times, to permit locating specific circuits quickly when they are known by a variety of names.

a companion volume . . .

Handbook of INDUSTRIAL ELECTRONIC CIRCUITS

By Markus and Zelfuff

Contains 433 different industrial electronic circuits for immediate practical use. For each circuit there is a clearly-drawn diagram along with a brief yet comprehensive description. 272 pages. 433 diagrams \$7.50.

10 DAYS' FREE TRIAL

McGraw-Hill Book Co., Inc. Dept. FL-1
327 W. 41st St., N. Y. 36.

Send me book(s) checked below for 10 days' examination on approval. In 10 days I will remit for book(s) I keep, plus few cents for delivery costs, and return unwanted book(s) postpaid. (We pay delivery costs if you remit with this coupon—same return privilege.)

Markus & Zelfuff—Indust. Elect. Control Circ.—\$8.75

Markus & Zelfuff—Indust. Elect. Circ.—\$7.50

(PRINT)
Name.....
Address.....
City.....Zone.....State.....
Company.....
Position.....
For price and terms outside U. S. Write McGraw-Hill Int'l., N. Y. C. FL-1

BRAND NEW
T-350XM
 RADIOTELEPHONE
 RADIOTELEGRAPH
TRANSMITTER

This modern precision built point-to-point transmitter is now available for delivery singly or in quantity to interested users at an attractive price. This transmitter is similar in characteristics to the RCA Model ET-4336. The T-350XM was manufactured by Technical Radio Corporation, San Francisco, California, for the U. S. Signal Corps. All are new, unused and export cased. Each transmitter carries our guarantee. Spare parts available. Quotations on request.

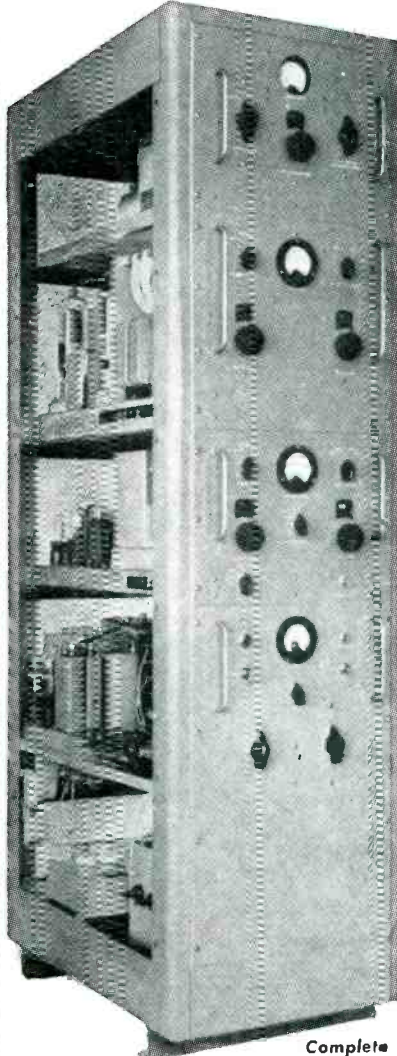

Complete

- 2,000-20,000 KCS • 350 watts—A1 Output • 250 Watts—A3 Output • Built in Master Oscillator • 5 Crystal Positions • Multi Range Impedance Antenna Tuning Network • Manual or High Speed Keying • Uses 2-813 P.A. and 2-805 Modulators Hi-Level Class B • Speech Amplifier, Remote. Mfg. by RCA • Technical Manuals (2) with Each Transmitter • Size 59" x 16" x 24" • Wt—690 Lbs. Net • Power Input: 210/250 Volts Single Phase 50/60 Cycles • Brand New—Complete—Unused

COMPLETE STATION INSTALLATION

We can supply with the T-350XM transmitter brand new receivers and complete station operating accessories.

Communication Devices Co., Inc.

2331 Twelfth Ave., N. Y. 27, N. Y.
 RWX-NY1-223
 Cable—Commudev, N. Y.
 Tel. ADirondack 4-6174

SPECIAL PURPOSE TUBES

OA2	\$.75	3X2500A3	100.00	12AP7	50.00	WE-352A	15.00	1625	.30
OA3/VR-75	1.00	3X2500F3	100.00	12DP7	15.00	WE-355A	10.00	1635	1.50
OA4G	1.00	4-65A	14.00	12GP7	15.00	371B	1.50	1846	50.00
OA5	3.50	4B31	17.50	FG-17	3.50	WE-388A	1.50	GL-1904	9.00
OB2	.60	4B32	10.00	RK-20A	6.75	WE-393A	4.00	1945	50.00
OB3/VR-90	.75	4C27	7.50	RK-23	2.00	394A	2.50	2000T	150.00
OC3/VR-105	.60	4C33	75.00	HK-24	2.00	WE-396A	3.00	2050	1.00
OD3/VR-150	.60	4C35	17.50	HK-24G	3.50	WE-403A	1.35	R-4330	7.50
EL-C1A	6.00	4E27	7.00	25E6WG	2.50	WE-404A	15.00	5528	6.50
1AD4	.90	4J38	100.00	26Z5W	3.00	WE-409A	1.25	5550	25.00
1AE4	1.00	4J39	100.00	FG-27A	10.00	GL-414	75.00	5551	40.00
1AF4	2.50	4J46	25.00	FG-32	4.00	GL-415	25.00	5552	55.00
1AG5	2.00	4J47	50.00	VX-32B	7.50	WE-416B	35.00	5553	75.00
1B22	1.25	4J52	50.00	FG-33	15.00	WE-417A	15.00	5556	6.75
1B23	2.00	4J61	100.00	VX-33A	5.00	WL-417A	2.00	5557	3.50
1B24	5.00	4X100A	10.00	35T	3.00	WE-418A	15.00	5558	4.00
1B35	3.50	4X150A	18.50	35TG	3.00	WE-420A	7.50	5559	10.00
1B35A	6.50	4X500F	55.00	VX-41	5.00	446A	.50	5560	15.00
1P21	35.00	5A6	2.25	FP-54	25.00	446B	1.25	5584	3.00
1P22	5.00	5ABP1	20.00	HK-54	3.00	450TH	35.00	5610	1.00
1P28	7.50	5AP1	5.00	VX-55	7.00	450TL	40.00	5632	7.50
2AF1	3.50	EL-5B	5.50	FG-57	10.00	464A	2.00	5634	6.50
2AP1A	5.50	5B1P	2.50	RK-60/1641	1.00	CK-503AX	.75	5637	3.75
2C36	30.00	5BP1A	7.50	RK-61	2.25	GL-575A	10.00	5638	6.50
2C39	5.00	5BP2A	5.00	RK-65/5D23	6.50	575A	5.00	5640	6.50
2C39A	10.00	5C22	25.00	FG-67	9.00	631-P1	6.00	5642	1.00
2C40	8.00	5CP1	2.00	HY-69	2.00	WE-701A	1.50	5644	6.50
2C42	8.50	5CP1A	7.50	RK-73	.75	707B	2.00	5645	5.50
2C43	8.75	5CP7	6.00	RK-75/307A	.50	715B	2.50	5647	5.00
2C46	5.00	5CP7A	8.00	75TL	7.50	715C	10.00	5650	60.00
2C50	6.00	5CP11A	9.50	FG-81A	3.50	717A	.35	5651	1.35
2C51	3.00	5CP12	10.00	FG-95	15.00	719A	7.50	5654	1.35
2C52	2.75	5FP14	6.50	100R	2.50	721A	.50	5656	4.50
2C53	10.00	5GP1	3.50	100TH	5.00	721B	7.00	5670	1.85
2D21	.70	5HP1	2.00	100TL	12.50	723A/B	7.50	5672	1.00
2D21W	.90	5HP1A	10.00	VU-1115	1.00	WE-725A	2.50	5675	7.00
2E22	2.50	5J23	20.00	WE-122A	1.50	726A	4.50	5676	1.00
2E24	2.25	5J29	4.00	WE-123A	2.50	726B	15.00	5678	1.00
2J21A	2.00	5J30	4.00	WE-124A	3.50	726C	20.00	5685	12.00
2J26	2.50	5J31	15.00	VT-127	1.50	802	2.50	5687	2.85
2J30	50.00	5J32	7.50	F-128A	7.50	803	2.50	5691	4.50
2J50	35.00	5J33	4.00	VXR-130	1.50	804	7.50	5692	5.00
2J51	150.00	5JP1	8.50	VT-158	10.00	805	5.00	5693	4.50
2J52	50.00	5JP2	5.00	FG-172	15.00	806	10.00	5696	1.00
2J53	2.50	5JP2A	7.50	FG-190	5.00	807	1.25	5703	1.00
2J54	25.00	5JP4	5.00	HF-200	10.00	807W	1.50	5719	1.50
2J55	35.00	5JP5A	10.00	CE-203	5.00	807WA	5.00	5720	15.00
2J56	50.00	5JP7A	25.00	203A	2.50	808	1.00	5725	2.25
2J59	50.00	5JP11A	10.00	207	75.00	809	2.25	5726	.75
2J61	15.00	5LP1	8.00	WE-211D	8.00	810	10.00	5727	1.25
2J61A	40.00	5LP1A	35.00	WL-218	15.00	811	3.00	5728	9.00
2J62	5.00	5LP2A	10.00	WE-222A	100.00	811A	3.75	5734	12.50
2J62A	40.00	5R4GY	1.30	233	250.00	812	2.50	5740	25.00
2J64	100.00	5R4WGY	2.50	CE-235A	5.00	813	10.00	5750	2.50
2K25	12.50	5RP1A	17.50	FG-235A	55.00	814	2.00	5755	7.50
2K29	25.00	5RP11A	35.00	WE-242C	10.00	815	.90	5762	125.00
2K30	50.00	5SP1	50.00	QK-243	50.00	816	1.25	5763	1.15
2K33A	57.50	5X3	2.50	WE-244A	7.50	826	.75	5771	275.00
2K34	100.00	5X3P1	35.00	WE-245A	6.50	828	7.50	5798	10.00
2K35	100.00	5XP1	50.00	WE-249B	3.00	829	3.50	5800	7.50
2K39	100.00	5Z2P7	25.00	WE-249C	2.00	829B	8.50	5801	5.00
2K41	100.00	5Z4P11	50.00	250R	5.00	832	2.50	5803	7.00
2K47	100.00	EL-C6J	12.00	WE-251A	50.00	832A	5.00	5827	5.00
2V3G	1.25	EL-C6L	6.50	WE-253A	2.00	833A	35.00	5828	7.50
2X2	.25	EL-C6	7.00	WE-254A	2.50	836	1.25	5829	1.00
2X2A	.85	6AC7W	1.00	WE-257A	3.00	837	1.25	5830	85.00
3ABP1	75.00	WE-6AK5	1.35	FG-258A	75.00	845	3.00	5842	15.00
3AP1	2.00	6AK5W	1.25	WE-262B	5.00	849	25.00	5847	15.00
3AP11A	5.00	6AL5W	.75	WE-267B	10.00	850	10.00	5876	7.00
3B21	3.50	6AN5	2.25	267B	5.00	851	7.50	5881	3.00
3B24	1.00	6AQ5W	1.85	WE-268A	5.00	860	2.50	5915	.75
3B24W	4.00	6AR6	1.35	WE-271A	5.00	866A	1.35	5932	3.73
3B24WA	8.00	6AR6WA	2.50	WE-274A	5.00	866 JR	1.25	5933	1.50
3B25	3.50	6AS6	1.25	WE-274B	7.50	868/PJ23	1.50	5933WA	5.00
3B26	2.75	6AS6W	2.25	WE-275A	3.50	869B	50.00	5948/1754	200.00
3B28	4.50	6AS7G	3.00	WE-276A	7.50	GL-872A	2.00	5949/1907	75.00
3B29	4.50	6AU6WA	2.50	WE-282A	2.25	872A	1.25	5962/BS-101	5.00
3BP1	2.00	6C21	15.00	WE-283A	3.50	874	1.00	5963	1.25
EL-3C	4.50	6J4	1.50	WE-285A	5.00	884	1.00	5977	3.00
EL-C3J	7.50	6J4WA	2.50	WE-286A	3.50	885	.85	5979/BS-1	10.00
EL-C3JA	9.00	6J6W	1.00	WE-287A	2.00	902-P1	2.00	5980/BS-2	8.50
3C23	3.75	6K4A	3.50	GL-299	2.00	913	17.50	5981/5650	60.00
3C24	3.50	6L4	3.50	WE-300B	6.00	917	1.50	6005	1.85
3C33	7.50	6L6WGA	3.75	304TH	10.00	918	1.50	6037	50.00
3C45	6.00	6L6WGB	.70	304TL	15.00	922	1.50	6098	2.50
3D21A	3.00	6Q5G	2.50	307A	.50	923	1.25	6136	2.50
3D22	7.50	6SK7W	1.00	WE-310A	4.00	927	.75	6280	35.00
3DPIA	5.00	6SK7WA	2.00	WE-311A	5.00	931A	3.50	6328	5.00
3E22	4.85	6SL7WGT	1.25	WE-313CD	4.00	956	.25	8002R	15.00
3E29	8.50	6SN7WGT	1.50	WE-316A	.50	958A	.35	8005	4.50
3FP7A	2.50	6SU7GT	3.00	WE-323A	9.00	959	1.25	8012A	3.50
3GP1	1.85	6X4WA	2.00	WE-323B	5.00	991/NE-16	.25	8013	2.50
3GP1A	10.00	6X5WGT	1.25	WE-328A	3.50	CK-1006	2.50	8013A	3.00
3HP14	2.00	7B7P	3.50	WE-336A	4.50	1500T	100.00	8020	1.00
3J21	50.00	7BP7A	7.00	WE-338A	4.50	1608	4.00	8025	1.00
3J31	40.00	7CP1	5.00	WE-339A	7.50	1611	1.00	PD-8365	75.00
3JP1	7.50	7HP7	10.00	WE-347A	2.50	1613	1.00	9001	.75
3JP12	10.00	7MP7	10.00	WE-348A	5.00	1614	1.50	9002	.50
3K27	150.00	10KP7	25.00	WE-350A	2.50	1619	.30	9003	1.00
3KP1	7.50	12A6	.60	WE-350B	2.00	1624	1.50	9005	2.50

ALL TUBES ARE NEW, INDIVIDUALLY CARTONED, FULLY GUARANTEED

Prices are F O B shipping point

western engineers

ELK GROVE, CALIFORNIA
 GEORGE WHITING, OWNER

Orders for less than ten dollars cannot be processed

RELAYS

world's largest stock

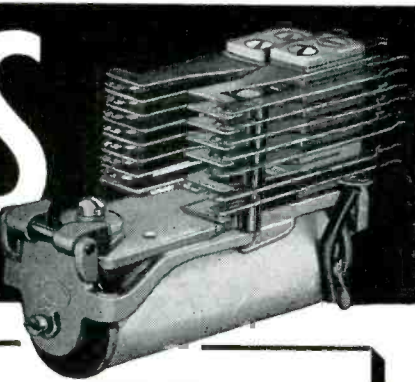

- ★ Immediate Delivery
- ★ Hundreds of Types
- ★ All Standard Makes
- ★ New-Inspected-Guaranteed

See our ad on page 105.

Multiple Contact
Standard Telephone Type Relay
 CODE 4 TWIN CONTACTS
 11-Form A 1-Form B 1-Form C 1-Form D
 Heavy duty armature bearing. Available in all standard coil resistances from 12 ohms to 12,000 ohms. Single or quantity prices on request. In stock.

24 HOUR DELIVERY OF THESE TYPES

Standard Telephone Relays
 Short Telephone Relays
 Midget Relays
 Timers
 Aircraft Contactors
 Rotary Relays
 Western Electric
 Type "E" Relays

Keyed Relays
 Hermetically Sealed Relays
 Voltage Regulators
 and Cutouts
 Differential and
 Polarized Relays
 Special Relays
 BK Series

Antenna and Ceramic Relays
 Motor and Control Relays
 Relay Assemblies
 Latching and Interlocking
 Relays
 Mechanical Action Relays
 Ratchet and Stepping Relays
 Time Delay Relays

Write for New Relay Sales
 Catalog, C-7

P. O. Box 186-AA, West Chicago, Ill. Phone West Chicago 1100



Electronic Components

DM36 24 v. input 220v. output Dyna-motors, large quantity \$2.95 each

All sizes Ceramic Mica Tubular Condensers, \$25.00 per thousand.

All sizes insulated 1/2, 1, & 2 watt resistors (5 million in stock) 1/2—\$10.00 per M, 1—\$15.00 per M, 2—\$25.00 per M.

We purchase surplus inventories

BELVISION, INC.

254 Greenwich St., N. Y. 7, N. Y.

Barclay 7-6063

BEARINGS —

MINIATURES; PRECISION; STAINLESS STEEL; SPECIAL SIZES, TOLERANCE & CONSTRUCTION.

BEARING DIV. Raway Sales

4-8 Forsyth St. Walker 5-8150 N. Y. C., N. Y.

Brand new radio tubes

10,000 each of type 12AT7
 10,000 each of type 12AU7
 10,000 each of type 12AX7

will be sold to the highest bidder.

Approximately 300,000 additional electron tubes are available at low prices. Send your price offers and write for further information to

FS-3471, Electronics

Class. Adv. Div., P.O. Box 12, New York 36, N. Y.

WRITE-WIRE or PHONE for:

- ★ POWER SUPPLIES ★ RADAR
- ★ PARTS — METERS — TUBES
- ★ TEST SETS ★ TELETYPE
- ★ AIRBORNE ELECTRONICS
- ★ NAVIGATION AIDS

NEW FREE FLYER!

Hundreds of excellent buys in air and ground electronics, air frame and electrical parts, components, etc. Get your copy.

TN-1/APR-1 TUNING UNIT

Receives and converts 38-80 MC RF to 30 MC IF. Requires only 250 V. DC and 6.3 VAC for heaters. Hand calibrated tuning chart. Originally used for radar counter-measures, receiver, but also ideal for noise and spectrum analyses. Brand new in storage case, with carton of spare tubes and other parts. A terrific value at **\$24.50** only.

VARIABLE VOLTAGE

AMERTRON TRANSSTAT, 11.5 KVA. Input 115 v., 60 cycles. Output continuously variable 0 to 115 V. up to 100 amperes. Brand new. Special. **\$99.50**

BRAND NEW

IMPEDANCE-BRIDGE SPECIAL

Designed not only to measure reactance and resistance of components, but also to measure antenna and transmission line resistance and reactance at frequencies from 25 kc to 5 mc. Complete with accessory box of plug-in standards and educational instruction book with a special section devoted to antenna measurements. No power is required for the bridge. Carry it anywhere you carry your signal generator. This is what you have always needed to load and trim antennas to get all the power of your customers' transmitters into the air. Here is accurate laboratory equipment, made for the U. S. Navy to exactly duplicate a commercial bridge presently being sold for \$590. Shpg. wt. 60 lbs. Only **\$125.00**

NEW ARRIVALS

All unused Excellent condition
 TS-3/AP \$95.00
 TS-3A/AP 125.00
 TS-92/AP 97.50
 TS-667A/AP, For APA-44 72.50
 1-203-A RF WATTMETER
 For SCR-720 79.50
 And MANY more What do YOU Need?

ARROW SALES, Inc.

OFFICE AND MAIN WAREHOUSE:
 7460 VARNA AVE., NORTH HOLLYWOOD, CAL.

Mail to: BOX 3007-E, NORTH HOLLYWOOD, CAL.

Phones: Stanley 7-0406 POpIar 5-1810

Telegraph: WUX, NO. HOLLYWOOD

Cable: ARROWSALES, NO. HOLLYWOOD

CENTRAL WAREHOUSE & SALES SHOWROOM

2441 S. MICHIGAN AVE., CHICAGO 16, ILL.

OTHER WAREHOUSES IN:

Atlanta, Ga., San Antonio, Tex., Pasco, Wash., Sacramento, Cal., Burbank, Cal., Los Angeles

MINIATURE 60MC IF STRIP uses 6 ea. 6AK5 tubes, with synchronous single tuned interstage coupling networks realizing an overall gain of 100db for a band width of 2mc. Weight 9 ounces, \$12.50. "BNC" COAXIAL SWITCH single pole double throw. New \$8.50.

DUMMY LOAD-X BAND, 50kw at a duty cycle of 1000, 50 watts average. UG40 flange, 9" long, 10 fms. Mig. for Gillilan. New \$27.50.

TRANSITION 1 1/4"x 3/4" to 1"x 1/2" (RG51 to RG52) Smooth electroformed taper. Standard flanges. New \$16.50.

WAVEGUIDE TO TYPE "N" coax adapter. RG52 waveguide 1"x 1/2". New \$14.50.

DIRECTIONAL COUPLERS. Three types a) uni-directional b) bi-directional c) cross guide. All 20db apx. All RG52 guide with standard flanges. New \$15.00.

COMPLETE RADAR PLUMBING FRONT END. c/o 2K25 local osc. mount, 2K25 beacon mount, type N adapter, crystal mount with tuning slug, variable attenuator, beacon xtal mt, beacon N adapter. Also matching duplexer assy. Latest type Navy Radar. Ideal for radar front end or as a complete laboratory bench set-up. Price incl. duplexer \$52.50. Less duplexer \$42.50. Brand new electrical and mech. tested.

DALMO-VICTOR HI-SPEED SCANNER rotating joint assembly 1200 rpm D/O AN/APIS-6 complete joint kit. New \$47.50.

X BAND THERMISTOR TS-36, \$7.50.
 TS35A/AP SIGNAL GENERATOR complete "X" band coverage CW output 0 to -70 dbm, peak pulse output plus 3 to -67dbm, 0 to 35db attenuator, 2K25 oscillator. Tunable wavemeter. Temp. compensated power meas. circuit -10 to plus 33dbm. 115

vac 60 cy input. Latest type. Absolutely new in orig. sealed carton w/spare parts, \$275 ea.

GUIDED MISSILE BEACON

FILTER CAVITY F-28/APN-19

2700-2900 mc, 1.5 db max. loss at ctr. freq. over band, 3db at 15 mc band ends. JAN spec. Brand new \$37.50.

CRYSTAL DETECTOR assembly p/o AN/APN-19 and 60. 10cm. Low level converter with matching transformer from kit line to crystal. New \$19.50.

COAX MIXER ASSEMBLY IN21 type crystal detector RF to IF "N" fittings, matching slug, duplex couplings, mig G.E. New, \$18.50.

ADAPTER RG48 WAVEGUIDE 3"x1 1/2" to type "N" coax. New \$34.50.

THERMISTOR MOUNT 10CM. Avg power range -3 to plus 11 dbm, 72 ohms type "N" coax input. Accuracy .5db at 6 to 10 mw. Temp range plus 32 to 115F. 2400 to 3400 mc. New \$18.50.

COMPLETE SURFACE SEARCH RADAR U. S. Navy type "SO" Raytheon 275kw nominal pulsed output 3000mc. "S" band. Rotating yoke plan position indicator with 2, 4, 20, 80 mile range selection. Input 115vdc, 32vdc, or 28vdc. Lightweight. Delivered complete with installation accessories, set of drawings, instruction books, export cased. Write, phone

TS46/AP FREQUENCY METER complete 3000mc band coverage with accuracy of .5mc relative, absolute plus and minus 3mc. 200 microamp. meter. Micrometer adjust. Equal to TS-117. New \$35.00.

Westinghouse 7P4 Block Osc. Xfmr.

134BW2F RADIATION LAB. # blocking osc. pulse voltage KV 2.5/2.5; 2.5/1.25 pulse duration 1 to 2.5 microsec. Duty ratio .002. Load imp. 1500. Test voltage 1500 rms. Last price \$22.90. Our price new \$9.75. Fosterized.

TS-311 ECHO BOX. Range 8730-8910mc. Dial direct reading. Accuracy plus minus 5mc. Ringtime 4000 yards nominal. Mig. Western Electric. Used exc. condition. \$225.00 each.

3KW 400 CYCLE SOURCE

Complete generator set, 115VDC 3HP speed regulated, compound motor. Generator output 115 volts, 400 cycle, single phase 17.4 amp. continuous duty (easily converted to 3 phase by transformer). Output electronically regulated. Perfect waveform. Built to rigid U. S. Navy spec. Drive motor easily swapped for any other input you wish. A perfect source of pure 115 volt 400 cycle. Excellent condition \$33.00 each.

AIRBORNE POWER SUPPLY DY30/APN-19 Complete shock mounted package input 19.5 volts DC 2.7 amps. Output 360 volts at 60 ma and 100 volts at 10 ma. Will operate 2C40 and 2C43. Part of guided missile radar beacon AN/APN-60. Fully regulated, \$34.50.

LORAN. RCA current type LR-8902. Complete coverage of S. L. H rate stations. Built in digital computer. Direct reading. Binary and decade counters actuated by stable 100kc crystal osc. 115v 60 cycle input, 3 inch CR tube. Total 67 tubes incl. 32 type

RADIO-RESEARCH INSTRUMENT Co.
 550 — 5 Ave., N. Y. 19, N. Y. Tel: JU 6-4691
 PAUL J. PLISNER

SAVE UP TO 70% OF WHOLESALE COST

COAXIAL CONNECTORS

PL-259.....\$.40	UG-87/U.....\$.40
SO-239......40	UG-88/U......65
M-359......30	UG-146/U.....1.75
UG-21B/U......85	UG-201/U.....1.50
UG-27/U......65	UG-255/U.....1.70
UG-29/U......75	UG-260/U.....1.65
UG-58A/U......75	UG-273/U.....1.10
UG-83/U.....1.50	UG-274/U.....1.95
UG-85/U......45	UG-290/U......65

Complete Listing of Factory Fresh JAN Approved Connectors Available at Similarly Low Prices !!!

POTENTIOMETERS
Full Range of Values Available From Stock for Immediate Delivery

Single Type J Units.....\$.95 Ea.
Dual Type JJ Units.....2.95 Ea.
Triple Type JJJ Units.....3.95 Ea.

SEND FOR COMPLETE LISTING

PRODUCTION QUANTITIES

PRECISION POTENTIOMETERS

50K 10 Turns 0.5% Linearity—Van Dyke Instr. Miniature Type 3/4" dia. x 2-1/4" lg.....\$7.95 Ea.
20K 10 Turns 0.1% Linearity—Gibbs Micropot.....\$6.95 Ea.
10K 25 Turns 0.1% Linearity—Helipot.....\$19.50 Ea.
10K 10 Turns 0.5% Linearity—Helipot.....\$6.95 Ea.
10K 10 Turns 0.1% Linearity—Helipot.....\$7.50 Ea.
2K 10 Turns 0.1% Linearity—Helipot.....\$6.95 Ea.

Helipot Duo Dials available for above.

HI CURRENT FILAMENT TRANSFORMERS

AMERTRAN TYPE W-PRI-105-125v 60cy 1 ph-SEC. 5V, 190amp, 35KV Ins Ea. \$29.50
KENYON-S-14940-PRI-105-125V 60 cy 1ph-SEC. 5V 115 amp.....Ea. \$19.50
MIL-T-27 Type-PRI-115/230V 50/60 cy SEC. 5V 10 AMP 10 KV Ins. Ea. \$6.25

ALL COMPONENTS 1ST QUALITY AND 100% GUARANTEED

TUBES

NEW—COMPLETELY GUARANTEED

750TL \$19.95 Ea.	807W \$1.75 Ea.
FG-172 \$15.00 Ea.	8002R \$12.95 Ea.

FULL LINE OF RECEIVING TUBES, POWER TUBES, MAGNETRONS, KLYSTRONS, CRYSTAL DIODES AVAILABLE AT SIMILARLY LOW PRICES.

IMMEDIATE DELIVERY

KOLLSMAN SERVO MOTORS WITH TACH GENERATOR

TYPE 890-0160640-NIOTOR-115V-60Cy-2 Ph. 3350 RPM-5 Watts Output Gen. 6.5V/1000RPM.....\$59.50 Ea.
TYPE 1623B-0410120 Motor-26V-400 Cy-2 Ph. -6500 RPM .045 Watts Output Gen. 0.34V/1000 RPM.....\$42.50 Ea.

SOUND POWERED PHONES U.S. NAVY Type "M" Head and Chest Sets

HEAVY DUTY-INCL. HEADSET, CHEST MIKE & 20 FT. OF CORD.....\$14.88 Ea.
TS-10 TYPE S. P. HANDSET \$9.48 Ea.

Terms: 20% cash with order, bal. C.O.D. unless stated. All prices net F.O.B. our warehouse Phila., Pa. subject to change without notice.

Special Discounts on Quantity Purchases

WE INVITE YOUR INQUIRIES FOR ALL YOUR ELECTRONIC NEEDS

SYNCHROS

1CT.....\$37.50	5N.....\$22.50
1DG.....37.50	5SDG.....12.50
1HCT.....42.50	5SF.....29.50
1F.....37.50	5SG.....29.50
1G.....37.50	6G.....34.50
3D.....62.50	6DG.....27.50
3HCT.....62.50	6HG.....42.50
5B.....22.50	7G.....42.50
5CT.....34.50	7DG.....47.50
5HCT.....42.50	23CX6.....45.00
5P.....34.50	211F1.....4.95
5G.....34.50	211G1.....3.95

MANY OTHER TYPES IN STOCK QUOTATIONS ON REQUEST

PULSE TRANSFORMERS

OVER 50 TYPES LOW AND HIGH POWER TYPES IN STOCK FOR IMMEDIATE DELIVERY

MFD. BY UTAH, G.E., RAYTHEON, PHILCO, WESTINGHOUSE, WESTERN ELECTRIC, ETC.

132AW2F.....7P1	\$6.95
134BW2F.....7P4	6.95
176AW2F.....7P10	7.50
139DW2F.....7P13	5.95
148DW2F.....7P15	7.60
Utah X124T2-9262	12.50
Utah X139T1-9278	3.75
G.E. 68G828	14.50
G.E. 68G627	16.50

SEND US YOUR INQUIRIES

POLYSTYRENE CAPACITORS
1% Tolerance
200VDCW.....500VVDCT
HERMETICALLY SEALED
0.5 MFD.....\$7.50 Ea.
1 MFD.....12.10 Ea.
MFD BY W.E.....BRAND NEW

FROM ONE OF THE LARGEST INVENTORIES IN THE U.S.A.

TEST EQUIPMENT

GENERAL RADIO

GR 222L Precision Condenser 1500MMF	\$55.00
GR 572B 1KC Hummer	7.50
GR 668A Decade Res.—1 Ω Steps	6.50
GR 668B Decade Res.—1 Ω Steps	7.50
GR 700P1 Volt. Divider	27.50
GR 713B Beat Freq. Osc.	\$225.00
GR 715 AE DC Amplifier	225.00
GR 720A Het. Freq. Meter	275.00
GR 722N Precision Capacitor	\$95.00
GR 723C VT Fork 1KC	\$85.00
GR 726A VTVM	\$85.00
GR 727A VTVM (Battery Oper.)	\$105.00

HEWLETT-PACKARD 325B Distortion Analyzer.....\$220.00
Measurements Corp 79B—Pulse Generator \$365.00

Waterman Raskope—Model S-12-B 3"	\$325.00
Dumont 208 Oscilloscope	\$89.00
BC-221 Freq. Meter	\$115.00
LAE-1 Signal Gen. (510-1300 MC)	225.00
LAF Signal Gen. (90-600 MC)	\$325.00
LAG Signal Gen. (1200-4000 MC)	\$375.00
LP-5 Signal Gen. 9.5 KC-50 MC	\$425.00

TS Types and Microwave Test Equipment and Components in Stock

All items new except where noted *(Excellent Used—Guaranteed)

2KVA POWERSTAT
Superior-115/230V 60cy. 1 ph input
—0-270V 9Amps Output
Special Price \$37.50 Ea.

WRITE FOR A COMPLETE LIST OF SURPLUS EQUIPMENT

LECTRONIC RESEARCH LABORATORIES
715-19 Arch St., Phila. 6, Pa. • MArket 7-6771-2-3
Cable Address: LECTRONIC, Philadelphia

COMMUNICATE HUNDREDS OF MILES BY RADIO — at Lowest Cost!



General Electric BC-375-E
100-watt Radio Transmitter
Reliable • Easy to Operate
—and priced far below cost to make!
PRICE... Only US \$99.50!
Literature upon request.

SPECIAL: BC-458-A Transmitters, \$5.00 ea.

Wholesale Quantities of **ELECTRONIC PARTS** in stock. Prompt Delivery; and, below factory Prices on:

CERAMIC CAPACITORS SOCKETS
TUBES (All Types) POTENTIOMETERS
RESISTORS SWITCHES

—and other parts for Television & Radio Sets
LIST WHAT YOU NEED—
Quotation, Pro Formas gratis.

COMPONENTS SUPPLY CO.
161-E Washington St., N. Y. 6, N. Y.

4 GUN 5" C.R.T. 200 in stock **\$28.50**
New Surplus—Not Rejects
K-1098P7 Long Persistence

5BP1.....	\$2.50
5CP1.....	3.50
51P2A (750 in stock).....	4.50
251A.....	22.50
829B.....	7.50
869B.....	22.50
4152.....	35.00



VHF Field Strength Meter
I-95-BM, New \$45.00

I-81-A 3" ADF Indicator.....	7.50
I-82-A 5" ADF Indicator.....	3.75
I-177-B Tube Tester.....	25.00
I-100 ADF Test Set.....	500.00
I-122 Signal Generator.....	75.00
AN/ARC-19 Complete.....	12.00
IE-19 Test Equip. 1/SCR-522.....	125.00

MICROWAVE EQUIPMENT CO.
Sam McIntosh PAOLI, INDIANA Phone 2801



SG-61/U I. F. Signal Generator
12-16mc 27-33-mc, New **\$125.00**

TS-175 85-1000mc Freq. Meter	\$300.00
BC 638A 100-156mc Freq. Meter	45.00
#80 2 400mc Signal Generator	250.00
#84 300-1000mc Signal Generator	350.00
#801C 8-300mc Signal Generator	150.00
TS-155B 10cm Signal Generator	175.00
TS-348 10cm Signal Generator	125.00



TS-100/AP SYNCROSCOPE
New **\$35.00**

NOT DEMILITARIZED!

R 249/APN-9A	
Loran Receiver 300.00	
TS-251 with Xtal.....	150.00
TS-35 3cm Signal Generator.....	275.00
TS-254 1cm Power Meter.....	115.00
Ferris #32A Noise Meter.....	225.00
Dumont #248A 5" Scope w/ =263A.....	250.00
TS-670 L band Spectrum Analyzer	2750.00

National Moldite Company	125
Nems-Clarke, Inc.	356
New Hampshire Ball Bearings, Inc.	86
New Hermes Engraving Machine Corp.	355
Ney Company, J. M.	335
Non-Linear Systems, Inc.	253
North American Aviation, Inc.	
Autonetics Div.	263
Los Angeles Div.	116
Missile Development Div.	267
Northern Radio Co., Inc.	68
Norwood Controls, Unit of Detroit Controls Corp.	111
Nothelfer Winding Laboratories, Inc.	317

Oak Mfg. Co.	107
Orange Products, Inc.	341
Oster Manufacturing Co., John	34

Panoramic Radio Products, Inc.	427
Perkin Engineering Corp.	25
Permag Corp.	369
Peters-Dalton, Inc.	49
Phelps-Dodge Copper Products Corp., Inca Mfg. Div.	72, 73
Philadelphia Bronze & Brass Corp.	52
Phillips Control Corp.	268
Pix Manufacturing Co., Inc.	372
Polarad Electronics Corporation	121, 235
Polytechnic Research & Development Co., Inc.	271
Potter & Brumfield, Inc.	219
Potter Company, Inc.	313
Precision Apparatus Co., Inc.	428
Precision Capacitors, Inc.	372
Precision Paper Tube Company	365
Progress Electronics Co.	422

Radiation, Inc.	245
Radio Corporation of America	102, 103 319, 4th Cover
Radio Engineering Products	316
Radio Materials Corp.	37
Ramo-Wooldridge Corp.	233, 330, 366
Raybestos-Manhattan, Inc.	60
Raytheon Mfg. Company	18, 19, 35, 65, 343
Reeves Instrument Corp.	57
Relay Sales, Inc.	105
Remington Rand Univac Div. of Sperry Rand Corp.	285
Resinite Corp., a Div. of Precision Paper Tube Co.	288
Reverse Corporation of America	311
Rogan Brothers	349
Royal Metal Mfg. Co.	353

Sanborn Company	47
Sanders Associates, Inc.	350

An Invitation TO MANUFACTURERS OF ELECTRONIC EQUIPMENT

1. Friendly labor supply.
2. Unusual city, county, and state tax advantages.
3. Industrial sites plentiful.
4. Good banking facilities.
5. Full cooperation guaranteed.
6. Strategic location.

for
SMALL
or
MEDIUM
INDUSTRIES

Businessmen of Lakeland, Florida will cooperate fully and furnish complete information to manufacturers who will consider relocating or establishing a branch unit in this fast-growing central Florida city

INDUSTRIAL COMMITTEE

LAKELAND CHAMBER of COMMERCE

P. O. BOX 979, LAKELAND, FLA.

sweep and marker

generators | IF VHF UHF

NEW! Telonic SWEEP GENERATORS



Model H-1 Shown

Model H-1
Portable Style

- ★ FREQ. RANGE: 1-950 mc.
- ★ CENTER FREQ. 1-420 mc. by heterodyning
- ★ SWEEP WIDTH: 100 kc.—40 mc. low end of range—over 60 mc. at high end.
- ★ OUTPUT VOLTAGE: Over .2 v.p. to p.—low band. Over 1.0 v.p. to p.—high band
- ★ FLATNESS: 10% high band
- ★ DISPLAY LINEARITY: 1.2:1

- MODEL H-3, Bench Style
- FREQ. RANGE: 1 to 350 MC.
- SWEEP WIDTH: 200 KC.—300 MC.
- TURRET ATTENUATOR.
- PULSE MARKER PRESENTATION.
- 6 CRYSTAL CONTROLLED MARKERS.

MODEL H-2
Portable Style

- FREQ. RANGE: 1-300 mc.
- SWEEP WIDTH: 200 kc.—200 mc.



New Telonic

R. F. DETECTOR XD series

- EXCELLENT MATCH: VSWR below 1.2:1.
- IMPEDANCE Models XD3—XD5; 50 ohms. Model XD4; 75 ohms.

WRITE

color test instruments

Telonic

INDUSTRIES
73 N. 2nd Ave.
Beech Grove, Indiana

white dot | color bar generators



consider the **PERSONNEL PLUS...**
that **GREATER MIAMI** offers

Compare Greater Miami by any check list with other areas as a location for your plant—you'll find it ranks favorably in every respect. But there's a special **hard dollar reason** for locating your plant in Greater Miami that no other area can equal—the **Personnel Plus**.

Critical, hard-to-find employees ... engineers ... skilled technicians ... are more readily available to a plant in Greater

Miami because the people you want—want to live here in South Florida where healthy outdoor living combines with all big city advantages.

This **Personnel Plus** translates into profits with increased productivity from better selected, satisfied employees. Send, on your letterhead, for 30-page Fact File ... **complete statistical area analysis**.

GREATER MIAMI INDUSTRIAL DIVISION
Dade County Advertising Dept. 197 • 141 N. E. 3rd Ave. • Miami, Fla. • Phone FR 1-3611

WANTED!

We're looking for engineers whose prime responsibility is to seek ways and means to make products or parts better, more efficient and at lower cost. To you, we recommend Frenchtown *Engineered Ceramics*.

Very possibly you can profit from the many valuable properties of Frenchtown *Engineered Ceramics* to give you resistance to *high temperatures* and low thermal expansion; excellent mechanical strength and wear resistance; superior dielectric strength at both high and low frequencies.

This helpful 4-page bulletin contains complete data on electrical and mechanical characteristics of Frenchtown high-performance bodies. Send for a free copy today.



frenchtown
PORCELAIN COMPANY
86 Muirhead Ave. • Trenton 9, N. J.

for Results



McGraw-Hill Mailing Lists
Will Help You

- Merchandise your advertising
- Conduct surveys
- Get inquiries and leads for your salesmen
- Pin-point geographical or functional groups
- Sell direct
- Build up weak territories
- Aid dealer relations

Direct Mail is a necessary supplement to a well rounded Business Paper advertising program.

Most progressive companies allocate a portion of their ad budgets to this second medium at the same time as they concentrate on the best business publications.

600,000 of the top buying influences in the fields covered by the McGraw-Hill publications make up our 150 mailing lists. Pick YOUR prospects out of our Industrial Direct Mail catalogue.

Write for your free copy.
It contains complete information.

Sel-Rex Precious Metals, Inc.	337
Shalleross Mfg. Co.	254
Shelding, Inc.	91
Sierra Electronic Corp.	264
Sigma Instruments, Inc.	305
Simpson Electric Company	82
Sola Electric Co.	50
Sorensen & Co., Inc.	4
Southern Electronic Corp.	67
Spencer-Kennedy Laboratories, Inc.	333
Sperry Gyroscope Company, Division of Sperry Rand Corp.	213
Sprague Electric Co.	11
Stackpole Carbon Co.	87
Standard Electric Time Co.	215
Star Porcelain Co.	370
Sterling Transformer Corp.	336
Stevens Arnold, Inc.	352
Stoddart Aircraft Radio Co., Inc.	334
Stokes Corporation, F. J.	54, 55
Stromberg-Carlson Company	23, 341
Superior Electric Company	287
Superior Tube Co.	211
Sylvania Electric Products, Inc.	98

Taylor Fibre Co.	134
Technology Instrument Corp.	315
Tektronix, Inc.	345
Telonic Industries	423
Texas Instruments, Incorporated	197, 282
Thermal American Fused Quartz Co., Inc.	368
Tobe Deutschmann Corp.	206
Tranco Products, Inc.	200
Transcoll Corp.	225
Transitron Electronic Corp.	63
Transitron, Inc.	266
Transradio, Ltd.	329
Trans-Sonics, Inc.	222
Triad Transformer Corp.	250
Triplett Electrical Instrument Co.	36
Tung-Sol Electric, Inc.	114, 115

U A C Electronics a Div. of Universal Atomics Corp.	340
Union Switch & Signal Div. of Westinghouse Air Brake Company	296, 297
U. S. Stoneware	85
United Transformer Co.	2nd Cover
University of California Radiation Laboratory	205

Van Keuren Co., The	427
Veeder-Root, Inc.	126

Waldes Kohneor, Inc.	79
Ward Leonard Electric Co.	41
Waterman Products Co., Inc.	244
Waters Manufacturing, Inc.	327
Weckesser Co.	354
Welch Scientific Co., W. M.	335
Westinghouse Electric Corp.	96, 100
Weston Electrical Instrument Corp., a Subsidiary of Daystrom, Inc.	44
Wheeler Laboratories, Inc.	352
Wheelock Signals, Inc.	329
Whitso, Inc.	353

Zell Products Corp.	366
Zophar Mills, Inc.	367

MANUFACTURER'S REPRESENTA- TIVES	373
---	-----

PROFESSIONAL SERVICES.....	373
----------------------------	-----

CLASSIFIED ADVERTISING
F. J. Eberle, Business Mgr.

EMPLOYMENT OPPORTUNITIES..	374-406
----------------------------	---------

SPECIAL SERVICES Contract Work	407
---	-----

EDUCATIONAL	407
-------------------	-----

BUSINESS OPPORTUNITIES	407
------------------------------	-----

EQUIPMENT (Used or Surplus New) For Sale	407-420
--	---------

WANTED Equipment	407, 414
---------------------------	----------

WHICH OF THESE PROBLEMS FIT YOUR FIELDS OF INTEREST IN ELECTRONICS

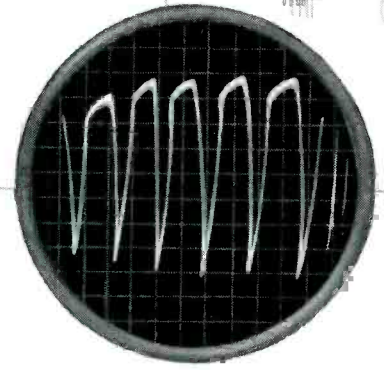

R & D work in microwaves and radiation. Technical work on electronic guidance and control systems for missiles and other electronic devices.

Design and development of complex guided missiles control systems, navigation systems, beacon systems, automatic aircraft landing systems, proportional control systems for remote control purposes and complex telemetering and instrumentation systems.

Associated with these developments...extensive design and development work on computers, microwave circuitry, antennas, autopilots, receivers and transmitters, modulators, transducers, instrumentation, transformers, pulse circuitry, coders and decoders, automatic tracking antennas and amplifiers. Component parts standardization and evaluation support these activities.

1. Devise an automatic frequency control system which will hold the frequency of an airborne power transmitter operating in the upper microwave spectrum to one part in 150,000 under varied stringent environmental conditions.

2. Develop a range tracking circuit capable of operating on intermittent signals in the presence of heavy noise and interference.

3. Design and develop a reciprocal phase shifter at x-band to vary phase by $\pm 0.125 \lambda_g$ in a sinusoidal manner using ferrite loaded waveguide. VSWR to be below 1.2 and insertion loss below 0.3 db over 6% bandwidth.

4. Design a low Q microwave band...rejection filter for s-band, for use over a 2 to 1 frequency spread. Insertion loss at midband to be between 10 and 12 db.

If your qualifications place you in a position to help solve these challenging problems...or if you are now limited in the scope of your opportunity and would like to participate in any of Bell's widely diversified activities in other fields, write today: Manager, Engineering Personnel, Department H-1, BELL AIRCRAFT CORPORATION, P. O. Box One, Buffalo 5, N. Y.



BUFFALO N. Y.



IF THIS IS YOUR PROBLEM

If you need effective, highly readable, smartly illustrated company literature (booklets, pamphlets, manuals) to display your products, inform the public of your operations, attract key personnel to your plant, train employees, and perform any of the other communicative functions that are vital to your business . . .

THIS IS YOUR ANSWER

The McGraw-Hill TECHNICAL WRITING SERVICE has a staff of more than 150 highly-trained writers, editors, and illustration specialists whose job it is to create technical and general literature for industry. We write, illustrate, design, and print Equipment Manuals, Product Bulletins, Handbooks, Company Histories, Annual Reports, and other specialized material. Save money and time. Let our staff be your staff for Technical and Business publications.

This service is available through ad agencies.

Write • Phone

TECHNICAL WRITING SERVICE
 McGraw-Hill Book Co., Inc.
 330 W. 42nd St., N. Y. 36, N. Y.
 LOngacre 4-3000

EMPLOYMENT OPPORTUNITIES ADVERTISERS INDEX

Admiral Corp.	390, 394, 401
Aircraft Radio Corp.	398
American Machine & Foundry Co.	392
Argonne National Laboratory	381
Arma Div., American Bosch Arma Corp.	400
Armour Research Foundation of Illinois Institute of Technology	399
Austin Co.	404
Avco Manufacturing Corp., Crosley Div.	394

Baird Associates-Atomic Instruments Co.	402
Beckman - Beckeley Div.	397
Beckman Instruments Inc.	394
Bendix Aviation Corp. Products Division	378
Radio Division	385
York Division	392
Burrhoughs Corp.	388

Collins Radio Co.	398
Continental Oil Co.	404
Convair, A Div. of General Dynamics Corp.	382

Edison Inc., Thomas A.	405
Edwards Employment Agencies	376

Farnsworth Electronics Co.	380
Federal Telecommunications Labs.	399

General Electric Co. Philadelphia, Pa.	393
Syracuse, N. Y.	396, 405

General Motors Corp. AC Electronics Div.	379, 384, 396, 404
General Precision Laboratory Inc.	402
Goodyear Aircraft Corp.	388
Goodyear Atomic Corp.	402

Haller Raymond & Brown Inc.	394
Honeywell Brown Instruments Boston	403
Philadelphia	380

Industrial Nucleonics Corp.	396
-----------------------------	-----

Johns Hopkins University	399
--------------------------	-----

Martin Co., Glenn L. (Baltimore Div.)	390
Maryland Electronics Manufacturing Corp.	386
Monarch Personnel	376
Motorola Inc.	386

WORRIED ABOUT PRECISION PIVOTS?

Call **WK**

Steel, chromium plated, or carbide precision pivots to .013" diameter. 1 RMS or finer surface finish. Diameter tolerances to .000010". Chamfers, radii, lapped ends, etc.

Also volume production lapping of flat or round production parts.

Submit your specifications

THE VAN KEUREN COMPANY
 176-D WALTHAM STREET
 WATERTOWN, MASS.

The photographer's nightmare at the left consists of a lump of sugar and four VK Precision Parts. The "eyes" are .080" long.

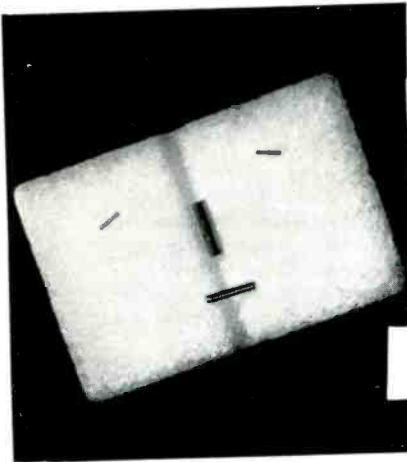

McGraw-Hill Mailing Lists Will Help You

for Results



Mc GRAW-HILL
 DIRECT MAIL LIST SERVICE

- Merchandise your advertising
- Conduct surveys
- Get inquiries and leads for your salesmen
- Pin-point geographical or functional groups
- Sell Direct
- Build up weak territories
- Aid Dealer relations

Direct Mail is a necessary supplement to a well rounded Business Paper advertising program.

Most progressive companies allocate a portion of their ad budgets to this second medium at the same time as they concentrate on the best business publications.

600,000 of the top buying influences in the fields covered by the McGraw-Hill publications make up our 150 mailing lists. Pick Your prospects out of our Industrial Direct Mail catalogue.

Write for your free copy of our Industrial Direct Mail catalogue with complete information.

New York State Employment Service..... 396
 Northeastern Engineering, Inc..... 376

Otis Elevator Co..... 390

Page Communications Engineers Inc..... 405
 Pennsylvania State University..... 400
 Philco Technical Representative Div..... 384

Radio Corp. of America..... 374, 375
 RCA Service Co., Inc..... 389
 Rand Corp., The..... 405
 Raytheon Manufacturing Co. 377, 383, 395, 401

Standard Electrical Products Co..... 402
 Stavid Engineering Inc..... 378
 Stromberg-Carlson Co.
 A Division of General Dynamic Corp..... 397
 Sylvania Electric Products Inc.
 Waltham, Mass..... 392

Texas Instruments, Inc..... 391
 Trans-Sonics, Inc..... 406

University Loudspeakers..... 406

**SEARCHLIGHT SECTION
 ADVERTISER'S INDEX**

Admittance-Nameco Corp..... 410
 Airborne Electronics Inc..... 414
 Arrow Sales, Inc..... 414, 418

Barry Electronics Corp..... 140
 Belvision Inc..... 418
 Binneweg Television..... 407
 Blan 416
 Bolton Laboratories..... 407

C&H Sales Co..... 413
 Communications Devices, Inc..... 417
 Communications Equipment Co..... 415
 Compass Electronics Supply..... 414
 Components Supply Co..... 419

Dutchess Labs..... 412

laboratory tool or production workhorse...

Panoramic PANALYZORS

have tremendous
 flexibility... many uses
3 models • 9 types

Actually automatic scanning superheterodyne receivers, these widely used instruments—

- permit visual observation and analysis of one or more signals simultaneously
- are unique in that they offer all the advantages of wide scan spectrum presentations, yet enable examination of signals so closely adjacent in frequency that their corresponding deflections normally tend to merge together or even completely mask one another in wide scan displays
- can be used to observe signals anywhere in the spectrum up to 1,000 mc by means of an external signal generator and an internal aperiodic mixer which translate the spectrum segment to be analyzed down to the input band of the Panalyzer.
- have a sweepwidth up to 10 mc.
- and many special features dependent upon the model selected, such as
 - variable resolution . . . variable scan rates
 - long or short persistence display
 - linear of log amplitude scales

Panoramic Panalyzers provide a measuring tool of utmost simplicity, tremendous flexibility and many uses. 3 models in 9 different types fulfill almost every need from low-cost general purpose instruments to those for highly special applications:

Model No.	Type	Maximum Sweepwidth	Scan Rate	Resolution Range
SB-12	T-100	100 kc	1/10-30 cps in steps	3.2 kc-10 cps
SB-8b	T-200	200 kc	1-60 cps (variable)	4.5 kc-50 cps
	T-1000	1 mc		10 kc-200 cps
	T-10,000	10 mc		100 kc-9 kc
SB-3	T-50	50 kc	30 cps	2.5 kc-1.9 kc
	T-200	200 kc		4.4 cc-3.8 kc
	T-1000	1 mc		11 kc-9 kc
	T-3000	3 mc		25 kc-20 kc
	T-6000	6 mc		50 kc-40 kc

Write, wire, phone TODAY for more information on how a Panoramic Panalyzer can help you!

A Panoramic Application Engineer is always available to discuss specific problems. Special instruments made to order.

Proved Performers:
 PANORAMIC SPECTRUM ANALYZERS (Sub-Sonic through Microwave) •
 PANORAMIC SWEEP GENERATORS •
 PANORAMIC FREQUENCY CALIBRATORS

PANORAMIC RADIO PRODUCTS, Inc., 10 South Second Avenue, Mt. Vernon, N. Y.
 Telephone: MOUNT VERNON 4-3970 — Cables: Panoramic, Mount Vernon, N. Y. State

For

- ▷ investigating pulsed RF signals
- ▷ analyzing AM and FM transmitters
- ▷ spotting spurious oscillations and modulation
- ▷ monitoring communications bands especially for signals very closely adjacent in frequency
- ▷ testing industrial RF equipment, diathermy and electro-surgical instruments



Model SB-12



Model SB-8b



Model SB-3



the pioneer
 is the leader

MORE RANGES VISIBILITY V.O.M.

the **PRECISION**

model

120

*Gives You What
You've Always
Wanted in a*

HIGH-SENSITIVITY MULTI-RANGE TEST SET

20,000 OHMS PER VOLT D.C.
5,000 OHMS PER VOLT A.C.



- ◆ MORE RANGES — 44 of them . . . starting lower and going higher . . . outranging any professional V.O.M. of similar size or type.
- ◆ AN EXTRA-LOW RESISTANCE RANGE — 2-ohm center scale range, powered by long-lived, internal 1.5 volt battery source.
- ◆ AN EXTRA-LOW VOLTAGE RANGE — 1.2 volts full scale, A.C. and D.C.
- ◆ AN EXTENDED LOW CURRENT RANGE — 60 microampere first D.C. current range.
- ◆ A LARGER AND EASIER-READING SCALE FACE — extra-large 5¼" meter with full 4¾" extra-wide window.
- ◆ SIMPLE, POSITIVE RANGE SELECTION — 18-position, positive-detenting, master range selector with low-resistance, dependable, silver-plated contacts.
- ◆ RUGGED, POSITIVE CONTACT JACKS and PLUGS — specially designed, low-resistance, solid brass, banana type plugs and jacks.

Compare these Wide-Spread Ranges and Special Features:

- ★ 8 DC VOLTAGE RANGES: 20,000 ohms per v. 0-1.2-3-12-60-300-600-1200-6000 v.
- ★ 8 AC VOLTAGE RANGES: 5,000 ohms per v. 0-1.2-3-12-60-300-600-1200-6000 v.
- ★ 8 AC OUTPUT RANGES: same as AC volt ranges. Built-in 600 volts blocking capacitor.
- ★ 7 DC CURRENT RANGES: 0-60-300 Microamperes. 0-1.2-12-120-600 Ma. 0-12 Amperes.
- ★ 5 RESISTANCE RANGES: self-contained. 0-200-2000-200,000 ohms. 0-2-20 megohms.
- ★ 8 DECIBEL RANGES: from -20 to +77 DB. 0 DB=1 Milliwatt, 600 ohms.
- ★ EXTRA LARGE 5¼" RUGGED 'PACE' METER: 40 microamperes sensitivity, 2% accuracy.
- ★ 1% MULTIPLIERS and SHUNTS: wire-wound and deposited-film types employed throughout.
- ★ ONLY 2 PLUG-JACKS SERVE ALL STANDARD RANGES: separately identified and isolated jacks provide for extra-high ranges.
- ★ "TRANSIT" SAFETY POSITION on master range selector protects meter during transportation and storage.
- ★ CUSTOM-MOLDED PHENOLIC CASE and PANEL: compact, efficient, laboratory instrument styling. Deeply engraved panel characters afford maximum legibility.

MODEL 120: complete with internal ohmmeter batteries, banana-plug test leads and operating manual. Over-all case dimensions: 5¾ x 7 x 3½ inches Net Price:



PRECISION Apparatus Company, Inc.

70-31 84th Street, Glendale 27, L. I., N. Y.

Export: 458 Broadway, New York 13, N.Y., U.S.A. • Cables: MORHANEX
Canada: Atlas Radio Corp. Ltd. • 50 Wingold Ave., Toronto 10, Ontario

PACE
THE METER OF PRECISION

Searchlight Advertisers Index

Electronics Parts 410
Emeltone Electronics 410
Engineering Associates 412

Fair Radio Sales 416
Fay-Bill Distributing Co. 412
Finnegan, H. 414

Harjo Sales Co. 410, 414

Instrument Service Co. 414
JSH Sales Co. 409

Klein & Schwab 408

Leetronic Research Laboratories 419
Liberty Electronics, Inc. 414

M. R. Co., The 410
McNeal Electric & Equipment Co. 408
Microwave Equipment Co. 419
Montgomery Equipment Co. 412

Pacific International University 407

Radalab Inc. 408
Radio & Electronics Surplus 407
Radio Research Instrument Co. 418
Raway Sales 418
Relay Sales 418

"TAB" 420

Universal General Corp. 411

Western Engineers 417
Wilgreen Industries 408

This index is published as a service. Every care is taken to make it accurate, but ELECTRONICS assumes no responsibility for errors or omissions.

WHERE DEPENDABILITY IS VITAL

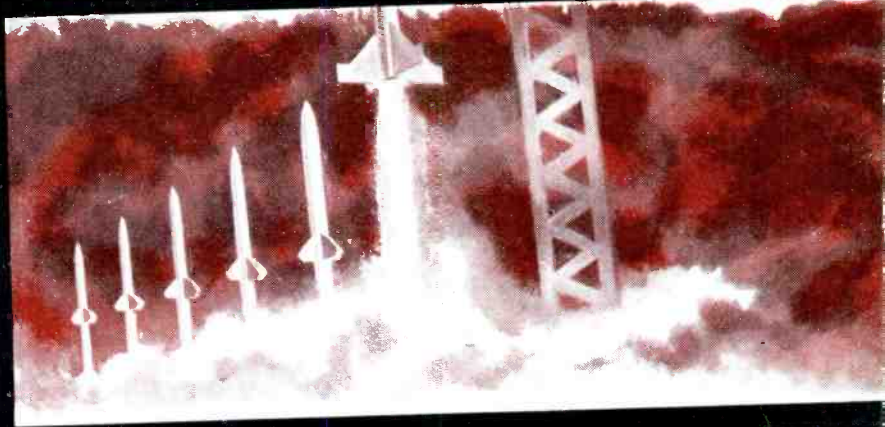
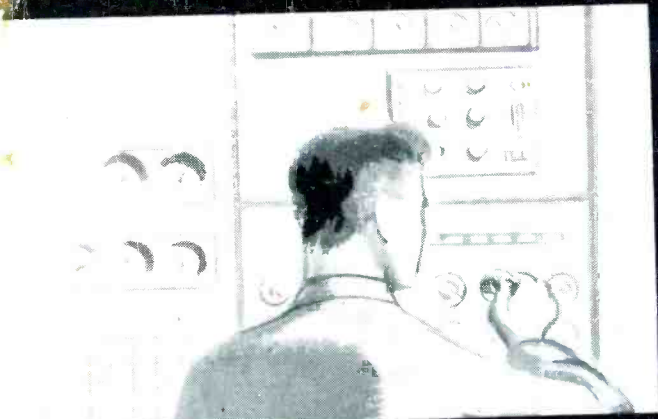

DAVEN

**ROTARY SWITCHES
ARE SPECIFIED**

Here's why: Positive solutions to critical rotary switch requirements can be found within the thousands of combinations of poles, positions and decks available from DAVEN's complete line of precision rotary switches.

- *Patented knee-action rotor*—ensures low and uniform contact resistance. It also provides tamper-proof and trouble-free operation over the life of the switch.
- *One-piece combination contact and solder lug*—solid-silver alloy contacts, gold plated to resist corrosion.
- *Turret-type solder lugs* for excellent mechanical and electrical connections.
- *Roller-type detent* gives positive indexing action.
- As many as *Eight poles* available on each deck—where minimum space is a factor.

Write for complete data, catalog and engineering information.

Action	Type	Maximum Number of Positions Per Pole	Number of Poles/Deck	Size
Shorting	11-BM	24	one	1 3/8 Dia. x 1 1/8 Depth
Shorting	12-CM	32	one	1 3/8 Dia. x 1 1/8 Depth
Shorting	25-EM	48	two	2 3/4 Dia. x 1 1/8 Depth
Non-shorting	85-EB	6	eight	2 3/4 Dia. x 1 1/8 Depth
Shorting	45-DM	23	four	2 1/4 Dia. x 1 1/8 Depth



THE DAVEN CO.
526 West Mt. Pleasant Avenue
Route 10, Livingston, New Jersey

TODAY, MORE THAN EVER, THE DAVEN 
STANDS FOR DEPENDABILITY!

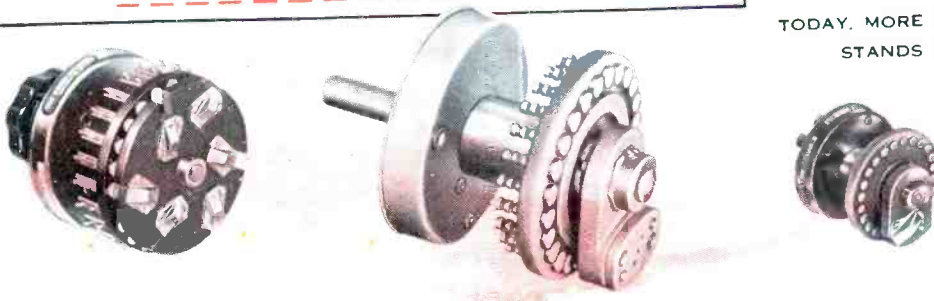

DISPLAY BRIGHTNESS . . .

GREATER THAN 1200 FOOT-LAMBERTS

. . . with the New RCA-6866
5-inch Display Storage Tube



Airport surveillance radar
capable of being moni-
tored in broad daylight.



"Freezing" transients—for
study in a fully lighted
area.



RCA-6866 Facts
Brightness—1750 foot-
lamberts (av.)
(screen voltage, 10,000v.)
Writing Speed—300,000
inches/sec.
Overall tube length—15 1/2"
Greatest bulb dia.—5 1/4"
(excluding high-voltage
cable)

RCA, a leader in display storage tube research and development, now offers equipment designers the RCA-6866—a direct-view type capable of presenting brilliant, non-flickering displays of electronic information for as long as 60 seconds after writing stops. The tube is capable of producing a full, 4-inch diameter display bright enough to study in a fully-lighted room. And it is capable of "writing" fast enough to "freeze" microsecond transients for a length of time adequate to examine and photograph, if desired.

In the RCA-6866, an electrostatically focused writing gun produces the electron beam which

is electrostatically deflected by two sets of deflecting electrodes. A viewing gun produces the electron stream that "floods" the tube electrodes controlling the storage function—and the brightness of the tube display.

If you are working with airplane-cockpit radar-display equipment . . . fire-control radar . . . airport surveillance . . . transient studies . . . data transmission, including half-tones . . . or visual communications requiring steady, non-flickering, narrow-bandwidth transmission over telephone-type lines . . . by all means look into the advantages of the RCA-6866.

EAST: Humboldt 5-3900
744 Broad Street
Newark 2, N. J.

MIDWEST: Whitehall 4-2900
Suite 1181
Merchandise Mart Plaza
Chicago 54, Ill.

WEST: Raymond 3-8361
6355 East Washington Blvd.
Los Angeles 22, Calif.

For sales information on RCA-6866—and on other display storage tubes now in development at RCA—contact the RCA Office nearest you. For technical data, write RCA, Commercial Engineering, Sec. A19Q, Harrison, N. J.



RADIO CORPORATION of AMERICA
ELECTRON TUBES
HARRISON, N. J.