

JANUARY · 1946

# electronics

COMMUNICATIONS  ON 2660 MC



A MCGRAW-HILL PUBLICATION





## BEFORE THE WAR

Accepted as the foremost manufacturer of quality transformers to the communications industry.



## DURING THE WAR

The largest manufacturer of communications transformers in the world.



## POSTWAR

Still leading the field in high quality transformers for broadcast applications, specialty fields and volume users.



*United Transformer Corp.*

150 VARICK STREET

NEW YORK 13, N. Y.

EXPORT DIVISION: 13 EAST 40th STREET, NEW YORK 16, N. Y., CABLES: "ARLAB"



# electronics

A McGRAW-HILL  
PUBLICATION

JANUARY • 1946

<b>RAILROAD RADIO</b> .....	<b>Cover</b>
Three dipoles fed by a stub-supported coaxial line provide a power gain of eight	
<b>RADAR COUNTERMEASURES</b> .....	<b>92</b>
Equipment for detecting and jamming enemy radars	
<b>RADAR ON 50 CENTIMETERS</b> , by Harold A. Zahl and John W. Marchetti .....	<b>98</b>
First of two articles describing the TPS-3, a 600-mc unit of significant design	
<b>VEHICULAR-MOUNTED MINE DETECTOR</b> , by H. G. Doll, M. Lebourg, G. K. Miller .....	<b>105</b>
Detection of a mine automatically sets the brakes of a jeep travelling at 8 mph	
<b>THE MPG-1 RADAR</b> , H. A. Straus, L. J. Rueger, C. A. Wert, S. J. Reisman, M. Taylor, R. J. Davis, and J. H. Taylor .....	<b>110</b>
Transmitting, r-f, receiver and antenna-positioning system details	
<b>2,660-MC TRAIN COMMUNICATION SYSTEM</b> , by E. A. Dahl .....	<b>118</b>
Details of microwave f-m system to be installed on Rock Island Railroad	
<b>CAPACITOR-CHARGING RECTIFIER</b> , by H. J. Bichsel .....	<b>123</b>
Experimental determination of design criteria for fastest charging of large capacitor bank	
<b>CAVITY MAGNETRONS</b> .....	<b>126</b>
Microwave pulse generators capable of producing four million watts peak power at 3000 mc	
<b>SUPERSONIC FLAW DETECTOR</b> , by Ralph B. De Lano .....	<b>132</b>
Industrial device permits nondestructive locating of minute flaws in castings and other solid objects	
<b>MINIMUM ATTENUATION IN AIR-CORE WAVEGUIDES</b> , by Edwin N. Phillips .....	<b>137</b>
Tabulation of design equations and graphical procedure for quickly finding optimum conditions	
<b>PICKUP WITH LOW MECHANICAL IMPEDANCE</b> , by Henry P. Kalmus .....	<b>140</b>
Light stiff moving element, which requires small tracking weight, amplitude modulates an oscillator	
<b>PULSE RESPONSE OF DIODE VOLTMETERS</b> , by Allan Easton .....	<b>146</b>
Corrections necessary for peak-reading voltmeter used to measure pulse amplitude	
<b>ELECTRONIC A-C VOLTAGE REGULATOR</b> , by L. Dale Harris .....	<b>150</b>
Vacuum-tube circuit absorbs fluctuations in line voltage, permitting calibration of a-c instruments	
<b>BRIDGING AMPLIFIER FOR F-M MONITORING</b> , by George E. Beggs, Jr. ....	<b>152</b>
Push-pull all-triode amplifier with good transient and frequency response characteristics	
<b>BETATRON PULSING SYSTEM</b> , by I. Paul and T. J. Wang .....	<b>156</b>
Circuit employs thyratron and ignitron to give 1,000-ampere pulse as capacitor discharges through orbit-shift coils	
<b>IMPEDANCE-ADMITTANCE CONVERSION CHART</b> , by Robert C. Paine .....	<b>162</b>
A short cut for speeding computation of value of impedances in parallel	
CROSSTALK .....	91
INDUSTRIAL CONTROL .....	164
TUBES AT WORK .....	200
ELECTRON ART .....	222
NEWS OF THE INDUSTRY .....	258
NEW PRODUCTS .....	300
NEW BOOKS .....	344
BACKTALK .....	356
INDEX TO ADVERTISERS .....	357

**KEITH HENNEY**, Editor; **DONALD G. FINK**, Executive Editor; W. W. MacDonald, Managing Editor; John Markus, Vin Zeluff, Associate Editors; Frank Rockett, A. A. McKenzie, Assistant Editors; J. A. Myers, Chicago Editor; Frank Haylock, Los Angeles Editor; Gladys T. Montgomery, Washington Editor; Jeanne M. Heron, Make-up Editor; Jeanne E. Grolimund, Editorial Assistant; Harry Phillips, Art Director; Eleanore Luke, Art Assistant

**H. W. MATEER**, Publisher; J. E. Blackburn, Jr., Director of Circulation, Electronics; Wallace B. Blood, Manager

D. H. Miller, H. R. Denmead, Jr., New York; Ralph H. Flynn, H. D. Randall, Jr., New England; F. P. Coyle, R. E. Miller, Philadelphia; C. D. Wardner, A. F. Tischer, Chicago; E. J. Smith, Cleveland

Contents Copyright, 1946, by McGraw-Hill Publishing Company, Inc. All Rights Reserved

McGRAW-HILL PUBLISHING COMPANY, INCORPORATED

JAMES H. McGRAW, Founder and Honorary Chairman

PUBLICATION OFFICE 99-129 North Broadway, Albany 1, N. Y., U. S. A.

EDITORIAL AND EXECUTIVE OFFICES 330 West 42nd St., New York 18, N. Y., U. S. A.

James H. McGraw, Jr., President; Curtis W. McGraw, Senior Vice-President and Treasurer; Howard Ehrlich, Vice-President (for business operations); Willard Chevalier, Vice-President (for editorial operations); Joseph A. Gerardi, Secretary; and J. E. Blackburn, Jr., Vice-President (for circulation operations).  
ELECTRONICS, January, 1946, Vol. 19; No. 1. Published monthly, price 50c a copy. Directory Issue \$1.00. Allow at least 10 days for change of address. All communications about subscriptions should be addressed to the Director of Circulation, 330 W. 42nd St., New York 18, N. Y.  
Subscription rates—United States and possessions, Mexico, Central and South American countries, \$5.00 a year, \$8.00 for two years, \$10 for three years. Canada (Canadian funds accepted) \$5.50 a year, \$9.00 for two years, \$11.00 for three years. All other countries \$7.00 for one year, \$14.00 for three years. Please indicate position and company connection on all subscription orders. Entered as Second Class matter August 29, 1936, at Post Office, Albany, New York, under the Act of March 3, 1879. BRANCH OFFICES: 520 North Michigan Avenue, Chicago 11, Ill.; 68 Post Street, San Francisco 4; Aldwych House, Aldwych, London, W.C. 2; Washington, D. C. 4; Philadelphia 2; Cleveland 15; Detroit 26; St. Louis 8; Boston 16; Atlanta 3, Ga.; 821 So. Hope St., Los Angeles 14; 38-9 Oliver Building, Pittsburgh 22.



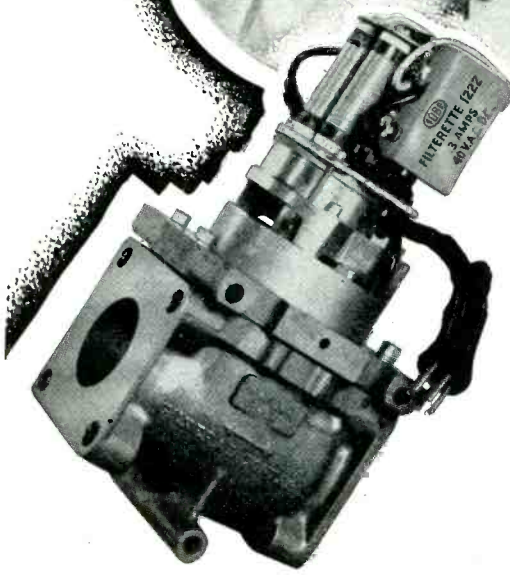
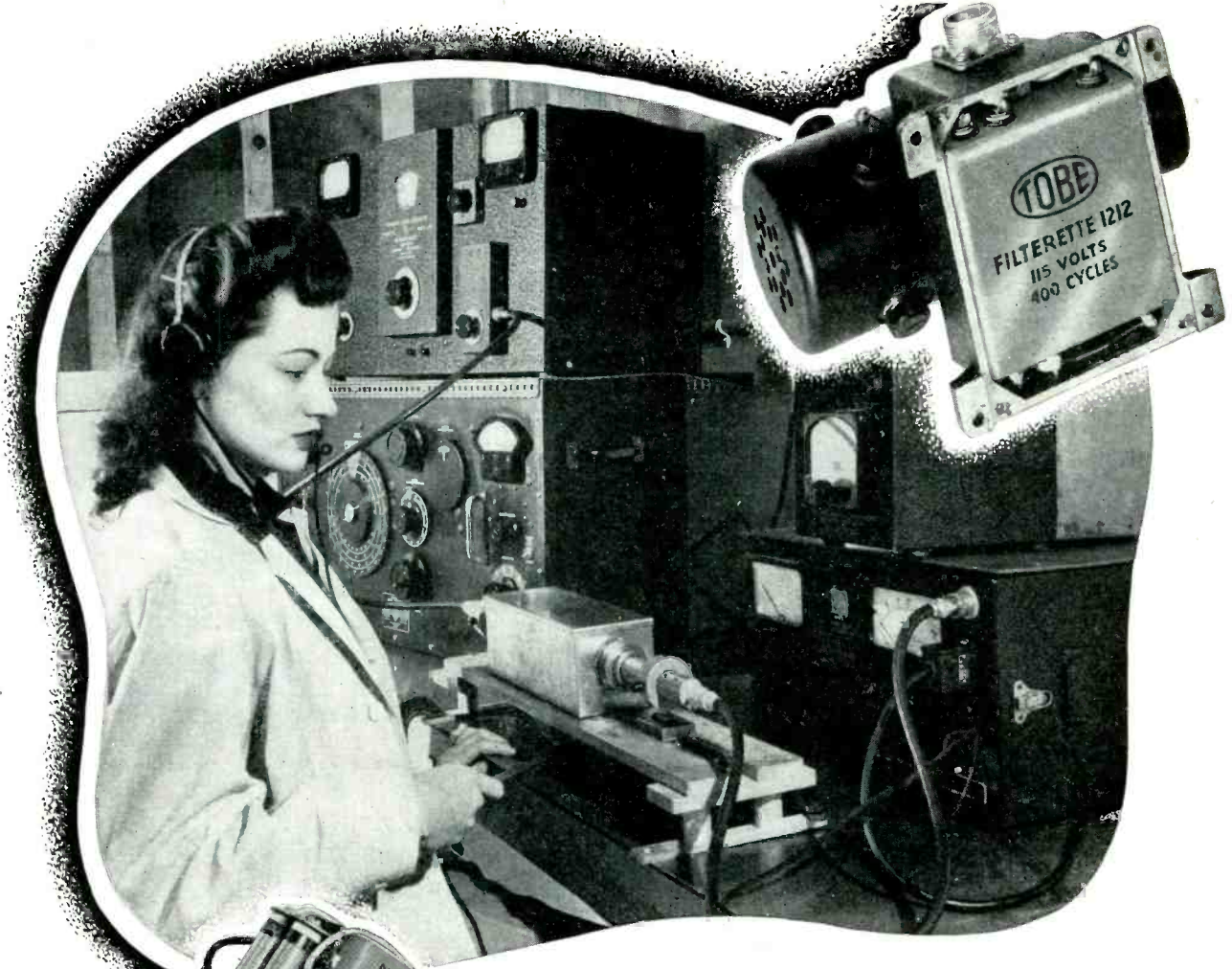

## THE CLINIC *that Cures Radio Noise*

For every evil  
under the sun,  
There is a remedy  
or there is none.  
Old Eng. Prov.

For radio noise, the remedy is Filterizing by Tobe . . . a complete service that enables you to guarantee that your electrical products will not interfere with radio reception. Filterizing by Tobe covers these three important aspects of every radio noise problem:

**R.F. Circuit Design** — Engineers with many years experience, thoroly versed in measurement techniques, and using the latest instruments, determine the radio noise output and r-f characteristics of your product and specify the correct circuit elements to stop radio interference over the desired frequency range.

**Electrical Design** — The filterizing circuit is checked for effect upon performance of the apparatus being Filterized and all components are selected so that normal performance is obtained after Filterizing; voltage drop, temperature rise, phase relationships — all are held within required limits.

**Mechanical Design** — The arrangement of circuit elements is co-ordinated with existing space limitations so that radio noise is quelled without need for extensive re-design of the apparatus.

These three design factors, embodied in every Tobe Filterette, are based on exact, scientific knowledge and, when applied by Tobe engineers, enable you to guarantee radio silence for your electrical apparatus. This guarantee, shown by the FILTERIZED label, helps build sales for your product. Ask us for details.



**TOBE DEUTSCHMANN CORPORATION • CANTON, MASSACHUSETTS**

**ORIGINATORS OF FILTERETTES • • • THE ACCEPTED CURE FOR RADIO NOISE**



● Many brilliant projects have been started with a K & E Slide Rule and the back of an old envelope. But between a new conception and its practical execution of the vital links are always the engineer and the draftsman. For through their techniques they construct the project on paper with unmistakable clarity and precision. In this their drafting instruments and equipment become part of their own hand and brain, and their partners in creating.

For 78 years Keuffel & Esser Co. Slide Rules, drafting equipment and materials have been partners in creating the greatness of America, in making possible our nationwide railway system, giant airports, fine radios for nearly every home . . . So universally is K & E equipment used, it is self-evident that every engineering project of any magnitude has been completed with the help of K & E. Could you wish any surer guidance than this in the selection of your own "engineering partners"?

In slide rules especially, you will find K & E precision invaluable. For it not only brings you a slide rule that is a joy to use, but it adds to your confidence in making every calculation. You will find Don Herold's booklet, "How To Choose A Slide Rule", amusing and very helpful. Write on your

letterhead to Keuffel & Esser Co., Hoboken, N. J.

## partners in creating

**K + E**  
 Drafting, Reproduction,  
 Surveying Equipment  
 and Materials,  
 Slide Rules,  
 Measuring Tapes.

  
 ...the greatest  
 airports

  
 ...the world's  
 safest trains

**KEUFFEL & ESSER CO.**  
 EST. 1867  
 NEW YORK • HOBOKEN, N. J.  
 CHICAGO • ST. LOUIS • DETROIT • SAN FRANCISCO  
 LOS ANGELES • MONTREAL



# Allis-Chalmers Electronic

## NEW KIND OF

➡ *Compare Engineering: A-C's years of industrial electronic experience give you superior operating features.*

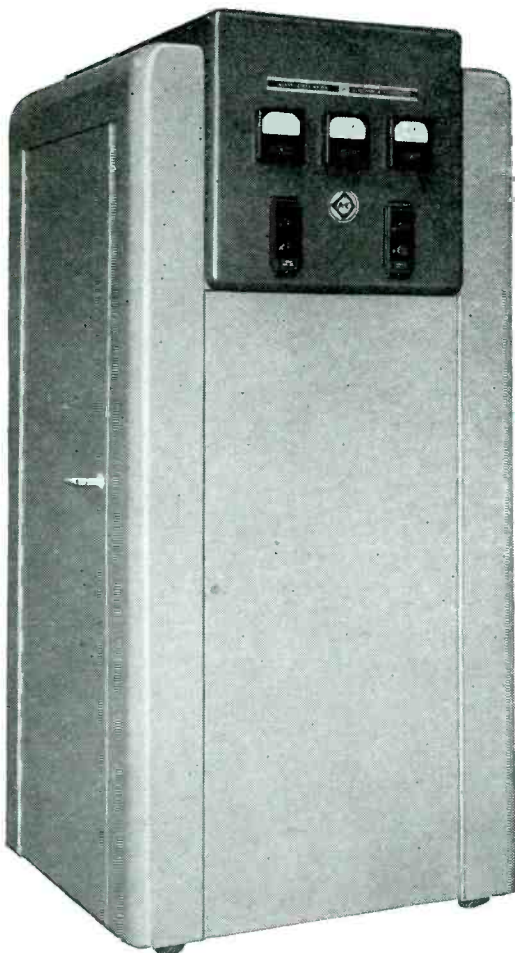

**C**ONVENIENCE, economy, low cost — the magic of induction heating at its finest — that's what Allis-Chalmers new Electronic Heater now offers you!

➡ **Completely Automatic:** Pre-set timer controls heat sequence from 2/10 seconds to 2 minutes — so that even unskilled operators can harden and braze metal parts in volume — uniformly — at simple touch of starter button. All controls are located on one panel for easy change in applications. Job settings are protected from tampering by door and lock.

➡ **High Efficiency:** 3-phase rectifying system guarantees maximum power from Electronic Heater, prevents unbalanced load on power lines. All tubes carry manufacturer's guarantee (minimum: 1000 hours), often have useful life in excess of 5000 hours. New coupling system keeps losses low, permits adaptation to most applications without use of radio frequency transformers.

➡ **Safety Features:** Operator and equipment are fully protected by heavy-duty control, fuses, high water-temperature relay, interlocking switches on door, choke coil, water filters and pressure switches.

Maybe your manufacturing operation can be performed better, faster, cheaper with this great new production tool. Write for further information, or send samples for free laboratory test. No obligation. ALLIS-CHALMERS, ELECTRONIC DEVICES SECTION, MILWAUKEE 1, WISCONSIN.

A 1914

*Pioneer Builders of Electronic  
Equipment for Industry.*

**Allis**





# Heater Now Offers You A

# METAL MAGIC

**Compare Results:** High frequencies, accurate control of A-C's new unit give you finer products at lower costs.



## INCREASES PRODUCTION

Joining parts by brazing is ideal for induction heating — an application of this new magic process which can slash product costs by doubling and redoubling production rates! Here's how A-C's Electronic Heater solved the problems of one lubricator manufacturer who formed sub-assemblies by torch-brazing. His rejects were high, his production was slow (15-20 units per hour), and slow heat affected cadmium plating on parts so that it peeled off in a short time. A-C's Electronic Heater was able to step production up to 200 units per hour! Rejects became negligible, and plating was not affected. Maybe Allis-Chalmers Electronic Heater can show you the same spectacular results!

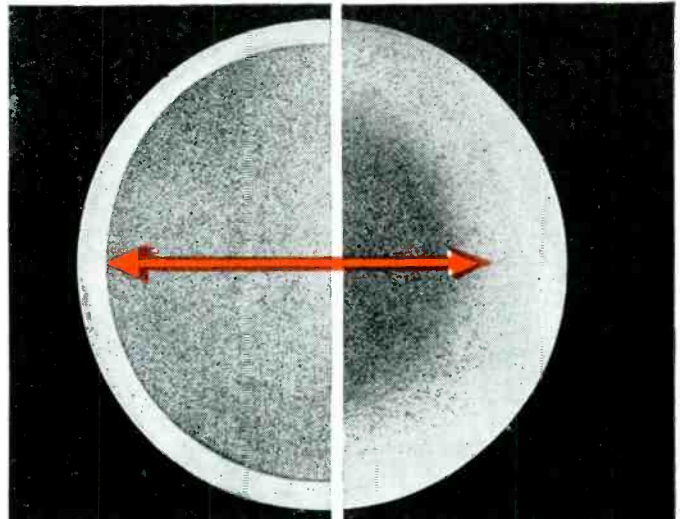

## MORE EFFICIENT HARDENING

Allis-Chalmers Electronic Heater gives you surface hardening to controlled depths — faster, cleaner, without heat, fumes, space-waste of conventional methods. Tendency of high-frequency currents (400,000 cycles and up) is to hug surface of conductor. Result: thin, hardened surface with healthy, ductile core — as shown above, left, in unretouched micro-photograph section of  $\frac{3}{4}$  inch bar of SAE 1045 steel — hardened by Electronic Heater. Compare this with micro-photograph section of  $\frac{3}{4}$  inch SAE 1045 steel bar hardened by conventional methods — above, right! Here, uncontrolled hardening has penetrated deep into the core, making the bar brittle and weak.

# Chalmers

MILWAUKEE  
WISCONSIN



Try  
it!  
Compare  
it!

**\$129\***  
AMATEUR NET  
LESS SPEAKER

# HQ-129-X



Price subject  
to change  
without notice.

Frequency  
31—.54  
Megacycles

Try—then compare, and you'll agree that this professional receiver is an outstanding value. It is built by craftsmen who specialize in communication equipment. The HQ-129-X has endless improvements which are fully described in an eight-page booklet.. Write today for complete technical information.



# HAMMARLUND

THE HAMMARLUND MFG. CO., INC., 460 W. 34<sup>TH</sup> ST., NEW YORK 1, N. Y.  
MANUFACTURERS OF PRECISION COMMUNICATIONS EQUIPMENT



OF SERVICE

is a full-rate  
am or Cable-  
unless its de-  
character is in-  
ed by a suitable  
pool above or pre-  
ing the address.

# WESTERN UNION

A. N. WILLIAMS  
PRESIDENT

1220

**SYMBOLS**

- DL = Day Letter
- NL = Night Letter
- LC = Deferred Cable
- NLT = Cable Night Letter
- Ship Radiogram

Time of receipt is STANDARD TIME at point of destination  
Time of origin is STANDARD TIME at point of origin.

D31CC 179 NL PD BKLY NY JAN 1 1946

ELECTRONIC TUBE USERS EVERYWHERE

OUR STAFF WELCOMES COMPETITIVE NEW YEAR NOW THAT UNCLE SAM'S "ONE MAN" MARKET IS GONE. FIRST CW TUBE WE MADE QUARTER CENTURY AGO IS JOINED BY OUR "E" CITATIONS IN AMPEREX MEMOIR CABINET. TO THE THOUSANDS OF ELECTRONIC TUBE USERS IN SCORES OF INDUSTRIES AND PROCESSES AS "OLD" AS COMMUNICATIONS AND AS NEW AS INDUCTION HEATING WE PLEDGE:

- 1) AMPEREX CREATIVE RESEARCH: 2) AMPEREX PRECISION MANUFACTURE: 3) AMPEREX HELPFUL SERVICE. THOSE ARE THE THREE CARDINAL PRINCIPLES ON WHICH WE BUILT AMPEREX DURING THE DECADES PRECEDING THE WAR. THEY KEPT US WITH VASTLY ACCELERATED DEVELOPMENTS AND RESPONSIBILITIES OF WAR YEARS. WE ARE STICKING TO OUR RECOGNIZED SPECIALTY—POWER TUBES AND THEIR APPLICATION IN ALL FIELDS. WE FACE THE BUYERS' MARKET NOW AT HAND WITH CONFIDENCE BASED ON LIFE, PERFORMANCE, RELIABILITY AND ECONOMY SO LONG ASSOCIATED WITH AMPEREX ELECTRONIC TUBES. SEE YOU AT THE ASTOR—HAPPY NEW YEAR.

AMPEREX ELECTRONIC CORPORATION  
79 WASHINGTON ST BKLYN 1. NY



# 3D23

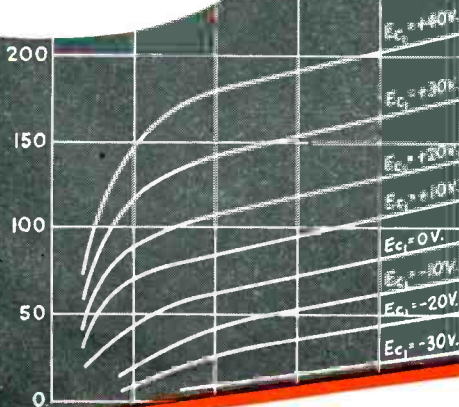

*This is the Tube you have  
been seeking to install in your  
postwar transmitters*

**A remarkable new TETRODE for fixed  
or mobile operation**

Filament Voltage . . . . . 6.3 AC or DC Volts  
 Filament Current . . . . . 3.0 Amperes  
 Amplification Factor . . . . . 65  
 Mutual Conductance . . . . . 2,750  
 Plate Dissipation . . . . . 35 Watts  
 Medium 4 Pin Ceramic Base  
 Maximum Power Output . . . . . 130 Watts  
 Approx. Driving Power . . . . . 4.5 Watts

**Inter-Electrode Capacities**

Input to Plate . . . . . .2 MMFD  
 Input, 6.5 MMFD . . . . . Output, 1.8 MMFD

Licensed under R. C. A. Patents

Catalog Sheet and Tubes Now Ready for  
Distribution

**Lewis at Los Gatos**

Manufacturers of all types of  
transmitting tubes — from 35  
Watt West Coast type triodes  
to 35 kilowatt external anode,  
multi-grid tubes — A new  
member of the Aireon  
family.

# Lewis Electronics, Los Gatos, Calif.

SUBSIDIARY OF **Aireon** MANUFACTURING CORPORATION



# Aireon

## Cinaudagraph Speaker

*... The Speaker  
of Tomorrow, TODAY*

The Aireon Cinaudagraph Speaker is a product of deft engineering, vast experience, daily profound research and proven performance. It has an international reputation for tone, stamina and perfection. The plus features that you get in Aireon Cinaudagraph Speakers are inherent—born of the highest standards of inspection

and use of the finest materials. You'll need these extra—these plus factors to help you do the better job you now require.

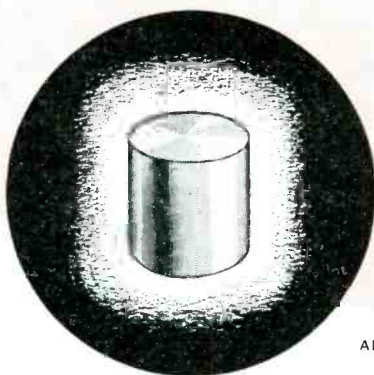

ALNICO 5

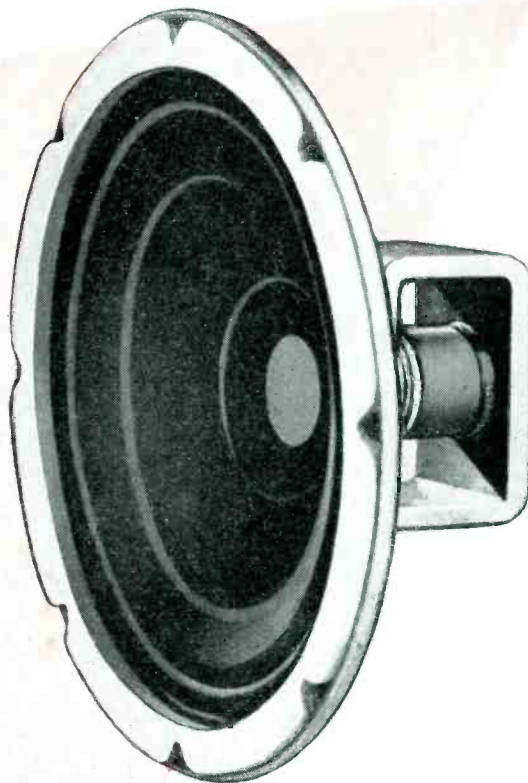

All P. M. Models of Aireon Cinaudagraph Speakers use Alnico 5, the miracle metal that gives you 4 times the performance without size or weight increase. No set-up is complete without at least one—write for information, today.

### Cinaudagraph Speakers, Inc.

Subsidiary of **Aireon** Manufacturing Corporation

3911 SOUTH MICHIGAN AVENUE, CHICAGO





# STRONG

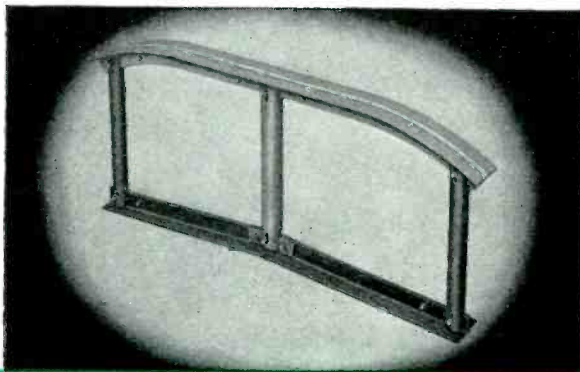

Strong, lightweight National Vulcanized Fibre serves efficiently in aircraft structural parts, as in this internal brace for self-sealing fuel cells.



## resilient...lightweight NATIONAL VULCANIZED FIBRE

*may be your answer to  
new, profitable products*

Just as National Vulcanized Fibre adds to the life and efficiency of structural parts in aircraft—this strong, durable material gives *your* products and equipment longer performance . . . at greater economy.

The unusual strength of National Vulcanized Fibre, combined with its other remarkable properties, makes it a “natural” for countless applications in every industry. Resilient and light in weight (about half that of aluminum), it has outstanding tensile and impact strength . . . excellent machinability and forming qualities . . . is high in dielectric strength . . . is extremely

resistant to wear and abrasion . . . and is one of the *strongest* materials per unit weight known.

This versatile material offers you no end of profitable possibilities in your products and plant equipment. Write for complete information now. Let one of our trained technical engineers show you how National Vulcanized Fibre can serve you advantageously in your plant equipment and in your products.

## NATIONAL VULCANIZED FIBRE CO.

WILMINGTON, DELAWARE

OFFICES IN PRINCIPAL CITIES



# USE

## SPRING LOCK WASHERS

### TO COMPENSATE FOR **BOLT AND SCREW S-T-R-E-T-C-H-I-N-G**

It's a well known fact that metal bolts and screws stretch, under constant service and temperature changes. If they didn't, lock washers, lock nuts and lock fastenings of any kind would be unnecessary.

Diamond G Spring Lock Washers . . . scientifically designed with CONTROLLED TENSION . . . assure unfailing spring tension PLUS thrust washer action. They permit full tightening of bolts and screws, and lock themselves against vibration, shock and excessive wear.

Specify Diamond G's today! Samples on request. Write for illustrated folder including new ASA and SAE specifications on Spring Lock Washers. Prompt delivery assured on all orders.

**GEORGE K. GARRETT CO., INC.**

1114 MORRIS BLDG., 1421 CHESTNUT ST., PHILADELPHIA 2, PA.

MANUFACTURERS OF

# DIAMOND PRODUCTS



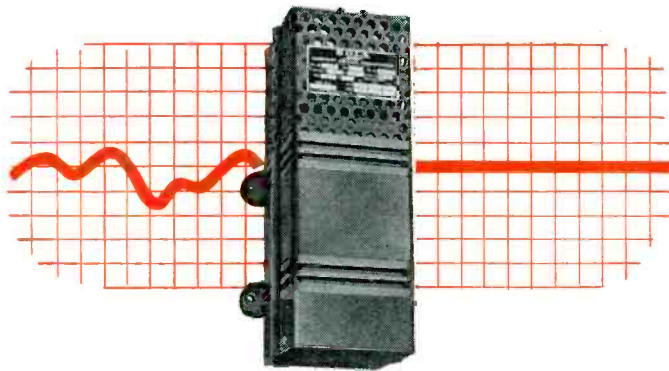

# Constant Voltage

... is always available to equipment protected by a  
**SOLA CONSTANT VOLTAGE TRANSFORMER**

Are you looking for new ways to—

1. Increase the efficiency of your product?
2. Lower its cost to the user?
3. Reduce maintenance expense?

Much of this can be accomplished with a SOLA Constant Voltage Transformer built into your product. Now, more than ever before, electrical equipment needs line-voltage protection.

Stable voltage, direct from supply lines, is *not* available to the users of your equipment. Voltage may vary as much as 15-20% from the rating on your label. *Your* equipment will be blamed for the inefficient operation that results.

Build a SOLA Constant Voltage Transformer into your equipment and operating voltages will always be within  $\pm 1\%$  of rated requirements

regardless of line fluctuation as great as 30%.

There is a wide range of sizes and capacities in SOLA Constant Voltage Transformers which can be built specifically for your product. The savings you can make through the elimination of other components and anticipated service calls, plus greater operating efficiency and satisfaction to your users, merit your consideration of SOLA Constant Voltage Transformers as a component in your equipment design.

SOLA Constant Voltage Transformers are fully automatic with no tubes, or moving parts. They require no supervision or manual adjustments.

There's a new SOLA handbook that describes fully the theory, operation and use of SOLA Constant Voltage Transformers. Write for your copy.

Ask for Bulletin DCV-102

# SOLA Constant Voltage Transformers

Transformers for: Constant Voltage • Cold Cathode Lighting • Mercury Lamps • Series Lighting • Fluorescent Lighting • X-Ray Equipment • Luminous Tube Signs  
Oil Burner Ignition • Radio • Power • Controls • Signal Systems • etc. **SOLA ELECTRIC COMPANY, 2525 Clybourn Avenue, Chicago 14, Illinois**

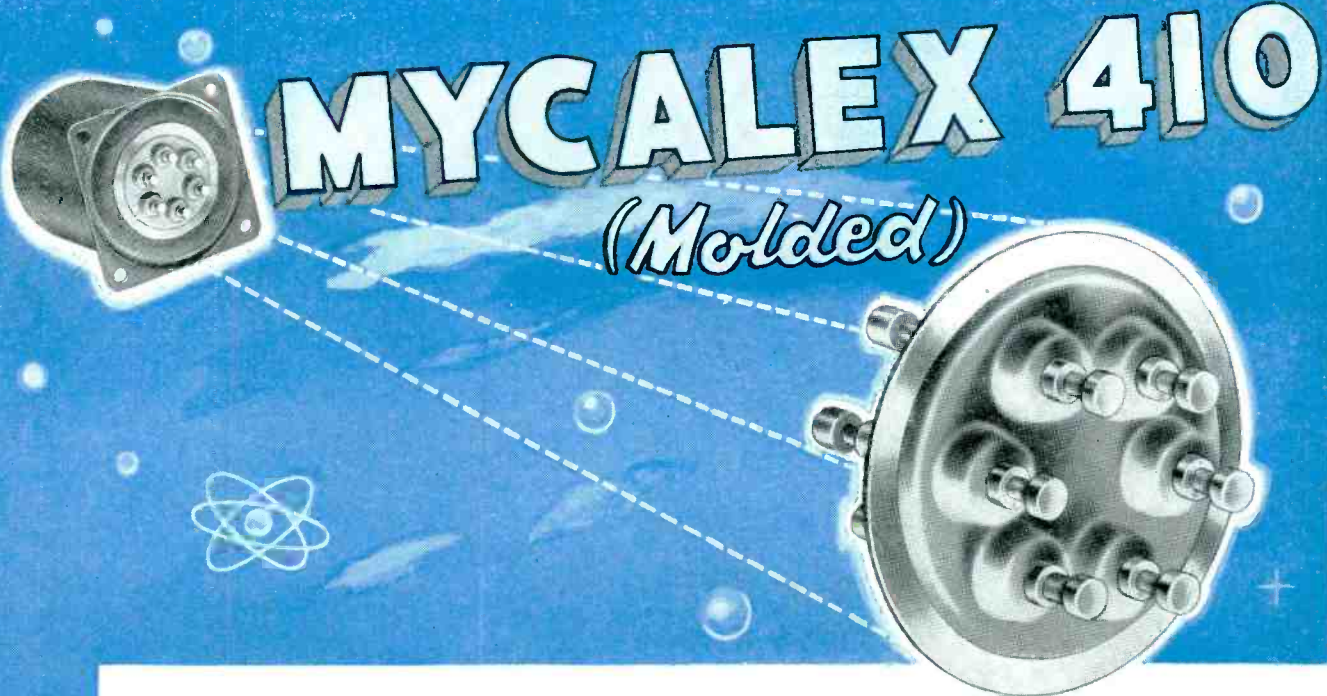

UNITED TRANSFORMER CORPORATION  
 150 VARICK STREET  NEW YORK 13, N. Y.

November 3, 1945

Mycalex Corp. of America  
 30 Rockefeller Plaza  
 New York 20, N. Y.

Attention: Mr. Jerome Taishoff

Gentlemen:

We have conducted the following test on the two-six terminal molded mycalex assemblies you submitted:

- 1 - Meg test - 500 megohms
- 2 - Place in oven at 40°C for 8 hours
- 3 - Place in hot sodium chloride at 65°C for 1 hour
- 4 - Place in cold sodium chloride at 0°C for 1 hour
- 5 - Leave overnight in salt water at room temperature 20°C
- 6 - Meg test - infinity test

This test was repeated three times. At the end of the test the unit was tested for leakage and showed a small amount. This amount was within the limitations imposed by the Army Signal Corps. After the assemblies had dried for about 15 minutes they indicated no leakage. We consider these terminals to be extremely satisfactory for hermetic sealing purposes.

We wonder what would happen if these same 6 terminals were compressed into a smaller diameter assembly? We would greatly appreciate receiving samples of your single terminal assemblies.

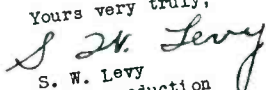
Yours very truly,  
  
 S. W. Levy  
 Chief Production  
 Engineer

**MAKES "EXTREMELY SATISFACTORY HERMETIC SEAL"**

**REPORTS** *United Transformer Corp.*

Are you seeking a hermetic seal for transformer terminals? Do you want a low loss, high frequency insulating material that will bond to metal and give positive assurance against oil leakage and the damaging effects of moisture?

Then read the United Transformer Corporation report made after tests of MOLDED MYCALEX in conjunction with Monel Metal in this application. The results speak for themselves.

For 25 years MYCALEX has been known to engineers the world over as the "most nearly perfect high frequency low loss insulation." Now, in highly perfected form, MYCALEX offers new opportunities for product improvement.

Specify MYCALEX where low loss factor and high dielectric strength are required. Our engineers are at your service.



**MYCALEX CORPORATION OF AMERICA**  
 "Owners of 'MYCALEX' Patents"  
 Plant and General Offices, CLIFTON, N. J.      Executive Offices, 30 ROCKEFELLER PLAZA, NEW YORK 20, N. Y.



# NEW REVERSING CONTACTOR



TYPE 135CXX Actual Size

These District  
Engineering Offices  
To Serve You

ATLANTA  
BALTIMORE BOSTON  
BUFFALO  
CHICAGO CINCINNATI  
CLEVELAND  
DALLAS DENVER  
DETROIT HARTFORD  
INDIANAPOLIS  
LOS ANGELES  
MINNEAPOLIS  
MONTREAL NEW YORK  
PITTSBURGH ST. LOUIS  
SAN FRANCISCO  
SEATTLE SYRACUSE  
TORONTO



**Much Smaller—Much Lower in Cost**  
**Fully Dependable for Heavy Duty Service**

**RATING**—1 HP polyphase,  $\frac{3}{4}$  HP single phase, to 600 volts AC.

**FEATURES**—Small Size— $5\frac{3}{4}'' \times 4'' \times 1\frac{7}{8}''$ .

Mechanically Interlocked.

Solid Frame—no laminations.

Simple Maintenance—all parts removable from front; all fixed contacts alike, all moving contacts alike.

Cost—appreciably lower than conventional units.

**APPLICATIONS**—Heavy duty reversing and jogging service such as hoists, door operators, and machine tool auxiliaries.

# STRUTHERS-DUNN

## 5,312 RELAY TYPES

**STRUTHERS-DUNN, INC., 1321 Arch Street, Philadelphia 7, Pa.**





**On an 18 mile  
circumference**



## **Super-Aire Speaker**

**D**IRECT as an arrow to the target—that's the way your voice can reach any point in a vast area with the G-E Super-Aire Speaker. The G-E Super-Aire Speaker is a complete public address system in an unusually compact and economical form.

Ruggedly designed for hard field usage, in any climate or weather, it can be employed in the tough day-by-day jobs of freight yard traffic control, harbor control, giant dam construction projects and a host of similar widespread operations. Even the pre-

cision voice element can "take it" without fracturing under the assault of terrific shock or vibration.

Where no power supply is available, a small gas engine can take over the work of operating the compressor and furnishing power for the amplifier. Mobility is just one among the many advantages of the Super-Aire Speaker that makes it the perfect unit for the job.

The G-E Super-Aire Speaker is modern—and today it is *available* "must" equipment on large projects. Write for complete information to:—

*Electronics Department, Specialty Division, General Electric Company, Syracuse, N. Y. See your G-E distributor for Universal Radio Parts, P. A. Systems, Crystals, Receiving, Industrial and Transmitting Tubes, Laboratory and Service Test Equipment.*



**EVERYTHING IN  
RADIO • TELEVISION • ELECTRONICS**

# **GENERAL ELECTRIC**





-AND NOW THE NEW

# CONSOLETTTE

STUDIO A



MICROPHONES



"ON-AIR" AND  
"REHEARSAL" LIGHTS



LOUDSPEAKER



4 SPECIAL  
CUE INPUTS

STUDIO B



MICROPHONES



"ON-AIR" AND  
"REHEARSAL" LIGHTS



LOUDSPEAKER

ANNOUNCE BOOTH



MICROPHONE



LOUDSPEAKER



"ON-AIR" LIGHT

8 REMOTE LINES  
(INCLUDING NETWORK)



STUDIO AND STATION EQUIPMENT • TRANSMITTERS

# GENERAL ELECTRIC

100-E1-0914

## CONTROL ROOM



HEADPHONES



ANNOUNCE MICROPHONE



TALK-BACK



LOUDSPEAKER



TRANSCRIPTION MACHINES



"ON-AIR" LIGHT

## 2 OUTGOING CIRCUITS TO "ST," LINES, OR TRANSMITTER

The new G-E two-studio Consolette is a compact, flexible and economical speech input equipment designed to meet the needs of every station, FM or AM.

A Partial List of the Features that make the G-E Consolette an Important Part of Every Station, FM or AM:

- Contains all amplifiers and controls for complete operation of 2 studios, announce booth, turntables, and remote lines.
- Input connections for 8 studio microphones, 2 announce microphones, talkback microphone, 8 remote lines (including network), 2 transcription turntables, and 4 special cue input circuits.
- Output connections for 2 outgoing lines, 4 loudspeakers, 4 sets of "on-air" and "rehearsal" lights, and headphones.
- 4 pre-amplifiers provide simultaneous operation of 4 microphones.
- 2 program amplifiers provide extreme flexibility in operation and reliability of service. Each amplifier has individual gain control and power supply.
- Monitor amplifier with individual power supply is also used for talk-back circuit with "over-ride" feature. All "interlocking" is built in.
- Simultaneous facilities for broadcasting and rehearsing.
- Electrical performance to meet FM requirements. At normal output level distortion is less than 1% rms, 50 to 7500 cycles. Response is within 2 db, 30 to 15,000 cycles. Noise level is 65 db below program level.
- Two-tone, blue-gray cabinet is only 10½ inches high, providing complete visibility over top of consolette.

## Big-Station Studio Control Flexibility for Every FM and AM Station

THE General Electric Consolette provides complete studio control facilities—monitoring, cueing, simultaneous broadcasting and rehearsing, and over-ride talk-back that operates without need for order wires—all at a price *any* station can afford, FM or AM.

Here is an outstanding control unit that contains all the amplifiers and controls needed for complete operation of one studio, two studios, or two studios and an announcer's booth—including ten microphone inputs. Two program amplifiers permit instantaneous switching of the program from one amplifier to the other.

A new improved push-button system and simplified switching gives the G-E Consolette exceptional flexibility and new freedom from operating errors. Careful arrangement of controls and a correctly sloped panel combine full visibility with operating ease unmatched by ordinary consolettes. A hinged top and a hinged-type chassis mounting provide complete accessibility.

Ask your nearest G-E office for a copy of the new brochure that gives complete data on the new G-E Consolette, or write: *Electronics Department, General Electric Company, Schenectady 5, New York.*

FOR EARLIEST POSSIBLE DELIVERY OF YOUR BROADCAST EQUIPMENT,  
PLACE YOUR ORDER NOW.

Use G-E Electronic Tubes in your station for maximum  
dependability and finer performance.

ANTENNAS • ELECTRONIC TUBES • HOME RECEIVERS

EVERYTHING FOR BROADCASTING

FM • TELEVISION • AM



# Check these features

## of Type GL-813 beam power TRANSMITTING TUBE



Low driving power requirements—as little as 0.5 watt (Class C telegraphy)

Neutralization unnecessary when used in adequately shielded circuits

260 watts of plate power output, Class C typical operation

30 megacycles maximum frequency at full ratings; up to 60 at reduced ratings

Type GL-813

Price \$22

✓ **HERE** is first-class G-E tube value—an economically priced beam power amplifier that delivers substantial plate output with very little driving power, and requires no neutralization in circuits which employ proper shielding.

Type GL-813 is an excellent high-power frequency multiplier, also an ideal power amplifier for the final stage of transmitters where quick band change without neutralizing adjustments is desirable.

Beam power design, and compact over-all tube dimensions making

for short internal leads—these features contribute to high power sensitivity and exceptional efficiency of operation.

Type GL-813 is but one of a wide range of popular transmitting tubes bearing the G-E monogram, and conveniently and *quickly* available from tube stocks in all parts of the country. Phone your G-E office or distributor. He can serve your tube needs promptly, and will be glad to discuss your requirements.

*Electronics Department,  
General Electric Company,  
Schenectady 5, N. Y.*

### Characteristics of Type GL-813

No. of electrodes.....	4
Filament voltage.....	10 v
Filament current.....	5 amp
Max. plate voltage.....	2,000 v
Max. plate current.....	0.18 amp
Max. plate input.....	360 w
Max. plate dissipation.....	100 w
Gm.....	3,750 micromhos

*Watch for announcements of NEW G-E tubes that set NEW standards of performance in FM and other transmitters operating at the higher frequencies.*

# GENERAL ELECTRIC

161-E1-0000

TRANSMITTING, RECEIVING, INDUSTRIAL, SPECIAL PURPOSE TUBES ★ VACUUM SWITCHES AND CAPACITORS

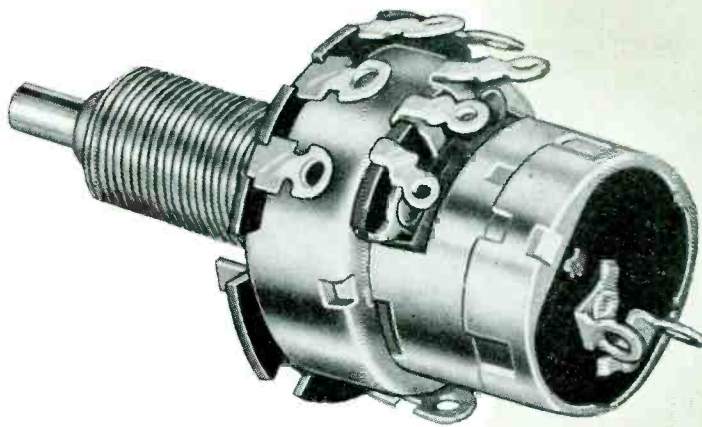

1 1/2 times actual size



## THIS 3-IN-1 ADAPTATION

## SOLVED ONE TOUGH PROBLEM

A certain auto radio had need of two controls and a switch but only had room on the panel for one unit. CTS solved that problem by devising the G-CIS7-45 featured here, a concentric shaft tandem tone control switch, volume control and on-off switch.

The tone control switch and volume control are operated from concentric shafts and the on-off switch is closed at the beginning of volume control rotation on the rear section. The tone control can be supplied with two, three or four positions.

The CTS reputation for dependability was acquired—and has been retained—because of their genius for solving difficult problems, and then delivering shipments which are uniform in quality and available for use at the time they are promised.

Bring your variable resistor problems to the CTS specialists.

### REPRESENTATIVES

R. W. Farris Co.  
406 West Thirty-fourth Street  
Kansas City 2, Missouri  
Phone: Logan 7495

Frank A. Emmet Co.  
2837 West Pico Boulevard  
Los Angeles 6, California  
Phone: Rochester 9111

George A. Coleman  
420 Market Street  
San Francisco 11, Calif.

### BRANCH OFFICES

S. J. Hutchinson, Jr.  
401 North Broad Street  
Philadelphia 8, Pennsylvania  
Phone: Walnut 5389

### IN SOUTH AMERICA

Jose Luis Pontet  
Cordoba 1472  
Buenos Aires, Argentina  
South America

Masculina 2624  
Montevideo, Uruguay  
South America

Avda. Conselheiro Rodrigues  
Alves 1057  
Villa Mariana  
Sao Paulo, Brazil  
South America

Walter Th. Kammann Willson  
Apartado 1891  
Norte 6 No. 17  
Caracas, Venezuela  
South America

### IN ENGLAND

Chicago Telephone Supply Co.  
St. Jahn's Woods  
103 Grove End Gardens  
London, N. W. 8, England

### CANADIAN ASSEMBLY PLANT

C. C. Meredith & Co.  
Streetsville, Ontario



**CHICAGO TELEPHONE SUPPLY**  
*Company*

VARIABLE RESISTORS AND ASSOCIATED SWITCHES

ELKHART • INDIANA

*Manufacturers of Quality Electro-Mechanical Components Since 1896*



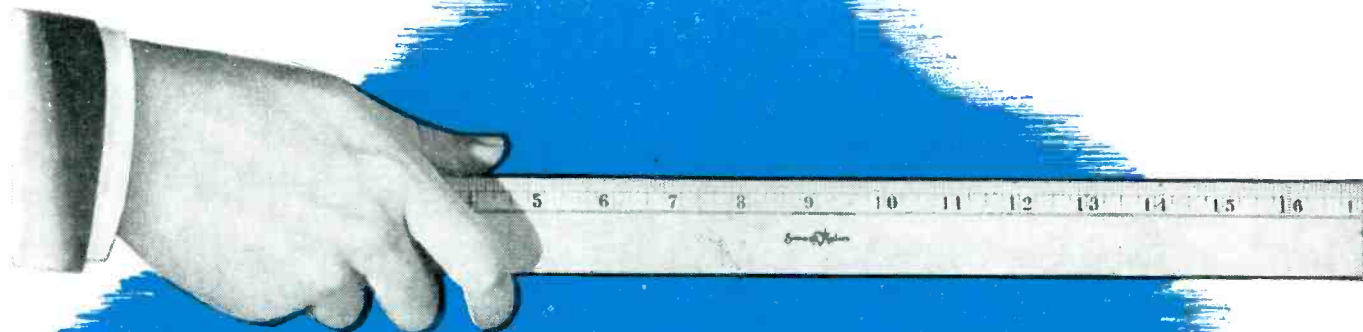

WHAT IS THE MEASURE OF

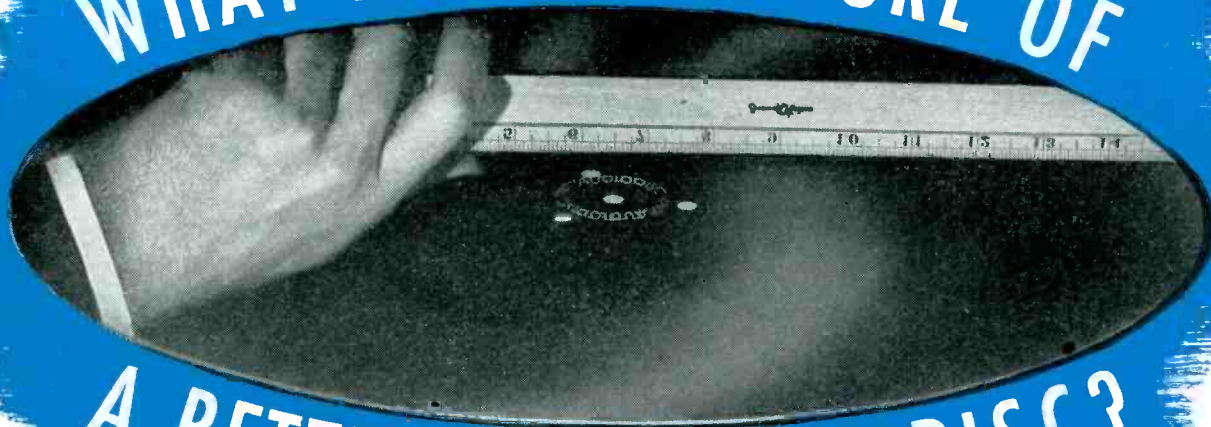

A BETTER RECORDING DISC?

**JUST** by the simple expedient of putting a ruler to a recording disc, you can, in one sense, "measure" recording quality.

The disc must reflect a *true* image. Any imperfection in the reflection means that you can expect corresponding imperfection in recording characteristics. That's just A-B-C.

But a *better* recording disc must possess many other in-built qualities in addition to a flat, smooth, mirror-like surface:

*For recording*, it must have (a) split-hair accuracy in thickness of coating (b) easy cutting characteristics (c) positive thread-throw with no annoying static and (d) these qualities must not change — *regardless of the age of the disc.*

*For playback*, it must have (a) brilliant high frequency response (b) no audible background scratch, even after many playings (c) no increase in surface noise from the time of recording to playback or processing.

— *And finally*, these qualities must last as long as the recording

is needed. *There must be no deterioration with the years.*

\* \* \*

You cannot discover these qualities in a recording disc, by any yardstick we know of — except one:

*Just look for the name Audiodisc* — because it assures you all the qualities named above — a combination you will not find in any other recording disc.

*Audiodiscs* are manufactured by a patented, precision-machine process which is *uniquely* theirs, and the *Audiodisc* recording lacquer is produced from a formula developed by our research engineers. Thus, *Audiodisc* quality is consistently dependable. It is fully controlled—straight through from raw materials to finished disc.

There is an *Audiodisc* designed and priced for every recording need. No matter what the purpose, the name *Audiodisc* is, and will remain, the measure of a *better* recording disc.

**AUDIO DEVICES, INC., 444 Madison Avenue, New York 22, N. Y.**

*Audiodiscs manufactured in U.S.A. under Exclusive License from La Societe Des Vernis Pyrolac — France.*



*they speak for themselves* **audiodiscs**

**RESEARCHED**  
**ENGINEERED**  
**DESIGNED**  
**PRODUCED**

by **R/C**

Radio Condenser is *not* an assembly plant. From the humblest mechanical detail to the completed, fully tested unit, every part of an R/C Variable Capacitor is designed and produced by us. Each is engineered for its specific function. From original laboratory research to final shipment, each is given full benefit of a wealth of specialized Variable Capacitor Know-How unmatched in the history of the Radio-Electronic profession.

Only in this way can maximum dependability be assured. Only by such methods can your exacting specifications be matched "on the nose."

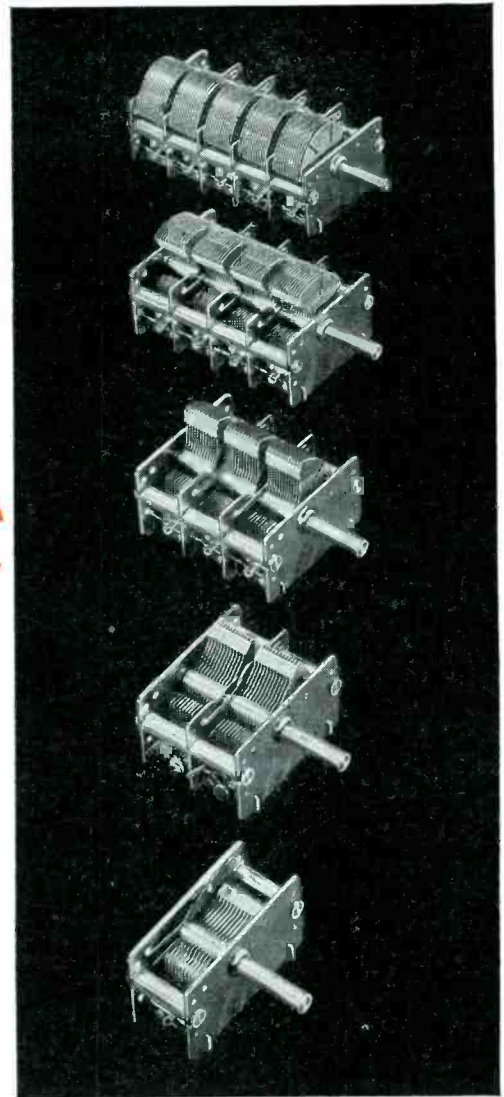
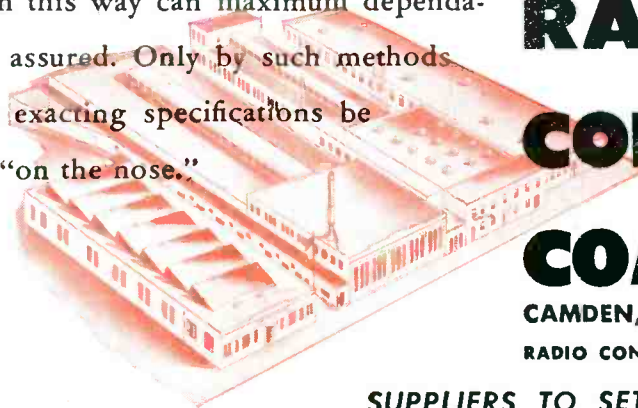

**RADIO**  
**CONDENSER**  
**COMPANY**

CAMDEN, N. J.

RADIO CONDENSER CO., LTD., TORONTO, CANADA

**SUPPLIERS TO SET MANUFACTURERS ONLY**



For a Bruiser  
he was  
always a

# "Weary Willie"



He was no weak sister. But that slow, nerve-straining, muscle-cramping drudgery of hand-driving slotted screws kept him a high-cost, low-output worker. In fact, Bill and his whole department were low all the time . . . in production, spirits, and health . . .

## . . . 'til AMERICAN PHILLIPS SCREWS stopped him from "beating his brains out"

Bill's boss got to analyzing his costs one day . . . found that his screw-driven assembly cost was the *only cost he could cut*, and that there was *only one way to do it*. So he threw out his hand-drivers and slotted screws . . . put in power-drivers and American Phillips Screws.

Now his assembly costs are down 50%. His output is at an all-time high, and so is product-quality. What's more, Bill's department has taken new interest in the job, and no longer bogs down from exhaustion toward the end of the shift. All because American Phillips Screws are:

1. "Fumble-Proof" . . . screw and 4-winged bit fit firmly into one straight unit that can't drive any way *but* straight. No wobbly starts, no dropped screws.

2. "Slip-and-Slash-Proof" . . . bit and screw can't twist apart till screw is driven up tight and flush. No spoiled work or gashed hands.

Now add a third advantage . . . American's 4-phase quality control that means higher "perfection-percentage" in every shipment of American Phillips Screws . . . and you have your top opportunity for cost-control looking you right in the face! Write.

**AMERICAN SCREW COMPANY, PROVIDENCE 1, RHODE ISLAND**

Chicago 11: 589 E. Illinois Street

Detroit 2: 502 Stephenson Building.



# AMERICAN PHILLIPS *Screws*

Guaranteed Free from Burrs and Split Heads

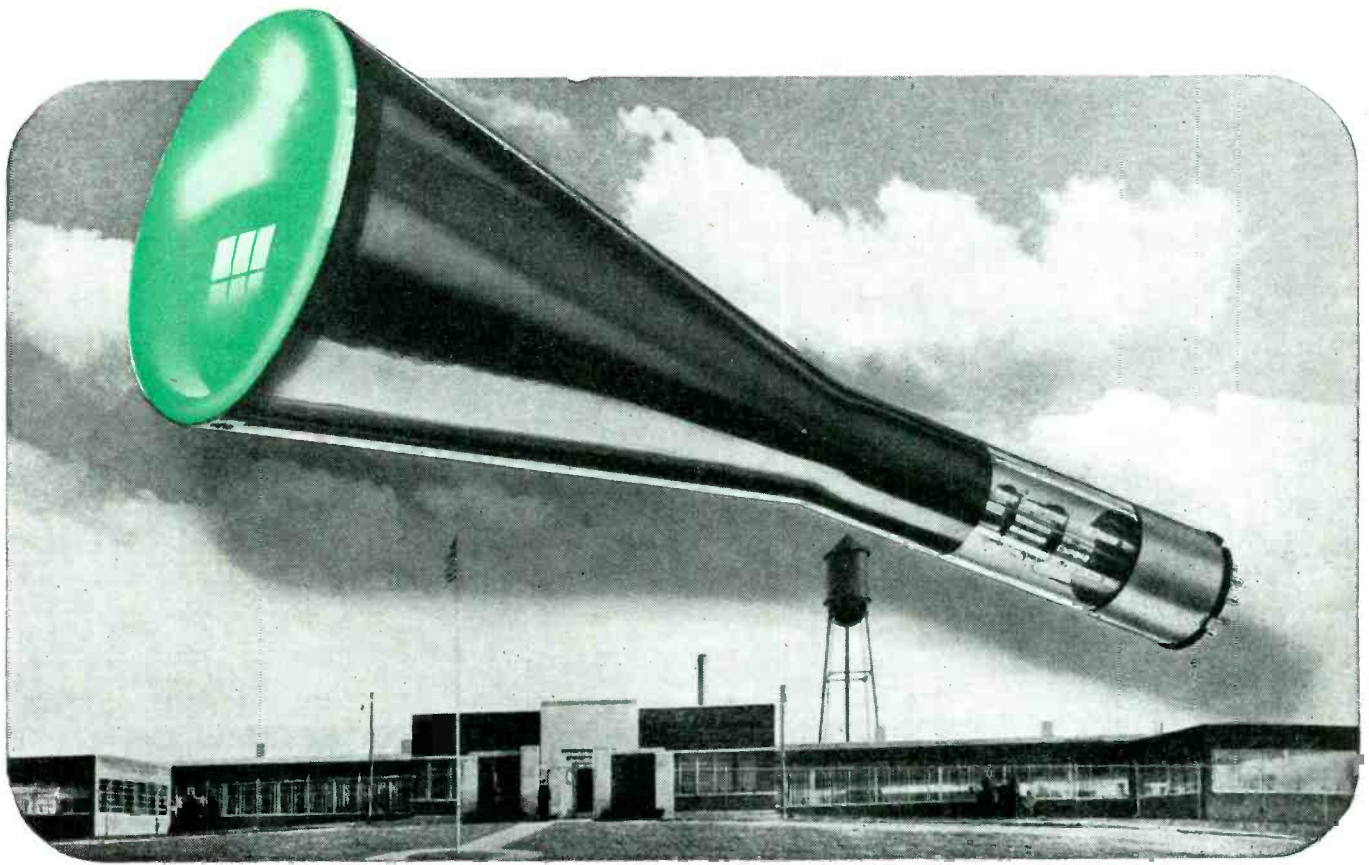

## A Bright Spot in the Television Picture

Now ready at National Union is a group of new cathode-ray tubes capable of picture reproduction superior to anything television has yet offered. Here are tubes whose ultra fine grain screens\* catch the most subtle gradations of light and shadow. Pictures are far more detailed, clearer, more brilliant. When enlarged by projection, they hold their distinct, high-definition quality and depth of tone. Here, too, ion burn, as a major television problem, is a thing of the past!

National Union enters the "Age of Television," ideally equipped to supply high-grade C-R Tubes at mass market prices. Here, is a large modern plant . . . an ultra-efficient pro-

duction line . . . equipment designed for the most advanced manufacturing techniques . . . the highest standards of quality control . . . skilled workers . . . able engineers. All backed by one of this Industry's most extensive and fruitful Electronic Tube Research programs —assurance that N. U. will contribute its full share to future C-R Tube progress.

---

*\*So fine is the texture of the special florescent material developed by National Union Research Laboratories, it is calculated that a 10-inch picture on the screen of a National Union cathode-ray tube is reproduced on 10 billion crystals!*

**NATIONAL UNION  
RADIO AND ELECTRON TUBES**

NATIONAL UNION RADIO CORPORATION • NEWARK 2, N. J.



# The Mark of Quality

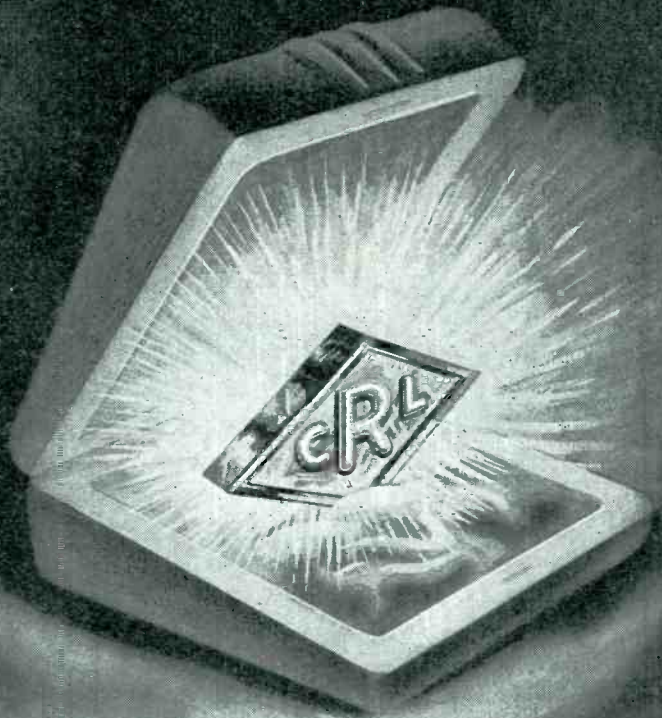

The initials "CRL" in the Diamond stand for Centralab

They are an integral part of the Centralab name, and for more than a quarter of a century have represented the utmost in engineering skill and precision . . . the height of manufacturing perfection.

Both in original equipment and in replacements, the symbol "CRL" is the Mark of Quality.

. . . Always specify Centralab.

Ceramic High Voltage Capacitors  
Bulletin 814

## Centralab

Division of GLOBE-UNION INC., Milwaukee

PRODUCERS OF

Ceramic High Voltage Capacitors  
Bulletin 814



Variable Resistors  
Bulletin 597

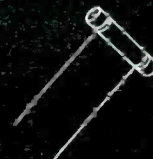

Tubular Ceramic  
Capacitors  
Bulletins 630  
and 586



Selector Switches  
Bulletin 722



Ceramic Trimmers  
Bulletin 655



# See!

## The New **TEMCO** High Fidelity **FM BROADCAST TRANSMITTER**

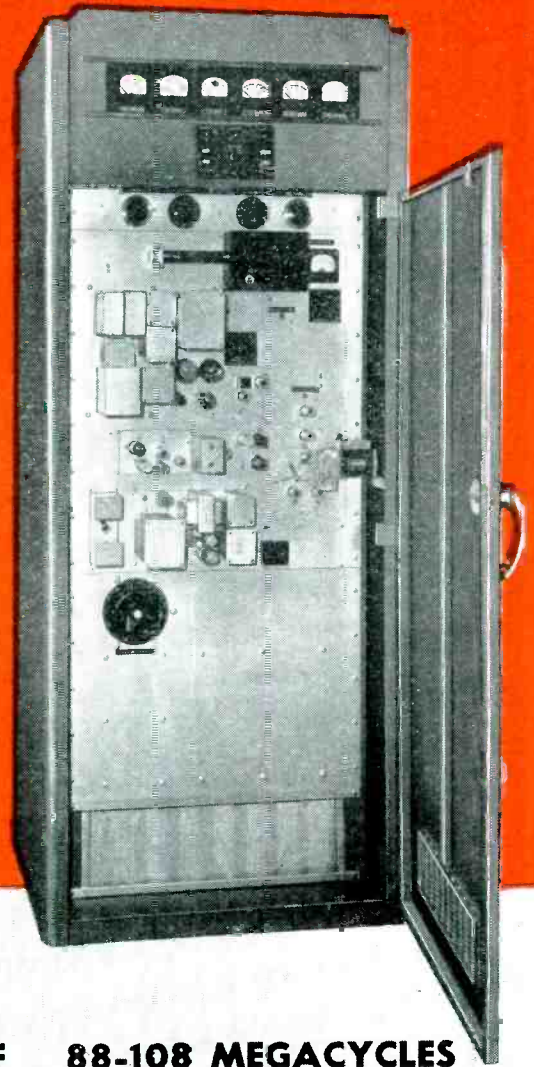

### *Ready for delivery*

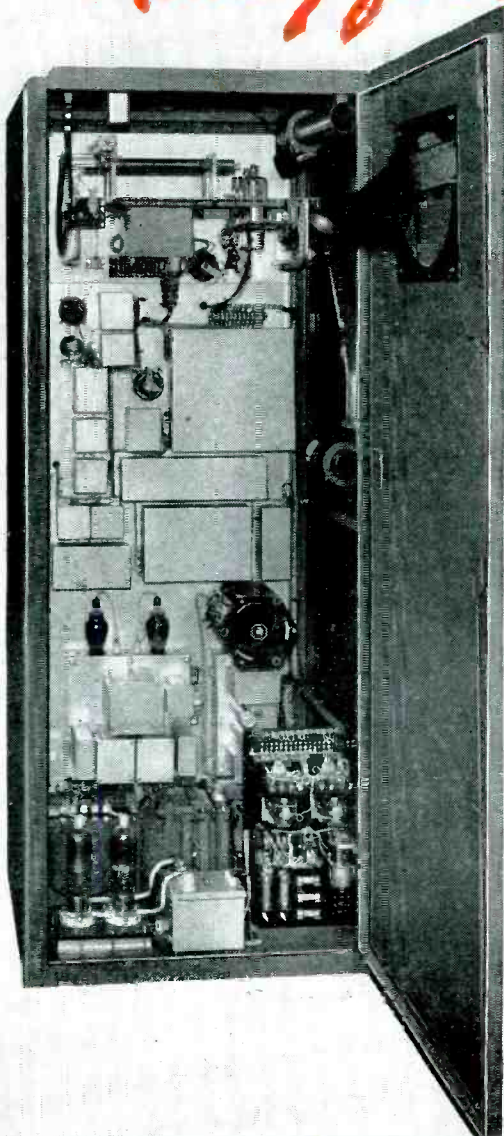

### **MODEL 250 BCF 88-108 MEGACYCLES**

TEMCO proudly presents this outstanding achievement in FM engineering—the result of 10 years of pioneering in custom-built, superlative communication equipment.

#### **HIGHLIGHTS OF THE TEMCO 250 BCF**

- Normal rated output power 250 watts. Maximum rated output power 375 watts.
- Continuous monitoring of the carrier frequency by a center frequency deviation meter calibrated directly in cycles.
- An exciter unit—heart of the transmitter—characterized by tuning simplicity accomplished by employing only 4 stages to raise the primary oscillator frequency to the carrier frequency.
- A new circuit of technically advanced concept which maintains a high degree of center frequency stabilization without introduction of distortion.
- Peak efficiency and great dependability are obtained by the use of new miniature V-H-F tubes in the exciter.
- Improved design in the IPA and PA stages eliminating tank radiation, feedback, radio frequency and high voltage potentials from the tank circuits and transmitter frame.

\*A limited quantity of the TEMCO Model 250 BCF will be available for January delivery. Orders will be filled in rotation as received. ACT NOW. Place your order at once.

**NOW ON DISPLAY FOR YOUR INSPECTION.**  
Phone or wire for an appointment.

# **TEMCO**

**RADIO COMMUNICATION EQUIPMENT  
TRANSMITTER EQUIPMENT MFG. CO., INC.**

345 Hudson Street, New York 14, N. Y.



Where **SPACE** and  
**PERFORMANCE** are Vital  
DUMONT OFFERS . . . .

The **TINYMITE**

**SMALLEST PAPER  
CAPACITOR . . . .  
yet 100%  
MOISTUREPROOF**

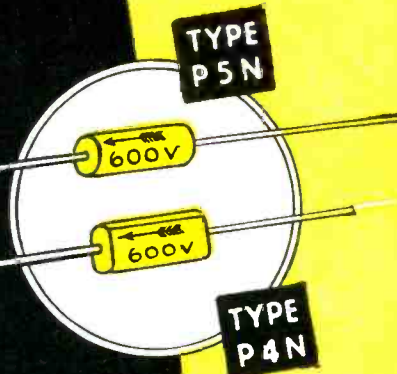

CLOCK RADIO



AUTO RADIOS

**FEATURES**

1. Bakelite Resinoid Ends. Lead wire cannot pull out, even under hot conditions.
2. Non-Inductive.
3. Excellent Temperature Coefficient.
4. Very high leakage Resistance.
5. Fine Power-Factor.
6. Range from 20 MMFD to .25 MFD. From 150 volts to 600 volts.
7. Types P4N, P5N for 100% humidity operation.
8. Types P4, P5 for 85% humidity operation.

*Samples and price list on request*



HEARING AIDS

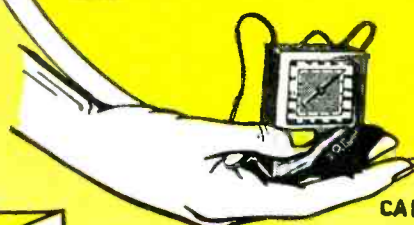

CARRYING RADIOS

PAT. PEND.

**DUMONT  
ELECTRIC CO.**  
MFRS OF  
CAPACITORS FOR EVERY REQUIREMENT  
34 HUBERT STREET NEW YORK, N. Y.

**KEEP ON BUYING VICTORY BONDS**

# A New and Better High Speed Counting Method...

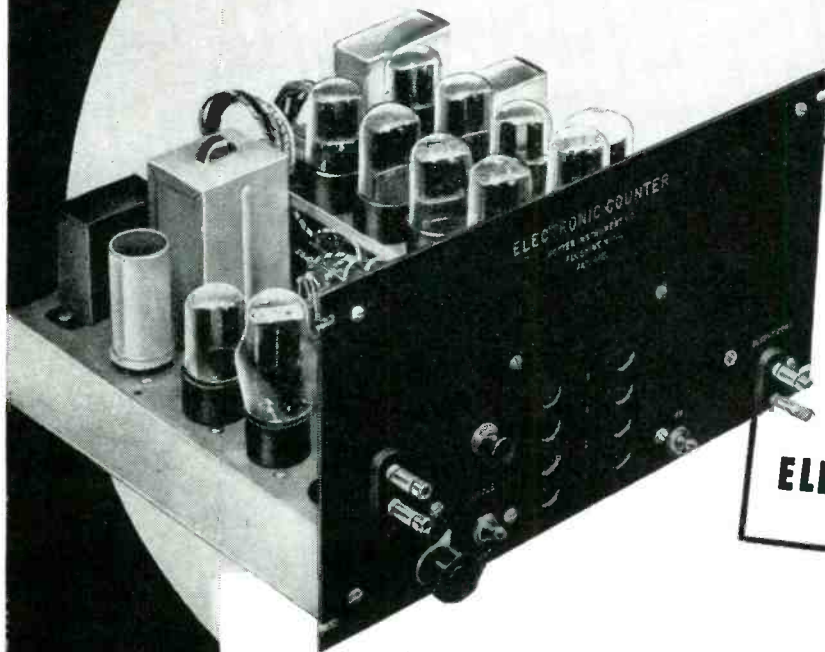

## Potter TWO DECADE ELECTRONIC COUNTER

***A versatile, efficient instrument for use as a counter, timer, interval controller, radiation counter, and many other applications***

- The Potter Two-Decade Electronic Counter is especially well suited for counting rates exceeding 10 cycles a second, a speed generally too fast for conventional counters.
- For continuous high speed operation, it will readily replace those mechanical counters that cannot stand up under such conditions.
- Another use for this versatile and efficient instrument is counting and calibration of cycles in resistance welding operations.
- It may also be used as an interval timer by connecting it through a switch to a known external frequency; readings are observed in terms of the number of cycles of the known input frequency.
- We can install dial switches on this unit to make it predetermining. It then becomes useful in a number of control applications.

The Potter Two-Decade Electronic Counter operates from a 60 cycle, 105 to 125 volt line, at speeds up to 1000 cycles a second. Each decade divides by 10, giving a scaling factor of 100. A telephone-type relay, whose contacts close once for each 100 input cycles, is connected to output terminals. An electro-magnetic counter may be added to this output to extend the count to as many places as desired. It uses 11 tubes. Delivery now in 60 days. Additional details will be forwarded promptly.

Other counter products are - RADIATION COUNTERS which resolve repetition rates of well over 2.5 microseconds; PREDETERMINED COUNTERS using several decades for control of industrial processes requiring a rapidly repeated operation to occur after a predetermined number of counts; COUNTER CHRONOGRAPHS for measuring projectile velocities to accuracies of one part in 10,000; INTERVAL GENERATORS that generate a predetermined time interval from 10 microseconds to 10 seconds in 999,999 steps of 10 microseconds.

INSTRUMENT  
**Potter**  
COMPANY

**ELECTRONIC COUNTER PRODUCTS...**

136-56 ROOSEVELT AVENUE

FLUSHING, NEW YORK



**ANOTHER IMPORTANT  
FROM MAGUIRE**

FOR FASTER, BETTER AND MORE COMPLETE SERVICE  
TO ALL CUSTOMERS

**MAGUIRE INDUSTRIES, INC.**

ANNOUNCES THE FORMATION OF ITS NEW

**ELECTRONIC DISTRIBUTOR**

and

**INDUSTRIAL SALES DEPARTMENT**

THIS NEW DEPARTMENT WILL ASSUME ALL

**MERCHANDISING**

**SALES**

and

**CUSTOMER RELATION**

DUTIES AND RESPONSIBILITIES ESSENTIAL IN  
MARKETING THE COMBINED PRODUCTS OF THE

**THORDARSON DIVISION**

**MEISSNER DIVISION**

**RADIART CORPORATION**



**ELECTRONIC DISTRIBUTOR AND  
INDUSTRIAL SALES DEPARTMENT**

# ANNOUNCEMENT

## INDUSTRIES, INC.

THESE SUPERIOR PRODUCTS NOW  
AVAILABLE FROM A SINGLE SOURCE

**THORDARSON**

### TRANSFORMERS

Precision engineered and quality built transformers for all requirements... replacement, communications, sound amplifier, industrial, experimental and amateur.

### TRU-FIDELITY AMPLIFIERS

In new, modern designs featuring advanced tone compensation, conservative ratings, ample ventilation, low hum level, multiple input channels and maximum flexibility of controls.

**Meissner**

### COMPONENTS

Precision-built components including antenna, R. F. and oscillator coils; standard, plastic and Ferro-cart transformers; windings, coils, chokes and accessories.

### SERVICE INSTRUMENTS

Meissner Analyst—operates by "signal tracing" method, fastest and most reliable—furnished complete. Signal Calibrator—a portable self-contained unit.

**Radiart**

### VIBRATORS

Radiart Correct Replacement Vibrators are individually engineered to meet exactly the physical as well as the electrical requirements of each application.

### RUST-PROOF AERIALS

A complete line of newly designed aerials to fit all cars; 3 and 4 section models—cowl, fender and under hood types... all made of finest materials.

### SEE FOR YOURSELF!

See the outstanding products of the Electronic Divisions of Maguire Industries, Inc., at the Winter Meeting of the I. R. E. at the Hotel Astor, New York on January 23 to 26.

# MAGUIRE INDUSTRIES, INC.

936 NORTH MICHIGAN AVENUE, CHICAGO 11, ILLINOIS



# RECEIVER MANUFACTURERS:

# RCA TEST EQUIPMENT

## to help speed your television-receiver production

If your television-receiver program has been held up because of inadequate test and measuring equipment, here's the answer. RCA will begin to deliver the instruments shown here in 60 to 90 days. They are not experimental or first post-war models, but service-tested equipment—developed before the war and perfected as a result of RCA's extensive television-research and manufacturing work during the war for the armed forces.

With items 1 through 4, a complete video signal can be produced, making it possible to measure and adjust accurately the focus, contrast, resolution, and scanning linearity of your television receivers.

Items 5 through 8 are other instruments we believe you will also find useful in easing your laboratory and testing problems.

An early indication from you of your test and measuring requirements will assure prompt delivery of this hard-to-get equipment.

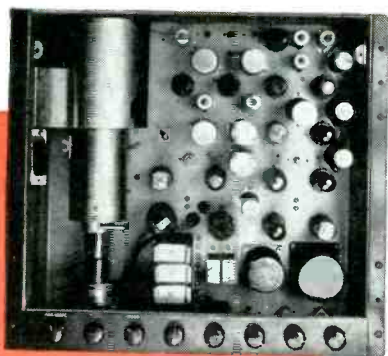

### 1 MONOSCOPE CAMERA

Produces a fixed television signal for aligning and testing equipment such as television receivers, transmitters, and monitors. The signal is produced by scanning a stationary pattern mounted permanently inside the monoscope tube. It is designed for rack mounting for use with the distribution amplifier and the synchronizing generator (items 2 and 4). The filament supply is self-contained, but a separate regulated plate supply is required. The 580-C unit (item 3) is ideal for this purpose.

### 2 DISTRIBUTION AMPLIFIER (TYPE TA-1A)

For use with the synchronizing generator and monoscope camera. Applications include: transmission over coaxial lines of pictures and synchronizing signals to various locations, feeding signals from program line to monitors, for isolating distributed pulses, as a mixer to combine synchronizing with picture signals to form the complete video signal. Designed for standard rack mounting, the unit requires a regulated plate supply.

### 3 REGULATED POWER SUPPLY (TYPE 580-C)

For supplying the plate power required by the monoscope camera and distribution amplifier. Regulation is better than .25 per cent over the range between 50 and 400 milliamperes; output voltage is adjustable between 250 and 300 volts; output ripple is lower than .012 per cent of the d-c output voltage. This unit may also be used for general-purpose work around the laboratory. Designed for standard rack mounting.

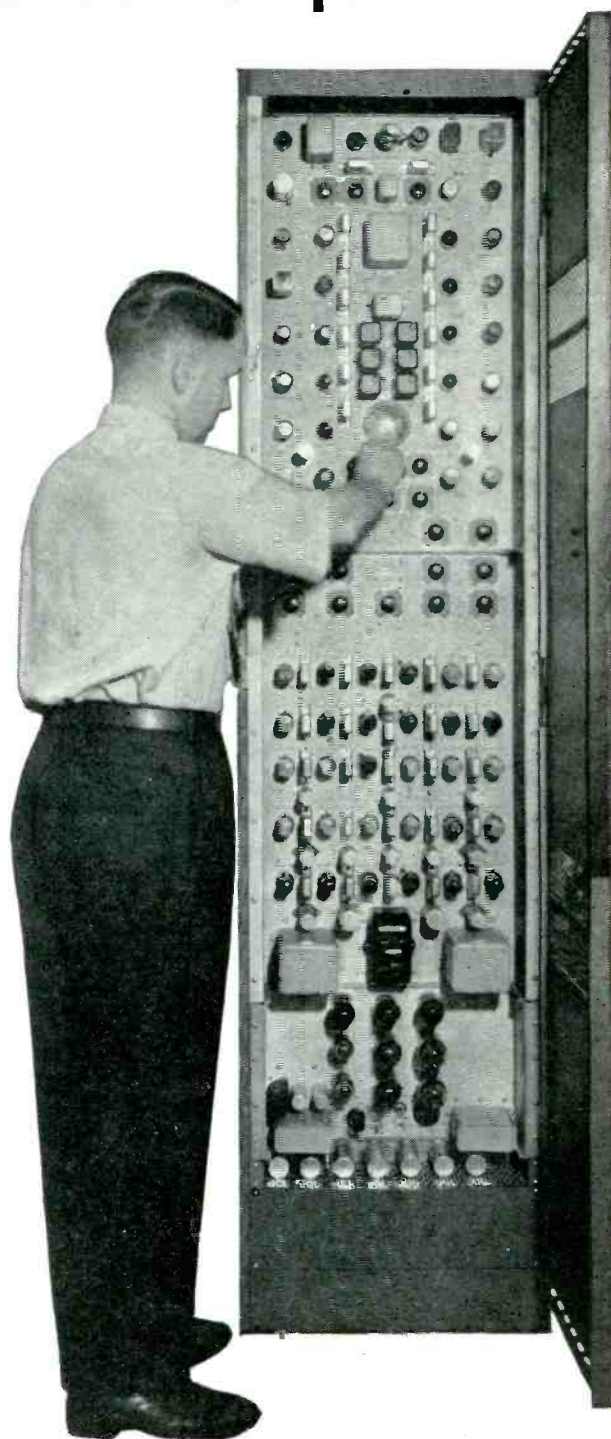
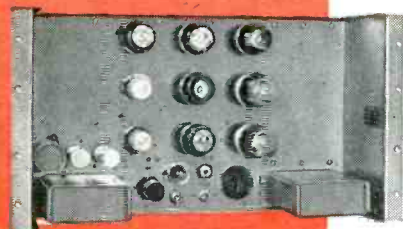

(TYPE TG-1A)

### 4 SYNCHRONIZING GENERATOR

Ideal for design and production testing of television receivers, and for application work in experimental laboratories engaged in television work. Provides "synchronizing" pulses of suitable wave shape and frequency for the production, in conjunction with camera equipment, of 525-line interlaced television signals. It keys together the scanning beams of the camera Iconoscope and the receiver Kinescope to form a perfectly synchronized picture. Conforms with proposed FCC Standards of Good Engineering Practice.



# AVAILABLE SOON



## 5 VIDEO SWEEP GENERATOR (TYPE 711-A)

A quick, accurate, convenient means of testing and adjusting wide-band video amplifiers. When this generator is connected to the input of a video amplifier, and the output of the amplifier is connected to an oscilloscope, a trace is produced on the screen that accurately shows the amplifier's dynamic-frequency characteristic. The lower-output-frequency limit of this unit is normally set at 100 kc, and the high frequency at 8 mc (but the latter can be easily adjusted to any frequency between 2 and 9 mc). The sweep to high frequency and return is smoothly accomplished in one cycle of the powerline frequency.



## 6 HIGH-FREQUENCY, WIDE-BAND SWEEP GENERATOR (TYPE 709-B)

When used in conjunction with an oscilloscope, this instrument will help you save time in accurately aligning the i-f and r-f stages of wide-band receivers. Stage-by-stage alignment is practical as the generator output voltage is continuously variable between .001 and .4 volts RMS over the entire frequency range. A calibration marker permits constant checking of band-width characteristics.



## 7 U-H-F SIGNAL GENERATOR (TYPE 710-A)

Provides an r-f signal of a known frequency and amplitude for easily obtaining the data needed to check the performance of high-frequency devices. This instrument provides smooth and complete attenuation throughout its range, plus precision frequency control. Output frequencies from 370 to 560 mc—just right for citizens' radio-phone and other development work within these bands.

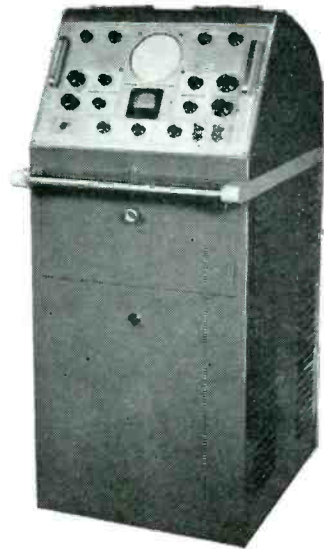

## 8 LABORATORY-TYPE OSCILLOSCOPE (TYPE 715-B)

Especially designed to permit close examination of extremely short, sharp-fronted pulses and other unusual wave forms. Produces steady, clear traces even with random recurrence of signal. Some of its advantages for modern development work include: Extended range (flat to 11 megacycles), triggered sweep (individually triggered by each signal), time-base marker (one microsecond intervals), input calibration meter (to permit direct determination of amplitude of any voltage component in signal), and many other new features.



**HERE'S A QUICK WAY  
TO GET DETAILS**



Radio Corporation of America  
Test and Measuring Equipment Section  
Box T9083B, Camden, N. J.

Please send me complete data on the RCA products corresponding to the numbers circled:

1   2   3   4   5   6   7   8

Name \_\_\_\_\_ Title \_\_\_\_\_

Company \_\_\_\_\_

Address \_\_\_\_\_

City \_\_\_\_\_ Zone \_\_\_\_\_ State \_\_\_\_\_



**RCA TEST AND MEASURING EQUIPMENT**

**RADIO CORPORATION of AMERICA**

**ENGINEERING PRODUCTS DIVISION, CAMDEN, N. J.**



# Announcing **STACKPOLE** SINTERED **ALNICO II**

Real economy for small magnet sizes and odd shapes  
Better uniformity characteristics  
Greater mechanical strength

Stackpole *sintered* Alnico II offers magnetic properties equal to those of the cast product—and with notable advantages in the production of weights up to two ounces either in standard or in odd shapes. Licensed under G. E. patents, Stackpole sintered Alnico II brings you all the features of a well-known product and the engineering experience of a firm which, since its inception, has specialized in the production of electrical components molded from powders.

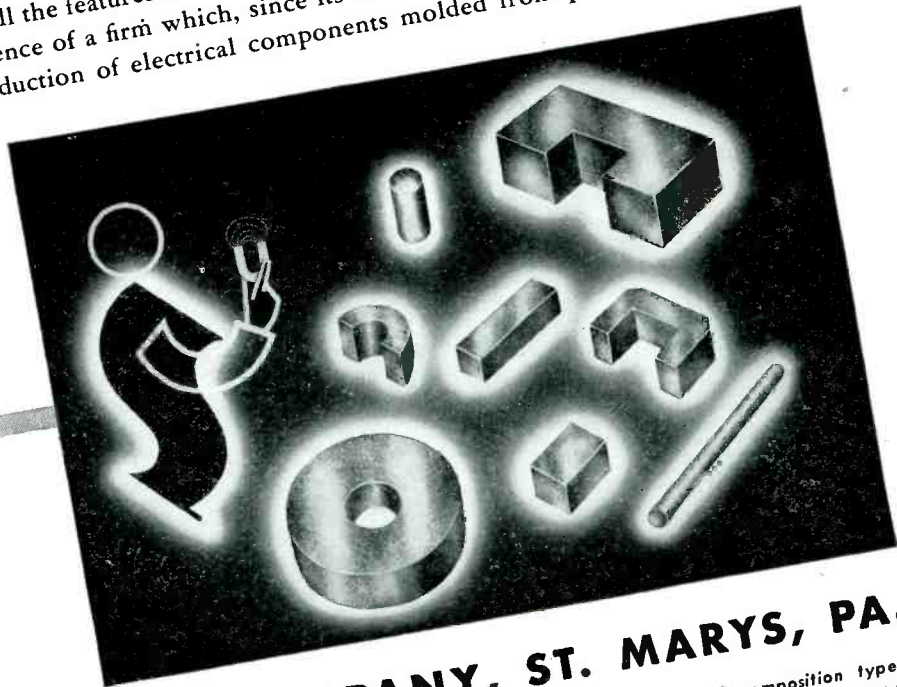

**STACKPOLE CARBON COMPANY, ST. MARYS, PA.**

BRUSHES and CONTACTS (All carbon, graphite, metal and composition types)  
IRON CORES • POWDER METALLURGY COMPONENTS HAVING SPECIAL  
ELECTRICAL PROPERTIES • RARE METAL CONTACTS • RHEOSTAT PLATES  
AND DISCS • CARBON PIPE • ANODES AND ELECTRODES, ETC., ETC.

# You Can Become A **Charter Member** of the **Best Informed Audience** in the World . . .

**A FACT!!**

An exciting new world is in the making — out of the developments of science — before our

very eyes.

**A DEMAND!!**

Every thinking American wants to know **HOW** these amazing achievements

will shape the pattern of his present and future life.

**A PROMISE!!**

Starting in

April, 1946, McGraw-Hill will publish a thrilling new non-technical general magazine that

will interpret, month by month, the impact of the scientists' world-shaping as it happens.

## **MEET A NEW AND DIFFERENT MAGAZINE**



The job that **SCIENCE ILLUSTRATED** has set for itself has never been done before.

The need for such a magazine has long existed but the *demand* was never as pressing . . . the American public was never as inquisitive minded . . . as science-hungry . . . as deeply conscious of impending changes in our social and economic life as it is today.

**SCIENCE ILLUSTRATED** will cover the broad fields of science, invention, mechanics and discovery. It will discuss the new challenges and opportunities that are coming out of radar, the heady secret of the atom, and the amazing, world shaking advancements in communication and transportation.

It will interpret, for the progressive thinking layman as well as for the business man, the great new triumphs in drugs, medicines, chemicals, metallurgy, textiles, fabrics, food processes, materials, methods, procedures — the entire range of scientific achievement — in terms of their contribution to better living.

**SCIENCE ILLUSTRATED** will *report, interpret,* and *project!* It will be fast and fascinating reading —

a thrilling new magazine for an exciting new world! In its pages, month after month, the products, developments, and horizons of scientific achievement will come alive in terse, sparkling text and dramatic colorful pictures.

The subjects discussed in **SCIENCE ILLUSTRATED** will be of vital importance to everyone in every walk of life. No matter where your interests lie — in the products and processes of business or in the things which make for better and more efficient living — you will read this new magazine with profit, and with interest.

**If you would like to keep abreast  
of the world of tomorrow  
make your reservation NOW  
for the first twelve issues of**

**Science**  
ILLUSTRATED  
A McGraw-Hill Publication







# FAST "Mijakon" HERMETICALLY SEALED TUBULAR Capacitors

Here is a line of midget size Capacitors that will fit into those many inaccessible places encountered in ELECTRONIC DEVICES, RADIOS and TELEVISION SETS.

These are hermetically sealed "Paper Dielectric" units—impregnated and filled with oil\* or wax—in tubular containers of brass with a heavy tin dip.

They are particularly suitable where a high quality capacitor is required to function under conditions of excess humidity and where stability and long life also are vital factors. They are fungus resistant—excellent units to use in radionic and

electronic equipment for operation in tropical or similar areas. In certain regions servicing may be a problem, consequently continuous and reliable performance is essential.

This line includes capacities from .00025 to .13 Mfd. and voltage ratings 100 to 600 V.D.C. Somewhat higher capacities and voltages can be supplied without increasing the size abnormally. Below is a *partial* listing of standard types.

Please write or telephone for prints or other data. We will be happy to serve you.

Class 20—Both Terminals Insulated					Class 22—One Terminal Grounded					WAX impregnated and filled units may be used for operation in temperatures up to 150°F (65°C)—the OIL* Group up to 194°F (90°C). Standard Capacity Tolerance on "Mijakons" is ±20%—except the .00025 Mfd. "Mijakon" which is ±25%. Closer tolerances may be obtained if required but at added cost.
Cap. Mfds.	Volts D. C.	Impreg-nant	Diameter (inches)	Length (inches)	Cap. Mfds.	Volts D. C.	Impreg-nant	Diameter (inches)	Length (inches)	
.001	100	Wax	3/32	5/8	.00025	100	Wax	1/4	1/2	
.006	100	Wax	1/4	1 1/32	.10	100	Wax	5/16	1 3/4	
.01	100	Wax	1 3/4	3/16	.13	100	Wax	5/16	2 1/2	
.02	100	Wax	5/16	1 5/16	.02	400	Oil	1 3/4	1 3/8	
.05	100	Wax	1 3/4	1 1/8						
.075	100	Wax	1 3/4	1 11/16	.001	600	Oil	1/4	1 5/16	
.001	600	Wax	3/32	3/8	.005	600	Oil	1/4	1 3/16	
.002	600	Oil	3/32	1 3/16	.009	600	Oil	1/4	1 5/8	
					.01	600	Oil	1/4	1 5/8	

### Standard or Special Units to Meet Every Need

FAST Capacitors are produced in many types and sizes in standard or special designs. We can supply paper capacitors—oil or wax impregnated—rectangular or tubular—in sizes from the smallest to the largest.

"When You Think of Capacitors . . . Think FAST"



## JOHN E. FAST & CO.

Capacitor Specialists for Over a Quarter-Century  
3101 N. Pulaski Road, Chicago 41

Canadian Representatives: Beupre Engineering Works, Reg'd.  
2101 Bennett Avenue, Montreal, for Power Factor Correction  
J. R. Longstaffe, Ltd., 11 King Street, W., Toronto 1, for Special Applications



# CLAIM STAKING

## Hallicrafters and Very High Frequency

Based on the facts in the case, Hallicrafters can stake out a very strong claim to leadership in the very high frequency field. The facts include such things as the Model S-37, FM-AM receiver for very high frequency work. The Model S-37 operates from 130 to 210 Mc.—the highest frequency range of any general coverage commercial type receiver.

Hallicrafters further supports its claim to domination in the high frequency field with the Model S-36A, FM-A M-CW receiver. The 36A operates from 27.8 to 143 Mc., covers both old and new FM bands and is the only commercially built receiver covering this range.

*Further developments in this direction can soon be revealed—adding further support to Hallicrafters claim to continued supremacy in the high frequency field.*

HALLICRAFTERS NEW \$600,000 HOME NOW UNDER CONSTRUCTION.



# hallicrafters RADIO



THE HALLICRAFTERS CO., MANUFACTURERS OF RADIO AND ELECTRONIC EQUIPMENT • CHICAGO 16, U. S. A.

©COPYRIGHT 1945 THE HALLICRAFTERS CO.



# Instruments FOR ALL PROBLEMS OF RECONVERSION

Utilities, manufacturers and maintenance contractors will find, within the broad WESTON line, instruments specifically suited to *all* problems of electrical reconversion . . . whether they involve quick repairs, rewiring for heavier loads, relocation of equipment, new testing stands or

laboratory installations, improved lighting, as well as for all electrical and electronic maintenance needs. Literature, or engineering cooperation on any instrument problem, is freely offered. Weston Electrical Instrument Corporation, 618 Frelinghuysen Avenue, Newark 5, N. J.

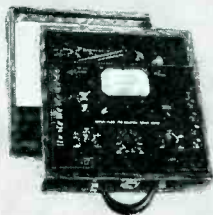

**(MODEL 785) INDUSTRIAL CIRCUIT TESTER** . . . the most versatile portable tester for laboratories, and plant maintenance, where an ultra-sensitive instrument is required. Provides 27 AC and DC voltage, AC and DC current, and resistance ranges. (dc sensitivity 20,000 ohms per volt.)

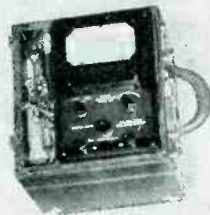

**(MODEL 796) INSULATION TESTER** . . . a direct-reading self-contained resistance tester that eliminates hand cranking. Tests up to 200 megohms at test potential of 350 to 500 volts dc., current at terminals only a few microamperes. Ranges 0-20-200 megohms, full scale . . . 0-.5-5 center scale.



**(MODEL 697) VOLT-OHM-MILLIAMMETER** . . . combines a selection of AC and DC voltage, direct current, and resistance ranges in a pocket-size meter. Ideal for maintenance testing and inspection needs.



**(MODEL 633) AC CLAMP AMMETER** . . . for quick, easy current measurements on insulated or non-insulated conductors. The clamping jaws are simply clamped around the conductor, and readings taken. Circuits are never disturbed. A real time saver in electrical maintenance.

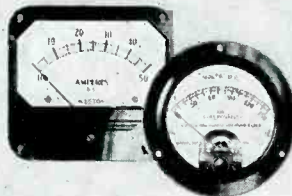

**PANEL AND SWITCHBOARD INSTRUMENTS** . . . available for all AC and DC requirements, in all types, sizes and ranges. The complete line is fully described in the WESTON Panel Instrument bulletin. Send for your copy.

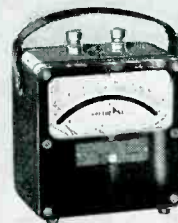

**(MODEL 430) AC AND DC TEST INSTRUMENTS** . . . combine dependability, ruggedness, compactness and scale readability. Equipped with hand calibrated, mirror scales. Available for AC and DC requirements, and as DC and single-phase AC Wattmeters.

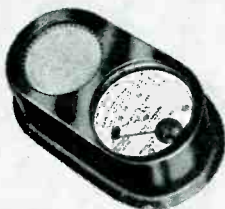

**(MODEL 703) SIGHT METER** . . . direct-reading, pocket size meter calibrated to measure light values in foot-candles, or by seeing tasks. Equipped with the WESTON VISCOR\* filter, it measures all light values direct, without correction factors.

# Weston Instruments

ALBANY • ATLANTA • BOSTON • BUFFALO • CHICAGO • CINCINNATI • CLEVELAND • DALLAS • DENVER • DETROIT • JACKSONVILLE • KNOXVILLE • LOS ANGELES • MERIDEN  
MINNEAPOLIS • NEWARK • NEW ORLEANS • NEW YORK • PHILADELPHIA • PHOENIX • PITTSBURGH • ROCHESTER • SAN FRANCISCO • SEATTLE • ST. LOUIS • SYRACUSE

In Canada, Northern Electric Co., Ltd., Powerlite Devices, Ltd.

# Your **GO-AHEAD GUN**

**GETS ITS AMMUNITION..**

The Atlas organization offers you ammunition, in the form of new tooling, to fire the starting gun signalling your return to industrial competition.

Here are hundreds of skilled technicians . . . engineers, designers, tool-makers . . . thoroughly experienced in the professions and crafts that contribute to the success of profitable manufacturing. Their work before and during the war has involved millions of dollars worth of intricate tools, dies, jigs, special automatic machinery, product design and improvement, pro-

duction line layout, processing, time studies, work sheets and the finest type of perspective drawings obtainable. In addition, our machine sections include the last word in modern equipment.

These technicians can become your staff . . . our machine sections, your plant . . . for any degree of help, partially or completely.

If time is short and trouble serious, wire us now. Otherwise, let's get together for a mutually beneficial talk.

**ATLAS TOOL & DESIGNING CO.  
ATLAS METAL STAMPING CO.**

Castor & Kensington Avenues  
Philadelphia 24, Pa.

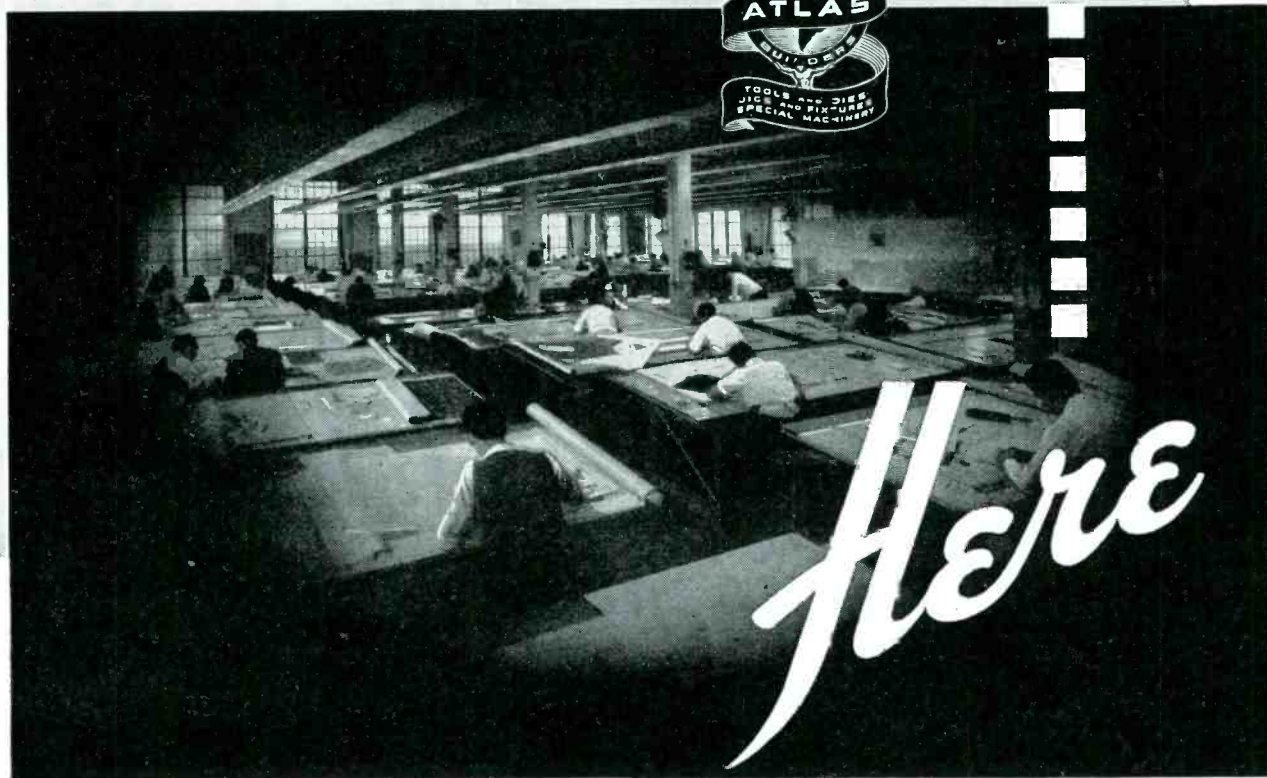

A Welcome Awaits You At Booth B-741, Metal Show, Cleveland, February 4-8



# Picture Performance

THAT REALLY "SELLS"

TELEVISION RECEIVERS

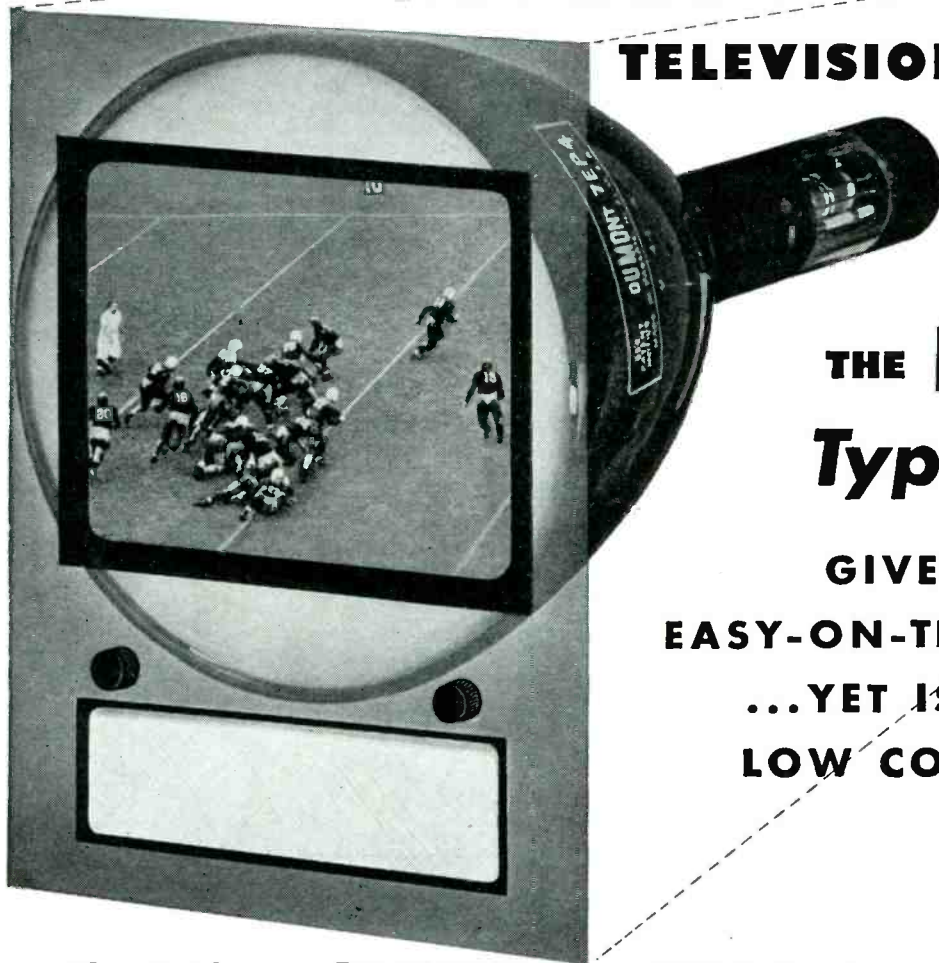

THE **DUMONT**  
Type 7EP4

GIVES A CLEAR  
EASY-ON-THE-EYES PICTURE  
...YET IS PRICED FOR  
LOW COST RECEIVERS

## Check these **DUMONT Type 7EP4** Features!

- ✓ special Du Mont "EYE COMFORT", soft quality screen (formerly only available in more expensive tubes)
- ✓ high level of light output at low accelerating potential
- ✓ short length for shorter cabinets
- ✓ designed by DuMont for low cost television receivers at the specific request of manufacturers
- ✓ backed by the DuMont reputation for dependability and quality

Now available in production quantities!!! ..

Order samples NOW and let us quote on quantity orders!

**DUMONT**

*Precision Electronics & Television*

ALLEN B. DUMONT LABORATORIES, INC., PASSAIC, NEW JERSEY • CABLE ADDRESS: ALBEEDU, PASSAIC, N. J., U. S. A.

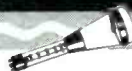

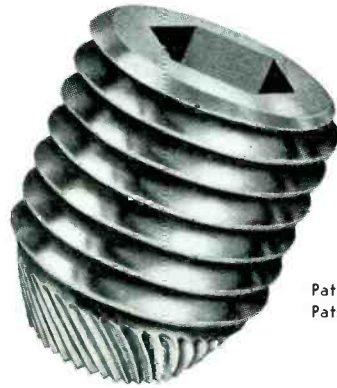
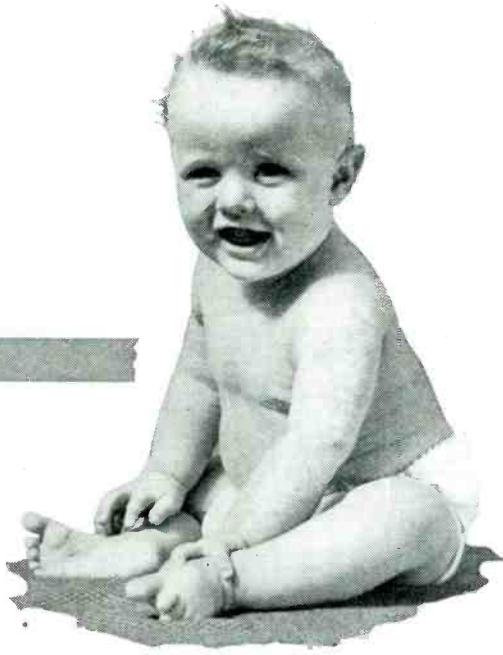

Pat'd &  
Pats. Pend.

# The "Baby"

of the **UNBRAKO** family

Reg. U. S. Pat. Off.

Tiniest member of the "Unbrako" family, the "Unbrako" *Self Locking Socket Set Screw with Knurled Point* is so small you can hardly see it. Yet, in that small size, are all the outstanding qualities that have come to be expected of products bearing the "Unbrako" name — strength, accuracy and absolute dependability. And the Knurled point makes it a Self-locker by resisting all attempts of vibration to shake it loose because the knurls dig-in and hold tight. Even so, it can easily be backed-out with a wrench and used over and over. In sizes for the special requirements of the small electrical and radio manufacturing industries: from #0 to 1½" — full range of lengths. Write today for the "Unbrako" Catalog.

Knurling of Socket  
Screws originated with  
"Unbrako" years ago.



## STANDARD PRESSED STEEL CO.

JENKINTOWN, PENNA. BOX 596

BRANCHES: BOSTON • CHICAGO • DETROIT • INDIANAPOLIS • ST. LOUIS • SAN FRANCISCO

OVER 40 YEARS IN BUSINESS



# Announcing New

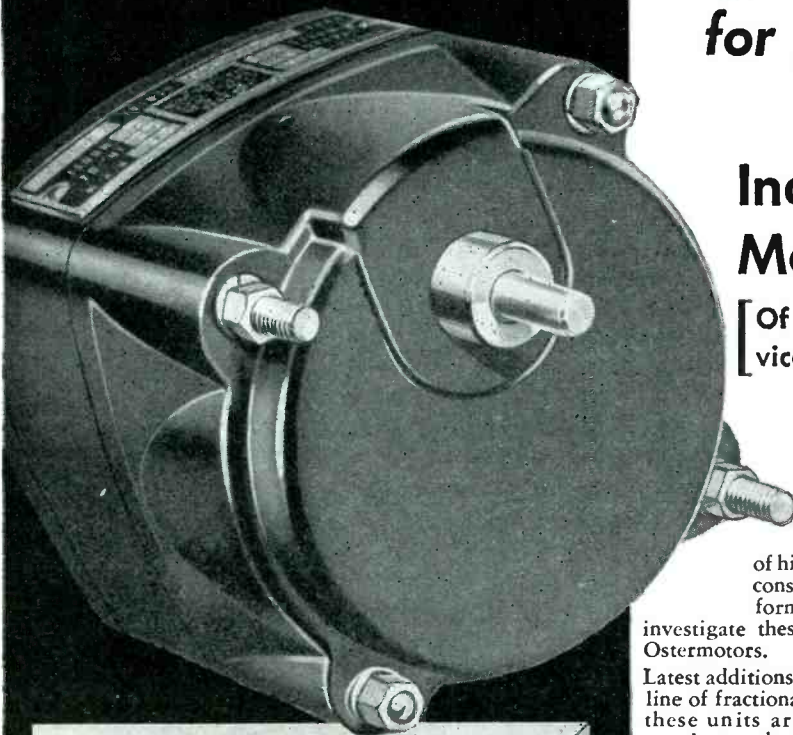

# Ostermotors

for prompt delivery . . .

## Synchronous and Induction Capacitor Type Motors and Gearmotors

[Of instrument quality . . . for timing devices . . . clock and control mechanisms . . .

*Immediate delivery on samples; prompt delivery on production lots.*

If your product calls for a small motor or gearmotor of highest quality where constant, unvarying performance is a "must,"

investigate these dependable new Ostermotors.

Latest additions to a comprehensive line of fractional h.p Ostermotors, these units are the result of 15 years' research and experience. They are conservatively rated, light, compact, smoothly operating units of uniformly high efficiency that add much to the performance and prestige of your product.

Check the features below. Catalog information on all Ostermotors is available. We are now in production of many units — can give prompt delivery on samples — surprisingly good delivery on production lots. Write today for further information.

### Specifications

Bearings: Wick-oiled self-aligning

porous bronze or sealed ball bearings on rotor shaft. Gearmotor output shaft equipped with precision needle bearing. Intermediate bearings are bronze, lubricated from the gear case.

**Stator and Rotor:** Laminations are annealed for highest efficiency. Rotor is squirrel cage type, skewed for silent operation and smooth starting.

**Gear Train:** Precision-cut spur gears run quietly in lubricant. Lubricant is not affected by temperature changes; will last the life of the unit.

**Capacitor:** Oil-filled type, externally mounted.

**Mounting:** Gearmotors equipped with alignment bushing at output shaft; motors and gearmotors have mounting studs in front end bell.

**Modifications:** Ostermotors are built to your order. Motors and gearmotors can be furnished with special shafts, gear ratios, motor characteristics, etc., and for odd voltages and cycles.

## Other Ostermotors

The Ostermotor line includes hundreds of variations of many different laminations from 0.944" to 3.690" dia. — 1/2,000 to 1/3 h.p. in series, split series, shunt — 1/2,000 to 1/12 h.p. in synchronous and induction types.

If you need a high-quality motor falling within this general classification, investigate Ostermotors. Types listed below now in production or going into production. Samples are available.

	H.P. Range at rated load	R.P.M.	Type	Dia.	Length
E.S.	1/50—1/30	1725	Induction Split Phase	3 3/16"	4 1/2" to 5 1/4"
E.C.	1/50—1/30	1725	Induction Capacitor	3 3/16"	4 1/2" to 5 1/4"
ESY	1/75—1/60	1800	Synchronous Split Phase	3 3/16"	4 1/2" to 4 7/8"
ECY	1/75—1/60	1800	Synchronous Capacitor	3 3/16"	4 1/2" to 4 7/8"
EU	1/25—1/10	5-10M	Series	3 3/16"	4 1/2" to 4 7/8"
KS	1/20—1/10	1725	Induction Split Phase	4 3/16"	5 1/2" to 8 1/4"
KC	1/20—1/10	1725	Capacitor Start & Run	4 3/16"	5 1/2" to 8 1/4"
KU	1/10—1/3	5-10M	Series	4 3/16"	5 1/2" to 6 7/8"
CU	1/150—1/75	5-10M	Series	1 1/8"	3 1/8"
BU	1/200—1/100	5-10M	Series	1 5/8"	2 3/4"

Oster Motor No.	Type	Motor	Power Source	Max. Output H.P.	Output Shaft R.P.M.
LCY	Motor	Capacitor Synchronous	115 V. 60 cycle	1/2000	1800 3600
LC	Motor	Capacitor Induction	115 V. 60 cycle	1/1000	1675 3350
LCYR	Gearmotor	Capacitor Synchronous	115 V. 60 cycle	1/2000	30° 60°
LCR	Gearmotor	Capacitor Induction	115 V. 60 cycle	1/1000	28° 57°

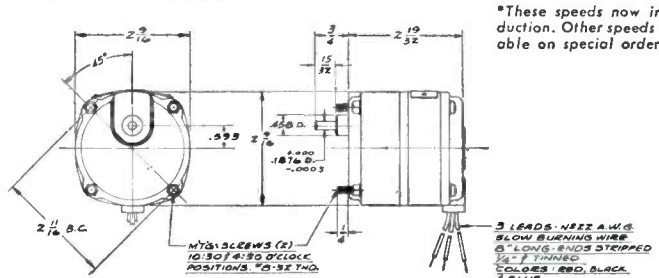

\*These speeds now in production. Other speeds available on special order.

# John Oster Mfg. Co., Dept. L-30, Racine, Wisconsin

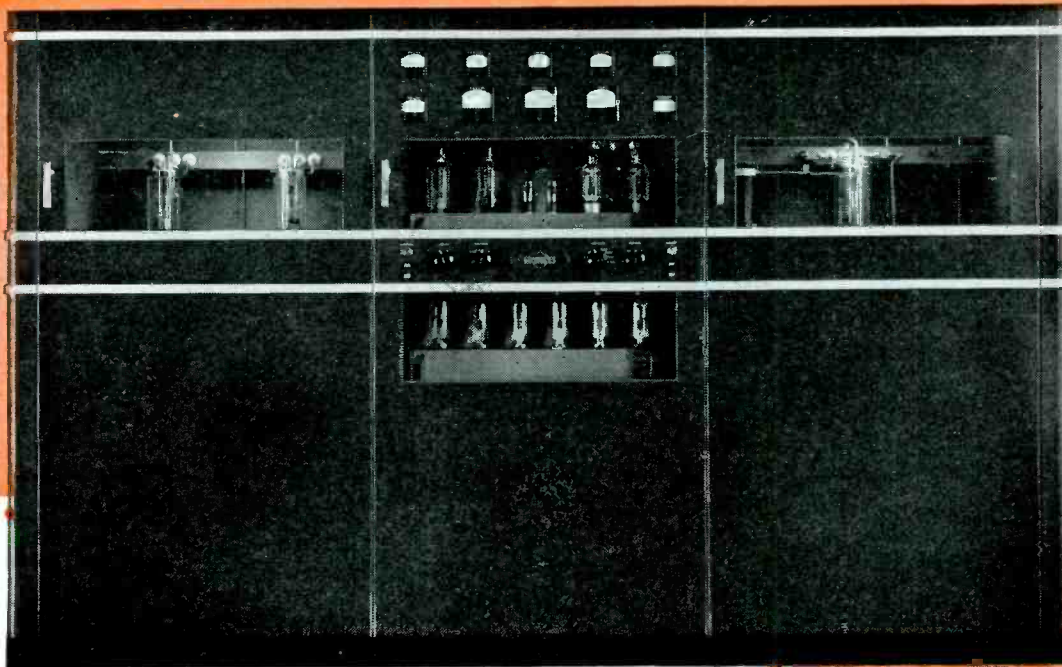

## Why WAAT bought its new 5 kw transmitter from Collins

The Bremer Broadcasting Corp., owners of WAAT, had had previous experience with Collins equipment. Mr. Frank V. Bremer, Technical Director, puts it this way:

"It is with interest and pride that I bring to your attention the performance of the Collins 20K one kilowatt AM transmitter installed at Kearny on April 14, 1941.

"This transmitter has been on the air a total of 39,000 hours, as of October 15, 1945, with a total elapsed lost time of only fifteen minutes.

"This makes a most remarkable record, since our station is on the air twenty-four hours per day, seven days per week, and it speaks well for your transmitter.

"According to the logs checked by Anthony Castellani, transmitter supervisor, the fifteen minutes total of lost air time was caused by defective bias tubes and a coupling

condenser in the audio circuit.

"At no time in the period of operation of the 20K have we had to make a refund or make up allowance to any sponsor due to lost air time.

"As director of the engineering department of WAAT and FM-WAAW, I give credit for this remarkable performance to your efficient design and to the capable operating supervision by our transmitter staff."

(Signed) Frank V. Bremer

With this background of satisfaction, the Bremer Broadcasting Corp. ordered a new 21A 5 kw AM Collins transmitter as soon as military restrictions were lifted in the fall of 1945. An illustrated bulletin, fully describing this transmitter, will be sent you on request.

FOR BROADCAST QUALITY, IT'S . . .

Collins Radio Company, Cedar Rapids, Iowa; 11 W. 42nd St., New York 18, N. Y.





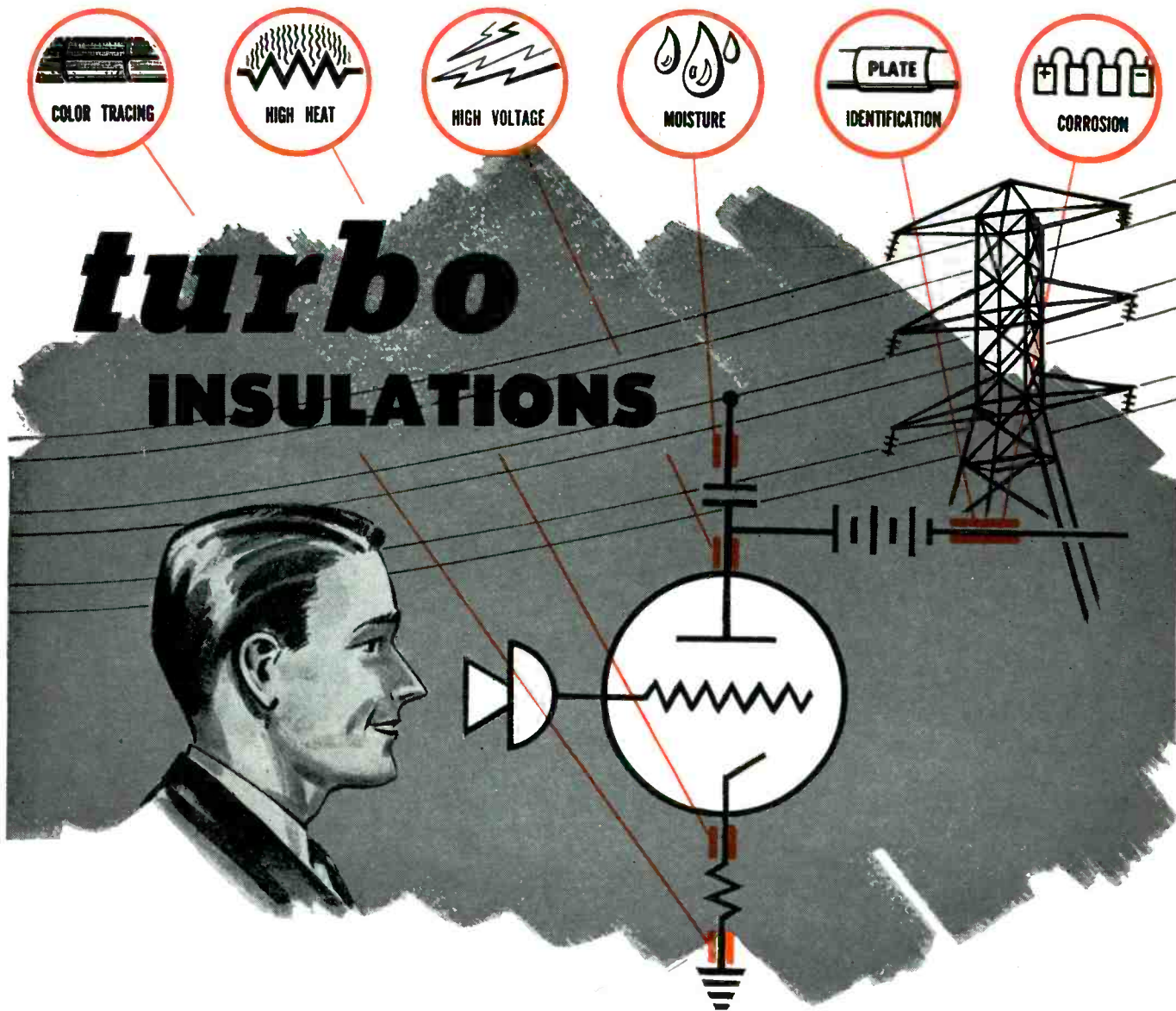

# turbo INSULATIONS

## ..meet critical indoor and outdoor needs!

**TURBO electrical sleeveings** provide economical solutions to most electrical and electronic insulating problems. Sizes range from small gauges for wires to large diameter suitable for cable or bus bar. All feature extra flexibility, smooth bore and wide choice of color. Important, too, TURBO meets severe operating conditions—heat, low temperature, acid, fumes and moisture—with a specific sleeving for each condition.

**FLEXIBLE VARNISHED OIL TUBING:** offers immunity to corrosive fumes, acid, alkalis and most solvents. It is impervious to moisture and non-hygroscopic.

**VARNISHED GLASS TUBING:** capable of functioning in high ambient temperatures—enclosed motors, unventilated areas, and general heavy duty installations.

**EXTRUDED TUBINGS:** smooth wall, withstand extreme low temperature without embrittlement. Provide dependable insulation in sub-zero cold. Retains flexibility at all times.

**WIRE IDENTIFICATION MARKERS:** two types—sleeve type that slips directly over pipes, tubes, conductors, and tab type with flexible flag attached to sleeve. Both available in any marking.

Write today for free Specimen Board with samples and sizes of each.

# TURBO



## WILLIAM BRAND & CO.

276 Fourth Ave., New York 10, N. Y. • 325 W. Huron St., Chicago 10, Ill.

OIL TUBING • SATURATED

SLEEVING • VARNISHED CAMBRIC • PAPER AND TAPE • MICA AND MICA PRODUCTS



1/2 ACTUAL SIZE

**RAYTHEON**

**TYPE 1006/CK1006  
A HEAVY DUTY  
FULL-WAVE GAS RECTIFIER**

**TYPE 1006/CK1006 RATINGS  
FULL-WAVE RECTIFIER SERVICE**

	Ionically Heated	Heated Directly
Filament Voltage	0	1.75 volts
Filament Current	0	2.00 amps
Maximum Peak Anode Voltage (per anode, no load)	880	800 volts
Maximum Peak Inverse Voltage	1500	1600 volts
Average D.C. Voltage Drop	30	25 volts
Maximum D.C. Output Current	200	200 ma.
Minimum D.C. Output Current	70	0 ma.
Minimum Starting Peak Voltage (half wave a-c)	650	450 volts
Minimum Starting Peak Voltage (full wave)	550	420 volts
Maximum Steady State Peak Anode Current per anode	600	600 ma.



*Excellence in Electronics*

**RADIO RECEIVING TUBE DIVISION**  
NEWTON, MASSACHUSETTS NEW YORK CHICAGO

To supply the requirements of small transmitters or other equipment where rectification efficiency must be maintained at a high level, Raytheon engineers developed type 1006/CK1006.

Utilization of an inert gas enables this tube to perform its functions through a wide range of ambient temperatures. The cathode may be directly heated as shown in the ratings—or where greater efficiency is desired, ionic heating is possible provided the specified minimum load is maintained without rapid intermittent operation. The internal drop is low even during the time rated peak current is flowing.

A very important feature of the 1006/CK1006 is the fact that *no cathode preheating time is required*. Full load can be handled immediately and starting is practically instantaneous.

Obviously, the foregoing electrical characteristics are applicable to many types of mobile equipment. Structurally, too, the 1006/CK1006 fits well into such service because rugged design allows it to withstand considerable shock without change in characteristics.

Many thousands of Raytheon 1006/CK1006 tubes have individually given hundreds of hours of reliable service in equipment subjected to adverse conditions of temperature and vibration. Another convincing "exhibit" of evidence that Raytheon builds *fine* tubes . . . tubes well worth considering for your postwar products!

**BUY  
VICTORY  
BONDS**



*Finer in Performance AND NOW — Smarter in Appearance with*

# INTERCHANGEABLE COLORED FLANGES

**ROUND OR SQUARE... AT NO EXTRA CHARGE**



## ***Marion Glass-to-Metal Truly Hermetically Sealed 2½" and 3½" Electrical Indicating Instruments***

Smart styling, sleek lines, more color are invading the radio and electronic industry... bulky packaging and drab blacks and grays are no longer in step with the times... appearance now takes equal rank with performance in consumer demand.

Sensing this important trend, we here at Marion present a "beauty treatment" for radio and electronic equipment in our new and attractive interchangeable colored flanges. There are 12 different iridescent shades, including blue, red, green, silver, gold and others—in both round and square shapes.

Manufacturers who specify Marion hermetically sealed instruments will find that the eye-appeal of these new flanges will give added sales value to their products. Amateur radio operators and experimenters will especially welcome the idea because the interchangeability feature will help reduce instrument costs by permitting universal application of Marion "hermetics" when building or modernizing their equipment.

Marion "hermetics" sell for no more than most competitive unsealed instruments... and they're being delivered in ever-increasing quantities. Write for our 12-page brochure.



**MARION ELECTRICAL INSTRUMENT CO.**  
MANCHESTER, NEW HAMPSHIRE

EXPORT DIVISION 458 BROADWAY · NEW YORK 13, N. Y. U. S. A.  
CABLE ADDRESS: MORMANEX

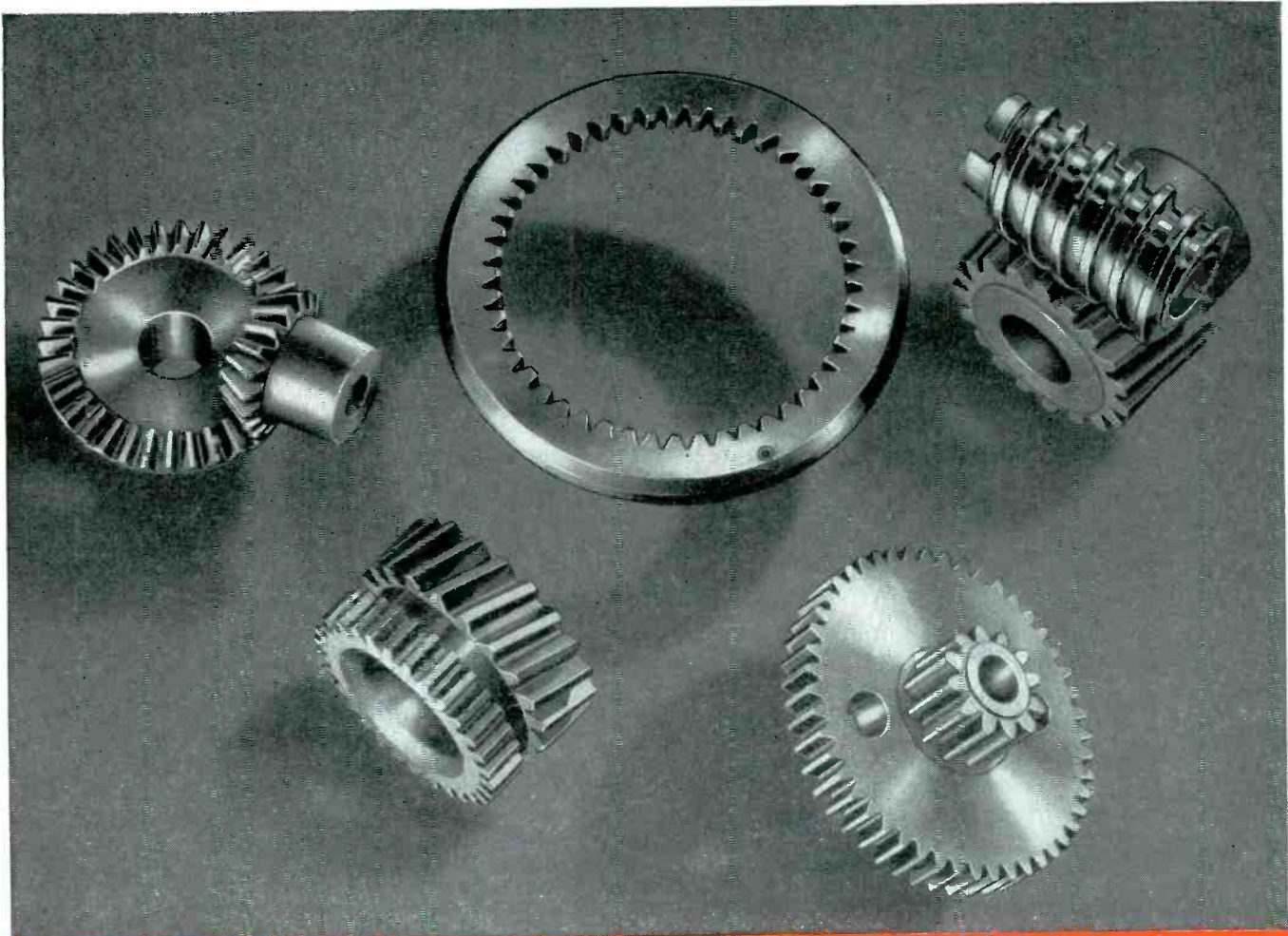

## IF BETTER SMALL GEARS ARE INVOLVED IT'S A JOB FOR

Making simple or intricate Fractional Horsepower gears to a degree of *uniform* accuracy heretofore considered impossible, is a highly developed specialty of ours. Quantity production is taken in stride by our long experienced craftsmen working with finest modern methods, machinery and inspection devices. That's why we say "If better small gears are involved, it's a job for G.S!" When your requirements call for *production runs* of gears from 12 to 96 d.p. by all means discuss your problems with G.S. Engineers. You'll welcome the seasoned counsel and friendly cooperation of men who have devoted a lifetime to the design and manufacture of *better* small gears.



# GEAR Specialties

Spurs • Spirals • Helicals • Bevels • Internals • Worm Gearing • Racks • Thread Grinding  
2635 WEST MEDILL AVENUE • CHICAGO 47, ILLINOIS

WORLD'S LARGEST EXCLUSIVE MANUFACTURERS OF FRACTIONAL HORSEPOWER GEARS



When your products require DC to AC Conversion

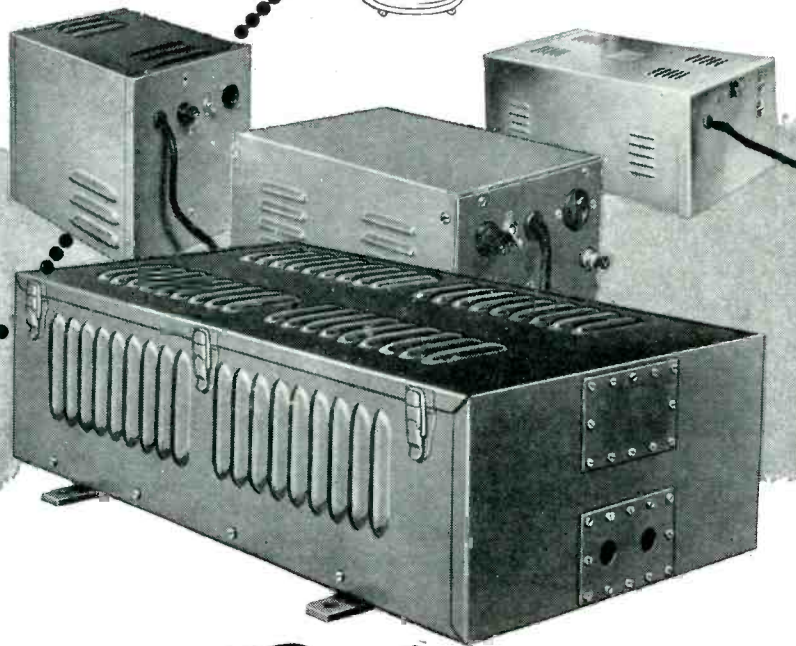
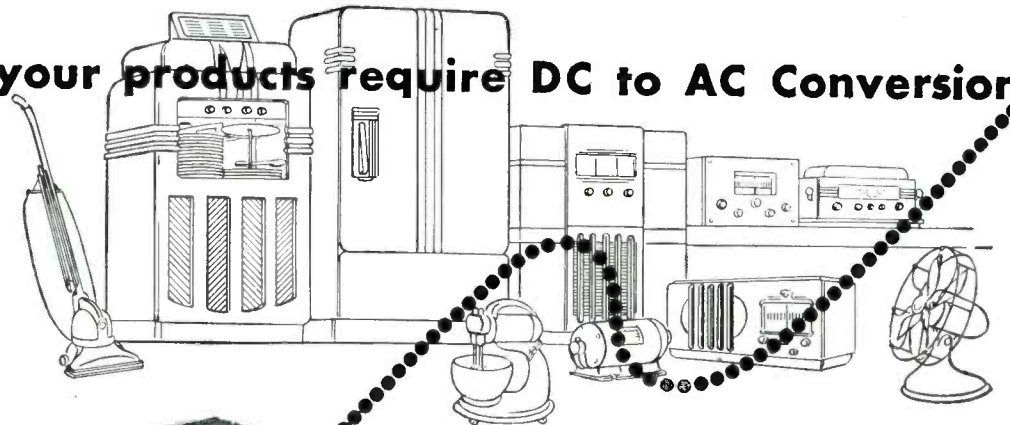

..THERE IS AN **E-L** VIBRATOR INVERTER for each important application

★ Greater efficiency ★ Increased capacity ★ Longer service ★ Lower cost... In your manufacture of communications equipment, appliances, electric motors and all similar products, **E-L** is equipped to serve your *exact* requirements with *efficient* DC to AC conversion units.

**SERVICE AND ECONOMY**

For coin-operated equipment, public address systems, neon signs, and electric razor operation there is a standard **E-L** inverter with longer service and lower cost. These results come from the simplicity of the **E-L** Vibrator Inverter, with *only one* moving part, plus precision construction in every detail.

No routine maintenance is required, since there are no brushes, armatures or bearings to lubricate or care for.

The design of each **E-L** Vibrator Inverter is preceded by a study of

product and application. Each **E-L** model fits an exact need and becomes a part of your pattern of quality manufacture.

**FOR EACH DC-AC APPLICATION**

In case of products with new or unusual requirements, **E-L** engineers are equipped and ready to design special power supplies. In every way **E-L** is set up to satisfy modern manufacturers and distributors of electrical and electronic products in *each important* DC-AC application.

MODELS ILLUSTRATED							
(Typical of 26 E. L. Models available to meet your requirements)							
MOD. NO.	INPUT VOLTS DC	OUTPUT VOLTS AC	OUTPUT WATTS	LOAD P.F. (%)	DIMENSIONS (in.)	WT. (lbs.)	PRINCIPAL APPLICATIONS
302	6	115	75	80-100	9 $\frac{3}{4}$ x6 $\frac{3}{8}$	15 $\frac{1}{2}$	Radio Receivers, Appliances
507	12	115	150	80-100	10 $\frac{3}{4}$ x7 $\frac{1}{2}$ x8 $\frac{1}{4}$	25	Radio Receivers, Transmitters, Appliances
146	32	115	350	80-100	16x10x8 $\frac{3}{8}$	48	Receivers, Transmitters, Coin Phonographs
268	115	115	750	80-100	20 $\frac{1}{2}$ x11 $\frac{3}{4}$ x7 $\frac{1}{2}$	66	Motors, Communications, Equipment

COPYRIGHT 1945 ELECTRONIC LABORATORIES, INC.



VIBRATORS AND VIBRATOR POWER EQUIPMENT FOR LIGHTING, COMMUNICATIONS, ELECTRIC AND ELECTRONIC APPLICATIONS



# BLUEPRINT

**YOUR MOVES  
WITH**

## **ALLIANCE MOTORS**

The Model RR Intermittent duty is enclosed reversible control motor-split phase resistor type, 60 cycles, 24 or 117 volts, with or without gear reduction.

The Model MS is shaded pole induction type for any A.C. voltage from 24 to 250 and frequency of 40, 50 or 60 cycles. Starting torques from one-half ounce inch at 10 watts input, to two ounce inches at 36 watt input.

New uses—electronic and electric controls, time, temperature, pressure and humidity controls, coin operated phonographs, drink and merchandise dispensers, fans, valves and blowers, door openers, signals, motion displays, movie projectors and scores of industrial applications.

**MINIATURE MOTORS THAT  
MAKE 'EM MOVE!**



Motion . . . instant action . . . compact pin-points of concentrated power—that's what you have in *ALLIANCE Miniature Motors*.

They're compact stand-by power stations, ready to obey and deliver just the right amount of power and drive where and when needed.

Where your plans call for continuous or intermittent action, remote actuation, starting, stopping and reversing, there's probably an Alliance motor already engineered and available in quantities, at low unit cost, to do the job!

**WHEN YOU DESIGN—KEEP**

# **alliance**

**MOTORS IN MIND**

**ALLIANCE MANUFACTURING COMPANY • ALLIANCE, OHIO**  
Alliance Tool and Motor Ltd., Toronto 14, Canada



**AND NOW!**

# UNITED

*Quality Standard*

## WATER COOLED TUBES

The progress of *United Electronics* has been characterized over the years, by the addition of new tubes in the higher power categories. It is with reasonable pride therefore that we now announce UNITED external anode tubes in both water cooled and air radiator designs.

Type 893-A illustrated is rated for 20 KW anode dissipation and maximum power output of 50 KW.

Write for engineering information bulletins on UNITED external anode tubes.

*Masterpiece of Skilled Hands*

**Ruggedizing:** A United feature which enables tubes to withstand terrific shocks.



**UNITED ELECTRONICS COMPANY**

NEWARK 2, NEW JERSEY

Transmitting Tubes EXCLUSIVELY Since 1934



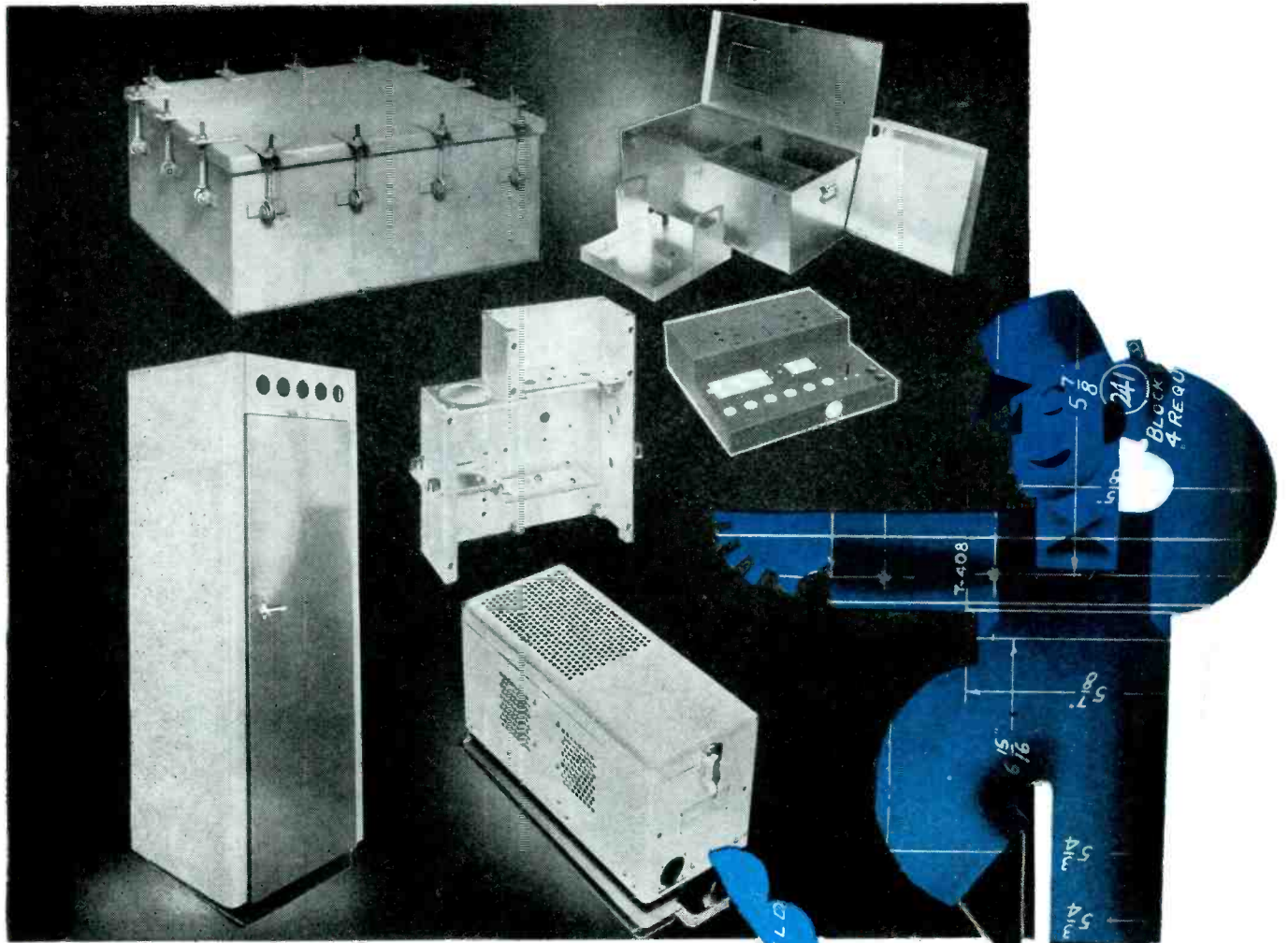

## WE STICK TO OUR ACT!

For more than 20 years we have adhered to our one specialty: the fabricating of sheet metal cabinets and other non-functional parts of electronic, electrical and mechanical apparatus.

We do this one thing with the pride of master craftsmen. Never have we been tempted to manufacture any complete products or assemblies. Ours always was and will continue to be a highly individualized service.

During the war years we never worked in an unfamiliar field. Consequently those years improved and intensified our specialized skill

and knowledge . . . expanded our facilities, but did not divert or split our interests.

Hence we have no reconversion problem. We're not switching over to any other form of manufacturing.

Our vast accumulation of dies and tools is available to save you special die costs. We offer custom craftsmanship to exact specifications, at "ready-made" economies. Try us for extra value in rugged construction and streamlined beauty.

ANY METAL • ANY GAUGE • ANY SIZE  
ANY FINISH • ANY QUANTITY

See our exhibit at the I. R. E. Technical Meeting,  
Booth 6-B, Hotel Astor, New York, Jan. 23-26

# KARP METAL PRODUCTS CO., INC.

124-30th Street, Brooklyn 32, N. Y.

*Custom Craftsmen in Sheet Metal*





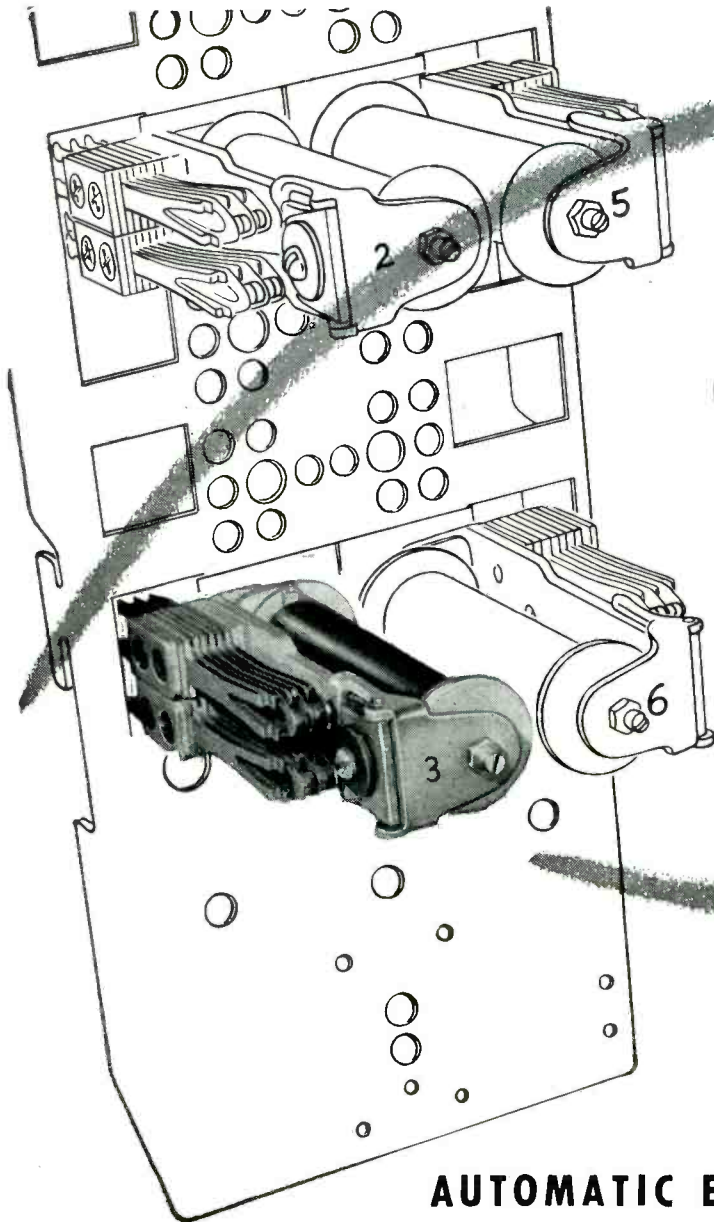

*More*

**THAN 300,000,000  
OPERATIONS**

### **AUTOMATIC ELECTRIC'S CLASS "B" RELAY**

Want real proof of relay ruggedness? Many months ago, several Class "B" relays, taken from regular production, were placed on "life test." Today, with no attention except for occasional lubrication, they are still functioning satisfactorily—and every one has hung up the amazing record of more than 300,000,000 operations! For ruggedness—for all the other features you need, specify Automatic Electric's Class "B" relays.

*Independent twin contacts for dependable contact closure... efficient magnetic circuit for sensitivity and high contact pressure... unique armature bearing for long wear under severe conditions... compact*

*design for important savings in space and weight. Now available for coil voltages to 300 volts DC and 230 volts AC, with capacities up to 28 springs; also with magnetic shielding cover, when specified.*

The Class "B" relay, and many others, are shown in Catalog 4071. Write today for your copy.

*Relays by*

**AUTOMATIC  ELECTRIC**

**AUTOMATIC ELECTRIC SALES CORPORATION**

1032 WEST VAN BUREN STREET • CHICAGO 7, ILLINOIS

*In Canada: AUTOMATIC ELECTRIC (CANADA) LIMITED, TORONTO*

**PARTS AND ASSEMBLIES FOR EVERY ELECTRICAL CONTROL NEED**

**Sherron  
Electronics**

**INSTRUMENTS**

**for Laboratory and  
Production  
Applications**



In anticipation of the needs of the electronic industry, we offer the following Sherron quality instruments . . .

Television Test Signal Generator  
Cathode Ray Null Detectors  
Reproducer Test Equipment  
Transmission and Measuring Unit  
Pulse Generator  
R. F. Null Detectors  
D. C. Null Detectors  
Comparison Oscilloscope

Crystal Controlled Clock  
Low Frequency Vibrator  
Sound Level Meter and Analyzer  
Curve Tracer  
Flow Meter  
Primary Frequency Standard



*Quality*

**SHERRON ELECTRONICS COMPANY**

*Division of Sherron Metallic Corporation*

1201 Flushing Avenue

Brooklyn 6, N. Y.

**"WHERE THE IDEAL IS THE STANDARD, SHERRON UNITS ARE STANDARD EQUIPMENT"**



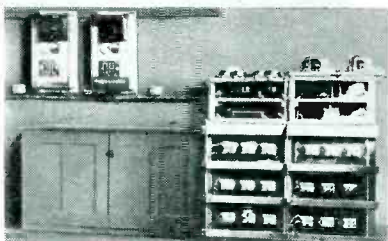

1915. World's first vacuum tube repeater, produced by Western Electric, made transcontinental telephone calls possible.

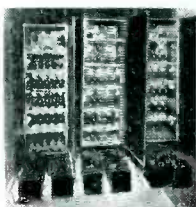

1919. Among the earliest P. A. amplifiers were these made by Western Electric and used at Victory Way Celebration in New York City after World World I.

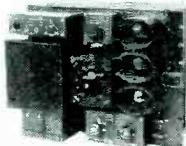

1922. First amplifier used generally in commercial broadcasting. Many of these 8-type amplifiers are still in use.



1931. Negative feedback principle introduced by Western Electric in telephone amplifiers, since applied to broadcasting and public address equipment.



1931. Western Electric developed this first all AC amplifier unit which eliminated batteries, made equipment more compact.



1936. One of the twenty 1000-watt amplifiers used in the world's largest commercial public address system at Roosevelt Raceway on Long Island.

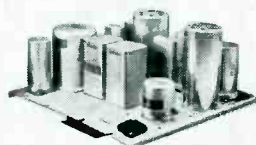

1937. 120-121 type Western Electric amplifiers for use in the finest audio systems for AM and FM transmission.



1942. New and improved battle announcing system amplifiers of the type that helped save the crippled carrier *Franklin*.

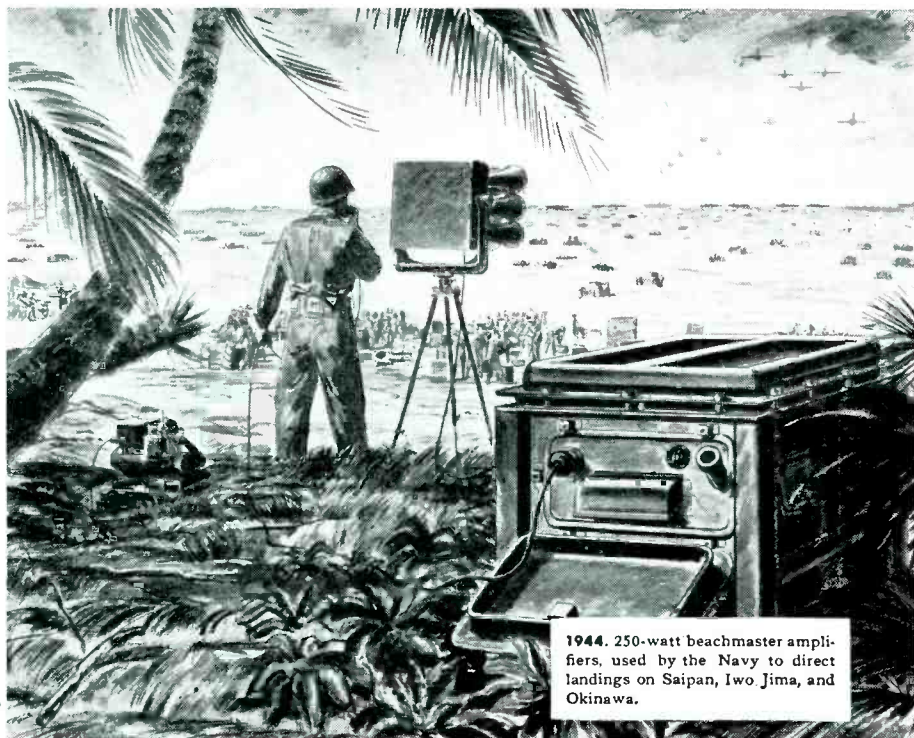

1944. 250-watt beachmaster amplifiers, used by the Navy to direct landings on Saipan, Iwo Jima, and Okinawa.

## AMPLIFIER HISTORY... Made by *Western Electric*

For more than 30 years, Western Electric has made amplifier history. The skill and ability that time alone can bring, plus experience gained producing highly specialized sound equipment for war, mean continued leadership for Western Electric in the years ahead.

**Buy Victory Bonds and hold them!**





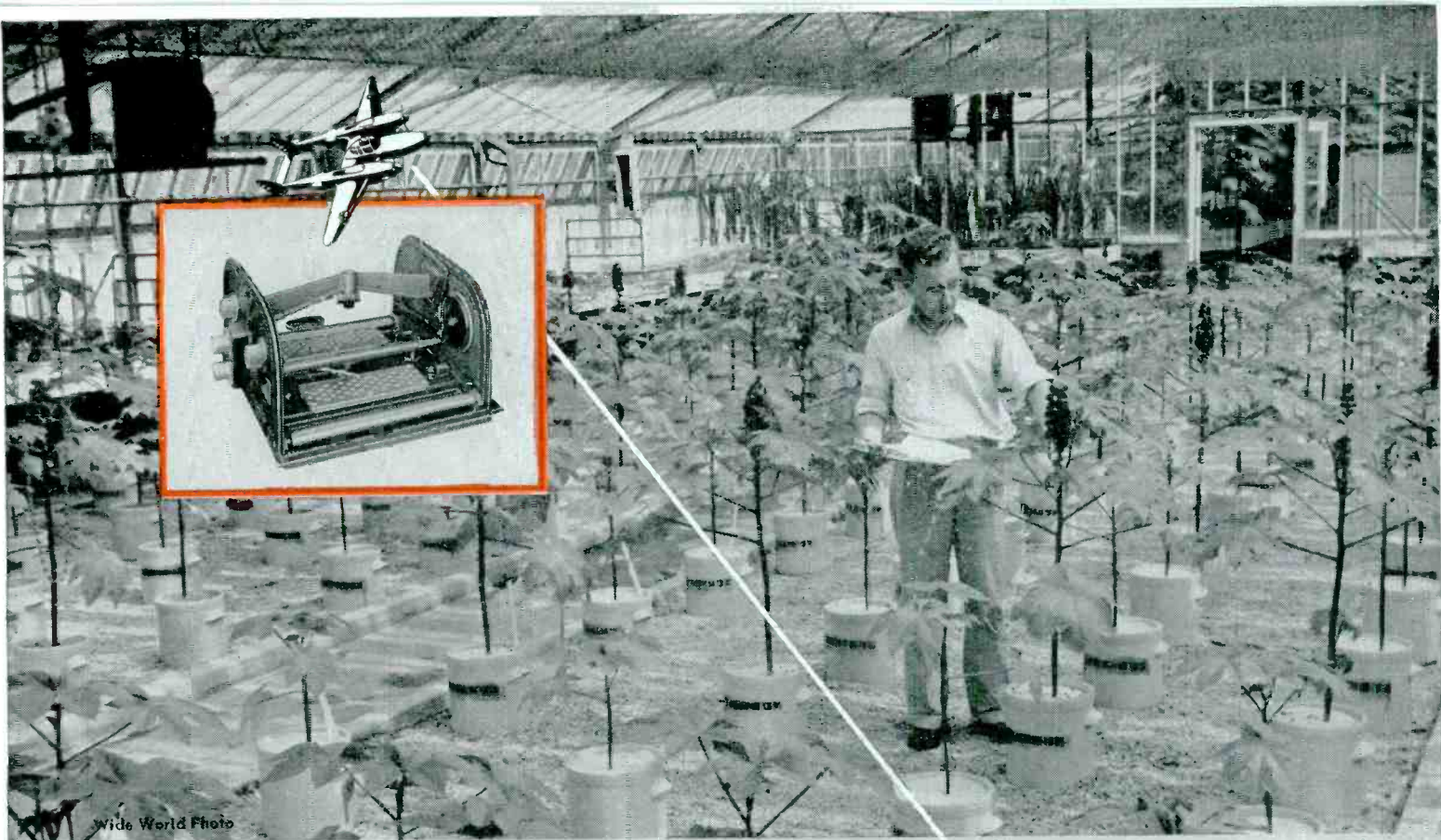

Wide World Photo

# TURN ON THE

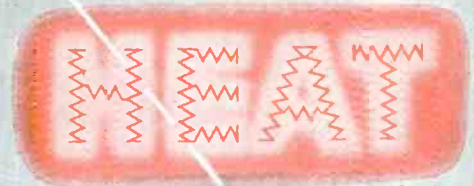

when and where you want it...

...with **NICHROME\***

In addition to toasters, electric irons, radiant heaters, stoves, etc., the uses for electrical heating elements have multiplied into an almost endless list of new and novel applications during the war.

From keeping aerial cameras warm in the stratosphere to protecting delicate roots underground, Nichrome heating elements have been impressed into service to deliver dependable heat . . . wherever and whenever it is required.

In all of these applications the vital factor of dependability leaves no room for compromise with quality.

For this reason and because Nichrome insures long heater life and close control over wide temperature range, it has been specified for more new electrical heating applications than any other alloy resistance wire.

Although there are several excellent Nickel-Chromium combinations there is only one NICHROME and it is made only by Driver-Harris. For improved performance and longer life in your new products, specify Nichrome and other resistance alloys by Driver-Harris. Tell us what you need.

\*Trade Mark Reg. U. S. Pat. Off.

NICHROME  
is made *only* by



*Driver-Harris*  
COMPANY  
HARRISON, N. J.

BRANCHES: Chicago, Detroit, Cleveland, Los Angeles, San Francisco, Seattle



# 341 OF THE 9,675 CAPACITOR AND RESISTOR TYPES

engineered by SPRAGUE and produced in 1944

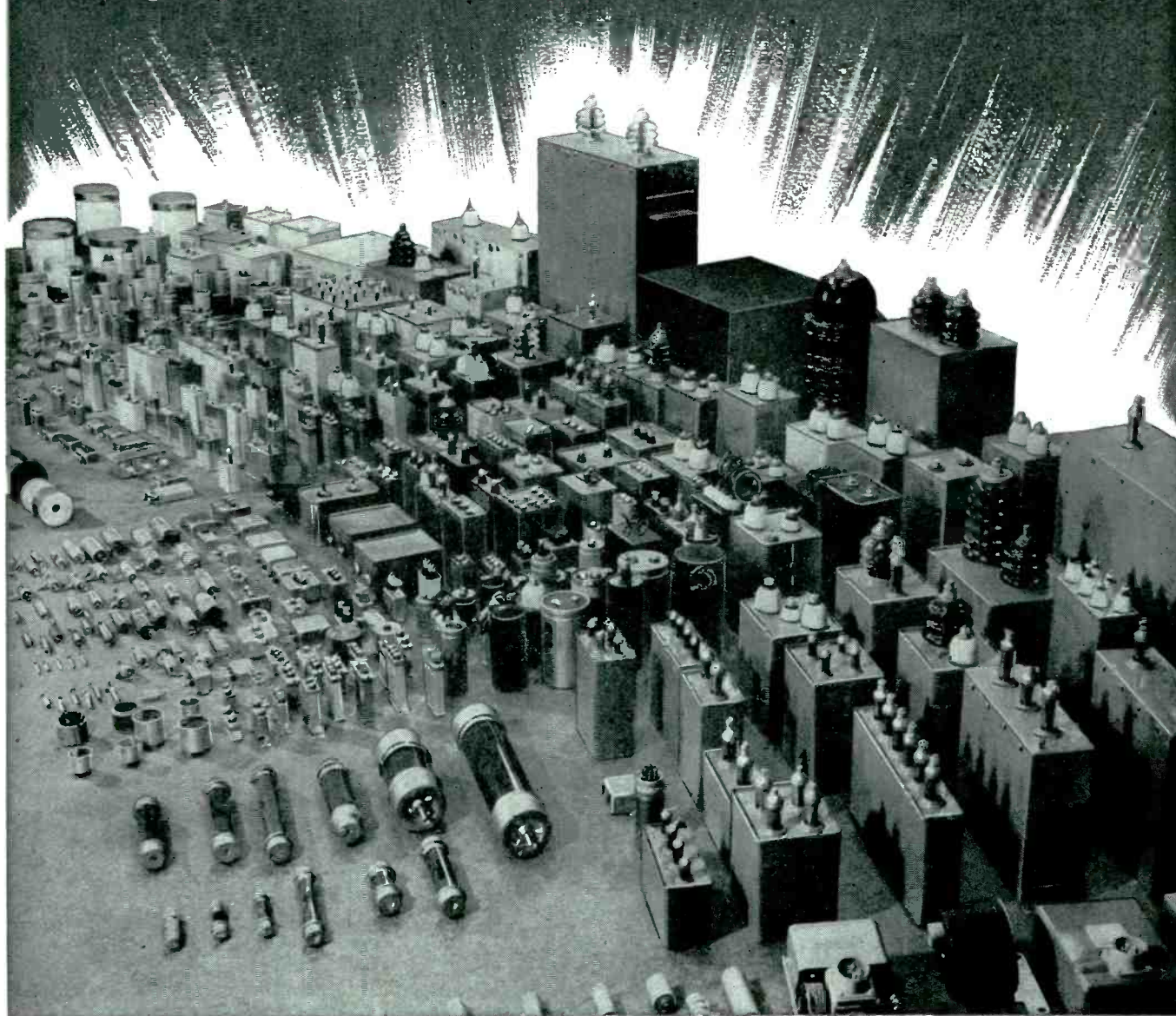

A good measure of any supplier is his ability to meet BOTH standard and highly specialized requirements. The Sprague war-time record offers convincing evidence in both respects.

**CAPACITORS • \*KOOLOHM RESISTORS • \*CEROC 200 INSULATION**



# SPRAGUE

**SPRAGUE  
ELECTRIC COMPANY  
NORTH ADAMS, MASS.**

\*Trademarks Registered U. S. Patent Office

**PIONEERS OF ELECTRIC & ELECTRONIC PROGRESS**

# IT'S THE **MB ISOMODE** MOUNT FOR POSITIVE VIBRATION CONTROL . . .

## STACK UP THESE PROPERTIES AGAINST YOUR DESIGN PROBLEMS

- Equal spring rates in all directions
- Non-directional—mount at any angle
- High load capacity in compact size
- Ample rubber for high deflection capacity
- Self-snubbing for overloading shocks
- Convenient mounting flange

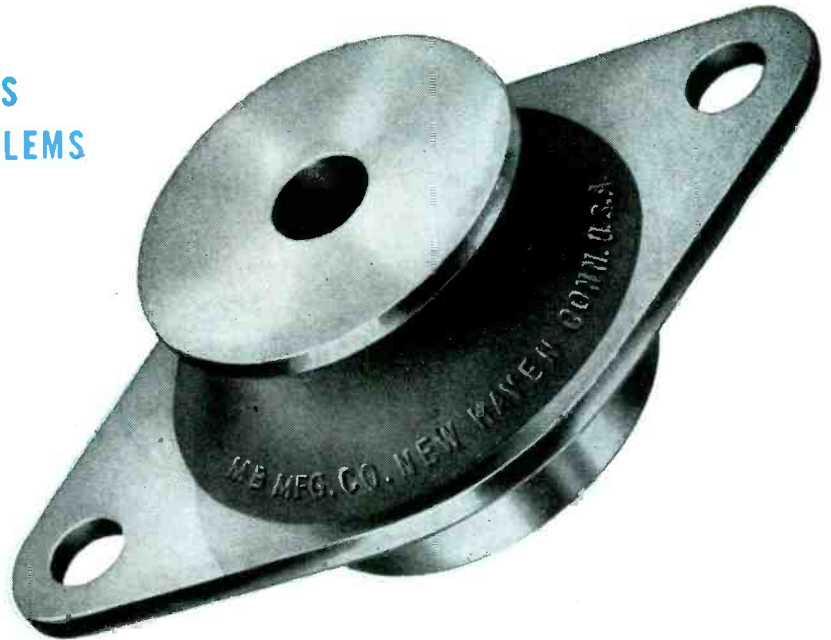

PREVENT TRANSMISSION OF ALL MODES of disturbing and damaging vibrations with these unusually effective MB mounts. Engineered by vibration specialists, Isomodes have the same softness axially and radially. They'll isolate, to a high degree, all modes of motion . . . horizontal, vertical and rocking. MB Isomodes come in a range of spring rates and sizes for your light, medium, and heavy-weight mechanisms. Let us show you how

Isomodes can fit into your present or proposed plans, save you considerable design effort, and assure top anti-vibration performance. Write for details.

**"ISOLATE ALL MODES FOR POSITIVE VIBRATION CONTROL"\***  
\*Copyright the MB Manufacturing Company, Inc.

**THE  
MB**  
**MANUFACTURING COMPANY, INC.**  
Vibration Division  
1066 State Street, New Haven 11, Conn.



VIBRATION ISOLATOR UNITS AND MOUNTINGS • SPECIAL VIBRATION TEST EQUIPMENT

### Another Helping Hand on Vibration Problems

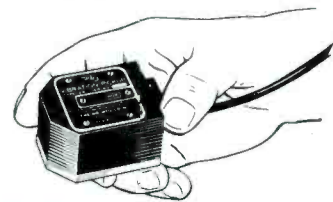

## **MB** VIBRATION PICKUP

Developed for both vibration detection and as an aid to its analysis, the MB Pickup features excellent response to very low amplitudes . . . exceptional durability under conditions of severe vibrations . . . negligible frictional effects . . . and calibration stability over broad temperature ranges. Output is proportional to vibratory velocity, with effective frequency range 5 to 1000 cps. The MB Pickup is usually operated as a seismic instrument, and is quickly converted for use in either horizontal or vertical plane without affecting calibration. Write for 4-page folder with full details and description.



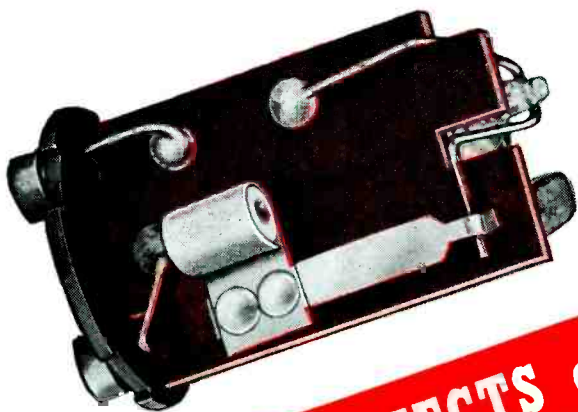

**FEWER REJECTS of precision-tolerance parts  
AT SYLVANIA ELECTRIC**

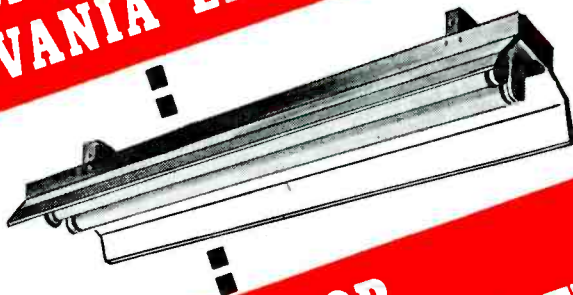

**NEW, COLD-PUNCHING PHENOL FIBRE  
with TAYLOR**

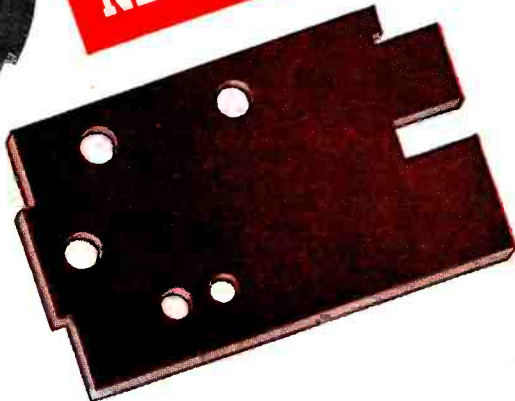
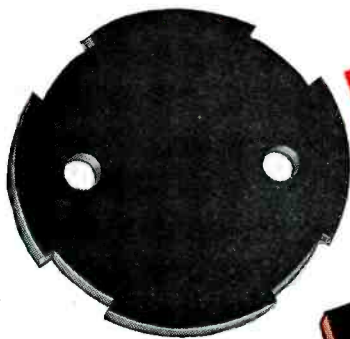

COP 40 starter switches in fluorescent lights produced by Sylvania Electric Products, Inc., call for precision tolerances. Taylor makes them by the thousands . . . and to perfection.

Wherever Laminated Plastics are called for, Taylor Fibre engineering skill is equal to the task of producing any fabricated part—no matter how complicated the design or how close the tolerances. Such parts can be mass-produced and speedily delivered. With Taylor fabricated parts, you can be assured of uninterrupted production, for our own inspection eliminates rejects in advance.

Sylvania Electric's experience is duplicated in hundreds of other plants where production engineers have discovered that "no one can turn out

accurate parts like Taylor." If you fabricate your own parts, you will have better success if you start with Taylor sheets, rods, or tubes, particularly the newly developed, cold-punching, paper base Phenol Fibre that handles satisfactorily in any kind of punch and die.

Tell us what you're interested in and we'll gladly send you completely descriptive folders or technical data concerning any Vulcanized Fibre or Phenol Fibre product. Our Engineering Department is available for free consultation.

# **TAYLOR FIBRE COMPANY**

LAMINATED PLASTICS: PHENOL FIBRE • VULCANIZED FIBRE—Sheets, Rods, Tubes, and Fabricated Parts  
NORRISTOWN, PENNSYLVANIA    Offices in Principal Cities    LA VERNE, CALIFORNIA

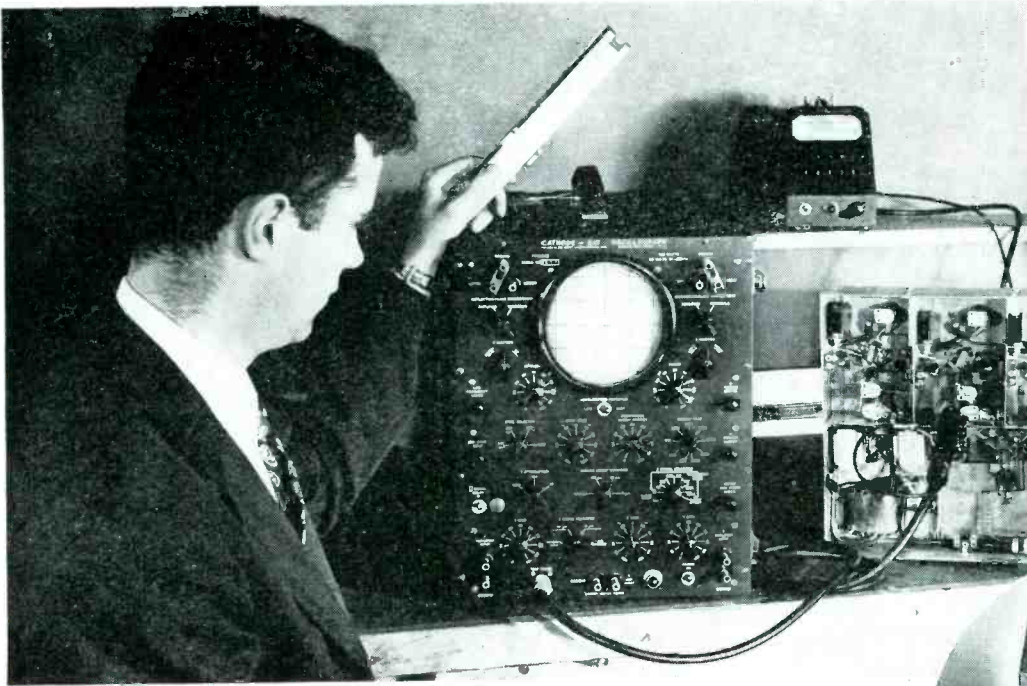

Left—Indicator Unit of Type 248 Oscilloscope

Below—Power Supply Unit of Type 248 Oscilloscope

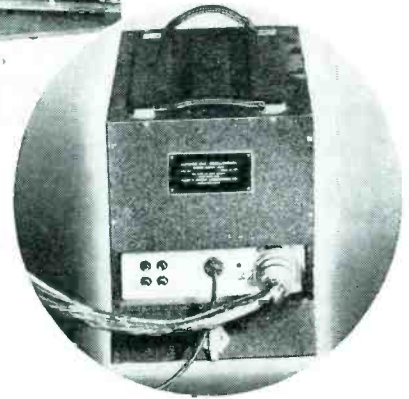

# PRECISION ACCURACY to the *Microsecond!*

▶ The Du Mont Type 248 Cathode-Ray Oscilloscope was developed to meet the need for a precision-measurement instrument of laboratory-standard accuracy... an instrument of such outstanding performance and dependability that it has no rival in the commercial field.

If your immediate or long-range program involves pulses, transient response, waveshaping circuits, video amplifiers or any problems which require the unusual combination of a cathode-ray synchroscope and oscilloscope, you'll find the Type 248 the perfect answer to all your requirements... with accuracy to the MICROSECOND!

**THE DU MONT TYPE 248 CATHODE-RAY OSCILLO-  
GRAPH IS NOW AVAILABLE FOR IMMEDIATE DELIVERY!  
FURTHER INFORMATION IS YOURS FOR THE ASKING.**

© ALLEN B. DUMONT LABORATORIES, INC.

## NOTE THESE UNUSUAL FEATURES

1. Driven or "slave" sweep speeds which exceed one inch per microsecond.
2. Visual display of non-repetitive transients which produce writing rates as fast as three or more inches per microsecond.
3. Better than one half microsecond signal delay which permits observation of the initial part of a transient or pulse.
4. Self-contained trigger pulse oscillator for synchroscope applications.
5. Internally provided timing markers at 1, 10, and 100 microsecond intervals which may be superimposed upon the observed wave.
6. Separate indicator and power supply units which add to its utility as a portable instrument.

# DUMONT

## Precision Electronics & Television

ALLEN B. DUMONT LABORATORIES, INC., PASSAIC, NEW JERSEY • CABLE ADDRESS: AUBEEDU, PASSAIC, N. J., U. S. A.





# NOW IN PRODUCTION FOR EARLY 1946 DELIVERY

## *Federal's Complete FM Broadcast Equipment*

**STUDIO EQUIPMENT • FM TRANSMITTERS • ANTENNAS AND TOWERS**

With production now under way, Federal will deliver 1 and 3 KW FM Transmitters early in 1946...delivery of the 10 and 50 KW following shortly thereafter...featuring the latest in design, circuits, tubes and technique for unsurpassed operations in the new 88-108 mc. band.

Available with these transmitters will be complete associated equipment — from microphone to antenna — entire FM Broadcasting Systems...supplied by one experienced and dependable

source—Federal...for more than three decades a leading contributor to radio progress.

Federal engineers are ready to consult with you...help plan every step of your installation...and then stay with the job until your station is in completely satisfactory operation. And Federal assumes full responsibility for the performance of its equipment.

Call in Federal now...be among the first on the air with the finest in FM Broadcasting.

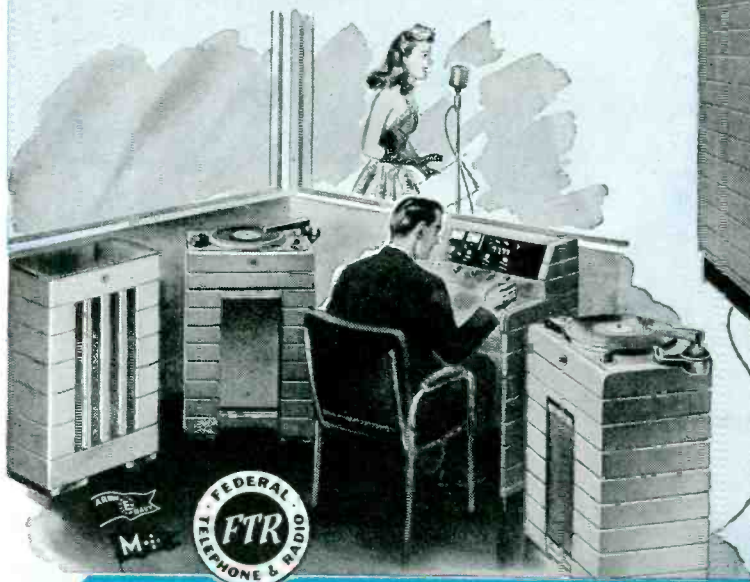

Write for brochure "Complete FM... by Federal" descriptive of Federal's complete FM Radio Broadcast Equipment from microphone to antenna.



## *Federal Telephone and Radio Corporation*



Newark 1, N. J.

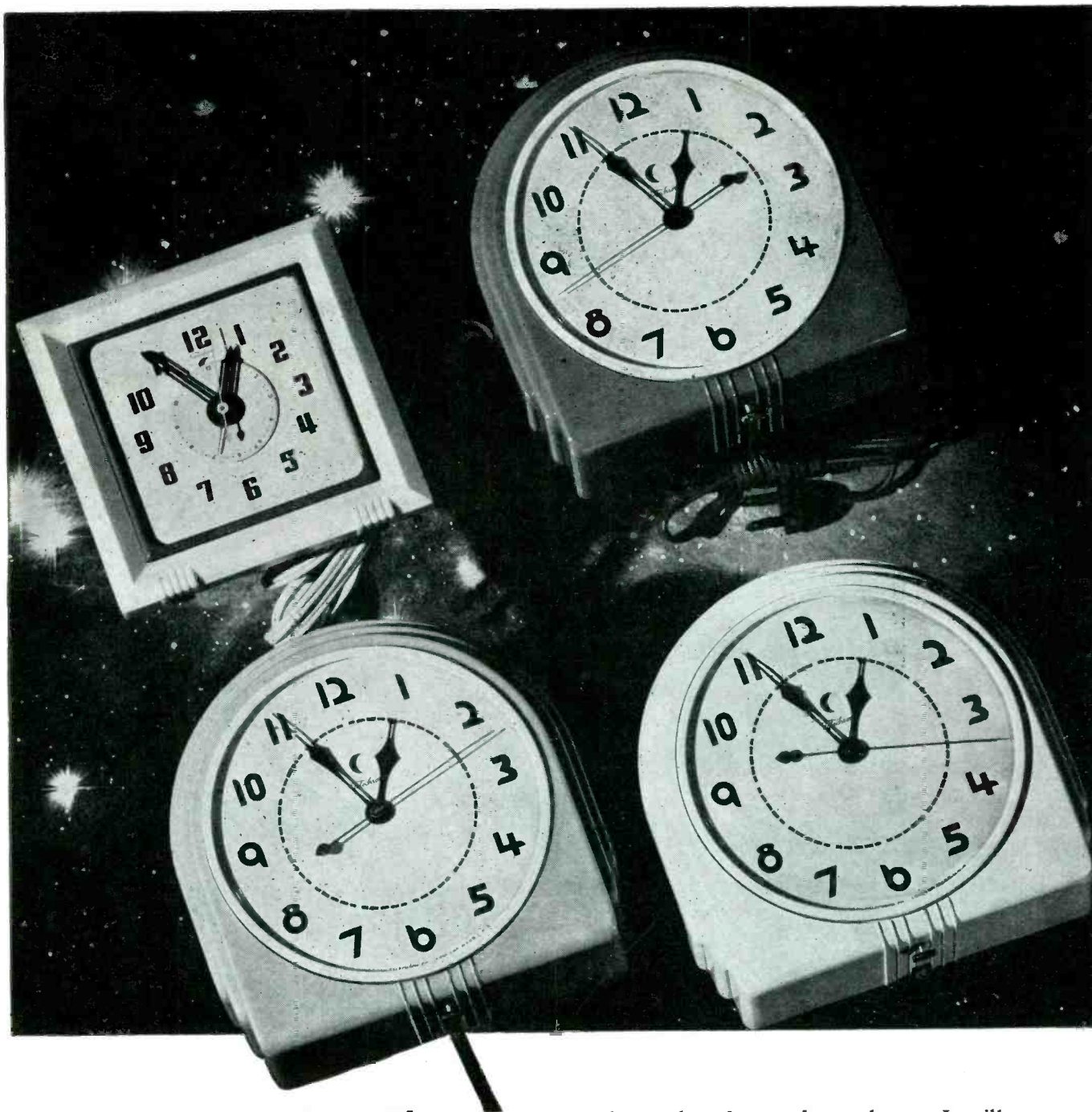

## Take Time to See Them...

take time to see these new timepieces—so modern and beautiful in their Plaskon Molded Color cases!

Dealer's shelves once more are being stocked with clocks for every need, thanks in a big way to quick conversion made possible by Plaskon plastic materials. Plaskon can be molded into almost any desired shape or design, in large quantities, at very economical prices. It is a high-utility material for a great range of applications, and possesses the added advantage of rich, striking colors for product enhancement.

Molded Plaskon has a gleaming, satiny surface, friendly

**PLASKON DIVISION • LIBBEY • OWENS • FORD GLASS CO. • 2136 Sylvan Ave., Toledo 6, Ohio**

In Canada: Canadian Industries, Ltd., Montreal, Quebec

to the touch and attractive to the eye. It will not rust, tarnish or corrode; it is not affected by oils, fats or greases; and is completely impervious to the effects of alcohol, acetone, and other common organic solvents. Because it is odorless, tasteless and inert, it has no effect upon any other material which it contacts.

Investigate the many manufacturing and sales advantages which Plaskon plastics offer you, for developing present markets and entering new ones. We can give you helpful assistance in suggesting designs, qualified Plaskon molders, and technical advice. Write today.

# PLASKON

TRADE MARK REGISTERED

**MOLDED COLOR**





Thermoplastic insulation specialists . . . producing a complete line from fine wires to heavy power cables . . . serving: Public Utilities, Radio, Electronic, Appliance and Instrument Manufacturers, Telephone Companies and Contractors.

*Now*

## THERMOPLASTIC INSULATION

Nothing is constant but change . . . and in the wire and cable field the "change" to thermoplastic insulation has been tried and proved in the test tube of war. When victory is won you will demand the maximum resistance which these new compounds and constructions offer to heat, flame, oxidation, chemical action, oil, grease, moisture, cold, abrasion, fungus growth and other severe conditions. Write NOW for complete information and samples engineered to your particular requirements. Remember . . . when you're thinking of PLASTIC you're thinking of US!

# PLASTIC

W I R E & C A B L E<sup>®</sup> NORWICH CONN  
C O R P O R A T I O N



For the NEW YEAR... Good Judgment says... STANDARDIZE on

# STUPAKOFF CERAMICS

*and Gain these Advantages:*

**IMPROVED PRODUCTS.** Many products require correctly engineered ceramic parts of highest quality for satisfactory performance and long service life. Stupakoff has the skill, experience and ability to produce such parts, thus helping you improve your products.

**FASTER ASSEMBLY.** The dimensional accuracy and sturdy structure of Stupakoff Ceramic parts help speed your fabrication processes. They fit exactly into the space provided for them, and provide correct spacing for parts assembled to them.

**GREATER SATISFACTION.** You will find fewer rejects, and greater overall quality and satisfaction when you standardize on STUPAKOFF CERAMICS!

Products for the World of Electronics

Export Department, 13 E. 40th Street  
New York 16, N.Y.

Cable Address: ARLAB, all codes

**STUPAKOFF CERAMIC  
& MANUFACTURING COMPANY**

**LATROBE, PENNSYLVANIA**



# NOW COMPLETED!

...over 500,000

## Chatham quality-built Mercury Vapor Rectifiers



CHATHAM engineering and production are devoted exclusively to the quality manufacture of vacuum, mercury vapor and inert gas rectifiers—for industry and communications.

CHATHAM rectifiers embody all the electrical and mechanical features that lengthen life and improve performance—a result of such specialization.

**IN PRODUCTION** and available for immediate delivery, are CHATHAM types 2A4G, 2B4G, 2D21, 3B28, 4B22, 4B32, 17, 394A, 866A, 872A, 884, 885, 2050, 2051.

### CHATHAM ELECTRONICS



475 WASHINGTON STREET,  
NEWARK 2, NEW JERSEY



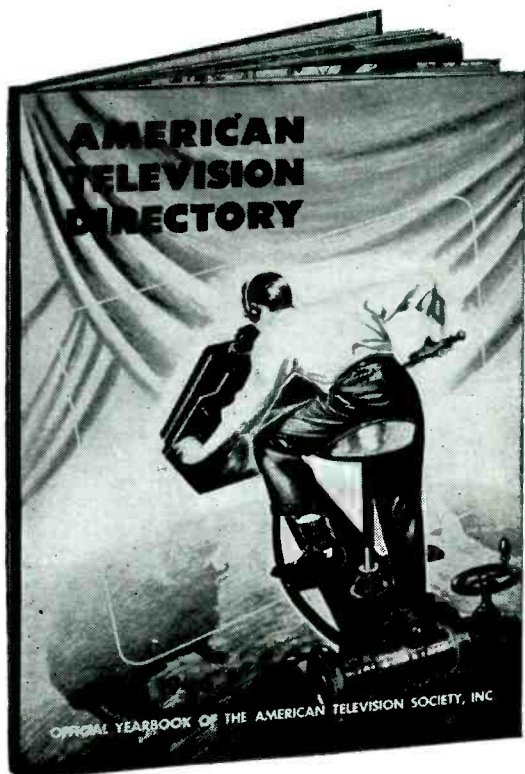

# HERE IS YOUR GUIDE TO THE NEW WORLD OF TELEVISION

A DESKBOOK prepared especially for advertisers, advertising agencies, radio stations and department stores . . . for those now in the industry and those whose business or careers may be affected by this swiftly expanding medium.

NOW ON  
THE PRESS!

**THIS IS A BIG  
9" x 12" BOOK  
OF 150 PAGES,  
LAVISHLY  
ILLUSTRATED**

**\$5.00 PER COPY  
WITH HARDBOARD  
COVERS**

**ADDITIONAL  
COPIES \$4.00 EACH**

**H**OW does television differ from radio? Will most tele-shows be pre-filmed? Is color television ready? Will advertising agencies control programming? How will this new medium handle the news? Will department stores rush into television? What is tele-time worth today? How fast will networks grow? What are the economics of station operation? What legal problems will television create? Will packaged shows boost programming quality? How will newsreel theatres handle television? Can tele-shows equal Hollywood standards? What are the visual fundamentals of program planning? What are television's job opportunities?

These questions and hundreds more are answered by Edgar Kobak, David Sarnoff, Paul Porter, Paul Raibourn, Allen B. DuMont, William Morris, Peter Goldmark, Lowell Thomas, H. V. Kaltenborn, Hoyland Bettinger, and two score others. And in the big Directory section are lists of all stations and personnel, proposed stations and market areas; all the television activities of advertisers, agencies, producers, organizations. Here in one book is every source and contact you'll need in 1946—your guide if you would get in on television's ground floor. The edition is limited; please use the coupon to reserve copies today!

Date .....	
American Television Society, Inc. 271 Madison Ave., New York 16, N. Y.	
Please reserve ..... copies of the 150-page AMERICAN TELEVISION DIRECTORY, 1946 edition, full-bound Smythe sewed book (board cover). First copy at \$5.00. Additional copies \$4.00 each.	
I prefer to pay:	Name .....
<input type="checkbox"/> By check, herewith,	Title .....
for \$ .....	Firm .....
<input type="checkbox"/> Ship C.O.D.	Address .....
<input type="checkbox"/> Ship & bill me.	City ..... State .....



# BEFORE PURCHASING ANY VOLTAGE CONTROL SEE SECO

- VARIABLE VOLTAGE TRANSFORMERS •
- AUTOMATIC VOLTAGE REGULATORS •
- TESTING EQUIPMENT •

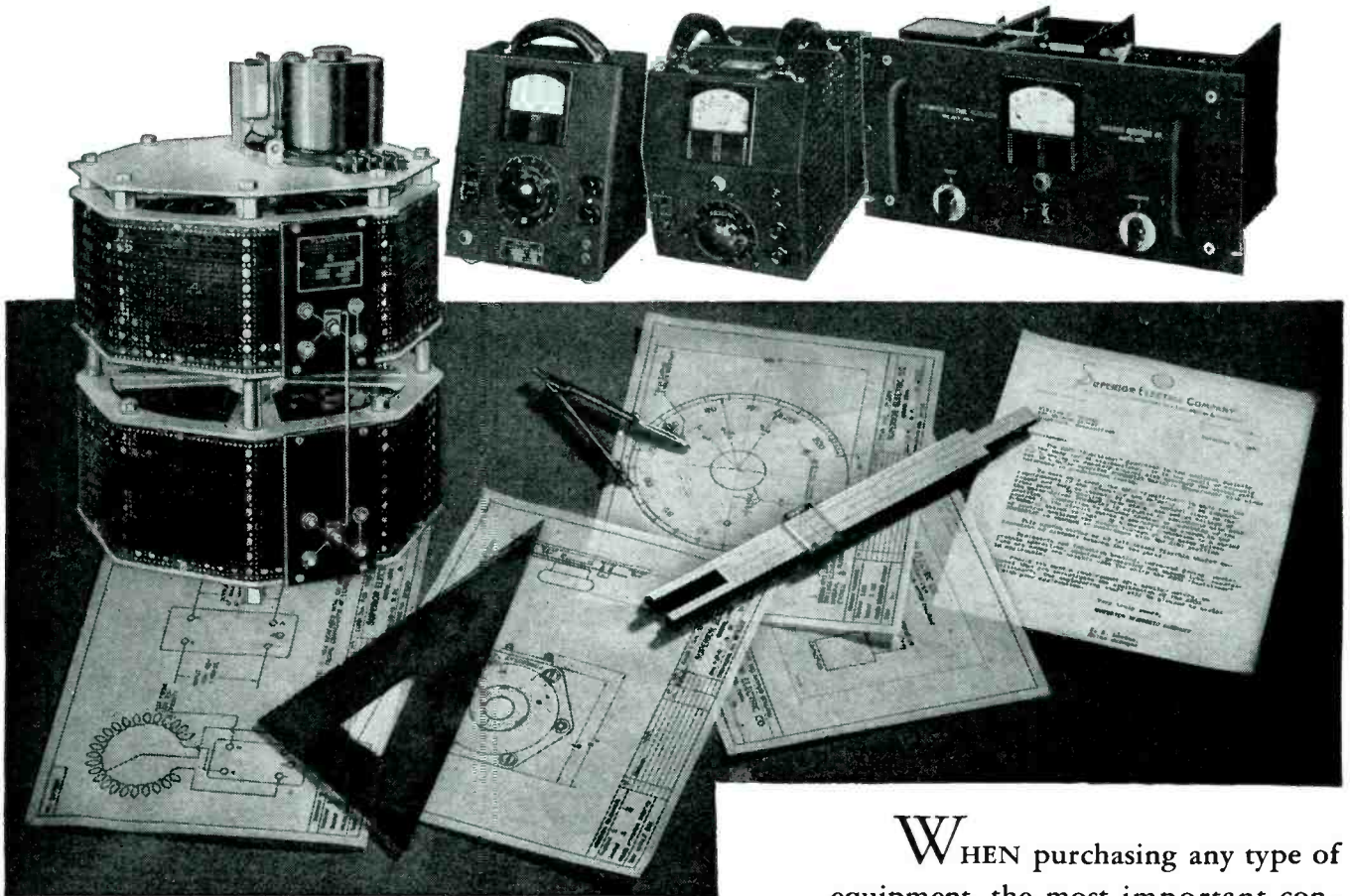

WHEN purchasing any type of equipment, the most important consideration is to obtain the correct apparatus for each application. This is especially true in regard to voltage control equipment. A misapplication or the adaptation of a standard unit to an unusual requirement (where really a special design is necessary) can only produce faulty performance. For this reason, it is our suggestion that a SECO engineer be consulted whenever there is need for an a-c voltage controller. His complete and comprehensive understanding of all phases of voltage control is your assurance of the right equipment for the job.

By simply outlining your particular problem to one of us at SECO results in a prompt recommendation whether it involves a POWERSTAT variable transformer to vary the output voltage from a-c power lines, a SECO Automatic Voltage Regulator to maintain a constant output voltage, or test apparatus such as the VOLTBOX a-c power supply. Call or write and take advantage of the SECO KNOW-HOW.

*Send for Bulletin LE*

## SUPERIOR ELECTRIC COMPANY

701 LAUREL STREET,

BRISTOL, CONNECTICUT

350,000 piece jig-saw puzzle . . .

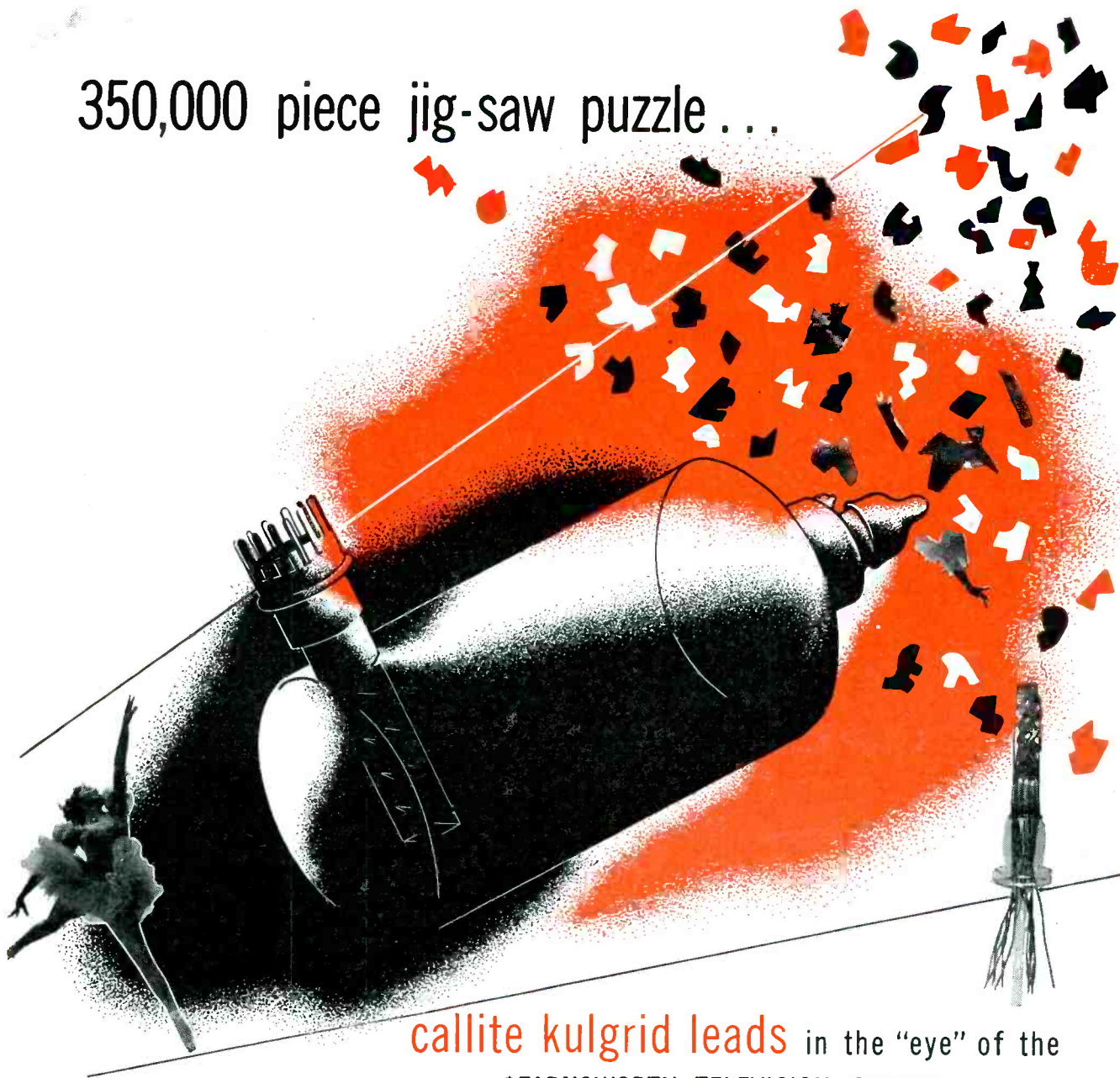

**callite kulgrid leads** in the "eye" of the  
\*FARNSWORTH TELEVISION CAMERA

**CALLITE DEVELOPED KULGRID** to meet the need for a stranded wire that does not oxidize nor become brittle at the high temperatures necessary in beading, stem-making, sealing-in and exhaust. Kulgrid is a composite wire having an inner core of copper alloy bonded to a nickel sleeve. Kulgrid welds readily to itself and to nickel, copperclad, tungsten, molybdenum and other related metals. It has 70% of copper's conductivity, plus nickel's strength and resistance to oxidation.

We will be glad to discuss applications of Kulgrid and send samples. It will pay you to investigate our specialized abilities and complete facilities for all kinds of metallurgical components. Callite Tungsten Corporation, 544 Thirty-ninth St., Union City, New Jersey. Branch Offices: Chicago, Cleveland.



\* Farnsworth's Television Camera dissects each picture it takes into as many as 350,000 separate pieces. Then it picks up the pieces one by one and sends them to the receiving set. There they are laid down so swiftly that your eyes see a complete picture all at once. The Farnsworth image-dissector tube, with its extraordinary step-up device called the electron multiplier, uses Callite Kulgrid Leads.

Hard glass leads, welds, tungsten and molybdenum wire, rod and sheet, formed parts and other components for electron tubes and incandescent lamps.

Kulgrid is covered by U.S. and foreign patents.



# complete **MOISTURE PROOFING** service

## DEHYDRATING

Parts are thoroughly dehydrated for the length of time needed to thoroughly extract moisture.

## AUTOMATIC DIPPING

Parts are waxed and varnished according to specifications and all areas are thoroughly coated.

## IMPREGNATING

Sufficient time is allowed to thoroughly impregnate all materials to the full extent of their porosity.

## CENTRIFUGING

All surplus wax and varnish is removed by this operation leaving all machined surfaces and counter bores clean and smooth.

## POLISHING

All smooth surfaces are polished to a dust-free hard finish.

## SPRAYING

Parts are sprayed with varnishes to protect the laminated bakelite edges.

## DOW CORNING FLUID #200 IMPREGNATION

This new method of waterproofing protects steatite ceramic parts against moisture absorption and fungus attack.

**VACUUM AND  
PRESSURE  
IMPREGNATING**

**DAILY PICK-UP  
AND  
DELIVERY IN  
METROPOLITAN  
AREA**

**WE MEET  
ANY AND  
ALL GOV'T.  
SPECIFICATIONS**

*Machine Built  
to Order*

We have the facilities to build vacuum and pressure impregnating machines to meet your special moisture proofing requirements.

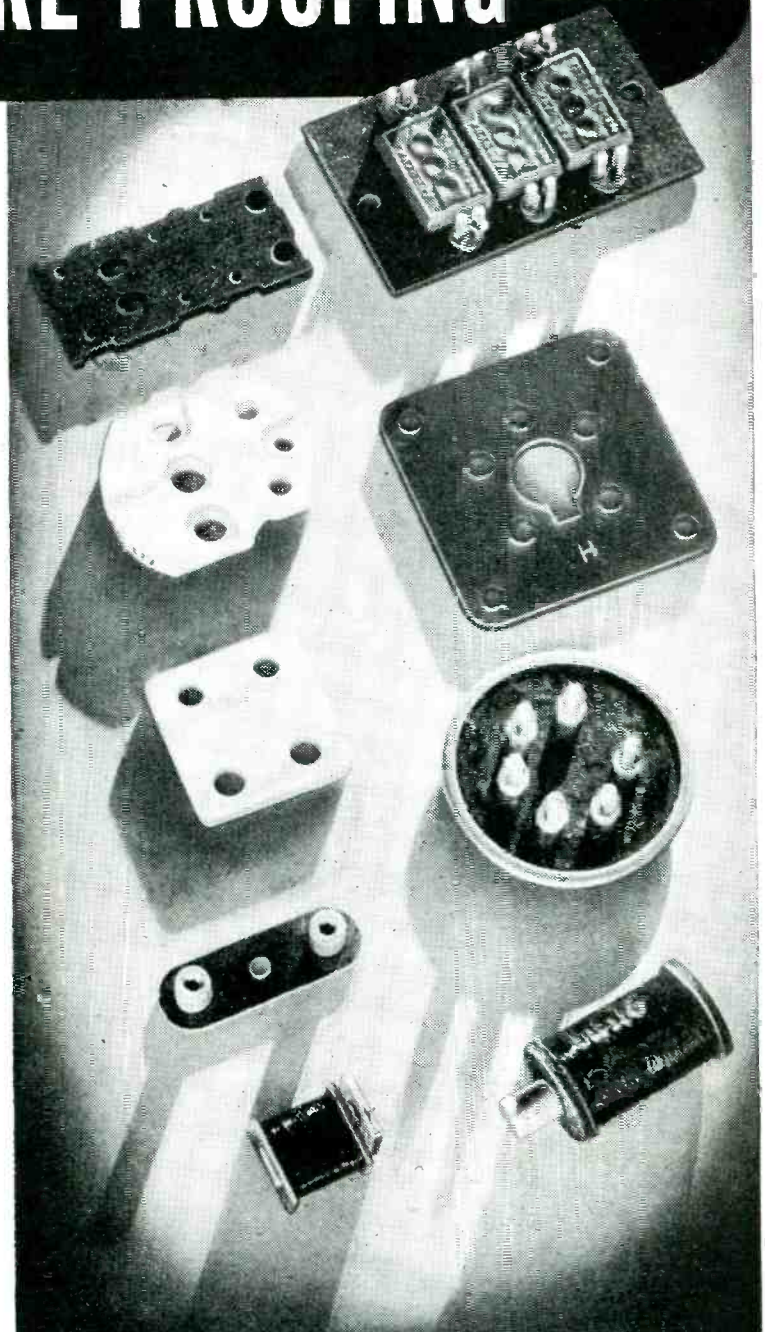

**PRODUCTION  
ENGINEERING  
CORP.**

**666 VAN HOUTEN AVENUE, CLIFTON, N. J.  
TEL. PASSAIC 2-5161**



# Still your best choice for V-H-F

● Pre-war pioneers, the HY75, HY114B, and HY615 offered new conceptions of low-cost efficiency on the very high frequencies. Radio amateurs, who did so much to open up these frequencies, piled up innumerable long distance transmitting and receiving records with the tubes. The HY75 and HY615 powered wartime WERS nets of amateurs almost exclusively

● A.R.R.L. and Radio handbooks have always been lavish in using the HY75, HY114B, and HY615 in equipment they described. The Abbott TR-4 transmitter-receiver contributed much to the fame of the HY75 and HY615. Maximum ratings up to 300 mc. (efficient circuit design permits even higher frequencies) spell continued popularity on the new "ham" bands.

● Popularity of this famous trio has not been confined to amateur circles. In all important war laboratories, the tubes were widely used. During many invasion thrusts in the Pacific, the HY75 and HY615 gave the Navy dependable intership communications. The HY75 design led to the Hytron 2C26A — r.f. pulse output tube of IFF (identification friend or foe), standard Army and Navy equipment for planes in combat areas. Developed from the HY615, the Hytron E1148 was in practically every British vehicular transmitter. The HY114B found its place in radar test equipment.

● Wherever real power output from small triodes is required on v-h-f, the HY75, HY114B, and HY615 still are your best choice. They fill a gap between "acorns" and miniatures which have limited power capabilities and larger triodes which cost much more. Brief data can give but a thumbnail sketch. You can best appreciate their superiority by putting the HY75, HY114B, and HY615 to work in your sockets.



## HYTRON V-H-F TRIODES

The HY75, HY114B, and HY615 are v-h-f triodes particularly suited as r.f. oscillator-amplifiers and as high sensitivity superregenerative detectors for fixed, mobile, or portable receivers, transmitters, transceivers, or transmitter-receivers. All three tubes feature short connection leads, low interelectrode capacitances, plate and grid connections to twin top caps, convenient octal bases, and a maximum operating frequency of 300 mc. for full plate input. Note in the HY75: low-loss lava insulation, rigidly supporting—for maximum resistance to shock and vibration—the graphite anode, vertical-bar grid, and instant-heating helically-coiled filament. The tiny HY114B and HY615 are capable respectively of 1.4 and 4 watts Class C output. The 1.4-volt filament of the HY114B makes it ideal for battery-operated portables.

CHARACTERISTIC	HY75	HY114B	HY615
Filament Potential (volts)	6.3	1.4	6.3
Filament Current (amps.)	2.6	0.155	0.175
Type of Filament	Thor.	Oxide	Cath.
Plate Potential (max. volts)	450	180	300
Plate Current (max. ma.)	80	12	20
Plate Dissipation (max. watts)	15	1.8	3.5
Grid-to-Plate Cap. (mmfd.)	3.8	1.3	1.6
Grid-to-Cathode Cap. (mmfd.)	1.6	1	1.4
Plate-to-Cathode Cap. (mmfd.)	0.6	1	1.2
Max. Operating Frequency (mc.)	300	300	300
Maximum Height (inches)	3 <sup>7</sup> / <sub>8</sub>	2 <sup>1</sup> / <sub>2</sub>	2 <sup>3</sup> / <sub>8</sub>
Maximum Diameter (inches)	1 <sup>1</sup> / <sub>16</sub>	1 <sup>3</sup> / <sub>8</sub>	1 <sup>3</sup> / <sub>8</sub>
Class C Power Output (watts)	21	1.4	4



OLDEST MANUFACTURER SPECIALIZING IN RADIO RECEIVING TUBES

# HYTRON

RADIO AND ELECTRONICS CORP.

MAIN OFFICE: SALEM, MASSACHUSETTS





# MASTER CRYSTAL OSCILLATORS

by Press Wireless

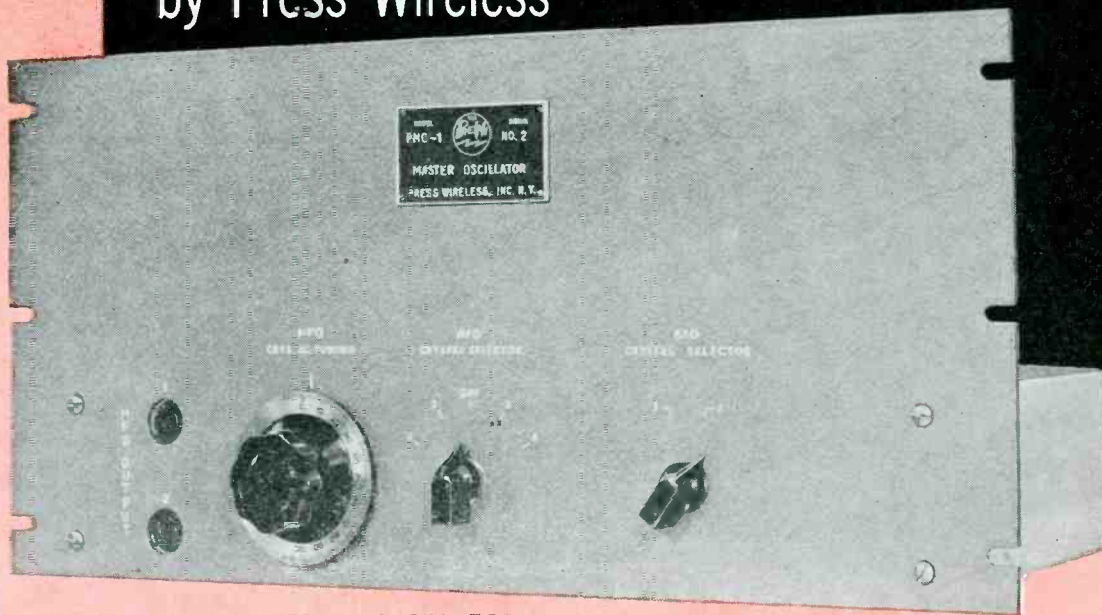

RECEIVER MASTER CRYSTAL OSCILLATOR  
Press Wireless Model RMO-1

Receiver Master Crystal Oscillator unit RMO-1 is easily adaptable to your present communication receiver to effectively eliminate troublesome frequency drift. Demands of modern mechanized radio communication systems require rigid frequency stability in both transmitters and receivers.

Increasing employment of "frequency-shift" circuits and the rapidly expanding developments in radio-facsimile, radio-photo, and high-speed automatic recording and printing instruments evidence the need for frequency control to close tolerances. This light-weight, compact, precision unit provides this exact control.

*Free engineering bulletin sent upon request.*

- Affords crystal HFO and BFO stability
- Two outputs for dual-diversity receiver operation
- Front panel selectors for HFO and BFO crystals
- Mounts four HFO and two BFO 2-pin crystals
- 2 to 24 mc HFO operation with 2 to 4 mc crystals
- Simple tuning control for precision adjustment of HFO
- No power supply required—uses power from receiver
- 19" Standard rack panel mounting

## PRESS WIRELESS, INC.

Executive and Sales Office, 1475 BROADWAY, NEW YORK 18



Awarded to our Hicksville, L. I. plant for outstanding achievement in war production.

PARIS · BUENOS AIRES · RIO DE JANEIRO · MONTEVIDEO · MANILA · BERNE · SANTIAGO DE CHILE · NEW YORK · SHANGHAI · LOS ANGELES · LONDON · HAVANA

# NEW PROBLEMS?

**C-D** has acquired the  
**KNOW-HOW**  
to help you apply  
**DIELECTRICS**



You will save time and worry . . . and avoid costly errors, by having C-D technicians help you select the appropriate material to meet your particular electrical insulating problem. They will also help you determine its most economical and efficient form to meet your design and performance requirements.

C-D technicians have helped thousands of manufacturers solve "What Material?" problems. The KNOW-HOW which they have acquired in solving such problems will enable them to help you. Their experience has not been limited to one or two Dielectrics, but to a wide range of products as shown in the C-D products listing. Their recommendations will, therefore, be unbiased.

The part illustrated herewith is made of DILECTENE—a pure resin product having extremely high and stable electrical insulating properties, even under abnormal moisture conditions. DILECTENE was developed by C-D technicians to provide an electrical insulating material that would meet the high standards and exacting requirements of U-H-F equipment.

Consult with C-D technicians while your designs are in the blue print stage. Make sure you are using the right electrical insulation in its best form . . . before your products go into production. Wire, phone or write the nearest C-D office and C-D technicians will get on the job.

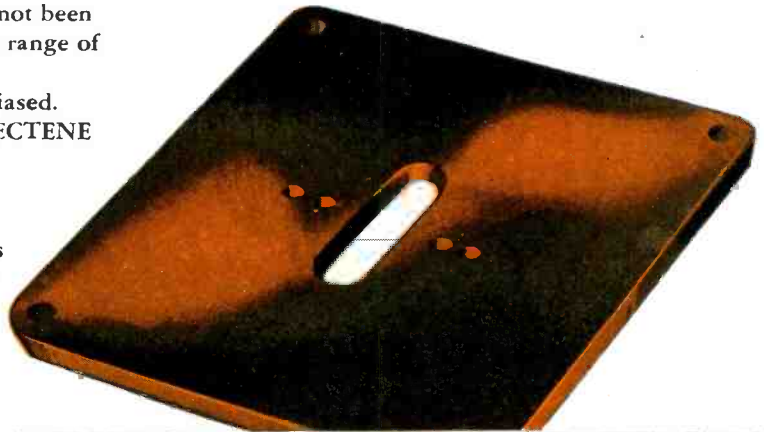

## C - D PRODUCTS

### The Plastics

**DILECTO**—Thermosetting Laminates.

**CELORON**—A Molded Phenolic.

**DILECTENE**—A Pure Resin Plastic Especially Suited to U-H-F Insulation.

**HAVEG**—Plastic Chemical Equipment, Pipe, Valves and Fittings.

### The NON-Metallics

**DIAMOND** Vulcanized FIBRE

**VULCOID**—Resin Impregnated Vulcanized Fibre.

**MICABOND**—Built-Up Mica Electrical Insulation.

### Standard and Special Forms

Available in Standard Sheets, Rods and Tubes; and Parts Fabricated, Formed or Molded to Specifications.

### Descriptive Literature

Bulletin GF gives Comprehensive Data on all C-D Products. Individual Catalogs are also Available.



RBC-46

### BRANCH OFFICES

NEW YORK 17 • CLEVELAND 14 • CHICAGO 11 • SPARTANBURG, S. C. • SALES OFFICES IN PRINCIPAL CITIES

WEST COAST REPRESENTATIVES: MARWOOD LTD., SAN FRANCISCO 3

IN CANADA: DIAMOND STATE FIBRE CO. OF CANADA, LTD., TORONTO 8



**Continental - Diamond** FIBRE COMPANY

Established 1895.. Manufacturers of laminated Plastics since 1911—NEWARK 16 • DELAWARE



# EVERYTHING **NEW** FOR FM

for **NEW** operating economy....

## NEW RCA POLYDIRECTIONAL MICROPHONE

(Type 77D)—The polydirectional feature helps you obtain better balance, clarity, naturalness, and selectivity in studio pickups.

By means of a screw adjustment at the back of the microphone a variety of non-directional, uni-directional, and bi-directional characteristic patterns can be produced. Undesired

sound reflections can be quickly eliminated merely by switching to the proper pattern. A three-position, VOICE-MUSIC switch permits the selection of the best operating characteristic.

This lightweight, multi-purpose microphone is finished in two-tone umber grey.

## NEW RCA TRANSMITTERS

RCA's line of FM transmitters (250 watt, 1, 3, 10, 25, and 50 kw) are completely new from exciter to power amplifiers—new circuits, new tubes, and a new type of construction.

The frames of all power sizes have been standardized thus assuring uniformity of dimensions, appearance, and easing installation problems. When increased power is desired, you merely add an amplifier. Appearance is equal to that of a single unit. Curved-end pieces add to the finished appearance.

A new, hollow base frame provides space for inter-unit wiring, and eliminates the need of wiring through units or conduits in the floor.

Air filters, flush-mounted centralized control panels, and concealed hinges are other features of the new RCA construction—*standardized* to assure you a better product at lower cost.

## NEW CIRCUITS

The new RCA Grounded-Grid amplifier circuits are at once simpler and more stable than any heretofore employed. As the name indicates, the grid of the tube is at r-f ground potential (instead of the filament as in conventional transmitters). The drive is applied between cathode and ground, either element being at the necessary d-c bias potential.

Special tubes have been developed for these circuits. Neutralization is either unnecessary, depending on frequency, or, if necessary, very easily achieved.

Other advantages: easier tuning, fewer tube types to stock, smaller, less-expensive tubes, lower operating costs, less distortion, and better program quality.

RCA's new "Direct FM" circuit for the exciter is something entirely different, too.

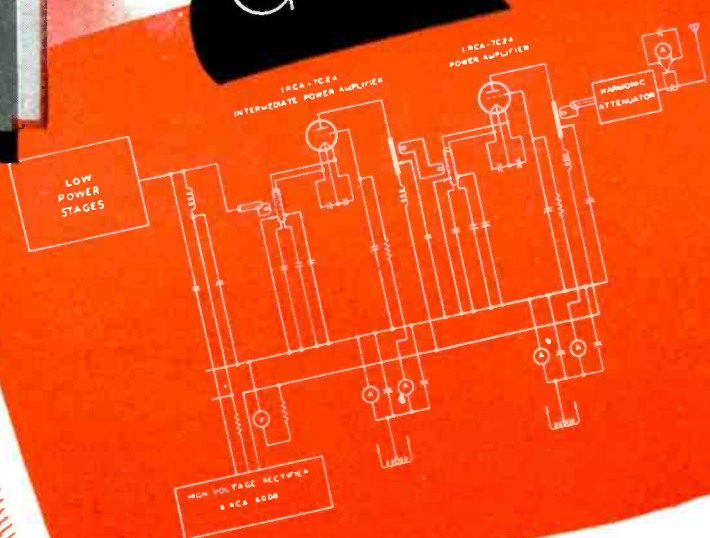



# —from MICROPHONE to ANTENNA

## NEW convenience, and NEW performance

THE NEW RCA equipment shown here is merely indicative of the advances that have been made by RCA in FM broadcast equipment. Similar improvements have been made on every item that goes into a completed broadcast station, including test and measuring equipment, monitoring assemblies, turntables, and recorders.

The resumption of broadcast-equipment construction, after wartime restrictions, offered us a unique opportunity to design an entirely new line—integrated in every detail. The various units incor-

porate all the latest FM improvements that have grown out of RCA's advanced war work on communications equipment for the armed forces.

If you are planning to build a new FM station, we believe that "RCA all the way" will help you to make it a *better* station. You will be assured of the same efficiency, convenience, operating economy, and performance that have made RCA's AM equipment the undisputed first choice of broadcast stations for the past decade. Radio Corporation of America, Camden, N. J.



### NEW RCA CONSOLETTA

(Type 76-B2)—Provides a complete high-fidelity audio system for FM, AM, and television at a price even the smallest station can afford.

Compact (39 by 17 by 10½ inches), it includes all the amplifying control and monitoring equipment needed to handle two studios, an announcement and a control-room microphone, two turntables, and six remote lines.

It enables simultaneous auditioning and broadcasting from any combination of the studios, turntables, or remote lines. The talk-back system is independent of program channel—no feed-back. Emergency amplifier and power supply circuits help prevent time off the air.

Differs from two previous RCA models now giving satisfactory service in more than 300 stations primarily in its frequency response—now extended to 15,000 cycles.



### NEW RCA SUPER TURNSTILE ANTENNA

The advantages of this antenna make up an impressive list. A few include: high-gain, permits the use of a lower transmitter power for a given coverage, full performance at any frequency from 88 to 108 mc, handles up to 20 kw, easy to install, wide band, pretuned at factory, no field adjustments whatever, a standardized low-cost "packaged" item—comes complete, de-icer units easily added, fewer end seals, entire structure can be grounded.

In addition, it has the usual advantages of any turnstile antenna: an inherently circular field pattern, low wind resistance, and simple, inexpensive, single-pole mounting.

The antenna, because of its relatively high gain and extended band width, is also ideal for television. Naturally, since it is of the turnstile type, both sound and picture transmitters can be fed into the same antenna.



**FM BROADCAST EQUIPMENT**

**RADIO CORPORATION of AMERICA**

**ENGINEERING PRODUCTS DIVISION, CAMDEN, N. J.**



# AGALLOY

## Tubing

You may be sure of  
proper surface condition  
**INSIDE** and **OUTSIDE**  
when you specify  
**AGALLOY**

Small accurately drawn  
tubing in

- MONEL metal
- INCONEL
- NICKEL
- 18-8 STAINLESS

Sizes up to and including  $\frac{5}{8}$ -inch out-  
side diameter. Welded or seamless  
construction.

Write for literature describing Agaloy's  
complete line of cold drawn Stainless,  
Carbon and Alloy tubing.



**AGALLOY TUBING COMPANY** • MILL: SPRINGFIELD, OHIO

EXECUTIVE AND SALES OFFICES: 1027 NEWARK AVE., ELIZABETH 3, N. J. • CHICAGO OFFICE: 221 NORTH LA SALLE ST., CHICAGO 1, ILLINOIS





# A New Jensen Coaxial

## TYPE H

### WITH *Compression-type* HIGH-FREQUENCY SPEAKER

The first of a new series of JENSEN Coaxial Speakers, combining in one coaxial assembly a horn-type high-frequency speaker with a cone-type low-frequency unit. By unique design, the cone of the low-frequency unit forms a part of the high-frequency horn, thereby dispensing with a separate horn. An integral two-channel network gives the desired crossover characteristics. Thus this new Coaxial Speaker provides the quality of reproduction so essential and desirable for radio receivers and phonographs for home entertainment, particularly for FM reception and high quality phonograph recordings.

The distribution characteristics of the Type H Coaxial are excellent and, when installed in a suitable enclosure such as a Bass Reflex cabinet, its performance covers the entire frequency range useful in home reproduction.\*

Type H Coaxial, illustrated here with field coil low-frequency speaker and *ALNICO 5* high-frequency unit, is designed for manufacturers. Other models for more general use, incorporating *ALNICO 5* design in both high-frequency and low-frequency units, will shortly be announced.

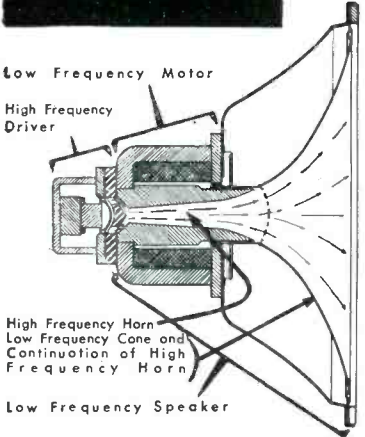
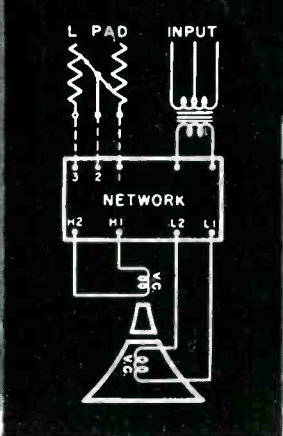

### TYPE H SPECIFICATIONS

Power rating 25 watts maximum, in speech and music systems. Input impedance 16 ohms. Field 14-20 watts. List price approximately \$100.00.

\*See No. 3 JENSEN Monograph: "Frequency Range in Music Reproduction," for discussion of useful frequency ranges.

### Other Coaxials Now Available!



These Type J Coaxials, improved over prewar design, offer low-cost Coaxial performance in home radio receiver and phonograph entertainment.

**JAP-60** (1.5-inch) with HF Control Switch. List price **\$79.45**

**JMP-52** (1.5-inch) with HF Control Switch. List price **\$56.15**

**JCP-40** (1.2-inch) HF Level Control extro. List price **\$33.45**

# Jensen

SPEAKERS WITH  
**ALNICO 5**

JENSEN RADIO MANUFACTURING COMPANY • 6607 S. LARAMIE AVE. • CHICAGO 38, ILLINOIS  
IN CANADA - COPPER WIRE PRODUCTS, LTD. • 137 OXFORD STREET, GUELPH, ONTARIO

*Specialists in Design and Manufacture of Fine Acoustic Equipment*



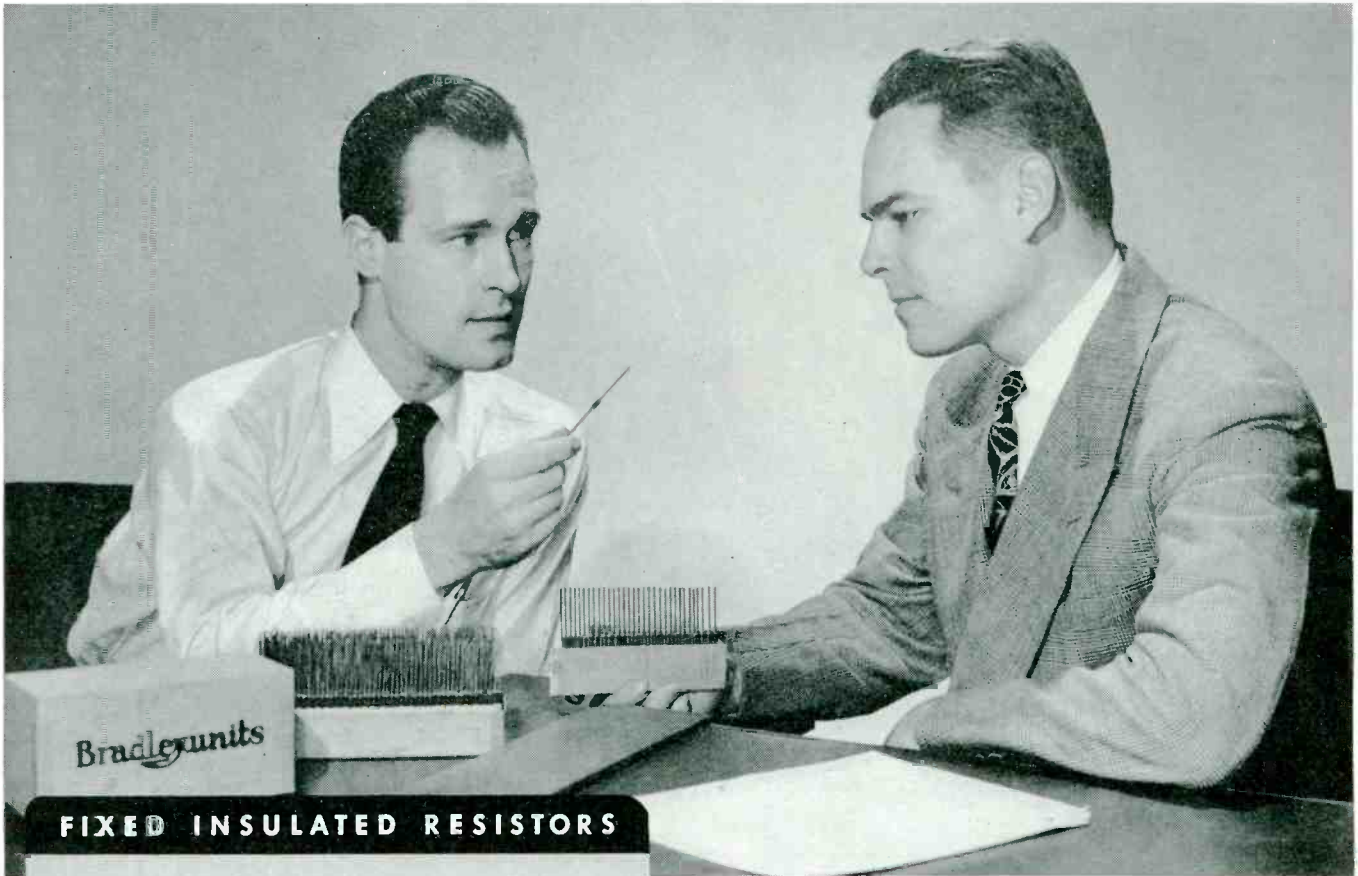

**FIXED INSULATED RESISTORS**

**½-WATT**

Length 3/8 in. Diam. 9/64 in.



**1-WATT**

Length 9/16 in. Diam. 7/32 in.



**2-WATT**

Length 11/16 in. Diam. 5/16 in.



Length of all leads—1 1/2 inches

**“A-B Fixed Resistors will not break down under the Cold Test”**

During wartime, a high official made this significant statement: “Allen-Bradley now is the only known source for a resistor that will not break down under the Cold Test requirements.”

War service, of course, called for top dependability in resistor performance. Hence, in every war zone, Allen-Bradley fixed and adjustable resistors were the choice of the men who required resistors that held up under all extremes of temperature, pressure, and humidity.

Allen-Bradley insulated fixed resistors are available in ½-watt, 1-watt, and 2-watt ratings with 1½-inch leads and tolerances of 5, 10, and 20 per cent. Specifications furnished on request.

Allen-Bradley Company  
110 W. Greenfield Ave., Milwaukee 4, Wis.



Type J Bradleyometers are furnished in single, dual, and triple construction, to be used as rheostats or potentiometers.



The molded resistor element has substantial thickness... approximately 1/32 inch. Any resistance-rotation curve is available.

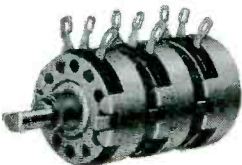

Bradleyometers have no rivets, no soldered or welded connections, and no conducting paints in the electrical circuits.

  
**ALLEN-BRADLEY**  
**FIXED & ADJUSTABLE RADIO RESISTORS**  
 QUALITY

**avoid damage  
from "in-the-package"  
moisture**



**SHIPPERS!** Your product can be seriously damaged by rust, corrosion, or mildew . . . because of "in-the-package" moisture. Avoid such damage. Include Jay Cee Silica Gel, the ideal drying agent, in the packages with your product.

Your container may be sealed "tight as a drum" against outside moisture. Yet, the vapor within can cause untold harm. Particularly, a slight drop in temperature can release dangerous moisture.

Jay Cee Silica Gel keeps the air in the package dry . . . adsorbs the vapor . . . prevents moisture damage. Jay Cee Silica Gel is a crystalline substance resembling rock salt in general appearance . . . chemically inert. Has amazing power to take up moisture without its particles changing in size or shape. Packed in 1, 2, 4, 8 oz. and 1 and 5 lb. bags. Used widely with shipments of metal parts, precision instruments, electronic equipment, dehydrated foods, fabrics, and chemicals.

**no rust  
no corrosion  
in this container**

The illustration shows Mr. Otto Mueller, packaging foreman, inspecting one of his Ampro Sound-On-Film Projectors sealed tightly within a representative moisture vapor-proof barrier, ready to be placed in a shipping carton. Packed within the barrier, with the Projector, are three small bags of Jay Cee Silica Gel . . . which adsorb "in-the-package" moisture and prevent damage from rust or corrosion.

(Cellophane packaging was used in this illustration as a substitute for the actual wrapping).



**SILICA GEL**

**JOLIET CHEMICALS, LTD.**  
106 INDUSTRY AVENUE  
JOLIET, ILLINOIS



# MICA CERAMIC INSULATION

*Molded* TO YOUR SPECIFICATIONS

**MYKROY**  
PERFECTED MICA CERAMIC INSULATION

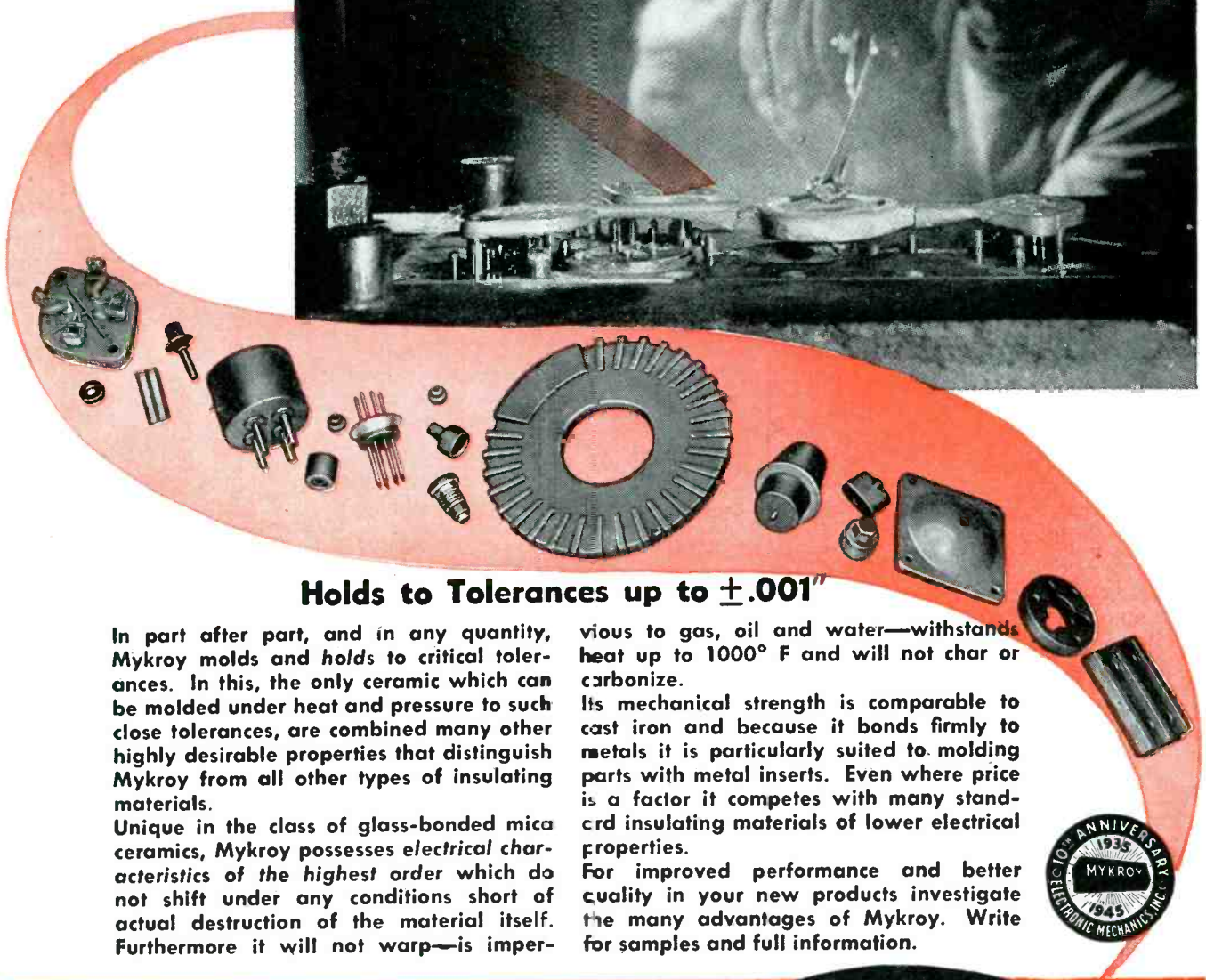

## Holds to Tolerances up to $\pm .001$ "

In part after part, and in any quantity, Mykroy molds and holds to critical tolerances. In this, the only ceramic which can be molded under heat and pressure to such close tolerances, are combined many other highly desirable properties that distinguish Mykroy from all other types of insulating materials.

Unique in the class of glass-bonded mica ceramics, Mykroy possesses electrical characteristics of the highest order which do not shift under any conditions short of actual destruction of the material itself. Furthermore it will not warp—is imper-

vicious to gas, oil and water—withstands heat up to 1000° F and will not char or carbonize.

Its mechanical strength is comparable to cast iron and because it bonds firmly to metals it is particularly suited to molding parts with metal inserts. Even where price is a factor it competes with many standard insulating materials of lower electrical properties.

For improved performance and better quality in your new products investigate the many advantages of Mykroy. Write for samples and full information.



MADE EXCLUSIVELY BY

**ELECTRONIC MECHANICS**  
INC.

70 CLIFTON BLVD., CLIFTON, N. J.  
CHICAGO 47; 1917 N. Springfield Ave., Tel. Albany 4310  
EXPORT OFFICE: 89 Broad Street, New York 4, New York

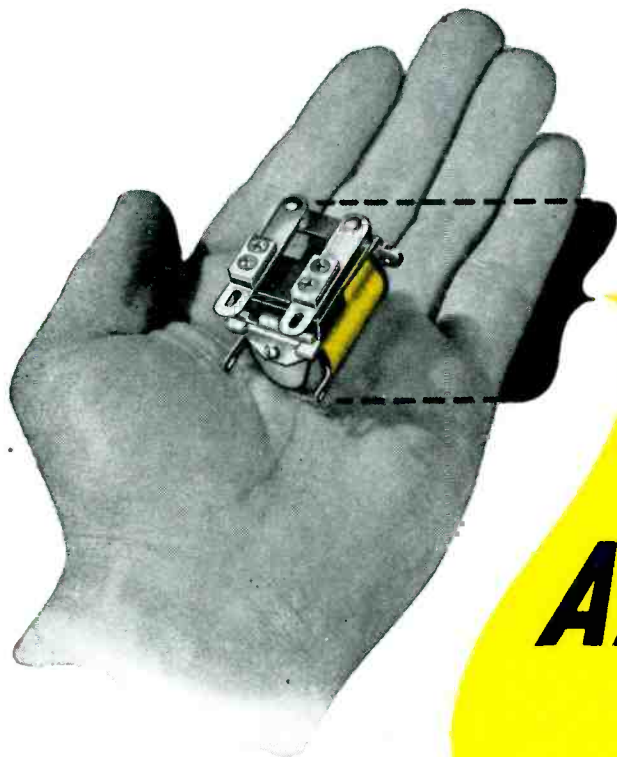

The "CR" relay illustrated is a single pole normally open double break arrangement. Standard insulation is molded bakelite. Contacts are silver, although alloy contacts can be supplied. Contact rating with  $\frac{1}{4}$ " silver is 15 amperes at 24 volts D. C. or 110 volts A. C. Non-inductive. The arrangement shown is  $1\frac{33}{64}$ " high;  $1\frac{3}{32}$ " wide and  $1\frac{25}{32}$ " long. Weight 3 ounces.

*Save Space  
in your controls!*

*use*

**Allied's "CR"**  
**Relays**

Remarkably small for a power relay the "CR" developed by Allied will enable you to materially reduce the size and weight of your electronic controls.

Having large contacts and heavy gram pressure the "CR" performs switching operations which usually require considerably larger relays. Highly adaptable the "CR" has two, three and four pole variations. Conveniently located contact and coil terminals permit speedy and simple assembly of the relay into your unit. For severe dust and dirt conditions the "CR" can be hermetically sealed with the handy plug-in base or with solder terminals.

The "CR" is but one of many types of relays produced by Allied to the high quality standards demanded by your product. Several modern, strategically located plants are available to furnish your immediate requirements. A check with Allied engineers will help you in the selection of the correct relay for your control. Write today.

## **ALLIED CONTROL COMPANY, INC.**

GENERAL OFFICES: 2 East End Ave. (at 79th St.) New York 21, N. Y.  
Factories: New York City (2 East End Ave.)—Plantsville, Conn. Chicago—4321 N. Knox Avenue, Chicago 41, Illinois. In California: Allied Control Co. of California, Inc., 1633 South Hope St., Los Angeles 15, Calif.



### **Allied Relay Types**

Power, Sensitive, Telephone,  
Differential and others.

Also—Solenoids and Electro-  
magnetic devices.

AC-1



✓✓✓✓ from **START to FINISH** insures **AEROVOX**  
**PAPER-CAPACITOR** *Craftsmanship*

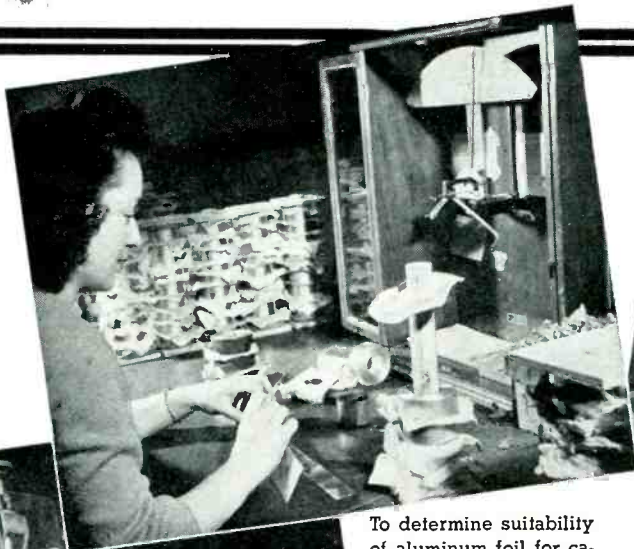

To determine suitability of aluminum foil for capacitor use, every lot is tested for thickness, unit weight and electro-chemical characteristics.

Uncased paper sections are checked prior to impregnation. Completed units are tested for capacitance, power factor, insulation resistance, terminal-to-terminal and terminal-to-can, as well as for dielectric strength and tightness of seal.

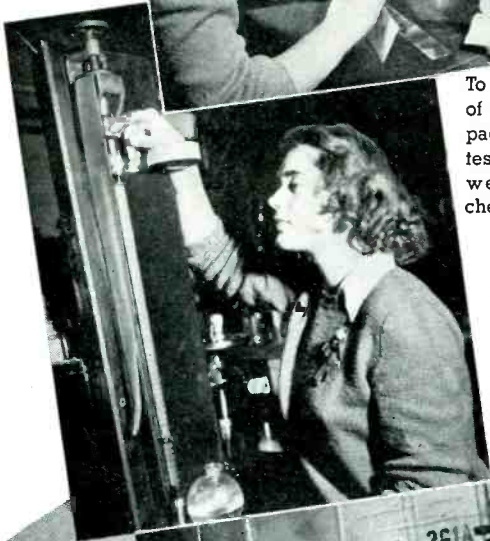

The porosity of paper dielectric is important. This porosity test is made on each roll of paper.

● A paper capacitor can be no better than its several layers of paper dielectric, the quality of the impregnant, and the thoroughness of the impregnation and sealing.

That is why there are so many routine check-ups in Aerovox paper capacitor production. Paper tissues, metal foils, oils and sealing compounds, are critically checked. Sections are checked before impregnation and casing. Completed units are subjected to a final check-up and inspection.

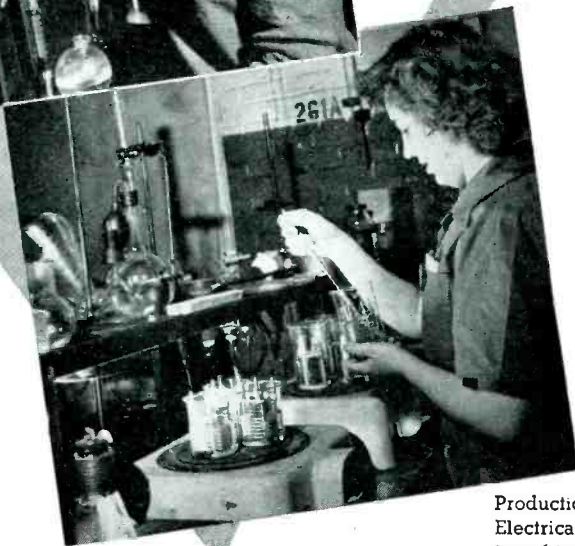

"Individually-tested" is no idle boast as applied to Aerovox capacitors. It means precisely what it says. And to the capacitor user, it is a guarantee of dependable and long-lasting and economical service for the smallest and cheapest quite as well as the largest and costliest of types that bear the Aerovox label.

● Write for engineering literature. Submit your capacitance problems.

Production control of impregnating materials. Electrical test is preceded by careful checking of temperature of oils.



**FOR RADIO-ELECTRONIC AND INDUSTRIAL APPLICATIONS**

AEROVOX CORPORATION, NEW BEDFORD, MASS., U.S.A.

SALES OFFICES IN ALL PRINCIPAL CITIES • Export: 13 E. 40th St., NEW YORK 16, N. Y.

Cable: 'ARLAB' • In Canada: AEROVOX CANADA LTD., HAMILTON, ONT.



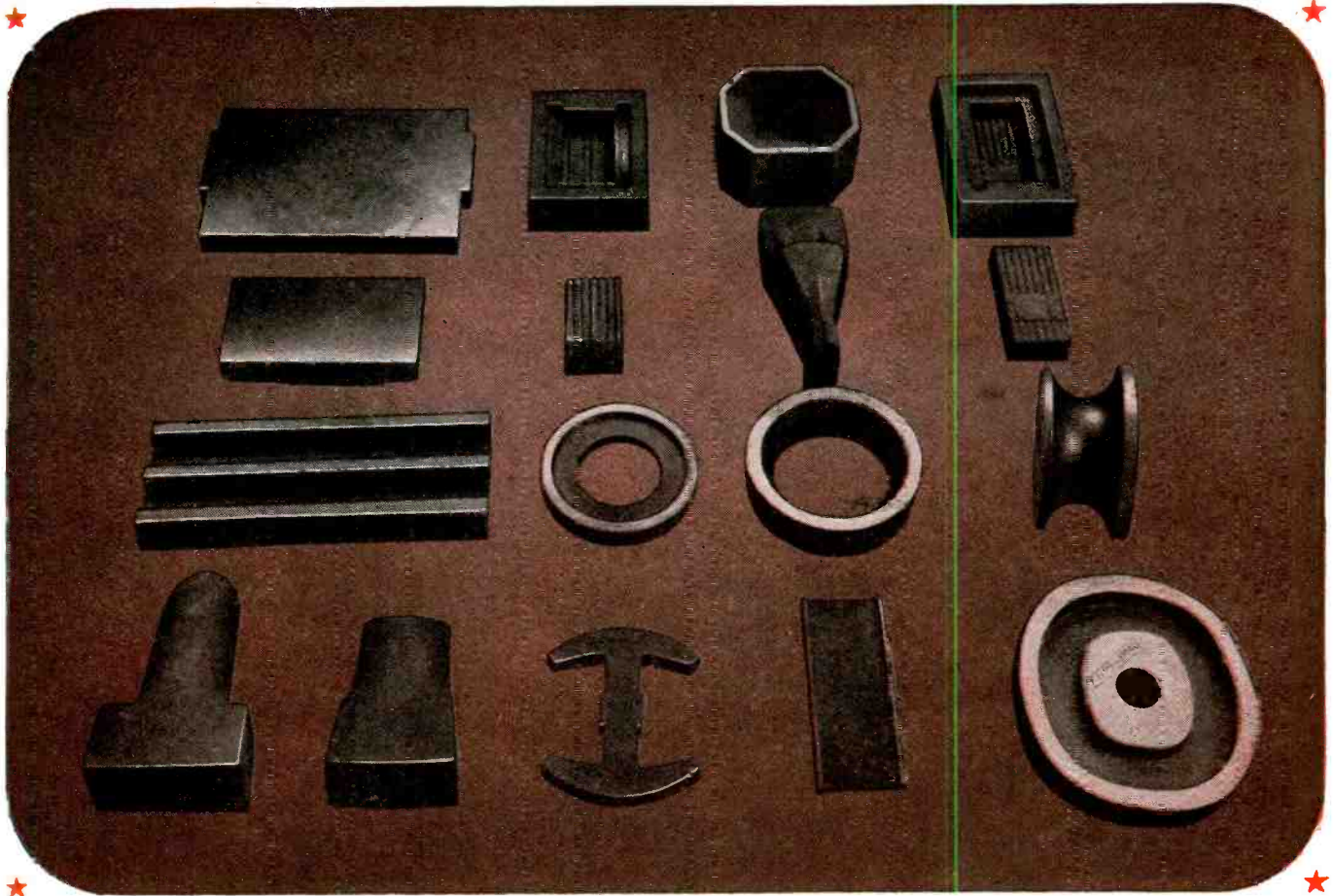

## START WITH YOUR JOB

# *Half Finished*

WRITE  
FOR THIS  
BOOKLET



It contains details of FCC Tool Steels *Cast-To-Shape* and of other important Forging and Casting Division specialties that may offer you money-saving production ideas. Get your copy—write for it today.

ADDRESS DEPT. . . . E-37

WHEN it's dies you're making—small or large—or various other forming tools or gages or certain fast-wearing parts of machines, FCC Tool Steel *Cast-To-Shape* can really save you money.

Very intricate shapes can now be cast in one piece within an eighth-inch of finished size. This means that you pay for less steel to begin with, and reduce machining time substantially.

Air Hardening, Oil Hardening and special Hot Work Tool Steels of various grades—each a thoroughly dependable performer in

its class—are promptly available in this modern, economical form.

Any Allegheny Ludlum branch office can give you full particulars, or write for data.



# ALLEGHENY LUDLUM

## STEEL CORPORATION

*Forging and Casting Division*  
DETROIT 20, MICHIGAN



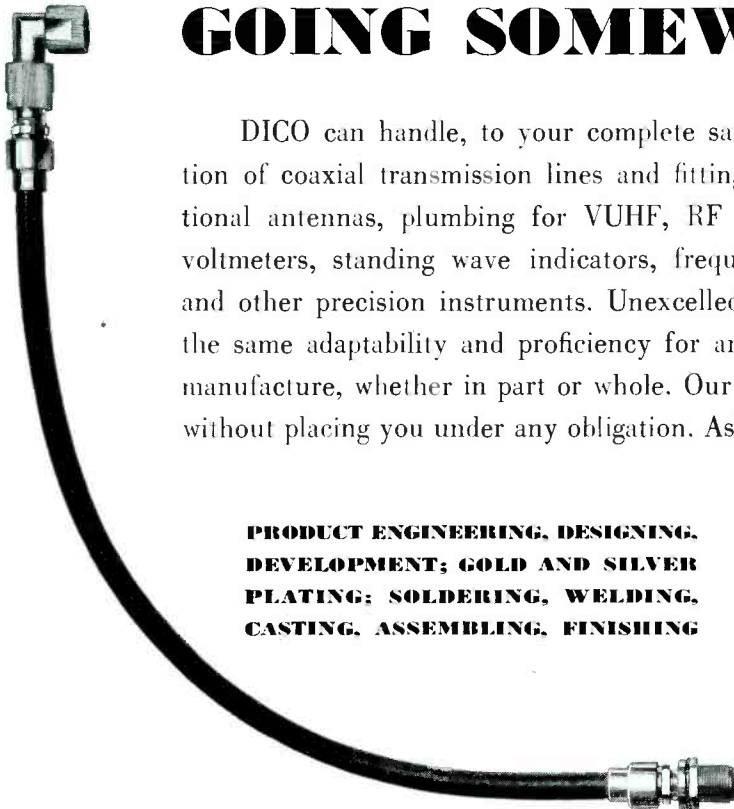
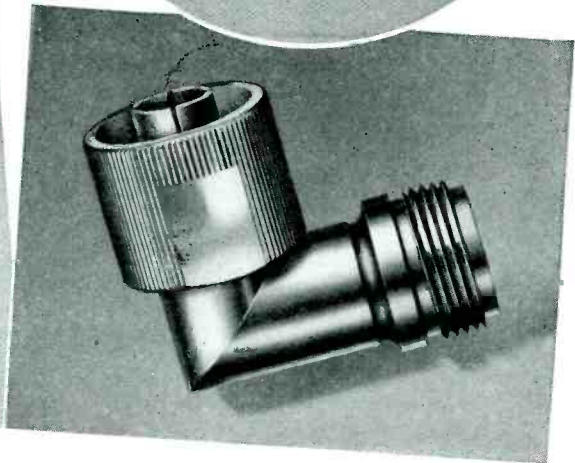
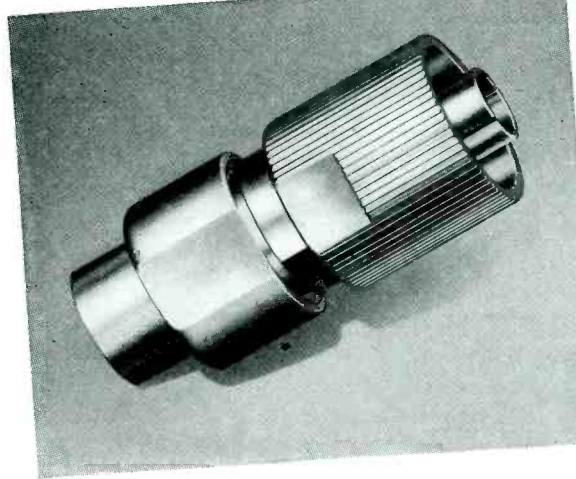
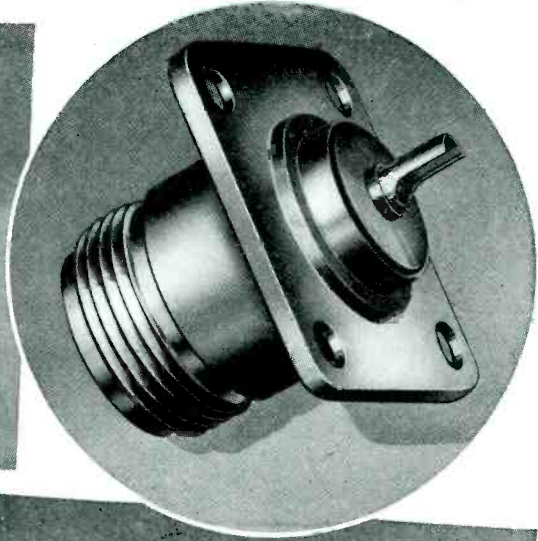
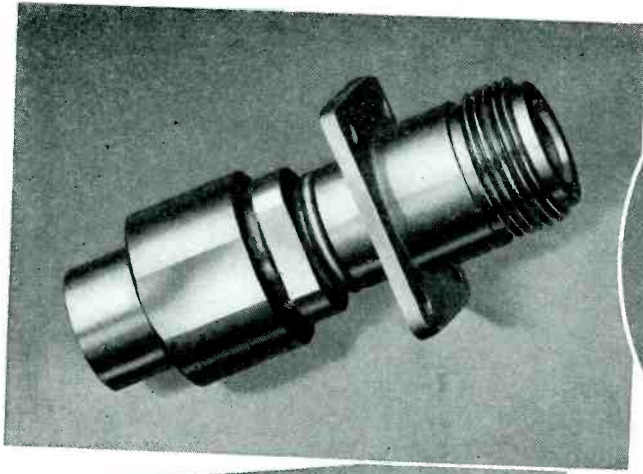

## GOING SOMEWHERE?

DICO can handle, to your complete satisfaction, the development and production of coaxial transmission lines and fittings, wave guides, dipole antennas, directional antennas, plumbing for VUHF, RF cable assemblies, slotted lines, probes, voltmeters, standing wave indicators, frequency measuring devices, wave meters, and other precision instruments. Unexcelled for its exactness, DICO can also offer the same adaptability and proficiency for any comparable type of development and manufacture, whether in part or whole. Our representative will call for consultation, without placing you under any obligation. Ask now.

**PRODUCT ENGINEERING, DESIGNING,  
DEVELOPMENT; GOLD AND SILVER  
PLATING; SOLDERING, WELDING,  
CASTING, ASSEMBLING, FINISHING**





### OUT GOES SPOILAGE!

Hamstrung by work-spoiling driver skids while he used slotted screws, a certain radio cabinet manufacturer made a complete switch-over to Phillips Recessed Head Screws. Result: production shot up like a rocket!

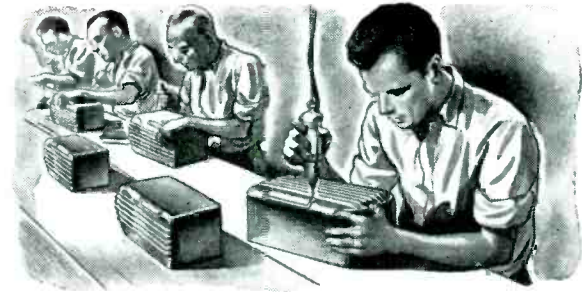

### DOWN GO COSTS!

With this upward swing in production, there was a consequent downward swing in costs. A downswing that was helped along plenty by the fact that Phillips Screws drive up to 50 percent faster!

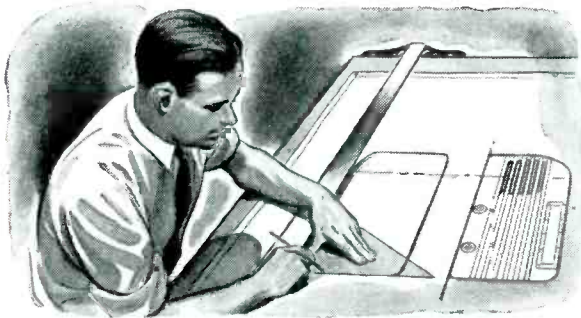

### UP GOES STRENGTH!

On production . . . on costs . . . yes, also on design, . . . use of Phillips Screws makes a big difference. Engineered for heaviest driving pressures, they help designers plan exceptional strength and rigidity into products!



### AWAY GOES SALES RESISTANCE!

Saleswise, too, use of Phillips Screws pays off. They not only add to a product's strength, smartness, and general good looks. They also banish burrs that snag clothes and sidetrack sales!

# It's Phillips <sup>the</sup> the engineered recess!

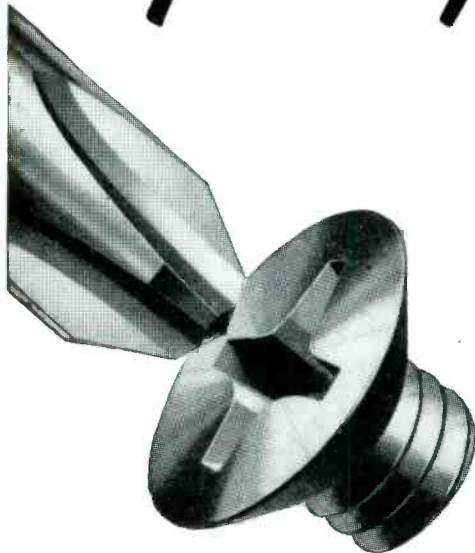

In the Phillips Recess, mechanical principles are so correctly applied that every angle, plane, and dimension contributes fully to screw-driving efficiency.

. . . It's the exact pitch of the angles that eliminates driver skids.

. . . It's the engineered design of the 16 planes that makes it easy to apply full turning power - without reaming.

. . . It's the "just-right" depth of recess that enables Phillips Screw Heads to take heaviest driving pressures.

With such precise engineering, is it any wonder that Phillips Screws speed driving as much as 50% - cut costs correspondingly?

To give workers a chance to do their best, give them faster, easier-driving Phillips Recessed Head Screws. Plan Phillips Screws into your product now.

## PHILLIPS <sup>Recessed Head</sup> SCREWS

WOOD SCREWS • MACHINE SCREWS • SELF-TAPPING SCREWS • STOVE BOLTS

Made in all sizes, types and head styles

**25 SOURCES**

American Screw Co., Providence, R. I.  
Atlantic Screw Works, Hartford, Conn.  
The Bristol Co., Waterbury, Conn.  
Central Screw Co., Chicago, Ill.  
Chandler Products Corp., Cleveland, Ohio  
Continental Screw Co., New Bedford, Mass.  
The Corbin Screw Corp., New Britain, Conn.  
General Screw Mfg. Co., Chicago, Ill.

The H. M. Harper Co., Chicago, Ill.  
International Screw Co., Detroit, Mich.  
The Lamson & Sessions Co., Cleveland, Ohio  
Manufacturers Screw Products, Chicago, Ill.  
Milford Rivet and Machine Co., Milford, Conn.  
The National Screw & Mfg. Co., Cleveland, Ohio  
New England Screw Co., Keene, N. H.  
Parker-Kalon Corp., New York, N. Y.  
Pawtucket Screw Co., Pawtucket, R. I.

Pheoll Manufacturing Co., Chicago, Ill.  
Reading Screw Co., Norristown, Pa.  
Russell Burdall & Ward Bolt & Nut Co., Port Chester, N. Y.  
Seovill Manufacturing Co., Waterville, Conn.  
Shakeproof Inc., Chicago, Ill.  
The Southington Hardware Mfg. Co., Southington, Conn.  
The Steel Company of Canada Ltd., Hamilton, Canada  
Wolverine Bolt Co., Detroit, Mich.





# WILCO TUNGSTEN Contacts

To manufacturers of medium or high speed make-and-break mechanisms, Tungsten offers the highest melting point of any contact metal, plus high density, low vapor pressure at elevated temperatures, good hardness, strength, resistance to oxidation, and arc-resisting properties. The superfine quality of WILCO Tungsten Contacts assures maximum longevity in service. Other Wilco Powder Metal Contacts include Tungsten Alloys, also Silver Molybdenum, Silver Tungsten, Silver Cadmium Oxide and Silver Tungsten Carbide.

**CONSULT OUR ENGINEERING DEPARTMENT**—The precision performance of WILCO Electrical Contacts in planes, ships, tanks and instruments presage their widespread usefulness for postwar manufacturing customers. A representative of the WILCO Sales and Engineering Department will gladly help develop the proper application of WILCO materials to your products.

**SEND FOR WILCO BLUE BOOK**—Send for FREE copy of the WILCO Blue Book. It contains charts, formulae, and full descriptions of WILCO Electrical Contacts, and other WILCO products.

#### WILCO PRODUCTS INCLUDE:

##### CONTACTS—

Silver  
Platinum  
Tungsten  
Alloys  
Sintered Powder Metal

##### THERMOSTATIC BIMETAL—

High and Low Temperature  
with new high temperature  
deflection rates

##### PRECIOUS METAL COLLECTOR RINGS—

For rotating controls

##### SILVER CLAD STEEL

##### JACKETED WIRE—

Silver on Steel, Copper,  
Invar or other combinations  
requested

##### ROLLED GOLD PLATE

##### SPECIAL MATERIALS

## THE H. A. WILSON COMPANY



105 Chestnut Street, Newark 5, N. J.

Branch Offices: Chicago • Detroit • Los Angeles

SPECIALISTS FOR 30 YEARS IN THE MANUFACTURE OF THERMO-METALS • ELECTRICAL CONTACTS • PRECIOUS METAL BIMETALLIC PRODUCTS

# El-Menco

CAPACITORS

*Trouble free*

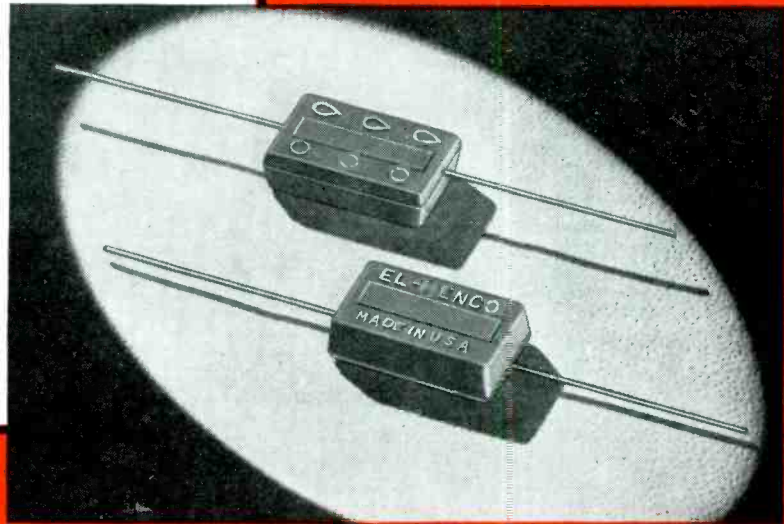
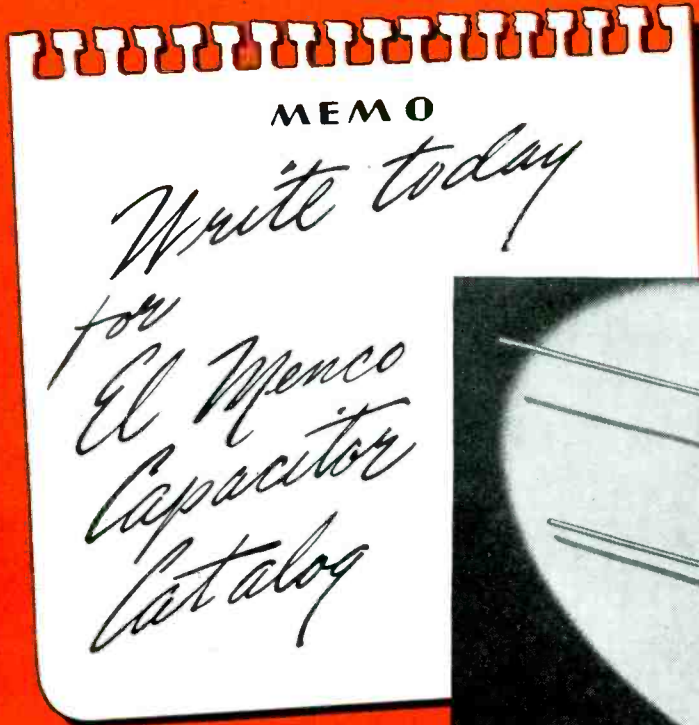

El Menco Capacitors — molded mica and mica trimmer — proved their absolute dependability in helping to maintain vital communications systems in all theatres of war all through the war. Electronics equipment manufacturers may install these truly tested products, confident that they will serve their special purpose long and well.

ELECTRO MOTIVE MFG. CO.  
WILLIMANTIC CONNECTICUT



MOLDED MICA

# El-Menco

CAPACITORS

MICA TRIMMER



**USE STANDARD PARTS—SAVE TIME AND MONEY**

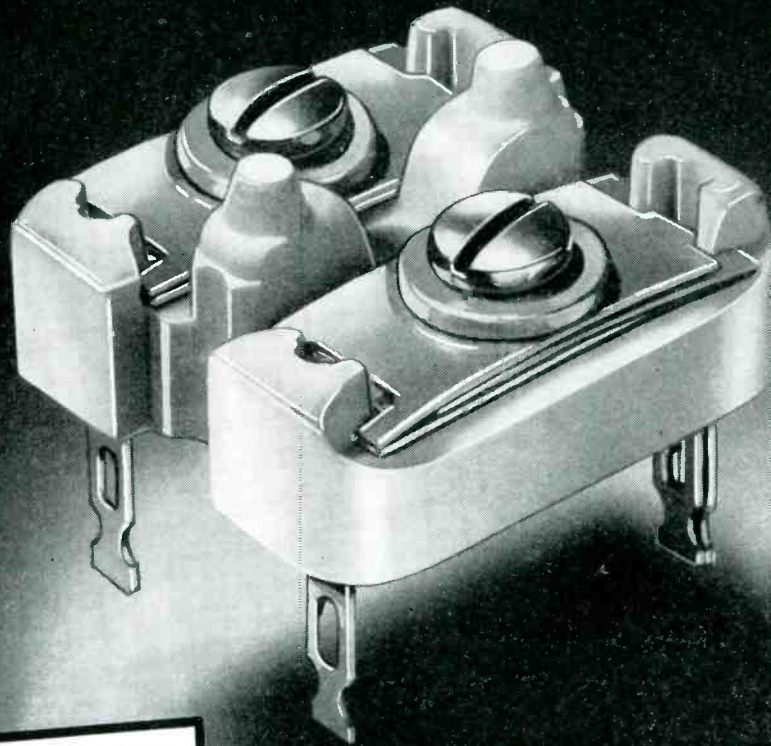

**SAVE**

*For many years  
Automatic has manufactured  
Coils and Trimmers for manufacturers.*

*Our mass-production methods  
will save you money and headaches.*

*Order your Coils and Trimmers from  
people who "know how".*



**AUTOMATIC**  
**MANUFACTURING**  
CORPORATION

**MASS PRODUCTION COILS & MICA TRIMMER CONDENSERS**

900 PASSAIC AVE.

EAST NEWARK, N. J.



# Turner Microphones

**W**HATEVER the need for a microphone in electronic recording, P.A., sound system, and commercial or amateur broadcast work, you can assure maximum performance when you Team Up with TURNER. Precision engineered to deliver smooth, accurate reproduction of any desired sound without harmonics or distortions . . . ruggedly built to withstand severe service conditions of shock, vibration, heat, cold, humidity and altitude. TURNER Microphones are CERTIFIED to help you select the right unit for your particular job.

Before leaving the factory, each and every TURNER Microphone is given an individual sound pressure test over the entire audio band. Its performance characteristics are checked and CERTIFIED to conform with established specification standards.

Whether you need a unit with "Weighted Response" to accent intelligible speech frequencies or a unit with an even response for general purpose use, you can depend on TURNER for accurate pick-up and clear, sharp reproduction.

Write for Free Illustrated Catalog describing TURNER Microphones for both specific and general applications. Turner Engineers will be glad to offer impartial suggestions in helping you choose the right unit for your purpose.

*Certified Performance*

## The TURNER Company

905 17th Street, N.E., Cedar Rapids, Iowa

Licensed under U.S. Patents of the American Telephone & Telegraph Company and Western Electric Company, Incorporated.  
Crystals licensed under patents of the Brush Development Company

**TURNER** Pioneers in the  
Communications Field



TURNER No. 99



TURNER Hen-D



TURNER No. 33



TURNER No. 211



TURNER No. L-40







## ... but what about television in 1950?

This advertisement is addressed to those receiving set manufacturers who are planning beyond the gadget phase in television . . . who are not being stampeded by the public clamor for low priced "wonder" sets . . . nor skimping on the essentials of good performance.

We would like to collaborate with such manufacturers by supplying them with the kind of television optical systems that will insure lasting acceptance for their products.

All through the war we have specialized in electronic optics. The Navy looked to us as its main source of supply for cathode ray tube face plates. Many other optical components for wartime electronic applications went through our plant in great quantities.

Long before V-J Day, we started to develop television optics. Many of the largest television set manufacturers are consulting us about the development of better optical systems.

Our compact group of precision optical specialists is trained to cooperate with other manufacturers. We make no complete products but concentrate on the production of optical components for others. Our plant is equipped with modern machinery to produce precision optical components in quantity at mass production prices.

Send for our new booklet, "Precision Optics by American Methods." Consult us now, if you need optics in quantity at interesting prices.

for precision OPTICS come to

### AMERICAN LENS COMPANY, INC.

45 Lispenard Street, New York 13, N. Y.



L E N S E S . . . P R I S M S . . . F L A T S . . . R E F L E C T O R S

*“This Structure  
is a  
Monument to Quality”*



**SUPERIOR** announces completion of the building in which will be installed the equipment especially designed for the production of nickel tubing for the Electronics Industry.

Certain operations in the new plant are scheduled to begin in December with full production by late January, or early February.

The ground floor of the structure is approximately 18,000 square feet; the manufacturing floor 30,000 square feet.

At the time of the ground-breaking exercises, May 24, 1945—HENRY F. GASTON, OF THE RADIO AND RADAR DIVISION OF THE WAR PRODUCTION BOARD SAID:

*“THIS STRUCTURE IS A MONUMENT TO QUALITY.”*

The building will house the company's entire Electronics staff—engineering, production, and sales.

S. L. Gabel says, “The management of Superior Tube Company looks upon this plant as its greatest effort with better materials for this growing industry.”

**SUPERIOR TUBE COMPANY**  
NORRISTOWN • PENNSYLVANIA





**four  
ways**  
to simplify  
core mounting  
with  
**hipersil  
cores**



Type "C" HIPERSIL Cores are wound and shaped from a continuous strip of steel, solidly bonded and then cut into two segments. Core can thus be quickly assembled on coils and entire assembly, including mounting bracket, banded together with steel banding strap.

\*Registered Trade Mark

Cumbersome castings . . . time-consuming assembly operations . . . are made unnecessary with HIPERSIL\* Cores for electronic transformer components.

Simple stampings form adequate bases—metal banding straps, speedily and easily applied, eliminate need for assembly bolts and bind the core, coil and base together in a single operation. Four typical examples of the simple assemblies thus made possible, three of which have eliminated the use of assembly bolts, are shown above. Savings in materials, time and space over conventional assembly methods are obvious.

These advantages are just a few that HIPERSIL Type "C" Cores provide. Up to 1/3 greater flux-carrying capacity reduces the weight and size of the transformer itself . . . makes possible smaller, lighter, more compact equipment. These factors result in further manufacturing economies that merit your evaluation on new designs.

Most important, HIPERSIL Cores are immediately available in a complete range of sizes. See your Westinghouse representative today or write Westinghouse Electric Corporation, P.O. Box 868, Pittsburgh 30, Pennsylvania. J-70464

AVAILABLE IN THESE GRADES		
Grade	Lamination Thickness	Space Factor
C-97	29 Gauge	95%
C-95	5 Mil	90%
C-98	3 Mil	89%
C-91	2 Mil	89%
C-90	1 Mil	88%

**Westinghouse**  
PLANTS IN 25 CITIES . . . OFFICES EVERYWHERE



**HIPERSIL CORES**

# INCENTIVES FURNISH THE DRIVE

**T**HE COMING YEAR, 1946, and the years to follow can bring unprecedented prosperity to the people of the United States if the incentives to secure it are provided.

We have the advantage of starting with an economy which has demonstrated a capacity for expansion unequalled in any other country in the world. Our economy has demonstrated, also, one grave weakness—a recurring interruption of the upward trend of production and living standards by wasteful and paralyzing periods of recession. Recovery from each depression always has carried us to new heights of economic welfare, but the toll of the years of blight has been harmful to everyone.

The job ahead of us is a dual one. We must maintain the vitality of an economy which, over the years, has yielded an enormous increase in the American standard of living, and we also must improve its stability.

## The Dynamics of American Production

In the last prewar year, 1940, the population of the United States was  $3\frac{1}{2}$  times as large as it was in 1870. But the national production, measured in dollars of constant purchasing power, was 10 times as large at the end of the period, and industrial output had increased 20-fold.

In the meantime, the average number of hours of factory workers had been reduced from about 63 per week in 1870 to less than 40 in 1940, while average hourly earnings had more than trebled in dollars of constant purchasing power. Thus "real" weekly or annual wages in manufacturing had doubled over the 70-year period, even though the work-week was cut by 35 per cent. This was made possible chiefly by a tremendous increase in the quantity and quality of the mechanical facilities which were provided in American manufacturing industry. Manufacturing capital investment per worker was multiplied by 6 times over the period in question. But the

return per dollar invested, while it has fluctuated widely between good years and bad, showed no general upward trend over that portion of the period for which measurement is practicable.

## Incentives in American Manufacturing

There has been, historically, a remarkably consistent pattern in the division of the realized income from the expanding manufacturing output of America. Reliable statistics are not available for as far back as 1870, but from 1899 through 1939 the average share of wages and salaries has been  $82\frac{1}{2}$  per cent against  $17\frac{1}{2}$  per cent as the share to investors (including dividends, interest, rents, royalties, and non-corporate profits). There have been, from year to year, relatively minor divergences from this pattern of distribution, but there is no discernible trend during the period away from the averages cited.

It is suggested that the persistence of the average  $17\frac{1}{2}$  per cent share of realized income from manufacturing that was maintained for the 40 years preceding World War II may represent the proportion that is needed to produce the dividends, interest, rents, royalties, and non-corporate return that will provide for the continuing investment upon which an expanding productivity such as we have had in the past depends. At any rate, it would seem reckless to depart too radically from such an established pattern at a time when unprecedentedly large private capital investment is counted on to make up for the drastic curtailment of such investment during the war years, and to carry us to the new high levels of civilian production set as our postwar goals.

## The Distribution of Manufacturing Income in War

At the beginning of the war, the Government adopted controls and a tax program designed to prevent wartime activity from resulting in un-



duly swollen private returns. Due primarily to huge volumes, the profits *before* taxes of manufacturing industry were very high, but throughout the war its profits *after* taxes averaged returns no larger than they had been in good prewar years. Relative to volume, they were considerably lower than in prosperous years in the past. Again, there can be no complaint at results that generally were in accord with a national wartime policy.

But it is fair to note that the wages of manufacturing labor were allowed to increase substantially during the war. Between January 1, 1941 and April, 1945, average weekly earnings per worker increased by 77 per cent. This was, in considerable part, a result of increased working hours and a shift from low- to high-paid industries, but straight-time hourly earnings on the same jobs increased about 40 per cent against a cost-of-living rise of about 30 per cent.

The net result was to alter drastically the 40-year relationship of the 17½-82½ per cent division of Realized Income from Manufacturing. The share of wages and salaries increased to over 90 per cent, and the investment share shrunk to less than 10 per cent.

#### Its Postwar Distribution

This wartime shift in the proportion of distributive shares has an important bearing upon current wage controversies. With union demands for wage increases ranging up to 30 per cent, and the economists of the Office of War Mobilization and Reconversion asserting that an average increase of 24 per cent is feasible without raising prices, it is pertinent to inquire how such increases would affect the prewar ratios that governed realized income distribution in manufacturing.

Forecasting is always hazardous, but if we assume (1) that in 1946 we shall reach the \$160 billion level of national output which the Government proponents of general wage increases expect, and (2) that there will be little increase in productivity because of the continuing process of reconversion, and (3) that the Government will succeed in carrying its announced purpose

to maintain present price ceilings, it appears that a 24 per cent general wage increase would reduce the share going to capital from 17½ per cent to 11 per cent even allowing for its increased return resulting from the repeal of the excess profits tax. The prewar ratios would be about maintained if wages remained at present levels.

#### Conclusion

Since the maintenance of these prewar ratios was accompanied by an unparalleled rise in the "real wage" of American workers, there is a powerful *prima facie* case for not tinkering with them. It should be noted, however, that some economists think that the size of the investment share of manufacturing income tends to provide more capital than can be absorbed by a mature economy, and thus contributes to those breaks in the expansion of the economy which, as stated at the outset, have been its principal blight.

Regardless of what may ultimately prove to be the validity of this view, no one can responsibly contend that at this early but crucial stage in the reconversion process is the time to test it. Now, no one knows whether, or what dimension of, additional wage increases can be supported without forcing up prices or reducing profits to a point that will discourage vitally needed private capital investment.

We want high and increasing wages in American manufacturing. We need them to provide an active incentive to workers to support expanding productivity, as well as to continue the trend of rising living standards in America. Equally, we need a continuing profit incentive of sufficient attractiveness to call forth the new investment upon which expanding productivity depends.

We can never attain our dual objective if we push one of these aims so far and so fast that it defeats the other.

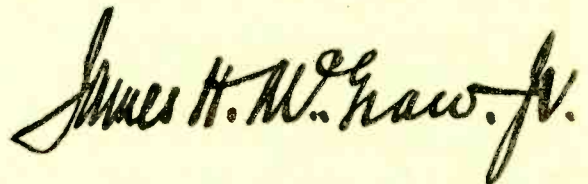

President, McGraw-Hill Publishing Co., Inc.

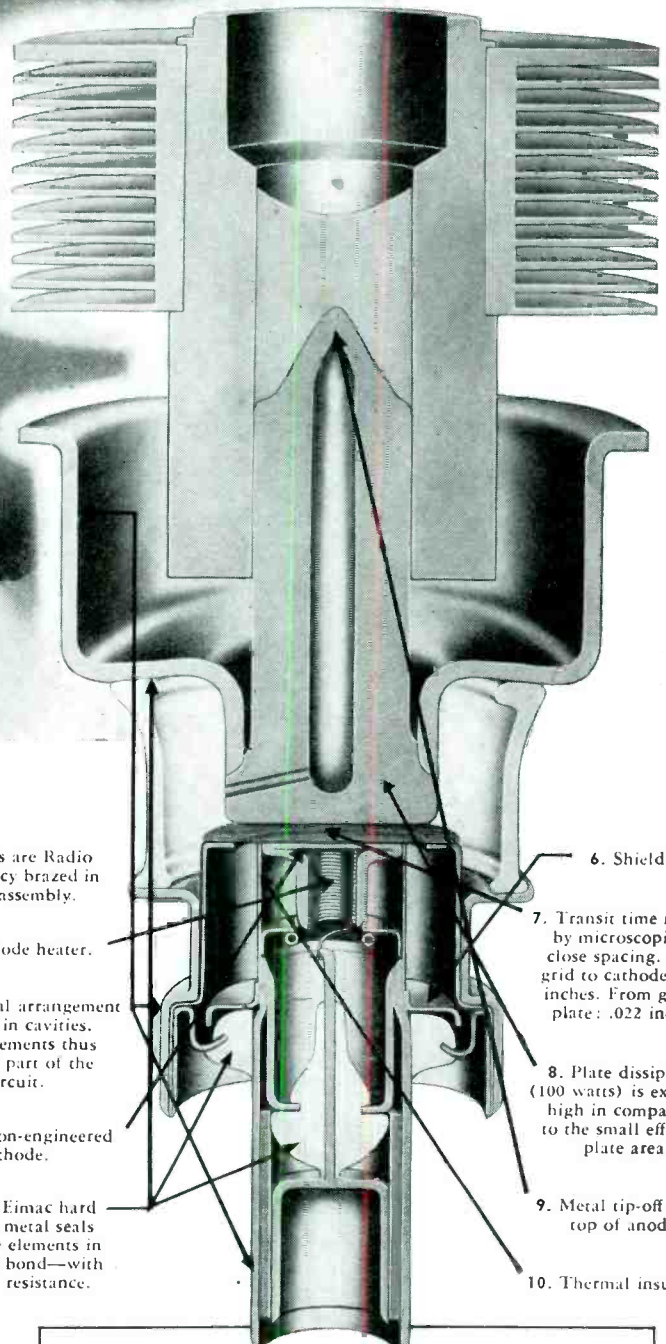
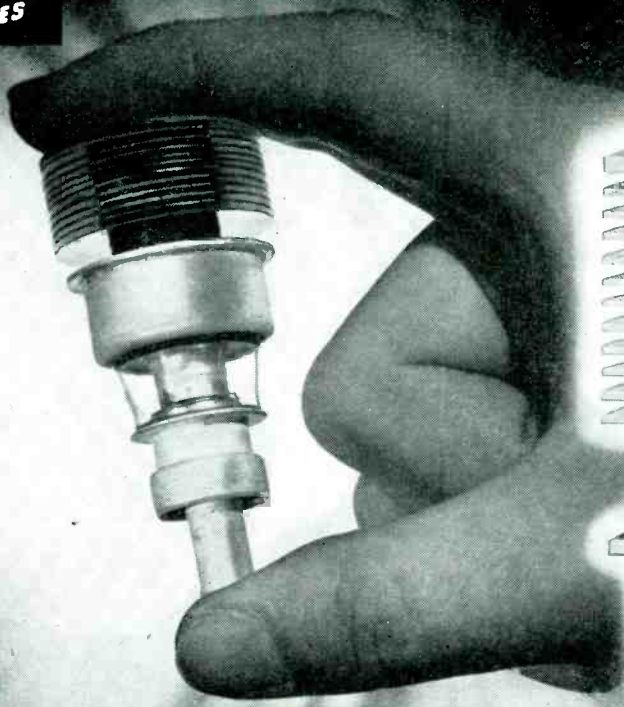

**PRECISION ENGINEERING  
ON A MASS PRODUCTION SCALE**

... that's the basic achievement of Eimac engineers in providing typically outstanding Eimac performance in these tiny triodes. Observe the many functions of the Eimac developed 3X100A11/2C39 triode—cross section view. Note actual size shown in photo above.

Designed for special military purposes—these tiny triodes will find valuable application in commercial fields. An indication of their high efficiency is their ability to operate on frequencies up to 2500 megacycles and their high plate dissipation (100 watts) despite the extremely small effective plate area—about the size of a dime.

By developing and improving the performance of this tiny triode Eimac has again demonstrated an extraordinary ability to accomplish outstanding results in Electronic vacuum tube engineering—an ability which has established Eimac as first choice of leading Electronics engineers throughout the world.

1148

- 1. Parts are Radio Frequency brazed in final assembly.
- 2. Cathode heater.
- 3. Terminal arrangement for use in cavities. Tube elements thus become part of the circuit.
- 4. Precision-engineered cathode.
- 5. New Eimac hard glass to metal seals join tube elements in a rugged bond—with low RF resistance.

- 6. Shield.
- 7. Transit time reduced by microscopically close spacing. From grid to cathode: .005 inches. From grid to plate: .022 inches.
- 8. Plate dissipation (100 watts) is extremely high in comparison to the small effective plate area.
- 9. Metal tip-off at the top of anode.
- 10. Thermal insulation.

FOLLOW THE LEADERS TO



EITEL-McCULLOUGH, INC., 1148 San Mateo Ave., San Bruno, Calif.

Plants located at: San Bruno, Calif., and Salt Lake City, Utah

Export Agents: Frazar and Hansen, 301 Clay St., San Francisco 11, Calif., U.S.A.

TYPE 3X100A11/2C39 EIMAC TRIODE GENERAL CHARACTERISTICS		
<b>ELECTRICAL</b>		
Cathode: Coated unitpotential		
Heater Voltage		6.3 volts
Heater Current		1.1 amps
Amplification Factor (Average) 100		
Direct Interelectrode Capacitances (Average)		
Grid-Plate		1.95 $\mu$ fd
Grid-Cathode		6.50 $\mu$ fd
Plate-Cathode		0.030 $\mu$ fd
Transconductance ( $i_b=75$ ma., $E_b=600$ v.) (Av.)		20,000 $\mu$ mhos
Maximum Plate Dissipation		100 watts
<b>MECHANICAL</b>		
Maximum Overall Dimensions		
Length	2.75 inches	Diameter . 1.26 inches

**CALL IN AN EIMAC ENGINEER FOR RECOMMENDATIONS**

**ROYAL J. HIGGINS (W9AIO)**... 600 South Michigan Avenue, Room 818, Chicago 5, Illinois. Phone: Harrison 5948. Illinois, Wisconsin, Michigan, Indiana, Ohio, Kentucky, Minnesota, Missouri, Kansas, Nebraska and Iowa.

**VERNER O. JENSEN, General Sales Co.**, 2616 Second Avenue, Seattle 1, Washington. Phone: Elliott 6871. Washington, Oregon, Idaho and Montana.

**M. B. PATTERSON (W5CI)**... 1124 Irwin-Kessler Bldg., Dallas 1, Texas. Phone: Central 5764. Texas, Oklahoma, Arkansas and Louisiana.

**ADOLPH SCHWARTZ (W2CN)**... 220 Broadway, Room 2210, New York 7, N. Y. Phone: Cortland 7-0011. New York, Pennsylvania, New Jersey, Maryland, Delaware and District of Columbia.

**HERB B. BECKER (W6QD)**... 1406 South Grand Avenue, Los Angeles 15, California. Phone: Richmond 6191. California, Nevada and Arizona.

**TIM COAKLEY (W1KKP)**... 11 Beacon St., Boston 8, Mass. Phone: Capitol 0050. Maine, Vermont, New Hampshire, Massachusetts, Connecticut, Rhode Island.

**CAUTION!** Look for the latest serial numbers on Eimac Tubes. Be sure you get the newest types.



Designing New Equipment?

# Choose the Contacts *first!*

YOU can speed up delivery, cut costs, improve the performance of your product, by using Mallory Preferred Type Contacts.

Mallory Preferred Types are contacts which experience has shown are *most commonly needed*—eight basic types that have solved most contact problems during the last 25 years.

For example, if you need a solid rivet contact, chances are 1,000 to 1 that the kind you need can be found easily and quickly in the Range Chart indicated below. By simply checking the catalog number, you cut time-consuming delays—rule out the need of special tools and cost estimates.

Of course, if your job demands a *special* type of contact, Mallory's quarter century of experience is ready to help you. But for all other jobs, consult the Mallory Contact Catalog *first*. It will simplify the problem of selecting the right contact for the job—very probably save you time and money. Write for your free copy today.

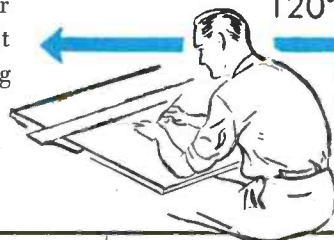
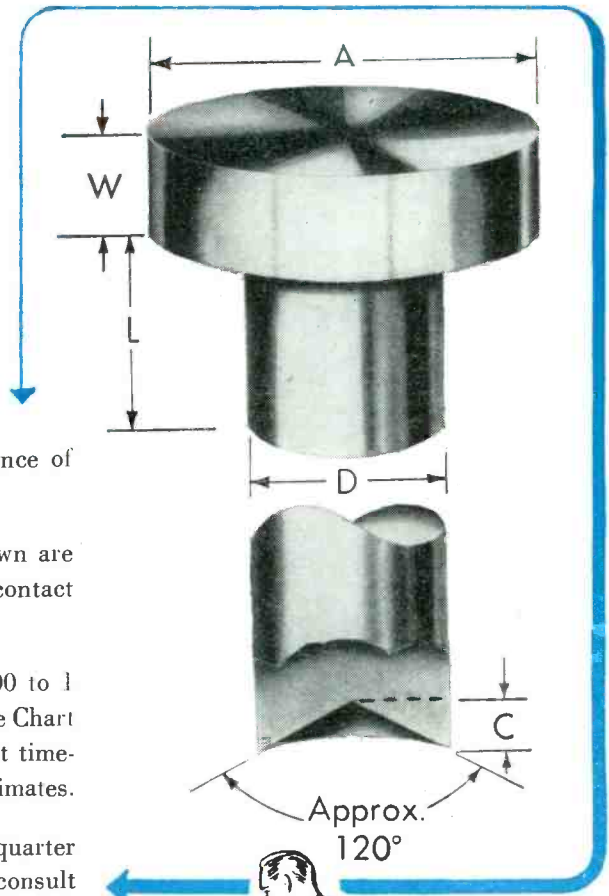

(ABOVE)  
TYPE 1 SOLID RIVET CONTACT

Head Dia. "A"	Head Thick. "W"	Shank Dia. "D"	Shank Length "L"				Recommended Radius "R" (if desired) (See Note 2)	Catalog No.
			Min. (See Note 1)	Max.	Recommended Short	Long		
.062	.015 .020	.040 .040	.028	.120	.046	.093	1/8" 1/8"	Type 1-614 Type 1-624
			.028	.120	.046	.093		
.078	.015 .020 .025 .030	.045 .045 .050 .050	.031	.135	.046	.093	1/8" 1/8" 1/8" 1/8"	Type 1-714 Type 1-724 Type 1-725 Type 1-735
			.031	.135	.046	.093		
			.035	.150	.046	.093		
			.035	.150	.046	.093		
.093	.015 .020 .025 .030	.045 .050 .062 .062	.031	.135	.046	.093	3/16" 3/16" 3/16" 3/16"	Type 1-914 Type 1-925 Type 1-926 Type 1-936
			.035	.150	.046	.093		
			.044	.186	.062	.093		
			.044	.186	.062	.093		
.125	.020 .025 .030 .035 .045	.050 .062 .062 .078 .093	.035	.150	.046	.093	1/4" 1/4" 1/4" 1/4" 1/4"	
			.044	.186	.062	.093		
			.044	.186	.062	.093		
			.055	.234	.078	.125		
			.065	.279	.078	.125		
			.065	.279	.078	.125		



P. R. MALLORY & CO. Inc.

# MALLORY ELECTRICAL CONTACTS & CONTACT ASSEMBLIES

P. R. MALLORY & CO., Inc., INDIANAPOLIS 6, INDIANA

MALLORY CONTACT CATALOG—Complete information about the Eight Basic Types of Preferred Contacts, including Range Charts as indicated above. Yours for the asking.



# CROSS TALK

► **PROGRAM** . . . Most impressive is the program planned for the new Research Laboratory of Electronics at M.I.T. This new research center, a successor to the Radiation Laboratory, will be sponsored jointly by Tech's Departments of Electrical Engineering and Physics. Experimental researches will be directed toward these objectives, among others: klystrons for 0.25 to 0.75 cm waves; magnetrons for 10 megawatts power output at 10 cm wavelength; single-anode magnetrons for use as reactance tubes; waveguides as elements of measuring devices, particularly waveguide bridges. Among the studies in physics are: absorption of 0.25 to 1 cm waves by gases; low pressure gas discharges at microwave frequencies; magnetic and electrical properties of materials near zero absolute temperature and at microwave frequencies. Not concerned with microwaves are plans for a super-voltage accelerator, supersonics at 30 mc, timing devices with pulse durations of 0.01 microsecond. Similar work will be carried out in microwave communication and electronic aids to computation. Coming when there is a tendency to let down on fundamental research, news of this high-powered attack on the unknown is heartening.

► **POWER** . . . We hear some mighty big numbers, these days, about power achieved at super-high frequencies. Peak power of four million watts at 3000 mc, for example, is the present record of the cavity magnetron. But old-timers may be skeptical of this "peak power" business, since what counts in a communication circuit is more nearly the average power. So we have gone hunting for information on c-w generators in the ultra- and super-highs and have come up with the chart printed herewith. This summary, prepared by John Byrne of the Radio Research Laboratory at Harvard, shows the record achieved in c-w oscillators developed by Division 15 of NDRC to jam enemy radars. Outstanding is

the resnatron tetrode, which generates a c-w output of about 50 kw at frequencies in the vicinity of 500 mc. C-w power in the hundreds and thousands of watts is obtainable from several forms of magnetron, some of which resemble the pulsed types used in radar. Not to be dismissed is the lowly triode. New forms of the "old reliable", notably disk-seal types, are up in power output at least three times over their pre-war brethren; and extend to 4000 mc as against the pre-war limit of slightly over 1000 mc.

This is progress indeed. Further study is required to show how these oscillators may be frequency-

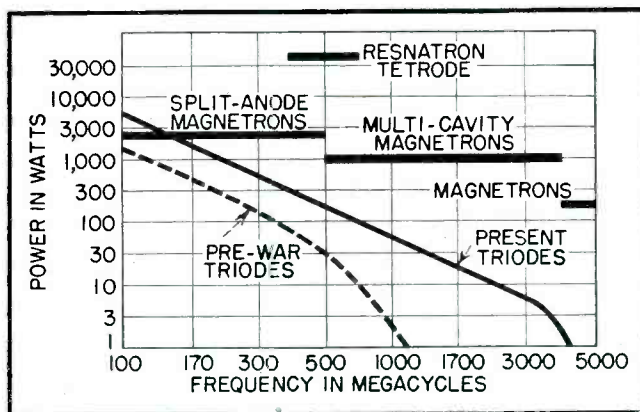

controlled and modulated for broadcast services. Up to now they have been modulated with noise and other non-critical waveforms. But our guess is that most of them are applicable to post-war needs. It has been argued, in fact, that the power output of the resnatron is *too* high for any peace-time purpose.

Fifty kilowatts will certainly saturate the horizon at 500 mc. But power is always necessary to penetrate the shadows, to overcome local interference, and to provide service beyond the horizon. We'll have use for all the power we can get.



# Radar COUNTERMEASURES

Equipment for detecting enemy radars, determining their location, analyzing their characteristics and then jamming them electronically or by means of chaff is described. Many of the devices used, such as shf direction-finders, wideband radiators, and the resnatron tube, have postwar applications

**I**N THE RADAR WARFARE just concluded there were two major campaigns. The first was to use radar against the enemy; the second to hinder the enemy in his use of radar against our forces. The second campaign was conducted by techniques known as radar countermeasures, (rcm) by which enemy radars were detected and put out of action.

In many ways rcm activity was the most fascinating aspect of the electronic war, since it involved direct contact with the enemy and required all the competitive strategy and inspiration of a campaign in the field. Technically, also, rcm commands attention, not only be-

cause the methods used were unique and different from those of radar, but also because many rcm devices have post-war uses which may outrank those of radar.

Radar countermeasures were developed and employed by the British in the early stages of the war. Prior to America's entry, rcm activity was also carried out in our own Army and Navy Laboratories, on a long-range basis. The need for coordinated activity led in 1942 to the formation, under Division 15 of the National Defense Research Committee, of an rcm laboratory at Harvard University. This laboratory was known as the Radio Research Laboratory. Of the \$300,-

000,000 spent by the U. S. on rcm equipment and materials, approximately two-thirds was for equipment developed in this NDRC activity. The remainder was spent developing methods originating with the British, and in the Naval Research Laboratory, Signal Corps, and Air Technical Service Command Laboratories.

#### Search and Jamming Functions

To knock out enemy radars, two basic functions are involved. The first is a search, conducted with receivers and direction finders, to determine where the enemy radar is located and as many as possible of its technical characteristics. The second is jamming, accomplished by means of aluminum-foil chaff or rope sowed in the sky by airplanes or by rockets fired from the ground and/or the transmission of signals which will interfere with the operation of the enemy equipment. In the initial stages of the program the two functions were separate. The search was conducted to obtain technical specifications and these specifications were sent home for use in the design of a suitable jammer. The jammer was then produced, on the fastest possible basis, and put into action.

The principal targets of Allied countermeasures in Europe were Wurzburg anti-aircraft radars such as this unit. The Germans had 4000, representing a billion-dollar investment. Jamming reduced their effectiveness to 25 percent of normal

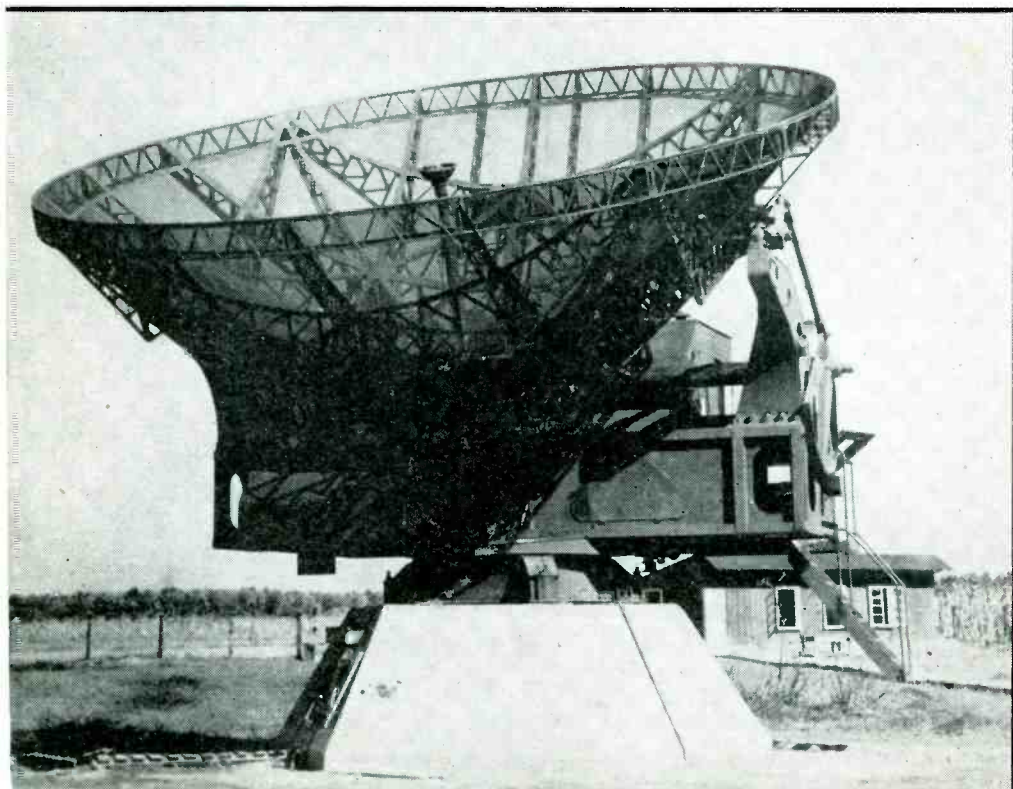



# electronics WAR REPORT



Ten million pounds of aluminum foil (chaff and rope) were dumped on Europe by Allied bombers to produce radar smoke screens within which German radars could not detect Allied bombers. Each package of chaff, one of which is shown being dispensed, contains several thousand dipole reflectors

Later, the two functions were combined in equipment of such flexibility that virtually all types of enemy radar could be detected and jammed in a single operation.

Some idea of the equipment flexibility required may be obtained from the accompanying table, which lists jamming transmitters, search receivers and direction finders. Since the enemy had, within reason, a free choice of frequency, it was necessary to build a group

of continuously tunable search receivers and direction finders to cover virtually the entire radar spectrum, from 25 to 6000 mc. Moreover, since the choice of pulse width lay with the enemy, bandwidths wide enough to accept a variety of pulses were required.

In the jamming transmitters the same continuously tunable frequency range was required. Moreover the transmitters were of necessity the continuous-wave variety,

since they had to block out echo signals which might occur at any time, depending on the timing of the enemy radar and the distance to its target. Moreover, the highest possible power was required, continuously, to blot out the enemy indicators at great distances. In the interest of conserving power, suppressed-carrier transmitters were often used, modulated with random noise over a bandwidth of several mc.

Underlying the design of these search and jamming equipments are several basic relationships which put the enemy radar at a fundamental disadvantage. In the first place, a radar must transmit at high power to detect targets at useful distances.

The radar operates by reflection of its signals, which introduces attenuation of the radar signal proportional to the fourth power of the distance to the target. The search receiver detects the radar signal by one-way transmission, which is at-

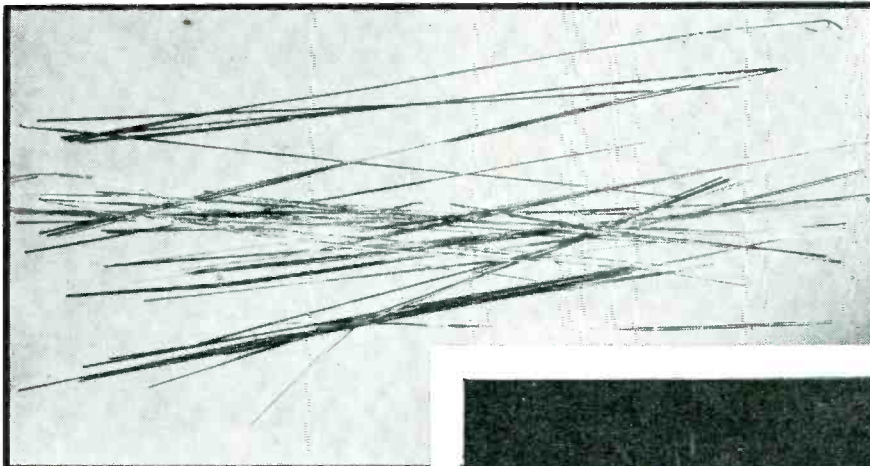

Chaff, aluminum halfwave dipoles of various lengths, tuned to the Wurzburg radar frequencies. Each strip is embossed and crimped along its length to assure wide dispersal and reasonable rigidity after being thrown from the aircraft

Effect of chaff on Wurzburg type-J indicator. At left, normal indication of Allied bombers (at right of circle). Right, a trail of chaff some 16 miles long totally obscures the bombers. These shots were taken from a German training film

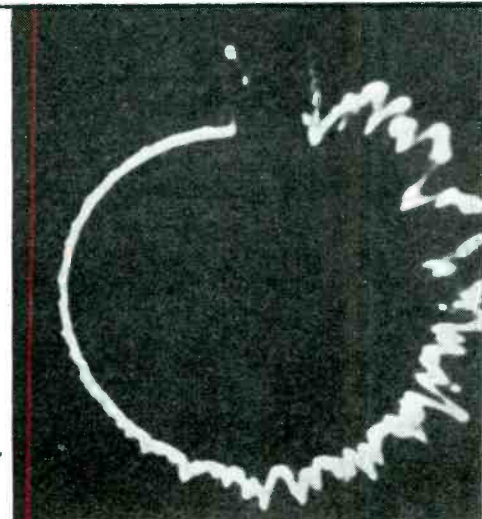
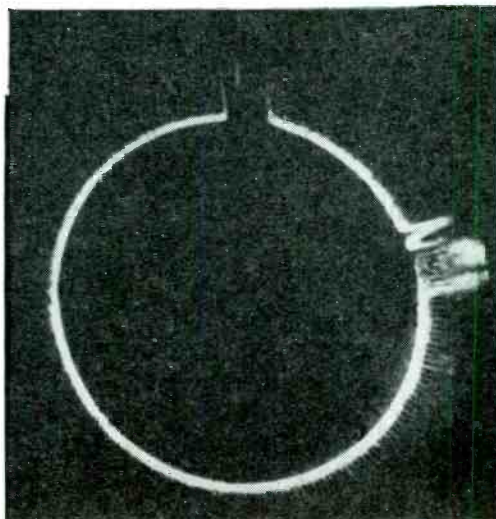



## EQUIPMENT FOR RADAR COUNTERMEASURES

### Jamming Transmitters

Frequency Range (mc)	Designation and Code Name	Bandwidth (mc)	Output Power (watts)		Description and Radars Jammed
			Carrier	Sidebands	
25-100	ARQ-8 Dina	0.15	0	40-20	Suppressed carrier, single sideband. German EW, Jap GL and SLC
85-150	APT-3 Mandrel	3	12-9	3-2	Grid-modulated MOPA. German EW
90-220	APT-1 Dina	6	0	15-8	Suppressed carrier, single sideband. German EW, Jap GL and SLC
200-550	APQ-2 Rug	7	20-5.5	5-1.25	Line oscillator, doorknob tubes. German coastal, Jap torpedo planes
450-720	APT-2 Carpet	7	8-3	1.6-0.6	Same as APQ-2. German Wurzburg GL
475-585	APQ-9 Carpet III	7	20	5	Parallel plate, using 8012's. German Wurzburg GL
350-1200	APT-5 Carpet IV	2.5-3.0	30-5	—	Lighthouse-tube cavity oscillator. German Wurzburg GL
150-780	APT-4 Broadloom	7-10	150	—	Current-modulated c-w magnetron. German Wurzburg GL
300-2500	APT-9	2-8	25-10	10-3	Cavity oscillator
2230-4030	APT-10	—	25-50	—	Tunable c-w magnetron, four heads to cover range

### Search Receivers

Frequency range (mc)	Designation	Input power (watts)	Description
25-100	ARQ-8	75 a-c	Dinamate, used with Dina and tuned electronically to transmitter frequency. Superheterodyne
40-3000	APR-4	90 a-c, 9 d-c	Bandwidth 4 mc or 0.5 mc. Single-dial tuning. Four r-f heads cover range. Motor-driven sector sweep. Superheterodyne
1000-3100	APR-5	150 a-c, 25 d-c	Coaxial-antenna input, cavity oscillator. Crystal mixer. Superheterodyne
3000-6000	APR-8	150 a-c, 25 d-c	Same as APR-5, but mixer operates on local oscillator harmonics. Waveguide input. Superheterodyne

### Direction Finders

100-450	APA-24	—	Vertical Adcock plus horizontal dipole, manual remote control. Null indication
300-1000	APA-17	125 a-c, 50 d-c	Whirling radiator for use with any search receiver. C-r indication on maximum of antenna pattern

tenuated only as the square of the distance. Consequently, a radar signal can be detected at distances far greater than the maximum range at which the radar can see a target. In the second place, the direction to the source of the radar signals may be observed by

the use of a directional antenna on the search receiver. Two or more bearings so obtained reveal the location of the radar. Radar reconnaissance can thus be carried out, with airborne search receivers for example, without fear of detection by the radar itself.

The same favorable discrepancy exists between radar range and jamming range, since the jamming signal competes only with a weak reflected echo on the radar screen. Consequently, a jamming power level in the tens of watts is sufficient to compete with a radar peak power in the hundreds of kilowatts. This advantage is reduced, however, by the necessity of jamming with a c-w signal, and so the average power of the jammer is often nearly as great as the average power of the radar.

The accompanying table illustrates the frequencies, power levels and bandwidths of the jamming transmitters. Power in the tens of watts, modulated over bands up to 10 mc, is obtained at frequencies up to about 700 mc using triode tubes, notably the door-knob types. Cavity resonators, using disk-seal (lighthouse) tubes, give about the same performance at frequencies up to 2000 mc. For higher power levels, especially at the highest frequency ranges, c-w magnetrons are used. One important example is the Broadloom jammer, which produces 150 watts

Electronic jamming, caused by noise-modulated c-w transmissions tuned to the radar frequency. Above, normal scope. Below, echo pulses obscured by artificial noise produced by jamming signal

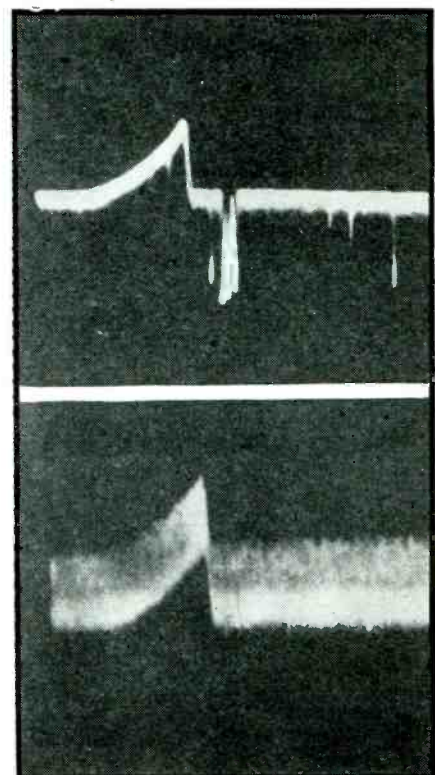

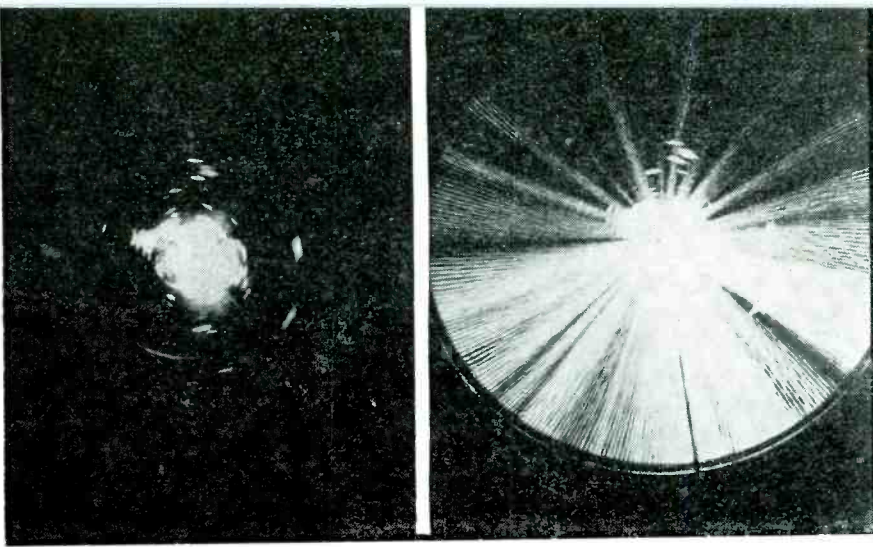

Effect of electronic jamming on plan position indicator (ppi). Left, normal indication. Right, radial traces, brightened by jamming signal, obscure echo signals

of cw carrier up to 780 mc.

Modulation of the jamming signal is, of course, essential to achieve the maximum blanketing effect. Experience has shown that random noise, such as may be obtained conveniently from the space current of a gaseous vacuum tube, provides the most effective modulation waveform. Noise modulation, received by the radar, has the effect of multiplying enormously the normal noise level present in the radar receiver.

#### Search Techniques

The technique of searching for enemy radar signals, as a preliminary to jamming them, consists simply in tuning the search receiver repeatedly over the radar spectrum. This is not only difficult technically, but physically tiring. The technical difficulties reside in the great width of the spectrum to be covered. One excellent example of how the problem is solved is the AN/APR-4, which covers the range from 40 to 3000 mc, using four r-f heads. The tuning is motor driven over a frequency sector which can be selected by the operator, thus relieving him of a considerable physical burden. An automatic tape-recording system is available to record the frequency at which signals are detected as the spectrum is swept, thus further reducing the attention demanded.

The simplest method of observing the radar signals is by an aural indication. Radar pulses are transmitted at repetition rates which lie within the audible spectrum. Moreover, the pulse represents, in effect, a high degree of overmodulation on a c-w carrier, and this modulation

can be recovered in a conventional second detector, amplified at audio frequencies, and fed to headphones. When a radar signal is intercepted a whine (repetition frequency plus harmonics) is heard in the headphones. The strength of the signal varies periodically as the radar beam sweeps past the search plane. So long as this variation continues, the radar is searching. But if the signal becomes steady, at maximum volume, the chances are that the radar has detected the search plane and is tracking it. Appropriate action is then taken to avoid enemy gunfire and aircraft.

While aural or tape-recording methods serve to identify the presence and carrier frequency of the enemy radar, they give little indication of the pulse characteristics. A cathode-ray pulse analyzer (oscilloscope) is available to determine the pulse repetition rate, the pulse width, the pulse shape and relative amplitude. Such an analyzer gives important clues to the type of radar under observation, since it reveals the radar's maximum range, minimum range, and range accuracy.

#### Wideband Radiators

Implicit in the wide frequency ranges covered by search and jamming equipment is the necessity for radiators which will cover these ranges without excessive tuning adjustments. The Radio Research Laboratory undertook to develop antennas which would cover frequency ranges of several thousand megacycles without any adjustment whatever. One of the most spectacular of these antennas is an approximately cylindrical structure which covers the range from 950

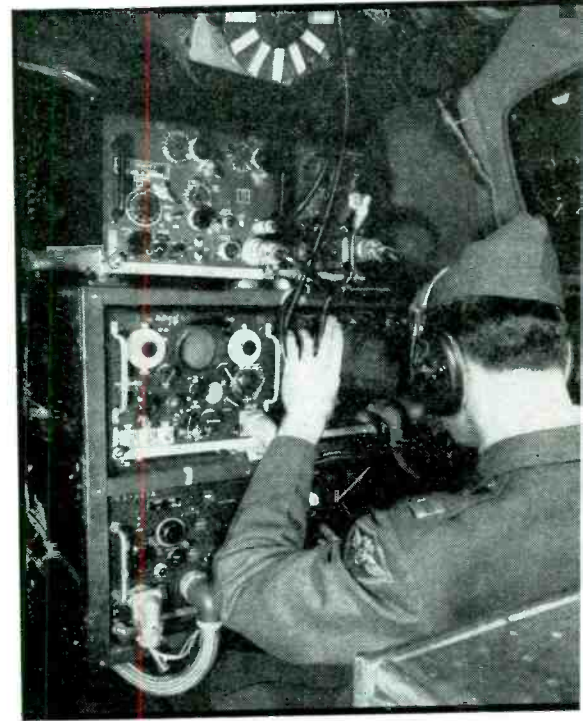

Search and jamming equipment on a Navy rcm plane: from top to bottom: antenna selector switch, APT-1 electronic jammer, panoramic adapter (to sweep receiver frequency) pulse analyzer, cathode-ray d-f indicator (in use by operator), second jamming transmitter, and search receiver (hidden by operator)

to 2900 mc, a frequency ratio of 3-to-1, matching the transmission line throughout this range. In general, the wideband antennas make use of the principle that a thick, stubby radiator has low stored energy and hence responds well over a wide band. Several of the wideband radiators are of the turnstile type, two dipoles at right angles, extending through massive collars.

Closely allied with the wideband antennas are suitable direction-finding structures. The direction-finding problem is complicated by the fact that the enemy may choose vertical or horizontal polarization at will. In the AN/APA-24, which operates in the range from 100 to 450 mc, a four-element Adcock system is used to receive vertical polarization, and a single horizontal dipole is used for horizontally-polarized signals. The system operates on the null of the pattern.

For higher frequencies (300 to 1000 mc), an automatic direction finder was produced, using a continuously rotating radiator. A cathode-ray oscilloscope, with polar sweep, indicates the strength of the received signal and plots a polar



diagram on the c-r screen, the maximum of which indicates the direction of the radar under observation. This equipment, when observing a point source, plots the polar radiation diagram of the antenna in use. It has found much use in measuring the polar diagram characteristics of developmental antennas.

#### Chaff Dipoles and Rope

An effective way to confuse enemy radar operators is to simulate targets by dispersing large quantities of reflecting material in the sky. The most efficient material for this purpose, from the standpoint of echo area per unit weight, is aluminum foil cut in strips one half wavelength long at the enemy

While apparently a simple device, chaff presented many interesting technical problems. The primary objective was to obtain as large as possible a reflecting area from a given weight of aluminum foil. This implies thin, pliable foil which tends to bend when thrown into the slip stream of the aircraft. Such bending causes interweaving of the strips in tangled bird's nests which present little area and fall rapidly. Moreover, adjacent strips of foil tend to adhere to one another, preventing rapid dispersal. These problems were solved by embossing the foil and crimping each strip along its length to give it rigidity. Chaff thus manufactured is highly dispersive and falls at the slow rate of 150 feet per minute. The mate-

material was only 2 ounces. Each heavy bomber carried with it sufficient chaff to simulate 700 bombers, and dispensed it at regular intervals over areas known to be protected by radar-controlled gunfire. Large areas of the German countryside thus became littered with aluminum strips, which were used by the natives to decorate Christmas trees.

On the indicator of a gun-fire control radar, the chaff-dispersing aircraft appears as if it were reproducing itself. As the pulse representing the aircraft moves across the indicator screen, additional pulses appear behind it and remain stationary. As the chaff disperses, the pulses assume an amorphous shape in which succeeding aircraft are nearly invisible. Aircraft outside the cloud of dipoles are not hidden. Aircraft behind (but not within) the cloud are detected by signals which pass through the dipoles.

The most effective protection against German radar-controlled flak was a combination of electronic jamming by transmitters tuned to the radar frequencies, and chaff dipoles. In addition to adding to the general confusion on enemy indicators, electronic jamming protected the first plane in a flight as well as succeeding planes. This combination reduced the effectiveness of anti-aircraft fire to about 25 percent of normal, which saved the U. S. forces an estimated 450 aircraft and 4500 casualties. The value of these aircraft alone more than equalled the cost of the countermeasures program directed against German flak. During the height of the campaign, 20 billion dipoles were scattered on Germany and France each month.

In the Pacific, chaff was not used to any great extent because the Japanese radars used many widely different frequencies, which would have required as many different sizes of chaff to combat them. Instead, very long strips of aluminum foil, about one half inch wide and 400 feet long, were dropped, sometimes supported from small parachutes. This device, known as rope, was effective over a very wide range, covering all of the many frequencies employed by the

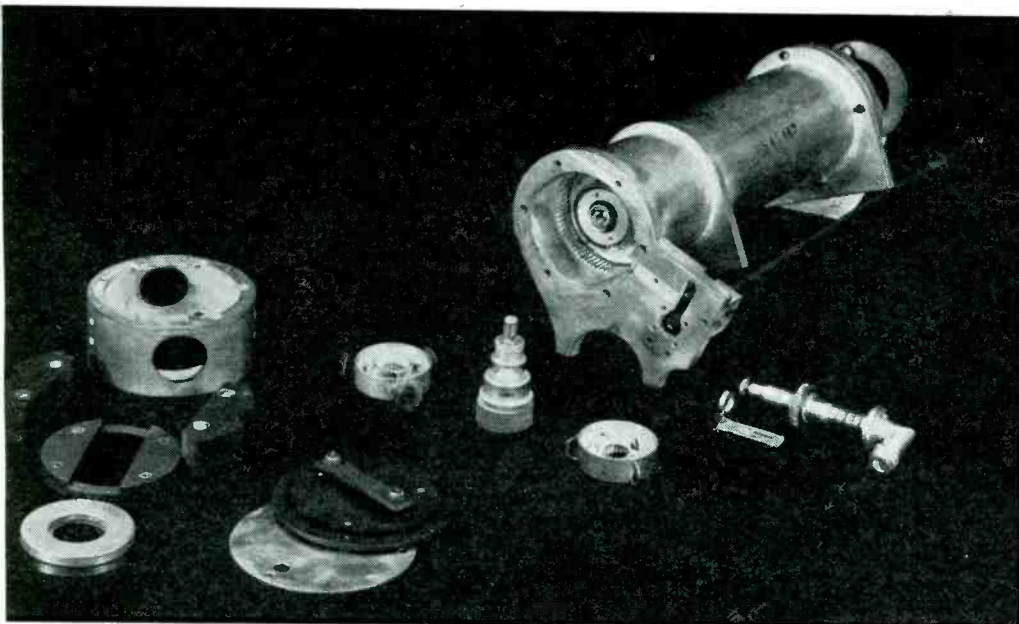

Oscillator of APT-9 jamming transmitter, using disk-seal tube. This oscillator covers the enormous range of 300 to 2500 mc with a power output of 10 to 25 watts, continuous wave

radar frequency. Such dipole strips, when used by the British, were called window. The American version is known as chaff. Three quarters of the entire wartime production of aluminum foil, some 20,000 tons in all, was devoted to the manufacture of chaff. Allied aircraft dispensed hundreds of packages of foil strips, each containing several thousand dipoles, on every flight over enemy territory. The material was designed to disperse widely and to remain aloft as long as possible, thus providing a radar smoke screen within which following aircraft could avoid detection by gunfire-control radars below.

rial most widely used over Europe was tuned to the region 450 to 600 mc, which covered the operating frequencies of the German Wurzburg fighter-direction and gunfire-control radars.

Since the resonance of the foil strips extends over a band only 8 percent of the center frequency (at 3 db down), it was necessary to provide two lengths in each package, roughly 10 and 11.5 inches long. About 1000 such dipoles, dispersed at an average separation of about four inches, were found to equal the echo area of a heavy bomber. The weight of these 1000 dipoles in the latest version of the



Typical wideband antenna structure, used to cover wide frequency range of jamming transmitter. Known as a fish-hook, this radiator produces circularly polarized signals to jam regardless of the polarization of an enemy antenna

Jap equipment. Eventually, each B-29 carried 600 pounds of this material on every mission. This weight necessarily subtracted from the bomb load, but was well worth it.

#### Tuba and the Resnatron

Perhaps the most spectacular of all rcm developments was the high-powered ground-based jammer known as tuba. Beginning in 1942 the Germans installed airborne Lichtenstein radars in their night-fighters, operating at about 500 mc, and designed to detect night-flying British bombers. So successful was this German equipment that consideration was given to an airborne jamming equipment to be carried in the British planes, but this plan was abandoned when it became clear that the Germans could locate the

bombers from the ground by accurate d-f equipment. So it was decided to install a super-power jammer on British soil, aimed at the coast of France and intended to blot out the screens in the night fighters as they chased the bombers home. To achieve this result, the highest possible power was required. Calculations indicated that tens of kilowatts, continuous wave, tunable from 375 mc to about 600 mc would be required to cover the possible tuning range of the German equipment with a sufficiently strong signal. The highest c-w power achieved up to that time at that frequency was measured in the tens of watts.

The answer was found in the resnatron, a water-cooled, continuously-pumped tetrode which overcomes the effects of electron transit time by a 90-degree phase shift introduced between grid and plate circuits. This tube achieved the astounding power output of 30 kw, continuously, at a frequency of 500 mc, and was pushed to an output of 100 kw for short periods. The upper frequency limit of the tubes developed for tuba was found to be about 700 mc.

The original design was modified to permit tuning it through the range (about 200 mc) over which the Lichtenstein airborne radars could be shifted by simple modifications. The tuba equipment consisted of two oscillators, noise modulators, power supplies, etc, mounted in trucks. Two oscillators were required to cover the frequency range, not only for convenience in tuning the resnatrons themselves, but also to permit the

Radiator of the tuba jammer, a chicken-wire horn 150 feet long. Based on the south coast of England, and fed with 30 kw of c-w power at 500 mc, this equipment successfully jammed the Lichtenstein radars over Europe. Note 22-by-6-inch waveguide feeding horn at left

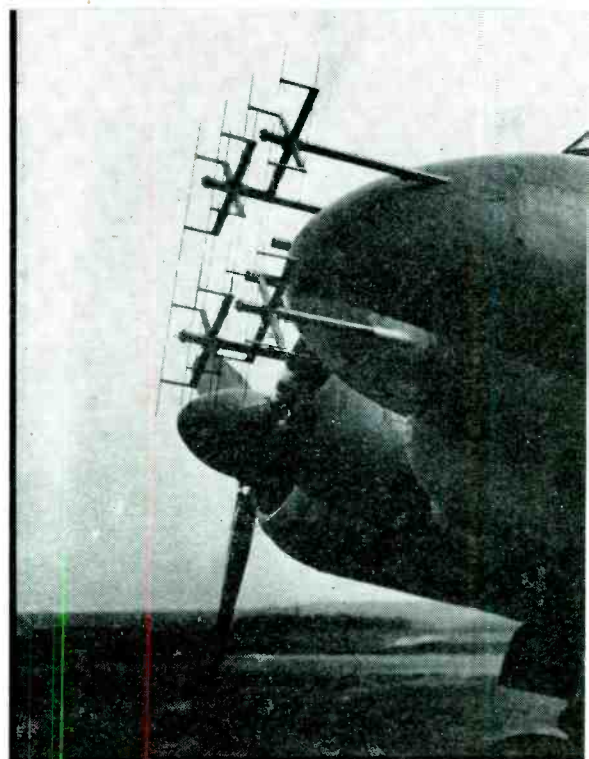
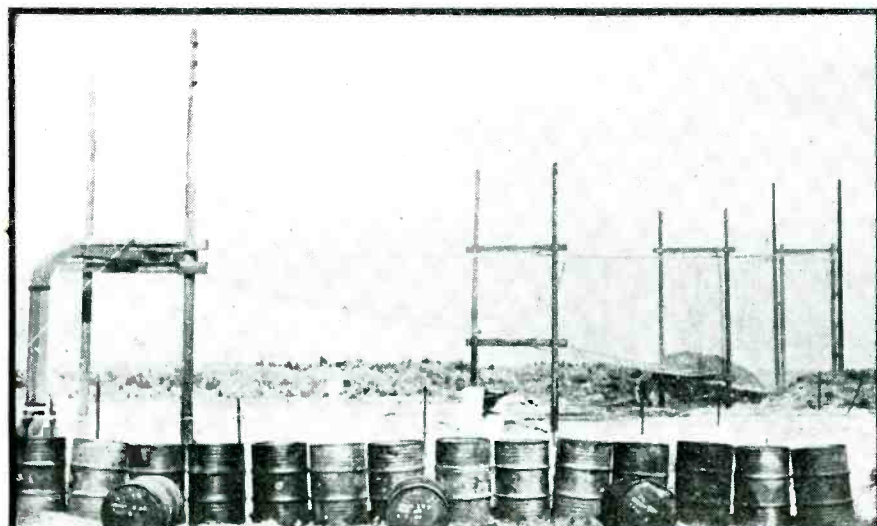

Antenna of German Lichtenstein airborne radar, operating at about 500 mc and used on night fighters to combat Allied bombers. This successful equipment led to the development of a super-high-power jammer known as tuba

use of waveguides. Since a waveguide of given cross-section can transmit power over but a limited range of frequency, two systems were used to cover the band. The waveguide cross-sections were respectively 16 by 6 inches and 22 by 6 inches, which is easily the largest waveguide system ever used. The radiator itself was a sectoral horn, constructed of chicken wire supported on telegraph poles, 150 feet long from neck to mouth. Work on tuba began in America early in 1943. The first operation against the enemy began from the south coast of England June 1944. In that month the Germans changed to a radically different type of airborne interception radar.

Aside from its military success, the resnatron is a major milestone in the history of electron tube development. It can develop more power than, perhaps, can be used economically for any peace-time purpose at frequencies above 100 mc. While its modulation capabilities have not been thoroughly investigated except for random noise waveforms, the advance indications are that it can be modulated in frequency, phase and amplitude over very wide sidebands. Its importance in the future of f-m and television broadcasting can scarcely be doubted.—D.G.F.



# RADAR

By

**LT. COL. HAROLD A. ZAHL**

*Signal Corps Engineering Laboratories,  
Bradley Beach, N. J.*

and

**MAJOR JOHN W. MARCHETTI**

*AAF Watson Laboratories,  
Red Bank, N. J.*

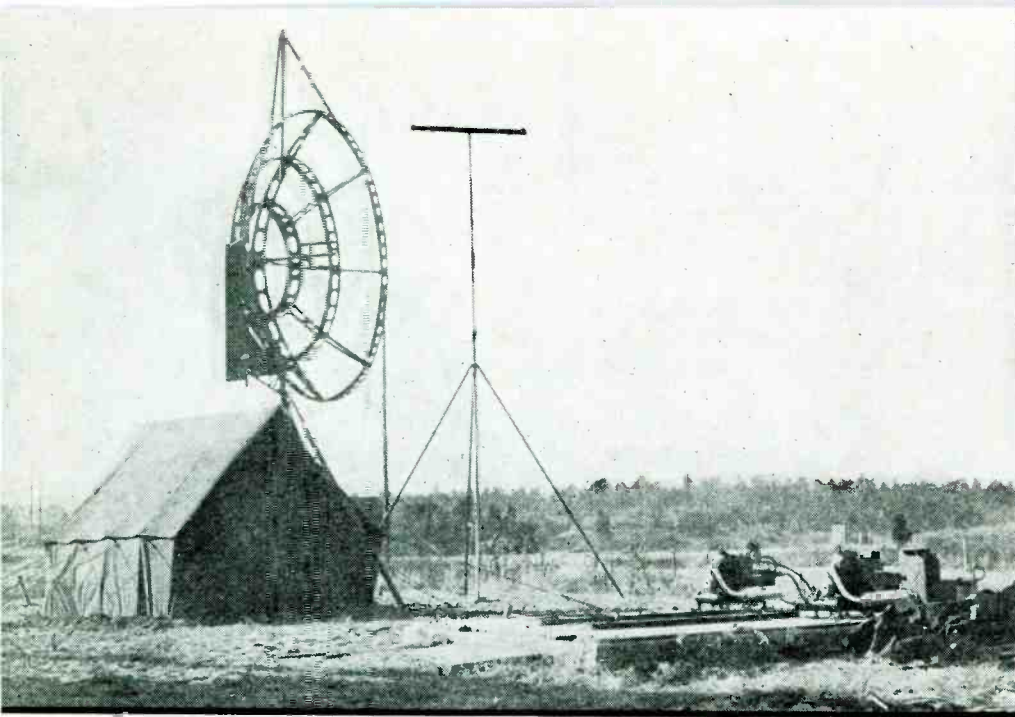

FIG. 1—Typical setup of the TPS-3 radar

**P**RIOR TO AMERICA'S entry in the war, available radar equipment operated on 100 and 200 mc. This equipment had been set up at the Panama Canal, but it was felt that additional measures were necessary to avoid surprise raids by low-flying aircraft against which the existing radars were least effective.

A plan was set up to construct a small number of radar sets which were to be mounted on small boats anchored in the vicinity of the Canal entrances. It was felt that in

these advance locations they would provide a radar screen making surprise raids impossible. After considerable experimentation, it was decided to construct these sets to operate on a frequency of 600 mc and, accordingly, a model was built up of components already developed by the Signal Corps and an installation was made on the motor vessel "Nordic."

Tests of this equipment were so successful that it was immediately apparent that extremely long ranges

and low angle coverage were obtainable in this frequency band even from a set only 15 feet above sea level, and that with the components available a very lightweight medium-warning radar could be constructed. At the request of Col. William Cody and others of the AAF, the Signal Corps was asked to repackage this equipment into a lightweight assault-type radar that could be both air transportable and hand-carried and have a range of well over 100 miles on bombardment aircraft.

To prove that the first laboratory model was air transportable it was flown from Newark Airport to Florida on February 27, 1943, in a B-18 and was set up and operating

FIG. 2—A view of the console and, at the right, of the console with the indicator and receiver units removed, showing the maintenance cable system

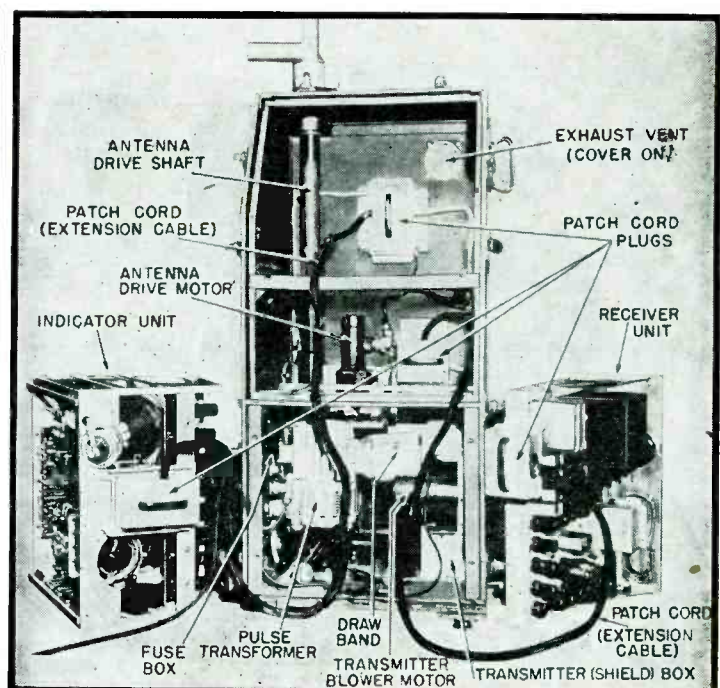
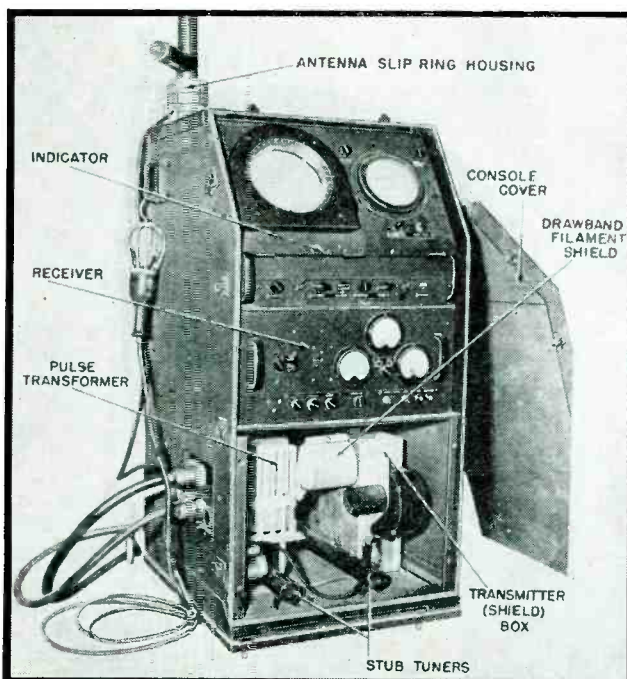



# ON 50 CENTIMETERS

Combining high power with light weight, the TPS-3 radar detects approaching bombers at 120 miles, yet can be carried by hand and set up by a four-man crew. This first of two articles on the equipment furnishes an important example of 600-mc technique

at the test site on March 1, 1943. The next two weeks were spent in calibrating and determining operational performance of this equipment in comparison with three other lightweight equipments. At the conclusion of the tests it was definitely determined that the AN/TPS-3 (then known as the 602-T8) had a range in excess of 110 miles and could be mass-produced. This performance was sufficient to indicate an immediate combat requirement. The model was flown back to Camp Evans, Belmar, N. J., on March 18, 1943. The engineers responsible for the design of the equipment took all of the information available to a manufacturer, along with the model, so that production might start as soon as possible. Nine hundred sets were ordered, and the first started coming off the production line about a year later.

To cover the interim period it was necessary to produce on a crash basis a small number of sets for immediate air shipment to critical theater areas. Accordingly, it was decided to construct 12 models within the Camp Evans Signal Laboratory. These 12 models were completed in three months with the aid of GI crews who later formed the operating teams for the equipment and were flown directly to the theaters.

**electronics  
WAR REPORT**

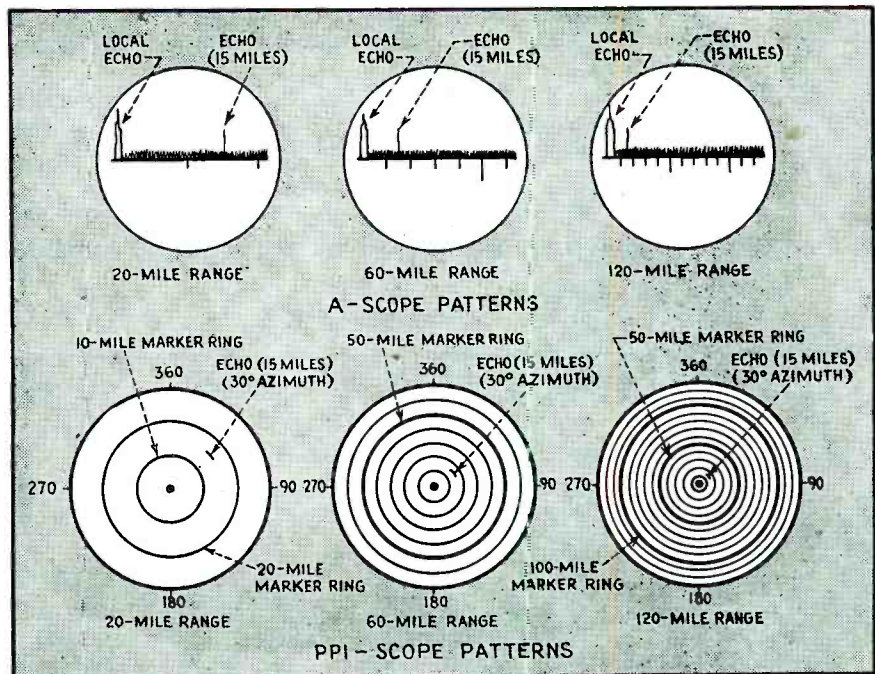

FIG. 3—A-scope and PPI-scope patterns

The production models of this set found their way to all the theaters of the war. The first 25 were produced in time to take an active part in the Normandy invasion.

#### General Description

The AN/TPS-3 was designed chiefly for medium-long-range early warning against aircraft. It is composed of units which are small and light enough to be either transported by air or hand-carried. Its total weight (including spare parts and power units) when packed for air transport is 1200 lbs. Maximum weight of any single component is 200 lbs. The set can be completely assembled and put on the air by a crew of four men within thirty minutes of arrival at a site. A typical installation is shown in Fig. 1.

The major component is a console which houses the receiver, the transmitter, the indicator, part of the modulating system and part of the r-f system. This unit is shown in Fig. 2. The console is normally housed in a tent which is provided with the set and acts as both a light-proof covering and a shelter. A section of transmission line with very heavy steel walls plugs into the top of the console and forms a pedestal upon which a 10-ft parabolic-reflector antenna system is mounted. This section of transmission line is braced by two wooden struts whose ends are buried in the ground. The top of the parabolic reflector is further secured by three guy wires and the entire structure is so made that the antenna can rotate continuously in either direction or be inched



slowly for accurate azimuth orientation.

The power unit and modulator are kept 50 ft from the tent and are connected to the console by means of cables. The power unit is a single-cylinder gasoline engine driving a 400-cycle alternator and a d-c generator mounted on the same shaft. The radar components of the set use 400-cycle power, thus effecting a great saving in weight and size. The d-c generator produces 28 volts that is used to drive fan motors and the antenna turning motor.

Unlike the SCR-268 previously described in *ELECTRONICS*, the AN/TPS-3 provides only range and azimuth information. This information is displayed on the indicator on two cathode-ray tubes used in an A-scope and in a PPI-scope. The A-scope resembles an ordinary test oscilloscope and presents a horizon-

tal sweep line with the signal appearing as vertical deflections along this line. The PPI presentation employs a sweep line which starts at the center of the tube and sweeps outward toward the edge. This sweep line is made to rotate about the center of the tube in synchronism with the rotation of the antenna and therefore indicates the position of the antenna. Signals are applied to this tube by intensity modulation so that they appear as bright dots on a dark background. Both of these tubes indicate the range of the target by the distance of the signal from the beginning of the sweep line. The PPI tube measures azimuth by noting the position of the sweep line when a signal appears. The two forms of presentation are shown in Fig. 3.

The pulse rate of the set is 200 pulses per second. The interval be-

tween pulses is 5000 microseconds. Using a sub-multiple of the alternator frequency for timing the pulses provides a clear and steady picture on the indicators with a minimum of filter weight. The transmitted radio-frequency power and the sensitivity of the receiver are such that the radar set will "see" a medium-size aircraft at 120 miles. The total time necessary to cover this 120 miles is approximately 1300 microseconds, and this amount of time is all that is used on each sweep of the cathode-ray tube. The remainder is dead time.

Figure 4 is a block diagram showing the flow of signals through the equipment. The modulator, in conjunction with a rotary spark wheel, mounted on the power unit, produces high voltage d-c pulses which are synchronous with the 400-cycle power supply at half its frequency.

FIG. 4—Block diagram of the complete TPS-3 radar

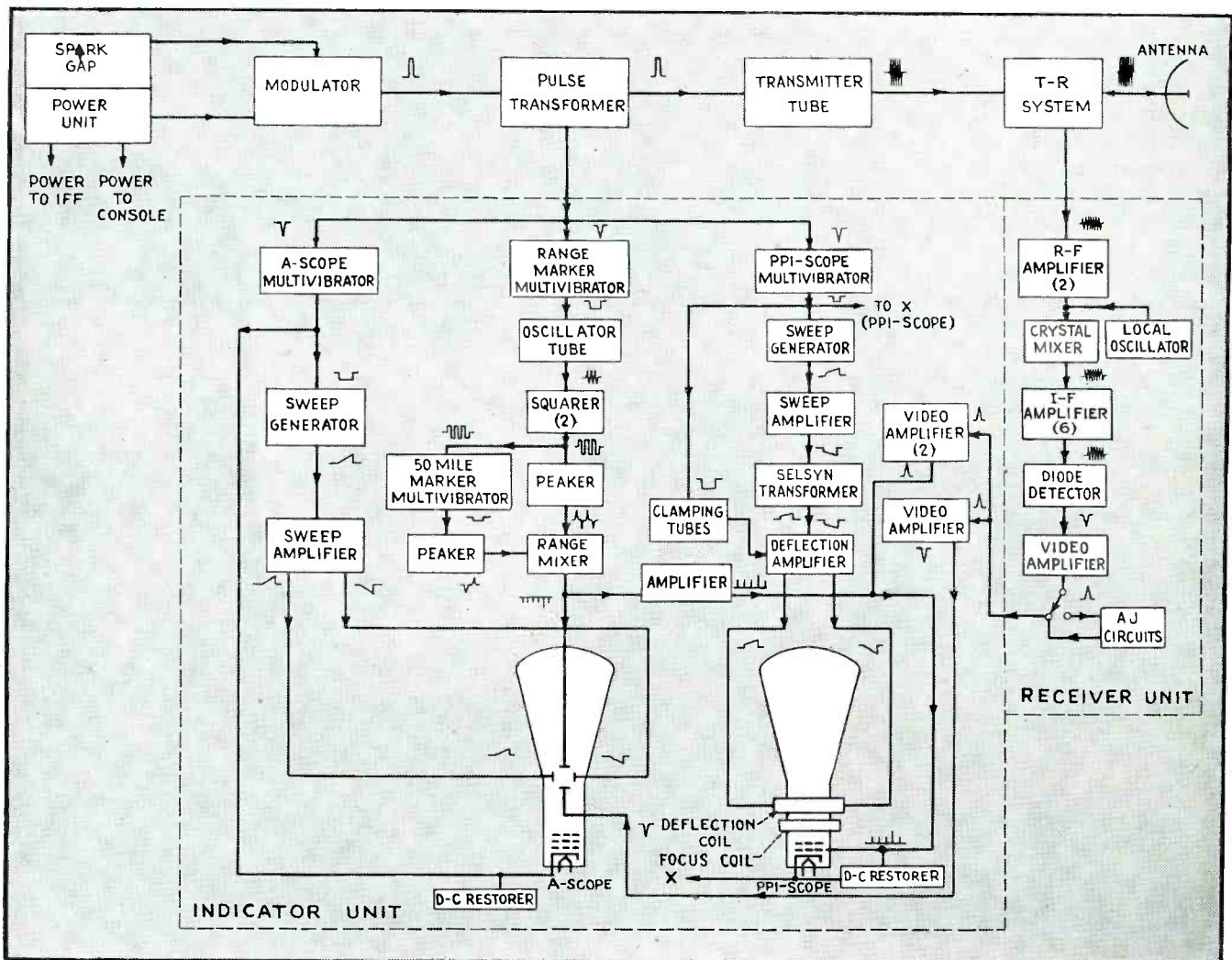

These pulses are applied to the transmitter, which converts them to pulses of 600-mc energy. They are then radiated from the antenna, which is coupled to the transmitter by means of a coaxial line. When one of these pulses strikes an object some of the energy is reflected. Measurement of range is facilitated by injecting into both cathode-ray tubes a series of markers spaced 107 microseconds apart, and also synchronized with the transmitted pulses. These markers represent 10-mile intervals and provide the scale by means of which the range is measured.

#### Antenna and Propagation

The antenna used with the AN/TPS-3 is a 10-ft parabolic reflector with a radiator at its focus. This produces a free-space beam which is about 10-deg wide at its half-power points. Consider such an antenna situated at height  $h$  above a plane earth as shown in Fig. 5. Assume a reflecting target at point  $p$  at a great distance from the antenna. The antenna will appear as a point source as seen from  $p$ . The radiation pattern shows the free-space pattern of the antenna. It is obvious that energy can reach the point  $p$  from the antenna by traveling two paths, one directly from the antenna and the second reflected from the ground. These will be called the direct ray and the reflected ray. The angle made by the direct ray with the horizontal is almost exactly equal to the angle made by the reflected ray and the horizontal. Therefore, the amount of energy reaching point  $p$  along each of these two paths will be almost equal. However, because the distances along the two paths are not equal, the phase of the direct ray and the reflected ray at point  $p$  will in general not be the same. Therefore, the total energy at point  $p$  is the vector sum of the energies reaching it along the direct path and reflected path.

In order to determine this total energy it is not necessary to know the length of each path but merely the difference between the path lengths, which will determine the difference between the phases of the direct and reflected rays at point  $p$ . It may be assumed that the

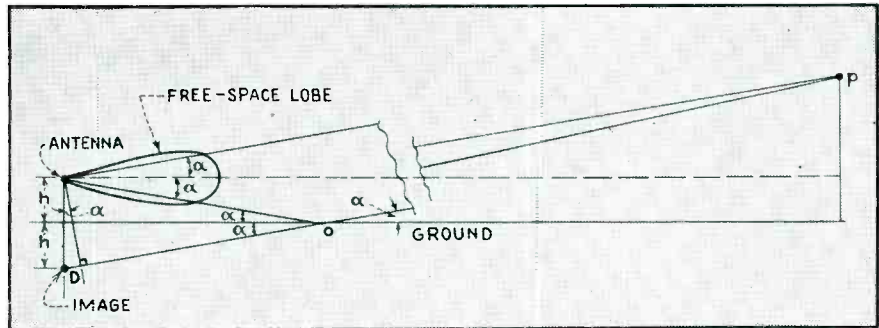

FIG. 5—Determination of reflected energy maxima and minima

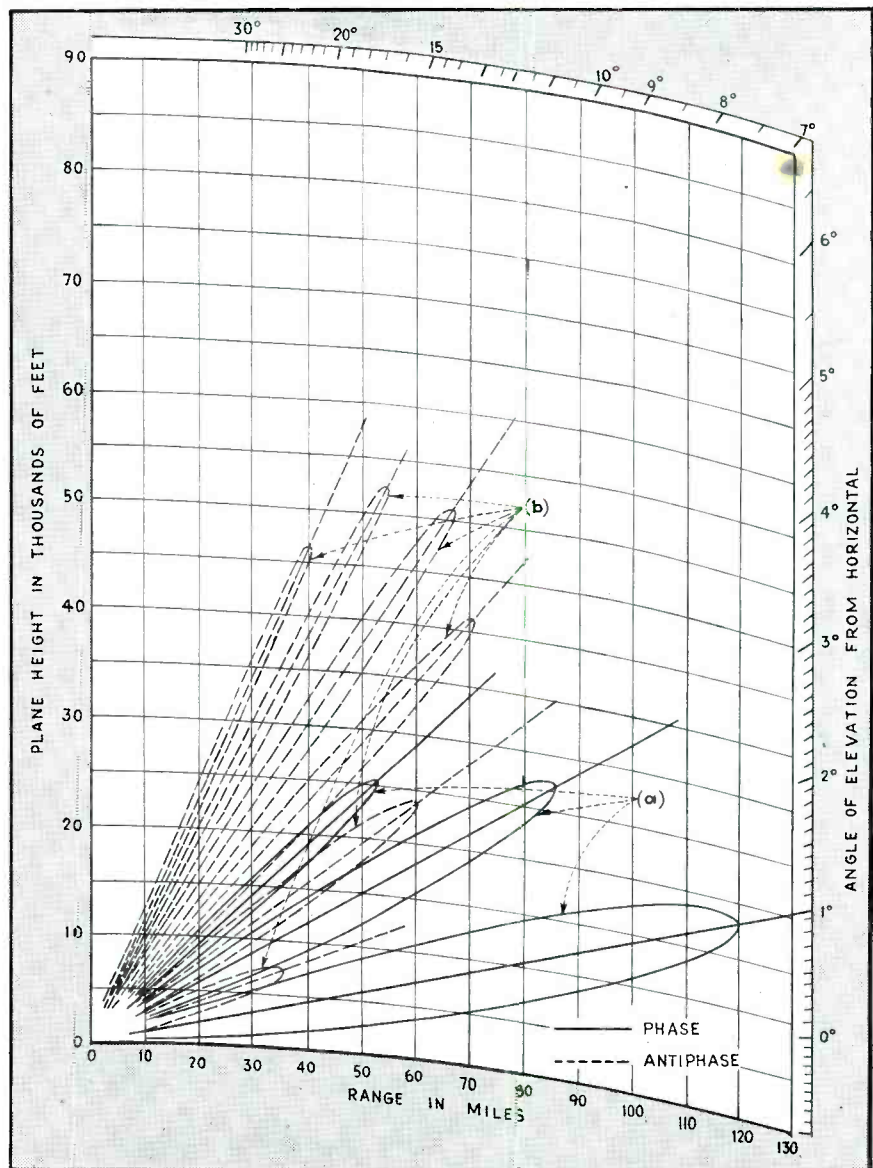

FIG. 6—Complete coverage pattern, with the antenna horizontally polarized and having a 24-ft effective height

earth is a perfect reflector. At the point of reflection there is a 180-deg change of phase. Because radio energy travels with the speed of light,

180-deg phase differences occur every half-wavelength in space. Therefore, in order for the direct ray and reflected ray to arrive in



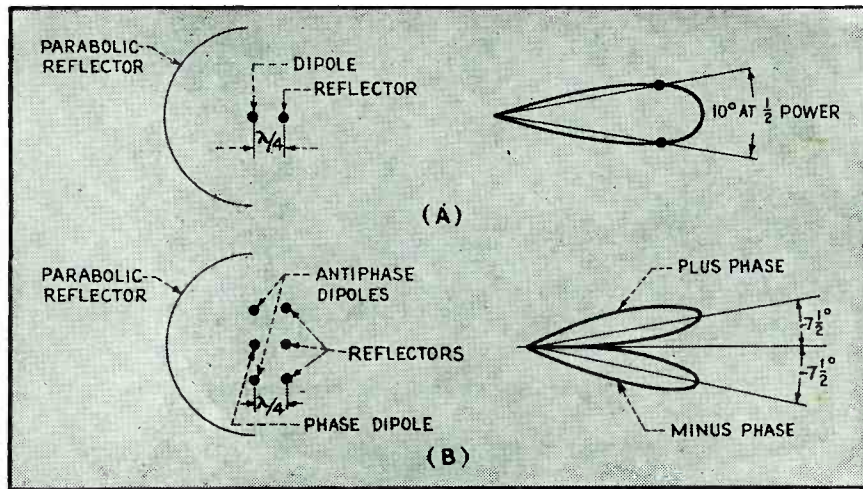

FIG. 7—Free-space patterns for the two TPS-3 radar antenna connections

phase at point  $p$  and add algebraically the path difference must be a half wave. Whenever the path differs from a half wave or some odd multiple of a half wave, the total energy at point  $p$  will be slightly less than the sum of the direct and reflected ray. Whenever the path difference is an even multiple of a half wave, the energy at point  $p$  will be zero, because the direct and reflected wave arrive 180 deg out of phase.

To find this path difference it is only necessary to extend line  $op$  through the point of reflection to a point directly under the antenna. It can be seen that the extension of  $op$  will intersect a vertical line through the antenna at a point the same distance below the surface of the earth as the antenna is above the surface of the earth. This point is called the image antenna and can be considered to be radiating energy toward point  $p$  with the same intensity as the true antenna but opposite in phase. A perpendicular is then dropped from the antenna to the extension of  $op$  and the distance  $D$  then represents the path difference. While there may be some objections to this procedure on geometrical grounds the distance  $op$  is so large compared with  $2h$  that for all practical purposes the results are correct.

If point  $p$  is moved up and down the vertical line it will be seen that the distance  $D$  varies greatly, passing through several odd and even multiples of half-wave lengths. This means that the distribution of energy along the vertical line through  $p$  will pass through max-

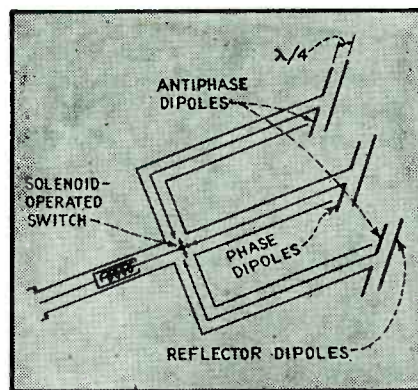

FIG. 8—Triple-head antenna system

ima and minima. The first maximum will occur when  $D$  is equal to a half-wavelength. The relationship between the angle of this first maximum and the height of the antenna for the small angles involved is then  $\alpha = \lambda/4h$  since  $D = \lambda/2$  for maximizing, where  $\lambda$  is the wavelength and  $h$  the height of the antenna. The first minimum occurs where  $D = 1$  wavelength and will therefore be twice the angle of the first maximum. The resulting complete radiation pattern is shown in Fig. 6 at (a). The succeeding lobes get shorter and shorter because although each one of them is the sum of direct and reflected ray, each of these rays gets smaller and smaller in energy value as the angle  $\alpha$  is increased and finally reach zero when the direct and reflected paths are tangent to the free-space radiation pattern. This means that the envelope of the complete radiation pattern will be the same as the free-space radiation pattern, although the length of the longest lobe will be twice the length of the free-space

lobe because it is the sum of two rays, each of which is nearly equal to the maximum energy in the free-space radiation pattern.

From the complete radiation pattern it can be seen that there are large areas where no radio energy is present. This would allow enemy aircraft to fly into these areas without being detected. Many schemes have been used to overcome this deficiency in early warning radar sets. The one adopted for the AN/TPS-3 is known as the phase-antiphase system. Looking again at Fig. 5 it can be seen that if point  $p$  is at a minimum and by some means the reflected ray could be moved 180 deg out of phase with the direct ray, point  $p$  would immediately become a maximum. This phase shift is the basis of the phase-antiphase system. The antenna is arranged so that by means of switching it can produce either the free-space pattern shown in Fig. 7A or the free-space pattern shown in Fig. 7B; in the latter case the upper lobe is 180 deg out of phase with the lower lobe.

The antiphase radiation pattern is shown in Fig. 6 at (b). Here the lobes are small at the low angles, pass through a maximum, and are small again at the high angles. This occurs because the energy in the free-space pattern is low at small angles, reaches a maximum at about  $7\frac{1}{2}$  deg, and then decreases again. Superimposing the phase and antiphase coverage patterns gives a pattern of the total coverage of the radar set. Contours can be drawn representing the loci of point where the energy is just sufficient so that the amount reflected from a medium-sized aircraft will be detectable by the receiver. Such contours represent the maximum range.

From the discussion on formation of maxima and minima it can be seen that the coverage diagram can be greatly altered by changing either the frequency or the height of the antenna. The height of the antenna is usually restricted by mechanical considerations and features of the terrain. Therefore, to get low-angle coverage as high a frequency as possible is used. That is why 600 mc gives more efficient low-angle coverage than the lower-frequency radar sets. Higher frequencies would give still better low angle coverage.



### Radio-Frequency System

As stated previously, the AN/TPS-3 employs a 10-ft parabolic reflector. It is also provided with two different antenna feeds that can be used interchangeably. One is a simple halfwave dipole at the focus of the parabolic reflector, with a parasitically excited halfwave reflector a quarter wave in front of it. This combination produces a single free-space lobe such as that shown in Fig. 7A. The purpose of the reflector is to prevent direct radiation from the dipole, and results in an increase in gain.

The second type of antenna feed is the one used to produce phase and antiphase patterns. This array consists of three dipoles spaced vertically a quarter wave apart in the plane of the focus, with center dipole at the focal point. Each one of these dipoles has its associated half-wave parasitic reflector a quarter wave in front of it. These three dipoles are so arranged that either the center dipole alone or the two outside dipoles may be driven. When the center dipole alone is driven the result is a single free

space lobe such as shown in Fig. 7A. The outside dipoles are so connected that they are fed 180 deg out of phase, which is very simply arranged by connecting the left side of the upper dipole to the center conductor and the right side of the lower dipole to the center conductor and then feeding the pair in parallel from a common point. When these two dipoles are driven the result is a split pattern such as that shown in Fig. 7B, with the upper lobe 180 deg out of phase with the lower lobe.

The switching between the phase dipole and the antiphase dipoles is done by means of a solenoid-operated plunger which is controlled from a switch on the panel of the radar set. The plunger merely connects the center conductor of the transmission line to either the center dipole or the outside dipoles as shown in Fig. 8.

The antenna radiators are connected to the transmission line by means of a 50-ohm rigid coaxial line. In order that this line be flat, or without appreciable standing wave, every precaution is taken to match the antenna radiator to this line. This is done by means of quarter-wave transformers consisting of sections of inner conductor of different diameter from the diameter of the inner conductor of the transmission line itself. By properly choosing the diameter and position of such a quarter-wave transformer, the antenna radiator can be

matched to the transmission line.

The requirement of a flat line precludes the use of insulating beads as supports for the inner conductor, since many beads in the line would produce reflections and, therefore, standing waves. Instead of beads, quarter-wave stubs are used to support the inner conductor. A section of transmission line, short-circuited at one end and a quarter-wave long, has an extremely high impedance looking into the open end. When such a section is shunted across the line it does not produce any appreciable reflection. Such quarter-wave stubs, spaced at intervals along the transmission lines, can be used to support the inner conductor. However, since a stub is a sharply tuned resonant circuit it can be used only at one frequency. The AN/TPS-3 operates over a band from 590 to 610 mc, so that provision must be made for allowing the transmission line to pass this band of frequencies without appreciable reflections. This is done by making the characteristic impedance of the support stubs 100 ohms as compared to 50 ohms for the transmission line proper.

Another interesting feature of this transmission line is the rotary joint. The antenna must be able to rotate continuously, so the transmission line must be broken at some point and means provided to pass energy from the stationary to the rotating side. This breaking is done

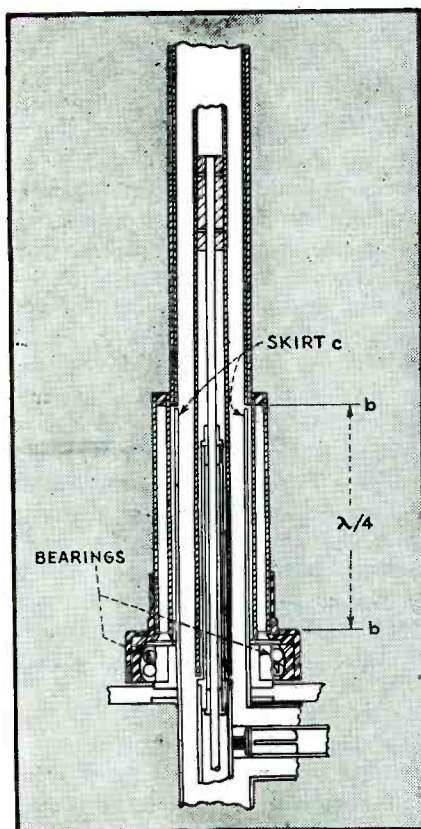

FIG. 9—Transmission-line capacitance joint

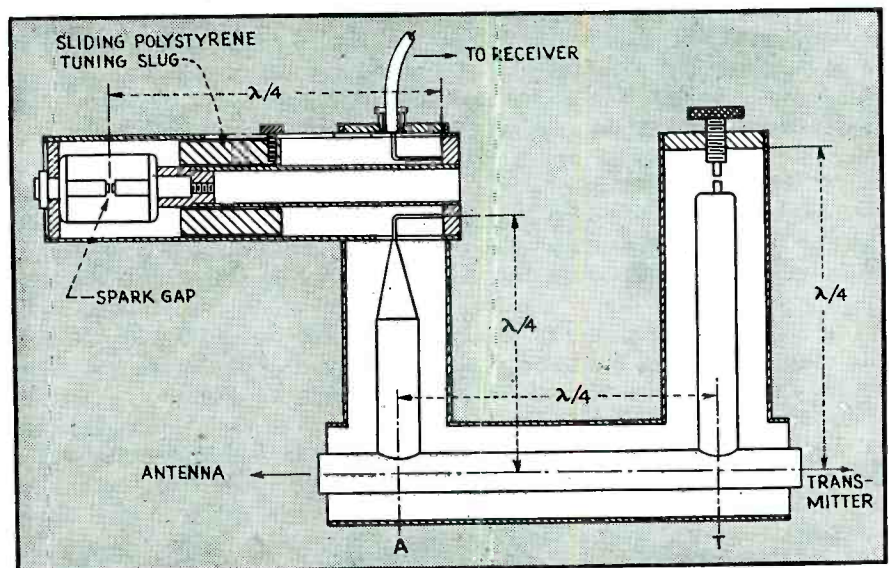

FIG. 10—Sketch of the t-r switching system



by means of a capacitance joint. A sketch is shown in Fig. 9.

The sections *bb* can be considered as forming a transmission line of very low characteristic impedance by themselves. Because this line is open circuited at the antenna end and is a quarter wave long, it is effectively short circuited at the transmitter end. The transmitter energy therefore passes from the stationary to the moving part. The function of the skirt *c* is for broad banding and also allows the bearing to be placed at a zero-current point. This bearing carries the total thrust load of the super-structure.

The inner conductor functions in essentially the same manner except that it is unnecessary to fold the line back upon itself in a skirt as in the case of the outer conductor. In the inner conductor, the  $\frac{1}{4}$ -inch rod extending beyond the rotary joint itself performs the same function as the skirt in the outer conductor. Oilite bearings are used on the inner conductor.

Moving down the transmission line toward the transmitter, the next interesting feature is the t-r or transmit-receive system. As shown in the block diagram (Fig. 4) the transmitter and receiver are connected to the same antenna. Some means must be provided to protect the input of the receiver from the high power present in the line when the transmitter is operating and to prevent the received signal from being dissipated in the transmitter instead of flowing into the receiver. This is accomplished by a combination called a receiver-disconnect switch and a transmitter-disconnect switch. The combination of these two components is called the t-r system. A functional diagram is shown in Fig. 10. The transmitter-disconnect switch consists of a quarter-wave section of line with a spark gap in the end. When the spark gap fires, this quarter-wave section is short circuited and therefore presents a very high impedance at its open end. When the spark gap is not firing, the quarter-wave section is open circuited and presents a short circuit at the transmission line. A quarter wavelength toward the antenna from the transmitter-disconnect switch is the receiver-disconnect switch. This consists of a high-Q cavity a quarter wave-

length long, short-circuited at one end with a spark gap between the center conductor and ground at the open end. The transmission line and the receiver are both coupled into this cavity by means of loops. When the spark in this cavity is firing, the cavity is detuned and the receiver is decoupled from the transmission line. When the spark gap is not firing the cavity is tuned and energy passes freely from the transmission line to the receiver.

The operation is as follows:

When the transmitter is operating, a high voltage is present in the line. This fires the spark gap in the transmitter-disconnect switch, which then acts as a quarter-wavelength short-circuited stub and has no effect on the line. A high voltage is also built up in the cavity of the receiver-disconnect switch, firing its spark gap as well. This effectively decouples the receiver from the transmission line. When a received signal comes down the transmission line from the antenna, the voltage is extremely small. This voltage is far too small to fire either the spark gap in the transmitter-disconnect switch or the spark gap in the receiver-disconnect switch. The transmitter disconnect switch will therefore be an open-circuited wavelength and will appear to be a short circuit at the transmission line end. A quarter wavelength toward the antenna, at the point where the receiver-disconnect switch ties in, this will be reflected as an open circuit. Therefore, no energy will flow toward the transmitter. On the other hand, the receiver-disconnect switch is now a high-Q tuned cavity. The received energy will therefore flow freely from the transmission line cavity into the receiver.

The transmission line is connected to the transmitter through a network which provides a means of matching impedances. This network consists of two stubs of variable lengths spaced  $\frac{3}{5}$  of a wavelength apart. These are known as tuning stubs. Since a short-circuited stub of variable lengths acts as a pure variable reactance either capacitive or inductive, depending on its length, such a stub when properly placed may be used to match a transmitter of arbitrary impedance to a transmission line.

However to avoid the mechanical difficulty of properly placing this stub on the transmission line two stubs are used and spaced  $\frac{3}{5}$  of a wavelength apart. By properly adjusting the length of these stubs, any impedance from infinity to one half the impedance of the line can be matched to the line.

The next and concluding installment on the AN/TPS-3 will describe the transmitter, modulating system, receiving and indicating system.

#### Acknowledgments

Responsibility for the construction of the AN/TPS-3 was directly assigned to J. W. Marchetti, who was assisted by William P. Goldberg as civilian engineer in charge. Many individuals of the Camp Evans Signal Laboratory contributed in the design of various features of this equipment. The modulator, indicators, and transmitter were turned over to a group headed by Dr. John E. Gorham. Within this group H. P. Pacini was responsible for the design of the indicators and I. Sager for the modulator. The transmitting tube, which was designed by the first named author, required very little additional development, since it had been in semi-production for some time and required only minor changes to adapt it for use in a lightweight radar set being styled for mass production. Later, when the set went into production, Dr. Gorham handled the manufacturing problems incidental to the construction of the transmitting tube. The physical arrangement of the set was due to William J. Smith and he further played a large part in the overall coordination. The major part of the mechanical design of this set was due to Arthur H. Hood.

The VT-158 vacuum tube, which is the heart of the set, is unique in that it includes all of the transmitter under vacuum in a single envelope, thus minimizing seal losses and arcing. The first model of this tube was built by H. A. Zahl in 1939 at the suggestion of Major General Roger B. Colton. The personal interest shown by General Colton, and his many valuable suggestions during the design of all elements of this radar, in no small way contributed to its success.

# Vehicular-Mounted MINE DETECTOR

Detection of a mine, or failure of the electronic apparatus, automatically sets the brakes of a jeep before the front wheels reach the explosive. False signals are discriminated against by phase selection. Variometer tube minimizes circuit drift

By

**H. G. DOLL**, *Director of Research*

**M. LEBOURG**, *Chief, Mechanical Engineering Dept.*

**G. K. MILLER**, *Electronic Research Engineer*

*Schlumberger Well Survey Corporation\*  
Houston, Texas*

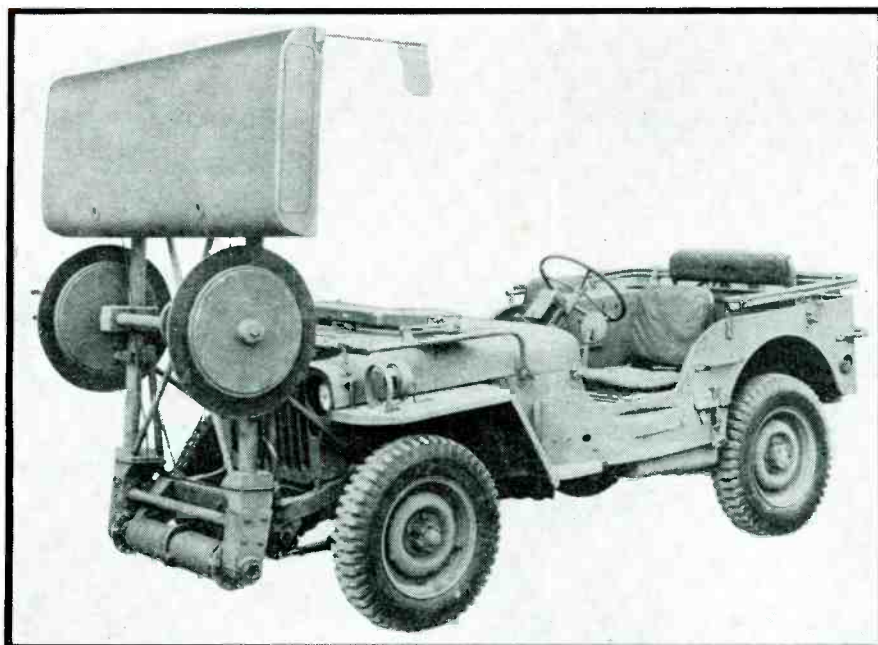

The mine detector mounted on a jeep, showing how articulation on the front bumper permits it to be raised to a vertical position when not in use

**I**N ORDER to speed up the clearance of mines in roads and fields a vehicular-mounted detector was developed during the war.

\* All three co-authors on leave of absence, at Electro-Mechanical Research, Inc., Houston, Texas

The problem was to devise a metallic-mine detector, the sensitive elements of which could be carried in front of a vehicle running at a reasonable speed, the system being so arranged that the vehicle would be automatically stopped before roll-

ing over the mine and exploding it.

The circuit adopted is similar to those used in portable mine detectors, comprising a transmitting coil energized by an oscillator, and a receiving coil connected to an amplifier, the mutual impedance between the two coils being nullified in the absence of mines. Vehicular operation calls, however, for a number of special features which are described in the following paragraphs.

#### The Boom

In a vehicular device the coils obviously have to be carried ahead of the vehicle, and therefore must be supported by some kind of boom. If a rigid attachment were used, the elevation of the coils above ground would vary too much in rough terrain, therefore an articulation must be provided which makes it possible

**electronics  
WAR REPORT**



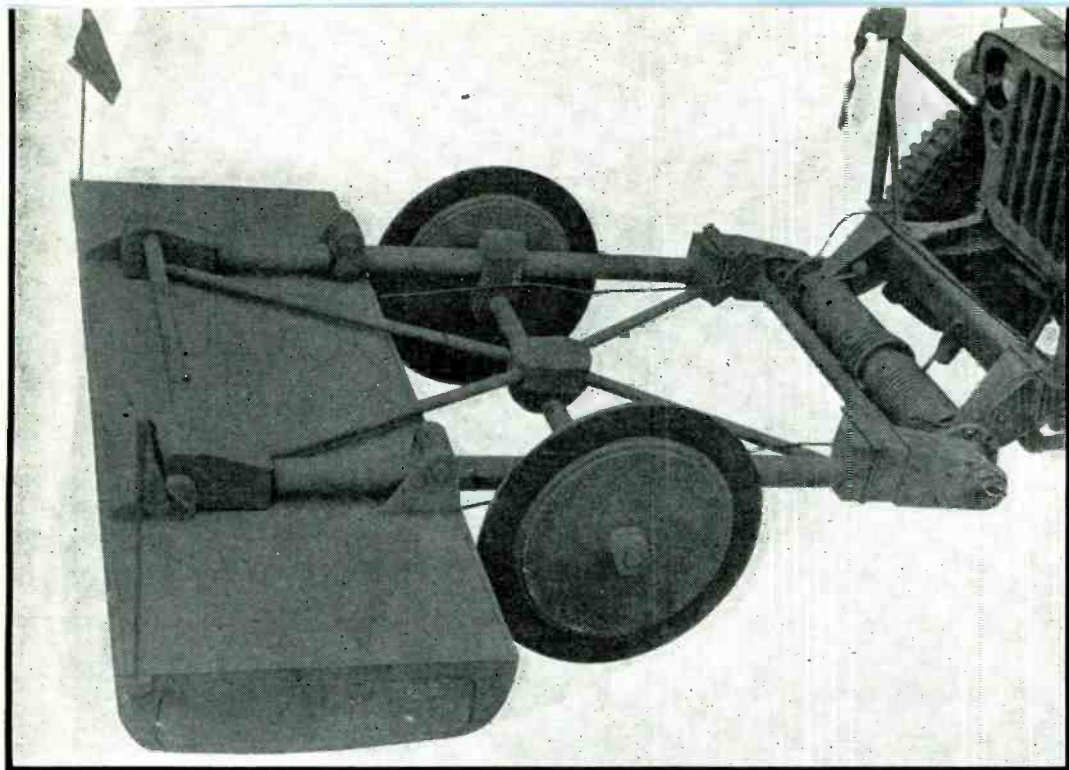

FIG. 1—The vehicular-mounted mine detector with boom lowered

to keep the coils at a reasonably short distance from the ground.

As a manual operation of the boom is impossible when the vehicle moves at a speed of 5 to 8 miles an hour, as required, and as a system of servo control would be complicated and bulky, the solution was to balance most of the boom weight by means of an adjustable torsion-spring system, and to rely on wheels supporting the boom exerting a low pressure on the ground. The boom structure, in other words, was made sufficiently sensitive so that its weight, working against the torsion system, keeps it at a reasonably uniform height above ground at the normal driving speed. The structure is shown in Fig. 1.

To prevent electromagnetic action on the coil system, the boom is built of plywood tubing and wooden blocks. Due to the articulation on the front bumper, the entire boom assembly can be set in a vertical position when not in use. This is the traveling position which provides adequate visibility for the driver through the boom frame.

#### The Flexible Wheels

The use of wheels to support the boom, even though they carried only a little weight, created a difficult problem of steering. On sharp turns, and especially in rough terrain, ordinary wheels would catch on the surface irregularities of the ground, and this would result in

tremendous stresses on their bearings and on the boom. The seriousness of this difficulty was further increased by the fact that the wheels, being necessarily in the vicinity of the coils, had to be of a nonmetallic nature in order not to give false signals.

The problem was solved by the use of special wheels. In these wheels the tire is replaced by a flexible rubber disc clamped between two wooden flanges of substantially smaller diameter. The rubber disc is rigid enough to support the small pressure on the wheel when the motion is forward, but when a turn is taken a lateral effort is exerted on the disc, which bends and slides over surface irregularities.

#### Brake and Declutching Mechanism

A fair driving speed is desirable to achieve efficient clearance of mined areas, and also to avoid staying in dangerous battle zones longer than necessary. If the car had to be manually stopped by the driver when a mine signal was received, a human time lag would be involved, and the coils would have to be carried far ahead to avoid accidents, while the operator would be constantly under strain. For these reasons, it was considered necessary to provide the equipment with an automatic stop system. This automatic stop system employs a combination of springs and trigger mechanisms working almost instantaneously on both the foot brake and the clutch,

FIG. 2—Equipment installed in a jeep. To the right of the driver's seat is a case that contains the power supply, oscillator, amplifier and balance controls. Visible between the spokes of the wheel is the control box which includes a meter indicating circuit balance and the presence of a mine, an automatic stop-control switch and warning lights. Two handles used for recocking the automatic stop system may be seen near the bottom of the steering column

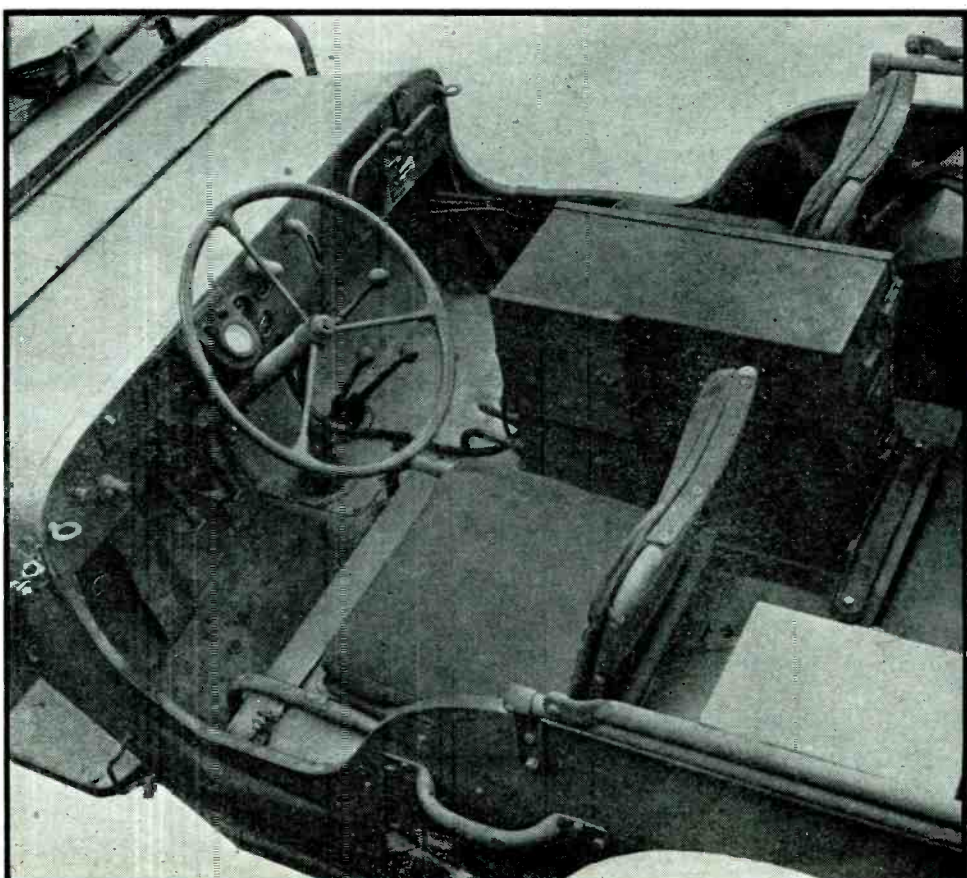



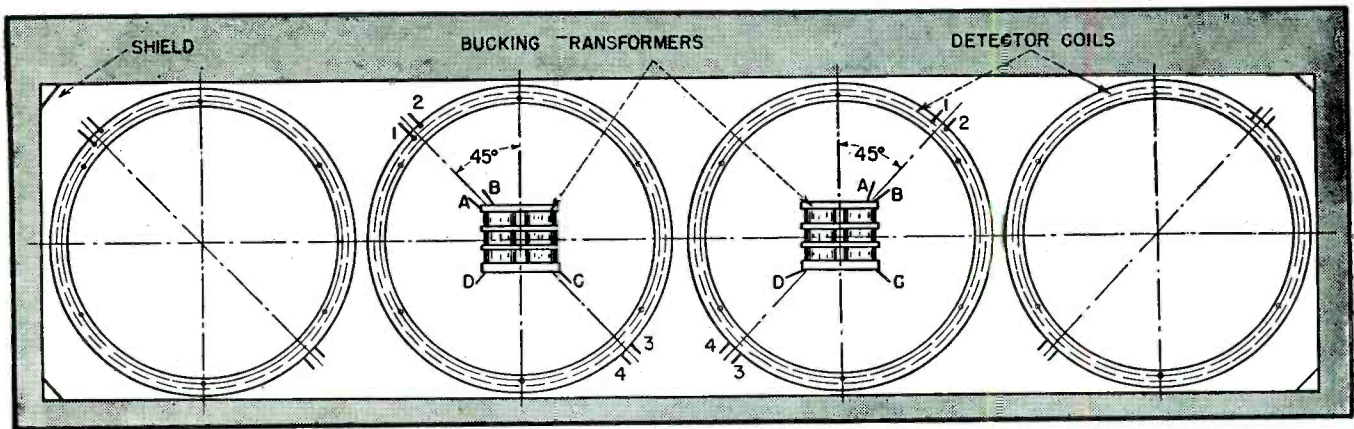

FIG. 3—The arrangement inside the coil box

and is actuated by the mine signal itself.

The automatic brake and clutch mechanism is fast and powerful; it applies 500 lbs on the brake master cylinder in a fraction of a second. It is so arranged that manual operation of the foot pedals by the driver is not impaired in any way. Guard plates are provided to prevent the driver's feet from being trapped by the pedals, as well as handles for recocking both pedals, as shown in Fig. 2.

#### Coil Box

The coil assembly must be wide enough to cover the whole width of the vehicle, which is about 6 ft for a jeep, and cannot be made rigid without adding unduly to the weight. In rough terrain the coil box is badly shaken, and when bumps are encountered which lift one boom-supporting wheel more than the other or when turns are made, substantial twisting effects take place. Were it not for the special construction used, this would result in substantial variations of the mutual inductance between the transmitter and the receiver coil, and therefore in false signals.

To minimize this difficulty, the coils are mounted in a hermetically-sealed and relatively thin rectangular wooden box which is fastened in the front housing through a three-point suspension. With this arrangement, motions or deformations of the front housing have very little tendency to produce any twisting effect on the coil assembly and practically no false signals result from mechanical shocks. Such false signals as might otherwise occur from that source are further discrimi-

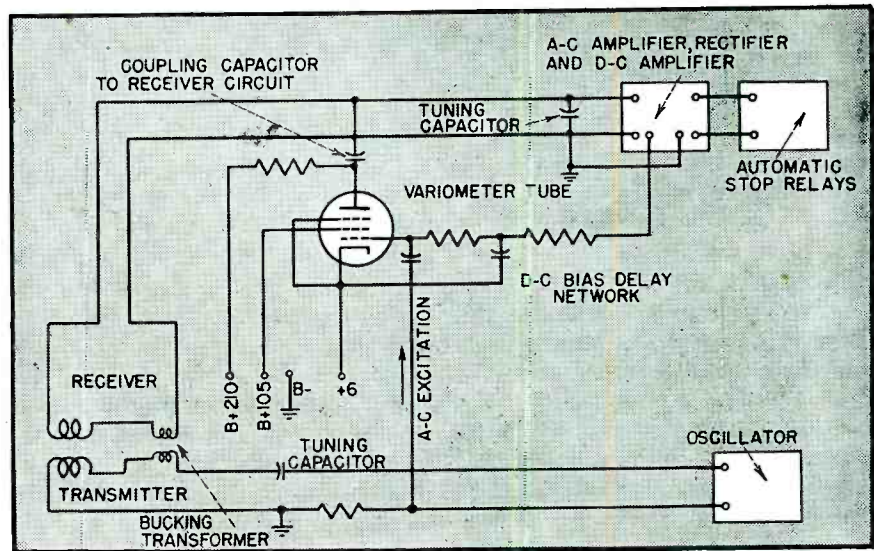

FIG. 4—Simplified schematic of the mine detector circuit, showing in particular the automatic drift stabilizing system of which the variometer tube is an essential part. A complete schematic is given in Fig. 6

nated against by phase selection, as will be explained later.

Four circular coils are laid side by side as shown in Fig. 3 and connected in a series. These four coils are used as a transmitter. A second series, also of four coils, mounted flat on the first ones, is used as a receiver. The mutual inductance between transmitter and receiver coils is nullified by a group of air-core transformers giving an equivalent mutual inductance of opposite polarity.

Electrostatic shielding, to avoid capacitance effects when the coils approach the ground, is provided by a Faraday shield of thin copper wires imbedded in the bottom part of the coil-box.

The front housing serves as a sunshade for the coil system and is provided with ventilating holes. These holes have the additional ad-

vantage of letting water fill the front housing when driving in streams or ponds, thus preventing the housing from floating on the surface, and allowing it to follow the ground.

#### Automatic Drift Control

In conventional detectors the mutual impedance between transmitter and receiver coils has to be manually nullified time and again, generally by means of two variometers corresponding respectively to the inductive and resistive components of the signal. This is primarily because changes in temperature of the coil assembly produce uneven thermal expansion, which results in a progressive change of the mutual impedance, with a corresponding drift of the output signal. In the vehicular detector drift is particularly undesirable. Rebalancing takes



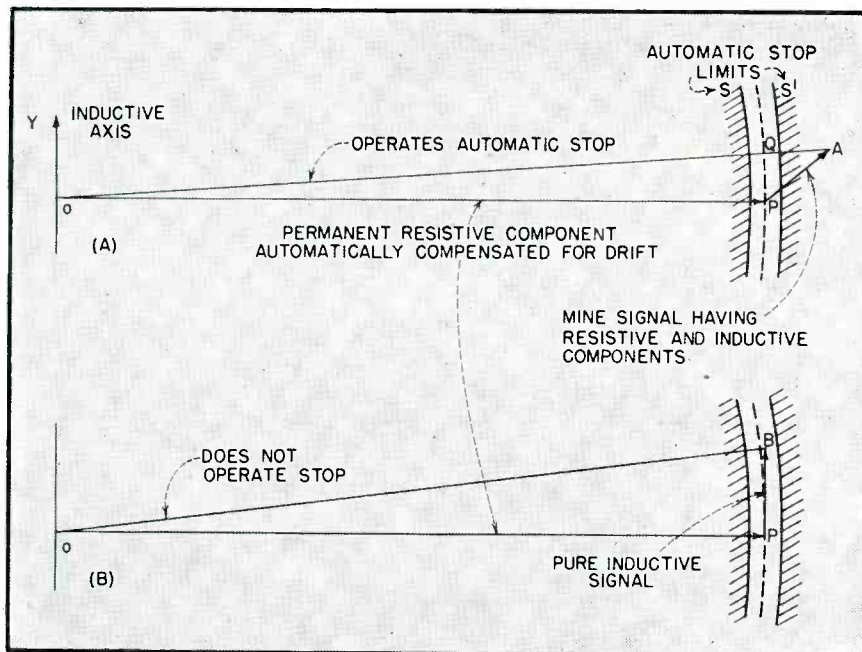

FIG. 5—Principle of phase relation which causes a mine signal to operate the automatic stop system (A), while a moderate inductive signal due to magnetic ground effect or mechanical deformation has no effect (B)

time, and in this case speed is the goal. For that reason, an automatic electronic system has been devised which practically eliminates the drift.

The drift compensator consists essentially of a variometer tube. This tube is a variable- $\mu$  pentode, the grid of which is a-c modulated by the transmitter current, while the plate is coupled to the receiver circuit, as shown in Fig. 4. A signal is therefore injected into the receiver circuit, and the magnitude of this signal depends on the d-c bias impressed on the control grid of the variometer tube. The signal at the output of the main receiver-amplifier is rectified and the d-c voltage obtained, after one stage of amplification required to get enough power to operate a relay, is fed back through a resistance-capacitance delaying network to the grid of the variometer tube.

It will be seen that with this arrangement the system is self-stabilizing, and tends to keep the output signal constant, or at least insensitive to slow drift. The action is somewhat similar to that of an automatic volume control, except for the fact that the use of a variometer tube makes it possible to predetermine the phase of the signal injected by proper choice of the excitation phase and coupling to the receiver circuit. The auto-

matic control takes into account not only drift due to thermal expansion of the coil assembly, but also any changes in the power output of the oscillator and of the overall gain in the a-c amplifier, rectifier, and d-c amplifier network.

Because of the automatic drift control, manual rebalancing of the system is very seldom required. While conventional detectors frequently have to be readjusted every five minutes, the vehicular detector will usually work without touching the manual controls for at least a whole day, whatever the weather conditions.

The drift control does not adversely affect the equipment's sensitivity to mines. When the detector coils pass over a mine, the signal is suddenly modified and the change is too quick for the automatic control to balance it. The output signal level changes and operates a differential relay which is normally in its neutral position. This trips a latch-type relay, which operates the brake and clutch mechanism.

The above system, based on the use of an automatically controlled permanent signal, has two additional advantages. One of them is to give some phase selection. The second is to provide a warning in the event of breakdown of the circuit. If conventional operation at true balance were used, there would be

no output signal under normal conditions, but something could deteriorate in the circuit with the result that the output would remain at zero even though a mine was encountered. In the vehicular device, every breakdown of the circuit automatically produces a substantial change of the output signal, either up or down, so that the brake and clutch mechanism is immediately tripped and the vehicle stopped.

### Phase Selection

The a-c excitation of the variometer tube, together with its coupling to the receiver circuit, can be so chosen as to give to the injected signal any desired phase with respect to the transmitter current. In the vehicular-mounted detector the phase of the injected signal has been chosen at 90 deg with respect to inductive signals, such as those produced by a change in the mutual inductance of the coils. The result is that the detector has been made substantially more sensitive to resistive components, which are always an important part of a mine signal, than to purely inductive components which might result from changes of elevation above magnetic ground, or sudden twists of the coil assembly when passing over rough ground.

The theory of the system of phase selection will be better understood by referring to the vectorial diagrams of Fig. 5. In these figures the vectors represent a-c potential differences applied to the input of the amplifier. These potential differences are characterized by both their amplitude and their phase. They are considered as inductive, and the corresponding vectors are plotted parallel to the inductive axis (OY), when they have the same phase as that which would be produced by a mutual inductance between transmitter and receiver coils. Conversely, they are considered as resistive, and the corresponding vector is plotted parallel to the OQ axis, when they are 90 deg out of phase with respect to the inductive voltage. A mine signal is neither purely inductive nor purely resistive, and is therefore represented by a vector which makes an angle with both axes.

The permanent resistive compo-

nent, which is injected into the receiving circuit by the automatic variometer tube, is much larger than the signals from mines or other sources. Its amplitude is kept substantially constant by means of the d-c feedback bias system already described. (Strictly speaking, it is not the input potential difference that is kept constant by the automatic control but the output current of the whole amplifier; the two things are equivalent only if the gain is constant, which was assumed here for simplicity.) As Fig. 5A shows, a mine signal, such as *PA*, combining with the permanent resistive component *OP*, will give a resulting amplitude *OA* which is outside of the narrow limits within which the automatic stop system is not operated (the automatic stop limits are represented by the circular arcs *S* and *S'*). If a pure inductive signal such as *PB* on Fig. 5B, which might be due to magnetic ground, or mechanical distortion of the coils, combines with the per-

manent resistive component *OP*, the resulting amplitude *OB* is little different from *OP*, and stays within the limits where the automatic stop is not operated.

### Field Operations

Before starting actual detecting operation, the circuit is balanced by means of manual controls which consist essentially of two variometers giving respectively inductive and resistive components of compensating voltage. While this adjustment is being made, the automatic control is put out of action by means of a switch. A waterproof cover is then set over the control panel of the oscillator-amplifier box, and from then on the operator uses a very simple control box mounted on the steering column. This control box contains a meter which enables the operator to know at all times if the circuit is still in good balance, and also indicates the presence of mines. In addition, it con-

tains a switch to disable the automatic stopping equipment when automatic stopping is not desired. A pilot light shows when the equipment is turned on, and another warning lamp tells whether all the switches and equipment are in operating condition for the detection of mines.

A complete circuit diagram of the vehicular-mounted mine detector is shown in Fig. 6.

### Acknowledgment

The responsibility for the development of mine detection equipment is assigned to the Engineer Board, the development agency for the Corps of Engineers, U. S. Army, and the device described above was developed for that agency. Brigadier General John W. N. Schulz is president of the Engineer Board, with Capt. G. S. Slaughter of the Applied Electronics Branch now assigned the responsibility of directing the work as project officer.

FIG. 6—Complete schematic of the vehicular mine detector

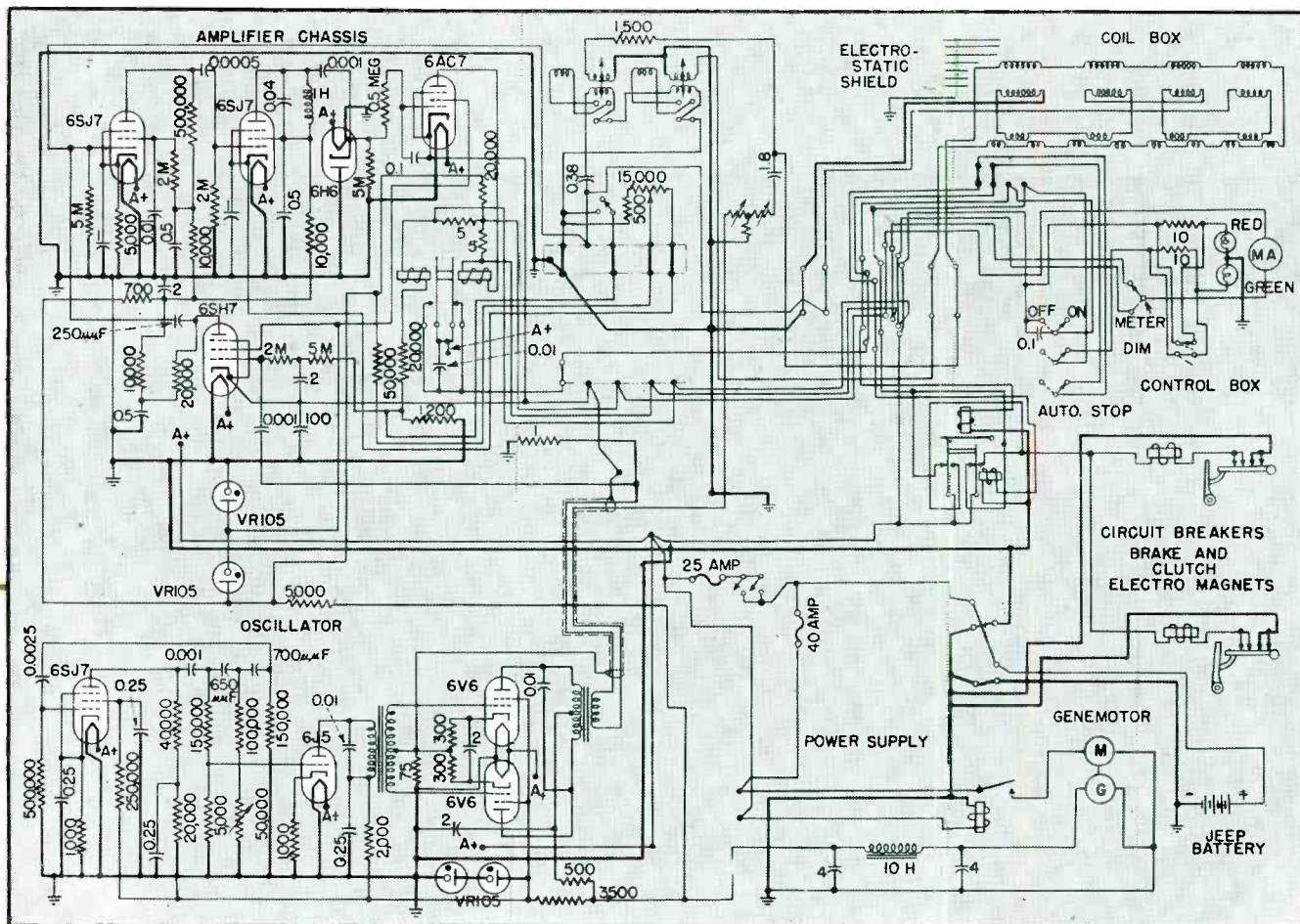



# The MPG-1 Radar

The transmitting, r-f, receiver and antenna-positioning systems of the 3-cm coastal defense radar are described in this second article of a series. Details of the scanner which swings the radiated beam over a 10-degree arc at a rate of 160 degrees per second are included

By **H. A. STRAUS, L. J. RUEGER, C. A. WERT**

*Radiation Laboratory, Massachusetts Institute of Technology, Cambridge, Mass.*

and **S. J. REISMAN, M. TAYLOR, R. J. DAVIS, J. H. TAYLOR**

*Radio Division, Bendix Aviation Corp., Towson, Md.*

**I**N THE FIRST installment of this series the history, characteristics and a general description of the AN/MPG-1 radar were presented. In this installment the transmitting system, r-f system, receiving system and antenna-positioning system are described.

## Transmitting System

Transmitted radar pulses must be narrow in width to give good

range resolution, and a steep leading edge is required to give good range accuracy. The peak power must be high in order to produce strong echoes from distant targets, since the intensity of received signals is inversely proportional to the fourth power of the target range. To obtain good definition a high repetition rate must be used. The AN/MPG-1 transmitting system is designed to produce r-f pulses at fixed intervals. The modulator

unit generates a high-voltage keying pulse which fires the magnetron transmitting tube. During the keying pulse, the magnetron oscillates, generating r-f pulses at approximately 10,000-mc frequency and at least 35 kw peak power (35 watts average).

When using the ppi-scope the keying rate is 1024 cps and the transmitted pulse width is 1.0 microsecond. On the B-scope, the keying rate is 4094 cps and the

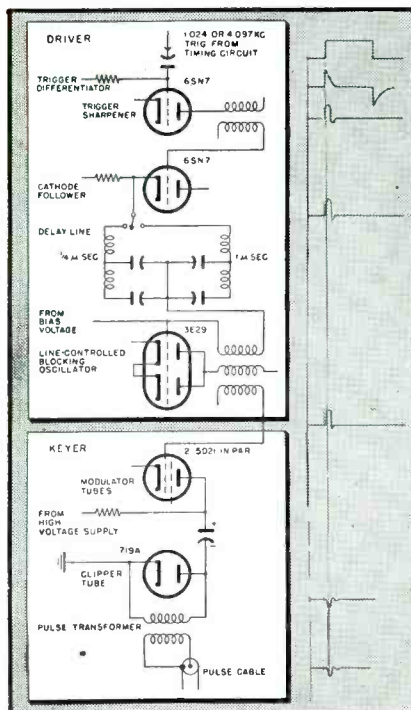

FIG. 1—Simplified schematic of the driver and keyer circuits

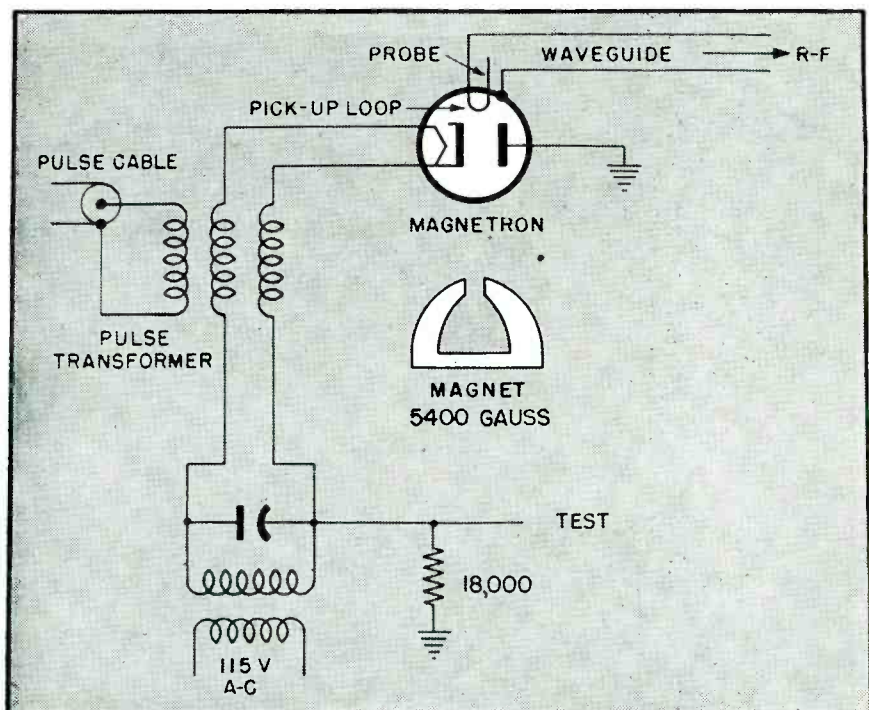

FIG. 2—Pulse transformer input to the magnetron. The magnetron operates at an efficiency of about 36 percent, producing 40-kw pulses in the output circuit



AN/MPG-1 trailer, tower and radiator. The "bath-tub" radiator is elevated within the tower to raise it to operating position

pulse width is 0.25 microsecond, to achieve better range resolution and definition on the B-scope than the ppi.

The modulator, shown schematically in Fig. 1, consists of two main circuits: driver and keyer. The driver circuit produces a synchronized pulse of the desired width and the keyer circuit generates a high-voltage, negative keying pulse which fires the magnetron. Basic timing is established by a 2-microsecond pulse from the timing system. In order to obtain stability and good range accuracy, the line-controlled blocking oscillator must be triggered by a narrow pulse which is accurately fixed with respect to the range circuit and has a very steep leading edge of high amplitude. Therefore the input trigger is differentiated, giving a positive and negative peak, and the positive peak is differentiated again and amplified before being used to trigger the blocking oscillator. The cathode follower matches the high imped-

ance of the trigger sharpening transformer to the lower impedance of the delay line.

The positive trigger is applied to the blocking oscillator control grid through the pulse-forming delay line, thus raising the grid bias above cutoff and initiating plate current flow through the primary of the plate transformer. The voltages induced in the grid winding and output winding of the transformer are proportional to the rate of change of magnetizing current in the plate winding. At the first increase in plate current, an induced voltage of positive polarity appears at the grid, making the grid more positive, which increases the plate current still more. The action is cumulative, resulting in a high, rapidly-induced positive grid voltage. Because of the inductance of the plate winding, the plate magnetizing current increases exponentially. Meanwhile, since a positive voltage appears at the grid end of the secondary winding, a negative

voltage appears at the delay line end, and the capacitors of the delay line begin to assume a negative charge at a rate determined by the L-C time-constant associated with the line. The time constant of the delay line and plate transformer are such that by the time the plate current has increased to some extent along the linear portion of the exponential the delay line has become fully charged and the grid voltage drops rather suddenly. This causes a sudden decrease in plate magnetizing current, which results in an induced negative voltage which lowers the plate current still more, inducing more negative grid voltage, etc. At the end of this degenerative process, which is very rapid, the grid is driven far below the fixed negative bias; but before the next trigger arrives it has returned to the fixed bias. The output of the blocking oscillator is a +1000-volt pulse having a steep leading edge, a relatively flat top and a duration of 0.25 or 1 microsecond, depending upon the pulse line used.

One plate of the pulse capacitor is connected to the plates of the modulator tubes and the other plate is grounded through the primary of the output pulse transformer. In the interval between synchronizing triggers, the pulse capacitor is a charge-storing reservoir, receiving a positive charge from the high-voltage power supply through the modulator plate resistor. When the synchronizing trigger arrives, the modulator grids are driven approximately 240 volts positive for the duration of the driver pulse, allowing the modulators to conduct, and thus providing a low-impedance-to-ground discharge path for the pulse capacitor. This is equivalent to shorting the capacitor to ground through the modulator plate resistance, causing the capacitor voltage to drop by 12.5 kv minus the 1.5 kv voltage drop across the modulator

**electronics**  
**WAR REPORT**



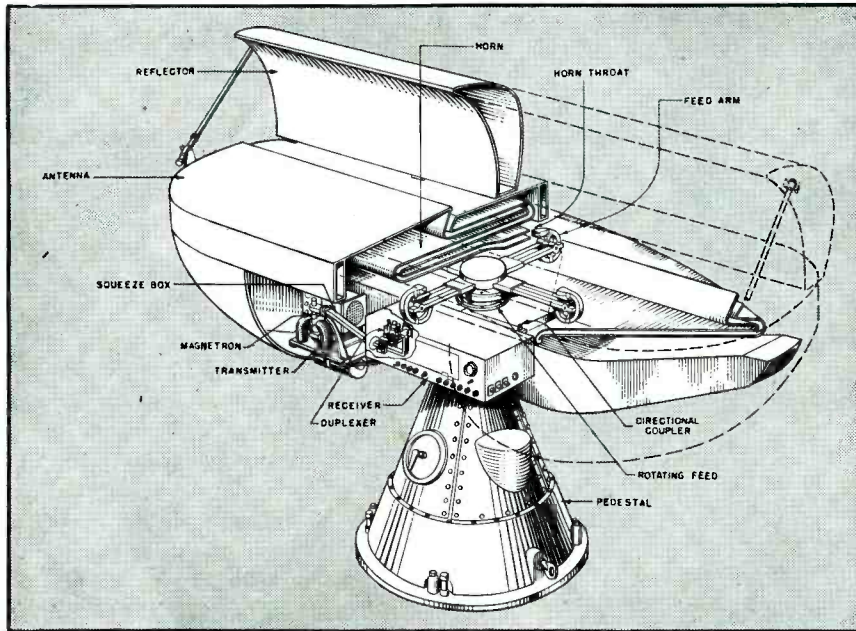

FIG. 3—Interior structure of the high-speed scanner and radiator. Waveguide feeds rotate past the input opening of a folded horn and reflector which produce a beam 0.6 degree wide

tube, ie, a net drop of 11 kv. The load side of the capacitor drops to  $-11$  kv, resulting in current flow to ground through the pulse transformer winding. Since the capacitor-resistor time constant is comparatively large, discharge takes place only on the linear portion of the exponential characteristic before the modulator tubes are cut off by the trailing edge of the driver pulse. Thus, the current surge through the primary winding of the transformer is such as to produce an output voltage of rectangular waveform. A 4 to 1 stepdown pulse transformer matches the keyer circuit impedance to the 50-ohm coaxial cable which conducts the pulse to the magnetron. At the magnetron, shown in Fig. 2, a 4:1 step-up transformer is used for impedance matching and voltage-change. This arrangement makes it possible to conduct the pulse at relatively low voltage, thus minimizing the danger of high-voltage flashover and breakdown. Another function of the step-up transformer is to make possible operation of the magnetron filament transformer at ground potential, despite the fact that the magnetron filament is made highly negative during the pulse.

One of two identical secondary windings of the pulse transformer is placed in each line from the filament transformer to the magnetron

filament. A potential of  $-11$  kv is induced across each winding and applied to the magnetron cathode. Since the filament transformer is connected across the low-voltage ends of the two windings, special insulation is unnecessary and the capacitance effect is negligible.

The transmitting tube is a magnetron which oscillates at approximately 10,000 mc when the keying pulse is applied. The magnetron current for the duration of the pulse is approximately 10 amperes, so the peak power input is approximately 110 kw. With magnetron efficiency at about 36 percent, the peak power output is approximately 40 kw.

Radio-frequency energy is inductively coupled to a pick-up loop and transferred to a short section of coaxial line terminated by a probe which radiates the energy down the waveguide toward the antenna. This coaxial line and waveguide are integral parts of the magnetron. The rectangular waveguide propagates the energy in the  $TE_{0,1}$  mode.

#### The R-f System

The r-f system is perhaps the most striking and original feature of the AN/MPG-1 radar. It consists of the "squeeze box," duplexer, directional coupler, rotating feed, horn and reflector. The r-f system is housed completely in a bathtub-

like structure commonly referred to as the antenna. Pivoted on a pedestal which contains the azimuth drive motor and gear train, the antenna is capable of 360-deg horizontal rotation, with control centered at the console in the trailer. Electrical connections between system components mounted in the antenna and those located in the trailer are made through a system of slip rings in the pedestal. Figure 3 shows the antenna semi-schematically and some of the units which it houses.

The chief features are (1) a suitable transmission system for conducting the magnetron output to the antenna feed, (2) an antenna-feed mechanism which provides a 10-deg scan 16 times per second on B-presentation so that fast, maneuvering targets can be tracked smoothly and accurately and, (3) a radiator which produces a fan-shaped beam very narrow in the horizontal dimension to assure good azimuth accuracy. A block diagram of the r-f system is given in Fig. 4.

Radio-frequency energy generated by the magnetron is conducted towards the antenna feed via rectangular waveguide. The squeeze box, or line stretcher, is a section of rectangular waveguide with a slot cut in the longitudinal dimension in the center of each wide face of the guide. By adjusting the width of the squeeze box it is possible to change the guide wavelength in the box and adjust the standing wave at the magnetron to the point where the magnetron has the greatest frequency stability.

The transmission system includes the duplexer (t-r) assembly which is located in the receiver. By means of the t-r and anti-t-r switch tubes, it is possible to use the same antenna for transmission and reception. The t-r tube is a high-speed gaseous switch which permits received signals to enter the receiving system, but prevents the high-power transmitted pulses from doing likewise, since this would result in destruction of the receiver crystal detector. The anti-t-r tube prevents received energy from entering, and being dissipated in, the magnetron cavity.

The directional coupler allows a small part of the transmitted energy to enter a test set, but blocks

the test set from receiving energy traveling in the opposite direction, ie, from the antenna towards the receiver.

The radiator is a folded, sectoral horn. Four waveguide feed arms (see Fig. 3), spaced 90-deg apart, rotate in front of the horn throat, transferring r-f energy to the horn from one feed arm at a time. Energy is conducted to the feed arms via a cylindrical rotating joint and r-f switch, shown in Fig. 5. Before reaching the cylindrical waveguide the energy is propagated in a rectangular waveguide in the  $TE_{0,1}$  mode. Symmetry considerations indicate that the lowest acceptable mode which may be used in a cylindrical waveguide is the  $TM_{0,1}$  mode. The necessary mode transformation is accomplished by means of a matching diaphragm and resonant ring placed near the junction of the rectangular and cylindrical waveguides. Impedances introduced by the mode transformer result in a broad band unit. At the junction of the stationary and rotating sections of the rotating joint a choke joint is fitted to permit free rotation of the upper member without having excessive loss by radiation. Feed-arm tuning is assisted by the resonant ring in the rotating member of the joint. Note that it is necessary to effect a transformation from the  $TM_{0,1}$  mode to the  $TE_{0,1}$  mode at the junction between the rotating joint and feed arms due to the fact that the feed arms consist of rectangular waveguide.

The rotating feed is tuned to the magnetron by means of a plunger in a closed cavity located above the feed arms. The inside diameter of the cavity is so chosen that the guide wavelengths of the  $TE_{0,1}$  and  $TM_{0,1}$  modes differ sufficiently to result in suppression of the former mode and enhancement of the latter by resonance.

The radiator, shown in Fig. 6, is a parallel-plate folded horn with a parabolic reflector which is a parabolic cylinder. The separation of the plates is held within such tolerances that the only modes which are propagated are those with the electric field perpendicular to the surface of the plates and having a wavelength equal to the space wavelength. Matching to the reflector is obtained by flaring the

horn mouth. To keep out moisture, a plastic member covers the horn mouth. Since the flare cover is built to a thickness of  $\lambda/2$ , reflections from the two surfaces of the cover cancel out and do not affect the match of horn to reflector. Any reflections resulting from local irregularities in the horn are scattered at random and do not reach the feed in appreciable quantity. The reflector, which reduces the vertical width of the beam, is illuminated by an equivalent line source of plane waves. The horn folds are so designed that when a feed arm is centered at the horn throat, the horn emits a plane wave propagated in a direction perpendicular to the length of the reflector. The principal sections of the horn folds are equivalent to the diametrical sections of the mirrors in an aplanatic optical system designed by J. G. Baker of Harvard.

The half-power beam-width on transmission is about 0.6 deg in the horizontal dimension and 3 deg vertically. The antenna system is relatively free from side lobes. Since the antenna is not frequency-sensitive, the system may be used with magnetrons covering a wide frequency range.

Scanning is accomplished by rotating the feed arms in front of the horn throat. Each of the four feed arms is a rectangular waveguide with a flared end which provides a good match between the guide and the horn. For each degree of displacement of a feed arm across the

horn throat, the emitted beam is displaced  $\frac{1}{2}$  of a degree in space. Thus a 10-degree scan is obtained by utilizing 80 degrees of feed arm rotation. This allows an adequate switching interval (10 deg) in which the next feed arm is brought into play. While one feed arm feeds the antenna through the opening in the fixed circular shorting ring, the other three arms are shorted by the ring. Each arm in turn feeds the antenna as the arm passes the opening in the ring.

When the B-scope is used for tracking targets the feed unit rotates steadily at approximately 4 rps. Since there are four feed arms, this results in 16 sweeps per second across a 10-deg sector in space. Smooth, accurate tracking of rapidly moving targets is greatly facilitated by a scan of this type.

When the ppi is used for surveillance one of the feed arms remains fixed at the center of the horn throat and the beam is always pointed along the antenna axis. In any case, whether on B-scope or ppi, the antenna axis may be rotated to any desired direction.

### Receiving System

The receiving system shown in Fig. 7 converts high-frequency echo signals into video pulses for presentation on the ppi, B, and remote-B scopes. The receiver itself is a sensitive superheterodyne with automatic frequency control, duplexer, an A-scope and power sup-

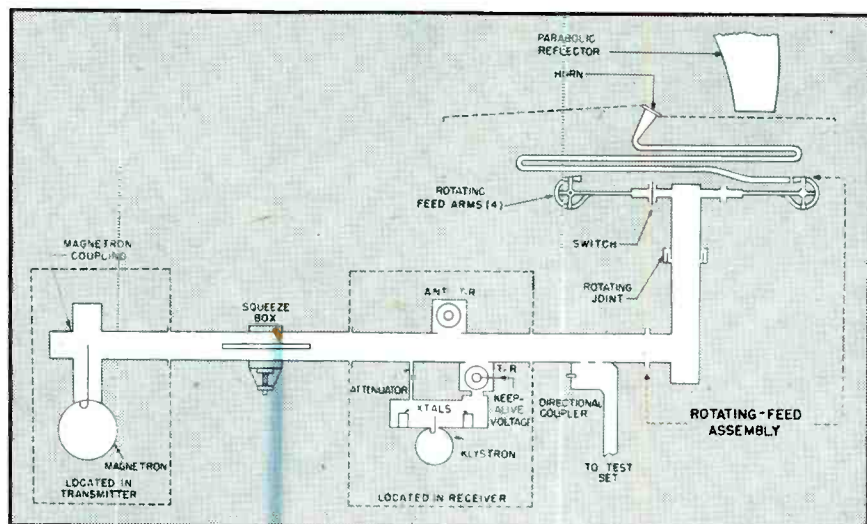

FIG. 4—The r-f system, showing the duplex switch (t-r and anti-t-r switch tubes), squeeze box, and rotating joints between transmitter and receiver and the radiator



ply. A sensitivity time control (stc) circuit is in the radar console in the trailer, but this circuit is properly considered part of the receiving system.

The mixer circuit consists of a klystron local oscillator and two crystals, one for a-f-c and the other for signal, as shown in Fig. 8. The afc crystal receives a small part of the transmitted energy through a 70-db attenuator, whereas the signal crystal receives echo signals from the r-f system. Since the transmitted energy and received signals are both of the same frequency, the same i-f signal (30 mc)

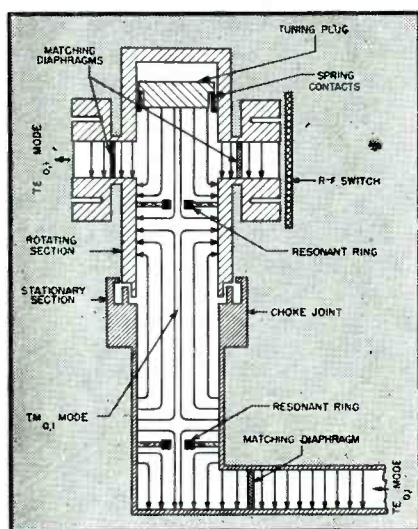

FIG. 5—Disposition of electric fields in the rotating joint and r-f switch, in which the wave is transferred from a rectangular to a cylindrical waveguide

is produced in each case as a result of mixing with the local oscillator output. It would have been possible to use a single crystal for generating 30-mc signals for the afc and i-f circuits, but the possibility of electronic jamming made it necessary to employ two crystals. If the signal-crystal output controlled the afc circuit, the enemy, using r-f energy of the proper frequency, could remotely tune the klystron frequency so far from the magnetron frequency that the resultant i-f signals would fall outside the frequency band of the i-f circuits, resulting in loss of normal signals.

The weak 30-mc signals from the signal crystal are amplified by the i-f circuits. In a radar receiver it is essential to preserve the steep leading edge of the echo pulse to

permit accurate measurement of target range. If the receiver bandwidth is too narrow the echo pulse becomes distorted. If the bandwidth is too wide, the pulse waveform remains good, but there is an increase in noise originating in the crystal and first i-f stage. A bandwidth of 106 mc with ample overall gain is obtained by staggered tuning of the i-f amplifiers and use of high-gm tubes (6AC7).

There are nine i-f amplifiers divided into 3 groups of staggered triples. In each staggered triple one stage is tuned to 30 mc, another to 24.8 mc and the third to 36.3 mc. The i-f coils are pretuned. The amplification of each staggered triple is made uniform over the working range by adjustment of the bandwidth and gain of each stage in the triple. Figure 9 shows the response of the i-f amplifiers. In order to prevent undesirable feedback between stages, the first eight stages of amplification are decoupled from one another in pairs. Bias is applied to the control grids of the second and third stages. The i-f gain is more than 110 db. The last i-f stage is coupled to a diode detector having a very low value load resistor (1200 ohms). The

negative video output from the detector is inverted and amplified by the following tube. The positive video output from the amplifier tube is used to drive the grid of a cathode follower. The cathode follower feeds a 70-ohm coaxial line which conducts the video signal to the video amplifier circuits in the range unit mounted in the operating console. Use of this low impedance coaxial line terminated at the console permits the video signal to be transmitted through slip rings in the pedestal and over a distance in excess of 100 feet with negligible distortion of the video pulse waveform.

An afc circuit keeps the klystron tuned to 30 mc above the transmitter frequency as shown in Fig. 10. When the afc circuit is used, the klystron frequency is regulated by automatic control of the repeller plate voltage which is governed by the voltage across capacitor  $C_2$ . By means of the action of  $C_1$ ,  $R$  and the 2050 control tube, the voltage across  $C_2$  is maintained at a little less than 100 volts.

The discriminator receives an amplified i-f signal and provides a negative output pulse if the transmitter has drifted below the proper

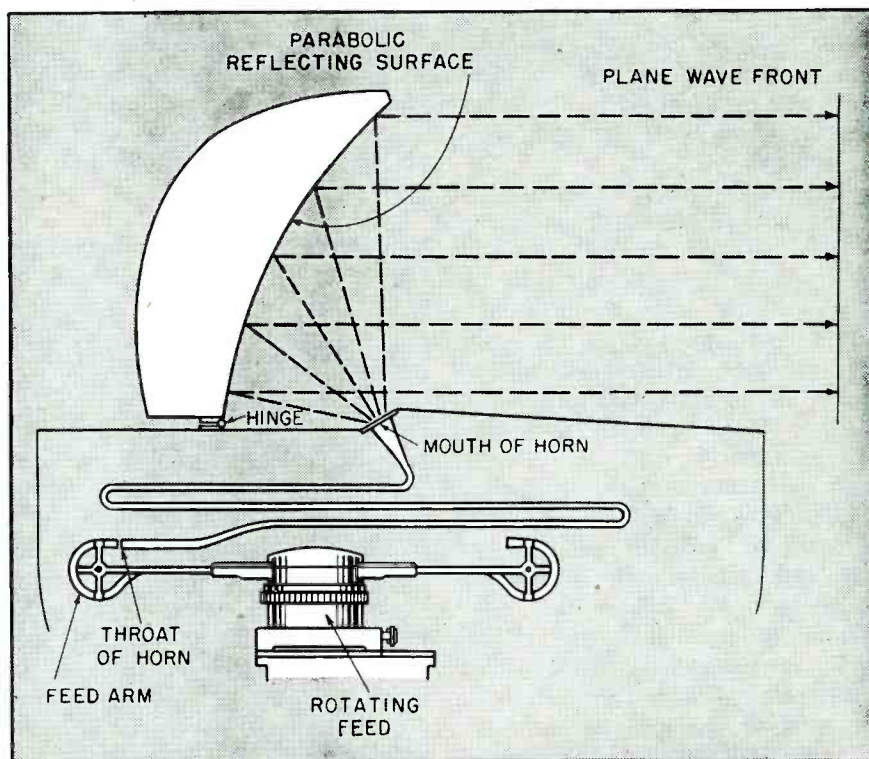

FIG. 6—Detail of waveguide feed, folded sectoral horn and reflector. As the feed rotates, the axis of the beam swings through a sector of 10 degrees

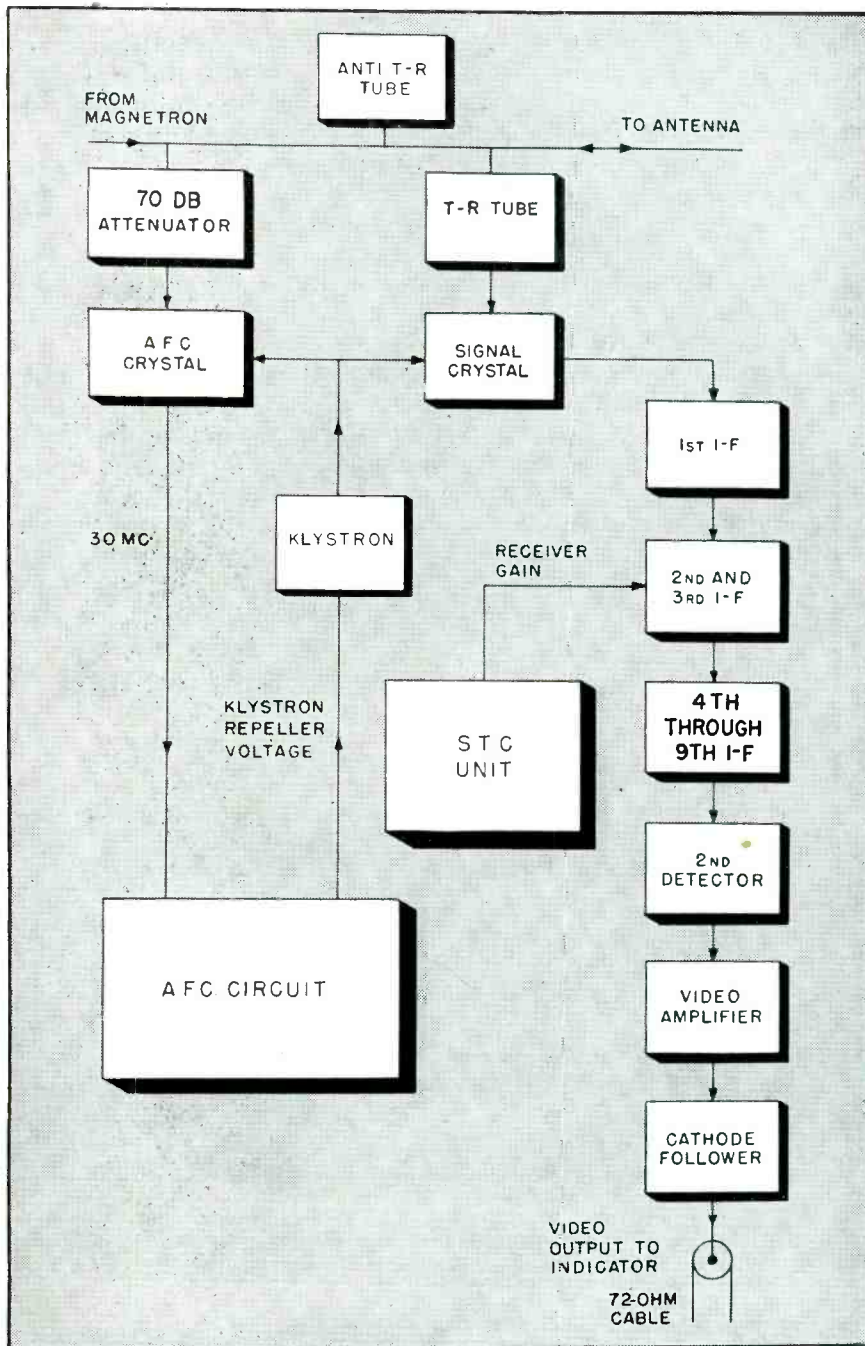

FIG. 7—Block diagram of the AN/MPG-1 radar receiver system. Two silicon crystals are employed, one for afc control, the other for the signal circuit

frequency, a positive pulse if the transmitter frequency is too high, and no pulse at all if the transmitter frequency is of the proper value to yield a 30-mc intermediate frequency. The discriminator output, if any, is applied to the pulse amplifier.

The sawtooth oscillator generates a saw tooth voltage waveform which causes the klystron frequency to vary over a considerable range. This pulse operates only when the transmitter frequency is very far from being 30 mc above the klystron. When the transmitter fre-

quency is close to 30 mc above the klystron the control tube takes control of klystron frequency and the sawtooth oscillator is inoperative. The sawtooth oscillator output is a positive-going sawtooth of approximately 100 volts amplitude and a repetition rate of  $\frac{1}{2}$  cps.

Once the sawtooth oscillator has set the klystron frequency to a value such that the intermediate frequency is slightly below 30 mc, the discriminator output will have become slightly negative. This triggers the control tube, resulting in a plate-voltage drop to approxi-

mately ground potential. The drop in plate voltage is applied to  $C_2$ , resulting in increased klystron frequency and an intermediate frequency which is slightly higher than 30 mc. The control tube triggers now become negative and the tube remains inoperative while  $C_2$  charges, causing the i-f to drift toward 30 mc again. When the i-f passes 30 mc the cycle is repeated. The sawtooth oscillator remains inactive as long as its plate voltage is maintained at less than 100 volts.

If the receiver gain were constant, signals from targets of a given size would appear much brighter on the scopes at short range than at long range. "Blooming" of the scopes due to multiple close-in targets or sea-return might interfere with the operators' ability to distinguish targets at close range. The sensitivity control circuits make it possible to adjust the receiver gain automatically so that signals from the same target appear equally intense on the scope regardless of range. This is done by superimposing on the bias level set by the manual gain control a trapezoidal voltage which is synchronized with the transmitted pulse by the method shown in Fig. 11. The receiver gain is made low for short ranges and higher for longer ranges. The receiver and r-f system can be tuned by reference to the built-in A-scope.

#### Antenna Positioning System

The antenna pointing direction is controlled by a servo. Selsyn generators geared to the tracking

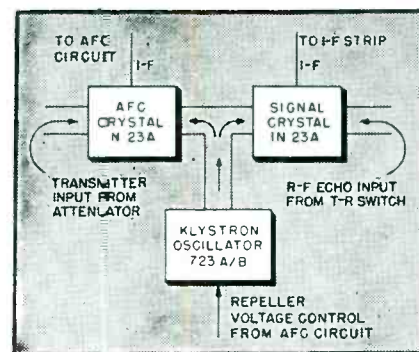

FIG. 8—The afc crystal employs a minute portion of the transmitter signal to operate the frequency control. A separate crystal develops the echo signal intermediate frequency



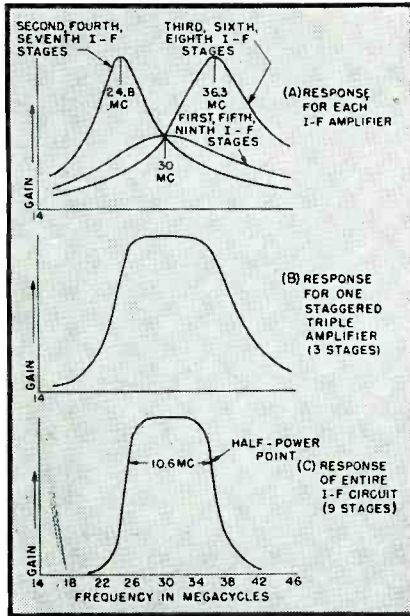

FIG. 9—Band-pass characteristics of the nine i-f stages: (A) Staggered tuning of the i-f stage groups produces a flat top response (B) for three stages. Nine stages produce the overall result shown in (C). This is one of the widest bands ever employed in radar equipment

output transmit electrical position data to selsyn control transformers geared to the antenna drive. The difference between the desired direction and the actual pointing direction is transmitted as an error voltage to an amplifying system, the output of which actuates the antenna drive motor to correct the pointing error as shown in Fig. 12.

The pointing error must be less than 0.05 deg. Due to inherent electrical error of selsyns, a gearing ratio of 1:1 does not provide sufficiently accurate pointing. Therefore a 36:1 system, which reduces the selsyn electrical error by a factor of 36, is normally used during the tracking operation. For pointing errors in excess of 4 deg, however, such as might occur when the operators switch from ppi to tracking or when the antenna is slewed rapidly back and forth, a 1:1 selsyn system takes control of the antenna. When the positioning error falls below 4 deg, the 36 to 1 selsyn resumes control and accurate positioning is reestablished. This is accomplished by applying the 1:1 rectified error voltage to the biased

control grid of a 6AG7 which has a relay coil in its plate circuit. When the rectified 1:1 error voltage reaches an amplitude corresponding to 4 deg of pointing error, the tube draws enough plate current to operate the relay, which removes the 36:1 error input from the servo amplifier and applies the 1:1 error input instead. When the pointing error falls below 4 deg the relay is de-energized and the 36:1 system takes control. Use of the 36:1 selsyn system reduces the peak inherent electrical and mechanical error to less than 0.5 deg. On ppi, however, where high accuracy is not required, the 1:1 selsyn system is used exclusively.

The error voltage from the 36:1 or 1:1 selsyn system is introduced into a phase-sensitive rectifier cir-

cuit located in the antenna servo amplifier and shown in Fig. 13. The reference and error voltages are mixed by applying each voltage to separate primaries of transformers  $T_1$  and  $T_2$ . In  $T_1$  the reference and error voltages add, while in  $T_2$  they subtract. Each transformer provides a 12:1 step-up ratio. Losses are kept very low as a result of the high impedance windings and silicon-steel cores. When the error input is zero,  $R_s$  sets the d-c level of points A and B, and the ripple voltages due to the reference voltage cancel out due to the manner in which rectifier  $V_1$  is connected. When an error voltage exists however, the outputs of the halves of  $V_1$  are unequal and total cancellation is impossible. This causes an unbalance between points A and B

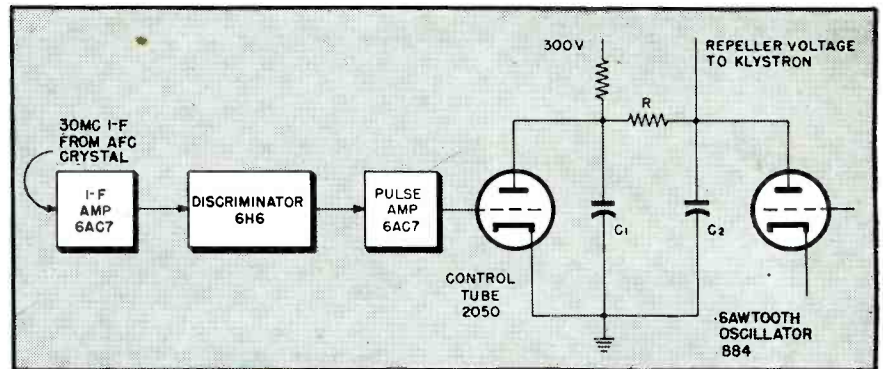

FIG. 10—Automatic frequency control system. When the transmitter frequency drifts excessively a sawtooth wave is applied to the tuning electrode (repeller) of the klystron local oscillator, causing it to hunt for the correct frequency

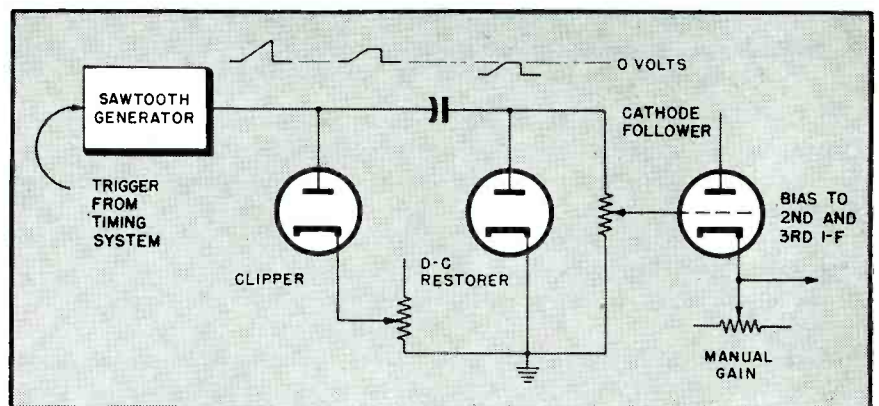

FIG. 11—Automatic brightness control scheme. The amplitude of echoes from nearby targets is automatically cut down to prevent "blooming" of the c-r tube screen

which appears on the grids of  $V_2$ . Tubes  $V_3$  and  $V_4$  therefore draw unequal plate current, resulting in an amplidyne output which has a maximum of approximately 500 watts. The amplidyne output is applied to a  $\frac{1}{2}$ -hp motor which drives the antenna. The velocity error constant is 1613 deg/sec/degree error and the torque error constant is about 122,000 ft lb/degree error. At constant antenna velocities up to 4.5 deg/sec the pointing error is less than 0.015 deg. For a step increase in angular velocity of 3 deg/sec the pointing error is less than 0.03 deg in 2 seconds. Antenna inertia is 7 ton-ft.

Excessive time lag in the filters  $R_1C_1$  and  $R_2C_2$  is prevented by tolerating 10 percent ripple. Integral response to very small error voltages is provided by the  $R-C$  network  $R_3, R_4, C_3, C_4$ , is a flutter filter.

On ppi the antenna may be made to scan automatically back and forth over any assigned surveillance sector or, by means of a lever switch, the antenna may be slewed either to left or right at a velocity of 20 deg sec. The ppi deflection yoke is part of a separate servo system which makes the yoke follow the antenna pointing direction. Operating details were published in a previous issue of *ELECTRONICS*.<sup>1</sup>

#### REFERENCE

(1) McNaney, J. T., A Continuous Control Servo System; *ELECTRONICS*, p 118, Dec. 1944

FIG. 12—Block diagram of the AN/MPG-1 radar antenna-positioning system. This electro-mechanical system must indicate the bearing of the beam correct to within 0.05 degree

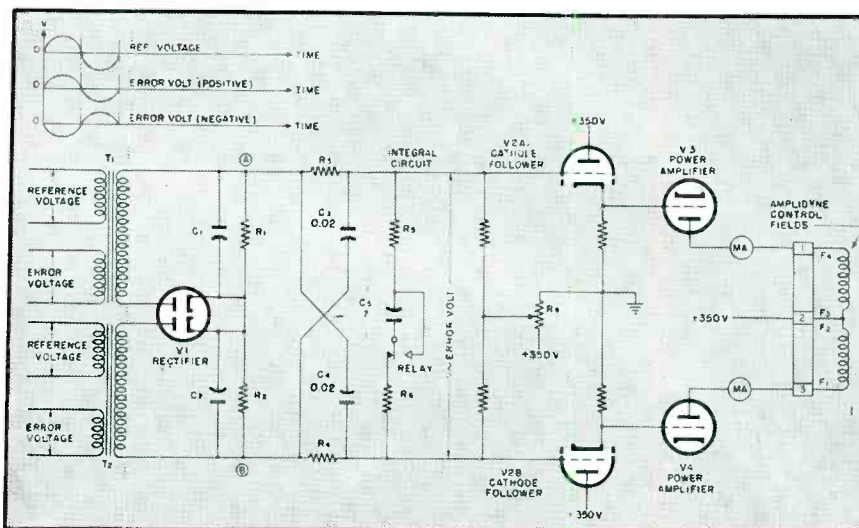
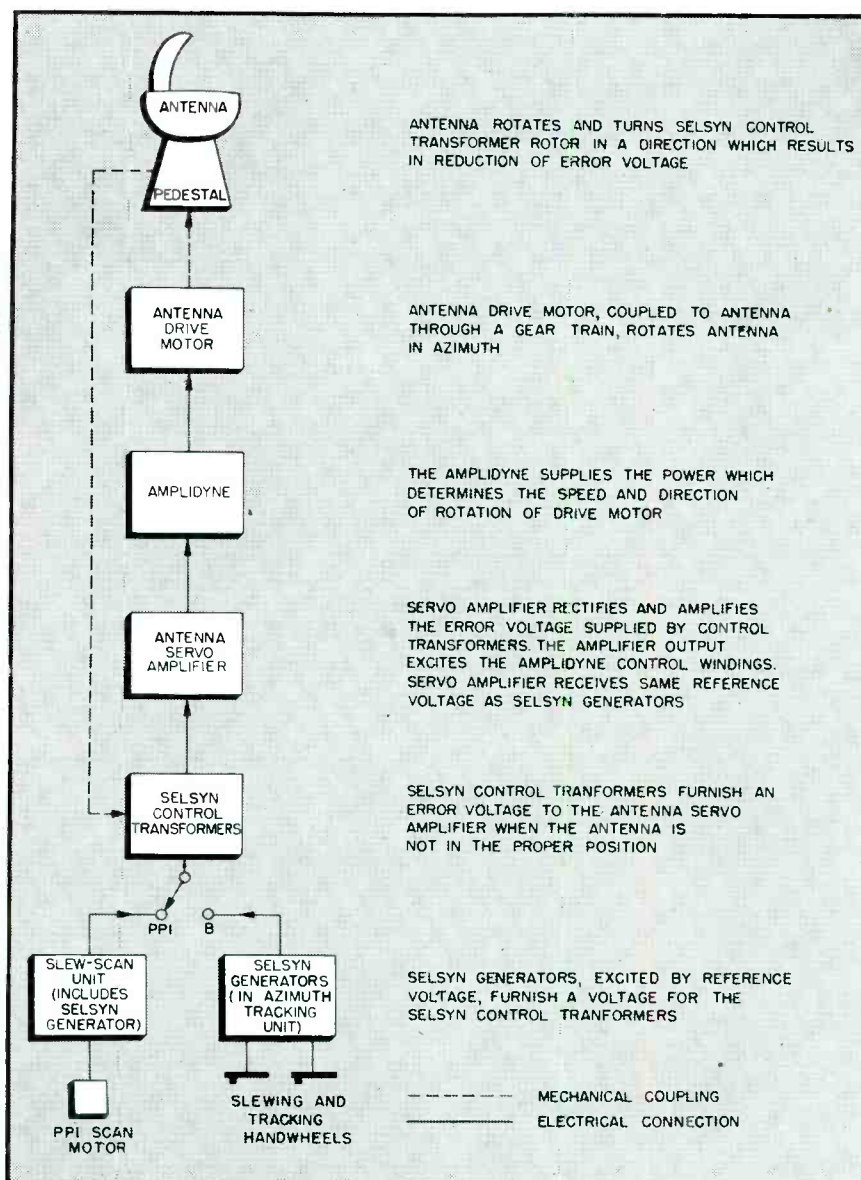
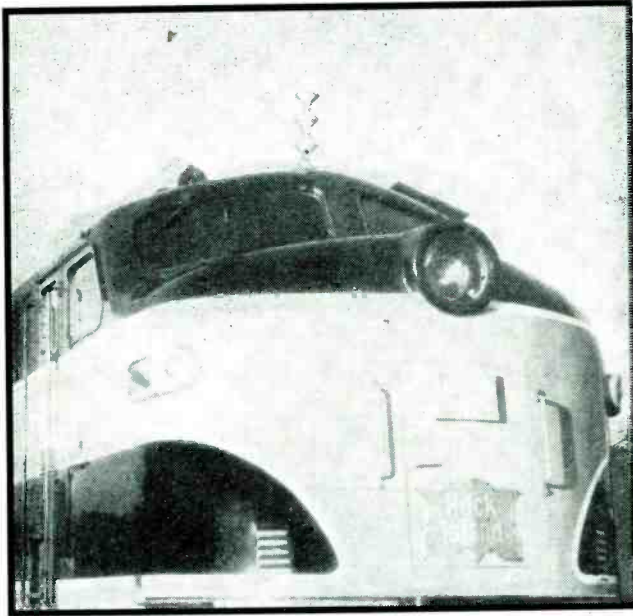

FIG. 13—Error voltage comparison circuit and amplidyne drive which controls the antenna-rotating motor





# 2,660-Mc Train



Reproduction of front cover of this issue, showing six-bank antenna array installed atop a locomotive

Details of complete two-way microwave f-m system to be installed on Rock Island Railroad. Transmitters and receivers are crystal-controlled and use klystrons as frequency multipliers and amplifiers. Antenna array has eight triple radial dipoles with biconical parabolic reflectors. Waveguide effect of train-filled tunnel is analyzed

By **ERNEST A. DAHL**

*Electronic Engineer  
Chicago, Rock Island & Pacific Railway Co.  
Chicago, Illinois*

**S**OME of the prerequisites of a train communication system are dependability, ease of operation, and low maintenance cost comparable to corresponding features of present telephone and telegraph facilities. The equipment must also be constructed so that servicing can be done by railroad telegraph and telephone maintenance crews.

Radio communication from engine to and from the rear of moving trains and to wayside stations is now considered highly desirable as an extension of existing wire lines and carrier communication circuits. Likewise, the need is seen for emergency radio equipment to bridge stretches where wires are down and to provide auxiliary communication channels in storm or flood-damaged areas.

To explore the possibilities of microwave radio communication for meeting these requirements of the railroad industry, the Sperry Gyroscope Co. carried out extensive tests in collaboration with the Rock Island Railroad on a frequency of approximately 2,660 mc. Engineering evaluation of results showed this system to be highly practicable. In general, microwave equipment was found to possess excellent propagating characteristics under the

conditions imposed in railroad operation. Except for interruptions lasting 15 to 20 seconds in unusual combinations of rolling hills and deep cuts, signals were consistently strong through all types of terrain, around curves, through gorges, and even in the long Moffat Tunnel.

#### Complete System Now Planned

Success of the operating tests resulted in the decision to lay out for the Rock Island Railroad a single radio communication system employing crystal control and fre-

quency modulation in the region of 2,660 mc. The first complete system is to be installed from Chicago to Rock Island, Illinois, a distance of 180 miles. Steam and diesel freight trains operating in this territory will be complemented with two-way front-to-rear radio continuously operated, as will high-speed passenger engines and wayside stations.

The maintenance of all railroad equipment will be simplified by using only complete units that are replaceable easily and quickly. Whether the equipment is to be used in mobile or fixed installations,

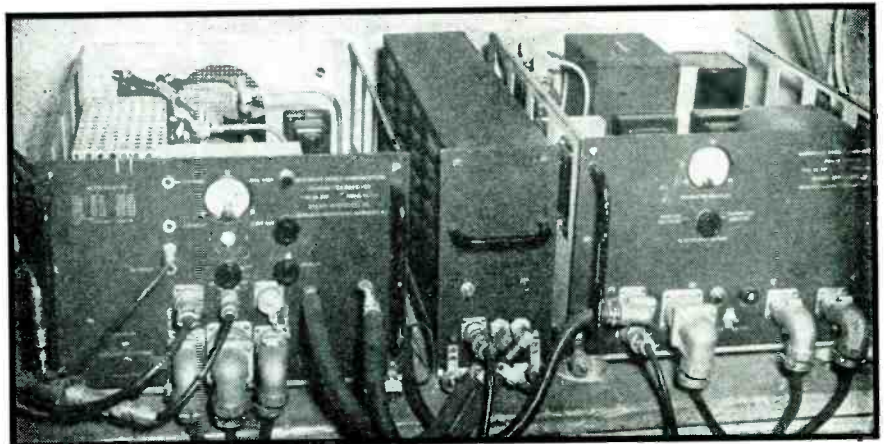

Microwave mobile communications transmitter-receiver (at left) with liquid-cooling unit for klystrons (center) and power supply (right), all made by Sperry Gyroscope Co.

# Communication System

it will be completely interchangeable since all units are designed for 115-volt, 60-cycle power. As failures occur, replacement of the unit will be the only servicing required in the field and the defective unit will be brought to a central point for repair. Frequency measurements and sensitivity tests will be continuously conducted by traveling field engineers to maintain the standards required of this important railroad service.

## Antenna Gain Required

In railroad service, an antenna gain of about 20 (13 db better than an isotropic radiator) is the maximum amount desirable and at 2,660 mc this corresponds to an array about 60 inches high.

An isotropic point receiving antenna has an absorption cross-section area of  $\lambda^2/2\pi$ . However, only half the energy picked up by the antenna is available at the terminals of a receiver whose input impedance is equal to that of the antenna. Therefore the effective absorption cross-section area of an antenna is  $\lambda^2/4\pi$ . Gain then becomes the ratio of the absorption cross-section area of an actual antenna to the absorption cross-section area of an isotropic radiator.

## Wave Propagation Problems

In free space or over reasonably flat terrain, a simple communication set will work well out to distances where the curvature of the earth has its effect. This is more than a sufficient range to satisfy the railroad service problem. The chief concern is with the effects of diffraction around an obstruction. This does not mean that the more normal propagation losses of free space are unimportant, but only that they are independent of frequency and can be overcome in almost any system. The modification of these free-space values as determined by tunnels, cuts, and curves in the railroad tracks is frequency-dependent and is the real heart of the problem of

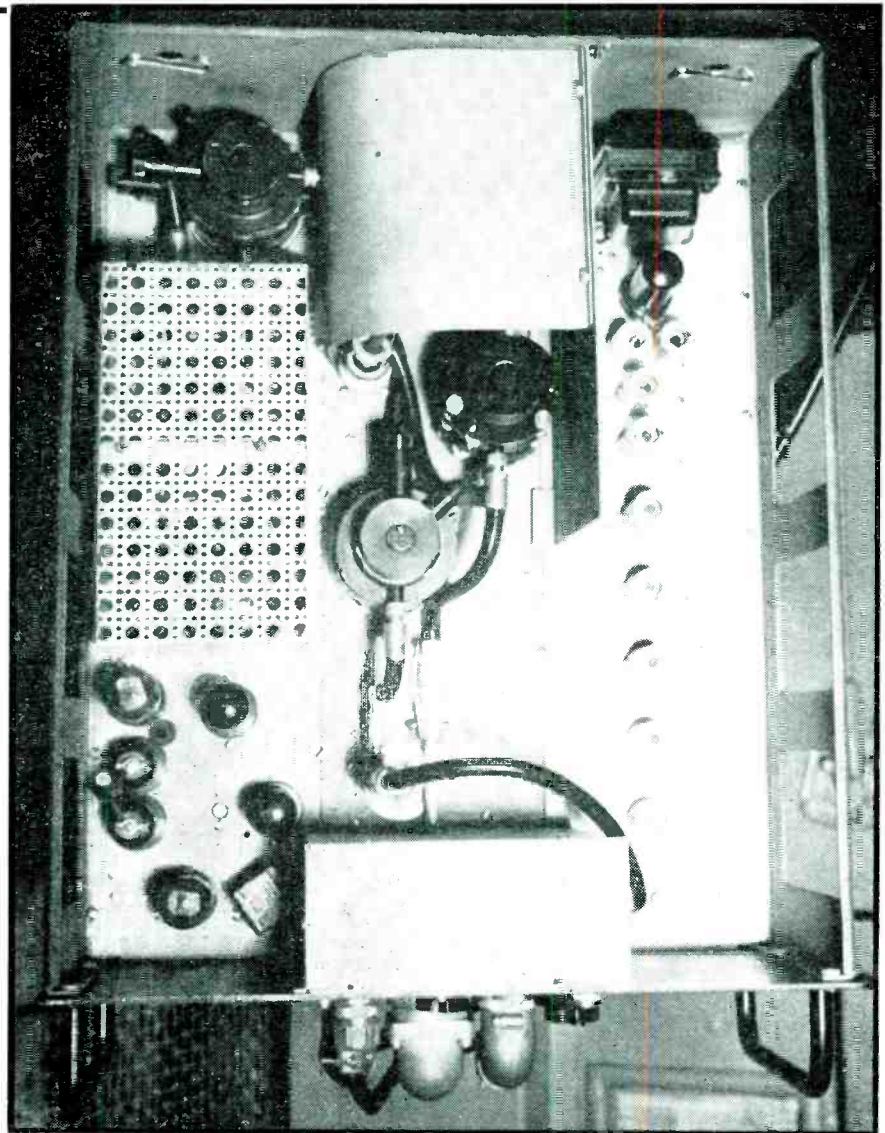

Complete 2,660-mc transmitter and receiver, with crystal multiplier and frequency-multiplier klystron at left, klystron power amplifier and klystron oscillator for receiver in center panel, and i-f stages on right-hand panel

finding the best operating wavelength for a railroad radio system.

## Waveguide Effect of Tunnels

In tunnels or deep cuts which have an appreciable length, microwave frequencies are very advantageous. The tunnel problem is one of transmitting through the tunnel when a train is already blocking most of the available space. The problem of deep cuts is much the same; in both cases the space volume available for the transmission of radio energy is extremely restricted. The construction of tun-

nels and cuts is expensive and they are notoriously built with small clearance. This situation has been aggravated by the constantly increasing size of the railroad equipment, so that free spaces having at least one dimension as small as 6 inches are not uncommon.

The transmission of radio energy in a rectangular waveguide gives a rough idea of the size of an opening through a tunnel or cut which is necessary to complete a transmission. In one waveguide mode, the cutoff frequency is given by  $f_c = c/2b$ , where  $c$  is  $3 \times 10^8$ ,  $b$  is the narrow dimension of the waveguide



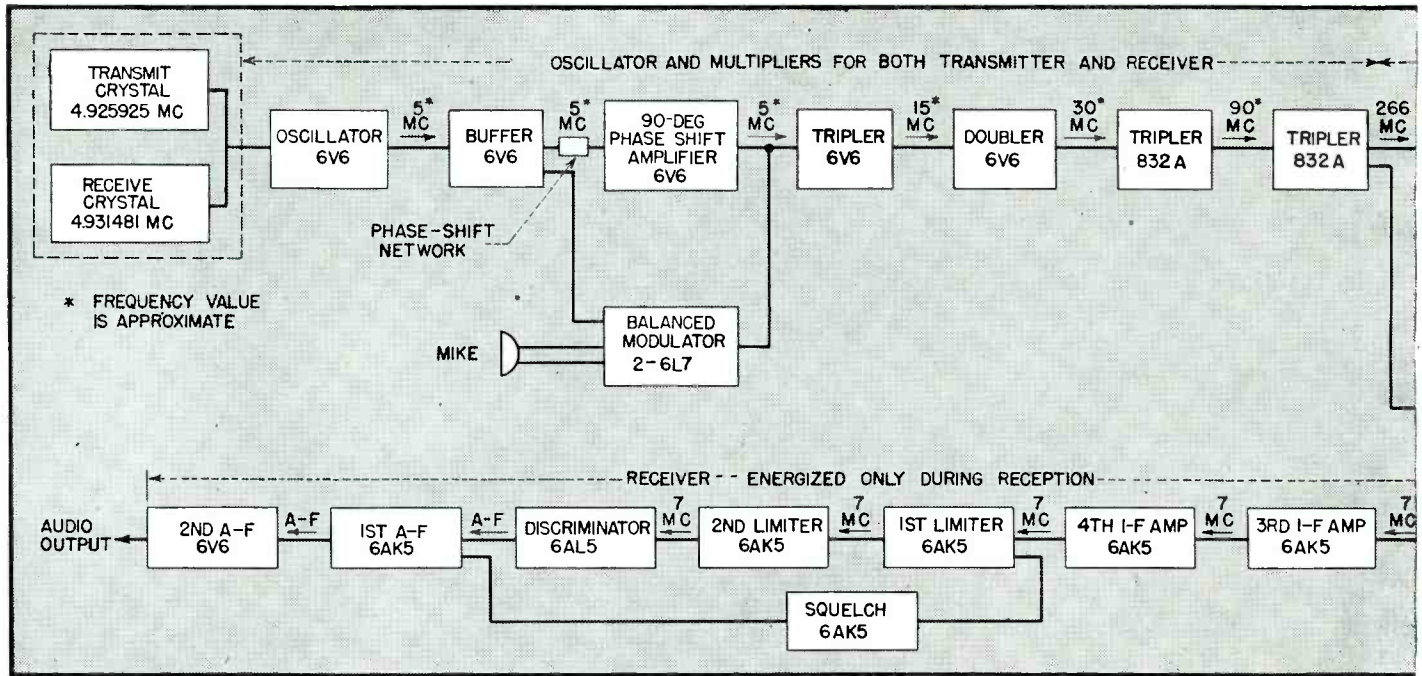

Block diagram of 2,660-mc transmitter and receiver developed for train communication systems. Depressing push-to-talk switch on handset connects transmit crystal to oscillator stage, removes plate voltage from receiver stages and receiver klystron, and applies plate voltage to the two transmitter klystrons

measured in cm and  $f_c$  is the cutoff frequency. No energy at a lower frequency than  $f_c$  can be made to pass through such a waveguide and in a practical case, the opening must have a dimension at least 20 percent greater than specified by the cutoff frequency in order that attenuation be reasonable.

It is true that in an opening which has a cross-section 6 inches by 6 feet, other modes (the  $TE_{0,1}$  mode for example) will be limited by the 6-foot dimension rather than by the 6-inch one. At best, modes of this sort will normally carry only half the energy so that restricting all transmission to them will reduce performance by a factor of 2.

In practice, the situation is even worse. Tunnels and cuts are not made up of plane surfaces. They are irregular and energy passing through them is, therefore, repeatedly coupled from one transmission mode to another and from that to a third and so on. It takes only one small dimension anywhere in the route to limit the frequency transmission characteristics of the path.

#### Diffraction Effects at Curves

When the railroad tracks curve around a hill or a similar obstruction, line-of-sight transmission from the transmitter to the receiver

is not possible. Energy must then reach the receiver by diffraction around the edge of the obstruction or by reflection from a second object. If the obstruction has a sharp edge and is truly large compared to any wavelength that is to be used, the case must be compared to the diffraction of energy around a straight edge. Since the obstruction is assumed to be large, this case is entirely independent of frequency.

At least three factors modify this case for actual practice. Two of them favor using as short wavelengths as possible, while the third says lower frequencies are better. First, the train antenna does not move exactly along a line grazing the edge of the obstruction. Instead, it misses the edge by at least the width of the track. This means that, depending on how great that distance is in terms of wavelengths, the signal strength is reduced less than it would be in the optical case just referred to. Second, the edge of the obstruction is not sharp and, as measured in terms of microwaves, it may easily have irregularities great enough to raise the energy levels at points behind the obstruction. Third, the obstructions are not of infinite size and whenever they are only a few wavelengths high or wide, additional

energy gets past. Larger obstacles satisfy this condition at longer wavelengths.

Because of the wide variations in the types of obstacles encountered, it is impossible to say from theory alone that a given wavelength is the best. This fact is the chief reason for the railroad tests which have been initiated and for additional tests scheduled for the future.

#### Transmitter Power Required

The transmitter power is limited chiefly by the bulk of the equipment and the power drain from the train's source that can be tolerated. Almost regardless of everything else, these considerations dictate a nominal 10 watts. It is true that this could be made 5 or 20 but since 20 watts adds only 3 db to a transmission link previously operating with 10 watts, it is not as great an advantage as might at first seem likely.

The cables connecting the antenna to the transceiver may be made to have very low loss if designed with care. The present microwave equipment uses stub-supported coaxial lines causing a loss of less than 3 db.

Receiver sensitivity, of course, depends on frequency bandwidth as well as on how well the receiver is

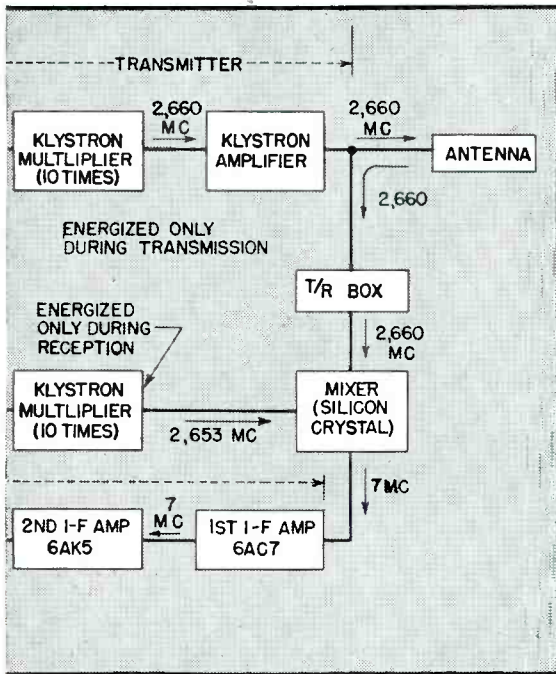

constructed. Because of variations in temperature, humidity, vibrations, and shocks that are encountered in actual service, a noise factor of about 15 db is present in the best receiver that can be built for railroad operation. This means that in the receivers used for the tests, at least a 15-db loss must be considered in conjunction with the 150-db-below-one-watt sensitivity which is theoretically possible.

#### The Equipment

The microwave transceiver is housed in a case measuring 16x11x 19 inches, containing all the microwave and audio circuits and a transmit-receive switch which automatically blocks the antenna connection to the receiver whenever power from the transmitter is fed to the antenna. The chassis also contains enough audio power to operate a loudspeaker in addition to the receiver of the handset. The power supply is housed in a case of the same size and converts the power from the train's supply system to produce all the necessary voltages.

When a transmission is being made, a crystal-controlled oscillator produces a signal which is frequency-modulated, multiplied in frequency to the microwave level, amplified and fed to the antenna.

During reception, the same frequency multiplier arrangement is used with a different crystal to produce a stable local oscillator signal at a frequency such that the receiver's intermediate frequency is produced as the difference. The local oscillator energy is fed into a microwave converter where it is mixed with the received microwave signal. The resulting intermediate frequency signal is amplified, limited and demodulated by methods well known to the art.

During transmission a quartz crystal is used to control an oscillator whose output is modulated, amplified, and multiplied. The stability of the crystal oscillator is 5 parts in a million or better under normal operating conditions.

The frequency multiplier chain is quite conventional in design. As is usual in frequency multipliers, the resonant plate circuits of each stage are tuned to a new frequency two or three times higher than their grid circuits. The electrode voltages on the tubes are then so adjusted that an optimum amount of

the proper harmonic of the grid frequency will be carried to the plate circuit and the oscillation there is, in consequence, excited so as to be locked in with the lower-frequency input to the grid.

Frequency multiplication is accomplished in four stages and raises the crystal oscillator frequency (with the modulation signal during transmission) up to a level where the klystron multiplier tube comes into operation. At high frequencies, conventional vacuum tubes are difficult or impossible to use because of the transit times of the electrons for which allowances must always be made. Fortunately, however, it is entirely feasible at 300 mc and higher to use resonant cavities in place of resonant circuits. This means that klystrons can be used for the final multiplication necessary to reach the desired microwave frequency. It is also fortunate that, because of the nature of velocity modulation, much higher multiplication factors can be used at frequencies where resonant cavities are of reasonable size.

During transmission, the microwave signal at 2,660 mc is obtained from the multiplier klystron and is amplified in a power-amplifier klystron. The amplifier tube is

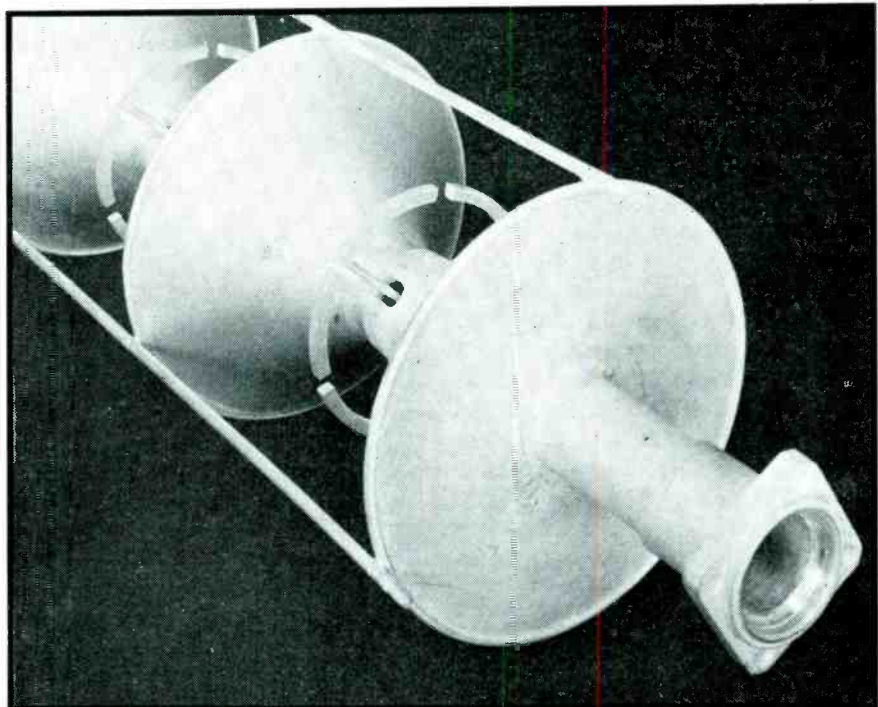

Closeup of portion of antenna array, showing method of mounting curved dipoles and energizing inward-projecting stub. All parts shown here are precision-machined metal



relatively simple. Its cavities are all tuned to 2,660 mc and consequently straight amplification is obtained. The nominal rated power output during transmission is 10 watts.

#### Superheterodyne Receiver Used

The receiver portion of the transmitter is a superheterodyne. Except that the modulator is inoperative during reception and except that a different crystal frequency is being used, the production of a microwave frequency is accomplished, except for power amplification, just as it is during transmission. Now, however, the klystron multiplier is tuned to a lower frequency and produces a signal at 2,653 mc which is used to supply local oscillator energy. The 2,653-mc signal is mixed with the received signal in a resonant cavity type mixer.

The purpose of the mixer is the same as it is in any heterodyne receiver. The 7-mc signal from the resonant cavity converter is fed to an i-f amplifier which has a bandwidth of 300 kc at 6 db down and is conventionally constructed.

#### Antenna Design

One of the most interesting components in the equipment used for the 1945 test on the Rock Island was the antenna. The general problem encountered in the design of a microwave antenna is that of getting as much gain as possible while supplying coverage in the desired azimuthal directions. In the present equipment, it was decided that coverage over a full 360 degrees horizontally was advisable. Antennas must also have sufficient elevation coverage to take care of tilts as the train travels up and down grades. If the solid angles which must be covered because of these factors are added and compared to the  $4\pi$  solid-angle radians of a completely isotropic radiator, a ratio of about 1 to 20 will be found. The gain which is desired for a fixed installation is, therefore, approximately 20 by definition.

If we can take all the energy from a transmitter and concentrate it in the desired directions alone, our signal strengths in those directions will be about 20 times as great as they would be if the energy were

equally spread in all directions. Similar, such an antenna will absorb 20 times as much power from the desired direction as would be absorbed if it were designed to handle messages which approach from any arbitrary direction.

The approach to the problem consisted essentially of three steps. The first was to design a small structure which would radiate nearly equally in all directions. The second was to mount several of

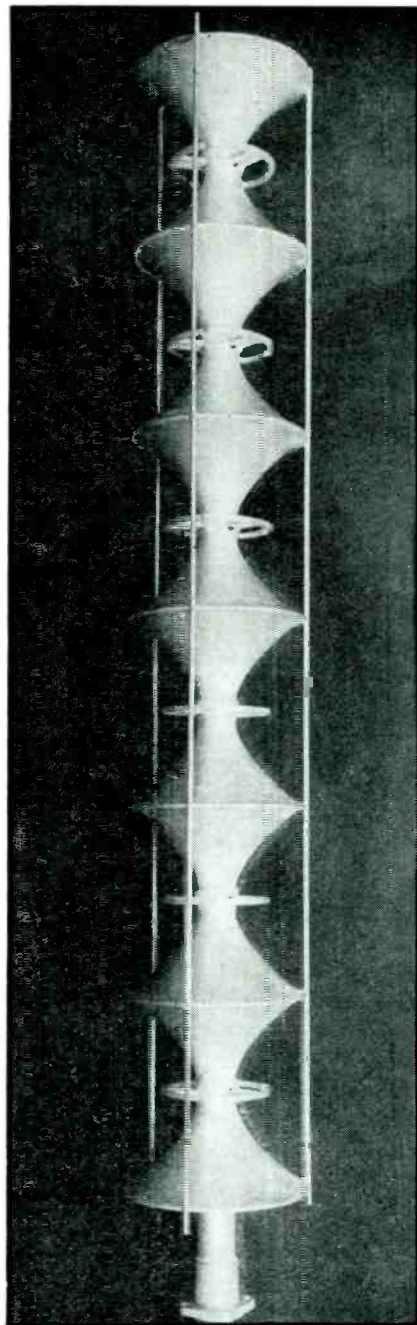

Antenna array used on mobile units. Each of the six banks of the array has three radial dipoles at the focus of a biconical parabolic reflector. Overall height of this array is only 27 inches

these elements, one above the other, at multiples of half-wave spacing so that much or all of the energy transmitted in the vertical direction would cancel because of phase differences introduced by the spacing. The third step consisted in adding biconical reflectors to further increase the efficiency.

It is well known that a half-wave dipole has a gain of 1.5. Such a unit used vertically does not have enough gain for this application and when mounted horizontally, the null which is found in the endwise direction makes it entirely impossible to consider the pattern near enough to isotropic to allow straightforward combination into a vertical array. Consequently, three such dipoles were combined and deformed so as to be able to produce a radiation pattern that is very close to being completely isotropic.

The general method of combining these triple units is to place them in a linear array with biconical parabolic cones acting as reflectors. For fixed installations in railroad yards or adjacent to the right of way, a stack of eight triple radial dipoles will be used with cones having a maximum diameter of about 8 inches. When mounted in a protective Plexiglass housing, the height is somewhat greater than the 54 inches occupied by the actual cones.

The antenna on a train (see front cover) is of similar construction but is smaller. It uses a stack of 6 radial dipoles, and the overall height of the antenna without the Plexiglass covering is 27 inches. This antenna has a gain of about 10.

#### Conclusion

While it is not believed that 2,660 megacycles is the optimum railroad communications frequency, it has been demonstrated that satisfactory operation at this frequency is now a reality. Further experimentation with this and other frequencies, perhaps higher, should reveal still more advantages of such a system. It is conceivable that railroads may find that those portions of the frequency spectrum which are devoid of man-made noise and static present the most practical solution for dependable communications.

# Capacitor Charging Rectifier

By HARRY J. BICHSEL

Welding Control Engineer  
Westinghouse Electric Corp.  
East Pittsburgh, Pa.

Experimental determination of design criterion for reactance-limited rectifier that will charge a large capacitor bank, which is used to supply power for industrial processes, in the shortest time and with the least power demand on the mains

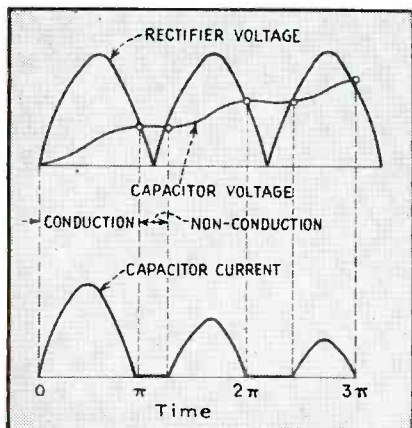

FIG. 1.—Capacitor is charged by sinusoidal current pulses which raise capacitor voltage as shown

**A** NUMBER OF INDUSTRIAL processes depend upon storage of electrical energy in a capacitor. One process employing this principle is spot welding aluminum, magnesium and other high conductivity materials. In this case, a high voltage rectifier charges a large capacitor bank from an a-c supply. When the capacitor voltage reaches a predetermined value, (between 1500 and 2500 volts) the rectifier is blocked and the capacitor energy discharged into a welding transformer. After the weld is made the capacitor bank is recharged and maintained at the correct voltage until another weld is made.

## Rectifier Design Problems

The rectifier used to charge the capacitor bank must be designed so that the initial charging current to the capacitor is limited. This can

be accomplished by the reactance in the rectifier transformer. Also, the rectifier transformer should be designed to take into account the intermittent operation and the decrease in rectifier current as the capacitor is charged.

The problem is to design a rectifier which will charge a given capacitance to a particular voltage in as short a time as possible with a minimum demand on the a-c supply. To design this rectifier, the characteristics of capacitor voltage and capacitor current versus time must be determined. A recent paper<sup>1</sup> on waveshapes of capacitor current and voltage obtained from a single phase rectifier with resistance-capacitance load points out that capacitor current is delivered

in discontinuous pulses as shown in Fig. 1.

To determine the capacitor voltage, a calculation must be made for each half cycle using the transient equation<sup>2</sup> for current delivered by a controlled rectifier to a complex load. Capacitor voltage at the end of each half cycle is used to determine starting voltage for the next half cycle.

While such calculations are possible when the instantaneous rectifier voltage is known and the current limiting resistance is constant, they become laborious if the time constant of the load is long. When transformer leakage reactance is used to limit the capacitor current, calculation of the capacitor voltage becomes very difficult, because the

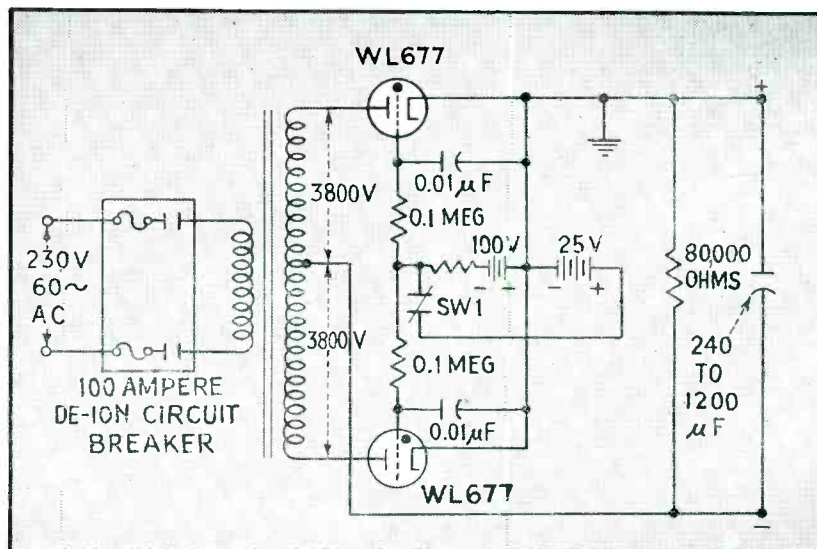

FIG. 2.—The controlled rectifier used for empirical determination of capacitor charging characteristics

EDITORS' NOTE: The material for this paper has been taken from the author's thesis toward a Master of Science degree at the University of Pittsburgh.



rectifier output voltage is a function of capacitor current.

In view of the impracticability of calculating the capacitor voltage, an empirical equation for capacitor voltage versus time was evolved from experimental data in a manner illustrated in the following sections.

#### Experimental Rectifier

The rectifier used in this investigation is shown in Fig. 2. It is a single phase full-wave type using thyratrons as grid-controlled rectifying elements.

The rectifier transformer is a special reactance-limited transformer. The leakage reactance of the transformer was sufficient to limit secondary short-circuit current to 5.8 amperes rms. This reactance was obtained by wide physical spacing of the primary and secondary windings, but could have been accomplished more compactly by inserting a magnetic shunt between the two legs.

A negative voltage of 100 volts was applied to the grids of the rectifier tubes to prevent them from conducting. The rectifier tubes were made conductive by closing SW 1 which changed the bias on the rectifier tube grids from 100 volts negative to 25 volts positive (measured outside of the grid resistor). An 80,000 ohm resistor was connected across the output terminals of the rectifier to serve as a bleeder on the capacitor bank.

Capacitor charging tests were made on capacitor banks of 240,

600 and 1200  $\mu\text{f}$ . Oscillograms showing capacitor voltage, capacitor current, and rectifier input current versus time were taken. From these oscillograms were derived the empirical equations for the capacitor voltage and current upon which rectifier design is based.

#### Oscillogram Observation

From oscillogram 1 of rectifier short-circuit current, a transient was observed during the first few cycles after the rectifier was started. This transient was observed in all capacitor-charging tests. It is of the same type that occurs in a-c circuits containing resistance and inductance when the circuit is closed at other than the natural-current zero instant.

In this rectifier the transient results in one tube carrying a higher peak current and conducting for a longer period (more than 180 degrees) than under steady state conditions. Because the second tube cannot begin to conduct until the first tube has ceased conducting, the second half cycle will be short and the tubes will carry unequal currents. Similar transients have been observed by the writer on other types of rectifiers such as the three-phase bridge type.

Such transients are undesirable because tube ratings may be exceeded. In practice the transient can be eliminated by starting with the rectifier tubes phased fully back and advancing the firing angle to full forward in several cycles.

Oscillogram 2 shows capacitor voltage and current versus time. By taking data from three such oscillograms, the curves shown in Fig. 3 were plotted. These curves do not contain the ripple which appeared on the oscillograms but are a plot of the maximum voltage attained during each half cycle. Consequently, the data presented here is not applicable to small capacitors being charged at high rates.

#### Development of Empirical Equation

From Fig. 3 it is apparent that the voltage curves follow a logarithmic law. Therefore, each of these curves was replotted on semi-logarithmic paper and the curves of Fig. 4, obtained. Each of these curves can be approximated by two straight lines with an error not exceeding five percent.

The first straight line (of slope  $M_1$ ) is used as long as the rectifier current pulses join each other as shown on oscillogram 2. The second straight line (of slope  $M_2$ ) approximates the observed curve after the current pulses become discrete. The change from one curve to the other occurred between  $0.6E_M$  and  $0.7E_M$  for each of the different capacitor banks.

#### Rectifier Design

From curves of slope  $M_1$ , the equation of the capacitor voltage versus time is  $e_c = E_M (1 - e^{-M_1 t})$  where  $E_M$  is the maximum no-load transformer secondary a-c voltage and  $M_1$  is the straight-line slope.

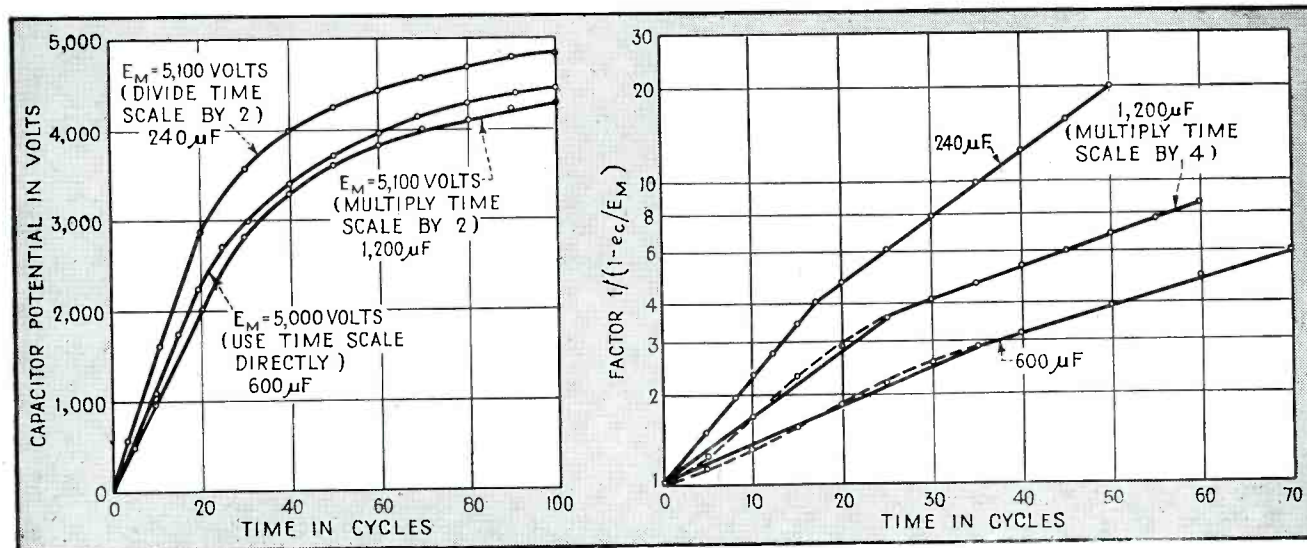

FIG. 3—Curves show the rate at which large capacitance banks charge when supplied from a full-wave rectifier

FIG. 4—Logarithmic plot shows that capacitors charge first at a fast rate, then change abruptly to a slow rate

Because the objective is to charge a capacitor in the shortest time with least demand on the power system, the no-load rectifier voltage should be selected so that the capacitor is charged to the desired voltage before the portion of the curve with slope  $M_2$  is reached.

The slope of the capacitor charging curve is a function of transformer reactance. This inductance is in turn proportional to the maximum no-load rectifier voltage divided by the rectifier short-circuit current  $K_{SC}$ .

Because the only variable in the tests was load capacitance, the slopes of curves in Fig. 4 could be compared. They were found to vary as the 1.16 power of capacitance.

The inductance in the reactance-limited case is somewhat comparable to the resistance in the resistance case where the slope is  $M = 1/RC$  when a steady d-c voltage is applied. Therefore the slope was assumed to be a function of the product of the inductance and the capacitance and was found to be  $M_1 = 0.95(K_{SC}/E_M C)^{1.16}$ . This assumption, although neglecting the reactance, is satisfactory for engineering design.

The equation for capacitor current can be found by differentiating the expression for capacitor voltage and multiplying by the capacitance, giving  $i_c = CE_M M \epsilon^{-M_1 t}$ .

The average capacitor current during the charging period is found by integrating the expression for the current during the charging period and dividing by the period  $T$  giving  $I_{av} = CE_c/T$ .

The expression for the rms capacitor current is slightly more complicated. Capacitor current consists of loops approximately sinusoidal in shape. Investigation on other types of rectifiers has shown that the form factor of these waves is within a few percent of being 1.11. Therefore the total rectifier rms current during the charging period can be expressed by

$$J = 1.11 EC_M \sqrt{\frac{M_1}{2} \left( \frac{1 - \epsilon^{-2M_1 t_1}}{t_1} \right)}$$

Because each secondary winding conducts current only one half of the time, the rms current rating of each secondary is  $J_{SEC} = 0.707 J$ .

The current rating of each secondary is also influenced by the time

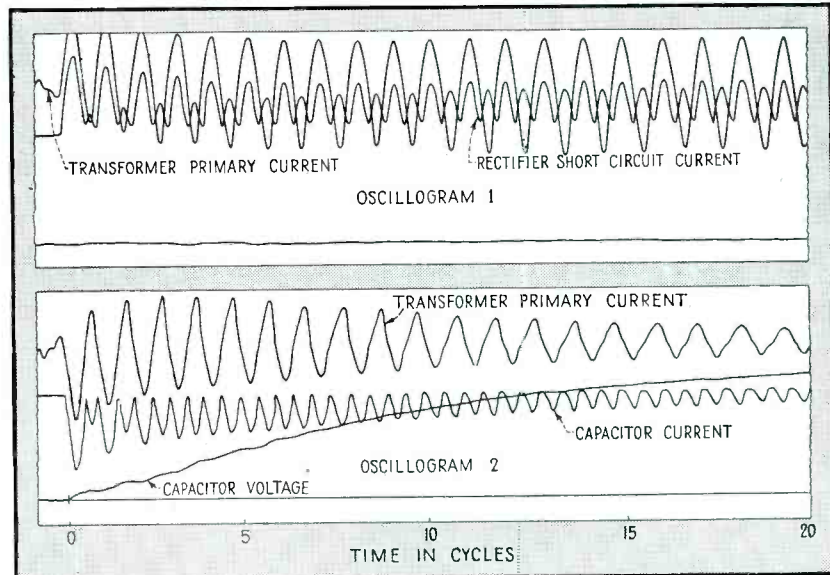

From oscillogram 1 an inequality in the current carried by two tubes was observed. From such curves as that of oscillogram 2 the charging conditions for various capacitances were determined

between charging periods. If the charging time is denoted as  $T_1$  and the time between charges is  $T_2$ , the continuous secondary current rating is  $J_{SEC} = 0.707 J \sqrt{T_1 / (T_1 + T_2)}$ , if  $T_1 + T_2$  is considerably less than the thermal time constant of the transformer.

When the rectifier is short circuited, the primary load current lags the applied voltage by about ninety degrees because of reactance limiting in the transformer. Therefore the magnetizing current of the transformer should not be neglected in calculating the kva of the primary winding. A satisfactory design can be obtained by adding the magnetizing kva to the load kva arithmetically.

#### Illustrative Calculations

To illustrate a practical rectifier design, assume that it is desired to charge a 1200  $\mu$ f capacitor bank to 2500 volts, 60 times per minute. About one-sixth of a second is required to discharge the capacitor for each operation. The kva demand on the power system should be as small as possible.

Let 2500 volts be about 0.6 of  $E_M$  or  $E_M = 4150$  volts if the capacitor is to be charged before the charging rate decreases to the slower rate.

From the equation for capacitor voltage, the slope is  $M_1 = (1/T_1) \times \log [1/(1 - E_c/E_M)]$ . When  $T_1$  is 5/6 second,  $M_1 = 1.1$ . Also, from the equation for slope in terms of rectifier impedance and this value of

slope, we obtain  $K_{SC} = E_M C$  antilog 0.132, or  $K_{SC} = 4150 \times 1200 \times 10^{-6} \times 1.14 = 5.7$  amperes.

The rms rectified current during conduction is

$$J = 1.11 E_M C \sqrt{\frac{M_1}{2} \left( \frac{1 - \epsilon^{-2M_1 t_1}}{t_1} \right)}$$

or  $1.11 \times 1200 \times 10^{-6} \times 4150 \times \sqrt{(1.1/2) (1 - \epsilon^{-2 \times 0.615}) / (5/6)} = 4.1$  amperes during conduction.

The secondary rms current during the charging period is  $J_{SEC} = 0.707 J = 2.9$  amperes. The total effective current in each secondary is  $J_{SEC} = 0.707 J \sqrt{T_1 / (T_1 + T_2)} = 2.9 \sqrt{50/120} = 1.875$  amperes.

Calculation of the kva rating of each secondary can be made by  $KVA_{SEC} = E_{SEC} J_{SEC} \div 1000 = 2920 \times 1.875 \div 1000 = 5.5$  kva, and the total secondary kva is 11.0 kva. The primary kva due to the load is  $KVA_{APP} = (E_{SEC} J_{SEC} / 1000) \sqrt{T_1 / (T_1 + T_2)} = 0.645 \times 2920 \times 4.1 \div 1000 = 7.75$  kva.

The transformer can now be designed. It should produce a short-circuit a-c secondary current of  $I_{SC} = 1.11 K_{SC} = 1.11 \times 5.7 = 6.3$  amperes. The primary should be built to carry 7.75 kva plus the magnetizing kva continuously; while each secondary should be built to carry 5.5 kva.

#### REFERENCES

- (1) Chin, P. T., Moyer, E. E., A Graphic Analysis of the Voltage and Current Wave Forms of Controlled Rectifier Circuits, *A.I.E.E. Trans.*, 62, p. 501-507, July 1944.
- (2) Kurtz, E. B., Corcoran, C. F., "Introduction to Electrical Transients", John Wiley and Sons, Inc., New York, 1935, p. 162.



# Cavity Magnetrons

First published information on microwave pulse generators capable of producing four million watts peak power at 3000 mc. Designed originally for radar but equally applicable to pulse communication systems, the cavity "maggie" is a milestone in electronics

**TYPICAL CAVITY MAGNETRON CHARACTERISTICS**

Type No. or Series	Frequency Range (mc)	Max. Peak R-f Power Output (kw)	Nom. Peak Anode Rating	Maximum Duty Cycle	Max. Pulse Duration ( $\mu$ secs)	Nom. Average Input Power (watts)
<b>L-Band (25-50 cm)</b>						
700A-D	680-710 (fixed)	100	12 kv 10 amp	1/400	2	120
728AY-Gy	920-970 (fixed)	400	21.5 kv 35 amp	1/1000	2	600
5J21-5J25	1060-1110 (fixed)	600	22 kv 50 amp	1/1000	2	750
4J21-4J30	1220-1350 (fixed)	800	28 kv 60 amp	1/500	6	1500
4J42	660-730 (tunable)	200	12 kv 10 amp	1/200	2	500
4J51	900-970 (tunable)	400	21.5 kv 20 amp	1/1000	2.1	500
5J26	1220-1350 (tunable)	800	27.5 kv 60 amp	1/500	6	1500
<b>S-Band (8-11 cm)</b>						
720Ay-Ey	2720-2890 (fixed)	1000	25 kv 70 amp	1/1000	2	1500
718Ay-Ey	2720-2890 (fixed)	200	11 kv 22 amp	1/500	5	600
4J45-4J47	2785-2890 (fixed)	600	25 kv 45 amp	1/1000	6.6	900
4J36-4J41	3400-3700 (fixed)	850	24 kv 43 amp	1/1000	2.5	1000
2J38-2J39	3249-3333 (fixed)	12.5	5.4 kv 5 amp	1/500	2	27
<b>X-Band (3 cm)</b>						
725A	9345-9405 (fixed)	60	12 kv 12 amp	1/1000	2.1	120
2J51	8500-9600 (tunable)	60	14 kv 10 amp	1/800	2	200
2J55-2J56	9215-9405 (fixed)	70	12.8 kv 12 amp	1/1000	2.5	150
4J52	9345-9405 (fixed)	60	15 kv 20 amp	1/500	6	300

ONE OF THE outstanding electron tube types developed during the war is the cavity magnetron, a device which combines the principles of the magnetron and the resonant cavity. This type of magnetron, the basic transmitting tube of all American and British microwave radar sets, was developed in England in 1940 at the University of Birmingham. In September of that year the British Technical Mission brought one of the early models to the United States and revealed its construction and operating principles to scientists of the NDRC, Army and Navy.

It was evident that this tube made microwave radar practical for the first time, so a British-American agreement was concluded whereby the development of microwave radar would be undertaken in the United States. Within five weeks, copies of the British model were made at the Bell Laboratories. In November, 1940 the Radiation Laboratory was set up at M.I.T. to exploit the microwave radar field, using the cavity magnetron as the central element.

Since that time some 50 varieties of the tube have been produced, varying in peak output power from 2500 watts to 1,500,000 watts, at frequencies throughout the microwave region (50 cm waves and shorter). Experimental tubes, operating at 10 cm, have developed a peak power level of 4,000,000 watts.

#### General Characteristics

The cavity magnetron, like the conventional magnetron, is a diode. It consists of a cylindrical unipotential-heater cathode surrounded by a massive copper anode. The anode has, cut into it, several resonant cavities. In a typical tube, the cross-section of each cavity has the shape of a keyhole. The cavity

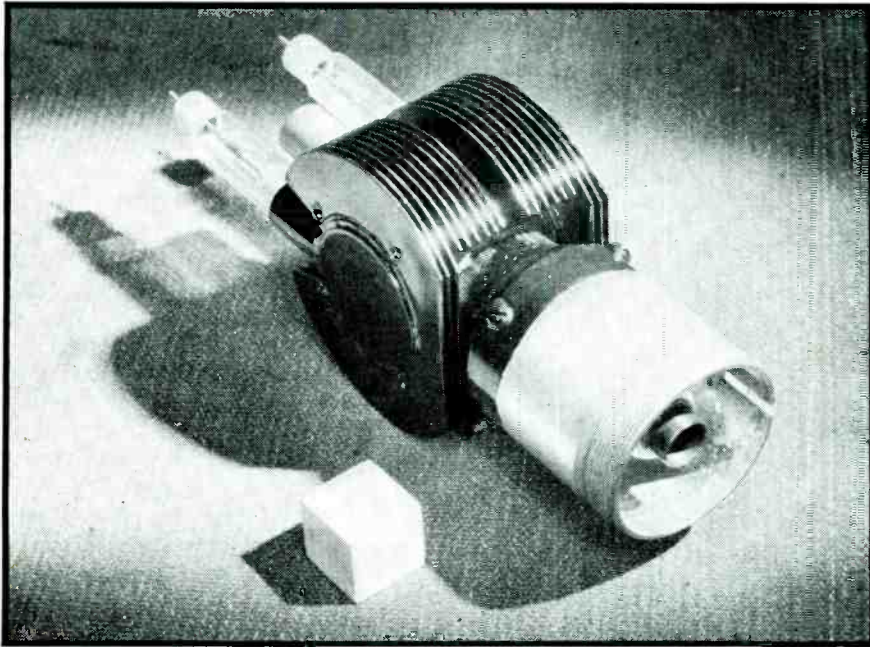

One million watts, peak r-f, is produced by this type 720 10-cm cavity magnetron. The heater leads, insulated to withstand the negative modulating pulse, are at the rear, coaxial r-f output fitting at front. The scale is indicated by the one-inch cube

proper is a cylindrical hole cut into the anode, which connects with the central cathode chamber through a thin slot. The cavities are excited by electrons emitted by the cathode and whirled in the cathode chamber, past the slots, by the action of an axial magnetic field.

The dimensions of the cavities are so chosen that their natural resonant frequency is the desired output radio frequency. The distance between slots is selected so that the adjacent cavities oscillate in reverse phase, that is, the voltage across one slot is opposite to the voltage across the adjacent slots. An even number of cavities is employed to permit maintaining this sequence of polarities throughout the structure. A coupling loop, inserted in one of the cavities, abstracts the power.

The cavity magnetron circuit is simple. For convenience and safety the anode is grounded, and negative modulating pulses are applied to the cathode. The shape of the modulating pulse must be as nearly rectangular as possible. When the pulse is applied, a current of several amperes (nearly 100 amperes in the high power types) flows between cathode and anode. Coincidentally, the cavities are excited and an r-f pulse appears across the coupling loop and its associated

coaxial line. The plate efficiency of the tubes varies from 20 to 60 percent. Thus from a modulating pulse input of 1150 kw (24 kv at 43 amperes), an r-f peak power of 490 kw is developed by the type 4J36-4J41 series of tubes, an efficiency of 47.5 percent.

Two power ratings must be considered in the use of the cavity magnetron; the peak power and the average power. The peak power input is the product of the peak value of modulating voltage times the

peak value of the resulting anode current. The peak power output is equal to this value multiplied by the plate efficiency of the tube. The peak power is limited fundamentally by the available emission from the cathode surface during the pulse, and also by the ability of the internal structure and output termination to withstand arcing.

The average power is, in effect, the peak power in each pulse spread evenly over the interval between pulses. Consider a one microsecond pulse, transmitted at a pulse repetition rate of 1000 pps. Then the interval between pulses is 1000 microseconds and the tube is operative for only 1 microsecond in 1000, or 0.1 percent of the time. The average power is then 0.1 percent of the peak pulse power.

The limitation of average power is the ability of the tube, primarily the cathode, to dissipate heat. Since the size of the structure is limited by the size of the cavities, it has not proved practical to dissipate more than a few hundred, or at most a few thousand, watts continuously even by forced air cooling. The peak power outputs are generally about 500 to 1000 times as great. The maximum allowable anode temperature is generally 100 deg centigrade.

In practice the ratio between average power and peak power is stated in terms of the duty cycle that is, the pulse length in seconds

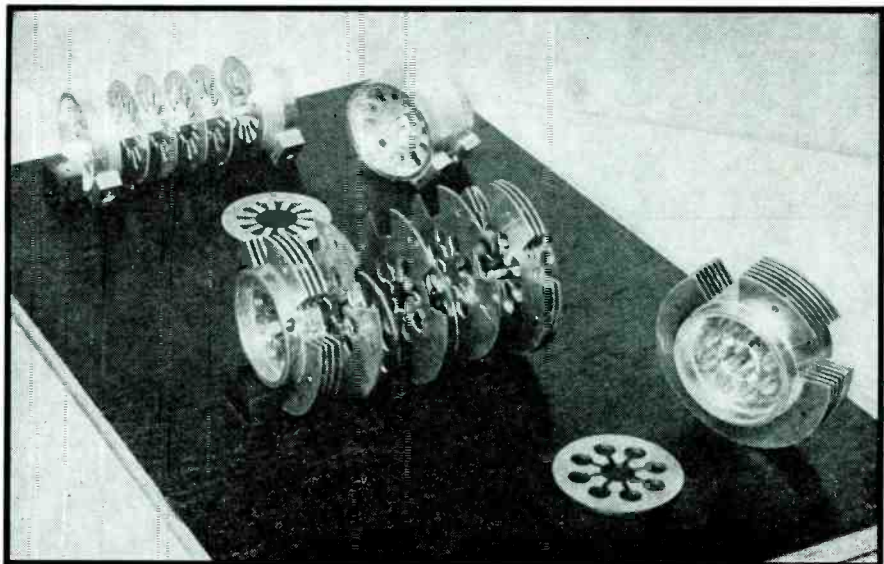

Construction of cavity magnetron anodes. Accurately punched laminations are built up to form a structure containing a number of cylindrical cavities surrounding a central chamber, which contains the cathode



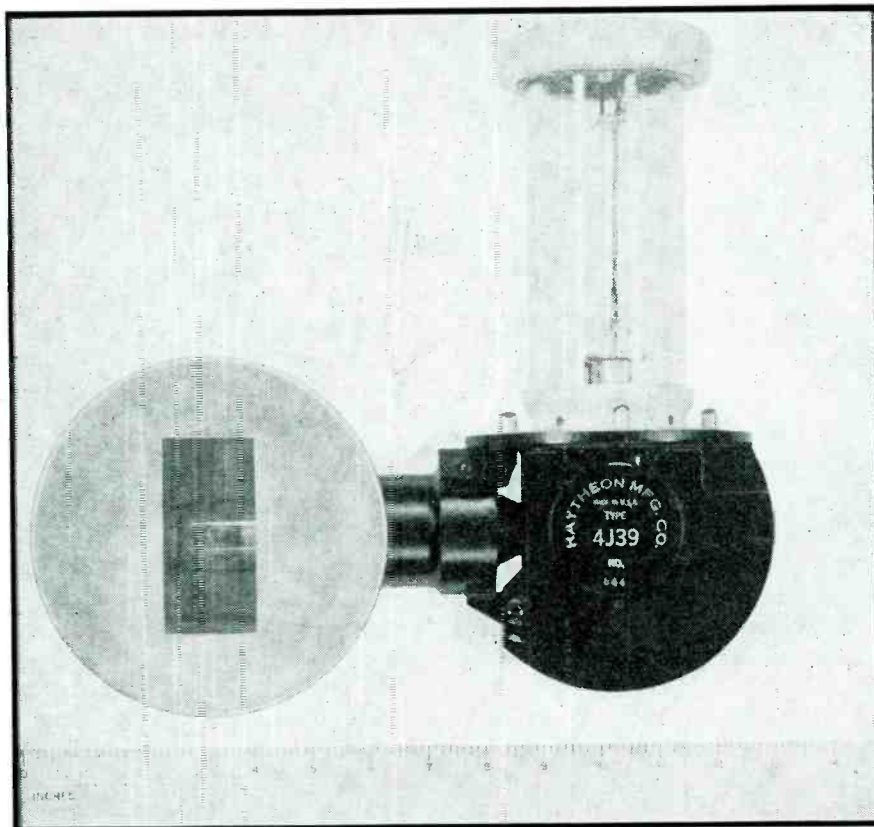

Another form of megawatt magnetron, type 4J39. The power is taken from the cavities by a coupling loop and coaxial line which in turn is matched to the waveguide fitting

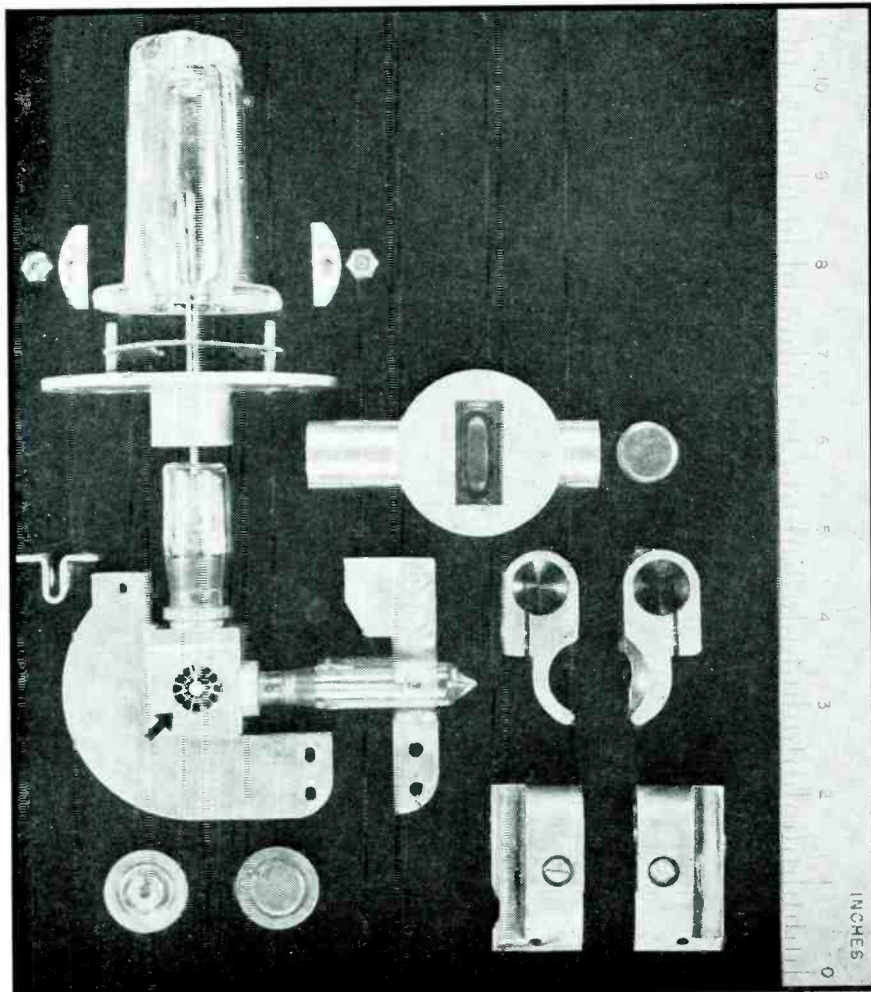

multiplied by the pulse repetition frequency in pulses per second. The duty cycles of typical production-type cavity magnetrons vary from 0.001 to 0.005. Within reasonable limits the average power capability may be used to produce long, widely-spaced pulses or short, closely-spaced ones. Pulses longer than a few microseconds are generally not recommended. Long operating life is achieved by operating at a low value of duty cycle.

#### Output Frequency and Undesired Modes

As might be imagined from the fixed nature of the resonant cavities, the output frequency of a cavity magnetron cannot be tuned over a wide range. The frequency can be shifted over a range of 1 to 2 percent of the carrier frequency, by adjustment of the load circuit connected to the r-f output. Tunable magnetrons are available which achieve wider variations in frequency (about 10 percent) by adjustment of an end plate which forms the top and bottom of the cavities and cathode chamber. When fixed magnetrons are used a series of tubes, having otherwise similar characteristics, is designed to cover overlapping regions of the spectrum. An example is the 4J36-4J41 series of six tubes which covers the range from 3400 to 3700 mc in six bands, each 50 mc wide.

Closely allied to the problem of obtaining the desired output frequency is the possibility of undesired frequencies due to improper operation of the tube. This effect, called moding, results from excitation of the cavities at modes different from the desired mode. Moding occurs when the anode current is lower than the normal value. Thus in the 2J38-2J39 series of tubes, operation at a peak anode current of less than 3 amperes is not recommended because the output frequency is then likely to be composed of many different modes, all of which require input power and thus lower the efficiency. More important is the fact that at low peak anode currents, the operation is

Exploded view of the 2J48 3-cm magnetron. The arrow marks the resonant cavity structure and cathode. The sealed-off coaxial output lead feeds the waveguide fitting. Power output, 50 kw



Type 4J52 2-cm magnetron within integral permanent magnet. This is among the latest designs, employing a coaxial cathode terminal (top) and waveguide for r-f output

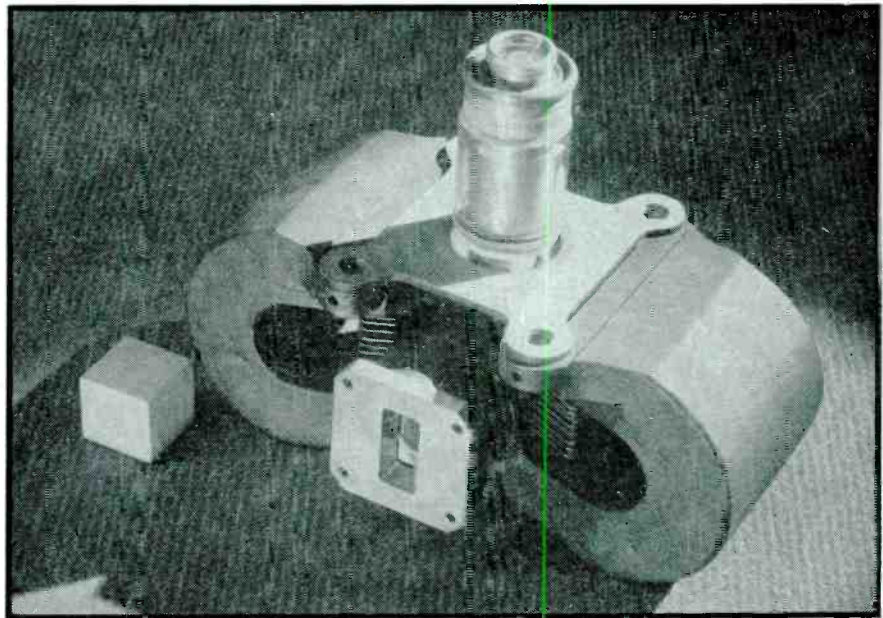

unstable, and the useful power output is apt to vary in amplitude and frequency. The same conditions may obtain at high space-currents with abnormally low peak anode voltage, which can occur if the magnetic field has too low a value.

The presence of off-frequency modes is minimized if the modulating pulse is closely rectangular in form, since the peak values of anode voltage and current are then attained almost instantaneously and the tube has no opportunity to oscillate at low values of current or voltage. The sideband spectrum of a rectangular pulse contains appreciable energy at frequencies far removed from the carrier, much more so than would occur if the modulating waveform were rounded. This outer sideband energy is generally not accepted by the radar receiver, and thus represents a waste of power as well as a source of interference to other receivers. But these disadvantages are outweighed by the advantage of stable magnetron operation which results from rectangular modulation. The time of rise of the pulse is generally about 0.1 to 0.2 microsecond and the time of fall about 0.4 microsecond.

#### Magnetic Aspects

The magnetic field applied to a cavity magnetron serves to deflect the electrons as they pass from cathode to anode, causing them to follow curved paths of cycloidal form. Values of magnetic field from 1000 to 3000 gauss are usual in 10-cm magnetrons, while higher values, up to 6000 gauss, are used in the 3-cm types.

In early equipment, electromagnets were occasionally used, but these have now been supplanted by permanent magnets composed of Alnico or similar high-energy material. In most equipments the magnet is permanently installed in the transmitter, and the magnetron in-

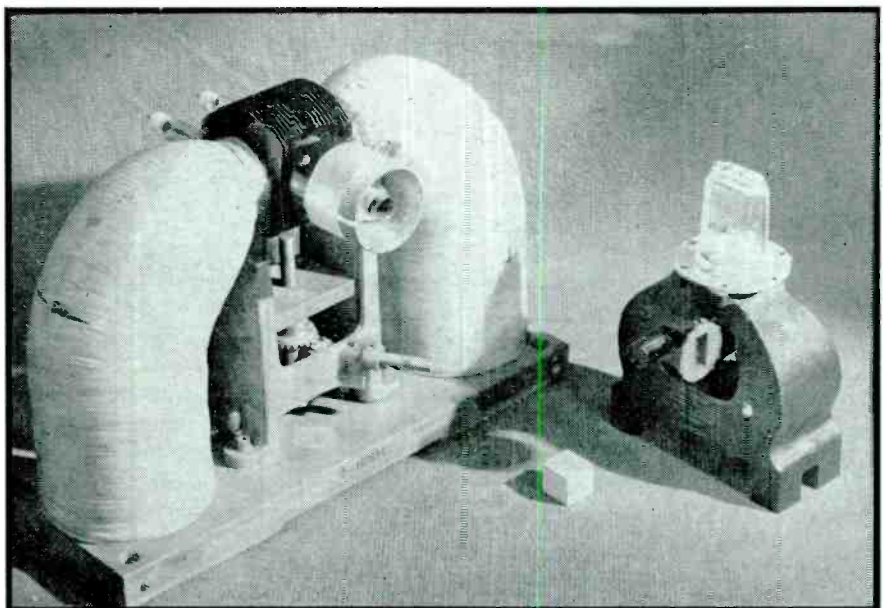

Typical magnet structures. At left a 2900-gauss unit for the type 720 10-cm megawatt tube. At right, type 725, 3-cm tube with cast 5500-gauss magnet

Tunable cavity magnetron, type 4J51. This tube covers the range from 900 to 970 mc, with a peak power of 400 kw. Cathode input at right, coaxial output at left

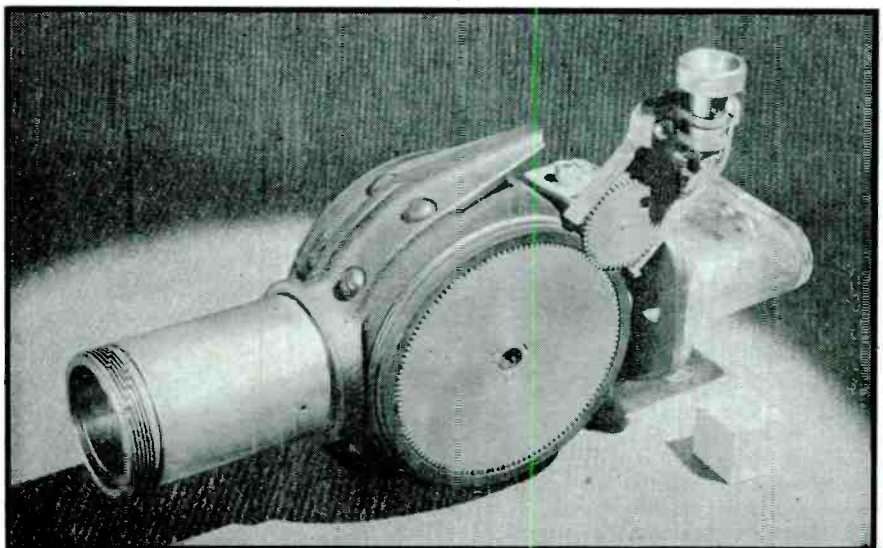



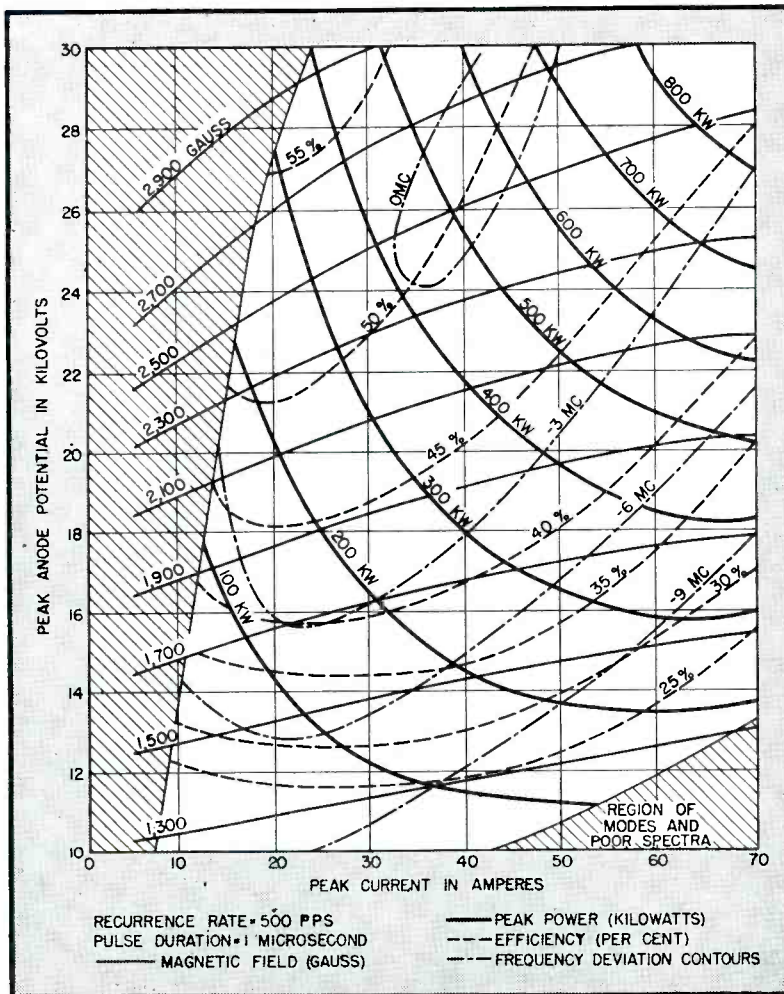

FIG. 1—Power output and efficiency of the 4J39 as functions of peak plate voltage, peak plate current and applied magnetic field. The shaded areas are regions within which unstable operation occurs due to the formation of multiple resonant modes within the cavities

achieve the desired value of anode current. High efficiency of operation is also associated with high

Variations in the magnetic field are to be avoided since they introduce, simultaneously, variations in output power, operating efficiency and output frequency. Highly constant fields may be achieved, fortunately, from permanent magnets, provided only that the reluctance in the air gap remains constant, which implies merely a steady support for the magnetron itself.

Those aspects of magnetron operation which are independent of the magnetic field are illustrated in Fig. 2, which applies to an integral-magnet 3-cm type. As the peak modulating current is increased, with constant magnetic field, the anode voltage rises slowly, the power output rises almost linearly, the efficiency drops, and the bandwidth of the r-f spectrum remains substantially constant.

**The Rieke Diagram**

served between the pole pieces. More recently the "packaged" magnetron has made its appearance. In this type the magnet is an integral part of the tube structure. This design is economical in types requiring small amounts of magnetic material, such as the 3-cm tubes and low-power 10-cm tubes. In the high-power 10-cm and 50-cm tubes, the magnet is a bulky and heavy affair, so the package form is seldom used.

Figure 1 illustrates the effect of the magnetic field on tube operation. The light solid lines, marked with values of magnetic field, are static characteristics, that is, corresponding values of d-c peak modulating voltage and resulting d-c peak anode current. As the magnetic field is increased, the curvature of the electron paths in the cathode-anode space becomes more

pronounced and the anode current drops. Thus high values of modulating voltage are associated with high values of magnetic field, to

An important representation of cavity magnetron operation is the Rieke diagram which indicates the values of magnetic field.

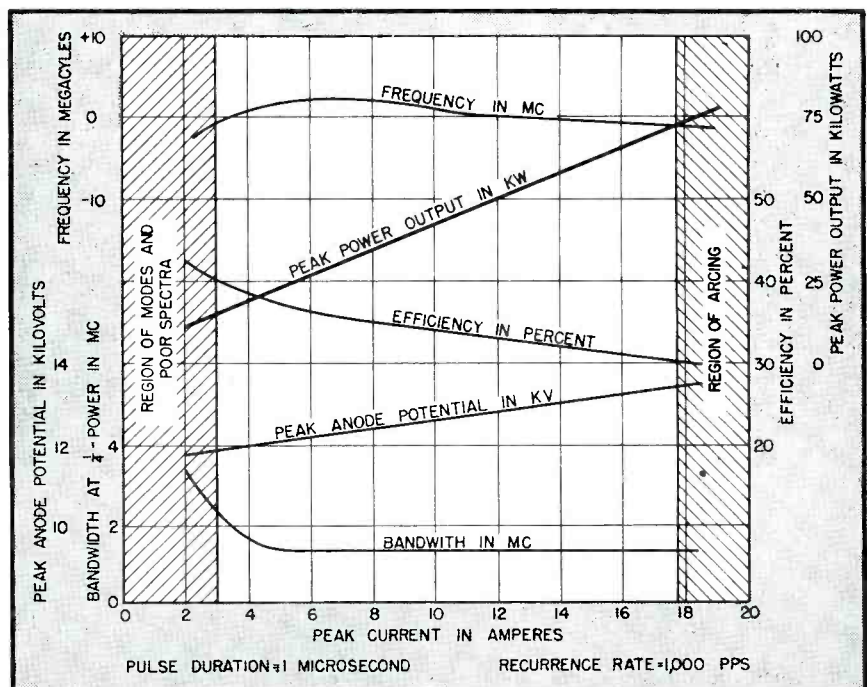

FIG. 2—Operating characteristics of the 2J55-2J56 3-cm tube, which operates at a fixed magnetic field supplied by the integral magnet. Note the increased bandwidth resulting from multiple modes at the lower values of anode current

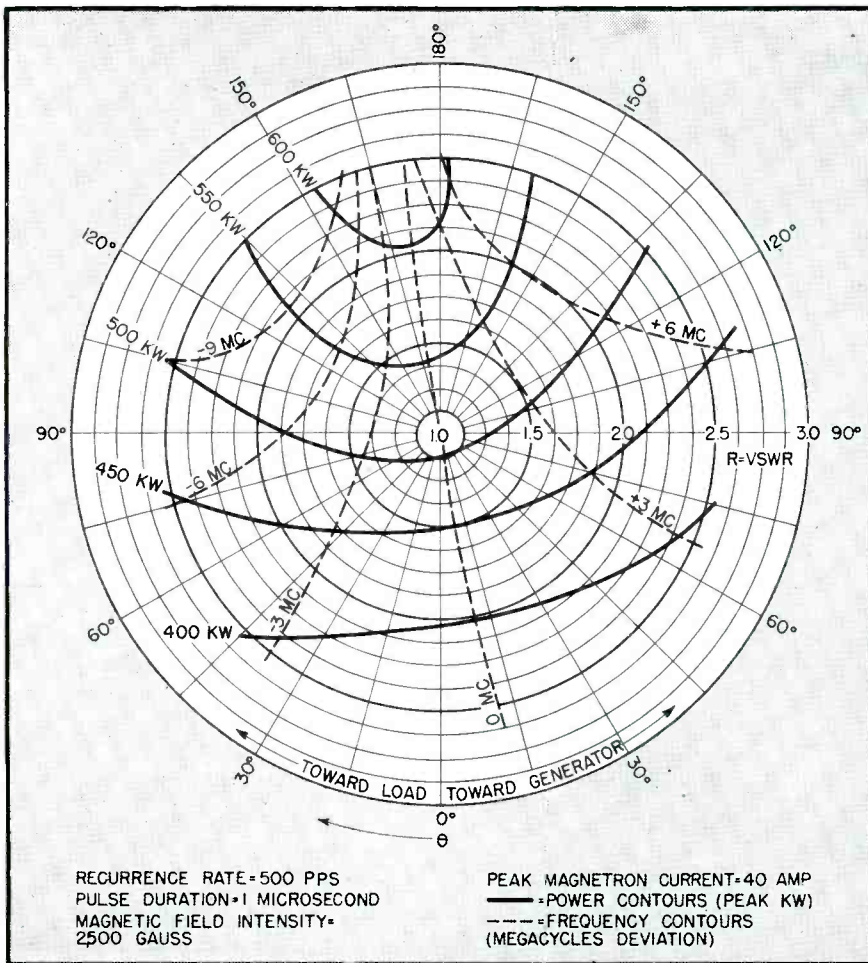

FIG. 3—Rieke diagram of the 4139 megawatt tube, a contour diagram showing the output frequency and power level as functions of the standing wave ratio and position of the voltage minimum along the attached transmission line or waveguide

effect of the impedance of the connected load. The impedance may be varied intentionally to tune the magnetron or to vary its power output. The diagram indicates the value of standing-wave ratio and the position of the voltage minimum required to achieve a given frequency and power output. More generally, the diagram is used to indicate the operating condition of the magnetron from impedance measurements. The recommended operating condition corresponds to the center of the diagram (matched load).

A typical Rieke diagram is shown in Fig. 3. The standing-wave ratio (ratio of maximum voltage to minimum voltage in the standing wave on the connected transmission line or waveguide) is measured radially

Type 706Y, a close copy of an early British model, with coaxial r-f output lead at right. Note fins surrounding anode for forced-air cooling. About 300 kw peak output at 3000 mc

from the center. The position of the voltage minimum, measured in electrical degrees from the output flange of the tube, is represented as an angle from 0 to 180 deg. On these coordinates are plotted con-

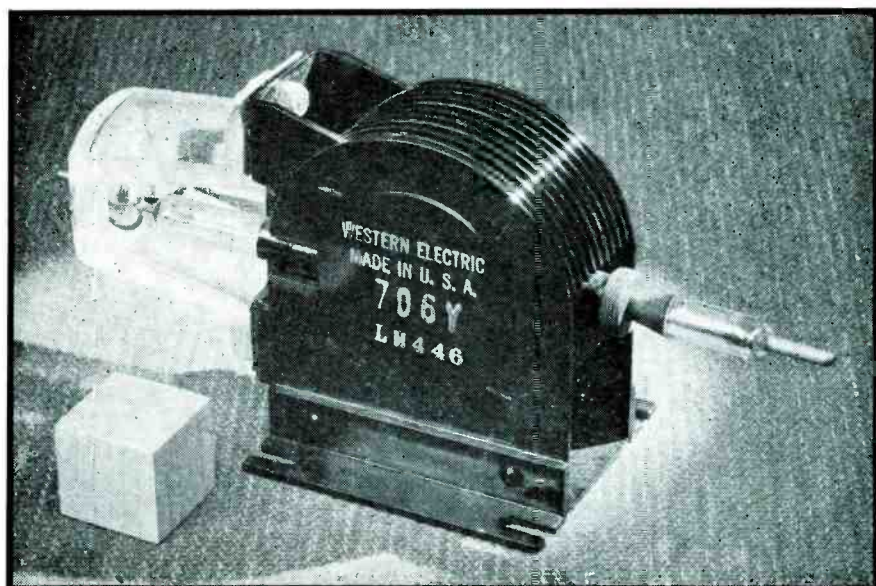

tours of peak power output and frequency deviation relative to the design value (the value at the center of the diagram corresponding to a matched load, with unity standing-wave ratio). The frequency contours tend to converge, in the case shown, along the angle 175 deg.

#### Mechanical Design

The mechanical features of typical cavity magnetrons are illustrated in the accompanying pictures. The cathode heater leads are insulated to withstand the high voltage modulating pulses. The r-f output is taken from the opposite side of the structure, in a terminal of the coaxial or waveguide form, depending on the r-f system to which the tube is connected. Since it has not proved practical to abstract the power except by means of a coupling loop, the output from the tube proper is always in the form of a coaxial line. When waveguide output termination is required, the coaxial segment is coupled to the waveguide by extending the inner coaxial conductor across the waveguide cross-section.

The editors wish to acknowledge the assistance of the following men, and their associates, in furnishing characteristics and photographs of the magnetrons described in this article: H. D. Hagstrum, Bell Telephone Laboratories; Ray Rice, Raytheon Manufacturing Company; and Clifford Johnson, Western Electric Company.—D.G.F.



# SUPERSONIC FLAW DETECTOR

Industrial electronic device reveals presence of internal defects in castings and other solid objects. Quartz transducer energized with supersonic pulses as high as 12 mc is held against object, and time for pulses to travel to flaw and back is measured with an oscilloscope

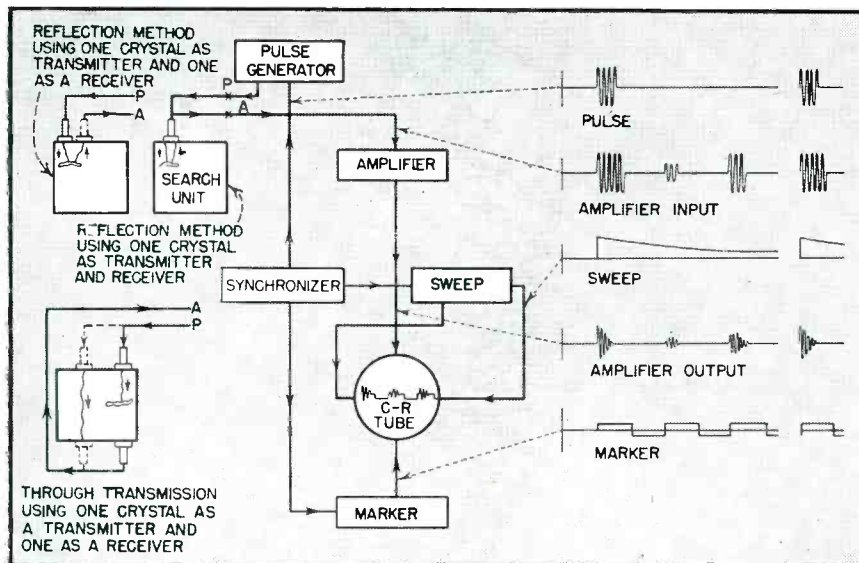

FIG. 1—Block diagram of supersonic flaw detector, with graphs of waveforms at various points in the circuit

**T**HE electronic instrument to be described uses supersonic energy to nondestructively test and measure solid parts. Internal defects are detected by sending supersonic pulses into the material under test and measuring the length of time it takes these pulses to penetrate the material, reflect from the opposite side or an internal defect, and return to the sending point. The instrument will locate defects at distances of the order of 10 feet from the testing surface.

### Frequencies Employed

The supersonic frequencies employed are between 0.5 and 12 mc, far beyond the audible range. This

band of frequencies is often considered as being occupied only by radio waves. Yet sound waves (which are waves of molecular vibrations) have been generated at frequencies up to and even above 500 mc.

Unlike radio waves, which travel mainly in air and on the surface of metallic objects, supersonic waves are very rapidly attenuated in air and travel best in matter such as metals, liquids, plastics, and wood. In travelling through one inch of air, a supersonic vibration with a frequency of 1 mc is attenuated by one half, whereas in water this same vibration would travel over 130 feet before being attenuated by

By **RALPH B. DE LANO, JR.**

*Research Engineer  
Sperry Products, Inc., Hoboken, N. J.*

the same amount as through air. Several types of sound waves may travel in solids, but in air most sound waves are of a compressional character. Since the main applications for supersonic testing have been confined to longitudinal waves (in which the molecules vibrate in the direction of propagation), this article will be concerned only with waves of that type.

### Properties of Supersonic Waves

The velocity of longitudinal sound waves travelling through a solid depends upon the density and elastic properties of the material. The two elastic properties involved are the extension or contraction of a body caused by a given force (the ratio of the stress intensity to the strain produced by

TABLE I. Ratio of Reflected Energy to Supersonic Beam Energy at Normal Incidence on Various Interfaces

Interface	$W_r/W_i$
Steel—oil	0.89
Steel—mercury	0.16
Steel—water	0.88
Glass—water	0.59
Glass—oil	0.68
Liquid—air	1.0
Solid—air	1.0

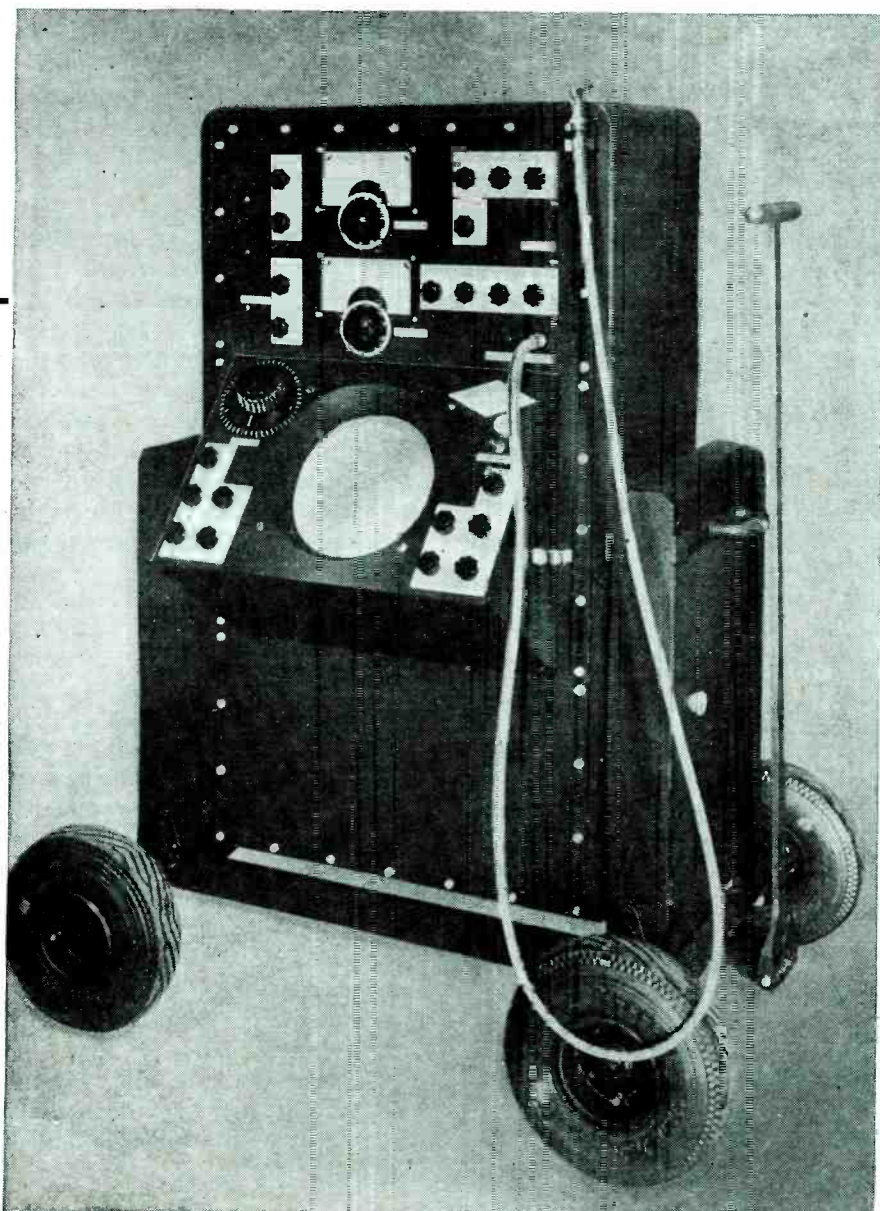

Type SR04 Supersonic Reflectoscope on rubber-tired carriage, with quartz crystal transducer mounted at end of cable

that stress) and the unrestricted change in width caused by a given change in length (the ratio of the compressional strain to the tensile strain, or vice versa). These two fundamental elastic properties are well known in the field of applied mechanics and are called Young's Modulus and Poisson's Ratio respectively. The velocity of longitudinal sound waves through solids is given by<sup>1</sup>

$$V_l = \sqrt{\frac{E}{\rho} \frac{1 - \sigma}{(1 + \sigma)(1 - 2\sigma)}} \quad (1)$$

where

$V_l$  = velocity of longitudinal waves in cm per sec

$E$  = Young's Modulus in dynes per sq cm

$\rho$  = density in grams per cu cm

$\sigma$  = Poisson's ratio (no units)

Wavelength, velocity, and frequency are related by the same equation as in other types of wave motions.

$$\lambda_l = V_l / f \quad (2)$$

where

$\lambda$  = wavelength in cm

$V_l$  = velocity of longitudinal waves in cm per sec

$f$  = frequency in cps

Because of their short wavelength, longitudinal sound waves may be presumed to be travelling through a uniform medium in a beam when they are generated in this form. Sound waves may be easily beamed at these frequencies since suitable electromechanical transducers having radiating surfaces of several wavelengths on a side are commonly available.

The factor which determines reflection at a boundary is the product of the density and velocity, and is known as the specific acoustic impedance. The equation which relates the reflected energy to the incident energy is<sup>2</sup>

$$W_r = W_i \left( \frac{\rho_1 V_1 - \rho_2 V_2}{\rho_1 V_1 + \rho_2 V_2} \right)^2 \quad (3)$$

where  $W_r$  is the reflected energy,  $W_i$  is the incident energy, and the subscripts 1 and 2 identify the properties of the two mediums. Any consistent system of units may be used. In the case of a steel-air interface nearly 100 percent of the energy is reflected. A few other common boundary reflection percentages are given in Table I. Table II gives the common acoustical properties of various mediums.

If the medium is composed of uniform particles of dimensions approaching those of the supersonic wavelengths, no reflections are observed due to scattering and absorption of the energy.

#### Description of Instrument

The functions of the various circuits are shown in Fig. 1.

The synchronizer provides three different output pulses sixty times a second. The first pulse is the rapid rise and exponential decay of the sweep voltage. The second pulse starts and stops the distance markers and may be delayed with respect to the sweep by a variable amount in order that the inch marks may be moved along the sweep. The third pulse is also delayed by a variable amount and determines the point at which the supersonic pulse generator is started.

The sweep amplifier provides push-pull horizontal deflection for the cathode-ray tube. The time of travel of the spot across the screen may be varied from 10 microseconds to 2000 microseconds approximately. Sweep expansion is also



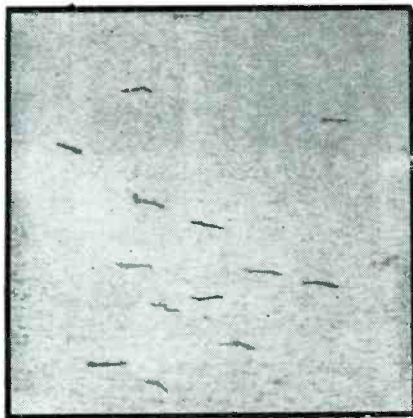

FIG. 2—Macroetch section of a forging, showing defects originally found by super-sonic testing

provided to obtain good resolution when inspecting over long distances.

The distance marker generates square waves in which the fundamental frequency is continuously variable from 5 kc to 130 kc. Therefore, one square-wave cycle can be made to represent any desired length from one to more than twenty-five inches of aluminum. The half-cycle points are made to divide the length equally.

The pulse generator provides a 1000-volt pulse and is continuously variable in overlapping ranges of frequency from 0.5 mc to 12 mc. The pulse length may also be varied from one to several microseconds.

#### Transducers are Quartz Crystals

For longitudinal waves, an X-cut piezoelectric quartz crystal is used as an electromechanical transducer and is normally operated near its thickness resonance to obtain maximum sensitivity. In this case, the crystal is one-half wavelength thick. It is clamped to damp out free vibrations rapidly. This same crystal (search unit) serves as a transducer for the transmitted pulse as well as for the received echoes. A metallic coating is provided on the back side of the crystal. For materials which are not good electrical conductors, an additional metallic coating must also be placed on the side that comes in contact with the material under investigation. Normally, however, the material is the other electrode.

To obtain good supersonic coupling, a film of liquid, usually oil, is applied between the crystal and the work. When inspecting cylindrical

surfaces, the crystal is ground to fit the piece being tested; in this case, both surfaces of the search unit must be curved in order to make the crystal a good transducer.

The amplifier is actually a superheterodyne receiver, all the reflected pulses being converted to one frequency before being amplified. Its bandwidth is variable from a fraction of a megacycle to several megacycles. Since sound absorption and the minimum size of the defect to be located vary with each application, the amplifier gain is variable. The indicator is a nine-inch cathode-ray tube.

Although single-crystal operation is usually most desirable, it is also possible to use one crystal as the transmitter and one as the receiver, as shown in the block diagram.

#### Design Problems

The requirement that the final instrument be as universal in use as possible presented certain problems. To test many materials of sizes ranging from a few inches to many feet, it was necessary to have a variable time scale as well as variable pulse length, sweep length, etc. The different grain sizes of various materials, the varying wavelength of sound in these materials, and the necessity of finding defects of a different size for each testing application also made it mandatory to provide a wide range of testing fre-

quencies for general industrial use.

Fatigue cracks in metal pieces tend to develop near shoulders and keyways. Since these shoulders often give reflections, high resolution and sweep expansion was required. The exponential type of sweep, which is the easiest sweep to generate, was also deemed advisable. From an operational point of view, it provides high resolution near the testing surface and yet, since the end reflection can also be seen, this type of sweep enables the operator to be certain of good supersonic wave transmission. It is necessary to adjust only 6 knobs to change the testing frequency. For ordinary testing, an operator can be trained in two weeks.

The necessity for rapid amplifier recovery immediately after the pulse was a difficult problem to solve. For example, in the case of a flaw  $\frac{1}{8}$ th inch below the surface of a piece of aluminum, only one microsecond elapses between the time the beginning of the pulse is applied to a crystal and the time when it is reflected back by the flaw. The instrument pictured herein can find small flaws  $\frac{1}{2}$  inch below the surface, and special techniques permit even closer testing.

A large cathode-ray tube was provided so that the person manipulating the search unit could see the indications directly. The spot trace



FIG. 3—Checking axle of Tournapull Super Model C tractor with Supersonic Reflectoscope

can be seen easily if direct light does not strike the screen, as the tube has about 3000 volts on its final anode.

For industrial use, the machine had to be easily wheelable and require only a small amount of electrical power. When built with a magnesium case and carriage the complete unit weighs 225 pounds and consumes less than 200 watts of power.

#### Applications

Present applications mainly involve testing of metals, although

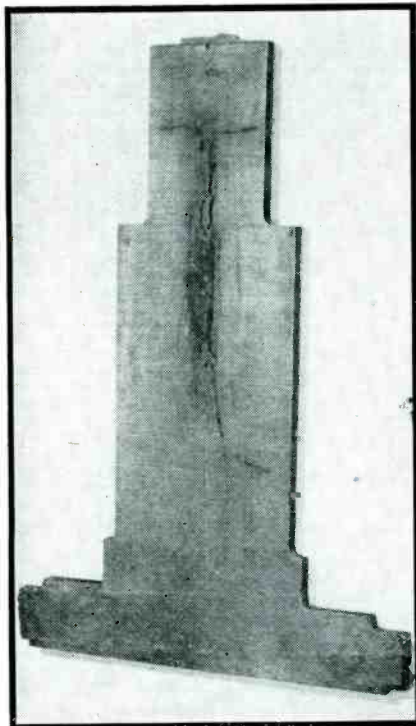

FIG. 4—Etched section of defective axle, showing flaws revealed by supersonic testing

both liquids and plastics will conduct supersonic waves at these frequencies and could be tested or measured by this instrument. The surface to be tested should be relatively smooth. If not already machined, it can be smoothed with a portable hand grinder. A finish equivalent to the GE number f5, which has an average roughness of 125 microinches or a peak-to-valley value of 450 microinches, is satisfactory; however, the maximum allowable surface roughness depends on the minimum size of defect it is desired to detect.

The average maximum distance

TABLE 2. Properties of Materials and Wavelengths of Supersonic Vibration in Materials at Three Frequencies

Material or Medium	$V_l$ cm per sec	Wavelength in cm at Freq. Indicated			Density grams per cu cm	Specific Acoustic Impedance (density x velocity)
		1 mc	$2\frac{1}{4}$ mc	5 mc		
Steel	$581 \times 10^3$	0.581	0.259	0.116	7.8	$4.54 \times 10^6$
Aluminum	$622 \times 10^3$	0.622	0.277	0.124	2.70	$1.68 \times 10^6$
Brass	$443 \times 10^3$	0.443	0.196	0.0886	8.4	$3.72 \times 10^6$
Copper	$462 \times 10^3$	0.462	0.206	0.0824	8.89	$4.10 \times 10^6$
Lead	$213 \times 10^3$	0.213	0.0947	0.0426	11.3	$2.41 \times 10^6$
Mercury	$142 \times 10^3$	0.142	0.0632	0.0284	13.6	$1.93 \times 10^6$
Glass	$520 \times 10^3$	0.520	0.231	0.104	2.5	$1.30 \times 10^6$
Quartz	$575 \times 10^3$	0.575	0.255	0.115	2.65	$1.52 \times 10^6$
Bakelite	$259 \times 10^3$	0.259	0.115	0.0518	1.4	$0.363 \times 10^6$
Polystyrene	$267 \times 10^3$	0.267	0.119	0.0534	1.1	$0.294 \times 10^6$
Transformer Oil	$139 \times 10^3$	0.139	0.0618	0.0278	0.92	$0.128 \times 10^6$
Water	$145 \times 10^3$	0.145	0.0645	0.0290	1.00	$0.145 \times 10^6$
Air	$34.4 \times 10^3$	0.0344	0.0153	0.00688	0.00120	41.3

which can be shot depends upon the material being tested. Steel and aluminum are quite homogenous and permit relatively deep penetration, while metals such as lead and copper are relatively hard to penetrate. Large grain size and the presence of small discontinuities make it hard to shoot long distances in any material when these discontinuities are of the same magnitude or larger than the supersonic wavelength being used.

The size of the indication on the scope is only roughly proportional to the size of the defect, but by moving the search unit over the testing surface and noting the indication on the cathode-ray tube the area of a large flaw may be plotted. For small flaws the testing frequency may be decreased in steps until the supersonic wavelength approaches the major dimension of the defect, whereupon its indication disappears, thus indicating the approximate size of small flaws. In some cases considerable information as to the type of defect may be determined from the shape of the indication.

A great many types of defects have been found with this instrument, such as hydrogen ruptures, coring, inclusions, fatigue cracks, shrinkage cracks, stringers, piping, segregations, and laminations. Relative grain size and thickness of material can also be measured. The latter measurement is especially valuable when one side is inaccessible. Defective bonds between like as well as dissimilar metals can be

found, and the soundness of welds may be determined, except in the case of paste welds.

#### Examples of Performance

An etched section of a steel billet containing defects found by non-destructive supersonic testing is shown in Fig. 2. The short, dark semihorizontal lines are the defects which were found before the sample was taken and etched. This type of a defect is known as a hydrogen rupture or flake, and is difficult to find by any other method except that of sectioning and etching.

An on-the-job test on the axle of a tractor is illustrated in Fig. 3. Many of these axles which had been assembled prior to the availability of the supersonic tester were later checked in this manner. There are many similar applications where fatigue cracks can be located in assembled equipment when only the end of the shaft or axle is accessible.

An etched section from a forged axle rejected by supersonic testing is shown in Fig. 4. The defect can be seen as longitudinal segregations with transverse cracks at either end. Figure 5 shows a series of reflectograms (pictures of cathode-ray tube beam traces) of the axle for different positions of the searching unit. The supersonic pulse reflections obtained are identified by the letters  $P_1, P_2$ , etc. The cause of these reflections and the corresponding positions of the searching unit on the axle are identified in Fig. 6. The reflection  $P_1$  was due to a  $\frac{1}{8}$ -inch diameter, 2-inch deep hole drilled in



a test axle for comparison purposes. Note the almost complete scattering and absorption of the beam obtained when shooting along the axis of the axle. Also note the reflected pulses  $P_1$  and  $P_6$  obtained from the transverse defects and the diminution of the end reflection  $P_3$ . The search unit crystal was in this case one inch square, hence a supersonic wave train having approximately the same cross-section was formed. Parts of this wave train were reflected by various discontinuities in the axle, causing multiple reflections on the cathode-ray tube sweep.

#### Advantages of Supersonic Testing

The supersonic method of testing does not necessarily require a change in density for its indications, due to the inherent properties of supersonic waves. Since it depends on the reflected energy caused by an area of discontinuity, it enables the operator to detect flaws of infinitely small depth regardless of the thickness of the part being tested.

The minimum area of the discontinuity required to give an indication depends on the distance of the discontinuity from the surface being tested and the homogeneity of the material. In aluminum, for example, a void with surface dimensions of 0.125 x 0.002 inch will give a reflection when this discontinuity

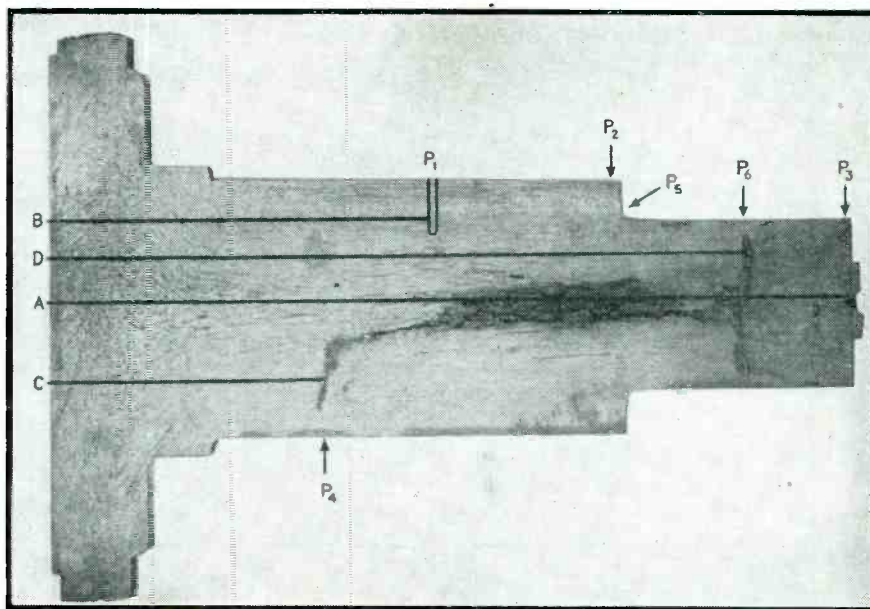

FIG. 6—Identification of scanning lines and reflections in Fig. 5. Crystal transducer was applied in turn to points A, B, C, and D on exposed end of axle

is 2 inches from the searching unit, and a  $\frac{1}{8}$ -inch diameter defect will give a reflection when the flaw is 10 feet from the crystal.

This method of testing gives results immediately to the operator as he tests the part, and the speed of testing does not depend on the thickness of the piece undergoing inspection. In the average application only a small amount of operator interpretation is required and the defect indication is plainly visible.

The fact that axles, shafts, etc.

may be inspected for fatigue cracks while still assembled, provided one end is accessible, is an obvious advantage in industrial use. It is not necessary that the flaw extend to the surface, nor is it necessary to remove wheels, etc. from the axle or shaft. Formerly, fatigue cracks, even though they extended to the surface, could be found only by disassembling the part and examining it closely. In the case of some crank pins which have wheels pressed on with great force, the disassembling method ruins the pin.

Such advantages, combined with high accuracy and ease of operation, make supersonic testing an important addition in the field of nondestructive testing.

The instrument described was invented by Dr. Floyd A. Firestone. The technical development of this model was under his direction and that of H. C. Drake, director of research at Sperry Products, Inc.

#### BIBLIOGRAPHY

- (1) Bergmann, L. and Hatfield, H. S., "Ultrasonics", John Wiley and Sons, Inc., New York, 1942, p. 162 (also contains an excellent bibliography).
- (2) Page 46 of reference 1.
- (3) Young, V. J., "Supersonic Fundamentals", *ELECTRONICS*, p. 122, March 1944.
- (4) Wood, R. W., "Supersonics—The Science of Inaudible Sound", Brown University, Providence, R. I., 1939.
- (5) Mason, W. P., "Electromechanical Transducers and Wave Filters", D. Van Nostrand Company, Inc., New York, 1942.
- (6) Wood, A., "Acoustics", Interscience Publishers, Inc., New York, 1943.
- (7) Firestone, F. A., "The Supersonic Reflectoscope for Interior Inspection", *Metal Progress*, p. 505, Sept. 1945.

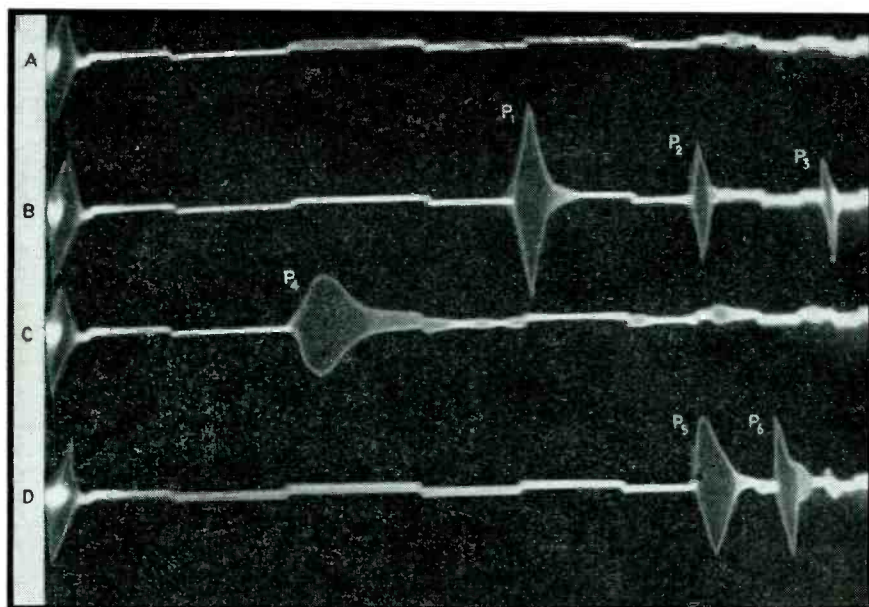

FIG. 5—Reflectograms of axle shown in Fig. 4, as photographed on screen of cathode-ray tube. Operators can be thoroughly trained in two weeks in use of supersonic tester and interpretation of traces like these in terms of flaws







TYPE MODE	CONFIGURATION	CUTOFF FREQUENCY $f_c$ IN MC PER SEC	ATTENUATION $\alpha$ IN DB PER FOOT OF AXIAL LENGTH	$\frac{f_{MIN}}{f_c}$	$\alpha_{MIN}$ IN DB PER FT OF AXIAL LENGTH
RECTANGULAR H WAVES $H_{0,m}$ $n \neq 0$ $H_{n,m}$	 $H_{2,1}$	$5905.5 \sqrt{\left(\frac{n}{a}\right)^2 + \left(\frac{m}{b}\right)^2}$	$0.01119 \frac{\sqrt{m}}{\sqrt{(b')^3}} \left\{ \frac{b}{a} + \left(\frac{n}{m}\right)^2 \left(\frac{b}{a}\right)^2 \right\} \left(\frac{f}{f_c}\right)^{\frac{1}{2}} + \left\{ 1 + \left(\frac{n}{m}\right)^2 \left(\frac{b}{a}\right)^2 \right\} \left(\frac{f}{f_c}\right)^{-\frac{1}{2}}$	$\frac{\sqrt{6}}{2} \sqrt{1 + \left(\frac{k_2}{k_1}\right)^2 + \left(\frac{k_2}{k_1}\right)^2 + \frac{14}{9} \left(\frac{k_2}{k_1}\right)^2} + 1$	$\frac{\frac{a}{b} + \left(\frac{n}{m}\right)^2 \left(\frac{a}{b}\right)^2}{k_2/k_1} + 1 + \left(\frac{n}{m}\right)^2 \left(\frac{a}{b}\right)^2$ $k_2/k_1 = 2 \frac{a}{b}$ $\alpha_{MIN}$ IS TO BE DETERMINED SEPARATELY FOR EACH CASE
	 $H_{0,1}$	$\frac{5905.5}{b}$ LOWEST CUTOFF FREQ	$0.01119 \frac{\sqrt{m}}{\sqrt{(b')^3}} \frac{\frac{b}{2a} \left(\frac{f}{f_c}\right)^{\frac{3}{2}} + \left(\frac{f}{f_c}\right)^{-\frac{1}{2}}}{\sqrt{\left(\frac{f}{f_c}\right)^2 - 1}}$ LOWEST ATTENUATION		
	 $E_{1,1}$	$5905.5 \sqrt{\left(\frac{n}{a}\right)^2 + \left(\frac{m}{b}\right)^2}$	$0.01119 \frac{\sqrt{m}}{\sqrt{(b')^3}} \frac{1 + \left(\frac{n}{m}\right)^2 \left(\frac{b}{a}\right)^2 \left(\frac{f}{f_c}\right)^2}{\left\{ 1 + \left(\frac{n}{m}\right)^2 \left(\frac{b}{a}\right)^2 \right\}^{\frac{1}{2}} \sqrt{\left(\frac{f}{f_c}\right)^2 - 1}}$		
CIRCULAR H WAVES $H_0$ $H_1$	 $H_0$	$\frac{7167.7}{a^2}$	$\frac{0.0061769}{\sqrt{(a')^3}} \frac{\left(\frac{f}{f_c}\right)^{-\frac{1}{2}}}{\sqrt{\left(\frac{f}{f_c}\right)^2 - 1}}$	$\infty$	THIS WAVE IS UNSTABLE AND CAN BE USED ONLY IN STRAIGHT TUBING
	 $H_1$	$\frac{3458.8}{a^2}$ LOWEST CUTOFF FREQ	$\frac{0.0042746}{\sqrt{(a')^3}} \frac{0.42 \left(\frac{f}{f_c}\right)^{\frac{3}{2}} + \left(\frac{f}{f_c}\right)^{-\frac{1}{2}}}{\sqrt{\left(\frac{f}{f_c}\right)^2 - 1}}$	$\frac{\sqrt{6}}{2} \sqrt{1 + \left(\frac{k_2}{k_1}\right)^2 + \left(\frac{k_2}{k_1}\right)^2 + \frac{14}{9} \left(\frac{k_2}{k_1}\right)^2} + 1$	$\frac{0.0041848}{\sqrt{(a')^3}}$ LOWEST MINIMUM ATTENUATION
	 $E_0$	$\frac{4520.85}{a^2} \rightarrow \frac{4521}{a^2}$	$\frac{0.0049}{\sqrt{(a')^3}} \frac{\left(\frac{f}{f_c}\right)^{\frac{3}{2}}}{\sqrt{\left(\frac{f}{f_c}\right)^2 - 1}}$	$\sqrt{3} = 1.732$	$\frac{0.0078953}{\sqrt{(a')^3}}$
	 $E_1$	$\frac{7167.7}{a^2}$	$\frac{0.0061769}{\sqrt{(a')^3}} \frac{\left(\frac{f}{f_c}\right)^{\frac{3}{2}}}{\sqrt{\left(\frac{f}{f_c}\right)^2 - 1}}$	$\sqrt{3} = 1.732$	$\frac{0.00995476}{\sqrt{(a')^3}} = \frac{0.01}{\sqrt{(a')^3}}$

TABLE I. DESIGN FACTORS FOR COPPER-WALLED AIR-CORED WAVEGUIDES

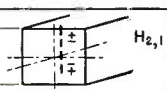
# Minimum Attenuation in Waveguides

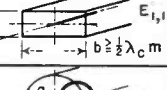
Tabulation of design equations covering attenuation, development of simplified versions applying to specific practical air-core guides most often encountered, and graphical construction for determining conditions for minimum attenuation at exciting frequency

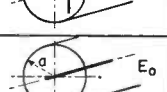
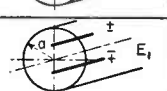
By EDWIN N. PHILLIPS

Drexel Hill, Pa.

IN recent literature dealing with the phenomena of signal transmission through air-cored waveguides, the conditions for propagation have been adequately dealt with, but the conditioning of the cross-sectional dimensions to obtain minimum attenuation at the exciting frequency has generally been dismissed with but a brief treatment. Since this aspect is of direct concern to the designer using wave-

guides, this paper presents the necessary formulas for predicting cross-sections giving minimum attenuation.

Practical formulas concerning attenuation in air-cored guides are listed by Sarbacher and Edson in their book, "Hyper- and Ultra-High-Frequency Engineering." These formulas, as converted into English units, appear in Table I. For material other than copper, multiply the value of attenuation by  $\sqrt{\rho/\rho_c\mu}$ , where  $\rho$  is the specific resistivity of the guide material,  $\rho_c$  is the specific

resistivity of copper, and  $\mu$  is the permeability of the guide material. It will be noted that the formulas for the  $H_{0,m}$  and the  $H_{n,m}$  excitation modes in rectangular cross-section guides and the  $H_1$  mode in circular cross-section guides can be expressed in the form

$$\alpha = k_1 \frac{\left(\frac{f}{f_c}\right)^{1.5}}{\left[\left(\frac{f}{f_c}\right)^2 - 1\right]^{0.5}} + k_2 \frac{\left(\frac{f}{f_c}\right)^{-0.5}}{\left[\left(\frac{f}{f_c}\right)^2 - 1\right]^{0.5}} \quad (1)$$

where  $\alpha$  is in db per foot and  $k_1$  and

It is to be understood that the opinions or assertions contained in this paper are the private views of the author, and are not to be construed as being official, nor as reflecting the views of the Navy Department or of the Naval Service at large.



$k_2$  are constants dependent on the material and the dimensions of the guide.

For copper guides, the ratio  $k_2/k_1$  for various excitation modes is

$H_{0,m}$ rectangular cross-section	$2 a/b$
$H_{1,1}$ circular cross-section	2.38
$H_{n,m}$ rectangular cross-section	

$$\frac{\left(\frac{a}{b}\right) + \left(\frac{n}{m}\right)^2}{\left(\frac{a}{b}\right)^2} \div \left[ 1 + \frac{\left(\frac{n}{m}\right)^2}{\left(\frac{a}{b}\right)} \right]$$

where  $a$  is the thickness of the rectangular cross-sectioned guide in inches or the radius of the circular guide,  $b$  is the width of the rectangular cross-sectioned guide, and  $n$  and  $m$  are subscripts defining the order of the wave propagated within the guide.

By differentiating Eq. 1 with respect to the frequency ratio  $f/f_c$ , where  $f$  represents the exciting frequency and  $f_c$  the cutoff frequency below which the guide will not transmit electromagnetic waves, and setting the resulting expression equal to zero, the following expression for  $f_{min}$ , the frequency of minimum attenuation, is obtained

$$\frac{f_{min}}{f_c} = \frac{\sqrt{6}}{2} \sqrt{1 + \frac{K_2}{K_1} + \sqrt{\left(\frac{K_2}{K_1}\right)^2 + \frac{14}{9} \left(\frac{K_2}{K_1}\right)}} + 1 \quad (2)$$

Because an approximate solution to this equation may be sufficiently accurate in certain cases, and to provide a rough check on computations,

the equation has been plotted as Fig. 1.

Because of the relative ease of excitation and the low overall attenuation, the  $H_{0,m}$  excitation mode is often used. For this case, Eq. 2 simplifies to

$$\frac{f_{min}}{f_c} = \frac{\sqrt{6}}{2} \sqrt{1 + 2 \frac{a}{b} + \sqrt{4 \left(\frac{a}{b}\right)^2 + \frac{28}{9} \left(\frac{a}{b}\right) + 1}} \quad (3)$$

While Eq. 2 and 3 are useful for fixed guide dimensions and variable input frequency, often the input frequency is fixed and the guide dimensions must be varied to secure minimum attenuation. Manipulation of Eq. 2 and 3 to isolate the dimensional factor gives for the general case

$$\frac{k_2}{k_1} = \frac{\left(\frac{f}{f_c}\right)^4 - 3 \left(\frac{f}{f_c}\right)^2}{3 \left(\frac{f}{f_c}\right)^2 - 1} \quad (4)$$

and for the  $H_{0,m}$  mode

$$\frac{a}{b} = \frac{\left(\frac{f}{f_c}\right)^4 - 3 \left(\frac{f}{f_c}\right)^2}{6 \left(\frac{f}{f_c}\right)^2 - 2} \quad (5)$$

In all these formulas, the condition for minimum attenuation is independent of the guide material, and dependent only on the cross-sectional dimensions of the guide and the order of the transmitted wave.

#### Formulas for E Modes

Treating the formulas for the  $E_{n,m}$  excitation mode in rectangular cross-sectioned guides and  $E$  excitation modes in circular cross-sectioned guides in a similar manner,

the general formula is

$$\alpha = k \cdot \frac{\left(\frac{f}{f_c}\right)^{1.5}}{\left(\left(\frac{f}{f_c}\right) - 1\right)^{0.5}} \text{ db per ft} \quad (6)$$

Setting the first derivative equal to zero gives

$$f_{min}/f_c = \sqrt{3} \quad (7)$$

Note that here the condition for minimum attenuation is independent of both the guide material and the guide dimensions. It will further be noted that Eq. 7 is the limit of Eq. 2 obtained when  $k_2/k_1$  equals zero, indicating in the  $H_{0,m}$  mode a zero guide thickness.

Thus, when the thickness  $a$  equals the width  $b$  of the guide and it is excited in the  $H_{0,m}$  mode, Eq. 3 gives  $f/f_c$  equal to 2.96; for a cutoff frequency of  $1.5 \times 10^9$  cps, the frequency of minimum attenuation is  $4.44 \times 10^9$  cps. For a guide of the same cross-section excited in the  $H_{1,1}$  mode,  $k_2/k_1$  will be unity, and Eq. 2 gives 2.416 for  $f/f_c$ ; for a cutoff frequency of  $2.12 \times 10^9$  cps, the frequency of minimum attenuation will be  $5.12 \times 10^9$  cps. For the same cutoff frequency, Eq. 7 gives  $3.67 \times 10^9$  cps as the frequency of minimum attenuation in a rectangular guide which is excited in transverse magnetic mode.

#### Approximate Plots

By means of Eq. 2, 3, and 7, approximate plots of the attenuation-vs-frequency relationship for air-cored waveguides can easily be made. The cutoff frequency  $f_c$  forms a vertical asymptote on a log-log grid, the point of minimum attenuation forms a horizontal asymptote, and since at a frequency much higher than that giving minimum attenuation the guide behaves as any metallic conductor whose attenuation varies as the square root of the frequency, a third boundary to the curve is formed. To illustrate this, Fig. 2 gives the attenuation curve of a brass guide (square root of the resistivity-ratio of brass to copper is 2.015) with inside dimensions of  $1.34 \times 2.84$  inches. This data combines with the formulas in Table I to give, for  $H_{0,1}$  excitation,  $f_c = 2,084$  mc,  $f_{min} = 4,960$  mc,  $\alpha_{min} = 9.42$  db per thousand feet, and  $\alpha = 110$  db per thousand feet at  $f = 10^{12}$  cps. The resultant curve closely approximates a point-by-

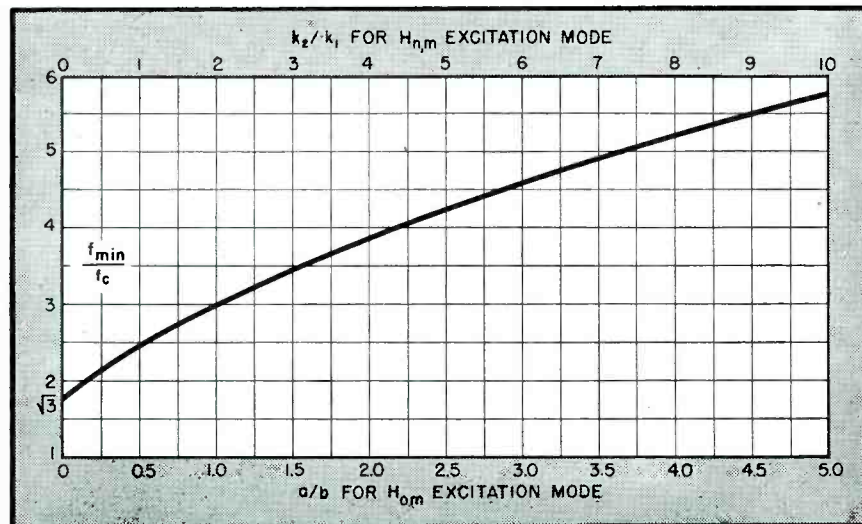

FIG. 1—Minimum attenuation in air-cored waveguide in terms of dimensional parameters

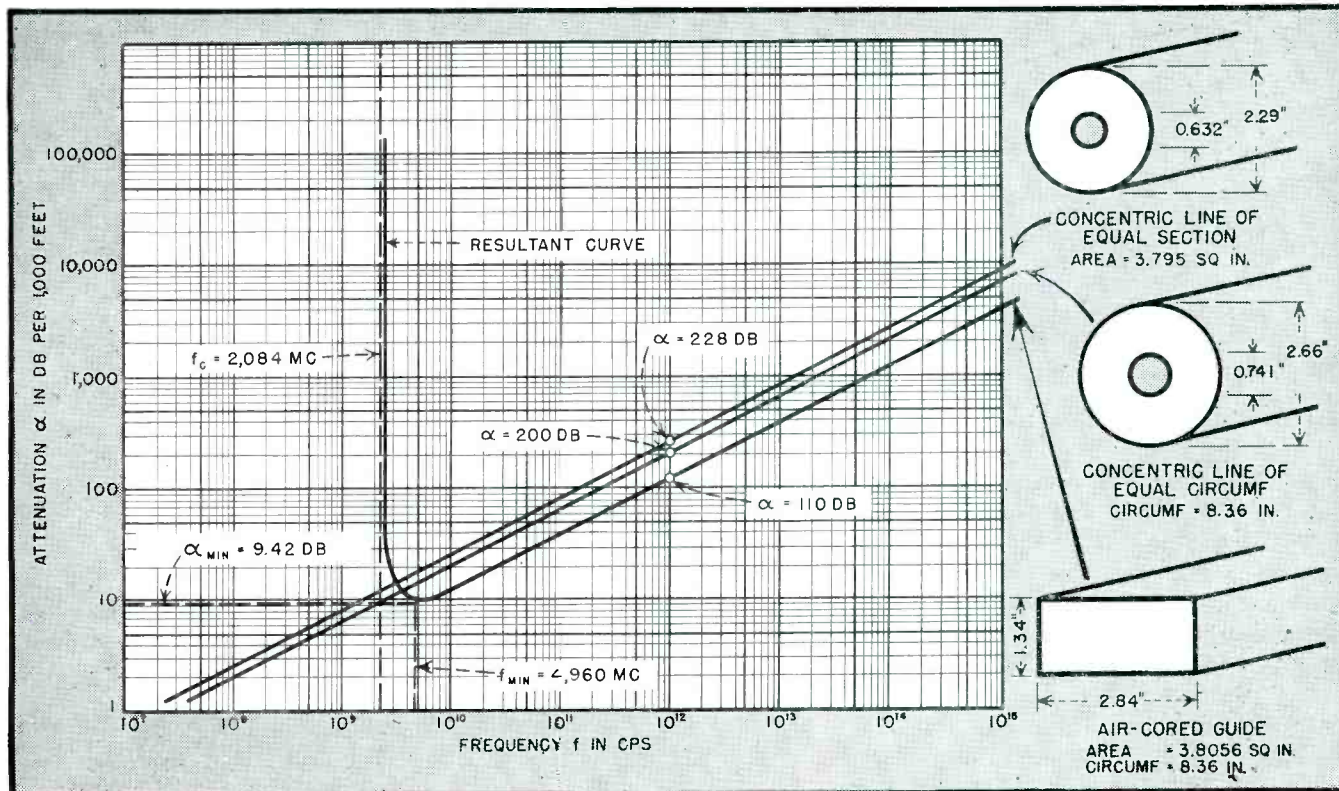

FIG. 2—Graphical construction of attenuation curve for 1.34 by 2.84-inch rectangular waveguide, and corresponding curves for two types of concentric lines

point plot, and saves much time.

Once the attenuation per unit length and the guide length are known, the transmission-line efficiency in percent is obtained from

$$\eta = 100 / \left( \log^{-1} \frac{\alpha l}{10} \right) \quad (8)$$

where  $l$  is line length in feet. A plot of this is shown in Fig. 3.

Also plotted in Fig. 2, as a matter of pertinent interest, are the attenuation curves of a zero-conductance brass concentric line for which  $D/d = 3.59$ , with the same inner periphery as the guide ( $\alpha = 200$  db per thousand feet at  $10^{12}$  cps), and a zero-conductance brass concentric line for which  $D/d = 3.59$ , with the same dielectric area as the guide cross-section ( $\alpha = 228$  db per thousand feet at  $10^{12}$  cps). It will be noted that above the point of intersection of the guide curve with these curves, the guide has less attenuation than concentric lines.

### Summary

Pertinent points to be mentioned as general guides in the use of waveguides of this type are (1) an infinite number of cross-sections will give minimum attenuation at any prescribed frequency, but the cross-sectional dimensions are not

independent of each other and both depend on the cutoff frequency chosen; (2) the lower the cutoff frequency-chosen, the lower will be the attenuation, the larger the guide dimensions will be, and the broader will be the bell of the curve at the minimum point in the  $H$  propagational modes, giving less distortion in the output of a com-

plex wave or a modulated carrier.

Concerning this last point, most of the present-day applications use pulsed modulation, and it can be shown that when the ratio of the carrier (or pulsed) frequency to the pulsing frequency is great, the sidebands are negligible, and attenuation can be computed for the carrier alone.

FIG. 3—Transmission-line efficiency in terms of cable length and attenuation per unit length

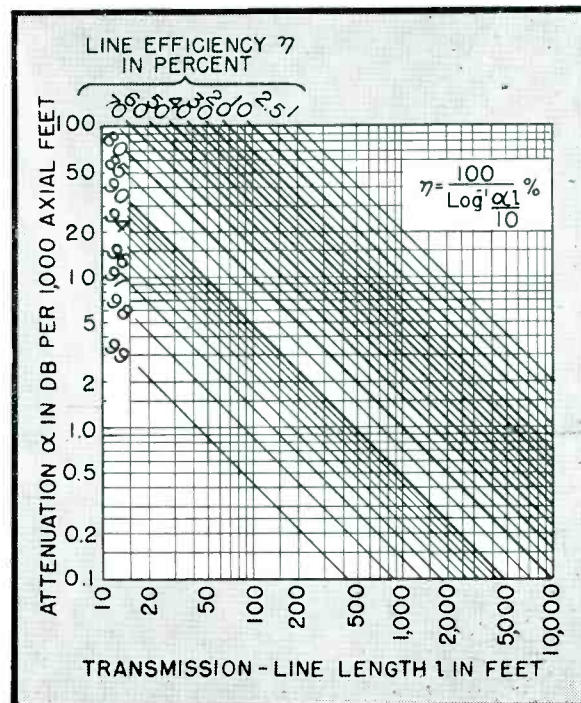



# PICKUP WITH LOW

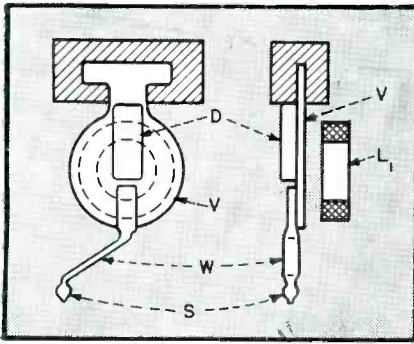

FIG. 1—Side and front views of pickup show the essential mechanical elements and their relation to the oscillator coil

**T**HE MECHANICAL IMPEDANCE of the pickup to be described is so low that not more than 14 grams weight is necessary for tracking, thus giving long record life. Distortion caused by eccentricity of records is approximately 0.5 db. Little mechanical noise is radiated from the pickup itself, giving quiet operation for open record players. The complete reproducer has an inherent high-frequency cutoff at 4,000 cps, which is desirable for high signal-to-noise ratio on commercial shellac pressings. Mechanical proportions of the pickup are shown in Fig. 1.

The pickup stylus moves a high-resistance vane in relation to the inductance of the resonant circuit in a radio-frequency oscillator. This relative motion varies the mutual inductance between vane and coil, thereby changing the resistance reflected into the coil. This action produces amplitude modulation of the oscillator by varying the loss of its resonant circuit. The amplitude modulation is detected to give the audio-frequency output from the electronic reproducer, the circuit of which is shown in Fig. 2.

## Mechanical Characteristics of Pickup

The moving element shown in Fig. 1 consists of three parts: the vane *V* made of resistance, non-magnetic, stainless steel with an essentially circular form 0.004 inch thick and  $\frac{3}{8}$  inch diameter; the compliant member *W* of wire, 0.02 inch diameter, and flattened to 0.008 inch for vertical compliance, which couples the stylus *S* to the vane; and a piece of damping material *D* cemented to the vane. The compliant member is spotwelded to the vane. The stylus is fused to the wire.

By HENRY P. KALMUS

Engineering Department  
Zenith Radio Corporation  
Chicago, Ill.

The compliance,  $C_M$  measured at the tip is  $9.6 \times 10^{-6}$  cm per dyne. The mass is distributed over the total length of the moving element. In Fig. 3A a lumped mass  $M$  concentrated at the needle tip is assumed. This mass  $M$  is  $14 \times 10^{-3}$  grams. If we neglect friction, the mechanical impedance for 1000 cycles equals

$$\begin{aligned} Z &= \omega M - 1/\omega C_M \\ &= (2\pi \times 10^3)(14 \times 10^{-3}) - \\ &\quad 1/(2\pi \times 10^3)(9.6 \times 10^{-6}) \\ &= 71.4 \text{ grams per sec} \end{aligned}$$

This is a very small value because of the high compliance and small mass of the moving element. A vertical weight of only 10 grams is necessary to keep the needle in the groove, and needle and record wear are extremely low. In addition, the mechanical impedance and the vertical compliance produced by the member *W* reduce the noise radiated from pickup and record to such a degree that it is scarcely noticeable even when no cover is used for the record player.

The mechanical impedance becomes zero for

$$\begin{aligned} \omega &= (MC_M)^{-1/2} \\ &= [(14 \times 10^{-3})(9.6 \times 10^{-6})]^{-1/2} \\ &= 2700 \text{ rad per sec} \\ f &= \omega/2\pi = 430 \text{ cps} \end{aligned}$$

In Fig. 3B a lumped mass is also assumed, but concentrated in the center of the moving element. At a certain frequency the element will be excited in its second mode of vibration. The amplitudes at the tip are then very small, but the center moves with large deviation as shown in Fig. 3B, and at this frequency a high output is obtained. The mechanical constants of the pickup are chosen in such a way that this peak in the response curve is at 4000 cycles. The output drops sharply beyond this frequency. Damping material *D* is used to keep the resonance peak at a desired level.

## Circuit Operation

Figure 4 shows the frequency-response curve, using the Columbia constant-tone record 10003M. The sharp cutoff beyond 4000 cycles is desirable for reproduction of commercial shellac records with minimum scratch. By proper choice of

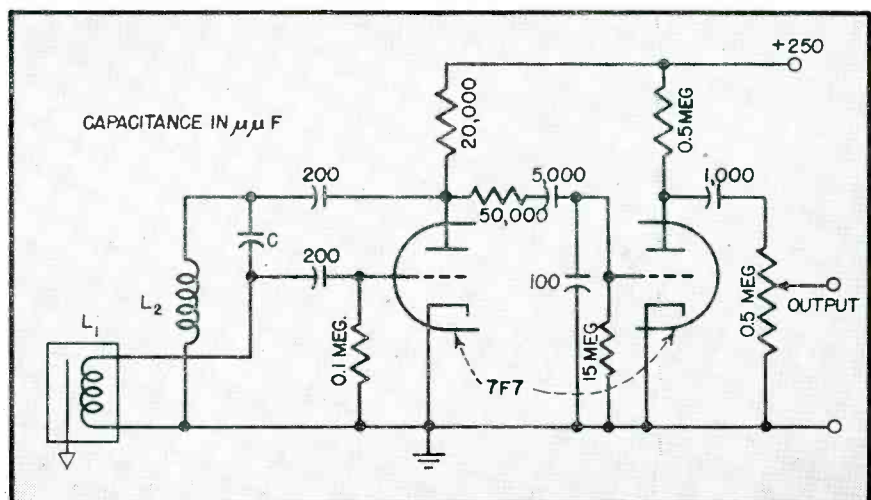
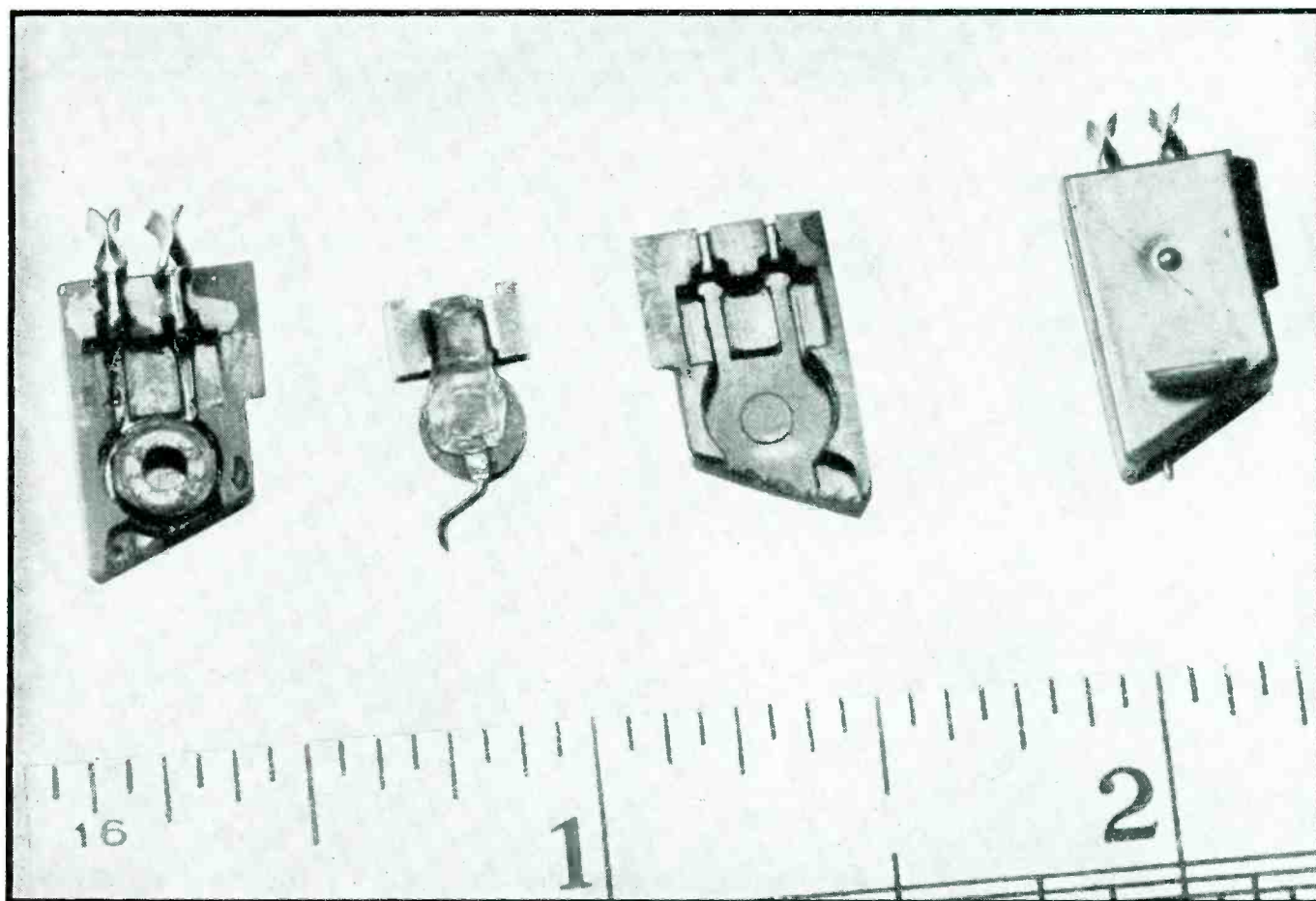

FIG. 2—Stylus movement amplitude-modulates an oscillating detector-amplifier from which audio output is obtained

# MECHANICAL IMPEDANCE

Metallic vane attached to stylus varies loss in radio-frequency oscillator circuit, thereby producing amplitude modulation. High compliance and small mass of moving element results in low mechanical impedance, thus reducing pickup weight required for tracking



Pickup cartridge, shown about three times normal size, carries stylus, vane, and coil, and plugs into a tone arm

mass and compliance the cutoff can be shifted between 3000 and 6000 cps.

Figure 2 shows the circuit in which the pickup is used. The two triodes are the two sections of a 7F7 or a 6SL7. The pickup coil  $L_1$ , together with a fixed coil  $L_2$  and the capacitor  $C$  form a tuned circuit which is excited by the first triode. The reflected vane resistance changes the  $Q$  of  $L_1$ , thereby varying the amplitude of the oscillations.

The first triode section works simultaneously as r-f oscillator, detector, and audio amplifier. The oscillation frequency is 2.5 mc. The r-f amplitude at the grid is 1.5 volts,

but the modulation is less than one percent so that an audio voltage of only 10 millivolts is developed at the first grid. The audio voltage at the plate is 30 millivolts. The audio gain is reduced to less than it could be were the triode used solely as an amplifier because of the action of plate-bend detection. A filter between the first plate and second grid eliminates r-f, passing only audio voltage. The attenuation of the low audio frequencies shown in Fig. 4 is obtained by the coupling elements between the two triodes of the dual tube and by an additional low-pass filter between second plate and volume control.

The second triode section acts as an additional audio amplifier and supplies one volt to the phono-amplifier.

The coil  $L_1$  consists of about 40 turns of No. 40 copper wire, and has an inductance of 20 microhenries. Its impedance is so low that a simple twisted pair can be used to connect the coil to the first tube. In this respect, a pickup using a coil has an advantage over a variable capacitance type which requires a well-shielded low-capacitance line.

Hum voltage induced in the coil  $L_1$  by the motor field or other 60 cps sources does not reach grid or plate of the first triode because of



the filter action of the 200  $\mu\text{f}$  coupling capacitor and grid and plate resistors. However, care must be taken that the vane is not made of magnetic material. A 60 cps flux changes the permeability of the vane so that the hysteresis loss changes during each 60 cps wave. If the hysteresis loss changes, the resistance reflected into the coil changes also, and amplitude modulation at 60 or 120 cps is produced, depending on the initial magnetic condition of the vane material. Stainless steel is almost non-magnetic and thus no hum modulation occurs in this model.

#### Detection Efficiency

In the first triode section of Fig. 2, which acts simultaneously as oscillator and grid detector, the plate current produces random noise. It is therefore desirable to improve the detection efficiency in order to produce as much audio voltage across the plate resistor as possible so as to obtain a good signal-to-noise ratio.

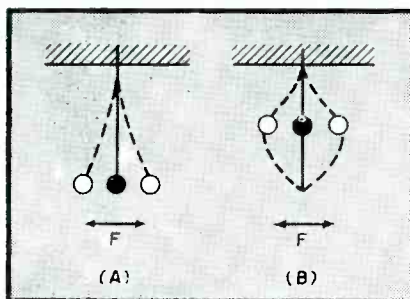

FIG. 3—Depending on the mode of vibration of the mechanical elements of the pickup, the mass can be considered either concentrated at the tip as at (A) or at the center as at (B)

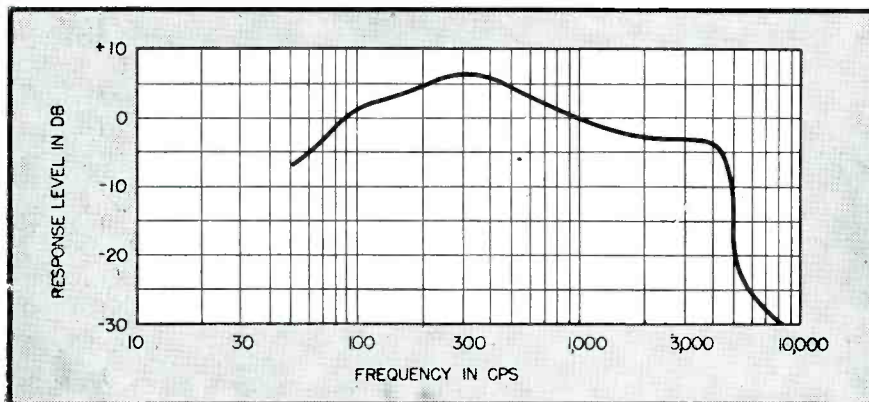

FIG. 4—Frequency response of the pickup, using a constant-tone record as the driving source

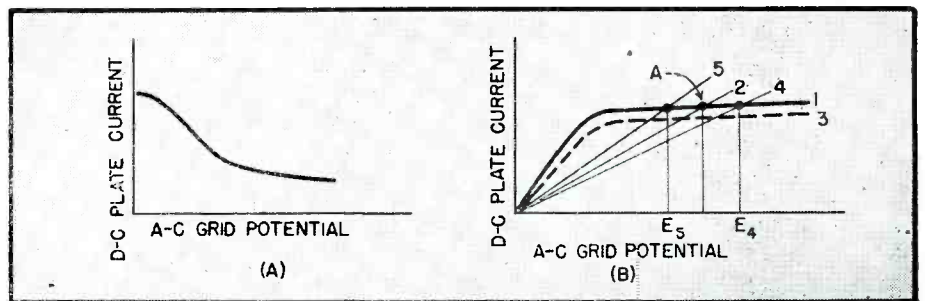

FIG. 5—(A) Conversion characteristics of grid-leak detector indicates the effect of the change of the type of detection from straight rectification to unequal amplification of positive and negative halves of the carrier cycle as the grid signal increases in amplitude. (B) From the characteristics of a feedback oscillator one can see how changes in the feedback efficiency vary the developed grid signal

Figure 5A shows the d-c plate current of a grid-leak detector plotted against a-c grid potential. For small voltages, the tube works like a diode, followed by an audio amplifier. For larger voltages a second form of rectification, plate-bend detection, counteracts the grid-leak detection and is responsible for the flattening of the curve.

It is therefore desirable to maintain small a-c grid voltages in order to obtain good detection efficiency. The percentage of modulation, however, is so small that negligible distortion occurs even for the largest grid voltages produced by this pickup.

As mentioned before, the first triode section develops an audio voltage of 30 millivolts which together with the plate current produces a signal-to-noise ratio sufficiently high for home record reproduction. However, if very high requirements are to be met, as when used in broadcast stations, there are two ways to increase the signal-to-noise ratio. By using a separate oscil-

lator and a diode-detector stage, the detection efficiency is made much higher because no plate-bend detection occurs. The other method is to use a low  $\mu$  tube such as a 6J5 as oscillator-detector, followed by an audio transformer. Plate-bend detection is reduced because of the remote cutoff characteristic and the higher voltage between plate and cathode. Again the result is higher detection efficiency.

#### Oscillator Stability

Returning now to Fig. 2, oscillator stability with aging tubes and changing line voltages must be investigated. It is usually assumed that low-amplitude oscillators are unstable. However, if a low-Q, low-impedance tank circuit, and the maximum feedback are used, stable operation is obtained with only 1 to 2 volts r-f voltage at the grid.

Curve 1 in Fig. 5B shows the oscillation characteristic of an amplifier tube. The curve is obtained by connecting the tank circuit to the plate and feeding variable r-f voltage into the grid. The resultant r-f plate current is then plotted.

Curve 2 shows the grid voltage produced by any given r-f plate current. It is a straight line because the feedback circuit which produces the grid voltage is a linear network. The slope of curve 2 depends on the Q and the L/C ratio of the plate circuit as well as on the feedback factor.

It is evident that the point of intersection A determines the actual oscillation condition. Now, even though the plate circuit has a low impedance, curve 2 may intersect curve 1 on its flat part if the feedback factor is low enough. In this

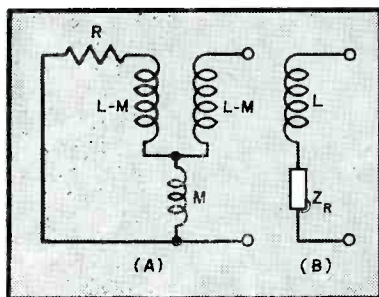

FIG. 6—(A) Equivalent circuit of pickup is that of a resistive coil coupled to the pickup inductance. (B) The equivalent circuit simplifies to an inductance and a variable impedance

case the r-f plate current has reached its maximum, although the produced voltage is still small. At the same time the oscillator tube operates with a transconductance approaching the maximum value for zero plate load. One or two volts on the grid are sufficient to cover the entire range from cutoff to where grid current starts flowing, and so provide the drive needed to reach the maximum amplitude of r-f current in the plate circuit.

If the voltage drops, or if the tube ages, curve 1 will assume a lower position such as curve 3. Curve 2 still intersects the flat part of the oscillation characteristic and stable oscillation is maintained.

As the vane swings, the  $Q$  of the circuit changes, and the slope of curve 2 is altered. Curve 2 will fluctuate between curves 4 and 5. Correspondingly, the grid voltage will be modulated between  $E_1$  and  $E_2$ .

#### Linearity

Figure 6A shows the equivalent electrical circuit of the pickup. Series resistance  $R$  can be considered as belonging to a flat coil which could be substituted for the vane. The impedance reflected from the vane into the tuned circuit is  $Z_R$  as shown in Fig. 6B, and is equal to

$$Z_R = \frac{R(\omega M)^2}{R^2 + (\omega L)^2} - j \frac{\omega^2 LM}{R^2 + (\omega L)^2}$$

(Do not confuse  $M$  used for mutual inductance and  $M$  used for mass.) The real part of the reflected impedance changes the  $Q$  of the oscillator circuit. The imaginary part shifts the oscillator frequency and need not be considered because no frequency discriminating elements are used in the circuit.

The mutual inductance between coil and vane increases if the distance is reduced. The reflected resistance grows with increasing mutual inductance. Finally, the oscillator amplitude decreases with increasing reflected resistance. The amplitude therefore changes with distance according to some function which is not necessarily linear. The linearity within the working range is sufficient to produce not more than two percent distortion.

Figure 7 shows an amplitude versus displacement characteristic, curve 1, plotted for a large scale model of a pickup with linear dimensions increased by a factor of 10. The point A corresponds to the minimum gap in the actual pickup. Points B and C determine the actual working range. They are 10 mils apart on the model, which corresponds to one mil on the pickup.

For a constant vane displacement, the audio output is proportional to the slope of curve 1 at the operating spacing. Curve 2 shows the first derivative of curve 1. The audio output at any spacing is proportional to the ordinate of curve 2 at that spacing. The pickup would be ideal if this curve were a straight horizontal line, because the audio output would then be independent of spacing.

As mentioned before, the distortion is very small. For certain applications, however, it may be of in-

terest to eliminate it entirely, and this is possible by designing a pickup with push-pull action.

#### Push-Pull Pickup

Two identical coils are arranged at both sides of the high resistive vane as shown in Fig. 8. Both are tuned to the same frequency and the two circuits are coupled either by their stray field or by external means. We shall neglect changes in inductance produced by the moving vane. This assumption is justified because the vane can be made of high resistive material with some permeability. The loss of inductance due to eddy currents is then compensated by the concentration of the magnetic flux in the vane.

The resistances  $R_1$  and  $R_2$  are now the impedances reflected from the vane into the two circuits. The impedance reflected from the left circuit into the right circuit is  $Z$ . If the vane moves to the right side it increases  $R_2$  and decreases  $R_1$ , which in turn results in an increase of  $Z$ . On moving to the left, the vane decreases both  $R_2$  and  $Z$ . The non-linear amplitude versus deviation for the two circuits are superimposed in such a way as to give a linear resultant curve over a wide range.

The following derivation will demonstrate this linearity. From the circuit of Fig. 8 and for the condition that both circuits are ad-

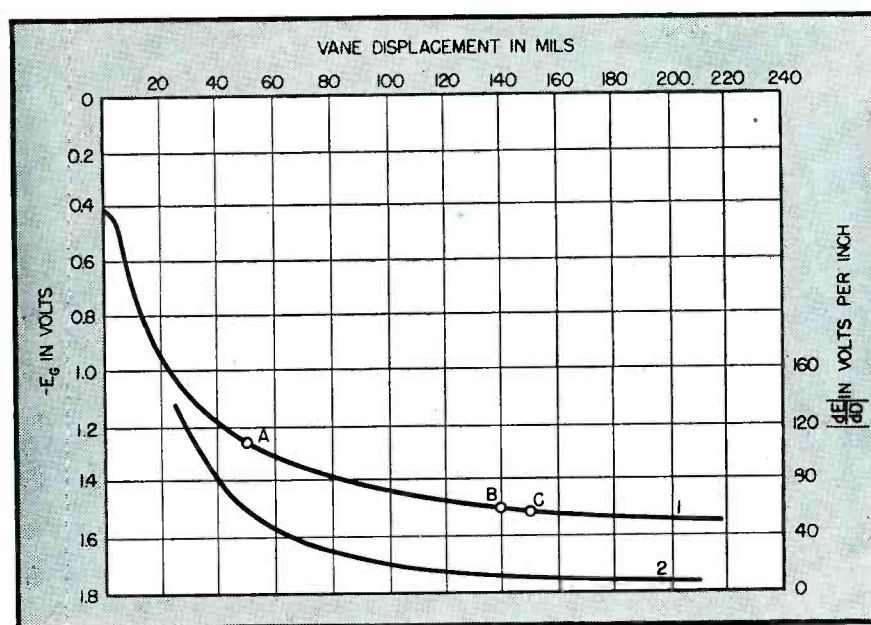

FIG. 7—Measured voltage change versus displacement, for a large scale model of the pickup, indicates linearity



justed to resonance, the impedance  $Z$  is

$$Z = (\omega M)^2 / R_1$$

Let the ratio  $(M/L) = k$  where  $k$  is the coupling factor between the two circuits. Then

$$Z = (\omega L)^2 k^2 / R_1$$

Now let  $m$  be the fractional change of resistance produced by the moving vane in one of the two circuits. If the vane moves to the right

$$R_{2R} = R_2(1 + m)$$

$$R_{1R} = R_1(1 - m)$$

If the vane moves to the left

$$R_{2L} = R_2(1 - m)$$

$$R_{1L} = R_1(1 + m)$$

The changes in resistance and impedance in the two circuits are then

$$\Delta R_{2R} = mR_2$$

$$\Delta R_{2L} = -mR_2$$

The changes in reactance are likewise determined, and are given by

$$\Delta Z_R = (\omega L)^2 \frac{K^2}{R_1} \left( \frac{1}{1 - m} - 1 \right)$$

$$\Delta Z_L = (\omega L)^2 \frac{K^2}{R_1} \left( \frac{1}{1 + m} - 1 \right)$$

For small values of  $m$  the fraction  $1/(1 - m)$  is approximately equal to  $1 + m$ , and the fraction  $1/(1 + m)$  is approximately equal to  $1 - m$ . Substituting these approximate values into the foregoing equations gives

$$\Delta Z_R = (\omega L)^2 \frac{K^2}{R_1} m$$

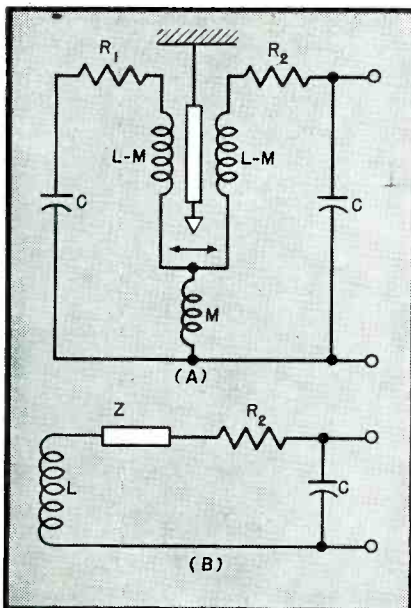

FIG. 8—(A) Electro-mechanical behavior of a push-pull modification of the pickup is analyzed from this circuit of which (B) is the electrical equivalent

$$\Delta Z_L = -(\omega L)^2 \frac{K^2}{R_1} m$$

As stated before, we see that both  $R_2$  and  $Z$  will increase if the vane moves to the right and will decrease if it moves to the left.

In Fig. 9  $\Delta R_2$  and  $\Delta Z$  are plotted versus the deviation  $D$ . The curve for  $\Delta R_2 + \Delta Z$  becomes most nearly linear if  $\Delta R_{2R} = \Delta Z_L$  and  $\Delta R_{2L} = \Delta Z_R$ , that is for

$$mR_2 = (\omega L)^2 \frac{K^2}{R_1} m$$

If we assume that the vane in its rest position is exactly in the center between the two coils,  $R_1 = R_2 = R$ . Thus  $R = \omega Lk$ , and by the definition  $\omega L/R = Q$  we obtain the relation

$$(1/Q^2) = K^2$$

This relation is the condition for critical coupling between the two circuits. Therefore we obtain perfect push-pull action if we couple the circuits critically for the center position of the vane. For this condition we also obtain  $R = Z$ .

Comparing the sensitivity of a double-coil pickup with one with a single coil, we find that there is no difference if we keep the gap the same. If the vane moves to the right, the total resistance that appears in the right circuit changes from  $2R$  to  $2R(1 + m)$ . For a single-coil pickup,  $Z_R$  changes from  $Z_R$  to  $Z_R(1 + m)$ . The percentage change, which determines the sensitivity, is therefore the same in both cases.

#### Effect of Eccentricity

Quite often in commercial records the hole is not accurately centered, and the tone-arm head is driven back and forth in a radial

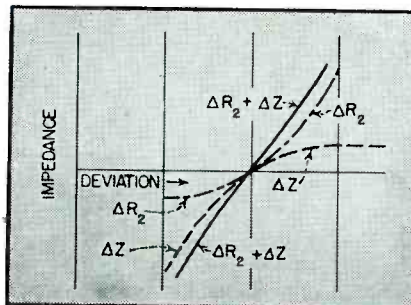

FIG. 9—From this plot of impedance versus deviation the most linear region of operation is chosen for the push-pull type pickup

direction during each revolution of the disc. Due to the moment of inertia of the arm, the stylus will swing with a frequency of 1.3 cycles per second, corresponding to the 78 revolutions per minute of the record. Deflection due to this motion is superimposed upon groove modulation. In pickups with large linear ranges (e.g. crystal or dynamic systems) eccentricity produces neither distortion nor amplitude changes. In electronic pickups however it can cause trouble. If the discriminator range of an f-m pickup is not wide enough, distortion appears once or twice during each disc revolution. In an a-m pickup of the type described herein, no distortion occurs, but amplitude changes can still be observed.

Figure 10A shows the rectilinear equivalent of the tone arm and pickup. The tone-arm mass assumed to be concentrated at the end of the arm, is represented by  $M$ . The compliance of the moving vane is represented by  $C_M$ . Groove displacement at the needle tip produced by record eccentricity at a frequency of 1.3 cycles per second is  $x_1$ , and  $x_2$  is the maximum deformation of the vane, considered as a spring, due to the groove displacement. The displacement of the end of the tone arm is designated as  $x_3$ .

If the mass were small and the moving element stiff, the arm would follow the needle tip and the vane would not be deformed and displaced relative to the tone arm, i.e.  $x_2$  would equal 0. In this case eccentricity would not produce any amplitude change.

However, there is motion and in order to calculate  $x_2$  we use the electrical equivalent of the pickup which is shown in Fig. 10B. The mechanical displacements,  $x_1$ ,  $x_2$ , and  $x_3$ , are equivalent in the electrical analogy to charges. However, it is more convenient to use currents (which actually correspond to velocity). This substitution is justified in this particular problem because the frequency is constant, thus charge and current are proportional.

The constant-current generator  $G$  of infinite internal impedance delivers a current of 78 cycles per minute or 1.3 cycles per second through the network of Fig. 10B; the electrical parameters of which

are proportional to the mechanical parameters of Fig. 10A as listed in Table I.

To determine  $x_2$  as a function of  $x_1$ , we have to determine the corresponding relation of  $i_2$  to  $i_1$ . From Fig. 10B this latter relation is

$$i_2 = i_1 \frac{\omega^2 LC}{\omega^2 LC - 1}$$

which corresponds to

$$x_2 = x_1 \frac{\omega^2 MC_M}{\omega^2 MC_M - 1} = -x_1 \frac{(2\pi f)^2 MC_M}{1 - (2\pi f)^2 MC_M}$$

If we assume an eccentricity of  $\frac{1}{8}$  inch, and that  $f = 1.3$  cps,  $M = 20$  grams, and  $C_M = 9.6 \times 10^{-9}$  cm per dyne, we obtain 0.8 mils for  $x_2$ .

Output of the pickup in db

**Table I—Electrical-Mechanical Proportionalities**

(For a fixed-frequency system)	
Electrical	Mechanical
$i_1$	$X_1$
$i_2$	$X_2$
$i_3$	$X_3$
$C_B$	$C_M$
$L$	$M$

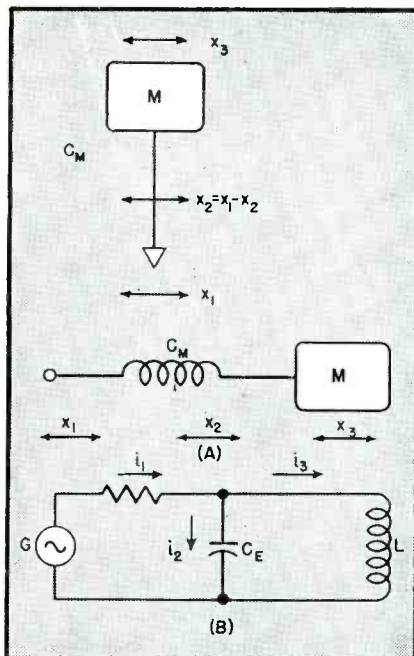

**FIG. 10—(A)** The mechanical equivalent of the pickup is composed of tip, spring, and mass, each having its own displacement. **(B)** The electrical equivalent of the pickup consists of constant-current generator, capacitance, and inductance, each having its own current

plotted for different gaps is given in Fig. 11. The curve is almost a straight line and this is not surprising if we again inspect curves 1 and 2 in Fig. 7. These two curves have essentially the same trend. Therefore, they are nearly exponential functions because only in this case does the first derivative have the same slope as the basic function. The curve in Fig. 11 corresponds to curve 2 in Fig. 7, and must therefore appear as a straight line if we choose a logarithmic (decibel) scale for the ordinate.

The gap is adjusted to about 12 mils. In this range the slope of the curve is 0.5 db per mil. If needle deflection due to eccentricity is 0.8 mils, the amplitude change is 0.4 db. This change is so small that it becomes unnoticeable.

#### Output and Distortion

Figure 11 can also be used to determine distortion. Assuming a sinusoidal movement with a maximum displacement of plus or minus 0.5 mil, the output will consist of a distorted wave in which the maximum and minimum amplitudes are increased and decreased by 0.25 db respectively, which is shown in Fig. 12. Curve 1 shows an undistorted sine wave, curve 2 is the output from the pickup.

The distortion consists of a 2.5 percent change of the amplitude maximum (0.25 db corresponds to 2.5 percent). This distortion can be represented by superposition upon the fundamental wave of a d-c component and a wave of double frequency, curve 3. It can be seen that the peak amplitude of this second harmonic is 1.25 percent of the peak amplitude of the fundamental wave. The distortion factor is therefore 1.25 percent, a very small value compared with the inherent record distortion and the tracing distortion produced by the spherical shape of the stylus surface. This distortion is for maximum needle excursion. For smaller swing, proportionately less distortion would occur.

This reproducer and its electrical circuit have not only been laboratory tested but also put into large scale production. The author expresses his thanks to C. W. Carnahan and Robert Adler for their assistance in preparing this article.

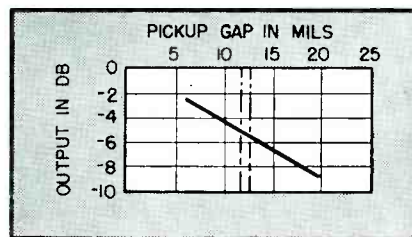

**FIG. 11—**Decibel output from the pickup is nearly a linear function of gap width

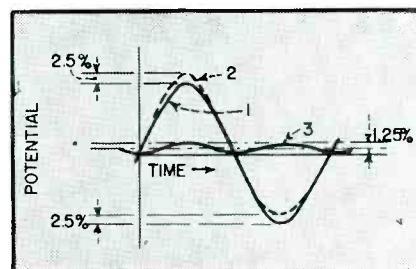

**FIG. 12—**Due to slight curvature of the pickup output characteristic, there is a small second-harmonic distortion component in the output

#### BIBLIOGRAPHY

- (1) Lindenberg, Theodore, Jr., Moving-coil Pickup Design, *ELECTRONICS*, June 1945, p 108. Mechanical resonances are used to obtain a wide-range, flat response.
- (2) Bauer, B. B., Notes on Distortion in Phonograph Reproduction Caused by Needle Wear, *Jour. Acou. Soc. Amer.*, April 1945, p 246. Analysis of needle wear indicates slight loss of highs on inside grooves.
- (3) Miessner, B. F., Frequency-modulation Phonograph Pickup, *ELECTRONICS*, Nov. 1944, p 132. Description of variable-capacitance pickup which provides automatic volume expansion.
- (4) Burt, A. D., Reduction of Record Noise by Pickup Design, *ELECTRONICS*, Jan. 1943, p 90. Design of pickup to reduce direct radiation of sound from pickup and record, and measurement of mechanically radiated noise.
- (5) Hunt, V. F. and Pierce, J. A., HPGA: A Radical Departure in Phonograph Pick-up Design, *ELECTRONICS*, March 1938, p. 9. Laboratory pickup having high fidelity as a consequence of low needle-point impedance and light weight operates on velocity-microphone principle.
- (6) Smeby, Lynne C., Recording and Reproducing Standards, *Proc. Inst. Radio Engrs.*, August 1942, p 355. Dimensional standards coordinated by NAB.
- (7) Miner, C. R., Wow Meter; Electronic Instrument for Measuring Instantaneous Speed Variations of Phonograph Turntables, *Gen. Elec. Rev.*, April 1941, p 31. Also Wickart, W. F., Turntable Wobble Indicator, *ELECTRONICS*, Feb. 1938, p 13.
- (8) Weeden, W. N., "Mass-less" Pickup, *ELECTRONICS*, May 1936, p 36. Considerations in improving mechanical design of magnetic pickup.
- (9) Glover, R. P., Record Saving Pickup, *ELECTRONICS*, Feb. 1937, p 31. Choice of needle tilt and inclination determines record wear.
- (10) Everitt, W. L., "Communication Engineering" second edition, McGraw-Hill Book Co., New York, 1937, Chapter XX, Electromechanical Coupling.



# Pulse Response of DIODE VOLTMETERS

Corrections necessary in the calibration of a typical peak-reading, vacuum-tube voltmeter used to measure pulse amplitudes are determined from theoretical analysis and checked against measurements. Means are suggested for calibrating, and improving performance

**P**EAK VALUES of pulse voltages must frequently be measured in such circuits as radar and pulse-modulation systems. There are several methods, the most popular being the cathode-ray oscilloscope and the diode, vacuum-tube, peak voltmeter. Each instrument has its own particular advantages, and is selected partly for its technical factors, partly for its convenience.

The familiar vacuum-tube, peak voltmeter, based upon the rectifying properties of a diode, has been used for many years for measurements of sinusoidal voltages. References in the literature are frequent

**BY ALLAN EASTON**

*Special Products Division  
Emerson Radio and Phonograph Corporation  
New York, N. Y.*

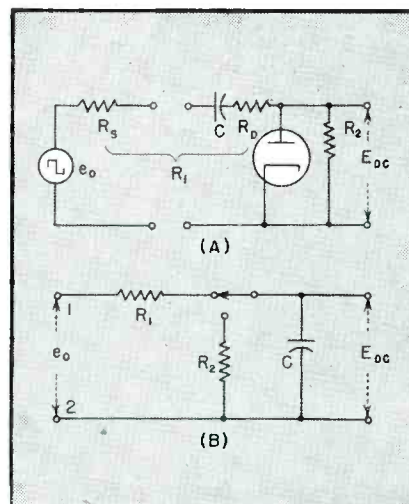

FIG. 1—(A) At the left is the rectifier portion of a typical diode voltmeter. At the right is the equivalent of a circuit under measurement. (B) The simplified, equivalent circuit of a diode voltmeter uses a switch to represent the diode

and the nature of its shortcomings has been discussed.<sup>1, 2, 3</sup> It is only possible to use this type of vacuum-tube voltmeter for pulse voltage measurements if sufficient information concerning the characteristics of the instrument, as well as the nature of the source to be measured, is available.

### Diode Voltmeter Action

A circuit diagram of a typical

vacuum-tube voltmeter is shown in Fig. 1A. Many variations of the circuit exist but the basic analysis is similar for each type. The magnitude of the direct voltage output (a measure of the source potential) is indicated by a d-c microammeter either directly, or through an amplifier. This part of the circuit is not shown as it has little bearing on the analysis to be presented.

Fig. 1B is the equivalent circuit. In order to derive an expression for the relationship between  $E_{DC}$  and  $e_o$ , defined in Table I, several assumptions are required. It is assumed that the source resistance  $R_s$  can be combined with the diode resistance  $R_d$  to form  $R_1$ . The diode is regarded as perfect, that is, the resistance in the conducting direction is constant and equal to  $R_d$ , and the resistance in the nonconducting direction is infinite. Leakages in capacitor  $C$  and in the rest of the circuit shunting  $C$  are combined in  $R_2$ . The duration of the pulse is assumed to be short compared with the period.

The positive pulse voltage, shown in Fig. 2A is impressed across the terminals marked 1 and 2 in Fig. 1B. During the charging interval  $t_1$ ,  $C$  is charged through  $R_1$  and then for a time  $t_2$  partially discharged through  $R_2$ . The phenomenon is repeated periodically and eventually reaches the steady state condition depicted by Fig. 2B.

The maximum value to which  $C$  can be charged is

$$e_1 = e_2 + (e_0 - e_2) (1 - e^{-\alpha t_1}) \quad (1)$$

TABLE I—DEFINITIONS OF SYMBOLS

$C$	—capacitance
$e$	—base of natural logarithm
$e_1$	—maximum value to which capacitor charges
$e_2$	—minimum value to which capacitor discharges
$e_o$	—peak amplitude of measured pulse
$E_{DC}$	—direct voltage resulting from rectification and integration of pulse waveform
$\alpha_1$	—time constant during $t_1$
$\alpha_2$	—time constant during $t_2$
$f$	—pulse repetition frequency
$k$	—correction factor for vtvm
$R_1$	—total resistance during charging
$R_2$	—total resistance during discharging
$R_D$	—diode conducting resistance
$R_s$	—source resistance
$t_1$	—duration of charging interval
$t_2$	—duration of discharging interval
$T$	—period of pulse



On top of the pulse generator used to check theoretical conclusions is a peak vacuum-tube voltmeter of the type analyzed in this article

ing assumptions stated above. The equation in this form is unwieldy but may be simplified considerably if

$$\begin{aligned} \alpha_1 t_1 &< 1 \\ \alpha_2 t_1 &< 1 \\ \alpha_2 T &< 1 \end{aligned} \quad (7)$$

This simplification is justified because the pulses under discussion are relatively short in duration. However the voltmeters will perform accurately with long pulses, as will be demonstrated later. Also  $\alpha_1$  and  $\alpha_2$  may be made as small as desired by increasing the size of capacitor  $C$ . This practice will be justified later in the discussion.

If Eq. 7 is correct, the approximation  $e^x = 1 + x$  may be employed. Equation 6 then reduces to

$$E_{DC} \simeq e_1 \quad (8)$$

$$= e_0 + (e_2 - e_0) e^{-\alpha_1 t_1}$$

The minimum potential to which  $C$  can fall is

$$e_2 = e_1 e^{-\alpha_2 t_2} \quad (2)$$

Equations 1 and 2 can be manipulated to obtain

$$e_1 = \frac{e_0 (1 - e^{-\alpha_1 t_1})}{1 - e^{-\alpha_1 t_1} e^{-\alpha_2 t_2}} \quad (3)$$

and

$$e_2 = \frac{e_0 e^{-\alpha_2 t_2} (1 - e^{-\alpha_1 t_1})}{1 - e^{-\alpha_1 t_1} e^{-\alpha_2 t_2}} \quad (4)$$

#### Practical Simplifications

It is desired to obtain an expression relating  $E_{DC}$  and the several factors appearing in the equations. The d-c potential across  $C$  is

$$E_{DC} = \frac{1}{T} \int_{t_0-c}^{t_1} e_1 dt + \frac{1}{T} \int_{t_1}^{(t_1+t_2)-T} e_2 dt \quad (5)$$

Integrating, evaluating, and simplifying, we obtain

$$\begin{aligned} E_{DC} = & \frac{e_0 t_1}{T} + \frac{e_1}{\alpha_1 T} (\epsilon^{\alpha_1 t_1} - 1) - \frac{e_0}{\alpha_1 T} (\epsilon^{\alpha_1 t_1} - 1) \\ & + \frac{e_1}{\alpha_2 T} (\epsilon^{-\alpha_2 t_1} - \epsilon^{-\alpha_2 T}) \end{aligned} \quad (6)$$

Equation 6 is an exact expression for  $E_{DC}$  limited only by the simplifi-

Equation 3 may be simplified, using the same assumptions, to

FIG. 2.—(A) Pulse applied to diode voltmeter, and (B) pulsating d-c developed across meter capacitor

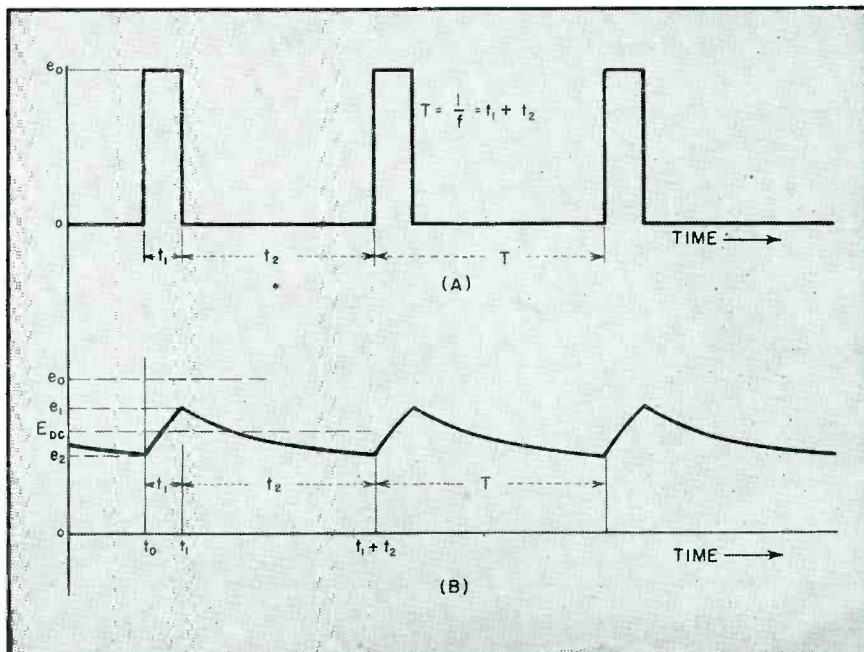



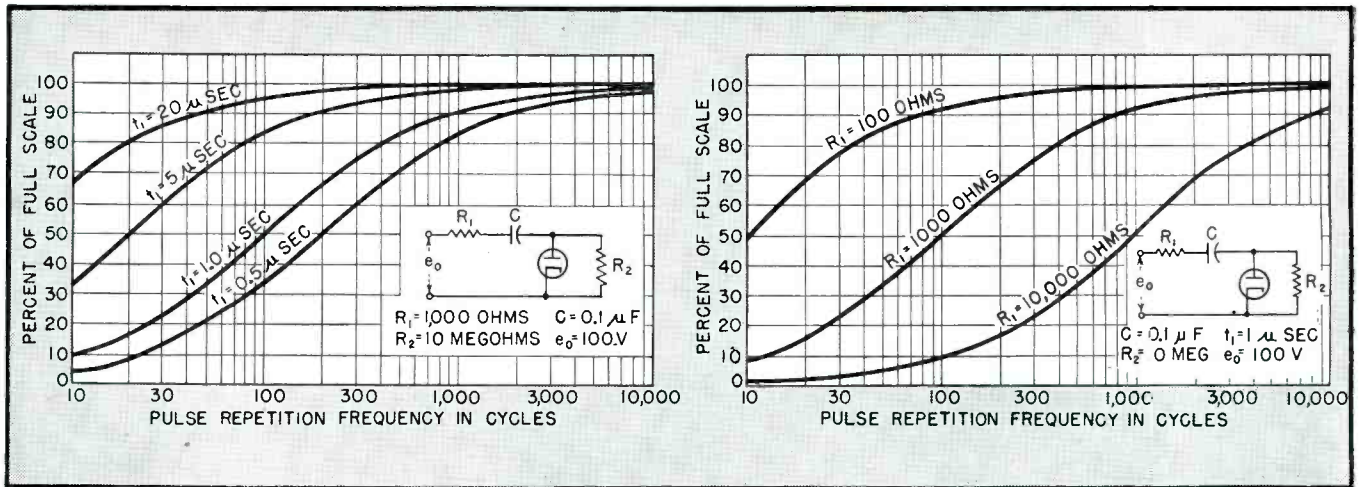

FIG. 3—Effect of pulse width on meter indication

FIG. 4—Source impedance affects meter indication

$$e_1 \approx \frac{e_0 \alpha_1 t_1}{\alpha_1 t_1 + \alpha_2 t_2} \quad (9)$$

From which

$$E_{DC} \approx \frac{e_0 \alpha_1 t_1}{\alpha_1 t_1 + \alpha_2 t_2} \quad (10)$$

Equation 10 may be restated, in terms of the original quantities, as

$$E_{DC} = e_1 = \frac{e_0 t_1 R_2}{t_1 R_2 + t_2 R_1} \quad (11)$$

It should be noted at this point that  $E_{DC}$  is independent of  $C$  as long as  $C$  is sufficiently large to make Eq. 7 valid. Intuitively, one might suspect from examination of the circuit that one could replenish the loss in amplitude of the charging voltage due to the long charging time constant by making  $C$  larger. Equation 2 shows this is not the case. Substitution of typical values

into Eq. 7 will show that over the larger part of the range of narrow pulse width and pulse repetition frequencies the approximation is not in great error.

Figures 3, 4 and 5 are plots of Eq. 11. Note the effect of the various parameters on the meter calibration. It can be seen from these curves that, unless the four factors can be evaluated, the diode vacuum-tube voltmeter may indeed be quite misleading. The curves of Fig. 4 and 5 are identical in shape indicating that it is possible to improve meter accuracy for any given values of  $t_1$  and  $t_2$  by either making  $R_1$  small or  $R_2$  very large. In practice,  $R_2$  is not usually made more than 10 megohms because of leakage difficulties. In certain military equipment destined for operation in

humid climates, use of resistors larger than one megohm is undesirable. The limiting value of  $R_1$  is the diode resistance plus the source impedance.

#### Corrections

A typical commercial diode-type vacuum-tube voltmeter uses approximately the following constants

$$\begin{aligned} R_1 &= 1000 \text{ ohms} \\ R_2 &= 10 \text{ megohms} \\ C &= 0.01 \mu\text{f} \end{aligned}$$

Reference to Fig. 4 indicates that this instrument will read approximately half the peak pulse value when a one microsecond pulse of 100 cps repetition frequency is impressed on its terminals, therefore a correction factor should be determined.

Equation 11 may be restated in a

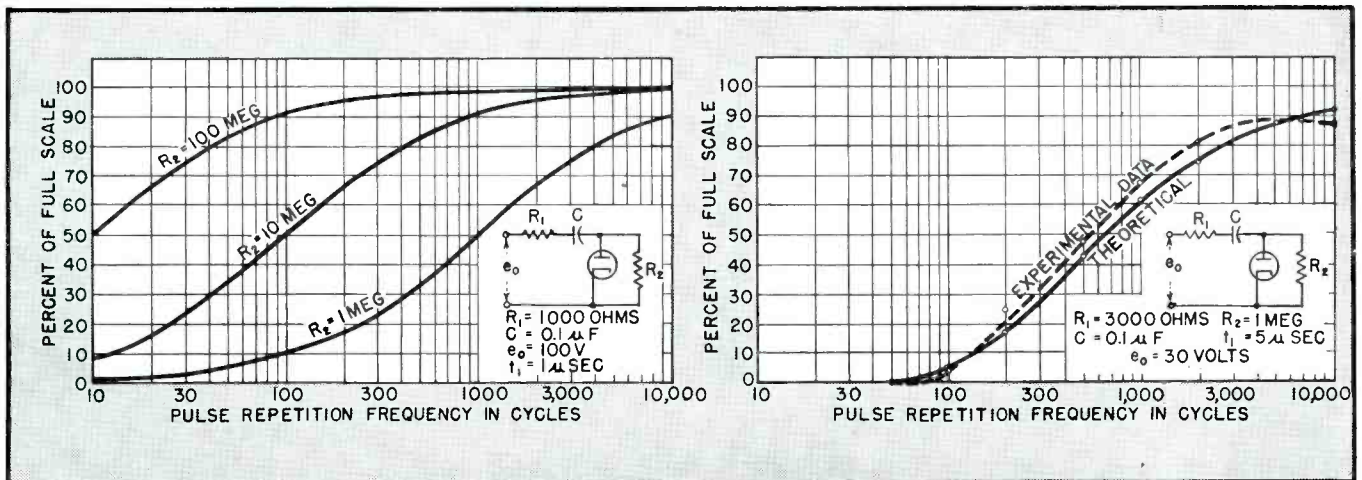

FIG. 5—Magnitude of capacitor discharging resistor affects meter calibration

FIG. 6—Experimental data verifies the results of the theoretical circuit analysis

slightly different form

$$e_0 = k E_{DC} \quad (12)$$

$$e_0 \approx E_{DC} \left[ 1 + \left( \frac{t_2}{t_1} \right) \left( \frac{R_1}{R_2} \right) \right] \quad (13)$$

and if  $t_2 \approx T$

$$e_0 \approx E_{DC} \left[ 1 + \left( \frac{T}{t_1} \right) \left( \frac{R_1}{R_2} \right) \right] \quad (14)$$

Because the usual commercial, diode, vacuum-tube voltmeter is calibrated in rms values, that is 0.707 of peak, Eq. 14 should be modified to

$$e_0 \approx \sqrt{2} E_{DC} \left[ 1 + \left( \frac{T}{t_1} \right) \left( \frac{R_1}{R_2} \right) \right] \quad (15)$$

and

$$k = \sqrt{2} \left[ 1 + \left( \frac{T}{t_1} \right) \left( \frac{R_1}{R_2} \right) \right] \quad (16)$$

Equation 16 gives an expression for a multiplying factor by which the meter reading must be corrected to indicate the pulse amplitude.

A circuit was set up similar to that shown on Fig. 1A. A 6AL5 diode with an  $R_D$  equal to 300 ohms, was used. Figure 6 shows the experimental results compared with the theoretical values computed from Eq. 16. The agreement is fairly close, within plus or minus ten percent.

It can be seen from the above discussion and from study of the curves that this type of voltmeter has anything but high input impedance under pulse conditions. The impedance of the diode voltmeter may be arbitrarily specified as being equal to the source impedance when

$$E_{DC} = \frac{1}{2} e_0 \quad (17)$$

It is difficult to define this impedance precisely because it is dependent on the pulse duration, repetition frequency, and amplitude, as well as circuit constants. Reference to Fig. 3, 4 and 5 shows that the input impedance may be well below 1000 ohms even though  $R_2$  is equal to 10 megohms.

#### Improving Voltmeter Performance

Utility of Eq. 16 is limited by the difficulty in evaluating the magnitude of  $R_1$ . In most cases it is possible to estimate the source resistance with fair precision; but the diode resistance is difficult to determine. The diode resistance differs from tube to tube and, what is worse, is dependent on current. Thus  $R_1$  depends on the magnitude

of  $e_0$ , as well as values of  $\alpha_1$  and  $\alpha_2$ .

A simple cathode follower similar to that shown in Fig. 7 will help improve the diode performance in some measure. Variations in  $R_s$  will have no effect on meter calibrations, providing  $R_s$  is small compared with the input resistance. Under this condition  $R_1$

will be quite small, possibly 600 ohms or less. This low resistance will enable calibration of an instrument and computation of a correction curve based only on pulse width and repetition frequency.

Pulse stretching can sometimes be utilized as a means of making the instrument usable on narrower pulses. Figure 8 illustrates a possible arrangement. It is necessary to proportion  $R_s$  and  $C_s$  so that complete recovery, 99 percent, can occur between successive pulses. At the highest repetition frequency,  $C_s$  should be small enough to permit  $e_s$  to reach at least 99 percent of final value during the narrowest pulse to be measured. These precautions are necessary to minimize loss of peak amplitude and consequent loss of accuracy.

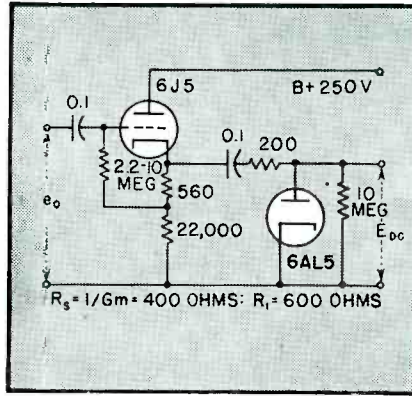

FIG. 7—A cathode-follower reduces circuit loading by the meter and prevents circuit impedance from affecting the meter indication

#### BIBLIOGRAPHY

- (1) Aiken, C. B., Theory of Diode Voltmeters, *Proc. I. R. E.*, 26, p 859, July 1938.
- (2) Terman, F. E., "Radio Engineers' Handbook", McGraw-Hill Book Co., Inc., New York, 1943, p 929-937.
- (3) Rider, J., "Vacuum Tube Voltmeters", John F. Rider Publisher, Inc., New York.

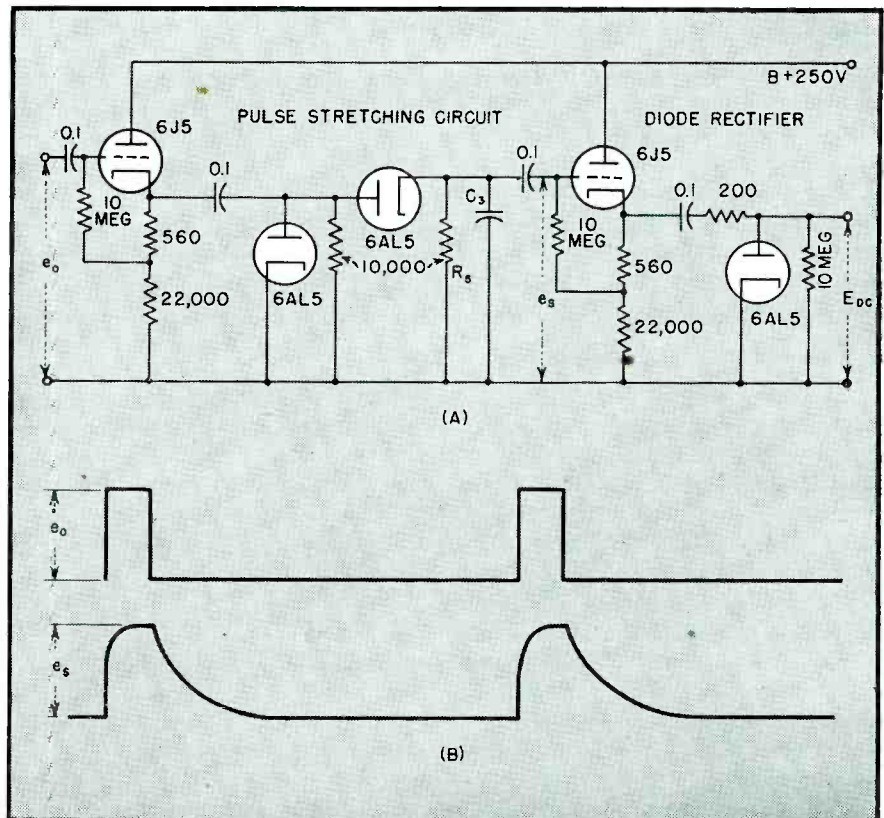

FIG. 8—(A) When measuring exceedingly short pulses, the reliability of the meter can be improved by introducing a pulse-stretching circuit ahead of the diode rectifier. The circuits are connected through cathode followers to prevent interaction. (B) The applied pulse shown at the top is stretched into a longer pulse by the circuit



# Electronic

# A-C VOLTAGE

Line voltage fluctuations are absorbed by a circuit using ordinary radio tubes and components, giving a regulated output suitable for calibration of a-c instruments.

Attenuation at 180 cycles improves wave form by suppressing third harmonic

**T**HIS PAPER describes an electronic regulator circuit developed to deliver a stabilized a-c voltage by absorbing the fluctuations of the input voltage. One of the important features of this circuit lies in the fact that the wave form of the output voltage is not altered appreciably by the regulator.

While such a device may have other applications, it was primarily developed as a power source for calibrating a-c instruments, where a constant voltage of sinusoidal shape is highly desirable. Those who must make precise alternating-current measurements know of the aggravation, inaccuracy, and wasted time caused by voltage fluctuations of the ordinary a-c power source. Voltage fluctuations at the output of a regulator based on the circuit under discussion were found to be only about six percent of the voltage fluctuations at the input.

### General Principle of Operation

The block diagram in Fig. 1 illustrates the principle of operation of the regulator circuit. The circuit automatically stabilizes the output voltage by adjusting the voltage drop across series transformer  $T_1$  to compensate for any change of input voltage. For example, if the input voltage should increase by one volt, the circuit automatically makes adjustments that increase the voltage drop across the primary side of transformer  $T_1$  to nearly neutralize the increase of input voltage.

A fractional part of any voltage change that appears at the input terminals will appear across the output terminals. This change is detected and amplified by the rectifier-

filter unit and the voltage-change detector, and an amplified voltage change or correction voltage is applied to the grid of a vacuum tube that acts as a load on the secondary side of  $T_1$ . A change of grid voltage on this tube changes its power con-

voltage across regulator tube  $V_6$ . The difference between voltage drops A-B and B-C is the grid-cathode voltage on voltage-change detector  $V_3$ . By this method a voltage change appearing at the regulated output produces a corresponding voltage change at the grid of  $V_3$ . This voltage change is amplified and applied to the grid of  $V_6$ , the loading tube. A change in the grid voltage of  $V_6$  produces a change in the impedance of winding 1 of  $T_1$ , changing the voltage drop across it enough to neutralize most of the change in input voltage.

If the voltage drop across winding 1 of  $T_1$  is to approximate a sinusoid, special consideration must be given to the values of circuit elements  $L_1$ ,  $L_2$ ,  $C_1$ ,  $C_2$ , and  $C_5$ . The network involving these impedance elements and rectifier tube  $V_1$  is used to convert the d-c resistance of  $V_6$  into a nearly linear a-c impedance appearing between the terminals of winding 1 of  $T_1$ .

The values of the circuit elements were determined by an experimental process. While making rough adjustments of these circuit elements, a cathode-ray oscilloscope was used to observe the wave form of the voltage across winding 1; for closer adjustments, the harmonic content of the regulated output voltage was measured by means of a wave analyzer. It was found not too difficult to make adjustments such that the harmonic content of the regulated output was essentially the same as that of the input.

A regulator based on this circuit may be built from simple radio receiver components. In the case of the regulator now in use in the

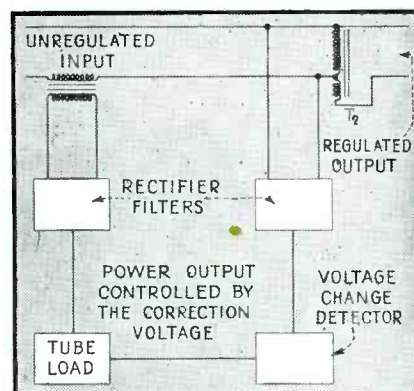

FIG. 1—Block diagram of voltage regulator for general laboratory use

sumption, thereby changing the voltage drop across both primary and secondary sides of  $T_1$ . The resultant voltage change across the primary side of  $T_1$  nearly neutralizes the original voltage change at the input terminals.

### Description of Circuit

The complete circuit of the regulator is given in Fig. 2.

The voltage rectified by  $V_2$  is supplied through transformer  $T_2$  from a part of the regulated output voltage. After filtering, this rectified voltage appears across the series combination of  $R_1$ ,  $R_2$ , and  $R_3$ . A portion of this rectified and filtered voltage is compared with a constant

# REGULATOR

By L. DALE HARRIS

Department of Electrical Engineering  
University of Utah  
Salt Lake City, Utah

Standards Laboratory of the University of Utah,  $T_1$  and  $T_2$  are conventional radio power supply transformers. Winding 3 of  $T_1$  is the 115-volt primary winding; winding 2 is the 1000-volt center-tapped secondary; winding 1 consists of two 5-volt windings connected in series. Winding 1 of  $T_2$  is a 115-volt winding; winding 2 is a 800-volt center-tapped winding; winding 3 is a 6.3-volt winding. Windings 1 and 3 of  $T_2$  are connected as an autotransformer to boost the voltage so that the output voltage has nearly the same value as the average of the input voltage.

Tubes  $V_1$ ,  $V_2$ ,  $V_6$ , and  $V_7$  are cold-cathode diode-type voltage regulator tubes. Tubes  $V_3$  supply a stabilized d-c voltage for the screen of

$V_5$ , and tubes  $V_6$  and  $V_7$  supply stabilized bias voltages for both of the grids of  $V_5$ .

## Performance

A test of the regulator was conducted in conjunction with a model 326 Weston laboratory standard wattmeter, which has a 12-inch scale with 750 divisions. The following test was conducted with the regulator feeding the wattmeter circuit. When the input voltage to the regulator changed from 120 volts to 122 volts, the wattmeter indication changed from 740.0 watts to 741.5 watts. Within the limits of the accuracy of these measurements, the corresponding change of wattage is 0.2 percent. This change in wattage would require a change

of 0.1 percent in output voltage of the regulator. Then a change of input voltage to the regulator of  $(2/120) \times 100$  or 1.67 percent produces a change of output voltage of 0.1 percent. The ratio, therefore, of output voltage fluctuation to input voltage fluctuation for this regulator is 6 percent.

The most troublesome variations in the voltage supplied by utility companies are often those continually fluctuating about a constant voltage to the extent of plus or minus 0.5 volt or less. When the regulator is not used, such a change of voltage is 0.42 percent and the corresponding change in wattmeter reading is 0.83 percent. The use of the regulator reduces the change of wattmeter reading to 0.05 percent, which is well within the limits of accuracy of many calibrations.

The regulator suppresses the third harmonic found in the input and leaves the other harmonics essentially unchanged, so that the output wave form is actually slightly better than that of the input. It has proved to be a time saver and an aid to accuracy in precision calibration. When the local utility company voltage was used as a source voltage for the calibration of a particular rotating standard against an indicating wattmeter, approximately 20 man-hours of time were required to complete the calibration. With the aid of the regulator this same calibration job now requires four man-hours of time. By using the regulator one man can perform a calibration in less time than was required previously of two men.

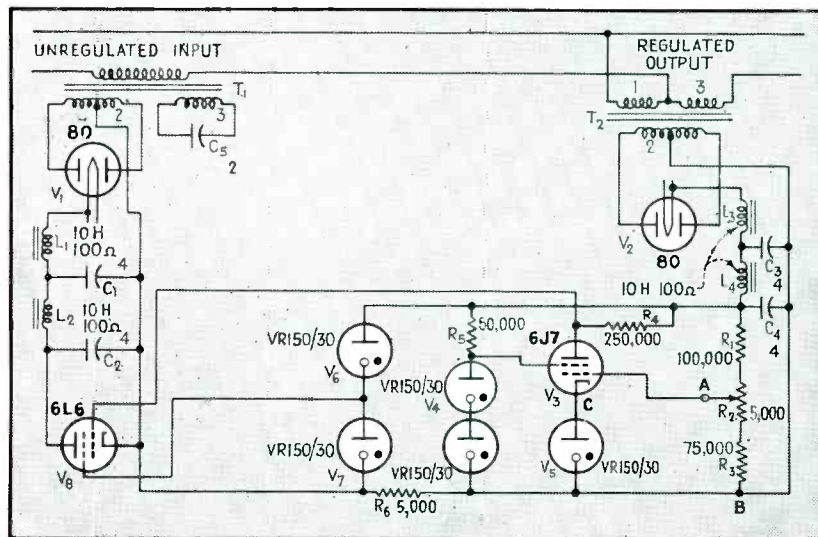
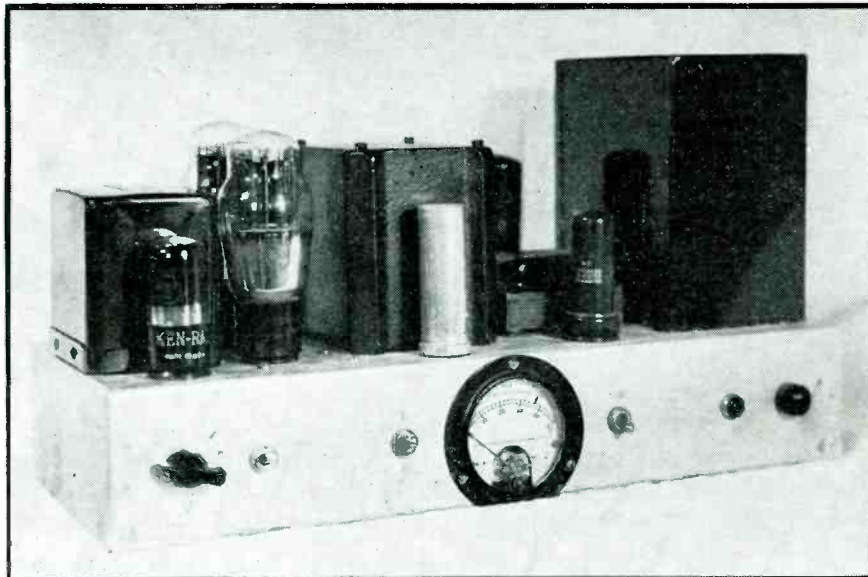

FIG. 2—Circuit diagram, with values of components. Transformers  $T_1$  and  $T_2$  are ordinary radio receiver power types. With the regulator, voltage changes at the output are only 6 percent of line voltage changes at the input



# BRIDGING

Complete data on a monitor amplifier whose signal-to-noise ratio at maximum power output is approximately 80 db. It contains a combination differential amplifier and cathode-coupled phase inverter for balanced line input and a response flat within 0.5 db from 20 to 25,000 cps



The bridging amplifier includes a meter that indicates plate current of either output tube

**I**NCREASING DEMAND for higher quality audio transmission requires apparatus capable of gaging the true quality of transmitted programs, especially in frequency modulated radio stations.

The amplifier to be described is capable of 15 watts output at frequencies as low as 20 cycles per second and as high as 25,000 cycles per second, having response flat within better than  $\pm 0.5$  decibel between these limits. This is obtained by the use of an all pushpull triode circuit particularly adapted to monitor bridging amplifier use, but also usable with single-ended input sources. Adequate gain for operation from a standard 500-ohm, 0-v-u ( $0 \text{ v-u} = 1 \text{ mw}$ ) line and good signal-to-noise ratio further justify its use in monitor applications.

Components and circuit details are such that the unit can be duplicated at relatively low cost with assurance that good performance will be obtained. The addition of a single-ended preamplifier would make the unit adaptable to applications other than monitor use, such as quality reproduction in homes.

The unit has excellent response, as shown in Fig. 1, low effective source impedance for loudspeaker or cutter operation, differential amplifier, cathode-coupled phase-inverter input in place of a bridging transformer, balanced inverse feedback, low noise level, and adequate gain.

Push-pull triode operation is utilized throughout, as shown in Fig. 2. The input stage, comprised of a 6SC7 dual triode, is employed in place of a standard bridging input transformer. Since it has 500,000-ohm resistors in the grid-return circuits, the load imposed on the standard 500-ohm line is negligible. An input voltage of the order of 0.3 volt rms grid-to-grid will drive the amplifier at full output.

This input stage has several useful features. By utilization of a 25,000-ohm unbypassed cathode resistor in place of the usual 1,000-ohm resistor, a combination differential amplifier<sup>1</sup> and cathode-phase-inversion amplifier<sup>2</sup> is obtained. In normal operation, when a push-pull signal is introduced to the grid, the cathode remains at a

fixed potential. However, if an in-phase signal is introduced to both grids, it will tend to drive grid A in a positive direction, and the cathode, due to the large value of cathode resistor, will also tend to go in a more positive direction. This is equivalent to grid B going in a negative direction. However, since grid B is also going in a positive direction, the in-phase signals cancel out, which is the desired characteristic to allow cancellation of hum pickup in balanced lines, etc. In spite of the high value of cathode resistor, full gain of the 6SC7 stage is realized with the circuit outlined.

## Single-Ended Input

The amplifier may be supplied with a single-ended input signal by grounding the unused grid. A signal fed to the other grid, the signal voltage being developed between ground and that grid, will appear as a push-pull signal in the plate circuits of the input tube. This is occasioned by a similar action to that outlined above, that is, if grid A goes in a positive direction, the cathode follows the grid, giving an equivalent negative signal to grid B, thus providing a push-pull signal reproduced in the plate circuits. With the circuit constants shown, a balance of five percent or better can be obtained between the two signals, that is, the ratio of a-plate signal A to plate signal B, will be approximately 1.05 or less.

The ratio of the plate signal magnitudes in the two plate circuits is given by the equation<sup>2</sup>:  $E_{PA}/E_{PB} = 1 + 1/G_m R_k$  where  $G_m$  is the mutual conductance of the tube and  $R_k$  is the cathode resistance.

When the amplifier is used with single-ended input, it is important that provision be made to ground

# AMPLIFIER for F-M Monitoring

BY GEORGE E. BEGGS, JR.

Warrington, Pa.

the unused grid directly, rather than depend upon the 500,000-ohm, grid-return resistor to furnish adequate ground return. If the grid is left at 500,000 ohms above ground, high-frequency response of the amplifier suffers (curve 3 of Fig. 1 results). Apparently the effective capacitance between grid and cathode causes the unused grid to follow the cathode at frequencies where the impedance of the capacitance approaches the value of the grid resistor, the effect becoming progressively more pronounced at higher frequencies. This decreases the overall gain at these frequencies by decreasing the input to the unused grid, that is, the differential voltage between the two grids is reduced.

In a sense, this effect is similar to the Miller effect<sup>3</sup> in usual triode operation, where the effective input capacitance  $C_i$  of a triode is many times the grid-cathode capacitance  $C_{gk}$ . The actual value of  $C_i$  is given by:  $C_i = C_{gk} + (M + 1)C_{gp}$  where  $M$  = stage gain at mid-frequency and  $C_{gp}$  = grid-plate capacity.

For a 6SC7 with plate load and plate voltage conditions noted on the circuit, this capacitance is about 90  $\mu\mu\text{f}$ , which is an impedance of 500,000 ohms at about 3,000 cps.

## Driver Stage

The basic circuit of the driver stage is conventional with certain exceptions. The gain control of the amplifier, which might be omitted under certain application conditions, is a push-pull gain control. In the circuit shown, a two-circuit, six points per circuit, switch was utilized to give five steps of gain and an off position, in steps of approximately six db, except for the last step which was made approximately 10 db. It is probable that a standard dual gain control, with a

resistance of 250,000 ohms per section, could be used.

The plate circuit of the driver stage and the grid circuit of the output stage can best be described jointly. A UTC type HA-107 interstage transformer having split secondaries is utilized to allow the application of fixed bias, with individual adjustment, to the output tubes. The two secondaries are individually loaded to reflect an impedance of approximately 10,000 ohms per plate to the 6SN7 driver sections. This serves to provide proper operation of the transformer over a wide range of frequencies. In the primary of the transformer, a 22-henry choke is utilized in the plate supply lead, to provide a high a-c impedance to ground from the center point of the driver transformer primary. This insures that the 6SN7 will maintain class A operation, since any tendency for the sum of the two plate currents to depart from a constant value (true class A operation) is offset

by the a-c impedance of the choke. Since there is no necessity to drive this tube into the grid-current region to obtain adequate driving voltage for the output tubes, class A operation is to be desired under all circumstances for low-distortion operation, and is assured by the inclusion of this choke.

## Output Section

The output tubes utilized are type 6A5G<sup>4</sup>. These tubes are similar to the 2A3 triode, but have two advantages over 2A3's. First, since they operate with 6.3 volts on the heater, no 2.5-volt transformer is needed. Secondly, the inclusion of a cathode internally tied to the center tap of the heater makes an equipotential electron source available. This has proved of great assistance in reducing the residual hum level present in the amplifier. The unit was previously constructed with 2A3's but the change was made to reduce hum. The output tubes are operated with a fixed bias of approximately 68 volts derived from the two potentiometers and the voltage divider network sup-

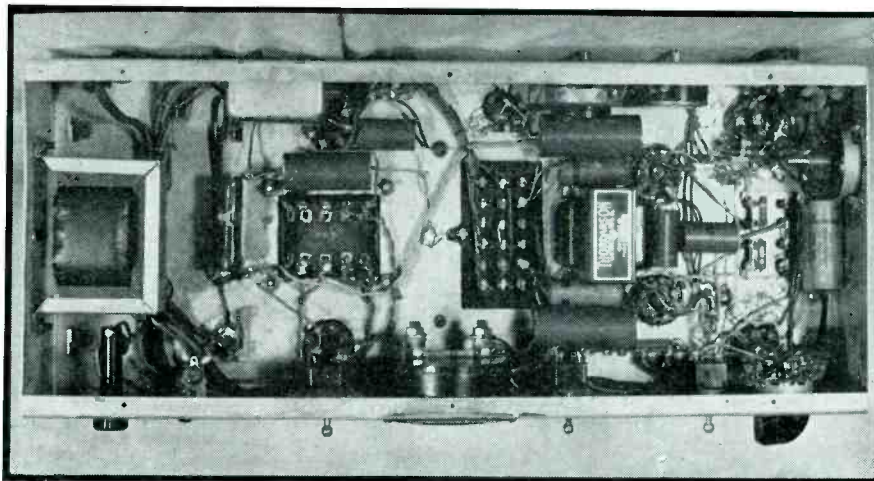

Components underneath the chassis are positioned for minimum pickup of stray fields



plied by the 5W4 bias rectifier. Individual adjustment of these tubes, so that they draw equal plate current, is accomplished by use of the two potentiometers and the 50-ma meter. The switch allows checking current of either tube independently. Each tube is adjusted to draw 40-ma with no output.

Since the cathodes are grounded, the center-tap ground return for all heaters is accomplished through the internal connection within the 6A5's, a common 6.3-volt supply being used for all three amplifier tubes. The output transformer utilized is an LS-55 UTC type.

#### Feedback

Monitor amplifier application requires excellent response over a wide range of frequencies. It is most desirable to obtain a response curve which is flat over a wide range and which contains no positive slopes within or near the range of frequencies normally supplied to

the amplifier. This last characteristic improves transient response.

Feedback is incorporated in the amplifier in a balanced fashion, in keeping with the overall push-pull characteristics, by feeding a portion of the output voltage from each output plate back to the appropriate driver cathode, through a large blocking capacitor, to reduce phase shift in the feedback circuit to negligible proportions. These bypass capacitors are 8  $\mu\text{f}$  electrolytics further bypassed by paper capacitors to reduce the impedance effect of electrolytics at high frequencies. A  $\mu\beta$  of 4 is provided<sup>5</sup> (corresponding to about 14-db feedback) without any tendency to oscillate.

Feedback could have included the output transformer under certain conditions but it was thought desirable to leave the output lines entirely independent of any relation to ground so that they could be operated with associated equipment in which one side of the output line

might be operated at ground or the output line might be floating or center tapped to ground. The frequency response does not appear to suffer from the omission of the output transformer from the feedback loop.

#### Frequency Response

The characteristics of the amplifier without feedback, with push-pull balanced line input, are shown in curve 2 of Fig. 1. Under these conditions, the amplifier is flat within  $\pm 2$  db from 40 cycles to over 20,000 cycles, which is reasonably good. However, with feedback, as shown in curve 1 of Fig. 1, response is within better than  $\pm 0.5$  db from 20 cycles to 25 kc. The usual low impedance of the 6A5G's is further reduced by the addition of feedback. Under these conditions, a power output of 20 watts at 1,000 cps may be realized before overloading.

Output capabilities at low frequencies are sufficient to allow 15 watts (+ 42 v-u) to be developed at frequencies as low as 20 cps, while a similar output may be obtained at 25 kc. In addition, the introduction of feedback lowers the overall noise and hum level of the amplifier to a point where the signal-to-noise ratio at maximum power output of the amplifier is approximately 80 db. The actual background noise at full gain, with the input open but shielded, is -40 v-u below zero (approximately seven mv across the 500-ohm output line), or 82 db below maximum signal. A noise level of this magnitude is practically inaudible even when the amplifier is utilized with speakers capable of excellent wide-band response<sup>6,7,8</sup>.

#### Other Features

The time constant of coupling circuits in the first two stages has been made quite large, 0.05 second, to maintain adequate low-frequency response. Input capacitors are included to allow coupling to sources having d-c components present.

The negative bias supply, in addition to being used to supply bias to the two output tubes, allowing operation as a fixed-bias amplifier, also supplies a point of return for the cathode circuit of the input tube. Since a large voltage drop occurs across the 25,000-ohm cathode re-

FIG. 1—Curves made at one-volt rms input to amplifier feeding a 500-ohm resistive load. For curve 1, the input was a balanced line and feedback was used in the amplifier. A similar curve was obtained with single-ended input and one grid grounded. Curve 2 resulted when feedback was omitted. Curve 3 was produced with single-ended unbalanced input to one grid and the other grid not directly grounded, with feedback

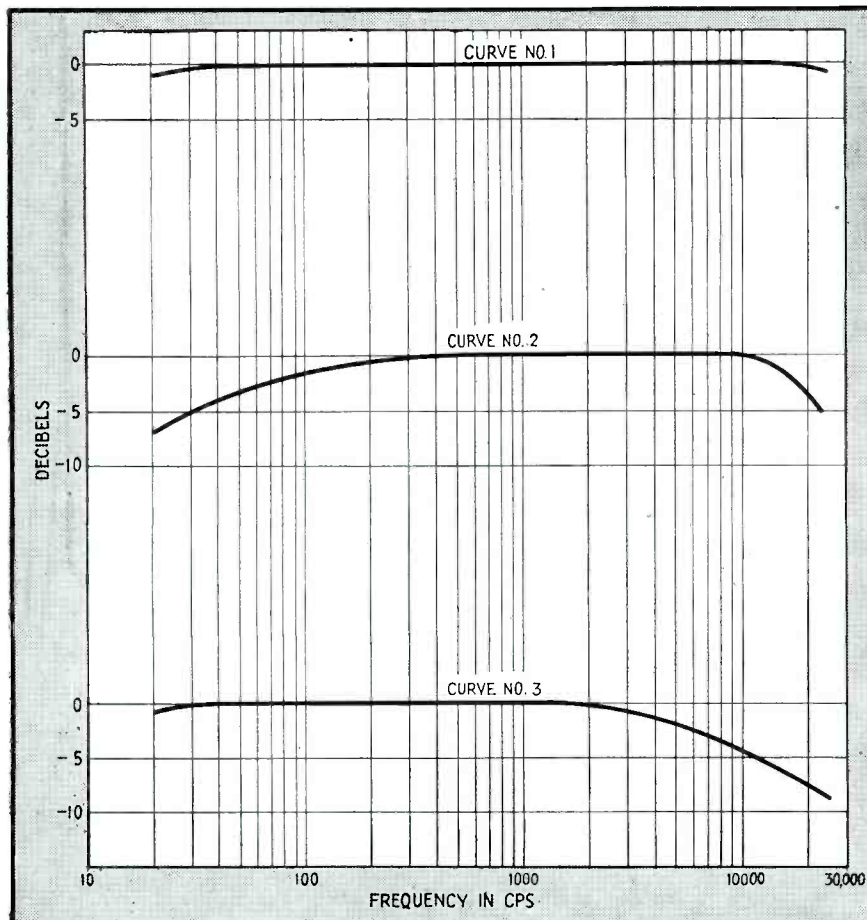

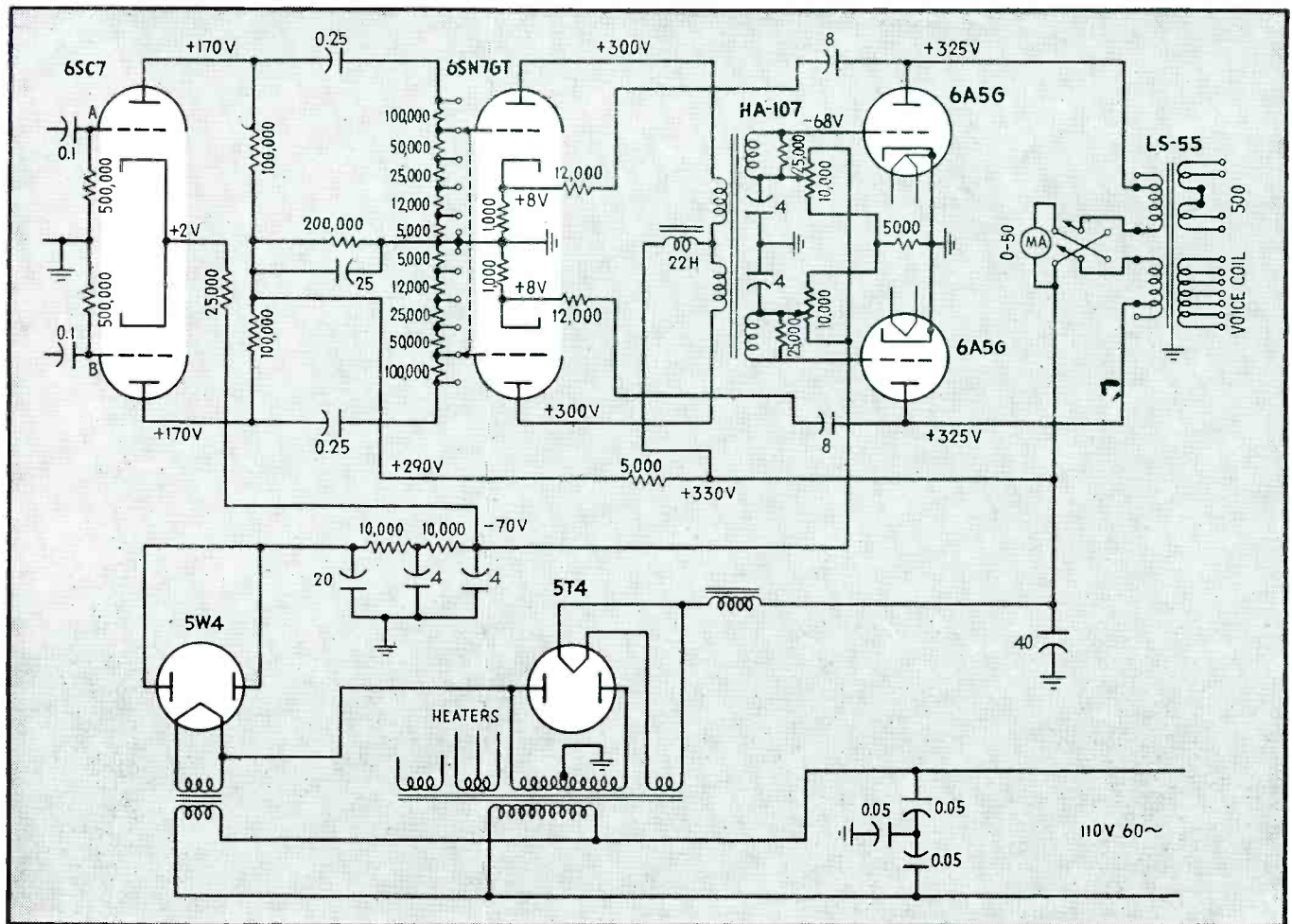

FIG. 2—Complete circuit of amplifier. For single-ended input, the unused grid is connected to ground

sistor (approximately 72 volts), it is desirable to return the cathode to a point at  $-70$  volts, so that the effective bias on the input tube is approximately two volts, the grids being returned to ground. While this is not essential, returning the cathodes to ground through 25,000 ohms would reduce the effective plate voltage on the tube by 70 volts, and necessitate returning the grids to a point above ground, thus reducing the overall gain of the tube and also creating a rather high heater-cathode potential which is not a favorable operating condition.

A study of the circuit diagram will indicate that upon applying power to the amplifier, the output tubes are initially biased practically to cutoff until all the heaters in the amplifier warm up, since the 6SC7 input tube initially does not draw any current, resulting in a smaller drop across the filter resistors in the bias supply, or effectively increasing the bias on the output tubes. This makes for longer life and lack of surge current conditions

in the output tubes during heating.

Individual adjustment was provided in an early model for the return point of the 6SC7 cathode but it was found that this was not required despite various tube changes and a fixed value was used which, with the other resistors, gives appropriate potential.

The output transformer is sufficiently well shielded so that it does not pick up appreciable hum from the power transformer. Grounding practice of returning single-stage grounds to a single point, with special care being taken to exclude any portion of the chassis from grid and grid-return circuits within a single stage, has been followed. This is straightforward r-f and audio practice but is particularly necessary to obtain the noise level realized in this amplifier. The output transformer was chosen to allow use with standard line impedances or voice-coil impedances, adequate match being obtained from 500 ohms down to approximately one ohm. Since triodes are utilized in the

output stage, with feedback, the damping characteristics of the circuit are excellent for applications in which the impedance of the driven device may vary over wide ranges. This is the case with almost all electroacoustic devices such as recording cutters and direct-radiator or horn-type loudspeakers. In addition, with direct-radiator loudspeakers, the damping provided by the amplifier tends to reduce distortion present at low frequencies to some degree. This unit has been successfully used with compact horn-type loudspeakers<sup>6, 7, 8</sup>.

#### REFERENCES

- (1) Toennies, J. F., Differential Amplifier, *Rev. Sci. Inst.*, p 95, 9.
- (2) Schmitt, O. H., Cathode Phase Inversion, *Rev. Sci. Inst.*, p 548, 12.
- (3) Radiotron Designer's Handbook, RCA Mfg. Co., p 46-48, 1941.
- (4) Technical Manual, Sylvania Elec. Prod. Inc., 1942.
- (5) Terman, F. E., "Radio Engineers' Handbook", McGraw-Hill Book Co., New York, 1943, p 395.
- (6) Klipsch, P. W., A Low Frequency Horn of Small Dimensions, *Jour. Acous. Soc. Am.*, 13, No. 2, p 137-144, Oct. 1941.
- (7) Klipsch, P. W., Improved Low Frequency Horn, *Jour. Acous. Soc. Am.*, 14, No. 3, p 179-182, Jan. 1943.
- (8) Klipsch, P. W., A Note on Acoustic Horns, *Proc. I.R.E.*, 33, No. 7, p 447, July 1945.



# BETATRON

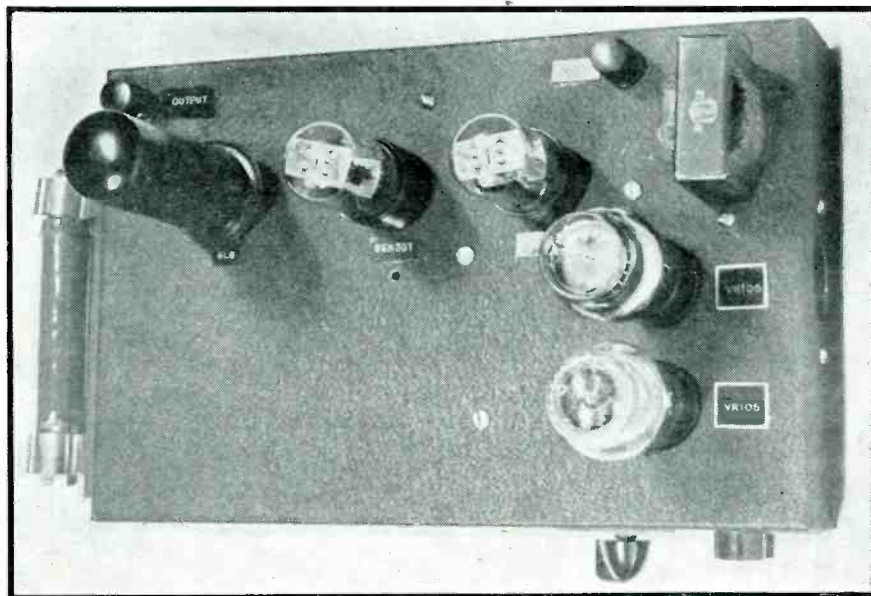

Input stages of orbit-shift pulse system used with Ohio State University betatron

By I. PAUL and T. J. WANG

The Ohio State University  
Columbus, Ohio

have reached the desired energy, the field-flux conditions for circular confinement are upset by the electronically triggered discharge of a capacitor through a set of orbit-shift coils.

The complete pulse-generating circuit with values of the components used is shown in Fig. 1. The arrangement of the final stages is similar to Kerst's,<sup>2</sup> employing a pair of gas tubes, a thyatron FG-41 and an ignitron GL-415, the thyatron firing the ignitron. The triggering unit which precedes the gas tubes consists of pulse generator  $V_2$  followed by pulse amplifier  $V_3$ - $V_4$ . The triggering unit is coupled front and back through cathode followers  $V_1$  and  $V_6$ .

In one possible arrangement the orbit-shift coils are single-turn loops mounted just outside the doughnut parallel to and directly above and below the electron orbit. The momentary surge of current

**T**HE BETATRON is an electron accelerator that employs the principle of electromagnetic induction for its accelerating action. Basically, the betatron is roughly equivalent to a high-voltage transformer. However, in the betatron the customary metallic secondary conductors are replaced by a toroidally shaped evacuated chamber in which the electrons traverse circular orbits in space. The evacuated chamber, or doughnut as it is called, is placed around the central leg of the transformer core. Electrons inside the doughnut are accelerated by the electric field which is associated with the time-changing magnetic flux of the primary. The force resulting from the interaction of magnetic field and electron velocity serves to confine the whirling electrons to a circular orbit.<sup>1, 2, 3</sup>

## Orbit-shift Coils

The electron injector is located within the doughnut at a point in the median plane just outside or just inside the circle in which electrons are ultimately confined and accelerated. Electrons are shot into the chamber in bursts by pulsing the injector. The electron beam avoids striking the injector as a consequence of a rapid shifting of

the beam circle to the ultimate equilibrium orbit together with a damped oscillatory motion of the individual electrons about their instantaneous circle. Acceleration of the electrons transpires for approximately a quarter cycle of the magnetic field, that is, for a period of  $1/240$ th second for a 60-cycle field or  $1/4,000$ th second for a 1,000-cycle field. At the instant in the cycle when the electrons

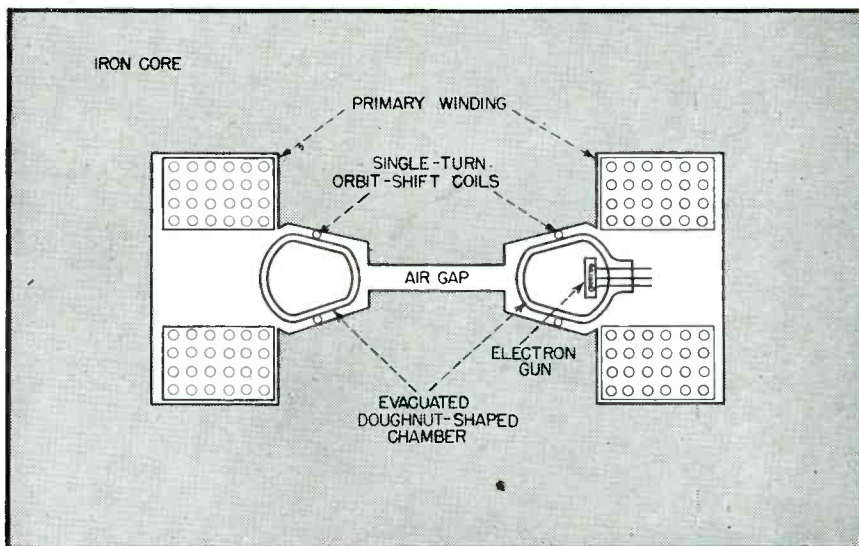

Cross-section through betatron accelerating unit, showing positions of orbit-shift coils that are energized by the 1,000-ampere pulse

# PULSING SYSTEM

Circuit used to generate high-current pulses for orbit-shift coils of betatron has many industrial applications, including resistance welding and stroboscopic inspection. Pulse generator having cathode followers and flip-flop amplifier triggers a thyatron that fires an ignitron, and the resulting capacitor discharge gives a 1,000-amp peak pulse

through these coils causes a strengthening of the central flux, with little change, however, in the field at the position of the orbit. The result is that the electrons receive an incremental acceleration without a correspondingly increased centripetal force, and the beam spirals outward.

## Pulse-generating Circuit

The pulse system of the Ohio State University betatron is described herein. The basic circuits are conventional; however, the design details are felt to be of general interest. The system has a wide variety of possible applications beyond the immediate use for which it was intended. It may be employed in any device which requires periodic high-power pulses at frequencies up to a few thousand cycles per second. Conceivable applications are to be found in television, in pulse-time modulation, in stroboscopic studies, in high-speed photography, and in resistance welding.

The 1-megohm resistor and 0.03-microfarad capacitor going from the betatron exciting coil to ground form an integrating circuit such that the voltage developed across the capacitor is in phase with the flux through the betatron coil. Pulse generator  $V_2$  is operated as a limiter so that a rectangular output wave is obtained corresponding to the sinusoidal input signal. The phase of the leading edge of the rectangular wave (and, incidentally, the width of the wave) are controllable through the variable bias on this stage. A differentiating circuit after the limiter provides a negative pulse corresponding to the leading edge of the rectangular wave and a positive pulse corresponding

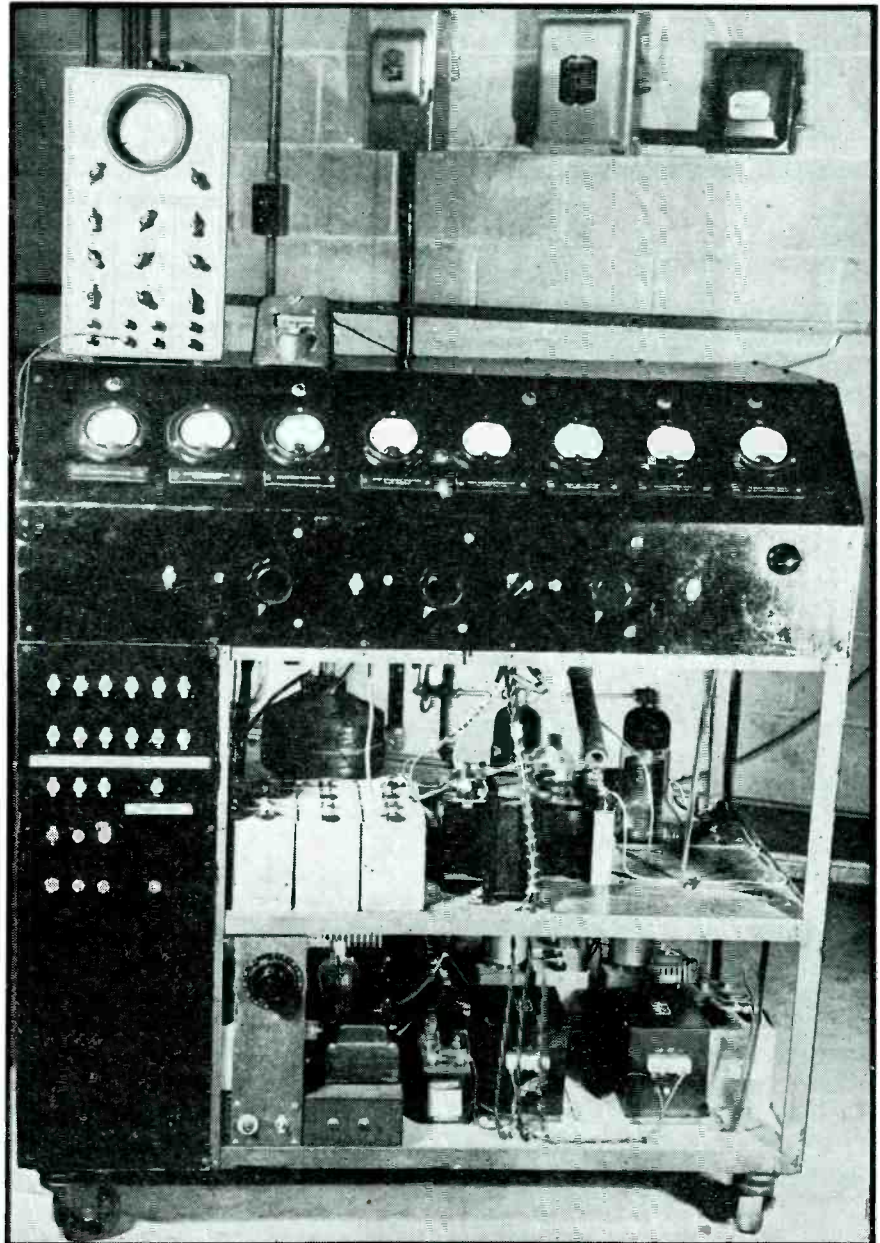

Control unit of betatron, including the orbit-shift pulse system described in this article. Input stages of orbit-shift system are mounted directly back of the meter panel

to the trailing edge. The latter pulse is ultimately clipped by high negative biasing of subsequent stages. However, the trailing-edge pulse is of no concern since it does

not affect the thyatron following. The pulse amplifier is connected as a flip-flop circuit with a very short time constant. Negative pulses trigger it and cause it to pro-



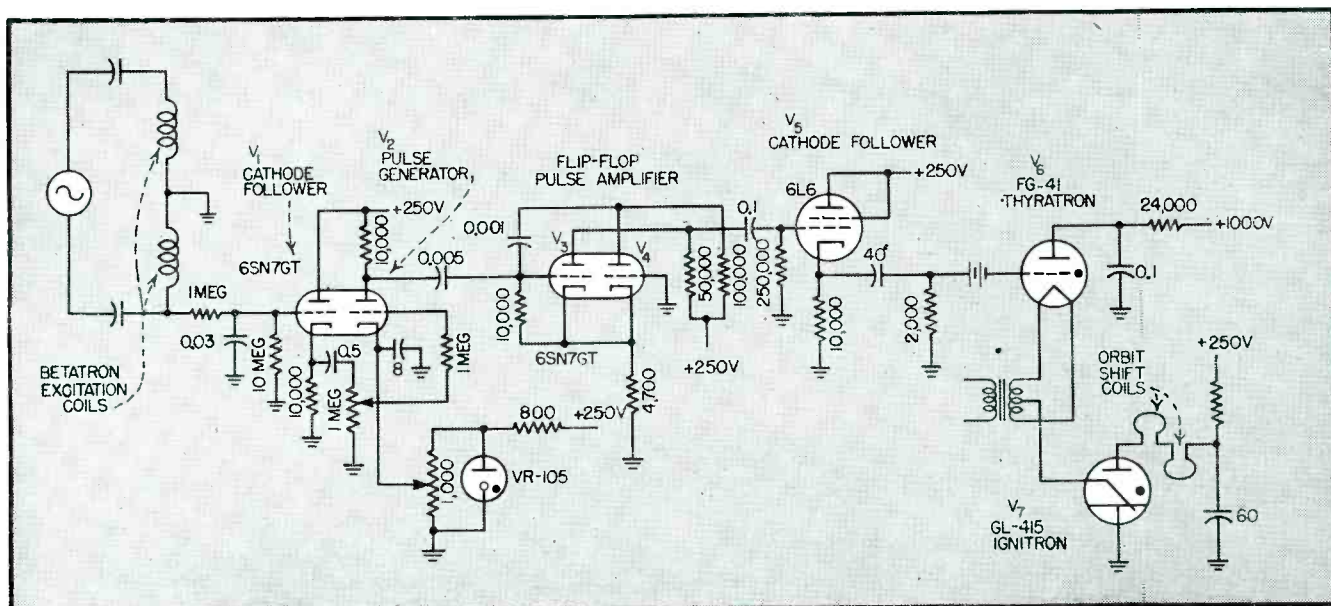

FIG. 1—Circuit diagram of complete pulsing system

duce positive pulses of larger amplitude. The amplitude of the output pulse is practically independent of the exciting pulse, so that the operation of subsequent circuits is independent of the magnitude of the exciting voltage. The peak value of the 6L6 output pulse is approximately 70 volts.

#### Thyratron Circuit

The FG-41 thyratron is biased with a battery so that the anode will not conduct before a pulse is applied. When a positive pulse large enough to overcome the grid bias is applied to the grid, the tube conducts. The capacitor discharges through the FG-41 anode and the GL-415 ignitron more rapidly than it can charge through the series resistance. The capacitor voltage falls to a value sufficiently low to extinguish the tube, and the grid regains control.

The sudden discharge of the thyratron capacitor serves to fire the ignitron, and the ignitron in turn discharges its own capacitor through the orbit-shift coils. This latter pulse is approximately 40 microseconds wide at half-amplitude and is of the order of 1,000 amperes peak value, as determined by a cathode-ray oscillograph across a measured small resistance.

The simplified circuit of Fig. 2 will serve for a study of the principles involved in the thyratron circuit. Figure 3 shows the lower extremities of a family of static characteristics for a typical thyratron

with various values of grid bias. The current scale in this figure is abnormally enlarged. The portions of the characteristics shown are for currents below 20 milliamperes for a tube which is designed to carry several amperes in conventional operation. The higher curves are for more negative values of grid bias. It will be noted that for any particular value of current the steepness of the characteristics varies with the grid bias, the steepness decreasing from one curve to the next as the grid bias becomes more negative. For current values much higher than those shown in Fig. 3 the various current-potential loci all merge into one single curve because, except for the lowest current values, the tube behavior is independent of grid bias.

Initially, capacitor  $C$  in Fig. 2 is presumed to be charged nearly to the supply potential  $E_{bb}$ , and the system is temporarily in an essentially stationary state while awaiting the positive grid pulse. Point  $A$  in Fig. 4 depicts the situation. The solid curve is the  $e_a-i_a$  static characteristic for the quiescent grid bias  $E_{cc}$ .

#### Analysis of Firing Action

On the application of a sufficiently strong brief positive pulse to the grid, the tube characteristic assumes a new position as indicated by the dotted curve of Fig. 4. For the instantaneous value of grid voltage  $E_{cc}'$  corresponding to the dotted characteristic, the existing

anode potential is sufficient to fire the tube, and operation jumps to point  $B$ .

Point  $B$  is actually on the  $E_{cc}'$  characteristic, and operation might be presumed to follow the  $E_{cc}'$  characteristic if the grid-cathode voltage were to remain at  $E_{cc}'$ . But since only a brief pulse is applied to the grid, the grid voltage returns to its quiescent value  $E_{cc}$  after a short time. It may be regarded that the characteristic followed is an intermediate one which coincides with that of  $E_{cc}'$  at the beginning of the pulse and with that of  $E_{cc}$  at the end of the pulse. However, in view of the approximate coincidence of the characteristics at all values of grid bias for the relatively high anode currents which obtain immediately after the firing, the characteristic for  $E_{cc}$  will be assumed as adequately describing the tube behavior.

Inasmuch as  $R_1$  is very much greater than the sum of  $R_2$  and the tube resistance, the discharge current of the capacitor, denoted by  $i_d$  in Fig. 2, exceeds the charging current  $i_c$  for an appreciable time following breakdown of the tube. During succeeding moments the capacitor potential falls, and the course of events is as described by successive points  $C$  and  $D$  in Fig. 5, where  $D$ , the point of tangency of the  $R_2$  load line with the tube characteristic, is the extinction point. Further decrease of capacitor voltage with time results in a transfer of operation to point  $E$ .

The tube in the dark stage presents a high resistance so that  $i_c$  rapidly exceeds  $i_d$ , and the capacitor recharges approximately to the potential  $E_{bb}$ , where the system awaits a new grid impulse.

### Capacitor-charging Equations

As long as the capacitor charges nearly to the supply potential  $E_{bb}$  in each cycle, the peak value of the current pulse through  $R_2$  depends only upon the values of  $R_2$  and of the potential  $E_{bb}$ , and not upon the size of the capacitor. This is evident on examination of the exponential charge-time decay curve of the capacitor. Neglecting the current  $i_c$ , the current  $i_d$  is the time derivative of the capacitor charge, and has its maximum value at the time  $t = 0$ . Thus, if the potential of the charged capacitor be taken as  $E_{bb}$ ,

$$i_d = \frac{d}{dt} (CE_{bb}e^{-t/R_2C})$$

$$= -\frac{CE_{bb}e^{-t/R_2C}}{R_2C}$$

For  $t = 0$ ,  $i_d = -E_{bb}/R_2$

The duration of the pulse is lengthened by the use of a high value of the product  $R_2C$  since with high  $R_2C$ , currents of small magnitude obtain only at large values of  $t$ .

The amplitude of the pulse will be lessened at high-frequency operation if the charge circuit time con-

stant,  $R_2C$ , is too long to permit the capacitor becoming charged nearly to the potential  $E_{bb}$  before the tube triggers.

Continuous conduction, that is, failure of the tube to extinguish at some time following breakdown, will occur in case (contrary to the previous assumption)  $i_c$  equals  $i_d$  in magnitude before the extinction point is reached on the down swing along the characteristic (Fig. 4 and 5). Once the condition is reached wherein  $i_c$  equals  $i_d$ , the source  $E_{bb}$  feeds the tube directly, and the plate current cannot be stopped thereafter unless  $E_{bb}$  is reduced substantially to zero. The particular point on the characteristic wherein  $i_c$  equals  $i_d$  is that point, hereinafter referred to as the critical point, where the tube characteristic intersects the  $R_1 + R_2$  load line. This load line is drawn through the point  $(E_{bb}, 0)$ . The position of the critical point as located above is evident because for equality of charging and discharging currents, the capacitor is effectively out of the circuit, and the tube is simply being supplied from the source  $E_{bb}$  through  $R_1$  and  $R_2$  in series.

### Dynamic Operation

The foregoing remarks are concerned only with tube characteristics obtained under static or steady

conditions, and the analysis is not entirely correct for transient states (dynamic operation). However, in a practical setup where some experimental control of the parameters is possible, the method serves successfully to indicate orders of magnitude and appropriate directions for adjustment.

One effect of dynamic operation which must be taken into account is the steeper slope of the dynamic characteristic which causes the extinction point (point of tangency of the  $R_2$  load line) to occur at a slightly lower current value than that which would be predicted from static considerations. The steepness of the characteristic depends upon the size of the capacitance used, and for very small values of capacitance the extinction point decreases as the capacitance is reduced. As can be observed from Fig. 5, the anode potential rises with the discharge of the capacitor. With this rise of anode potential there occurs a current flow  $i_s$  through the grid resistor (in addition to any current which may flow during continuous static operation) by virtue of the presence of the inherent grid-anode capacitance of the tube, as indicated in Fig. 6. The current  $i_s$  is in such a direction that the associated drop across the grid resistor changes the grid potential

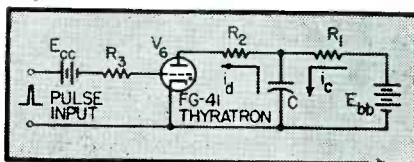

FIG. 2—Idealized thyatron pulse circuit. Arrows indicate current flow

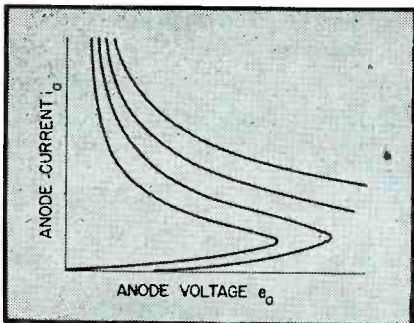

FIG. 3—Lower portions of the family of anode current-anode voltage characteristics of a thyatron

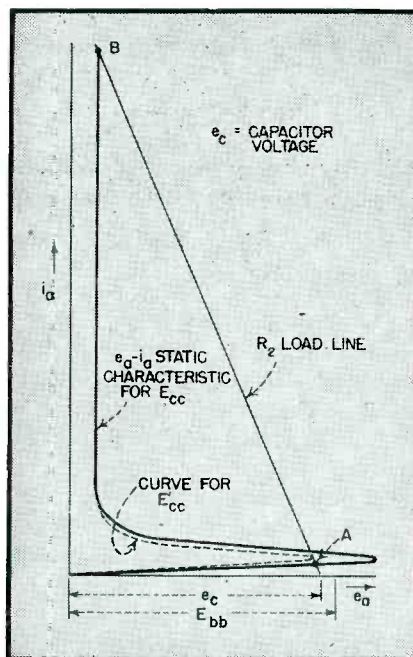

FIG. 4—Operation immediately before firing (point A) and immediately after firing (point B) of the thyatron in the pulse circuit

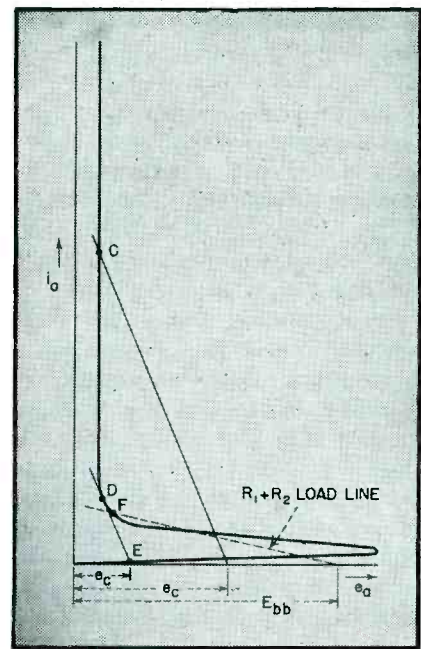

FIG. 5—Operation at intermediate time during capacitor discharge (point C), just before extinction (D), and after extinction (E)



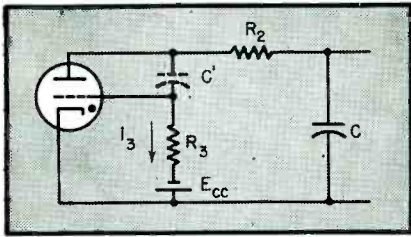

FIG. 6—Current flow through grid resistor associated with rapid increase of anode potential

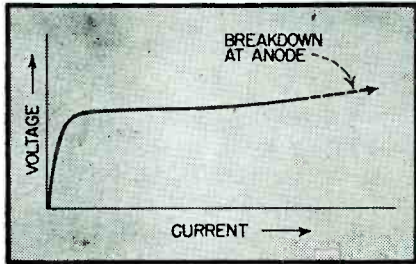

FIG. 7—Voltage-current characteristic of ignitor rod for d-c operation

in a positive sense. As has been noted in connection with Fig. 3, this serves to steepen the characteristic and therefore to lower the extinction point. In a similar gas tube arrangement Puckle<sup>4</sup> was able to enhance the depression of the extinction point with reduction of the main capacitance by deliberately shunting additional capacitance across the stray grid-anode capacitance.

#### Ignitron Characteristics

A specific distinction between the ideal circuit of Fig. 2 and the actual circuit which was employed lies in the thyatron load resistor  $R_2$ . Actually,  $R_2$  consisted of the ignitron striking element, whose resistance was found to vary with the current through it in the manner shown in Fig. 7. For values of current below about  $\frac{1}{2}$  ampere the ignitron behaves as an essentially uniform resistance of about 25 ohms, whereas for larger current values the ignitron presents a varying resistance which decreases with the current in such a manner as to produce a voltage drop which is practically independent of the current. Hence, when during the course of the cycle the point of operation moves downward along the tube characteristic toward smaller currents, the slope of the  $R_2$  load line steadily decreases and  $R_2$  approaches its maximum value of about 25 ohms. The bend in the

experimentally determined static characteristic curve for the FG-41 thyatron sets in below about 14 milliamperes (above this value of current the curve is nearly vertical); thus, when operation on the downward swing of the characteristic reaches the neighborhood of the extinction region the ignitor has attained its maximum resistance.

#### Design Procedure

The first step in the design of the actual circuit was the choice of an appropriate value for  $C$ . A small value of  $C$  was deemed to be advantageous since for any suitable time constant  $R_1C$  a small value of  $C$  would permit a large value of  $R_1$ , the latter being desirable to ensure bringing the critical point below the extinction point. On the other hand, the capacitor could not be too small because small capacitances serve to lower the extinction point. A compromise value of 0.1 microfarad was selected somewhat arbitrarily, and values for  $R_1$  and  $E_{bb}$  were determined as follows:

During the charging period, and neglecting the dark current, the voltage across the capacitor is given by

$$e_c = E_{bb} (1 - e^{-t/R_1 C}) \quad (1)$$

A second relation involving  $R_1$  and  $E_{bb}$  arises from the requirement of fixing the critical point below the extinction point. If the critical point has the coordinates  $e_o, i_o$ , it is seen from Fig. 8 that

$$\frac{E_{bb} - e_o}{i_o} = R_1 + R_2$$

For all practical purposes the above equation may be written simply as

$$\frac{E_{bb} - e_o}{i_o} = R_1 \quad (2)$$

since  $R_2 \ll R_1$ .

Numerical values of  $e_o$  and  $i_o$  were selected to correspond to a point safely below the extinction point on the experimentally determined static characteristic of the thyatron, and a value of  $1/500$ th second was assigned to  $t$  as the approximate time allotted for charging the capacitor with 500-cycle operation. With these numerical values of  $e_o, i_o$ , and  $t$ , Eq. 1 and 2 were solved together graphically. Several curves of  $E_{bb}$  versus  $R_1$  for Eq. 1 were plotted with  $e_o$  as a parameter, and the intersections

with the graph of Eq. 2 yielded the characteristic curve for the  $E_{bb}$ -versus- $E_{bb}$  relation shown in Fig. 9. The knee of the curve corresponds roughly to 1,000 volts for  $E_{bb}$ , indicating the desirability of using approximately 1,000 volts for the source. This value provides a high capacitor voltage just prior to the discharge, which in turn assures an adequate pulse for firing the ignitron. Any higher source potential does not appreciably increase the capacitor voltage. The value of  $R_1$  follows at once from Eq. 2.

A similar set of considerations holds for the ignitron circuit, except that here the load resistance is constant and of sufficiently low value that the tube action is not critical to wide variations of circuit parameters. It was found with the ignitron, just as with the thyatron, that too low a value of the charging resistor resulted in continuous conduction. For very high values of charging resistance the ignitron fired spasmodically, indicating that the capacitor voltage was not adequate to insure spread of the discharge to the anode at the time of the ignitor pulse.

#### REFERENCES

- (1) Kerst, D. W., *Physical Review*, 60, p 47, 1941.
- (2) Kerst, D. W., *Review of Scientific Instruments*, 13, p 387, 1942.
- (3) Wang, T. J., The Betatron, *ELECTRONICS*, p 128, June 1945.
- (4) Puckle, O. S., "Time Bases", John Wiley & Sons, Inc., 1943, p 172.

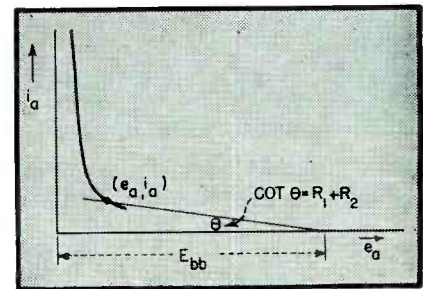

FIG. 8—Critical point, safely below extinction point

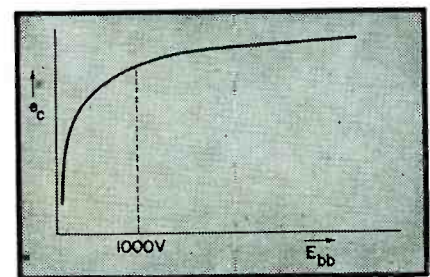

FIG. 9—Effect of supply voltage on fully charged capacitor voltage





# IMPEDANCE-ADMITTANCE CONVERSION CHART

Simple chart for quickly converting  $Z = R \pm jX$  to  $Y = G \mp jB$  and vice versa when combining impedances in parallel. One-decade range requires use of multipliers for most problems, but accuracy is adequate for quick, rough estimating work

By **ROBERT C. PAINE**

*Boonton, New Jersey*

**W**HEN impedances are to be combined in parallel it is necessary to convert them to admittances so they can be readily added together. Such conversions can be conveniently performed with reasonable accuracy by the aid of the chart shown. Resistance  $R$  is plotted in a horizontal direction and reactance  $X$  in a vertical direction, being considered positive or negative depending on whether it is inductive or capacitive. Passing through each impedance point  $R \pm jX$  is an arc centered on the horizontal axis for conductance  $G$ , and another arc centered on the vertical axis for susceptance  $B$  of the corresponding admittance  $Y = G \mp jB$ . The susceptance is read as negative for inductances and positive for capacitances.

### Examples of Use

(1) Impedance  $Z_1 = R + jX = 8 + j5$ . On the chart this corresponds to an admittance  $Y_1 = G - jB = 0.09 - j0.057$ .

(2) Impedance  $Z_2 = 2 - j1.5$ . The corresponding admittance is  $Y_2 = G + jB = 0.32 + j0.24$ . Because  $Z_2$  lies near the origin, greater accuracy can be attained by using a multiplier such as 4. Then  $4Z_2 = 8 - j6$ , the corresponding value of  $Y$  is  $0.08 + j0.06$ , and this value multiplied by 4 gives the correct value,  $Y_2 = 0.32 + j0.24$ .

(3) The impedances of examples 1 and 2 are combined in parallel. The sum of their admittances is  $Y_3 = Y_1 + Y_2 = 0.41 + j0.183$ .

Changing the scale by a factor of  $\frac{1}{4}$  we obtain  $\frac{1}{4} Y_3 = 0.102 + j0.046$ , and  $Z_3 = \frac{1}{4} (8.2 - j3.6) = 2.05 - j0.9$ .

(4) Impedance  $Z_4 = 20 - j15$ .

Multiply  $Z_4$  by  $1/10$  to get values within range of chart, find admittance values as in example 1, and multiply them by  $1/10$  to get  $Y_4 = 0.032 + j0.024$ .

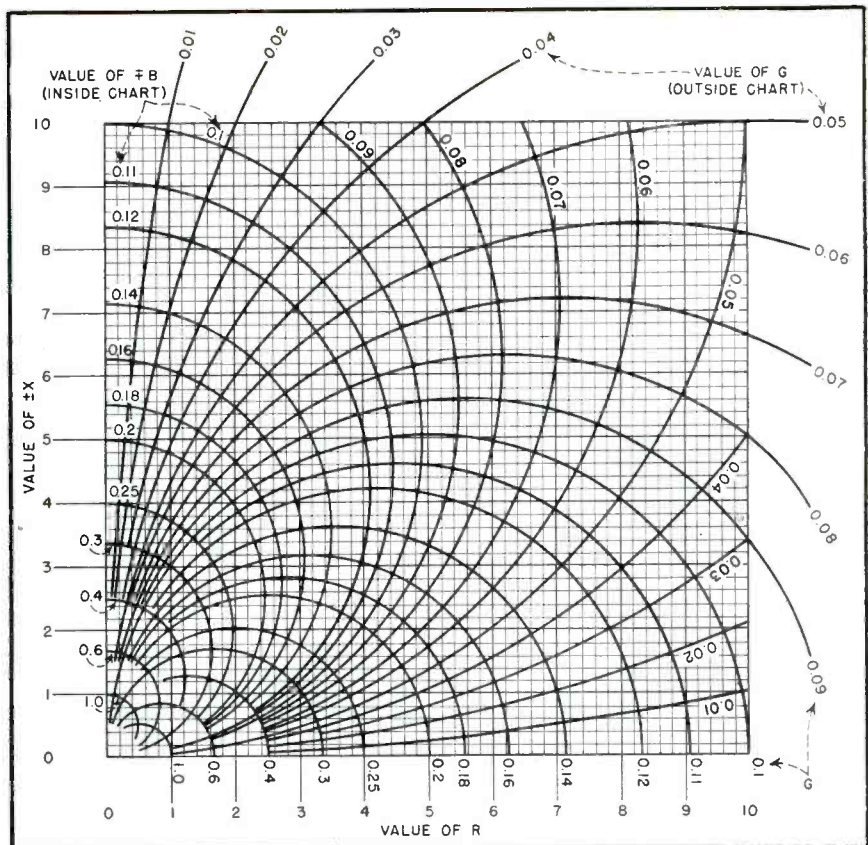

When known values are outside range of chart, multiply by any convenient value that brings them within range, find equivalent values from chart, and multiply them by that same multiplier to get final answer. Values of  $R$  and centers of circles for corresponding  $G$  values are on horizontal reference axis. Values of  $X$  and centers of circles for corresponding  $B$  values are on vertical reference axis

**ELECTRONICS REFERENCE SHEET**

# THE FIRST Grade 1, Class 1, Vitreous Enamel RESISTORS

"RN" RESISTORS WITHSTAND:



THERMAL SHOCK from 275° C. to 0° C.



CONTINUOUS OPERATION at 275° C.



MOMENTARY OVERLOADS up to ten times the rated load



NINE CYCLES OF IMMERSION in Salt Water



MALLORY engineers are first to solve the tremendous technical problems involved in developing a tab-type vitreous enamel resistor that completely meets JAN (Joint Army and Navy) Specification, Characteristic F!

This new "RN" Resistor, which does what only a hermetically-sealed glass-enclosed ferrule type resistor could formerly do, will also pass Grade 2

Class 1 Characteristic D, Grade 1 Class 3 Characteristic H, and Grade 1 Class 2 Characteristic E! Now in full-scale production, the Mallory "RN" Resistor comes in six basic sizes with a wide variety of ratings. Other sizes will be made available shortly. For complete information, write for Bulletin RN1045 or see your Mallory representative. Standard Mallory Resistors are available from your nearest Mallory Distributor.

## TYPICAL MALLORY "RN" RESISTORS

JAN-R-26 Style	WATTAGE 275° C. New	TUBE DIMENSIONS			RESISTANCE—OHMS Using Wire Dia.		Tap Available
		Length	Outside Dia.	Inside Dia.	.010 Min.	.0025 Max.	
RW 30 F	7	1	1/2	3/16	2	630	No
RW 31 F	10	1 1/2	1/2	3/16	10	2000	No
RW 32 F	12	2	1/2	3/16	18	3100	Yes
RW 33 F	18	3	1/2	3/16	35	6300	Yes
RW 34 F	30	3	3/4	3/16	50	9000	Yes
RW 35 F	38	4	3/4	3/16	71	12000	Yes

P. R. MALLORY & CO. Inc.  
**MALLORY** RESISTORS  
(FIXED AND VARIABLE)

P. R. MALLORY & CO., Inc., INDIANAPOLIS 6, INDIANA



# INDUSTRIAL CONTROL

X-Ray Snapshots Used in Atomic Bomb Production.....	164
Electronic Vulcanizing on Commercial Basis.....	164
Electronic Package Inspection in Post Office.....	166
Synchronizing Electric Motors.....	166
Control and Recording with Floating Grid.....	172

## X-Ray Snapshots Used in Atomic Bomb Production

EQUIPMENT WHICH makes possible millionth-of-a-second x-ray photographs was used extensively in connection with the atomic bomb experiments, according to Dr. Charles M. Slack, assistant director of research for the Westinghouse Lamp Division, Bloomfield, N. J. The specific role of high-speed x-ray pictures in atomic bomb experiments must remain confidential at this time.

The new picture-making technique also contributed to the science of ballistics during the war by making possible studies such as determining the realignment of a bullet as it zipped down the bore of a gun barrel and the swelling, bursting and disintegration of a high explosive shell resulting when it chewed through steel plate.

The evidence was obtained by

comparing photographs of the original missiles with several high-speed sequence pictures made as the bullet raced down the bore of the gun or as it entered the steel plate.

Typical of the amazing discoveries uncovered by high-speed x-ray pictures in ordnance experiments during wartime was one which at Aberdeen Proving Grounds, Md., cleared up the mystery of why certain armor-piercing bullets failed to penetrate the armor. The reason, the pictures disclosed, was that the cap on the bullet, designed to break up the case hardening on the armor plate at the point of penetration, ripped free of the bullet after it left the barrel. Later the bullet caught up with the cap and shattered it just prior to reaching the target.

## Electronic Vulcanizing on Commercial Basis

THE FIRST commercial electronic vulcanizer in the rubber industry has been placed in operation in the manufacture of Foamex mattresses at the Fall River, Mass. subsidiary plant of Firestone Tire and Rubber Co.

Designed for mass production, the three-story machine uses 125 kilowatts of r-f power to service two complete vulcanization chambers. It was designed by Firestone engineers and the Westinghouse Electric Company in Baltimore, Maryland. With the electronic machine, large double-bed mattresses that previously required a 35-minute cure by the old steam jacket method, are completely cured in 5 minutes by 13.6-mc r-f power.

Close examination of the electronic-cured mattress reveals that

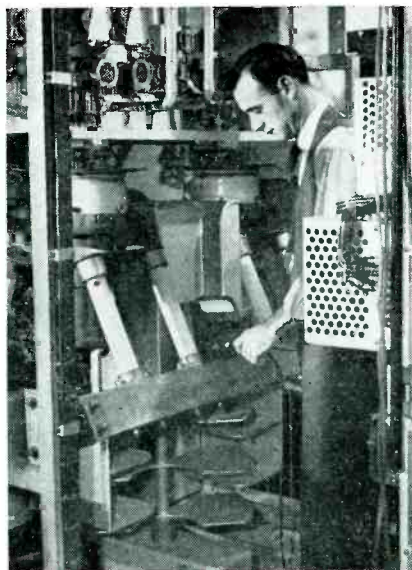

Power tubes and tuning capacitor of the 125,000-watt electronic vulcanization unit installed at the Firestone plant in Fall River, Mass.

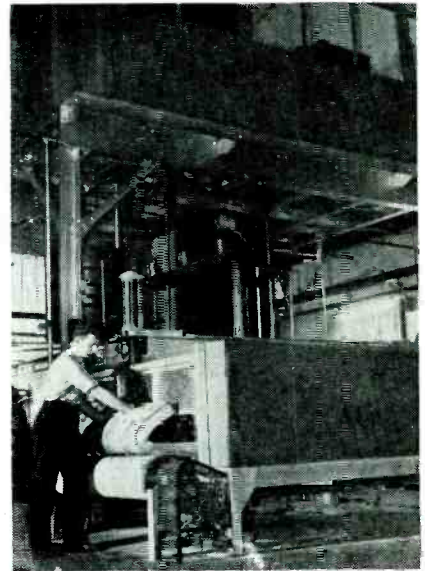

Cured by electronic heating, a Foamex mattress is removed from the drying oven where dielectric heating is also used to reduce moisture. The three levels of the equipment include the vulcanization chambers, remote control panel and power unit.

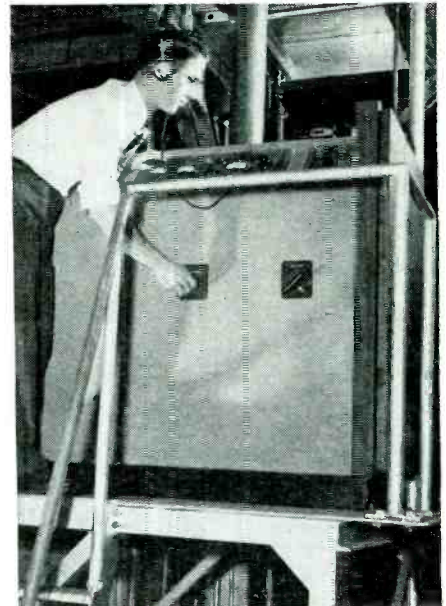

A Firestone engineer adjusts the remote control panel on the second level of the electronic vulcanization unit.

the final product is far superior structurally to the old type. This is due largely to instantaneous heat supplied uniformly to all parts of the mattress, as contrasted to the conventional steam method in which the foamed rubber is vulcanized slowly from the outside of the mattress to the interior. Since in this method, the process cannot always be precisely controlled, parts of a steam-cured mattress may be com-

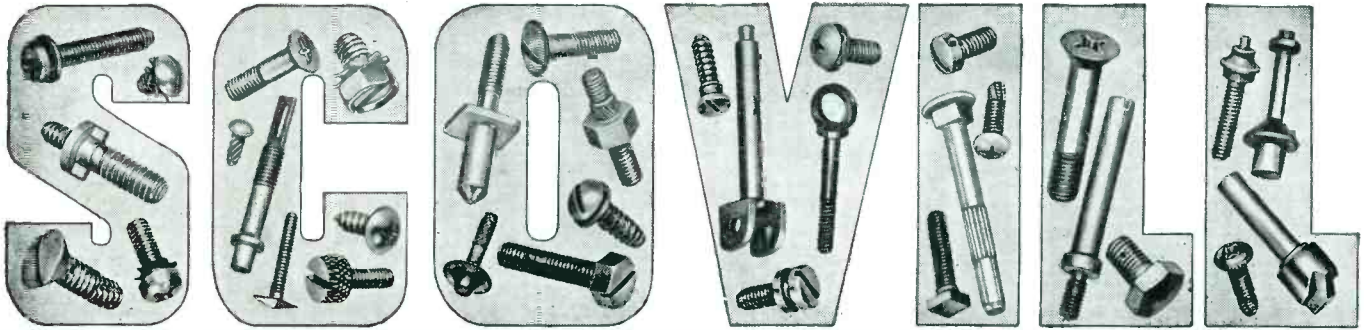
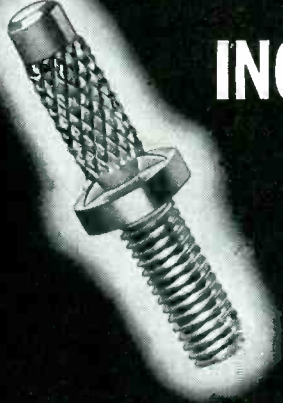
**INCREASED COMPETITION DEMANDS  
FAST, PRECISE ASSEMBLY...  
PLAN FASTENINGS NOW**

"Cold-forging"—proof #36... more each month

### 3 Standard Fastenings for Production Efficiency

- 

**1 Phillips Recessed Head Screws**—The modern, effective, time-saving fastening device proven in tens of thousands of assembly lines. Other standard head styles are also available.
- 

**2 Self-Tapping Machine Screws**—Eliminate separate tapping operations for fastenings to castings, heavy gauge sheet metal, and plastics. Also available with Phillips Recessed Head.
- 

**3 Washer-Screw Assemblies**—When use of lock washers is indicated, the time-saving of pre-assemblies is obvious. Also available in standard slotted head styles.

#### Plan Well Ahead:

The need for planning fastenings early in the product design stage becomes more and more urgent as competition increases. Early action may solve your vital assembly problem... It enables you to make that exacting choice—a featured standard fastening or a part especially designed to meet your specific requirements. No assembled product is better than its fastenings—and no fastenings are better than Scovill fastenings.

#### Select Scovill:

Qualified fastening experts, backed by our many years of experience in fastenings, will help you make that choice. Our demonstrated ability in special design\* will make it pay to select Scovill. Service and quality, plus our special processing, our ingenuity in cold-forging, mean a substantial saving in *money—materials—motions*.

#### Call A Scovill Fastenings Expert Today

\*Illustrated above is one of many special-purpose items—proof of Scovill ingenuity in cold-forging and ability in special design.

**SCOVILL MANUFACTURING COMPANY**

**WATERVILLE SCREW PRODUCTS DIVISION**

WATERVILLE 48, CONN.  TEL. WATERBURY 3-3151

NEW YORK, Chrysler Building • DETROIT, 6460 Kercheval Avenue • CHICAGO, 135 South LaSalle Street • PHILADELPHIA, 18 W. Chelton Avenue Building  
PITTSBURGH, 2882 W. Liberty Ave. • SYRACUSE, Syracuse - Kemper Insurance Bldg. • LOS ANGELES, 2627 S. Soto St. • SAN FRANCISCO, 434 Brannan St.



pleted and other parts of the same product under-cured.

Electronic curing is being applied to the manufacture of other rubber products at Firestone. Large hard rubber wheels that required

five hours of curing by steam may be vulcanized electronically in 18 minutes and brake blocks that required seven full hours by steam are done in 48 minutes by electronic heating.

## Electronic Package Inspector in Post Office

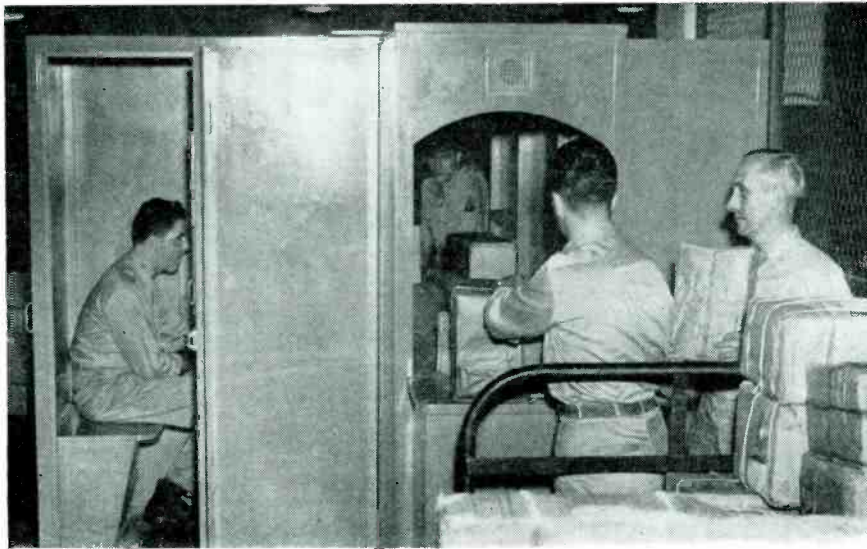

Fig. 1—Military mail clerks at the right are placing packages from soldiers abroad into the examining bay of the Inspectoscope which x-rays them for illegal objects

X-RAY APPARATUS is now used by the army to forestall such GI activities as the mailing home of a jeep, piece by piece, as reported of one



Fig. 2—Operating position of the Inspectoscope. Contents of the packages are viewed through the window above the panel

enterprising soldier. Installed at The New York and San Francisco Army Post Offices, the equipment has a window through which the homebound parcels are passed as shown in Fig. 1.

While they are on the central counter they are exposed to x-rays

under control of the operator at the left whose booth is shown in more detail in Fig. 2. He also acts as observer, examining the packages for illegal material of which considerable has been recovered. Built by The Sicular Co. of San Francisco, the Inspectoscope does away with opening all packages.

### Synchronizing Electric Motors

APPLICATION OF ELECTRONIC controls in industry sometimes involves the synchronizing of several operations that are ultimately accom-

plished by electric motors. A simple method of maintaining synchronism of motors is suggested by the system employed in the SCR-502, a semiportable radio direction finder. It employs two fixed Adcock antenna arrays, one being used from 1.5 to 10 mc and the other for 10 to 30-mc operation. Instantaneous visual azimuths are indicated on the screen of a five-inch cathode-ray tube by means of deflection coils driven in synchronism with motor-driven goniometers that scan the output of their respective antenna arrays.

The motors that drive the goniometers operate on 115 volts, 60 cps, and are single-phase types rated at 1/50 horsepower. The motor that rotates the deflecting coils of the cro is a 1/4-horsepower synchronous 1800-rpm unit. The motors are some distance apart and one of the problems is to maintain synchronism between them.

### Contactors

Open-close contacts are operated by eccentric cams on the drive shafts of the goniometer and the bearing indicator drive motors. These two sets of contacts are wired in series with one end grounded and the other end terminal connected to the grid of a 6SL7 tube. The contacts are so arranged that the indicator contactor is closed for about 270 degrees of its rotation and the goniometer contacts close for about 30 degrees of rotation during the time the contacts at the indicator are open. In normal synchronous operation, the two contactors never close at the same time and, therefore, the grid of the 6SL7 is not grounded. In fact, the tube is biased to cutoff during the

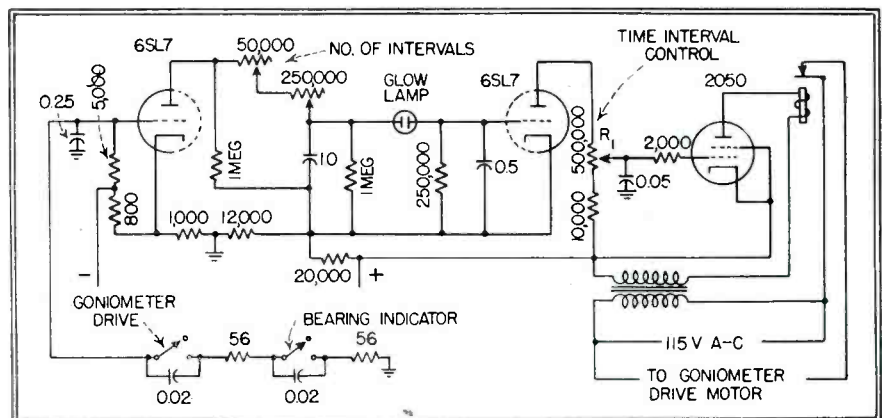

Fig. 1—Circuit of electronic unit for synchronizing electric motors



*Announcing*  
**THE NEW**  
**SPERRY *Microline*\***

As a reading glass aids visual search, so MICROLINE test and measurement equipment provides means for making all measurements at microwave frequencies.

Sperry announces a comprehensive line of microwave test and measurement equipment for labora-

tory and field use. The new line... the MICROLINE... is the outgrowth of years of research and experience in modern microwave techniques beginning with the development of the Klystron.

Write our Special Electronics Department for further information.

- Available now:**
- WAVEMETERS • WATTMETERS
  - BARRETTOR ELEMENTS AND MOUNTS
  - DIRECTIONAL COUPLERS
  - KLYSTRON SIGNAL SOURCES
  - STANDING WAVE DETECTORS
  - ATTENUATORS
  - IMPEDANCE MATCHING EQUIPMENT
  - WAVEGUIDE AND COAXIAL COMPONENTS

Visit the Sperry booth at the I.R.E. Convention

TRADE MARK

**SPERRY GYROSCOPE COMPANY, INC.** GREAT NECK, N. Y.



*Division of the Sperry Corporation*

★  
 LOS ANGELES • SAN FRANCISCO • SEATTLE • NEW ORLEANS  
 CLEVELAND • BROOKLYN • HONOLULU

**GYROSCOPICS • ELECTRONICS • RADAR • AUTOMATIC COMPUTATION • SERVO-MECHANISMS**



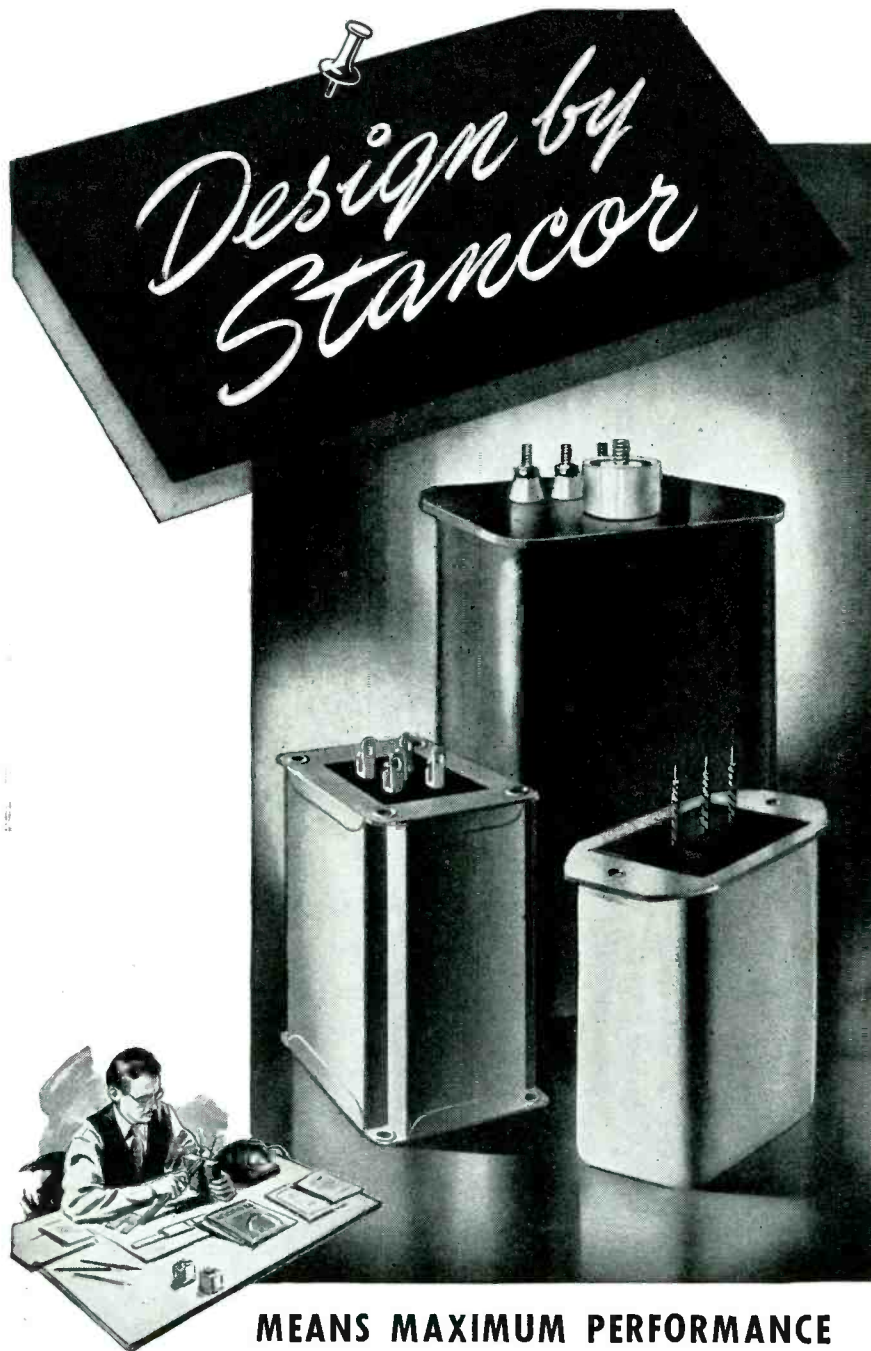

## MEANS MAXIMUM PERFORMANCE AT AN ECONOMICAL PRICE . . .

**T**HERE is more to STANCOR design than theory and paper engineering. Behind-the-scenes operations reveal unremitting *fact-finding*—nothing is taken for granted. For the STANCOR engineer is as persistent as he is practical, demanding—and receiving—high standards of performance.

Engineering design implies more than mere conversion of the customer's electrical requirements to manufacturing specifications. At STANCOR it includes the employment, to the greatest advantage, of selected materials to achieve optimum performance—all with the constant practical thought—more *useful* watts per dollar.

Competent laboratory and sales engineering facilities are available **NOW** to meet your most exacting transformer specifications:



**STANCOR**  
STANDARD TRANSFORMER CORPORATION  
1500 NORTH HALSTED STREET CHICAGO 22, ILLINOIS

synchronous condition.

The circuit of the synchronizing unit is shown in Fig. 1 and consists of a twin-triode 6SL7 and a 2050 thyratron. When the first grid of the 6SL7 is cut off, the grid and cathode of the second triode are at the same potential so that this tube draws current through resistor  $R_1$  and produces bias at the 2050 grid so that it does not draw current. The plate circuit of the 2050 contains a relay with its contacts arranged so that when the 2050 does not draw current, the a-c supply is connected to the goniometer drive motor.

### Operation

If the motors are not synchronized on the same pole, then closing of the goniometer contactor will not occur during the open interval of the indicator contactor and, during some part of the revolution, the grid of the first half of the 6SL7 will be grounded. When this occurs, this tube draws plate current. Since each time the grid is grounded the tube draws current, pulses of voltage will appear across the load resistor and an associated RC circuit. After several pulses, the number depending upon the setting of the *No. of Intervals* control, the potential across the capacitor reaches the flashing voltage of the glow lamp.

When the glow lamp conducts, current flows through the resistance in series with it, overbiasing the second triode of the 6SL7. With this tube cut off, bias is removed from the 2050 which fires and operates the relay in its plate circuit, opening the power line to the goniometer motor. As the negative bias leaks off the second tube, its plate current rises and ultimately the thyratron is again shut off. The time interval during which current is cut off the goniometer motor depends upon the setting of the *Time Interval* control.

With the power circuit to the goniometer motor open, this motor slips behind the rotation of the indicator drive motor until the series contactors are again situated so that the series circuit in which they are connected no longer grounds the grid of the first half

# WHY SPEED NUTS ARE FIRST

*with management*

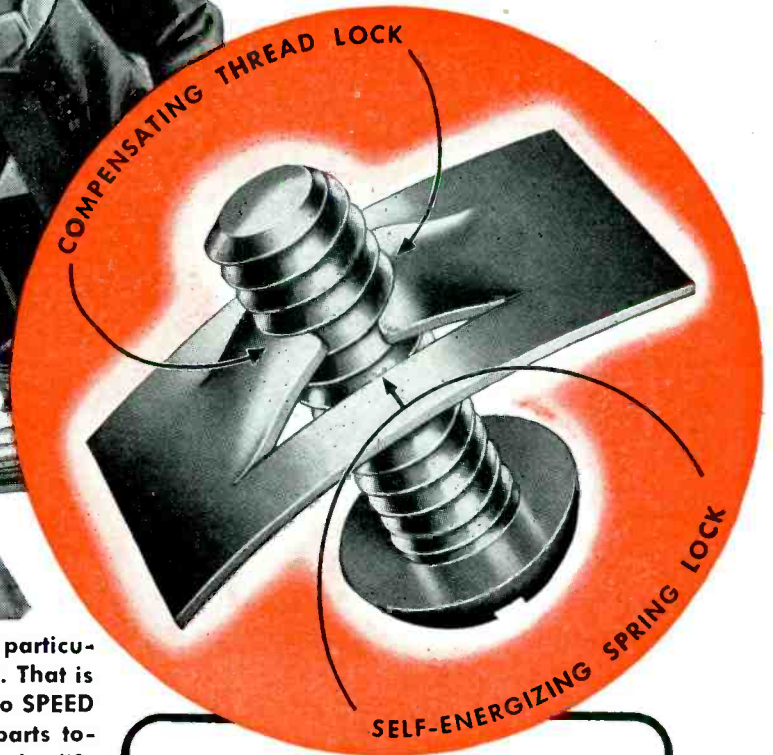

**M**anagement in any plant must be concerned particularly with the quality and durability of its product. That is why so many manufacturers are changing over to **SPEED NUTS**. For **SPEED NUTS** do more than just hold parts together . . . they improve the quality and prolong the life of the finished product.

Despite the most severe vibration, anywhere along the line from factory to consumer, products remain tightly assembled with **SPEED NUTS**. The nuisance of tightening or replacing loose bolts and nuts is eliminated, increasing dealer and consumer satisfaction.

**SPEED NUTS** protect the product against damage, too, for the same spring tension that produces the exclusive **SPEED NUT** lock also provides a resiliency that absorbs expansion and contraction, vibration and shock, even preventing damage to porcelain enamel, glass or plastic parts.

Write for literature today and you'll soon be assembling the **SPEED NUT** way.

## NOTHING LOCKS LIKE A SPEED NUT

Only **SPEED NUTS** provide a **COMPENSATING** thread lock and a **SELF-ENERGIZING** spring lock. As the screw is tightened the two arched prongs move inward to lock against the root of the screw thread. These free-acting prongs **COMPENSATE** for tolerance variations. Compression of the arch in prongs and base creates a **SELF-ENERGIZING** spring lock. These two forces combine to definitely prevent vibration loosening.

**TINNERMAN PRODUCTS, INC. • 2106 Fulton Road, Cleveland 13, Ohio**

*In Canada: Wallace Bornes Co., Ltd., Hamillan, Ontario  
In France: Aerocessoires Simmonds, S. A., Paris*

*In England: Simmonds Aerocessories, Ltd., London  
In Australia: Simmonds Aerocessories, Pty. Ltd., Melbourne*

**Speed Nuts**   
PATENTED \* Trade Mark Reg. U. S. Pat. Off.

**FASTEST THING IN FASTENINGS... OVER 3000 SHAPES AND SIZES**



# STANDARD CRYSTALS

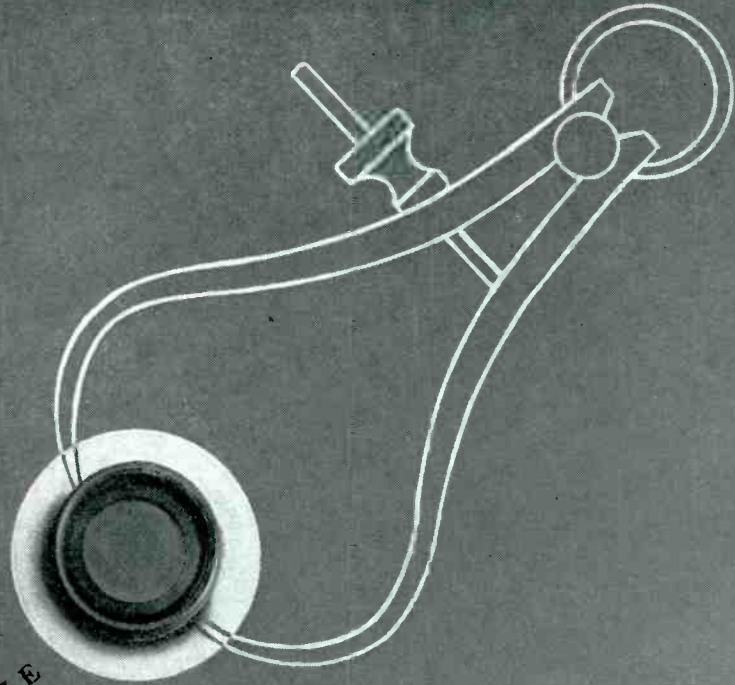

STANDARD MIDGET  
ACTUAL SIZE

The *STANDARD MIDGET* can save you time, cost, space, weight, and circuit losses. It is easy to mount, is dust and moisture proof, corrosion resistant and withstands severe vibration.

There is a *MIDGET* type for your application; let us know your needs.

Regular *STANDARD* quartz crystals are also available to your specifications for all uses.

Send today for our new catalogue.

## ***STANDARD PIEZO COMPANY***

Established 1936

Quartz Crystals and Frequency Control Equipment

*Office and Development Laboratory*

SCRANTON, PA.

CARLISLE, PA., P. O. Box 164

CARLISLE, PA.





*Engineered*  
**Especially for HEAVY DUTY  
 Industrial Applications**

This high power industrial tube built by Federal is the result of the widening use of induction heating for heavy applications...especially designed for the purpose...built to meet the exacting demands of severe operating conditions.

Federal's 9C23 is a tube that can stand the gaff...with extra ruggedness for stamina...heavy duty filament for long life and high power output...

and with the inherent reliability and exceptional qualities that characterize every tube in the extensive Federal line.

Here is another instance where Federal's long experience and leadership in tube design and construction contribute to electronic progress. And it is a good reason to see Federal first for industrial power...rectifier...transmitting tubes.

Remember—"Federal Always Has Made Better Tubes."

Technical Data for Type 9C23	
Maximum Ratings for Maximum Frequency of 20 Megacycles	
D C Plate Voltage . . .	15,000 volts
D C Plate Current . . .	4.0 amperes
Plate Dissipation . . .	25 kilowatts
Filament Voltage . . .	22 volts
Filament Current . . .	82 amperes
Overall Length . . .	19½ inches
Type of Cooling . . .	water



***Federal Telephone and Radio Corporation***



Newark 1, N.J.



# INSTRUMENTS YOU CAN AFFORD TO USE

... on everyday jobs

**INEXPENSIVE**

**ACCURATE**

**RUGGED**

**EASILY REPAIRED  
IN CASE OF MISUSE**

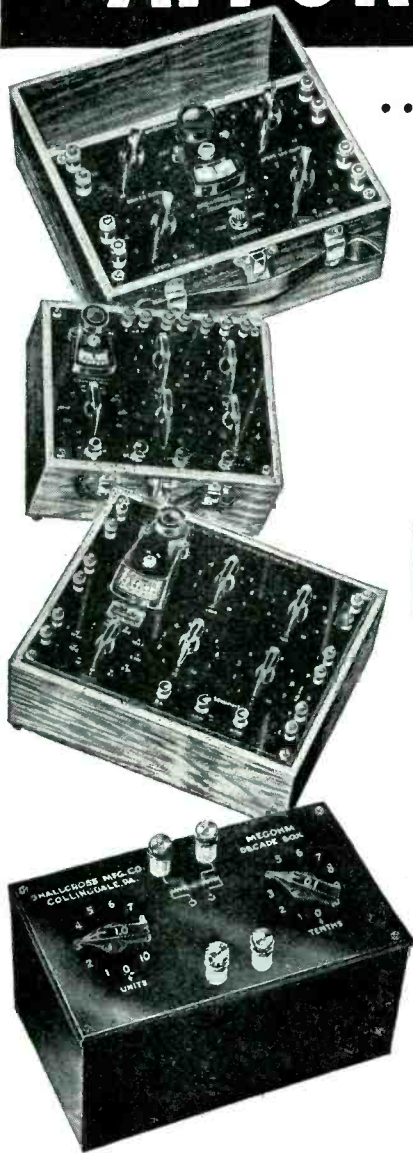

Hundreds of production line testing jobs and field investigations, in addition to laboratory tests require dependable instruments of a type that don't have to be kept under lock and key because of their extreme delicacy and high cost. Shallcross answers this need with many types of

**BRIDGES — DECADE BOXES  
RESISTANCE STANDARDS  
DECADE POTENTIOMETERS  
HIGH-VOLTAGE TEST EQUIPMENT, etc.**

These instruments are accurate for every commercial and laboratory need up to the point of the most exacting research in pure physics. They are rugged, easy to operate and decidedly moderate in price. In case of misuse, they can quickly be repaired to full efficiency by any reasonably competent individual without the expense and delay of returning them to the factory.

## WRITE FOR BULLETINS

- Bulletin 810, Shallcross Resistance Standards
- Bulletin 825, Resistance Decades
- Bulletin D-1, Bridges
- Bulletin LRT, Low Resistance Test Sets
- Bulletin G, Electrical Measuring Apparatus for schools and colleges

SHALLCROSS MFG. CO., DEPT. E16, Collingdale, Pa.

# SHALLCROSS

Electrical Measuring Apparatus • AKRA-OHM Resistors • Precision Switches • Electronic Engineering

of the 6SL7. In other words, the synchronizing cycles continue until the two motors are in step. When the controls are properly set, there will be one, three, or five synchronizing cycles requiring approximately one to three seconds.

• • •

## Control and Recording with Floating Grid

By E. L. Deeter

Naval Ordnance Laboratory  
Washington, D. C.

THE BLOCKING EFFECT of a floating grid charged to a high potential has long been known but until recently little use has been made of the phenomenon in electronic devices. Some applications of the blocking effect in connection with a low-impedance input relay and a recording system will be described.

If the control grid of a vacuum tube is disconnected, and the proper voltages applied to the filament and plate, the grid will assume a negative charge. This charge is the result of velocity emission from the cathode, grid leakage current, gas ions and true contact potential. The electrostatic potential of the grid under such circumstances is low, usually around one volt negative. When an alternating potential is applied to the grid through a small ca-

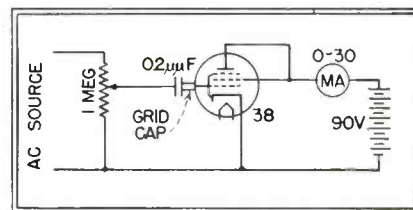

Fig. 1—Basic grid-blocking circuit from which the relay unit and recorder were developed

pacitor, electrons from the grid collect on the inner capacitor plate during the time that the outer plate is positive. During the next half cycle, when the outer plate is negative, the accumulated electrons are trapped in the circuit between the inner plate and the grid. The electron accumulation continues on the following cycles, and the plate current in the tube becomes blocked, the extent depending upon the potential applied to the grid and the leakage resistance from grid to



**WL-857B**  
Mercury Vapor Rectifier for 22 kv operation.



**WL-895R**  
Used in final stage of 50 K.W. Broadcast transmitters.



**WL-473**  
For F.M., Standard Broadcast, and R. F. Heating Applications.



**WL-678**  
15,000 volt grid controlled Rectifier for power supplies.



**WL-891R**  
Forced Air Cooled Tube for Radio Transmitting and R. F. Heating Applications.

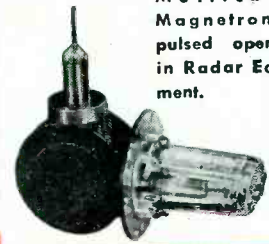

**2J31**  
Multicavity Magnetron for pulsed operation in Radar Equipment.

**WL-417A**

Reflex Klystron for use as local oscillator in U. H. F. equipment.

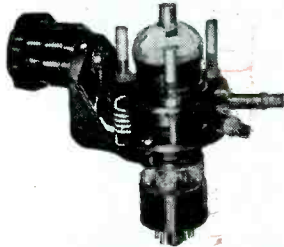

**WL-532A**  
Sparkgap for voltage protection and for T-R uses.

## WESTINGHOUSE

### Electronic tube "know-how" will help you solve your electronic tube problems

No matter whether your electronic tube needs are for low frequency, high frequency, low power or high power applications, Westinghouse can serve you.

The ingenuity of Westinghouse tube engineers is illustrated by the types shown, which were developed for a wide variety of civilian and military applications. These tubes range from the midget 1B24 used in microwave equipment, to the giant WL-895R used in broadcasting

and RF heating.

When you are designing or modifying your equipment it will pay you to consult these Westinghouse engineers. They will be glad to discuss your problems with you.

The newest Westinghouse electronic tubes will be exhibited at the next IRE Convention. Be sure to see them.

Electronic Tube Sales Department, Westinghouse Electric Corp., Bloomfield, N. J.

# Westinghouse

## *Electronic Tubes at Work*

TUNE IN: John Charles Thomas, Sunday, 2:30 P. M., EST—NBC.  
Ted Malone—Monday through Friday, 11:45 A. M., EST—ABC.



**1B24**  
T-R tube for use between transmitter and receiver in Radar Equipment.



**WL-530**  
Oscillator tube for generating high power at ultra high frequencies.



# FERRANTI

is NOW in the

## POSTWAR SPOTLIGHT!

Just as Ferranti led the prewar field, Ferranti is again the focal point of attention!

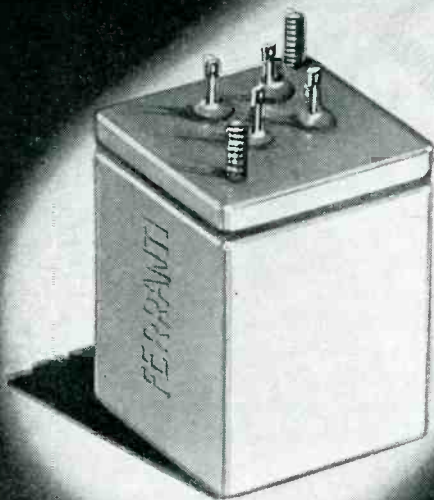

ACTUAL  
SIZE

Before the war the Ferranti name was synonymous with QUALITY . . .

Now thru' experience gained in mass war-time production Ferranti gives you

# Quality!

## AT LOW COST •

Ferranti has a large stock of standard items for immediate shipment without priority.

Special items to your specification on short notice!

Send us your specifications or write your requirement NOW!

**TRANSFORMERS • CHOKES • FILTERS • WIRING and ASSEMBLIES**

**FERRANTI ELECTRIC, Incorporated**  
RCA BUILDING • New York 20 • NEW YORK

## The Public expects...

and visualizes Postwar Radio Receivers vastly superior to anything known during Prewar years. Forward looking manufacturers of radio receivers will serve the public with what it wants... the latest in radio receivers... with every known improvement in design and component.

**Most significant** of newly developed components is the Franklin AIRLOOP. Its values, by comparison with prewar and conventional loops, are amazing.

- Optimum Sensitivity
- High Uniform "Q" Over Entire Band
- Inductance to Close Tolerance Without Adjustable Turn
- Low Distributed Capacity
- 27% Greater Effective Loop Area
- Electrical and Mechanical Stability
- Backboard and Loop In One
- Lower Cost
- Elimination of Individual Loop Adjustment on Assembly Line
- Maximum Space Utilization (cabinet depth)
- No Haywire

# Franklin AIRLOOPS

...SYMBOLIC OF  
POSTWAR RADIO  
RECEIVERS!

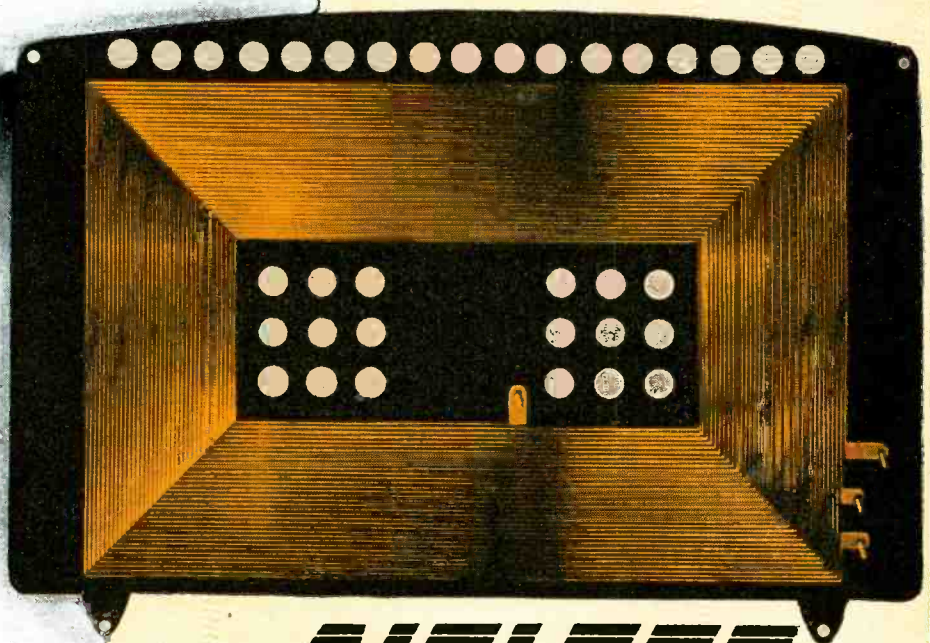

## THE AIRLOOP

**AIR DIELECTRIC THROUGHOUT ITS ENTIRE LENGTH**

A radio engineers' dream come true... Flat sheets of copper die-stamped into perfect super-sensitive loops... The greatest development in loop antenna design and manufacture since 1920... Being rectangular the Airloop has 27% more effective area... Better performance at lower cost... No set builder can afford to overlook the significance of the Airloop.

**INVESTIGATE....and you will...SPECIFY AIRLOOPS**

Franklin **AIRLOOP** corp.  
175 VARICK ST., NEW YORK 14, N. Y.



# Seletron

## SELENIUM RECTIFIERS

25 milliamperes to 1000's of amperes output

MADE ON ALUMINUM

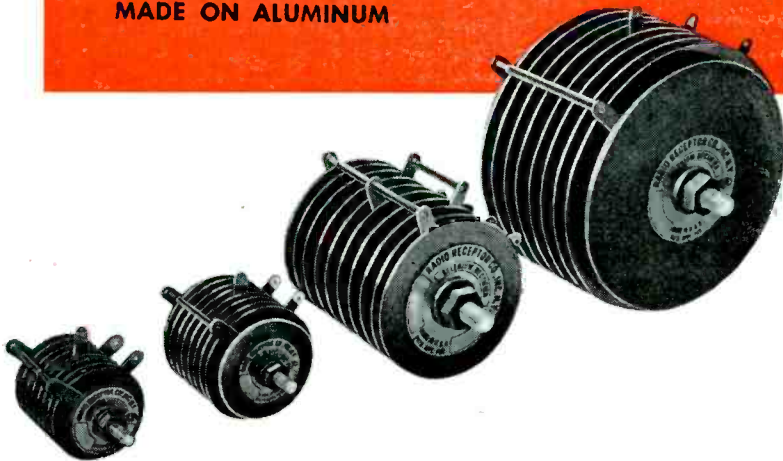

### LIGHT • RUGGED • COMPACT

Preference for the selenium rectifier over all other types of converters has been proven in its extensive use for battery charging, electroplating, and power supplies. Its light weight characteristic, compactness, long life, and efficiency assure a service unit to the electrical field—WHERE QUALITY IS THE TEST. The absence of fragile or moving parts reduces maintenance costs to a minimum.

- Seletron rectifiers are produced by Radio Receptor Company, Inc. in seven standard sizes from 1" to 4 $\frac{3}{8}$ " diameter and a 5" x 6" rectangular plate, and can be hermetically sealed, if desired.

- Excellent delivery schedules. Write for brochure, "Seletron," giving complete technical information.

(Be sure to see our booth at the Institute of Radio Engineer's show at the Astor Hotel—January 23 thru 26.)

**RADIO RECEPTOR COMPANY, INC.**

Since 1922 in Radio and Electronics

251 WEST 19th STREET



NEW YORK 11, N. Y.

cathode or ground over the grid supports and surface of the tube. Grid-leak detection employs this principle, but with low applied potentials and an essential leakage path of proper value to control the time constant of the blocking effect.

#### Basic Circuit

When the maximum blocking effect is desired, tubes with low leakage between grid and cathode, or other elements, must be used. Tests revealed the type 38 tube to be superior for this application. With the control grid brought out to a cap on the apex, surface leakage is reduced to a minimum. Since the tube is a power-amplifier type, an adequate supply of plate current is available for control operations.

A fundamental circuit is shown in Fig. 1. The special capacitor in the grid circuit consists of two metal plates,  $\frac{1}{2}$ -inch square and separated about  $\frac{1}{4}$  inch. This results in a capacitance of about 0.2  $\mu$ f. One plate is attached to and supported by the tube grid cap and the other plate is supported by other means that assures a high-resistance path between grid and cathode or ground.

A variable source of 60-cycle potential is applied between the outer capacitor plate and cathode. The tube and capacitor plates are enclosed in a metal cabinet about eight inches square, to shield them from alternating potentials other than those purposely applied, as well as capacitance changes introduced by moving objects near the unit.

#### Operating Point

Figure 2 presents the plate current vs applied potential. Capacitance existing between the tube grid capacitor and metal cabinet, as well as the d-c plate potential, will affect the shape of the curve, which will also straighten to some extent when a load resistor is inserted.

With the set-up described, the plate current changes rapidly with applied potentials between 10 volts and 80 volts, rms. Transfer characteristics taken on the tube in the metal cabinet indicate an equivalent change in plate current when a d-c negative bias from 1 to 5 volts is used. Alternating potentials over

# AMPLICALL

**FINEST PAGING, TWO-WAY COMMUNICATION  
AND PUBLIC ADDRESS SYSTEMS FOR INDUSTRY**

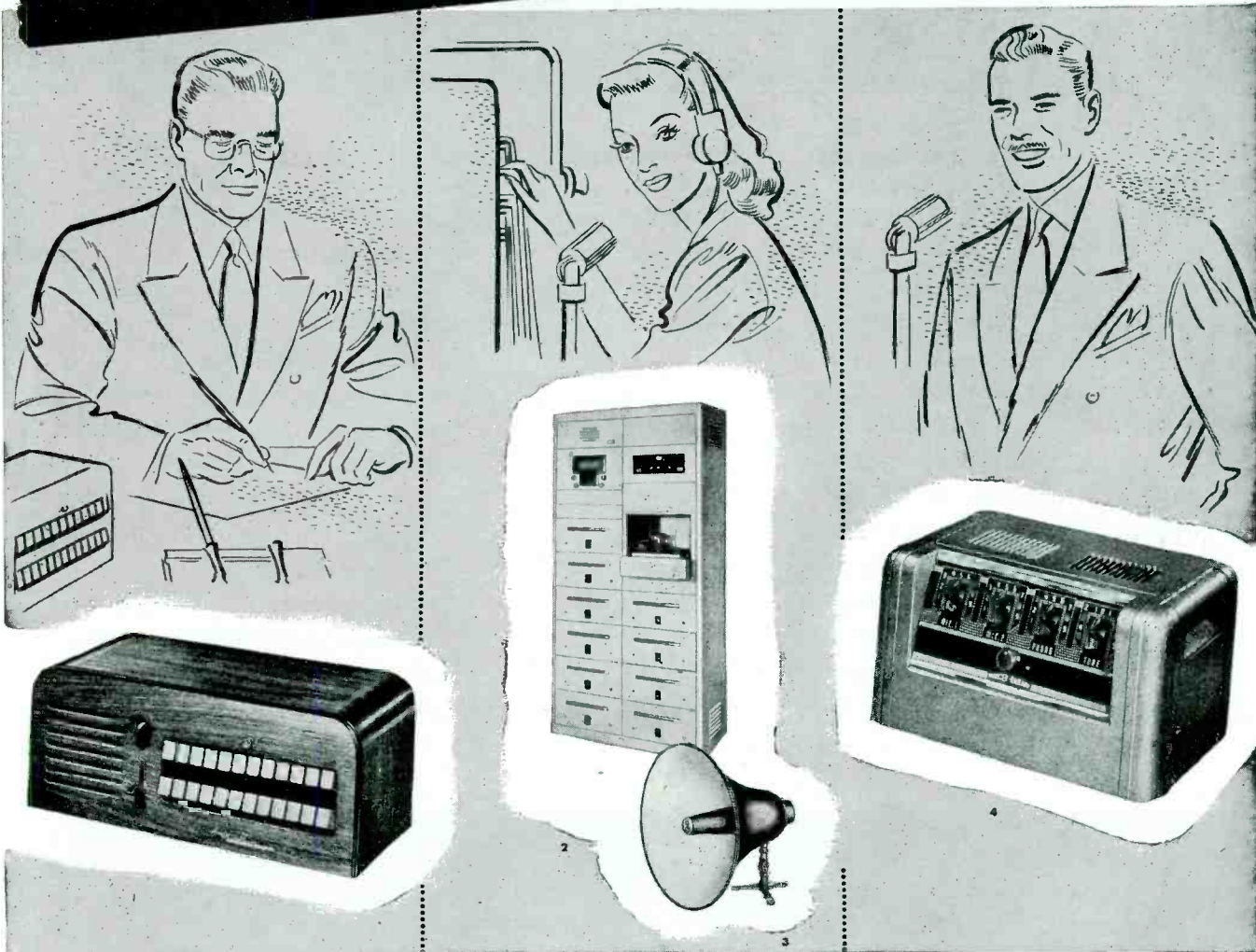

Thousands of Rauland AMPLICALL Systems are serving industry today with a performance dependability second to none! Engineering, quality materials and craftsmanship have been combined to insure AMPLICALL's dependability . . . multiple uses, flexibility of design, superb tonal quality, low maintenance cost and trouble-free operation are additional reasons for its preferred rating. Whether you need an adequate Paging, Intercommunication or Public Address System, or all three, be sure to check AMPLICALL . . . you'll find a system of the exact design and capacity to answer all of your requirements perfectly.

1. **AMPLICALL** Intercommunication unit, available for two-way communication between multiple stations.
2. **AMPLICALL** Paging Control Unit.
3. **AMPLICALL** Weatherproof Speaker.
4. **AMPLICALL** Audio Amplifier unit for laboratory, test equipment and general applications.

RADIO • RADAR • SOUND

## Rauland

COMMUNICATIONS • TELEVISION

*Electroneering is our business*

THE RAULAND CORPORATION • CHICAGO 41, ILLINOIS



# PERMANENT MAGNETS MAY DO IT BETTER



## Perfection in a Permanent Magnet Foundry

All melting of permanent magnet materials at *The Indiana Steel Products Company* is done in a battery of coreless induction furnaces to avoid any contamination of the pure metals.

For each furnace charge the materials are weighed individually on an automatic scale, which prints the weight of each constituent on an individual heat record, copies of which accompany the castings from each heat to the laboratory, production departments and permanent file. Chemical analyses and tests for mag-

netic characteristics are conducted to insure uniform high quality.

The perfection of permanent magnets has been our specialty for over 35 years.

Manufacturers having problems in the use and application of permanent magnets are invited to consult our engineers. For information on permanent magnet application, design and materials, write for new technical "Permanent Magnet Manual" prepared by *The Indiana Steel Products Company*, 6 N. Michigan Ave., Chicago 2, Ill.

Permanent  
Magnets May  
Do It Better



An Alnico  
Tachometer Magnet

Copyright 1946 The Indiana Steel Products Co.

**THE INDIANA STEEL PRODUCTS COMPANY**  
6 NORTH MICHIGAN AVENUE, CHICAGO, 2 ILLINOIS

**SPECIALISTS IN PERMANENT MAGNETS SINCE 1910**

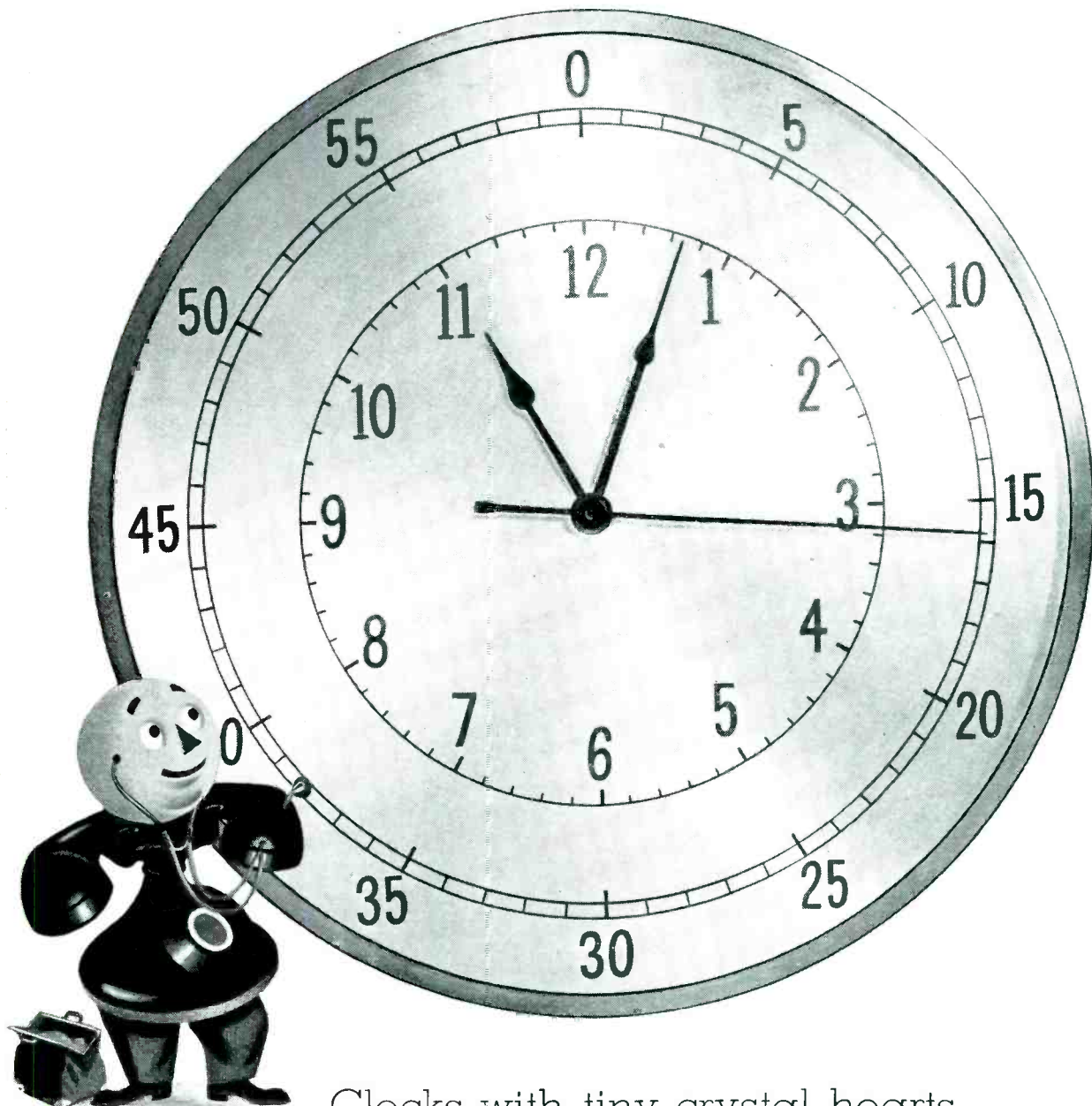

## Clocks with tiny crystal hearts that beat 100,000 times a second

CRYSTAL HEARTS beat time in Bell Telephone Laboratories, and serve as standards in its electronics research. Four crystal clocks, without pendulums or escapements, throb their successive cycles without varying by as much as a second a year.

Precise time measurements may seem a far cry from Bell System telephone research, but time is a measure of frequency, and frequency is the foundation of modern communication, whether by land lines, cable, or radio.

These clocks are electronic devices developed by Bell Laboratories, and refined over years of research. Their energy is supplied through vacuum tubes, but the accurate timing, the controlling heart of the clock, is provided by a quartz crystal plate about the size of a postage stamp.

These crystal plates vibrate 100,000 times a second, but their contraction and expansion is submicroscopically small—less than a hundred-thousandth of an inch. They are in sealed boxes

to avoid any variation in atmospheric pressure, and their temperatures are controlled to a limit as small as a hundredth of a degree.

Bell Laboratories was one of the first to explore the possibilities of quartz in electrical communication, and its researches over many years enabled it to meet the need for precise crystals when war came. The same character of research is helping to bring ever better and more economical telephone service to the American people.



**BELL TELEPHONE LABORATORIES** *Exploring and inventing, devising and perfecting for continued improvements and economies in telephone service.*



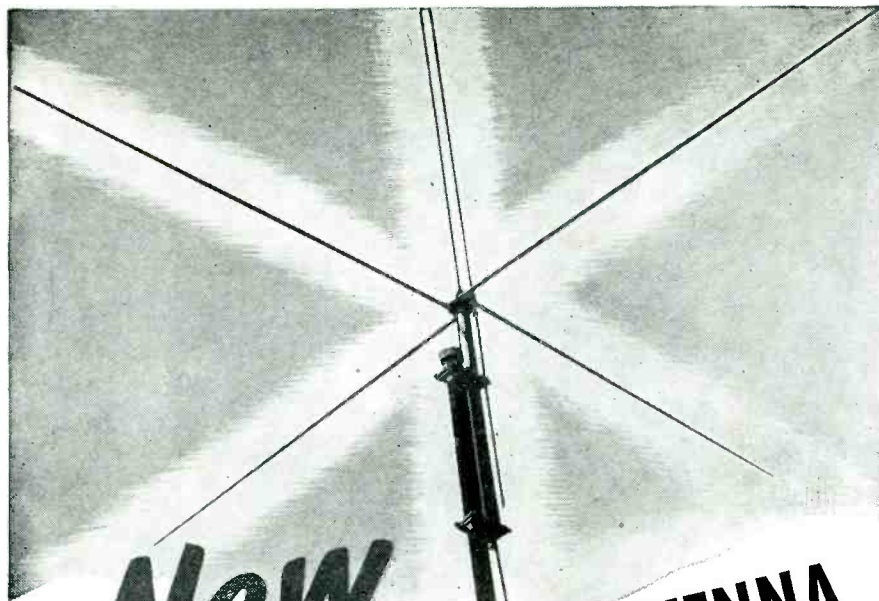

# New FOLDED UNIPOLE ANTENNA

Another Example of ANDREW Ingenuity in Engineering

Concentrating on electrical performance, Andrew engineers have designed a unique Folded Unipole Antenna which—according to comparative tests—easily outperforms other antennas at several times the price.

Used for transmitting and receiving at frequencies from 30 to 40 MC and for powers up to 5,000 watts, this antenna has proved so successful that similar models for higher frequencies are now being designed.

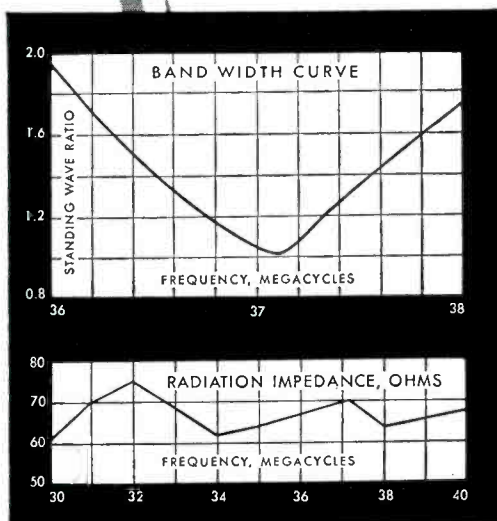

## FEATURES:

- Light weight — only 15 pounds — simplifies installation.
- Lightning hazard minimized by grounded vertical element.
- "Slide trombone" calibration permits exact adjustment for any frequency between 30 and 40 MC, using only a wrench. Optimum performance for that frequency is guaranteed without "cut and try" methods.
- Proper termination of coaxial transmission line. Unlike other "70-ohm" antennas, the Folded Unipole actually provides a non-reactive impedance with a resistive component varying between 62 and 75 ohms (see lower curve).
- Excellent band width, ideal for FM (see upper curve).

Andrew Co. specializes in the solution of antenna problems. For designing, engineering and building of antenna equipment, consult Andrew Co.

# ANDREW CO.

363 EAST 75th ST., CHICAGO 19, ILL.

WRITE FOR FULL INFORMATION

80 volts cause less change as the value increases and the lower part of the curve becomes a nearly straight line.

If an a-c potential of about 60 volts (point A in Fig. 2) is applied as a bias potential, the swing of the plate current will be fairly linear over the slope of the curve, with an increase or decrease of capacitance in the grid capacitor, while the

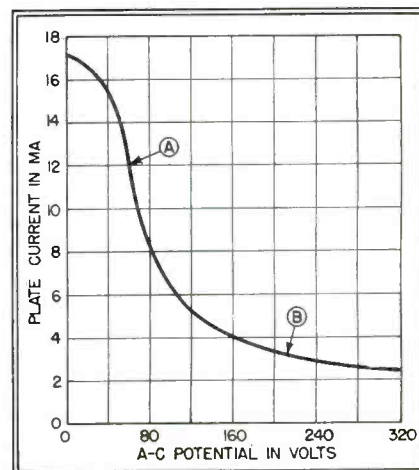

Fig. 2—Remote cutoff characteristics obtained with circuit of Fig. 1

plate current remains on the relatively straight portion of the upper slope. Furthermore, the capacitance change of the grid capacitor is proportional to the distance between the metal plates. Thus a variable controlling current is obtained from the plate circuit of the tube, a total of about five ma change, when very small capacitance changes affect the grid.

## Mechanical Features

The small value of the grid capacitor makes it possible to use small lightweight plates on the device, and the movable plate may be supported by a d'Arsonval meter indicating arm, or the arm itself may be used as the variable plate. In this instance, the arm should pass close to the grid-cap plate, which may be a short piece of wire, parallel to the moving arm at maximum capacitance.

The plate current change may be increased by mechanically arranging the meter arm to pass quite close to the grid plate. Conditions may be improved also by increasing the length of the meter arm. This

LEPEL HIGH FREQUENCY LABORATORIES, INC.  
39 West 60th Street New York 23, N. Y.  
**LABORATORY TEST REPORT**  
No. 2370

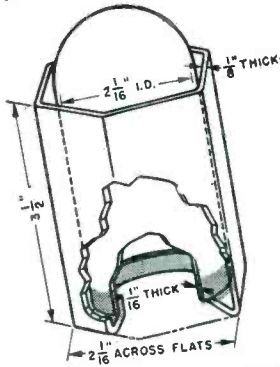

Operation: Bronze dome to nose cup  
Alloy: Silver Solder Grade 4  
Flux: Fluoride  
Temp. Limit: Flow Solder  
Lepel Unit: 30 K.W. Input  
Approx. Temperature: 1250° F  
Heating Time: One piece, 13 sec.  
4 pieces simultaneously, 55 sec.

LEPEL HIGH FREQUENCY LABORATORIES, INC.  
39 West 60th Street New York 23, N. Y.  
**LABORATORY TEST REPORT**  
No. 1076

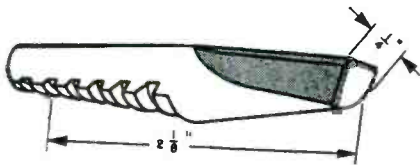

Operation: Harden Chuck Jaws  
Steel Analysis: Tool Steel  
Temperature: 1550°-1600° F  
Quenching Medium: Water  
Hardness Obtained: Rockwell C60  
Depth of Hardness: Approx. 3/32"  
K.W. Input: 7½  
Heating Time: 10 sec.

LEPEL HIGH FREQUENCY LABORATORIES, INC.  
39 West 60th Street New York 23, N. Y.  
**LABORATORY TEST REPORT**  
No. 1780

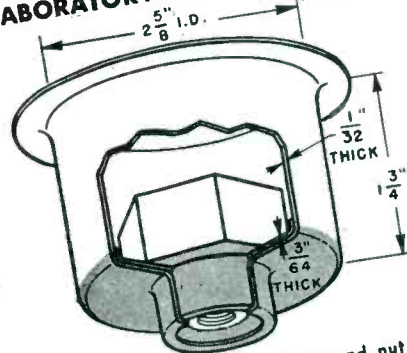

Operation: Braze steel disc and nut  
inside cup  
Alloy: Silver Solder Grade 4  
Flux: Fluoride  
Temp. Limit: Flow Solder  
Lepel Unit: 30 K.W. Input  
Approx. Temperature: 1250° F  
Heating Time: One piece, 16 sec.  
6 pieces simultaneously, 92 sec.

# Tough Heating Jobs Simplified with Lepel Induction Heating

The illustrations show some of the hundreds of difficult industrial heating problems solved in Lepel laboratories.

Lepel High Frequency Induction Heating Units make simple work of the most complicated heating operations, often performing work impossible by other methods.

- Actual heating time is reduced to a matter of seconds.
- Heat is applied exactly where it is needed — at the exact temperature and for the exact time required.
- Any worker, after brief training, can produce consistently good results with Lepel Induction Heating.
- Any Lepel Unit can be used without alteration for hardening, annealing, stress relieving, soldering, brazing or melting small charges of common or precious metals.

Put your heating problems up to Lepel laboratories. Send samples and specifications of work to be performed — or ask a Lepel engineer to call.

VISIT THE LEPEL EXHIBIT

Booths K615, K617, National Metal Congress and Exposition, Public Hall, Cleveland, Feb. 4-8, 1946.



**Lepel**  
High Frequency  
INDUCTION HEATING UNITS

**LEPEL HIGH FREQUENCY LABORATORIES, INC.**

PIONEERS IN INDUCTION HEATING

General Offices: 39 West 60th Street, New York 23, N. Y.

DO IT FASTER, BETTER, MORE ECONOMICALLY BY LEPEL INDUCTION HEATING



# *The Curtain is Rising*

on the most sensational development, hitherto undreamed of, in amateur radio history! There isn't a "ham" operator in the United States, or in the entire world for that matter, who won't be interested in knowing what is behind this curtain. Watch for the Kluge advertisements to follow.

The Kluge secret will soon be  
a reality



1031 N. ALVARADO • LOS ANGELES 26, CALIF.

# NEED SOLUTIONS TO PROBLEMS LIKE THESE?

Electrostatic Shielding

Corona Prevention

Undesired Thermionic Emissions

Variable Condenser Lubrication

Electrodes for Light Sensitive Cells

Scan this list of typical trouble spots in the electronics industries. Then take 60 seconds to read why many alert plants with similar knotty production problems are turning to "dag" colloidal graphite.

The answer is versatility — the surprising versatility of "dag" dispersions. Applications include very high and very low temperature lubrication, conductive films, parting compounds, surface coatings.

18 Products to choose from — so even if you know "dag" colloidal graphite for one application, look over the free literature offer below. It may suggest new, even more valuable uses in your plant.

**dag** colloidal graphite

**ACHESON COLLOIDS CORPORATION**  
Port Huron, Michigan

This new literature on "dag" colloidal graphite is yours for the asking:

- 430** A general booklet on the story of "dag" colloidal graphite. 12 pages profusely illustrated.
- 440** A complete list of "dag" colloidal graphite dispersions with applications.
- 421** "dag" colloidal graphite for ASSEMBLING AND RUNNING-IN ENGINES AND MACHINERY.
- 422** "dag" colloidal graphite as a PARTING COMPOUND.
- 423** "dag" colloidal graphite as a HIGH TEMPERATURE LUBRICANT.
- 431** "dag" colloidal graphite for IMPREGNATION AND SURFACE COATINGS.
- 432** "dag" colloidal graphite in the FIELD OF ELECTRONICS.

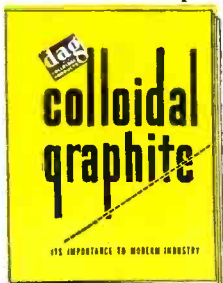

ACHESON COLLOIDS CORPORATION JMLCo A-A1  
PORT HURON, MICHIGAN DEPT. A-5

Please send me, without obligation, a copy of each of the bulletins checked:

NAME \_\_\_\_\_

POSITION \_\_\_\_\_

FIRM \_\_\_\_\_

ADDRESS \_\_\_\_\_

ZONE No. \_\_\_\_\_ STATE \_\_\_\_\_

OUR PRESENT OIL SUPPLIER IS \_\_\_\_\_

(Lubricants containing "dag" colloidal graphite are available from major oil companies.)



Because of the bakelite-insulated metal-clad resistance element, these **CLAROSTAT SERIES MMR RESISTORS** in actual operation are . . .

# Definitely COOLER

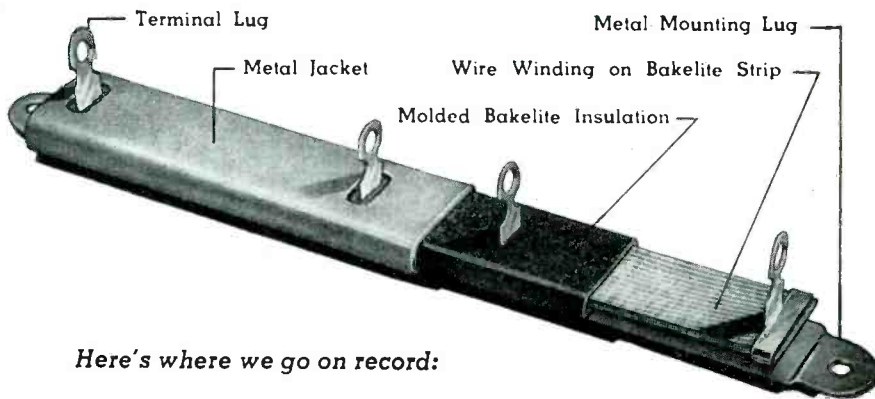
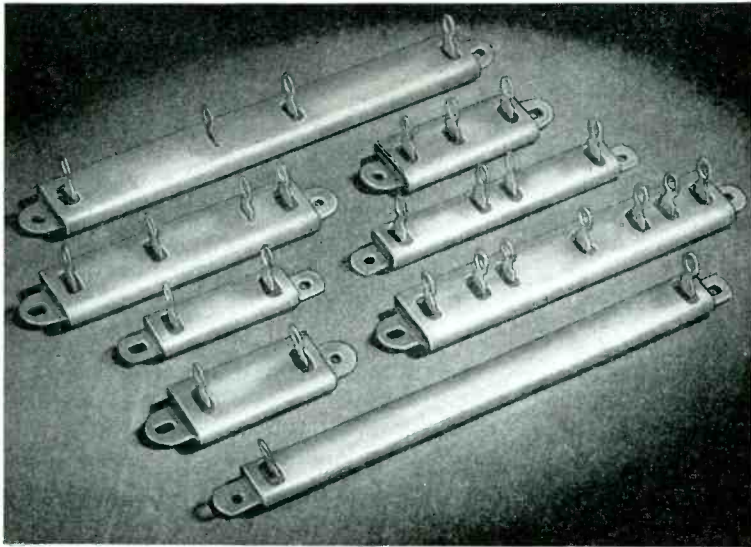

Here's where we go on record:

★Clarostat Series MMR bakelite-insulated metal-clad resistors are definitely **COOLER** than any other similar types, **SIZE FOR SIZE**; or putting it another way, these resistors will **DISSIPATE MORE POWER** for the same temperature rise, **SIZE FOR SIZE**.

That's our statement. We invite your own tests. Sample on request if you write on your business letterhead. Also detailed literature.



## Controls and Resistors

CLAROSTAT MFG. CO., Inc. · 285-7 N. 6th St., Brooklyn, N. Y.

will increase the arc over which the arm travels, and allow the meter movement to be placed at a greater distance from the tube, reducing capacitance and improving efficiency. The length and weight of the meter arm will be limited by the movement construction, jewel bearings, etc. Any additional weight should be balanced.

The meter arm must be connected to the high potential. Since the arm is electrically connected to one side of the coil in some instances, only certain circuit inputs could be tolerated, and it will be necessary to employ a movement in which the arm is isolated.

The high impedances involved demand special consideration if stability is to be expected. Even slight changes in humidity cause the input impedance to vary due to dielectric changes in the capacitor and leakage over the surface of the tube. Unless shielded, with controlled humidity, the device becomes a virtual hygrometer. Used in the manner described, the capacitor arm has continuous control over the plate current, unless the travel arc of the

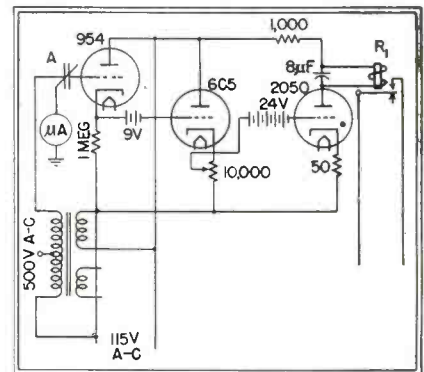

Fig. 3—Improved stability resulted when the three-plate capacitor shown at A was used in this control circuit

arm is great. This is not always an advantage in control work, especially when relays are employed and a trigger action is desirable.

### More Stable Version

Improved stability and an instantaneous operating point were obtained in a second model by employing a three-plate capacitor in the circuit shown in Fig. 3. One plate connects to the grid and the other stationary plate is connected to the high potential a-c to bias the

# MEASURES ACTUAL MICROWAVE POWER OUTPUT

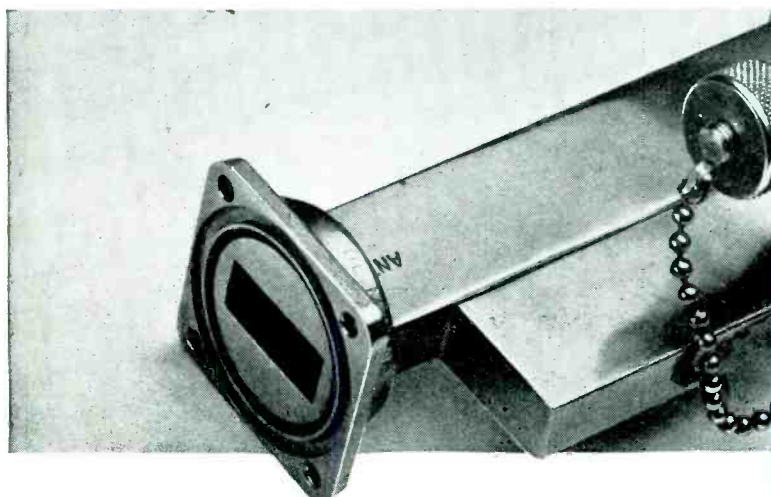

DeMornay-Budd  
#316  
Directional Coupler

*This* device insures *actual* power output measurements in microwave transmitters. The coupler can be permanently installed in any part of the transmission line. Calibrated attenuation between main and auxiliary transmission lines permits making power measurements at much lower level for greater accuracy.

The DeMornay-Budd #316 Directional Coupler has a nominal coupling of 20 decibels, which is the amount of attenuation between the energy in the main transmission line and that available at the "N" connector of the auxiliary transmission line.



Consultation on your transmission line problems is invited, without obligation. The benefit of our extensive experience with wartime radar problems is at your disposal.

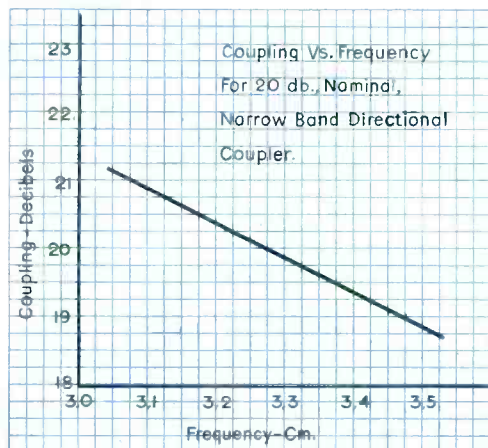

The curve shows theoretical variation in coupling versus frequency for the DeMornay-Budd #316 narrow band uni-directional coupler shown above.

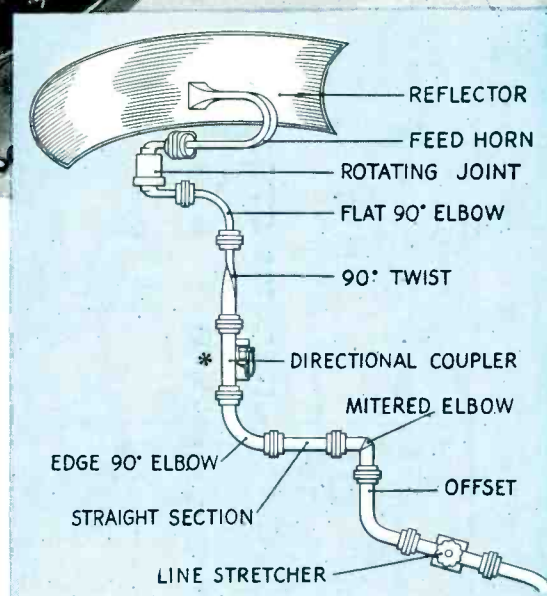

This plumbing arrangement indicates variety of standard items currently available. Standard couplers are available for frequencies of 2500 megacycles to 30,000 megacycles. Various couplers are also available in other frequencies and band widths:

- Broad Band Couplers (10% Band Width)
- Narrow Band Couplers (3% Band Width)
- Uni-Directional Couplers
- Bi-Directional Couplers

Special order couplers can be made to operate at any frequency from 500 megacycles upward.

## DE MORNAY BUDD *inc.*



**EQUIPMENT  
FOR  
97% OF ALL  
RADAR SETS**

475 GRAND CONCOURSE, NEW YORK, N. Y.



Two big NEWARK stores well stocked to serve your needs and staffed by people who know and can help solve your problems.

# THIS MONTH'S FEATURES



## HALLICRAFTERS

- SX-28A Super Skyrider with crystal, less speaker \$223.00
- S-20R Sky Champion with built-in speaker... 60.00
- S-22R Skyrider Marine with built-in speaker... 74.50
- SX-25 Super Defiant with crystal, less speaker 94.50
- S-39 Sky Ranger portable, AC/DC and battery 110.00
- SX-36 FM/AM receiver 415.00
- S-37 V.H.F. FM/AM receiver 591.75
- 10" PM speaker in cabinet for use with SX-25, SX-28A 15.00

## HAMMARLUND

- HQ-129X (with tubes)..... \$129.00
  - ASPC-210X ..... 318.00
  - ASP-210SX ..... 318.00
- Available for rack mounting at same prices

## NATIONAL

- NC-2-40C and speaker..... \$240.00

## RME

- RME-45 and speaker..... \$166.00



## WESTERN ELECTRIC MICRO AMMETERS



Bakelite case fits 3 3/4" hole. Radium dial 150-0-150. Can be used with 0-200 micro and amp scale listed below. Excellent as a 5,000 ohm-per-volt meter or null, sound level and galvanometer indicator. Instructions included. No priority required. \$7.50  
0-200 paper scale for above..... .15

## THORDARSON TRANSFORMER

(POWER TRANSFORMERS AND CHOKES)

- T-45556 or T-92R21 leads out of side, 778 V. C.T. at 200 MA. 115 V. 60 Cycle 6.3 V. C.T. at 5A. 5 V. at 30 amp. 9 lbs. \$5.29
- T-13C30 8H. 150 MA. 200 ohm 1600 V. Insulation 2 1/4 lbs. 1.41
- T-4557 or T-74C29 leads out of side, 1 5H. 150 MA. 200 ohm 2000 V. Insulation 5 1/4 lbs. 2.82

## THE FAMOUS NEWARK BARGAIN OIL - FILLED, OIL - IMPREGNATED

# FILTER CONDENSERS

FULLY GUARANTEED AT RATED VOLTAGES

Capacity	Working Voltage	Height	Width	Depth	Wt.	Price
1 mfd.	1500 V. D.C.	2 3/16	1 3/4	1"	4 oz.	\$.79
17 1/2 mfd.	1500 V. D.C.	3 7/8	4 7/8	3 1/8	3 lbs.	2.75
11 1/2 mfd.	1500 V. D.C.	5	3 3/4	1 1/2	1 lb. 10 oz.	2.00
5 mfd.	1500 V. D.C.	4	2 3/8	1 1/4	14 oz.	1.65
5 mfd.	2000 V. D.C.	4	3 3/4	1 1/4	1 lb. 4 oz.	2.15
8 mfd.	2000 V. D.C.	4 1/2	3 3/4	2 1/2	2 1/2 lbs.	2.75
.25 mfd.	2000 V. D.C.	3 3/4	1 3/4	1	6 oz.	.69
Special Porcelain Insulators						
10 mfd.	3000 V. D.C.	4 7/8	3 3/4	3 1/4	3 lbs. 8 oz.	4.75
15 mfd.	3000 V. D.C.	4 3/4	4 3/8	3 7/8	5 lbs.	5.25
6 mfd.	3000 V. D.C.	6 7/8	6 1/2	3	5 lbs. 6 oz.	3.25
with mounting feet, width includes mounting feet						
8 mfd.	3000 V. D.C.	7 3/8	6 1/2	3 3/8	7 lbs. 4 oz.	3.95
2 mfd. & 4 mfd.	600 V. metal can	4 7/8	2 1/2	1 1/4	14 oz.	.80

## McELROY KEY

The Deluxe - Model CP 810 ..... \$9.75

## GENERAL ELECTRIC METERS

0-500 D.C. MA. 2" round Bakelite case.. \$3.50  
0-8 RF ammeter, 2" round Bakelite case.. \$4.00

## ABBOTT TR-4

Compact, efficient 2 1/2 meter transmitter-receiver \$39.00

## GET YOUR NAME ON YOUR MAILING LIST

Be first to get announcements of merchandise available, special bargains, etc., etc. Send name and address on post card. State whether amateur, engineer, school, industrial or service man. Address orders and inquiries to Dept. E, at NEWARK store nearest you.



ALL PRICES SUBJECT TO CHANGE WITHOUT NOTICE

115-117 W. 45th St.  
NEW YORK 19  
Bryant 9-4735  
(Adolph Gross)

CHICAGO  
Newark **ELECTRIC** Company  
NEW YORK

"Dependable Service is the Foundation of our Business"

323 W. Madison St.  
CHICAGO 6  
DEArborn 0083  
(Sam Poncher)

## IRONING OUT A MATERIALS PROBLEM



A typical "postwar" item is this Silex Steam Iron illustrated. Like so many new products which are a part of our long-awaited civilian economy, this revolutionary home appliance makes prudent use of Durez phenolic plastics.

### Why Plastics?

Notice the eye-appealing, heat-resistant handle. Exhaustive tests proved that plastics were better suited for this purpose than any other material known. Their use resulted not only in a better finished product but also in a product which could be produced very economically.

### Why Phenolic Plastics?

Of all plastics, the phenolics are the most versatile. Naturally, this makes

them the logical starting point for the design engineer with a materials problem. The handle of this Silex Steam Iron, for example, called for heat resistance, smart appearance, pleasant and hand-fitting "feel," moisture resistance, and excellent moldability . . . all inherent characteristics of phenolic plastics.

### Why Durez Phenolic Plastics?

The more than 300 multi-proprietary Durez phenolic molding compounds available today are the direct result of a quarter century's continuing research and product development on the part of Durez laboratory technicians. This rich background and the high quality of the materials themselves are convincing reasons why

manufacturers in every field of industry look to Durez for the plastics that fit their jobs.

### Experienced Assistance Available

Do you have a plastic materials problem? If so, see your custom molder. Wartime developments have endowed him with many new molding methods and processes so that his services are even more valuable than before. Should further assistance be necessary, the competent advice of experienced Durez service engineers and a wealth of proved product development data await your request.

Durez Plastics & Chemicals, Inc., 3213 Walck Road, North Tonawanda, N. Y.  
*Export Agents: Omni Products Corporation, 40 East 34th Street, New York 16, N. Y.*



PHENOLIC RESINS

MOLDING COMPOUNDS

INDUSTRIAL RESINS

OIL SOLUBLE RESINS

**PLASTICS THAT FIT THE JOB**



# ELECTRONIC AC VOLTMETER

## with Logarithmic Scale

Percentage Accuracy  
of reading is uniform  
over entire scale!

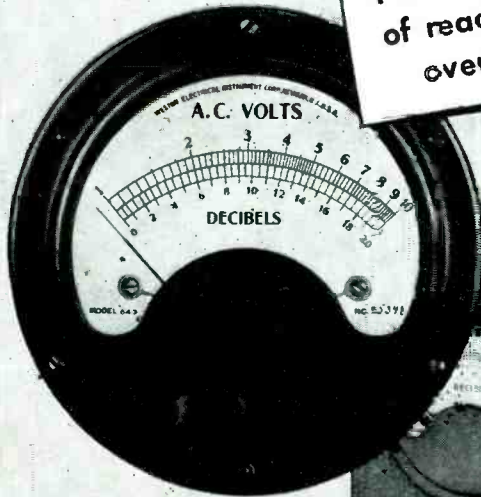

MODEL 300  
ELECTRONIC  
VOLTMETER

**ACCESSORIES**  
MODEL 220 DECADE AMPLIFIER  
MODEL 402 MULTIPLIER



*Since its development in 1935 the Ballantine Electronic AC Voltmeter is the only instrument of its kind with a Simplified Logarithmic Scale.*

The important feature of logarithmic scale indication in the Ballantine Voltmeter provides the same degree of accuracy at 1 as at 10. Also the simplicity of this scale reduces errors in visual observation, common with most multi-range instruments. Finally, the care taken in overall calibration combined with the inherent stability of the circuits used permits reliable readings within the 2% specified tolerance over the complete range of operation.

Write for descriptive  *technica! Bulletin 8*

## BALLANTINE LABORATORIES, INC.

BOONTON, NEW JERSEY, U. S. A.

FLOATING GRID

(continued)

tube. The third plate is the movable arm which is grounded and passes between the outer and inner plates to reduce the capacitance and blocking bias.

The applied a-c potential is increased to a value that reduces the plate current to near cut-off so that the tube operates on the lower part of curve *B* in Fig. 2. Small voltage changes due to imperfect regulation, tube leakage, and capacitance variations become of less consequence.

Trigger action is obtained by virtue of the fact that in this system the capacitance of the grid capacitor is not altered or reduced by the moving arm until it traverses the path directly between the two plates, when considerable capacitance change occurs. This assumes that the plates are closely spaced. Additional stability is secured by employing a cathode resistor of high value.

Compactness was obtained by using the 954 acorn tube and both

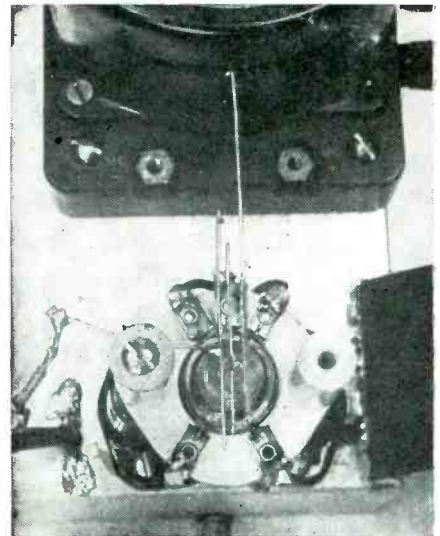
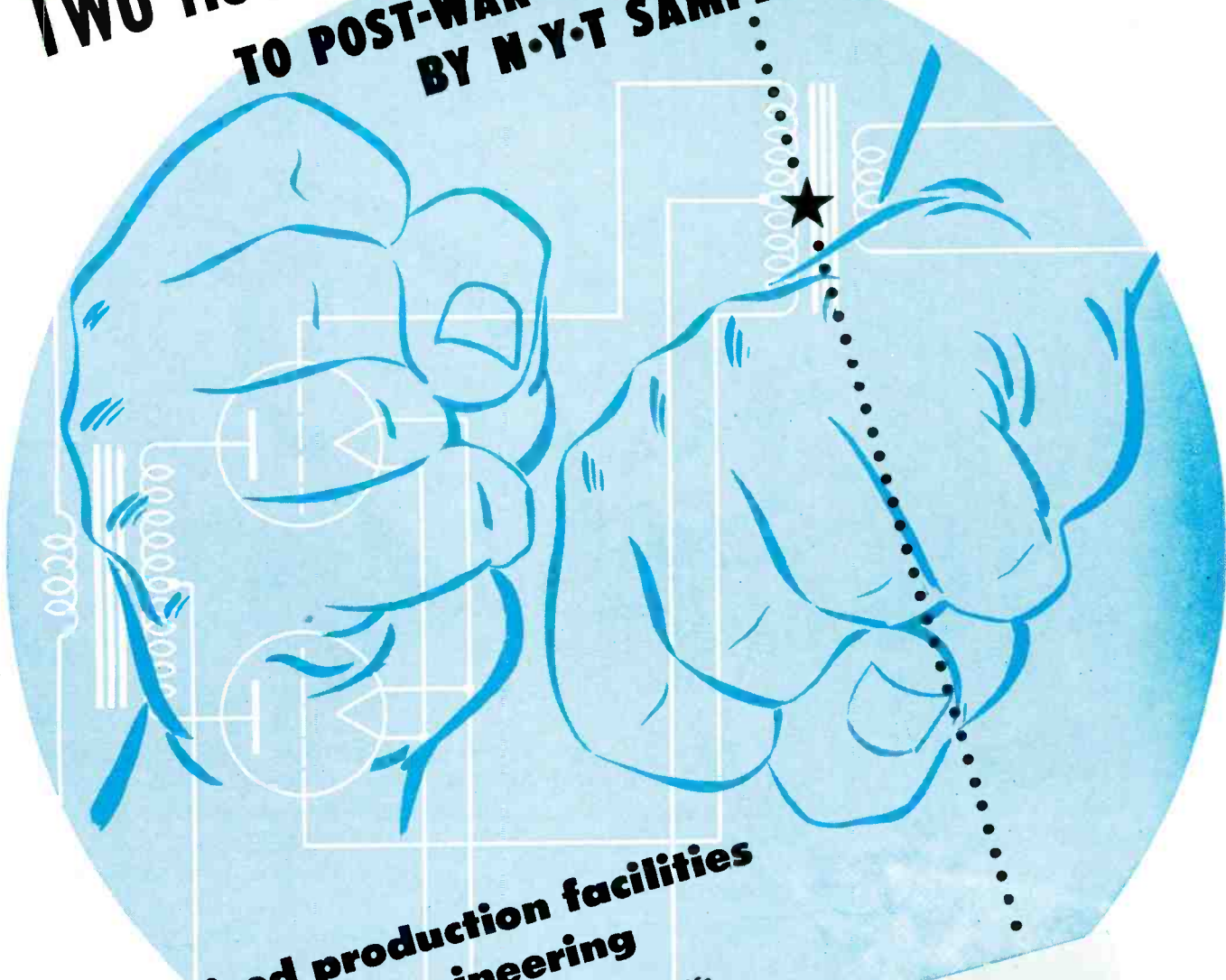

Fig. 4—Details of the three-plate capacitor. Each plate is a short section of wire

the tube and socket are ideal from the leakage viewpoint. The grid capacitor comprises two pieces of tinned copper wire about two inches long. One piece is soldered directly to the grid connection of the tube. A Weston relay, type 534, was modified to operate the variable capacitor. The extended arm is a section of aluminum tubing of the type manufactured for meter indicator arms. The tubing was slipped over

# Two-fisted solutions... TO POST-WAR TRANSFORMER PROBLEMS BY N.Y.T SAMPLE DEPARTMENT!



1. Specialized production facilities
2. Experienced engineering

There are two good reasons why N-Y-T facilities "crack" transformer, choke and filter design and production bottlenecks.

ONE: Extensive, modern, single-purpose manufacturing method, geared for economical production under rigid quality-control.

TWO: Experienced specialized-engineering linked to the accelerated tempo of new developments. Engineering capable of effecting economies in design and manufacture.

This is what we mean by "two-fisted" N-Y-T problem solutions — production that follows thru, ever under labor and material shortages; engineering that lowers costs and betters product.

**NEW YORK TRANSFORMER CO.**  
*Address inquires to Dept. E*  
26 WAVERLY PLACE  
NEW YORK 3, N. Y.





# BEWARE !!!



Send for our pamphlet  
**PERMANENT MAGNET  
DESIGN**

**2 SELLECK STREET  
STAMFORD, CONN.**

"What's one man's meat is another man's poison" . . . so said a bearded old sage. All of which means when it comes to permanent magnets that de-magnetizing influences such as A.C. magnetic fields, opposing D.C. fields, heat, shock, metal contacts, etc., are both bad and good. To me at work they're poison. I don't like them but personal feelings go by the board when science is involved. These same destructive influences that are so bad for a magnet at work are used to determine what the chaps in the laboratory call the "Stabilization Point" of the magnet. This is important, they tell me, for without it no one would know where he was. He wouldn't know what he could count on in the way of a **permanent** magnetic field.

It's all Greek to me but my people—CINAUDAGRAPH—have discussed this subject at length in their booklet "Permanent Magnet Design". Send for a copy. You'll find it replete with meaty information about permanent magnets . . . real practical information gathered and prepared by a firm that has long specialized in the design and manufacture of permanent magnets.

1-CC-1

**CINAUDAGRAPH  
CORPORATION**

# Wilcox Type 99A Transmitter

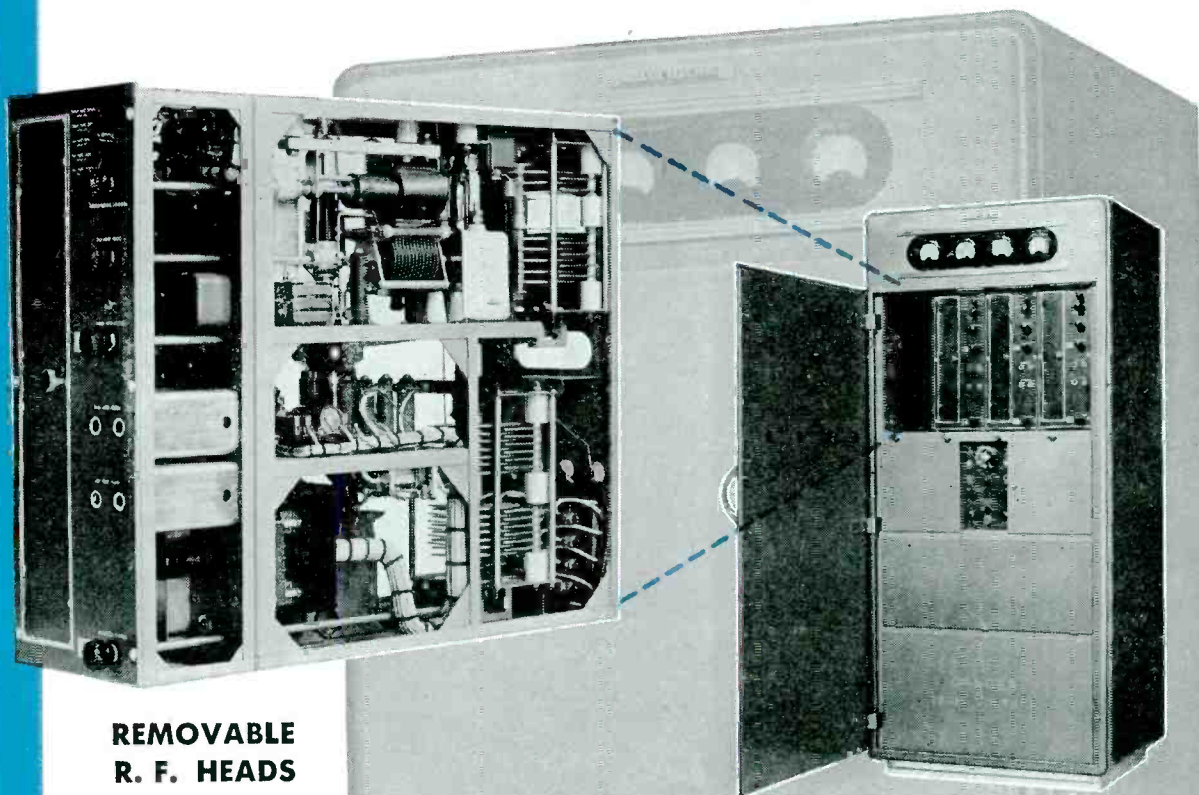

## REMOVABLE R. F. HEADS

All radio frequency circuits are included in the 2-20 Mc. R.F. head shown above. All connections to the transmitter cabinet are by means of plugs and receptacles.

A medium power transmitter, designed particularly for aeronautical service. Equally adaptable to other fixed services. Check these features for their application to your communication problems:

- ★ Four transmitting channels, in the following frequency ranges:  
125-525 Kc. Low Frequency.  
2- 20 Mc. High Frequency.  
100-160 Mc. Very High Frequency.  
Other frequencies by special order.
- ★ Simultaneous channel operation, in following maximum combinations:  
3 Channels telegraph.  
2 Channels telephone.  
1 Channel telephone, 2 Channels telegraph.
- ★ Complete remote control by a single telephone pair per operator.
- ★ 400 Watt plus carrier power.
- ★ Low first cost. Removable radio frequency heads are your protection against frequency obsolescence.
- ★ Reliability backed by two years of engineering research, one year of actual field operation.
- ★ Available with all-steel, or wood pre-fabricated transmitter house complete with primary power, antenna, and ventilation fittings.
- ★ Not a "post-war plan," but a field-tested transmitter now in production.

An inquiry on your letterhead outlining your requirements will bring you complete data.

## WILCOX ELECTRIC COMPANY, INC.

Manufacturers of Radio Equipment

Fourteenth and Chestnut      Kansas City, Missouri





# Seamless [PATENTED] RADIO PINS

DEVELOPED AND MANUFACTURED BY  
**THE AMERICAN BRASS COMPANY**  
WATERBURY BRASS GOODS BRANCH



## Check the advantages...

These *seamless, patented* Radio Pins are uniform in size, with smooth surfaces for smooth operation. In staking, the ends roll over easily and without splitting. When molded into composition parts the closed end keeps out the molding compound.

If you use pins for vacuum tubes or adapters, fluorescent lights, plugs, or electrical equipment of any kind, the chances are you'll save time, money and rejections by using these seamless, patented Radio Pins. They are available in a wide variety of styles and sizes. Simply send a sketch, sample or description, with quantity, for quotation.

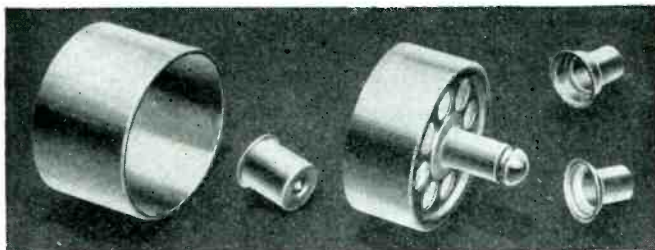

### RADIO OR RADAR EQUIPMENT?

In addition to Radio Pins, we produce large quantities of top caps, base shells and adapter shells for vacuum tubes; also a wide variety of other metal products including deep drawn shells and cups, blanks and stampings, ferrules, grommets, washers, vents, fasteners—and the world's largest assortment of eyelets.

45406

**THE AMERICAN BRASS COMPANY**  
WATERBURY BRASS GOODS BRANCH  
WATERBURY 88, CONNECTICUT

the balance end of the relay contact arm, after removing the balance coil weight, and the relay case slotted to accommodate the movement of the arm. The end of the extended arm was flattened to increase capacitance.

In this model, the plate current change of the blocked tube has been reduced to a very low value, with increased stability. The plate current change operates a 2050 thyatron and a relay capable of handling a one-kw output is used for control purposes. The input required to secure control operation is around five microamperes.

### Temperature Control

The relay could be made to operate from a thermocouple. This system might be operated from the arm of a galvanometer indicating on a scale calibrated in degrees of temperature, and the position of the tube and capacitor made adjustable

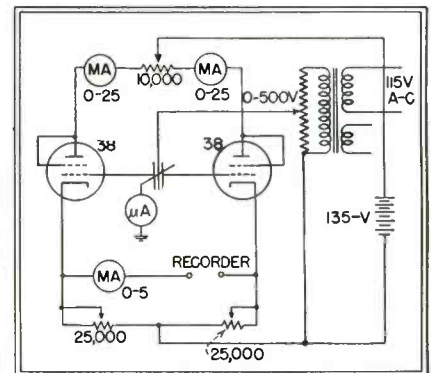

Fig. 5—Balanced bridge circuit used with a recording milliammeter

over the arc to realize operation at any desired point on the scale.

Figure 4, a close-up view of the capacitor plates and grounded arm, shows how the outer plate is offset to allow overswing of the moving arm without losing control. This action is imperative in many control operations. When one side of the input is connected to ground, it will not be necessary to isolate the arm and conventional types of galvanometers may be used with modifications.

An attempt was made to adapt the grid-blocking principle to a low-impedance recording system. The circuit is shown in Fig. 5. This circuit makes use of two type 38

**THIS IS IT!**

## The New 1000 Watt **F**requency-**M**odulation Broadcast Transmitter\*

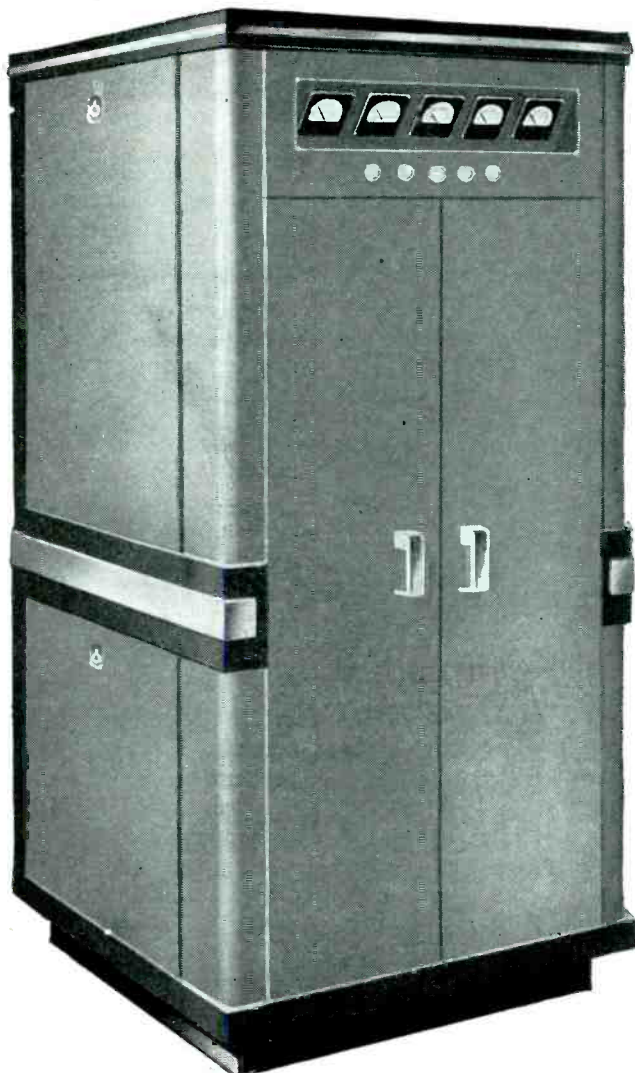

Using the Armstrong Dual Channel Direct Crystal Controlled Modulator

### Other REL FM Broadcast Equipment Available for ordering

	Cat. No.
250 Watt F M Broadcast Transmitter .....	549 A-DL
3,000 Watt F M Broadcast Transmitter .....	519 A-DL
10,000 Watt F M Broadcast Transmitter .....	520 A-DL

### Speech Equipment

- Cat.
- 603—Studio Speech Console, Table type, 6 position.
  - 604—Station Speech Console, table type, combined with Cat. 600 Monitor and transmitter desk control.

### Monitoring Equipment

- Cat.
- 600—FM Station Frequency and Modulation Monitor.

*Place Your Order Now for Early Delivery!*

**SIMPLE  
STABLE  
EFFICIENT PERFORMANCE**

\*We invite your inspection of this equipment in production at our plant. Arrange to visit us during the I.R.E. Winter Technical Meeting at the Hotel Astor—Jan. 23-Jan. 26.



#### SALES REPRESENTATIVES

MICHIGAN	MIDWEST	PACIFIC COAST
M. N. Duffy & Co., Inc. 2040 Grand River Ave., W. Detroit, Mich.	REL Equipment Sales, Inc. 612 N. Michigan Blvd. Chicago, Ill.	Norman B. Neely Enterprises 7422 Melrose Avenue Hollywood 46, Calif.

PIONEER MANUFACTURERS OF FM TRANSMITTERS EMPLOYING  
ARMSTRONG PHASE-SHIFT MODULATION

**RADIO ENGINEERING LABS., INC.**

*Long Island City, N.Y.*





**ONE OF THE REASONS WHY MORE AND MORE GIBBS MICROPOTS ARE SPECIFIED**

The coiled resistance element is threaded on the mould core and made ready for the moulding process.

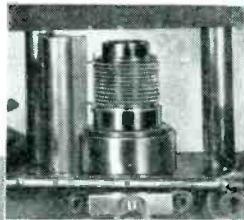

Core, holding resistance element, ready for mould closure and injection of bakelite. Note side core holding terminals.

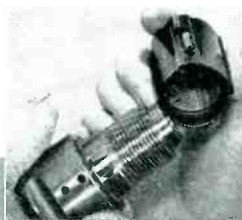

Finished potentiometer unscrewed from core—resistance element and terminals are one integral part of housing.



# GIBBS MICROPOT

*The World's Finest*

## PRECISION TEN TURN POTENTIOMETER

and here are the reasons why!

- 1** Moulding of resistance element as integral part of housing solidly locks every turn of resistance wire in place—No loosening or shifting.
- 2** Precision ground, stainless steel, double thread, lead screw guides the rotating contact, *guarantees* smooth action, low uniform torque and accurate settings—*permanently*.
- 3** Rotor assembly, supported on two bearings, assures long life and low torque.
- 4** The Gibbs 10 turn Micropot has terminals *moulded-in* as integral part of housing.
- 5** Ends of resistance element *soldered* to terminals *before moulding*.
- 6** Anti backlash spring in contact guide—assures you positive setting and resetting.

**7** The 43½" length of resistance element gives you a finer resolution.

**8** The resistance wire used in the element, is processed through diamond finishing dies in our laboratories to insure a constant, uniform resistance over its entire length.

**WRITE TODAY!**

For engineering specifications and numerous recommended applications. Submit any problems to our engineering staff for recommendations. Units for immediate shipment — 1,000 to 30,000 ohm range. Special resistance values made to order.

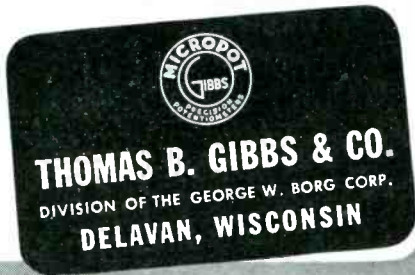

tubes connected as triodes in a bridge circuit, the blocking potential being applied to a slotted plate to provide a push-pull connection.

*Recording Application*

The first model constructed as a recorder is shown in Fig. 6. The grid caps are removed from the tubes to reduce capacitance from grid to ground, increasing the effectiveness of the grid wires or plates.

Since a balanced bridge circuit is used, it was assumed that humidity

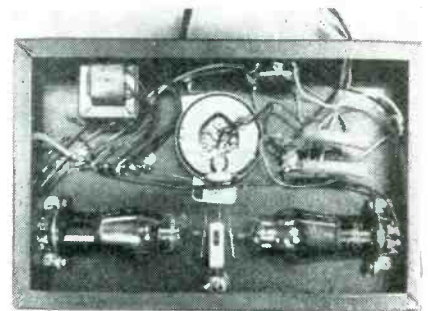

Fig. 6—Mechanical arrangement of tube and components in the balanced bridge circuit. The a-c blocking potential is applied to the slotted plate mounted on a standoff insulator

changes would affect both tubes in a similar manner and the effects would cancel out. The model exhibited promising results; however, lack of adjustment of essential parts prevented attainment of linearity between input and output. Sensitivity was also reduced, because of the high capacitance between grid plates and cabinet.

*Improved Model*

A third model was constructed with all essential elements made adjustable as to position. The tubes and capacitor unit were isolated in a large cabinet. The power supply and monitoring meters were located on a separate chassis.

The tubes are mounted on a track as shown in Fig. 7 and each may be positioned by means of a screw shaft terminating in an external knob. The meter movement and arm, and the a-c potential plate, may be moved in a vertical direction. The capacitor plates, attached to the grid caps with screws, may be adjusted for alignment with the grounded arm.

Since it was not necessary to util-

To bring out **ALUMINUM'S** *ELECTRONIC* **BEST...**



You may have selected Alcoa Aluminum for its low magnetic susceptibility. But do you realize that in machining or forming it with certain types of tools, enough of their metal can be picked up to cancel some of that nonmagnetic advantage?

Two solutions are possible:

Use tools which do not contaminate the surface of the aluminum; or pickle the finished part in nitric acid. Your product

will then perform as you intended.

Of course, this case is very special, and you may never encounter it. Ordinary electronic equipment is fabricated by the usual methods. But Alcoa can assist on these everyday problems, too—which Alcoa Aluminum Alloy to use, fabricating methods, finishes, and so on. For such help, write to the ALUMINUM COMPANY OF AMERICA, 2136 Gulf Bldg., Pittsburgh 19, Pennsylvania.

**ALCOA** **FIRST IN**  
**ALUMINUM**



Reg. U.S. Pat. Off.



# THE LAST WORD ON VACUUM PUMPING PRACTICE

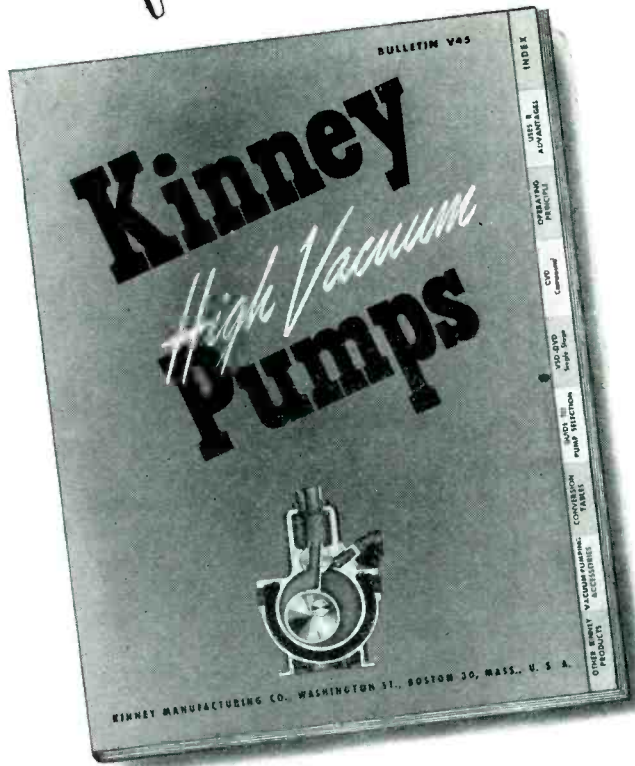

Send  
for this  
**FREE**  
**Bulletin**  
**TODAY**

- VACUUM PUMP APPLICATIONS
- PRINCIPLE OF MECHANICAL VACUUM PUMPS
- SELECTING THE PROPER PUMP
- CONVERSION TABLES FOR VACUUM ENGINEERING
- INSTALLATION DATA
- VACUUM PUMPING ACCESSORIES

Just off the press . . . this new catalog contains latest technical information on the design and operation of Kinney High Vacuum Pumps. Here are complete reference tables and engineering data to guide you in the rapidly expanding field of vacuum processing.

**ALSO AVAILABLE** — "The Design of High Vacuum Systems" by Dr. C. M. Van Atta with chapters on "Mechanical and Diffusion Pumps", "Refrigerated Traps", "Pipe Line Sizes", "Testing for Leaks", "Vacuum Accessories" and other data vital to the design of high vacuum systems — price \$3.00.



KINNEY MANUFACTURING CO., 3565 Washington St., Boston 30, Mass.

- Send free Vacuum Pump Bulletin V45.  
 Send ..... copies of "Design of High Vacuum Systems" (\$3.00 each).

Company Name .....  
 Your Name ..... Title .....  
 Address .....  
 City ..... Zone ..... State .....

ize an isolated arm, a precision type of meter movement was used. The permanent magnet was rotated 90 degrees with respect to the armature coil, to a vertical position to decrease capacitance to ground.

An Esterline-Angus recorder with a full-scale sensitivity of one milli-ampere was operated from the output taken from across the cathodes of the tubes.

A systematic analysis, involving complicated formulas, is necessary to arrive at a correct procedure for obtaining linearity, with minimum adjustments. It is perhaps more logical to adopt the trial-and-error method, in steps as follows:

(1) If the recorder is to be used to register positive and negative peaks, with zero center, the

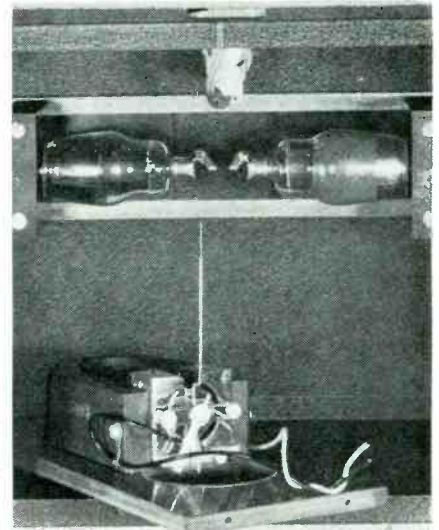

Fig. 7—In the final version, the tubes were mounted on a track and the meter movement made rotatable so that stray capacitance effects could be compensated

first step involves centering the grounded arm on the blocking recorder, as well as the Esterline-Angus writing pen.

(2) Adjustment should be made to obtain a plate current balance in the two tubes.

(3) An input to the arm movement is applied sufficient to deflect the grounded arm to a position over each capacitor plate in turn. While the arm is over a plate, the a-c potential is adjusted to give full-scale deflection on the recorder.

(4) Adjustments are made on applied potential, position of poten-

# MINIATURE POWER PLANT

when it fails . . . your product fails

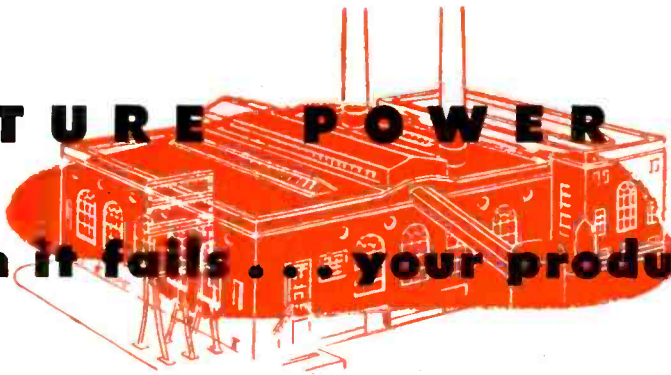

If, in your product there's a compact little power plant—commonly called a spring—you depend on that spring to deliver mechanical power as planned. Its function may be active or passive, but it *must* perform when called upon. If it doesn't, the *product* is blamed, not the spring.

Insure your product's good reputation with springs from Accurate . . . where everything possible is done to

give you springs you can depend upon. Our experienced spring engineers will help you be sure you have planned the right spring for the job . . . our skilled craftsmen and modern machinery assure you of fine workmanship . . . and, careful testing through critical stages of manufacture will give you springs that you can rely on to function well and long. Call us. We'd like to work with you.

*Accurate—  
for springs  
that won't  
let your  
product down*

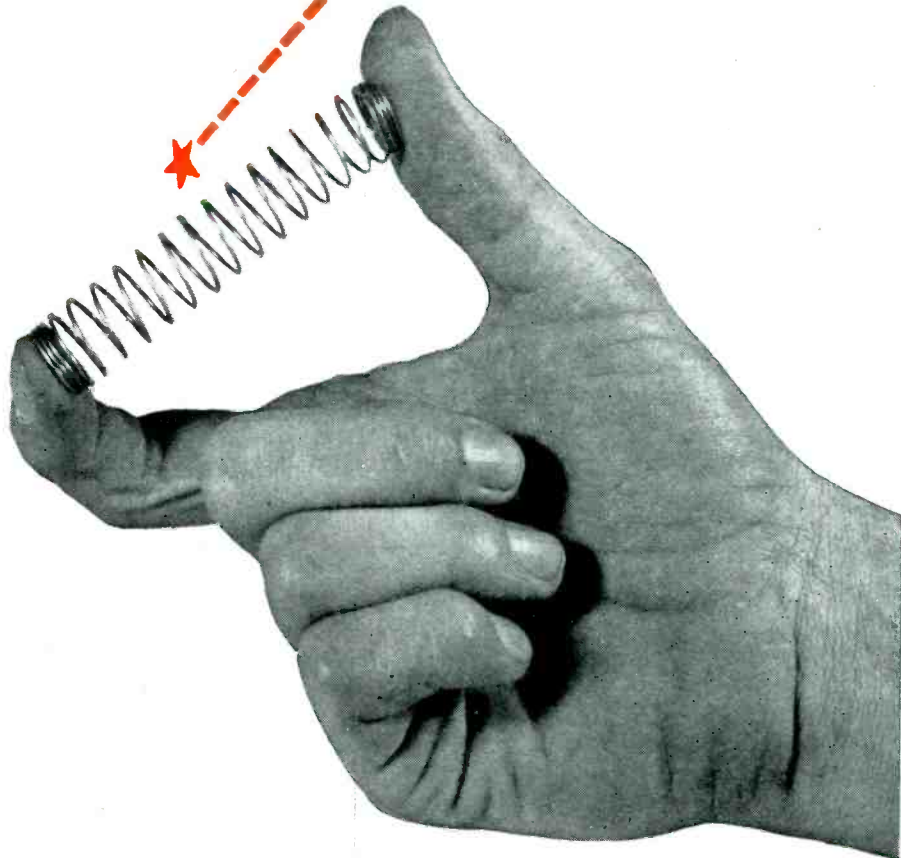

Send for your copy  
of the new Accurate  
Spring Handbook.  
It's full of data  
and formulae  
you will find useful.  
No obligation,  
of course.

SPRINGS  
WIREFORMS  
STAMPINGS

*Accurate*  
*Springs*

**ACCURATE SPRING MANUFACTURING, 3830 West Lake Street, Chicago 24, Illinois**



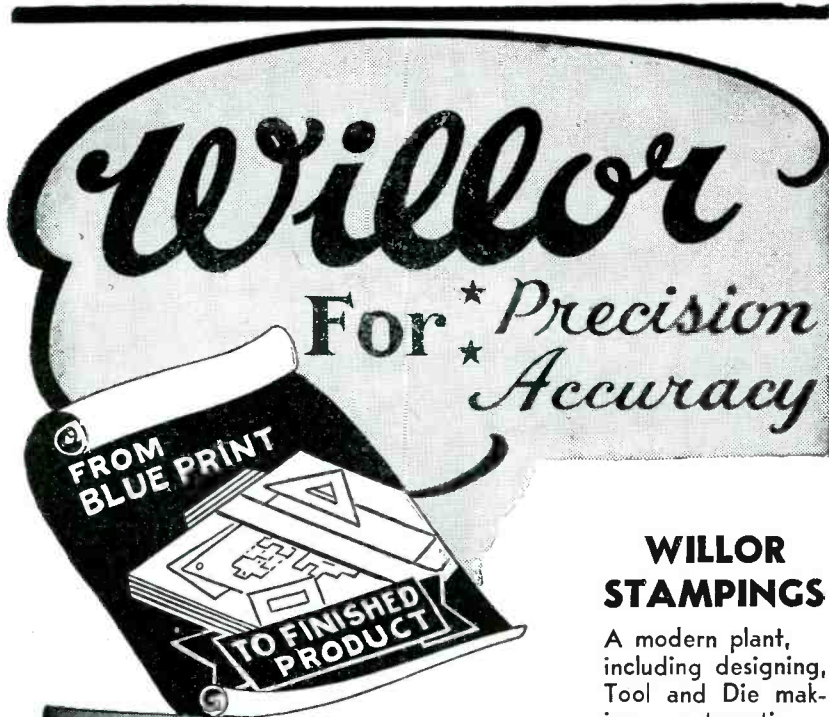

**WILLOR STAMPINGS**

A modern plant, including designing, Tool and Die making — automatic stamping — machining — welding — assembling — spraying — large or small production runs — special custom built products, at low cost.

**A Service . . . Complete from Design to Finished Product**

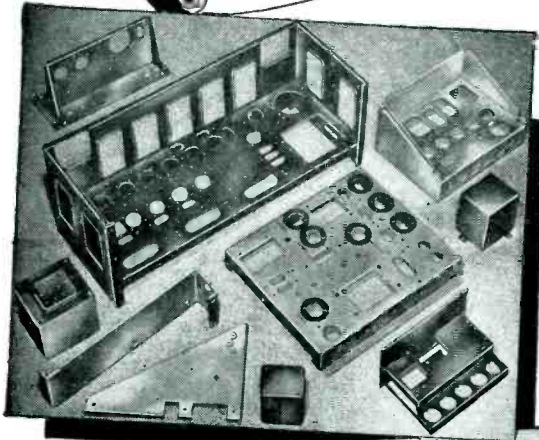

**WILLOR**

is your definite assurance of **SKILL and ACCURACY** for **PERFORMANCE.**

If your product is in the development stage or finished blue-print, write **WILLOR** for quotations. You will find our plant is prepared to produce to meet your needs.

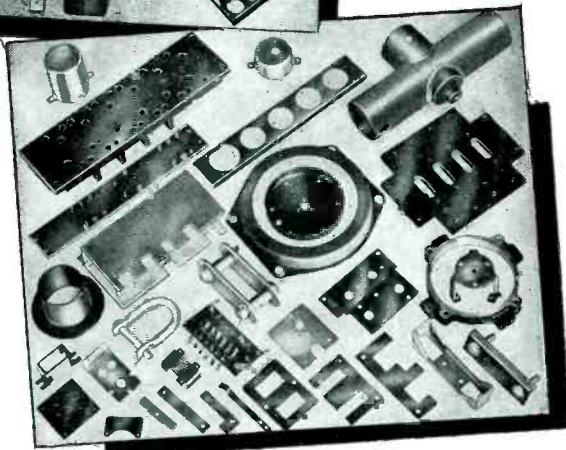

Our large assortment of stock dies may fit your requirements and result in real savings for you.



794 B EAST 140th STREET, NEW YORK 54, N. Y.  
MELROSE 5-6085

**OVER 40 YEARS OF EXPERIENCE**

tial plate and distance between the moving arm and grid capacitor plates. By following the method outlined, good linearity was obtained.

The sensitivity of the recorder will depend entirely on the sensitivity of the movement employed for moving the arm.

The period or resolving power of the system is dependent on the period of the meter movement and the inherent period or time constant of the electrical system which is associated with the blocking principle. With the model described, the resolving power was equal to that of the recorder, about one second for full scale deflection.

• • •

**SCR-545 Radar**

THE ATTENTION of the editors has been called to the fact that certain specifications of the SCR-545 Radar listed on page 118 of the November 1945 issue of **ELECTRONICS** are in error, or not computed on the same basis as the data listed for other equipments. The correct values are: weight 26,000 pounds; frequency 2700-2900 mc (t); receiver noise figure 15 db (t); maximum range 46 statute miles (s), 23 statute miles (t); range accuracy 18 yards (t); angular accuracy 1 degree (s). The SCR-545 equipment has completely automatic circuits for tracking in range as well as in angular coordinates.

**RECONVERSION CABINETS**

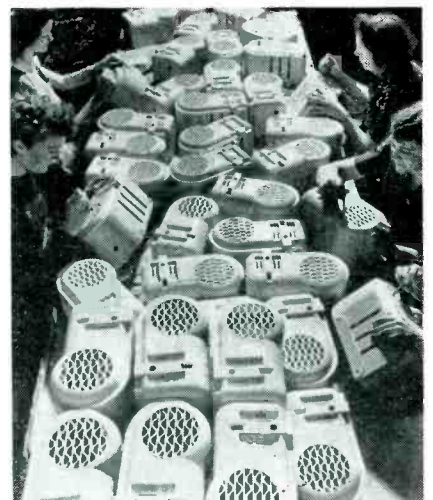

Plastic cabinets roll off the assembly line at Firestone Tire & Rubber Co. where plastic helmet liners were made prior to V-J Day



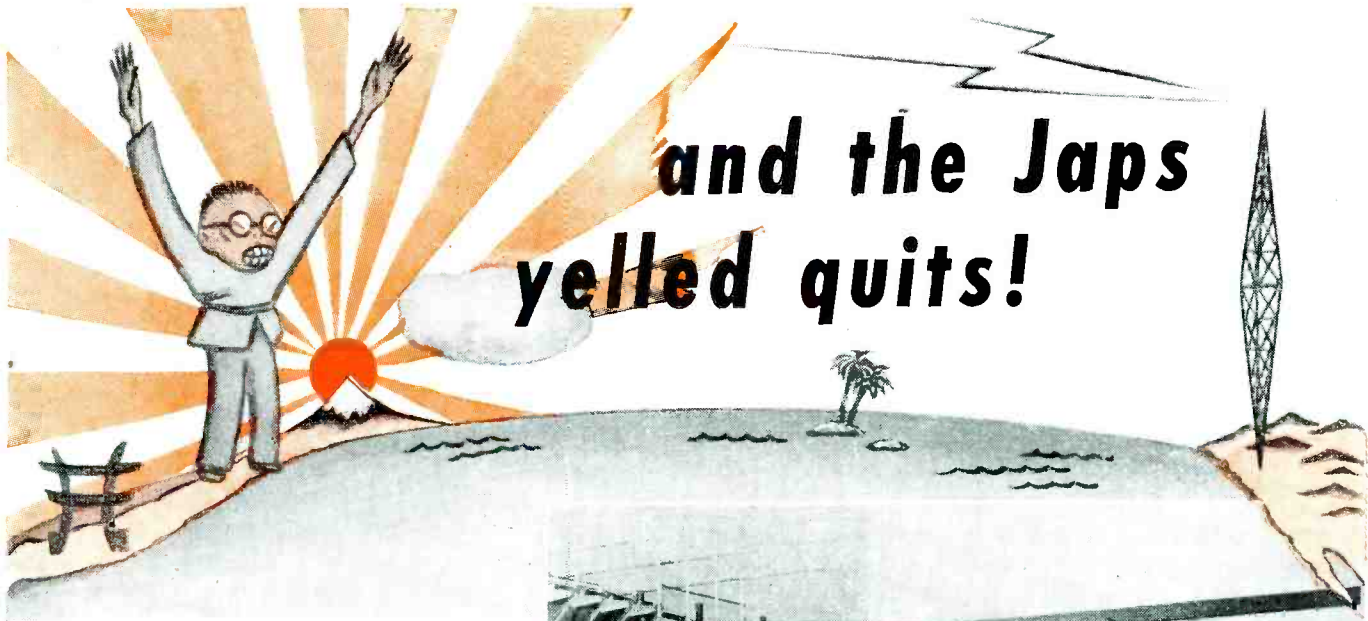

and the Japs  
yelled quits!

● The OWI did a neat and decisive job with their 200 KW short wave trans-Pacific radio stations. Their Tokyo broadcasts are credited with a definite part in ending the war in the Pacific.

AmerTran transformers and reactors were used in the rectifier plate and modulation circuits. The rectifier filament transformers shown here are typical of AmerTran adaptability to a unique problem. Both stations were designed and equipped by Federal Telephone and Radio Corp.

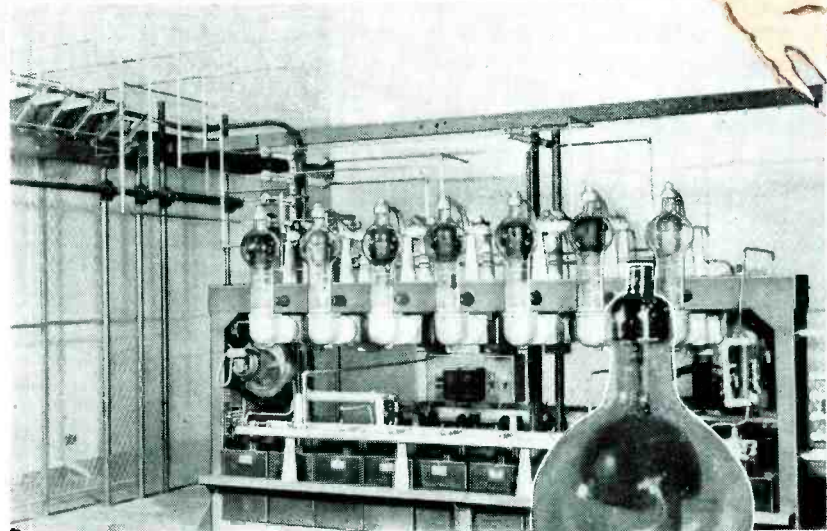

Efficiency figures for this O.W.I. installation: Overall audio frequency response of the audio amplifier—modulator equipment is within 0.5 db of the 1000 cycle level from 30 cycles to 7500 cycles at 95 per cent modulation.

**AMERICAN TRANSFORMER COMPANY**  
178 EMMET STREET      NEWARK 5, N. J.

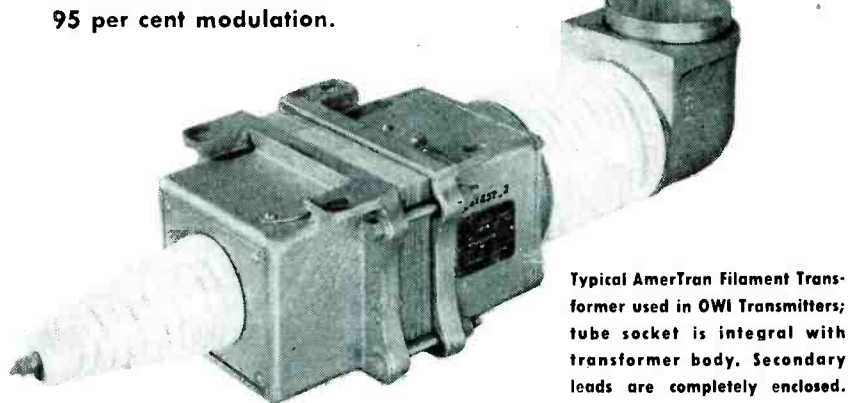

Typical AmerTran Filament Transformer used in OWI Transmitters; tube socket is integral with transformer body. Secondary leads are completely enclosed.

Pioneer Manufacturers  
of Transformers, Reactors  
and Rectifiers for Electronics  
and Power Transmission



**AMERTAN**

MANUFACTURING SINCE 1901 AT NEWARK, N. J.



# TUBES AT WORK

Visible Speech Patterns Transmit Intelligence . . . . .	200
A Cathode-Coupled Isolating Amplifier . . . . .	202
Photoelectric Aid for the Blind . . . . .	204
Remote Indicating Antenna Ammeter . . . . .	210
Electronic Sounds Effect Circuit . . . . .	214

## Visible Speech Patterns Transmit Intelligence

AN ELECTRONIC METHOD of making speech sounds visible in patterns that can be read by a totally deaf person was demonstrated recently by Bell Telephone Laboratories. The patterns appear on a moving belt for observation by a large group or on the screen of a special cathode-ray tube for viewing by a small group.

The system involved in the moving belt arrangement is shown in the accompanying diagram. Speech sounds picked up by the microphone are amplified and fed to a number of analyzing filters or cut-off amplifiers. These operate at different bands of frequencies up to about 3000 cps and feed their output to gas-filled glow lamps mounted vertically next to the surface of the belt. The belt is continuous and is coated with a phosphor material held in place by a plastic lacquer. As each lamp brightens and dims with modulation, the belt moves to the left and holds the speech pattern visible until it reaches the take-up drum. When the pattern

passes out of sight, it is erased by infrared illumination to leave a new surface for following patterns.

Typical sound patterns produced by the instrument are also illustrated. That these can easily be read by persons trained in interpreting them back into intelligence was demonstrated by personnel of the Laboratory. An engineer who has been deaf since birth watched the sound patterns and repeated aloud members and words which had been spoken by members of the audience. Although he has practiced lip reading all his life, he has become more proficient in reading the visual representation of speech after ten months practice than in lip reading.

A serious problem to the deaf person is learning to talk. Unable to hear the shadings of his own voice, he usually speaks in a monotone and often his voice is distinctly unpleasant and difficult to understand. This has proved a serious social handicap to the totally deaf. The man who took part

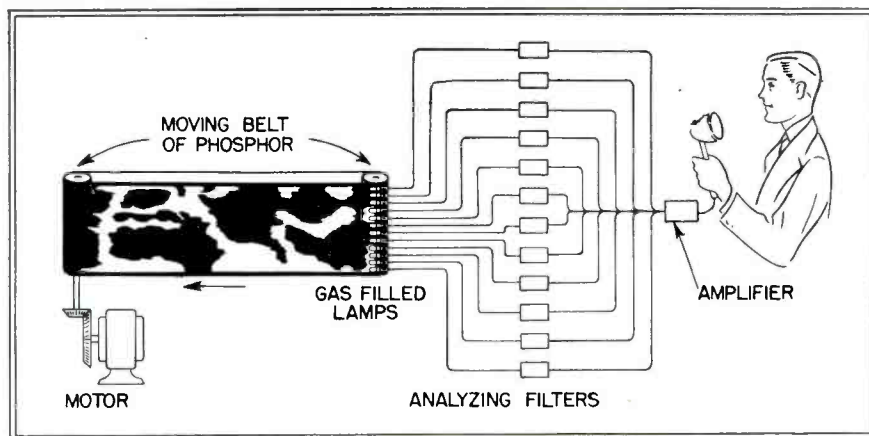

Basic elements of the translator that converts speech sounds into visible patterns on a moving belt

in the demonstration has greatly improved his ability to talk, and has also learned to add emotional color to his speech.

### Special C-R Tube

For observation by an individual or a small group of people, another instrument that contained a special cathode-ray tube was shown. The tube contains a continuous band of phosphor on the inside of the glass

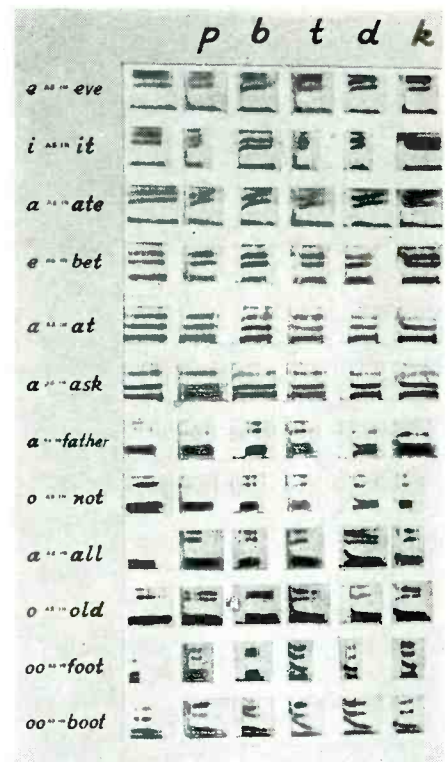

Typical speech patterns for representative syllables as they appear on the moving belt or the fluorescent screen

envelope and the tube revolves slowly to expose this band to the viewer. The electron beam sweeps the phosphor band vertically; synchronized with the sweep is a selector which gives each filter control of the intensity of the electron stream as the latter reaches the appropriate point in its sweep. Hence the beam, as it passes a point where a filter is passing no current, is extinguished and the tube surface is dark. When a filter is passing current, the beam increases and a bright spot is recorded. The spots blend into a speech pattern as the tube rotates and visible speech appears.

Another type of visible speech instrument was demonstrated that made permanent records. Speech

# wherever a tube is used...

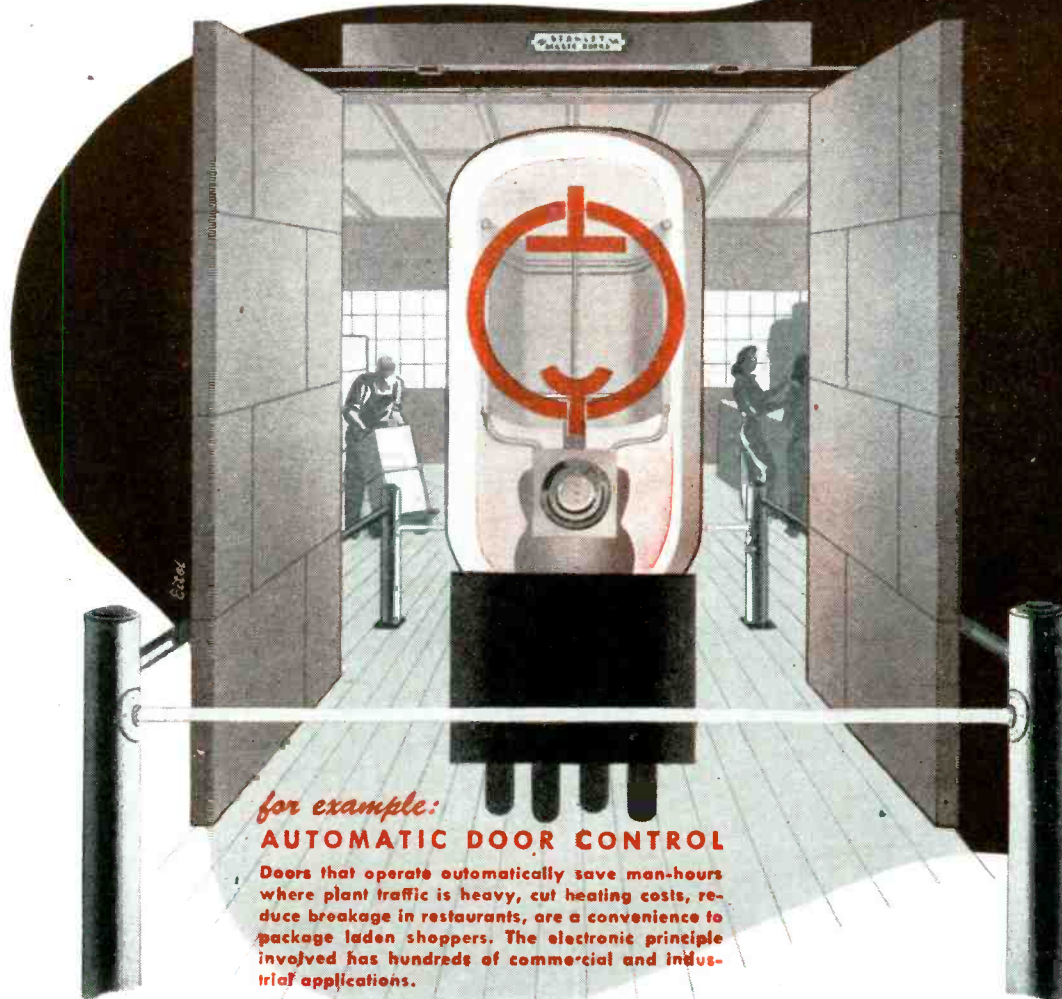

*for example:*  
**AUTOMATIC DOOR CONTROL**  
 Doors that operate automatically save man-hours where plant traffic is heavy, cut heating costs, reduce breakage in restaurants, are a convenience to package laden shoppers. The electronic principle involved has hundreds of commercial and industrial applications.

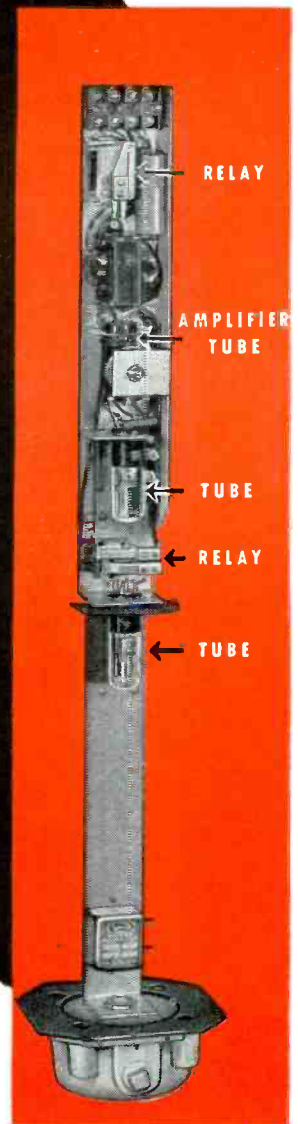

**PHOTO-ELECTRIC DOOR CONTROL**  
 Above unit manufactured by General Electric Co., is a part of STANLEY "MAGIC DOOR" CONTROLS.

THERE'S A JOB FOR

## *Relays* BY GUARDIAN

★ The "Magic Door" made by The Stanley Works of New Britain, Conn., uses a General Electric control unit which operates automatically at the approach of a pedestrian or vehicle. In this unit a beam of light focused on the cathode of a phototube causes a tiny current to flow. Enlarged through an amplifier tube this current operates a sensitive telephone type of relay such as the Guardian Series 405. Another phototube with an auxiliary relay, Guardian Series R-100, is employed to hold the doors open for anyone standing within the doorway.

The telephone type of relay is extremely sensitive and able to operate on the small current supplied through the electronic circuit. The auxiliary relay, Series R-100, is required to handle a greater current. It is a small, efficient relay having a contact capacity up to 1 KW at frequencies up to and including 28 megacycles. Contact combinations range up to double pole, double throw. Standard coils operate on 110 volts, 60 cycles, and draw approximately 7 V. A. Coils for other voltages are available. For further information write for Bulletin R-6.

Consult Guardian whenever a tube is used—however—Relays by Guardian are NOT limited to tube applications but are used wherever automatic control is desired for making, breaking, or changing the characteristics of electrical circuits.



Series 405 Telephone Type Relay

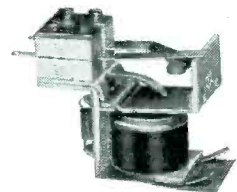

Series R-100 H. F. Relay

# GUARDIAN ELECTRIC

1625-A W. WALNUT STREET

CHICAGO 12, ILLINOIS

A COMPLETE LINE OF RELAYS SERVING AMERICAN INDUSTRY



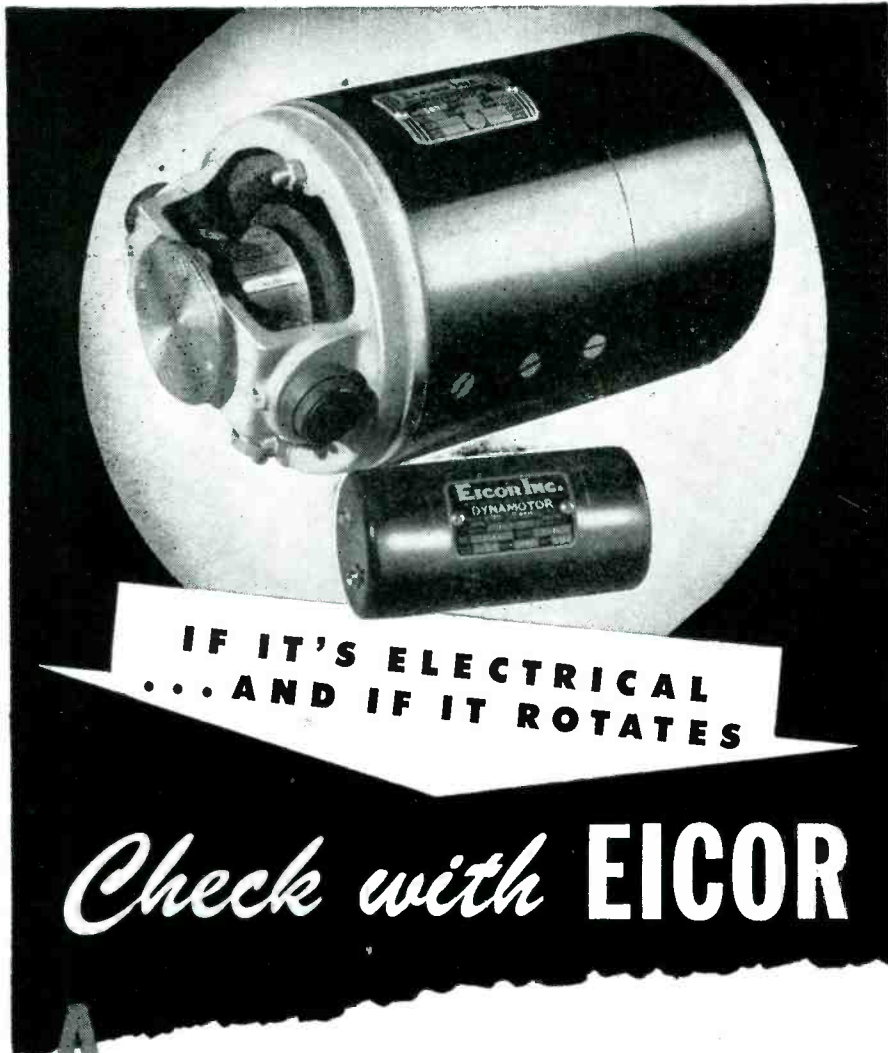

**IF IT'S ELECTRICAL  
... AND IF IT ROTATES**

*Check with* **EICOR**

**A** roster of all Eicor products, in their various types and sizes, shows an astonishing number and diversity. But of special interest to users of rotary electrical equipment is our ability to produce units unusual in design or performance . . . and do it quickly, accurately, and at reasonable cost.

Serving in an endless list of special applications, these developments include . . . the smallest commercially produced dynamotor, for 10 watts continuous output, in a 2-5/16" diameter frame and weighing only 34 ounces . . . a motor rated 1/5 hp at 3800 rpm for intermittent duty, 2-5/16" in diameter, weight 38 ounces . . . an aircraft inverter to supply output of 100 va, 400 cycle, single or three phase, in a 3" frame and unit weight of 5 3/4 lbs. . . . a .6 hp, 4000 rpm, intermittent duty motor, 4" in diameter and 9 1/2 lbs. weight . . . a dynamotor 4-1/16" in diameter which supplies 32 watts continuous output per pound weight . . . a 12 vdc motor rated 1/4 hp at 1700 rpm with 150 in. lbs. lock torque in a 5 1/4" frame.

These highlights are an indication of what EICOR has done in the past. In the days to come our creative engineering will solve similarly difficult problems involving motors, dynamotors, and generating equipment for industry. Your inquiry is invited.



**EICOR, INC.** 1501 W. Congress St., Chicago, U. S. A.  
DYNAMOTORS • D. C. MOTORS • POWER PLANTS • CONVERTERS  
Export: Ad Auriema, 89 Broad St., New York, U. S. A. Cable: Auriema, New York

was first recorded on a loop of magnetic tape and then repeatedly played back at the same rate as a paper-covered recording drum was rotated. On each play-back, a variable filter was tuned to a different band of frequencies to control the intensity of the blackening of successive strips caused by a stylus contacting the paper. Thus after the tape had made a number of repetitions and the drum an equal number of rotations, there appeared on the paper a pattern of lines which expressed the sound in terms of visible speech. In this machine, as in the others, the filter determines whether the pattern will exhibit either fine detail or broad outline.

*Applications*

The sound patterns are expected to be of great value in the instruction of the 20,000 deaf children in this country. Such a child learns to speak only about six words in his first school year and about fifty words by his third year, as compared with nearly 3000 words in that time for the normal child. The device should also be useful for linguistic studies. Visible speech records can be printed in books as halftones along with text which points out dialect peculiarities and may ultimately be used for speech improvement and correction and to teach pronunciation of foreign languages. It was found that the women trained in reading speech patterns of English could pronounce French words quite understandably although they did not know the language.

• • •

**A Cathode-Coupled Isolating Amplifier**

BY EARLE TRAVIS  
*Chief Engineer, KVEC*

THE CATHODE-COUPLED AMPLIFIER whose circuit is shown in Fig. 1 is designed to isolate a monitoring line from the network line. This monitoring line is more than three miles long and is part cable and part open wire.

If the cathode resistors are matched carefully, the noise level of

Insulated with

Du Pont **POLYTHENE**

Jacketed with

Du Pont **NYLON**

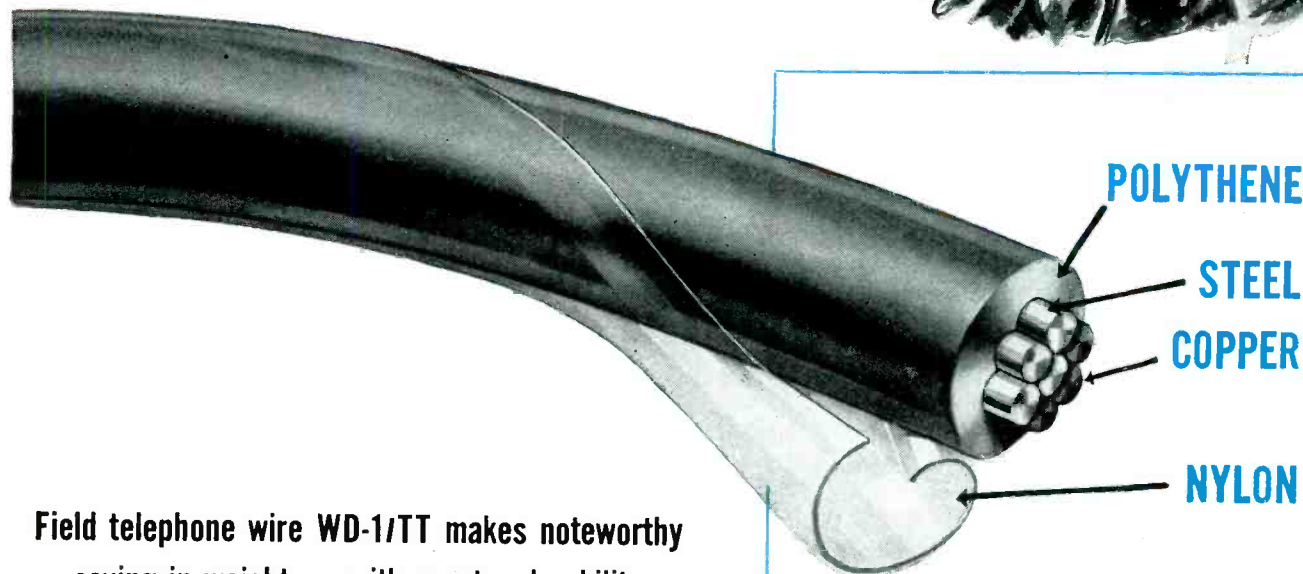

**Field telephone wire WD-1/TT makes noteworthy saving in weight . . . with greater durability**

Here's where *two* Du Pont plastics teamed up to fill a recent urgent need of the Signal Corps. Specifications called for a considerably lighter field telephone wire, which would possess the necessary durability as well as a talking range equal to that of the heavy Army field wire.

Du Pont polythene, because of its outstanding electrical properties, needs less weight to do a given job of insulation. Polythene alone is widely used as insulation on some of the lightest types of Army wire. But for this field wire it was necessary to protect the insulation against all kinds of weather, and abrasion from rocks, trees, sharp corners. That's where the toughness of nylon was called on to help. A wall thickness of only 5-6 mils of nylon, extruded rapidly over the polythene insulation, gave the necessary protection—and the finished wire weighs a little more than a third as much as the heavier type of Army field wire—though the talking range is the same.

For information on nylon, polythene and other Du Pont plastics, write E. I. du Pont de Nemours & Co. (Inc.), Plastics Dept., Arlington, N. J.

**Share in the Victory — Buy Bonds**

Section of Field Wire WD-1/TT, magnified approximately 12 times. Wall thickness of polythene insulation; 18 mils. Wall thickness of nylon jacket; 5-6 mils. Overall diameter; 80-82 mils. Average weight per mile: 48 lbs.

**FOR PLASTICS..  
CONSULT DU PONT**



**BETTER THINGS FOR BETTER LIVING  
... THROUGH CHEMISTRY**



# LOOK <sup>TO</sup> ACRO

for the solution of your  
*Switch Problems*

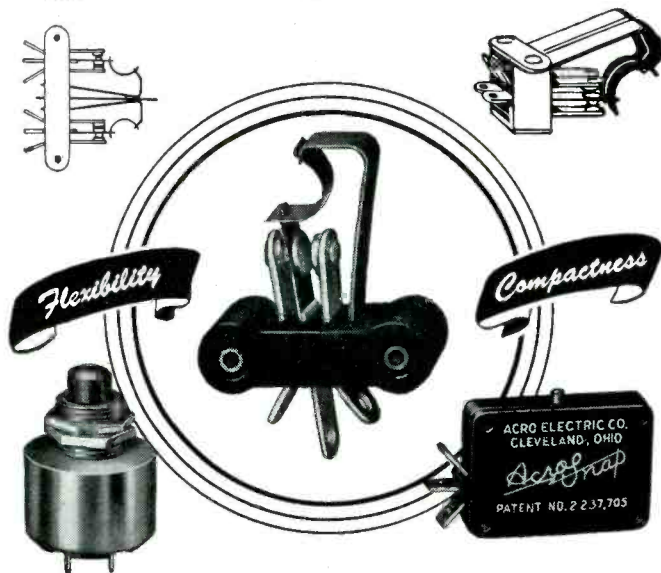

## Conventional Types or Specials . . .

Hundreds of switch problems are being solved the ACRO way because the ACRO-SNAP engineering design with its patented beryllium ROLLING SPRING permits countless variations in shapes and sizes. With the ACRO, you can design for greater COMPACTNESS and longer life. Mount them vertically, horizontally, or at any angle—singly or in multiples. Pressure ranges from 2 GRAMS to 1 1/4 lbs. Open blade, button, leaf bracket or fully enclosed types. Ratings: 10 and 15 amps. at 125 volts A.C. Circuits: single pole, normally open, normally closed and double throw. Send us details of your problem now if you want better switch performance with prompt service.

★ THE ACRO ELECTRIC COMPANY ★

1316 SUPERIOR AVENUE, CLEVELAND 14, OHIO

the amplifier and line will be satisfactory. The advantages of using a cathode-coupled amplifier for this purpose are; availability of parts, small size and low cost.

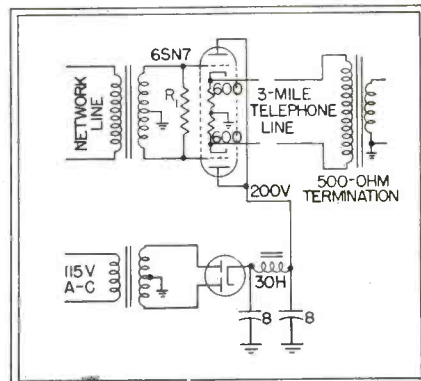

Fig. 1—Isolation of a long monitoring line from a network line is accomplished by this circuit

Note that no coupling capacitors are used. This is possible where the receiving end of the line is not grounded and this is the recommended termination. If a grounded termination must be used, coupling capacitors will be necessary and should be four  $\mu\text{f}$  or larger.

The input transformer  $T_1$  is an ordinary inter-stage push-pull transformer. The value of the load resistor  $R_1$  depends upon the transformer. In this case, a value of 75,000 ohms increased the square-wave response from 1,000 to 3,000 cycles.

• • •

## Photoelectric Aid for the Blind

AN ELECTRONIC CANE for blind persons that is carried like a lunchbox and is turned from side to side to scan the path ahead has been under development by the Signal Corps. The device projects a beam of light that is reflected by objects within a 20-foot radius. The reflection is detected by a photoelectric cell which creates coded tone signals in an earphone.

Development of the device was initiated by the Signal Corps last April at the request of the Surgeon General. Other development pro-

# SYLVANIA NEWS

ELECTRONIC EQUIPMENT EDITION

JAN.

Published by SYLVANIA ELECTRIC PRODUCTS INC., Emporium, Pa.

1946

## NEW T-3 TUBE FILLS NEED FOR SMALLER UNIT IN TINY BROADCAST RECEIVERS

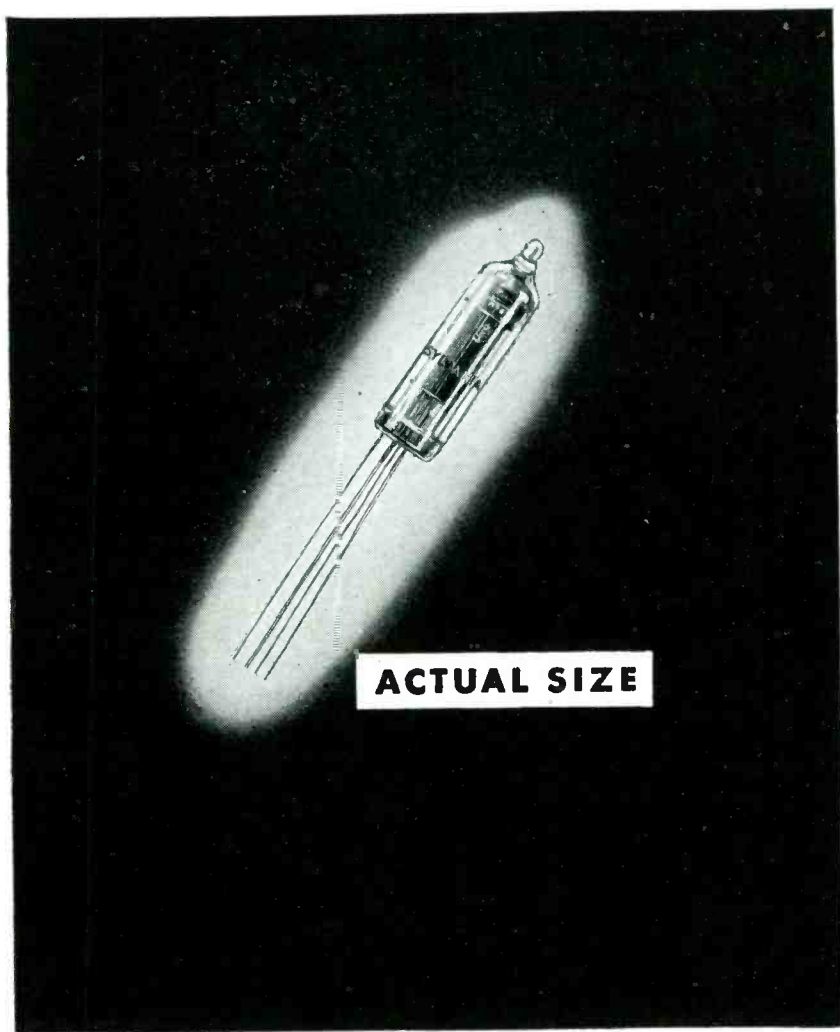

*For any further details, or questions you may want answered about this tiny, sturdy vacuum tube, do not hesitate to write or call Sylvania Electric Products Inc., Emporium, Pa.*

### *Commercial Version of Proximity Fuze Tube Is Rugged, Has Long Life*

Following Sylvania Electric's recent announcement about the sensationally small vacuum tube—originally developed for the now-famous proximity fuze transceiver—have come many inquiries concerning this super-midget.

#### SET MAKERS ESPECIALLY INTERESTED

Since the commercial version of the "war-baby" is being produced, many set manufacturers are extremely interested in its qualities — with a view toward making radios about the size of the average wallet or package of cigarettes, miniature walkie-talkie sets and other units.

This new tube, then, is being made in a low-drain filament type and is able to operate at 1.25 volts. This takes advantage of a new, small battery developed during the war which, of course, is a further aid in the manufacture of remarkably small radio sets.

#### WILL BE AVAILABLE FOR ALL TYPES

Future designs of this versatile tube can be incorporated in radios ranging in size from tiny pocket sets up to deluxe receivers. It has a life of hundreds of hours, is rugged and exceptionally adaptable to operation at high frequencies.

# SYLVANIA ELECTRIC

Emporium, Pa.

MAKERS OF RADIO TUBES; CATHODE RAY TUBES; ELECTRONIC DEVICES; FLUORESCENT LAMPS, FIXTURES, WIRING DEVICES; ELECTRIC LIGHT BULBS



# Unusual and Vital ELECTRONIC EQUIPMENT

PRODUCED BY

## TECH LAB

SUBCONTRACTING DEPT.



Special Short Wave Transmitter  
Range: 1-16 megacycles on  
one dial.



Development of special  
hearing aid analyzer for  
Western Electric Company.



Production Test Set to test varistors. A sensi-  
tive wheatstone bridge arranged with  
switching means for  
quickly checking a  
number of varistors  
in rapid sequence.

Manufacturers have continually called upon the modern facilities of Tech Lab Subcontracting Department to assist them in the production of unusual and vital electronic equipment. Our Engineering Department is ready to assist you with your production problems.

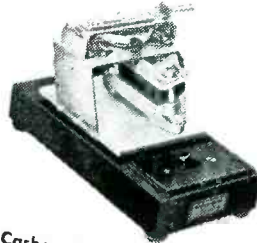

Carbon filling machines for  
precision filling of carbon  
microphones.

**TECH**  
LABORATORIES

MANUFACTURERS OF PRECISION  
ELECTRICAL RESISTANCE INSTRUMENTS

15 LINCOLN STREET, JERSEY CITY 7, N. J.

AID FOR BLIND

(continued)

grams, utilizing both supersonic and radar waves for the same purpose, are also being conducted by the Signal Corps. The experimental model of the photoelectric unit comprises a nine-pound case the size of a loaf of bread. It was designed and constructed by Lawrence Cranberg, a civilian physicist at Evans Signal Laboratory, Bradley Beach, N. J.

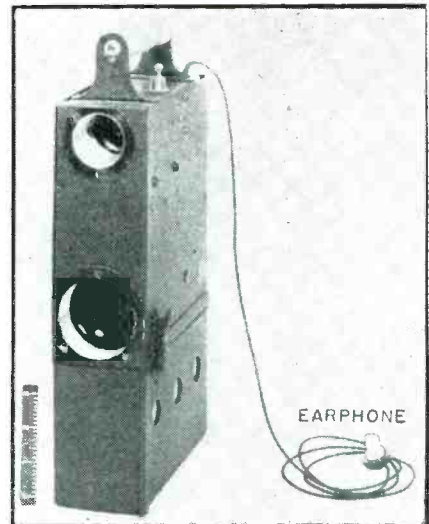

Experimental model of the sensory aid  
for the blind developed at the Signal  
Corps Engineering Laboratories

Light from a three-watt lamp is focused by a lens into a very narrow ray. When that ray is directed upon any object within 20 feet of the device, a spot of light about two inches in diameter appears upon that object and the reflected light is directed back toward a second lens in the front of the case.

The second lens focuses the reflected ray to a revolving disk mounted in front of a photoelectric cell. A ray reflected from an object at the maximum range of 20 feet would be focused just below the center of the disk, and would gradually move downward on the disk as the reflecting object neared the device.

The revolving disk is used to code the reflected light signal in order to indicate the distance of the reflecting object. It is divided into five concentric rings, each of which contains one or more holes through which the light can shine upon the photoelectric cell.

The inner ring, on which the

## BH EXTRA FLEXIBLE FIBERGLAS SLEEVING



MAKE THIS

# FLAME TEST



Hold a match under a piece of BH Extra Flexible Fiberglas Sleeveing. The flame does not burn, char or otherwise affect it. And temperatures much higher than usually encountered electrically are just as readily resisted by the inorganic Fiberglas!

**BH EXTRA FLEXIBLE FIBERGLAS SLEEVING**

### 2 WAYS BETTER

**NON-FRAYING • NON-STIFFENING**



ALSO SLOW-BURNING IMPREGNATED MAGNETO TUBING • SLOW-BURNING FLEXIBLE VARNISHED TUBING • SATURATED AND NON-SATURATED SLEEVING

## BENTLEY, HARRIS MANUFACTURING CO.

Dept. E, Conshohocken, Penna.

**F**EW electrical insulations can double in brass as heat insulations. Yet so effectively heat resistant is BH Extra Flexible Fiberglas Sleeveing that actual service records show it refuses to burn even in direct contact with heat units. The reason—both yarns and impregnation are non-inflammable!

A special gum base and dye applied by an exclusive BH process is responsible for many more features. It permanently prevents fraying, stiffening and abrasive wear. The sleeveing is unusually flexible and takes the roughest handling without fraying. It does not harden and crack with age—lasts indefinitely without deterioration. It is also non-crystallizing at low temperatures.

Fiberglas is non-absorbent and unaffected by moisture, oil or grease—qualities ideally suited to appliance manufacture for instance. And it has high dielectric and tensile strength.

“Punishment” tests prove that BH Extra Flexible Fiberglas Sleeveing is the most logical insulation for a host of tough jobs. Why not see for yourself? It’s available in all standard colors and all sizes from No. 20 to  $\frac{5}{8}$ ”, inclusive. Write for samples today and compare!

**BH SPECIAL TREATED FIBERGLAS SLEEVING UNAFFECTED BY HEAT UP TO 1200°F!**

This is a high quality sleeveing that will not fray when cut and withstands heat up to 1200°F. Yet no saturant is used in the exclusive BH process! Flexible as string, too. Made in natural color only—all standard sizes. Try it!



# JOB AHEAD

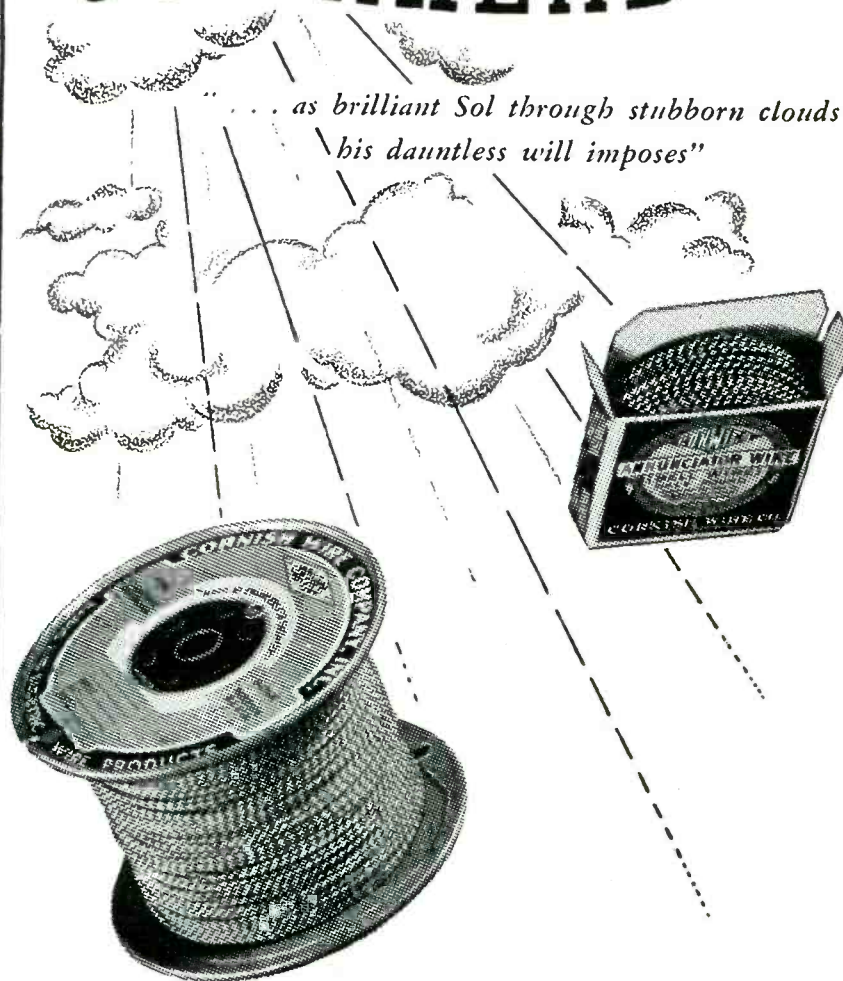

... as brilliant Sol through stubborn clouds  
his dauntless will imposes"

RECONVERSION to national peacetime economy is on the march . . . perhaps not as swift as you and we would like it. Vast displacements, inevitable as we "shift our gears", must be absorbed and neutralized . . . in short, there's a JOB ahead.

Each day supplies of famous CORWICO Wire, so important in the war and so important now, will be made available for civilian use.

Patience! We've moved mountains before . . . . .



## cornish

WIRE COMPANY, INC.

15 Park Row, New York City, New York

"Made by Engineers for Engineers"

ray would be focused if the reflecting object were from 17 to 20 feet distant, contains only a single small hole. The next ring, on which the ray would be focused if the object were about 11 feet distant, contains a single large hole which is shaped like a crescent and follows the curve of the disk. The next three rings, upon which the reflection would be directed from distances of eight, five, and three feet respectively, contain successively two small, a small and a large, and three small holes.

A reflection from an object five feet distant would be directed upon the fourth ring, which contains one small hole and one large hole. As the disk revolves, at a rate of once a second, the light would shine through upon the photoelectric cell once briefly as the small hole came in line with the ray and again for a longer time when the larger hole intersected the ray.

As the light penetrated to the photoelectric cell, the cell would produce one short and one long impulse each time the disk revolved. These two bursts would create tone signals—one short and one long—in the earphone.

### Operation

The handle of the case is parallel to the direction of the first light ray, and the blind user can sense the position of his hand in determining the direction from which reflections are received.

It has been found that a blind person with little practice easily determines the exact distance, to within one foot, of obstacles detected by the device. While a reflection from an object 11 feet distant would produce a tone signal of one dash, and a reflection from eight feet distant would produce a signal of two dots, a reflection from an object ten feet distant would produce a strong dash and two weaker dots, and a reflection from nine feet would produce a weak dash and two stronger dots. Distances between the five principle distance signals can similarly be measured by means of intermediate combination signals.

One difficulty encountered was



Wherever shown, the new Type 554 Ceramic Trimmer has attracted the attention and admiration of the radio industry. First, its original and compact design, its obvious ease of installation and adjustment; later, its demonstrated superb performance—these qualities have not only aroused curiosity and interest, they have won immediate acceptance. Type 554 will be standard equipment on many receiving sets, from now on.

Note, in photograph and drawing, that the metal rotor completely covers the stator track. Contact surfaces of both rotor and stator are lapped, providing a high degree of stability, excluding dust, and keeping noise level to a minimum at high frequencies.

Capacity change is essentially constant per degree of rotation, and full range is covered in 180° rotation. Type 554 Trimmers will be available shortly in production quantities in the following capacity ranges: in zero temperature coefficient, 3-12 MMF and 5-25 MMF; in -750 parts/million/°C, 5-30 MMF and 8-50 MMF. They will also be available in an intermediate temperature coefficient. Trimmers are held firmly in place in a D-hole in the chassis by means of a multiple-tooth spring clip, furnished with the trimmer.

Specifications and capacity ranges are given in the table at right. For complete information, contact our nearest representative or write us direct.



ACTUAL SIZE

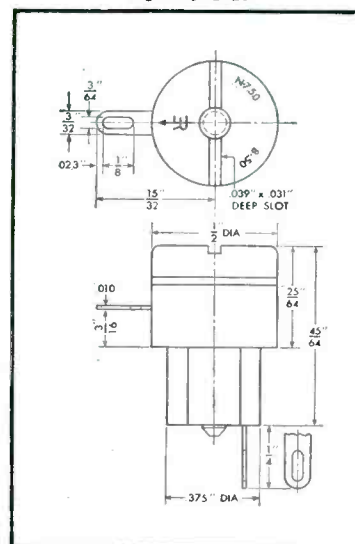

ERIE 554 CERAMICON TRIMMER

Voltage Rating: 350 volts D.C.  
Flash Test: 700 volts D.C. for 15 seconds.  
Initial Q Factor at 1MC: 500 minimum  
Initial Leakage Resistance: 10,000 meg. min.



*Electronics Division*  
**ERIE RESISTOR CORP., ERIE, PA.**

LONDON, ENGLAND

TORONTO, CANADA.



## *Big* News About Small Speakers

Permeflux leads again with the development of a new permanent magnet dynamic speaker providing maximum performance with minimum magnet weight.

With less than a 1½ ounce Alnico Five magnet weight, Permeflux now achieves performance only obtainable before by using a much heavier Alnico Five magnet.

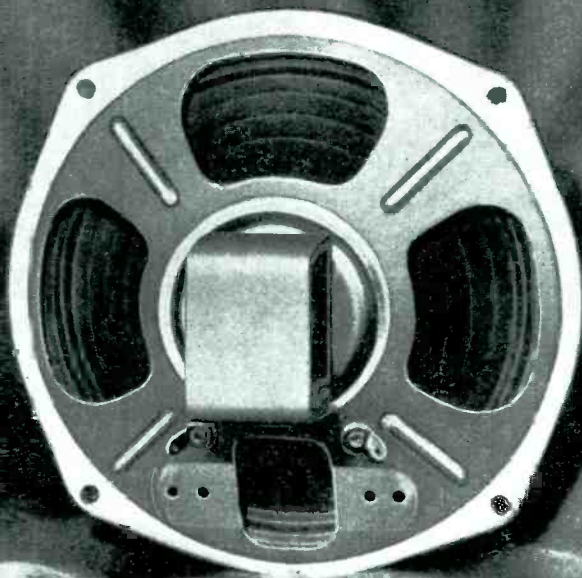

Setting a new standard for speakers up to 6", this new unit is particularly adaptable to portables and farm radios—in fact to all receivers, battery or power line operated, wherever weight is an important factor.

TRADE MARK  
**PERM-O-FLUX**  
PERMOFLUX CORPORATION  
4900 WEST GRAND AVE., CHICAGO 39, ILL.

PIONEER MANUFACTURERS OF PERMANENT MAGNET DYNAMIC TRANSDUCERS

the problem of filtering out signals from sunlight and incandescent lamps. This was solved by making the amplifier sensitive only to modulated light, and then modulating the light ray to the exact frequency at which the circuit is most sensitive.

It is hoped that the weight of the unit can be reduced to about two pounds and that it can be sold around the hundred-dollar mark. Although it is not expected to be of value in distinguishing approaching cars, until they reach the 20-foot limit, the ability to determine the color of traffic lights would be a distinct help to the blind user when crossing intersections.

• • •

### Remote Indicating Antenna Ammeter

By C. R. Cox  
Andrew Co.  
Chicago, Illinois

ONE OF THE FCC REQUIREMENTS relating to broadcast station operation is that the magnitude of the antenna current be recorded in a log book at intervals of one-half hour. Since in the majority of standard broadcast installations the antenna is located at a distance of several hundred feet or more from the transmitter, some means of indicating the antenna current at the transmitter is highly desirable. To fill this purpose, the type 708 remote indicating antenna ammeter was developed by Andrew Company engineers.

In designing the instrument, it was thought desirable to avoid the use of thermocouples, because of their susceptibility to lightning damage. While the occasional loss of a thermocouple due to lightning presents no problem to the owner of a broadcast station, the time spent in shutdown, while thermocouples are being replaced, is very serious and expensive because it means loss of revenue to the station. Accordingly, the ammeter was designed on entirely electronic principles, and contains no thermocouples. In several instances, remote ammeters of this type have withstood without damage a direct



No more scenes like this  
when you use the

**HALLOWELL**  
**KEY UNBRAKO KIT**

*New*



**Pocketsized, Versatile,  
Useful, Rugged,  
Durable**

Think how much easier, how much more convenient to have all your bits assembled in one kit, . . . so small that it will fit in the palm of your hand. It saves space, eliminates carrying around a lot of bulky, heavy wrenches and screw drivers, lessens the chance of misplacing them. The "Hallowell" "Unbrako" Key Kit is a compact, complete screw-driver service. The kit itself is only about 6" long, has an indestructible, hollow, shiny black plastic handle which holds the bits. To use, simply remove the top, select the bit you want, and insert it in the chuck. The swivel chuck enables you to have the direct drive of a straight handle screw driver, or, you can lock it at an angle, or at a right angle position for reaching those "hard-to-get-at" places.

Incidentally, this is a rugged, durable tool. The bits and swivel chuck are made of the finest alloy steel to assure you of long and satisfactory service.

The "Unbrako" Speed Tool Key Kit is made in two sizes:

- No. 25: contains seven hex, two Phillips, one slotted screw bit.
- No. 50: contains six hex, two Phillips, one slotted screw bit.

If your Distributor does not carry it, send his name to us, along with yours, and you will be taken care of promptly.



Over 40 Years in Business

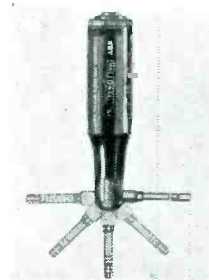

Illustration shows different positions to which swivel chuck permits bit to be swung.



Easily managed, fits comfortably in hand. Bits are placed in hollow plastic handle.

**STANDARD PRESSED STEEL CO.**

JENKINTOWN, PENNA., BOX 596 • BRANCHES: BOSTON • CHICAGO • DETROIT • INDIANAPOLIS • ST. LOUIS • SAN FRANCISCO



# INSULATION'S MOST DEPENDABLE SPECIFICATION

*Insul-x  
Means  
Modern  
Insulation*

**N**OW, more electrical and electronic manufacturers than ever before specify INSL-X insulation coatings. They know that INSL-X Research Leadership is their guarantee of un-failing effectiveness.

*Literature Upon Request*

**INSL-X**  
MEANS MODERN  
INSULATION

**THE INSL-X COMPANY INC.**

857 MEEKER AVE., BROOKLYN 22, N. Y.  
CHICAGO • DETROIT • LOS ANGELES • PHILADELPHIA  
CLEVELAND • ST. LOUIS

REMOTE AMMETER

(continued)

stroke on the tower, while in other instances the remote ammeter has been burned to a crisp by lightning, but no loss of broadcasting time resulted.

### *Rectifier Circuit*

In the circuit shown, a current transformer with a primary consisting of a heavy copper rod and an electrostatically shielded secondary feeds a 1-V diode rectifier tube which actuates a d-c microammeter.

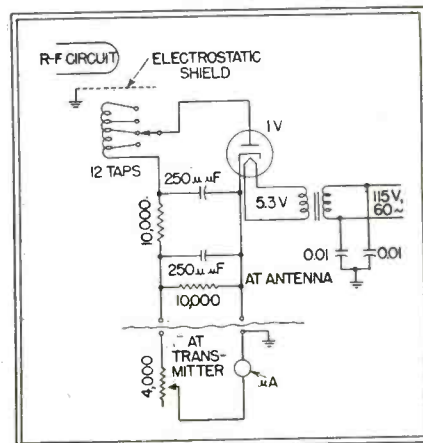

Circuit of electronic antenna ammeter for reading antenna current at the transmitter

The microammeter is calibrated in r-f amperes and provides an approximately linear calibration because the diode load resistance is made large in comparison to the tube impedance. An instrument of this type is not absolute and must be adjusted to agree with the regular thermocouple ammeter. FCC regulations provide that this adjustment must be made once a week. When not in use for calibrating purposes, the thermocouple may be switched out of the circuit.

The time constant in the rectifier circuit is such that the instrument is essentially peak reading but this is much smaller than the period corresponding to the highest modulation frequency. Thus, the indication of the meter remains constant with amplitude modulation, provided there is no carrier shift. In contrast, the reading of a thermocouple ammeter increases with modulation.

The photograph shows a rectifier

Not jet propelled...

but just as **NEW!**

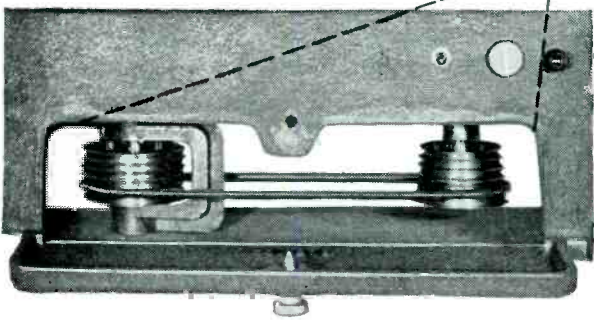

The belt on step pulleys slips instantly to any position to set cutting pitch at 96-104-112-120-128 or 136 lines per inch. Other pitches available on special order.

PRESTO'S newest *turntable*... for highest quality master or instantaneous recordings. The 8-D features instantaneous change of cutting pitch. An improved cutting head provides higher modulation level, more uniform frequency response and retains its calibration under all normal temperature conditions.

The heavy cast-iron turntable and mounting base insure exceptionally low background noise. Adjustable feet permit accurate leveling on bench or stand at a height to suit the operator.

**PRESTO**



**RECORDING CORPORATION**

242 West 55th Street, New York 19, N. Y.

Walter P. Downs, Ltd., in Canada

**WORLD'S LARGEST MANUFACTURER OF INSTANTANEOUS SOUND RECORDING EQUIPMENT AND DISCS**



# The Answer TO YOUR INSTRUMENT PROBLEMS

## Burlington

### PANEL INSTRUMENTS

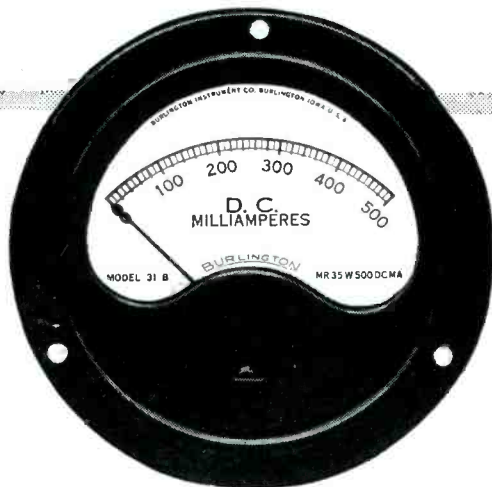

Burlington Panel Instruments are designed and built to give dependable service with guaranteed accuracy. They are available in a complete line of AC or DC Ammeters, Voltmeters, Milliammeters, and Microammeters. The wide selection of sizes and case styles offer instruments that are ideal for your particular application.

Write today for full details — our engineers will recommend the precise Burlington Instruments required to solve your instrument problems.

**BURLINGTON INSTRUMENT CO.**

105 Fourth St., BURLINGTON, IOWA



PANEL INSTRUMENTS • VOLTAGE REGULATORS • AUTOMATIC SYNCHRONIZERS • FREQUENCY REGULATORS

REMOTE AMMETER

(continued)

assembly for a five-kw installation. The two large insulators support the ends of the primary coil, which

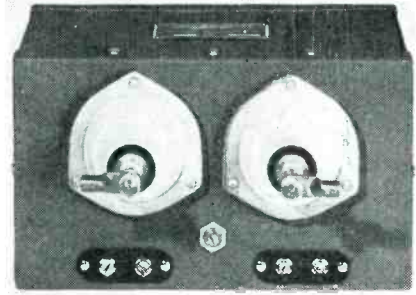

Rectifier assembly of the electronic ammeter. A half-turn of copper rod mounts on the insulators and forms the primary of a current transformer

is a half turn of  $\frac{1}{4}$ -inch diameter copper rod offering negligible impedance to the circuit in which it is connected. The small terminal strips receive a pair of conductors from the remote instrument, and a pair of 115-volt leads for the filament transformer. For a 50-kw station, a larger rectifier assembly incorporates the same circuit but with more insulation between the primary circuit and ground.

• • •

### Electronic Sound Effects Circuit

BY HOWARD SYZLING  
*England*

DETAILS HAVE RECENTLY been released of an interesting piece of apparatus constructed for use in training men for the army and to give them a good representation of what battle sounds are like. The reproduction of these sounds is entirely electronic and involves consideration of the precise analysis of real sounds.

Essentially the equipment consists of sixteen separate panels of gear, eight being involved in generating the sound. Four are power amplifiers, four are mixing amplifiers and in addition there is a power pack and two loudspeakers. The total output is 200 watts and the operation is entirely automatic when once started.

The best method of describing the apparatus is to deal with specific sound effects and explain how they are produced. Many of them



# May the New Year

be the beginning  
of the biggest,  
brightest era  
your business  
has ever known.

**SCHWEITZER PAPER CO.**

142 MILLER STREET, NEWARK, N. J.  
Plants: Newark, Jersey City, N. J., Mt. Holly Springs, Pa.  
Research Laboratories: Chrysler Bldg. New York, N. Y.

SPECIALISTS IN **THIN GAUGE** INSULATING PAPERS





The urgent demand, in peacetime days, by the aircraft and radio industries for a compact, efficient D.C. motor was the challenge that led Pioneer to develop the Pincor BX series. Today Pincor BX motors flow from our plant in a steady stream to the producers of aircraft and radio equipment for the armed services.

Pincor BX motors, in their classification, meet the varied requirements of aircraft and radio manufacturers that demand light weight, compact motors for efficient and dependable application. Pincor BX motors are direct drive, ball bearing, high speed units wound for continuous or intermittent duty. Shunt, series or split series windings are for operation on 12 to 24 volt battery systems currently used and may be easily modified to meet your product demand.

Depend on these rugged Pincor quality-proven motors in the BX series. Send your problem to Pioneer engineers and let them put their years of experience to work for you. Consultation with these men will not obligate you in the least.

DYNAMOTORS • CONVERTERS  
GENERATORS  
POWER PLANTS • GEN-E-MOTORS



**PIONEER GEN-E-MOTOR CORPORATION**

5841-49 DICKENS AVENUE CHICAGO 39, ILLINOIS

Export Office, 25 Warren Street, New York 7, U.S.A.  
Cable Address: Simontrice, N. Y.

**BUY MORE BONDS!**

introduce the use of an aperiodic generator, so called because its output consists of a signal with an irregular waveform and created by amplifying the random noise voltages appearing across a small neon tube.

*Distant Shell Burst*

Typical shell bursts are obtained from the circuit shown in Fig. 1. The output of the aperiodic generator is fed in at the point shown and is filtered by the resistance-capacitance combination of  $R_2$  and  $C_1$  to remove the higher frequencies. It is then passed to the grid of tube  $V_1$  via capacitor  $C_2$ , the tube being normally biased beyond cutoff by resistors  $R_4$  and  $R_5$  so that no signal appears on the anode.

A rotating cam wheel having shaped teeth operates the switch  $SW$  so that in one direction  $C_3$  is charged via  $R_1$  to a positive potential and in the opposite direction is connected in parallel with capacitor  $C_1$  via resistor  $R_3$ . This results in the grid of  $V_1$  swinging fairly rapidly in a positive direction (since  $R_3$  is small) and then returning more slowly to cutoff as  $R_5$  is comparatively large, so producing a voltage at  $V_1$  grid with a steep-front waveform and a slow exponential recovery and containing also a measure of the aperiodic noise. In other words,  $R_3$  controls the "attack" and  $R_5$  the "decay".

Capacitor  $C_3$  is small compared with  $C_1$  so that the decay is constant even if  $C_3$  is disconnected from  $C_1$  during the decay period. The combination of resistor  $R_1$  and capacitor  $C_3$  is designed to have a

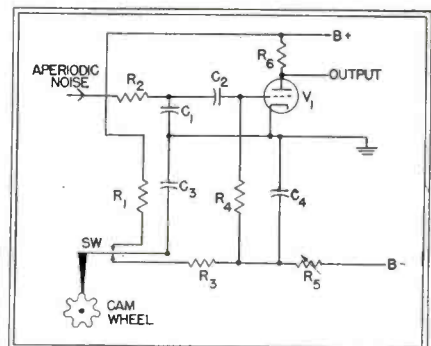

Fig. 1—Wave-forming circuit for simulating shell bursts. The rotating cam wheel changes the connections of capacitor  $C_3$ .

**STILL**

*flexible*

**— AFTER VARNISHING  
AND BAKING**



**Fibron** #5373

CHEMICAL AND HEAT RESISTANT

## **FLEXIBLE PLASTIC TUBING**

This new especially formulated Irvington tubing, Fibron #5373, has all the advantages of conventional plastic tubings — plus the ability to remain flexible after varnishing and baking or extraordinary exposure to continuously high temperatures.

### PARTIAL TEST DATA ON FIBRON #5373

Tensile Strength . . . . . 3000 P.S.I.

Dielectric Strength  
(.020" wall)

Wet . . . . . 1000 VPM

Dry . . . . . 1000 VPM

Life at 105° C. . . . . 2000 Hrs.

Chemical Resistance  
(room temperature)

50% Sulfuric Acid . . . . . Unaffected

30% Sodium Hydroxide . . . . . Unaffected

Does not support  
combustion

Low Temperature Flexibility

I.V.I. Pinch Test . . . . . —40° C.

Bell Test . . . . . —30° C.

Heat Endurance (.166" ID tubing,  
.016" wall) (ASTM-D350-43T)

7 days @ 125° C. — Did not crack when bent 180° around 1/8" mandrel — Retains flexibility after being varnished and baked for 22 hours at 260° F. — No flow or drip during 8 hours at 300° F.

Fibron #5373 is produced in all standard colors and sizes — and can be supplied in heavy wall thicknesses — in 36" lengths, continuous coils, or cut pieces. For full particulars, and samples, write Dept. 106, Irvington Varnish and Insulator Co., Irvington 11, New Jersey.

"Look to Irvington  
for Continued Leadership  
in Insulation"



# **IRVINGTON**

**VARNISH & INSULATOR CO.**

**Irvington 11, New Jersey, U. S. A.**



**DEPENDABLE** performance and durability of a Test Instrument is assured by its design and sturdiness of construction. All B. R. C. instruments are ruggedly built to give exacting and precise direct reading measurements with simplicity of operation.

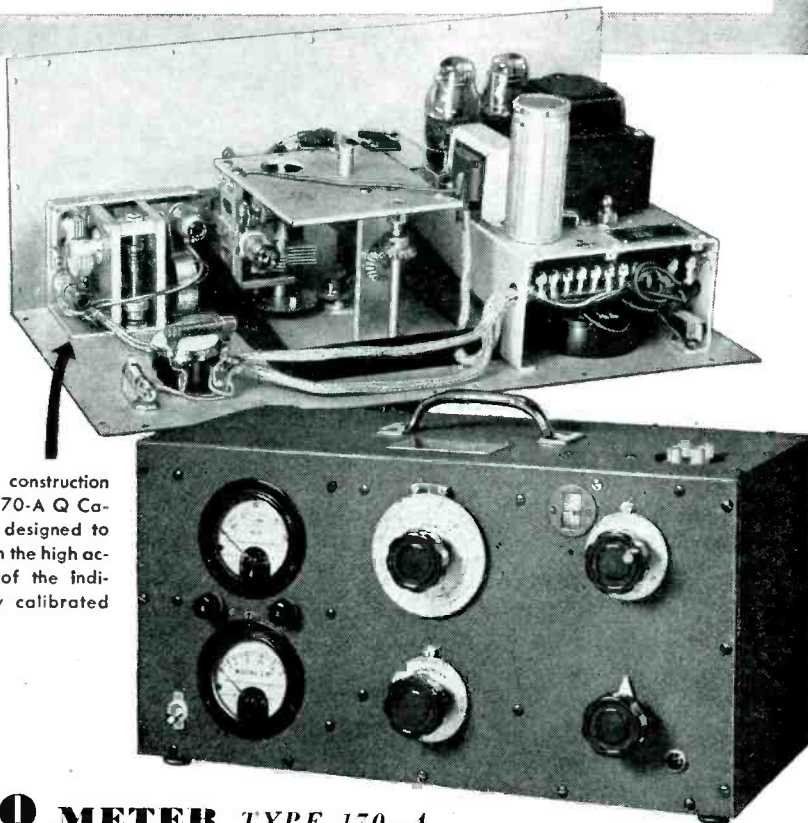

Rugged construction of the 170-A Q-Capacitor designed to maintain the high accuracy of the individually calibrated dial.

### **Q** METER TYPE 170-A

This instrument embodies the general operating principles and characteristics of the 160-A Q-Meter but with such design and structural modifications as are required for accurate performance at higher frequencies. Has a frequency range of 30 mc to 200 mc.

**Q METER TYPE 160-A**—A standard for "Q" measurements with a reputation for accurate and dependable service. Has a frequency range of 50 kc to 75 mc which may be extended with external oscillator down to 1 kc.

**BOONTON RADIO Corporation**  
BOONTON, N. J.

DESIGNERS AND MANUFACTURERS OF THE "Q" METER . . . QX-CHECKER . . . FREQUENCY MODULATED SIGNAL GENERATOR . . . BEAT FREQUENCY GENERATOR . . . AND OTHER DIRECT READING TEST INSTRUMENTS

long time-constant so that  $C_3$  does not have time to charge fully to the anode potential but varies according to the shape of the teeth on the cam and so varies the volume of the shell burst.

Capacitor  $C_2$  and resistor  $R_1$  are proportioned so that  $R_1$  presents a fairly high impedance to the aperiodic noise frequencies while  $C_2$  presents a similar high impedance to the envelope shape of the effects. Resistor  $R_3$  is made variable so that it can be used to vary the echo produced.

#### *Local Shell Burst With Whine*

In the case of a nearby shell burst, the explosion is far louder and is always preceded by a whistling which falls in frequency and then stops suddenly as the shell explodes. The whine is generated by a triode connected as a squegging oscillator and the frequency is caused to fall by varying the grid bias so that the audio output varies from the supersonic region down to a few hundred cps. When the oscillations stop, the cathode current drops to zero and gives a pulse into a cathode-follower tube and thus discharges a negatively charg-

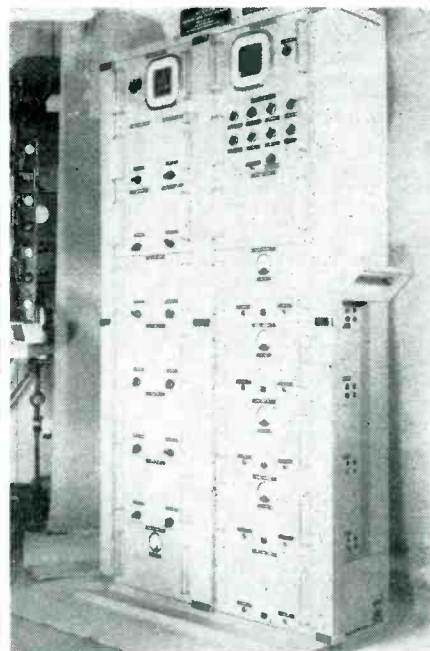
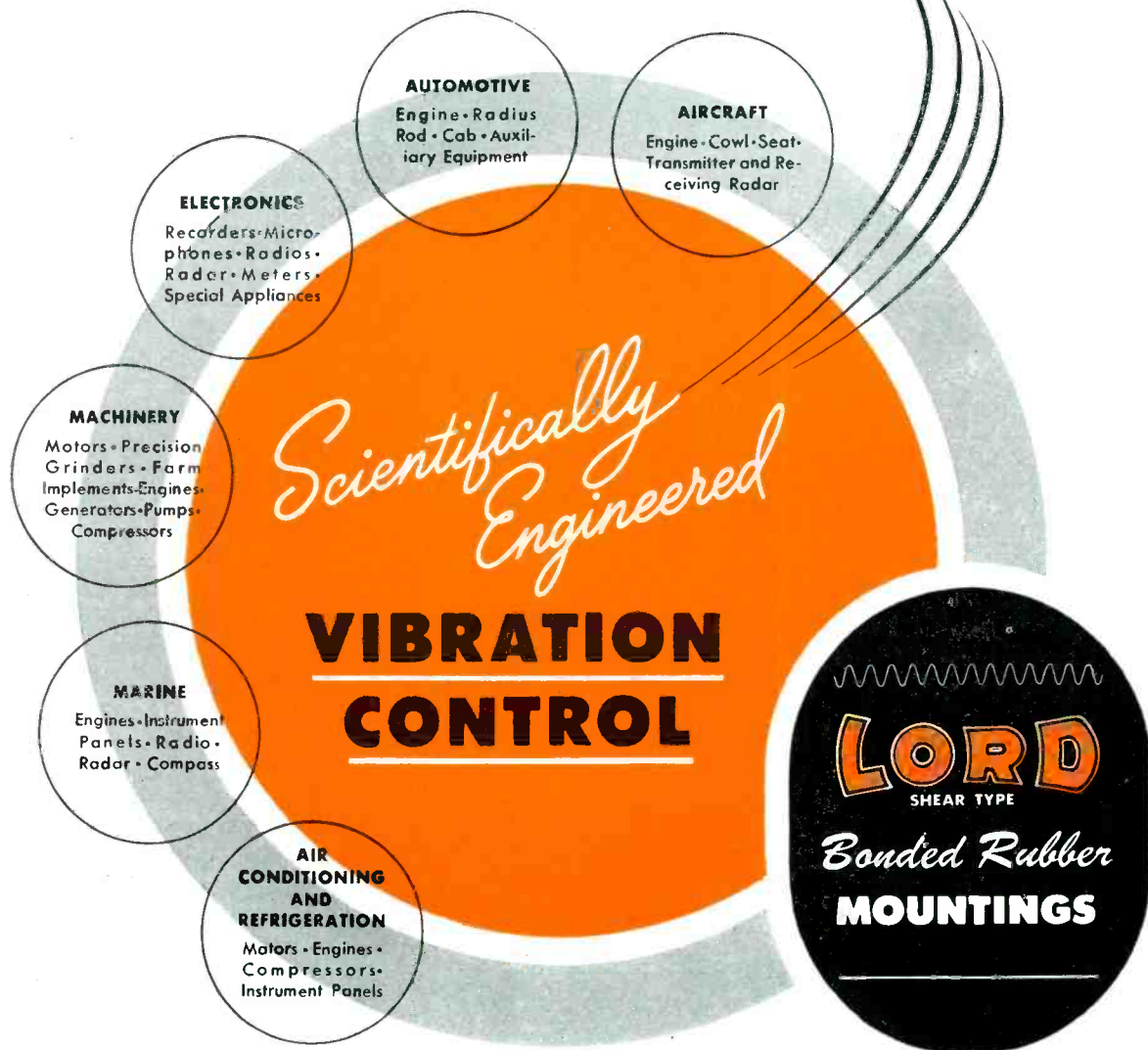

Fig. 2—Electronic sound-effects machine. The panels at the left provide a choice of the sounds of distant and local machine-gun fire, shell bursts, tank, airplane and motorcycle noise

we sell only **ONE** thing



*F*OR twenty-five years Lord has pioneered the science of vibration control and isolation. We studied vibration, wherever we found it—vibration caused by regular or intermittent shock, by rotating parts, by impact, by concussion, by sound waves, by irregular and accidental shock.

What we have to sell is relief from vibration—relief from its wear and tear on machines and men, relief from its attacks on quality and quantity of production, relief from its interference with proper functioning of delicate instruments, and sound transmitting and receiving apparatus.

Our research and experience proved that rubber, bonded to metal, used as the absorbing element, if correctly designed,

as to shape and size, stressed in free shear at predetermined deflections for specific applications, is superior to any other material because it combines almost unlimited controllability, with great elasticity.

Today we use rubber, natural and synthetic, of many stiffnesses; we use steel, we use brass, monel, dural. But we're not selling any of these—we're selling precision engineered vibration control and isolation.

The most important ingredient of any Lord Mounting you buy is—brains. You can't buy them, either, except as they are embodied in the assured protection you buy when you make sure that the name LORD is stamped or molded in the product.

IT TAKES **BONDED RUBBER** *In Shear* TO ABSORB VIBRATION

**LORD MANUFACTURING COMPANY**  
ERIE, PENNSYLVANIA

SALES REPRESENTATIVES  
NEW YORK - 280 MADISON AVE.  
CHICAGO - 520 N. MICHIGAN AVE.  
DETROIT - 7310 WOODWARD AVE.  
BURBANK, CAL. - 245 E. OLIVE AVE.  
CANADIAN REPRESENTATIVES  
RAILWAY & POWER ENGINEERING CORP., LTD.  
TORONTO, CANADA

★  
BUY VICTORY BONDS  
★

*Originators of Shear Type Bonded Rubber Mountings*



NO PRICE INCREASE on

# Conant Instrument Rectifiers

Despite rising material and labor costs, and the upward price trend on many products, you can still get CONANT rectifiers at pre-war prices.

There's a CONANT Instrument Rectifier for every need. CONANT's 4 basic assemblies in 3 series (500, 160 and 160-C) can serve over 90 percent of all instrument rectifier requirements.

## Other Great CONANT Developments

**BALAC**—for applications that involve the balanced bridge principle in AC operation.

**UNI-SCALE**—the rectifier assembly that completely eliminates temperature variations.

Instrument  
Rectifiers

Get this **BOOK!**

"Instrument Rectifiers and Rectifier Type Instruments," by H. B. Conant. It's "must" reading for every user of instrument rectifiers. Send 25c to cover handling and mailing to

*Instrument Rectifiers*

**ELECTRICAL LABORATORIES**

6500 O STREET, LINCOLN 5, NEBRASKA, U. S. A.

20 Vesey St., New York 7, New York  
85 E. Gay St., Columbus, Ohio  
600 S. Michigan Ave., Chicago 5, Ill.  
1215 Harmon Pl., Minneapolis 3, Minn.

2017 Grand Ave., Kansas City 8, Mo.  
1212 Camp St., Dallas 2, Texas  
378 Boulevard N. E., Atlanta, Ga.  
4018 Greer Ave., St. Louis, Mo.

1526 Ivy St., Denver, Colo.  
4214 Country Club Dr., Long Beach 7, Cal.  
Export Div., 89 Broad St., N. Y. 4, N. Y.  
50 Yarmouth Rd., Toronto, Canada

ed capacitor into the grid circuit of the output.

The sound of nearby machine guns is obtained from two triodes used as a multivibrator with a common cathode resistor and unequal time constants in the grid couplings. This setup gives a large positive pulse across the cathode resistor followed by a smaller positive pulse and is applied to the grid of a triode normally biased to cut-off. A small measure of aperiodic noise is also mixed in. The effect of the double pulse is to create the characteristic "tutter" of an automatic gun while the aperiodic noise generates the sharper "bark".

Other effects which can be produced by this equipment are distant machine-gun fire, teleprinters, tanks, aeroplanes, cars, motorcycles and include such effects as starting up, driving off, changing gears, fading away, exhaust, varying engine speed and the like.

### *Prevents Repetition*

The mixing and power amplification of the effects follows conventional lines but there is a simple though ingenious mechanism to prevent any combination of sounds from being repeated too often. It consists of five synchronous motors driving cams running at speeds varying from one revolution in 30 seconds to one in 18 minutes. Four of the motors have an extra cam which opens the motor circuit of an adjacent motor, so that one runs continuously while the others stop at irregular intervals. By this means various sounds can be mixed and yet particular combinations or sequences will only repeat at very long intervals.

Figure 2 shows a photograph of this sound-effects machine, the product of the Mervyn Sound and Vision Co. Ltd. of Great Britain.

It contains two monitor speakers mounted behind the grilles near the top of the cabinet, four power amplifiers and a power supply behind the right-hand panels. Choice of noise facilities is made from the panels at left which are labeled aeroplane, tank, etc. Mixing of these is accomplished by the various controls at upper right.

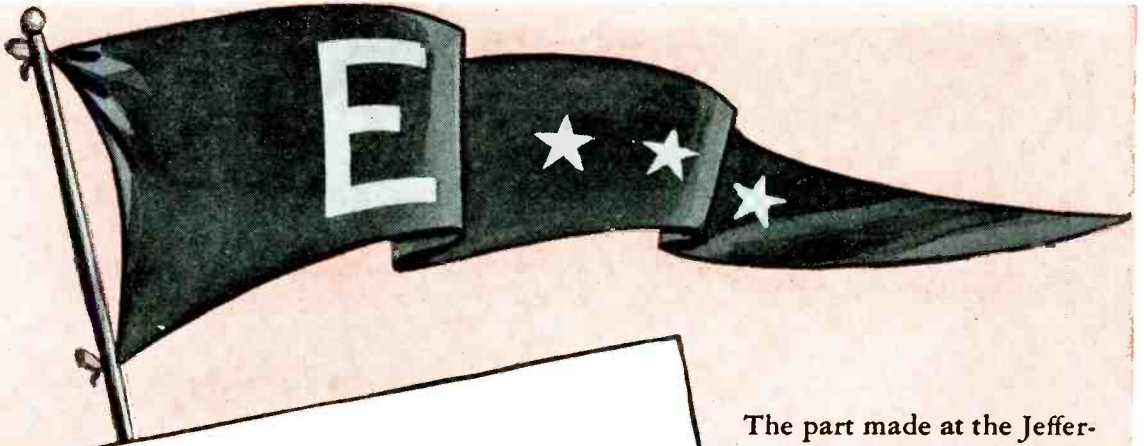

ADDRESS REPLY TO  
BUREAU OF ORDNANCE, NAVY DEPARTMENT  
AND REFER TO

NAVY DEPARTMENT  
BUREAU OF ORDNANCE  
WASHINGTON 25, D. C.

September 26, 1945

P15  
(Ad5)

Sirs:

It is my great pleasure to announce the award of the Bureau of Ordnance "g" to your company and to other firms who participated in one of the most important of our wartime ordnance projects — the successful development and manufacture of the VT fuze.

The Bureau of Ordnance has never underestimated the value of your services and has regretted the necessity for maintaining secrecy on your product throughout the war and even beyond that, so long as there remained any doubt that security restrictions could be lifted with safety. Maintenance of these security safeguards unfortunately has prevented the award of this Army-Navy "g" to producers of the VT fuze who otherwise would have been eligible for consideration. We have appreciated your understanding of the reasons why your excellent production job had to be performed behind a veil of secrecy.

Now that the story can be told, the Bureau of Ordnance wants to recognize publicly the importance of the part you have played. The Bureau of Ordnance "g" is being revived exclusively as a means of paying proper tribute to the Navy contractors who worked on the VT fuze.

Each plant receiving the award will be furnished with a Bureau of Ordnance flag, a Navy "g" pennant and "g" buttons in sufficient quantity to supply all workers who assisted in making the VT fuze. In the case of plants which would have been eligible for renewal awards, stars will be affixed to the pennants, one for each six months of eligibility.

Please inform the Bureau where your flags should be shipped and how many pins are desired. You will be informed of the probable delivery date of these items.

The Bureau of Ordnance is grateful for your devoted efforts and is happy to congratulate you on the excellence of your performance of a wartime task of the first magnitude. A hearty "Well Done!"

Sincerely yours,

  
G. F. HUSSEY, JR.  
Rear Admiral, U. S. Navy  
Chief of the Bureau of Ordnance

Jefferson Electric Company  
Bellwood, Illinois

The part made at the Jefferson Electric plant is designated the Mercury Unshorter Switch. This was developed to prevent muzzle bursts (premature explosion) for the protection of the gun crew and yet close the circuit quickly to operate the device. In all, 12 types or sizes of mercury switches were manufactured, and special techniques were developed to achieve huge production rates while conforming to the most precise tolerances. We are proud to have performed such an important service in this vital ordnance project.





# THE ELECTRON ART

## 1945 Rochester Fall Meeting

RADIO ENGINEERS had their first opportunity en masse at the 1945 annual Rochester Fall Meeting held November 12 and 13 to begin their postwar reorientation which will occupy them for some time to come. Papers on war developments, and on the present and future states of communicational and navigational applications of electronics were presented before a registered attend-

ance approaching one thousand.

Dr. Lee DuBridge, who "as head of the Radiation Laboratory of MIT, operated under NDRC, contributed in an outstanding manner to the development of radar apparatus for all branches of the armed services in all fields in which this new science was employed," was awarded the fourth Fall Meeting Plaque.

## Abstracts of Papers Presented at the Rochester Fall Meeting

### *Coaxial Modification of the Butterfly Circuit*

By E. E. GROSS  
General Radio Company  
Cambridge, Mass.

OSCILLATORS FOR THE UHF RANGE of variable frequency can be built for general laboratory use by using a coaxial modification of the butterfly circuit and, in particular, the 2C43 lighthouse tube (McArthur, E. D., Disk-Seal Tubes, *ELECTRONICS*, Feb. 1945, p. 98.).

Although lumped, inductance-capacitance resonant circuits can be used in the vhf range if compactly

constructed, such circuits can not be used at higher frequencies. Feedback to sustain oscillation can be obtained within the tube itself by using grid-cathode and plate-cathode capacitances thus eliminating a troublesome external coupling circuit, but tube lead inductances in the uhf range vary the effect of interelectrode capacitances. Best results are obtained if grid-cathode and plate-cathode capacitances are approximately equal.

Uhf triode oscillators were made possible by the introduction of such tubes as the Western Electric 368-A

and 703-A doorknob types with their high resonant frequencies. However these tubes were designed for operation with transmission-line tanks which are not readily adjustable for variable-frequency oscillators. Butterfly circuits were used with these tubes, but because of the high current requirements for their thoriated tungsten filaments the tubes themselves are not particularly suitable for laboratory test equipment.

The General Electric lighthouse tubes such as the 2C43 and the 2C40, which have higher resonant frequencies than earlier triodes, are designed for coaxial-line circuits. The low ratio of plate-cathode to grid-cathode capacitances limited their upper frequency as an oscillator, however. The 6F4 acorn type tube, having a more favorable internal capacitance ratio will oscillate at higher frequencies than these lighthouse tubes if just a tuned circuit between plate and grid is used, but lacks the power of the lighthouse tubes. Therefore the problem became that of designing a tunable circuit in which a lighthouse tube would oscillate up to its highest possible frequency.

A coaxial variation of the butterfly circuit was developed. Basically it is a coaxial line shorted at one end, open at the other. The outer

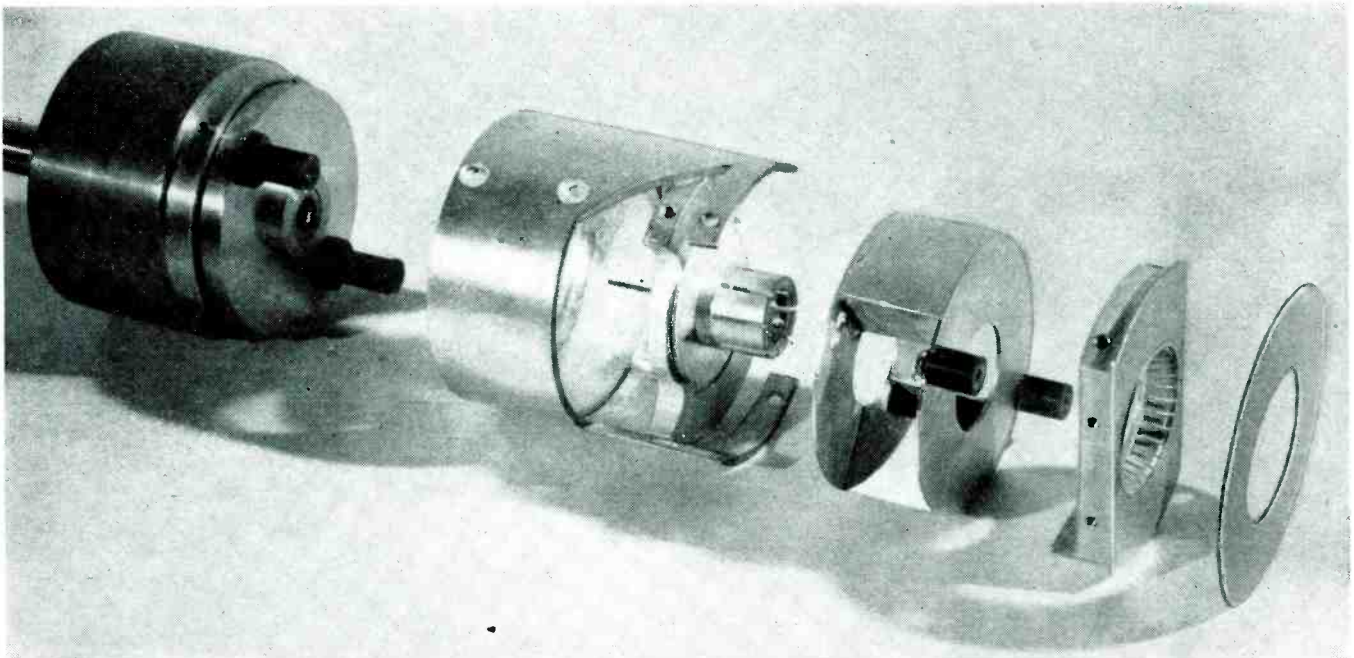

Coaxial butterfly circuit is built, starting from the left, of the rotor supports on their mounting; the plate-end assembly, which is the shorted end of the line in this model; the rotor; the grid disc, sections of which have been sliced off so that the feedback ring can be coupled to the rotor; and the feedback ring itself at the extreme right

# OHMITE

## RITEOHM PRECISION RESISTORS

*Non-Inductive... Pie-Wound... 1% Accurate*

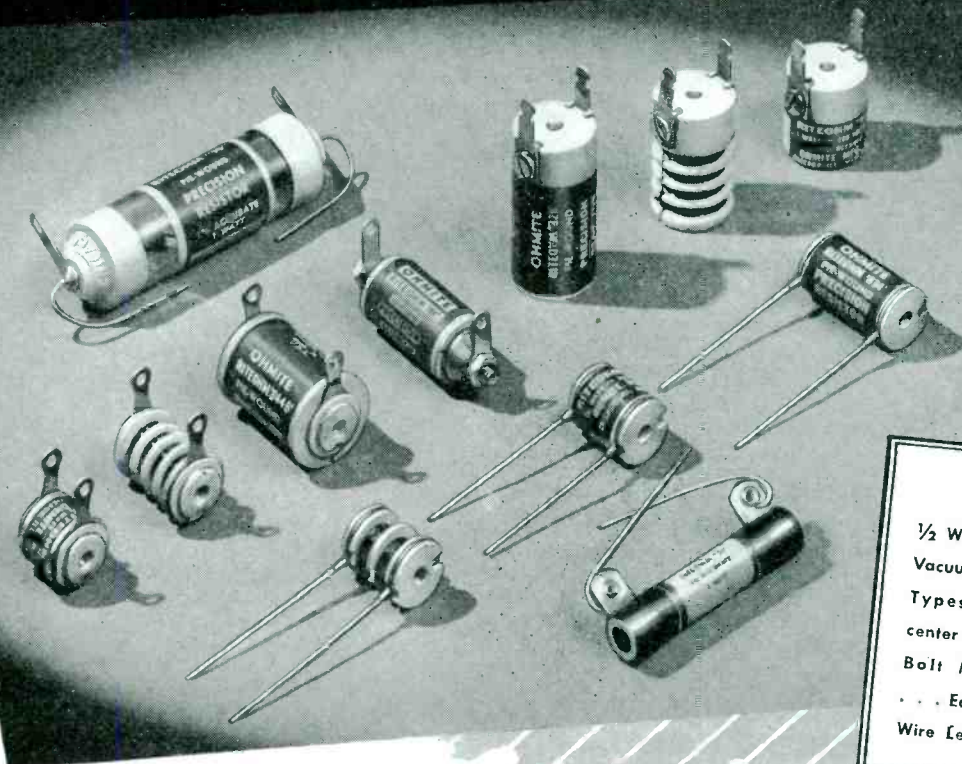

### NEW

1/2 Watt and 1 Watt  
Vacuum Impregnated  
Types... Hole in  
center for Through-  
Bolt Mounting  
... Equipped with  
Wire Leads or Lugs

### Available from Stock... or Made to Order

OHMITE presents a *new* line... a *full* line... of finer precision resistors! Every type... every size... ready for every need! Each Riteohm is designed and built with all the specialized skill and experience that have made OHMITE units the standard in this field. However critical the application... consistent accuracy and reliability are assured. In these Riteohms you get *time-proved protection against humidity, temperature and corrosion.*

Ideal for use in voltmeter multipliers, laboratory equipment, radio and electrical test sets, attenuation pads, and in electronic devices requiring *extremely accurate* resistance components.

AVAILABLE FROM STOCK in 1/2 watt and 1 watt units in a wide range of values, in various types of mountings and terminals... or made to order. Complete line of 6 different series includes non-inductive pie-wound vacuum impregnated units... single-layer wound vitreous enameled units... and non-inductive pie-wound hermetically glass sealed units. Some units are in a range of 0.1 ohm to 2,000,000 ohms. *Get full facts today!*

OHMITE MANUFACTURING CO., 4816 Flournoy St., Chicago 44, U. S. A.

### Send for Bulletin No. 126

This handy Riteohm Bulletin makes it easy for you to select the exact units for your needs. Gives complete data... lists stock units and made-to-order units... includes dimensional drawings. Write for it now.



Be Right with **OHMITE**

**RHEOSTATS • RESISTORS • TAP SWITCHES • CHOKES • ATTENUATORS**



## Industrial Condenser Corporation's NEW HOME



### THE WORLD'S MOST MODERN CONDENSER PLANT with these outstanding features

- ★ 1,000,000 VOLT RESEARCH LABORATORY
- ★ VERY LATEST PRODUCTION EQUIPMENT
- ★ SPECIALIZED WAR-LEARNED TECHNIQUES

From this NEW ultra-modern factory come capacitors carefully engineered and accurately produced. Staffed by skilled engineers and backed by 16 years of technical progress, Industrial Condenser Corp. is supplying capacitors for every application. If your specifications call for Electrolytic, Paper, Oil, or Motor capacitors, look to Industrial Condenser Corporation.

## INDUSTRIAL CONDENSER CORPORATION

3243-65 NORTH CALIFORNIA AVENUE, CHICAGO 18, U. S. A.  
District Offices in Principal Cities

PAPER, OIL AND ELECTROLYTIC MOTOR CAPACITORS

conductor has two sections that are cut away. Two smaller sectors rotating between inner and outer conductors vary the frequency. The tube, connected across the open end of the line, electrically foreshortens the line in proportion to the amount of capacitance loading presented by the tube. This loading depends upon the characteristic impedance of the line. Rotating the intermediate sectors varies the characteristic impedance of the line and thus changes the loading thereby controlling the electrical length of the line and therefore the oscillating frequency of the circuit.

One possible form that the coaxial butterfly circuit for a lighthouse tube can take is shown in the accompanying drawing. Disks *P* and *C* are located for proper feedback at

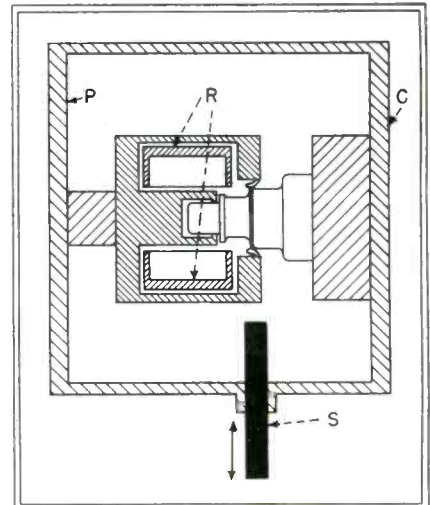

The coaxial butterfly resonator is mounted inside a cavity the end plates (*P* and *C*) of which form part of the feedback loop. Plunger *S* adds to the feedback at the low frequency end of the tunable range. Rotors *R* vary the frequency

the highest oscillating frequency. Additional feedback at lower frequencies is obtained by adjusting plunger *S*. The coaxial tank with the variable sectors *R* fits over the lighthouse tube. If the tuning drive that operates the rotating sectors also controls the feedback plunger, a fairly wide frequency range with a single control can be obtained.

There are other variations of this construction. The sliding contact between chamber and plunger can be eliminated. For pulsed oscilla-

GET THESE 2 ROLLER-SMITH FEATURES  
IN YOUR SWITCHBOARD INSTRUMENTS

*Large Easy-to-Read Scale*  
*Accuracy to within 1%*

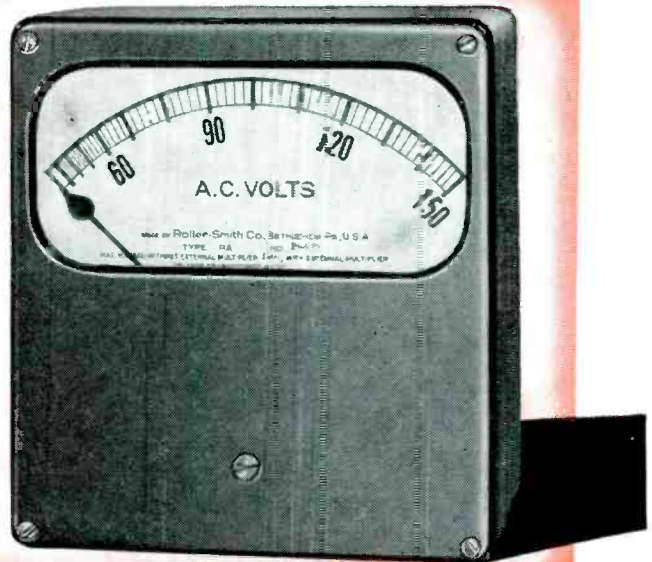

★ The large 5¼ inch scale printed in jet black on a bone white background makes all Foller-Smith switchboard instruments easy-to-read.

The accurate calibration and careful construction and design hold the instrument to an accuracy of 1%. Each instrument is individually calibrated and the scale then accurately drawn.

There is a mounting and style to meet individual preferences and needs. Round cases for surface mounting. Rectangular cases for surface or flush mounting. A full range of sizes and capacities is available in each type case and mounting. For full information, write for Catalog 422C to Department E-5

**FOR EVERY SWITCHBOARD NEED**

Round—Surface Mounted

Rectangular—Surface or Flush Mounted

Direct Current

Ammeters

Voltmeters

Alternating Current

Ammeters

Power Factor Meters

Voltmeters

Frequency Meters

Wattmeters

Synchrosopes



**ROLLER SMITH**

*Switchboard Instruments*

**BETHLEHEM • PENNSYLVANIA**

In Canada: Roller-Smith Marland, Ltd., Kitchener, Ontario

STANDARD AND PRECISION ELECTRICAL INSTRUMENTS • AIRCRAFT INSTRUMENTS • SWITCHGEAR  
AIR AND OIL CIRCUIT BREAKERS • ROTARY SWITCHES • RELAYS • PRECISION BALANCES



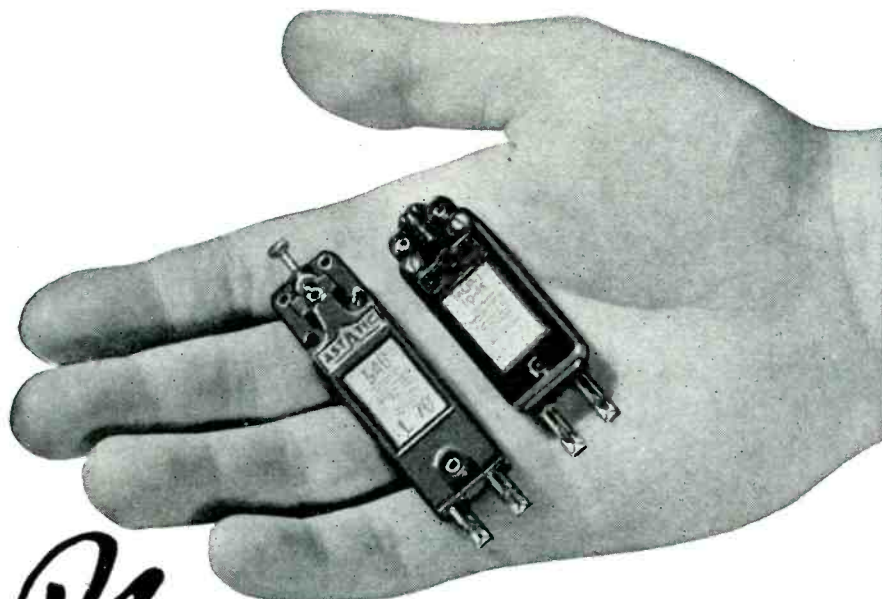

# New Astatic Cartridges

## Improve Phonograph Reproduction

**I**NTENDED for use with both automatic record changers and manually operated equipment, these new Astatic Cartridges, in MLP and L-70 Series, assure a degree of fidelity heretofore unparalleled in the reproduction of recorded sound. All new Astatic Phonograph Pickup Arms will include these finer Cartridges.

L-70 Series Cartridges are of the replaceable needle type, are designed with streamlined housing, high output voltage and low needle pressure.

MLP Series Cartridges are of the permanent or fixed stylus type and are engineered to operate at one-ounce pressure, with increased vertical compliance, higher output voltage and reduced needle talk.

*"You'll HEAR MORE  
from Astatic"*

• Astatic Crystal Devices  
manufactured under Brush  
Development Co. patents.

**THE**  
*Astatic*  
**ASTATIC CORPORATION**  
CONNEAUT, OHIO  
IN CANADA. CANADIAN ASTATIC LTD., TORONTO, ONTARIO

tors, greater feedback than for continuous wave oscillators must be provided. Output coupling loops can be variously placed but give greatest output if located opposite the feedback loop. Special designs give wider frequency range.

### *Radio Proximity Fuze*

By HERBERT TROTTER, JR.

*Eastman Kodak Co.  
Rochester, N. Y.*

THE IDEA of proximity fuzes is old. Patent offices of the United States, Germany, England, and Switzerland contain references to such devices. These patents are only ideas.

Work on fuzes started in England as far back as 1940 and in Germany, in 1930. Germany was still working on the fuzes at the end of the war, but had put none into service. German scientists said that Germany was not interested in the development of fuzes for shells because, even if engineering difficulties could be overcome, production difficulties were beyond the scope of any country in the world.

Work in the United States on the proximity fuzes was started in the fall of 1940, at the Carnegie Institute, Department of Terrestrial Magnetism, in Washington, by Dr. Tuve and his associates (Proximity Fuze, *ELECTRONICS*, Nov. 1945, p 110.) This paper deals with subsequent work done on shell fuzes.

The problem of building a radio device that could be shot out of a gun meant the development of special components. To test component parts and to see if the fuze assembly would withstand firing forces, an experimental test field was set up with a 57-mm gun. This gun was mounted vertically so that the shells would land in a relatively small area and could then be recovered and the contents examined. In this way, the various components were studied and designs changed until the unit was mechanically dependable.

The problem of getting the fuze to operate properly in flight was more difficult because it was not possible to study the unit while it was being tested. From results, one could only postulate the causes of failure and try to correct the faults one at a time.

Later, fuzes were tested in 5-inch

How do  
you guard against  
**CORROSION?**



Do it with corrosion-free

**LUMARITH<sup>\*</sup> CA**

(CELLULOSE ACETATE)

**FILMS & FOILS**

Electro-chemical corrosion—the corrosion that occurs when current-carrying copper wire and insulation get together with humidity—is a prime cause of electrical equipment failure.

Many insulation materials serve well under ideal conditions, but only a few stand up to current and moisture. Lumarith CA (cellulose acetate) is one.

Lumarith films and foils are resist-

ant to electro-chemical corrosion. Their dielectric strength and arc resistance is high.

Used as interlayer insulation, coil covers and forms, laminates and wire wraps, Lumarith CA gives full protection to even the most delicate electrical equipment. Celanese Plastics Corporation, a division of Celanese Corporation of America, 180 Madison Avenue, New York 16, N. Y.

*Just Published!*

"Celanese Synthetics for the Electrical Industry." It contains complete electrical and mechanical data on Lumarith plastics films, foils, sheets, rods, tubes and molding materials. Write for your copy.

*A  
Celanese<sup>\*</sup> Plastic*

\*Reg. U. S. Pat. Off.



# Glaser

**SOLDER  
PRODUCTS**

*For Quality  
Products—use  
a Quality Solder*



In Electronics "Quality" is vital! A lowering of "Quality" in any integral unit means shorter life and poor performance.

In close assembly and confined spaces, or where extremities of heat and cold reaction occur, the demand for a positive, lasting solder bond is imperative.

For that extra quality so essential to your capacitors, resistors, transformers, relays etc. use Glaser Plastic Rosin Core Solder—it is your guarantee of *dependable service*.

Electronic Engineers and Technicians appreciate the fine quality of Glaser Solders and Fluxes—the result of metallurgical research extending over a period of twenty-three years.

Use Glaser Solders and you'll understand why so many leading solder users in the field of electronics and radio speak of them in terms of the highest praise.

Consult our Engineering Department on your soldering and flux problems, without obligation.

**GLASER LEAD CO., INC.**

31 Wyckoff Avenue,

Brooklyn 27, N. Y.



**OTHER  
GLASER  
PRODUCTS**

Silver Brazing  
Solder and Flux

Fluxes for  
every purpose.

Lead Products of  
every description.

Lead Lining of acid  
and plating tanks.

Glaser Plastic Rosin  
Core Solders exceed government  
specifications in  
purity, and are  
guaranteed to meet  
A.S.T.M. Class A  
specifications  
for solder.

Navy guns over water and finally in August of 1942, radio-controlled planes were shot down in Chesapeake Bay. Every time a change was introduced into the fuze, elaborate testing had to be undertaken to insure that the performance of the fuze was not impaired. Throughout the war, rigid quality control was followed, and each lot of fuzes turned over to the services had samples tested by firing.

*Proximity Fuze Tubes*

By MARCUS A. ACHESON  
*Sylvania Electric Products, Inc.*  
Kew Gardens, N. Y.

ALTHOUGH SYLVANIA developed and manufactured tubes for non-rotating projectiles, our major contribution to proximity fuze tubes was the development and manufacture of triodes, pentodes and thyratrons required for rotating projectiles. Some of the design problems of such tubes is the subject of this report.

While there is nothing unique about the idea of a proximity fuze for rotating projectiles, there is interest in the successful development achieved in this country. Basic fuze development was finished in the United States less than a year after Pearl Harbor.

German failure to develop a successful fuze lay in their inability to develop the ultra-rugged tubes as was indicated in discoveries by American scientists in Germany since VE-Day. They had, however, developed an ampule-activated battery, a development in this country which had been considered as equal in importance to the tube development.

Several of these British and German attempts to develop a manufacturable proximity fuze were known to Section T of OSRD when developmental work was undertaken by request of the Navy in 1940. Section T searched the tube industry for small, battery tubes which could withstand great stresses and strains. Hearing-aid tubes received attention because they were both small and available, had quick heating time, and were good amplifiers. However their mechanical strength was far below that needed.

Tubes for rotating VT fuzes were

OUR 23RD YEAR OF DEPENDABLE SERVICE TO AMERICAN INDUSTRIES

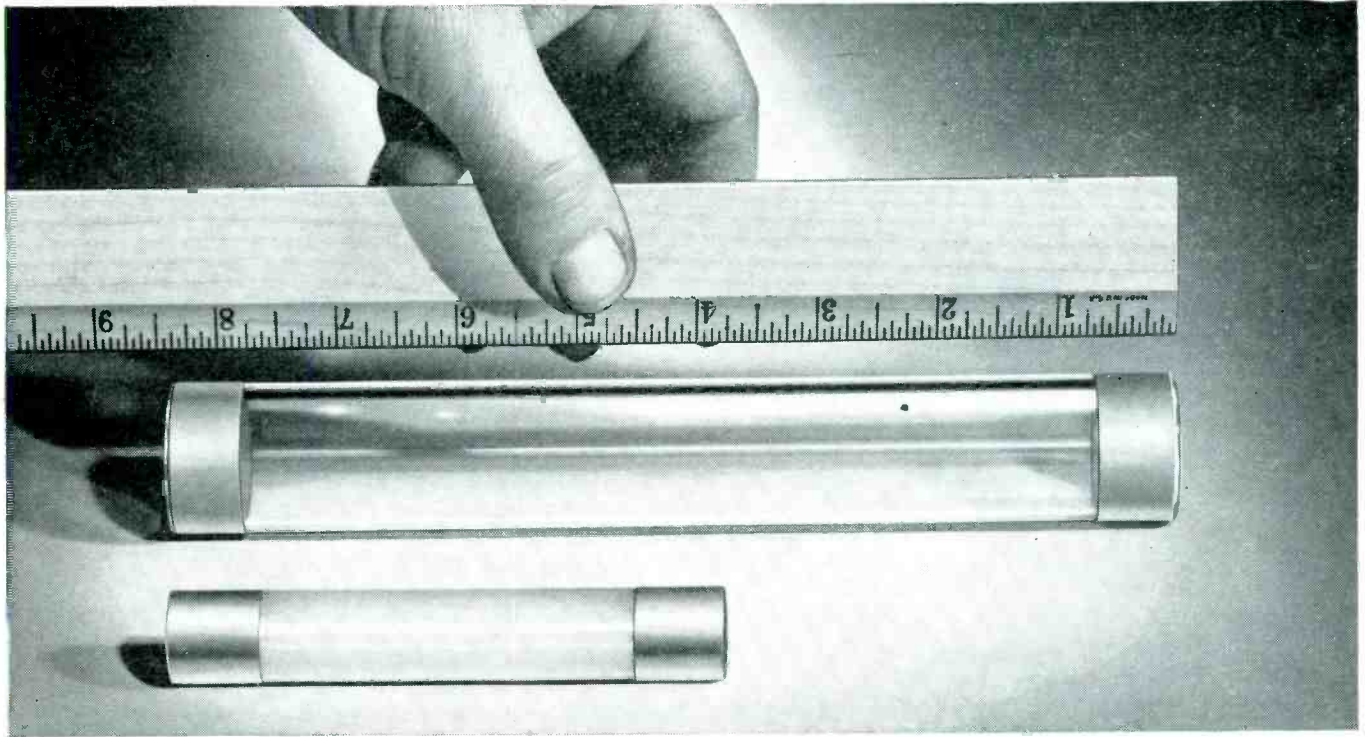

## THESE GLASS TUBES HAVE A RULE AGAINST LETTING THE OUTSIDE IN!

**T**HE point is—they're metallized at each end with the famous Corning process that makes a permanent bond between the glass and metal. This means these tubes for resistors, capacitors, etc. can be soldered into place to form a permanent hermetic seal. No dust, moisture, or corrosive atmosphere can get in.

Besides, these are pretty tough babies. They have two to three times the strength of ordinary glass. Assembled with heavy metal end caps, they will withstand thermal shock up to 275°C.—spot heat to ice water. Their electrical properties are good, too, with high surface and volume resistivity. They're no Johnny-

come-lately's either. Millions have been made and used successfully. 20 standard sizes from  $\frac{1}{2}$ " x 2" to  $1\frac{1}{4}$ " x 10" can be mass-produced for immediate shipment.

If metallized glass can improve your product through hermetic seals or faster assembly, Corning can help you. Look at the Corning Electronic Products below. If something like these are what you have been looking for, write, wire or phone The Electronic Sales Department, E-1, Technical Products Division, Corning Glass Works, Corning, New York. We'll have an engineer at your doorstep in nothing flat ready to help you work out your problem.

**NOTE**—The metallized Tubes and Bushings, Headers and Coil Forms below are all made by the famous Corning Metallizing Process. Can be soldered into place to form true and permanent hermetic seals. Impervious to dust, moisture and corrosion.



**Metallized Tubes** for resistors, capacitors, etc. 20 standard sizes  $\frac{1}{2}$ " x 2" to  $1\frac{1}{4}$ " x 10". Mass-produced for immediate shipment.

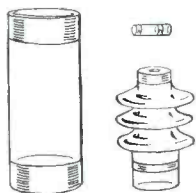

**Metallized Bushings.** Tubes in 10 standard sizes,  $\frac{5}{16}$ " x  $2\frac{3}{4}$ " to 1" x  $4\frac{1}{2}$ " in mass production for immediate shipment.

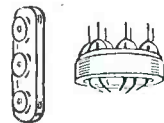

**Headers**—The best way to get a large number of leads in a small space for assembly in one operation.

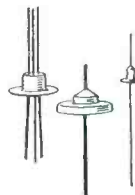

**Eyelet Terminals**—Single or multiple eyelets permit design flexibility. Standard items readily available in quantity.

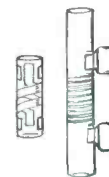

**Coil Forms**—Grooved for ordinary frequencies—metallized for high frequencies. In various designs and mountings.



**VYCOR Brand cylinders**—very low loss characteristics. Stands thermal shock up to 900°C. Can be metallized.

# CORNING

— means —

## Research in Glass

# Electronic Glassware

"PYREX", "VYCOR" and "CORNING" are registered trade-marks and indicate manufacture by Corning Glass Works, Corning, N. Y.



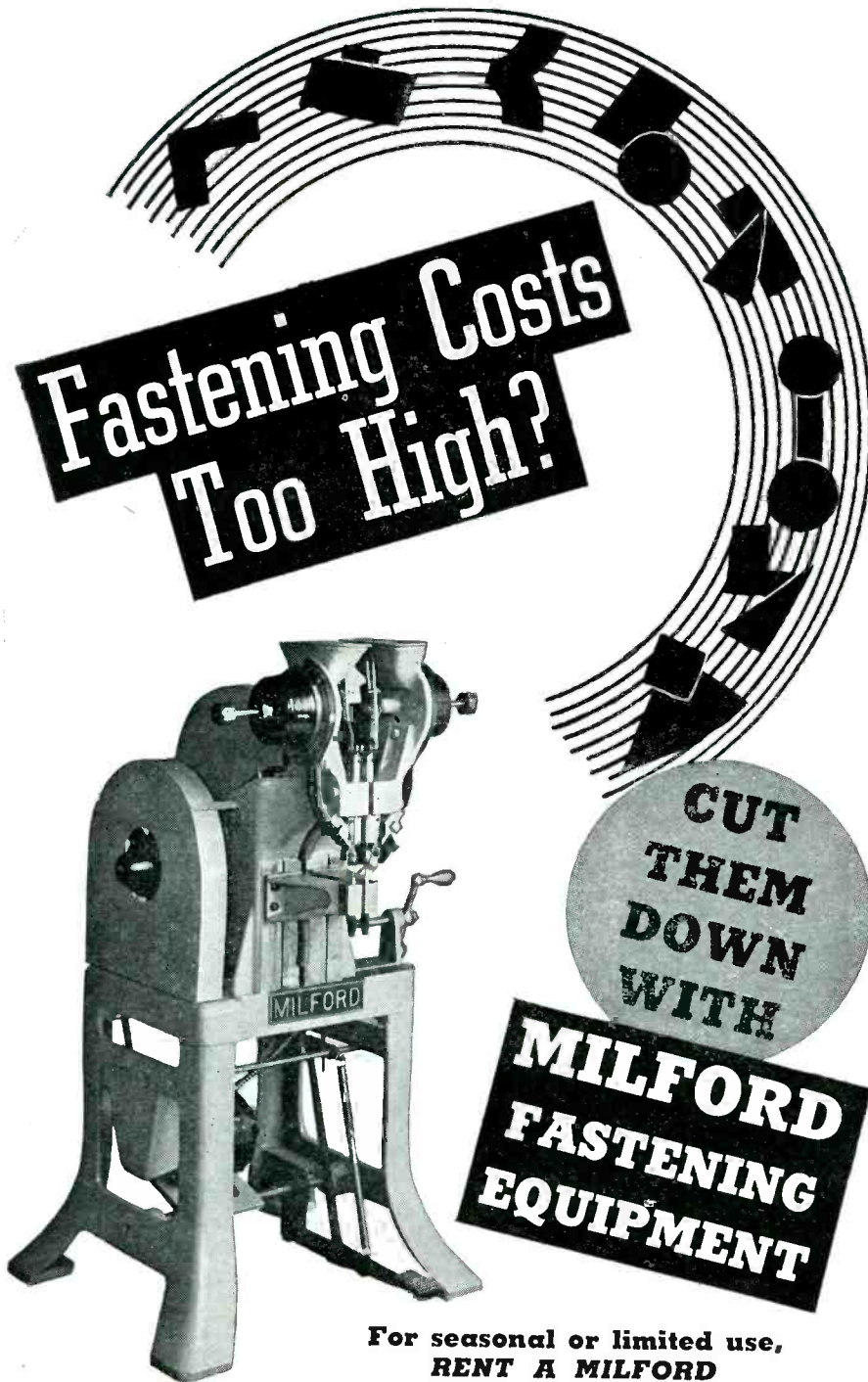

**Fastening Costs Too High?**

**CUT THEM DOWN WITH MILFORD FASTENING EQUIPMENT**

**For seasonal or limited use, RENT A MILFORD RIVET-SETTING MACHINE**

Not alone cost of fasteners, but cost of fasteners AND of time in getting parts in position, determine the real costs of a fastening operation.

Such cost comparisons, on the most diverse products requiring small metal fasteners, have repeatedly proved that Milford semi-tubular rivets and rivet-setting machines (in several models) shrink costs to a remnant of what they

were with other types of fasteners.

No matter how low your present fastening costs, the possibility that Milford products and service may reduce them still further—or may speed fastening operations—makes investigation worthwhile.

Without obligation, send a sample of your product for study by Milford engineers.

**THE MILFORD RIVET & MACHINE CO.**  
MILFORD, CONN. ELYRIA, OHIO

*Inquiries may also be addressed to our subsidiary:*

**THE PENN RIVET & MACHINE CO., PHILADELPHIA 3, PENNA.**

*Designers and Manufacturers of: SPECIAL COLD-HEADED PARTS; SPLIT, SEMI-TUBULAR AND DEEP-DRILLED RIVETS; RIVET-SETTING MACHINES; SPECIAL MACHINE SCREWS AND SCREW MACHINE PARTS.*

expected to endure an acceleration of 20,000 g's, and centrifugal forces caused by rotations of approximately 30,000 rpm. The problem was so complex that an entirely new approach was necessary.

Of the three main requirements—mechanical and electrical features and adaptability to high-speed production—it was necessary to determine the exact relationship of each to the other. Uppermost importance was placed on mechanical features.

An object shot from a gun is not only subjected to the violent impact of explosion; it is also forced to travel through the gun barrel in a spin that is not smooth, but is more like a shudder. This combination of

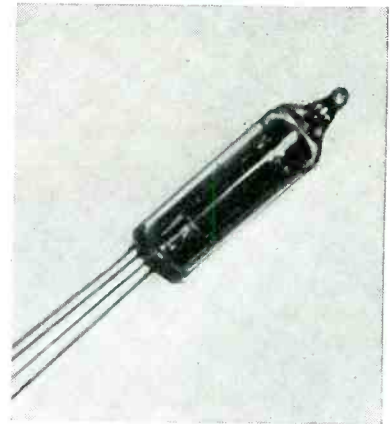

Full size photo of triode designed for mechanical strength and quantity production

spin and shudder (termed "yaw") produces a rapid side-slap, which, when applied under conditions that increase the weight of the parts 20,000 times, greatly complicates the tube design problem.

Space limitation in the shells added another problem to tube design. There was no limit to the minimum specification, except that the size must be manufacturable.

A review of the fundamental knowledge on hand revealed valuable techniques for solving four of the structural problems. These techniques were: (1) glass strain control and fracture analysis by polarized light, (2) a method for making bulbs from tubing, and a method of tubulation that gave unusual strength around the tip, (3) the cataphoresis method of coating very fine tungsten filaments, and (4) the

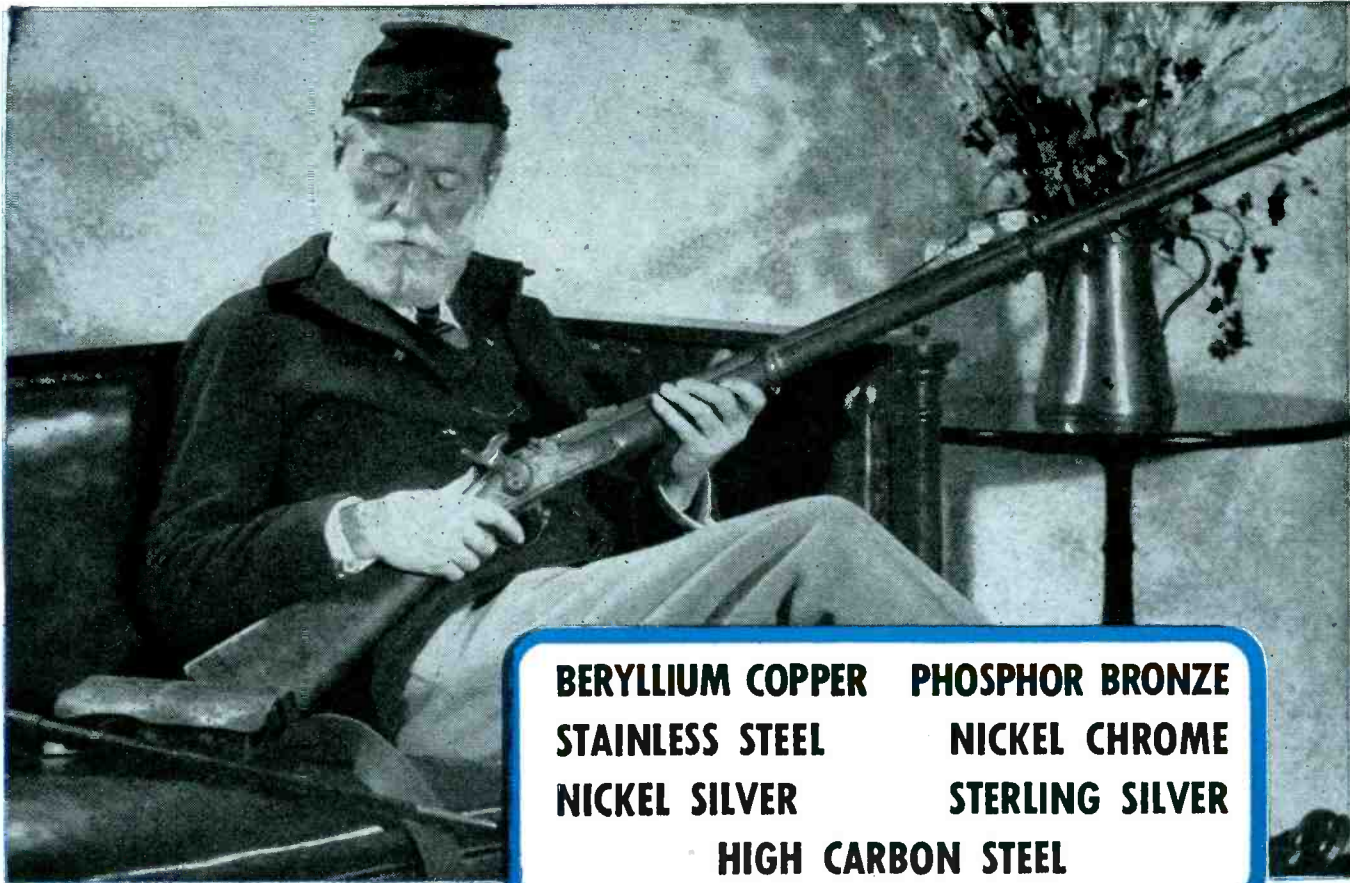

**BERYLLIUM COPPER    PHOSPHOR BRONZE**  
**STAINLESS STEEL     NICKEL CHROME**  
**NICKEL SILVER        STERLING SILVER**  
**HIGH CARBON STEEL**

## Grandpa did all right . . . in '63!

Muzzle-loaders, like crudely drawn wires, were acceptable in the old days. Now, however, the stringent requirements of modern products and modern engineers demand that perfection be built into every hank, coil and spool of wire. The Spencer

engineering department is staffed with capable men to produce quality steel and alloy wire of exacting standards in all fine sizes. Write Dept. EL-11 for engineering information on your fine wire requirements.



**SPENCER WIRE COMPANY**

WEST BROOKFIELD PLANT

WEST BROOKFIELD - MASS.



# Consult Sigma

IF YOUR RELAY REQUIREMENTS ARE:

## PRECISION — RUGGEDNESS SENSITIVITY

TYPE 4F

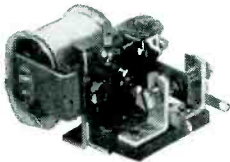

TYPE 4F

This is the Series 4 relay with open frame construction. It is compact ( $1\frac{5}{8}$ " x  $1\frac{3}{8}$ " x  $1\frac{5}{32}$ "), fast (2 - 3 milliseconds with sufficient power), sensitive (.010 watts minimum).



TYPE 4A

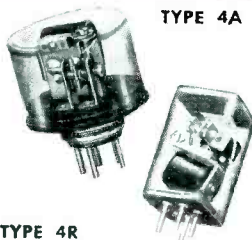

TYPE 4R

TYPES 4A AND 4R

These are the basic Series 4 construction with enclosures. The 4A is  $2\frac{1}{8}$ " diameter and  $2\frac{1}{8}$ " high, the 4R  $1\frac{1}{2}$ " x  $1\frac{1}{2}$ " x  $2\frac{5}{8}$ ". Both have a 5-pin plug in base. The 4A can be sealed (4AH).



TYPE 5F

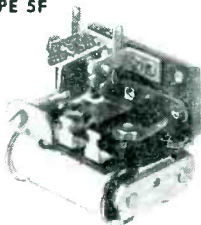

TYPE 5F

This is the Series 5 relay with open frame construction. It is exceedingly sensitive (.0005 watts minimum), very rugged, precise in operation even under extremes of temperature and vibration.



TYPE 5R

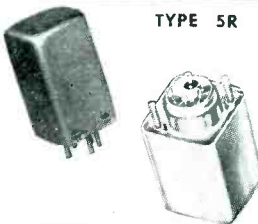

TYPE 4 (or 5) RJB2

TYPES 5R AND 4 (or 5) RJB2

5R is the Series 5 construction in an enclosure ( $1\frac{1}{2}$ " x  $1\frac{1}{2}$ " x  $2\frac{1}{4}$ ") with a 5-pin plug in base. The RJB2 is a hermetically sealed enclosure with two mounting bolts available for both the Series 4 and 5 relays.

Sigma specializes in Relay Applications where precision of operation and dependability, under any adverse condition, are essential.

Sigma, . . . A recognized leader in the Sensitive relay field, offers YOU a quality product, priced right and engineered to meet your specifications.

Write today explaining your requirements.

**SIGMA**  
**Sigma Instruments, Inc.**  
*Sensitive* **RELAYS**

62 CEYLON ST., BOSTON 21, MASS.

use of straight-through leads as mount supports.

The first important design consideration was to select the material best suited for the envelope. Sylvania decided that an all-glass tube could be expected to endure the severe abuse imposed by gunfire, and at the same time avoid difficulties that had been experienced in making filamentary tubes of other than a glass construction, especially problems of outgassing.

The second consideration was to determine the smallest size that could fulfill the combined, physical, electrical and production requirements. Coupled with this problem was also the one of shape. The flat-press hearing-aid type of tube used in early experimental fuzes was unsatisfactory because of (1) weakness on the flat side which made the tube crack at the press, (2) microphonics caused by mount movement, because only two sides are supported in the flat seal, (3) the high capacitance and leakage problems between leads in the same plane, (4) leads in only one plane are not the most suitable foundation for a rigid mount structure, and (5) all leads in the same plane are not adaptable to streamlining to the tube structure so as to make the most manufacturable type of tube. For these reasons a cylindrical bulb and leads on more than one plane are essential.

The first size selected was  $\frac{3}{8}$  of an inch outside diameter, and  $1\frac{1}{4}$  inches overall length. A triode in this size has a volume of slightly more than one-tenth of a cubic inch, and weighs a little more than one-tenth of an ounce, but at 20,000 g's the effective weight of the tube is 125 pounds.

An abnormally strong header construction was required for this size because the header was subjected to the strain of overcoming the inertia of the mount structure as its weight was increased 20,000 times. Header design was not only a success from the mechanical standpoint, but also (1) provided a method of processing small tubes that prevents excessive heat from reaching the elements, (2) freed the mount from dependence for support upon perfectly fitted miccas, which in turn



# NEW 73 SERIES

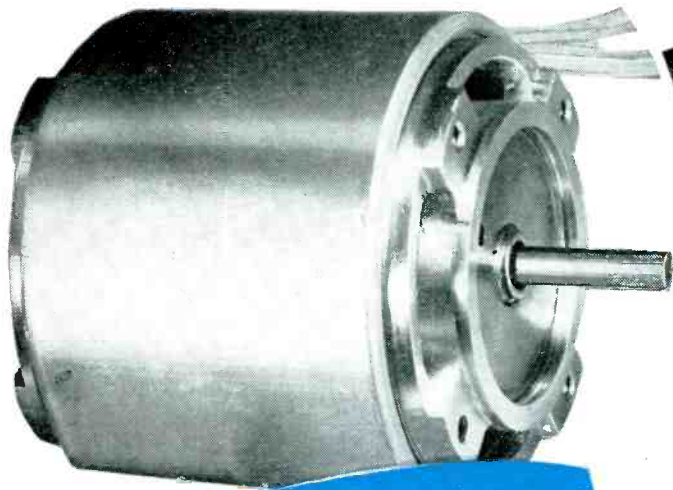

**SLEEVE BEARING**  
Fractional HP Motors

**115 VOLTS - 60 CYCLES**  
**1/200 HP to 1/15 HP**

- Capacitor
- Shaded Pole
- Synchronous

#### TECHNICAL FEATURES

- 1 Noiseless operation—Hydraulically locked lamination stacks.
- 2 Long life—extremely large oil reservoir 1 1/8 in. diameter.
- 3 Maximum horsepower for size and weight.
- 4 Bearings with oil reservoirs contained in removable capsules. Snap ring replacement.
- 5 Precision machined mounting face, concentric with shaft.
- 6 Ground rotor and shaft.
- 7 Die cast aluminum—End covers for rigidity and light weight.
- 8 Aluminum shell for efficient cooling.

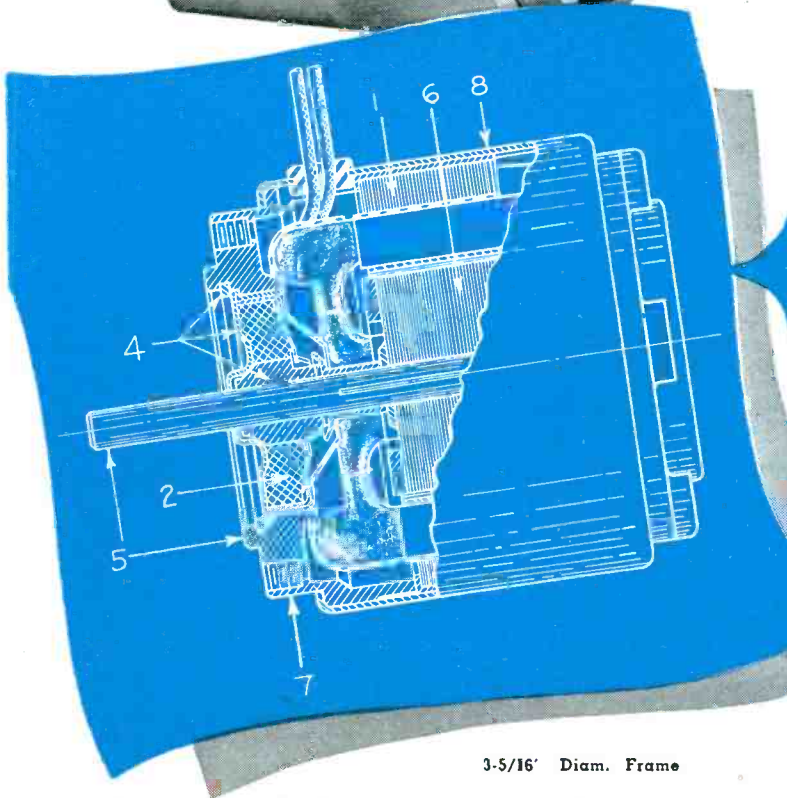

3-5/16" Diam. Frame

CLASSIFICATION	H. P.	SPEED	REMARKS
INDUCTION (CAPACITOR START AND RUN)	1/20, 1/30, 1/50	1600 RPM 3200 RPM	Continuous Duty Fully Enclosed
SHADED POLE	1/20, 1/30, 1/50, 1/100	1425 RPM	"
SYNCHRONOUS (CAPACITOR START AND RUN)	1/50, 1/100, 1/200	1800 RPM 3600 RPM	"

These motors are ideal for use in original equipment such as recorders, business machines, automatic devises, record players, on circulators and driving fans and blowers.

**ORDERS ARE INVITED**  
Prompt deliveries ranging from one to four months. Further data on request.



## EASTERN AIR DEVICES, INC.

585 Dean Street • Brooklyn 17, N. Y.

An Affiliate of The Fred Goat Co., Inc., Est. 1893



# CML 1420

## ELECTRONIC GENERATOR

Frequency stability of the CML 1420 is better than 2% after initial warm-up. Maximum distortion at full output into resistive load is 10%. Regulation no-load to full load within 4%. Nominal regulated voltage output 80-120-135-215-255 or 270 volts. Power input 115 volts 60 cycles 1200 watts single phase.

**TEST  
POWER  
for  
Continuous  
Duty**



### FREQUENCY RANGE:

50 to 6,000 Cycles in 4 bands

### POWER OUTPUT:

250 Watts Continuous Duty

### FREQUENCY CONTROL:

Single dial, direct reading, linear scale in 4 ranges—50-180; 170-600; 500-1800; 1700-6000 cycles.

Send For Descriptive Bulletin

# COMMUNICATION MEASUREMENTS LABORATORY

120 Greenwich St., New York 6, N. Y.

Rotobridge • Electronic Generators • Power Supply Units

required absolutely uniform glass thickness, (3) eliminated waste caused by selecting glass tubing to such fine tolerances, and (4) permitted using automatic equipment for high-speed operations both in assembly and glass working.

A smaller size— $\frac{1}{4}$  inch outside diameter and 1 inch overall length—was later developed and manufactured in large quantities. This size weighs slightly more than one-twentieth of an ounce and has an effective weight of 70 pounds at 20,000 g's. This type could be made on a wafer header, because strain on the header is well within the strength of wafer construction.

The internal parts of these tubes are, of course, very small. Consequently, it was necessary to make studies on simplification of parts, and to find means of assembly that mounting operators could perform. (Sylvania operators were presented and acclaimed for their skill and patriotism by Dr. L. Grant Hector before the Radio Club of America in New York, N. Y., on October 11, 1945 during his talk on the Radio Proximity Fuze. Ed. Note.) Mounters learned to combine touch with sight to produce as many assemblies per hour as are produced for conventional tube types.

Electrical requirements were strict. For example, (1) low microphonic output in the presence of mechanical shock and vibration, (2) less than a second allowed for the tube to reach full and stable operation after application of voltages, (3) low power drain to permit use of small batteries, and (4) dependable performance after months of storage, regardless of climatic conditions.

Coating of the fine filament wire required both chemical and electrical research and development because uniform coating weights and exact control of emission characteristics were necessary for meeting the first three electrical requirements.

Another phase of the filament problem was the structure of the tungsten wire itself. A better grade of fine wire was needed than had been made up to that time. The metallurgical laboratory accordingly developed materials and con-



**HOME for them!**

**and the  
HOME STRETCH  
for YOU!**

You still have time! In December, your employees' allotments to the Victory Loan through your company's Payroll Savings Plan offer a final chance to help speed the proud homecoming of our fighting men—and do all in medical power for our hospitalized heroes!

Make December a plantwide TOP-THE-QUOTA drive! Now's the time to spotlight your Payroll Savings Plan—and "brief" your Bond-selling organization for fast, last minute action!

**Resolicit every employee to buy  
the New F.D.R. Memorial \$200 Bond**

The new Franklin Delano Roosevelt \$200 Bond—better than actual cash because it earns interest—is a strong building stone toward the secure future of every employee-purchaser!

From now 'til the New Year—with plant rallies, interdepartmental contests and resolicitation—keep Payroll Savings Plan Bond-buying at a new Victory Loan high! Buying a Victory Bond is the best way of saying "Welcome Home" to our returning veterans! Also an active aid in assuring prosperity to your nation, your employees—and your own industry!



*The Treasury Department acknowledges with appreciation the publication of this message by*

**ELECTRONICS**

*This is an official U.S. Treasury advertisement prepared under the auspices of the Treasury Department and War Advertising Council*



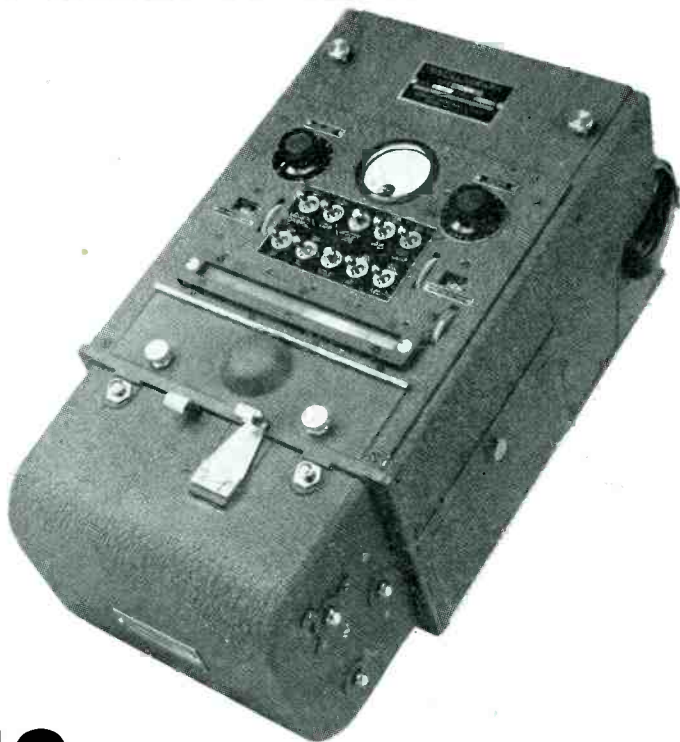

## 12 CHANNEL CAPACITY

*...yet as easy to take with  
you as a brief case!*

HATHAWAY TYPE S-12 OSCILLOGRAPH combines portability and small size convenience with excellence of results—without sacrificing capacity, accuracy or record quality

Measures only 18"x 9"x 8", yet accommodates up to 12 channels and gives permanent record on paper or film 6" wide by 100 feet. Interchangeable galvanometers available in natural frequency from 200 to 10,000 cycles per second to a sensitivity of 50 milliamperes per millimeter at one meter.

**Automatic features:** record length control; record numbering device; and time coordinate device which produces time lines clear across the record, quickly adjustable to either 1/100 or 1/10 second spacing. Viewing screen permits simultaneous viewing and recording.

Performance plus portability makes this instrument indispensable for field testing where accuracy and ease of control are imperative.

**DELIVERY — 60 to 90 Days**

● Write for bulletin SP-167. Hathaway Instrument Co.,  
1315 S. Clarkson Street, Denver 10, Colorado

*Hathaway* INSTRUMENTS

tinued quality control of them. It was also necessary that this group work directly with the manufacturers of fine tungsten wire, because the very secret nature of the OSRD project prevented giving wire manufacturers reasons for the strict requirements which at times seemed impossible to meet. The filament tensioning problem was one of the most crucial in the tubes' development.

Dependable performance after storage and under various climatic conditions was provided by the all-glass structure and flexible leads which eliminated the need for bases. Sealing and exhaust techniques prevented leakage paths and provided a thorough removal of occluded gases from the metal parts.

### *Microwave Radar*

By DONALD G. FINK  
McGraw-Hill Pub. Co.  
New York, N. Y.

ADVANTAGES and disadvantages of the microwaves in radar was the subject of this paper. These very short waves are used, first, to obtain a suitably narrow beam from a reflector of convenient size, and second, to minimize the gap in coverage in the horizontal direction. Also, as the wavelength is decreased, the maximum range of detection increases when a reflector of given size is used (The Radar Equation, *ELECTRONICS*, April 1945, p 92.).

Disadvantages, largely overcome during the war, were lack of high-power r-f generators for the transmitters, sensitive r-f mixers and reliable local oscillators for the receivers.

Microwave radar equipment was illustrated by slides of the SCR-584 and AN/MPG-1 radars, which are currently being described elsewhere in this publication. Radar oscilloscope photographs taken with microwave equipment were also shown.

### *High Quality Sound Recording on Magnetic Wire*

By LYNN C. HOLMES  
Stromberg-Carlson  
Rochester 3, N. Y.

MAGNETIC WIRE high-quality recording, like photographic film or embossed disc recording, is judged on

# 5 REASONS WHY

PIERCE GOVERNOR SPECIFIES

WALDES TRUARC  
RETAINING RINGS

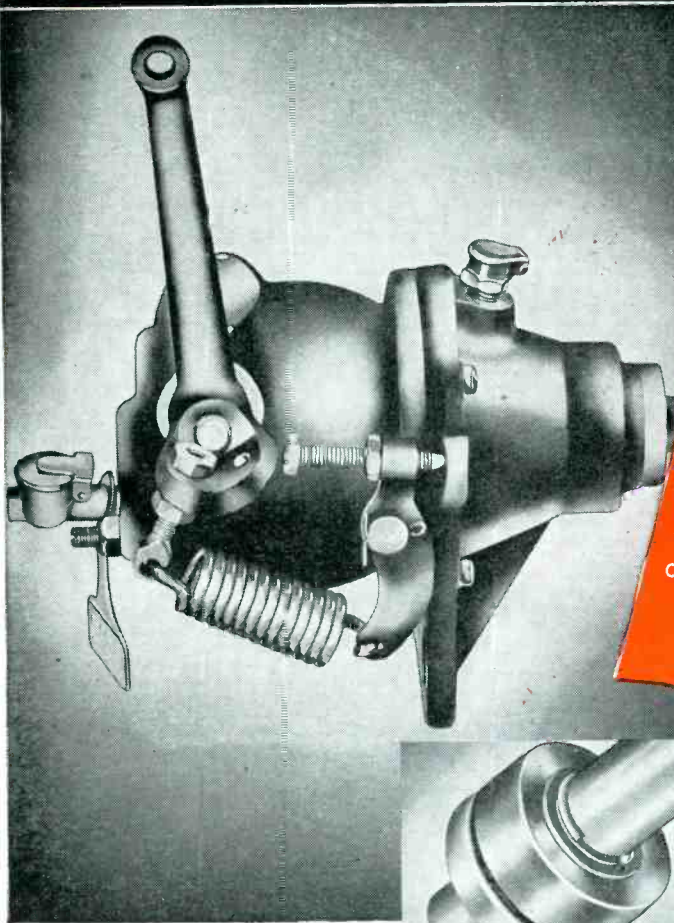

**THE PIERCE UNIVERSAL GOVERNOR**  
used on most industrial applica-  
tions of automotive motors.

"Waldes Truarc Retaining Rings on our precision flyball governors had five distinct advantages over wire snap rings previously used:  
1. speedier assembly and disassembly—  
2. elimination of injury to shafts when installing and removing—  
3. greater thrust power—  
4. narrower groove—  
5. greatly reduced production costs. Truarc rings are completely satisfac-  
tory, and we plan to extend their use to other models that were out of production during the war."  
Signed: Pierce Governor Co.  
Anderson, Ind.



## 1 BEFORE TRUARC

—Bearings on rocker arm were pressed against shoulders at the bottom of the cast iron housing. Wire snap rings were required, adjacent to inside face of bearings to position the shaft and keep it from moving sideways.

## 2 AFTER TRUARC

—It was possible to slip-fit the bearings. Truarc Retaining Rings have greatly simplified the design by performing the dual function of *positioning the shaft and holding the entire assembly securely in place.*



Waldes Truarc Retaining Rings have increased the efficiency and simplified design of countless machinery products by saving weight, space, cost and man hours. For holding and positioning machine parts, they have definite advantages over nuts, shoulders, collars and pins. They can be put on and taken off time and again—and still retain the perfect circularity which gives them their unfailing grip. Make your own tests. We'll gladly furnish samples and complete data. Write Dept. H-1.

**WALDES TRUARC**  
TRADE MARK  
**RETAINING RINGS**

WALDES KOHINOOR, INC., LONG ISLAND CITY 1, NEW YORK  
CANADIAN REPRESENTATIVE: PRENCO PROGRESS CORP., LTD., 72-74 STAFFORD STREET, TORONTO

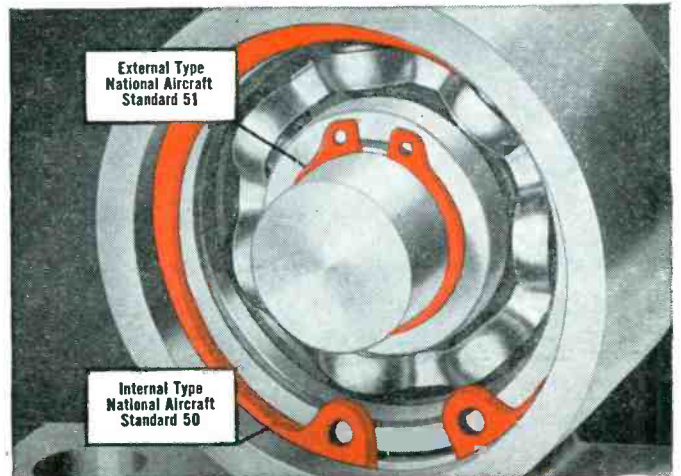

U.S. PAT. RE-16,144



# Permanent Magnets

FOR

## LOUD SPEAKERS

From ½ oz. to over 30 lbs. . . . and from start to finish . . . Arnold manufactures better Alnico permanent magnets for loud speakers. They are now available for all civilian applications, and include the proposed Radio Manufacturers Association standard speaker magnets in Alnico V.



The speaker magnets illustrated above are representative, yet are just one type of permanent magnets described in the new 24-page Arnold bulletin, "Permanent Magnets for Industry."

WRITE TODAY on your company letterhead  
FOR THIS NEW BULLETIN



**THE ARNOLD ENGINEERING COMPANY**

147 EAST ONTARIO STREET, CHICAGO 11, ILLINOIS

Specialists in the manufacture of  
ALNICO PERMANENT MAGNETS

its distortion, frequency response, signal-to-noise ratio, and wow.

Distortion can be reduced to a negligible amount by supersonic bias. In magnetic recordings, we are interested in the residual flux-density magnetization curve which always lies under the normal magnetization curve and has sharper bends than that curve. The action of the supersonic bias is to make the over-all transfer characteristic nearly linear, at the same time permitting use of a wider dynamic range because the wire is effectively unmagnetized, as it would not be were d-c magnetization employed.

Aural demonstration of the effect of supersonic bias (given at

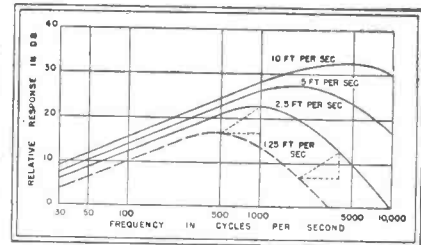

To obtain high-frequency response from a given wire, it must be run at high speed (Supersonic Bias for Magnetic Recording, L. C. Holmes and D. L. Clark, *ELECTRONICS*, July 1945, p 126)

the meeting) show the correspondence between optimum experimentally determined bias and that bias determined from the slope of the magnetization curve. The difference so determined is an indication of the effectiveness of the recording head in magnetizing the wire.

Also demonstrated were the effect on frequency of wire speed (illustrated in the accompanying figure), gap length in recording and playback heads, and pre-equalization to improve high-frequency response.

The magnetic property of greatest importance in determining response at higher audio frequencies is coercive force. Self-demagnetization, which is more effective for stubby magnets than for slender ones, tends to decrease the recorded strength of high-frequency signals. Use of finer wires has improved high-frequency response. Also the coercive force has been increased since wire recording began from 16 to 850 oersteds.

Tests to determine the perma-

# POSITIVE CONTROL

*of Varying Power Supply*

## Raytheon Voltage Stabilizers

DELIVER OUTPUT VOLTAGE CONSTANT TO  $\pm 1/2\%$

FLUCTUATION of line voltage need not impair the performance of your electrical equipment. Such variations are easily corrected with magnetic-type, entirely automatic Raytheon Voltage Stabilizers.

Positive control is gained. Power supply is stabilized to  $\pm 1/2\%$ . Reliability and accuracy of performance are effectively improved, *and at low cost.*

Investigate. Determine how positive control of line voltage can benefit your equipment. Our Bulletin DL-47-537 gives the detailed story. Write for it today.

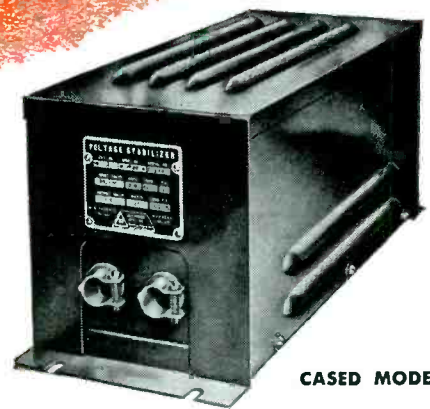

CASED MODEL

Get These Principal  
Operating Advantages:

- Control of output voltage to within  $\pm 1/2\%$  of 115 or 230 V.
- Stabilization at any load within rated capacities.
- Quick response. Stabilizes varying input voltage within 1/20 second.
- Entirely automatic. No adjustments. No moving parts. No maintenance.





*Originated by*

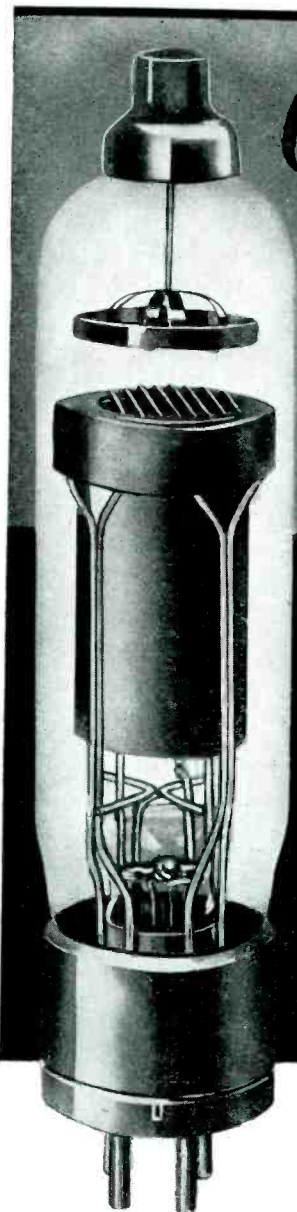
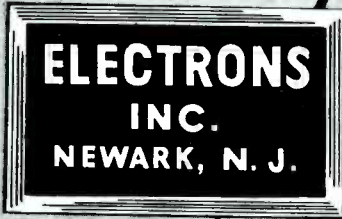

**EL C6J**  
**GRID CONTROL RECTIFIER**  
 XENON GAS-FILLED TANTALUM ANODE

FILAMENT VOLTS . . . . .	2.5
FILAMENT AMPERES . . . . .	21.0
D. C. OUTPUT . . . . .	6.4
PEAK ANODE CURRENT . . . . .	77.0
PEAK FORWARD VOLTS . . . . .	750
PEAK INVERSE VOLTS . . . . .	1250
NET PRICE, \$21.50	

We have specialized in the manufacture of rectifier and grid-control rectifier tubes to meet the demand for power tubes of extreme reliability. Our extensive research has resulted in the development of Xenon gas-filled tubes, with tantalum anodes and tough cathode coatings, a combination which successfully withstands the intense ion bombardment met with in industrial applications of rectifier tubes.

Send for descriptive literature

**ELECTRONS, Inc.**

127 SUSSEX AVENUE

NEWARK 4, N. J.

**EL** *Rectifier* **TUBES**

nency of magnetic records have been made by constantly running a closed loop of wire through a playback head. After 1400 playings, a drop in response of 7 to 8 db, occurring mostly during the first few playings, was measured. This test is believed to be more severe than would occur in practice.

*Recent Developments in Converter Tubes*

By W. A. HARRIS & R. F. DUNN  
*Radio Corp. of America  
 RCA Victor Division  
 Harrison, N. J.*

TYPE 6SB7Y IS A developmental converter tube similar to the 6SA7 in basing and structure. The conversion transconductance is 950 micromhos and the oscillator transconductance is 8,000 micromhos. The tube gives high conversion gain and improved signal-to-noise ratio

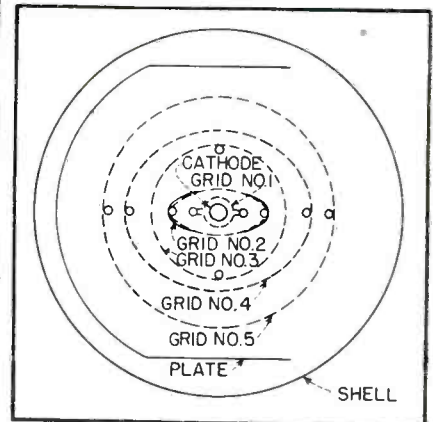

Electrode structure of 6SB7Y

in the standard and short-wave broadcast bands. The oscillator circuit should be adjusted to develop an oscillator-frequency voltage at the cathode of approximately 0.8 volt rms at the low-frequency end of each frequency range. The avc system should be arranged so that the gain of the converter does not decrease more rapidly than the gain of the r-f or i-f stages decreases with increase in avc voltage.

Some tests were made in the 88-to-108 mc band using the 6SB7Y as the converter and the 6SG7 as an r-f amplifier. In this band, best results were obtained with the cathode tap on the oscillator coil a little below the position giving maximum oscillator grid current. The

**MAILED FREE on request!**



At last! Industries' *new and revolutionary heating process* explained in a language understandable to everyone. In fifteen minutes reading time, you will gain a complete basic knowledge of Electronic Heating. This important handbook discusses all the essential facts you have to know in considering the application of Electronic Heating to your own manufacturing methods.

It contains a brief record of the historical background and development of the process — explains the principle of its operation — describes the two chief methods and fields of application and lists many proved present-day uses.

Let us send you a complimentary copy at once. Fill in the coupon or write on your company letterhead.



Manufacturers of Vacuum Tube and Spark Gap Converters since 1921

*Scientific Electric*

DIVISION OF "S" CORRUGATED QUENCHED GAP COMPANY

107 Monroe Street

Garfield, New Jersey

**USE THIS COUPON FOR CONVENIENCE**

SCIENTIFIC ELECTRIC  
107 Monroe Street, Garfield, N. J.

Please rush my complimentary copy of *The ABC of Electronic Heating* today to:

Name..... Title.....

Company Address.....

City..... State.....



Here's a soldering iron with . . .

**HEAVY POWER**  
(225 WATTS)

**LIGHT WEIGHT**  
(14 OUNCES)

made possible by  
**KWIKHEAT'S BUILT-IN THERMOSTAT**

- ★ HEATS IN ONLY 90 SECONDS
- ★ MAINTAINS PROPER HEAT
- ★ CAN'T OVERHEAT
- ★ LESS RETINNING NEEDED
- ★ TIPS LAST LONGER
- ★ COOL, SAFE HANDLE
- ★ LIGHT WEIGHT

The Kwikheat Soldering Iron has ample reserve power for your soldering jobs—225 watts held in check by a thermostat built right into the iron\*—maintaining ideal temperature for perfect soldering—preventing overheating (which causes deterioration in other irons)—prolonging life of tips and eliminating the need for constant retinning. Besides these big advantages, the Kwikheat Iron is hot, ready to use only 90 seconds after plugging in. It is extremely light (14 ounces), well-balanced, and has a safe, cool handle. No wonder Kwikheat is a sensation wherever it is used. Ask your jobber. With choice of #0, 1, 2, or 3 tips. \$11.00

- 6 INTERCHANGEABLE TIP STYLES**
- |   |        |   |        |   |        |   |        |   |        |   |        |
|---|--------|---|--------|---|--------|---|--------|---|--------|---|--------|
|  | #0     |  | #1     |  | #2     |  | #3     |  | #4     |  | #5     |
|   | \$1.25 |   | \$1.25 |   | \$1.25 |   | \$1.25 |   | \$1.75 |   | \$1.25 |

**kwikheat**  
THERMOSTATIC SOLDERING IRON  
A Division of  
Sound Equipment Corp. of Calif. • 3903 San Fernando Rd., Glendale 4, Calif.

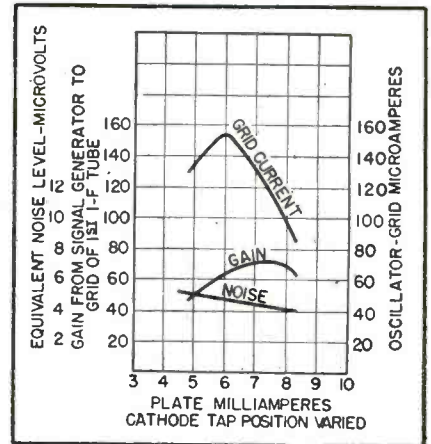

Characteristics of 6SB7Y

input resistance at the signal grid is negative, and therefore would cause the input circuit to oscillate under some conditions of adjustment. However, such oscillations can be avoided by connecting the plate of the 6SG7 and the signal grid of the 6SB7Y to a tap on the interstage coil. Use of a series resistor of about 3 ohms at the signal-grid terminal was found to be helpful in maintaining uniform and stable gain.

*The Aurora and Geomagnetism*

By C. W. GARTLEIN  
Cornell University  
Ithaca, N. Y.

THE AURORA POLARIS, like geomagnetism and the ionosphere, is believed to be a manifestation of particles radiated from the sun. The sun is a variable star, the total radiation varying only about two percent during the 11 year sun-spot cycle, but near enough for detailed observation. Most of the cyclonic sun spots have magnetic fields, some as strong as 9,000 oersteds. Typical spots appear in pairs with one magnetic pole in one hemisphere and the other pole in the other hemisphere. The sunspot latitudes rotate with a period of about 27 days which is the period of magnetic storms and auroras, thus their relation is clear.

Magnetic storms are produced by changes in the electric currents circulating in the earth's upper atmosphere. The total current in the northern hemisphere may exceed a million amperes and changes at the rate of 100,000 amperes per minute. It is this changing current that dis-

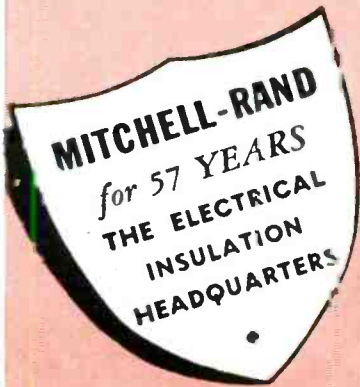

# WANTED

a superlative  
to denote the  
great strength of

# DUROK

The cleanest, purest, toughest,  
most uniform paper board  
for electrical insulation

**DUROK** assures faster, more economical production . . . higher winding speeds, fewer torn slot insulators, fewer failures. It has stiffness, rigidity, hardness and snap.

**DUROK** has the color of natural purified non-cotton cellulose . . . the advantages of this color should be apparent to motor makers whose production speeds and accuracy are increased by the greater visibility of wires during winding operations.

**DUROK** is the optimum insulation for hermetically sealed refrigerator motors.

**DUROK** with its high dielectric purity and high specific gravity, means maximum insulation with minimum thickness, greater safety factor and more wires per slot.

**DUROK** is free of chemicals and sizing and retains the best natural properties of cellulose . . . this means faster, more complete absorption of insulating varnish, quick elimination of moisture and less baking time required.

**DUROK** . . . with its great mechanical strength, great tear strength and high stretch (elongation) before rupture, permits greater speed in motor winding, more wires in a given slot for greater horsepower, fewer torn slot insulators, fewer failures, increased production and lower costs. It is stiff, rigid, hard and has quite a "snap".

. . . is made of a non-cotton cellulose by laminating many thin, continuous, layers while wet and under high pressure, without the use of adhesives or chemicals, and is dried without tension.

. . . is now available, from stock, in sizes from .007-.010-.015-.020-.025 and .030 inches. Standard sheets are 36 x 24". The grain is parallel to the second dimension.

## SPECIFICATIONS

Thickness — "	.007-.010 .015-.020 .025-.030	Elmendorf Tear CMD gms/.001"	100-110
Specific Gravity gms/cc	1.30-1.40	pH	6.5-7.0
Tensile MD #/sq. in.	15,000-19,000	Ash % — less than	1
Tensile CMD #/sq. in.	6,000-7,000	Methanol Extractable %	.02-.12
Elongation MD %	9-11	Naphtha Extractable %	.02-.08
Elongation CMD %	15-18	Chlorides-parts per million	8-12
Dielectric Volts/.001" thickness	400-600	Water abs. 15 min. approx. %	100
Shrinkage MD %	.4-7	Water abs. 24 hrs. approx. %	120
Shrinkage CMD %	1.4-1.9	Approx. Wgt. #/M sq. ft./001"	7.6
Mullen #/.001" thickness	34		
Elmendorf Tear MD gms/.001"	60-75		

MD = parallel to grain = Machine Direction  
CMD = across the grain = Cross Machine Direction

WRITE FOR DUROK SAMPLE CARD

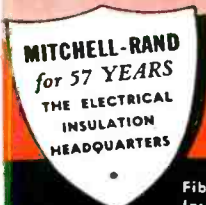

**MITCHELL-RAND INSULATION COMPANY, INC.**  
51 MURRAY STREET      Cortlandt 7-9264      NEW YORK 7, N.Y.

Fiberglas Varnished Tape and Cloth  
Insulating Papers and Twines  
Cable Filling and Pothead Compounds  
Friction Tape and Splice  
Transformer Compounds

A PARTIAL LIST OF M-R PRODUCTS  
Fiberglas Saturated Sleeving, Varnished Tubing  
Asbestos Sleeving and Tape  
Varnished Cambric Cloth and Tape  
Mica Plate, Tape, Paper, Cloth, Tubing

Fiberglas Braided Sleeving  
Cotton Tapes, Webbing and Sleeving  
Impregnated Varnish Tubing  
Insulating Varnishes of all types  
Extruded Plastic Tubing



# "TOPS" FOR DIELECTRIC HEATING...

*and other general purpose rotary coil uses*

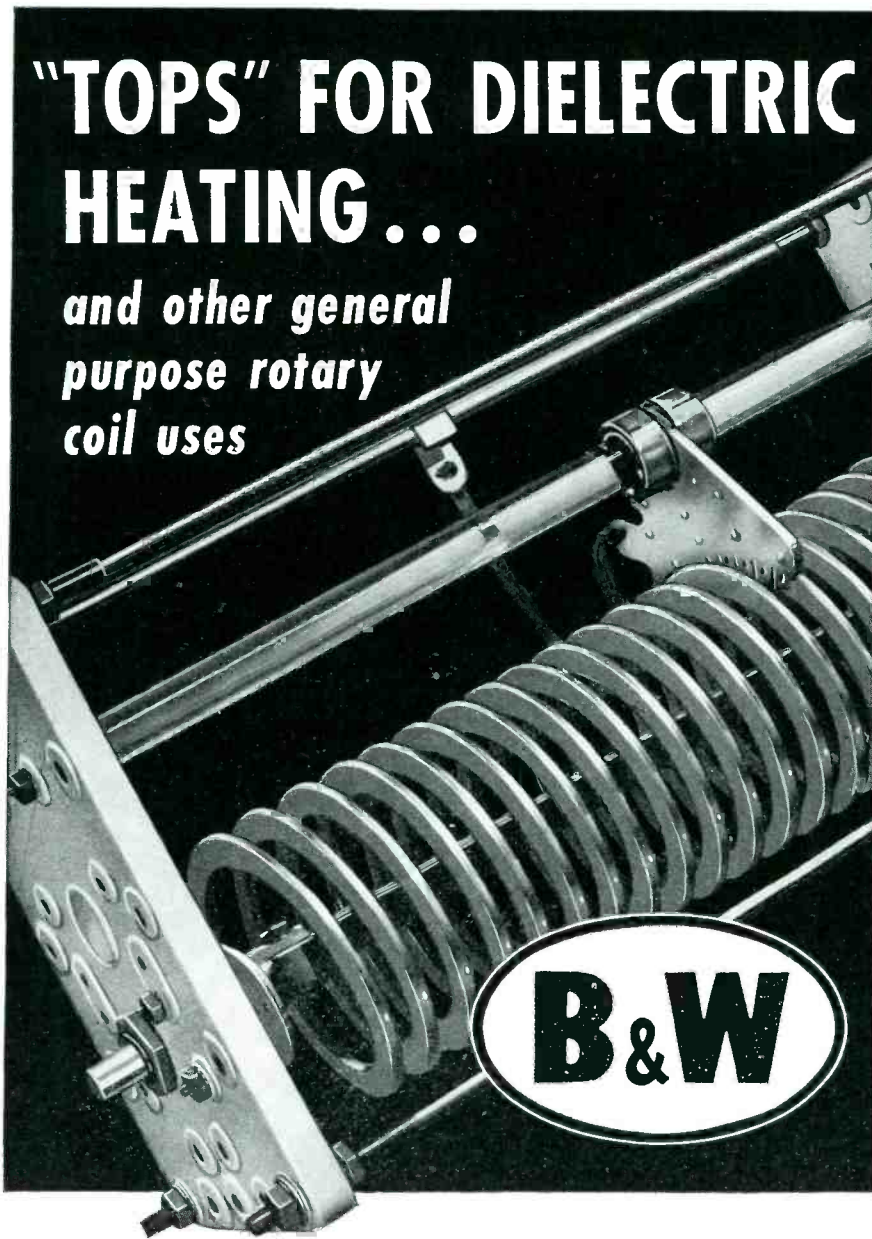

B & W has the answers to Inductor Coils of all types for Dielectric Heating uses! Many requirements can be matched by standard B & W heavy duty Air Inductors of which the big rotary coil illustrated above is

a typical example. Beyond these, more than a decade of specialized coil engineering experience is here at your disposal for the design of whatever type of special inductor your application may require.

## CUSTOM AND PRODUCTION BUILT ELECTRONIC EQUIPMENT ASSEMBLIES



In addition to Air Inductors and Heavy-Duty Variable Capacitors, B & W offers specialized facilities for the design and production of custom-built electronic equipment such as special transmitters, test equipment, antenna tuning units, ultra-high frequency equipment, high voltage equipment, etc. Let us quote on your requirements.

# BARKER & WILLIAMSON

AIR INDUCTORS • VARIABLE CONDENSERS • ELECTRONIC EQUIPMENT ASSEMBLIES

DEPT. E-16, 235 FAIRFIELD AVENUE • UPPER DARBY, PA.

Export: LINDETEVES, INC., 10 Rockefeller Plaza, New York, N. Y., U. S. A.

rupts wire communication and occasionally interferes with power transmission.

The layers of the ionosphere, upon which all long distance radio communication depends, vary seasonally in relation to the sunspot cycle, and the mean ion density of the F<sub>2</sub> region follows the sunspot numbers. Disturbances of the ionosphere follow the sun spots as do the aurora.

A photoelectric recorder has been used in studying the aurora, and with it a spectograph from which correlations with magnetic field changes have been detected.

### *Industrial Standardization Work in Television*

By DAVID B. SMITH

*Philco Corporation  
Philadelphia, Pa.*

THE RADIO TECHNICAL PLANNING BOARD was established about two years ago with a panel on television to make recommendations to the FCC on both allocations and standards. RTPB recommended, and FCC accepted in general, that commercial operation be resumed after the war on 6-mc channels below 275 mc with a few changes in the prewar standards. A higher frequency band was set aside in the 500 to 1,000 mc region for experimentation and eventual utilization when standards could be agreed upon (ELECTRONICS, July 1945, p 92, and Aug. 1945, p 304.).

Basic standards for 6 mc channels have been adopted. Space higher in the spectrum has been specifically set aside for experimentation. Finally, the commission has designated all of the microwave region as experimental which means that there is room for a third television band.

The lowest frequency band, developed and authorized for commercial operations, gives excellent black and white pictures. Standards work is starting on a second band which offers the possibilities of color. This band may be ready for commercial operation in a few years.

Those designing television receivers for the 1946 market will probably be wondering whether changes may be made in the 6 mc channel standards. The answer is that there

# R.C.P.

first in world sales\*



\*Radio City Products have built and sold more vacuum tube voltmeters than any other manufacturer in the world.

VACUUM TUBE AC AND VACUUM TUBE DC voltmeters are provided in this quality testing unit. A highly accurate instrument, sensitive and flexible, designed to speed production testing.

**RANGES** — DC VACUUM-TUBE VOLTMETER — Direct Reading. Sensitivity: 160 to 16 megohms. Six ranges: 0-6-30-150-600-1500-6000 Volts. Voltmeter readings can be taken without affecting circuit constants. ★ AC VACUUM-TUBE VOLTMETER — Direct Reading. Input capacity 0.00005 mfd. at terminals of instrument. Input resistance: 160 to 16 megohms. Seven ranges: 0-3-6-30-150-600-1500-6000 volts. Measures signal and output voltages from 10 cps to 10,000 cps. ★ VACUUM TUBE OHM-METER — Direct reading. From 0.1 ohm to 1,000 megohms. Seven ranges: 0-1,000-10,000-100,000 ohms; 1-10-100-1,000 megohms. ★ CAPACITY METER — Accurate measurements from 0.00005 to 2,000 mfd. Seven ranges: 0-0.002-0.02-0.2-2-20-200-2,000 mfd.



**MODEL 668.** Size  $9\frac{3}{4}'' \times 9\frac{1}{4}'' \times 7\frac{3}{8}''$ . Weight  $7\frac{3}{4}$  lbs. Available for 110 volt, 60 cycles a.c.; 210-270 volt, 50-60 cycles.

**ACCURACY** — Line Voltage Adjustment gives accuracy on capacity measurements.

Matched-pair multiple resistors are  $\pm 1\%$  accurate. Circuit eliminates all errors due to line voltage fluctuations.

Constant accuracy of low resistance ohmmeter ranges assured by test of ohmmeter battery under load to determine need for battery replacement. Accurate capacitymeter reads direct in microfarads — 40,000,000 to 1 measurement ratio.

**SAFETY** — Meter cannot be damaged by using low range on high voltage reading.

No danger of shock on high resistance or low capacity measurements.

Entire instrument is thoroughly shielded. Easy replacement of line fuse at front panel.

**RADIO CITY PRODUCTS COMPANY, INC.**  
127 West 26th Street • New York 1, N. Y.

MANUFACTURERS OF PRECISION ELECTRONIC LIMIT BRIDGES • VACUUM TUBE VOLTMETERS • VOLT-OHM-MILLIAMMETERS • SIGNAL GENERATORS • ANALYZER UNITS • TUBE TESTERS • MULTI-TESTERS



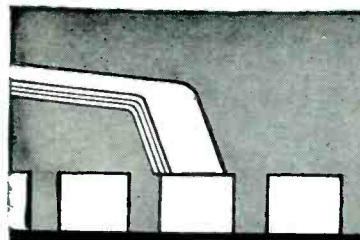

# FLAT Contacts

reduce noise, prolong service life



**VARIATEN #1218**

"T" Circuit— $1\frac{1}{2}$  db per step; 30 to 600 ohms impedance. Price, F.O.B...\$17.50

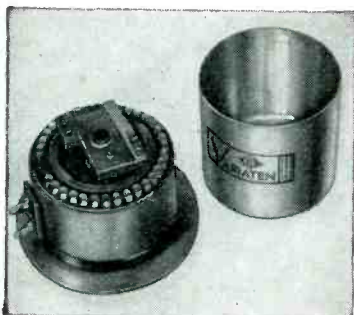

**VARIATEN #1156**

Ladder Circuit— $1\frac{1}{2}$  db per step; 30 to 600 ohms impedance. Price, F.O.B...\$12.50



**VARIATEN #1384**

Ladder Circuit— $2\frac{1}{2}$  db per step; 30 to 600 ohms impedance. Price, F.O.B...\$7.50

**VARIATEN** contacts and brush surfaces make contact over their entire area because the contacts are ground flat and the brushes stone-lapped, *not* buffed. Buffing produces rounded surfaces and therefore a "point" contact highly susceptible to noise. Variaten brushes move from one contact to the next without rocking motion. The resulting perpendicular spring pressure at all positions allows us to take advantage of the natural resiliency of metals to provide a completely flat contact over the entire brush surface at all times and so reduce noise and lengthen service life.

**No carbon resistors are used in any Variaten Mixer...**

All are of stable, wire-wound construction. Most are step type. Where quiet operation is the major consideration, we recommend ladder type mixers because the circuit requires only one contact brush operation on the input side of the circuit and any possible brush noise is therefore attenuated along with the signal.

By all means compare circuits, construction and features of these mixers. From the hundreds of Variaten attenuators you may select the attenuators best adapted to your specific needs. Write for the Variaten Catalog today.



**CINEMA ENGINEERING CO.**  
Established 1935 • Burbank • California

will be no further change in the basic standards for the commercial 6 mc channels in the foreseeable future. We will undoubtedly find, however, as experience is gained in their use that some additional refinements will be necessary.

Some such problems have already arisen. For example, the present standards propose an inverse logarithmic relation between light output and modulation level. But there are numerous logarithmic relations which might be employed. The exact one will depend upon the best camera and picture tube characteristics. Again some difficulty has been reported recently with frequency-stabilized sync circuits as a result apparently of lack of continuity in transmitted sync in switching remotely-located cameras. The standards now establish a tolerance for sync stability but apparently continuity of sync will also be required. As circuits are developed, standards will become more strict.

Improvement in performance is being sought through this standardization, but lack of particular standards is no bar to the commercial use of the system. In general the two criteria by which new standards will be judged are, first, that their use will result in improved service and, second, that their use will not interfere with the operation of existing receivers in the hands of the public. Hence, the net result of this work should be a gradual improvement in the quality of the service with, however, no changes which would obsolete existing receivers in those channels. Although different standards may be adopted for higher channels, such standards will not affect the present channel.

*War Influence on Acoustic Trends*

By HUGH S. KNOWLES  
Jensen Radio Manufacturing Co.  
Chicago, Ill.

IN COMMUNICATION of intelligence by either voice or code, the acoustic link between sender and receiver has an important bearing on security. The spatial pattern of such a link, compared to radio, is predictable—the sound does not go too far. Attenuation is frequency selective, the higher frequencies falling off

# TALK IS QUICK!



Pick up a 'phone and talk—to an airplane; a speeding train; an inter-city bus; a boat at sea.

Aireon's radio 'phones make this as simple, sure and easy as using a conventional telephone.

Aireon radio equipment for airlines is used by twenty domestic, four foreign companies; Aireon railroad radio, introduced under war-time restrictions, is *already in use* by four leading railroads. Aireon truck, taxi and bus communications equipment has been proved in service on the trucks of one of the nation's largest fleet operators. It's now in production. Aireon marine equipment will be available soon.

On the crowded highways and skyways of the future, radio 'phone communication will keep traffic moving under quick, efficient control.

**Aireon** MANUFACTURING CORPORATION

**Radio and Electronics • Engineered Power Controls**



**1 ACETATE LABEL**

Tougher, cleaner, more durable covering. Protects winding from mechanical handling. Prevents lugs from piercing label. Affords fungus protection to winding.

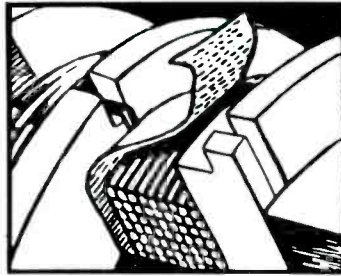

**2 ADDED INTERNAL INSULATION**

Cross-over wires are insulated from rest of winding with acetate cloth. An exclusive Mepco feature (patent pending).

**3 DOUBLE SEAL IMPREGNATION**

Prevents breakdowns and shorted turns. Withstands humidity and salt spray tests better. Is fungus resistant.

**MEPCO**  
**TRU-TOLERANCE**  
**RESISTORS**

*Triple improved - Better than Ever!*

When the war ended, ONE THIRD of all unfilled orders for precision resistors specified Mepco—according to WPB reports! A few of the reasons: Non-Hygroscopic Ceramic

Forms. Highest grade Alloy Wire. Extra Terminal Protection. Standard Tolerance of 1%. Special to 0.10%. Severe Breakdown test on every unit. Careful Calibration.

sooner so that at distances beyond the horizon intelligibility decreases rapidly.

Various sounds have been used as signals during the war, notably warble notes and frequency jumps for certain warning purposes. While these are new uses of sounds, older sounds—like the boatswain's pipe—were continued, especially in the Navy. Gongs, bells, Klaxon sounds, all were utilized in amplified form for one purpose or another.

Another useful and interesting phase of acoustics in wartime hinged upon the use of sounds for

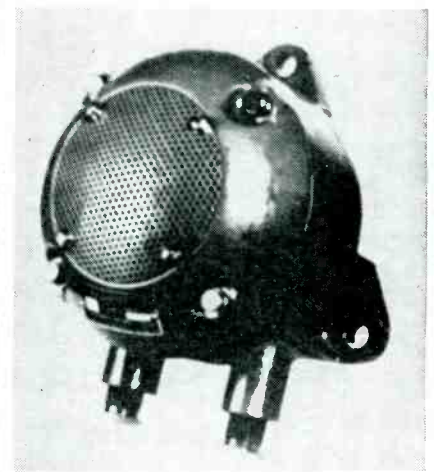

Pressure proof submarine reproducer

morale purposes, positive in the case of our own troops, negative in the case of the enemy. Thus the early use by the Germans of sounds which engender fear—loud noises, screaming bombs, noises of dive bombers—was a particular usage in this category.

Application of acoustics to sound ranging and detection was still the preferred medium at the beginning of the war no matter whether the medium was the air where the velocity of sound is slow or water where it is much faster. Even at the end of the war some acoustic work for ranging was continuing in spite of the advent of radar. Acoustic detectors have some advantages in that the low velocity makes ranging somewhat simpler at short distances compared to radio methods, and due to the fact that with acoustic methods, the enemy makes the noise, we detect it. Acoustic systems were used for detecting

**THE MEPCO LINE**

**THE SAME** high quality of material and construction which boosted Mepco "Tru-Tolerance" Resistors to the front rank in the radio and electronic industries, is evident in the entire Mepco Line.

**I.F. TRANSFORMERS, COILS**—R.M.A. Standard or to your specifications.

**R.F. TRANSFORMERS**—R.M.A. Standard or to your specifications.

**RESISTORS-POWER WIRE WOUND**—See Mepco Resistor Guide.

**METER MULTIPLIERS**—Up to five meg-ohms (wire wound).

**ELECTRONIC TEST EQUIPMENT**—Tube checkers, VT Voltmeters, Signal Generators, Circuit A.T.C. Analyzers, Etc.

**COILS**—Layer wound, bobbin wound, paper wound or honeycomb. Most modern winding methods. Get our quotations.

**ANTENNA KITS**—All types made up with your name on carton.

**LOOP ANTENNAE**—To your specifications.

**TRIMMER CONDENSERS**  
To your specifications.

Get your copy of the Mepco Resistor Guide—complete data.



**MADISON ELECTRICAL PRODUCTS CORPORATION**  
**MADISON, NEW JERSEY**

DESIGNED AND ENGINEERED AT NO. 1 PLASTICS AVENUE

**PROBLEM:** MOLD A PHOTO-FLASH  
TUBE BASE THAT WON'T CRACK UNDER  
EXTREME HEAT AND ARCING.

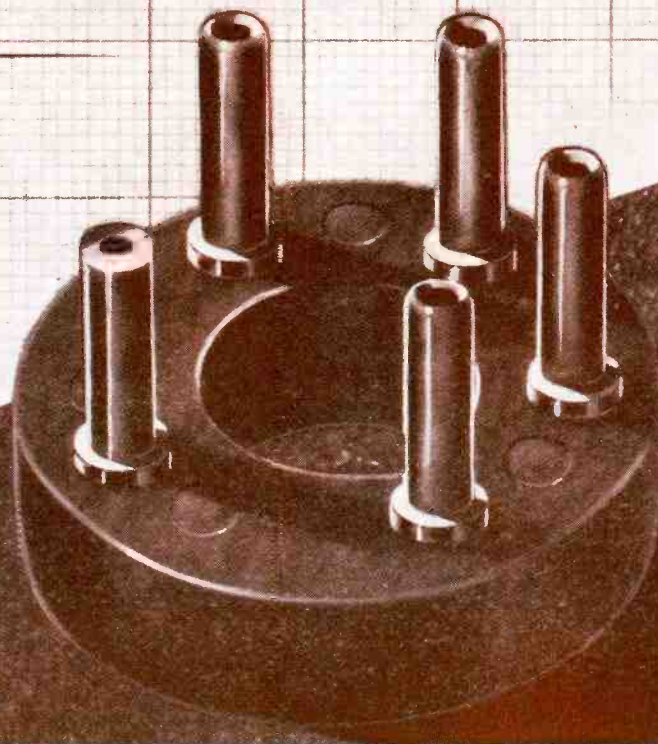
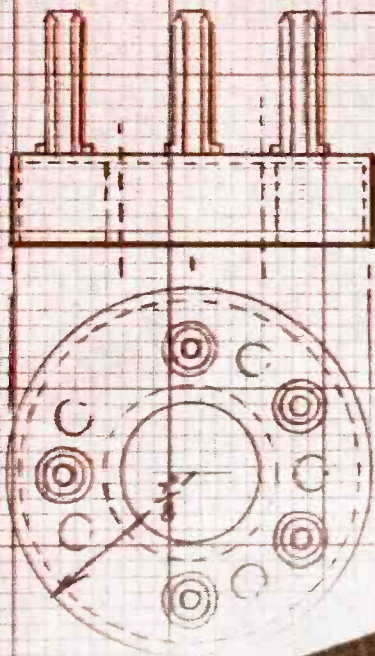

## NEVER FAILS TO GET THE PICTURE

● More dependable photo-flash tube bases were needed for war photography—too many of them failed. They cracked under high heat and arcing conditions.

The problem was brought to No. 1 Plastics Avenue and was solved by specifying G-E mycalex—compound of glass and powdered mica with a unique combination of properties.

Again G-E mycalex did an outstanding job. This material could be molded to a five-prong design with firm anchorage for accurately placed contact pins. And its resistance to high temperatures and electrical arcs assured freedom from cracking.

G-E mycalex photo-flash tube bases have stood up so well that not a single failure has been reported.

It will pay you to investigate G-E mycalex as a solution to your special insulation problems. It is available to all manufacturers in standard sheets and rods or custom-molded to your own design. For complete information, write Section S-6, Plastics Divisions, General Electric Company, 1 Plastics Avenue, Pittsfield, Mass.



### G-E MYCALEX

#### *A Unique Combination of Properties*

1. High dielectric strength
2. Low power factor
3. Prolonged resistance to electrical arcs
4. Chemical stability—no deterioration with age
5. Dimensional stability—freedom from warpage and shrinkage
6. Imperviousness to water, oil, and gas
7. Resistance to sudden temperature changes
8. Low coefficient of thermal expansion
9. High heat resistance

*Samples Supplied on Request*

GENERAL  ELECTRIC

CD46-M6





**ENGRAVING**



*Production and precision engraving on plastics, metals and other materials, on flat, convex and concave surfaces.*

**PROFILING**

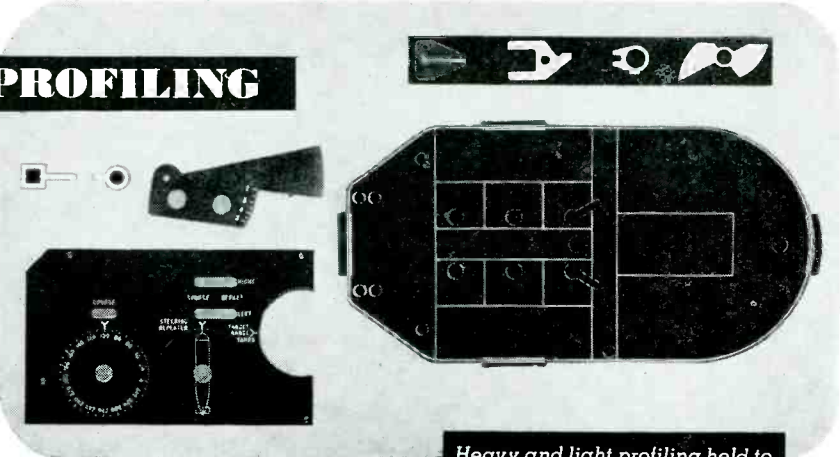

*Heavy and light profiling held to close tolerances. Contours, slots, holes, etc., all made in one operation from single master.*

**NEW HERMES ENGRAVERS**  
821 BROADWAY, NEW YORK 3, N. Y. • ALgonquin 4-6894

enemy artillery and motor boats. Another aspect of acoustics which got considerable wartime attention was the problem of quieting noises not only to prevent detection by the enemy but to reduce ambient noises surrounding communication operators, and to get preferred sounds out of locations where the noise is high. The question of the inherent limitations of the ear enter into this picture as do the problems of getting intelligent sounds to a man in the intervals between other unwanted but high amplitude sounds. Another phase of the subject is that of training men to be familiar with sounds of battle and of segre-

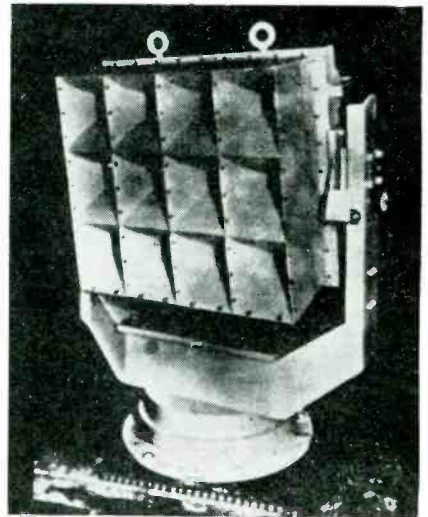

Navy high-power bull horn

gating men by their nervous characteristics. Some can tolerate noises while other men seem unable to adapt themselves to noisy conditions.

The whole problem of acoustic materials adapted to high altitudes and wide humidity or temperature ranges came to have an important bearing on the production of devices made from these materials and acoustic components.

Among the materials developed during the war are: Alnico 5 which is about five times lighter than Alnico 3 for the same flux, diaphragm materials which will not corrode, and new adhesives to attach voice coil to diaphragm.

Interesting devices such as the bull horns on carriers, of decoys such as that used at Quetarra Depression near Alexandria where the

**PROTECT THE CONTINUITY**  
of electrical currents

*with*  
**AMPHENOL**  
**CONNECTORS**

As the aviation industry again swings into peacetime production, Amphenol is ready to offer practical aid in many forms. Amphenol components helped to fight a winning war . . . and now Amphenol engineers with their "know-how"—deepened and strengthened by wartime experience—are cooperating in creating peacetime applications for aviation communications, electrical circuits and electronic controls. Amphenol connectors, cable assemblies and other parts provide positive electrical contacts within all types of equipment. For detailed technical data on Amphenol products—send for Condensed Catalog No. 72.

AMERICAN PHENOLIC CORPORATION  
CHICAGO 50, ILLINOIS  
In Canada • Amphenol Limited • Toronto



U.H.F. Cables and Connectors • (A-N, U.H.F., British) • Conduit • Cable Assemblies • Radio Parts • Plastics for Industry



*Case Histories from the RICHARDSON files*

## POST FORMED LAMINATED PLASTICS

**Problem:** Produce an aircraft cable guard for use where the cost of hand-working metal is prohibitive. Must be light, strong, and rigid.

**Solution:** Richardson Plastics used laminated thermosetting post forming materials. Specially designed tools, plus precision production methods, resulted in a laminated INSUROK cable guard that is light, strong, rigid, economical, and easy to install.

Why not discuss your product design plans with The Richardson Company? Here you will find the expert personnel, diversified facilities, and manufacturing skill to help solve your plastics problems — whatever they may be. Write today for full details.

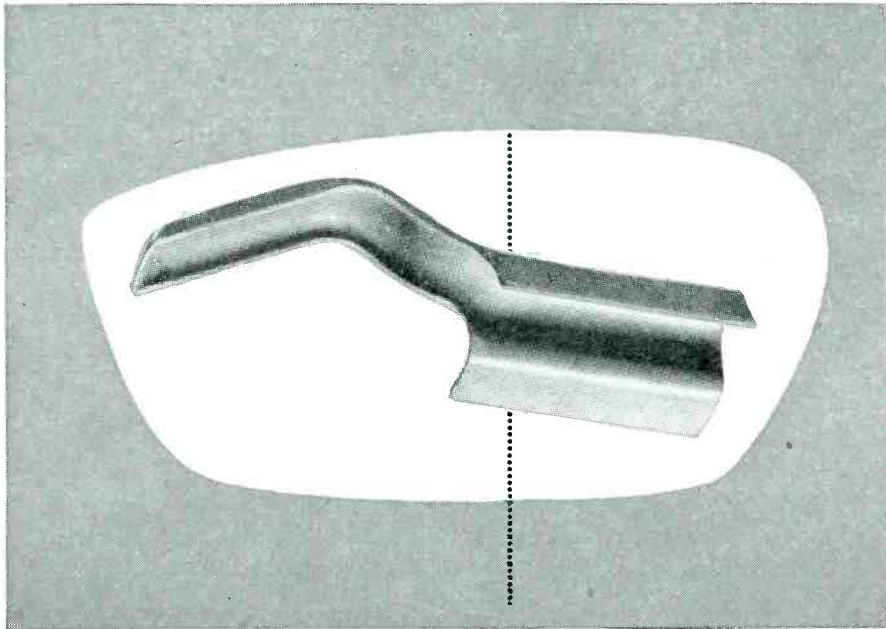

# INSUROK *Precision Plastics*

*The* RICHARDSON COMPANY

LOCKLAND, CINCINNATI 15, OHIO    FOUNDED 1858    Sales Headquarters: MELROSE PARK, ILL.

Sales Offices: NEW YORK 6 • CLEVELAND 15 • DETROIT 2

Factories: MELROSE PARK, ILL.    NEW BRUNSWICK, N. J.    INDIANAPOLIS, IND.

Germans were enticed into sending men and planes to a portion of the seacoast where fake sounds indicated landing operations were taking place, of new microphones, ear plugs, the beach master system of directing traffic—are acoustic instrumentalities of contemporary war.

### *Germanium Crystal Diode*

By EDWARD C. CORNELIUS  
*Sylvania Electric Products, Inc.*  
Emporium, Pa.

NONLINEAR CURRENT-VOLTAGE characteristic of the contact barrier layer between a metal and a non-metal is partially explainable by modern subatomic physical theories. These phenomena can be utilized in a germanium crystal diode by using a fine tungsten wire whisker which has the strength to hold itself against the crystal and the conductivity not to introduce excessive loss into the circuit. The german-

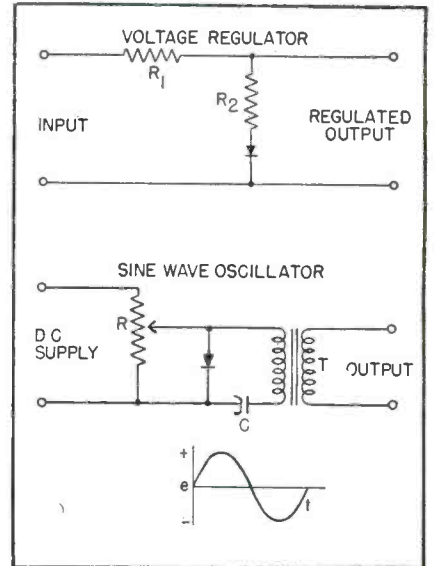

Nonlinear germanium crystal can be used as modulators, detectors, d-c restorers in television receivers, and, shown above, as voltage regulators, and low-frequency oscillators for small-current applications

ium is alloyed with a small amount of tin which partially dissolves in the crystals, forming a lattice-imperfection semiconductor necessary for best rectification, and also collects at the grain boundaries to lower the resistivity of the semiconductor thereby minimizing con-

stop that **noise!**

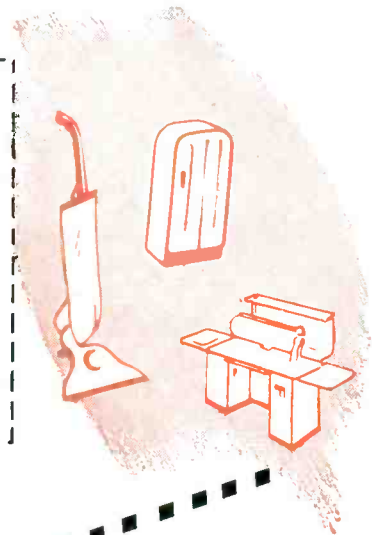

**Capacitor  
Engineering  
That Licked  
Radio Noise**

Vehicular radio equipment manufactured for military use was free from radio noise . . . thanks to the engineering that produced small compact capacitors and filters for generators, inverters, motors and other equipment. Now these can be adapted to a multitude of peace-time products where noise suppression is a "must".

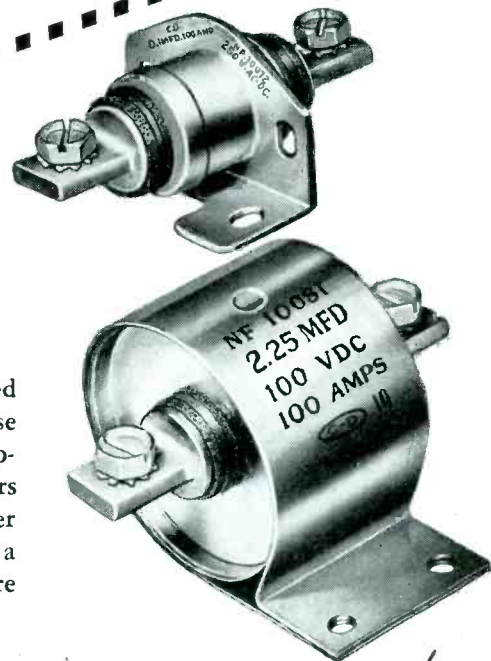

**The NF series of C-D feed-thru capacitors is specially designed and built for this service . . . to reduce radio noise.**

Small and compact, they can be mounted in any position and will operate over a temperature range of plus 85° to minus 55° C. One power line can be fed through the unit, reducing internal inductance and resistance and increasing filtering efficiency. Rated up to 250 V AC-DC, 100 amps., in sturdy, round metal containers.

Other types of filters and feed thru capacitors are available in a range of sizes and ratings. Write for information. Cornell-Dubilier Electric Corporation, South Plainfield, N. J. Other plants at New Bedford, Brookline, Worcester, Mass., and Providence, R. I.

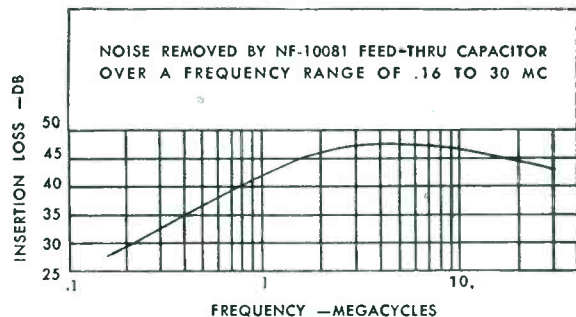

1910 1946



MICA ★ DYKANOL ★ PAPER ★ ELECTROLYTICS

**CORNELL-DUBILIER  
CAPACITORS**



# THE ART OF ACCURACY

THE

QUAKER CITY CRAFTSMEN, USING THE MOST

MODERN MACHINES PRODUCE PRECISION GROUND

FORM WORMS ... OUR RIGID STANDARDS ARE NOW

MEETING EXACTING DEMANDS OF THE ELECTRONICS

INDUSTRY ... YOUR INQUIRY WILL BE APPRECIATED

AND WILL BE GIVEN PROMPT ATTENTION.

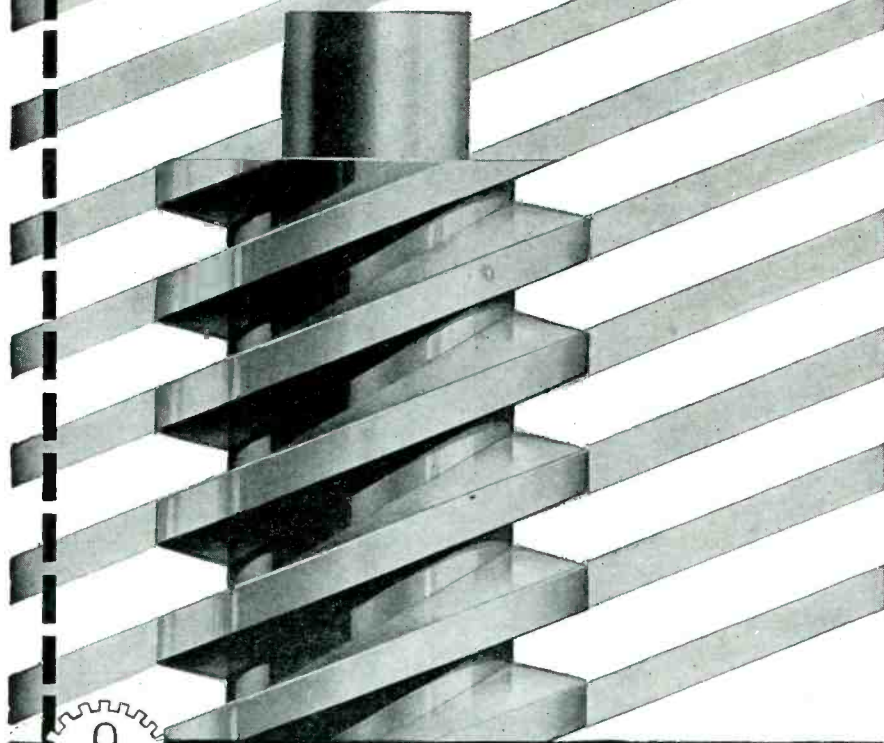

**QUAKER CITY GEAR WORKS, INC.**

1918 NORTH FRONT ST.

PHILADELPHIA 22, PENNA.

FALL MEETING

(continued)

duction losses in that part of the circuit.

The nonlinear electrical element so produced has several uses in circuits. Its low shunt capacitance suits it for use in f-m and television receivers which have high intermediate frequencies. For operation into low-resistance loads this crystal rectifier is superior to vacuum-tube diodes.

Cathode-to-anode capacitance of the 1N34 germanium diode is  $3 \mu\text{mf}$ . Life tests of 1,000 hours on this type rectifier indicated neither failure nor deterioration, thus indicating the feasibility of soldering the unit, as it is intended to be, into the circuit. In the audio range, production units vary less than  $\pm 5$  percent, and above 20 mc the units vary about  $\pm 15$  percent; operation above 100 mc is not recommended.

### *Future of Radar*

By L. A. DuBRIDGE

*Massachusetts Institute of Technology  
Cambridge, Mass.*

RADAR WILL HAVE two important fields of application—navigation of ships, and navigation and traffic control for aircraft. Techniques developed during the war for radar will find use throughout the field of electronics and radio. These electronic and high-frequency techniques may, indeed, be the most important peace-time result of the radar war research. But the peace-time applications of radar itself will be the main subject of this discussion.

Radar for navigation is in such widespread use in naval vessels that it is hard to realize that commercial ships do not yet have this facility. With a suitable radar set a ship may sail safely in the thickest weather or the darkest night through congested harbors, narrow waters, and iceberg infested seas.

Ship radar for this purpose should, for best results, use a centimeter wavelength. Techniques for using these wavelengths have now been highly perfected. For special purposes, wavelengths of around one centimeter may be used.

Very short wavelengths are needed because they provide sharp beams with a small antenna. Thus

# 3 Easy Steps

FOR SOLVING A METAL PROBLEM

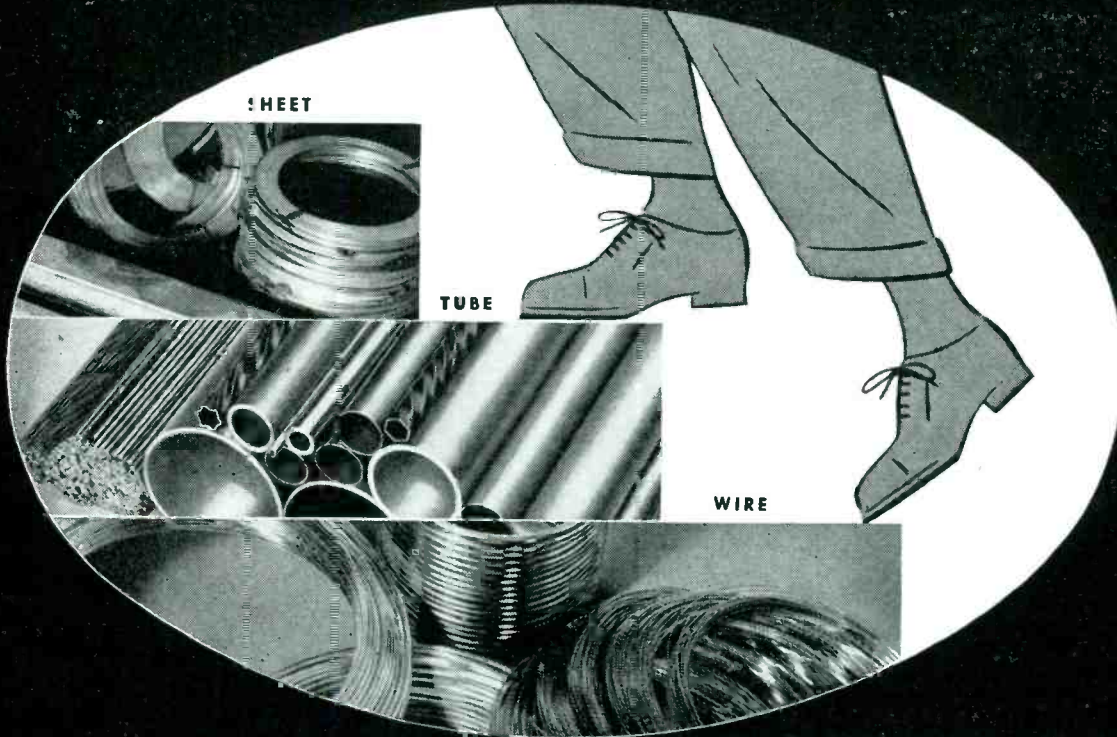

## General Plate LAMINATED METALS

A few typical combinations produced by General Plate

S = SHEET W = WIRE T = TUBING OTHER Combinations on Request

	PLATINUM	PALLADIUM	GOLD	SILVER	ALUMINUM	BRASS	BERYLLIUM COPPER	COPPER	IRON	INVAR	STAINLESS STEEL	PHOS. BRONZE	MONEL	NICKEL	SILVER SOLDER	STEEL SAE 10-10	NICKEL SILVER			
PLATINUM				SWT	SWT		SWT	SWT		SW	SW		SWT	SWT	SWT	SW	SW	SWT		
PALLADIUM				SWT	SWT		SWT	SWT		SW	SW		SWT	SWT	SWT	SW	SW	SWT		
GOLD	SWT	SWT		SWT	SWT	SWT	SWT	SW	SWT	SW	SW	SWT	SWT	SWT	SWT	SWT	SWT	SWT		
SILVER	SWT	SWT	SWT		SWT	SWT	SWT	SW	SWT	SW		SWT	SW	SW	SWT	SWT	SWT	SWT		
ALUMINUM				SWT	SWT		S	SWT												
BRASS	SWT	SWT	SWT	SWT	SWT	S				SW	SW	S	SW	SW	SWT	SWT	SWT	SWT		
COPPER	SW	SWT	SWT	SWT	SWT	SWT				SWT	SW		S	SW	SWT	SWT	SWT	SWT		
BERYLLIUM COPPER				SW	SW															
IRON	SW	SW	SWT	SWT			SW	SWT			S	S	S	SW	SW	S		SW		
INVAR	SW	SW	SW	SW			SW	SW			S		S	SW	S	S		S	SW	
STAINLESS STEEL				SW			S				S	S			S	S		S		
PHOS. BRONZE	SWT	SWT	SWT	SWT			SW	S			S	SW			SW	SWT	SWT	SW	SWT	
MONEL	SWT	SWT	SWT	SW			SW	SW			SW	S	S	SW				SW	SW	
NICKEL	SWT	SWT	SWT	SW			SWT	SWT			SW	S	S	SWT				SW	SW	
SILVER SOLDER	SW	SW	SWT	SWT			SWT	SWT			S				SWT	S	S		S	SWT
STEEL SAE 10-10	SW	SW	SWT	SWT			SWT	SWT			S				SW	SW	SW	S		SW
NICKEL SILVER	SWT	SWT	SWT	SWT					SWT		SW	SW	S	SWT	SW	SW	SWT	SW		SWT

General Plate Laminated Metals . . . sheet, wire and tube . . . provide many performance and economy advantages not found in single solid metals. These permanently bonded combinations of base metal to precious metal give you precious metal performance at a fraction of the cost of solid precious metal. Base to base metal combinations give special performance requirements not found in single base metals. Typical advantages include—better electrical performance, corrosion resistance, workability, ease of fabrication, ease of soldering, long wearing life and economy.

General Plate Laminated Metals will increase production and cut costs in such applications as electrical contacts, giant turbines, radar and radio tubes, instruments, chemical apparatus, mobile equipment.

Investigate General Plate Laminated sheet, wire and tube . . . wholly covered, inlaid, one side or both sides and stripe. Our engineers will gladly help you with your problems. Write for their services.

**GENERAL PLATE DIVISION**  
of Metals & Controls Corporation  
ATTLEBORO, MASSACHUSETTS



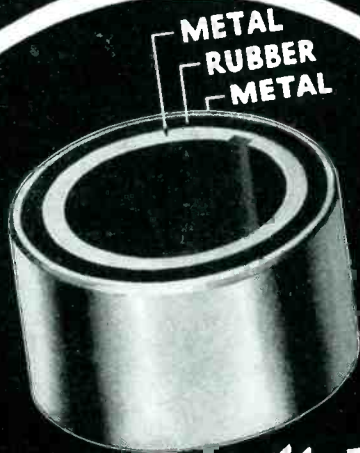

**Torflex Flexible BEARINGS  
HARNESSES  
VIBRATION AND NOISE**

● Three of the most destructive enemies moving parts have to contend with are vibration, noise and shock. They impair smooth operation, cut down efficiency, produce excess wear and shorten the life of any piece of equipment. Torflex Flexible Bearings were created, engineered and designed to control and eliminate vibration, noise and shock and are manufactured by Harris Products Company, pioneers in the field of engineered vibration control.

Torflex Flexible Bearings consist of a tube or ring of rubber stretched longitudinally between two concentric metal sleeves which prevent the rubber from returning to its original state. The pressure thus exerted by the rubber, on the metal sleeve, insures a high capacity mechanical bond between the rubber and metal under all operating conditions. Torflex Flexible Bearings are free from wear, also have long life, compensate for parallel and angular shaft misalignment, require no lubrication, and are widely used to transmit torque. They come in a wide range of sizes, are simple and easy to incorporate in designs and to install.

We welcome the opportunity to discuss with engineers and manufacturers the possibilities and the many advantages of Torflex Flexible Bearings in the control and elimination of vibration, noise and shock. Drop us a line today.

**HARRIS  
PRODUCTS COMPANY  
CLEVELAND 4, OHIO**



a boat which can carry only a small antenna will have an accurate set. A narrow beam gives higher resolution so that objects close together can be seen separately and irregularities in coast lines can be seen. Shorter wavelengths hug the water better. Narrow beams readily obtainable at from two to five centimeters wavelengths see less of the surface of the sea which, when rough, gives rise to a confusing clutter, due to reflections from the waves, that obscures small objects.

Airplane navigation and traffic control presents a series of complex problems. No one technique or equipment can possibly solve them all. A system of radio and radar needs to be developed and integrated. Some of the elements of which such a system could be built are loran navigation for long flights, especially over water, radar in the airplane for detecting obstacles and for seeing the lay of the land at night or through clouds, and long-range ground radar to give traffic control officers at ground stations complete pictures of the air traffic over a wide area.

Heavy storm clouds are visible on the radar screen, and planes can be given instructions from ground radar stations which will enable them to avoid such storm areas. Short-range, high-precision radar at each airport will give local controllers an accurate picture of traffic in their vicinity and will assist in giving instructions for approach, avoiding collisions, and generally keeping an orderly traffic pattern even in bad weather.

Radar and radio equipment can be used for blind landings. A microwave radio glide path or an accurate ground radar for talking a plane in, or both, may be used.

Static-free and, if desired, directional communication links at microwave frequencies to provide noiseless reliable radio communication from ground to plane can be built from the techniques developed in research on radar. These and other newly developed techniques, used in conjunction with present radio techniques, give promise of providing all-weather reliable flying, the first requirement of really successful air transportation.

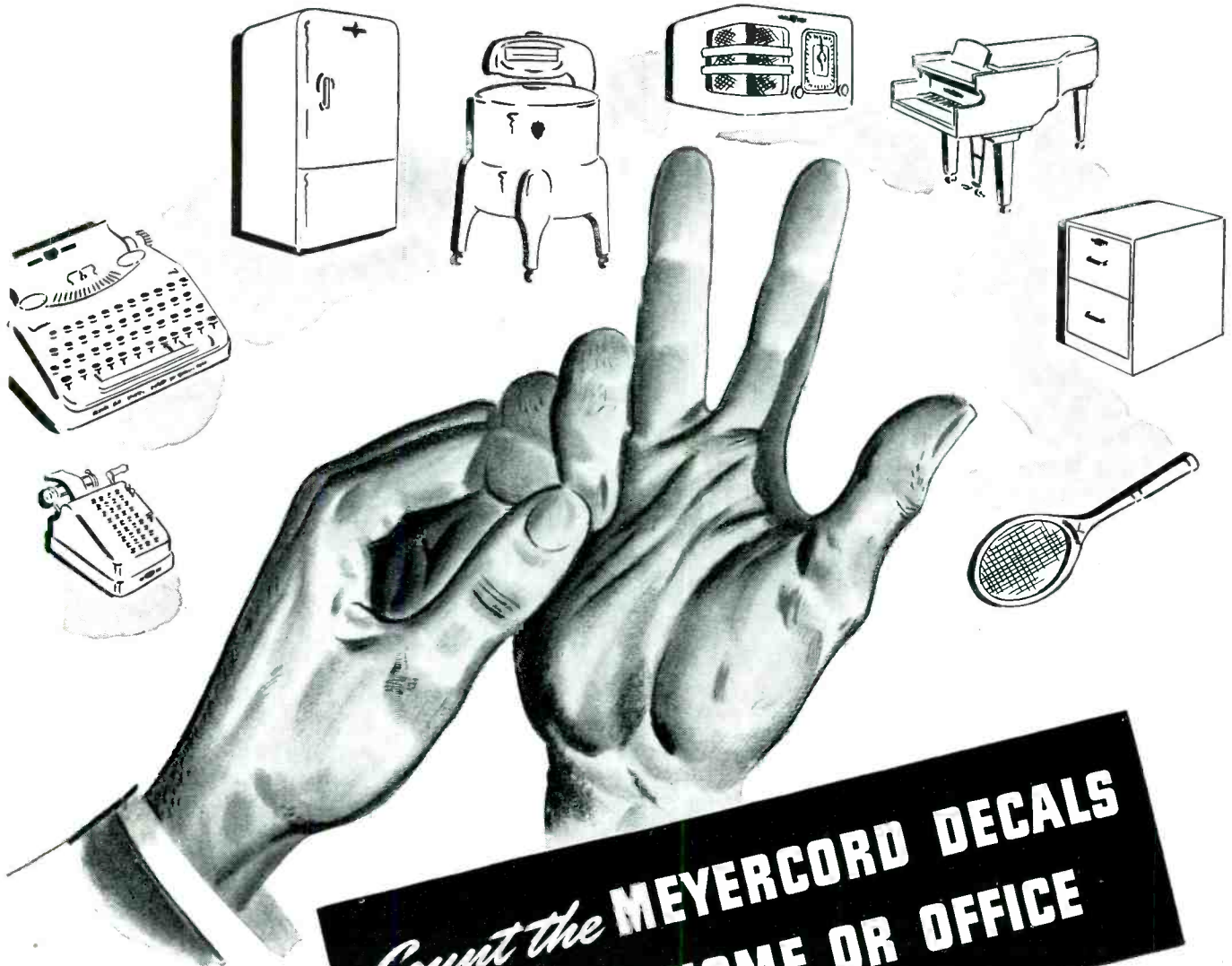

*Count the* **MEYERCORD DECALS**  
**IN YOUR HOME OR OFFICE**

**THE MODERN METHOD FOR APPLYING**  
*Trademarks...Instructions...Diagrams...*

Decal men like to wager they can find 20 decals in your home or office in half as many minutes. They seldom lose because more trademarks, instructions, patent data, wiring diagrams, etc., are made from Decalcomania than any other material. And Meyercord Decals lead the field. In the home—radios, pianos, washers, heaters, stokers, tools, furniture, even toilet goods. In the office or factory—desks, typewriters, filing cabinets, safes, machinery are but a few of the items your count will

include. Meyercord Decals are durable, easily applied at production speeds and can be produced in any colors, size or design for application to all commercial surfaces. Investigate their use on your product. Free technical service. Address inquiries to Department 9-1



**THE MEYERCORD CO.**

*World's Largest Decalcomania Manufacturers*

5323 WEST LAKE STREET • • • CHICAGO 44, ILLINOIS



# NEWS OF THE INDUSTRY

**IRE convention program and data on other meetings to come; counter-mortar radar; guided missiles; f-m channel numbers; many engineers change jobs**

## Outline of Proposed National Science Foundation

A NATIONAL SCIENCE Foundation having an integral and independent position in the structure of the Government is now definitely assured. It remains for Congress to define the executive setup of the agency, the types of research with which it will concern itself, the nature of its financial support by the Government, and the status of patents obtained by research contractors.

The reasons advanced for formation of a science foundation are: (1) requirements of national security; (2) promotion and maintenance of better national health through medical research; (3) expansion and stimulation of basic scientific research; (4) further development of industrial facilities in the interest of full employment; (5) revival of America's badly depleted scientific talent; (6) publication and dissemination of scientific knowledge including important items held back for security reasons, and the unfettered exchange of basic scientific knowledge, nationally and internationally.

Basic research is to be given top priority in the work of the foundation. This type of research is very



Dr. Vannevar Bush, OSRD director speaking before a Senate committee considering a national science foundation, stated, "A nation which depends upon others for its new basic scientific knowledge will be slow in industrial progress and weak in its competitive position in world trade, regardless of its mechanical skill."

expensive and often slow in bringing results, hence Government will assume part of it as a public responsibility.

### Purpose

Basic operating principles now generally accepted are: The function of the foundation will be to implement and energize, and in no sense to supplant any existing

agency whether private or governmental. It would not operate laboratories or research facilities of its own. It would work primarily through the colleges, universities and research institutions, rather than through industrial laboratories, except for special products for which these are especially fitted.

### Executive Setup

Opinions differ as to top authority for the entire project. One plan would place top power in a board of nine men, chosen by the President on the basis of their demonstrated capacity for the work of the foundation, without regard to political affiliation. They would select the executive head of the foundation and lay down the policies and programs to be followed. Another plan would give the top power to a director, selected by the President with the advice and approval of the Senate, who would set up an advisory board of sixteen, eight of whom would be government officials and the other eight public members.

The foundation will be subdivided into various sections, each of which will deal with one of the major areas of the foundation's work, such as: national defense; medical research; physical science; publications and exchange of information; scholarships; possibly others, including a division of social sciences.

### Patents

Another highly controversial issue is the control of patents. Existing government agencies work

## RADIO PIONEERS GET TOGETHER IN NEW YORK

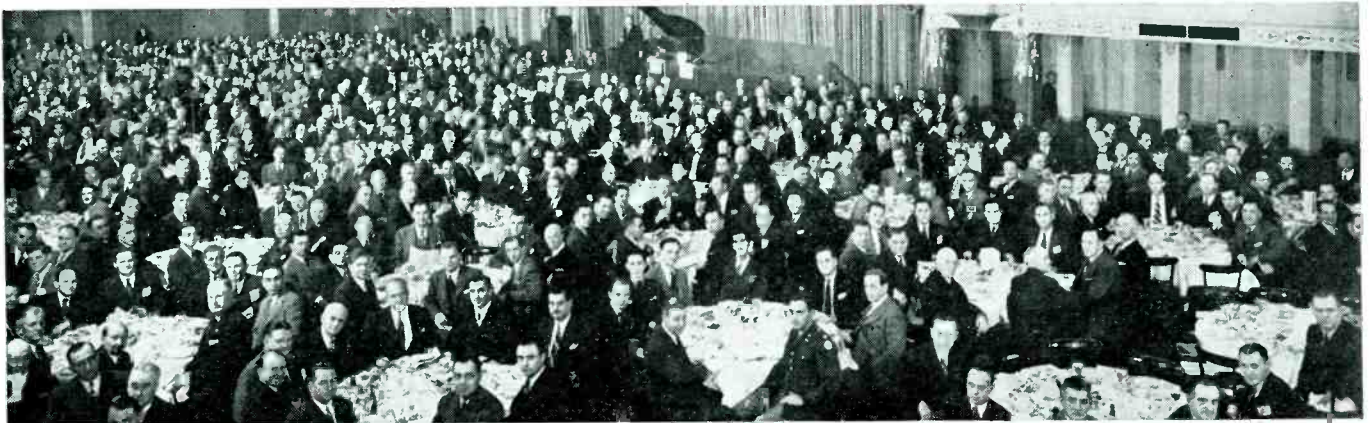

Over 900 radio pioneers and future pioneers attended the annual Radio Pioneers dinner staged by the New York section of the Institute of Radio Engineers, held Nov. 8, 1945 at the Hotel Commodore. A program featuring reminiscences of the good old days followed the dinner



**C-200 Harmonic  
Frequency Generator**



## **Lavoie Laboratories**

. . . . are *Specialists* in the design, development and manufacture of High Frequency equipment. LAVOIE plant procedure, personnel and equipment are developed especially for this type of production. The LAVOIE trade mark is your guarantee of precision manufacture and dependable performance.

LAVOIE products include:

- **FREQUENCY STANDARDS**
- **FREQUENCY METERS**
- **RECEIVERS**
- **TRANSMITTERS**
- **ANTENNAS and MOUNTS**

*Lavoie Laboratories*

RADIO ENGINEERS AND MANUFACTURERS  
MORGANVILLE, N. J.



**Write for detailed  
information.**

*Fixed  
Frequency  
Receiver*

**Specialists in The Development of UHF Equipment  
and in The Manufacture of UHF Antennas**





*In War or Peacetime..*  
**THE STANDARD SOLDER**  
*for Every Application*

- Whatever the production changeover . . . from Radar to FM Receivers or tanks to roadsters . . . Kester Cored Solders remain industry's standard—right for every type of precision and quality manufacturing!
- Kester Cored Solders, a number-one aid to speedy reconversion, are virtually mistake-proof in application—trouble-free in operation. The flux is right in the core, scientifically balanced with superior alloys, ready to be applied in one simple operation. Solder-bonds formed the Kester way are clean, tight, and hold permanently against shock, vibration, bending, and the contraction and expansion of temperature extremes.
- *Kester Rosin-Core Solder*, specially compounded for electrical application, will not harm insulation nor cause corrosion. *Kester Acid-Core Solder*, for general work, is the ideal all-purpose solder. Both are available in a wide range of strand and core sizes, flux and alloy combinations.
- The 47 years of practical Kester experience and research are at your service. Kester engineers will gladly work with you on any solder problem—and at no obligation. Write them fully, anytime.

**KESTER SOLDER COMPANY**  
**4204 Wrightwood Avenue, Chicago 39, Ill.**  
 Eastern Plant: Newark, N. J. Canadian Plant: Brantford, Ont.



out such patent arrangements with research contractors as are in line with public interest.

Some believe that all inventions or discoveries resulting from projects which have been financed in whole or even in small part by the foundation shall be the sole property of the United States Government.

Others, feeling that industrial laboratories and inventors who have put a considerable investment in a certain field of research would be hesitant to take on government research on such terms, believe that the patent rights which the Government should acquire depend upon the relative degree of the Government's contribution to the particular research project as compared with the contribution of the private organization. Here the Government would get full patent rights to inventions in fields of particular public importance, such as medicine, but otherwise the contractor would hold the rights and grant a royalty-free license in favor of Government.

*Finances*

Rough estimates indicate that the cost for the first year of operation would be approximately thirty-three and a half million dollars, rising in the fifth year to about 122.5 million dollars as follows:

Activity	Millions of Dollars	
	First Year	Fifth Year
Medical Research . . . . .	\$5.0	\$20.0
Natural Sciences . . . . .	10.0	50.0
National Defense . . . . .	10.0	20.0
Scientific Personnel and Education . . . . .	7.0	29.0
Publications and Scientific Collaboration . . . . .	0.5	1.0
Administration . . . . .	1.0	2.5
	<b>33.5</b>	<b>122.5</b>

**IRE Winter Technical Meeting and Radio Engineering Show**

THE FIRST POSTWAR Winter Technical Meeting and Radio Engineering Show of the Institute of Radio Engineers at the Hotel Astor, New York, January 23rd through 26th, 1946, gives indications of being one of the largest and most significant gatherings of its type ever held.

The 150 booths originally planned, including three theater booths, were all taken in November by 124

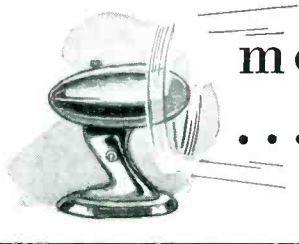
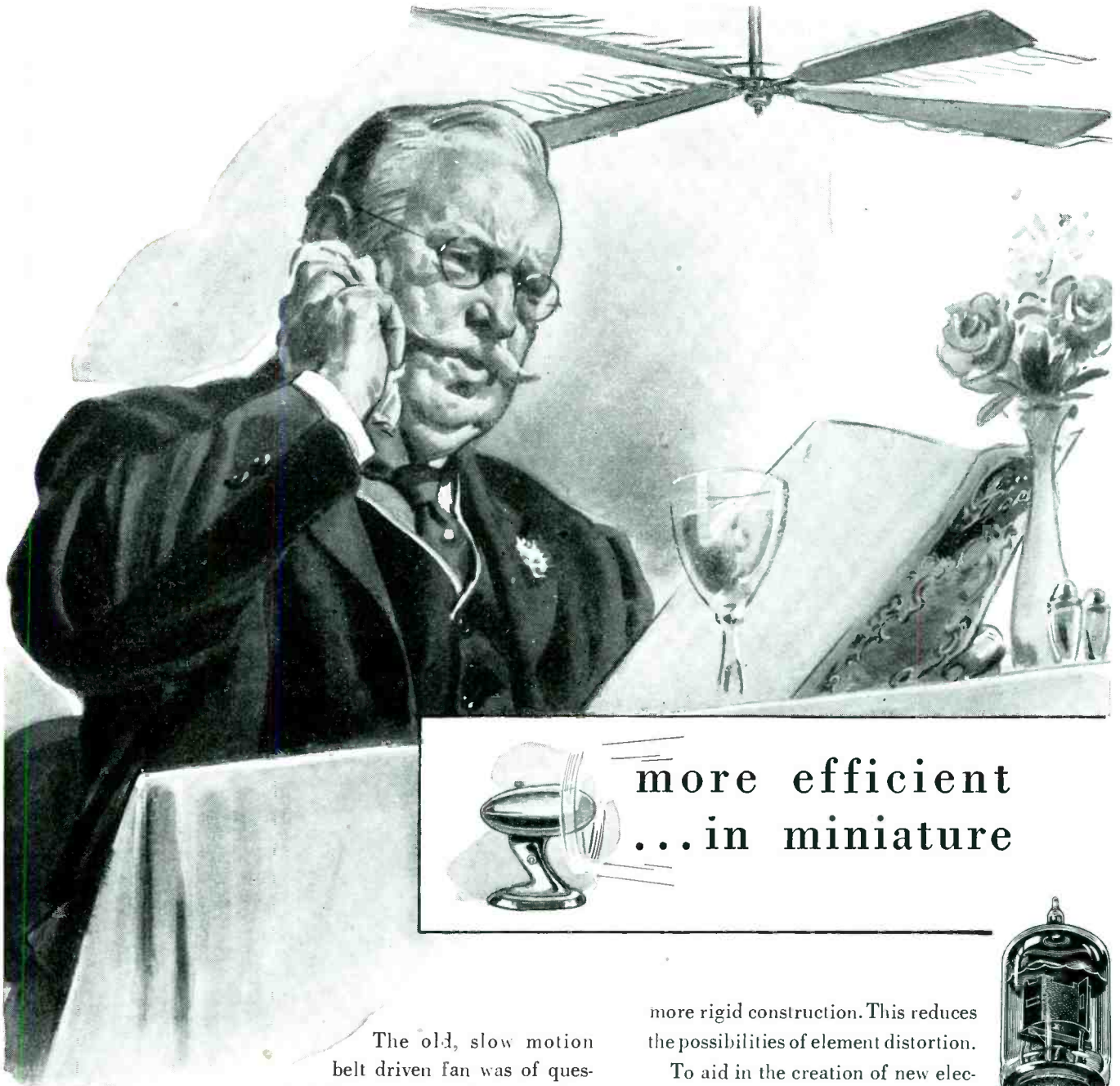

more efficient  
...in miniature

The old, slow motion belt driven fan was of questionable value as a breeze maker. Perhaps its best service was that of chasing flies with fluttering streamers. Then came the modern high speed electric fan. Like the miniature electronic tube, it is an outstanding example of the current trend toward increased efficiency in miniature.

TUNG-SOL Miniature Tubes are a part of the trend to smaller component parts. They are a factor in reducing the over-all size of equipment. Shorter leads with low inductance, and low capacity with high mutual conductance make the miniature tube ideal for high frequency circuits. The smaller elements weigh less, tending to reduce the effects of vibration. The smaller size also makes possible a

more rigid construction. This reduces the possibilities of element distortion.

To aid in the creation of new electronic equipment and in the improvement of old, TUNG-SOL engineers will draw upon their experience and work with manufacturers in the designing of circuits and in the selection of tubes. Of course your plans will be held in strictest confidence.



ACTUAL SIZE

# TUNG-SOL

*vibration-tested*

**ELECTRONIC TUBES**



**TUNG-SOL LAMP WORKS INC., NEWARK 4, NEW JERSEY**  
Sales Offices: Atlanta • Chicago • Dallas • Denver • Detroit • Los Angeles • New York  
Also Manufacturers of Miniature Incandescent Lamps, All-Glass Sealed Beam Headlight Lamps and Current Intermittors



# THERMOTECHNICS

IS IT  
METALLURGY?



IS IT A  
THERMAL SCIENCE?

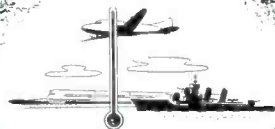

IS IT A METHOD OF  
COMMUNICATION?

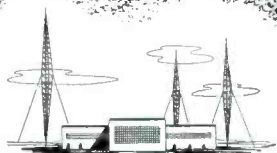

IT IS  
ALL  
THREE!

**THERMOTECHNICS** — a new art in temperature detection . . . based upon known phenomena of the expansion and contraction of metals; it includes regulatory media that harness temperatures to industry's bidding; and, it communicates silently and invisibly critical observations by the action of **THERMOTECHNICS'** unique instrument, the **THERMOSWITCH**, and directs appropriate action.

**HAVE YOU LOOKED INTO THERMOTECHNICS? DO YOU KNOW WHAT IT CAN DO FOR YOU?**

To learn about **THERMOTECHNICS**, send for the latest brochure which will be mailed to you upon request . . . of course, no obligation. Then fill out the information sheet which is enclosed with the brochure and submit the data to our **THERMOTECHNIC Analysis Group** which will be glad to make a **THERMOTECHNIC** analysis of your problem and submit the most effective application of **THERMOSWITCHES** to your specific requirements.

Today, **THERMOTECHNICS** serves a thousand industries, from Aviation to X-ray equipment.

**THERMOTECHNICS** can serve you, too . . . economically, efficiently, simply and ruggedly.



**Fenwal**  
INCORPORATED  
THERMOSWITCHES  
FOR COMPLETE TEMPERATURE CONTROL

43 Pleasant Street, Ashland, Massachusetts

exhibitors, for displays of postwar products. The show is scheduled to open at 4:00 p.m., Wednesday, January 23rd, and will close at 4:00 p.m. Saturday, January 26th.

## PROGRAM OF EVENTS

### WEDNESDAY, JANUARY 23, 1946

9:00 a.m.—5:30 p.m. Promenade—Registration and Sale of Tickets  
9:30 a.m.—12:30 p.m. Coral Room—Annual Meeting of Sections' Representatives  
12:30 p.m.—2:00 p.m. Rose Room—Luncheon for Sections' Representatives  
2:00 p.m.—5:00 p.m. Coral Room—Annual Meeting of Sections' Representatives  
4:00 p.m.—8:00 p.m. Eighth and Tenth Floors—Radio Engineering Show  
6:00 p.m.—10:00 p.m. Engineering Societies Building—Joint Meeting of A.I.E.E. and I.R.E.

### THURSDAY, January 24, 1946

8:30 a.m.—5:30 p.m. Promenade—Registration and Sale of Tickets  
9:00 a.m.—7:00 p.m. Eighth and Tenth Floors—Radio Engineering Show  
9:45 a.m.—10:30 a.m. Grand Ballroom—Annual Meeting of The Institute of Radio Engineers, Inc.

### TECHNICAL SESSIONS

10:30 a.m.—12:30 p.m.

Group A—Grand Ballroom  
Military Applications of Electronics

Group B—Rose Room  
Frequency Modulation and Standard Broadcasting

Group C—Coral Room  
Circuits and Theory

### TECHNICAL SESSIONS

2:00 p.m.—5:00 p.m.

Group A—Grand Ballroom  
Television

Group B—Rose Room  
Radio Navigation Aids

Group C—Coral Room  
Vacuum Tubes

Annual I.R.E. Banquet (Dress Optional) 7:30 p.m.—10:30 p.m. Grand Ballroom

Awarding of Medal of Honor, Morris Liebmann Memorial Prize, and Fellowship Awards. Address of Retiring President

Speaker—Dr. Frank B. Jewett, President of the National Academy of Sciences

Toastmaster—Mr. Edgar Kobak, President of the Mutual Broadcasting System, Inc.

### FRIDAY, JANUARY 25, 1946

9:00 a.m.—5:00 p.m. Promenade—Registration and Sale of Tickets

9:00 a.m.—10:00 p.m. Eighth and Tenth Floors—Radio Engineering Show

### TECHNICAL SESSIONS

9:30 a.m.—12:00 Noon

Group A—Grand Ballroom  
Microwave Vacuum Tubes

Group B—Rose Room  
Antennas

President's Luncheon Honoring Dr. Frederick B. Llewellyn 12:30 p.m. Grand Ballroom.  
Speaker—Mr. Paul Porter, Chairman, Federal Communications Commission. Master of Ceremonies—Mr. Lewis M. Clement

# “Railroads . . . Like a Giant Conveyor Belt”

“The war has emphasized the importance of American railroads. Like a giant conveyor belt, they link up the industrial, agricultural and mining areas of this country with the many thousands of markets that dot our land. With reconversion a fact, far-sighted railroad management is carefully exploring many technological war developments, and, in particular, radio, with the expectation that radio will help keep American railroads the safe, efficient and modern network of transportation which has so ably served the Nation during the war.”



*S. P. Russiman*

President, Detroit, Toledo & Ironton R. R. Co.

**R**ADIO has a story to tell the railroads . . . a story that will contribute to their continued safety, efficiency and economy of operation. Through its Mobile Communications Division, the Farnsworth Television & Radio Corporation is now telling its railroad radio story to railroads in all parts of the country.

Farnsworth brings to railroad radio specially designed, thoroughly tested equipment, utilizing either space radiation or induction principles . . . equipment which gives positive, unfailing voice communication between the operating units of a railroad, whether moving or stationary.

Furthermore, Farnsworth brings sound engineering, backed up by adequate facilities and by eight years of research into the problems of railroad radio . . . the experience of the Halstead Traffic Communications Corporation, whose assets and key personnel were recently acquired by Farnsworth. *For instance, the corrosive effects of coal gases on radio equipment is one of a number of problems which have been solved in the design of Farnsworth Mobile equipment.*

Write for the complete story of Farnsworth railroad radio. Address the Farnsworth Television & Radio Corporation, Dept. E-1, Fort Wayne 1, Indiana.

# FARNSWORTH

## TELEVISION & RADIO CORPORATION

Farnsworth Radio and Television Receivers and Transmitters • Aircraft Radio Equipment • Farnsworth Television Tubes • Halstead Mobile Communications and Traffic Control Systems for Rail and Highway • the Farnsworth Phonograph-Radio • the Capehart • the Panamuse by Capehart



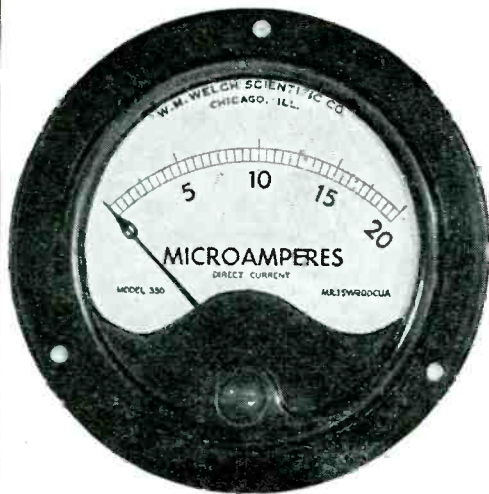

MODEL NO. 350  
CASES Molded Bakelite for Flush Mounting

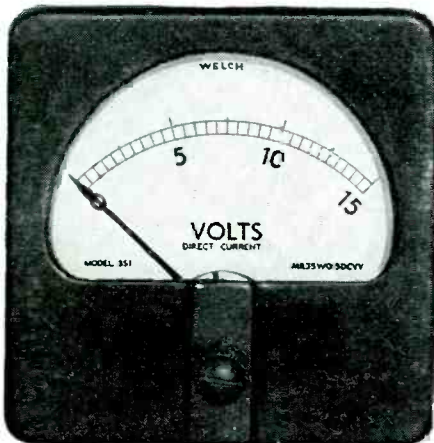

MODEL NO. 351



MODEL NO. 451

# WELCH METERS

## D. C. PANEL INSTRUMENTS

Accuracy  
2% of Full Scale

### FEATURES

- Alnico Magnets
- Sapphire Jewel Bearings
- Selected Steel Pivots
- Fume-proof White Metal Scales
- Extremely Rigid Mounting

### MODELS

350—3½ inch round—2.4 inch scale  
351—3 inch square—2.4 inch scale  
451—4½ inch rectangular—  
3.5 inch scale

### TYPES

Microammeters 0-20  
up to 0-500  
Milliammeters 0-1 up  
to 0-500  
Ammeters 0-1 up to  
0-30  
Vollmeters, various  
ranges, 100 to  
50,000 ohms per  
volt  
Zero Center Amme-  
ters  
DB Meters  
Rectifier Instruments  
Thermocouple Me-  
ters  
Special Sealed Me-  
ters

### PRICES

\$9.00 to \$26.00

THE PRODUCT OF MORE THAN 50 YEARS EXPERIENCE IN  
BUILDING HIGH GRADE INSTRUMENTS

## W. M. WELCH SCIENTIFIC COMPANY

Established 1880

1515 Sedgwick Street, Dept. H, Chicago 10, Illinois, U. S. A.

Vice President in charge of Research and  
Engineering, The Crosley Corporation

### TECHNICAL SESSIONS

2:00 p.m.—5:30 p.m.

Group A—Grand Ballroom  
Radar

Group B—Rose Room  
Microwave Technique

6:30 p.m.—8:00 p.m.—Cocktail Party

SATURDAY, JANUARY 26, 1946

9:00 a.m.—3:00 p.m. Promenade—Registration

9:00 a.m.—2:00 p.m. Eighth and Tenth Floors—  
Radio Engineering Show

### TECHNICAL SESSIONS

9:30 a.m.—12:00 Noon

Group A—Grand Ballroom  
Industrial Electronics

Group B—Rose Room  
Communication Systems and Relay Lines

Group C—Coral Room  
Radio Propagation

### TECHNICAL SESSIONS

2:00 p.m.—4:00 p.m.

Group A—Grand Ballroom  
Broadcast Receivers

Group B—Rose Room  
Quartz Crystals

Group C—Coral Room  
Crystal Rectifiers

Final Adjournment—4:00 p.m.

### COMMITTEE MEETINGS

(Open to Members of Committees Only)

WEDNESDAY, JANUARY 23, 1946

Morning: Antennas; Radio Receivers; Fre-  
quency Modulation; Radio Wave Propaga-  
tion.

Afternoon: Circuits; Research; Membership;  
Television; Vacuum Tubes; Railway and  
Vehicular Communication

THURSDAY, JANUARY 24, 1946

Morning: Standards

Afternoon: Education; Public Relations

WOMEN'S PROGRAM  
(Tentative)

THURSDAY, JANUARY 24, 1946

11:00 a.m.—4:00 p.m.

Museum of Costume Art—Sloane's House of  
Years—Luncheon and Art Exhibition, Town  
Hall Club—Television Tour of Radio City

FRIDAY, JANUARY 25, 1946

11:00 a.m.—5:00 p.m.

St. John's Cathedral—Luncheon, Stoddards—  
Riverside Church—Tea, Castleholm

### Counter-mortar Radar

TO REDUCE THE NUMBER of casual-  
ties among American ground forces  
from enemy mortar fire, the SCR-  
584 antiaircraft fire control radar  
was modified to search at a low  
angle. It then revealed the rise and  
fall of enemy mortar shells, giving  
points on the trajectory from which  
the position of the mortar could be



**THE CORRECT ANSWER  
TO YOUR RECTIFIER PROBLEM IS HERE**

*G-E Builds All Three*

Selecting the rectifier best suited for a particular d-c application is not a decision that can be made on a "guess" basis. Construction, basic materials, operating characteristics, weight, size, cost and life expectancy are all factors that should be considered.

G.E. and only G.E. builds the three types of low-voltage rectifiers most generally used—copper-oxide, selenium and Tungar. All three are tops in quality and leaders in their field. To say that one type is better than another is as fatuous as saying a bomber is better than a fighter plane. Each performs best when doing the job for which it was specifically designed.

When blueprints call for rectifiers choose the correct size and type from the G-E line. If you're not sure of what is best for your need let G-E engineers help you. Years of experience qualify them to recommend the rectifier which will give you the most economical, most efficient and most reliable performance. Whether they recommend copper-oxide, selenium or Tungar you can be sure their selection is impartial because G.E. offers all three.

For more information write to Section A1613-119, Appliance and Merchandise Dept., General Electric Co., Bridgeport, Conn.

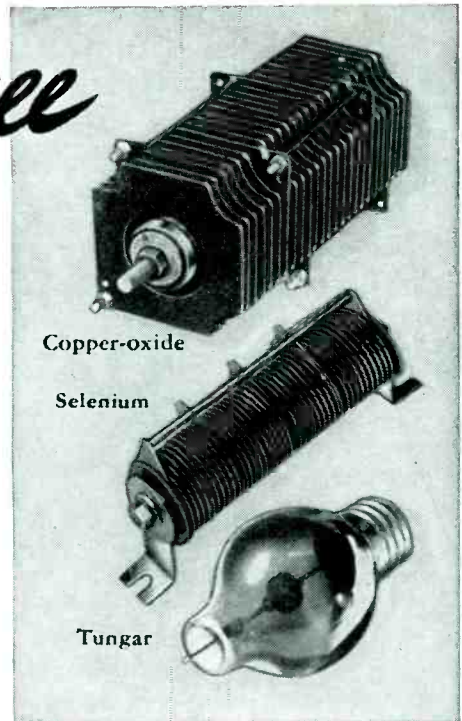

Copper-oxide

Selenium

Tungar

Hear the General Electric radio programs: "The G-E All Girl Orchestra" Sunday 10 p.m. EST, NBC. "The World Today" news every weekday 6:45 p.m. EST, CBS. "The G-E House Party" Monday through Friday 4:00 p.m. EST, CBS.

**BUY VICTORY BONDS AND KEEP THEM**

**GENERAL  ELECTRIC**



# READY NOW!

A MULTI-FEATURE PILOT LIGHT:

"DIALCO" Presents:—

## The New PLN-849 PILOT LIGHT

featuring

THE NEW NE-51 NEON BULB

### with BUILT-IN RESISTOR

FOR 110 VOLTS (and higher)

A RUGGED UNIT, CONSUMES A SMALL AMOUNT OF CURRENT (under one milliamper), and HAS DEPENDABLE LONG LIFE.

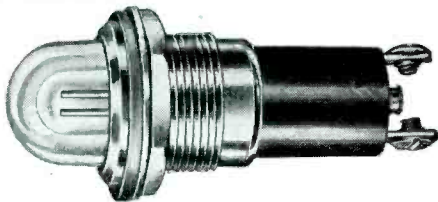

PATENT PENDING

#### NOTE THESE IMPORTANT FEATURES OF THE PLN-849 PILOT LIGHT:—

1. RESISTOR INTEGRAL WITH SOCKET ASSEMBLY—VALUE TO SUIT SUPPLY VOLTAGE
2. Moulded Bakelite Socket.
3. Full-view Jewel Plastic Cap for visibility at all angles.
4. Rugged Terminals: Binding Screw or Permanent Soldering Type.
5. High resistance to vibration or shock.

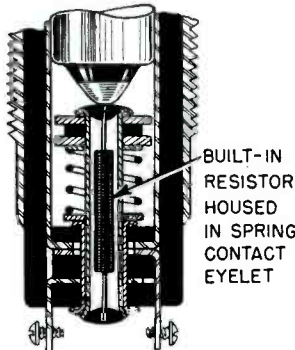

Manufacturers . . . here's the ultimate in Pilot Light design. A compact, rugged unit—housing a BUILT-IN RESISTOR as an integral element of the assembly (not externally attached, or fastened to body or terminal).

The PLN-849 is supplied complete with General Electric Neon NE-51 Bulbs. May also be adapted to accommodate General Electric Radio Panel Bulbs such as 47, 44, etc., for low voltage circuits. Bulbs are removable from front of panel. Plastic Jewel Cap may be had in choice of 7 colors. Units are suitable for all panel thicknesses.

Dialco mass production methods make possible a price so low that you can have the advantage of the PLN-849 110-V. Neon Pilot Light on all of your newly designed products.



Write today for samples and prices.  
There is no obligation.

WRITE FOR NEW  
ILLUSTRATED  
BROCHURE

# DIAL LIGHT CO. of America, Inc.

900 BROADWAY • NEW YORK 3, N. Y.

Telephone: ALgonquin 4-5180-1-2-3

plotted. This unique tactical use of radar led to the design of a new set specifically for directing counter-mortar fire.

Another wartime application of the SCR-584 was in detecting enemy patrols and vehicles in the dark. Its use enabled the Allies to keep Germans off their main supply roads near the front lines at night with minimum expenditure of ammunition. Radar made it possible to fire only when targets actually appeared on the roads, without resorting to costly random interdictory fire. The same radar often alerted American outposts when German patrols and raiding parties approached on dark nights and thereby contributed materially to the Allied collection of German prisoners.

### New IRE Officers

THE ELECTION OF Dr. Frederick B. Llewellyn of Summit, New Jersey, as president of the Institute of Radio Engineers for the year 1946, has been announced. He succeeds Dr. William L. Everitt, head of the Department of Electrical Engineering of the University of Illinois.

Dr. Llewellyn, a consulting engineer on the staff of Bell Telephone Laboratories, has specialized in the



Dr. Frederick B. Llewellyn, IRE president for 1946

design of vacuum tubes for communication and electronic control purposes. In 1936 he received the Morris Liebmann Memorial prize for his analysis of reactions within the vacuum tube.

E. M. DeJoraine, president of International Telecommunication Laboratories, New York, becomes the new vice president. Three directors were also elected: Dr.

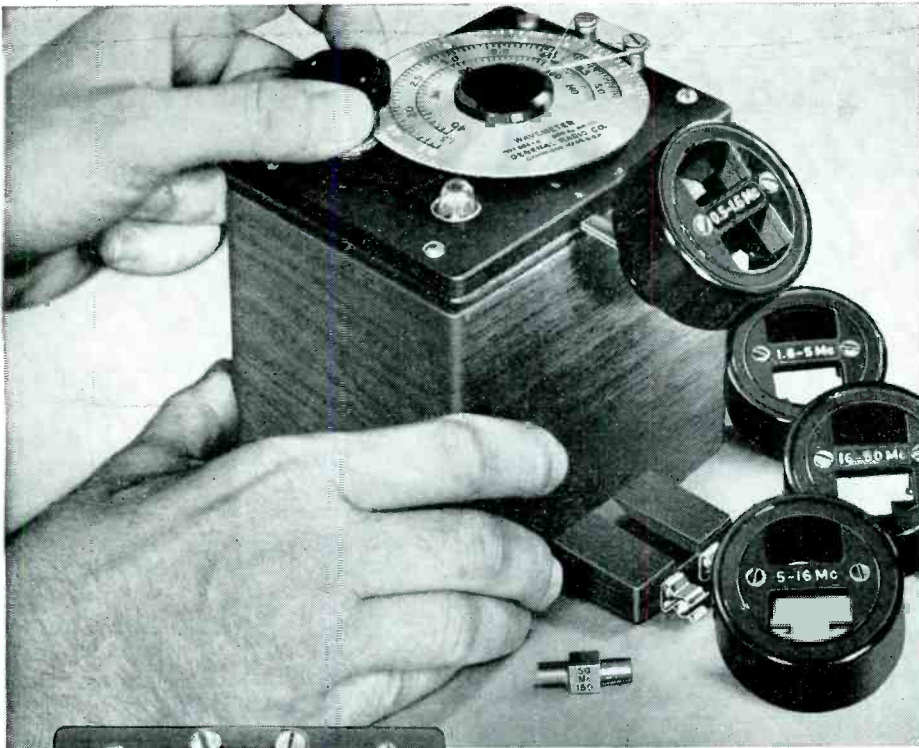

**SPECIFICATIONS  
TYPE 566-A WAVEMETER**

**FREQUENCY RANGE:** 0.5 to 150 Mc

**COILS:** Five plug-in coils furnished

**DIAL:** Direct reading in frequency to 2% or better

**ACCURACY:** 2% for 0.5 to 16 Mc; 3% for 16 to 150 Mc

**RESONANCE:** Indicator is small incandescent lamp. Two spares supplied

**DIMENSIONS:** 4¾ x 5¾ x 5¾ inches, overall

**NET WEIGHT:** 3 pounds

**PRICE:** \$45.00

## A WAVEMETER with very useful range

Now AVAILABLE (at the moment from stock) the popular Type 566-A Wavemeter leaves the war effort to return to the civilian laboratory. This meter with its very wide range of 0.5 to 150 Mc (600 to 2 meters) is an extremely handy gadget in any laboratory. Its accuracy is sufficient for a large number of measurements such as determination of coil ranges, oscillator spans, lining up oscillators and transmitters, locating and naming harmonics in either the receiver or the transmitter, and for general experimental work.

All five plug-in coils are stored in a rack on the side of the cabinet. It weighs only three pounds and can be held in the palm of one hand.

Despite its modest price, this wavemeter is built with the same care and is calibrated with the same thoroughness as the most expensive piece of G-R measuring gear.

ORDER NOW. Shipment probably can be made from stock.



# GENERAL RADIO COMPANY

Cambridge 39,  
Massachusetts

90 West St., New York 6 920 S. Michigan Ave., Chicago 5 1000 N. Seward St., Los Angeles 38



# Now... a compact audio signal source for laboratory and production test applications

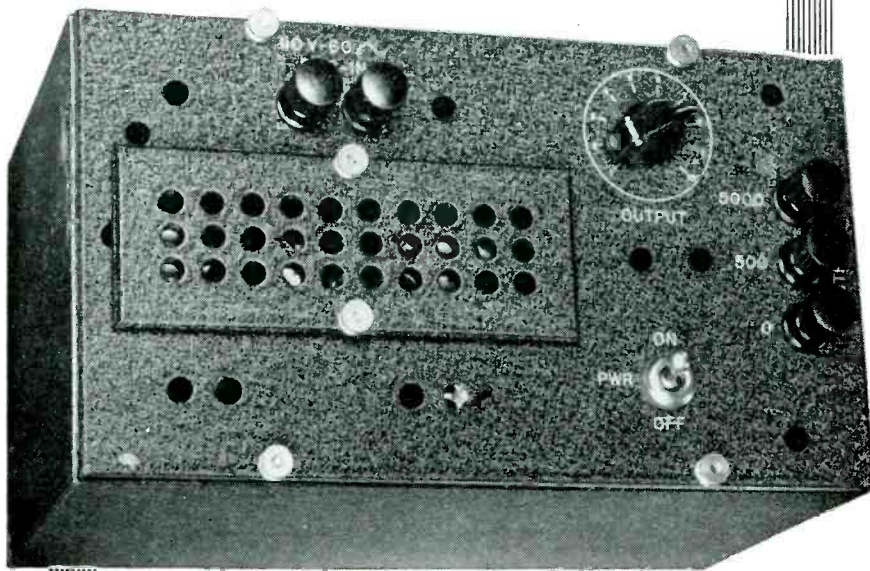

The Type MR-1000 is a compact source of audio frequency power producing up to 35 MW of signal energy at output impedances of 500 or 5000 ohms.

The distortion at maximum output is less than 2% over all. The built-in attenuator features an arbitrary scale of 1 to 10 units.

The Type MR-1000 operates from a standard source of 110 volts, 60 cycles.

The case, panel and subchassis are 1/4" aluminum. A removable ventilator panel at the top permits easy tube replacement.

Using a new type of oscillating amplifier circuit, this unit maintains an output frequency of 1000 cycles at plus or minus 1 cps over 24 hours and will operate continuously for 720 hours with a variation of less than 4 cps.

**OPERATION:**—The MR1000 serves to replace tuning forks and offers a source of audio test energy for bridges etc. and can be substituted in existing test positions without wiring changes. The MR-1000 can be furnished at frequencies other than 1000 cps at slight additional cost.

**SIZE:**—6 1/4" deep x 5 3/4" high x 9 1/4" long.

**WEIGHT:**—13 1/2 lbs.

**PRICE:**—\$149.00 f.o.b. Chicago—Guaranteed—2 years.

**TELEVISO PRODUCTS CO.**  
7466 IRVING PARK ROAD CHICAGO 34, ILL.

Walter R. G. Baker, vice president of General Electric Co., Syracuse, New York; Dr. Donald B. Sinclair, assistant chief engineer of General Radio Co., Cambridge, Mass.; Virgil M. Graham, plant manager of Sylvania Electric Products, Inc., Williamsport, Pa. Installation of the new officers will take place at the annual meeting in New York on Jan. 23 which is the first day of the Winter Technical Meeting.

## Chicago Engineering Conference

THE CHICAGO SECTION of the Institute of Radio Engineers announces the Chicago Engineering Conference and Banquet, February 9th, 1946, to be held at the Merchants and Manufacturers Club in the Merchandise Mart.

Dr. W. L. Everitt, IRE president in 1945, will deliver the opening address at 9:30 a.m. In one of two concurrent technical sessions the subjects discussed will be F-M Receiver Design Problems, Scanning and High Voltage Supplies for Television, Design of Signal Frequency Circuits for F-M and Television, and Broad Band Antenna Design. In the other session the subjects will be The Vacuum Tube Proximity Fuse, The Loran System, Atomic Energy, and High-Frequency Heating. Nationally known speakers will discuss each subject. The technical sessions will run from 10:00 a.m. to 5:00 p.m. Dinner and dancing will conclude the evening's entertainment.

## Guided Missiles

AN EXTENSIVE PILOTLESS aircraft program now being carried out by Naval aviation planners includes such successful devices as the



Model of gorgon II-C, a guided missile that carries 1,000 pounds of explosive to its target at 400 miles per hour. The ring at the top is the jet-propulsion engine

## POLISHED POLYSTYRENE ROD AVAILABLE NOW

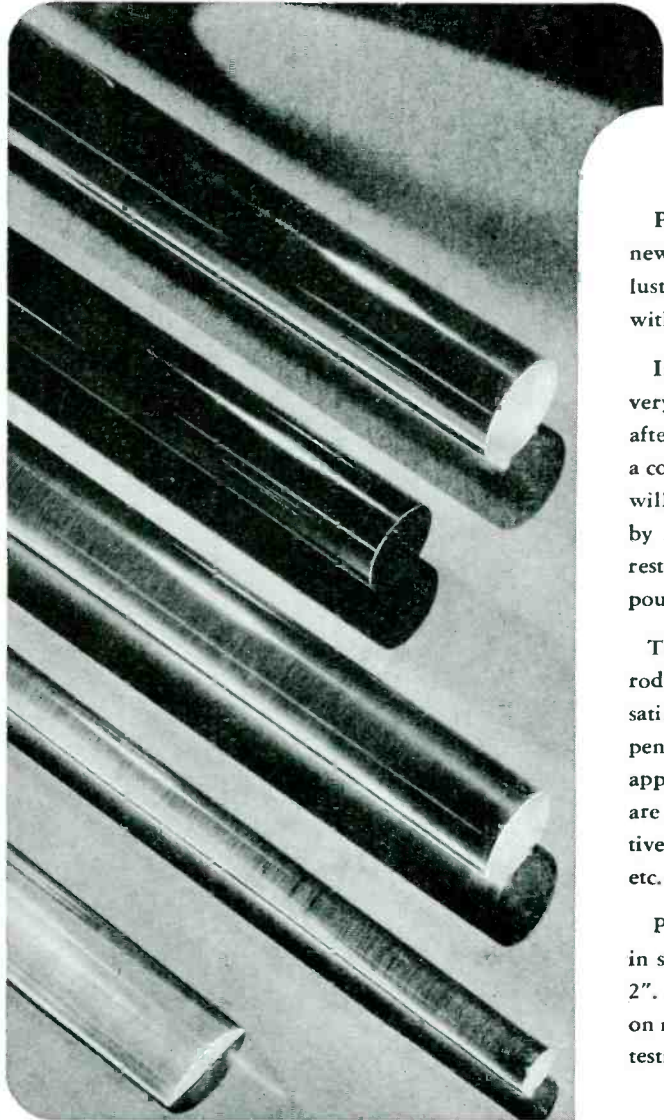

Plax polystyrene rod is now available in a new form: with a highly polished surface lustre. Thus designers may now readily work with crystal-clear rods of this unique material.

In this form, Plax polystyrene rod requires very little fabricating and it is easily polished after fabrication. A cutting-down wheel, using a compound held by a non-petroleum grease, will remove any surface imperfections caused by machining — and the final high lustre is restored by a soft cotton buff, free of compound.

The availability of crystal-clear polystyrene rod will suggest many new uses for this versatile material, which is light, hard, inexpensive, and easily fabricated. A few of the applications which immediately come to mind are push bars and racks, display and decorative fixtures, edge lighting effects, novelties, etc.

Plax polished polystyrene rod is available in standard 4' lengths in all diameters up to 2". Special lengths and colors are available on minimum order. Samples are available for testing purposes.

### POLYSTYRENE LITERATURE AVAILABLE:

Bulletins on how to machine, polish and cement polystyrene; on what to tell machinists about polystyrene; and on how to use coolants with polystyrene are available on your request.

While Plax has been the leader in development of uses for polystyrene, we also offer several other plastic materials in unique forms and shapes.

In fact, between the resources of Plax and the Shaw Insulator Company, Irvington 11, N. J., you can obtain help and counsel in the use of most plastic materials and processes. For the literature mentioned above . . . write Plax.



133 WALNUT STREET ★ HARTFORD 5, CONNECTICUT



Designed for



Application

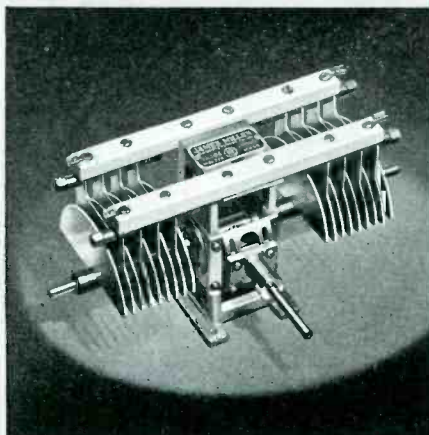

### 04000 Series

#### Transmitting Condensers

A new member of the "Designed for Application" series of transmitting variable air capacitors is the 04000 series with peak voltage ratings of 3000, 6000, and 9000 volts. Right angle drive, 1/1 ratio. Adjustable drive shaft angle for either vertical or sloping panels. Sturdy construction, thick, round-edged, polished aluminum plates with 13/4" radius. Constant impedance, heavy current, multiple finger rotor contactor of new design. Available in all normal capacities.

**JAMES MILLEN  
MFG. CO., INC.**

MAIN OFFICE AND FACTORY  
**MALDEN  
MASSACHUSETTS**



glomb, gorgon, and gargoyle. Each of these is guided to its target after launching either by self-seeking electronic equipment in the missile or by radio and television control.

The glomb is a glider bomb that carries a 4,000-pound bomb. It can be towed by a Navy fighter plane, and when released can be directed into a target through radio control and television.

The gorgon is a jet-propelled missile that can be carried by a bomber and sent into an enemy aircraft either by radio control or by its own automatic target-seeking device.

The gargoyle, also jet-propelled, carries a 1,000-pound bomb and

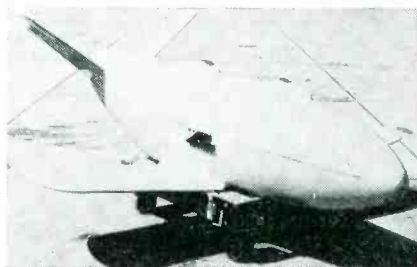

The gargoyle, a stub-winged pilotless dive bomber having a top speed better than 600 mph and carrying a 1,000-pound special all-purpose bomb

serves as a pilotless dive bomber that automatically seeks and collides with a ship target.

As early as 1940, successful demonstrations of pilotless aircraft were made with a torpedo plane that was radio-controlled and television-directed from a control plane up to ten miles away. From these early experiments several types of guided assault missiles were developed and some were actually used against the Japanese base at Rabaul.

Electronic techniques of guided missiles have also proved important in advancing the design of piloted planes. New planes controlled from the ground can be flown under conditions expected to produce structural failure or that would cause injury to a pilot, and essential test data can be transmitted by radio to the control station on the ground or in a piloted plane overhead.

Man will be too slow for combat of the future, but man's mind can devise both defense and offense. Out of the Navy's research and development programs are expected

# Quality PLASTIC NAME PLATES



**FABRICATED TO YOUR  
EXACT SPECIFICATIONS**

For name plates or any other plastic parts, it will pay you to consult Sillocks-Miller specialists. This is particularly true if your products demand fabrication to close tolerance. This experienced organization can help you in four ways:

1. In working out your own ideas.
2. In developing new ideas for you.
3. In advising you on the most practical and economical methods of fabrication.
4. In selecting the right plastics for your requirements.

Remember, it costs you less to pay a little more for Sillocks-Miller quality.

*Write for Illustrated Booklet*

### THE SILLOCKS-MILLER CO.

10 West Parker Avenue, Maplewood, N. J.  
Mailing Address: South Orange, N. J.

Specialists in High Quality, Precision-Made Plastics Fabricated for Commercial Technical and Industrial Requirements



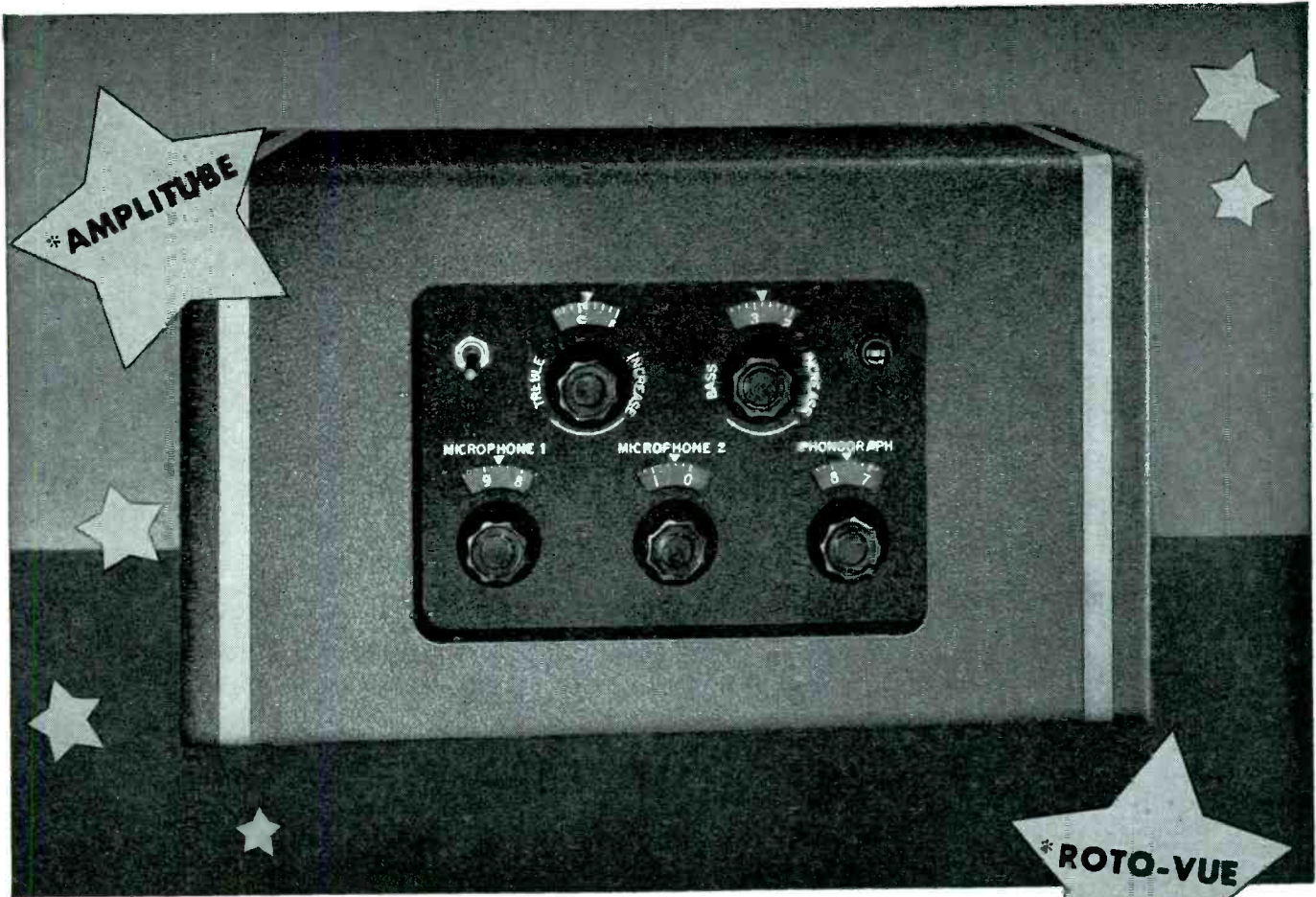

\*AMPLITUDE

\*ROTO-VUE

# *Ethical Engineering* is the Basis of

## Eastern's 21 STAR FEATURES

\*UNICABLE



Ethical engineering at Eastern is the history of many years in the service of sound amplification. The 21 Star Features are the result of intensive experience dating back to the early days of radio—the pioneer 20s! Today this engineering background accounts for the many innovations we have designed for the new 1946 Eastern Amplifiers—the 21 Star Features that produce Eastern's

famous *Quality Performance*. No other amplifiers, regardless of price, incorporate so many novel and useful features. . . . For complete information and price list—for the first edition of our 1946 Catalog—write today! . . . Eastern Amplifier Corporation, 794 East 140th Street, New York 54, N. Y. Dept. 1-F.

RECESSED CONTROLS

CODED CABLE

# **EASTERN** **AMPLIFIERS**

\*U.S. Reg'n Applied For.



# ARE YOU PREPARED



## FOR THE TIDAL WAVE ?

That Great Wave of Modern Appliances,  
Radios, etc., that will use Indicator Lights—



as a basic design utility. Your first consideration is an Indicator Light that will add quality, as well as utility to your product. The Gothard No's. 1142, 1143 and 1144 Indicator Lights will do this double job for you with the rich glow of long-life neon lamps. They have built-in resistors for use on 115 V. circuits that are easily changed or removed if necessary. Lucite cap adds to beauty and gives protection to lamp. Also available for Mazda No's. 44, 313 and 1815 lamps. These Lights are tops in beauty, utility, quality and economy.

Ask for catalog of other Gothard Lights.

Gothard Lights are an official requirement in the National All-Amateur Transmitter Contest.

# Gothard

MANUFACTURING COMPANY  
2114 CLEAR LAKE AVE., SPRINGFIELD, ILL.

EXPORT DIVISION: 25 WARREN STREET, NEW YORK 7, N. Y.

## OPTICAL MIRRORS and REFLECTORS

FOR ELECTRONIC, OPTICAL  
AND SCIENTIFIC APPARATUS

WE specialize in the production of front or rear surface mirrors, made to your specifications. Closest optical and dimensional tolerances observed.

Because of their proven superiority, ZENITH mirrors are preferred by many leading manufacturers of precision equipment.

- EXCEPTIONAL REFLECTIVITY
- ALUMINUM, SILVER, GOLD, etc.
- OPAQUE OR SEMI-TRANSPARENT
- PERMANENT CHARACTERISTICS
- PROMPT SERVICE

We invite your inquiry. Samples and quotations will be submitted promptly.

# ZENITH OPTICAL LABORATORY

SPECIALISTS IN  
VACUUM DEPOSITION



123 WEST 64th STREET  
NEW YORK 23, N. Y.

to come airborne radars that can initiate defense automatically, by triggering automatic control circuits that instantly release the appropriate airborne counter-missile.

The Navy's Bureau of Aeronautics, which has the overall responsibility for new aircraft and equipment, will lean heavily on electronics for these future offensive and defensive weapons. It will have the assistance of the Navy's new Office of Research and Inventions, now engaged in enlarging the airborne electronic facility at Naval Research Laboratory.

### F-m Gets Channel Numbers

A SIMPLIFIED SYSTEM of identifying frequencies of stations on f-m receiver tuning dials has been adopted by the FCC. The first channel frequency (88.1 mc) will be numbered 201; the second frequency (88.3 mc) will be numbered 202, and so on up to and including channel number 300 (107.9 mc). This system provides for extension of the f-m band either upstairs or downstairs without disturbing the numbering on existing receivers. The FCC action allows set manufacturers to proceed with production of simplified tuning dials with standardized numbering of dial calibrations.

### Proposed RMA Standards

THE FOLLOWING MATTERS have been proposed by various committees of Radio Manufacturers Association for standardization as recommended practice and are being submitted to the RMA membership for comment.

(1) The intermediate frequency for vhf broadcast receivers shall be 10.7 megacycles.

(2) The sound-channel intermediate frequency of television broadcast receivers shall be located in the region 21.25 to 21.9 mc, and the oscillator frequency shall be higher than the signal frequency, thus placing the corresponding upper-frequency limits of the video channel between 26.5 and 27.15 mc.

(3) The antenna-to-set transmission line for television broadcast receivers shall be an unshielded, parallel line of 300 ohms impedance.

(4) The number of tubes counted

# ULTRA HIGH SPEED RELAY OPERATES AT 1,000 TIMES A SECOND

DEPARTING from conventional design to produce a hermetically-sealed relay only slightly larger than a metal receiving tube, Stevens Arnold engineers have developed the MILLISEC relay operating on  $\frac{1}{2}$  milliwatt of power, carrying 5 amperes, and functioning in 1 millisecond. We don't claim that all of these features can be incorporated simultaneously in the same relay, but these accomplishments give an indication of the range of operations attainable.

The MILLISEC relay may be used as the basis for a square-wave generator for frequencies up to 1,000 cycles per second. It has possibilities for replacing electron tubes in electronic switches for viewing simultaneously two traces on the screen of a cathode ray oscilloscope.

Because its mechanical resonance can be adjusted over a wide range, the moving element of the ultra-high speed relays provides the basis for the control element of another unconventional Stevens Arnold development — frequency operated switches. Having a band-width of 10 cycles per second, these frequency responsive switches will operate at any selected frequency from 20 to 800 cycles per second. This characteristic makes them admirably suited to remote control applications in radio or wire guided carrier systems.

We don't know all of the potentialities of our relay, but we do know that its unusual characteristics enable it to perform functions not ordinarily expected of relays. We shall be glad to co-operate with your engineers in exploring the possibilities of having MILLISEC relays — or our frequency selective switches — serve your requirements.

In designing the MILLISEC relay our engineers were not handicapped by restrictions which tradition sometimes imposes. In fact, we encourage new ideas and original approaches. We feel that this is one of the reasons why we have been able to build a well-balanced, efficient organization whose engineering achievements we shall report from month to month.

*Stevens Arnold Co.*

22 ELKINS STREET

SOUTH BOSTON 27, MASS.





The  
**SPINTITE  
WRENCH**  
Works Like a  
Screw Driver

Speeds Production on  
the assembly line.

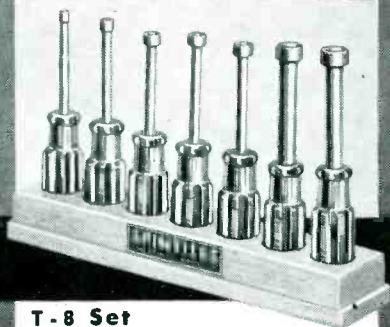

T-8 Set

Seven Standard Hex  
sizes in a Convenient  
Holder.

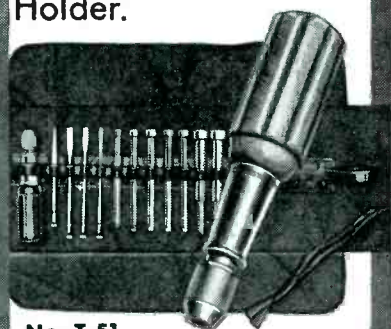

No. T-51

**CHUCK TYPE  
SPINTITE**

with Seven SPINTITES, three  
Screw Drivers and Ream-  
awl in Leatherette Roll.

Send for Catalog No.  
141 picturing a full line  
of Automobile, Aircraft  
and Radio Tools.

**WALDEN**  
WORCESTER  
WRENCHES

**STEVENS WALDEN, INC.**  
468 SHREWSBURY STREET  
WORCESTER, MASSACHUSETTS

in an export radio receiver shall include the total number of evacuated envelopes exclusive of such of these as provide enclosure solely for illuminants.

(5) In specifying the frequency coverage of export broadcast receivers, the assured upper and lower frequency limits of all continuous frequency bands shall be stated in terms of: (a) kilocycles where the lower limit of frequency is less than two megacycles; (b) megacycles where the lower limit of frequency is between one megacycle and one kilomegacycle; (c) kilomegacycles where the lower limit of frequency is between one kilomegacycle and one megamegacycle.

(6) For export receivers, the values or ranges of power supply voltage and frequency on which satisfactory operation of the receiver is assured shall be specified. (Examples: 90-130 volts; 180-260 volts; 50/60 cycles.)

(7) When color coding is used for chassis wiring, it shall be standard to employ the following schedule of solid colors for wire insulation:

No.	Color	Circuit
0	Black	Grounds, grounded elements, and returns
1	Brown	Heaters or filaments, off ground
2	Red	Power supply B plus
3	Orange	Screen grids
4	Yellow	Cathodes
5	Green	Control grids
6	Blue	Plates
7	Violet	Not used
8	Gray	A-c power lines
9	White	Above or below ground returns, etc.

**New Call Areas for Amateurs**

IN ORDER TO PERMIT assignment of thousands of additional calls without exceeding a limit of five symbols, the Federal Communications Commission has set up a new system of assigning call letters to identify amateur radio stations. The number of U. S. call areas was increased from nine to ten by reassignment of some areas within certain states. Full use of the prefix K will be made in the continental United States also, rather than in outlying areas only. Distinctive 2-letter prefixes will be reserved for outlying areas, such as KG6AA to KG6ZZ for Guam and KV4AA to KV4ZZ for the Virgin Islands. It is expected that in a great majority

**Attention  
GI JOE!**

Here's Your Opportunity to be First to

**Start Your Own  
RADIO SERVICE  
SHOP**

Complete Starting-in-Business  
Package Stocks of

**TEST EQUIPMENT  
TUBES, PARTS, TOOLS** **\$350 up**

Act quickly! Meet the pent up demand for radio service. Turn your special service training into a profitable business of your own. No fuss. No worry. Here's everything you need—\$350 up. Details upon request! Write, wire or phone



**TRIPLET**  
Volt-Ohm-Milliammeter

**A. C.-D. C. Volts**  
0-10-50-250-1000-5000  
at 1000 ohms per volt.  
**D. C. Milliampers**  
0-10-100-500  
**Ohms** 0-300-250,000  
**Case** Black molded  
3 1/4" x 5 1/8" x 2 1/8".  
**\$16.00 net**

**Good News!** ALL  
PRIORITIES LIFTED

**HALLICRAFTERS SX-28A**



**\$223**

SUPER DEFIANT ..... SX25 **\$94.50**  
SKY CHAMPION ..... S20R **60.00**  
SKYRIDER MARINE ..... S22R **74.50**  
SKY RANGER ..... S39 **110.00**  
ECHOPHONE ..... ECIA **29.50**  
ORDERS FILLED AS RECEIVED!!!

**MASCO AMPLIFIERS**



Complete  
with tubes.

17 Watt **30.30**  
25 Watt **42.60**  
35 Watt **54.60**  
50 Watt **70.50**  
17 Watt with Phono-top ..... **42.30**  
25 Watt with Phono-top ..... **52.20**  
35 Watt with Record-changer ..... **69.10**

**PHILCO BEAM OF LIGHT**

Selenium Cell only, no holder ..... **1.80**

20% deposit required on all C.O.D. orders. 2% transportation allowance on orders of \$25.00 or more accompanied by payment in full.

**RADIO SUPPLY &  
ENGINEERING CO., Inc.**  
127 SELDEN AVE. DETROIT 1, MICH.

Write for  
FREE CATALOG



ANOTHER WILCO DEVELOPMENT

**WILCO THERMOMETAL**  
(Thermostatic Bimetal)

# Morflex

Higher Deflection Rate • Greater Electrical Resistivity

This new high action WILCO Thermometal broadens the range of Thermostatic Bimetal application.

**PROPERTIES AND CHARACTERISTICS**—Morflex provides a 40% higher temperature deflection and electrical resistivity for devices or instruments requiring extremely high sensitivity from 50° to 350°F. Whether the desired function is Temperature Indication, Temperature Control, or Temperature Compensation, Morflex operates dependably and uniformly . . . saves space.

**WIDE APPLICATION FOR DOMESTIC AND INDUSTRIAL DEVICES**—Morflex is supplied in strip or in straight cantilever blades, U-shapes, spirals and helices . . . or as parts of assemblies with shafts, studs, brackets, contacts, braids or springs.

**CONSULT OUR ENGINEERING DEPARTMENT**—Write the WILCO Engineering Department for help in developing the proper application of WILCO materials to your products. Send for FREE copy of the WILCO Blue Book. It contains charts, formulae, and full descriptions of *all* WILCO Thermometals and other products:

#### WILCO PRODUCTS INCLUDE:

**CONTACTS—**

Silver  
Platinum  
Tungsten  
Alloys  
Sintered Powder Metal

**THERMOSTATIC BIMETAL—**

High and Low Temperature with new high temperature deflection rates.

**PRECIOUS METAL COLLECTOR RINGS—**

For rotating controls

**SILVER CLAD STEEL**

**JACKETED WIRE—**

Silver on Steel, Copper, Invar or other combinations requested.

**ROLLED GOLD PLATE**

**SPECIAL MATERIALS**



**THE H. A. WILSON COMPANY**

105 Chestnut Street, Newark 5, N. J.

Branch Offices: Chicago—Detroit—Los Angeles

**SPECIALISTS FOR 30 YEARS IN THE MANUFACTURE OF THERMOMETALS**

• ELECTRICAL CONTACTS • PRECIOUS METAL BIMETALLIC PRODUCTS



Speed peacetime goods  
to market with...



**Clippard**

**Electro-Magnetic Windings  
and R. F. Coils**

The same personalized skill and service that helped us produce hundreds of thousands of components and sixteen separate types of test equipment for the Navy's V.T. proximity fuse can now help you produce better, sturdier, more salable products for civilian use. We're equipped to fulfill your Electro-Magnetic Winding, R.F. Coil, Sub-Assembly or special Test Instrument requirements with intelligence and dispatch. Send your specifications for quotes, TODAY!

**NEW! Laboratory-Type**

**ELECTRONIC  
Volt-Ohmeter**



Incorporates features and accuracy of expensive custom-built laboratory equipment—yet priced within reach of all wanting the best. Low capacity, high impedance input. Balanced circuit. Wide Audio, H.F. and V.H.F. response. New small-diameter diode probe reaches difficult places with minimum lead length. Full scale sensitivity of 1 volt. Determines resistances from fraction of 1 ohm to 1000 megohms. Decibel scale for measuring audio gain. Sturdy oak case. Handy carrying handle. Write for details.

SPECIAL INSTRUMENTS FOR ELECTRICAL  
AND ELECTRONIC TESTING

ELECTRO MAGNETIC WINDINGS

R. F. COILS

SUB-ASSEMBLIES

**Clippard**  
INSTRUMENT  
LABORATORY  
1440 CHASE AVE. CINCINNATI 23, O.

of instances, more than 75 percent, a former call can be assigned without any change.

The old call area boundaries cut through a number of states, tending to cause confusion and delay in processing applications. The new areas will follow state boundaries, eliminating such confusion.

The new call areas are as follows:

- |     |   |
|-----|---|
| No. | Area  |
| 1   | New England (six states).   |
| 2   | New York, New Jersey.   |
| 3   | Pennsylvania, Delaware, Maryland, District of Columbia.   |
| 4   | Virginia, North and South Carolina, Georgia, Florida, Alabama, Tennessee, Kentucky, Puerto Rico and Virgin Islands. |
| 5   | Mississippi, Louisiana, Arkansas, Oklahoma, Texas, New Mexico.  |
| 6   | California, Hawaii and Pacific possessions except those included in Area 7.   |
| 7   | Oregon, Washington, Idaho, Montana, Wyoming, Arizona, Nevada, Utah, Alaska and adjacent islands.                    |
| 8   | Michigan, Ohio, West Virginia.  |
| 9   | Wisconsin, Illinois, Indiana.   |
| 0   | Colorado, Nebraska, North and South Dakota, Kansas, Minnesota, Iowa, Missouri.                                      |

**FCC Establishes Laboratory**

A LABORATORY DIVISION recently established within the FCC Engineering Department will study the civilian uses of radar as they affect frequency allocations, conduct wave propagation and allocation studies, develop new monitoring equipment, test all types of transmitters for type approval, and test diathermy and industrial heating equipment.

Chief of the Laboratory Division will be Charles A. Ellert, formerly technical supervisor of the Radio

**JAPANESE MAGNETRONS**



Japanese radar receiving magnetron (held by Col. Marvin Hobbs, consulting engineer for Scott Radio Laboratories, Inc.), transmitting magnetron of cavity resonator type (held by Lorraine Pellegrini), and other Japanese tubes brought back from Japan by Col. Hobbs

**GOULD-MOODY**

*Improved*

**Professional Quality  
"Black Seal"**

**ALUMINUM  
INSTANTANEOUS  
RECORDING BLANKS**



Technological advancements brought about by our wartime assignments provide critical engineers with "Black Seal" blanks of improved cutting and reproduction qualities plus more satisfactory play-back life.

**Rapid Deliveries to**

- Broadcasting Stations
- Recording Studios
- Motion Picture Sound Studios
- Schools and Colleges
- Governmental Agencies

*Old Aluminum Blanks Recoated with  
"Black Seal" Formula on Short Notice*



395 BROADWAY, NEW YORK 13, N. Y.  
Cable Address: Recordisc, New York, N. Y.  
Export Dept: Royal National Company, Inc.  
89 Broad Street, New York

# Insulation for HIGH Operating Temperatures



Natvar Varnished Fiberglas is available in 36" width rolls and sheets, or cut to any desired tape width.

**N**ATVAR Varnished Fiberglas is used *primarily* to insulate equipment which must operate at temperatures above the safe working range of other insulating materials. It is approved Class B insulation.

But there are actually *three* advantages. For, in addition to its superior heat resistance, Natvar Varnished Fiberglas has excellent mechanical and dielectric strength, because it is carefully processed with special varnish to take fullest advantage of the Fiberglas base.

Write, wire, or phone us for quick deliveries, either from nearby wholesaler's stock or from our own.



- Varnished cambric — straight cut and bias
- Varnished cable tape
- Varnished canvas
- Varnished duck
- Varnished cellulose acetate
- Varnished special rayon
- Varnished Fiberglas cloth
- Varnished papers
- Varnished tubings and sleeveings
- Varnished identification markers
- Lacquered tubings and sleeveings
- Extruded vinyl tubing
- Extruded vinyl identification markers

Write for Catalog No. 20

## THE NATIONAL VARNISHED PRODUCTS CORPORATION

TELEPHONE  
RAHWAY 7-2171

CABLE ADDRESS  
NATVAR: RAHWAY, N. J.

201 RANDOLPH AVENUE



WOODBIDGE NEW JERSEY



The **FINEST MICROPHONES**  
for P.A. and RECORDING!



**AMPERITE VELOCITY MICROPHONE**  
WITH PATENTED ACOUSTIC COMPENSATOR

**New P.G. DYNAMIC**  
WITH NEW SUPERIOR ELIPSOID PICK UP PATTERN!

**AMPERITE KONTAK MIKES**  
IDEAL FOR AMPLIFYING STRINGED INSTRUMENTS  
USED WITH ANY AMPLIFIER AND WITH RADIO SETS.

ASK YOUR JOBBER . . . WRITE FOR FOLDER

# AMPERITE

561 BROADWAY NEW YORK



Intelligence Division (RID). Willmar K. Roberts will be assistant chief.

Testing of diathermy equipment will be done to prevent such apparatus from interfering with radio communications. Diathermy equipment manufactured since May 25, 1945 is required to operate within the three frequency bands designated for that purpose, with reasonable suppression of harmonic radiations. If the equipment is operated outside these bands, it must be operated in accordance with prescribed engineering standards to prevent interference. Equipment manufactured prior to the above date will be permitted to operate indefinitely as in the past; however, if interference will result from such operation, steps necessary to eliminate the interference must be taken.

The Commission will test for type-approval diathermy equipment submitted by manufacturers designed to operate within one or more of the frequency bands allocated for such equipment. Equipment found to be capable of operation within one or more of such bands with reasonable suppression of harmonic radiations will be included in a list made available to the public.

### Amateurs Go On Air

THREE BANDS of frequencies were released Nov. 15, 1945 by the Federal Communications Commission for use by radio amateurs: (1) the 28,000-kc band which in prewar days carried many an international conversation; (2) the 56 to 60-mc band, due to be shifted to 50 to 54-mc on March 1, 1946 when television stations are moved to a new channel; (3) a 144 to 148-mc band.

### New F-m Detector Circuit

A TRUE FREQUENCY-modulation detector circuit employing a new seven-element vacuum tube has been announced by Philco Corporation. The new circuit replaces the discriminator and limiter in conventional f-m circuits, thereby saving either one or two tubes depending on whether a one or two-tube limiter is considered. Radio-frequency signals are used to control a

# "DIE-LESS" DUPLICATING

SAVES MAN HOURS AND DELAYS

DIE ACCURACY WITHOUT DIES

Send for CATALOG



**BENDER**

**SHEAR**

**BRAKE**

**"DIE-LESS" DUPLICATING**  
The DI-ACRO System of METAL DUPLICATING Without Dies

**DI-ACRO**  
PRECISION MACHINES  
DIE-LESS DUPLICATING

## O'NEIL-IRWIN MFG. CO.

321 EIGHTH AVENUE SO. • MINNEAPOLIS 15, MINN.



# GOLD goes to work

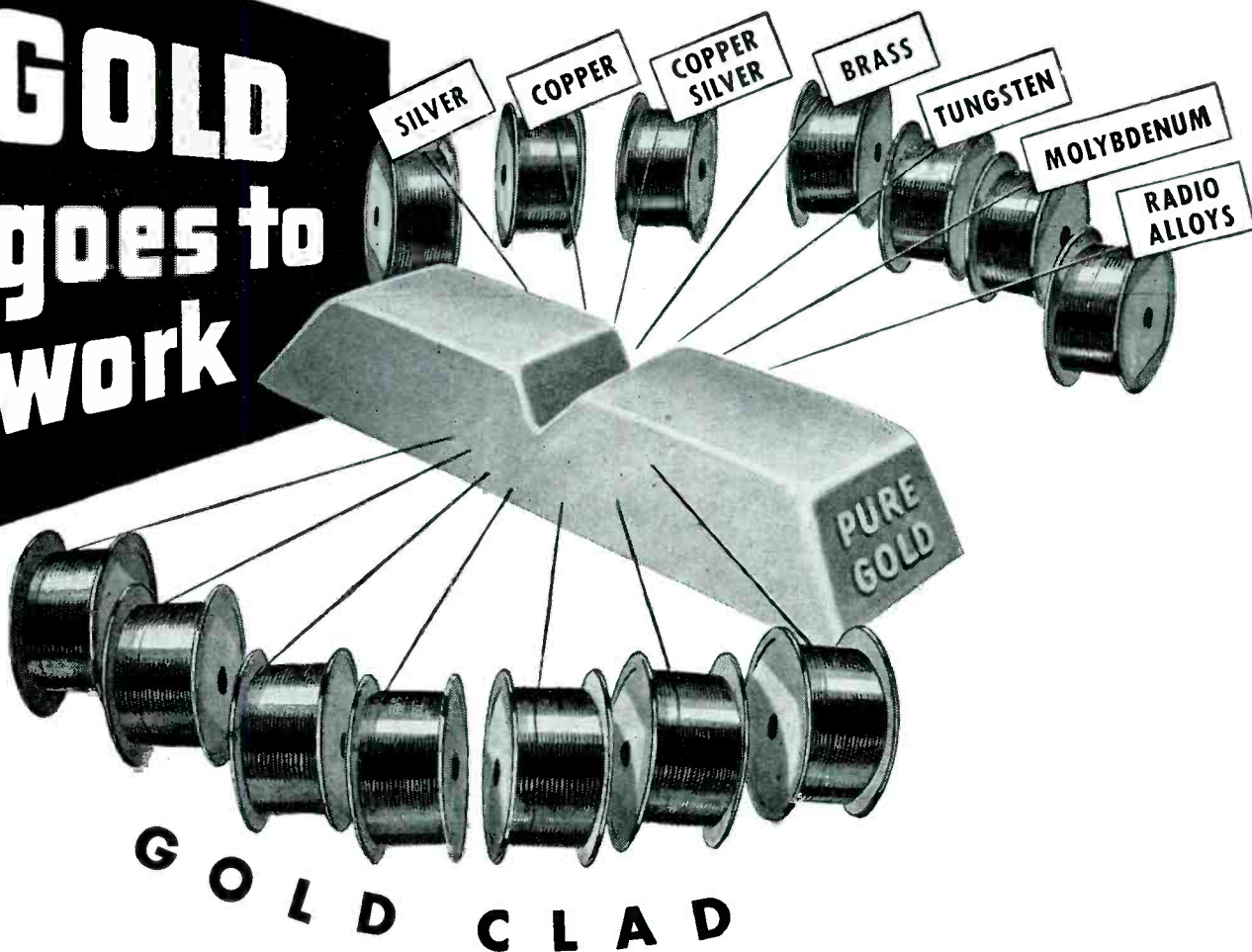

From America's *precision* producer of gold clad fine wire... a complete line of sizes and materials.

Gold clad wires available include silver, copper silver, copper, brass, molybdenum, tungsten and radio alloys. Sizes .010 to .0005.

Besides, wire can also be furnished clad with silver, copper and other material on almost any base metal. All with the same high standards of quality.

And not only a wide variety of sizes and materials — but the assurance of a coating which is smooth and even, which will not blister, is non-porous and *sticks* to the wire.

That's the reason why fine wire users rush

right to fine wire headquarters when they have a tough problem — they have found North American Philips is *wired for quick action*. Do you have a question about the application of fine wire to your products? Then write, wire or telephone — North American Philips.

*In Electronic Tubes:* Gold clad wires guard against undesirable grid emission.

*In Decorations:* The Admiral's braid, women's clothing decorations, religious vestments, decorators braid, fraternal uniforms and jewelry, all use this smart, non-tarnishable and tough gold clad wire.



**Norelco** Electronic Products by  
Reg. U. S. Pat. Off.

OTHER PRODUCTS: Quartz Oscillator Plates; Cathode Ray Tubes; Searchray (Industrial X-ray) Equipment; X-ray Diffraction Apparatus; Medical X-ray Equipment, Tubes and Accessories; Fine Wire; Diamond Dies. • We invite you to visit our office and showroom when in New York City.

**NORTH AMERICAN PHILIPS COMPANY, INC.**

Dept. S-1, 100 East 42nd Street, New York 17, N. Y.  
Factories in Dobbs Ferry, N. Y.; Mount Vernon, N. Y. (Metalix Div.); Lewiston, Me. (Elmet Div.)



# HARVEY

## HAS IN STOCK

### QUALITY SHALLCROSS MEASURING INSTRUMENTS

Trust HARVEY to supply you with hard-to-get Shallcross Measuring Instruments when you need them. The models described below are on our shelves now. Delivery information concerning Shallcross products not listed herein can be obtained by writing directly to us. Remember, HARVEY carries the lines of many other leading American radio and electronic manufacturers, too. Tell us what you need. We promise efficient, courteous service - prompt deliveries.

#### SHALLCROSS MODEL 637 KELVIN-WHEATSTONE BRIDGE

An extremely accurate and versatile bridge for the measurement of resistance over a wide range. Range is from 0.001 ohm to 11.1 megohms. Built-in galvanometer with a sensitivity of 1 microampere per millimeter division is supplied with the instrument. The rheostat arm consists of three decades variation in steps of 10 ohms when used as a Wheatstone bridge, or 10 micro-ohms when used as a Kelvin bridge. Accuracy of component resistors is 0.1%, except 1 ohm resistors, on which the accuracy is 0.25%. Portability; weight approximately 7 lbs. \$80.00

#### SHALLCROSS MODEL 638-2 KELVIN-WHEATSTONE BRIDGE

Combining both Kelvin and Wheatstone networks in a single, portable unit, the Model 638-2 provides a range of resistance from 0.0001 ohm to 11.11 megohms. Separate keys are provided for the battery and galvanometer circuit. Accuracy of component resistors is 0.1%, except the 1 ohm resistors, on which accuracy is 0.25%. For laboratory, school use, maintenance work, field investigations, and many forms of production line testing, this compact instrument is supplied with built-in galvanometer, sensitivity 0.25 microampere per m.m. Weight approximately 9 lbs. \$120.00

#### SHALLCROSS MODEL 630 WHEATSTONE BRIDGE

A basic electrical measuring instrument for laboratory and industrial use, providing accurate and direct electrical resistance measurements from 0.1 to 11,100,000 ohms in between 10 ohms and 1,000,000 ohms is normally better than 1 percent. Supplied with built-in galvanometer having a sensitivity of 1 microampere per millimeter division. Weight approximately 6 lbs. \$60.00

#### SHALLCROSS DECADE RESISTANCE BOXES

Used extensively as laboratory standards, A.C. and D.C. bridge and ratio arms, voltage dividers, etc. The accuracy adjustment of resistors as follows: 0.1 ohms—1%; 1 ohm—0.25%; all others—0.1%.

No. 544—One dial; 1.0 ohm steps; 10 ohms total resistance \$13.50  
Model 550—One dial; 1,000,000 ohm steps; 10,000,000 ohms total resistance \$45.00

Telephone: LOngacre 3-1800

# HARVEY

RADIO COMPANY

103 WEST 43rd ST., NEW YORK 18, N. Y.

quadrature circuit and an oscillator in such a way that a-m noise signals are ignored completely, eliminating the need for limiter action.

### 20,000,000-Volt Betatron Used in Industrial Radiology

USE OF A 20,000,000-volt betatron during the past two years at a Government arsenal has been disclosed by the University of Illinois and Allis-Chalmers Manufacturing Co., who cooperated in the design and construction of the equipment. The betatron generates x-rays powerful enough to take pictures through 15 inches of solid steel. Laboratory development of the betatron was carried on by Dr. D. W. Kerst of the University of Illinois.

### Two New Elements Discovered

DISCOVERY OF TWO new elements, 95 and 96 in the periodic table, was announced by Dr. Glenn T. Seaborg of the University of California at a recent American Chemical Society symposium. Dr. Seaborg, co-discoverer of plutonium, element 94, which was used in the atomic bomb dropped on Nagasaki, said the new elements belong to the heavy type and are of importance from the standpoint of atomic energy.

The new elements were discov-

### A COMPLETE STEAL

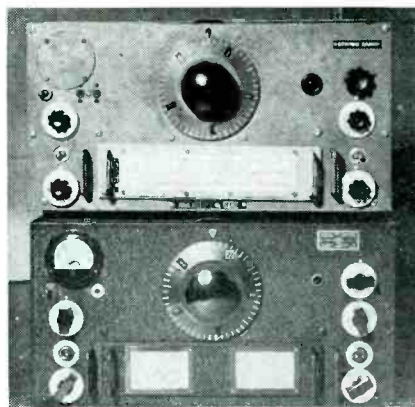

Nine-tube German communications receiver made by Korting-Radio, shown on top of National Radio Company's type HRO which it imitates in electrical and mechanical design. Both craftsmanship and materials were inferior in the German copy, indicating it was rushed to meet heavy production schedules



In its multiplicity of wiring problems the many new and precious features of Surco Spiralon Keyed Insulation, with the widest range of identification in all sizes and lengths, is proving invaluable to Farnsworth Television & Radio Corp. of Fort Wayne, Ind. The ease with which this new insulated wire can be used in small compact areas or in large or intricate installations found instantaneous favor with this famous concern which is taking full advantage of Spiralon's diverse uses.

Spiralon is non-inflammable, non-fogging, non-corrosive, yet flexible and tough; and highly resistant to oils, dilute acids and alkalis to prove ideal for wiring under any and all conditions. Identification stripes are easily seen even on diameters as small as .025. The absence of all pigment fully preserves every electrical property, increases insulating resistance and allows for greater voltage.

With a Nylon jacket added—resistant to high heat and low temperatures—Spiralon further protects all electrical properties, reduces creepage while soldering terminals, offers a higher rupture point than braids and lacquers, checks deterioration, fungi attack, voids and pin holes.

- SHIELDED WIRE
- HIGH FREQUENCY WIRE and CABLE
- VINYL RESIN SHEETING
- INSULATING TUBING
- INSULATING TAPE

Address Dept. C

**Surprenant**  
ELECTRICAL INSULATION CO.  
84 Purchase St., Boston 10, Mass.



**IT'S  
NEW**

**RESISTORS**

**WARD LEONARD ELECTRIC CO.**  
MOUNT VERNON, NEW YORK

**SEND FOR THIS  
RESISTOR DATA**

For the convenience of designers of products requiring resistors, Ward Leonard offers this new Resistor Handbook. It describes in detail the full line of wire-wound resistors giving complete information on mountings, enclosures, terminals and resistance values. Write for your copy today.

★  
★  
BUY  
MORE  
★  
★  
WAR BONDS  
★



**WARD LEONARD**  
**RELAYS • RESISTORS • RHEOSTATS**

Electric control  devices since 1892.

**WARD LEONARD ELECTRIC COMPANY • 32 SOUTH ST. • MOUNT VERNON, N. Y.**



**FOR**  
*Easy*  
**LISTENING**



## MURDOCK RADIO PHONES

MURDOCK Radio Phones are built by sound manufacturing methods to give service—traditionally outlasting ordinary radio phones by years of service.

No other listening experience is like hearing through the "Ears-of-a-Nation"—produced by MURDOCK. Thousands are now listening without strain or discomfort. They get the message right . . . the first time . . . all the time!

MURDOCK Radio Phones have been a FIRST for over 40 years with unusual features that mean effective, easy listening. Be sure to consult with MURDOCK for sturdy, solid-built HEAD PHONES!

Write for Catalog

### JOBBERS

MURDOCK RADIO PHONES are now available to you in greater quantities. Write us for full information.

**WM. J. MURDOCK CO.**  
219 Carter St., Chelsea 50, Mass.

ered as the result of bombardment of uranium 238, an isotope or twin of uranium, and plutonium 239, an isotope of plutonium, with helium ions of 40,000,000 electron volts in the cyclotron at the University of California.

A new hypothesis regarding the relationship of these heavy elements was advanced, suggesting that elements from actinium (number 89) through the newly discovered elements 95 and 96 form a series corresponding to the only previously known series of elements which also have similar properties, the Rare Earths, elements 58 to 71.

### Weather-Predicting Radar

A HIGH-ALTITUDE bombing radar set, designed by the Signal Corps to spread destruction in enemy countries, has now been adapted to peaceful meteorological use in detecting the approach of storms.

Developed at the Signal Corps Engineering Laboratories at Bradley Beach, N. J., and originally installed in B-29 bombers, these sets are being dismantled and mounted in observation stations where they foretell the direction, intensity and other characteristics of imminent weather disturbances.

The intensity and distance of an approaching storm are indicated on one oscilloscope, the signals appearing as vertical deflections on a time scale. Another oscilloscope (Plan Position Indicator) records direction by means of glowing points of light that appear on a moving arm. The set is known as the AN/APQ-13 and has located storms as far distant as 200 miles.

### Television Schedules for Intercity Coaxial Cable

HERALDING REGULARLY scheduled intercity television to begin early in January over the Bell System coaxial circuit between New York and Washington, the Army-Navy football game in Philadelphia was brought to the NBC television audience in the New York metropolitan area over a portion of this coaxial link. Twenty wide-band amplifiers spaced five miles apart in the coaxial cable made up for line losses.

The Washington-New York cable

# NOW 8 SIZES OF CREATIVE GROMMETS

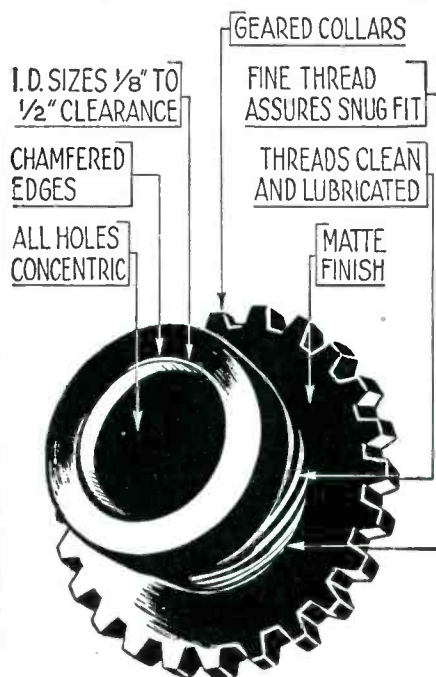

Four new larger sizes of **CREATIVE 100% PHENOLIC PLASTIC GROMMETS** (up to  $\frac{1}{2}$ " i. d.) are now available for radio, electronic and electric instruments...*Send for a sample of each of the eight standard stock sizes, mounted on a convenient card.*

### CREATIVE'S CUSTOM SERVICE

You don't have to build molds to get Plastic Parts with Inserts such as knobs, terminals, etc. Get the facts about this unusual custom service... **CALL ON CREATIVE.**



# The Alphatron

A REALLY NEW VACUUM GAUGE  
FOR THE ELECTRONICS INDUSTRY

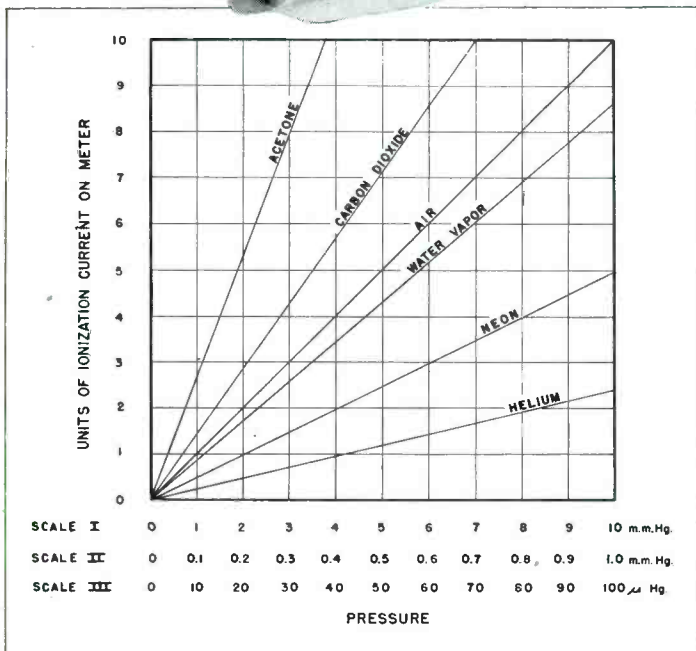
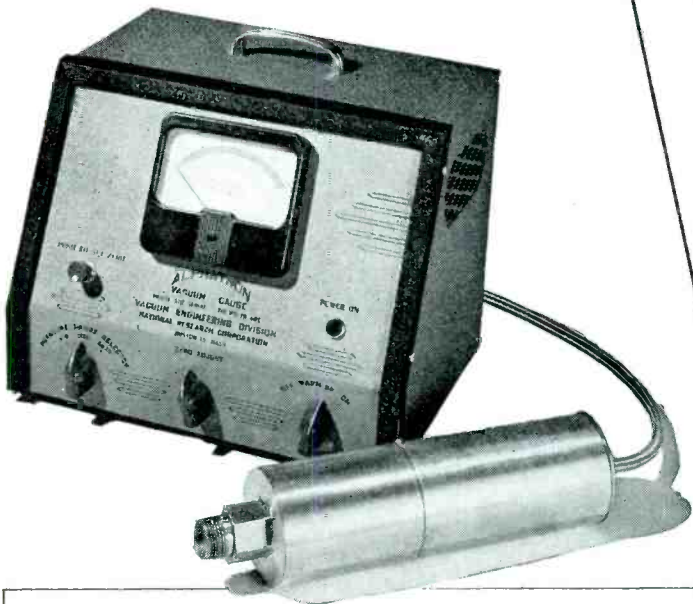

See the Alphatron in operation  
at the I. R. E. Convention.

Continuous linear pressure indication for any atmosphere from 0 - 10 millimeters in three ranges: 0 - 0.1 mm., 0 - 1 mm., and 0 - 10 mm.

Simple to operate. Ideal for production gauging in the hands of inexperienced operators.

Radioactive source of ionization is undamaged by exposure to atmospheric pressure.

Contamination originating in gauging is eliminated. Instantaneous response for accurate pressure control and convenient leak detecting.

Reads pressures of gas mixtures directly.

For full particulars send for  
Bulletin G-3

**Vacuum**  
ENGINEERING DIVISION

NATIONAL RESEARCH CORPORATION  
BOSTON 15, MASSACHUSETTS, U.S.A.

*High Vacuum for Industry*



To test  
over-all  
performance



## SQUARE-WAVE GENERATOR

● This unit, generating its own frequency or synchronized from an external source, will be found invaluable in many fields. FM, AM and Television Broadcasting—Telephone and Telegraph Communications—Manufacture of Transmitting and Receiving Equipment and Parts.

● Many additional functions will recommend it for use in school and college research projects and in scientific laboratories.

For additional information write: *Electronics Department, General Electric Company, Syracuse, New York.*

Electronic Measuring Instruments

**GENERAL ELECTRIC**

164-E1

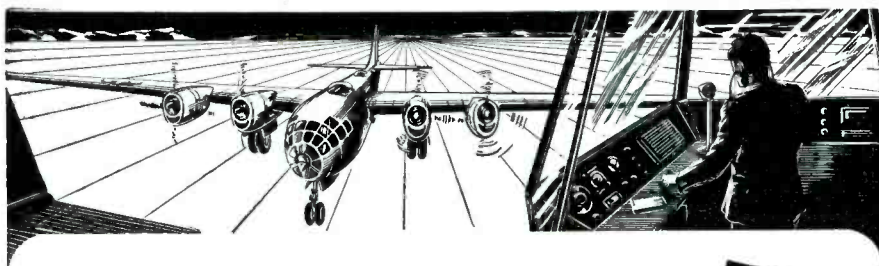

An Invitation to All Electrical Designers to  
**TRY SILVER GRAPHALLOY**

### FOR BRUSHES

High current density, low contact drop, low electrical noise, and self-lubrication are characteristics of this silver-impregnated molded graphite that may be the answer to your electrical brush problems

SAMPLES of Silver Graphalloy will be gladly furnished for test on your applications. Silver Graphalloy is usually silver plated to permit easy soldering to leaf springs or holders. Why not WRITE NOW for your test samples?

### FOR CONTACTS

Low contact resistance and non-welding when breaking surge currents are inherent properties of this unique combination of conductive silver and self-lubricating graphite.

**GRAPHITE METALLIZING CORPORATION**

1055 NEPPERHAN AVE • YONKERS, NEW YORK

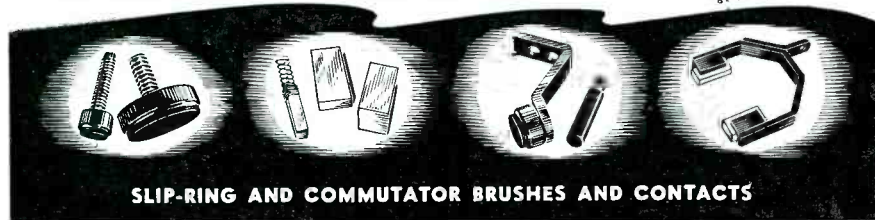

SLIP-RING AND COMMUTATOR BRUSHES AND CONTACTS

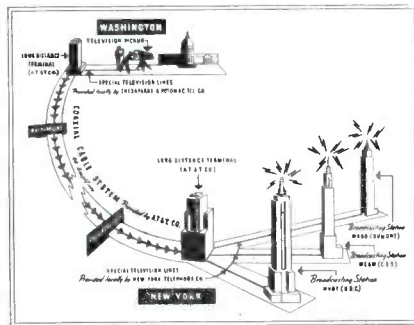

Diagram of experimental intercity television system utilizing coaxial network between Washington and New York

is to be made available to CBS, DuMont, and NBC for two nights per week during an extended experimental period, as well as to other television interests as soon as they have facilities for using this intercity service.

### MEETINGS TO COME

JAN. 9; AMERICAN INSTITUTE OF ELECTRICAL ENGINEERS; Transient Analysis of Linear Servomechanisms, by John R. Ragazzini, professor, Columbia University; Room 301, Pupin Hall, Columbia University; H. E. Farrer, AIEE Headquarters, 33 West 39 St, New York 18, N. Y.

JAN. 23-26, INSTITUTE OF RADIO ENGINEERS, 33d Annual Winter Technical Meeting; Astor Hotel, New York, N. Y.; E. J. Content, chairman of meeting committee, WOR, 1440 Broadway, New York 18, N. Y.

FEB. 6-8; AMERICAN INDUSTRIAL RADIUM & X-RAY SOCIETY, Annual Convention; Hollenden Hotel, Cleveland, Ohio.

FEB. 9; INSTITUTE OF RADIO ENGINEERS, Chicago Section; Chicago Engineering Conference and Banquet; Merchants and Manufacturers Club, Merchandise Mart, Chicago.

FEB. 13; AMERICAN INSTITUTE OF ELECTRICAL ENGINEERS; Frequency Spectrum Theory Applied to Servomechanisms, by E. B. Ferrel, Bell Telephone Laboratories; Room 301, Pupin Hall, Columbia University, 7 p.m.; H. E. Farrer, AIEE Headquarters, 33 West 39 St., New York 18, N. Y.

MARCH 13; AMERICAN INSTITUTE OF ELECTRICAL ENGINEERS; Non-Linearity in Servomechanisms, by

**FLEXY**—the S.S.White Flexible Shaft Man—says . . .



# END YOUR MISALIGNMENT TROUBLES!

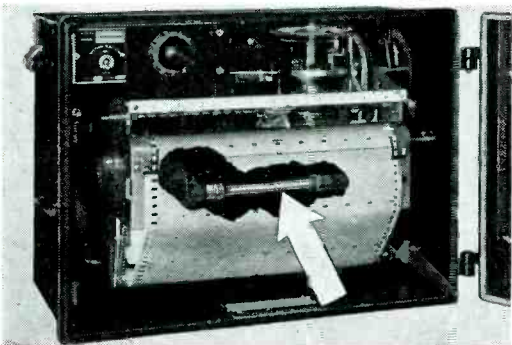

Coupling driving to driven mechanisms with S.S.White flexible shafting—as in this recording instrument—provides a smooth-running, vibration-proof drive and makes accurate alignment of connected spindles unnecessary.

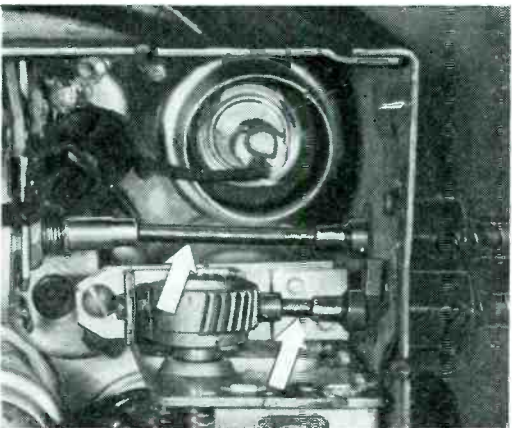

Coupling external control shafts to tuning elements—as in this radio receiver—damps noise-causing vibration, eliminates need for precise mounting and alignment of tuning elements—also gives complete freedom in their location.

*I*N all power drive and control applications within the wide range of flexible shafts, you can readily eliminate misalignment as a factor.

For example, take a small power drive — like the one in the top illustration at the left. By using an S.S.White flexible shaft as a connecting link between driving and driven members you eliminate the need for accurate alignment — and with it the expensive close-tolerance workmanship and assembly needed to obtain accurate alignment. And you eliminate the vibration and uneven operation that any misalignment in a solid shaft drive would cause.

For coupling elements requiring operational adjustments — as in the lower example — S.S.White flexible shafts offer the same advantages.

This is only one of the many ways in which S.S.White shafts can serve and save. To get the complete story —

## SEND FOR THIS FLEXIBLE SHAFT HANDBOOK

This 256-page standard handbook size volume covers the subject of flexible shafts from every angle including all essential technical data. A complimentary copy is yours if you will write for it on your business letterhead.



**S.S. WHITE INDUSTRIAL**  
 THE S. S. WHITE DENTAL MFG. CO. DEPT. E. 10 EAST 40th ST., NEW YORK 16, N. Y.



FLEXIBLE SHAFTS • FLEXIBLE SHAFT TOOLS • AIRCRAFT ACCESSORIES  
 SMALL CUTTING AND GRINDING TOOLS • SPECIAL FORMULA RUBBERS  
 MOLDED RESISTORS • PLASTIC SPECIALTIES • CONTRACT PLASTICS MOLDING

*One of America's AAAA Industrial Enterprises*



## PRECISION PARTS

### SMALL PARTS PLAY BIG ROLES

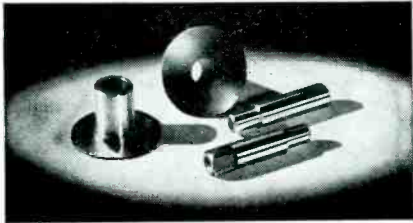

These intricate radio parts are typical of the precision and highly specialized production-capacity that have followed Ace products around the world.

For Ace has acquired the knack of machining and grinding delicate parts to incredible accuracies . . . doing it fast, on a mass-production basis. And this is important to every manufacturer engaged in conversion and production of specialized equipment.

Here at Ace, you'll find the ingenuity and modern machinery to help you design parts for *your* product . . . get them into production, and then turn them out faster, with greater accuracy, and to amazingly close tolerances.

If your production problems involve small parts and assemblies requiring stamping, machining, heat-treating, or grinding, check with Ace now. Send sample, sketch, or blueprint for quotation.



PARTS REQUIRING THREAD GRINDING A SPECIALTY. All types of threads up to 5" in diameter by 8" long on parts up to 20" between centers.



**ACE MANUFACTURING CORPORATION**  
for Precision Parts

1255 E. ERIE AVENUE, PHILADELPHIA 24, PA.

Dr. L. A. MacColl, Bell Telephone Laboratories; same place as Feb. 13 meeting.

MARCH 18-23; BROADCAST ENGINEERING CONFERENCE; developments since 1942 in broadcast engineering, including f-m and television; directed by Dr. W. L. Everitt, head, Department of Electrical Engineering, University of Illinois, Urbana, Ill., who requests addresses of those interested so they can be kept informed on program details.

#### BUSINESS NEWS

RESEARCH CORPORATION, New York, N. Y., offers \$2,500,000 in grants to college laboratories in order that talented young scientists will be able to undertake important peacetime research in pure science. This nonprofit institution was established in 1912 with the gift by Dr. F. G. Cottrell of patent rights on electrical precipitation, and revenues from this and other patents assigned to it by public-spirited inventors are used to advance research and technology.

MAGUIRE INDUSTRIES, INC., announces its purchase of Radiart Corp., Cleveland.

AIREON MFG. CORP., Kansas City, Kansas, is making available to railroad operators and related groups a one-reel natural-color sound film titled "Railroading by Radio", depicting two-way combined induction and space radiotelephone equipment for train communication. Aireon recently acquired Lewis Electronics, Inc.

GALVIN MFG. CORP., Chicago, Ill. announces use of Motorola two-way radiotelephone equipment by the Greyhound Bus Lines of Chicago on an experimental basis for dispatching and for maintaining contact with buses while enroute. Frequency is in 30-44 mc band; output power of f-m terminal station is 250 watts, with 50 watts output from transmitters in buses.

FARNSWORTH TELEVISION & RADIO CORP. has purchased another plant at Huntington, Ind., in which to manufacture component parts. An east wing will be added to the company's administration and engineering building at Fort Wayne where

RESISTORS  
CONDENSERS  
CONTROLS • WIRE  
TRANSFORMERS • CABLE  
HEADPHONES  
RELAYS • SWITCHES  
SOLDERING IRONS  
BATTERIES • TUBES  
TOOLS

## RIGHT OFF THE SHELF!

**Radio-Electronic  
Parts and Mater-  
ials . . .**

**Dalis carries an  
outstanding  
stock, most items  
right off the  
shelf.**

**IN A HURRY!**



'Phone, wire,  
or write . . .

# H. L. DALIS

Wholesale Distributors  
RADIO-ELECTRONIC SUPPLIES & PARTS  
17 Union Square  
NEW YORK 3, N. Y.

Phones: ALgonquin 4-8112-3-4-5-6-7

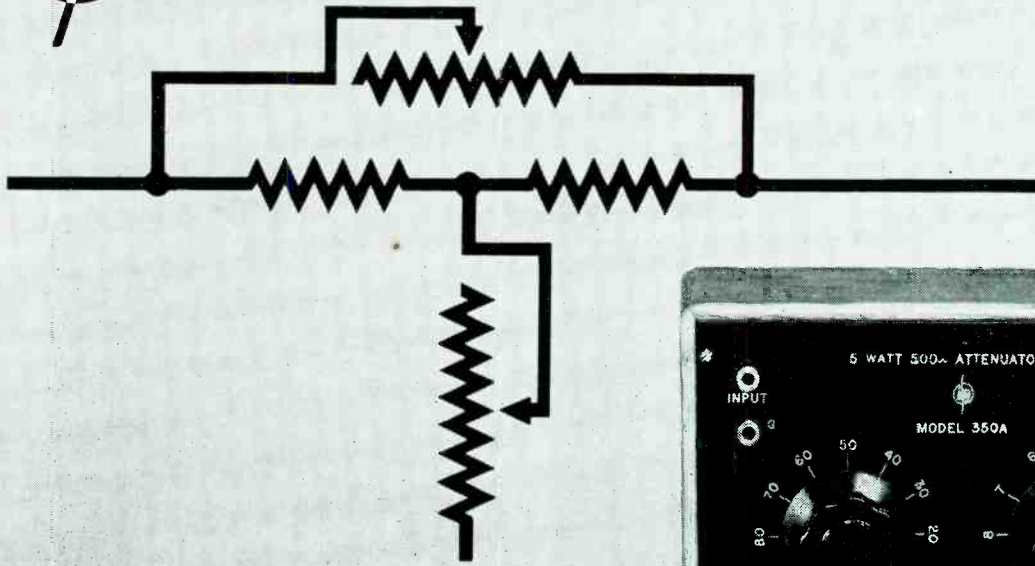

### THE -hp- MODEL 350A BRIDGED-T ATTENUATOR

#### A Small Instrument With a Lot of Uses

The schematic diagram above shows the basic bridged-T circuit, two of which make up the -hp- 350A attenuator set. One is a 100 db attenuator, calibrated in 10 db steps, and one is a 10 db attenuator, calibrated in 1 db steps. Response is substantially flat at frequencies as high as 100 k.c. See figure 3. Accuracy is assured because the resistors are adjusted to plus or minus 1/2%.

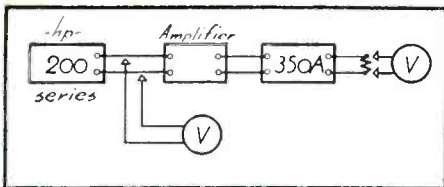

FIG. 1

In conjunction with an -hp- Audio Oscillator and two voltmeters, this -hp- Model 350A Attenuator may be used to make exact measurements of power gain . . . See figure 1.

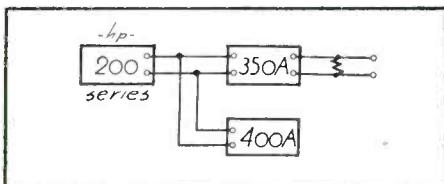

FIG. 2

The 350A may also be used to augment an -hp- audio oscillator and a vacuum tube voltmeter (-hp- 400A) to form a signal generator. See figure 2.

#### FOR MEASUREMENT CONTROL

The 350A is built with a large power handling capacity—5 watts continuous duty. It is particularly adapted to work in the supersonic field, and for other measurement work above the range of the conventional AF attenuator. It may also be used down to zero frequency.

The 350A like all -hp- instruments is held to a minimum size for convenience in use; actual dimensions are 5" by 8" by 4 1/2". Input and output binding posts are available on the front panel; the unit is completely shielded from moderate fields.

Write today for more information on this and other -hp- instruments.

1163

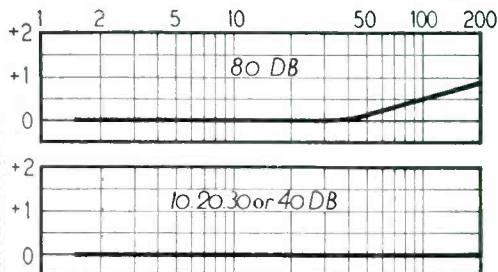

FIG. 3

## HEWLETT-PACKARD COMPANY

BOX 1163 • STATION A • PALO ALTO, CALIFORNIA

Audio Frequency Oscillators

Signal Generators

Vacuum Tube Voltmeters

Noise and Distortion Analyzers

Wave Analyzers

Frequency Meters

Square Wave Generators

Frequency Standards

Attenuators

Electronic Tachometers

#### OTHER -hp- INSTRUMENTS

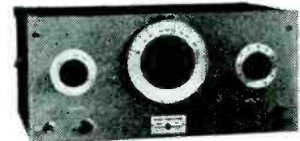

#### RESISTANCE-TUNED AUDIO OSCILLATORS

Require no zero setting! Several models available in 200 series, covering frequencies from 2 cps. to 200 kc.

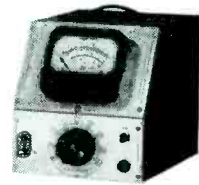

#### VACUUM TUBE VOLTMETERS

For speed and accuracy in making voltage measurements from 1 cycle to 1 megacycle. The 400A covers 9 ranges (.03 to 300 volts) with full scale sensitivity.

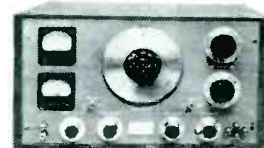

#### AUDIO SIGNAL GENERATOR

The Model 205 AG consists of an -hp- resistance-tuned audio oscillator, combined with input and output meters, attenuator, and impedance matching system—all in one compact instrument.



*Compression Molded*  
**PLASTIC PRODUCTS**

★ Here at Rogan, you are invited to avail yourselves of our complete knowledge and long experience in all phases of plastic molding. Our staff of trained experts will be glad to assist you with your plastic problems, no matter how involved or comprehensive.

In addition to compression molding, we also offer an exclusive "deep relief" branding process that goes a long way toward reducing the cost of plastics that must bear markings, lettering or other descriptive matter.

Write for facts on this lower cost, combination service today.

**ROGAN BROS.**

Compression Molders and Branders of Plastics  
2003 S. MICHIGAN AVENUE • CHICAGO 16, ILLINOIS

**EISLER EQUIPMENT**  
..complete and diversified for every phase  
of electronic\* manufacture!

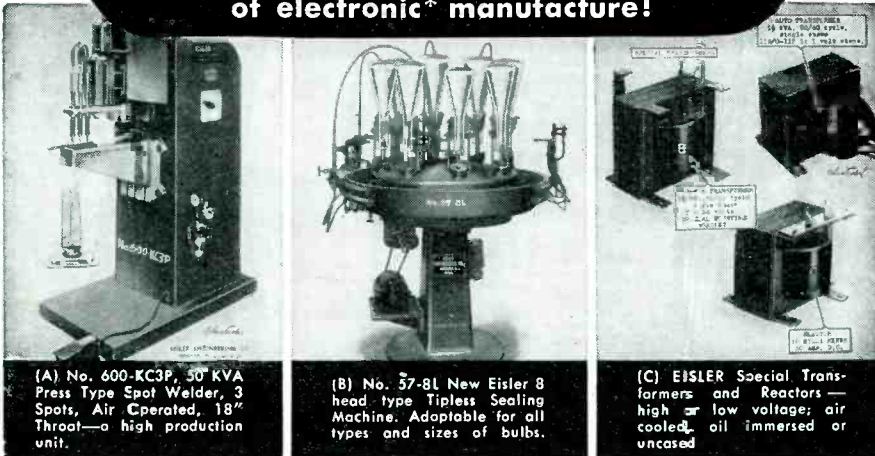

(A) No. 600-KC3P, 30 KVA Press Type Spot Welder, 3 Spots, Air Operated, 18" Throat—o high production unit.

(B) No. 57-8L New Eisler 8 head type Tipless Sealing Machine. Adaptable for all types and sizes of bulbs.

(C) EISLER Special Transformers and Reactors—high or low voltage; air cooled, oil immersed or uncased

The CHAS. EISLER line of specialized electronic tools, machines and devices is complete and diversified. Included are innumerable types of welders—spot, seam, butt, rocker, arm, pneumatic and special types. Also included are hundreds

of devices for vacuum tube manufacture—glass tube cutters, slicers, stem and sealing machines as well as an all-inclusive line of transformers for every industrial and general need.

\* EISLER serves 99% of American vacuum tube producers today. Write for completely illustrated catalog.

**CHAS. EISLER  
EISLER ENGINEERING CO.**

751 SO. 13th STREET (Near Avon Ave.) NEWARK, NEW JERSEY

radio and television transmitters, communication, and other special apparatus will be made. Manufacture of phonographs, radios, and television sets continues at their Marion and Bluffton plants.

BELMONT RADIO CORP. has purchased a one-story plant near Waukegan, Ill., to secure additional space for manufacturing operations. When in full production, 250 workers will be employed.

CAMBURN PRODUCTS Co. announces plans for erection of modern manufacturing plants on Long Island, including a laboratory staffed with electronic engineers assigned to development of antennas and other new products for f-m and television entertainment applications as well as communications systems.

COMMUNICATION PRODUCTS Co., INC. has moved from Jersey City to a new location at Route 36 and Palmer Avenue, Keansburg, N. J.

THE GRENBY MFG. Co., manufacturers of precision machine tools and electronic equipment, has acquired full control of the Allen D. Cardwell Mfg. Corp., one of the pioneer manufacturers of radio parts. The manufacturing division has been moved into its new plant at Plainville, Conn., where greatly increased production capacity is available. Ralph H. Soby, vice president and director of Grenby, becomes president of the Allen D. Cardwell Mfg. Corp., following the retirement of Mr. Cardwell.

E. F. JOHNSON Co., Waseca, Minn., has acquired all tools, inventory and manufacturing rights for the cable connectors, pilot and dial light assemblies, tip plugs and tip jacks that were formerly Mallory-Yaxley products.

ELECTRONICS MANUFACTURERS ASSOCIATION, Inc., New York, N. Y., reelected I. W. Wyckoff of Pilot Radio Corp. as president. Newly elected officers for the coming year are A. Freed of Freed Radio Corp. and A. P. Hirsch of Micamold Radio Corp. as vice presidents, I. A. Mitchell of United Transformer Corp. as secretary, and S. J. Novick of Electronic Corp. of America as treasurer.

HALLICRAFTERS Co., Chicago, Ill., has purchased the plant of Shelby





**FOR THOSE WHO SEEK**

*The Finest  
Cored Solder in the World*

Ersin Multicore Solder contains 3 cores of non-corrosive Ersin Flux and provides just that extra rapidity of fluxing action which ensures a precision standard of consistently reliable solder joints. Only 3 independent cores of flux, evenly distributed across the cross-section of the solder wire, can give this extra efficiency. The cost of an individual solder joint in electronic apparatus is so little and each joint so vital that it must pay you to buy the best cored solder—Ersin Multicore.



**3 CORES OF ERSIN  
THE ACTIVE NON-  
CORROSIVE FLUX**

Ersin, which is contained in the 3 cores of Multicore Solder, is a pure high grade rosin which has been subjected to a complex chemical process to increase its fluxing action to the highest degree without impairing the well known non-corrosive and protective properties of the original rosin. In effect, Ersin as a flux suffices only as an agent to avoid oxidation during soldering, whereas Ersin will not only remove surface oxides, but also prevent their formation during the soldering operation. NO extra flux is required. The flux does not tend to run out of cores, so there is always a supply available for the next joint. The utmost economy of flux and solder is achieved.



**ALLOYS**

Five standard antimony free alloys are available. Ersin Multicore Solder is supplied in bulk quantities in any other tin-lead alloy to special order. Recently 45 tin and 55 lead alloy has been in most demand for electronic equipment. Colour coding of reels and packages makes different alloys instantly recognisable.

**GAUGES**

Ersin Multicore Solder is made in a wide range of gauges. Standard gauges supplied are from 10 S.W.G. - 22 S.W.G. (-128" - .028") (3.251 - .7109 mm) 13 S.W.G. (.092", 2.336 mm) and 16 S.W.G. (.064", 1.625 mm) are the most widely used sizes for the production of electronic equipment.

**ERSIN MULTICORE**

THE SOLDER WIRE CONTAINING  
*3 cores* OF NON-CORROSIVE ERSIN FLUX

**MULTICORE SOLDERS LTD.**

MELLIER HOUSE, ALBEMARLE STREET, LONDON, W.1, ENGLAND

Telephone: REGENT 1141 PBX 4 lines

Telegrams: DUSTICKON. WESTCENT, LONDON

U.S.A. DISTRIBUTORS:  
BRITISH INDUSTRIES SALES CORPORATION  
401 BROADWAY, NEW YORK, N.Y. 13

CANADIAN DISTRIBUTORS:  
SNI-DOR RADIOELECTRIC LTD.,  
455 CRAIG ST. WEST, MONTREAL



# Specialists in Special Crystals

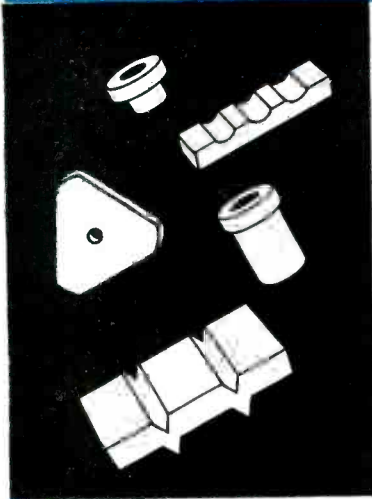

## PRECISION PROCESSING FUSED QUARTZ

Fused quartz . . . has the lowest coefficient of expansion of any known material . . . high melting point (approximately 1756°C) . . . great resistance to thermal shock, high resistivity . . . low dielectric losses . . .

New skills of processing and metallic coating now allow for more precise engineering. New uses are suggested, new feats of design effected by taking advantage of Crystalab's techniques which allow precision processing of fused quartz to  $\pm .001"$ .



*Yankee Ingenuity  
makes us*

SPECIALISTS IN SPECIAL CRYSTALS



## CRYSTAL RESEARCH LABORATORIES

INCORPORATED  
LABORATORIES AND MAIN OFFICE: 29 ALLYN STREET, HARTFORD 3, CONN  
New York Office: 15 E. 25th Street, New York 10, N. Y. Phone MU. 5-2952



Table model electric stop clock with a-c clutch and toggle switch

## ACCURATE INSTRUMENTS for PRECISION TIMING

The Stoelting table model electric stop clock is an accurate timer for a wide variety of industrial and laboratory tests . . . such as measuring start-to-stop intervals of relays and instruments, and for checking sequence operations.

Timer with a-c clutch has toggle switch for manually starting the pointer. Timer with d-c clutch has binding posts only for attaching d-c control circuit for starting and stopping the pointer. Both timers have a-c clock motors, and pointers are reset with knob.

The Stoelting electric timer and impulse counter is an accurate, dual-purpose instrument for counting individual electric impulses or for use as a chronoscope.

When used as timer, 11-16 v current is taken from step-down transformer. When used as counter, direct current only is used. Counter capacity—7,200 impulses.

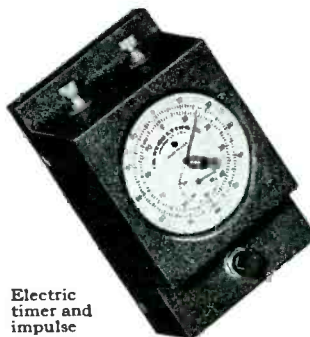

Electric timer and impulse counter

### FREE ILLUSTRATED BULLETIN

Send for Stoelting Timer Bulletin No. 1100. Includes illustrations, wiring diagrams, technical data, and complete information on stop clocks, chronoscopes, impulse counters, stop watch controllers, and X-ray timers.

## C. H. STOELTING CO.

INDUSTRIAL DIVISION  
424-A N. HOMAN AVE. • CHICAGO 24, ILLINOIS

Shops, Inc., Shelbyville, Ill. and will use it to produce part of the cabinet requirements of the firm's Echophone Division. Daily output will be about 250 cabinets.

GENERAL PRECISION LABORATORY INC. has been established to conduct centralized research for General Precision Equipment Corp. and its subsidiaries. The laboratory, to be set up on the Manville estate at Pleasantville, N. Y., will conduct research and development in electronics and supersonics as well as other fields.

ELECTRONICS CORP. OF AMERICA, New York, N. Y., has acquired a plant in Brooklyn to supplement its two Manhattan factories in the production of radio receivers, electro-medical equipment, and other products.

FRANK RIEVER announces moving of his laboratory to 127 E. 73rd St., New York, N. Y.

MACHLETT LABORATORIES, INC., Springdale, Conn., has approximately doubled the size of its Springdale plant and will eventually consolidate all activities there.

WIRE RECORDER DEVELOPMENT CORP., Chicago, announces licensing of four additional manufacturers to produce Armour magnetic wire sound recorders, bringing the total to 24. Newcomers are Bendix Aviation Corp., Baltimore, Md.; Bang and Olufsen, Copenhagen, Denmark; Pyrox Proprietary, Ltd., Melbourne, Australia; St. George Recording Equipment Co., New York, N. Y.

WCAU, CBS affiliate in Philadelphia, plans to erect a \$2,000,000 radio and television center occupy-

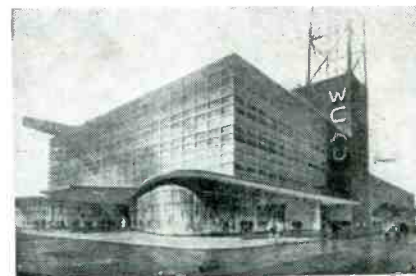

Proposed WCAU radio and television center in Philadelphia, with helicopter landing field on roof

*Eastern Electronics Corp.*

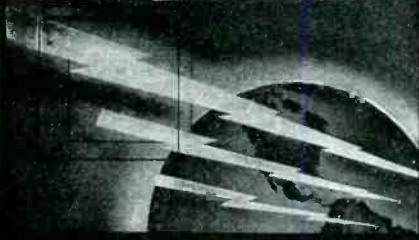

- PRECISION WIRE WOUND RESISTORS
- WHEATSTONE BRIDGES
- RADIO & ELECTRONIC TEST EQUIPMENT
- RADAR ASSEMBLIES



*Eastern Electronics Corp.*

**PHONOGRAPH TURNTABLE UNIT**

The need at this time for large quantities of phonograph turntable assemblies has prompted us to quickly design and tool up for the immediate production of this item. Engineers will find this compact turntable meeting all of their requirements for performance. We are prepared to make immediate deliveries and suggest that purchasing agents place their orders at once.

**PERFORMANCE:** — Correct and uniform speed is secured through the use of a motor of ample capacity, preloaded to operate on the flattest portion of the torque-speed characteristic.



**ROTARY SELECTOR SWITCH**

Designed for use where low contact resistance and mechanical sturdiness is required. Its construction insures long wear with low contact resistance of less than .001 ohm. May be arranged to have several sections to obtain multi-polar switching.

Well suited for precision test instruments; shunt ammeters, thermo-couple types, Wheatstone Bridges, and similar devices.

**Korect-Ohm Precision Wire Wound Resistors**

*General Specifications*

KORECT-OHM Resistors are wound on a sectional Ceramic bobbin, the direction of the winding being alternated on each section so that the resistor is non-inductive. Resistors can also be inductively wound when required.

To insure stability Korect-Ohm Resistors are aged and treated to relieve strains due to winding before the final adjustment is made.

Final resistance adjustment to an accuracy of better than .1%.

**TEMPERATURE COEFFICIENT.** Resistors are wound with selected alloy wire having a resistance change vs. temperature of less than .08% between —55 degree C and plus 55 degree C.

**IMPREGNATION.** A radically new material, INSO-FLEX, used for impregnating Korect-Ohm resistors has been developed by our engineering laboratory. This new material has several outstanding advantages, being extremely flexible it does not chip nor crack due to expansion or contraction under temperature variations. INSO-FLEX has high insulating qualities and is highly resistant to alkalies and weak acids, is resistant to moisture and mechanical shock. It forms an intimate bond between the ceramic bobbin, winding and lead wires. Being flexible, the lead wires may be bent and formed without disturbing the moisture-proof bond between the lead wires and INSO-FLEX covering.

Korect-Ohm resistors can also be supplied impregnated with our anti-fungi varnish or anti-fungi wax.



Type C  
Maximum resistance 500,000 ohms.

Type A  
Maximum resistance 1,000,000 ohms.

Type B  
Maximum resistance 1,000,000 ohms.

Type XM  
Instrument resistance shunt .1 ohms or lower. 25 watts.

We will make special resistors to any value or tolerance.  
Our Regular Line of Resistors are ready for delivery.

*Eastern Electronics Corp.*

41 CHESTNUT STREET, NEW HAVEN, CONN.

**Boston Sales Office**  
11 Pemberton Square  
Tel. Capitol 2425

**New York Sales Office**  
Turney & Beale  
215-05 27th Ave.  
Bayside, Long Island, N.Y.  
Tel. BA 9-8958

**Chicago Sales Office**  
Bauman & Bluzat  
2753 West North Ave.  
Tel. Humboldt 6809

**Los Angeles Sales Office**  
Norman B. Neeley  
7422 Melrose Ave.  
Hollywood, Calif.  
Tel. Whitney 1147



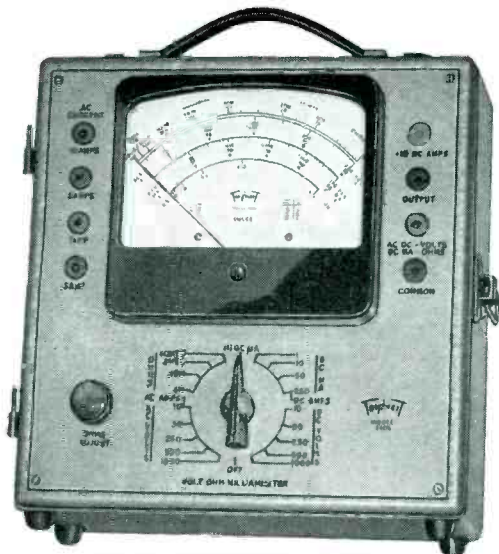

**MODEL 2405**  
**Volt · Ohm**  
**Milliammeter**

25,000 OHMS PER VOLT D. C.



**SPECIFICATIONS**

NEW "SQUARE LINE" metal case, attractive tan "hammered" baked-on enamel, brown trim.

■ **PLUG-IN RECTIFIER** — replacement in case of overloading is as simple as changing radio tube.

■ **READABILITY** — the most readable of all Volt-Ohm-Milliammeter scales — 5.6 inches long at top arc.

*Model 2400 is similar but has D. C. volts Ranges at 5000 ohms per volt.*

Write for complete description

**Triplet**

**ELECTRICAL INSTRUMENT CO.**

BLUFFTON ■ OHIO

**NEW ENGINEERING**  
**NEW DESIGN · NEW RANGES**  
**50 RANGES**

- Voltage: 5 D.C. 0-10-50-250-500-1000 at 25000 ohms per volt.
- 5 A.C. 0-10-50-250-500-1000 at 1000 ohms per volt.
- Current: 4 A.C. 0-.5-1-5-10 amp.
- 6 D.C. 0-50 microamperes—0-1-10-50-250 milliamperes—0-10 amperes.
- 4 Resistance 0-4000-40,000 ohms—4-40 megohms
- 6 Decibel -10 to +15, +29, +43, +49, +55
- Output Condenser in series with A.C. volt ranges

ing an entire city block on Broad Street, with a television and f-m tower extending 612 feet above ground level. Completion by December 1947 is expected.

**PERSONNEL**

HOWARD DOOLITTLE, formerly of Radiation Laboratories, NDRC, has joined the engineering staff of Machlett Laboratories, Springdale and Norwalk, Conn., and will be in charge of high-frequency research and development. At Radiation Laboratories, he was in charge of the group responsible for the development of pulse generators for radar purposes, and before then held a professorship of physics at Trinity College.



Dr. H. Doolittle



Dr. R. L. Freeman

ROBERT LEE FREEMAN is now chief electronics engineer for Lewyt Corp., Brooklyn, N. Y. Dr. Freeman was formerly senior and consulting engineer for Hazeltine Corp., and previously served in various engineering capacities for Farnsworth Television, Inc., and Crosley Radio Corp.

JULES G. SIMMONDS and JOHN J. GUARRERA, until recently staff members of Radiation Laboratory at MIT, are now affiliated with the engineering staff of Bernard Rice's Sons, Inc. in New York City, which is continuing to develop, engineer, and manufacture in the uhf and r-f fields.

RUSSELL A. NIELSEN heads the new Pacific coast high-frequency laboratory opened recently by Westinghouse Electric Corp. He has been a research engineer for Westinghouse at East Pittsburgh, Pa.

H. M. BEVILLE, JR., who recently returned from duty as Lt. Colonel with Headquarters Staff, Intelligence, 1st Army, to assume his ex-

**BAKELITE SHEETS,**  
**RODS AND TUBES**



On special mill shipments we can give prompt delivery. Also complete fabrication service backed by over 20 years of experience.

**ELECTRICAL**  
**INSULATION CO., INC.**

12 Vestry St., New York 13, N. Y.

# FREED *Transformers*

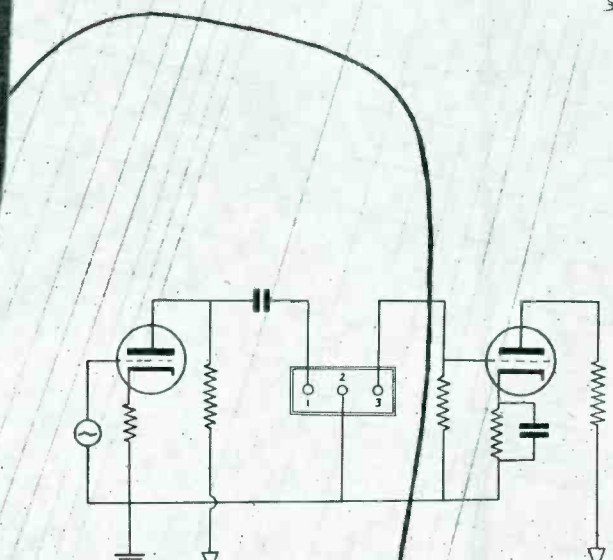
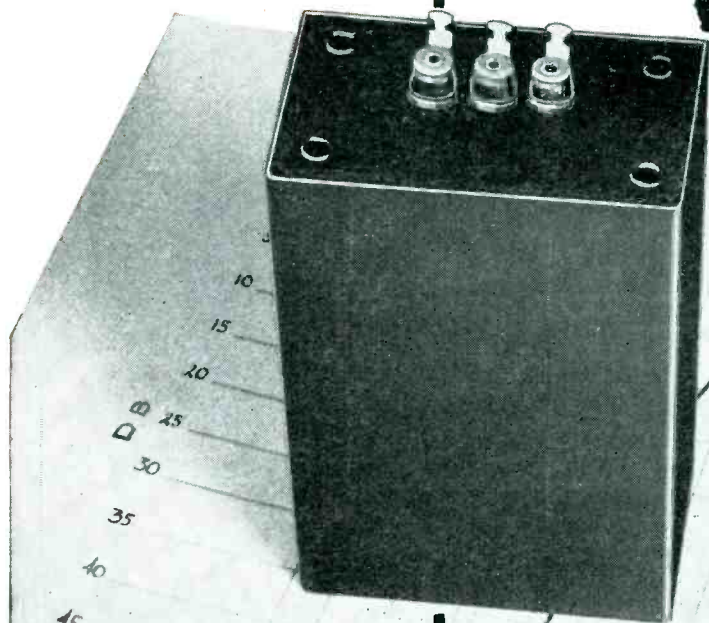

*are engineered to  
meet the requirements  
of YOUR job!*

This Band Pass Interstage Filter is a new development incorporating unusual performance in the smallest size ever built. For use in communications work, the unit is designed for an input impedance of 10,000 ohms and an output impedance of 40,000 ohms. Provides a step-up ratio of 6 DB. Attenuation at 300 and 3000 CPS is less than 6 DB. Attenuation below 100 CPS and above 7000 CPS is 40 DB. Dimensions in hermetically sealed cans are 1 5/8" x 2 5/8" x 4".

**FREED**  
72 SPRING ST.



**TRANSFORMER CO.**  
NEW YORK CITY 12, N. Y.



# Full Range

HIGH AND LOW FREQUENCY  
REPRODUCTION IN ONE ASSEMBLY!



HORIZONTAL SOUND DISTRIBUTION 80°

## TRU-SONIC CO-AXIAL SPEAKER

The Tru-Sonic Co-Axial Speaker combines a high frequency metal diaphragm reproducer and a low frequency paper cone reproducer, mounted together with the dividing network in a single, compact assembly, 15" in diameter and 9" in depth giving a horizontal sound distribution of 80 degrees. Outstanding for custom quality, and excellence before the war, the Tru-Sonic Speaker is finer than ever, but is available at a lower price, because of quantity production. Available now! Write for illustrated brochure.

Licensed under Western Electric Patents

### STEPHENS MANUFACTURING CO.

10416 NATIONAL BLVD.  
LOS ANGELES 34, CALIF.

ecutive position as research director of National Broadcasting Co., has been appointed a member of the Technical Research Committee of Broadcast Measurement Bureau, New York City. This committee now has equal representation of radio advertisers, advertising agencies, and broadcasters.

FREEMAN A. SPINDELL has been appointed chief engineer of Browning Laboratories, Inc. after working there since the spring of 1941 on design of radar units and radar test equipment.

RAYMOND K. MCCLINTOCK is serving as engineering consultant for the international division of Sylvania, after experience since 1936 on tube design and development and circuit development for Sylvania, as



liaison engineer between Sylvania's Ipswich, Mass. plant and the Applied Physics Laboratory of Johns Hopkins University in Silver Spring, Md., and as engineer at Colonial Radio Corp. in Buffalo, a Sylvania subsidiary.

ARTHUR H. JONES, who as Lieut. Colonel was radar officer for the First Army, has been released from the services under the new point system. He rose from the rank of private in less than four years, and during planning for the European invasion was responsible for all anti-aircraft warning systems and utilization of radar equipment. He has served in all major theatres of operation and was at Luzon with the First Army headquarters staff at the time of the Japanese surrender.

CLINTON R. HANNA, associate director of the research laboratories at Westinghouse Electric Corp., was presented with the degree of Doctor of Engineering at Purdue University in recognition of his development of the gyroscopic tank gun stabilizer and other inventions

# IMMEDIATE DELIVERY ON ALL ATR QUALITY PRODUCTS

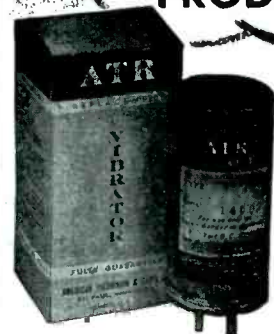

## AUTO RADIO Replacement VIBRATORS

Designed for Use in Standard Vibrator - Operated Auto Radio Receivers. Built with Precision Construction for Longer Lasting Life at **PRE-WAR PRICES!**

## HEAVY DUTY VIBRATOR PACKS

For Inverting Low Voltage D.C. to High Voltage D.C. for Operation of Portable Receivers and Transmitters, Aircraft Apparatus, Public Address Systems, Amplifiers, and Scientific Apparatus.



## STANDARD AND HEAVY DUTY INVERTERS

Specially Designed for Operating A.C. Radios, Television Sets, Amplifiers, Address Systems, and Radio Test Equipment from D.C. Voltages in Vehicles, Ships, Trains, Planes, and in D.C. Districts.

WRITE for LATEST ATR CATALOG —  
Just off the press!

**AMERICAN TELEVISION & RADIO CO.**

Quality Products Since 1931  
ST. PAUL 1, MINN.

U. S. A.

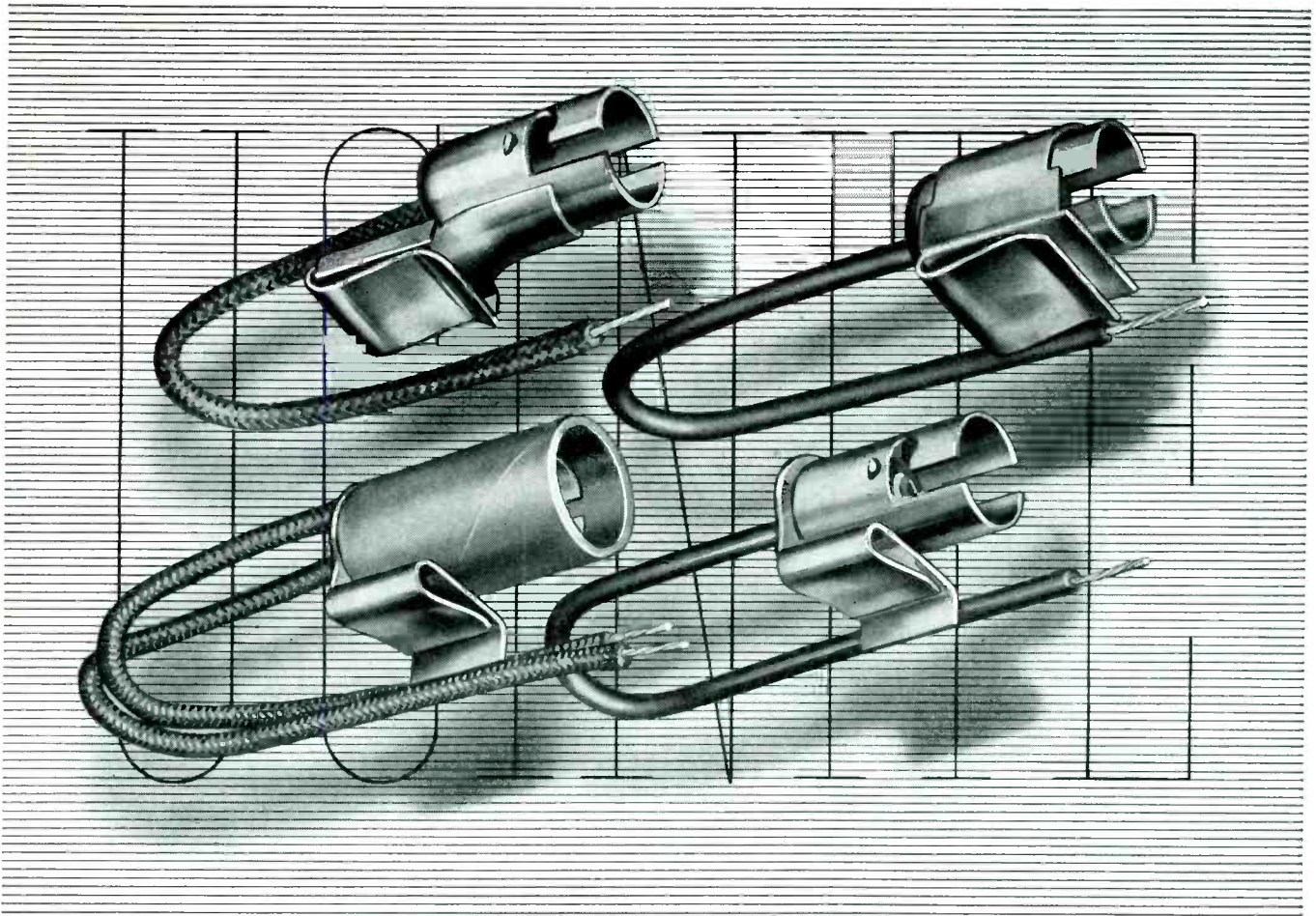

## *Where the special is standard*

These pilot lamp assemblies illustrate types we now make regularly for postwar radio sets. We hesitate to call them typical, however, because at Ucinite we have the skill, ingenuity and adaptability to manufacture any other style of pilot lamp assembly our customers might require . . . To us the "special" is "standard." We make *what* you want, the *way* you want it, *when* you want it.

**The UCINITE CO.**

*Newtonville 60, Mass.*

Division of United-Carr Fastener Corp.

**Specialists in RADIO & ELECTRONICS  
LAMINATED BAKELITE ASSEMBLIES  
CERAMIC SOCKETS • BANANA PINS &  
JACKS • PLUGS • CONNECTORS • ETC.**



**Build the competitive advantages of longer life better performance into your products...with**

## SPERTI HERMETIC SEALS

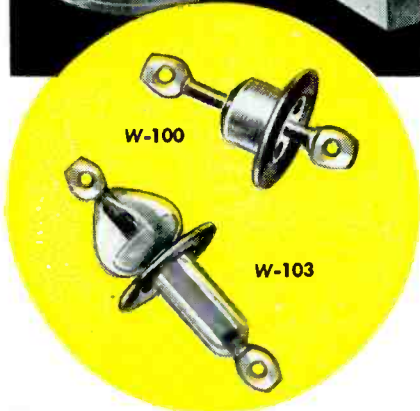
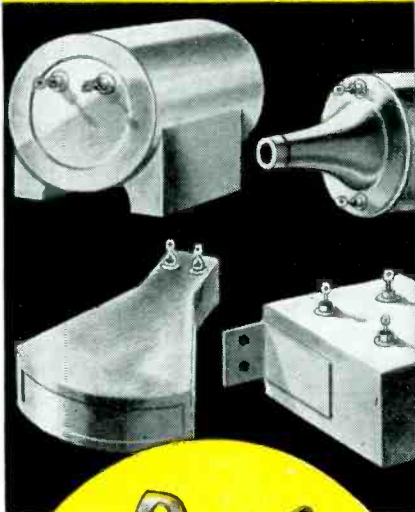

**BUYERS** who have waited through the war years will be looking for big improvements in your products. You'll have to meet civilians' expectations... just as you have met military specifications.

You can do it by building longer life, better performance, more trouble-free operation into your products. That calls for Sperti Hermetic Seals, the rugged, dependable, war-proved seals that effectively shut out dust, moisture and deteriorating agents.

Sperti Hermetic Seals are durable, one-piece units, easily soldered-in at less expense. Because of Sperti's advanced manufacturing methods, plus exhaustive tests and inspections, you'll get "true" seals that cut down production delays and costly rejects in the inspection line.

**WRITE, TODAY.** Get the facts. Find out about the many product applications of Sperti Hermetic Seals and their performance advantages.



### Sperti

Incorporated, Dept. E-16,  
Cincinnati 12, Ohio

RESEARCH • DEVELOPMENT • MANUFACTURING

covered by more than 90 patents. His 23 years at Westinghouse have included research on loudspeakers, power tubes for radio receivers, microphones, and noise-measuring equipment.

NELSON P. CASE has joined the Hallicrafters Co., Chicago, as chief engineer of its receiver division. For the last two years he had been director of engineering design and development for Hamilton Radio Corp., and for 13 years prior was with Hazeltine Electronics Corp. He holds approximately 30 patents on radio receiving circuits.



Nelson P. Case



Paul H. Merriman

PAUL H. MERRIMAN has assumed new duties as head of the electrical and electronics section of the laboratories of The Glenn L. Martin Co., Baltimore, Md. Among his recent achievements is the Martin PBM Mariner radar production installation.

HENRI BUSIGNIES becomes director of the laboratories of Federal Telephone and Radio Corp. in Newark, N. J. He has been active in development of direction finder equipment for naval and marine operations, and has been with the Federal laboratories since 1940.

HAROLD V. NIELSEN has been made chief engineer of United States Television Mfg. Corp., New York, N. Y., in charge of all radio, television, and special product design and production. For 12 years previously he was with Sparks-Withington Co., Jackson, Mich., lately as chief engineer of their radio division.

JOSEPH N. BANKY received a \$3,000 graduate fellowship for a year of study at Illinois Institute of Technology in Chicago, awarded by Allis-Chalmers Mfg. Co. of Milwaukee, Wis. He will study electrical

**Quiet • POWERFUL**  
**SM Fractional**  
**H. P. Motor**

**The Home Power Servant also handles many other jobs efficiently, dependably**



For quiet operation, dependable performance, long life, maximum

power per ounce of weight and per inch of space, use SM Fractional H.P. Motors. Models from 1/10th to 1/200th H.P. Speeds of 3,000 to 20,000 R.P.M. Voltage from 6 to 220 AC-DC Large volume production to your exact specifications.

## Small Motors, Inc.

DEPT. 50  
1308 ELSTON AVE. • CHICAGO 22

Manufacturers of special small universal, fractional H. P. motors, dynamometers, shodded pole motors, heater motors, generators.

**Design, Engineering, Production**

# For Heat and Flame Resistant Radio and Electronic Hookups, Motor and Transformer Leads . . .

## ROCKBESTOS FIREWALL HOOKUP WIRE

REG. U. S. PAT. OFF.



Construction: (1) Lacquer finished, color-coded glass braid. (2) Impregnated felted asbestos firewall. (3) High dielectric synthetic tapes. (4) Stranded tinned copper conductor, perfectly and permanently centered in helically applied insulation. Sizes No. 22 to 4 AWG in 1000 volt rating, and No. 12, 14 and 16 AWG in 3000 volt.

Unusual dielectric strength for its small diameter, high current carrying capacity, and ability to operate continuously at rated voltage under temperatures ranging from a maximum of 125°C. to minus 50°C., are a few of the reasons why Rockbestos Firewall Hookup Wire is being used in many varied applications.

Designed with a heatproof, flameproof firewall to meet the demands of airborne radio equipment manufacturers for a flame resistant hookup wire . . . widely used since in ground, marine and mobile communications systems . . . it has proven ideal for leads for small motors, transformers, dynamotors, battery chargers and rectifiers; miniature switchboard and relay wiring; and various applications in voice recorders, control devices, alarm systems, blood processing equipment and aircraft heaters, to name a few in a growing list.

This wide degree of adaptability is true of many other wires, cables and cords in the Rockbestos line of 125 permanently insulated standard constructions ranging from tiny multi-conductor cable to 5000 volt power cable. And if a "standard" won't fill requirements we are always willing to put Rockbestos Research to work on a "special" that will. For recommendations, samples or wire-engineering assistance, write or phone the nearest district office or:

ROCKBESTOS PRODUCTS CORPORATION  
431 Nicoll Street  
New Haven 4, Conn.



### ROCKBESTOS RESEARCH

#### Solves Difficult Wiring Problems

NEW YORK, BUFFALO, CLEVELAND, CHICAGO, SEATTLE, ST. LOUIS,  
LOS ANGELES, SAN FRANCISCO, PITTSBURGH, PORTLAND, ORE.

★ DO YOUR SHARE—BUY VICTORY BONDS ★

A few of the 125 different wires, cables and cords designed for severe operating or unusual conditions by Rockbestos.

#### SHIELDED ROCKBESTOS FIREWALL HOOKUP WIRE

This is a Rockbestos Firewall Hookup Wire, insulated and covered with a color-coded braid exactly like the construction detailed to the left, and shielded with a tinned copper braid. It is highly resistant to heat, flame, moisture, oil, grease and gasoline, won't bake out under a maximum operating temperature of 125°C., and won't become brittle at minus 50°C. Sizes No. 22 to 4 AWG in 1000 volt construction, and No. 16 to 12 AWG in 3000 volt. Also available in twisted pair and various multi-conductor constructions.

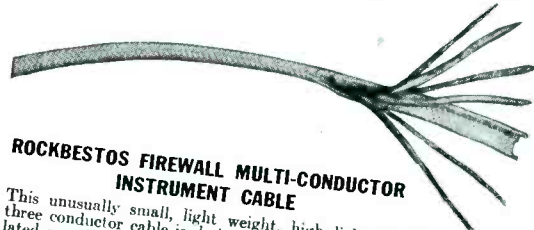

#### ROCKBESTOS FIREWALL MULTI-CONDUCTOR INSTRUMENT CABLE

This unusually small, light weight, high-dielectric No. 20 AWG three conductor cable is designed with unbraided individuals insulated exactly like the big illustration of hookup wire above, cabled with asbestos fillers, and braid-covered to make an extremely compact, mechanically strong, multi-conductor cable for use where space is at a premium and dependable performance is essential. It is made to a nominal diameter of .125" and is smaller than a No. 14 AWG Rockbestos Firewall Hookup Wire. Also in 4, 5 and 6 conductor

#### ROCKBESTOS ASBESTOS INSULATED LEAD WIRE

Sizes No. 22 to 4 AWG solid or stranded copper, monel or nickel conductors insulated with .031" or .040" of impregnated felted asbestos in black, white or colors. Heatproof and flame-resistant, this lead wire will not bake brittle and crack under vibration, won't rot, swell or flow when in contact with oil or grease, and has ample moisture resistance for most applications. For high dielectric strength and added moisture resistance specify Type CA Lead Wire with synthetic tape next to the conductor.

#### ROCKBESTOS ASBESTOS INSULATED MAGNET WIRE

Round, square and rectangular asbestos insulated conductors finished to meet varying winding conditions and coil treatment requirements. Designed for Class B windings and also suitable for use as insulated bus wire where high-dielectric strength is not required. The insulation is non-checking and is unaffected by heat or aging.

#### Another New Rockbestos Firewall Construction!

War-developed Rockbestos High-Temperature Wire—with a maximum operating temperature of 400°F.—designed for jet propelled plane applications and circuits to hot-wing de-icers, fire detectors and extinguishers, and air conditioning and heating units where baking temperatures destroy ordinary insulation. Under continuous operation at rated temperature it retains its original dielectric strength and inherent resistance to heat and flame, and progressively improves in its resistance to moisture and abrasion. It is now available for these and other severe applications. Write for complete information and samples.



**ANTICIPATE  
YOUR REQUIREMENTS!**

**First Come . . .  
First Served!**

Orders for transformers are pouring in so fast that we will soon be booked to capacity for several months to come. If your product requires heavy duty filter reactors, swinging reactors, or plate transformers, anticipate your requirements and place your order NOW!



**DONGAN ELECTRIC MFG.CO.**  
2977 Franklin      Detroit 7, Mich.

**DONGAN**  
**TRANSFORMERS**  
*The Dongan Line Since Nineteen-Nine*



Joseph N. Banky (left) and Dr. Louis T. Rader, director of electrical engineering department at Illinois Institute of Technology, stand before a-c network calculator board

problems that can be solved through use of the school's new \$90,000 a-c network calculator board.

PETER KAYE has been released by the Canadian Army to resume his former post as associate director of Canadian Research Institute, Toronto. His activities will include supervision of the electronic instrument division.

**AWARDS**

For excellence in production of military equipment, Army-Navy. E burgeses were awarded to:

Technifinish Laboratory, Inc.  
Rochester, New York

Les Laboratories, L.M.T.  
Paris, France (IT&T affiliate)

For meritorious participation in the VT fuze development, the Bureau of Ordnance E was awarded to:

Sprague Electric Company  
North Adams, Massachusetts

For exceptionally distinguished service to the United States Navy, the Distinguished Civilian Service Award, highest bestowed on civilians by the Navy, has been presented to:

Dr. Robert M. Page, Naval Research Laboratory, Washington, D. C.—for electronic research, and his outstanding contributions to the development of radar since 1934.

Dr. Herbert Friedman, physicist, Naval Research Laboratory, Washington, D. C.—for development and adaptation of the tube counter to x-ray diffraction methods used in production of quartz crystals.

**HOPP**  
*Plastic*  
**RADIO DIALS**  
DIAL WINDOWS, NAME PLATES, SCALES, GAUGES, CHARTS, CALCULATORS, ETC.

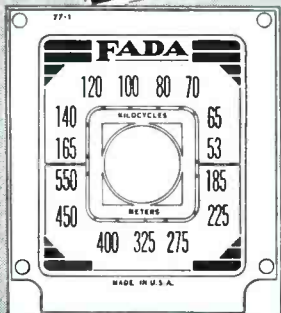

PLASTIC RADIO DIALS combine the beauty of radiant color with the utility of perfect light transmission.

The possibilities of design, size, shape and color combination are limitless.

Whether your problem is dials, or any of hundreds of allied applications, let Hopp artists and engineers "sit in" on your designing problem.

Send us your blueprints or samples for quotation.

**THE HOPP PRESS, INC.**  
460 WEST 34th STREET, NEW YORK 1, N. Y.  
ESTABLISHED 1893

# Making Steel Talk

## with CHRONOVOX

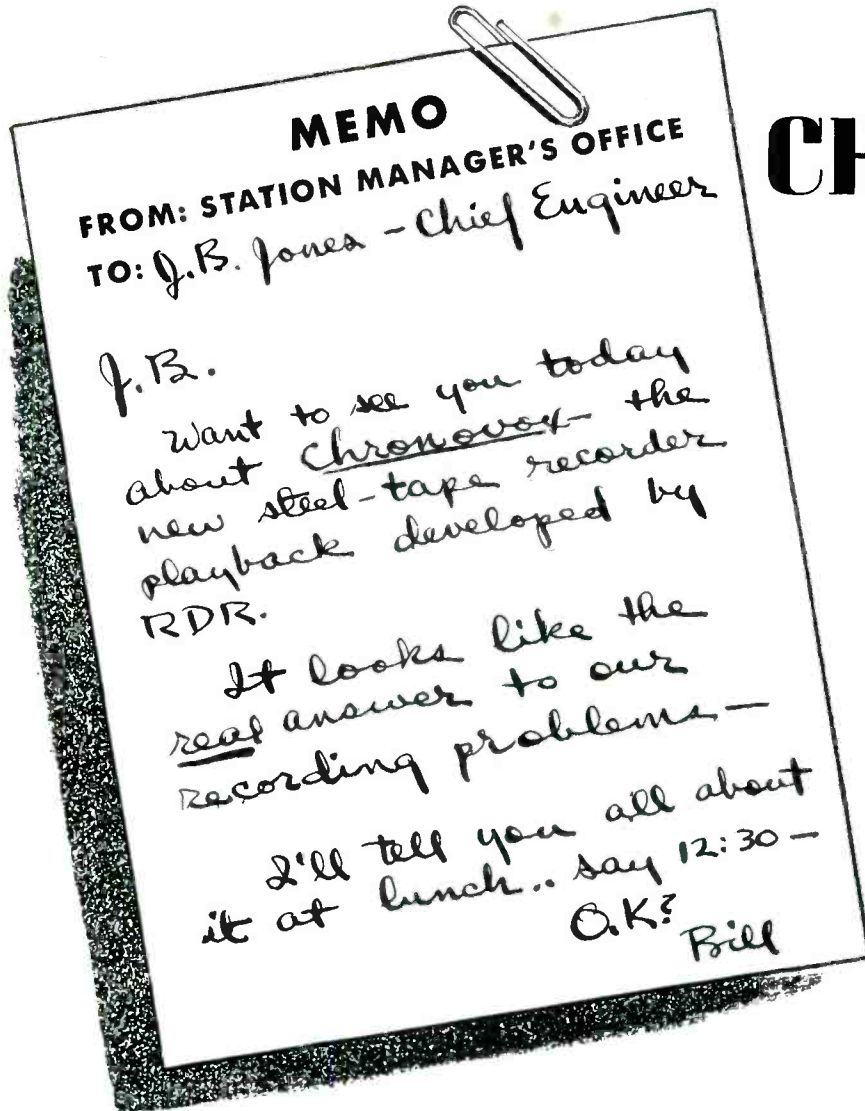

### Know these Facts about Chronovox!

- The cost of discs is eliminated!
- The steel tape is permanent ... indestructible!
- Recordings are erased at will!
- Surface noise lower than any other method of recording!
- Recordings reproduce indefinitely with less than 3DB attenuation!
- It's a complete, self-contained unit!
- Plugs in any 110 volt AC source!
- For a permanent record, "dub" from the final—perfect—Chronovox impression to your disc recorder!

Yes, memos like this one are being written daily. Radio executives KNOW that Chronovox will solve many of their recording problems. The RDR Chronovox is a precision instrument employing an improved method of recording sound on an indestructible steel tape. Recordings are made magnetically not physically—and the Chronovox will repeat the last recording indefinitely or until a new one is made.

FOR MORE INFORMATION - CONTACT;

## RADIO DEVELOPMENT & RESEARCH CORP.

233 WEST 54TH STREET · NEW YORK 19, N. Y.

AFFILIATE: TRANSFORMER PRODUCTS, INC.  
143 W. 51st Street, N. Y. C.

MIAMI: SALES—SERVICE  
1415 N. E. 2nd Ave., Miami, Fla.





# NEW PRODUCTS

**New materials, new components, new assemblies; new measuring equipment; new technical bulletins, and new catalogs**

1

## High Frequency Video Amplifier

COMPACT, RUGGED, high-frequency amplifiers are now available from Sylvania Electric Products Inc., Industrial Electronics Division, Boston, Mass. Supplied for center frequencies between 30 and 70 mc with any bandwidth from 2 to 10 mc, these sets are designed particularly for use as i-f amplifiers in uhf and shf receiver applications.

A typical amplifier has an overall gain of 100 db with a center frequency of 60 mc and a half-power bandwidth of 9.0 mc. An external gain control is easily provided. Unless otherwise specified, a standard 500-ohm input impedance is supplied. The output stages are cathode followers designed to operate into impedances of 75 to 100 ohms with voltages ranging from 0.5 to 2.0 volts, negative or positive.

The video detector may take one of several forms according to the special application of the amplifier.

In broad-band circuits the frequency characteristics of the rectified video components will be such that the output at 8 mc will be reduced not more than 3 db from the output at 1 mc. These amplifiers will thus pass a square-top pulse having a duration of 0.15 microsecond or greater without appreciable frequency or phase distortion, making them suitable for television receiver applications.

Either single-ended or balanced-input circuits are supplied. The balanced-input circuits are designed for use with dual-input systems and will distinguish between in-phase and out-of-phase signals from two channels. In one such unit this discrimination is 33 db.

Power supply for a typical amplifier includes 105 d-c at 90 ma, 300 d-c at 20 ma, and 6.3 a-c or d-c at 1.7 amp. External gain control requires 0 to -12.5 v d-c at 1.5 ma.

circuit that gives a faithful reproduction of the audio envelope for distortion and noise measurements. The linear rectifier is designed for use at a low power level, so that the problem of coupling to the transmitter is greatly simplified. The required r-f power input is only 0.5



Amplitude-modulation monitor

watt, far less than that necessary to operate pre-war modulation monitors. It operates over a range from zero to 110 percent on positive peaks and from zero to 100 percent on negative peaks; carrier frequency range is 0.5 to 60 mc.

The Type 1932-A distortion and noise meter is a direct-reading instrument for measuring distortion, noise, and hum in audio-frequency systems. When used for measurements on broadcast transmitters, the distortion meter operates from the high-impedance output circuit of the Type 1931-A modulation monitor. A continuous frequency range of 50 to 15,000 cycles, fundamental, is covered by a single dial

2

## Miscellaneous New Instruments

NEW BROADCAST MONITORS; UHF Wavemeter; Light Source for High-Speed Photography General Radio Co., 275 Massachusetts Ave., Cambridge 39, Mass. announces four new instruments, as follows:

Two of these instruments are Type 1931-A, an amplitude-modulation monitor, and Type 1932-A, a distortion and noise meter.

The Type 1931-A amplitude-modulation monitor measures percentage modulation on either positive or negative peaks and gives a continuous indication of modulation peaks in excess of a predetermined percentage set by means of a dial. It can also be used for program-level monitoring and for measuring transmitter audio-frequency response. Two audio output circuits are provided, one at 600 ohms for audible program monitoring, and the other a high-impedance



Complete equipment for high-speed flash photography

# ANNOUNCING

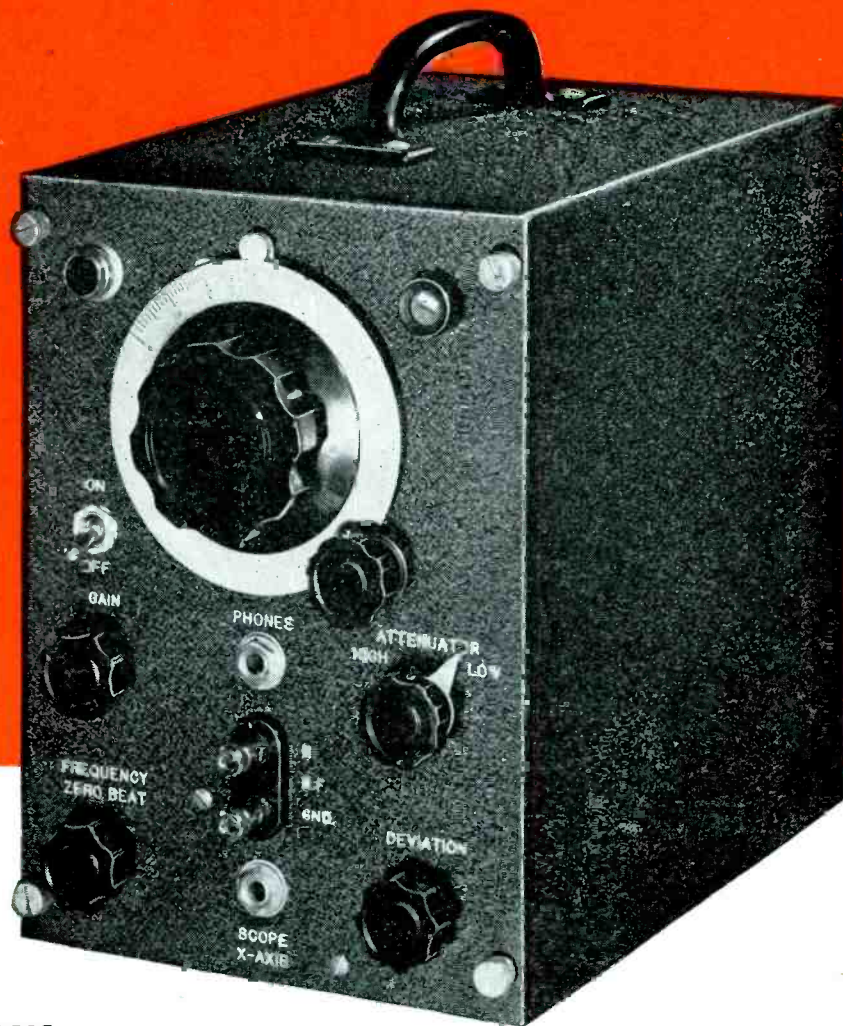

## The New HAR-CAM VISUAL ALIGNMENT SIGNAL GENERATOR

This new HAR-CAM unit provides the most efficient and effective method of aligning the IF circuit of FM receivers. By use of an oscil-

lograph screen, the performance of the IF circuit is shown visually, and rapid, accurate alignment is easily accomplished.

### SPECIFICATIONS

1. Frequency range 100kc to 20mc with direct reading dial calibrated in megacycles.
2. Linear frequency sweep deviation adjustable from zero to 900kc peak to peak.
3. Vernier frequency control of 100kc allows zero beat calibration of main tuning dial or for vernier frequency deviations about main dial frequency setting.
4. Stable rf gain control independent of frequency.
5. Five-step attenuator of rf output

giving over-all voltage range of 1 microvolt to 1 volt when used in conjunction with the gain control.

6. Output impedance, 1 ohm to 2500 ohms.

7. Phone jack for aural monitoring of zero beat calibration of main tuning dial.

8. Panel jack to feed linear sweep voltage to x-axis amplifier of oscilloscope, thus synchronizing the frequency linear sweep of the generator with the spot trace on the scope screen.

9. Voltage regulated supply for internal oscillators.

10. Careful oscillator design to minimize drift.

11. Stable and proven circuit principles used throughout to insure complete reliability.

12. Size, 7" wide, 9½" high, 10½" deep. Weight, 18 pounds.

For complete information on the HAR-CAM Visual Alignment Signal Generator, write for Bulletin H-40.

## HARVEY RADIO LABORATORIES, INC.

439 CONCORD AVENUE • CAMBRIDGE 38, MASSACHUSETTS

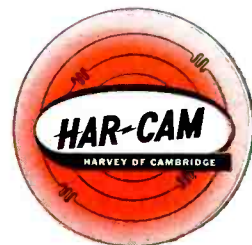





180,000 of these engine thermo-couples were EASY-FLO brazed in quick time with the foot-controlled carbon electro heating set-up below.



# EASY-FLO

**- JUST RIGHT FOR FABRICATING thin-gauge METALS**

For joining thin-gauge metals — either for current-carrying or structural purposes — brazing with the low-temperature silver alloy EASY-FLO meets all requirements from both the physical and economic angles.

From the physical angle — EASY-FLO brazed assemblies are fully up to solid metal in strength, in ability to stand severe stresses and strains, and in current-carrying efficiency. And EASY-FLO's low working temperature makes it possible to guard against heat damage to thin metals.

From the economic angle, EASY-FLO brazing means fast production and big savings in labor and machine-hours.

## SEND FOR BULLETIN 12-A

This bulletin gives full details about EASY-FLO and tells you how to get the full benefit of its fast, economical production on your metal joining. Write for a copy today.



**HANDY & HARMAN**  
 82 FULTON ST., NEW YORK 7, N. Y.  
 Bridgeport, Conn. • Chicago, Ill. • Los Angeles, Cal.  
 Providence, R. I. • Toronto, Canada  
 Agents in Principal Cities



and push-button multiplier. Distortion and noise components up to 45,000 cycles are included in the measurement. The direct-reading distortion meter provides full-scale ranges of 0.3%, 1%, 3%, 10%, and 30% full scale; noise range to 80 db below 100 percent modulation or 80 db below zero v-u.

Type 1140-A wavemeter is useful for rapid measurements of frequency in the range 240 to 1200 mc. This range is covered in a single

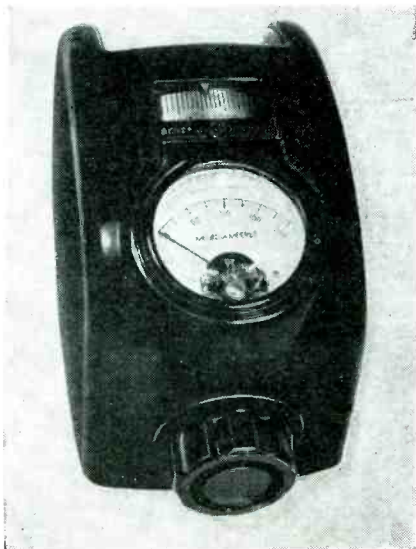

direct-reading dial with an accuracy of  $\pm 2$  percent. The tuning element is a butterfly-type circuit which is coupled to a standard cartridge-type crystal detector. Crystal current, as indicated on a microammeter, gives an indication of resonance. Where the available power is not sufficient to actuate the microammeter, the reaction of the wavemeter upon the current in the circuit under measurement can be used. The entire assembly is housed in a small molded plastic case that can be conveniently held in one hand. Overall dimensions are  $3\frac{3}{4} \times 7\frac{1}{4} \times 4\frac{1}{2}$  inches; net weight,  $3\frac{1}{4}$  pounds, price: \$65.

The latest addition to the General Radio line of stroboscopic equipment is the Microflash, a light source for photographic exposures

of the order of 2 microseconds. Originally designed for war use in the development and test of new types of ammunition, this instrument provides both knowledge and a record of mechanical phenomena occurring in a very small fraction of a second.

The Microflash consists of a power supply, which charges a capacitor to a high voltage, and means for discharging it through a special gas-filled lamp, designed to dissipate most of the energy in about 2 microseconds, producing an intense, extremely short flash. The flash may be tripped by a make or break contact, by an electrical impulse, or by a microphone which picks up a sound impulse from the phenomenon to be photographed. The microphone is supplied, and an amplifier with built-in gain control.

Ordinary film and camera equipment can be used with the Microflash. Lamp and power supply are mounted in separate metal cases, which lock together in a single unit for transportation. Dimensions (assembled),  $24\frac{1}{2} \times 13\frac{1}{4} \times 11\frac{1}{4}$  inches; net weight, 72 pounds; price, \$525.00 (plus current Federal tax on photographic equipment.)

3

## Interval Timer

A NEW ELECTRONIC TIMER is suitable for all photographic and industrial applications requiring precise time control. Time range is from 1 to 120 sec in increments of 1 sec. Accuracy is rated better than 5 percent. Two dials provide time selection. One dial is calibrated in single seconds; the other in 10-sec steps. Tap switches are controlled by dials.

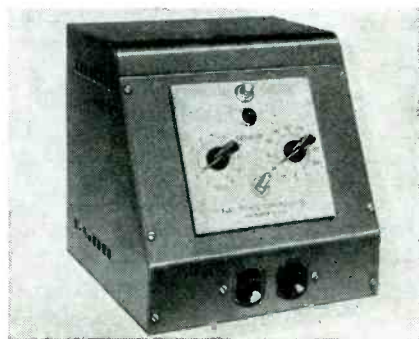

Snap-positioning step-switches are used to assure precision control, with exact values of resistance inserted in the circuit at each posi-

# REVERE FREE-CUTTING COPPER ROD

## ... INCREASES ELECTRONIC PRODUCTION

SINCE its recent introduction, Revere Free-Cutting Copper has decisively proved its great value for the precision manufacture of copper parts. Uses include certain tube elements requiring both great dimensional precision, and exceptional finish. It is also being used for switch gear, high-capacity plug connectors and in similar applications requiring copper to be machined with great accuracy and smoothness. This copper may also be cold-upset to a considerable deformation, and may be hot forged.

Revere Free-Cutting Copper is oxygen-free, high conductivity, and contains a small amount of tellurium, which, plus special processing in the Revere mills, greatly increases machining speeds, makes possible

closer tolerances and much smoother finish. Thus production is increased, costs are cut, rejects lessened. The material's one important limitation is that it does not make a vacuum-tight seal with glass. In all other electronic applications this special-quality material offers great advantages. Write Revere for details.

# REVERE

## COPPER AND BRASS INCORPORATED

*Founded by Paul Revere in 1801*

*Executive Offices: 230 Park Avenue  
New York 17, N. Y.*

*Mills: Baltimore, Md.; Chicago, Ill.; Detroit, Mich.; New Bedford, Mass.; Rome, N. Y.—Sales Offices in principal cities, distributors everywhere*

 Listen to Exploring the Unknown on the Mutual Network every Sunday evening, 9 to 9:30 p.m., EST.

### CUSTOMERS REPORT:

"This material seems to machine much better than our previous hard copper bar; it cuts off smoothly, takes a very nice thread, and does not clog the die." (Electrical parts.)

"Increased feed from 1-1/2" to 6" per minute and do five at one time instead of two." (Switch parts.)

"Spindle speed increased from 924 to 1161 RPM and feed from .0065" to .0105" per spindle revolution. This resulted in a decrease in the time required to produce the part from .0063 hours to .0036 hours. Material was capable of faster machine speeds but machine was turning over at its maximum. Chips cleared tools freely, operator did not have to remove by hand." (Disconnect studs.)



## 3 OF A KIND -

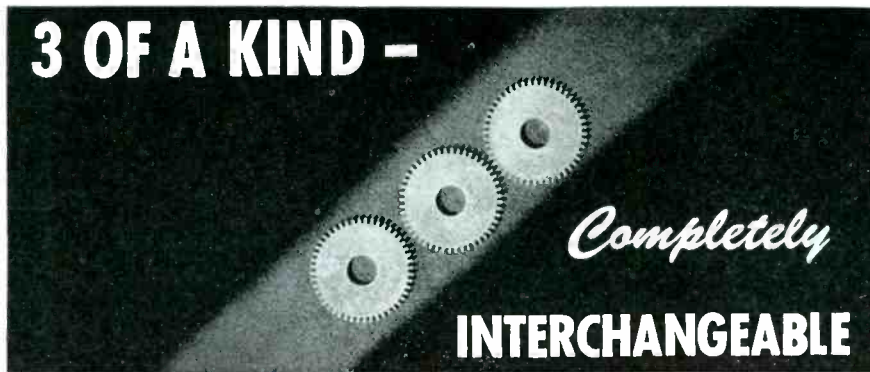

*Completely*

**INTERCHANGEABLE**

Complete interchangeability is highly important today in units which operate continuously or for long periods under a variety of conditions. If breakdown should occur, a new part may easily be installed and operation resumed in short order.

Original gears for such units, and also replacements must have positive guaranteed accuracy, tooth form and finish, or the mechanism may fail. Our completely modern shop, equipment and methods, can serve you with assurance on such requirements. Write us for quotation on your specifications.

### THREAD GRINDING

SMALL OR MEDIUM  
WORMS AND GEARS



SPUR, HELICAL, BEVEL.  
SPROCKETS AND SPLINES

*Beaver Gear Works Inc.*

1021 PARMELE STREET, ROCKFORD, ILLINOIS

## SIMPLIFY METHODS

OF ASSEMBLING AND SERVICING  
with **WALKER-TURNER**  
**FLEXIBLE SHAFTING**

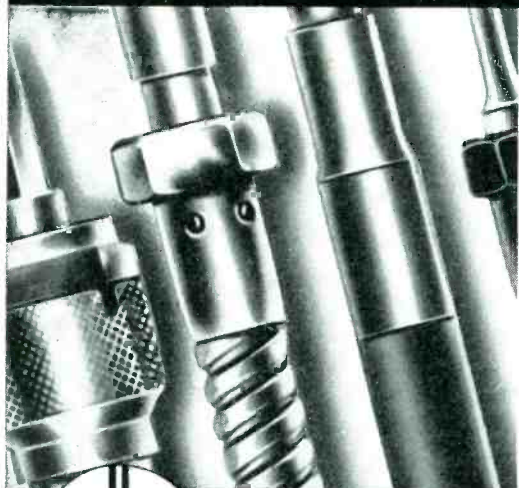

• You can put controlled elements wherever good design dictates . . . when you use Walker-Turner Flexible Shafting in your products. It goes around and over obstacles—takes up minimum space—centralizes controls for convenient operation, no matter where the condensers, rotary switches, etc., are located.

Scientifically engineered and carefully wound to produce smoother power flow, sensitive control and trouble free operation. Write for further information.

**WALKER-TURNER CO., Inc.**  
PLAINFIELD, NEW JERSEY



**FLEXIBLE SHAFTING**

FOR REMOTE CONTROL AND POWER TRANSMISSION

tion. A pilot light, toggle on-off switch and a push-switch are included. A double receptacle permits timing two circuits simultaneously. Contacts are normally wired spdt with double break and are rated at 25 amp, 32 v d-c, 25 amp, 125 v a-c, and 10 amp, 230 v, a-c. Contacts can be wired dpdt at correspondingly lower ratings. The cabinet measure 8 x 8 x 8 in. The tube used in the unit is a 2050 thyratron. High accuracy resistors assure precise timing and timing is independent of the length of time the tripping push button is depressed. A dial switch is provided with a position for continuous circuit closure. The unit is compact, easy to operate and supplied for 115-v a-c operation. Electronic Controls, Inc., 44 Summer Ave., Newark 4, N. J.

4

### Vacuum Capacitor

TENTATIVE characteristics of Jennings 1000- $\mu$ fd high voltage vacuum capacitor: peak voltage 10 kv (increased voltage ratings may be obtained on request); peak current 100 amp; capacity 0.001  $\mu$ fd; overall length approximately 7 $\frac{1}{4}$  in.;



maximum diameter at center 4 $\frac{3}{8}$  in. The capacitor is for use in heavy industrial applications, or for broadcast studios and experimental laboratories where rugged mechanical construction is essential. Jennings Radio Mfg. Co., 1098 E. William St., San Jose 12, Calif.

5

### Pulse Generator

DESIGNATED AS Micro-Pulser, a newly developed electronic instrument generating short pulses simplifies production testing of television and radar systems, compon-

# electronics READER SERVICE...

**TO BRING YOUR LIBRARY  
UP TO DATE ON  
LITERATURE AND  
NEW PRODUCTS**

Manufacturers' Literature as well as further information on New Products described in this issue are important "working tools" for design and production departments. To make it easy to keep up to date, ELECTRONICS will request manufacturers to send readers the literature in which they are interested. Just fill out card—we do the rest.

## HOW TO ORDER

Fill out, completely, one coupon for each piece of literature you order. This gives your request authority and allows the manufacturer to address your copy correctly, thus assuring prompt delivery. Just detach cards along dotted lines and drop in the mail. We do the rest.

Write in circle number of item describing one catalog wanted →

Your Company Name *Jones Mfg. Co*  
Address *3217 Lewis Ave.*  
*Chicago, Illinois*  
Your Name *John Smith*  
Your Title *Chief Engineer*  
ELECTRONICS, 330 W. 42nd St., New York 18, N. Y.

**CARDS NOT GOOD  
AFTER MAY 1, 1946**

Write in circle number of item describing one catalog wanted →

Your Company Name.....  
Address.....  
.....  
Your Name.....  
Your Title.....  
ELECTRONICS, 330 W. 42nd St., New York 18, N. Y.

Write in circle number of item describing one catalog wanted →

Your Company Name.....  
Address.....  
.....  
Your Name.....  
Your Title.....  
ELECTRONICS, 330 W. 42nd St., New York 18, N. Y.

Write in circle number of item describing one catalog wanted →

Your Company Name.....  
Address.....  
.....  
Your Name.....  
Your Title.....  
ELECTRONICS, 330 W. 42nd St., New York 18, N. Y.

Write in circle number of item describing one catalog wanted →

Your Company Name.....  
Address.....  
.....  
Your Name.....  
Your Title.....  
ELECTRONICS, 330 W. 42nd St., New York 18, N. Y.

Write in circle number of item describing one catalog wanted →

Your Company Name.....  
Address.....  
.....  
Your Name.....  
Your Title.....  
ELECTRONICS, 330 W. 42nd St., New York 18, N. Y.

Write in circle number of item describing one catalog wanted →

Your Company Name.....  
Address.....  
.....  
Your Name.....  
Your Title.....  
ELECTRONICS, 330 W. 42nd St., New York 18, N. Y.

Write in circle number of item describing one catalog wanted →

Your Company Name.....  
Address.....  
.....  
Your Name.....  
Your Title.....  
ELECTRONICS, 330 W. 42nd St., New York 18, N. Y.

Write in circle number of item describing one catalog wanted →

Your Company Name.....  
Address.....  
.....  
Your Name.....  
Your Title.....  
ELECTRONICS, 330 W. 42nd St., New York 18, N. Y.

Write in circle number of item describing one catalog wanted →

Your Company Name.....  
Address.....  
.....  
Your Name.....  
Your Title.....  
ELECTRONICS, 330 W. 42nd St., New York 18, N. Y.

Write in circle number of item describing one catalog wanted →

Your Company Name.....  
Address.....  
.....  
Your Name.....  
Your Title.....  
ELECTRONICS, 330 W. 42nd St., New York 18, N. Y.

Write in circle number of item describing one catalog wanted →

Your Company Name.....  
Address.....  
.....  
Your Name.....  
Your Title.....  
ELECTRONICS, 330 W. 42nd St., New York 18, N. Y.

Write in circle number of item describing one catalog wanted →

Your Company Name.....  
Address.....  
.....  
Your Name.....  
Your Title.....  
ELECTRONICS, 330 W. 42nd St., New York 18, N. Y.



# An electronics service designed for READERS and MANUFACTURERS

FIRST CLASS

PERMIT No. 64  
(Sec. 510 P.L.&R.)  
NEW YORK, N. Y.

**BUSINESS REPLY CARD**

NO POSTAGE STAMP REQUIRED IF MAILED IN THE UNITED STATES

4c. - POSTAGE WILL BE PAID BY —

**ELECTRONICS**

**330 WEST 42nd STREET**

**NEW YORK 18, N. Y.**

1-1-46

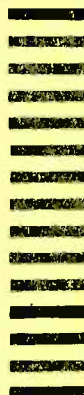

FIRST CLASS

PERMIT No. 64  
(Sec. 510 P.L.&R.)  
NEW YORK, N. Y.

**BUSINESS REPLY CARD**

NO POSTAGE STAMP REQUIRED IF MAILED IN THE UNITED STATES

4c. - POSTAGE WILL BE PAID BY —

**ELECTRONICS**

**330 WEST 42nd STREET**

**NEW YORK 18, N. Y.**

1-1-46

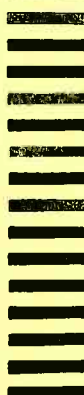

FIRST CLASS

PERMIT No. 64  
(Sec. 510 P.L.&R.)  
NEW YORK, N. Y.

**BUSINESS REPLY CARD**

NO POSTAGE STAMP REQUIRED IF MAILED IN THE UNITED STATES

4c. - POSTAGE WILL BE PAID BY —

**ELECTRONICS**

**330 WEST 42nd STREET**

**NEW YORK 18, N. Y.**

1-1-46

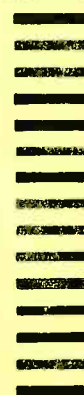

## For the Reader . . .

ELECTRONICS' fundamental policy has always been to supply its readers with all the pertinent and timely industry news. The ELECTRONICS' Reader Service supplements this policy by offering the reader an easy and effective means of obtaining complete, up to the minute data on new products and of maintaining at his fingertips comprehensive, practicable information on "who's doing what" in the industry.

There's complete coverage in every issue of ELECTRONICS of the month by month development by manufacturers of new materials, components and equipment, as well as brief mention of all the important, new, manufacturers' technical pamphlets and catalogs. Some of these items will be of particular interest to specific design and plant engineers, buyers, executives and others of our readers. They will want to make further inquiry concerning the new products described, or they will want to read and make a permanent part of their industrial library some of the manufacturers' literature and catalogs. ELECTRONICS' Reader Service makes it easy for them to obtain in readily accessible and usable form the information they desire.

## For the Manufacturer . . .

ELECTRONICS' Reader Service will also be welcomed by manufacturers who are desirous of placing the complete news of their product developments as well as their technical bulletins and catalogs in the hand of those members of the electronic industry . . . including design, electrical, and production engineers, researchers, physicists, executives, and buyers — who have a particular interest in, or represent a potential buying power, for their products.

## SUGGESTIONS FOR THE IMPROVEMENT OF OUR READERS' SERVICE ARE INVITED

ELECTRONICS is constantly seeking new and improved ways of providing its readers with the news and information they want and need, and of assisting the manufacturer in effectively delivering his message to electronic markets. If you have any ideas for us, send them along. They'll receive prompt and grateful consideration.

January, 1946—ELECTRONICS

Presenting...

# NEW MINIATURE METERS BY MB

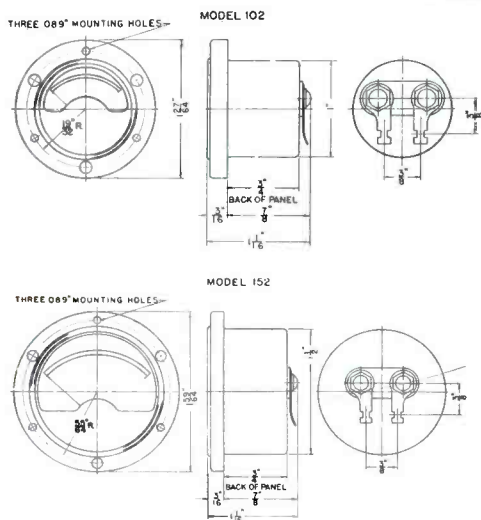
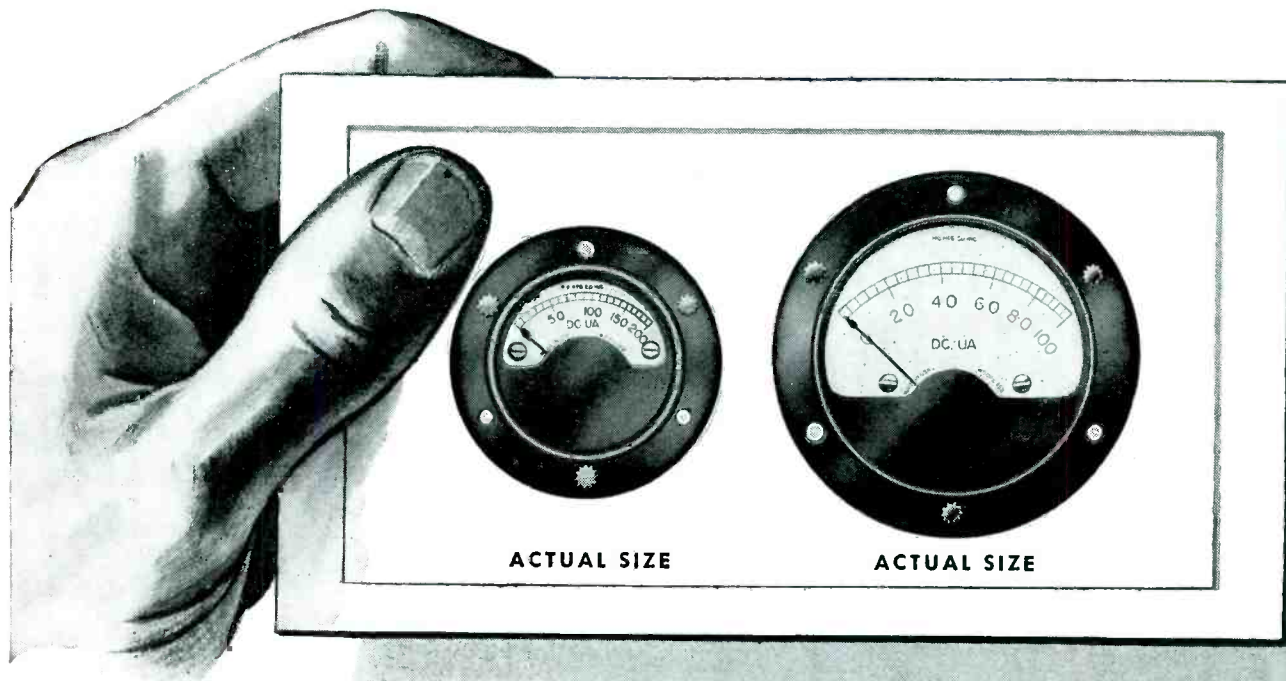

PRECISION AND PRICE—both have been given the utmost consideration in the design of these two additions to the MB family of quality miniature indicating instruments.

They bring to your portable products or panel-board the economies of simplified manufacturing and production methods, *plus* the advantages of small size and standard accepted accuracy.

The fine performance of these new lines will fulfill your every expectation . . . for good reasons! Scales are clear, sharply defined. The sensitive, feather-weight element moves in the field of an Alnico No. 5 magnet—response is fast. Because they're built with jewel bearings, and are precision pivoted, these rugged instruments will withstand hard usage. The anodized, pressed aluminum cases are securely sealed. Model 152 mounts in a 1½ inch opening . . . model 102 in a 1-inch opening—it's the most compact construction made!

Write for full details and description. We invite your inquiries for special scales, accessories, or adaptations . . . or qualified engineering assistance.

THE  
**MB**

**MANUFACTURING COMPANY, INC.**

Instrument Division

331 East St., New Haven 11, Conn.



**ELECTRICAL METERS FOR AIRCRAFT AND PORTABLE EQUIPMENT**



**UTILIZED by the  
BUSIEST  
PURCHASING AGENTS**

**MacRae's  
Blue Book**

**A DIRECTORY OF AMERICAN INDUSTRY...  
RATES, CALL YOUR AGENCY OR WRITE... FOR ADVERTISING AND BOOK...  
29 E. HURON ST., CHICAGO 11, ILL.**

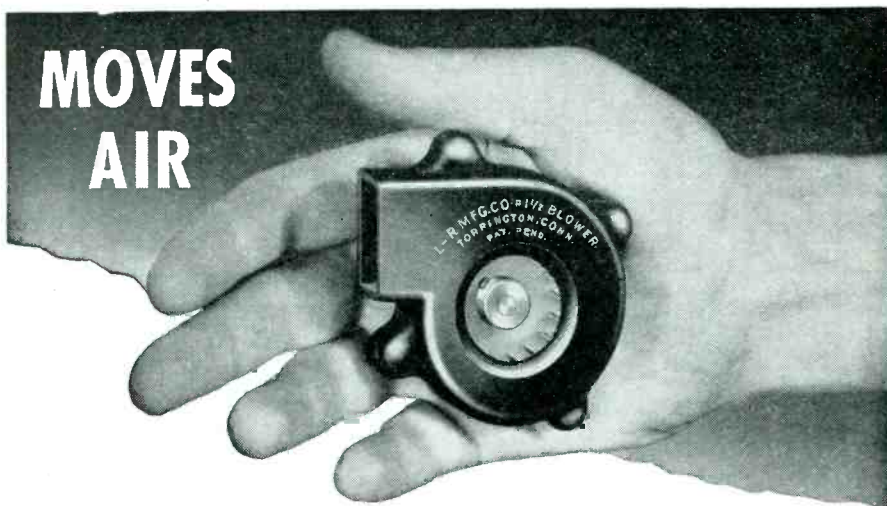

**MOVES  
AIR**

**... 15 CUBIC FEET A MINUTE**

The No. 1½\* is one of many blowers manufactured by the L-R Mfg. Div. with C.F.M.'s at 8000 R.P.M. ranging from 15 to 270. They will outperform many larger types and where size and weight are factors, they solve cooling problems presented by electronic tubes or circuit components in airborne communication units as well as in many industrial applications.

\*WEIGHT: 2 oz.; CAPACITY: 15 C. F. M. at 8000 R.P.M.; CONSTRUCTION: Housing of high impact phenolic plastic. Wheel is turbotype cadmium-plated steel; SIZE: 2¾" long x 61/64" wide x 2½" high.



**BLOWER DIVISION**  
13 NEW LITCHFIELD STREET TORRINGTON, CONNECTICUT

ents, or video amplifiers, or can be used to obtain transient response study of electrical networks, or as a microsecond timing device, or pulse modulating source for high frequencies, or as a laboratory unit for student instruction in radar or in pulse techniques. The generator produces a pulse width of from one-half to 5 microseconds, a pulse repetition rate of 200 to 2000 and from 2000 to 20,000 cps. It will trigger from external positive or negative pulse. Other features include: variable delay in two ranges (from 10 to 100 and from 100 to 1000 microseconds); output pulse is both positive and negative (low impedance positive pulse at approximately 150 ohms, and negative pulse at approximately 400 ohms); amplitude of pulse is continuously variable between zero and 50 v. A positive and negative synchronizing pulse is furnished to trigger external equipment. The generator has a self-contained power supply (117 v, 60-cycle operation). It measures 10 x 14 x 8 in., weighs about 30 lb, and is priced at \$150, F.O.B. East Orange. Kay Electric Co., 8 Eaton Place, Newark, N. J.

6

**Recorder-Reproducer Unit**

MANUFACTURED BY Utah Radio Products Co., 812 Orleans St., Chicago 10, Ill., and designated as Magicwire, a portable recording reproducing device records on a moving steel-wire, reproducing sounds immediately. Overall dimensions of the unit are 13½ x 11½ x 9 in. and the total weight is 37½ lb. Used re-

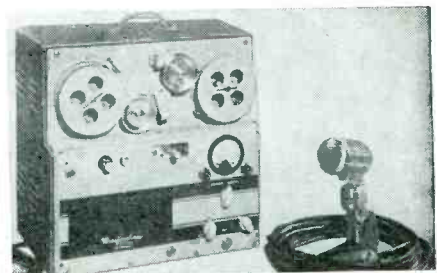

ording wire can be preserved indefinitely, or it can be cleared of its record and used again. Recordings can be made regardless of the position of the recorder. Climate, temperature or vibration have no effect on the unit. A timing device enables one to select only a portion

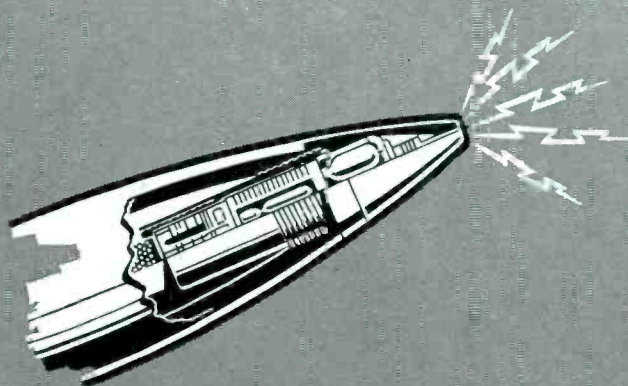

★ *Waterbury Companies, inc.*

MANUFACTURED

★ **5,132,000** ★

**COMPONENT PARTS** *for the* **VT FUSE**

★ **NOW IT CAN BE TOLD**

Waterbury's technical skill . . . the same skill that produced intricate plastic parts for this secret weapon which affected the course of the war . . . is available to manufacturers who use plastic parts and assemblies in their products.

Highly intricate mold making and precision plastic molding by transfer, injection, and compression is a specialty with Waterbury Companies. Let our complete engineering and design staff work with you on the production of your plastic parts.

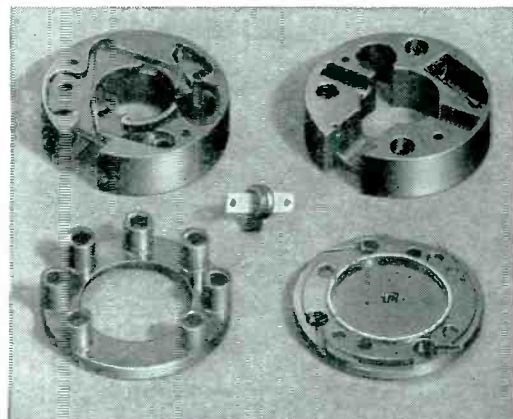

These small but highly intricate plastic pieces are vital parts of the new famous VT fuse.

**WATERBURY COMPANIES, INC.**  
FORMERLY WATERBURY BUTTON CO., EST. 1812  
**McGRAW AVE., WATERBURY, CONNECTICUT**



# ALDEN RADIO COMPONENTS ALDEN

## CATHODE RAY SOCKETS

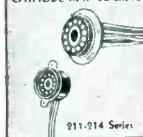

911-914 Series

## 801-5 PLUGS



## 411-5 SOCKETS



## MINIATURE CONNECTORS

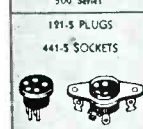

500 Series

## 191-5 PLUGS



AC OUTLET

## AC OUTLET 402AC

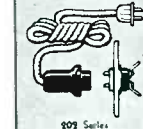

402 AC

## AC LINE CORDS



AC LINE CORDS

## 202 SERIES



202 Series

## FUSEHOLDER

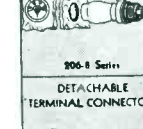

440 FH

## TUBE CAP CONNECTORS



206-8 Series

## TUNING EYES

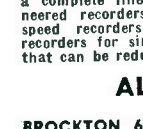

200-8 Series

## DETACHABLE TERMINAL CONNECTORS



200-8 Series

## NEW ITEMS

## 211 and 214 SERIES CATHODE RAY TUBE CONNECTOR WITH LEADS

Any requirements in a cathode ray tube connector complete with the proper leads attached are specially engineered as a complete assembly to insure high safety factors in all kinds of service. For octal, magnum, diaphragm bases and any new cathode ray tube, have super-long leakage paths, rounded, "coronaless" clips and individual pocket type insulation and strain relief for each lead. Buying the complete assembly gives you the best obtainable connector plus the economies of standardization.

## 801-5 SHIELDED PLUGS AND 441-5 METAL SOCKETS

Shielded plug and socket for automobile sets or for any other equipment where leads must be shielded and shield grounded to chassis. One to five circuits. Individual insulation for each lead prevents shorting by vibration. Shield is easy to put on and solder to plug. Supplied with or without shielded cable.

## MINIATURE CABLE CONNECTORS 500 SERIES

One to four circuit cable connectors—famous for connecting AC motors in combination sets and all kinds of "through-panel" work. Overall diameter only  $\frac{3}{4}$ ". Eliminates ponderous "ball and chain" devices. Save labor costs by having our special wire equipment put on leads to your particular needs. Each lead has individual "pocketed" insulation and strain relief. Underwriters approved.

## 121-5 MINIATURE PLUGS AND 441-5 SOCKETS

Compact plug and metal seal socket of 1 to 5 circuits. Use when you want connector to come directly out of chassis. Plug supplied with leads to your specifications. Socket has easy to solder tabs. "Pocket" type individual insulation on each lead and clip.

## AC OUTLET 402AC

Smallest possible outlet that can be cycled or riveted to chassis like other components. Solder tabs designed for easy soldering.

## AC LINE CORDS 202 SERIES

Here is a detachable AC line and with socket, that is neat and compact. Socket eyelets or rivets in place like other components. Underwriters approved. Special cords and plugs to your specifications.

## FUSEHOLDER 440FH

Here is a fuseholder that rivets or eyelets in place like other components in your set. Cannot twist or turn, does not require special wrenches for assembly. Has spring to eject fuse if it breaks. Spring makes contact at base of fuse and prevents rattling. Top contact slotted for easy removal of fuse ferrule when glass breaks. Tabs are of special design for ease in attaching primary leads of ample size for any current carrying requirements.

## 90 SERIES TUBE CAP CONNECTORS WITH LEADS

Any requirement in tube cap connectors supplied with leads of proper voltage handling characteristics. Many made special, hundreds of moldings, stampings and wire to draw on.

## 206-8 TUNING EYES WITH LEADS

Socket supplied with tailor-made leads attached. Without enclosure and bracket. Individual insulation and strain relief for each lead.

## 200 SERIES DETACHABLE TERMINAL CONNECTORS

Two to eight circuit detachable connector. Replaces terminal strips. Supplied with leads attached. Each lead has individual insulation and strain relief.

## WIRE AND CABLE

Any kind of wire or cable laced, braided, woven or assembled with any of our components or those of other make. Many types of wire in stock and in process.

## NEW ITEMS

When you want to get into production fast, Alden is a specialist in bringing through special electrical assemblies, new items in small or large quantities. Samples made promptly.

(if desired) of the recording in playback. The unit operates on 115 v, 60-cycles, a-c and is for use in radio stations, home and other non-commercial entertainment. A full-wave rectifier tube (5W4), three-

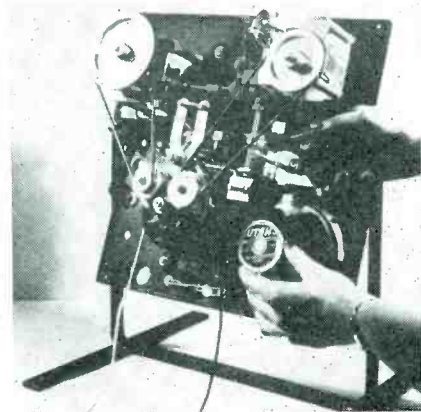

stage audio amplifier, 30-ke oscillator tube (6V6), record-listening mechanism, drive motor and associated mechanism and necessary accessories comprise the recorder and reproducer. The wire used on the machine is 0.004 inch in diameter, and each spool, which is about 3 in. in diameter, will take 66 minutes of recording.

7

## Hermetic Cans, Terminals

FUSITE "HermetiCans" and Fusite multiple hermetic terminals are available from Cincinnati Electric Products Co., Carthage St. at Han-naford, Cincinnati 12, Ohio. "HermetiCan" is a registered trade name, identifying a new series of metal containers incorporating the hermetic terminals. The terminals are ready for connection to the elec-



trical part. The part is placed in the HermetiCan, and by means of either a manually-operated or motor-driven closing machine, is hermetically sealed at the rate of 150

## PLASTIC ENCLOSED



TYPE 1200

## ADVANCE ULTRA SENSITIVE\* D. C. RELAYS

- ★ 2½ TO 5 MILLIWATT OPERATION
- ★ 25% TO 15% DIFFERENTIAL

**COVER:** Moulded Plastic, Cellulose Acetate, Clear, Tough Single Screw Attachment • No dust or dirt on contacts • No accidental operation • No short circuits • Instant visual inspection • Low maintenance of contact adjustment

**BASE:** Moulded black BAKELITE • Good mechanical strength • High dielectric strength and insulation • Negligible water absorption • Compactness and fine appearance

**OPERATING POWER:** 5 Milliwatts for positive operation • 2½ Milliwatts with careful adjustment and light contact loads

**MAGNETIC CIRCUIT:** Armature and pole of Nickel-Iron alloy, Hydrogen annealed for high permeability and low retentivity • High overall sensitivity • Small make-break coil current differential—(25% to 15% less current to break than to make)

**ARMATURE:** Counterbalanced • Prevents action of relay due to moderate vibration • Allows operation in any position

**SENSITIVITY ADJUSTMENT:** Vernier screw for coil spring tension on armature • Accuracy • Permanent setting, easily changed

**CONTACTS:** Pure Silver (palladium, platinum or other specified materials at extra cost) • Single pole, double throw • 1 ampere on 110 volt A.C., non-inductive load • Screwdriver adjustment

**COIL:** Standard resistance from 1 ohm to 10,000 ohms, up to 30,000 ohms at small extra cost • Cellulose acetate insulation • Varnish vacuum impregnation

**TERMINALS:** Solder lugs and screws, recessed on bottom of base, accessible through panel or through knockouts on side of base

**MOUNTING:** Surface mounting, any position, fastens with two No. 6 screws

**SIZE:** 2" x 2-9/16" x 1½" high

**WEIGHT:** 6¼ ounces

**PRICE:** Moderate

Write for quotations and catalogs on the Advance Type 1200 Ultra Sensitive D. C. Relay and other Advance Relays

**Advance Relays**

**ADVANCE**  
**ELECTRIC & RELAY CO.**  
1260 West 2nd Street  
Los Angeles 26, Calif., U. S. A.  
Phone Michigan 9331

## Electrical Recording Instruments

Special instruments to record electrical impulses as they occur with all the minute variations of intensity and duration, free from the lag and inertia of present systems. "Electrographic" recorders we can supply, include a complete line of facsimile recorders, specially engineered recorders for high speed signal analysis, slow speed recorders for day by day events, multi-trace recorders for simultaneous recording of any phenomena that can be reduced to electrical impulses.

**ALDEN PRODUCTS**  
**COMPANY**

BROCKTON 64E3

MASS.

# ELECTRONIC AND MECHANICAL POWDER METALLURGY

IN the twin fields of electronic and mechanical powder metallurgy, where close attention to dimensional tolerance, porosity, density control, etc., is a production "must", Micro-Ferrocart's reputation for strict adherence to such requirements is well established.

•Typical examples of this attention to "quality in production", are the Radacor Iron Cores shown here. Precision-made, subjected to rigorous tests, they are designed for use at all frequencies in television and FM.

•If you contemplate the manufacture of a product requiring electronic or mechanical powder metallurgy parts, designed to close tolerances and of specific densities, why not outline your problems in a letter to us today. Our mechanical powder metallurgy parts replace those heretofore requiring much expensive milling and machining. Our complete engineering and plant facilities are at your disposal.

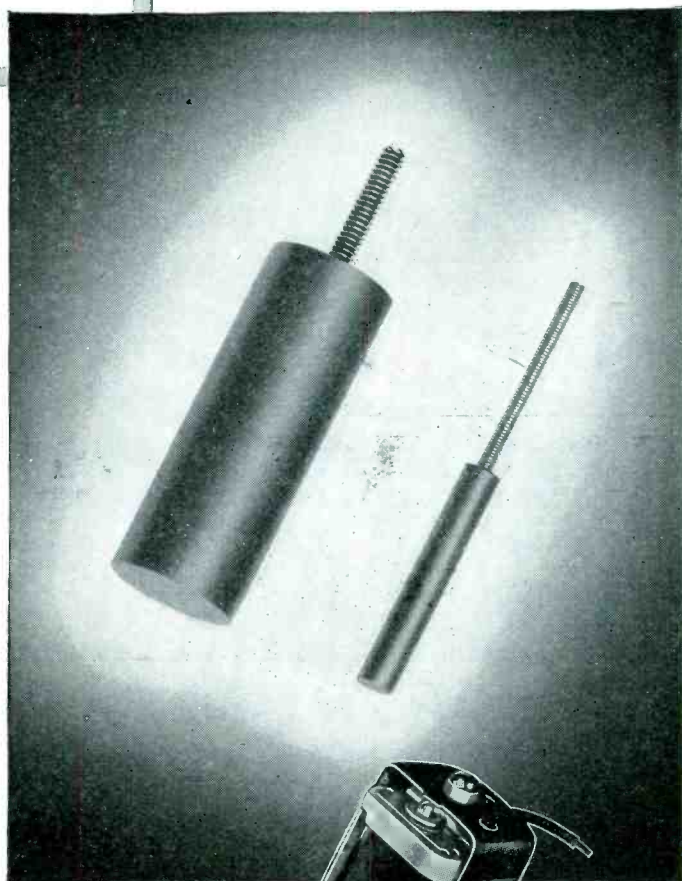

The Radacor Iron Core used in this Meissner I. F. Transformer permits higher "Q" with a resultant increase in selectivity and gain.

ELECTRONIC & MECHANICAL POWDER METALLURGY

**MICRO-FERROCART**  
**PRODUCTS DIVISION**

MAGUIRE INDUSTRIES, INCORPORATED

375 FAIRFIELD AVENUE, STAMFORD, CONN.



# S.S. White **MOLDED RESISTORS** The "All-Weather" Resistors

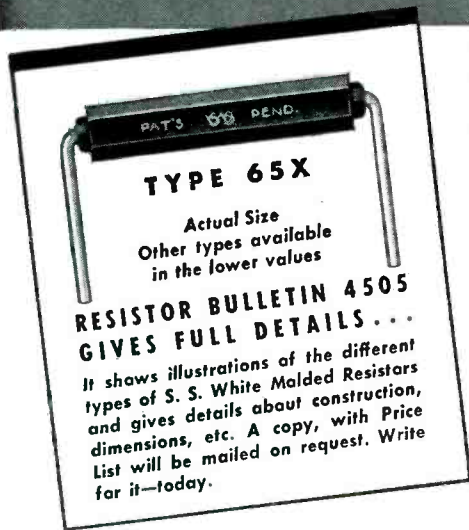

- Noiseless in operation
- Strong and durable
- Good performance in all climates

## STANDARD RANGE 1000 ohms to 10 megohms

- NOISE TESTED •

At slight additional cost, resistors in the Standard Range are supplied with each resistor noise tested to the following standard: "For the complete audio frequency range, resistor shall have less noise than corresponds to a change of resistance of 1 part in 1,000,000."

## HIGH VALUES 15 to 1,000,000 megohms

# S.S. WHITE INDUSTRIAL DIVISION

THE S. S. WHITE DENTAL MFG. CO. DEPT. R, 10 EAST 40th ST., NEW YORK 16, N. Y.



FLEXIBLE SHAFTS • FLEXIBLE SHAFT TOOLS • AIRCRAFT ACCESSORIES  
SMALL CUTTING AND GRINDING TOOLS • SPECIAL FORMULA RUBBERS  
MOLDED RESISTORS • PLASTIC SPECIALTIES • CONTRACT PLASTICS MOLDING

One of America's AAAA Industrial Enterprises

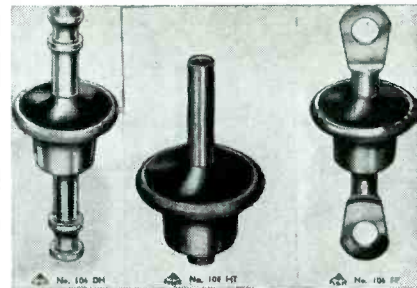

to 300 per hour, easily and quickly without solder or heat by means of a double seam formed in the automatic closing machine. Containers (of various lengths, range from 1½ to 4 in. in diameter) are sturdy, withstand internal and external pressures satisfactorily. Lids are equipped with either 600 or 800 series hermetic terminals (one of 26 glass-to-metal types). Terminals are available in any number from one to nine or combinations and come in two different styles, hollow tube and flattened and pierced.

8

## General Electric Products

AN ELECTRONIC switch, two new thermoplastic cements and a loud-speaker are all new items available from General Electric Co., 1 River Rd., Schenectady, N. Y.

The electronic switch is type YE-9 designed for special electrical studies of wave form, phase, frequency



relationship, and for the comparison of amplitudes. By using two of these switches in cascade, three independent circuits can be studied simultaneously, using any oscilloscope with a horizontal sweep voltage and available connections to the plate of the cathode-ray tube. Operating on any sweep frequency

# Janette

## D.C. to A.C. CONVERTERS

The Janette Rotary Converter is a simple, practical method for obtaining Alternating Current when only D.C. power is available.

### .1 to 3.2 K. V. A.

Janette was one of the first manufacturers to build converters especially for use with A.C. electronic tube devices. Since their inception these machines have established a world wide record for reliable, efficient, quiet, trouble free operation, under the most adverse conditions.

**TWO TYPES** are available; one for commercial applications, the other for marine service. Special filters for suppressing conducted and radiated noise voltage interference can be supplied.

If you want a really dependable converter, guaranteed for one year, we suggest you **TRY A JANETTE!**

**May We Send Literature?**

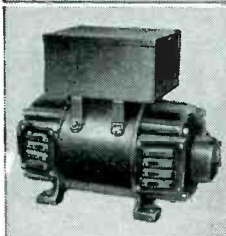
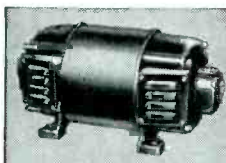
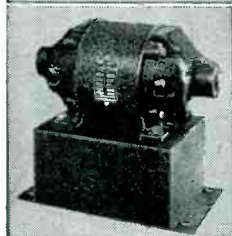

**Janette Manufacturing Company**  
556 W. Monroe St. Chicago 6, Ill.

# *Is* FLUCTUATING LINE VOLTAGE *interfering with your*

Test Equipment  
Measuring Devices  
Calibrating Operations  
Laboratory Work

## A SORENSEN ELECTRONIC A. C. VOLTAGE REGULATOR

*will hold your Line Voltage*  
CONSTANT to 2/10%

## NOT AFFECTED *by variations in*

Input Voltage  
Load  
Frequency  
Power Factor

### READILY ADAPTED TO CONSTANT CURRENT APPLICATIONS

*Write the factory or your nearest representative (see below) for catalog describing various models available and how they function.*

*Price and delivery information included.*

### • *Sales Representatives at your Service* •

*East Coast*

BURLINGAME ASSOCIATES, LTD.  
11 PARK PLACE  
NEW YORK CITY

*West Coast*

N. B. NEELY ENTERPRISES  
7422 MELROSE AVE.  
HOLLYWOOD, CALIF.

*Middle West*

ALFRED CROSSLEY ASSOCIATES  
549 WEST RANDOLPH STREET  
CHICAGO, ILLINOIS

*New England*

IRVING I. KAHN CO.  
3324 MAIN ST.  
HARTFORD, CONN

# SORENSEN AND CO., INC.

375 FAIRFIELD AVE.

STAMFORD, CONN.



# SUN RADIO

in

*New and larger  
quarters!*

**AMERICA'S**  
*most*  
**COMPLETE**  
**SOURCE** of  
**SUPPLY**

Where the impossible becomes the usual. 6,000 square feet of space and a considerably enlarged staff, enable us to improve a service that has always been TOP FLIGHT.

With over 10,000 items in stock, of Standard Nationally advertised products, you have a wide selection to fill your every requirement.

*Note our New Address*

**SUN RADIO**  
& ELECTRONICS CO., Inc.  
122 Duane St., New York 7  
Tel. BRa clay 7-1840

from 10 to 12,000 cps, continuously variable, the YE-9 has an amplifier with frequency response flat within 3 db from 4 cps to 450 kc. The device's input power voltage is 110-125 v, 50-60 cps, and its maximum signal input is 250 rms.

The two thermoplastic cements, Nos. 2142 and 2160, are developed specifically for use in the manufacture of quartz crystals and loudspeakers. Their properties insure a clean, dry and efficient union between porous and non-porous surfaces.

Long-range projection of the human voice was demonstrated by General Electric engineers to officers of the Air Technical Service



Command at Wright Field, Dayton, Ohio, recently. G-E's "Old Loudmouth", a new super loudspeaker was used. The loudspeaker can deliver a whisper a mile. It operates with compressed air on much the same principle as the lungs are used in transmitting human speech. Under average weather conditions, the speaker delivers audible speech two miles. It has been heard at varying distances up to five miles. It is particularly useful in applications where a system is needed to override high noise levels.

9

## New Ceramics

A THERMAL EXPANSION coefficient in the same range as that of Invar, and high resistance to extreme thermal shock are among the properties of a ceramic material recently developed by General Ceramics and Steatite Corp., Keasbey, N. J. The ceramic is designated as Material M-244, and can be used in such applications as in high-temperature furnaces, insulation for high precision instruments in which dimen-

## RESISTANCE WIRE

ALLOY "A": Nickel-chromium alloy, resists oxidation at extreme temperatures. Essential for operating temperatures up to 2100° F. Also used for cold resistance. Resists chemical corrosion by many media. Non-magnetic; specific resistance, 650 ohms/C.M.F.

**C. O. JELLIFF MFG. CORP.**  
123 PEQUOT AVE. • SOUTHPORT, CONN.

## RESISTANCE WIRE

ALLOY "C": Nominally contains 60% nickel, 15% chromium, and balance iron. High resistance to oxidation and corrosion. Widely used in resistances for radio and electronics, industrial, and domestic equipment. Operating temperature up to 1700° F. Specific resistance 675 ohms/C.M.F.

**C. O. JELLIFF MFG. CORP.**  
123 PEQUOT AVE. • SOUTHPORT, CONN.

## RESISTANCE WIRE

ALLOY "180": Nickel-copper alloy with resistivity of 180 ohms/C. M. F. Widely used for resistor elements up to 750° F. (400° C). For radio controls, magnets, rheostats and voltage control relays.

**C. O. JELLIFF MFG. CORP.**  
123 PEQUOT AVE. • SOUTHPORT, CONN.

## RESISTANCE WIRE

ALLOY "45": Alloy of 55% copper, 45% nickel with a constant electrical resistance over wide range of temperatures. Specific resistance 294 ohms/C.M.F.; temperature coefficient 0.00002 ohms per degree F; 32 to 212 degrees range. Used in winding of precision resistors.

**C. O. JELLIFF MFG. CORP.**  
123 PEQUOT AVE. • SOUTHPORT, CONN.

## RESISTANCE WIRE

KANTHAL: Exclusive manufacturers of KANTHAL, an outstanding achievement in resistance-wire development. Now available—complete data upon request.

**C. O. JELLIFF MFG. CORP.**  
123 PEQUOT AVE. • SOUTHPORT, CONN.

*Note: All alloys are produced in high-frequency type furnaces, and are furnished bright, dull or oxidized finish, also with enamel, silk, or cotton insulation.*

*At your fingertips -*  
**THE COMPONENTS YOU WANT**  
*when you want them!*

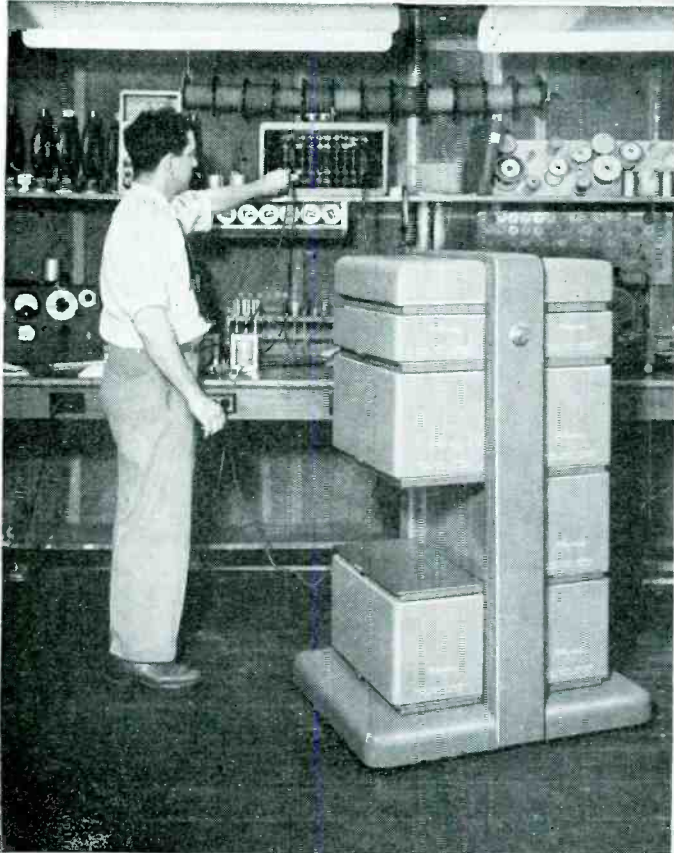

Now—at a moment's notice—you have an almost limitless number of circuit components and power sources at your command with the Harvey-Wells Decade Unit.

Entirely new and unique both in design and application, this unit saves time and expense in laboratories, schools or workshops working on DC or low frequency AC electrical circuits. A few of the possible applications are filter circuits, power supply loads, phase shift circuits, phase correction circuits, inductive or capacitive loads for testing relay contacts, resonance circuits, control circuits, voltage divider circuits, etc.

A complete technical data booklet is now available. Send for it today.

**HARVEY - WELLS ELECTRONICS, INC.**  
**SOUTHBRIDGE, MASS.**

*Harvey* - **WELLS**

**ELECTRONICS, INC., SOUTHBRIDGE, MASSACHUSETTS**

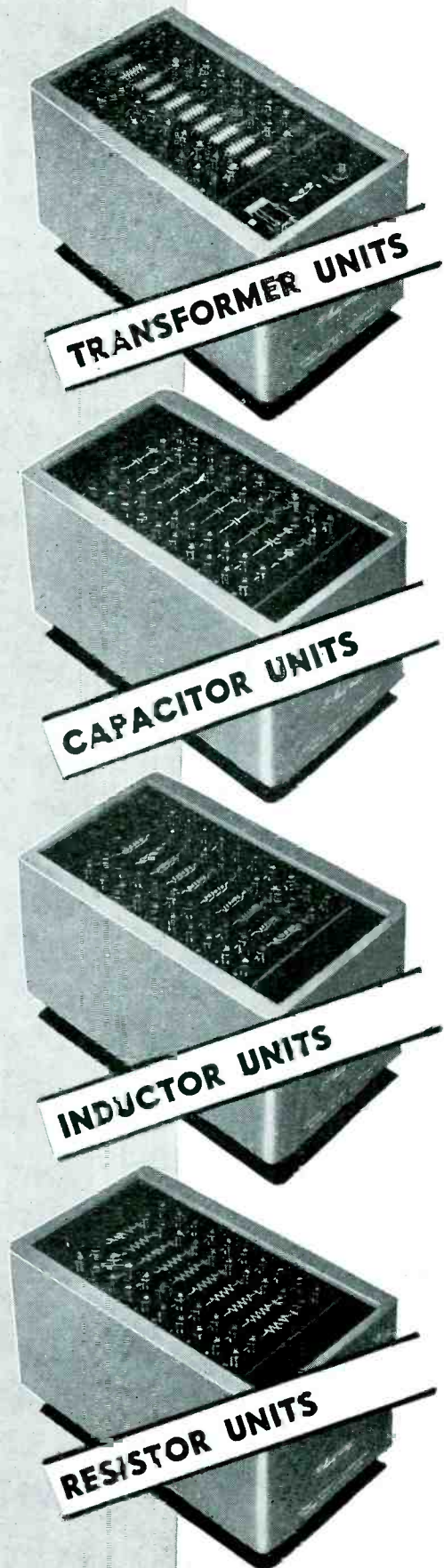



# IN-RES-CO RESISTORS

**Close tolerance units for  
precision performance**

IN-RES-CO resistors are engineered to meet all important electronic application needs. They are wire wound for permanent, exact resistance value and both inductive and non-inductive types are standard. Standard tolerances are 1 and 2%—closer tolerances on special order. Rigid quality control assures a uniform standard of excellence and modern manufacturing facilities result in low unit cost and prompt delivery. Manufacturers of electrical and electronic instruments and equipment should investigate the advantages of designating IN-RES-CO as their exclusive wire wound resistor source.

TYPES RN AND SN Tropi-put resistors—  
RN: 3/4" long x 5/8" dia., Max. Res. 1/2 Megohm, 1/2 watt; SN: 1-3/16" long x 5/8" dia., Max. Res. 1 Megohm, 1 watt



**INSTRUMENT  
RESISTORS CO.**

25 AMITY STREET, LITTLE FALLS, N. J.



sional changes must be absolutely minimized, and for many electrical and electronic purposes where a low thermal expansion coefficient is necessary. Some of the technical data is as follows: Coefficient of thermal expansion up to 600 deg F  $1.6 \times 10^{-6}$ , and up to 1000 deg F  $1.9 \times 10^{-6}$ ; dielectric constant (1000 kc) 5.30; power factor 0.540 percent; dielectric strength 90 v/mil; withstands a temperature of 2500 deg F. The ceramic will be available in any shapes that can be formed by pressing, extruding, or casting.

10

## Snap Switch

ILLUSTRATED BELOW is a new type smaller size open blade snap switch (designated as Model M) for vertical mounting. It can be mounted singly or in multiples. Overall di-

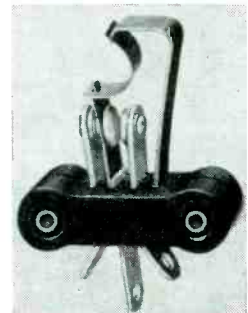

mensions are approximately  $1\frac{1}{2} \times 1\frac{1}{4} \times \frac{1}{8}$  in. Standard operating pressure is 6 to 10 oz. The switch is furnished for sp, normally open, normally closed and dt circuits. Rated at 15 amp, 125 v a-c, and  $\frac{1}{2}$  hp 110 a-c. Acro Electric Co., 1316 Superior Ave., Cleveland 14, Ohio.

11

## Communications Receiver

TYPE HQ-129-C is a professional or amateur receiver manufactured by The Hammarlund Mfg. Co., Inc., 460 West 34th St., New York 1, N. Y. It has the following characteristics: full range 0.54 to 31 mc, accurately calibrated; band spread on 4 calibrated amateur bands and one arbitrary scale; three i-f amplifier stages; two audio stages; low drift beat oscillator for code; antenna compensator to provide maximum image rejection and high sensitivity; and a compensated oscillator to reduce drift during warm-up. Voltage regulation reduces effects of

**WEAR RESISTANT**

**NON-CORROSIVE**

**NON-ABRASIVE**

**PERMOPIVOTS**

**NON-MAGNETIC**

**SUPER-POLISHED**

*Yes, Extra Value!*

Long after the ordinary pivot has worn out you'll find PERMOPIVOTS in the prime of life—faithfully keeping precision instruments precise! It's all due to the special PERMOMETAL tip—the ideal osmium alloy. . . . Made to your specifications. Write for information!

**PERMO  
INCORPORATED**

6427 RAVENSWOOD AVE., CHICAGO 26  
MANUFACTURING METALLURGISTS

# A NEW AND DIFFERENT SWEEP GENERATOR

Needed in  
**TELEVISION, FM, RADAR, HIGH FREQUENCIES**

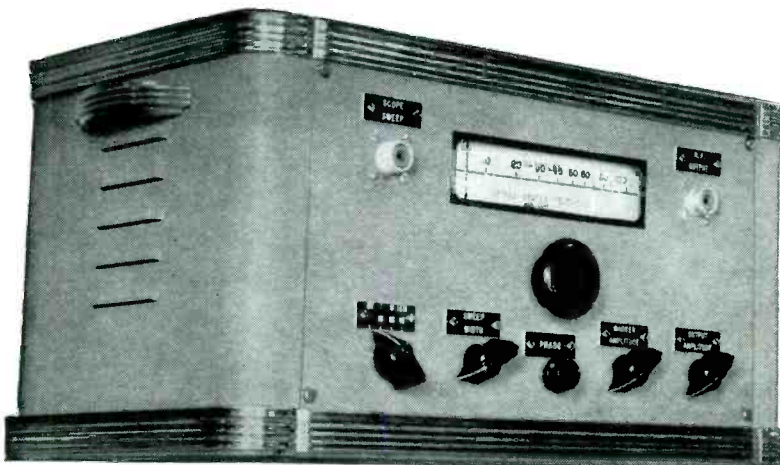

.1 Volt, Max., 500 Kc to 110 Mcs;  
100 Ohms, 10 Mc. Sweep Width

**SAVES TIME**

— In Production and in Testing

**LIGHT**

— Only 16 lbs.

**SMALL**

— 14½" x 8" x 8"

**\$395.00** APPROXIMATE PRICE

For your work in television, FM, radar, high frequencies, etc., you will need one of these newly developed electronic frequency modulated signal generators covering a continuous range between 500 Kc and 110 Mc. Designed primarily for use for field, laboratory, or production alignment of wide band r.f., i.f., or video amplifiers used in radar, direction finders, television, or other wide-band systems.

Sweep range is adjustable from 10 Mc. down to 5,000 cycles at any frequency within the above range for alignment of narrow-band receivers or amplifiers. Self-contained power supply. Input 110 V., 50-60 cycles. A.C. 60 watts. Two internal "markers" are provided, one at intervals of 10 Mc., the other at intervals of 1 Mc. for band-width measurement. The amplitude of these markers is adjustable from the panel. The main dial is



*Also Available Immediately  
In Sample Quantities*

**HIGH VOLTAGE RF POWER SUPPLIES**  
(10 KV, 24 KV, or 30 KV) for 7, 10, 12, or 14 inch direct-viewing Kinescopes and for projection sets

**ICONOSCOPE YOKES**

**CATHODE RAY RECEIVING TUBE YOKES**

**DEFLECTION TRANSFORMERS**

Write for preliminary technical data. A limited number of orders placed now for the Sweep Generator can be filled immediately.

marked in megacycles/sec. and when set at any frequency the sweep is plus and minus 5 Mc. from this setting.

An attenuator is provided which reduces the output signal of .1 V. to about 30 microvolts, which is well below the gain control region of most receiver or amplifier systems.

**UNITED STATES TELEVISION MFG. CORP.**

106 Seventh Avenue • New York 11, N. Y. • CHelsea 2-1154

**RADIO • TELEVISION • ELECTRONIC PRODUCTS**



✓ these tube characteristics to meet the most exacting requirements of fine instrumentation.

They are intended primarily for service where ordinary commercial tubes are not suitable.



*Actual Size*

### Series VW-41 Characteristics

Filament Current	0.015 amperes
Filament Voltage	1.5 volts
MU G-1	18
Transconductance	65 micromhos
Plate Resistance	275000 ohms

Especially suitable for measuring very small currents or voltages in very high resistance circuits particularly where input resistance may be of the order of  $10^{12}$  ohms or greater.

Also available as . . .  
Electrometers Triodes  
Pentodes Diodes

### Hi-Meg Resistors

Designed for high precision instrumentation where ranges of 10 millivolts to 10 volts are used. The same physical size is maintained for all values from 1 meg-ohm to 1,000,000 meg-ohms. Vacuum sealed in special treated glass—size of envelope  $1\frac{1}{8}$  inches long  $\frac{3}{16}$  inches in diameter.

**THE VICTOREEN INSTRUMENT CO.**  
5806 HOUGH AVENUE  
CLEVELAND 3, OHIO

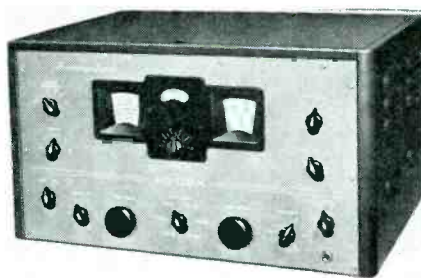

line voltage fluctuation. Earphone jack cuts out speaker when phones are used. The set has 11 tubes, including voltage regulator and rectifier. A 10-in. permanent magnet dynamic speaker with cabinet (to match) is priced at \$10.50 net, the unit itself sells for \$129. Overall dimensions are 13-in. deep,  $19\frac{1}{2}$ -in. wide, and 11-in. high. Speaker cabinet dimensions are  $7\frac{1}{2}$ -in. deep,  $12\frac{1}{2}$ -in. wide, and  $12\frac{1}{2}$ -in. high.

12

### Pilot Light Assemblies

A BUILT-IN RESISTOR is an integral element of Series PL-849 pilot light assemblies, manufactured by Dial Light Co. of America, Inc., 900 Broadway, New York 3, N. Y., to enable direct connection to 115-v circuits. Ratings for the resistor are available as follows: 100,000 ohms for bright glow, 200,000 for dimmer flow; 270,000 ohms for 220-v circuits. Jewel caps are available in 7 different colors.

13

### Battery Eliminator

DESIGNED TO REPLACE two dry cells, this new ElectroX battery eliminator (type A3V) is for use where 3 volts of direct current is required. It operates on 110 v, 60 cycles, and delivers a smooth, noiseless d-c output of 3 v, 150 ma. It is enclosed in a metal can housing which measures  $3 \times 2\frac{1}{2}$ -in. Schauer Machine Co., ElectroX Div., 2048 Reading Rd., Cincinnati 2, Ohio.

14

### High Voltage Capacitors

THESE UNITS are especially adaptable for radar and similar applications, and incorporate special high dielectric-strength refractory film and an exclusive fabrication technique. Capacitors are made to individual specifications only (an example of the types available is a 15

# HUDSON AMERICAN TRANSFORMERS

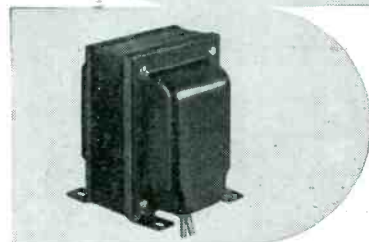
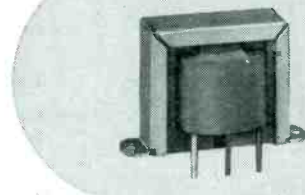
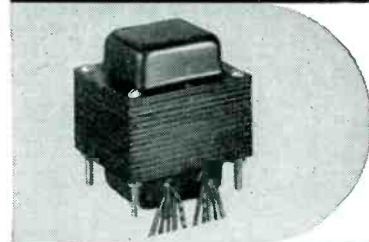

## FOR GENERAL ELECTRONIC AND RADIO APPLICATIONS

HUDSON AMERICAN'S 20 years engineering experience has developed 6 outstanding points of perfection in the manufacture of high quality Transformers:

- 1 Most modern coil producing machinery available.
- 2 Vacuum impregnating equipment for wax or varnish.
- 3 Completely automatic production test equipment.
- 4 Precise winding and meticulous assembly.
- 5 Thorough impregnation and careful finishing.
- 6 Maximum uniformity.

Specify HUDSON AMERICAN TRANSFORMERS for your radio and electronic requirements.

Write for catalog 1045



**HUDSON  
AMERICAN  
CORPORATION**

A subsidiary of Reeves-Ely  
Laboratories, Inc.

25 WEST 43rd STREET, NEW YORK 18, N. Y.

GET HIGH FIDELITY, BI-DIRECTIONAL ADVANTAGES

with *Electro-Voice*

# Velocity Microphones

Flat Frequency Response  
Insures True Reproduction

Dead at Sides, Top, Bottom—  
To Reduce Unwanted Sounds

Wide-Angle Pick-up—  
Greater Pick-up Range

Usable Front and Back  
at the Same Time

Model V-1



Years of special E-V "know how" make possible the full utilization of the ribbon velocity's high fidelity characteristic.

In Model V-1, you get true reproduction without imposed peaks and dips. Pole pieces are designed to insure adequate high frequency reproduction and provide ample output. One-piece frame and internal mounting structure is exclusively E-V—jars and mechanical shocks cannot shift parts.

Bi-directional polar pattern provides equal front and back pick-up, zero pick-up at sides, top, and bottom. Proper tilting reduces feedback and unwanted sounds.

Excellent for solo or orchestra—for individual or chorus—for single speaker or groups . . . in public address, broadcasting, and recording.

Substantially flat from 40-9000 cps. May be used with any modern amplifier designed for crystal or dynamic microphones. Handy size. Easily tilted. Standard 5/8"-27 thread. "On-Off" switch.

**Model V-1** Hi-Z (direct to grid), 50, 200, 250 or 500 ohms. List Price..... **\$30**

Model V-2 List Price \$37.50      Model V-3 List Price \$50

AUTHORIZED DISTRIBUTORS EVERYWHERE

No finer choice than

# Electro-Voice

## MICROPHONES

ELECTRO-VOICE, INC., 1239 South Bend Ave., South Bend 24, Indiana  
Export Division: 13 East 40th St., New York 16, N.Y., U.S.A.—Cables: Arlab



SEND FOR CATALOG  
Valuable data on Micro-  
phones for Communications,  
P. A., Broadcasting,  
Recording. Includes Refer-  
ence Level Conversion  
Chart.



# New! The EL Menco FUSED PLUG

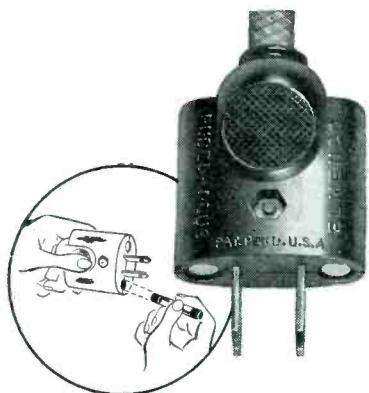

Here's a plug that carries its own fuses . . . in fact two small fuses, which provide complete protection against damage to the appliance and to the main line . . . fuses are standard, available wherever electrical supplies are sold and are easy to replace when blown.

**NORMAN H. LAWTON** ENGINEERING  
SALES • SERVICE

NEW YORK: 1775 Broadway, 19 INDIANAPOLIS: 635 Pennsylvania St., 4

### DIRECT FACTORY REPRESENTATIVE

- A. W. FRANKLIN MFG. CORPORATION—Sockets . . . Terminal Strips . . . Plugs . . . Assemblies
- ELECTRO-MOTIVE MFG. CORPORATION—Moulded Mica Capacitors . . . Mica Trimmer Capacitors . . . Fused Plugs . . . etc.
- QUAKER CITY GEAR WORKS—Precision Gears for Industry
- UNITED TRANSFORMER COMPANY—Transformers
- MICA PRODUCTS COMPANY—Mica Sheets and Fabricated Parts
- F. W. SICKLES COMPANY (Eastern Representative)—I. F. Transformers . . . Antenna Loops . . . Trimmer Condensers (mica and air dielectric) . . . Tuning Units

Leading makes of  
**RELAYS**  
and  
**SWITCHES**

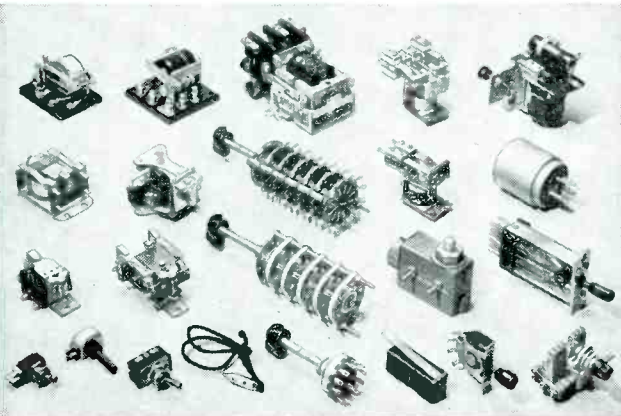

*Stocks on Hand for Immediate Delivery*

You get faster service from Allied, because many makes and types are centralized here—such as:

**RELAYS:** POTTER & BRUMFIELD—ALLIED CONTROL—EBY—GENERAL ELECTRIC—CUTLER-HAMMER—SIGMA—GUARDIAN—LEACH . . . Heavy-Duty Power; Plate Circuit; Sensitive; Overload; Keying; Antenna Transfer; Medium Duty in all Combinations of Contacts and Coil Voltages.

**SWITCHES:** MALLORY—CENTRALAB—CUTLER-HAMMER—HART & HEGEMAN—GENERAL ELECTRIC—FEDERAL—MU-SWITCH—ACRO—UTAH . . . Toggle, Simple Rotary; Multi-Ganged; Multi-Contact; Cam Lever Action; Mercury; Low-Pressure Actuating; Knife, Key, Button.

Save Time and Work—Call ALLIED First. Write, Wire, or Phone Haymarket 6800.

Everything in Radio and Electronics  
**ALLIED RADIO CORP.**

833 W. Jackson Blvd. • Dept. 24-A-6 • Chicago 7

Helpful  
**BUYING  
GUIDE**  
on request  
Write for it!

kv type which is rated 0.0022 mfd and measure  $2\frac{1}{8} \times 1\frac{1}{8} \times \frac{1}{8}$  in. and weighs 1.5 oz). Peak performance at high temperatures, unlimited size of sheets and minimum capacitance drift (less than 0.015 percent per deg C over a range of -60 deg to 100 deg C) are features of the special dielectric used. Units are made in one-piece. Aircraft-Marine Products Inc., 1591B North 4th St., Harrisburgh, Pa.

15

### Thermoplastic Insulated Wire

THIS EXTRUDED thermoplastic insulated wire (designated Turbo-Therm) is resistant to high temperatures, oils, organic solvents, acids, etc. Because of its poly-

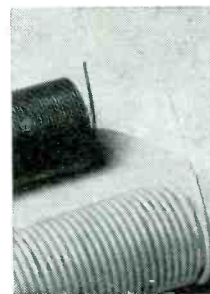

vinyl insulation it has breakdown strength in excess of 1000 v per thousandth inch wall thickness. For the time being the wire is available in gauges from 24 to 30. William Brand & Co., 276 Fourth Ave., New York 10, N. Y.

16

### Insulator Test Set

THE NEW INSULATION TEST set type RD-50, manufactured by Radio Development Labs., 362 Atlantic Ave., Brooklyn 2, N. Y., is designed as a safe, simple and quick means for testing the breakdown voltage of materials and components. It has a continuous duty rating of 50 kv d-c at 10 ma. It can also deliver up to 50 kv peak, a-c. Output voltages are continuously variable and are divided into three ranges, 0-10 kv, 0-25 kv, and 0-50 kv. Full 315 degree rotation of a variac is employed for each range of output. The output voltage is measured directly in the output circuit with a 4 in. long instrument scale, accurate to 2 percent.

Safety features, include range-

FOR ALL TYPES OF PACKAGE MACHINERY

## 3 IN 1 ELECTRONIC PRECISION CONTROL OF REGISTRATION

A small, rugged, compact, one-piece, triple scanner easy to install, which will regulate cutting of printed paper, cloth, cellophane, tinfoil and similar materials of any color, or combination of colors with precise relation to position of printed matter.

A turn of a switch gives:

- (1) Transmitted light for use with transparent material.
- (2) Reflected light for use with opaque material.
- (3) Both transmitted and reflected lights for use with translucent material.

Color variety is no problem. A set of internal color filters eliminates the need for a synchronous selector for use where registration mark is a color contrast in the printed design.

Amplifier can be installed anywhere within 25 feet of scanner. Includes heavy duty relay rated at 30 amps. 110 v. inductive load and 50 amps. 110 v. non-inductive load contained in a sturdy steel housing. As is customary with all of our controls, a large safety factor is incorporated in all components. Made for 110 v. and 220 v.

Write for Catalog #8231

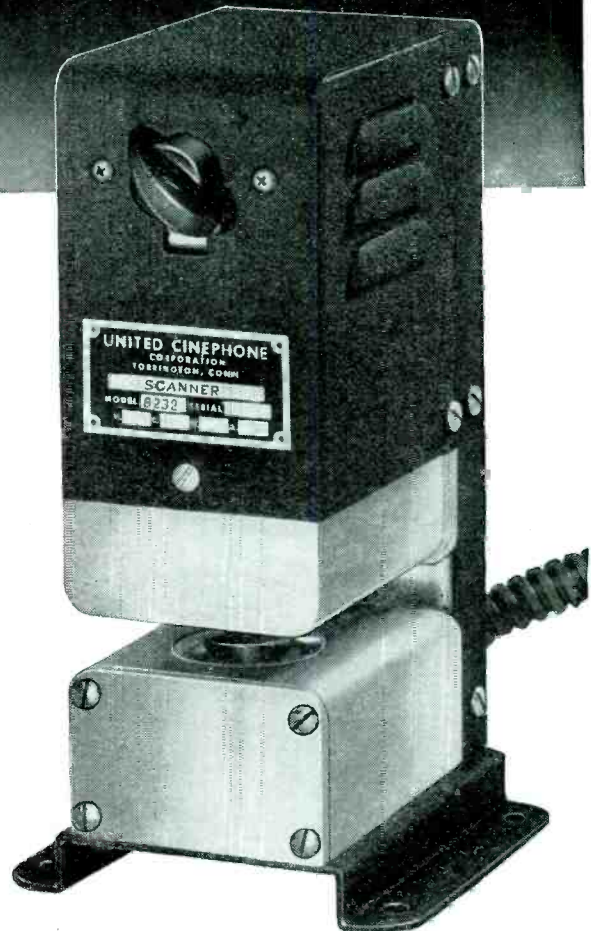

SCANNER MODEL No. 8232  
Approximate size: 7½" x 4" x 3¾"

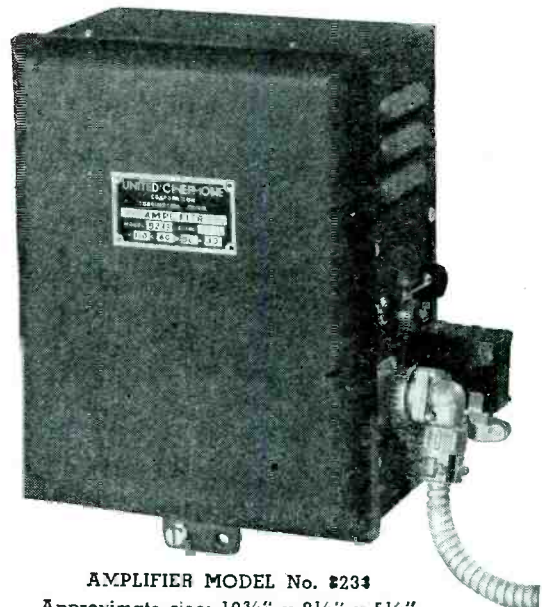

AMPLIFIER MODEL No. 8234  
Approximate size: 10¾" x 8¾" x 5¼"

# UNITED CINEPHONE CORPORATION

*Designers, Engineers and Manufacturers of Electronic Products*

13 NEW LITCHFIELD STREET

TORRINGTON, CONNECTICUT



# EBY #60 SPEAKER CONNECTORS

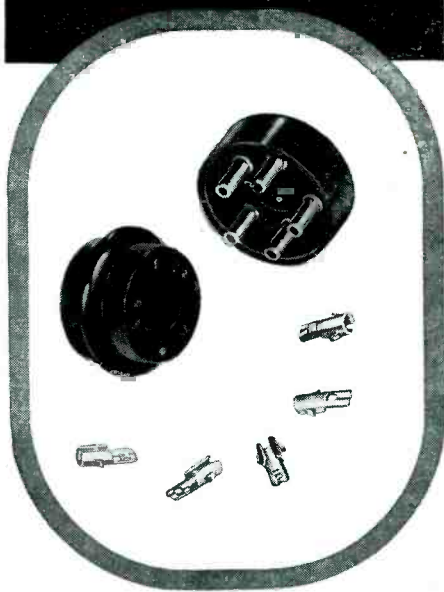

## SAVE APPROXIMATELY 25% IN ASSEMBLY TIME

Only 2 parts to Female Assembly:

1. The bakelite casting.
2. Eby patented snap-lock contacts.

Here's assembly speed! It's as simple as this:

Attach contact to wire and push into cavity.  
Contact automatically locks in place.  
(Casting and contacts supplied unassembled.)

Male Assembly — nickel-plated brass prongs.  
Bakelite casting — Standard arrangement for 3, 4, and 5 prongs. Other arrangements to specifications.

Write today for samples and prices.

Eby #60 Male and Female Speaker Connectors  
Are the Standard of the Industry

HUGH H.  
**EBY**  
INCORPORATED  
18 W. CHELTEN BLDG.  
PHILA., PENNA.

IF IT'S IN A CIRCUIT  
... EBY COMPONENTS  
AND SERVICES WILL  
HELP YOU DO IT BETTER

switching interlock, oil immersed 50 kv filter-capacitor-shorting switch interlocked with the rear door, electrically operated power cutoff switch also interlocked with the rear door.

A repeating chime gives continuous audible warning that high voltage is being generated and a red

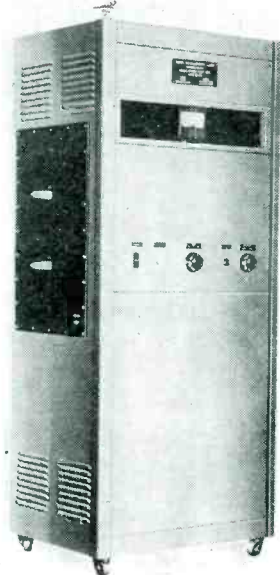

indicator light simultaneously gives visual indication.

To insure adequate protection for the components, current limiting devices are provided in both a-c and d-c circuits, while an adjustable overload relay is provided in the output circuit.

The cabinet is 80 x 32 x 24 in. deep, gray crackle finish, and has a total weight of 700 lb. Operation is from 115 v 60 cps; power consumption is 1 kw.

17

## Megohm Meter

UNUSUAL STABILITY, portability, and a range from 400,000 ohms to 100,000 megohms in five ranges on single-scale four-inch meter, are among the outstanding features of the new model 1500 megohm meter,

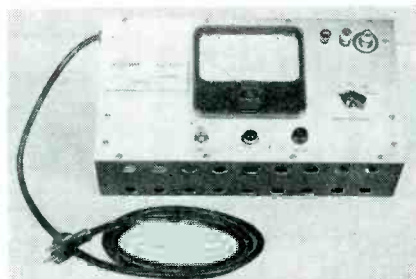

NOW

a really high-powered

## RADIO ENGINEERING LIBRARY

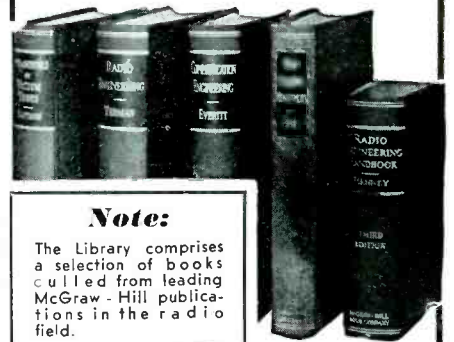

### Note:

The Library comprises a selection of books culled from leading McGraw-Hill publications in the radio field.

- ▷ especially selected by radio specialists of McGraw-Hill publications
- ▷ to give most complete, dependable coverage of facts needed by all whose fields are grounded on radio fundamentals
- ▷ available at a special price and terms

These books cover circuit phenomena, tube theory, networks, measurements, and other subjects—give specialized treatments of all fields of practical design and application. They are books of recognized position in the literature—books you will refer to and be referred to often. If you are a practical designer, researcher or engineer in any field based on radio, you want these books for the help they give in hundreds of problems throughout the whole field of radio engineering.

5 volumes, 3559 pages, 2558 illustrations

Eastman's FUNDAMENTALS OF VACUUM TUBES, 2nd edition

Terman's RADIO ENGINEERING, 2nd edition

Everitt's COMMUNICATION ENGINEERING, 2nd edition

Hund's HIGH FREQUENCY MEASUREMENTS

Henney's RADIO ENGINEERING HANDBOOK, 3rd edition

SPECIAL LOW PRICE • EASY TERMS

Special price under this offer less than cost of books bought separately. In addition, you have the privilege of paying in easy installments beginning with \$3.00 in 10 days after receipt of books and \$3.00 monthly thereafter. Already these books are recognized as standard works that you are bound to require sooner or later. Take advantage of these convenient terms to add them to your library now.

FOR 10 DAYS' EXAMINATION SEND THIS

ON-APPROVAL COUPON

McGraw-Hill Book Co., 330 W. 42nd St., N.Y.C. 18

Send me Radio Engineering Library for 10 days' examination on approval. In 10 days I will send \$3.00 plus few cents postage and \$3.00 monthly till \$24 is paid, or return books postpaid. (We pay postage on orders accompanied by remittance or first installment.)

Name .....

Address .....

City and State .....

Company .....

Position ..... L 1-46



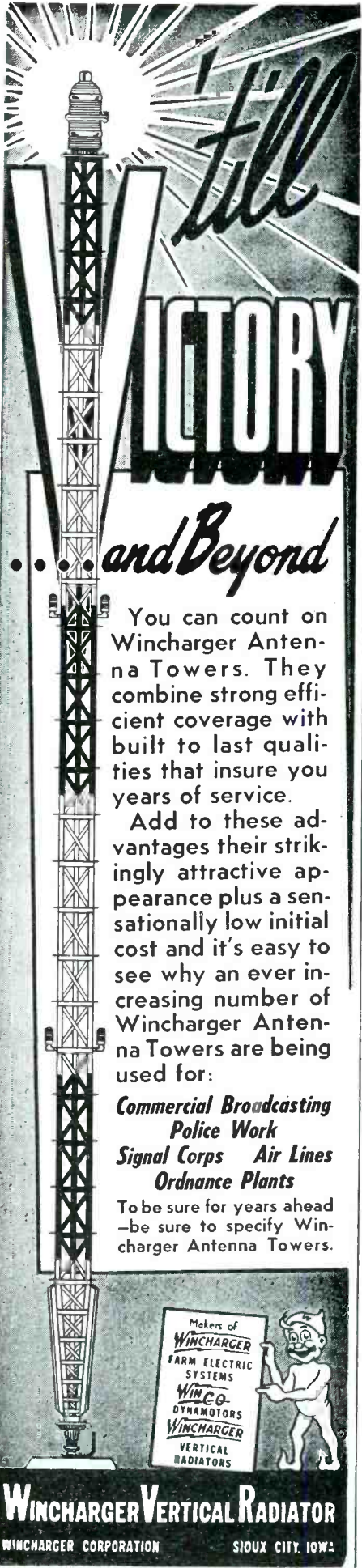

*Fill*

# VICTORY

*...and Beyond*

You can count on Wincharger Antenna Towers. They combine strong efficient coverage with built to last qualities that insure you years of service.

Add to these advantages their strikingly attractive appearance plus a sensationally low initial cost and it's easy to see why an ever increasing number of Wincharger Antenna Towers are being used for:

**Commercial Broadcasting  
Police Work  
Signal Corps Air Lines  
Ordnance Plants**

To be sure for years ahead  
—be sure to specify Wincharger Antenna Towers.



Makers of  
**WINCHARGER**  
FARM ELECTRIC  
SYSTEMS  
**WINCO**  
DYNAMOTORS  
**WINCHARGER**  
VERTICAL  
RADIATORS

## WINCHARGER VERTICAL RADIATOR

WINCHARGER CORPORATION      SIOUX CITY, IOWA



## Cameras Binoculars Telescopes

**Lined with  
Cellusuede Flock**

When used as an interior lining, black Cellusuede flock does an efficient job of "blackening out" the insides of cameras, binoculars, and telescopes, because the flock does not reflect light rays... it absorbs them. A trial application will convince you that Cellusuede is inexpensive and easy to apply. Available for immediate shipment.

# Cellusuede FLOCK

Write for Color Card, Prices, Samples and Booklet explaining Uses and Methods of Application.



**Cellusuede  
Products, Inc.**  
ROCKFORD, ILLINOIS



The WINSLOW line includes Wheatstone, Kelvin, Varley, Murray, Limit and Megohm bridges.

## Winslow ELECTRIC MEASURING AND TESTING INSTRUMENTS

**AIRCRAFT THERMOCOUPLES, IGNITION TEST SETS, INSULATION TEST SETS, BRIDGES, MEGOHMMETERS, POTENTIOMETERS, TACHOMETERS, VACUUM GAUGES.**

The WINSLOW line of portable electrical instruments for measuring direct currents, alternating currents, resistance, temperature, speed, vacuum and insulation, etc., are attractively housed, convenient to use. All are ruggedly constructed to maintain accuracy under severe usage. Special design precautions are incorporated for complete immunity to dust, dirt and moisture. A complete line of rare and base metal thermocouples for all industrial and laboratory applications is included as well as all accessories—switches, leads and meters. Write for details today—no obligation of course.



WINSLOW megohmmeters are available in ranges to 300 megohms at 500 volts.

# THE WINSLOW CO.

9 LIBERTY ST., NEWARK 5, N. J.



IN 100-HOUR  
SALT SPRAY TEST

**DC**  
means  
**SC**

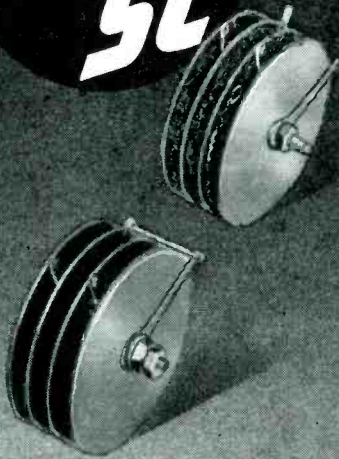

DC means SC . . .

Selenium Conversion and Selenium Control. SC Type "K" Selenium Rectifier is especially designed to pass the 100-hour salt spray test at 50° Centigrade. Again proving that DC means SC...Selenium Conversion and Selenium Control. If you use DC . . . get the facts on SC.

**SEND FOR  
BULLETIN**

**SELENIUM CORPORATION  
of AMERICA**



1719 WEST PICO BOULEVARD  
LOS ANGELES 15, CALIFORNIA

EXPORT DIVISION: FRAZAR & HANSEN  
301 CLAY STREET, SAN FRANCISCO, CALIFORNIA

IN CANADA: BURLLEC LTD., TORONTO 13, ONTARIO, CANADA

# "ALNICO"

## PERMANENT MAGNETS

Specializing in the production of highest quality Alnico Magnets in all grades including new triple strength No. 5.

Production material checked to assure highest uniform quality of product.

Castings made to customer's special order on the basis of sketches or blueprints furnished.

Information and suggestions furnished on request.

## GENERAL MAGNETIC

C O R P O R A T I O N

MANUFACTURERS OF HIGH COERCIVE MAGNETIC ALLOYS

2126 E. Fort Street

Detroit 7, Michigan

**FOR ENTERPRISING  
INDUSTRY...THIS NEW  
SIGNALLING TIMER!**



Designed to give precision where seconds count, and accuracy is imperative. The New Signalling Timer, Model Series S does just that; set it to any specific time cycle, and when that desired interval has elapsed, visual and audible attention is registered to the operator as the circuit is stopped. It eliminates guess-work, mistakes, and spoilage in industry, and gives the highest degree of precision timing. Write for details.

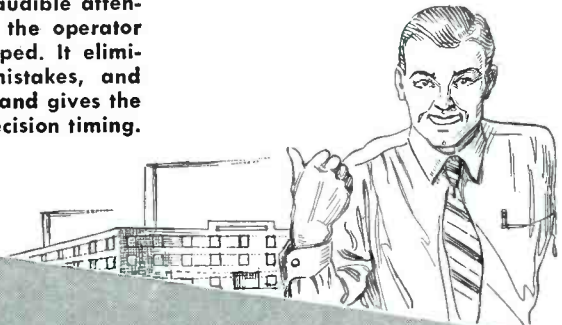

**INDUSTRIAL TIMER CORPORATION**

110 EDISON PLACE

NEWARK, NEW JERSEY

developed by Communication Measurements Laboratory, Meter Division, 120 Greenwich St., New York 6, N. Y., now available.

Weighing only eight pounds, the meter is extremely stable despite line voltage fluctuations. A change in line voltage from 90 to 130 volts produces a change of less than 3% in meter reading at mid-scale. Single zero-reset adjustment is provided for all ranges and drift after initial warm-up period is substantially zero. Efficiently guarded on all ranges to prevent distortion of readings due to atmospheric conditions. Safety measures prevent shock to operator. Accuracy guaranteed better than 5% on all ranges at all points on scale. Line voltage; 115 volts, 60 cycles. \$135.00 net, F.O.B. New York.

18

### Midget Vibrator

The Radiart Corporation, 3571 W. 62nd St., Cleveland 2, Ohio, has available a new midget vibrator type VR-2, it measures 2½ inches high by 1½ inches in diameter. A war development designed for operation from a small 6-volt storage battery to furnish power for certain communications equipment, the entire power supply including the storage battery had to be made for a space 6½ x 3½ x 1½ inches.

Specifications of the VR-2 are as follows:

Vibrator frequency, 185 cps ±10 percent; input voltage nominal, 6.0 v; input voltage range, 4.5 v to 7.5 v; input current, 1.5 amps max at 6.0 v; output voltage, 200 v d-c max; potential difference between primary reed and secondary reed, 25 v Max.

The manufacturer offers blue prints and engineering cooperation.

19

### Special Terminal for Heavy Duty Switches

DONALD P. MOSSMAN, INC., 612 N. Michigan Ave., Chicago, Ill., has announced an optional special terminal arrangement for its Series 4100 and 4500 heavy duty lever switches, and its Series 6300 and 061T heavy duty turn Switches.

The addition of the 41ET and 41ETM terminals does not change the operation of the switch in any manner, and the terminals corre-



# New!

## A SIMPLIFIED VERTICAL MOUNTING FOR SMALL TRANSFORMERS

Sizes fit Core Stacks with  
½" to ¾" center legs

To fully mount the smaller sizes of transformers, Chicago Transformer has developed a new, vertical, shield-type construction possessed of many outstanding characteristics.

- Readily adaptable to various chassis mounting requirements.
- Flexible in application to varying core thicknesses.
- Simple in design: two-unit construction makes for economy.
- Allows grounding of core by direct contact with mounting surface.
- Meets the requirements of the Underwriters' Laboratories.

# CHICAGO TRANSFORMER



DIVISION OF ESSEX WIRE CORPORATION

3501 WEST ADDISON STREET

CHICAGO, 18





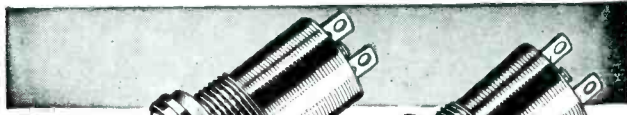

## NEON PILOT LIGHTS

EMBODY THESE IMPORTANT FEATURES:

*Penetrating orange-red glow . . . Long life . . . Low current consumption . . . Resistance to vibration and shock . . . Operate direct on high voltage circuits . . . Emit practically no heat —*

These advantages of Neon Glow Lamps are enhanced by "SIGNAL" Pilot Light Assemblies. We manufacture a complete line, featuring types fitted with Full-View Plastic Heads. Specialists in supplying completely assembled units, housing G.E. or Westinghouse Lamps. Send specifications for prompt estimates and suggestions . . . Write for Catalog.

# SIGNAL INDICATOR

*Corporation*

894 BROADWAY . . . NEW YORK 3, N. Y.

Telephone: ALgonquin 4-4770

For COMMUNICATIONS and INDUSTRIAL Jobs

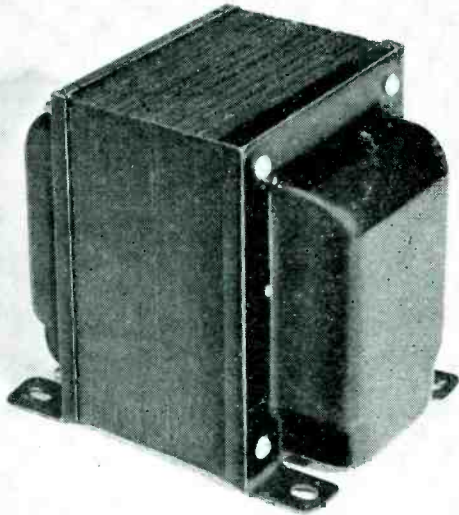

Power  
Transformers  
(Up to 1 kw.)

Audio  
Transformers

High-Voltage  
Transformers

Filter Chokes

Coils

**DINION COIL COMPANY, Inc.**  
CALEDONIA, N. Y.

*Specialists in Difficult Designs*

**STAR** Makes More  
Than Just **STEATITE**

Find Out Now About

## STAR CERAMICS

There are many kinds for special uses, such as applications calling for resistance to electricity, heat, moisture, chemicals or weathering agents. There are more than a score of formulas in actual production at one time in our factory.

Send for "A Brief Survey of Technical Characteristics of Molded Ceramic Products." It is right to the point.

★  
*The* **STAR**  
**PORCELAIN Co.**

Electronics Dept.

Trenton 9, N. J.

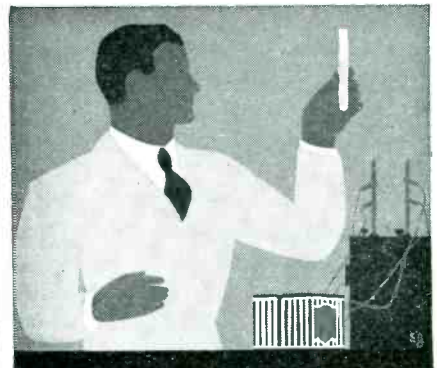

PREFERRED  
BY ENGINEERS

# BURGESS BATTERIES

RECOGNIZED BY THEIR  
STRIPES • REMEMBERED  
BY THEIR SERVICE

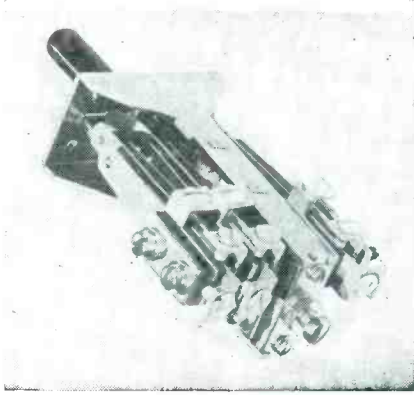

spond with the spring pile-ups. This new type terminal, however, is more effective for specific applications, because by elimination of all soldering, the switch may be installed and serviced more easily.

The terminals are heavy, silver-plated brass with 6-32 binding head machine screws and a No. 6 plain washer. Up to No. 10 wire may be used.

The switch is particularly adapted to heavy loads or in installations which, of necessity, are not serviced for long periods of time.

20

### Small Pie-wound Resistors

A NEW SERIES of precision resistors, mounted by means of a through-bolt and equipped with a radial lug at each end, types 842A, 844A, 844B, is being produced by Ohmite Manufacturing Company, 4835 Flournoy St., Chicago 44, Ill.

The Riteohm 84 is pie-wound to 1 percent accuracy and is available in 3 sizes— $\frac{1}{8}$  in. diam by  $\frac{1}{8}$  in.

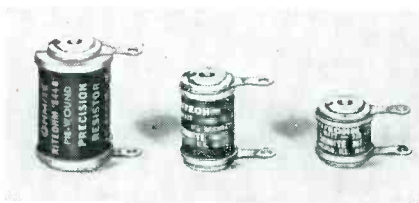

long,  $\frac{1}{8}$  in. diam by  $\frac{1}{8}$  in. long, and  $\frac{3}{4}$  in. diam by  $1\frac{3}{16}$  in. long. The smallest is a 2 pie while the other two are 4 pie units. The minimum resistance is 1.0 ohm for the 2 pie unit and small 4 pie unit, and 0.10 ohm for the large 4 pie unit. The maximum resistance is 200,000 ohms for the 2 pie, 400,000 ohms for the small 4 pie, and 1.5 meg for the large 4 pie unit.

Enameled alloy resistance wire is

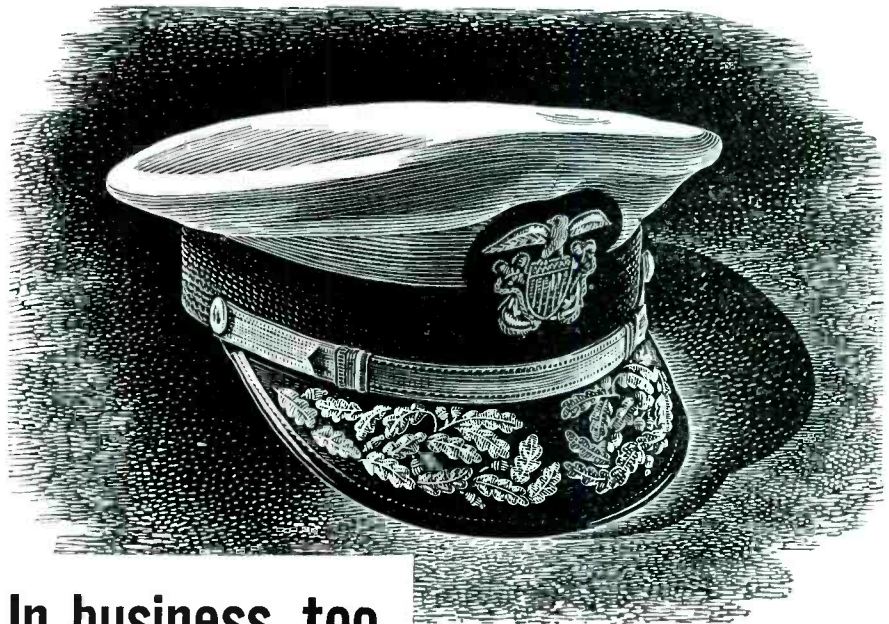

## In business, too, TRAINED men reach the top!

Like commissioned officers in our armed forces, business men and industrialists who "reach the top" have a working knowledge of *fundamentals*.

They know how the basic principles underlying business and industry operate; they understand marketing, accounting, finance AND production.

It is this broad knowledge which enables them to hold executive positions—to supervise the activities of specialists, technicians and others.

The Institute's Modern Business Course and Service is designed for men who recognize the obvious necessity of understanding all FOUR important departments of business and industry. It is practical, intensive and scientific!

With the help of Institute training, ambitious men can strengthen their present positions while preparing for bigger,

better jobs tomorrow.

Among the prominent men who have contributed to the Course are: Thomas J. Watson, President, International Business Machines Corp.; Frederick W. Pickard, Vice President and Director, E. I. du Pont de Nemours & Co.; Clifton Slusser, Vice President, Goodyear Tire & Rubber Co.

### Send For "Forging Ahead in Business"

The Institute's story is factually told in the fast-reading pages of its famous little book, "Forging Ahead in Business." There is no charge for this booklet; no obligation involved. To men who are genuinely interested in self-improvement, "Forging Ahead in Business" has a message of distinct importance. Simply fill in and return the coupon below, and your FREE copy will be mailed to you promptly.

## ALEXANDER HAMILTON INSTITUTE

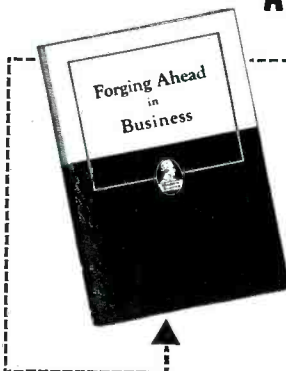

Alexander Hamilton Institute  
Dept. 353, 71 West 23rd St., New York 10, N. Y.  
In Canada: 54 Wellington Street, West, Toronto 1, Ont.

Please mail me, without cost, a copy of the 64-page book—  
"FORGING AHEAD IN BUSINESS."

Name .....

Firm Name .....

Business Address .....

Position .....

Home Address .....



# Solder Fast

TRIGGER CONTROL  
EASY HANDLING



Pats. Pending

• The BAKER Flash is the revolutionary gun-type soldering iron that answers industry's demand for a FASTER, HANDIER tool.

The tip flashes to soldering heat almost instantly following pressure on the trigger control. Correct temperature for most efficient work is easily maintained, overheating and unnecessary oxydation avoided, cleaning and re-tinning time saved.

Natural gun grip; cool, protected plastic handle; light weight; perfect balance—these are advantages that make the BAKER Flash extremely easy to use, *ideal for work in close places.*

Completely equipped for immediate operation from 110-volt transformer or from standard storage battery.

Write or Wire for Complete Information

Order sample today—only \$4.75 postpaid. With HT transformer, \$9.95. Remit check or money order unless C O D is preferred.

THE YEAR'S  
BIGGEST  
NEWS IN  
SOLDERING

**BAKER-PHILLIPS CO.** 3057 LYNDALE AV. SO.  
MINNEAPOLIS 8, MINNESOTA

# flexible shafts

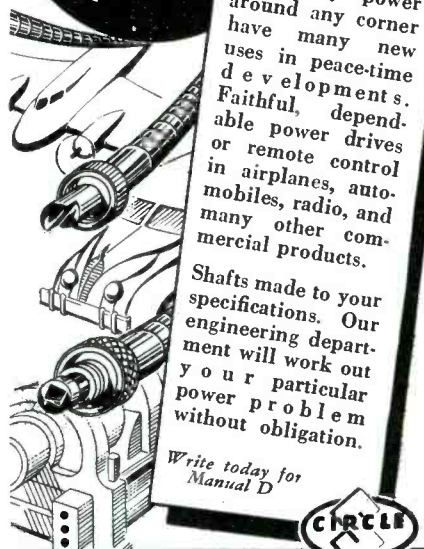

**Flexible Shafts**

that carry power around any corner have many new uses in peace-time developments. Faithful, dependable power drives or remote control in airplanes, automobiles, radio, and many other commercial products.

Shafts made to your specifications. Our engineering department will work out your particular power problem without obligation.

Write today for Manual D



**F. W. STEWART MFG. CORP.**

4311-13 RAVENSWOOD AVE.

CHICAGO 13, ILL.

WEST COAST BRANCH:

431 Venice Blvd.; Los Angeles 15, Cal.

ARGON HELIUM KRYPTON  
NEON XENON MIXTURES

# Linde

RARE GASES  
AND MIXTURES



... Spectroscopically Pure  
... Easily removed from bulb  
without contamination

Scientific uses for LINDE rare gases include—

1. The study of electrical discharges.
  2. Work with rectifying and stroboscopic devices.
  3. Metallurgical research.
  4. Work with inert atmospheres, where heat conduction must be increased or decreased.
- Many standard mixtures are available. Special mixtures for experimental purposes can be supplied upon request.

The word "Linde" is a trade-mark of

**THE LINDE AIR PRODUCTS COMPANY**

Unit of Union Carbide and Carbon Corporation

30 E. 42nd St., New York 17 Offices in Principal Cities

In Canada: Dominion Oxygen Company, Ltd., Toronto

POWDERED METAL CORES

# PyroFerric's

EXCLUSIVE SPECIALTY

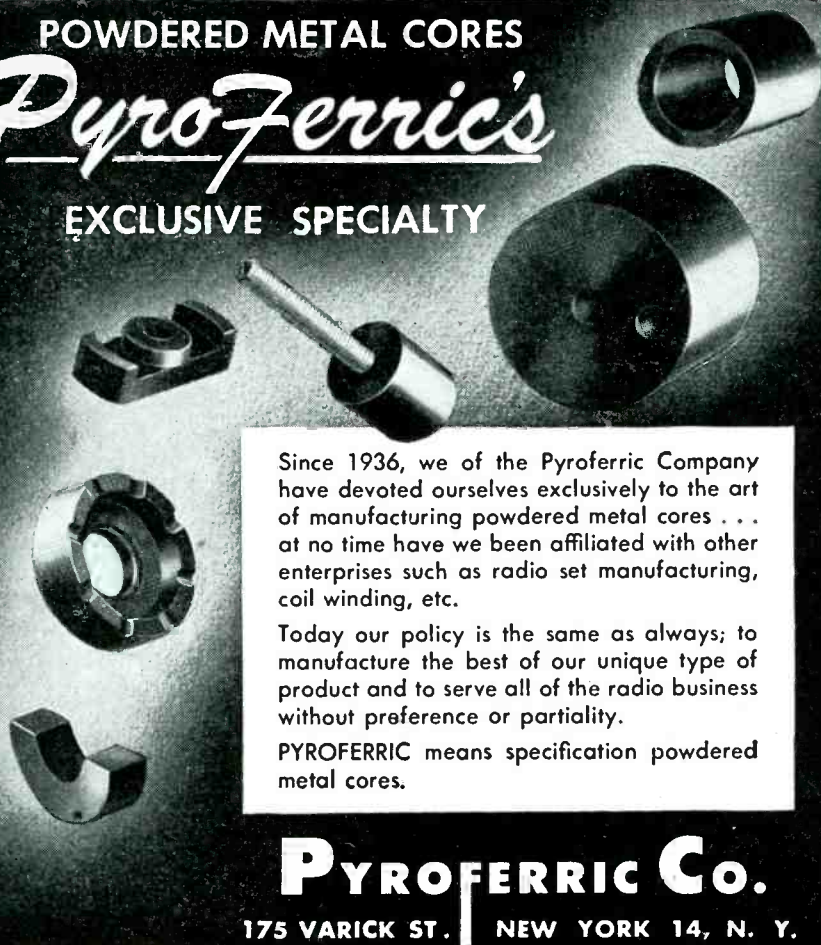

Since 1936, we of the Pyroferric Company have devoted ourselves exclusively to the art of manufacturing powdered metal cores . . . at no time have we been affiliated with other enterprises such as radio set manufacturing, coil winding, etc.

Today our policy is the same as always; to manufacture the best of our unique type of product and to serve all of the radio business without preference or partiality.

PYROFERRIC means specification powdered metal cores.

# PYROFERRIC Co.

175 VARICK ST. NEW YORK 14, N. Y.



non-inductively pie-wound on a non-hygroscopic ceramic bobbin which has a hole through the center for a No. 6 screw. Lug type terminals are firmly fastened to the bobbin. After being wound, the unit is vacuum impregnated with a special varnish which provides additional insulation and thoroughly protects the winding against humidity. The resistor can be supplied with a varnish coating containing a fungicidal agent, thus making the unit particularly suited for use in the tropics.

21

### High Vacuum Television Rectifier

TYPE 2BT RECTIFIER manufactured by Electronic Enterprises, Inc., 67 Seventh Ave., Newark 4, N. J. closes the gap in available types of rectifiers for television applications. It is a high vacuum type having

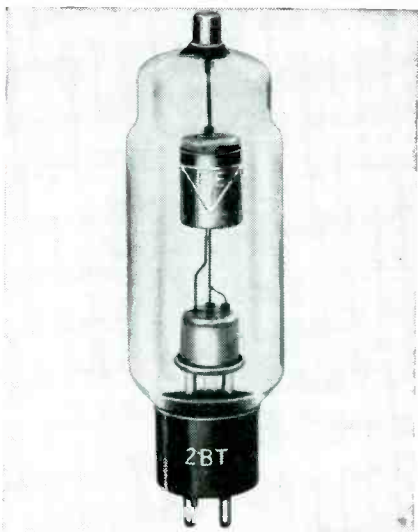

high peak inverse rating and expressly designed for plate supply in video receivers requiring potentials to 12,700 volts on the projector tube. Flashback is eliminated in television design without specifying a rectifier with ratings in excess of actual requirements.

22

### Remote Antenna Ammeter

OPERATING ON a new principle without the usual thermocouples, an electronic remote antenna ammeter is described by the Andrew Company, 363 E. 75 St., Chicago 19, in

# RADIO PARTS

## ELECTRONIC EQUIPMENT



Mail Coupon NOW for  
**CONCORD**  
Victory Clearance  
Flyer . . . FREE!

● Ready now! 32 Bargain-packed pages listing thousands of standard-make, top-quality radio parts and electronic supplies—now available without priority at low VICTORY CLEARANCE prices. The values listed at the left are typical of the important savings offered in Meters, Condensers, Transformers, Resistors, Controls, Switches, Relays, Test Equipment, Generators, Microphones, Tools, and hundreds of Repair, Replacement, and Accessory Parts. On special requirements, Concord experts are ready to help you in expediting and speeding action on essential needs.

Order Today for Shipment  
Tomorrow from  
**CHICAGO OR ATLANTA**

Huge stocks in TWO convenient warehouses—one in CHICAGO and one in ATLANTA—are ready to supply you quickly with needed parts of dependable, nationally-known quality—and at VICTORY CLEARANCE prices that mean real savings. Mail the coupon below NOW for your FREE copy of CONCORD'S VICTORY CLEARANCE Flyer.

### Check These Typical CONCORD VALUES



**D. C. Milliammeters**  
2 1/2" flange mtg. type. Metal case dull black finish. G. E. 0-200 M. A. C10650. Specially Priced . . . . . \$4.95



**Plate Power Transformer**  
Pri. tapped at 115, 117 and 120 V.A.C. Sec. output 850 V. at 200 ma. c. t. 4 1/2" L x 3 3/4" W x 3 3/4" H. 5B5035. Your cost . . . . . \$4.29



**Mobile High Voltage Power Unit**  
Input 12 V. at 10 amps. Output consists of two voltage ranges: (1) 275 at 50 ma. 5B9518. Your cost . . . . . \$39.50

**Output Transformer**  
Hermetically sealed. Six studs. 1, 2, and 3 are pri. 4, 5, and 6 the sec. Pri. ind. at 5 V. 1000 cy.; .20 H. Ratio sec. to pri. 3.02:1. size: 3 1/4 x 2 41/64" 5B5045. Your cost . . . . . \$1.95



**Dry Electrolytic Condenser**  
Hermetically sealed. Size, 1 1/2" x 3". Can negative. Cap.: 40 mfd. at 475 volts; 15 mfd. at 350 volts; 15 mfd. at 150 volts; 20 mfd. at 25 volts. 5B3161. Each . . . . . 59c



## CONCORD RADIO CORP.

LAFAYETTE RADIO CORPORATION

CHICAGO 7, ILL. \* \* ATLANTA 3, GA.  
901 W. Jackson Blvd. \* \* 265 Peachtree Street



**300 Watt Rheostat**  
Wire wound. Vitreous enameled. Cast aluminum base. 6" dia. 2 1/2" deep. 1400 ohms. 5B9517. Your cost . . . . . \$3.95

CONCORD RADIO CORPORATION  
901 W. Jackson Blvd.  
Dept. G-16  
Chicago 7, Ill.



Please RUSH FREE copy of CONCORD'S new 32-page VICTORY CLEARANCE Flyer.

Name . . . . .  
Address . . . . .  
City . . . . . State . . . . .



## Stokes MICROVAC Pumps

HEART OF HIGH VACUUM SYSTEMS



- Higher Vacuum (in the low micron range)
- High volumetric efficiency
- Low power requirement
- Complete discharge of air — no re-expansion
- Continuous dehydration of oil — no moisture to re-evaporate
- Discharges sudden slugs of liquid without injury
- Easily accessible, non-corrosive discharge valve
- Rugged, compact, simple construction
- Long life . . . negligible maintenance
- Five sizes—from 10 to 235 cu. ft. per min.

## Stokes VACUUM GAUGES

(Patented McLeod Type)

Are Always Accurate



- Require no calibration
- Rapid readings
- Simple to operate—just tip and read
- Two models (AA) 0 to 5000 microns—(BB) 0 to 700 microns, with readings to 1/10 micron.

**F. J. STOKES MACHINE CO.**  
6046 Tabor Road Philadelphia 20, Pa.

**Stokes High Vacuum**  
PUMPS • GAUGES • EQUIPMENT

## PRECISION CRYSTALS

S  
I  
N  
C  
E



1  
9  
3  
4

TYPE Z-1

### THE NEW STANDARD CRYSTAL UNIT FOR ALL HIGH FREQUENCY SERVICE

FREQUENCY 1.5 TO 10.5 MC.

TEMPERATURE COEFFICIENT LESS THAN 2 CYCLES PER MC. PER DEGREE CENTIGRADE

CALIBRATION ACCURATE TO WITHIN .005% OF SPECIFIED FREQUENCY

MADE BY

**PETERSEN RADIO COMPANY**  
COUNCIL BLUFFS, IOWA

*Of Importance to You:*

# COMMUNICATION PARTS

Is prepared to serve you with a widely diversified list of components, especially those in the fields of radio coils, and special transformers.

Communication Parts has broad experience in design, engineering, and production "know-how" . . . will aid you in adapting these components you require to better production methods.

If you contemplate a high daily production of these types of radio or electronic components you will be interested in the strides made by Communication Parts in engineering to meet quantity production requirements.

A phone call or letter will receive prompt attention without any obligation whatever.

**COMMUNICATION PARTS**  
NOT INC.

1101 NORTH PAULINA STREET • CHICAGO 22, ILL.



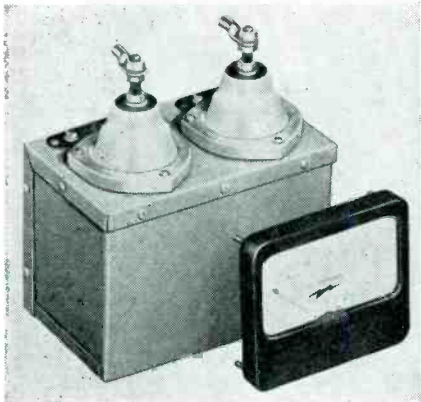

Bulletin 28A. The remotely-located d-c microammeter is actuated by a current transformer feeding a diode-rectifier tube located at the antenna. Since the regular thermocouple antenna ammeters can be disconnected most of the time, the station using this unit is spared the frequent cost of meter replacement. Likewise, station shutdowns due to thermocouple failure in lightning storms are eliminated.

23

### Supersonic Inspection for Quality Control

RAPID AND NON-DESTRUCTIVE testing of materials for internal defects is accomplished with the Supersonic Reflectoscope manufactured by Sperry Products, Inc., 15th and Willow Ave., Hoboken, N. J.

The apparatus sends supersonic vibrations through material under test and measures the length of time it takes the vibrations to penetrate, reflect from the opposite side, or an internal defect, and return to the sending point.

An oscilloscope pattern is viewed by the operator who can be trained in a short time to evaluate the pattern. Access to only one side of material as thick as 10 feet and ability to inspect assembled components make quality control easy.

24

### Hand-Held Microphone and Retrax Cord

THE AVIOMETER CORP., 370 W. 35th St., New York, has improved its hand-held microphone, usable on all radio and interphone systems, giving 8 milliwatts output for input of 100 dynes per square centimeter (normal close-speaking voice.) An



## Face the Facts:

### You Must Train Now to Step Ahead of Competition Into A Good-Paying Job in Radio-Electronics

— or be left behind because you lack the understanding of new electronic techniques

CREI home-study courses are for professional radiomen only and this CREI message is for those who are not afraid to face the facts! The bars are down on radio-electronics progress! You are facing a completely new era in the radio-electronics world. The war-restricted curtains of secrecy have been pulled aside, revealing each day momentous, revolutionary applications of new radio-electronics principles and theories, and their complicated circuits, equipment, individual parts, etc.

No matter what your past radio-electronics experience has been, no matter what your training, you must start anew to add to your store of radio-electronics knowledge. You must keep pace with the new developments and ahead of competition if you expect to get ahead in this new world of radio-electronics — or even maintain your present position in the field.

How much do you know about U.H.F. Circuits, Cavity Resonators, Wave Guides, Klystrons, Magnetrons and other tubes? All these revolve largely around U.H.F. applications. And here is where CREI training can help you. In our proved home-study course, you learn not only how . . . but why! Easy-to-read-and-understand lessons are provided well in advance, and each student has his personal instructor who corrects, criticizes and offers suggestions on each lesson examination.

Let CREI train you now to trade that "screwdriver" for a slide rule. Do something about increasing your technical ability and advance to the better-paying radio jobs that offer security and opportunity. The facts are in the free booklet. Send for it today.



WRITE FOR  
FREE 36-PAGE  
BOOKLET

"Your Opportunity  
in the New World  
of Electronics"

If you have had professional or amateur radio experience and want to make more money, let us prove to you we have something you need to qualify for a better radio job. To help us intelligently answer your inquiry—PLEASE STATE BRIEFLY YOUR BACKGROUND OF EXPERIENCE, EDUCATION AND PRESENT POSITION.

## CAPITOL RADIO ENGINEERING INSTITUTE

HOME STUDY COURSES IN PRACTICAL RADIO-ELECTRONICS  
ENGINEERING FOR PROFESSIONAL SELF-IMPROVEMENT

Dept. E-1, 3224 16th Street, N. W., Washington 10, D. C.

Contractors to U. S. Navy—U. S. Coast Guard—Canadian Broadcasting Corp.  
Producers of Well-trained Technical Radiomen for Industry

Member: NATIONAL COUNCIL OF TECHNICAL SCHOOLS



SMALL CAPACITY



# SOLDER POTS

for  
TINNING OPERATIONS

- Operates 110 A.C. or D.C.
- Available 220 V.

Lectrohm Solder Pots are particularly suited for individual operator use in production-tinning of small wires, leads, etc. They are ruggedly constructed to render real service. The single-heat, porcelain nickel-chrome heating element will rarely burn out, but can be quickly and easily replaced if necessary. Available as Model No. 200 with 1¾ lbs. capacity or Model No. 250 with 2 lb. capacity.

List — \$3.50 each.  
Order from your Jobber

Division  
The National Lock Washer Co.  
Newark, N. J.

**LECTROHM**  
INCORPORATED

5127 West 25th St., Cicero 50, Ill.

*Integrity of Design*

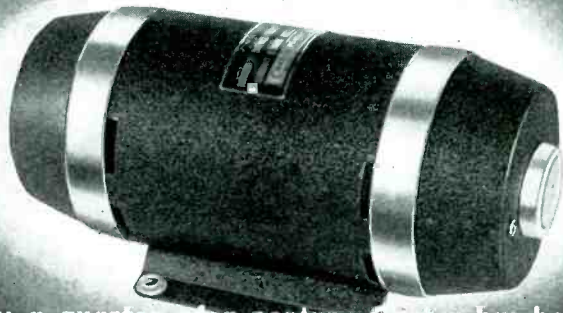

For nearly a quarter of a century Carter has been a well known name in radio and has led the industry in designing and manufacturing the finest Rotary Electrical Power Supplies.

The preference and specification of Carter Products is an attribute to their precision performance and integrity of design. Write for latest catalog today.

**Carter Motor Co.**  
*Chicago, Illinois*

1606 Milwaukee Ave. Carter, a well known name in radio for over twenty years. Cable: Genemotor

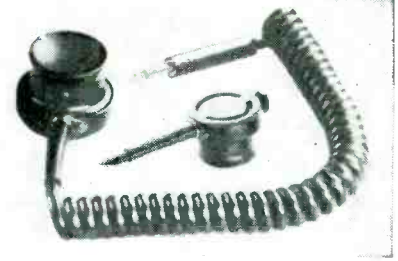

acoustic low-frequency cutoff and response to 5000 cycles guarantees performance under extreme noise conditions.

The plunger, with recessed finger grip, moves against a strong detent spring, giving clear disconnect warning. The unit is spray-proof and equipped with flexible rubber Retrax cord which extends 40 inches on less than a 2-pound pull.

25

## Dielectric Filament Coaxial Cable

A NEW LOW-LOSS coaxial line called CO-X using dielectric filaments between outer and inner conductors to maintain concentric alignment is a new product of the Boston Insulated Wire & Cable Co., Uphams Corner, Boston, Mass.

The lines, suitable for high-power, high-frequency transmission, are furnished in either a flexible or rigid sheath, in both of which gas pressure can be maintained. The dielectric filaments which may be varied to obtain a range of line properties, allow operation up to 250° C without breakdown.

Fabrication of coaxial harness in a systems network and other difficult mechanical processes which involve bending the line, can be accomplished more easily with this than with some conventional air core lines.

26

## Plywood Tubing Masts

TWO NEW LIGHTWEIGHT masts are in production by the Plymold Corporation, Lawrence, Mass., for civilian, f-m, television and amateur use.

Mast, antenna system, and all fittings suitable for erecting atop a roof or side of a building are designed to retail for about \$20.

The Ham-Mast is designed for amateur radio uhf and vhf opera-

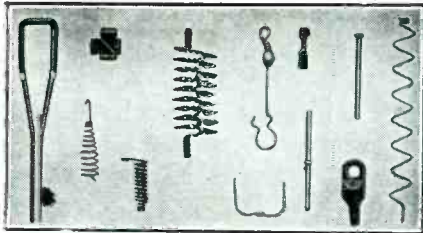

## SMALL PARTS

Filaments, anodes, supports, springs, etc. for electronic tubes. Small wire and flat metal formed parts to your prints for your assemblies. LUXON fishing tackle accessories, double pointed pins, fine sizes wire straightened. Inquiries will receive prompt attention.

### ART WIRE AND STAMPING CO.

227 High St.

Newark 2, N. J.

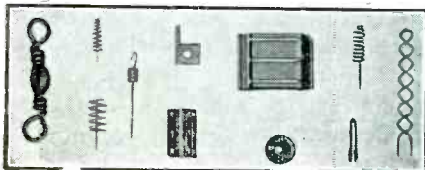

## CAPACITORS -

OIL, PAPER and ELECTROLYTIC



**Illinois**  
**CONDENSER COMPANY**  
1'60 N. HOWE ST. • CHICAGO 10, ILL.



New ATLAS  
"Hi-Conversion"  
Re-entrant Speakers

## Portrait of Progress



Under ordinary circumstances, progress is slow. War-time urgency speeds it amazingly! War-time experience, providing that "Extra Margin" of efficiency, is now available for commercial peace-time application.

Atlas Sound Equipment is completely redesigned and restyled, incorporating every modern improvement evolving from War's research and proving ground . . . your guarantee of modern up-to-the minute performance!

## ATLAS SOUND

CORPORATION

1449 39th Street

Brooklyn 18, New York

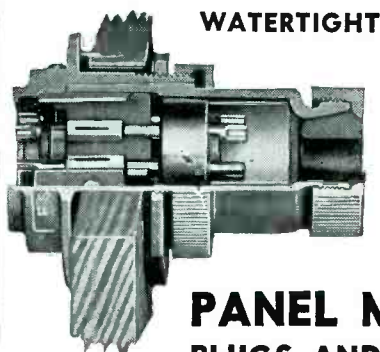

WATERTIGHT

## PANEL MOUNTING PLUGS AND RECEPTACLES

### VIBRATION-PROOF ASSEMBLIES

For locknut or bolted style mounting to panels 1/16" to 5/8" thick. Precision built housings — light weight, ample wiring space.

Contacts fully machined, self wiping and free floating. All terminals identified. Polarized, grounded and shielded.

Interior moulded bakelite. Moulded rubber gaskets on watertight style.

Thousands in use for vital war service.

Since 1902

Please address  
Dept. No. H



## RUSSELL & STOLL COMPANY

EXPLOSION-PROOF, WATER-TIGHT, INDUSTRIAL LIGHTING FIXTURES AND EQUIPMENT. AUTOMATIC LOCKING "EVERLOK" CONNECTORS  
125 BARCLAY STREET • NEW YORK 7, N. Y.

## EVERLOK

AUTOMATIC LOCKING

FOR  
PORTABLE SOUND  
AND SIGNAL SYSTEMS  
2 to 12 POLE

FOR  
POWER  
10 to 200 AMP.  
2, 3 & 4 POLE





# Electricity

**0** ELECTRIC PLANTS  
**Onan**

## FOR RADIO AND ELECTRONIC APPLICATIONS

ONAN ELECTRIC GENERATING PLANTS supply reliable, economical electrical service for electronics and television applications as well as for scores of general uses. Driven by Onan 4-cycle gasoline engines, these power units are of single-unit, compact design and sturdy construction. Suitable for mobile, stationary or emergency service.

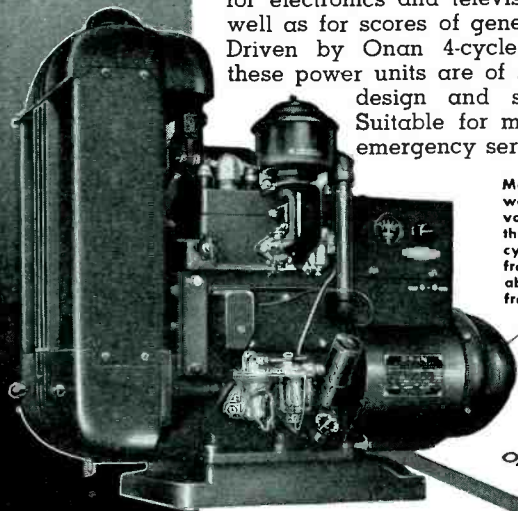

Models range from 350 to 35,000 watts, A. C. types from 115 to 660 volts, 50, 60, 180 cycles, single or three-phase and 400, 500 and 800 cycles, single phase. D. C. types from 6 to 4000 volts. Also available in dual voltage and special frequency types.

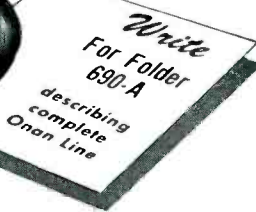

Model shown is from W2C series: 2000 to 3500 watts; powered by Onan two-cylinder, water-cooled engine.

**D. W. ONAN & SONS**

3272 Royalston Ave.

Minneapolis 5, Minn.

tions, but can be modified for f-m and television reception. It is made up of four telescoping sections of plywood, guyed at two levels, and can be speedily erected.

Mast, fittings and an erection kit are priced at \$98.50.

Each section is 14 feet 3 in. long and four sections together weigh 29 lb. Fittings weigh 41 lb. and the erection kit, 15 lb.

27

## Two-Decade High-Speed Counter

A COUNTER UNIT particularly applicable for counts exceeding 10 cycles per second, a rate too fast for conventional counters is being built by Potter Instrument Company of 136-56 Roosevelt Avenue, Flushing, N. Y. It is also recommended for installations where mechanical counters would wear out prematurely because of the high-speed continuous operation.

Used alone as a two-decade instrument, the maximum count capacity of the electronic counter is 100. A tube-operated relay is provided for cases where the quan-



tity to be counted exceeds 100. The relay has a spdt contact which is brought out to terminals on the front panel of the unit, and operates once for each 100 counts. An electro-mechanical counter may be connected in series with these terminals and an appropriate external power source, such as the a-c line. Each 100 counts of the electronic counter will then cause one operation of the electro-mechanical counter. When operation of the relay and an external mechanical counter are not involved in the application of the two-decade electronic counter, it may be used alone, at counting rates up to 20,000 per second.

Contact closure, pulse signals,

• The meeting of extraordinary applications—the designing and developing of new and specialized transformers—these are the day-by-day jobs Electronic Engineering is known for doing well.

**ELECTRONIC**  
*Engineering*  
**COMPANY**

# Transformers

will meet your most exacting requirements, ordinary or unique—and the finest engineering talent and most complete electronic laboratories available are ready today to consult with and help you.

"SPECIALIZED

*Transformer*  
ENGINEERS"

ELECTRONIC ENGINEERING COMPANY • 3223-9 WEST ARMITAGE AVE. • CHICAGO 47, ILLINOIS

## Optical Glass Specialties



### Television Reflectors

Precision-polished optical  
face plates for cathode ray  
tubes

Optical lenses, prisms  
and flats

FS Precision-Bore Glass Tubes  
with bore exact within .0002"

Contact us for  
such requirements

FISH-SCHURMAN CORPORATION  
230 East 45th St., New York 17, N. Y.

**Fish-Schurman**

FOR  
**ELECTRONIC USE**



## SILVER

WIRE - SHEET - TUBING  
SILVER BRAZING ALLOYS & FLUXES

## PLATINUM

WIRE - RIBBON - FOIL  
SEAMLESS TUBING

WE INVITE INQUIRIES RE-  
GARDING ALL APPLICATIONS  
OF PRECIOUS METALS TO  
ELECTRONIC PRODUCTS.

PRECIOUS  
METALS



SINCE  
1875

THE  
**AMERICAN PLATINUM  
WORKS**

N. J. R. R. AVE. AT OLIVER ST.  
NEWARK 5, N. J.

# PHENOL AND VULCANIZED FIBRE FABRICATIONS

by

# BAER

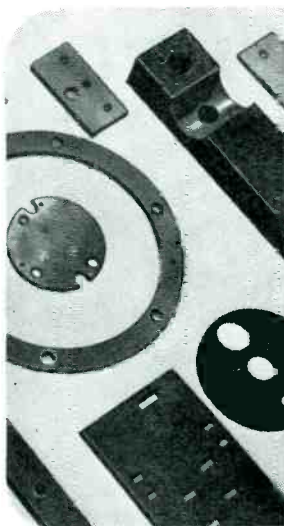

Available now  
to your exact  
specifications!



**PUNCHED, STAMPED, SHAVED, SAWED,  
DRILLED, MILLED, TAPPED, THREADED**

If you have stiff production schedules investi-  
gate BAER facilities for volume production and  
accuracy. Orders for any quantities, shapes  
and sizes to your specifications. For details,  
write today for descriptive Bulletin 120.

**N. S. BAER COMPANY**

*Craftsmen in Fibre Fabrication*

7-11 MONTGOMERY ST. • HILLSIDE N. J.

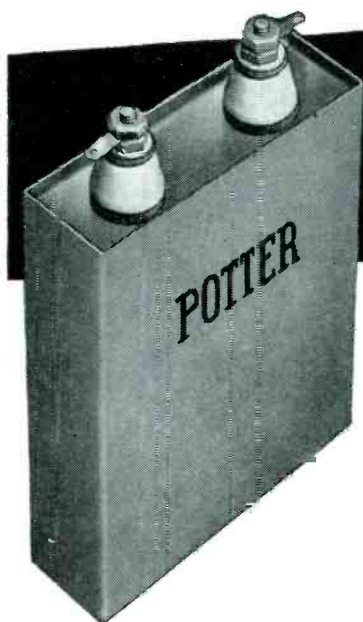

Why **POTTER**  
TRANSMITTING CAPACITORS  
ARE PREFERRED FOR  
**RELIABILITY**

Over 20 years of specialized engineering  
concentration, design and construction ac-  
counts for the outstanding reputation of  
POTTER Capacitors for dependable per-  
formance under most exacting require-  
ments.

War-time records have thoroughly justified  
the selection of POTTER Capacitors for  
U. S. military and naval equipment.  
POTTER Capacitors are contributing to the  
supremacy of our newest fighting machines  
under every demand and emergency.

The superiority of POTTER Oil-Filled Ca-  
pacitors of conservative design rating, and  
high safety factor is evidenced by their per-  
formance wherever used. They are capable  
of withstanding wide range of temperatures  
and operating conditions. All official speci-  
fications complied with. All standard and  
special mountings available.

Special Capacitors of all types for every purpose.

*Send us your Specifications for Prompt Service!*

**THE POTTER COMPANY**  
ESTABLISHED 1925  
1950 SHERIDAN ROAD, NORTH CHICAGO, ILLINOIS



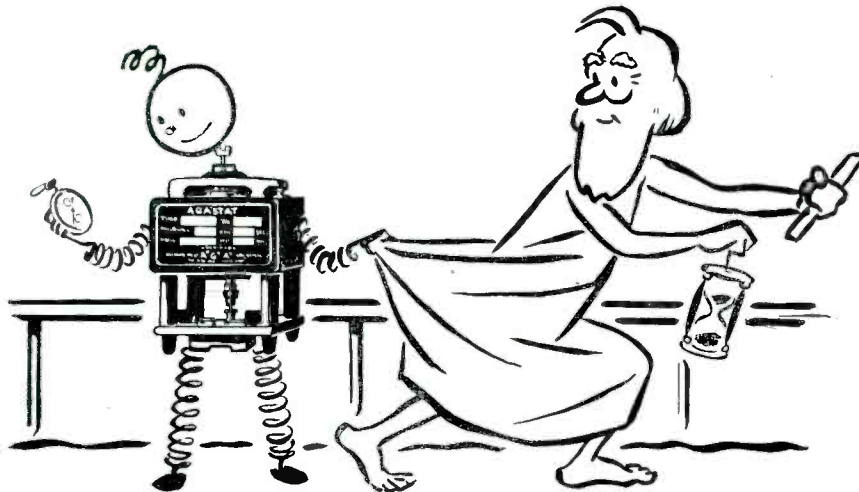

## Time Delay Relay

Reliable, low cost circuit timing. Positive action with easily adjusted time delay range—from a fraction of a second to several minutes. Write for circular.

# AGASTAT

Electro-Pneumatic *TIME DELAY RELAY*

ELIZABETH **A'G'A** NEW JERSEY  
AMERICAN GAS ACCUMULATOR COMPANY

## FREE DATA FOLDER!

### HERMETICALLY-SEALED MULTIPLE HEADERS AND SEALED LEADS...

*Six pages of complete and detailed information!*

A concise, informative piece of literature. Fully illustrated with straightforward data that simplifies proper choice and facilitates ordering to exactly meet your requirements. Covers all standard items as well as custom built sealed leads and multiple headers. Break-down voltages, high voltage, skirted units are included. E-I components can be furnished on short notice—often in quantity direct from stock. Write for your copy of this new folder today. No obligation.

- Types . . . sizes . . . standard
- material . . . construction
- features . . . voltage
- ratings . . . dimensional
- data and coding system

**ELECTRICAL INDUSTRIES • INC**  
 42 SUMMER AVENUE, NEWARK 4, N. J.

sine-wave signals, and square-wave signals can all be used to actuate the units decade and the tens decade counters.

The two-decade electronic counter is complete with output-relay stage, power supply, and is ready for operation from a 115-v, 60-cps, a-c power line. Special selection of vacuum tubes is not required for the counter's 12-tube complement.

Outside dimensions of the cased instrument are: width 13½ in., height 8¾ in., depth 10 in., weight is 26 lb.

28

### Testing Clips

A NEW TYPE OF CONNECTOR designed and manufactured by the Rapid Specialties Company, 327-9 West Huron Street, Chicago 10, Illinois, promotes quick test wiring on test panels and bridges. The clips hold

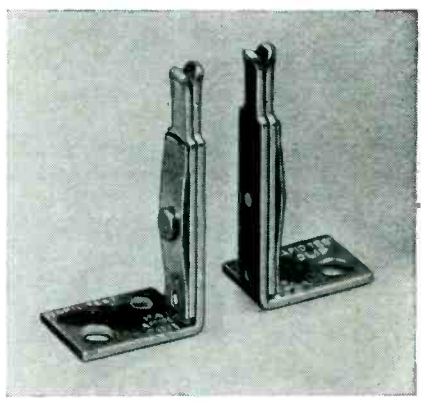

wire leads firmly without injury. Each clip has a base, ⅝ in. x ½ in., and is 1½ in. high made of 0.051 polished brass with a 0.016 phosphor bronze spring.

29

### Aircraft Transceiver

A LIGHTWEIGHT, compact, and highly sensitive transmitter-receiver unit, the ATR-3, which serves as a means of radio communications from personal plane to ground and ground to plane, as a direction finder to insure navigational safety, and for broadcast entertainment is now available from Harvey-Wells Electronics, Inc., Department N, Southbridge, Massachusetts.

Functional in design, the transceiver weighs only 12¾ lb, measures 4½ in. high x 5½ in. wide x 8 in. deep, and will operate on a 6- or

# 2 VITAL AIDS

TO THE MANUFACTURER OF  
*Miniature Tube Radios*

★ **STAR**

**DOUBLE-CHECK SYSTEM**



#JE-10—Miniature socket wiring plug for accurate alignment of miniature socket contacts during wiring. Precision cast of zinc base alloy—Pins of stainless steel.

#JE-12 — (Hardened tool steel insert) or JE-13 (Stainless steel insert) Miniature tube pin straightener to obtain a perfect fit when the tube is placed in the set.



For complete information  
and prices—write  
RADIO ACCESSORY DIVISION

**STAR EXPANSION PRODUCTS CO.**  
147 Cedar St., New York 6, N. Y.

# SPECIAL UNITS...

We have had such success in cooperating with engineers of our customers that we do not hesitate to offer you this special service in development of sample units.

You may have an unusual problem for reconversion, one in which greater efficiency for a tough job will save money and give better service.

Let our engineers consult with yours. We are well equipped for this type of cooperation.

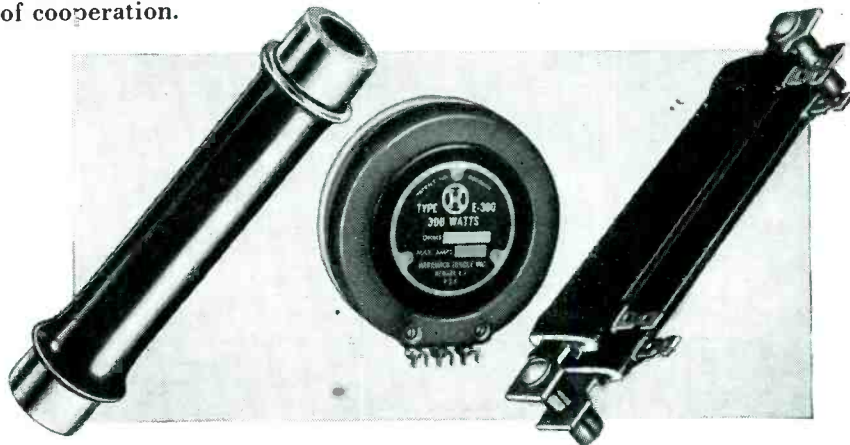

**HARDWICK, HINDLE, INC.**  
RHEOSTATS and RESISTORS

Subsidiary of THE NATIONAL LOCK WASHER COMPANY  
NEWARK 5, N. J. ESTABLISHED 1886 U. S. A.

# DIALS PANELS and PLATES

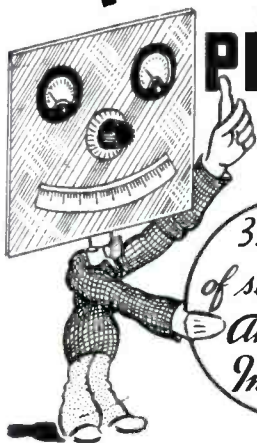

35 years  
of service to  
American  
Industry

**DIALS • PANELS • PLATES**  
made to your precise engineering specifications in etched metals and finishes.

**PREMIER  
METAL ETCHING CO.**  
21-03 44th AVE.  
LONG ISLAND CITY, NEW YORK

# IT'S NEW! IT'S POST-WAR SUPREME Model 565 VACUUM TUBE VOLTMETER

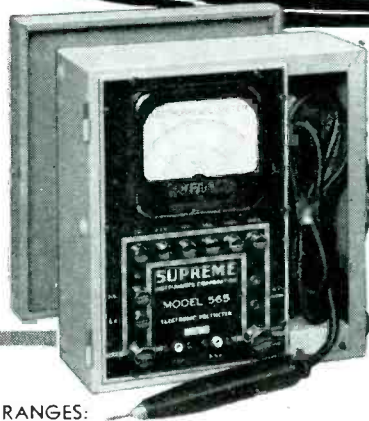

NEW PROBE Streamlined  
Hand Fitting Incorporating  
new High Frequency Diode

RANGES:  
DC 0-1, 2.5, 10, 50, 250, 500  
AC 0-1, 2.5, 10, 50, 250  
EXTENDED TO 5000 VOLTS BY EXTERNAL MULTIPLIERS

INPUT RESISTANCE:  
DC—80 megohms on 1 volt range; 40 megohms on 500 volt range  
AC—40 megohms on 1 volt range; 20 megohms on 250 volt range

INPUT CAPACITY OF PROBE: 5 micro-micro farads

FREQUENCY RANGE  
Negligible frequency error from  
50 cycles to 100 megacycles.

**SUPREME INSTRUMENTS CORPORATION GREENWOOD MISSISSIPPI**



# CAPACITOR QUESTIONS Answered!

JUST OUT!

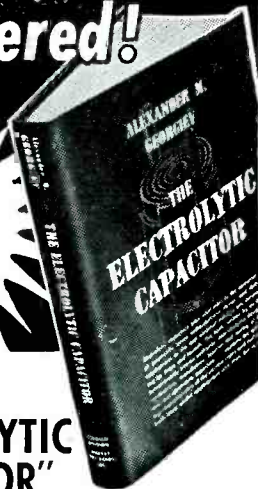

## "THE ELECTROLYTIC CAPACITOR"

by Alexander M. Georgiev

Probably no Radio-Electronic component is more important than the Electrolytic Capacitor, and this new book by Alexander M. Georgiev who has devoted more than 15 years to Capacitor research and development answers all the many questions engineers, designers, servicemen and others have been asking about this subject. Abundant data are presented as to Electrolytic Capacitor constructional features—where, when and how to use them to best advantage in preference to non-electrolytic types—in short, everything you need to know in order to utilize, buy, specify replace, or service Capacitors intelligently and efficiently. A comprehensive bibliography and list of patents will prove of far-reaching value. Contains over 200 pages and eighty illustrations including graphs, photomicrographs, oscillograms, etc. Just out in limited edition—the first modern book to be written on this vital component! Order today while the supply lasts.

**WHAT TYPE?  
WHY?  
WHERE?**

**\$3.00**

\$3.25 foreign

### ALL THE FACTS ON A LITTLE KNOWN SUBJECT

Electrolytic Capacitor Construction Characteristics; Advantages; Applications; Operation; at low and high voltages and frequencies; a-c or pulsating d-c; ambient conditions; wets versus dries; electrolytics versus non-electrolytics; behavior of various types; choosing the best type for a given application and operating conditions; servicing; testing; replacement and emergency repairs—and dozens of other subjects of foremost interest to all who design, handle, or service equipment incorporating capacitors.

**ORDER NOW!**

MURRAY HILL BOOKS, Inc.  
Dept. E-16, 232 Madison Ave., New York 16, N. Y.

Enclosed find \$..... for ..... copies of Alexander M. Georgiev's "THE ELECTROLYTIC CAPACITOR" (Price \$3 each; \$3.25 foreign) or  send C.O.D. (in U.S.A. only) for this amount plus postage.

Name .....

Address .....

City & Dist. No. .... State .....

12-volt synchronous vibrator power supply. The equipment has been tested for altitudes far in excess of those gained by private fliers, and extreme degrees of temperature and humidity not encountered under normal operational conditions, as well as vibrations of varying frequencies and positions.

Standard equipment includes tubes, crystal, headset, and push-to-talk aircraft microphone. Loudspeaker, loop antenna system, and trailing antenna with reel, can be furnished.

30

### Organic Conducting Paint

A MATTE-BLACK electrical-conducting coating with an adhesion to plastics that is resistant to the strongest fingernail is now generally available from Alfred Hague & Co., Inc., 227-34th Street, Brooklyn, N. Y. The resistance can be varied through a wide range of values by proportioning the carbon content of the finish, the vehicle for which is a vinyl type. A suggested use is coating the inside of plastic housings for electrostatic shielding.

31

### Video Amplifier for CRO

A NEW VIDEO AMPLIFIER designed primarily for amplifying complex waves to be viewed on an oscilloscope is announced by the United Cinephone Corporation, Torrington, Connecticut. The amplifier is also useful in laboratory work as an audio amplifier, for tracing and

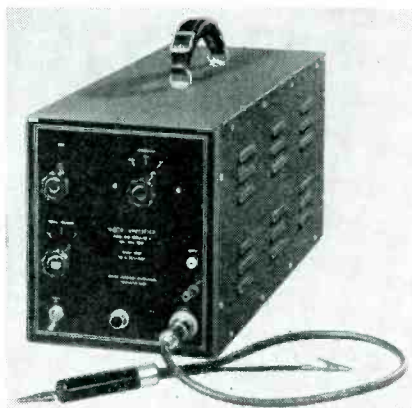

measuring small r-f voltages in the early stages of radio receivers and in similar applications.

The frequency response is flat within 1.5 db of the 10 kc response

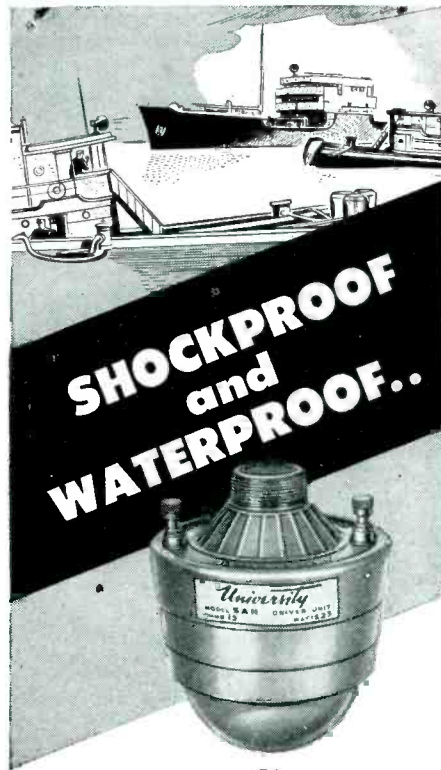

**SHOCKPROOF and WATERPROOF..**

*University*

## BREAKDOWN PROOF DRIVER UNITS

UNIVERSITY permanent magnet driver units represent an outstanding contribution in the sound reproduction field. Employing rim center construction—with consequent close magnetic gap and 20% increase in field strength—these units have greater power capacity than any other units of similar size and weight.

Many exclusive features—rim centering, bakelite flexing surfaces, heat-proof voice coil suspension and hermetically sealed dust covers—make possible the famous unconditional UNIVERSITY breakdown-proof guarantee. Power capacity 25 watts, frequency 100 to 6000 cycles.

Write today for complete information on this all-inclusive line of sound projectors, speakers and driver units.



**UNIVERSITY LABORATORIES**  
225 VARICK STREET  
NEW YORK 14, N. Y.

**IN STOCK...FOR  
IMMEDIATE DELIVERY**

*Wheatstone  
Bridge*



- Standard laboratory instrument design and workmanship.
- Wheatstone Bridge Type RN-1 Four resistance dials. Nine positions each. 9x1, 9x10, 9x100, 9x1000 ohms.
- Ratio resistance guaranteed to plus minus .05%. Resistance coils to .1%.
- Moving coil galvanometer. Sensitivity of 1 microampere per division. 4½ v. internal battery. External battery and galvanometer connections.
- Resistance Decades Types DR. .9 to 999,999 ohms. Accuracy plus/minus .1%.
- Manganin wire coils. Bifilar-wound on ceramic tubes.
- Self-cleaning, multi-blade phosphor-bronze spring wiper switches.
- Standard walnut cases.

• Yes, these Wheatstone Bridges are now carried in stock and ready for immediate delivery. Rugged, simple, dependable and economical. Highly popular with workers in the radio and electronic fields. Ideal for use in laboratory, shop, production line, or out in the field. Model RN-2 has a Murray & Varley loop, and is a favorite with wire chiefs and trouble-shooters in the communications field. • Also Decade Boxes in standard models, likewise in stock and shipped promptly. No priorities. Order immediately and get immediate shipment.

• **Literature on request**

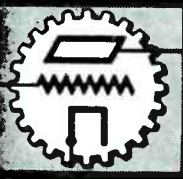
<b>Industrial</b> 	PLANT and OFFICES:
	17 POLLOCK AVENUE
	JERSEY CITY 5, N. J.
<b>Instruments:</b>	

**ANOTHER  
SPECIAL BY  
PROGRESSIVE**

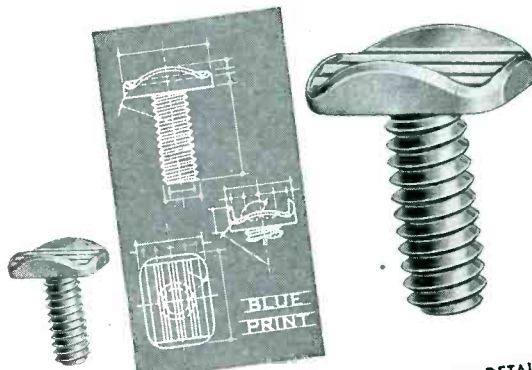

ACTUAL  
SIZE

ENLARGED FOR DETAIL

**CATALOG SHOWS DOZENS MORE**

Special heads, threads and finishes on any metal or alloy adapted to cold upset. Weekly output: 25,000,000 pieces. Many specials, suggesting production savings for you, illustrated in latest catalog. Includes weights per 1M standard pieces, dec. equivs. of fractions, other purchasing and engineering helps. Write for Catalog 18.

**The PROGRESSIVE MFG. CO.**  
50 NORWOOD ST. TORRINGTON, CONN.



**FINE APPLIANCES**

deserve the best plugs

The continuing performance of your product in the consumer's hands depends upon the plug that transmits the power for its operation. In the competitive post-war market, you can safely use nothing but the best . . . .

**ELECTRIX  
PLUGS**

**ELECTRIX**  
*Corporation*

140-158 MIDDLE STREET  
PAWTUCKET • RHODE ISLAND

UNITED STATES RUBBER COMPANY  
Exclusive Selling Agents



# First Choice

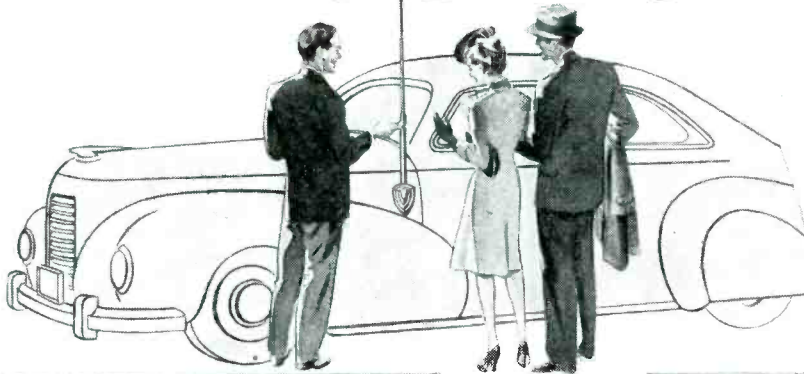

## ... OF AMERICA'S AUTO DEALERS

The same precision workmanship and the same fine quality mark Ward Antennas now as before the war. But now there are added reasons of new design and newly-engineered efficiency which will give Ward Antennas an even greater margin of preference with America's auto dealers. For extra profits that satisfied customers always bring, order Ward—world's finest antennas for car and home.



Buy Victory Bonds  
THE WARD PRODUCTS  
CORPORATION  
1523 E. 45th St., Cleveland 3

# WARD

## Antennas

from 15 cps to 4 mc, and 3 db from 10 cps to 4.5 mc. The phase shift is reduced to a minimum to provide satisfactory reproduction of pulses of the order of one microsecond, and square waves at repetition rates as low as 100 a second.

The gain is approximately 1000 when direct input is used. Input is normally through a probe, furnished with the equipment, having an attenuation of 10 times. The amplifier direct input, without probe, is approximately 2.2 meg of resistance in parallel with 40  $\mu\mu\text{f}$ . This compares with 1.1 meg resistance in parallel with approximately 18  $\mu\mu\text{f}$ . when the probe is used. The output voltage can be adjusted from zero to 50 v rms with sine-wave signals. The ripple output is less than 0.5 v for all operating conditions and all positions of gain control.

The equipment operates on 110 to 120 v, 60 cps with power consumption 100 w. Complete with tubes and probe, it measures 7 $\frac{1}{2}$ x9x20 $\frac{1}{2}$  in. and weighs 35 lbs.

32

## Electronic Motor Control

THE ELECTRON Equipment Corp., 917 Meridian Ave., South Pasadena, Calif., offers among its new products a series of variable-speed drives called Varitronic Motor Controls. These devices provide automatic starting, fast, stepless, acceleration and dynamic braking. All makes or sizes of standard d-c motors can be operated, with the aid of the control, from a-c lines. Preselected speeds may be set at any point required and single lever control of starting, stopping, reversing and automatic braking may be provided.

33

## Heat Dissipating Unit

A NEW HEAT dissipating unit for use in television, radar, short-wave radio communication, high pressure mercury lamps, x-ray tubes, induction heating unit is available from The Eastern Engineering Co., New Haven, Connecticut.

Originally designed for the ground, airborne and water services of the armed forces, the units are now being manufactured for commercial heat-dissipating appli-



## FOR SAFETY'S SAKE

Safety first for personnel is of the utmost importance. This protection can be guaranteed through the use of G-E Interlock Switches on radio transmitters, X-ray and therapeutic machines, burglar alarms, and signal controls for fire doors.

Safety first for equipment is important, too. G-E Indicator Lamps give visual evidence of what is going on inside equipment, and circuit troubles can be corrected before they become serious. Write: Electronics Department, General Electric Company, Syracuse, New York.

**GENERAL**  **ELECTRIC**  
168-E1

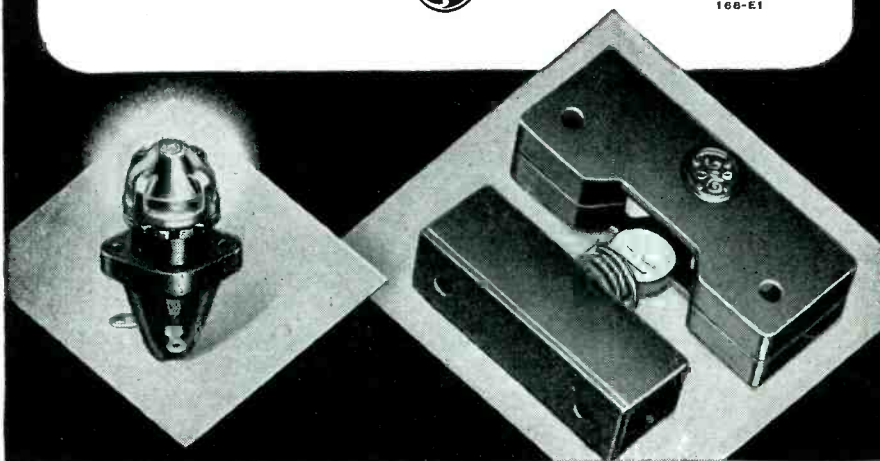

# TERMINALS

FOR  
ELECTRIC WIRES

CONDENSER PLATES  
SMALL METAL STAMPINGS

in accordance  
with Customer's Prints

ACCURACY • PRECISION  
REASONABLE DIE CHARGES

Modern Equipment and Factory  
No Screw Machine Parts

PATTON-MAGGUYER COMPANY  
17 VIRGINIA AVENUE  
PROVIDENCE, R. I.

JUST PUBLISHED

*The Most Indispensable Reference in Radio-Electronics*

## Electronic Engineering Master Index

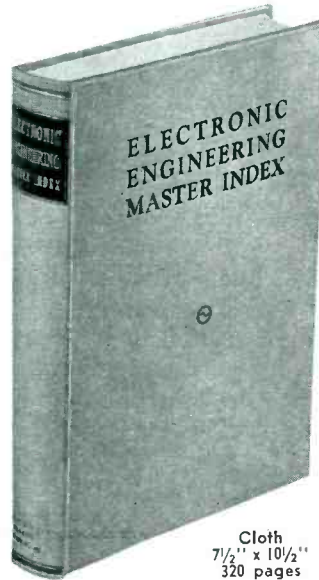

Cloth  
7 1/2" x 10 1/2"  
320 pages

A master compilation of over 15,000 titles, articles and texts selected for their value to the research engineer, this INDEX covers the years 1925-1945 and enables you to survey twenty years of research literature on any subject in a matter of minutes!

*Vitaly Needed in Every Laboratory and Library*

COMPLETE IN ONE VOLUME

PART I

January 1925 to  
December 1934

PART II

January 1935 to  
June 1945



PARTIAL LIST OF PERIODICALS INDEXED:

Bell Laboratories Record	Journal of I.E.E.
Bell System Technical Journal	General Electric Review
Communications	Physical Review
Electrical Communication	Proceedings I.R.E.
Electrical Engineering	Transactions of A.I.E.E.
Engineering	Transactions of A.S.M.E.
Electronics	Radio News
Electronic Industries	R.C.A. Review
Jour. of Applied Physics	Wireless Engineer

*A \$500 Reference Library in One Volume for \$17.50*

Descriptive circular on request.

**ELECTRONICS RESEARCH PUBLISHING COMPANY**  
238 East 44th Street  
New York 17, N. Y.

*New...* CRANKLESS  
MODEL C-2 MEGOHMER  
INSULATION TESTER

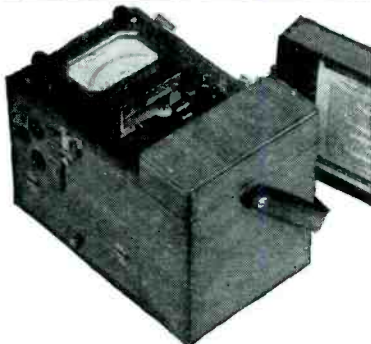

Test Potential to 600 Volts DC. Ranges to 1000 megohms with two or three additional ohm ranges in each instrument. Long mirror scales, hand drawn, individually calibrated, with more scale divisions for superior readability and split hair accuracy. Automatically decreasing test potential protects equipment of low resistance value.

Truly a Precision Instrument  
WRITE FOR BULLETIN 445

HERMAN H. *Sticht* COMPANY, INC.  
27 PARK PLACE NEW YORK, N. Y.

ALWAYS GETS A HAND!

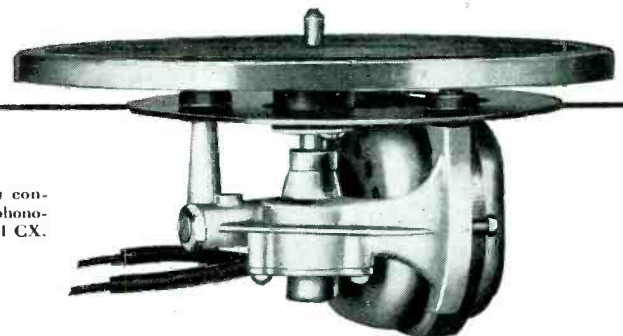

General Industries constant-speed electric phonograph motor—Model CX.

Users and the trade have always given hearty applause to General Industries phonograph mechanisms. Owners like the fine fidelity of every note or syllable—and sales and service departments are strong for their reliability and freedom from maintenance troubles.

You get this same old-time satisfaction from our *Smooth Power* turntable motors, recording assemblies and record-changer recorder com-

binations as we return to civilian production. As always, General Industries equipment will earn your approval.



THE **GI** GENERAL INDUSTRIES COMPANY  
DEPT. M ELYRIA, O.



Here is how you can acquire a better knowledge of electronics without trying to be a radio engineer . . .

. . . SEND FOR

# Elementary Engineering Electronics

With Special Reference to Measurement and Control

by Andrew W. Kramer,

Managing Editor, *Power Plant Engineering*,  
Member American Institute of Electrical Engineers,  
Associate Member Institute of Radio Engineers

Cloth, 344 pages, 259 Illustrations  
\$2.00 postpaid

This is a practical treatment of principles and applications. It is NON-MATHEMATICAL—no equations beyond elementary-algebra level in the text—fewer than a dozen of these to be learned.

ORDER THIS UNIQUE BOOK NOW

Check, money order or cash must accompany order.

Instruments Publishing Co.,  
1121 Wolfendale St., Pgb. 12, Pa.

Enclosed is \$..... for ..... copies of  
Kramer's ELEMENTARY ENGINEERING  
ELECTRONICS (at \$2.00 each).

Name .....

Address .....

## Instruments

THE MAGAZINE OF  
Measurement and Control

This unique magazine offers a BALANCED DIET of articles and special features appealing to production men as well as to research men—to executives and apprentices! It covers all subjects within the growing fields of Measurements, Inspection, Testing, Automatic Control, Metering, etc.

Many important methods have been disclosed for the first time in exclusive *Instruments* articles; many more will be disclosed through its pages.

Several outstanding books appeared first as serials in *Instruments*. The one advertised above is but one example.

SUBSCRIBE NOW!

Instruments Publishing Co.,  
1121 Wolfendale St., Pgb. 12, Pa.

Enclosed is \$2.00 for which send me  
*Instruments* for ONE YEAR.

Name .....

Position .....

Company .....

Products .....

ADDRESS .....

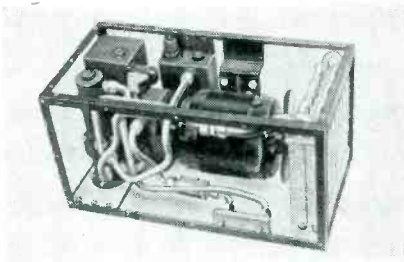

cations. They are furnished complete with thermostat control, thermostatic valves and flow switch. A unit 16 x 7½ x 7½ in. will dissipate up to 1200 watts with a constant-controlled temperature, irrespective of surrounding temperature, within a control range of 2° C. Other models can be built to dissipate up to 5000 watts.

## Literature

34

**High Fidelity PA Amplifier.** Form No. 130 describes in detail the first in a new series of high-fidelity P-A Amplifiers available from Clark Radio Equipment Corp., 4313 Lincoln Ave., Chicago 18, Ill. Response and distortion curves, as well as specifications, are included.

35

**Aircraft and Electrical Circuit Plugs.** A revised edition of electric connectors (type K and RK plugs) are described in a 64-page catalog from Cannon Electric Development Co., 3209 Humboldt St., Los Angeles 31, Calif.

36

**Training Material.** Bulletin No. GES-3303A illustrates and describes a complete set of training material on industrial electronics. The material described in the bulletin includes sound slide films designed to present industrial electronic instruction in a practical and easily understood manner. General Electric Co., 1 River Road, Schenectady, N. Y.

37

**Micro Switch House Organ.** "Uses Unlimited" designates the title of a bulletin published every now and then by Micro Switch, Freeport, Ill. to describe uses of their products. Vol. 1, No. 4 contains an ar-

# DESIGNED FOR PEAK PERFORMANCE

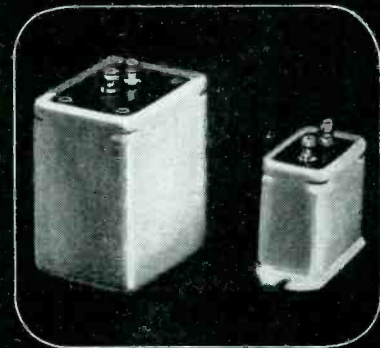

SEALED, ALUMINUM CASE  
AIR-BORNE TRANSFORMERS

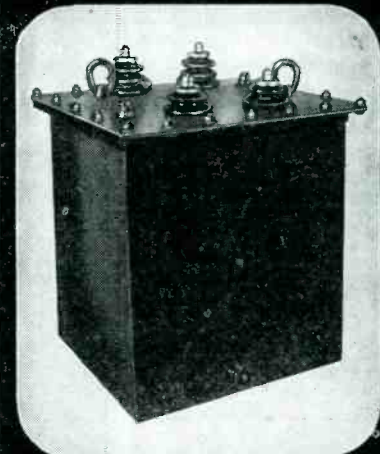

OIL-COOLED, PLATE SUPPLY  
TRANSFORMERS

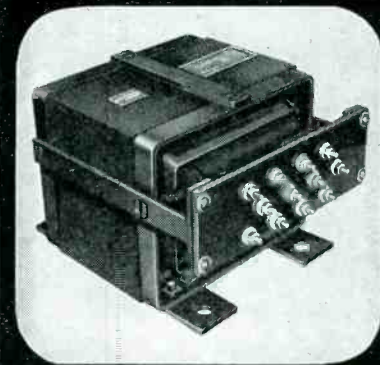

AIR-COOLED TRANSFORMERS  
WITH 10 VOLT SEC. TAPS

THE ACME ELECTRIC & MFG. CO.  
CUBA, NEW YORK • CLYDE, NEW YORK

**Acme Electric**  
TRANSFORMERS

## CERAMIC PORCELAIN & STEATITE INSULATORS

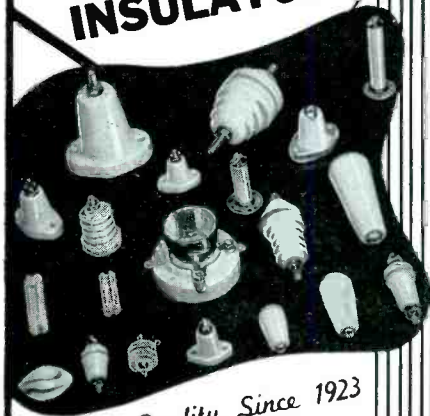

*Quality Since 1923*

MANUFACTURERS OF RADIO  
HARDWARE and ANTENNAS

Also Carrying a  
COMPLETE LINE of  
WIRES, CABLES  
and HOOK-UP  
WIRES

*Inquiries  
Invited!*



**BIRNBACH RADIO CO., Inc.**  
143 HUDSON ST. NEW YORK, 13, N. Y.

## JONES SHIELDED TYPE PLUGS and SOCKETS



P-101-1/4"



S-101

Low loss Plugs and Sockets suitable for high frequency circuits. Ideal for antenna connections, photo-cell work, microphone connections, etc. Supplied in 1 and 2 contact types. The single contact type can be furnished with 1/4", .290", 5/16", 3/8", or 1/2" ferrule for cable entrance.

Knurled nut securely fastens units together. All metal parts are of

brass suitably plated to meet Navy specifications. No. 101 Series Plugs have ceramic insulation and Sockets have XXX Bakelite. For complete listing and information write today for your copy of catalog No. 14.

**HOWARD B. JONES COMPANY**  
2460 W. GEORGE ST. CHICAGO 18

## NEW! *Pressuregraph*

**LINEAR PRESSURE  
• TIME-CURVE INDICATOR**

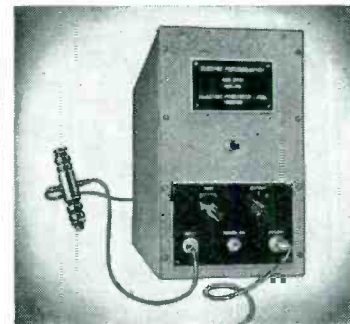

Indicates in linear response, on screen of cathode ray oscillograph, the pressure-time-curve of any internal combustion engine, pump, airline, or other pressure system where pressure measurements are desired. Covers wide range of engine speeds and pressures up to 10,000 p. s. i. Screws into cylinder and can be calibrated using static pressures. Vibration-proof. Accurate, dependable for frequent engine tuning.

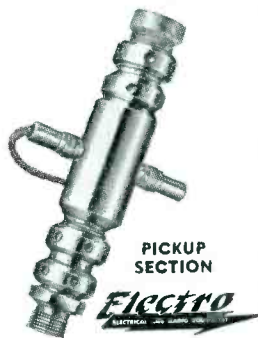

PICKUP  
SECTION

**Electro**  
LABORATORIES

### SIMPLE OPERATION—ONLY ONE CONTROL

Pick-up section (at left), actuated by pressure, is inserted in cylinder, chamber of airline, etc. Amplified pickup response is transmitted to oscillograph screen (or to string oscillograph for photographic recording). Now used for pressure-time-curve of C.F.R. aviation fuel test engines, on 2-cycle engines for pressure-time-curve of main cylinder or crankcase, and for Diesel engines and many other applications.

For complete information write

## ELECTRO PRODUCTS LABORATORIES

549 W. Randolph St., Chicago 6, Ill.

Phone STAt 7444

*Have you a High  
Temperature  
Capacitor  
Application?*

**PLASTICONS** 256° F.  
*Operate at*

Plasticon Types AS are silicone impregnated plastic film dielectric capacitors. They will operate from -80° F. to +256° F. with less than 10% capacitance change. Plasticons are small in size as they are not "voltage derated."



**Condenser  
Products Company**

1375 NORTH BRANCH STREET • CHICAGO 22, ILLINOIS



**N**ow  
**Bud metal**  
**wall type**  
**speaker cabinets**  
*with superior*  
*tonal qualities*

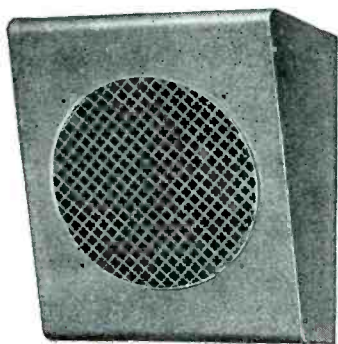

Reproduction equal to the finest wood housings — that is what you find in the new BUD metal wall-type speaker cases. Now offered after months of research and testing by BUD engineers, this new line of wall-type speaker cases is truly outstanding for its fidelity of tone reproduction. Modernity of design and ease of installation are other features which place these speaker cases far ahead of anything on the market today. Made in sizes to house 4" to 12" speakers . . . available for immediate delivery.

**Chokes, Coils, and Condensers**  
to meet  
your needs

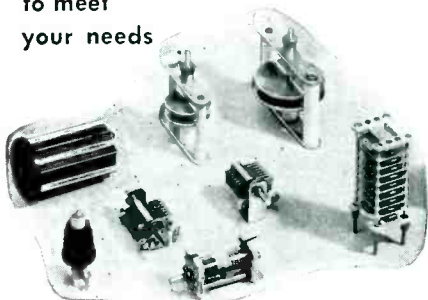

BUD makes an outstanding line of chokes, coils, condensers and other radio and electronic parts — engineered and tested for superior performance. You assure yourself of the latest developments in the field when you specify BUD. Get acquainted by writing for the free new 60-page BUD catalog.

**BUD**  
**BUD RADIO, INC.**  
CLEVELAND 3, OHIO

ticle on "The Micro Switch in Temperature Controls" as well as short article on "The Make Before Break Switch."

38

**Guide to Electronics.** "The Business Man's Guide to Electronics" (Form A4726) booklet of 28 pages from Westinghouse Electric Corp., Electronic Tube Sales Dept., Bloomfield, N. J. attempts to help one determine how electronic equipment can be profitably applied to business by giving explanations of the six fundamental functions of electronic tubes and describing the applications of electronic equipment that have found widespread use. Most of the applications given can be handled by standardized electronic equipment.

39

**Variable Voltage Transformer.** Bulletin No. 149-A contains 12 pages of data (including motor-drives, capacities and applications) on a variable transformer designated Powerstat which is designed to obtain continuously on variable output voltage from a-c power lines. Superior Electric Co., Bristol, Conn.

40

**Rotary Solenoids.** Solenoids made by George H. Leland (development engineers), 123 Webster St., Dayton 2, Ohio, are illustrated and described in an 8-page booklet.

41

**Plastics Primer.** This designates the title of a booklet which features a concise chart that points out the physical and chemical properties of a representative group of Durez phenolic molding materials. Included also, are two pages devoted to uses of resins. Durez Plastics & Chemicals, Inc., North Tonawanda, N. Y.

42

**C-R Tubes for Television.** This bulletin illustrates and lists several 5, 7, 10, 12 and 20-in. tubes of both the electrostatic and the magnetic deflection categories, together with the more significant characteristics. It also announces a 15-in. magnetic-deflection tube now in the development stage. Allen B. DuMont Laboratories, Inc., 2 Main Ave., Passaic, N. J.

**WIRE SO FINE**  
**IT MUST BE**  
*Magnified*  
**TO BE SEEN**



**WOLLASTON PROCESS**

*Wire as small as*

$\frac{1}{100,000}$  { OF AN INCH  
IN DIAMETER

. . . available in **Platinum**  
and some other **Metals**

.00001" is less than 1/30 the diameter of the smallest wire die commercially available. Yet our Wollaston Process wire (drawn in a silver jacket) closely meets your specifications for diameter, resistance and other characteristics.

This organization specializes in wire and ribbon of smaller than commercial sizes and closer than commercial tolerances. Write for List of Products.

**SIGMUND COHN & CO.**



44 GOLD STREET NEW YORK 7

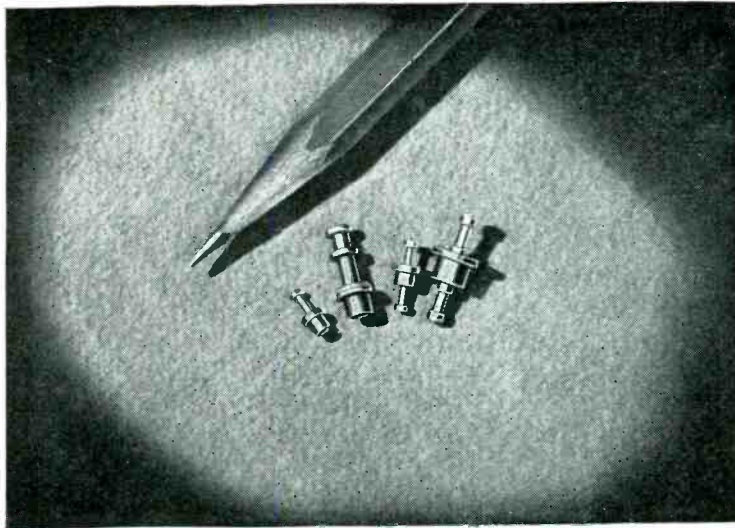

## Now C.T.C. MIDGET TERMINAL LUGS Are In The Spotlight

This newest C.T.C. addition to their quick-anchoring, swift-soldering line of Terminal Lugs incorporates all the advantages of the standard sizes plus the additional advantage of their midget size.

Pictured above, actual size with standard C.T.C. lugs, you can readily see how their size

and construction make them perfect for use where space is limited.

C.T.C. Midget Terminal Lugs are available in two types — Midget Turret Terminal Lugs to fit  $\frac{1}{32}$ ",  $\frac{1}{16}$ " and  $\frac{3}{32}$ " board thicknesses and Midget Double End Lugs to fit  $\frac{1}{32}$ " and  $\frac{1}{16}$ " board thicknesses.

For complete information on C.T.C. Midget Terminal Lugs write for C.T.C. Catalog No. 100 or drawings No. 1463 and 1457.



**CAMBRIDGE THERMIONIC CORPORATION**  
439 Concord Avenue • Cambridge 38, Mass.

## Draftsman Wanted

Also

## Designer, Detailer, Tracer and Engineer

We are one of the largest manufacturers of a wide variety of communication and electronic equipment in the world, fully prepared and ready to go ahead with a very ambitious, expansion program as quickly as we are permitted. There will be unlimited possibilities for creative, ambitious men to advance to key positions both in research development and production field.

### Good Starting Salaries

Exceptionally fine working conditions

Apply: Personnel Office, 8 A. M. to 5 P. M.

## Federal Telephone & Radio Corp.

the Mfg. unit of the International Tel. & Tel. Corp.

591 BROAD ST., NEWARK, N. J.



## INTER-COMMUNICATION AND PAGING SYSTEMS For Every Requirement

With its reputation for quality earned over the years, and more recently its importance in war, specification of BOGEN inter-communication and paging equipment is your guaranty of functional efficiency and dependability.

The BOGEN line is diversified and complete, with units and systems to meet every particular need; economy features—including installation, maintenance, and service—assure self-amortization in a short time. Investigate BOGEN today; complete details on request.

Address inquiries to Department D

### TYPE A COMMUNO-PHONE



Inter-communication system comprises Master Unit and up to 18 remote stations. Two way talk and call. Volume control. Remotes can reply at distance of 20 to 30 feet

from their unit. No need to interrupt routine or work. Other models provide group and all call features.



**David Bogen CO. INC.**

663 BROADWAY, NEW YORK 12, N. Y.

BOGEN SOUND SYSTEMS • AMPLIFIERS  
COMMUNO-PHONES • ELECTRONIC EQUIPMENT





... A long-sought combination correctly engineered into "SKYPLY"—the miracle material now available for your electronics cabinet needs.

Rigidly tested on fighting fronts throughout the world, where "SKYPLY" radar and radio cabinets proved their resistance to heat, cold, moisture, vibration and sound—this modern Skydyme Sandwich Construction is the perfect

answer to your product housing requirements. And results of the "Drop Test" show that "SKYPLY" is *twice as strong with half the weight*, thereby reducing dead weight and lowering shipping costs.

Adaptable to all types of designs because "SKYPLY" is form-moulded, this Skydyme Sandwich Construction offers a beautiful, smooth surface, with curvatures easily attained.

WRITE TODAY FOR OUR FREE BROCHURE

*Skydyme Inc*

PORT JERVIS, NEW YORK



# AMERICAN CAPACITORS

## DRY ELECTROLYTIC &

## PAPER DIELECTRIC



SPECIFICATION SHEETS ON REQUEST

ALL STANDARD TYPES • PRECISION ENGINEERED FOR DEPENDABILITY

**AMERICAN CONDENSER CO.**

4410 NO. RAVENSWOOD AVE. • CHICAGO 40, ILL.

## NEW BOOKS

### Tables of Associated Legendre Functions

By MATHEMATICAL TABLES PROJECT, National Bureau of Standards. Columbia University Press, New York 27, 1945, 303 pages, \$5.00.

A TABLE to about six significant figures at intervals of 0.1, filling an important gap in existing literature dealing with the application of mathematics to engineering. Included are fourteen major tables of functions and their first derivatives, and five useful supplementary tables giving more exact values of certain functions.—J.M.

• • •

### Bibliography on Industrial Radiology

By H. R. ISENBURGER. St. John X-Ray Service, Inc., Long Island City 1, N. Y., 16 mimeographed pages, \$1.00.

AUTHORS, TITLES, and locations of about 400 articles on industrial radiology published in the period 1942-1945. This list supplements the compilation of over 1,300 references in the book "Industrial Radiology", Second Edition, by Ancel St. John and H. R. Isenburger, which was published in 1943 by John Wiley & Sons, New York. Together these works are an impressive testimonial to the increasing use of x-ray equipment in industry for visual inspection of materials.—J.M.

• • •

### Electronics Dictionary

By NELSON M. COOKE, Lieut. Comdr., USN, Executive Officer, Radio Materiel School, Naval Research Laboratory, and JOHN MARKUS, Associate Editor, ELECTRONICS. McGraw-Hill Book Co., New York 18, 433 pages, \$5.00.

To OTHERS, like this reviewer, who have spent hours in Engineering Society committee meetings formulating a few dozen definitions, the task of setting down thousands of them would indeed seem a colossal undertaking. It must have been.

This work is up-to-date, including, for example, the lighthouse tube and a number of radar terms. Of special interest and value are the many words used in connection

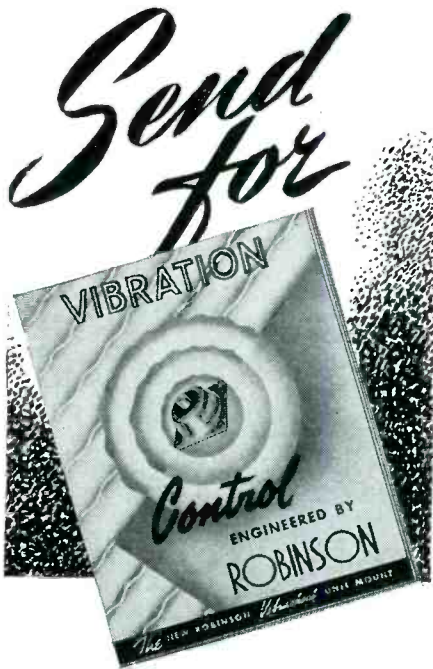

It's new—amazingly effective and surprisingly inexpensive. Vibrashock\* triple-action unit mounts really absorb vibration and cushion shock. Compare Vibrashock with any other unit type mount—and see the marked improvement in performance. We believe Vibrashock will solve your vibration problems.

\*trade mark

**ROBINSON AVIATION, INC.**  
Teterboro Air Terminal, Dept. E. 1.  
Teterboro, New Jersey  
3757 WILSHIRE BLVD., LOS ANGELES 5, CALIFORNIA



**HOW TO BUILD**

**LAMP ANNUNCIATORS**

Kirkland Bulls-I-Units are ideal for this purpose. Just provide the proper size holes in the panel, then insert the Kirkland units and lock into place. Many different units to choose from. Assembly is then ready for installation. Connect incoming wires and place in service. Typical unit illustrated above made with T2 units.

**KIRKLAND Pioneer**  
INDICATING LAMPS

**TYPE T2 UNIT**



Small and modern, molded of bakelite. For use with slide-base switchboard bulb (24 volts, 0.038 Max. Amp) with resistor on 120-220-440 volts. Overall dia. Lens-Cap 3/4".  
LIST PRICE (less bulb) 70¢.

Write Today for Catalogue  
Where Quality is the Foremost Consideration

The H. R. KIRKLAND CO., Morristown, N. J.

**NEW SOLDERING GUN**

**THE SPEED IRON\***



Patent Applied For

100 Watts 115 Volts 60 Cycles

*Soldering Heat in 5 Seconds*

Wherever you have a soldered joint in radio, electrical or electronic repair and service work, the Speed Iron will do the job faster and better.

The transformer principle gives high heat—in 5 seconds—after you press the trigger switch. Convenient to hold with a pistol grip handle, the compact dimensions of this new soldering tool permit you to get close to the

\*T.M. Reg U. S. Pat. Off.

joint. The copper loop soldering tip permits working in tight spots. The heat is produced by the high current flowing through the soldering tip—permitting direct and fast transfer to the soldered connection.

If you want to save time on soldering jobs with a tool that is ready to use in 5 seconds, get a Speed Iron today. See your radio parts distributor or write direct.

**WELLER MFG. CO.**

515 NORTHAMPTON STREET, EASTON, PA.



**CUP WASHERS**  
for Binding Screws

*Preferred*

as a source of precision-made WASHERS and STAMPINGS manufactured to your specifications



**WHITEHEAD STAMPING CO.**

1691 W. Lafayette Blvd.

Detroit 16, Michigan

- INSTRUMENT HOUSINGS
- PANELS
- CHASSIS
- STAMPINGS
- SCREW MACHINE PARTS



**METAL AND PLASTIC SPECIALTIES**  
*Manufactured to your Requirements*

Experienced fabrication and dependable service for all types of radio and electronic parts. Send us your drawings and specifications for quotation.

**STAMFORD METAL SPECIALTY CO., 428 BROADWAY, N. Y. 13**

*Metal Work of Every Description*



## EASTERN HEAT DISSIPATING UNIT

The Eastern Heat Dissipating Unit is used in connection with television, radar, short wave radio communications, high pressure mercury lamps, X-Ray tubes, induction heating units, and many other applications. It was developed for military requirements in conjunction with radar and electronic tube cooling problems. Units were designed in various sizes and capacities, some with the close heat control range of 2 degrees C. Used successfully for ground, water and airborne service, they combine rugged construction, compactness and light weight.

The model illustrated will dissipate up to 1200 watts with a constant controlled temperature, irrespective of surrounding temperatures, within 2 degrees C. It is complete with Thermostat control, Thermostatic valves and flow switch. Eastern has built airborne units of much smaller sizes and industrial units of much larger sizes and capacities. The specifications for the unit shown are: SIZE: 16" x 7 1/2" x 7 1/2"; METALS: Steel, Bronze, or Aluminum. Other models can be designed to dissipate up to 5000 watts.



Closed View

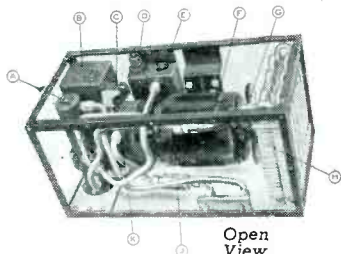

Open View

- |                          |             |
|--------------------------|-------------|
| A. Thermo flow-regulator | F. Motor    |
| B. Reservoir             | G. Fan      |
| C. Flow Switch           | H. Radiator |
| D. Thermostat            | I. Filter   |
| E. Auxiliary Heater      | J. Pump     |

Eastern's experience in solving heat control problems, especially where compactness and light weight are necessary, makes them the logical people with whom to discuss heat control applications. If you are designing or planning to build equipment that calls for heat dissipation or the close control of operating temperatures, Eastern will design and build the entire unit for you to meet your specific requirements.

An inquiry about your heat dissipating needs will not obligate you in the slightest.

A large part of Eastern's business is the designing and building of special pumps, in quantities ranging from 25 to several thousand for the aviation, electronic, chemical, machine and other special fields. Eastern builds over 600 models, both centrifugal and positive pressure, ranging in size from 1/100 H.P. to 3/4 H.P. as standard units.

*Eastern Engineering Co.*

84 FOX STREET, NEW HAVEN 6, CONN.

with waveguides. Here the authors' policy of including diagrams is particularly helpful.

The authors have made a bold and broad approach to the troublesome problems of abbreviations and compound words. All too few abbreviations have been adopted by ASA but this book continues the general policies that have been standardized. In the case of compound words, the system followed is consistent, even if at times somewhat unorthodox. Engineers in general will devoutly hope that such a uniform system "takes", but reformers of the English language have had hard going over the years. Some of the results of this standardization look a little strange at first glance, as for example antinode and leadin.

A casual glance at a few pages might give the impression that it is an elementary text, but this is far from the case. What would be your score if confronted with the problem of defining these ten words: allochromatic; anelectrotonus; aniseikon; Barnett effect; barytron; Bronson resistance; episcotister; Matteucci effect; trauntonium; daraf.

A considerable number of words in the electromedical field are included and may be useful to workers in electronics as medical dictionaries are conveniently available only to very few engineers. Included also are some colloquialisms in the field of sound recording and studio operation.

By frequent repetition, the newly adopted abbreviations vlf, vhf, uhf, etc, are emphasized and, although this system for designating frequency bands is not universally liked, it will be most helpful to have these terms mean the same whenever used.

Engineers are by nature individualists and many of them examining this dictionary would list a considerable number of definitions with which they would not agree or would feel that the wording was not sufficiently qualifying. These would be questions of engineering opinion in general, as the book seems to be remarkably free from errors. This reviewer is sending to the authors, as suggested in the preface, a detailed list of his comments and, if a considerable num-

## ENGINEERED TO THE APPLICATION

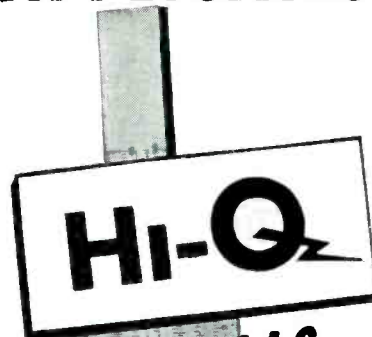

CERAMIC CAPACITORS

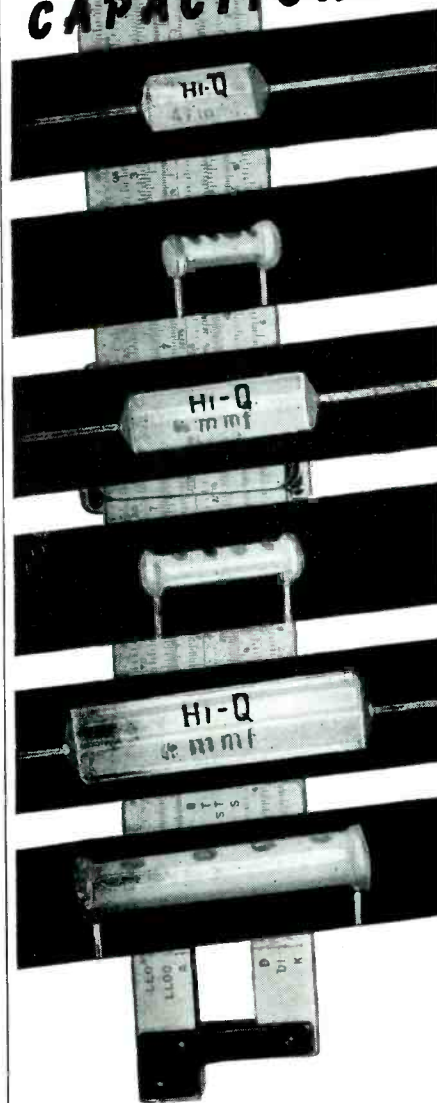

**ELECTRICAL REACTANCE CORPORATION**  
FRANKLINVILLE, N. Y.

Look it up . . .  
in these 3 new  
McGraw-Hill Books

See one  
or all  
10 days  
on approval

## ELECTRONICS DICTIONARY

By NELSON M. COOKE,  
Lt. Com. U. S. N.

Executive Officer, Radio Materiel  
School, Naval Research Laboratory,  
Washington, D. C.

and JOHN MARKUS  
Associate Editor, *Electronics*



Here are 6500 clear-cut definitions and reference data—all the terms used in electronics and its extensive practical applications, radio, television, communications, and industrial electronics. For clear, precise definitions, accurate usage, well-illustrated descriptions, and for standardized spelling, abbreviating, and hyphenating policy, this book will be a constant aid to everyone working with electronics and radio engineering—whether student or engineer, editor, or engineering secretary. 433 pages, over 600 illustrations, \$5.00.

## ELECTROMAGNETIC ENGINEERING

Volume I—Fundamentals

By RONOLD W. P. KING

Associate Professor of Physics and Communication Engineering,  
Harvard University

Offers a new approach to electromagnetism, giving a systematic introduction to those basic concepts of electromagnetism which are fundamental to the study of electromagnetic waves, antennas, electromagnetic horns, wave guides, and ultra-high frequency and microwave circuits. Beginning with the first principles, the physical and mathematical essentials of electro-dynamics are logically developed and critically discussed for the purpose of applying them to engineering problems. 580 pages, 75 illustrations, \$6.00.

## APPLIED MATHEMATICS

For Radio and Communication Engineers

By CARL E. SMITH

Assistant Chief, Operational Research Branch, Office of  
the Chief Signal Officer, War Dept.

Teach yourself mathematics for big new jobs in radio, television, radar. Here's the manual which can make you master of mathematics, from arithmetic to calculus, used in radio and communication engineering. Especially arranged for home study, the book gives all the mathematics you need, from basic fundamentals to more detailed concepts—to help you get ahead in radio, television, frequency modulation, radar development. 336 pages, 97 figures, \$3.50.

Simply send this coupon!

McGraw-Hill Book Co., 330 W. 42 St., N.Y.C. 18  
Send me the books checked below for 10 days examination on approval. In 10 days I will pay for books, plus few cents postage, or return books postpaid. (Postage paid on cash orders.)

- Cooke and Markus, *Electronics Dictionary*, \$5.00  
 King, *Electromagnetic Engineering, Vol. I, Fundamentals*, \$6.00  
 Smith, *Applied Mathematics, for Radio and Communication Engineers*, \$3.50

Name .....

Address .....

City and State .....

Company .....

Position ..... L 1-46

In Canada: Mail to Embassy Book Co., 12 Richmond St. E., Toronto, 1

# Standard Relays

TO FIT YOUR JOB . . .

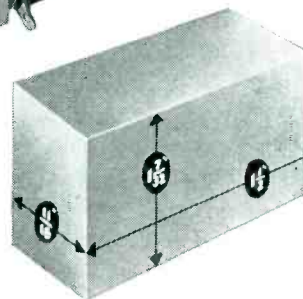
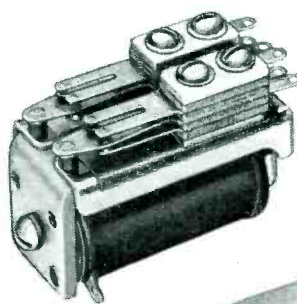

ILLUSTRATED ABOVE (actual size) is a Potter & Brumfield standard "MT" Series telephone type relay. This relay will handle operating voltages up to 60 volts DC. Overall dimensions, 1 1/2" long, 1 3/32" high, 1 1/8" wide. Weight 1 3/4 oz. One of the smallest, most compact ever built. Twin contacts, high contact pressure, particularly resistant to vibration.

This "MT" relay is typical of Potter & Brumfield standard relay models. Well designed, proven in actual service, they are sturdily constructed of the finest materials and will give the maximum of reliable, uninterrupted service.

Potter & Brumfield standard relays will fit many applications and they give you most in dollar value. IF A STANDARD RELAY WILL DO THE JOB, THAT'S THE ONE TO BUY!

105 North 10th St.

Potter & Brumfield

Mfg. Co., Inc.

PRINCETON, IND.

## PERMANENT MAGNETS

All Shapes—All Sizes—for All Purposes  
COBALT—CHROME—TUNGSTEN

Stamped, formed and cast

Alnico (Cast or Sintered)

Also: Laminations for Radio Transformers  
TOOLS—DIES—STAMPINGS

Heat Treating of Metals and Alloys

THOMAS & SKINNER STEEL PRODUCTS  
COMPANY

1116 EAST 23RD STREET • INDIANAPOLIS 5, INDIANA

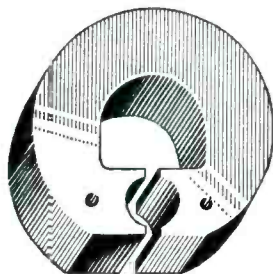

WALSCO

PRODUCTS  
help the radioman

### Prompt Deliveries On . . .

**DIAL CORDS & CABLES**—Braided and twisted. All materials—Nylon, Rayon, Hemp, Metals, etc.

**SPECIAL HARDWARE**—Grommets, C. Washers, Retaining Rings, Mounting Nuts, Cable Clamps and other radio hardware.

**CHEMICALS**—Polystyrene cements and dopes, Vinylite Products, Vibration-proof cements and other special compounds.

Deliveries on practically all orders from stock.  
Write us about your problems care of Dept. E.

WALTER L. SCHOTT CO.  
BEVERLY HILLS, CALIFORNIA • CHICAGO 5, ILLINOIS



# CHASSIS • CABINETS • PANELS • RACKS

*Skill in* **METAL**

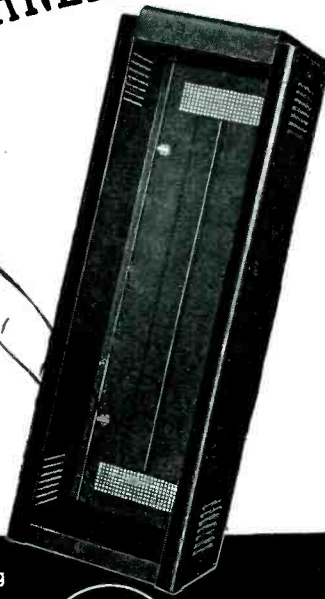

PAR-METAL . . . a specialized manufacturing plant employing modern high-speed methods. Nevertheless, Par-Metal products have a definite quality of Craftsmanship—a "handmade" quality born of genuine skill and long experience. Write for Catalogue.



Serving the  
Electronics  
Field  
Exclusively

**PAR-METAL PRODUCTS CORPORATION**

32-62—49th STREET . . . LONG ISLAND CITY, N. Y.

Export Dept.

100 Varick St., N. Y. C.

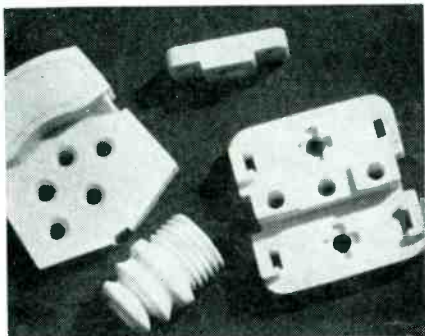

## Lavite STEATITE CERAMIC

Properties and Characteristics of Our  
LAVITE S1-5 Steatite Ceramic Body

Compressive Strength	96,000 lbs. per square inch
Tensile Strength	7,200 lbs. per square inch
Flexural Strength	10,500 lbs. per square inch
Modulus of Rupture	20,000 lbs. per square inch
Dielectric Strength	235 volts per mil
Dielectric Constant	6.42
Loss Factor	2.90
Power Factor	446
Bulk Specific Gravity	2.664
Density (from above gravity)	0.096 lbs. per cubic inch
Hardness (Mohr scale)	2,350
Softening temperature	7,000°F
Linear Coefficient of Expansion	8.13x10 <sup>-6</sup>
Moisture Absorption (ASTM D-116-42-A)	0.009%

Design engineers and manufacturers in the radio, electrical and electronic fields are finding in LAVITE the precise qualities called for in their specifications . . . high compressive and dielectric strength, low moisture absorption and resistance to rot, fumes, acids, and high heat. The exceeding low loss-factor of LAVITE plus its excellent workability makes it ideal for all high frequency applications.

We will gladly supply samples for testing.

**D. M. STEWARD MFG. COMPANY**

Main Office & Works: Chattanooga, Tenn.  
Needham, Mass. Chicago Los Angeles

## TEST YOUR MAGNETIC CIRCUITS



RAWSON FLUXMETER TYPE 504

The only portable fluxmeter available which returns rapidly to zero when a single button is depressed. Simple and fast in operation. Convenient and light in weight.

Not limited to a single type of measurement. Has universal application for laboratory or production. Measures strength of magnets and electromagnets, permeability and hysteresis loops for iron and steel, total flux lines in circuit, flux lines developed in air gap, etc.

Has a mechanical clamp to protect the pivots and jewels when in transit.

Low price \$125 net FOB Cambridge, Mass.

## RAWSON ELECTRICAL INSTRUMENT COMPANY

111 Potter Street, Cambridge 42, Mass.  
Representatives

CHICAGO

New York City

ber of other engineers do this, the authors will have material for consideration in subsequent editions. As is stated in the preface "In the end, it is personal preference and opinion that govern style in technical terminology."

Writers and typists, as well as engineers, will find this book a handy desk companion. — W. C. WHITE.

• • •

## Pulsed Linear Networks

By ERNEST FRANK, *Research Laboratories, Sperry Gyroscope Co., Inc., McGraw-Hill Book Co., New York, 1945, 262 pages, \$3.00.*

CIRCUIT RESPONSE to a rectangular pulse is analyzed by classical calculus methods. The first two chapters summarize the necessary circuit theorems and differential equations for attacking the subsequent problems. The body of the book consists of analyses of progressively more complicated circuits of resistance, inductance, and capacitance. In the concluding chapter several typical circuits are studied to illustrate the method of a complete solution.

The basis of approach used throughout the book is that the differential circuit equation is written. This equation is then simplified by

• • •

## TROLLEY-CAR SET



Because the control that advances the tube on the turntable to its testing position works like the speed control lever on a streetcar, workers at the Westinghouse Lamp Division have nicknamed this transmitting tube tester the "trolley car set". Tubes are heated for two minutes on the adjoining rack prior to testing

# PROFESSIONAL SERVICES

Consulting — Patents — Design — Development — Measurements

in

Radio, Audio, Industrial Electronic Applications

## ASSOCIATED ELECTRONICS COMPANY

**INDUSTRIAL ENGINEERING SPECIALISTS**  
Engineering Research & Development  
Product Design      Market Research  
Sales Brochures      Technical Manuals  
Field Surveys      Laboratory Analysis  
Complete Engineering Service For All Industries  
132 Nassau Street, New York 7, N. Y.

## The Consulting Engineer

*By reason of special training, wide experience and tested ability, coupled with professional integrity, brings to his client detached engineering and economic advice that rises above local limitations and encompasses the availability of all modern developments in the fields where he practices as an expert.*

## HODGSON & ASSOCIATES

**Physics, Mathematics, Research, Development & Patent Consultants.**

Satisfaction guaranteed. Submit your problem for a preliminary survey without cost.  
Sherman Oaks, California

## MICHAEL BOZOIAN

*Consulting Service In Electronics*  
Instrumentation & Controls Design—Development—Models Literature & Patent Survey Recommendations For New Laboratories.  
Telephone 8521  
702 Fifth Street      Ann Arbor, Mich.

## J. L. A. McLAUGHLIN

**Designer of Communications Receivers**  
Specializing in the elimination of heterodyne interference.  
P. O. Box 529, La Jolla, Calif.

## COOPER & FLEMING

*Consulting Electronic Engineers.*  
AM & FM Broadcasting.  
Industrial & Medical Electronics  
420 Market St.      Sutler 8854 San Francisco, Calif.

## ELM LABORATORIES

*Research and Design*  
**RADIO TRANSMITTERS AND RECEIVERS**  
Designs for Home Radios, Electro-Mechanical Devices and Components.  
20 South Broadway      Dobbs Ferry, New York  
Phone—Dobbs Ferry 4058

## NATIONAL DESIGN SERVICE

*Designers and Developers of*  
**FACTORY TEST EQUIPMENT,  
TELEVISION R.F. SWEEP GENERATORS  
F.M. SIGNAL GENERATORS  
COMPLETE CENTRALIZED MODULATED SYSTEMS**  
96 Liberty St.      New York 6, N. Y.

## E. STUART DAVIS

*Consulting Engineer*  
**Research—Design—Development**  
Radio - Carrier Current - Supersonics - Radiant Energy - Control and Measurement - Methods and Devices. Communication - Transportation & Industrial applications.  
Marine Laboratory facilities aboard the yacht "ELECTRON"  
422 N. E. River Drive      Ft. Lauderdale, Florida

## F. T. FISHER'S SONS

**LIMITED**  
*Consulting Engineers*  
Broadcast Transmitters, Antenna Systems, Studio Equipment, Mobile and Fixed Communication Systems.  
1425 Dorchester St. West, Montreal

## ALBERT PREISMAN

*Consulting Engineer*  
Specializing in Television and Pulse Techniques, Video Amplifiers, Industrial Applications.  
616 St. Andrews Lane,      Silver Spring, Md.

## STANLEY D. EILENBERGER

*Consulting Engineer*  
**INDUSTRIAL ELECTRONICS**  
**Design—Development—Models**  
Complete Laboratory and Shop Facilities  
6309-13—27th Ave.  
Kenosha, Wis.      Telephone 2-4213

## DON FOSTER

*Engineering Consultant*  
Electrical      Specialists in      Mechanical  
Analysis      Sound and Electronics      Development  
30 Burns Ave., Wyoming 15, Ohio

## JOSEPH RAZEK, Ph.D.

*Consulting Physicist*  
Electrical and Mechanical Engineering Problems Instruments and Control Devices      Electronics Specialists in Colorimetry, Spectrophotometry and Industrial Color Control  
Laboratory and Shop Facilities  
202 Darby Road      Llanerch, Pa.  
Phone Hilltop 6910

## ELECTRONIC ENGINEERS

*Designers and Consultants*  
Radio and Electronic Product Design  
Radio Equipment to Order  
Industrial Electronic Devices to Order  
Broadcast Station Allocation  
Complete Research and Constructional Facilities  
Phone Citrus 1-6884  
611 E. Garfield Ave.      Glendale 5, California

## PAUL E. GERST & CO.

**CONSULTING ENGINEERS**  
**Specialists in**  
**Electrical Product Design**  
El. Machinery, Apparatus & Applications  
El. Appliances, Hi-Frequency Apparatus  
Electronics, Radio Communication  
205 W. Wacker Dr.      Chicago 6, Ill.

## G. W. RHEIN

*Engineering Consultant*  
**Radio Communication      Electronics**  
Complete Development and design for manufacture with engineering models.  
St. Paris Pike      Springfield, Ohio

## ELECTRONIC RESEARCH ASSOCIATES

ERA will apply progressive, war-proven developments in electronic research . . . counting . . . timing . . . measuring . . . Industrial controls . . . to your manufacturing advantage.  
Box 333, 305 Linden Av., So. San Francisco, Cal.

## SEYMOUR C. HYMAN, Chem. Eng.

*Consultant for Industry on*  
**MOISTURE AND FUNGUS PROBLEMS**  
For the duration of the war, Chief of Moisture and Fungus Proofing Section developing and applying tropic-proof materials for U. S. Army communications equipment. Now available to manufacturers and materials suppliers for consultation on protective coatings, insulation and choice of engineering materials.  
P. O. BOX 111      Long Branch, N. J.

## PAUL D. ZOTTU

*Consulting Engineer*  
**INDUSTRIAL ELECTRONICS**  
High Frequency Dielectric and Induction Heating Applications, Equipment Selection, Equipment and Component Design, Development, Models.  
314 Washington St.,      Newton, Mass.  
BIG-9240

## At your service . . .

The Searchlight Section brings business needs and "opportunities" to the attention of men associated in executive, management, sales and responsible technical, engineering and operating capacities with the industries served by these McGraw-Hill publications. USE IT.

Air Transport  
American Machinist  
Aviation  
Aviation News  
Business Week  
Bus Transportation  
Chem. & Met. Eng.  
(SEE PAGES 462-473)

Coal Age  
Construction Methods  
Electrical Contracting  
Electrical Merchandising  
Electrical World  
Electronics  
Engineering & Mining Jour.

Engineering News-Record  
E. & M. J. Markets  
Factory Mgt. & Maintenance  
Food Industries  
Power  
Product Engineering  
Textile World

Departmental Staff, McGraw-Hill Publishing Co.  
330 W. 42nd St., New York 18, N. Y.



**IMMEDIATE DELIVERIES**

# VACUUM TUBE VOLTMETER

RF — AC — DC



**The result of 10 years of Vacuum Tube Voltmeter Engineering.**

## MODEL VM-27

1-3-10-30-100 volts full scale  
Peak response, r.m.s. calibration.

**HIGH IMPEDANCE**—4 megohms at 50 cycles, 60,000 ohms at 100 megacycles. 7 megohms for d-c.

**ACCURATE**—Better than 2 percent on d-c and 60 cycles thru 50 megacycles.

**SELF-CONTAINED**—115 or 230 volt 50-60 cycle line operation.

### RF PROBE

Interchangeable probe included for convenience and efficiency in making AC and RF measurements. Input capacity 5 micro farads. Ruggedly mounted 6H6 tube in balanced circuit. Complete voltmeter with probe \$150 net f.o.b. Flushing, N. Y.

**ALFRED W. BARBER LABORATORIES**  
34-06 Francis Lewis Blvd. Flushing, N. Y.

**ACCESSORIES**

- To increase VM-27 range to 1000 volts.
- **10X AC MULTIPLIER MODEL ACM-27**  
Input impedance even greater than probe alone. Flat response from 20 cycles to 200 megacycles. \$17.00 net f.o.b. Flushing, N. Y.
- **10X DC MULTIPLIER MODEL DCM-27**  
5 megohms input resistance. \$8.00 net f.o.b. Flushing, N. Y.

**Would a vibration meter locate trouble in your WASHERS?**

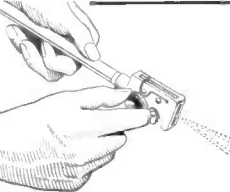

Electrical equipment requires super-precision rigidity—dependability. Make sure with

## QUADRIGA Quality Washers

Washers to specifications, of any type, purpose or material; which can be fabricated by punch press, Flat, Special Dimensions, Irregular Contour, Tension and spring, Friction, Formed and Drawn, Cupped and Finishing etc. Wire Terminals. Send for complete catalog.

Also **SMALL METAL STAMPINGS, any design** **Prompt delivery**

**THE QUADRIGA MANUFACTURING CO.**  
Inc. 1894 "Half a Century" 221-AW. Grand Ave., Chicago 10, Ill.





# GASES

## HYDROGEN NITROGEN · OXYGEN

COMPLETE GAS PRODUCTION PLANTS INSTALLED FOR LOWEST COST OPERATION

FORMING MIXTURES  
CARBON DIOXIDE  
ACETYLENE

HIGHEST QUALITIES · ANY QUANTITY DELIVERED ANYWHERE

### AMERICAN GAS & CHEMICAL CO.

HARRISON, NEW JERSEY • Contracted Complete Service on All Gases

ARGON · NEON  
HELIUM · KRYPTON  
XENON



collecting all like terms, thus giving apparent resistance, inductance and capacitance. The variety of differential equations that must be solved is thus kept to a minimum. Furthermore, the author points out that in a practical circuit under most conditions, stray impedances and other impedances of extreme values can be omitted, thereby simplifying still further the mathematics.

In his introduction the author calls attention to the weakness of the classic approach used throughout the book, and justifies it on the basis of its familiarity to most engineers and the necessity of obtaining a solution. In the problems, curves and oscillographs indicate the response of circuits and the effects of varying circuit parameters, thus illustrating the design knowledge that can be obtained from the analysis, cumbersome as it is in some instances.

The reader should read the text with a critical mind; there are some misleading statements. On page 236 the author states, "Since the period of the applied pulses, 200 microseconds, is *small* compared with the discharging time constant, 700 microseconds, the transit due to a given pulse is very large when the next pulse arrives." What he means is that because the period of the applied pulses is *comparable* to the circuit discharging time, the circuit has appreciably discharged by the time the next pulse arrives.

In connection with a resonant circuit, the text on page 239 explains that "... the transit due to one pulse does not have time to diminish to a negligible value before the subsequent pulse arrives, unless the pulse period is extremely large compared with the *natural or freely oscillating* period of the plate circuit." What is meant is that the pulse period is extremely long compared to the *decay* period of the resonant circuit. Had the technical editor been familiar with transient behavior he could have caught such inaccuracies; as it is, the book will have to be read with care. Another fault of the editing is the describing of pulse periods as large and small, which does not give as readily visualized a concept of the time functions as would the conventional designation of long and short.—F.R.

# CONTACTS

FOR THE FIELD OF ELECTRONICS

MORE RF KILOWATT HOURS  
PER DOLLAR WITH

## F & O TRANSMITTING TUBES

Inquiries Invited—Let us explain how Savings are effected and the F & O greater guarantee.

**FREELAND & OLSCHNER PRODUCTS Inc.**  
611 Baronne St., New Orleans 13, La.  
Raymond 4756

High Power Tube Specialists Exclusively  
(5 KW to 100 KW)

## Strip Insulated Wires QUICKER... BETTER

with "Speedex"  
AUTOMATIC WIRE STRIPPER  
... Speeds Production

Strips Insulation from all types of wire— instantly, easily, perfectly. Just press the handles and the job is done. Cuts wire too. Strips 800 to 1000 wires per hour. Available for all size solid or stranded wires—No. 8 to No. 30. List Price \$6.00. Write Dept. E for Full Particulars



**GENERAL CEMENT MFG. CO.**  
Rockford, Illinois, U.S.A.

FINE RIBBONS  
OF  
TUNGSTEN and MOLYBDENUM

Quality and accuracy in our fabrication of Tungsten & Molybdenum Ribbons have characterized our service to the Electronic industry.  
A development of

**H. CROSS Co.**  
15 Beekman St., New York 7, N.Y.

## MICROMETER FREQUENCY METER

for checking Transmitters  
from 1.5 to 56 mc.,  
within 0.01 per cent

**LAMPKIN LABORATORIES**  
Bradenton, Fla., U. S. A.

## We manufacture a complete line of equipment

SPOT WELDERS, electric from ¼ to 50KVA  
TRANSFORMERS, special and standard types  
INCANDESCENT LAMP manufacturing equipment  
FLUORESCENT TUBE MAKING EQUIPMENT  
ELECTRONIC EQUIPMENT, vacuum pumps, etc.  
WET GLASS SLICING and cutting machines for laboratory use  
GENERAL GLASS working machines and burners  
COLLEGE GLASS working units for students and laboratory

AC ARC  
WELDERS  
from 100 to  
400 Amps

EISLER ENGINEERING CO.  
731 So. 13th St. (near Avon Ave.) Newark, New Jersey

## HETERODYNE ELIMINATORS

If you are troubled by heterodyne interference consult

**J. L. A. McLaughlin**  
P. O. Box 529, La Jolla, Calif.

## MINIATURE PRECISION BALL BEARINGS

(WORLD'S SMALLEST BALL BEARING)  
For precision instruments, laboratory equipment, electronic devices, to minimize friction, space, weight; overcome starting torque.

ENLARGED SIX DIAM.

Radial Series (5 Sizes)  
1/8" to 5/16" O. D.  
Pivot Series (6 Sizes)  
2 mm to 10 mm O. D.

Write for data sheet EL

**MINIATURE Precision BEARINGS**  
KEENE, NEW HAMPSHIRE, U.S.A.

## Burned Out or Broken Electric Heating Elements

repaired with NICHRO-CITE PASTE. Simply overlap ends, apply paste, turn on current. Used by utility companies, etc. Family size, \$1.00. 4 oz. size \$2.50. Satisfaction guaranteed.

**Armstrong Mfg. Co., Box 861G Minneapolis, Minn.**

## This WHERE TO BUY Section

supplements other advertising in this issue with these additional announcements of products and services essential to efficient and economical power operation and maintenance. Make a habit of checking this page, each issue.

Departmental Staff  
**ELECTRONICS**

## Electron Tube Machinery

of every type, — standard, and special design

Specialists in Equipment for the manufacture of Radio Tubes, Cathode Ray Tubes, Fluorescent Lamps, Incandescent Lamps, Neon Tubes, Photo Cells, X-ray Tubes and other glass or electronic products, on production or laboratory basis.

**Kahle  
ENGINEERING COMPANY**

1307-1309 Seventh St., North Bergen, N. J.

Your inquiries to advertisers will have special value . . .

—for you—the advertiser—and the publisher, if you mention this publication. Advertisers value highly this evidence of the publication you read. Satisfied advertisers enable the publisher to secure more advertisers and—more advertisers mean more information on more products or better service—more value—to YOU.

## FREE TO RADIO MEN

**COLOR CODE and  
OHMS LAW CALCULATOR**

Burstein-Applebee of Kansas City offers you this great convenience FREE. Easy to work. Solves many problems in a jiffy. FREE to radio men, electronic engineers and others in the business. Attach coupon to your letterhead.

MAIL COUPON NOW

**BURSTEIN-APPLEBEE CO.**  
1012 McGEE, KANSAS CITY 6, MO.  
Send me FREE Color Code and Ohms Law Calculator along with latest catalog.

I am \_\_\_\_\_  
STATE CONNECTION IN INDUSTRY

NAME \_\_\_\_\_

ADDRESS \_\_\_\_\_

TOWN \_\_\_\_\_ STATE \_\_\_\_\_





## DEVELOPMENT AND DESIGN ENGINEERS WANTED

Opportunities for advancement are greater with a reputable company that is continually growing and expanding.

We need qualified engineers for permanent positions:

1. In our Radio Division, to carry on research and development of Receivers, Transmitters, Direction Finders, F-M Equipment, Broadcast & Television Receivers, and specialized Aircraft & Marine Equipment.
2. To interpret & prepare Specifications, Instruction Books, & Engineering Estimates.
3. In our Railway Signal Division, to develop and install Carrier Current Equipment.

Write for application form and state condition of availability.

**AIRPLANE & MARINE INSTRUMENTS, INC.**  
CLEARFIELD, PA.

### POSITIONS VACANT

**TEACHING POSITION:** A church-related liberal arts college in middle west has an opening for a physicist with a Ph.D. to head a department of Physics. Permanent position beginning September 1946, or at a time to be mutually agreed upon. Training, character, personality, and interest in teaching important. Recent graduate preferred. P-978, Electronics, 520 N. Michigan Ave., Chicago 11, Ill.

**ENGINEER WITH** several years experience in design and production of small and medium transformers. P-979, Electronics, 330 W. 42nd St., New York 18, N. Y.

### EMPLOYMENT SERVICE

**SALARIED POSITIONS** 2,500-\$25,000. Reconversion is creating lifetime opportunities now. This thoroughly organized confidential service of 35 years' recognized standing and reputation carries on preliminary negotiations for supervisory, technical and executive positions of the calibre indicated, through a procedure individualized to each client's requirements. Retaining fee protected by refund provision. Identity covered and present position protected. Send only name and address for details. R. W. Bixby, Inc., 278 Delward Bldg., Buffalo 2, N. Y.

### POSITIONS WANTED

**MAN INHERENTLY** Lazy, no college graduate, no correspondence schooling, but 20 years in U. of H.K. (University of Hard Knocks), in installation, maintenance, service and troubleshooting on wiring, motors and generators, radio and radar. Anything in electronics considered (particularly industrial electronic control equipment) where I stand around and watch the other fellow work. More money and less work desirable. Midwest location. Present salary \$6,000 per year. Available within the next 60 or 90 days. Give complete details in first letter. PW-958, Electronics, 330 W. 42nd St., New York 18, N. Y.

### Curt E. Patton Personnel Engineers

53 W. Jackson Blvd. Chicago 4

offer industry a confidential Personnel Service, selecting and presenting men for positions open on either a fee or retainer basis.

Outstanding men in electronic and allied fields, with legitimate reasons for seeking a change, are invited to file applications at NO CHARGE, in confidence, so we may present their qualifications to our clients.

## for CAMERAS and PROJECTORS

Highly rated firm in the East manufacturing established line of amateur photographic equipment is interested in securing executive engineers or designers now commanding good salaries in camera goods or kindred type of work. Consideration given to original letters giving complete necessary details including home phone number, names of present or former employer, etc.

P-963, Electronics  
330 West 42nd Street, New York 18, N. Y.

### POSITIONS WANTED

**FACTORY PRODUCTION** Engineer presently employed as supervisor of test equipment design for large eastern radio manufacturer desires position with progressive midwest or west coast organization actively planning mass production of television receiver. Have organized successful prewar television receiver production department. Familiar with preproduction model analysis, establishment of standards, production methods of assembly and test, test equipment and costs, quality and reject control. Age 34. Position should preferably lead to opportunity for plant management. PW-985, Electronics, 330 W. 42nd St., New York 18, N. Y.

**INDUSTRIAL PHYSICIST**, Ph.D., extensive experience in development and production of electronic tubes, gas discharge tubes, and other vacuum devices desires appropriate position. PW-938, Electronics, 520 N. Michigan Ave., Chicago 11, Ill.

**YOUNG ENGINEER** seeking position in foreign service, 30 years old, 4 years experience industrial electronics, 3 years engineering design, 1 year high vacuum and mass spectrometer. Prefer South America, Australia, or East Indies. \$7500. PW-983, Electronics, 520 N. Michigan Ave., Chicago 11, Ill.

**VETERAN** 32, electronics engineer, 12 years experience, teaching experience, Navy radio radar training, interested developing, designing, trouble shooting, or television. PW-984, Electronics, 330 W. 42nd St., New York 18, N. Y.

(Continued on opposite page)

### AVAILABLE

## DIRECTOR OF RESEARCH AND DEVELOPMENT

Engineer, at present chief engineer for radio manufacturer, seeks position with more technical and fewer executive duties. Specialties: FM, television, modulators, navigation aids. Strong points: Originality, analytical skill, practical ability. Can wield a soldering iron, a differential equation, or a cost analysis with equal facility. Publications, patents, engineering education. Would be at home in a department of 25 to 75 persons within a technically minded company. Normal earnings \$12,000 to \$18,000.

Reply to PW-974, Electronics  
330 West 42nd St., New York 18, N. Y.

**EXECUTIVE ENGINEER** \* Direct Electronics Rsch. & Production; Lt. Comdr. Naval Research on Top Projects 5 yrs.; G.E. Television & Circuit Rsch. 2 yrs.; Bell Labs. & RCA exp.; B.S., M.S., E.E., Doct. Work in E.E. and Phys.; National Coffin, Tau Beta Pi, Sigma Tau Fellow, M.I.T. & U. of Pa.; Bus. Sense, Pats. Exp., Product Conscious, Estab. Mgr. & Producer; Desire Resp. Managerial Pos. with Prog. Org.; NYC, S.F. or L.A. Highest Contacts, Refs. & Comdtns. PW-969, Electronics, 330 W. 42nd St., N. Y. 18

## Attention Communications Equipment Manufacturers!

Aggressive young sales executive with 15 years aviation experience wants responsible position with substantial, wide-awake organization. Thoroughly capable of guiding all or any part of your program. Plenty of technical, industrial, and merchandising experience supported by an up-to-the-minute acquaintance with Canadian and Domestic markets. Also familiar with marine, police, broadcast, and other allied fields. If YOU don't know where you are going DON'T take me with you! If you DO and need some level-headed help, write or wire—

PW-992, Electronics  
330 West 42nd St., New York 18, N. Y.

## ENGINEERS

MEN for design and development work on radio and television receivers.

We have openings in our laboratory for a senior and two junior engineers. Senior engineers should be graduates in electrical or communication engineering and have had industrial experience in radio or television design. Junior engineers should be graduates in electrical or communication engineering, but industrial experience is not necessarily required.

Please address Director of Engineering, giving details of education, experience, and salary requirements.

**Majestic Radio & Television Corporation**  
St. Charles, Illinois

### WANTED

## ELECTROLYTIC CONDENSER ENGINEER

Chicago Manufacturer desires services of competent Electrolytic Capacitor Engineer, capable of management and installation of all phases of production of electrolytic capacitors. Exceptional opportunity. To start at once. State qualifications and salary desired.

P-971, Electronics  
520 North Michigan Ave., Chicago 11, Ill.

## Acoustic Engineer

To take charge of design and development of phones and public address microphones. In replying give education, experience, and salary expected.

P-973, Electronics  
520 North Michigan Ave., Chicago 11, Ill.

## Permanent Employment Executive Engineer

Leading eastern manufacturer of electronic equipment requires graduate E. E. with project engineering experience to be responsible for administration of all engineering and research. Immediate and post-war opportunity.

P-871, Electronics  
330 West 42nd St., New York 18, N. Y.



## EXECUTIVE ENGINEER

Qualified by education, ability and experience in directing technical personnel, wishes to contact manufacturer relative to development and manufacture of a line of merchandise such as, home radios, television, aviation radio and accessories and/or photography and home movies. Permanent position preferred with salary plus profit participation as a basis of compensation.

PW-993, Electronics  
520 North Michigan Ave., Chicago 11, Ill.

## POSITIONS WANTED

**RESPONSIBLE POSITION:** in research or administration of research desired by Physicist. Ph.D. Industrial research and administrative experience. Good organizer. Age 36. Salary requirement \$8000. PW-980, Electronics, 330 W. 42nd St., New York 18, N. Y.

**ELECTRONICS ENGINEER:** M.A. in Physics. six years experience in the development and design of test equipment for radio and electronics manufacturers desires permanent position in electronics development in New England. PW-981, Electronics, 330 W. 42nd St., New York 18, N. Y.

**ARMY VETERAN Radar Electronics Officer,** age 30, desires position as development engineer or maintenance supervisor on radar, radio or industrial electronics equipment. Qualified by three years college radio engineering education, and nearly four years overseas engaged in ground and airborne radar field development and maintenance supervision. PW-982, Electronics, 330 W. 42nd St., New York 18, N. Y.

## SELLING OPPORTUNITIES OFFERED—WANTED

Selling Agencies—Sales Executives  
Salesmen—Additional Lines

## OFFERED

**WANTED: GRADUATE electrical engineer.** To apply and sell small fractional horsepower motors to industry. To work direct from sales office of established manufacturer in Rochester, N. Y. Manufacturer's representatives not considered. State fully education, experience, age, salary required. Box 322, Rochester 2, N. Y.

## WANTED

**LT. COL Signal Corps** being discharged. Former General Sales Mgr. for South's largest industry. Excellent record and references. Desires lines as manufacturer's representative in South Eastern states. Atlanta headquarters. RA-986, Electronics, 520 N. Michigan Ave., Chicago 11, Ill.

**MANUFACTURERS OF any electronic equipment** who desires California representation for sales and service of their products will find exceptionally qualified, progressive concern in the planning. RA-987, Electronics, 68 Post Street, San Francisco 4, Cal.

**SALES ENGINEERING position** desired by engineer, B.S. in E.E., having 15 years radio receiver design experience in U. S. and Europe. Neat appearance, some supervisory and technical contact experience. Desires connection with reputable firm or sales representative office. Will consider various locations. In reply please give details. SA-988, Electronics, 520 N. Michigan Ave., Chicago 11, Ill.

**RADIO ENGINEER: M.S., E.E. degrees,** experience in practical design and development, desires to join manufacturers of electronic instruments, receivers, transmitters, tubes or parts, etc., as sales engineer and technical representative in China, on commission base, many years electronic business experience in China. SA-989, Electronics, 330 W. 42nd St., New York 18, N. Y.

Nationally known manufacturer of aircraft radio is seeking top-flight representatives to contact aircraft manufacturers and distributors. Previous radio experience necessary. Aircraft experience desirable, but not essential. Generous salary and permanent connection for right men. When writing, the more background information you supply the better your chances for a prompt interview.

RW-990, Electronics  
330 West 42nd St., New York 18, N. Y.

## SALES REPRESENTATION EAST COAST

A group of experienced engineering consultants desire to represent manufacturers of Radio & Electronic products. Please reply with description of products.

RA-951, Electronics  
330 West 42nd Street, New York 18, N. Y.



## Export for Profit

Roburn Agencies, Inc. have represented leading manufacturers of radio and electrical equipment, parts and accessories, in world-wide markets since 1935. Extensive facilities relieve you of all export headaches - correspondence, advertising, sales, finance, packing and shipping. A few additional clients seeking experienced, reliable representation are invited. Write for information on Profits Through Exports.



**Roburn Agencies, Inc.**

115E Fulton Street New York 7, N. Y.

## RADIO and TELEVISION

Leading Danish manufacturer of radio sets and parts wants connection with American manufacturers in the Radio, F.M., Television and Electrical Music industry, who would be interested in cooperating to exploit present potentialities of Denmark market.

A/S Rasmus Rudholt  
Howitzvej 11—Copenhagen F.  
Denmark

## Attention Manufacturers

Established sales representative located in Chicago looking for additional quality lines. Fifteen years experience calling on distributors and manufacturers in Minnesota, Wisconsin, eastern Iowa and northern Illinois. Have engineering service available for customers and clients in addition to dealer sales promotion for distributors. Will be in New York the last 10 days in January and February.

Address  
RA-991, Electronics  
330 W. 42nd St., New York 18, N. Y.

## FOREIGN SALES

### Chinese Radio Engineer

27, married, US educated. Two years production and design experience on Nation's No. 2 secret project, "PROXIMITY FUZE", with leading tube manufacturer. Two years communication equipment experience. Wishes to represent electronic manufacturers in China on salary or salary and commission. Either individual or group representation. For interview please write

RA-970, Electronics  
330 West 42nd St., New York 18, N. Y.

## SELLING RELAYS

and associated electrical control apparatus has been my business for over 15 years. Engineering know-how and past sales record to outstanding accounts will interest you.

Can these facts work to our mutual advantage?

SA-975, Electronics  
330 West 42nd St., New York 18, N. Y.

# MANUFACTURERS ATTENTION

## Greater Distribution at Lower Cost

We buy, carry, stock and sell to Radio Parts Jobbers and small manufacturers. We are interested in 2 or 3 more lines.

State products you have to offer. We are financially responsible. Balance sheet available.

RA-965, Electronics

330 West 42nd St., New York 18, N. Y.

# Would You Hire Me As SALES ENGINEER

1. I don't want to make money for you, but for your customers.
2. I'd be choosy—no job unless convinced of your product's superior values.
3. I'm too confident, perhaps—I have excellent sales aptitudes.
4. I'm a bookworm—I have a broad background knowledge, and an extremely high vocabulary.
5. I may be conceited—I have a pleasing appearance and ability to get along with people.
6. I'm a Phi Beta Kappa man—too smart for the mediocre sales job.
7. I may be too academic — sales knowledge from textbooks and magazines.

**BUT, if you still would like to talk to me, write**

SA-966, Electronics  
330 West. 42nd St., New York 18, N. Y.

## SALES REPRESENTATION WEST COAST

If you are a manufacturer of electrical or electronic equipment for industrial applications, let our staff of experienced engineering consultants represent your products on the west coast. Address

RA-934, Electronics  
68 Post St., San Francisco 4, Calif.



# SURPLUS BARGAINS

(All New Equipment)

- Westinghouse A.C. Voltmeter — Type NA-35—3½" Round—0 to 150 Volts. . . . . \$2.95 ea.
- Westinghouse A.C. Ammeter—Type NA-35—3½" Round—0 to 50 Amps . . . . . \$2.95 ea.
- Battery Charging Ammeter—2" Round—30-0-30 Amps. . \$30 ea.
- Heavy Duty Cutler-Hammer Toggle Switch—Double Pole Double Throw—20 Amps. . . . . \$18 ea.
- Heavy Duty Cutler-Hammer Toggle Switch—Single Pole Single Throw—20 Amps. . . . . \$16 ea.
- Ward-Leonard Rheostat—75 Ohms—150 Watts . . . . . \$95 ea.
- Mica Condenser—.01 Mfd.—600 Volts—D.C. Working . . \$13 ea.
- A.C. Synchronous Generator with Built-in Exciter—2½ KW—60 Cycle—Single Phase—120 Volts 1800 RPM. . . . . \$75.00 ea.
- Square D Multi-Breaker—2 Pole—60 Amp. . . . . \$3.95 ea.
- Magnet Wire—#11 Single Cotton—Heavy Formvar—12" or 24" Reels . . . . . \$18 lb.
- Magnet Wire—#9 Flexible Armature Wire (41 Strands of #25 with White Cotton Braid) \$.23 lb.

Engine Driven A.C. Generator Sets—Complete with Engine, Generator and Switchboard—Various Sizes: 3, 5, 7½, 10 and 15 KW—3 Phase and Single Phase—50 to 60 Cycles. Prices on Request.

## PIONEER ELECTRIC COMPANY

3700 East Olympic Blvd.  
Los Angeles 23, California

## Remler Appointed as Agent for R. F. C.

... to handle and sell government owned electronic equipment released for civilian use.

Write for Bulletin Z-1A listing a wide variety of equipment covering entire electronic field.

Remler Co., Ltd. • 2101 Bryant St.  
San Francisco 11, Calif.

# REMLER

SINCE 1918

Communications • Electronics

### BEST QUALITY, USED ELECTRON TUBE MACHINERY

Equipment for the manufacture of all kinds of electron tubes, radio tubes, incandescent lamps, neon tubes, photo electric cells, X-ray tubes, etc.

AMERICAN ELECTRICAL SALES CO., Inc.  
65-67 East 8th St. New York, N. Y.

### CAPACITORS

5000 new G.E. Pyranol 4000 v. d.c. working, 2 mfd. in original cartons. Complete with mounting bracket. Price \$5.00 each freight prepaid. Six units minimum order.

GREGORY ELECTRIC COMPANY  
2630 So. State St. Chicago, Ill.

### PRICED FOR IMMEDIATE DISPOSAL

NEW—(1) Raytheon Magnitron 2161 Westinghouse Ignitrons (1) 653-B, (2) 655/658.  
(2) Eimac 250TH/VT220.  
8000 5/8" diameter porcelain Insulators 1/16 wall, 5/8" long.  
USED—Industrial X-Ray Tube envelope type BD.  
WANTED—Discarded Transmitting Tubes, Shrinkage Tubes, Metal Components, any quantity.  
FS-977, Electronics, 330 W. 42 St., New York 18, N. Y.

WRITE FOR 24 P. CATALOG OF

# METERS

AND INSTRUMENTS

VOLTMETERS	BRIDGES (Wheatstone)
AMMETERS	MEGOhmmeters
MICRO	RHEOSTATS
AMMETERS	VARIABLE
Ohmmeters	TRANSFORMERS
FREQ. METERS	RELAYS

**ELECTRO-TECH** Equipment Co.  
329 CANAL ST., N. Y. 13, N. Y.

## LINES WANTED

Manufacturers Agent located in Chicago, established over 40 years, contacting Electrical, Automotive and Radio Manufacturers, want additional lines. Technical Personnel covering Illinois, Indiana and Wisconsin.

RA-967, Electronics  
520 North Michigan Ave., Chicago 11, Ill.

### Representation In Switzerland

Successful and energetic representative of radio parts wants connection with American manufacturer of radio parts either as representative or dealer. Write details to

HERMANN HOLZHEU

1 Wybuelstrasse, Zurich-Zollikon (Switzerland)

### WANTED

## SALES REPRESENTATION CHICAGO AND VICINITY

Materials and parts for manufacturing and assembly of electrical, mechanical and radio products.

Insulation products (sheet, molded, extruded, paper, paper tubes, ceramics, standard and custom molding), insulated wire, resistance wire, stampings, washers, screw machine products, drawn and extruded containers, wire forms, springs, headed products, etc.

Thorough experience will properly represent you.

RA-976, Electronics  
520 North Michigan Ave., Chicago 11, Ill.

## NOTICE MANUFACTURERS

Manufacturers representative seeking lines for distribution Southwest territories new postwar products.

RA-968, Electronics  
621 So. Hope St., Los Angeles 14, Calif.

### Chicago Representation

Established Chicago distributor desires several part-time exclusive established lines for Chicago territory; commission or resale; or special sale assignments or follow-up work. Local representation and address for nominal charge, sales and service.

RA-972, Electronics  
520 North Michigan Ave., Chicago 11, Ill.

### NATIONAL DISTRIBUTION AVAILABLE

For Manufacturers who make products suitable for sale to radio and electronic jobbers. We have a complete sales staff for national and export distribution. Reply with samples or description of products.

RA-870, Electronics  
330 West 42nd St., New York 18, N. Y.

### 32 PHILCO RECEIVERS

26 Model 821 and 822, \$20.00 each.  
6 Model 811, \$15.00 each and four Motorola Station Receivers for use A.C. current, \$40.00 each, All 30,580 K.C.. Apply G. M. Gordon,  
Purchasing Agent, City of Jacksonville, Jacksonville, Florida

### WANTED

Your Business

"ANYTHING containing IRON or STEEL"

MORE FOR YOUR DOLLAR  
IRON & STEEL PRODUCTS, INC.

40 years' experience  
13422-A S. Brainard Ave., Chicago 33, Ill.



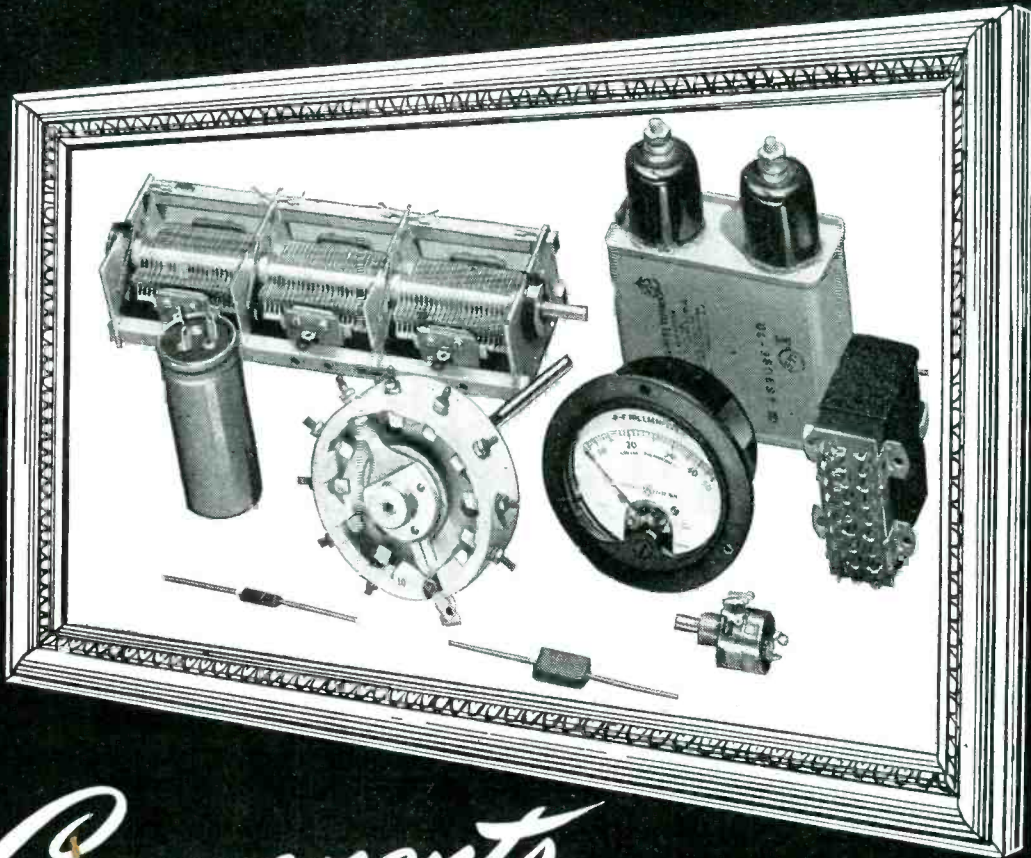

# Components

The flow of surplus radio components will tend to increase as more and more parts are released for general distribution by the government. Hallicrafters, acting as agent for the RFC is in an especially advantageous position to see that these components reach the people who need them most. And Hallicrafters, through its national organization can see that this distribution is accomplished with the utmost economy and efficiency. As thousands and thousands of components are received they are checked, tested and

evaluated by Hallicrafters engineering corps—highly qualified experts in the field. On hand now or certain to show up soon in the government's disposal inventories are such interesting components as those shown above, including items like high voltage oil filled capacitors, meters and indicating instruments, electrolytic capacitors, volume controls and variable resistors, connectors, jacks, plugs, terminals, etc., mica capacitors, carbon resistors.

## hallicrafters RADIO

THE HALLICRAFTERS CO., AGENT FOR RFC UNDER CONTRACT SIA-3-24  
MANUFACTURERS OF RADIO AND ELECTRONIC EQUIPMENT

THESE VALUABLE ITEMS *Available Now* or very soon. Write, wire or phone for further information • head phones • test equipment • component parts • marine transmitters and receivers • code practice equipment • sound detecting equipment • vehicular operation police and command sets • radio beacons and airborne landing equipment.

### CLIP THIS COUPON NOW

HALLICRAFTERS - RFC DEPARTMENT 517  
5025 West 65th Street, Chicago 38, Illinois, E.U.A.  
 Send further details on merchandise described above  
 Send listings of other available items  
Especially interested in \_\_\_\_\_  
STATE \_\_\_\_\_  
NAME \_\_\_\_\_  
CITY \_\_\_\_\_ ZONE \_\_\_\_\_  
ADDRESS \_\_\_\_\_



# EMERGENCY ENGINEERING

to push your LAGGING development and engineering program through—today . . . spare you lost production PROFITS tardy engineering costs you.

Our specially trained crews of reconversion engineers are geared for speed. Work in our shop, or under your supervision in your own drafting rooms—for a week, or month or longer until you get caught up. Right now more than 30 B & R crews, numbering 1 to 33 men, are helping anxious manufacturers get into production FASTER.

## WHAT WE DO THAT'S IMPORTANT TO YOU

- 1 Electronics Engineering
- 2 Product Engineering
- 3 Machine Design
- 4 Tool Design
- 5 Plastics Engineering
- 6 Drafting
- 7 Food Technology
- 8 Product Creation, Styling
- 9 Plant Layout
- 10 Instruction Manuals
- 1 Model Making
- 2 Package Development

**Action**  
WHEN YOU  
NEED IT  
FAST

# BARNES & REINECKE

INDUSTRIAL DESIGNERS & ENGINEERS  
230 E. OHIO STREET  
CHICAGO 11 DELAWARE 6350

STAFF OF 187

TWELFTH YEAR

## Backtalk

This department is operated as an open forum where our readers may discuss problems of the electronics industry or comment upon articles which **ELECTRONICS** has published.

### Ultraviolet Barriers

Dear Sir:

IN THE OCTOBER issue of **ELECTRONICS** 1945, page 242, I find an article on Transparent Ultraviolet Barriers.

It may perhaps interest you to know that I have used this type filter since early 1937 and had even better results with a similarly prepared and used filter of picrolonic acid (3-methyl-4-nitro-1-p-nitrophenyl-5-pyrazolone). Solutions of 2.5 to 5 p.b.w. of picric or picrolonic acid, respectively, in ethyl alcohol, this mixed with a chemically neutral thinner at a ratio of 3:100 to 10:100, and a chemically neutral cellulose lacquer added to this mixture until it was ready for spraying (at about 1:1), proved satisfactory.

I also used this solution to black-out the fluorescence of any materials which were wanted for a particular reason but whose fluorescence would have been prohibitive.

I would like to take this opportunity to tell you how much I appreciate the high standard **ELECTRONICS** is setting. I enjoy every issue of it.

DR. W. SOMMER  
Birmingham, England

. . .

### As a Hen's Tooth

Gentlemen:

ALTHOUGH COPIES of the November issue of **ELECTRONICS** are probably scarce, I would certainly like to obtain another one. This issue is certainly spectacular, and unmistakably shows **ELECTRONICS** to be way out in front of similar publications.

ERNEST FRANK  
Sperry Gyroscope Company  
Nassau County, L. I., N. Y.

## SHOCKPROOF INSULATION BREAKDOWN TESTERS

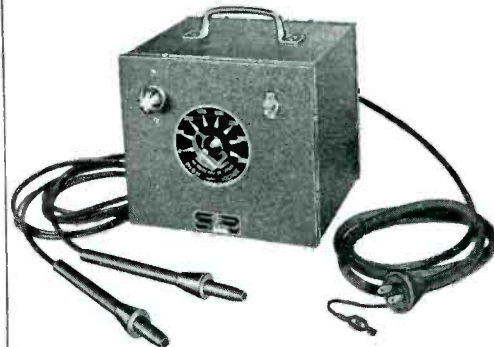

MODEL IT-25

### Features:

- ★ Designed for accurate testing of apparatus at fixed voltages.
- ★ High Reactance Power Transformer is burn-out proof.
- ★ Neon Lamp permits accurate indication of material under test.
- ★ Heavy bakelite Shock-proof Test Handles with disappearing points.
- ★ Eight point switch varies with secondary voltage.
- ★ Input 115 Volts 60 Cycle, Rating 500 VA.

Price Net \$40.00



MODEL IT-306

### Features:

- ★ Smooth variable voltages from 0 to 3000 or 0 to 6000 Volts A.C.
- ★ Instantaneous trip Circuit Breaker indicates breakdown.
- ★ Heavy bakelite shockproof Test Handles with disappearing points
- ★ Voltmeter indicates output voltages 0-3000 or 0-6000 volts.
- ★ Heavy gauge steel cabinet, gray finish.
- ★ Input 115 Volts 60 Cycle—Rating 1 KVA.

Price net \$125.00

## INDUSTRIAL TRANSFORMER CORP.

2540 Belmont Ave. New York, N. Y.

# INDEX TO ADVERTISERS

	Page		Page
Accurate Spring Manufacturing Co.	197	Communication Parts	328
Ace Manufacturing Corporation	286	Conant Electrical Laboratories	220
Acheson Colloids Corporation	183	Concord Radio Corporation	327
Acme Electric & Mfg. Co.	340	Condenser Products Company	341
Acro Electric Co.	204	Continental-Diamond Fibre Co.	69
Advance Electric & Relay Co.	308	Cornell-Dubilier Electric Corp.	253
Aerovox Corporation	78	Corning Glass Works	229
Agaloy Tubing Company	72	Cornish Wire Company, Inc.	208
Aireon Manufacturing Corp.	8, 9, 247	Creative Plastics Corporation	282
Alden Products Company	308	Cross, H.	351
Allegheny Ludlum Steel Corp.	79	Crystal Research Laboratories, Inc.	290
Allen-Bradley Company	74		
Alliance Manufacturing Company	47	Dalis, Inc., H. L.	286
Allied Control Co., Inc.	77	Daven Company	Inside Back Cover
Allied Radio Corp.	318	De Mornay Budd, Inc.	185
Allis-Chalmers, Electronic Devices Section 4,	5	Deutschmann Corp., Tobe	2
Aluminum Company of America	195	Dial Light Co. of America, Inc.	266
American Brass Co.	192	Diamond Instrument Co.	80
American Condenser Co.	344	Dinion Coil Co., Inc.	324
American Gas Accumulator Co.	334	Dongan Electric Mfg. Co.	298
American Gas & Chemical Co.	350	Driver-Harris Co.	53
American Lens Co., Inc.	86	Dumont Electric Co.	26
American Phenolic Corp.	251	DuMont Laboratories, Inc., Allen B.	38, 57
American Platinum Works	333	du Pont de Nemours & Co. (Inc.), E. I.	203
American Screw Co.	22	Durez Plastics & Chemicals, Inc.	187
American Television & Radio Co.	294		
American Television Society, Inc.	63	Eastern Air Devices, Inc.	233
American Transformer Co.	199	Eastern Amplifier Corporation	271
Amperex Electronic Corporation	7	Eastern Electronics Corp.	291
Amperite Co.	278	Eastern Engineering Co.	346
Andrew Co.	180	Eby, Inc., Hugh H.	320
Armstrong Mfg. Co.	351	Eicor, Inc.	202
Arnold Engineering Co.	238	Eisler Engineering Co.	288, 351
Art Wire & Stamping Co.	331	Eitel-McCullough, Inc.	89
Astatic Corporation	226	Electrical Industries, Inc.	334
Atlas Sound Corp.	331	Electrical Insulation Co., Inc.	292
Atlas Tool & Designing Co.	37	Electrical Reactance Corp.	346
Audak Co.	359	Electrix Corporation	337
Audio Devices, Inc.	20	Electronic Engineering Co.	332
Automatic Electric Sales Corp.	50	Electronic Laboratories, Inc.	46
Automatic Mfg. Corporation	84	Electronic Mechanics, Inc.	76
		Electronics Research Publishing Co.	339
Baer Company, N. S.	333	Electrons, Inc.	240
Baker-Phillips Co.	326	Electro-Motive Mfg. Co.	83
Ballantine Laboratories, Inc.	188	Electro Products Laboratories	341
Barber Laboratories, Alfred W.	350	Electro-Voice, Inc.	317
Barker & Williamson	244	Electronic Laboratories, Inc.	46
Barnes & Reinecke	356	Erie Resistor Corp.	209
Beaver Gear Works, Inc.	304	Essex Electronics	357
Bell Telephone Laboratories	179		
Bentley, Harris Mfg. Co.	207	Farnsworth Television & Radio Corp.	263
Birnback Radio Co., Inc.	341	Fast & Co., John E.	34
Bogen Co., Inc., David	343	Federal Tel. & Radio Corp.	58, 171, 343
Boonton Radio Corp.	218	Fenwal, Inc.	262
Brand & Co., William	42	Ferranti Electric, Inc.	174
Bud Radio, Inc.	342	Fish-Schurman Corporation	333
Burgess Battery Co.	324	Franklin Airloop Corporation	175
Burlington Instrument Co.	214	Freed Transformer Co.	293
Burstein-Applebee Co.	351	Freeland & Olschner Products, Inc.	351
Callite Tungsten Corp.	65	Garrett Co., Inc., George K.	11
Cambridge Thermionic Corporation	343	Gear Specialties	45
Capitol Radio Engineering Institute	329	General Cement Mfg. Co.	351
Carter Motor Co.	330	General Electric Co.	15, 16, 17, 18, 249, 265, 284, 338
Celanese Corp. of America	227	General Industries Co.	339
Cellusuede Products, Inc.	321	General Magnetic Corp.	322
Centralab, Div. of Globe-Union, Inc.	24	General Plate Div. of Metals & Controls Corp.	255
Chatham Electronics	62	General Radio Company	267
Chicago Telephone Supply Co.	19	Gibbs & Company, Thomas B.	194
Chicago Transformer Corp.	323	Glaser Lead Co., Inc.	228
Cinaudagraph Corporation	190	Goodrich Chemical Co., B. F.	360
Cinch Mfg. Corp.	161	Gothard Manufacturing Company	272
Cinema Engineering Co.	246	Gould-Moody Co.	276
Clarostat Mfg. Co., Inc.	184	Graphite Metallizing Corp.	284
Clippard Instrument Laboratory	276	Guardian Electric Mfg. Co.	201
Cohn & Co., Sigmund	342		
Collins Radio Co.	41		
Communication Measurements Laboratory	234		

ONE OF A SERIES...

**ESSEX**

Showing complete manufacturing facilities from raw material to finished product!

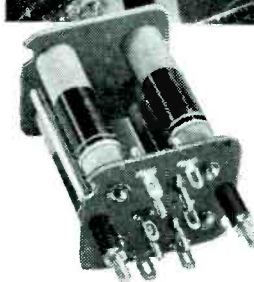
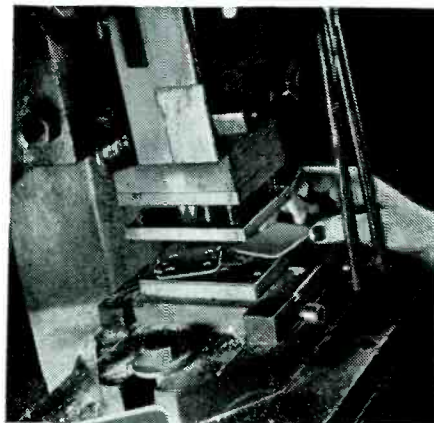

**Power  
Press  
Facilities**

**for Punching and Forming  
Our Own Forms for  
all Types of Coils**

ESSEX has the production equipment to meet the most rigid specifications of the radio industry. The skills and techniques that made ESSEX a reliable source for high quality transformers during the hectic period of the war, is now available to the producers of the more perfect radio instruments that will serve a peaceful world. Whatever your component need may be, now . . . as before . . . you can always rely on ESSEX.

Precision manufacturers of all types of IF and RF coils, chokes, and transformers.

**ESSEX  
ELECTRONICS**  
1060 Broad St., Newark, N. J.



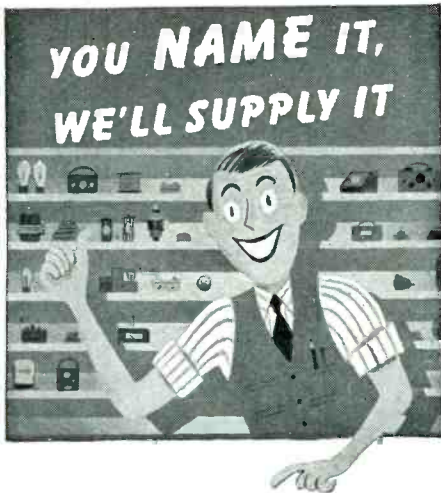

## EVERYTHING IN RADIO AND ELECTRONICS

R. W. T., world's oldest and largest Radio Supply House is ready again with tremendous stocks of sets, parts and equipment. You can depend on our quarter-century reputation for quality, sound values and super-speed service. Orders shipped out same day received. All standard lines already here or on the way, including: National, Hammarlund, R. C. A., Hallicrafters, Bud, Cardwell, Bliley and all the others you know so well.

Originators and  
Marketers of  
the Famous

*Lafayette Radio*

## Radio Wire Television Inc.

100 Avenue of the Americas, New York 13  
(Formerly Sixth Avenue)  
Boston, Mass. • Newark, N. J.

"No supplier anywhere has a bigger stock of Radio and Electronic equipment, Test equipment, Public Address equipment, Communications equipment. If your engineering problem requires special equipment, we'll make it. Write today Dept. EA-6."

# INDEX TO ADVERTISERS

Continued

	Page		Page
Hallicrafters Co. ....	35	National Vulcanized Fibre Co. ....	10
Hamilton Institute, Alexander .....	325	New Hermes Engravers .....	250
Hammarlund Mfg. Co., Inc. ....	6	New York Transformer Co. ....	189
Handy & Harman .....	302	Newark Electric Co. ....	186
Hardwick, Hindle, Inc. ....	335	North American Philips Co., Inc. ....	279
Harris Products Co. ....	256		
Harvey Radio Company .....	280	Ohmite Mfg. Company .....	223
Harvey Radio Laboratories, Inc. ....	301	Onan & Sons, D. W. ....	332
Harvey Wells Electronics, Inc. ....	313	O'Neil-Irwin Mfg. Co. ....	278
Hathaway Instruments .....	236	Oster Mfg. Co., John .....	40
Hewlett-Packard Company .....	287		
Hopp Press, Inc. ....	298	Par-Metal Products Corporation .....	548
Hudson American Corporation .....	316	Patton-MacGuyer Co. ....	339
Hytron Radio & Electronics Corp. ....	67	Permo, Inc. ....	314
		Permoflux Corporation .....	210
Illinois Condenser Co. ....	331	Petersen Radio Co. ....	328
Indiana Steel Products Co. ....	178	Phillips Screw Manufacturers .....	81
Industrial Condenser Corp. ....	224	Pioneer Gen-E-Motor Corp. ....	216
Industrial Instruments .....	337	Plaskon Div., Libbey, Owens, Ford Glass Co. ....	59
Industrial Timer Corporation .....	322	Plastic Wire & Cable Corp. ....	60
Industrial Transformer Corp. ....	356	Plax Corporation .....	269
Insl-X Co., Inc. ....	212	Potter & Brumfield Mfg. Co., Inc. ....	347
Instrument Resistors Company .....	314	Potter Company .....	333
Instruments Publishing Co. ....	340	Potter Instrument Co. ....	27
Irvington Varnish & Insulator Co. ....	217	Premier Metal Etching Co. ....	335
		Press Wireless, Inc. ....	68
Janette Manufacturing Co. ....	310	Presto Recording Corp. ....	213
Jefferson Electric Co. ....	221	Production Engineering Corp. ....	66
Jelliff Mfg. Corp., C. O. ....	312	Progressive Mfg. Co. ....	337
Jensen Radio Mfg. Co. ....	73	Pyroferic Co. ....	326
Joliet Chemicals, Ltd. ....	75		
Jones Co., Howard B. ....	341	Quadrige Mfg. Co. ....	350
		Quaker City Gear Works, Inc. ....	254
Kahle Engineering Co. ....	351		
Karp Metal Products Co., Inc. ....	49	Radio City Products Co., Inc. ....	245
Kester Solder Co. ....	260	Radio Condenser Co. ....	21
Keuffel & Esser Co. ....	3	Radio Corp. of America, Victor Div. ....	30
Kinney Manufacturing Co. ....	196	31, 70, 71, Back Cover	
Kirkland Co., H. R. ....	345	Radio Development & Research Corp. ....	299
Kluge Electronics .....	182	Radio Engineering Lab's, Inc. ....	193
		Radio Receptor Co., Inc. ....	176
Lampkin Laboratories .....	351	Radio Supply & Engineering Co., Inc. ....	374
Lapp Insulator Co., Inc. ....	33	Radio Wire Television, Inc. ....	358
Lavoie Laboratories .....	259	Rauland Corporation .....	177
Lawton, Norman H. ....	318	Rawson Electrical Instrument Co. ....	348
Lectrohm, Inc. ....	330	Raytheon Mfg. Co. ....	43, 239
Lepel High Frequency Laboratories, Inc. ....	181	Revere Copper & Brass, Inc. ....	303
Linde Air Products Co. ....	326	Richardson Company .....	252
Lord Manufacturing Co. ....	219	Ripley Company, The .....	306
		Robinson Aviation, Inc. ....	345
MacRae's Blue Book .....	306	Rockbestos Products Corp. ....	297
Madison Electrical Products Corp. ....	248	Rogan Brothers .....	288
Maguire Industries, Inc. ....	28, 29	Roller-Smith Co. ....	225
Mallory & Co., Inc., P. R. ....	90, 163	Russell & Stoll Company .....	331
Marion Electrical Instrument Co. ....	44		
MB Manufacturing Co., Inc. ....	55, 305	Schott Co., Walter L. ....	347
McGraw-Hill Book Co. ....	320, 347	Schweitzer Paper Co. ....	215
McLaughlin, J. L. A. ....	351	Scientific Electric Div. of "S" Corrugated Quenched Gap Co. ....	241
Meyercord Company, The .....	257	Scovill Mfg. Co., Waterville Screw Products Div. ....	165
Micro-Ferrocort Products, Div. of Maguire Industries, Inc. ....	309	Selenium Corporation of America .....	322
Milford Rivet & Machine Co. ....	230	Shallcross Mfg. Co. ....	172
Millen Mfg. Co., Inc., James .....	270	Sherron Electronics Co. ....	51
Miniature Precision Bearings .....	351	Sigma Instruments, Inc. ....	232
Mitchell-Rand Insulation Co., Inc. ....	243	Signal Indicator Corp. ....	324
Multicore Solders, Ltd. ....	289	Sillcocks-Miller Co. ....	270
Murdoch Co., William J. ....	282	Small Motors, Inc. ....	296
Murray Hill Books, Inc. ....	336	Skydyne, Inc. ....	344
Mycalex Corporation of America .....	13	Sola Electric Co. ....	12
		Sorensen & Company, Inc. ....	311
National Research Corporation .....	283	Sound Equipment Corp. of Calif. ....	242
National Union Radio Corporation .....	23	Spencer Wire Co. ....	231
National Varnish Products Corp. ....	277	Sperry Gyroscope Company, Inc. ....	167

	Page
Sperti, Inc. ....	296
Sprague Electric Co. ....	54
Stackpole Carbon Co. ....	32
Stamford Metal Specialty Co. ....	345
Standard Piezo Company ....	170
Standard Pressed Steel Co. ....	39, 211
Standard Transformer Corp. ....	168
Star Expansion Products Co. ....	335
Star Porcelain Co. ....	324
Stephens Manufacturing Co. ....	294
Stevens Arnold Co. ....	273
Stevens-Walden, Inc. ....	274
Steward Mfg. Co., D. M. ....	348
Stewart Mfg. Corp., F. W. ....	326
Sticht Co., Inc., Herman H. ....	339
Stoelting Co., C. H. ....	290
Stokes Machine Co., F. J. ....	328
Struthers-Dunn, Inc. ....	14
Stupakoff Ceramic & Mfg. Co. ....	61
Sun Radio & Electronics Co., Inc. ....	312
Superior Electric Co. ....	64
Superior Tube Co. ....	87
Supreme Instruments Corp. ....	335
Suprenant Electrical Insulation Co. ....	280
Sylvania Electric Products, Inc. ....	205

Taylor Fibre Company ....	56
Tech Laboratories ....	206
Teleso Products Co. ....	268
Thomas & Skinner Steel Products Co. ....	347
Tinnerman Products, Inc. ....	169
Transmitter Equipment Mfg. Co., Inc. ....	25
Triplett Electrical Instrument Co. ....	292
Tung-Sol Lamp Works, Inc. ....	261
Turner Company ....	85

Ucinite Company ....	295
Union Carbide & Carbon Corp. ....	326
United Cinephone Corp. ....	319
United States Television Corporation ....	315
United Electronics Co. ....	48
United Transformer Corp. ....	Inside Front Cover
University Laboratories ....	336

Victoreen Instrument Co. ....	316
-------------------------------	-----

Waldes Kohinor, Inc. ....	237
Walker-Turner Co., Inc. ....	304
Ward Leonard Electric Co. ....	281
Ward Products Corporation ....	338
Waterbury Companies, Inc. ....	307
Welch Scientific Company, W. M. ....	264
Weller Mfg. Co. ....	345
Western Electric Co. ....	52
Westinghouse Electric Corporation ....	88, 173
Weston Electrical Instrument Co. ....	36
White Dental Mfg. Co., S. S. ....	285, 310
Whitehead Stamping Co. ....	345
Wilcox Electric Co. ....	191
Willor Manufacturing Corp. ....	198
Wilson Co., H. A. ....	82, 275
Wincharger Corporation ....	321
Winslow Company ....	321

Zenith Optical Laboratory ....	272
--------------------------------	-----

PROFESSIONAL SERVICES ....	349
----------------------------	-----

SEARCHLIGHT SECTION  
(Classified Advertising)

EMPLOYMENT ....	352, 353, 354
USED EQUIPMENT ....	354, 355
American Electric Sales Co., Inc. ....	354
Electro-Tech. Equipment Co. ....	354
Hallicrafters Co. ....	355
Iron & Steel Products Inc. ....	354
Gordon G. M. ....	354
Gregory Electric Co. ....	354
Pioneer Electric Co. ....	354
Remler Co. Ltd. ....	354

**5** letter-word for PICK-UP PERFORMANCE

# Audax



... the substantially unanimous verdict of experts and music lovers who have put the

**RELAYED-FLUX**  
*Microdyne*

to the only test that really matters ... the **EAR TEST**

*"The Standard by Which Others Are Judged and Valued"*

## SPECIALIZATION

has made AUDAX a leader in its field. World-wide recognition such as ours could never "just happen". Rather it is the product of KNOW-HOW that comes only through years of specialization.

For twenty years—since pick-ups first became important commercially—the distinguished products of AUDAX have been **SELECTED** wherever the requirements were exacting.

The leadership which we have won the hard way will never be jeopardized by making pick-ups a side line. Of future MICRODYNE improvements—and of course we are planning them now—we can tell you one thing NOW:—They will uphold and carry forward the AUDAX quality tradition of *fac-simile* performance, regardless of external conditions.

Send for complimentary copy of  
**"PICK-UP FACTS"**

# AUDAX COMPANY

500 Fifth Avenue, New York 18

"Creators of Fine Electronic-Acoustical Apparatus since 1915"





**For 11 advantages in**

**radio hookup and**

**appliance wiring**

use  
★ Wire insulated  
with **Geon**  
★ Wire carrying  
Underwriters  
approval

- ... Excellent electrical properties
- ... Thin coating — smaller OD
- ... Non-inflammable — self-extinguishing
- ... Ease of installation
- ... Good resistance to heat and cold
- ... Light weight
- ... Extreme age and ozone resistance
- ... Resistance to oils, acids, chemicals
- ... Ultra-high flexlife
- ... Entire NEMA color range
- ... SAFETY assured by Underwriters tests

The next time you order wire or cable from your supplier be sure to specify—

Wire insulated with **GEON**

Wire carrying Underwriters approval

For additional information please write Dept. F-1, B. F. Goodrich Chemical Company, 324 Rose Bldg., Cleveland 15, Ohio.



**B. F. Goodrich Chemical Company**

A DIVISION OF  
THE B. F. GOODRICH COMPANY



ATTENUATION BOX



DECADE VOLTAGE DIVIDER

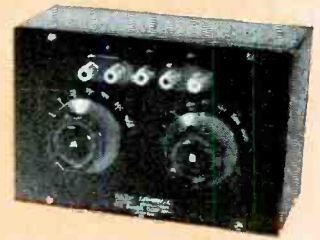

RATIO ARM BOX

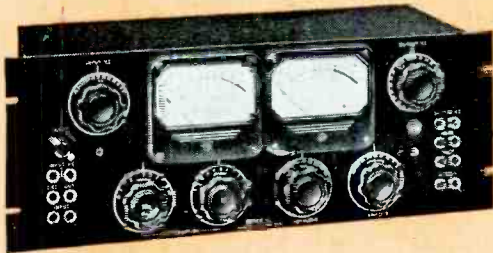

TRANSMISSION MEASURING SET



OUTPUT METER



ELECTRONIC FREQUENCY METER



VOLUME LEVEL INDICATOR



# DAVEN

## MEASURING, TESTING AND CONTROL EQUIPMENT

These DAVEN instruments are the "trusted aides" of audio communications and general electronic engineers the world over. Each type of equipment is built to the highest standards of precision and durability, and is available in a wide selection of standard models.

Many other test sets and control units, specially designed by DAVEN, are in long service with America's key radio stations, leading sound recording studios, and the Armed Forces.

Full details gladly furnished upon request. Write to . . .  
THE DAVEN COMPANY, 191 Central Ave., Newark 4, N. J.



POWER OUTPUT METER



DECADE RESISTANCE BOX





# Short Waves Demand Small Dimensions



*ACTUAL SIZE. RCA Leads the Way In Metal, Glass and Miniature Electron Tubes*

## IN TUBES, RCA MINIATURES ARE THE ANSWER for FM—for Television—for HF Communications

Consider these advantages of RCA Miniature Tubes for high-frequency applications:

**HIGH GAIN**—Lower inter-electrode capacitances and reduced lead inductance values improve circuit performance.

**LOW LOSS**—The short, low-resistance element leads serve as the contact pins; these, with the glass button seal provide a low-loss base.

**LESS SPACE**—Small dimensions of tubes permit closer spacing of components on a smaller chassis.

**PREFERRED TYPES**—Mass production is concentrated

on a few types that meet all normal design requirements, resulting in higher tube quality at lower prices.

RCA tube application engineers are ready to consult with manufacturers on any problems, concerning the use of electron tubes—metal, miniature, or glass. For technical information on RCA tubes, write RCA Commercial Engineering Department, Section D-6A, Radio Corporation of America, Harrison, N. J.

**THE FOUNTAINHEAD OF MODERN TUBE DEVELOPMENT IS RCA**



**TUBE DIVISION**

**RADIO CORPORATION of AMERICA**

**HARRISON, N. J.**