

NOVEMBER • 1944

# electronics

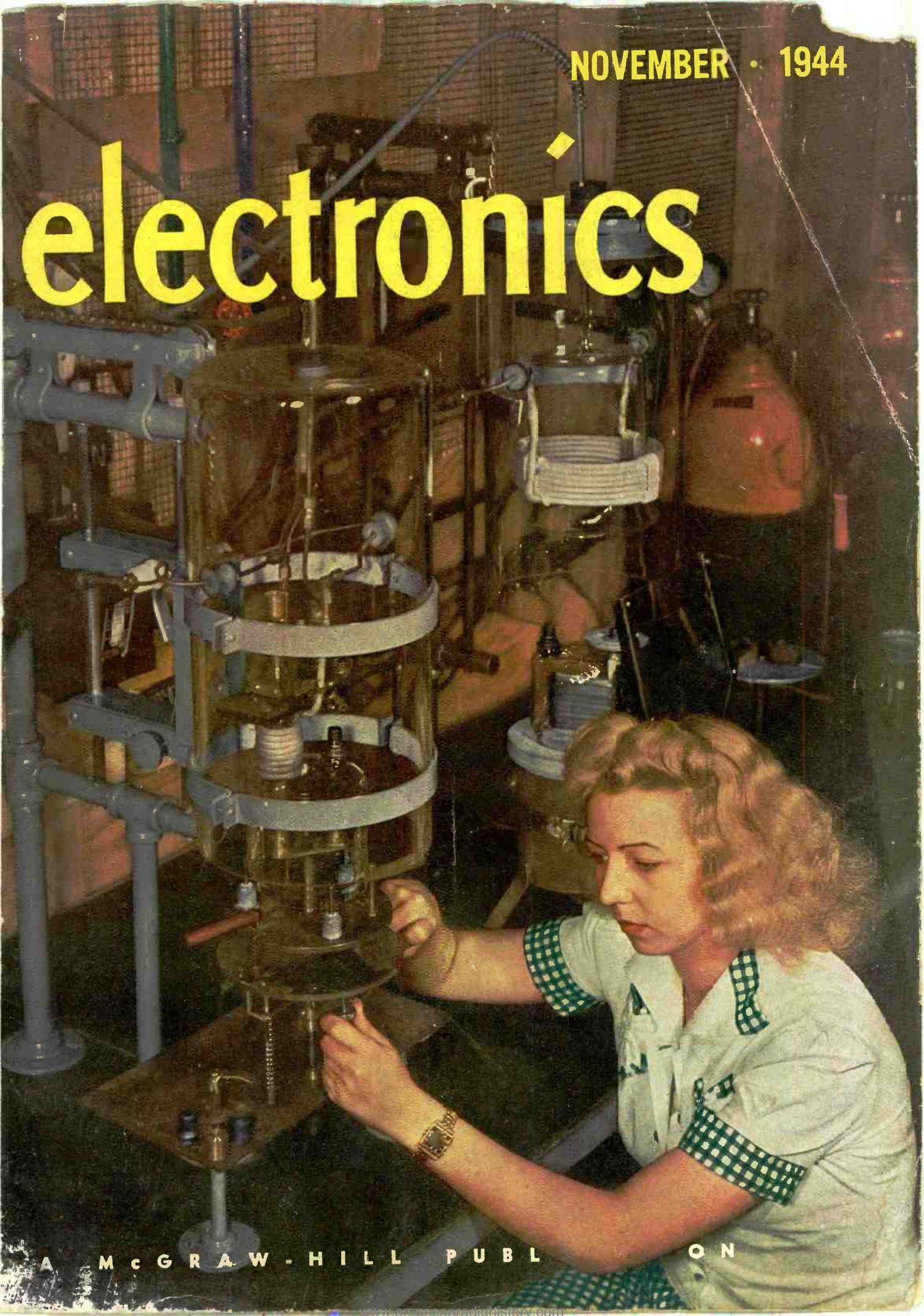

A MCGRAW-HILL PUBLICATION



# LOW PASS (TYPE L. P. I.) FILTERS

# HIGH PASS (TYPE H. P. I.) FILTERS

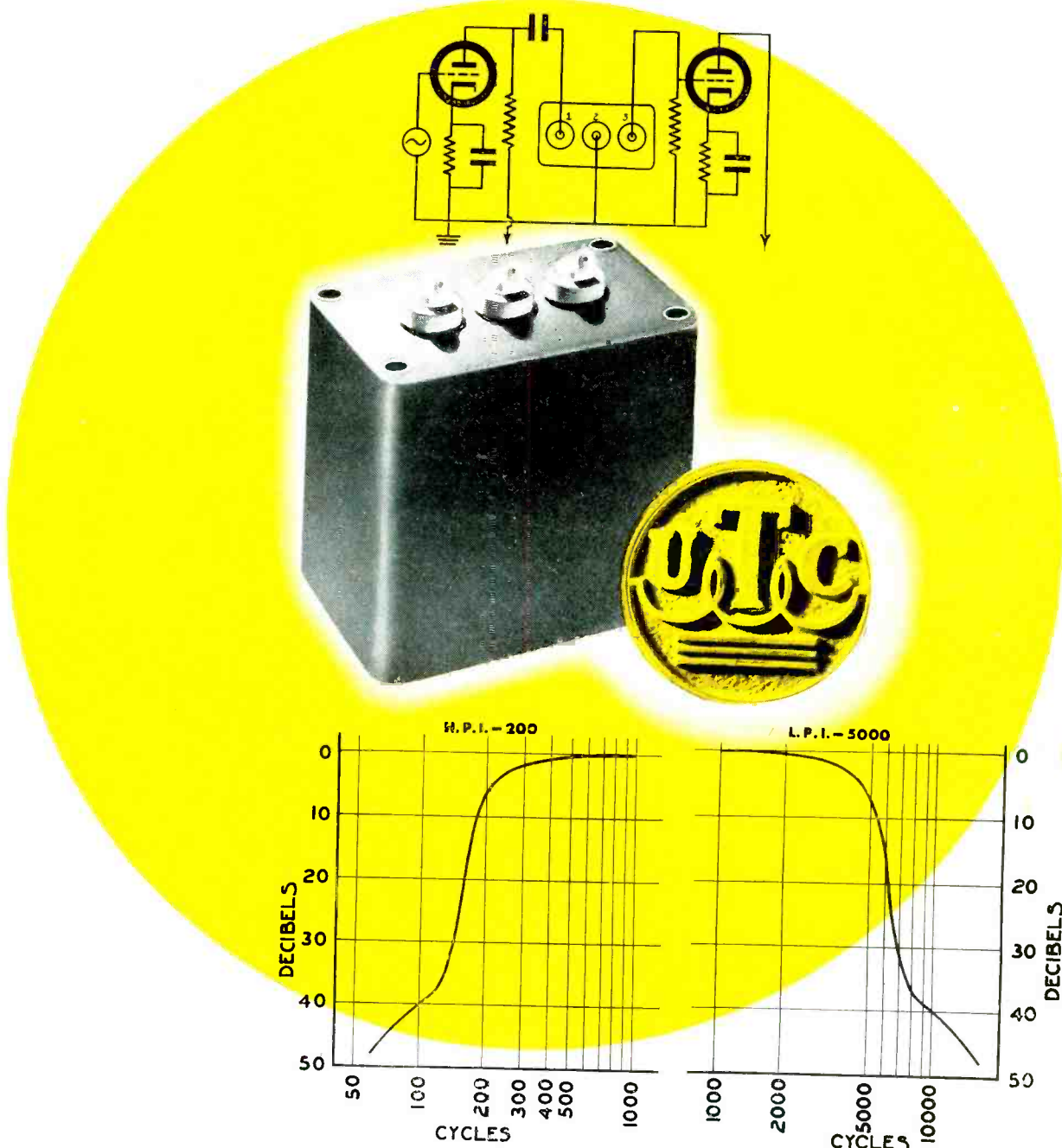

New additions to the UTC Interstage Filter family are now available in the type HPI and LPI units, respectively high pass interstage and low pass interstage filters.

The units are designed with a nominal impedance of 10,000 ohms to be used in a circuit as illustrated. Typical curves obtainable are shown above. Loss at cutoff frequency is less than 6 DB. At .75 times cutoff or 1.5 cutoff frequency respectively, the attenuation is 35 DB, and at one-half or twice cutoff frequency respectively, the attenuation is 40 DB.

These units employ a dual alloy magnetic shield which reduces inductive pickup to 150 Mv. per gauss. The dimensions in hermetically sealed cases are 1½" x 2½" x 2½". Filters of the HPI and LPI type can be supplied for any cutoff frequency from 200 to 10,000 cycles. Specify by type followed by frequency, as: LPI-2500.

*May we cooperate with you on design savings for your application . . . war or postwar?*

*United Transformer Co.*

150 VARICK STREET

NEW YORK 13, N. Y.

EXPORT DIVISION: 13 EAST 40th STREET, NEW YORK 16, N. Y.. CABLES: "ARLAB"



# electronics

NOVEMBER • 1944

SEALING TUBE CAPS .....	Cover
Electronic heating within nitrogen-filled bell-jars minimizes oxidation at a North American Philips plant	
INTERNATIONAL RADIO FREQUENCY PROPOSALS .....	92
Preliminary discussions of State Department committee point toward things to come	
AUTOMATIC MAP TRACER FOR LAND NAVIGATION, by D. J. Faustman .....	94
Army's land equivalent of blind-flying apparatus uses a precision magnetic compass with electronic follow-up	
KLYSTRON OSCILLATORS, by A. E. Harrison .....	100
Comparison of theoretical operation of velocity-modulation oscillators with performance of 410-R/2K30 Klystron	
DUAL TIME SIGNAL AT WQXR, by Russell D. Valentine .....	108
Method utilizing a pulse from a clock reset circuit without connection to the line	
LOCATION OF LINE FAULTS, by M. A. Honnell .....	110
The nature and location of line faults are determined by oscillosopic observation of pulses	
CAPACITOR-MATCHING OSCILLATOR, by Harold H. Tepper .....	114
Description of a direct-reading production capacitor-matching oscillator	
ARMY RADIO D-F NETWORKS, by G. L. Twist .....	118
Signals from lost aircraft are utilized by direction-finder networks to establish geographical positions	
RTPB ON FM .....	125
FM panel presents recommendations for post-war v-h-f entertainment and educational broadcasting	
FREQUENCY-SHIFT RADIOTELEGRAPH AND TELETYPE SYSTEM, by Robert M. Sprague .....	126
Improved signal-to-noise ratio for services using pulse transmission	
FREQUENCY-MODULATION PHONOGRAPH PICKUP, by F. B. Miessner .....	132
Improved characteristics obtained by using capacitor translation to frequency-modulate an oscillator	
QUALITY ENGINEERING IN TUBE MANUFACTURE, by Eugene Goddess .....	134
Procedures for making electrical, mechanical, life, and appearance tests on random samples of vacuum tubes	
DIFFERENTIATING AND INTEGRATING CIRCUITS, by James G. Clarke .....	138
Development of practical circuits from theoretical considerations, with experimental verification	
NATIONAL ELECTRONICS CONFERENCE PAPERS .....	190
Abstracts of selected papers given at meeting recently held in Chicago	

## DEPARTMENTS

Crosstalk .....	91
Industrial Control .....	144
Tubes at Work .....	166
Electron Art .....	190
News of the Industry .....	254
New Products .....	278
New Books .....	292
Backtalk .....	300
Index to Advertisers .....	378

**KEITH HENNEY**, Editor; **W. W. MacDonald**, Managing Editor; **Beverly Dudley**, Western Editor; **John Markus**, Associate Editor; **Assistant Editors**—**Vin Zeluff**, **Frank Haylock**, **Frank Rockett**, **J. M. Heron** and **M. L. Matthey**; **G. T. Montgomery**, Washington Editor; **Donald G. Fink** (on leave); **Harry Phillips**, Art Director

**H. W. MATEER**, Publisher; **J. E. Blackburn**, Jr., Director of Circulation, Electronics; **Wallace B. Blood**, Manager

**DISTRICT MANAGERS**, **D. H. Miller**, **H. F. Denmead, Jr.**, New York; **R. H. Flynn**, New England; **F. P. Coyle**, Philadelphia; **C. D. Wardner**, A. F. Tischer, Chicago; **E. J. Smith**, Cleveland

Contents Copyright, 1944, by McGraw-Hill Publishing Company, Inc.

**McGraw-Hill Publishing Company, Inc.**  
**JAMES H. McGRAW**, Founder and Honorary Chairman

PUBLICATION OFFICE 99-129 North Broadway, Albany, N. Y., U. S. A.  
 EDITORIAL AND EXECUTIVE OFFICES 330 West 42nd St., New York 18, N. Y., U. S. A.

**James H. McGraw, Jr.**, President; **Howard Ehrlich**, Executive Vice President for Business Operations; **John Abbink**, Executive Vice President for Editorial Operations; **Curtis W. McGraw**, Vice President and Treasurer; **Joseph A. Gerard**, Secretary. Cable address: **McGraw-Hill**, New York. Member A. B. C.

**ELECTRONICS**, November, 1944. Vol. 17, No. 11. Published monthly, price 50c a copy. June Directory issue \$1.00. Allow at least 10 days for change of address. All communications about subscriptions should be addressed to the Director of Circulation, 330 West 42nd St., New York 18, N. Y.

Subscription rates—United States and possessions, Mexico, Central and South American countries, \$5.00 a year, \$8.00 for two years, \$10.00 for three years. Canada (Canadian funds accepted) \$5.50 a year, \$9.00 for two years, \$11.00 for three years. Great Britain and British possessions, 36 shillings for one year, 72 shillings for three years. All other countries \$6.00 for one year, \$12.00 for three years. Entered as Second Class matter August 29, 1936, by Post Office, Albany, New York, under the Act of March 3, 1879. **BRANCH OFFICES**: 520 North Michigan Avenue, Chicago 11, Ill.; 69 Post Street, San Francisco 4; Aldwych House, Aldwych, London, W.C. 2; Washington, D. C. 4; Philadelphia 2; Cleveland 15; Detroit 2; St. Louis 8; Boston 6; Atlanta 3. Ga.; 821 So. Hope St., Los Angeles 14; 38-9 Oliver Building, Pittsburgh 22.

A McGraw-Hill PUBLICATION



## CHANGE OF ADDRESS

**McGraw-Hill Publishing Company**,  
 330 West 42nd Street, New York 18, N. Y.

Director of Circulation:  
 Please change my address on Electronics

From .....

To .....

Signed .....



# STILL GOING STRONG

LONG, UNINTERRUPTED service under all operating conditions is the characteristic you want most in a capacitor. Tobe Capacitors serve so well and so long because every step in their manufacture is checked and cross-checked by rigid inspections. Constant improvement through constant research is the promise performed by Tobe engineers. An example is the Tobe TRS Capacitor, shown below, a skillfully designed transmitting condenser. Why not call on Tobe for prompt, specialized help on *all* your capacitor problems?



**TRS 605,**  
5 mfd. 600  
volts

**SIZE—**  
Overall  
height 5"

**CONTAINER—**  
1-3/16" x 2-1/2" x 4"  
*Dimensions of  
other TRS models  
on request.*

**OLD FAITHFUL GEYSER**, Yellowstone National Park. Geologists believe it began erupting before the last glaciation, about a million years ago. Within record, Old Faithful has erupted continuously at about 65-minute intervals, spouting a column of water 95–130 feet high for 4½ minutes.

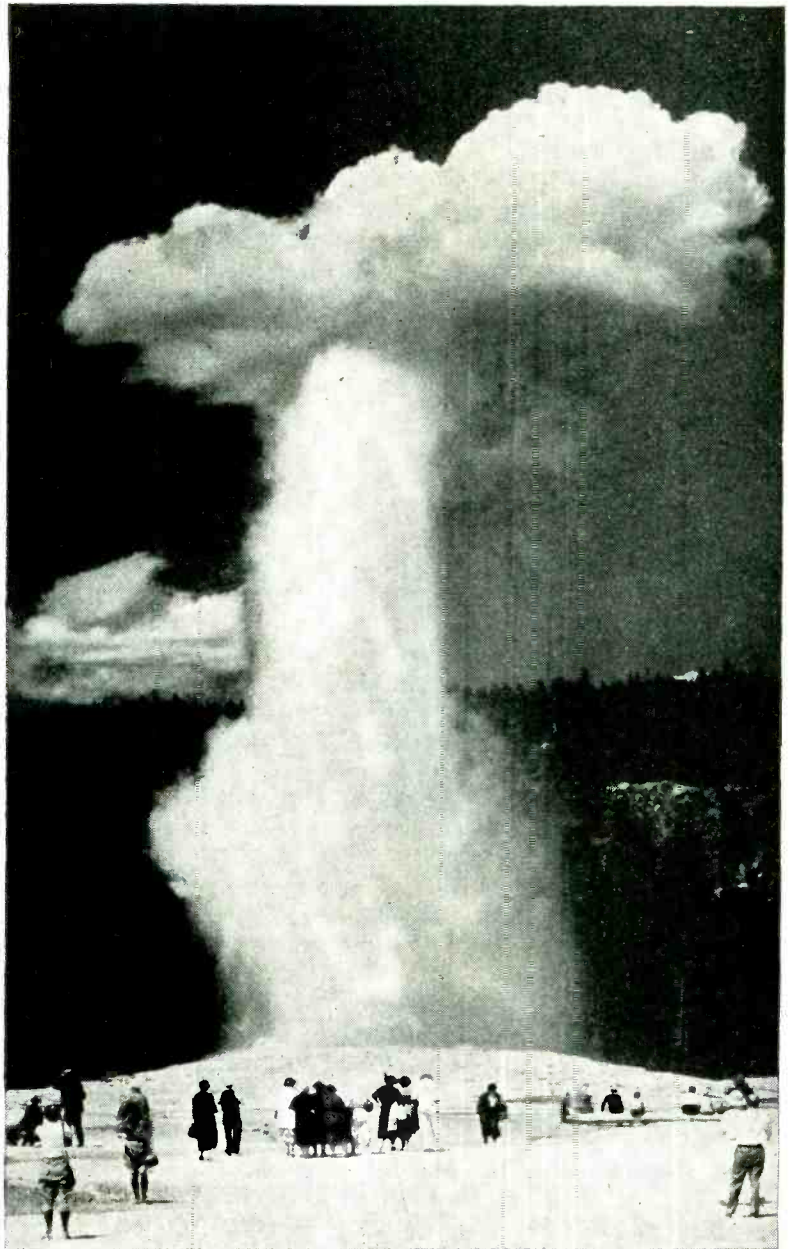

## SPECIFICATIONS FOR TRS CAPACITORS

**CAPACITY** . . . . .1 to 20 mfd.

**WORKING VOLTAGE** . . . 600  
volts DC to 6,000 volts DC.

**SHUNT RESISTANCE** . . . 6,000  
megohms per mfd.

**RESISTANCE**, Terminal to Case . .  
10,000 megohms minimum:

**POWER FACTOR** . . . .002 to .005

**VOLTAGE TEST** Terminal to Case  
2,500 VDC for 600 volt condenser.

Capacitor unit tested at 2 times rated voltage.

Universal (wrap around) L or foot type and screw  
Spade-lug mounting brackets can be supplied.



*A small part in Victory today . . .*  
**A BIG PART IN INDUSTRY TOMORROW**



Your originals belong

HERE

...not on the machines

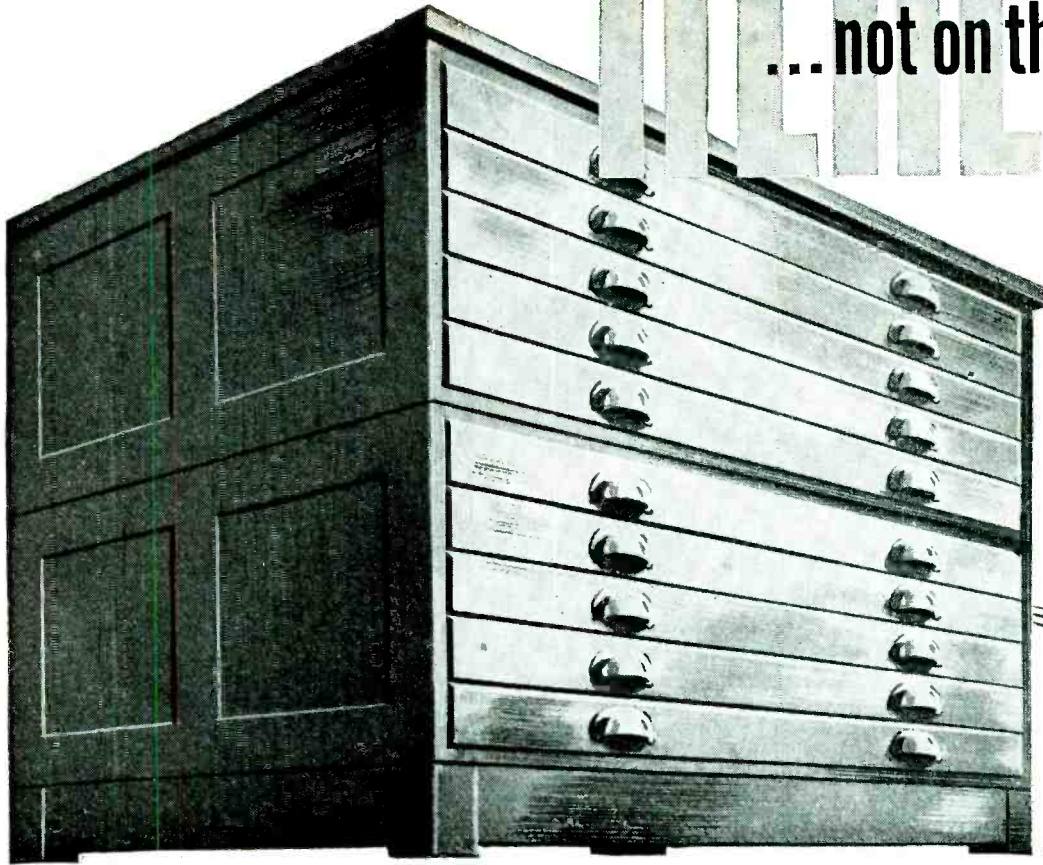

**P**ENCIL originals are precious, but even when they are new they often give unsatisfactory shop prints. When they are handled, they wear and blur. Prints made from them get cloudier still.

So use your pencil originals only once—to make PHOTACT Prints with *ink-intense* lines on PHOTACT Tracing Paper or Cloth.

Then make all the blueprints, blue or blackline prints or brownprint negatives you need from your PHOTACT Prints. They will be more legible than any made from the average pencil original.

For full information, write on your letterhead to PHOTACT Department, Keuffel & Esser Co., Hoboken, N. J.

**PHOTACT**

Reg. U. S. Pat. Off.

**REPRODUCTION PAPERS AND CLOTHS**

**K+E**

TRADE MARK



**KEUFFEL & ESSER CO.**

ESTABLISHED 1867

*Drafting, Reproduction, Surveying  
Equipment and Materials.  
Slide Rules. Measuring Tapes.*

CHICAGO • DETROIT • ST. LOUIS • NEW YORK • HOBOKEN • SAN FRANCISCO • LOS ANGELES • MONTREAL





**a new tool  
speed**

**QUICK LOCAL SERVICE  
ON INDUSTRIAL  
ELECTRONIC TUBES**

Looking ahead to continued development of electronic equipment in industry, postwar, we now have a plan to make Westinghouse Electronic Tubes quickly and easily available. Stocks of the most widely used tubes are now available through Westinghouse Electronic Tube Distributors and Westinghouse District Warehouses. As rapidly as possible additional types will be added to local stocks to make a complete line of Quality Controlled Westinghouse Electronic Tubes available to everyone.

# of incredible and versatility . . .

**T**he electronic tube may easily prove to be one of your most useful tools when you are confronted with reconversion headaches. Electronic tubes have proved that they save money in innumerable operations by increased speed and accuracy.

Take welding for example. For years resistance welding was limited to steel fabrication, permitting a considerable tolerance for electrode marking, discoloration and warping. Today—with the introduction of Westinghouse Electronic Tubes in welding and timing circuits—spot, seam, butt and projection welding is accomplished accurately, efficiently and quickly. This modern welding technique can be applied to stainless steel, aluminum and a wide variety of alloys in varying sheet thicknesses.

But—the use of electronic tubes is not confined to welding. In countless other applications such as heat treating, speed control, current regulations, conversion and measuring, they help do a better job.

For electronic devices you now have in service, or for new equipment you are planning, *always* specify and insist on Westinghouse Electronic Tubes—the tubes of assured uniformity and dependable performance.



**Westinghouse**  
PLANTS IN 25 CITIES    OFFICES EVERYWHERE

*Quality Controlled Electronic Tubes*



**WESTINGHOUSE PRESENTS:** John Charles Thomas — Sunday 7:30 EWT—NBC • Ted Malone — Monday, Wednesday, Friday — 10:15 EWT—Blue Network.



*Radio and Electronics*

# ENGINEERS

**HAMMARLUND has a POST WAR PLAN for:**

**2 MECHANICAL ENGINEERS**

**1 SR. ELECTRICAL ENGINEER**

**1 SR. HOUSEHOLD RECEIVER ENGINEER**

**3 JUNIOR ENGINEERS, for life-test  
and quality control**

Hammarlund offers you a permanent position in a well-equipped and modern engineering department. Here is an opportunity for a good-paying position with a future in an organization whose thirty-four years of manufacturing quality products have earned for it top rating in the radio industry.

---

*Write giving personal history and qualifications*

---

**THE HAMMARLUND MANUFACTURING CO., Inc.**  
**460 West 34th Street • New York 1, N. Y.**

# Why

# AMPEREX

## WATER and AIR COOLED TRANSMITTING and RECTIFYING TUBES

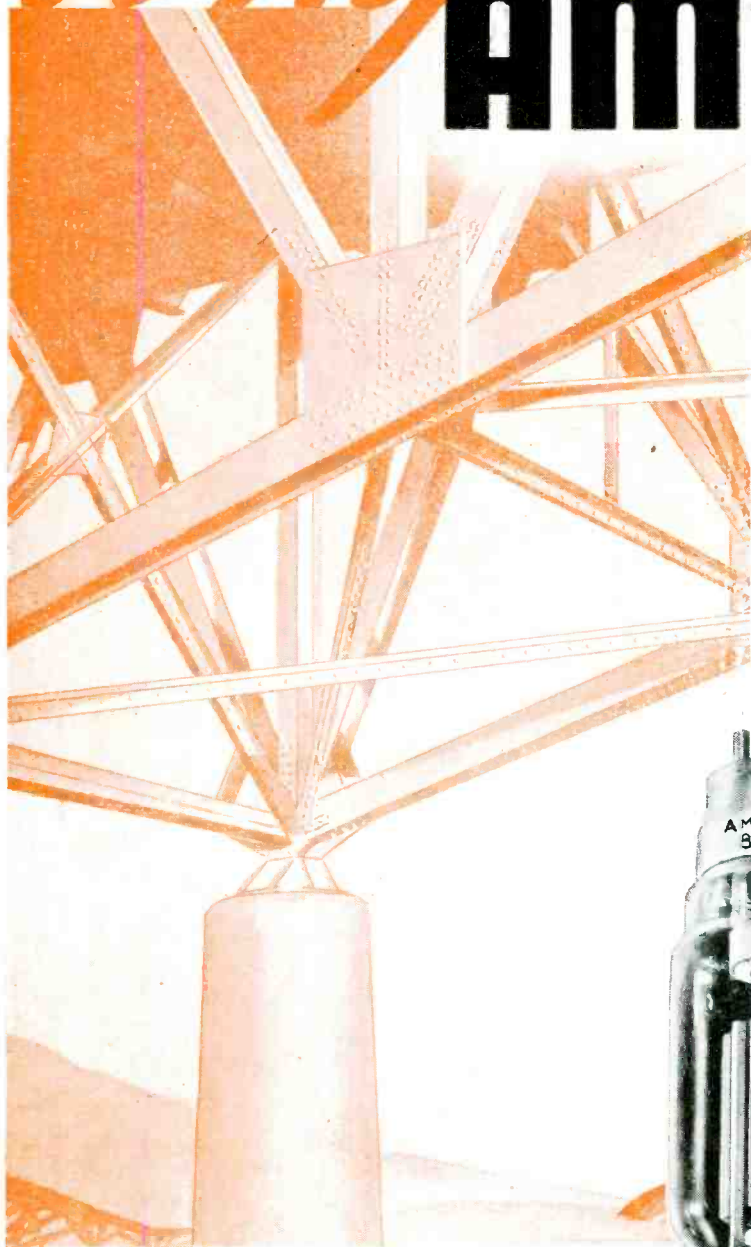

**Of exclusive Amperex design!** These four words, denoting an "Amperextra" reflected in better performance, have been used in a number of instances when describing our products. Of exclusive Amperex design, for example, is the channel support of our transmitting tubes. This feature results in more rigid support of tube elements. Exact inter-element alignment is assured. This, in turn, means absolute freedom from change in characteristics that might ordinarily arise from shock and vibration either in shipment or service.

There are more than 100 different types of **Amperex** tubes for broadcasting, industrial and electro-medical applications. An **Amperex** engineer will gladly assist you with your present or postwar problems.



**AMPEREX** . . . *the high performance tube*



*Keep Buying . . .  
Keep Holding . . .  
More War Bonds*

# AMPEREX ELECTRONIC CORPORATION

79 WASHINGTON STREET . . . . . BROOKLYN 1, N. Y.  
Export Division: 13 E. 40th St., New York 16, N. Y., Cables: "Arlab"



# BRINGING BOMBERS HOME!

Radio direction-finders, designed and manufactured by Press Wireless Inc., are now in war-time service throughout the world, helping to guide bombers and other aircraft safely home after completion of their missions.

Production of units of this type is part of the Press Wireless program which includes the manufacture not only of radio communications equipment of the highest efficiency but also of a diverse range of radio instruments and installations for ground use in modern aviation.

Press Wireless recognizes that communications and aviation go hand in hand and invites inquiries now concerning the products it plans to have available when peace comes.

## PRESS WIRELESS, INC. IS DEVELOPING OR MANUFACTURING

- HIGH POWER TRANSMITTERS
- DIVERSITY RECEIVERS
- AIRCRAFT AND AIRFIELD RADIO EQUIPMENT
- RADIO PRINTER SYSTEMS
- MODUPLEX UNITS "TRADEMARK"
- CHANNELING DEVICES
- RADIO PHOTO TERMINALS
- FACSIMILE MACHINES

AND OTHER TYPES OF RADIO AND COMMUNICATIONS EQUIPMENT



Awarded to our  
Hicksville, Long Island Plant  
for outstanding Achievement  
in War Production

Sales Office, Manufacturing Division  
1475 BROADWAY, NEW YORK 18, N. Y.

# PRESS WIRELESS, INC.

Executive Offices  
435 N. MICHIGAN AVENUE, CHICAGO

RIO DE JANEIRO • MONTEVIDEO • BERLIE • SANTIAGO DE CHILE • NEW YORK • CHICAGO • LOS ANGELES • LONDON • HAVANA

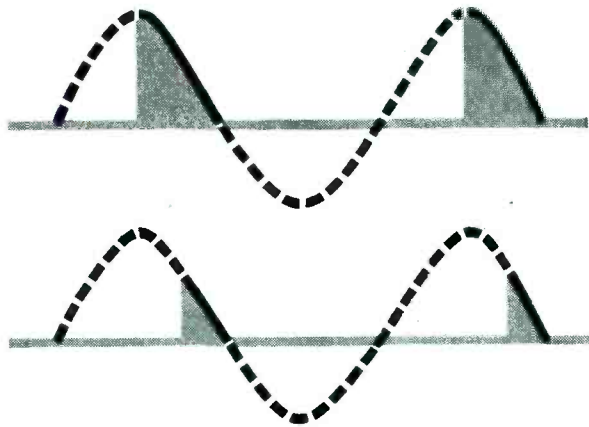

## THYRATRON

the trigger tube that made precision control of industrial equipment possible

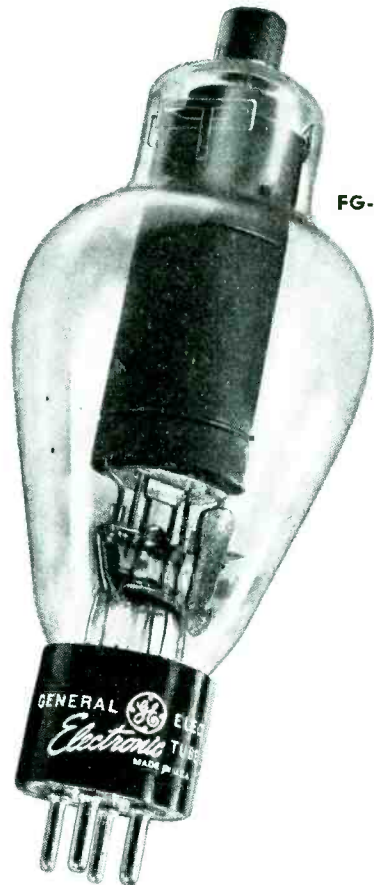

FG-57

*another G-E electronic* **FIRST!**

**D**EVELOPED by General Electric, the thyatron is often credited with being "the most versatile electronic tube in industry."

It is the tube which triggers the current supplied through such other tubes as the ignitron.

It is the tube which, as a synchronous switch, times the shots with split-cycle precision in high-speed resistance welding. It offers control so accurate that it can be fired at any point in the a-c half-cycle (see examples above), time after time in predetermined and automatic sequence.

The thyatron can also act as a self-controlled power tube. It can run d-c motors directly from a-c lines, feeding current in exactly the right amount to maintain a constant preset speed in machine-tools regardless of load variations.

The thyatron executes the orders of the phototube, or electric eye, in sorting, grading, counting,

detecting flaws in steel plates, operating doors, burglar alarms and safety devices.

General Electric is the manufacturer that can provide thyratrons, or any other electronic tubes, in quality that is unsurpassed for dependability, long life and economical operating.

### OTHER G-E TUBES ARE WIDELY USED IN INDUSTRY, TOO!

The ignitron, for example—frequent teammate of the thyatron—is the rugged steel-jacketed water-cooled tube that is capable of handling the heavy shots of current in resistance welding. It is also used in place of rotating machinery for changing alternating current into direct current.

Write for Bulletin ET1-12, a convenient listing of all G-E electronic tubes for industrial applications. Address *Electronics Department, General Electric, Schenectady, N. Y.*

• Tune in "The World Today" and hear the news direct from the men who see it happen, every evening except Sunday at 6:45 E.W.T. over CBS. On Sunday listen to the G-E "All Girl Orchestra" at 10 P. M. E.W.T. over NBC.

G. E. HAS MADE MORE BASIC ELECTRONIC-TUBE DEVELOPMENTS THAN ANY OTHER MANUFACTURER

**GENERAL ELECTRIC**

161 C8-8851



## G-E electronic tubes help cut finishing time from 13½ hours to 5 minutes



The G-E all-metal thyatron tube is the "heart" of the Thy-mo-trol unit that maintains correct machine speed for every load.

G-E electronic tubes in the G-E Thy-mo-trol Drive provide the multiple-timing control that has speeded up finish time on milling of aluminum spar beams for aircraft wings from one unit in 13½ hours to one unit in 5 minutes!

Onsrud Machine Works, Inc., met the requirements for increased production by designing its giant contour milling machine to include the G-E Thy-mo-trol Drive—the electronic-tube control unit that provides the smooth, stepless motor control for handling such complex factors as varying feed speeds for synchroniz-

ing with tool-cutting depths, controlling changing feeds, and high accelerations for fast "skips" when no cutting at all is required.

Electronic-tube control of d-c motors is applicable to drill presses, pump drives, lathes, boring mills, screw machines, and all other motor-driven machinery where a right speed is required for the job.

The heart of the electronic motor control, the G-E Thy-mo-trol Drive, is the G-E thyatron tube. This tube is a virtual stepless rheostat that controls with no moving parts the flow of current to give smooth, stepless

control of motor speed from almost zero speed up to its maximum rating. The thyatron is but one of the complete line of G-E electronic tubes for industrial applications. Through its nation-wide distributing system, General Electric is prepared to supply users of electronic devices with replacement tubes. Ask your distributor for information on G-E thyatrons or any other type of industrial tube, or write *Electronics Department, General Electric Company, Schenectady, N. Y.*

*Tune in General Electric's "The World Today" and hear the news from the men who see it happen, every evening except Sunday at 6:45 E. W. T. over CBS network. On Sunday evening listen to the G-E "All Girl Orchestra" at 10 E. W. T. over NBC.*

G. E. HAS MADE MORE BASIC ELECTRONIC-TUBE DEVELOPMENTS THAN ANY OTHER MANUFACTURER

**GENERAL  ELECTRIC**  
162-C12-6850

November 1944 — ELECTRONICS



# Specify

# C.T.C.

CRYSTALS

I-F TRANSFORMERS

TURRET TERMINAL LUGS

SPLIT LUGS

DOUBLE END TERMINAL LUGS

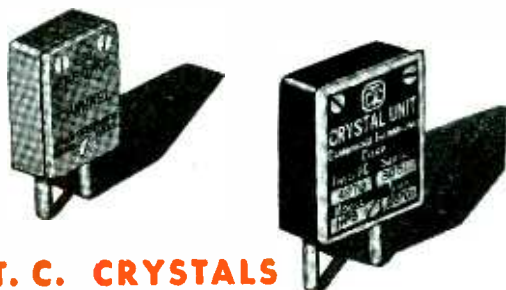

## C. T. C. CRYSTALS

Accurate cutting of each slice — thanks to X-RAY ORIENTATION — insures constant frequency over a wide temperature range. Multiple mechanical lapping operations; dimensioning by edge lapping and finishing to final frequency by etching, are other important steps in the manufacture of C.T.C. Crystals that guarantee high activity and constant frequency throughout their entire life.



## I-F TRANSFORMERS

These tiny, *ultra-high frequency*, slug tuned I-F Transformers are doing an efficient, thoroughly dependable job in many important radio and electronic applications.

Ask us about LS-1 (pictured above actual size) and LS-2 transformers.



## C. T. C. TURRET TERMINAL LUGS

Just swage these heavily silver plated Turret Terminal Lugs to the board and in a jiffy you have a good, firm turret terminal. Quick soldering, too. Sufficient metal is used in the Lugs to give them strength but not enough to draw heat thus increasing soldering time.

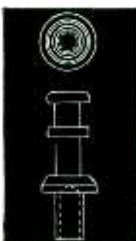

C. T. C. Turret Terminal Lugs are stocked to meet  $\frac{1}{32}$ ",  $\frac{1}{16}$ ",  $\frac{3}{32}$ ",  $\frac{1}{8}$ ",  $\frac{5}{32}$ ", and  $\frac{3}{16}$ " board thicknesses.

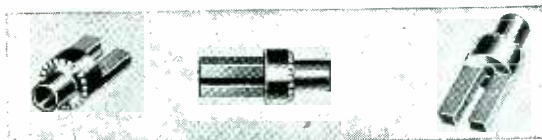

## C. T. C. SPLIT LUGS

.050 hole through the shaft permits wiring to these Split Lugs from either top or bottom without drilling or cutting. Just swage them to the board, then wire. Made of brass, heavily silver plated, C. T. C. Split Lugs are available in two sizes to fit  $\frac{3}{32}$ " and  $\frac{1}{16}$ " boards.

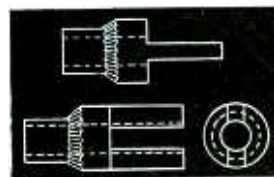

## DOUBLE END TERMINAL LUGS

Use these Double End Terminal Lugs when you need terminal posts on both sides of the board. Like C.T.C. Turret Terminal and Split Lugs, C.T.C. Double End Lugs simply swage to the terminal board — provide twin terminal posts which may be wired from top and bottom. Heavily silver plated brass. Stocked to fit  $\frac{3}{32}$ " terminal boards.

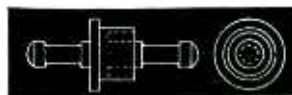

For complete information get in touch with  
**CAMBRIDGE Thermionic CORP.**

439 CONCORD AVENUE  
CAMBRIDGE 38, MASSACHUSETTS



# FIRST OFFICIAL PICTURE

Of the New

**HARVEY REGULATED**

**POWER SUPPLY 206 PA**

**RANGE 500 to 1000 VOLTS**

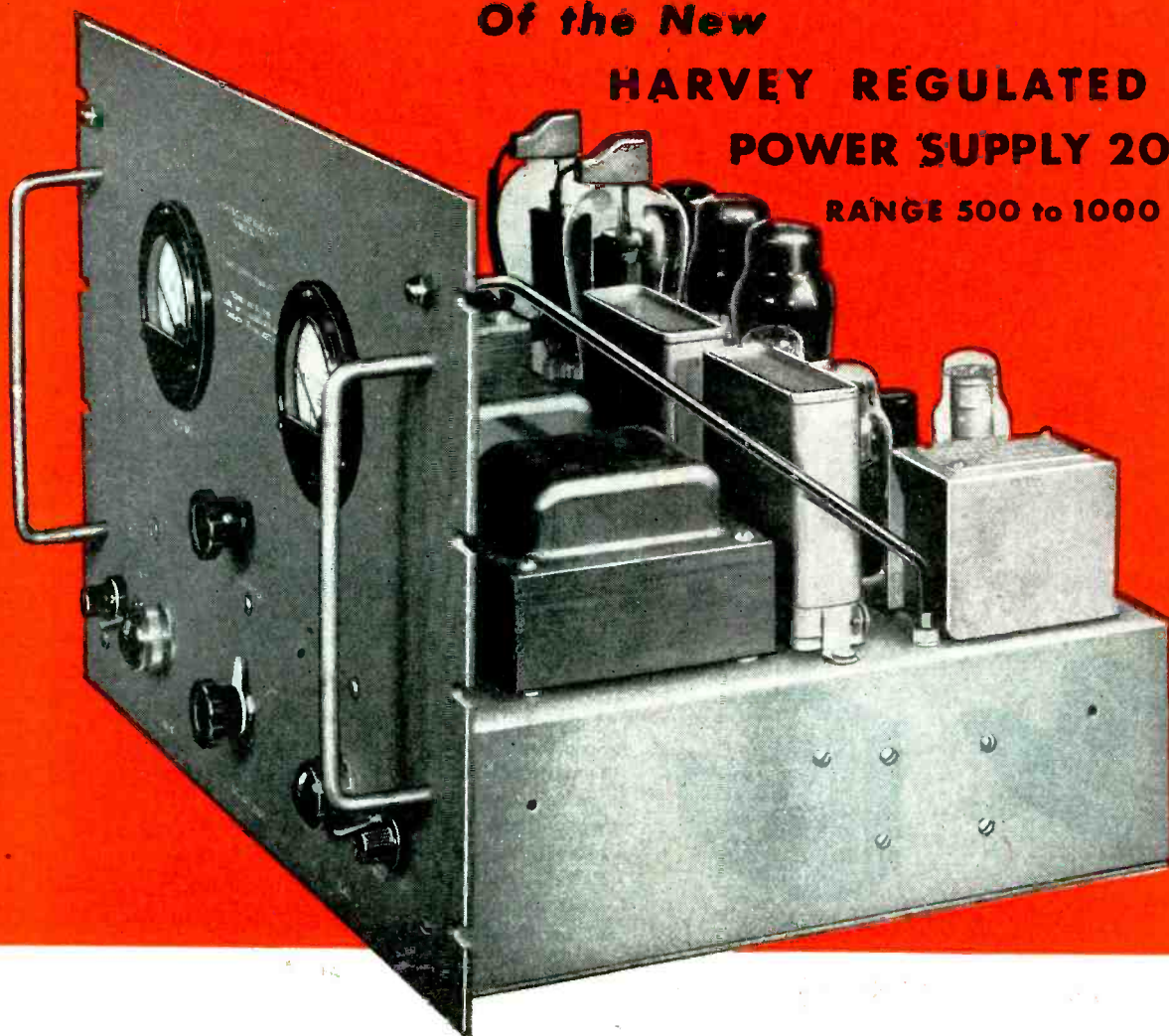

*Look It Over!* You'll see the quality craftsmanship and compact construction of this new HARVEY 206 PA—its sound design, precision assembly and easy accessibility. Notice the gray, crackle-finish panel and the copper plated chassis.

The new Harvey 206 PA is equipped with spare fuses, a generous 6 ft. heavy duty Typex cord, two interlocks for safety, overload and time delay relays—everything to make it a thoroughly dependable, easy-to-operate source of laboratory D. C. power.

Although the picture gives you an indication of why the HARVEY 206 PA operates smoothly and efficiently, it can't show you how this precision instrument operates in two ranges—500 to 700 volts at  $\frac{1}{4}$  of an ampere; 700 to 1000 volts at .2 of an ampere—with both ranges accurately regulated within one per cent. That's up to the instrument and us. We'd like nothing better than the chance to show you just what this important new development can do. Get in touch with

**HARVEY**

OF CAMBRIDGE

**HARVEY RADIO LABORATORIES, INC.**

439 CONCORD AVENUE • CAMBRIDGE 38, MASSACHUSETTS

# STRUTHERS-DUNN

INC.

5312

~~5,288~~

TYPES OF

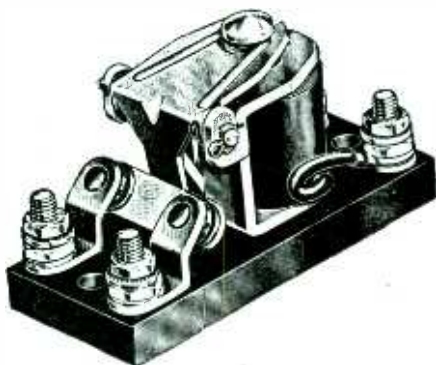

# RELAYS

Each available in  
countless coil combinations

**1321 ARCH STREET, PHILADELPHIA 7, PA.**

**DISTRICT ENGINEERING OFFICES: ATLANTA • BALTIMORE • BOSTON • BUFFALO • CHICAGO • CINCINNATI • CLEVELAND  
DALLAS • DENVER • DETROIT • HARTFORD • INDIANAPOLIS • LOS ANGELES • MINNEAPOLIS • MONTREAL  
NEW YORK • PITTSBURGH • ST. LOUIS • SAN FRANCISCO • SEATTLE • SYRACUSE • TORONTO • WASHINGTON**





# MEC-RAD

MANUFACTURERS OF MECHANICAL-ELECTRICAL  
COMPONENTS FOR RADIONICS

## TRAVELING WITH YOU ON THE STRAIGHT ROAD OF POST-WAR PLANNING

The period after the war may well become known as the "Electronic Era". In the development of the many ingenious post-war products, there will be a need for specialized engineering of precise and intricate high frequency components. This is our field. Our organization, with years of experience designing and making such products is at present devoting its manufacturing facilities 100% to war work. These unusual facilities will soon be available for the peacetime needs of our industry, and our engineering "know-how" is at your service now to help you with your post-war planning.

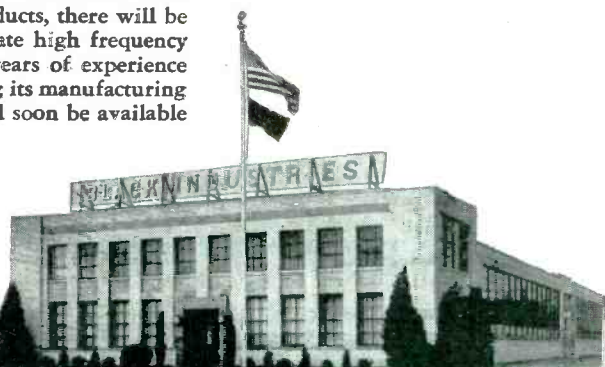

# MEC-RAD

**DIVISION-BLACK INDUSTRIES**

1400 EAST 222ND STREET ☆ CLEVELAND 17, OHIO



# New VARIABLE RESISTOR

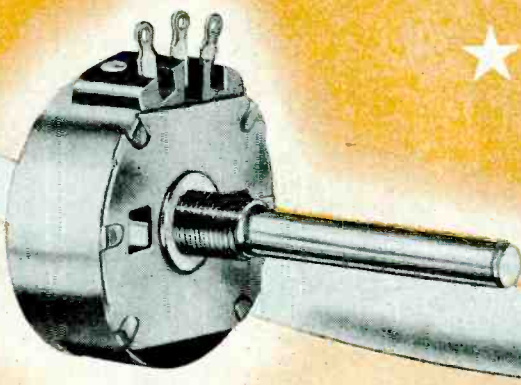

★ Chicago Telephone Supply Company now offers a new 1 3/8" diameter, wire wound variable resistor, 352 Series, with resistance value up to 20,000 ohms linear and with the same bakelite housing and grounded metal construction as the popular 1 1/4" 252 Series. This potentiometer may be used with switches attached and in tandem construction.

This new resistor is another expression of the many years of intensive research and development behind Chicago Telephone Supply Company, a scientific manufacturing

organization devoted to high standards in the mass production of variable resistors, both wire wound and carbon types.

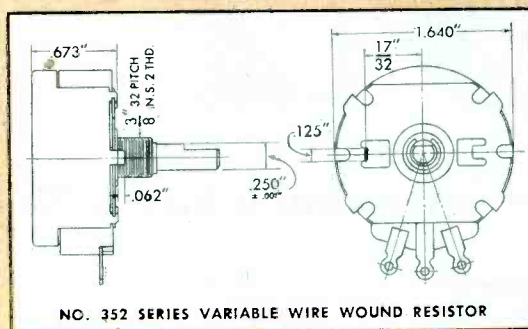

*Manufacturers of Quality Electro*

*Mechanical Components Since 1896*

VARIABLE RESISTORS, PLUGS AND JACKS

SWITCHES, TELEPHONE GENERATORS, RINGERS

REPRESENTATIVES  
 R. W. Farris  
 2600 Grand Avenue  
 Kansas City 8, Missouri  
 Phone: Victory 3070  
 Frank A. Emmet Co.  
 2137 West Pico Boulevard  
 Los Angeles 6, California  
 Phone: Rochester 9111



BRANCH OFFICES  
 S. J. Hutchinson, Jr.  
 401 North Broad Street  
 Philadelphia 8, Pennsylvania  
 Phone: Walnut 5369

IN CANADA  
 C. C. Meredith & Co.  
 Streetsville, Ontario

ELKHART ★ INDIANA



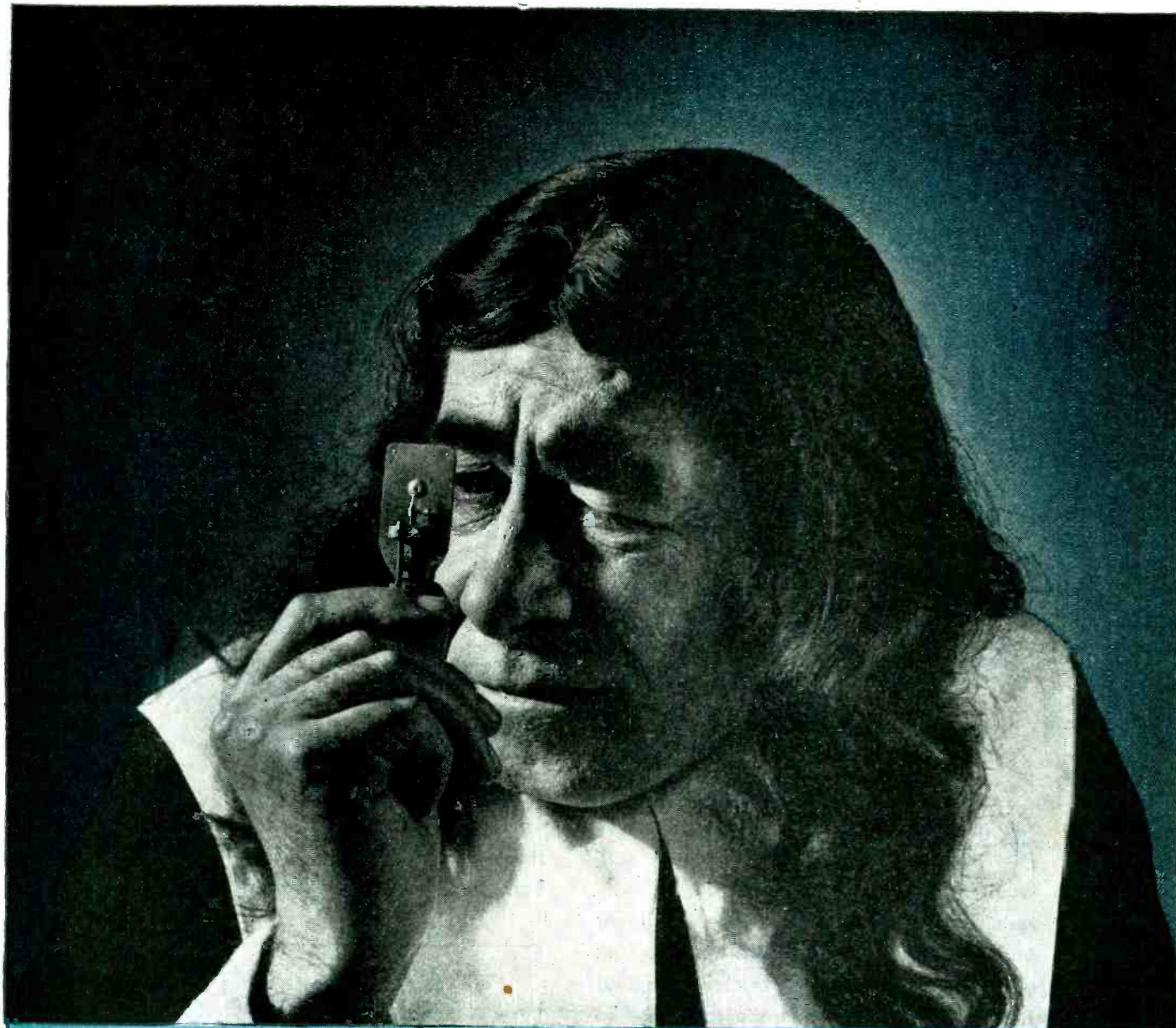

## Leeuwenhoek Saw a New World in a Tiny Bead of Glass



**H**ISTORY does not reveal who invented the microscope. But it was a Dutch merchant, Anthony Van Leeuwenhoek, who made it practical. Peering through a tiny bead of glass he ground into a lens, he became the first to see the organisms of the microscopic world.

This kind of inquisitiveness still pays. For example, present-day investigators are bringing into view many practical new uses for plastics. You

may initiate and benefit from these newer or wider uses. Here's how. You know best what properties—physical, electrical, chemical or mechanical you require of a material. Give us this information to start on and we'll be glad to let you know whether our type of technical plastics can help you in current or future plans. In any case, write today for the complete catalog of Synthane technical plastics.

Synthane Corporation, Oaks, Penna.

### SYNTHANE TECHNICAL PLASTICS

SHEETS • RODS • TUBES • FABRICATED PARTS

**SYNTHANE**

MOLDED • LAMINATED • MOLDED • MACERATED

*Plan your present and future products with Synthane Technical Plastics*



# THERE ARE A THOUSAND USES FOR SYNTHANE LAMINATED PLASTIC TUBING

*Tubing is the start in the production of many products*

**SYNTHANE TUBING** is produced in various shapes, diameters, wall-thicknesses, lengths, colors and finishes. The uses of tubing, simply as tubing, however, are obviously limited. It is imagination and machining plus a combination of many desirable properties that make Synthane tubing the useful material it is. Tubes can be easily and quickly machined into coil forms, fuse cases, chemical piping, motor brush holders, bushings, ferrules, ball bearing retainers, pump valves and a legion of other products. Tubing, then, is the first step in the ready and economical production of many parts.

Machining can be done by you or by us. Many prefer us to handle the complete job to relieve them of the responsibility for dies, jigs, tolerances, and other production details.

## PROPERTIES — GENERAL (Varies with grades)

**PHYSICAL:** Hard, Rockwell M-60 to M-100, dense, uniform. Light in weight (specific gravity 1.1 to 1.3), non-hygroscopic, (24 hour water absorption 0.5 to 5.0 per cent). Stable over wide temperature range. Low coefficient of thermal conductivity.

**MECHANICAL:** High tensile, compressive and crushing strength. High resistance to rupture (under internal pressure). May be easily sawed, turned, punched, riveted, drilled, reamed, milled, threaded, tapped or polished.

**ELECTRICAL:** High dielectric strength, low dielectric constant, low power factor, low loss factor.

**CHEMICAL:** Resists common solvents, oils, weak acids. Will not corrode metal inserts, bushings, ferrules, etc.

### Kinds of stock, properties

There are three principal kinds of SYNTHANE tubing, classified according to the materials used in their manufacture:

1. The paper base grades—X and XX.
2. The fabric base grades—C, CE, L and LE.
3. The asbestos base grades—A and AA.

The properties and characteristics of SYNTHANE tubing depend mainly upon the base used, the type of resin and the time of cure. By combining the raw materials and varying the method of manufacture, it is possible to alter the physical, mechanical, electrical or chemical properties, strengthening one without wholly sacrificing the others, to secure the exact balance of properties required.

The services of SYNTHANE engineers are at your disposal to aid in selecting or developing tubing to meet your particular needs.

### Special shapes

Special tubular sections can be produced in a wide variety of forms by applying the basic principles of tube molding. SYNTHANE sections, being laminated, are considerably stronger than ordinary powder molded shapes.

The simplest molded-laminated shapes are square, rectangular or oval. More intricate examples include horns, cones and irregular inside or outside contours.

Automatic screw machining can be advantageously used for low cost quantity production of numerous parts from Synthane tubing.

From tubes like these . . . products like these →

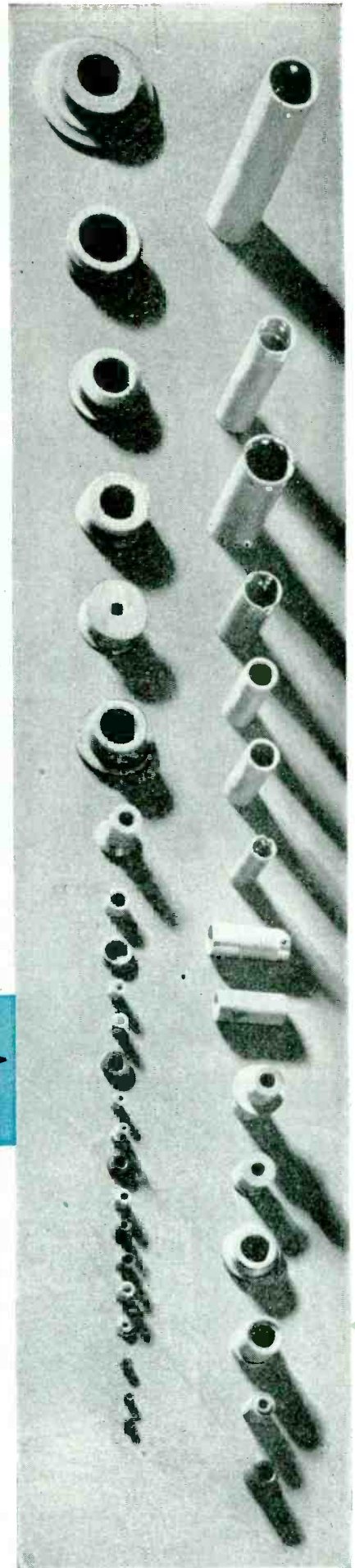
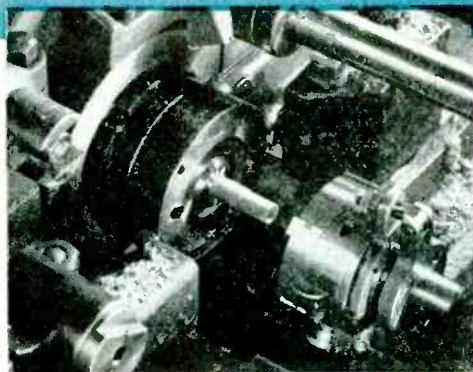

**SYNTHANE CORPORATION, OAKS, PENNA.**

REPRESENTATIVES IN ALL PRINCIPAL CITIES



# The TINYMITE

SMALLEST PAPER  
CAPACITOR - - -

yet 100%

MOISTUREPROOF

TYPE  
P5N

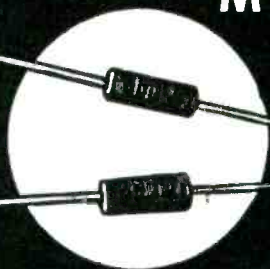

TYPE  
P4N

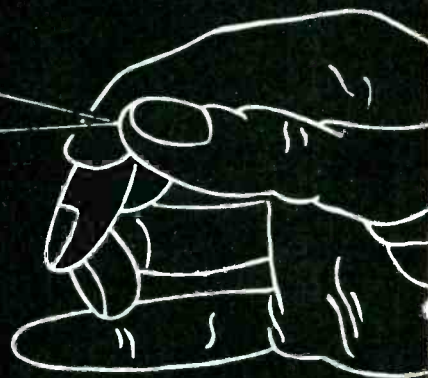

## FEATURES

1. Bakelite Resinoid Ends. Lead wire cannot pull out, even under hot conditions.
2. Non-Inductive.
3. Excellent Temperature Coefficient.
4. Very high leakage Resistance.
5. Fine Power-Factor.
6. Range from 20 MMFD to .25 MFD.  
From 150 volts to 600 volts.
7. Types P4N, P5N for 100% humidity operation.
8. Types P4, P5 for 95% humidity operation.

*Samples and price list on Request*

BUY EXTRA WAR BONDS . . .  
... 'TIL THE WAR IS OVER.

Pat.  
Pend.

# DUMONT ELECTRIC CO.

MFR'S OF  
CAPACITORS FOR EVERY REQUIREMENT  
34 HUBERT STREET NEW YORK, N. Y.



1895

1905

1910

1915

1926

1932

1942

# DEVELOPMENT!

## WARD LEADS THE WAY in the Antenna Field . . .

THE WARD PRODUCTS CORPORATION has long been the leader in the design and manufacture of antennas for automobiles and home radios. Since its beginning WARD has been the recognized pace-setter. Many important design changes, pioneered by WARD, have become accepted standards in the industry. All products bearing the WARD name are quality products, workmanship of craftsmen using modern equipment under ideal conditions. For finest antennas for all automobile and home applications, look to WARD!

BUY WAR BONDS

# WARD



## Antennas



THE WARD PRODUCTS CORPORATION  
1523 E. 45TH STREET • CLEVELAND 3, OHIO



# Sherron Electronics



TRANSMITTER  
CONTROL DESK

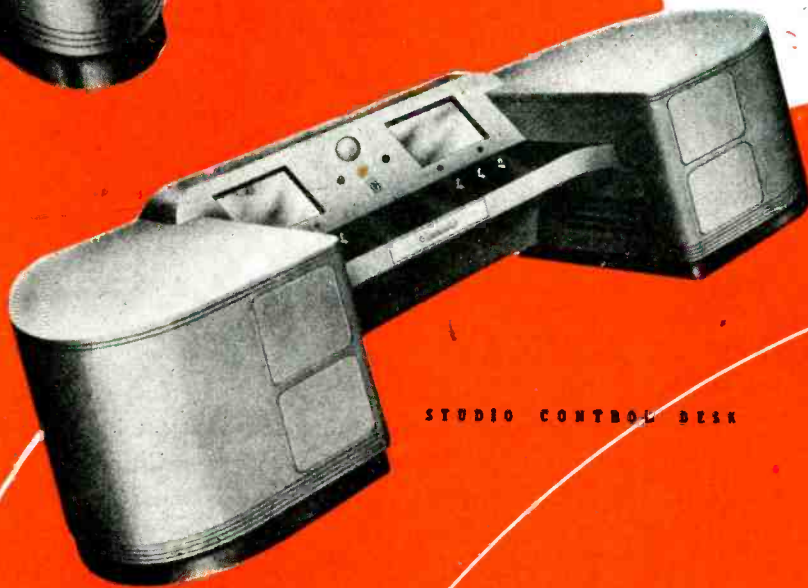

STUDIO CONTROL DESK

- LABORATORY
- DESIGN
- DEVELOPMENT
- MANUFACTURING

**"Where the Ideal is the Standard, Sherron Units are Standard Equipment"**

# TELEVISION

## Studio and Transmitting Equipment

As a source of supply for television equipment manufacturers, we are prepared to design, develop and manufacture—to their specifications—the full range of units shown on these pages.

Notable for its quality-protecting dependability, Sherron equipment is serving many of America's most vital manufacturers in the fields of electronics and radionics.

We are an intensively specialized organization, expertly staffed in all departments—laboratory through manufacturing. All our equipment is custom built exclusively for manufacturers. Our laboratory and engineering staff are at your disposal for consultation.

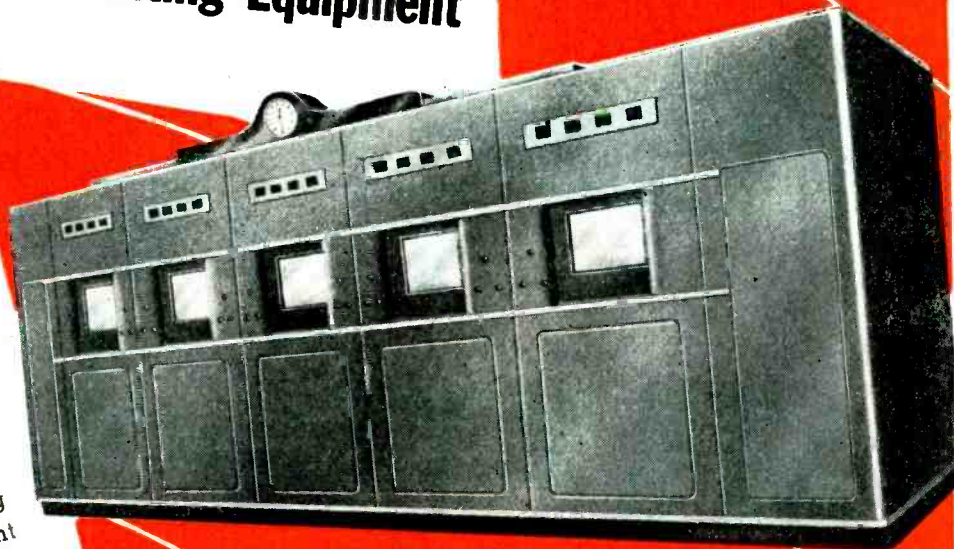

VIDEO-AUDIO  
TRANSMITTED

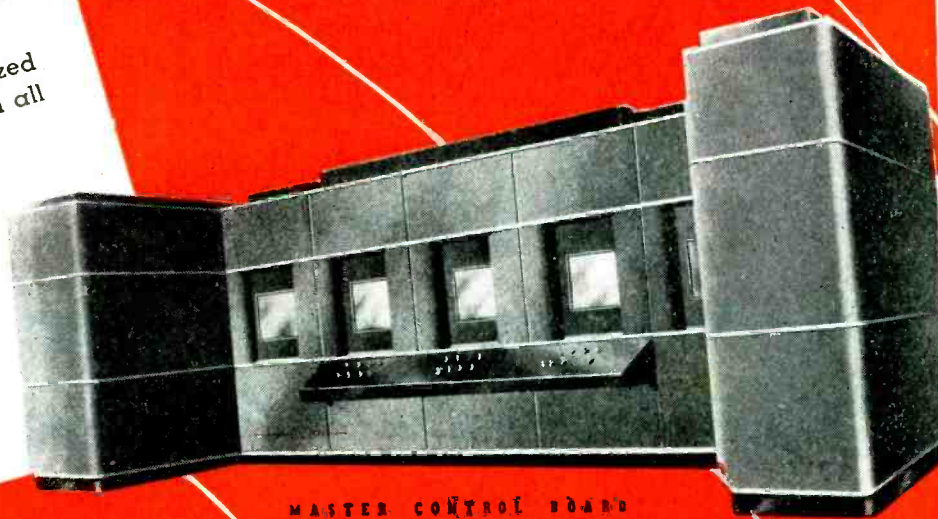

MASTER CONTROL BOARD

# SHERRON ELECTRONICS CO.

Subsidiary of Sherron Metallic Corp.

1201 Flushing Avenue • Brooklyn 6, N. Y.



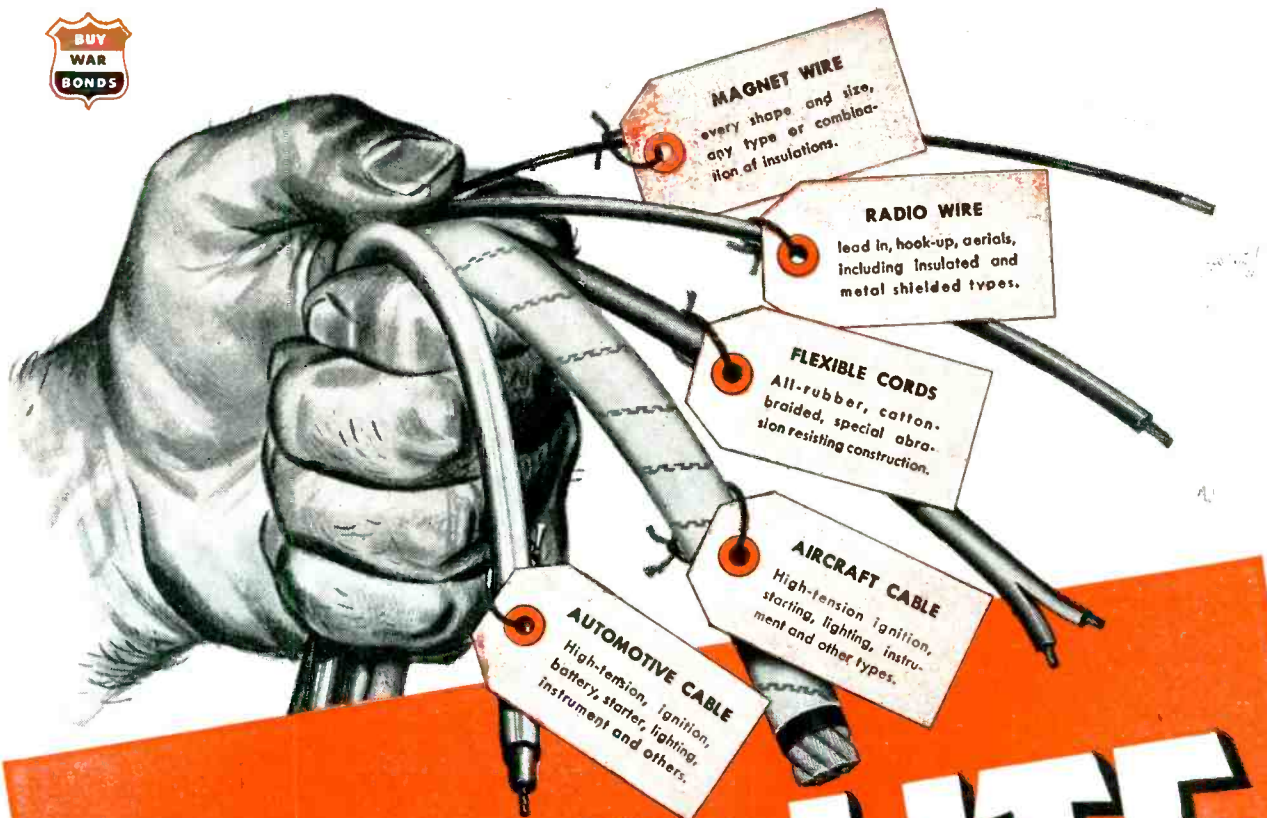

**MAGNET WIRE**  
every shape and size,  
any type or combina-  
tion of insulations.

**RADIO WIRE**  
lead in, hook-up, aerials,  
including insulated and  
metal shielded types.

**FLEXIBLE CORDS**  
All-rubber, cotton-  
braided, special abra-  
sion resisting construction.

**AIRCRAFT CABLE**  
High-tension ignition,  
starting, lighting, instru-  
ment and other types.

**AUTOMOTIVE CABLE**  
High-tension, ignition,  
battery, starter, lighting,  
instrument and others.

# AUTO-LITE

## Wire AND Cable

*Custom made to fit your wire job*

Supplying the precise type of wire and cable to meet the specific problem of your product is a speciality of Auto-Lite. Years of experimentation to achieve characteristics like increased heat resistance and improved performance lie behind every reel of Auto-Lite's electrical wire and cable.

Ample manufacturing facilities permit custom-made production whenever necessary, and a firmly established reputation for dependability assures specified performance. For help on any wire or cable problem that you may have, write to

**THE ELECTRIC AUTO-LITE COMPANY**

SARNIA, ONTARIO

Wire and Cable Division

PORT HURON, MICH.

TUNE IN "EVERYTHING FOR THE BOYS" STARRING DICK HAYMES—EVERY TUESDAY NIGHT—NBC NETWORK

# BAKELITE

TRADE-MARK

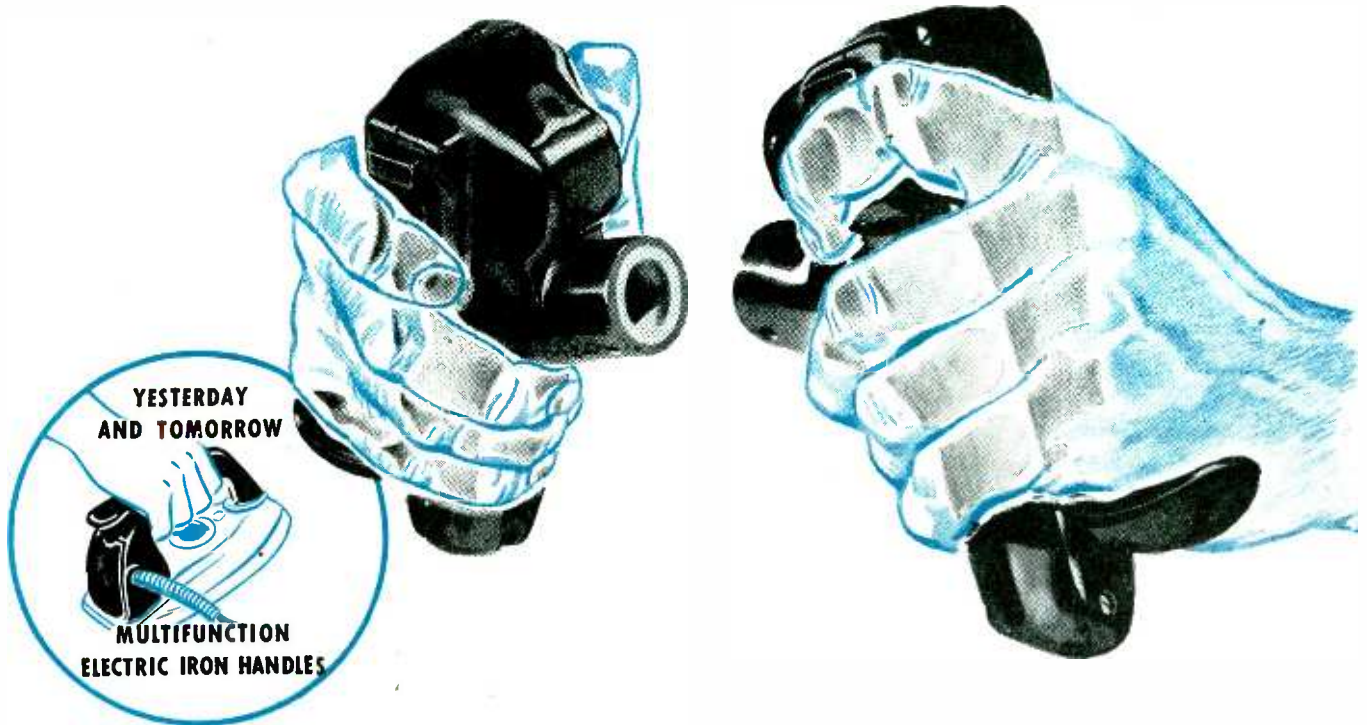

## Today . . . Two-Fisted Gun Grips

THESE GRIPS, molded from a BAKELITE impact-resistant phenolic plastic, give aircraft gunners instant command of turret rotation, gun firing, and the microphone system. They are miniature switchboards—alive with electrical controls and ready for instant action. But at the same time they are lightweight, tough to withstand impact, and highly dielectric. Temperatures ranging from  $-70$  deg. F. to  $180$  deg. F. do not affect their form or operation because they are dimensionally stable. Their fine, lustrous, integral finish withstands the roughest handling.

The designing and molding of gun turret control grips closely parallels that of producing peacetime appliances, such as flatiron handles. And both call for the same combination of physical, electrical, and thermal

characteristics in the construction material. The right answer for thousands of other products has come from the use of the *right* BAKELITE plastic, plus the coordinated teamwork of designer, molder, and materials supplier.

Our field engineers and development laboratories will gladly work with you on any product that you wish to improve or that is now in the planning stage. Write for Booklet 7M, "Bakelite Molding Plastics."

TRADE  MARK

BAKELITE CORPORATION, 30 E. 42 St., New York 17  
Unit of Union Carbide and Carbon Corporation

UCC

# Molding Plastics



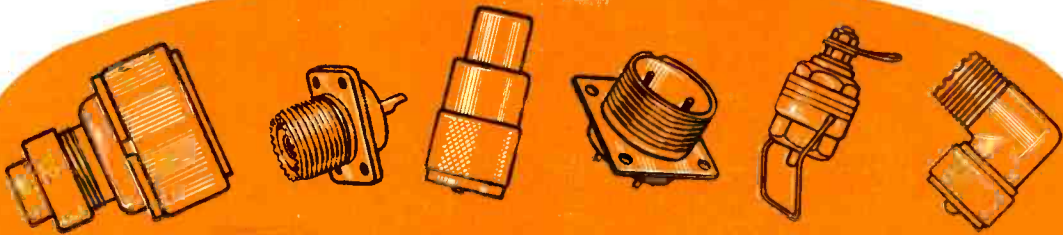

# For Your Postwar Needs in Connectors and Related Units

Will coaxial cable connectors, cable plugs or special design parts in this general category, play roles in your postwar products? If so, we suggest you carefully consider both our offerings and exceptional facilities.

Connector Division, in addition to making a representative line of standard units, is uniquely staffed and equipped to serve your needs in this field on a mass production basis.

Our engineers will be happy to consult with you on specific problems or send you more detailed information.

**AVAILABLE ON PRIORITY ORDERS**

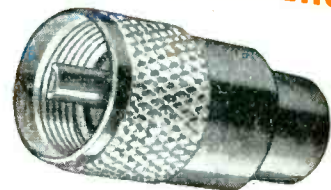
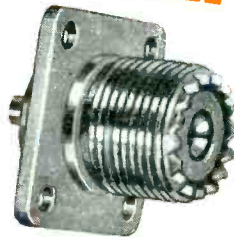

(Actual Size)

## U. S. ARMY-NAVY COAXIAL CONNECTORS

Built in accordance with U. S. Army-Navy designs and specifications, these precision units interlock firmly, when coupled, to assure positive, vibration-proof contact. The die cast, zinc housings and other metal parts are heavily silver plated. Contact parts (both pins and sockets) are made of specially tempered spring-brass. Cable plugs and receptacles alike are insulated with low-loss mica filled bakelite. Plugs may be had in either Signal Corps #PL-259, or Navy #C1-49195 models. Connector receptacle #50-392-1 is standard for each of these designs.

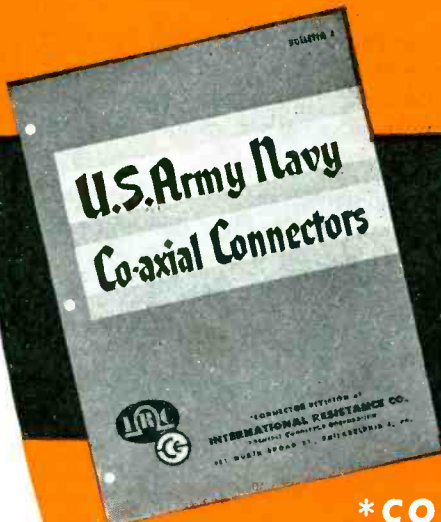

*Write for Bulletin 4*



\*CONNECTOR DIVISION OF  
**INTERNATIONAL RESISTANCE CO.**

401 N. BROAD ST., PHILADELPHIA 8, PA.

\*FORMERLY CONNECTOR CORPORATION

Illustration by Robert R. ...

Illustration by Robert R. ...

Illustration by Robert R. ...

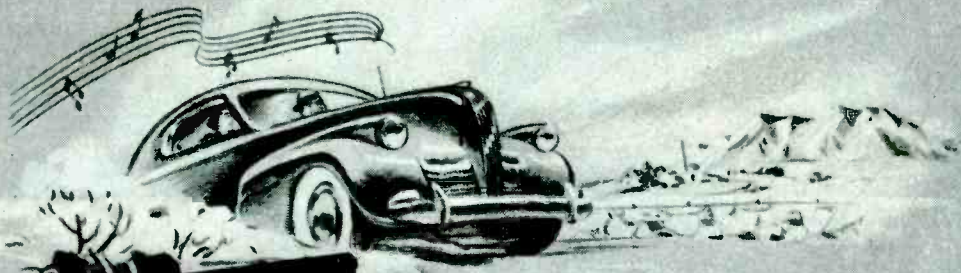

*Partners in Development...*  
**HOW PHILCO ENGINEERS WORKED WITH THE AUTOMOBILE INDUSTRY**

Philco's long association with the automobile industry has been a fruitful partnership. Philco engineers worked with automotive experts to develop the first practical auto radio. It was an immediate success. Then Philco went a step further, setting up laboratories and an engineering staff devoted exclusively to designing and developing automobile radios.

Soon this research organization became the world's largest of its kind. Close cooperation with motordom's leading technical brains led to many brilliant "firsts" by Philco engineers. Among them, the first superheterodyne circuit in a com-

mercial auto radio; the first electro-dynamic speaker; the first A. V. C.; the first cowl antenna; the first instrument panel controls; pioneering in motor noise suppression; invention of the Loktal tube, universally used in modern auto radios. Year by year, Philco radio design kept pace with automotive design.

Meanwhile, car manufacturers found in Philco production facilities the answer to their radio requirements—for quantity, quality and value. The manufacturers of thirty-one leading American automobiles standardized on Philco radios. And Philco earned world leadership in building automobile as well as home radios—for 12 straight years before the war.

After Victory, when Philco turns its vast research and manufacturing resources again to peacetime progress, there will be new opportunities for similar partnership. Then Philco engineers will again welcome the responsibility of working with and for American industries... as well as American homes.

**PHILCO**

*Famous for Quality the World Over*



# MYCALEX 400

(PATENT PENDING)

The 'Last Word' in Low-Loss Insulation — Perfected after 25 years of Research Leadership

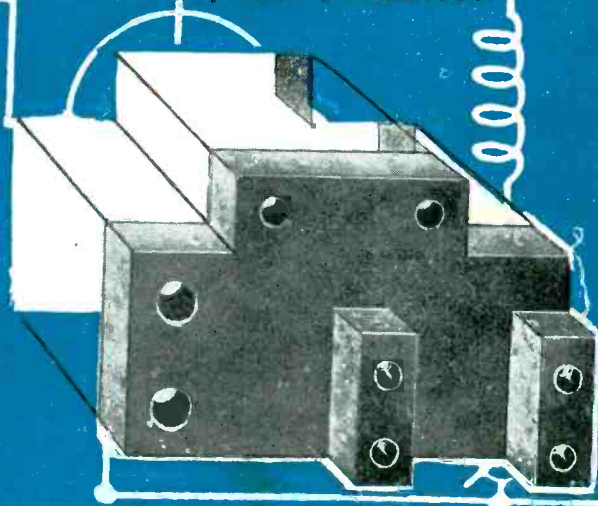

## FITS PERFECTLY Into High Frequency Design

AT last designers of tomorrow's high frequency apparatus have an improved type of glass-bonded mica insulation to specify where new advancements in low-loss characteristics are desired, as in ultra high frequency applications.

Behind this new product is a history of 25 years of research leadership. Just as the original MYCALEX, developed by the MYCALEX (Parent) Company of Great Britain 25 years ago, was a vast improvement over other ceramics, so the new MYCALEX 400, developed exclusively by the MYCALEX Corporation of America, is a comparable advancement over all early forms of glass-bonded mica.

MYCALEX 400 meets government specifications for L-4 characteristics, by virtue of its pronounced low-loss factor of 0.013 at 1 megacycle. Its surface resistivity is 300,000 megohms. Its power factor is 0.0018 at 1 megacycle, in accordance with American War Standard C-75.1-1943 (Jan. 1-10). Its dielectric constant is unchanged from 50 kilocycles to 10 megacycles. MYCALEX 400 can be machined with greater precision . . . drilled, tapped, milled, sawed, turned and threaded.

Improved postwar h-f equipment deserves this newly refined and perfected electronic insulation. Let us supply your stock requirements in sheets and rods; or have us fabricate component parts to your specifications. Write for full details and samples.

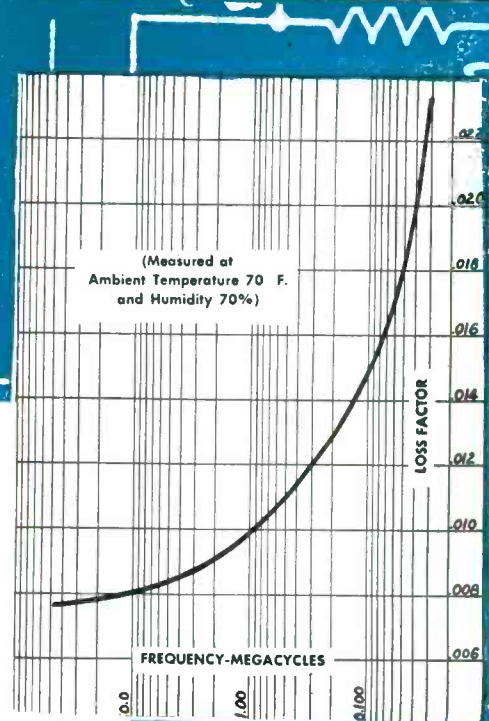

## MYCALEX CORPORATION OF AMERICA

"OWNERS OF 'MYCALEX' PATENTS"

CLIFTON,  
NEW JERSEY

Executive Offices: 30 ROCKEFELLER PLAZA  
NEW YORK 20, N. Y.



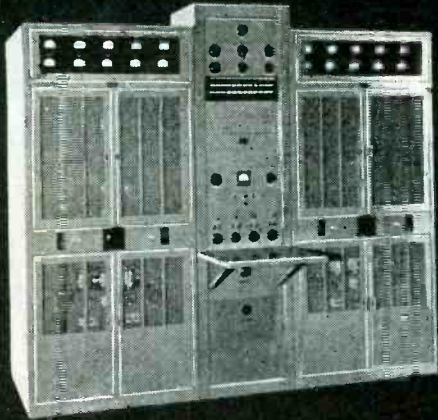

BROADCAST STATION EQUIPMENT

AVIATION GROUND  
STATION EQUIPMENT

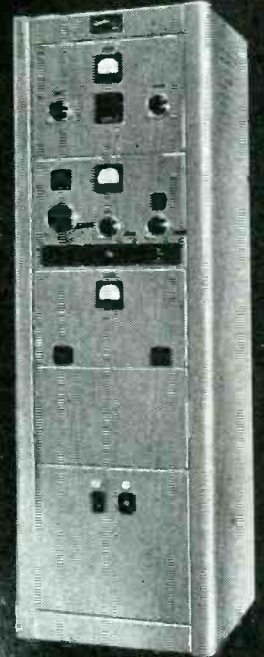
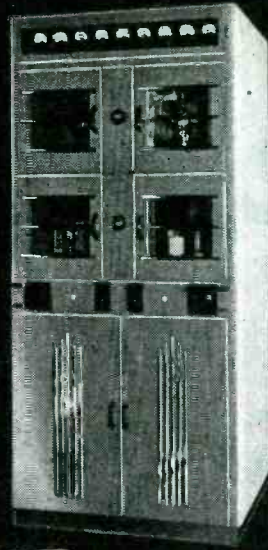

COMMERCIAL  
POINT-TO-POINT  
TRANSMITTERS

# Coming Soon

The Army and Navy have found Temco to be a dependable source for the development and production of technically advanced communication equipment. Because Temco is one of the very few organizations endowed with that rare combination . . . engineering versatility — production flexibility plus peerless standards of craftsmanship, our war contribution has stationed us at the forefront of advanced radio communication research.

Radio is no longer simple! As a result of war-born Radar requirements which have introduced mechanical and electrical complexities of the highest standards — Temco best war equipment will reflect and incorporate great technical achievements.

As rapidly as our war program draws to completion our efforts are turning to peacetime production. New types of Temco communication equipment are under way — will be ready for delivery at an early date.

Watch our advertisements for announcements about new models.

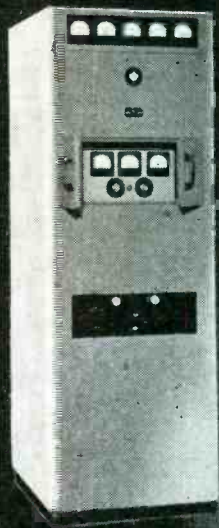

MUNICIPAL SERVICES  
CENTRAL STATIONS

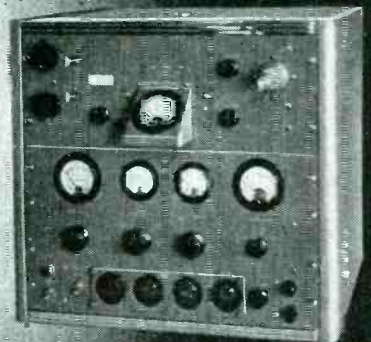

SPECIAL VHF LABORATORY  
TEST EQUIPMENT

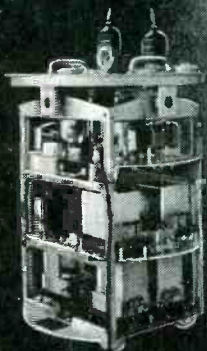

MARINE RADIO  
BEACONS

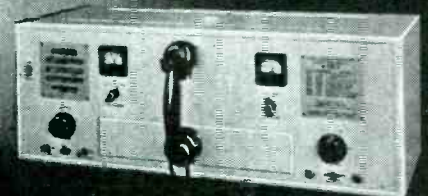

MARINE RADIO TELEPHONES

# TEMCO

RADIO COMMUNICATION EQUIPMENT

TRANSMITTER EQUIPMENT MFG. CO., INC.  
345 Hudson Street, New York 13, N. Y.



MUNICIPAL MOBILE COMMUNICATIONS



# Centralab

## CERAMIC CAPACITORS

for  
**HIGH VOLTAGE**

These capacitors are engineered by Centralab for special applications . . . accumulative capacities ranging from 2MMF to 20MMF in zero temperature coefficient . . . to 4MMF to 40MMF in maximum negative (N750 PPM) temperature coefficient.

Individually the capacity ranges are as follows:

- 855 2MMF to 5MMF in zero T. C.  
4MMF to 10MMF in N750
- 854 5MMF to 10MMF in zero T. C.  
10MMF to 20MMF in N750
- 853 10MMF to 20MMF in zero T. C.  
20MMF to 40MMF in N750

Working voltages from 8,000 to 10,000 D.C. Energy dissipation up to 2 KVA with 15°C rise.

End lead or axial screw terminals available.

Send for Bulletin No. 814.

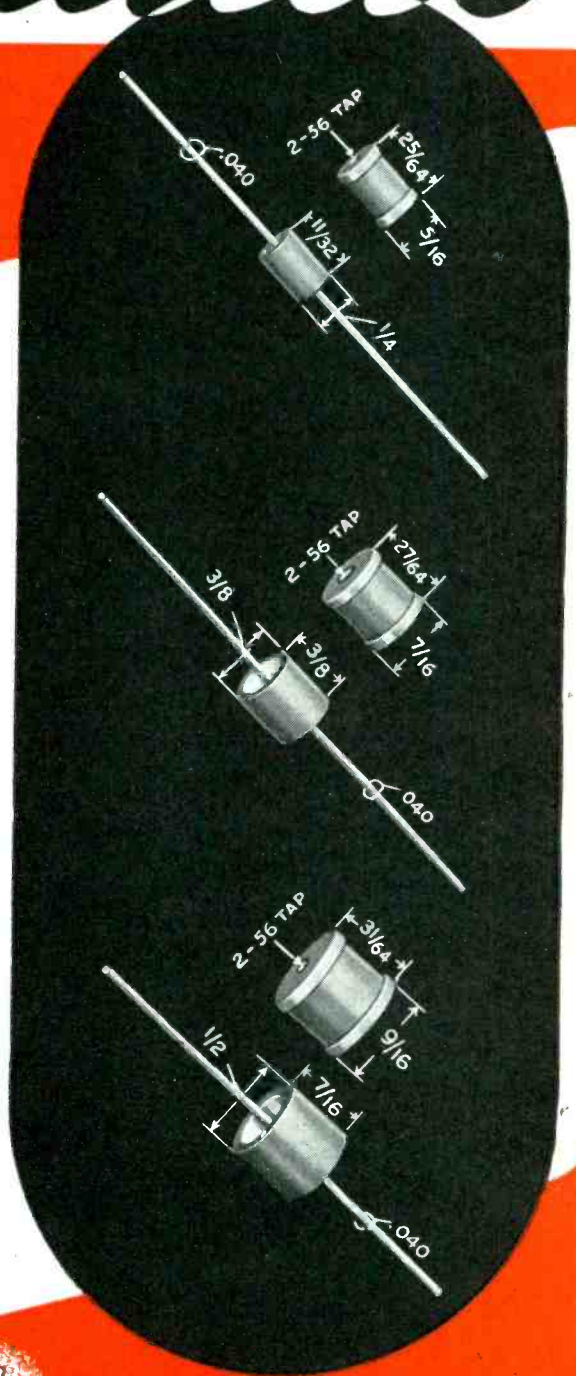

Producers of Variable Resistors • Selector Switches  
• Ceramic Capacitors, Fixed and Variable •  
Steatite Insulators.

**Centralab**  
CRL

Division of GLOBE-UNION INC., Milwaukee

**77  
WATTS  
OUTPUT  
FROM A PAIR  
AT 200  
MEGACYCLES**

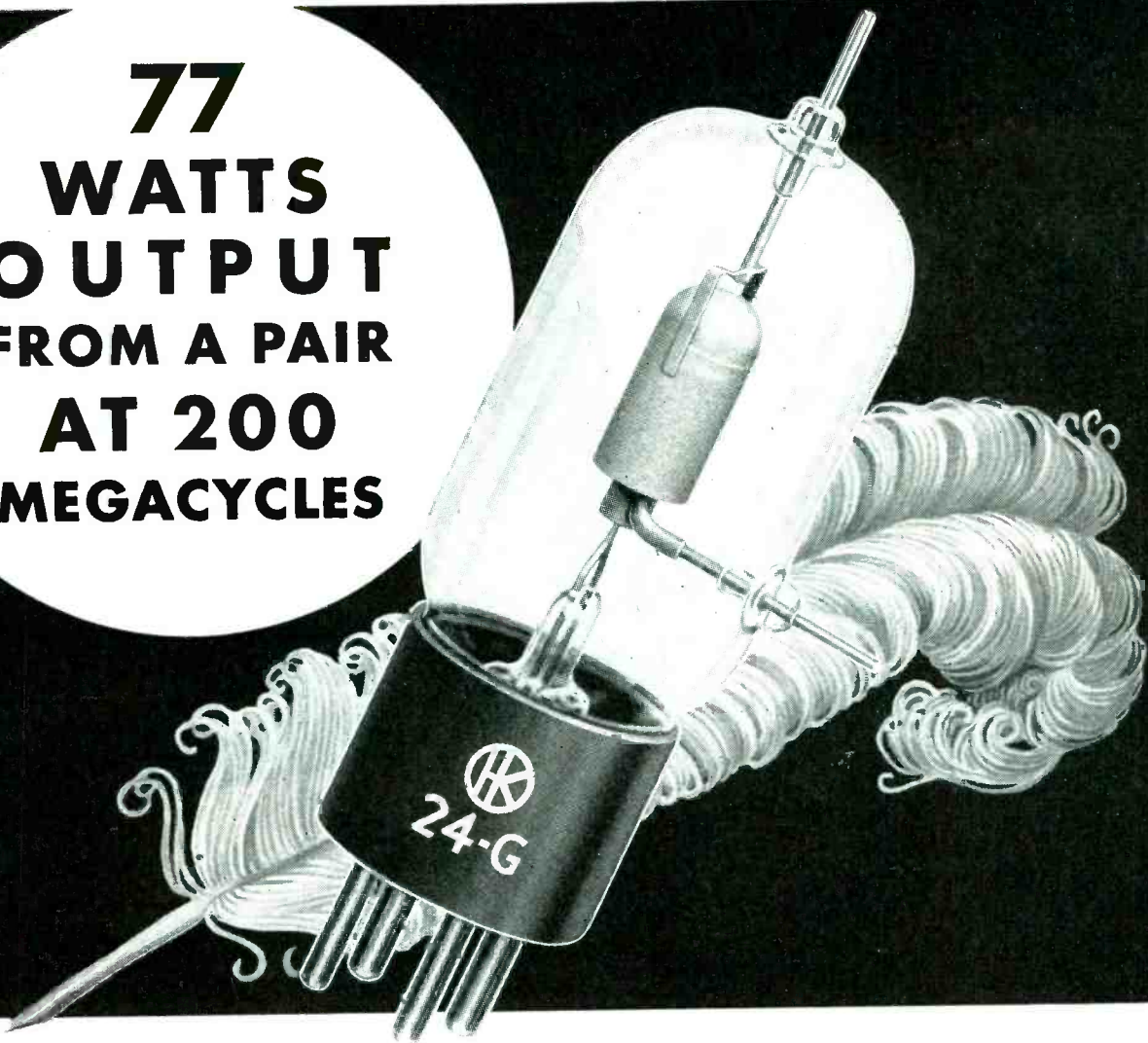

**H & K developed this *featherweight* to pack a wallop in the VHF region**

The only thing that's small about this 4½-inch, 1½-ounce Gammatron is its size. Heintz and Kaufman engineers originated and perfected this powerful little tube to put out a 77 watt signal from a pair at 200 Mc. as a Class C unmodulated amplifier... 116 watts at 100 Mc. Even at peak frequency, 300 Mc., a pair of HK-24G Gammatrons develop a remarkable 44 watts.

The high efficiency of the HK-24G in the VHF region results from (1) the long, capped tantalum plate, typical of Gammatrons, which confines the entire electron stream for useful output, and (2) the fact that this grid is closely spaced to the filament for short electron time-flight.

The HK-24G triode is easy to neutralize, and parasitic oscillation is avoided, because the inter-electrode capacities are very low, and the grid and plate leads are short. For typical operating ratings of the HK-24G as an r. f. power amplifier, audio amplifier, crystal oscillator, doubler, or tripler, write today for data.

**HK-24G MAXIMUM RATINGS**

Power Output  
Class "C" R. F. . . . . 90 Watts  
Plate Dissipation . . . . . 25 Watts  
Amplification Factor . . . . . 25  
Plate Voltage . . . . . 2000 Volts  
Plate Current . . . . . 75 MA  
Grid Current . . . . . 25 MA  
Frequency . . . . . 300 MC

INTER-ELECTRODE CAPACITIES  
C Grid-Plate . . . . . 1.6 UUF  
C Grid-Filament . . . . . 1.8 UUF  
C Plate-Filament . . . . . 0.2 UUF

**FILAMENT**

Volts, 6.3 Amperes, 3

**LOAN YOUR DOLLARS  
DONATE YOUR BLOOD  
FOR EARLY VICTORY**

**HEINTZ AND KAUFMAN LTD.**  
SOUTH SAN FRANCISCO • CALIFORNIA



*Gammatron Tubes*



**Here's an ESSENTIAL TOOL for Radio-Electronic Engineers, Designers, Equipment Builders, Manufacturers...**



**NEW 152-PAGE  
CAPACITOR  
CATALOG**

**Contains Application Engineering Data and Separate Sections on MICA, PAPER, and ELECTROLYTIC CAPACITORS**

• Why essential? That's a big statement. Let us qualify:

This new Aerovox Catalog contains that information which is essential to those who design and build radio-electronic equipment. Here is general and specific engineering data on capacitors and their applications; detailed specifications on various types; listings of recommended types and ratings; special notes covering special features and special types; color codes; etc.

For greater convenience, the catalog is divided into four sections, each with its tab-indexed cover. These sections comprise Mica Capacitors, Application Engineering Data, Paper Capacitors, Electrolytic Capacitors. The plastic binding permits pages to lie absolutely flat.

In preparation for a year and a half—involving widespread gathering of data and intensive compilation—this combination manual-catalog represents an outstanding contribution to the working library of the radio-electronic engineer and executive. It was prepared BY engineers FOR engineers; contains absolutely no advertising—just information on capacitance and capacitors. And because of cost, its circulation is strictly limited to engineers and executives.

• **Write for Your Copy...**

*If you are engaged in designing or building radio-electronic equipment of recognized standing, write on your business letterhead for your registered copy. Also submit your capacitor problems and requirements for our collaboration.*



*Capacitors*

**INDIVIDUALLY TESTED**

**AEROVOX CORPORATION, NEW BEDFORD, MASS., U. S. A.**

**SALES OFFICES IN ALL PRINCIPAL CITIES**

**Export: 13 E. 40 ST., NEW YORK 16, N. Y. • Cable: 'ARLAB' • In Canada: AEROVOX CANADA LTD., HAMILTON, ONT.**



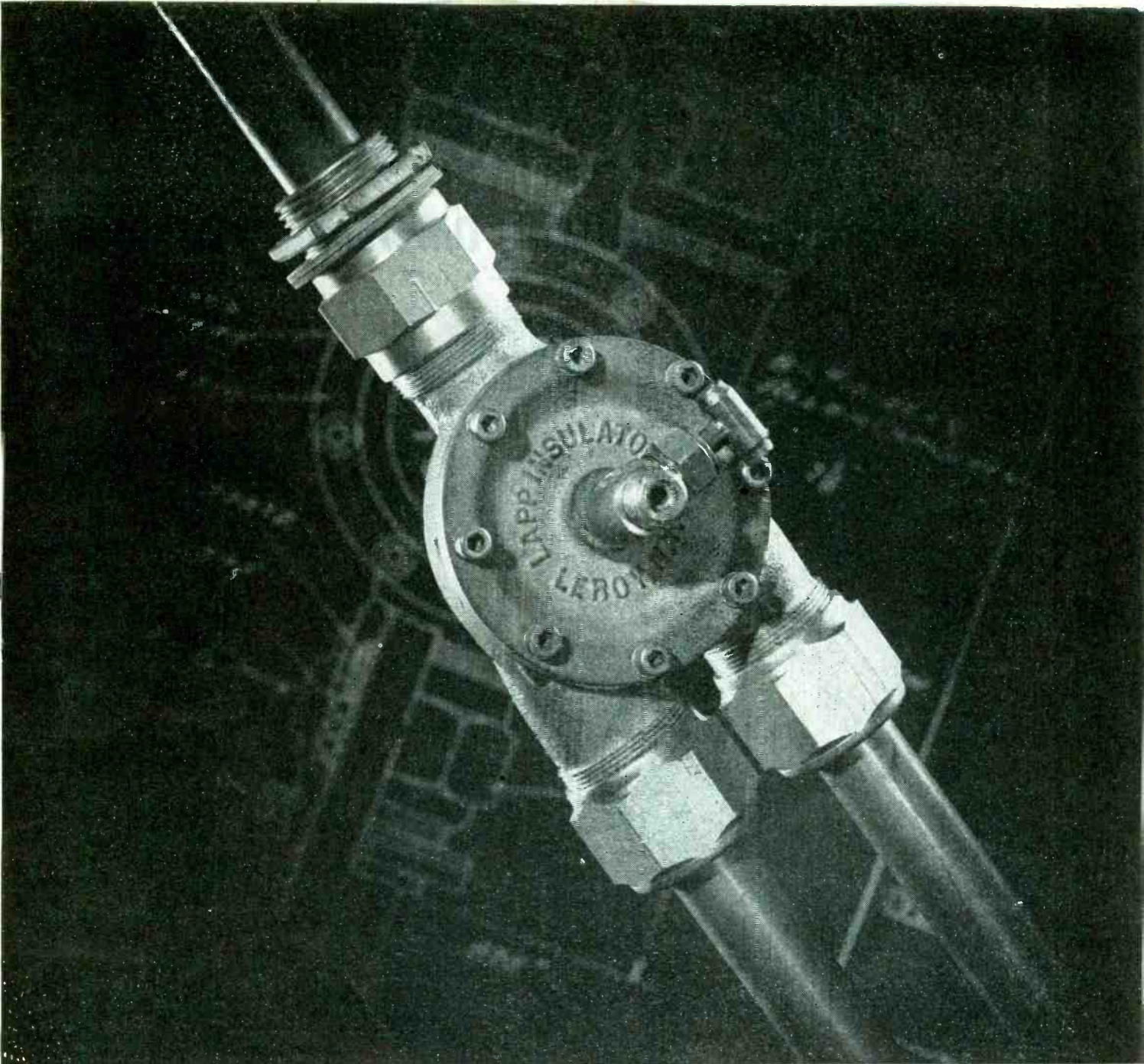

## *Electronic Parts* : ENGINEERING AND PRODUCTION

The gadget above is a junction box for a co-axial gas-filled transmission line. It is one of a series of coupling units, end seals and other fittings for high-frequency transmission—designed and built by Lapp.

To this type of construction, Lapp brings several innovations and improvements. For example, such a line from Lapp parts is genuinely leak-proof. Every gasket is under spring loading, so there's no leakage created by vibration or thermal change.

Whether or not you're interested in gas-filled transmission lines, you ought to know about Lapp. Here is an organization of engineers and manufacturers with broad basic knowledge of ceramics and their application. With experience in hundreds upon hundreds of special-purpose electronic parts, we have been able countless times to improve performance, or reduce costs, or cut production time through

the application of our specialized skills to design and manufacture of parts involving porcelain or steatite and associated metal parts.

For quick and efficient assistance on a war production subcontract—or for the competitive advantage Lapp-designed and Lapp-built parts will give to you in the postwar battle—an inquiry to Lapp now may pay you dividends. *Lapp Insulator Co., Inc., LeRoy, N. Y.*

# Lapp





# FOR SAFETY'S SAKE!

## *Electro-Voice* Hand-Held Differential Microphone

Model 205-S

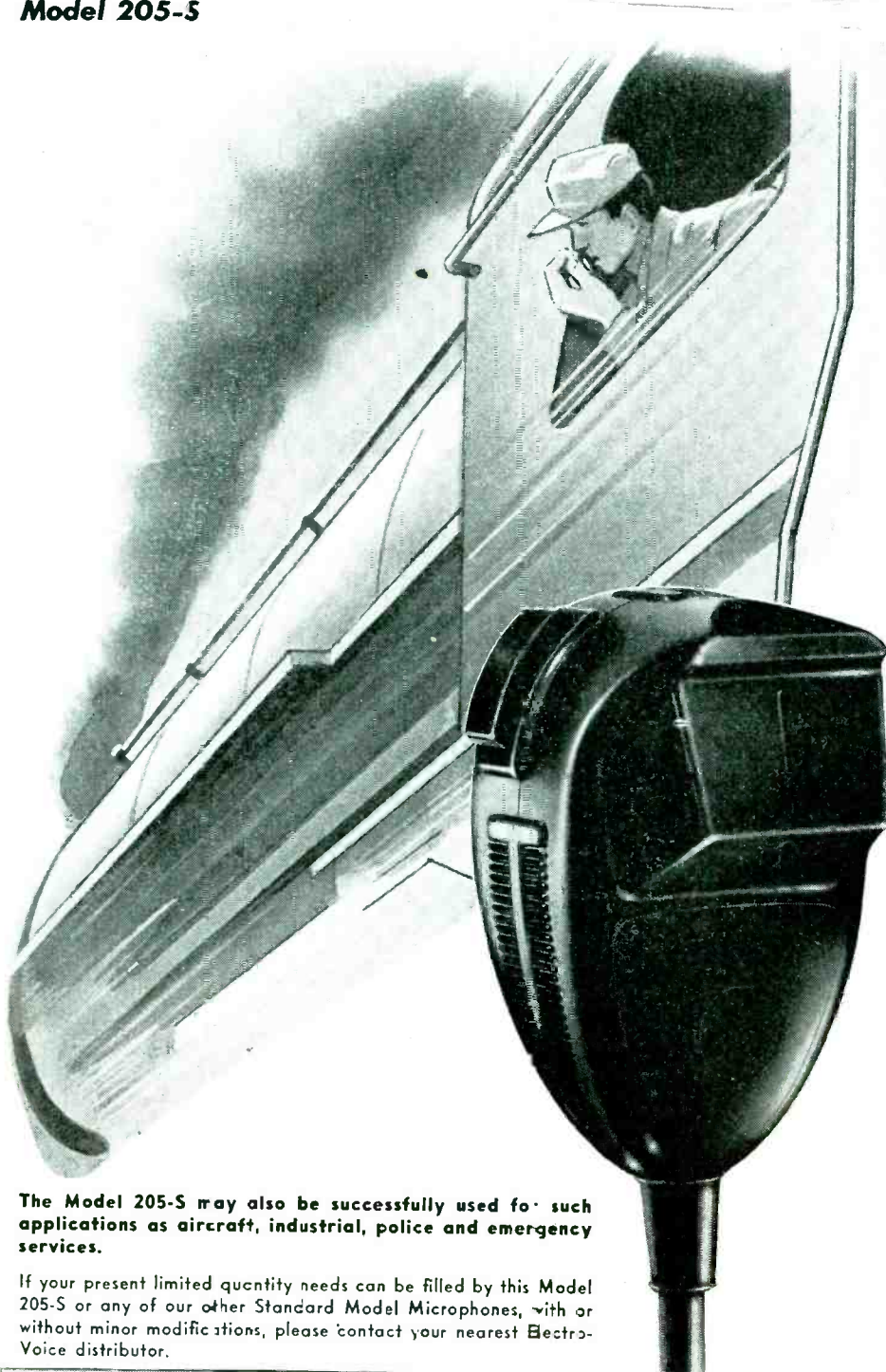

The appalling number of railroad accidents in recent months has stimulated the demand for installation of radio communications on railway lines. Eventually, all lines will be thus equipped. Splendidly suited "for safety's sake" is the Electro-Voice Differential Microphone Model 205-S. A noise-cancelling microphone, it enables the transmission of voice clearly and distinctly, unaffected by shrieking whistles or grinding wheels. Ruggedly constructed, it can "take" the punishment of a hard-riding locomotive.

**FREQUENCY RESPONSE:** substantially flat from 100-4000 c.p.s.

**LEVEL:** -20 DB (0 DB = 1 volt/dyne/cm<sup>2</sup>)

**ARTICULATION PERCENTAGE:** 97% under quiet, 88% under 115 DB ambient noise

**TEMPERATURE RANGE:** -40° to +185°F

**WEIGHT:** Less than eight ounces

**INPUT REQUIREMENT:** standard single button input

**BUTTON CURRENT:** 10-50 milliamperes

**MECHANICAL DETAILS:** molded, high impact phenolic housing. Minimum wall thickness, 1/8". Vinylite carbon retainer.

**SWITCH:** press-to-talk, with or without hold-down lock. Double pole double throw contacts provide an optional wide assortment of switch circuits. Standard circuit provides closing of button circuit and relay simultaneously.

**THERMAL NOISE:** Less than 1 millivolt with 50 milliamperes through button

**IMPACT RESISTANCE:** capable of withstanding more than 10,000 drops

**POSITIONAL RESPONSE:** plus or minus 5 DB of horizontal

**CABLE:** 5' three conductor, overall synthetic rubber jacketed

**BACKGROUND NOISE REDUCTION:** 20 DB and higher, depending on distance from noise source

The Model 205-S may also be successfully used for such applications as aircraft, industrial, police and emergency services.

If your present limited quantity needs can be filled by this Model 205-S or any of our other Standard Model Microphones, with or without minor modifications, please contact your nearest Electro-Voice distributor.

# *Electro-Voice* MICROPHONES

ELECTRO-VOICE CORPORATION • 1239 SOUTH BEND AVENUE • SOUTH BEND 24, INDIANA

Export Division: 13 East 40th Street, New York 16, N. Y., U. S. A. Cables: Arlab



# STUPAKOFF

FOUNDED IN 1897

*Ceramics for the World of Electronics*

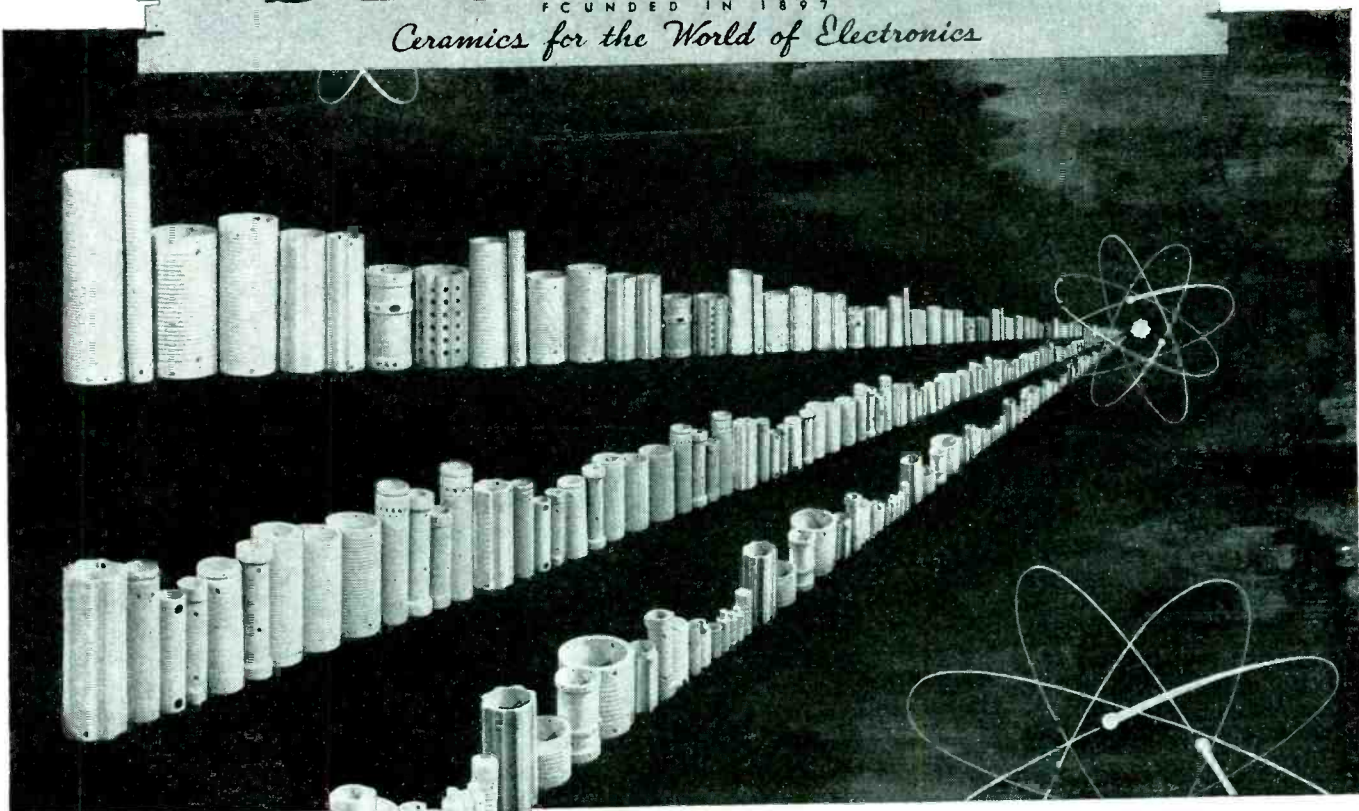

## PRECISION MADE COIL FORMS ... PRODUCED IN QUANTITY

**L**IMITLESS styles and sizes of coil forms, embodying the exacting specifications required of this type of insulator, are manufactured by Stupakoff for the electronic industry. Backed by two generations of experience in the science of ceramics, Stupakoff engineers have the necessary knowledge to produce insulators having the optimum mechanical and electrical properties. Modern production facilities plus trained and efficient personnel are additional assurance that your specifications will be accurately interpreted.

Stupakoff coil forms of steatite and other materials—unglazed, glazed or metallized—can be delivered promptly. Write today for dependable assistance in developing correct insulators for your electronic apparatus. Your inquiries will be given prompt attention by our technical staff.



Do More Than Before—Buy EXTRA War Bonds

**STUPAKOFF CERAMIC AND MANUFACTURING CO., LATROBE, PA.**



# RESEARCH

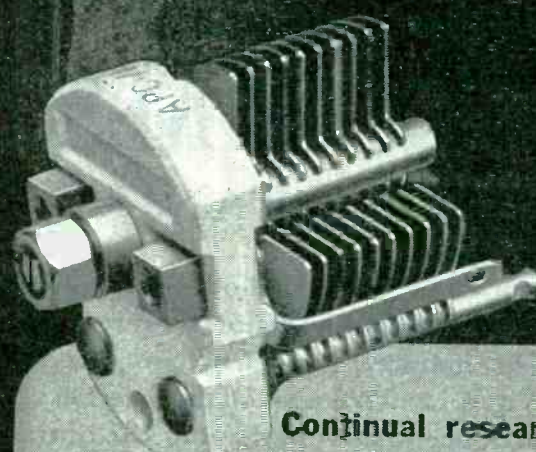

Continual research in chemistry, metallurgy and effects of various atmospheres on different plating finishes assures you that your Hammarlund variable capacitor will stay on the job.

# HAMMARLUND

THE HAMMARLUND MFG. CO., INC., 460 W. 34<sup>TH</sup> ST., N. Y. C.  
MANUFACTURERS OF PRECISION COMMUNICATIONS EQUIPMENT

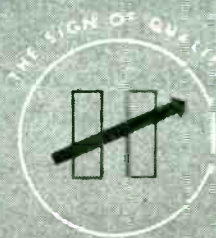

ESTABLISHED 1916



# AMERICAN SCREWS

*Phillips*

drive with Straight-Line **SPEED**  
to Keep Production Rolling at "Full Throttle"

Are you slow-poking along with the same old outdated, slotted screws? . . . Or are you using the modern, streamlined American Phillips Screw Driving method which drives you straight to new speed records in production, without accidents either to workers or their work?

All that *any* worker . . . skilled or unskilled, man or woman . . . has to do is this: Fit the recessed head of an American Phillips Screw onto the 4-winged Phillips bit of a power-driver. Aim this *automatically self-aligned* driving unit at the work, and pull the trigger. *That's all.* Every American Phillips Screw sets up straight, flush, and tight, with its head unburred . . . and with no gouges on surrounding work-surfaces. And that's why so many plants in every industry keep on using American Phillips Screws *right from the first time they tried them . . .* because with this straighter, speedier method, it costs less to do more and better work.



4-WINGED DRIVER CAN'T  
TWIST OUT OF ENGINEERED  
TAPERED RECESS IN AMERICAN  
PHILLIPS SCREW HEAD

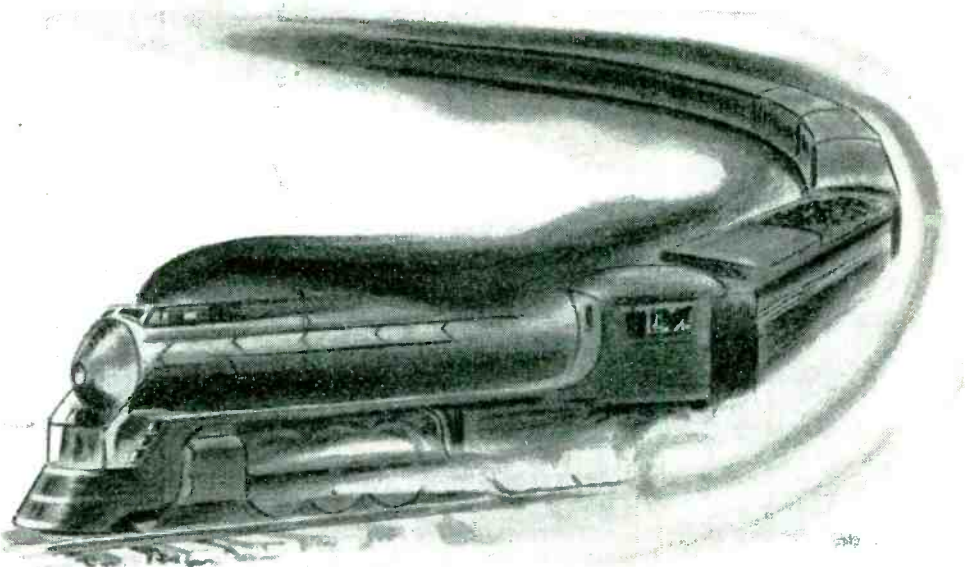

**AMERICAN SCREW COMPANY**

PROVIDENCE 1, RHODE ISLAND

Chicago 11: 589 E. Illinois Street      Detroit 2: 502 Stephenson Building

**Put the Screws on the enemy . . . BUY BONDS!**



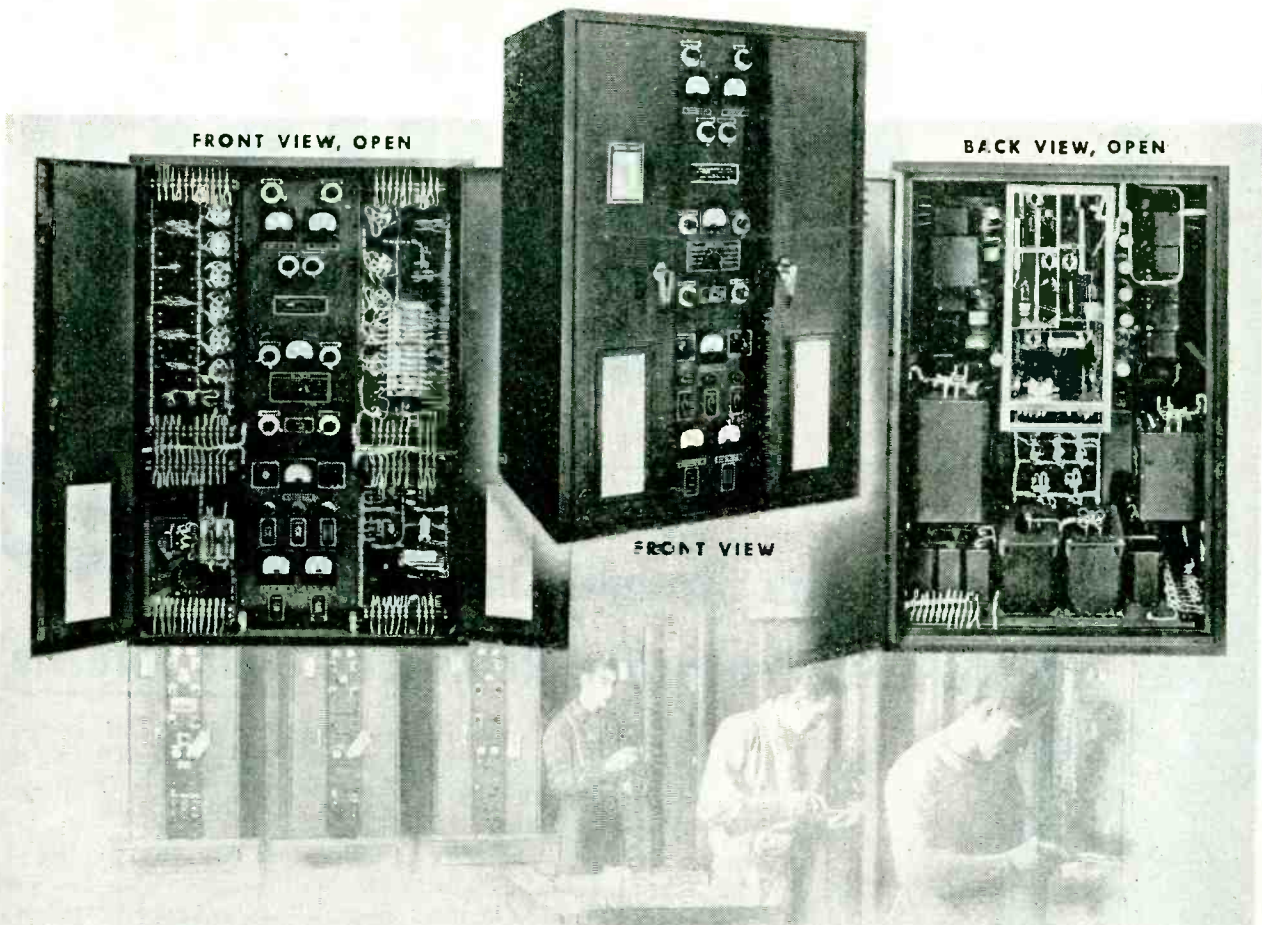

## AIRPORT TRAFFIC CONTROL TRANSMITTER

**Type U-459—50 watt—116-145 mc. range**

Type U-459 is a ground station transmitter intended for airport traffic control, airline and itinerant communication. It can be supplied with 125 watt output and other frequency bands.

A similar transmitter, supplied by us for the use of the Army Air Forces, is meeting severe service in all sections of the globe.

### PRINCIPAL OPERATING CHARACTERISTICS

Power Supply . . . . .110-120 v., 60 cycle single phase	Distortion of other frequencies at 90% modulation . . . . .Less than 12%
Power Input, Unmodulated . . . . .690 watts	Frequency Response from Line Input . . . . . $\pm 1$ db from 100 to 3000 cycles
Power Input, 100% Modulated . . . . .750 watts	Operating Temperature Range . . . . .—15 to $\pm 50^{\circ}$ c.
Unmodulated Carrier Output . . . . .45 watts	Operating Humidity Range . . . . .0 to 100%
Output Frequency in Bands . . . . .116 to 145 mc.	Carrier Noise with Audio Input shorted and Gain Control at maximum . . . . .Less than 2%
Antenna Load Impedance . . . . .72 ohm concentric transmission line	Effective Operating . . . . .To the horizon. Depends on height of transmitting and receiving antennas
Permissible Modulation . . . . .100%	
Distortion of 1000 cycles at 90% modulation . . . . .Less than 7%	

**ACCESSORY EQUIPMENT — Also available:** Remote Control Unit; Microphone push-to-talk, release-to-listen type for local control without amplification; Horizontally and Vertically Polarized Antennas.

COMPLETE DETAILS, PRICE AND DELIVERY ON REQUEST



# RADIO RECEPTOR COMPANY, Inc.

251 WEST 19th STREET • NEW YORK 11, NEW YORK

AIRWAY AND AIRPORT RADIO • SOUND SYSTEMS • INDUSTRIAL ELECTRONICS • ELECTRONIC H. F. HEATERS

SINCE 1922 IN RADIO AND ELECTRONICS

7/8" DIAMETER x 1 1/4" HIGH



**midget**

IN SIZE!

**GIANT**

IN STAMINA!

**This Audio Oscillator  
Transformer Meets 5-Cycle  
Temperature Test Requirements**

**STURDY TERMINALS  
ASSURE  
SECURE CONNECTIONS**

HI-MU alloy plus a special sealing process! There, in a nutshell, is the reason why this capsule-size transformer operates with great stability under all climatic conditions . . . This is only one of our complete line of midget audio transformers and filter reactors . . . Our many years of pre-war experience has not only helped us solve the problems of war demands, but also prepares us to serve in the postwar future.

**SUPER ELECTRIC PRODUCTS CORP.**  
1057 Summit Ave., Jersey City, N. J.

**Manufacturers of Transformers for Power,  
Audio Frequency, Luminous Tube, Testing**



# This SOLA CONSTANT VOLTAGE TRANSFORMER has an important postwar future in

# YOUR

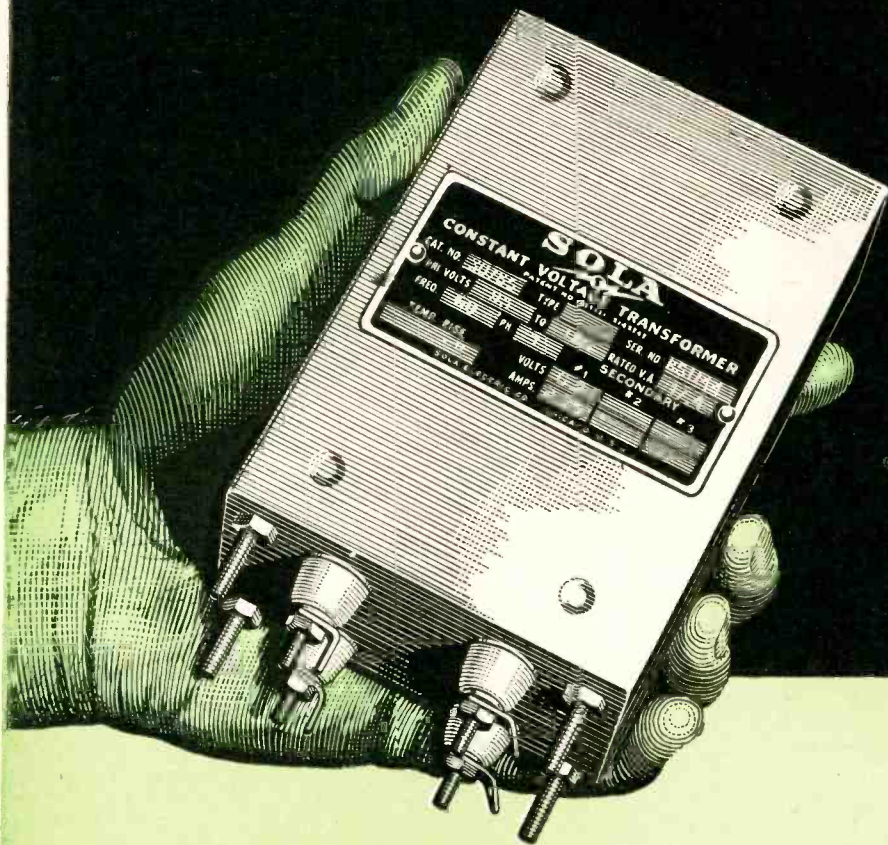

HEATING CONTROLS •  
REFRIGERATION CONTROLS • TELEVISION SETS • E-M RADIO • VACUUM TUBE VOLT-METERS • ELECTRONIC GAUGING AND INSPECTION EQUIPMENT • PHOTO-METRIC INSTRUMENTS... there are other applications of course

Here is a SOLA Constant Voltage Transformer that should be a built-in part of your equipment—

**First:** because it will stabilize output voltage at your rated requirements regardless of line voltage fluctuations as great as  $\pm 12$  to 15 %.

**Second:** because its small, compact size is ideal for chassis mounting.

**Third:** because of its low, economical cost.

**Fourth:** because of the saving that can be made through the elimination of other components.

**Fifth:** because a majority of anticipated service calls can be eliminated from your cost calculations.

**Sixth:** because the users of your product will get greater satisfaction from trouble-free service.

This particular transformer is rated at 6.3 volts, 17VA output and is designed primarily for the stabilization of vacuum tube filament and heater voltages. Other voltages and capacities for chassis mounting can be supplied on the same low cost, economical basis to meet your exact requirements.

#### To Manufacturers:

Complete specification details covering this new Constant Voltage Transformer will be furnished at your request.

Ask for Spec. No. DCV-103

## Constant Voltage Transformers

Transformers for: Constant Voltage • Cold Cathode Lighting • Mercury Lamps • Series Lighting • Fluorescent Lighting • X-Ray Equipment • Luminous Tube Signs • Oil Burner Ignition • Radio • Power • Controls • Signal Systems • Door Bells and Chimes • etc. SOLA ELECTRIC CO., 2525 Clybourn Ave., Chicago 14, Ill.



**pioneer for tomorrow**

The world of tomorrow will be one of electronics. Pioneer for that world is the electronic engineer. His vitally important effort during this wartime period in devising electronic equipment is helping to defeat the enemy. Tomorrow, he devotes his specialized scientific knowledge to aid peacetime industries.

Raytheon is applying its efforts to the development of advanced electronic tubes and equipment for the war effort. When that job is done, the knowledge that has been gained will be used to guarantee that post-war radio, industrial and electronic equipment manufacturers will receive Raytheon tubes and equipment with even greater "Plus-Extra" quality.



**ARMY-NAVY "E" WITH STARS**

Awarded All Four Divisions of Raytheon for Continued Excellence in Production

**RAYTHEON**

Raytheon Manufacturing Company

ELECTRICAL EQUIPMENT DIVISION

Waltham and Newton, Massachusetts

DEVOTED TO RESEARCH AND THE MANUFACTURE OF TUBES AND EQUIPMENT FOR THE NEW ERA OF ELECTRONICS





REG. U. S. PAT. OFF.

# PLASTICS

## CAST RESINS

"Catalin" Cast Phenolic Resins offer the most complete and beautiful range of gem-like colors, from crystal-clear through every conceivable hue, to jet black. It is not a molding powder and does not require the construction of expensive molds.

Because of Catalin's unexcelled machinability, an infinite variety of products may be fabricated to precision specifications from standard sheets, rods, tubes or shapes. Catalin has excellent physical properties.



## MOLDING COMPOUNDS

"Loalin" is Catalin's Polystyrene extruding and molding compound. A thermoplastic material, it possesses many outstanding properties... among them, its low cost and zero water-absorption, high dielectric strength, excellent chemical resistance and unrivalled dimensional stability. In addition to these, "Loalin" is the lightest in weight of all the plastics.



## LIQUID RESINS

"CATABOND" and "CATAVAR", "LOABOND" and "LOAVAR" identify a wide variety of thermosetting and thermoplastic liquid resin formulations employed in coating, laminating, gluing, bonding and impregnating wood, plywood, abrasives, paper, sisal, glass fibres, leather, cloth, cork, etc. All embody special properties and are designed to do a specific job in some particular industry. There is no evident limit to their useful application.

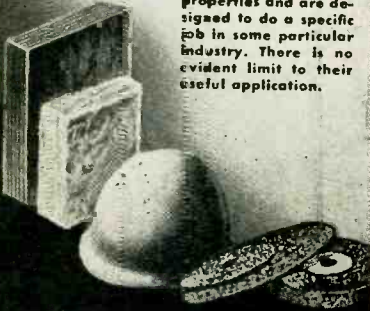

**CATALIN CORPORATION**  
ONE PARK AVE., NEW YORK 16, N.Y.

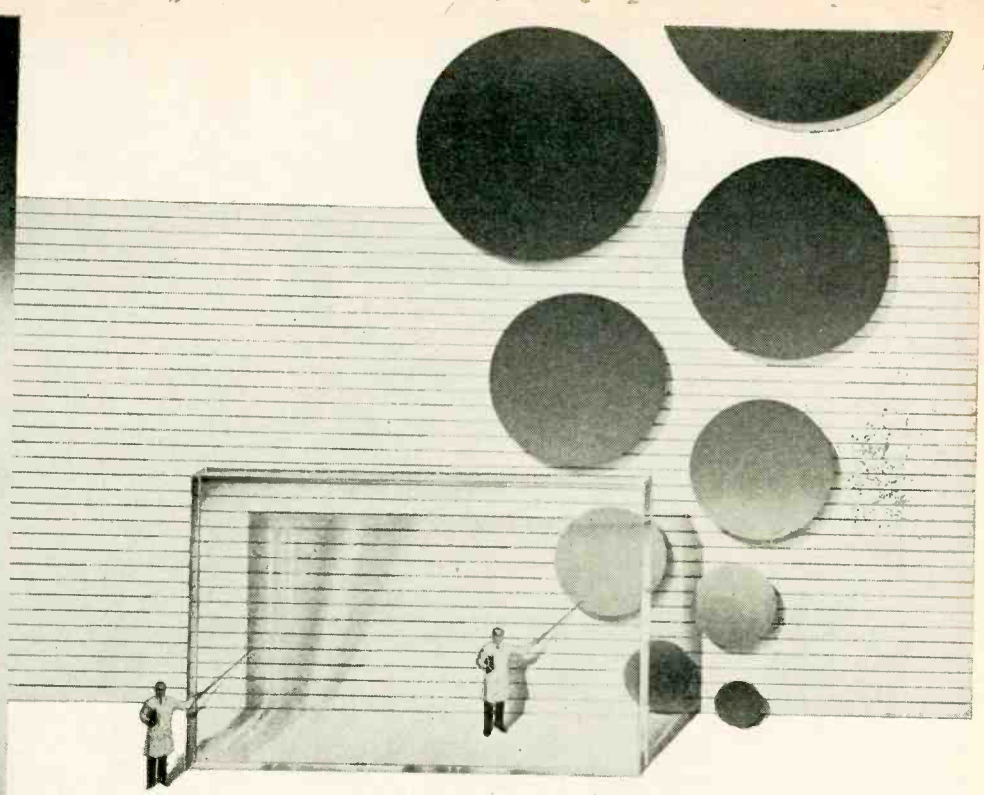

# transparency :: color

Probably no two physical characteristics have played more important roles in the original and increasing acceptance of Plastics than have the properties of transparency and color.

The acknowledged sales-appeal and design-potentials of color and the many decorative and practical applications for crystal-clear, tough materials helped write the history of the early years of this Plastic Age. When war replaced the automobile with the airplane and the luxury liner with the "PT" boat and submarine, lightweight colored and transparent plastic handles, knobs, signal dials, instrument panels, etc., brought the quick identification of controls so essential to fighters and war-workers.

Fabricators of "CATALIN", our cast phenolic resin, and molders of "LOALIN", our polystyrene compound, know them for their unlimited range of pure, gem-like colors and their brilliant transparency. No other plastic can match Catalin's depth and richness of color—not only in opaque and transparent forms, but in various degrees of translucency, as well. Its

refractive index is 1.58-1.62...Loalin's is 1.59. Catalin's light transmission (in crystal-clear) is 80-90%...Loalin's is 88-90%. In addition, Loalin possesses the unique advantage of "bending" light around curves—of especial interest in current scientific applications and for industrial and home lighting in the immediate future.

Whatever else that future holds, we may be certain that the technical assets of the transparent plastics and the refreshing and stimulating properties of the color these miracle materials will bring into our everyday lives in homes, offices and factories, alike, will make important contributions to our fuller enjoyment of the fruits of Peace.



Cast Resins  
Molding Compounds  
Liquid Resins



ONE PARK AVENUE • NEW YORK, N. Y.



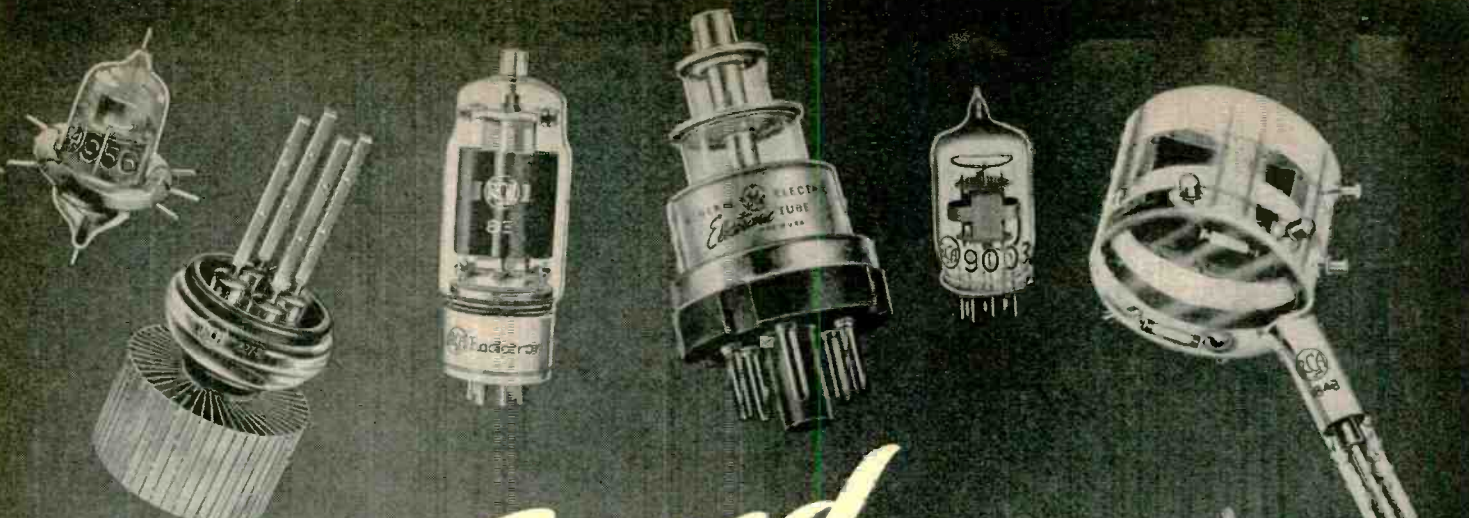

# Speed

## REVOLUTIONARY RADIO TUBE DESIGN

### WITH METALS

Frequencies of 2000 Megacycles and more—Electronic Heating—Frequency Modulation—Television—Radar... these and other phenomenal radio inventions have brought about radical changes in radio tube design like these.

New concepts of tube function and revolutionary methods of construction have necessitated equally new developments in radio metallurgy. In Driver-Harris research laboratories and factories are being produced the radio alloys essential to the speedy and successful manufacturing of these tubes... in quality controlled quantities adequate for the great demands of war.

When you are striving to make standard tubes rate higher and last longer—or are engaged in the development of new types, depend on Driver-Harris to supply you with the radio metals required. Send us your metal specifications.

- Driver-Harris makes these and other time-tested alloys for every radio and vacuum tube requirement:
- \*NICHROME
  - \*GRIDNIC ALLOYS
  - \*FILNIC ALLOYS
  - \*NICKEL "A," "D," "E," "Z"
  - #42 ALLOY
  - #52 ALLOY
  - \*NILVAR

\*Trade Mark Reg. U. S. Pat. Off.



# Driver-Harris

## COMPANY

HARRISON, NEW JERSEY

BRANCHES: CHICAGO • DETROIT • CLEVELAND • LOS ANGELES • SAN FRANCISCO • SEATTLE





# LARGEST SHEET OF MICA CERAMIC INSULATION

*ever made*

19 $\frac{1}{4}$ " x 29 $\frac{3}{4}$ "

**MYKROY  
SHEETS**

*now ready*

THIS new size plate of MYKROY glass-bonded mica ceramic insulation is *more than 2 times LONGER* than the maximum size available heretofore affording Production and Design Engineers many important new application advantages:

1. **Because of increased size** MYKROY can now be used for: Switchboard panels—Large inductance bars—Insulated table tops—Large meter panels—Transformer covers—Switch connecting rods—Bases for Radio Frequency or Electrical Equipment assemblies and structural members in R. F. equipment where low-loss insulation is indispensable.
2. **Lower cost per square inch** of MYKROY in the 19 $\frac{1}{4}$ " x 29 $\frac{3}{4}$ " sheet makes possible savings as high as 33 $\frac{1}{2}$ % depending upon workpiece size, considerably reducing the cost per fabricated unit.
3. **Better cutting efficiency** in the new plate lowers unit cost still further and permits employing the superior insulating properties of MYKROY in a broader range of electronic applications.



All fabricators of glass-bonded mica materials should seriously consider the use of these larger plates to reduce costs and amount of time required in filling their orders. Ready for Immediate Delivery. Most thicknesses carried in stock.

## WRITE FOR MYKROY SHEET BULLETIN #102

Just off the press, Bulletin #102 is a complete engineer's data book which combines practical data with a brief account of the dramatic story behind the development of the 19 $\frac{1}{4}$ " x 29 $\frac{3}{4}$ " sheet. It is replete with working data and comparison charts on the various sizes of MYKROY sheets. Write for your copy NOW!



MYKROY IS SUPPLIED IN SHEETS AND RODS . . . MACHINED OR MOLDED TO SPECIFICATIONS

MADE EXCLUSIVELY BY **ELECTRONIC MECHANICS**  
INC.

70 CLIFTON BOULEVARD • CLIFTON, NEW JERSEY  
Chicago 47: 1917 NO. SPRINGFIELD AVENUE . . . TEL. Albany 4310  
Export Office: 89 Broad Street, New York 4, N. Y.



# *Life Testing* ON THE GRAND SCALE!

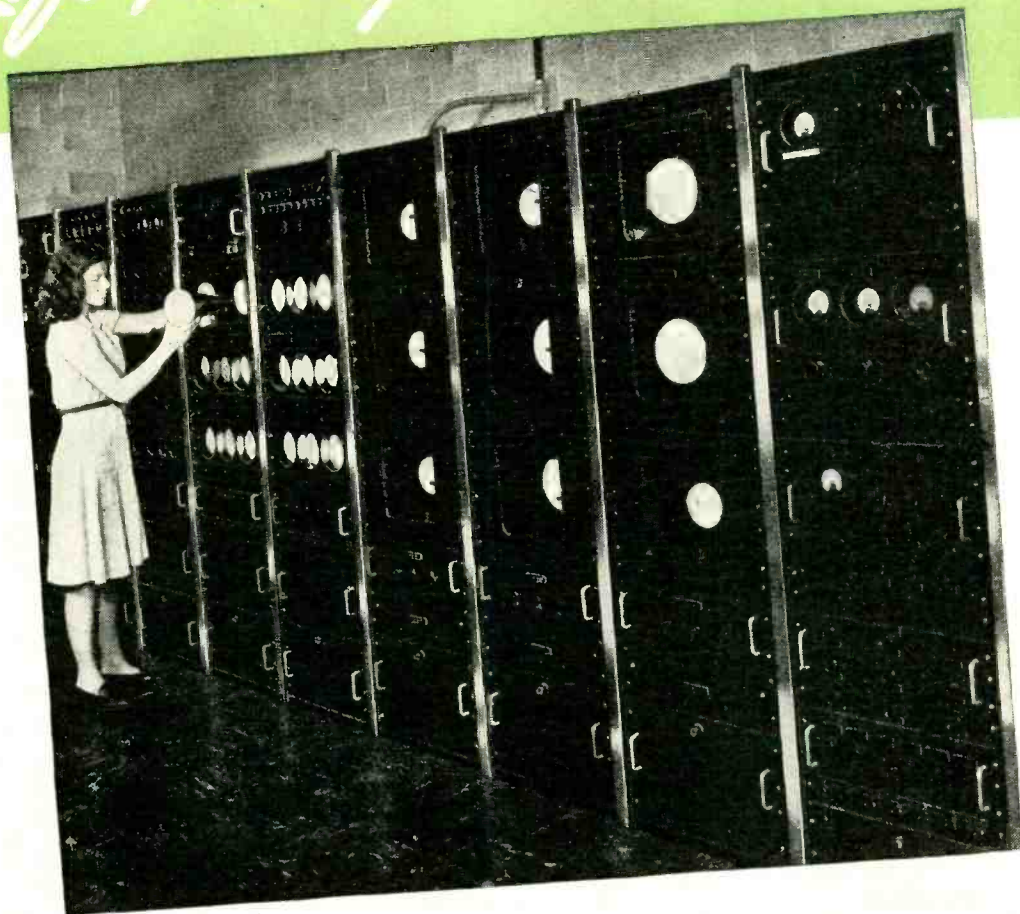

One of the most elaborate cathode-ray tube test racks in this country operates day and night, seven days a week at National Union. For, at N. U., cathode ray tube production is now reaching heights undreamed of in pre-war days. To achieve this production, entirely new testing techniques, on an unprecedented scale, have been developed.

Examples of the newest tried and proven N. U. products are the four cathode-ray tubes illustrated. All of these N. U. cathode ray types

can be produced in a variety of screen materials, which will have various postwar applications in television and industrial electronics.

Here at National Union are many such ultra-modern products ready to serve your peacetime needs. Ready, yes, in large volume—and backed by as fine an electronic tube research service as has ever been available to industry. Ready, indeed, from the day our present obligations are fulfilled and reconversion can get under way. Count on National Union.

**NATIONAL UNION RADIO CORPORATION, NEWARK, N. J.**  
*Factories: Newark and Maplewood, N. J.; Lansdale and Robesonia, Pa.*

# NATIONAL UNION RADIO AND ELECTRONIC TUBES



*Transmitting, Cathode Ray, Receiving, Special Purpose Tubes • Condensers • Volume Controls • Photo Electric Cells • Panel Lamps • Flashlight Bulbs*



# Concentric Transmission Line

*by Doolittle*

*A Standard Product Since 1934*

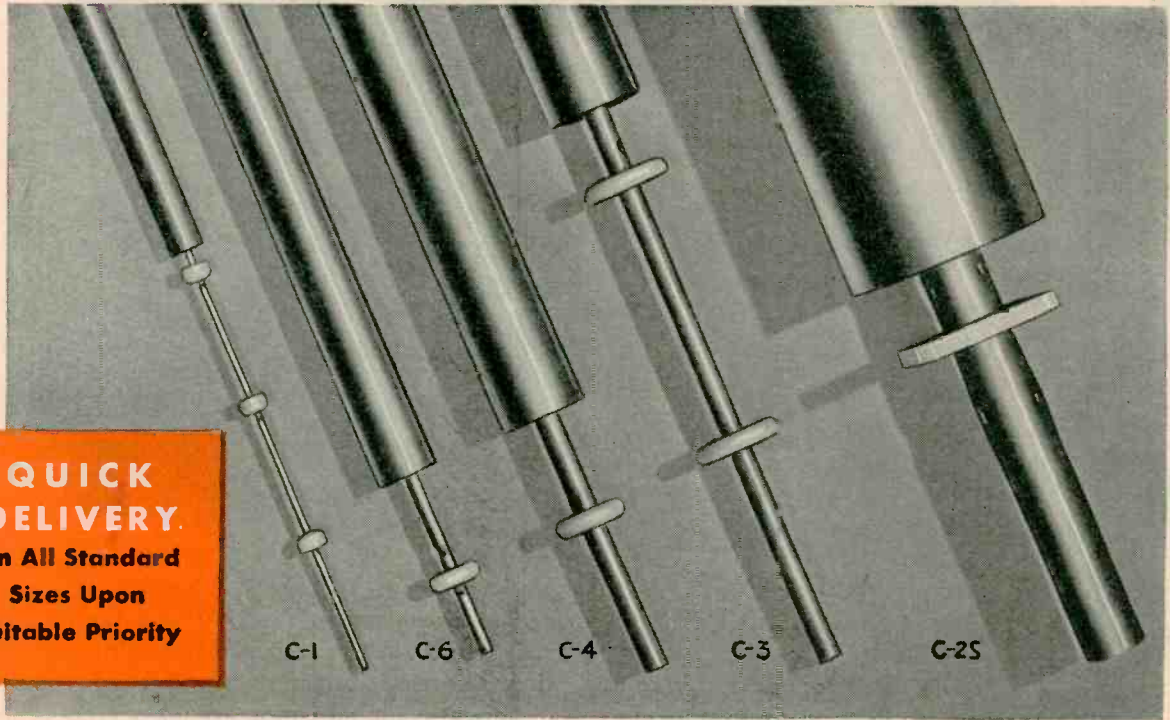

**QUICK DELIVERY.**  
On All Standard Sizes Upon Suitable Priority

Ten years of experience in building concentric transmission line and associated impedance matching equipment assures you highest quality and workmanship.

Seven standard sizes of Doolittle Lines are listed below. Each line uses seamless copper tubing for the outer and inner conductor, except Types C-1 and C-6 which use solid inner conductors. The insulating heads are made of low loss ceramic—impervious

to moisture—spaced and fastened securely for maintaining proper electrical and mechanical characteristics. Carefully designed fittings and accessories for any requirement are also available.

Special sizes are made to order. For engineering information concerning installation and use, feel free to consult our engineering staff.

WRITE FOR CATALOG AND PRICES

Type of line	C-1	C-2	C-25	C-3	C-4	C-5	C-6
Diameter of outer conductor.....	3/8 in.	2 in.	2 in.	1 in.	3/8 in.	3 in.	5/8 in.
Diameter of inner conductor.....	.081 in.	3/8 in.	1/2 in.	1/4 in.	1/4 in.	3/4 in.	.144 in.
*Standard section length, feet.....	50	20	20	20	20	14	50
Net weight per ft.....	2 oz.	10 oz.	1 lb. 1 oz.	8 oz.	8 oz.	1 lb. 10 oz.	4 oz.
Power rating-kilowatts.....	1	50	50	10	10	100	5
Surge impedance-ohms.....	70	100	82	75	66	80	73
Loss per 1000 ft. at 1 mc. decibels.....	.94	.156	.083	.31	.33	.095	.55
Capacity per ft. mmfds.....	19.8	10.5	12.5	14.1	16.0	12.8	14.8

\*A set of couplings for the inner and outer conductors is furnished with each length.

**Doolittle**  
**RADIO INC.**  
*Builders of Precision Communications Equipment*  
7421 SOUTH LOOMIS BLVD.  
CHICAGO 36, ILLINOIS



# We knew what you wanted!

## IT'S THE REINER VACUUM TUBE VOLTMETER

### A QUICK DIGEST OF THE REINER No. 450 Vacuum Tube Voltmeter

The Model 450 Vacuum Tube Volt-Ohm Milliammeter offers: Wide frequency range AC Voltmeter; One linear scale for all voltage and current scales; Freedom from the effects of temperature and humidity; single zero adjust for all AC and DC ranges. Measure 100 ohms to 1,000 megohms without battery—the latter used only for measurements below 100 ohms. Voltage regulated supply—stable operation. No more mislaid or lost test probes and connectors—convenient, adequate storage space in case.

**AC VOLTAGE RANGES**— .005 to 250 volts, 5 ranges 0—2.5—10—25—100—250 v.; Linear scale all ranges. Frequency range—50 cps. to 50 megacycles; Input resistance 1 megohm at 1000 cps. all ranges; Input capacitance—10 mmf. Diode probe with 4-foot cable; Accuracy 2% of full scale values; maximum frequency error to 10 megacycles—5%. Single zero adjust for all ranges.

**DC VOLTAGE RANGES**— .005 to 1000 volts; 6 ranges 0—2.5—10—25—100—250—1000 volts. Linear scale; Input capacitance—less than 2 mmf. Input resistance—11 megohms all ranges. Accuracy 2% of full scale values.

**DC CURRENT RANGES**— 50 microamperes to 1 ampere; 6 ranges 0—2.5—10—25—100—250—1000 milliamperes. Accuracy 2% of full scale values. Effective resistance at 1 ampere—45 ohms; at 2.5 milliamperes—180 ohms.

**OHMMETER RANGES**— 6 ranges—.1 ohm to 1000 megohms. Center Scale Resistance—10<sup>1</sup>, 10<sup>2</sup>, 10<sup>3</sup>, 10<sup>4</sup>, 10<sup>5</sup>, 10<sup>6</sup> ohms. Center Scale Accuracy—2%. 3 low ranges battery operated. 3 high resistance ranges internally powered. Complete, with all accessories, as illustrated, ready to operate, Model 450 costs only

\$13500

It's as if we had been reading your mind. You thought that some day some one would devise one all-purpose instrument that would be simpler, more flexible—cover a wider range of functions and applications than any of the usual commercial vacuum tube voltmeters. Well, here it is—the complete answer to your needs—the new Reiner Model 450!

Look at its special features! You'll discover we have anticipated your every requirement. In the Reiner Model 450, you'll find that somehow we knew exactly what you wanted when we designed this superb instrument.

For more information on this and other Reiner equipment such as square wave generators, oscilloscopes, and signal generators, write Reiner Electronics Co., Inc., 152 West 25th Street, New York 1, N. Y.



# Reiner

ELECTRONICS





# Plan now for future design . . .

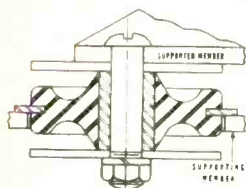
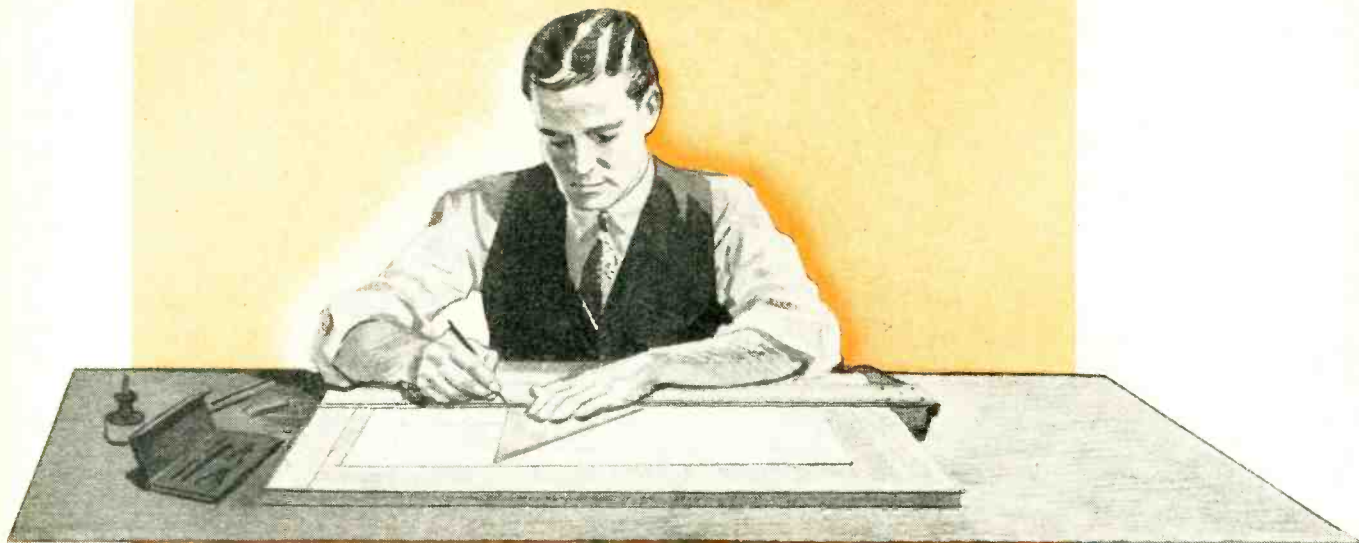

**LORD PLATE FORM MOUNTING**

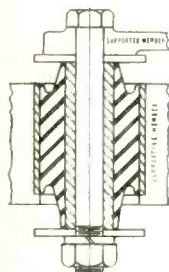

**LORD TUBE FORM MOUNTING**

What are you going to do—what are you going to make—how are you going to make it—in the post-war world?

It's going to be a different, and we hope a better world. But it's going to be a faster-moving world; nerves, more than ever, are going to be under strain.

Faster trains, faster cars, faster planes—and more of them: faster machinery, faster production lines—it all means more vibration, more strain on the nervous system; and much greater need for vibration control.

For over twenty years the Lord Manufacturing Company has pioneered the application of shear type rubber mountings for the control and isolation of vibration. The war has greatly accelerated both the science of vibration control and the recognition of its practical necessity and financial economy. Every U. S. military plane, as an instance, has many units, from the giant engines to the most delicate instrument, protected from harmful vibration with Lord Shear Type Mountings.

Whatever you manufacture or plan to manufacture, if its efficiency is affected by vibration, internal or external, Lord engineers can help you. In the meantime, our free literature will bring you up to date in your general information on vibration control.



**Buy More War Bonds**

IT TAKES RUBBER *In Shear* TO ABSORB VIBRATION

**LORD MANUFACTURING COMPANY**  
ERIE, PENNSYLVANIA

SALES REPRESENTATIVES  
NEW YORK - 280 MADISON AVE.  
CHICAGO - 520 N. MICHIGAN AVE.  
DETROIT - 7310 WOODWARD AVE.  
BURBANK, CAL. - 245 E. OLIVE AVE.  
CANADIAN REPRESENTATIVES  
RAILWAY & POWER ENGINEERING CORP., LTD.  
TORONTO, CANADA

*Originators of Shear Type Bonded Rubber Mountings*





So convert paper plans  
to sheet metal products is

# KARP'S JOB

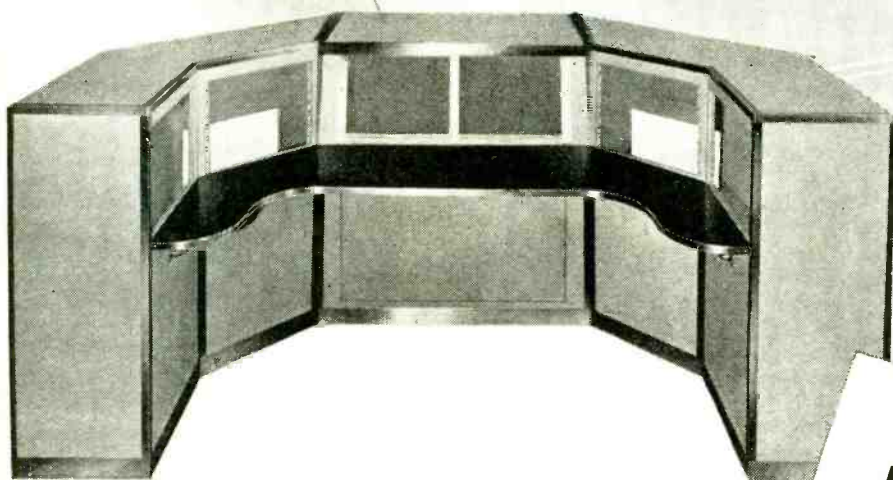

Give us the specifications or plans for your sheet metal requirements, and KARP will produce a superior finished product because . . .

- ★ We have engineers and craftsmen with a "golden touch" to create anything in sheet metal.
- ★ We have complete metal working facilities, including hundreds of stock dies to lower or eliminate die costs.
- ★ All orders are custom built with typical KARP ingenuity.
- ★ Competitive prices! Prompt deliveries!

SUPPORT THE SIXTH WAR LOAN DRIVE

**KARP METAL PRODUCTS CO., INC.**

124 30th STREET • BROOKLYN 32, N. Y.

**KARP Sales Representatives**  
*are strategically located all over the country. A card to this office will bring our representative in your district to consult with you.*



*NOW—fluids that stay fluid!*

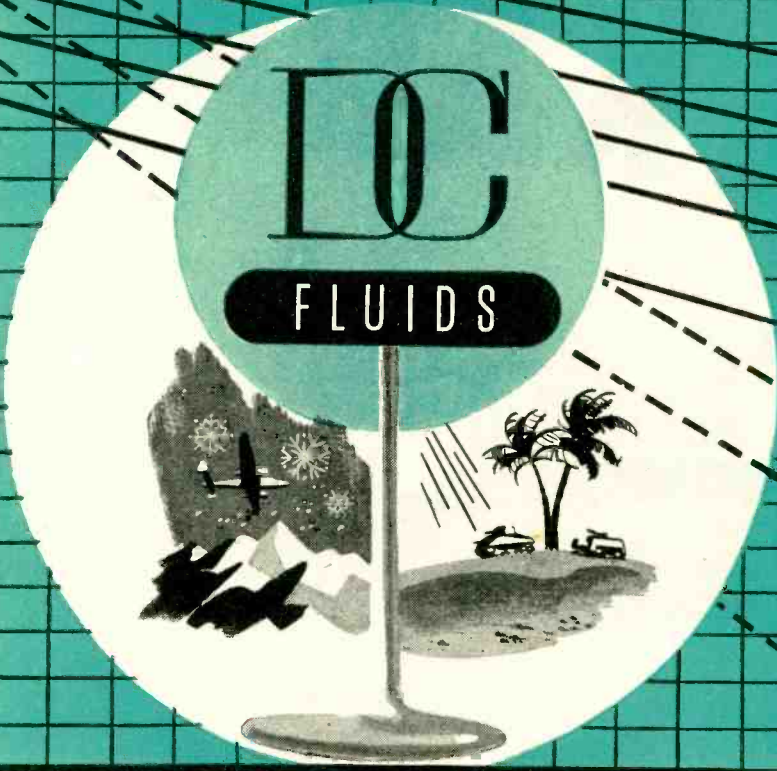

-30°F

210°F

## High or Low Temperatures— There's Little Viscosity Change

Small change in viscosity over a wide temperature range is one of several important properties that distinguish Dow Corning Fluids. These new silicone products are available in two series, depending on the viscosity grade and freezing point required. In both Type 200 and Type 500 the viscosity change is much smaller than that of any known liquids of equivalent viscosity.

The simplified graph above shows the viscosity grade and temperature slope of Type 200 Fluids compared with hydraulic oils over a temperature range of -30°F. to 210°F. Note the flat slope of the DC Fluid. This illustrates a characteristic that has awakened keen interest. Here are fluids that *stay fluid*, even at temperatures far below zero. Such remarkable properties indicate that these new inert liquids are ideal for many precision instrument damping applications.

DOW CORNING CORPORATION  
BOX 592, MIDLAND, MICHIGAN

### DOW CORNING SILICONE PRODUCTS INCLUDE:

**RESINS**—High temperature insulating varnishes for use with heat stable electrical insulating materials.

**GREASES**—For lubrication of valves in high temperature or corrosive chemical services. Plug Cock Grease—for metal valves. Stopcock Grease—for glass and ceramic valves.

*Dow*Corning



# THE EFFECTIVE REPRODUCTION OF SPEECH...

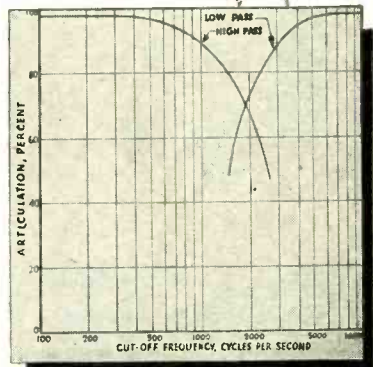
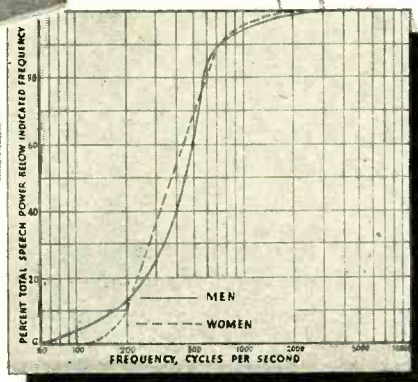
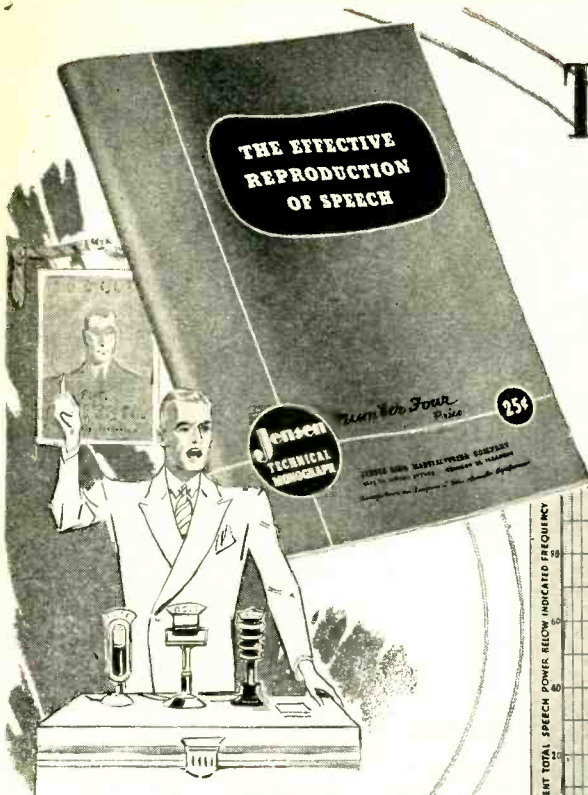

When casually considered, the reproduction of speech may appear to present less exacting requirements than the reproduction of music. Yet *faithful* speech reproduction requires a frequency band almost as wide as for music. Amplified speech for strictly communication purposes usually presents a different requirement. Here, such matters as articulation, loudness, masking, power requirements and the ability to deliver the message through noise, become the more important considerations.

"The Effective Reproduction of Speech"—Number 4 in the series of JENSEN Technical Monographs—presents much up-to-date data on this important subject in convenient form, together with useful conclusions and practical information for everyone interested in sound reproduction. Get your copy from your JENSEN jobber or dealer, or fill out the coupon and mail it with 25c for each copy ordered.

### The Series So Far Issued

- No. 1. Loud Speaker Frequency-Response Measurements.
- No. 2. Impedance Matching and Power Distribution.
- No. 3. Frequency Range in Music Reproduction.
- No. 4. The Effective Reproduction of Speech.

FREE to men in the Armed Services, and to Technical Schools, Colleges and Libraries.



# Jensen

**RADIO MANUFACTURING COMPANY**

6607 South Laramie Avenue

Chicago 38, Illinois

- Send me  The Effective Reproduction of Speech.  
 Frequency Range in Music Reproduction.  
 Impedance Matching and Power Distribution.  
 Loud Speaker Frequency-Response Measurements.  
 (Check one or more. Send 25c for each book ordered.)

NAME \_\_\_\_\_

ADDRESS \_\_\_\_\_

CITY \_\_\_\_\_ ZONE \_\_\_\_\_ STATE \_\_\_\_\_





# Some

# INTERESTING FACTS ABOUT HYTRON



- ★ Hytron is the oldest manufacturer in the United States specializing on radio receiving tubes. The first Hytron tube was made by hand in 1921.
- ★ The now standard BANTAM GT receiving tube is a Hytron origination. Hytron designed and developed over 70 of the popular GT types. These small glass receiving tubes contributed to the development of the miniature table radio and to large scale production of radio and radar equipment for the Services.
- ★ The tiny BANTAM JR. tubes originated by Hytron were the first sub-miniatures. They made possible hearing aids and pocket radio sets. Similar Hytron tubes serve in wartime electronic devices.
- ★ Hytron has pioneered transmitting and special purpose tubes for the radio amateur and for police radio. Its very-high-frequency tubes and its instant-heating r.f. beam tetrodes for mobile communications, have also become extremely popular with the Services.
- ★ Hytron combines long experience in high-speed receiving tube techniques with the know-how of special purpose tube engineering. The result is economical mass production of special tubes.
- ★ First of the receiving tube manufacturers to convert 100% to war production, Hytron will be just as alert in serving the post-war market.

CONSULT HYTRON regarding your needs for these tubes: receiving, ballast, hearing aid, very-high-frequency triodes and pentodes, miniatures, medium and low-power transmitting triodes, r.f. beam tetrodes (particularly instant-heating), r.f. pentodes, gaseous voltage regulators, and rectifiers.

OLDEST EXCLUSIVE MANUFACTURER OF RADIO RECEIVING TUBES

**HYTRON**  
CORPORATION  
ELECTRONIC AND  
RADIO TUBES

SALEM AND NEWBURYPORT, MASS.



**BUY ANOTHER WAR BOND**



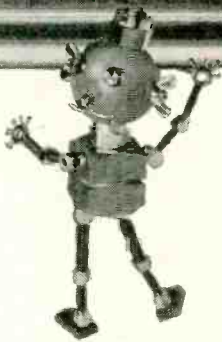
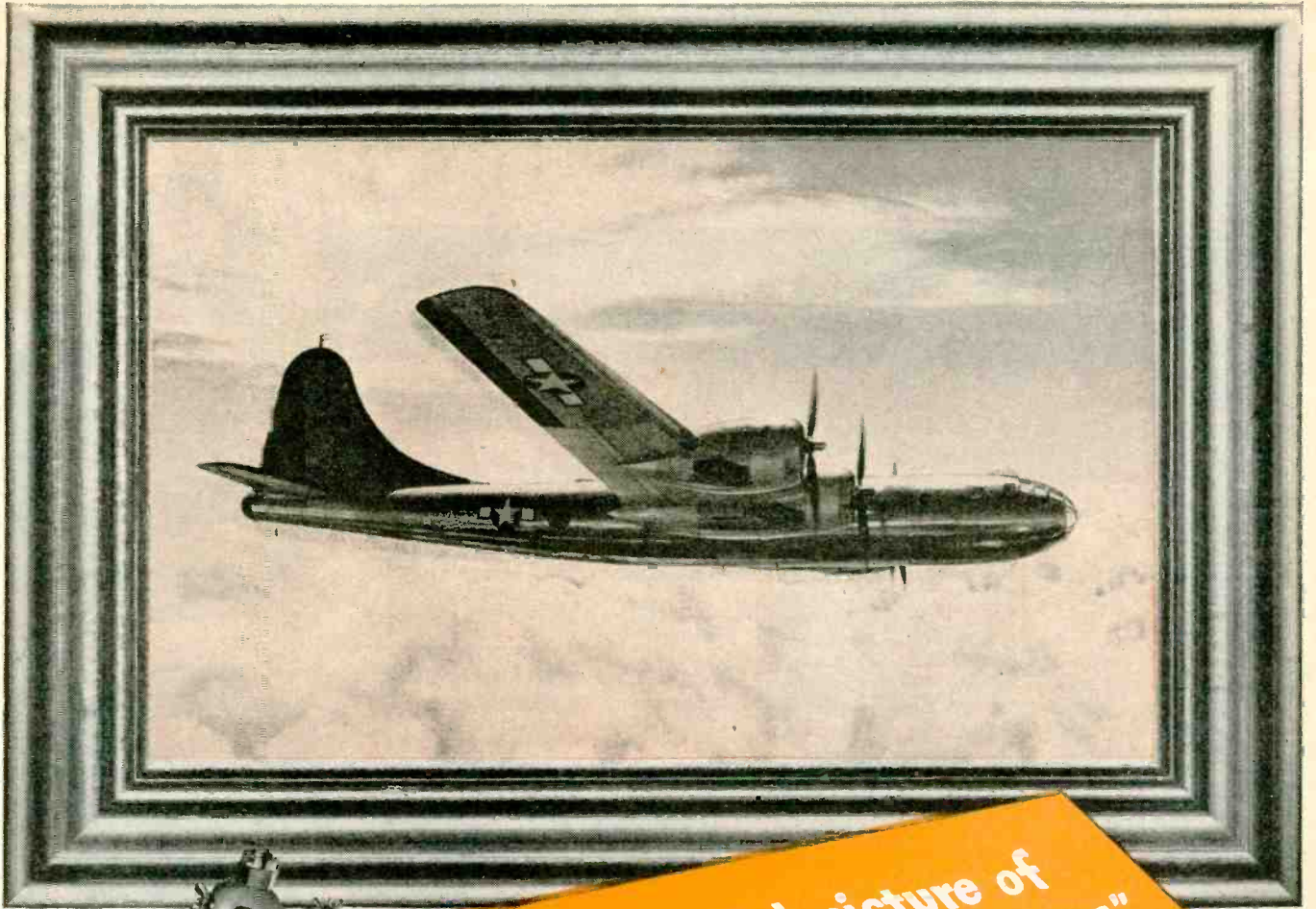

a beautiful picture of  
**"MILLIONS OF FASTENERS"**

A sizable segment of American industry shares in the production of the Boeing B-29. Like the old fable of the blind men and the elephant, the Superfortress means many things to many people. To us at National Screw it means the last word in fasteners.

Throughout this giant plane, both in the airplane proper and in the instruments and armament, *National* screws, bolts, nuts, studs, rivets, cotters and many special fasteners are used by the thousands.

Following are a few of the *National* fasteners in the B-29:

- NAS and BAC close tolerance bolts.
- NAS internal wrenching bolts.
- BAC bearing bolts.
- AN bolts, nuts and screws—complete line.
- Carburetor Studs.
- Instrument Screws.

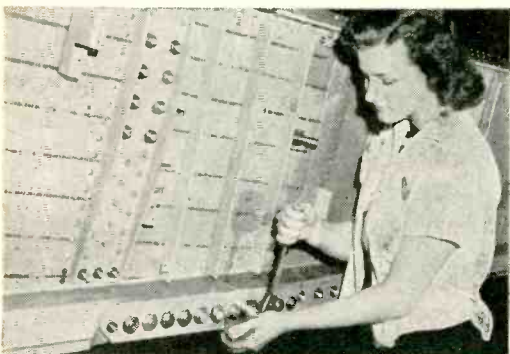

Photograph shows National Screw AN hex head and NAS close tolerance bolts being used in fabrication of a main structure of the Boeing B-29 Superfortress.

**THE NATIONAL SCREW & MFG. CO., CLEVELAND 4, O.**



# "INSIDE" DEPENDABILITY

## De JUR Electrical Indicating Instruments

These instruments are normally calibrated for mounting on non-magnetic materials. If desired, instruments will be calibrated for use on magnetic panels. Thickness of the panel should be stated. Scales other than standard type can be supplied and prices will be sent upon request. Special divisions, markings and color combinations are available. Spade pointers are standard equipment. Knife-edge pointers can be supplied at additional cost. Should it be desired to shield the instrument from external magnetic fields, shields can be supplied. These shields increase the body diameter by 3/32 of an inch. Provisions can be made for rear-illumination. For this purpose, translucent scales are necessary. Instruments can be modified to special requirements on orders where the quantity permits such special work. Where these modifications are external, prices will depend upon the instrument sensitivity and range.

Models No. S-210 and No. S-310 are designed to comply with the standards adopted by the American Standards Association for electrical indicating instruments (2 1/4" and 3 1/2" round, flush mounting, panel type).

### THREE AND ONE-HALF INCH METERS ROUND, SQUARE AND RECTANGULAR TYPES

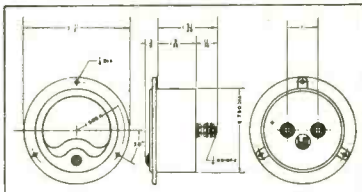

Cross-Section — S-310

### TWO AND ONE-HALF INCH METERS ROUND, SQUARE AND RECTANGULAR TYPES

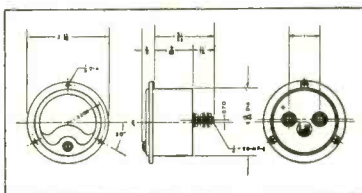

Cross-Section — S-210

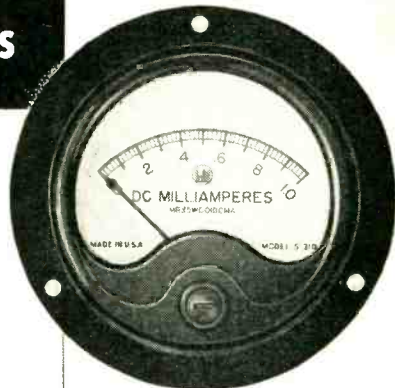

Model S-310 MR 25 1 DCMA

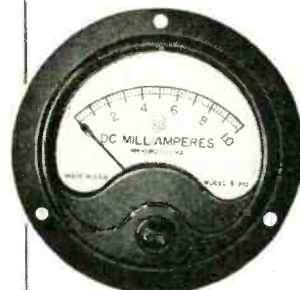

Model S-210 MR 25 W00 1 DCMA

## De JUR Rheostat-Potentiometers

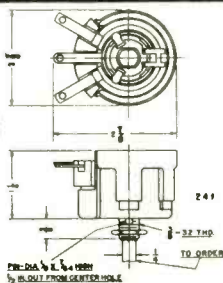
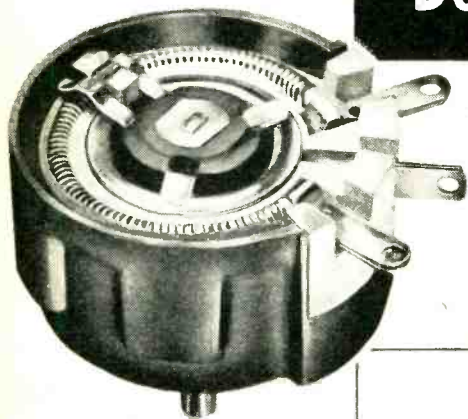

### MODEL 241 SPECIFICATIONS

50 WATTS	RANGE IN OHMS	MODEL No.
RANGES—10 to	0- 10	241
10,000 Ohms.	0- 50	241
	0- 100	241
MECH. ROTATION—300°	0- 500	241
ELEC. ROTATION—270°	0- 1,000	241
	0- 5,000	241
WEIGHT—7 OZ.	0-10,000	241

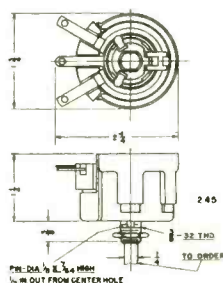

### MODEL 245 SPECIFICATIONS

25 WATTS	RANGE IN OHMS	MODEL No.
RANGES—10 to	0- 10	245
10,000 Ohms.	0- 50	245
	0- 100	245
MECH. ROTATION—300°	0- 500	245
ELEC. ROTATION—270°	0- 1,000	245
	0- 5,000	245
WEIGHT—7 OZ.	0-10,000	245

# De Jur-Amsco Corporation

GENERAL OFFICE: NORTHERN BLVD. AT 45th ST., LONG ISLAND CITY 1, N. Y.



## WHY HOURS?



✓ HEAT IT

✓ DRY IT

✓ CURE IT

✓ OR GLUE IT

# *in minutes!*

That's right—*minutes*—for radio frequency heating makes minutes do the work of hours. To cite an example: one heating operation that used to take six hours is now being done *in less than 9 minutes!*

The answer is Westinghouse Radio Frequency Heating . . . it creates the heat within the material itself—*instantly—uniformly—and under precise control.* No waiting for heat to “soak in” . . . no rejects due to heat-damaged surfaces. Applications include wood, chemicals, plastics, paper, rubber, textiles and foodstuffs.

Westinghouse design “packages” all the radio frequency generating equipment and controls into a single, safe, space-saving cabinet.

These units are available in output capacities of 1 kw to 200 kw !!! at a range of frequencies wide enough to meet most dielectric and induction heating needs.

The highly-developed automatic operation turns tricky heating operations into simple “push button” jobs requiring no skilled help.

For more information, ask for Booklet B-3261-A and Descriptive Data 85-800, which describes radio frequency applications, benefits and Westinghouse equipment available. Or, for aid on a specific application, ask for a Westinghouse engineer to call. Westinghouse Electric & Mfg. Co., P.O. Box 868, Pittsburgh 30, Pa.

J-08085

# Westinghouse

PLANTS IN 25 CITIES . . . OFFICES EVERYWHERE

## RADIO FREQUENCY HEATING

*Electronics at Work*

### Westinghouse 2 Kw Radio Frequency Generator

This unit is ideal for small work. The “table top” work surface eliminates the need for special worktables, and the controls are conveniently located on the protected sloping panel. Mobility—often highly desirable—is provided by large, sturdy casters.

- Single unit construction
- Automatic operation
- “Long life” air-cooled tubes
- Shielded to minimize radio interference
- Move into position—plug in—and use
- Sturdily built cabinet





# NEW VIBRATOR CIRCUIT BY ELECTRONIC

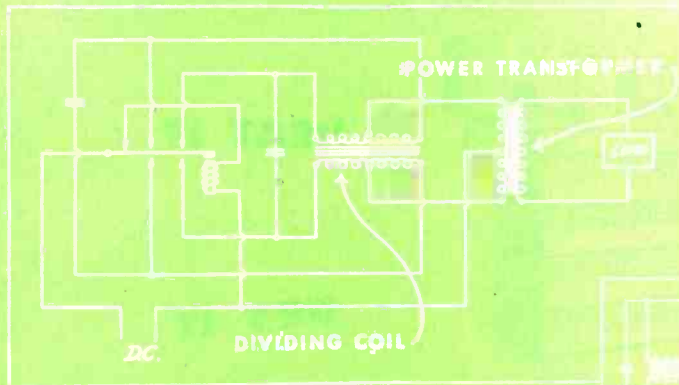

Typical E-L Circuits Which Divide Current Equally Between Multiple Vibrator Contacts

*Triples*  
**POWER SUPPLY**  
*Capacity!*



## Electrical Current Division Circuit Between Contacts

A tremendous increase in wattage output is one of the striking advances made by Electronic Laboratories in Vibrator Power Supplies in the last few years. Now, 1,000 watts output capacity is easily attainable for Heavy-Duty use while still maintaining all the inherent advantages of vibrator power supply.

The crux of the problem was the development and perfection of a current dividing circuit which actually distributes the current equally between the vibrator contacts. This was necessary because the wattage output of vibrator power supplies depends on the volt-ampere capacity of their vibrators. This in turn is determined by the ability of the electrical contacts which make and break the current at each cycle to resist disintegration. E-L engineers found that *multiple and enlarged contacts operating in parallel were not enough*. The contacts could not be adjusted with sufficient precision to assure striking at the same instant. Therefore, the first contact which closed received the full burden of the electrical load which caused pitting and burning.

Equal division was finally accomplished with a special electrical current dividing circuit which incorporates a balancing reactor of small inductance relative to that of the main transformer of the power supply. When properly combined with the buffer network, this reactor effectively forces the equal division of the make and break energy in each cycle and at the same time retains the economic advantage of a single large transformer.

The current limiting reactor in the typical circuits shown above, *limits by reactance* the current which flows in the leg which has the completed circuit. When the second contact closes, the reactive effects are

cancelled and the current is limited only by the DC resistance of the reactor. In the tandem type vibrator the division is carried out by first equalizing the current between the pairs of contacts. Then, by additional reactors, the current is equally divided between the individual contacts. This exclusive and patented\* E-L development opens many new fields and applications to the benefits and advantages of Vibrator Power Supplies. Consider your needs in the light of this increased capacity.

E-L Vibrator Power Supplies have wide application in many fields: radio, marine, railroad, electronic and electrical. Their high versatility with multiple input and output voltages enables them to meet many power supply needs. They may be designed to provide any wave form needed for specific equipment. Another important and exclusive E-L feature that can be built into your vibrator power supply is constant output voltage, despite wide fluctuations of input voltage . . . economy is assured because of long, efficient service with minimum maintenance. E-L Engineering Service is available to discuss your power supply problem and to design a vibrator power supply to meet specific voltage, power, size and weight requirements.

(Below: A typical tandem type vibrator, which, used in conjunction with the electric current division circuit (see write-up above) has an input capacity of 1,000 volt-amperes at 110 volts DC.)

\*Patent Number 2327577

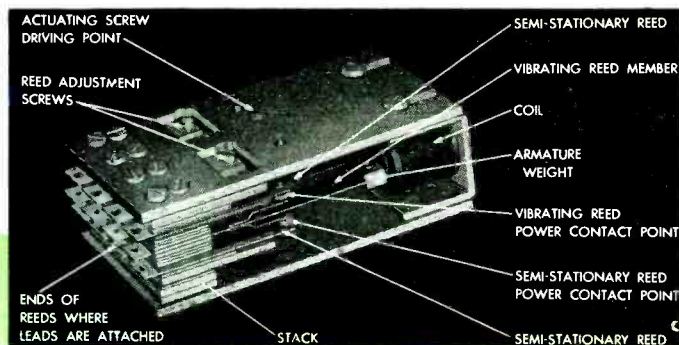

**Electronic**

**LABORATORIES INC. INDIANAPOLIS**

VIBRATOR POWER SUPPLIES FOR LIGHTING, COMMUNICATIONS, AND ELECTRIC MOTOR OPERATION - ELECTRIC, ELECTRONIC AND OTHER EQUIPMENT



# There's no ONE-MAN-BAND in Electronic Heating

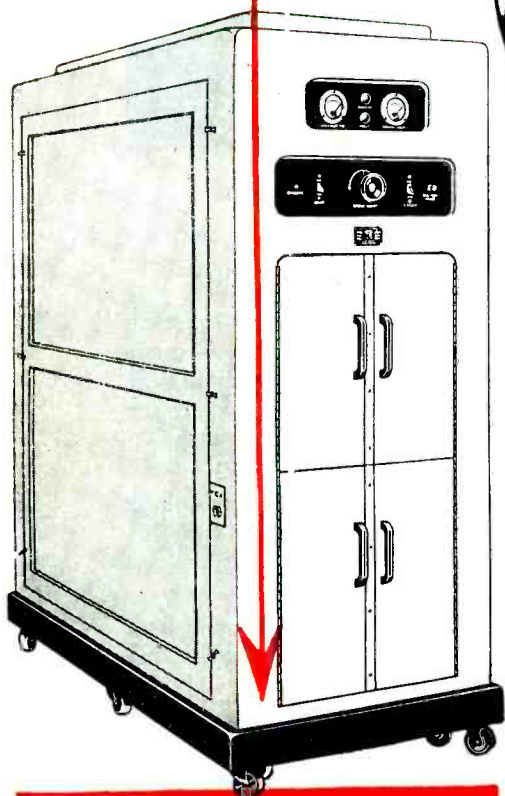

Although it is possible to construct an electronic heater that will generate a great range of high frequency currents, it will not perform *all* heating jobs efficiently and it would be very costly in use.

Virtually every application of electronic heating requires a specific **FREQUENCY AND POWER** combination. Therefore, to realize the maximum advantages of this improved heating method, *each installation should be designed and built for its particular application.* For example: when a heating operation can best be done at 5 kw and 22 megacycles it would be *wasteful and inefficient* to use a machine that delivers 20 kw at 500 kc.

Many first-time users of electronic heating are induced to buy "misfits" when they try to find an all-purpose machine. Our extensive line of equipment offers you the broadest range of power and frequency combinations at *prices lower* than other makes of comparable quality.

Investigate the production economies and advanced engineering designs offered by our greater variety of units . . . each one time-tested for high efficiency.

*Before you buy write to us for detailed information*

## Scientific Electric



DIVISION OF "S" CORRUGATED QUENCHED GAP COMPANY  
119 Monroe Street Garfield, New Jersey

Manufacturers of Vacuum Tube and Spark Gap Converters since 1921

Our equipment offers you a selection of frequencies up to 300 megacycles — and the following power range, with stepless control from zero to full load:

- 3 Kw
- 5 Kw
- 7½ Kw
- 10 Kw
- 12½ Kw
- 15 Kw
- 18 Kw
- 25 Kw
- 40 Kw
- 100 Kw



# RAYTHEON VOLTAGE STABILIZERS

CONTROL FLUCTUATING VOLTAGE TO  $\pm 1/2\%$

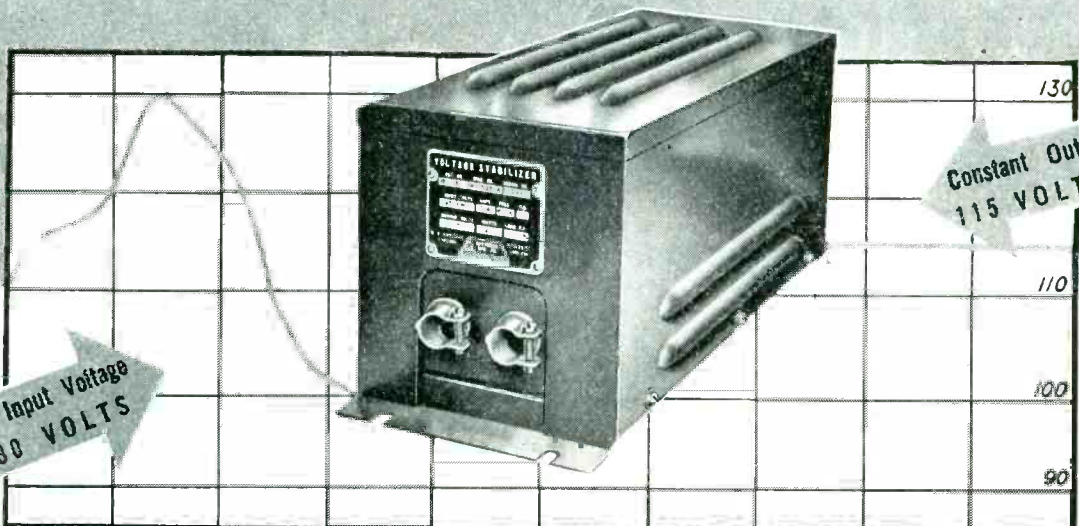

**A MAGNETIC UNIT WITHOUT MOVING PARTS**  
*Nothing to replace or adjust*

## FOR

- Television
- Colorimeters
- Radar & Radio
- Signal Systems
- X-Ray Machines
- Sound Recording
- Electronic Devices
- Testing Equipment
- Photo-Cell Devices
- Production Machinery
- Constant Speed Motors
- Motion Picture Equipment
- Communications Apparatus
- Precision Laboratory Apparatus
- Other Applications Requiring Regulated Voltages

New Stabilizer bulletin DL48-537. Contains operating characteristics, graphs and complete specifications. Write for your copy, today.

Constant AC voltage is essential for reliable, accurate operation of a wide variety of electrical equipment. When these devices are connected to ordinary supply mains, the unstabilized input voltage often varies as much as from 95 to 130 volts thus impairing the accurate operation of the equipment. A Raytheon Voltage Stabilizer, incorporated into the product, overcomes the disadvantages of fluctuating line voltages by providing an accurately controlled source of power held to  $\pm 1/2\%$ .

Entirely automatic in operation, the Raytheon Voltage Stabilizer has no moving parts . . . nothing to wear out, consequently requires no maintenance. Simply connect it to line and from there on it will take care of itself.

Raytheon Voltage Stabilizers built-in new equipment or offered as an accessory not only improve the performance but also increase the salability of the product.

Users of many types of electrical equipment not having voltage stabilization will find that Raytheon Voltage Stabilizers improve the performance and reliability of their equipment.

Raytheon Voltage Stabilizers are equally suitable for use in equipment for the laboratory, production or unattended locations.



**RAYTHEON**  
**MANUFACTURING COMPANY**  
190 WILLOW STREET, WALTHAM, MASS.

MANUFACTURERS OF VOLTAGE STABILIZERS, RECEIVING AND TRANSMITTING TUBES AND COMPLETE ELECTRONIC EQUIPMENT

The coveted Army-Navy "E", for Excellence in the manufacture of war equipment and tubes, flies over all four Raytheon Plants where over 15,000 men and women are producing for VICTORY.





*When it's* **FIRE EXTINGUISHERS**  
*instead of Flame Throwers*

Strict adherence to specifications for brass and other copper-base alloys produced by Western has enabled manufacturers to meet more successfully the problems of producing war materials. Our years of experience enabled us to meet these important requirements.

When the flames of war have burned out and attention is again turned to peacetime products, Western metals will be available in stamped parts, sheet, strip and long coils. New designs...

possibly in fire extinguishers, as well as hundreds of other products... will require the workability, ageless beauty and long life of copper and related alloys.

The skill and facilities of Western's mills at East Alton, Ill. and New Haven, Conn., are at the disposal of all who work with metals or combine metal parts with non-metallic substances. We'll do our utmost to serve you well... now, or in the months to come.



**Western** BRASS MILLS

Division of WESTERN CARTRIDGE COMPANY, East Alton, Ill.

BRASS • BRONZE • PHOSPHOR BRONZE • NICKEL SILVER • COPPER



# How's this for POWER FACTOR and DIELECTRIC CONSTANT

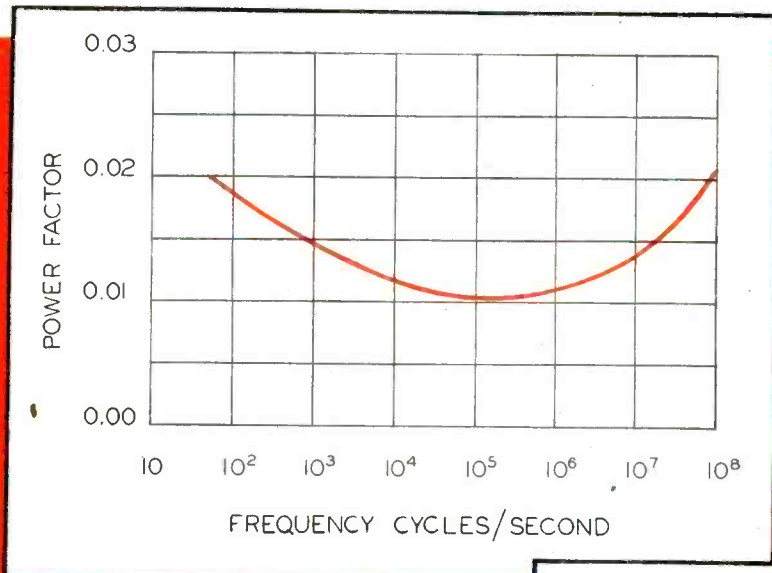

*In a  
Machinable,  
Easily Worked  
Material?*

**T**HESE curves show how closely Formica MF-66, glass mat base laminated phenolic insulating material, approaches ceramics and other high quality insulators at high frequencies. It can perform many of the functions for which these materials were once thought necessary.

At the same time it has the mechanical strength to withstand sharp blows and the vibration that is so often present where airborne, ship, and ground installations must be used. Dimensions are stable under changes in temperature and humidity. MF-66 resists the growth of fungi and may be used in the tropics.

It has the usual Formica characteristics of machinability and workability — speeding production and reducing labor costs.

This combination of qualities opens a wide field for the application of the material which as yet has scarcely been scratched.

Test samples are available on request.

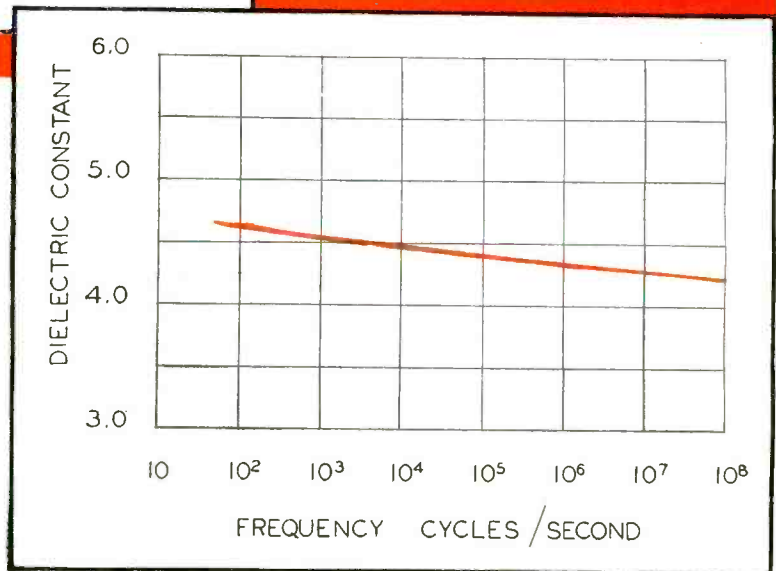

● These data represent average values measured at normal laboratory conditions of temperature and humidity on specimens not previously conditioned.



**THE FORMICA INSULATION COMPANY**  
4661 Spring Grove Avenue, Cincinnati 32, Ohio



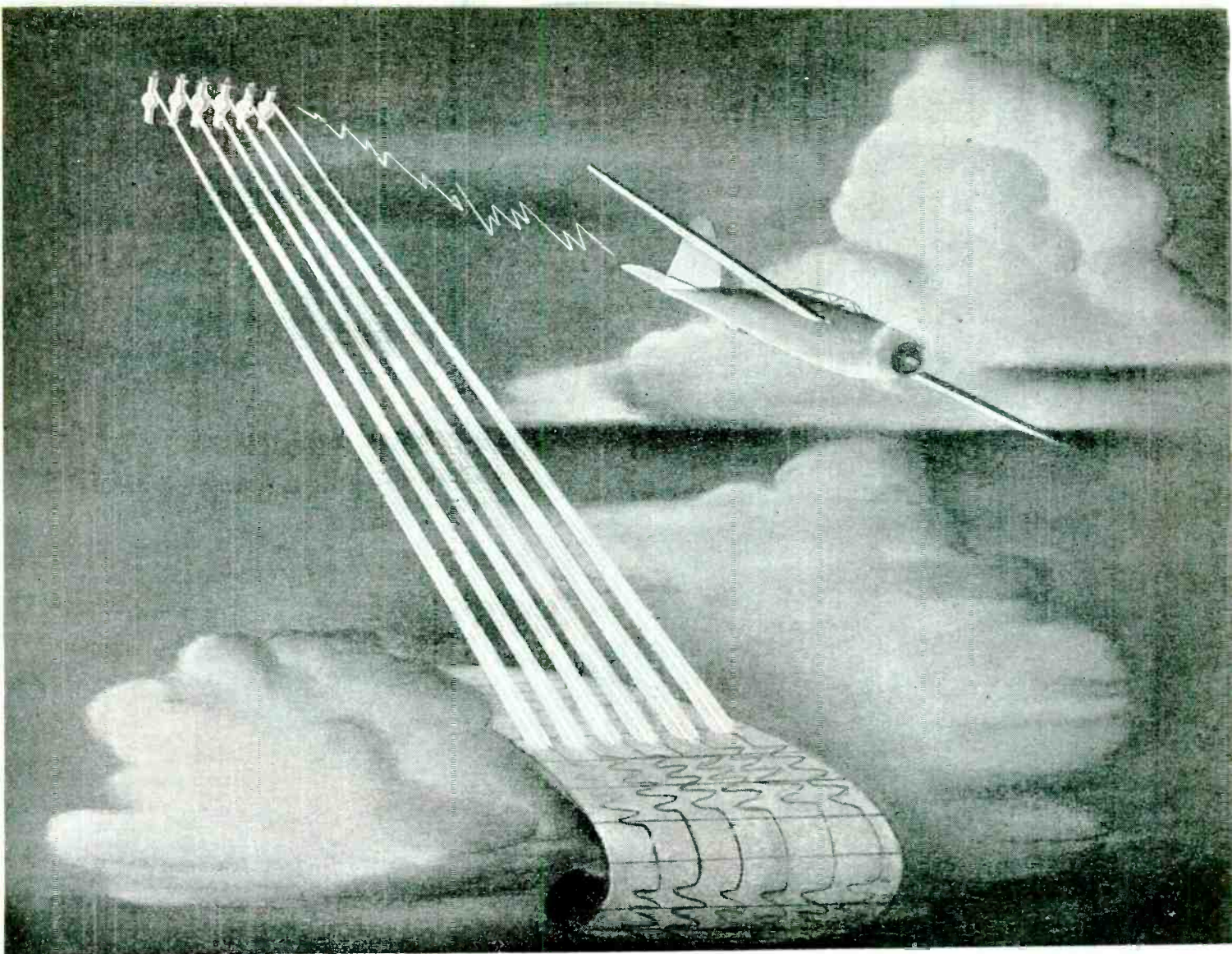

# WRITES WITH BEAMS OF LIGHT

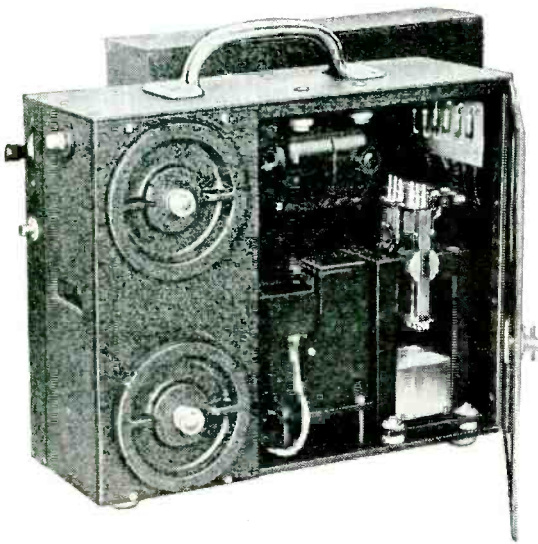

For recording dynamic strains and vibrations of *aircraft in flight*, we offer an extremely sensitive and accurate six channel Oscillograph, weighing less than 20 lbs., exclusive of battery, occupying less than  $\frac{3}{8}$  of a cubic foot of space and selling for only \$1500. Operates from its own or the plane battery. Sensitivity is such that many dynamic strains and vibrations can be recorded directly without amplification. Takes hundred foot roll of paper 2" wide operating at 3, 5 or 12 inches per second.

Write for further details.

Write for rental list and service manual on your business letterhead.

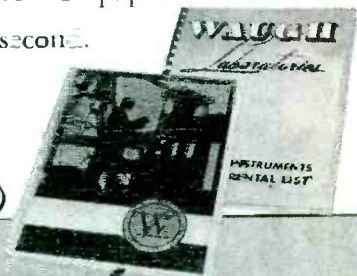

## WAUGH

*Laboratories*

A complete line of indicating and recording instruments available.

Pacific Coast Branch: 180 East California St., Pasadena 5, California

• 420 LEXINGTON AVE., NEW YORK 17. N. Y.



# OHMITE

*Close Control* **RHEOSTATS**

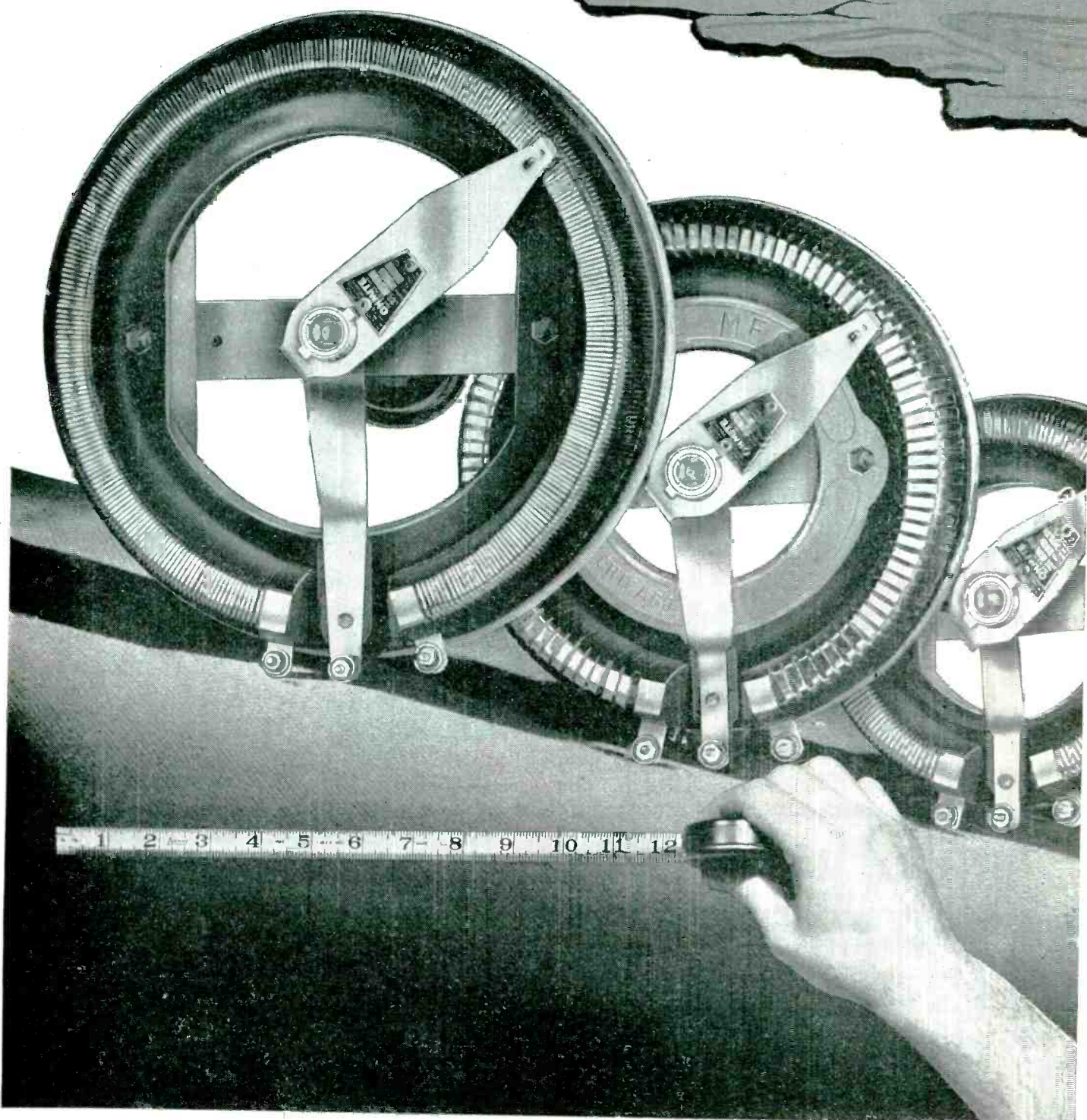





*First in Quality*

*First in Range*

*First in Quantity*



**10 WATTAGE SIZES  
FOR EVERY  
RHEOSTAT NEED  
Stock or  
Special Units**

The constant and exacting test of experience has proved the high quality of Ohmite Rheostats. Special Ohmite design features assure permanently smooth, gradual, close control under varying conditions of shock, vibration, temperature, humidity and altitude. The Ohmite series of 10 wattage sizes illustrated here is the most extensive made today—ranging from 25 to 1000 watts, from 1 $\frac{9}{16}$ " to 12" diameter, in a wide range of resistance values. This assures the best unit for each application. As a result—Ohmite has produced more close-control power rheostats for war equipment and war industries than any other manufacturer.

Consult Ohmite Engineers on your war or postwar rheostat-control problem. Get the benefit of Ohmite experience.

**OHMITE MANUFACTURING COMPANY**  
4817 FLOURNOY STREET • CHICAGO 44, U. S. A.

*Write on company letterhead for Industrial Catalog and Engineering Manual No. 40. Gives helpful data on Rheostats, Resistors, Tap Switches and Chokes.*



**Be Right with OHMITE**  
RHEOSTATS • RESISTORS • TAP SWITCHES



In **QUARTZ CRYSTALS**, the most significant advancements  
have been introduced by *Bliley*

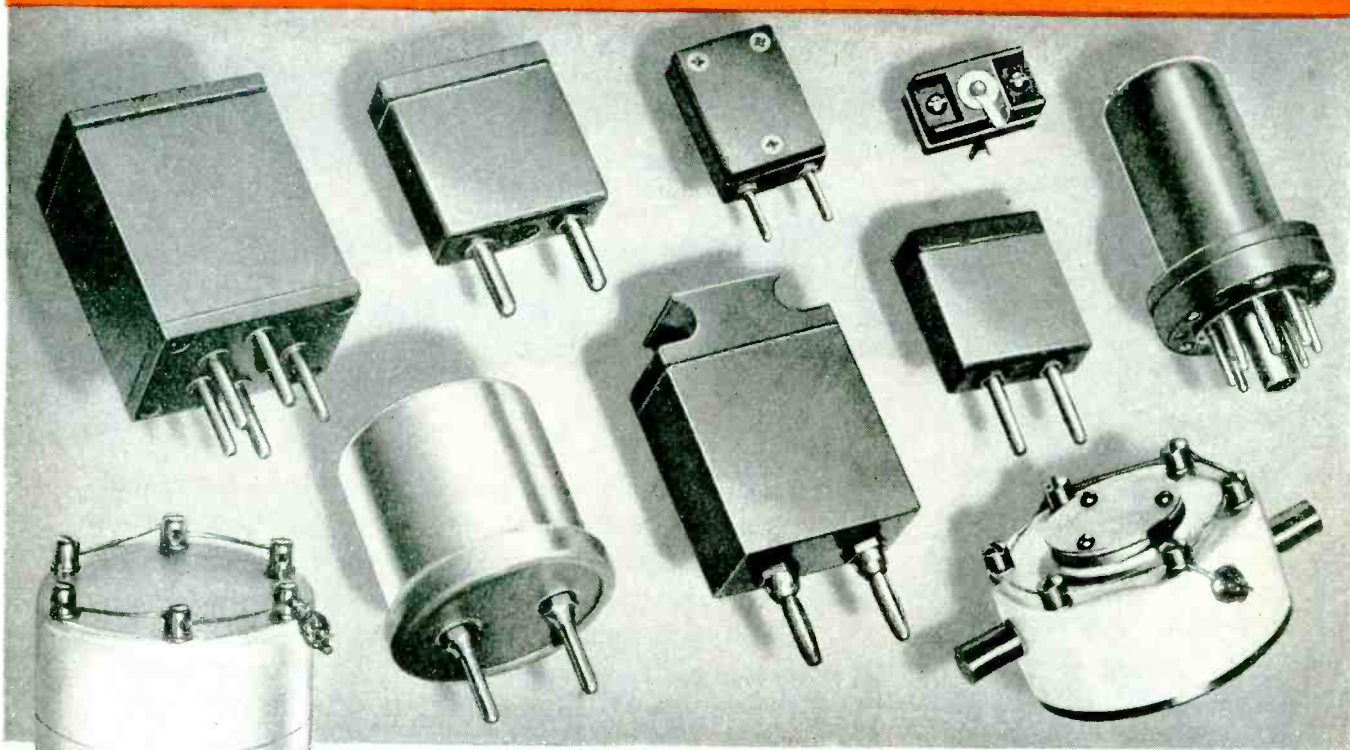

This is a message from Bliley to the thousands of amateurs and professional engineers who are now serving their country in the armed forces and in essential communications industries. Bliley "grew up" with them.

To these men and women Bliley crystals are still a familiar sight. They recognize, in the military crystal units used by our armed forces, many basic features that were pioneered by Bliley for application in peacetime services.

When tremendous production was demanded by our armed forces Bliley had the engineering background, the facilities and the production experience to provide a firm corner stone on which this volume production of radio crys-

tals was successfully built. And, from the ranks of talented amateurs and radio engineers came a host of long-time friends who knew exactly how to use them.

But research has continued and experience has grown mightily to meet the challenge of war requirements. With the return to peace, and relaxation of wartime restrictions there will be better Bliley crystals for every application as well as new Bliley crystals for the new services that loom on the horizon. That's a promise.

To our old friends, amateurs and professional engineers, we say, "Look to Bliley for crystal units that embody every advanced development."

Do more than before . . .

buy extra War Bonds

**BLILEY ELECTRIC COMPANY**  
UNION STATION BUILDING • ERIE, PENN.



*Bliley*  
**CRYSTALS**



THIS BIG FAMILY OF

**Intelin**

**High Frequency Cables**

**MEASURES TO EVERY HIGH STANDARD**

A big family — 29 types of high frequency cable — yet so high are their standards of construction and performance that every one of the following Intelin High Frequency Cables meets all the requirements of the most exacting specifications:

1. Coaxial, Solid-dielectric, Semi-flexible Lines: \*RG-5/U, 6/U, 8/U, 9/U, 10/U, 11/U, 12/U, 13/U, 14/U, 15/U, 17/U, 18/U, 19/U, 20/U, 29A/U, 54/U, 54A/U, 58/U, 59/U.
2. Coaxial, Air-spaced, Low Capacitance Lines: 7/U, 62/U, 63/U.
3. Coaxial, Attenuating Lines: RG-21/U, 42/U.
4. Coaxial, High Impedance, Spiral Delay Line: RG-65/U.
5. Dual (balanced) Lines: RG-22/U, 57/U.
6. Dual-coaxial, Highly Balanced Lines: RG-23/U, 24/U.

To date, for every new high frequency cable need, Intelin has developed and produced the answer. Whatever your requirements in high frequency cable, consult Federal first.

\*Type number designations are those of the Army-Navy R. F. Cable Coordinating Committee.



**Federal Telephone and Radio Corporation**

Newark 1, N. J.







**ASSURANCE OF PRECISION**

*Radio Communications Equipment*

**WILCOX  
ELECTRIC  
COMPANY**

Fourteenth and Chestnut  
Kansas City, Missouri

The Wilcox trademark on aircraft radio, communications receivers, transmitters and other radio equipment is a symbol of advanced engineering, precision manufacturing and proved performance. Today, Wilcox equipment is in use all over the world in military operations and for the major airlines of the United States. In postwar developments, you can depend on Wilcox for continued leadership in radio communications!

*Manufacturers of Radio Equipment*





## *object — longer life*



Here in our laboratory on a test rack these Utah Vibrators are placed in continuous operation against the time-clock . . . until they finally break down.

Thus Utah engineers prove the worth of design and the quality of materials that give their product such an enviable record of long, trouble-free service.

Such tests as this have been the reason for Utah reliability in war—and are the Utah guarantee of industry and consumer satisfaction in peace.

★ ★ ★

**Every Product Made for the Trade, by Utah, is Thoroughly Tested and Approved**





**Keyed to "tomorrow's" demands: Utah transformers, speakers, vibrators, vitreous enamel resistors, wirewound controls, plugs, jacks, switches and small electric motors.**



**Utah Radio Products Company, 857 Orleans Street, Chicago 10, Ill.**

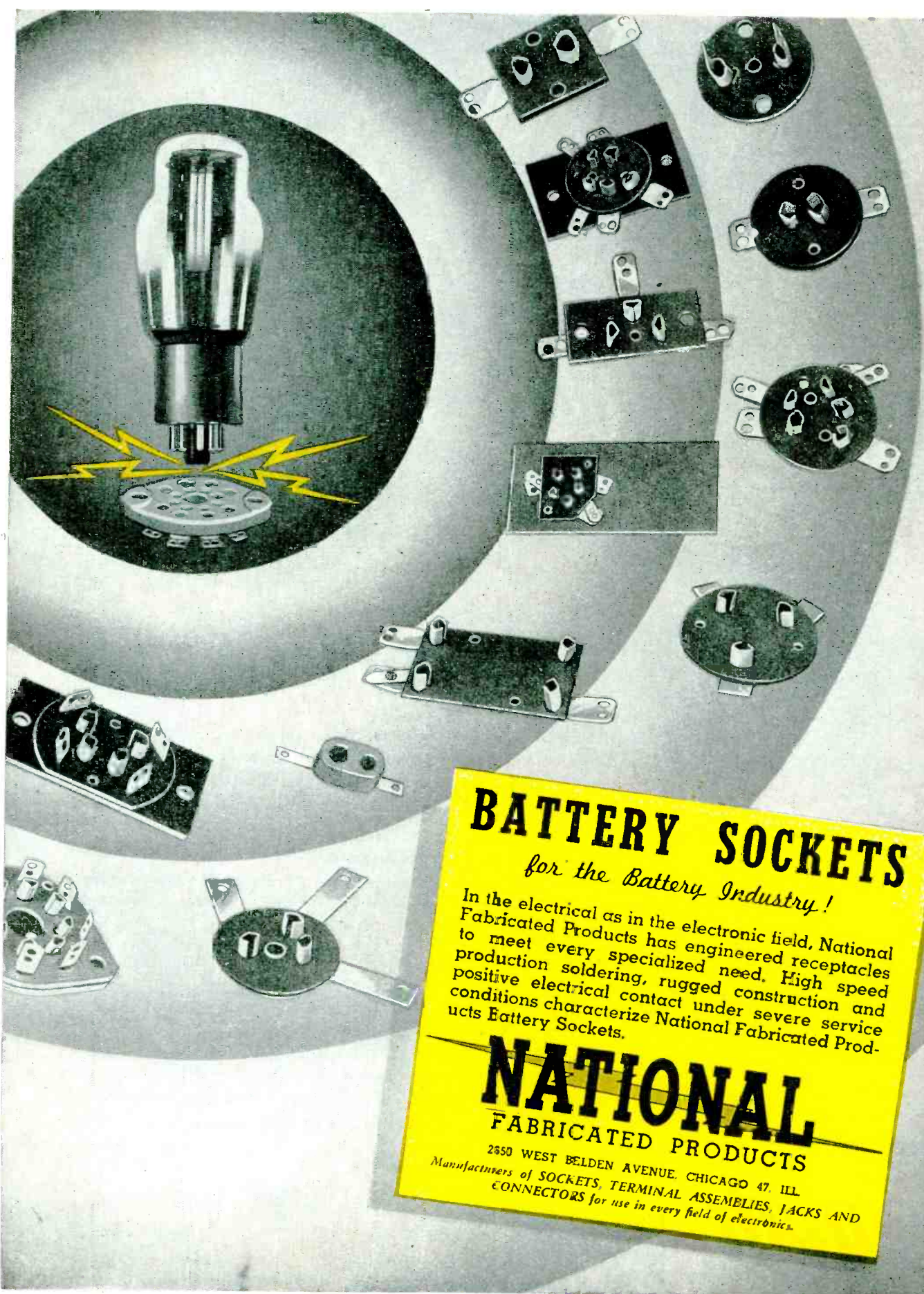



# BATTERY SOCKETS

*for the Battery Industry!*

In the electrical as in the electronic field, National Fabricated Products has engineered receptacles to meet every specialized need. High speed production soldering, rugged construction and positive electrical contact under severe service conditions characterize National Fabricated Products Battery Sockets.

## NATIONAL FABRICATED PRODUCTS

2550 WEST BELDEN AVENUE, CHICAGO 47, ILL.  
Manufacturers of SOCKETS, TERMINAL ASSEMBLIES, JACKS AND  
CONNECTORS for use in every field of electronics.





... with Callite tube components



Electronic controls of high speed welding equipment rely on the efficiency of thyratron tubes to minimize transient currents, the cause of non-uniform welds. The Cetron grid control rectifier tube, Type CE 306, a precision timer, provides maximum rectifier efficiency with minimum internal heating. The Cetron thyratron is a long life product built to stand the "gaff" of industrial use in handling primary currents of small re-

sistance welders, light control, arc welding control, motor control, etc. The Continental Electric Co. of Geneva, Ill., uses Callite thoriated tungsten filaments and grids for their extra quality and stamina in the manufacture of CE 306 tubes. Callite research has developed many improvements in the processing of tube components. That's why the electronic industry looks to us for dependable hard glass leads,

tungsten and molybdenum wire, rod and sheet, formed parts and other components. Callite Tungsten Corporation, 544 Thirti-ninth Street, Union City, New Jersey. Branch Offices: Chicago and Cleveland.



**Callite** tube components

**R<sub>x</sub> FOR R<sup>\*</sup>-DAY** (\*Reconversion)  
 Discuss your post-war products with a C-T development engineer now. We may be able to help you in the selection of materials or in cutting your production costs. Write today.

# Why MICRO SWITCH Provides a Long Snap-Act.

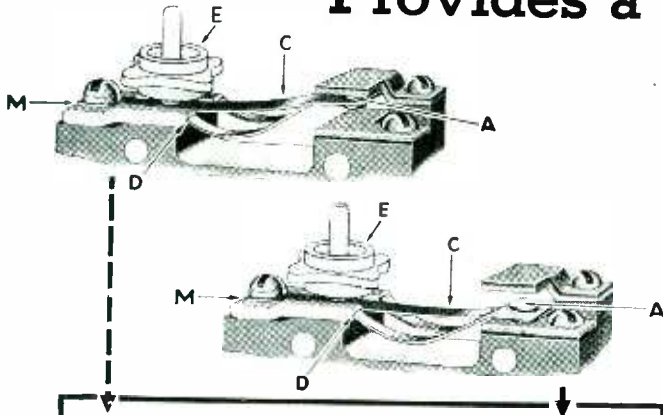

## Micro Switch Operating Principle

The operating principle of the Micro Switch as illustrated here is simple and fundamentally correct. The long member of the one-piece spring "C" is supported as a cantilever at "M". The two shorter compression members of the spring rest in specially shaped (patented) V's. When the plunger "E" deforms the long tension member, the cantilever force overcomes the vertical force supplied by the compression members and the free end of the spring "A" snaps the contact from one stop to the other with lightning-fast speed. Snap action in the reverse direction occurs when the deformation of the tension members of the spring by plunger "E" is removed.



This one-piece beryllium copper spring is heat treated to provide the high fatigue resistance necessary to insure a minimum of 5,000,000 trouble-free mechanical operations, at full overtravel.



The rivet type contact is of superfine silver 99.95% pure.



The operating plunger is a highly polished, hard, stainless steel pin molded into an accurate Bakelite head. This head is so shaped that it cannot rotate, hence bears on the switch spring at the same point through millions of operations.

The basic Micro Switch is a thumb-size, feather-light, plastic enclosed, precision, snap-action switch, Underwriters' listed and rated at 1200 V. A., at 125 to 460 volts a-c. Capacity on d-c depends on load characteristics. Accurate repeat performance is experienced over millions of operations. Wide variety of basic switches and actuators meets requirements varying from high vibration resistance to sensitivity of operating force and motion as low as 2/1000 ounce-inches. Many types of metal housings are available.

© 1944



**MICRO** MARK  
TRADE **MS** SWITCH

A DIVISION OF FIRST INDUSTRIAL CORPORATION

FREEMONT, ILL., U.S.A., Sales Offices in New York, Chicago, Cleveland, Los Angeles, Boston, Dallas, Portland, (Ore.)

Micro Switch provides lightning-fast, control of electric circuits with reliable operation accurately repeated over million.

This performance is made possible by a unique, field tested, and proven operating principle of the Micro Switch. The snap motion of the Switch contact is in the same direction as the operating plunger. There are no reverse bends in the Micro Switch spring, and there is no life-limiting "oil can" action.

The experience of design engineers with millions of Micro Switches in a great variety of applications has shown performance ability and operating characteristics never before found in snap-action switches.

Its small size, its high electrical rating, its ability to operate satisfactorily for millions of operations on minute movement and force differentials, its availability in various types of housings and a wide range of actuators . . . have made Micro Switch the choice of design engineers for precise operation of many types of plant equipment.

*Micro Switch Handbook-Catalog No. 60* will give you complete details as to electrical characteristics, construction, applications and dimensions. If you happen to be specializing in aircraft equipment, also send for *Handbook-Catalog No. 70*.

## HUNDREDS OF SPOTS FOR MICRO SWITCHES



An explosion-proof Micro Switch is used with a spray gun to cut off the ventilating system of the spray booth automatically when the gun is hung up.



Micro Switches are used as safety switches on high tension cabinet doors. A normally open switch breaks circuit as door is opened.



Two Micro Switches with spring type plungers are used to insure correct position of material in jigs and fixtures.



Spring plunger Micro Switches serve as break indicators in textile and paper mills.

... USES



UNLIMITED

"Uses Unlimited"—a dramatic talking motion picture of Micro Switches, in color, is available to industrial groups, training classes, schools and colleges, through Y.M.C.A. Motion Picture Bureau, New York, Chicago, San Francisco. Size: 16 mm. Length: 40 minutes. Write us for details.

A star has been added to our "E" flag as further recognition to the men and women of Micro Switch for maintaining our war production standards.



Let's All Back the Attack—Buy Extra War Bonds



Micro  
Principles  
of the

cycles.  
and positive

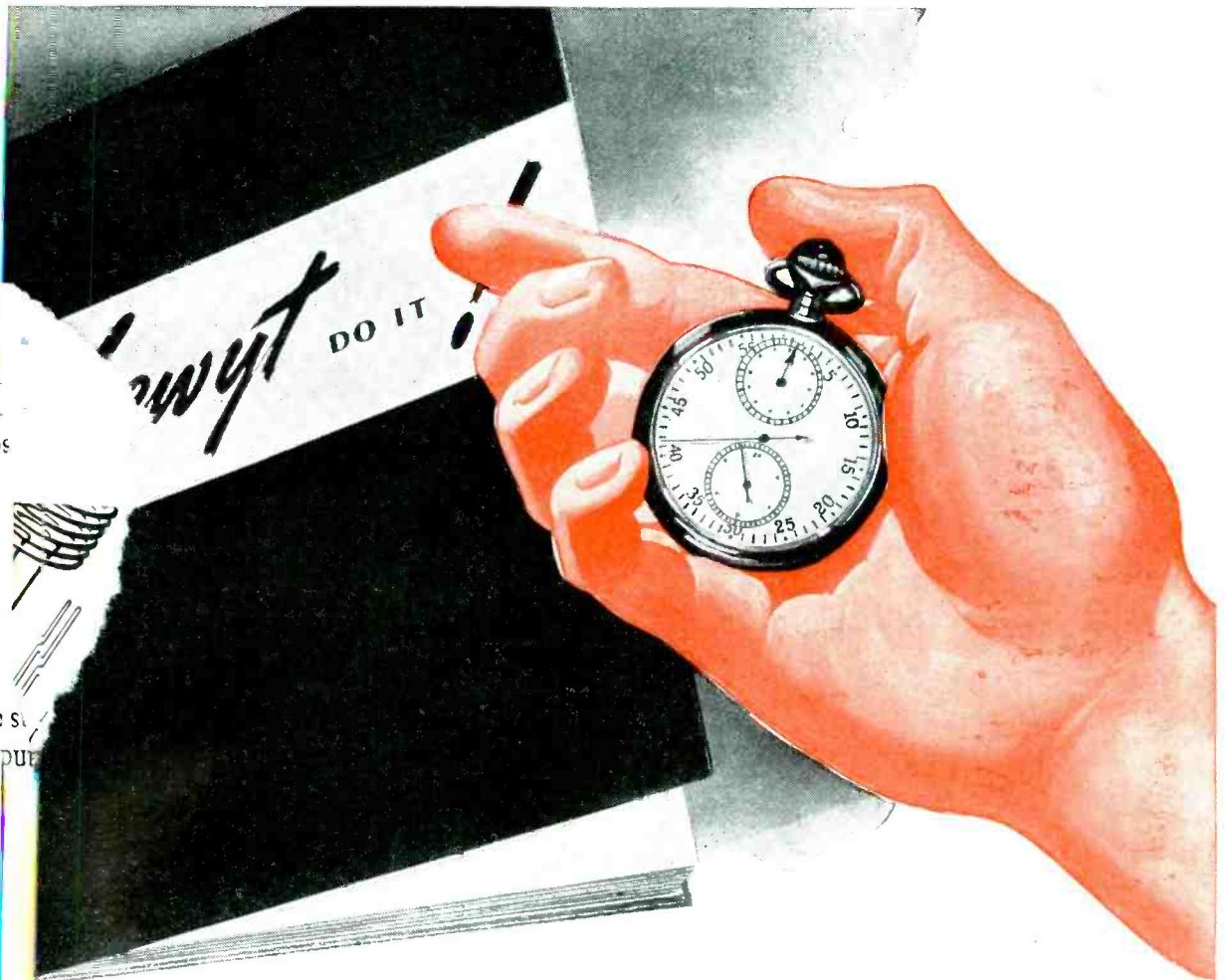

## YOU WILL HOLD A STOP WATCH...

**THIS BOOK** is designed to help you prepare for CONVERSION DAY . . . it presents the story of a unique institution that may have the answer to your production problem . . . it suggests a plan for putting your new product development *in training* for the post-war starter's gun.

When materials are no longer ear-marked for war . . . when civilian goods are price-marked for peace . . . there will be no glory or profit at the *finish line* for any but the *winners!*

"Cost-Plus" profits will be outlawed . . . wartime regulations will give place to time studies . . . the stop watch will take over control in the competitive race for manufacturing economies.

Lewyt has set the pace in contract manufacturing ingenuity through two post-war periods of business readjustment. We've had long training in cost-sensitive specialization. We're ready to partner with other manufacturers in producing their component electrical and electronic assemblies, chasses and housings . . . or complete units.

With our exceptional facilities and skills in electrical and mechanical parts manufacture carefully developed through 56 years, it will pay you to talk with us . . . at least write for this 48-page book. Ask for "Series B". There is no cost or obligation.

LEWYT CORPORATION, 62 BROADWAY, BROOKLYN II, N. Y.



# Lewyt

LET LEWYT DO IT

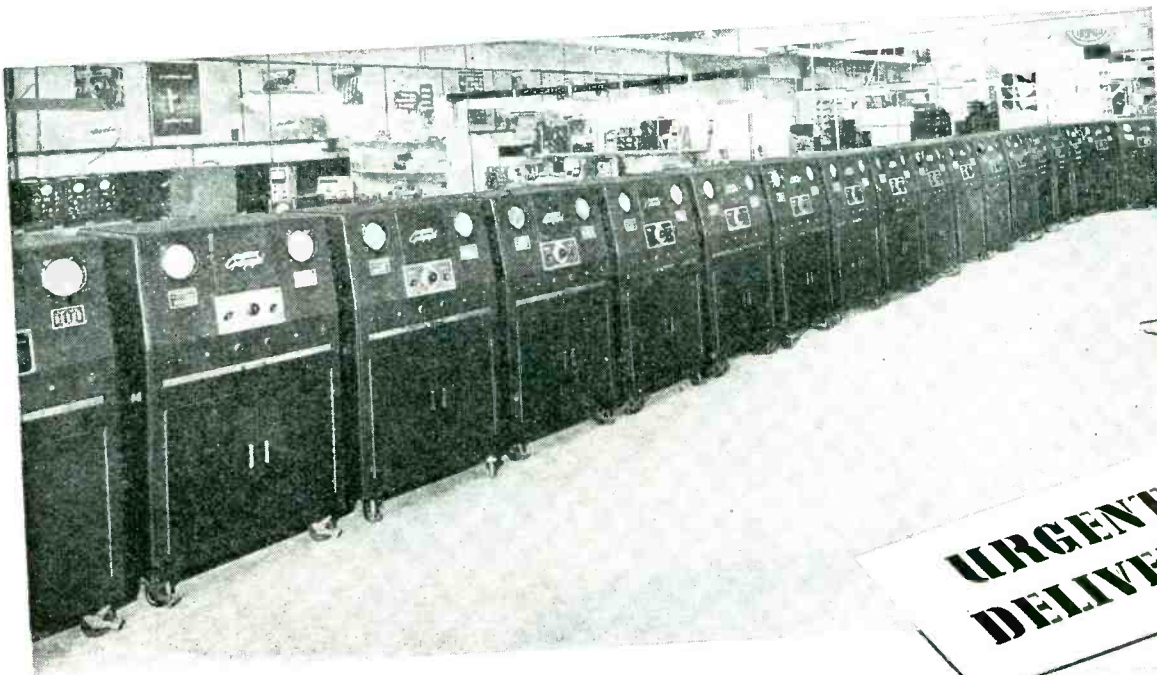

When you have urgent need for this 100% quality inspection, present production of instruments now assures early delivery and installation of your

**DUMONT**

*Cyclograph*



◆ DuMont Cyclographs are rolling off the production line. With details and circuits refined and set, the building of these instruments has now passed to our manufacturing plant. Early delivery and installation is now assured for those who have real need for this 100% quality inspection means.

Meanwhile, the Cyclograph is proving indispensable in one plant after the other. This technique is

making a notable contribution to the war effort in manpower and material savings, in product uniformity, and in production speedup. Likewise in the postwar industrial situation, the Cyclograph promises to be a vital factor in reducing production costs and increasing product uniformity.

From now on it's PROMPT delivery and installation — when you need 100% quality testing.

**TYPICAL CYCLOGRAPH  
100% QUALITY TESTING . . .**

- ✓ Non-destructive testing for machinability of metal stock to be machined in automatic high-speed equipment.
- ✓ Pre-checking iron castings for machinability.
- ✓ Sorting of mixed lots of forged steel.
- ✓ Inspecting 150,000 pounds of packaged welding electrodes for critical magnetic properties, *without opening packages.*
- ✓ Automatically sorting six and a half million copper-clad steel cups to discard those accidentally reversed in the stamp.
- ✓ Sorting large quantities of mixed bolts according to their SAE analyses.
- ✓ Checking gears for case hardening.
- ✓ 100% quality inspection and control of incoming materials and outgoing products, according to metallurgical analyses, case depth, depth of decarburization, amount of cold working, brittleness (stress gradients), structure, etc., on either non-ferrous or ferrous metals.



► Write for Literature . . .

© ALLEN B. DUMONT LABORATORIES, INC.

**DUMONT** Precision Electronics & Television

ALLEN B. DUMONT LABORATORIES, INC., PASSAIC, NEW JERSEY • CABLE ADDRESS, WESPXLIN, NEW YORK



# 'MUSTS'

## INSULATION

for future product

*efficiency*



Industry—by unqualified fulfillment of its war-time obligations in quality, efficiency and dependability — has set a particularly high standard for future manufacture. Post-war products, appliances and equipment must be good . . . for it's the repeat sale that counts. TURBO insulation materials — Flexible Varnished Tubing, Saturated Sleeving, Extruded Tubing, Varnished Glass Tubing, Wire Identification Markers, etc.—offer the essentials for later design, manufacture and service-life. All the advantage-factors, properties and characteristics evolved by rigorous research and ex-

perimentation are embodied in TURBO products—your guarantee of a peacetime quality comparable to present military exigencies. Whether your particular requirements are high dielectric strength, great mechanical strength, resistance to abrasion, sub-zero temperatures, high heat, corrosion, acids, fumes, etc.—there's a TURBO product to do your job . . . economically and efficiently.

Free Specimen Board with samples and sizes of each will be sent promptly on request on company letterhead. Write today.

**WILLIAM BRAND & COMPANY**  
276 FOURTH AVENUE, NEW YORK, N.Y. 325 W. HURON STREET, CHICAGO, ILL.

IF IT'S **TURBO** IT SAFEGUARDS

**FLEXIBLE VARNISHED OIL TUBING:** this TURBO insulation meets the diversity of requirements necessary to stand up against breakdowns, impairment through moisture absorption, and the general deteriorating influences caused by acids, alkalis, fumes, corrosion, etc.

**VARNISHED GLASS TUBING:** the extensive use of this TURBO product is directly attributable to its excellent characteristics under high heat conditions. Heavy duty operating conditions, confined areas where ventilation is minimized and other similar problems are solved.

**EXTRUDED TUBING:** where the effects of temperatures are apt to induce insulation embrittlement, TURBO Extruded Tubing is especially suited. Sudden climatic changes, wide fluctuations in temperature, or refrigerant operating conditions will not affect its dependability.

**WIRE IDENTIFICATION MARKERS:** the facilitating of production and assembling operations, with corresponding increases in functional efficiency, are effected with this TURBO insulation product. Available in any size, length or color. TURBO markers meet UL requirements.



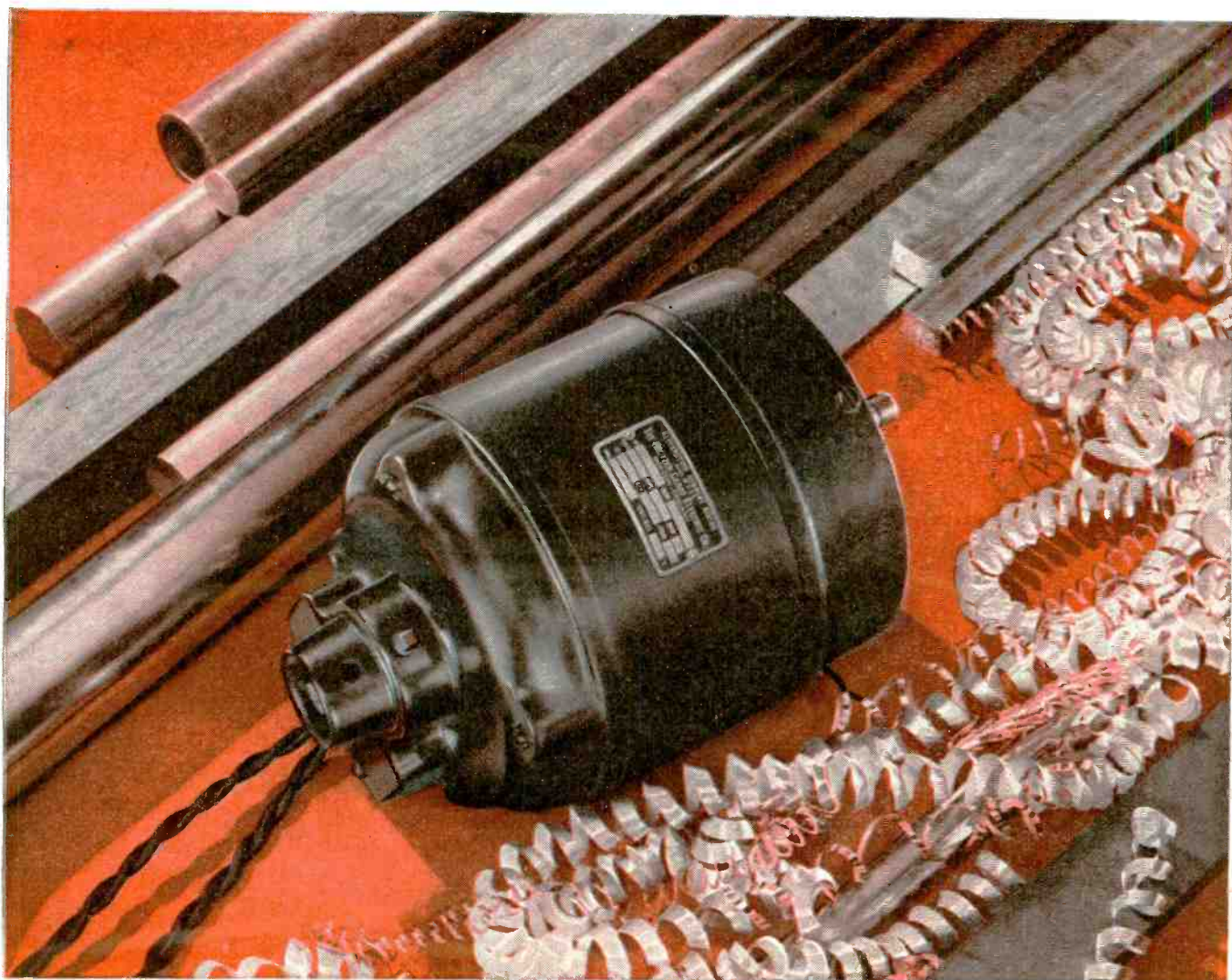

## Meet Design and Performance Requirements in Machine Tools

The motor requirements for the precision machine tool, illustrated at the right, called for motors that met certain performance characteristics and special mechanical requirements.

Holtzer-Cabot motor development engineers solved the problem by designing a special motor that exactly met all the operating and design conditions . . . and today these machine tools are operating at peak efficiency because of the dependability of the motors.

Whether you build machine tools or cash registers, it will pay you to investigate Holtzer-Cabot special fractional HP motors.

Our engineers will gladly cooperate with you on your motor problems for post-war products. There is no obligation.



SPECIAL MOTORS DESIGNED TO FIT THE APPLICATION

# HOLTZER-CABOT

Division of First Industrial Corporation

Designers and Builders of Special Fractional HP Motors and Electrical Apparatus

125 AMORY STREET, BOSTON 19, MASSACHUSETTS • CHICAGO, ILLINOIS • NEW YORK, NEW YORK • PHILADELPHIA, PENNSYLVANIA

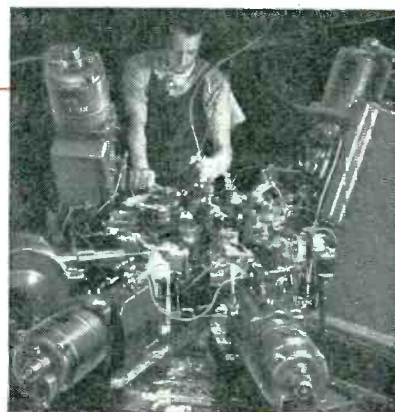





The United States Navy has awarded the men and women of Hallicrafters a special "Certificate of Achievement" . . . first award of its kind . . . for outstanding service with the radar-radio industries of Chicago in speeding vital war material to the Navy. Added to the four Army-Navy "E" awards, this makes five times Hallicrafters workers have been cited for distinguished service. They promise that this kind of service will be continued until total victory is ours.

★ BUY A WAR BOND TODAY

**hallicrafters RADIO**



THE HALLICRAFTERS CO., MANUFACTURERS OF RADIO AND ELECTRONIC EQUIPMENT, CHICAGO 16, U. S. A.

# SYLVANIA NEWS

ELECTRONIC EQUIPMENT EDITION

NOVEMBER

Published in the Interests of Better Sight and Sound

1944

## PM Lamps Offer Easy Way of Measuring RF Power Output

The group of Power Measurement Lamps introduced by Sylvania a little over a year ago have fully demonstrated their merits as a simple, accurate means of measuring the high-frequency power output of radio equipment.

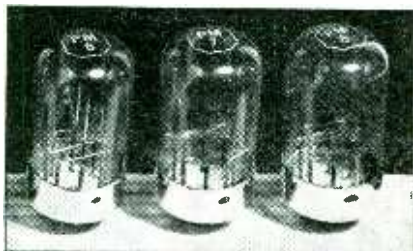

3 of the 6 Sylvania PM Lamps

The present series consist of 6 lamps, with which power outputs ranging from 0.05 to 25 watts can be measured directly, with the aid of ordinary meters. Accuracy of the measurements is within 5%, without any special calibration of the lamps.

Full information on the principle of operation of these lamps, and on their ratings and characteristics, is available from Sylvania.

## DID YOU KNOW...

That fluorescent lights are now helping with the job of guiding Pan American Clippers to port? They illuminate seadrome landing strips which were developed by Sylvania in cooperation with Pan American.

\* \* \*

That 7½-watt ruby lamps have been developed by Sylvania for use in Army photographic printing equipment? Smaller than most lamps of its type, the 7½-watt size is easily installed in portable printers.

\* \* \*

That the Army Medical Corps' new ten-car hospital train is fluorescent lighted throughout? Patients in the tropics will be more comfortable under these lights, which radiate little heat.

## Regulator Tube Maintains Voltage within Narrow Limits

### Maximum Regulation of Type OC3/VR105 Is 4 Volts over Operating Current Range

A voltage regulator tube, for applications where practically constant voltages must be delivered to a load, was recently placed on the market by Sylvania. Like previous tubes in the Sylvania line of voltage regulators, the new tube, designated as Type OC3/VR105, is of the gas filled, cold cathode type.

## 28D7 USEFUL AS VOLTAGE BOOSTER

With 28-volt operation of radio equipment attracting increasing interest in its current aircraft applications, and in its commercial potentialities, the Sylvania Type 28D7 is finding new fields of usefulness.

The 28D7 is a Lock-In output tube specifically developed for operation direct from a 28-volt source. The 28D7 can be used as a convenient voltage booster. This feature is particularly important where the 28-volt supply may drop too low to operate tubes having a critical minimum voltage.

For voltage boosting, the 28D7 is coupled as an oscillator to a load coil of the required characteristics, and the output rectified by a diode. Output voltages up to 500 to 600 volts can be obtained in this way.

Its outstanding difference from earlier types lies in its lower voltage regulation. With a design center operating voltage of 105, the OC3/VR105 has a maximum regulation of 4 volts over the operating current range from 5 milliamperes minimum to 40 milliamperes maximum. Characteristics of the new tube are compared with those of the OB3/VR90 and OD3/VR150 in the accompanying curves.

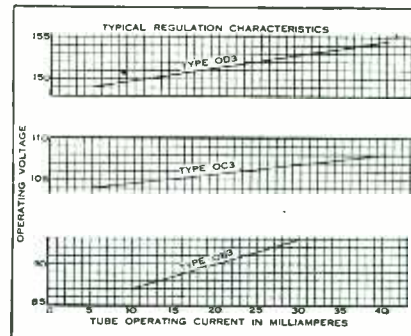

Comparative regulation characteristics of Sylvania voltage regulator tubes.

It should be noted that individual tubes may not deliver identical voltages to the load. However, the voltage will be within the specified operating limits of 105-112 volts, and the regulation 4 volts or less for any tube.



Base diagram of OC3/VR105

The tube is mounted in an ST-12 bulb with a standard small 6-pin octal base.

A current-limiting resistor should always be used in series with the OC3/VR105, to keep the operating current through the tube down to 40 milliamperes if the load should be disconnected.



"Car 54 go to 8th and Main — Signal 17 and doesn't the transmitter sound swell since I put in those Sylvania tubes? That is all."

# SYLVANIA ELECTRIC

# PRODUCTS INC.

Radio Division • Emporium, Pa.

MAKERS OF FLUORESCENT LAMPS, FIXTURES, ACCESSORIES, INCANDESCENT LAMPS, RADIO TUBES, CATHODE RAY TUBES, ELECTRONIC DEVICES



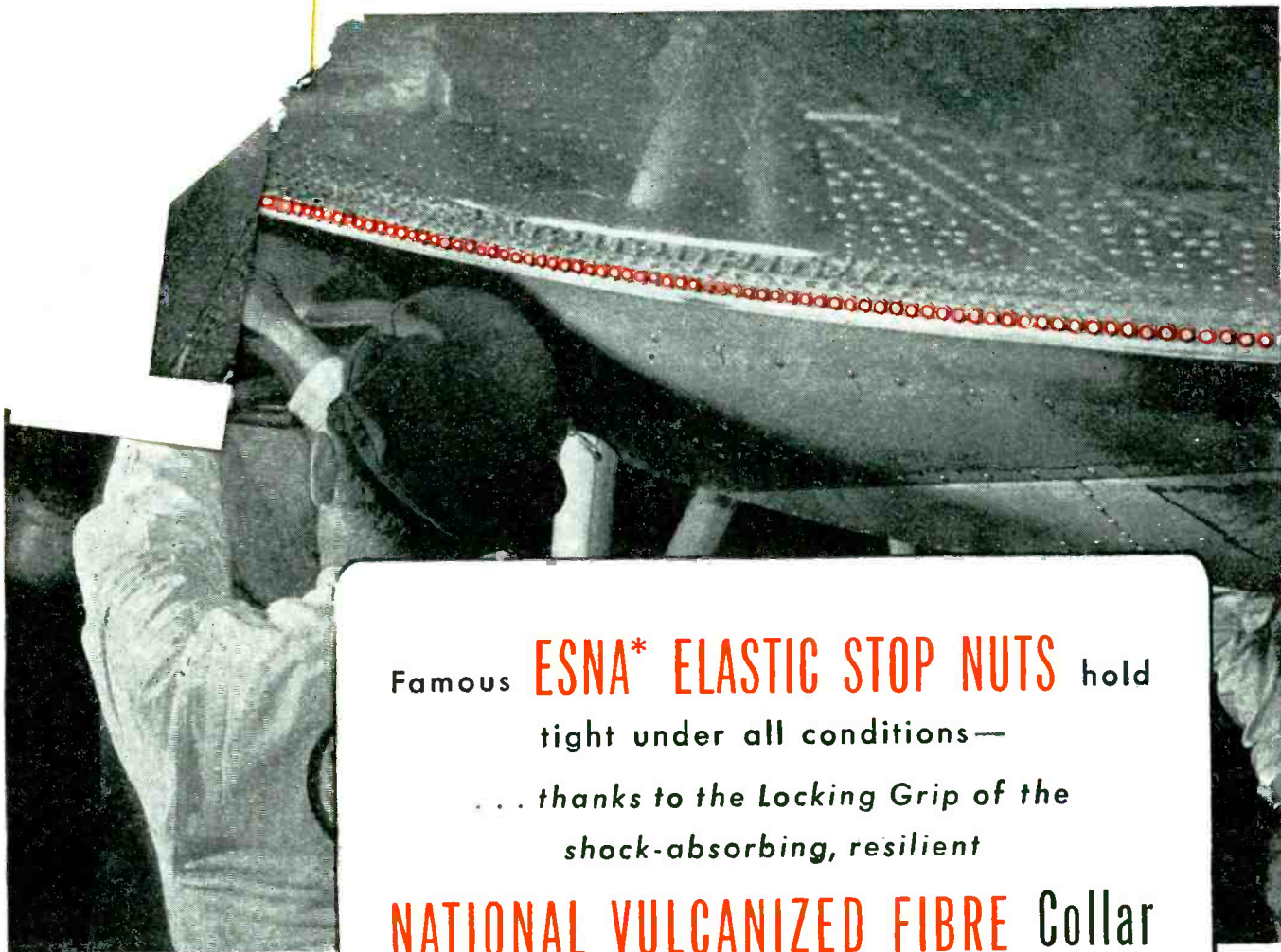

Famous **ESNA\* ELASTIC STOP NUTS** hold  
 tight under all conditions—  
 . . . thanks to the Locking Grip of the  
 shock-absorbing, resilient

**NATIONAL VULCANIZED FIBRE** Collar



In thousands of applications—in countless industries, can be seen the familiar red collar that marks Elastic Stop Nuts. This well-known red collar is National Vulcanized Fibre, the remarkable material that possesses such an unusual combination of properties. These properties are toughness, great mechanical strength, resilience, light weight, good machinability and forming qualities, high dielectric strength, exceptional durability.

Because of these combined, outstanding qualities, National Vulcanized Fibre will, as it does in the ESNA nut, help make needed peacetime products safer, stronger and longer-lasting. Your inquiry on your use of this material will receive the prompt attention of our trained technical men.

Send for Free Copy of National  
 Vulcanized Fibre Hand Book. Please  
 write on your company letterhead.

\*ESNA is the trade mark of Elastic  
 Stop Nut Corporation of America.



Here's why the **ESNA ELASTIC STOP NUT** locks fast and stays put even under shock or severe vibration.

This nut and its mating bolt are put together like any ordinary nut and bolt—up to a point. This point is where the bolt meets the unthreaded compression-locking National Vulcanized Fibre Collar.

The bolt then impresses its own thread path into the elastic National Vulcanized Fibre compression collar. In passing through the collar the bolt threads squeeze the locking fibre—the locking fibre collar squeezes back. Thus the compressed fibre collar, in its confined pocket, grips the bolt threads on both sides—with a grip which never relaxes.

This grip keeps the nut from turning loose. Only when the nut is removed is the gripping action relieved. When this happens, the fibre collar goes back to an "undersize thread" condition. So the nut can be used again and again.

**National Vulcanized Fibre Co.**

Wilmington 99, Delaware

Offices in Principal Cities



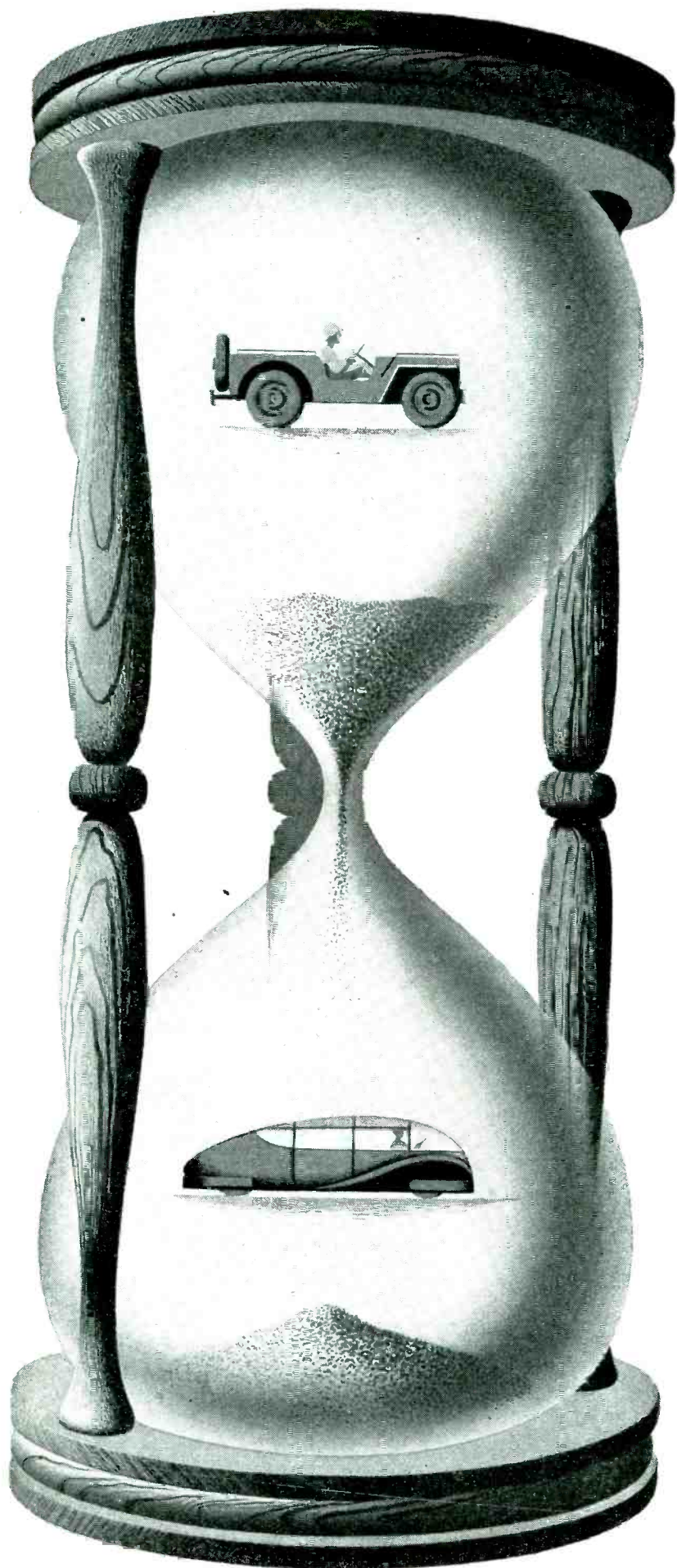

**MANUFACTURING**

## Will Benefit

**Industrial users of WILCO Products will find the increased facilities, the new products and techniques developed by WILCO for war service of great advantage to their own postwar products.**

As the Hourglass indicates . . . with the coming of peace, many WILCO products now making for precision performance in airplanes, ships, tanks, guns and instruments of the Army and Navy will play an equally important role in meeting civilian needs for hundreds of useful and reliable products.

The demand of all branches of the service for Thermostatic Bimetals and Electrical Contacts has motivated many WILCO developments of great potential value to postwar industry. New products added to an already extensive line; increased facilities for refining and fabricating precious metals; greatly extended rolling mill facilities—these new additions and improvements, now devoted principally to the war effort, will prove equally helpful to manufacturing customers in meeting their peacetime production and marketing problems.

**WILCO PRODUCTS ARE:** *Contacts*—Silver, Platinum, Tungsten, Alloys, Sintered Powder Metal. *Thermostatic Bimetal*—High and Low Temperature with new high temperature deflection rates. *Precious Metal Collector Rings* for rotating controls. *Silver Clad Steel*. *Jacketed Wire*—Silver on Steel, Copper, Invar, or other combinations requested. *Rolled Gold Plate*. Special materials.

**THE H. A. WILSON COMPANY**  
105 Chestnut Street, Newark 5, New Jersey

*Branches: Detroit • Chicago*



**Thermometals—Electrical Contacts  
Precious Metal Bimetallic Products**



*Extensive*

# STOCKS OF FIBERGLAS TAPES

are available at M-R

*"Electrical Insulation  
Headquarters"*

for **IMMEDIATE  
DELIVERY**

and

**Complete Protection  
of your  
Electrical Equipment**

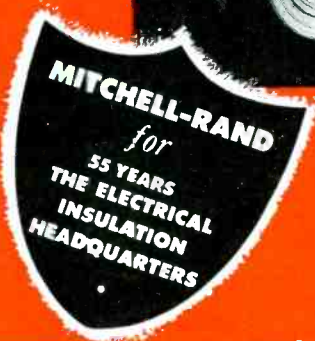

Overloading . . . high or low temperatures . . . moisture . . . corrosive acids, vapors or fumes . . . oils . . . greases . . . dust or dirt, the destructive elements of ordinary electrical insulations **WON'T AFFECT M-R FIBERGLAS INSULATION.**

The success story of Fiberglas Insulation abounds with fewer breakdowns, less maintenance, elimination of waste, savings in labor and materials and proves its value as the optimum in electrical insulation protection.

Widths range from  $\frac{3}{8}$  to  $1\frac{1}{2}$  inches; Thicknesses: .003"-.005"-.007" and .010".

Tensile Strength: extraordinary — example — tape  $\frac{1}{2}$ " wide and .003 thick — 80 pounds.

*Obtain your Fiberglas  
Electrical Insulation from  
**MITCHELL-RAND***

**ELECTRICAL INSULATION  
HEADQUARTERS FOR 55 YEARS**

Write for booklet describing  
Fiberglas and its electrical insulation  
uses and properties.

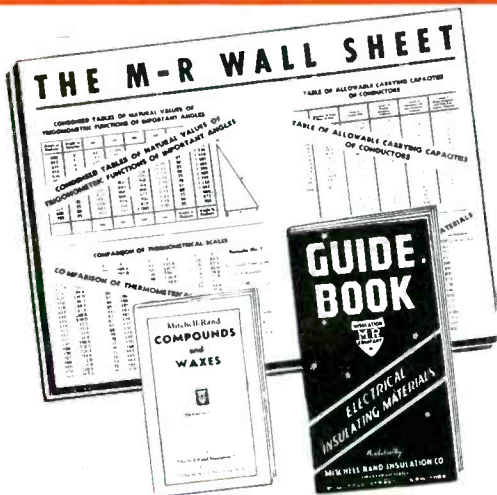

## **FREE FOR THE ASKING**

A Sample Card of Varnished Tubings; samples to fit sizes from B&S wire #20 (.032") to #0 (.325") . . . a Wall Chart with quick easy to read reference tables of electrical symbols, capacity of conductors, dielectric averages of insulating materials, mathematical tables, tap drill sizes, standards of varnished tubing sizes . . . Wax and Compound Guide Book and the M-R Book of Electrical Insulations . . . all are Free for your asking . . . write for them on your letterhead.

# **MITCHELL-RAND INSULATION COMPANY, INC.**

**51 MURRAY STREET**

**COrtlandt 7-9264**

**NEW YORK 7, N. Y.**

Fiberglas Varnished Tape and Cloth  
Insulating Papers and Twines  
Cable Filling and Pothead Compounds  
Friction Tape and Splice  
Transformer Compounds

**A PARTIAL LIST OF M-R PRODUCTS**  
Fiberglas Braided Sleeving  
Cotton Tapes, Webbing and Sleeveings  
Impregnated Varnish Tubing  
Insulating Varnishes of all types

Fiberglas Saturated Sleeving and Varnished Tubing  
Asbestos Sleeving and Tape  
Extruded Plastic Tubing  
Varnished Cambric Cloth and Tape  
Mica Plate, Tape, Paper, Cloth and Tubing

*Just an Old Smooty!*

MAXIMUM RATINGS	
Frequency	0 - 150 Cycles
Condensed Mercury Temperature	20° - 50° C.
Peak Inverse Voltage	10,000 Max. Volts
Peak-to-Peak Current	5.0 Max. Amperes
Plate Current	1.25 Max. Amperes

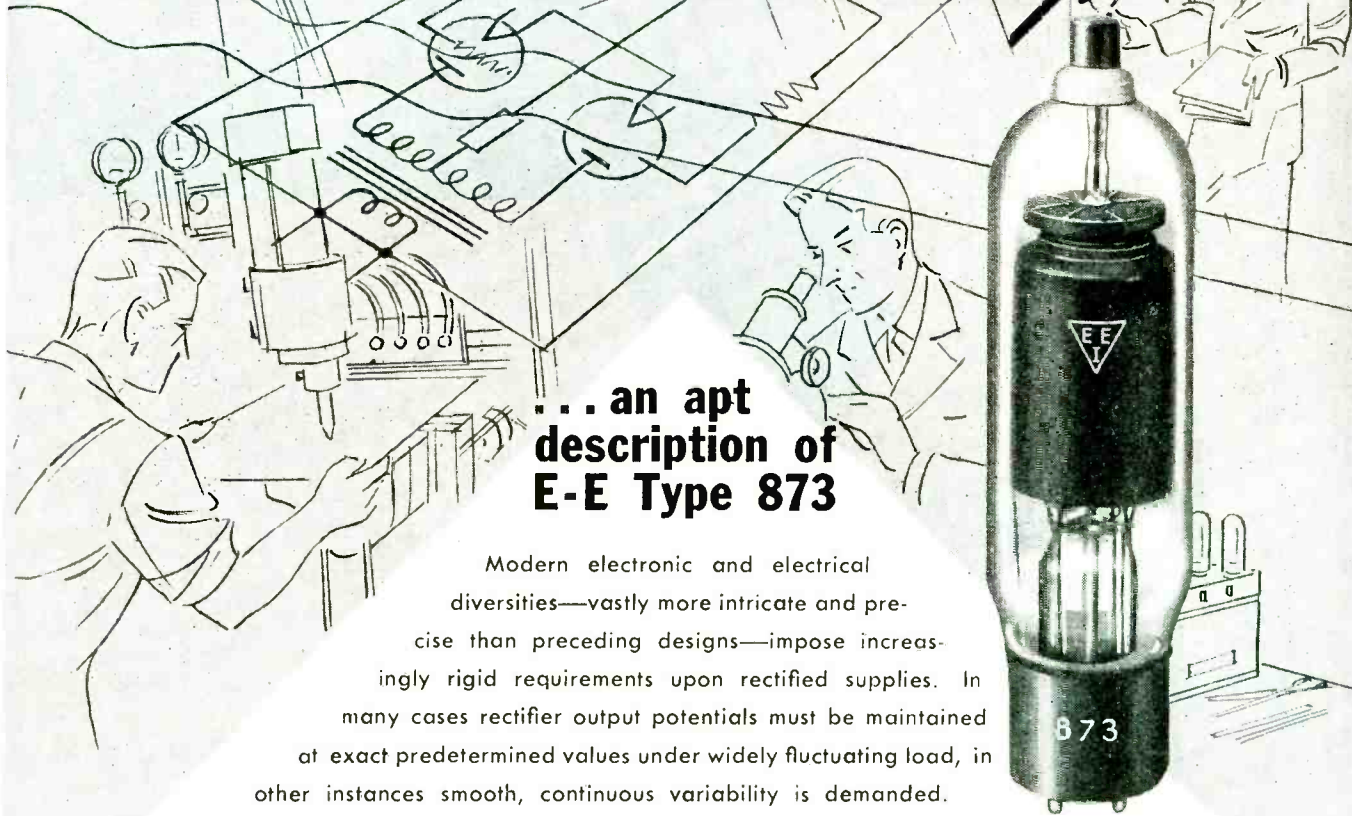

**... an apt description of E-E Type 873**

Modern electronic and electrical diversities—vastly more intricate and precise than preceding designs—impose increasingly rigid requirements upon rectified supplies. In many cases rectifier output potentials must be maintained at exact predetermined values under widely fluctuating load, in other instances smooth, continuous variability is demanded.

E-E grid control rectifiers, specifically designed for present day applications, offer complete manual or automatic control of rectifier output plus rugged mechanical features invaluable in industrial or portable utilization.

Additionally, these tubes offer economy of filter design due to inherent hum reduction tendencies.

Write today for the E-E Data Book containing complete technical information.

**ELECTRONIC ENTERPRISES, INC.**



GENERAL OFFICES: 65-67 SEVENTH AVENUE, NEWARK, 4, N. J.  
 EXPORT DIVISION: 25 WARREN STREET, NEW YORK, 7, NEW YORK  
 CABLE ADDRESS: SIMONTRICE NEWYORK



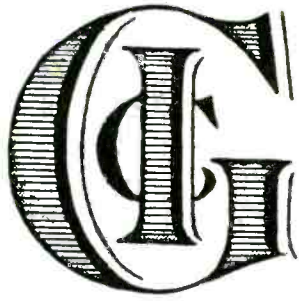

# radio components exclusively

As before, our total facilities will be devoted exclusively to the production of variable air condensers, push-button tuning devices, record changers and other radio components.

We will continue our established policy of producing a full line of types, sizes and specifications *plus exclusive special designs.*

## GENERAL INSTRUMENT CORP.

829 NEWARK AVENUE, ELIZABETH 3, N. J.



variable air condensers

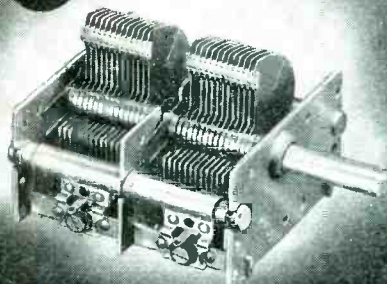

and push button tuning devices

record changers...



A line of new volume production models — simple — reliable — appealing.

NEW components?...



We're working on 'em now. Tell you later.



# better recordings

The thrill of great music and the vital discussions of our national life are now carried with uniform fidelity to millions. You who make transcriptions appreciate the exacting science and never-ending research we employ in producing these recording blanks. AUDIO DEVICES, INC., 444 Madison Ave., New York.



*... they speak for themselves* **audiodiscs**



# RUSSIA

## *Threat . . . or Promise?*

**W**HEN this war is ended, two nations—the United States and Russia—will possess the bulk of the world's military and industrial might.

Whether this new situation will hold seeds of catastrophe or of unprecedented opportunity will be determined by policies . . . still to be formulated.

If this concentration of power leads to a bitter struggle for supremacy, then the world will be turned into a giant munitions factory.

If it is used cooperatively to maintain order, then, I believe, the stage is set for a long era of prosperity . . . and peace.

It is time that Americans, whether of the Right or the Left, face this basic issue squarely and open-mindedly.

☆ ☆ ☆

No group in this country has a greater stake than have business and industry in seeing that a satisfactory Russian-American understanding is reached.

Without such an understanding there can be no reasonable hope for more than a temporary and insignificant reduction of our crushing wartime tax burden. If the threat of a clash between these two giants impends, neither bankers nor governments will run the risk of lending on a scale adequate to maintain international trade at levels necessary for our future prosperity. Potential international customers, instead of buying freely in open world markets, will be forced—as during the dangerous period introduced by Hitler in the early 1930's—into the trading camp of whichever power they fear most.

If, however, Moscow and Washington will agree on cooperative plans for maintaining the peace, American business will enjoy enormous new trade opportunities after the war.

☆ ☆ ☆

Russia, during the three and one-half years since it was attacked by Hitler, has conclusively proved to a doubting world that it is a top-flight military power.

Soviet railroads did not break down under the strain of war.

Regions accounting for nearly 70 per cent of Stalin's key industries were engulfed by the invading Nazis, but before they fell, Soviet management engineers performed a near miracle by transplanting entire industries a thousand miles to the Urals with the loss of as little as four months' production in many cases.

Though American planes, trucks, and medical supplies have been welcomed by Moscow, fairness demands the admission that more than 98 per cent of American production has *not* gone to the Russian front.

Russian planning and Russian equipment won the victories of Leningrad, Stalingrad, and the Caucasus.

☆ ☆ ☆

But these measures of Soviet military strength—indicative as they are of an unsuspected economic development—fail to picture in adequate detail the startling potential of the Russian market after the war.

Russia, for instance, has two and one-half times the area of the United States.

It has a population of nearly 200,000,000, and this is increasing at the rate of 2,500,000 a year.

*And statistics just released show that Russia has three times as many youngsters under 16 as has the United States. This is a measure both of war potential and of a vast commercial market.*

And remember that in no part of the world before the war was per capita production rising as rapidly as in the Soviet Union.

☆ ☆ ☆

German armies occupied a region in Russia roughly equivalent to the territory in the United States north of Richmond, Virginia, and east of the Mississippi.

This huge area—with its counterparts of Pittsburgh, Buffalo, and Bridgeport; of Illinois corn fields, New York dairy farms, and Maine potato harvests—was *twice* subjected to the most withering destruction; first by the Russians themselves when they retreated before the Germans, and then by the Germans when they withdrew before the victorious Russians.

As a result, 30,000,000 people are in urgent need of complete reoutfitting. They need houses and shoe laces, trolley cars and baby carriages, tractors and livestock, hydroelectric plants and electric light bulbs.

Many of these needs will be met at home. It is doubtful, for instance, if Moscow will import cooking utensils or sewing machines, for many of Russia's huge war factories can quickly be converted to peacetime production of such consumer goods.

But for the rebuilding and expansion of her industries Russia looks to the United States for equipment.

Soviet representatives already are in this country with authority to negotiate for technical men and the equipment necessary to rebuild the great Donbas coal mines according to the most modern American methods.

It is important to remember that Russia's whole iron and steel industry, its non-ferrous mining and processing, some of its chemical production, much of its coke roasting and gas recovery, practically its entire automobile and tractor industry, and the largest of its hydroelectric plants, are based on American machinery and processes.

It is known among manufacturers that Russia recently has asked for bids on shipbuilding equipment, construction and roadbuilding machinery, alloy steels, textile machines, plastics, and a long list of rail, air, and water transport supplies.

☆ ☆ ☆

The Soviet Union, however, has more than a rehabilitation job on its drawing boards.

The first Five-Year Plan, which, as we all remember, was completed ahead of time in 1932, was devoted almost exclusively to heavy industry. Russia set out to build for itself the machines and the factories which, in later years, could turn out, at home, modern equipment for a vast range of light industries.

Stalin, when he inaugurated the second of his famous Five-Year Plans, promised that before it was completed Soviet factories would begin to turn out a flow of con-



sumer goods—ready-made dresses, canned foods, soap, cosmetics, shoes, kitchenware, automobiles, telephones, and modern houses.

But, by 1935, Moscow realized that Russia could not afford to enjoy such luxuries in the face of growing political tension in Europe. So, when the third Five-Year Plan was launched, there was no fanfare. Russians continued to wear their old clothes, to eat whatever simple food was available, and began grimly to build the industries which ultimately produced enough tanks, planes, and guns to turn the tide of battle at Stalingrad.

It is characteristic of Moscow that even before the last battles with the Nazis are over, Russia is planning to pick up its Five-Year Plans where the war had interrupted them.

Invitations to participate in a permanent exhibition in Moscow already have been mailed to American manufacturers. Soviet officials want their public to see samples of our new machine tools, aluminum and alloy products, oil-drilling machinery, bulldozers, and prefabricated kitchen equipment. Russia already is projecting specific plans to resume the job (1) of making the country an industrial giant comparable to the United States, and (2) of making life more pleasant for a long-suffering people.

★ ★ ★

What is the measure of this postwar market in the Soviet Union?

Some estimates place the total quantity of goods which Russia might take from the United States during the first two or three years after the war as high as \$5,000,000,000 a year. Then, as Russian industry is restored, imports from the United States might taper off perhaps to \$2,000,000,000 a year.

Actually, these estimates are far too optimistic, unless the United States is prepared (1) to help Russia pay by buying vast quantities of Soviet raw materials, and (2) to provide large credits to handle the purchases during the first few years of rehabilitation.

The relations of American exporters with Russia during the period covered by the three Five-Year Plans have been eminently satisfactory. Moscow has met all of its obligations punctually; fifteen years of experience have reduced contract forms to the point where they cause a minimum of misunderstanding between the Russian representatives and the American producers; individual American companies with extensive prewar experience in handling Soviet business already are offering large credits on initial postwar orders though these may yet be replaced by large government credits at lower interest rates.

But the volume of trade with Russia after the war hinges upon Moscow's ability to pay. Never before the war did the United States buy more than \$30,000,000 of goods a year from Russia. As late as 1938, Soviet exports to this country amounted to as little as \$23,500,000, far less than enough to pay even the service charges on the credits which would have to be extended in connection with exports of several billion dollars a year. Only South Africa produces more new gold each year than the Soviet Union. But the United States does not want gold; more of it would only complicate the problem of controlling prices here.

If the United States, however, is to achieve, after the war, the high level of national income which is necessary (1) to keep our expanded factories in operation, and (2) to service the national debt, it might absorb from \$90,000,000 to \$100,000,000 a year of the kind of goods bought from Russia before the war—furs, timber,

manganese, chromium, and handicrafts. But unless this volume of purchases from Russia can be boosted by another \$50,000,000 annually, credits of the size necessary to fill immediate Russian needs could not be serviced without large supplemental importations of undesirable gold.

The nub of the situation is that Russia offers an extraordinary potential market particularly for our heavy industries which have grown so enormously during the war. But if this sales outlet is to materialize, then the United States must find a way to import from Russia (or from Russia's debtors if any) from ten to twenty times as much as we did before the war. Instead of merely going after the export business, American businessmen must explore with the Russians the possibility of buying bigger supplies of Soviet products.

★ ★ ★

But more than the Russian market itself hinges upon sound cooperative action by the world's two leading military-industrial nations.

If trade between them is held to a minimum and if relations are strained, the flow of trade all over the world will be adversely affected.

Europe, long this country's biggest export outlet, certainly will never take the bold steps necessary to reconstitute its economy on a peacetime basis if Russia and the United States drift into a race for military supremacy.

The Balkan states, which may be industrialized by Moscow in order to reduce their dependence on Germany, and the Arab world with its huge need for transportation, irrigation, and sanitation, will not dare accept American credits or make big contracts with American engineers if Moscow frowns on the deals.

And refusal of Russia and the United States to work cooperatively to maintain the peace would kill, in their present embryonic stage, all dreams of a vast industrialization program for China.

★ ★ ★

The opportunity to make a major change in the trade map of the world and at the same time to achieve a sharp rise in our own standard of living is before us.

It demands of American business leaders the kind of boldness and imagination that their predecessors displayed when they pioneered this country's unknown West.

It demands realistic action by men who know that the solution to this country's real foreign trade problem under today's conditions lies in boosting imports not exports alone . . . men who are not afraid of being paid for what they sell.

It calls for leaders who will approach Moscow and other major customers at once with constructive plans that would parallel in scope those on which this country is waging war . . . leaders who will make it clear at the outset that this bid for cooperative action emphatically demands that each nation shall have complete freedom to determine its internal political and economic organization without interference from the other.

It is *this* caliber of leadership upon which our future hinges.

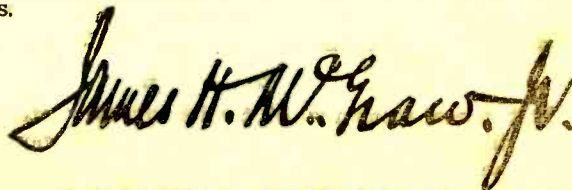

President McGraw-Hill Publishing Company, Inc.



# Eimac "X" Grid

*Solves grid emission problem!*

Grid emission, with the resulting instability of operation, parasitic oscillations and prematurely burned out filaments, has become a thing of the past. The new Eimac "X" grid will not emit electrons even when operated at incandescent heat.

The solution to the problem of grid emission lifts a great barrier which has long stood in the path of electron vacuum tube development and the progress of electronics. Eimac Engineers in developing the "X" grid have made a real contribution . . . and a very important one . . . toward the development of new and more efficient vacuum tubes. It is such heads-up Engineering that has made Eimac first choice of leading electronic engineers throughout the world . . . and maintained them in that position year after year.

Follow the leaders to



**ELECTRONIC  
TELEVISION**

The layman's handbook of Electronics will be sent you upon request without cost or obligation.

# Eimac

REG. U. S. PAT. OFF.

## TUBES

**EITEL-McCULLOUGH, INC., 874 San Mateo Avenue, SAN BRUNO, CALIF.**  
Plants located at: San Bruno, California and Salt Lake City, Utah

Export Agents: **FRAZAR & HANSEN, 301 Clay St., San Francisco 11, Calif., U.S.A.**

*The Science Behind the Science of Electronics*  
is the focusing of all branches of science upon the development and improvement of electron vacuum tubes.



**PHYSICS**... Especially designed electron microscope enables operator actually to view electron emission



**OPTICS**... Photomicrographic studies help achieve perfection in processing.



**POWDER METALLURGY**... Compounding special alloys.



**CHEMISTRY**... Experimentation with metallic components and preparation of chemical compounds.



**THERMO-DYNAMICS**... Vacuum furnaces heat materials to exceedingly high temperatures

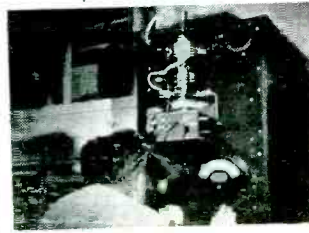

**ELECTRONICS**... Determining facts about and recording data on vacuum tube capabilities.



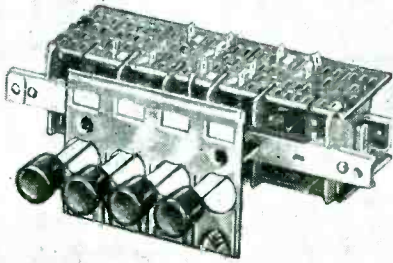
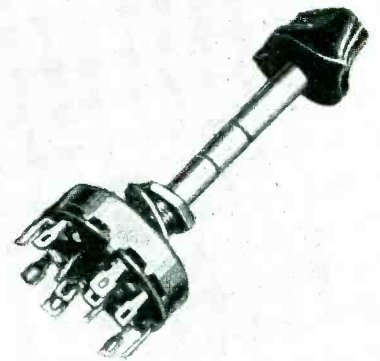
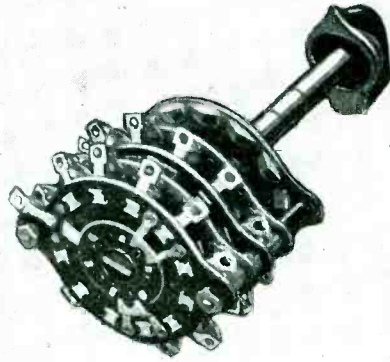
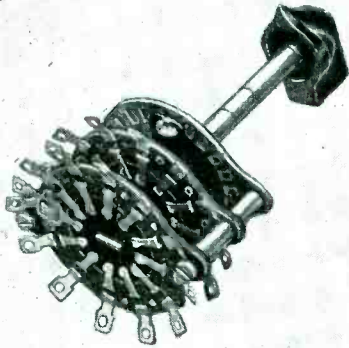

## Easy Answers To Difficult Problems



### Other Versatile Mallory Parts

- Dial Light Assemblies
- Long Frame Jacks
- Midget Jacks
- Mounting Hardware
- Plugs
- Potentiometers
- Push Button Switches
- Rheostats
- "T" and "L" Pad Attenuators
- Tip Jacks
- Tip Plugs
- Twin Tip Jacks
- Variable Resistors
- X P Jacks

Mallory standard stock switches not only have a reputation for dependability and long life—they've shown an amazing adaptability to new and unusual requirements.

That's why Mallory standard single gang, multi-gang and push button switches—longtime favorites in the radio and industrial fields—are serving wartime needs in tanks, ships, planes and in many types of industrial and electronic equipment.

Note such outstanding characteristics as silver-plated contact members, low electrical resistance, high quality insulation throughout, ready accommodation to complex circuit and coil combinations. These same advantages have been recognized by alert designers—resulting in more and more Mallory switches being specified for modern jobs.

A Mallory standard stock switch, ordered by catalog number, can save many costly delays involved in designing "specials." The same Mallory catalog which lists these switches contains other electronic parts, equally serviceable and versatile in use. See your nearest Mallory distributor or write direct for your free copy.

P. R. MALLORY & CO., Inc., INDIANAPOLIS 6, INDIANA



Finish the Fight—  
Buy War Bonds

P. R. MALLORY & CO. Inc.  
**MALLORY**

# Approved Precision Products





# CROSS TALK

►**SHARE** . . . From a service man in the South comes the plea: "I am seeing so much that is electronic in my work that I wish to supplement my work with reading in this field. I wonder if some of your readers who do not file their copies could forward them to me after they are through? In this manner they will help keep another soldier boy's intellect alert."

Seems like a marvelous idea. Anyone want Pvt. So-and-So's real name?

►**ADJUSTMENT** . . . Not all of the adjustments, post-war, are going to be made by industry nor by returning service men. Many of the adjustments will have to be made by men who have stayed at home, making their contribution in any one of a dozen ways which have very little in common with their jobs before the war.

Consider the college professor, perhaps from a small and not too rich institution, who will be constantly surrounded by youngsters taking his courses because the curriculum requires it; always wishing for more apparatus than his department budget will tolerate, apparatus not only for demonstration but for some of his own research.

During the war he has been surrounded by colleagues whose intellectual background and interests and scientific attainments may not only equal his own but may even surpass them so that he learns while working; whose every request for research equipment is quickly gratified.

Or, consider a small-company engineer or scientist who will have limited funds for research, with a small staff, under the constant necessity of producing profitable items, never quite free to work on his own ideas because they are not right down the company line.

During the war he has unlimited funds, his staff

may be numbered in the scores of hundreds, and his sole aim is to produce devices the success of which is gaged solely by their excellence for the job.

Colleges and industry must be cognizant of the emotional problems of such men when they return to our humdrum world; must remember that their returning personnel may have had visions which cannot possibly be duplicated on the home grounds. Somehow, means must be found to condition favorably the atmosphere in which these war-time contributors do their peace-time work.

►**MAKEUP** . . . In all businesses there are exigencies; unexpected things that crop up to plague an otherwise pleasant setup. In the publishing business, one of the exigencies is the article that is a column or two too long to fit into the allotted space. One way out of the difficulty is to "turn-over" the extra column or two into the rear of the book.

ELECTRONICS readers are particularly busy at this time and should not have to paw through the rear of the book to read the end of any technical article. Beginning in this issue, the editors intend to make articles "break even" up front, to end them in the feature section where they start if this is humanly possible. Only in makeup emergencies and to avoid emasculating material will they diverge from this new policy.

►**FIRE** . . . It seems to be a normal male desire to chase fires. Well, out in Ohio several electronic engineers enjoyed this pastime so much they got busy and developed a whole fire alarm system for their particular town, presented it to the town and had themselves cut in on the circuits so they could really chase fires efficiently!

# INTERNATIONAL Radio Frequency Proposals

Preparing for forthcoming Treaty Conferences, a committee of industry and government representatives is currently meeting under the sponsorship of the State Department. Its work is far from completed but some of the initial suggestions do point toward things to come

**I**NTERNATIONAL ASPECTS of the radio art are attracting the close attention of post-war planners in a series of meetings currently being held in Washington.

The State Department, which is charged with the preparation of proposals for international treaties in the telecommunications field, has undertaken to obtain the advice and guidance of other government departments and the industry, looking toward the next Treaty Conference at which existing international law and regulations will be revised to meet new technical and economic conditions. Such a revision is long overdue.

## Major Committee Objectives

The present international radio law rests in the International Telecommunications Convention formulated at Madrid in 1932, and the General Radio Regulations as revised at the Cairo Conference in 1938.

Since 1938, much water has gone over the dam. New regions of the ether spectrum have been opened to extensive use. Existing allocations and services have assumed new relative positions of importance. The interference problem, due in part to disregard of international service assignments, has become so acute that it borders on the chaotic. The war has brought with it many new developments in aviation and long-distance communication, many of which will continue in peacetime.

Many of the aspects of the work now in progress are legal in nature, particularly the delicate questions

of the sovereign rights of nations and the enforcement of treaty agreements. But an equally large part of the work is technical, and it is this task which has been assigned to a committee under the chairmanship of Dr. J. H. Dellinger.

The committee consists of members from industry, including many active in the Radio Technical Planning Board, and from government departments including the Army, Navy, and the FCC. The meetings began August 11 and 12, were resumed on September 20 and 21, and later meetings are scheduled to follow the Allocation Hearings of the FCC which began on September 28.

The Technical Committee has been charged with two main investigations: (1) A general survey of the definitions and standards which should govern international allocation and standardization of frequency assignments, and (2) a specific study of frequency allocations to particular services.

The work has by no means been completed, so it is not possible to report official conclusions. But at the initial meeting, representatives of the State Department stated that the proceedings might be reported in the press as they proceeded provided that no direct quotations were made from the draft proposals and minutes.

## Definitions and Standards

The first portion of the work of the technical committee, relating to definitions and standards, is concerned with proposed changes in the Radio Regulations (Cairo,

1938). Changes may be extensive.

It is evident that the introduction of frequency modulation has changed concepts in a number of particulars. It is proposed, for example, to classify the emission of a transmitter as "A" for amplitude modulation, "F" for frequency modulation (and phase modulation) or "AF" for emissions combining the two types. Following this designation is a number which denotes the bandwidth occupied by the transmissions, expressed in kilocycles. Thus a standard broadcast station would bear the designation A10, and a standard frequency modulation station F150. (The symbol "T" has also been suggested for keyed signals.)

The methods of calculating the bandwidth of given classes of station are stated in the proposed regulations as follows: A pure cw telegraph station has a bandwidth in kc equal to  $0.0005 BW$ , where  $B$  is the average bauds per letter (a number ranging from 5.0 for a five-unit teleprinter signal to 8.4 for international Morse code), and  $W$  is the number of words per minute transmitted. The bandwidth of a modulated cw telegraph station is equal to the above expression, plus twice the modulation frequency. An amplitude-modulated station (voice or music) has a bandwidth equal to twice the modulating frequency. A frequency-modulated station (voice or music) has a bandwidth of twice the maximum frequency swing, in kc, provided the swing is equal to or greater than the highest modulating frequency,



which it is in nearly all practical cases.

To assist in comparing various transmissions on an equal footing it is proposed to rate transmitters in terms of the peak power supplied to the antenna in normal operation.

Emissions outside the authorized bandwidth must be at least 26 db below the maximum radiated field within the authorized band, and if interference is caused by such "extra-band" emissions they must be further reduced.

Only two types of services are defined, "fixed" and "mobile." A portable station assumes the classification of the service in which it operates, even if such operation is on a temporary basis. Thus a portable station temporarily operating from a specified fixed location is a fixed station. If used while in motion, or at unspecified fixed locations en route, it is a mobile station.

It is proposed that in the future, station assignments be specified in frequency, in kilocycles or megacycles, and not in terms of wavelength.

Specific limits to the permissible amount of radiation on harmonics of the assigned frequency are proposed; the peak power of the radiated harmonic is to be 40 db below the peak power of the fundamental, and in no event greater than 200 milliwatts.

It is proposed that the use of damped radio-frequency oscillations be specifically forbidden.

#### Proposed Table of Allocations

The proposal most of interest to the readers of *ELECTRONICS* is the Frequency Allocation Table. This table is in no sense in final form, and was offered to the Committee primarily as a means of "starting the argument."

The table was drawn up by the Inter-Department Radio Advisory Committee (IRAC), the official government committee on radio allocations. The proposed table may be viewed as a preliminary statement of the government interest in frequency allocations. The interest of the industry, in contrast, is being formulated by the Radio Technical Planning Board, and its recommendations have been separately presented before the Alloca-

tions Hearings of the FCC.

The IRAC set up the various radio services in general order of priority as follows: (1) Services concerned with the preservation of life and property, particularly navigation aids and distress calling service, (2) communication services of an essential nature which cannot be supplied by non-radio means, such as maritime and aeronautical communications not covered in the first classification, (3) broadcasting, including standard, fm, television and facsimile, (4) communication services using radio because the use of wire lines is not expedient, such as transoceanic telegraph and telephone, and (5) other radio services.

#### Amateurs Well-Protected

A most important aspect of the table is the extent of the spectrum covered, from the lowest frequencies, about 10 kc, to an upper limit at 30,000,000 kc (30,000 Mc, or 1-centimeter wave length).

The highest specific service proposed is a band from 21,000 to 22,000 Mc for amateur service. The amateur bands, which are of outstanding interest to an industry composed largely of amateurs and ex-amateurs, are proposed as follows: 3500-3900 kc, 7000-7400 kc, 14,000-14,400 kc, 21,000-22,000 kc, 28,000-30,000 kc, 144-149 Mc, 218-225 Mc, 420-460 Mc, 1125-1225 Mc, 2500-2700 Mc, 5200-5750 Mc, 10,000-10,500 Mc, and 21,000-22,000 Mc. The pre-war bands at 15 meters and 5 meters are deleted, and a new band at 15 meters is proposed, as well as six new bands at wavelengths less than one meter.

No provision is made for international high-frequency broadcasting in the IRAC Table. This omission has caused considerable opposition on the part of the industry representatives, who feel that space must be found for this activity.

#### FM and Television Proposals

Frequency modulation and television receive an unbroken assignment from 42 to 108 Mc, divided in two regions, 42 to 54 Mc for fm, and 54 to 108 Mc for television. This proposal conflicts with that of the RTPB Television Panel which recommends assignments of six-

megacycle channels from 50 to 246 Mc, excluding the 56-60 Mc region. The RTPB Panel on v-h-f Broadcasting recommends the region from approximately 40 Mc to approximately 56 or 60 Mc for fm.

The IRAC Table also makes provision for television on higher frequencies, presumably with wider bandwidths than the 6 Mc currently used. These television assignments lie in the bands 460-508 Mc and 524-956 Mc.

#### Standard Broadcasting and Aviation

In the standard broadcasting band it is proposed to add one additional 10-kc channel at 540 kc.

Standard frequency broadcasting (of the WWV type) is proposed for international standardization at 2500 kc, 5000 kc, 10,000 kc, 15,000 kc and 20,000 kc.

Aviation radio in all its forms occupies a large place in the Table, as indeed it must in any post-war plan. It is proposed that all purely domestic aviation traffic control, airport communication and plane-to-plane and plane-to-ground communication be carried out on the u-h-f bands where no interference will be caused.

#### Navigation and Safety Devices

It may be wondered why the region of the spectrum above 30 Mc should be allocated definitely in an international agreement, since direct interference between nations on such frequencies is restricted to over-the-border cases, which could be solved by regional agreements within continental areas.

This fact is generally admitted. But it is equally evident that the maritime and aeronautical mobile services will employ v-h-f and u-h-f equipment for traffic control, instrument landing, harbor approach, navigation, collision prevention, and the like. Such "common carriers" engaged in international trade must be able to use the same equipment in any harbor or airport in the world.

Whether or not the proposed Table will remain in its present form when the Treaty Conference meets depends on the action taken by the State Department Committee, as well as on such action as the FCC may take following the presentation of the RTPB proposals.

# Automatic Map Tracer

The odograph, now in production for installation in jeeps, utilizes phototubes and thyatrons to transfer the indications of a precision magnetic compass to a plotting unit actuated by a speedometer drive cable, causing a pencil to trace on an appropriate map the exact course taken on roads or on cross-country movements

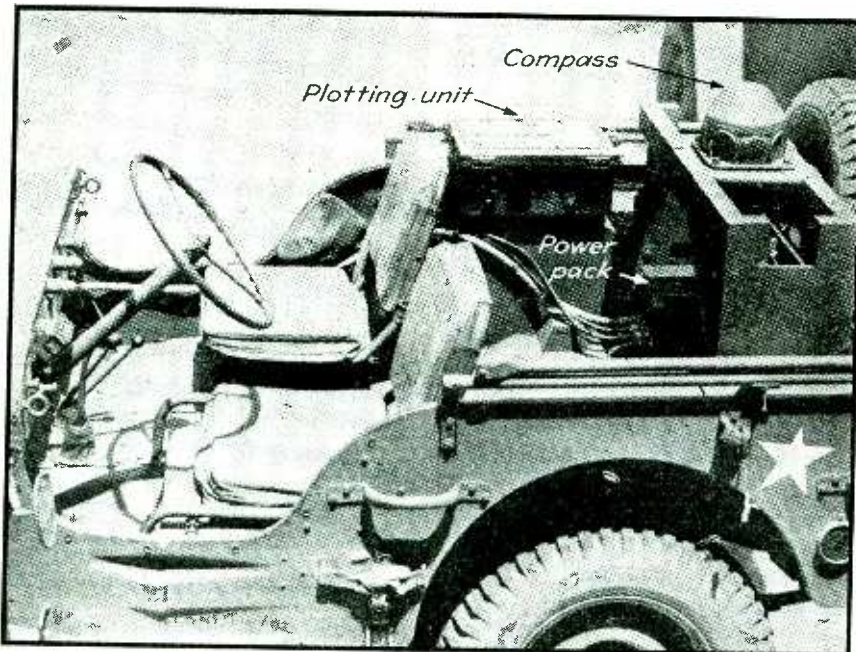

Land odograph, M-1, installed in a ¼-ton Army truck for road reconnaissance. Installations in this type of vehicle have given the most satisfactory performance so far because the compass can be mounted away from large magnetic masses

By D. J. FAUSTMAN

Captain, U. S. Army  
Applied Electronics Branch  
The Engineer Board  
Fort Belvoir, Virginia

**I**N military use the Odograph, Land, M-1 is installed in ¼-ton trucks (jeeps), to achieve two basic purposes: (1) Map making, or plotting the positions of objectives relative to a given base; (2) Navigation, or finding objectives whose position relative to a given base is known. These two functions are often combined.

Since the odograph automatically plots the course taken by a moving vehicle, unknown terrain is readily mapped by driving over it. In addition to obtaining maps of the roads, it is possible to plot locations of important points or objects either by driving the vehicle to the point, or estimating its distance and azimuth from a known location of the vehicle with a range finder. In transport or reconnaissance, a map having the desired course can be placed directly on the odograph map table and the trace formed by the plotting pencil can be watched to make sure the correct route is being followed.

When travelling to a given objective whose position is known relative to the starting point, it is possible to plot the objective on the odograph map table and then drive the vehicle in the general direction of the objective by following roads or other convenient routes. Since at any given time the relative locations of the objective and the vehicle are always shown on the odograph map, the vehicle can reach the objective even though the driver has no previous knowledge of the road net and terrain.

Mapmaking and navigational

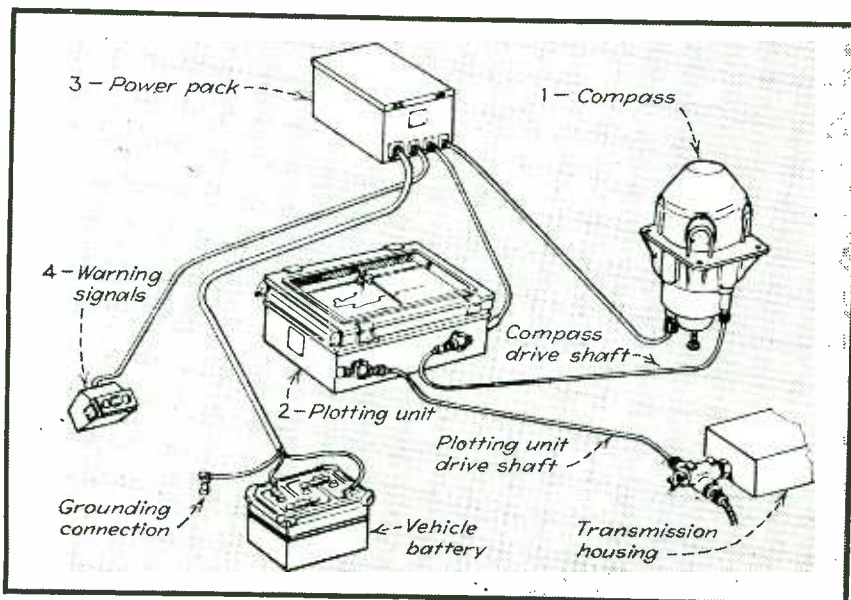

FIG. 1—Interconnection of units in an odograph installation. One warning signal blinks continually while the instrument is in operation. The other signal lamp flashes when the tracing pen is about to go off the map table, indicating that the vehicle is moving out of the area covered by the map being used



# for Land Navigation

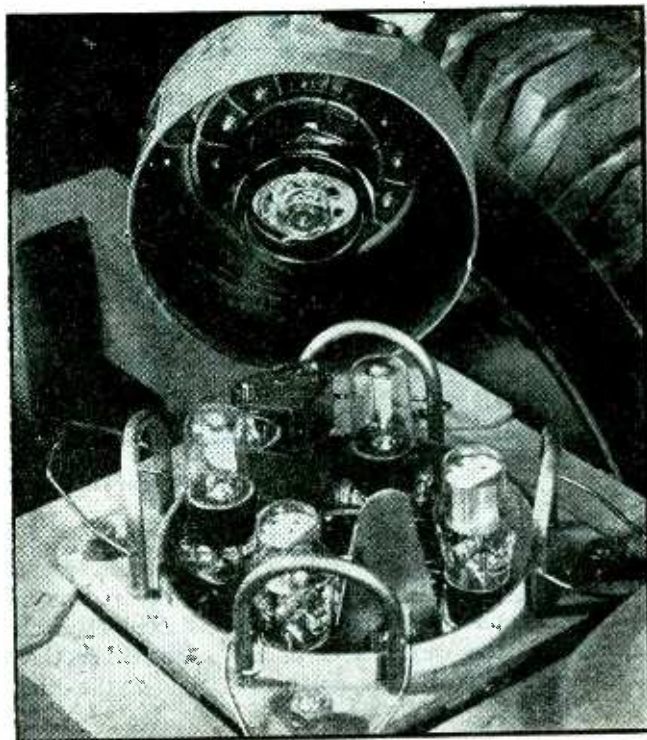
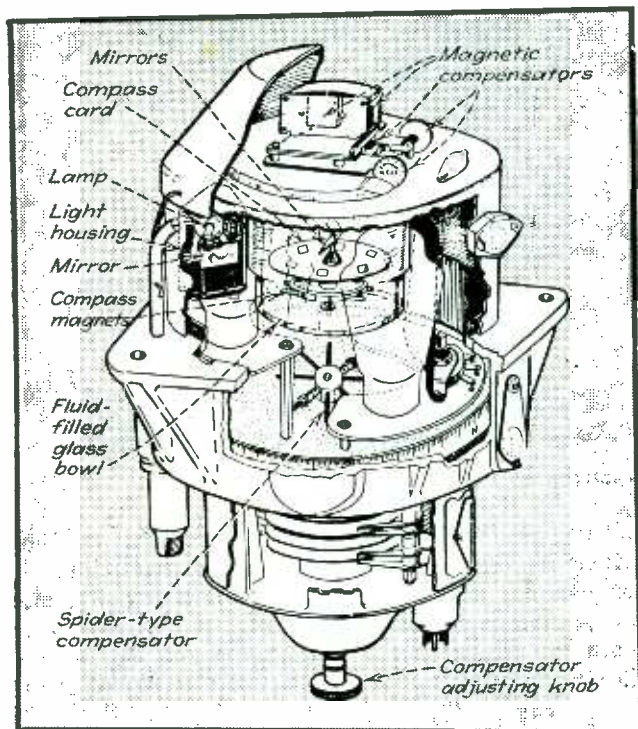

FIG. 2—Cutaway drawing of magnetic compass unit, which also contains the phototubes and thyratrons with their associated light source and deflecting mirrors

Lifting of compass bowl assembly exposes phototube-thyratron follow-up system that transfers compass indications to the plotting unit

functions of the odograph are often combined by using either the same or different instruments. Thus, maps made by one or more odographs can be used by other odograph-equipped vehicles. The unit is particularly valuable at night when guiding landmarks are not readily visible.

Some of the more important uses of the odograph may include tactical reconnaissance by armored and cavalry forces, navigation in unmarked terrain, rendezvous of units by various forces, surveys by field artillery forces, and reconnaissance and mapping by engineer forces.

The word odograph comes from the Greek, and literally means "writes the way" ("hodos" means "way" and "graph" means "write").

### General Description of Installation

The installation involves three component parts: (1) A magnetic compass with its electronic conversion system; (2) A plotting unit with its 8½ by 11-inch map table, tracing pencil and mileage dials;

(3) A power pack operating from the vehicle storage battery. Interconnections but not positions of these units are shown in Fig. 1; when installed, the plotting unit is positioned for accessibility and the compass for good magnetic conditions.

The plotting unit is actuated by the vehicle speedometer drive. The azimuth indication of the compass is transmitted to the plotting unit through the electronic control circuit. The total distance traveled and the proper directions are combined in the plotting unit to give a record of the course. A magnetic compass is used because of the relative complexity and size of a complete self-directing or north-seeking gyroscopic compass, and because the shock and rapid changes in direction involved in land operation are too severe for such an apparatus.

### Details of the Compass

In order to plot a course, both the distance traversed and the direction must be known. Direction sensing

in the odograph is accomplished by the compass, which has for its basic element a magnetic card assembly inclosed in a glass bowl, as illustrated in Fig. 2. The bowl is filled with a petroleum fluid which exerts a retarding influence on fins which project downward into it from the compass card proper. This gives damping to prevent erratic motion.

Mounted at the center of the card are two mirrors which are assembled at a dihedral angle having a horizontal axis as shown in Fig. 2. Response of the magnetic card to the influence of the earth's magnetic poles causes the card mirrors to face in a northerly direction immediately following any displacement of the compass housing.

The rest of the compass unit is related to the card only by optical means. A focused beam of light shines through the glass bowl onto the center point of the compass-card mirrors and is reflected back toward mirrors on the outside of the light housing, as shown in Fig. 3. The housing and the phototubes and thyratrons are mounted on a revol-



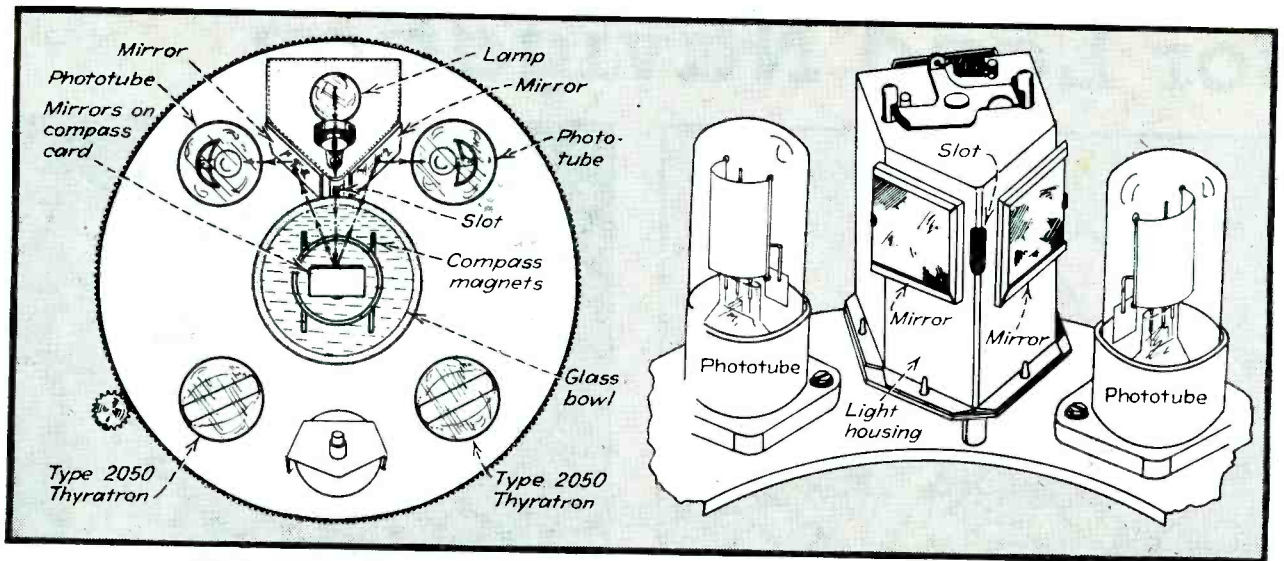

FIG. 3—Details of optical system employed in the compass unit

ing table geared to a flexible shaft which connects the compass with the plotting unit.

If this table is in correct alignment with the compass card, the light is reflected by the north-fac-

ing mirrors directly back into the aperture from which it comes. However, if the compass card is deflected by a change of heading of the vehicle, the beam of light strikes one or the other of the two mirrors

mounted on the outside of the light housing and is reflected onto the cathode of one of the two phototubes. This fires the related thyatron, which energizes one of the electromagnetically operated clutch

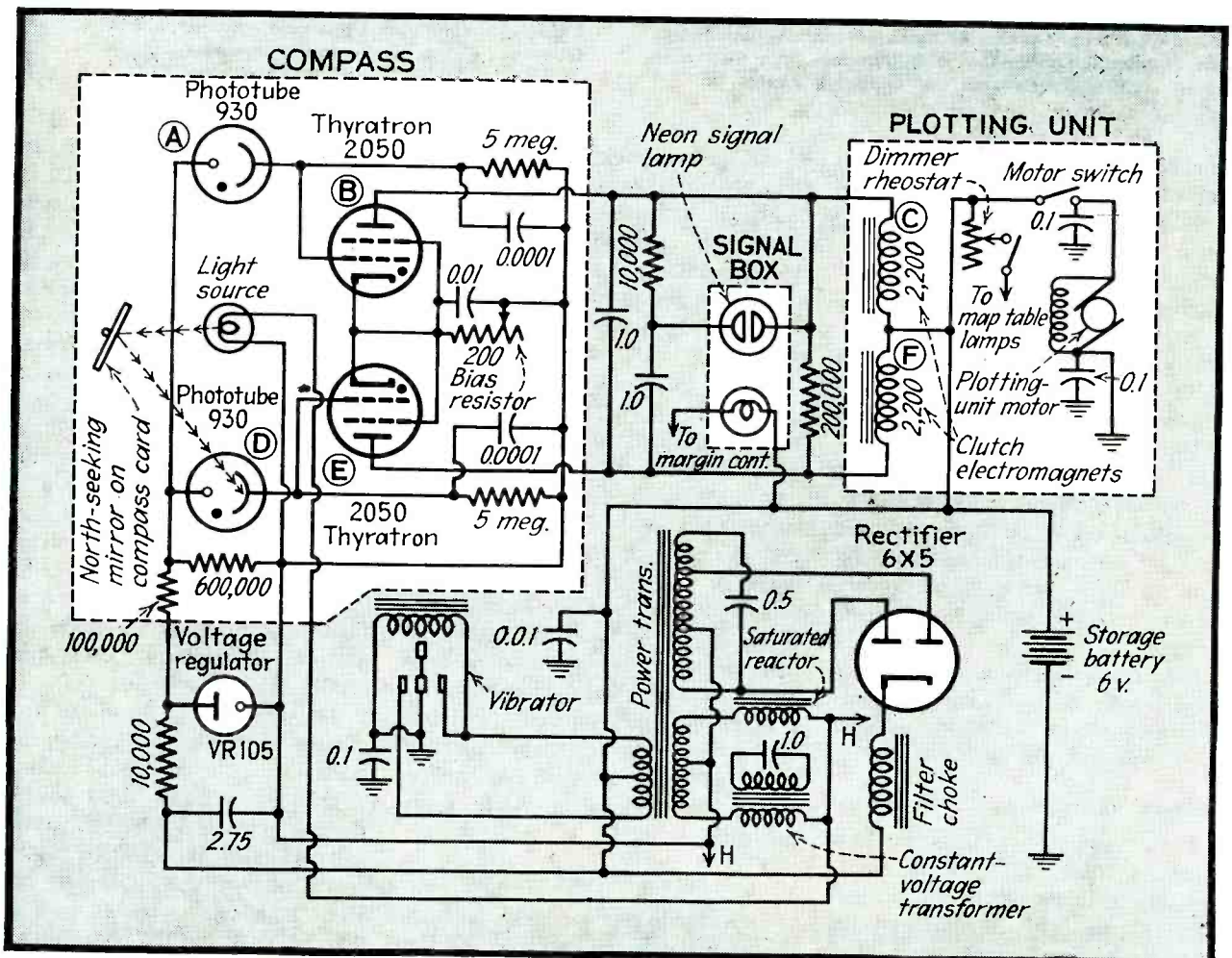

FIG. 4—Schematic circuit diagram of odograph. All parts not in the labelled boxes are in the power pack unit



yokes in the plotting unit and thereby causes the driving motor in that unit to rotate the flexible shaft until the compass table is back in alignment with the compass card.

#### Functioning of Electronic Circuit

The complete electronic circuit of the odograph is shown in Fig. 4. When plate voltage is first applied to the thyratrons by the power pack, no current is flowing through the 200-ohm rheostat serving as cathode bias resistance, and one of the thyratrons will fire. (Theoretically, both tubes should fire simultaneously, but in practice one tube will nearly always fire first since it is practically impossible to build two tubes with identical characteristics. If both do fire, the power switch is momentarily turned off.)

Assume that thyatron *B* fires first. It permits current flow through the bias resistor, providing a voltage drop that prevents the other thyatron from firing. Plate current of thyatron *B* flows through clutch electromagnet *C*, actuating the clutch and causing the plotting-unit motor to rotate the compass table in one direction. At the same time, the 1.0- $\mu$ f capacitor connected between the thyatron plates becomes charged to approximately 185 volts.

Rotation of the compass table in the direction associated with clutch *C* soon results in light being reflected from the compass card mirror onto phototube *D*, which controls nonconducting thyatron *E*. This light reduces the resistance of the phototube, allowing current to flow through the 5-Megohm resistor in the grid circuit of thyatron *E* in such a direction as to make the grid of *E* positive with respect to its cathode. As a result, this tube fires, and its plate-cathode voltage drops from 200 volts to 15 volts. For an instant both thyratrons are conducting, but the plate-to-plate capacitor discharges, placing a negative voltage of minus 170 volts on the plate of thyatron *B* long enough to block this tube and enable its grid to gain control.

Now thyatron *E* sends plate current through clutch *F*, causing the compass table to rotate in the opposite direction. Rotation continues until the light beam has swung over onto phototube *A*, triggering off

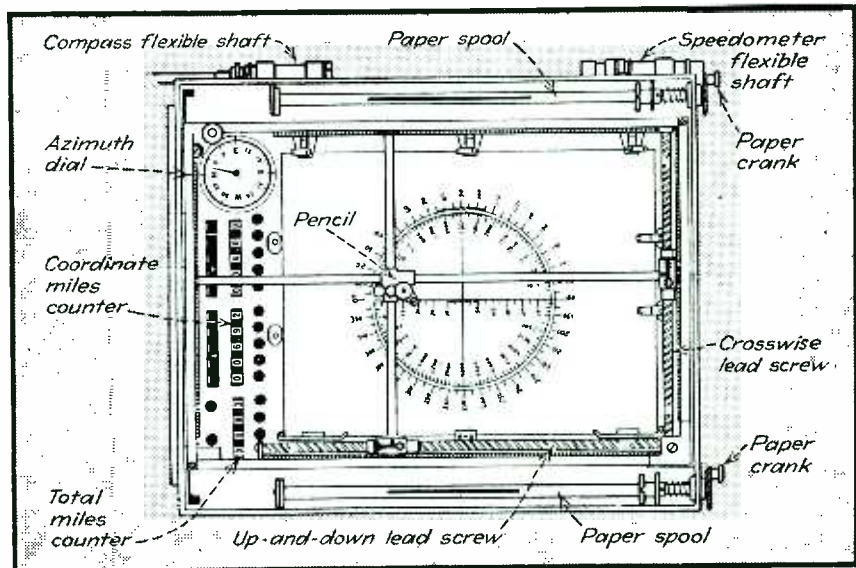
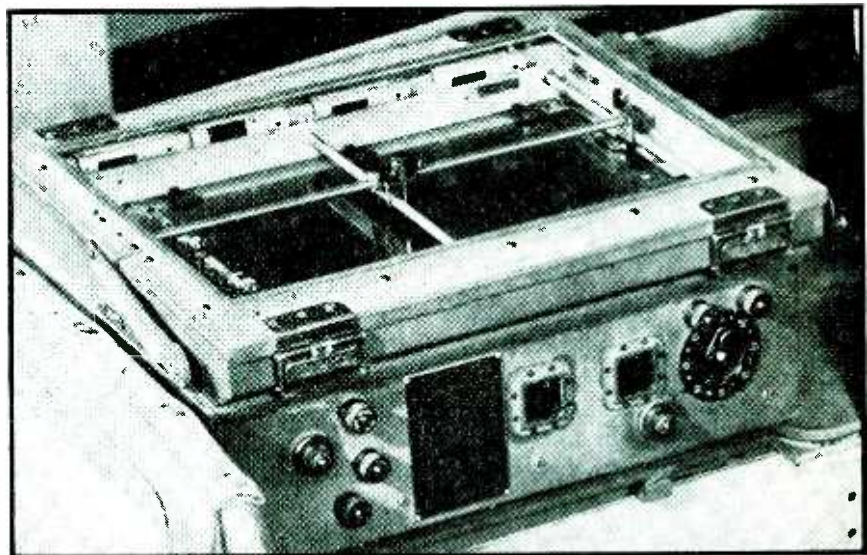

FIG. 5—Top view of plotting unit



Closeup of plotting unit with glass cover in place. A stubby automatic pencil is moved over the map table by the lead screws

thyatron *B* and thereby starting a new hunting cycle. This hunting action goes on continually while the odograph is in use, and circuit adjustments are normally such as to give a 5-degree hunt on each side of the compass course at a rate of approximately 100 to 115 complete cycles per minute.

The hunting action eliminates back-lash in the flexible shaft and associated gearing, and is also valuable in connection with the design of the plotting unit.

Sensitivity of the thyratrons is controlled by adjusting the 200-ohm bias rheostat. Since a tube will fire on zero grid bias, if the resistance of the bias rheostat is entirely out of the circuit the tube will fire re-

gardless of the signal from the phototube.

At the other extreme, if the entire 200 ohms is in the cathode circuit, the thyatron will never fire. In practice, a setting is used between these two extremes or at about 120 ohms. A lower resistance than this will tend to speed up the hunting cycles of the apparatus and reduce the angle of hunt, while higher resistance will have the opposite effect.

So that the operator of the vehicle can observe the operation of the unit, a signal box is located on the dashboard. It contains a  $\frac{1}{4}$ -watt neon lamp which, in normal operation, glows on alternate electrodes in synchronism with the hunting



speed of the system. On d-c power, only the negative element of the neon lamp glows. As shown in Fig. 4, this indicator lamp is connected so that a 1- $\mu$ f capacitor discharges through it with opposite polarity as the polarities of the two thyatron plates alternate in the hunting cycle. Thus one cathode of the neon lamp represents one of the thyratrons and its electromagnet, and the other cathode represents the other combination. Any variation in hunting action can be detected by observation of this signal lamp.

The signal box also contains an incandescent lamp which comes on to signal the approach of the tracing pencil to the margin of the plotting table. Other lights are provided for illuminating the map table, and can be controlled in brilliance by a dimmer resistance to provide operation on a brightly lighted street or, at the other extreme, in complete darkness where light must not be visible from the air.

Power for the recording odograph is obtained from the storage battery of the vehicle. When the main switch is closed, the drive motor in the plotting unit is energized directly by the battery. A power pack relay is also energized, connecting the vibrator to the battery. Power supply switching cir-

cuits are omitted from Fig. 4, for simplicity.

Two voltage regulators are incorporated in the power pack. A VR105 regulator tube keeps phototube anode voltages constant at approximately 105 volts despite battery voltage variations from 6 volts up to 8 volts. A resonant-type transformer in series with a saturated reactor holds the voltage of the light source and the thyatron heaters constant at 6.3 volts.

#### The Plotting Unit

The plotting unit shown in Fig. 5 has four functional purposes: To draw a map showing the course taken by the vehicle in which it has been installed, to register on counters the distances traveled by the vehicle, to actuate the azimuth dial indicator to show the direction the vehicle is traveling at a given instant, and to actuate the compass drive shaft for rotation of the compass table.

To achieve these purposes, the plotting unit must combine the information given by the odometer (the speedometer drive from the vehicle transmission) and by the compass in such a way that the motion is separated into north-south and east-west components. In other words, the plotting unit must perform the mathematical operation of integrating the components

of  $S \sin \alpha$  and  $S \cos \alpha$ , where  $S$  is the distance traveled and  $\alpha$  is the angle of azimuth or heading with respect to the reference direction—usually north—maintained by the compass. This operation is achieved by means of a sine-disk and two Scotch yokes controlling an elaborate transmission and gear train arrangement serving to couple the distance input from the speedometer drive to the two lead screws controlling the movement of the pencil on the map table.

Alongside the map table on the plotting unit is a dial or azimuth indicator which repeats the reading of the completely enclosed and remotely located compass. Also on the plotting unit are counter dials that algebraically add up the two components of motion. These are calibrated in miles to give the total distance north or south and east or west of the starting point at which they were set at zero. Another set of dials is used to give the total distance travelled by the vehicle.

The scale of the map produced ranges from 1:20,000 to 1:500,000, depending on which of the available gear ratios is selected.

The compass is installed far enough away from the generator and other electrical equipment and wiring of the vehicle so that magnetic deviation due to these sources is eliminated. However, it is necessary that auxiliary units such as radios installed near the compass be double-wired from the battery instead of grounded to the vehicle frame, to maintain balanced magnetic fields which cancel each other.

In a vehicle containing an odograph, standard magnetic conditions are established. There are fixed positions for all tools, metal containers, and other metal objects usually carried in the vehicle and armament, and loose metal objects must be kept at least three feet away from the compass. Parking of the vehicle for a period as long as overnight requires that it be kept 15 feet away from other vehicles or else excessive changes in magnetism will result, and any changes such as removing the top or the spare tire make it necessary to recheck the compensation.

Checking of the compensation of the odograph is done by driving the

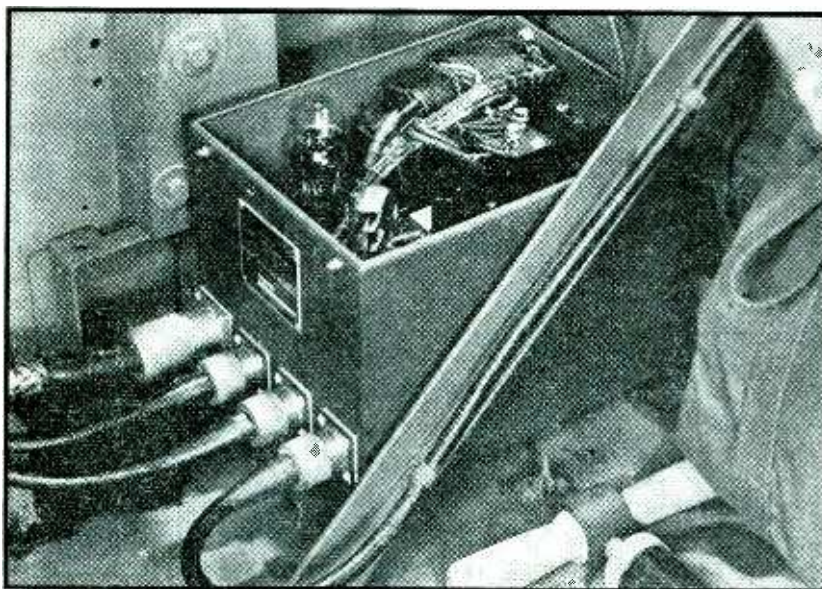

Power pack unit, containing voltage regulators, a type 6X5 rectifier, power transformer, vibrator, and reactors. Note rigid clamp for tire pump. All movable magnetic objects must be in fixed positions during operation of the odograph



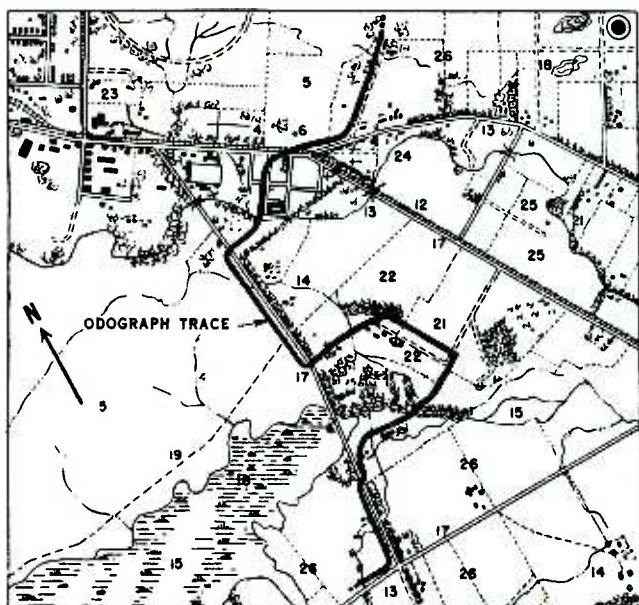

Use of odograph with accurately detailed map, to reach a given objective by traveling in its general direction as necessity dictates

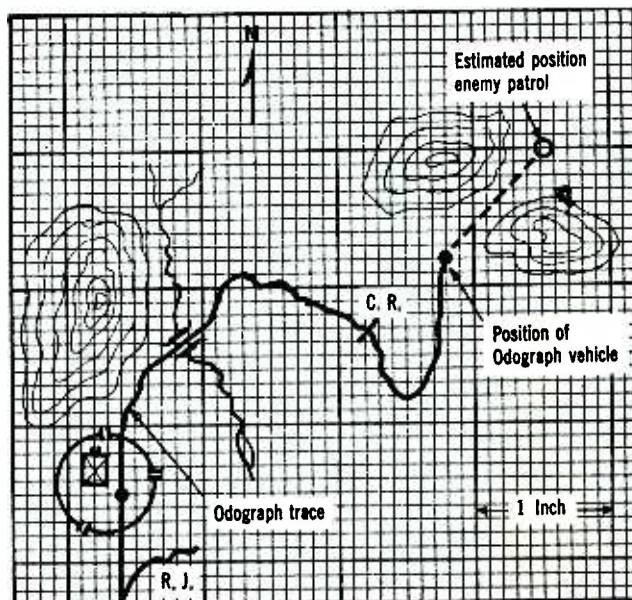

Use of odograph to plot on cross-section paper a rough map from which observed landmarks or enemy positions can be determined

vehicle approximately north by the azimuth dial for a distance of  $\frac{1}{4}$  mile or more. The vehicle is then turned around and driven back over the exact route to the starting point. A compensator adjusting wheel is then turned to rotate the azimuth dial through half as many degrees as the angle between the north- and south-drawn traces. This procedure is then repeated on an east-west heading. When the compensation is correct, the plotting unit will exactly retrace its path on a north-south run and an east-west run.

#### Sources of Inaccuracy

In use, the odograph is subject to distance error, direction error, and slope distance error. The first of these, distance error, will be at a minimum when the vehicle is operated on a hard surface with standard tires at the recommended air pressure. Changes in size of tires or operations on loose or rough surfaces introduce factors which reduce the accuracy of the unit. When a vehicle becomes stuck in sand or mud, the wheels may spin considerably before the vehicle gets out. In such a case the practice is to turn off the unit until the vehicle is free. The distance input error may amount to as much as two percent under bad conditions of weather or

terrain which cause an unusual amount of slippage.

Constant errors, such as those brought about by changes in tire sizes or pressures, are taken care of by a correction factor which is calculated by the average of a number of trial runs over accurately measured distances. After that, operations performed with the odograph are modified by the previously established correction factor being set in permanently as a scale change.

Direction errors are those caused by deviation from standard magnetic conditions in the vehicle, or by errors in compensation. Their correction is accomplished with appropriate compensators like those used on ship compasses. Slope-distance error is the difference between the actual distance traveled over the ground and the distance indicated by that projection on the map. In terrain with a great many hills, the odograph will show a slightly greater distance than the mileage scaled from the map. Unless an unusual series of up and down grades is involved, the error is small.

Overall accuracy on paved, unpaved, straight or crooked roads can be kept to one mile of error over 50 to 150 miles of travel. Over rough terrain, the error may be twice as great. Overall error is com-

puted by running a closed course and observing the distance by which the trace fails to return to the starting point.

#### Future Uses

As a rapid means of surveying unfamiliar territory for the purpose of making maps, locating most favorable highway or rail routes, or simply traveling to a desired destination without the aid of landmarks, the odograph offers many post-war commercial and governmental applications. Examples are for survey, mineral exploration or rescue work in sparsely populated territory, charting of possible oil-producing sites in the deserts, and exploring polar wastes with odograph-equipped vehicles.

#### Acknowledgements

Research and development work on the odograph was carried out by three agencies: The Department of Terrestrial Magnetism of Carnegie Institute in Washington, the Monroe Calculating Machine Co. of Orange, N. J., and the International Business Machines Corp. of Endicott, N. Y. The work was directed and coordinated by the War Department, The Office, Chief of Engineers, Engineer Board, Ft. Belvoir, Va. and the National Defense Research Committee.

# KLYSTRON OSCILLATORS

Operation of velocity-modulation oscillators is explained by correlating the theory of electron bunching with the performance of two coupled tuned circuits. Effects of resonator tuning, feedback and electrode voltages are analyzed and compared with experimental results obtained with a type 410-R/2K30 tube. Similarity to triodes is shown

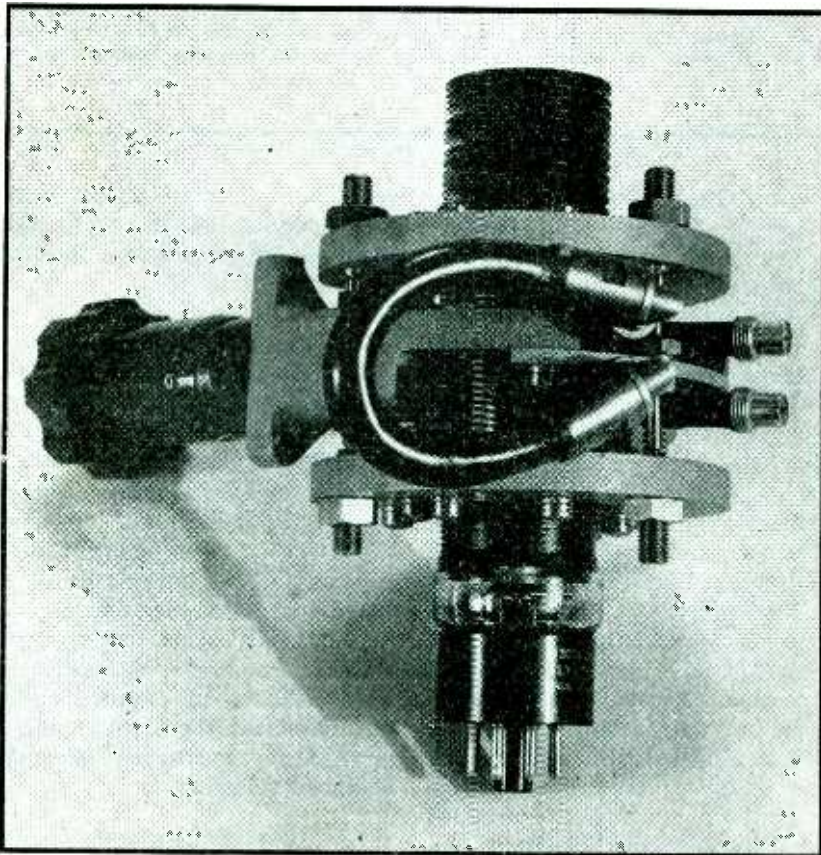

**Type 410-R/2K30 Klystron in tuning mount, showing coaxial feedback loop, coaxial output connectors, and cooling fins**

**T**HAT Klystron\* oscillators and other velocity-modulation tubes utilize electron transit-time effects to convert an electron beam into radio-frequency energy introduces certain characteristics which will undoubtedly be of interest to radio engineers. This dependence upon transit time in a Klystron

\* Registered Trademark of the Sperry Gyroscope Company, Inc.

oscillator causes the frequency of such tubes to be affected by the voltage applied to the tube. Another equally important characteristic which is due to the dependence upon the transit time is the occurrence of voltage modes, i.e., a Klystron oscillator will operate at certain voltages for a given adjustment of the other variables, but is inoperative in the voltage region be-

tween these modes.<sup>1</sup> In other respects these newer types of tubes are quite similar to the more familiar triode oscillators, and it will be convenient to use these comparisons in an explanation of the characteristics described above.

## Review of Bunching Theory

A brief review of the principle of electron bunching will be made in order to compare the characteristics of velocity-modulation tubes with the plate current characteristics of more conventional vacuum tubes. The results from an analysis of coupled tuned circuits can then be combined with the tube characteristics obtained from the electron bunching theory to explain the behavior of Klystron oscillators as adjustments are made of the tuning of the resonators, or as the voltage applied to the tube is varied. The effect of the phase and the magnitude of the feedback will also be considered, and the theoretical conclusions will be compared with experimental results obtained from

**By A. E. HARRISON**

*Sperry Gyroscope Company, Inc.  
Research Laboratories  
Garden City, New York*



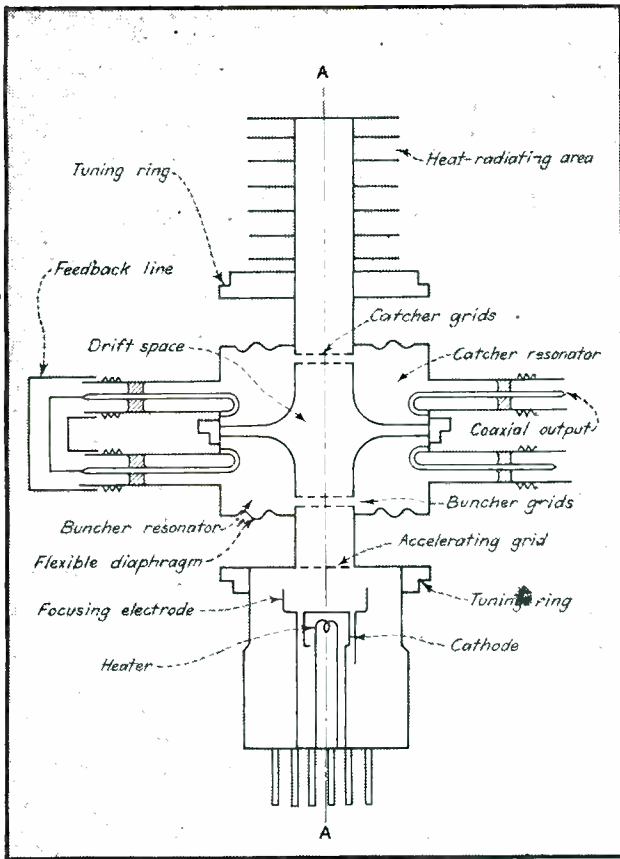
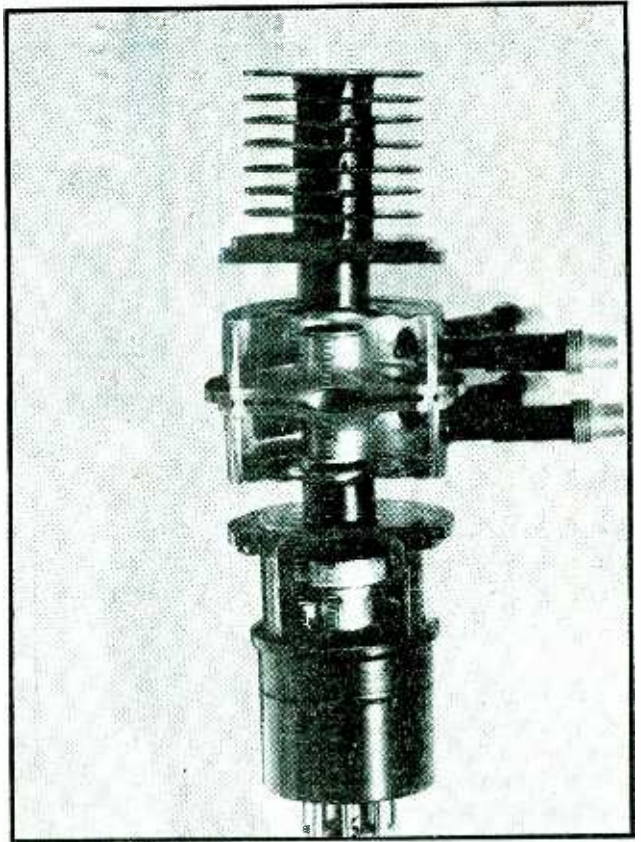

FIG. 1—Sectional view of the double-resonator Klystron of the type discussed in the text



Cutaway photograph of the interior of the 410-R/2K30 Klystron. The electron gun projects partly into the standard octal base

the operation of a type 410-R/2K30 Klystron used as an oscillator.

References to the theory of electron bunching have appeared in a number of publications<sup>2,4</sup>. A short review of this material will aid in the understanding of velocity-modulation tubes.

The sectional view of one type of Klystron which is shown in Fig. 1 will be used to explain the theory of electron bunching. The tube is a figure of revolution about the axis AA. An electron gun furnishes a beam of electrons which are accelerated in the space between the cathode and the accelerating grid. The beam continues to move beyond this grid with a high average velocity, and therefore the transit time of the electrons past the resonator grids corresponds to a small fraction of a cycle. The fact that the electrons are accelerated to a high velocity before being acted upon by a radio-frequency field overcomes one of the disadvantages of triodes at ultrahigh frequencies.

A radio-frequency field in the

buncher resonator produces an alternating electric field between the buncher grids. This field will speed up certain electrons and slow down other electrons which pass the buncher grids during a different part of the cycle. Consider a group of electrons which pass the buncher grids at the time when the field is changing from a retarding field to an accelerating field. An electron which leaves early in the cycle will be slowed down and will continue along the drift space with less than average velocity. An electron which passes the grids when the field is zero will not be affected and will continue with average velocity. Other electrons which leave later in the cycle will be accelerated and will move along the drift space with greater-than-average velocity. The variation of velocity will be small compared to the average velocity.

As a result of this velocity modulation, electrons which leave later in the cycle travel faster and overtake the slower electrons which left earlier in the cycle. The electron

beam is given an alternating component of its electron density as it travels along the drift space. This conversion process requires time; a transit time in the drift space corresponding to several cycles is typical. This transit time is quite important in the analysis of a Klystron oscillator, and the number of cycles corresponding to the transit time in the drift space will be designated by  $N$ . The electron bunches center around those electrons having average velocity, and therefore the value of  $N$  is determined by the average velocity. The following relations between the frequency  $f$ , drift distance  $s$ , transit time  $T$ , transit angle  $\tau$ , average velocity  $v_0$ , and the acceleration voltage  $E_0$  will be used frequently.

$$N = \tau/2\pi \quad (1)$$

$$N = fT = fs/v_0 \quad (1a)$$

The average velocity is related to the acceleration voltage by

$$v_0 = \sqrt{\frac{2e}{m}} E_0 \quad (2)$$

where  $e$  and  $m$  are the charge and

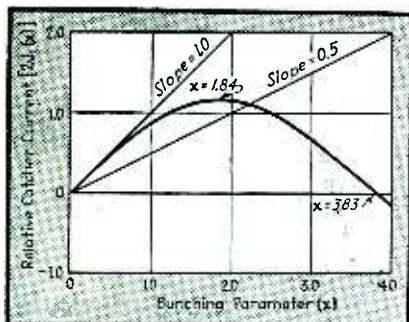

FIG. 2—Klystron bunching characteristic curve, analogous to  $E_r I_p$  curve of ordinary tubes

mass of an electron. Therefore Eq. (1a) can be rewritten

$$N = \frac{fs}{\sqrt{\frac{2e}{m} E_0}} \quad (1b)$$

The degree of bunching is directly proportional to the transit time in the drift space and is also proportional to  $E_1$ , the peak radio-frequency voltage between the buncher grids.  $E_1$  will also be referred to as the buncher voltage. The degree of bunching is expressed by a bunching parameter which will be designated  $x$ , whose value is given by

$$x = \pi N \frac{E_1}{E_0} \quad (3)$$

which with Eq. (1b) gives

$$x = \frac{\pi fs}{\sqrt{\frac{2e}{m} E_0}} \frac{E_1}{E_0^{3/2}} = \sqrt{\frac{m}{8e}} \frac{\omega s E_1}{E_0^{3/2}} \quad (3a)$$

The radio-frequency component of the bunched beam current, frequently called the catcher current, will be designated  $i_2$  and is related to the bunching parameter by the expression

$$i_2 = 2I_0 J_1(x), \quad (4)$$

where  $I_0$  is the d-c beam current and  $J_1$  is a Bessel function of the first order and first kind. This relation is illustrated by Fig. 2. The curve will be recognized as the Klystron bunching characteristic which has been described frequently.<sup>2,4</sup> This curve may be considered analogous to an  $I_p$  vs.  $E_0$  characteristic for a conventional vacuum tube where relative catcher current corresponds to  $I_p$  and the bunching parameter corresponds to  $E_0$ , although it differs in appearance because the out-

put reaches a maximum at a bunching parameter of 1.84, and then decreases as the bunching parameter increases. Underbunching refers to values of less than 1.84, usually very small values, and the term overbunching is used to describe the conditions when the bunching parameter is greater than this optimum value.

#### Phase Relations in a Klystron Oscillator

These principles of electron bunching will now be applied to the analysis of a Klystron oscillator. Any amplifier will oscillate if the gain of the tube is greater than unity and sufficient energy to overcome tube losses is returned from the output to the input in the proper phase.

An equivalent circuit for a Klystron oscillator is shown in Fig. 3. A multiple-grid tube is shown to emphasize the fact that only electron coupling exists between the elements of this type of velocity-modulation tube. The input and output circuits are completely isolated unless a means of feedback is supplied. The voltage between the grids of the buncher resonator is  $E_1$ , and this voltage is also indicated as the voltage across the input circuit of the equivalent diagram. A voltage  $E_2$  is shown across the output circuit, and represents the voltage between the grids of the catcher resonator.

A current  $i_2$  is shown flowing into the output circuit. This current represents the radio-frequency component of the bunched beam current, and is related to the input voltage  $E_1$  by Eq. (3) and (4). A

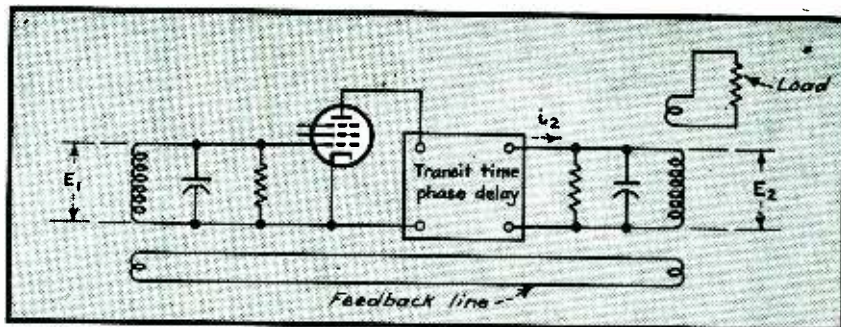

FIG. 3—Equivalent circuit for a Klystron oscillator. The pentode is used to indicate that only electron coupling exists between input and output in this velocity-modulated tube, of which the 410-R/2K30 is a typical example

four-terminal network is used to represent  $\tau$ , the transit-time phase-angle. A means of feedback is indicated as a link circuit between the output and input circuits, and an output load is also coupled to the circuit.

Oscillation will occur when the sum of the phase angles around the complete loop is equal to some integral number times  $2\pi$  radians, provided the magnitude of the feedback is sufficient to maintain oscillation. J. R. Ragazzini has suggested the diagram in Fig. 4 to illustrate these phase angles and the relations between them. The electrons which passed the buncher grids at zero phase (i.e., when  $E_1$  was zero and changing from deceleration to acceleration) become the center of the bunch. These electrons correspond to a maximum value of the electron current and arrive at the catcher grids after a phase delay equal to  $\tau$ . This phase delay corresponds to slightly less than  $2\frac{1}{4}$  cycles in Fig. 4 and is indicated by an oblique line connecting the zero axes of the  $E_1$  and  $i_2$  curves.

In order to transfer maximum energy to the resonator field, the electrons in the bunch must pass the catcher grids when the resonator field is a maximum and in a direction which will decelerate the electrons. The current in the equivalent circuit must be in phase with the voltage if maximum power is to be transferred. This means that  $i_2$  is a minimum when the electron current is a maximum. The transit phase angle  $\tau$  corresponds to the phase between a zero value of  $E_1$



and a negative peak of  $i_2$  and therefore the phase angle between  $E_1$  and  $i_2$ , introduced by the transit time and bunching considerations, is equal to  $(\tau + \pi/2)$ .

A phase angle  $\phi_2$  between  $i_2$  and the catcher voltage  $E_2$  is shown because  $E_2$  need not be in phase with  $i_2$ . However, this phase angle is not used in this analysis of oscillator theory. The angle  $\phi$  represents the phase between  $i_2$  and  $E_1$ , introduced by the two coupled circuits. The phase relation which must be satisfied for oscillation can be written

$$\tau + \pi/2 + \phi = 2\pi n \quad (5)$$

where  $n$  must be an integer. The value of  $n$  in Fig. 4 is 3 cycles. If  $\tau$  is changed by varying the acceleration voltage, a corresponding change in  $\phi$  must occur.

#### Coupled Circuit Theory

An analysis<sup>5</sup> of the phase relations in two tuned coupled circuits shows that  $\phi$  will change if the frequency of oscillation is varied. These conditions explain the fact that the frequency of a velocity-modulation oscillator varies when the acceleration voltage is changed,

in order to maintain the necessary phase relations.

The equivalent circuit in Fig. 3 shows that a Klystron oscillator may be considered as two parallel resonant coupled circuits, fed by a constant-current source  $i_2$ . The analysis of such a circuit to obtain the phase and magnitude of the voltage across the primary and secondary can be obtained, with some slight modifications, from radio engineering handbooks and other sources.<sup>5,6,7</sup> This information about the phase and magnitude of the feedback can then be combined with the bunching characteristic of a Klystron tube, as illustrated by Fig. 2 and Eq. (4), to obtain a prediction of the output characteristics of a Klystron oscillator as the acceleration voltage is varied.

Certain assumptions will be made to simplify the analysis. The resonant frequencies of both circuits will be considered identical; this assumption will make the characteristics symmetrical with respect to frequency. A feedback line of zero length will be assumed so that the analysis for lumped constant circuits at low frequencies can be used.

The  $Q$  of the two circuits will not be equal because one circuit has been loaded. The  $Q$  of the output circuit in Fig. 3, which corresponds to the primary of the two coupled circuits, will be considered half as great as the  $Q$  of the input circuit, which corresponds to the secondary. Calculations will be carried out for two degrees of coupling between the two circuits. In one case the coupling will be assumed five times greater than the value for critical coupling, and critical coupling will be assumed for the second case.

Curves of primary and secondary voltage as a function of frequency are usually given in the reference texts<sup>5</sup>. The curves in Fig. 5 will be recognized as typical illustrations of these characteristics for two coupled tuned circuits. Ratios of  $E_1/i_2$  and  $E_2/i_2$  are plotted so that unit coordinates may be used, and the maximum ratio of  $E_1/i_2$  is indicated by a value of unity. Increasing the value of  $i_2$  will increase the value of voltage across the circuit but will not affect the ratio. The phase relation between  $i_2$ , the constant-current source in

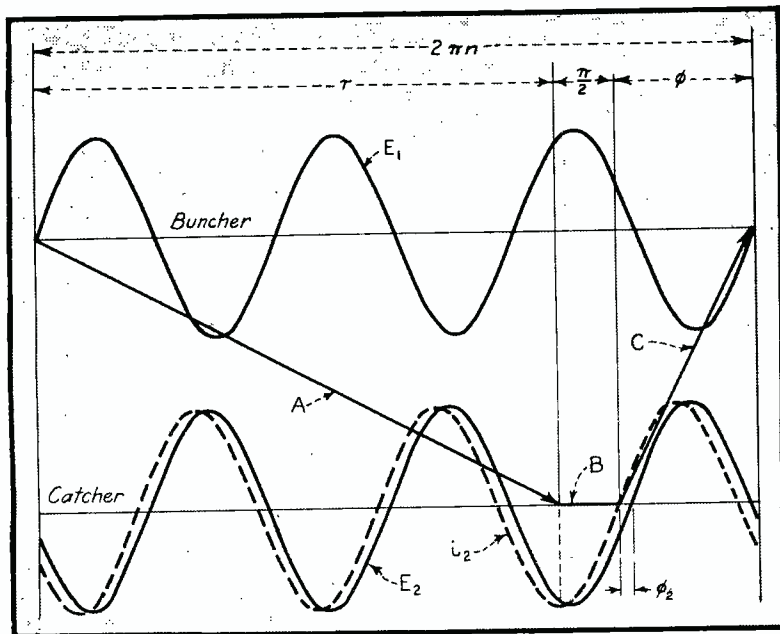

FIG. 4—Phase relations in a Klystron oscillator. The phase change from buncher to catcher along the electron beam drift is represented by vector A. The phase shift between the bunched electron stream and the catcher resonator-field current component is represented by vector B. The phase shift due to the coupling from the catcher to the buncher is represented by vector C. The transit-time phase-angle is represented by the angle  $\tau$

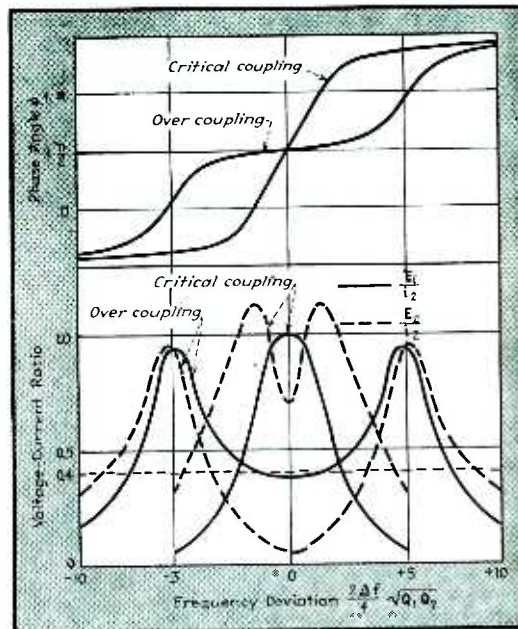

FIG. 5—Phase and voltage relations in coupled circuits where the primary  $Q$  is half the secondary  $Q$ . The over-coupling condition is for five times critical coupling. The phase angle at the top of the graph is that between primary (catcher) current and secondary (buncher) voltage

the analysis, and secondary voltage  $E_2$  is also shown as a function of frequency.

The form of the curves in Fig. 5 is not ideally suited to the analysis of a Klystron oscillator where the frequency is dependent upon the beam voltage as well as upon the tuning. To examine the behavior of such an oscillator as the acceleration voltage is changed, it will be convenient to replot the frequency as a function of voltage. This step is illustrated by the frequency vs. voltage curves in Fig. 6, which correspond to Fig. 5.

The previous discussion has concerned only the coupled circuit theory. It is necessary to relate these results to the bunching characteristic of a Klystron tube, shown in Fig. 2, in order to complete the analysis and obtain the power output curves shown in Fig. 7.

The Klystron oscillator characteristic illustrated by Fig. 8, which has been obtained by modifying the presentation of the information in Fig. 2, has been used to convert the data in Fig. 6 into the Klystron

output characteristics in Fig. 7. Frequency curves have been transferred directly to the corresponding figures, for the values of acceleration voltage which permit oscillation.

#### Oscillator Characteristics

Calculations for the procedure described briefly in the preceding paragraph are quite simple, and the steps will be outlined in detail. The relation between voltage and frequency is obtained by evaluating  $\tau$  in terms of  $E_0$ , the acceleration voltage, and correlating the values of  $\tau$  with values of  $\phi$  in Fig. 5. Separate calculations must be made for each value of coupling. Values of  $\tau$  for chosen values of  $E_0$  are tabulated from

$$\tau = \frac{2\pi fs}{\sqrt{\frac{2e}{m} E_0}} \quad (6)$$

which is obtained by equating Eq. (1) and (1b). The percent change in frequency is small, and therefore all factors except  $E_0$  may be lumped into a single constant. Corresponding values of  $\phi$  are obtained by sub-

stituting the values of  $\tau$  into Eq. (5). These values of  $\phi$  are used to determine the frequency which corresponds to the acceleration voltage chosen for the tabulation. Then these data are replotted to give the frequency curves in Fig. 6, and the values of  $E_1/i_2$  and  $E_2/i_2$  are transferred from Fig. 5 to Fig. 6, using this  $f$ -vs.- $E$  characteristic.

The necessary correlation between the feedback circuit and the bunching characteristic of a Klystron tube (see Fig. 2), can be obtained by evaluating  $E_1/i_2$  in terms of the bunching parameter defined by Eq. (3) and (4). Equation (3), which relates  $E_1$  and the bunching parameter  $x$ , can be rewritten

$$E_1 = E_0 x / \pi N \quad (7)$$

Substitution of Eq. (7) and (4) in the ratio  $E_1/i_2$  gives

$$\frac{E_1}{i_2} = \frac{E_0}{\pi N I_0} \frac{x}{2 J_1(x)} \quad (8)$$

The ratio  $E_0/I_0$  may be replaced by  $R_0$ , which is known as the beam resistance of the tube. Equation (8) can be rewritten

$$\frac{x}{2 J_1(x)} = \frac{\pi N I_0}{E_0} \frac{E_1}{i_2} = \frac{\pi N E_1}{R_0 i_2} \quad (9)$$

FIG. 6—These curves are for the same conditions as in Fig. 5 but are plotted against accelerating voltage, which is related to frequency by Eq. (5) and (6). The upper curves give the relative frequency deviation vs. accelerating voltage

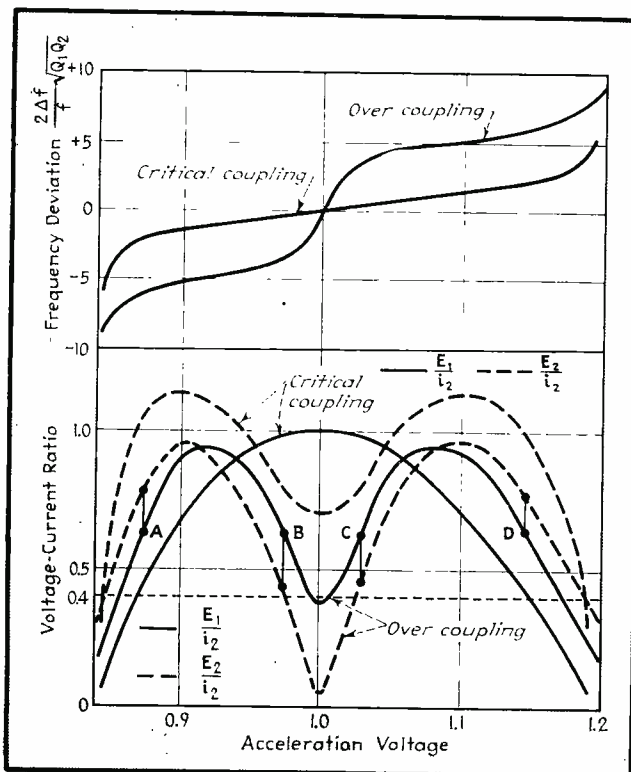
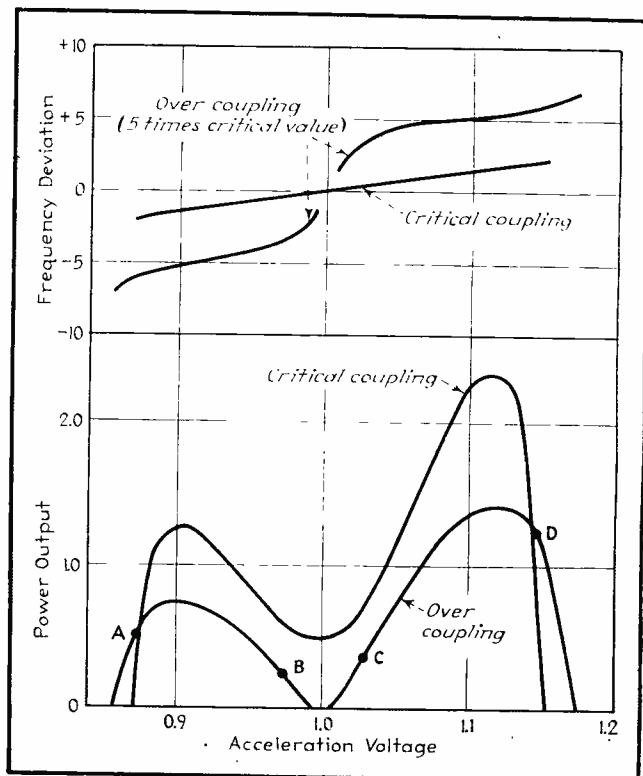

FIG. 7—Taking the power output as proportional to the catcher voltage squared, these curves are obtained from the curves of Fig. 6. Note the linearity between frequency deviation and accelerating voltage for the critical coupling condition





These equations furnish the correlation between the feedback circuit characteristic which determines  $E_1/i_2$ , and a modification of the bunching parameter.

The significance of the factor  $x/2J_1(x)$  can be illustrated by reference to Fig. 2. This factor is merely another form of bunching parameter. Any line from the origin with a slope less than unity will intersect the curve at some point other than zero and less than  $x = 3.83$ , where the Klystron output again becomes zero. A line with a slope of 0.5 is shown, and this line intersects the curve at a point somewhat beyond the maximum. Another line with a slope of unity is tangent to the curve at the origin. This line does not intersect the curve, and represents the conditions when oscillations start. This starting-characteristic line with a slope of unity corresponds to a unity value  $x/2J_1(x)$ . Lines with slopes less than unity correspond to values of  $x/2J_1(x)$  greater than unity, since the slope of a line is equal to the reciprocal of  $x/2J_1(x)$ .

Each point on the curve in Fig. 2 corresponds to some operating condition for a Klystron oscillator. It will be convenient to replot  $2J_1(x)$ , which is proportional to  $i_2$ , as a function of  $x/2J_1(x)$ . This modification of the bunching characteristic makes it possible to obtain the value of  $i_2$  from a value of  $E_1/i_2$ , since Eq. (9) shows that  $x/2J_1(x)$  is proportional to  $E_1/i_2$ . Figure 8 shows such a characteristic, and has been obtained by plotting the ordinate of a point on the curve in Fig. 2 as a function of the reciprocal of the slope of a line drawn from the origin to that point on the curve. The curve in Fig. 8 is used to obtain the value of  $E_2$  from the information in Fig. 6.

Figure 8 is used to obtain data for the curves of power output vs. acceleration voltage in Fig. 7 in the following manner. Typical operating conditions would determine the starting conditions for the Klystron oscillator. We will assume that  $E_1/i_2$  equal to 0.4 corresponds to these starting conditions. For this assumption, Eq. (9) can be rewritten

$$x/2J_1(x) = 2.5 E_1/i_2 \quad (10)$$

The dash lines in Fig. 6 represent the starting conditions for the Klystron oscillator. The acceleration voltage corresponding to the intersection of the dash line and the  $E_1/i_2$  curve in Fig. 6 is noted. The output for this value of acceleration voltage is zero. A higher value of  $E_1/i_2$  for a different acceleration voltage is substituted in Eq. (10) to obtain the value of  $x/2J_1(x)$ , and a corresponding value of  $2J_1(x)$  is determined from Fig. 8.

The beam current  $I_0$  is computed from the 3/2 power law and the acceleration voltage. The value of  $i_2$  is then obtained by substitution of  $I_0$  and  $2J_1(x)$  in Eq. (4).  $E_2$  is calculated from  $i_2$  and the value of  $E_2/i_2$  from Fig. 6 corresponding to

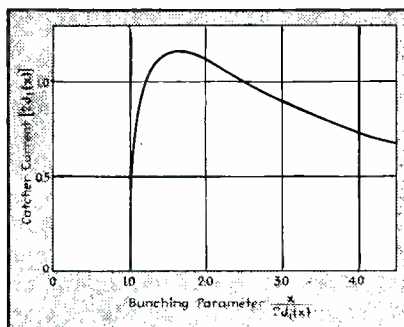

FIG. 8—A change of abscissa converts the bunching characteristic of Fig. 2 to this more convenient form

the acceleration voltage which was chosen. The power output is proportional to the square of  $E_2$  and is plotted as such in Fig. 7. The frequency curve is transferred directly from Fig. 6 to Fig. 7.

The two sets of theoretical output curves in Fig. 7 are typical of two different types of Klystron oscillators. The curves for five times critical coupling represent a tightly coupled oscillator and exhibit the familiar pair of voltage modes. The maxima of the two modes occur when the frequency has values corresponding approximately to  $\phi = 0$  and  $\phi = \pi$  in Fig. 5. If these values of  $\phi$  are substituted in Eq. (5), the value of  $\tau$  is given by

$$\tau \cong 2\pi (n \pm 1/4) \quad (11)$$

Equation (11) is often stated in the form, "The number of cycles of oscillation during the transit of an electron from the buncher to the catcher is an integer plus or minus one quarter." It should be noted

that this statement is a special case which does not apply to all Klystron designs.

The more loosely coupled oscillator illustrated by the critical coupling curves of Fig. 7 has the two modes merged into continuous output. The latter characteristic is typical of the type 410-R/2K30 Klystron oscillator, and differs from overcoupled types which exhibit two separate families of voltage modes.

#### Comparison of Experimental Results with Theory

Experimental curves for a number of voltage modes in a type 410-R/2K30 Klystron oscillator are shown in Fig. 9 and 10. These curves were obtained by a dynamic method which eliminated tuning changes due to thermal variations caused by changing the power input to the tube. The similarity of Fig. 9 to the theoretical curve in Fig. 7 for critical coupling indicates that the assumptions used in obtaining the theoretical curve are reasonably good. The equal height of the two peaks of each mode in Fig. 9 was obtained by purposely detuning the tube to produce the flattest characteristic, and does not represent a deviation from theory. Detuning the tube in the opposite direction emphasizes the higher voltage peak and produces maximum power output and efficiency. This effect is illustrated by Fig. 10.

Note that the frequency deviation characteristic in Fig. 9 is almost linear with accelerating voltage over the useful range of output. This characteristic is gained by some sacrifice in power. (Compare with Fig. 10). Because of this, the type 410-R/2K30 Klystron is quite useful as an oscillator in frequency-modulation circuits. The frequency modulation is obtained by varying the acceleration voltage. However, considerable modulation power is required.

#### Effect of Tuning the Klystron

The effect of tuning the Klystron oscillator, as described in the discussion of the output characteristics in Fig. 9 and 10, can be derived from circuit theory but the details will be omitted. Certain important conclusions can be obtained from a qualitative analysis of the over-

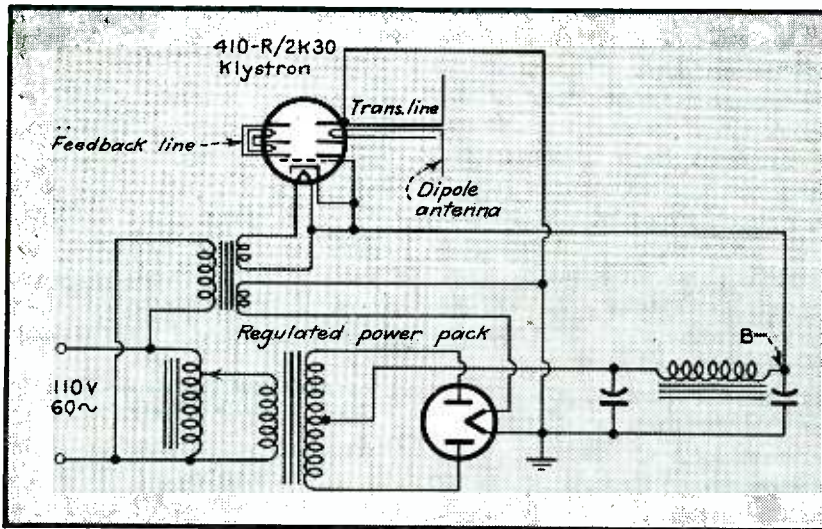

Basic Klystron oscillator circuit, showing the extreme simplicity of the voltage requirements. Like all electron oscillators the frequency is affected by the power pack voltage, but in the case of the Klystron the effect is large (shown in Fig. 9). A coaxial transmission line delivers the uhf energy from the oscillator to the load, which is an antenna in this case

coupled case, and the general nature of these results applies equally well to the behavior of the type 410-R/2K30 Klystron. However, electron bunching theory must be considered in some detail before returning to a discussion of the effect of tuning.

One of the principal factors in the explanation of Klystron oscillator power output characteristics is introduced by the variation of  $i_b$ , the radio-frequency component of the bunched beam current, as the value of  $E_1$  is increased. Figure 2 and Eq. (3a) and (4) illustrate this variation of the radio-frequency current. The term overbunching is applied when the current is de-

creased from the maximum value because the voltage  $E_1$  is too great. It is more important to analyze overbunching in a diagram similar to Fig. 8, since  $x/2J_1(x)$  is more useful than the bunching parameter  $x$  in analyzing an oscillator. Optimum bunching in Fig. 8 corresponds to the maximum in the curve when  $x/2J_1(x)$  is equal to 1.59, which corresponds to a value of 0.635 for  $E_1/i_b$ . Larger values of  $E_1/i_b$  cause overbunching.

Overbunching does not necessarily reduce the output. Note in Fig. 6 that the ratio  $E_2/i_b$  is increasing rapidly at the acceleration voltages corresponding to points A, B, C,

and D, which represent the ratio of  $E_1/i_b$  required for optimum bunching. Increasing the ratio of  $E_1/i_b$  above the optimum value does not reduce  $i_b$  very rapidly, since  $i_b$  is proportional to  $2J_1(x)$ , and Fig. 8 shows that this factor decreases slowly beyond the point of optimum bunching. The increased  $E_2/i_b$  ratio allows the output to increase in the region between A and B, also in the region between C and D. Corresponding points have been marked on Fig. 7 to illustrate this effect.

Any deviation from identical tuning will decrease one peak in the  $E_1/i_b$  curve when the losses in the two resonators are unequal. The other peak may remain approximately the same, or it may increase slightly, depending upon the ratio of the losses in the two resonators. The effect of detuning the buncher resonator to a lower frequency, leaving the catcher resonator tuned to the frequency corresponding to the identical tuning represented in Fig. 5, is illustrated in Fig. 11 for the case when the losses in the catcher resonator are twice as great as the losses in the buncher resonator. Both patterns are moved in the direction of lower frequency and the patterns are no longer symmetrical. The higher-frequency peak in  $E_1/i_b$  is reduced and the corresponding peak in  $E_2/i_b$  is increased.

As a result of the detuning, the degree of overbunching in the high-frequency mode will be less and  $i_b$  will increase. Since  $E_2/i_b$  has also

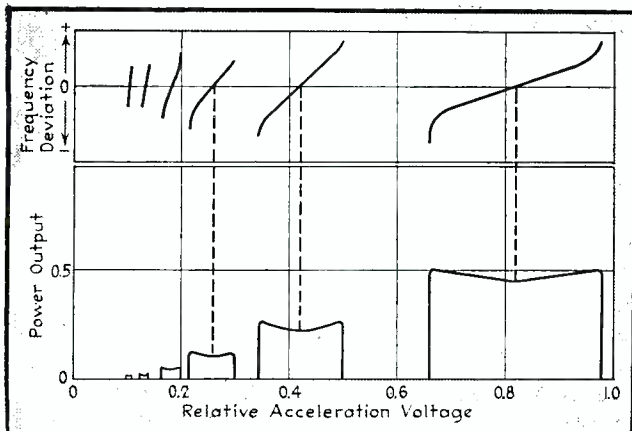

FIG. 9—Experimental characteristics for 410-R/2K30 Klystron oscillator with critical coupling. The tuning was adjusted to give flat output. Compare these curves with the critical coupling curves of Fig. 7

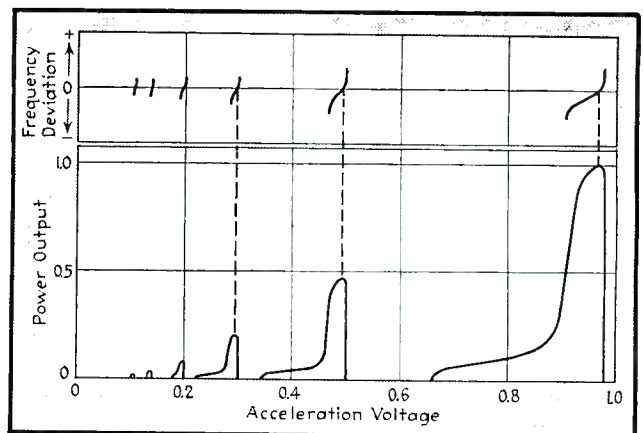

FIG. 10—By adjusting the tuning, the output can be made a maximum. This has been done to obtain these experimental curves. One peak is accentuated at the sacrifice of the other. Operation is more critical of accelerating voltage



been increased by the detuning, the output of this mode will increase considerably. In contrast, the over-bunching remains about the same in the lower-frequency mode but the ratio of  $E_2/i_2$  is decreased, and therefore the output of this mode decreases slowly. However, the ratio of  $E_1/i_1$  for the higher-frequency mode can be reduced to the value corresponding to the starting conditions while the lower-frequency peak in  $E_1/i_1$  remains greater than this value. This relation means that continued detuning of the buncher resonator to a lower frequency causes the higher-frequency mode to increase at first, then disappear before the lower-frequency mode is eliminated. The frequency of the higher-frequency mode approaches the frequency of the tuning of the catcher resonator. The lower-frequency mode can be accentuated by detuning the buncher resonator to a higher frequency than the tuning of the catcher resonator.

#### Effect of Length of Feedback Line

The previous discussion has been based upon a zero length of feedback line. This assumption obviously does not apply to a type 410-R/2K30 Klystron, since an external feedback line of considerable electrical length must be used. The problem is complicated when the line is not terminated with its characteristic impedance. However, it is fairly satisfactory to assume that the phase shift in the line can be represented by an angle  $\phi_L$ , and rewrite Eq. 5 in the form

$$\tau + \frac{\pi}{2} + \phi + \phi_L = 2\pi n. \quad (12)$$

The logical conclusion from Eq. (12) would be that the acceleration voltage, which determines  $\tau$ , could be arbitrarily chosen by adjusting the length of the feedback line. Some choice of the operating voltage is permitted by such an adjustment. However, the feedback line is not usually matched, and certain line lengths prevent operation at the frequency which may be required. Therefore, it is not always possible to correct for changes in the transit time by changes in the length of the feedback line. As a result, there are some regions of acceleration

voltage where oscillation can not be obtained by any simple adjustment of the tube or feedback line.

All of the previous discussion is influenced by the output load which is connected to the tube, but this effect has been included implicitly in the assumption that the losses in the output resonator were twice as great as the losses in the buncher resonator. This assumption is equivalent to the statement that the resonators are identical and that the power transferred to the load is equal to the power losses in the output resonator itself.

#### Power Output

Data have been obtained which relate the output power which can be transferred from a Klystron oscillator to a given load resistance. These data are shown by the points in Fig. 12. The curve in Fig. 12 represents a constant-current source feeding a parallel resonant circuit with internal losses and a coupled load. The theoretical curve was made to coincide with the observed maximum output from the Klystron oscillator. Zero load resistance in this illustration corresponds to a light load, i.e., the load resistance is an equivalent series resistance. The agreement between the experimental points and the theoretical curve in the region beyond the maximum output fails because the Klystron does not oscillate when the load becomes too great.

#### Conclusions

It is apparent that the characteristics of velocity-modulation tubes must be considered carefully when equipment is designed to use these tubes. In some respects these tubes are similar to the more familiar types of vacuum tubes. They can be used as oscillators or amplifiers, and when equipped with the proper resonators, they can also be used as frequency multipliers. Klystron oscillators are more dependent upon the voltage applied to them than triode vacuum tubes, and both frequency and output will vary if the voltage is changed. Operation is possible at a number of different voltage modes, but oscillation does not occur in the region between these modes. When these character-

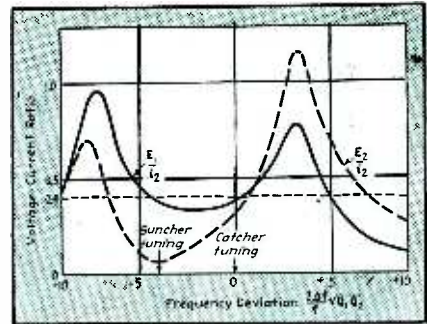

FIG. 11—Detuning the buncher to a lower frequency shifts the peaks to lower frequencies. Except for this detuning of the buncher, these curves represent the same conditions as those illustrated by the over-coupling curves of Fig. 5

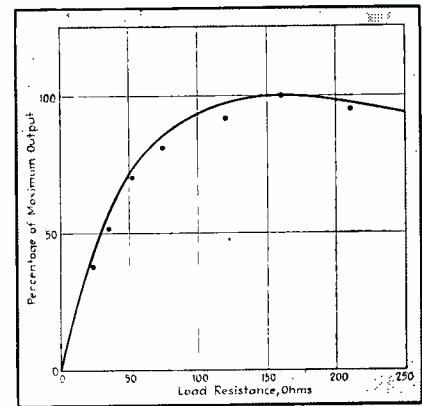

FIG. 12—Theoretical output curve and experimental output points measured for the 410-R/2K30 Klystron oscillator

istics are either used or circumvented in the design of the equipment, these factors do not limit the application of the tubes and actually make it possible to accomplish results which are difficult to achieve in any other way.

#### REFERENCES

- (1) Varian, R. H., and Varian, S. F. A High-Frequency Oscillator and Amplifier. *Jour. Appl. Phys.* 10, No. 5, p. 321-327. May 1939.
- (2) Webster, D. L., Cathode Ray Bunching. *Jour. Appl. Phys.* 10, No. 7, p. 501-508, July 1939.
- (3) Webster, D. L., The Theory of Klystron Oscillations. *Jour. Appl. Phys.* 10, No. 12, p. 864-872, Dec. 1939.
- (4) Harrison, A. E., "Klystron Technical Manual." Sperry Gyroscope Company, Inc. Great Neck, N. Y., 1944.
- (5) Terman, F. E., "Radio Engineer's Handbook." McGraw-Hill Book Co., New York, 1943.
- (6) Aiken, C. B., Two-Mesh Tuned Coupled Circuit Filters. *Proc. IRE*, 25, No. 2, p. 230-272, Feb. 1937.
- (7) Ragazzini, J. R., Ultra-High Frequency Techniques. Lecture Notes, Columbia University Bookstore, 1943.

# Dual Time

Ingenious method of automatically broadcasting an hourly chime signal and synchronizing a remote transmitter clock with the studio clock. Both operations are initiated by a pulse from a Western Union master clock line without making any direct connections to the circuit

By **RUSSELL D. VALENTINE**

*Chief Engineer, WQXR  
New York City*

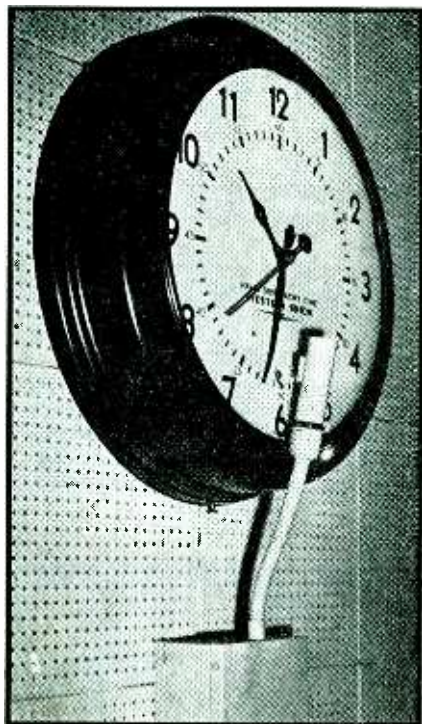

Mounted on a gooseneck, the phototube intercepts the light from the red lamp on the clock when the hourly reset pulse is received

**A**BOUT a year ago, WQXR decided to include in its program services an hourly time signal. It was felt that this time signal should not be the customary harsh "beep," but rather a musical chime consistent with the station's classical programs.

Finding a suitable tone at first posed a problem. Numerous schemes were tried and discarded for one reason or another. Finally a single-plate electromagnetic door chime provided the answer.

As shown in Fig. 1, a hole was cut in the top of the chime case to accommodate a 2000-ohm headphone. With the cap and diaphragm removed, the headphone functions as an inductive microphone, with the chime plate serving as a diaphragm. The headphone should be mounted fairly close to the chime plate, the distance between them in a large measure determining the output.

The degree of damping or hang-over of tone is controlled by means of a set screw and lock nut which is threaded through the top of the chime case to one end of the chime plate. The surface of the plate at

the point of contact is covered with a thin layer of felt.

A variable resistance, placed in series with the chime solenoid, is adjusted to give positive operation and reduce the thump which occurs if too high a voltage is applied. Proper spacing between the chime plate and phone, the correct amount of damping, as well as application of the required solenoid voltage, will result in a rather pleasing tone. Construction of this signal source is simple and inexpensive.

## Hourly Pulse Problem

To operate the chime, Western Union was asked to supply a line similar to the one used to pulse-reset WQXR's master control room clock. Western Union was prepared to do this but pointed out

that WQXR is on a "master clock circuit" which includes an additional pulse fifteen minutes after the hour. The clock reset mechanism is so designed that the fifteen-minute pulse does not operate the reset relay. They said that in most stations using the service for time signals the engineer manually opens the circuit after the hourly pulse and closes it again some time after the fifteen-minute pulse.

Since it was desired to make our time signal completely automatic as well as distinctive, this method was deemed unsatisfactory.

The control room clock contains a red lamp that lights only on the hourly reset pulse. If the chime could be connected to the lamp circuit, a ready answer to the pulse problem would be provided. For some reason, however, Western Union was unable to supply, or grant permission to connect a pair of wires from the lamp circuit to operate the chime.

Speculating on the matter further, we thought, "Well, there's nothing wrong with looking at the red light!" This we did, and with a phototube.

As can be seen from the diagram of Fig. 2, the time signal picked up by the phototube is amplified and energizes a sensitive relay; this in turn operates the chime. The tone is picked up in the headphone and then fed to the WQXR

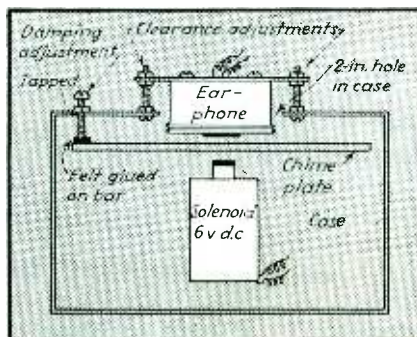
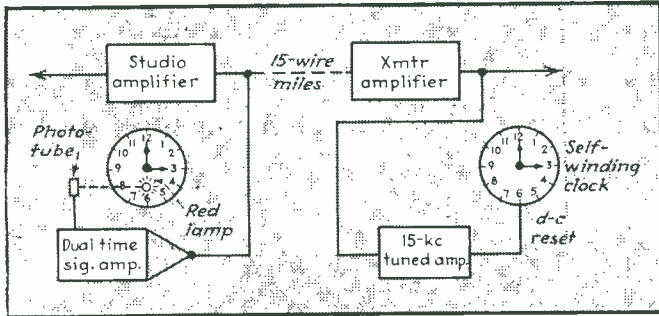

FIG. 1—Method of mounting the headphone on the case of the door chime



# Signal at WQXR



Block diagram of complete system for transmitting an hourly chime signal and pulsing the transmitter clock at the same time

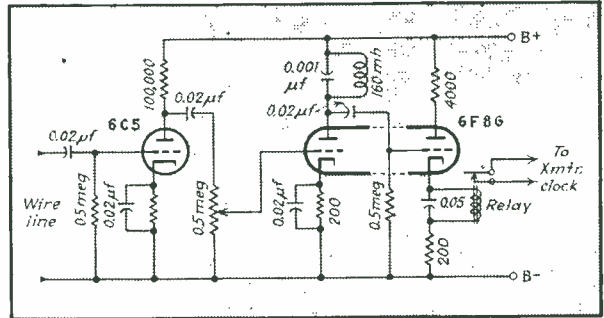

FIG. 3—This bridging amplifier closes the transmitter clock reset circuit when the 15-kc signal comes over the studio line

transmitter over the wire line.

For years we had wanted a Western Union clock at the transmitter for time synchronization with the studio. The idea had to be abandoned, however, as no reset pulse circuits were available at our transmitter location.

## Synchronizing Studio and Transmitter Clocks

After the Western Union red-light phototube-controlled time signal was put into operation, the thought occurred that the phototube might simultaneously be put to work to reset a clock at the transmitter.

Using the phototube as the motivating force to bring a pulse from the studio in New York to the transmitter in Long Island was a relatively simple matter. This was accomplished by installing at the studio a 15-kc RC oscillator combined with a dual amplifier so that both the time tone and the transmitter clock-reset tone (15-kc) are sent simultaneously over the speech line to the transmitter. The circuit of both of these units is shown in Fig. 2.

The time tone is thus fed directly to the transmitter through the transmitter speech equipment. The 15-kc clock-reset tone is picked up at the output of the transmitter line speech amplifier through a 15-kc tuned bridging amplifier.

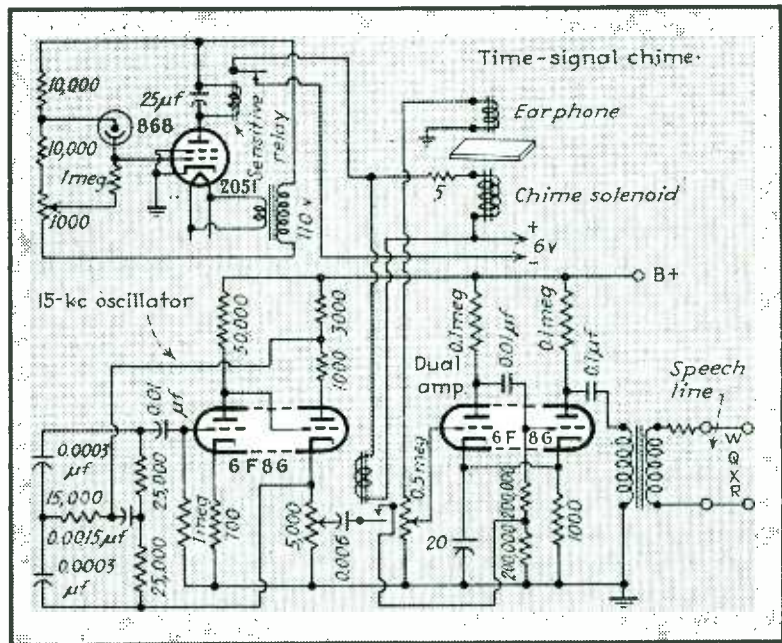

FIG. 2—Complete circuit of equipment installed at the studio. When the red lamp flashes on the clock, the phototube amplifier operates the chime and permits the 15-kc oscillator to feed a signal to the transmitter

This unit is shown schematically in Fig. 3. A plate-circuit relay in the bridging amplifier serves to close the transmitter clock reset circuit.

Independent volume controls are used on the time-tone and the 15-kc signals, with both set to leave the studio at  $-10$  vu. This level for the time tone is not too loud, yet permits the signal to be heard through voice. At this line input level, the 15-kc signal arrives at the tuned bridging amplifier with sufficient amplitude for positive

relay operation. Power for the amplifiers is obtained from the regular speech-amplifier power supplies.

Those stations not using a high-quality line could still reset a transmitter clock from the studio by use of an 8 to 10-kc pulse and possibly a slightly higher level. The 15-kc tone can be heard over WQXR if a good receiver and loud-speaker are used. The system has given fool-proof and maintenance-free service since its installation a year ago.

# LOCATION

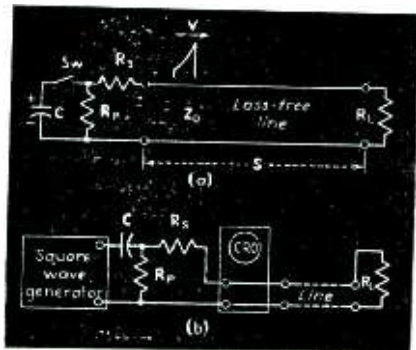

FIG. 1—Basic circuit (a) and measuring circuit (b) used in pulse measurements on transmission lines

A pulse technique determines location and nature of transmission line faults. The reflected pulse, as shown on an oscilloscope, indicates the condition of the line. Photographs of test results on artificial and actual open-wire lines indicate the utility of the method

By M. A. HONNELL

Associate Professor of Elec. Engineering  
Georgia School of Technology  
Atlanta, Georgia

**M**ANY techniques have been developed for the location of faults on transmission lines. Each specific method presents certain advantages for the location of a particular type of fault.<sup>1</sup> With the exception of continuity tests, most of the fault location techniques involve the use of a bridge. A well-known impedance measurement method for locating a fault on a transmission line was recently described in the literature.<sup>2</sup>

### The Pulse Method

A highly informative method for measuring the distance to discontinuities on transmission lines utilizes the familiar pulse technique used to measure the height of the ionosphere.<sup>3</sup> This technique requires the use of a pulse-modulated carrier when applied to measurements in free space, and hence elaborate transmitting and receiving apparatus are usually necessary. Fortunately, the pulse method may be utilized to make measurements on transmission lines with comparatively simple apparatus.

This paper describes an experiment originally developed to give students a background of visual experience with travelling waves and reflection phenomena. Tests on a 146-mile open-wire line from Atlanta to Birmingham indicate that the pulse technique will accurately measure the distance to several discontinuities simultaneously present on a line.

### Travelling Waves on an Ideal Line

A lucid treatment of the subject of travelling waves on transmission lines is presented in standard texts.<sup>4</sup>

Referring to Fig. 1(a), if a

charged capacitor is momentarily connected to the resistor  $R_p$ , a voltage wave of the type shown will travel along an ideal, loss-free transmission line with a velocity  $V$  equal numerically to the velocity of propagation of light in free space. At the end of an interval of time  $T = S/V$  seconds, the voltage wave will travel the length of the line and will impinge upon the load resistor  $R_L$ .

If  $R_L$  is equal to the surge im-

pedance  $Z_0 = \sqrt{L/C}$  of the loss-free line, the energy of the wave is completely absorbed by  $R_L$ , and no reflection takes place. On the other hand, if  $R_L$  is not equal to  $Z_0$ , there will be a partial reflection of the incident wave by  $R_L$ . The magnitude and phase of the reflected wave depends upon the magnitude of the departure of  $R_L$  from the value of  $Z_0$  according to the equation

$$e_R = e_I (R_L - Z_0) / (R_L + Z_0) \quad (1)$$

It is apparent that if  $R_L$  is greater than  $Z_0$ , the reflected voltage wave is not reversed in sign; but if  $R_L$  is smaller than  $Z_0$ , the reflected voltage wave is reversed in sign. In the limiting cases, when the line is open-circuited,  $R_L$  is infinite in magnitude, and  $e_R = e_I$ ; when the line is short-circuited,  $R_L$  is zero, and  $e_R = -e_I$ .

The voltage wave is necessarily accompanied by a current wave directly related to the voltage wave by the equation

$$e/i = \sqrt{L/C} = Z_0 \quad (2)$$

The magnitude and the phase of the reflected current wave is obtained from the relation

$$i_R = -i_I (R_L - Z_0) / (R_L + Z_0) \quad (3)$$

Continuing with the observation of the voltage wave, if reflection takes place at the load, the reflected voltage wave  $e_R$  travels to the sending end of the line in the time  $T = S/V$ . Here again there will be either complete absorption or partial reflection of this returning voltage wave, depending upon the magnitude and nature of the sending-end impedance encountered by the re-

### Nomenclature

- $e$ —Voltage at any point along the line.
- $e_I$ —Incident voltage at receiving end of line.
- $e_R$ —Reflected voltage at receiving end of line.
- $e_S$ —Reflected voltage at sending end of line.
- $e_L$ —Resultant voltage due to  $e_I$  and  $e_R$  at end of line.
- $i$ —Current at any point along the line.
- $i_I$ —Incident current at receiving end of line.
- $i_R$ —Reflected current at receiving end of line.
- $C$ —Line capacitance per mile.
- $G$ —Line-to-line conductance per mile.
- $R$ —Line resistance per mile.
- $L$ —Line inductance per mile.
- $R_0$ —Sending-end impedance.
- $R_L$ —Load resistance.
- $R_p$ —Pulse generator impedance.
- $R_s$ —Calibrated variable resistance.
- $S$ —Length of transmission line in miles.
- $T$ —Time in seconds required for wave to travel  $BS$  miles.
- $T_1$ —Period of a half cycle of pulse signal.
- $T_2$ —Period of pulse signal in seconds.
- $V$ —Velocity of propagation of pulse in miles per second.
- $Z_0$ —Line surge impedance.



# of LINE FAULTS

turning voltage wave. The magnitude and phase of the wave reflected from the sending end are obtained from an expression identical in form to Eq. (1):

$$e_s = e_x (R_s - Z_0) / (R_s + Z_0) \quad (4)$$

It now becomes apparent that if both  $R_s$  and  $R_L$  are not identically equal to  $Z_0$ , many successive reflections take place on the line until the total energy in the travelling wave is dissipated in the terminating resistors. In a practical case, the wave is also attenuated by the line losses as it travels back and forth.

## Wave Velocity

The velocity of propagation of the travelling wave depends upon the characteristics of the transmission line. The velocity of propagation of the wave front is given by the expression<sup>4</sup>

$$V = 1/\sqrt{LC} \quad (5)$$

where  $L$  is the inductance per unit length and  $C$  is the capacitance per unit length. On the usual open-wire line with a conductor spacing which is much greater than the conductor diameter, the velocity of propagation of travelling waves approaches the free-space velocity of propagation of light. The velocity of propagation of travelling waves on cable circuits is, however, much lower than that on open wire lines. In the discussion to follow, it will be seen that the apparent velocity of propagation of a particular pulse wave on a line can be determined by placing a discontinuity at a known distance from the sending-end of the line.

## Examples of Reflection

The reader is now in a position to predict the type of picture to expect on the screen of a cathode-ray oscilloscope connected to any point along an ideal transmission line. As an example, assume that  $R_s = Z_0$  and that  $R_L = Z_0/2$ . Upon substituting these values in Eq. (4) and (1) respectively, it is seen that  $e_r = -e_i/3$  and that  $e_s = 0$ .

If the original pulse sent out on

the transmission line has a magnitude of six volts, and assuming no attenuation or distortion of the pulse in its travel, the wave impinging upon the load has a magnitude of six volts. As a result the reflected voltage wave  $e_r$  has a value of  $-2$  volts. The picture seen on the screen of an oscilloscope connected across the load resistor  $R_L$  is that of a single resultant pulse with an amplitude of  $e_L = 6 - 2 = 4$  volts.

A simple calculation reveals that the polarity of the resultant pulse at the receiving end of the line is the same as that of the incident pulse irrespective of the magnitude of  $R_L$ , according to the equation

$$e_L = e_i + e_r = e_i (2R_L) / (R_L + Z_0) \quad (6)$$

Thus, it is evident that the pulse viewed at the receiving end is always of the same polarity as the incident pulse and has a magnitude in the range from zero to  $2e_i$ , depending upon the relative values of  $R_L$  and  $Z_0$ .

It is apparent that the reflected voltage wave of the preceding example,  $e_r = -2$  volts, travels back to the sending end of the line. There it encounters a resistance  $R_s = Z_0$  which completely absorbs the returning wave.

The picture viewed on an oscilloscope connected across the sending end of the line consists of the original six-volt positive pulse, and a two-volt negative pulse displaced from the initial pulse by a time interval  $T = 2S/V$ . Of course, if  $R_s$  were not equal to  $Z_0$ , reflection would take place at the sending-end as well as at the load end of the line, and many reflected pulses would appear on the oscilloscope screen.

## Distortion of Waves

There is always a finite amount of attenuation of a wave on a transmission line due principally to the effective resistance  $R$  of the conductors and to the conductance  $G$  between the wires. If the line con-

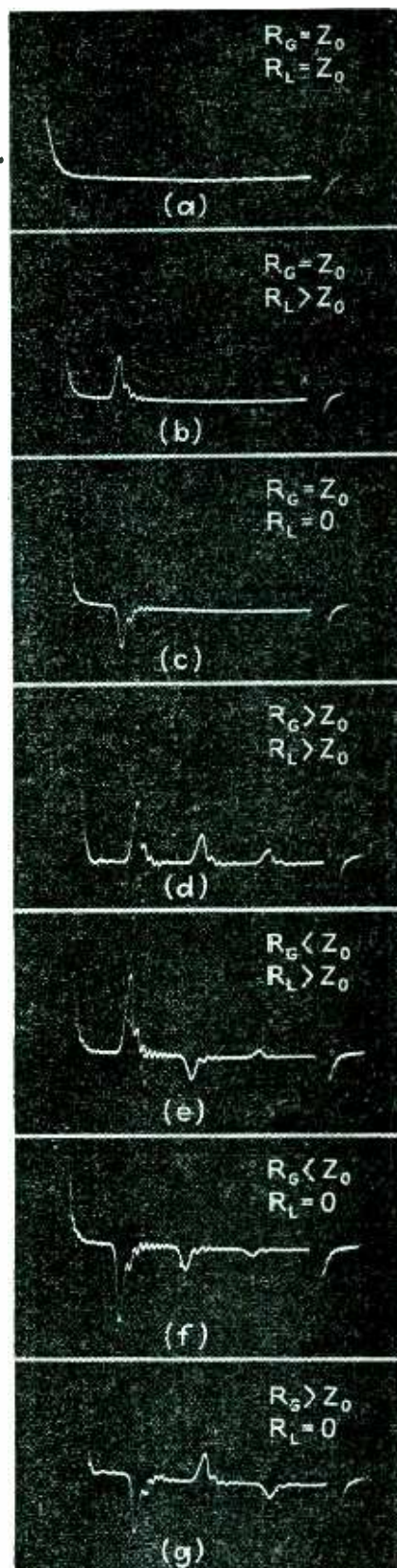
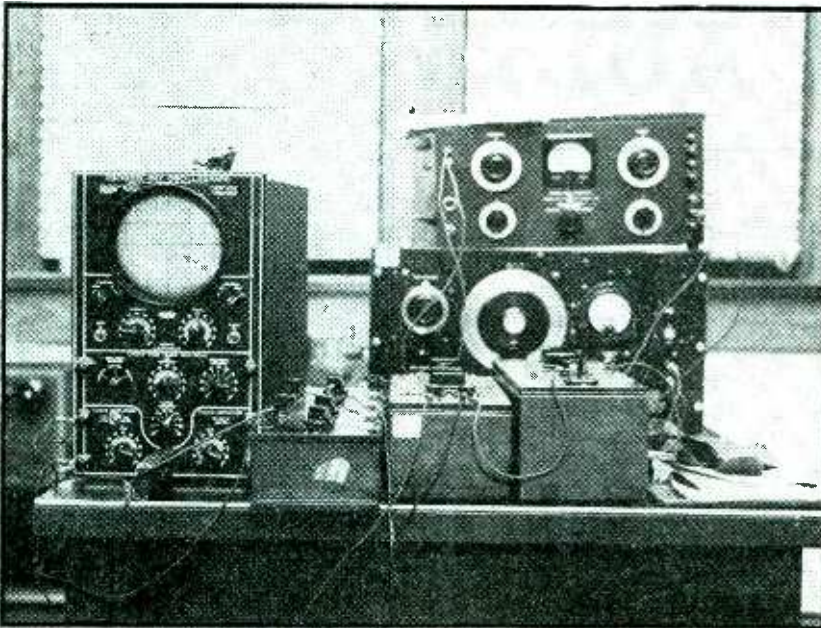

FIG. 2—Oscillograms illustrating the reflection phenomena on an artificial transmission line. In (a) where both ends of the line are terminated in the line's characteristic impedance there are no reflections. In (b) and (c) the sending end of the line is terminated in its characteristic impedance. The others have repeated reflections from both ends





Equipment used to test transmission lines by the pulse method. The output of the square-wave generator (top right) is differentiated, the resulting pulse is fed to the line, and reflected pulses are observed on oscilloscope

stants are so proportioned that  $RC$  equals  $GL$ , the line is distortionless. A wave travelling on this line is attenuated as it moves along the line, but it retains its original shape as a function of time as viewed at any point along the line.

#### Laboratory Arrangement

The constants of the usual power and telephone transmission lines do not satisfy the condition for a distortionless line. The type of wave distortion to be expected on these lines is a rounding of sharp points on the wave and a sloping-back of the wave front. From the Fourier viewpoint, the component frequencies in a recurrent pulse travel with different phase velocities and undergo different degrees of attenuation, with the result that the pulse is distorted. This type of distortion is present in the photographs described later. Additional distortion in the form of a damped oscillation trailing each pulse is apparent in the photographs taken on an artificial lumped constant line. This transient oscillatory distortion of pulses is absent on all observations made on an actual open-wire line where the impedance is uniformly distributed along the line.

The artificial laboratory line used to check the pulse technique consists of 25 balanced-H sections of inductance and capacitance, and

simulates a non-loaded open-wire line of No. 12 wire approximately 200 miles long. The characteristic impedance of the line measured at 800 cps is  $669 - j19$  ohms. The line is reasonably well terminated over a wide band of frequencies by a resistance of 670 ohms.

The laboratory arrangement used to obtain the photographs is shown in Fig. 1(b). The sending-end impedance  $R_G$  consists of  $R_s$  in series with the pulse generator impedance  $R_p$ . The square-wave generator internal impedance is large compared to  $R_p$ . It is desirable to make  $R_p$  much smaller than  $Z_0$  in order that  $R_G$  will be essentially equal to  $R_s$ . The sending-end impedance is then conveniently changed simply by changing the value of the resistor  $R_s$ .

The pulse signal is obtained by differentiating a square wave using the coupling capacitor  $C$  and the resistor  $R_p$ . Thus, the fundamental frequency of the pulse wave is the same as that of the square wave, and the pulse width is varied by changing the  $RC$  values of the differentiating circuit. Other types of pulse generators are suitable.

#### Laboratory Photographs

The series of photographs in Fig. 2 demonstrate clearly the behavior of the pulse wave on a transmission line. In examining the

photographs, it is well to remember that the oscilloscope connected across the sending end of the line gives a picture of the resultant pulse at the sending end, and that this resultant pulse is of the same polarity as the returning pulse incident on the generator. The duration of the traces of Fig. 2 is  $1/120$  second, and therefore a half cycle of a differentiated 60-cycle square wave is shown.

In Fig. 2(a) no reflected pulse is present, because the line is properly terminated in its surge impedance. Only one reflected pulse is present in Fig. 2(b) and in Fig. 2(c), as the sending-end impedance is equal to  $Z_0$ , so that the returned pulse is absorbed by this impedance. In the remainder of the photographs, three reflected pulses appear. Note that the pulses are spaced at equal intervals representing the time required for the pulse wave to travel twice the length of the transmission line.

The following detailed explanation of the excursions of the pulse shown in the oscillogram of Fig. 2(g) assists in an understanding of the other oscillograms. The initial positive pulse travels the length of the line and impinges upon a short-circuit at the receiving end of the line. Hence, the first reflected pulse is of negative polarity and travels back to the sending end where it is seen as a downward pulse. This first-returning wave encounters a sending-end impedance which is greater than  $Z_0$ , and therefore a negative reflected pulse is sent out on the line. This negative pulse is reversed in polarity at the load end of the line, with the result that it is seen as a positive pulse on its second return to the sending end. From here on, the previously-

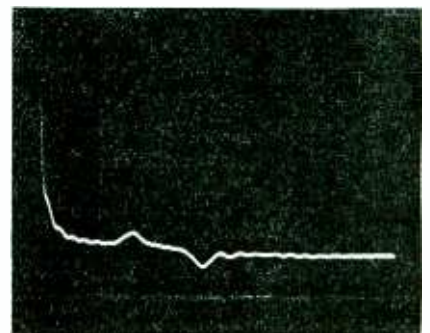

FIG. 3—Irregularities on a lumped-constant artificial line are quickly determined by their oscilloscope trace



described action takes place so that alternate pulses are of like polarity.

The photograph in Fig. 3 shows the effect of two different types of discontinuities simultaneously present on the transmission line with both the sending-end and load resistances equal to the line surge impedance. The positive pulse is caused by a 74-ohm resistor inserted in series with each side of the line at the 13th section, while the negative reflected pulse is caused by a 2,500-ohm resistor shunted across the line at the 22nd section. The multiple reflections which occur between the two discontinuities are distorted and of minor magnitude, hence they are not visible in the photographs.

Convenient lattice diagrams of great assistance in the calculation of the reflections to be expected at any point and at any instant of time on a transmission line containing several discontinuities are described by Bewley.<sup>5</sup>

The length of a transmission line, or the distance to a discontinuity, is easily determined by measuring the time interval between the initial pulse and the particular reflected pulse in question. This measurement is made by any of the standard methods. The most primitive method is to measure both the length of the entire trace as well as the length from the initial pulse to the reflected pulse with a rule, or with the cross-section coordinates on the oscilloscope screen.

Information for a calculation of this type is presented in Fig. 4. The fundamental frequency is 600 cps. The pulse is traveling on an open-wire line and therefore its velocity  $V$  is very nearly 180,000 miles per second. From the figure,

$T$  is measured to be  $(2/3)T_1 = (2/3)(1/2F) = 1/1800$  second. Therefore the length of the line  $S$  equals  $(1/2)VT = (1/2)(18 \times 10^4)(1/18 \times 10^3) = 50$  miles.

More rapid methods of measuring the distance to a discontinuity involve the use of a Z-axis timing signal, or a timing signal flashed over the pulse trace by an electronic switch.

#### Tests on an Open-Wire Line

Through the courtesy of Mr. L. C. Bomar of the Southern Natural Gas Company, the writer had the opportunity to check the pulse technique on an open-wire line 146 miles long paralleling a gas pipeline from Atlanta to Birmingham. Figure 5 is a pulse panorama of the entire line. The last reflected pulse of positive polarity is caused by the Birmingham end of the line, where the line is terminated in a 2500-ohm relay. The remainder of the reflections are due to similar relays shunted across the line at various stations, and due to several short lengths of cable circuit interposed in the line.

Figure 6 shows the reflected pulse obtained upon open-circuiting the line at a point 80 miles from the sending end. When the line is short-circuited at the same point, the identical pulse appears but with a negative polarity.

#### Conclusion

The pulse technique appears promising as a method of measuring the distance to a discontinuity on a transmission line. If the normal pulse history of a particular line is photographically recorded, any new discontinuity can be readily detected by placing the negative

of the photograph over the oscilloscope screen.

An advantage of the pulse technique over other methods of measuring the distance to discontinuities is that a complete instantaneous picture of the entire line is revealed at a glance. In addition, the nature of the discontinuity is immediately apparent.

Possible applications of the pulse technique are: (1) To measure the distance to an open or short-circuit on transmission lines. (2) To measure the distance to irregularities on lines. (3) To measure the velocity of propagation of pulse signals on transmission lines of known length. (4) To rapidly check the value of the characteristic impedance of a transmission line, or to determine whether or not a line is terminated in its characteristic impedance. (5) To continuously monitor a line to determine where and when a break occurs during inclement weather, or during periods when sabotage is expected.

A fruitful field for research exists in the use of pulse-modulated carriers as a test for discontinuities on transmission lines. The writer believes that the pulse technique can be advantageously used to locate discontinuities on telephone, telegraph, and power lines in areas stricken by wind and ice storms.

#### REFERENCES

- (1) "Notes on Fault Location in Cables", notebook E-53-441, Leeds & Northrup Co., Phila., Pa., 1938.
- (2) Blankmeyer, W. H., "Power Line Fault Locator," *ELECTRONICS*, p. 166, Jan. 1944.
- (3) Breit, G. and Tuve, M. A., "A Test of the Existence of the Conducting Layer," *Phys. Rev.*, 28, p. 554, Sept. 1926.
- (4) Skilling, H. H., "Transient Electric Currents", McGraw-Hill Book Co., Inc., New York, 1937.
- (5) Bewley, L. V., "Travelling Waves on Transmission Systems", John Wiley & Sons, Inc., New York, 1933.

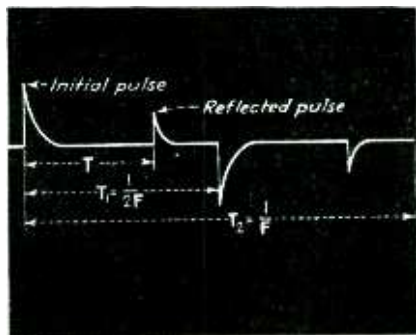

FIG. 4—The length of line is found by correlating an oscilloscopic trace with the fundamental pulse frequency

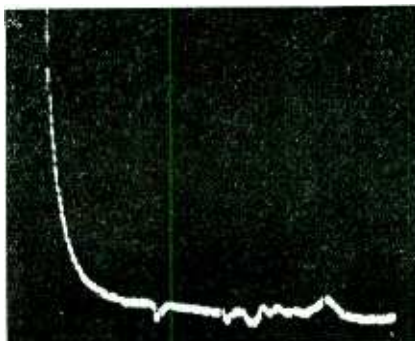

FIG. 5—This panoramic pulse view taken from Atlanta shows the Atlanta-Birmingham telephone line in its normal state

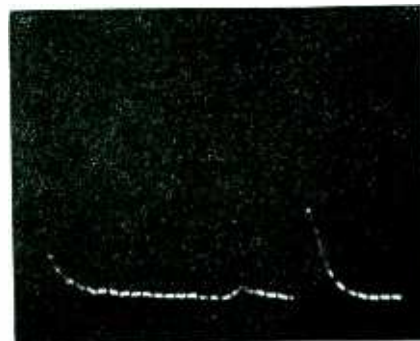

FIG. 6—An open circuit 80 miles from Atlanta on the line shown in Fig. 5 produces the positive pulse shown here

# CAPACITOR-MATCHING

Construction and calibration of a direct-reading beat-frequency oscillator for use in production matching of variable capacitors. Principle involves comparing frequencies of two duplicate oscillators, one containing the standard capacitor, the other containing the production capacitor

**P**RECISION calibrating and matching on a mass-production basis is one of the greatest problems in the manufacture of variable capacitors. The trend in recent years toward higher frequencies, compactness, and higher standards in receiver design has resulted in corresponding limitations in capacitor tolerances.

Any limitations on the tolerance of the capacitance curve require closer control throughout the stages of production. Today the tolerances have approached such narrow limits that the manufacturer has to hold to rigid standards on the mechanical structure in order to approach as closely as possible the specified capacitance curve. Only when great mechanical accuracy exists can the capacitor be calibrated and matched with any success.

## Calibration Techniques

Calibration of a capacitor is a tedious job, whether for experimental work or for a production run. The term calibration as used in the variable-capacitor field applies to adjusting the capacitance of the unit to the required capacitance curve by bending serrations on the rotor plates of a single-section variable capacitor, or in the case of a ganged capacitor, the one section which is generally used to tune an oscillator.

Calibrating in the past was accomplished by taking readings at specified degrees of rotation and comparing them to the original curve in order to determine the

necessary loss or gain in capacitance, and then bending the serration at each reading to produce the required results. The operation was speeded up by the use of a simple beat-frequency oscillator and a standard capacitor adjusted to the desired curve. This method, although much faster, was still handicapped because of the necessity for continuously switching between the standard and the capacitor being calibrated.

Matching a ganged capacitor which consists of adjusting the remaining sections to conform to the calibrated section was handled in the same manner. It will readily be seen that if the tolerances were held to comparatively small limits, 0.5  $\mu\mu f$  or smaller, a continual switching between the capacitor being calibrated and the standard would be necessary.

To solve this problem, Hammarlund engineers decided to limit the switching to an absolute minimum. To do this, of course, means taking a comparison reading of the capacitance directly from a dial on the test instrument. With this object in mind, a search was made for a design that would answer the purpose.

## Improved Method

It was discovered that with some modification, existing beat-frequency oscillators could be made to serve for calibrating and matching capacitors, and greatly speed production over existing methods.

In order to check by direct com-

parison it is necessary to have two variable oscillator circuits beating against each other. The final circuit is shown in the schematic diagram, Fig. 1. The standard capacitor  $C_{x1}$  is placed across one oscillator, and the capacitor to be calibrated ( $C_{x2}$ ) across the other oscillator. Both capacitors are set to minimum capacitance and locked to a single shaft as shown in Fig. 2. By means of trimming capacitors  $C_1$  and  $C_2$  the oscillators are brought to zero beat as indicated by a null reading of meter  $M$ . The capacitor under test and the standard are then rotated together and the oscillators held at zero beat by means of the calibrated capacitor  $C_1$ . The change in  $C_1$  necessary to accomplish this is a direct indication of the difference between the curve of the capacitor being calibrated and the required capacitance curve.

## Design of Tester

The inductors  $L_1$  and  $L_2$  are variable, having movable iron core slugs. The shielding effect obtained with  $L_2$  mounted above the chassis and as far away from  $L_1$  as possible, is sufficient for all practical purposes.  $C_1$  is a straight-line capacitor whose value depends on the capacitance to be covered in the tolerance specifications for the required capacitor curve.  $C_1$  should be sufficiently rugged mechanically to withstand constant use during production tests. It was found that a total value of approximately 15  $\mu\mu f$  gave the required swing of 10  $\mu\mu f$  without using the full 180 deg



# OSCILLATOR

By HAROLD H. TEPPER

Condenser Engineering Dept.  
Hammarlund Mfg. Co. Inc.  
New York, N. Y.

swing of the capacitor, thereby using only the linear portion of the capacitance curve. A value of  $5 \mu\mu\text{f}$  each side of zero gave sufficient capacitance variation so that all tolerances could be met.  $C_2$  and  $C_3$  are trimming capacitors used to bring the two oscillators to zero beat.  $C_4$  is used for making coarse adjustment in trimming whereas  $C_5$  is used for final adjustments. Consequently,  $C_5$  has a smaller capacitance than  $C_2$ . These trimmers are connected in parallel with one oscillator circuit to correct for small differences in capacitance that might exist between the capacitors under test due to their minimum capacitance and the leads.

$C_4$  and  $C_5$  are loading capacitors which give a total base capacitance in each oscillator circuit of approximately  $2000 \mu\mu\text{f}$ . They are added so that the frequency of the oscillator circuits would be rela-

tively low, approximately 400 kc without external load, thereby minimizing the inductive effects of test leads. Care must be taken to keep the values of  $C_4$  and  $C_5$  as nearly alike as possible so that trouble will not be encountered in balancing the inductances  $L_1$  and  $L_2$ .

The capacitors  $C_6$  and  $C_7$  couple the oscillator plates to the detector. These capacitors should have relatively small values (in the order of a few  $\mu\mu\text{f}$ ) so that the coupling between the two oscillators will not be great enough to cause the oscillators to lock. They should be as closely matched as possible.

### Construction of Tester

Both oscillator circuits must be kept as nearly alike as possible in the values of their component parts as well as in their wiring. Any great differences may cause serious unbalance between the circuits. All

precautions should be taken in the matter of placement of parts in order that coupling effects will be a minimum. If too much coupling is present the lock-in between the oscillators will be such as to decrease the sensitivity of  $C_1$ . Either the capacitor under calibration will appear to track perfectly because the two oscillators lock, producing a permanent null indication, or the change in  $C_1$  necessary to upset the balance will be abnormally large because of the tendency of the oscillators to remain at zero beat until tuned to widely different frequencies.

The mechanical structure of the beat-frequency oscillator must be sufficiently rugged so that momentary strains set up by external sources will not throw the instrument off calibration due to variations in the inductances. All points of ground contact in the wiring as

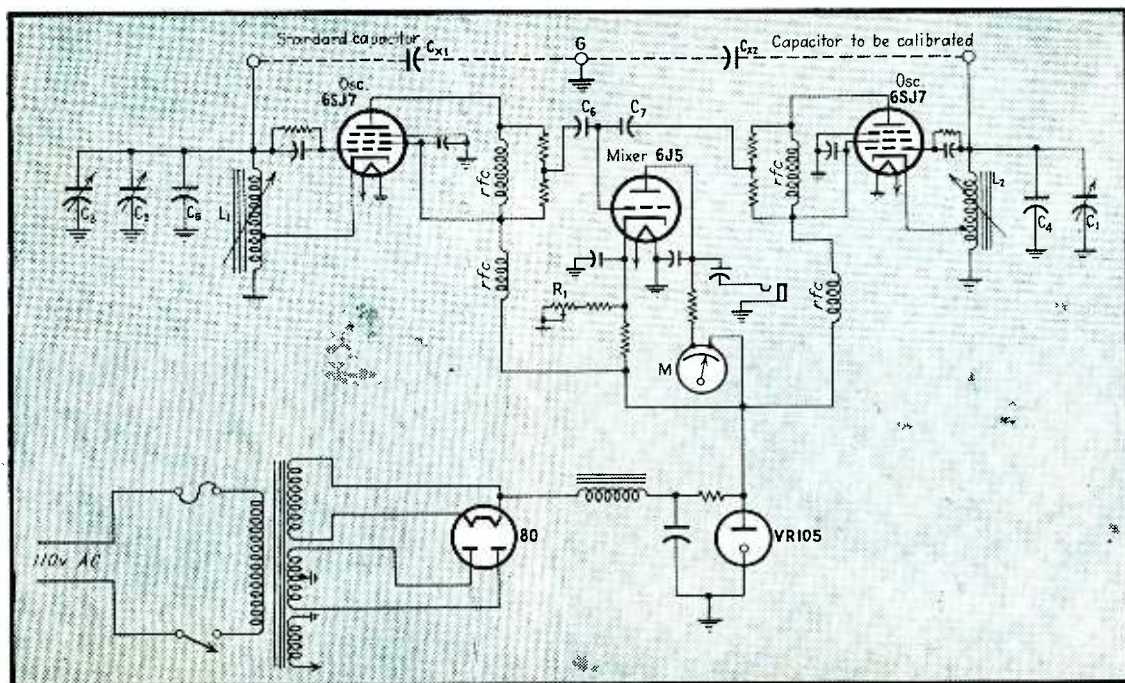

FIG. 1—Circuit diagram of the capacitor-matching oscillator. The outputs of the two oscillators are heterodyned in the 6J5. When both frequencies are the same the meter M gives a null indication. If the capacitor

under test differs slightly from the standard, capacitor  $C_1$  in the oscillator containing the unknown capacitor is adjusted to give a null on the meter. This change in  $C_1$  gives directly the error in the unknown capacitor



well as in the fastenings of the dust cover and bottom plates should be made as secure as possible in order to overcome any difficulties from this source.

#### Calibration of Tester

Before the beat-frequency oscillator is calibrated, a simple balancing set-up will be required. The set-up consists of two fixed capacitors which have three or four times the maximum capacitance of the capacitors that will be calibrated in production. One should have a capacitance of from 1 to 2  $\mu\text{f}$  greater than the other. The use of a much greater capacitance for balancing, over the values to be used during the production test, proportionately reduces the final errors.

The two fixed capacitors should be tied together and the common point fastened to the binding post at  $G$  on the front panel. The remaining terminal of the standard capacitor is fastened to  $C_{v1}$ , and the terminal of the other capacitor is fastened to  $C_{v2}$ , as shown in Fig. 1. The leads fastened to  $C_{v1}$  and  $C_{v2}$  should be checked for length and symmetry. When the balancing

set-up has been made as symmetrical as possible it is removed from the binding posts and placed to one side until some preliminary adjustments are made, prior to final balancing.

The next step is to set the movable slug in  $L_2$ , which is above the chassis. This is done by backing it out as far as it will go and then screwing it in approximately three or four turns. The dust cover is then put in place and securely fastened, using lock-washers under the screw heads to give good ground contact and rigidity. The variable potentiometer  $R$ , is of sufficient resistance to cause a full-scale deflection of meter  $M$ , which is preferably a 200-microampere meter.  $R$  is set so that the meter shows half-scale deflection. The bottom plate is then placed in position and fastened securely.

The oscillator is now ready to be balanced. The pointer of  $C_1$  is set in the center of the dial, where a reference line is drawn.  $C_2$  and  $C_3$  are set so that their rotor plates are half-way out of mesh.  $L_1$  is then adjusted by means of the movable slug until the meter deflection takes

the lowest dip. A pair of headphones plugged into the phone jack will come in very handy to listen for the decrease of the beat pitch and to detect the null.

#### Unique Balancing Technique

The fixed capacitor set-up that was made previously is now fastened between  $C_{x1}$  and  $G$  and  $C_{x2}$ .  $C_1$  is then turned to the right or left, as the case may be, until the meter indicates the null point and the distance of the pointer on  $C_1$  from the reference line measured. Here use is made of the 1 to 2- $\mu\text{f}$  difference between the two capacitors of the balancing set-up. Remove the set-up from the test terminals and reverse its position. The lead formerly connected to  $C_{x1}$  should now be connected to  $C_{x2}$  and vice versa. Measure the deviation of  $C_1$  as outlined above. The inductance value of  $L_1$  is then adjusted by means of its movable slug until, with the oscillators balanced, the pointer on  $C_1$  is the same distance from the center line on the one side as it was on the other before the test set-up was reversed. Note that it is necessary to re-bal-

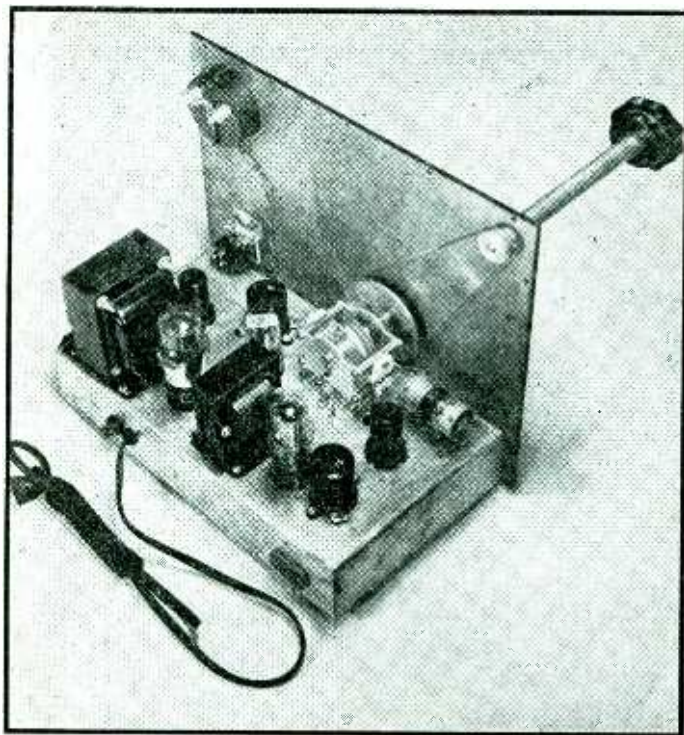

Chassis assembly, showing the iron-core inductor of one oscillator at the right on top of the chassis, and the straight-line error-measuring capacitor at the center

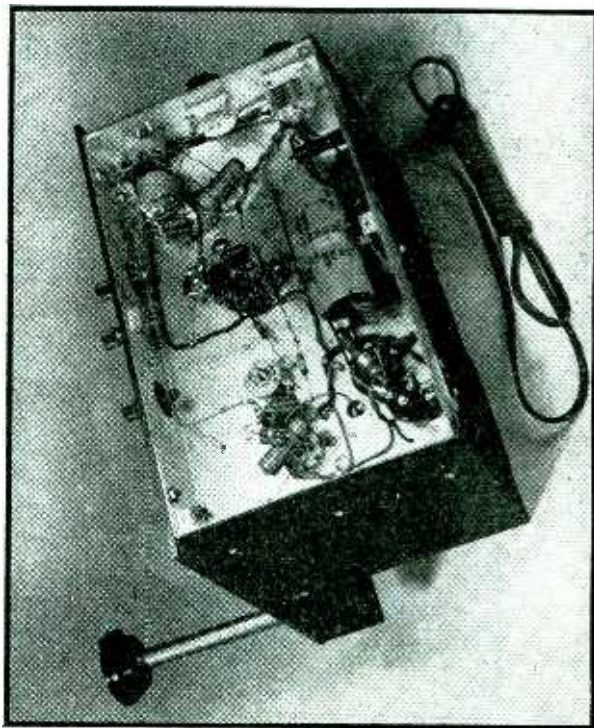

Under-chassis wiring, showing the similarity between the two oscillator circuit lay-outs. The balancing capacitors,  $C_2$  and  $C_3$ , are at the top in this view



ance the equipment each time the inductance value is changed, by means of  $C_2$  or  $C_3$  with the capacitor set-up disconnected.

Some means should be made for locking the inductor adjustment once balance is reached. The headphones prove very useful in checking the unbalance between the oscillators because occasionally the unbalance is of such a nature that no deflection is shown on the meter, the capacitance of  $C_1$  at the moment being either too great or not great enough. An increase or decrease in the frequency of the audio signal as heard over the earphones is noted when  $C_1$  is rotated. The movable slug of the inductor is then adjusted so that there is a constant decrease in the frequency of the signal until with  $C_1$  set somewhere near the reference point a null is obtained. The final balance can be made without the headset inasmuch as the balance between oscillator circuits has been determined to fall on the dial of  $C_1$ .

#### Dial Calibration

The beat frequency oscillator should be perfectly balanced with the pointer of  $C_1$  in the center of the dial. However, there are two values which will have to be precisely determined in order to calibrate the instrument accurately. These values are the base frequency and base capacitance with the instrument set and balanced at the reference point. These values need only be determined for the oscillator circuit in which  $C_1$  is included, because the other oscillator circuit is balanced to it. The base frequency can be determined by any of the standard frequency-measuring methods.

#### Substitution Determination of Capacitance

The base capacitance can be determined by selecting two silvered mica capacitors whose capacitance values differ from each other by at least 1000  $\mu\mu\text{f}$ . These capacitors should be measured accurately and marked and their readings recorded. They are then fastened separately across the  $C_{x2}$  and  $G$  terminals, and the frequency produced by the addition of each capacitor is determined by the same

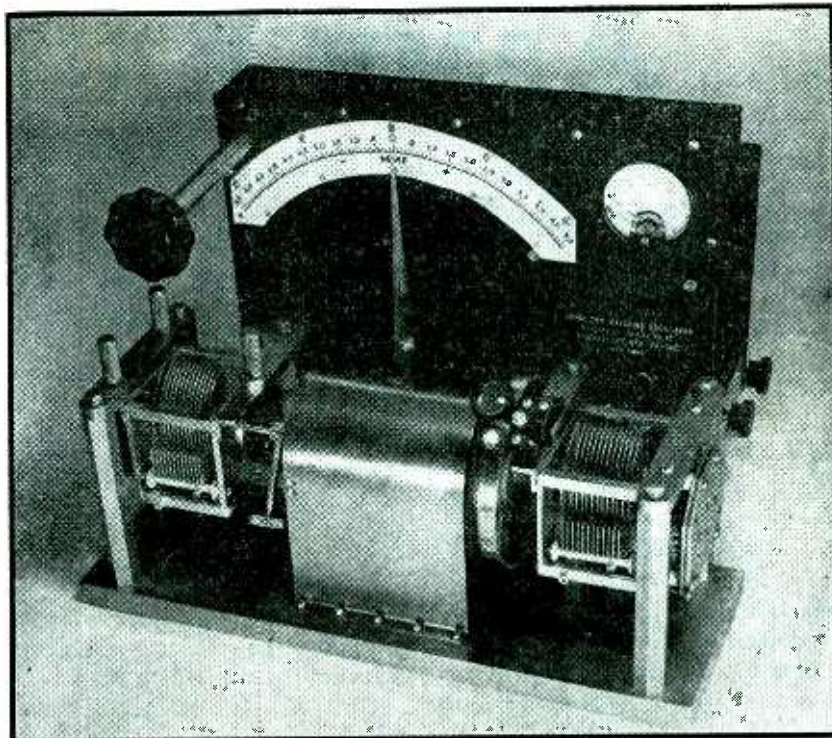

FIG. 2—The production capacitor is ganged to the standard capacitor, and connections are made to the terminal posts on the matching oscillator. The two capacitors are rotated, and the oscillators are kept in balance (as indicated by the meter) by adjusting the straight-line capacitor. The error between the unknown and the standard capacitor is read directly from the scale. The controls at the right balance the oscillators before measurements are made. This capacitor-matching oscillator was designed and built in the Hammarlund Laboratories

method used in determining the base frequency. Then by use of the two-frequency method the base capacitance can be calculated from the following equations:

$$\begin{aligned} C_x &= \text{base capacitance to be found} \\ f_1 &= \text{the higher frequency in kc} \\ f_2 &= \text{the lower frequency in kc} \\ C_{v1} &= \text{the capacitance added to produce } f_1 \\ C_{v2} &= \text{the capacitance added to produce } f_2 \end{aligned}$$

$$\left[ \frac{f_1}{f_2} \right]^2 = \frac{C_x + C_{v2}}{C_x + C_{v1}} = FR^2$$

Writing  $\left[ \frac{f_1}{f_2} \right]^2$  as the frequency ratio,  $FR^2$ , the following formula is derived:

$$C_x = \frac{C_{v2} - FR^2 C_{v1}}{FR^2 - 1}$$

The base frequency and base capacitance for the oscillator circuit whose tuning capacitor is to be calibrated are now known. When the pointer of  $C_1$  is set on the reference line the equipment should be in balance.

#### Calibration of $C_1$

A good audio oscillator and an oscilloscope will be needed to do the final calibrating. The audio signal from the beat-frequency oscillator

can be picked up from the phone jack.

The method of calibrating  $C_1$  is to compare the beat frequency of the matching oscillator to the frequency of an audio oscillator by means of the oscilloscope and Lissajous figures. The minimum change in frequency which can be measured in this manner depends on the calibration and stability of the audio oscillator, but this consideration need not limit the size of divisions to which the scale of  $C_1$  can be calibrated. As was stated previously, the capacitor  $C_1$  has a straight-line characteristic, and is only used over the central portion of its range where its linearity is highly reliable. If in addition it has a substantial air gap, it can be calibrated every 0.5  $\mu\mu\text{f}$ , for example, and subdivisions every 0.1  $\mu\mu\text{f}$  added. It was found at Hammarlund that by using this method the errors were so small as to be negligible. With  $C_1$  calibrated, the capacitor-matching oscillator is ready for use.

# ARMY RADIO D-F

Description of SCR-291 radio direction finder, used by AACS to provide accurate bearings for military pilots on world-wide air routes. Indications appear on a cathode-ray tube screen. Operating procedures and factors affecting choice of sites are covered

**R**ADIO DIRECTION-FINDING is a method employed to determine in degrees the direction of a transmitting agent, such as an off-course airplane, from a direction-finder station. Such operation is accomplished by the use of a receiver coupled to a specialized type of antenna with which the horizontal angle of incidence of incoming signals from a remote transmitter can be found relative to some predetermined standard, usually true or magnetic North.

Because the individual d-f station is capable of obtaining directive bearings only, a number of stations, properly located with respect to the distances over which operation is desired, can be grouped together in a d-f net for the purpose of determining geographical positions. These positions, or "fixes" as they

are commonly called, are determined by the central or control station of the net. Individual bearings are obtained from each satellite station and plotted on a chart. Proper evaluation of the point of intersection of the collected bearings results in the fix, which may be reported back to the original transmitting agent or to rescue forces, depending on the circumstance.

The direction finder is a natural outgrowth of radio development and radio control. For many years surface vessels and aircraft controlled their movements visually, as no other method was available. Visual control, however, is obviously limited by the surrounding terrain, the prevailing atmospheric conditions, the spherical construction of the earth's surface, and many other factors that tend to re-

strict its usefulness to the immediate surroundings of the observer. With the advent of wireless communications, these limitations were greatly minimized, and the use of direction finding became increasingly important.

This discussion is concerned chiefly with the use of direction finding as a radio navigational aid operating in the field of military aviation. While the direction finder is not infallible, nevertheless it has proved itself a vital element in the safe conduct of airplanes over our farflung Army Airways.

## The Actual Equipment

There are many types of d-f equipment in use throughout the world—most of them employing a loop or Adcock-type antenna array. Generally speaking, the choice of equipment is determined by the operating characteristics desired and the circumstances and conditions peculiar to the sphere of operation. Surface vessels, for example, ordinarily make use of a direction finder whose antenna is of modified loop design, whereas shore-based units usually employ an Adcock arrangement.

As Army aircraft radio operation is normally confined to a frequency range between 2 and 12.5 Mc, d-f equipment must be capable of supplying continuous bearing coverage within these limits.

Another requirement of satisfactory equipment is the need for obtaining bearings rapidly and with a minimum of the human element involved. Then, too, there are definite advantages in semi-portable equipment which can be installed quickly and disassembled with relative ease.

A direction finder manufactured by Federal Telephone and Radio

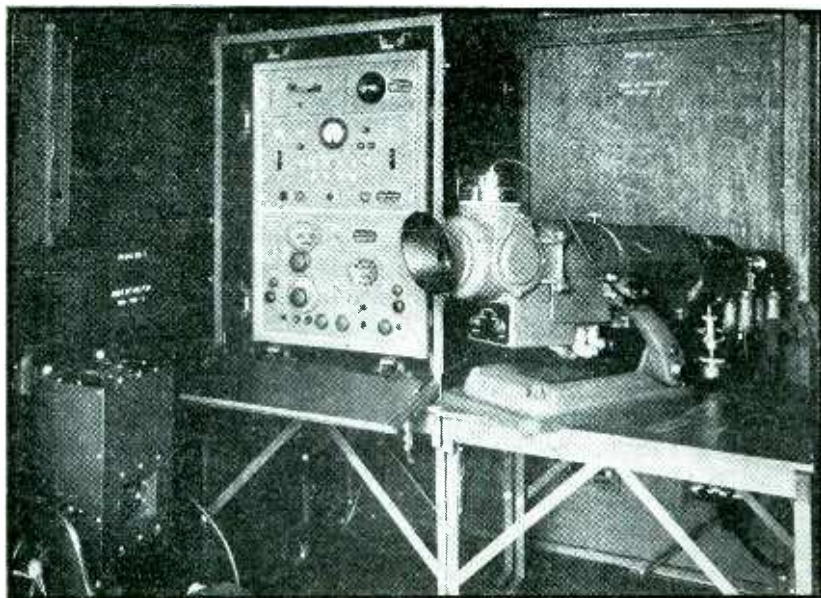

Direction indicator is at the right in this interior view of an SCR-291 direction-finder shack. Receiver, control panel, and telephone panel are rack-mounted at the left



# NETWORKS

By Major Giltner Twist, A.C.

*Army Airways Communications System  
Asheville, N. C.*

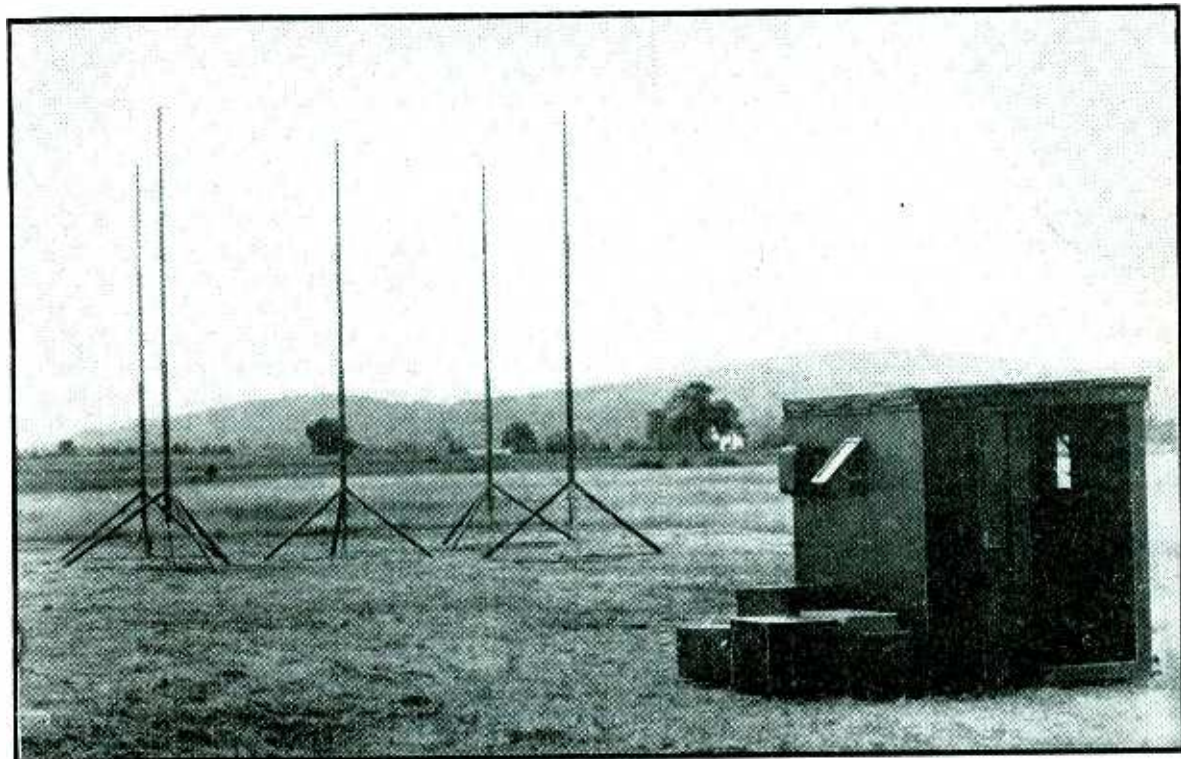

Complete installation of direction-finding station. It can be disassembled for air transportation in 23 chests and crates. To the left of the operating shelter are the five masts of the modified U-Adcock antenna, each with its ground mat below

Corp. is used by the AACS. It possesses desirable features for this operation. It is semi-portable and employs a U-Adcock antenna designed for fixed station use. A cathode-ray tube and a motor-driven goniometer provide instantaneous bearings with a minimum of the operator's time and attention.

The set is built to withstand the effects of vibration, concussion from gunfire, and general rough use. When used for direction finding, the equipment is continuously variable over a frequency range of from 2 to 10 Mc, while its average sensitivity is approximately 5 to 15 microvolts per meter for a  $\pm 2$ -deg bearing reliability. The indications of the d-f set are continuous and automatic—automatic in the sense that if the direction of the received signal should shift with respect to the azimuth, the indication on the cathode-ray screen would shift accordingly without further tuning on the part of the operator.

Through the operation of the goniometer, the cathode-ray tube, and their associated electrical network, a visual trace pattern is projected on the face of the tube. The operator tunes the signal in, reads the two directions indicated, determines the true direction by pressing the sense switch, and reports his findings. As the signal is reproduced in visual form, all searching for aural nulls is eliminated. The operator can read the signal as he takes the bearing, and thus determines the type of transmission, the strength of the signal, the existing noise level, and numerous other wave characteristics common to radio transmission.

The modified U-Adcock-type antenna used with the set consists of five antenna masts. Four are installed on the corners of a square measuring approximately 25 ft. on each side, and provide two directional pairs of antennas. The fifth mast is placed on the intersection of the diagonals between the corner masts. The five antennas are con-

nected to the goniometer by phase-inverter coupling units and r-f transmission lines. Each phase-inverter coupling unit is installed between the twin coaxial transmission lines and the antenna to combine impedance matching and aperiodic operation. It thus provides a uniform transfer of energy throughout the entire frequency range of the equipment with minimum attenuation from the long transmission lines.

The goniometer is a series of r-f transformers which eliminate the necessity for revolving the antenna. It is composed of six specially designed coils, the coils being wound at critical angles on a special stator. The coils are connected to the two pairs of balanced coaxial transmission lines, which in turn are connected to the antenna.

The coils, arranged so as to eliminate the need for slip rings and brushes, which are often delicate and troublesome, operate in conjunction with the motor-driven rotor to provide the same effect as

that obtained by rotating the antennas manually. With the signal properly tuned and the sensitivity adjusted, there appears on the cathode-ray screen a pattern similar to a twin leaf.

The sharpness of the points of this pattern depends on the signal polarization and the effect of surrounding structures on this polarization. The twin-leaf pattern on the screen shows both the true bearing and its 180-deg reciprocal. To distinguish the true bearing from the reciprocal, the fifth antenna is connected through the goniometer so as to change the appearance of the pattern when the sense switch is pressed. It is this pattern change which indicates the true or actual direction of the transmitting agent.

While this equipment is subject to errors resulting from conditions of atmosphere and terrain, it has proved quite satisfactory from a mechanical point of view, and is so simple in operation as to perform reasonably accurately even when operated by relatively inexperienced personnel.

#### Determinations Possible

The operations of a d-f system are usually such as to provide one

or more of the five following types of bearing: A true bearing from the d-f station to the transmitting agent, a true bearing from the transmitting agent to the d-f station, a magnetic bearing from the d-f station to the transmitting agent, a magnetic bearing from the transmitting agent to the d-f station, and a geographical fix.

The first of these are two bearings secured with respect to true north; the third and fourth are obtained with respect to magnetic north. Since greater simplicity of net operation is realized when reported bearings are true rather than magnetic, AACS d-f stations are being installed and oriented so that the equipment automatically furnishes a true bearing.

When a magnetic bearing is desired, the operator must compute it from the true bearing obtained by the equipment. In order to guard against mistakes on the part of operating personnel, there is being developed a simple computer which, once it has been set to the magnetic declination existing at the station where it is used, will automatically indicate the magnetic bearing.

The ideal site for a direction finder would be the center of a uni-

form plane of good conductivity. This type is rarely found in practice, but good operation can be obtained from the average site if the operator is acquainted with the compromises that can be made.

#### Installation Factors

In selecting a site, the final criterion is, of course, the actual performance of the d-f station. To save time, the best site within the area in which the d-f station is to be installed is selected by visual inspection. Such inspection takes into consideration the suitability of the site with regard to its size and shape, its receiving qualities and capabilities, the character and homogeneity of the soil, and the signal-to-noise level.

Proper selection of the d-f site is of utmost importance to the accurate operation of the equipment. The following notes will serve to illustrate the types of serious error that may result under certain conditions:

*Coastal Effects.* A station located a few miles inland will find unreliable such bearings as are secured on radio waves which cross the coast line at acute angles.

*Topographical Features.* Hills or

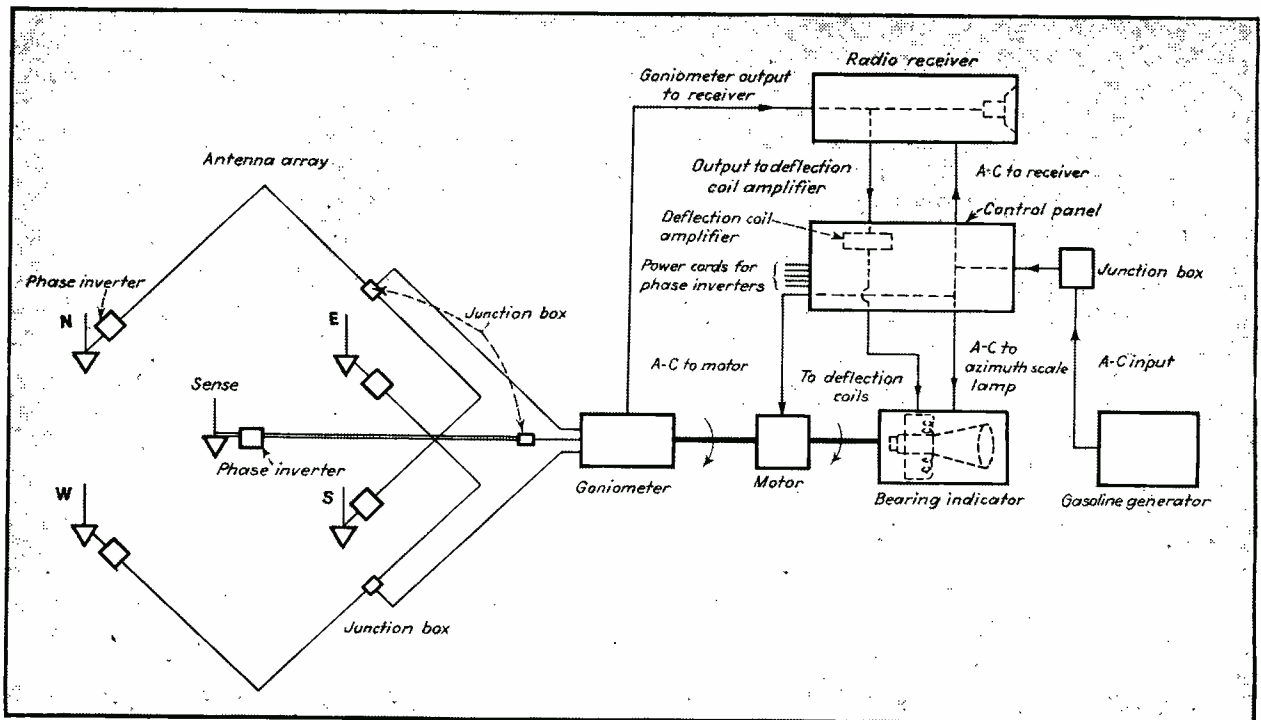

Functional diagram shows connections between parts of AACS direction-finder station. Signals from the antenna array pass through the goniometer to the receiver and from there to the deflection coils and the indicator which provides the bearing required



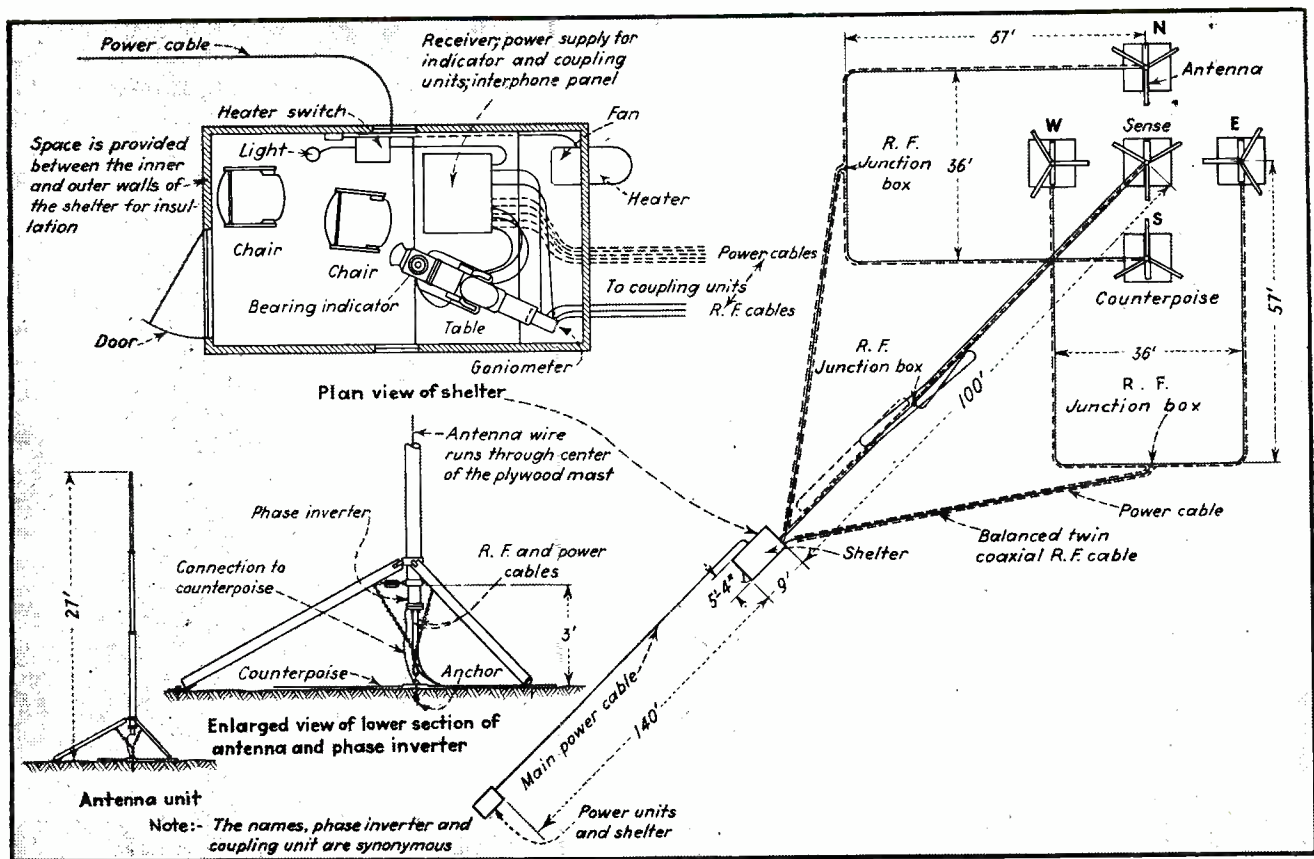

Plan of direction-finder site, giving detailed disposition of components with dimensions

mountains adjacent to d-f stations often produce constant or fluctuating bearing errors. Sites within one wavelength of cliffs or large rocky out-croppings will render bearings inaccurate with respect to wave-length, angle of elevation, and azimuth.

**Adjacent Structures.** Large buildings, overhead wires, metallic fences, and trees can have a very appreciable effect on the accuracy of d-f bearings. Every effort is made to install the equipment such a distance from obstructions of this nature as to avoid the possibility of error.

**Ground Characteristics.** A uniform, highly-conductive soil acts as a mirror for radio waves, thus attenuating the abnormally polarized components of the wave and preventing path distortion of the incoming wave. For this reason flat, salt marshland is far more desirable for d-f purposes than other types of soil. Practical difficulties normally encountered in such areas, however, usually preclude their use as d-f sites. Rocky or sandy soil is most unsuitable for d-f work by reason of changes and non-homoge-

neity in its electrical conductivity.

In addition it frequently has been found that sites which visual inspection would indicate to be inadequate furnish quite satisfactory bearings, and that sites which seem to be ideal produce large bearing errors. This is due to a number of technical considerations which are too involved to be discussed here.

After the equipment is installed, it is calibrated before being put into regular operation. This calibration is effected by means of either a target transmitter, distant fixed radio stations, aircraft, or any combination of the three.

The equipment at AACS d-f stations is calibrated by having an airplane circle the set at a distance of approximately 10 miles. The bearing of the airplane is observed visually through a surveyor's transit or a theodolite, and a d-f bearing is obtained at the same time. This process is completed at 4 or 5 degree intervals for 360 degrees of the compass, after which an error curve is prepared from the differences noted in the two sets of bearings.

It is readily apparent that the proper selection of sites constitutes

a most serious problem for the AACS. Its stations must be situated along the air routes—in mountainous areas, or sandy beaches, in ice-covered regions, and desert expanses. Operating personnel often find it necessary to install and disassemble d-f equipment many times in an area before a satisfactory site can be found.

#### Scope of Operation

As the AAF air routes encircle the world, the AACS expands with them. These routes include long flights over both tropical and arctic oceans, as well as overland flights through dangerous jungle and mountainous countries.

Installation of the individual stations has progressed to such a point that in the very near future an army pilot will be able to fly almost anywhere in the world and expect a reply to his request for a bearing.

One of the major problems concerns the communications system to be employed for collecting the individual bearings for plotting purposes. It goes without saying that such a system must be rapid and efficient if it is to provide a fix to

an airplane before the ship has traveled too far from the point at which individual bearings were taken. While the most satisfactory method would prescribe separate communications facilities for each net installed, in terms of world-wide coverage this becomes impractical, expensive, and undesirable, particularly where there are already in existence AACs radio stations which might be used for this purpose.

Procedures have been established to permit certain existing radio stations to act during d-f operations as communication agents for d-f nets in addition to fulfilling their regular operational requirements. This has worked quite satisfactorily up to the present.

It should require usually only a matter of a few minutes—seldom over ten—from the time an aircraft requests a geographical fix to the time the fix is delivered to it.

Further difficulties involve the proper interpretation of ionospheric effects on the incoming signals. While this problem can never be completely solved, action has been initiated which will lessen these effects.

The program planned by the AACs is concerned primarily with long-range operation employing the

sky wave. The ionospheric or Heaviside layer reflects the high-frequency waves back to the earth and certain disturbances in this region tend to affect these reflections by distorting or blocking them. As it will at once be seen, this is of great importance since d-f equipment, which indicates only the direction from which the incoming signal is being received, will translate into bearings both accurate signals and those that are reflected inaccurately from the ionospheric regions.

Ionospheric sounding stations located strategically throughout the world will aid in solving this problem by providing forecasts of ionospheric conditions to be expected in various areas and thus permit a more accurate interpretation of bearings affected by these conditions.

Still another major problem was presented with regard to the proper frequencies for d-f operation. The distance between the end of the ground wave and the beginning of the reflected sky wave is called the skip zone. Within this skip zone, communications are said to be impossible, but sporadic E conditions, scattered reflections or ionospheric storms often permit communication in part or all of the zone. Bear-

ings obtained from transmissions within this space, however, are faulty and require correction by means of skip distance charts predetermined for each frequency during each of the six four-hour periods of the day.

Most reflections are controlled by the F<sub>2</sub> layer. This is the layer nearer the sun and for that reason is ionized to a greater degree. Sometimes during daylight hours, however, the E layer (the one nearer the earth) controls these reflections. In plotting frequency-skip curves, the maximum usable frequencies and the optimum working frequencies are first found for each ionized layer. The optimum working frequencies for each four-hour period are then compared. The layers possessing the larger number of optimum working frequencies are then selected as the controlling layers for the various four-hour periods.

Skip-distance charts are being prepared to enable d-f evaluators of each net plotting station to ascertain the frequency characteristics of the satellite stations whose bearings it receives for evaluation.

As previously stated, the greatest benefit to be derived from direction finding is the position fixing of air-

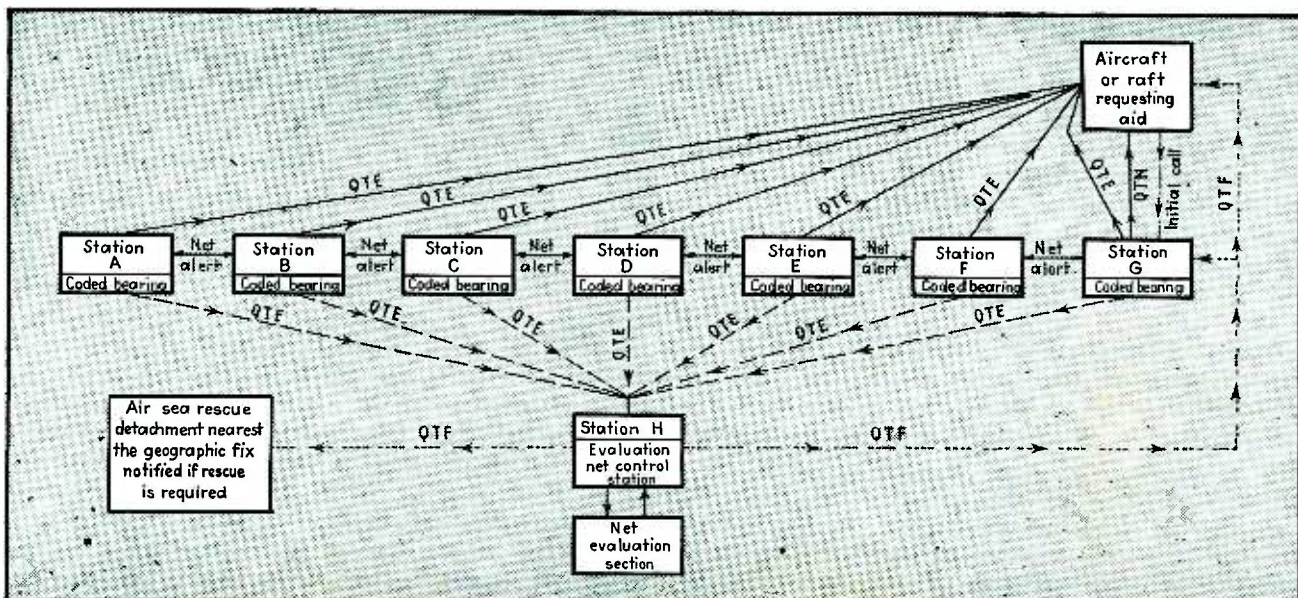

Typical action sequence of a d-f net follows the notations on this chart. Aircraft at upper right makes initial call for d-f fix, and station G alerts all other stations in the net on point-to-point frequencies or land lines. Next, the called station (G) requests the aircraft to transmit call signs and dashes (QTN) by which all net stations obtain bearings (QTE) and report

them to the evaluation net control station (H) where geographical fix is plotted. Finally, the fix is reported (QTF) directly to the aircraft if contact can be established, or otherwise to the originating station. If the plane has crashed or if the transmitter is on a life raft, the fix is reported directly to the air-sea rescue detachment nearest the fix (QTF)



craft in flight. In order to use its equipment to the fullest in the accomplishment of this, the AACS first assigns to the various air routes, areas of 1000 to 1500 miles in diameter. It then establishes within each area a net consisting usually of five or six strategically-located individual reporting stations and a central plotting station.

The reporting stations will be from 100 to 600 miles apart, depending upon the size of the area. In many cases, of course, it is impossible to install these individual stations at ideal distances, either because locations cannot be found (as in mid-ocean) or because point-to-point communications do not exist or cannot be used.

#### Operation of Nets

The most desirable arrangement for net stations in an operational area 1000 miles in diameter consists of a reporting d-f station installed on each corner of a square measuring 600 miles on each side. The evaluation station with its adjacent d-f reporting station (the fifth in the net) should be located at the intersection of the diagonals between the corners. Such an arrangement is seldom if ever possible in actual practice, and over long ocean routes and in foreign countries the right-angle bearings so important to plotting a fix are sometimes unobtainable.

A geographical fix, to be accurate, must have a series of intersecting base lines (individual bearings) from angles as widely separated as possible. If each of them is accurate, only four or five bearings are needed to provide an excellent fix. A larger number of bearings would prove cumbersome and retard the speed of net operation. On the other hand, if the direction finders furnishing these four or five bearings are not properly located, the resultant fix will suffer in accuracy.

For example, let us assume that a net of six stations has been placed in operation and that these stations are spaced from 200 to 400 miles apart in a fairly straight line. A very satisfactory fix could be given to an aircraft located approximately 300 miles out on a line perpendicular to the axis line drawn between the stations—if a majority of the

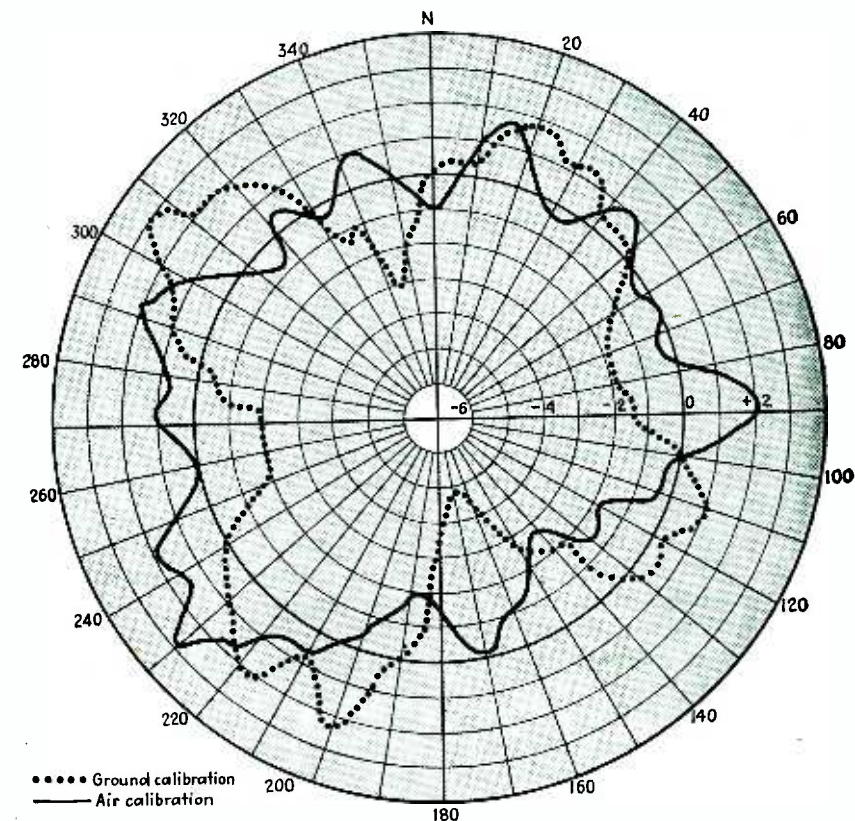

Ground and air calibration procedures produce two sets of figures which are plotted on circular or linear forms to show error in degrees around station. A third curve is later added to represent computed average error

stations obtained accurate bearings.

On the other hand, if the aircraft were 800 miles from the axis line, a poor fix would result unless other nets were employed to provide the necessary right-angle base lines.

In this assumed net an airplane proceeding along the axis line joining these stations would be in such a position that it would be almost impossible for the stations to secure a good fix, again because of absence of right-angle base lines.

It is clear, then, that care must be taken to locate the various installations so that they can provide multilateral coverage. To obtain this coverage it has been necessary to set up installations at points located well off the established air routes. This provides sufficient depth to offset the detrimental factor of skip distance and provide right-angle base lines in a greater number of cases.

It is possible, of course, that more than one net may be operating along the same air route. Under these conditions it will sometimes happen that an aircraft requesting a fix is so located that its position

cannot be accurately determined unless bearings are obtained from two or more nets. The procedure governing operation of nets has therefore been developed to include regulations for inter-net coordination.

It thus becomes possible to obtain individual bearings necessary for a fix from all d-f stations receiving the transmitted signal and to report such bearings to the plotting station concerned. Inter-net operation does, it is true, involve a greater time loss, but this delay is justified by the importance of satisfactory operating coverage.

#### Tracking Charts for Plotting Fixes

The success of a d-f net system depends in large measure on the type of chart employed in plotting the individual bearings. As AACS operations were planned to cover larger distances, the gnomonic projection type chart was selected for this purpose.

A gnomonic chart is a projection of a given area of the surface of the world as it would appear if viewed from the center of the earth.

Direction-finding stations are shown in their proper locations in a particular area and provided with compass roses arranged so that a straight line drawn from any station through its corresponding compass rose will result in a true great circle path.

The evaluating or plotting station of each net is furnished with gnomonic tracking charts which represent the area covered by its net and include the d-f stations with their compass roses. As the bearings are reported by the reporting stations they are entered on one of these tracking charts and evaluated into a fix. Since a new copy of the chart is used for each fix requested, there is provided a permanent record of all fixes evaluated by each plotting station.

The making of these tracking charts is a most complicated and detailed process. The AACS is fortunate in having its charts prepared by both the Hydrographic Office of the Navy Department, and the Aeronautical Chart Service of the Army Air Forces, to which it sends data as new charts are required.

#### Things to Come

Since the beginning of the war, stories have been told in great num-

ber of people drifting helplessly for days on a tiny life raft in the middle of the ocean. Happily, some of them have lived to recount the horrors of their experiences. When a ship is sunk or an airplane forced down on the water, the survivors can only wait in lifeboats or rafts until they are discovered by searching parties or a passing ship.

Imagine then what it would mean under such conditions to have an emergency transmitter, capable of long distance communications, particularly if shore-based direction finders could obtain a fix on its transmission. The AAF is developing a program to provide such transmitters.

The apparatus is powered by a manually-operated generator, and when used on a high frequency will operate over considerable distances. Equipped with this set, a party in a life raft will be able to transmit signals from which shore-based direction finders can compute a geographical fix—to be sent immediately to the nearest sea rescue organization.

The same method is employed to secure bearings and determine a geographical fix on a life raft as on an aircraft in flight, and the large-scale production of the proposed

emergency transmitters will unquestionably prove of tremendous assistance to the men who must make the long, dangerous flights that are inevitable in this war.

#### Conclusion

The many and complex problems inherent to the placing in effect of such a huge program are too detailed to be treated at any length in this discussion. By the very nature of its operations, which must be accurate in the extreme, radio direction-finding suffers from conditions which do not prove deleterious to the efficiency of ordinary radio communications.

Some of these conditions can in certain instances be anticipated and thus corrected or minimized. Others must remain factors constantly limiting the consistent accuracy and efficiency of the equipment.

Fully conscious of these limitations and the difficulties it will have to face, the AACS continues to expand its facilities. The value of direction-finding in emergencies, in aiding disabled or lost aircraft, more than compensates for every expenditure of time, money, and energy incidental to the installation and operation of the equipment.

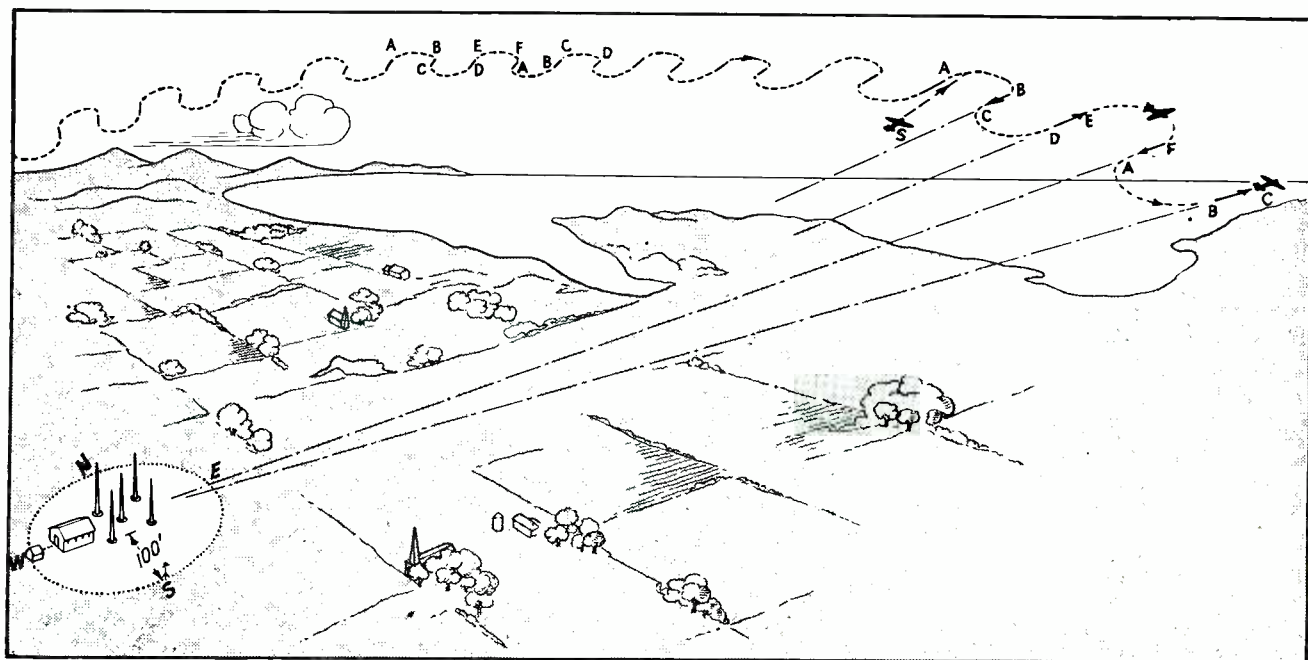

Method of air-calibrating a d-f station involves a theodolite at point S and an aircraft flying at 5000-ft. altitude 10 miles from the d-f station. Sequence, which is repeated throughout, is as follows: From A to B, aircraft transmits a series of single dots

while approaching course. From B to C, D to E, and F to A, while on course, ten-second dashes are sent. From C to D are transmitted a series of two dots and from E to F, a series of three dots



# RTPB on FM

Panel 5 reaffirms existing standards of transmission, and proposes allocation of a continuous band of 80 to 100 channels, each 200 kc wide, from 40 Mc upward. "Bursts" and multipath distortion are found to be of minor importance

**T**HE V-H-F Broadcasting Panel of the Radio Technical Planning Board has issued its report on post-war plans for frequency modulation. The Panel recommendations make no break with past practice, since all the basic standards of transmission are reaffirmed, and one additional standard proposed. In the matter of proposed frequency assignments, a conflict arises with the previous recommendations of the RTPB Television Panel, in the region of 50 to 60 Mc. Here the proposals of the two groups overlap somewhat, with the amateurs sandwiched in between.

## Recommendations

The specific recommendations of the FM Panel are as follows: (1) Frequency modulation is the system best suited for v-h-f broadcasting. (2) The f-m broadcast band should extend upward from approximately 40 Mc. (3) The width of each f-m channel should be 200 kc (this implies 75 kc maximum frequency swing and 15,000 cps maximum audio frequency). (4) From 80 to 100 channels are necessary for a national allocation, allowing for educational stations as well as commercial broadcasters. (5) The direction of polarization should be horizontal.

Sudden increases of signal strength lasting from a fraction of a second to several seconds have been noticed recently on distant stations operating in the 40 to 50-Mc band, due possibly to reflections from ionized patches caused by the passage of meteors. It was argued that the existence of such bursts of interference, as well as the probable increase of long-distance propagation at times of sunspot maximum (every eleven years)

would cause difficulty to f-m service if the present region between 40 to 50 Mc were preserved for future use. The issue was finally referred to Dr. J. H. Dellinger of the Bureau of Standards, who reported that the existence of short bursts of long-distance interference is probably closely connected with sporadic E reflections in the ionosphere, and thus not connected with the sunspot cycle. In any event, he stated, the effects were not prevalent enough to impair the value of the frequencies seriously. He stated further that no frequency in the spectrum can be said to be free of transmission vagaries.

The Panel discussed at some length the multipath distortion effects reported by DuMont, which arise when a wave reflected from a building or other structure arrives at a receiver in strength comparable to that of the directly propagated wave, causing wave cancellation and a-f distortion. The panel came to the same conclusion reached earlier by the Television Panel, namely that such effects could be found, but that they were not sufficiently prevalent to warrant any change in the method of modulation or in the frequency swing.

## Channel Width

A reduction of the channel width from 200 kc to 100 kc was discussed at length. The advantages claimed are reduction in the amount of ether space for the required 80 to 100 channels, consequent improvement in image rejection, reduction in multipath interference effects, and higher gain per stage in i-f amplifiers without loss in interchannel selectivity. The disadvantages are a loss of 6 db in signal-to-noise ratio throughout the service area,

a reduction of the service area within which 60-db maximum signal-to-noise ratio could be realized at the receiver, and a two-to-one decrease in the permissible frequency tolerance of the local oscillator in push-button operated receivers. The possibility of multiplex operation on the f-m channel would also be removed if the channel were reduced.

It was brought out that the optimum frequency swing for 60-db maximum signal-to-noise ratio (assuming a maximum modulating frequency of 15,000 kc) is about 125 kc, a figure considerably greater than the 75-kc swing now used and proposed for future standardization. The 125-kc swing permits the greatest area to be served with 60 db signal-to-noise ratio. Smaller swings, e.g., 75 kc, serve a smaller area with this signal-to-noise ratio, but a larger area with somewhat lower signal-to-noise ratio. The choice is thus a compromise between space used in the spectrum and area covered with the desired low level of noise interference.

The proposed number of channels for a national allocation, 80 to 100 channels, is based on a service comparable in scope to the present system of standard broadcasting, in which 105 channels are available. The greater interference radius of the standard broadcasting frequencies makes it impossible to provide noise-free service from all stations, particularly at night. Therefore a smaller number of f-m channels can be expected to give an equal or greater choice of program with virtually no interference at any time. Of the channels proposed, about 15 are expected to be reserved for educational stations.

The proposal to standardize on horizontal polarization is a distinct step forward, and should ultimately correct the present situation in New York, where eight f-m stations are about equally divided between vertical and horizontal polarization, making it difficult if not impossible to obtain optimum reception from all stations with a single receiving antenna.

# FREQUENCY-SHIFT Radiotelegraph

Frequency-shift transmission of telegraph, teletype, facsimile and radio-photograph signals provides the advantages of f-m over a-m without the usual increase of bandwidth. A special circuit eliminates the effect of mean-frequency drift. A limiter that is free from loading and transients is described

**C**OMMERCIAL radio communication by Morse Code has been standard since the advent of radio. The dot-dash system has never been entirely superseded by voice. Though code has its drawbacks and is subject to error in transmission, and requires highly schooled personnel, it is still the basic means of handling high-speed commercial and press traffic.

Anyone who has operated on noisy long-distance circuits realizes how much more accurate it is to receive by ear than by automatic slip recorders. When the signal is strong and no noise is present, tremendous speeds may be attained by using automatic equipment, but if the noise level rises, automatic equipment fails, speeds decrease and manual operation must take over; traffic piles up.

Developments over the past five years have produced a new system of automatic code transmission and reception which performs electronically what the human ear or brain does with a signal in the presence of noise. This system reaches in and picks out the signal despite the noise.

#### Noise Suppression Without Increased Bandwidth

Everyone is familiar with the improvements in signal-to-noise level in broadcasting that frequency modulation provides over amplitude modulation. Frequency modulation presents only one disadvantage, the required bandwidth is over ten times that required for a-m systems. Developments in the

transmission of telegraph signals are now being made which are analogous to f-m broadcasting. Instead of keying a carrier on and off to designate the mark and space of telegraph signals, the transmitter maintains radiation at full power, but the carrier is shifted back and forth between two distinct frequencies to designate mark and space. The same beneficial reduction in signal-to-noise ratio is derived in transmitting telegraphy in this manner as is derived from f-m broadcasting. However, in regard to bandwidth the analogy fails. The bandwidth required by frequency-shift transmission is no greater than that required by the carrier make and break system.

This new type of transmission is not only applicable to the transmis-

sion of telegraph signals, but can also be used for transmission of teletype mark and space signals, or for facsimile where one radiated frequency corresponds to black and the other to white. This system can be extended further to the transmission of radio photographs. In this application the half tones are represented by frequencies intermediate between the extreme black and white frequencies.

#### Early Use of Frequency-Shift

Frequency-shift transmission was used long before it was recognized as such. In the days of arc transmitters it was impossible to interrupt the arc in accordance with telegraph signals, so instead the frequency of the transmitter was shifted during the space. Here

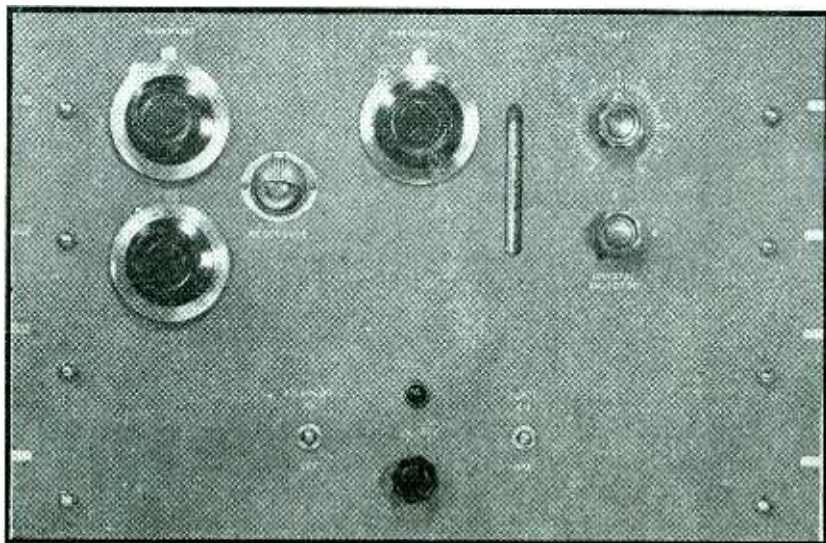

Front panel of frequency-shift transmitter terminal equipment used by Press Wireless, Inc.



By **ROBERT M. SPRAGUE**

*Director of Research  
Press Wireless, Inc.  
Little Neck, New York*

# and Teletype System

was true frequency-shift transmission, but at the receiver no use was made of the all-important space wave. By the late 1930's the advantages which seemed inherent in this system were being developed in the laboratory.

When the Byrd South-Pole expedition of 1939-1940 was about to leave, equipment from Press Wireless laboratories was rushed into readiness and, with Times Wide World wirephoto equipment, was sent along with the expedition. Pictures published in daily newspapers during the expedition gave ample proof of the effectiveness of this type of transmission. Pictures coming over 8000 miles from a small 500-watt transmitter were received with the clarity of standard wirephoto pictures. Further developments were made over circuits from Berlin, Moscow, London and Chungking. Such transmissions are now commonplace.

Frequency-shift transmission for radio telegraph was slower in coming, but when it was proved that a 20-db increase in signal-to-noise ratio was available, the system was applied to this service. Now many

commercial circuits are operating both telegraph and teletype by means of carrier shift.

### Frequency-Shift Transmitter

Several types of carrier-shift equipment are being used. The transmitting equipment developed by Press Wireless, Inc. takes energy from a crystal oscillator and beats it against an extremely stable self-excited 200-kc oscillator. The frequency of the self-excited oscillator is shifted by the signal which is to be transmitted, being increased in frequency on mark and decreased on space.

The incoming signal, usually in the form of a square wave, is filtered to eliminate frequencies higher than the third harmonic of the highest keying frequency required. The filter must be designed so that the fundamental to third harmonic phase relation is not changed. Such filtering introduces only 1.35 percent characteristic distortion, and aids in reducing the bandwidth which must be transmitted.

From the output of the mixer stage of the crystal oscillator and

the self-excited oscillator, the upper side band is selected and applied to doublers and power amplifier stages of the transmitter, and radiated on frequencies varying symmetrically about the assigned frequency.

A frequency shift of 850 cycles has been adopted as standard because it gives the best compromise between signal-to-noise level and bandwidth. However, this shift is varied between 400 cycles and 1200 cycles for special services. For example, high-speed facsimile and photograph services use a 1200-cycle shift.

### Transmission Bandwidth

Consider the bandwidth for the case of teletype, the signal for which is a 23-cycle fundamental and a third harmonic of one-third the fundamental amplitude. If the carrier were keyed make and break by this signal, the ideal bandwidth would be twice the third harmonic frequency, or 138 cycles. Such a narrow band is never attained because the amplifier stages of the transmitter tend to square the keying signal. The best possible transmitter adjustment will require a bandwidth of approximately 1200 cycles. Only side bands greater than 40 db below the unmodulated carrier level are considered in this value. If, on the other hand, the carrier is shifted 850 cycles by the teletype signal, the emitted bandwidth is 1100 cycles. Were the carrier shift reduced to 250 cycles with the same signal, the emitted bandwidth would be only 480 cycles. Thus frequency shift can result in a much lower bandwidth than carrier make-break.

The calculation of frequency-shift bandwidth is comparatively simple. Assume that the carrier is shifting from mark to space frequencies sinusoidally, for teletype at a frequency of 23 cps. This is equivalent to frequency modulation

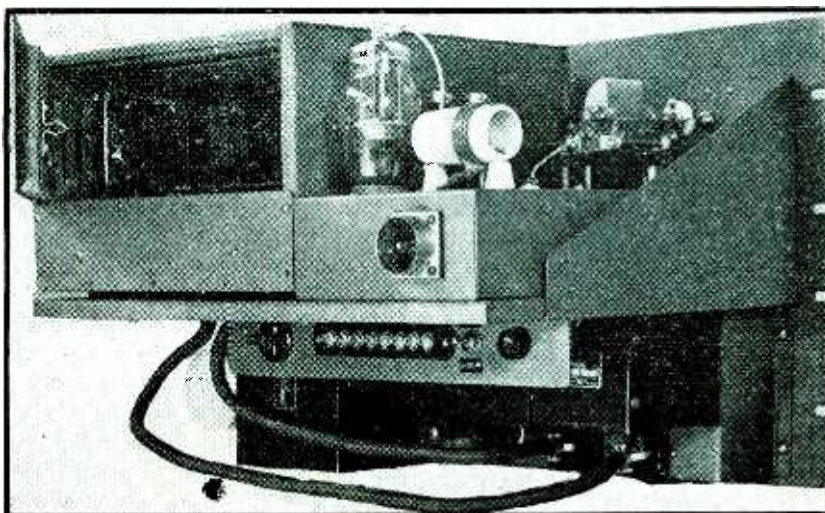

Rear view of frequency-shift transmitter unit showing crystal oven and shifting oscillator

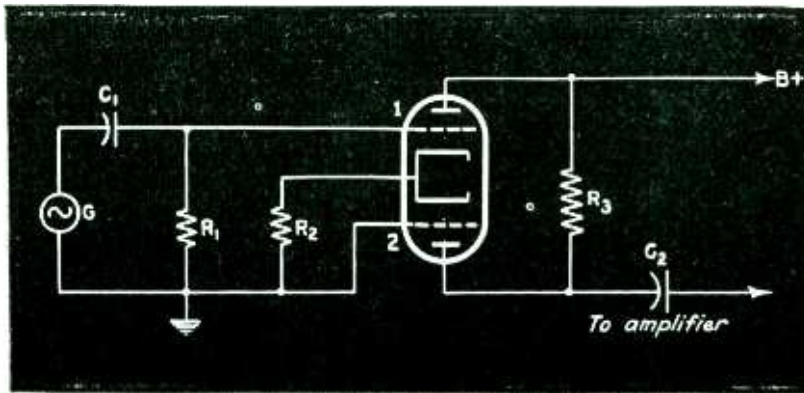

FIG. 1—Transient-free limiter in which the first section of the double triode limits the negative peaks, and the second section, cathode-coupled to the first, limits the positive peaks

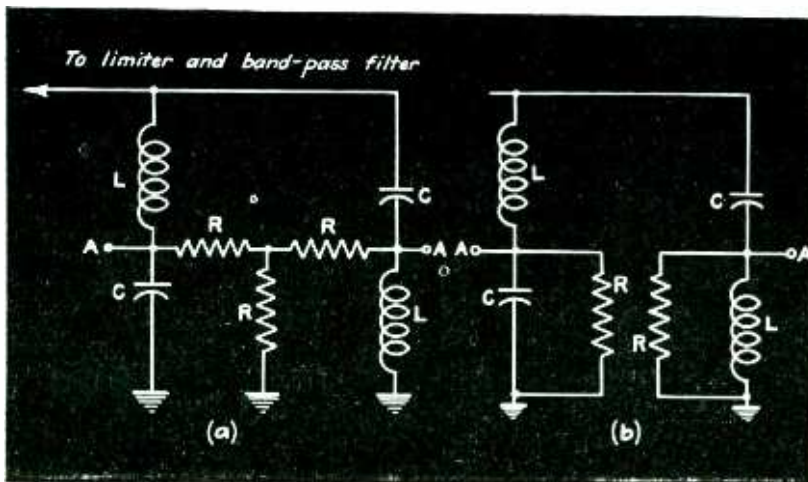

FIG. 2—Two forms of discriminator. The discriminator for frequency-shift reception must be flat over a band far wider than the deviation limits, so as to avoid amplitude modulation in the output produced by the noise in the input

of a carrier whose frequency lies midway between the mark and space frequencies, by a 23 cps signal. The modulation index  $B$  is the deviation from the carrier frequency divided by the modulation frequency. For a total shift of 460 cycles,  $B = 230/23 = 10$ . Under this condition there are 14 pairs of side frequencies greater than 40 db below the unmodulated carrier level. Therefore, the bandwidth is  $23 \times 28 = 645$  cycles.

Now consider the third harmonic along with the fundamental. The keying wave is a signal of varying frequency and amplitude. At any instant the transmission band is determined by the instantaneous frequency and amplitude of the keying wave. Therefore, the transmission band varies between maximum and minimum values. The maximum instantaneous keying frequency, with its corresponding amplitude, deter-

mines the transmission bandwidth. This maximum instantaneous frequency in this case is 1.5 times the fundamental frequency, and its amplitude is equal to the amplitude of the keying wave. Therefore, the deviation is the same as for the actual keying signal.

The corresponding modulation index is  $B' = \Delta F/1.5 f$ . This value can be used to calculate all bandwidths where the keying wave is composed of a fundamental and its third harmonic. Returning to the original example,  $B' = (B/1.5) = 6.67$ , and the maximum instantaneous frequency is  $f' = 1.5 f = 34.5$ . For a  $B$  of 6.67 there are ten significant pairs of side frequencies, and therefore the maximum bandwidth is  $20 \times 34.5 = 690$  cycles.

#### Frequency-Shift Receiver

The receiving systems of various commercial companies using fre-

quency-shift transmission are similar in principle, but use different types of equipment.

Press Wireless, Inc. uses an a-m communications receiver which receives the radio signal and delivers an audio beat note to a band-pass filter. The beat note shifts in frequency about a mean frequency of 2550 cycles in accordance with the transmitter frequency variations. The band-pass of the filter must be wide enough to pass not only the two frequencies between which the audio beat-note shifts, but also all sidebands produced by the frequency modulation which are one-tenth or more of the carrier level. It must also be wide enough to tolerate possible transmitter or receiver drift. Noise signals outside the band are not completely eliminated but, due to filter transients, are reintroduced as signals of much lower amplitude and at frequencies within the filter pass-band.

#### Transient-Free Limiter

From the filter, the signal goes to a power limiter. The requirements of this limiter are much more stringent than those of the rf limiter used in f-m broadcasting because the carrier and intelligence frequencies are comparable. Thus transients must be extremely short compared to both carrier and intelligence frequencies.

Such a limiter is shown schematically in Fig. 1. The tube is a dual high-mu triode. Consider the effect of a high-amplitude signal applied through capacitor  $C_1$  to the grid of the first section. Small negative voltages cut off the tube and so the voltage across  $R_2$  due to current in the first triode is zero during most of the negative half cycle. The load resistance of the generator is only  $R_1$ . As the grid swings positive with respect to ground, the tube space current increases, increasing the voltage across  $R_2$ .  $R_2$  is made sufficiently large so that at no time does grid voltage exceed cathode voltage. Thus the grid never goes positive with respect to its cathode, and the generator load is still only  $R_1$ . Since no grid current flows, no charge appears on  $C_1$  which must leak off through  $R_1$  in accordance with the time constant  $R_1 C_1$ . Therefore the circuit is instantaneous in its action and no transients result.



Also, the load presented to the generator remains constant.

As the voltage across  $R_2$  increases because of positive swing of the first grid, the second triode is cut off. This second triode is essentially a cathode drive stage excited by the first triode acting as a cathode follower. The gain of the second triode is low because its plate resistor  $R_3$  is small. It cuts off at about the same positive swing of the first triode grid as does the first triode for negative swings of its own grid. Therefore the action of the limiter is symmetrical about the zero axis, and is both transientless and instantaneous for any abrupt level or frequency change. The limiter gives about 30 db of limiting. Two limiter stages separated by a class A amplifier supply the needed 60 db of limiting.

**Discriminator Requirements**

Once the signal has been limited, it is fed into a sloping discriminator circuit prior to detection. The requirement of the discriminator is that it be linear over a frequency range far in excess of the deviation band. It need not be the back-to-back variety which is symmetrical about zero, zero voltage corresponding to the mean frequency. Following is the argument for these statements.

In f-m receivers, the tuned circuit following the limiter is usually part of the discriminator circuit. The circuit is linear only over the deviation band. Beyond this band, the response of the tuned circuit falls rapidly to zero. Therefore, any signal outside the deviation

band is not received by the detector. With an input level variation of 60 db the limiter delivers a constant output. Whether the input consists of one or a thousand frequencies, the output energy is constant and is made up of one or a thousand frequencies. With one frequency fed into the limiter, the output is of the same frequency, plus its odd harmonics due to the wave squaring of the limiter. But when noise is present, side bands of the original signal become evident, and these side bands extend far beyond the band-pass filter, which accepts noise at the input of the limiter. The greater the intensity of noise in relation to the desired signal, the greater the amplitude of these side bands, and the greater their coverage of the spectrum beyond the deviation band.

In f-m receivers the tuned circuit following the limiter eliminates these frequencies which lie outside the deviation band. Since the energy output of the limiter is constant, the output of the tuned circuit following the limiter must change in amplitude as noise is impressed with the signal on the limiter input. This amplitude change will be as evident after detection as will be the desired change due to frequency modulation. Therefore, a back-to-back discriminator is required.

Such a discriminator operates in push-pull for frequency changes, but in push-push for noise-caused amplitude changes. These latter, therefore, tend to balance and be eliminated. The discriminator need not be linear beyond the deviation

band, as no side bands are present, having been filtered out by the tuned circuit following the discriminator. Notice that the back-to-back discriminator is superior to a single-ended non-symmetrical discriminator only in suppressing the amplitude-modulation effects of noise, and not phase or frequency-modulation effects. These latter effects are additive in each half of the back-to-back discriminator and no noise reduction results.

**Single-Ended Discriminator Preferred**

In many commercial types of converters, the limiter is followed by a single-ended slope circuit. No attempt is made to eliminate noise sidebands outside the deviation spectrum. When such a discriminator is used, it must be of the extended range type, i.e., it must be linear far beyond the deviation band so as not to discriminate against noise components. Otherwise, amplitude modulation resulting in noise will result. Under these conditions, no advantage whatsoever accrues from the use of a back-to-back discriminator. After the discriminator and detector, the signal should be fed through a low-pass filter to eliminate noise caused by phase modulation of the signal at frequencies higher than the desired intelligence frequency. For teletype this filter passes the third harmonic, which may be 70 to 100 cps; for high speed Morse, 250 cps, and for photograph and facsimile, 600 cps.

An extended-range, single-ended discriminator eliminates all amplitude modulation due to noise, but

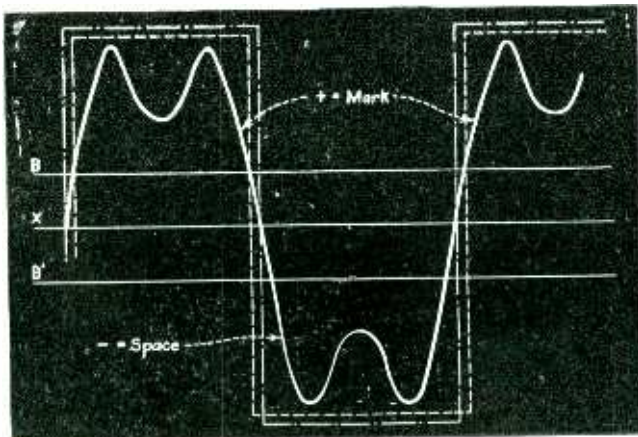

FIG. 3—The pulse consists of the fundamental and third harmonic. Pulses should vary about the central axis

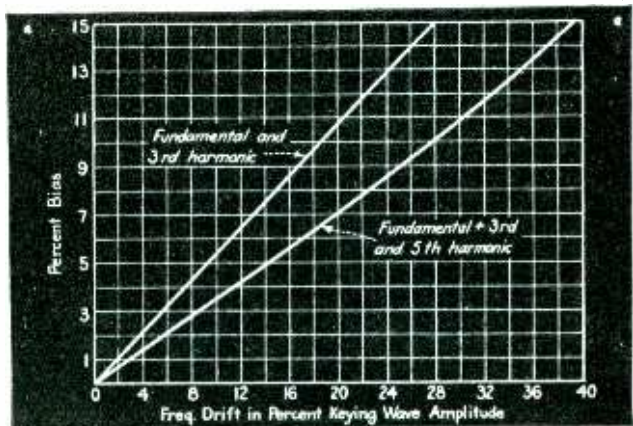

FIG. 4—Bias introduced by transmitter or receiver frequency-drift for two types of keying waves

accepts a wider band of noise to phase-modulate the signal, whereas the pre-filtered back-to-back discriminator only partially eliminates amplitude modulation due to noise, but limits the band of noise to phase-modulate the signal. Experiments have shown a small but definite advantage in the latter type; therefore its use is recommended in all types of terminal equipment for teletype, photo and facsimile.

Such a discriminator is shown in Fig. 2(a). The differential voltages to be detected are taken off at points A. In both Fig. 2(a) and 2(b), the input impedance of the discriminator is a constant over the band equal to  $R$ .  $L$  and  $C$  are given by

$$LC = \frac{1}{\omega^2} \quad \frac{L}{C} = 2R^2$$

where  $\omega$  is  $2\pi$  times the cross-over frequency. The configuration of Fig. 2(a), although it does not give linear response over as wide a frequency range as does that of Fig. 2(b), delivers a higher output voltage and is perfectly symmetrical.

#### Frequency-Drift Compensation

The output of the detector and noise filter is the recreated pulse that originally keyed (frequency-shifted) the transmitter. If the mean frequency of the signal being fed to the converter equals the cross-over frequency of the discriminator, the pulse will alternate symmetrically about a zero axis. The solid curve of Fig. 3 represents such a keying signal, composed of fundamental and third harmonic, oscillating about the  $X$  axis. A local oscillator may be arranged to key on and off around this zero axis. However, if the frequency of the receiver or transmitter drifts so that the mean frequency no longer corresponds to the discriminator cross-over point, the local oscillator will no longer key on and off symmetrically about the  $X$  axis, but about some other axis  $B$ .

When keying takes place about the  $X$  axis, a square wave shown by the dot-dash line results from the fundamental-third harmonic keying wave. This square wave is unbiased. That is, for equal mark and space of the transmitted wave, the square-wave mark and space are

equal. However, when keying about the  $B$  axis, it can be seen that mark and space are no longer equal and a bias (expressed in percent as 100 times mark-length minus space-length, divided by mark-length plus space-length) results. For an acceptable minimum number of errors, teletype signals can contain no more than 5 percent bias; therefore, any frequency drift will result in more errors.

Figure 4 shows the bias introduced by transmitter or receiver drift expressed as a percent of the frequency shift for the fundamental-third harmonic keying wave and for a fundamental plus third and fifth harmonic keying wave.

To eliminate bias due to frequency shift, the circuit shown in Fig. 5 is used. Here the keying

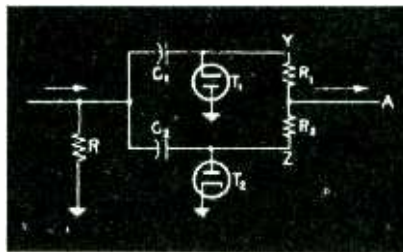

FIG. 5—Balancing circuit used to center the received pulse about the zero potential axis in the event that frequency drift throws it off

wave is developed across  $R$ , which is capacitively coupled through  $C_1$  and  $C_2$  to rectifiers  $T_1$  and  $T_2$ , connected as shown. The load circuit consists of equal resistors  $R_1$  and  $R_2$ , with the keying signal taken off at their junction, point A. As the signal across  $R$  increases positively, capacitor  $C_2$  charges through rectifier  $T_2$ , thus holding point Z at zero potential. At the same time this positive potential is passed through capacitor  $C_1$  to point Y. Rectifier  $T_1$  is non-conducting for this polarity. As the voltage across  $R$  falls to zero and swings to its negative value, the charge on  $C_2$  is applied to point Z and the full peak-to-peak voltage appears at Z. The voltage at point Y falls to zero and capacitor  $C_1$  is charged through rectifier  $T_1$  to the negative value of the voltage across  $R$ .

On the next positive swing of the cycle, the full peak-to-peak voltage is applied to point Y. Thus, point Y is varying between a positive

value equal to the peak-to-peak voltage across  $R$  and zero, while the voltage at Z is varying between zero and this same peak-to-peak value, but in a negative direction. Therefore, the voltage at point A is always varied symmetrically, plus and minus, around zero. Any direct component in the voltage across  $R$  is not transmitted to point A.

The conditions to be satisfied in this circuit are that the time-constant  $RC_1$  or  $RC_2$  be small in comparison with the length of the keying pulses, and that the time constant  $C_1(R_1 + R_2)$  is large in comparison with the time interval between pulses. With this circuit, the system is always operating essentially about the  $X$  axis of Fig. 3.

#### Gas Tubes Block Noise

The keying pulse, as shown in Fig. 3, is now set to key on and off around axis  $X$ . However, if the crest of the signal has been reached and is holding the local oscillator in its mark position, a noise crash which causes the voltage to drop below the  $X$  axis will shift the local oscillator, causing it to record a false space. Much greater signal-to-noise ratio can be obtained by using gas control tubes, which strike on and off only after a critical voltage is reached. Under such conditions, these tubes can be adjusted to key the mark signal on at, say, level  $B$  of Fig. 3, and off at level  $B'$ . Thus, when the keying voltage is on its positive swing a noise crash must force the keying wave to pass the  $X$  axis and deviate all the way to the  $B'$  axis before a false space will be recorded. Similarly, when the keying wave is on its negative half-cycle a noise crash must force the voltage beyond the  $B$  axis before a false mark will be recorded. The use of gas tubes does not introduce bias, but merely displaces the keying wave slightly, and gives a much greater signal-to-noise ratio.

#### Combining Circuit for Diversity Reception

Still more faithful reproduction is had by using diversity reception. However, the receiver output in a two-receiver diversity system cannot be combined directly, as fading and phase shift would cause the resultant signal to fluctuate violently



in level. Furthermore, a signal fading in relation to noise on one circuit would, because of the limited action, result in a high noise output of the limiter. Instead, the signal from each receiver is fed through two similar channels, each consisting of an input filter, limiter, discriminator, detector and noise filter. Combination of the signals takes place at this point, where the frequency is low and time delay effects are at a minimum.

Referring to Fig. 6, the keying wave appears across  $R_1$  for one channel and across  $R_1$  for the second channel. These keying waves are varying symmetrically around the zero axis. The voltage across  $R_1$  and  $R_1'$  are combined through four rectifiers poled as shown in Fig. 6.  $R_2$  and  $R_2'$  are the load resistors for these rectifiers. The centers of the rectifier circuit are also connected by resistors  $R_3$  and  $R_3'$ , and the combined voltage taken out at their junction point A. With either a positive or negative voltage simultaneously on  $R_1$  and  $R_1'$ , half this voltage appears at point A. However, if due to diversity action the voltage across  $R_1'$  drops to zero, while the voltage across  $R_1$  remains constant, the voltage at point A will also remain constant, thereby giving full diversity effect. Even though the voltage across  $R_1'$  should go negative when a positive voltage is desired, the voltage at point A will not drop to less than zero. Using the gas tube action outlined

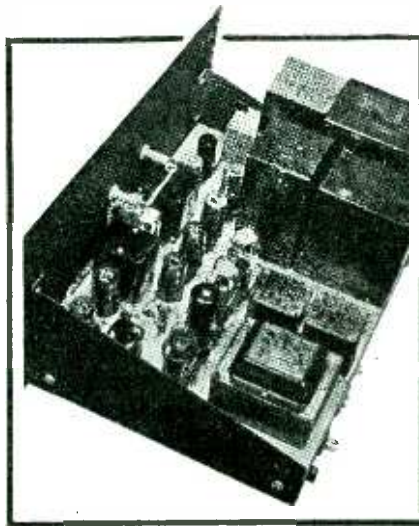

Frequency-shift converter for receivers

above, no false signal will be recorded as long as one circuit maintains its full voltage. Use of this type of diversity combination results in 10 to 20-db increase in signal-to-noise ratio. In the circuit shown,  $R_2$  must be large compared to  $R_1$ , and  $R_3$  and  $R_3'$  large compared to  $R_2$ .

#### Cause of Lower Signal-to-Noise Ratio

The signal-to-noise improvement using frequency-shift transmission occurs for the same reasons that such improvement is obtained in f-m broadcasting. The following remarks may serve to clarify the reasons why there is such improvement. With constant-frequency carrier make-break transmission, noise in the presence of the mark signal tends to amplitude-modulate the signal in direct relation to the

signal-to-noise ratio. Noise in the presence of no signal will cause interference depending only on the amplitude of the noise. Where a large mark-to-space signal-ratio is required for automatic recording, a small amount of noise will, therefore, introduce false mark and space signals.

In frequency-shift transmission, however, the signal is first fed through a limiter. This limiter eliminates all amplitude modulation caused by noise. There is always a signal feeding the limiter whether it be of mark or space frequency, and thus noise effects will act the same on mark as on space. If noise is fed into a limiter simultaneously with the signal, only phase modulation of the signal results. If this noise consists, for the purpose of analysis, of only one frequency, the phase modulation of the signal is given by

$$\frac{r^2 + r \cos \phi}{r^2 + 2r \cos \phi + 1}$$

where  $r$  is the noise-to-signal voltage ratio and is less than 1, and  $\phi$  equals  $2\pi ft$ ,  $f$  being the difference between the noise and signal frequencies. In the case of noise consisting of many frequency components, only those components whose vector sums are frequencies lying within the band passed by the noise filter following the detector need be considered. All other components are eliminated by this filter.

From the above expression it can be shown that in the case where the vector sum of the noises is as much as half that of the signal there is only one radian of phase modulation. But frequency-shift transmission employs many radians of shift. The modulation index  $B$  is often as high as 10 or 20. Therefore, noise, even though it be half that of the desired signal ( $B = 1$ ) will, after detection, be small in comparison to the signal.

As much as 20 db signal-to-noise increase can be expected using frequency-shift transmission. A small, mobile 400-watt frequency-shift transmitter on the beachhead in France is transmitting press traffic to this country at a rate of 500 words a minute, over a million words a month, where in former days a 50-kilowatt transmitter had trouble in maintaining the circuit.

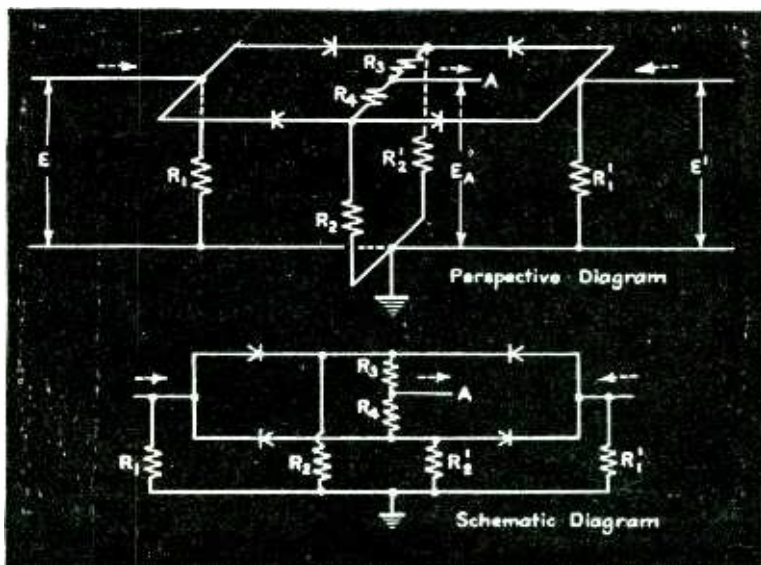

FIG. 6—Coupling circuit used between the outputs of two diversity receivers and the recording apparatus

# Frequency-Modulation Phonograph Pickup

Description of a phonograph pickup having a flat frequency characteristic over the audio range, with self-contained volume expansion and less than one ounce of needle weight. Needle varies capacitance in tuned circuit of oscillator, causing frequency modulation

**T**O reduce the mass of the moving part of a phonograph pickup, the principle of capacitance translation has been adapted to pickup design. The needle alone is the moving member. Although the variation in capacitance between the vibrating needle and a fixed electrode is small, it is sufficient to frequency-modulate an oscillator operating in the very-high-frequency range. This reduction in mass of the moving part improves the mechanical properties of the phonograph. The frequency-modulation method of translation, being independent of the rate at which the needle vibrates, gives flat frequency response over a wide audio range.

## Mechanical Construction

In a simple frequency-modulation pickup the needle constitutes a part of the electrical circuit and therefore should not require replacement more often than absolutely necessary. A semi-permanent needle having a sapphire tip meets the requirements. The upper end of the needle shaft is ground to a point and presses upward into a conical metal socket of slightly larger taper than the shaft point, as shown in Fig. 1. The needle is maintained in position by a soft rubber disk mounted in the bottom of the pickup head and through which the needle passes. A small shoulder on the needle causes the rubber to belly slightly downward so that it exerts an upward force on the needle to hold it in the conical socket. The needle is thus free to move in any

By **B. F. MIESSNER**

*Miessner Inventions, Inc.  
Morristown, N. J.*

horizontal direction. The upper point and socket act as a pivot of microscopic size, with only the slight compliance of the rubber disk restricting the needle motion.

The pickup electrode is mounted to one side of the needle shaft near the lower end, and is roughly parallel to the record groove. Lateral movements of the needle, caused by the record groove, serve to vary the distance between the needle and the electrode.

The only work required of the record groove is to vibrate the minute mass of the needle and overcome the small compliance of the rubber disk, hence needle pressure can be low. This reduces surface noise. Many conventional pickups require three to four ounces of tone arm and pickup head weight on the needle, but this

f-m pickup requires only about one-half to one ounce of weight on its needle.

## Automatic Volume Expansion

A unique feature of this pickup is its volume expansion. Since the needle is free to move in all directions perpendicular to its axis, there is motion in the direction of the record groove caused by the drag of the record on the needle. This drag is nearly proportional to the deviation of the groove. The groove undulations for stronger sounds are larger than for weaker ones, although not as large as they should be for full dynamic reproduction because of the volume compression used in the recording.

With the pickup electrode at an angle to the groove as illustrated in Fig. 2(a), the increased drag on the needle caused by the larger groove undulations of Fig. 2(b) and 2(c) serves to decrease the average spacing between the

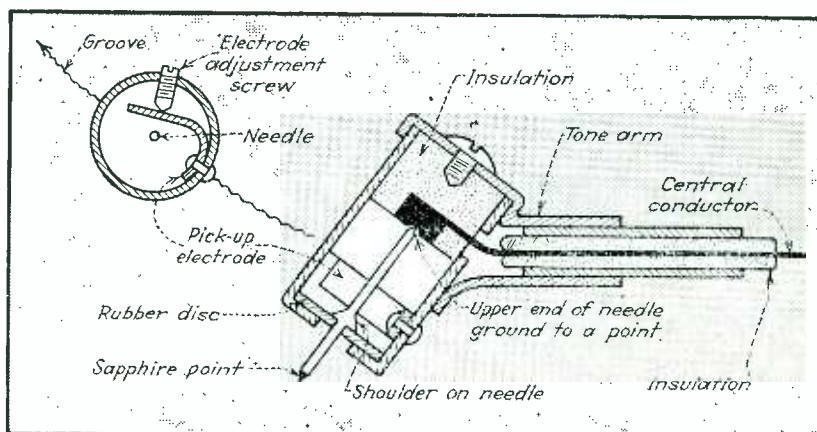

FIG. 1—Head assembly of the f-m phonograph pickup. The arrow indicates the direction of record groove movement



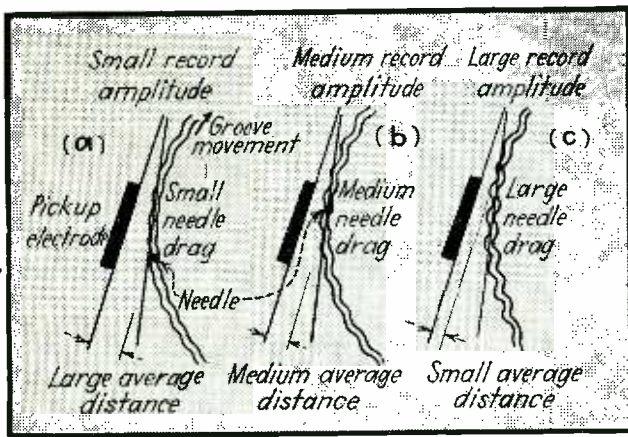

FIG. 2—Volume expansion is obtained by placing the pickup electrode at an angle to the record groove motion. The movement of the needle by groove drag produces volume expansion

needle and the electrode. Under this condition the variation in needle-electrode capacitance becomes a greater part of the average needle-electrode capacitance, and the translation efficiency is increased. In this manner the recording is volume-expanded to recover the original compression.

The degree of volume expansion can be regulated by adjusting the angle of the electrode surface to the record groove. An angle of thirty degrees gives a realistic degree of expansion. If the electrode surface is parallel to the record groove at the point of needle contact, there will be no expansion.

Surface noise is already much decreased by the low needle pressure on the record groove, and volume expansion gives further reduction. As a result, surface noise is hardly audible with the weakest sounds, and is inaudible with stronger sounds. Amplifier gain control as a means of volume expansion maintains the reproduced signal-to-noise ratio at the recorded ratio, whereas this volume-expansion method of translation-efficiency control reduces the relative noise level as the signal is increased.

#### Flat Wide-Range Frequency Response

Another contribution to the fidelity of reproduction is given by the flat frequency response characteristic of the pickup itself. For a given needle deflection in the audio range, no matter whether it be at a rate of ten or ten thousand cycles per second, the frequency deviation of the oscillator is the

same amount. Thus the frequency characteristic of the system is not influenced by the pickup itself.

The needle is locked at its upper end in the fixed socket, is locked into the record groove at its lower end, and is itself extremely stiff in comparison to the stiffness of the rubber centering disk, hence the needle can have no mechanical resonances in the audible range. This feature eliminates mechanical resonances and the distortions which they introduce, and thus contributes further to reproduction fidelity. Conventional pickups have one or more resonance periods due to freely swinging parts such as a crystal or armature.

Since the needle scratch is very low, no scratch filter is required. Full use can be made of the high-frequency response of the pickup.

#### Circuit and Operation

An f-m receiver is used for reproduction of the output of the f-m phonograph. To change from station reception to the phonograph, the receiver is tuned to the f-m phonograph oscillator, a simple form of which is shown in Fig. 3. The tube and circuit components can be located in the mounting box containing the gimbals for the tone arm. The tone arm is a tube with a central conductor wrapped with cotton or other electrical insulation. The insulated conductor should be pulled tightly into the tone arm, to maintain constant capacitance between the central conductor and the tone-arm tube. The wrapping effectively damps any tendency of the inner con-

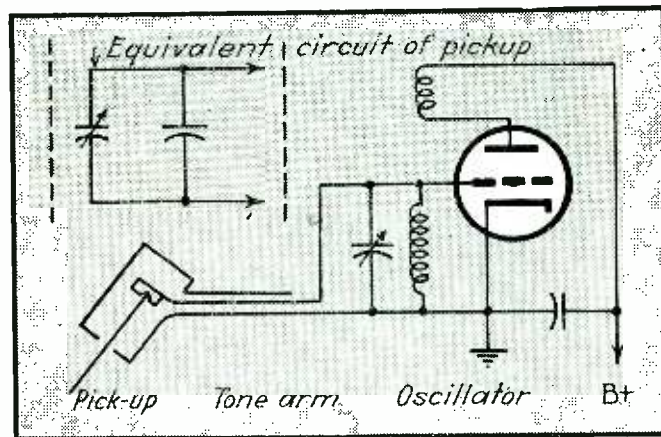

FIG. 3—Schematic diagram of a simple oscillator, showing the connection to the pickup. The equivalent electrical circuit of the pickup is a fixed capacitor paralleled by a variable capacitor

ductor to vibrate. Lower-loss insulation may be used, but it should have mechanical damping properties.

The central conductor connects with the phonograph needle through the conical metal socket. The pickup electrode connects to the tone arm, which is grounded to provide shielding and to minimize stray capacitance effects. The capacitance of the central conductor to the tone arm is in parallel with the pickup capacitance between the needle and the pickup electrode, hence this capacitance should be minimized for highest percent frequency modulation by the needle vibrations. A tube with an inner diameter of  $\frac{3}{8}$  inch is satisfactory. Condenser microphone cable with the shield removed serves satisfactorily for the inner conductor.

To decrease variations of the oscillator mean frequency due to movements of the tone arm, and to reduce to a minimum the shunting capacitance of the line through the tone arm, the oscillator can be built into the tone arm or the pickup head.

For a complete f-m receiver with audio amplifying and reproducing systems already available, only the pickup assembly and f-m oscillator of very low power, together with switching arrangements for starting the oscillator, are required. The f-m phonograph oscillator is set for some unused part of the f-m band and tuned in on the receiver as are broadcast stations. The phonograph unit may be separate and remote from the receiver.

# QUALITY



Operator preparing to apply a static quality test to a type 833A transmitting tube

By EUGENE GODDESS

*Special Projects Engineer  
North American Philips Company, Inc.  
Dobbs Ferry, N. Y.*

discharge circuit in which the tube capacitance discharges through a known resistance. Since  $C = t/R$ , the capacitance is easily determined. Both time (in the order of microseconds) and resistance (in the order of megohms) can be determined with reasonable accuracy.

(2) Capacitance can be measured as the terminating impedance of a coaxial transmission line. The reactance is measured by placing the tube in the transmission line as a terminating element. The line is then tuned to resonance by varying its length.<sup>2</sup>

#### Mechanical Performance Tests

Tubes must perform satisfactorily and must possess reasonable life; in addition, they must be rugged. This does not imply that it is permissible to play hockey with a two-inch u-h-f transmitting tube. On the other hand, it should not be necessary to transport the tube in a push-lined case. The usual points of mechanical weakness can be divided into four main headings:

- (1) Metallic bodies (filaments, grids, plates, etc.)
- (2) Metallic joints (welds)
- (3) Glass bodies (glass envelopes, beads)

**P**RESENT-DAY mass production lends itself admirably to quality engineering practices. Although this article is centered on vacuum-tube manufacture, the approach and much of the technique are directly applicable to other phases of industry.

#### Quality Tests

In order to determine vacuum-tube *quality*, it is necessary to have a criterion of acceptability; in other words, the tube must pass some sort of a test. One method tests a random sample (typical of the day's production) for static characteristics and dynamic performance. All conditions of the test are recorded and readings are meticulously observed, with the exact nature of the test depending on the type of tube involved.

For the usual transmitting or receiving tube, test instructions should specify voltages for filament, plate, control-grid, screen-grid, and suppressor-grid as required to observe filament, plate, control-grid, and screen-grid currents. Emission, plate resistance, amplification factor, and mutual conductance should

be determined; furthermore, it is desirable that interelement capacitances be measured also.

Cathode-ray tubes should be checked for light output, line width, deflection sensitivity, focusing voltage, leakage, gas ratio (or cross), interelement voltage breakdown, and anode currents.

Specifications for dynamic testing should include load resistance (or impedance), signal voltage, and power output at normal and reduced filament voltage. In addition, specifications should give operating voltage and current ranges for all other tube elements.<sup>3</sup>

#### Measurement of Interelectrode Capacitances

For the measurement of capacitances of  $1 \mu\text{f}$  or less, several methods are available. Perhaps the most accurate procedure uses a precise capacitance bridge. Another satisfactory method uses a vacuum-tube voltmeter to measure the voltage developed across a capacitance at a fixed frequency. Alternative methods are:

(1) Capacitance can be measured as part of a resistance-capacitance

#### QUALITY ENGINEERING

Articles to Come

Shrinkage Analysis in Tube Manufacture

DECEMBER 1944 ELECTRONICS

Quality Control in Tube Manufacture

JANUARY 1945 ELECTRONICS



# ENGINEERING

## in Tube Manufacture

Testing of random samples can indicate when vacuum-tube production deviates from quality standards. Procedures given, applicable to other products as well, cover static and dynamic performance tests, life tests, mechanical tests, and checking of appearance

(4) Glass joints (either glass-to-glass or glass-to-metal)

Among the methods used for checking the mechanical durability of the tube are: 1. Bump tests; 2. Vibration tests; 3. Thermal shock tests.

In a bump test, a pendulum of prescribed weight and length is allowed to strike the tube, which is so suspended that it swings freely on impact. The tube is then tested for mechanical failure, static characteristics and interelement capacitance (revealing changes in electrode spacings).

The vibration test is essentially the same as the bump test. Instead of causing acceleration through impact, the tube is placed on a shake table and is subjected to acceleration values that are several times that of gravity. Both of these tests can be made with voltages on the elements, so that results can be observed on a cathode-ray-tube oscilloscope. In this way, temporary interelement shorts and undue voltage excursions can be observed.

Thermal shock tests are concerned with the condition of the glass. In general, they reveal improper annealing or defective sealing.

The foregoing are the most common mechanical performance tests. It is possible to make as many tests as there are mechanical performance weaknesses.

### Life Testing of Tubes

Tube life can be determined on the basis of either static or dynamic performance. In any event, the life will depend (among other factors) upon: 1. Filament voltage;

2. Tube operating temperature; 3. Amount and nature of the free residual gases in the tube and in the metallic parts.

Within a thoriated tungsten filament, thorium is diffused to and evaporated from the surface at a definite rate. The ideal filament voltage is one which causes a cur-

ated tungsten filament operated at equivalent temperature. As a result, the emission drops rather sharply and the tube ends its useful life abruptly and prematurely.

Such a tube can be brought to life again by means of the so-called "hot shot" treatment, which consists of operating the filament at a rather high temperature (2800 deg K) for a few minutes. This reduces some of the thoria (thorium oxide) within the filament to metallic thorium. Then, operation of the fila-

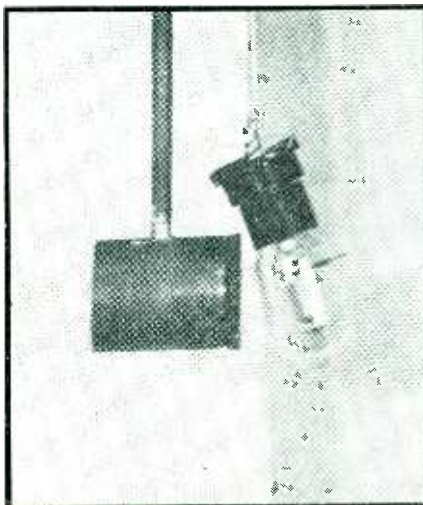

Type 24G tube an instant after being struck by the pendulum hammer used in the bump test

rent flow of such magnitude that the heat produced establishes an equilibrium between these two rates.<sup>3</sup>

If the filament temperature is too low, insufficient emission will result. If filament temperature is too high, the rate of evaporation will exceed the rate of diffusion. Under this condition, the surface is stripped of its thorium and soon acquires the properties of a pure tungsten emitter, which is about 1/1000th the emission of a thori-



Laboratory assistant placing a type 24G tube in a static life test rack

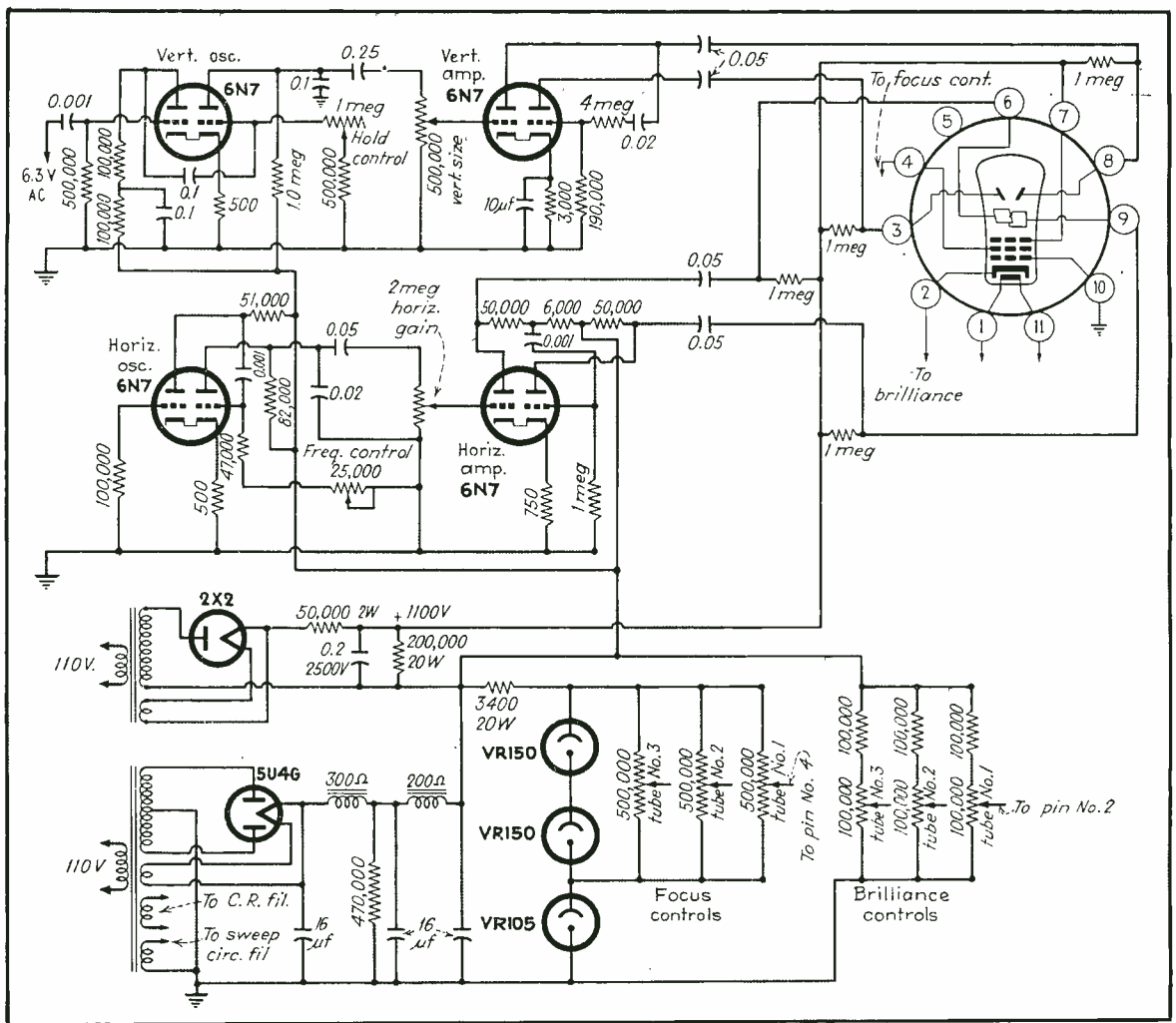

Schematic circuit of three-position life test set for use on type 2AP1 cathode-ray tubes

ment at a lower temperature (2200 deg K) diffuses the newly reduced thorium to the surface. However, life obtained by rejuvenation is not a true test of life, but rather is a test of the renewing process.

It has been pointed out that the voltage at which a filament is operated determines its temperature. Temperature determines the fraction of the surface which is covered with a monatomic layer of thorium. Emission may drop below acceptable limits as the fraction of the covered surface is reduced. Since good life depends upon good emission, any factors which disturb or deteriorate the emissive properties of the filament contribute to the early demise of the tube. Operation at excessive filament voltage is one such factor.

Another factor which can result in reduced emission is the presence of excessive amounts of oxygen in

the tube. Should this highly-active gas be available to form a chemical union, layers of thorium and tungsten oxides are formed. If this happens, emission quickly drops to the vanishing point.

If the power supply voltage varies over a considerable range, the life test will operate at various temperatures; in other words, anode and filament power dissipation will vary. It is therefore necessary that the power line voltage for life test equipment be regulated within close limits.

Complete and carefully prepared records should be kept of all test conditions and causes of failure. This latter point cannot be overemphasized since one of the primary objects of all life tests is to reveal the weaknesses which cause tube failure. For example, to state that a cathode-ray tube failed due to low light output is not

enough; it is much more significant to point out that the low light-output was caused by a deteriorated cathode surface which resulted from the failure of a metal-to-glass seal.

The tube that performs properly is interesting and indeed welcome; nevertheless, it is the defective tube that uncovers weaknesses and helps us evolve new and better production techniques.

#### Other Tests

Samples should be selected and tested at periodic intervals, in order to ascertain the life of the shipped product. Factory engineers, design engineers, and persons responsible for maintaining production should be advised of all failures occurring in non-experimental tubes. All innovations in processing or structure should be successfully life-tested before becoming a regular



part of the manufacturing procedure.

### Appearance Tests

A sizeable quantity of tubes should be selected at random from the packing room and should be examined for appearance. This inspection should answer the following questions:

- (1) Is the tube clean?
- (2) Is the tube identification brand clean and legible?
- (3) Is the company trademark clean and legible?
- (4) Are the base pins neatly soldered? Has extra flux been wiped away?
- (5) Is the tube base on straight?
- (6) Are the critical dimensions within specification?
- (7) On the basis of the perfect tube being rated as 100 percent, what is the rating of the average of these tubes?

The basic purpose in making this type of examination is to rate the tube's appearance from the standpoint of saleability.

### Maintenance of Primary Standards

It is inadequate to say that the vacuum-tube industry sells "tubes". We are offering measurements when we offer tubes. Some assurance must be given that the meters which check those measurements are correctly calibrated.

Tubes are saleable because they have certain characteristics—characteristics which are measurable by meter. Quality, as determined by electrical testing, implies the use of meters, and the testing is no better than the meters that performed the work. Improperly calibrated meters give rise to three risks:

- (1) The possibility that acceptable tubes may be rejected.
- (2) The possibility that rejectable tubes may be accepted.
- (3) The possibility (almost certainty) that the quality will be indeterminate.

Proper calibration of test meters is normally a function of a meter maintenance unit, acting under the jurisdiction of an equipment section. This meter-maintenance unit will generally have a set of secondary standards. However, the quality control activity is so definitely tied up with measurement problems

that it is advantageous to have the primary standards retained by the quality engineering division.

Certified standard cells, high-precision potentiometers, volt boxes, current and voltage transformers, highly sensitive galvanometers and accurate wavemeters are a few of the primary standards which should be available to the quality control engineer. Then, when a question comes up involving the accuracy of factory readings, unquestionable evidence can be produced by the quality engineering laboratory. Unless a standards laboratory is set up to do the job, the quality engineering department should act as the "Bureau of Standards" for the factory.

With a test procedure set up, the next step in utilization of quality engineering is analysis of the test results to determine exactly where the trouble is when shrinkage (loss during production) exceeds permissible manufacturing limits. This subject will be taken up in the next issue, and will be followed by the final article covering process control charts and other statistical methods of controlling quality during manufacture.

### REFERENCES

- (1) Report published by Institute of Radio Engineers, New York, "Standards on Electronics, Methods of Testing Vacuum Tubes, 1938".
- (2) Nergaard, L. S., A Survey of Ultra-High-Frequency Measurements, *RCA Review*, Oct., 1938.
- (3) Koller, L. R., "Physics of Electron Tubes," McGraw-Hill Book Co., New York.

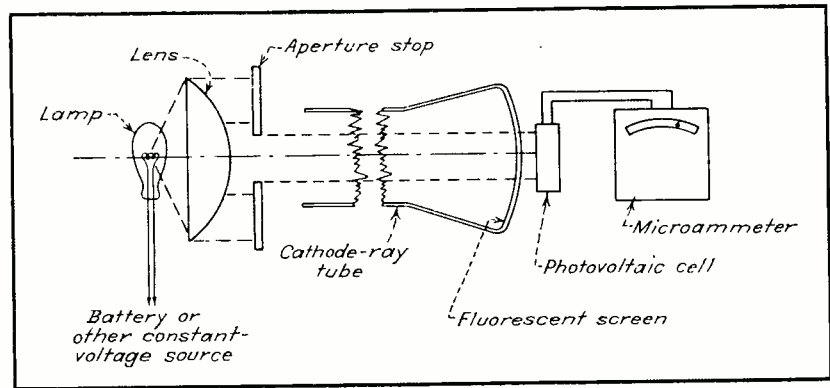

Arrangement used for measuring light transmission of a cathode-ray tube screen

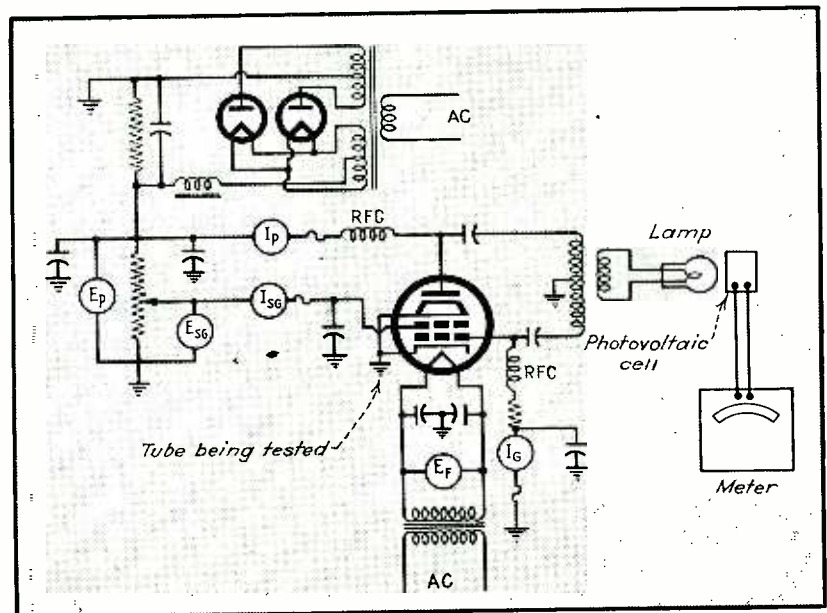

Simplified schematic of oscillator used to determine power output of a beam-power tube. The circuit is essentially a Hartley oscillator in which the inter-electrode capacitances of the tube under test serve as the capacitive elements of the tank circuit. The cathode is grounded to complete the plate circuit

# DIFFERENTIATING and

Engineering and laboratory applications of differentiating and integrating circuits are described, including anti-hunting circuits for servo mechanisms and other control systems. Practical circuits are developed from a mathematical basis and test results are given

**T**HE need for an electrical circuit to differentiate a wave of voltage with respect to time often arises in various types of problems. As an example, it is desired to determine the sequence of arrival of several overlapping impulses. The sharper the impulses the more easily they can be separated. Since the rate-of-change of a received impulse will start at zero, rise to a maximum, and fall back to zero in the same interval of time that the impulse itself rises from zero to its maximum, the wave-front of the differentiated impulse is shorter and sharper than that of the original impulse. This is demonstrated in Fig. 1. The signal announcing the arrival of the original impulse can be made as short and sharp as desired by taking successive derivatives of the original impulse by cascading several differentiating circuits.

### Anti-Hunting Applications

Differentiating circuits can also be used to prevent servo-mechanisms and other control systems from hunting. As an elementary example of this, consider the speed-governing system shown in Fig. 2(a). The speed of the turbine is to be held constant at the value  $N_0$  which makes the voltage of the magneto-tachometer equal and opposite to a selected portion of the battery voltage. If it is not, the difference voltage drives a motor (probably through an amplifying system) which actuates the valve to correct the speed of the turbine.

A sudden load of short duration can cause the turbine speed to be low, as shown at the time  $t_1$  on the curves of Fig. 2(b). Under this condition the difference voltage drives the motor to open the valve,

By **JAMES G. CLARKE**

*Assistant Professor of Engineering  
Dunham Laboratory, Yale University  
New Haven, Connecticut*

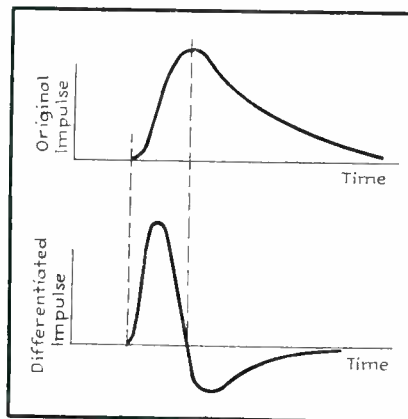

FIG. 1—One application of differentiating circuits is to sharpen impulses

accelerating the turbine until the time  $t_2$ . At  $t_2$  the turbine speed has been corrected and, as there is no difference voltage, the motor stops. However, the valve is open too wide and the turbine continues to accelerate, so that the motor reverses to close the valve. At  $t_3$  conditions are set to reverse and the oscillations continue. These oscillations, which are desirable in many applications, are usually kept small by damping the motion of the valve with a dashpot. The valve is in its equilibrium position when the rate-of-change of its displacement is greatest. The dashpot opposes the motion of the valve with a force which is proportional to the rate-of-change of its displacement.

From the curves, it is seen that the difference voltage also has its greatest rate of change when the valve is at its equilibrium position. This offers the possibility of introducing an electrical circuit to pro-

duce an effect similar to the dashpot. Let a voltage proportional to the difference voltage be put into a differentiating circuit, and the output of the differentiating circuit be placed in series with the voltages of the speed-control circuit of Fig. 2(a). By adjusting the magnitude of this voltage, the oscillations may be critically damped, over damped, or under damped, whichever is the more desirable.

### Research Applications

Integrating circuits can be used in many measurement and research problems where the summation of some function is required at every instant. Mechanical methods of integration are most convenient when the function being integrated is fairly constant and uni-directional. However, for alternating and rap-

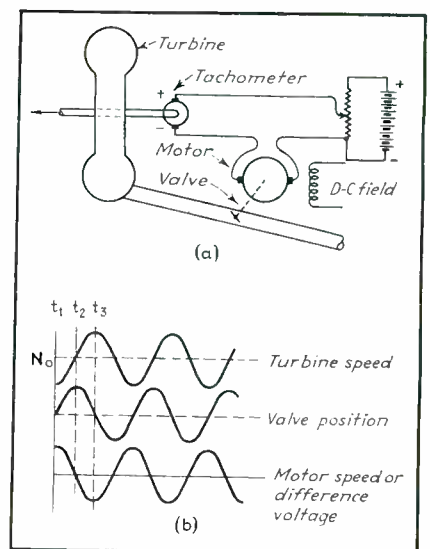

FIG. 2—Instead of damping the valve in the turbine steam-line with a dashpot, a differentiated voltage can be applied to the motor to prevent the system from hunting



# INTEGRATING CIRCUITS

idly changing variables, electrical integrating circuits such as are described in this paper are more satisfactory.

A common application is in oscillographic studies of magnetic flux. To obtain an oscillogram of the magnetic flux linking a search coil, the voltage induced in the search coil can be applied to an integrating circuit, and the output of the integrating circuit delivered to the oscillograph. The integrator voltage is proportional to the flux because the induced voltage is proportional to the rate of change of flux;

$$E_{ind} = -N \frac{d\phi}{dt} \times 10^{-8} \text{ volts} \quad (1)$$

The flux is then proportional to the integral of the induced voltage:

$$\phi = \int d\phi = -\frac{10^8}{N} \int E_{ind} dt \text{ lines} \quad (2)$$

Figure 3 shows hysteresis loops that were taken using an integrating circuit. These loops and the associated exciting current waves are for the iron-cored inductor of a series  $R-L-C$  circuit experiencing subharmonic oscillations.<sup>1</sup>

Similarly, an oscillogram of the displacement of a moving object can be obtained with a dynamic pickup if the object moves the conductors of a coil perpendicular to a magnetic field. The voltage induced in the coil is applied to the integrator, and the voltage from the integrator is applied to the oscillograph. This integrated voltage is proportional to displacement because the induced voltage is proportional to the velocity of the coil;

$$E_{ind} = BLV \times 10^{-8} \text{ volts} \quad (3)$$

Displacement is then equal to the time integral of the velocity.

$$\text{Displacement} = \int (\text{Velocity}) dt = \frac{10^8}{BL} \int E_{ind} dt \text{ cm} \quad (4)$$

This is useful in various mechanical problems, such as studying the vibration of a piece of machinery, or following the motion of a moving part such as the intake valve on a diesel engine.

In physiological studies, nervous activity or other responses can be

integrated to compare total activity or response under various conditions. If the signal being integrated is not uni-directional, it is usually necessary to rectify the signal before it is integrated.

Integrating circuits can be used in many other applications requiring the totalling or the summation of some variable.

## Inductance as a Differentiating Circuit Element

To perform differentiation electrically, the function which is to be differentiated must first be made proportional to every instant of time to some electrical quantity. This can then be impressed on some circuit element which yields another electrical quantity which is proportional to the derivative of the impressed quantity.

The voltage applied to an inductance is

$$E_L = L \frac{di}{dt} \text{ volts} \quad (5)$$

If the current through the inductance can be made proportional at every instant to the function

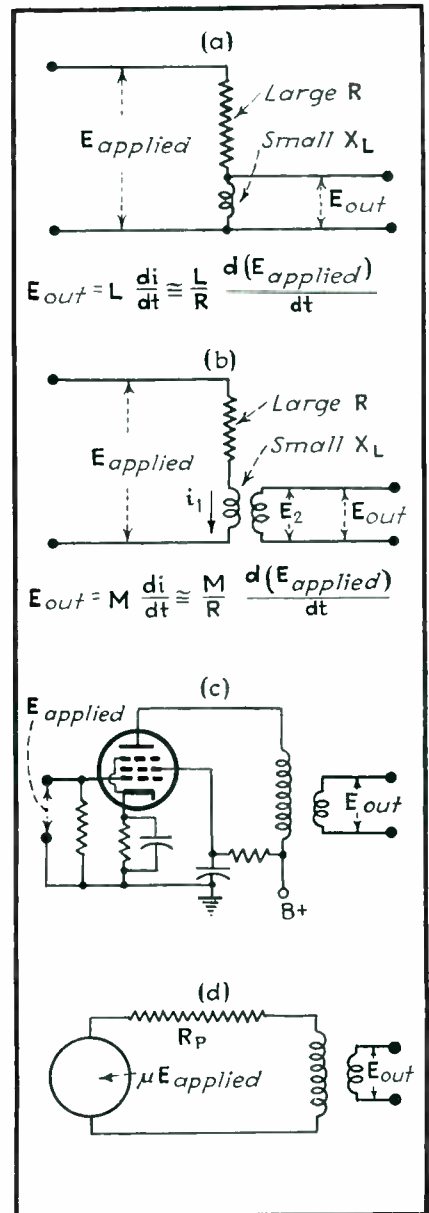
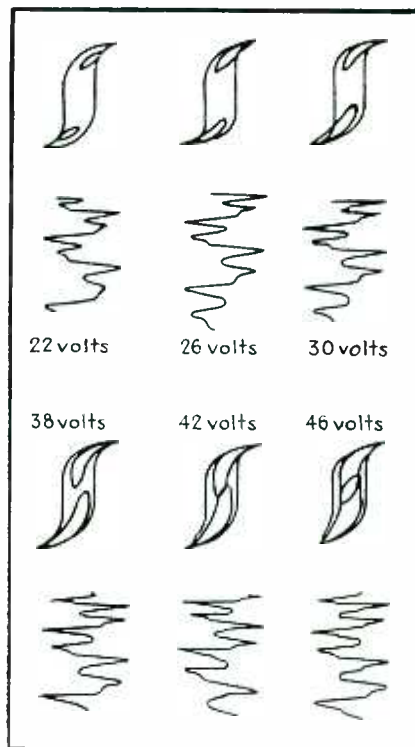

## ABOVE

FIG. 4—(a) An inductance in series with a large resistance forms a voltage differentiating circuit. (b) The use of a mutual inductance to couple to the output improves the differentiating action of the circuit. (c) A pentode replaces the series resistance of the above circuits, and also provides amplification. (d) The equivalent circuit of (c)

## AT LEFT

FIG. 3—Exciting current and resulting hysteresis loops for an iron-cored inductor in an  $R-L-C$  circuit undergoing subharmonic oscillations. The hysteresis curves were obtained by differentiating the voltage induced in a search coil

which is to be integrated, the voltage across the inductance will be proportional to the derivative of the function.

In general, however, a voltage wave which is proportional to the function is available rather than a current wave. Several methods are available by which this voltage wave will cause a current that is proportional to the voltage function to flow in the inductance. In the basic circuit shown in Fig. 4(a), a resistor is connected in series with the inductor. If the resistance is large compared to the reactance at the highest-frequency component of the impressed wave, the voltage across the coil will be negligibly small, and the current will be nearly proportional to the applied voltage:

$$i \cong \left( \frac{E_{\text{applied}}}{R} \right) \text{ amperes} \quad (6)$$

Since the voltage across the reactance is small compared to the voltage across the resistance, the output of the integrating circuit is necessarily much smaller than the impressed voltage. The minimum ratio of resistance to reactance which is permissible is discussed later.

If the voltage of Eq. (5) is to be measured across the coil directly, the resistance of the coil must be quite small to insure that the  $iR_L$  voltage drop is negligibly small. This  $iR_L$  voltage drop can be completely eliminated if the output voltage is obtained by mutual inductance from a second coil on the same core as the first, as shown in Fig. 4(b). This is a much more desirable circuit in most applications, because the resistance of the first coil does not distort the output wave-form. It simply aids the series resistor in making the current proportional to the applied voltage. The output voltage induced in the second coil is

$$E_2 = \frac{M}{L} \frac{di_1}{dt} \text{ volts} \quad (7)$$

Its magnitude can be adjusted by adjusting the turns on the secondary coil.

The current through the inductance can also be made proportional to the applied voltage by using a tetrode or pentode vacuum tube. The plate current of these tubes is almost independent of the

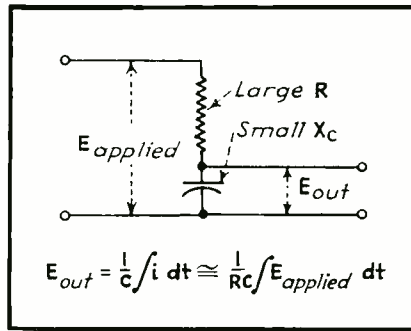

FIG. 5—A large inductance in series with a small resistance forms an integrating circuit

plate voltage. If the signal to be differentiated is applied to the control grid, the resulting plate current will be proportional to the signal and nearly independent of the load impedance. As shown in Fig. 4(c) and 4(d), this is equivalent to substituting the plate resistance of the vacuum tube for the series resistance used in the basic circuits of Fig. 4(a) and 4(b). These circuits offer two advantages over using the tube as a conventional amplifier with the basic circuit: First, more voltage is available at the output for a given input voltage; second, a greater swing of plate voltage is permissible for a given battery voltage.

#### Inductance as an Integrating Circuit Element

Inductance can also be used to integrate. From Eq. (5), it is seen that

$$di = \frac{1}{L} E_L dt \text{ amperes} \quad (8)$$

and

$$i = \frac{1}{L} \int E_L dt \text{ amperes} \quad (9)$$

Thus if the voltage that is to be integrated is applied to an inductance, the resulting current is proportional to the integral of the applied voltage. If the integrated function is to be amplified or applied to an oscillograph, this current must be converted into a proportional voltage by passing it through a resistance as shown in Fig. 5.

If it is to be assumed that the applied voltage is the voltage across the inductance, the total resistance of the circuit must be negligibly small compared to the reactance of the coil at the lowest-frequency component of the applied

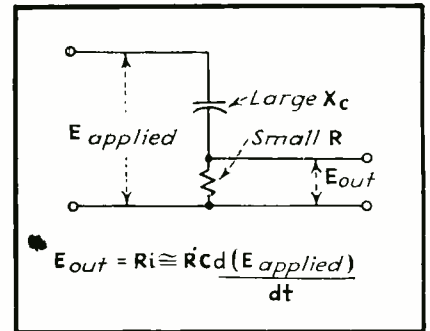

FIG. 6—If the voltage to be differentiated contains only a-c components, a capacitor can serve for differentiating

voltage. This means that the output voltage is again very much smaller than the impressed voltage.

The inductance is best suited for use as a differentiating and integrating circuit-element when this portion of the circuit must carry a direct component of current. It is unsatisfactory for use in many applications. At low frequencies, a large coil is necessary to give a reactance which is high compared to its own resistance. At high frequencies, the current through the distributed capacitance of the coil becomes large, so that Eq. (5) and (7) are no longer valid. If an iron core is used, an air-gap should be inserted to insure that the self inductance and the mutual inductance remain essentially constant.

#### Capacitance as a Differentiating Circuit Element

Because of their low cost, small size and freedom from residual resistance and inductance, capacitors are generally more satisfactory than inductors for differentiating or integrating circuit elements. However, they cannot carry direct components of current, as the inductors do, which is a disadvantage in some applications.

The charge on a capacitor of  $C$  farads and the current through the capacitor are

$$q = CE_c \text{ coulombs} \quad (10)$$

$$i = \frac{dq}{dt} = C \frac{dE_c}{dt} \text{ amperes} \quad (11)$$

This enables the capacitor to be used as a differentiating circuit element. If the function to be differentiated is proportional to the voltage applied to the capacitor, the resulting current through the capacitor is proportional to the derivative of



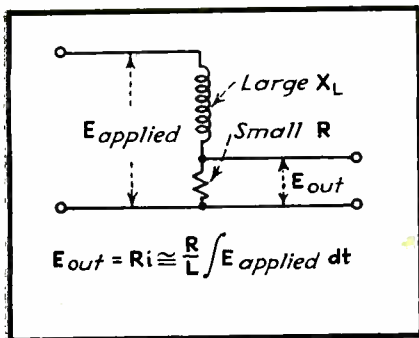

FIG. 7—Compare this capacitance integrating circuit with the inductance differentiating circuit of Fig. 4(a)

the applied voltage. As shown in Fig. 6, a small resistance can be placed in series with the capacitor to give an output voltage proportional to this current.

#### Capacitance as an Integrating Circuit Element

The charge,  $q$ , which is delivered by a current  $i$ , from Eq. (11).

$$q = \int i dt \text{ coulombs} \quad (12)$$

Any circuit element which yields a measure of the charge when a current is passed through it can be used in an integrating circuit. An example of this was the old electrolytic ampere-hour meter, which measured the ampere-hours taken by a customer in terms of the change of weight of a plate in an electrolytic cell.

Several circuits, which can be adapted for use over a wide range of frequencies, measure the charge delivered by the current in terms of the voltage across a capacitor. From Eq. (10) and (12), it is seen that the voltage across a capacitor is

$$E_c = \frac{1}{C} \int i dt \text{ volts} \quad (13)$$

Thus if the current through the capacitor is made proportional at every instant to the function which is to be integrated, the voltage across the capacitor is proportional to the time integral of the function. To obtain a current which is proportional to the function from a voltage which is proportional to the function, connect a resistor in series with the capacitor as shown in Fig. 7. If the resistance is large compared to the reactance of the capacitor at the lowest-frequency component of the impressed wave, the voltage across the capacitor will

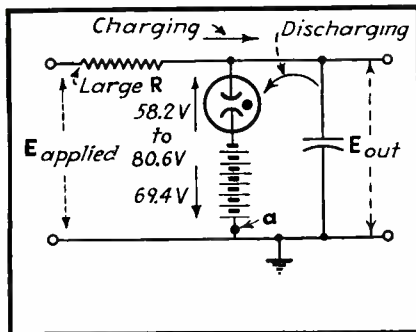

FIG. 8—Neon lamp circuit used to periodically discharge the integrating capacitor when charging is unidirectional

be negligibly small, and the current will be nearly proportional to the applied voltage at every instant.

$$i \cong E_{applied} / R \quad (14)$$

If the current being integrated is uni-directional, or has an average value predominantly in one direction, the voltage across the capacitor will rise continuously, so that it will not remain small compared to the voltage across the resistor. Under these conditions, the capacitor can be discharged through a thyatron or glowtube when its voltage reaches a predetermined value. The discharge current can be made to operate a counter by passing it through a small resistance inserted at  $a$  in Fig. 8, and applying the resulting positive pulse of voltage to the grid of a thyatron. The plate current of the thyatron can actuate a solenoid-operated counter. In this way the counter indication times the charge accumulated before each discharge gives the total integral.

The bias battery used in series with the gas-glow tube should have a voltage approximately half-way between the voltages at which the glow tube ignites and extinguishes. With this bias voltage, the average leakage through the tube and capacitor will be zero. Circuits of this kind can be used to measure very small currents by integrating the current to evaluate the charge delivered in a measured interval of time.

#### Practical Circuits

As with the inductor, the output voltage from circuits using a capacitor to integrate is much smaller than the applied voltage. If the output voltage is to be amplified by

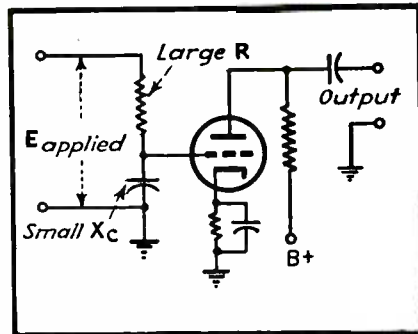
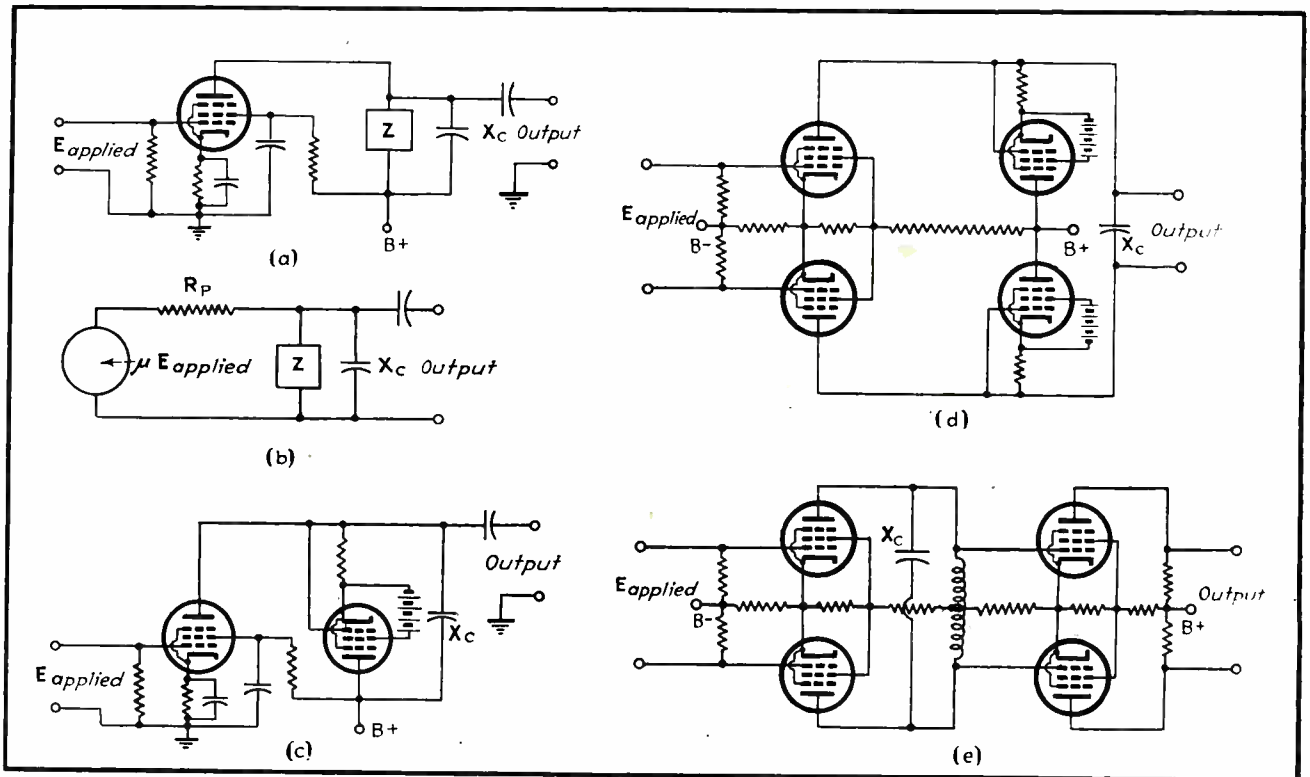

FIG. 9—Basic integrating circuit using a capacitor and amplifier. The signal source provides a d-c path to ground

a conventional amplifier, the voltage across the capacitor should be applied directly to the grid of the amplifier, without a grid resistor, as shown in Fig. 9. A grid resistor would be in parallel with the capacitor, and would tend to disturb the integral relationship between current and charge. To prevent the grid from floating, the input circuit should provide a d-c path to ground.

As was discussed earlier, the plate resistance of a tetrode or pentode vacuum tube can be substituted for the series resistor used in the basic circuit of Fig. 7. The ideal load impedance,  $Z$ , in Fig. 10(a) and 10(b) would carry only the direct component of the plate current, so that all variations of the current which were caused by the signal on the control grid would be forced to flow through the capacitor. The best impedance to use depends chiefly on the frequency of the signal being integrated. Since the signal component of the current in  $Z$  should be small, the impedance of  $Z$  must be large compared to the reactance of the capacitor at the lowest-frequency component of the impressed wave.

A resistor is generally unsatisfactory for use as the load impedance  $Z$ , because if it is large enough to prevent the flow of an appreciable portion of the signal current, an excessive battery voltage is required to give a reasonable plate voltage. Since a pentode vacuum tube with constant control-grid voltage carries a plate current which is nearly constant and independent of plate voltage, a pentode could be used for this load impedance, as shown in Fig. 10(c);



**FIG. 10**—(a) The large resistor of Fig. 7 can be replaced by a pentode if integrating capacitor  $X_c$  can be bridged by an impedance  $Z$  which will pass direct current, but will have a very high (ideally infinite) impedance to alternating current. The equivalent circuit is shown at (b). (c) A pentode can be used for the impedance  $Z$ . (d) Push-pull version of the circuit

of (c) eliminates the need for by-pass capacitors, thereby providing unlimited low-frequency integration. Where the wave to be integrated does not contain an extremely low-frequency component, the circuit at (e) can be used. The inductor is the impedance  $Z$  of (a). The circuit shown has been designed for direct coupling to an amplifier stage

this is equivalent to using the plate resistance of the pentode for a load impedance. If the cathode bias resistor is made large, its degenerative effect will help maintain a constant current through this tube. This circuit is somewhat similar to the Schmitt<sup>2</sup> amplifier.

If these circuits use tubes in push-pull, as shown in Fig. 10(d) and 10(e), they are much more stable, and have the many other advantages of push-pull circuits. Wider voltage swing is permissible. Distortion from non-linearity of the characteristics is balanced out. No net direct current magnetizes the core of an iron-core inductive load. No net direct voltage appears across the integrating capacitor.

**Tests**

The output of the various circuits discussed in this paper is only approximately proportional to the derivative or the integral of the impressed quantity, depending on the ratio of the selected reactances and resistances. The differentiation or integration becomes more accurate as the impedance from which the output voltage is taken is made smaller. However, the output voltage is also made smaller as this impedance is decreased.

To serve as a guide in selecting the ratio of resistance to reactance, the  $R$ - $C$  integrating circuit shown

in Fig. 7 was tested with a rectangular wave input. The resistance was 10,000 ohms. Since

$$\int K dt = K t \quad (15)$$

the integral of the rectangular wave should be a triangular wave.

For the first curve of Fig. 11, the capacitance was set at zero, so that the square-wave input appeared across the output. For the following curves, the capacitance was set to give the values of  $R/X_c$  that are indicated, where  $X_c$  is calculated for the lowest-frequency component of the square-wave input. It was necessary to increase the gain of the oscillograph to hold the pattern at approximately the same size when the capacitance was increased.

These tests indicate that a ratio of  $R$  to  $X$  greater than eight is satisfactory for most oscillographic work.

**REFERENCES**

(1) Spitzer, Charles F., Subharmonic Response in Non-Linear Series Circuits (paper, Yale University, New Haven, Conn.). Accepted for publication by *Jour. Applied Physics*.  
 (2) Schmitt, Otto H. A., A Method of Realizing the Full Amplification of High-Mu Tubes, *R. S. T.*, December, 1933.

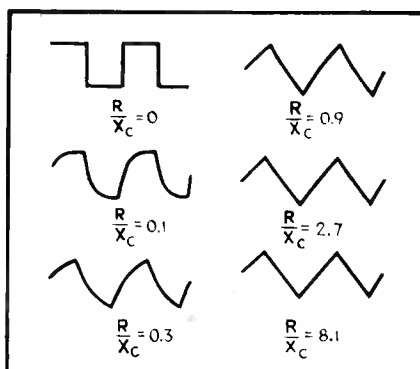

**FIG. 11**—Using the integration circuit of Fig. 7, with  $R = 10,000$  ohms and the impedance of  $X_c$  at the lowest frequency component of the applied square wave related to  $R$  as tabulated above, it is seen that a ratio of  $R/X_c = 8$  provides effectively perfect integration





More often than not, the socket in service is a **CINCH**

it's **Know How**



Sixteen years ago Cinch started manufacturing sockets for radio sets. As the years went along we kept expanding and adding to our line. Continual pioneering on socket development as new tubes were designed has always been the Cinch policy. In addition to original research on sockets, both laminated and molded, we were first in the field with a complete line of miniature socket assemblies together with nut straps, shields

and associated items. Special types, too, have been an important contribution to the electronic program. Such a performance indicates socket engineering **KNOW HOW** and the Cinch socket line is as complete as practical volume considerations would warrant.

"First in the field" with a complete line of **Miniature Socket Assemblies and Mountings**

TWO-THIRDS  
ACTUAL SIZE

**CINCH Fasteners** ★ **Miniature Sockets**  
**Filler Necks** ★ **Octal Sockets** ★ **Lugs**  
**Terminal Strips** ★ **Metal Stampings**

**CINCH MANUFACTURING CORPORATION**  
2335 West Van Buren Street, Chicago 12, Illinois  
Subsidiary of UNITED CARR FASTENER CORPORATION Cambridge, Mass.



# INDUSTRIAL CONTROL

Electronic Indicator for Oil Refining Plant.....	146
Electronic Heating in Textile Industry.....	146
30-Year Old Grinders Use Electronic Control.....	148
Five Uses of Electronics in the Electric Light and Power Industry..	150
Portable Flutter Recorder for Planes.....	150
10,000-kw Electronic Converters in Steel Plant.....	154
Oscillograph Checks Aircraft Engine Ignition.....	160

## Electronic Indicator for Oil Refining Plant

IN MODERN OIL REFINERY methods, accurate boiling points of the various vapors, to be separated in fractionation, must be pre-determined in the laboratory. This is now accomplished with electronic equipment.

The instrument, manufactured by Brown Instrument Co., is a continuous balance potentiometer pyrometer, which utilizes electron tubes to magnify a small temperature gradient. This is mechanically connected to a conventional Brown recording potentiometer. A special high-sensitivity fine wire thermocouple, consisting of six individual couples spaced about one-half inch apart, is located in the reflux zone of the fractionating col-

umn. The electromotive forces produced by these thermocouples are amplified by the electron tubes and recorded continuously by pen on a time-temperature strip chart.

The instrument finds particular application at present in the rapid and accurate analyses of four and five-carbon hydrocarbons. The special thermocouple covers all possible positions of a wandering condensation ring, which is known to vary several inches up or down in the fractionating column. Thus the true boiling point of a compound is accurately recorded no matter which couple is located in the coldest zone. This could never be accomplished by a single-*junction* thermocouple. The electronic recorder and the spe-

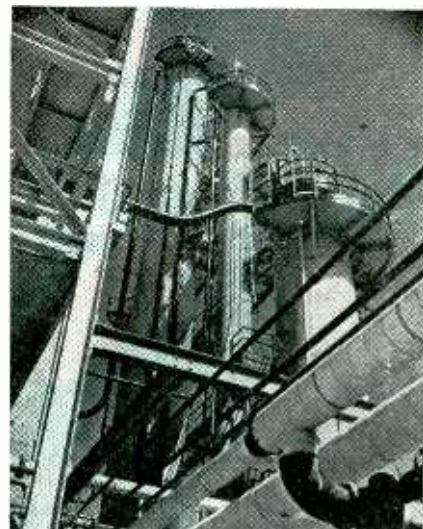

Towers of the alkylation unit at the Richfield refinery where electronic apparatus is used to indicate the boiling point of the various vapors. In the unit above, iso-pentane and iso-butane are combined into alkylate, the blending agent that puts long range into super-octane aviation gasoline .

cial Podbielniak fractionating column make possible rapid and accurate separation of compounds whose boiling points are only one and one half degrees apart, a feat which cannot be accomplished by the older type of apparatus.

The new development considerably reduces distilling time, with increased accuracy, and opens up a new field in fractional distillations. To accomplish the perfect blendings necessary in producing the new "100-plus" octane gasoline used in war planes, Richfield Oil Corp. has installed this electronic equipment in its newly expanded refinery near Los Angeles.

## Electronic Heating in Textile Industry

TESTS CONDUCTED with electronic heating have shown that resin-impregnated fabrics may be cured in roll form. Curled selvages are eliminated by this form of drying, and uniformity of curing is obtained because temperature may be controlled accurately. Resin which is deposited on the innermost section of the fabric structure receives the same degree of heat as that on the outside. Laminated fabrics may also be cured in roll form.

Successful setting of twist in rayon and in nylon, handling yarn

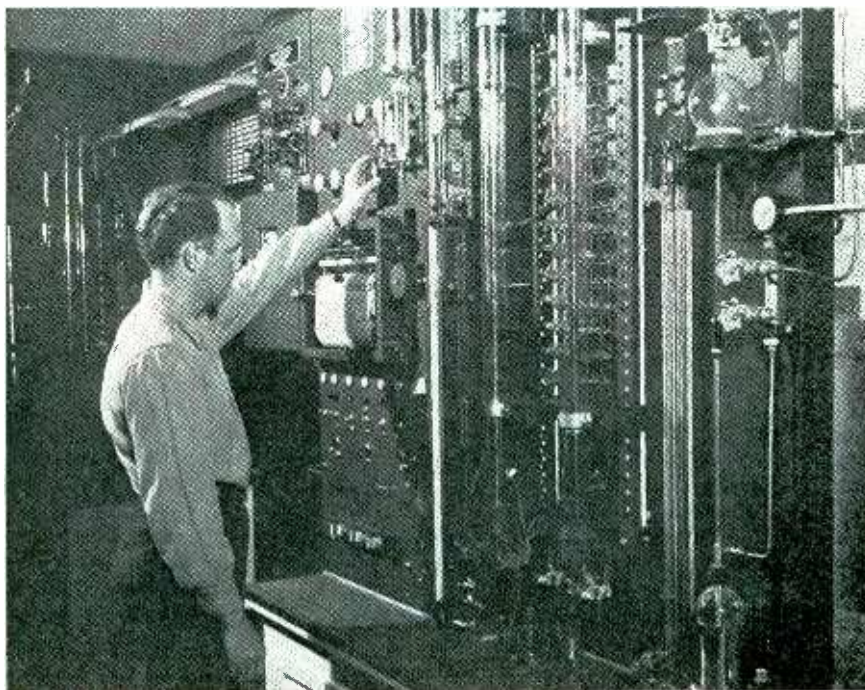

The boiling point of any hydrocarbon fraction an oil refiner desires to separate can be determined by electronic apparatus used in conjunction with this pilot fractionation tower recently installed at the Richfield 100-plus octane refinery. In the photo above, the engineer is adjusting the equipment while noting readings on the Brown Instrument recorder



# This Vibrator Carries Its Own Air Protection

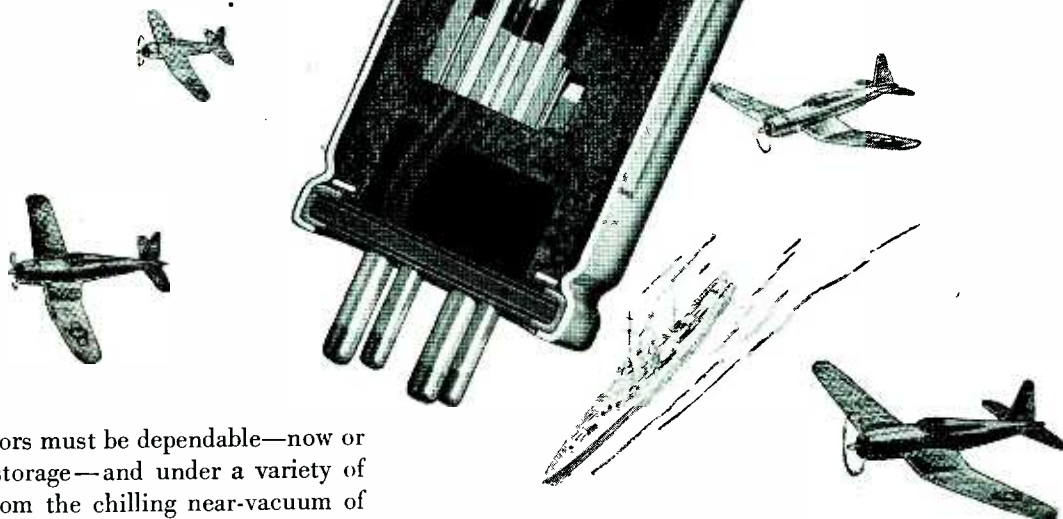

**"FIGHTING"** vibrators must be dependable—now or after months of storage—and under a variety of conditions ranging from the chilling near-vacuum of the stratosphere to the moist, corrosive atmosphere of a submarine. Ordinary peacetime vibrators just can't meet these war requirements. Their containers breathe and admit trouble-making fumes. They fail to function in some types of high-altitude aircraft equipment, because lack of internal air pressure causes ionization breakdowns.

That's why this Mallory vibrator is enclosed in a specially designed case, hermetically sealed to keep it air-tight. This is double assurance that fine tungsten contacts and other precision parts will function perfectly under the toughest assignments.

Today, Mallory hermetically sealed vibrators flow from the production line to every battle front. They're used on ships and planes and tanks—and they take their own three cubic inches of normal atmosphere with them. To test this "breathing space," each vibrator is subjected to an internal pressure of twenty pounds per square inch.

If you manufacture receivers or transmitters for war-time use—or any other battery-powered equipment subject to unusual atmospheric stresses—get the complete facts about Mallory hermetically sealed vibrators. See your Mallory distributor, or write direct.

## Built to Take Rough Treatment— MALLORY Vibrapack \*



Flexible heavy-duty vibrator power supplies, built to take rough handling and to operate under great extremes of heat, cold and humidity. Widely used under war conditions: ideal for peacetime products.

\*Vibrapack is the registered trademark of P. R. Mallory & Co., Inc., for vibrator power supplies.

P. R. MALLORY & CO., Inc., INDIANAPOLIS 6, INDIANA

Buy More  
War Bonds

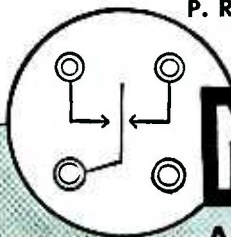

P. R. MALLORY & CO. Inc.  
**MALLORY VIBRATORS**  
AND VIBRATOR POWER SUPPLIES



★Advt. No. 529—2nd Cov., 2 cols.—Electronic Industries—December, 1944  
★Advt. No. 529-A—1 page, B&W—Electronics—November, 1944

ELECTRONICS — November 1944

145

on cones as large as 18 lb, was reported in *ELECTRONICS* for September, 1944.

Rayon cakes may also be dried with high-frequency equipment and can be handled in throwing mills after tinting or other processing operations where it is advisable to handle the yarn in cake form. This type of drying permits dyeing of rayon in cake form as the cakes may be dried either in a vacuum or at atmospheric pressure. Handling rayon in cake form eliminates skeining and other handling operations.

Electronic heat for drying in slashing operations holds possibilities, and other uses suggested by *Textile World* include the drying of heavy paper-makers' felts, heavy carpets, and other textile fabrics of great bulk, either in roll or in sheet form.

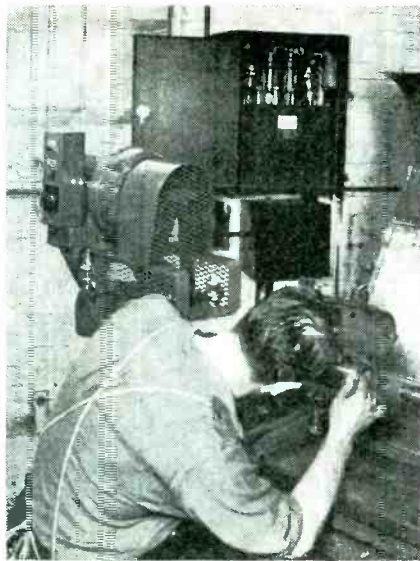

Electronic equipment in the cabinet supplies current to the shunt-wound motor at left. The pushbutton and speed control panel permits stepless operation over a 20-to-1 range while the grinder is running

### 30-Year Old Grinders Use Electronic Control

ELECTRONIC CONTROL can provide old machines with greatly improved operating characteristics when it is impractical to obtain new machine tools. Use of electronic motor drives on three 30-year old Heald grinders resulted in improved quality of precision finishing, vibration-free, stepless speed control over a 20-to-one speed range and better

working conditions. The electronic drive (called Mot-O-Trol by Westinghouse) consists of an electronic rectifier to change alternating current to direct current, plus a d-c driving motor whose stepless speed is controlled by a potentiometer in the pushbutton station.

At the Axelson Manufacturing Company, problems in machining

hardened pump liners were augmented by specifications which require a finished tolerance of 0.001 of an inch. The variation in liner sizes and materials used required grinding speeds over a wide, closely regulated stepless range in order to secure the desired tolerance and finish. This stepless quality in speed regulation permits the operator to choose just the right speed for size of hole material to be finished and grade and grit of the wheel. This helps to eliminate vibration and chatter marks in the work and gives a straight, true, round hole, an ideal condition for the honing operations that follows, for unless a perfect hole is presented to the hone it is apt to follow any irregular conditions of the ground hole.

#### Advantages

In addition to the advantages gained by providing stepless adjustable speed over a wide range, physical advantages were gained by new layouts of the machines. The three grinders were reset on a 35-degree angle with a saving in floor space of about one-third. Removal of all overhead pulleys, belts and shafting resulted in increased safety, improved illumination and elimination of vibration.

The time study department at Axelson reports that an appreciable

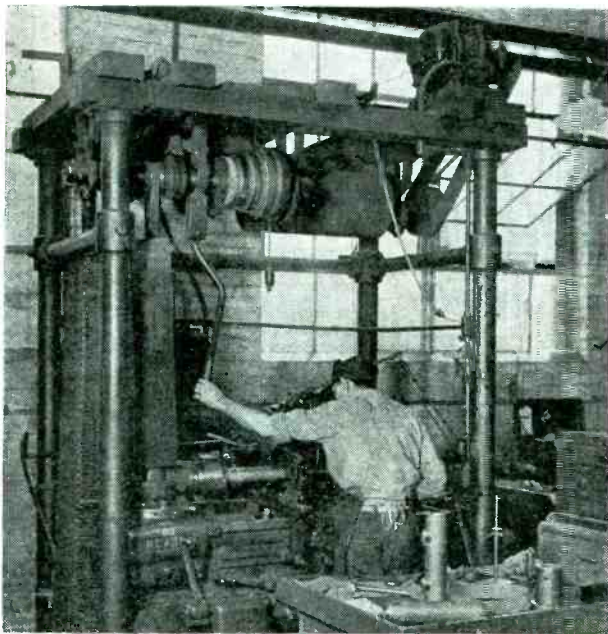

Before the advent of electronic control, these 30-year old Heald grinders were powered by belt-and-pulley drive that allowed only four speeds to machinists, occupied considerable space on the floor and blocked light and ventilation

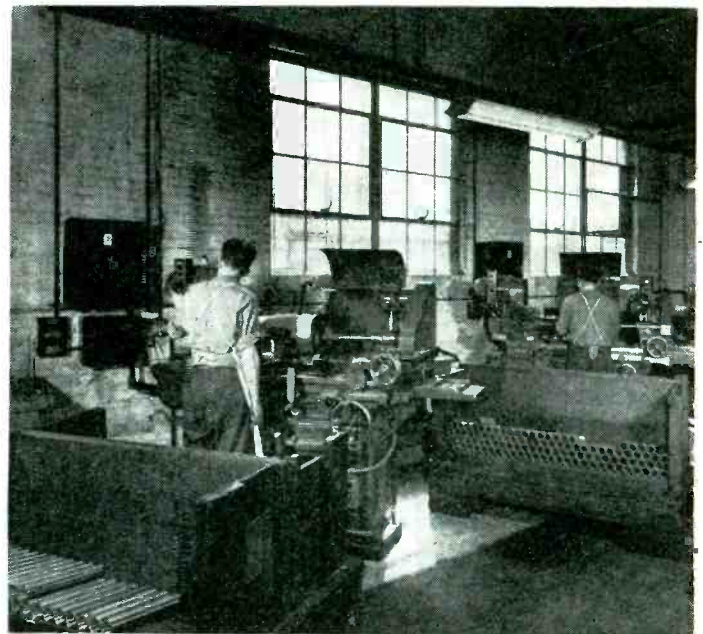

After replacing the overhead countershaft with a Westinghouse electronic drive, additional working space, smooth speed change over a 20-to-1 range and pushbutton speed adjustment were provided for the grinders



# WANT 10 OR 20 MILLION... IN 30 OR 60 DAYS?

*BTR 1/4-Watt. IRC Insulated "Metallized" Resistor L. 3/8" - Di. 3/32"*



No, it's *not* a dream! It's an actual postwar reality. For that's the kind of production capacity we've developed at the IRC plants for turning out these midget 1/4-watt insulated resistors for Uncle Sam. And that's the way we can continue to turn them out . . . for you, immediately we have fulfilled our basic obligation and restrictions are eased to any appreciable extent.

### *World's Smallest 1/4-Watt Resistor*

You'll find the same high quality standards present in these tiny trojans that you have long recognized in the popular IRC type BT's. One of the smallest insulated resistors on the market, the BTR will find wide application in all types of postwar electronic equipment requiring low-power resistors. Samples and technical data sent on request.

## INTERNATIONAL RESISTANCE CO.

401 NORTH BROAD STREET

PHILADELPHIA 8, PA.



*IRC makes more types of resistance units, in more shapes, for more applications than any other manufacturer in the world.*



saving in set-up time has been effected. V. Mancuso, works manager, believes this is due largely to the better illuminated working area, plus less complicated controls and speed changing apparatus on the grinders. The machinist can pre-set work speed either before starting work or change speed while the motor drive is running. Since speed change can be made smoothly, this can be done without danger of spoiling the work in process.

Besides a wide speed range, the Mot-O-Trol provides regulation that is effective in maintaining a constant motor speed with wide changes in load and limits the motor current to a definite maximum safe value. Speed control rheostats are so small that they can be built into a pushbutton station.

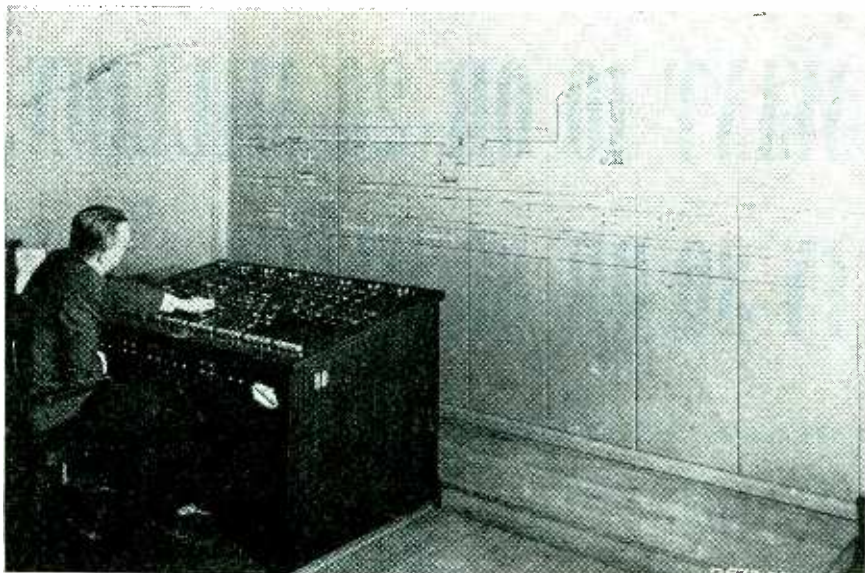

The photo above shows a Westinghouse electronic control desk and monitoring panel in a utility company office where it is used with power-line carrier equipment for supervisory control and fault correction

## Five Uses of Electronics in the Electric Light and Power Industry

UTILITY COMPANIES have used the following five applications of electronic apparatus to extend and assure continuity of electric service, as well as conserve electric energy by reducing the time normally required to perform the operation.

1—Hi-speed power line carrier relaying to disconnect the circuit in case of faults in the protected section.

2—Power-line carrier intersystem communication.

3—Telemetering to expedite load dispatching or load control so as to assure adequate power when and where needed.

4—Supervisory control using power-line carrier equipment.

5—Meter and instrument testing, plus load-regulating equipment.

### *Carrier Relaying*

Supplying more kilowatts on existing transmission lines is one of the many problems faced by utilities; not only more kilowatts, but better and faster clearing of line faults as well as high-speed opening and closing of circuit breakers. To do this, many schemes have been proposed. Electronic equipment has provided the answer in the form of power-line carrier relaying.

For good system operation, the high-speed clearing of faults on transmission lines is important. The best overall protection is pro-

vided by the method known as differential relaying, in which conditions at the two ends of the line are compared. This determines whether the fault is on the line section or external to the protected zone and assures simultaneous tripping of circuit breakers in 1 to 3 cycles. Such action is desirable from the standpoints of stability, continuity of service, quick reclosing, and minimum damage to equipment.

### *Power-Line Carrier*

Power-line carrier provides a highly reliable type of communication by utilizing the power line for the communication channel.

Improvements and developments such as electronic switching, high-voltage line-coupling equipment and other refinements have been given an impetus unequalled in more normal times.

The frequencies usually utilized range from 50 to 150 kc. The r-f energy is confined almost entirely to the wire lines and not radiated into space as is common in radio broadcasting. This results in greater efficiency and makes it possible to transmit greater distances with less high-frequency energy.

An important application of power-line carrier is to provide reliable, high-quality voice communication between various points on the system, such as generating sta-

tions and dispatchers offices, or between dispatchers offices of interconnected systems.

### *Telemetering*

Transmitting electrical values from remote points on a transmission system to a central point where they are summed up and interpreted, then sent back as control impulses to the point of origin or to any other point on the system, is called telemetering. With electronic apparatus, speed and accuracy are obtained, coupled with the advantage of not having parasitic burdens imposed on the measuring devices such as watt-hour meters, indicating and recording instruments.

Electronics has made the transmission of essential operating intelligence not only accurate and fast, but also brings together significant quantities which can be used independently for manual system control or totalized to initiate automatic load-control equipment.

### *Supervisory Control*

Essential circuit breakers serving vital power areas, when disturbed by line faults, can be rapidly restored to normal service by power-line carrier systems. Apparatus switching at distant generator, transformer or conversion stations are all electronic functions.

The cost of older but well ac-



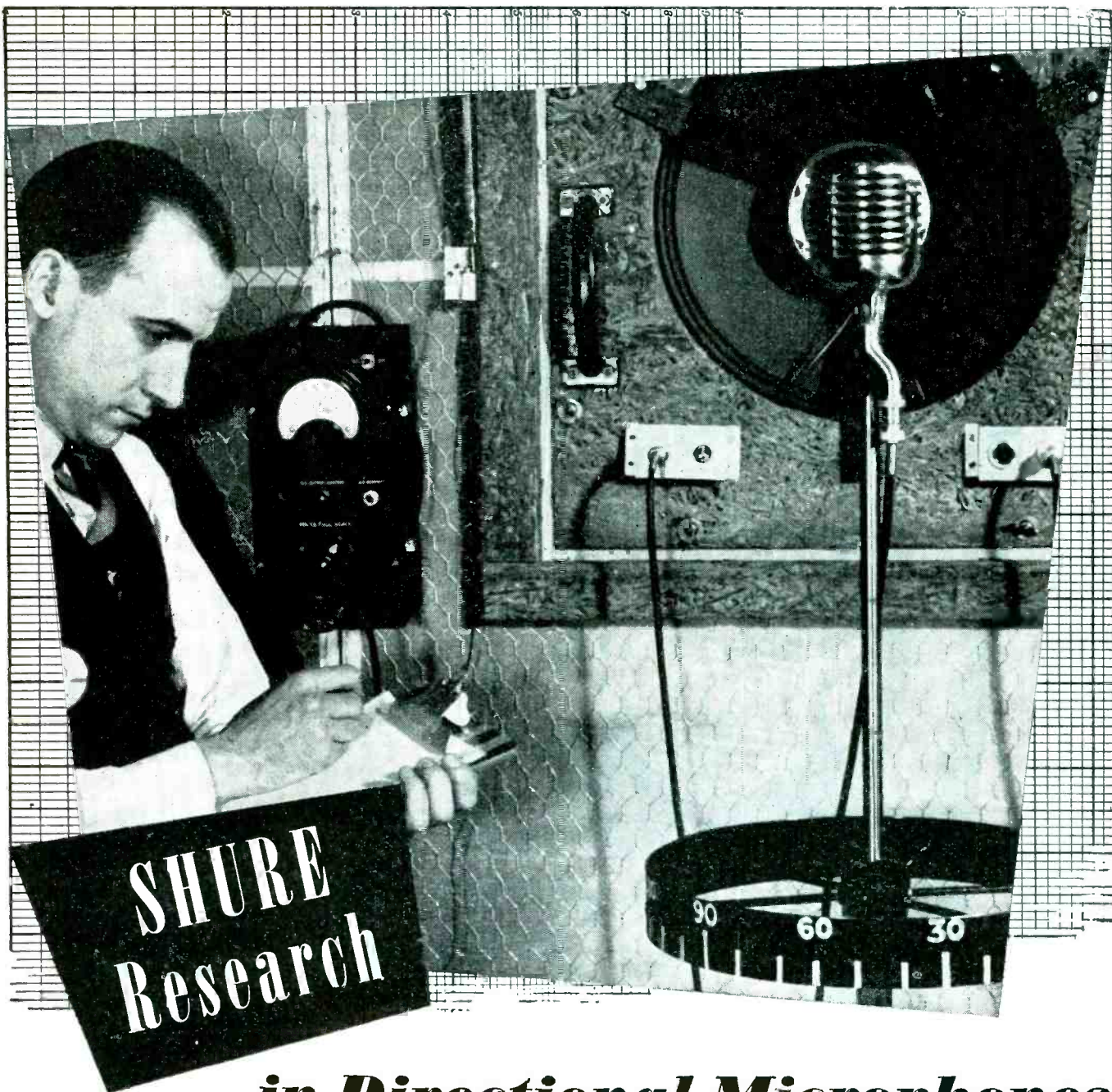

**SHURE  
Research**

## *... in Directional Microphones*

It is not enough to design a Microphone that merely converts sound waves into electrical impulses. A Microphone, to be truly useful in modern broadcasting, should be discriminating enough to accept wanted sounds — and reject unwanted sounds. Shure Research was the first to develop a single unit uni-directional Microphone, both crystal and dynamic.

Shure Research is the reason why practically every major broadcasting station uses the Shure 556 Unidyne. Shure Research is your assurance of postwar microphone superiority.

**SHURE BROTHERS, 225 West Huron Street, Chicago**  
*Designers and Manufacturers of Microphones and Acoustic Devices*





IT WON'T BE LONG NOW . . .

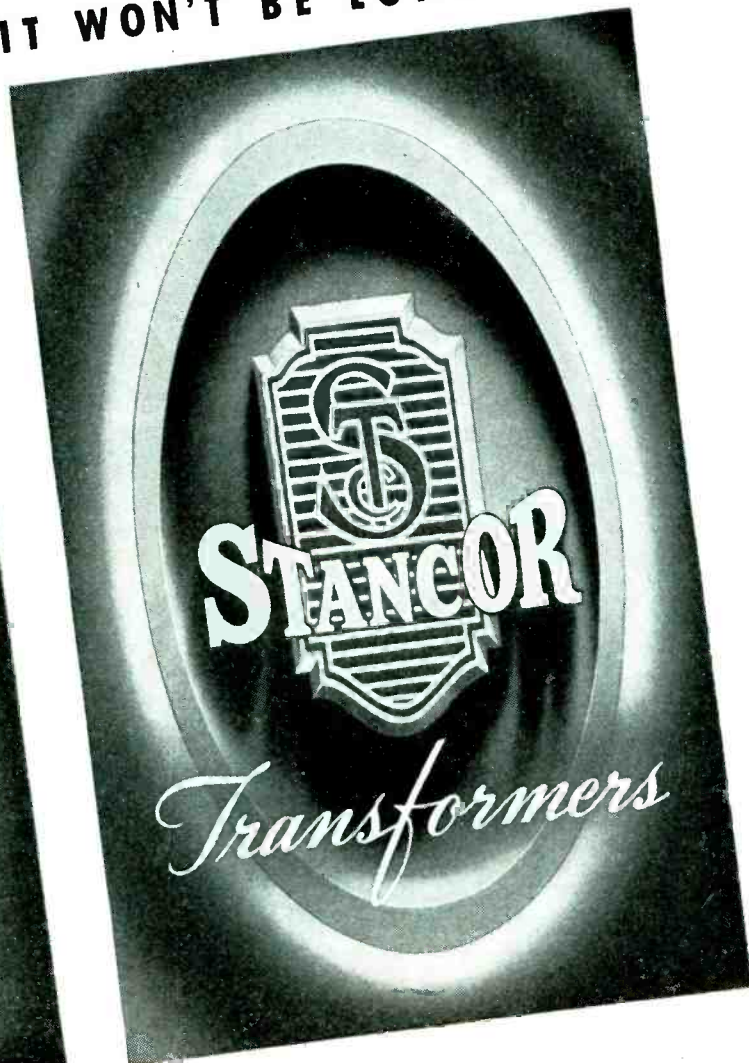

. . . and Stancor will "step ahead" with postwar plans that not only will include units for most every communication and electronic apparatus, but will have inherent in those transformers, design technique which our extraordinary war production has demanded . . . Yes, Stancor is worth waiting for. So, before you specify —consult "Stancor for Postwar."

**STANDARD TRANSFORMER CORPORATION**  
1500 NORTH HALSTED STREET, CHICAGO 22, ILLINOIS

cepted systems was a function of distance because of cables, telephone lines and other associated apparatus. Powerline carrier circumvents these costs by using existing transmission lines, leaving only terminal facilities to be installed. Since distance is no longer a controlling limitation, power-line carrier operates over greater distance than pilot wire, and permits wider application for this type of control.

#### *Meter Calibration*

Meter and instrument testing has always been an essential part of any electric light and power company. By the use of electronic apparatus, the human element is minimized and greater speed and accuracy are obtained.

Under the present system of manual testing of watt-hour meters, a good meter laboratory can average approximately 50 meters per eight hour day per man.

With visual types of electronic equipment, as many as 135 meters per day are being tested.

#### *Load Control*

The bug-a-boo of indicating instrument and integrating meter testing has been load control. Automatic electronic load regulators now speed up instrument testing and increase accuracy with subsequent conservation of manpower. In addition, a reduction of electrical energy is effected by cutting down the time previously required to make the test.

That electronic devices have and will continue to perform an important part in the distribution and control of electrical energy was also predicted by Amos J. Germaine, of the electronics section of Westinghouse, in addressing members of the Iowa State Utilities Association at a recent meeting.

#### **Portable Flutter Recorder for Planes**

FLUTTER CAN BE, and in most cases is, avoided in designing planes. Especially in large planes, it rarely appears in the first model, in any severe form. Sometimes it appears in a particular plane after months of use where it did not exist in the prototype. With a new flight vibration recorder, velocity or acceler-



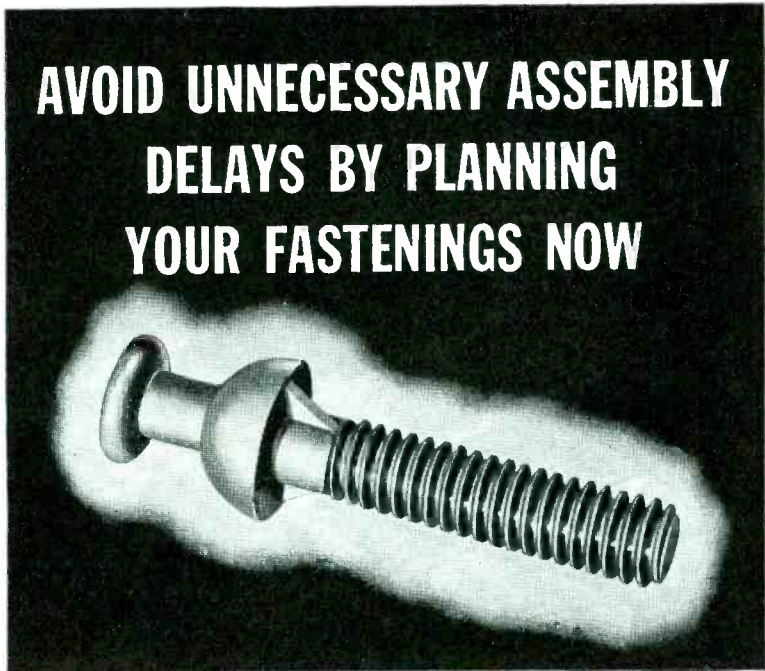
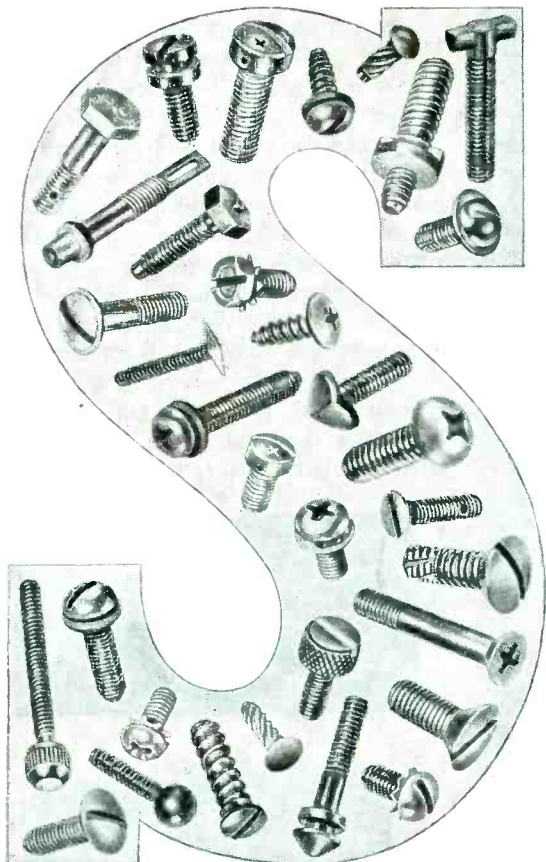

**AVOID UNNECESSARY ASSEMBLY DELAYS BY PLANNING YOUR FASTENINGS NOW**

**"Cold-forging"—proof #25  
...more each month**

### 3 Standard Fastenings for Production Efficiency



**1 Phillips Recessed Head Screws**—The modern, effective, time-saving fastening device proven in tens of thousands of assembly lines. Other standard head styles are also available.



**2 Self-Tapping Machine Screws**—Eliminate separate tapping operations for fastenings to castings, heavy gauge sheet metal, and plastics. Also available with Phillips Recessed Head.



**3 Washer-Screw Assemblies**—When use of lock washers is indicated, the time-saving of pre-assemblies is obvious. Also available in standard slotted head styles.

Forethought, when your product is still in the design stage, can mean timely delivery of fastenings for that "long planned" fast assembly job. Your early and precise choice of fastenings—standard or special—may be vital to the fast and exacting assembly job required for an advantageous start on postwar production.

That's where Scovill comes in . . . our broad experience in fastenings and ingenuity in special design qualify us as specialists in the fastenings field. Let us help you determine the best modern fastenings to use—a featured standard fastening or a part especially designed to suit your needs.

The part shown above is one of Scovill's many special purpose cold-forged items. Our special processing of this part meant substantial savings in money—materials—motions. Call our Fastenings Expert for assistance so that you likewise may profit. Call him **now**.

## SCOVILL MANUFACTURING COMPANY

### WATERVILLE SCREW PRODUCTS DIVISION

WATERVILLE 48, CONN.



TEL. WATERBURY 3-3151

NEW YORK, Chrysler Building • DETROIT, 714 Fisher Building • CHICAGO, 1229 W. Washington Boulevard • PHILADELPHIA, 18 W. Chelton Avenue Building  
PITTSBURGH, 2882 W. Liberty Ave. • SYRACUSE, Syracuse • Kemper Insurance Bldg. • LOS ANGELES, 2627 S. Soto St. • SAN FRANCISCO, 434 Brannan St.



# HARDWICK, HINDLE

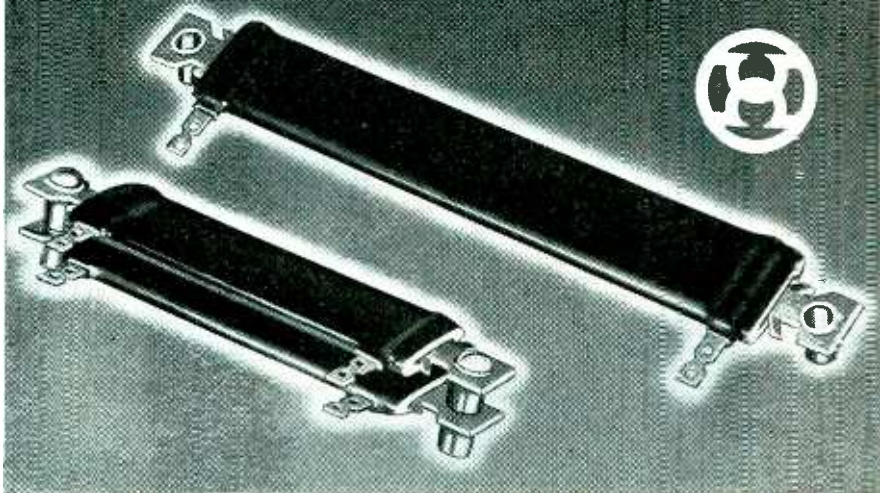

## STILL LEADING THE FIELD

Our Blue Ribbon Resistors were unique in their entirely new design and their advanced engineering when we introduced them in 1939.

They still lead the field as the most efficient:—their compactness, their toughness, and their remarkable performance offer you more than just higher wattage ratings for unit space required.

—And in our other types of resistors and rheostats we also offer you important exclusive advantages.

### HARDWICK, HINDLE, INC.

RHEOSTATS and RESISTORS

DIVISION OF

THE NATIONAL LOCK WASHER CO.

ESTABLISHED 1886

Newark 5, N. J., U. S. A.

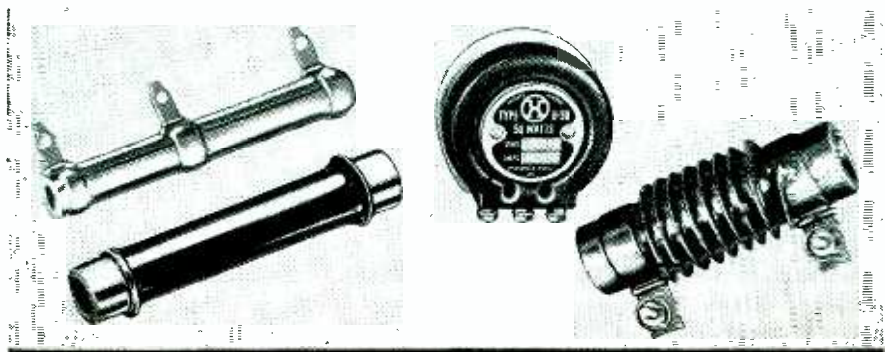

ometer type pickups can be placed at many places about the plane and two of these can be operated simultaneously. A selector switch permits many points to be studied in the same flight. The recorder contains its own batteries, amplifier, electronic switch, and cathode-ray tube as well as a camera to photograph the oscillograph record.

For exhaustive flutter study, equipment weighing between 300 and 500 pounds previously has been used. Installation and tests by this method required about two weeks. Frequently, after the equipment

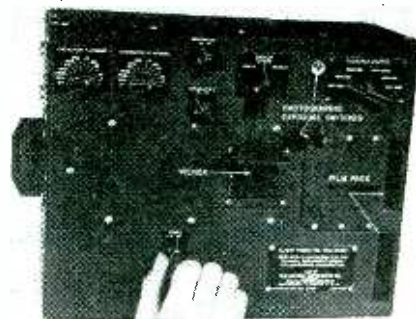
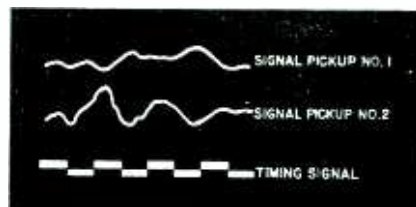

Panel view of the portable flight recorder and a typical photograph of the vibration encountered by pickups located at two positions of stress in the plane

was removed, additional information was needed during analysis of the observations, and the new recorder is ideal for such re-examination. Light enough to be held on the lap of the observer, it can be installed and put into use in a few hours. The machine is also useful in studying vibration in motor mounts, cowling and small accessories, where its ease of installation as a special-purpose instrument is important.

Present knowledge of flutter has been built up over years, and has been gathered from experiments on the ground and in flight. Vibrating machines are still used to simulate flight conditions on the ground. In a few cases, radio-controlled planes have been used with recordings transmitted to the ground during





# DOUBLE WINNERS

## STROMBERG-CARLSON'S WARTIME ADVERTISING — AND STROMBERG-CARLSON'S POSTWAR RADIOS!

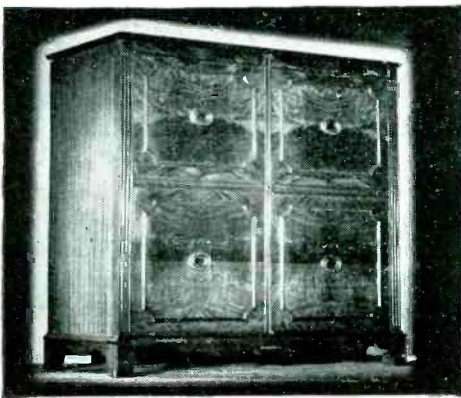

Stromberg-Carlson, Rochester 3, New York  
Radios, Television, Telephones, and Sound Equipment

What wartime radio advertising can show such a record of dealer approval—and of public readership—as the current Stromberg-Carlson pages in the national magazines? *None*—the Daniel Starch advertising check-ups have proved that, *plenty!*

And the postwar Stromberg-Carlson FM and AM radios, radio-phonographs, and television sets will be equally far out in front. Tailor-made to the postwar market—as established by our recent 5,000-radio home market survey—they will give the public exactly what it's looking for.

*This 5,000-radio home survey brings home clear as a bell the buyers' tremendous insistence on top quality in radio equipment. They expect and will seek out the very best...and back up their insistence with plenty of cold cash.*

The distribution of your radio sales promises some important changes, too. Changes in the ratios between radios and radio phonographs, between consoles and table models. Changes and improvements which people want, and which will be reflected in all postwar Stromberg-Carlson equipment... a pretty pleasant prospect for every Stromberg-Carlson dealer!



HERE'S THE **STROMBERG-CARLSON** POSTWAR  
SET-UP IN 21 SECONDS READING TIME!

**1** We will have—soon after Victory—a fine line of Stromberg-Carlson FM and AM radios, phonograph combinations, and television receivers in a wide range of prices.

**2** We will have a policy of distribution planned to give every Authorized Dealer a good profit opportunity on the Stromberg-Carlson line.

**3** And the Stromberg-Carlson name will be even more widely and more favorably known than ever before.

**Now  
Available  
For Prompt  
Delivery**

**LINGO  
VERTICAL TUBULAR  
STEEL RADIATORS**

are now back in production and  
can be supplied promptly,  
subject to existing regulations.

Now, after two years of producing thousands of tubular towers for the Armed Forces, Lingo is again ready to serve the Broadcasting Industry. From the earliest days of "wireless" to the threshold of a new era in broadcasting, Lingo has been constructing and erecting vertical structures that have been setting outstanding efficiency and performance records. Vertical tubular radiators are available in standardized heights from 100 to 500 feet. Lingo also produces tubular steel supporting poles for the accommodation of FM, Television and other UHF antennas.

*Our staff will be pleased to provide you with the complete story as it applies in your own case. In writing, please give location, power, frequency of station, and indicate radiator height desired.*

**JOHN E. LINGO & SON, INC.**  
EST. 1897 CAMDEN, NEW JERSEY

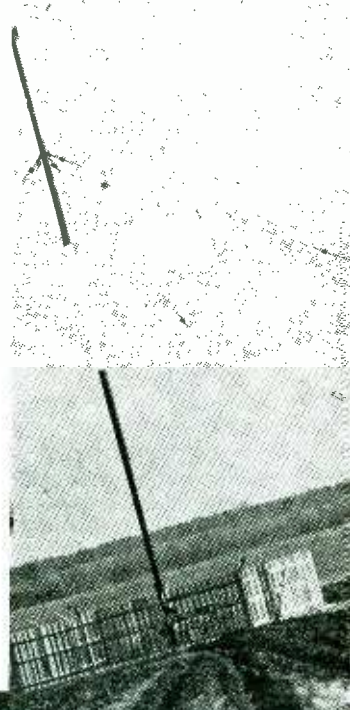

**LINGO VERTICAL  
TUBULAR STEEL  
RADIATORS**

flight, and test pilots have flown planes equipped with recorders which transmit their reports by radio to the ground. For all of these methods, the new recorder is a valuable auxiliary.

Development of the new recorder was made by the CAA in cooperation with Brown Instrument Company.

• • •

**10,000-kw Electronic  
Converters in Steel Plant**

AN ELECTRONIC POWER converter designed to exchange power, reversibly, between 25-cycle, 44-kv and 60-cycle, 69-kv systems has been installed as two complete 10,000-kw units at a plant of Carnegie-Illinois Steel Co. The arrangement permits operation at 125 percent load for one hour and 200 percent load for one minute.

Twelve tubes form the rectifying element for converting 10,000-kw a.c. to d.c. and twelve additional tubes convert the d.c. back to a.c. The direct-current link operates at approximately 30,000 volts. When changing from rectifier to inverter operation for reverse power flow, the phase position of the grid voltage is shifted by a phase-shift network approximately 150 deg.

In operation, the electronic converter is held to a constant power output independently of relative system frequencies and voltages. It contributes no current to faults in the supply system, little more than load current to receiving system faults, while controls suppress power flow to internal faults. Switching is resorted to only for persistent faults. Reactive overexcited current is supplied by synchronous apparatus of both systems, excess losses of which are chargeable to the converter. Efficiencies remain high throughout the load range.

*Suppression of Faults*

As a result of practical experience with electronic converter systems in the operation of a direct-current power transmission, it has been learned that the electronic converter is subject to occasional faults such as arc backs which apparently cannot be entirely avoided. However, the practical effect of electronic faults can be suppressed so that they do not interfere with



ONE OF A SERIES PORTRAYING THE "SPEED NUT FAMILY OF FASTENINGS"

FLAT TYPE  
SPEED NUT

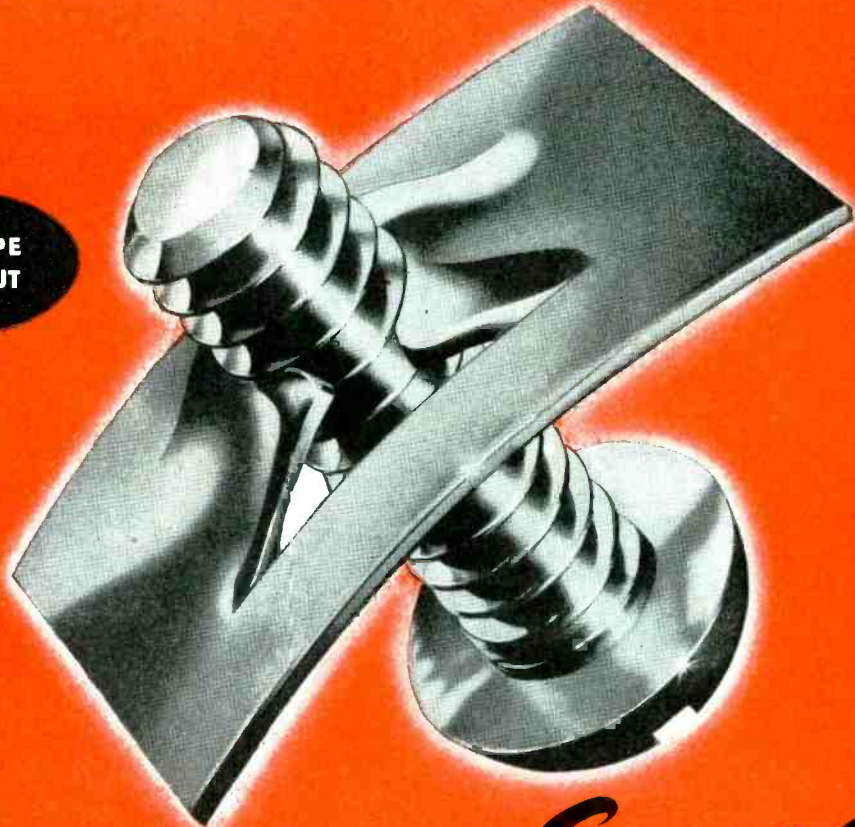

...AND WE DO MEAN *Speed!*"

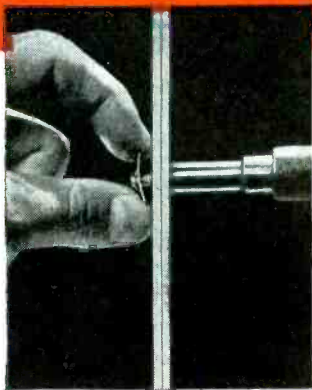

STARTING POSITION

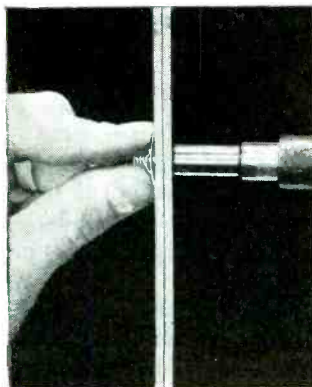

LOCKING POSITION

## Greater Speed Reduces Assembly Time Greater Speed Cuts Assembly Costs

● This ad is devoted to speed. The word appears 5 times in this message because we want to stress speed first and foremost.

Why? Because you will need better and faster assembly speed in order to win postwar markets in big volume on any product—metal, wood, or plastics.

Designing beautiful postwar products is only the beginning. The winners will be those good

looking products that are engineered for better and faster assembly. We have already produced over 2,000 shapes and sizes that have drastically cut assembly time, reduced costs and improved the quality of the finished product. Write for literature.

### TINNERMAN PRODUCTS, INC.

2106 Fulton Road, Cleveland 13, Ohio  
In Canada: Wallace Barnes Co., Ltd., Hamilton, Ontario  
In England: Simmonds Aerocessories, Ltd., London

*Speed Nuts*★  
Patented \*Trademark Reg. U. S. Patent Office

FASTEST THING IN FASTENINGS



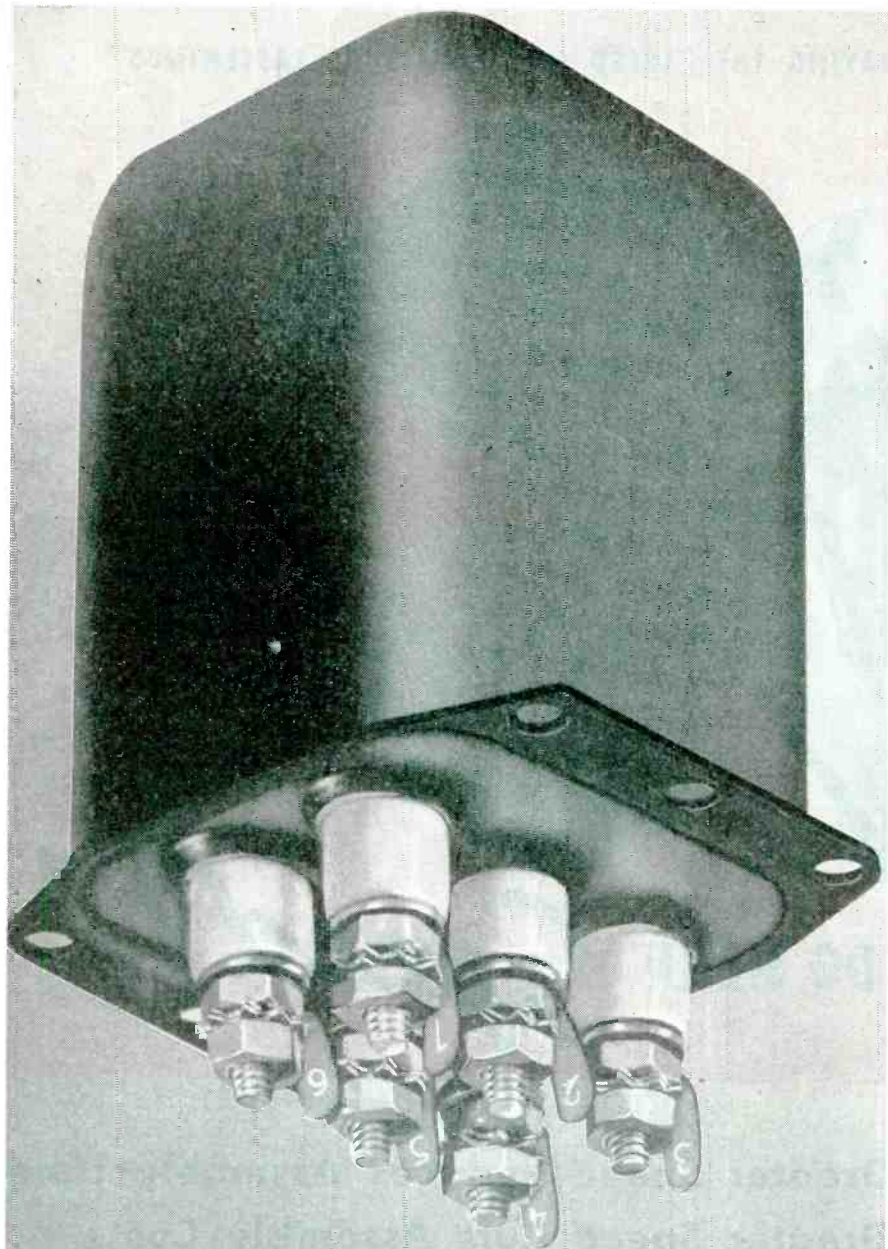

## DEPENDABLE

Dependability, long life and accuracy must be built into transformers from the drafting board to final rigid testing.

Our large engineering staff, constant material control, modern manufacturing equipment and careful testing are your insurance of Dependable

# CHICAGO TRANSFORMER

DIVISION OF ESSEX WIRE CORPORATION

3501 WEST ADDISON STREET

CHICAGO, 18



operation but can be detected by sensitive instruments. The means developed to suppress electronic faults have incidentally introduced the ability to suppress the effects of lightning so that the direct-current power transmission has a remarkably good record for reliability during lightning storms.

Four pentode ignitron groups of 6 tubes each make up a converting equipment. The pentode tube, es-

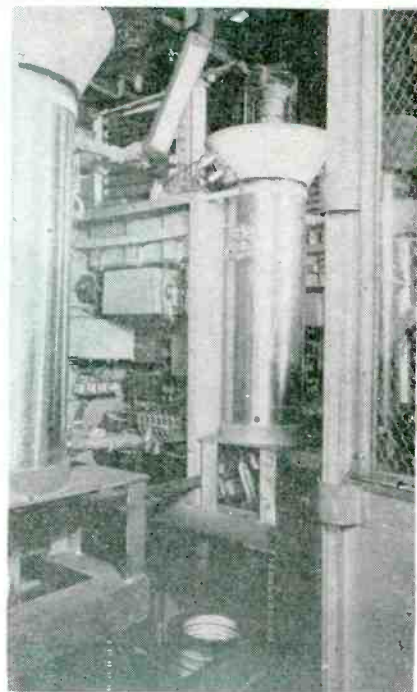

A portion of the electronic power converter unit at Carnegie-Illinois Steel Corp. The large cylinders are pentode-ignitron inverter-rectifier tubes. Grid control equipment is in the background

pecially developed for rectifier and converter service, is an ignitron of the permanently evacuated, sealed steel type having the control characteristics of a thyratron tube. One or more grids control the starting of current conduction, aid in deionization at the end of conduction, and reduce the time required to regain control.

### Tube Data

Physically, the tube is of a cylindrical shape approximately 10 in. in diameter, 45 in. in length, and weighs 100 pounds. Two concentric stainless steel cylinders form the enclosing envelope. Water circulates in the space between the cylinders to remove the losses. Tube losses are a fraction of one percent at the usual operating voltage.

Development, design, operating



# LUMARITH insulation protects against the **BLACK HAND OF CORROSION!**

LUMARITH insulation is effective protection against electro-chemical corrosion even under severe conditions—for example, applications involving fine wire under conditions which ordinarily cause electrolysis, such as the presence of moisture and direct current.

Lumarith isn't subject to that built-in hazard of many types of insulation—organic decomposition. Lumarith resists

moisture and contains no materials which combine with moisture to form free acids. It is outstanding for high dielectric strength, and its softening point makes it applicable for many types of coils.

Available in films, sheets, rods, tubes and molding materials. Films are supplied in plain or in special mat finish that reduces slippage and increases visibility for easier winding.

\*Reg. U. S. Pat. Off.



Send for "Lumarith for the Electrical Industry" a valuable reference booklet. Celanese Celluloid Corporation, a division of Celanese Corporation of America, 180 Madison Avenue, New York 16, N. Y.

**LUMARITH** <sup>\*</sup>  
*A Celanese <sup>\*</sup>Plastic*

# BROADCASTERS

**COMPACT... COMPLETE... ECONOMICAL...** that's the 76-B2 Speech Input Console.

The ease of its push-button control, the completeness of its amplifying and control equipment and a host of other features have made this equipment the favorite of small and medium-sized stations the country over. (We venture to say even a postwar visionary would have difficulty in visualizing a better speech input system!)

Here are some of the features which have made the 76-B2 Console so popular:

- \* Includes all amplifying and control equipment for operating one studio, two studios or two studios and an announce booth, six remote lines and two turntables.
- \* Frequency response 30 to 15,000 cycles.
- \* Push-button control of monitoring, auditioning, remote lines, cueing and talk-back.
- \* Independent auditioning and program channels.
- \* High-fidelity program channel affords 6 mixer controls, 4 microphone pre-amplifier input channels with switching control for up to 6 microphones.
- \* High-fidelity monitoring channel operates control room and studio loudspeakers.
- \* Emergency amplifier and power supply circuit.
- \* Meets all FCC requirements for AM and FM broadcasting.

The 76-B2 Console at  
Station WBOC, Salisbury, Md.





# TELL US....

## "That 76-B2 is a honey!"

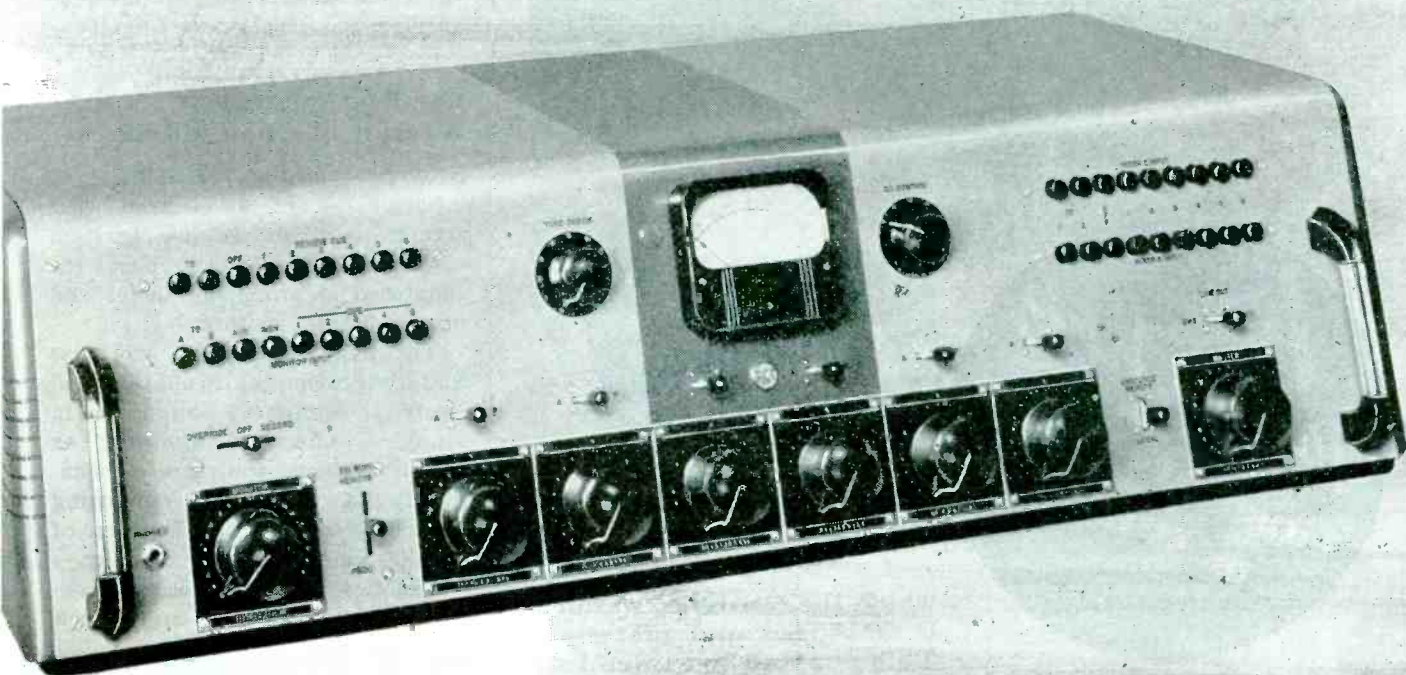

**COMPACT**... Console measures 39" wide, 17" deep and 10½" high.

**COMPLETE**... Answers every speech input need of the small and medium-sized broadcast station.

**ECONOMICAL**... At a price the smallest station can afford.

Perhaps your station lacks the efficient service of an RCA 76-B2 Speech Input System. For further information on its advantages and availability, please address the Broadcast Equipment Section of RCA at Camden, N. J. (Interested in reserving a postwar AM, FM or Television Transmitter? The RCA Broadcast Equipment Priority Plan will interest you. Write today for details.)

War Bonds... Your Best Investment

1919  
1944



25 Years of Progress  
In Radio  
and Electronics

### RADIO CORPORATION OF AMERICA

RCA VICTOR DIVISION • CAMDEN, N. J.

In Canada

RCA VICTOR COMPANY LIMITED, MONTREAL



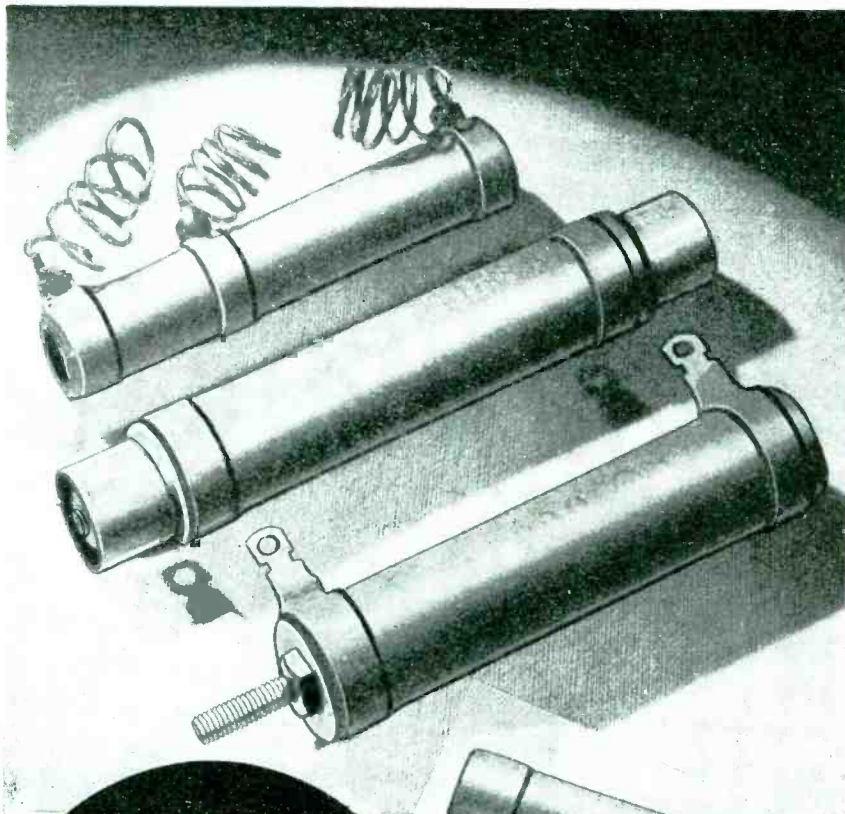

**Greenohms**  
either STANDARD  
or SPECIAL

★ Those green-colored (for identification) power resistors found more and more in severe-service electronic, radio and electrical assemblies these days are **Greenohms**.

They are **extra-rugged**, as proven by impartial tests and the service records out in the field. The extra safety factor is due to the exclusive inorganic cement coating in

which the resistance winding is imbedded and protected. This coating provides improved radiation of heat for cooler operation. Also, this coating will not crack, flake or peel despite severe overloads and heat shock.

Standard types in 5 to 200 watt sizes as fixed resistors, and 10 to 200 watt sizes as adjustable resistors. Special types in widest range of terminals, mountings, taps, sliders, etc.

★ For that assembly in which you seek extra safety factor, consider GREENOHMS. They cost no more. Remember, only Clarostat makes GREENOHMS. Let us quote on your high-priority requirements. Literature on request.



results and possible applications for the 20,000-kw electronic power converter installed by General Electric were discussed at the AIEE summer meeting in St. Louis. Switchgear, control and pentode ignitron tubes for the converter were also reported upon at the symposium.

The electronic converter is applicable to certain cases requiring control of power flow between systems of like or dissimilar frequency and voltage or, with suitable modifications, to systems furnishing power to isolated loads which have sufficient synchronous capacity for commutation, etc., at fixed or variable frequencies.

• • •

### Oscillograph Checks Aircraft Engine Ignition

STOPPING SPARK FLASHES at 0.0000001 second, an electron beam records airplane engine ignition actions to help control problems encountered in producing faster and more powerful motors.

The new oscillograph will also find application in insulation and electrical equipment design and in study of effect of lightning on power systems and transmission-line faults. War plants now using it include the Scintilla Division of Bendix and the Bosch Company.

The new electronic oscillograph that is giving aircraft engine men

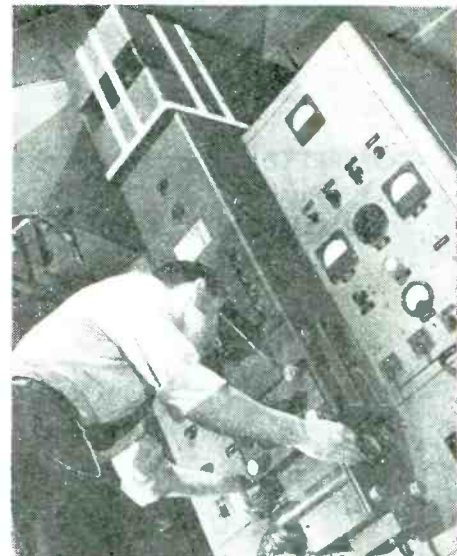

A Westinghouse engineer checks the positioning of the film pack in the new oscillograph being used in plane plants to photograph ignition sparks traveling 5000 miles an hour. It will also be useful in insulation and electrical equipment design

**CLAROSTAT** *Controls and Resistors*  
CLAROSTAT MFG. CO., Inc. - 285-7 N. 6th St., Brooklyn, N. Y.



Micarta antenna masts to  
**"HIT THE BREEZE"**  
 at 600 mph!

**Another Example of Versatile Micarta at work**

That thin, long mast rides outside in the fury of a 600 mph gale. It is made of Micarta—the light, tough plastic.

Requirements for antenna mast performance are exacting. The mast must withstand extremes of air pressure and temperature. It must be rigid, hold the antenna taut without yield or wobble.

Micarta's unusual combination of characteristics—strength with lightness, resistance to heat, cold, humidity and chemicals—has been of particular interest to the Communications Industry for many years. All these same properties are retained in Micarta "444"—a new development in plastics—a process of manufacture permitting the formation of structural shapes from completely cured flat sheets. A versatile product . . . suited to simple and low-cost fabrication . . . with unlimited application possibilities in the Communications Industry.

Investigate Micarta and the new "444" product—write for the new Micarta Data Book—B-3184A. Westinghouse Electric & Manufacturing Co., P. O. 868, Pittsburgh 30, Pa. J-06347-B

OFFICES EVERYWHERE



PLANTS IN 25 CITIES



**CAMS**, made of Micarta, are used where high dielectric plus long wear are important. Other applications include terminal blocks, coil forms, switch spacers and tube sockets.

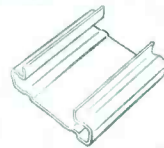

**AMMUNITION FEED CHUTES** made of the new Micarta "444" guide bullets accurately into firing position. It is thin, light, strong, easily formed with inexpensive dies.

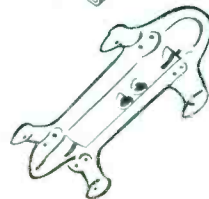

**BOMB RACKS** have been successfully molded with Micarta . . . furnish an excellent example of Micarta's strength and the skill of Westinghouse engineers in intricate molding assignments.

# Why we pull Relay Screws apart

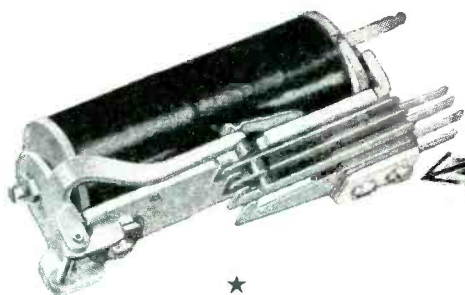

★

Vibration, humidity and extremes of temperature can be bitter enemies of relay dependability. That is why the contact springs on Automatic Electric relays are clamped by special screws, which exert the necessary pressure without breaking or stretching. Such screws must meet the exacting tensile tests prescribed by our designers.

These tests, and scores of others like them, are vital contributions to the long life and dependability for which Automatic Electric relays are famed.

When you need relays or other electrical control devices, take advantage of our unique fund of design data and experience. First step is to write for the Automatic Electric catalog. Then, if you need sound technical advice on your problem, call in our field engineer. He will be glad to put his knowledge to work for you.



**AUTOMATIC ELECTRIC SALES CORPORATION**  
1033 WEST VAN BUREN STREET • CHICAGO 7, ILLINOIS  
In Canada: Automatic Electric (Canada) Limited, Toronto

*Relays*  
AND OTHER CONTROL DEVICES  
by **AUTOMATIC ELECTRIC**

PARTS AND ASSEMBLIES FOR EVERY ELECTRICAL CONTROL NEED



Marvels of Electronics—

and the steelmaking

skill of **Follansbee**



Many of the electrical and electronic devices which are providing a margin of superiority to our fighting men are necessarily closely guarded military secrets. But it is no secret that their manufacture requires new standards in the production of Electrical Sheets.

The need for such combinations in high silicon steels as thin sheets to close gauge tolerances, exceptionally clean surfaces and

excellent punching qualities, together with essential magnetic characteristics, created problems never before encountered in the tonnage production of Electrical Sheets.

The success of Follansbee in quickly meeting these new standards is evidence of the skill of its compact, highly trained organization. It is an important reason why you can entrust these and other difficult steelmaking jobs to Follansbee.

## FOLLANSBEE STEEL CORPORATION

GENERAL OFFICES • PITTSBURGH 30, PA.



*Sales Offices*—New York, Philadelphia, Rochester, Cleveland, Detroit, Milwaukee.  
*Sales Agents*—Chicago, Indianapolis, St. Louis, Nashville, Los Angeles, San Francisco, Seattle; Toronto and Montreal, Can. *Plants*—Follansbee, W. Va. and Toronto, O.

ALLOY BLOOMS, BILLETS, BARS, SHEETS & STRIP • COLD ROLLED SHEETS & STRIP  
POLISHED BLUE SHEETS • ELECTRICAL SHEETS & STRIP • SEAMLESS TERNE ROLL ROOFING

*Crystal and Dynamic*  
**MICROPHONES**

**PHONOGRAPH PICKUP ARMS  
 CARTRIDGES and RECORDING  
 HEADS**

Known for efficiency, quality and durability. Available with proper priority ratings.



Manufacturing radio cable connectors, antennas, and special sound detection devices for wartime equipment

**THE**  
*Astatic*  
**ASTATIC CORPORATION**  
 CONNEAUT, OHIO  
IN CANADA: CANADIAN ASTATIC LTD., TORONTO, ONTARIO

more data about the ignition systems of high-powered airplane engines than has ever existed before takes pictures on camera film in much the same manner as an x-ray.

To prevent the beam from registering on the film before the ignition study is made, the unit incorporates a beam trap that deflects the electrons out of the photographic channel. Periods as short as 0.00000001 of a second are photographed on a stationary film strip. Slower speeds, less than 0.000008 second, are recorded on a revolving drum that turns 7,000 times a minute. The rotating film drum is necessary for certain uses because stationary film does not register intervals of 0.02 second.

Westinghouse research engineers collaborated with warplane engine manufacturers in testing ignition systems with the oscillograph and the results pointed the way to better engines by making ignition improvements.

• • •  
**AMERICAN MINE  
 DETECTOR**



Now operating in Europe, this mine detector made by International Detrola Corp. contains three coils in the search head. Two of these are connected in series opposition so that the combined mutual inductance to the third coil is neatly zero. Complete balance is provided by tuned compensator coils in the control box on the handle. Any metallic mass in the 'coils' field changes the mutual inductance, affecting a meter and an earpiece to provide both audible and visual indication



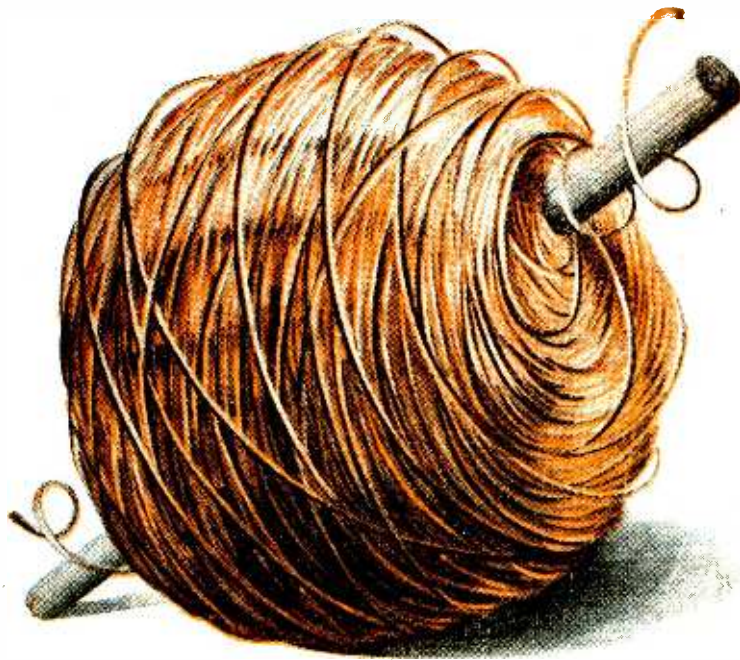

## *A Coil is more than just a bundle of wire*

ANACONDA COIL ENGINEERS have designed over 15,000 individual types of coils during their many years of experience. Some have weighed as little as 1/100th of a pound; others as much as a quarter of a ton.

But each coil began with a blueprint. Type, shape, size, winding, insulation, treatment, cost—every factor entering into designing the best coil for the use intended was pre-determined by Anaconda engineers.

Anaconda Coils derive dependability from still another advantage. The magnet wire used for winding them is also a product of Anaconda engineering—with quality carefully controlled from ore to finished wire.

It is a highly effective combination: Coil producers who can command the complete experience of magnet wire specialists! Magnet wire producers who

enjoy the close cooperation of coil experts!

And back of each are exceptional manufacturing facilities. Modern plants . . . efficient equipment likewise engineered . . . experienced, skilled personnel.

Any Anaconda sales office will be glad to refer inquiries on coils or magnet wire to our engineering staff. 44239



View of a modern coil winding department at one of the Anaconda plants.

 *Magnet wire and coils*



### ANACONDA WIRE & CABLE COMPANY

GENERAL OFFICES: 25 Broadway, New York 4

CHICAGO OFFICE: 20 North Wacker Drive 6 • Sales Offices in Principal Cities

*Subsidiary of Anaconda Copper Mining Company*





# wherever a tube is used...

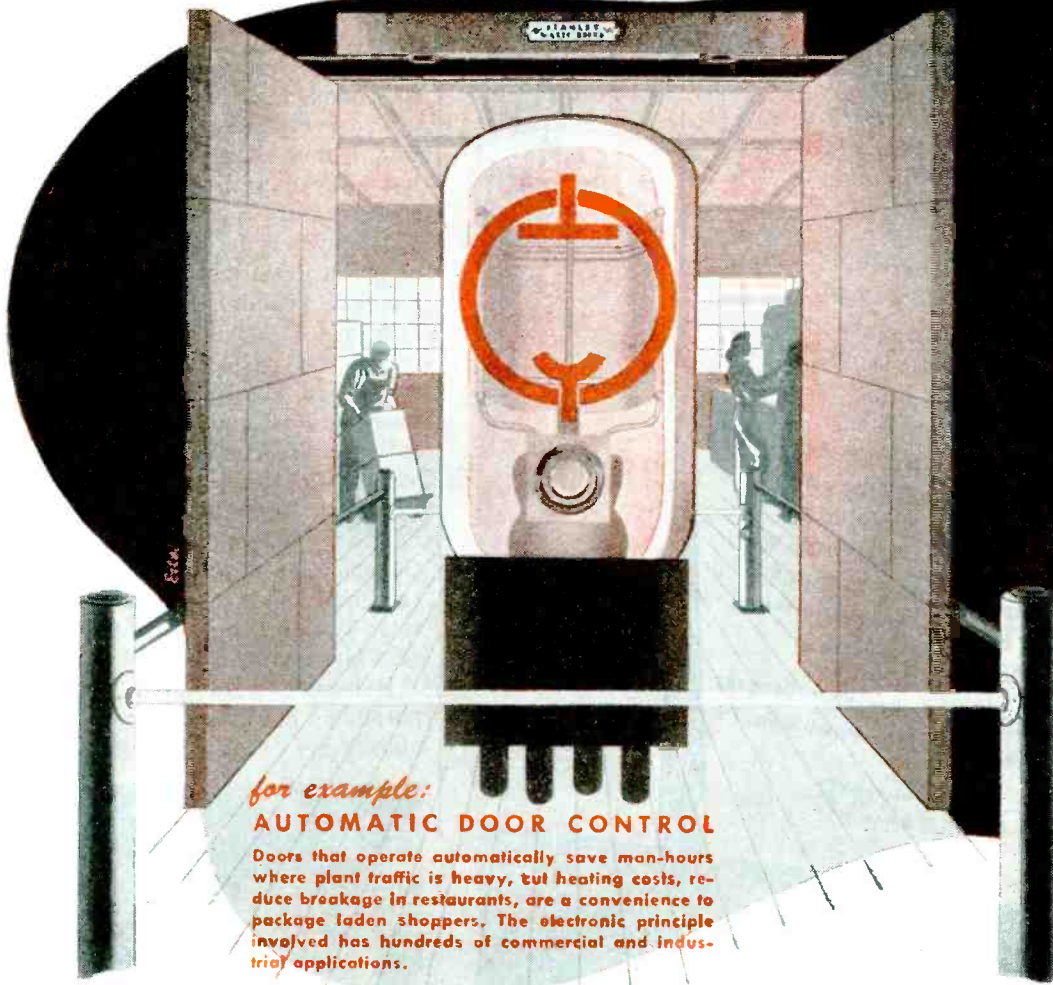

*for example:*  
**AUTOMATIC DOOR CONTROL**  
 Doors that operate automatically save man-hours where plant traffic is heavy, cut heating costs, reduce breakage in restaurants, are a convenience to package laden shoppers. The electronic principle involved has hundreds of commercial and industrial applications.

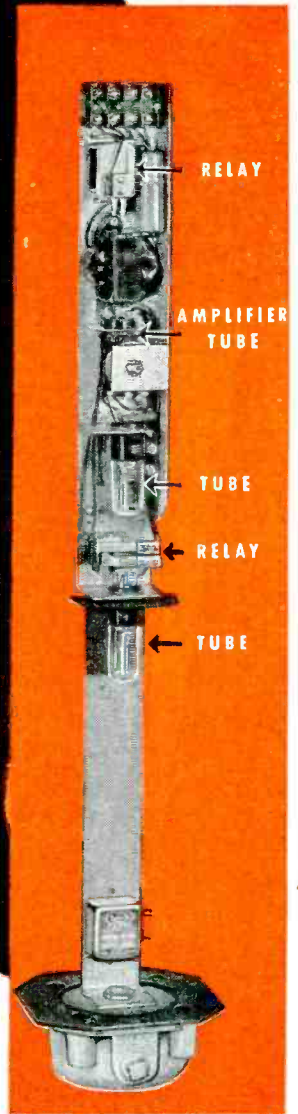

**PHOTO-ELECTRIC DOOR CONTROL**  
 Above unit manufactured by General Electric Co., is a part of STANLEY "MAGIC DOOR" CONTROLS.

THERE'S A JOB FOR

## *Relays* BY GUARDIAN

★ The "Magic Door" made by The Stanley Works of New Britain, Conn., uses a General Electric control unit which operates automatically at the approach of a pedestrian or vehicle. In this unit a beam of light focused on the cathode of a phototube causes a tiny current to flow. Enlarged through an amplifier tube this current operates a sensitive telephone type of relay such as the Guardian Series 405. Another phototube with an auxiliary relay, Guardian Series R-100, is employed to hold the doors open for anyone standing within the doorway.

The telephone type of relay is extremely sensitive and able to operate on the small current supplied through the electronic circuit. The auxiliary relay, Series R-100, is required to handle a greater current. It is a small, efficient relay having a contact capacity up to 1 KW at frequencies up to and including 28 megacycles. Contact combinations range up to double pole, double throw. Standard coils operate on 110 volts, 60 cycles, and draw approximately 7 V. A. Coils for other voltages are available. For further information write for Bulletin R-6.

Consult Guardian whenever a tube is used—however—Relays by Guardian are NOT limited to tube applications but are used wherever automatic control is desired for making, breaking, or changing the characteristics of electrical circuits.



Series 405 Telephone Type Relay



Series R-100 H. F. Relay

**GUARDIAN**  **ELECTRIC**  
 1625-M W. WALNUT STREET CHICAGO 12, ILLINOIS  
 A COMPLETE LINE OF RELAYS SERVING AMERICAN WAR INDUSTRY



# When present Electronic Developments become an "Open Book"...

We all agree that recent developments in electronics must remain closely guarded military secrets. But when the story can be told it will surprise many what an important part Blaw-Knox has had in the advancement of this newest marvel in the sciences. More than likely the public announcements of the commercial use of war-born electronic devices will be broadcast from stations equipped to give them effective coverage with Blaw-Knox Vertical Radiators.

BLAW-KNOX DIVISION of Blaw-Knox Company  
2077 Farmers Bank Bldg., Pittsburgh, Pa.

DISTRIBUTOR  
**Graybar**  
ELECTRIC COMPANY

# BLAW-KNOX VERTICAL RADIATORS

FM & TELEVISION TOWERS



communicate with all departments, twenty-one telephone stations are used.

During the past ten years a number of electronic telephone systems have been tried, but with limited success, due mainly to the fact, that after a system was installed it was too complicated for the majority to use, or was not entirely practical. The system diagrammed, however, has proven satisfactory for over three years.

The system is designed for ease of operation. Pushbuttons on each handset permit calling over all speakers at one time. After the initial call is made, consisting usually of one or two words, the pushbutton is released and conversation is carried on by means of handsets located in all the buildings. Feedback between speakers and handsets is eliminated by placing the speakers at the opposite end of each building away from the handsets. The amplifier is located on top of a large safe in the office.

Handsets were used wherever possible, however, some of the phones are from a salvage lot and

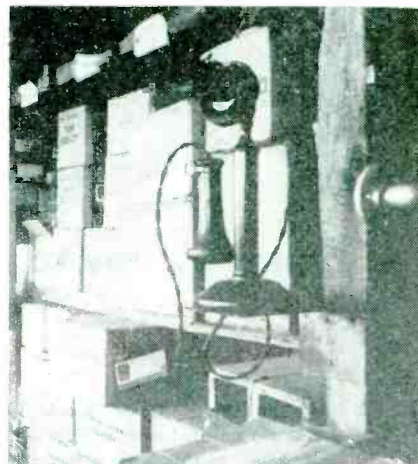

One of the telephone installations in a stock-room. Not shown in the photo, a loudspeaker is used for paging employees and then cut off during the phone conversation

are the vertical type with receiver hanging on a hook on the side. These are mounted by means of an L-shaped piece of steel to the building wherever used. In the beginning, several of the "toy" type phones were installed, but these were none too successful.

### *Relay-Controlled Amplifier*

A jack is provided in the amplifier for "phono" use for keeping the



*The bolt can learn from the jewel*

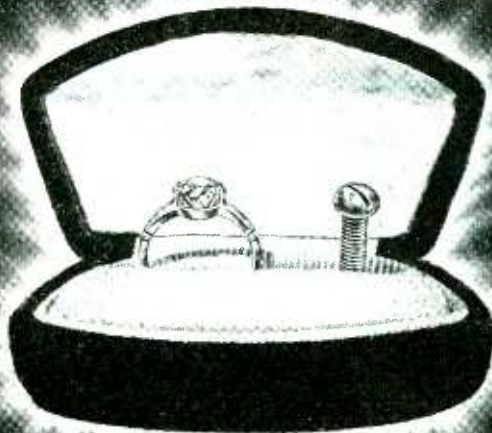

**how to use a versatile product in a new way**



**H**ERE IS THE RESULT of fabricating a ROGERS laminated sheet material, which is easily and economically shaped, formed, drawn, bent and punched. The resultant product—a jewel box—is tough enough to resist a mallet blow and light enough to replace metal forever.

When you think of the improvements in weight, economy, appearance, ease of assembly, etc., that your product must have to meet its competition, you'll want to profit by help from ROGERS, with 112 years' experience. To see how ROGERS can help you, ask for:

- Details of the ROGERS PROCESS of wet laminating so that fibers stay interlocked after fabrication, giving parts extra strength.
- Data on the unique electrical, chemical and mechanical characteristics of ROGERS wet-laminated, cellulose sheet materials.
- SAMPLES OF FABRICATED PARTS, some of which are shown at right. Extensive tool and die facilities are available.
- Information about the ROGERS method of producing, with only 25 lbs. of materials, production samples of brand new fibrous and plastic materials—in 48 hours. "You name it, we'll make it."

Address The Rogers Paper Manufacturing Co.,  
107 Mill Street, Manchester, Conn.

**Rogers**  
PAPER MANUFACTURING CO.  
MANCHESTER, CONNECTICUT



amplifier on at all times. Two 6-volt d-c relays are controlled by the pushbuttons. Relay A switches the amplifier into the telephone circuit without the phono in use, and relay B applies the line voltage to the primary of the high-voltage transformer. A battery of 12 volts was necessary to operate the two 6-volt relays as they are connected in series, but they operate without fail from the pushbutton switch most distant from the amplifier.

The microphone input transformer permits matching from a 50-100-150-200 ohm source to the grid of the tube. The 50-ohm tap is used, as there are always at least two phones in the circuit at one time, and at many times several. There seems to be no difference in the level of conversation.

Use of the primary winding of the microphone transformer permits the phones to operate. Almost any iron-core choke would work as

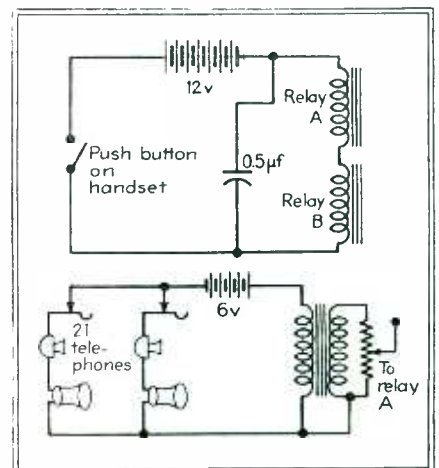

Fig. 2—Battery circuits for operating the relays and telephones

a substitute if telephone conversation alone was all that was required, but since it is also needed for the amplifier, this primary winding serves a dual purpose.

The filament transformer case was bored full of holes for freer circulation of air around the core. It is left on the line continuously to keep moisture out of the amplifier. No trouble has been experienced from burnout.

#### *Two Types of Lines*

The wire lines between buildings are run on 25-foot creosoted poles except for one 125-foot section that is underground. This section consists of a lead cable in 4-in. tile. The overhead lines are No. 14 sin-





## *Sangamo Capacitors Can Take It!*

Mica capacitors play a vital part in the correct functioning of many types of equipment. Radio receivers, transmitters, hearing aids, underwater sound equipment, induction heating, and many other devices depend upon the faithful performance of capacitors to enable them to function properly.

Many applications of capacitors in these various equipments necessitate a wide range of sizes, shapes, voltages, and current carrying ability in order that the proper capacitor may be used, depending upon the physical space limitations and electrical characteristics to be met.

As illustrated, Sangamo manufactures a large variety of capacitors from the small wire lead type having a body size of only  $23/32$ " in length,  $15/32$ " in width, and  $.20$ " thick to the large ceramic case type capable of operating at voltages up to 35,000 and handling large amounts of radio frequency current. This wide variety of capacitors insures the availability of the proper unit for almost any mica capacitor requirement.

**SANGAMO ELECTRIC  
COMPANY**  
SPRINGFIELD, ILLINOIS



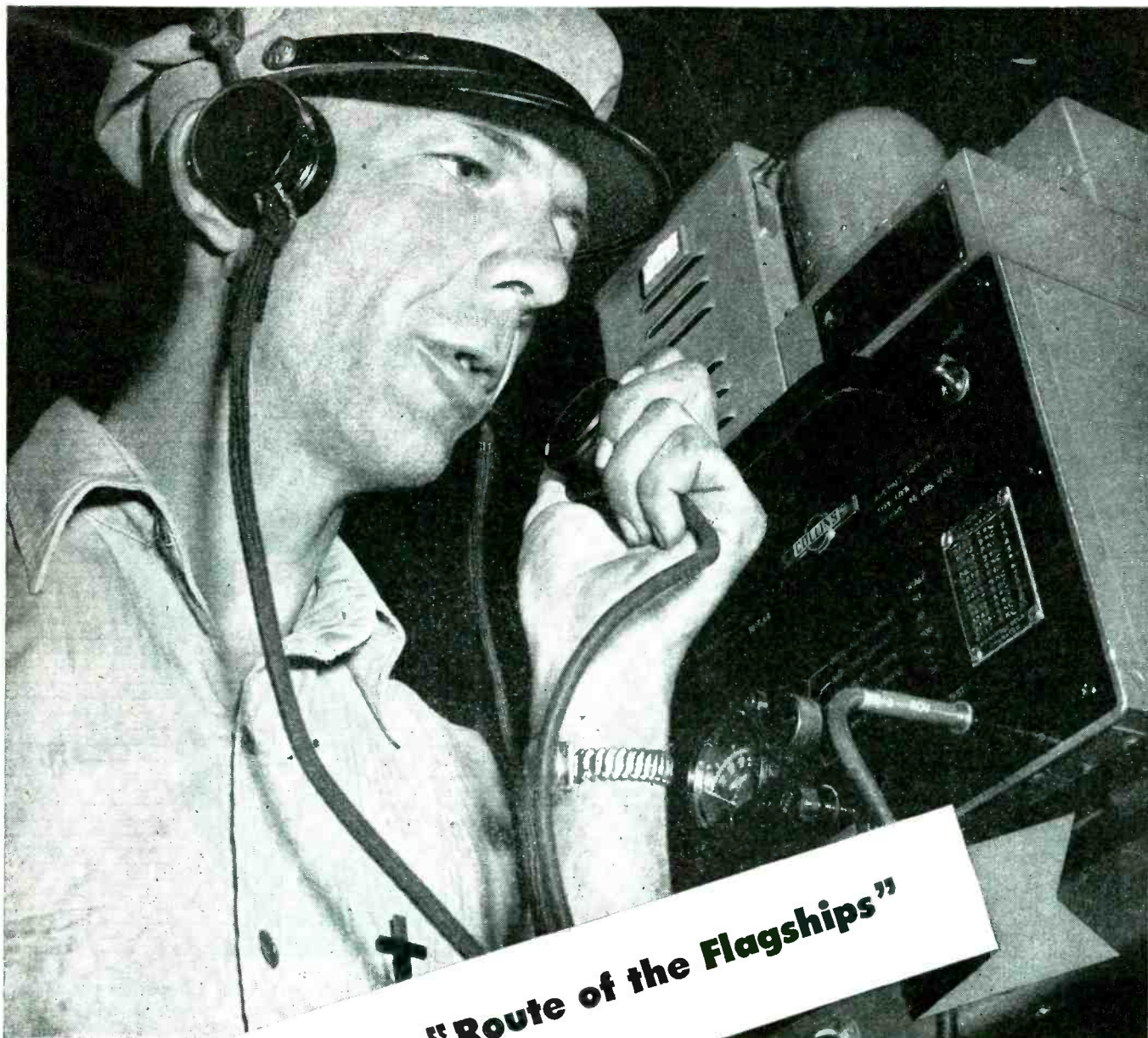

## Standard on the "Route of the Flagships"



IN 1939, American Airlines adopted the Collins 17F Autotune\* aircraft transmitter as standard equipment for its entire fleet.

Previous experience on a lesser scale had indicated the wisdom of this step. Succeeding experience has confirmed it.

Compared with previous equipment, the 17F's doubled the power output (to 100 watts) with slight increase in weight, and the Autotune\* provided thirteen quickly available operating frequencies instead of three.

Daily through the years, these rugged, uniquely efficient airborne 17F's and powerful Collins ground transmitters have given trustworthy support to a superb

Operating Department in maintaining the great American Airlines tradition of safety and dependability.

After the war, Collins will again specialize in the development and production of advanced types of communication equipment for commercial aviation.

Its designs will bear the fruit of intense research and outstanding engineering achievement now engaged in meeting the hard demands of military service all over the world. Collins Radio Company, Cedar Rapids, Ia.

\*The Collins Autotune is a repositioning mechanism which quick-shifts all transmitter or receiver controls simultaneously and with extreme precision to any one of a number of pre-determined frequencies. U. S. Patents issued and pending.





# HOW ELECTRONIC PREHEATING INCREASES PLASTICS OUTPUT

## Complete Softening of Plastic Before Molding Speeds Press Operation; Improves Quality

Compression and transfer molding of plastic materials is greatly speeded, rejects are reduced, heavier or more intricate parts can be made, and mold damage is practically eliminated when the molding material is preheated electronically. Some users have reported overall increases in output of as much as 1300% (including increases due to improved quality); a 50% increase in the output of a compression press is a fair average!

**WHAT ELECTRONIC HEAT DOES:** These remarkable improvements in plastics output are due to the uniformity and speed of heating possible when high-frequency electricity is passed through the plastic material. Although at ordinary frequencies (60 cycles, for example) most plastics are insulators, at high frequencies (million of cycles) they behave like conductors.

The high-frequency current, produced by electron tubes, flows uniformly through the plastic, and is instantly converted to heat. Thus the inside receives as much heat energy as the outside—and at the same time. Temperature increases quickly and evenly. This same heating method can be applied to many other substances—wood, glue, paper, textiles, glass, ceramics, foods, rubber, etc.

**RESULTS:** Because the plastic material is heated to molding temperature quickly, it has no time to “set” prematurely. The plasticity is high, hence flow into even intricate molds is quick, and molding pressure usually is greatly reduced. This, together with freedom from hard “cores,” means less stress on the mold, and virtual elimination of mold damage! Thus runs can be continuous, without shutdowns and expense for mold repairs.

Mold closing is usually speeded, and since heat supplied through the mold has only to advance the temperature relatively little to the “cure” point, the curing time in the mold is reduced. Uniform curing tends to reduce internal stresses, and thus increase dimensional stability and reduce cracking and other rejects. The easy flow of the molding material puts less stress on molded inserts, and is less likely to displace them during molding.

With electronic preheating, no ovens are needed, and the molding material can be heated as needed instead of in batches; heating time totals only a few seconds—usually under one minute—hence molding can begin as soon as the presses are up to temperature in the morning.

**IS EQUIPMENT AVAILABLE?** Yes. RCA can supply electronic generators for plastics molding, and for many other applications—on priority, of course. If you have a problem, please write us about it in detail. (We'll keep it in confidence.) The coupon will bring you further information. Address: Radio Corporation of America, Electronic Apparatus Section, Box 70-4911, Camden, N. J.



**THIS 4-OZ. PIECE** of plastic was thoroughly softened for molding in about 15 seconds by an RCA 2000-watt electronic generator.



**EASE OF OPERATION** is a feature of the RCA 2-kw generator. When plastic material is thoroughly heated, power goes off and cage pops open.

### RCA ELECTRONIC HEAT



**BUY  
WAR  
BONDS**

**RADIO CORPORATION  
OF AMERICA**

RCA VICTOR DIVISION • CAMDEN, N. J.

## WANT ADDITIONAL INFORMATION?

**RCA, Electronic Apparatus Section, Box 70-49H, Camden, N. J.**

Please send me “Electronic Heat Speeds Plastics Molding”

Please send me information on heating.....by RCA electronic heat.

I understand that this places me under no obligation.

Name .....

Company .....

Address .....

City..... Zone.....State.....

70-5231-49



# DESIGN FOR ~~WAR~~ PRODUCTION

*peace*

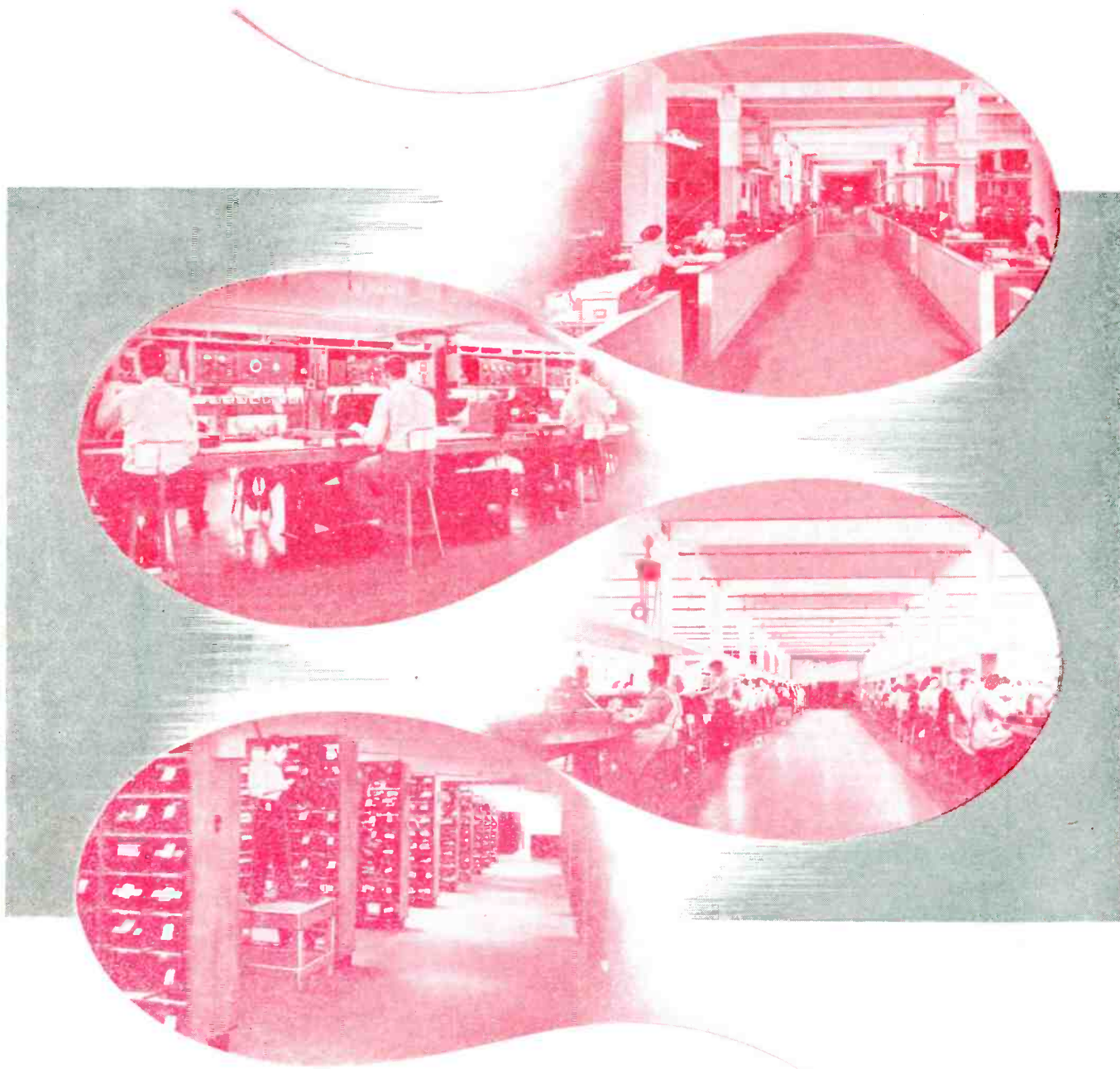

During the war, all departments of International Detrola's great radio-electronics plant have been brought to peak efficiency for volume manufacture of vital military equipment. Hundreds of thousands of square feet of production space have been re-allocated. Interiors and fixtures have been modernized, streamlined. These improvements have enabled skilled workers to chip precious minutes from production time while maintaining highest quality. All this will contribute to the excellence of manufacture *in quantity* of radio receivers, automatic record changers, television receivers and other peacetime electronic products. *Keep Buying War Bonds.*

## DETROLA RADIO

DIVISION OF INTERNATIONAL DETROLA CORPORATION - HEADQUARTERS AT CHATFIELD, DETROIT 8, MICH.

C. RUSSELL FELDMANN



PRESIDENT

**SHOULD THE WAR END tomorrow . . .**

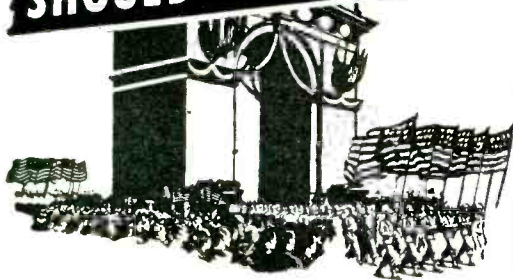

# ELCO WOULD CONTINUE

to produce and deliver promptly

# PRECISION *wire-wound* RESISTORS!

ELCO, too, awaits the go-ahead signal to start producing those "battle-tested" resistors for America's new Electronic industries.

Whatever the application—no matter how exacting the specifications—ELCO will deliver resistors as you want them—when you want them.

**FOR TODAY'S WAR REQUIREMENTS—  
FOR TOMORROW'S PEACE NEEDS—  
specify *ELCO!***

**SPECIFICATIONS:**

"A-1"—15/32 long x 1/2" dia.—Mountable with 6-32 flat or filester screw. No. 21 tinned copper wire leads. 1 to 300,000 ohm value—1/2% standard accuracy—non inductive pie wound—1/2 watt, 30° C. temperature rise in free air—100° C. maximum operating temperature—200 D. C. maximum operating voltage. Baked varnish finish.

"A-R"—Same as A-1. with leads reversed.

"B-1"—15/16 long x 1/2" dia.—Mountable with 6-32 flat or filester screw. No. 21 tinned copper wire leads. 1 to 500,000 ohm value—1/2% standard accuracy—non inductive pie wound—1 watt, 30° C. temperature rise in free air—100° C. maximum operating temperature—300 D. C. maximum operating voltage. Baked varnish finish.

"B-R"—Same as B-1. with leads reversed.

"T"—1-1/32 long x 7/16" dia.—Inductively wound—1/8 x .015 thick strap terminals—35 to 35,000 ohms—2 watts, 100° C. maximum operating temperature—normal accuracy 1%. Baked varnish finish.

"M"—1-13/32 long x 1/4" dia.—Mountable with 6-32 screw—1/8 x .015 thick strap terminals—non inductive wound—1 meg ohm maximum resistance—600 volts maximum operating voltage—100° C. maximum operating temperature—1.5 watts—1% normal accuracy Baked varnish finish.

"G"—15/32 long x 1/4" dia.—Mountable with 6-32 flat or filester head screw. No. 21 tinned copper wire leads. 1 to 500,000 ohm value. 1/2% standard accuracy—non inductive pie wound .8 watts, 30° temperature rise in free air, 100° C. maximum operating temperature. 200 D. C. maximum operating voltage. Baked varnish finish.

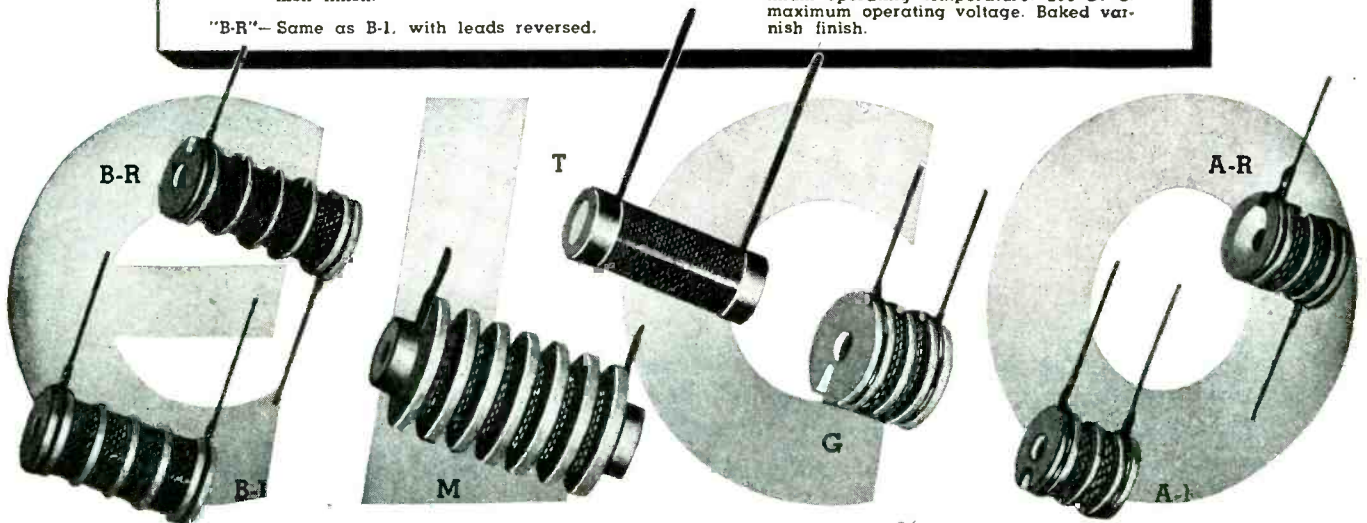

*Get to know*



**RESISTORS COMPANY**

114 West 18th Street, New York, N. Y.

Telephone - Watkins 9-4774-5



# ROLLER-SMITH 4.5" PANEL INSTRUMENTS...

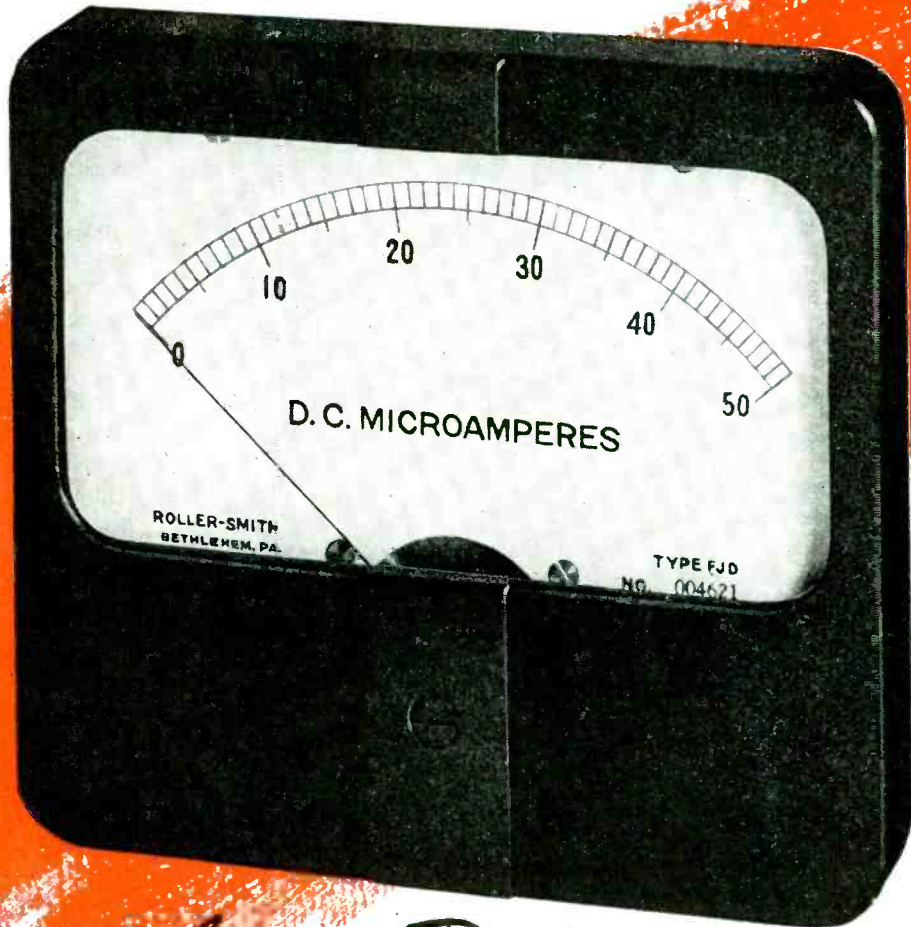

*for Quick and Accurate Readings*

Where panel conditions permit their installation these 4.5" semi-flush Bakelite case instruments provide maximum readability. Scale length of d-c instruments is  $3\frac{1}{2}$  inches and for a-c instruments is  $3\frac{3}{4}$  inches. All instruments except rectifier types are accurate within 1% of full scale value at any point on the scale. Rectifier types, approximately 5%.

Incorporating the long life and dependability developed during 40 years of fine instrument manufacture, R-S 4.5" panel instruments have a diversified field of application which includes: Radio Transmitters; Control Panels; Battery Testers and Chargers; Electronic Tube Testers and Analyzers; Automotive Analyzers; Instrument Test Units; Sound Movie Equipment; Motion Picture Control Panels; Arc Welding Equipment; Experimental and Amateur Radio; General Electrical Laboratory Testing; General Communications, etc.

Any practical range can be supplied on short notice in d-c and a-c (Repulsion iron-vane and Rectifier type) models, with single or multi-range scales. Correspondence is invited.

**OTHER R-S INSTRUMENTS:** Panel, switchboard and portable instruments of practically every standard size, shape, capacity, type and style are included in the R-S line of electrical instruments. Shown here are (upper) 3.5" Miniature Panel Ammeter conforming to American War Standard C39. 2-1944 and (lower) "Steel-Six" Portable Ammeter.

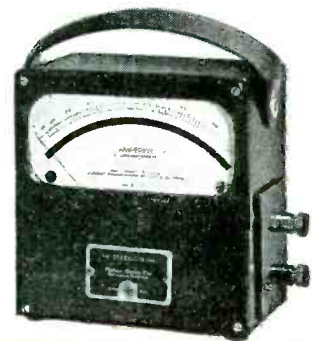
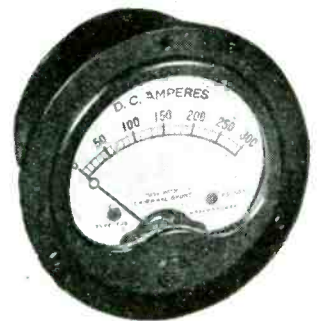

and don't forget . . . BUY WAR BONDS



Sales Representatives  
In all Principal Cities

## ROLLER-SMITH BETHLEHEM, PENNA.

Canadian Plant: ROLLER-SMITH MARSLAND, LTD., Kitchener, Ontario

STANDARD AND PRECISION ELECTRICAL INSTRUMENTS • AIRCRAFT INSTRUMENTS • SWITCHGEAR •  
AIR AND OIL CIRCUIT BREAKERS • ROTARY SWITCHES • RELAYS • PRECISION BALANCES

# Tames the wild waves

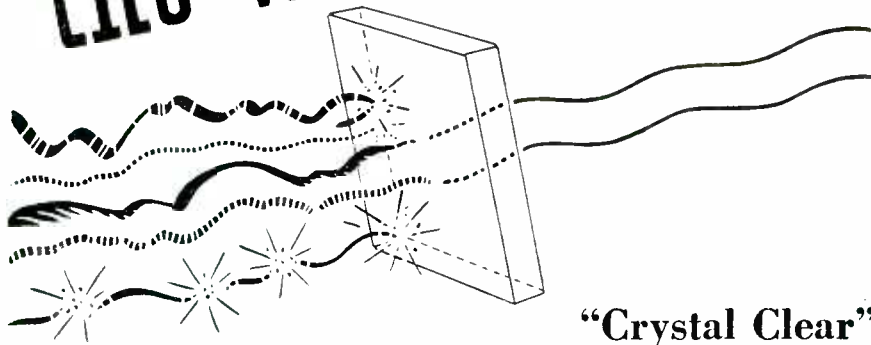

## "Crystal Clear"

radio reception is a fundamental of the public's expectation postwar. It is the very cornerstone of broadcast receiver sales. There can no longer be any doubt about it.

So you, as an Electronics Engineer, are interested in a postwar source of Control Crystals that will "tame the wild waves" . . . that will keep radio "traffic" clear . . . that will give your circuit the precise definition, the rejection of stray signal, which you want it to have, and which the public demands.

We offer such crystals, out of a wealth of experience in the realm of the near-impossible. After what we have been doing, making what you need, however difficult, will be like a normal production job to our people. And after the problems they have licked, helping you solve your postwar circuit puzzlers will be a welcome relief to our staff of war-experienced engineers.

May we help you . . . Now?



**PAN-ELectronics LABoratories, Inc.**  
500 Spring St., N. W., Atlanta, Georgia

QUANTITY PRODUCERS OF STANDARD AND SPECIAL

# Control Crystals

gle-strand wire spaced about 6 to 10 inches apart. Colored wires were used for coding the six wires needed.

In connecting the overhead line to the underground line, a special transformer was found necessary. A transformer of the type used to match the plate of a vacuum tube to a 500-ohm line was found suitable. Without the transformer, the capacitance of the line was 0.01  $\mu$ f and speech signals were considerably distorted. There seemed to be no noticeable difference when the line was connected or disconnected after the transformer was installed.

Total length of the lines has not been measured, but it is estimated to be  $\frac{1}{4}$  mile. There are no ground connections to the various lines anywhere except at the amplifier and this is tied to a 1 $\frac{1}{2}$ -inch water main.

Each station is set up with two-wire terminal blocks. The lines are wired to one side of the blocks and the phones, pushbuttons and speakers wired to the other side. This facilitates quick change of units without disturbing the lines. All joints in the lines were soldered.

Since the voice coils are connected in series, each speaker is supplied with a short-circuiting switch for testing. So far, none of the voice coils has failed. Resistance may be inserted in series with the speaker line to compensate for mismatch with the output transformer.

Additions to the installation were made gradually over a period of two years and no improvements have been made recently.

• • •

## Production Tester for Mica

THE BEST RUBY MUSCOVITE mica has come from India, but there are large deposits of ruby and other types of muscovite mica in the United States, South America, and Canada. If these were available for mica capacitors, not only would the supply be greatly increased, but the transportation difficulties would be lessened.

Because of this situation, the War Production Board appealed to Bell Laboratories in the fall of 1942 to devise a method of testing and classifying mica that would give more positive results and insure that no good mica of any type was rejected. What was urgently needed was a quick and easy method of detecting conducting regions, and for



# POLYETHYLENE

## A "Carbide Chemicals" Production Achievement for the Navy

### Important New Plastic Has Many Unusual Properties

A little over two years ago, the U. S. Navy learned that Carbide and Carbon Chemicals Corporation in collaboration with an associate company, The Linde Air Products Company, had developed a high pressure synthesis of a new material, Polyethylene, and it was found that this material was exactly suited to meet the Navy's requirements of an insulation for coaxial cable used in radar equipment.

At the Navy's request, these two companies, working together but entirely independent of anyone else, designed in their own Engineering Department and built with their own Construction Organization a plant to produce polyethylene by a process different from any other commercial polyethylene process.

Within thirteen months from the date the project was authorized, this plant was producing at 180 per cent of rated capacity.

At the conclusion of the first full year of production the Navy Department told the plant:

"One year ago your plant commenced the production of polyethylene, a component of radio cable essential to the efficiency of electronic communications units and, therefore, vital to the success of naval operations. Production for the year has equalled 240 per cent of the rated output for the facilities. Everyone engaged in developing the product, planning, engineering, and managing the plant, and each of you engaged in producing polyethylene may be justly proud of a valuable contribution to the war effort."

Today, approximately two years after Carbide was given the assignment, this plant is producing polyethylene at 600 per cent of rated capacity and is providing the Navy's requirements of this material for use in coaxial cable.

**THE IMPORTANT NEW PLASTIC!** Polyethylene resins have the most favorable electrical characteristics of any plastic material for use in this electronic application. In addition, this new plastic material has many other exceptional characteristics, which suggest widespread application in many different fields. Polyethylene plastics are tough and impact-resistant. They are inherently flexible and extensible. They have an extremely low water vapor transmission coefficient and will absorb an unusually low percentage of water. Their chemical resistance is outstanding. Polyethylene is one of the lightest plastics, so light that it will float in water. It maintains its valuable properties over a wide range of temperature. It remains usable at temperatures lower than 90 degrees below zero, Fahrenheit, and is sufficiently rigid for use in temperatures up to 230 deg. F.

Polyethylene is colorless and translucent as originally manufactured but it can be formulated to produce colored products of exceptionally high lustre. These products can be fabricated by standard processes on existing plastics equipment.

Molded and extruded products, cloth coatings, flexible sheeting and film, and monofilaments are among the polyethylene plastic products which will be available in the future.

Polyethylene plastics are now restricted to applications covered by WPB Limitation Order No. 348. Technical data and samples for controlled end uses can be obtained by manufacturers with plastic-processing equipment by writing Department 18.

BAKELITE CORPORATION, 30 E. 42 St., New York 17, N. Y.  
Unit of Union Carbide and Carbon Corporation

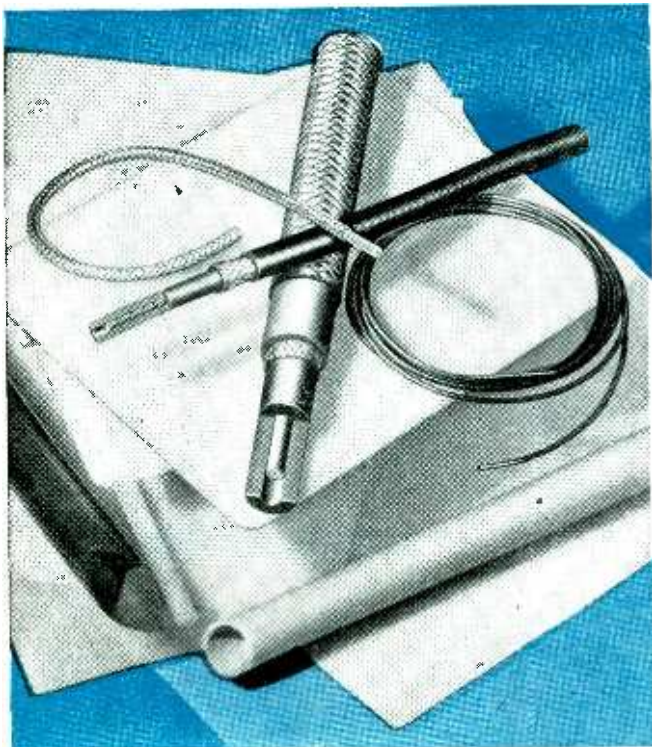

(This advertisement has been reviewed and approved by the U. S. Navy Department)



This is the **APPROVED**  
**MINIATURE**  
**TUBE SOCKET**  
THAT MEETS  
ARMY-NAVY SPECIFICATION  
**JAN-S-28**

PHOTOGRAPHS  
TWICE SIZE

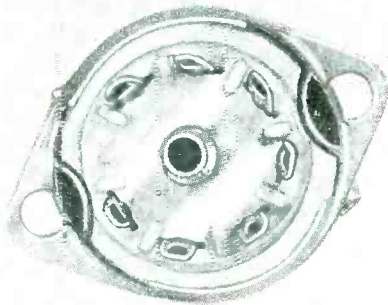
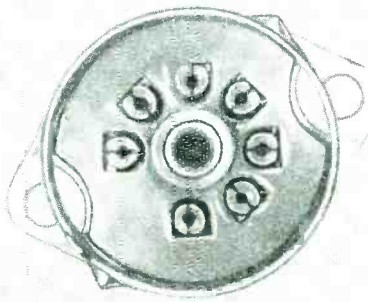

**HUGH H.**  
**EBY**  
INCORPORATED  
18 W. CHELTEN AVE.  
PHILADELPHIA 44, PA.





CONSIDER *Ease of Maintenance*  
 WHEN YOU SELECT A NEW TRANSMITTER

Modern transmitters require little maintenance—but when they do, *ease of maintenance* is important.

In Westinghouse Transmitters all *units are easily accessible*, both for inspection and maintenance.

*Complete protection to operators* is assured by interlocks on doors to all compartments in which dangerous voltages are present. Controls are of the dead front type, instruments at ground potential for maximum safety.

*Indicator lights flash circuit conditions* to the operator in case of overload, making it easy to check up for the possible cause of the interruption.

We will gladly furnish complete information on these and other advantages of the HG-5-KW and HG-50-KW Transmitters, such as: *Low Operating Cost, High Fidelity Signals, Continuity of Operation, Simplicity of Control.*

**PLACE YOUR ORDER NOW  
 FOR YOUR POSTWAR TRANSMITTER**

By placing your order today for a Westinghouse Transmitter, you assure yourself of the fastest possible delivery following the lifting of wartime manufacturing restrictions. We are scheduling deliveries in the sequence in which orders are received. For details, write Westinghouse Electric & Mfg. Company, Dept. 1NB, P. O. Box 868, Pittsburgh 30, Pa.

J-08078

**Westinghouse** RADIO DIVISION  
 PLANTS IN 25 CITIES... OFFICES EVERYWHERE



**A M • E L E C T R O N I C S • F M**

# ERCO MW-60 RESONANCE METER



**IT'S NEW**

ERCO scores again with this highly efficient instrument for the resonance indication method of measurement in the ultra-high frequency range of 85 to 600 MC.

## IMMEDIATE DELIVERY ON PROPER PRIORITY

This dependable, sensitive indicator meets the need for providing a convenient and accurate means of determining resonance in oscillators and transmitters:

STANDARD WAVE RATIOS  
TRANSMISSION LINES  
ANTENNA SYSTEMS

TANK CIRCUITS  
COUPLING DEVICES  
MODULATION INDICATION

*Ruggedly constructed*, it is ideal for resonance measurement of transmitting equipment in the field and laboratory, such as:

ABSOLUTE ALTIMETERS  
BLIND LANDING MARKERS  
GLIDE PATH MARKERS

AIRPORT TRAFFIC CONTROL  
WEATHER TELETYPE  
BROADCAST RELAY CIRCUITS

Because it is a rectifier type vacuum tube voltmeter, it is not subject to damage by severe over-loads.

The MW-60 is the result of ERCO'S specialized engineering knowledge and manufacture of custom radio communication equipment.

ERCO ENGINEERING has perfected the MW-70, now in production. This new instrument has a frequency coverage of 500 to 1500 MC.



LITERATURE ON REQUEST



**ERCO RADIO LABORATORIES** INC.

HEMPSTEAD, NEW YORK

Manufacturers of CUSTOM BUILT RADIO APPARATUS

determining the dielectric loss under the influence of the alternating voltages the mica would encounter in service. To meet these needs, the Laboratories undertook an investigation that culminated in the design of two test sets: one to detect conducting regions, and one to measure the dielectric loss of raw mica in "block" form. This term applies to sheet mica ranging from 7 to 30 mils in thickness. The test sets are described by K. G. Coultee in the September, 1944 issue of *Bell Laboratories Record*.

One test set determines loss by measuring the power factor of the current flowing through the mica when high-frequency voltage is applied across it. Since ordinary methods of measuring power factor

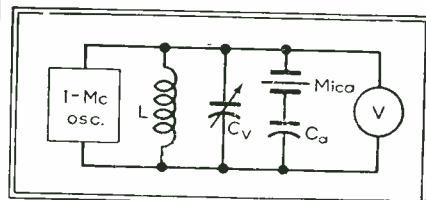

Fig. 1—Simplified circuit illustrating the principle of operation of the tester for measuring the dielectric loss of raw mica

are too slow for a commercial test of this type, a circuit was designed that gave a suitable measure of loss as a single reading of a voltmeter. The principle of the circuit employed is illustrated in Fig. 1.

A high-frequency oscillator is coupled to a circuit consisting of an inductance  $L$ , an adjustable capacitor  $C_v$ , and a fixed air capacitor  $C_a$  of negligible loss. The mica sheet to be tested is placed in series with the air capacitor  $C_a$ . A voltmeter across the circuit measures the voltage both before and after the mica is in place. Prior to a series of tests, and before any mica has been inserted in series with  $C_a$ , the circuit is tuned to the applied frequency, and the input is adjusted to give full scale reading on the voltmeter.

### Operation

When a sample of block mica is now inserted in series with  $C_a$ , it detunes the circuit, which is retuned to resonance by adjusting  $C_v$  until a maximum reading is obtained on the voltmeter. If there were no loss in the mica, that is, if the power factor were 0, the meter



# Franklin's 39

## RADIO SOCKET

*The favorite yesterday, the favorite for tomorrow*

THE MANY MILLIONS INSTALLED IN 1941 IS

*Positive Testimony to its*  
**POSTWAR VALUE**

The story of Franklin's series 39 Radio Socket, with patented "U" shaped bow spring action contacts, is most remarkable... developed and patented early in 1938 it received immediate acceptance and approval by practically all the radio set manufacturers and became standard equipment with most.

Series 39 sockets should be riveted to the chassis to become a permanent part of the set... no replacement will be necessary as the socket will outlive the set.

Series 39 sockets were the favorite yesterday and will be the favorite tomorrow for standard broadcast receivers.

For the details of the 39, Diheptal, Miniature, Lock-in, Battery and Sockets for other applications, moulded or ceramic... and a complete line of Radio Components... write for the New Franklin Catalog with which is included a complete Buyers Guide for the Electronic Industries.



This series 39 socket has a 39G Contact with a soldering tab which eliminates wiring to ground.

Illustrating the "U" shaped bow spring action contacts... 39H and 39G... used in Franklin's series 39 Sockets.

Bow spring act or maintains resiliency even after installation of oversize pins.

Direction of metal grain prevents breaking of soldering tail and permits rough handling in production.



"U" shaped contact provides separate soldering tail which prevents solder from flowing into contact body.



The 39G contact has a soldering tab to eliminate wiring to ground... can be inserted in any position where grounding is desired.



# A.W. FRANKLIN MANUFACTURING CORP.

SOCKETS • TERMINAL STRIPS • PLUGS • SWITCHES • PLASTIC FABRICATION • METAL STAMPINGS • ASSEMBLIES

175 VARICK ST., NEW YORK 14, N. Y.





## An Army that Travels on its Ears

**C**ERTAINLY, today's armies have Stomachs, but they have something Napoleon's armies *did not* have . . . Ears. Ears that can hear, not for just a few feet, but over any distance on Land, in the Air and on the Sea. Electronic ears that link every unit of our fighting forces in instant and complete Communication . . . that spell the difference between success and failure.

As a pioneer designer and manufacturer of  
**THE ROLA COMPANY, INC. • 2530 SUPERIOR AVENUE • CLEVELAND 14, OHIO**

Sound Reproducing Equipment, it is only natural that Rola should be in the forefront of the effort to supply our Military with the delicate, dependable components for Communications Systems . . . Headsets, Transformers, Coils and other Electronic parts. Knowing the power of Communication on the Home Front, it is only natural that Rola suggests, "Consider everything you SAY; check the source of everything you HEAR."

# ROLA

Let's do more



in forty-four!

**MAKERS OF THE FINEST IN SOUND REPRODUCING AND ELECTRONIC EQUIPMENT**



TESTED  
TESTED  
**MULTIPLE-TESTED**

**X-RAY  
OK.**

**JUST ONE OF FEDERAL'S**

**MULTIPLE TUBE TESTS**

*X-Ray O.K.-your final assurance  
of a perfect tube from Federal.*

*Every Federal water cooled tube must  
pass this pre-shipment test.*

*It is only one of the "Multiple Tests"  
Federal makes to bring you the ultimate  
in vacuum tubes. Every known test of  
mechanical and electronic perfection is a  
Federal "must" . . . tubes are tested for  
high-voltage overload . . . shelf life is given  
to prevent shipment of tubes with glass strains  
or slow leaks . . . and a final, all-inclusive, op-  
eration test leaves nothing to conjecture.*

*Federal's "Multiple Testing" adds up to longer  
tube life . . . uniform electrical characteristics . . .  
and lower cost of operation. Radio men acknowl-  
edge that "Federal always has made BETTER Tubes."*



*Radio Ranges and Instrument  
Landing Systems manufactured  
by Federal mark the  
principal air routes of the  
nation and control the land-  
ing at many leading airports.  
Pioneers in the develop-  
ment of Aerial Navigation  
Equipment, Federal has  
made spectacular contri-  
butions to aviation prog-  
ress.*

**Federal Telephone and Radio Corporation**

Newark 1, N. J.





Send for it **NOW!**

# CONCORD RADIO CORPORATION'S

*New* 16-page supplement!



## HARD-TO-GET RADIO PARTS

Listing hundreds of different and hard-to-locate components, including

- Resistors
- Condensers
- Switches
- Speakers
- Wire
- Volume Controls
- Rheostats
- Test Accessories
- Transformers
- Relays

Here's a real bonanza of radio parts. All items listed have been designated by Concord customers as "urgently needed." All are from well-known manufacturers. All are priced right. Remember, however, that they'll go fast—rush your request for this Special Supplement immediately!

Only the name has been changed! Just another reminder that the

# Lafayette Radio Corp.

is now known as the  
**CONCORD RADIO CORPORATION**



For more than 22 years, the Lafayette Radio Corporation has been one of the great arsenals of the nation for radio and electronic equipment. Although we are now known as the Concord Radio Corporation, we assure you that *only the name has been changed*. Both in Chicago and Atlanta, you will find the same personnel, the same high qualities of merchandise, the same low prices, and the same reliable, speedy services as heretofore. You may shop by mail or visit us personally . . . fully confident of guaranteed satisfaction. Be sure that your name is on our mailing list for postwar catalogs, and literature. You won't want to miss the unusual developments in radio and electronics which the Concord Radio Corporation will introduce after V-Day.

*Mail Coupon Today* for the New, 16-page Supplement of "Hard-to-Get Radio Parts" by the Concord Radio Corporation!

**CONCORD RADIO CORPORATION**  
901 W. Jackson Blvd., Chicago 7, Ill., Dept. G-11  
just published by the Concord Radio Corporation.

NAME .....

ADDRESS .....

CITY .....

STATE .....

# CONCORD RADIO CORPORATION

## Lafayette Radio Corporation

901 W. Jackson Blvd., CHICAGO 7, ILLINOIS ★ 265 Peachtree St., ATLANTA 3, GEORGIA

reading would be at full scale as before. Any loss in the mica appears as a series resistance and less current flows causing the voltmeter to indicate less than full scale.

The circuit actually employed is shown in Fig. 2. Tube  $V_1$  is in the oscillator circuit, which is adjusted to a frequency of one megacycle and proper output power by adjusting  $C_1$  and  $P_1$ . Tube  $V_2$  forms part of a vacuum-tube voltmeter. Its reading, taken on meter  $M$ , is used for classifying the mica in terms of power factor.

On the panel of the tester is a knob used for raising and lowering  $C_2$  so that a sheet of mica can be inserted between it and the lower electrode. This dial is also arranged to

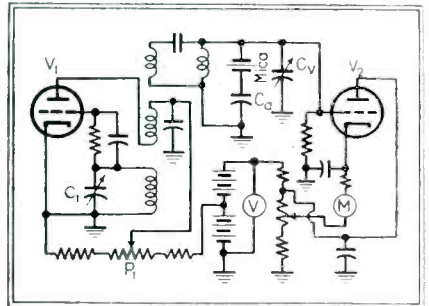

indicate the thickness of the sample of mica under test. For each test, the sheet of mica is placed between  $C_2$  and the lower electrode, and the sheet of mica is placed between  $C_2$  and the lower electrode, and the knob is turned to clamp it in place. Capacitor  $C_2$  is then adjusted to give a maximum reading on the meter.

It was found possible to correlate the results obtained from the tests with the power factor indication of the test set. As a result of the correlation, three ranges of power factor were established, each lying between certain pointer readings on the test set. These ranges appear as diagonal lines on the scale of the meter. The reading of the test set also varies with the thickness of the mica as shown by the clamping dial, and the scale of the meter is arranged to permit this factor to be taken into consideration. With the unit, it is possible to test as many as fifteen samples of block mica per minute, while with the more conventional methods at least fifteen minutes would be required for each test.

To discover conducting regions in stained mica prior to the power fac-



*A new member*  *of the Family*

**Rauland**  
**VISITRON**  
**Phototubes**



*now identified with this well-known group:*

- ★ **Rauland *AMPLICALL* Intercommunicating and Sound Systems**
- ★ **Rauland Microphones**
- ★ **Rauland Cathode Ray Tubes**

RAULAND VISITRON TUBES ARE NOW IN PRODUCTION AND AVAILABLE

RADIO • RADAR • SOUND •

**Rauland**

COMMUNICATIONS • TELEVISION

*Electroneering is our business*

THE RAULAND CORPORATION • CHICAGO 41, ILLINOIS

Buy War Bonds and Stamps! Rauland employees are still investing 10% of their salaries in War Bonds



# a 4<sup>th</sup> CITATION

*for continuing  
leadership in war  
instrument production*



This succession of citations and stars awarded to WESTON is recognition of WESTON'S unremitting war effort . . . and their record in supplying instruments to the exacting standards essential for the most vital assignments of our armed forces.

That WESTON has been first in this highly specialized instrument field to receive each of these successive honors is the inevitable consequence of a leadership acknowledged throughout the years by governments and industry alike. Weston Electrical Instrument Corporation, 618 Frelinghuysen Avenue, Newark 5, New Jersey.

# Weston

**FOR OVER 56 YEARS LEADERS IN ELECTRICAL MEASURING INSTRUMENTS**





**... Completing the Post-War radio**

Planning post-war manufacture of radio sets?

Variable air condensers of Radio Condenser

Co. — because they provide such *accurate* and

*distinct* tuning—should be included in your sets.

Today, our armed forces, using them, are

assured of receiving every

message distinctly.

Investigate Radio Condenser

Company's air condensers and push

button tuning devices for your

post-war radio.

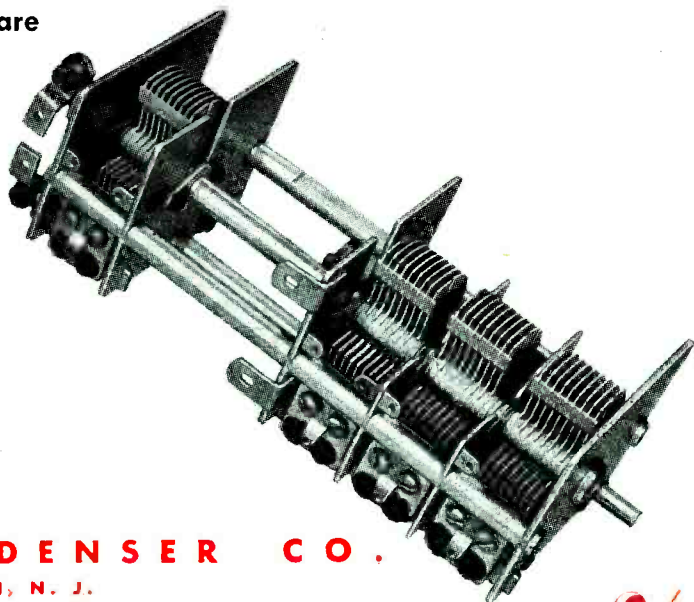

**RADIO CONDENSER CO.**

CAMDEN, N. J.

**RADIO CONDENSER CO. LTD., TORONTO, CAN.**



**... Doing a war job today**



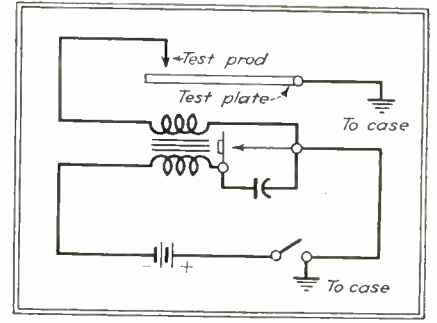

Fig. 3—This spark coil setup shows conducting regions in mica when a sheet of it is placed on the test plate and the test prod moved over the surface

## A Quick, One-Man Test for Bonds AND OTHER LOW-RESISTANCE CONTACTS

- ✓ Weight with battery, only 5.25 pounds.
- ✓ Ranges 0.003 and 0.3 ohms, or 0.005 and 0.5 ohms.
- ✓ Accuracy calibrated  $\pm 3\%$  at full scale.
- ✓ Overall length, 12".
- ✓ Price, \$80.

The Shallcross Aero Gun Model Low-Resistance Test Set can be used rapidly and efficiently by one man. Operation is positive and simple. Without previous technical training, an inspector can do a quick, accurate job of bond testing on a "Go, No-Go" basis, demonstrating instantly whether an electrical bond or joint is good or bad by comparison with a predetermined standard.

The Aero Gun Model is completely self-contained. The exploring probes extend from the muzzle, the battery is in the barrel, the control equipment and indicating meter are on the butt facing the operator, and the cable to the fixed clamp is attached to the pistol grip. Low-resistance comparison tests can be made by the hundred—faster than by any other method. Write for Aero Gun Model Catalog.

### OTHER TYPES FOR LABORATORY, FIELD OR PRODUCTION USE

Shallcross Low-Resistance Test Sets were first produced over 10 years ago. Since then, hundreds of sets in use on a wide variety of jobs have proved the outstanding advantages of this method of testing. . . . The present Shallcross line includes Test Sets for practically every field service, laboratory, or industrial production line requirement. Write for the complete Low-Resistance Test Set Catalog.

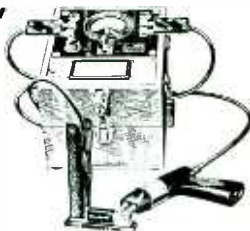

tor test, a battery-operated spark coil was arranged as shown in Fig. 3. A sheet of mica is placed on the test plate and the test point is moved over its surface. Any defective regions are indicated by sparking at or in the vicinity of the point. Only a few seconds are required for each test.

By the use of these two test sets, a large quantity of block muscovite mica, considered unusable for capacitors by the previous methods, was selected and used in about 40,000 capacitors by several manufacturers. These capacitors fully met thorough performance and life tests made by the manufacturers, and proved the reliability of the test set classification. As a result of this commercial trial, an increase of about 50 percent in the muscovite mica suitable for use in capacitors has been realized.

• • •

### Tester for Invasion Telephone Wire

FIELD TELEPHONE WIRE at a U.S. Army invasion base in southern England is tested for breaks and salvaged for further use by an ingenious device designed by Staff Sergeant Pasqual L. Wamil of Santa Barbara, Calif.

The tester consists of pipes through which the wire passes while being wound onto spools, and a control box with a bell. When a break in the insulation is encountered, a spark jumps between the pipe and the wire and causes the bell to ring. After the original model operated successfully, three additional pipes were added. Drop-out annunciator tabs show which pipe is carrying the defective wire.

# SHALLCROSS MFG. CO.

DEPT. E-114, COLLINGDALE, PA.

ENGINEERING • DESIGNING • MANUFACTURING



**THIS  
ONE'S  
"ON  
RCA"**



AVERAGE COST PER PREFERRED TYPE TUBE

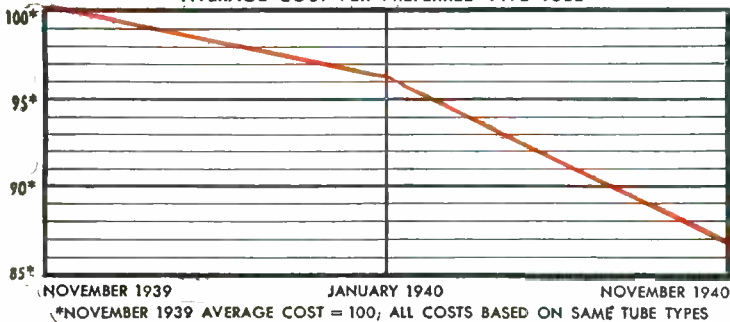

*Here's Why—* **RCA's Preferred-Type Program Slashed Tube Costs to Manufacturers More Than 13% During Its First Year . . . Giving You One Tube in Eight "On the House" by Former Price Standards**

The Preferred-Type Idea makes sense. And, it works!

Introduced by RCA in January, 1940, the Preferred-Type Program aimed at concentrating a larger demand and production on fewer tube types. This would allow greater manufacturing efficiency, because of longer runs, and would mean higher-quality, lower-cost tubes for you.

Even before civilian radio manufacturing was suspended by war, the program paid off. By November, 1940, the average cost to you of tubes on the RCA preferred list was lower by 13% than the average cost of the same tubes in November, 1939 . . . before the program started.

Yet all the time their cost was being lowered, the tubes improved in quality and performance. And the way was being cleared for simplified tube warehousing and stocking.

Since Pearl Harbor, the value of the "preferred-type" idea has been proved beyond a doubt on the world's battlefields. Most military electronic equipment has been designed around an Army/Navy Preferred List of Vacuum Tubes . . . and our fighting men on every continent are assured

speedy replacements of high-performance tubes as a result.

Will RCA continue the Preferred-Type Program after the war? You bet it will! If you already have specific tube complements in mind for postwar and would like to know if the tubes you need will be on the preferred list, let us know what they are. Write to Radio Corporation of America, Commercial Engineering Section, Dept. 62-12E, Harrison, New Jersey.

*The Magic Brain of all electronic equipment is a Tube . . . and the fountain-head of modern Tube development is RCA.*

1919  
1944



25 Years  
of Progress  
in Radio  
and Electronics

62-6131-12

**RADIO CORPORATION OF AMERICA**

RCA VICTOR DIVISION • CAMDEN, N. J.

# THE ELECTRON ART

## Technical Papers Delivered at National Electronics Conference

DESIGNED TO SERVE as a national forum on electronic developments and their application, the National Electronics Conference was held at the Medinah Club, Chicago, early in October. To the 2300 in attendance, about 50 technical papers and addresses were delivered by leading electronic engineers. Besides use in communications, the subjects discussed covered electronic applications in measurement and control, high-frequency heating of dielectrics and metals, aviation, industrial uses, power generation and distribution, industrial radiography and medicine.

The Conference was sponsored by the Illinois Institute of Technology, Northwestern University, the Chicago Section of IRE and the Chicago Section of AIEE, with the cooperation of the Chicago Technical Societies Council. Proceedings of the Conference will be printed in booklet form. Abstracts of some of the papers delivered at the technical meetings and forums follow.

In a paper entitled "Audible Audio Distortion," H. H. Scott of General Radio Co. pointed out that the non-technical listener judges the quality of sound reproduction subjectively and that such listening evaluations do not always agree with the result obtained by engi-

neers from various methods of measurements.

In his opinion, too much attention has been paid in the past to the amplitude-frequency characteristics and harmonic distortion measurements on sound equipment and serious intermodulation products resulting from so-called harmonic distortions have not been adequately evaluated in determining the engineering characteristics of such systems. While moderate deviations from a flat frequency response and small variations in the level of harmonics are not considered by the non-technical listener to represent distortion, they do represent undesirable attributes to the engineer. It was pointed out that within given price limits, electro-acoustic equipment can be designed and built to give considerably better performance with respect to subjective evaluations than has been usual in the past. To substantiate this point of view, Mr. Scott reviewed various measurement techniques and the results which have been achieved by numerous workers in the field.

### New Oscillator

The use of a double-beat oscillator for intermodulation measurements was advocated. A block diagram of such an oscillator is shown



At the Conference, the speakers' table was flanked by enlarged photos of (left) Joseph R. Redman, chief of Naval Communications, and Major General H. C. Inglis, Chief Signal Officer of the Army. Speeches from the two officers were recorded in Washington on a General Electric magnetic wire recorder and played back at the banquet

in the illustration; it consists of one fixed oscillator, a variable oscillator and an adjustable high-frequency oscillator. The output from these oscillators may be heterodyned in various combinations so as to provide a single variable output frequency, two variable output frequencies having a constant sum or a constant difference, or two independently variable output frequencies. Mixing controls for adjusting the relative amplitudes of the two output frequencies, as well as the usual output circuits for varying the total output over wide ranges, are useful adjustments in the measuring technique. The result of measurements made with such a double-beat oscillator technique were shown.

G. L. Beers described "A Frequency Dividing Locked-In Oscillator F-M Receiver" in which a continuously operating local oscillator is frequency modulated by the received signal. The frequency of the oscillator is locked-in with the received signal at one-fifth of the intermediate frequency. With this five-to-one relationship between the intermediate frequency and the oscillator frequency, an equivalent reduction in the frequency variations of the local oscillator is obtained.

The locked-in oscillator circuit diagram is shown herewith. The tube generally used in this circuit has been an A-5581, an experi-

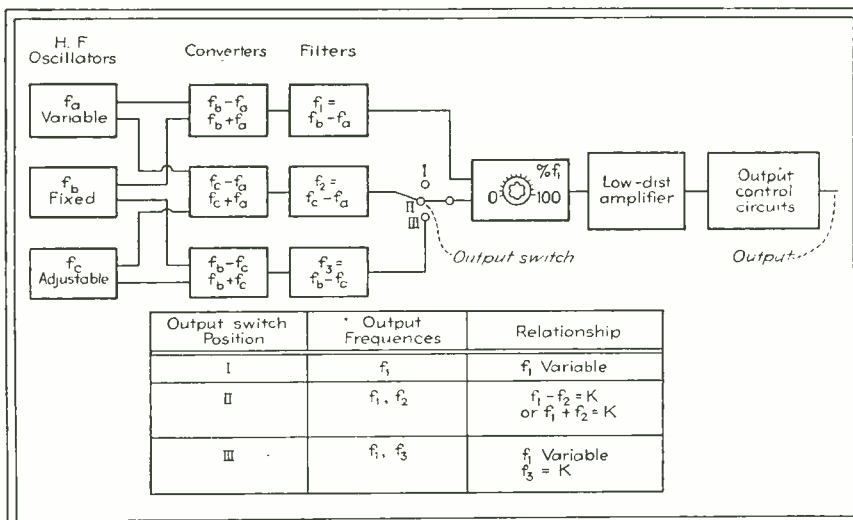

Block diagram of a double-beat oscillator arrangement for measurement of intermodulation. The chart shows the various outputs that are provided



*A Sure Bet...*

*200 to 1*

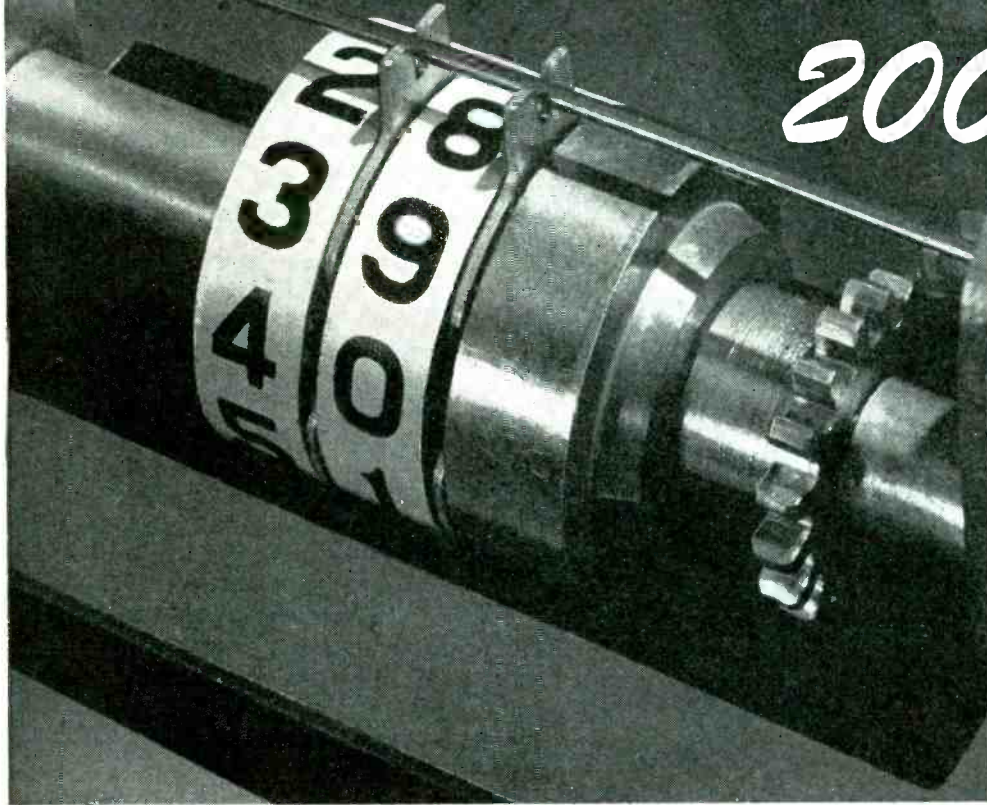

*The counterdial in an antenna network application*

## A NEW Interpolating COUNTERDIAL

**200 accurate settings with each turn of the dial**

Here is a really extraordinary new piece of equipment—an Interpolating Counterdial which combines the familiar drum counter with a flat interpolating disc scale—and custom built features at mass production prices.

This new Techrad interpolating counterdial offers numerous advantages which at once will be apparent to the electronic engineer. It gives an accurate log of any position, making it possible to return *exactly to a previously established setting*. When used with a roller coil, the Techrad counterdial gives an accurate record of the position of the roller on the coil at any time.

The Techrad counterdial is extremely simple mechanically, having no parts to get out of adjustment. Movement is transmitted through a simple gear mechanism, without the customary use of worms. The interpolating dial is graduated from 0 to 100 and each graduation has two divisions, giving a total of 200 parts on the dial. *One revolution of the dial thus breaks significant counter figures into 200 readable parts.*

The counter can be supplied in two digit (00 to 99) or three digit (000 to 999) numbers. Stock models drive directly through stem shaft without gear ratio.

The numbers on the counter scale read horizontally, making for speed and accuracy in reading. This new Techrad Interpolating Counterdial is sure to find valuable application in your particular field. Write now for complete information and price data. *Master Engineering takes nothing for granted.*

**TECHRAD**

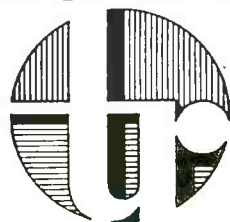

**Technical Radio Company**

*Over ten years of continuous experience*

**275 Ninth Street • San Francisco 3, California**

*Export Agents: Frazer & Hansen, 301 Clay St., San Francisco 11, California, U. S. A.*

**Richardson Plastics  
put an END to this  
WHISPERING  
CAMPAIGN**



They've taken the mystery out of forming Laminated INSUROK plastic sheets! For actually it is a simple process . . . one you can do yourself if you *know how*. And here is a small booklet that puts you in the know . . . the A B C's of how to form laminated plastic sheets yourself.

*It is as easy as this:*

- A. HEAT the laminated sheet uniformly slightly below the blistering point.
- B. INSERT the heated sheet in the forming fixture and apply pressure.
- C. ALLOW part to cool and then remove.

*Result . . . the shape is now permanent.*

Laminated INSUROK plastic sheets for forming have varied uses. They combine strength with lightness . . . are resistant to sudden changes in temperature . . . withstand the destructive actions of most chemicals, reagents, and solvents.

Write today for the booklet that tells all about forming laminated plastic sheets . . . "HOW TO FORM LAMINATED INSUROK SHEETS." It's FREE for the asking. Send for it on your company letterhead.

You may prefer to have the forming done for you. If so, the working knowledge and years of practical experience of Richardson Plastics are at your disposal.

**INSUROK** Precision Plastics

**The RICHARDSON COMPANY**  
 MELROSE PARK, ILL.    NEW BRUNSWICK, N. J.    FOUNDED 1858    INDIANAPOLIS 1, IND.    LOCKLAND, CINCINNATI 15, OHIO  
 DETROIT OFFICE: 8-257 G. M. BUILDING, DETROIT 2, MICHIGAN    NEW YORK OFFICE: 75 WEST STREET, NEW YORK 6, N. Y.  
 CLEVELAND OFFICE: 328-7 PLYMOUTH BLDG., CLEVELAND 15, OHIO

mental converter tube which is similar to the 6SA7 but has a higher transconductance. The oscillator tuned circuit is connected to the plate of the tube and the feedback coil is connected to the No. 3 grid. This grid is operated with self bias. The received signal is applied to the No. 1 grid of the tube from a 4300-kc i-f transformer. The No. 1 grid is likewise operated with self bias.

*Discriminator*

The output of the local oscillator is fed to the discriminator as shown. This circuit has a pair of diodes connected with the load resistors in opposition so the discriminator is balanced at the center frequency. One diode has a tuned circuit in series with it and the other has a tuned circuit across it. The audio frequency output of the discriminator is fed through a de-emphasis network to the audio amplifier.

The oscillator is designed to

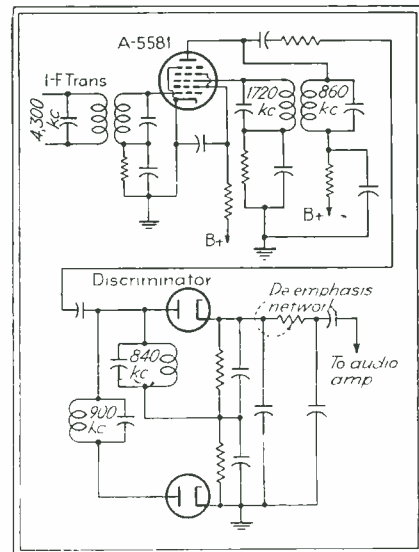

At the top of the diagram is the oscillator which is locked in with the received frequency. Output of the oscillator feeds directly to the discriminator at bottom

lock in only with frequency variations which occur within the desired signal channel and is therefore prevented from following the frequency variations of a signal on an adjacent channel. A substantial improvement in selectivity is thus obtained. The voltage required to lock in the oscillator with a weak signal is approximately 1/20th of the voltage applied to the discriminator. Since this voltage gain is obtained with a different and lower frequency than the intermediate frequency, the stability of the re-



*Casting the International Meter Rods in Paris 1874. The degree of accuracy attained 1/10,000,000 of a quadrant of a terrestrial meridian.*



**WHO SETS THE**

*Quality Standard*  
**FOR TRANSMITTING TUBES**



371-B



BW-II



KU-23



813



905



949-A



CV-II



967



972-A

**UNITED**



**TRANSMITTING  
TUBES**



**I**N every art or craft, the work of some acknowledged master sets the standard.

Since 1934 UNITED has won recognition by specializing exclusively in the engineering, design and building of transmitting tubes which are unchallenged for excellence. UNITED tubes excel in every electronic application . . . including radio communication, physiotherapy, industrial control and electronic heating. In these and other applications, tubes by UNITED continue to win top honors for uniformly dependable performance.

In communication equipment for airlines, commercial broadcasting, police radio stations and other vital civilian services, UNITED transmitting tubes set the standard. Accept nothing less than UNITED quality tubes for your requirements.

*Order direct or from your electronic parts jobber.*

**UNITED ELECTRONICS COMPANY**

NEWARK, 2

New Jersey

*Transmitting Tubes EXCLUSIVELY Since 1934*





# "Nails" for HITLER'S COFFIN

Milling machine designed and built by Remler for difficult operations requiring precision accuracy.

**T**HE ENGINEER who helped design this special machine has a son in the South Pacific, the girl who feeds in the "nails" has a boy friend with General Patton. Like other Americans with a stake in Victory, these Remler workers take a personal interest in improving techniques to lower costs and speed up deliveries. • For complete sound transmitting systems; radio; plugs and connectors and other electronic components in metal and plastic, consult . . .

REMLER COMPANY, LTD. • 2101 Bryant St. • San Francisco, 10, Calif.



## PLUGS & CONNECTORS

Signal Corps • Navy Specifications

Types:		PL			NAF	
50-A	61	74	114	150		
54	62	76	119	159		
55	63	77	120	160		1136-1
56	64	104	124	291-A		
58	65	108	125	354		No.
59	67	109	127			212938-1
60	68	112	149			

PLP		PLQ		PLS	
56	65	56	65	56	64
59	67	59	67	59	65
60	74	60	74	60	74
61	76	61	76	61	76
62	77	62	77	62	77
63	104	63	104	63	104
64		64			

OTHER DESIGNS TO ORDER

# REMLER

SINCE 1918

*Announcing & Communication Equipment*



# COMIN' AT YOU!



*Buy War Bonds*

... and some for all!

Here comes aluminum . . . rolling out to meet the highest *record* demand in its history . . . and back to do a bigger and better job in PRESTO RECORDING DISCS!

PRESTO *ALUMINUM* RECORDING DISCS are now available in all sizes from 6½ inch to 17¼ inch. That's *good news* for broadcasting stations, recording studios and schools all over the nation . . . who know through valued experience that PRESTO is

simpler to handle—doesn't require fussy adjustments . . . and, in fact, is the smoothest cutting disc they've ever used!

Order PRESTO *ALUMINUM* DISCS from your regular electronics distributor. May we suggest that you split your order—50% aluminum and 50% glass base for the time being, so that we can fairly distribute PRESTO *ALUMINUM* DISCS over the first big demand?

## PRESTO RECORDING CORPORATION

242 West 55th Street

New York 19, N. Y., U. S. A.

*Walter P. Downs Ltd., in Canada*



# Air-Cooled RADIATORS

... by **ARPIN**

Immediate shipment on several sizes for Air-cooled transmitting tubes in types:

889-R	892-R
891-R	893-R
127-R	

Write for information and prices.

*Also Try Us For*

*Mercury Vapor Rectifier Tubes*

## **ARPIN MANUFACTURING CO.**

422 Alden St.  
**ORANGE, NEW JERSEY**

ceiver from the standpoint of overall feedback is materially improved. Not only is adjacent-channel selectivity increased but reduction in noise is also obtained.

### *Advantages*

Theoretical and experimental investigations indicate that the system has the following advantages:

(1) By restricting the locked-in range of the oscillator to follow only the frequency variations which occur within the desired signal channel, a material improvement in selectivity is obtained.

(2) An equivalent voltage stepup is secured at a different and lower frequency than the intermediate frequency and a corresponding improvement in freedom from overall feedback is secured.

(3) The constant voltage is applied to the discriminator irrespective of the strength of a received signal, and arrangement for minimizing amplitude variations in a received signal are therefore not required.

(4) The system provides a means for incorporating in a f-m receiver a type of selectivity which can be used to discriminate between the desired signal modulation and frequency modulation noise component.

The following characteristics should also be considered in evaluating the system: (1) Adequate receiver gain ahead of the locked-in oscillator must be provided if distortion of the weaker signals (due to oscillator falling out of step) is to be prevented. (2) When the receiver is tuned to a signal, more noticeable distortion occurs at the edges of the receiver response characteristic than is obtained with the corresponding conventional receiver.

A paper by Dr. Leon Brillouin of Columbia University and the Federal Telegraph Radio Laboratories of New York emphasized the importance of a well-known theorem originally due to Larmor. This theorem permits a definition of "momentum" and "moment of momentum" for electrons in the magnetic field. As typical examples of application two special cases were discussed: (1) a plane electron beam; (2) a cylindrical electron beam with longitudinal magnetic fields. In



# File This For Reference...

**CRYSTALS**

**QUARTZ CRYSTAL CUTS**



**CRYSTALS**  
FOR PRECISE FREQUENCY CONTROL IN VARIOUS  
TYPES OF ELECTRONIC EQUIPMENT



**QUARTZ CRYSTAL  
FINISHING**



**USEFUL INFORMATION ABOUT PRESENT-  
DAY AND FUTURE APPLICATIONS OF  
QUARTZ OSCILLATOR PLATES**

**CRYSTAL HOLDER Design**



Here is common-sense, understandable data about the characteristics, production, and adaptation of quartz crystals. Graphically illustrated, these papers are combined in a convenient file for instant accessibility. Write for your copy today.



1519 MCGEE STREET, KANSAS CITY, MO.

Producers of Approved Precision Crystals  
for Radio Frequency Control

When  
You Use This

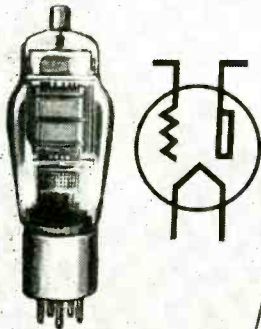

P. R. MALLORY & CO. INC.  
**MALLORY**

Type FP\* Capacitor

\*Trademark Registered



**YOU NEED THIS**



Your Country Needs Your Help:  
Buy War Bonds

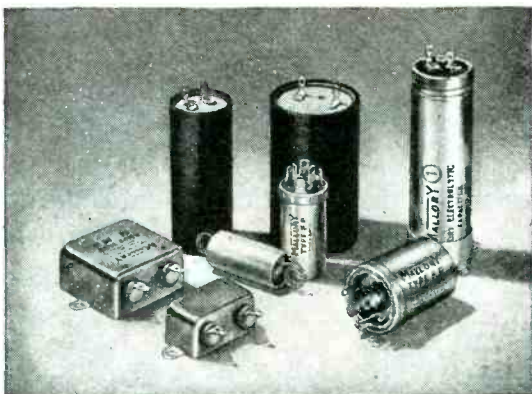

P. R. MALLORY & CO. Inc.  
**MALLORY**  
ELECTROLYTIC,  
FILM AND PAPER  
**CAPACITORS**

**R**ADIO, television, movie apparatus, control devices—in these and hundreds of other applications, condensers are a vital necessity. With the majority of makers of such equipment, Mallory FP Capacitors are preferred.

For one thing, the patented "twisted ear" mounting feature found in Mallory FP Capacitors requires no other parts for mounting. This assures quick assembly and a rugged installation job.

For another, Mallory FP Capacitors have the advantage of being the smallest capacitors available for a given electrical rating.

Again, they are reasonable in price—improved production facilities have made them so.

But above all, of course, they are completely dependable. Long and gruelling life tests have proved *that* point again and again. Widespread acceptance after six years of use has dissipated the last shadow of doubt.

Do you have a problem involving electrolytics? Then let us show you how Mallory FP Capacitors can provide a ready answer. Free literature or engineering counsel are both available without charge. See your Mallory distributor, or write direct.

P. R. MALLORY & CO., Inc., INDIANAPOLIS 6, INDIANA





*Looks Simple?*



—here's what it takes to make a good DISCONNECT PLUG

● There are more than 25 precision-made parts in the average Multiple Circuit Electrical Connector. When assembled, they perform their function—that of making or breaking many electrical circuits simultaneously—with the utmost simplicity and efficiency. Such simplicity in operation is the end result of years of research, many refinements and great skill in manufacture. The Breeze Multiple Circuit Electrical Connector reflects in the efficiency with which it does its job, the experience which went into its production—the background which has made Breeze a leading producer of many different types of aircraft and electrical accessories.

**Breeze**  
**BREEZE**  
**MARK**  
**CORPORATIONS, INC.**  
NEWARK, N.J.

PRODUCTION FOR VICTORY — PRODUCTS FOR PEACE

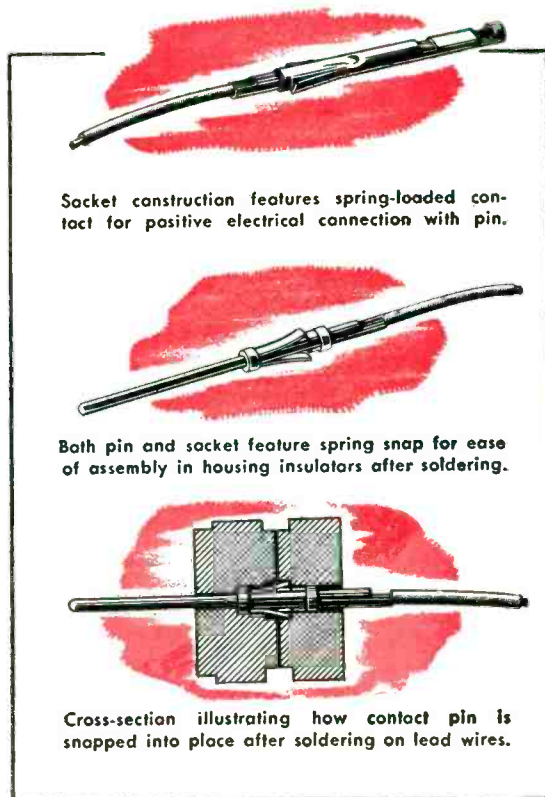

Socket construction features spring-loaded contact for positive electrical connection with pin.

Both pin and socket feature spring snap for ease of assembly in housing insulators after soldering.

Cross-section illustrating how contact pin is snapped into place after soldering on lead wires.



## VACUUM PUMPS



With the demand for tubes at an all time peak the electronic industry is carrying the ball and out for a touchdown in production records. Manufacturers are counting heavily on the efficient performance and unfailing service of Kinney Vacuum Pumps to save production time and decrease percentage of rejections in the manufacture of electronic tubes, lamps and other electronic products. A vital factor to-day, where the vacuum pump is working on a new lamp or tube every few seconds, is the exceptional vacuum and rapid recovery speed of the Kinney Vacuum Pump.

Before shipment, every Kinney Compound Dry Vacuum Pump must pass an acceptance test showing a reading of 0.2 microns (.0002 mm) or better on the McLeod Gauge and is suited to working conditions down to 0.5 microns.

WRITE FOR BULLETIN 18

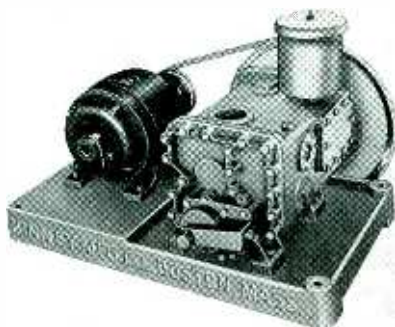
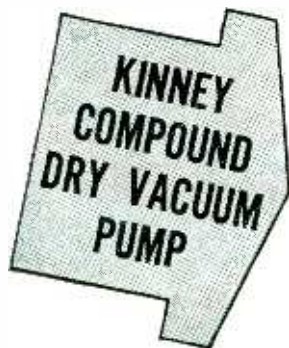

Kinney Compound Dry Vacuum Pump

**KINNEY MANUFACTURING CO.**

3565 Washington St., Boston 30, Mass.

Now York Chicago Philadelphia Los Angeles San Francisco

We also manufacture Vacuum Tight Valves, Liquid Pumps, Clutches and Bituminous Distributors.

both cases, it was found that the space charge density of the beam is entirely controlled by the magnetic field, and the maximum current is obtained for a suitable optimum magnetic field.

### *Space Charge and Magnetic Field*

Dr. Brillouin's general conclusion, as the result of a mathematical treatment, is that such problems as Larmor's theorem introduces an additional condition of conservation for either the momentum or the moments of momentum which has been too often overlooked. If taken into account, it shows that the space charge density is entirely conditioned and controlled by the magnetic field. Caution is therefore urged not to introduce in a discussion separate assumptions about space charge and magnetic field. It is especially advised not to speak of the behavior of a device under an infinite or arbitrarily large magnetic field, since this would also mean infinite space charge density, a very troublesome factor.

"The Supersonic Reflectoscope, An Instrument for Inspecting the Interior of Metal Parts by means of Sound Waves" was the title of a paper by Dr. F. A. Firestone, University of Michigan.

The supersonic reflectoscope sends into the metal part to be inspected a short train of supersonic sound waves. Any flaws on the interior give reflections back to the sending point before the reflection is received from the other side of the piece. Many feet of metal can be penetrated.

In addition to the detection of flaws, the thickness of a piece can be measured when its opposite side is inaccessible, and discontinuities of bond of plated or soldered surfaces can be detected.

A paper by Dr. E. U. Condon, of the Westinghouse Research Laboratories, gave an elementary discussion of the way in which the behavior of class C oscillators, intended for use at microwave frequencies, is limited by the speed of electron motions. The paper, entitled "Microwave Oscillation Generators Using Velocity Modulated Electron Beams," presented the main results of the elementary theory of three kinds of velocity-modulated tubes, namely, the monotron, the Klystron, and the reflex Klystron. The mono-



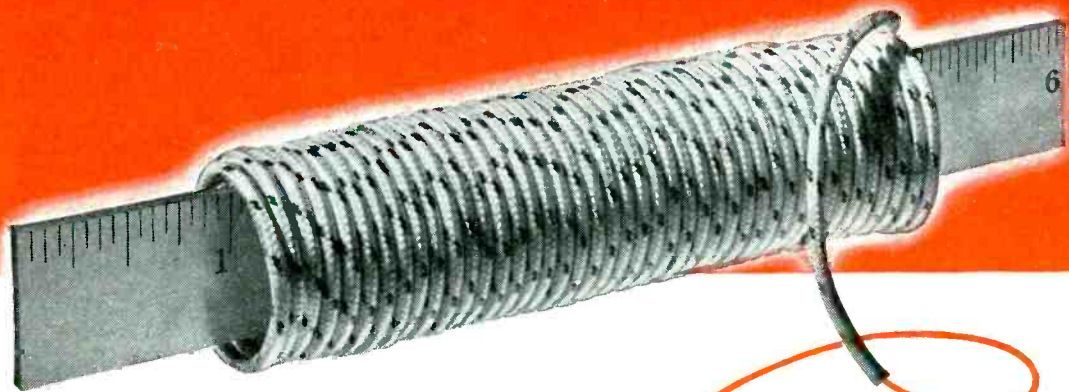

**MORE SPACE FOR**

**WITH LEXEL INSULATED WIRE**



For a wide variety of low-tension uses, where space is scarce, the small bulk and low weight of Lexel insulated wire offer proven advantages. These are evident in such applications as instruments, controls, lead-in and hook-up wire and electronic circuits.

Then there's the important matter of preventing "cross talk" in such installations.

When wires are encased in Lexel's continuous helical tube, the conductor is always automatically and permanently center-sealed throughout the entire length of the circuit. Yet no extra material is required for this extra precaution against off-centering.

The value of Lexel (cellulose acetate butyrate) has been proved in many critical military installations. High dielectric strength and insulation resistance and low moisture absorption permit major improvements in numerous new peacetime products.

Send for test samples and the names of manufacturers supplying Lexel insulated wire and cable—and see for yourself its practical value for your own products.

#### CUSTOM-MADE INSULATION

As a regular service, Dobeckmun engineers also develop laminated insulation products, custom-made to special purpose specifications, such as slot cell and phase insulation for motors, insulation for shipboard cables and other uses. If your requirements are unusual, call on us.

"LEXEL" is a registered trade-mark of The Dobeckmun Company.



Made by the  
makers of  
DOBAR  
Insulation

THE

**DOBECKMUN**

COMPANY

INDUSTRIAL PRODUCTS DIVISION • CLEVELAND 13, OHIO  
WESTERN SALES HEADQUARTERS • SAN FRANCISCO

# Don't lay that pencil down



## ... till you show where the Short Cut Fastening Method can be used!

Choosing the fastening device for use in the assembly of your post-war product is a very important decision. It should be settled now, while the product is still in the design stage. Too many products are tooled up and ready to go into production before somebody starts to really question fastening methods. This frequently leads to needless expense, troublesome delays, and costly changes.

You will want to use P-K Self-tapping Screws wherever possible, because this *short cut fastening method* can save you from 30% to 50% in assembly time and labor! It is the *simplest* way to make most assemblies. You eliminate tapping for machine screws, and tap expense - fumbling with bolts and nuts - costly inserts in plastics - riveting in hard-to-reach places.

Whether you are working with light or heavy steel, cast iron, aluminum, brass, plastics - you'll find you can use P-K Screws to advantage in 7 out of 10 cases.

A P-K Assembly Engineer will help you plan ahead for savings, and you'll find his advice unbiased. He'll recommend only the best Self-tapping Screw for the job, because Parker-Kalon makes *all* types. Write and tell us when you would like him to call, or send details of your fastening jobs for recommendations.

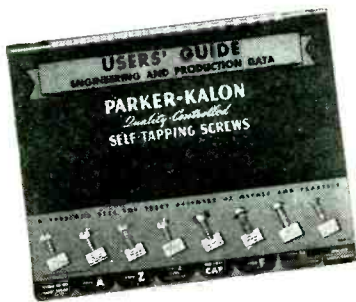

### HELPFUL GUIDE FREE!

The P-K "User's Guide" is crammed full of information on where and how to use P-K Self-tapping Screws, arranged so you can find the facts you need quickly. Write for it, Parker-Kalon Corp., 208 Varick St., New York 14.



**SELF-TAPPING SCREWS FOR EVERY METAL AND PLASTIC ASSEMBLY**

### HERE'S HOW PUROLATOR PRODUCTS, INC. PLANNED AHEAD FOR ASSEMBLY SAVINGS

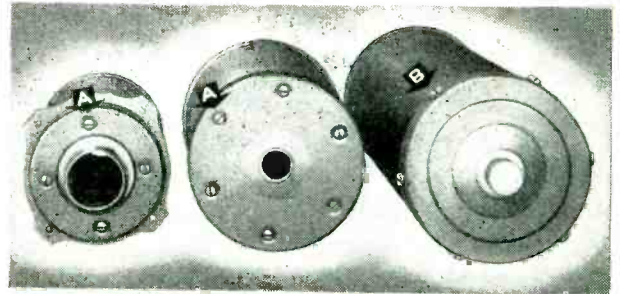

(A) 4 Type "Z" Screws fasten sheet metal cap to steel (or aluminum) frame. (B) 6 Type "Z" P-K Screws fasten the cast iron cap to steel tubing wall.

A Purolator executive says, "We designed most of our filters with P-K Screws in mind... to eliminate tapping."

"At least 4 P-K Screws are used in each Purolator unit. If we had to tap holes (800,000 per year) for machine screws, it would require ten times our present labor force, or lower production by the same ratio."

Purolator Products, Inc., make a wide variety of filters for gasoline, oil, air, etc., which are standard equipment on many vehicles, vessels, and airplanes.

# PARKER-KALON

*Quality-Controlled*

## SELF-TAPPING SCREWS



# Brazing—

Tool of the Honeycomb Makers



Cross-section of a brazed joint magnified 10X

Fabrication of lightweight aluminum cores for many types of heat exchangers—aircraft radiators, oil coolers, heaters—is accomplished by brazing. Aluminum alloys contribute strength and light weight, superior heat conductivity and resistance to corrosion. The brazing process provides speed and uniformity of production.

In the tubular-core section pictured above, thin-walled aluminum tubing and Alcoa sheet, perforated to receive the tubes, are assembled in a fixture which holds all parts firmly in place. Furnace-brazing is then em-

ployed to join them into a rigid, pressure-tight unit. Other fabricators may employ flux-bath brazing, hand welding and brazing, or combinations of all methods.

How the molten brazing alloy flows at the line of contact, forming a fillet which bonds all parts securely together, is seen in the above photomicrograph.

Alcoa will assist you in adapting the brazing process to your products, advising on initial and final cleaning methods, fluxes and brazing temperatures. For this help, write ALUMINUM COMPANY OF AMERICA, 2136 Gulf Building, Pittsburgh 19, Pennsylvania.

# ALCOA



# ALUMINUM



*How*  
**WAR-TIME**  
*Efforts Improve*  
**PEACE-TIME**  
**PRODUCTS**

Under the imperative demands of war, the processes and products of Industry advance far more swiftly than in times of peace.

For example, Chace research and engineering efforts have produced, for war use, new alloys for Thermostatic Bimetals . . . so quickly responsive that aircraft may soar from temperatures of 130°F. above to 60° below in a matter of minutes—with complete reliance on their thermal controls.

Because of this increased sensitivity, the new alloys also permit the use of smaller actuating elements; and therefore smaller and lighter temperature responsive devices, where space or weight limitations require.

These and other Chace developments may be vitally important to the efficiency of your peace-time products. For among its many types of Thermostatic Bimetals, Chace has one exactly suited to your particular need.

For specific and confidential recommendations, write us detailing your problems.

**W.M. CHACE Co.**  
*Manufacturers of*  
Thermostatic Bimetals and Special Alloys  
1630 BEARD AVE • DETROIT 9, MICH.

tron is a tube in which a cavity resonator is placed between the grid and plate to act as a tank circuit, and a steady unmodulated electron beam is sent through the grid from the cathode with no attempt at any kind of modulation of the beam before it arrives at the control grid. In the Klystron, electrons are emitted from a thermionic cathode and are accelerated by means of a cathode potential in a beam, through the grid or cavity resonator, the buncher. After traversing these grids, electrons travel through the axis of the tube to another cavity resonator, the catcher.

*Use of Reflex Klystron*

The reflex Klystron has been used principally as a low-power tube and is especially useful as the local oscillator of a heterodyne receiver. Electrons are accelerated from the cathode by a voltage between the cathode and a single cavity resonator, where they experience velocity modulation. They are then repelled by a negative reflector voltage and revert back to the grid of the resonant cavity.

After a mathematical analysis, it was shown that the slowness with which electrons travel at ultra-high frequencies rules out the possibility of making oscillators designed on the principle of a class C amplifier or oscillator. It is for this reason that oscillators using velocity modulated beams have been so thoroughly investigated within recent years.

A paper, "The Principles of Klystron Amplifiers," by Dr. R. O. Haxby of Sperry Gyroscope Co., dealt with the fundamental principles governing the operation of Klystron amplifiers rather than the description of any particular tube. It was shown that there are two principal reasons for the unsatisfactory operation of amplifiers at very high frequencies: (1) the transit time of electrons to pass the control grid takes an appreciable part of a cycle of the high frequency, thereby causing loading and loss of gain; (2) the size of the electrodes and circuit becomes comparable to a wavelength, making it difficult to design efficient circuits and obtain radio-frequency power.

In the Klystron amplifier, the transit time of electrons is used to advantage rather than to disadvan-





# PRODUCTION TESTING WITH PANORAMIC

Any variation in magnitude which can be converted to a variation in frequency—quantities such as length, permeance, volume, and height—can be more quickly and accurately measured by the PANORAMIC COMPARISON TECHNIQUE. Capacitors, inductors, resistors, and crystals are "naturals" for PANORAMIC production testing. A simple jig and a PANORAMIC COMPARATOR will provide your tester with an unbeatable combination for speed and accuracy on the production line.

In application, the component under test is placed into the jig containing the standard. The chosen tolerance may be established quickly by means of the panel control on the PANORAMIC COMPARATOR. From the deflections which appear on the PANORAMIC screen, deviations from the standard become immediately apparent both as to percentage and type. The instrument is usually adjusted so that a visible deflection indicates that the production unit is within the predetermined tolerance range, while the absence of deflection indicates an error in excess of the permissible tolerance. Coincident deflections indicate zero error; displaced deflections tell their own story regarding the percentage of error. PANORAMIC COMPARISON TECHNIQUE is economical in time and energy . . . but extremely accurate in results.

Our engineers will gladly suggest simple jigs for use in any type of production testing.

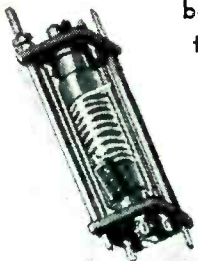
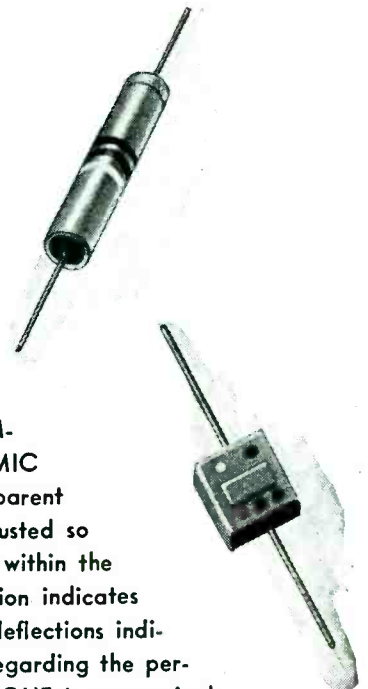

PANORAMIC

RADIO CORPORATION

242-250 WEST 55<sup>TH</sup> ST., New York 19, N.Y.



**"AFTER TURNING HIMSELF INSIDE OUT FOR TWO MONTHS TRYING TO GET SOME COILS, THE BOSS JUST LEARNED THAT ALL HE HAD TO DO WAS CALL ALBION..."**

**SUPER-QUALITY COILS AT REASONABLE PRICES**

More and more every day, the industry is turning to Albion for fast, quality and quantity production of coils, chokes, and transformers. That's because here you benefit from the unbeatable combination of management "know how," skilled workmanship, streamlined facilities, and central location. Your requirements will be given prompt and thoughtful attention.

**ALBION  
COIL COMPANY**

ALBION, ILLINOIS

R. F. AND TRANSMITTING COILS AND CHOKES;  
I. F. TRANSFORMERS



**ALLIED**

# POWER RELAYS

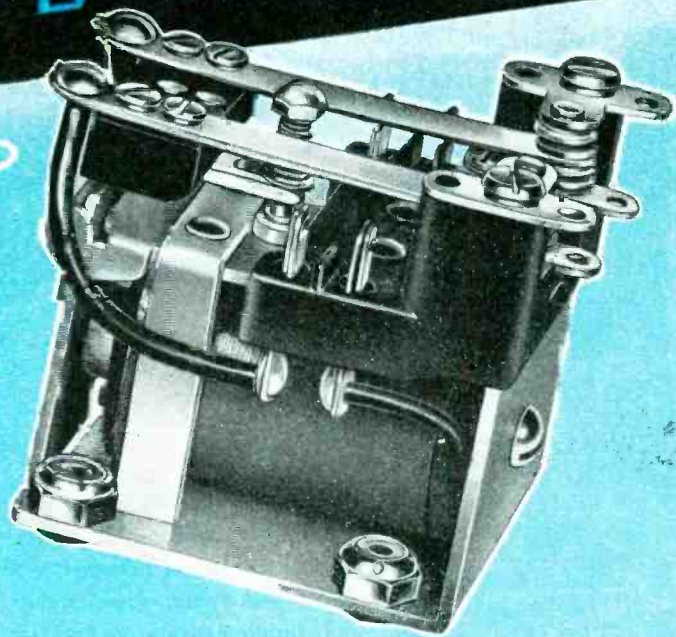

MODEL  
" **BOL** "  
RELAY

The Allied BOL relay—a power relay built to operate on 2.5 watts and to withstand 5.0 watts continuously applied.

Can also be supplied as a time delay relay slugged for slow operation—slow release or slow-action.

Now available in 2 pole construction. 3 and 4 pole construction available shortly.

Overall size  $2\frac{1}{4}'' \times 1\frac{1}{2}'' \times 1\frac{1}{2}''$   
Weight 8 ozs.



*Write for the latest Allied catalog describing type BOL and other precision-built relays.*

**ALLIED CONTROL COMPANY, INC.**  
**2 EAST END AVE. (AT 79th STREET) NEW YORK, N.Y.**

FACTORIES: NEW YORK • PLANTSVILLE • CHICAGO • LOS ANGELES





Whatever  
Your Product . . . . .  
**ONE DEPENDABLE SOURCE  
FOR ALL YOUR FASTENERS**

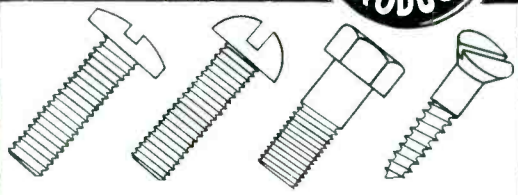

**T**HE FASTENER range and resources of STRONGHOLD are as wide and varied as the requirements of industry itself—all types, sizes, metals, finishes; all supplementary operations such as drilling, multiple drilling, chamfering, knurling and plating.

**Ask for Current  
"In-Stock" Record**

Issued periodically, it lists a wide range of reserve stocks available for immediate delivery—thousands of standard items, with the quantity of each on hand at the date of issue. Mailed regularly on request.

**It's Faster to Telephone  
Call Whitehall 4680**

**MANUFACTURERS  
SCREW PRODUCTS**

270 W. Hubbard St., Chicago 10, Ill.

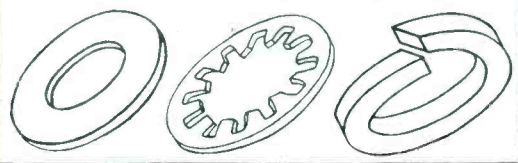

tage, with the resonant circuits designed as an integral part of the tube. The Klystron consists of an electron emitting gun, a smoother grid, a pair of buncher grids in one cavity resonator, a pair of catcher grids in another cavity resonator, and output and input terminals to the two cavity resonators.

*Operation*

In the operation of this tube, a small amount of power is fed into the buncher resonator through its coupling loops. This power builds an alternating voltage across the buncher gap. Assuming that the electrons in the beam take only a very small fractional of a cycle to get through the resonator, they either gain or lose an amount of energy equal to the electronic charge times the instantaneous voltage across the gap. Consequently, each electron is speeded up or slowed down as it passes through the grid, by an amount depending upon the instantaneous voltage of the resonator. This process is called "velocity modulation."

*Bunching*

A beam of electrons which has been velocity modulated will be density modulated or "bunched" at some point within the tube. This bunched grouping of electrons travels down the tube until it reached the grid of the catcher, where the electrons are slowed down in going through the catcher when the voltage is in a direction to slow them down. That is, the electron beam has lost energy, on the average, because of interaction with the field of the resonator. This energy loss by the beam must have gone into the catcher resonator to maintain its oscillation and supply power to an external load. Thus the catcher resonator extracts some energy from the beam. Since there are always some electrons which are not in the bunch, there will always be some electrons speeded up by the catcher, so the efficiency of the tube is limited to a value considerably less than 100 percent. A mathematical derivation of the process shows that it cannot exceed 58 percent.

Dr. Haxby provided a mathematical and graphical analysis of the behavior of the Klystron amplifier, noted some of the factors which



# Proving ground for Norelco Cathode Ray Tubes

Reg. U. S. Pat. Off.

**T**HE uniform characteristics, long life and outstanding performance of NORELCO Cathode Ray Tubes are the result of exceptional manufacturing skill supplemented by rigid tests applied to each tube as it comes off the production line.

As an example of the care exercised, the electronic test set, shown here, subjects every cathode ray tube to 30 different checks, such as line width, light output, plate alignment, base-to-shell alignment, uniformity of cathode surface, astigmatism, presence of gas, and screen condition. A total of 90 exacting tests of raw materials, parts, sub-assemblies, assemblies and performance guard cathode ray tube quality.

This is typical of the great lengths to which North American Philips goes in producing high performance NORELCO electronic tubes. Behind this company is an organization with world-wide experience resulting from over fifty years of electrical research and development.

Although all the tubes we produce now go to the armed forces, we invite inquiries from prospective users. A list of tube types we are especially equipped to produce will be sent on request.



Uniformly bright spot on screen of 15-CPI cathode ray tube in test set indicates perfectly formed cathode.



Pattern used for measuring light output by means of photoelectric cell. Frequency—60 x 2940 cycles.

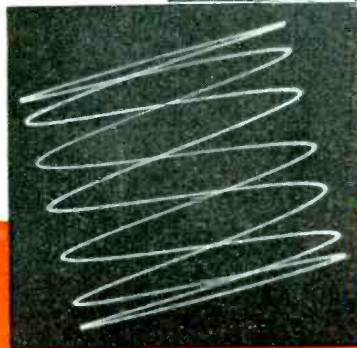

Trace showing absence of astigmatism. Frequency—60 x 420 cycles.

Write today for interesting booklet, describing the background of North American Philips in the science of electronics.

**Norelco** Electronic Products by  
Reg. U. S. Pat. Off.

NORELCO PRODUCTS: Quartz Oscillator Plates; Amplifier, Transmitting, Rectifier and Cathode Ray Tubes; Searchray (X-ray) Apparatus; X-ray Diffraction Apparatus; Medical X-ray Equipment, Tubes and Accessories; Electronic Measuring Instruments; High Frequency Heating Equipment; Communications Equipment; Tungsten and Molybdenum products; Fine Wire; Diamond Dies. When in New York, be sure to visit our Industrial Electronics Showroom.

**NORTH AMERICAN PHILIPS COMPANY, INC.**

Dept. C-11, 100 East 42nd Street, New York 17, N. Y.  
Factories in Dobbs Ferry, N. Y.; Mount Vernon, N. Y. (Metalix Div.); Lewiston, Me. (Elmet Div.)

# Avoid Future Wire-Failures by WIRE-PLANNING NOW

Check Your Design and Operating Characteristics Against the Chart, and then Check Your Wire Requirements for Trouble-free Performance

BEND RADII	✓	FLEXIBILITY	✓
WIRE DIAMETERS	✓	CONDUIT DIAMETERS	✓
BUSHING DIAMETERS	✓	POSSIBLE OVERLOADS	✓
OPERATING VOLTAGE	✓	INSULATION RESISTANCE	✓
DIELECTRIC STRENGTH	✓	UNDERWRITERS' APPROVAL	✓
AMBIENT TEMPERATURES	✓	CURRENT CARRYING CAPACITY	✓
OPERATING TEMPERATURES	✓	RESISTANCE TO OIL	✓
RESISTANCE TO HEAT	✓	RESISTANCE TO COLD	✓
RESISTANCE TO FLAME	✓	RESISTANCE TO GREASE	✓
RESISTANCE TO ABRASION	✓	RESISTANCE TO MOISTURE	✓
RESISTANCE TO VIBRATION	✓	RESISTANCE TO CORROSIVE FUMES	✓

## ROCKBESTOS FIREWALL HOOKUP CORD

Sizes No. 22 to 12 AWG in 1000 volt rating. Individual conductors insulated with synthetic tape, impregnated felted asbestos, and covered with glass, cotton or rayon braids.

This flame-resistant high dielectric hookup cord, made up of single conductor Rockbestos Firewall Hookup Wires, is obtainable in either two or three conductors with plain or color-coded braids. Operating temperature range 125°C. to minus 50°C. Widely used in aircraft radio and ground installations, and instruments. Also available with tinned copper shielding braid. Single conductor Rockbestos Firewall Radio Hookup Wire, 1000 volt rating, is available in sizes No. 22 to 4 AWG, and 3000 volt in sizes 12, 14 and 16 AWG.

## ROCKBESTOS MULTI-CONDUCTOR FIREWALL INSTRUMENT CABLE

This unusually small diameter, light weight, high-dielectric No. 26 AWG three conductor cable was designed for an electronic device in which three No. 22 AWG single conductor aircraft circuit wires previously used had proved too bulky. It is made to a nominal diameter of .125" (smaller than a No. 14 AWG single conductor 1000 volt Rockbestos Firewall Radio Hookup Wire). Also in four and five-conductor construction.

## ROCKBESTOS ASBESTOS INSULATED LEAD WIRE

Sizes No. 22 to 4 AWG solid or stranded copper, monel or nickel conductors insulated with .031" or .040" of impregnated felted asbestos in black, white or colors.

Heatproof and flame-resistant, this lead wire will not bake brittle and crack under vibration, won't rot, swell or flow when in contact with oil or grease, and has ample moisture resistance for most applications.

## ROCKBESTOS MULTI-CONDUCTOR FIREWALL RADIO HOOKUP CABLE

This type of cable is made up of 1000 volt rated individual Firewall Radio Hookup Wires of required size and number of conductors, cabled, and braided or shielded according to customer's specification. For example, this special 14 conductor No. 22 AWG cable was tinned, shielded with tinned copper braid, then jacketed with a black glazed cotton braid with a flame-resistant finish. Also in other multiples and sizes.

A few of the 122 wires, cables and cords developed by Rockbestos to meet unusual operating conditions.

## Investigate ROCKBESTOS Permanently Insulated WIRES, CABLES and CORDS

If you want to make sure your post-war jobs keep running . . . for *your own good* as well as your customers' satisfaction . . . give a little thought to wire-failure protection.

Foresighted designers can offset a lot of unnecessary repairs, replacements and service by double-checking all future trouble-making possibilities in advance . . . and then selecting wires that will not only meet specific design and operating requirements, but will also provide an ample safety factor as well.

Whatever your contemplated peace products, you can protect them against wire-failure with Rockbestos *permanently insulated* wires, cables and cords. Among the 122 standard Rockbestos constructions there probably are wires ideally suited to the particular conditions under which your planned products will operate . . . and, if not, we'll do our best to design what you need.

If you want our recommendations on a specific wire, engineering advice or a complete wire plan for your product, Rockbestos Research will be glad to be of service . . . just write or call the nearest branch office or —



Rockbestos Products Corporation, 417 Nicoll Street  
New Haven 4, Connecticut

## ROCKBESTOS RESEARCH

Solves Difficult Wiring Problems

NEW YORK, BUFFALO, CLEVELAND, CHICAGO, SEATTLE, ST. LOUIS,  
LOS ANGELES, SAN FRANCISCO, PITTSBURGH, PORTLAND, ORE.

★ FOR VICTORY . . . BUY WAR BONDS ★



come in and leave  
your worries



**M**anufacturing worries, we mean. Worries about production costs that are too high . . . schedules that are too tough.

Users of Foote, Pierson contract service increase their output in a way that's sure, practical. Like adding a wing to a plant . . . like bringing a force of skilled craftsmen to a factory in the manpower doldrums . . . F-P assistance can give many a manufacturing company just the lift it needs to welcome post-war competition instead of dreading it.

Let us show you as well as tell you about Foote, Pierson facilities . . . about the trained personnel which makes a machine shop more than a collection of millers, lathes, drills and presses.

Sound executive leadership gives proper direction to every operation. At Foote, Pierson, this starts with engineering and planning, extends through metal-forming, plating and finishing. It covers not only assembling, inspection and packaging but also packing, storage and shipping by rail, air and water.

Whether you're making a new product now or planning to make it . . . whether you're making a complete article or a component . . . Foote, Pierson can help in manufacture. It costs nothing to get acquainted.



"like adding a wing  
to your plant"

**FOOTE · PIERSON & Co · INC**

Ⓜ 6327

MANUFACTURERS OF PRECISION INSTRUMENTS SINCE 1896

73 Hudson Street



Newark 4, N. J.



## For more than 10 years

we have been manufacturing crystals. Not only are we crystal manufacturers, but crystal specialists as well. Consult us on your "crystal problems".



**PETERSEN RADIO CO.**

Council Bluffs, Iowa

CRYSTALS EXCLUSIVELY SINCE 1934

were not taken into the mathematical theory and explained how these would modify the behavior of the Klystron amplifier.

### Cascade Resonators

Since the gain of a Klystron amplifier may be increased by adding more resonators, a very high gain amplifier may be constructed, using a single cathode and electron beam. An  $n$ -stage cascade amplifier with  $n + 1$  resonators will have a gain which is approximately the  $n$ th power of the gain of a single-stage amplifier. The last stage of a cascade amplifier is used as a power amplifier with optimum bunching in the last drift space. Thus, a Klystron tube may serve as a combined high-gain amplifier and power amplifier.

Amplitude modulation may be produced by changing the magnitude of the beam current, and phase modulation is produced by varying the beam voltage around the point of optimum bunching. Phase modulation is also accompanied by a small amount of amplitude modulation unless special precautions are taken to avoid the latter.

A thorough analysis of vacuum-tube frequency-converting devices for use at moderately high frequencies was given by Dr. Harry Stockman, Cruft Laboratory, Harvard University, in a paper, "U-H-F Converters and Conversion Diagrams." Using mathematical as well as graphical methods of analysis, Dr. Stockman showed that a broadcast frequency converter functions as a fixed path-of-operations device or as a changing path-of-operations device. As the frequency is increased, the conventional changing path-of-operations device ceases to function properly, and the action of the other type of converter becomes more and more intricate. This action usually cannot be explained by a few measured characteristics and simple additional mathematical analysis.

### Present Design

Modern converter theory deals with the transconductance characteristics of the mixer-oscillator combination rather than the current-voltage characteristics of the mixing device. The variation of

ENGINEERS: Here's  
the **BIG POINT** about  
**AMPERITE  
REGULATORS**

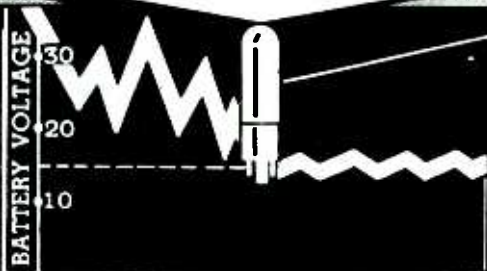

VOLTAGE OF 24V  
BATTERY & CHARGER  
VARIES APPROX

**50%**

WITH AMPERITE  
VOLTAGE VARIES  
ONLY

**2%**



### Features:

1. Amperites cut battery voltage fluctuation from approximately 50% to 2%.
  2. Hermetically sealed — not affected by altitude, ambient temperature, humidity.
  3. Compact . . . light . . . and inexpensive.
- Used by U.S. Army, Navy, and Air Corps.

**DELAY RELAYS:** For delays from 1 to 100 seconds.  
Hermetically sealed. Unaffected by altitude. . . . Send for catalogue sheet.

NEW! 4-page folder will help you solve Current and Voltage Problems; contains much valuable data in practical form—Write for your copy now

**AMPERITE CO., 561 Broadway, New York (12), N. Y.**

In Canada: Atlas Radio Corp., Ltd., 560 King St., W. Toronto



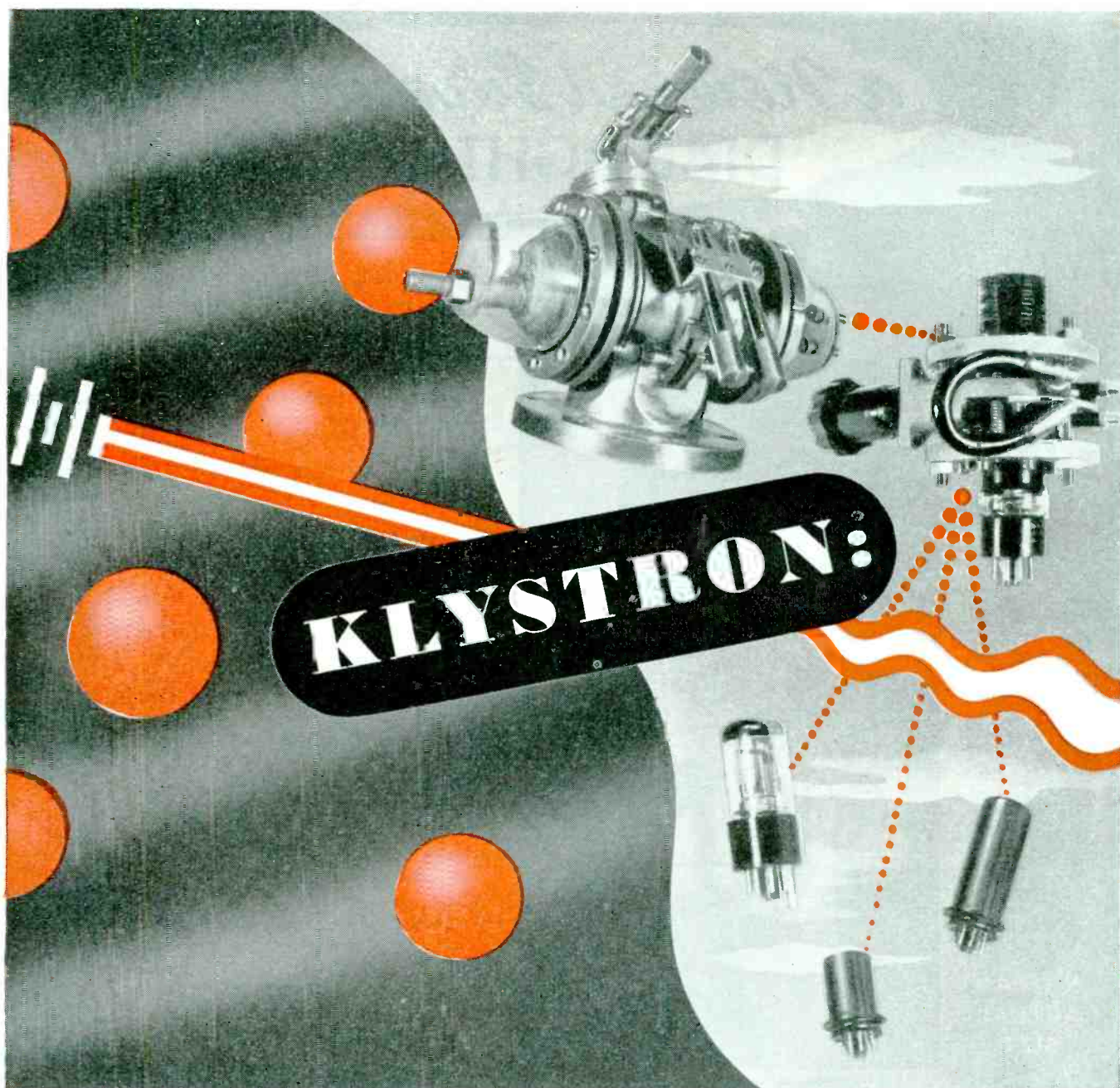

## How many Klystrons *are* there?

COMPARED with the early Klystrons which Sperry first developed some years ago, the more recent forms represent dramatic improvements in both size and performance.

And this is only the beginning!

Information on the newer types is presently restricted to those qualified under Military regulations.

But Sperry Klystrons are in use on many battle fronts, and in many applications...

There are small Klystrons, and large ones... low-powered ones and high-powered ones. There are Klystrons which generate, amplify, and multiply. Where required, frequency stability (better than that required for

broadcast purposes) is readily applied by conventional means.

Klystrons are easily modulated for new and all conventional purposes. And, by means of a single knob, they can be tuned continuously over a wide band, or the operator can snap-tune them to previously selected bands.

Write us for further information.

### Sperry Gyroscope Company

GREAT NECK, N. Y. • DIVISION OF THE SPERRY CORPORATION

GYROSCOPICS • ELECTRONICS • RADAR • AUTOMATIC COMPUTATION • SERVO-MECHANISMS

ELECTRONICS — November 1944

213



# *a New and Superior* DIAL LIGHT SOCKET

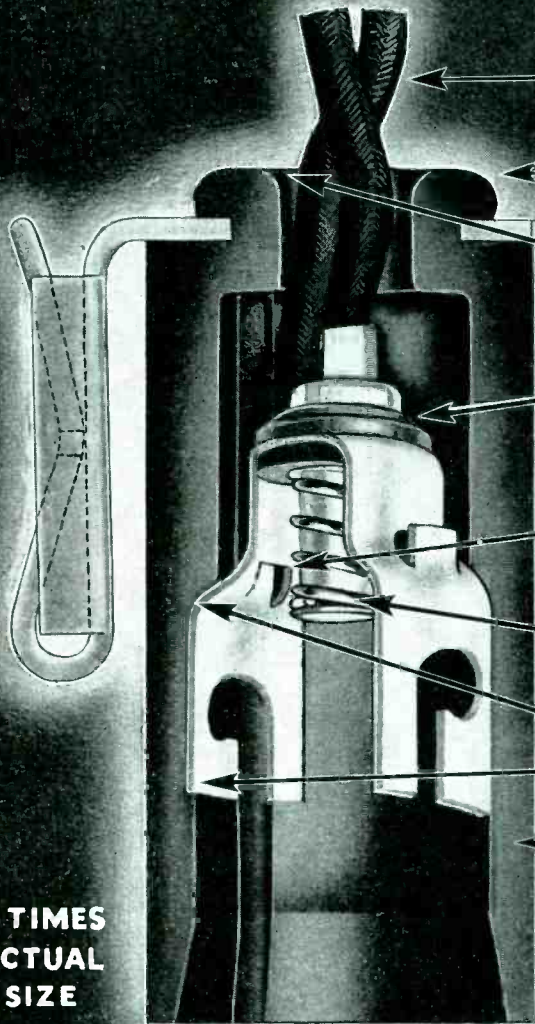

**4 TIMES  
ACTUAL  
SIZE**

Tensile strength of leads and connections far in excess of requirements.

Tough, plastic shell molded around bracket providing a secure bond with mechanical strength far beyond any normal requirement.

Rounded edge will not cut or fray wire insulation.

Voltage Breakdown between contacts—1200 Volts. Voltage Breakdown to ground—5000 Volts.

Lug on contact fits in groove in shell so that contact cannot be turned or twisted when inserting lamp.

Center contact mounted so that it cannot protrude from shell and short on chassis when lamp is removed.

Plastic shell is recessed for contacts, which cannot be pushed or pulled out of position.

Stronger, tougher, neavy walled plastic shell.

A variety of different mounting bracket styles available, suitable for practically any mounting.

## **For Your Present and Post-War Production**

**40th ANNIVERSARY  
1904—1944**

This year Lenz celebrates its 40th year of service to the communications industry.

Lenz Dial Light Sockets have always been known for their superior mechanical qualities and electrical characteristics.

Now these sockets are still further improved, with even greater mechanical strength. A stronger, tougher plastic shell is attached to the bracket with a new type of construction that provides a virtually unbreakable bond between shell and bracket. Its excellent electrical characteristics are maintained.

Consider these Lenz Dial Sockets for your present and post war production. Write for sample today.

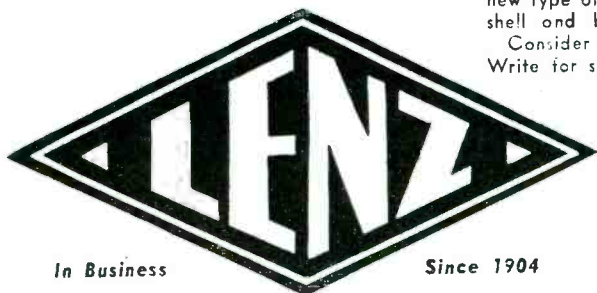

In Business

Since 1904

**LENZ ELECTRIC  
MANUFACTURING CO.**

1751 N. WESTERN AVE.

CHICAGO 47, ILLINOIS

ELECTRIC CORDS, WIRES AND CABLES



**3  
SIMPLE  
STEPS**

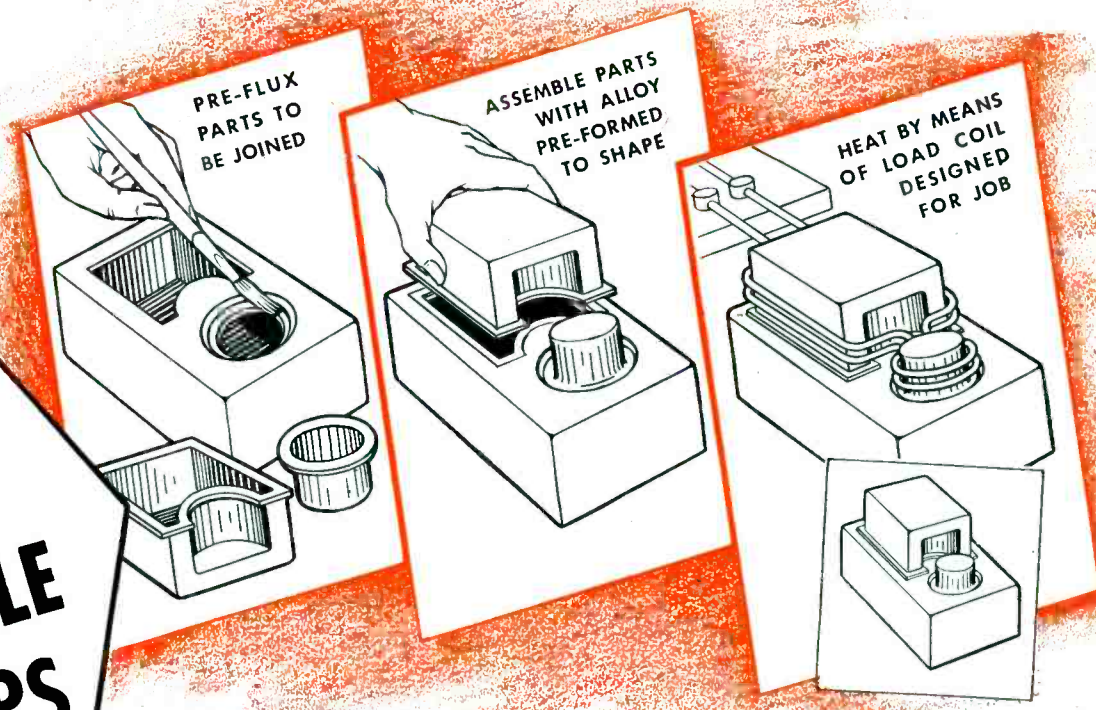

## to **BETTER METAL JOINING** – **FASTER** and at **LOWER COST**

Many manufacturers, seeking faster, and better methods of assembling metal parts to meet war production demands, have found the answer – and important economies – in brazing and soldering by the Lepel Induction Heating process.

Using brazing and soldering alloys of any melting point, Lepel Induction Heating reduces the most intricate metal joining jobs to three simple operations, so easy that women or unskilled workers can perform them with a minimum of training. Frequently, intricate jobs, impractical by other metal-joining methods, can be performed in a few seconds – often with gang set-ups that

raise production to astounding levels.

Quality is improved because the human element is eliminated, time cycles are automatically controlled, and the heat is generated within the metal, assuring thorough penetration of the alloy.

“Runs” are rare since only the required amount of alloy is used and, since excessive heating is impossible, discoloration is minimized and scaling practically eliminated. Thus, little, if any, cleaning up or refinishing is necessary.

If you have a metal joining problem – present or projected – involving ferrous or non-ferrous metals, or both, a Lepel field engineer will be pleased to call to discuss the advantages and possibilities for economy which Lepel Induction Heating offers.



**LEPEL HIGH FREQUENCY LABORATORIES, INC.**  
**PIONEERS IN INDUCTION HEATING**  
**39 W. 60th STREET** **NEW YORK 23, N. Y.**

# Designed for Application



Millen "Designed for Application" components are different! As a designer and manufacturer for many years of complex electronic and communication equipment, we are our own best customer for component parts. Consequently, we have to perform an outstanding job of designing and manufacturing such parts in order to satisfy our own applications. Our parts are "different", also, because as symbolized by the "Gear wheel" of our registered trade mark, they are designed by mechanical engineers working in close cooperation with our electronic circuit group. Below are illustrated a typical half dozen of the thousand-odd items we manufacture. Unfortunately, at this time, it is not possible to list herewith some of the intriguing "classified" components developed in connection with our ultra high frequency war production work. Our new 1944 general catalogue of non-classified parts has just been released.

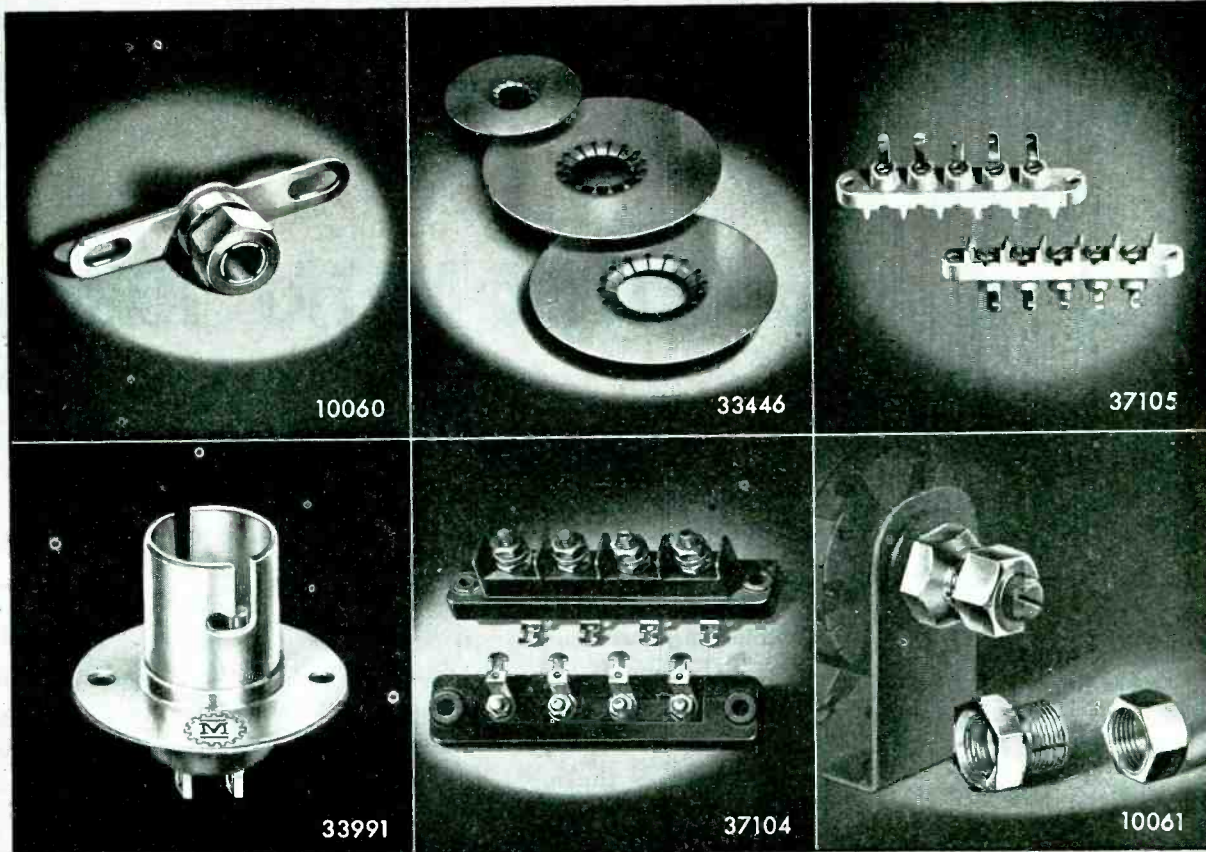

Illustrated above, left to right; Top Row: No. 10060 shaft lock with Universal mounting bracket; No. 33446 socket contact discs for use with GL446 lighthouse ultra high frequency tube; No. 37105 steatite barrier style terminal strip with through bushings. Bottom Row: the No. 33991 tube socket for neon voltage regulator tube; No. 37104 molded bakelite terminal strip; and the No. 10061 combination shaft lock and mounting nut for converting standard type potentiometer etc., to shaft locked type.

## JAMES MILLEN MFG. CO., INC.

MAIN OFFICE AND FACTORY

NEW YORK OFFICE  
259 W. 14th ST.

MALDEN  
MASSACHUSETTS

CHICAGO OFFICE  
549 W. WASHINGTON BLVD.

SALES OFFICES IN ALL OTHER PRINCIPAL CITIES



## RESISTANCE WIRE

ALLOY "A": Nickel-chromium alloy, resists oxidation at extreme temperatures. Essential for operating temperatures up to 2100° F. Also used for cold resistance. Resists chemical corrosion by many media. Non-magnetic; specific resistance, 650 ohms/C.M.F.

**C. O. JELLIFF MFG. CORP.**  
123 PEQUOT AVE. • SOUTHPORT, CONN.

## RESISTANCE WIRE

ALLOY "C": Nominally contains 60% nickel, 15% chromium, and balance iron. High resistance to oxidation and corrosion. Widely used in resistances for radio and electronics, industrial, and domestic equipment. Operating temperature up to 1700° F. Specific resistance 675 ohms/C.M.F.

**C. O. JELLIFF MFG. CORP.**  
123 PEQUOT AVE. • SOUTHPORT, CONN.

## RESISTANCE WIRE

ALLOY "D": Nominally contains 30% nickel, 15% chromium, and balance iron, and has a specific resistance of 600 ohms/C.M.F. Pure Monel and nickel resistance wire also obtainable.

**C. O. JELLIFF MFG. CORP.**  
123 PEQUOT AVE. • SOUTHPORT, CONN.

## RESISTANCE WIRE

ALLOY "45": Alloy of 55% copper, 45% nickel with a constant electrical resistance over wide range of temperatures. Specific resistance 294 ohms/C.M.F.; temperature coefficient 0.00002 ohms per degree F; 32 to 212 degrees range. Used in winding of precision resistors.

**C. O. JELLIFF MFG. CORP.**  
123 PEQUOT AVE. • SOUTHPORT, CONN.

## RESISTANCE WIRE

KANTHAL: Exclusive manufacturers of KANTHAL wire; although unavailable for duration, we will be pleased to supply information for your post-war requirements.

**C. O. JELLIFF MFG. CORP.**  
123 PEQUOT AVE. • SOUTHPORT, CONN.

Note: All alloys are produced in high-frequency type furnaces, and are furnished bright, dull, or oxidized finish, also with enamel, silk, or cotton insulation.

transconductance from this point of view may be written in the form of a Fourier analysis containing a constant term and an infinite number of harmonically varying terms whose frequency components are integral multiples of the oscillator frequency. Accordingly, a frequency converter may be considered as a device with periodically varying transmittance or transconductance, the periodicity of which determines the frequency of each possible output component.

Converter design is frequently carried out by means of measurements only, or by means of cut-and-try methods backed by experience. The amount of computation that enters into such a procedure depends upon the nature of the work, the importance of this design, and similar factors of engineering importance. An experimental method, using conversion diagrams, make possible the theoretical investigation of the behavior of mixer circuits under various conditions of operation. The experimental and graphical techniques for establishing such conversion diagrams were outlined, and the result of measurements on diode converters at a frequency of 7 Mc or higher were presented. The paper was primarily concerned with a discussion of the mechanism by which satisfactory frequency conversions at ultrahigh frequencies could be accomplished by a combination of mathematical, experimental, and graphical methods of analysis.

The making of ultra-high-speed radiographs, using exposures of the order of one microsecond, requires the passage of electron currents of from 2,000 to 3,000 amperes, according to Dr. C. M. Slack of Westinghouse and Edward R. Thilo of Frankfort Arsenal, Philadelphia, who delivered a paper, "Field Emission Applied to Ultra Speed X-Ray Technique." It is not practicable to obtain such large currents from a tungsten filament, but such currents can be supplied by an electron source utilizing field emission from a cold-cathode electrode in a high vacuum. While investigating the phenomena of spitting or backfiring, with a capacitor discharge machine, it was found that the magnitude of bursts of current were surprisingly large. The problem of controlling these currents so that

# 1 Two-Way Speaker



### READY FOR INSTALLATION!

• The Altec Lansing multi-cellular two-way speaker is ready for installations. It provides broadcasters, manufacturers and audiences with quality sound in a frequency range up to 15,000 cycles plus. One of the exclusive reasons why the Duplex speaker revolutionizes the methods of sound reproduction.

SEND FOR BULLETINS

# ALTEC

LANSING CORPORATION

1210 TAFT BLDG., HOLLYWOOD 28, CALIF.

# KEN-RAD

## *Cathode Ray*

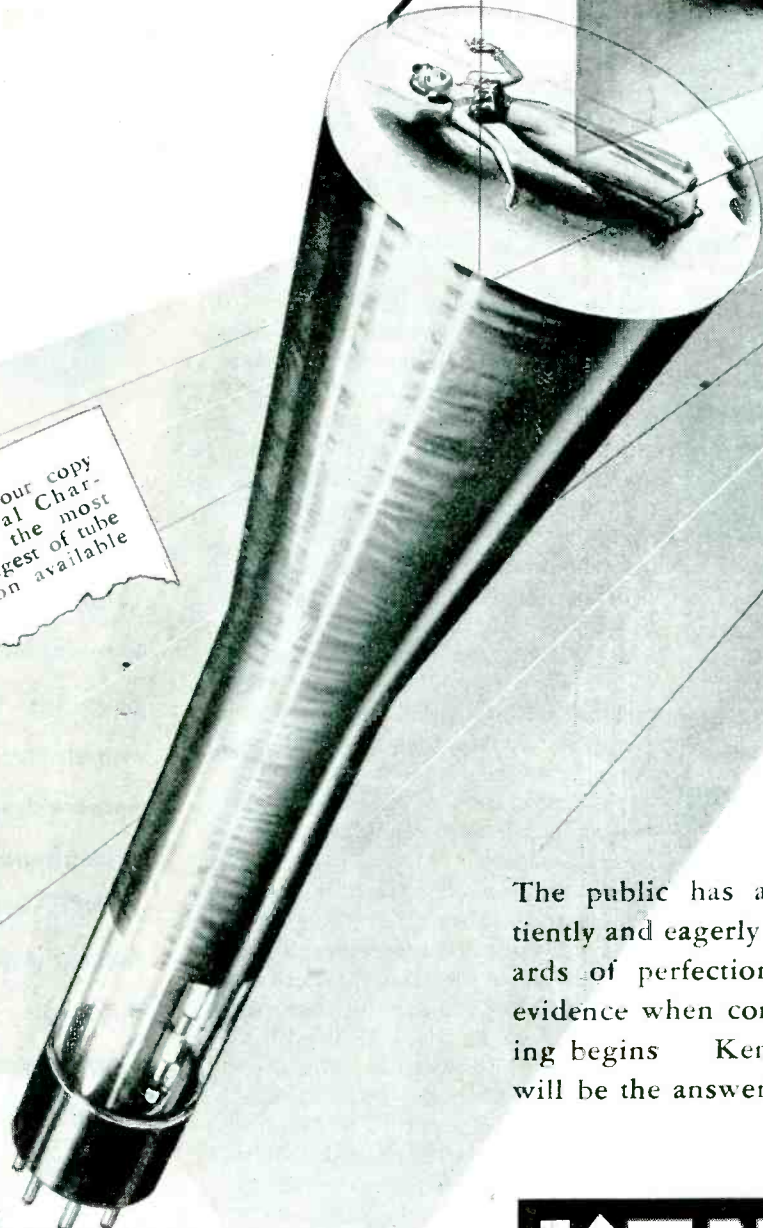

• Write for your copy of "Essential Characteristics" the most complete digest of tube information available



The public has awaited television so patiently and eagerly that unprecedented standards of perfection must be in immediate evidence when commercially sound marketing begins. Ken-Rad Cathode Ray Tubes will be the answer.

**KEN-RAD**  
EXECUTIVE OFFICES  
OWENSBORO · KENTUCKY  
EXPORTS 18 MOORE STREET NEW YORK

TRANSMITTING TUBES    RECEIVING TUBES  
CATHODE RAY TUBES    INCANDESCENT LAMPS  
SPECIAL PURPOSE TUBES    FLUORESCENT LAMPS



**AS A WEAPON FOR KNOCKING  
 PRODUCTION COSTS DOWN  
 IT'S HARD TO MATCH THIS →**

**THE SCREW WITH THE ENGINEERED  
 RECESS THAT STEPS UP SCREW  
 DRIVING SPEED AS MUCH AS 50%**

**→→→ IT'S PHILLIPS**

**THE ENGINEERED RECESS**

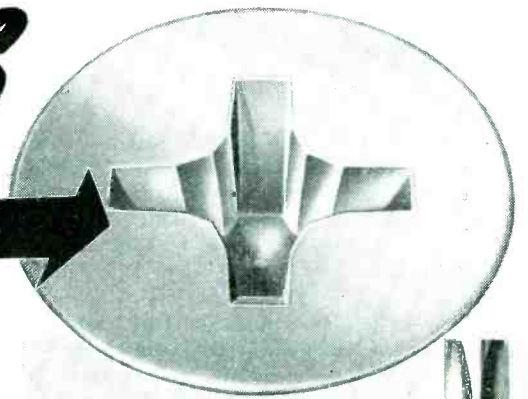

Right at your command is one of the most potent and efficient weapons for speeding up assembly and cutting costs that you could hope to find. It's Phillip's - the Engineered Recessed Head for all kinds of screws. It's the screw recess that eliminates fumbling, wobbly starts, slant driving, and dangerous skids - the troubles that have long made screw driving slow, awkward - and costly!

It's the screw recess that makes driving easier for workers - helps keep them going at top speed through a full shift.

It's the screw recess that lets you adopt spiral and power driving for assemblies where speed tools have never been practical.

Hundreds of plants have increased screw-driving speeds as much as 50% ... and cut costs correspondingly ... simply by switching to Phillips Recessed Head Screws. Can you do the same? Make the switch to Phillips Screws now - and you'll see. You'll see they cost *less* because they help you produce much *more!*

**TO MAKE WARTIME QUOTAS  
 AND PEACETIME PROFITS**

**Faster Starting:** Driver point automatically centers in the Phillips Recess ... fits snugly. Fumbling, wobbly starts, slant driving are eliminated. Work is made trouble-proof for green hands.

**Faster Driving:** Spiral and power driving are made practical. Driver won't slip from recess to spoil material or injure worker. (Average time saving is 50%.)

**Easier Driving:** Turning power is fully utilized. Workers maintain speed without tiring.

**Better Fastening:** Screws are set-up uniformly tight, without burring or breaking of screw heads. The job is stronger, and the ornamental recess adds to appearance.



**IDENTIFY IT!**

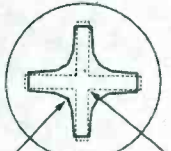

Center corners of Phillips Recess are rounded ... NOT square.



Bottom of Phillips Recess is nearly flat ... NOT tapered to a sharp point.



**PHILLIPS** *Recessed Head* **SCREWS**

WOOD SCREWS • MACHINE SCREWS • SELF-TAPPING SCREWS • STOVE BOLTS

**24 SOURCES**

- American Screw Co., Providence, R. I.
- Atlantic Screw Works, Hartford, Conn.
- The Bristol Co., Waterbury, Conn.
- Central Screw Co., Chicago, Ill.
- Chandler Products Corp., Cleveland, Ohio
- Continental Screw Co., New Bedford, Mass.
- The Corbin Screw Corp., New Britain, Conn.
- General Screw Mfg. Co., Chicago, Ill.
- The H. M. Harper Co., Chicago, Ill.
- International Screw Co., Detroit, Mich.
- The Lamson & Sessions Co., Cleveland, Ohio
- Manufacturers Screw Products, Chicago, Ill.
- Milford Rivet and Machine Co., Milford, Conn.
- The National Screw & Mfg. Co., Cleveland, Ohio
- New England Screw Co., Keene, N. H.
- Parker-Kalon Corp., New York, N. Y.
- Pawtucket Screw Co., Pawtucket, R. I.
- Pheill Manufacturing Co., Chicago, Ill.
- Reading Screw Co., Norristown, Pa.
- Russell Burosall & Ward Bolt & Nut Co., Port Chester, N. Y.
- Scovill Manufacturing Co., Waterville, Conn.
- Shakeproof Inc., Chicago, Ill.
- The Southington Hardware Mfg. Co., Southington, Conn.
- Wolverine Bolt Co., Detroit, Mich.

# NEW TYPE NO. 6NAO SELF-LOCKING PALNUTS

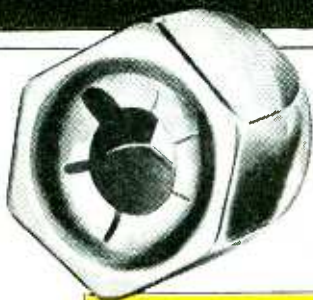

With the **TRIPLE GRIP**

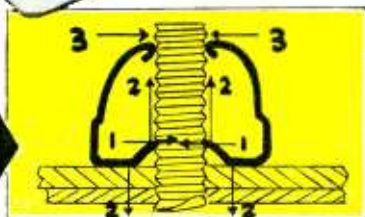

When the Type 6NAO Palnut is tightened, its arched, slotted jaws grip the bolt like a chuck (1-1), while spring tension is exerted upward on the bolt threads and downward on the part (2-2), securely locking both. A third grip is exerted around the top of the bolt by spring tension at 3-3.

The new Type 6NAO Self-Locking Palnut may be used as a one-piece locknut to securely fasten parts—or as an adjusting nut to maintain accurate settings anywhere on the screw. (See typical use herewith.)

When used as a fastening, the full triple grip is utilized to keep parts tight under vibration, without need of lockwashers. When used as an adjusting nut, the third gripping action (3-3) locks it firmly in position.

Type 6NAO Palnuts are single thread locknuts, made of tempered spring steel. Light in weight, low in cost, easily, speedily applied. Send details of your assembly for samples and suggestions. Write for new data sheet and copy of Palnut Manual No. 2, giving information on all types of Self-Locking Palnuts.

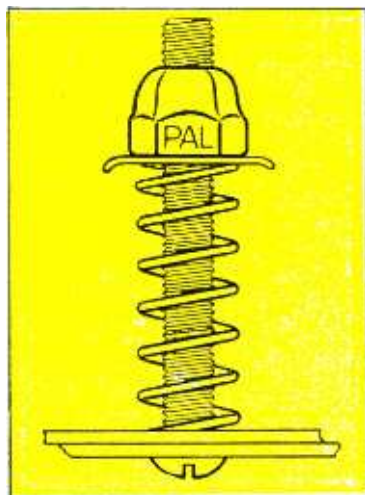

Adjusting Nut on Relay

## THE PALNUT COMPANY

77 CORDIER ST. IRVINGTON 11, N. J.



# Self-Locking PALNUTS

the electron stream would strike a suitable anode with the necessary velocity to produce x-rays was next undertaken.

### Arc as Cathode

A control electrode placed in close proximity to a sharp edge gave promise of fulfilling the necessary conditions. The diagram shown may be used to explain the method of operation of the device. The capacitors are charged by the transformer  $E_1$  through rectifiers  $V_1$  and  $V_2$  to a voltage somewhat less than that required to break down the spark gap  $L$ . Simultaneously, capacitor  $C_1$  is charged to about 1,000 volts. When the circuit is broken

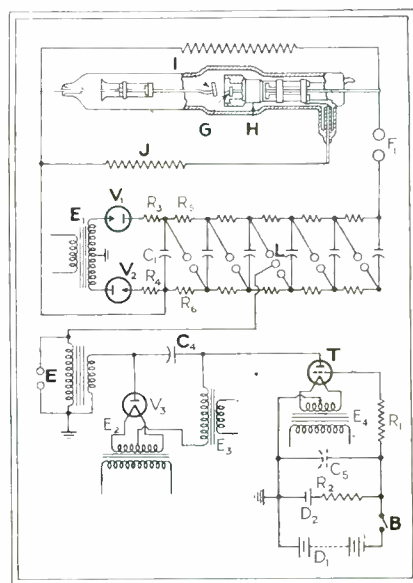

Circuit developed for utilizing field emission to provide heavy electron currents in high-speed radiography

at point  $B$ , the charge on the grid of thyatron  $T$  leaks off, permitting  $C_4$  to discharge through the primary of induction coil  $E$ , which gives a sufficient impulse to the high-voltage circuit to cause the gap  $L$  to flash over. This causes the surge generator gaps to break down, which impresses a high voltage inside the x-ray tube between points  $G$  and  $H$ . Electrons are drawn from  $G$  and this initial discharge becomes an arc between points  $G$  and  $H$  which spreads out into the focusing cup and becomes a virtual cathode at apparently unlimited current-carrying capacity. Due to the action of resistance  $J$ , the discharge transfers to the anode,  $I$ , with consequent production of x-rays. The properties of



# BH NON-FRAYING FIBERGLAS SLEEVING



**BH EXTRA FLEXIBLE  
FIBERGLAS SLEEVING**

**2 WAYS BETTER**



**THIS**



**NOT THIS**

**NON-FRAYING**

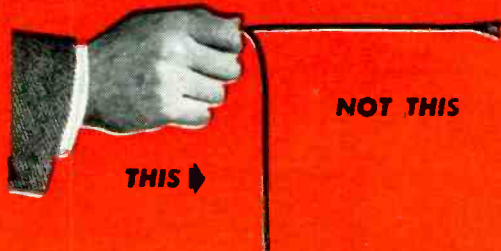

**THIS**

**NOT THIS**

**NON-STIFFENING**

**A**SEMBLERS and electricians don't have to be contortionists when working with non-fraying BH *Extra Flexible* Fiberglas Sleeving. Remarkably resistant to stiffening, this always supple insulation won't crack or rot with age. Whether in tough, active service or dead storage, it remains "fresh" and easy to work, retaining its full insulating efficiency *indefinitely*.

This special-processed sleeving won't burn and is non-crystallizing at low temperature. It offers all the natural advantages of Fiberglas—high dielectric and tensile strength—chemical and moisture resistance—and many more—in addition to its own unusual properties.

You'll want to see for yourself the cleaner cutting, non-fraying and non-stiffening features of the sleeving that simplifies assembly, lasts longer and cuts repair costs. BH *Extra Flexible* Fiberglas Sleeving is available in all standard colors. Sizes from No. 20 to  $\frac{5}{8}$ ", inclusive. Write for *your* samples today and compare!

**BH SPECIAL TREATED FIBERGLAS SLEEVING  
FLEXIBLE AS STRING!**

Here's another high quality BH Fiberglas Sleeving. Due to the BH exclusive process no saturant is used, yet it will not fray out when cut and will withstand heat up to 1200°F. Made in natural color only—all standard sizes. Test it and try it!



**NON-BURNING IMPREGNATED MAGNETO TUBING • NON-BURNING FLEXIBLE  
VARNISHED TUBING • SATURATED AND NON-SATURATED SLEEVING**

**BENTLEY, HARRIS MANUFACTURING CO.**

**Dept. E Conshohocken, Penna.**

# MULTI-SWAGE . . . THE MOST ECONOMICAL METHOD OF MAKING SMALL METAL PARTS LIKE THESE . . .

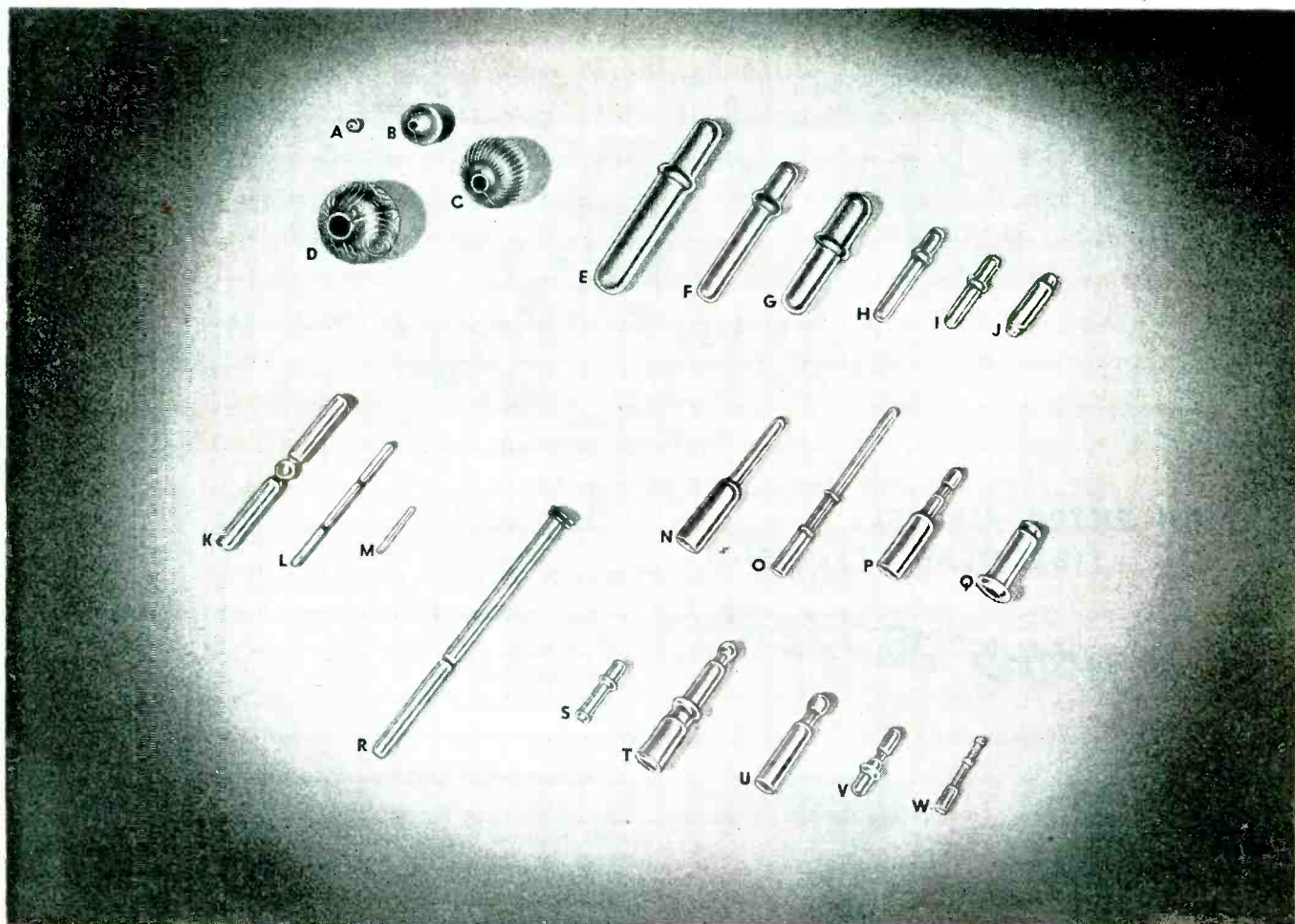

**THESE ITEMS, PICTURED ACTUAL SIZE, ARE TYPICAL MULTI-SWAGE PRODUCTS. THEY SHOW THE APPROXIMATE LIMITATIONS OF THE PROCESS AS TO DIAMETERS AND LENGTHS**

MULTI-SWAGE is an advanced swaging process which forms hollow or solid parts from flat stock, seamless tubing, rod, or wire, without scrap. Tolerances are maintained accurately and most metals can be worked. Quantity is a factor to be considered. Because MULTI-SWAGE is a high speed process, 100,000 pieces on other than stock items are usually necessary to justify tool and setting up costs. Compare any small parts you use to those shown above. If the nature of the parts and the quantities indicate they can be made by MULTI-SWAGE, it can be well worth your while to consider the BEAD CHAIN MULTI-SWAGE PROCESS.

*Send Samples and Specifications of Your Parts for Specific Information*



**BACK THE ATTACK  
BUY MORE WAR BONDS**

THE MOST ECONOMICAL METHOD OF PRODUCING SMALL

METAL PARTS TO CLOSE TOLERANCES WITHOUT WASTE

**THE BEAD CHAIN MANUFACTURING COMPANY**  
88 MOUNTAIN GROVE STREET, BRIDGEPORT 5, CONNECTICUT





## **WHITAKER HAS THE "KNOW HOW" for producing precision made wiring harnesses**

You can save a lot of time, and avoid grief, by arranging to have your wiring harness requirements produced by Whitaker . . . Our quarter of a century of specialized experience backs up your judgment when you turn jobs over to us.

You will find our experts capable of turning out wiring jobs in volume, exactly to specifications, and in a minimum of time.

In our modern plants we have ample ca-

capacity and complete facilities for producing custom-built wiring harnesses, bonding jumpers, cable assemblies, and flexible leads.

Regardless of whether your wiring needs are for war production, or are contemplated for post-war products—it will pay you to get in touch with us . . . In addition to custom-built engineered wiring assemblies, Whitaker also offers a quality line of standard stock cable products—Catalog on request.

### **WHITAKER CABLE CORPORATION**

General Offices: 1307 Burlington Avenue, Kansas City 16, Missouri  
Factories: Kansas City, Mo. • St. Joseph, Mo. • Philadelphia • Oakland

**Cables, Wiring Harnesses and Assemblies for Automotive, Aircraft, Marine and Radio Equipment**



*All to your advantage*

**CANNON QUALITY CONTROL** is our investment but you collect the dividends. Let's see how.

We mill all contacts to extremely close tolerances. You get the benefit of low voltage drop. We die cast fittings. You gain strength and save weight. We pioneered the split shell. You (collectively) save hundreds of thousands in the cost of wiring and assembly.

All along the line we take extra care in manufacture. We test, inspect and check again. You have the assurance that, whatever else may fail, the Cannon Plugs you use are dependable.

All that is worth a lot to you isn't it? It's our investment in your good will.

## CANNON ELECTRIC

Cannon Electric Development Co., Los Angeles 31, California

Canadian Factory and Engineering Office:  
Cannon Electric Company, Limited, Toronto

Representatives in principal cities — Consult your local telephone book



World's largest connector—Cannon DPL with 135 contacts.

### DP Connector Bulletin

32 pages giving complete data. Free on request. Address Department A-120, Cannon Electric Development Co., 3209 Humboldt Street, Los Angeles 31, California.

such a field emission should find application to electronic devices other than x-ray tubes, particularly where pulse techniques are important.

### X-Ray Stress

The very short exposures possible with this tube and generator have permitted sharp radiographs to be made of extremely rapidly moving objects. The chief use of this development so far has been in ballistics research to observe the realignment of component parts inside a bullet when it is fired. A stationary x-ray picture is taken of the bullet, which is then fired and a high-speed x-ray picture taken of this same bullet in flight. A comparison of the two x-ray pictures reveals any shift of the component parts which has taken place.

Dr. Wesley Roberds, in a talk "The Use of Radio Frequencies to Obtain High Power Concentrations for Industrial Heating Applications," stated that the use of radio frequencies makes possible the application of power to metal objects in concentrations up to 100 kw per sq in. Under favorable conditions, this may represent the expenditure of 2,000 kw of power per cu in. of material being heat treated. A study of heat distribution in metals treated by high-frequency furnaces illustrates two important facts: (1) the heating time must be very short (in the order of microseconds) if the high temperatures are to be closely confined to the volume occupied by the induced current; (2) the greatest heating effect occurs at the boundary between magnetic steel and its non-magnetic form when magnetic materials are treated. As the steel is heated above the Curie temperature, the maximum heating effects move inward.

### Practical Conditions

The optimum frequency is determined principally by the size and shape of the work to be heated. In general, the smaller the piece, the higher is the frequency which should be used. Power concentration is obtained with the use of electronic generators having output powers up to 200 kw at 400 kc. For dielectric heating, the power concentrations are much lower than in induction heating but it is usually



# TWO *New* LINES OF



TYPE 504B—RC-21



TYPE 518B—RC-31

ACTUAL SIZE



## ERIE RESISTORS

**E**RIE Resistor announces two new lines of insulated carbon resistors, covering six different A.W.S. ratings, RC10, RC20, RC21, RC30, RC31, and RC40.

The well-known Types 504 and 518, 1/2 and 1 watt units with ceramic insulation, have been replaced with Types 504B and 518B. These new units are identical with the Types 504 and 518 with the exception that they have a one-piece, natural brown, molded phenolic case, instead of the ceramic insulation. The molded construction results in better protection against humidity and salt water immersion. Types 504B (RC21) and 518B (RC31) are available in resistance values from 0.5 ohm to 100 megohms.

In addition, Erie has a new line of compact, hot molded, insulated resistors in 1/4, 1/2, 1, and 2 watt ratings. The resistance mix and insulation material are molded simultaneously as an integral unit. These resistors are manufactured only in RMA preferred values from 220 ohms up to and including 4.7 megohms. Type 524 (RC10 and RC20), and Type 525 (RC30) are now in production, and Type 526 (RC40) will be available shortly.

Nominal dimensions of these Erie Resistors are given above. Samples will be sent to interested engineers on request.



TYPE 524—RC-10, RC-20



TYPE 525—RC-30



TYPE 526—RC-40

ACTUAL SIZE

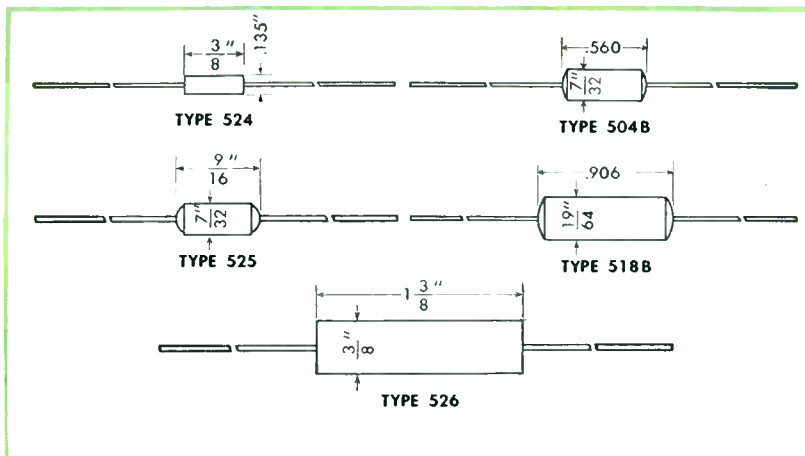

DO MORE THAN BEFORE—BUY EXTRA WAR BONDS



*Electronics Division*  
**ERIE RESISTOR CORP., ERIE, PA.**  
 LONDON, ENGLAND • • TORONTO, CANADA

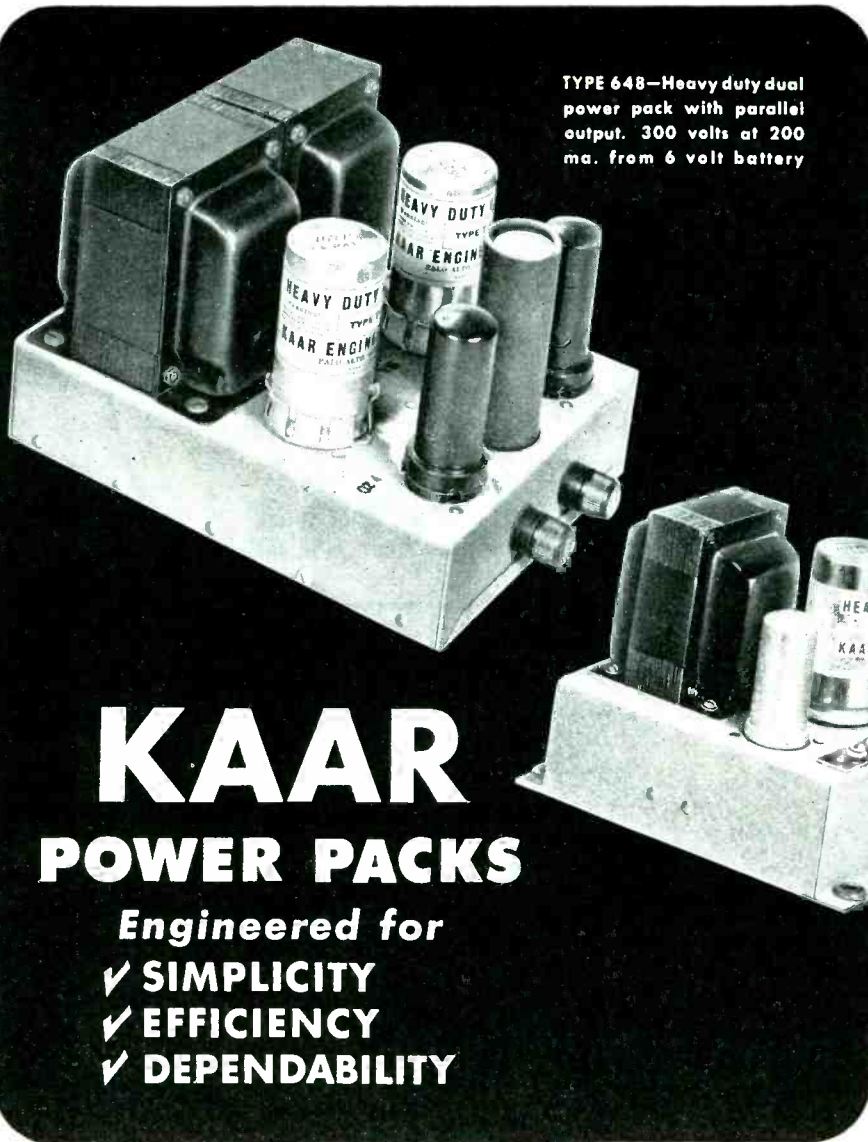

TYPE 648—Heavy duty dual power pack with parallel output. 300 volts at 200 ma. from 6 volt battery

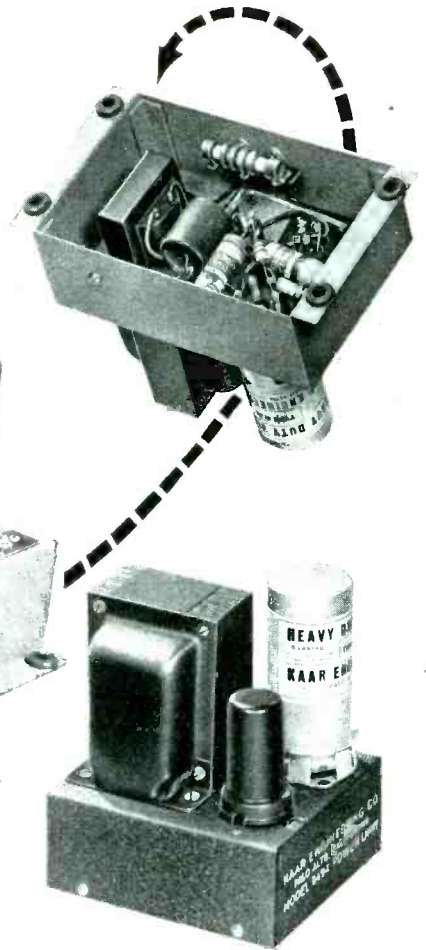

TYPE 650—Standard: 200 volts at 50 ma. Optional: 200 volts at 75 ma. This type available for 6, 12, or 32 volt operation. Has built-in filter. Notice simplicity of construction.

TYPE 649—Provides 240 volts at 50 ma. Available at other standard ratings, and for operation from 6 or 12 volt batteries. Type 647, not illustrated, provides 240 volts at 75 ma.

# KAAR POWER PACKS

- Engineered for
- ✓ SIMPLICITY
  - ✓ EFFICIENCY
  - ✓ DEPENDABILITY

## Use this West Coast source for vibrator power packs

Kaar Engineering Company offers prompt delivery of standard and special types of vibrator power packs for operation from 6, 12, or 32 volt sources. In addition, laboratory facilities are available for a variety of power

packs designed to your own specifications.

Take advantage of this convenient West Coast source of exceptionally efficient low-drain packs, designed for simplicity and dependability.

# KAAR ENGINEERING CO.

PALO ALTO, CALIFORNIA



Export Agents: **FRAZAR & HANSEN**  
301 Clay Street • San Francisco 11, Calif.

**MOBILE RECEIVERS**—Crystal controlled superheterodynes for medium and high frequencies. Easy to service.



**CRYSTALS**—Low-drift quartz plates. Fundamental and harmonic types available in various holders.



**TRANSMITTERS**—Mobile, marine, and central station transmitters for medium and high frequencies. Instant heating, quickly serviced.

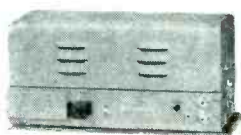

**MICROPHONES**—Type 4-C single button carbon. Superb voice quality, high output, moisture proof.



**CONDENSERS**—Many types of small variable air condensers available for tank circuit and antenna tuning.

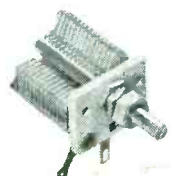



# CHALLENGE!

As you look through the ads in this magazine...

## FIND THE GLASS PARTS NOT MADE AT CORNING

IT'S really not much of a gamble on our part. The truth is that most of the electronic glass equipment built today comes from Corning Glass Works. Bulbs, flares, insulators, transformer bushings, tubing, resistor tubes, coil forms, are just a few of the hundreds of electronic glassware products produced under our Army-Navy "E" flag. Here you will find glasses with high electrical insulating qualities; glasses with an expansion coefficient practically equal to that of fused quartz; glasses extremely resistant to mechanical shock; glasses that can now be made into intricate shapes formerly considered impossible. And be-

hind them all, 75 years of pioneering in glass research and experience gained in the development of more than 25,000 glass formulae.

We hope this doesn't scare you. All it means is this: If you have a problem you think glass might be helpful in solving, feel free to call on Corning! Everything we know about glass is at your service. Just to get started we'd like to send you a copy of an informative new booklet, "There Will Be More Glass Parts In Post-war Electrical Products." If interested, write Electronic Sales Dept. E-11, Bulb and Tubing Division, Corning Glass Works, Corning, New York.



**CORNING**  
— means —  
Research in Glass

# Electronic Glassware

T.M. REG.  
CORNING  
U.S. PAT. OFF.

T.M. REG.  
PYREX  
U.S. PAT. OFF.

"PYREX" and "CORNING" are registered trade-marks of Corning Glass Works

# Products of "MERIT"

**MERIT**  
COIL AND TRANSFORMER CORP.  
ENGINEERS AND MANUFACTURERS OF TRANSFORMERS AND ELECTRICAL WINDING  
TELEPHONE 450-0743 CH 6311  
4427 N. CLARK STREET  
CHICAGO 40, ILLINOIS

## Announcing!

Our new plant is now in full production, greatly increasing our capacity. We believe it to be the most modern and efficient unit now engaged in the production of transformers, coils and allied electronic equipment.

Please take note of our new address, where you will always receive a cordial welcome.

Sincerely yours,

*W. C. Kohl*  
President.

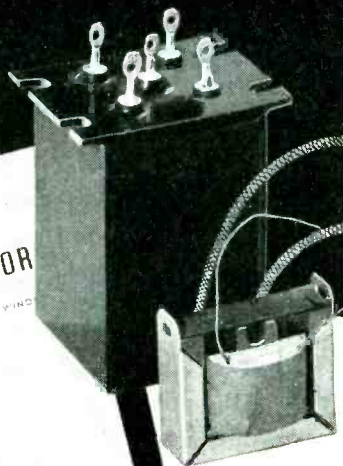

**OUTPUT  
TRANSFORMER**  
Hermetic-Sealed  
Glass Terminals

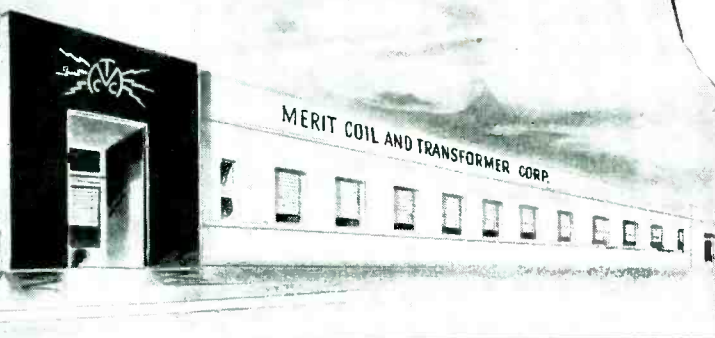

## MERIT COIL & TRANSFORMER CORP.

4427 North Clark St.

CHICAGO 40, ILL.

possible to apply energy at far higher levels. Since the electrodes are good electrical conductors, they are not heated by the current and therefore are generally cooler than the work. Thus the surfaces of the work are usually kept cooler than the interior and the conduction of heat from the work to the electrode is one of the limiting factors in producing high energy concentration of work.

A complete description of a two million volt mobile x-ray unit was described in a paper by Dr. E. E. Charlton and W. F. Westendorp of the Research Laboratory of General Electric Co. The new unit consists principally of a low-frequency resonance transformer with a coaxially mounted multi-section x-ray tube within, both contained in a steel tank and insulated with compressed gas. The x-rays are generated at a target mounted in the end of a chamber projecting from one end of the tank. The unit is 5 ft in diameter and 8 ft in length and weighs 5,000 lb. It is mobile in the sense that it can be readily moved by crane and positioned for operation at any angle by pushbutton control of fractional-horsepower motors.

### Transformer Construction

The transformer has a low-voltage winding consisting of two flat coils of rectangular wire, and a high-voltage coil consisting of 243 thin flat sections spaced apart for cooling. The resonance principle of operation makes an iron coil unnecessary in this type of transformer and the central space of the high-voltage coil is occupied by the x-ray tubes, thus facilitating the making of connections to various tube electrodes and providing the benefit of electrostatic shielding by the transformer coil. The multi-section high-voltage coil serves a quadruple purpose; (1) to generate voltage; (2) to grade the potentials so as to prevent creepage; (3) to shield the x-ray tubes electrostatically from the grounded tank; (4) to support the grounded shield mechanically.

A 24-section x-ray tube, which seals off the pump for operation at two million volts, was especially designed for this resonant transformer. It has a filamentary cathode, a copper-backed tungsten tar-



# NEW!

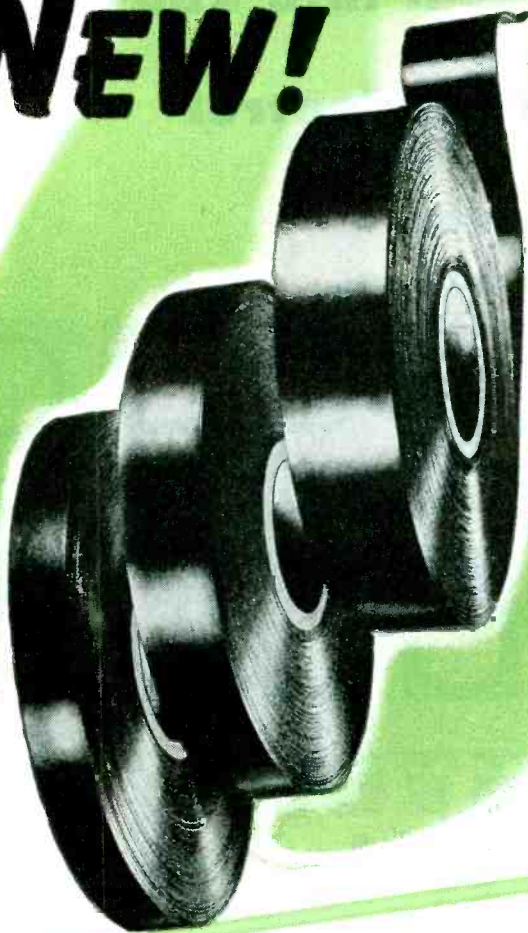

# Fibron

THE  
"ALL-PURPOSE"  
Tape

**FOR INSULATING** wires, cables and electrical equipment . . . **FOR PROTECTING** electrical wires and cables exposed to caustic or corrosive fumes, oil, grease, acids, alkalis, or moisture...**FOR SPLICING** cables with a continuous, protective covering . . . **FOR COVERING** exposed piping in chemical plants, equipment exposed to moisture or severe atmospheric conditions.

These widely diversified applications of FIBRON TAPE No. 1 are made possible by its combination of outstanding electrical, physical, and chemical properties. (See adjacent panel.) This *flexible, elastic*, "Vinylite"\* resin tape is heat sealing, flame resistant, high in dielectric strength, strong mechanically, and highly resistant to oils, acids, alkalis, moisture, and normal variations in temperature and climate.

FIBRON TAPE is a new addition to the already extensive line of Irvington products. It is offered with the usual guarantee that applies to all Irvington Insulation — to protect equipment in accordance with specifications.

Plan now to test the new FIBRON TAPE. A generous sample will be sent on request — without obligation. For further information on FIBRON, or other IRVINGTON INSULATION, write Dept. 106.

\*Reg. Trade Mark—CARBIDE & CARBON CHEMICALS CORP.

### OUTSTANDING PROPERTIES FIBRON TAPE No. 1

Tensile strength	1700 lb. per sq. in.
Dielectric strength	1000 VPM (.012")
Low temperature flexibility	-40° C.
Elongation	250% - 400%
Power Factor @ 30° C. (60 cycles)	—6.5%
Dielectric Constant @ 30° C. (60 cycles)	(1 kilocycle)—6.2%
	(1 kilocycle)—7.6%
Bonding temperature	Approximately 150° C.

### IRVINGTON for INSULATION

- |                                    |                           |
|------------------------------------|---------------------------|
| EXTRUDED PLASTIC TUBING            | VARNISHED TUBING          |
| INSULATING VARNISHES               | VARNISHED RAYON           |
| VARNISHED PAPER                    | VARNISHED FIBERGLASS      |
| VARNISHED CAMBRIC                  | VARNISHED SLOT INSULATION |
| VARNISHED CANVAS AND DUCK          | OIL STOPS                 |
| VARNISHED AND PLASTIC WIRE MARKERS |                           |

### IRVINGTON VARNISH & INSULATOR COMPANY

6 Argyle Terrace, Irvington 11, New Jersey, U. S. A.  
Plants at  
Irvington, New Jersey and Hamilton, Ontario, Canada  
Representatives in 20 Principal Cities



## IRVINGTON

# Electrical

## INSULATION

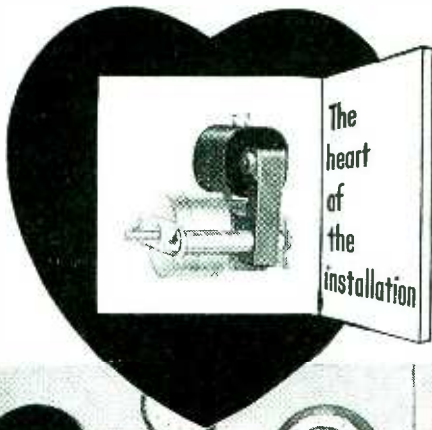

# Turning coal into kilowatts— with Record Control by Telechron

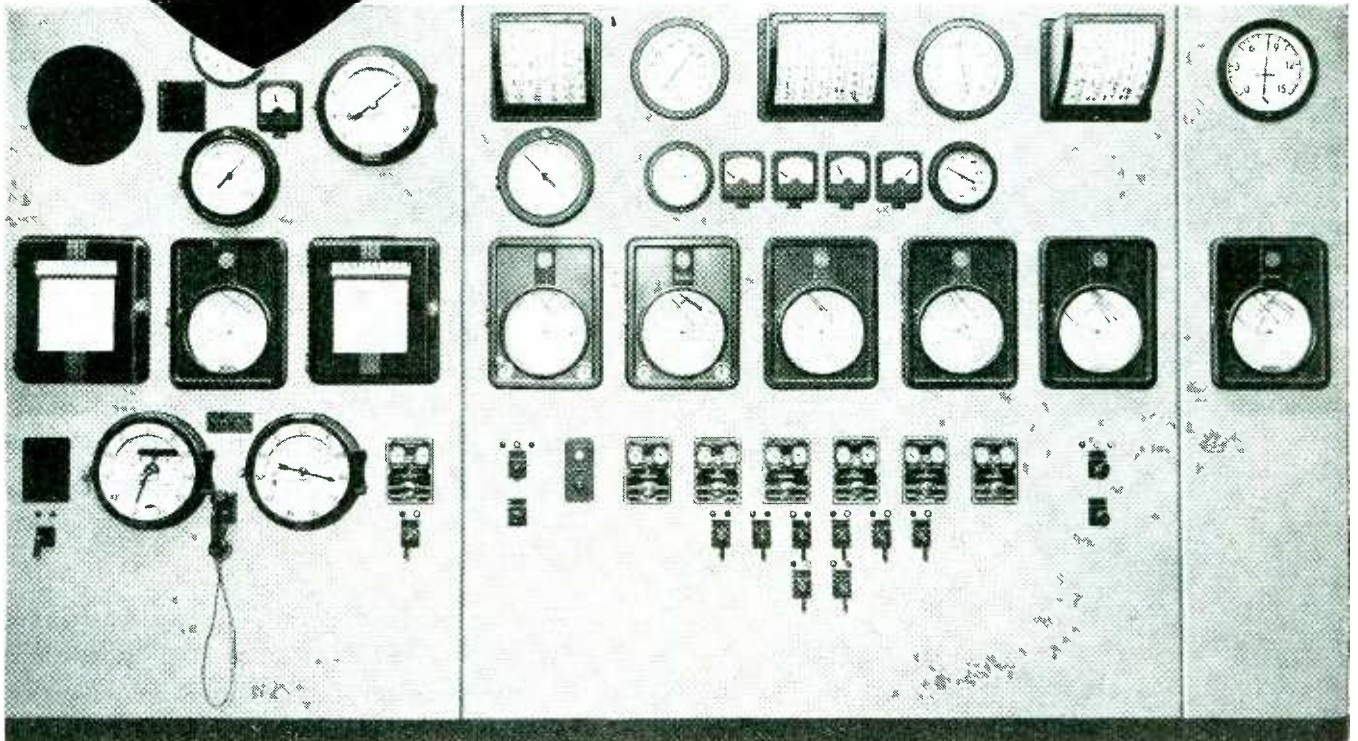

Up to 30,000 pounds of pulverized coal an hour is economically converted into electricity under the supervision of this automatic boiler control panel in a large generating plant. And each of the recording meters is equipped with self-starting, synchronous Telechron motors.

They record steam pressure, control fuel and water flow to the boilers, and indicate and record various factors affecting fuel efficiency. Accurate and dependable, their smooth, constant speed helps to keep furnaces at peak performance, no matter what the load.

And Telechron motors are adaptable, too, to all kinds of controlling, timing and recording

functions in many different fields. They are available in sizes from 12 to 250 volts for all commercial frequencies — and from 1 to 1800 rpm. Among their industrial applications are:

- |                    |                           |                       |
|--------------------|---------------------------|-----------------------|
| <i>Timing</i>      | <i>Cycling operations</i> | <i>Gaging</i>         |
| <i>Controlling</i> | <i>Signaling</i>          | <i>Regulation</i>     |
| <i>Metering</i>    | <i>Fixed process</i>      | <i>Communications</i> |
| <i>Recording</i>   | <i>controlling</i>        |                       |
| <i>Switching</i>   | <i>Measuring</i>          |                       |

We're the largest and oldest makers of synchronous, self-starting motors for instrumentation. Our experience in the field may be of use to you. If you think we can help, just write Motor Advisory Service, Dept. C.

## Telechron

REG. U. S. PAT. OFF.

WARREN TELECHRON COMPANY, ASHLAND, MASSACHUSETTS

MAKERS OF TELECHRON ELECTRIC CLOCKS AND SYNCHRONOUS ELECTRIC MOTORS





# This Book Tells 3 Ways Your Product May Be Improved with Silentbloc

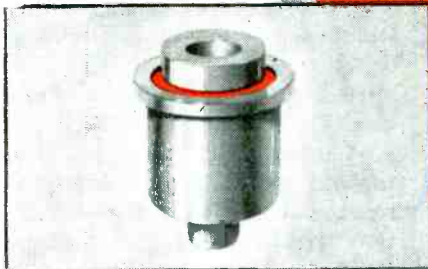

## **SILENTBLOC** Controls Vibration and Absorbs Shock Loads

General Silentbloc rubber mountings damp or isolate vibration, cushion shock loads and absorb noise in motors and moving equipment. Silentbloc is not just "a piece of rubber." It is an engineered mounting, made of any metal and rubber, designed to give predictable performance with specified rate of deflection in any plane. Its better control of vibration and shock load may enable you to lighten your product, step up efficiency and lengthen life.

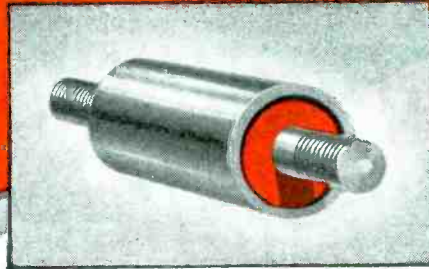

## **SILENTBLOC** Gives Torque Action Without Lubrication

If your product has oscillating parts, you may make a radical improvement with General Silentbloc rubber torque bearings. Silentbloc construction gives indestructible rubber-to-metal union—no chemical bond—can't slip. Needs no lubrication; unharmed by dust. General engineers can design a Silentbloc bearing for your specific needs, with controlled amplitude, using any metal and rubber. Eliminating lubricated bearing may cut your production cost.



## **SILENTBLOC** Corrects for Misalignment in Bearings and Shafts

General Silentbloc bushings are used to correct for misalignment in needle or ball bearings in a series, in long shaft supports and in hinges. Loading and stress caused by misalignment are taken up by the resilient rubber between metal sleeves. Silentbloc bushings offer a double advantage: 1. Protection against wear and damage. 2. Saving on machining and fitting to close tolerances. Bushings can be made of any metal and any rubber, including oil-resistant synthetics.



*Write for Booklet* showing details of patented Silentbloc construction—outer metal sleeve into which rubber ring is compressed and inner sleeve or shaft "shot" through rubber. Radial compressive force of elongated rubber forms indestructible rubber-to-metal union. Address The General Tire & Rubber Company, Dept. 94, Wabash, Indiana.



**THE GENERAL TIRE & RUBBER CO.**  
Mechanical Goods Division, Wabash, Indiana

# 500,000,000 to ONE

## 0.00002 TO 10,000 VOLTS



MODEL 300

## ELECTRONIC VOLTMETER



MODEL 402  
MULTIPLIER

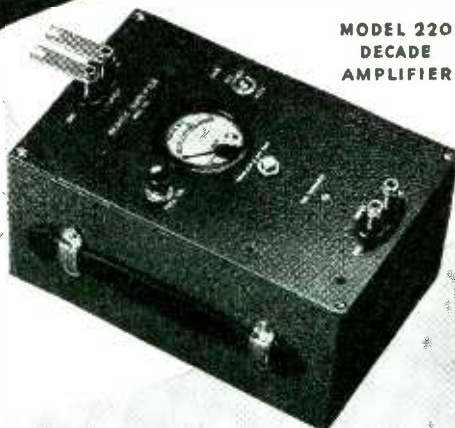

MODEL 220  
DECADE  
AMPLIFIER

This enormous range of voltages—five hundred million to one—is accurately covered by our Model 300 Electronic Voltmeter and some of the accessories shown above. Frequency range 10 to 150,000 cycles. Accuracy 2% over most of the range. AC operation. Five decade ranges with logarithmic scale make readings especially easy. Uniform decibel scale also provided. May also be used as a highly stable amplifier, 70 DB gain, flat to 150,000 cycles.



## BALLANTINE LABORATORIES, INC.

BOONTON, NEW JERSEY, U. S. A.

get and accelerating cylindrical electrodes in each of the intermediate sections.

In a broad survey of recent developments in the electronics field, M. J. Maiers of the Commonwealth Edison Co., Chicago, outlined the characteristics of dielectric heating and gave a list of applications for which dielectric heating has been proved economically successful, or on which extensive research work has been done.

A survey of the role which electronics plays in the laboratory and industrial instrumentation was given by H. D. Middel of General Electric Co. One of the first applications of electronics was the measurement of potentials produced by the dissociation of acids and known as pH or hydrogen ion concentration meters. With the introduction of low grid current tubes, such as the FP-54, it became possible to pre-amplify the output of the glass electrode and utilize it to drive more or less conventional forms of automatic potentiometers, thus making continuous measurements of pH and subsequent control possible. Meters of this type are being used in the manufacture of penicillin.

Electronics has made possible a wide variety of servo-mechanisms or follow-up systems which will amplify small torques so that the motion of a heavily loaded output mechanism will correspond closely without imposing any restraint or reaction upon its motion either in the direction of its rotation or axially.

### *Gas Analysis*

Electronics has introduced an entirely new principle of gas analysis and has provided a means for obtaining higher accuracy and precision as well as automatizing the measurements. One method of analyzing gas is by means of the mass spectrometer, described by Hipple in the November 1943 issue of *ELECTRONICS*. To the other forms of gas analysis, using absorption in the infra-red and ultraviolet regions and variation of thermal conductivity, may be added a new method depending upon the variation in molecular weight or density of the gas with changes in its constituents. A column of the gas under analysis is excited by the output of an audio oscillator, and the frequency at res-



## THE READILY-WORKABLE GAS GETTER

INCREASING PRODUCTION of pure Ductile Zirconium by the Foote Process (decomposition of zirconium tetraiodide in vacuum) brings close to realization commercial quantities of a workable gas getter for vacuum tubes.

Now you can enjoy the recognized advantages of Zirconium in a form readily workable into anodes, grids, supports and other shapes requiring structural strength.

Ductile Zirconium is a continuous getter at high temperatures, sorbing all except the rare gases. A better vacuum is produced in less pumping time. Oxygen, nitrogen and hydrogen can be sorbed in large quantities without forming new phases—up to 40 atomic per cent of oxygen and 20 atomic per cent nitrogen without X-ray detection of a compound. And, except with hydrogen, the process is not reversible. Sorbed oxygen or nitrogen are not released even at temperatures above 1500°C.!

Ductile Zirconium will act as a continuous getter if it can be located in the tube

so that a temperature of approximately 500°C. or over is maintained. A small piece of .005" sheet Zirconium spot welded to the anode is all that is needed in many tubes.

In cathode-ray and other tubes where plate temperatures are low, it is possible to use a separate gettering filament of Zirconium, electrically heated, or sometimes a Zirconium slip coil over one filament lead will serve the purpose.

Foote Ductile Zirconium, because of the way it is produced, is extremely pure, free from compounds such as zirconium oxide or nitride. Freedom from volatile contaminating substances prevents mirroring of tube surfaces and consequently reduces inter-element leakage and losses. Tube quality and life are greatly increased by pure Ductile Zirconium.

If you are not already using Foote Ductile Zirconium for electronic tubes, investigate the advantages of this new development now. Experimental and production quantities of Ductile Zirconium sheets and wire are available.

## THE ESSENCE OF THINGS TO COME

Our business is to locate and process ores and minerals and keep an eye open for ways to use them. This means research in cooperation with others and original research in the Foote laboratories. From recent investigations have come pure

Ductile Zirconium, a Lithium base for greases that will withstand brutal temperatures, and better ceramics with Strontium salts. Other possibilities are brewing—perhaps for your industry.

Get in touch with us and we'll keep in touch with you.

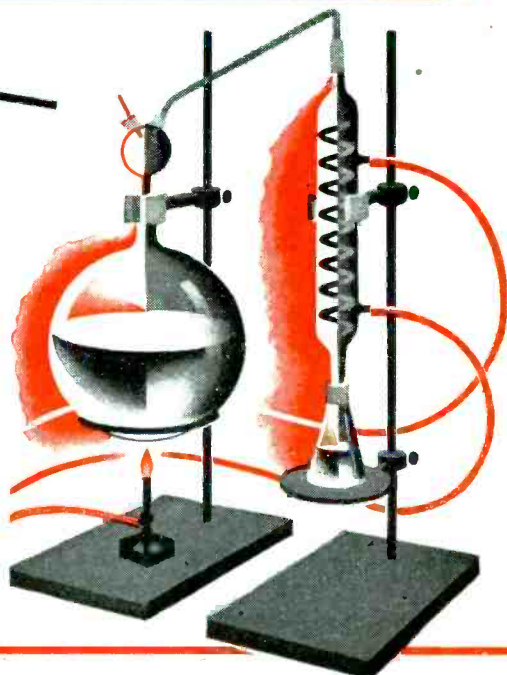
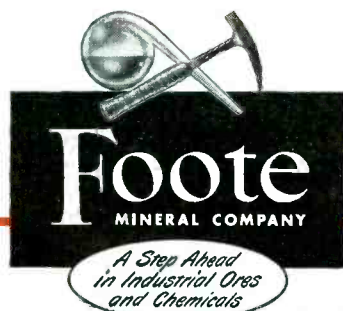

PHILADELPHIA • ASBESTOS • EXTON, PENNSYLVANIA  
Home Office: 1617 SUMMER STREET, PHILADELPHIA 3, PA.

West Coast Repr.: Griffin Chemical Co., San Francisco, Calif. • English Repr.: Ernst B. Westman, Ltd., London, Eng.



## **Perfection is Our Aim!**

In every industry there are various methods of turning out products for similar use requirements. Usually there is *one best way* — a way based on developing and following certain tested techniques — proved processes that in themselves guarantee uniform quality every step of the way.

James Knights owes its reputation for unquestioned dependability to a steadfast determination of finding the *one best way* of carrying out every manufacturing operation. The culmination is a certainty — the positive assurance of better operating performance for every James Knights Crystal.

**The JAMES KNIGHTS Co.**  
SANDWICH, ILLINOIS



**CRYSTALS FOR THE CRITICAL**



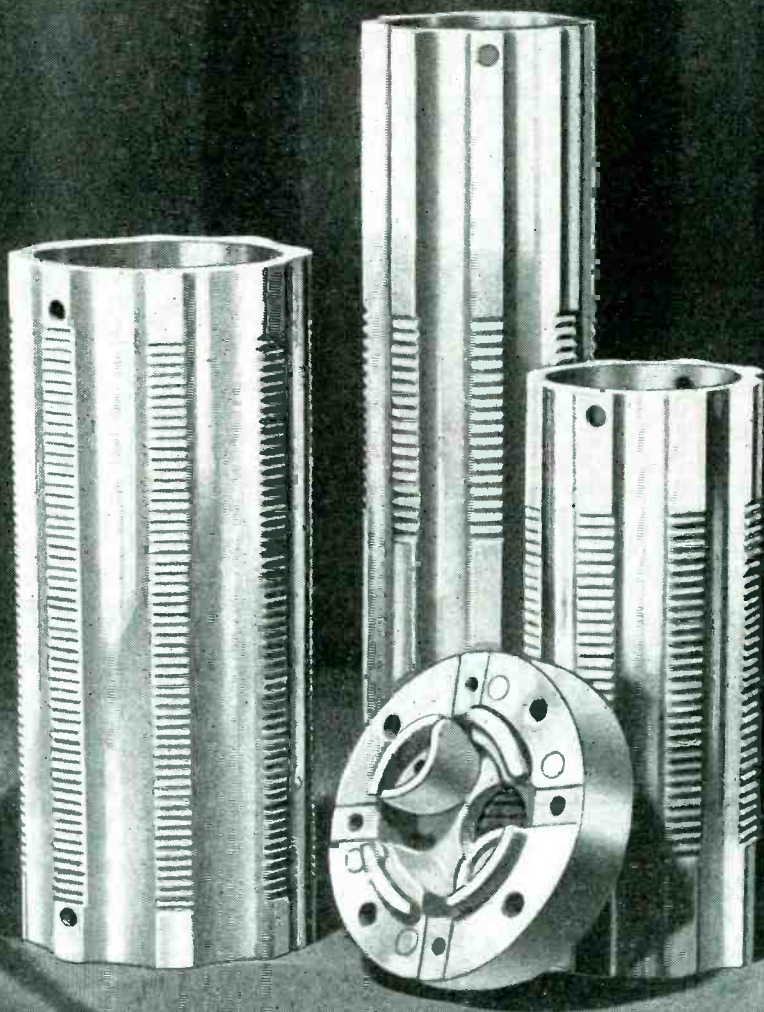

*Fine ceramics by*



**Centralab**

Division of GLOBE-UNION INC., Milwaukee



Built  
By **HOWARD**



To Your  
**SPECIFICATIONS**

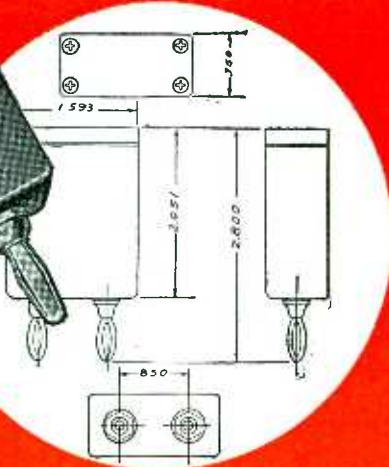

HOWARD Crystal Holders, precision made, accurate, and dependable, will serve the radio, electronic and allied fields in peace as they have the armed forces in war. Undisputed leadership in the manufacture of Crystal Holders, and proved performance of HOWARD Holders calls for: "Specifications to HOWARD."

★ BUY WAR BONDS ★

# HOWARD MANUFACTURING CORP.

COUNCIL BLUFFS, IOWA

## Announcing

### THE NEW BUD "MASTER A" SERIES ULTRA HIGH FREQUENCY CONDENSER

BUD "MASTER A" series of Dual Section Transmitter Condensers has been expanded to give a choice among sixteen items in four groups. This greatly increases the spread of BUD service in the ultra-high frequency area of the radio and electronic field. "Master A" condensers eliminate most of the "bugs" in UHF operation. Full description and characteristics in the new BUD catalog, ready about October 20th. Ask for it.

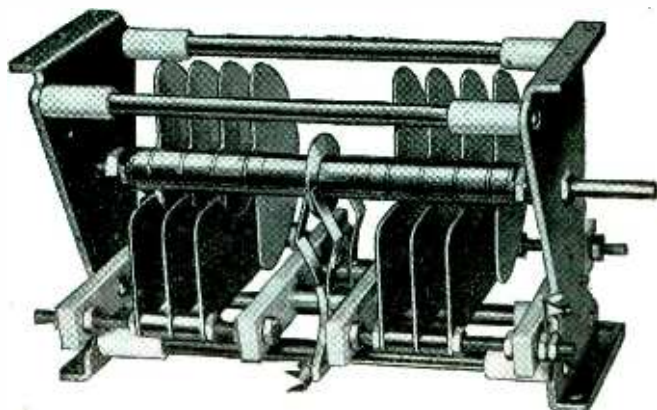

Condenser shown is BC-1636, Cap. 35 MMFD. per section.

**BUD**

**BUD RADIO, INC.**

CLEVELAND, OHIO

onance or the phase shift is measured by electronic means. Through the use of such an instrument, explosive mixtures may be avoided in the operation of the hydrogen cooled alternator.

#### Measuring Pressure

Pressure may be measured by any one of the following three methods: (1) by balancing an unknown pressure against a known force; (2) by measuring the deformation of an elastic membrane; (3) by utilizing a quantitative change in the physical properties of materials. Electronic devices may be applied to any or all three of these methods of pressure measurements. One interesting application of the third group is that in which the thermal conductivity of a gas varies with pressure to effect a change in resistance or temperature of a wire filament supplied with a constant current and immersed in the gas.

Mr. Middel pointed out that it is not improbable that a pressure-responsive element like a spring-loaded bellows or a diaphragm might be incorporated in an electronic tube to modify the plate-to-grid and cathode spacing and provide a plate output proportional to pressure. Attempts have also been made to produce variable-mu tubes by moving the grid within the tube by mechanical means.

In measurements of the flow of fluid, the pressure differential may be measured by a bellows type of pressure-measuring element in which the motion of the free end of the bellows may be used to alter the inductive relations in an adjustable iron-core transformer. The variation thus produced may be regarded as a signal which may be transmitted over a pair of wires to an electronic servo mechanism to accomplish any desired result.

A considerable portion of the paper was devoted to the measurement of temperature by means of the thermocouple, resistance thermometry, radiation pyrometry, self-balancing potentiometers, photoelectric and electronic potentiometers. A photoelectric potentiometer using a reflecting-type galvanometer and phototube combination is shown in the circuit diagram. Light variations on the type 930 phototube produce grid voltage variations on the 6J5 triode which in turn deflects





# STACKPOLE

## CONTINUOUSLY ADJUSTABLE CARBON RHEOSTATS (CARBON PILES)

**U**nder impetus of war requirements demanding resistance adjustments for more critical, more precise, smoother, and more dependable control than is possible with conventional variable resistance units, Stackpole engineering has developed the Continuously Adjustable Carbon Rheostat formed of carbon disc piles to a high degree of efficiency. Simply by changing the pressure applied to the pile, every possible resistance value within its range is available without opening the electrical circuit in which it is connected. The pressure to vary the resistance to the most critical adjustment may be applied electrically, mechanically, centrifugally or hydraulically. Uses range from both generator and line voltage regulator applications to remarkable speed control through governed field current on motors. Many other projects incorporating the Carbon Pile Resistor are now in the development stage.

Stackpole regularly supplies Carbon Piles in practically any length pile and diameter required. Resistance ranges have been materially expanded and a greater degree of resistance variation may now be obtained in a pile of a given size. Careful engineering control of manufacture assures a high degree of uniformity on a quantity production basis. Write for bulletin giving complete data.

**STACKPOLE CARBON COMPANY**  
St. Marys, Pa.

### CARBON DISCS FOR OTHER APPLICATIONS

Other Stackpole types include carbon discs for electric brakes for trucks, speed governors—or wherever a little power must control a lot of power with utmost precision, smoothness, and dependability.

### OTHER STACKPOLE PRODUCTS

BRUSHES - CONTACTS (All carbon, graphite, metal, and composition types)  
WELDING CARBON PRODUCTS  
PACKING, PISTON, and SEAL RINGS

VOLTAGE REGULATOR DISCS

IRON CORES

POWER TUBE ANODES, etc.

RARE METAL CONTACTS  
BATTERY CARBONS



# THE N-Y-T SAMPLE DEPARTMENT will check-mate your post-war transformer problems too!

Diversification in transformer engineering, for vital equipment and apparatus, has been a "must" in this highly-specialized field ever since electronics superseded the human element in various operating phases. Aircraft applications—with attendant drastic temperature fluctuations, marine installations—with constant corrosion and moisture influences, mobile units—with vibration and impact as deterrents—all required unusual

transformer design technique. The N.Y.T. Sample Department has aided materially in forestalling or solving problems for the Army, Navy and Air Forces. Practically every conceivable obstacle to efficient transformer performance has been overcome—unequivocally—by N.Y.T. Your post-war transformer, rectifier or solenoid perplexities can be check-mated in similar immediate manner.

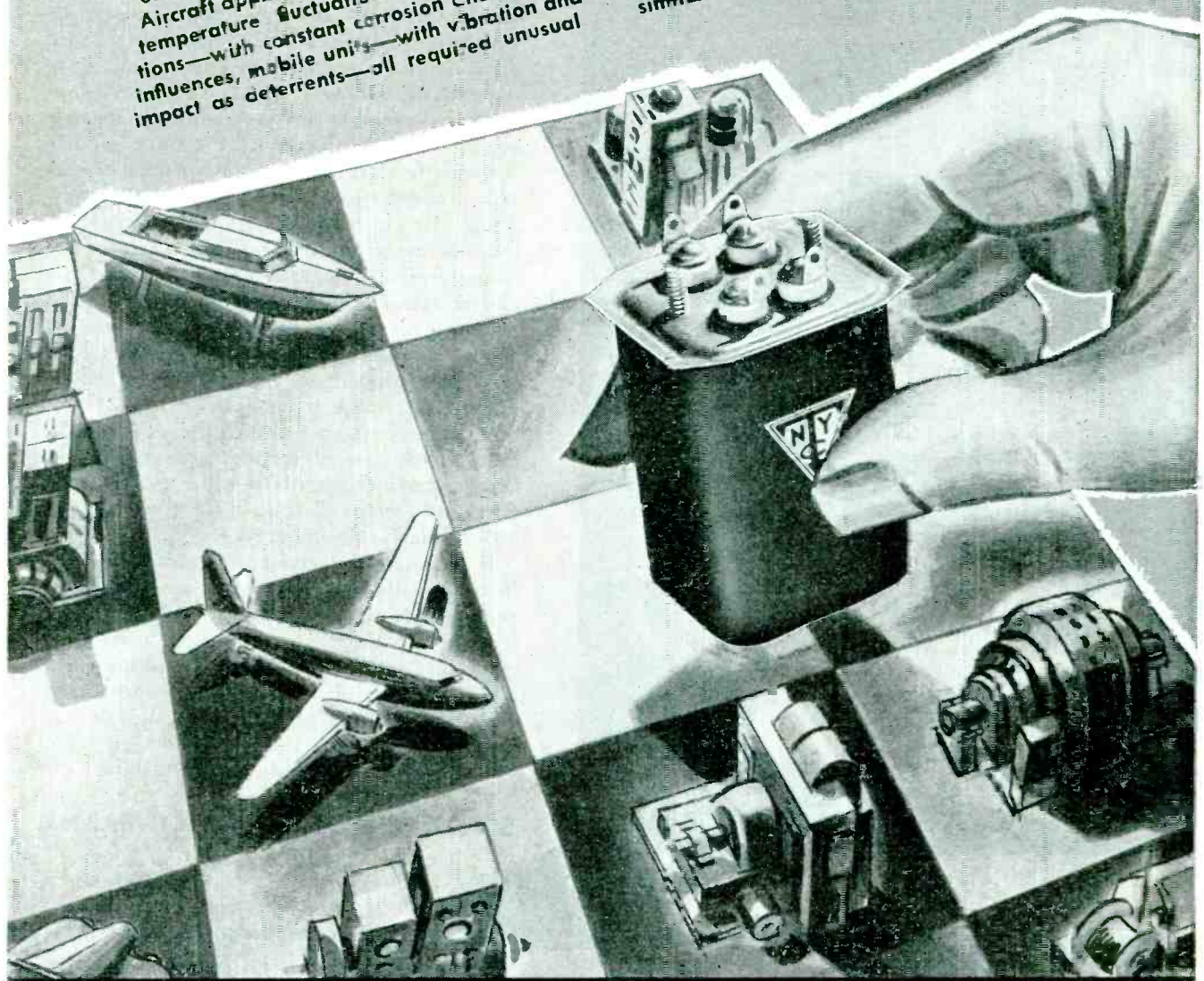

**NEW YORK TRANSFORMER COMPANY**

26 WAVERLY PLACE, NEW YORK, N. Y.



# TUBING . . .

*of Spherical Importance*

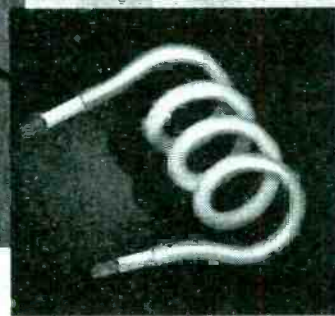
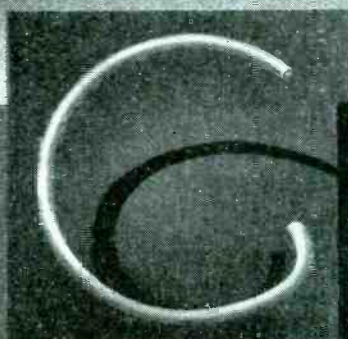
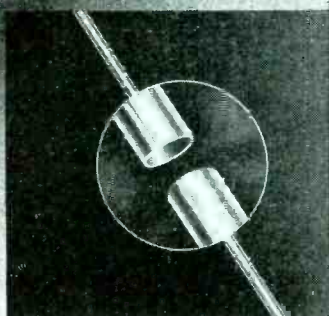

## AIRCRAFT

## INSTRUMENTS

Precise Instruments, vital to all Communications, must depend upon accurately made, positively balanced Foster Tubing. Today Precision Tube Company supplies this high grade Aluminum Alloy Foster Tubing to over 80% of the Instrument Manufacturers in this free land. There must be a reason.

Rate of Climb, Air Speed and similar Aircraft Instruments depend for their accurate measurements upon the amount of air passing through a predetermined length of formed tubing. Precision Tube Company's new method of manufacture steps up production 800%.

## ELECTRONICS

Metal Shielded Wire — Insulated wires shielded with Seamless Aluminum or Copper Tubing offers the only positive protection against Moisture, Electrical Interference and Mechanical damage. It is a MUST for dependable Electronic Equipment where failure cannot be tolerated. Made in a wide variety of sizes and combinations.

Geographically and mechanically men today are more fully aware of "spherical importance" than ever before.

New concepts of spherical distances are reshaping world strategy and geography—but of most importance is spherical accuracy upon which the lives and destinies of all nations—all men—depend.

We at Precision Tube Co. are specialists in spherical accuracy. Aluminum, brass, copper and nickel tubing manufactured to close tolerances. Metal Shielded Wire for electronic and Radar devices. Precision Tubing for electrical instruments of all types.

Our facilities and engineering department are at your disposal.

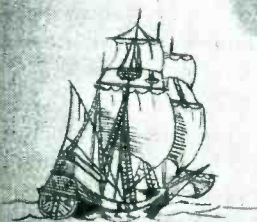

# PRECISION TUBE CO.



SPECIALISTS IN ACCURATELY DRAWN TUBING AND METAL SHIELDED WIRE

Factory: 3824-26-28 TERRACE STREET • PHILADELPHIA, PA.

BRANCHES IN ALL PRINCIPAL CITIES

SALES DEPT. 215-05 27TH AVE. BAYSIDE, L. I., N. Y.



# PORTABLE POWER PROBLEMS

THIS MONTH—G-E MODEL "B" ELECTROCARDIOGRAPH

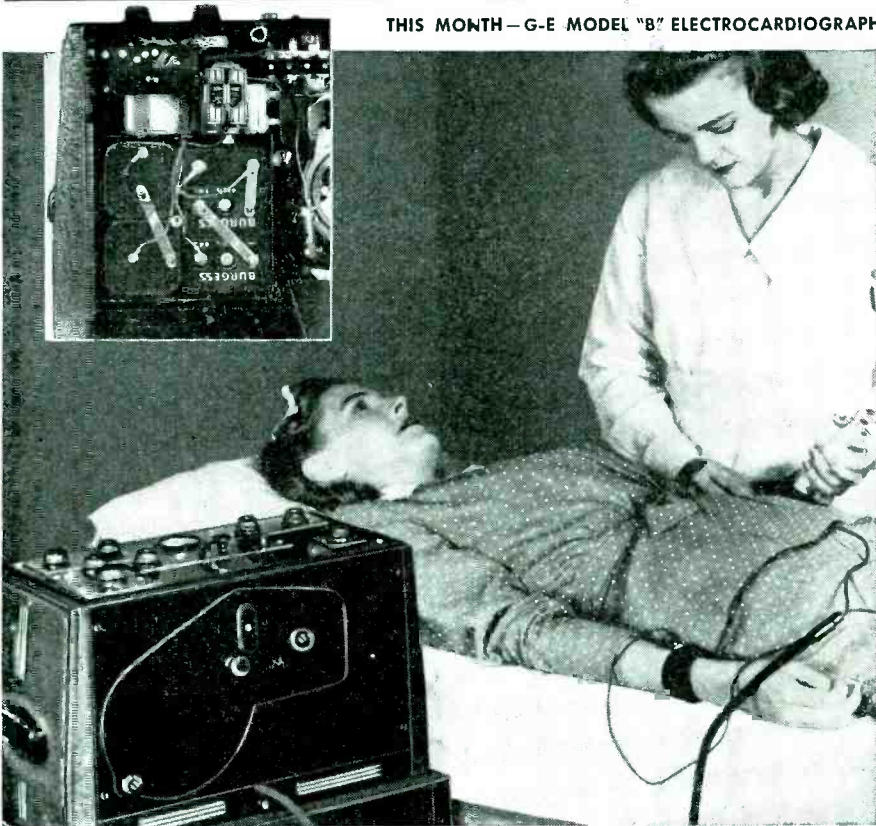

HIGH SENSITIVITY and standardized operation characterizes the General Electric Model "B" Electrocardiograph which assists doctors in quickly establishing accurate diagnosis and prognosis of heart conditions. A true photographic record of minute change in heart potential waves is given by this remarkable lightweight, battery-powered instrument. As a result, it quickly and economically makes available information that would otherwise be very difficult to obtain.

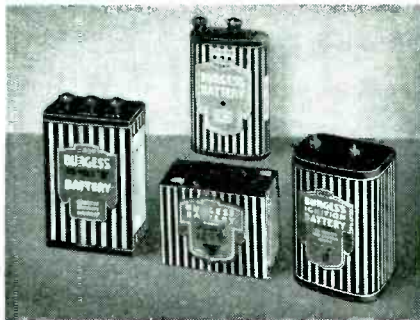

**BATTERY COMPARTMENT**, shown upper left, houses the power heart of the G-E Model "B" Electrocardiograph (Burgess "A" and "B" Batteries are standard equipment.) General Electric descriptive literature emphasizes that "batteries provide the most dependable source of power—always smooth." Battery power assures operation anywhere— independent of commercial electric supply. Burgess engineers are constantly adapting special-purpose batteries for specific commercial and industrial requirements. Let them solve your portable power problems. Send coupon for free Engineering Manual.

## FREE . . . 80-PAGE ENGINEERING MANUAL!

31 descriptive pages, 25 charts and 36 data tables on dry battery characteristics for electronic applications. Tabbed for ready-reference. Write Dept. 9 for your free copy. Burgess Battery Company, Freeport, Ill.

Name .....

Company .....

Address .....

City ..... State .....



# BURGESS BATTERIES

the pointer of the galvanometer, G.

The tube is used as a variable resistance in one arm of a Wheatstone bridge. Light variations on the phototube thus unbalance the bridge. In series with the load is a resistor so arranged that a voltage proportional to output current is fed back in opposition to the input voltage. This causes the galvanometer to take up a stable position as some function of the remaining un-

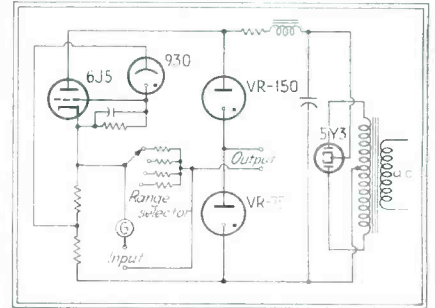

Circuit of a photoelectric potentiometer that operates on light variation for measuring temperature

balanced current. The magnitude of this current is not constant, but varies with the basic element sensitivity, the kind of optical system and input voltage.

The present status of the use of fluoroscopic rather than radiographic methods of examining industrial products was reviewed by Dr. Scott W. Smith of Kelley-Koett Mfg. Co. in a paper, "Industrial Fluoroscopy of Light Materials," in which attention was directed to various factors contributing to the success of this method, and the outlook for future developments was discussed. It was pointed out that the possibility of using fluoroscopy as a means of relieving radiography of part of the burden of industrial inspection, where the degree of sensitivity required is within its limitations, is being given serious consideration. It seems quite reasonable to expect fluoroscopy to augment rather than to supplant radiography.

### Present Applications

Since industrial specimens do not necessarily require a short exposure, and are not subject to movement during exposure, these advantages have permitted the development of fluoroscopy for many industrial applications. In fact, the fluoroscope has been used for quite a



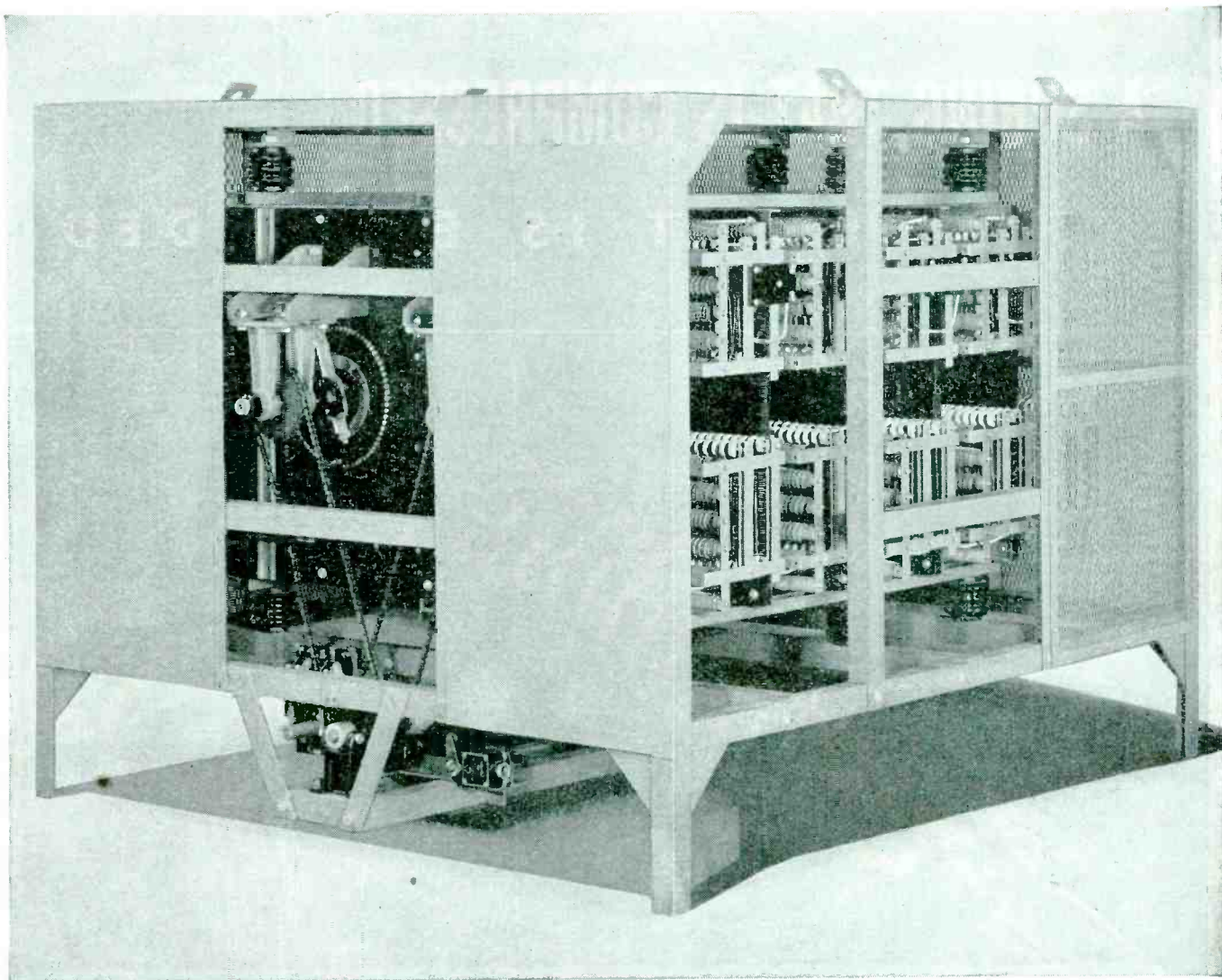

## ASSEMBLED RHEOSTATS

Here is a Ward Leonard assembled rheostat designed for production testing of grid-controlled rectifier tubes. It consists of five face plates with each face plate composed of two rheostats. Each rheostat will drop from 0 to 375 volts at any current between 15 and 0.15 amperes. The rheostats are mechanically connected but electrically independent. They may be connected in series to give a maximum drop of 3750 volts or in parallel to give a maximum current of 150 amperes. The assembly is tested at 10,000 volts to ground and 2,000 volts between rheostats. Whenever you have an electric control problem Ward Leonard engineers are at your service.

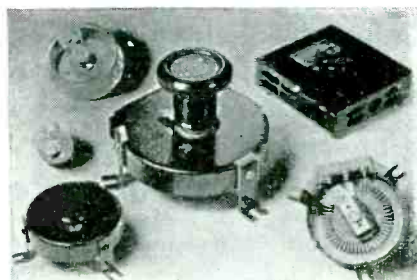

The Ward Leonard line of rheostats includes steel plate types, porcelain ring types and ribohm face plate types. These rheostats provide control for the minute current requirements of the laboratory and the heaviest current demands in industrial applications. *Send for rheostat bulletins of interest to you.*



# WARD LEONARD

## RELAYS • RESISTORS • RHEOSTATS

Electric control  devices since 1892.

**WARD LEONARD ELECTRIC COMPANY, 32 SOUTH STREET, MOUNT VERNON, N. Y.**



# A SPRING THAT IS COMPRESSED

# WHEN IT IS EXTENDED

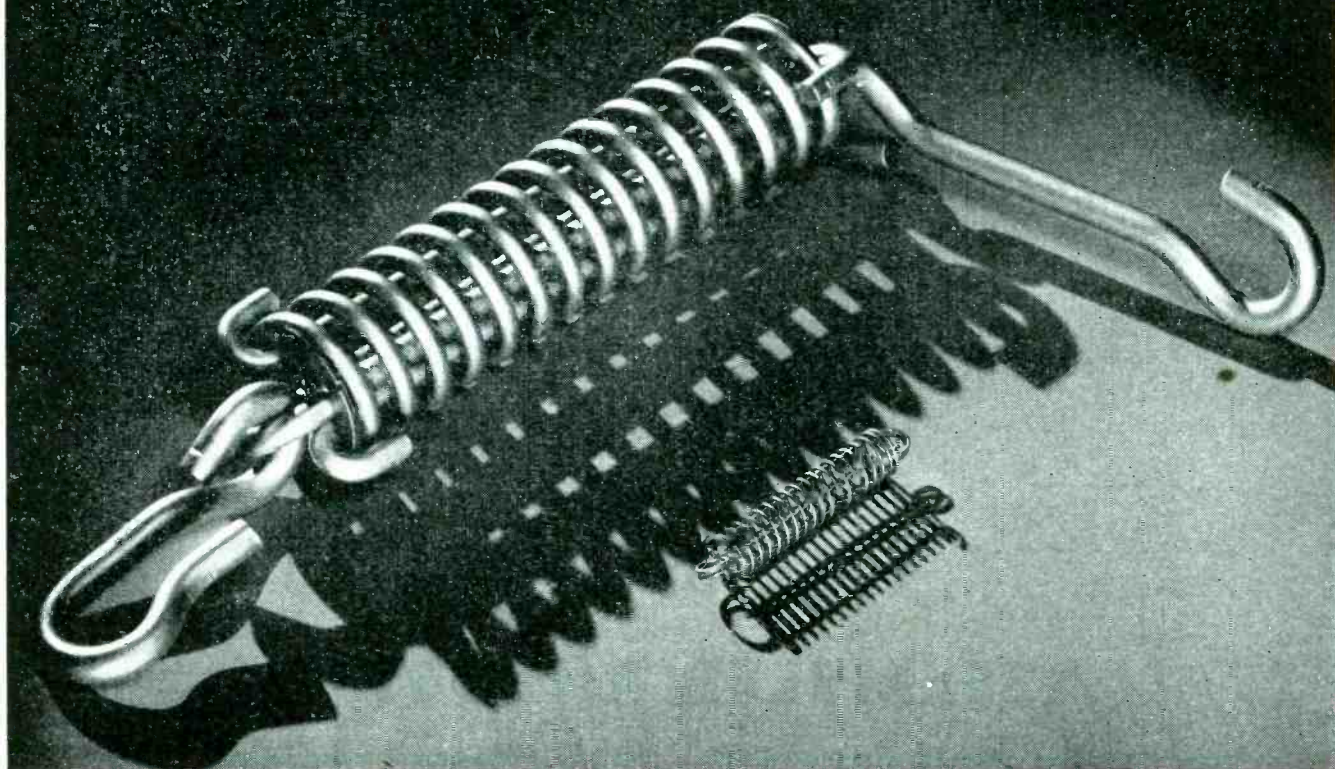

**T**YPICAL of the many unusual springs made by Muehlhausen is this *compression* spring which serves as an *extension* spring—designed for applications requiring an unusually high factor of safety. Interlocking drawbars—passing through the spring and looping around opposite ends—

absorb the pulling force by compression instead of extension, and prevent a total separation of the suspended parts, should an extreme overload cause spring breakage.

**MUEHLHAUSEN SPRING CORPORATION**  
Division of Standard Steel Spring Company  
750 Michigan Avenue, Logansport, Indiana

**MUEHLHAUSEN**



**SPRINGS**

EVERY TYPE AND SIZE



PERMANENT MAGNETS MAY DO IT BETTER

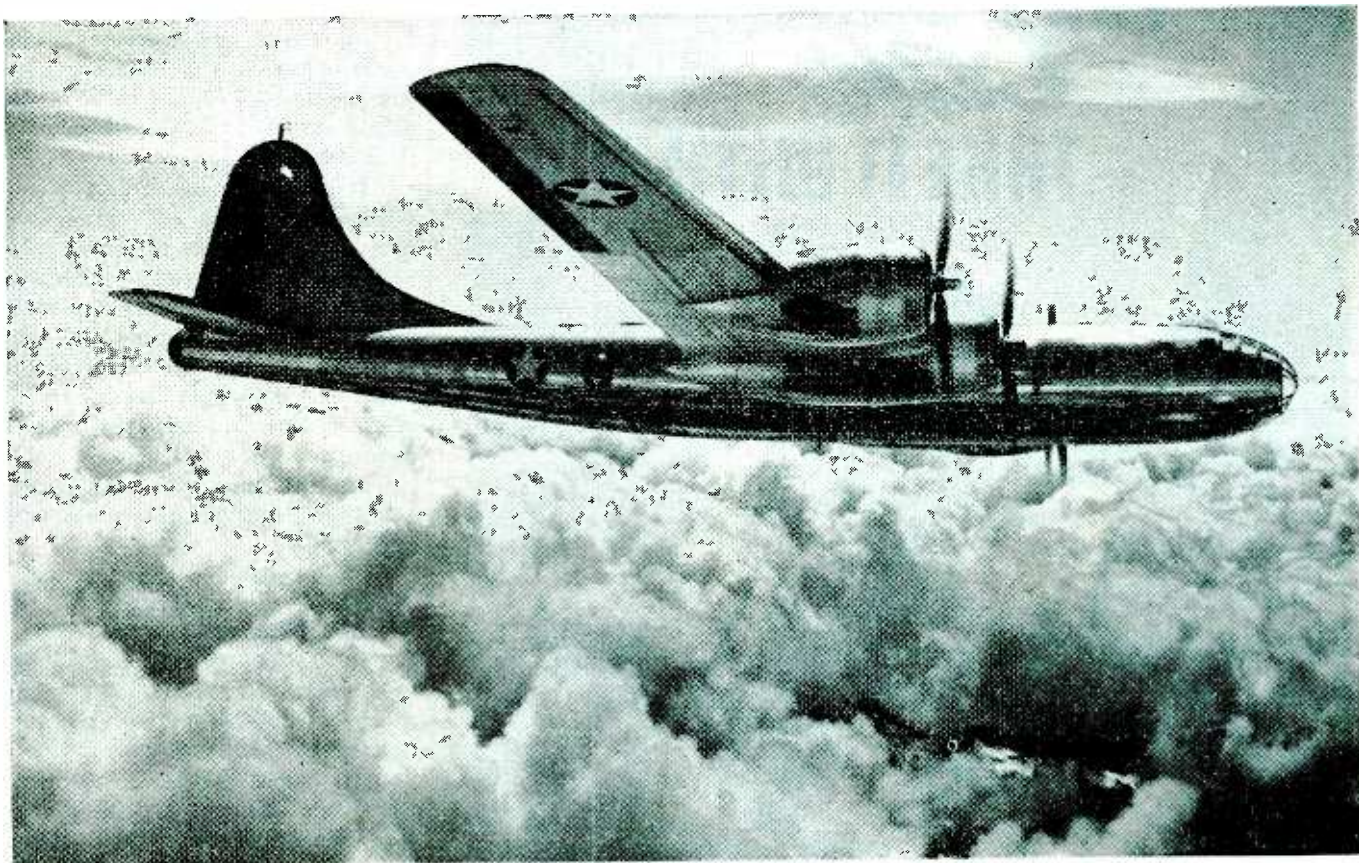

## America's Pride Flies with the B-29!

AS the giant Boeing B-29 Superfortress carries destruction to Japan, the pride of America echoes in the roar of her mighty engines. And to the ingenious Boeing engineers who created her, the Nation owes a great debt.

We have special reason to be proud of the B-29's performance, for Boeing incorporated no less than 300 permanent magnets in her magnetos, instruments, compasses, audio speakers, radio equipment, automatic pilot, remote gun controls and other vital devices.

It is our job to manufacture a large

portion of these permanent magnets, as well as those for other types of war equipment. And our specialized designing skill has often resulted in increased efficiency and lower costs.

Our engineers are in an excellent position to help solve your permanent magnet problems. Write for a copy of our "Permanent Magnet Manual."



Copyright 1944—The Indiana Steel Products Co.

---

*The*  
**INDIANA STEEL PRODUCTS**  
*Company*

★ SPECIALISTS IN PERMANENT MAGNETS SINCE 1910 ★  
6 NORTH MICHIGAN AVENUE • CHICAGO 2, ILLINOIS

---



**"YOU** *Can* **TAKE IT WITH YOU"**



Type S-12  
Size 8" x 9" x 18"

## **HATHAWAY OSCILLOGRAPH**

*The last word in performance and portability*

### **Available Soon—Order Now**

The ideal instrument for portable use, such as geophysical work, field testing, and aviation flight testing.

Ten channels: Galvanometers available covering wide range of characteristics: Daylight loading of 6-

inch paper or film: Recording speeds quickly adjustable: Automatic record length control: Automatic record numbering: Simultaneous viewing and recording: All controls convenient on top panel. Early delivery. Hathaway Instrument Co., Denver, Colorado.

*Write for Bulletin and Prices*

*Hathaway* INSTRUMENTS

long time for such applications as spotting a foreign body in packaged food, candy and tobacco, as well as sorting fruits, determining the filling level in cans, the shape and position of the core of golf balls, or the alignment of the elements in electron tubes.

After a historical resumé of fluoroscopic methods and screens, it was shown that an improved zinc sulfide screen, treated in such a way as to reduce afterglow, is commonly used at the present time and that photographs of the fluoroscopic image on small films has been generally employed in induction centers during the war with a considerable saving in film over the usual 14 x 17-in. radiograph previously employed.

It was concluded that the widespread use of radiography for the control of foundry technique and the inspection of light alloy castings can be further augmented by the use of fluoroscopy with a reduction in the cost factor.

In a paper entitled, "Aircraft Electronic Applications" A. P. Upton, Minneapolis-Honeywell Regulator Co., described a complete electronic control system as used in modern aircraft. The electronic turboregulator and the electronic autopilot forming the major parts of this system were described in detail in the May 1944 and Sept. 1944 issues of *ELECTRONICS* respectively.

A paper was presented by John M. Gage of Allis-Chalmers Mfg. Co. entitled "Negative Feedback Amplifier Theory Applied to Regulators." The paper considered the mechanical problem of regulator operation, which may be most conveniently solved by the mathematics originally developed in connection with electrical theory. Such a procedure requires the necessary transformations of the terms of the dynamical differential equations from the physical concepts of one system to the physical concepts of another.

The paper also outlines an experimental procedure for measuring and studying the frequency responses of actual systems employing regulators.

W. R. Mehaffey, of Armour Research Foundation, opened the treatment of his paper, "Strain Gage Amplifier Design," by a discussion of the advantages of resis-



... "Among their Latest Triumphs is an inter-communicating telephone for interior use in buildings, which furnishes in itself, by pressing buttons, complete exchange connections, with all parts of the building, and releases the same automatically and comprises the only successful system of its kind of the present age."

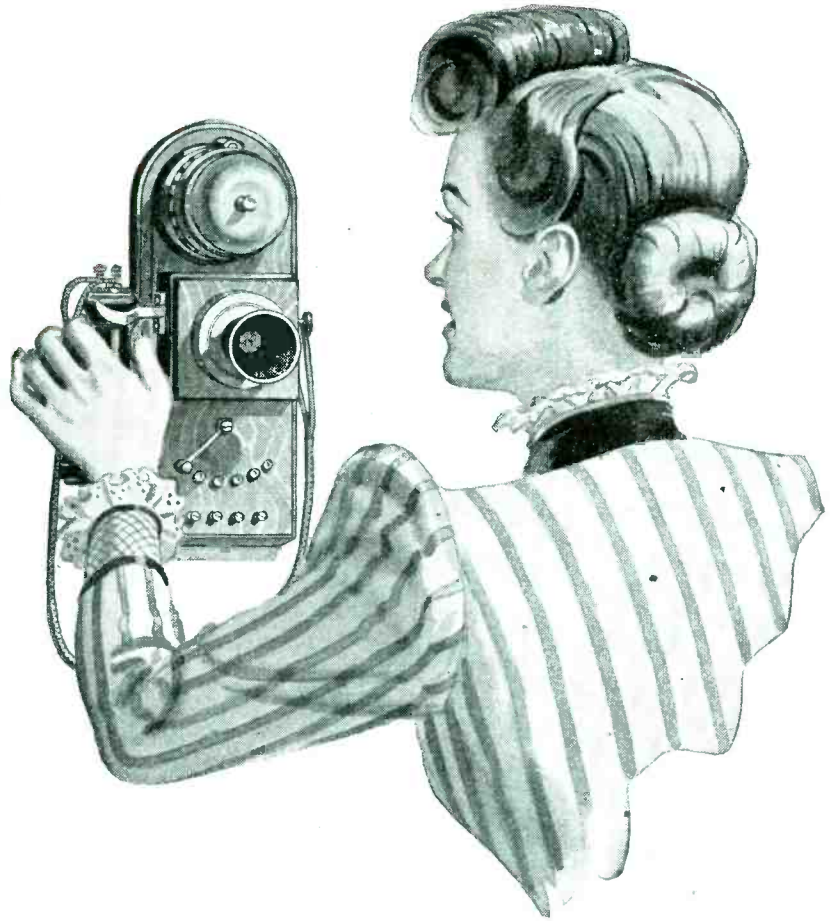

The glowing phrases above, written not long after the turn of the century, describe a Connecticut Telephone and Electric "First" which doubtless caused grandpa to wonder, "What won't they think of next!"

The things our engineers are thinking up today in cooperation with U. S. Army engineers are full of interest and promise, but they can't be talked about now. You can count on better communications...in fact, you can confidently expect war-born improvements in all branches of electrical and electronic science.

If your product-development plans involve a problem of electrical or electronic engineering and manufacturing, perhaps we can be of assistance. We also invite preliminary inquiries connected with inter-communicating and signalling systems for postwar buildings now in the design stage.



## CONNECTICUT TELEPHONE & ELECTRIC DIVISION

GREAT AMERICAN INDUSTRIES, INC.  
MERIDEN, CONNECTICUT

TELEPHONIC SYSTEMS • SIGNALLING EQUIPMENT • ELECTRONIC DEVICES • ELECTRICAL EQUIPMENT • HOSPITAL AND SCHOOL COMMUNICATIONS AND SIGNALLING SYSTEMS • IGNITION SYSTEM





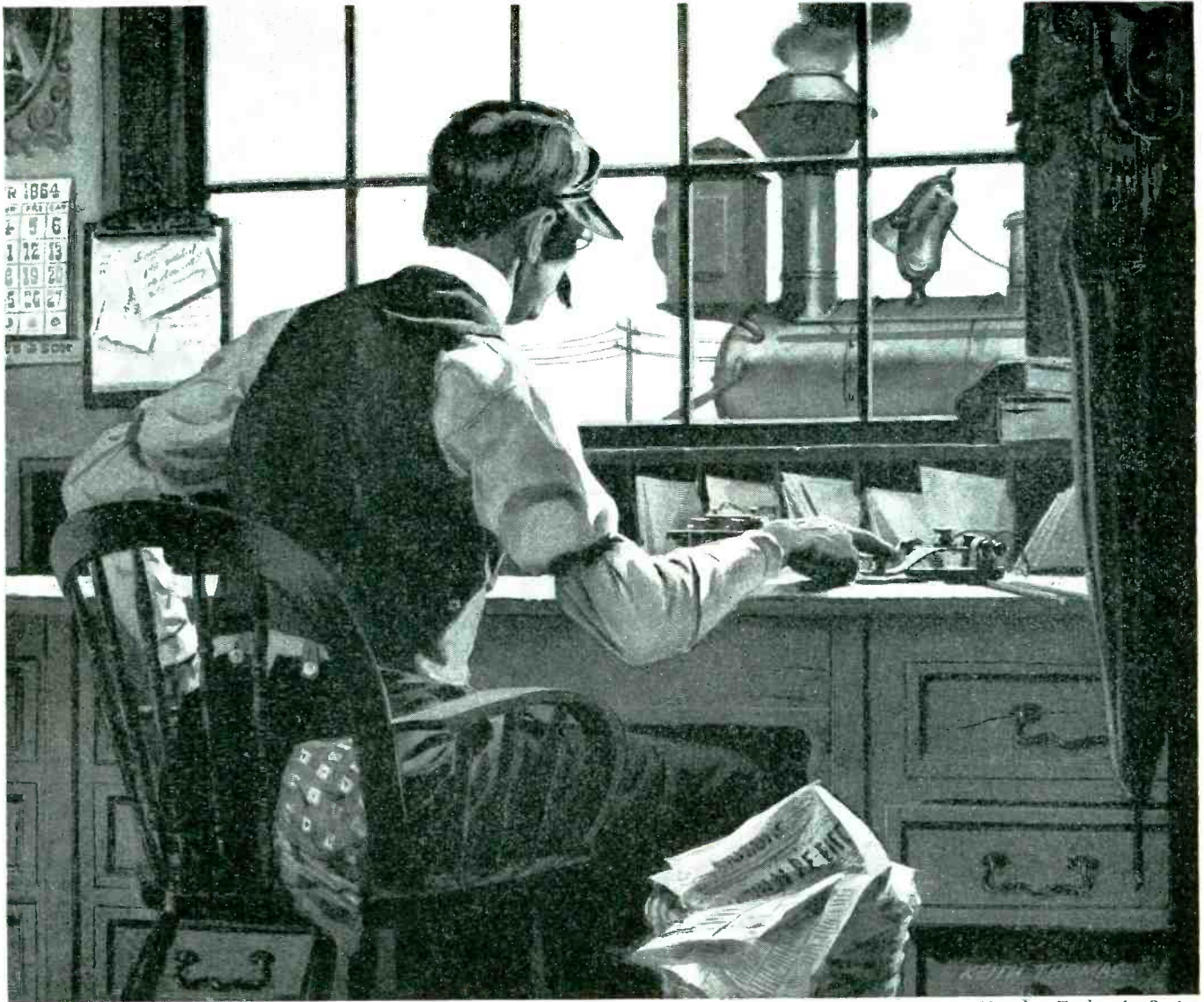

*History of Communications. Number Eight of a Series*

## EARLY RAILROAD COMMUNICATIONS BY TELEGRAPH

Communication by telegraph was probably one of the first of the electronic arts which met with commercial success in America. Of constant interest to every boy in a small town, the telegrapher down at the depot was a hero — a man of great science. With the advent of faster locomotives, telegraphy was a speedy method of traffic control.

Today, and for the postwar period, the picture will include electronic voice communications for the streamlined trains which travel one hundred miles per hour. There must be a more flexible control via electronics, plus the added possibility of passenger luxury in radio telephones. Universal stands ready as an electronic manufacturer to serve in the era of applied electronics.

*< Model 1700-UB, illustrated at left, is but one of several military type microphones now available to priority users through local radio jobbers.*

MODEL  
1700-UB



**UNIVERSAL MICROPHONE COMPANY**  
INGLEWOOD, CALIFORNIA



FOREIGN DIVISION: 301 CLAY STREET, SAN FRANCISCO 11, CALIFORNIA — CANADIAN DIVISION: 560 KING STREET WEST, TORONTO 1, ONTARIO, CANADA



# Continental-Diamond Engineered Dielectric Materials

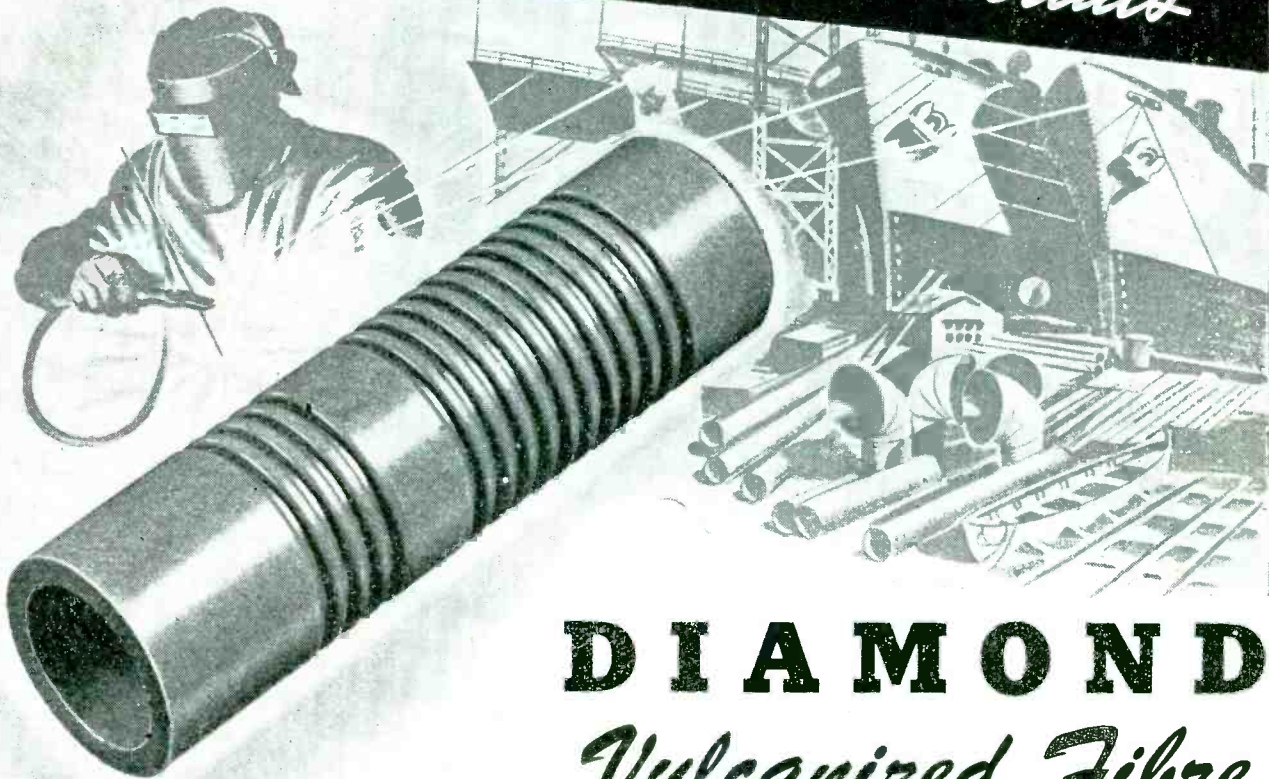

## DIAMOND Vulcanized Fibre

The DIAMOND Vulcanized Fibre part illustrated is a handle for a welder's torch. It is made from tubing. DIAMOND Vulcanized Fibre is used for this part because DVF is tough, strong and light in weight... because it insulates electrically and thermally. The handle is economically made from DVF because DVF is readily machined, formed, spun, sawed or otherwise fabricated. For complete technical data on this C-D NON-Metallic, write for catalog DF.

KA-44

### C-D PRODUCTS

#### The Plastics

**DILECTO**—A Laminated Phenolic.  
**CELORON**—A Molded Phenolic.  
**DILECTENE**—A Pure Resin Plastic Especially Suited to U-H-F Insulation.  
**HAVEG**—Plastic Chemical Equipment, Pipe, Valves and Fittings.

#### The NON-Metallics

**DIAMOND Vulcanized FIBRE**  
**VULCOID**—Resin Impregnated Vulcanized Fibre.

**MICABOND**—Built-Up Mica Electrical Insulation.

**Standard and Special Forms**  
 Available in Standard Sheets, Rods and Tubes; and Parts Fabricated, Formed or Molded to Specifications.

#### Descriptive Literature

Bulletin GF gives Comprehensive Data on all C-D Products. Individual Catalogs are also Available.

#### DISTRICT OFFICES

NEW YORK 17 • CLEVELAND 14 • CHICAGO 11  
 SPARTANBURG, S. C. • SALES OFFICES IN PRINCIPAL CITIES

WEST COAST REPRESENTATIVES  
 MARWOOD LTD., SAN FRANCISCO 3

IN CANADA:  
 DIAMOND STATE FIBRE CO. OF CANADA, LTD., TORONTO 4

Continental - Diamond FIBRE COMPANY

Established 1895. Manufacturers of Laminated Plastics since 1911—NEWARK 16 • DELAWARE



Photo courtesy of  
Simpson Electric Co.  
Chicago, Ill.

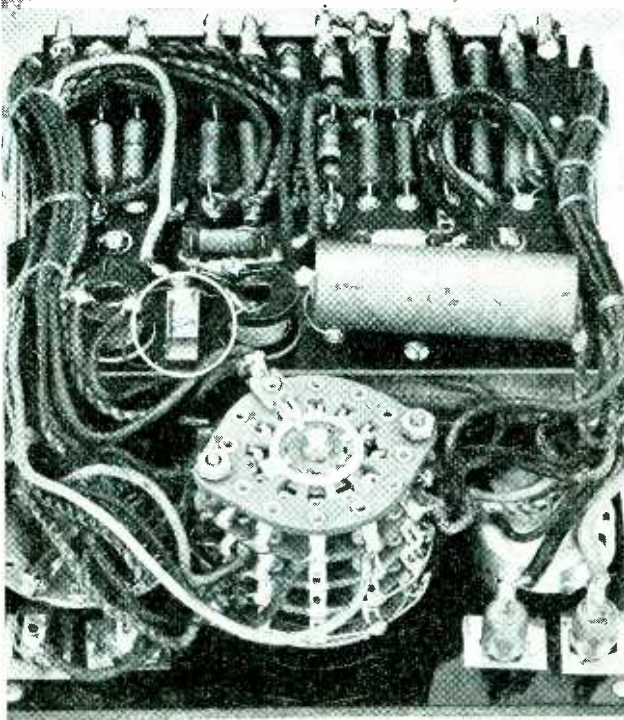
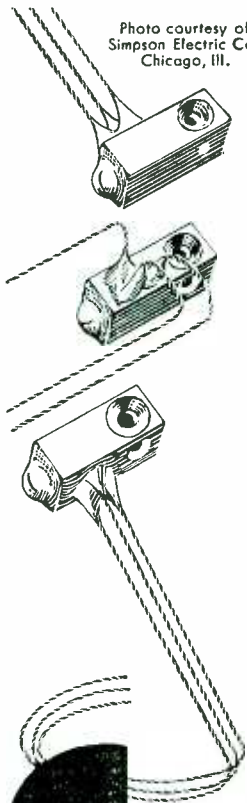

## Conant's standard midget (series 160) LEADS A 3-WAY LIFE!

Yes, indeed, the standard midgets of the Conant family (160" diameter discs) are versatile. The unique full metal case protects the rectifier assembly from damage and permits mounting in any of three positions with a single screw. Combining the three positions with angular mounting permits the leads to extend from the rectifier in almost any direction. Thus, one standard rectifier serves for all models. Further protection is provided by a special moisture proof seal.

Design and construction of Series 160 are the result of years of experience and close cooperation with instrument manufacturers.

For all applications requiring high sensitivity operation over an extended frequency range, you can count on Conant's Standard Midget—Series 160.



**CONANT**

*Instrument Rectifiers*

**ELECTRICAL LABORATORIES**

6500 O STREET, LINCOLN 5, NEBRASKA, U. S. A.

20 Vesey St., New York 7, New York  
85 E. Gay St., Columbus, Ohio  
600 S. Michigan Ave., Chicago 5, Ill.  
1215 Harman Pl., Minneapolis 3, Minn.

2017 Grand Ave., Kansas City, Mo.  
7935 Eustis St., Dallas 18, Texas  
4018 Greer Ave., St. Louis, Mo.  
1526 Ivy St., Denver, Colo.

4214 Country Club Dr., Long Beach 7, Cal.  
4205 N.E. 22nd Ave., Portland 11, Ore.  
Caixa Postal 930, Sao Paulo, Brazil  
50 Yarmouth Rd., Toronto, Canada

tance strain gages for indication.

The electrical circuits used with strain gages are of two general types, the amplitude-modulated system and the a-c potentiometer circuit. The amplitude-modulated system is used at low frequencies and for static measurements, whereas the potentiometer system is primarily used for dynamic impact studies.

A block diagram of a circuit suitable for measuring mechanical strain by means of strain gages in a bridge circuit is shown. The resistance in one arm of the bridge is the strain gage, while a complemen-

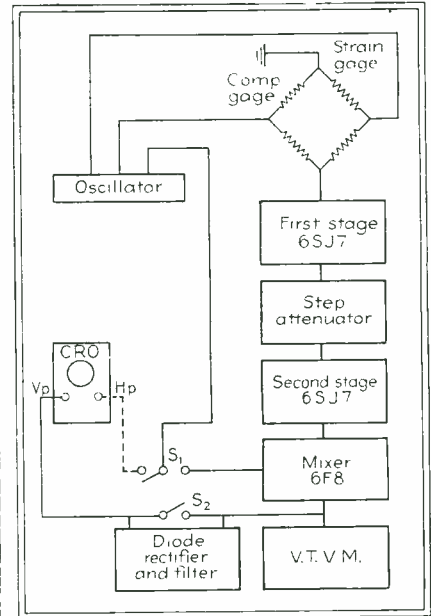

Block diagram of units forming a gage for measuring mechanical strain

tary gage is located near the measuring gage but is mounted in such a way that it does not measure strain. A resistance could be used but the use of a complementary gage permits temperature compensations to be easily obtained. Both capacitance and resistance balance must be provided in this bridge circuit if a sharp null indication is to be achieved. The transformer for supplying power to this bridge must be carefully shielded and have balanced construction. The output from the bridge may be coupled directly to the grid of the first stage of amplification.

### Methods of Operation

In general, there are three basic methods of operation of this bridge circuit. In the first, adaptable particularly to static conditions, the



# NOTES ON DESIGN AND ASSEMBLY OF PLAX

# POLYSTYRENE

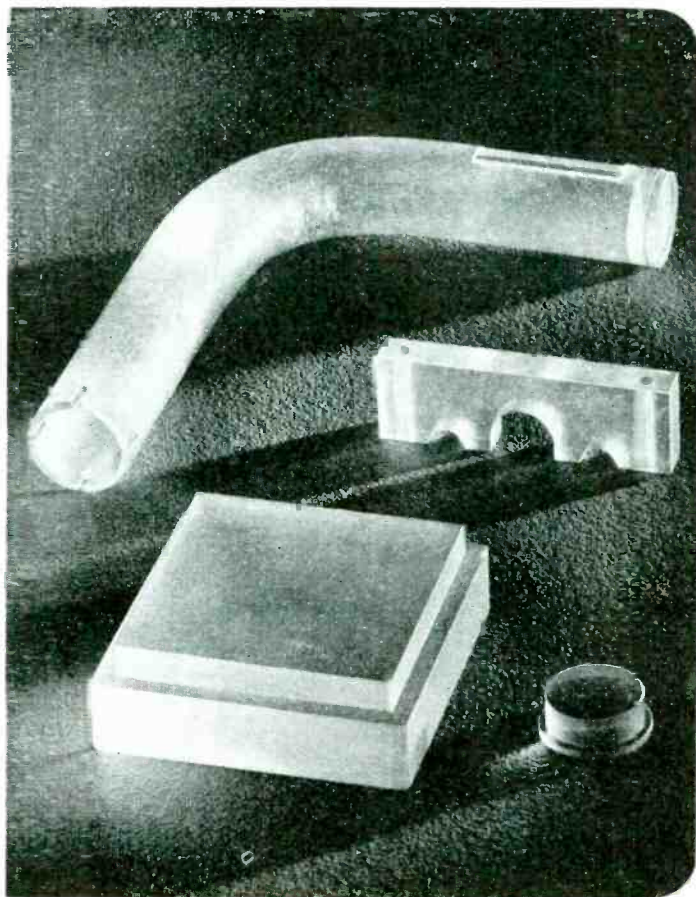

Other PLAX POLYSTYRENE bulletins — entitled **Fabricating, What to Tell Machinists, How to Use Coolants When Machining, and How to Cement** — have been published in preceding months. They will be sent as you request them.

Plax supplies polystyrene in sheets, rods, tubes and in the famous Polyflex\* Sheet and Polyflex Fiber — tough, flexible extruded forms with wide insulation possibilities.

Machined parts such as those shown above are produced by Plax to your exact specifications. Plax also supplies a polystyrene cement and anneals machined parts.

Write for bulletins which interest you, and for complete details of polystyrene's properties.

\*Trade Mark Reg. U. S. Pat. Off.

**DESIGN.** Engineers have recently found it fairly simple to design around the limitations of polystyrene at service temperatures greater than 75°C or 167°F, above which temperature polystyrene's exceptional electrical characteristics lose constancy. For instance, instead of using a solid coil form, polystyrene slabs are cemented to the coil, thus giving a lighter unit with greater heat dissipation.

When used for low loss dielectric plates and insulating film, polystyrene is positioned away from heat sources and exposed to air circulation wherever possible. The use of polystyrene for stand-off insulators, cable heads and spacers, high-voltage bushings and shields offers little difficulty.

**ASSEMBLY.** Screws tapped into polystyrene should not be more than hand tight, so as to prevent deformation of the material to more than ¼ to ½ percent. If the screw must be held tight against vibration, a cement is usually used, though in some cases a cork or rubber washer will hold the screw tight.

When a flat panel is fastened in place, the holding channel or frame should be kept flat, to avoid bending the panel. A channel is preferred to bolting. If bolts are used, they must be placed to distribute the load equally, and all of them should be under the same tension. Using a cork or rubber washer makes it easy to obtain uniform tension. In general, all sources of stress concentration greater than 1200 p.s.i. should be avoided. This means eliminating direct clamping, riveting, or re-entrant angles.

Polystyrene strips may be welded together or around coils by heating to 230°F and pressing. Rod may be bent to any shape by pre-heating to 230°F and cooling in position. Any machining should be done before heating and bending.





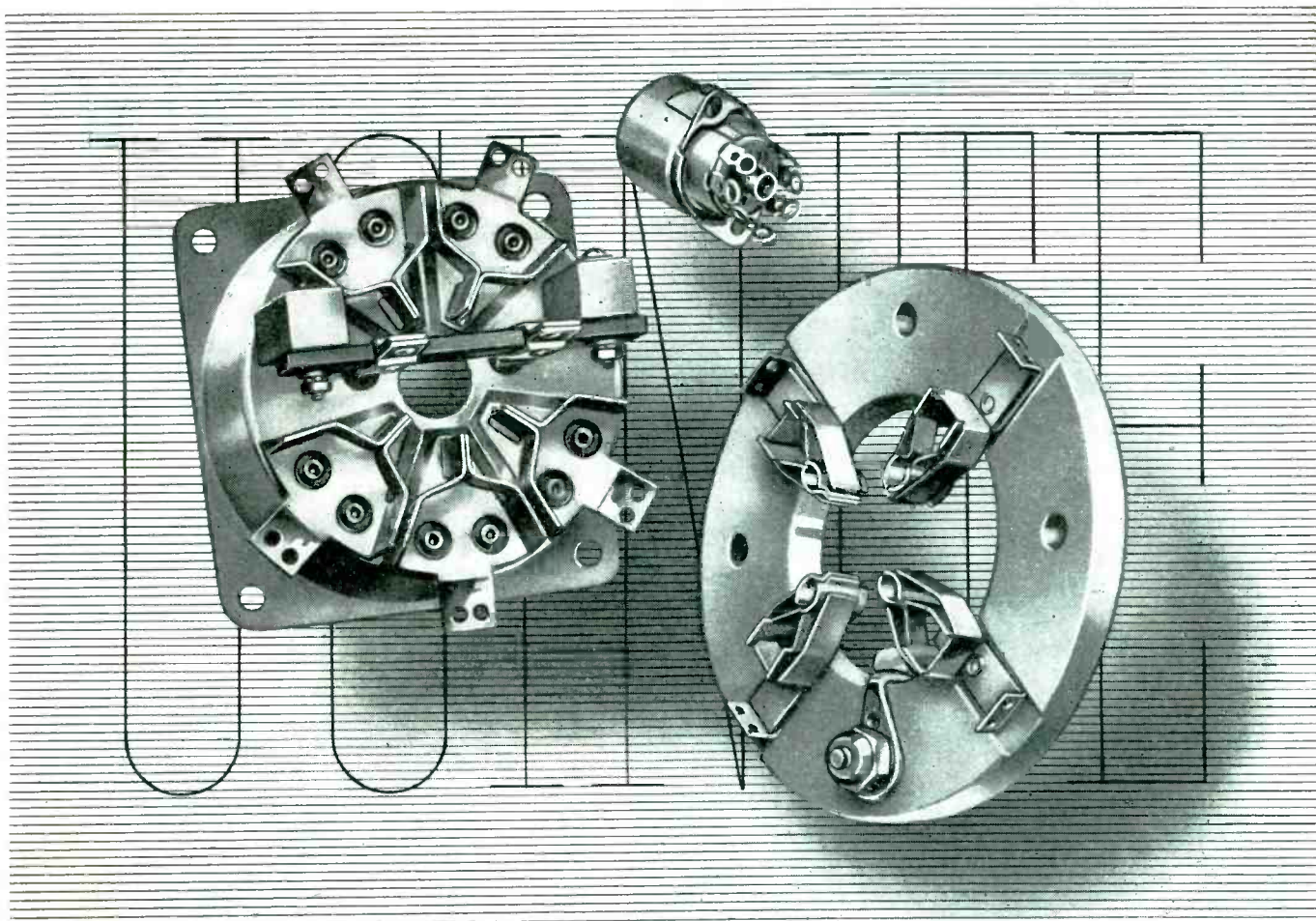

## *Departures from standard*

These three socket bases are typical of Ucinite. What makes them typical is the way they differ from the standard types of socket bases.

Each is an assembly of small metal parts combined with various kinds of ceramic, plastic or mycalex insulation. But each also represents a certain necessary departure, however small, from standard practice in design, materials or production methods. Each required specialized and individual attention.

Ucinite has a unique organization for work of this kind. We specialize. We like doing standardized, run-of-the-mill jobs. But our real specialty is making hard jobs into easy ones.

**The UCINITE CO.**

*Newtonville 60, Mass.*

Division of United-Carr Fastener Corp.

**Specialists in RADIO & ELECTRONICS**

**LAMINATED BAKELITE ASSEMBLIES**

**CERAMIC SOCKETS • BANANA PINS &**

**JACKS • PLUGS • CONNECTORS • ETC.**



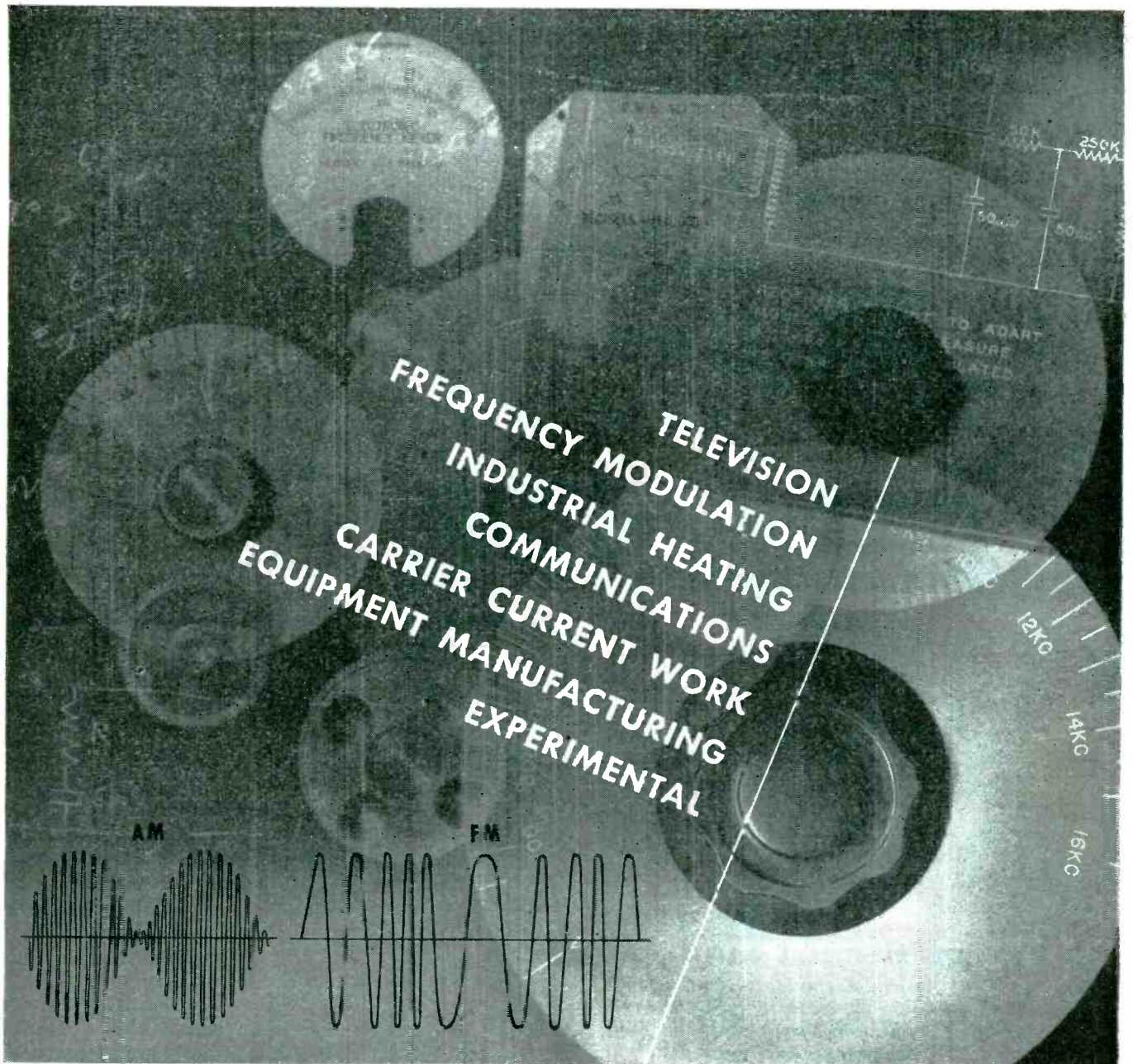

## Post-war electronics demands new instruments

 As the "era of electronics" approaches, it is increasingly evident that the need for more accurate, highly specialized instruments becomes greater. Many of the forerunners of such instruments are already perfected and in use today, but they are still under cover of strict military censorship. When these new developments and others now in the process of development are released — not all, but certainly a good many of the commonly known instruments will instantly become obsolete. In your plans for post-war activity you should make careful note of this fact, for it may save you valuable time in future plant or product conversion.

*-hp-* instruments are in the vanguard of these new developments. New *-hp-* oscillators, signal generators and vacuum tube voltmeters are setting new standards for rugged construction and split-hair accuracy. Technical data on these and others not yet perfected are, of course, not available today, but the time is not far off when they can be released.



In contemplating the improvement of your laboratory or the alteration of your production with post-war activities in mind, it will pay you to consult *-hp-* engineers. These new instruments may be the answer to your problem. Please give us full details so we can be of maximum assistance.

**HEWLETT-PACKARD COMPANY**

**BOX 931A STATION A • PALO ALTO, CALIFORNIA**

CANADIAN OFFICE: 560 KING STREET WEST, TORONTO 2



**MOTOR DATA**  
No. 125

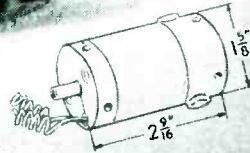
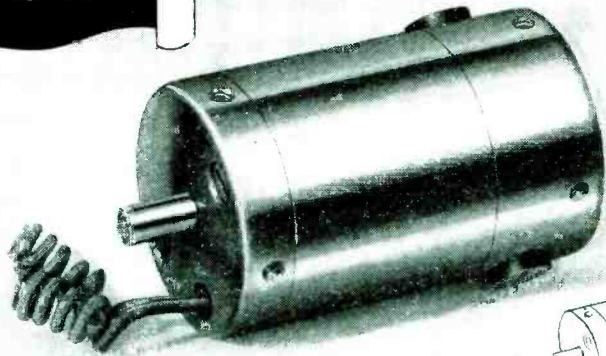

**EICOR**

**1600 FRAME MOTOR**

Torque 4.5 in. oz. at 5800 RPM

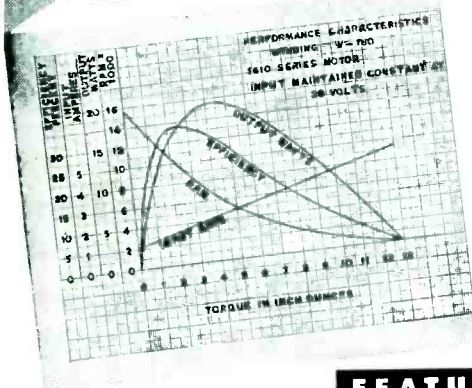

The power output of this precision motor is exceptionally high in proportion to its light weight and small size. Originally developed for numerous aircraft and portable applications, the characteristics of its performance can readily be modified for a variety of new uses.

**FEATURES**

**ELECTRICAL MECHANICAL**

- |                               |                               |
|-------------------------------|-------------------------------|
| Series or shunt wound         | Completely enclosed           |
| Unidirectional or reversible  | Adaptable for any mounting    |
| High starting torque          | Laminated field poles         |
| Low starting current          | Stainless steel shaft         |
| Low RF interference           | Two precision ball bearings   |
| Armature and field windings   | Mica insulated commutator     |
| Varnish impregnated and baked | Permanent end play adjustment |

1600 FRAME MOTORS		Series	Shunt
Watts Output, Int.	(max.)	22	
Watts Output, Con.	(max.)		5
Torque at 8500 RPM	(in. oz.)	3	
Torque at 5800 RPM	(in. oz.)	4.5	1
Lock Torque	(in. oz.)	12	3
Volts Input	(min.)	5	5
Volts Input	(max.)	32	32
Shaft Diameter	(max.)	.250"	.250"
Temperature Rise		50°C.	40°C.
Weight		12 oz.	12 oz.

**EICOR INC.** 1501 W. Congress St., Chicago, U. S. A.

DYNAMOTORS • D. C. MOTORS • POWER PLANTS • CONVERTERS

Export: Ad Auriema, 89 Broad St., New York, U. S. A. Cable: Auriema, New York

bridge is initially balanced before the member is strained, then rebalanced after the member is strained, the change in the reading of the calibration dial on the slide wire is then proportional to the deflection or strain. The second method of operation is the so-called voltage unbalance method in which the bridge is initially balanced before the application of the strain and the unbalanced voltage as indicated by a metering circuit is used as a measure of the strain. The third method is that in which the bridge is usually operated with an off-balance initial condition to provide an indication that the strain is either tension or compression.

The author concluded that the amplitude-modulated system provides a simple and reliable means for amplifying the output from electrical strain gages without the need for direct-coupled amplifiers. The basic problems in the design of this type of equipment for use as null system or a voltage unbalance system were treated in the paper.

*Tube History*

A rather comprehensive outline of the development of electron tubes was given by I. E. Mouromtseff of the Westinghouse Electric & Mfg. Co. He pointed out that although beam tubes are usually considered to be a recent development, the first practical result of electron tube research was the production of x-ray tubes in 1895 making use of the electron emission as a beam.

In discussing high-frequency tubes, it was pointed out that the first vacuum tube used in high-frequency circuits was built in 1892 by Zehnder for demonstrating Hertzian waves to large audiences. The Zehnder tube was a small gas-filled tube in which the gas discharge was triggered by high-frequency oscillation. The development of high-vacuum pumping techniques and the invention of the glass-to-copper seals by Houskeeper in 1922 gave a new impetus to the development of radio tubes. Mr. Mouromtseff anticipates tubes of 500 kilowatts as perhaps representing the ceiling for practical rating of individual sealed-off tubes, for at power greater than this, the cost of the tube will probably be out of proportion to their advantages because of design difficulties.



# GLASS-TO-METAL SEALS

*by the Thousand!*

**HUMIDITY-PROOF  
SHOCK-PROOF  
LEAK-PROOF**



## ***Another modern electrical development pioneered and perfected by Sprague***



Pioneered many months ago by Sprague, glass-to-metal seals for Sprague Capacitors and hermetically-sealed \*Koolohm Resistors

have progressed far beyond any "laboratory curiosity" stage. Not only are they being produced commercially at better than 10,000 seals per day, but they have proved highly efficient both electrically and mechanically. Seal sizes range from very small up to 3" diameter. They work equally well with practically any metal including steel, brass, and monel metal, and do not require the use of glass bushings and adjacent metal rings with "matched" temperature coefficients of expansion.

There are, of course, plenty of "scientific" reasons why glass-to-metal seals of this type are not feasible.

Here again, however, the allegedly impossible has simply provided the incentive for another outstanding Sprague engineering achievement. Actually, the only disadvantage to the seals so far uncovered is the fact that corona voltages are a little lower than we'd like them to be—yet this limitation only becomes a factor at voltages upwards of 25 KV. In all respects, the Sprague glass-to-metal seal answers the old problem of guarding Capacitors and Resistors adequately against leaks and moisture—and without organic bushings or other materials which might be attacked by fungus.

Today, glass-to-metal sealed Sprague Capacitors and \*Koolohm Resistors are available in 8,000 electrical characteristic combinations—which is another way of saying that there is a sealed unit for every application that needs one. Details gladly sent on request.

**SPRAGUE ELECTRIC COMPANY, NORTH ADAMS, MASS.**  
(Formerly Sprague Specialties Co.)



\* T. M. REG. U. S. PAT. OFFICE

# SPRAGUE

**PIONEERS OF ELECTRICAL-ELECTRONIC PROGRESS**

# NEWS OF THE INDUSTRY

**Conference notices; new television studios opened; Washington News on transformers, production of electronic equipment, broadcast power, tubes and parts**

## Collective Bargaining for Engineers

PROTECTION OF THE INDIVIDUAL engineer, suggests C. A. Powel, newly-elected president of AIEE, could probably be provided most effectively by an overriding association embracing all engineering and devoted specifically to the welfare of the profession as a whole and the individual members comprising it.

Speaking before the Los Angeles Section Meeting of AIEE, Mr.

Powel, who is manager of headquarters engineering at Westinghouse Electric and Manufacturing Company, said that such an organization must have constant and intimate contact with the rank and file of engineers and must bring its weight to bear in community and civic affairs. "The desire for collective action," Mr. Powel stated, "is as powerful among engineers as it is among members of labor or

white-collar unions." Two other plans of joint action have already been tried, but had serious shortcomings. One is the move of the American Society of Civil Engineers to have local sections act as bargaining units, while the other favors the inclusion of engineers in the general white-collar unions. However, as Mr. Powel pointed out, the first presents a number of legal obstacles and the second subjects the engineers to many decisions and rules which are clearly intended for a great majority of people doing an entirely different class of work.

## Therapeutic Music

THE EFFECTS OF MUSIC on certain types of mental and nervous disorders is being determined by experiments conducted through the surgeon general of the U. S. Army and

## ARMY-NAVY PREFERRED ELECTRON TUBES—SUPERSEDES PREVIOUS LISTS

RECEIVING TYPES											MISCELLANEOUS	
Filament Voltage	Diodes	Diode Triodes	Triodes	Twin Triodes	PENTODES			Power Output	Indicators	Rectifiers	Cathode Ray	Crystals
					Remote	Sharp	Converters					
1.4	1A3	1S5†	1LE3	3A5	1T4	1L4 1LN5 1S5⊕	1LC5 1R5	1LB4 3A4 3S4		1006	2AP1 3BP1 3DP1 3FP7 5CP1 5CP7 5FP7	1N21B 1N23B 1N25 1N26 1N27 1N28
5.0										5U4G 5Y3GT	5JP1 7BP7 12DP7 12GP7 913	Phototubes 927 929 930 931A
6.3	6AL5 6H6* 659	6AQ6 6SQ7* 6SR7*	2C22 2C40 6C4 6F4 6J4 6J5* 7E5/1201 9002	6J6 6SL7GT 6SN7GT 7F8	6AB7 6AG7 6SK7* 9003	6AC7 6AG7 6AJ5† 6AK6 6AS6 6SJ7* 7W7 9001	6SA7	6B4G 6G6G 6L6GA 6N7GT/G 6V6GT/G 6Y6G	6AF6 8E5	6X5GT/G 1005		Voltage Regulators OA3 /VR75 OC3 /VR105 OD3 /VR150
12.6	12H6*	12SQ7* 12SR7* 14E6**	12J5GT	12SL7GT 12SN7GT 14N7**	12SG7* 12SK7* 14R7**	12SJ7* 14H7# 14W7	12SA7* 14J**	12A6*	1629			
25 and above								25L6GT/G 28D7**	991	25Z6GT/G		

TRANSMITTING TYPES										
Triodes	Tetrodes	Twin Tetrodes	Pentodes	Pulse Modulators	RECTIFIERS			Grid Control	Clipper Tubes	Gas Switching
					Vacuum	Gas	Gas			
2C26A	826	807	815	2E22	3D21	2X2A	4B25	2D21	3B26	1B32/532A
2C39	833A	813	829B	4E27	3E29	3B24	83	3C23	719A	
2C43	862A	814	832A	803	6C21	5R4GY	867B	3C31/C1B		
3C24	880	827R		837	715C	371B	868A	C5B		
CV92 (Br.)	889R	1625				705A	869B	8D4		
100TH	893A					836	872A	394A		
250TH	1626					1818		884		
304TH	8025					8016		2050		
827						8020				
811										

\*Where direct interchangeability is assured "GT" and "L" counterparts of the preferred metal tube may be used.

†Diode Pentode.

\*\*These tubes are the only types with characteristics specified for 28-volt plate supply, and may be used in this type of application. Any of the types listed under "Receiving Diodes" may be used for 28-volt plate supply applications.



● **Recommended for Fast, Easy, ACCURATE Calibration of Wavemeters, Signal Generators, Oscillators, Receivers, etc.**

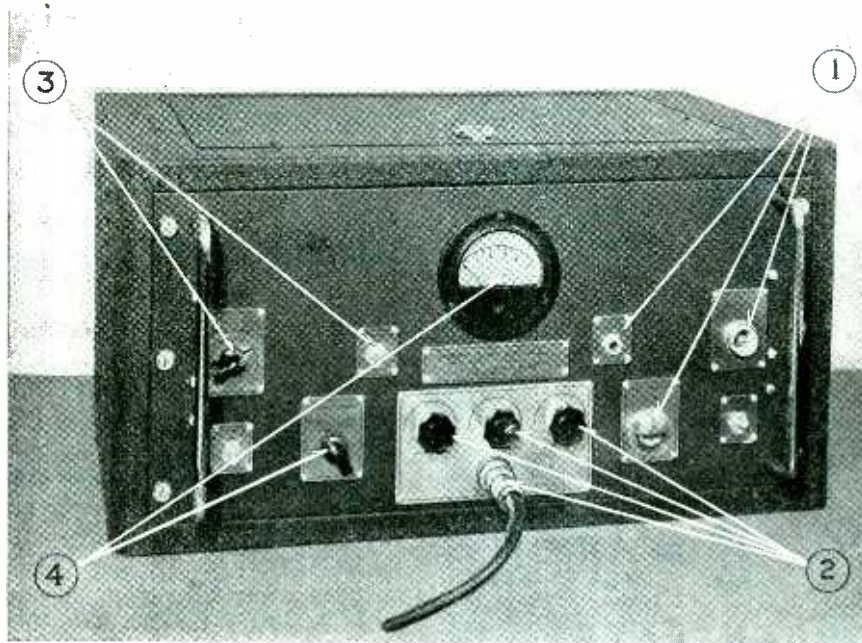

★ ★ ★

### *High Lights*

1. BEAT DETECTOR UNIT provides easy calibration with either aural or visual indication of zero beat.
2. OUTPUT and ADJUSTMENTS give crystal-controlled harmonic frequencies up to 2000 megacycles.
3. MODULATION CONTROLS permit selection of either modulated or unmodulated output as well as degree of modulation.
4. MILLIAMMETER and SELECTOR SWITCH facilitates easy adjustment of output controls.

★ ★ ★

## The Secondary Standard **LAVOIE C-200 CALIBRATOR**

The LAVOIE C-200 Calibrator is an instrument that establishes *crystal-controlled* frequencies at UHF up to and beyond 2000 megacycles. By means of a switch it cuts out 10's and produces only 40's on the megacycle frequency range . . . or by means of an Identifier, selects any ONE of these frequencies for purposes of identification. A detector and amplifier on the panel expedite the calibration of signal generators, etc. Detailed information promptly upon request.



# *Lavoie Laboratories*

RADIO ENGINEERS AND MANUFACTURERS  
MORGANVILLE, N. J.

**Specialists in the Development of UHF Equipment**

# Insl-x - First in Fungicides



Capacitor with standard wax.



Capacitor with INSL-X treated wax.

After 5 days' actual exposure

## INSL-X I-1T

### FUNGICIDAL CONCENTRATE for ELECTRONIC WAXES

MEETS U. S. ARMY SIGNAL CORPS REQUIREMENTS

- Prominent manufacturers find INSL-X I-1T Fungicidal Concentrate for Electronic Waxes highly effective in the treatment of impregnating waxes for coils and parts • in the surface treatment of phenolic resistors, tube sockets, etc. • for protection of cotton wire coverings • for wax paper, labels, etc.

- INSL-X I-1T will not vaporize or lose potency at bath temperatures. *Official tests show INSL-X Fungicides are non-toxic to humans. INSL-X fungicides are non-corrosive to metals.*

*For chlorinated naphthalene ("Halowax") INSL-X I-2T is recommended.*

INFORMATIVE LITERATURE ON FUNGUS PREVENTION AVAILABLE UPON REQUEST

**THE INSL-X CO., Inc. • 857 Meeker Ave. • Brooklyn 22, N. Y.**

Chicago

Detroit

Los Angeles

Philadelphia

the Institute of Applied Music. Music as an aid to treatment has been tried before, but has never been properly or adequately controlled nor has its application been evaluated scientifically.

The music itself, which in this experiment is regarded solely as an aid to treatment and not as entertainment or recreation, will be presented by the highest type of professional musicians. Presumably, successful results from these tests will point the way to wider use of recorded and transcribed presentations.

### Television on SMPE Agenda

A PAPER ON PROJECTION TELEVISION delivered, at the 56th Semi-Annual Technical Conference of the Society of Motion Picture Engineers, by Dr. D. W. Epstein of RCA Laboratories and Dr. I. G. Maloff of RCA Victor Division, Radio Corp. of America. The conference, held in the Hotel Pennsylvania, New York, on Oct. 16, 17, and 18, also included a talk on coaxial cable and other facilities for television networks, by H. S. Osborne, chief engineer, AT&T.

### CONVENTIONS TO COME

Nov. 2-3. National Time and Motion Study Clinic, Chicago, Ill. INDUSTRIAL MANAGEMENT SOCIETY, C. S. Becker, vice president, 205 West Wacker Drive, Chicago 6, Ill.

Nov. 9-10. Fall Meeting, Dayton, Ohio. INSTITUTE OF THE AERONAUTICAL SCIENCES, Robert R. Dexter, secretary, 1505 RCA Bldg. West, Rockefeller Center, New York 20, N. Y.

Nov. 13-14. Rochester Fall Meeting & War Radio Conference, Rochester, N. Y. ROCHESTER FALL MEETING COMMITTEE, Virgil M. Graham, chairman, PO Box 750, Williamsport, Pa.

Nov. 13-14. Annual Fall Convention, New York, N. Y. SOCIETY OF THE PLASTICS INDUSTRY, C. S. Shoemaker, meeting chairman, Dow Chemical Co., 30 Rockefeller Plaza, New York 20, N. Y.

Nov. 15-19. AMERICAN CHEMICAL SOCIETY, Chicago section. Third Bi-



# Great Events in the History of...

## COMMUNICATIONS!



**The Telephone Talks!** "Mr. Watson, come here, I want you!"—this sentence uttered by Alexander Graham Bell on the evening of March 10, 1876, was the first ever transmitted by telephone. This great event soon led to the beginnings of the Bell Telephone System—for which Western Electric has been the manufacturer ever since 1882.

**EVEN BEFORE** the first of these events Western Electric—founded on November 18, 1869—was making electrical communications equipment. Bell Telephone maker since '82—pioneer in radio since its beginning—the Company today is the nation's largest producer of electronic and communications apparatus for war. In the peace that's coming, count on Western Electric—with its unique 75-year experience—for continuing leadership.

*During the 6th War Loan Drive, buy more Bonds than ever!*



**The Telephone Spans the Continent!** On January 25, 1915, Alexander Graham Bell talked once more to Thomas A. Watson on a momentous occasion—the first time a telephone message crossed America. This great advance was made possible by the use of Western Electric vacuum tube repeaters—the first of many millions we have produced for the Bell System.



**Radio Telephone Spans the Atlantic!** Just before dawn on October 21, 1915, the first spoken words spanned the Atlantic—transmitted from Arlington, Va., and received in Paris by radio telephone apparatus designed and made by Western Electric. Out of this pioneering came world-wide telephony—broadcasting—aviation, marine and mobile radio.



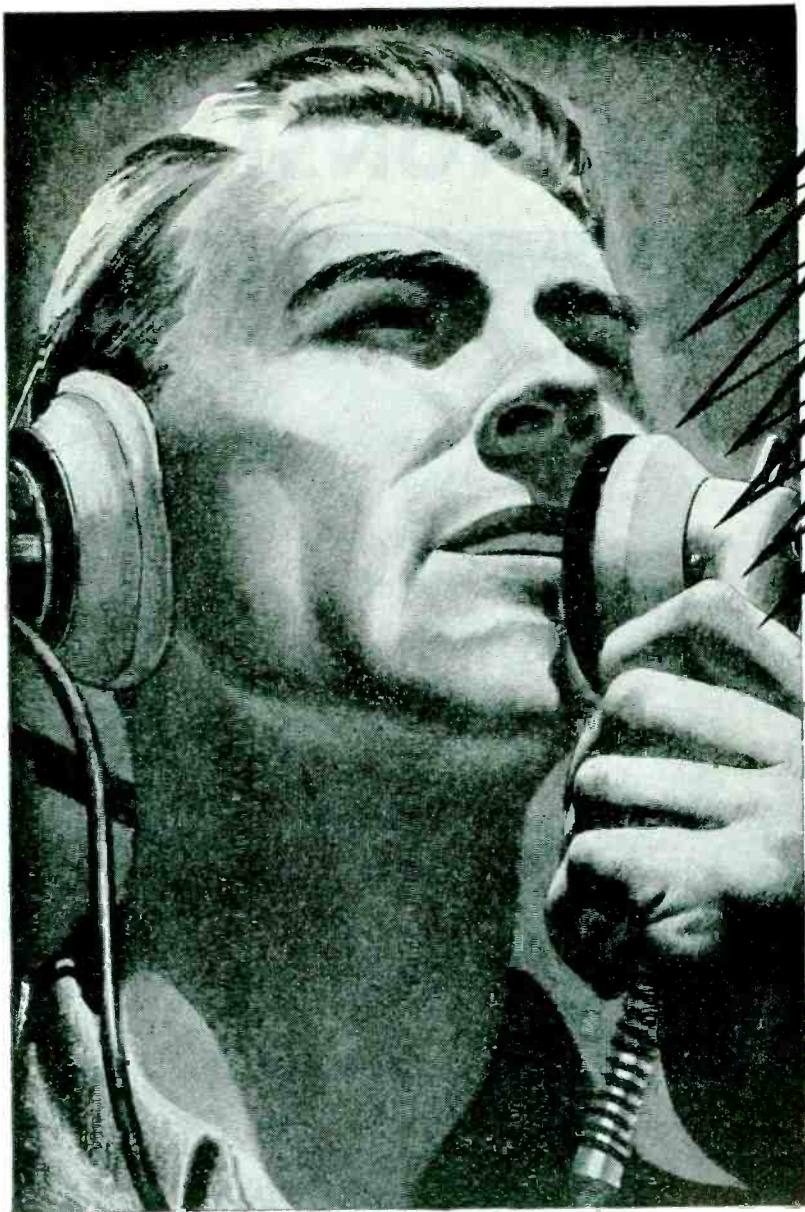

# VOLTAGE REGULATORS "VIBRATION PROOFED"

How can a Voltage Regulator be made to operate efficiently in spite of vibration?

That's a question which faced design engineers responsible for the communications systems on our fighting planes. The answer was found in a little piece of scientifically compounded rubber safely bonded between two pieces of metal. When the regulators were mounted on these, the trouble was over.

The mountings themselves look quite simple—but behind them is a backlog of scientific knowledge—the Science of Smoothness. By this is meant the science of engineering rubber and metal into resilient supports which will isolate vibration and shock.

Men of the engineering staff of United States Rubber Company have been working in this particular field of science for many years. They have helped to solve a wide variety of difficult problems for engineers confronted with the necessity of preventing vibration and shock from interfering with the operation of their equipment.

They will be glad to work with you.



SERVING THROUGH SCIENCE

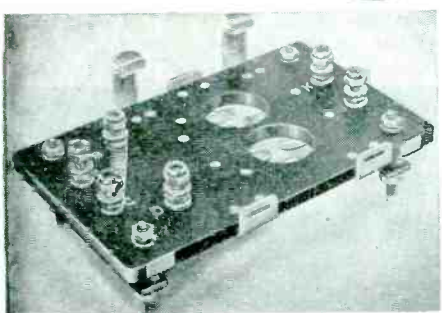

**ONLY WHEN ISOLATED FROM VIBRATION** can aircraft-type voltage regulators keep the flow of electricity constant for more efficient communication. This is accomplished through the use of "U.S." engi-

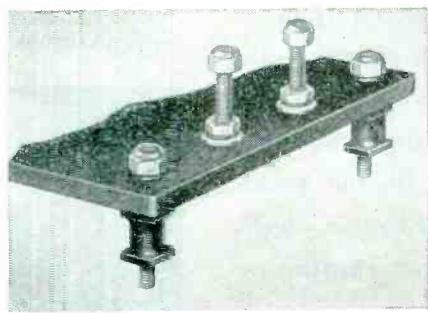

neered rubber mountings designed specifically for each type of base. Quality of performance is predetermined before installation.

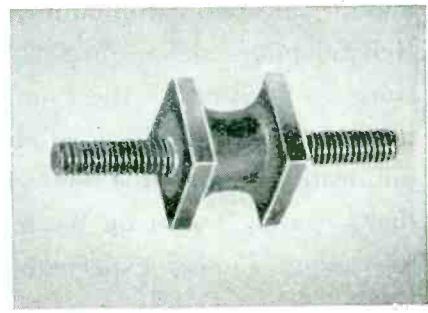

**THIS VOLTAGE REGULATOR MOUNTING** is only one of many types designed by "U.S." engineers for mechanisms ranging from sensitive electronic instruments to heavy industrial equipment.

*Listen to the Philharmonic-Symphony program over the CBS network Sunday afternoon, 3:00 to 4:30 E.W.T. Carl Van Doren and a guest star present an interlude of historical significance.*

## UNITED STATES RUBBER COMPANY

1230 SIXTH AVENUE • ROCKEFELLER CENTER • NEW YORK 20, N. Y. • In Canada: DOMINION RUBBER COMPANY, LTD.



# New INTERNAL-PIVOT 2 1/2 - INCH PANEL INSTRUMENTS ... 1 INCH DEEP

Designed for thinness—but G-E engineers took advantage of the new magnetic materials to improve performance and add unusual values. Comol was selected for the magnet, and it thus became the basic part around which the internal-pivot element was designed.

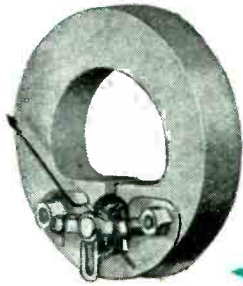

Moving element mounted on one-piece comol magnet

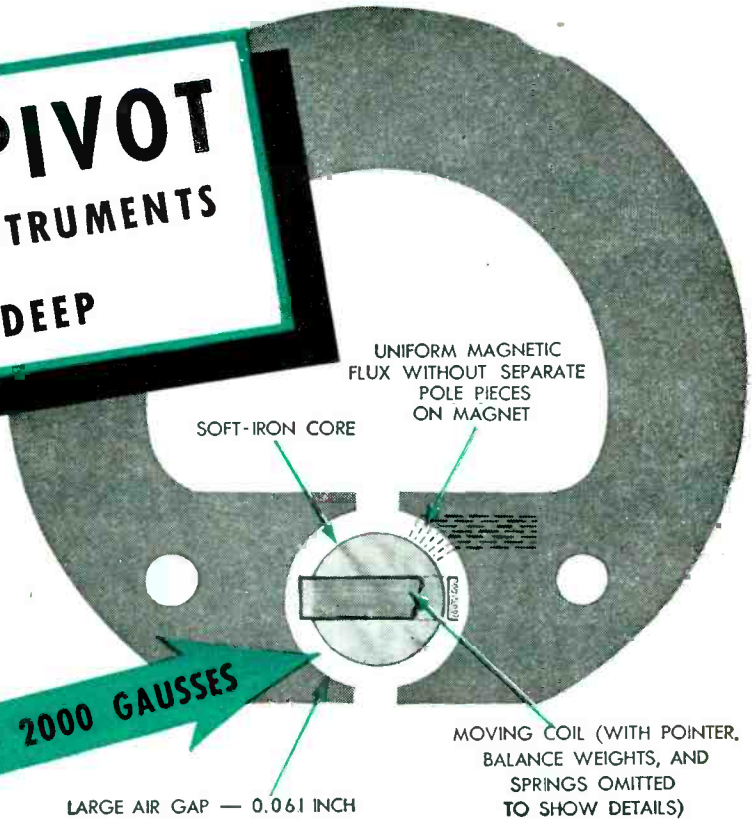

## Extra Values That the Comol Magnet Gives You

**A**N air-gap flux density of approximately 2000 gaussses—made possible by the comol magnet—means a magnetic field some 50 per cent stronger than that of the conventional chrome-steel magnet.

**Higher Torque** This greater magnetic strength provides a substantial increase in torque. Since the weight of the moving element is about the same as that of other designs, the torque-to-weight ratio is much higher.

**Faster Response** The greater flux density also allows the use of a larger air gap, which minimizes any tendency toward stickiness. Faster response, which is assured by the high torque and lightweight moving system, enables accurate readings to be taken more quickly.

**Improved Performance** Large-radius pivots and good damping are among the other good features in the internal-pivot design—a design that packs all-round fine performance in a small space. They all add up to an instrument that is well able to withstand abnormal vibration and shock and maintain its rated accuracy.

For complete information, ask our nearest office for Bulletin GEA-4064, which covers instruments for use in radio and communications equipment; or Bulletin GEA-4117, which describes those suitable for naval aircraft. *General Electric Company, Schenectady 5, N. Y.*

Buy all the BONDS you can—and keep all you buy

**GENERAL  ELECTRIC**

602-78-6200

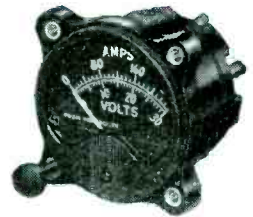

Type DW-53 d-c voltmeters, ammeters, and volt-ammeters. Designed to measure voltage and current in battery and battery-charging circuits on naval aircraft. Designed to meet all applicable Navy specifications.



For radio and other communications service: Type DW-51 d-c voltmeters, ammeters, milliammeters, microammeters, Type DW-52 radio-frequency ammeters (a-c thermocouple type). Cases are brass or molded Textolite.



HEADQUARTERS FOR  
ELECTRICAL MEASUREMENT

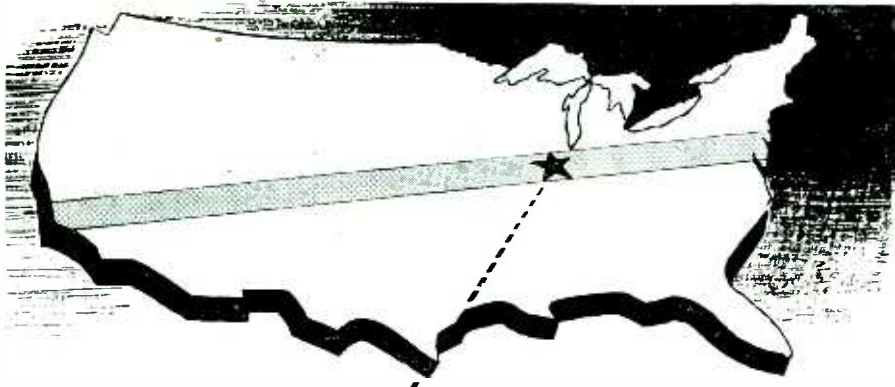

**FAST, EFFICIENT  
NATION-WIDE SERVICE  
on *Everything* in  
ELECTRONICS and RADIO**



**save time . . . call ALLIED first**

From every corner of the Nation . . . come calls to ALLIED for "rush delivery" of vital supplies — supplies to keep production humming . . . aid laboratory research . . . help men in training and men in action. For it's well-known that in this arsenal of supply are centralized today's *largest and most complete stocks under one roof* . . . over 10,000 electronic and radio items!

Furthermore, our close contact with all leading manufacturers enables us to speed procurement of "hard-to-get" items.

Wherever you are . . . whatever you need . . . call *Allied First*. Our central location in the heart of U. S. transportation means faster service . . . all-ways!



**NEW R-F RESONANCE and  
COIL WINDING CALCULATOR**

Easy to use! For fast accurate determination of resonance factors and coil winding data. No. 37-955, Postpaid, 25c.

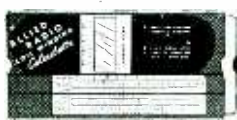

**FREE**  
Complete Up-to-date  
**BUYING GUIDE**

Write, Wire or Phone Haymarket 6800

**ALLIED RADIO CORP.**  
833 WEST JACKSON BLVD., DEPT. 24-L-4, CHICAGO 7, ILLINOIS

**OVER 10,000 ITEMS—such as:**

- |             |               |                |
|-------------|---------------|----------------|
| Tubes       | Transformers  | Microphones    |
| Condensers  | Relays        | Headphones     |
| Capacitors  | Switches      | Public Address |
| Resistors   | Rectifiers    | Test Equip.    |
| Rheostots   | Wire & Cable  | Intercom.      |
| Coils       | Speakers      | Power Supplies |
| Sockets     | Receivers     | Converters     |
| Photo Cells | Training Kits | Generators     |
| Batteries   | Code Equip.   | Chargers       |



ennial National Chemical Exposition & National Industrial Chemical Conference, Coliseum, Chicago, Ill. Marcus W. Hinson, manager, 330 South Wells St., Chicago 6, Ill.

Dec. 11-12. First Annual Conference New York, N. Y. TELEVISION BROADCASTERS ASSOCIATION, Will Baltin, secretary, 500 Fifth Ave., New York 18, N. Y.

Jan. 22-26. AMERICAN INSTITUTE OF ELECTRICAL ENGINEERS. Winter Technical Meeting, New York, N. Y. H. H. Henline, secretary, 33 West 39 St., New York 18, N. Y.

Jan. 30-Feb. 1. INSTITUTE OF THE AERONAUTICAL SCIENCES. Thirteenth Annual Meeting, Pupin Physics Laboratory, Columbia University, New York, N. Y. Meetings Committee, 1505 RCA Building West, 30 Rockefeller Plaza. New York 20, N. Y.

**Multi-Studio Television**

FACILITIES of the DuMont television station in New York, WABD, have formerly consisted of a single studio alongside the transmitter, film projection room, and laboratory on the 42nd floor of a Madison-Avenue building. Recently a new studio on the second floor of the same building was put into service. Larger than the first, it still follows the principle of low-cost, small-staff, and minimum-space operation—showing the possibilities of television broadcasting for the relatively small operator.

Among problems which proved troublesome to company engineers installing the new studio were vibrations from the subway under the building and magnetic fields from the passing trains. These deflected the cathode-ray pictures three-quarters of an inch and required special shielding. A coaxial link was used between the 2nd and 42nd floors.

**WASHINGTON NEWS**

TRANSFORMERS. Officials of WPB have asked transformer makers to refuse orders when they cannot deliver and to notify WPB of the fact. The board will then aid in passing the orders on to other manufacturers with available capacity. Ade-



# 2 POPULAR RCA INSTRUMENTS

for high-precision measurement work

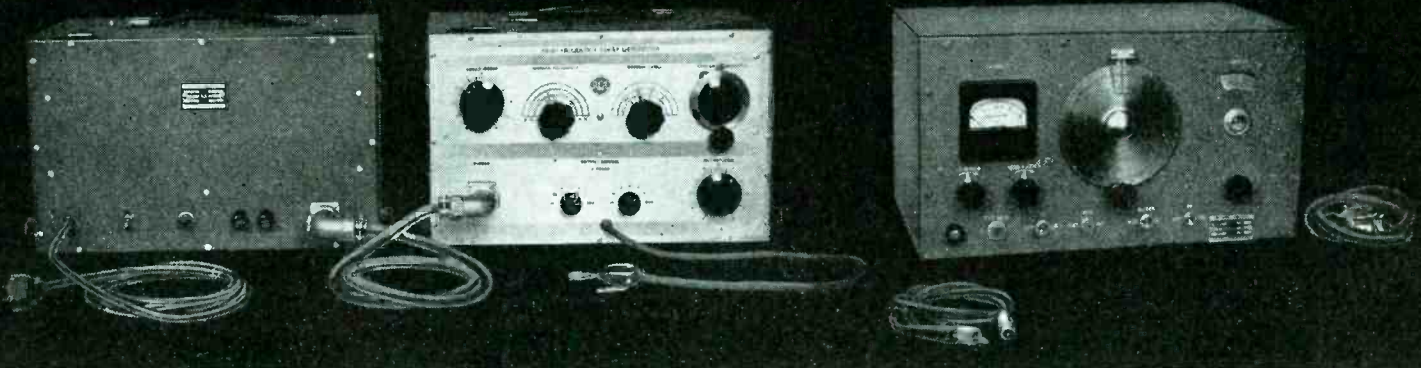

RCA High-Frequency Wide-Band Sweep Generator

*Type 709 B*

RCA Ultra-High Frequency Signal Generator

*Type 710 A*

**T**HE big job is done—valuable development, production and field test experience are combined in two quality products—the 709 B Sweep Generator and the 710 A Signal Generator. Here are two instruments every Television, FM and H.F. Laboratory can rely on for postwar design applications.

The 709 B Sweep Generator covers the frequency band of 5 to 65 megacycles (center frequency). It is ideal for high frequency I. F. curve response study. Its calibration marker permits constant checking of band width characteristics.

The 710 A Signal Generator, with a frequency range of 370 to 560 megacycles, is widely used for checking high frequency devices. This instrument provides

smooth and complete attenuation throughout its range, plus precision frequency control.

Planning your postwar activity means planning your laboratory facilities as well. Now is the time to investigate the characteristics of these reliable RCA instruments.

*RCA bulletins containing complete descriptions and specifications of the 709 B Sweep Generator and the 710 A Signal Generator will be sent promptly on request.*

*Please note that deliveries of these instruments are subject to regulations of WPB General Scheduling Order M-293.*

*Buy More War Bonds* 



**RADIO CORPORATION OF AMERICA**

**RCA VICTOR DIVISION • CAMDEN, N. J.**

*In Canada:*

**RCA VICTOR COMPANY LTD., MONTREAL**



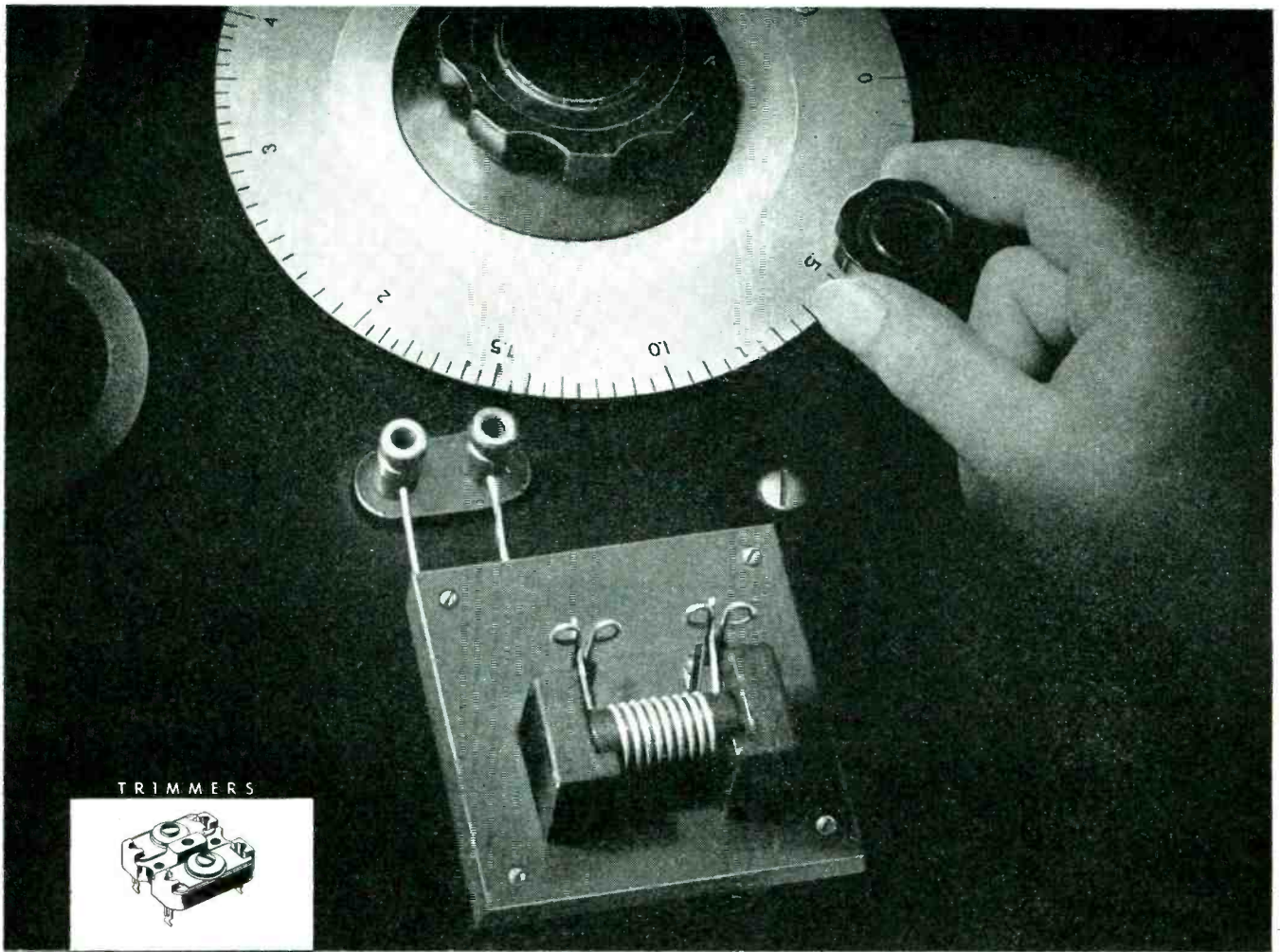

TRIMMERS



TRANSFORMERS



R.F. COILS

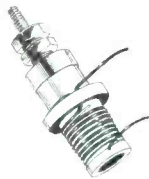

I.F. COILS



CHOKE COILS

## CRUCIAL MOMENT

The indispensable attribute of a component destined for an assembly line is absolute uniformity.

The "Crucial Moment" in the manufacture of a coil is the measurement and adjustment point, at which this uniformity is achieved.

Our years of experience assure the best in production testing apparatus. Our Engineering is equipped for the most elaborate basic type testing . . . at high and low temperatures . . . extremes of humidity . . . under vibration and impacts and electrical characteristics at low or high frequencies.

For your requirements . . . whether coils or trimmers, depend on *AUTOMATIC* for uniformity and reliability at no greater cost.

***AUTOMATIC***  
***WINDING CO., INC.***

KEEP BACKING  
 THE ATTACK!  
 BUY MORE  
 WAR BONDS

COMPLETE ELECTRONIC ASSEMBLIES & COMPONENT PARTS

900 PASSAIC AVE.

EAST NEWARK, N. J.





## MEETING THE HIGHEST INDUSTRIAL STANDARDS

Nationally recognized engineering talent . . . sharpened by intelligent specialization . . . broadened by the exacting tests of war . . . explains, in part, PLASTIC'S amazing progress in the field of thermoplastic insulation. Also responsible are latest equipment, careful materials control, and a personnel whose loyalty and devotion is "above and beyond the call of duty." You can utilize to advantage . . . in today's planning and tomorrow's production . . . this experience and ability. Available for the asking is the "know how" which can make your product a BETTER product. You can **DEPEND** on PLASTIC for design . . . development . . . delivery.

**THERMOPLASTIC  
SPECIALISTS**

# PLASTIC

**WIRE & CABLE  
CORPORATION**

*NORWICH • CONNECTICUT*

L. W. LORD, President    M. H. PHILLIPS, Vice President and Treasurer    A. O. BLADES, Plant Manager

# Haydon MAKES D.C.

## Behave

### IN A TIME DELAY RELAY

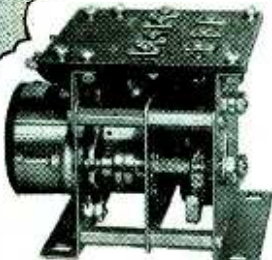

Where 60 cycle alternating current is not available; wherever interval timing and time delay operation are needed with Direct Current, the Haydon D.C. Clutch Unit functions like the proverbial charm.

It isn't magic — but its action is smooth, certain, automatic. Magnetically operated, it engages and disengages the switch operating arm, while the motor runs independently. At the end of the timed period, the clutch is still engaged, holding the contact in final position until the circuit is broken externally, when the arm resets automatically. Satisfactory operation on widely varying voltages and temperatures.

Haydon AC and DC timing motors and devices are finding even wider scope in new applications for after the war — for homes and factories — in the new automatic devices of tomorrow.



**3100 SERIES  
HEAVY GEAR  
UNIT**

Manufactured to your specific requirements in voltage, frequency and speed. Gear train designed for applications up to 15" lbs. torque at the output shaft.

Write today for your copy of this catalogue.



# Haydon

MANUFACTURING COMPANY  
\* INCORPORATED \*

Forestville, Connecticut

quate supplies of components will be available if manufacturing facilities are thus distributed. Backlogs of transformer orders were described as slowly decreasing in most plants and reductions in delivery time anticipated. In connection with cutbacks related to VE day, even though quantities might be reduced as much as 30 percent, much of the remaining production would involve tropicalization with attendant production problems.

**PRODUCTION INDICES.** Figures released by WPB reveal June production figures in communication and

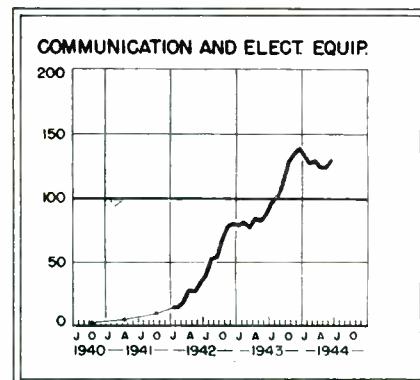

electronic equipment increasing 4 percent over May and raising the index 6 points to 130. See chart. Airborne equipment led the way with an increase of 8 percent. Ship equipment remained at the May level while ground equipment went up 4 percent.

**RADIO PARTS COMMITTEE.** OPA announces a radio parts manufacturers' industry advisory committee consisting of: Octave Blake, Cornell-Dubilier Electric; Samuel I. Cole, Aerovox Corp.; Monte Cohen, F. W. Sickles; Russell E. Cramer, Radio Condenser; Allen Fritzsche, General Industries; Robert C. Sprague, Sprague Electric; Leslie F. Muter, Muter; W. G. Roby, Cinch Mfg.; J. H. Stackpole, Stackpole Carbon; Thomas A. White, Jensen Radio Mfg.; A. Blumenkranz, General Instrument; George Fraser, Astatic Microphone; Hugh H. Eby, Hugh H. Eby, Inc.; L. W. Howard, Peerless Electrical Products; Jerome J. Kahn, Standard Transformer; Harry E. Osmun, Centralab; Harry Ehle, International Resistance; and C. L. Walker, Utah Radio Products.

**BROADCAST POWER.** By an amendment to section 3.64 of its rules governing standard broadcast stations,



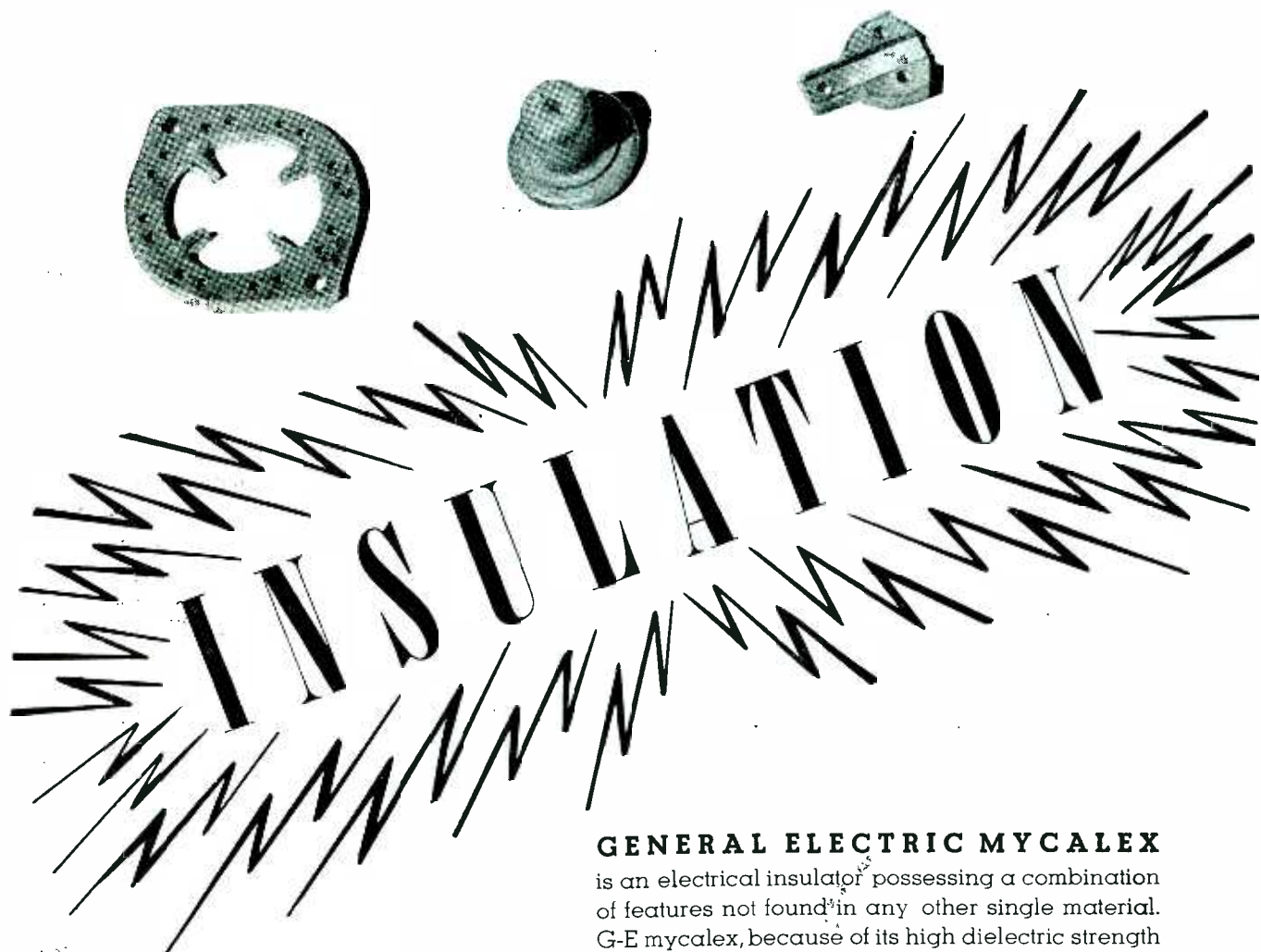

# INSULATION

## GENERAL ELECTRIC MYCALEX

is an electrical insulator possessing a combination of features not found in any other single material. G-E mycalex, because of its high dielectric strength and low power factor, is ideally suited for use as a high frequency insulator in radio equipment and for ignition assemblies in high altitude aircraft. Arcs occurring at high altitudes do not cause permanent conductive tracks.

Because intricate shapes may be molded with G-E mycalex with "molded-in inserts", because these parts are made to extremely close tolerances and because their dimensional stability is high, G-E mycalex is a superior material for assemblies which must stand up under severe operating conditions. Although G-E mycalex can be drilled, milled, and ground, these operations are seldom necessary due to the fact that parts can be molded to shape.

For further information write section N-253, One Plastics Ave., Pittsfield, Mass.

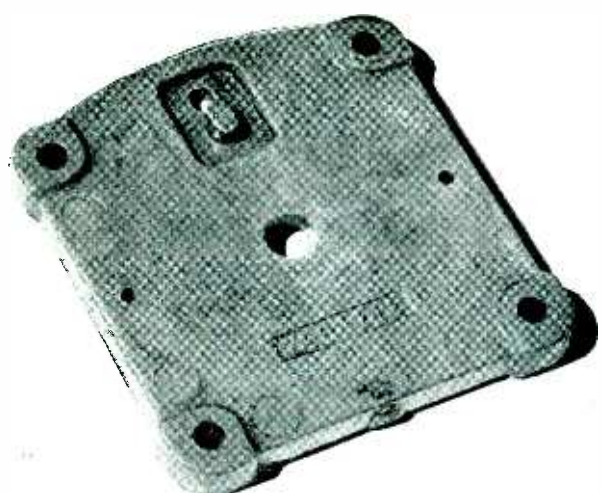

PLASTICS DIVISIONS  
**GENERAL ELECTRIC**



PD-258

# Dependable Power..



Probably the most important single factor in modern warfare is complete, dependable communications. Dependable communications require a dependable power supply. Pincor is proud of its part in furnishing portable gasoline-driven and other electrical power supply units to the fighting front as well as to the home front.

Look to Pincor for your postwar needs in power plants, motors, converters and battery chargers.

**DYNAMOTORS . . . CONVERTERS  
GENERATORS . . . D C MOTORS  
POWER PLANTS...GEN-E-MOTORS**

**BUY WAR BONDS!**

**PINCOR**  
*Products*

**PIONEER  
GEN-E-MOTOR**

**CORPORATION  
5841-49 DICKENS AVENUE  
CHICAGO 39, ILLINOIS**

**EXPORT ADDRESS: 25 WARREN STREET, NEW YORK 7, U. S. A. • CABLE ADDRESS: SIMONTRICE, NEW YORK**

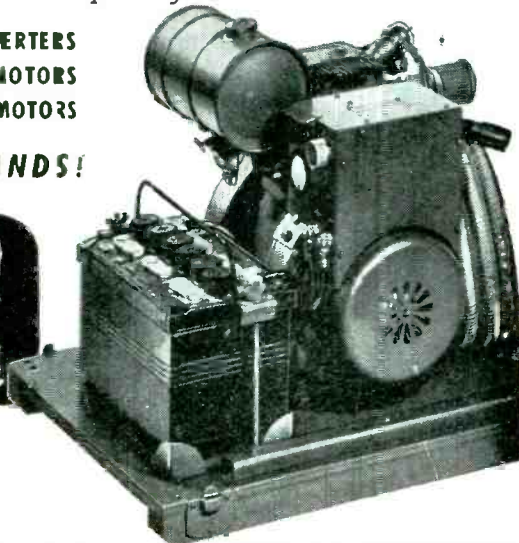

FCC makes it possible for a station operating with different power day and night to get a license authorizing the use of alternate transmitters. Requirements are that both be located at one place and that both be substantially the same as to frequency stability, reliability of operation, radio harmonics and other spurious emissions, audio frequency range, and audio harmonic generation.

**AUTOMATIC PHONOGRAPHS.** The following individuals have been appointed by WPB to constitute the commercial automatic phonograph industry advisory committee: J. E. Broyles, Rudolph Wurlitzer; Robert Gabel, John Gabel Mfg.; Carl T. McKelvy, J. P. Seeburg; David C. Rockola, Rock-Ola Mfg.; E. E. Rullman, Automatic Instrument; and V. G. Wahlberg, Mill Industries.

**TUBES AND RADIO PARTS.** Changing conditions have made it possible for the radio and radar division of WPB to revoke two limitation orders. Since distribution and production of several hundred types of tubes are now scheduled under M-293, their limitation by L-76 is no longer necessary. Replacement parts for home radios have been subject to L-293 which was designed for maximum conservation of materials without regard to the most efficient use of production facilities. Its removal will allow production of these components on the same lines that are running other parts.

## APCO Conference

ACCENT ON the importance of retaining present police radio channels and providing for additional radio frequencies in the postwar period was made at the 11th annual national conference of Associated Police Communication Officers in a three-day session at Toledo, Ohio, during September.

Selection was made by the 300 members present of a large police radio committee to appear at the FCC allocations hearing in Washington in October.

Acclamatory re-election of the principal officers for 1945 included: president Frank W. Walker; first vice-president Ray S. Groenier; *Bulletin* editor Capt. J. M. Wherritt



# FIRE!

## REDUCE THE HAZARD WITH AMERTRAN ABESTOL IMMERSED TRANSFORMERS

Single phase, half wave rectifier plate transformer, 60 cycles, 220 volts primary, 110,000 volts secondary.

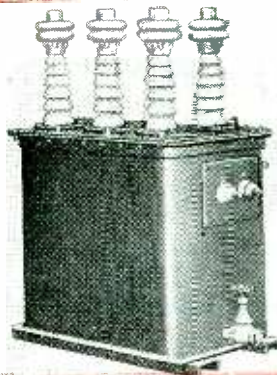

300 VA Filament transformer, single phase, 60 cycles, 3 secondary windings of 5 volts each; 3 secondary windings operating 50 KV above ground and 3 secondaries operating 20 KV above ground.



60 KVA, three phase, 60 cycles, 211 volts, Delta primary, 2900 / 6755 / 7800 / 13510 volts Wye secondary.

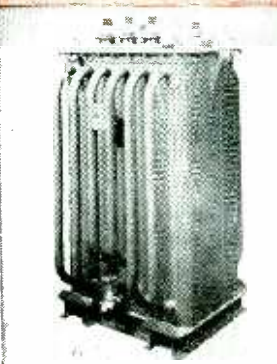

150 KVA Distribution transformer, single phase, 600 high voltage, 240/120 low voltage.



Fireproof AmerTran Abestol Immersed Transformers reduce both the possibility and the extent of fire damage. That's why they earn lower insurance rates and permit vaultless indoor installation, with its convenience, flexibility and accessibility. To industry, AmerTran Abestol Immersed Transformers offer the advantages of load center installation: copper savings, finer voltage regulation, lower line losses and improved motor performance. If necessary, they may be mounted overhead because the chemically inert Abestol, which requires no maintenance, is sealed. In comparison to transformer oil, Abestol possesses higher insulating properties and similar heat transmission characteristics.

Send for further information.

**AMERICAN TRANSFORMER COMPANY**  
178 EMMET STREET, NEWARK 5, NEW JERSEY



Pioneer Manufacturers of Transformers, Reactors and Rectifiers for Electronics and Power Transmission

# Fungi

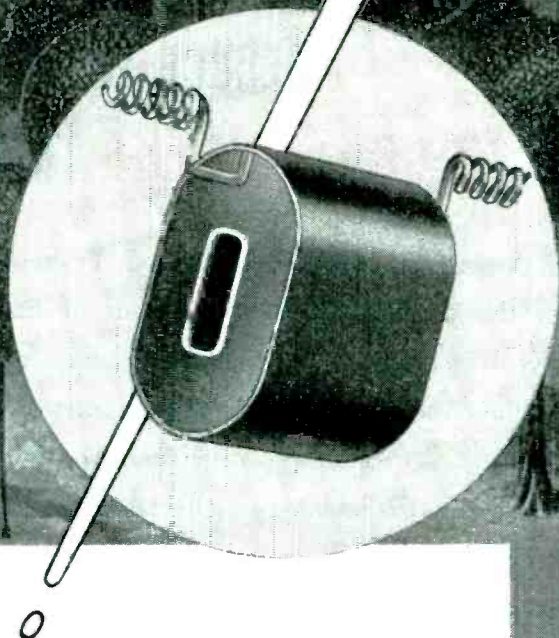

## Deadly Agents of Destruction

This is not a balloon barrage. It is an actual photograph, highly magnified, of parasitic organisms (fungus growths), the control of which poses one of the toughest problems our armed forces have to contend with in keeping electrical and communication equipment in operation.

If your present contracts utilize electrical coil windings, and call for "tropicalization" or "anti-fungus" treatments, our 27 years of experience are at your service to provide proper coil design and treatment.

COIL SPECIALISTS SINCE 1917

**COTO-COIL CO., INC.**

65 PAVILION AVE.

PROVIDENCE 5, R. I.

and secretary-treasurer Ero Erickson. D. J. McFarlane is new second vice-president and C. H. Knudel was chosen sergeant-at-arms.

Meeting in full session during the APCO conference, and prefaced by an address by RTPB chairman Dr. R. G. W. Baker, RTPB Panel 13 was headed by D. E. Noble and formalized all of the 9 committee reports by approving the frequency allocations already resolved within the Panel and transmitted the findings to the Planning Board.

A police allocations sub-committee agreed to support an interspersed frequency allocations scheme in preference to a block system of assignments and emphasized the need of low-frequency police radio channels in mountainous regions of California and the east, in addition to the retention of essential point-to-point radiotelegraph and voice channels now in use.

## Experimental Canadian FM

FOLLOWING UP EXPERIMENTS which had previously been made at Montreal, Canadian Broadcasting Corp. plans to establish an experimental f-m transmitter in that city. Funds will come from the \$100,000 reserves of the Corporation, according to Dr. Augustin Frigon, assistant and acting general manager.

## Electronics on the Super-Fortress

COMMUNICATION AND navigational aids have an outstanding importance to the AAF's 20th Air Force, operators of the B-29 Boeing Superfortress task force. Communications are under the direct command of Brigadier General Harold M. McClelland, air communications officer for the AAF.

When each of the Superfortresses takes off on bombing flights over Japan it carries approximately 2,000 lb of Signal Corps aircraft radio equipment.

Composed of many different radio sets and devices, all of which were either developed or improved in the Signal Corps' aircraft radio laboratory at Wright Field, the radio complement for this super-bomber was the largest single installation job ever undertaken by the laboratory, according to Col. Hobart R. Yeager, commanding of-



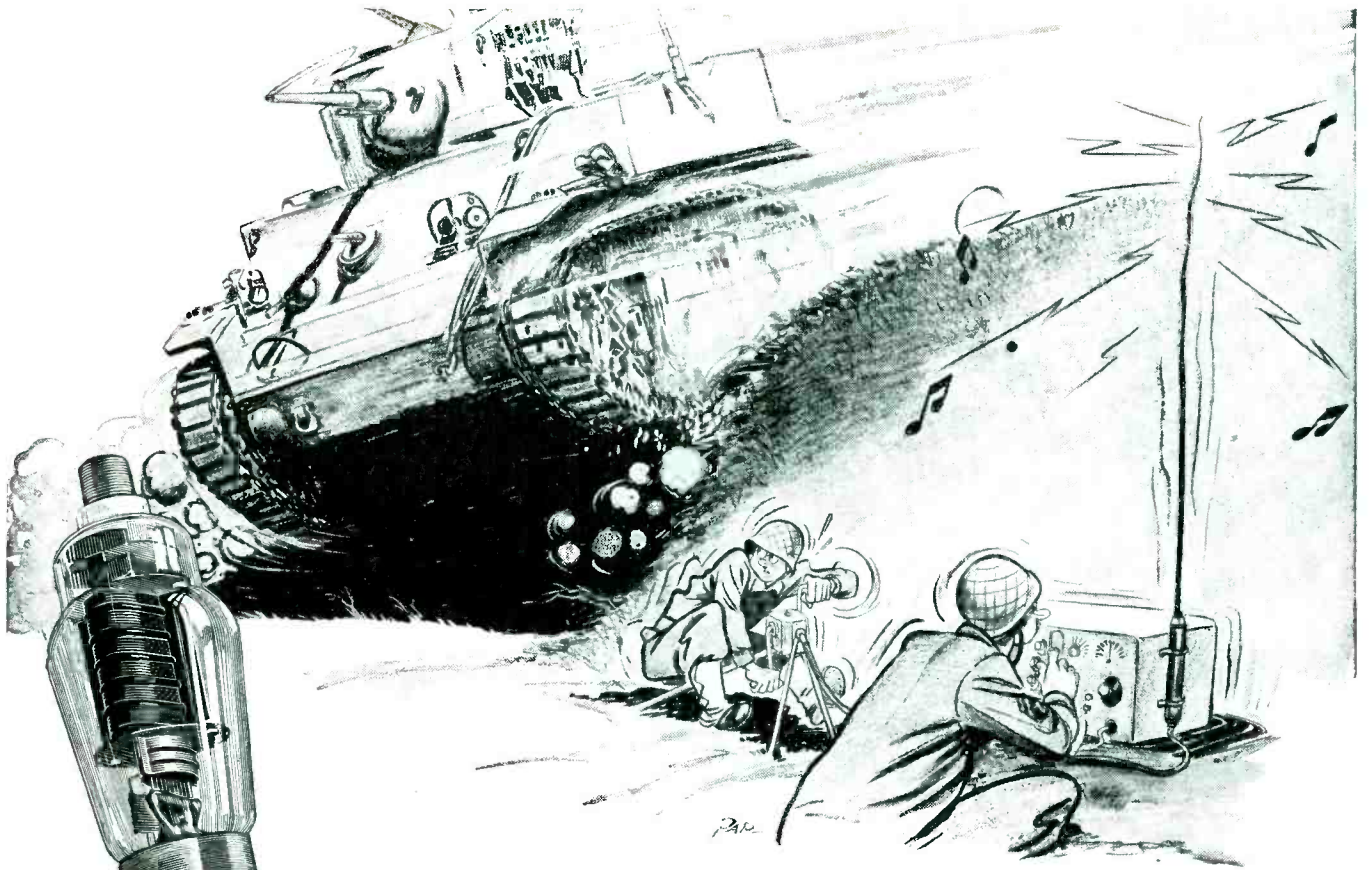

## DEPENDABLE . . . UNDER ALL CONDITIONS

By concentrated abuse, the war has proved the relative merits of materials and construction in many kinds of equipment. This is particularly true in the case of Electronic Tubes.

The fact that TUNG-SOL Tubes have given long and efficient service in all kinds of electronic devices is no happy accident. It is the result of many years of intensive research . . . tests for performance in screen rooms by radio scientists . . . tests for ruggedness by engineers to find possible weaknesses . . . redesigning to make sure that tubes meet the

most exacting requirements of use. For instance, in one particular transmitting type, the tendency of the filament wires to go out of alignment from vibration was a common shortcoming. This was remedied by a change in one simple construction feature as shown below.

Manufacturers and users of electronic devices may be assured that the sending, receiving and amplifying TUNG-SOL Tubes they buy for initial equipment and replacement are as uniform and as dependable as it is humanly possible to produce them. TUNG-SOL's engineering development staff is ready to work with you on your Electronic Tube requirements.

### HOW TUNG-SOL FILAMENTS STAY IN ALIGNMENT

One method of holding the filament wire in tension was to hook the tension wire to a flat suspension bar. However, TUNG-SOL engineers found that vibration often caused the spring connection to shift along the bar, thus forcing the filament out of alignment. The improved suspension arch eliminated this possibility.

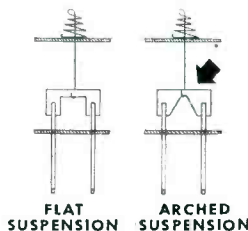

# TUNG-SOL

*vibration-tested*

## ELECTRONIC TUBES

TUNG-SOL LAMP WORKS INC., NEWARK 4, NEW JERSEY  
ALSO MANUFACTURERS OF MINIATURE INCANDESCENT LAMPS, ALL-GLASS SEALED BEAM HEADLIGHT LAMPS AND CURRENT INTERMITTORS



"I'm too busy right now taking care of a BIG JOB for Uncle Sam, but when it's over and I come home to peace, I want to pick up those loose strings in Radio again. I've learned a lot serving with the Signal Corps and that experience will come in handy when I return to my job in radio communications. But there's one thing I'm going to insist on, and that's MURDOCK Radio Phones—I'm mighty fond of their clearness and light weight—and I want that same cushioned comfort later on. Yes, sir!"

For 40 years MURDOCK precision engineering has been devoted to making the keenest ears in Radio. In War and Peace, MURDOCK means crystal clear and dependable communications.

#### SUB-CONTRACTS ACCEPTED

Though most of our facilities are devoted to government work, we can make more Radio Phones and related parts for you on a sub-contract basis. We'll be glad to help you.

**WM. J. MURDOCK CO.**  
139 Carter St., Chelsea 50, Mass.

## RADIO PHONES

Here are some of  
**MURDOCK'S**  
Exclusive Features:

1. CUSHIONED COMFORT for long listening.
2. VENTILATED for ease and coolness—prevents condensation.
3. SUPER-SENSITIVITY for clear and accurate reception.
4. STURDY, SOLID-BUILT by precision methods—close tolerances.
5. TWO-WAY ADJUSTMENT to control position.
6. CONCEALED TERMINALS—plus long cords for easy movement.

*Write for  
Catalogue*

ficer of Signal Corps Aircraft Signal Agency.

Installations in the B-29 nearly double the number normally carried by the Flying Fortress, the Liberator, or other heavy bombers in actual operations, he added. These radio sets range in weight from one-half pound, to 550 pounds.

None of the radio equipment in the B-29 was designed specifically for it as most of the sets have been used in both fighter and bomber aircraft. Wherever a choice existed between two or more different sets of a similar type, a selection was made after exhaustive tests of the equipment to determine which would give maximum performance on long-range flights.

Communication equipment provides for conversations between aircraft in flight, between the bombers and their far-distant bases and between crew members within a plane.

Navigational devices allow the pilot to fly a direct or diverse route as desired, to locate bases on return with the precision of a homing pigeon, and to execute safe landings. Devices to guide rescuers in are included in the B-29 radio installation.

Technical problems encountered by Aircraft Radio Laboratory were numerous because of the great number of different types of radio equipment which had to be installed and made to operate without conflicting with or neutralizing each other.

#### PERSONNEL

L. J. Chatten, formerly assistant director, has been made director of the radio and radar division, WPB. He succeeds Ray Ellis who is returning to his post at General Motors Corp.

Head of research on electronic products at Littelfuse Inc., Chicago, Ill., is Bernard F. McNamee, previously in charge of the engineering department of Consolidated Engineering Co.

Harold Hadden, control and studio supervisor at WOR, New York, N. Y., is coordinating technical assignments and operations between that station and WABD on television productions.

At Philco Corp., Philadelphia, Pa.,



# ANNOUNCING

## The New General Plate Laminated Metal

# *Silver on Beryllium Copper*



\* PAT. PENDING

- **FOR TINY SWITCH BLADES TO HEAVY STRIPS**
- **FOR EXTRA CONDUCTIVITY**
- **SILVER CLAD (NOT ELECTROPLATE)**

First in the parade of new General Plate Metals for post-war use is the new laminated combination of *Silver on Beryllium Copper*.

Made by permanently bonding silver to beryllium copper, it gives you the extra conductivity of silver . . . so badly needed where only beryllium copper meets the requirement . . . plus the springiness of beryllium copper.

No matter whether your requirements call for tiny switch blades or heavy strips, General Plate laminated *Silver on Beryllium Copper* will provide better performance. It is available in combinations of silver on one side or both sides in any thickness—or centre-lay (silver between two layers of beryllium.)

Find out about this new General Plate laminated metal . . . Silver on Beryllium Copper. Write for full information today.

## **GENERAL PLATE DIVISION**

OF METALS & CONTROLS CORPORATION  
50 Church St., New York, New York 205 W. Wacker Drive, Chicago, Illinois  
2791 Kensington Place East, Columbus, Ohio  
2635 Page Drive, Altadena, California

**ATTLEBORO, MASSACHUSETTS**

*Where  
Dependability Counts*

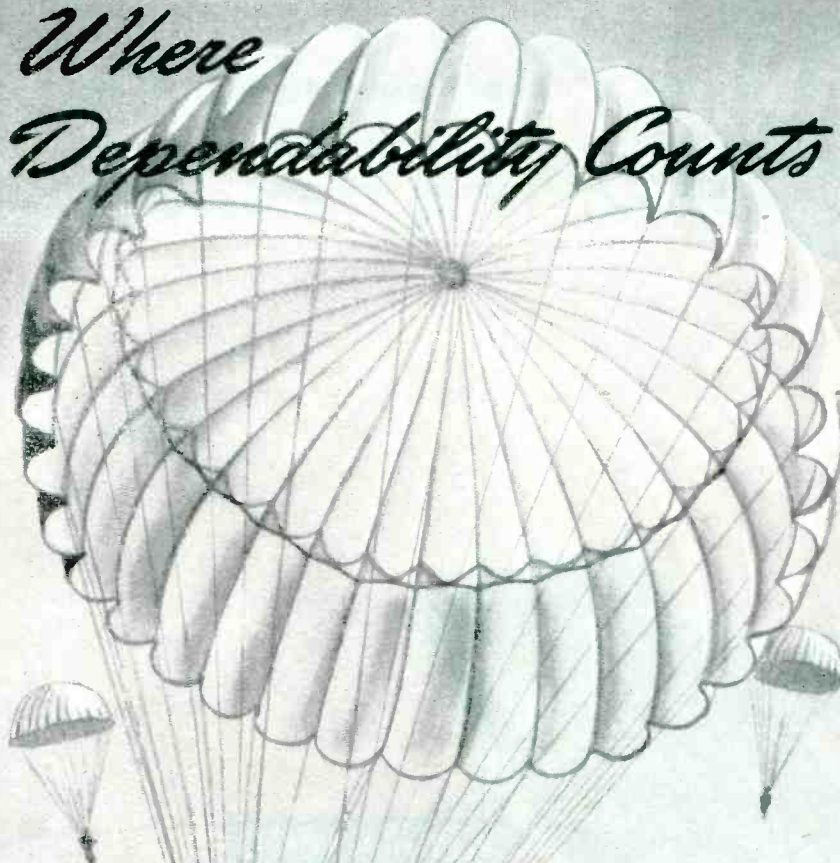

## **Permoflux Acoustical Devices Are Proving their Superiority!**

Much of today's communication equipment is but remotely related to that in use when the war began. New Permoflux developments have meant increased efficiency for our fighting forces. The wide frequency response, extreme sensitivity and rugged mechanical design of Permoflux products have helped to achieve a standard of intelligibility heretofore unknown. Permoflux products will be available for many new post war applications.



TRADE MARK  
**PERMOFLUX**

**PERMOFLUX CORPORATION**  
4916-22 W. Grand Ave., Chicago 39, Ill.

PIONEER MANUFACTURERS OF PERMANENT MAGNET DYNAMIC TRANSDUCERS

William Balderson goes from vice president in charge of the commercial division to take charge of operations and become a member of the executive committee.

Allen B. Du Mont has been made honorary doctor of engineering by



Rensselaer Polytechnic Institute. Dr. Du Mont is head of Du Mont Laboratories, Inc., Passaic, N. J.

C. W. La Pierre has been made assistant engineer of the general engineering laboratory at General Electric Co., Schenectady, N. Y. He was formerly in charge of the electro-mechanical section there.

John H. Miller has been made chief electrical engineer at Weston Electrical Instrument Corp., Newark, N. J. He was formerly assistant chief electrical engineer.

Philip F. Siling has been made engineer in charge of the frequency bureau of Radio Corp. of America. He was formerly assistant chief engineer in charge of broadcasting for FCC.

Frank J. Hajek has been made president of Taylor Tubes Inc., Chicago, Ill. He was formerly secretary-treasurer.

James C. Filmer has been made vice-president in charge of engineering at Taylor Tubes Inc., Chicago, Ill.

Dr. Lee de Forest has been active in the organization of a center for electronic research, a factory for the production of radio



# WILCO

## Now EQUIPPED

for large scale production of

# JACKETED WIRE

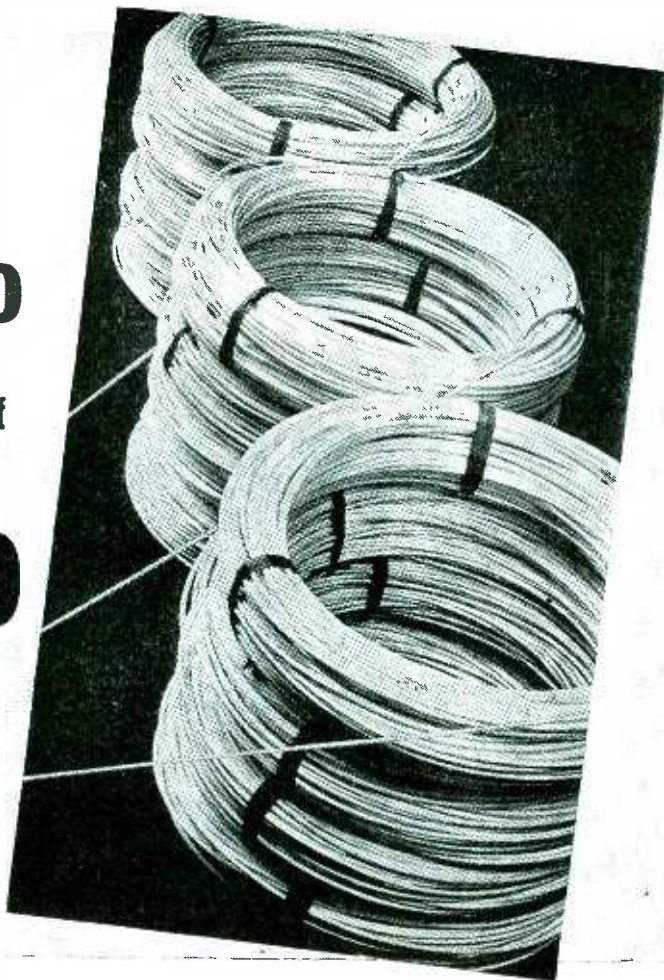

WILCO wire, tubing and other products are used in various electronic applications for the Army and Navy. In response to the wartime demand for these various products, the H. A. Wilson Company has enlarged its plant, increased its manufacturing facilities, added essential new equipment and developed new products and techniques. Both present and future customers will find these new WILCO developments of great advantage.

The H. A. Wilson Company manufactures and is interested in receiving inquiries regarding the following typical products—

#### WILCO JACKETED WIRE

Silver (Fine, Sterling or Coin)  
 Silver Jacketed Copper  
 Silver Jacketed Invar  
 Silver Jacketed Brass  
 Silver Jacketed Steel  
 Gold Jacketed Silver (Fine, Sterling, Coin)  
 Gold Jacketed Brass or Bronze  
 Copper Jacketed Monel  
 Nickel Jacketed Copper

#### WILCO JACKETED TUBING

Silver Tubing (Fine, Sterling or Coin)  
 Gold Tubing (any Color or Karat)  
 Silver Jacketed Brass or Bronze (one or both sides)  
 Gold Jacketed Silver (one or both sides)  
 Gold Jacketed Brass or Bronze (one or both sides)

#### WILCO STRIP MATERIAL

Silver (Fine, Sterling or Coin) on Brass or Bronze (Inlay or Overlay)  
 Gold on Silver (any Karat on Fine, Sterling or Coin)  
 Gold on Brass or Bronze

#### Other WILCO products include Electrical Contacts—

Silver, Platinum, Tungsten, Alloys, Powder Metal, *Thermostatic Bimetal* (High and Low Temperature with new high temperature deflection rates.) *Precious Metal Collector Rings*—For Rotating controls. *Silver Clad Steel*. *Rolled Gold Plate*. *Special Materials*.

*Let us analyze your problems.*

## THE H. A. WILSON COMPANY

105 Chestnut Street, Newark 5, N. J.

Branches: Detroit • Chicago





**"You're still coming  
thru clearly!"**



IN NEW CALEDONIA Telex Receivers were given an assignment where super-sensitivity was vital—the clear reception of enemy reconnaissance information.

Photograph Signal Corps, U.S. Army



**TELEX**

**Experience Offers:**

**Magnetic Receivers:**

**Cu. Vol.**—Approx. 0.3 cu. in.  
**Impedance**—Up to 5000 ohms.  
**Sensitivity**—18 dynes/sq. cm. for 10 microwatt input.  
**Construction**—Rugged and stable, using only finest materials, precisely machined—no diaphragm spacing washers in Telex receivers.

**Transformers and Chokes:**

**Cu. Vol.**—Down to .15 cu. in.  
**Core Material**—High permeability steel alloys.  
**Windings**—To your specs. (Limit of six outside leads on smallest cores.)

GATHERING enemy information often calls for trips inside enemy lines. When the messages are dispatched Telex Magnetic Receivers deliver them with distinct clearness.

The engineers of Telex stressed super-sensitivity and high-fidelity performance in perfecting these tiny receivers for the U. S. Army Signal Corps. An unusual ruggedness prepares them to meet world-wide conditions. That's why it's first in dependability if it's made by Telex.

Let Telex engineers help you to solve your present and near future electronic development problems. In creating the first wearable Electronic Hearing Aid and in serving the U.S. Army Signal Corps they are prepared to put ingenuity and experience to work for you. Write to us.

**ELECTRONICS PRODUCTS  
DIVISION**

**TELEX**

**PRODUCTS COMPANY**

**TELEX PARK • MINNEAPOLIS • MINNESOTA**

and television equipment, and a commercial television station, all at Mexico, D. F., Mexico.

Maurice H. Hobbs has been made manager of the engineering department in the switchgear and control division at Westinghouse Electric & Mfg. Co.

William Vassar has been made administrative assistant to the vice-president in charge of engineering and production at Emerson Radio & Phonograph Corp., New York, N. Y. He was formerly an executive engineer at Crosley Corp.

Frank X Lamb has been made assistant chief electrical engineer at Weston Electrical Instrument Corp., Newark, N. J. He was formerly a project engineer.

Charles F. Kettering has been made a member of the subcommittee on applied cyclotronics of the post-war program committee of the State of Ohio. He is head of General Motors Corp. research.

Wendel C. Fowler has been made president of the Fort Worth Electronics Club, Fort Worth, Tex.

Roy Siren has been made engineer in charge at Milwaukee Industrial Designers, Milwaukee, Wis. He was formerly with Nordberg Mfg. Co.

Karl M. Lederer has been made assistant director of research at Weston Electrical Instrument Corp., Newark, N. J. He was formerly assistant chief engineer.

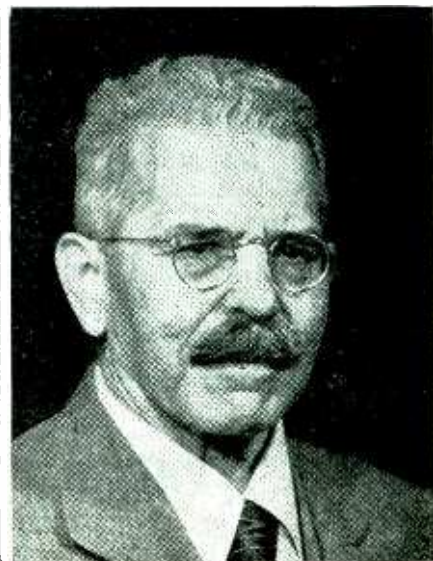



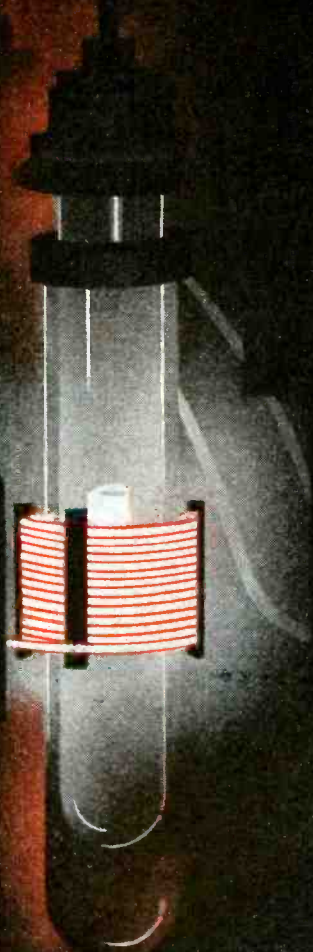

# Casting in a vacuum— Electronically



One of the many vital processes that give Machlett vacuum tubes their remarkable quality is a novel method of casting electrodes in a vacuum. Complex parts of high-frequency oscillators, as well as X-ray tube anodes, are made by this unusual technique. Purified copper rod is placed over a mould in a graphite crucible, and the whole enclosed within a double-walled water-cooled quartz-silicon tube, which is encircled by a high-frequency coil. A vacuum of about  $10^{-5}$  mm. of mercury is maintained.

When the current is turned on, the metal melts and flows into the mould. Cooling is precisely controlled by adjusting the position of the heating coil, so that crystals form longitudinally, for

maximum heat transfer under operating conditions.

This method accomplishes a number of things, quickly and simply. No gases can be occluded in the metal to shorten tube life by reducing the vacuum. Oxides cannot form. There are no "pipes" in a casting thus poured. Dimensions can be held to about  $1/10,000$ th of an inch—and accurate dimensions are as important as metal purity in protecting transmitting tube performance, both assuring the maximum designed performance and long life. Techniques such as this make possible the production of the tube shown above . . . Machlett Laboratories, Inc., Springdale, Connecticut.

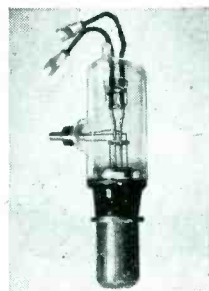

*ML-846—An U. H. F. transmitting tube for television and F. M. and short wave broadcasting.*

**MACHLETT**  
RAY TUBES SINCE 1898  
TODAY THEIR LARGEST MAKER

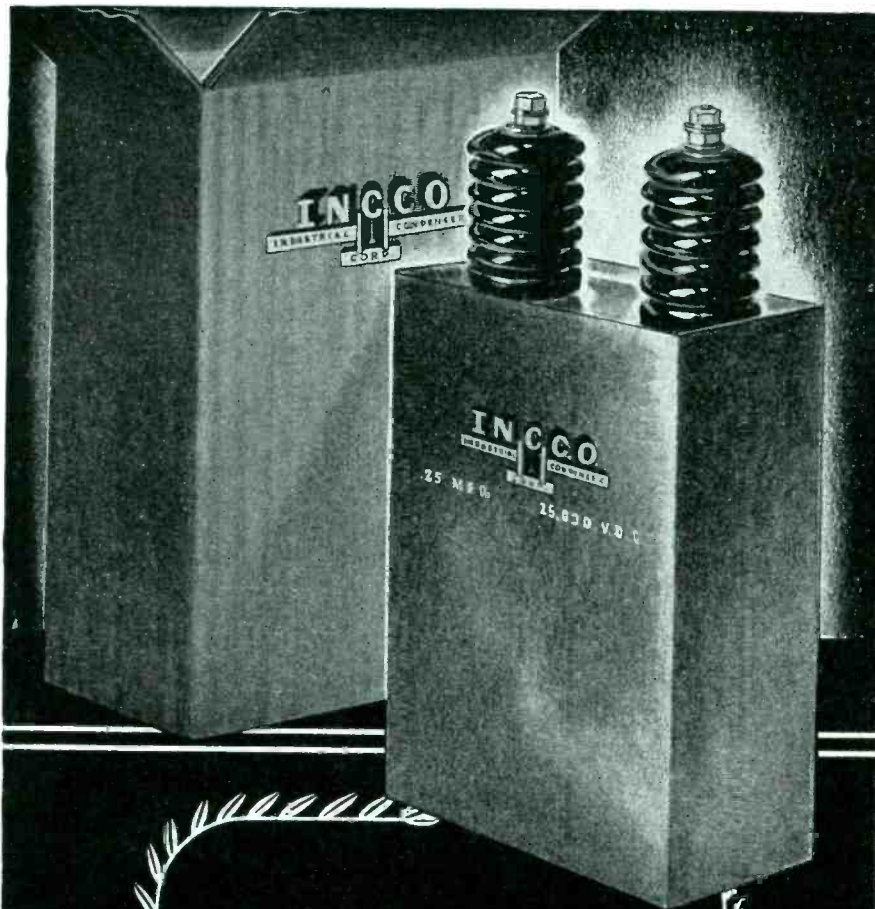

THE  
CONDENSER  
LINE OF  
UNSURPASSED  
QUALITY

PAPER, OIL AND ELECTROLYTIC CONDENSERS

**INDUSTRIAL**

CONDENSER CORPORATION

1725 W. NORTH AVE., CHICAGO, U. S. A.

DISTRICT OFFICES IN PRINCIPAL CITIES  
QUICK DELIVERY FROM DISTRIBUTOR'S STOCKS

At Westinghouse Electric & Mfg. Co. R. T. Muench is made manager of the x-ray products department. Since 1942 he has been manager of the Detroit x-ray office.

I. Walter Wyckoff has been made president of Electronics Manufacturers Association, New York, N. Y. He is connected with Pilot Radio Corp.

**AWARDS**

ON THE SECOND ANNIVERSARY of the presentation of the first Army-Navy "E" Awards, the War Department announces that the award had been granted to 3,097 plants. Based on various statistical reports, it has been estimated that approximately 3½ percent of the Nation's eligible plants have received the award.

Adel Precision Products Corp.  
Huntington Precision Prod. Div.  
Huntington, W. Va.

Aerovox Corporation  
New Bedford, Mass.

Eagle Signal Corp.  
Moline, Ill.

Electrical Research Labs., Inc.  
Evanston, Ill.

Electro-Voice Mfg. Co., Inc.  
South Bend, Ind.

General Electric Co.  
Transmitter Div.  
Syracuse, N. Y.

Hytron Corp.  
Salem, Mass.

The Indiana Steel Prods. Co.  
Valparaiso, Ind.

Litton Engineering Labs.  
Redwood City, Calif.

Sonotone Corporation  
White Plains, N. Y.

Union Aircraft Products Corp.  
New York, N. Y.

**CHIEF SIGNAL OFFICER'S  
CERTIFICATES OF  
APPRECIATION**

These awards are testimonials to the contribution of individuals and organizations not eligible for Army-Navy recognition.

Louis H. Lamotte  
International Business Machines Corp.

Chester W. Latimer  
Vice-Pres. and Chief Engineer  
RCA Communications

Samuel Ruben  
New Rochelle, N. Y.

George E. Smith  
Vice-President  
Crosley Corp.

William A. Winterbottom  
Vice-Pres. and General Mgr.  
RCA Communications, Inc.



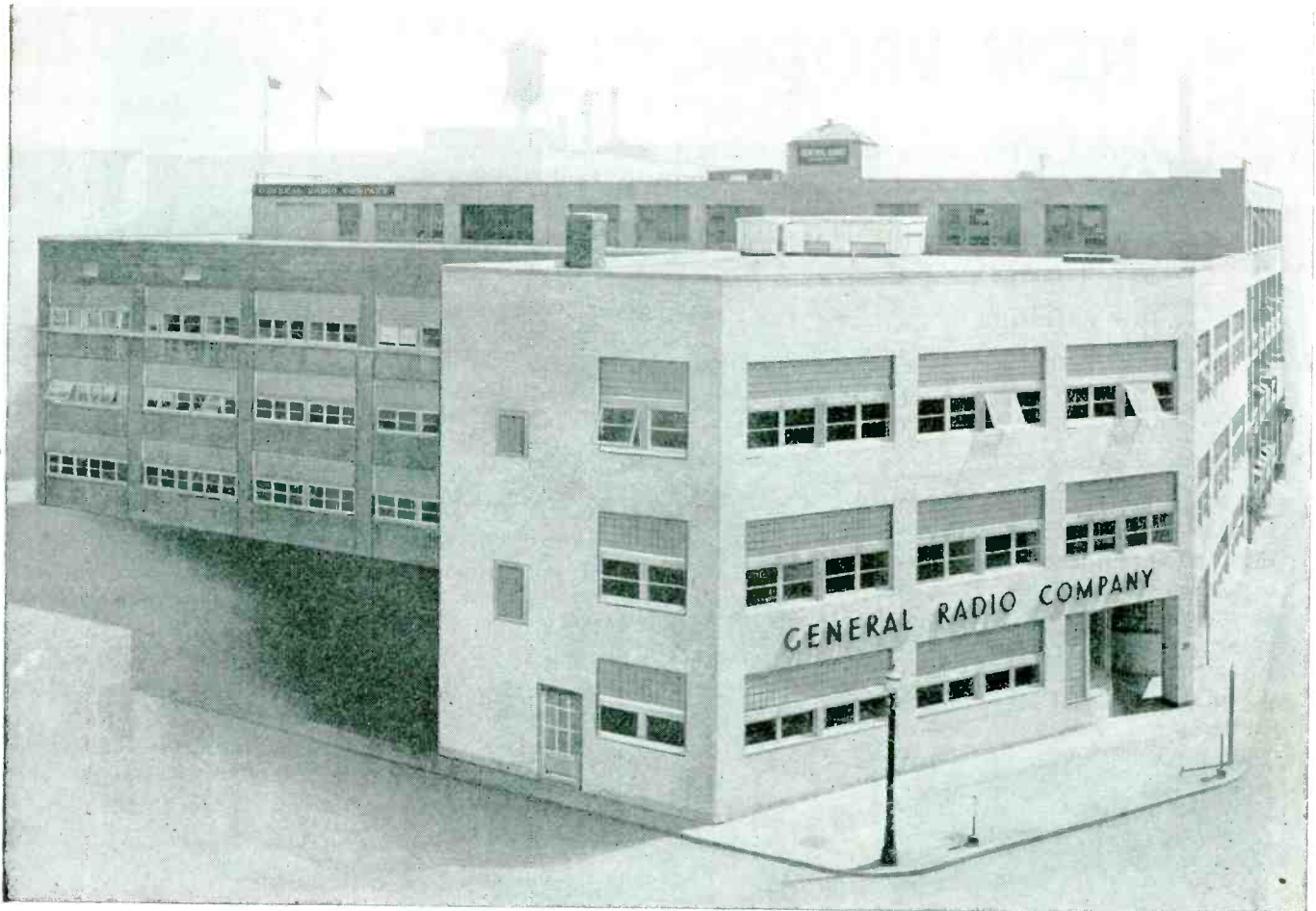

## JUST AROUND THE CORNER

● LATELY, persons corresponding with us have noted a new address . . . 275 Massachusetts Avenue. We've moved our engineering and general business offices into a remodeled building at this location. It's just around the corner from 30 State Street, which is still ours, and which is now devoted exclusively to manufacturing.

For a long time we have felt the need for re-arranging our space; for one thing we have been badly cramped in the shop; and our engineering department has been spread over several floors and mixed up with many other activities.

The new building, which is connected by ramps on two floors with the older one, provides about 30 per cent more manufacturing space, and allows all of the engineering department to be on one floor.

Under pressure of the war we have expanded our output in several ways. We have let out the manufacture of several instruments to subcontractors; we have turned over the designs, draw-

ings and models of several instruments to other manufacturers for their exclusive use; we have rented considerable extra space in two outside buildings, in one of which we have contracted for a large number of war-time workers under our own foremen.

After the war when the armed guards have left us, we hope that you will come to see our new laboratories and offices. In the meantime we continue to devote our energies to filling war orders for electronic laboratory test equipment.

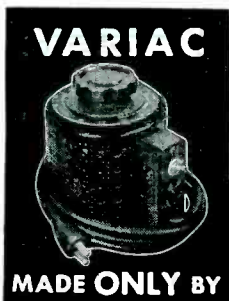
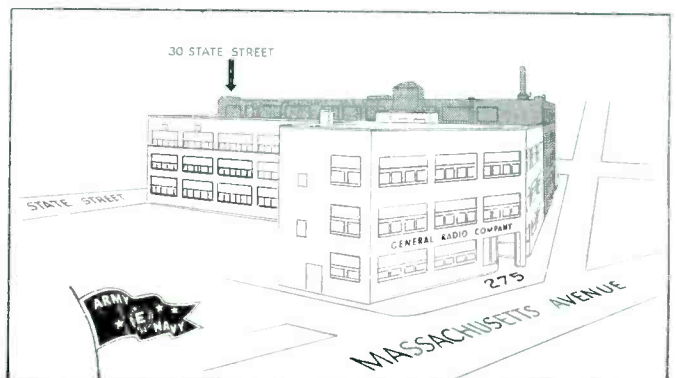

# GENERAL RADIO COMPANY

Cambridge 39, Mass.

NEW YORK  
CHICAGO  
LOS ANGELES

# the degree

to which your communications problems are solved may determine the degree of your postwar business success.

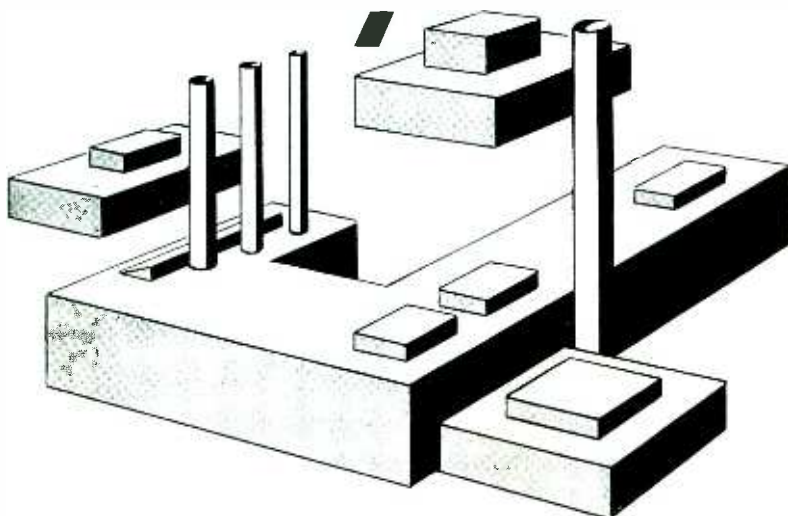

WRITE NOW FOR "CRYSTIONICS" INFORMATION

## VALPEY

*Crystal Corp.*

CRAFTSMANSHIP IN CRYSTALS SINCE 1931  
HOLLISTON, MASSACHUSETTS

©1944

### Wax Dipping-Baths

NEW AND IMPROVED electrically-heated and automatically-controlled wax dipping-baths are available which permit fast, efficient and economical wax-coating of coils, resistors, capacitors, panels and other

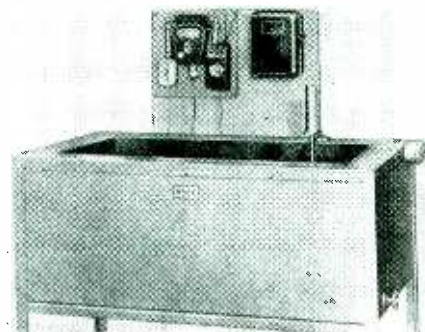

electrical parts. The units may also be used to wax-coat packages to guard against moisture absorption. Bath temperatures can be adjusted from 100 to 550 deg F. The baths are built to order.

Barnstead Still & Sterilizer Co.,  
Forest Hills, Boston, Mass.

### Sound Reproducer

MODEL NO. HF-6 is a new baffle-type reproducer unit which provides duo-directional high fidelity reproduction of both voice and music for plant broadcasting. The speaker is a 6-in. permanent magnet type with a 6-ohm voice coil. It delivers from 4 to 6 watts of output power, and is especially adaptable

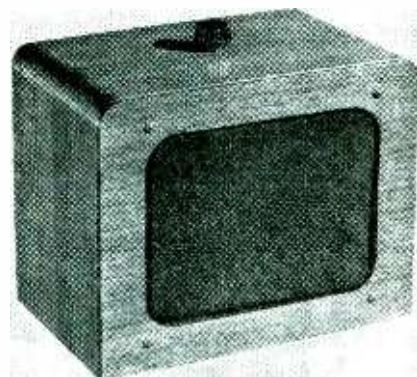

for wide-angle coverage of medium and low noise level areas. A bass compensation circuit progressively increases the bass response with each decrease of volume. The unit measures 9 x 10½ x 6½ in. and is suitable for desk or wall use.

Executone Corp., 415 Lexington Ave., New York 17, N. Y.



From GATES Engineering Laboratories—A Preview of New  
Transmitter Designing for the Post-War Radio Industry

# Gates "BC-10"

## 5-10 KW BROADCAST TRANSMITTER

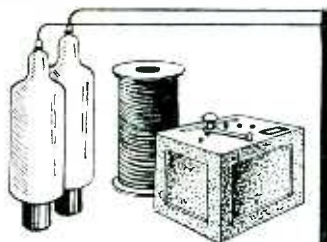
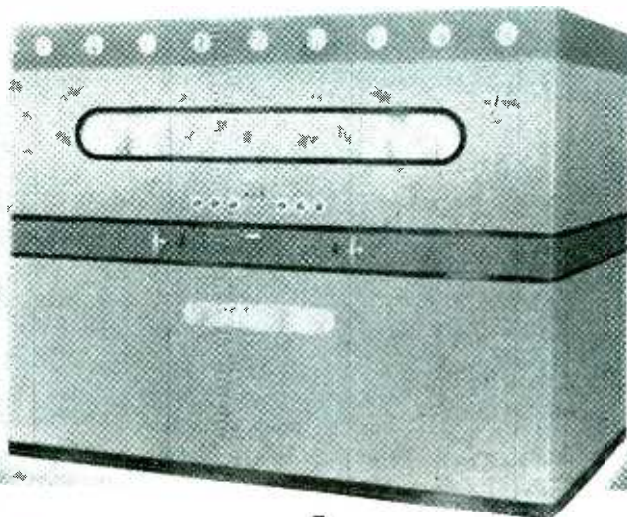

CAREFULLY ENGINEERED  
COMPONENT DESIGN

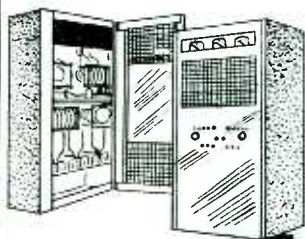

BUILT-IN  
PHASING EQUIPMENT

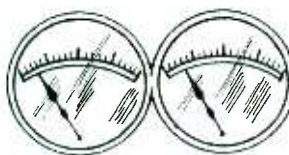

HIGH TRANSMITTER  
EFFICIENCY

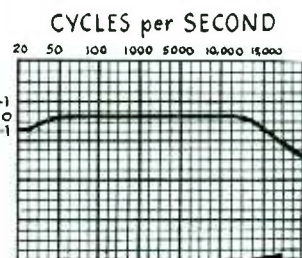

HIGH FIDELITY RESPONSE  
CHARACTERISTICS

Here is one of the new things to come from Gates! Our engineers have already developed and approved engineering designs for this transmitter to be produced as quickly as the demands by the military on Gates' production no longer exist. The "BC-10" may be used for either 5,000 or 10,000 watt carrier. It is high level modulated and will be available complete with built-in phasing equipment.

May We Send You Details Regarding the Gates  
Priority System for Prompt Post-war Delivery

*(Wartime restrictions do not allow the sale of new broadcasting equipment without priority; therefore, this equipment is presented merely to acquaint you with Gates' developments.)*

Gates

RADIO and  
Supply CO.

QUINCY, ILLINOIS, U.S.A.

MANUFACTURERS OF RADIO BROADCAST TRANSMITTERS, SPEECH EQUIPMENT,  
RECORDING APPARATUS AND ALLIED EQUIPMENT IN THE ELECTRONICS FIELD

# ELECTRONICS



IN PEACETIME, Boonton Radio direct reading instruments were standard equipment for the Electronic Laboratory.

IN WARTIME, these dependable instruments are on the Front Lines safeguarding and protecting our fighting men against Communication Failures.

POSTWAR, these instruments will again be available for the Electronic Industry contributing to the development of the New Era of Electronics that is to come.



## BOONTON RADIO

BOONTON, N. J.

Corporation



DESIGNERS AND MANUFACTURERS OF THE "Q" METER . . . QX-CHECKER . . . FREQUENCY MODULATED SIGNAL GENERATOR . . . BEAT FREQUENCY GENERATOR . . . AND OTHER DIRECT READING TEST INSTRUMENTS



## This New Jig Speeds Your Radio Assembly

- 1) Can be loaded and unloaded in two seconds.
- 2) Indexed 360° fixture to hold chassis in any position to step up soldering and all other assembly operations.
- 3) Adjustable to any size to base limits of the Jig. Comes in various sizes or we will make Jigs to your chassis or specifications.
- 4) Sturdy, rigid construction.
- 5) Holding adapters to fit your chassis.

Send us your chassis or specifications for quotations. We are ready to meet your delivery schedules.

**ROBERT L. STEDMAN** MACHINE WORKS  
SPECIALISTS IN MASS PRODUCTION TOOLS  
OYSTER BAY, LONG ISLAND NEW YORK

**Technical Monograph.** "Loud Speaker Frequency Response Measurements" is the first publication of a series of technical monographs to help the amateur and the professional in the field of acoustics. Each publication will be devoted to one important aspect of the science of sound as applied to loud speakers. The first booklet (available for 25c) explains how one can use measured frequency response as essential data in development and design work, and describes some of the equipment and methods that may be used. Technical Service Dept., Jensen Radio Mfg. Co., 6601 S. Laramie Ave., Chicago 38, Ill.

**Altitude Chambers.** Altitude chambers for controlled temperature, humidity and pressure are described and illustrated in a 12-page booklet which contains a page of general specifications, plus information about Models AC-107, ACR-262, AC-36, 2000V, ACR-20, AC-8. Parts, instruments and accessories are also illustrated and described. Kold-Hold Mfg. Co., 424 N. Grand Ave., Lansing, Mich.

**R-F Coils and Assemblies.** This manufacturer makes coils for every application in the r-f spectrum, including radar and television, and has issued a 4-page bulletin entitled "Radio Frequency Coils and Associated Assemblies" as introductory literature. Stanwick Winding Co., Newburgh, N. Y.

**General Products Catalog.** Variable capacitor, plugs, jacks, inductors, chokes, terminals, tube sockets, couplings, antenna equipment and r-f insulators are all illustrated and described in Catalog No. 968 available from E. F. Johnson Co., Waseca, Minn. Another booklet, available from this manufacturer, is entitled "Johnson. In War and Peace" and it also illustrates and describes the types of products listed above, plus the particular catalogs which are available on these products.

**Facsimile.** This 12-page booklet is designed to bring about a better understanding of facsimile and its possibilities. The booklet contains actual reproductions as reproduced from receiver copy. Radio Station WELD, Columbus, Ohio.



# SMALL!

*The G-E  
Switchette*

**Don't  
handicap  
your important  
designs for lack of  
a SMALL electric  
switch**

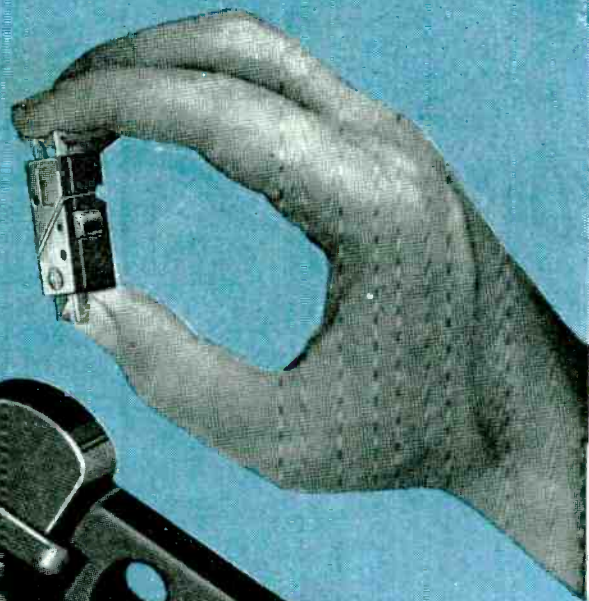

● Here's an inside view of the tiny, versatile G-E Switchette, enlarged to show you the double-break contact construction, which makes possible many ingenious wiring arrangements to solve tricky circuit problems. This is a standard form for controlling one normally open and one normally closed circuit. Variations of this arrangement are available to provide control of a single circuit, either normally open or normally closed. Other modifications include a form for simultaneously opening two circuits and closing one, or vice versa; also single-break forms for more sensitive operation.

**B**ECAUSE of its unusually small size and light weight, its lightning-fast snap action, and its long life, the G-E Switchette is becoming more and more popular with designers for circuit control where space is at a premium.

Switchettes are available in ratings up to 10 amperes at 24 volts d-c (230 volts a-c), are provided with solder-lug terminals for wiring. They meet government specifications covering corrosion and vibration resistance, and operate at altitudes up to 50,000 feet and in ambient temperatures from 200 F to -70 F.

More than 200 modifications have already been developed to meet special circuit requirements and to fit into special mechanical arrangements. Dimensions, operating characteristics, and ordering directions for standard Switchettes and many typical modifications are given in our new catalog, No. GEA-3818C. For your copy, mail the coupon. If you don't find the forms you need in the catalog, our engineers will be glad to work with you in adapting Switchettes to meet your requirements.



## SWITCHETTES

GENERAL ELECTRIC COMPANY, SECTION C676-141  
SCHENECTADY 5, NEW YORK

Please send me Bulletin GEA-3818C giving dimensions, ratings, and operating characteristics of Switchettes

NAME .....

COMPANY .....

ADDRESS .....

CITY ..... STATE .....

8930

# GENERAL ELECTRIC

Buy all the BONDS you can — and keep all you buy



Designed for



Application

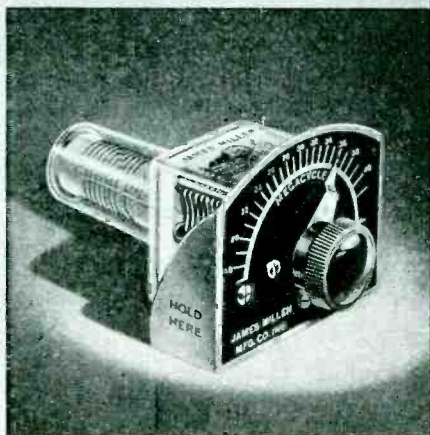

The No. 90600 Series  
of Absorption Frequency Meters

Both inexpensive laboratory and protected sturdy field types of this popular series of compact direct reading frequency meters are available in ranges from 300 megacycles to 200 kilocycles. Can be poked into small shield compartments, coil cans, corners of chassis, etc., to check harmonics; parasitics; oscillator-doubler, etc., tank tuning; and a host of other such applications. Quickly enables the design engineer to find out what is really "going on" in a circuit.

**JAMES MILLEN  
MFG. CO., INC.**

MAIN OFFICE AND FACTORY  
MALDEN  
MASSACHUSETTS



Switches. Catalog MC 448 is designed to simplify the selection of this manufacturer's multi-circuit switches for simultaneous operation of independent or interconnected electrical circuits. Twenty standard contactors are listed. Metallic Arts Co., 243 Broadway, Cambridge 39, Mass.

Tubes. The "1944-1945 Catalog and Manual" contains full information on all tubes manufactured by this firm, as well as some of the new tubes developed for war uses. Sixteen pages are devoted to tube characteristics. Another section is devoted to pertinent technical information on transmitters and transmitter tubes. The catalog is available, without charge, at local distributors, or may be obtained at a cost of 25¢ from Taylor Tubes, Inc., 2312 Wabansia Ave., Chicago, Ill.

Frequency Modulation Bulletin. This is the name of a bulletin which is published as source information on fm. Volume 1, No. 4 contains an article entitled "FM for 100,000,000 Americans" which states that more than 150 of the 210 applications for

**PLATINUM  
and PLATINUM ALLOYS . . .**

**SHEET**  
**WIRE**  
**TUBING**

For all Electronic Applications

Platinum metals scrap and residues refined and re-worked on toll charges; or purchased outright by us . . .

Write for list of Products.  
Discussion of technical  
problems invited . . . .

**SIGMUND COHN & CO.**  
44 GOLD ST. NEW YORK  
SINCE 1901

**IN-RES-CO  
RESISTORS**  
offer unusual  
post-war

**PRODUCTION  
ECONOMIES**



Type P-2 and P-4, illustrated, emphasize the low-cost factor inherent in all custom-designed, high-accuracy IN-RES-CO resistors. Type P-2 has a maximum resistance of 500,000 ohms, standard tolerance of 1/2%, 1/2 watt rating and measures 9/16" long by 9/16" in diameter. Type P-4, also non-inductive, has a maximum resistance of 1 megohm, measures 1" long by 9/16" in diameter, and has 1 watt rating.

Especially suited for precision apparatus and equipment applications, these types are representative of the all-inclusive IN-RES-CO wirewound resistor line. Here, engineering ingenuity—plus exclusive manufacturing techniques—can mean substantially lowered costs in post-war plannings.

A note on your company letterhead will bring your copy of the new IN-RES-CO catalog; no obligation.

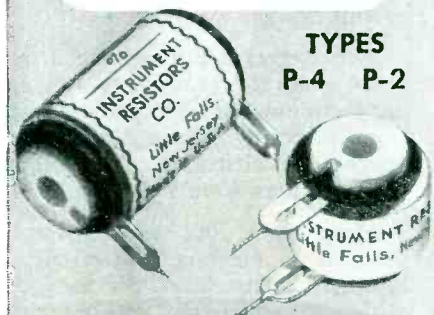

**INSTRUMENT  
RESISTORS CO.**



25 AMITY STREET  
LITTLE FALLS, N. J.



# WADSWORTH SKILLS

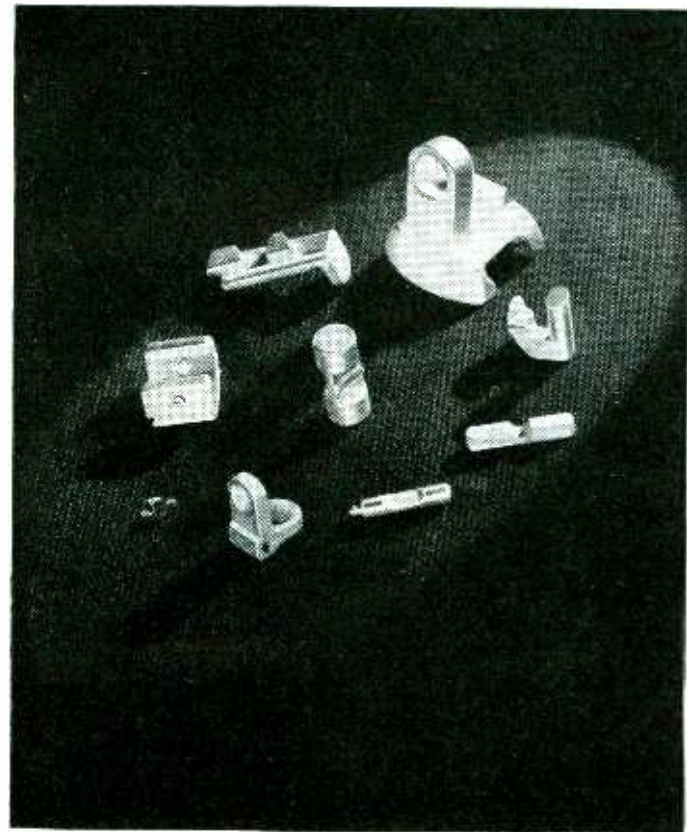

## WADSWORTH FACILITIES

Die Making  
Jigs & Fixtures  
Gage Making  
Model Building  
Milling  
Drilling  
Turning  
Stamping  
Screw Machining  
Hard Soldering  
Heat Treating  
Line Assembly  
Polishing  
Lacquering  
Photo Etching  
Silk Screening  
Product Decorating  
Metals Laboratory  
Engineering Design  
Product Design

## CURRENTLY SERVING THESE INDUSTRIES

Aircraft  
Automotive  
Bearing  
Electronics  
Instruments  
Machine Tool  
Small Arms  
Refrigeration

... built up through half a century of leadership in the exacting Watch Case Industry will be available soon to many manufacturers who will require large quantities of small precision parts for their postwar assemblies.

Work of this character is now being supplied to many leading companies which normally produce radio equipment, refrigerators, automotive parts, precision instruments.

Illustrated are nine small components of an Ordnance assembly which Wadsworth furnishes in great numbers. The production of these pieces, which are held to very close tolerances, brings a score of special Wadsworth facilities into play.

Wadsworth workers' feeling for precision and their ability to get work out on time will ease postwar headaches for many producers.



SMALL PARTS DIVISION

THE *Wadsworth* WATCH CASE CO., Inc.  
DAYTON, KENTUCKY, SUBURB OF CINCINNATI, OHIO  
PHONE COLONIAL 8194 • (CINCINNATI EXCHANGE)



# LUXTRON<sup>®</sup> PHOTOCELLS

Luxtron<sup>®</sup> Photo-Electric Cells Operate Instruments and Instrument Relays Without Auxiliary Voltage or Amplification.

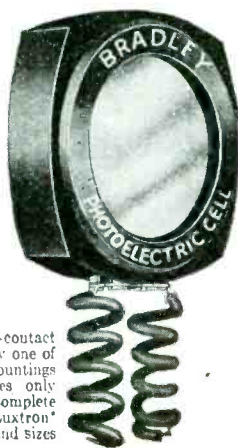

This pigtail-contact model is only one of a series of mountings and indicates only one of the complete range of Luxtron<sup>®</sup> cell shapes and sizes available.

Their high-efficiency conversion of light energy into electric power, permits applications in great variety.

Bulk and complexities are minimized. War applications impress their dependability and durability daily.

Luxtron<sup>®</sup> Photocells are wholly American in both materials and manufacture.

Send for illustrated, engineering literature and let us co-operate with you on special problems and applications.

<sup>®</sup>Reg. U. S. Pat. Off.

## BRADLEY LABORATORIES, INC.

82 Meadow Street, New Haven 10, Conn.

fm broadcast stations now in the hands of the FCC have been filed since the first of the year. The article further states that a comparison of requests for new broadcast services reveals that fm has maintained a 3-to-1 ratio over standard broadcast applications and a 3½-to-1 ratio over television applications. Three pages of this 4-page bulletin are devoted to a geographic listing showing frequencies, coverage, power and transmitter-studio locations. FM Broadcasters, Inc., 711 Colorado Bldg., Washington, D. C.

Phenol and Vulcanized Fibre. Data and information for the correct specification of this manufacturer's phenol and vulcanized Fibre is contained in a 6-page leaflet. N. S. Baer Co., 9-11 Montgomery St., Hillside, N. J.

Plastics. A booklet called "Precision-Made Plastics" describes and illustrates the many types of plastics products which have been fabricated to close tolerances by The Sillcocks-Miller Co., South Orange, N. J.

## JONES BARRIER STRIPS SOLVE MOST TERMINAL PROBLEMS

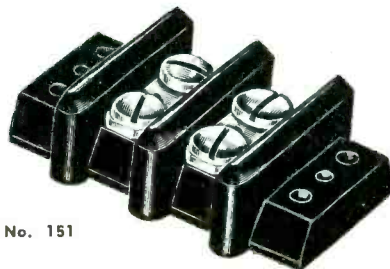

No. 151

A compact, sturdy terminal strip with Bakelite Barriers that provide maximum metal to metal spacing and prevent direct shorts from frayed wires at terminals.

### 6 SIZES

cover every requirement. From ¾" wide and 13/32" high with 5-40 screws to 2½" wide and 1/8" high with ¼"-28 screws.

Jones Barrier Strips will improve as well as simplify your electrical intra-connecting problems. Write today for catalog and prices.

**HOWARD B. JONES COMPANY**

2460 West George Street

CHICAGO 18

ILLINOIS

# COPROX RECTIFIERS

Include Many  
Extras for  
Longer Life



"COPROX" MODEL CX-2E4-A9, ring-connected and mounted in tube base, detects phase differentials in A.C. currents and small D.C. potentials applied to balanced A.C. circuits. Maximum 4.5 volts continuous. Shown here in actual size.

Special terminals, or pre-soldered lead wires, prevent overheating during assembly. Standard units sealed with waterproof lacquers, critical-application units potted in wax. Standard "pellets" gold coated on front surface, forming positive contact, for critical applications, gold used on both sides. High leakage, but very low forward resistance. Highly adaptable mountings. To these extras, add Bradley's ability to produce "Coprox" rectifiers for special applications, then:

Ask for samples and full technical data.

## BRADLEY LABORATORIES, INC.

82 Meadow Street, New Haven 10, Conn.



# THE 400 SERIES

# Input Transformers



*D*esigned to occupy minimum space with excellent frequency response, the 400 Series Input Transformers are intended for high quality amplifier requirements. Combines high permeability shield with rotatable strap mounting for minimum stray field pick-up. Equipped with 10" Surprenant color-coded leads. 2" center to center mounting, 1 1/2" O.D. x 2 1/4" high. Baked gray enamel finish. Available for immediate delivery.

## TYPE 401-A INPUT TRANSFORMER

30/250/600 ohms to 30,000 ohm secondary center tapped. Maximum operating level +10 V.U. at .001 milliwatt reference level.

## TYPE 400-C BRIDGING INPUT TRANSFORMER

Nominal impedance 600/15,000 ohms to 60,000 ohm secondary. With proper input circuits, input impedance range 0/25,000 ohms. Maximum operating level +10 V.U. at .001 milliwatt reference level.

## TYPE 402-A INPUT TRANSFORMER

Nominal 30/120 ohm primary to 50,000 ohm secondary. Input impedance range 0/250 ohms. Maximum operating level +10 V.U. at .001 milliwatt reference level.

Frequency response characteristics as usually expressed for input transformers of wide frequency response are not complete due to variables in circuit constants. Therefore we have prepared an engineering bulletin illustrating exact operating measurements, which is available upon request.

# The Langevin Company

INCORPORATED

SOUND REINFORCEMENT AND REPRODUCTION ENGINEERING

NEW YORK  
37 W. 65 St., 23

SAN FRANCISCO  
1050 Howard St., 3

LOS ANGELES  
1000 N. Seward St., 38



# Baer FIBRE FABRICATIONS

*...for critical applications!*

These precision components—of vulcanized fibre and phenol fibre—are used in machines, apparatus, equipment and appliances—whenever a tough insulation material is required. Vulcanized fibre is used for high insulating qualities and great mechanical strength; phenol fibre has the extra advantage of low moisture absorption and corrosion resistance.

Stamped, punched, drilled, sawed and machined, BAER fibre fabrications perform dependably and efficiently even under severe operating conditions. Write for Bulletin 120.

**Specify BAER FOR WASHERS, STAMPINGS, GASKETS, SPECIAL SHAPES, TERMINAL BOARDS AND BUSHINGS**

**N. S. BAER COMPANY**  
CRAFTSMEN IN FIBRE FABRICATION  
9-11 MONTGOMERY ST., HILLSIDE, NEW JERSEY



**Fungus Proofing Booklet.** "Fungus Proofing for the Electronics Industry" is the name of a booklet which tells about this manufacturer's types (25-A, 25-X, 200-T, 95-T, 85-T) of fungus-proofing materials. A page is devoted to a discussion of fungus prevention facts. Also available is a reprint of an article "Fungus Proofing Procedure" which appeared in June 1944 issue of **ELECTRONICS**. The Insl-X Co., Inc., 855 Meeker Ave., Brooklyn, 22, N. Y.

**Western Electric Publication.** Western Electric's publication published before the war is now being published again under the new name of **The Western Electric Oscillator**. The first issue of this new publication contains several articles on radio in the war. There is also a spread of pictures devoted to "75 Years of Pioneering by Western Electric." Another editorial is an article on "AT & T Plans for Television." Western Electric Co., 195 Broadway, New York, N. Y.

**Radio Transmitters.** Two separate 12-page booklets on radio transmitters are available. The first booklet tells about a 10-kw, low frequency transmitter (designated as Model LF) which is crystal-controlled and designed for point-to-point communication circuits. The second booklet illustrates and describes a 50-kw standard broadcast radio transmitter (designated as Type 162) which is designed for metropolitan broadcasting stations. Federal Telephone & Radio Corp., Newark, N. J.

**Electronic Heating.** A new job service specializing in electronic heat treating is the subject of a 6-page, illustrated folder. The folder points up the fact that this company's electronic heat treating department is available to industry as a new shop service. Central Boiler & Mfg. Co., 5818 Rivard St., Detroit 11, Mich.

**Electrical Test Equipment.** Instruments available for production testing are illustrated and described in a 16-page catalog (No. 10). Industrial Instruments, Inc., 17 Pollock Ave., Jersey City 5, N. J.

MADE BY *Engineers* FOR *Engineers*

# CORWICO

# WIRES

*Now in daily use "over there"*



**cornish**  
WIRE COMPANY, INC.  
15 Park Row, New York City, New York





# METAL INSERTS FOR STRONGER MECHANICAL ASSEMBLIES

- Where extra strength is required or where insulators or assemblies are subjected to unusual mechanical strains and stresses, greater strength can be had by using General Ceramics metal inserts. These threaded metal inserts are *permanently bonded* into the steatite body, thus assuring an extremely solid construction. The metal inserts are drilled and tapped so that a perfect thread is obtained.

Our engineers will be glad to cooperate with you in designing steatite insulators with metal inserts for your special use.



*General Ceramics*  
**AND STEATITE CORP.**  
GENERAL  
INSULATORS AND ELECTRICAL EQUIPMENT  
KEASBEY  
NEW JERSEY

⊕ 6327

for **TODAY** or

**TOMORROW**

**It's WINCO ROTARY  
ELECTRICAL EQUIPMENT  
for Your TOUGH  
POWER PROBLEMS**

Whether you need rugged, sturdy dependability for today's battle conditions—or designing foresight for tomorrow's sales markets—Winco can help you with special rotary Electrical Equipment. Our engineers are at your service. Consult them when you have a problem involving—

- Built-in and Shell Type Motors
- Adjustable Speed Motors
- Synchronous Motors
- Rotary Electrical Equipment for Aviation
- Dynamotors and Inverters
- Motor Generator Sets
- Railroad Car Lighting Generators

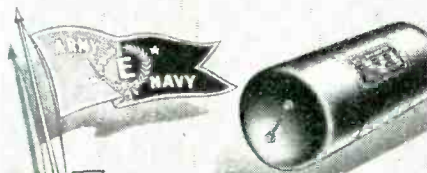

**WINCO ROTARY  
ELECTRICAL EQUIPMENT**  
WINCHARGER CORPORATION . . . SIOUX CITY, IOWA

**NEW BOOKS**

**Electrical Essentials of Radio**

By MORRIS SLURZBERG AND WILLIAM OSTERHELD, McGraw-Hill Book Co., 330 W. 42ND ST., NEW YORK 18, 530 pages, price \$4.

STUDENTS, as young as high school age with limited mathematical background, can obtain an understanding and solid foundation of electrical principles from this book either at home or with classroom instruction. The questions and problems at the end of each chapter are designed to increase familiarity with the subject.

The material is covered in an interesting manner with many helpful illustrations. Its orderly arrangement is particularly noteworthy. The opening chapter gives an inspirational overall picture of communication down through the ages, finally bringing out the importance of a knowledge of electricity for present communication methods. This is followed by a chapter on the fundamentals of electricity, then by chapters dealing

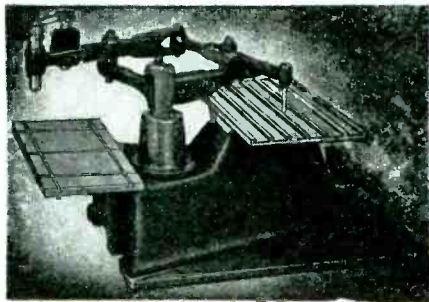

DUPLICATING and PROFILING

**AUTO ENGRAVER**

*Accurate Engraving  
with Unskilled Operators*

Unskilled operators will profile or accurately reproduce in smooth lines any design, number, letter, emblem, signature; on iron, brass, copper, aluminum, soft steels and all plastics. Here are some of its other uses . . .

- Drills a series of holes, or profiles small parts.
- Cuts an even channel for wiring on panels. Increases accuracy and production.
- Works from original drawing or templates.
- Etches glass and similar items.
- Will not cause distortion.

For complete information on this and other models and prices write Dept. K.

**AUTO ENGRAVER CO.  
1776 BROADWAY, NEW YORK 19**

*I'll*  
**VICTORY**  
*and Beyond*

You can count on Wincharger Antenna Towers. They combine strong efficient coverage with built to last qualities that insure you years of service.

Add to these advantages their strikingly attractive appearance plus a sensationally low initial cost and it's easy to see why an ever increasing number of Wincharger Antenna Towers are being used for:

*Commercial Broadcasting  
Police Work  
Signal Corps Air Lines  
Ordnance Plants*

To be sure for years ahead—be sure to specify Wincharger Antenna Towers.

Makers of  
**WINCHARGER**  
FARM ELECTRIC  
SYSTEMS  
**WINCO**  
DYNAMOTORS  
**WINCHARGER**  
VERTICAL  
RADIATORS

**WINCHARGER VERTICAL RADIATOR**  
WINCHARGER CORPORATION SIOUX CITY, IOWA



# THE TRUMBULL TYPE ATA CIRCUIT BREAKER

... another interesting plastic development story

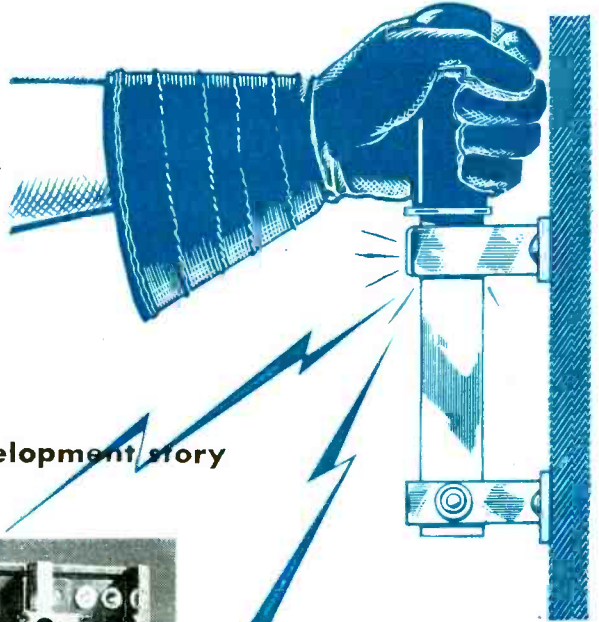

To the designer and manufacturer of electrical products this plastic development story should prove of unusual interest because it is indicative of the tremendous progress which the electrical manufacturing industry is making through the intelligent application of plastics.

**T**O fulfill the need for devices which could stand temporary overloads and which could be put immediately back into operation, reclosing the circuit without replacing any parts, the Trumbull Electric Manufacturing Company has produced a line of circuit breakers for light and power distribution boards, switchboards, and various types of industrial control.

The development of the ATA Circuit Breakers for Trumbull, as is the case in the successful development of all plastics products, centered around (1) the product designer, (2) the custom molder, and (3) the manufacturer of plastic molding compounds.

In this particular instance, the problem faced was unusually difficult because of the complex nature of the construction and the stringent requirements for electrical resistance and ruggedness in the material used.

As the first basic step, a mold design was worked out, so ingenious that the circuit breaker case comes from its mold (compression molded by the Watertown Manufacturing Company) as a finished product, smooth and ready

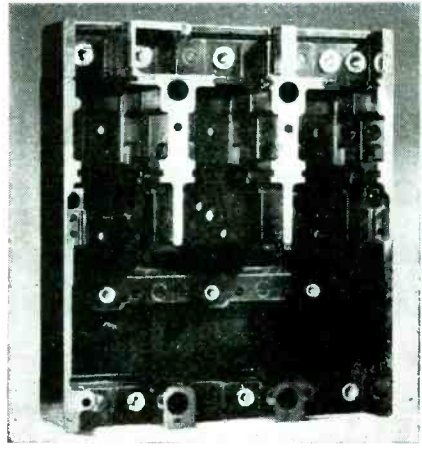

for assembly of internal mechanisms. Metal inserts, holes, sections, ribs, and cut-outs are *molded-in*, simplifying construction to an amazing degree.

Next came the careful selection of a plastic molding compound. For this purpose, a Durez phenolic compound was chosen because, in addition to possessing exceptional electrical properties, its versatility extended to other needed qualities such as impact strength, moisture resistance and moldability. *A plastic that fits the job*

The unusual versatility of the more than 300 Durez phenolic molding compounds has made their use practically universal throughout industry. As a result of this usage Durez laboratory technicians have gained a wealth of

experience which embraces practically every field of endeavor.

Add to this extensive background the most modern methods of research and you can readily appreciate the value which their assistance has to the product designer and custom molder.

You may be assured of the utmost cooperation of the Durez staff, at any time, in helping your product designer and custom molder work out any materials problem which you may have. Durez Plastics & Chemicals, Inc., 811 Walck Road, North Tonawanda, N.Y.

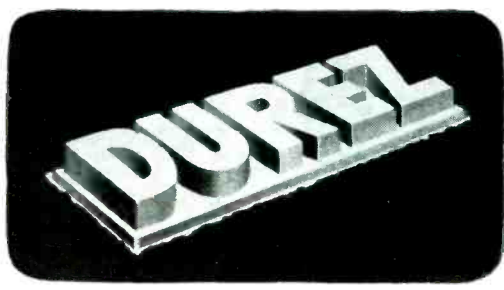
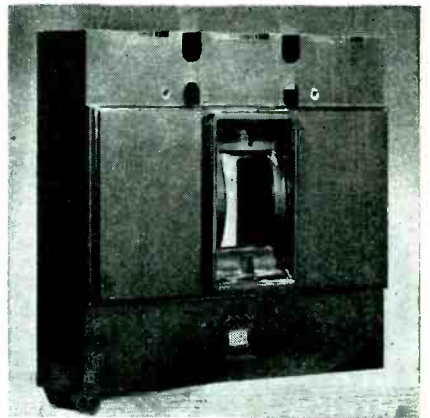

**PHENOLIC  
MOLDING COMPOUNDS  
AND RESINS**

**PLASTICS THAT FIT THE JOB**

## BROADCAST ENGINEERS — POLICE RADIOMEN

*Write Now!*

— on your phasing and  
tuning gear problems



• Let us know *now* your requirements and specifications for *phasing and tuning gear* for your directional antenna. Andrew custom built equipment will again become available as soon as Uncle Sam releases our engineering and manufacturing facilities from production for war.

This release may come at any moment. Be sure that your needs are listed at the top of our peace-time back-log. The planning you do now will speed your own reconversion to the new high standards of the future.

Andrew engineers will gladly apply their years of skilled experience to the

solution of your special problems in the field of directional antenna equipment:

- Phasing networks and equipment
- Antenna tuning units
- Remote reading antenna ammeters
- Phase monitors
- Coaxial transmission lines and accessories

**ANDREW CO.**

363 East 75th Street  
Chicago 19, Illinois

with particular phases of electricity: batteries, electric circuits and their computation, and magnetism. Two chapters describe electrical instruments and their operation, and the application of electricity in motors, generators and transformers. In preparation for the final chapter on basic radio circuits and resonance, the book devotes three chapters to inductance, capacitance, and alternating current circuits. It should be emphasized that this book adheres rigidly to the scope implied by its title, and hence no complete practical radio circuits are given. Miscellaneous information and tables are given in a 32-page appendix.—M.G.V.

### Communication Circuits

By L. A. WARE and H. R. REED, *State University of Iowa. John Wiley and Sons, New York, 2nd ed., 1944, 330 pages, price \$3.50.*

To THOSE WHOSE primary interest is in filters, transmission lines, four terminal networks, and wave guides, this book should fill the requirements for an analytical treatment of these topics. It is written to serve as first-course material for those interested in communication engineering, but a knowledge of Maxwell's equations and Bessel functions is necessary for an understanding of all parts of the text.

The subject matter is divided into the following broad topics: networks, transmission lines, filters, impedance transformation, and wave guides. One chapter is devoted to transmission line experiments, and there are nine appendices of mathematical character. Throughout, emphasis has been placed on the concepts at extremely high frequencies.

Three chapters on wave guides constitute the largest section devoted to a single topic. The first chapter lays the general groundwork and physical interpretation of wave guides in general. The remaining chapters deal, respectively, with rectangular and cylindrical wave guides.

Chapter XV outlines the electromagnetic theory of coaxial lines. In Chapter XVI will be found a brief outline of a dozen experiments which may be made on wave guides and transmission lines. Problems are provided.

Since the volume emphasizes

# ELECTRICITY

★ ONAN ELECTRIC GENERATING PLANTS supply reliable, economical electric service for electronics applications as well as for scores of general uses.

Driven by Onan-built, 4-cycle gasoline engines, these power units are of single-unit, compact design and sturdy construction. Suitable for mobile, stationary or emergency service.

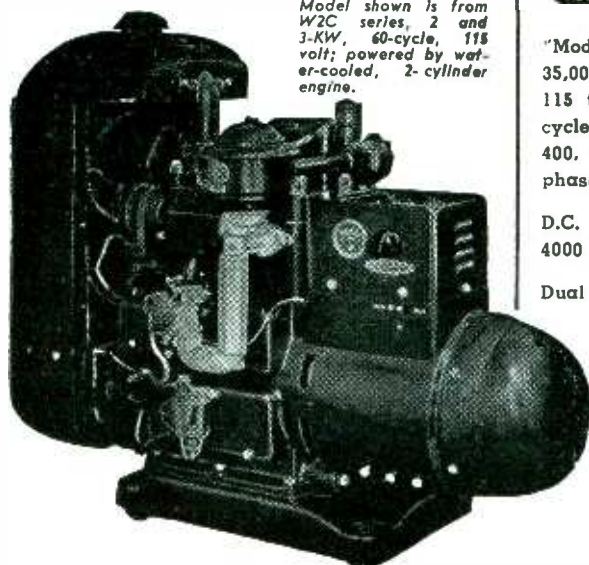

Model shown is from W2C series, 2 and 3-KW, 60-cycle, 115 volt; powered by water-cooled, 2-cylinder engine.

FOR ANY JOB  
—ANYWHERE



"Models range from 350 to 35,000 watts. A.C. types from 115 to 660 volts; 50, 60, 180 cycles, single or three-phase; 400, 500, and 800 cycle, single phase; also special frequencies.

D.C. types range from 6 to 4000 volts.

Dual voltage types available.

Write for engineering assistance or detailed literature".

**D. W. ONAN & SONS**

3257 Royalston Ave.  
Minneapolis 5, Minn.



# A COMPLETED POSTWAR PLAN

## *Based on Mutual Experience*

Two kinds of experience went into the formulation of our postwar plan.

1 **Our Customers' Experience** with our wartime services. So far as we can determine, it has been thoroughly satisfactory. Our prewar customers called upon us for stepped-up quality and quantity in communication and electronic specialties for wartime. We met that demand promptly.

Many new customers who, before the war, manufactured all parts of their equipment, placed their problems in our hands. We believe that their experience will point to the continued use of our facilities after Victory.

2 **Our Own Experience** with wartime production has been tremendous. No one can say whether the past three years have been worth six, twelve or twenty years of normal peacetime experience. But the fact is clear that it has helped us develop production "muscles" that enable us to carry greater loads than ever before.

So, based upon our customers' and our own experiences, we have a very simple postwar plan. It is to continue to serve our host of customers with our facilities, skills and experience in producing equipment to meet their specialized needs for performance, quality, quantity and low cost. We are confident that our customers' wartime experiences assure us a sound future.

**THE F. W. SICKLES COMPANY • CHICOPEE, MASSACHUSETTS**



### SOME SICKLES FIRSTS

1. 1933—Dual Miza Trimmers\*
2. 1936—Silver Cap Condensers\*
3. 1940—Low-loss "Ripple" Loops\*
4. 1941—Midget I.F. Assemblies
5. 194V—More Coming

\* Patented

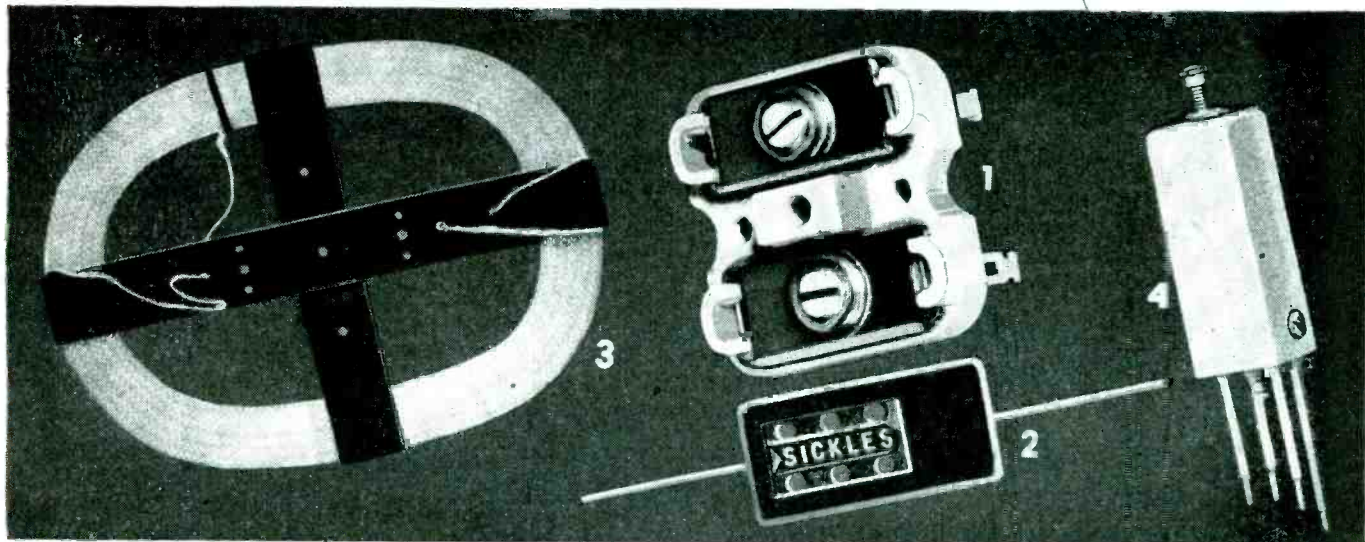

*Radio and Electronic Specialties for Today and Tomorrow*

# SICKLES



# FERROCART

## Exclusively IRON CORES

*Used wherever  
performance  
counts*

Thousands of FERROCART cores are serving effectively and efficiently wherever performance counts. Used by leading manufacturers of communication and electronic equipment, especially in radio receivers and transmitters, even at ultra high frequencies, particularly for R.F. and I.F. coils, and R.F. filters. Each core is precision-made of the finest materials and rigidly tested. Molded . . . light . . . uniform permeability. Our engineering staff of core specialists and laboratory facilities are available for helping to meet your specific requirements.

### FERROCART CORPORATION OF AMERICA

Plant and Laboratory: HASTINGS-ON-HUDSON 6, NEW YORK  
Indianapolis: 108 E. 9th St., Queisser Bros. Jenkintown, Pa.: P. O. Box 246, D. M. Hilliard. Montreal: 995 St. James St., West. W. T. Hawes

Specify



Quality

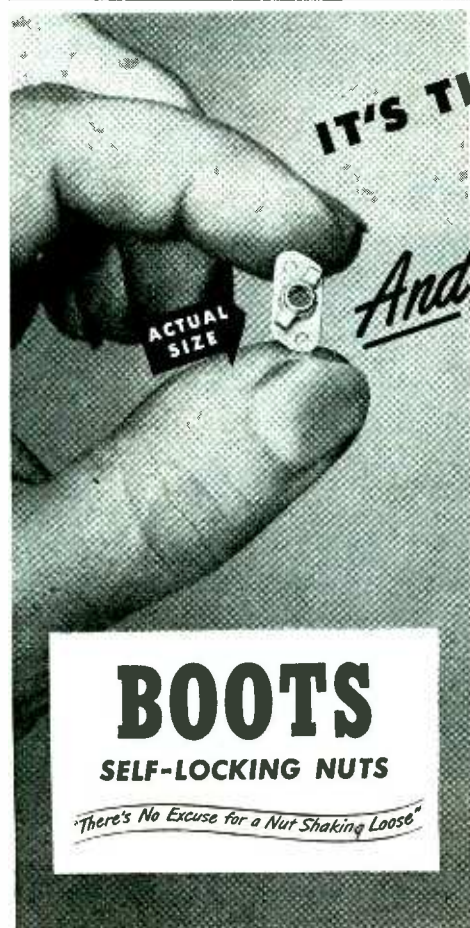

**IT'S TINY!  
LIGHT!**

*And it Stays Tight!*

### THE BOOTS SELF-LOCKING RADIO ANCHOR NUT SIZE NO. 6

designed especially for Radio and Electronic Products

A giant's grip is packed into this tiny, one-piece Boots Self-Locking Nut. Held by its all-metal, built-in lock, it can't shake loose even under the severest vibration. You can use it over and over again. Unaffected by heat changes or corrosion. Makes assembly and maintenance simpler.

Note these plus-values in a Boots Nut—

- Saves space—tiny but sturdy—a help to smart, compact design.
- Will not vibrate loose.
- Easier to apply than a clinch nut.
- No threads distorted—no punch needed.
- Permits flush surface on opposite side without chamfering.

Motion picture—"All Work And No Play"—16 mm. sound—30 minutes.

For information write Dept. A-7

Boots Aircraft Nut Corporation

General Offices • New Canaan, Conn.

Representatives in New York • Chicago • Detroit • Indianapolis • Los Angeles • Kansas City • Dallas • Toronto • Montreal • Vancouver

## BOOTS

### SELF-LOCKING NUTS

*"There's No Excuse for a Nut Shaking Loose"*

u-h-f techniques and principles, it should be a welcome addition to the library of anyone working in that field. However, the omission of any treatment of vacuum tubes and of lumped circuits precludes it from serving all engineering needs of the communication engineer.—B.D.

### Shop Job Sheets in Radio Book II—Service Problems

By ROBERT N. AUBLE, *The Macmillan Co., New York, 1944, 128 pages, 11x8½ in., paper covers punched for standard binder, price \$1.50.*

TWENTY-FIVE JOB SHEETS are provided, similar in format and designed as a follow-up to the radio fundamentals covered in Book I (reviewed in August 1944 *ELECTRONICS*). The first five job sheets cover testing radio resistors, condensers, transformers, filter chokes, and vacuum tubes. The next three are lessons in the construction of a power supply, a high-gain audio amplifier stage, and a power amplifier with phase inverter driver. One job is an overall test of an audio amplifier. There are nine jobs dealing with the superheterodyne receiver. The last seven of the job sheets deal with transmitters and cover the Hartley oscillator, electron-coupled oscillator, quartz-crystal oscillator, radio-frequency amplifiers, frequency-doubler circuits, the power supply, and modulation.—J.K.

### Books Received for Review

**MAINTENANCE AND SERVICING OF ELECTRICAL INSTRUMENTS.** By James Spencer; edited by Major M. F. Behar, editor of *Instruments*. The Instruments Publishing Co., Inc., Pittsburgh, 1944, 256 pages, \$2.00. Reprint of serialized articles published since Aug. 1941 in *Instruments* magazine; practical and well illustrated.

**METHODS OF ADVANCED CALCULUS.** By Philip Franklin. McGraw-Hill Book Co., Inc., New York 18, 1944, 486 pages, \$4.50. Arranged for use as college text, but suitable for reference or self-study by practicing engineers. Covers partial derivatives of implicit functions and Jacobians, vector notation, Fourier analysis, calculus of variations, Bessel functions and related topics.

**TECHNIC OF ELECTROTHERAPY.** By S. L. Osborne and H. J. Holmquest. Charles C. Thomas, Publisher, Springfield, Ill., 1944, 780 pages, \$7.50. Medical electronics and electricity, presented essentially as taught to classes for physicians, medical students and technicians at Northwestern University Medical School. Divided into four major sections: Effects and technical application of direct current; electrical muscle stimulation, with new technic for stimulating vocal cords; radiation—physics and application, both heat-producing and ultraviolet; high-frequency currents, occupying over half the book and covering circuit theory, generation, general diathermy applications and surgical diathermy including electrodeposition, electrocoagulation and electrocutting.

**DIRECT-CURRENT CIRCUITS.** By Earle M. Morecock. Harper & Brothers, New York



# AROUND THE GLOBE...

# Tropicalized

# Q-MAX

## A-27 H. F. LACQUER



... Provides Dependable Protection For Communication  
And Electrical Equipment Against **FUNGI**

**ASPERGILLUS  
NIGER**



**PENICILLIUM  
DIGITATUM**



**CHAETOMIUM  
GLOBOSUM**



**RHIZOPUS  
NIGRICANS**

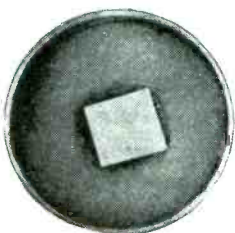

Our armed forces fight on many fronts in this global war, but in some, notably in Burma and the South Pacific, they must often face another insidious foe—the ever-present mold and fungus growths that impair the successful operation of radio, electronic and electrical equipment.

Manufacturers of such war matériel, disturbed by this dangerous field interference to their carefully built-in factory precision performance, came to us with their problem. After months of experimentation, our chemists found the ideal fungi-

cide to blend with Q-Max A-27 H.F. Lacquer, the outstanding dielectric coating material. Other fungicides had failed because they interfered with electrical characteristics or caused corrosion of metals.

Now Tropicalized Q-Max A-27 H.F. Lacquer offers dependable protection against all fungi illustrated on this page, the prevalent types. No mixing is necessary, for Q-Max is blended at the factory for you. Just look for the word **TROPICALIZED** on the Q-Max label.

Q-MAX DIVISION

**Communication**

PRODUCTS  COMPANY, INC.  
744 BROAD STREET NEWARK, N. J.

Coaxial Transmission Line & Fittings • Sterling Switches • Auto-Dryaire  
Antenna & Radiating Systems • Q-Max A-27 Radio Frequency Lacquer



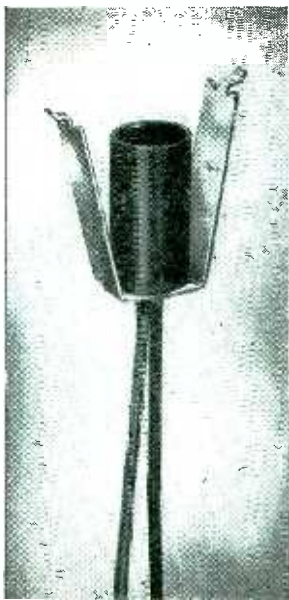

NO. 527-F TYPE

## Built-In Resistor Adapts this Drake Assembly for use with No. N.E.51 NEON Lamps.

**T**HE DRAKE 500 Series Dial Light Assemblies are ideally suited for use with 110V NEON Lamps, when equipped with a built-in resistor. Their many fine features have made the 500 Series a favorite. In fact, *millions have been used* since they were first introduced in March 1940! As world's largest exclusive producer of Dial and Jewel Pilot Light Assemblies, DRAKE facilities and long specialized experience assures top quality and speedy deliveries in any quantities. If you have a dial or jewel light problem submit it to our capable engineers. Should a standard type prove unadaptable, they'll design and build a special type for your particular need. The Drake catalog contains a wealth of information on a big line of Pilot Light Assemblies. Do you have a copy?



### PILOT LIGHT ASSEMBLIES

## DRAKE MANUFACTURING CO.

1713 WEST HUBBARD ST., CHICAGO 22, U.S.A.

## TODAY in WAR .. TOMORROW in PEACE



On mile-a-minute PT boats, as on hurtling jeeps, rumbling tanks, amphibian tractors and "walkie-talkies", Brach Antennas are doing their part in the vital task of communications. Today, our entire output goes exclusively to the nation's armed forces—on land, on sea, and in the air. But after the war, for the best in radio antennas and accessories, remember the name —BRACH.

## L. S. BRACH MFG. CORP.

World's Oldest and Largest Manufacturers of Radio Antennas and Accessories  
55-65 DICKERSON STREET • NEWARK N. J.

18, 1044, 387 pages, \$3.25. For use in technical institutes, junior colleges, industrial and extension schools. Questions, problems, lab experiments. Elementary circuits, magnetism, instruments and measurements, power, conductors, batteries, Kirchhoff's laws, magnetic circuits, d-c motors and generators, capacitors and electrostatic fields.

**THERMIONIC VALVE CIRCUITS.** By Emrys Williams. Sir Isaac Pitman & Sons, Ltd., London, 1944, 207 pages, 12s. 6d. Second Edition. Theory of operation and design of thermionic tube circuits, primarily for third-year electrical engineering students, with new material in this edition on f-m circuits, gaseous tubes, time bases, multivibrators, cathode followers and v-t voltmeters.

**MARINE RADIO MANUAL.** Edited by M. H. Strichartz. Cornell Maritime Press, New York 11, 1944, 518 pages, \$4.00. One-volume guide for beginners, students and experienced radio operators, covering operation, maintenance, repair, laws, regulations, radio navigation, code, signals, calls, auto-alarms, bookkeeping, sample messages, radio medical aid.

**INTERNATIONAL TELECOMMUNICATIONS.** By Osborne Mance. Oxford University Press, New York 11, 1944, 90 pages, paper cover, \$1.00. Discussion of problems of last 20 years, with suggestions for handling some of the present unsolved international communications problems.

**RADIO—FUNDAMENTAL PRINCIPLES AND PRACTICES.** By F. E. Almstead, K. E. Davis and G. K. Stone. McGraw-Hill Book Co., Inc., New York 18, 1944, 219 pages, \$1.80. Foundation training, for high-school classes, evening classes for adults, and Armed Forces schools.

**MEET THE ELECTRON.** By David Grimes. Pitman Publishing Corp., New York 19, 1944, 120 pages, \$2.00. The story of 20 years of electronics, interestingly presented for non-technical readers. Based on lectures given before the author's fatal airplane crash in Ireland.

**SAMPLING INSPECTION TABLES.** By H. F. Dodge and H. G. Romig. John Wiley & Sons, Inc., New York 16, 1944, 106 pages, \$1.50. Three papers that appeared originally in *Bell System Technical Journal*, describing sampling inspection tables developed for use in manufacture of communication apparatus and equipment for the Bell Telephone System, reprinted with a brief introduction covering advantages and shortcomings of sampling as contrasted to complete inspection of production output.

**SHOP JOB SHEETS IN RADIO; BOOK II—SERVICE PROBLEMS.** By R. N. Auble. The Macmillan Co., New York, 1944, 128 pages, \$1.50. Twenty-five job sheets covering testing of radio components, construction of basic receiving and transmitting circuits, and circuit experiments.

**MODERN OPERATIONAL MATHEMATICS IN ENGINEERING.** By R. C. Churchill. McGraw-Hill Book Co., New York 18, 1944, 306 pages, \$3.50. Solution of differential equations of engineering and physics by Laplace transformations and other methods.

**THE LIQUIDATION OF WAR PRODUCTION.** By A. D. H. Kaplan. McGraw-Hill Book Co., New York 18, 1944, 133 pages, \$1.50. Recommendations of an economist for contract cancellations, disposal of surpluses and plant conversions.

**ALTERNATING CURRENT BRIDGE METHODS.** By B. Hague. Isaac Pitman & Sons, New York, 1943, 816 pages, \$8.50. Fifth edition, with minor changes and addition of material on copper-oxide and cathode-ray detectors and an appendix on bridge circuits.

**MATHEMATICAL AND PHYSICAL PRINCIPLES OF ENGINEERING ANALYSIS.** By W. C. Johnson. McGraw-Hill Book Co., New York 18, 1944, 345 pages, \$3.00. Essential physical and mathematical principles needed for analysis of practical engineering problems, with emphasis on methods of attack, setting up equations and interpreting results.

**AIRCRAFT INSTRUMENTS.** By G. E. Irvin. McGraw-Hill Book Co., New York 18, 1944, 607 pages, \$5.00. Second edition, with new material on many newly developed electrical aircraft instruments.

**SPEAK WELL—AND WIN.** By W. P. Sanford. Whittlesey House, New York 18, 1944, 176 pages, \$2.00. Practical advice on speaking convincingly and clearly, for those who must present technical problems to the public.

**AIRCRAFT PRODUCTION ILLUSTRATION.** By G. Tharratt. McGraw-Hill Book Co., New York 18, 1944, 201 pages, \$2.75. Presentation of the various illustrative techniques available to all industrial drafting departments, with aircraft problems serving as examples.





# *Light?* We call it "LIGHT FANTASTIC"!

... a transformer headed for 65,000 feet "altitude" ... at 350 degrees temperature!

And to top it off, it had to be "lighter than anything on the market," \*they said. What, we asked, was it for? They couldn't tell us, and we don't know to this day, but we do know it was badly needed.

It has to operate not only on a 60-cycle current at ground level, but from 400 to 2600-cycle current, and what's more, at a simulated altitude of 65,000 feet."

Thermador built this special transformer equipment. It passed the above mentioned requirements. That wasn't enough. They gave it another test, in which they changed the temperature from ambient (the temperature of a fairly warm room) to 350—in two hours. It passed that test, too. This is all we know of one of the most mysterious jobs

we ever did, in the not-mysterious method in which we built all of our transformers.

\*For reasons of military security names cannot be given.

BUY WAR BONDS

**THERMADOR  
TRANSFORMERS**

DEFEAT HEAT • COLD • HUMIDITY





**THERMADOR ELECTRICAL MANUFACTURING CO.**  
5119 SOUTH RIVERSIDE • LOS ANGELES 22, CALIFORNIA





**A New dielectric  
thermosetting  
Liquid Plastic  
with many unique  
characteristics**

**DIELECTRIC CONSTANT 1.37  
SPECIFIC GRAVITY 0.76  
NO VACUUM IMPREGNATION**



*For spraying  
or dipping*

**430 F— FUNGICIDE**... a non-volatile, non-toxic coating, resistant to Fungi and Mold growth.

**900 OPAQUE**... Insulating coat acts as vitreous enamel coating... withstands temps. of 550° F. made in variety of colors.

**430 GC—TRANSPARENT**... For very deep penetration. Forms very strong mechanical bond between wire and coil.

**COILS • RESISTORS**

**CONDENSERS**

**LAMINATIONS ETC.**

*Write for detailed Factor-Data*

**Thermolex LIQUID  
PLASTICS CO.**

**ELIZABETH & NEPPERHAN AVES.  
YONKERS 3, N. Y.**

## Backtalk

This department is operated as an open forum where our readers may discuss problems of the electronic industry or comment on articles which **ELECTRONICS** has published.

### On Frequency Recommendations

Dear Sirs:

I AM MOST UNPLEASANTLY surprised to notice in your August report on the plans of the television committee of the RTPB for frequency allocation that you have not brought it to the attention of your readers that the 50-56 Mc channel is disputed territory. As you probably know, Frequency Modulation Broadcasters, Inc. has proposed that this band be allocated to frequency modulation. You state, "Since the report

### To Serve You Better

**AN ALTERNATE SOURCE  
OF GENUINE BIRTCHER  
TUBE CLAMPS**

### Prompt Delivery

We are fully licensed to manufacture the complete BIRTCHER line of locking type, stainless steel tube clamps. Orders placed with us for prompt delivery using BIRTCHER part and identification numbers will be filled at prices as favorable as those to which you are accustomed. All clamps will be identical with those manufactured by the Birtcher Corporation.

SOLE LICENSED MANUFACTURER  
OF BIRTCHER TUBE CLAMPS

**THE GEORGE S. THOMPSON  
CORPORATION**

5240 HUNTINGTON, DR.  
LOS ANGELES 32, CALIF.

## STOP VIBRATION GREMLINS WITH BIRTCHER TUBE CLAMPS



Where vibration is a problem Birtcher Locking TUBE CLAMPS offer a foolproof, practical solution. For ALL types of tubes and similar plugs in components.  
**83 VARIATION**

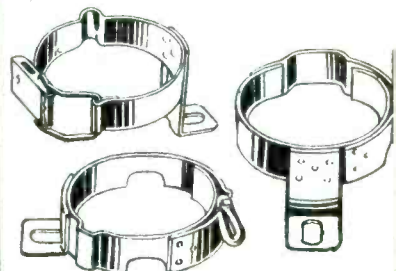

**OVER TWO MILLION IN USE**  
Send for our standard catalog and samples of corrosion-proof Birtcher Tube Clamps.



**THE BIRTCHER CORPORATION**  
Manufacturers of AIRCRAFT  
and RADIO PARTS  
5087 HUNTINGTON DR. LOS ANGELES



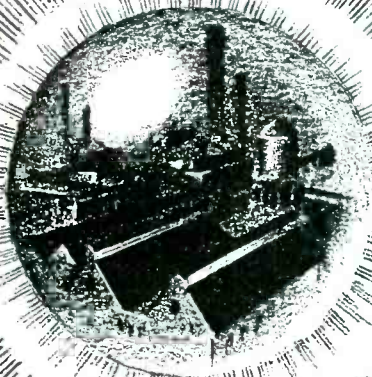

# A NEW Magic!

## In the modern industrial plant

articles are counted faster than human eye can function. Electronic devices inspect the interior of solid objects. Electronic equipment controls temperatures, eliminates smoke, operates lights, classifies colors . . . establishes heretofore undreamed of standards of accuracy and increased production.

And that only begins to tell the story. New methods . . . new materials . . . new uses of electricity . . . will be matched by the new and improved standards of design and construction now being perfected by Ferranti Transformer precision and craftsmanship.

In the tempo of things to come, you can rely with confidence upon the things Ferranti is doing today . . . Ferranti Quality and increased facilities will enable you to solve your PRESENT as well as your postwar problems . . . to meet the increased complexities of today's and tomorrow's production.

**CONSULT WITH FERRANTI NOW** — *wherever Quality and prompt delivery are of paramount importance.*

PLAN WITH

# Ferranti

**FERRANTI ELECTRIC, INC. • RCA BUILDING • NEW YORK CITY**

## FERRANTI

*Mark of Progress and Quality*

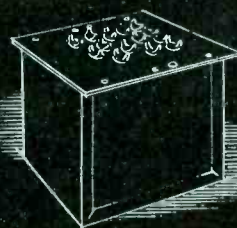
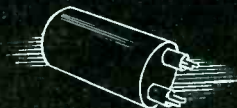
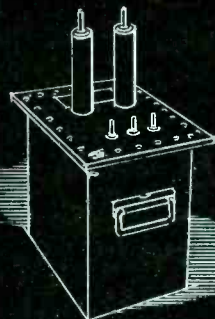
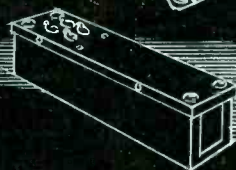
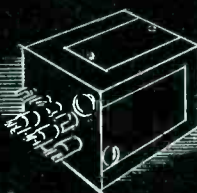



# EXTRA! EXTRA!



## UNBRAKO

Reg. U. S. Pat. Off.

### HOLLOW SET SCREWS

"UNBRAKO" now offers you hollow set screws in very small sizes—an important development from the standpoint of radio and electronic manufacturing. Smaller set screws make smaller shaft fits possible, thereby saving space in electronic and radio equipment.

Sizes from No. 0  
(0/80 x 1/16) to  
No. 10 (No.  
10 x 3/8)



All the usual qualities of "Unbrako" screw products — *Accuracy, Hardness and Strength* — are present in these smaller screws. And the hex-shaped socket in all "Unbrako" Hollow Set Screws permits easy tightening in constricted areas — another space-saving feature.

OVER 40 YEARS IN BUSINESS

**STANDARD PRESSED STEEL CO.**

JENKINTOWN, PENNA. BOX 596

should be given for the fullest discussion of the issue.

L. B. ARGUMBAU  
Assistant Professor  
Massachusetts Institute of Technology  
Cambridge, Mass.

See RTPB on FM, in this issue. Statements of position and other comments are most welcome. (Ed.)

### Polarized Speech

Dear Sirs:

MR. LEE CLOUGH's letter in Back-talk of the April 1944 issue of *ELECTRONICS* inquired about subject matter relating to polarized speech and commented on the lack of information on this subject in current manuals and texts. . . .

Information on this subject can be found in an article by Mr. J. L. Hathaway in the October 1939 issue of *ELECTRONICS*, dealing with the effect of microphone polarity upon modulation percentage.

It may also be possible Mr. Clough has reversed leads in some studio or line amplifier input circuit. An article in December 1939 issue of *Radio*, dealing with extended positive peak modulation, points out how this condition may

## SMART IDEA:

Though we're all absorbed in vital war work, let's give some thought to the future. Do a smart thing now — get thoroughly acquainted with Insuline's vast line of Radio-Electronic Products and the Insuline Manufacturing Facilities . . .

*These 2 books tell the story. Write for them now.*

48-page Catalogue describes Insuline's vast line of Radio-Electronic Products.



8-page Brochure presents Insuline's organization and manufacturing facilities.

What are your requirements? Send data for immediate assistance.



# INSULINE

CORPORATION OF AMERICA

INSULINE BUILDING • LONG ISLAND CITY, N.Y.



### FLEXIBLE SHAFTS

that carry power around any corner is our specialty. Faithful, dependable power drives or remote control in airplanes, tanks, signal corps radio, and many other war and commercial products. Shafts made to your specifications. Our engineering department will work out your particular power problem without obligation.

Write today for  
Manual D.



**F. W. STEWART MFG. CORP.**  
4311-13 RAVENSWOOD AVE. CHICAGO, ILL.

West Coast Branch 431 Venice Blvd., Los Angeles, Calif.



SHARING THE RESPONSIBILITY OF

# Security at Sea

Amphenol R.G., U.H.F. Cable, in full range of sizes, solid dielectric, braided metal shield, tough vinyl and armored jacket.  
Amphenol, approved design, ultra low-loss connectors.

• Today and for all tomorrow, ships at sea everywhere — home port or base. The long wartime strides of electronics' progress have assured this for the world. Lifeline of this instant constant contact is the high frequency, low-loss cable. Amphenol R.G. type is an outstanding example which is serving today on the ships of every sea and flying in every formation. Amphenol has been closely allied to the development work and pioneered the manufacturing processes of solid dielectric ultra-high-frequency cables. The result is quite naturally a cable of unusual quality built in many sizes and with vinyl or armored outer jacket—a husky, serviceable high frequency cable built to the needs of shipbuilders, and manufacturers of electrical equipment for every type of service. Write for Amphenol Catalog Section D.

Depend upon



Quality

AMERICAN PHENOLIC CORPORATION  
1235 S. 54th AVENUE, CHICAGO 50, ILLINOIS

- Connectors (AN, British, U. M. F.)
- Cable Assemblies
- Conduit (Flexible)
- AN Fittings
- UHF Cable
- Radio Parts and Equipment
- Plastic Products





THE **EYE** CAN'T SEE ITS EXCELLENCE

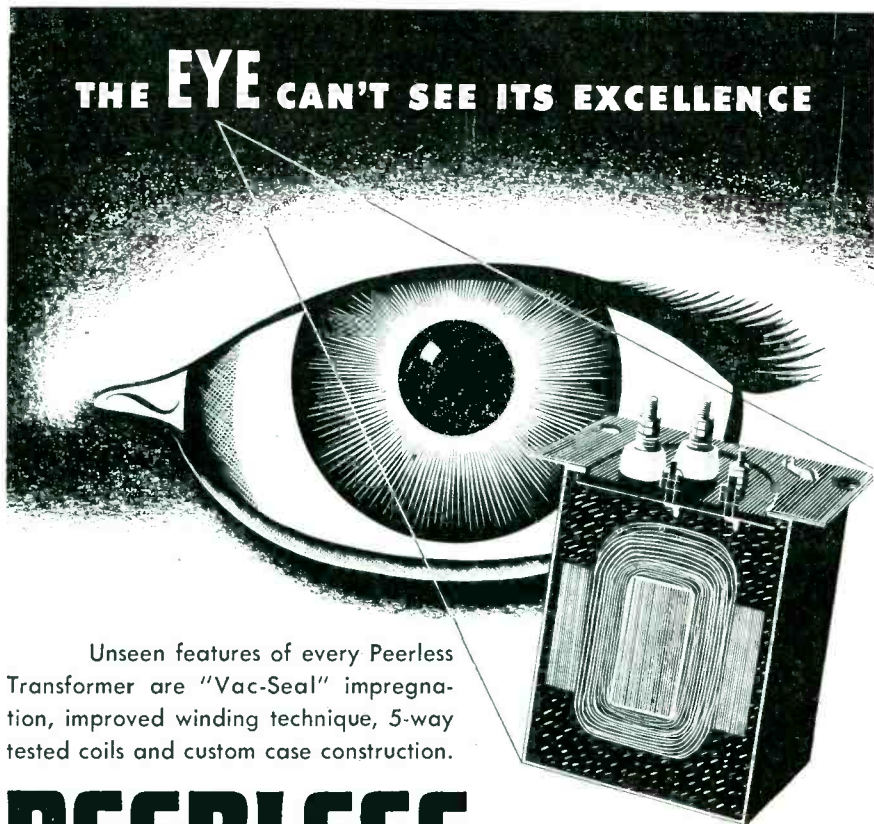

Unseen features of every Peerless Transformer are "Vac-Seal" impregnation, improved winding technique, 5-way tested coils and custom case construction.

**PEERLESS**  
ELECTRICAL PRODUCTS CO.

5920 MCKINLEY AVENUE • LOS ANGELES 1, CALIFORNIA

**Fungus-Proofed Waxes**

As a vital service to the Armed Forces we now offer Fungus Resistant Materials. These recently developed products are the answer to Communications requirements where the impregnation or coating of radio parts and equipment are concerned.

ZOPHAR waxes and compounds meet every specification of both the Army and Navy for waterproofing and insulating all electrical and radio components. They also have wide application in packaging of every description.

**ZOPHAR MILLS** INC  
112-130—26th STREET ESTABLISHED 1846  
BROOKLYN, N.Y.

markably well as contrasted with similar unpainted tubes.

Perhaps this is attributable to the fact that a black body radiates heat more effectively, thus permitting the internal elements of such tubes to operate at a lower temperature.

PHILIP ROSS  
Staff Engineer, WENX  
New York, N. Y.

### A Correction

Dear Mr. Henney:

RECENTLY I have belatedly been going over an interesting article in the July 1943 issue of *ELECTRONICS*, Transmission Line Charts, by R. F. Baum. One point puzzled me until I became convinced it must be an error.

At the top of page 158 is the statement, "going along the line X'Z' in Chart I we have for the point X', the value  $T = 0.58$  and  $\tau = 157$  deg. X' is previously given as,  $-33 + j10.6$  on page 94 and it corresponds to approx.  $T = 0.64$ ,  $\tau = 157$ , on Chart I, which I believe to be the correct value. The value given as  $T = 0.58$ , appears to correspond to X' on Chart II instead

**AT 100 MC  
DILECTENE**

A C-D Engineered  
U-H-F Insulation

POWER FACTOR  
0.0033

**STABLE UNDER**

High Humidity

Temperature Extremes

Mechanical Stress

Chemical Conditions

DIELECTRIC CONSTANT  
3.57

READILY MACHINED

For complete technical data, send for Bulletin DN

**CONTINENTAL-DIAMOND  
FIBRE COMPANY**  
NEWARK 16, DELAWARE





IT IS EASY to see that both these gentlemen are satisfied customers of General Industries. One acclaims our "know-how" in molded plastic parts — the other our velvety *Smooth Power* motors. Yes, we do both jobs under one roof and one management.

## GENTLEMEN, *YOU'RE BOTH* RIGHT!

 The plastic parts buyer has profited from the ingenious skill of our mold makers, who enable us to turn out tricky jobs economically and on time. Quite likely he has seen our up-to-date equipment for compression, transfer and injection molding of large or small parts in any quantities. Our engineers have made sensible and workable suggestions, by reading between his blueprint lines. He is typical of leading manufacturers in many fields who rely upon General Industries plastics division.

 The speaker on *Smooth Power* motors might be a radio-phonograph builder who uses our turntables, record changers and recorders. Or he might be a designer who depends upon these fine low-torque drives to power electric, electronic or mechanical devices. In any case, he's well acquainted with the facilities of our *Smooth Power* motor division.

We want to emphasize the point that we're a thoroughly able producer of both these products. If your plans call for either or both, we'd like to work with you. In your request for details, please address the respective division . . . *small motors or plastics.*

THE  
**GI** GENERAL INDUSTRIES  
 COMPANY  
 ELYRIA, OHIO





**cuts a  
Purchasing Agent's  
time to minimum**

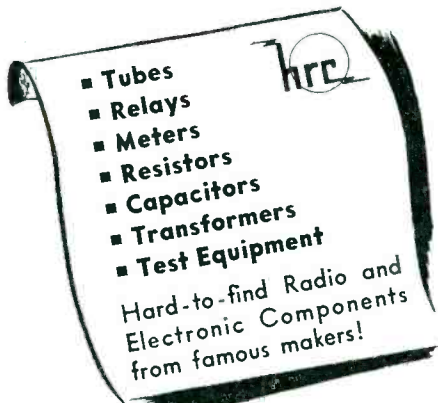

On our shelves, we've got the merchandise you need. At our fingertips, we have the answers to questions you ask . . . about priorities, about technical problems, about the effectiveness of substitutes. **And we DELIVER!** Trained expeditors ship your orders by the fastest-possible methods. And there's guaranteed satisfaction on every purchase. HARVEY is a "find" for harassed purchasing agents . . . try us, and you'll know the reason why!

**P. S.** HARVEY now distributes AUDAX, the "royal family" of Pickups, Cutters and Jewel Points.

Telephone Orders to LOnacre 3-1800



## NOW YOU CAN DO YOUR OWN BRANDING on PLASTICS!

**WE SHOW YOU HOW  
WE ENGINEER THE JOB  
WE BUILD THE TOOLS**

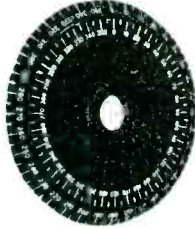

★ Rogan's exclusive plastic branding process has been employed extensively to speed production of many important war plastics. The bakelite Azimuth Dial illustrated, is one example of Rogan's accuracy in branding. In fact, this important assignment was entrusted only to Rogan.

However, wartime demands for this service in some ordnance plants, have required the application on their own premises. So, Rogan engineers have arranged a method whereby anyone can do his own branding on plastics right in his own plant. Rogan will engineer each job completely and build all the necessary tools. Will provide clear, simple instructions that will permit anyone to do the job expertly. All you need do is to send us blue prints and other specific data, and we'll give you a quick cost and time estimate.

Take advantage of this new Rogan service . . . send us your specifications today.

### ROGAN BROTHERS

2003 S. MICHIGAN AVE.

CHICAGO 16, ILLINOIS

**Quality  
AND LOTS OF IT**

★  
**Transformers  
for Combat**

**In Active Service  
Over the Entire Globe**

## DINION COIL COMPANY

CALEDONIA, N. Y.



# LOOK AT THIS EXCLUSIVE HARWOOD FEATURE . . . .

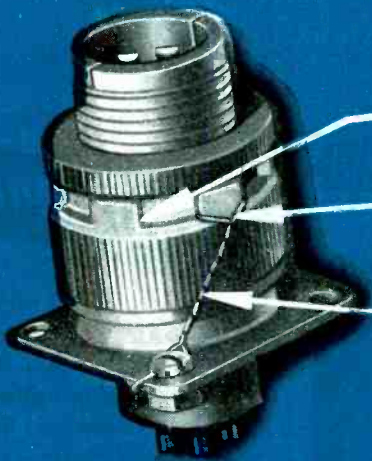

Castellated coupling nut, adapted to spanner or strap wrench, has many important advantages.

Safety wire is instantly attachable to any one of six positions, or lugs, on the coupling nut — without drilling a hole. Rounded edges of lugs prevent crimping of wire.

Release of wire presents no difficulty. Wire pulls clean; no drilling out.

FIELD CHECKS for a "short" or an "open" are quick and easy jobs if the connectors are Harwood with castellated coupling nuts. Simply cut the safety wire, untwist and pull out. It comes away clean, as it has not been crimped on the sharp edges of a tight-fitting drilled hole

Reassembly is as easy. No holes to drill. Just loop the wire over a lug on the castellated coup-

ling nut, which will be in correct locking position when the nut is tightened, then secure. This Harwood feature is an advantage in shop assembly, too. Write for details today.

**THE HARWOOD CO.**

Division of Los Angeles Corp

540 N. LA BREA AVE., LOS ANGELES 36, CALIF.

AN STANDARDS FROM 10S TO 44S IN  
QUANTITY DELIVERIES ON SCHEDULE



# Oil Type EC CAPACITRON

... in a Wide Range  
of Ratings for  
Single Hole Mounting!

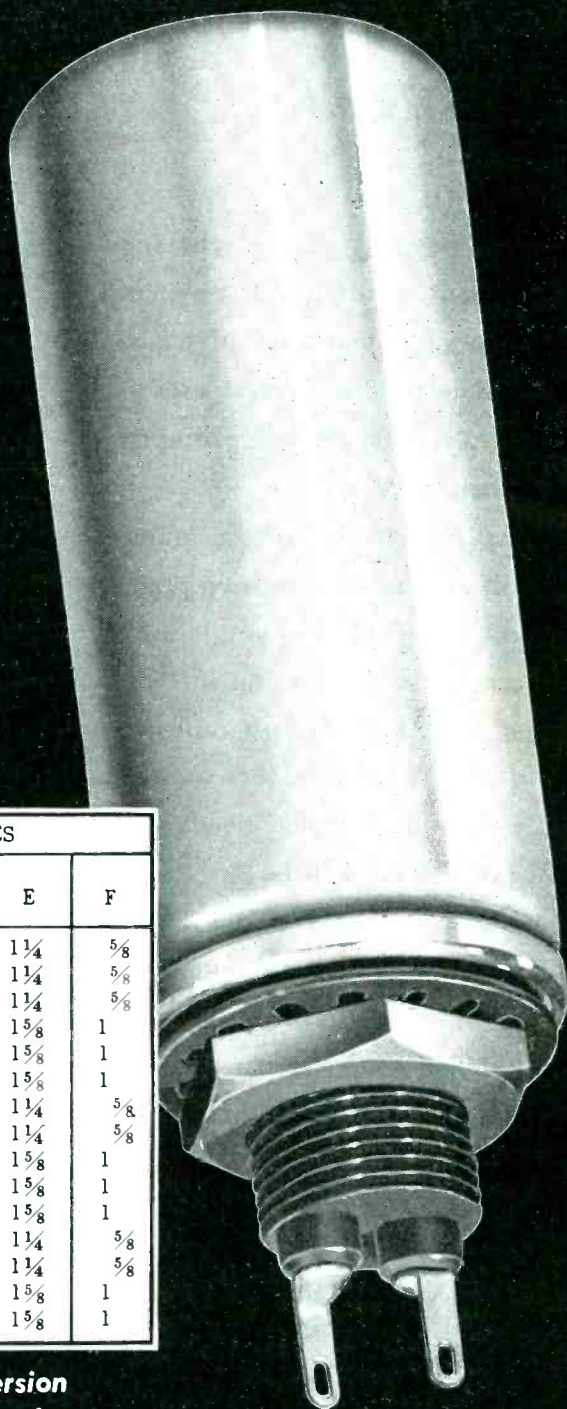
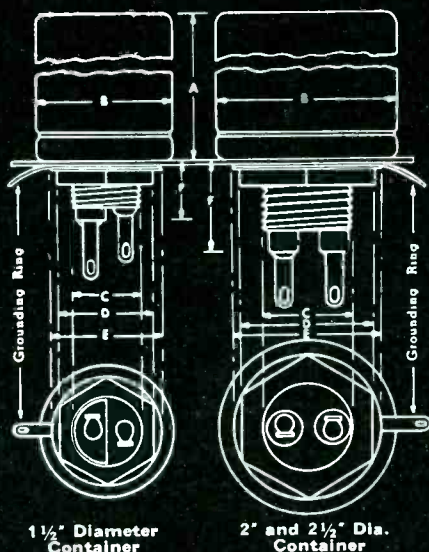

Catalog Number	Capacity in Mfd.	Working Voltage D.C.	DIMENSIONS IN INCHES					
			A	B	C	D	E	F
6EC200	2.0	600	2 <sup>3</sup> / <sub>4</sub>	1 <sup>1</sup> / <sub>2</sub>	3/4 x 16thd	1	1 <sup>1</sup> / <sub>4</sub>	5/8
6EC300	3.0	600	4 <sup>1</sup> / <sub>2</sub>	1 <sup>1</sup> / <sub>2</sub>	3/4 x 16thd	1	1 <sup>1</sup> / <sub>4</sub>	5/8
6EC400	4.0	600	4 <sup>1</sup> / <sub>2</sub>	1 <sup>1</sup> / <sub>2</sub>	3/4 x 16thd	1	1 <sup>1</sup> / <sub>4</sub>	5/8
6EC600	6.0	600	4	2	1 x 14thd	1 <sup>7</sup> / <sub>16</sub>	1 <sup>5</sup> / <sub>8</sub>	1
6EC800	8.0	600	4 <sup>1</sup> / <sub>2</sub>	2	1 x 14thd	1 <sup>7</sup> / <sub>16</sub>	1 <sup>5</sup> / <sub>8</sub>	1
6EC1000	10.0	600	4	2 <sup>1</sup> / <sub>2</sub>	1 x 14thd	1 <sup>7</sup> / <sub>16</sub>	1 <sup>5</sup> / <sub>8</sub>	1
10EC100	1.0	1000	2 <sup>3</sup> / <sub>4</sub>	1 <sup>1</sup> / <sub>2</sub>	3/4 x 16thd	1	1 <sup>1</sup> / <sub>4</sub>	5/8
10EC200	2.0	1000	4 <sup>1</sup> / <sub>2</sub>	1 <sup>1</sup> / <sub>2</sub>	3/4 x 16thd	1	1 <sup>1</sup> / <sub>4</sub>	5/8
10EC400	4.0	1000	4	2	1 x 14thd	1 <sup>7</sup> / <sub>16</sub>	1 <sup>5</sup> / <sub>8</sub>	1
10EC600	6.0	1000	4	2 <sup>1</sup> / <sub>2</sub>	1 x 14thd	1 <sup>7</sup> / <sub>16</sub>	1 <sup>5</sup> / <sub>8</sub>	1
10EC800	8.0	1000	5	2 <sup>1</sup> / <sub>2</sub>	1 x 14thd	1 <sup>7</sup> / <sub>16</sub>	1 <sup>5</sup> / <sub>8</sub>	1
15EC50	.5	1500	2 <sup>3</sup> / <sub>4</sub>	1 <sup>1</sup> / <sub>2</sub>	3/4 x 16thd	1	1 <sup>1</sup> / <sub>4</sub>	5/8
15EC100	1.0	1500	4 <sup>1</sup> / <sub>2</sub>	1 <sup>1</sup> / <sub>2</sub>	3/4 x 16thd	1	1 <sup>1</sup> / <sub>4</sub>	5/8
15EC200	2.0	1500	4	2	1 x 14thd	1 <sup>7</sup> / <sub>16</sub>	1 <sup>5</sup> / <sub>8</sub>	1
15EC400	4.0	1500	4 <sup>1</sup> / <sub>2</sub>	2 <sup>1</sup> / <sub>2</sub>	1 x 14thd	1 <sup>7</sup> / <sub>16</sub>	1 <sup>5</sup> / <sub>8</sub>	1

All of the Above A.W.S. Army-Navy Submersion  
Proof Units Available in Production Quantities for  
Prompt Delivery. Write, Wire or Telephone — Now!

Telephone: MICHigan 9656

The CAPACITRON Company

318 West Schiller St. Chicago 10, Illinois



# RIVET IT WITH A CHERRY

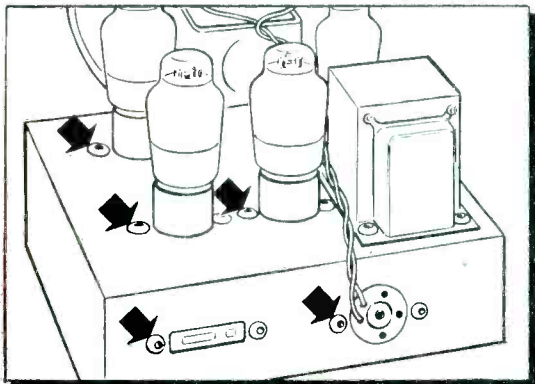

Rivet the parts to the radio chassis. It's sound production practice—and economical, too—when Cherry Rivets are used.

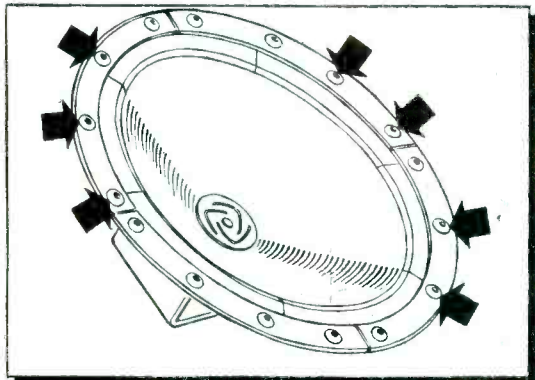

For fastening soft or brittle materials—rubber, plastics, fabrics, porcelain surfaced metal—use Cherry Rivets for sure success.

Don't limit your use of Cherry Rivets to blind riveting. Use them in all hard-to-get-at places. No bucking bar or other backing required. Use Cherry Rivets in soft and brittle material as well as metal. They are upset with a pulling force so they don't bend, buckle or spread. Use them for short runs or experimental work. No special tool-up or make-ready needed.

Cherry Rivets are easy and fast to apply. Working "blind" from one side of the job only, one man does it alone. They hold tight with a strong, firm clinch. And for blind rivets they are not critical as to hole size or material thickness. Figure out for yourself how Cherry Rivets will help cut your production costs. Or if you would like some help, put the matter up to the Cherry Rivet engineers.



Get this book—Cherry Handbook No. A-43—that describes the many uses of Cherry Blind Rivets. Write to Department A-120, Cherry Rivet Company, 231 Winston Street, Los Angeles 13, California.

CHERRY RIVETS, THEIR MANUFACTURE AND APPLICATION ARE COVERED BY U. S. PATENTS ISSUED AND PENDING

**Cherry Rivet**  
Company  
LOS ANGELES, CALIFORNIA

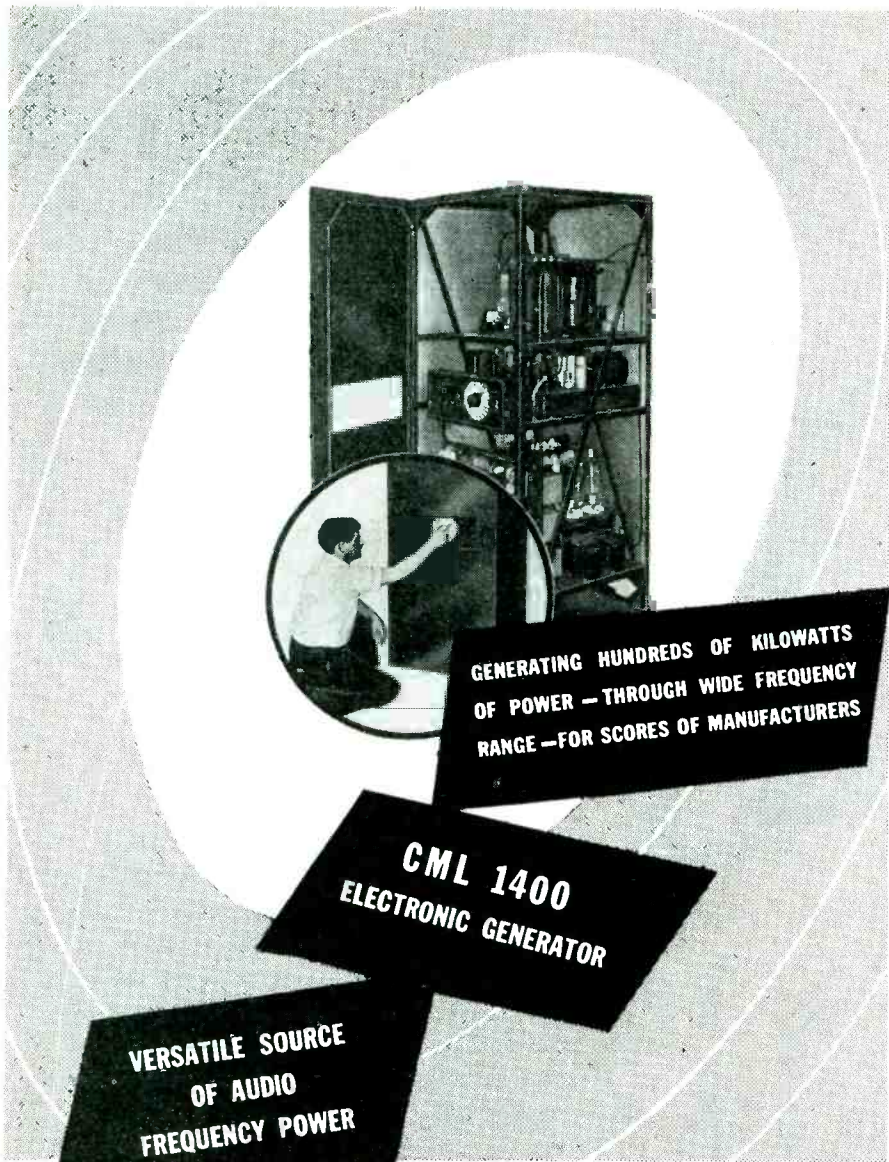

GENERATING HUNDREDS OF KILOWATTS  
OF POWER — THROUGH WIDE FREQUENCY  
RANGE — FOR SCORES OF MANUFACTURERS

**CML 1400**  
ELECTRONIC GENERATOR

VERSATILE SOURCE  
OF AUDIO  
FREQUENCY POWER

• Especially valuable for complete tests on the production line, the Model 1400 delivers 1400 watts of power from 300 to 3500 cycles single phase. Regulation from no load to full load is within 4%. Maximum distortion with a resistive load is within 10%.

Included with this generator is a variable frequency oscillator followed by several driver stages. The output stage employs a pair of 833-A tubes in Class B. By means of a special control circuit — which maintains output voltage at a substantially constant level from no load to full load—The CML 1400 overcomes the usual control difficulties of this type of high impedance power source.

WRITE FOR  
DESCRIPTIVE  
BULLETIN

## COMMUNICATION MEASUREMENTS LABORATORY

Rotobridge • Electronic Generators • Power Supply Units  
120 GREENWICH ST., NEW YORK 6, N. Y.



## SPINTITE WRENCH

WORKS LIKE A  
SCREW DRIVER  
only **FASTER**  
and **BETTER**  
sizes and styles  
for many uses.  
FIXED HANDLE  
and CHUCK TYPE  
SPINTITES in  
Standard Hex sizes.

Special SPINTITES for  
SQUARE, KNURLED or  
FLEXIBLE SHANK  
APPLICATION.

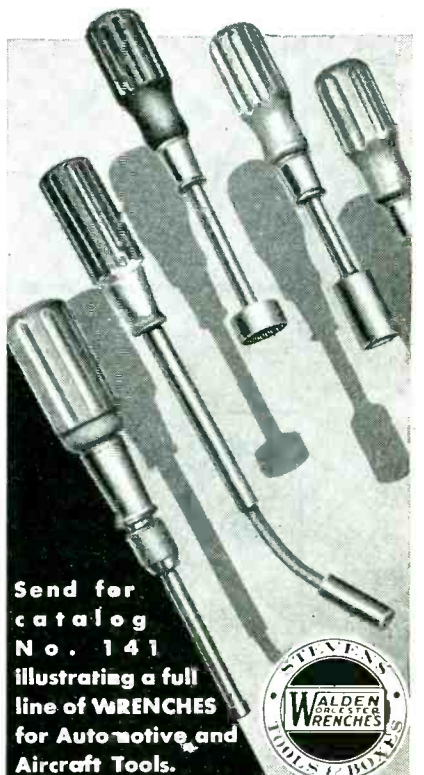

Send for  
catalog  
No. 141  
illustrating a full  
line of WRENCHES  
for Automotive and  
Aircraft Tools.



**STEVENS WALDEN, INC.**  
466 SHREWSBURY STREET  
WORCESTER, MASSACHUSETTS



TO THE POINT



# Perhaps We Can Help You With Your Post-War Electronic Control Problem

*Do your post-war production plans call for some electronic device or sub-assembly in quantity? Perhaps we can apply our broad experience in the development and manufacture of electronic controls and equipment to your problems. Your inquiry will put you under no obligation.*

• Electronic Sound Devices • Intercommunicating Systems • Industrial Voice-Paging and Broadcasting Equipment • Permanent and Portable Amplifying Systems • Recording and Disc-Playing Units • Electronic Controls • Operating Sequence Recorders • Other Special Electronic Devices.



**BELL SOUND SYSTEMS, INC.**  
1189 Essex Ave. Columbus 3, Ohio  
Export Office: 4900 Euclid Ave., Cleveland 3, Ohio

## Now, Even Greater Facilities

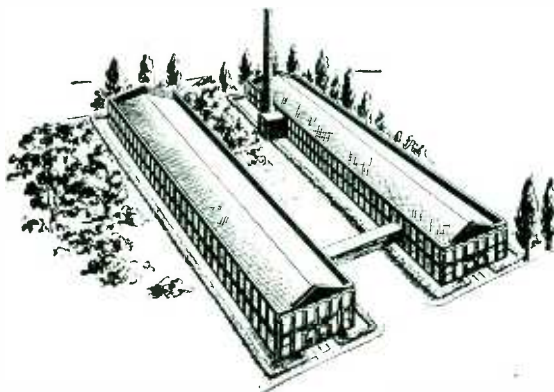

### *The new and larger Templetone plant at New London, Conn.*

Within a few weeks our entire Electronics Division will move into new quarters—affording not only greater facilities to meet ever-expanding wartime production, but also greater scope to anticipate the great electronics developments of peacetime. From this vast, new plant—containing 100,000 square feet of space—will come rich contribution to the vast commercial requirements at war's end.



*Electronics Division*

**TEMPLETONE RADIO MFG. CORP.**

*New London, Conn.*

*The New*  
**ALLEN-BRADLEY TYPE HB-**  
**2-WATT**  
**INSULATED RESISTOR**

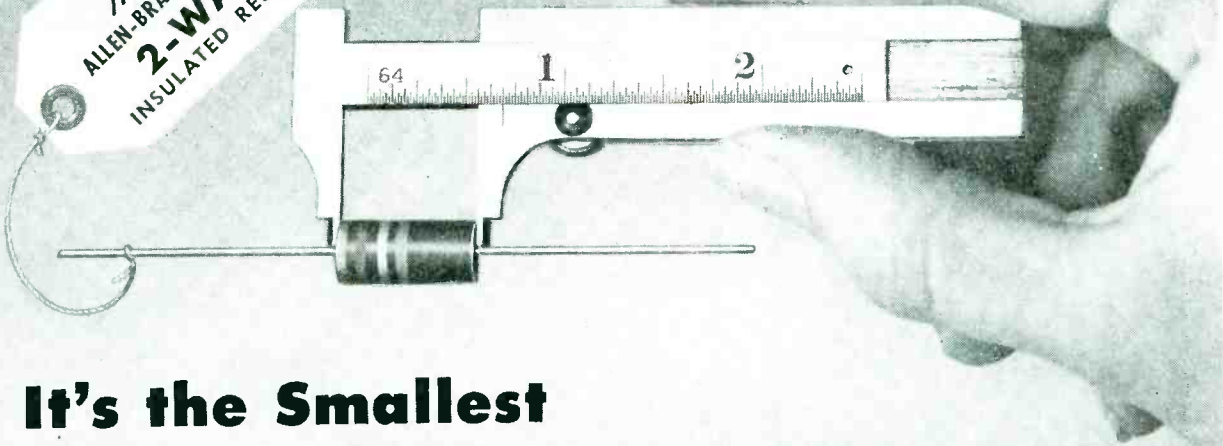

## It's the Smallest 2-Watt Fixed Resistor

### BRADLEYOMETER

The World's Finest  
 Continuously Adjustable Resistor

The only continuously adjustable composition type resistor (only 1 inch diameter) having a rating of 2 watts with substantial safety factor. Has solid molded resistor unit... not a film, spray, or paint type. Any resistance-rotation curve available.



Type JS Bradleyometer with built-in line switch. Not affected by heat, cold, or moisture.



Type J Bradleyometers may be used singly or assembled into multiple controls.



Low resistance carbon brush makes contact with surface of molded resistor.

ONLY  $\frac{1}{8}$ -inch long... and  $\frac{5}{16}$ -inch diameter... those are the remarkably small dimensions of the NEW Type HB Bradleyunit. It is the smallest 2-watt insulated fixed resistor ever produced, but you can use it safely right up to its listed rating. You don't have to derate it for even the toughest application.

The Type HB 2-watt Bradleyunit will pass all American War Standard tests: It is outstanding in its humidity and temperature characteristics. It matches in dependability and fine appearance the Allen-Bradley  $\frac{1}{2}$ -watt and 1-watt Bradleyunits (see below) which are recognized as "tops" by all radio and radar men.

Available in R. M. A. standard values from 10 ohms to 0.47 megohms in tolerances of 5, 10, and 20 per cent. Specify the Type HB 2-watt Bradleyunit and be safe in your engineering.

Allen-Bradley Co., 110 W. Greenfield Ave., Milwaukee 4, Wis.

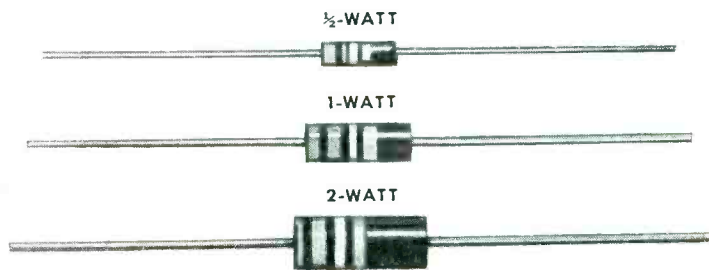

# ALLEN-BRADLEY

FIXED & ADJUSTABLE RADIO RESISTORS

QUALITY



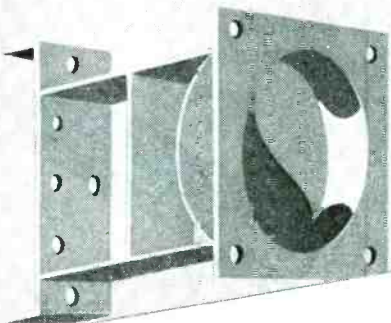
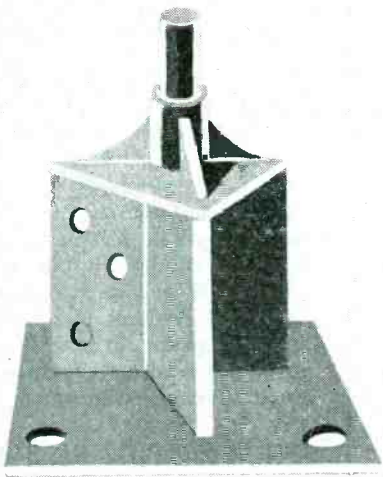
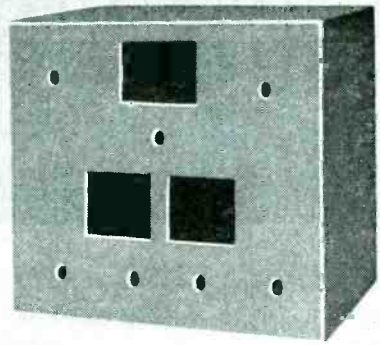
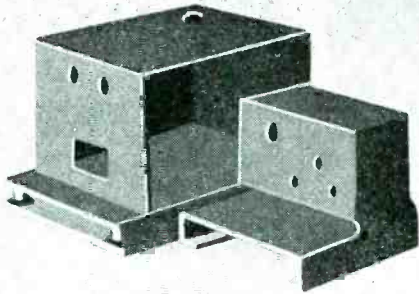

## SHEET METAL FABRICATION

Long before the war, "Cole Steel Equipment" had earned its reputation for quality. Tough assignments are part of our everyday job... instrument housings... boxes... and chassis. If your blueprints call for close tolerance sheet metal fabrication, send us your specifications.

Send for our Brochure  
"The Plant Behind Your Plant"

# COLE

## STEEL EQUIPMENT CO.

349 Broadway, New York 13, N. Y.

Factory: Brooklyn, N. Y.

**COLE STEEL  
OFFICE EQUIPMENT**  
will again be available  
after the war

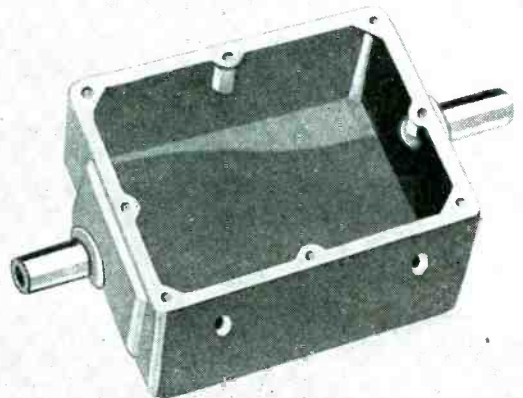



**"PACKAGED METAL ENGINEERING"**  
 saves you time, money, labor on  
 INTRICATE, UNUSUAL, COMPLEX JOBS

**ETCHED PANELS, DIALS, AND INSTRUCTION PLATES**  
 with precision fabrication and decorative ingenuity

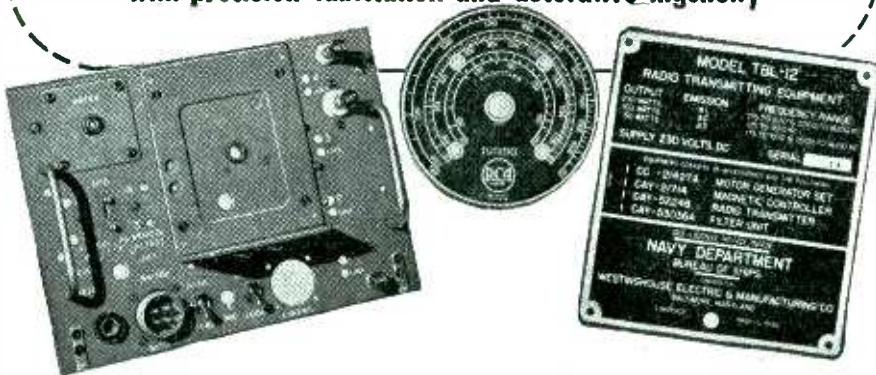

Grammes unique and complete facilities produce intricate, varied, and unusual Etched Panels, Dials, Name and Instruction Plates, Escutcheons, and Bezels. The Radio Panel shown has combination metal etching, decorative enamel finish, contrasting color fill-in of letters, 62 accurately positioned holes, entailing the manufacture of separate parts, and assembly of parts to panel.

With 69 years of precision fabricating skills, broad "know-how," and cleverly devised assembly methods, Grammes can save you time, money, and materials on your parts or product...centralized facilities provide economical production.

**GRAMMES CONTRACT SERVICE—your COMPLETE manufacturing source**

...available NOW for Research, Design and Engineering—complete facilities, from idea development to post-war manufacturing—confidence assured.

*"Packaged Metal Engineering" ... in one package ... one service ... we take over ALL responsibility, acting as Your factory from Design Research to Drop Shipments.*

If you have a metal fabrication problem, send for booklet "Contract Service by Grammes" today—Dept. 1-10.

- STAMPING
- DRAWING
- SPINNING
- WIRE FORMING
- ETCHING
- LITHOGRAPHING
- TOOLS & DIES
- EMBOSSING
- HARD ENAMELING
- SCREW MACHINES
- LINE ASSEMBLY
- MACHINING
- SPRAYING
- HEAT TREATING
- DRILLING
- WELDING
- PLATING
- ENAMELING

**DECORATED METAL PRODUCTS SPECIALISTS**

—applying artistic designs and finishes that add beauty and color to your product.

"MASTER CRAFTSMEN IN METAL"  
**Grammes**

L. F. GRAMMES & SONS, INC., ALLENTOWN, PA.

ESTABLISHED 1875



NEW YORK      CHICAGO      DETROIT      CLEVELAND      MILWAUKEE      PHILADELPHIA



DECORATED METAL PRODUCTS • ETCHED DIALS • PANELS • PLATES • CONTACTS • TERMINALS • CLIPS • LUGS • ETC.

**A STRONGER FACTOR**  
 in TODAY'S NEW  
**COMPLETE CIRCUIT PROTECTION**



**EXTRACTOR POSTS**

**WITH WELDED ANTI-VIBRATION SIDE TERMINALS**

**NOW UNDERWRITERS' APPROVED**

Resistance to extremes of shock, vibration and temperatures is provided by the new Littelfuse Extractor Posts with electrically welded side terminals. By Littelfuse process, terminals are made integral with inside metal shell. Maximum conductivity is insured. Other Littelfuse improvements for dependability, durability, and convenience make these extractor posts outstanding examples of Littelfuse complete circuit protection.

**EXTRACTOR POST No. 342001**  
 for 3 A G Fuses

Finger-operated. Welded side terminals. Knob and body black bakelite. Positive fuse grip. Full visual shock-proof inspection. Spring-activated cup. Specially designed grip prevents fuse from dropping out.



*Also furnished screw-driver operated (341001), meeting Underwriters' specifications.*

**Send for B/P and ENGINEERING DATA**  
**Ask for Samples**

Safeguard new equipment, or irreplaceable present equipment. Fuses, Fuse Clips, Fuse Panels, Circuit Breakers, Thermocouples, Fine Wire Products, Indicators, etc.

**LITTELFUSE INCORPORATED**

**Lf** 4757 Ravenswood Ave., Chicago 40, Ill.  
 200 Ong St., El Monte, Calif.



# The PROOF of Fine Wire is in the TESTING

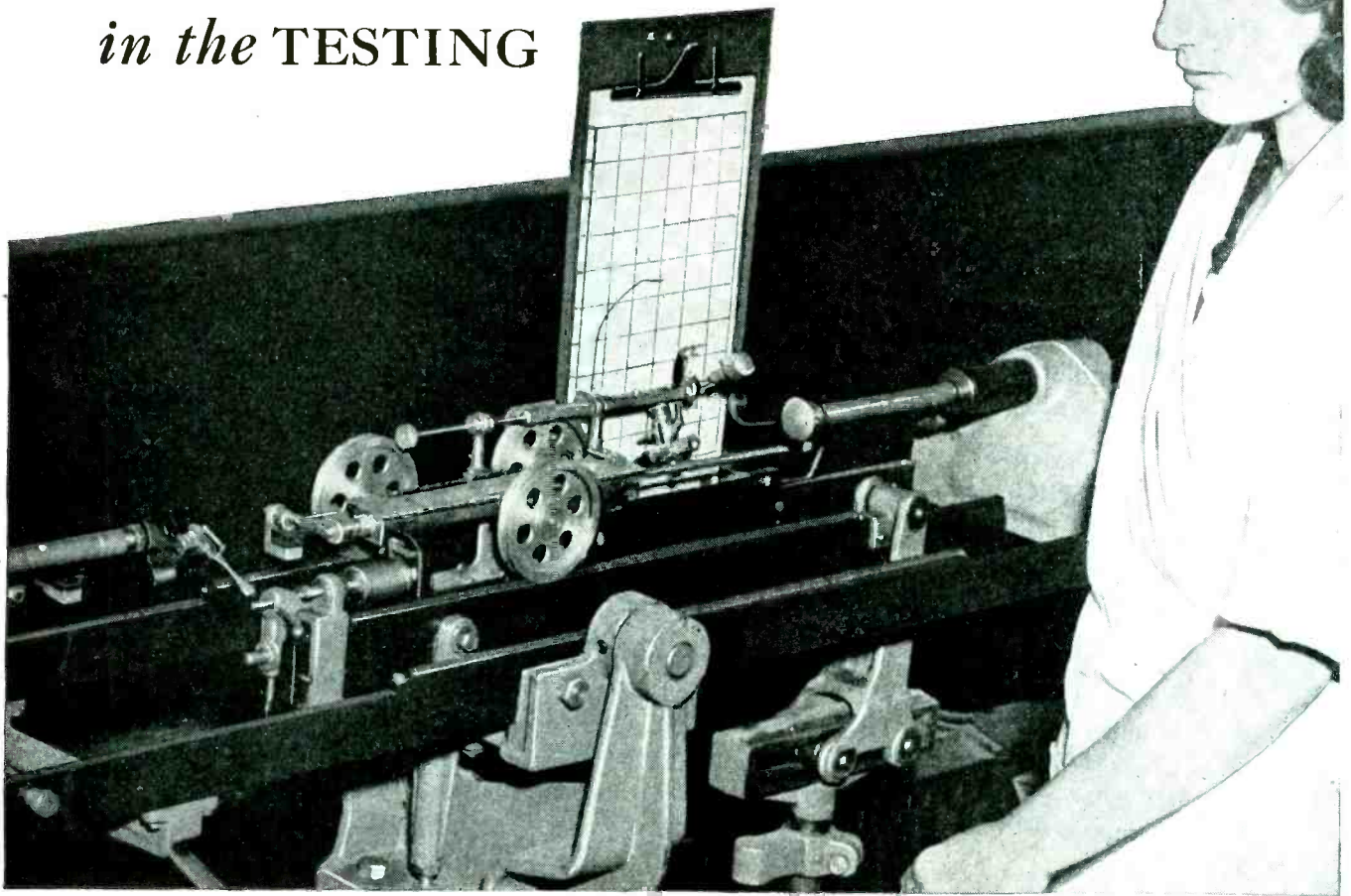

AS SPECIALISTS in the drawing of fine wire of close tolerances, perfect roundness and faultless surface condition, North American Philips have set up their own exacting specification standards, meeting the most rigid customer requirements.

To maintain these standards, special test equipment is in constant use, such as the Scott Tester, illustrated, that provides a precise measure of wire elongation, yield point and tensile strength. This relentless pursuit of perfection is your guarantee of a quality product.

North American Philips manufacture fine wire below .003" diameter in silver, nickel, copper, nickel chrome and aluminum alloy—bare or enameled.

We also plate many types of wire, such as silver, tungsten, molybdenum and alloys up to .010" with gold, copper or other metals.

Many manufacturers have found our unusual skill of great value in helping them meet wartime

production schedules and in developing new instruments and apparatus. North American Philips have the knowledge of processes and techniques developed by a technical organization with a background of over fifty years' experience in its fields.

Call on our specialized engineering service whenever you have a fine-wire problem.

## WHERE NORELCO FINE WIRES ARE USED IN THE ELECTRONICS FIELD

Precision wire-wound resistors • Hearing Aids  
Radio headphones • Sensitive recording and  
indicating meters • Sensitive relays • Electronic  
tube grids and filaments • Sound recording on  
steel wire • Fractional horsepower motors • Wire  
braid and cloth • And hundreds of other uses  
wherever very fine wire is required.



**Norelco** Electronic Products by  
Reg. U. S. Pat. Off.

**NORELCO PRODUCTS:** In addition to fine wire and diamond dies for our own drawing, we make: Tungsten and Molybdenum products; Quartz Oscillator Plates; Amplifier, Transmitting, Rectifier and Cathode Ray Tubes; Searchray (Industrial X-ray) Equipment; X-ray Diffraction Apparatus; Medical X-ray Equipment, Tubes and Accessories; Electronic Measuring Instruments; High Frequency Heating Equipment; Communications Equipment. • When in New York, be sure to visit our Industrial Electronics Showroom.

**NORTH AMERICAN PHILIPS COMPANY, INC.**

Dept. EW-11, 100 East 42nd Street, New York 17, N. Y.  
Factories in Dobbs Ferry, N. Y.; Mount Vernon, N. Y. (Metalix Div.); Lewiston, Me. (Elmet Div.)



**PRECISION FABRICATORS, INC.**

**EAST ROCHESTER, N. Y.**

**AN OPEN LETTER  
TO OUR MANY FRIENDS  
AND CUSTOMERS . . . .**

Because of an extreme labor shortage which seriously affected production, we have been obliged to seek a new locality where labor conditions are more stable and more favorable to the conduct of a highly specialized business such as ours.

I am happy to say that such a location has been found in East Rochester, N. Y. Our new plant, which we now occupy, is equipped on a larger scale with modern production facilities capable of producing precision parts to customer specifications-- in large or small quantities.

To those customers who have stuck by us through our recent crisis, I wish to extend our heartfelt thanks and gratitude for their loyalty and patience. And to those manufacturers with whom we have not yet had the pleasure of doing business, may I extend a cordial invitation to consult us on present or future plans concerning products of our manufacture.

Cordially yours,

PRECISION FABRICATORS, INC.

*Charles H. Major*  
President.



**Branch Offices:**

NEW YORK: 420 LEXINGTON AVE.  
DETROIT: 14319 STRATHMOOR AVE.  
CHICAGO: 4317 RAVENSWOOD AVE.



*Specification Fabricators of*  
**VULCANIZED FIBRE, CORK,  
CORPRENE, PHENOL FIBRE,  
RUBBER, ASBESTOS AND  
OTHER MATERIALS**



# ELECTROPLATING WITH POWERSTAT CONTROL

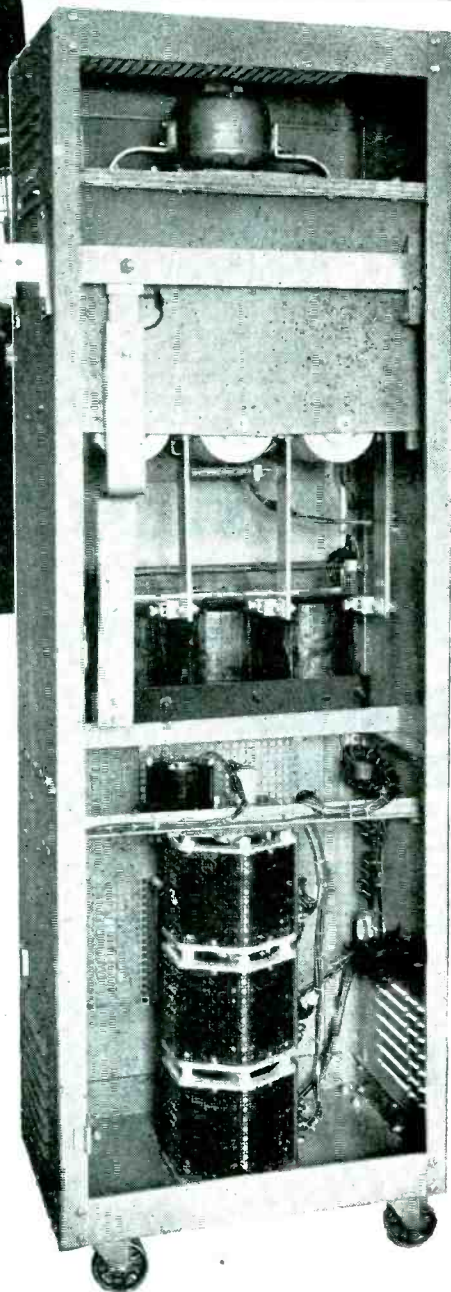
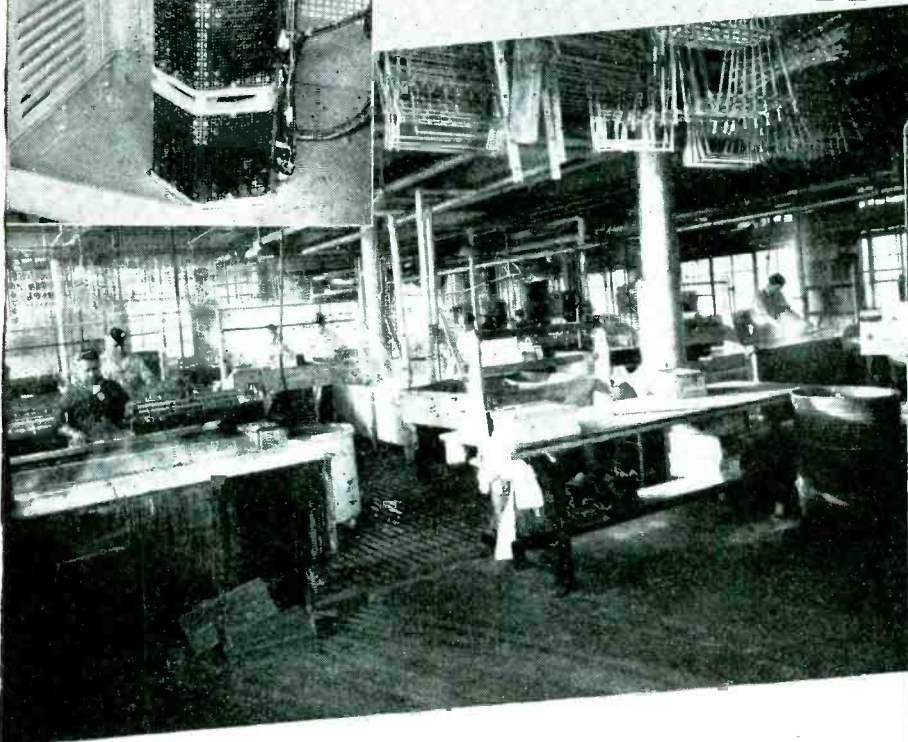
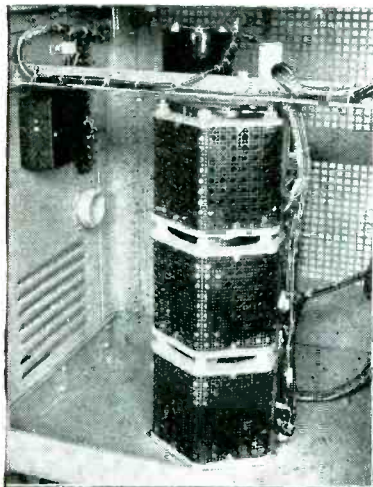

In order to conserve vital floor space and to keep the rectifying equipment away from a corrosive atmosphere, an eastern manufacturer specified that the power supply for the plating tanks be located outside the processing room. This meant remote control of tank voltage and current. To satisfy this requirement the engineers of the W. Green Electric Co., builder of rectifier units, replaced the usual tapped transformer with a Motor-driven POWERSTAT Variable Transformer type M1226-3. Installation of a push-button station in the plating room to control the POWERSTAT'S highly damped synchronous reversible motor provided the remote control feature. By simply pressing a button, any current from zero to maximum flows through the plating tanks.

The use of POWERSTATS in electroplating offers other advantages in addition to finger-tip remote control. Regulation is not limited to "steps" but is continuously variable; there is no interruption of current so characteristic of the tap changing system; and POWERSTATS have a long life with no tap switches to wear out.

For specific information on POWERSTAT control of electroplating processes, consult SECO engineers.

*Send for Bulletins 149 LE and 163 LE*

**SUPERIOR ELECTRIC CO., 210 LAUREL STREET BRISTOL, CONNECTICUT**

**SUPERIOR** *Electric Company*



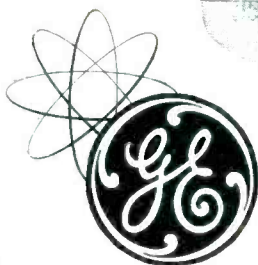

Compact and easily moved from place to place.

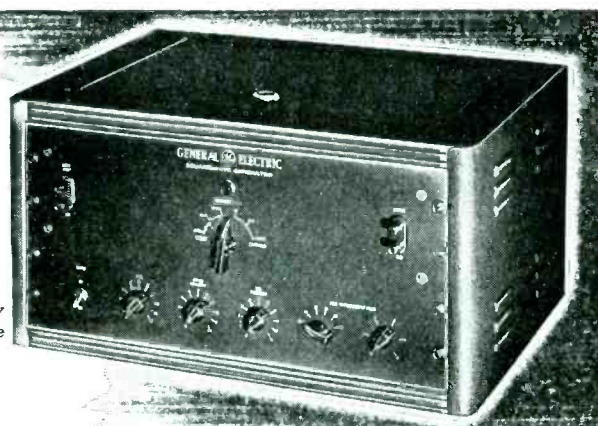

## SQUARE-WAVE GENERATOR

Designed for testing over-all performance of radio systems and networks, this self-contained instrument generates its own frequency with remarkable stability. Can be synchronized from an external source.

Other units in the new General Electric line of ELECTRONIC MEASURING EQUIPMENT include: G-E wave meters, capacitometers, power supplies, wide-band oscilloscopes, signal generators and various other instruments in the ultra-high frequency and micro-wave fields for measuring electronic circuits and checking component parts.

**GENERAL ELECTRIC**  
Electronic Measuring Instruments

164-G11



*We're ready now...*  
TO DESIGN THE

**COILS  
CHOKES**

AND

**TRANSFORMERS**

*You are planning!  
for POST-WAR!*

The advances in radio during the war have been tremendous... changes in technique have been rapid and urgent... ESSEX'S skill has kept pace with your every demand. Today, this experience is being translated into new designs and better components for tomorrow's needs.

Tomorrow, your models will be different and more efficient. ESSEX, a reliable source for quality chokes, coils and transformers, is anticipating your changing picture. Our engineers are ready NOW to work with you on samples for your post-war requirements!

**ESSEX  
ELECTRONICS**  
1060 Broad St., Newark, N. J.

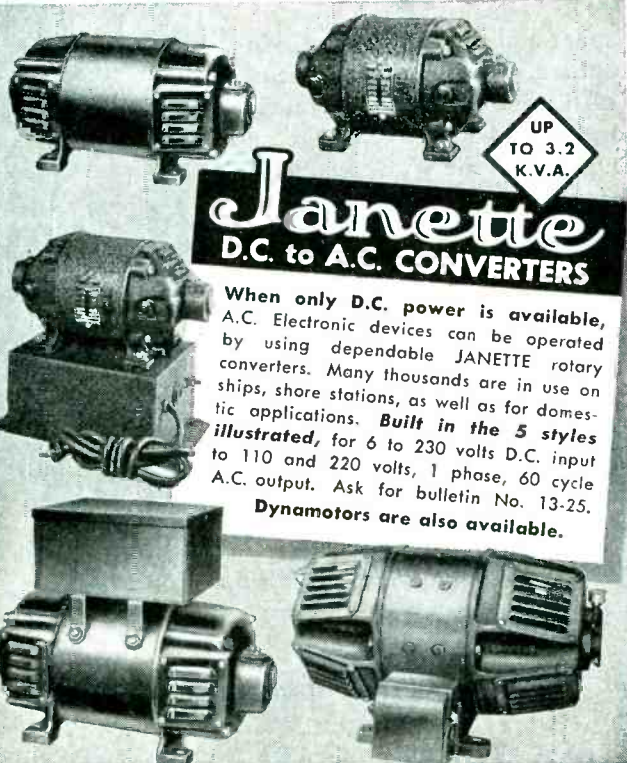

UP  
TO 3.2  
K.V.A.

## Janette D.C. to A.C. CONVERTERS

When only D.C. power is available, A.C. Electronic devices can be operated by using dependable JANETTE rotary converters. Many thousands are in use on ships, shore stations, as well as for domestic applications. *Built in the 5 styles illustrated*, for 6 to 230 volts D.C. input to 110 and 220 volts, 1 phase, 60 cycle A.C. output. Ask for bulletin No. 13-25. *Dynamotors are also available.*

Wherever there are ships, you will find Janette converters.

**Janette Manufacturing Company**  
556-558 W. Monroe St. Chicago, Ill.

**D.C. to  
A.C.**

By **JANETTE**



# FOR HEAT DISSIPATION

*under all conditions of temperature and climate*

L-R Blowers produce maximum C.F.M. with minimum space and weight. Lightweight, high-impact plastic housings. Turbo-type wheels. Clockwise or counter-clockwise rotation.

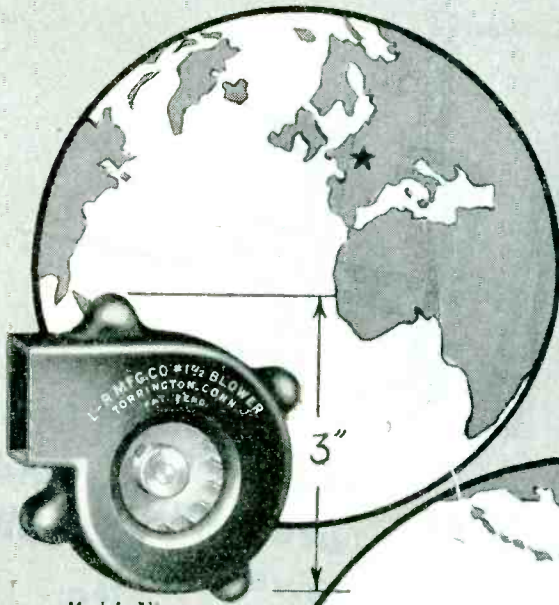

Model 1 1/2  
Weight (less motor):  
2 oz.  
Output: 15 C.F.M. at  
8000 R.P.M.

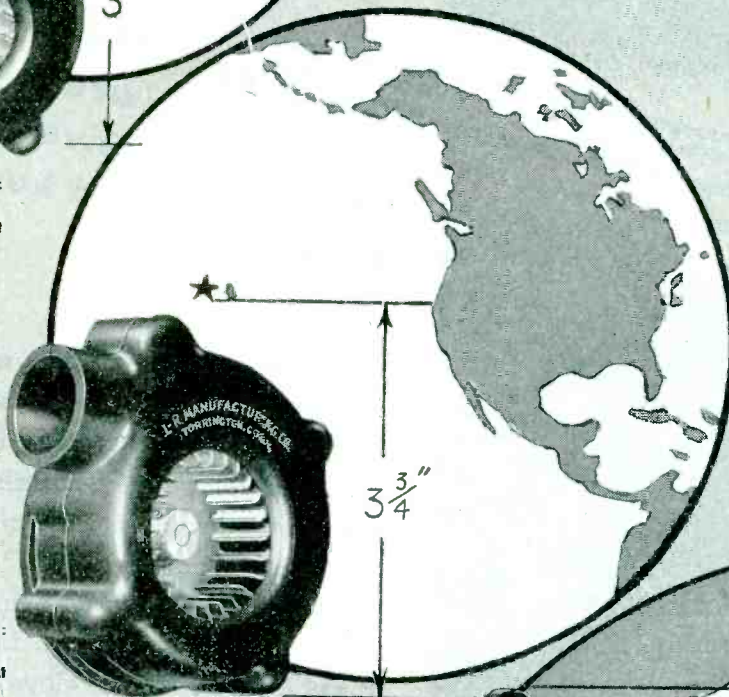

Model 2  
Weight (less motor):  
4 1/2 oz.  
Output: 25 C.F.M. at  
8000 R.P.M.

Model 3  
Weight (less motor):  
12 oz.  
Output: 260 C.F.M. at  
8000 R.P.M.

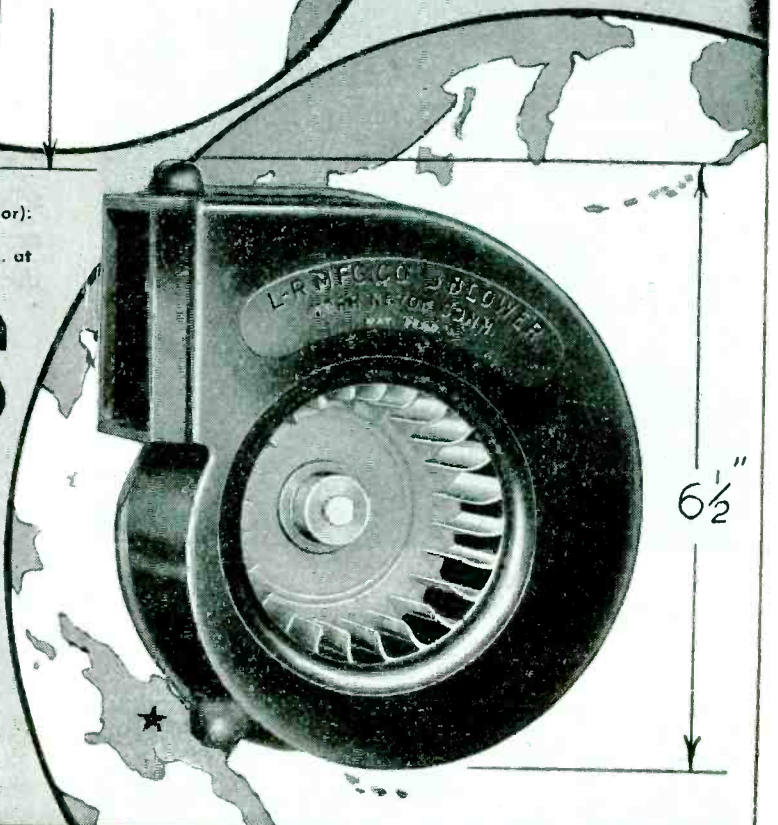

## L-R BLOWERS

★  
LIGHT • COMPACT  
EFFICIENT

★  
L-R MANUFACTURING COMPANY  
TORRINGTON, CONNECTICUT



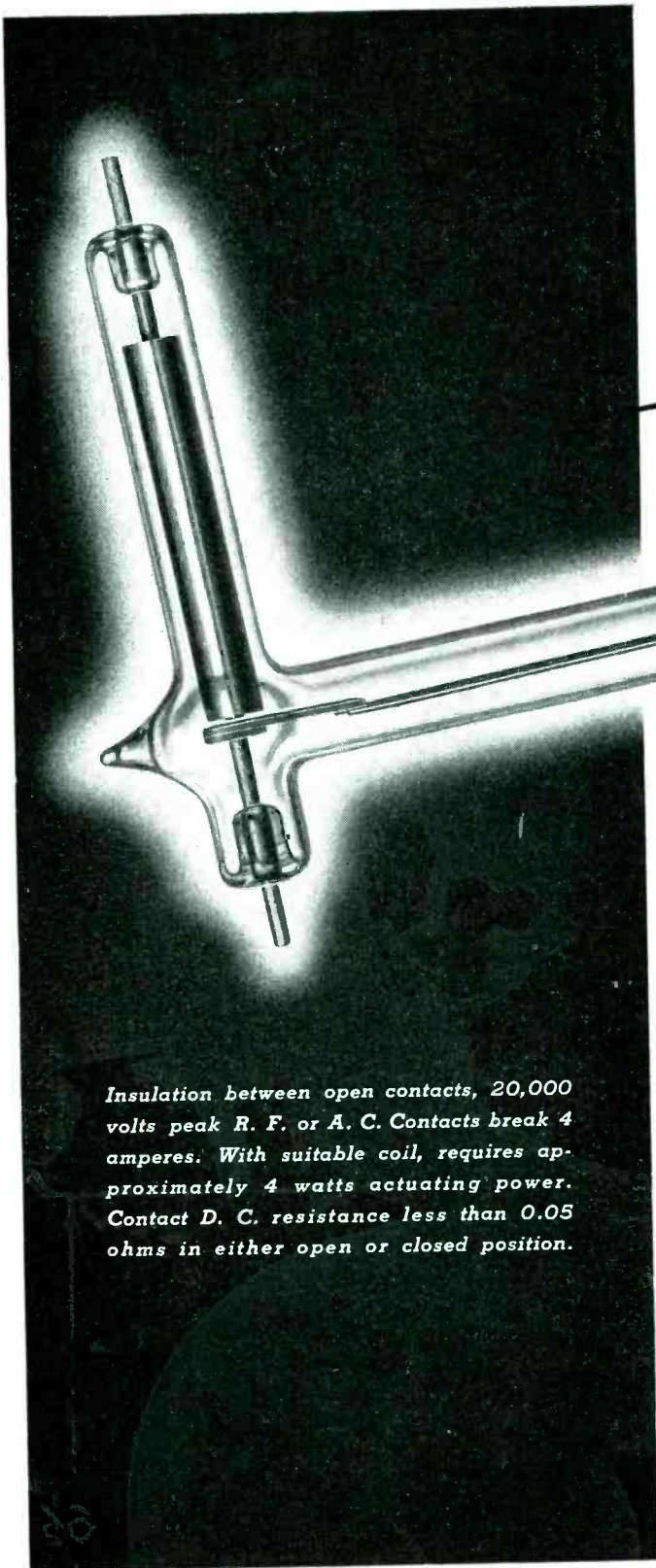

*Insulation between open contacts, 20,000 volts peak R. F. or A. C. Contacts break 4 amperes. With suitable coil, requires approximately 4 watts actuating power. Contact D. C. resistance less than 0.05 ohms in either open or closed position.*

**VACUUM RELAYS**  
**are Rugged and**  
**Versatile . . . Give you Reliable**  
**Operation and Long Life**

Excellence of construction means this I. C. E. Relay has the strength to resist vibration, shock and exposure . . . resulting in reliable operation and long life. Versatility means that it can be used to do a score of different jobs for you. And of course . . . I. C. E. *precision engineering* is your assurance of correct adjustment to close tolerances. Large quantities of these I. C. E. vacuum relays are proving themselves on battlegrounds all over the world. We can give immediate delivery, in quantity, of these fine relays . . . your inquiries are invited.

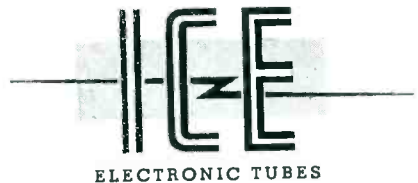

**INDUSTRIAL & COMMERCIAL ELECTRONICS**  
 BELMONT, CALIFORNIA



**PLYTUBE OFFERS YOU . . .**

- High Mechanical Strength**
- Corrosion Resistance**
- High Dielectric Strength**
- Wide Variety of Sizes**
- Easy Workability**
- Low Costs**



**MEET INDUSTRY'S NEW  
LIGHTWEIGHT MATERIAL**

**PLYTUBE**

*and explore its unlimited possibilities  
in design, fabrication and application*

Reg. U. S. Pat. Office

To know about PLYTUBE\* is but a first step in a search for applications where its many unique advantages can be put to practical, effective use.

PLYTUBE is plywood tubing made by building up veneers by automatic wrapping in such a way that stress or strain in any direction acts on the total grain fibres of the total structure of the column. By varying the angle of wrap, the strength characteristics of the tube section can be determined. These angles of wrapping can be combined to produce a tube column of maximum strength.

The fact that PLYTUBE is made up of lightweight, strong material results in a tubing which, weight for weight, is capable of carrying a much heavier load than steel tubing. This outstanding feature of PLYTUBE can be taken advantage of by industry in a

host of applications where it is desired to reduce weight and still maintain strength in the finished product. What many of these applications are still remain to be uncovered. Each new use suggests another. PLYTUBE's war uses have demonstrated its remarkable versatility, a fact that points to its almost unlimited future as a material of construction having characteristics of outstanding value to designers and manufacturers of products of all kinds.

Our engineers are prepared to study all possible applications and help you apply this new, lightweight tubing to meet your requirements. Use coupon below for further information.

\*Manufactured under U. S. Pat. No. 2,352,533, exclusively by PLYMOLD CORP.

**PLYMOLD  
CORPORATION**  
*Lawrence, Mass.*

**PLYMOLD CORPORATION**  
Lawrence, Mass.

Please send me further engineering data and information about Plytube.

Name .....

Company .....

Street .....

City ..... State .....

# WHERE TOMORROW MEETS TODAY

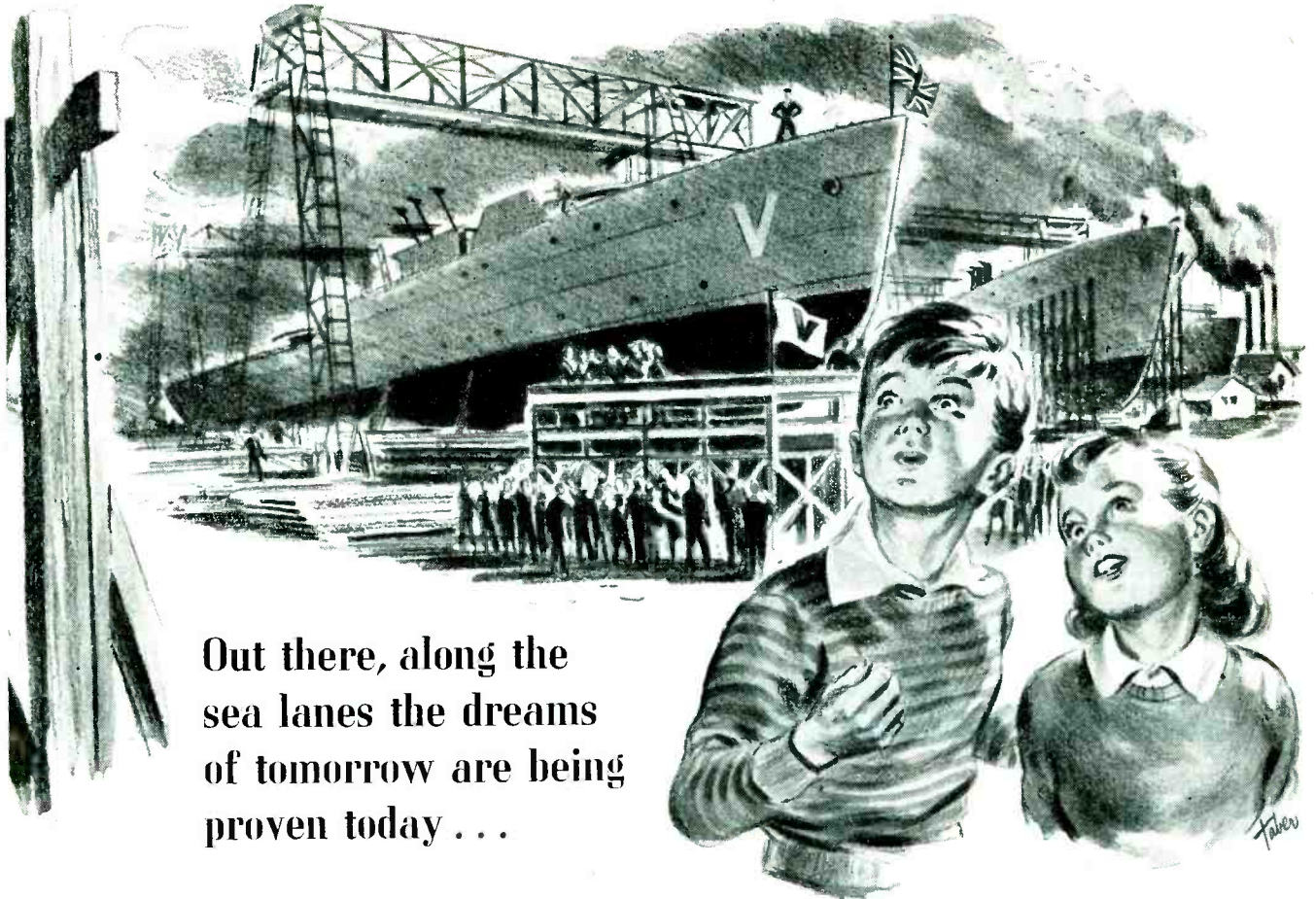

Out there, along the sea lanes the dreams of tomorrow are being proven today . . .

**C**ORVETTES "turn on a dime"—destroyers race at abnormal speed—that's the navy of today! Mastery of the sea depends on new and ever-improved equipment.

Today on our fighting ships, many pieces of electrical apparatus are designed and produced by Small Electric Motors (Canada) Limited. At the moment we are devoting all our efforts to turning out material of an advanced scientific nature. Research, engineering and inventive genius work hand in hand to produce equipment that normally would be much longer in developing.

In the days to come you may wish to benefit by this "know-how." These experiments and achievements in technical war contributions will be reflected and recognized in the electrical world of tomorrow. Small Electric Motors plan with confidence a noteworthy role in the post-war era.

**DESIGNERS  
AND MANUFACTURERS  
Of All Types of Precision  
Electrical Apparatus  
Including:**

*D.C. & A.C. Motors for  
Specialized Purposes  
Aircraft Generators  
Aircraft Engine Starters  
Alternators  
Motor Generators  
Electric Pumps  
Motors with Governors  
Gyros, etc.*

**SMALL**  **Electric Motors**  
(CANADA) LIMITED

LEASIDE - TORONTO - CANADA



**SOUND EQUIPMENT** - *precisionized* - mechanically and electronically - for finer performance

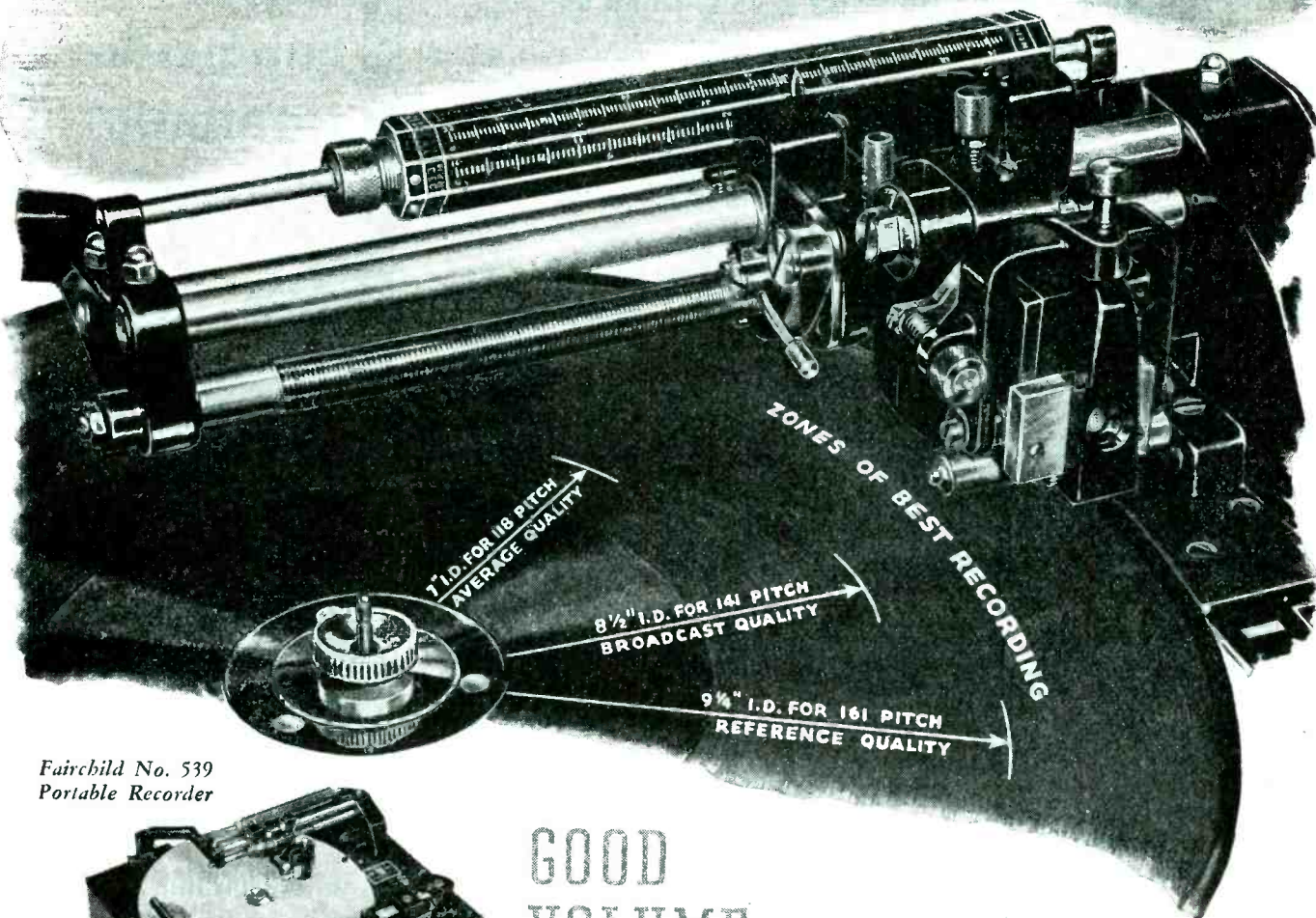

Fairchild No. 539  
Portable Recorder

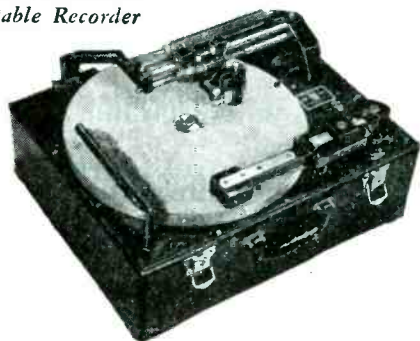

**GOOD  
VOLUME  
LEVEL**

**as high as 161 lines per inch**

Good volume level is the direct result of uniform cutting . . . uniform cutting at each pitch, speed, direction . . . uniform cutting controlled by the distinctive design of Fairchild's precision-built carriage mechanism and lathe.

Study these design features:

Two accurately ground and polished stainless steel guide rods. Each securely anchored to provide a rigid framework, not only to guide the cutterhead carriage travel, but also to carry its entire weight.

One feed screw with a single task to perform: To move the cutterhead carriage transversely across the turntable by means of a split nut which engages *six* accurately ground threads

*instead of the usual one or two.*

The convenience of disc handling without disturbing the feed screw and carriage mechanism.

The convenience of a calibrated reading scale that shows the minutes of recording completed; the minutes remaining for each pitch, speed, direction.

The Fairchild No. 539 Portable Recorder is built with long practiced precision skill to meet the exacting demands of radio and communications for studio-quality recording in the field. Descriptive and priority data are available. Address *New York Office: 475 - 10th Avenue, New York 18; Plant: 88-06 Van Wyck Boulevard, Jamaica 1, N. Y.*



*Fairchild* **CAMERA**  
AND INSTRUMENT CORPORATION

**SOUND  
EQUIPMENT**



# KESTER-SEALED

means

*Trouble-Free*



Photo Courtesy The Hallicrafters, Inc.

## KESTER CORED SOLDERS

• Forty-five years experience puts at your disposal Kester Cored Solders that are fool-proof in application and trouble-free in service—solders that protect electrical circuits for communications and control against service difficulties.

• Kester Rosin-Cored Solder contains a patented rosin flux that prevents terminal resistance. It eliminates fire-hazard because it will not cause corrosion or injure insulation. It forms tight connections that hold against shocks, vibration, bending, contraction and expansion—for the life of the apparatus.

• Kester Cored Solders are available in a wide range of alloy and core combinations, and core and strand sizes, to give you just the right solder for any job—from the most delicate electrical circuit up to the heavy duties, and for general metal forming uses as well. Solder and flux are in perfect balance to make application in one operation easy, quick and certain.

• Kester experience is at your service to determine the best solder formula and practice for your operation. You can draw on this experience without obligation by consulting Kester engineers.

### KESTER SOLDER COMPANY

4204 Wrightwood Avenue

Eastern Plant:  
Newark, N. J.

Chicago 39, Illinois

Canadian Plant:  
Brantford, Ont.



# KESTER

*Cored Solders*

STANDARD FOR INDUSTRY

A Complete  
Fungicide  
treatment  
(Wax or Varnish).

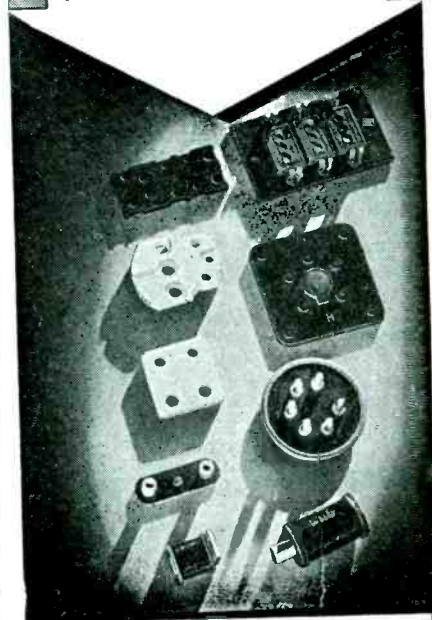

- Dehydrating
- Automatic Dipping
- Vacuum Impregnating
- Pressure Impregnating
- Centrifuging
- Spraying
- Polishing

Daily

PICK-UP AND DELIVERY  
in METROPOLITAN AREA

★

## PRODUCTION ENGINEERING CORP.

666 VAN HOUTEN AVE.  
CLIFTON, N. J.



FOR EVERY PURPOSE  
**RCP**  
 TEST INSTRUMENTS

*cutting testing time  
 to the bone!*

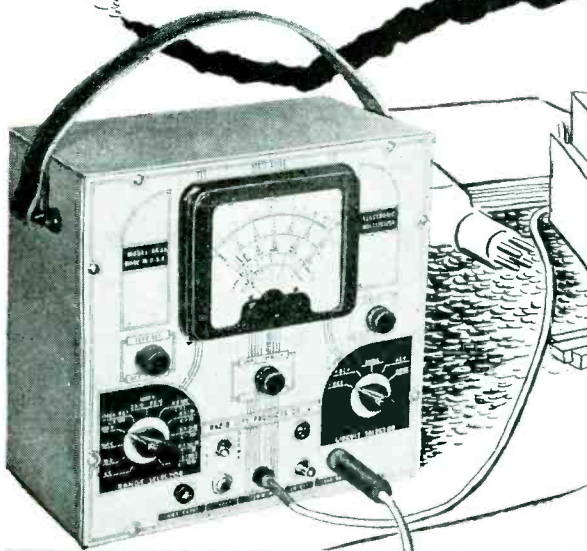

For important assignments in the testing grounds of well-known manufacturers, the speed, accuracy and advanced engineering design of RCP Test Instruments are proving their superiority. *For example:*

In the laboratories of the Lewyt Corporation, manufacturers of electrical and mechanical parts for 56 years, RCP Test Instruments check quality and accuracy of electrical and electronic assemblies to meet highest precision standards. Here RCP instruments' flexibility and simplicity save valuable engineering time on testing operations.

*Our complete line of standard test instruments is described in Catalog No. 128, sent promptly on request. Our engineers will be glad to confer with you on your test problems or to design special instruments.*

### RCP MODEL 663A Voltmeter-Ohmmeter-Capacitance meter

An outstanding example of advanced design plus flexible performance is this RCP Model 663A. Designed to save time and speed production tests, this model is used extensively by U. S. Signal Corps, Navy Yards and in the laboratories of Government suppliers.

**Model 663A** combines vacuum tube D. C. voltmeter, A. C. voltmeter, ohmmeter and capacitance meter. It cannot be damaged by measuring resistance when resistors are "live", or by using a low range on high voltage readings. Matched pair multiplier resistors are accurate within 1%. Errors due to voltage fluctuations are eliminated by VR105-30 tube and associated circuits. There is no danger of shock on high resistance measurements.

**Model 663A**, complete, for operation on 110-volt, 60 cycle A. C. —\$55.50; on 210-270 volt, 50-60 cycle—\$59.50; on 25 cycle—\$63.50.

MANUFACTURERS OF PRECISION ELECTRONIC LIMIT BRIDGES — VACUUM TUBE  
 VOLTMETERS—VOLT-OHM-MILLIAMMETERS—SIGNAL GENERATORS—ANALYZER  
 UNITS — TUBE TESTER — MULTI-TESTERS — OSCILLOSCOPES — AND SPECIAL  
 INSTRUMENTS BUILT TO SPECIFICATIONS



**RADIO CITY PRODUCTS  
 COMPANY, INC.**

127 WEST 26th STREET NEW YORK 1, N. Y.

# REGULATED POWER SUPPLIES

**Excellent Regulation—Line Stability—Low Hum Level**

## OUTPUT VOLTAGE

Variable from 10 to 15 Volts DC

## OUTPUT CURRENT — 500 MA Max

This model suitable for use in place of A Batteries where a source of AC power is available



Model 42A

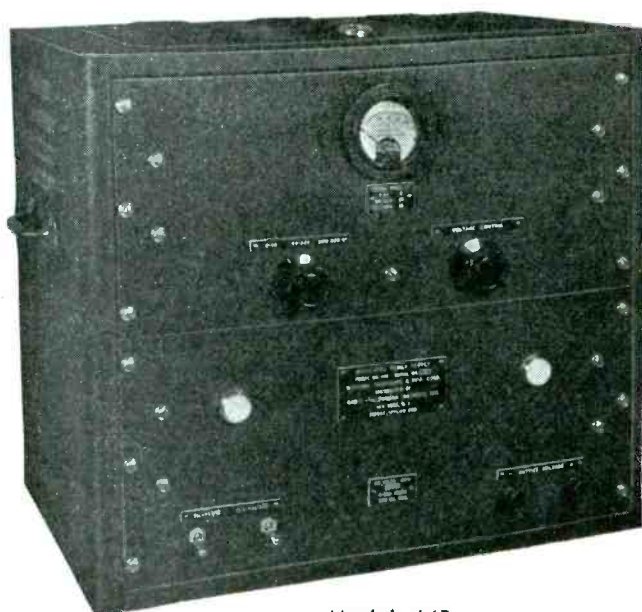

Model 44B

**OUTPUT VOLTAGE** — Continuously variable from 0-300 Volts DC.

## OUTPUT CURRENT — 250 MA Max

General purpose supply which will deliver well-regulated DC at any voltage from 0-300



Model 44

**OUTPUT VOLTAGE** — Continuously variable from 0-300 Volts DC

## OUTPUT CURRENT — 100 MA Max

Same characteristics as Model 44B except for lower current rating.

**Other units can be designed to specifications.**

**Inquiries are invited, both on power supplies and on our electronic consulting service.**

DISTRIBUTED BY  
**RADIO-TELEVISION INSTITUTE, INC.**  
OF NEW YORK  
480 LEXINGTON AVENUE PLAZA 3-4585 NEW YORK 17, N. Y.





# Confidence...

**IN HIS COMMANDER  
and his EQUIPMENT**

In this highly mechanized war, the fighting man must have as much faith in his equipment as he has in his leaders. Harvey-Wells electronic units are precision war machines which have earned the full confidence of the Armed Forces under battle conditions. In addition to rugged construction and dependable service, the many exclusive features developed entirely in Harvey-Wells laboratories will be found in all our products designed for commercial and civilian use. If you are interested in high-grade equipment covered by factory service, we solicit your inquiries.

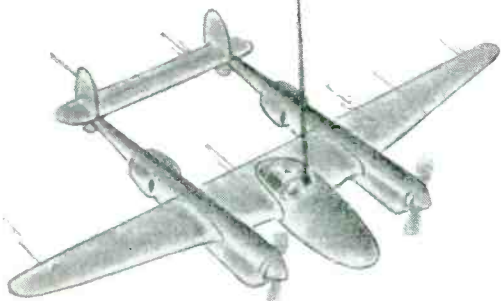

*Communications  
Aids to Navigation  
Electronic Safety Devices*

*Know the company that  
wants your business!  
Our CASE BOOK tells  
the story of Harvey-  
Wells and its place in  
Electronics. Send for it  
today. Your name on  
your letterhead is suf-  
ficient.*

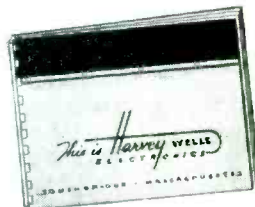

**Harvey-WELLS**  
ELECTRONICS

HARVEY-WELLS ELECTRONICS, INC. SOUTHBRIDGE, MASSACHUSETTS

ELECTRONICS — November 1944

# STUPAKOFF METAL-GLASS TERMINALS

*Engineered for*  
**IMPROVED PRODUCTION  
AND PERFORMANCE . . .**

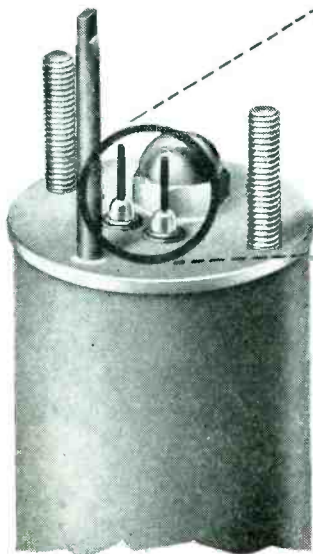
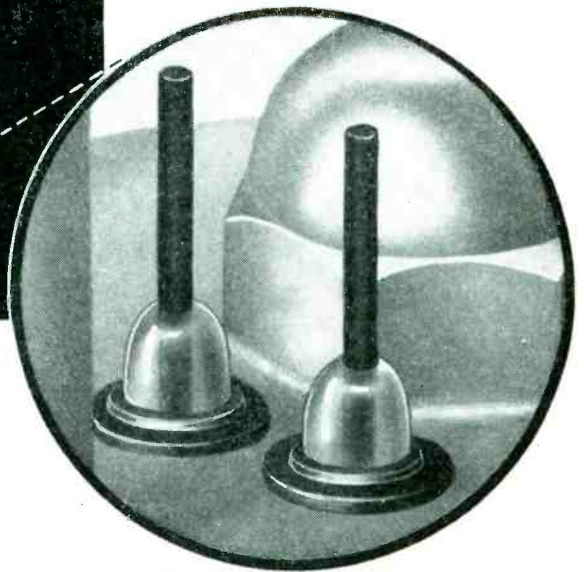

TEMPERATURE COMPENSATED  
TUNING FORK  
Courtesy American Time Products Inc.

**B**UILT into an evacuated container (illustrated on the left) is a temperature compensated tuning fork, component of a multi-frequency generator, accurate to 10 parts in 1,000,000 per degree C.

Kovar-glass terminals contribute to the maintenance of the vacuum required. They enable the manufacturer to effectively reduce the size and weight of the cylinder, and facilitate quicker, easier, more dependable and more economical assembly of the unit.

Kovar, a cobalt, nickel iron alloy, forms a chemical bond with hard glass through a heating process, in which the oxide of Kovar is dissolved into the glass. The result is a permanent vacuum and pressure tight seal, effective under the most extreme climatic conditions.

Stupakoff manufactures Kovar-glass seals with single or multiple, solid, or tubular electrodes. For those equipped to do their own glass working, Stupakoff supplies Kovar as sheet, rod, wire or tubing or fabricated into cups, eyelets, etc.

Write Stupakoff today for more information on the advantages of Kovar-glass seals for electronic components.

## Use KOVAR\* for sealing

**ELECTRONIC TUBES  
TRANSFORMERS  
RESISTORS  
CAPACITORS  
CONDENSERS  
VIBRATORS  
SWITCHES  
RELAYS  
INSTRUMENTS  
GAUGES  
METERS  
RECEIVERS  
TRANSMITTERS**



**Do More Than Before—  
Buy EXTRA War Bonds**

\*TRADE MARK 337962 REGISTERED IN U. S. PATENT OFFICE.

**STUPAKOFF CERAMIC AND MANUFACTURING CO., LATROBE, PA.**



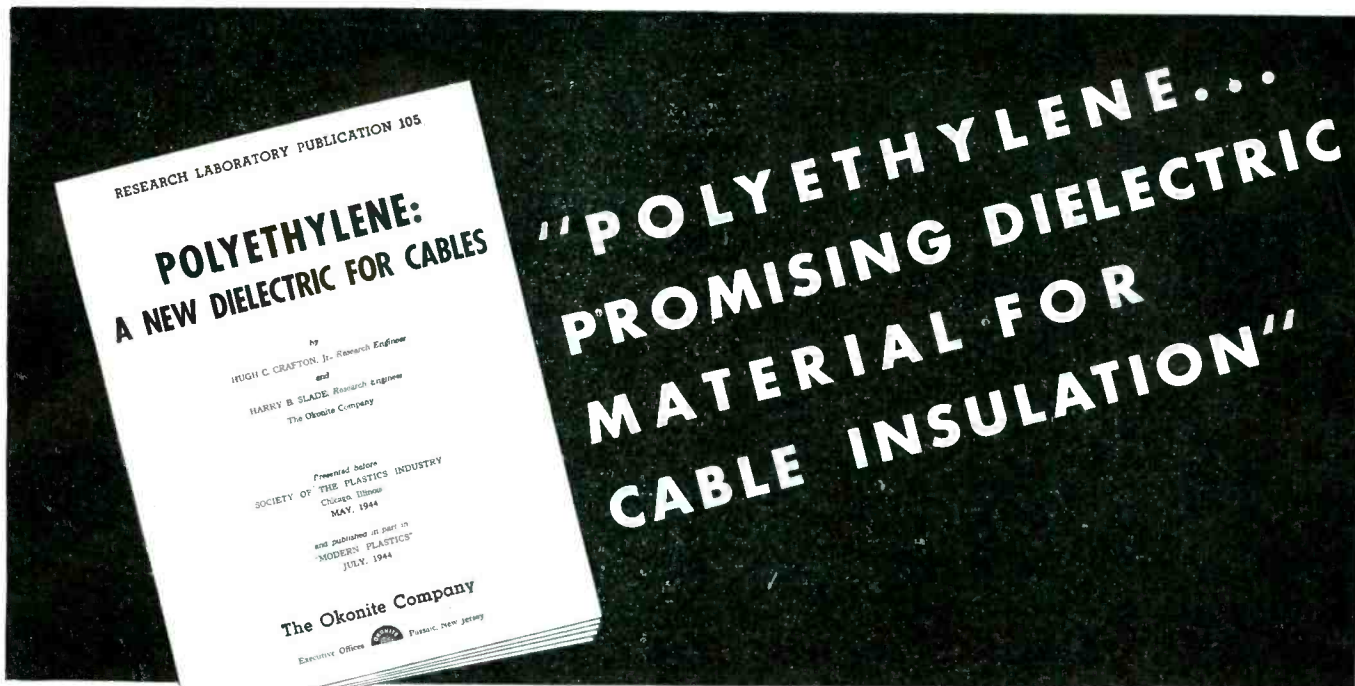

As electrical cable manufacturers, The Okonite Company is thoroughly familiar with all types of cable insulation. Okonite Research is constantly working on new dielectrics and has found a considerable interest in polyethylene among electronic engineers. To answer the many queries received, we have reprinted a paper, prepared by two Okonite Research engineers for the annual convention of the Society of Plastics Industry.

Of polyethylene, this paper says "At the present time polyethylene is being used principally for high-frequency cables where its low losses and general physical and chemical properties are unequalled by any other material. As the production of polyethylene is now greater than the demand for high-frequency cable, many other uses are being developed. Foremost among them are radio, communication, control and submarine cables — all for military use. It is quite possible that

power cables and outer protective jackets may be made from the material because of its excellent dielectric properties, ozone resistance, moisture resistance and chemical stability . . . It is probably safe to say that polyethylene is the most promising dielectric material for cable insulations developed in many years."

There are, however, many other potential uses for cables insulated with polyethylene suggested by the data in this paper. A copy will be sent you on request. The Okonite Company, Passaic, New Jersey.

**MEMO**  
**TO: X-Ray Cable Users**  
 WE HAVE CAPACITY AVAILABLE for manufacture of x-ray cables for delivery early in 1945, but because of the complexity of production and the care required in making this important type of cable, orders should be placed NOW.  
 Sizes—all customary two- or three-conductor sizes.  
 Voltages—Up to 110,000 volts.  
 Finish—any desired, such as dry, weatherproofed or lacquered braids and synthetic sheaths.



**OKONITE**   
 insulated wires and cables

No matter  
how modern  
the electronic  
application

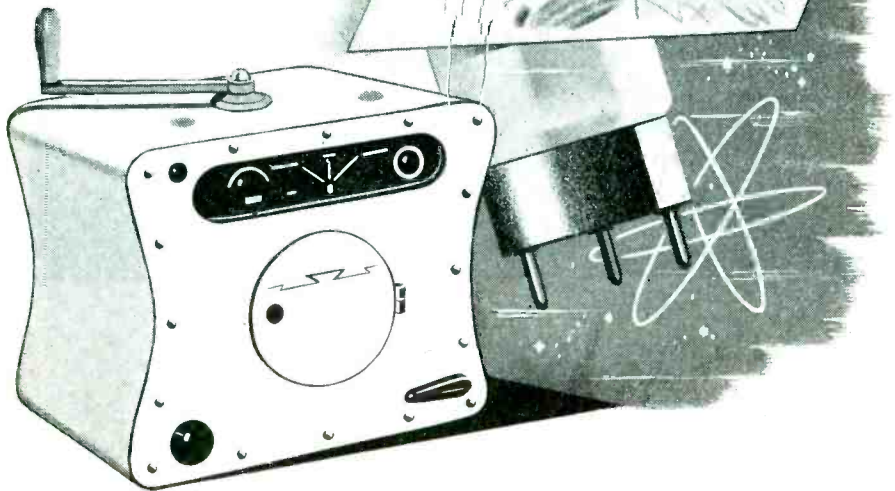

*its performance depends on*  
**BOLTS-NUTS-SCREWS-RIVETS-WASHERS**

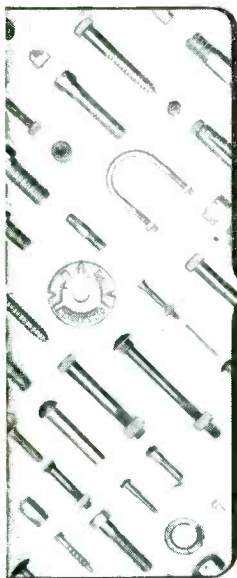

Obtain the rated performance of your electronic equipment by using fastening devices supplied by Sterling. Sterling Bolt Company products are accurate, uniform, with clean threads, uniform heads, true-centered slots, straight shanks, free from scale and burrs. These assure dependable performance, quick assembly and increased production.

Sterling Bolt Company is a reliable, single source of supply for bolts, nuts, screws, rivets and washers of every type and size, of every metal, plain or plated, for every fastening purpose. Try Sterling's prompt, dependable service for your fastening needs.

*Write today for quotations*

**PRECISION MADE FOR PRECISION FASTENING**

**STERLING BOLTS**

STERLING BOLT COMPANY • 211 W. JACKSON BLVD., CHICAGO 6, ILL.

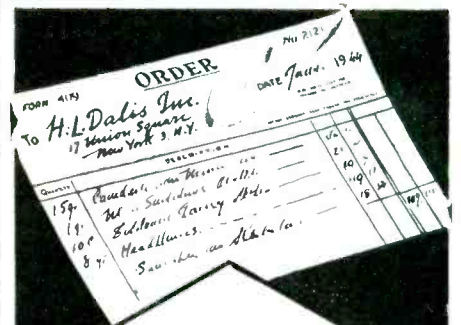

**FAST  
WORK ON  
YOUR WAR  
ORDERS**

• If your needs are urgent, take advantage of our exceptionally large and complete stock of radio-electronic supplies and parts. Most orders can be filled immediately from stock, and shipped the same day received.

And to help you order just what you need, we have the big Dalis catalog which is yours for the asking. Write on your business letterhead for your copy.

• Try Dalis—just wire, 'phone or write . . .

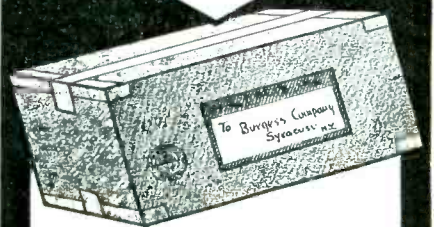

**H. L. DALIS, INC.**

Wholesale Distributors  
RADIO-ELECTRONIC SUPPLIES & PARTS  
17 Union Square  
NEW YORK 3, N. Y.

Phones: ALgonquin 4-8112-3-4-5-6-7



**THIS SOLVES  
OUR PROBLEM  
ON POST-WAR  
PRECISION  
PARTS!**



**WRITE for THIS  
ADECO  
GUIDE - BOOK**

It points the way to a dependable source of supply for precision parts and assemblies for your post-war requirements on a contract basis. As specialists in close-tolerance production, the Adeco organization offers complete facilities to meet your most exacting specifications—particularly in the field of hydraulics.

Send for this helpful book today.



**AIRCRAFT & DIESEL EQUIPMENT CORP.**

4405 North Ravenswood Avenue  
Chicago 40, Illinois

Your Partners in Precision



THE

**Acro Miniac**  
SMALLEST SWITCH MADE

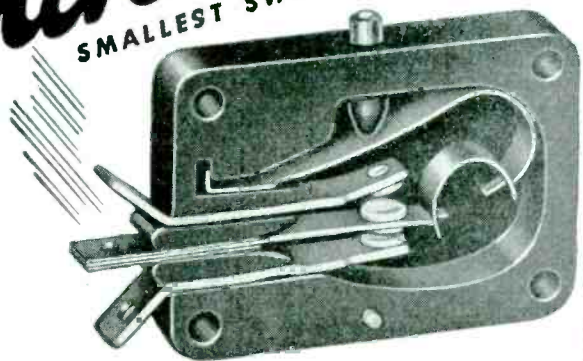

**Greater Resistance to  
VIBRATION**

Engineered with the patented ROLLING SPRING, the ACRO MINIAC has a faster snap-action which holds arcing to a minimum. This ROLLING SPRING also gives a steeper contact angle which produces contact pressures having greater resistance to vibration. Beautifully adapted to stacking in multiple assemblies. Only 1-3/16" long, 13/16" wide, and 1/4" thick. Fully enclosed in Bakelite case. Four mounting holes 3/32" diam. All parts are non-corrosive. Contacts of fine silver. Blades and rolling spring are beryllium copper. Single pole normally open or closed and double throw. Made with air gaps of .010" to .040". Operating pressures in 3 ranges from 5 oz. to 20 oz. Rated at 15 amps., 115 volts A.C. Weighs only .016 lbs. Write for details.

**THE ACRO ELECTRIC COMPANY**  
1316 SUPERIOR AVENUE CLEVELAND 14, OHIO



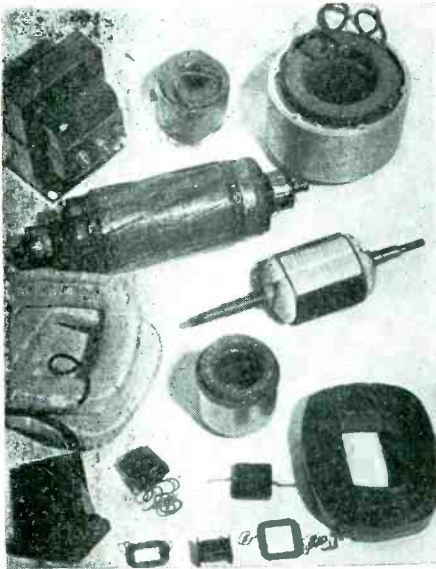

## TROPICALIZATION

with

# DOLPH'S

## INSULATING VARNISHES

Humid climate has a tendency to foster fungus growth. Needless to say this has a deteriorating effect on electrical units. To prevent this growth, use DOLPH'S Fungus Resisting Varnish which meets Signal Corps Approval.

Most recent of fungus resisting materials, and one of the first of the baking types is DOLPH'S SYNTHITE PG-4-FC Clear Baking Varnish. This grade is excellent for use in vacuum impregnation of transformer and stator coils as well as armatures.

Through the use of our modern laboratory facilities, we are in a position to treat some of your newly designed electrical units which require varnish insulation. Upon completion of this experimental work, a report will be issued covering the treatment cycles followed and recommendations made accordingly. Of course this service is offered without any obligation on your part.

Why not consult us regarding your insulating varnish problems where fungus resisting properties are desired.

**JOHN C. DOLPH COMPANY**

*Insulating Varnish Specialists*

169-A Emmet St., Newark, New Jersey

## New STOKES 50-Ton Hydraulic

*Completely Automatic*

### PLASTICS MOLDING MACHINE

- LARGER PIECES
- HIGH SPEED OPERATION
- LOWER MOLDING COST

#### OUTSTANDING FEATURES

Human errors are eliminated. Patented Automatic Cycle Controller times every machine operation.

The molded pieces literally "run the press." Patented Super-sensitive Trap checks every molded sort made.

Capacity to 48 cu. in. of molding powder. Multiple Feed.

High Speed Operation (100 in. per min.) with controlled final compression speed adjustable to flow characteristics of molding material.

One man operates a score of presses.

Self-contained, completely automatic.

Write for further information.

F. J. STOKES MACHINE CO.  
6046 Tabor Road, Philadelphia 20, Pa.

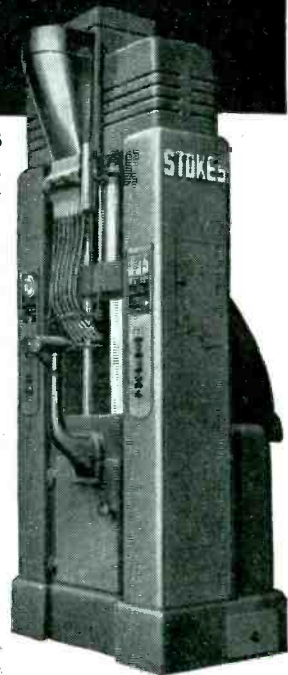

**F. J. Stokes** MOLDING EQUIPMENT



# G-R

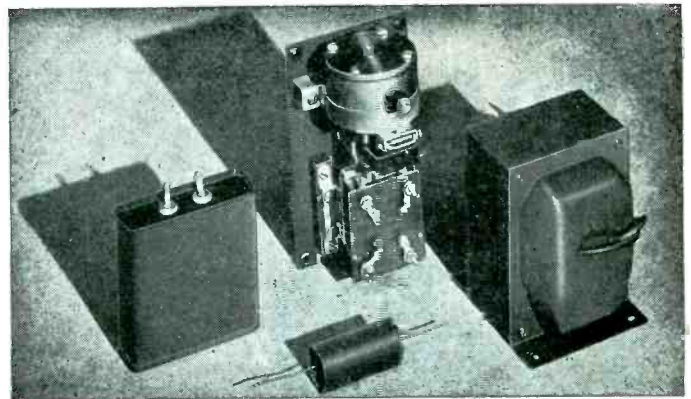

## Components by GLENN-ROBERTS

LONG MANUFACTURED as integral parts of famous G-R Welders, electrical and electronic components by Glenn-Roberts are now available to the industry.

Your specifications are invited for production runs of oil and wax type capacitors, pneumatic timers, a. c. solenoid-type relays, power and radio transformers.

ELECTRONICS DIVISION

## GLENN-ROBERTS COMPANY

1009 FRUITVALE AVENUE  
OAKLAND, CALIFORNIA

2107 ADAMS STREET  
INDIANAPOLIS, INDIANA



# The New "Midget"



PHOTO IS  
ACTUAL SIZE

**THE LIGHTEST LEVER SWITCH MADE...  
GENERAL CONTROL COMPANY'S NEW  
MODEL MCL-MT WEIGHS BUT  $3\frac{1}{2}$  OZS.**

The NEW General Control Company "Midget" is designed especially for electronic and communications circuits in aircraft, and for other light duty applications. It is a "Midget" in both size and weight... it saves precious space and weight, yet is so ruggedly constructed that it will stand severe use.

## The New "Midget"

is a "featherweight," designed especially for aircraft and other light duty applications. It weighs only  $3\frac{1}{2}$  ozs. with 12 contact springs!

## The New "Midget"

is compactly constructed for restricted space. It is only  $2\frac{3}{4}$ " long x  $1\frac{1}{4}$ " wide x  $1\frac{1}{4}$ " thick.

## The New "Midget"

has all the quality construction features of the well known "Master" Line of MCL Cam Lever Switches built by General Control Company.

Like other General Control lever switches, the contact possibilities are unlimited... contact assemblies can be removed from the frame by removing a single bolt... all parts are non-corrosive... easy, positive roller action, regardless of number or arrangement of contacts on each side of the switch... rated from 5 to 10 amperes, 125 volts A. C.

The standard "Midget" has either three positions as shown in illustration, or can be supplied with two positions (no neutral).

General Control Company will be pleased to send complete information, and arrange delivery schedules to meet your requirements.

### OTHER GENERAL CONTROL COMPANY PRODUCTS



**MODEL MCL-CS**  
Coil spring construction gives perfect balance regardless of contact arrangements. For all electronic applications.



**MODEL MCL-MR**  
For one to six index positions. Actuates practically any number of circuits in sequence with single control knob.



MC



MI



MH



MF

#### MANUALLY OPERATED (FOOT) SWITCHES

These switches relieve the machine operator, prevent fatigue, increase production and safety. The 35 types cover every application. Send for catalog No. 441.



#### SEMI-AUTOMATIC GAGES

For high speed, automatic acceptance and rejection of production parts to desired tolerances. Also available for manual operation.



## GENERAL CONTROL COMPANY

1202 SOLDIERS FIELD ROAD, BOSTON 34, MASS.

**NEW  
KURMAN  
Ideas**

**A NEW FEATURE  
OF GREAT IMPORTANCE  
ADDED TO OUR "OLD TIMER"**

Now . . . Chatterless operation is added to the known sensitivity of our "Old Timer" (200 Series) . . . The new feature consists of an energy absorbing material sealed within a contact carrying cage. The compound used is not affected by age, oil, or moisture.

**No Bounce! No Chatter!**  
... in the new Kurman  
200S Flat Keying Relay

**KEYING FEATURES:**

1. No bounce. No chatter.
2. Input 50 Milliwatts.
3. Will key up to 150 words per minute, or 60 impulses per second.
4. Armature is mica insulated; is suitable for keying a 50 Megacycle R.F. signal.
5. Contacts will carry up to 2 Amps.

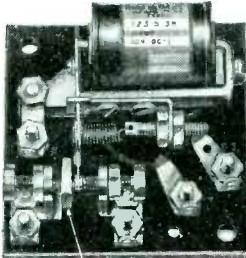

New Feature . . . eliminates  
"bounce" and "chatter"

Oscilloscopic wave form  
looks like this



NOT like this



Send also for complete information on the  
new line of KURMAN vibration-proof RELAYS.

**KURMAN ELECTRIC CO.**



35-18 37th STREET • LONG ISLAND CITY 1, N. Y.

**COUNTLESS USES in SHOP and  
OFFICE with *Absolute Accuracy***

**A-PE-CO**  
"Photo Exact" Copies  
Made Fast by Anyone, Anytime

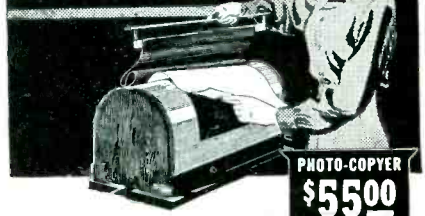

**PHOTO-COPYER  
\$5500**

**EXPEDITE OFFICE AND SHOP  
WORK THIS MODERN, ACCURATE, SPEEDY WAY**

Accurate A-PE-CO photo-copies are made direct of anything on paper, cloth or film, written, printed, drawn or photographed, or bound in books. A-PE-CO 'photo-exact' copies are so useful, so easily and quickly made, that the versatile A-PE-CO Photo-Copier is a modern necessity in thousands of shops and offices. A valuable aid in postwar planning.

**Legally Accepted Photo-Copies of**

- Letters
- Pictures
- Documents
- Drawings
- Records
- Receipts
- Blueprints
- Shop orders

A-PE-CO photo-exact copies are permanent, easy-to-read. Same-size copies up to 18"x22" made easily and quickly. Mistakes are impossible. Any girl or boy quickly becomes expert. Saves steno-copying, proofreading, tracing. No camera or film. Nothing to get out of order. Use on any desk or table.

This modern, versatile method assures accuracy in every department. Make sure your copies are "A-PE-CO-perfect". Immediate delivery. Write for A-PE-CO folder, today!

**AMERICAN PHOTOCOPY EQUIPMENT CO.**  
2849 N. Clark St., Dept. AG-114, Chicago 14, Ill.  
Representatives in principal cities and Canada

**To Protect the  
Performance of Your  
Electrical Equipment—**

**USE** *Pedigree*  
**INSULATING VARNISHES**

It's especially important to select the right electrical insulating varnish because it provides the protection that will add extra life to your electrical product. Good varnishes protect the quality of the parts they cover. Whether yours is a problem of water proofing, resistance to abrasion, oils, acids, alkalis, greater flexibility, or greater penetration, there is a Pedigree insulating varnish with qualities correctly balanced to give you the results you want.



**The P. D. GEORGE CO.**

5200 North Second Street, St. Louis, Missouri

Call In the Pedigree Varnish Man Nearest You.

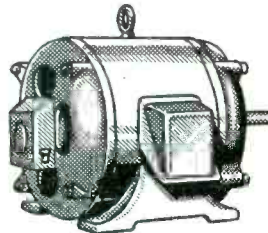
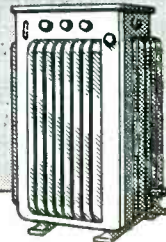

**NUMBERALL**

**MULTI-WHEEL NUMBERING  
MACHINE • MODEL 70**

The Most Efficient Method of  
Stamping Numbers into Metal  
*Adapted for Hand or Press Use*

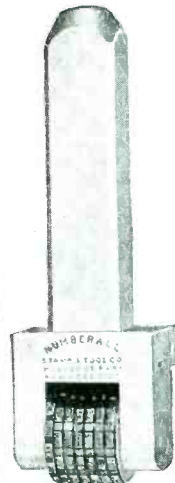

**REPEATS THE SAME  
NUMBERS UNTIL  
CHANGED**

Model 70 NUMBERALL machines are used in all industries to mark various parts. Stamp numbers, etc., quickly . . . neatly. Perfectly aligned. Much better marks are produced by these machines than by single stamps or steel type, and at a far lower cost. Shank for Hand or Press and with any number of wheels from 3 to 20.

Model No. 70 Write for Bulletin E 70.

**NUMBERALL STAMP & TOOL CO.**  
HUGUENOT PARK STATEN ISLAND 12, N. Y.



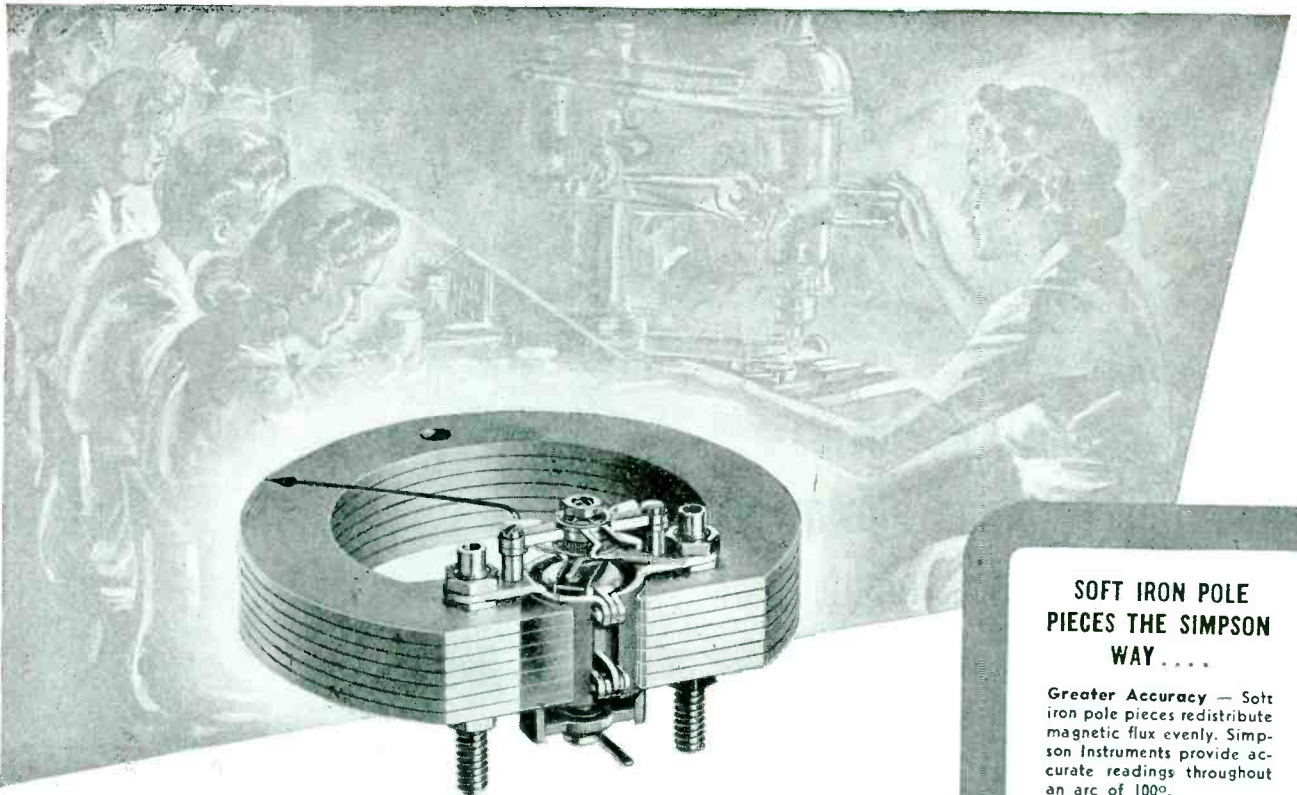

## These soft iron pole pieces tell the story—

**E**XPERIENCE is a much used, and too often abused, word. Yet in any field experience is the only source of practical knowledge—the only sound basis for further advance.

Measured in terms of time alone, the experience of the Simpson organization is impressive enough. For more than 30 years this name has been associated with the design and manufacture of electrical instruments and testing equipment. But the real value of this experience is to be found in the many fundamental contributions Simpson has made to instrument quality.

The use of soft iron pole pieces in the patented Simpson movement serves as an example. An admittedly finer type of design, these soft iron pole pieces have been employed by Simpson to provide maximum strength as well as accuracy, and to achieve a simpler assembly that permits faster, more economical manufacture.

For today's vital needs, this experience enables Simpson to build "instruments that stay accurate" in greater volume than ever before. For your postwar requirements it will insure the correct interpretation of today's big advances.

### SOFT IRON POLE PIECES THE SIMPSON WAY . . . .

**Greater Accuracy** — Soft iron pole pieces redistribute magnetic flux evenly. Simpson Instruments provide accurate readings throughout an arc of 100°.

**Greater Strength** — Pole pieces are used to anchor full bridges across top and bottom of movement. Moving assembly is locked in permanent alignment.

**Smooth Walled Air Gap**  
No cracks or irregularities to invite dust or other foreign particles, which might interfere with movement of armature. Reamed to accurate dimensions after assembly.

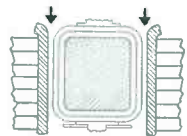

**Speed and Economy**—Pole pieces are stamped, not machined. This is one of many ways Simpson has speeded construction, and lowered costs, of this basically better movement.

SIMPSON ELECTRIC CO.

5200-5218 Kinzie St., Chicago 44, Ill.

# Simpson

INSTRUMENTS THAT STAY ACCURATE

Buy War Bonds and Stamps for Victory

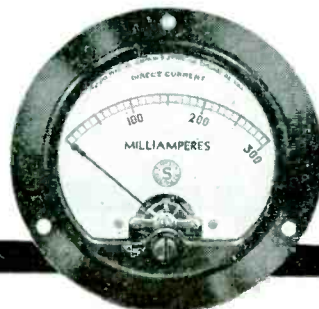

# This Oster Motor

REG. U. S. PAT. OFF.

gives you smooth performance on many aircraft and blower installations . . . saves weight, too!



Here is a dependable fractional horsepower motor with features that result from over fifteen years' experience in building this type of quality motor. Its light weight, space-conserving size, and dependability make it ideal for aircraft and blower installations. It may suggest itself as the answer to the motor problem in your peacetime product. You can depend on Oster motors to live up to the world-wide reputation of pre-war Oster appliances, and to deliver results that add to the prestige of your product. Let us help you fit this or other Oster motors to your requirements.

## FEATURES OF TYPE B-6A MOTOR

**Housing:** Die cast aluminum, totally enclosed.

**Finish:** Black anodized.

**Weight:** 10 oz.

**Bearings:** Single shielded ball bearings lubricated with grease suited for any specific application. Bearing housings fitted with steel inserts to assure permanent bearing alignment and proper bearing fits.

**Mounting:** Flange or standard 3/4" dia. air corps rabbet.

**Brushes:** Metal graphite of

ample size to assure unusually long brush life.

**Windings:** Available in shunt, series, and split series reversible, 12 and 24 volt, intermittent and continuous duty.

**Temperature Rise:** 55°C max. frame temp. rise at rated load.

**Modifications:** Special shaft extensions, mounting arrangements, leads etc. also furnished for operation in high ambient temperatures and high altitudes.

**Applications:** Suitable for operation of blowers, switching arrangements and other similar aircraft applications.

*All data and ratings are approximate*

## TYPICAL RATINGS OF B-6A MOTOR, CONTINUOUS DUTY

Maximum H.P.	1/100	1/150	1/200
R.P.M.	7500	5800	3800
Full load amps. at 24 volts	1.00	.70	.55
Starting torque in % of full load torque	200 min.	200 min.	200 min.

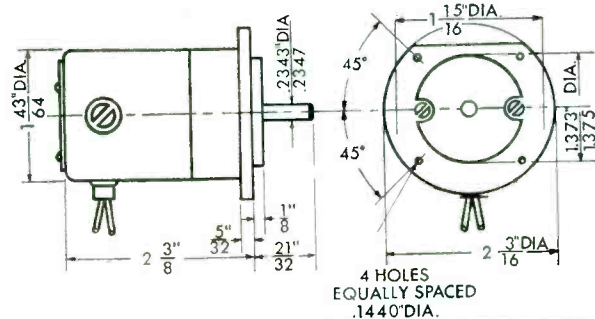

**John Oster Manufacturing Company**  
DEPARTMENT L-20  
RACINE, WISCONSIN

November 1944 — ELECTRONICS



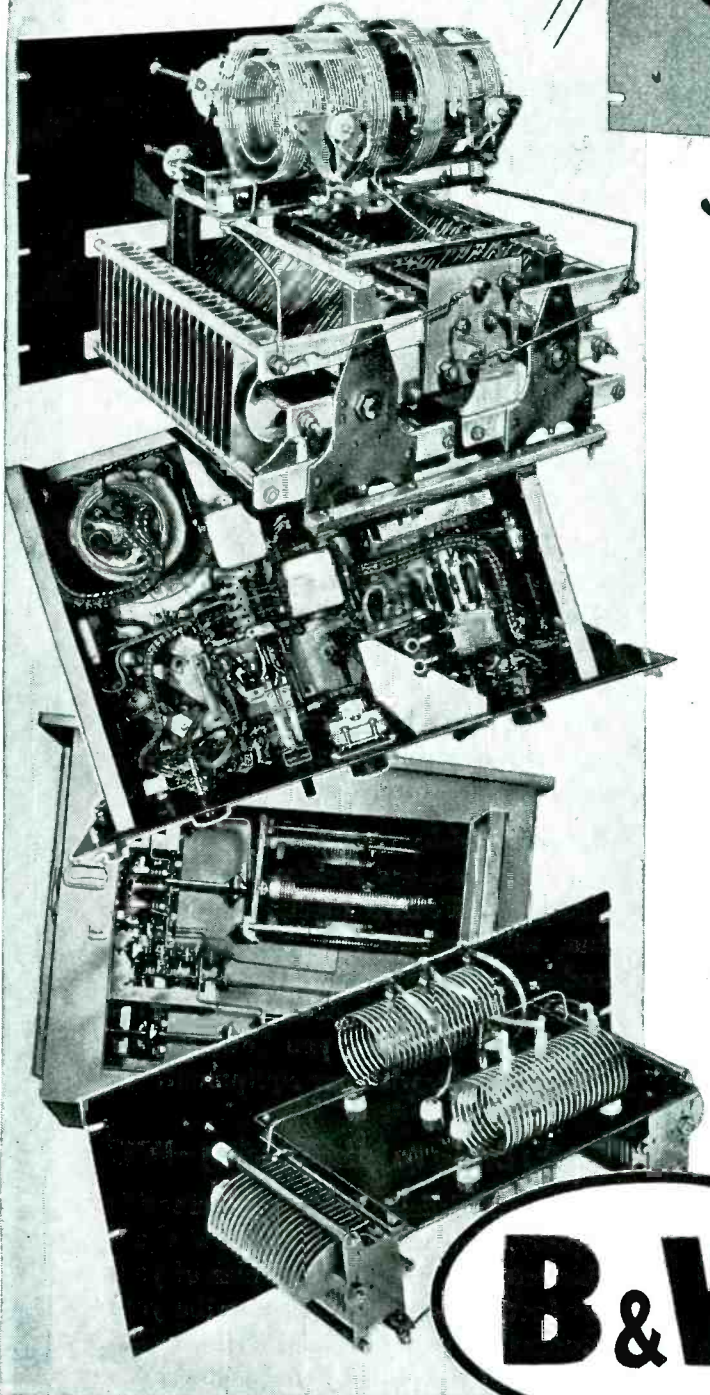
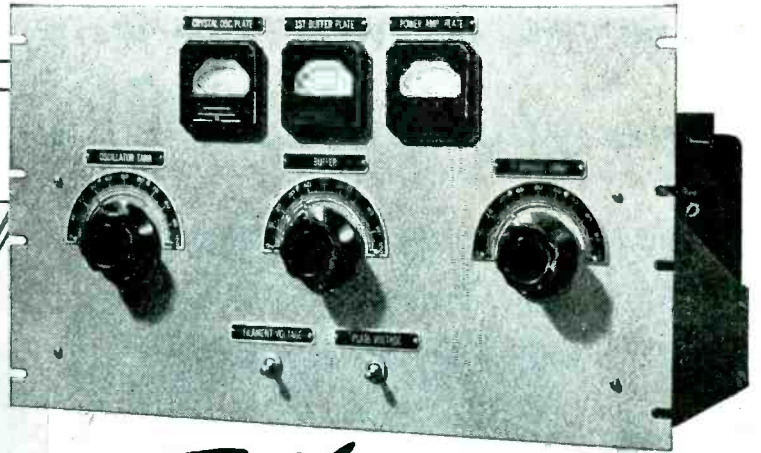
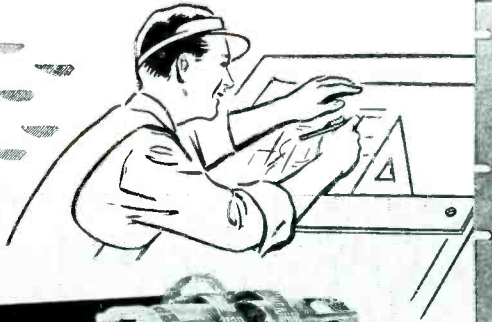

*"Tailor-made"*  
**ELECTRONIC  
 EQUIPMENT  
 ASSEMBLIES**

Designed and produced from stem to stern by recognized experts to match your needs *exactly*.

**DIELECTRIC AND INDUCTION  
 HEATING EQUIPMENT • TUNING  
 UNITS • TEST EQUIPMENT • RADIO  
 TRANSMITTERS • HIGH AND ULTRA-  
 HIGH FREQUENCY EQUIPMENT**

*B & W is neither too large for the smallest job nor too small for the largest. Write for details, outlining your requirements.*

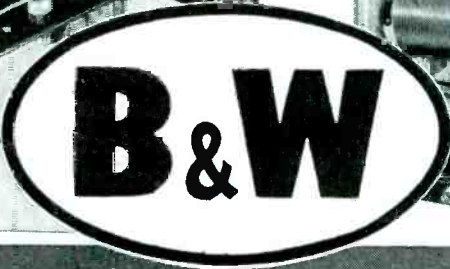
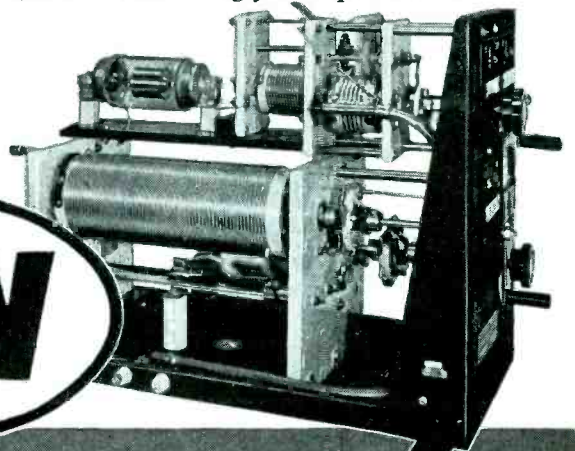

**BARKER & WILLIAMSON**

**AIR INDUCTORS • VARIABLE CONDENSERS • ELECTRONIC EQUIPMENT ASSEMBLIES**

**DEPT. E-114 235 FAIRFIELD ROAD, UPPER DARBY, PA.**

Export: LINDEEVES, INC., 10 Rockefeller Plaza, New York, N. Y., U. S. A.



# How to assure *Environment-Free* operation: have your product **FEDELCO-SEALED**

by Federal Electric Company, Inc. Fedelco Sealing Service

## How we Fedelco-Seal a Clare Type "G" Relay



1. Metal base with holes for contacts, mounting studs, and evacuating tube.



2. Base, with terminals sealed in.

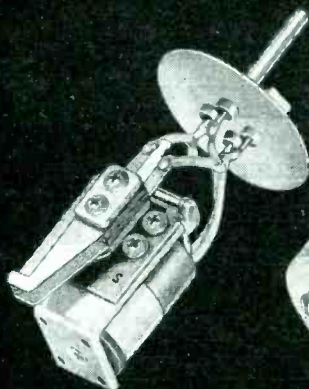

3. Relay with leads soldered to terminals.

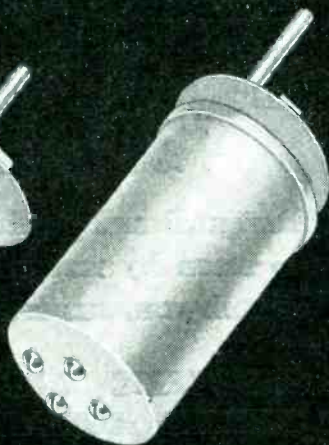

4. Metal enclosure. Mounting screws sealed to top hold relay solidly in the enclosure.

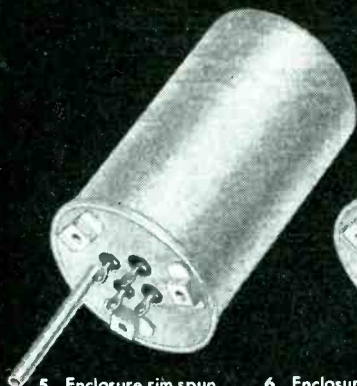

5. Enclosure rim spun over base and hermetically sealed.

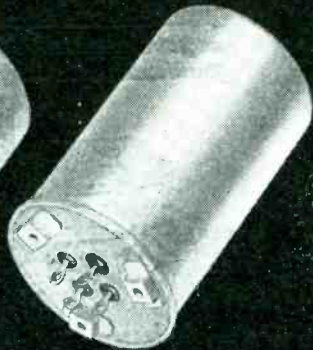

6. Enclosure may be evacuated and filled with dry air, or inert gas, at atmospheric or higher pressure. Evacuating tube is sealed off, completing the Fedelco-Sealing process.



DUST

INSECTS

Ideal working conditions are sealed-in, environment sealed-out, by Fedelco-Sealing.



TAMPERING

MOISTURE

To assure the long, reliable operation designed and built into your product, take this final step: *control environment*—dust, bugs, tampering, and moisture—with Fedelco-Sealing.

Fedelco-Sealing is a new method of sealing-in ideal working conditions for electrical and mechanical devices. It surrounds your product with a hermetically-sealed metal enclosure. The enclosure may be evacuated and filled with dry air or inert gas, at atmospheric or higher pressure.

*We can Fedelco-Seal your product for you . . . or you can Fedelco-Seal in your own plant.* Federal Electric Company, Inc. will Fedelco-Seal your products and return them to you. Or you can do your own Fedelco-Sealing. Fedelco Engineers will show you how, by our own methods, with our equipment.

### Get the details on Fedelco-Sealing—NOW

The use of Fedelco-Sealing is increasing rapidly. You will want to know about this method. Send us samples of your product to be sealed, or describe your product and your problem. Write or call any of the offices listed below.

**FEDERAL ELECTRIC COMPANY, INC.**  
8700 South State Street, Chicago 19, Illinois • Phone VINcennes 5300

E. B. Mathewson Company, sales agents • 612 North Michigan Avenue, Chicago 11, Illinois • Phone WHIttehall 4822  
Sales offices: New York 17, N. Y.—Graybar Bldg. • Chicago 11, Ill.—612 N. Michigan Ave. • Philadelphia 7, Pa.—Real Estate Trust Bldg.  
Kansas City 8, Mo.—2017 Grand Ave. • Atlanta, Ga. • Troy, N. Y.—17 Bank Street



# THE NEW MULTIRANGE FLUXMETER

MODEL F

FOR THE  
MEASUREMENT OF  
MAGNETIC CIRCUIT  
CONDITIONS  
AND  
ASSOCIATED TESTS



ACCURACY  $\frac{1}{2}\%$

RANGE  
5 LINES PER SQ. CM.  
TO  
30,000,000 LINES PER SQ. CM.

SEARCH COIL RESISTANCE  
INCREASED TO 15 OHMS.

THIS NEW DESIGN REPRESENTS THE FIRST MAJOR IMPROVEMENT IN THIS TYPE OF INSTRUMENT IN THE PAST 25 YEARS. A COMPLETE TECHNICAL BULLETIN WILL BE GLADLY SENT ON REQUEST.

**SENSITIVE**  
INSTRUMENT

9-11 ELM AVE.

*Electrical Instruments*



**RESEARCH**  
COMPANY

MOUNT VERNON N.Y.

*of Precision since 1927*



## Small, but OH, MIGHTY!

Yes, here is a mighty important little unit designed and developed by Cook engineers. Here is a small relay, one of the "400" series of Cook relays (illustration above is actual size) that will meet the most exacting requirements of all engineers and manufacturers. Here is a space-saver that makes no sacrifice of sturdiness, accessibility, life of service or all round quality in comparison with larger standard type relays. Like all Cook relays, the "400" is built of the finest materials. Stainless steel bearing pins for long life and permanent adjustment, new coil terminal design to prevent coil losses due to breakage of lead wires, wide spacing of

spring terminals, and elongated holes to facilitate wiring, high permeable magnetic materials annealed in controlled atmosphere, coils wrapped in serving and bakelite impregnated against moisture to Air Corps specifications with single or twin contacts and single or double spring pile-ups.

Production of all types of these relays is still limited to high priority Government contracts; however, our home and field engineers will be pleased to consult with you on your post-war requirements, on this as well as all Cook products.

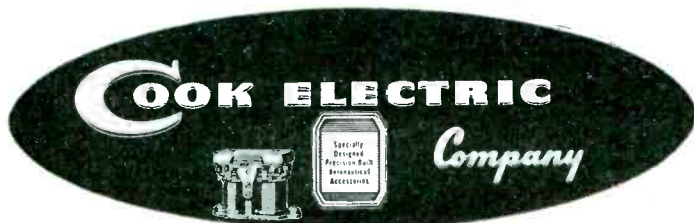

2700 SOUTHPORT AVENUE

CHICAGO 14, ILLINOIS



## MEASURES QUANTITIES

*with greater sensitivity & range than ever before accomplished*

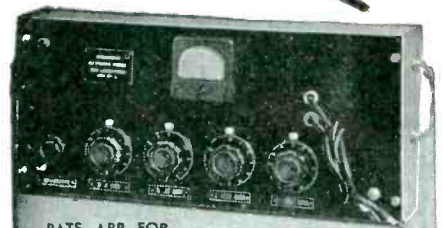

PATS. APP. FOR

### TECH LAB MICROHMMETER

... gives direct and instantaneous readings of resistance values down to 5 microhms and up to 1,000,000 megohms. Accuracy in all measurements to better than 2%. Output is sufficient to drive recorder. Entirely AC operated. Furnished in two models. Reasonably prompt deliveries. For complete data regarding other applications write for Bulletin No. 432.



Quality manufacturers of attenuators and other electrical instruments. For complete data write for Bulletin No. 431.



7 LINCOLN STREET  
JERSEY CITY 7, N. J.



Get the Specifications  
On This Improved  
**one-Piece**  
Solderless Terminal

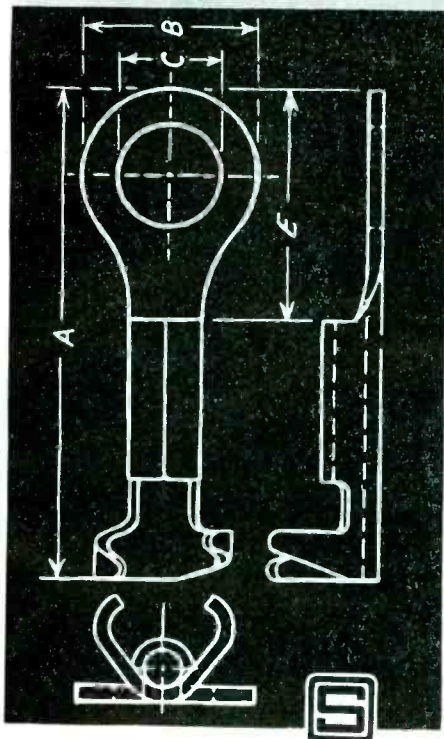

You'll be amazed to see how production can be increased and performance improved, with the Sherman UNI-CRIMP One-Piece Solderless Terminal.

Here's a terminal that insures highest conductivity. It is made of fine grain, specially rolled, pure electrolytic copper, rated at 100% conductivity. And — the entire inside of the barrel is serrated, which provides a strong grip on the entire circumference of the wire, and greatly increases the contact area.

Write for Bulletin UC-2, giving full specifications. See for yourself why the UNI-CRIMP is stronger mechanically, more efficient electrically, easier to install, and more economical.

Find out how you can switch over to the UNI-CRIMP and speed up production, without any change in your present set-up.

H. B. Sherman Mfg. Co.,  
Battle Creek, Mich.

The Sherman  
**UNI-CRIMP**  
Solderless Terminal

A *Tough* PROBLEM  
DEVELOPED INTO

BIG  
VOLUME!

OVER  
ONE MILLION  
GASKETS  
A MONTH

Problems are the order of the day and few there be who have not one or more problems in designing, engineering and manufacturing that are marking time, waiting to be solved. If it's a problem involving rubber, we here at the Johnson Rubber Company welcome it.

We like the tough ones, take, for instance, the "one piece" ammunition box gaskets. Here was a "toughy" and our engineers came through with what is now called the Welch gasket method of production, something new and entirely different. We are now producing the largest volume of these gaskets in the country today. This new method has greatly increased production, reduced the time element — all of this at a tremendous savings in material and money. This is an illustration of what we mean by solving problems in rubber.

*Perhaps you have a good idea tucked away that "couldn't be done"; if so, let us work on it. If it can be done with rubber, we will have the answer for you.*

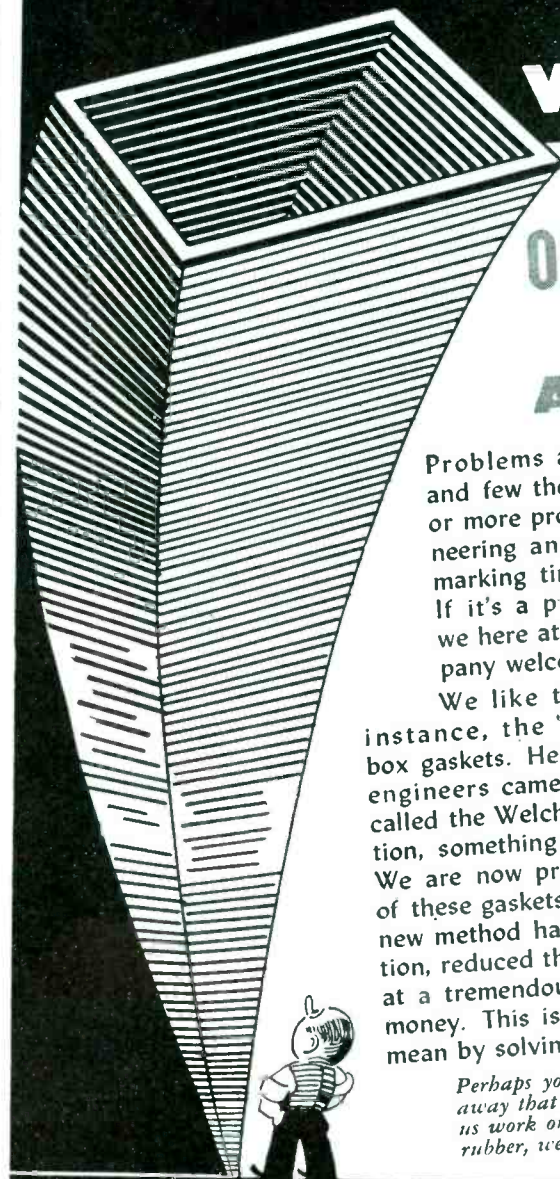

**JOHNSON RUBBER CO.**



Middlefield, Ohio U.S.A.



THE BRICKS ARE OLD...



The Ideas are New

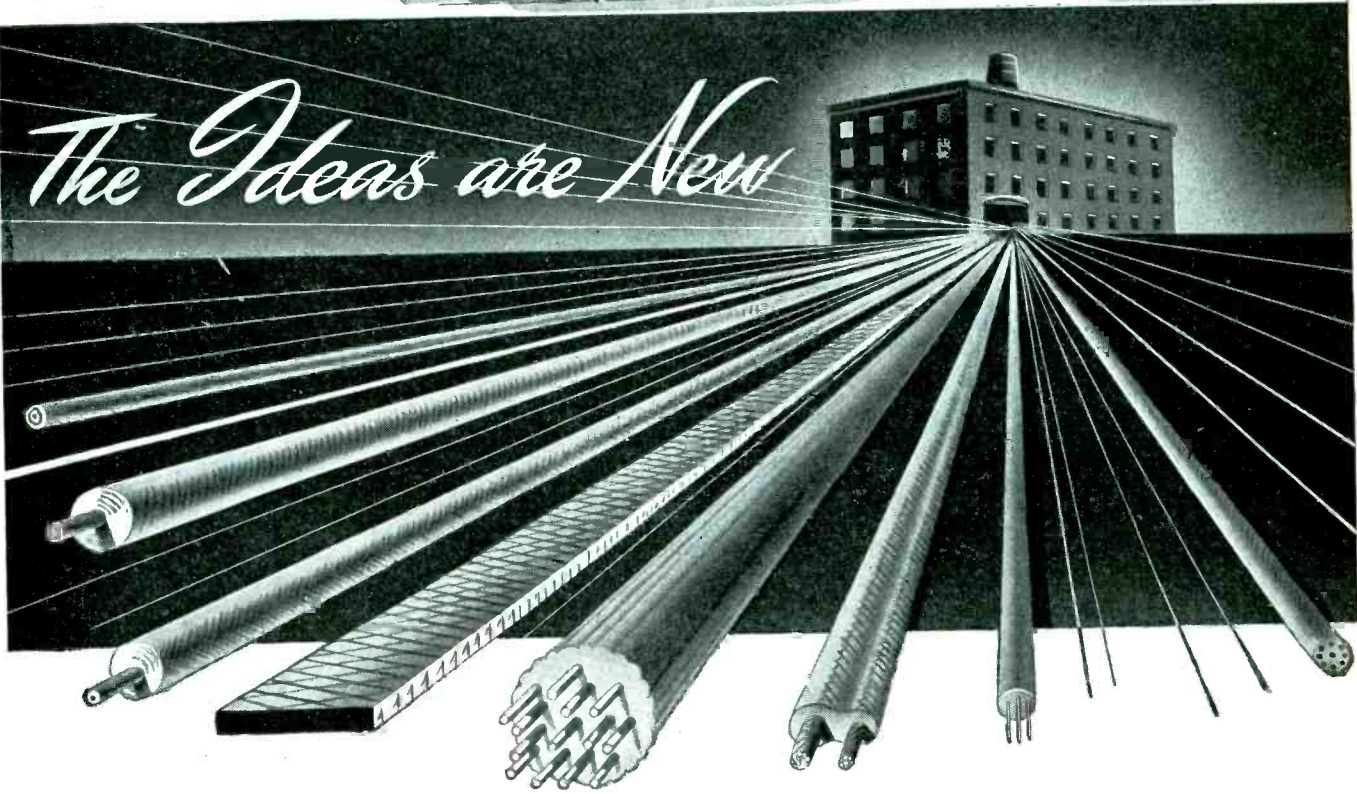

THE true power of America is not, as our enemies thought, in our great factories, our natural resources ...it is in the know-how to meet new situations in new ways... summed up in a phrase known throughout the entire world — "Yankee Ingenuity!"

At Ansonia, for example, war found us with no experience in making cables of the exact type required by the Army and Navy, with their unique specifications. Yet we have produced them in staggering quantities —which, like their exact nature and use, must remain secret. But we can say that re-

quirements were not only met but that one new and particularly vital kind of cable was first produced here at Ansonia — in an old brick building typical of the Naugatuck Valley. This type of thinking and action continues to be available to our forward-looking government in war, to industry in peace.

**ANKOSEAL** multi-conductor insulated cables are among the most promising of Ansonia war-proven developments. If you have, or expect to have, a use for electrical cables—

CHECK ANKOSEAL!

**THE ANSONIA ELECTRICAL COMPANY**

Specializing in "Ankoseal" a Thermoplastic Insulation  
ANSONIA • CONNECTICUT



A Wholly-Owned Subsidiary of

**NOMA ELECTRIC CORPORATION**

GENERAL OFFICES • NEW YORK, N. Y.

—In peacetime makers of the famous Noma Lights—the greatest name in decorative lighting. Now, manufacturers of fixed mica dielectric capacitors and other radio, radar and electronic equipment.



# The "PASSWORD"

to reliable Control  
or Protection



Type RT Thermostat. Adjustable Temperature Control.

Type C-2851 Thermostat. For such use as Roughing Controls on Outer Crystal Ovens.



Type C-6363 Switch Circuit Breaker.

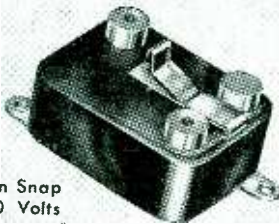

Type C-7220 Precision Snap Switch. 12 amps. 30 Volts D.C., 125 Volts A.C.

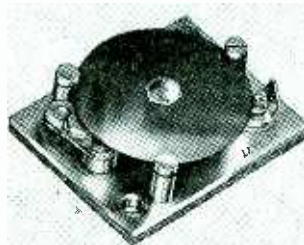

Type B-3120 Thermostat and Heater, Crystal Dew Point Control.

Type ER Series. Ambient Compensated Time Delayed Relays.

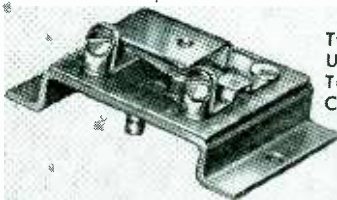
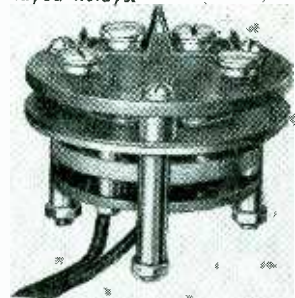

Type C-4351 Thermostat Used for Tube Warming, Tube Cooling, High Limit Controls, etc.

# "KLIXON"

## SNAP-ACTING CONTROLS

Only Klixon snap-acting controls give you the enormous advantage of simplicity of operation. Actuated by the simple scientifically calibrated Spencer thermostatic disc . . . Klixon controls have no complicated operating mechanisms . . . nothing to wear out or get out of adjustment. That's why they always provide accurate, reliable control or protection no matter where they are used.

Small, compact, light in weight, Klixon controls "snap open" to a quick, clean break or "snap close" to a solid make, no matter how often they operate. Their accurate, dependable performance is unaffected by shock, motion, vibration or altitude.

If you have a control problem, such as motor

or transformer overheat protection, electrical circuit overload protection, thermal time delays, or temperature control for radio equipment, investigate Klixon snap-acting controls. They are available in a wide range of standard types. Write for complete information.



SPENCER THERMOSTAT COMPANY, ATTLEBORO, MASS.

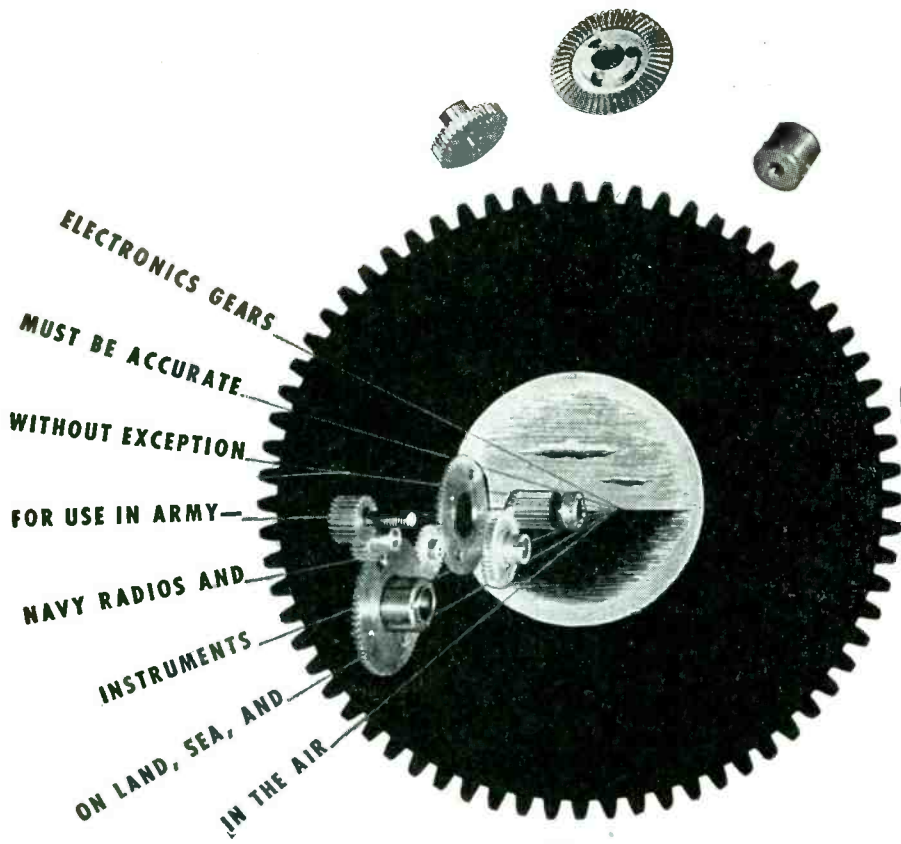

ACCURACY CANNOT BE COMPROMISED WITH IN THESE WAR DAYS OF LIGHTNING SPEEDS AND WORLD WIDE COMMUNICATIONS, ALL TUNED INTO OUR PRESENT TEMPO BY PRECISION GEARS.



**Quaker City Gear Works**  
 INCORPORATED  
 1910-32 North Front Street, Philadelphia, Pennsylvania

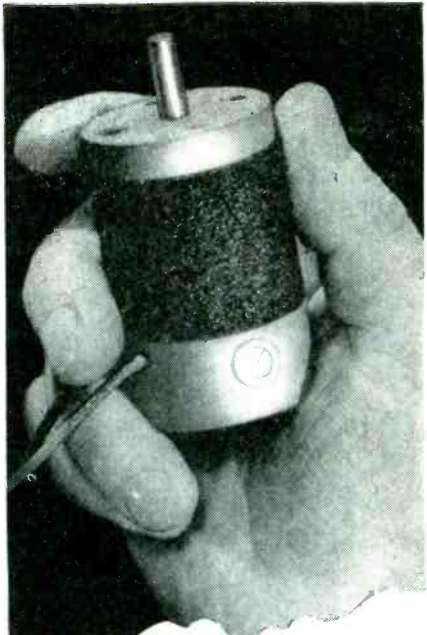

IT PACKS A  
**BIG PUNCH**



It's small but lusty —concentrated power for dependable performance on many types of jobs requiring maximum power per ounce of weight. 1/20th to 1/200th H. P. From 3000 to 20,000 R. P. M. 6 to 115 volts AC-DC. It's engineered and precision-built to your exact specifications. What type of small fractional H. P. motor do you need? Send specifications and quantity wanted. Write today.

*Small Motors, Inc.*  
 1318 ELSTON AVE., CHICAGO 22, ILLINOIS

Manufacturers of special small universal, fractional H. P. motors, dynamotors, shaded pole motors, heater motors, generators.

Design · Engineering · Production



# THEY INCREASE TUBE EFFICIENCY



**T**UBE efficiency depends largely upon the ability of the Anode to withstand the rapidity of bombarding electrons under high frequencies and increased power.

Speer Graphite Anodes are manufactured by a method which insures greater plate dissemination—not only of heat but also of power. This process eliminates warping and shrinkage generally brought about by high operating power as well as completely expelling all gases from the anodes.

The uniform operating characteristics of Speer Graphite Anodes remain constant. This permits closely matching of tubes for transmitting and rectifying and achieves efficient performance throughout the life of the tube. Speer Graphite Anodes are available in various designs to conform carefully with standard tube construction. Then too, special anodes can be made to meet special requirements. For high tube efficiency, plus other advantages listed at the right, specify Speer Graphite Anodes.

## SPEER GRAPHITE ANODES

- Increase allowable plate power dissipation.
- Lower temperatures of associated tube parts.
- Withstand severe overloads.
- Defy warping.
- Prevent hot spots or fused holes.
- Minimize bulb darkening and insulator leakage.
- Improve degassing qualities.
- Decrease gas troubles.
- Enhance tube appearance.
- Provide precise anode dimensions.
- Produce uniform tube characteristics.
- Retain original dimensions in service.
- Maintain normal tube characteristics.
- Allow wide latitude of anode design.

**SCC** →  
**SPEER**  
CARBON COMPANY  
ST. MARYS, PA.  
CHICAGO · CLEVELAND · DETROIT  
MILWAUKEE · NEW YORK · PITTSBURGH

6582



**BROADCASTING STATIONS!**  
**RECORDING STUDIOS!**  
**SCHOOLS!**

You Can Get Them  
*Without Delay!*



**GOULD-MOODY**  
*"Black Seal"*  
**GLASS BASE**  
**INSTANTANEOUS**  
**RECORDING BLANKS**

The tributes paid to "Black Seal" discs by many leading engineers have been earned by distinguished service on the turntable. Your ears will recognize the difference in quality of reproduction, and the longer play-back life will prove the superiority of "Black Seal" construction. Choice of two weights — thin, flexible, interchangeable with aluminum, or medium weight — both with four holes.

An AA-2X rating is automatically available to broadcasting stations, recording studios and schools. Enclosure of your priority rating will facilitate delivery. Old Aluminum Blanks Recoated with "Black Seal" Formula on Short Notice



**THE**  
**GOULD-MOODY**  
**COMPANY**

RECORDING BLANK DIVISION  
 395 BROADWAY • NEW YORK 13, N. Y.  
 EXPORT DEPT. ROYAL NATIONAL COMPANY, INC.  
 89 BROAD STREET, N. Y.

... BUT THERE IS

*No Such Handbook*

... SO LET OUR TWENTY YEARS  
 OF EXPERIENCE GUIDE YOU

**ELECTRICAL INSULATION CO., INC.**  
 12 Vestry St., New York 13, N. Y.

**BAKELITE SHEETS, RODS, TUBES • FABRICATED PARTS**

*If you want*

- CRYSTALS
- CABLES
- HARNESES
- ELECTRONIC ASSEMBLIES
- CABINETS

Telephone Peru, Indiana  
**151**

*Serving the Radio and Electronic Industries with precision engineered products.*

**Wm. T. WALLACE MFG. Co.**  
 General Offices: PERU, INDIANA  
 Cable Assembly Division: ROCHESTER, INDIANA





# PRESTO RESISTORS

VITREOUS ENAMEL and  
PRECISION WIRE WOUND

75 Winding Machines  
Backed by 20 years of Winding Experience

ALSO  
TELEPHONE SWITCH KEYS & JACKS  
Telephone Communication  
and Cable Assemblies

PROMPT  
DELIVERY

## PRESTO ELECTRIC COMPANY

Manufacturers of Signalling Devices UNION CITY, N. J.

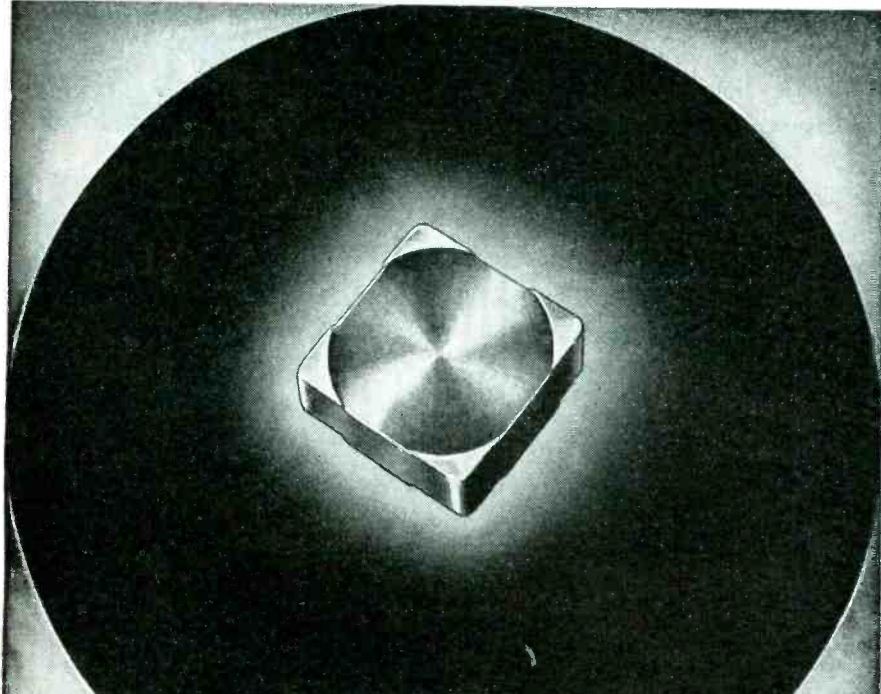

### FINISHED ELECTRODES FOR CRYSTALS

Size and types made to your specification with  
air gap tolerance held within 5 microns

STAMPED

LAPPED

HEYMAN MANUFACTURING COMPANY  
(Electronic Div. E), KENILWORTH, N. J.

## RELAYS FOR INDUSTRY

READY FOR EMERGENCY SHIPMENT

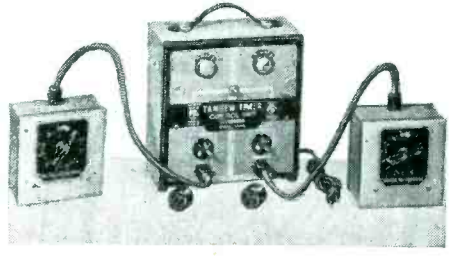

Here's a **FASTER** Coast-to-Coast Service That Helps You Maintain Rush Schedules!

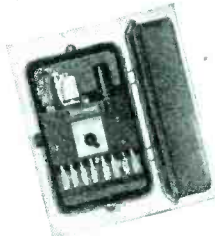

Industrial demand for good Relays, Photo - electric Equipment and Timers grows greater month by month. Newly discovered applications for these vital units are constantly raising production to new heights of speed and efficiency. These modern electronic units control combustion, count and sort products, act as burglar alarms, time life tests . . . in fact find application in countless industrial processes.



We picture a few of many makes and sizes of Relays and Timers speedily available to industry everywhere by our unique Emergency Service. Our specially organized Industrial Department is streamlined, stocked and manned to give you an entirely new type of service. Whether you need expert technical advice or a demonstration of what we mean by "Emergency Service", phone or write today!

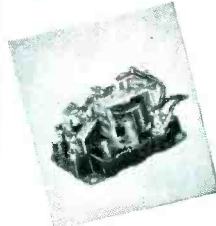

ASK FOR W-J  
AVAILABILITY LIST



Radio and  
*Electronic Supplies*

**WALKER-JIMIESON, INC.**  
311 S. WESTERN AVE., CHICAGO 12  
PHONE: CANAL 2525



# S.S. White **MOLDED RESISTORS** The "All-Weather" Resistors



**TYPE 65X**  
Actual Size  
Other types available in the lower values

**RESISTOR BULLETIN 37 GIVES FULL DETAILS . . .**

It shows illustrations of the different types of S. S. White Molded Resistors and gives details about construction, dimensions, etc. A copy, with Price List will be mailed on request. Write for it—today.

**WIDELY FAVORED** because of **NOISELESS** operation, **DURABILITY** and fine **PERFORMANCE** in all climates . . .

## STANDARD RANGE 1000 ohms to 10 megohms NOISE TESTED

At slight additional cost, resistors in the Standard Range are supplied with each resistor noise tested to the following standard: "For the complete audio frequency range, resistors shall have less noise than corresponds to a change of resistance of 1 part in 1,000,000."

## HIGH VALUES 15 megohms to 1,000,000 megohms

**S.S. WHITE INDUSTRIAL** DIVISION  
THE S. S. WHITE DENTAL MFG. CO. DEPT. R, 10 EAST 40TH ST., NEW YORK 16, N. Y.

FLEXIBLE SHAFTS      AIRCRAFT ACCESSORIES  
MOLDED PLASTICS      MOLDED RESISTORS  
MOLDED RESISTORS      FLEXIBLE SHAFT TOOLS

## Particular **WASHERS** FOR ELECTRONIC PRODUCTS

# Quadrige Quality WASHERS

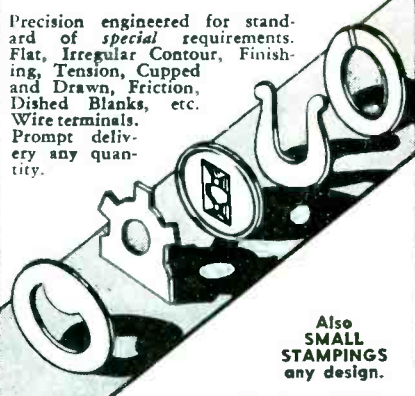

Precision engineered for standard of special requirements. Flat, Irregular Contour, Finishing, Tension, Cupped and Drawn, Friction, Dished Blanks, etc. Wire terminals. Prompt delivery any quantity.

Also **SMALL STAMPINGS** any design.

Ask for Quadrige Catalog, Photos and valuable washer data. Send specifications for quotation.

The **QUADRIGE MFG. CO.**  
Incorporated 1894 "Half a Century"  
221A West Grand Ave.,  
CHICAGO 10, ILL.



Communications 'round the world depend on **PERFECTION TELETYPE ROLLS**

**I**N a time of greatest emergency, **PERFECTION** Teletype Rolls again and again have offered convincing *proof* of superiority. In every corner of the globe they're doing their part to keep vital war messages ticking smoothly over the wires.

In addition to Teletype Rolls, the **PERFECTION** Line includes Perforator and Ticker Tapes, Morsegraph Tapes and Recorder Tapes for all machines. Rigid laboratory control keeps quality consistently uniform. All **PERFECTION** Rolls are tightly wound, accurately slit, smooth and free from lint.

*Paper Manufacturers Company*

**PHILADELPHIA 23, PA.**

THE WORLD'S PREFERRED SOURCE FOR COMMUNICATION ROLLS

**MADE BETTER TO WORK BETTER**

• The combination of high tensile strength that assures a lasting bond, and faster, cleaner-work made possible by quick-acting flux of pure water white rosin, has given Gardiner Rosin-Core Solders an outstanding reputation for efficiency and economy on radio work by expert or amateur. Yet, due to modern production methods and large production, Gardiner Solders cost less than even ordinary kinds. Made in various alloys and core sizes . . . and in gauges as small as .020 inches in diameter . . . in 1, 5 and 20-lb. spools.



4889 S. Campbell Avenue, Chicago, Ill.



# finch facsimile

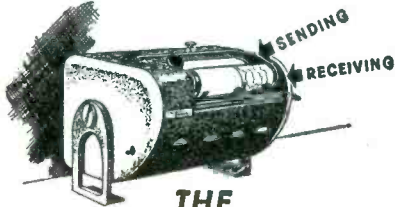

## THE "INSTANT COURIER"

(Transmits pictured messages by radio or wire)

★

For the present, Finch manufacturing facilities are being devoted to special radio apparatus for . . .

- U. S. SIGNAL CORPS
  - U. S. NAVY
  - U. S. ORDNANCE DEPT.
  - F. C. C.
  - F. B. I.
  - U. S. TREASURY DEPT.
- and WAR MANUFACTURERS

**FINCH TELECOMMUNICATIONS, Inc.**  
PASSAIC, N. J.



# Latest Permanent Magnet MANUAL

**NEW!** A valuable, up-to-the-minute manual on the design, production and application of the modern permanent magnet. Prepared by The Arnold Engineering Company, this is an authoritative treatise based on many years' experience in the

production of Alnico permanent magnets for a wide range of applications.

Contents include such subjects as Magnet Materials, Resistance Comparisons, Physical and Magnetic Properties, Demagnetization and Energy Curves, Fabrication, Design and Testing. Charts and tables illustrate and explain various aspects of the discussion.

*Recent improvements have opened many new fields for permanent magnets to reduce the cost and improve the efficiency of many devices.*

● Write TODAY for your copy on your company letterhead.

## THE ARNOLD ENGINEERING COMPANY

147 EAST ONTARIO STREET, CHICAGO 11, ILLINOIS

Specialists in the Manufacture of ALNICO PERMANENT MAGNETS

## TO LEARN MORE ABOUT RADIO-ELECTRONICS



USE THESE INTRIGUING PARTS AND ASSEMBLIES IN SPARE TIME AT HOME

Many men holding good-pay jobs still study, experiment - their eyes on better jobs, bigger pay, or a business of their own, in postwar's most promising billion-dollar opportunity field—RADIO ELECTRONICS. It will pay you to learn about the splendid present and future opportunities this broad field offers trained men. Learn how you, too, may improve your situation - at home in your spare time - with the use of DeFOREST'S exclusive *Learn-by-Doing, Learn-by-Seeing, 3-Way* Combination of (1) 50 modern text lessons prepared under the supervision of Dr. Leo DeForest; (2) instructive Training Films and Movie Projector; and (3) 153 interesting experiments from eight Big Kits of Practical Radio Parts. Learn also about free Employment Service. Get colorful "VICTORY FOR YOU" book and KIT FOLDBEE - FREE! Convince yourself. Mail the coupon. Act now - - today!



DeFOREST'S TRAINING, INC.,  
Dept. E-2, 2833-41 N. Ashland Ave.,  
Chicago 14, U.S.A.

Please send "VICTORY FOR YOU" and RADIO KIT SUPPLEMENT.

Name ..... Age .....

Address .....

City ..... State .....

( ) If a veteran of World War II, check here.

**DeFOREST'S TRAINING, INC.**  
CHICAGO 14, ILL.

# CARTER SOLVES YOUR Dynamotor PROBLEMS

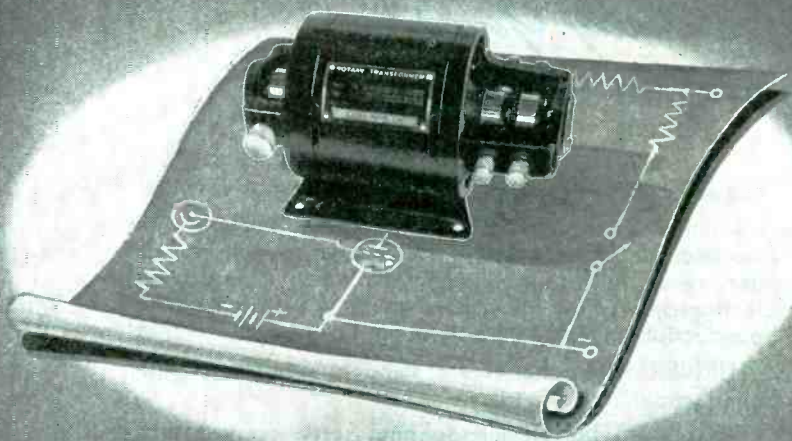

For many years, Carter Dynamotors have been a familiar part of the specifications of leading Communication Equipment Manufacturers, Police Departments, Government Agencies, etc. May we suggest you submit your Dynamotor requirements too, and see for yourself the reason for this recognized preference.

The latest catalog of Carter Dynamotors, Converters, Permanent Magnet Generators and Dynamotors, and special rotary equipment will be sent upon request.

**Carter Motor Co.**  
Chicago, Illinois

1606 Milwaukee Ave. Carter, a well known name in radio for over twenty years. Cable: Gesemotor





# TURNER

## MICROPHONES

Present **SOUNDSCRIBER**  
TRADE MARK

... another TURNER Application in Electronic Developments



*Confidentially Yours!*  
SOUND IN AN ENVELOPE

SoundScriber is creating new standards in business life.

Whether you are discussing important matters with associates or others, giving instructions to employees, interviewing or writing letters, your voice is registered Electronically while you talk — giving you an immediate SoundScript on a featherweight plastic disc.

TURNER Microphones are standard equipment with SoundScriber.

Today — TURNER microphones serve every branch of the armed forces in addition to business, education, the professions and science. Tomorrow will open even wider use for Turner applications in electronic communications.

*Crystals Licensed under Patents of the Brush Development Co.*



TURNER — Pioneers in the communications field

The **TURNER** Company  
CEDAR RAPIDS, IOWA

Let Us Help You  
Build a *Better* Product

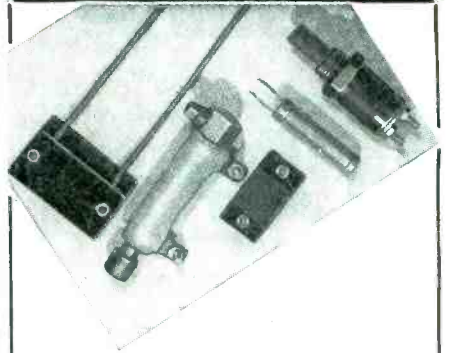

HERE'S A COMPLETE  
PRODUCTION DEPARTMENT

- 65 Skilled Workers
- Modern Equipment
- Trained Supervision

ready to go to work for you. Keep your costs in line.

TRY TUTTLE FIRST

for Strip Resistors — Porcelain Heating Elements — Standard and Special Heating Elements

Write for Bulletin S101C

**H. W. TUTTLE & CO.**  
ADRIAN, MICHIGAN

*Lavite* **STEATITE  
CERAMIC**

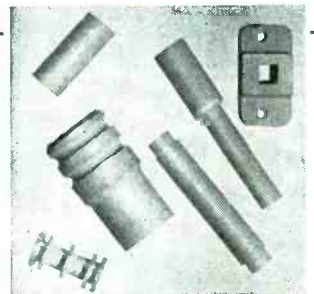

CHARACTERISTICS

Specific gravity of only 2.5 to 2.6 cent. Per cent power factor.  
Water absorption S. 1.5-0.001 per S. 1.5 to 60 cycles was only 0.0165.  
Dielectric constant at 60 cycles was 5.9-1000 KC 5.4.

Makers of electrical and radio apparatus destined for war service are finding in LAVITE the precise qualities called for in their specifications . . . high compressive and dielectric strength, low moisture absorption and resistance to rot, fumes, acids, and high heat. The exceedingly low loss-factor of LAVITE plus its excellent workability makes it ideal for all high frequency applications.

We will gladly supply samples for testing.

**D. M. STEWARD MFG. COMPANY**

Main Office & Works, Chattanooga, Tenn.  
New York Needham, Mass. Chicago Los Angeles





## After The Others Failed...

SpeedWay's "know how" was able to develop new gearmotor designs for the Armed Forces that did the required job. Today, expanded needs for these motors take SpeedWay's capacity, as well as the capacity of other large motor manufacturers, working to SpeedWay Specifications.

If you need motors or gearmotors for a standard or special application bring your problem to SpeedWay. Motor outputs range from 1/3000 to 1/3 h.p. Unlimited gear ratios available from stock gears. Write for our recommendations on your war or postwar problem.

Write for SpeedWay's new Motor Bulletin showing standard A.C., D.C., and Universal Motors and generators.

**SPEEDWAY MANUFACTURING CO.**  
1898 S. 52nd Ave., Cicero 30, Ill.



# PLATINUM AND SILVER

for electronic use

## PLATINUM

WIRE • FOIL • RIBBON  
SEAMLESS TUBING

## SILVER

SHEET • WIRE  
BRAZING ALLOYS & FLUX

## THE AMERICAN PLATINUM WORKS

Refiners & Manufacturers  
N.J.R.R. Ave. at Oliver Street  
Newark 5, N. J.

## GEARED FOR WARTIME GOOD FOR PEACETIME

Sigma Relays Form the Vital Link  
Between Machine and Monitor in  
This Typical Industrial Application  
of Sigma High Speed Relays

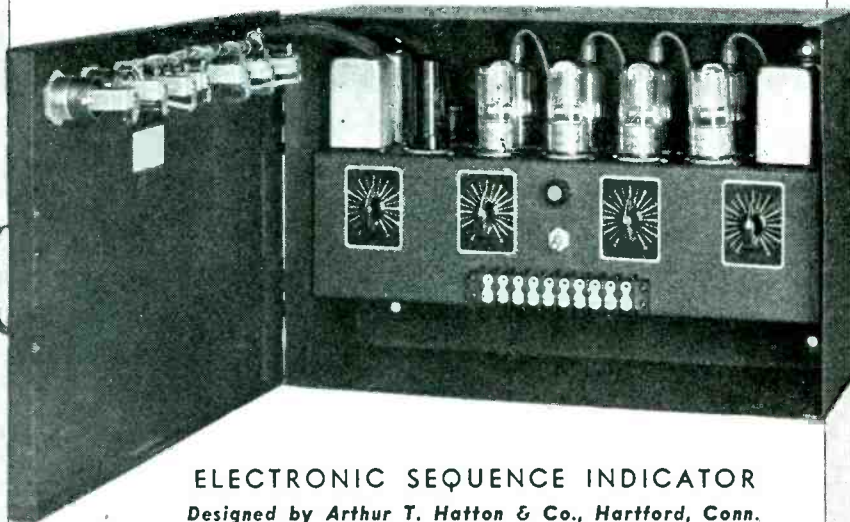

**ELECTRONIC SEQUENCE INDICATOR**  
Designed by Arthur T. Hatton & Co., Hartford, Conn.

An automatic machine completing 130 cycles of operation each minute is electronically monitored at four points in each operation. The door of this indicator carries a row of tell-tale lights of different colors to indicate failure at certain points in the machine cycle. The failure imparting an impulse for only one milli-second will cause a sustained brightness of the indicator lamp.

Sigma Relays are famous for reliable fast operation. Perhaps you have a problem requiring special engineering. Our staff is at your service.



Same as relays shown in above equipment photo except hermetically sealed for tropical service.

**SIGMA**  
**Sigma Instruments, Inc.**  
*Sensitive* **RELAYS**

**NEW ADDRESS** 62 CEYLON STREET  
BOSTON 20, MASS.

**For Accurate Checking of Crystals  
In Sub-Zero Range!**

# ELEMATIC HIGH RESISTANCE PYROMETER

Here is a precision laboratory instrument, developed by our engineers at the request of radio manufacturers, for the specific purpose of checking crystals under sub-zero conditions. Produced only after exhaustive tests, this Elematic Pyrometer is guaranteed to be accurate within 2% of the full scale.

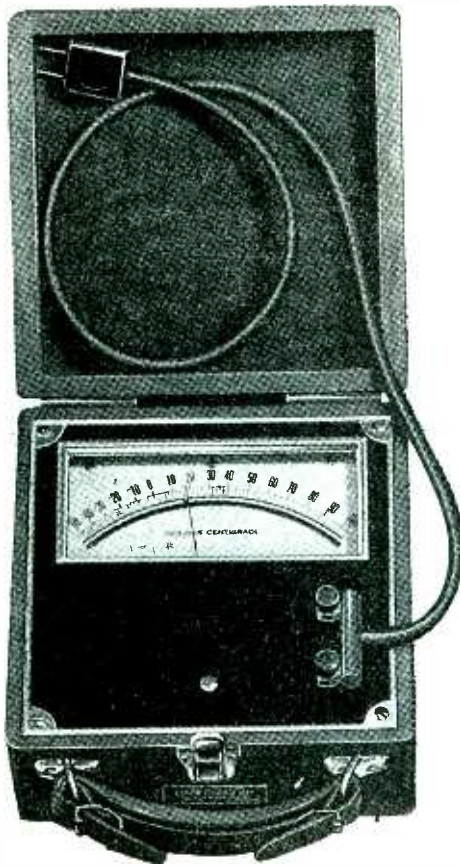

**MODEL 40**

Standard model illustrated equipped with Minus 50° C. to Plus 100° C. but is also available in scale range of 0—150° C.—Minus 40° to Plus 50° C.—Minus 85° to Plus 85° C. and Minus 60° to Plus 100° C.

The Elematic Model 40 is housed in a finely finished walnut case, with hinged removable cover and leather carrying handle. It has a high resistance movement. Mirror on scale to avoid parallax errors, 5¾" scale, 6" knife edge pointer, automatic compensation, two sapphire jewels and lapped pivots. Adaptable for all types of crystal holders and available in all standard ranges and thermocouple accessories.

Write for full information on the Model 40 High Resistance Pyrometer and other Elematic Instruments and Accessories.

**ELEMATIC EQUIPMENT  
CORPORATION  
6046 WENTWORTH AVE., CHICAGO 21, ILL.**

# PLASTIC NAME PLATES

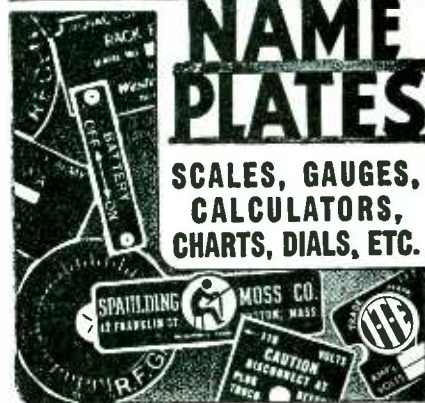

**SCALES, GAUGES,  
CALCULATORS,  
CHARTS, DIALS, ETC.**

- Impervious to moisture, grease, oils, acids, alkalis.
- Printing guaranteed not to wash or rub off.
- Non-inflammable, non-corrosive plastic.
- Printed and laminated vinylite and cellulose acetate.

SAMPLES AND ESTIMATES GLADLY SUPPLIED ON REQUEST. WRITE DEPARTMENT E. I.

**THE HOPP PRESS, INC.**  
PRINTING — FABRICATING — FORMING  
460 W. 34th STREET, N. Y. C.  
ESTABLISHED 1883

## Wanted ENGINEERS

- Radio
- Chemical
- Electrical
- Electronic
- Mechanical
- Metallurgical
- Factory Planning
- Materials Handling
- Manufacturing Planning

Work in connection with the manufacture of a wide variety of new and advanced types of communications equipment and special electronic products.

Apply (or write), giving full qualifications, to:

R. L. D.

EMPLOYMENT DEPARTMENT

**Western Electric Co.**

100 CENTRAL AV., KEARNY, N. J.

Applicants must comply with WMC regulations



**Need Wire Now!**  
**COLUMBIA**  
**is reliable!**

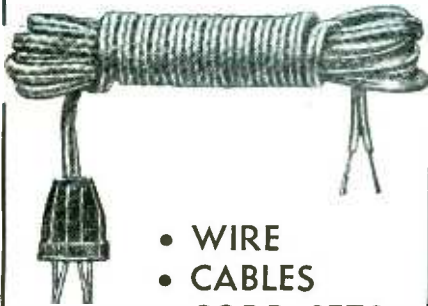

- WIRE
- CABLES
- CORD SETS

We Serve the  
**RADIO & ELECTRONIC**  
**INDUSTRY**

We cut, strip, and tin wire; attach lugs and eyelets to meet your requirements.

INQUIRIES ARE WELCOME

**COLUMBIA WIRE & SUPPLY CO.**  
 4110 N. PULASKI ROAD  
 CHICAGO 41, ILLINOIS

*We wish to  
 acquaint you with*

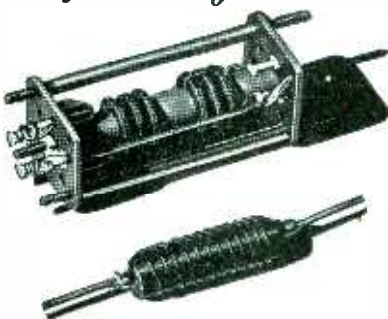

**STANWYCK**  
**R. F. COILS**

*and  
 Associated Assemblies*

There is a Stanwyck coil for every application in the Radio Frequency Spectrum — coils that have met the requirements of war and which will meet your requirements when the war is won . . . Send for folder describing our line and facilities.

**STANWYCK**  
*Winding Company*

NEWBURGH

NEW YORK

## Ingenious New Technical Methods

Presented in the hope that they will  
 prove interesting and useful to you.

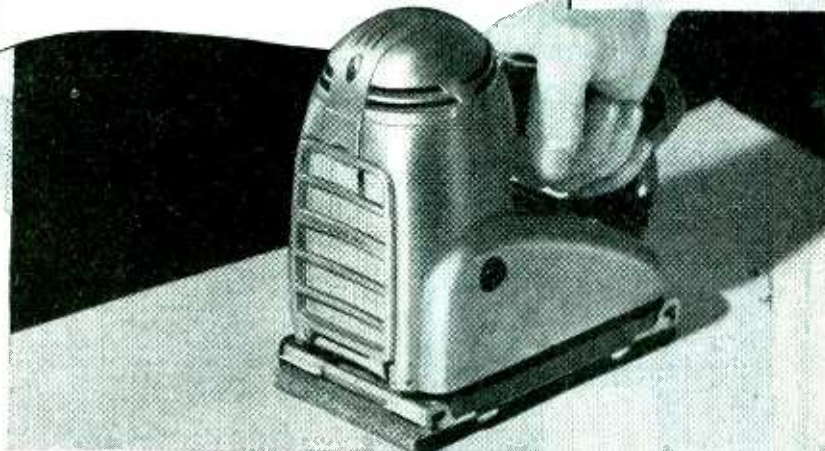

## No Vibration in New "Orbital Action" Portable Electric Sander; Relieves Workers' Fatigue

A boon to workers' nerves and health, this new "Orbital Motion" electric sander is actually vibrationless. A great saver of workers' energy as well as man-production hours, the sander can be operated easily in horizontal, vertical or inverted position with one hand. Compared to manual sanding, this machine achieves superior results at least eight times faster. It performs equally well on wood, metal or plastics.

Developed for war industry, this revolutionary new sander has done yeoman duty in this country's manufacturing plants and in allied maintenance and repair depots all over the world.

Wrigley's Spearmint Gum renders a real service to workers too—eases dry throat and relieves tension that brings on fatigue, leaving both hands free to stay on the job. The Army and Navy were quick to appreciate these benefits, that's why they are now shipping to our fighting forces overseas only, our entire limited production of Wrigley's Spearmint. Just as soon as we can supply the home front, too, industry will again enjoy the benefits of Wrigley's Spearmint Gum now proving so important on the battle fronts.

*You can get complete information from Sterling Tool Products Company, 155 East Ohio Street, Chicago 11, Illinois*

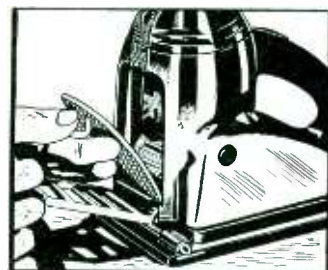

Easily-removed filter cleans air that cools motor—prolongs motor life and reduces maintenance costs.

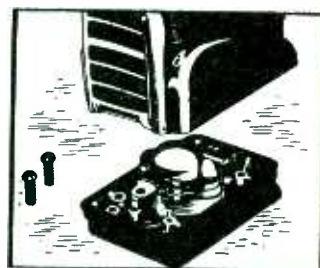

Dustproof transmission synchronized to eliminate vibration. Oil supply lubricates for 100 operating hours.



**Proven!**  
 25,000 OHMS PER VOLT  
 PUSH BUTTON OPERATED  
 SPEED TESTER  
 SUPREME MODEL  
 592



- ★ Design proven by over 5 years production
- ★ Dual D.C. Sensitivity—25,000 ohms per volt and 1000 ohms per volt.
- ★ Matched resistors of 1% accuracy
- ★ Push button operated—no roaming test leads
- ★ Open face—wide scale 4 1/4" meter. 40 microamperes sensitivity.
- ★ 1 Microampere first scale division.

**SPECIFICATIONS**

D.C. MICROAMPERES:  
 0-70-700 microamperes  
 D.C. MILLIAMMETER:  
 0-7-35-140-350 milliamperes  
 D.C. AMMETER  
 0-1.4-14 amperes  
 D.C. VOLTS, 25,000 OHMS PER VOLT:  
 0-3-5-7-35-140-350-700-1400 volts  
 D.C. VOLTS, 1000 OHMS PER VOLT:  
 0-3-5-7-35-140-350-700-1400 volts  
 A.C. VOLTS, 1000 OHMS PER VOLT:  
 0-7-35-140-350-700-1400 volts  
 OUTPUT VOLTMETER:  
 0-7-35-140-350-700-1400 volts  
 DECIBEL METER:  
 0 db to plus 46 db  
 OHMMETER:  
 0-500-5000-50,000-500,000 OHMS  
 0-5-50 MEGOHMS  
 POWER SUPPLY  
 Battery Operated

With the above specifications the Supreme Model 592 Speed Tester meets today's requirements for general laboratory use, assembly line tests and inspection, radio and other electronic repair and maintenance.

**SUPREME**  
 TESTING INSTRUMENTS

SUPREME INSTRUMENTS CORP.  
 Greenwood, Miss., U. S. A.

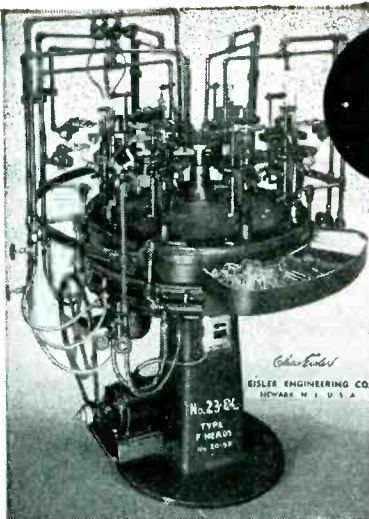

(TOP) No. 23-81 Stem Machine, one of several in the EISLER line, speeds production and reduces breakage losses.  
 (RIGHT) No. 95-L Butt Welder, has simplified control, and assures perfect welds with minimum damage to metal grain structure.  
 (EXTREME RIGHT) No. 11-TU Glass Tube Slicer, makes clear, sharp cuts—does not require skilled operator.

**EISLER ELECTRONIC EQUIPMENT... the plus factor in tube manufacture**

The CHAS. EISLER specialized facilities are supplying high-efficiency manual, automatic and semi-automatic machinery for vacuum tube and electronic component production. Hundreds of devices for every phase of manufacture are included—glass tube slicers, stem and sealing machines, flaring units, laboratory apparatus, etc. A note on your company letterhead will bring details without obligation; write today.

★ EISLER serves 98% of American vacuum tube producers today!



*Chas. Eisler*  
**Eisler**

**ENGINEERING COMPANY**

751 SO. 13th STREET NEWARK 3, NEW JERSEY

*PyroFerric*

**IRON CORES**

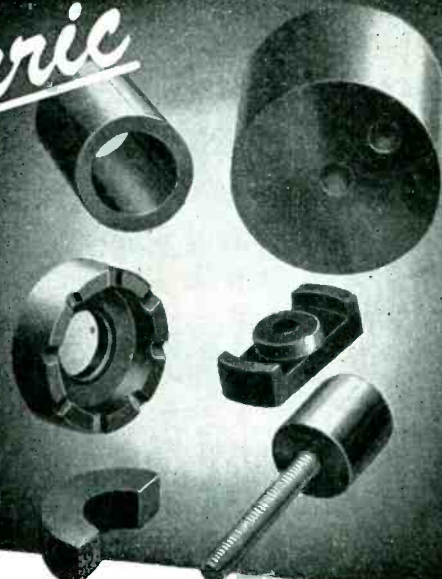

PyroFerric powdered metal cores have kept pace the vital precision instrument development. They are manufactured to specification:

PERMEABILITY } HIGH  
 "Q" } as desired  
 RESISTANCE } LOW  
 FREQUENCY } HIGH  
 } MEDIUM  
 } LOW

Consult PyroFerric on your rower Metallurgy requirements

**PYROFERRIC Co.**  
 175 VARICK STREET NEW YORK, 14, N. Y.



# Tough Transformer Problems?

WE LOVE THEM...

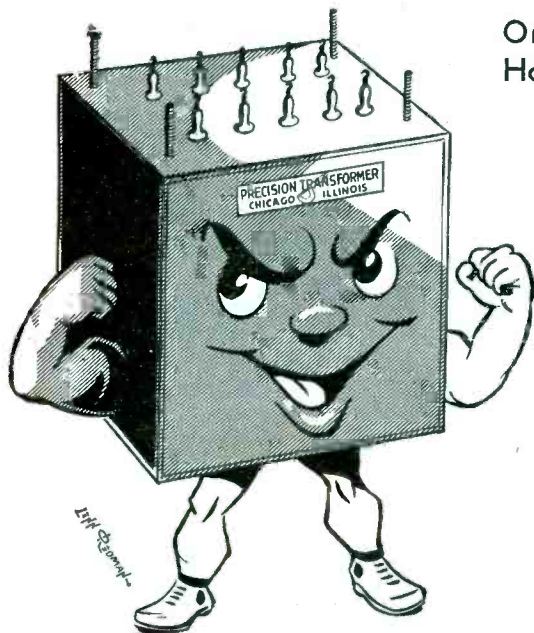

On Previous Problems  
Have You Heard This...

- TOO PRECISE
- QUANTITY TOO SMALL
- WANTED TOO SOON

That, Mr. Engineer is because you have not formed the habit of going to Precision for your transformer needs.

- NO JOB TOO TOUGH
- NO QUANTITY TOO SMALL
- NO DELIVERY PROBLEM AT PRECISION

## PRECISION TRANSFORMER CO.

733 W. OHIO STREET

CHICAGO 10, ILLINOIS



# Global BRAND TRADE MARK SEMI-INSULATED CERAMIC RESISTORS

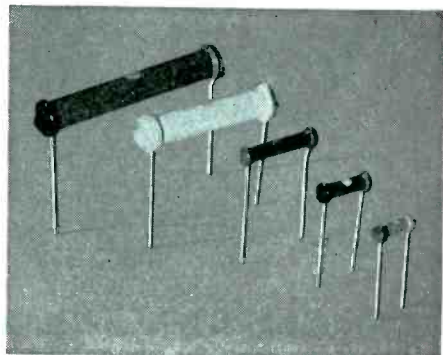

- Low ohmic values are made in body type "CX" only whereas type "A" body is offered in a wide range of resistance values.

Global Brand Resistors are unusually rugged as your tests will prove. Those illustrated are standardized sizes and resistance values. In case you require resistors having special characteristics we can furnish them. Larger units or special sizes can be provided.

Write us outlining your resistor problem, it will receive prompt and careful consideration.

PHYSICAL AND ELECTRICAL SPECIFICATIONS—  
TYPE "A" RESISTORS

PART NUMBER	WATT RATING	RESISTANCE RANGE	OVERALL LENGTH	OVERALL DIAMETER
997-A	1/5	150 Ohms to 4.7 Megohms	2 1/64"	7/64"
763-A	1/4	47 Ohms to 15 Megohms	5/8"	7/32"
759-A	1/2	33 Ohms to 15 Megohms	3/4"	1/4"
766-A	1	47 Ohms to 15 Megohms	1 1/8"	1/4"
792-A	3	22 Ohms to 150,000 Ohms	1 7/8"	15/32"
774-A	5	33 Ohms to 220,000 Ohms	2 5/8"	15/32"

TYPE "CX" RESISTORS

PART NUMBER	WATT RATING	RESISTANCE RANGE	OVERALL LENGTH	OVERALL DIAMETER
997-CX	1/4	1 to 150 Ohms	2 1/64"	7/64"
763-CX	1/2	1 to 47 Ohms	5/8"	7/32"
759-CX	1	1 to 33 Ohms	3/4"	1/4"
766-CX	2	1 to 47 Ohms	1 1/8"	1/4"
792-CX	4	1 to 22 Ohms	1 7/8"	15/32"
774-CX	6	1 to 33 Ohms	2 5/8"	15/32"

STANDARD RESISTANCE (Tolerances 5% - 10% - 20%)  
ALL RESISTORS COLOR CODED According to R. M. A. Standards.  
ORDER BY PART NUMBER, RESISTANCE VALUE AND TOLERANCE.

Global Division  
**THE CARBORUNDUM COMPANY**  
TRADE MARK

NIAGARA FALLS, N. Y.

(Carborundum and Global are registered trade marks of [and indicate manufacture by The Carborundum Co.]

**AN AMERICAN SOLUTION TO  
YOUR CAPACITOR PROBLEMS**

ALL TYPES • BY-PASS  
AND ELECTROLYTIC  
DATA SHEETS  
ON REQUEST

**AMERICAN CONDENSER CO.**  
4410 No. Ravenswood Ave. • Chicago 40, Ill.



## MODEL 201



### The Time-Tested, Reliable **VIBROTEST** Insulation Resistance Tester

Since 1938 VIBROTESTS have proven the soundness of this modern method of testing insulation resistance. Superbly engineered, ruggedly built, this pioneer instrument in CRANKLESS INSULATION TESTING offers the utmost in usefulness and value.

### **VIBROTEST** Is Thoroughly Modern —

No handcranking, no levelling, no shocks to the operator. Wide range of 0-200 megohms covering values usually encountered in general testing are instantly available from a self-contained power service providing a constant potential of 500 volts DC. Other models at 1000 volts DC. Available in this one compact instrument are a convenient ohmmeter scale, as well as AC and DC voltage scales of all required ranges, covering every testing problem usually encountered in industry.

### Many Other VIBROTESTS

are designed for specific uses involving unusual ranges of operating conditions. WRITE for full information at your earliest opportunity.

**ASSOCIATED**   
**RESEARCH**  
*Incorporated*

223 So. Green St.  
Chicago 7, Ill.



*Compare!*

**SIGNAL**

**PILOT LIGHT ASSEMBLIES**

GIVE YOU THESE 5 ADVANTAGES:

- (1) Extensive line covers every known application...
- (2) Assemblies complete with Lamps...
- (3) Top-flight engineering...
- (4) Personalized service...
- (5) Rapid-fire deliveries.

*Write for Catalog.*

**SIGNAL INDICATOR**  
*Corporation*

894 BROADWAY... NEW YORK 3, N. Y.  
Telephones: ALgonquin 4-4770

**Gibsiloy**  
ELECTRICAL CONTACTS

*with*

**PRE-DETERMINED CHARACTERISTICS**

*through*

**POWDER METALLURGY**

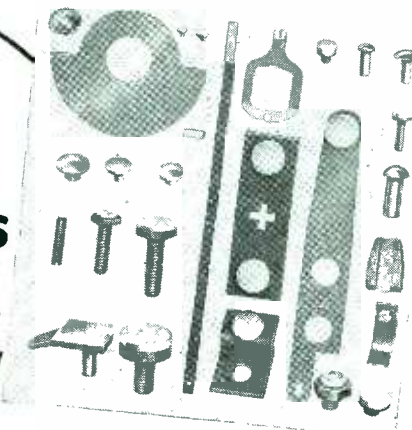

★ Many possibilities for contact metal combinations that cannot be achieved by alloying are opened through powder metallurgy. With Gibsiloy's powder metallurgy process, silver is combined with other elements that do not naturally alloy with each other. The resulting material combines all the properties of each element. Thus, the desired characteristics can be pre-determined.

Silver is used for its high electrical and thermal conductivity and low contact resistance. The addition of nickel imparts toughness, hardness and long life. When graphite, molybdenum or tungsten is added, non-welding characteristics are obtained. Many combinations are practical. Consult us on your contact problems.

★  *Manufactured by*  
**GIBSON ELECTRIC COMPANY**  
8361 Frankstown Ave., Pittsburgh 21, Pa. ★



# Specialists

... in Assembly and sub-assembly of Precision Electronic Products

- Complete Facilities for Production and Testing of Audio Equipment
- Consult us with your Production Assembling Problems

## RADELL CORPORATION

6323-27 GUILFORD AVENUE, INDIANAPOLIS 5, INDIANA

*Protect* INSIDE AND OUTSIDE  
THREADS, CUTTER TEETH,  
FINISHED CYLINDRICAL SURFACES with  
*Spiral Wound Paper Tubes!*



Guard against damage in intra-plant handling or during shipment; save time and work in packing operations. Tubes made to your requirements in diameters from  $\frac{3}{8}$ " to 6"—any length—from kraft, chipboard, special compositions; available waxed or plain. Write for complete information; get details, too, on our other lines of paper tubes and cans, gaskets, die-cut paper products.



**PIERCE PAPER PRODUCTS CO.**  
2726-D AUBURN ST., ROCKFORD, ILLINOIS

Manufacturers  
of  
Electronic Tube

**BASES .. CAPS  
TUNGSTEN  
LEADS and  
Vacuum Tube  
MACHINERY**

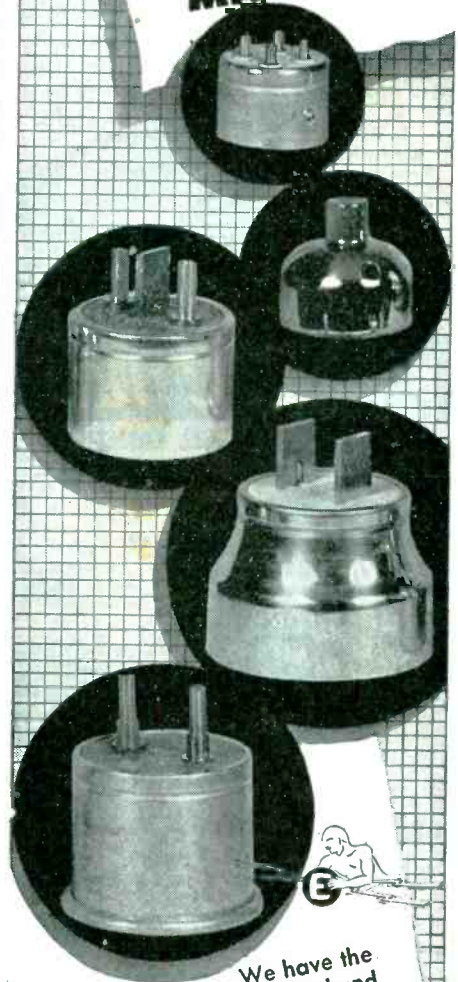

We have the engineering background and modern production facilities for the precision manufacture of Electronic Tube Bases, Caps, Tungsten Leads and Glass Working Lathes up to 6" for transmitting tubes. Consult our Engineering Department on your "special design" problems.

**ELECTRONIC  
MANUFACTURING  
COMPANY**  
20 ORANGE STREET  
NEWARK 2, N. J.



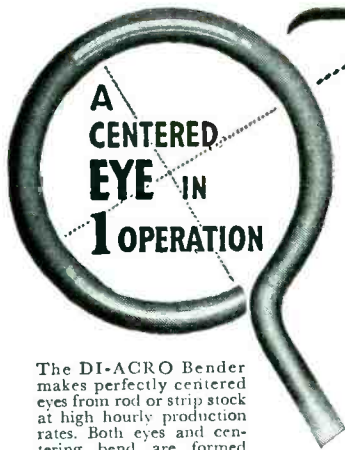

A  
CENTERED  
EYE IN  
1 OPERATION

The DI-ACRO Bender makes perfectly centered eyes from rod or strip stock at high hourly production rates. Both eyes and centering bend are formed with one operation. Any size eye may be formed within capacity of bender and ductile limits of material.

# Precision CENTERED EYE Bending

## With DI-ACRO Benders

DI-ACRO Precision Bending is accurate to .001" for duplicated parts. DI-ACRO Benders bend angle, channel, rod, tubing, wire moulding, strip stock, etc. Machines are easily adjustable for simple, compound and reverse bends of varying radii.

### DI-ACRO Bender No. 1

Forming radius 2" approx. Capacity 3/8" round cold rolled steel bar or equivalent.



Send for CATALOG "DIE-LESS" DUPLICATING showing many kinds of "dieless" duplicating produced with DI-ACRO Benders, Brakes and Shears.

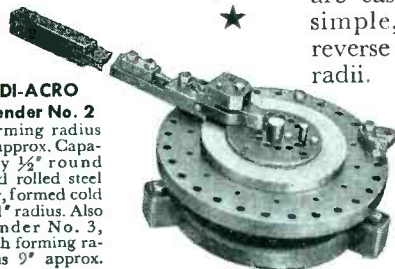

DI-ACRO Bender No. 2 Forming radius 6" approx. Capacity 1/2" round cold rolled steel bar, formed cold to 1" radius. Also Bender No. 3, with forming radius 9" approx.



DI-ACRO is Pronounced "DIE-ACK-RO"



# O'NEIL-IRWIN MFG. CO.

321 EIGHTH AVENUE SOUTH • MINNEAPOLIS 15, MINN.

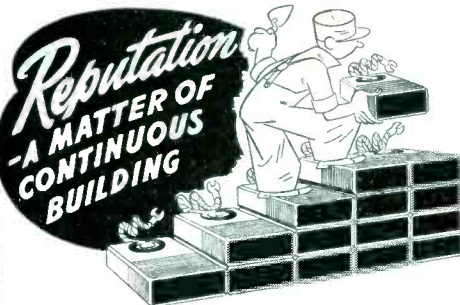

Reputation - A MATTER OF CONTINUOUS BUILDING

SUPERIOR CARBON PRODUCTS, INC.

9117 George Avenue CLEVELAND 5, OHIO

After 25 years we're still at it, and expect always to be. For reputation-building is a job that's never finished . . . Constant change and improvement rule the electrical industry. These advances are steadily making old practices, old viewpoints, old products, obsolete. Good old Superior brush grades, regardless of how good or how old, have to go when they no longer "deliver". New brushes take their place, stemming from consistent laboratory research and a close study of our customers' needs.

Will you outline your problem to us?



## SUPERIOR CARBON BRUSHES

# SPEED UP

MINIATURE TUBE SET ASSEMBLY . . . CUT TUBE FAILURES WITH THE

## ★ STAR DOUBLE-CHECK SYSTEM



Assure high set production by equipping your Assembly Departments with STAR MINIATURE SOCKET WIRING PLUGS\* to align socket contacts during wiring, and STAR MINIATURE TUBE PIN STRAIGHTENERS\* to provide an easy, perfect fit when tube is inserted. A simple "double-check" that insures smoother assembly flow and fewer tube failures. \*Fills a requirement for your Assembly Department and meets the specifications of WPB Sub-Committee on Miniature Tubes.

"THE ORIGINAL MANUFACTURER OF MINIATURE SOCKET WIRING PLUGS"

For complete information and prices — write RADIO ACCESSORY DIVISION

STAR EXPANSION BOLT CO. 147 Cedar Street, New York, 6, N. Y.

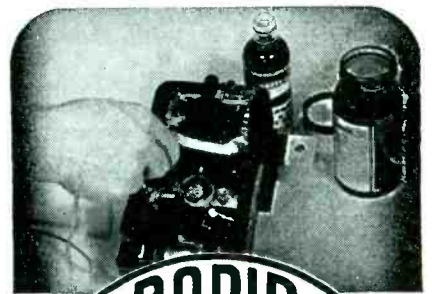

# RAPID

## METAL-COATING PROCESS

- FAST AND ECONOMICAL
- FOR HEAVIER COATINGS

REQUIRES ONLY RAPID ELECTROLYTE—RAPID METAL CLEANER—RAPID APPLICATOR

• Plating current is obtained from dry cells, storage battery, or any convenient source of direct current at 3 to 6 V., or use Rapid Plating Rectifier for heavy work.

• For silver surfacing bus bar connections, lugs, switch blades, etc. For plating or touching up miscellaneous surfaces with cadmium, nickel, zinc, copper and gold. Building up limited areas. Hard surfacing with nickel. Used in shop or field. Special applicators designed to speed up production line jobs.

Our laboratory is glad to cooperate. No obligation

Rapid Electroplating Process, Inc.

1414 S. Wabash Ave., Chicago 5, Ill.  
621 Graybar Bldg. 237 Biello Bldg.  
New York, N. Y. San Francisco, Calif.

## Test Insulation the Modern Way with a MODEL B-5 MEGOHMMER

### NEW BATTERY-VIBRAIOR TYPE

No more tiresome cranking of a hand-driven generator . . . Entirely self-contained, steady test potential of 500 volts DC, available at the touch of a switch. Direct reading in insulation resistance.



VARIOUS NEW MODELS AND RANGES

HERMAN H. STICHT CO., INC. 27 PARK PLACE NEW YORK, N. Y.

WRITE FOR BULLETIN No. 430



## 20-WATT UNIVERSAL AMPLIFIER

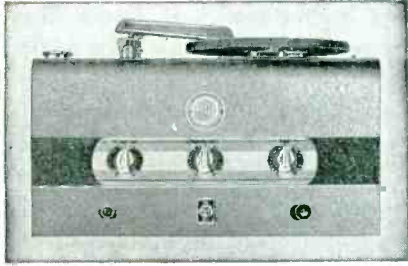

Plug in for A.C. or 6-volt auto battery; no power pack necessary. Uses mike and built-in phono at same time. 78 RPM motor, 9-inch turntable, crystal pick-up, separate on-off switch. Long-playing needle included. Continuously variable tone control on inclined eye-level con-

trol panel. Use one or two 8-ohm speakers without need of extra transformer. Has one 6SJ7GT, one 6SC7, two 6L6Gs in push-pull, two 6X5GTs. Model 6720, with tubes, F.O.B. New York **\$56.28** Model 6721, same as 6720, less phono player **\$42.87**

### TERMINAL RADIO CORP.

85 CORTLANDT ST. NEW YORK 7, N.Y.  
PHONE WORTH 2-4415

### Get the Best Technical Men...



Overnight you may be in a new field with new products for new markets. Can your men take hold? Or are you faced with a long, drawnout, complicated training program—a screening out of unsuitable personnel?

Build your organization for the pool of trained technical man power offered you by National Schools—men you need—skilled, proficient—expert in their fields. *They have prepared themselves at their own expense, for the many technical jobs you are confronted with.*

National Schools is one of the largest technical vocational training institutions in the Country. Its thousands of graduates are located all over the United States, Canada, South America. Many may be located near you. Others may be willing to move. Let us tell you about the National men that are available to you right now. Write

### NATIONAL SCHOOLS

Employers' Service Division

4000 So. Figueroa St. Los Angeles 37, Cal.

# SUB-ZERO

## Temperatures

### "LICKED" THE NAZIS

#### IN RUSSIA



One of the fatal mistakes the Nazis made in developing their army equipment was to underestimate the intense cold of the Russian winter. Motor lubricants, hose lines for fuel and hydraulic connections, and other armament components had not been designed for that type of service. Likewise, our aircraft before we entered the war was not equal to the very high altitudes at which many aerial battles have been fought.

There is only one sure way to determine the effects of extremes in temperature, pressure and humidity—a properly engineered test chamber in which any kind of weather from that of the tropics at sea level to the stratosphere may be duplicated at will and in accordance with close timing.

**KOLD-HOLD MANUFACTURING COMPANY**  
446 NORTH GRAND AVENUE, LANSING 4, MICH.

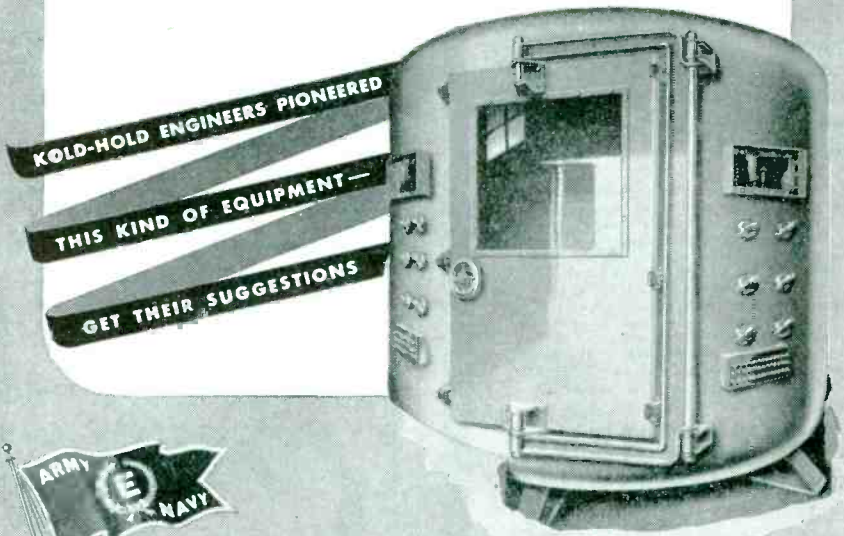

## KOLD-HOLD

## TECHNICAL NOTES

Excerpts from New Home Study Lessons Being Prepared under the Direction of the CREI Director of Engineering Texts

### Circuit Equivalents

The November issue of CREI NEWS continues with a discussion of Circuit Equivalents.

First the meaning of physical realizability is taken up and examples of circuits are given that are physically realizable in one form of configuration and not in another. Then the general problem of network synthesis and analysis is discussed so that the reader will be able to appreciate what is meant when it is desired to have one circuit equivalent to the other on a two-terminal basis or on a four-terminal basis.

Part II together with Part I which appeared in last month's issue will enable the reader to understand more completely the significance of the practical examples that are to follow in subsequent issues.

In case you are not aware, these articles, which appear in the CREI NEWS, monthly house organ of the Capitol Radio Engineering Institute, are examples of the material appearing in our advanced lesson section that we believe will be of interest to practicing engineers and students alike. If you have not already written for a free copy, do so now and become better acquainted with our activities.

*These articles are available free of charge. Simply write to the Institute and request the November issue of "The CREI NEWS" containing the article on "Circuit Equivalents."*

The subject of "Circuit Equivalents" is but one of many that are being constantly revised and added to CREI lessons by A. Preisman, Director of Engineering Texts, under the personal supervision of CREI President, E. H. Rietzke. CREI home study courses are of college calibre for the professional engineer and technician who recognizes CREI training as a proven program for personal advancement in the field of Radio-Electronics. Complete details of the home study courses sent on request. . . . Ask for 36-page booklet.

### CAPITOL RADIO Engineering Institute

E. H. RIETZKE, President

Home Study Courses in Practical Radio-Electronics Engineering for Professional Self-Improvement

Dept. E-11, 3224 — 16th St., N.W.  
WASHINGTON 10, D.C.

Contractors to the U. S. Navy — U. S. Coast Guard — Canadian Broadcasting Corp. — Producers of Well-trained Technical Radiomen for Industry.

# RME



The RME-43 Communications Receiver 550 to 33,000 K.C.



## Precision Backs RME Performance

Each step in the building of RME Radio Communications equipment reflects careful precision manufacturing.

Into every piece of RME equipment, for example, goes the highest quality materials money can buy — plus the benefits of many years research and designing experience possessed by the RME engineering staff. This assures longer lasting and better performing radio equipment for both amateur and commercial.

Write for the new free RME catalog today, giving latest information on our equipment. A copy will be mailed to you promptly.



RME assemblies are made by efficient, well trained personnel. Left: A skilled technician making accurate adjustments on an RME Receiver before its final inspection.

### G-E Safety Door Interlock Switch

OPEN the door and the power's off! Prevents accidents, protects equipment. Will not fail mechanically. For complete details, write:

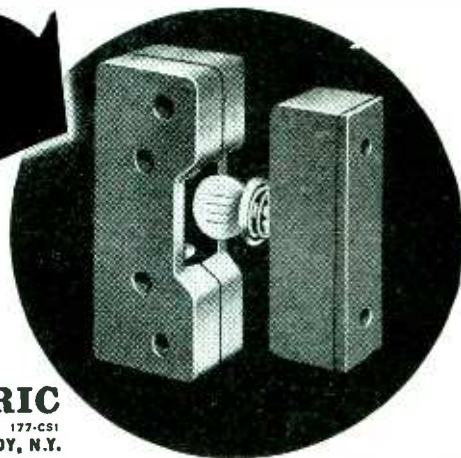

**GENERAL ELECTRIC**  
ELECTRONICS DEPARTMENT SCHENECTADY, N.Y.

## PERMANENT MAGNETS

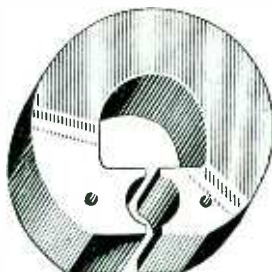

All Shapes — All Sizes — for All Purposes  
COBALT — CHROME — TUNGSTEN  
Stamped, formed and cast

**Alnico** (Cast or Sintered)  
under G. E. License

Also: Laminations for Radio Transformers  
TOOLS — DIES — STAMPINGS

Heat Treating of Metals and Alloys

**THOMAS & SKINNER** STEEL PRODUCTS COMPANY  
1116 EAST 23RD STREET • INDIANAPOLIS 5, INDIANA



# GET THIS SAMPLE OF *E-Z Code* WIRE MARKERS

ILLUSTRATION  
APPROX. 1/2 SIZE

1	2	3	4	5	6	7	8	9	10	11	12	13	14	15	16	17	18	19	20	21	22	23	24	25	26	27	28	29	30	31	32	33
1	2	3	4	5	6	7	8	9	10	11	12	13	14	15	16	17	18	19	20	21	22	23	24	25	26	27	28	29	30	31	32	33
1	2	3	4	5	6	7	8	9	10	11	12	13	14	15	16	17	18	19	20	21	22	23	24	25	26	27	28	29	30	31	32	33
1	2	3	4	5	6	7	8	9	10	11	12	13	14	15	16	17	18	19	20	21	22	23	24	25	26	27	28	29	30	31	32	33

SEE FOR YOURSELF  
HOW QUICK AND EASY IT IS TO  
**CODE WIRES**

Cuts Time, Saves Money... on Assemblies  
... Installations and Maintenance Work

E-Z CODE is the quickest known method of coding electrical wires. Made on handy cards, ready to use, they stick quickly — no moistening — stay on — stand abuse. Styles in stock fit most coding requirements. Special sizes or codes can be made to order. Mail requests to:

**WESTERN LITHOGRAPH COMPANY**  
Dept. NI, 600 East 2nd St., Los Angeles 54, California

*E-Z Code* WIRE MARKERS

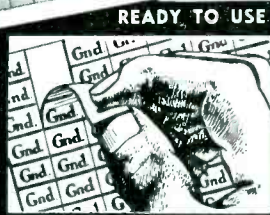

READY TO USE

FEEL OFF STRIP

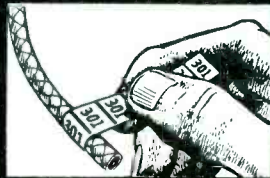

WRAP AROUND WIRE

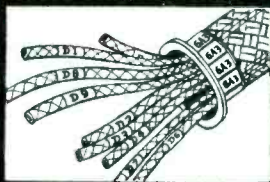

EACH WIRE CODED

It costs you **LESS**  
To pay a little more  
For **SILLCOCKS-MILLER**  
Precision-made Plastics

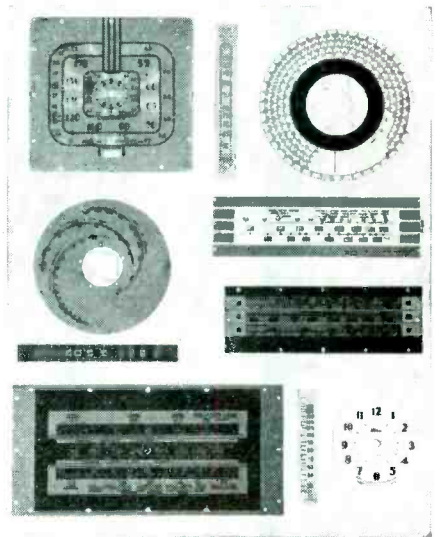

**YOUR QUALITY SOURCE  
FOR DESIGN, DEVELOP-  
MENT AND CLOSE-  
TOLERANCE PRODUCTION**

If your plastic parts or products call for fabrication to extremely close tolerances, look to Sillcocks-Miller specialists... pioneers of precision-made plastics.

Recognized everywhere for high quality fabrication, The Sillcocks-Miller Company offers you a combination of long experience, know-how and outstanding facilities to help you in the design, development and production of your plastic parts requirements.

You may pay a little more for Sillcocks-Miller quality, but it costs you less in the long run — performance, satisfaction and savings considered.

*Write for free booklet presenting a 4-point service to help designers and manufacturers.*

**SILLCOCKS-MILLER CO.**

Office & Factory

10 W. PARKER AVE., MAPLEWOOD, N. J.  
Mailing Address: SOUTH ORANGE, N. J.

**It Costs You Less to Pay a Little  
More for Sillcocks-Miller Quality**



## COMPONENT PARTS for RADIO TUBES

*Cleve-Tung makes tungsten  
products exclusively*

25 Years'  
Experience in  
the Utilization of  
Tungsten Products

**CLEVELAND TUNGSTEN, INC.**

10200 MEECH AVENUE

CLEVELAND, OHIO



### How ABOUT YOUR POSTWAR TRANSFORMER NEEDS?

#### THE PEACE-PLANNING PERIOD IS HERE!

You can save valuable time in postwar days by taking time now to arrange for the transformers you will need in building your peacetime product.

A few days' delay at this time may mean months of waiting in the postwar period when our plant becomes booked with orders to the limit of its capacity.

Be far-sighted! Send us your specifications today for a quotation!

**DONGAN ELECTRIC MANUFACTURING CO.**

2977 Franklin

Detroit 7, Mich.

"The Dongan Line Since 1909"

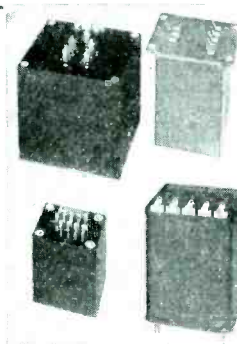

**"DONGAN"**

**ANOTHER SPECIAL BY PROGRESSIVE**

QUALITY PROMCO BRAND

ACTUAL SIZE

ENLARGED FOR DETAIL

71 other "specials" are illustrated in Catalog 18, which includes tables of weights per 1M standard pieces, dec. equivs. of fractions, etc. Write for it.

Special heads, threads, and finishes — on fastenings of any metal or alloy adapted to cold-set — are Progressive's specialty. Weekly output: 25,000,000.

**The PROGRESSIVE MFG. CO.**  
50 NORWOOD ST., TORRINGTON, CONN.

BUY MORE WAR BONDS

AVIATION COMMUNICATION EQUIPMENT

QUARTZ RADIO CRYSTALS

**ELECTRONIC EQUIPMENT  
QUARTZ CRYSTALS**

MANUFACTURING  
ENGINEERING  
DESIGNING  
TO ORDER

**REX BASSETT**  
INCORPORATED  
FORT LAUDERDALE  
FLORIDA

# NORTON **N** INSTRUMENTS

## Hand Calibrated for Your Exact Needs

The scales of Norton Instruments are hand drawn and hand calibrated to meet your special requirements, thus assuring accuracy at every reading point.

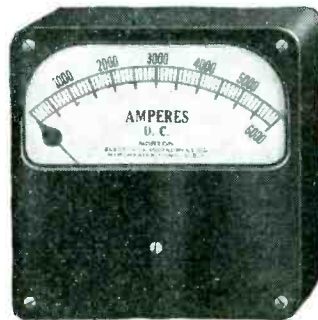

Furnished for both switchboard and portable use. Magnetically shielded. Hardened, specially ground pivots, supported by sapphire jewels.

Norton has served the industrial and marine fields for fifty years. Wherever accurate measurement of electrical units is called for, there is a Norton Instrument to meet the requirements.

Send for our new catalog

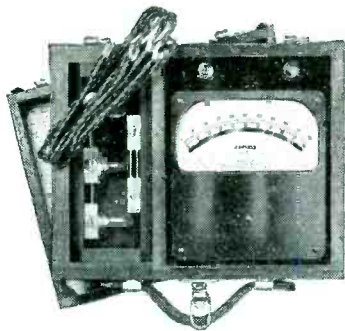

**NORTON Electrical Instrument Co.**  
59 HILLIARD ST., MANCHESTER, CONNECTICUT

## DIALS PANELS and PLATES

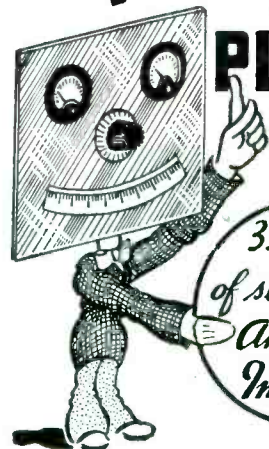

35 years  
of service to  
American  
Industry

### DIALS • PANELS • PLATES

made to your precise engineering specifications in etched metals and finishes.

**PREMIER**  
**METAL ETCHING CO.**  
21-03 44th AVE.  
LONG ISLAND CITY, NEW YORK



**Immediate Delivery!**  
**WIDE RANGE**  
**VACUUM TUBE**  
**VOLTMETERS**



- High input impedance for both AC and DC measurements.
- Convenient, low capacity "Probe," especially adapted to high frequency radio use—100 megacycles and over.
- Self-regulating operation from power line; no batteries.
- Multiple voltage ranges—accurate and stable.

**BULLETIN ON REQUEST**  
**ALFRED W. BARBER**  
**LABORATORIES**

34-04 Francis Lewis Blvd. Flushing, N. Y.

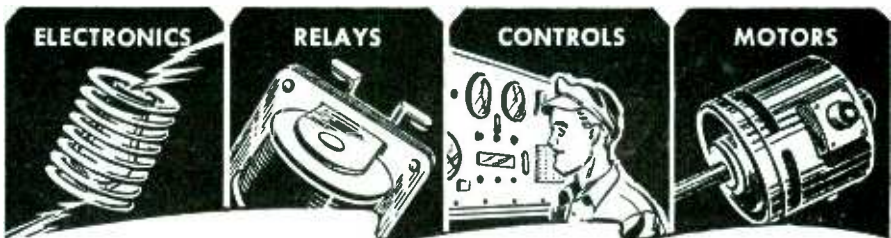

An Invitation to All Electrical Designers

## TRY SILVER GRAPHALLOY

### FOR BRUSHES

High current density, low contact drop, low electrical noise, and self-lubrication are characteristics of this silver-impregnated molded graphite that may be the answer to your electrical brush problems.

### FOR CONTACTS

Low contact resistance and non-welding when breaking surge currents are inherent properties of this unique combination of conductive silver and self-lubricating graphite.

SAMPLES of Silver Graphalloy will be gladly furnished for test on your applications. Silver Graphalloy is usually silver plated to permit easy soldering to leaf springs or holders. Why not WRITE NOW for your test samples?

**GRAPHITE METALLIZING CORPORATION**  
 YONKERS, NEW YORK



SLIP-RING AND COMMUTATOR BRUSHES AND CONTACTS

**El-Menco**  
 MOLDED  
 MICA  
 CAPACITORS

**IMMEDIATE DELIVERY—**  
 ALL SIGNAL CORP ORDERS BEARING  
 INSPECTION AT SOURCE, INSPECTED  
 ON PREMISES & SHIPPED IMMEDIATELY

All R.M.A. or A.S.A. color coded  
 A complete stock is ready for immediate  
 shipment of quantities, ranging from 500  
 to 5,000 of each capacity in regular MICA  
 CAPACITORS in 5%, 10% and 20% tolerance  
 and silvered MICA CAPACITORS in 2%, 5%  
 and 10% tolerances.  
 Write for price sheets and  
 complete information.

**Territory  
 open for  
 JOBBERS**

SEND FOR OUR  
 SPECIAL INITIAL  
 ORDER OFFER.



**ALBERT ROTHENSTEIN**  
 National Distributor  
 135 LIBERTY ST. New York 6, N.Y.

# ENGINEERS....

## Are You Concerned With ? YOUR POST WAR FUTURE ?

The Federal Telephone & Radio Corporation, the manufacturing unit of the International Telephone & Telegraph Corporation with its multiple business activities extending to all parts of the civilized world, will accept applications from experienced men for immediate employment with almost limitless post war possibilities. These positions should interest those with an eye to the future and whose interest lies in forging ahead with this internationally known organization whose expansion plans for post war are of great magnitude covering all types of radio & telephone communications. Advancement as rapid as ability warrants. Majority of positions are located in the New York area!

We need the following personnel!  
 Men with long experience or recent graduates considered.

- **ENGINEERS**
- **ELECTRONICS**
- **ELECTRICAL**
- **RADIO**
- **MECHANICAL**
- **CHEMICAL**
- **TRANSFORMER DESIGN**
- **SALES AND APPLICATION ENGINEERS**
- **PHYSICISTS**
- **DESIGNERS**
- **DRAFTSMEN**
- **TOOL DESIGNERS**
- **TECHNICAL WRITERS**

## Look Ahead With Federal!

If inconvenient to apply in person, write letter in full, detailing about yourself, education, experience, age, etc., to Personnel Manager

**FEDERAL TELEPHONE & RADIO CORP.**  
 EAST NEWARK NEW JERSEY

39 Central Avenue



# G-M TYPE 27 RELAY

**SMALL**

**COMPACT**

**SENSITIVE**

**POWERFUL**

**A MULTI-POLE RELAY**



**FOR AIRCRAFT AND MOBILE EQUIPMENT**

The G-M Type 27 relay is designed for permanence of adjustment. Exceeds usual aircraft specifications for temperature, humidity, elevation, salt spray, requirements. The following are actual examples of type 27 characteristics.

- 1 Type 27, specification 12700, single pole single throw relay—contact pressure 50 grams minimum; acceleration 10g.; coil power 90 milliwatts at 25° C. ambient; contact gap .010 inch; weight 5¼ ounces.
- 2 Type 27, specification 12746, three pole relay with two double throw contacts and one single pole normally open contact—contact pressure, 30 grams minimum; acceleration, 10g.; pickup 3.75 milliamperes maximum with 10,550 ohm coil (148 milliwatts); contact gap .010 inch; weight 5½ ounces.

Comparable relays with a variety of contact forms and coil resistances can be supplied. We invite your inquiries.

**G-M LABORATORIES INC.**

4313 NORTH KNOX AVENUE, CHICAGO 41, ILLINOIS

*Buy* WAR BONDS & STAMPS

## G-E INDICATOR LAMPS

- Vibration-proof Lock-on Cap • With or without adjustable "Dimmer" feature
- Choice of five colors • Well-insulated plastic body • Rugged construction
- Easy to mount • Light weight.

For complete details, write to

**GENERAL**



**ELECTRIC**

ELECTRONICS DEPARTMENT  
SCHENECTADY, NEW YORK



## If You Are Having Difficulty Maintaining Your Mailing Lists...

Probably no other organization is as well equipped as McGraw-Hill to solve the complicated problem of list maintenance during this period of unparalleled change in industrial personnel.

McGraw-Hill Mailing Lists cover most major industries. They are compiled from exclusive sources, and are based on hundreds of thousands of mail questionnaires and the reports of a nation-wide field staff. All names are guaranteed accurate within 2%.

When planning your direct mail advertising and sales promotion, consider this unique and economical service in relation to your product. Details on request.

**McGraw-Hill Publishing Co., Inc.**

DIRECT MAIL DIVISION

330 West 42nd Street

New York, 18, New York

*for Results*



**Mc GRAW-HILL**  
DIRECT MAIL LIST SERVICE

**NOW**

## a really high-powered **RADIO ENGINEERING LIBRARY**

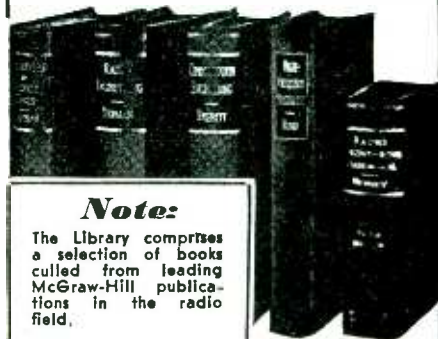

**Note:**

The Library comprises a selection of books culled from leading McGraw-Hill publications in the radio field.

- especially selected by radio specialists of McGraw-Hill publications
- to give most complete, dependable coverage of facts needed by all whose fields are grounded on radio fundamentals
- available at a special price and terms

These books cover circuit phenomena, tube theory, networks, measurements, and other subjects—give specialized treatments of all fields of practical design and application. They are books of recognized position in the literature—books you will refer to and be referred to often. If you are a practical designer, researcher or engineer in any field based on radio, you want these books for the help they give in hundreds of problems throughout the whole field of radio engineering.

**5 volumes, 3559 pages, 2558 illustrations**

Eastman's **FUNDAMENTALS OF VACUUM TUBES**, 2nd edition

Terman's **RADIO ENGINEERING**, 2nd edition

Everitt's **COMMUNICATION ENGINEERING**, 2nd edition

Hund's **HIGH FREQUENCY MEASUREMENTS**

Henney's **RADIO ENGINEERING HANDBOOK**, 3rd edition

**SPECIAL LOW PRICE • EASY TERMS**

Special price, under this offer less than cost of books bought separately. In addition, you have the privilege of paying in easy installments beginning with \$3.00 in 10 days after receipt of books, and \$3.00 monthly thereafter. Already these books are recognized as standard works that you are bound to require sooner or later. Take advantage of these convenient terms to add them to your library now.

**FOR 10 DAYS' EXAMINATION SEND THIS**

**ON-APPROVAL COUPON**

McGraw-Hill Book Co., 330 W. 42nd St., N.Y.C. 18

Send me Radio Engineering Library for 10 days' examination on approval. In 10 days I will send \$3.00 plus few cents postage, and \$3.00 monthly (till \$24 is paid, or return books postpaid. (We pay postage on orders accompanied by remittance of first installment.)

Name .....

Address .....

City and State.....

Position .....

Company .....L-11-44



# CONTACTS

FOR THE FIELD OF ELECTRONICS

## CUP WASHERS



for Binding Screws



**WHITEHEAD**  
STAMPING CO.

1691 W. Lafayette St., Detroit 16, Michigan

## Strip Insulated Wires

QUICKER... BETTER

with "Speedex"  
AUTOMATIC WIRE STRIPPER  
... Speeds Production

Strips insulation from all types of wire — instantly, easily, perfectly. Just press the handles and the job is done. Cuts wire too. Strips 800 to 1000 wires per hour. Available for all size solid or stranded wires — No 8 to No. 30. List Price \$6.00.

Write Dept. E For Full Particulars



**GENERAL CEMENT MFG. CO.**  
Rockford, Illinois, U.S.A.

## Electron Tube Machinery

of every type.—standard, and special design

Specialists in Equipment for the manufacture of Radio Tubes, Cathode Ray Tubes, Fluorescent Lamps, Incandescent Lamps, Neon Tubes, Photo Cells, X-ray Tubes and other glass or electronic products, on production or laboratory basis.

*Kable*  
**ENGINEERING COMPANY**

1307-1309 Seventh St., North Bergen, N. J.

Continuously  
Since 1930

PRECISION GROUND

*Crystals*  
BY  
**HIPOWER**

AIRCRAFT  
MARINE • BROADCAST  
POLICE • COMMERCIAL • AMATEUR

**HIPOWER CRYSTAL COMPANY**  
Sales Division — 205 W. Wacker Drive, Chicago 6  
Factory — 2033 Charleston St., Chicago 47, Ill.

## ONLY 3 OUNCES

Small 3-Stage  
AMPLIFIER

Only 2½" by 3" by ½"

DOES YOUR PRODUCT  
REQUIRE A MORE  
COMPACT AMPLIFIER?

We are specialists in  
the art of conserving space.  
Your inquiries are invited.

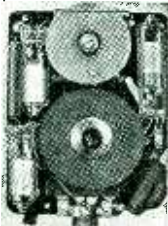

**PARAPHONE HEARING AID INC.**  
2056 East 4th Cleveland 15, Ohio

## We Manufacture a complete line of equipment

SPOT WELDERS, electric from ½ to 50 KVA  
TRANSFORMERS, special and standard types  
INCANDESCENT LAMP manufacturing equipment  
FLUORESCENT TUBE MAKING EQUIPMENT  
ELECTRONIC EQUIPMENT, vacuum pumps, etc.  
WET GLASS slicing and cutting machines for laboratory use  
GENERAL GLASS working machines and burners.  
COLLEGE GLASS working units for students and laboratory

**EISLER ENGINEERING CO.**

731 So. 13th St. (near Avon Ave.)

AC ARC  
WELDERS  
From 100 to  
400 Amper.



Newark, New Jersey

## FINE RIBBONS

OF

## TUNGSTEN and MOLYBDENUM

Making a modest but effective contribution  
in Electronics' War accomplishments.

**H. CROSS**

15 Beekman St.

New York

## MICROMETER

FREQUENCY  
METER

for  
checking  
transmitters  
from 1.5 to 56 mc.,  
within 0.01 per cent

**LAMPKIN LABORATORIES**

Bradenton, Fla., U. S. A.

## Save Fingers with Steel-Grip Finger Guards



Hundreds of factories are saving time and injuries in war production by protecting workers with Steel-Grip Finger Guards. Used for handling rough or sharp articles, for buffing, grinding, sanding, polishing, punch press work and hundreds of other jobs. Protect fingers or thumb, front or back, from cuts, abrasions or blisters. Made of durable leather with elastic web back for snug, cool, comfortable fit. Easy on and off. One size fits all, men or women. Send 10c each for samples or trial order box of 50 at 8½¢ each, less 10%.

Catalog of Steel-Grip Safety  
Apparel free on request

**OLD HICKORY  
STEEL GRIP**

Famous Industrial  
Safeguards Since 1910

**INDUSTRIAL GLOVES COMPANY**

325 Garfield, Danville, Illinois  
(In Canada: Safety Supply Co., Toronto)

**MINIATURE BALL BEARINGS**  
for precision instruments, electronic devices  
RADIAL SERIES (see left) 1/8" to 5/16" outside diameter  
PIVOT SERIES 2 to 10 mm. outside diameter  
For complete specifications, prices—write for catalog 4312C.

**MINIATURE Precision BEARINGS**  
KEENE, NEW HAMPSHIRE, U.S.A.

MORE RF KILOWATT HOURS  
PER DOLLAR WITH

**F & O**

TRANSMITTING TUBES

Inquiries Invited—Let us explain how  
Savings are effected and the F & O  
greater guarantee.

**FREELAND & OLSCHNER PRODUCTS, Inc.**

611 Baronne St., New Orleans 13, La.  
Raymond 4756

High Power Tube Specialists Exclusively  
(¼ To 100 KW)

Available for IMMEDIATE DELIVERY

## TAUREX MINIATURE RECTIFIERS

Moderate quantity of these full wave  
low current meter rectifiers available on  
priorities of AA5 or better.

Consist of 4 sets of copper oxide discs  
arranged in the four arms of a wheat-  
stone bridge. Offer an excellent source  
of D.C. for sensitive realsys and other de-  
vices.

**NATIONAL ELECTRONICS CO.**

Service Dept. 13

11 Park Place

New York 7, N. Y.

*Radio*  
AND  
**ELECTRONIC  
DEVICES**

**BURSTEIN-APPLEBEE CO.**  
1012-1014 McGee St. • Kansas City 6, Missouri



### POSITION VACANT

WANTED RADIO radar television set engineer for specialized export organization. Must be capable of analyzing sets to establish bill of materials, know sources of supply, suggest circuit modifications when necessary, etc. Knowledge of a foreign language especially Spanish extremely helpful. Experience with a set designing laboratory or manufacturer necessary. State fully experience, age, etc. Enclose non-returnable recent photo. P-726. Electronics, 330 W. 42nd St., New York 18.

(Additional Position Vacant ads on pages 360, 371, 375 & 376)

### EMPLOYMENT AGENCY

ELECTRONICS—More positions are coming in daily for well qualified men in Electronics. Our service is Nation wide and covers all branches of Engineering. More than 51 years at the same address. The Engineering Agency, Inc., 53 W. Jackson Blvd., Chicago 4, Illinois.

### EMPLOYMENT SERVICE

SALARIED POSITIONS — This advertising service of 34 years' recognized standing negotiates for high salaried supervisory technical and executive positions. Procedure will be individualized to your personal requirements and will not conflict with Manpower Commission's. Retaining fee protected by refund provision. Identity covered and present position protected. Send for details. R. W. Bixby, Inc., 278 Delward Bldg., Buffalo 2, N. Y.

### POSITIONS WANTED

ELECTRONICS ENGINEER, graduate of accredited school, four years experience in design of government radio including radar. Desires to join small staff in advanced design. Can obtain certificate of availability. Please indicate responsibilities and approximate salary. Not interested in household radio. PW-746, Electronics, 620 N. Michigan Ave., Chicago 11, Ill.

ENGINEER: Age 32, American, 8 years experience in industrial and aircraft electronics, electrical instruments, radio and refrigeration, desires position in design, development on manufacturing. PV-747, Electronics, 330 W. 42nd St., New York 18, N. Y.

### REPRESENTATIVE WANTED

SALES REPRESENTATIVES for established line of resistors, telephone switch keys and telephone jacks. Experienced men in electronics industries, and jobbers preferred. Several excellent territories open. RW-748, Electronics, 330 W. 42nd St., New York 18, N. Y.

## Quick Market for

### Patents

### New Products

### New Ideas

covering Consumer Items, Industrial Products, Mechanical Equipment

THIS COMPANY has been retained to acquire new post-war products for approximately 200 industrial and manufacturing concerns. Negotiations are being conducted on an extremely ethical plane, so that no inventor need hesitate to respond. Compensation is generous and equitable. Absolute confidence maintained and inventor's rights fully protected. Each presentation investigated and answered. Funds to finance development and patents will be advanced where necessary. Please give essentials of product and application when responding. If desired to do so personally, write for appointment.

Ringling Manufacturing Research  
Room 3800—20 N. Wacker Drive, Chicago

# CANADIAN Manufacturing Rights ★ WANTED

Canadian rights wanted for the manufacture of electronic, light mechanical, or electrical products by a well known Canadian Manufacturer equipped for quantity production on a precision basis having an organization familiar with Canadian markets and capable of handling the Distribution, Sales and Service of such products throughout Canada.

All communications will be held in strict confidence. Address replies to

BO-719, Electronics  
330 W. 42nd St., New York 18, N. Y.

### TO INVENTORS TO MANUFACTURERS

Inventors: Have you patents for disposal here or abroad?

Manufacturers: Are you seeking important new products or processes for present or future exploitation?

W. B. KAHN CO., 551 Fifth Ave., N. Y.  
International Patent Brokers • Est. 1904

### BEST QUALITY, USED

### ELECTRON TUBE MACHINERY

Equipment for the manufacture of all kinds of electron tubes, radio tubes, incandescent lamps, neon tubes, photo electric cells, X-ray tubes, etc.

AMERICAN ELECTRICAL SALES CO., INC.  
65-67 East 8th St. New York, N. Y.

## PROFESSIONAL SERVICES

### WALLACE CLARK & COMPANY

Consulting Management Engineers

25 years Planning in the Fields of Research, Development, Sales, Engineering, Production Finance and Overall Management.

521 Fifth Avenue New York 17, N. Y.

### STANLEY D. EILENBERGER

Consulting Engineer

INDUSTRIAL ELECTRONICS

Design—Development—Models  
Complete Laboratory and Shop Facilities  
6300-13—27th Ave.

Kenosha, Wis. Telephone 2-4913

### J. L. A. McLAUGHLIN

Designer of

Communications Receivers

P. O. Box 529, LaJolla, Calif.

### WANTED!

1000-Cycle Inductance Bridge  
(G-R Type 667-A Preferred)

## STANDARD SIGNAL GENERATOR

(G-R Type 605-A Preferred)

Priority Available

Please write or phone Dept. HJB stating description, condition, price and terms—if you have either.

THE F. W. SICKLES COMPANY

Phone: 3-6621 Mail: Box 920  
SPRINGFIELD, MASSACHUSETTS

# SURPLUS

WANTED

Meters-Transformers-Rheostats  
Control Devices  
Electronic Components

## ELECTRO-TECH EQUIPMENT CO.

331 Canal St. New York, 13, N. Y.

### SPECIAL SALE

2000 Lbs.	.014 x 1 1/2
1000 Lbs.	.014 x 1 1/2
4000 Lbs.	.014 x 1 1/2
25,000 Lbs.	.014 x 2 1/2
5000 Lbs.	.014 x 3 1/2

### ELECTRIC SILICON STEEL

GRADE A — 4% SILICON BALANCE  
COLD ROLLED BASE—9 FT. LENGTHS

## OST HARDWARE CO.

CANAL 6-4192

133 Mercer St. New York, N. Y.

Meters — Panel instruments 3 1/2" size, microammeters, voltmeters, ammeters, R.F. meters, milliammeters. Large variety. Multi-range small portables. Prompt deliveries. Advise what you want for quotation. Hallicrafters SX-28, 25.

### HATRY AND YOUNG

203 Ann Street, Hartford 3, Connecticut

### E. MITTLEMAN

Consultant Engineer

ELECTRONIC EQUIPMENT

BUILT TO ORDER

Rm. 503 168 Washington St., N.Y.C., N.Y.

Beekman 3-0462

### M. F. M. OSBORNE ASSOCIATES

Consulting Physicists

Mathematical Analysis of Physical Problems. Higher Mathematics, Approximations. Electronic Design. Fluid Dynamics. Mechanics, Electromagnetic and Acoustic Wave Propagation. Literature Surveys, Reports.

703 Albee Bldg. Washington 5, D. C.  
Telephone District 2415

### JOSEPH RAZEK, Ph.D.

Consulting Physicist

Electrical and Mechanical Engineering Problems  
Instruments and control Devices Electronics  
Specialists in Colorimetry, Spectrophotometry and

Industrial Color Control  
Laboratory and Shop Facilities  
202 Darby Road Philadelphia, Pa.  
Phone Hilltop 6910





## WANTED

### Radio or Electronic ENGINEER

For design and development of Army-Navy Electronic Equipment. The position offers an excellent opportunity with a well-established and expanding company in Connecticut, employing over 100 personnel. The company's big postwar program in the industrial electronics, audio and aircraft communication fields assures a continued opportunity to engineering personnel for advancement.

P-743, Electronics  
330 West 42nd St., New York 18, N. Y.

## ENGINEERS WANTED

### Acoustic Experimental Engineer

Wanted, for our Engineering Laboratory, a graduate engineer with experience in theoretical and experimental acoustic design work in the field of home radio speakers.

### Electromechanical Design Engineer

Wanted, also, a graduate engineer experienced in design of phonograph pickups and similar electro-magnetic devices.

Salaries open.

Call or write, giving full details of education, experience and salary desired, and include a statement of availability.



## COLONIAL Radio Corporation

254 RANO STREET  
BUFFALO 7, N. Y.



## ELECTRONIC ENGINEERS TECHNICIANS DESIGNERS DRAFTSMEN TUBE TECHNICIANS

**EXCELLENT OPPORTUNITIES IN A MAJOR POST-WAR FIELD!**  
Openings available at our Research Laboratories and Electronics Manufacturing Unit. Leaders in the design and development of vital electronic equipment for the Armed Forces. Essential workers need release. Write, stating Experience, Education, Draft Status, Salary. Include snapshot if available. Or apply to

### SPERRY

GYROSCOPE COMPANY, INC.  
RESEARCH LABORATORIES  
STEWART AVE. & CLINTON RD.  
GARDEN CITY, NEW YORK

## WANTED

### DESIGNER

A Central New England manufacturer employing over 1000 people needs Draftsman-Designer on telephone and signaling (mechanical) apparatus. Knowledge of die-casting and plastic applications desirable.

WMC Regulations Prevail

P-724, Electronics  
330 West 42nd Street, New York 18, N. Y.

## SENIOR RADIO ENGINEERS

Project development engineering positions open with excellent postwar future assured. Salaries open. Confidential inquiries respected. International Detrola Corporation.

P-734, Electronics  
620 N. Michigan Ave., Chicago 11, Ill.

## WANTED

### DRAFTSMAN

Well-established electronic tube manufacturer located in middle west has opening for experienced draftsman familiar with electronic tube design and electrical circuits. Excellent working conditions and good future. Please reply giving details concerning yourself. Must comply with WMC regulations.

P-744, Electronics  
520 North Michigan Ave., Chicago 11, Ill.

## WANTED

### Three Research Engineers and Three Product Design Engineers

experienced in mechanical, electrical or acoustical field. Openings offer good postwar opportunity with aggressive company in a midwestern city of 35,000, in continuous operation for 70 years, leader in its field, highest possible financial rating of AA-A1. State age, experience, education. Address

P-738, Electronics  
520 North Michigan Ave., Chicago 11, Ill.

## ELECTRICAL ENGINEERS WANTED

For research and development in the field of radio communication and electrical test equipment. Good postwar opportunity.

Also Openings Available For  
DRAFTSMEN and JUNIOR DESIGNERS  
ALLEN D. CARDWELL MFG. CORP.  
81 Prospect St. Brooklyn, N. Y.

## RESEARCH ENGINEERS

For development work on electro mechanical servo mechanisms and communication equipment. Prefer A1 men who can take charge of complete project. Salary, commensurate with ability. Permanent position with excellent post war opportunity.

Box 992, 1474 Broadway, N. Y.

## RADIO TELEVISION ENGINEERS

Developmental Engineers thoroughly experienced in design of radio or television equipment required immediately. Post war permanence assured right men.

Write full details including education, experience and status of availability.

P-785, Electronics  
880 West 42nd St., New York 18, N. Y.

## WANTED

### A CONSULTING ENGINEER OR LABORATORY

with adequate facilities to take on the design of R.F. precision measuring instruments on a contract basis.

P-741, Electronics  
330 West 42nd St., New York 18, N. Y.

## SELLERS BUYERS TRADERS

More **IRON & STEEL** 39  
for your **PRODUCTS, Inc.** *Experience!* *Dollar!*  
13422-A S. Brainard Ave., Chicago 33, Illinois  
**"ANYTHING Containing IRON or STEEL"**

(Additional Employment Advertising on pages 360, 367, 371, 374 & 376)



## RADIO ENGINEERS

Medium-sized, progressive, Midwest manufacturer has openings for one senior and two junior engineers. Desire men for work on military projects now who will be adaptable later to postwar engineering. Prefer men with experience in radio receiver or television laboratory, and with college education in communication engineering. Our staff knows of this advertisement.

**P-739, Electronics**

520 No. Michigan Ave., Chicago 11, Ill.

## Senior Electronic Engineers

Preferably graduates of communication engineering courses are required for designing receiving-type electronic equipment covering all frequency ranges, and other specialized electronic apparatus. Design experience necessary, and knowledge of production is desirable. Excellent post-war opportunities. Salary open. Requirements urgent. Proof of citizenship and certificate of availability are necessary. Write giving detailed qualifications, and if satisfactory, interview will be arranged at our expense.

### Submarine Signal Co.

Dept. 420

175 State St. Boston, Mass.

**WANTED**

## CHIEF LOUD SPEAKER ENGINEER

The Rola Company, Inc. requires the services of an engineer who has had several years experience and is capable of heading this division.

*Present work is on 100% urgent war products.*

Excellent post-war opportunity with an outstanding, financially sound, long-established manufacturer of radio loudspeakers and transformers.

This Company now has definite plans for an extensive expansion in its Engineering and Manufacturing Divisions.

*Salary open. — Write to*

**THE ROLA COMPANY, INC.**  
2530 Superior Avenue Cleveland, 14, Ohio

**WANTED**

## EXPERIENCED ELECTRICAL ENGINEERS

Graduate or non-graduate Electrical Engineers with at least three years of recent radio circuit or laboratory experience are needed for the development and design of pocket size radio and audio frequency equipment. The company is well established in the electronics field and offers the right man a salary dependent on his experience and also the opportunity to grow in a relatively new field. The company is located in the suburbs of a large New England City.

**P-712, Electronics**

330 West 42nd St., New York 18, N. Y.

**CHIEF ENGINEER or**

## ELECTRICAL ENGINEER or CHEMIST OR ELECTRO-CHEMIST

Experienced in the manufacture of capacitors and well versed in the theory of dielectrics. This is an unusual opportunity for an engineer capable of directing the research and development activities of a middle size midwestern concern. Reply stating full particulars regarding age, education, experience.

**P-737, Electronics**

620 North Michigan Ave., Chicago 11, Ill.

## ENGINEERS DRAFTSMEN

**Work in New York City**

Large mfr. of Aeronautical Instruments & accessories desires electrical & mechanical engineers as well as design, layout & detail draftsmen for N Y City engineering dept. Excellent post war opportunities.

**P-739, Electronics**

330 W. 42nd St., New York 18, N. Y.

**WANTED**

## ELECTRONIC ENGINEER High Frequency Heating Experience

● Good postwar opportunity for well qualified electronic engineer with broad experience in designing high frequency dielectric and induction heating equipment.

● Executive ability and good personality required in this responsible position handling a group of engineers.

● Familiarity with equipment requirements of plastics and rubber industries desirable.

● State age, education, experience, draft status in letter to

**P-740, Electronics**

330 W. 42nd St., New York 18, N. Y.

Statement of availability required.

## MACHINE DESIGNERS

An exceptional opportunity is available for three qualified men, on post-war production of small electro-mechanical devices.

Apply by letter, giving a brief resume of qualifications and experience, to

**P-736, Electronics**

330 W. 42nd St., New York 18, N. Y.

**WANTED**

## DEVELOPMENT ENGINEERS

Mechanical and electrical. Graduate or equivalent training. Required for development work in the following branches:

1. Electro-mechanical devices, communication systems. Must be interested in development and familiar with magnetic circuits.
2. Measuring and control instruments. Background should be in electrical engineering, including electronics.

Statement of Availability Required.

**P-725, Electronics**

330 West 42nd St., New York 18, N. Y.

**WANTED**

## DESIGNERS AND DRAFTSMEN

Backlog of military electronic and electrical postwar projects. Large engineering firm. Location Manhattan. Write detailing experience, salary and availability or call:

**YORK RESEARCH CORP.**

Dept. E, 63 Park Row, NYC

Rector 2-8336



# INDEX TO ADVERTISERS

	page		page
Acro Electric Company.....	339	Connector Div. of International Re-	
Aerovox Corporation.....	34	sistance Co.....	28
Aircraft & Diesel Equipment Corp..	339	Continental-Diamond Fibre Co. 247,	308
Albion Coil Co.....	206	Cook Electric Co.....	348
Allen-Bradley Co.....	320	Cornell-Dubilier Electric Corp.....	67
Allied Control Co., Inc.....	207	Corning Glass Works, Bulb & Tub-	
Allied Radio Corp.....	260	ing Div.....	227
Altec Lansing Corp.....	217	Cornish Wire Company, Inc.....	290
Aluminum Company of America.....	203	Coto-Coil Co., Inc.....	268
American Condenser Co.....	363	Cross, H.....	373
American Phenolic Corp.....	305	Crystal Products Co.....	197
American Photocopy Equipment Co. 342		Dalis, Inc., H. L.....	338
American Platinum Works.....	359	Daven Company.....	Inside Back Cover
American Screw Co.....	39	DeForest's Training, Inc.....	357
American Transformer Co.....	267	DeJur Amasco Corporation.....	56
Amperex Electronic Corporation.....	7	Deutschmann Corp., Tobe.....	2
Amperite Co.....	212	Dial Light Co. of America, Inc.....	310
Anaconda Wire & Cable Co.....	165	Diamond Instrument Co.....	64
Andrew Co.....	294	Dinton Coil Co.....	312
Ansonia Electrical Company.....	350	Dobeckmun Company.....	201
Arnold Engineering Co.....	357	Dolph Co., John C.....	340
Arpin Mfg. Co.....	196	Dongan Electric Mfg. Co.....	369
Associated Research, Inc.....	364	Doolittle Radio, Inc.....	48
Astatic Corporation.....	164	Dow Corning Corporation.....	52
Audak Co.....	377	Drake Manufacturing Co.....	298
Audio Devices, Inc.....	88	Driver-Harris Co.....	15
Auto Engraver Co.....	292	Dunont Electric Co.....	22
Automatic Electric Sales Corp.....	162	DuMont Laboratories, Inc., Allen B. 78	
Automatic Winding Co., Inc.....	262	Durez Plastics & Chemicals, Inc....	293
Baer Co., N. S.....	290	Eastern Air Devices, Inc.....	311
Bakelite Corporation.....	27, 177	Eby, Inc., Hugh H.....	178
Ballantine Laboratories, Inc.....	232	Eicor, Inc.....	252
Barber Laboratories, Alfred W.....	371	Eisler Engineering Co.....	362, 373
Barker & Williamson.....	315	Eitel-McCullough, Inc.....	89
Bassett, Inc., Rex.....	370	Elco Resistors Co.....	174
Bead Chain Manufacturing Company	222	Electric Auto-Lite Co.....	26
Bell Sound Systems, Inc.....	319	Electrical Insulation Co., Inc.....	354
Bentley, Harris Mfg. Co.....	221	Electronic Corp. of America.....	279
Bircher Corporation, The.....	300	Electronic Enterprises, Inc.....	86
Blaw-Knox Company.....	168	Electronic Laboratories, Inc.....	58
Biley Electric Company.....	70	Electronic Mfg. Co.....	365
Boonton Radio Corp.....	284	Electronic Mechanics, Inc.....	46
Boots Aircraft Nut Corp.....	296	Electro-Voice Mfg. Co., Inc.....	36
Brach Mfg. Corp., L. S.....	298	Elementary Equipment Corp.....	360
Bradley Laboratories, Inc.....	288	Erco Radio Laboratories, Inc.....	180
Brand & Co., William.....	79	Eric Resistor Corp.....	225
Breeze Corporations, Inc.....	199	Essex Electronics.....	326
Bud Radio, Inc.....	236	Fairchild Camera & Instrument Corp. 331	
Burgess Battery Co.....	240	Federal Electric Co., Inc.....	316
Burstein-Applebee Co.....	373	Federal Tel. & Radio Corp. 71, 183, 371	
Callite Tungsten Corp.....	75	Ferranti Electric, Inc.....	301
Cambridge Thermionic Corporation	15	Ferrocarril Corp. of America.....	296
Cannon Electric Development Co....	224	Finch Telecommunications, Inc.....	357
Capacitron Company.....	316	Follansbee Steel Corporation.....	163
Capitol Radio Engineering Institute. 368		Foot Mineral Company.....	233
Carborundum Company.....	363	Foot, Pierson & Co., Inc.....	211
Carter Motor Co.....	357	Ford Radio & Mica Corp.....	302
Catalin Corporation.....	44	Formica Insulation Company.....	62
Celanese Celluloid Corp.....	157	Franklin Mfg. Corp., A. W.....	181
Centralab, Div. of Glove-Union,		Freeland & Olschner Products, Inc... 373	
Inc.....	32, 235	Gardiner Metal Co.....	356
Chace Co., W. M.....	204	Gates Radio & Supply Co.....	281
Cherry Rivet Co.....	317	General Cement Mfg. Co.....	314, 373
Chicago Telephone Supply Co.....	19	General Ceramics & Steatite Corp... 291	
Chicago Transformer Corp.....	156	General Control Company.....	341
Cinch Mfg. Corp.....	143	General Electric Co....11, 12, 13, 14, 259,	
Clarostat Mfg. Co., Inc.....	160	265, 285, 326, 368, 372	
Cleveland Tungsten, Inc.....	369	General Industries Company.....	309
Cohn & Co., Sigmund.....	286	General Instrument Corp.....	87
Cole Steel Equipment Co.....	321	General Plate Div. of Metals & Con-	
Collins Radio Co.....	170	trols Corp.....	271
Columbia Wire & Supply Co.....	361	General Radio Company.....	277
Communication Measurements Lab-		General Tire & Rubber Co.....	231
oratory.....	318	George Co., P. D.....	342
Communication Products Co., Inc... 297		Gibson Electric Co.....	364
Communications Company, Inc.....	282	Glenn-Roberts Co.....	340
Conant Electrical Laboratories.....	248	G-M Laboratories, Inc.....	372
Concord Radio Corporation.....	184	Goodrich Co., B. F., Chemical Div... 380	
Connecticut Telephone & Electric		Gothard Manufacturing Company... 314	
Division of G.A.I.....	245	Gould-Moody Co.....	354

# AUDAX

## RELAYED-FLUX

### Microdyne

Long before this war began AUDAX Pickups and Cutters were in

## SELECTIVE SERVICE

Since pickups first became important commercially, the distinguished products of AUDAX have been SELECTED wherever and whenever the requirements were exacting.

Today AUDAX magnetically powered pickups are SELECTED for War contracts that demand the highest standards of performance... irrespective of climatic variations or severe handling.

Our stern peacetime standards, maintained for so many years, have proven comfortably adequate to meet government specifications.

The sharp, clean-cut facsimile reproduction of MICRODYNE is a marvel to all who have put it to the only test that really matters... the EAR TEST.

**AUDAK COMPANY**  
500-E Fifth Ave. New York 18, N.Y.

Creators of High Grade Electrical and Acoustical Apparatus Since 1915

Send for your copy of our informative "PICK-UP FACTS"

★ BUY WAR BONDS

"The Standard by Which Others Are Judged and Valued"





# Star Steatite

Should Be In YOUR  
Post War Picture!



Far-sighted manufacturers are learning NOW about reliable sources of supply for STEATITE after the war. If you want to be sure of a product able to meet your most rigid requirements, and a supplier that can be depended on, get in touch with STAR.

The  
**STAR**  
PORCELAIN COMPANY

Electrical Department

TRENTON, NEW JERSEY

	page
Grammes & Sons, Inc., L. F.	322
Graphite Metallizing Corp.	371
Guardian Electric Mfg. Co.	167
Hallicrafters Co.	81
Hammarlund Mfg. Co., Inc.	6, 38
Hardwick, Hindle, Inc.	152
Harvey Radio Company	312
Harvey Radio Laboratories, Inc.	16
Harvey-Wells Electronics, Inc.	335
Harwood Company	313
Hathaway Instruments Co.	244
Haydon Mfg. Co., Inc.	264
Heintz & Kaufman, Ltd.	33
Hewlett-Packard Company	251
Heyman Manufacturing Co.	355
Hipower Crystal Co.	373
Holtzer-Cabot, Div. of First Ind. Corp.	80
Hopp Press, Inc.	360
Howard Manufacturing Corp.	236
Hunter Pressed Steel Co.	65
Hytron Corporation	54
Indiana Steel Products Co.	243
Industrial & Commercial Electronics	328
Industrial Condenser Corp.	276
Industrial Gloves Co.	373
Insl-X Co., Inc.	256
Instrument Resistors Company	286
Insuline Corp. of America	304
International Detrola Corporation	173
International Resistance Co.	147
Irrington Varnish & Insulator Co.	229
Janette Manufacturing Co.	326
Jefferson Electric Co.	315
Jelliff Mfg. Corp., C. O.	217
Jensen Radio Mfg. Co.	53
Johnson Co., E. F.	283
Johnson Rubber Co.	349
Jones Co., Howard B.	288
Kaar Engineering Co.	226
Kahle Engineering Co.	373
Karp Metal Products Co., Inc.	51
Kelnor Mfg. Company	310
Ken-Rad Tube & Lamp Corp.	218
Kester Solder Co.	332
Keuffel & Esser Co.	3
Kinney Manufacturing Co.	200
Kirkland Co., H. R.	302
Knights Co., James	234
Kold-Hold Mfg. Co.	367
Kurman Electric Co.	342
Lampkin Laboratories	373
Langevin Company, Inc.	289
Lapp Insulator Co., Inc.	35
Lavoie Laboratories	255
Lenz Electric Mfg. Co.	214
Lepel High Frequency Laboratories, Inc.	215
Lewyt Corporation	77
Lingo & Son, Inc., John E.	154
Littelfuse, Inc.	322
Lord Manufacturing Co.	50
L-R Manufacturing Co.	327
Maas & Waldstein Company	303
Machlett Laboratories, Inc.	275
Mallory & Co., Inc., P. R.	90, 145, 198
Manufacturers Screw Products	208
McGraw-Hill Book Co.	372
Mec-Rad Div., Black Industries	18
Merit Coil & Transformer Corp.	228
Micro Switch Corp.	76
Millen Mfg. Co., Inc., James	216, 286
Miniature Precision Bearings Corp.	373
Mitchell-Rand Insulation Co., Inc.	85
Muehlhausen Spring Corporation	242
Murdock Co., Wm. J.	270
Mycalex Corporation of America	30
National Electronics Co.	373
National Fabricated Products	74
National Schools	367
National Screw & Mfg. Co.	55
National Union Radio Corp.	47
National Vulcanized Fibre Co.	83
New York Transformer Co.	238
North American Philips Co., Inc.	209, 323

Craftsmanship by

# PAR-METAL



**CABINETS**

**CHASSIS**

**PANELS**

**RACKS**

When skill of a high degree becomes habitual, and shows up in the smallest detail — that's *Craftsmanship!*

Having specialized for many years, Par-Metal has this habit of *Craftsmanship* — expressed throughout the entire line, which ranges from small chassis to housings for huge transmitters.

To get a picture of what Par-Metal can do now (and the post-war possibilities) write for a copy of Catalogue No. 41-A.

**PAR-METAL PRODUCTS CORPORATION**

32-62 34th STREET . . . LONG ISLAND CITY, N. Y.      Export Dept. 129 Vesich St. N. Y. C.



	page		page
Norton Electrical Instrument Co.	370	Standard Transformer Corp.	150
Numberall Stamp & Tool Co.	342	Standard Winding Co.	314
Ohmite Mfg. Company	68, 69	Stanwyck Winding Co.	361
Okonite Company	337	Star Expansion Bolt Co.	366
Onan & Sons, D. W.	294	Star Porcelain Co.	378
O'Neil-Irwin Mfg. Co.	366	Stedman Machine Works, Robert L.	284
Oster Mfg. Co., John	344	Sterling Bolt Company	338
Palnut Company	220	Stevens Walden, Inc.	318
Pan-Electronics Laboratories, Inc.	176	Steward Mfg. Co., D. M.	358
Panoramic Radio Corp.	205	Stewart Mfg. Corp., F. W.	304
Paper Manufacturers Company	356	Sticht Co., Inc., Herman H.	366
Par Metal Products Corporation	378	Stokes Machine Co., F. J.	340
Paraphone Hearing Aid, Inc.	373	Stromberg-Carlson Co.	153
Parker-Kalon Corp.	202	Struthers-Dunn, Inc.	17
Peerless Electrical Products Co.	308	Stupakoff Ceramic & Mfg. Co.	37, 336
Permoflux Corporation	272	Sun Radio & Electronics Co.	306
Peterson Radio Co.	212	Super Electric Products Corp.	41
Phileo Corporation	29	Superior Carbon Products, Inc.	366
Phillips Screw Manufacturers	219	Superior Electric Co.	325
Picker X-Ray Corporation	66	Superior Tube Co.	8, 9
Pierce Paper Products Co.	365	Supreme Instruments Corp.	362
Pioneer Gen-E-Motor Corp.	266	Sylvania Electric Products, Inc.	82
Plastic Wire & Cable Corp.	263	Synthane Corporation	20, 21
Plax Corporation	249	Tech Laboratories	348
Plymold Corporation	329	Technical Radio Company	191
Precision Fabricators, Inc.	324	Telex Products Co.	274
Precision Transformer Co.	363	Templetone Radio Mfg. Corp.	319
Precision Tube Co.	239	Terminal Radio Corp.	367
Premier Metal Etching Co.	370	Thermador Electrical Mfg. Co.	299
Press Wireless, Inc.	10	Thermolex Liquid Plastics Co.	300
Presto Electric Co.	355	Thomas & Skinner Steel Products Co.	368
Presto Recording Corp.	195	Thompson, George S.	300
Printloid, Inc.	310	Tinnerman Products, Inc.	155
Production Engineering Corp.	332	Transmitter Equipment Mfg. Co., Inc.	31
Progressive Mfg. Co.	370	Triplett Electrical Instrument Co.	306
Pyroferrie Co.	362	Tung-Sol Lamp Works, Inc.	269
Quadriga Mfg. Co.	356	Turner Company	358
Quaker City Gear Works, Inc.	352	Tuttle & Co., H. W.	358
Radell Corp.	365	Ucinite Company	250
Radio City Products Co., Inc.	333	Union Carbide & Carbon Corp.	27, 177
Radio Condenser Co.	187	United Electronics Company	193
Radio Corp. of America, Victor Div.	158, 159, 169, 189, 261, Back Cover	United States Rubber Co.	258
Radio Mfg. Engineers, Inc.	368	United Transformer Co. Inside Front Cvr	246
Radio Receptor Co., Inc.	40	Universal Microphone Company	246
Radio Television Institute, Inc.	334	Utah Radio Products Company	73
Rapid Electroplating Process, Inc.	366	Valpey Crystal Corp.	280
Rauland Corporation	185	Wadsworth Watch Case Co., Inc.	287
Raytheon Mfg. Co.	43, 60	Walker-Jimieson, Inc.	355
Reiner Electronics	49	Wallace Mfg. Co., Wm. T.	354
Remler Company, Ltd.	194	Ward Leonard Electric Co.	241
Richardson Company, The	192	Ward Products Corporation	23
Rockbestos Products Corp.	210	Warren Telechron Company	230
Rogan Brothers	312	Waugh Laboratories	63
Rogers Paper Manufacturing Co.	172	Western Brass Mills, Div. of Western Cartridge Co.	61
Rola Company, Inc.	182	Western Electric Co.	257, 360
Roller-Smith Co.	175	Western Lithograph Co.	369
Rothenstein, Albert	371	Westinghouse Elec. & Mfg. Co.	4, 5, 57, 161, 179
Sangamo Electric Co.	171	Weston Electrical Instrument Corp.	186
Scientific Elec. Div. of "S" Corrugated Quenched Gap Co.	59	Whitaker Cable Corp.	223
Scovill Mfg. Co., Waterville Screw Products Div.	151	White Dental Mfg. Co., S. S.	356
Sensitive Research Instrument Co.	347	Whitehead Stamping Co.	373
Shalleross Mfg. Co.	188	Wilcox Electric Co.	72
Sherman Mfg. Co., H. B.	349	Wilson Co., H. A.	84, 273
Sherron Electronics Co.	24, 25	Wincharger Corp.	292
Shure Brothers	149	Wrigley Jr. Co., Inc., Wm.	361
Sickles Company, F. W.	295	Zierick Mfg. Corp.	379
Sigma Instruments, Inc.	359	Zophar Mills, Inc.	308
Signal Indicator Corp.	364		
Sillocks-Miller Co.	369		
Simpson Electric Co.	343		
Small Electric Motors (Canada) Ltd.	330		
Small Motors, Inc.	352		
Smith Mfg. Co., Inc., F. A.	302		
Sola Electric Co.	42		
Speedway Manufacturing Co.	359		
Speer Carbon Co.	353		
Spencer Thermostat Company	351		
Sperry Gyroscope Co.	213		
Sprague Electric Co.	253		
Stackpole Carbon Co.	237		
Standard Pressed Steel Co.	304		
Standard Products Co.	307		

# SAVE MAN HOURS

## SMALL METAL PARTS

### by ZIERICK



**Clips**  
**Lugs**  
**Terminals**  
**Hardware**  
**Grid Caps**  
**Fuse Clips**  
**Light Sockets**  
**Dies**  
**Wire Forms**  
**Hot Tinning**  
**Automatic Stampings**

•

Our standard parts are usually shipped on day order comes in.

•

Many of these parts are approved by the Army and Navy.

PLEASE TEAR AND MAIL TO  
Zierick Mfg. Corp.  
385 Gerard Ave., New York City 51, N. Y.

---

**ZIERICK MFG. CORP. DEPT. E**  
385 Gerard Avenue  
New York City 51, N. Y.  
Telephone MOtt Haven 9-2727

Please send your descriptive catalog.

NAME.....

COMPANY.....

ADDRESS.....

---

**PROFESSIONAL SERVICES** ..... 374

**SEARCHLIGHT SECTION**  
*(Classified Advertising)*

**EMPLOYMENT**.....360, 367, 371, 374, 375, 376

**USED EQUIPMENT**

American Electric Sales Co., Inc. .... 374  
Electro-Tech Equip. Co. .... 374  
Hafry and Young ..... 374  
Iron & Steel Products Inc. .... 375  
Ost Hardware Co. .... 374  
Sickles Co., F. W. .... 374





**ACID, OIL, GREASE**  
**... Geon Insulation**  
**resists them all**

With **Geon** it's the *combination* of properties that counts

**I**N an Eastern rayon mill, increased production demands returned to service a number of old and outmoded spinning machines. In this old equipment the electric motor leads are constantly exposed to 10% sulphuric acid fumes as well as oil and grease. The photograph gives some idea of the conditions. And just to make it harder, spare leads are stored in an unheated warehouse where winter temperatures go well below zero. Ordinary wire insulation material might do the job. But frequent shutdowns would be necessary to change the leads as they deteriorated. And shutdowns had to be avoided if production were to stay up.

So—GEON was selected because GEON could deliver the needed *combination* of properties: excellent

electrical characteristics, resistance to acid, oil and grease, flexibility over a wide range of temperatures.

These are just a few of GEON'S unusual properties that can be had in a wide variety of combinations to meet specific service conditions. Here are some additional characteristics of GEON, the *new* insulation material: resistance to practically all chemicals; resistance to heat, cold, light, aging, abrasion; lightweight; easy to process on standard equipment; can be brightly colored for quick identification; and many others.

Right now the use of GEON is subject to allocation by the War Production Board. Our development staff and laboratory facilities are available to help you work out any special problems or applications. For more complete information, write Department F-6, Chemical Division, 324 Rose Building, E. Ninth and Prospect, Cleveland 15, Ohio.



**CHEMICAL DIVISION**  
**THE B. F. GOODRICH COMPANY**  
ROSE BUILDING, E. NINTH & PROSPECT, CLEVELAND 15, OHIO



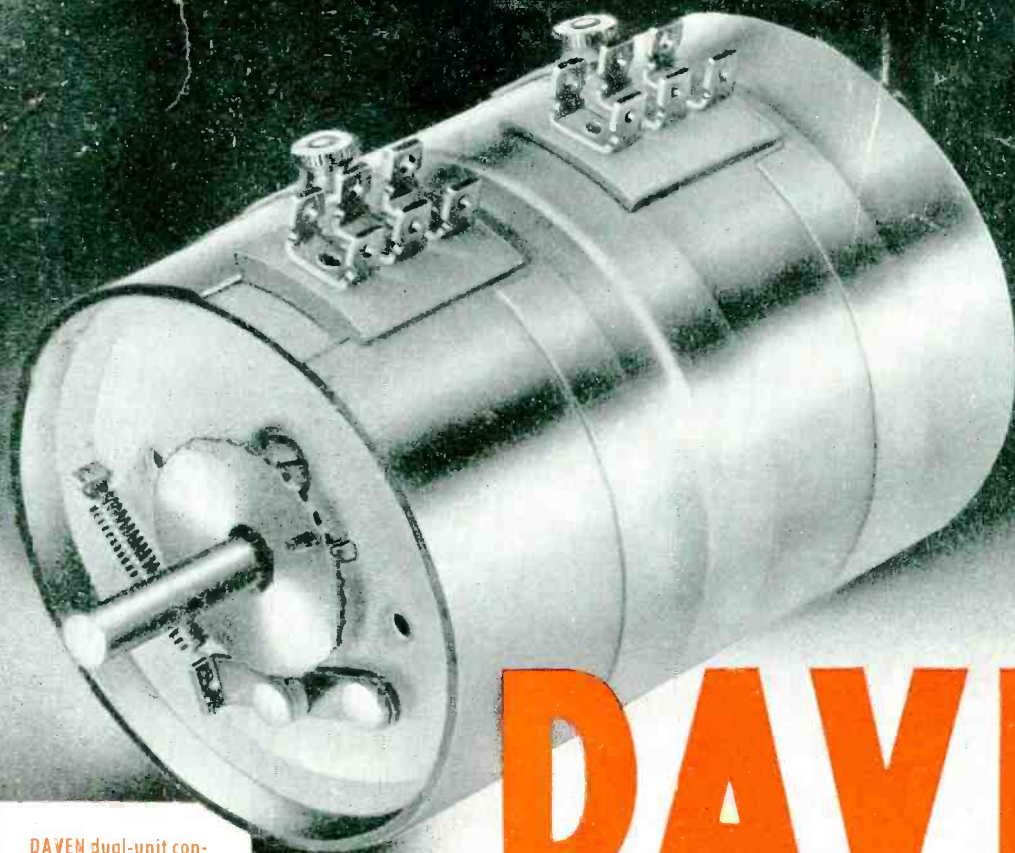

DAVEN dual-unit construction finds most important application in balanced "H" attenuators, as well as in special multiple-circuit controls of the Potentiometer, "T", Ladder, "L" and Rheostat types.

# DAVEN

## ANNOUNCES A NEWLY-IMPROVED MODEL for DUAL-UNIT\* ATTENUATORS

DAVEN engineers have incorporated into the improved dual-unit all the important new features recently announced for DAVEN standard single-unit attenuators. A noteworthy addition in the dual-unit is the improved method of coupling front and rear attenuators. The respective shafts of each meet in a lap joint within a long, snug collar, providing quick and complete access to either unit. By loosening a knurled nut and releasing a snap-on fitting, the front or rear switch may be reached without dismounting the front unit from the instrument panel.

\*Patent Pending

### Features of DAVEN Dual-Unit Attenuators

**SEPARABLE COUPLING**—Front and rear units now easily separated: gives quick access to either unit. Simple, durable, foolproof construction illustrated at left.

**IMPROVED SHIELDING**—Sturdy, snug fitting, 3 piece steel cover affords superb electrical and dust shielding, as well as greater all around ruggedness.

**NEW DETENT DEVICE**—Large gear and roller mounted in recessed front end of front unit, separate from resistive network, gives accurate indexing. (Illustrated.)

**GREATER COMPACTNESS**—Rear-of-panel depth only 3 7/8"; 9/16" less than former models.

**CERTAIN STOP**—Extrusion of detent gear and steel attenuator cover form sturdy stop to rotation, eliminating rotor-hub strain of previous method.

**CAPTIVE TERMINAL BOARD**—Solder-lugs eye-letted to bakelite boards, which are grooved to fit securely into slots in their respective can sectors.

**ANTI-FUNGUS TREATED**—Bakelite parts and resistive windings treated to resist fungus and mildew.

**SILVER ALLOY**—Contacts, switch arms and returns of tarnish-resisting silver alloy lower internal resistance. Other metals optional.

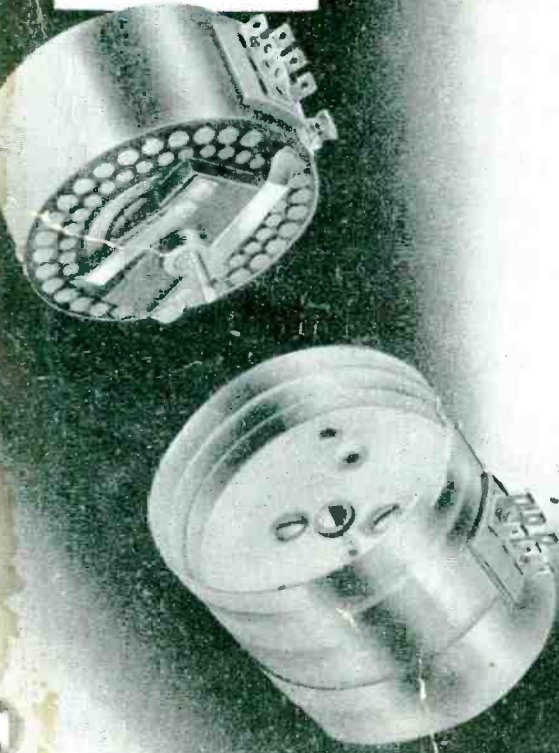

**DON'T LET UP UNTIL OUR BOYS REACH TOKYO**

# THE DAVEN COMPANY

131 CENTRAL AVENUE  
NEWARK 4, NEW JERSEY



# REVOLUTIONARY TUBE DESIGN

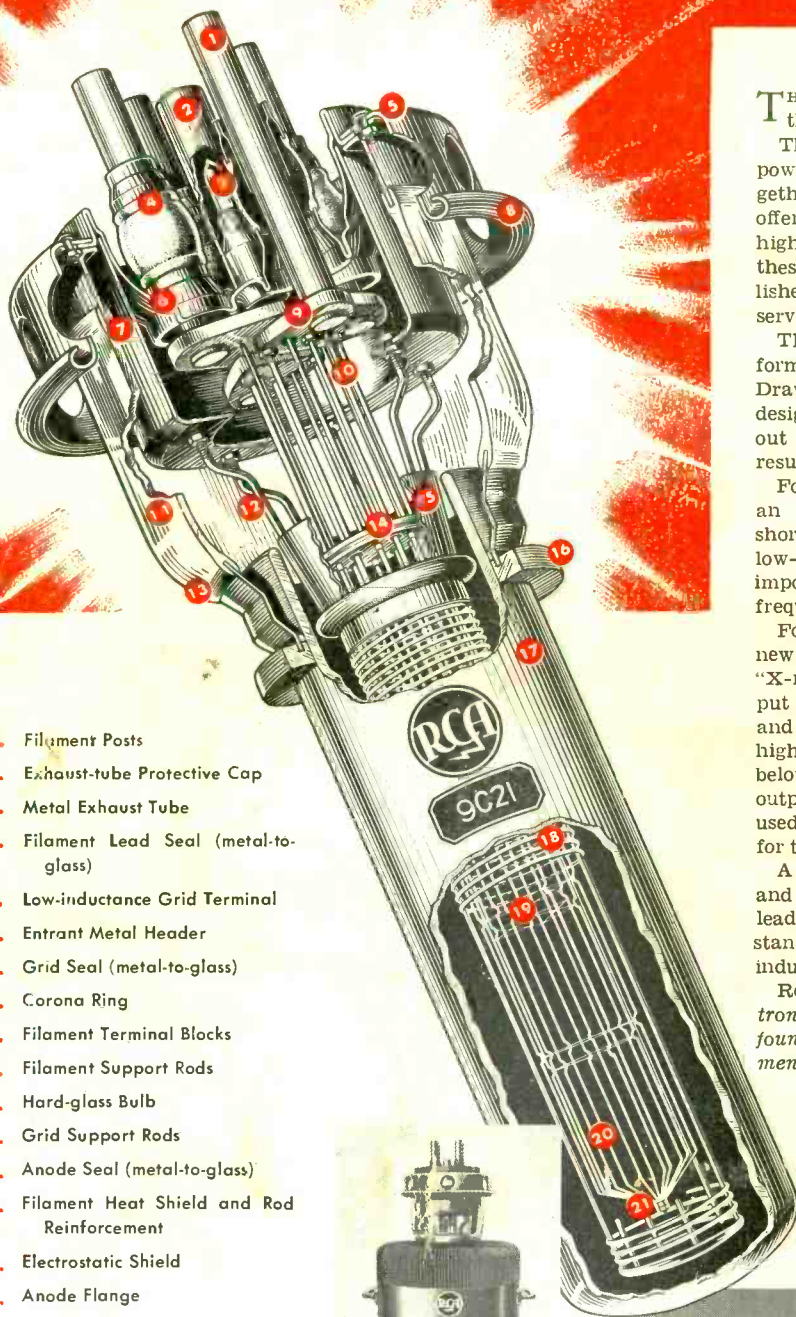

1. Filament Posts
2. Exhaust-tube Protective Cap
3. Metal Exhaust Tube
4. Filament Lead Seal (metal-to-glass)
5. Low-inductance Grid Terminal
6. Entrant Metal Header
7. Grid Seal (metal-to-glass)
8. Corona Ring
9. Filament Terminal Blocks
10. Filament Support Rods
11. Hard-glass Bulb
12. Grid Support Rods
13. Anode Seal (metal-to-glass)
14. Filament Heat Shield and Rod Reinforcement
15. Electrostatic Shield
16. Anode Flange
17. Anode (1/4-inch thick copper)
18. Grid Welded to Supports
19. Tie Wires for Self-Supporting Filament Assembly
20. Filament Strands
21. Common Tie of Self-Supporting Filament Assembly



RCA 9C22, air-cooled twin of 9C21, also offers high performance in industrial and radio broadcast service

**T**HIS is the story of a new tube design that "rewrites the rule book."

The tube is the new RCA 9C21, a high-power, water-cooled triode . . . which, together with its air-cooled twin, the 9C22, offers important advantages in high-power, high-frequency equipment. In designing these tubes, RCA engineers have established new concepts of tube design for such service.

Their goal was higher frequency performance for tubes of high-power design. Drawing upon their years of experience in designing and building tubes, they worked out unique innovations that produced the results they sought.

For example, one of these innovations is an *entrant metal header* which allows short, internal filament leads, and a short, low-inductance path to the grid . . . highly important factors in improving high-frequency performance.

For industrial oscillator service these new design features, shown here in an "X-ray" view, give the 9C21 a 50-kw output at a maximum frequency of 25 mc, and a 100-kw output at 5 mc or below. In high-level modulated service (at 5 mc or below) the 9C22 provides 38-kw maximum output. Thus a pair of 9C22 tubes may be used conservatively as a tube complement for the output stage of a 50-kw transmitter.

A better tube, for better performance . . . and another example of the engineering leadership that makes RCA tubes the standard of comparison in the electronic industry.

Remember, *the Magic Brain of all electronic equipment is a Tube . . . and the fountain-head of modern Tube development is RCA.*



62-6231-23

## RADIO CORPORATION OF AMERICA

RCA VICTOR DIVISION • CAMDEN, N. J.

Listen to "THE MUSIC AMERICA LOVES BEST"  
Sundays, 4:30 p.m., E. W. T., NBC Network





# Money is unimportant here!!



Land of Cockayne (COCKAYNE). This is a modern artist's idea of that delightful paradise which was part of the folklore of Europeans many, many centuries ago.



This is the Land of Cockayne.

It's a wonderful place where the houses are built of cake, and the shops are eager to give you their merchandise for free.

Here, roast geese and other fowl wander about inviting folks to eat them. Here, buttered larks fall from the skies like manna.

Wonderful place Cockayne . . . this Land that's always free from want . . . where business cycles are unknown . . . where money is unnecessary.

Only trouble is you won't find this mythical place on any up-to-date map of the world.

We live in a land blessed with plenty—true enough. But the rub is that we will always need hard cash to buy the things we want.

You will need money to make a good down payment on a new home . . . to send the children to college when the time comes . . . or to keep well-supplied with fine food and little luxuries when it comes time to retire.

One of the best ways you can assure yourself that you *will* have the money you need for the things you want later in life is to *save* away some of the money you now earn in U. S. Savings Bonds.

These Bonds are the safest in the world. And they make money for you. Each \$75 you save today will grow to \$100 in just 10 years.

So start saving now . . . the automatic way, on the Payroll Savings Plan where you work, or buy them regularly through your bank or post office.

**AUTOMATIC SAVING  
IS SURE SAVING—  
U.S. SAVINGS BONDS**

Contributed by this magazine in co-operation with the Magazine Publishers of America as a public service.

