



electronics

radio, communication, industrial applications of electron tubes ... engineering and manufacture

SEPTEMBER • 1941

PRICE 50 CENTS

McGraw-Hill Publishing Co., Inc.

FOR BETTER
DELIVERIES

•
ANOTHER



PLANT

Added facilities in another UTC plant now bring the size of UTC to thirty times that in 1933. This new plant assures a continuance of UTC's fine delivery record.



For Better Products ... **Continuous Research**

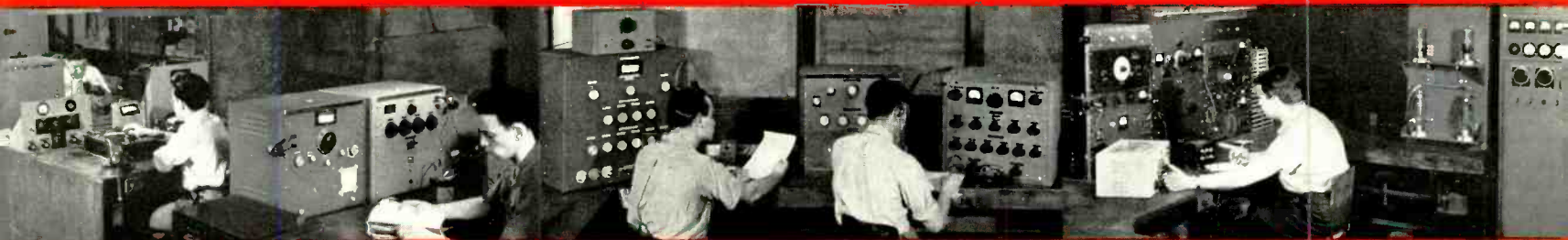

As an organization founded on research and design ingenuity, the UTC research laboratories are unusually fine. A continuous research and development program is maintained to improve the quality and dependability of UTC products. In addition, customers' problems and their solutions are handled by a competent staff of application engineers.



UNITED TRANSFORMER CORP.

150 VARICK STREET



NEW YORK, N. Y.

EXPORT DIVISION: 100 VARICK STREET NEW YORK, N. Y. CABLES: "ARLAB"

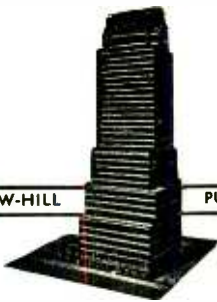

A McGRAW-HILL

PUBLICATION

electronics

CONTENTS—SEPTEMBER, 1941

TELEVISIONING A FASHION SHOW Cover

Reminder of Hollywood production activities is this "behind the scenes" photograph showing the televising of a fashion show at NBC studios

RADIO MEETS PRIORITIES CHALLENGE, by Beverly Dudley 24

ELECTRONICS surveys the radio industry to determine how engineers and manufacturers are meeting the increased demands for materials and technical personnel. A report on probable shortages and bottlenecks, new designs which engineers are producing, and outlook for 1942 is given

INTERCOMMUNICATION USING ELECTRONIC INTERLOCKING, by Harold J. McCreary 30

Electronic instead of mechanical relays are used in intercommunicating system to provide improved two-way service without speech clipping or feedback

GAS CONTROL TUBES, by W. E. Bahls and C. H. Thomas 33

Hot cathode gas tetrodes of high stability and sensitivity, capable of handling powers up to 65 watts, open the possibility of increased flexibility of operation and design in industrial and communication fields

ELECTRONICS IN AUDITORY RESEARCH, by David M. Speaker 38

Electronic equipment is a requisite in the modern study of hearing. Some experimental techniques employed at the Abington Memorial Hospital are given by Mr. Speaker who is responsible for this installation

ANTENNAS FOR F-M RECEPTION, by Julius G. Aceves 42

Important as is the f-m method of reception, best results cannot be obtained with makeshift antennas. Design problems and considerations which enable the most to be extracted from the antenna are discussed

REGULATED SELENIUM RECTIFIERS, by J. E. Yarmack 46

Selenium rectifiers are performing admirably in applications requiring continuous operation with little attention and servicing. Mr. Yarmack illustrates some uses of such rectifiers and gives rectifier design data

PRESELECTION IN INEXPENSIVE RECEIVERS, by E. B. Passow 50

With improved operation at less expense becoming of increasing importance, this description of a \$15 receiver using a tuned r-f stage of amplification should be of interest to set designers and constructors

DESIGN OF HEAT GENERATORS, by Eugene Mittelman 51

Failure of many heat treatment generators for medical or industrial purposes can be traced to incorrectly designed output-coupling unit. This Reference Sheet gives a graphical method of determining the power output

DEPARTMENTS

CROSSTALK	23	THE ELECTRON ART	73
REFERENCE SHEET	51	TUBES	84
TUBES AT WORK	54	INDUSTRY IN REVIEW	98
NEW BOOKS	66	BACK TALK	111

INDEX TO ADVERTISERS 112

KEITH HENNEY
Editor

Donald G. Fink
Managing Editor (on leave)

Beverly Dudley Craig Walsh
Acting Associate Editor
Managing Editor

M. L. Matthey J. M. Heron
Assistant Editor Assistant Editor

Edward Grazda Harry Phillips
Assistant Editor Art Director

H. W. MATEER
Manager

Wallace B. Blood
Sales Manager

Contents Copyright, 1941, by
McGraw-Hill Publishing Company, Inc.

McGRAW-HILL
PUBLISHING COMPANY, INC.

JAMES H. McGRAW
Founder and Honorary Chairman

Publication Office
99-129 North Broadway, Albany, N. Y.
U. S. A.

Editorial and Executive Offices
330 West 42nd St., New York, N. Y., U.S.A.

James H. McGraw, Jr., President
Howard Ehrlich, Executive Vice President
Mason Britton, Vice Chairman

B. R. Putnam, Treasurer
D. C. McGraw, Secretary
J. E. Blackburn, Jr., Director of Circulation

Cable Address:
MCGRAWHILL, New York
Member A. B. P. Member A. B. C.

ELECTRONICS, September, 1941. Vol. 14, No. 9. Published monthly, price 50c a copy. Allow at least ten days for change of address. All communications about subscriptions should be addressed to the Director of Circulation, 330 West 42nd Street, New York, N. Y.

Subscription rates—United States and possessions, Mexico, Central and South American countries, \$5.00 a year, \$8.00 for two years, \$10.00 for three years. Canada (Canadian funds accepted), \$5.50 a year, \$9.00 for two years, \$11.00 for three years. Great Britain and British Possessions 36 shillings for one year, 72 shillings for three years. All other countries \$6.00 for one year, \$12.00 for three years. Entered as Second Class matter, August 29, 1936, at Post Office, Albany, New York, under the Act of March 3, 1879. BRANCH OFFICES: 520 North Michigan Avenue, Chicago; 68 Post Street, San Francisco; Aldwych House, Aldwych, London, W.C. 2; Washington; Philadelphia; Cleveland; Detroit; St. Louis; Boston; Atlanta, Ga.

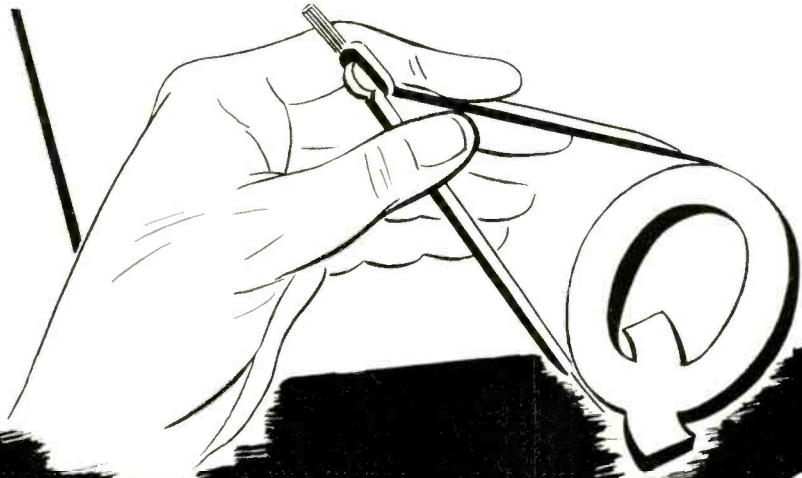

Centralab

... the Standard
by which Quality is Measured

In these hectic times when SPEED takes precedence it is gratifying to know that here at Centralab QUALITY is still the first consideration. We cannot afford to let the reputation of two decades be questioned.

That is why (through calm and perilous times) CENTRALAB Radiohms maintain a constant, undeviating, standard of perfection. ... and that is why manufacturers and engineers have been so partial to CENTRALAB down the long years. And, today the advice is better than ever to "ALWAYS SPECIFY CENTRALAB."

CENTRALAB: Division of Globe-Union Inc.
MILWAUKEE WISCONSIN

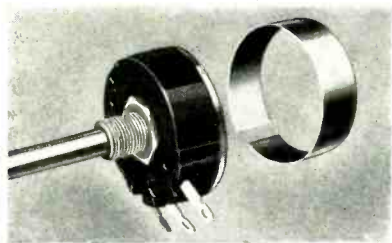

STANDARD: Wall type resistor hugs inner circumference of black moulded bakelite case. Exclusive non-rubbing contact band for quiet, smooth rotation and long life. 1 3/8" diameter x 9/16" deep. Available single, twin, or triple, plain or taped with one or two taps ... with S.P.S.T., D.P.S.T., or S.P.D.T.

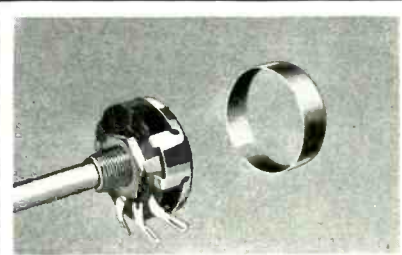

MIDGET: Companion to "Standard" ... small size but large control efficiency. Available single, dual or triple ... plain or one, two or three taps ... with S.P.S.T., S.P.D.T., or D.P.S.T. Moulded bakelite case, 1 1/8" diameter.

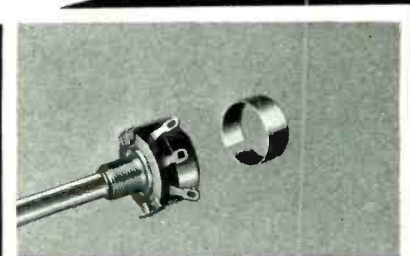

ELF: Small, but also features the long, straight resistor strip. Available plain or tapped with S.P.S.T. Switch ... with or without dummy lug. Switch rated 2 Amps, 125 V. Underwriter's approved. Bakelite case 57/64" diameter, 17/32 deep (less switch) 25/32" deep with switch.

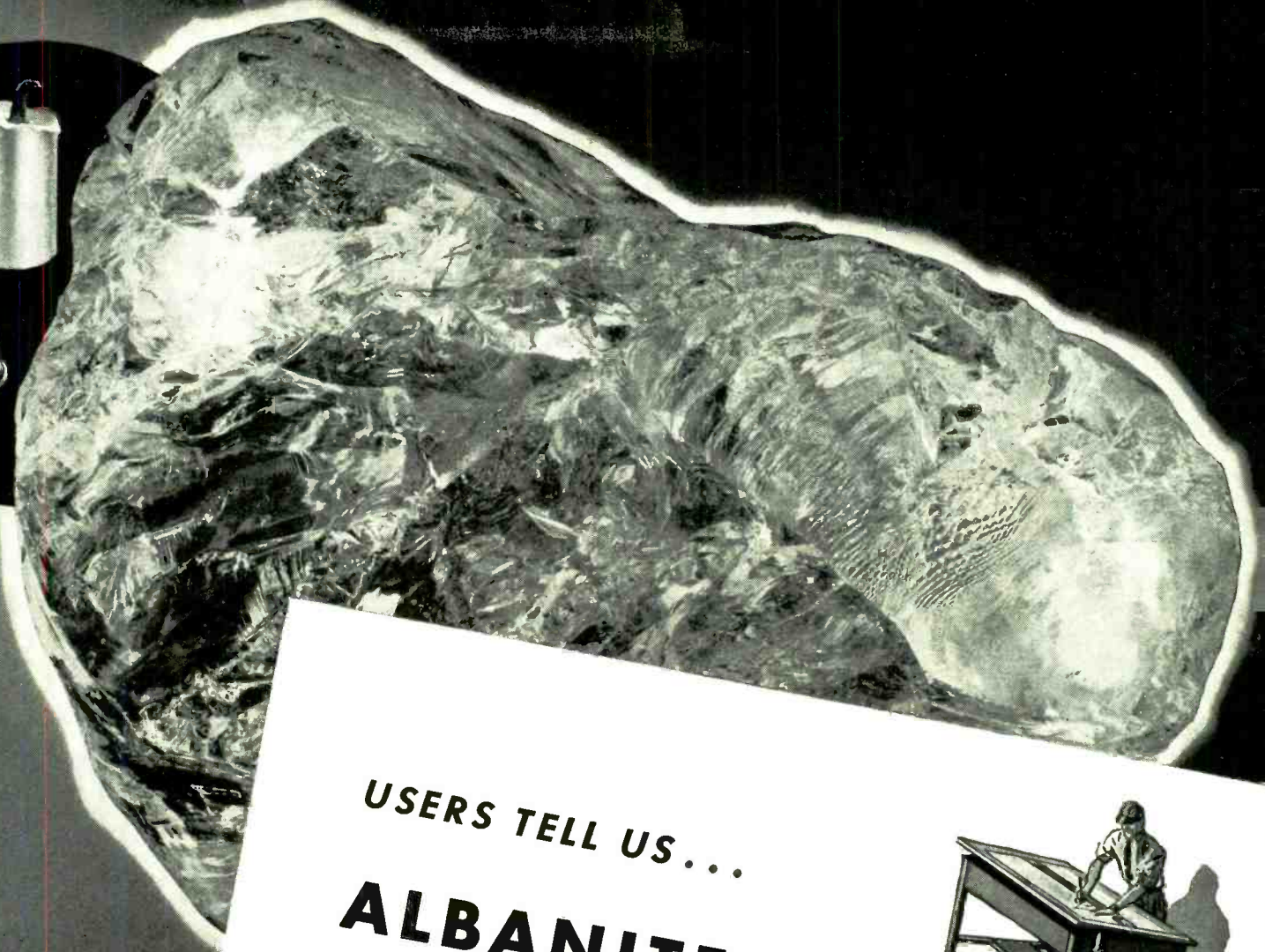

USERS TELL US...

ALBANITE produces a Better Tracing Paper

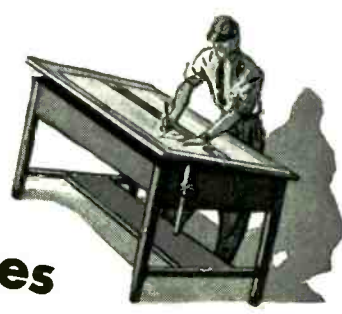

No wonder this remarkable new tracing paper has found its way into the best drafting rooms in America. It gives you every possible drawing advantage, *and a permanence that protects your tracings against the ravages of time!* e

with ease... A high degree of transparency that makes tracing simple, produces strong, sharp blueprints... Extra strength to stand up under constant corrections, filing and rough handling. ALBANENE has *all* the working qualities you have always wanted *and it will retain all these characteristics indefinitely.* Let ALBANENE prove its merits on your own drawing board, under actual drafting conditions. Ask your K & E dealer, or write us for an illustrated brochure and a generous working sample...

For ALBANENE is made of 100% long fiber pure white rags—treated with ALBANITE—a new crystal clear synthetic solid developed in the K & E laboratories. It is free from oil and wax, physically and chemically inert. ALBANENE will not oxidize, become brittle or lose transparency with age. Even more to the point, ALBANENE has an improved drawing surface that takes ink or pencil fluently and erases

EST. 1867
KEUFFEL & ESSER CO.
NEW YORK—HOBOKEN, N. J.
CHICAGO · ST. LOUIS
SAN FRANCISCO · LOS ANGELES · DETROIT · MONTREAL

K&E *Albanene*
REG. U. S. PAT. OFF.
THE STABILIZED TRACING PAPER



MINERAL OIL. Most tracing papers are treated with some kind of oil. Mineral oil is physically unstable, tends to "drift", never dries completely. Papers treated with mineral oil pick up dust, lose transparency with age.



VEGETABLE OIL, chemically unstable, oxidizes easily. Papers treated with vegetable oil become rancid and brittle, turn yellow and opaque with age.



ALBANITE is a crystal-clear synthetic solid, free from oil and wax, physically and chemically inert. Because of this new stabilized transparentizing agent Albanene is unaffected by harsh climates—will not oxidize with age, become brittle or lose transparency.

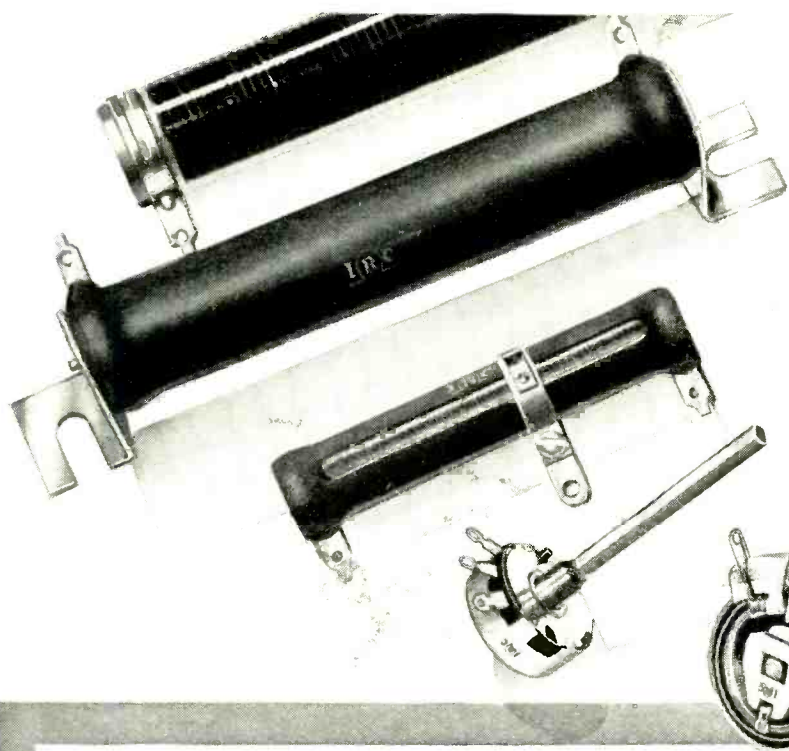

RESISTORS FOR DEFENSE

Resistors to satisfactorily meet the government's exacting and unusual requirements are an old story to IRC.

Many years of close collaboration with government agencies in the preparation of resistance specifications and in the development of special resistor types have been a natural result of IRC's acknowledged leadership in a highly-specialized technical field.

Today, with the tempo greatly accelerated in the face of national emergency, this background of specialized experience is proving of immeasurable benefit to defense manufacturers and their subcontractors.

It means informed engineering cooperation. It means the availability of tested and proven resistors of the many types required for the comprehensive defense program. It means elimination of guesswork and experimentation in obtaining with all possible speed the *right* resistor for any particular application.

Bring your fixed and variable resistance problems to IRC. Our engineers will be glad to cooperate.

INTERNATIONAL RESISTANCE COMPANY

403 North Broad Street, Philadelphia, Penna.

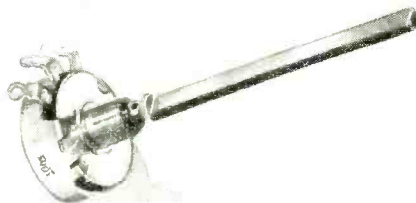
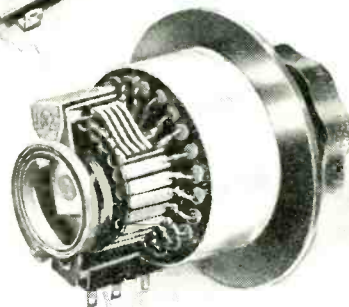
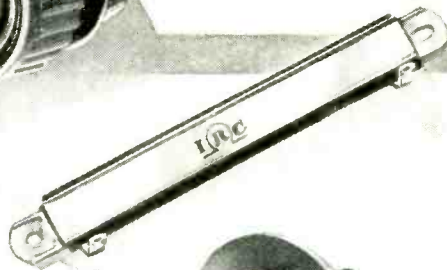

Makers of Resistance Units of More Types, in More Shapes, for More Applications Than Any Other Manufacturer in the World.

FEWER PARTS -- FEWER TUBES

when you choose G.E.'s
SIMPLIFIED CIRCUIT

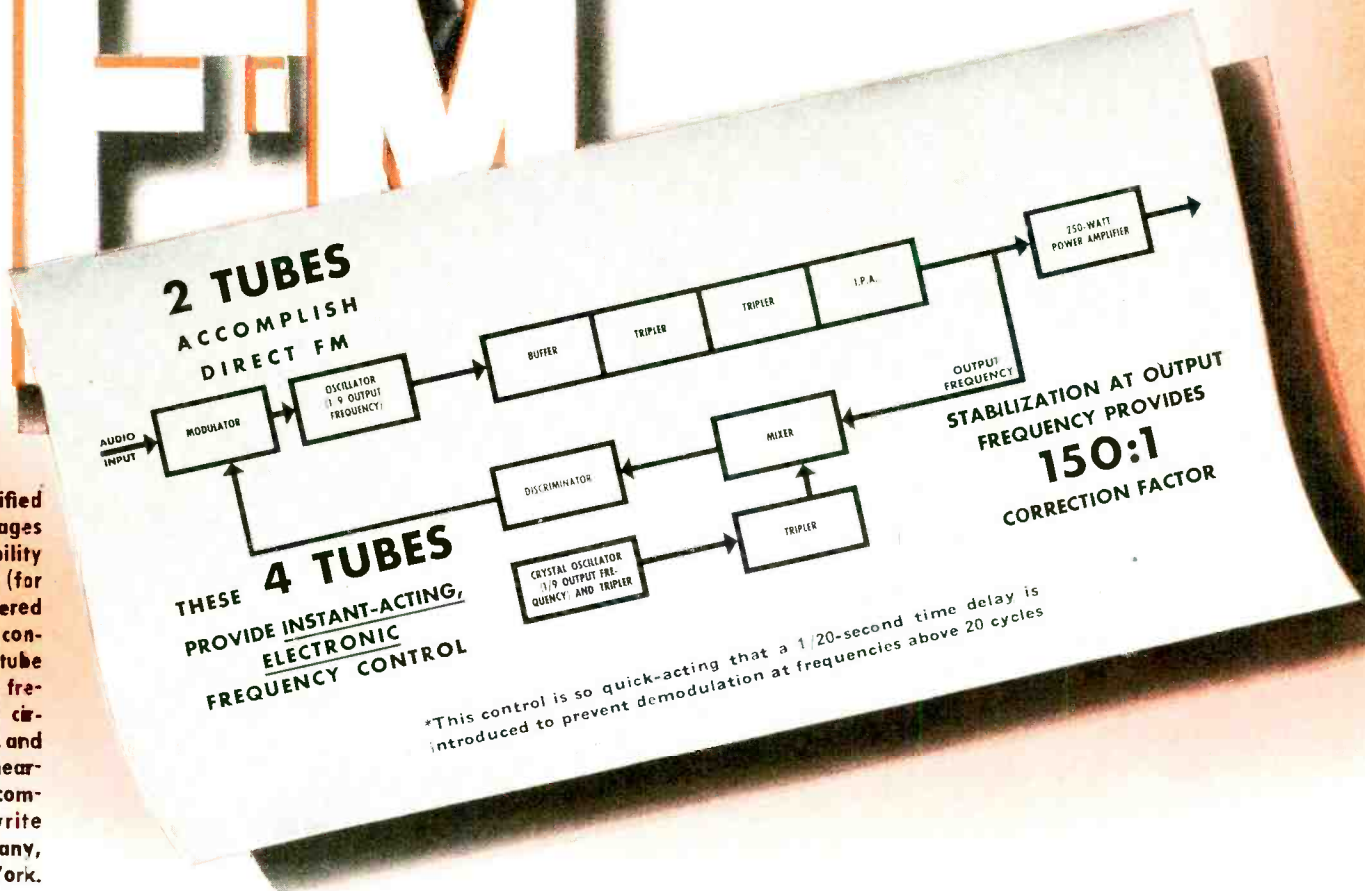

Inherent in this simplified circuit are the advantages of complete accessibility without disassembly (for every tube and soldered joint), low power consumption plus low tube replacement cost. The frequency stabilization circuit is simple, positive, and fast in action. Your nearby G-E man has the complete story. Or write General Electric Company, Schenectady, New York.

Engineers, look at this performance!

GUARANTEED PERFORMANCE CHARACTERISTICS

FREQUENCY STABILITY

± 1000 cycles over a normal room temperature.

FM CARRIER NOISE LEVEL

Down 70 db at 100% modulation.

HARMONIC DISTORTION

At 100% modulation less than 1 1/2% for modulating frequencies between 30 and 7500 cycles.

AUDIO-FREQUENCY RESPONSE

The a-t characteristic from 30 to 16,000 cycles is within ± 1 db, with or without pre-emphasis.

MEASUREMENTS ON TYPICAL PRODUCTION TRANSMITTERS

For weeks Station W2XOY, General Electric's FM proving ground, has operated 10 hours a day within ± 200 cycles. Stability was measured every hour, using G.E.'s primary laboratory standard.

Production transmitters average 72 db down at 100% modulation.

Actual performance based on units built to date indicates, at 100% modulation, less than 1% harmonic distortion for modulating frequencies between 30 and 16,000 cycles; less than 0.75% at 50% modulation; and less than 0.5% at 25% modulation.

Without pre-emphasis, about -0.3 db from 30 to 16,000 cycles; with pre-emphasis, about -0.8 db.

The performance values on the right are not to be construed as G-E guarantees. They represent typical measurements made on stock transmitters and, as such, reflect General Electric's conservative guarantee policy.

GENERAL ELECTRIC

160-15-6914

OHMITE

Doubles Factory Size - Boosts Production of Rheostats, Resistors, Tap Switches

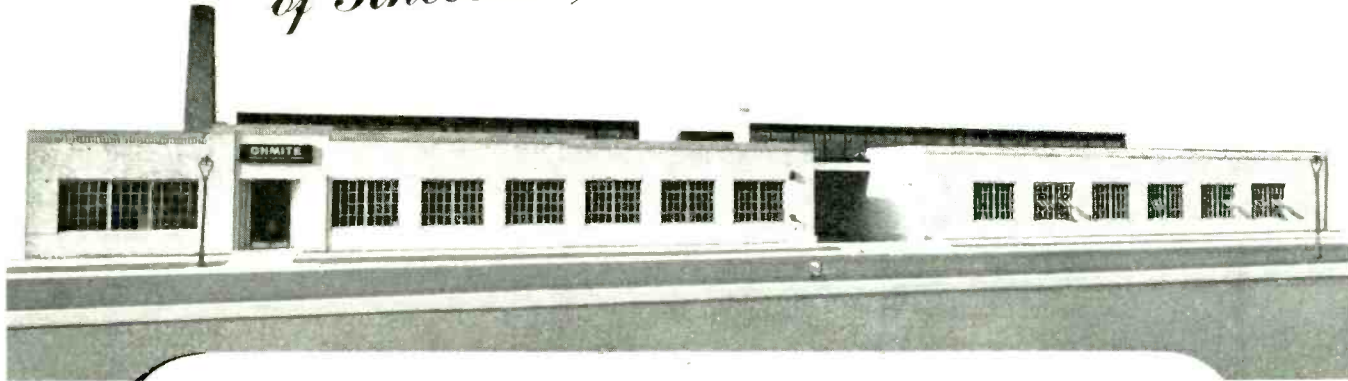

TO MEET the increased requirements of Industry and National Defense, Ohmite has completed a large new factory addition and greatly expanded production facilities. The enlarged plant, devoted exclusively to the manufacture of quality Rheostats, Resistors, Chokes and Tap Switches, is working day and night to provide dependable units for industrial, aviation, radio, electronic and scientific applications. Everything possible is being done, under present emergency conditions, to keep Ohmite service, as always, foremost in the field.

Ohmite Products are veterans of service on land and sea, in the air and on the ground, in industry and in the armed forces of the nation. They are available in the most extensive range of types and sizes to meet each need best. There are over 1000 stock items. Special units are produced to exact specifications or engineered for you.

If you want dependable units to safeguard the life-line of performance in your application, let the specialized, experienced Ohmite Organization help you.



Be Right with
OHMITE
RHEOSTATS • RESISTORS • TAP SWITCHES

Send For Helpful 96-Page
Catalog and Manual

Write on company letterhead for
Ohmite Catalog and Engineering
Manual No. 40. It's full of valuable
information and data.

OHMITE MANUFACTURING CO.
4818 Flournoy St., Chicago, U.S.A.

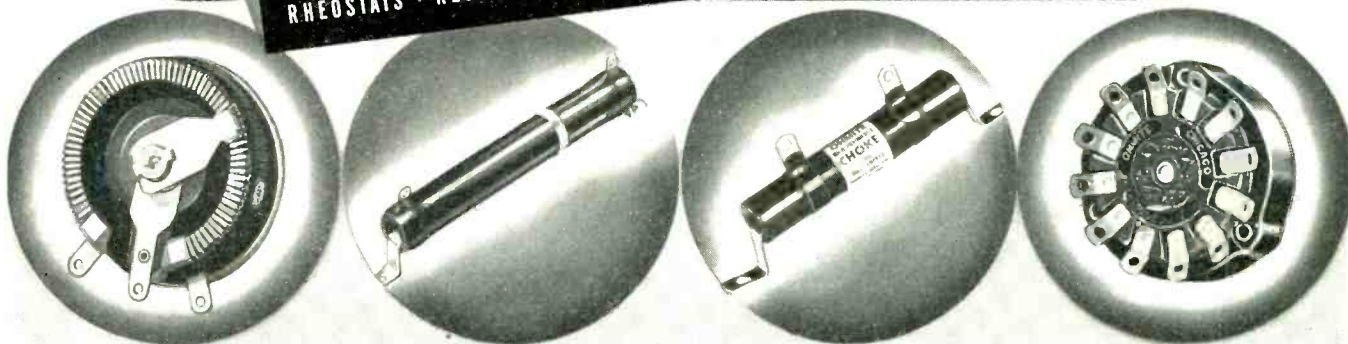

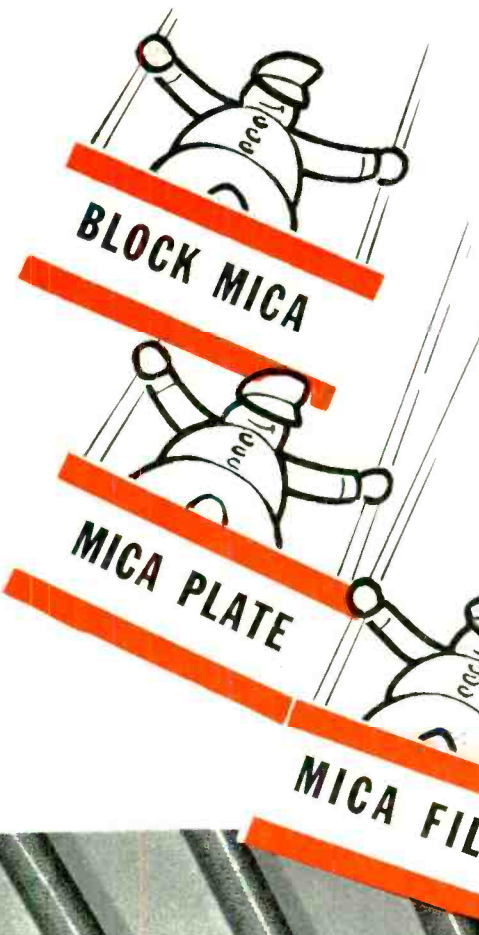

The Swing
IS TO

TURBO

VARNISHED TUBING &
SATURATED SLEEVING

MICA FILMS

MICA PLATE PRODUCTS AND SEGMENTS

VARNISHED CAMBRIC

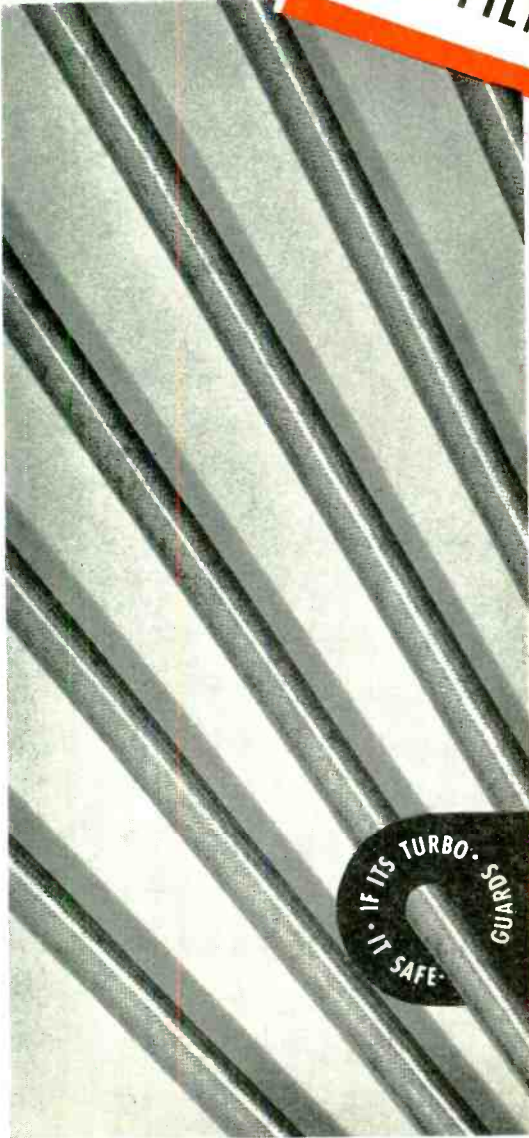

IF ITS TURBO - SAVARDS
IT SAFE

Watch the unmistakable trend of leading designers and manufacturers toward the new TURBO in critical applications. Notice when it is used. . . usually in close proximity to heat, acid, moisture and electro-chemical influences. TURBO'S greater flexibility—a prerequisite to maximum life—promotes safety in bending and resistance to splitting. Its inside impregnation feature facilitates snaking and fishing operations, and provides other assembly line acceleration.

Investigation of its many advantages will prove that the Swing is definitely to TURBO—the dependable, safe insulation for transformers, generators, motors, switchboards, etc.

TURBO a "MUST" for trustworthy insulation.

WILLIAM BRAND & CO.

Block Mica, Mica Plate & Products—Varnished Oil Tubing, Saturated Sleeving, Varnished Cambric, Tapes, Cloths & Composites

276 FOURTH AVE., NEW YORK, N. Y. 217 No. DESPLAINES AVE., CHICAGO, ILL.

Write for new sample card with complete list of standard sizes

*Ready for
immediate delivery*

**1 KW Western Electric
AM Transmitters!**

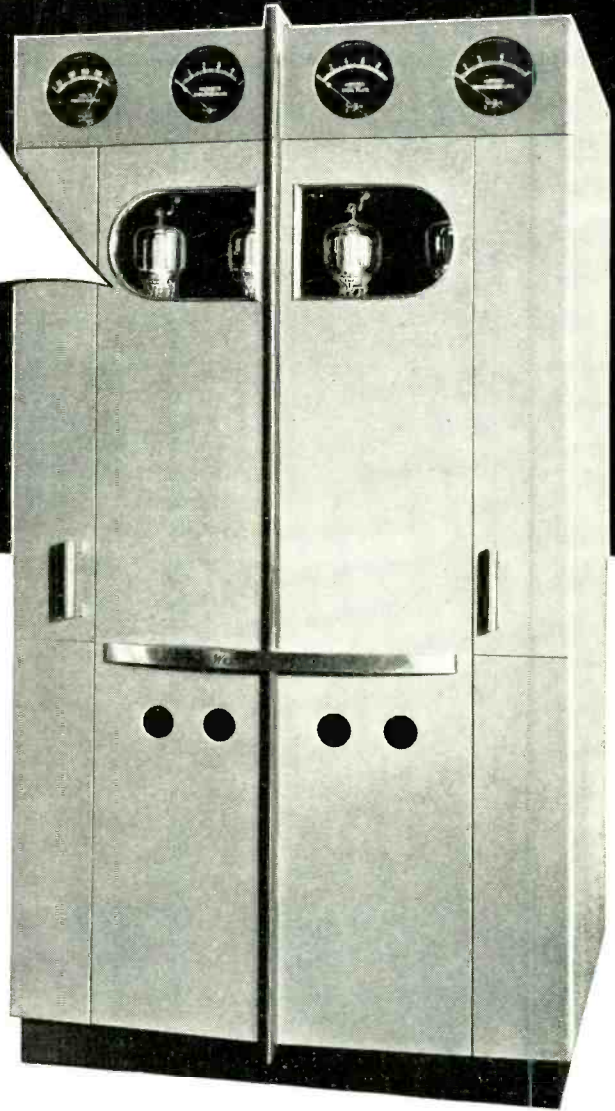

NO NEED to wait for your Western Electric 443A-1—the 1 KW that's been labeled "tops" by stations from coast to coast!

Designed by Bell Telephone Laboratories, it is complete in one unit 44" wide, 39" deep, 78" high—requires about one-half the floor space of former 1 KWs. It employs the famous Doherty Circuit for increased stability and efficiency—plus grid bias modulation. It has overload protection through magnetic circuit breakers and stabilized feedback.

You can get delivery as soon as you want it. Better ask Graybar for details.

Western Electric

Ask your Engineer!



DISTRIBUTORS

In U. S. A.: Graybar Electric Co., New York, N. Y. In Canada and Newfoundland: Northern Electric Co., Ltd. In other countries: International Standard Electric Corp.

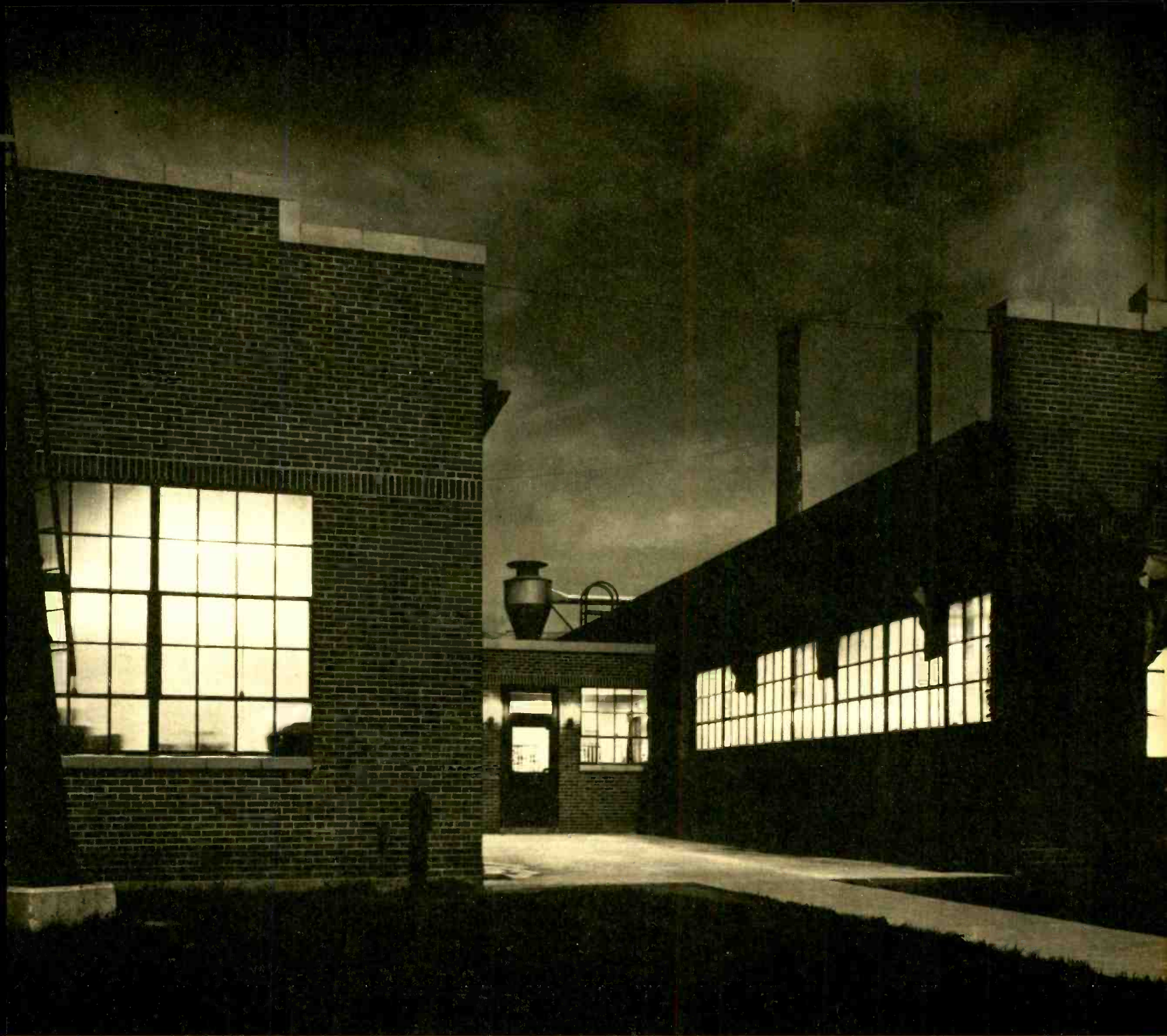

Night Watch

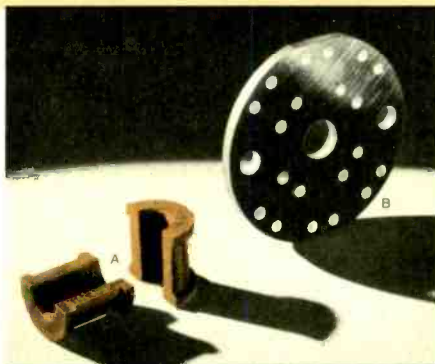

A—Aircraft fairlead—machined on automatic screw machine, and milled.

B—Insulator—sawed, turned, drilled, and milled.

Nothing unusual about this picture of SYNTHANE at night. Similar activity goes on at all plants producing Bakelite-laminated for Defense. As in the case of other essential industries, a working day is twenty-four working hours. SYNTHANE CORPORATION, OAKS, PENNSYLVANIA.

SYNTHANE TECHNICAL PLASTICS

SHEETS • RODS • TUBES • FABRICATED PARTS



SILENT STABILIZED GEAR MATERIAL

PRACTICAL METHODS OF MACHINING SYNTHANE IN YOUR OWN SHOP

● CIRCULAR SAWING

Ordinary circular saws commonly used in the woodworking industry are satisfactory.

SMOOTH SAW BLADES—without any set are generally used. This type of blade can be used with *Straight Parallel* sides or can be *Hollow Ground*, depending on the class of work. For best all-round service solid Carbon Steel blades will give best results with regard to clean cut and no chipping.

Keep saws sharp at all times for smooth, accurate cutting. Round gullets at the bottom in sharpening to help free chips.

SPEED—Best results can be had with blades running at an approximate speed of 13,000 ft. per minute.

TO PREVENT CHIPPING—Dull saw will cause excessive chipping of the edges. Chipping is possible with a sharp saw if there is an improper elevation of the saw above the table. When chipping is noticed either on the top or bottom, raise or lower saw until eliminated.



● THREADING

Threads can be cut on a lathe or by using taps and dies. Follow same procedure as for brass. A small quantity of oil gives a cleaner thread. When threading in a lathe, fine cuts should be taken at high speed.

DIE HEADS—Self-opening die heads are valuable for quantity production. If proper die head is used a smooth, accurate thread can be cut.



● GEAR CUTTING

SYNTHANE Stabilized Gear stock is readily machined as described above.

CUTTING TEETH—The same standard cutters and machines are used as for metallic gears, namely, standard milling machines with index heads, single cutter automatic gear machines, hobbing machines and gear shapers.

● BAND SAWING

Band Sawing is the simplest method of cutting SYNTHANE. Teeth should be kept sharp at all times and properly set for different classes of work.

SETTING—For circles the set should be increased as the diameter is decreased to provide a wider saw cut for turning the piece. For straight cutting the set should be just enough to provide clearance for the back of the blade.

SIZE OF BLADE—For ordinary run of sawing and for circles 1-1/4" and larger, a blade 1/2" wide—20 gauge thick and having 5 points per inch should be used. For smaller circles use a blade 3/8" or 1/4" wide. For straight sawing the width of the blade may be increased to 1" or 1-1/4". For extremely heavy material, from 3" to 8" in thickness, a blade with 3 points per inch is recommended.

SPEED—Blades should operate at 5000 to 8000 ft. per minute.

FEED—Work should be advanced at a rate of feed to allow for free cutting. Do Not Force the Work into the Blade.

CAUTION—Keep blades sharp, properly set, do not force; keep saw guides low and you will never be bothered with excessive blade breakage.

● MILLING

Milling operations on SYNTHANE are performed the same as on brass.

CUTTERS—Use standard cutting tools.

SPEEDS—High-speed steel cutters should run at a maximum of 400 ft. per minute.

FEEDS—The feed depends entirely upon the degree of finish desired.

Back up the material being cut with wood or any rigid material to prevent splitting.



● TURNING AND BORING

A round nose tool is best for a good finish. To get an extra-smooth polished finish, cut with the heel of the tool with very little clearance. This is particularly true when facing parallel with the laminations.

SPEED—When using high-speed steel operate at a maximum of 600 ft. per minute.

1500 ft. per minute can be obtained if tungsten carbide is used.

When boring always back up SYNTHANE with wood or any other rigid material to prevent burrs where the tool comes through.

● PUNCHING

SYNTHANE can be punched either hot or cold, according to the grade and thickness. Special grades may be sheared and punched cold upwards to 3/32" and to greater thicknesses, depending on the temperature of the material and type of die.

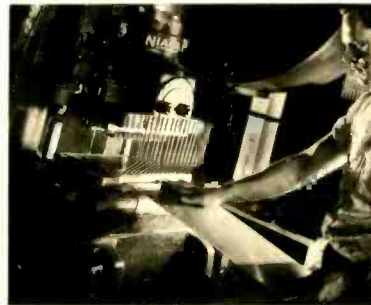

DIES—Punching dies are practically the same as those for metals with the exception that little clearance is allowed between the punch and die. The holes in the stripper plate are also a close fit to the punches. This latter helps prevent lifting of the material around the holes when the punches are withdrawn.



DESIGN OF DIES—When designing a die for hot punching allowance must be made for shrinkage. SYNTHANE when punched hot or warm will contract when cool, and all punches must be made larger than the size required. The increase in size depends on the size of hole, thickness and punching temperature of stock.

SPEED—For high-speed production progressive dies should be used whenever possible.

SHAVING—SYNTHANE can be shaved either hot or cold. Thickness up to 1/8" cold and up to 3/4" hot.

SHAVING CUTTERS—For shaving SYNTHANE first cut out the shape to be shaved, then bevel at 45° from the edge of the shape, leaving a knife edge at the contour.

TEMPERATURES FOR HOT PUNCHING AND SHAVING—The degree of heat depends entirely upon the thickness and hardness of the material. Taking off the chill (120° F.) is often enough. In some cases 200° to 250° is advisable, especially for materials 3/32" and heavier.

Do not exceed 275° F. as higher temperatures will burn and blister as well as remove the high gloss finish.

A piece of asbestos cloth between the hot plate or oven floor and the SYNTHANE will tend to heat the material evenly and slowly without premature burning.

● AUTOMATIC SCREW MACHINES

SYNTHANE Rods and Tubes can be efficiently machined on automatic screw machines at high speeds and feeds.

SPEED—As high as 6000 r.p.m.

LUBRICANT—Under most circumstances, lubricant is unnecessary, but with some operations as, for example, threading, flooding the work with lard oil and kerosene will be found helpful.

Diamond and Tungsten Carbide turning and boring tools can be used to advantage.

● DRILLING

Drilling is not difficult, but care must be taken to back up the hole being drilled so that the side where the drill comes through will be clean and free from burrs.

DRILL JIGS—Whenever the quantity will permit, a drill jig should be used. This jig should be designed so that the top plate containing the layout can be clamped down hard on the SYNTHANE, holding it rigid with the bottom plate of the jig. Allow drill to run into this bottom plate. Such a design will largely eliminate breaking out at the bottom and lifting at the top. Drill in multiple whenever possible, with a total thickness of not over 1/2".

DEEP DRILLING—Back out the drill several times when drilling deep holes, especially if drill is small. The average small size drill under No. 10 will tend to run off if the hole is much deeper than 1/2".

DIRECTION OF LAMINATIONS—Drilling at right angles with laminations can be done easily with a commercially ground drill. When drilling parallel with laminations the tendency of the drill is to split the material. To overcome this, increase the included angle of the drillpoint and clamp the work securely with side pressure in a vise or drill jig. Withdraw the drill several times when drilling parallel with the laminations.

SPECIAL DRILLS—For all practical purposes a regular twist drill will produce accurate and efficiently drilled pieces. However, special drills for Bakelite can be purchased having a steeper twist and wider flutes. This type provides more clearance for the chips. Recommended for high production.

SPEED—Keep drills sharp at all times. Maximum speed of high-speed drill, 400 ft. per minute.

COUNTERSINKING—Use either a regular countersink or a twist drill. When a drill is used it should have little clearance on the point and if a chattering action is set up the cutting point should be broken on the inside of the flute.

TAPPING—Tap with standard taps either by hand or machine. 200 ft. per minute is recommended.

SYNTHANE
Bakelite —  laminated

SYNTHANE CORPORATION, OAKS, PA.

PRECISELY...RIGHT

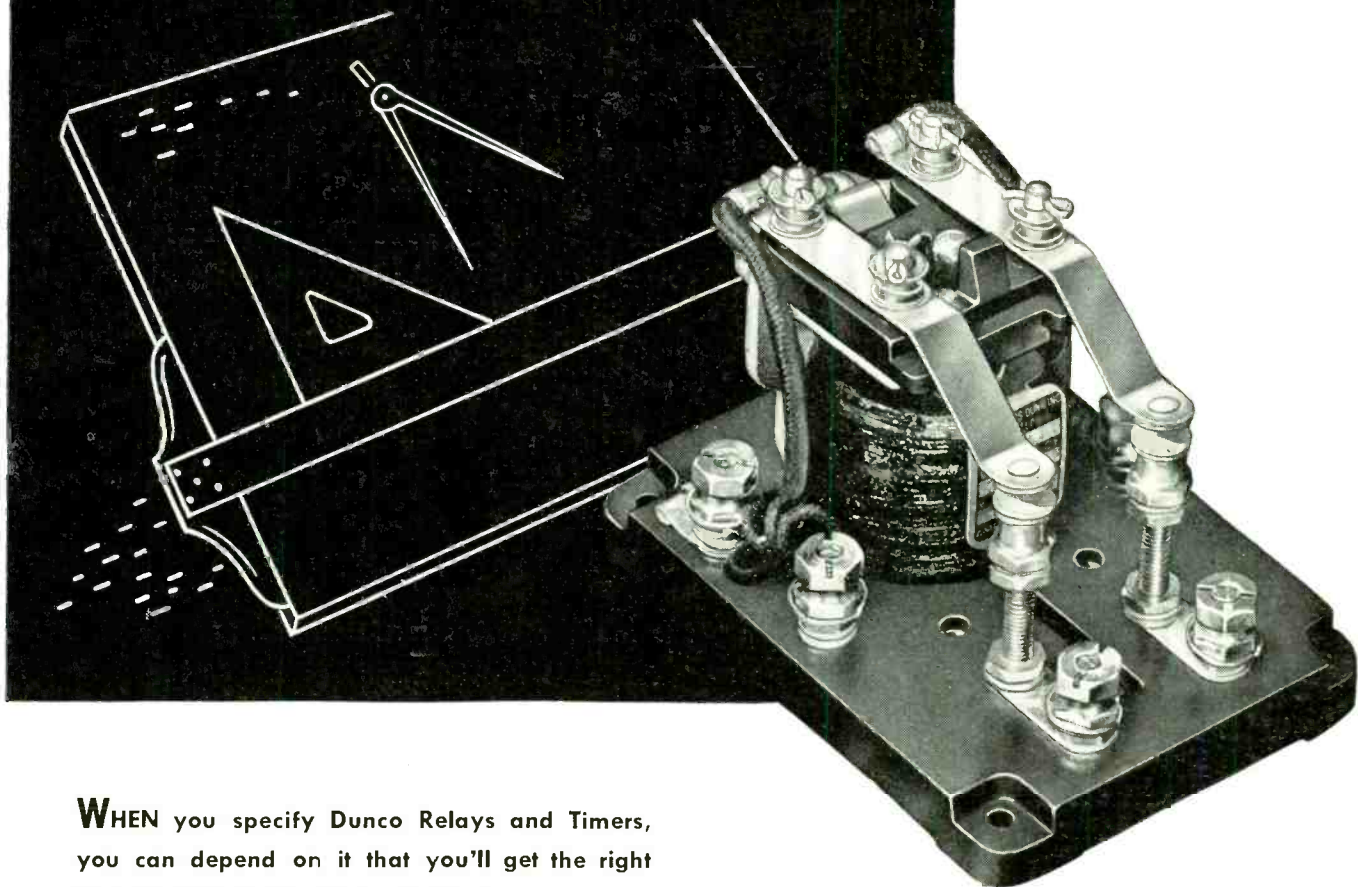

WHEN you specify Dunco Relays and Timers, you can depend on it that you'll get the right type for your particular application.

Throughout the years, Dunco's reputation with leading users has been based on its ability to solve exacting relay problems—to produce exactly what is required for a given application—and to extend to them full cooperation based on the broadest sort of experience in practically every field where fine relays are used.

In many instances, standard Dunco units will

fill the bill. Inexpensive adaptations of these standard units meet countless other requirements—and from here Dunco engineering and manufacturing capabilities extend to whatever special unit may be indicated.

Our engineers will be glad to make their recommendations without obligation. Complete new catalog gladly sent on request.

DUNCO RELAYS TIMERS

A Complete, Quality Line—Individually Adapted to Your Specific Needs

STRUTHERS DUNN, INC., 1326 CHERRY ST., PHILADELPHIA, PA.

ELECTRONICS — September 1941

WE'RE UP TO OUR EARS, TOO

GENERAL RADIO COMPANY has refrained from advertising its contribution to the arming of the Country through supplying equipment for the Armed Forces for National Defense. We have accepted the added strain upon our manufacturing facilities as a patriotic duty to the country in which we plan and propose to be doing business for countless years to come; and we have felt little inclination to burden the readers of ELECTRONICS with an account of the magnitude of our Defense business.

As manufacturers go, General Radio is a small organization. In normal times we have been able to produce instruments in sufficient quantity to take care of the requirements of Industry. In these emergency times, the volume of orders received from the Government plus the priority orders from subcontractors has sorely taxed our facilities. We have expanded in personnel and output to the limit of our physical structure.

As a result, without a priority preference rating it is sometimes difficult for us to fill orders, even for stock catalog items. How long this condition will continue, no one knows.

We ask the forbearance of our thousands of long-time friends. We assure them that our engineering staff is intact and busier than ever in developing devices and techniques for National Defense projects, which will benefit users of General Radio instruments in the future. Many new instruments have been brought up to the point of manufacture. New instruments will be developed constantly. At the very first sign of return to normal times these instruments will be available in quantity, immediately.

We do hope, however, in future advertisements in this magazine to do a thing we have been wanting to do for a long time . . . we propose to take you into General Radio's plant as far as Government regulations will allow . . . to describe a number of unique methods of design, manufacture and calibration which, we believe, contribute in no small measure to our long-standing position in the instrumentation field.

We shall try to make these advertisements of sufficient value to hold your interest. We will welcome your comments.

GENERAL RADIO Co., Cambridge, Mass.



NEW!

Below is a reproduction of a section of the new Engineering Data and Property Chart, No. 416. A full size chart in colors, complete with graphs showing physical characteristics difficult to express in figures, will be sent free on request. Address: American Lava Corporation, Chattanooga, Tenn.

PROPERTIES OF CERAMIC INSULATING MATERIALS OF THE AMERICAN LAVA CORPORATION

The data below represents average rather than optimum values obtained on standard test pieces. While these data are typical, it is well to remember that they may vary slightly depending upon size, shape, and method of manufacture of the article in question and the uses to which put. Values omitted in the table are of no importance considering the technical use of the material.

ITEM	UNIT	TEST METHOD	ALSIMAG 35	ALS. MAG 196	ALSIMAG 197	ALSIMAG 211	ALSIMAG 72	ALSIMAG 202	ALSIMAG 203	ALSIMAG 222	ALSIMAG 190	ALSIMAG 192	LAVA GRADE "I"	LAVA GRADE "M"	LAVA GRADE "A"			
TYPE OF MATERIAL			Dense stellite materials, consisting chiefly of clinenstatite crystals, (MgO·SiO ₂)				Magnesium-aluminum silicates, consisting chiefly of cordierite crystals (2MgO·2Al ₂ O ₃ ·5SiO ₂)		Aluminum silicate, consisting chiefly of mullite crystals. (3Al ₂ O ₃ ·2SiO ₂)		Magnesium silicate		Titanium dioxide materials, consisting chiefly of rutile crystals. (TiO ₂)		Natural fired stone magnesium silicate.		Natural fired stone aluminum silicate.	
PREDOMINANT CHARACTERISTICS		ASTM METHOD NUMBER UNLESS OTHERWISE SPECIFIED	Good electrical characteristics; high mechanical strength, close dimensions.	Low dielectric loss, good electrical characteristics, high mechanical strength.	High dielectric strength, low dielectric loss, high mechanical strength.	Extremely low dielectric loss at both low and elevated temperatures.	Low coefficient of thermal expansion, excellent heat shock and electrical properties. Can only be extruded, not pressed.	Low coefficient of thermal expansion, excellent heat shock and electrical properties. Can be pressed, extruded, and machined by us to close dimensions.	Highly refractory body.	A refractory material which can be machined in the fired state.	High dielectric constant, low dielectric loss.	High mechanical strength, great hardness.	Good electrical properties, close limitations on size and form.	Fair mechanical strength. Good electrical properties. Close dimensions.	Available in larger sizes than Grade "I" and "M". Close dimensions.			
Specific Gravity			2.6	2.7	2.6	2.7	2.1	2.1	2.1	2.0	4.0	4.0	2.8	2.8	2.3			
Density	lbs. in. ³		.094	.098	.094	.098	.076	.076	.076	.072	.144	.144	.102	.102	.085			
Volume	in.3 lb.		10.65	10.26	10.65	10.26	13.20	13.20	13.20	13.85	6.93	6.93	9.76	9.76	11.75			
Water Absorption	%	D116-39	00-00	05-00	10-00	08-00	80-50	50-10	150-100	180-140	.05-00	.00	15	10	25			
Chemical Resistance			At room temperature resistant to all alkalis and acids (excepting hydrofluoric acid). For special problems consult American Lava Corporation.															
Color			White 1	Cream	White 2	White	Yellow-Tan	Grey-Brown*3	White	Light Brown	Tan	Tan	Light Brown	Brown	Pink			
Softening Temperature	°C. °F.	C24-35	1450 2642	1440 2624	1445 2633	1400 2552	1410 2570	1430 2606	1650 3002	1625 2957	1650 3002	1650 3002	1465 2669	1475 2687	1600 2912			
Resistance to Heat (Safe limit for constant temp.)	°C. °F.		1000 1832	1000 1832	1000 1832	1000 1832	1250 2282	1250 2282	1350 2462	1300 2372	1000 1832	1000 1832	1200 2192	1200 2192	1100 2012			
Hardness	Mohs' Scale Talc = 1 Diamond = 10		7.5	7.5	7.5	7.5	7	7	6	6	8	8	6	6	6			
Linear Coefficient of Thermal Expansion	per °C. 20-100° C. 20-600° C.		6.9x10 ⁻⁶ 8.7x10 ⁻⁶	6.3x10 ⁻⁶ 7.8x10 ⁻⁶	7.7x10 ⁻⁶ 10.4x10 ⁻⁶	7.3x10 ⁻⁶ 9.2x10 ⁻⁶	1.5x10 ⁻⁶ 2.5x10 ⁻⁶	1.3x10 ⁻⁶ 2.8x10 ⁻⁶	3.5x10 ⁻⁶ 4.9x10 ⁻⁶	8.0x10 ⁻⁶ 9.8x10 ⁻⁶	7.1x10 ⁻⁶ 8.6x10 ⁻⁶	7.3x10 ⁻⁶ 8.7x10 ⁻⁶	8.3x10 ⁻⁶ 10.5x10 ⁻⁶	8.9x10 ⁻⁶ 10.4x10 ⁻⁶	2.9x10 ⁻⁶ 3.4x10 ⁻⁶			
Tensile Strength	lbs. in. ²	D116-39	8500	10000	8500	7500	1500	3500	2000	2500	7500	7500	2000	2000	2500			
Compressive Strength	lbs. in. ²	D116-39	75000	85000	75000	65000	30000	40000	10000	25000	80000	80000	20000	30000	20000			
Modulus of Rupture	lbs. in. ²	D116-39	20000	22000	20000	18000	4000	8000	6000	8000	20000	20000	8000	9000	9000			
Resistance to Impact	Charpy ft. lbs. in. ²	D256-38	1.8	2.1	1.8	2.0	0.9	0.9	0.9	0.8	2.4	2.4	1.3	1.3	1.4			
Thermal Conductivity (Approx. values)	cal./sec. cm. per °C.		.006	.006	.006	.006	.003	.003	.003	.005			.005	.005	.003			
Dielectric Strength (step 60 cycles) Test discs 1/4" thick	Volts/mil.	D116-39	225	240	210	240					100	100	< 100	< 100	< 80			
Volume Resistivity at Various Temperatures	25° C 77° F	Ohms per Centimeter ³ Cube	> 10 ¹⁴	> 10 ¹⁴	> 10 ¹⁴	> 10 ¹⁴	> 10 ¹⁴	> 10 ¹⁴	> 10 ¹²	> 10 ¹⁴	> 10 ¹²	> 10 ¹²	> 10 ¹⁴	> 10 ¹⁴	> 10 ¹²			
	100° C 212° F		2.1x10 ¹²	1x10 ¹³	8.1x10 ¹³	> 10 ¹⁴	4.0x10 ¹³	6.1x10 ¹²	1.2x10 ¹¹	> 10 ¹⁴	9.8x10 ¹¹	9.8x10 ¹¹			3.2x10 ¹¹			
	300° C 572° F		6.0x10 ⁷	1.8x10 ⁹	2.5x10 ¹⁰	1.0x10 ¹²	4.8x10 ⁹	8.2x10 ⁸	7.8x10 ⁷	1.8x10 ¹¹	1.0x10 ⁹	1.0x10 ⁹	1.4x10 ¹⁰	5.7x10 ¹⁰	3.2x10 ⁸			
	500° C 932° F		3.2x10 ⁵	9.0x10 ⁶	8.8x10 ⁷	3.5x10 ¹⁰	2.0x10 ⁷	4.8x10 ⁶	7.3x10 ⁵	9.5x10 ⁸	1.7x10 ⁶	1.7x10 ⁶	1.7x10 ⁶	2.6x10 ⁸	1.7x10 ⁵			
	700° C 1292° F		2.3x10 ⁴	5.0x10 ⁵	4.2x10 ⁶	4.8x10 ⁸	1.5x10 ⁶	3.2x10 ⁵	5.3x10 ⁴	4.1x10 ⁷	2.5x10 ⁴	2.5x10 ⁴	1.5x10 ⁶	1.3x10 ⁷	1.1x10 ⁵			
900° C 1652° F	< 10 ³	7.0x10 ⁴	6.8x10 ⁵	2.5x10 ⁷	2.2x10 ⁵	7.0x10 ⁴	1.0x10 ⁴	5.0x10 ⁶	< 1x10 ⁴	< 1x10 ⁴	2.6x10 ⁵	1.8x10 ⁶	2.0x10 ⁴					
T _e -value %	°C.		440	640	840	> 1000	720	600	480	> 1000	520	520	740	> 1000	530			
	°F.		824	1184	1544	> 1832	1328	1112	896	> 1832	968	968	1364	> 1832	986			
Dielectric Constant	60 Cycles 1000 K. C. 10 M. C.	D150-39T and U.S. Navy Spec. RE 13A-317-F and U.S. Army Spec. 71-229-D	6.5	6.3	6.3													
			6.2	6.0	6.0	5.8	4.1	5.0	4.0	4.3	85	85	5.6	5.6	5.3			
			6.0	5.8	5.8	5.7	4.0	5.0	3.9	4.2	85	85	5.5	5.5	5.3			
Power Factor	60 Cycles 1000 K. C. 10 M. C.	U.S. Navy Spec. RE 13A-317-F and U.S. Army Spec. 71-229-D	.30	.14	.20													
			.20	.08	.12	.02	.40	.40	.40	.02	.08	.08	.30	.45	1.0			
			.18	.06	.10	.01	.30	.30	.30	.01	.06	.06	.25	.40	.9			
Loss Factor	60 Cycles 1000 K. C. 10 M. C.	U.S. Army Spec. 71-229-D	1.95	.88	1.26													
			1.24	.48	.72	.13	1.64	2.00	1.60	.09			1.68	2.52	5.30			
			1.08	.35	.58	.06	1.20	1.50	1.17	.04			1.37	2.20	4.77			
Capacity Change Per °C. Between 20-80° C.			+1.6x10 ⁻⁴	+1.4x10 ⁻⁴	+1.6x10 ⁻⁴	+1.2x10 ⁻⁴				+1.0x10 ⁻⁴	-6.8x10 ⁻⁴	-6.8x10 ⁻⁴						

*1 Can also be obtained in brown (AISIMAG 207) and in grey (AISIMAG 206).
*2 Can also be obtained in brown (AISIMAG 210) and in grey (AISIMAG 209).

*3 Can also be obtained in white-grey (AISIMAG 178).
*4 T_e-value is the temperature at which one centimeter cube has a resistance of one Megohm.

ALSIMAG

Trade Mark Reg. U.S. Pat. Off.

FROM CERAMIC HEADQUARTERS

AMERICAN LAVA CORPORATION • CHATTANOOGA • TENNESSEE
CHICAGO • CLEVELAND • NEW YORK • ST. LOUIS • LOS ANGELES • SAN FRANCISCO • BOSTON • PHILADELPHIA • WASHINGTON, D. C.

Full Size Chart Free at Your Request

Quality

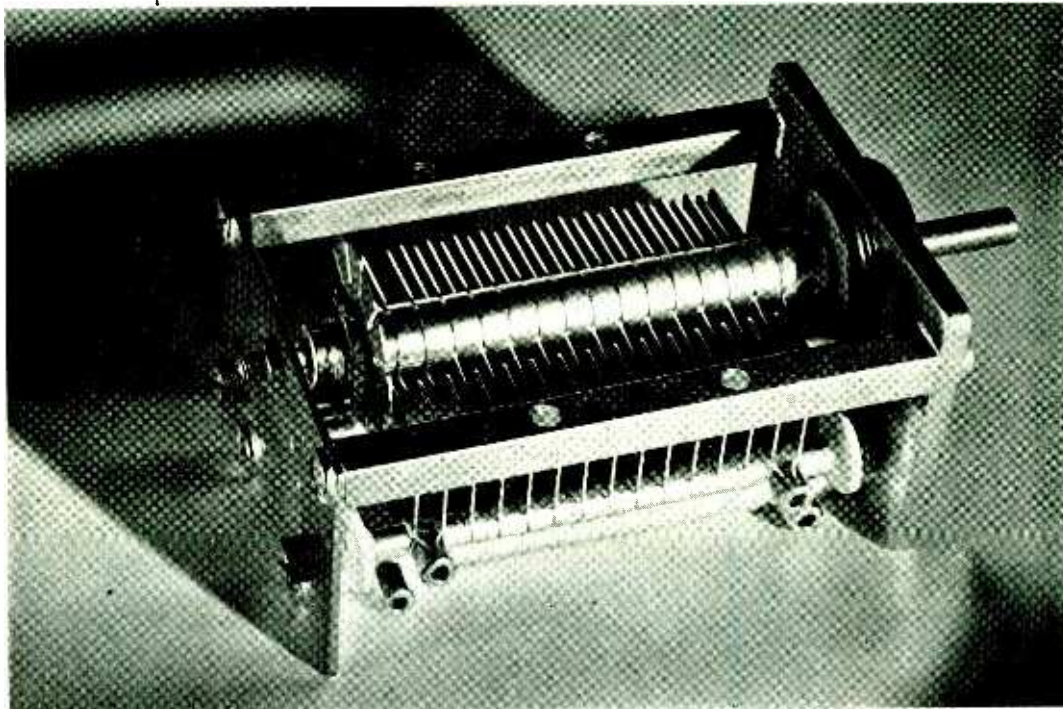

Zero temperature coefficient capacitor for use in aviation.

THE extremely rigid requirements for defense equipment just naturally suggest Hammarlund capacitors. Years of experience have equipped us with the knowledge and production facilities necessary to build precision capacitors for every branch of the communications field.

THE HAMMARLUND MANUFACTURING CO., INC.

424-438 West 33rd Street, New York, N. Y.

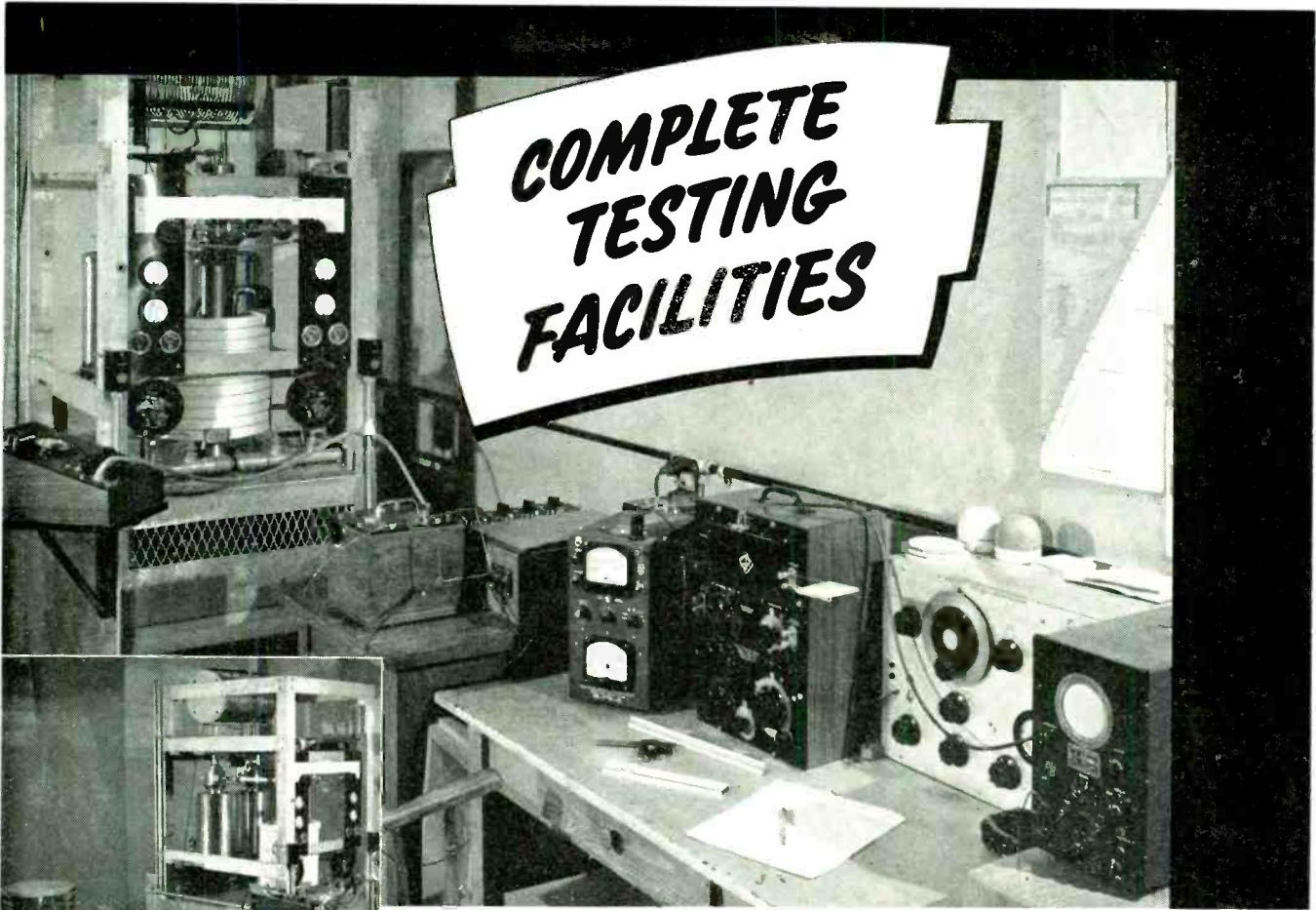

PERFORMANCE CHARACTERISTICS OF LAPP RADIO INSULATORS ARE DEPENDABLE FACTORS

Lapp's contributions to radio broadcast engineering are recognized as highly significant in the advance of the science. Practically every development of antenna structure design, for example, has been worked out with the co-operation of Lapp engineers. Since Lapp developments have been wholly pioneering in nature, it has been necessary to maintain complete testing facilities. In the Lapp laboratory is the usual equipment for 60-cycle electrical, mechanical and ceramic testing. In addition is complete equipment for determining characteristics of units at radio frequency—heat run, radio frequency flashover, corona determination and capacitance. For mechanical testing (lower picture), a 1,500,000 lb. hydraulic testing machine is used—for test of new designs, and for proof-test of every insulator before shipment.

In the construction of new broadcast equipment—or the modernizing of old—the safe bet is to specify "insulators by Lapp." Descriptive literature on Lapp antenna structure insulators, porcelain water coils and gas-filled condensers is available on request. Lapp Insulator Co., Inc., LeRoy, N. Y.

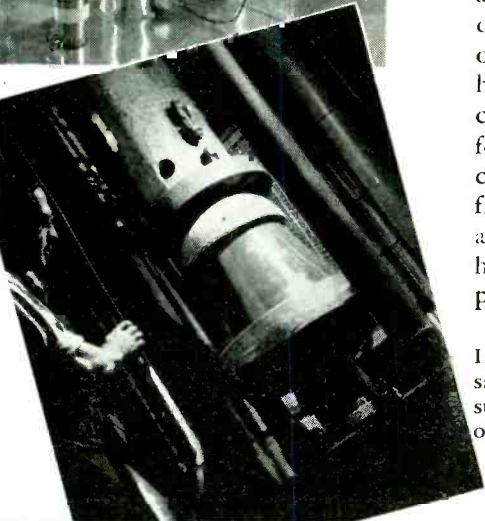
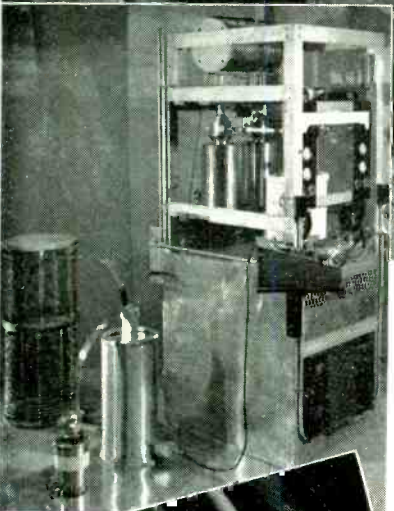

Specify **LAPP**
FOR SECURITY IN ANTENNA STRUCTURE INSULATORS

Erie Ceramicon Trimmers

REG. U.S. PAT. OFF.

DEPENDABLE STABILITY for precision equipment at high frequencies

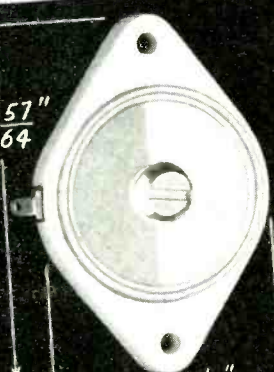
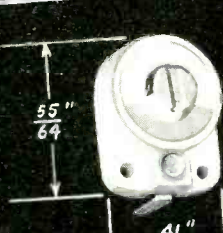
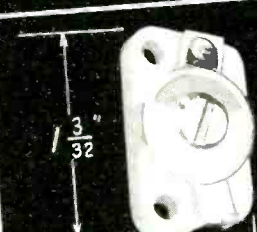
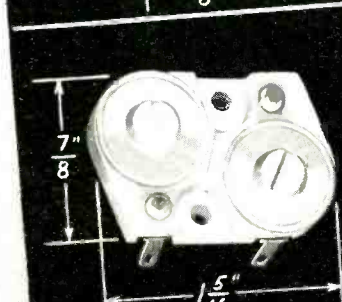
 <p>Dimensions: $1\frac{57}{64}$" height, $\frac{1}{4}$" width</p>	<p>Capacity Ranges in Max. Negative Temperature Coeff.</p> <p>STYLE TS 5D</p> <table border="0"> <tr> <td>MIN.</td> <td>MAX.</td> </tr> <tr> <td><8</td> <td>>75</td> </tr> <tr> <td colspan="2" style="text-align: center;">or</td> </tr> <tr> <td><10</td> <td>>110</td> </tr> </table> <p>Mounting holes for #6 Screw</p>	MIN.	MAX.	<8	>75	or		<10	>110		
MIN.	MAX.										
<8	>75										
or											
<10	>110										
 <p>Dimensions: $\frac{55}{64}$" height, $\frac{41}{64}$" width</p>	<p>STYLE TS 2A</p> <table border="0"> <tr> <td>MIN.</td> <td>MAX.</td> </tr> <tr> <td><4</td> <td>>30</td> </tr> <tr> <td colspan="2" style="text-align: center;">or</td> </tr> <tr> <td><7</td> <td>>45</td> </tr> </table> <p>Mounting holes for #4 Screw</p>	MIN.	MAX.	<4	>30	or		<7	>45		
MIN.	MAX.										
<4	>30										
or											
<7	>45										
 <p>Dimensions: $1\frac{3}{32}$" height, $\frac{5}{8}$" width</p>	<p>STYLE TS 2B</p> <table border="0"> <tr> <td>MIN.</td> <td>MAX.</td> </tr> <tr> <td><4</td> <td>>30</td> </tr> <tr> <td colspan="2" style="text-align: center;">or</td> </tr> <tr> <td><7</td> <td>>45</td> </tr> </table> <p>Mounting holes for #6 Screw</p>	MIN.	MAX.	<4	>30	or		<7	>45		
MIN.	MAX.										
<4	>30										
or											
<7	>45										
 <p>Dimensions: $\frac{7}{8}$" height, $1\frac{5}{16}$" width</p>	<p>STYLE TD 2A</p> <table border="0"> <tr> <td>MIN.</td> <td>MAX.</td> </tr> <tr> <td colspan="2" style="text-align: center;">(Each Section)</td> </tr> <tr> <td><4</td> <td>>30</td> </tr> <tr> <td colspan="2" style="text-align: center;">or</td> </tr> <tr> <td><7</td> <td>>45</td> </tr> </table> <p>Mounting holes for #6 Screw</p>	MIN.	MAX.	(Each Section)		<4	>30	or		<7	>45
MIN.	MAX.										
(Each Section)											
<4	>30										
or											
<7	>45										

PRECISION laboratory tests show that Erie Ceramicon Trimmers are inherently stable over a wide range of temperature change. For example, a Style TS 5D unit with a rated zero temperature coefficient of capacity changed less than 1.0% when subjected to continuous temperature change from 0°C. to +100°C. (+32°F. to +212°F.).

Everything possible has been done in designing and manufacturing Ceramicon Trimmers to insure the maintenance of this high degree of stability under all types of mobile services. The four illustrations below show the outstanding mechanical advantages of these units.

Ceramicon Trimmers are made in four standard styles, shown with their capacity ranges at the left. They are available in three temperature coefficients of capacity; zero, $-.0003/^\circ\text{C.}$ and $-.0005/^\circ\text{C.}$ Copies of a data sheet giving complete characteristics will be sent on request.

Thick, sturdy base

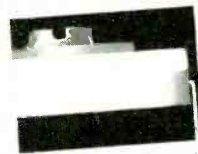

made of dense steatite that will not fracture when mounted tightly.

Soldered connections

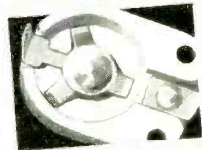

prevent open circuiting and insure low-loss electrical path.

Completely covered track



with adjoining surfaces of rotor and stator lapped optically flat.

Vibration-proof adjustment



assured by statically balanced rotor and turning torque averaging 1 inch pound.

ERIE RESISTOR CORP., ERIE, PA. LONDON, ENGLAND · TORONTO, CANADA.

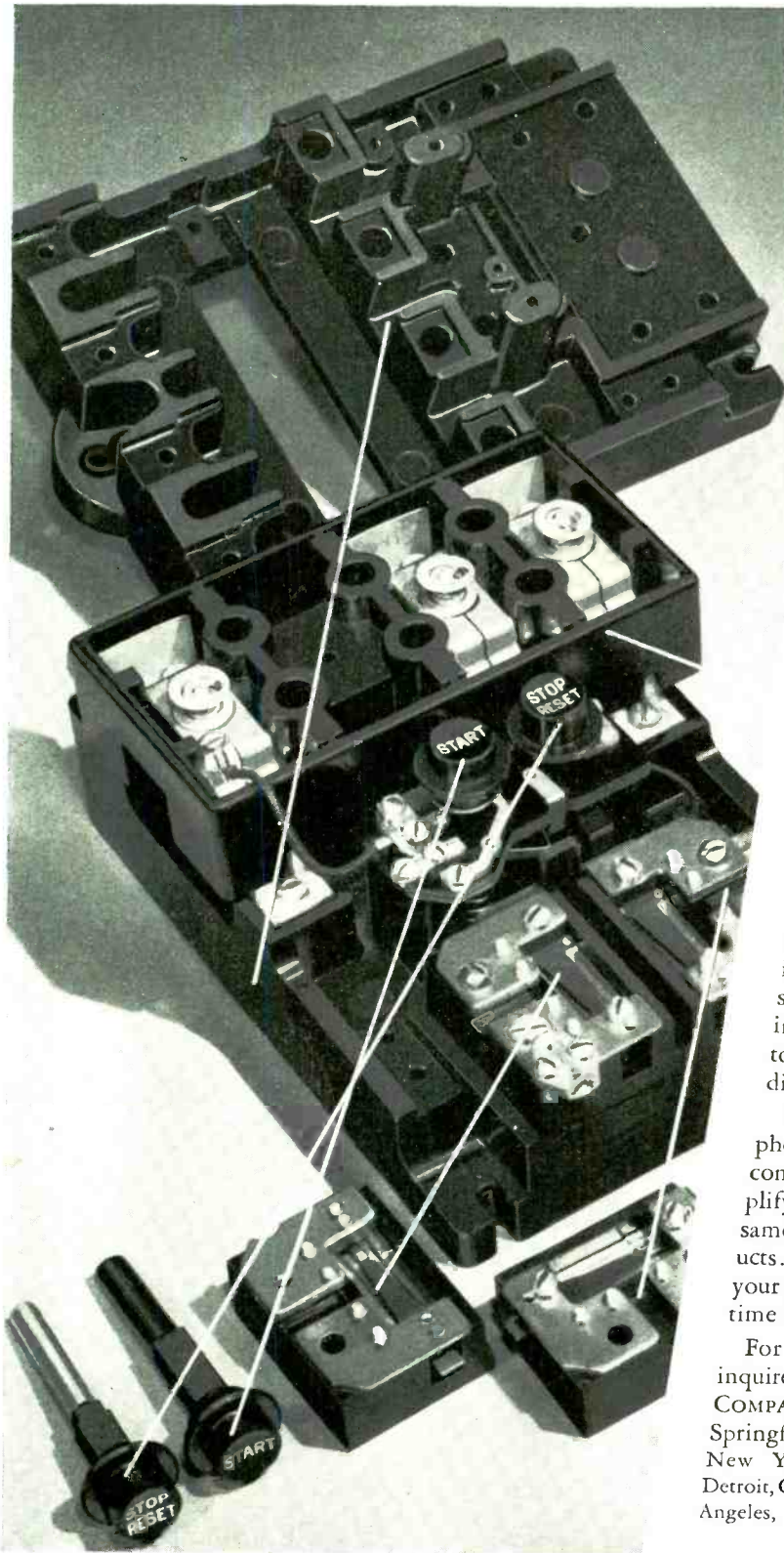

Resinox HELPS



DEFENSE PRODUCTION LINES

The entire intricate skeleton of this new solenoid starter manufactured by the Industrial Control Division of the Arrow-Hart & Hageman Electric Company consists of just six parts, each unit of Resinox, produced with mass production speed and economy.

The result: light, compact controls that require lower wattage coils, use less current, operate cooler... and at the same time, have the tough, sturdy construction that can take the day-in, day-out beating of present-day all-out industrial operations. Fast, easy replacement of any of the six parts can be made as original and replacements are held to hair-like tolerances.

Five qualities make Resinox ideal for such assignment: high impact strength, high dielectric strength, ready adaptability to intricate moldings, adaptability to mass production methods, dimensional stability.

With Resinox, Monsanto's phenol-formaldehyde molding compound, you can often simplify your production and at the same time improve your products... trim excess weight from your products and at the same time add extra strength!

For complete information, inquire: MONSANTO CHEMICAL COMPANY, Plastics Division, Springfield, Mass. District Offices: New York, Chicago, Boston, Detroit, Charlotte, Birmingham, Los Angeles, San Francisco, Montreal.



MONSANTO PLASTICS

SERVING INDUSTRY... WHICH SERVES MANKIND

Now You can Hear them ALL at their BEST!

...with a New Jensen Coaxial Speaker

↑ "FM," Television Sound
↑ Transcriptions, Quality "AM"
↑ "AM" Radio
↑ Phono Records, "SW" Broadcast

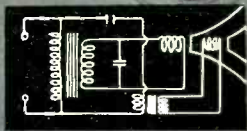
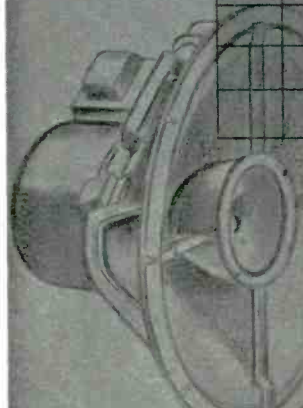

Separate coaxially-mounted speakers for low and high frequencies, with integral two-channel network. (Range control not shown. Some models have simplified bridging network.)

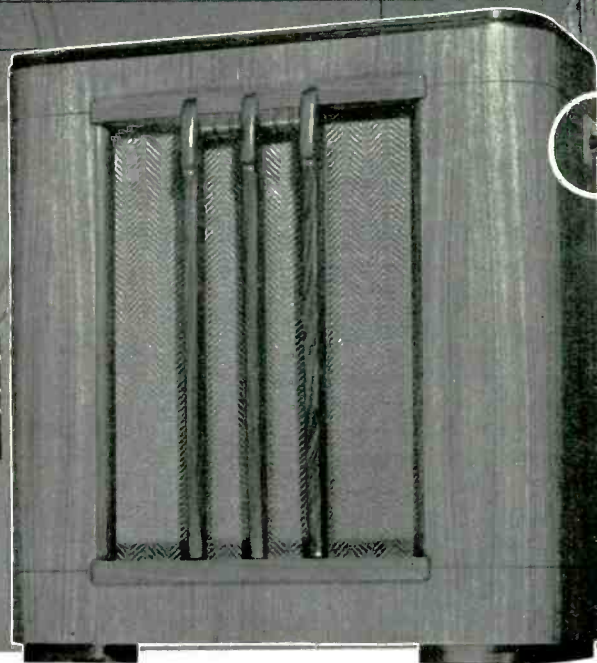

Jensen High Frequency Control gives you the kind of reproduction you want when you want it... all the way from two-way system high-fidelity, to conventional single speaker performance. Now you can adjust for best results on every program, every record, every type of service.

Jensen Bass Reflex

Acoustically - correct Bass Reflex Cabinet gives smoothly extended low register. Better than an "infinite" baffle...efficiently uses backradiation too.



A New Series of Fine Reproducers

Designed to Meet Your Needs Now...and for Years to Come!

- ★ Two Speakers, Co-axially mounted.
- ★ Built-in Frequency-Dividing Network.
- ★ Jensen High Frequency Range Control for all-purpose flexibility.
- ★ Jensen "Bass Reflex" enclosure for full low register.
- ★ Beautifully styled walnut cabinets.

Never in the history of sound reproduction have you been able to buy so much performance...such complete versatility...at so low a cost! For now Jensen brings you the ultimate in general purpose reproducers, with top performance so fine, so nearly ideal acoustically that obsolescence is eliminated for years to come...yet you can instantly adjust response for most pleasing results with every type of input in use today. Ideal for professional and home use for FM-AM reception and monitoring, transcriptions, commercial phono records... for practically every moderate-level high-quality application. Write now for Data Sheet 120 for technical descriptions and prices.

Four complete reproducer types with 12" to 15" speaker sizes, priced at \$75.25 to \$118.75 list in striped walnut cabinets. Utility cabinet models down to \$64.25 list. Coaxial speakers only as low as \$29.50 list.

Jensen

6601 SOUTH LARAMIE AVENUE, CHICAGO, ILLINOIS
CABLE ADDRESS: JERAD, CHICAGO

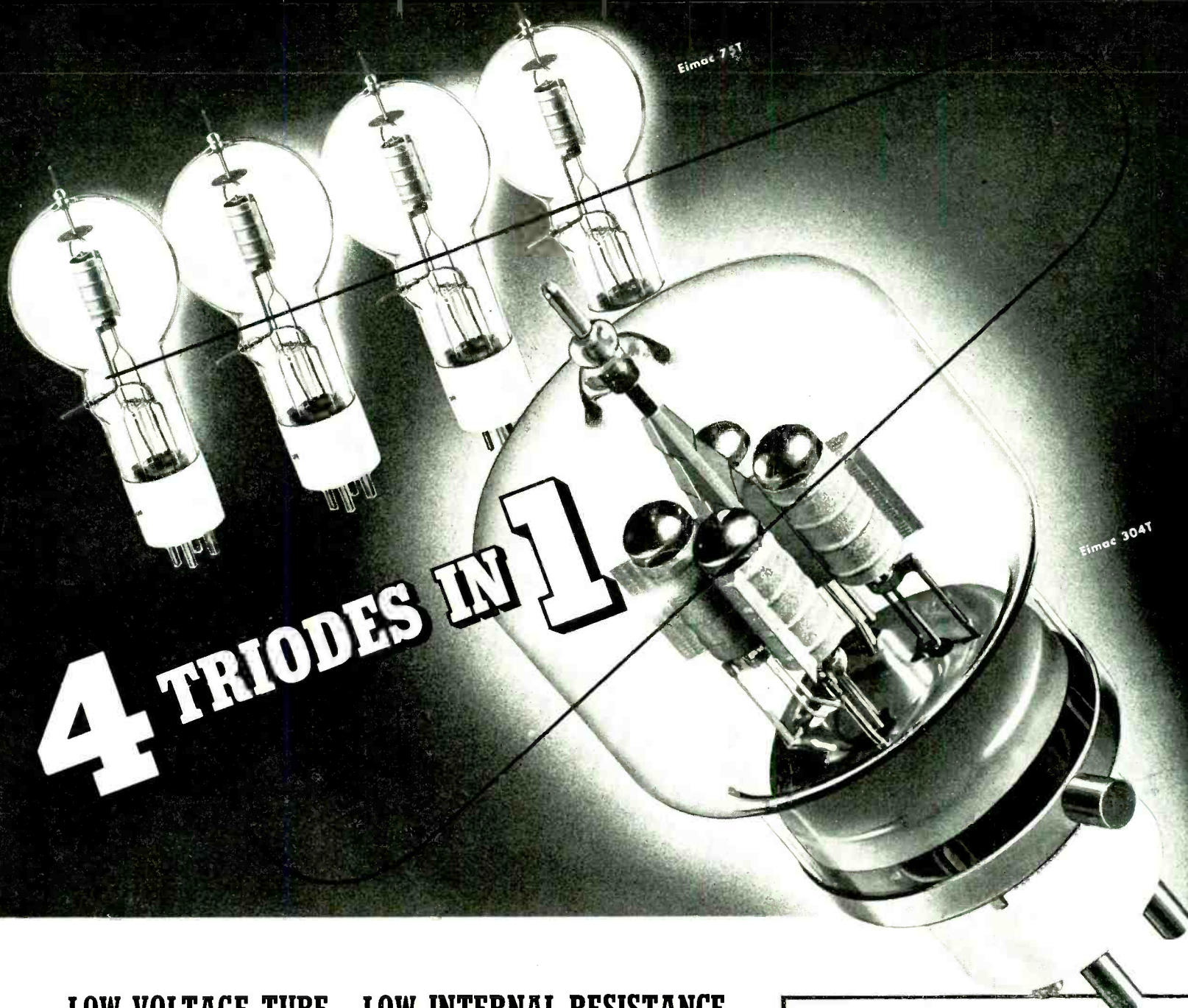

4 TRIODES IN 1

LOW VOLTAGE TUBE...LOW INTERNAL RESISTANCE
with a 10 to 1 safety factor

More than a year ago, Eimac announced these Multi-Unit tubes to the industry under the statement "A Revolutionary Change in Vacuum Tube Design." They were developed in the Eimac laboratories for the precise purpose of providing a high power, low voltage (1000 to 2500 volts) tube having an extremely low internal resistance which would operate efficiently up to 200 megacycles. In actual operation Eimac 304T tubes are seeing service with as much as 20,000 volts on the plates...10 times the rated voltage. Where else is there a tube offering such a safety factor? It's just typical of Eimac's leadership... another reason why Eimac tubes are to be found in the key sockets of most of the important radio transmitters throughout the world.

FOLLOW THE LEADERS TO
Eimac
TUBES

Eitel-McCullough, Inc. San Bruno, California

Export Agents: FRAZAR & CO., LTD. • 301 Clay Street, San Francisco, Calif.

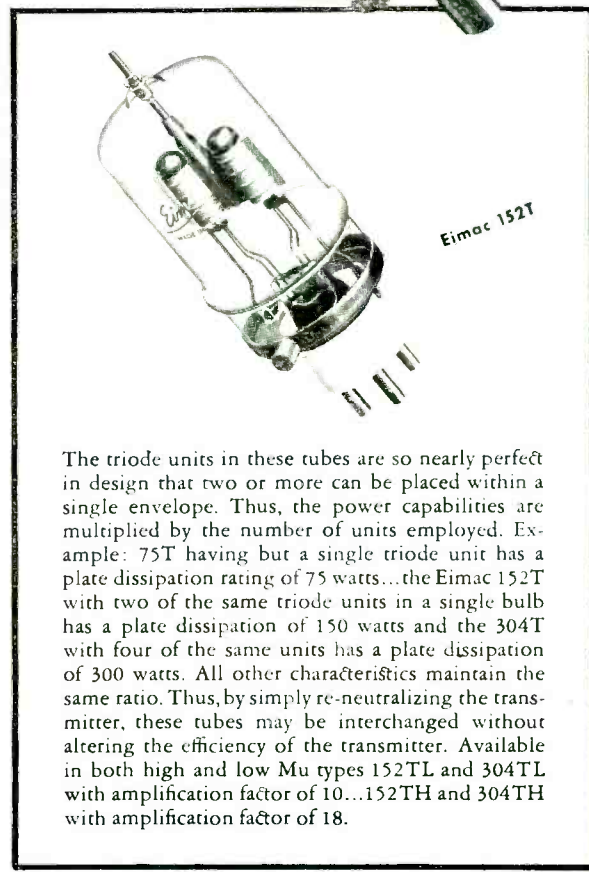

The triode units in these tubes are so nearly perfect in design that two or more can be placed within a single envelope. Thus, the power capabilities are multiplied by the number of units employed. Example: 75T having but a single triode unit has a plate dissipation rating of 75 watts...the Eimac 152T with two of the same triode units in a single bulb has a plate dissipation of 150 watts and the 304T with four of the same units has a plate dissipation of 300 watts. All other characteristics maintain the same ratio. Thus, by simply re-neutralizing the transmitter, these tubes may be interchanged without altering the efficiency of the transmitter. Available in both high and low Mu types 152TL and 304TL with amplification factor of 10...152TH and 304TH with amplification factor of 18.

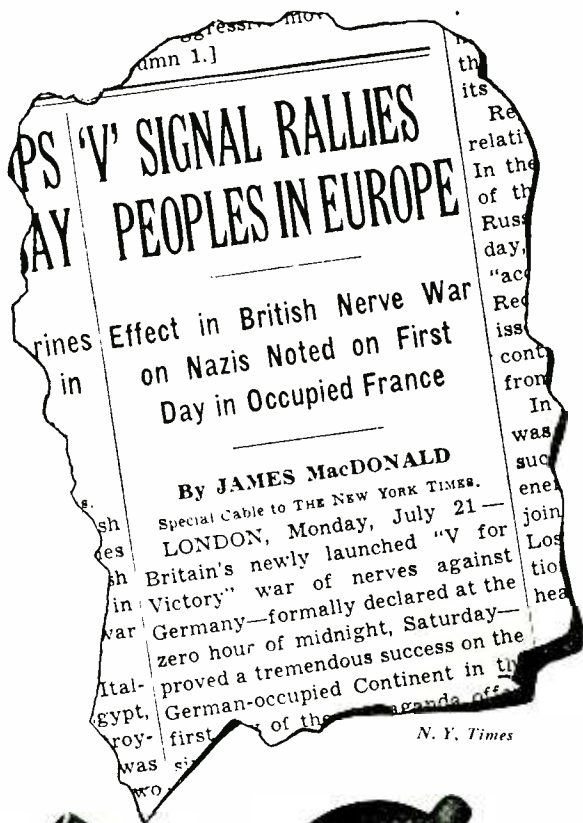
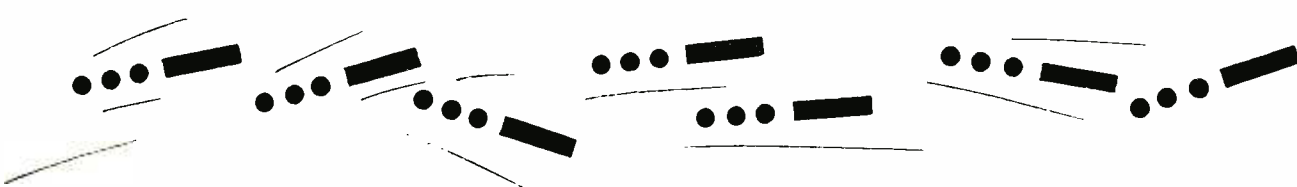

"V for Victory" is a call for SPEER Graphite Anodes

Use tubes with SPEER Graphite Anodes to assure victory over the tyranny of anode-conquering heat. Of all anode materials, graphite is the only one that heat cannot fuse—cannot even soften or warp.

Not only does graphite withstand heat as no other anode material can, but it also sheds heat—has many times the relative heat-dissipating value.

For longest service-life and power, use tubes with SPEER Graphite Anodes. Leading tube manufacturers can supply you. Write for list and SPEER Graphite Anode Booklet.



SPEER CARBON CO. 
ST. MARYS, PA.

Five Years of Flying Northeast Airlines Weather

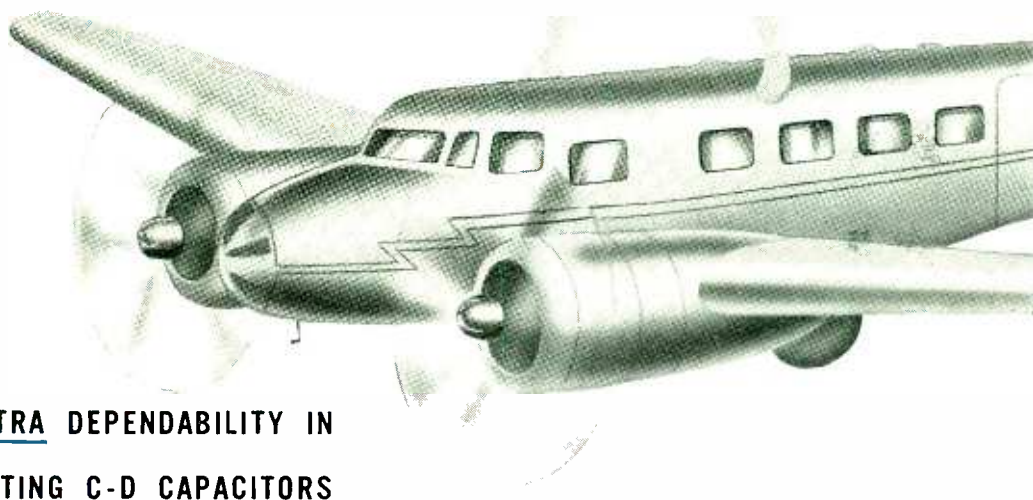

THERE'S EXTRA DEPENDABILITY IN LONGER LASTING C-D CAPACITORS

Many a proud New Englander has heard the hum of "the Boston plane" when ground temperature was as low as 20° below zero! To maintain a regular flying schedule, and enjoy its high safety record, in Northeast Airlines weather speaks well for the performance of radio equipment.

Cornell-Dubilier capacitors have served Northeast

Airlines for five years. Its radio engineers recognize in Cornell-Dubilier's thirty-one years of specialization an *extra* measure of dependability . . . capacitor quality that can't be matched.

That is why Northeast joins the chorus of American air lines who praise the performance and reliability of Cornell-Dubilier capacitors.

CAPACITORS MAY LOOK ALIKE BUT . . . *There is extra long life, extra uniformity and*

dependability built into C-Ds. Next time you specify capacitors look for the

Cornell-Dubilier seal of experienced engineering. And get the hidden extras

at no extra cost. Send for Catalog, Cornell-Dubilier Electric Corporation,

1006 Hamilton Blvd., South Plainfield, New Jersey.

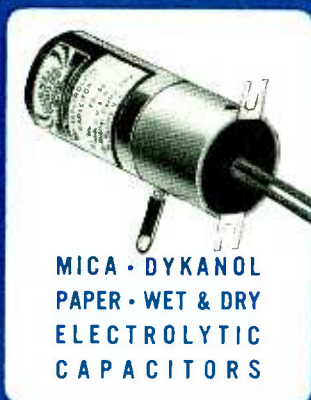

MICA • DYKANOL
PAPER • WET & DRY
ELECTROLYTIC
CAPACITORS

Cornell Dubilier

SOUTH PLAINFIELD, N. J.

NEW BEDFORD, MASS.



. . . MORE IN USE TODAY THAN ANY OTHER MAKE . . .

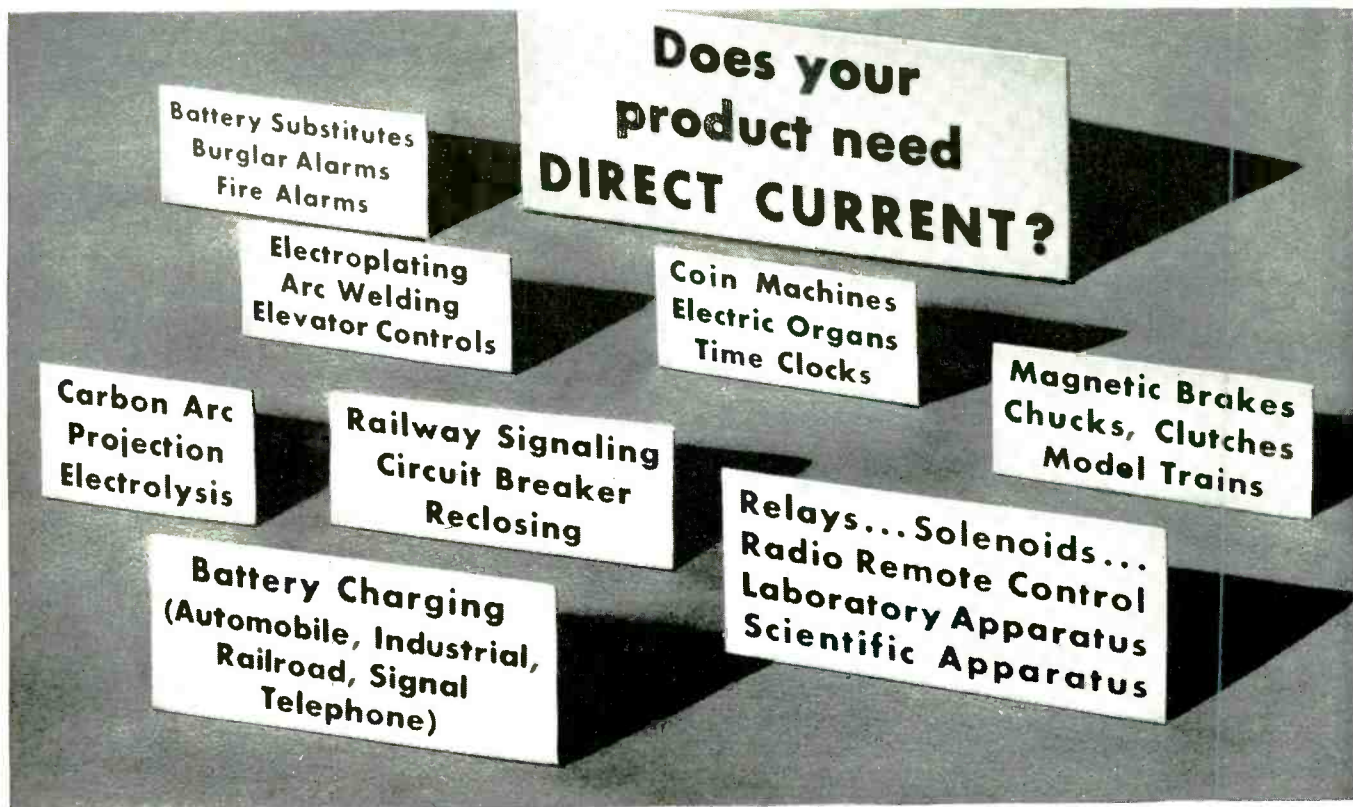

Many times it is possible to simplify mechanisms, cut costs and improve reliability of operation by the use of direct current for control or power circuits, or electrically operated equipment.

And many D.C. power applications may be made more reliable, more efficient and more compact if available A.C. power is converted to D.C.

The function of Mallory Rectifiers is to convert A.C. to D.C. They are noiseless, long-lived, compact—furnished in standard capacities or built to your particular requirements.

If your product requires A.C. rectification, write for the new Mallory booklet. It contains a wealth of information on the selection and application of the proper rectifier for your need.

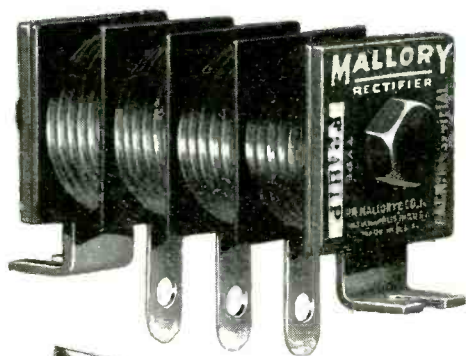

P. R. MALLORY & CO., Inc., INDIANAPOLIS, INDIANA Cable Address—PELMALLO

MALLORY
P.R. MALLORY & CO. Inc.

NATION-WIDE SERVICE THROUGH 253 SELECTED DISTRIBUTORS



CROSS TALK

► **WAR . . .** The war that is now being fought is a metallurgical war. Estimates indicate that 8 times as much steel per soldier will be used in this struggle as in the last World War. Other metals will be used up as fast. It can be seen, therefore, why there can be no fooling, no wishful thinking about this priorities business. More and more raw materials will be diverted from peacetime products into defense machinery. For example, there will probably be less than one-third the normal quantity of copper available for non-defense use.

Now this brings up a most important point. This is the conservation of metals and materials. No one can afford to overlook any chance to reclaim any existing metal, to use any allotted metal to best possible advantage, to find substitutes for materials now difficult or impossible to get. It seems reasonable that bidders on contracts for defense machinery might get additional consideration if they have a good story on the conservation angle, as well as price. In the long run dollars can be created easier than basic raw materials.

On the matter of substitutes, it is useless for an industry or an isolated manufacturer to run to the government for advice. Industries themselves must find substitutes and to share the knowledge of such substitutes through their trade organizations, the periodicals of their learned or engineering societies, or through technical papers like *ELECTRONICS*.

On its side, government must keep awake to the problems introduced by putting ceilings on prices of materials,

but not on prices of labor. For example, it is conceivable that a ceiling on steel without a corresponding damper on continuously rising wages for labor would encourage a manufacturer to use more steel and less labor.

America has not yet jelled on this defense proposition. Too many of us are still trying to see what we can get out of it. We must have returns on our money investment, we must have time and a half for overtime, we must still cling to the idea that this is still somebody else's war, not ours. We are not yet organized and oriented in one gigantic effort to save ourselves and our system.

► **INDEX . . .** Annually, in December, *ELECTRONICS* publishes an index of the contents of the twelve-month period. Several readers have requested a cumulative index starting from Volume 1, Number 1, April 1930, this index to include small items appearing in *Tubes at Work* and other departments. This would be a sizable undertaking and would cost money to assemble and to print. How many readers would be interested at one dollar or less?

► **CENSORSHIP . . .** We have felt for a long time that censorship ought to be clamped on outgoing communications from this country. Anyone listening occasionally to code on the short waves cannot but be struck with the volume of traffic in 5-letter and other codes. There need not be the slightest doubt that much information goes out of this country daily that can be used against our friends and against us.

We need not doubt a second but that this data had better be kept at home, or that it will be used against us, now and in the future.

► **RECORDING . . .** NAB Engineering Committee held a meeting in late June of engineers engaged in using or producing transcriptions or other records for broadcast purposes to determine the advisability of effecting certain standardization in the manufacture and use of such records. As part of this work, which is to continue, 182 NAB member stations answered a questionnaire on recording.

Of these stations 42 percent were in favor of vertical, 37 in favor of lateral recordings. On the question of pre-emphasis, 58 percent were in favor, among these stations there were 4096 hours per week of lateral transcription broadcasting, 1512 hours per week of vertical record use, and 1478 hours of phonograph record broadcasting. About 30 percent of the hours per week of time on the air represented by these stations came from records or transcriptions. The stations recorded some 695 hours per week; 90 percent of the stations have recording equipment.

All such attempts at standardization represent assets to the industry and the work of this NAB committee will produce the benefits to broadcasters and manufacturers of recording equipment that accrue to all such efforts.

► **357A . . .** By an oversight credit for last month's cover was not included. The good looking tube was the 357A used widely in Western Electric 1-kw transmitters.

OH, WE'VE GOT PLENTY

No substitutes for aluminum, copper, steel, but radio industry cooperates in receiver design to maintain essential public service. RMA Materiel Bureau active. OPM gives high rating to replacement tubes and electrolytics, but Army and Navy come first

THE "all out" defense activity in which the United States is now engaged, is a tremendous production and distribution project. It occupies so much of the country's productive capacity that few of the many articles to which the consumer has become accustomed are likely to be available in the future at the same prices and sufficiency as in the past. This is especially true for those industries which are not regarded as completely essential to defense activities, and civilian radio is in this classification. Consequently, the outlook for the future for radio manufacturers is entirely different than any time during the history of radio industry. There will be ample purchasing power and demand for civilian radio receiving equipment but to a large extent manufacturers will have to forego this otherwise lucrative market in their effort to produce items which, from the defense point of view, are considered much more urgent. Furthermore, substitute materials and new designs which conserve materials, manpower, and production facilities will be required for that equipment which is produced.

At the crux of the problem is the heavy demand for defense orders. These have increased to such an extent that there is an insufficient supply of raw materials, productive capacity, and adequately trained personnel to meet usual civilian needs plus defense requirements. In such a situation, defense comes first whether we like it or not.

This is as it should be, of course. But OPM believes that in the case of certain materials (aluminum, copper, and steel, for example) there will not be enough for even the defense program in spite of the establishment of reserve pools for "emergency" use. In such a case, the distinction between defense and non-

By **BEVERLY DUDLEY**

Acting Managing Editor, Electronics

defense activities breaks down and all effort to develop substitutes immediately becomes a defense project.

That the defense program is throwing a monkey wrench into the usual radio business cannot be denied and that it is causing uncertainty and confusion is self evident to anyone even remotely associated with production. Most annoying, if not a most serious element in the entire chain of events, is the uncertainty of the future for which no reasonable predictions can be made, and, consequently, for which adequate plans and preparations cannot be executed with assurance.

Problems of the Radio Industry

The radio engineer and production manager are trained to cope with physical and economic laws; for years they have known the uncertainty of mass markets and public taste. Now, however, they must also face man-made restrictions which are sometimes issued with startling suddenness. They must devise new designs utilizing less of those materials required for defense work.

In general, radio engineers and manufacturers are taking a constructive point of view toward the situation. Under the circumstances it appears that the radio manufacturing industry is doing a remarkably good job of not only willingly supplying essential communication equipment for defense purposes, but is making every effort—with the personnel it has for the purpose—to supply parts and complete sets for the coming year. Indeed, it is solely to the ingenuity and resourcefulness of the engineer and manufacturer that we must entrust the mainte-

nance of existing receivers and the supply of new and replacement models. But even a radio engineer can't pull fireside chats out of the hat indefinitely on an increasing amount of "plenty of nothing".

Let's look at some of the problems which the radio industry faces in production of civilian sets. There is no problem in manufacturing defense equipment, for now "guns instead of butter" is not a slogan solely applied to the "Nazfascistitarian" countries. The chart shows a list of the more important components going into the manufacture of radio receivers, together with the more important raw materials used in their construction. Nearly every one of the constituent materials in the first column is under priorities rating, mandatory control, or is relatively difficult to obtain because of scarcity. Likewise, the substitutes for most of these constituents are in the first column. But this is merely a list of raw materials, it does not indicate the situation with regard to production facilities—the men and machines to fabricate the raw materials into the finished article.

Obviously, this brief picture is not a pleasant one. But, the sensible and logical thing to do is to make the best of a nasty situation and to ease the burden as much as possible. To that end the experiences of the British should be helpful, and ELECTRONICS has plans for early publication of a report on the activities of British radio engineers and manufacturers.

RMA Activity

In this country the Radio Manufacturers Association has taken the lead in solving the new man-made problems facing the industry. Its Board of Directors has established a Materiel Bureau whose function is to find substitutes for, or more effective use of, materials under priority

OF NOTHING!

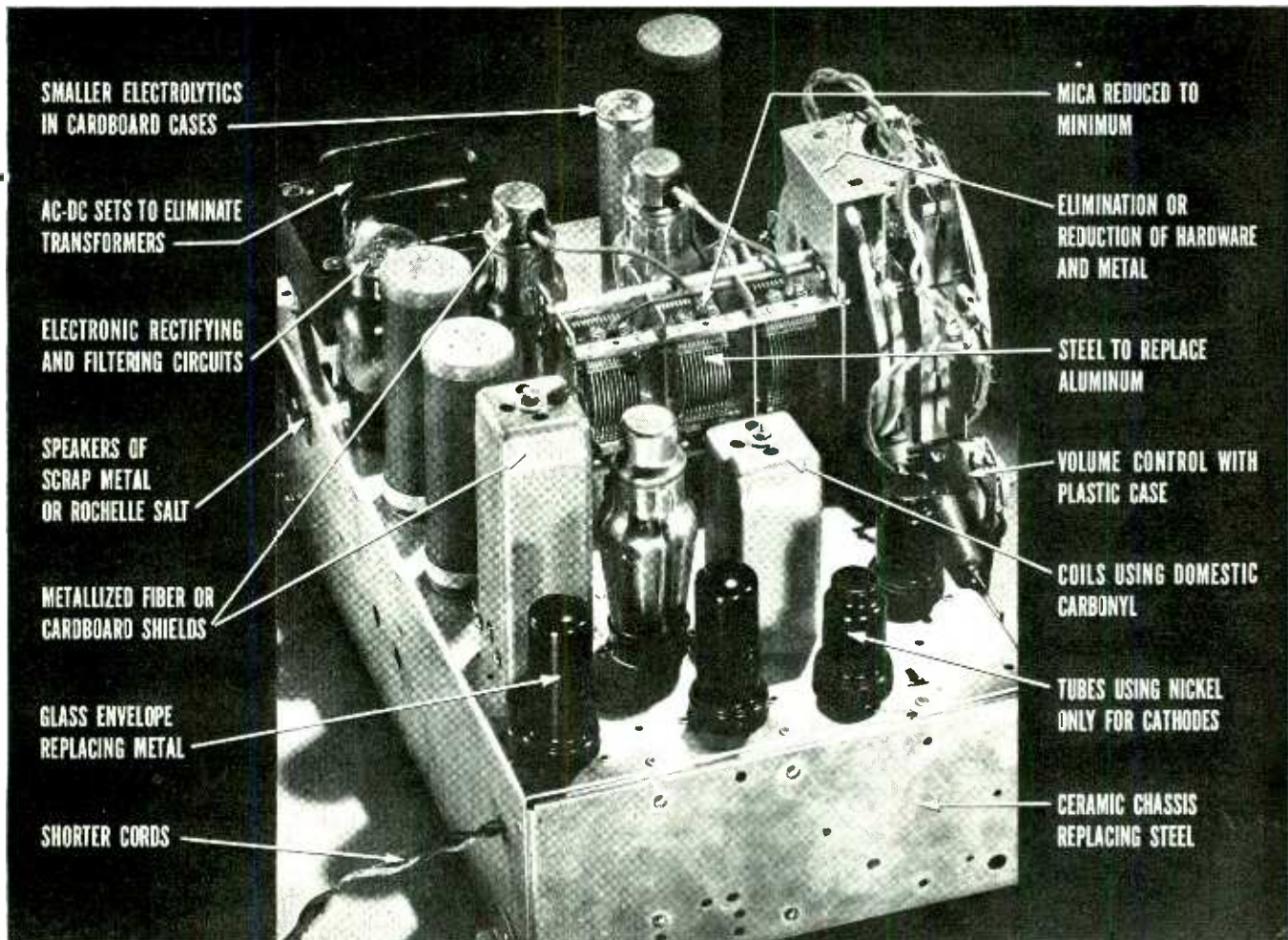

In this photograph are illustrated a number of changes which may be found in the 1942 radio receivers to conserve labor and materials

regulations. This Bureau, with the cooperation of the engineers of the industry, is to undertake the problem of material utilization, not only through substitute materials, but also from the viewpoint of mechanical design, circuit design, and standardization, both electrical and mechanical. It is planned that the Materiel Bureau will cover all product lines in which the members of RMA are interested, such as receivers, transmitters, tubes, and other component parts.

The RMA Materiel Bureau has been organized by W. R. G. Baker, Director of the Engineering Department of RMA with L. C. F. Horle as Director of the Bureau. The Materiel Bureau has set up groups of specialists to deal with specific technical problems. At present, there are ten groups actively at

work. These groups, and some of the work in progress are given below.

Group 1—Aluminum and Nickel Bearing Magnetic Alloys. Much progress has been made in use of scrap metal. An important consideration is that Alnico No. 5 is of such magnetic properties as to require only about one-third as much metal as formerly. Use of this metal promises to bring permanent magnet speakers again into the picture.

Group 2—Electrolytic Condensers. Use of aluminum is reduced to a minimum through program of standardization in which all available aluminum is used only for active electrodes of minimum weight while terminals, cases, and other non-active parts are made of substitute materials. Physical dimensions have also been reduced to a minimum to conserve aluminum. The 110,000

pounds of aluminum made available in July for civilian needs have enabled the most urgent civilian needs to be met.

Group 3—Receivers. Much activity has occurred in this group with most promising developments being in the use of metal sprayed on cardboard for interstage shielding and tube shields, filtering with unusual circuits and at the point where filtering is required most, instead of filtering the entire power supply. return to simpler and older receiving circuits which are more economical of material and man-power, and the use of fibrous or ceramic materials for chassis pans to conserve steel.

Group 4—Receiving Tubes. Much activity has been directed toward elimination of nickel, and at present it appears that tubes can be made completely free of nickel except for

the cathodes. Use of rare metals not on critical list to replace common metals which are scarce is also planned.

Group 5—Radio Transmitters. Workers forming this group have been so busy with defense orders that little time has been available for re-design and conservation activities. Moreover, need here is not so important as in other fields as radio transmitters are essential for national defense and it is felt that the broadcasting system will be maintained under any circumstance. Silver-plated iron wire is being given consideration for circuits operating at ultra-high frequencies.

Group 6—Variable Air Condensers. Main effort has been to substitute steel altogether for aluminum and brass in tuning condensers. Tests indicate that this can be done if certain precautions are taken, and that the performance of steel condensers is entirely satisfactory.

Group 7—Transmitting tubes. Situation is pretty much the same as that facing Group 5.

Group 8—Plastics. Considerable dependance is being placed on chemists to avert bottleneck by their ingenuity in manipulating molecules. No insufficiency of materials, although shortage of most efficient materials may occur. Fabrication rather than raw materials likely to be bottleneck if one exists.

Group 9—Paper Condensers. Possibility of paper, cellophane, or similar dielectric on which metal is sprayed or deposited holds promise of being important production method even after defense program no longer puts pressure on radio manufacturers.

Group 10—Loud Speakers. Development of 2½-inch Rochelle salt crystal feeding a horn appears to have important bearing on the speaker situation. Magnetic speakers may be more in evidence than for many years. Use of Alnico No. 5 indicates electromagnetic and permanent magnet speakers by no means out of the picture.

ELECTRONICS has made its own survey by sending questionnaires to important manufacturers in the radio and allied fields. The results of this survey indicate a genuine and willing cooperation on the part of nearly all. Nevertheless many replies were prefaced with the statement that the conclusions and opinions were

based on surmises, intelligent guesses, and best judgment (under the circumstances) but could not be regarded as being too precise. Much uncertainty was expressed and few ventured predictions without considerable modification of one type or another. Nevertheless, it is believed that the general concensus of those who participated in this survey will provide about as good an insight of present conditions and as good a prophecy for the future as can be expected at the present time. To those many individuals who cooperated in this survey, our grateful appreciation is extended.

The reason for the decrease in set production, and the direction which production activities for the coming year are likely to take, can be gleaned from examination of what is happening to the various component raw materials.

Plastics

Important raw materials used in the manufacture of plastics are phenol formaldehyde, hexamethyl tetramine, acetone, phthalate esters, nitric acid, cotton linters, ammonia, cresylic acids, and cresol. Most are on the OPM critical list so that production is curtailed in certain cases and necessitating allocation of raw materials to fabricators on a sort of rationing basis. The major problem of both phenolic and urea manufacturers is the supply of formaldehyde which is produced from methanol. Equipment for producing methanol can be converted to the production of synthetic ammonia and since ammonia is an important constituent of explosive manufacture, the government requirements for explosives have a direct effect on plastics manufacture. Ammonia is difficult to obtain for plastics in sufficient amounts according to one manufacturer. The government is building new plant capacity for ammonia and it is anticipated that the formaldehyde shortage will be alleviated when these plants go into production in the latter part of 1941 or perhaps in 1942.

Plastics have been suggested as a "grand substitute for everything which will be short in the future." As a result there may be a shortage of finished plastics due to limited molding facilities even though the raw materials are sufficient to meet plastics demands, which is not cer-

tain. In fact some manufacturers feel that the plastics industry will suffer as much as other industries, if not more, from shortages of necessary materials due to defense work. Other manufacturers anticipate that in the future preference ratings to conserve plastics containing formaldehyde for essential uses will be placed into effect.

Defense activities have affected plastics output by demands on skilled tool and die makers in the case of molders and fabricators. The cost of tools and dies has risen markedly, and the only answer is to plan tools far enough ahead to have them when needed. Skilled tool and die makers cannot be developed overnight, and to this extent, shortage of men is not being met. Lack of raw materials is a factor with some molders.

Sharply restricted civilian use of synthetic resins and plastics made directly or indirectly from formaldehyde is provided for in a civilian allocation program promulgated August 5 by OPACS, which went into effect August 23. The large demand on plastics for defense items, coupled with the ever-increasing demand of plastics as substitutes for materials placed under priorities at an earlier date have caused the shortage of plastics which made this ruling necessary.

Senior preference for supplies of resins made directly or indirectly from formaldehyde for civilian use is directed for a wide range of industries and activities essential to the public welfare. Given senior preference will be technical instruments, material and equipment for scientific research and applications in the communications industry. Secondary preference will be given to less essential civilian needs such as cabinets for radio receivers, automobiles, and commercial cameras. No preference is provided for items in Class C. Furthermore, if substitutes are available for plastics, preferences will not be granted. Here then is a case of a material, designated as a substitute, becoming sufficiently scarce so that its use is restricted, thereby still further aggravating the problem of substitute seeking.

Ceramics

There is, as yet, no shortage of raw materials for ceramic insulators,

nor is a shortage likely, so far as can be foreseen at present. However, suitable insulators make use of metal ends and fittings which may be forged or cast of almost any metal and these have to be machined and supplied with various finishes and platings. Consequently, the priorities on metals enters into the consideration and for this reason there may be a shortage of finished articles. Where reasonable priorities are available to obtain the metal, reasonably prompt shipments are being made except possibly where aluminum and certain copper alloys are specified.

Shortages in the ceramics field are likely to occur more because of lack of man-power than because of shortage of raw materials. Plant expansion is under way to meet the present heavy demand.

Since there is no shortage of raw materials, no substitutes are being considered.

Mica

Two mica firms reporting indicate that shipments from India are progressing in considerable volume and that Brazilian mica formerly going to Japan will now probably reach this country. Madagascar mica, not an important item in the electronics field, is scarce, but this situation is expected to be remedied shortly. Shortages due to government stocks rather than to actual consumption is a possibility.

There will probably be a curtailment of mica for household appliances and other articles for civilian use. Restrictions have already started, and may become more acute in the next six months. Dealer sales and inventories will undoubtedly be reduced during this period.

Condensers

It is convenient to break down the classification of condensers into variable tuning condensers, fixed mica and paper condensers and electrolytic condensers. In any case the scarcity of aluminum is an important factor in all three types.

Electrolytic Condensers

The production of electrolytic capacitors of any type requires aluminum and there is no substitute with the exception of tantalum which is, economically, out of the picture even if it could be obtained in sufficient

quantities. The virtual stoppage of manufacture of this type of condenser for civilian use affects all radio receiving equipment and there appear to be only four possible answers to this dilemma: (1) Use of paper condensers of less capacity, letting hum come where it may, (2) development of electronic filtering devices, and (3) design of filters using relatively more inductance and less capacitance than formerly, provided the necessary copper and iron can be obtained, or (4) convince the government to release sufficient aluminum.

On August 22, OPACS announced allotment of 23,000 pounds of aluminum for replacement electrolytic condensers. It is expected that this program will make provision for normal replacements for the last quarter of 1941. Apportionment to manufacturers is in accordance with their fraction of total industry dollar sales during 1940.

Paper and Mica Fixed Condensers

Shortage of aluminum will also be effective in reducing supply of fixed condensers, but tin and lead foil can be used in certain cases. Silver or

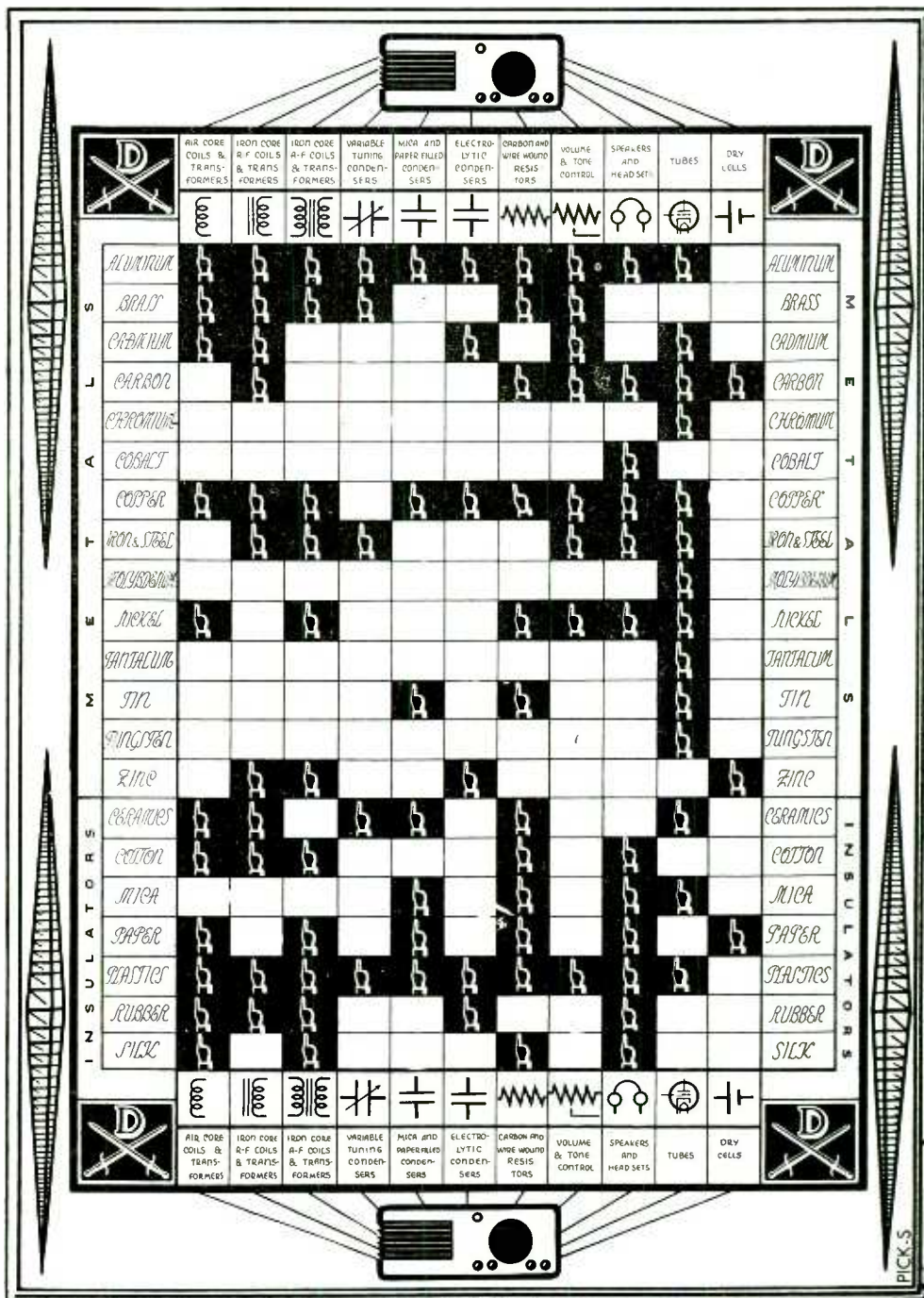

Components going into radio receiver production, and raw materials from which they are manufactured

other metallic films on thin dielectrics show promise of success. Possible shortages of mica and paper may also curtail production. Shortages of metal fittings and plastics may also be a factor in supply of such condensers for civilian needs. As a result of these scarce materials major changes in design may be expected, and are already taking place.

Variable Tuning Condensers

One of the first radio components to be affected by priorities was all types of condensers.

Again, aluminum shortage is affecting production. Other metals are likewise scarce. Steel, zinc and brass could be used as substitutes but these are under control. Use of steel throughout is the most likely prospect for continued production.

Resistors and Volume Controls

Succinctly stated by one manufacturer is the situation with respect to resistors: "We use all of the major critical materials in our products, all of which have been assigned priorities and on non-defense business these priorities will serve to eliminate production unless the situation is relieved."

Efforts are being made to find substitutes. There appear to be no substitutes for the ceramic spools, eyelets and wire used in high quality wire-wound resistors, no satisfactory substitute for Bakelite cases of volume controls. Tin or lead plated steel may replace cadmium plated steel parts and steel may replace brass, although it is under control. Raw material for molded resistors does not appear to be a problem.

Some manufacturers are troubled by shortage of technical and skilled help; others not. Those who are, are trying to train inexperienced help to bridge the gap during the shortage.

Coils and Transformers

Aluminum, brass, zinc, copper, steel, all used in making audio- and radio-frequency inductances are under priorities. Substitutes for these materials are impossible and consequently there are no plans for devising substitutes. Powdered iron is an important material for iron-core r-f coils and there does not appear to be a shortage of this. In fact new plants for producing carbonyl iron have been built with government encouragement, within the last

magnets, speakers and headsets, the only substitutes for which appear to be scrap metals. The chase from one material as a substitute, to another substitute for the substitute is wearing out some producers who feel that it is merely a matter of time before all materials will be under control anyway so that the determining factor will be what point of view Washington economic and political leaders take with regard to the production of any specific item. A possible substitute is Rochelle salt speakers for the more customary type, and we have not yet heard of priority ratings on this material.

The plan for future production in this field, as elsewhere, is to climb on the bandwagon of defense production and this may be one reason why no shortages of labor have been reported.

At present, speakers are supplied in some cases with minor differences in finish and other factors not affecting operation of the unit. It is expected, however, that because of being forced to use of scrap metals, the consumer will ultimately receive more expensive, bulkier and less efficient product. It is expected by some that production will

dwindle to almost the vanishing point by next year.

Tubes

For some reason or another, tube manufacturers are reluctant to discuss their production problems and the industry outlook with the free abandon of manufacturers of other radio components. Consequently, the remarks under this heading must be regarded as even more tentative than for other sections of this report.

The difficulty of manufacturing tubes with substitute materials should not be minimized, especially if little is allowed for making the necessary changes in processing.

USE FIELD OFFICES FOR PRIORITIES INFORMATION

PRIORITIES Division of the OPM has established a number of field offices to assist manufacturers in their questions and problems relating to defense manufacturing activities. Make inquiries of your regional field office on all priorities problems instead of traveling to Washington.

Field offices which have been established to date, and Field Service District Managers are:

Atlanta, Ga.....	John B. Reeves, 104 Marietta St.
Boston, Mass.....	William P. Homans, 30 Pearl St.
Chicago, Ill.....	Warren G. Bailey, 164 W. Jackson Blvd.
Cincinnati, O.....	Bruce W. Burroughs, 34 East Fourth St.
Cleveland, O.....	William T. Walker, East Sixth St. and Superior Ave.
Dallas, Tex.....	James B. Crockett, Wood and Akard Sts.
Denver, Colo.....	Virgil L. Board, U. S. National Bank Bldg.
Detroit, Mich.....	Walter Hall, 160 Fort St., West
Kansas City, Mo.....	Clifford H. Carr, Federal Reserve Bank Bldg.
Los Angeles, Calif.....	G. Howard Hutchins, 1151 S. Broadway
New York, N. Y.....	Phillip M. McCullough, 33 Liberty St.
Philadelphia, Pa.....	Frederick W. Slack, 925 Chestnut St.
Pittsburgh, Pa.....	Charles C. Cruciger, Grant St. and Ogle Way
San Francisco, Calif.....	Andrew L. Kerr, 400 Sansome St.
Seattle, Wash.....	William D. Shannon, 957 Stuart Bldg.
St. Louis, Mo.....	Louis E. Crandall, 411 Locust St.

several months, and domestic carbonyl is equal to that formerly supplied from Europe according to recent tests.

There are shortages of skilled and technical labor in some plants and this problem is not being solved. In other plants working on defense contracts there are no shortages. In some cases deliveries are still being made, but one manufacturer says of the civilian consumer, "He will go without, beginning now."

Magnets, Speakers and Headsets

Aluminum, nickel, cobalt, copper, steel, brass and zinc are normally used in manufacture of permanent

Materials essential to tube manufacture on which there are priority ratings include aluminum, chromium, copper, nickel, nickel alloys and nickel-bearing steels. Aluminum is used only in small quantities for getters and some allotments of this metal have been made, moreover substitutes can be made. Nickel appears to be serious, and mercury may be a factor in high power rectifiers. Wherever possible substitute metals are being used but the list of substitutes is increasing rapidly and the tube manufacturer may easily increase shrinkage when a substitute is introduced. The number and variety of tubes is being reduced and some obsolete types are no longer being manufactured. Quality is being maintained, even with substitutes.

Elimination of shields, reduction in size and weight of certain parts, and similar changes can be effected in most cases without affecting quality too adversely.

Tube engineers are in demand, for a number of them have found their way into Governmental service. The situation is being met by training younger men. Other shortages are being overcome by overtime work.

One supplier of phototubes has overcome his difficulties by having his entire production consumed for defense problems.

Radio tube replacements will benefit by allotment of metals announced August 22 by OPACS, and intended to meet requirements for the last

quarter of 1941. Metals released include 36,000 lb. of nickel, 144,000 lb. of cold rolled steel, 8 lb. of barium, 18 lb. of aluminum, 2,700 lb. of chromium, 230 lb. of manganese, 11,500 lb. of copper, 100 lb. of silver, 16,500 lb. of iron, 1,600 lb. of molybdenum powder and wire, 180 lb. of tungsten wire and powder, 1,200 lb. of steel wire, 3,300 lb. of tin, 2,200 lb. of lead, 310 lb. of cobalt, 43,500 lb. of brass and 35 lb. of magnesium. Tubes made with metals provided under this program must be marked for replacement use only.

Tube manufacturers will share in this allotment according to their part of 1940 industry dollar sales.

Miscellaneous Components

Copper represents a major threat in case of phonograph motors although a shortage of rubber could prove serious. Brass, aluminum and cadmium are also materials for which substitutes are required. Priority ratings for such motors would be so far down on the list as to be meaningless. Some manufacturers experience shortage of skilled labor due to defense activities. Tool and die makers are needed most. Efforts have been and are being made to standardize designs and conserve materials and new designs are being shelved but unless some materials are released the production of phonograph motors in 1942 will be seriously curtailed.

Steel, brass, nickel and cadmium, all under control, affect hardware

for radio sets. Likewise there is shortage of fabricating facilities such as automatic screw machines.

Instrument makers report virtually all of their essential materials under priority regulation so that only orders carrying priority ratings can be accepted. Other customers will have to wait their turn or pay premium for overtime. Shortage in help is being overcome in at least one plant by holding training classes in the plant, for which the worker is paid. Plastics are being considered as substitutes for metals wherever possible. Defense makes such heavy demands that it is questionable whether consumers will be able to purchase electrical instruments; at least this is the present outlook. Standardization has been found of considerable help.

Aluminum, copper and permanent magnets employing steel and nickel are important items in sound recording for which there are no substitutes. Glass and to some extent steel and paper may be used for aluminum in records as a base for records. Electrical workers are adequate but there is a shortage of skilled machine shop labor.

Consumers will pay higher prices and will eventually receive inferior products, with higher prices already in effect. Dealers will have an immense potential market which will be difficult or impossible to supply, according to one manufacturer of sound recording equipment.

(Continued on page 96)

INDUSTRIAL SUPPLIERS REQUIRE CUSTOMER COOPERATION

IN connection with a plan to bring under priority control all products manufactured in advance of sale (i.e., for stock) OPM officials point to a danger confronting all branches of industry. The flow of tools, supplies, and equipment, which every plant must have in order to maintain production, is threatened unless the producers of such items are given priority consideration for their purchases of raw materials. Before priority can be given, manufacturers of such items must have evidence that their products will be used for defense, and accordingly, they require the following information from their customers: (1) Items which are to be used for defense purposes should be so indicated on the order, (2) a monthly notarized affidavit from the customer stating the percentage of defense sales to total sales made by the customer.

These requests are being made now by the supply manufacturer, his sales staff, or by the industrial distributors who represent him in the various territories. Because many customers have stocks on hand, they have been indifferent or hostile to such requests, but consumers for industrial supplies are helping themselves in filling out such requests by assuring flow of needed products for defense orders which they manufacture.

The industrial buyer should protect himself as much as possible by taking the following four steps:

1. Identify all defense orders. Stamp each defense order you place with your supplier, either distributors or manufacturers, as a defense order using thereon the contract, project or preference rating which covers the particular work for which this material is required.
2. If such identification is impossible, analyze your sales by determining the percentage of your previous month's total dollar sales volume which was delivered to defense buyers.
3. Obtain analysis of your sales by submitting to your customers the standard approved form of affidavit prepared by the Priorities Division of the OPM.
4. Users of industrial supplies should obtain the highest possible percentage figures by accurate means of analysis which can be supported.

By following this procedure, the manufacturer of industrial supplies is assured that he may obtain the required amount of raw materials to manufacture new products for defense orders in advance of receipt of an order for his products.

ELECTRONIC INTERLOCKING

An electronic method is used to automatically prevent howling caused by acoustic feedback in an intercommunicating system. Part of the signal of the active channel is used to reduce the screen grid voltage of the other amplifier tube and thus lower its gain below the howling point to permit normal conversation without switching

STATED in a simple manner the problem of office and factory intercommunication systems may be said to be a method of conducting normal conversation between two persons who may be in different offices or who may be separated by a comparatively long distance with the requirement that the method be simple, reliable and relatively inexpensive. The logical and straightforward answer would seem to be to place a two-channel sound system between the two offices. However, when

this is done we are rather forcibly reminded of an old acquaintance, acoustic feedback. When the voice is radiated from the loudspeaker with enough power for comfortable listening several feet away, it is picked up by the microphone, amplified and transmitted back to the original station where the same thing happens. In a very short time this vicious circling results in a sustained howling with which most of us are familiar.

A number of methods have been

By
HAROLD J. McCREARY

*Consulting Engineer
Chicago, Ill.*

used to eliminate this howling. They range from a switch at each unit which is flipped whenever the person wants to change from talking to listening or vice versa, to very elaborate and expensive automatic methods using electron tubes and relays. In one system the "talk-listen" switch has been replaced by a voice operated relay. The results have been somewhat unsatisfactory due to clipped sounds, that is, sounds used to operate the relay are partly lost during the time of operation of the relay. Next came the time delay circuits so that the sounds did not reach the relay contacts before the relay contacts closed. Some such proposed systems use 40 or 50 vacuum tube or rectifier elements and this, of course, is unwieldy and impractical. Another common solution is to just eliminate the loud speaking feature at one end by installing a hand-set or ordinary telephone.

Preventing Acoustic Feedback

Something similar to this problem of acoustic feedback causing singing has been encountered in long line telephone work. Here it is due to electrostatic coupling or non-uniform lines so that electrical echoes result. Voice operated magnetic type relays were developed to short out the electrically generated echoes. As time went on more and more equipment was added to the voice operated relays until a new system of equipment called a Vodas resulted.

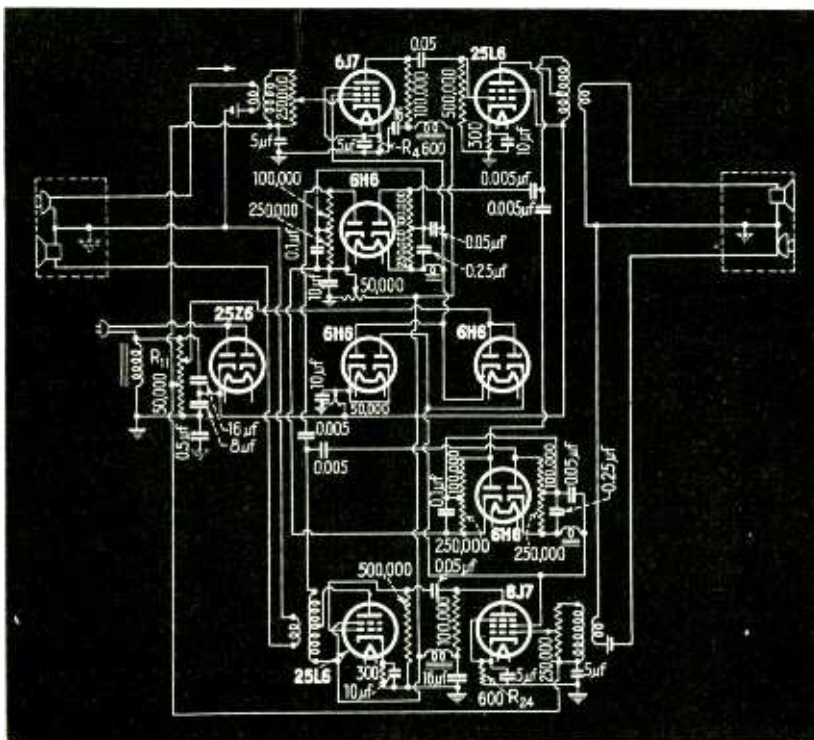
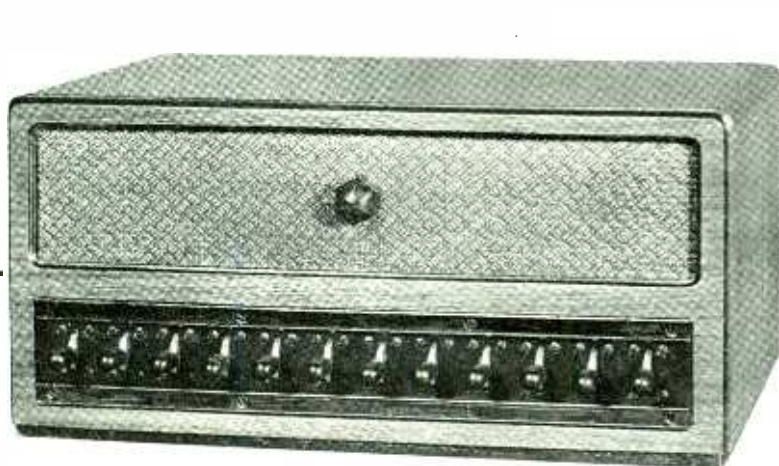
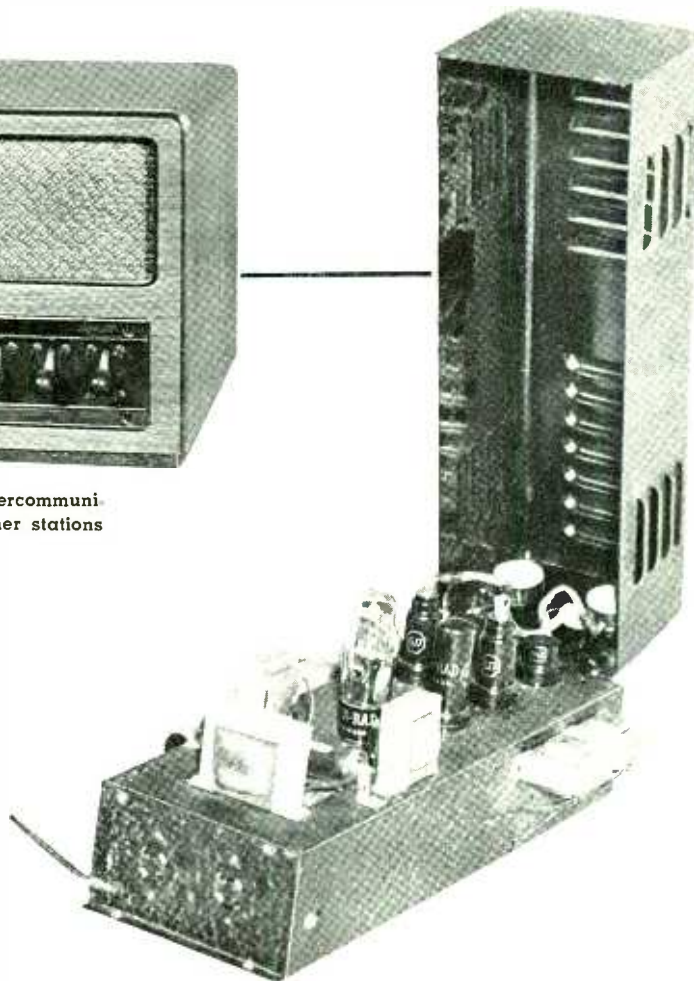

Fig. 1—Circuit diagram of the intercommunicator. Each channel has a resistance coupled amplifier and a signal in one channel acts through a system of diode rectifiers to kill the operation of the other channel

for INTERCOMMUNICATORS



Commercial model of the automatic intercommunicator. The switches are used to call other stations



The experimental model of the intercommunicator which eliminates the necessity of operating a switch to talk or listen

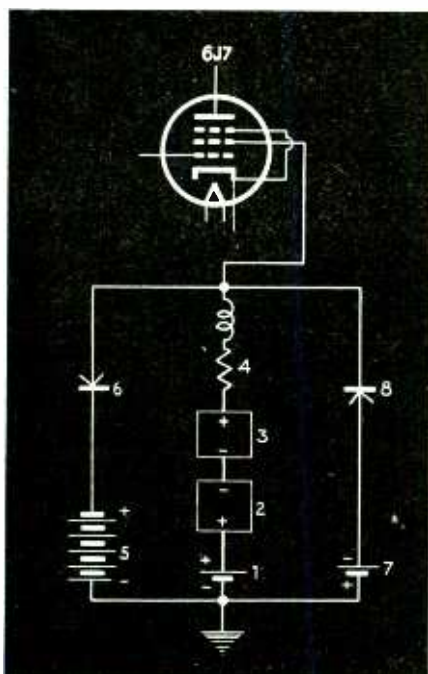

Fig. 2—Simplified diagram of the circuit which controls the potential of the screen grid of the 6J7

An article entitled "The Vodas" by S. B. Wright of the Bell Telephone Laboratories in the *A.I.E.E. Journal* of August 1937 summarizes what he considers to be possible ways to prevent singing as follows:

1. The terminal can normally be blocked in one direction and connected through in the other.
2. Both directions of transmission can normally be blocked and activated in either, but not both directions by the voice waves.
3. The circuit can remain activated in the last direction of speech and blocked in the other direction.

Electronic Interlocking

Unfortunately this article did not include in this list the method which I use so let us call it No. 4 and state it as follows:

4. Both directions of transmission are normally activated, but the total gain or loss of both transmission channels plus the acoustic loss be-

tween the transmitter and loud speaker of each station is kept at a constant value, or below a certain value which may be designated the howl level. The transmission efficiency is then increased in one channel and decreased in the other by the same amount and at the same instant.

Furthermore, when methods 1, 2, and 3 are built around the old voice operated magnetic type relay, which is somewhat inflexible, there are inherently lost and clipped sounds when the metallic contacts open or close. All these difficulties are overcome in the new system of electronic interlocking which uses method No. 4. Incidentally, this scheme of electronic interlocking as applied to the solu-

tion of this problem is very flexible and practically every element is independently adjustable in its function although there are no mechanical moving parts. Furthermore, it can be made operative for each vibration, or a group of vibrations as desired which no magnetic relay can follow. In the system described here gain in the used channel, and the corresponding decrease of gain in the other channel, are inserted in the system after the first few vibrations of the speaker. The listener could not actually hear the very first vibration alone even if the volume level were a maximum due to the fact that the nervous system cannot sense any phenomena before the sound nerves begin to function. Since the electronic interlocking system is capable of functioning and does function during this period when the ear is getting ready to hear the objectionable trouble of clipping and lost syllables is absent in this system. Likewise it is true that the first vibration is actually reproduced although the next few succeeding vibrations are reproduced at successively higher levels until the fixed level of gain is reached, so that the very first vibration does contribute towards getting the ear ready to hear. The loss of vibrations or syllables on the actual instruments is so small it cannot be discerned by the most critical so that the system operates and is practical without any loss of intelligibility. The improvement over mechanically operated relay systems of clipping speech is very marked, and speech is free from metallic ring.

Acoustic Treatment

It has been pointed out that the gain in both channels plus that between loudspeaker and microphone at each station must be below a certain value which is called the "howl level." Hence, it is obvious that the greater the acoustic loss between microphone and receiver of one station the greater can be the normal gain of the two amplifiers in the two directions. It is apparent that the more effective the acoustic treatment at each station, the higher this normal gain can be in both directions and the less can be the gain shifted automatically from one channel to the other for satisfactory loudspeaker intercommunication. However, it has been found possible to make the electronic interlocking sys-

tem work very satisfactorily under the very worst possible acoustic feedback conditions.

Amplifiers

The component parts used in the construction of the amplifiers are familiar to all electronic engineers and are in no respect unusual.

The circuit diagram is shown in Fig. 1. A 6J7 tube is resistance coupled to a 25L6 tube in each of two amplifier circuits working in opposite directions. Each amplifier is standard with the exception that some energy from each of the outputs is fed to the control system and also the second grid of each of the 6J7 tubes is used for control purposes. It is perhaps worth noting that the driving grids of the 6J7 tubes both have two sources of biasing potentials. They are biased by a cathode resistor to ground (R_c or R_{c1}) and likewise by a constant grid voltage to ground supplied by a potential divider R_{11} .

The Control System

The second grid of either one of the 6J7 tubes is connected to a network and the elements of a 6H6 tube in such manner that a positive potential is supplied to this grid when no sounds are being transmitted. This grid may be thrown more or less positive when sounds are transmitted depending on which channel is active. The potential of the second grid of the 6J7 tube is raised to a certain fixed positive value very quickly when sound is being transmitted principally by that channel. The fixed positive value to which it is raised is determined and limited by another 6H6 tube whose plate is connected to the 6J7 second grid and whose cathode is connected to the desired fixed positive limiting potential. The potential of the second grid of the 6J7 tube is lowered to a certain fixed positive or negative potential instantly, when sound is being transmitted principally by the other channel. The fixed positive or negative value to which this 6J7 second grid is lowered is determined and limited by another 6H6 tube the plate of which is connected to the desired fixed limiting potential.

In order to clarify action of this circuit refer to drawing of Fig. 2, a simplified diagram of the circuit for controlling the potential of the second grid of the 6J7. It consists of

three branch circuits. In the center branch, which is of high impedance and filtered, there is a fixed positive potential of say 1.5 volt represented by battery 1 and in series therewith is an element 2 which normally is neutral but may produce or tend to produce 150 volts of negative potential when the other channel is active. Also in series is an element 3, which may produce or tend to produce 150 volts of positive potential when the channel of the 6J7 shown is the principal carrier. It is apparent that 150 volts is considerably more than required either positive or negative, but it is also apparent that the voltage which actually tends to result on the grid is the algebraic sum of the voltage 1, 2 and 3. This resultant voltage is highly filtered and applied through a high impedance to the grid as shown in the diagram.

In addition to the center branch of the circuit is shown two other branches in which 5 is a battery, which would place a positive potential of 15 volts on the grid, but due to the rectifier tube 6 no current would normally flow. Likewise 7 is a battery which would place a negative potential of 1 volt on the grid but due to rectifier 8 no current can flow. Now assume that the channel containing the 6J7 tube is very active and unit 3 tends to generate 150 volts positive. It is obvious that the grid cannot go more positive than battery 5 or current will flow through the rectifier 6 in its normal direction so that there is a tendency to charge the battery 5. Similarly when 2 generates 150 volts negative it is obvious that the grid cannot go more negative than battery 7 or current will then flow through rectifier 8 in its normal direction so that there is a tendency to charge the battery 7. Since the elements 5 and 6 of one circuit and 7 and 8 of the other are of low impedance, they definitely place limits to the voltage of the grid of +15 volts and -1 volt or whatever other limits are desired. When neither channel is active the voltages of 2 and 3 soon become zero and the grid then floats at the intermediate voltage of battery 1. The impedance of the rectifiers in the reverse directions however are practically infinite so that the voltage of the grid between the limits of +15 and -1 is unaffected by the limiting tubes.

New, Sensitive, and Inexpensive Gas Control Tubes

Hot cathode tetrodes of high sensitivity and stability offer improved operation for circuits controlling power up to 65 watts. High input impedance makes these tubes particularly well suited to direct control by phototubes

THE use of a grid in hot-cathode gas-discharge tubes for controlling the initiation of the discharge is well-known and a variety of such tubes employing grids are available. Most of these are quite large, are capable of passing considerable current, and, in general, are relatively expensive. It has been apparent for some time that a small tube having uniformity and stability of control characteristics, high sensitivity, and low cost would find wide application. With this in mind, two tubes of novel design have been developed and are now available as the RCA-2050 and the RCA-2051.

Structurally these tubes are the same, the difference being in the gas-filling and processing. Before the constructional features are described, however, it will be well to consider the general subject of sensitivity of a grid-controlled gas-discharge tube; as well as other important points which determine the design.

The grid in a tube having a negative control characteristic takes no part in aiding the initiation of a discharge but serves solely to hold-out or prevent the discharge which would normally occur between a cathode and a positive anode. To prevent a discharge, the grid is made sufficiently negative so that no electrons can flow from the cathode, through the grid opening, into the anode region. This condition is the same as bias beyond cut-off potential for a like tube exhausted to a high-vacuum. As the grid is made less negative, the retarding field at the cathode decreases until a potential is reached where electrons from the cathode can just begin to get through the grid into the anode region. This potential corresponds to

By **W. ENDRES BAHL** and **C. H. THOMAS**

*RCA Manufacturing Co.,
Harrison, N. J.*

the cut-off point for the equivalent vacuum tube. These electrons are accelerated by the field from the anode and initiate a discharge by means of ionizing collisions with gas molecules. The grid voltage change between the off and the on potential is very minute and, in this respect, all gas control tubes can be said to have a high sensitivity.

For many tubes, however, it is usually not feasible to bias them close to the control potential (critical voltage) during inoperative periods, because instabilities in the tubes, fluctuations in supply voltage, or shifts in characteristics during life are apt to trip the tube. It is, therefore, necessary to bias the grid more negative than the critical voltage, and then to apply a sufficient signal to the grid to overcome the additional bias when it is desired to start the tube. It follows that the more stable and uniform the tubes can be made, the closer they may be biased to the critical voltage, with an increase in apparent sensitivity.

Since the grid of a negative-control tube collects no electron current up to the point of initiation of a discharge, it should be possible to employ large values of resistance in the grid circuit. This is desirable for phototube applications because a small change in current through a large resistor in the grid circuit, as controlled by the illumination on the phototube puts a large signal voltage on the grid, and the overall sensitivity of the resulting circuit is then high. The use of high values of grid resistance is also desirable in many other types of circuits, as it limits the ion current flowing to

the grid after a discharge is initiated and is, therefore, effective in isolating the control tube from the circuit preceding it. Such isolation is often essential to provide satisfactory operation of some circuits.

For satisfactory operation with high values of grid-circuit resistance, the composite of all grid currents should be negligible and constant as compared to the current from the external source which is to actuate the tube. The total grid current should be negligible because all current flowing through the grid resistor tends to put a voltage on the grid which must be counteracted with more grid-bias voltage; it should be constant in order that the same minimum value of signal can always start the tube. For d-c operation, the various factors which determine the composite grid current include: gas ionization either inside the electrode structure itself or between exposed leads inside the tube, produced by the high voltage between grid and anode; leakage across insulating members between grid and anode, and between grid and cathode; electron flow to the grid when its potential is near or greater than cathode potential; and electron emission from the grid if its temperature becomes high enough, or if it is illuminated by light which would cause photo-emission. For a-c operation, the additional factor of capacitance currents, principally between anode and grid, which flow through the grid resistor must be included. This last factor is usually not considered as a separate item in a discussion of grid currents, but it is of considerable importance and often accounts for some of the peculiar results obtained in grid-current measurements.

A circuit commonly used for the determination of grid currents is shown in Fig. 1. The dashed resistor and capacitor shown represent the leakage resistance, R_a , and capacitance, C_a , respectively, between grid and anode inside the tube, across the tube base and socket, and between the anode wiring and the grid lead connecting the grid resistor to the grid. Leakage resistance and capacitance between the grid and cathode are shown as the dashed symbols R_c and C_c , respectively. (If the impedance of the capacitor and resistor between grid and cathode are of the same order of magnitude as between grid and anode, they may be neglected in most computations, as they cause only minor corrections). R_g is the resistance in the grid circuit, E_{cc1} is the grid-supply potential, and e_c is the actual grid potential at any instant.

A common method of measuring grid current is as follows: With an alternating voltage of some definite value for the anode-supply voltage and the grid resistance zero, the grid voltage is first adjusted to such a value as to permit conduction, and then decreased until the tube will just fail to conduct. The value of grid voltage at this point is recorded as V_p . A value of grid resistance, R_g , of from one to ten or more megohms, is then placed in the circuit and the same procedure is repeated. The value of grid voltage at which conduction stops for this condition is recorded as V_r . It is then stated that the grid current

$$i_g = (V_1 - V_2)/R_g$$

This definition of grid current is useful for comparisons between tubes, or as a production check of the quality of a particular tube type. Technically, it is of very little value since it lumps the effect of many different factors, and can not, therefore, be used for the calculation of performance of circuits other than the one for which the measurements were taken. For this reason the above definition will not be used in this article; instead, each component of grid current will be treated separately.

One of the important components of grid current is that due to grid-anode coupling by means of the leakage resistance, R_a , and capacitance, C_a . Although R_a may be very high and C_a small, the coupling may be sufficient to account for a good

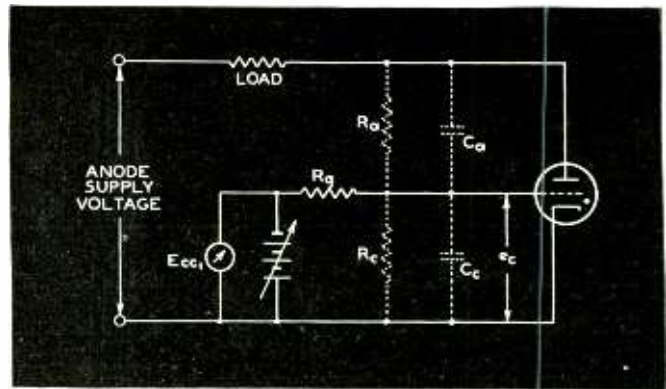

Fig. 1—Schematic wiring diagram for determining flow of grid current in a gas tube

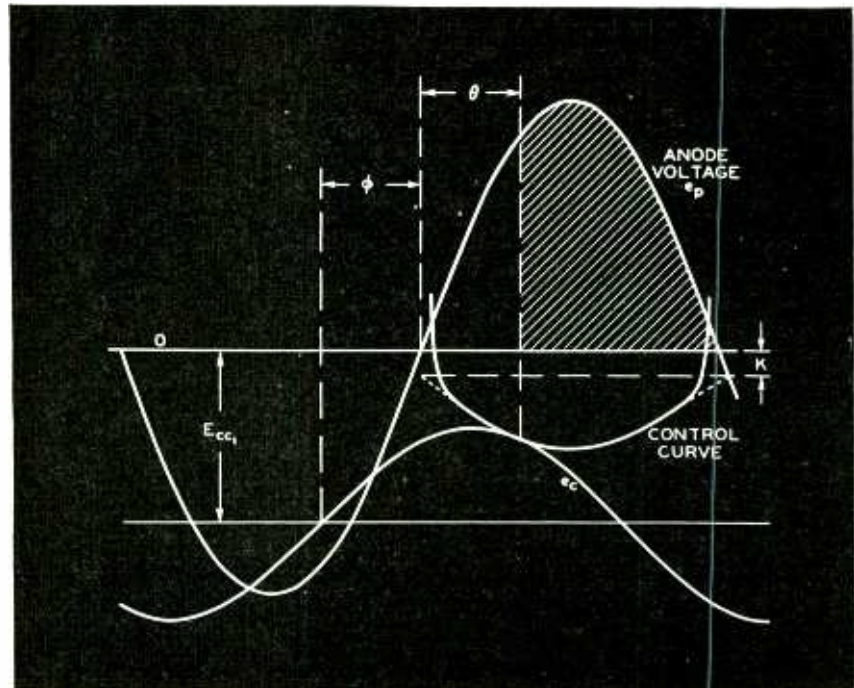

Fig. 2—Typical operating voltage wave forms for gas tube operated from alternating current. Conduction takes place during that part of the cycle when the plate is positive and the grid voltage is more positive than the control curve

many volts across the grid resistance, if the resistance is high. Because of the capacitive nature of the coupling, the current leads the anode voltage. The effect of this component of grid current, which increases proportionally to the anode-supply voltage, is illustrated in Fig. 2. The anode-supply voltage is represented by e_p , and the control potential for each particular anode voltage is shown as the "control curve". The grid-supply voltage, E_{cc1} is so adjusted that the true grid potential, e_c , is just sufficient to cause the tube to fire.

The a-c component of the grid potential is due to anode-to-grid coupling and leads the anode poten-

tial by an angle of ϕ electrical degrees. The grid potential, e_c , becomes sufficient to fire the tube at angle θ and conduction occurs over the remainder of the positive half-cycle of anode potential. Conduction starts before the peak of the cycle of anode voltage as a result of the grid-anode capacitance coupling.

It can be shown that the angle by which the coupling grid voltage leads the anode voltage is approximately

$$\phi = \tan^{-1} R_a / X_c$$

where $X_c = \frac{1}{2\pi f C_a}$ (1)*

f = frequency of the supply voltage. It can also be shown that the angle θ

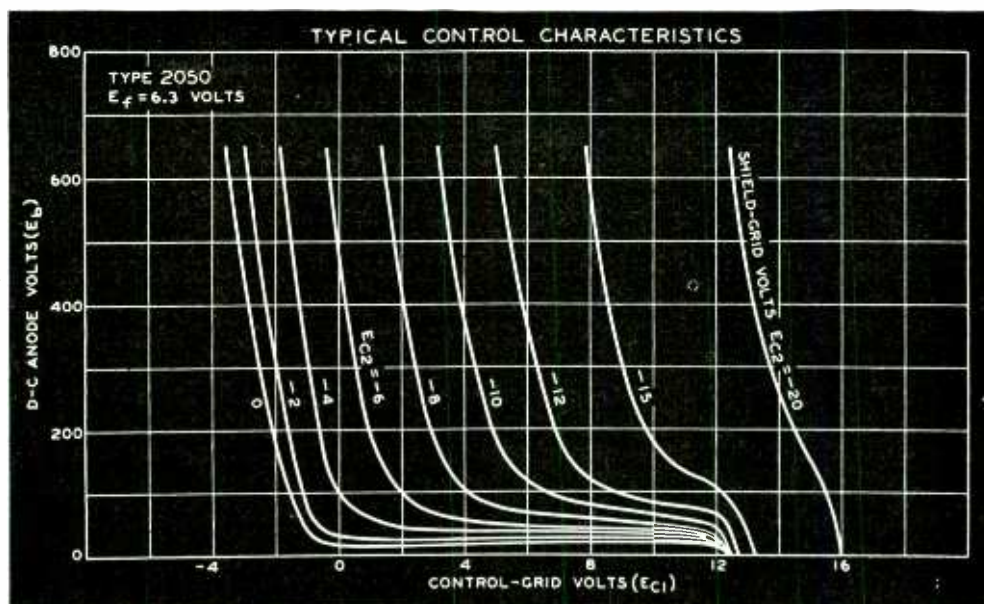
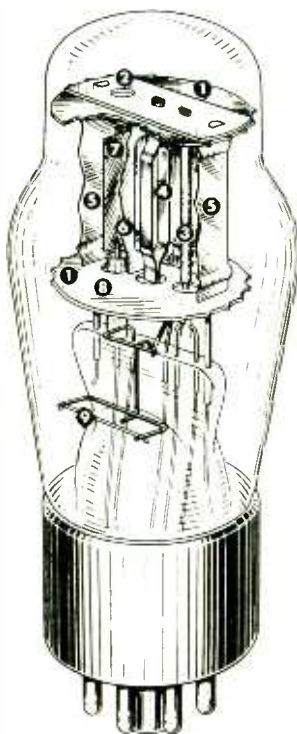

Fig. 3—Sectional drawing showing the construction of gas tetrodes. Numbered parts are described in the text

Fig. 4—Typical control characteristics of the type 2050 for various values of plate, control grid, and shield-grid voltage

for conduction is approximately

$$\theta = \tan^{-1} \left(\frac{X_o}{R_a} - \frac{X_a}{\eta R_o} \right) \quad (2)^*$$

where η = slope of the control characteristic. (For most gas control tubes, η is negative).

The only way that a tube can be made to start at the peak of the cycle is to have $X_a = \infty$ ($C_a = 0$) or $R_o = 0$, although when C_a is very small departure from the peak is not great until R_o becomes large. The grid-bias voltage at starting is greater than the control characteristic would indicate is necessary for the peak anode voltage, because the anode-grid coupling current flowing through the grid resistor must be counteracted. The additional bias needed is approximately

$$\frac{\Delta E_{cc1}}{\eta} \left[\sin \theta - \frac{\eta R_o \sin(\theta - \Phi)}{X_a \sin \theta} - 1 \right] \quad (3)^*$$

where E_p = rms anode voltage.

In order that this voltage should be as low as possible for a given value of grid resistance, R_a should be as large as possible, and C_a should be as small as possible. If the previously described definition for grid

current were used, then the component of grid current, due to anode coupling, might logically be defined

$$\text{as } (i_g)_a = \frac{\Delta E_{cc1}}{R_o}. \quad \text{It will be observed}$$

that, if this were done, grid current would appear to be a function of grid resistance, a condition of course which is not in keeping with our usual ideas of current. Actually, the grid current produced by anode coupling is an alternating current, and both its magnitude and phase must be known to be of any value in circuit calculations.

In the foregoing equations, only grid current due to anode-to-grid capacitance and leakage resistance coupling has been considered. Another path for current from the anode to the grid is through the gas. Normally, some ions and electrons produced by extraneous causes, such as cosmic radiation, are present in the anode-grid region of the tube. The electrons will be accelerated toward the anode by the high field between the grid and anode. If these electrons make many collisions with gas molecules in traveling along their paths, a considerable amount of ionization by collision can occur, and a fairly large current to the grid can result. This current will

flow through the grid resistor to produce an iR drop which must be compensated for by additional grid bias. Even with the use of low values of grid resistance, this gas current is undesirable as it is the preliminary step to cold-cathode breakdown of the gas between grid and anode and its presence indicates that the allowable limit of voltage for either the positive or negative half-cycle of anode voltage has nearly been reached. It is, therefore, essential to insure that the tube design is such that only a minimum number of ionizing collisions are made. The number of possible collisions can be decreased in two ways, namely: (1) by decreasing the gas pressure so that an electron in traveling a given path will find fewer molecules to collide with, or (2) for a given gas pressure, by decreasing the length of path that an electron must travel before reaching an electrode.

Too great a reduction in gas pressure is undesirable, as the tube drop in potential then must become higher during the conduction cycle in order to produce sufficient ionization to neutralize space charge. The most desirable method of insuring low gas current is to select a structural design in which all field lines

* Since these equations are approximate, their error may be appreciable for very high values of grid resistance. The equations apply to the circuit of Fig. 1.

between the anode and the grid are as short as possible. The gas pressure can then be made as high as is consistent with the voltage rating of the tube.

Tube Construction

The unique design of the RCA-2050 and RCA 2051 has made possible the incorporation of the many desirable features suggested by the above analysis. Figure 3 is a cut-away drawing of these tube types.

The cathode is the conventional oxide-coated type, indirectly heated by means of a 6.3-volt, 600-ma filament. It is located on one side of the stem and is shown as 3 in the figure.

The anode is located on the other side of the stem and is indicated as 7 in the cut-away drawing. It consists of a small, flat plate and is supported entirely by a heavy lead in the stem. A glass sleeve or pant leg 8 which is part of the stem, completely surrounds the anode lead, and extends up through the mica. The sleeve completely insulates the anode lead, externally to the tube structure proper, from all the tube elements and the other leads. It insures that there will be no gas discharge leakage current between the anode lead and any other elements, and also in providing a long surface leakage path between the anode and any other elements keeps the grid-anode resistance (R_a) very high.

Surrounding the anode and cathode is a metallic shield 5. A partition having a slot aperture 6 separates the anode from the cathode and divides the shield structure into two compartments. The shield is normally at cathode potential and serves several different functions. Nearly all lines of force emanating from the anode end upon this shield or mica shields 1 which close the end of the shield structure 5. The length of any of these field lines is short, so that few ionizing collisions will be made in this region, and gas leakage current will be kept low. Nearly all the gas current which does flow through this region goes to the shield instead of the grid and consequently, produces no voltage drop in the grid resistor. The shield partition, by its location, is very effective in raising the control ratio of the tube. It is in reality a grid electrode (shield grid); a change in the starting potential can be obtained by shifting its potential.

The control grid is the small electrode on the cathode side of the shield partition. It forms a slot aperture of some depth and in alignment with the shield grid aperture 6. The control grid is almost completely shielded from the anode by the shield grid. This arrangement reduces the grid-to-anode capacitance of the electrodes proper to a minimum. To carry this capacitance shielding

within the tube still further, a transposition of the leads is made so that the cathode lead comes through the stem between the grid and anode leads, partially shielding them from one another, and thus reducing the grid-to-anode capacitance.

As may be seen from the drawing, the grid is a small electrode. The use of a small grid is made possible by the shielded structure and is desirable in that the capacitance of the grid to other elements is small, and in that the ion or electron current collected by the grid during the discharge is small.

Two micas are used at the top of the mount and two at the bottom of the mount. The micas labeled 1 are coated with a conductive coating and complete the electrical shielding of the structure. They are electrically connected to the shield grid 5 and 6. These shield micas do not support the cathode and grid, this function being performed by insulating micas 2, one above the top shield-mica, and another underneath the bottom shield-mica. The shield-micas act as guards to prevent sputtered material or evaporated barium from the cathode depositing on the insulating support micas and building up leakage between the grid and cathode or shield-grid. Thus, the grid-cathode resistance (R_c) is high initially and remains so throughout life.

All parts are punched or pre-

Fig. 5—Grid current characteristics of the control grid of the 2050 after gas discharge

Fig. 6—Voltage-current characteristics of the shield grid after breakdown of gas in the 2050

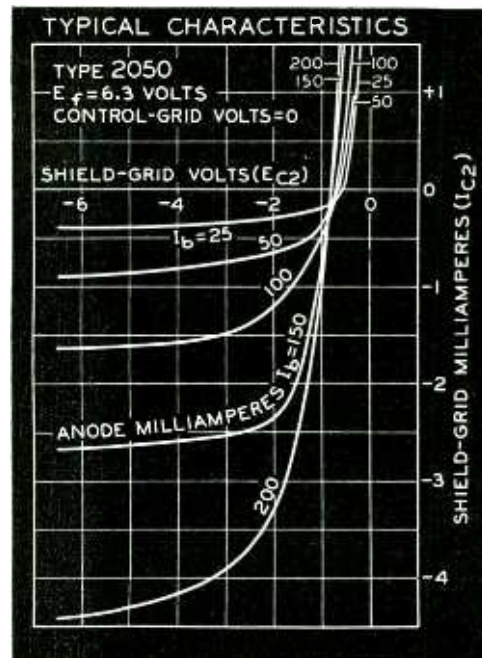
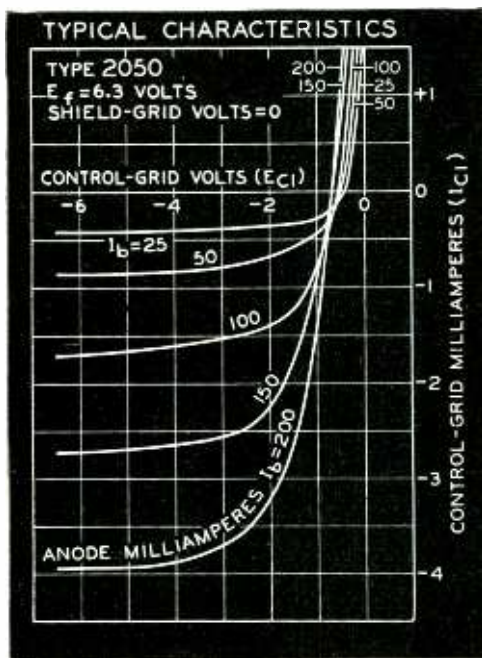

formed, and are designed for quick and easy assembly. The micas space and self-align the parts, and insure a high degree of uniformity of the characteristics between tubes.

Characteristics and Ratings

The control characteristics for the RCA-2050 are shown in Fig. 4. The potentials given are the potentials at the electrodes and therefore represent the true control characteristics. As was previously mentioned, the grid control characteristic can be shifted by applying different potentials to the shield grid.

It is not recommended that high values of grid resistance be used when the control-grid voltage is more positive at starting than about minus one volt, for then an electron current from the cathode flows through the grid circuit. This current can be as much as 5 to 10 microamperes depending upon the voltages on the various electrodes.

After a discharge has initiated, the grid collects either positive ions or electrons from the discharge, depending upon the grid potential. The magnitude of this current is indicated by the grid-current characteristics after breakdown. Figure 5 shows this characteristic for the control grid; and Fig. 6, for the shield grid.

The characteristics of only the

2050 are shown. The control characteristics of the 2051 are very similar except that the curves at the low anode voltages bend over at a higher value than for the 2050. This is because the ionization potential of the argon gas which is used in the 2051 is higher than for xenon which is used in the 2050.

Tube ratings and other data are given in Table I.

TABLE I — RATINGS of 2050 and 2051

Heater voltage.....	6.3 volts
Heater current.....	0.6 amp.
Heating time.....	10 sec.
Grid-anode capacity.....	0.02 μmf
Other control grid cap.....	3.8 μmf
	2050
Pk. fwd. voltage..	650
Pk. inv. voltage..	1300
G ₂ voltage.....	0
Peak value I _p *....	500
Average I _p	100
Tube voltage drop	8
Grid resistor	0.01
in megohms	10
	2051
Pk. fwd. voltage..	350 max.
Pk. inv. voltage..	700 max.
G ₂ voltage.....	0 volts
Peak value I _p *....	375 ma. max.
Average I _p	75 ma. max.
Tube voltage drop	14 approx.
Grid resistor	0.01 min.
in megohms	10 max.
*Averaged over period of not more than 30 seconds.	

Stability of Characteristics

For proper design of circuits using gas-control tubes, it is important to know how stable the characteristics of the tubes are from cycle to cycle, and over long periods of time. Tests made over periods of a few hours with both the 2050 and

the 2051 show no noticeable change in the control characteristics. This has also been verified by tests with a cathode-ray oscillograph. These show the starting voltage from cycle to cycle to be very uniform.

However, continuous operation of the tubes at maximum rated current causes a shift in the control characteristics to become apparent in a few days. The rate and amount of this change is not always the same but varies somewhat from tube to tube. The rate and amount of the shift is also dependent upon the load current, being greater for larger values of load.

If the grid control voltage for maximum rated anode voltage is plotted as a function of time of operation at maximum rated peak and average current, a curve similar to Fig. 7 is obtained. Most of the change has occurred in a period of about 200 to 500 hours, little change being observed from then on until the tube finally fails due to a loss of cathode emission. The magnitude of the shift is greater for the 2051 than for the 2050, the maximum change for the 2051 being about 0.8 to 1.0 volts and for the 2050 about 0.3 to 0.4 volts.

The shift in the control characteristic is attributed to two factors. The first of these is a change in the contact potential between the grid and a contacting surface layer (probably barium) on the grid, caused by bombardment and heating of the grid by the discharge. The second is a localized lowering of the cathode emission opposite the grid aperture caused by positive ion bombardment of the cathode by high velocity ions during the formation of the discharge. Both these phenomena cause a shift in the characteristic which must be compensated for by a reduction in negative grid voltage.

If the surface layer could be re-deposited on the grid, and if the cathode could be reactivated, the control characteristic should again shift back toward its original position. This actually occurs in practice if the tube stands with cathode heated, and the grid biased negatively enough to prevent a discharge. The control characteristic will shift back to nearly its original position in less than an hour with rated heater voltage. Thus, for conditions where op-

(Continued on page 94)

Fig. 7—Variation of breakdown voltage throughout the life of the tube. This value is about 0.9 volt for the 2051 and about 0.3 volt for the 2050

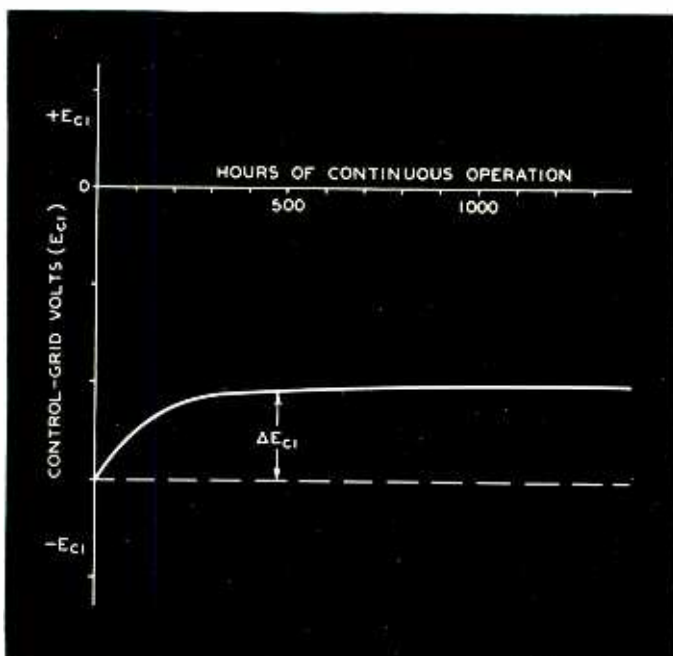

Electronics in Auditory Research

Electronic instruments are used to study the nature of hearing and to diagnose deficiencies so that the proper corrective treatment may be applied. Considerable material on the process of hearing, which should be useful to communication engineers is given

By DAVID M. SPEAKER

Otological Research Laboratory
Abington (Penna.) Memorial Hospital

THE communication engineer is primarily concerned with the conversion of sound into electrical energy, its transmission at audio or higher frequencies, and its ultimate reappearance as an acoustic signal. His function, though not necessarily his interest, usually ceases at this point. There remains, however, one important link in the chain which in the final analysis provides the motivation of his efforts and that is the physiological sense of hearing.

The ear is divided, both anatomically and physiologically, into three parts, the outer, middle, and inner ear. The outer ear includes the auditory canal and ends internally in the ear drum or tympanic membrane. The middle ear is a cavity containing three small bones called ossicles which, with the ear drum, provide mechanical linkage between physical sound vibrations and the inner ear. The inner ear includes a spiral cavity known as the cochlea which is filled with a fluid. Within this cavity and continuously bathed in the fluid are thousands of minute nerve endings which unite to form the auditory nerve whose function it is to convey acoustic stimuli to the brain where they are interpreted as sound sensations. There is evidence to show that frequency discrimination is connected with the localization of the cochlear nerve endings. Those near the apex of the spiral apparently respond to lower frequencies and those near the base to higher. It is also within the cochlea that the conversion of mechanical to neural transmission of sound takes place.

It is a general law of physiology that whenever a healthy nerve is stimulated local changes of electrical

potential are produced. If a tone of specific frequency, say 1000 cps, is presented to the ear, it is possible to pick off a 1000 cps emf from the nerve or from the cochlear wall. A certain amount of distortion is introduced by the inherent non-linearity of the ear and if two different frequencies are employed, sum and difference frequencies occur along with the fundamentals. The electrical output from the nerve, or "action potential" as it is called by physiologists, may be amplified and measured by comparing it with a standard signal of the same frequency. By altering the hearing mechanism in appropriate ways, as through surgical or chemical intervention, one can raise or lower the signal level from the cochlea or nerve. These changes provide a means of accurately estimating the results derived from the particular technique employed and often lead, sometimes directly, sometimes indirectly, to additional information about the ultimate nature of the hearing process. The general experimental procedure outlined in this paragraph is in use at this laboratory and such work is performed upon animals under ether anesthesia.

Most of the difficulty encountered in the satisfactory amplification of

action potentials of this type results from their extremely low values which may be of the order of three to ten microvolts. This requires the use of high gain equipment which, in turn, results in a rather high noise level. The amplifier used for this purpose (Figs. 1 and 2) consists of five single ended resistance-capacitance coupled stages and a sixth stage, also single ended, which has some inductance in series with the plate load resistor. The first four stages, which comprise the first unit of the amplifier, use Western Electric type 102G tubes. These tubes were chosen because of their inherently low microphonic and emission noise levels and their reasonably constant characteristics. Mica capacitors are used for coupling to reduce leakage, and precision wire wound resistors are used throughout to minimize thermal noise. A storage battery furnishes the filament voltage. The plate supply consists of two parts. The first is a conventional full-wave rectifier and filter in connection with a voltage regulator of the degenerative amplifier type. This feeds into a stabilizer circuit whose output is shunted by sufficient capacity to remove any hiss generated by the amplifier tube of the voltage regulator.

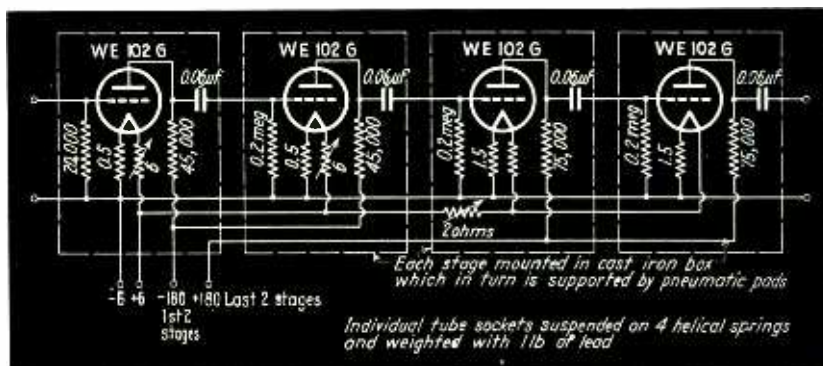

Fig. 1—Circuit diagram of the first four stages of the action potential amplifier. Tubes with low emission noise and low microphonics are used

The last two stages of the amplifier are mounted on a small relay rack and they use a type 27 tube and a type 38 tube. The output of the 38 may be fed into a cathode ray oscillograph, a loudspeaker, or a dynamic telephone receiver. The dynamic receiver is usually used when actually measuring signal levels by the comparison method. The power supply for this unit is like that of the first except that the stabilizer is omitted.

five db steps which is used for accurate adjustment of the output level. The loudspeaker in the sound proof box is connected with the oscillator output in these experiments. It is joined by a Siamese connection to two rubber hoses which convey the acoustic signal to the ears of the animal under test. Valves are provided so that either ear may be stimulated independently. The output from the animal is then amplified by the equipment described above. The

notes in one side of a double throw switch, the other side of which is connected through an attenuator box directly back to the oscillator. During an experiment this attenuator is adjusted until the two signals are heard at equal loudness through the telephone receiver, and with practice it is possible to obtain results which are reproducible within one db. Measurements are made in this way at each desired frequency both before and after the animal's ear is operated upon or altered. The resulting change in signal level indicates the effect of the procedure.

Audiometry

Measurements of human hearing all involve the general principle of exposing the subject to an acoustic stimulus of some kind and then inferring the result from his or her subjective reaction. Consequently, not only the actual hearing mechanism alone is involved, but an additional psychic factor as well.

It is well known that there exists a threshold of sound intensity below which no sensation is evoked and that this threshold varies with frequency. From the engineering point of view, the ear is afflicted with frequency distortion as well as non-linear distortion. It may be mentioned in passing that the response curve is flatter at high than at low intensity levels. At threshold levels the ear is most sensitive within the one to four thousand cps range. At fifty cps the response falls off by forty or more db. Similarly, the threshold rises at higher frequencies and after sixteen to twenty thousand cps, and often much lower, no sound is heard however intense the signal may be. The low frequency limit is a little difficult to determine with precision because at this end of the audio spectrum the sensation of tone changes almost imperceptibly into that of feeling. The figure of sixteen cps is accepted as marking this limit.

The measurement of the frequency response of the ear, and indeed of the overall hearing mechanism, is called audiometry and the equipment used an audiometer. Audiometers of many types have been constructed and several designs are commercially available. However, they all contain three fundamental components, an audio oscillator, an attenuator, and a receiver. In order to com-

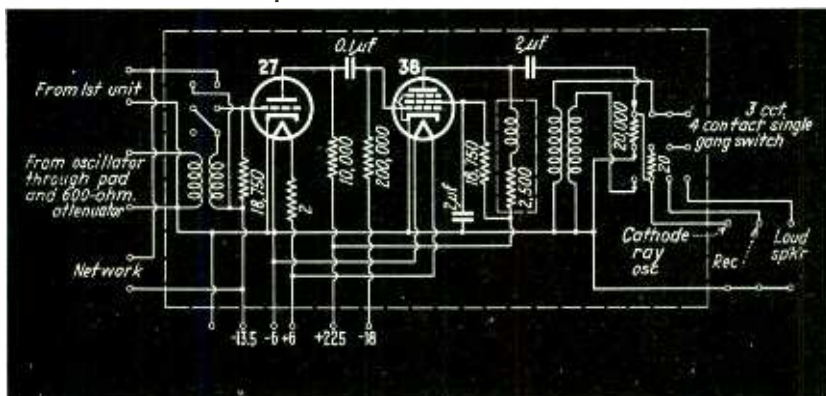

Fig. 2—Circuit of the last two stages of the action potential amplifier which are contained in a separate case. This amplifier is used to amplify voltages picked off the auditory nerves

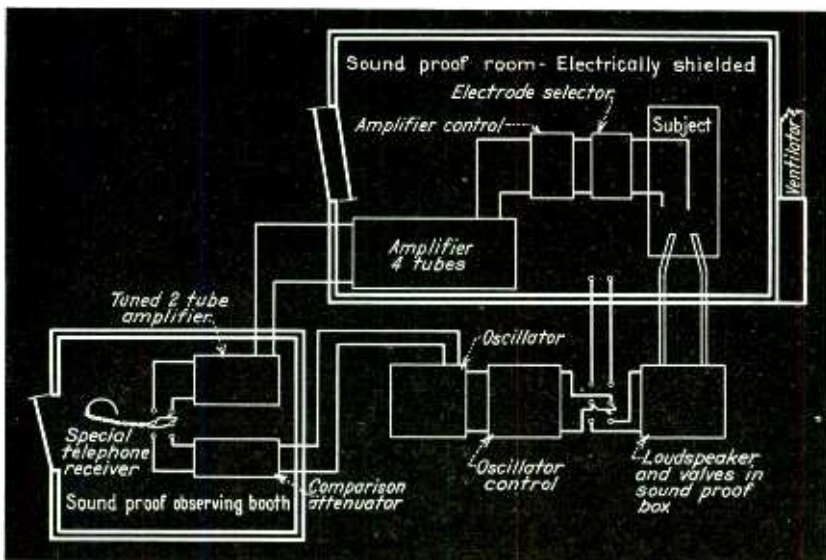

Fig. 3—Arrangement of the apparatus for measuring the action potentials of the auditory nerves for various frequencies and sound levels

Reference to Fig. 3 will indicate the layout of the equipment as set up for an experiment. The oscillator shown is the beat frequency type with an effective range from 20 to 20,000 cps. This is used as a source of frequency for all tests and measurements made at this laboratory. The oscillator control indicated in the figure is a T-pad arranged in

tuning of the final amplifier is accomplished by a parallel resonant circuit which may be adjusted to any of the frequencies used in these experiments and it serves to eliminate much of the tube hiss and thermal noise which would otherwise mask the desired signal. Selected frequencies from about 180 to 8000 cps are employed. The amplifier termi-

ply with the standards established by the American Medical Association through its Council on Physical Therapy certain minimum requirements must be met. These concern such points as attenuator tolerance limits, allowable harmonic content, and the decibel ranges available at these frequencies. In this laboratory the oscillator mentioned previously is used for audiometric measurements. The frequencies used are 128, 256, 512, 1024, 1448, 2048, 2896, 4096, 5792, and 8192 cps. The oscillator output is passed through a filter circuit, tunable to reject any undesired harmonic component present in the signal, and then into the sound proof room shown in Fig. 3. This room contains the other two parts of the audiometer, the attenuator and the receiver. A standard diaphragm type receiver is used for air conduction measurements. A special type in which the diaphragm is replaced by a piston which may be held against the skull is used for bone conduction. During actual test conditions the person being examined listens to a tone of given frequency while the intensity is varied in steps of five db. It is universal practice to attempt a precision no greater than this since smaller variations are not considered clinically significant. The subject signals by means of a push button connected with a pilot lamp as long as the tone is audible. The faintest audible level is recorded for each frequency. All readings are measured in terms of loss or gain with respect to a statistically determined threshold for the frequency in question.

From this it follows that the audiogram of a person whose hearing curve corresponded with the statistical normal would read zero for each frequency indicating no deviation. The net information derived from the use of this equipment is essentially the knowledge of how the individual's threshold audibility curve varies from what is considered on the basis of experience to be normal. This knowledge may prove of benefit in three ways. It may afford some basis for diagnosis of the condition responsible for the hearing loss, if such exists, through the shape of the response curve; under certain circumstances, in connection with other findings, it may enable the specialist to venture a reliable guess as to the future course of the

condition; and, lastly, it may be used, if the test is repeated periodically, as a means of evaluating the merits of the particular form of therapy employed.

Nerve and Conductive Deafness

Most types of deafness are traceable to defects of the middle ear, the inner ear, or the acoustic nerve. This classification omits hearing impairments due to damage to the hearing centers of the brain and to such essentially trivial causes as the obstructing presence of some foreign body in the auditory canal. Defects of the middle ear resulting in deafness usually involve the ossicles in such a way as to interfere with their mechanically conductive function.

establish a differential diagnosis of these two kinds of deafness on the fact that persons afflicted with the conductive type can be made to hear, often quite well, through the aid of bone conduction. That is, a source of audio frequency vibration such as a tuning fork or piston receiver if suitably brought into contact with the skull, produces a sensation of tone. In this case it is clear that the bones of the skull supply an acoustic transmission system physically analogous to that previously provided by the now ineffective ossicles. Also, in these cases normal air conduction via the auditory canal is obviously impaired because there is no longer a satisfactory connection between the cochlea and the ear drum. In the case of nerve deafness, how-



Fig. 4—Audio oscillator and associated equipment used for delivering sound to the subject. The loudspeaker is contained in the sound proof box at the right

The precise nature of this defect may vary from a limitation of their normal motions to the complete absence of these bones, but the end result is always a partial or complete failure of acoustic impulses to reach the cochlea. Deafness of this type is called conductive deafness.

Pathological disturbances of the cochlear structure or of the auditory nerve are responsible for a type of hearing loss called nerve deafness. Such cases are often characterized by a relatively higher impairment in the upper than in the lower audio range. In the past it was common to

ever, the problem is obviously quite different. The cochlea or nerve doesn't respond, no matter how the stimulus may be conveyed to it. Under such conditions, as would be anticipated, the use of bone conduction methods lead to essentially negative results. Within recent years, however, more precise and quantitative techniques have been developed.

The reader will perhaps recall that sensations respond logarithmically, up to an overload point, to increase of stimulus intensity. If we were to plot loudness as a function of sound intensity for a normal ear

using the same number of decibels as a unit for both ordinate and abscissa, we would get a straight line passing through the origin at an angle of forty-five degrees. If this hypothetical ear suffered from conductive deafness, we would expect a similar line, with the same slope, only displaced to the right by an additive constant representing the attenuation of this impaired ear. This attenuation would be the same at all sound levels. With nerve deafness, however, it is found that the sensation of loudness increases more rapidly than in the previous cases and hence the line would have an angle greater than forty-five degrees. With sufficient increase in intensity, it would tend to intersect the line of normal hearing. This means, essen-

only, no sensation will occur. A normal ear, however, will respond to the extent of five fibers. If the intensity is increased to the level needed to excite twenty fibers, the nerve deafened ear will respond with ten while the normal will of course respond with twenty. At the point where the whole hundred fibers would respond in the normal, ninety will respond in the impaired. Thus, with increase of intensity the ratio of impaired to normal response approaches unity. This phenomenon has been called recoupment.

A relatively simple diagnostic procedure, based upon the recoupment principle, is employed. This test is known as the loudness balance test. As in the usual audiometric measurements, the oscillator is used as a

short of that of the good one. This test is repeated for various higher levels, the loudness being balanced each time. From the discussion in the paragraph above, it is clear that in cases of conductive deafness the reading of the second attenuator will remain constant, indicating a constant hearing loss at all intensity levels. In nerve deafness cases on the other hand this loss will decrease as the input level is increased.

Speech Reception

It will be recalled that the audiometer is used to measure discrete frequency response at threshold level. From time to time the objection has been raised that this procedure does not necessarily result in a valid indication of the ability to understand speech at normal vocal levels. And it is, after all, the estimation of this ability which is of vital importance to the deafened individual. For this reason another type of hearing test is employed. It is called a speech intelligibility or perhaps more properly a speech reception test. The equipment used is, essentially, a modified public address system and consists of four components. These are a microphone, an amplifier with a volume indicator, an accurate attenuator, and a telephone receiver. These are illustrated in Fig. 5. The microphone is a Western Electric dynamic unit, type 630A. The amplifier was built at this laboratory for specific application to the test to be described. The circuit consists of five push-pull stages, the last of which consists of a pair of 6A5G tubes. These output tubes are operated in class AB_1 at fixed bias which may be adjusted separately for each tube. The two end controls and milliammeters shown in the illustration are used for this purpose. The center instrument is the volume indicator and its zero reading may be controlled by the range switch next to it. The first two stages of the amplifier use 6J7's designed to have a low noise level. The intermediate stages employ 6A6's. The power supply unit is separate as shown. It provides A, B, and C voltages for the amplifier. Rectified and filtered current is supplied to the heaters of the first two stages to minimize hum. A voltage regulated power supply provides B voltage for all stages but the last. A transformer, not il-

(Continued on page 92)

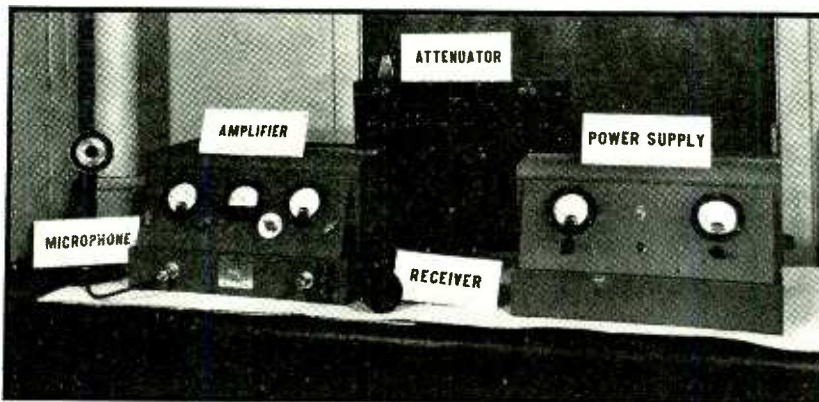

Fig. 5—Apparatus used for administering the speech reception test. Standard sentences are spoken into the microphone and sent to the subject at various levels. The level at which the sentence is no longer intelligible gives a measure of the quality of the subject's hearing

tially, that for low intensities the hearing loss is relatively greater than for high. In fact, at high intensities it may become quite small, giving nearly normal response.

The theory accounting for this curious and diagnostically valuable phenomenon, has been advanced in the following terms. It is supposed that the apparent loudness of a sound is a function of the number of nerve fibers excited during a given interval of time, the more intense the sound, the more fibers being stimulated. Suppose now, for the sake of simplicity, that the auditory nerve contains exactly one hundred fibers (a ludicrously small figure). Assume further that in a given case of nerve deafness ten of these are for some reason inoperative. If a very faint sound is presented to the subject, sufficient to excite five fibers

signal source. Its output, after filtering, is fed into an attenuator which feeds a telephone receiver. This we will call receiver A. Across the junction of these is connected another attenuator which terminates in a second receiver B. By means of an automatic switching arrangement, the signal may be sent to either ear alternately. Suppose that the subject has one normal and one impaired ear. Receiver A is held against the poorer ear and receiver B against the better one. By means of the input attenuator the input level to A is adjusted to threshold value. As the signal is thrown from ear to ear, the second attenuator is then adjusted to the threshold level of the other ear. At this point the reading of the second attenuator indicates the number of decibels by which the acuity of the bad ear falls

Antennas for F-M Reception

OPTIMUM operation of any radio receiving system requires a relatively strong, noise-free signal from the antenna. For this reason the signal pickup device should be located most advantageously with respect to the signal field strength and the signal-to-interference ratio.

Another important reason for the proper selection of an antenna system for f-m reception is that many f-m receivers are used to receive amplitude-modulated programs, in the standard as well as in the short wavebands.

If a very marked difference in signal-to-noise ratio is noticed when changing from an f-m station to a-m station, the listener is bound to be disappointed and annoyed. It is therefore imperative to incorporate in the antenna system all the noise-reducing features now available for use in a-m reception.

Antennas for F-M Reception

The three considerations governing the selection of antenna structures in general, and in particular for f-m reception, are signal strength pickup, directivity, and inherent ability to reject interference. From the standpoint of signal strength pickup, a structure that is resonant or nearly resonant to the frequency to be received, is always preferable. This requirement is hard to fulfill when the band is wide, as for example, the standard broadcast band of 550 to 1,500 kc. The f-m band is relatively narrow, about 8 percent above and below the mean frequency. Hence, a resonant structure such as a half-wave dipole is very well suited for the purpose.

From the standpoint of directivity, the requirements vary with the locality. In general, however, the antenna should be non-directive, except when it is desirable to receive a particular station which delivers

a relatively weak signal at the receiver location. When two f-m stations operate on the same frequency, or very nearly so, the only way of separating them is by the directional properties of the antenna. Outside of these particular cases, which are the exception rather than the rule, the f-m antenna should be non-directional.

From the standpoint of the third requirement (rejection of spurious radiation from sources other than from the transmitting station to be received), the type of antenna structure should be such that it receives signals by virtue of phase displacements in the signalling electromagnetic wave in space as it strikes the antenna, rather than by differences of potential between the antenna and ground.

The symmetrical dipole is a structure which operates upon this principle as a signal collector. The transmission line, either the balanced, or the concentric type, if properly coupled to the dipole at one end and to the receiver at the other, will be immune to radiated waves which reach it in the same phase at all points. Therefore differences of potential cannot be produced across the transmission line and consequently, no voltage appears across the receiver terminals. The angle of polarization has an effect, but it is too complex for analysis here.

From these considerations, it appears that the dipole type is the most suitable structure for f-m reception. But we said before that most receivers operate in one or more a-m bands. It is clear that some expedient must be resorted to, in order to make these short dipoles operative as Marconi type antennas which function as elevated capacities actuated by differences of potential with respect to ground. How this is done, will be shown somewhat later,

when we study the antenna coupler.

Dipoles for F-M Reception

Doublets are highly responsive to frequencies which are related in odd multiples of half wavelengths to the length of the dipole. When the length of the doublet is an even multiple of a half wavelength, its impedance is high and it is necessary to use a device that will reverse the voltage of one arm with respect to the other to obtain a difference of potential across the transmission line. This is often done by means of a quarter-wave matching stub. Its dimensions and the difficulties of installation make its use undesirable. Therefore, doublets of one, three or five half wavelengths are more practical because they need no phase-reversing devices and their impedance is low and not far from that of the average transmission line. From the point of view of ultrahigh-frequency reception, the line may be connected directly to gap of the dipole.

The directivity of a half-wave dipole is concentrated in a line at right angles to the dipole structure. As the length is increased to various multiples of one-half wavelength, the directivity assumes patterns such as shown in A, B and C of Fig. 1 and begins to swing from a direction perpendicular to the structure to directions forming angles with it of less than 60 degrees, as in Figs. 1B and 1C.

The three-halves wave dipole is the best for f-m reception from all directions, but for greater directivity the half wave dipole is better. The latter is so simple and such an easy structure to erect, that ordinarily it is the most advantageous for all-around purposes.

Ordinarily, the standard a-m broadcast band can be received in a very satisfactory manner with the length of conductors required by the

The requirements of an antenna system for frequencies of the order of 45 Mc are discussed together with the merits of dipole antenna for this service. An antenna system for the combination f-m, a-m, short-wave receiver is described

By J. G. ACEVES

Amy, Aceves & King, Inc.

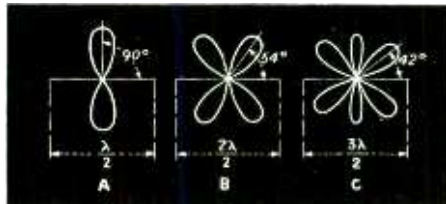

Fig. 1—Directional characteristics of antennas of various lengths relative to the wavelength

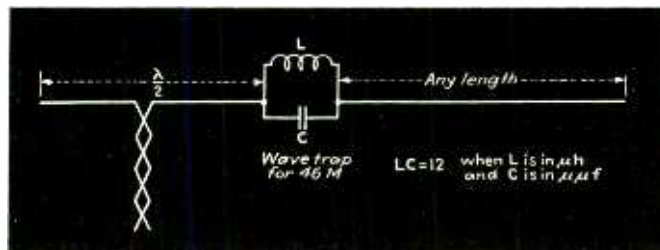

Fig. 2—Method used for obtaining sufficient signal strength in the standard broadcast band. An additional length of wire is connected to one side of the dipole through a 46 Mc wave trap

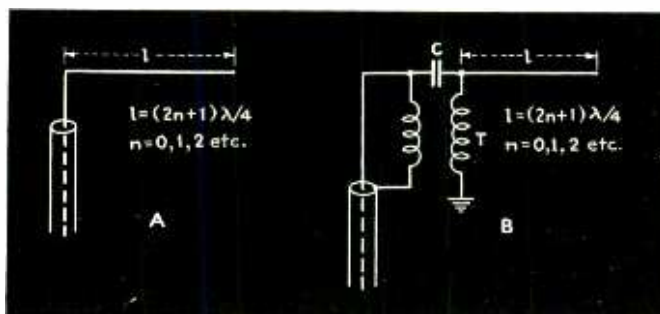

Fig. 3—A half doublet antenna with concentric line. If this is to be used also for standard broadcasting, a suitable coupler (B) must be inserted

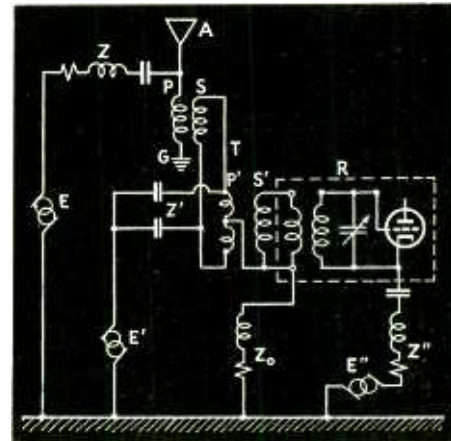

Fig. 4—Antenna and receiver circuit showing sources of signal and noise

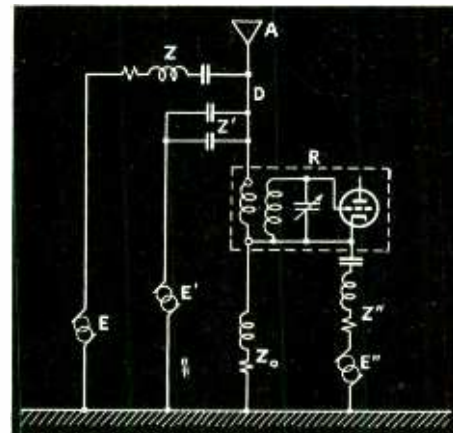

Fig. 5—Method of eliminating noise. A transmission line is connected to the antenna and receiver by transformers

dipole for 40 to 50 Mc, which is in the vicinity of ten feet, provided that a suitable coupler is interposed between the dipole and the line. However, if the signal strength is weak and a longer conductor is needed, a very simple method can be used of the dipole at high frequencies, but will permit a longer antenna conductor to be used at a-m broadcast

frequencies only. This is shown in Fig. 2. It consists of adding a much longer wire to one arm of the dipole, but interposing a wave trap or anti-resonant circuit for 46 Mc (mean f-m frequency). A practical form of this trap is a single layer solenoid one inch in diameter, wound over an insulator, with 16 turns of No. 18 enamel copper wire so that all turns touch each other. This coil, with its

distributed capacity, has an impedance slightly over 50,000 ohms at 46 Mc, and it remains high enough throughout the entire f-m band.

When the noise is not very severe in the ultrahigh-frequency band and the field strength is at least fair, it is possible to replace the doublet type of antenna by half a doublet. A half-doublet, or quarter-wave arm arrangement is shown in Fig. 3A

where a concentric line has its inner conductor attached directly to it. If this structure is to be used also for a-m reception, a suitable coupler must be interposed, otherwise the signal pickup of this short rod would be very weak at say one megacycle. Fig. 3B shows a step-down transformer for the lower frequencies and a capacity coupling for ultrahigh frequencies. The length of the single arm structure should be an odd multiple of one-quarter wavelength.

Interference Reduction in the A-M Bands

In order to get noise reduction in the a-m bands, such as the standard broadcast band, it is necessary to completely isolate the paths of the noise-producing currents from those resulting from the signal pickup. The theory of noise reduction in a-m reception has been analyzed in various papers some of which were presented by the author before the Radio Club of America.¹

Consider the simple receiving antenna and radio set in Fig. 4. The antenna A will pick up signal energy as if a generator E in series with the antenna impedance Z was supplying energy in the series circuit E, Z, A, D, R, Z_0 , where A is the antenna, D the downlead, R the radio set and Z_0 the impedance of the ground connection. In addition to the current flowing from the source E there are a number of spurious currents originating from sources of interference that could be represented as follows: A source of direct radiation to the downlead E' in series with a high impedance, Z' will force a flow of current through the radio set R back to ground. Another source E'' in series with an impedance Z'' equivalent to interference which comes by the power line connection of the receiver, will send a current returning to ground via impedance Z_0 and also via the antenna circuit which of course includes the input of the radio receiver. A method of eliminating the effects of these spurious currents is shown in Fig. 5. The signals follow a path of their own through the antenna A , the primary P of the antenna transformer and back to the ground. The secondary S will deliver a voltage across the

transmission line T which will force a circulating current in the line and enter the receiver coupler through its primary winding P' and deliver a signal voltage across the secondary S' to the radio set. Note that the path of the interference from source E' is a balanced one with respect to ground. Currents of equal magnitude and in phase will flow to ground via the two wires of the transmission line and the center tapped primary P' of the receiver coupler, thereby inducing no secondary voltage. Consider now the most prolific source of interference, that from the source

represents a coupler for this type of structure. Voltages induced by the passage of ultrahigh-frequency signals in the dipole DD' cause currents to flow through the primary winding P'' of the transformer designed for the f-m band. A voltage will be induced across the secondary S'' which is connected to the transmission line and delivers the signal energy through the very low reactance condensers C and C' for u-h-f currents in series with the wires of the line. The presence of these condensers does not interfere with the normal passage of ultrahigh-frequency sig-

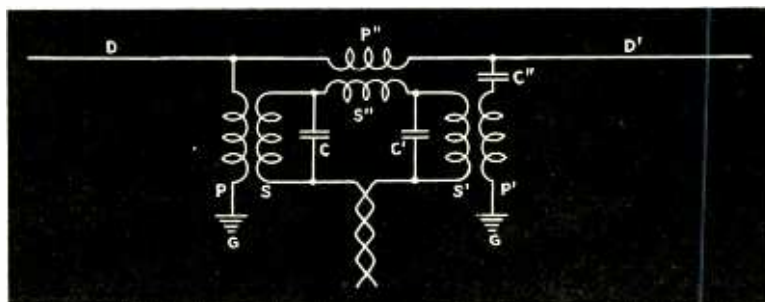

Fig. 6—Dipole antenna system for both f-m and a-m reception. The u-h-f signal is passed through transformer $P''S''$ and the standard broadcast signal through transformers PS and $P'S'$

E'' . It simply does not have a common circuit with the paths of the signal. Current will flow through Z'' to ground and up towards the antenna but will meet a "dead end" at the antenna coupler provided that the capacity between primary and secondary is made extremely small.

When a number of broadcast frequency bands are to be received, it is a matter of providing suitable transformers with suitable condensers for the various bands so that there are no interfering reactions between them. The general principles, however, remain unaltered.

Antenna Couplers

Let us consider the antenna of the dipole type for f-m reception, which is used as a Marconi antenna for the lower frequency bands. Figure 6

represents a coupler for this type of structure. Voltages induced by the passage of ultrahigh-frequency signals in the dipole DD' cause currents to flow through the primary winding P'' of the transformer designed for the f-m band. A voltage will be induced across the secondary S'' which is connected to the transmission line and delivers the signal energy through the very low reactance condensers C and C' for u-h-f currents in series with the wires of the line. The presence of these condensers does not interfere with the normal passage of ultrahigh-frequency sig-

nal currents as delivered by the secondary S'' . Two transformers designed to pass more efficiently currents of frequencies in the broadcast and short-wave bands respectively, have their primary windings P and P' connected to a local ground. Their secondaries S and S' are in series with each other. The two primary windings allow currents proceeding from the antenna structure forming the dipole, acting as a whole as an elevated capacity, to pass from this antenna to a local ground. In so doing, voltages are induced in the secondary windings S and S' which are impressed across the transmission line through the low inductance f-m secondary S'' in series with them which has low reactance for the broadcast and shortwave currents. A third condenser, C'' pro-

(1) *Proceedings of the Radio Club of America*, November 1935 and May 1938.

vides a low reactance path to ground for frequencies in the shortwave band, but high for those in the broadcast band. From the foregoing considerations it follows that there is no substantial mutual interference between the various transformers and associated circuits in the antenna coupler designed to cover the three bands.

Receiver Couplers

In considering the receiver coupler, let it be assumed that the re-

radio receiver and the transmission line. There is also a minimum of capacitive coupling between windings, achieved by careful construction of the three transformers. The use of iron dust cores permit a reduction of mutual capacity for a given mutual induction. In this manner, spurious currents finding their way through the chassis of the radio receiver by virtue of its connection to the power line (either directly as in ac-dc sets or through the capacity of the 60 cps transformer sup-

where a 25 $\mu\mu\text{f}$ condenser and a 10 μh choke accomplish the desired frequency selections and prevent spurious interactions.

Transmission Lines

In the foregoing descriptions of the a-m, f-m noise-reducing antenna system, it was assumed that the transmission line was of the balanced type. Since in the design of the antenna and receiver couplers just described, there is no physical connection between the line and the

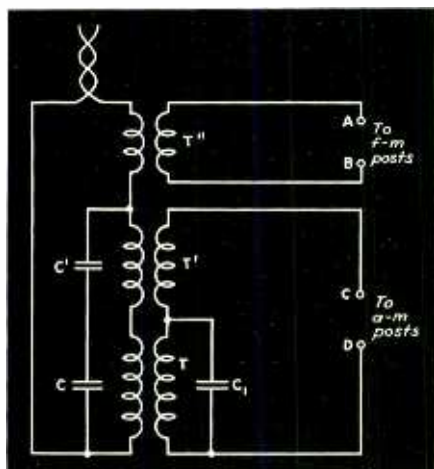

Fig. 7—Antenna transmission line connections to a receiver with separate f-m and a-m antenna binding posts

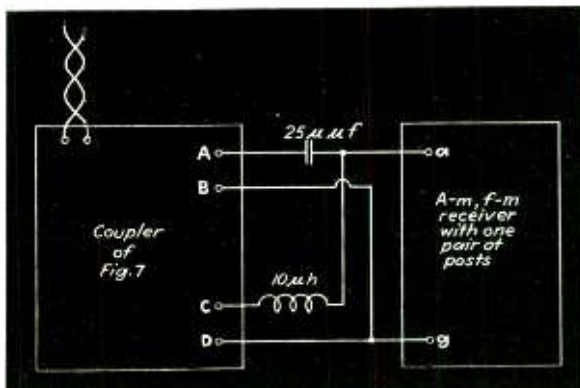
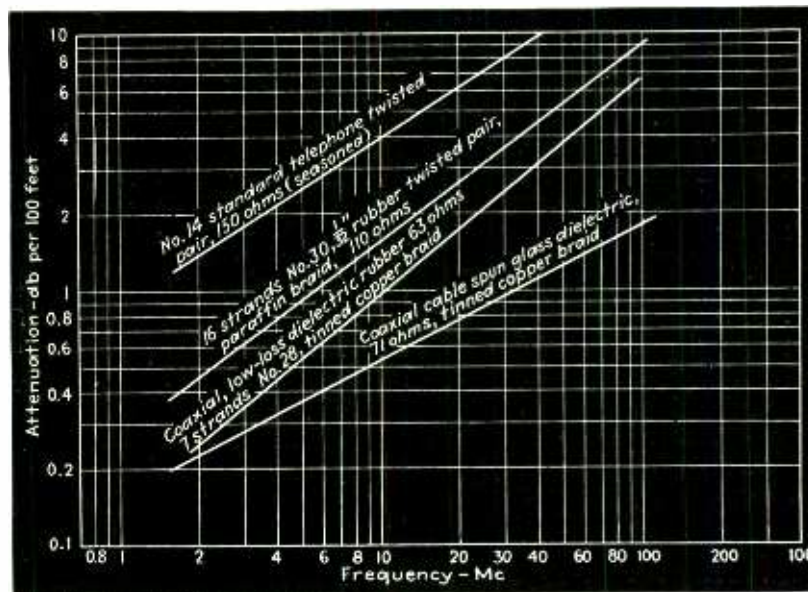

Fig. 8—Antenna transmission line connections to a receiver with only one pair of antenna binding posts

Fig. 9—Losses of several typical transmission lines commonly used for radio reception at various frequencies



ceiver itself has two pairs of binding posts, one for f-m and the other for a-m. Figure 7 shows a typical receiver coupler in which the f-m signal currents delivered by the transmission line pass through the transformer T'' . The secondary of this transformer will deliver an ultrahigh-frequency voltage to the terminals of the receiver.

The transformers T and T' with their primary windings as well as their secondaries in series with each other, will serve to transfer signaling energy in the lower frequency bands delivered by the line, to the terminals C and D of the receiver. The frequency selection for the various transformers is accomplished by suitable bypass condensers whose functions are quite obvious from the circuit. In this coupler there is no metallic connection between the

plying the power) will not pass into the transmission line.

In case the radio receiver is equipped with only one pair of terminals, and by internal switching the a-m and f-m connections are changed, it is necessary to connect one of the terminals of the coupler of Fig. 7 as indicated in Fig. 8

antenna or receiver, it follows that a concentric conductor may be used in lieu of the balanced twisted pair. Such conductors are made with various kinds of low-loss dielectrics that can result in an attenuation as low as 2 or 3 db per hundred feet. Figure 9 gives attenuation of typical samples of lines for f-m reception.

Selenium Rectifiers for

Consideration of the static and dynamic load characteristics of bridge connected selenium rectifiers indicates that close control of voltage can be easily attained

By J. E. YARMACK

International Telephone and Radio Manufacturing Corp.

RECTIFICATION of alternating current power to direct current power is becoming increasingly common in the United States due to the prevalence of alternating current mains supplies combined with steadily increasing direct current applications. Many types of equipment are employed to furnish direct current power, but the convenience, economy and simplicity of selenium rectifiers make them almost indispensable for numerous applications. In many cases the source of direct current must provide a substantially constant output voltage under varying load and power supply condi-

tions, a type of service for which selenium rectifiers are ideally suited.

The inherent static voltage regulation of selenium rectifiers is in the neighborhood of 10 to 20 percent. Its exact value depends upon the degree and nature of loading, the type of rectifier circuit and the effective rectifying area of the selenium rectifier plates employed. Moreover, when required, measures can be adapted for achieving extremely close regulation of the order of 2 percent. Such a scheme is described in detail in the latter part of this article. In designing selenium rectifiers to give the required rectified current output

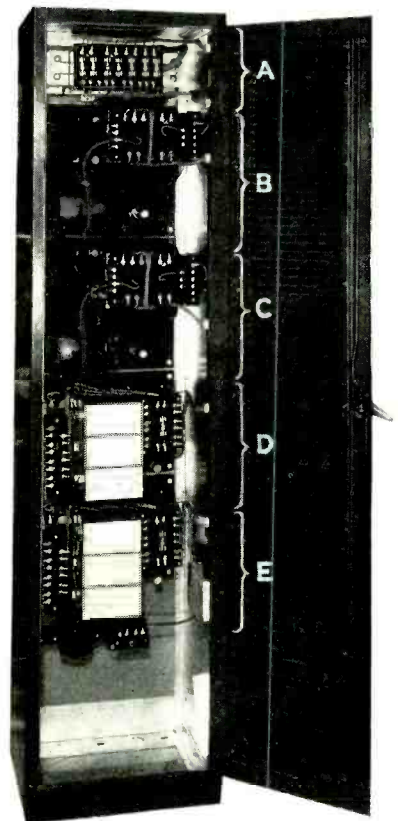
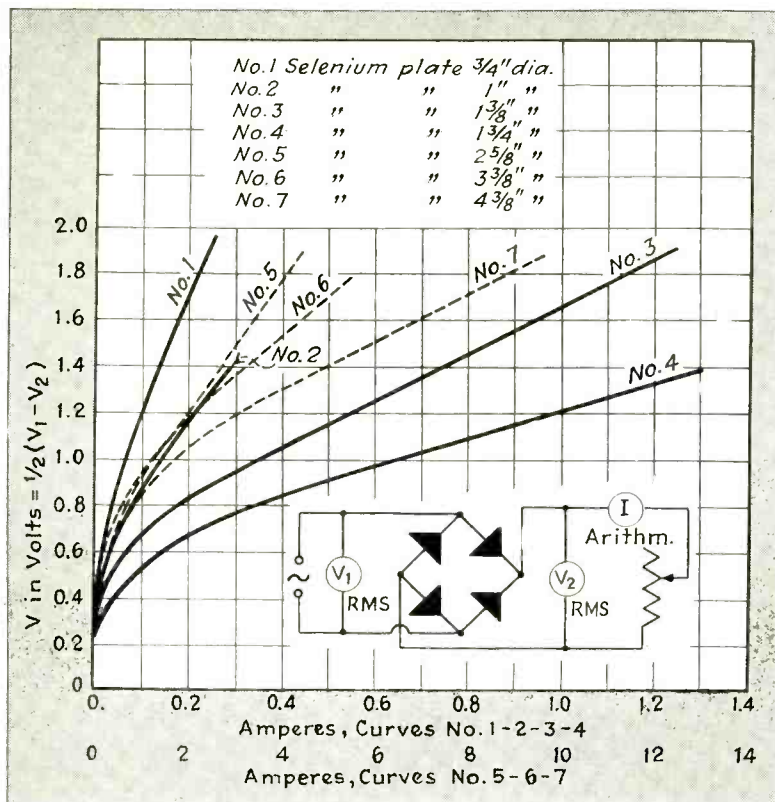

Fig. 2. Teletype rectifier unit. (A) Metering and switching panel. (B, C) Transformer panels. (D, E) Rectifier and filter panels. Power Equipment Company of Detroit



the engineer must select the proper size of plates and if necessary determine their number in parallel to provide adequate current capacity, compute the alternating current voltage to be impressed on the rectifier elements and analyze various factors involved in the selected type of circuit, such as the character of the load, duty cycle, ambient temperature and cooling requirements.

Design of Selenium Rectifier

The size and, when necessary, the number of rectifier plates in parallel is determined by examination of ratings of all available selenium plates. The required alternating current voltage to be impressed upon the rectifier elements, V_{ac} , is usually computed by the following formula:

$$V_{ac} = k_1 V_{dc} + k_2 n v \quad (1)$$

Fig. 1. Rectification characteristics of 7 different rectifier plates

Closely Regulated Voltages

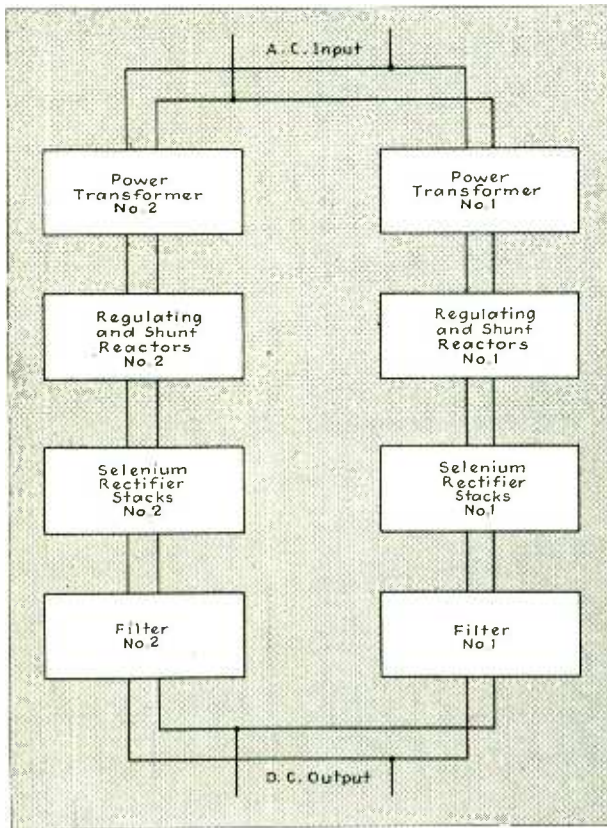

Fig. 3. Block diagram of Teletype rectifier of Fig. 2

and the number of plates in series is computed by the formula:

$$n = 1.1 k_1 V_{dc} / (V_p - 2v) \quad (2)$$

where k_1 is the form factor, that is, the ratio of the effective or root-mean-square value of the wave to the average value of rectified voltage wave from either bridge or center tap single phase circuit,

V_{dc} is the required direct current output voltage,

k_2 is the circuit factor and is 2 for the single phase bridge circuit or 1 for the center tap circuit,

V_p is the maximum safe permissible root-mean-square voltage per plate, and

v is the voltage drop per selenium rectifier plate in root-mean-square values.

The ten percent or 1.1 factor is the voltage variation factor and is se-

Fig. 4. A teletype rectifier showing filter and four selenium stacks connected for two separate bridge units. Output is 6 amperes at 120 volts

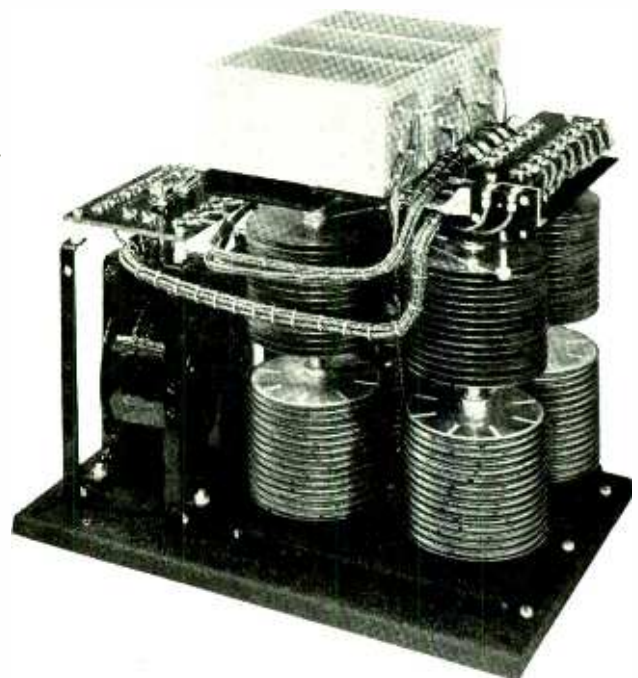

lected upon the designer's consideration of possible alternating current input voltage fluctuations.

The quantity v plays a most important role in the performance of the rectifier and changes slightly during the first 10,000 hours of fully loaded service, after which it remains constant. Quantitatively, the voltage drop of the selenium rectifier plate may vary from 0.9 to 1.3 volts for the rated plate current. At ambient temperatures less than 35 degrees C its value is increased,

(Characteristic C, Fig. 7), but at ambient temperatures higher than 35 degrees C its value is slightly decreased. For practical use in designing rectifiers the relation of the quantity v to the arithmetical values of the rectifier output current have been determined experimentally for seven basic sizes of selenium plates and are portrayed in Fig. 1.

In designing the teletype rectifier unit (a rear view of which is shown in Fig. 2 and a block diagram of its component parts in Fig. 3) capable of delivering the dual output of 6 amperes, 120 volts each, the No. 7 selenium rectifier plate, 4 3/8 inches in diameter and rated at 4 amperes

for the single phase bridge circuit, was selected as ample and provides a safety factor for extended current rating. The safe maximum reverse voltage rating of this plate is 14 volts rms. Inasmuch as the complete circuit calls for a 14-volt drop between the output terminals of the rectifier and the output terminals of the unit, the alternating voltage into the rectifier can be computed by Eq. (1). Hence, on the basis of an operating plate rating for this case of only 3 amperes at 134 volts:

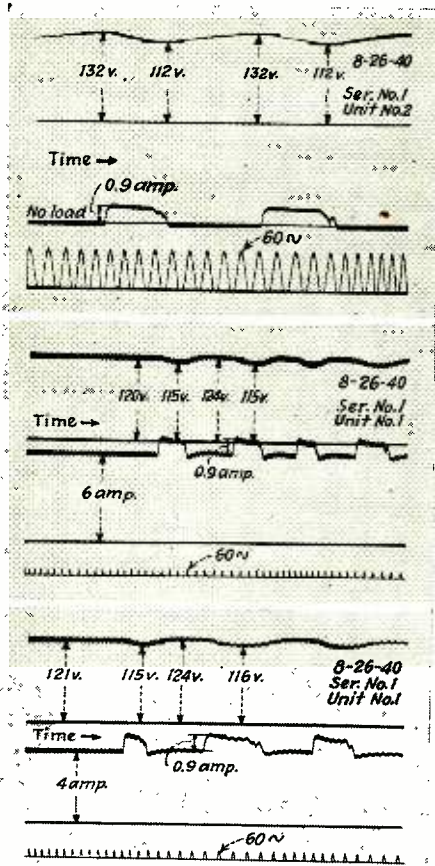

$$V_{dc} = (190 - 2 \times 15 \times 0.3) / 1.15 = 157 \text{ volts}$$

Hence, the voltage regulation is $(157 - 134) / 134 = 0.172$ or 17.2 per cent.

Static and Dynamic Regulation

In the application of rectifier equipment two types of output voltage regulation are of interest and must be considered in designing power supply units for various purposes. These are the static and dynamic regulation characteristics. The static regulation characteristic, the computation of which is exemplified above, represents the relation of the rectifier output voltage to the output current and is plotted from D'Arsonval meter readings of the current and voltage for various steady-state conditions from no load to full load (Fig. 5).

The dynamic regulation characteristic also represents the relation between the rectifier output voltage and current, but is obtained while keying or interrupting the load or a combination of loads at varying rates and measuring the instantaneous voltage and current conditions (Fig. 6).

The best method of measuring this type of regulation is with the oscillograph. Current and voltage characteristic curves are photographed simultaneously with a 60-cps wave which is used for time

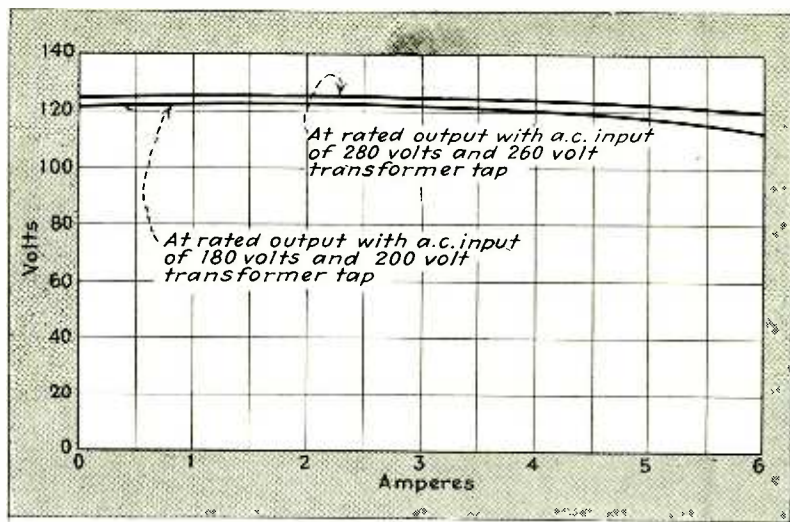

Fig. 6—Output voltage characteristics of 6 ampere, 130 volt rectifier for three different load conditions

Fig. 5—Static characteristics of 6 ampere, 120 volt rectifier, corrected by regulating and shunt reactors

calibration. Measurements of the ordinates of the characteristic curves provide instantaneous values from which the regulation may be computed.

In certain applications of rectifiers, such as those in which the load is keyed, dynamic regulation may be of great importance. Where several load circuits are operated from a common source it is usually important that none of the individual output circuits should interfere with any of the others.

The variation in output voltage of a typical regulated circuit of the type described below, with a keyed load alone, and with the keyed load superimposed upon fixed loads of different values is shown in Fig. 6. It will be noted that the voltage variation decreases with an increase in the magnitude of the fixed load. Figure 5 shows the static regulation characteristic curve of the same type of rectifier from no load to full load. From this curve it can be seen that the regulation is less than 5 percent throughout the operating range even though the applied line voltage of 280 volts is in excess of the rated input voltage of 260 volts for the transformer tap used in making this test.

The static voltage output characteristic of another rectifier under various ambient temperatures is illustrated in Fig. 7 and its rear view shown in Fig. 8. The output voltage, while lower at sub-zero temperatures than at normal room temperature, is nevertheless remarkably constant throughout the rated current range. The four volts lower output voltage of this unit is due to the increase of the v value at minus 5°C ambient temperature.

As compared to mercury vapor and gas filled hot cathode tube type rectifiers, selenium rectifiers have relatively high internal forward resistance. In order to apply dry plate rectifiers to devices requiring constant applied voltage it is often necessary to provide means for compensating for the internal resistance of the rectifier and for the transformer and filter reactor voltage drops by means of devices controlling the alternating current voltage applied to the rectifier.

A large variety of methods of voltage regulation have been developed and used. Some of them are universally successful; others are effective only within a limited field. Certain types of regulating circuits use gas or vacuum tube characteristics while other circuits employ saturable reactors to accomplish the same purpose. The circuit illustrated in Fig. 9 and described here as an example of such compensation utilizes two iron core reactors to regulate the voltage applied to the rectifier and requires no rectifier stack other than the main one.¹

Circuit for Voltage Regulator

In the simplified typical circuit of Fig. 9 the control elements consist of a direct current controlled saturable three-legged reactor and an alternating current controlled saturated reactor, each having a separate core with no magnetic relation to the other. These two reactors are so proportioned that, for the rectifier with which they are used, the output voltage is held within close limits from no load to full load despite line voltage variations. By

(1.) U. S. Patent No. 2,182,666.

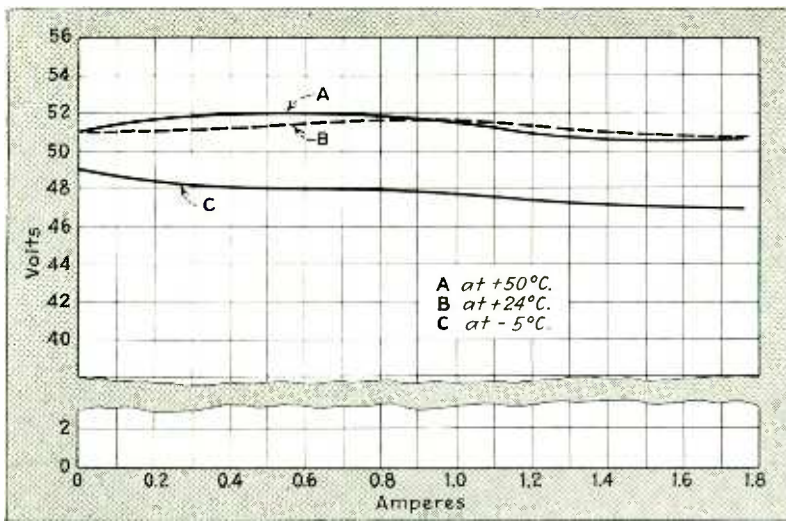

Fig. 7—Curves for Strowger switch rectifier: 0.75 ampere continuous, 1.75 ampere intermittent load

Fig. 8—Rear view of selenium rectifier for Strowger switch operation. Characteristics are given in Fig. 7

in the direct current series winding, *D*, the reactance *A* may be decreased and the alternating current input voltage to the rectifying elements may be increased. This offers a convenient means of compensating for the increase in resistance of the rectifier stack or stacks that may take place as they reach their final condition upon full aging. The short circuited winding, *F*, usually provided, serves the purpose of eliminating the pulsating fluxes, due to the unbalanced ampere-turns in the two halves of winding *A*, in the

proper design of the regulating coils it is possible to arrange a circuit to give either a rising, a flat, or a dropping static voltage characteristic.

The basic circuit of Fig. 9 consists of a series reactance, *A*, and a shunt reactance *B*, connected between the transformer secondary winding, *G*, and the input terminals of the rectifier, *H*. The value of the series impedance is controlled by two direct current windings, *C* and *D*, associated with the output circuit of the rectifier. One of the windings, *D*, is connected in series with the load circuit and the other winding, *C*, is connected in parallel with the load circuit. The amount of current that flows through the shunt direct current winding, *C*, is controlled by means of the variable resistor, *E*, and this circuit permits adjustment of the no load output voltage. Both direct current windings are connected additively.

The shunt reactor, *B*, serves to increase the voltage drop in the series reactor, *A*, under light loads and thereby to reduce the voltage applied to the rectifier stack and to

keep the light load voltage within the desired limits. Reactor *B* is also effective in compensating for line voltage variation. An increase in line voltage results in increased current in this coil and increased voltage drop in reactor *A*, so that the voltage applied to the rectifier is held approximately constant.

The series direct current winding, *D*, effects the output voltage characteristic under all load conditions and serves the purpose of lowering the impedance of the series alternating current winding, *A*, as the output current increases by increasing saturation of the core of the regulating coil. The decrease in the series reactance causes a net increase in the alternating current voltage applied into the rectifying elements, thereby maintaining the output voltage relatively constant over the rated output current range. By selecting the proper tap on the winding, *D*, the shape of the characteristic can be varied over a wide range and can be made to give a higher voltage at heavy loads than at lighter loads.

By increasing the number of turns

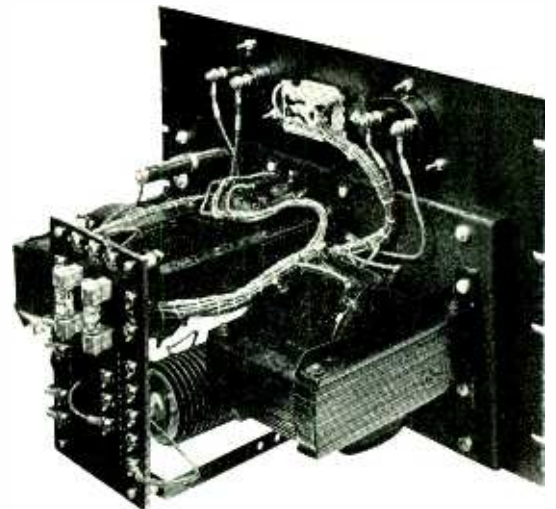

center leg of the three-legged regulating reactor.

The alternating current taken by the rectifier stacks when the direct current load is disconnected stabilizes within one minute with the selenium type plates. This stabilization period with other types of dry plate rectifiers may be anywhere from a half hour to six hours. This usually effects the light load portion of the output voltage characteristic.

The foregoing method of regulating the rectified output voltage is also frequently extended to automatic battery chargers. In the direct current power supply equipment, however, the dynamic type of regulation or the promptness with which the voltage is restored to its rated value upon sudden application of the load deserves attention because of the ever increasing demand for the power units operating directly from commercial alternating current power lines.

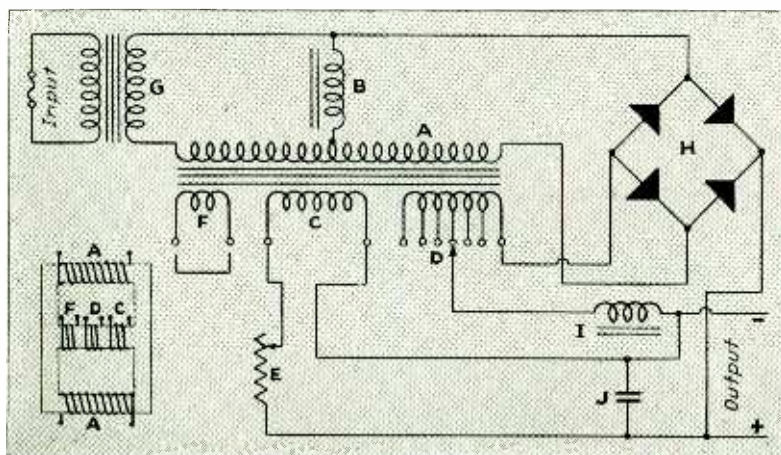

Fig. 9—Electrical and mechanical diagrams showing principle of controlled output voltage by regulating and shunt reactors

Preselection in Inexpensive Broadcast Receivers

By E. B. PASSOW
Zenith Radio Corp.

EARLY in the last decade inexpensive receivers were put on the market without any preselection other than that provided by tuning the input circuit to the converter tube. In other words, two-gang condenser tuned receivers appeared and gradually replaced receivers with a tuned-radio-frequency stage or three-gang condensers. These receivers were mostly five-tube a-c and ac-dc receivers and were sold in large quantities. Their performance was characterized by poor image rejection, tweets, internal cross modulation interferences, poor selectivity, and other interferences brought about by omitting pre-selection.

Three years ago low priced loop operated receivers appeared on the market in large quantities, but they had the disadvantage of low sensitivity or signal pickup. The loop, however, added considerable advantage to its directional characteristics because the receiver could be rotated in order to reduce to a minimum the pickup from undesired signals. There are other advantages, of which minimum pickup of electrostatic disturbances is an example. From this it is seen that the important problem in inexpensive loop-operated receivers was securing more sensitivity so that they could be used in isolated communities throughout the country rather than in metropolitan areas only.

At that time, the most logical solution to this problem, while keeping costs and size down, was to add an untuned r-f stage ahead of the converter tube. In a typical ac-dc receiver this stage gave an improvement of from four to seven times in sensitivity, but unfortunately in some instances bad interferences were created. These interfering responses were generated in most cases as a result of the increased gain without additional selectivity. The increased voltages appearing at

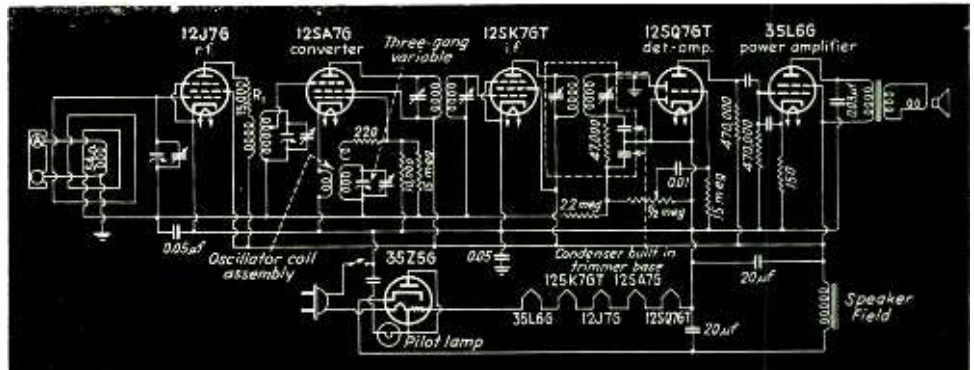

Fig. 2—Circuit diagram of the inexpensive receiver. A low impedance r-f primary coil in series with a 15,000-ohm resistor is used for economy and to level off the gain at the high frequency end of the range

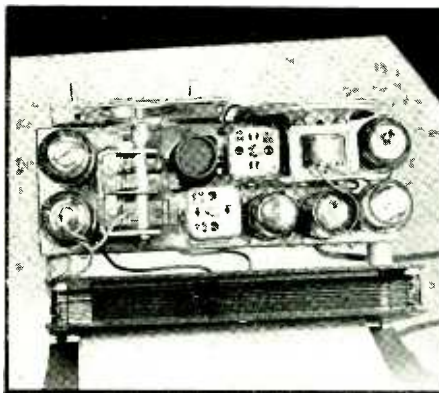

Fig. 1—Chassis of the \$14.95 receiver using a tuned r-f stage. Note that the 3-gang tuning condenser has no shielding between the antenna and r-f gangs

the converter tube caused that tube to generate spurious responses, repeat points, etc. But because sensitivity, loops, and low costs were necessities, some interferences had to be tolerated. Sensitivity could also have been increased by adding an extra i-f stage, but this was not as desirable as an r-f stage which would result in a much improved signal-to-noise ratio. Measurements

TABLE I

	Oscillator	R.F.	Antenna
Minimum ..	8 $\mu\mu\text{i}$	8.5 $\mu\mu\text{i}$	10 $\mu\mu\text{i}$
Maximum ..	80 $\mu\mu\text{i}$	202.7 $\mu\mu\text{i}$	333.1 $\mu\mu\text{i}$
Trimmer range	16 $\mu\mu\text{i}$	15.5 $\mu\mu\text{i}$	17 $\mu\mu\text{i}$
Number of plates	9	13	21

on two 6-tube receivers having the same overall sensitivity and the same tube complement, the difference being that one had an r-f stage and the other two i-f stages, showed the receiver with the r-f stage to have approximately three times better signal-to-noise ratio.

Early this spring there appeared on the market inexpensive ac-dc receivers priced at \$14.95 incorporating a tuned r-f stage made possible by the development of a new three-gang condenser and circuit making such a combination, economically speaking, practical.

Figure 1 shows the condenser used in the new receiver. The front section is a cut plate oscillator section, the middle section is the r-f section, and the rear section is the antenna or loop tuning section. A shield is of necessity interposed between the antenna and r-f section because with both sections being tuned to the signal frequency regeneration or oscillation would occur unless capacity coupling between the two sections were eliminated. A shield between the oscillator and r-f sections was found to be unnecessary inasmuch as a 455 kc difference in frequency exists between the oscillator and r-f circuits. It was found necessary, however, to keep the oscillator voltage as low as possible consistent with good conversion in order that oscillator voltage would

(Continued on page 95)

Design Chart for R-F Heat Treatment Generators

Many heat treatment generators using capacitive electrodes do not produce expected power output because of improper coupling to the load and because the designer usually does not have sufficient information about the load impedance. In this Reference Sheet, the power absorbed can be quickly determined for normal operating conditions

THE principal difficulty in the design of generators using the condenser field method for r-f heat treatment is due to the characteristic potential distribution in the output circuit of such generators. The actual r-f potential across the object itself is a small fraction of the total high frequency voltage across the electrodes. The potential distribution is a rather complicated function of a great number of variables including the wavelength, the capacity between the electrodes and the object (which in turn is a function of the size of the electrodes, their distance from the object and the dielectric constant of the space between the electrodes), and the conductivity and dielectric constant of the object itself.

In general, both in the industrial and in the electromedical fields of application, the load impedance represented by the object is small compared to the reactances of the coupling capacities between object and electrodes. Hence the necessity for an excessively high frequency voltage across the electrodes for the achievement of a certain required power absorption by the object.

Chart Design

The chart is designed to give the high frequency voltage E across the electrodes as a function of the distance D between object and electrodes for any arbitrary values of the other variables as parameters. The chart may also be used to determine the power designated in the

By **EUGENE MITTELMAN**

*Consulting Engineer
Chicago, Ill.*

load when the area of the electrodes and the load impedance are known. It shows up the limitations of the condenser field method especially when large spacing is required. On the other hand, it demonstrates that under favorable conditions considerable power absorption may be obtained even with relatively low values of the high frequency voltage across the electrodes. This latter fact is of special importance in the design of some special purpose generators.

As the maximum available high frequency voltage in the tank circuit of an oscillator is about 0.9 the plate voltage or 1.8 in case of the push-pull type generators, the chart will prove helpful in the proper choice of the oscillator tubes.

Use of the Chart

Select the lines of desired power absorption and load impedance at the lower left corner of the chart. From their intersection erect a vertical line and extend upward to the 30-degree line corresponding to the correct electrode area. From this intersection project horizontally to an intersection with a vertical line drawn through the proper wavelength on the wavelength scale. Through this last intersection point, a 45 degree line extending into the grid of logarithmic scales will give the r-f potential as a function of the

electrode spacing. For dielectrics between object and electrodes, having constants greater than unity, the readings on the horizontal scale, giving the distances between object and electrodes, must be divided by the dielectric constant.

Examples of Use of Chart

The correct use of the chart can be best explained by solving several examples.

(1) Given a generator with wavelength of 6 meters and a pair of electrodes 15 square inches in area, determine the voltage across the electrodes for a 70-ohm load to absorb 50 watts, provided the spacing between object and electrodes is one inch on both sides. From line 1 corresponding to this case we read off 1600 volts rms. The voltages for other spacings may be taken from the same line.

(2) Given the same wavelength and the same geometrical conditions, a load impedance of 8.5 ohms, and a desired power absorption of 50 watts, find the r-f voltage across the electrodes. From line 2 we find the voltage must be increased to 3700 volts rms.

(3) The power absorption can be greatly increased even with less r-f voltage across the electrodes if the area of the electrodes is increased. Line 3 corresponds to a 6-meter generator yielding 200 watts power absorption in a 8.5-ohm load between two electrodes whose area is 45 square inches.

(4) With a 12 meter generator the maximum available r-f voltage,

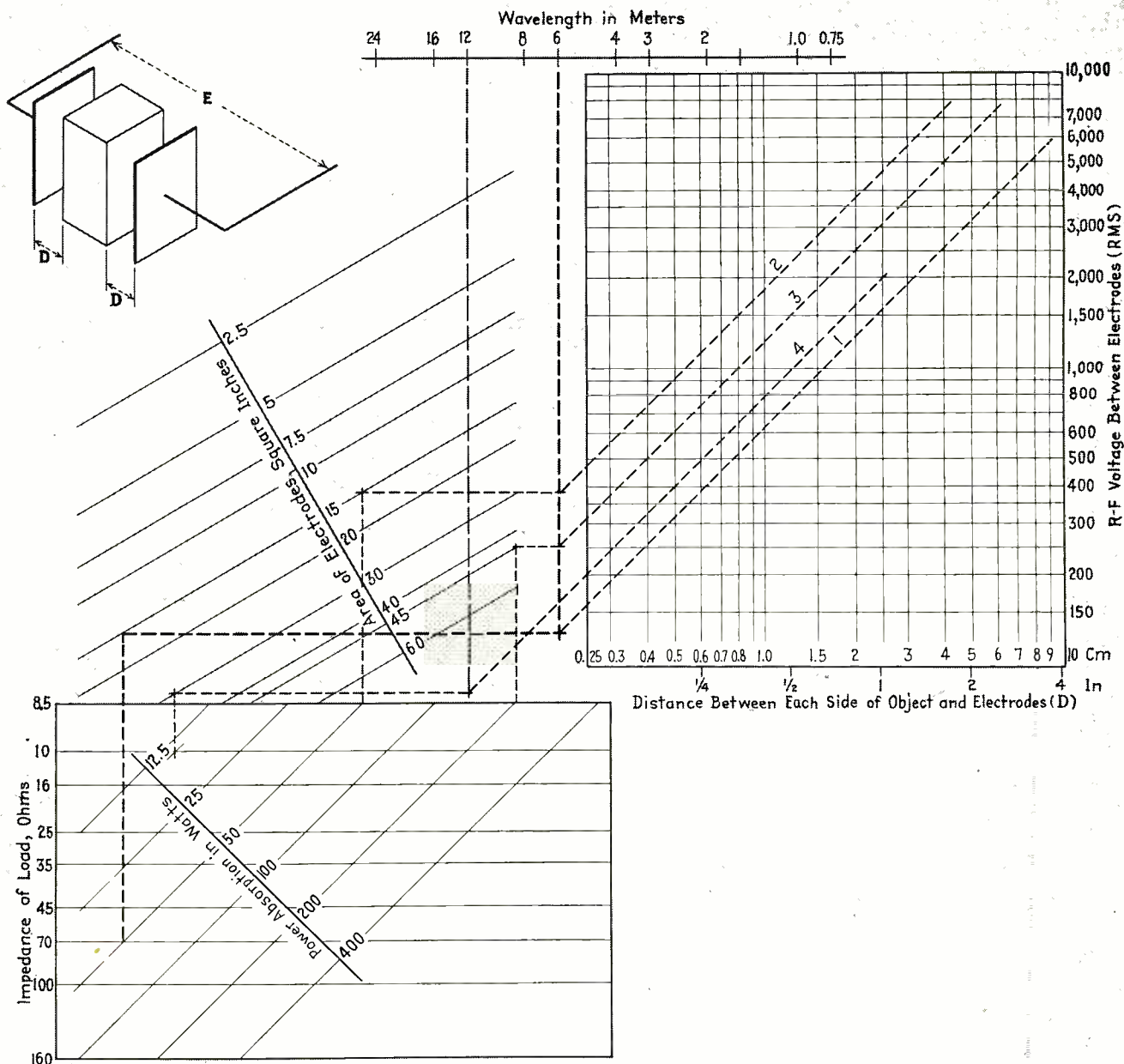

Nomographic type of chart for determining operating conditions of high frequency generators using condenser electrodes

with electrodes whose area is 30 square inches, shall be 2000 volts rms. What power absorption can be expected if a load of 10 ohms equivalent impedance is placed between the electrodes separated by 2.5 cm (1 inch) air spacing on each side of the electrodes? We find the answer by drawing a straight line at 45 degrees through the point corresponding to 2000 volts and 2.5 cm (1 inch) on the graph (line 4) until it intersects the vertical 12 meter line. From here draw a horizontal to the 30 square inch line and project down to the 10-ohm line. The power absorption will not exceed about 14 watts.

It is well to point out that the physical arrangement of the chart is such that any of the variables can be taken as the independent factors merely by entering the chart at the right place. This feature is of particular advantage when the exact operating conditions are not known, and when several factors may be varied to obtain the desired power absorption. The manner in which the various factors influence the power absorption is also immediately apparent from the geometry of the chart.

Thus, for example, increasing the area of the electrodes increases the power absorption (all other factors

remaining constant) in proportion to the increase in electrode area. Likewise, by halving the wavelength, the power absorption is doubled, if this is the only change in operation. Doubling the distance between electrodes and object means that the voltage must be doubled to maintain the same power absorption. or, conversely, for a given impedance and power absorption, the voltage of the generator must be doubled if the spacing, D , is doubled.

As a result of many actual measurements on practical generators, it is found that the chart gives results in good agreement with practice.

ELECTRONICS REFERENCE SHEET

* TENSION!

READY AND ABLE TO SERVE IN AN ARMY OF USES



Of the right metal, CINCH parts in all communication lines "do their duty". Contacts of highly resilient metal, plated by CINCH *exclusive method*, have a *spring tension, that puts them at alert... *always* at your command! For sockets, contact strips, connectors... it's CINCH for *satisfaction*.

CINCH is especially equipped with modern machinery and skilled, efficient labor, available for assembling small parts in large volume... Send us blueprints for estimate.

*Cinch and Oak Radio Sockets are licensed
under H. H. Eby Socket Patents*

CINCH MANUFACTURING CORPORATION

2335 WEST VAN BUREN STREET, CHICAGO, ILLINOIS

SUBSIDIARY OF UNITED-CARR FASTENER CORP., CAMBRIDGE, MASS.

TUBES AT WORK

Luminous scale for cathode-ray tubes, midget amplifier, oscilloscope marker, television beacon, and electric eye breaker boy are discussed

Luminous Scale for Cathode Ray Tubes

By HEINZ E. KALLMANN

CATHODE RAY TUBES are preferred as indicators for many measuring purposes because of their freedom of inertia and the absence of moving parts; and by their ability to show at a glance a complete series of observations as a diagram or as a pattern on a two dimensional screen they are bound to find numerous new applications. Among their disadvantages two are prominent; the one difficulty is to see the image under bright external illumination, unless high anode voltages are used, costly both in supply components and signal amplification to provide the proportionally higher deflection voltages. The other difficulty is the lack of an accurate and especially parallax-free scale.

Observation of a faint image under bright external illumination is aided by showing it on a dark background. A very efficient arrangement to this end is to concentrate the light of the image in a comparatively narrow spectral

band, e.g. the green between 5,000 and 5,600 Angstrom units if a Willemite screen is used, and to place in front of the screen a color filter which will pass only the narrow spectral band and absorb the light of all other wavelengths. The image from the screen remains substantially unaffected by the filter, but external stray light, which may be reflected from the screen, will then have to pass the color filter twice and all of it, except a comparatively small part in the transmission range of the filter, will be absorbed. Thus much fainter images can be observed under bright external illumination than is now possible.

A luminous image on a dark background calls for a luminous scale. One possible scheme to produce this without parallax has been described on pages 357-8 in the *Proceedings of the Institute of Radio Engineers* for August 1940. It provides a complete little projector, the image of a suitable slide being thrown directly on the cathode ray tube screen material as the projection screen. Although satisfactory, this scheme is costly and if the scale is

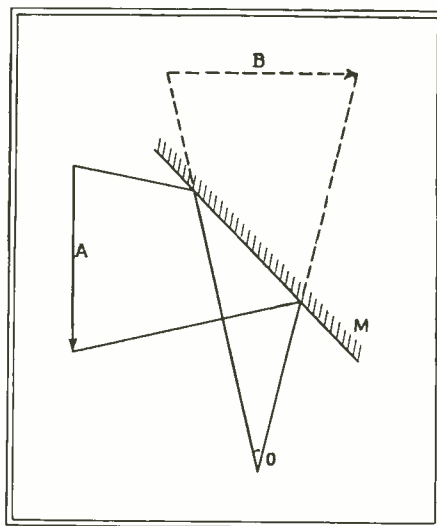

Fig. 1—Optical arrangement using mirror at *M*, so that object at *A* appears to be at *B*

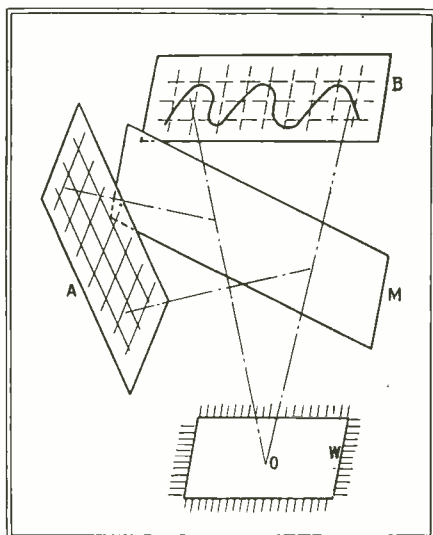
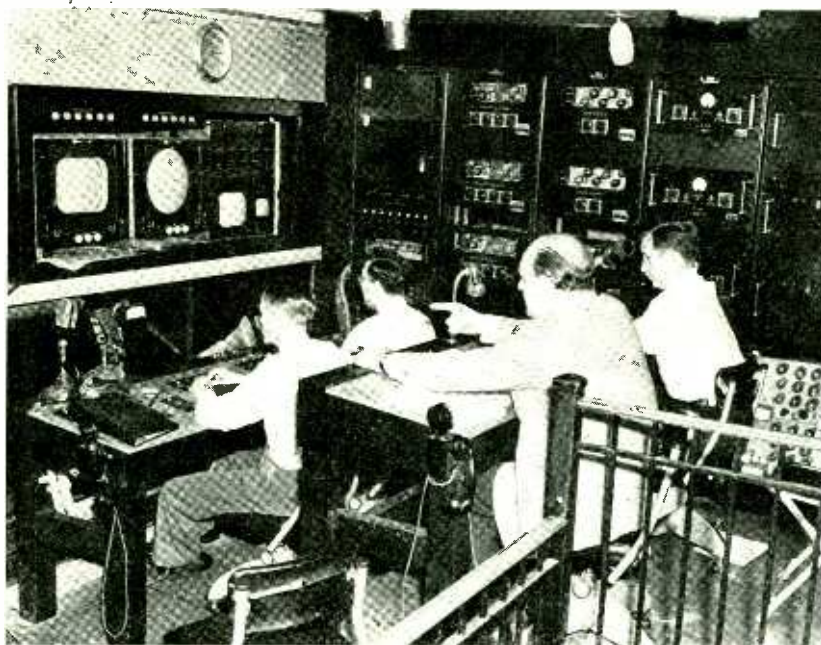

Fig. 2—Simplest arrangement, based on fundamentals of Fig. 1, of providing scale for cathode ray tube

TELEVISION BROADCAST REHEARSAL



The control room from which the television program director issues his instructions to the actors as he watches the scene being enacted on the picture tube screen

made of a color contrasting with that of the image for purposes of clarity (e.g. an orange scale for a green image) this scheme excludes the use of the above mentioned selective color filter for the elimination of external stray light on the screen. Another arrangement has been found which is much simpler than the foregoing, although not inferior, and which also allows the use of the selective color filter.

It is well known that an object *A*, when seen by an observer *O* in a mirror *M*, will appear to be in the position *B*, Fig. 1. Each point of *B* has the same distance from the mirror *M* as the corresponding point of *A*, thus as a whole *B* forms the same angle with the mirror as does *A*; its apparent position is thereby fixed in space and independent of the location of the observer *O*.

This fact is made use of by placing an illuminated scale, black with white lines, in the plane indicated by *A*, and the screen of the cathode ray tube

Shown are new types developed for modern applications.

1054



454



158

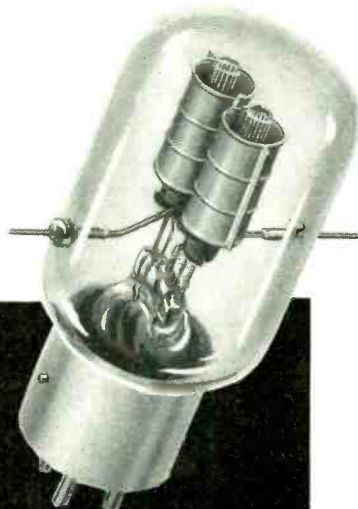

854



Constant Progress Consistent Quality

That's why radio engineers everywhere are sticking to Gammatron tubes, and why every day still more switch to Gammatrons. The good will built by years of fair dealing and making a better transmitting tube is your guarantee of complete satisfaction.

The first tantalum tube pioneered by Gammatron 14 years ago immediately proved its stamina and dependability. Today, constant research and consistent high quality have earned Gammatron first preference with tube users.

Investigate Gammatrons. Write for data on the complete power range of 50 to 5000 watts today!

GAMMATRONS of course

**GAMMATRON
SALES OFFICES**
Wash., Ore., Idaho, Mont.
MARSH AGENCIES
104 Battery Street
Seattle, Washington
Mo., Kansas, Nebraska
H. A. ROES
2017 Grand Avenue
Kansas City, Missouri
Ind., Ohio, Kentucky
W. E. McFADDEN
915 Montrose Ave., Bexley
Columbus, Ohio

New York State
W. F. SEEMAN
523 Ellicott Square
Buffalo, New York
Pa., Va., W. Va., Md.,
Wash., D. C., Del., N.J.
S. K. MACDONALD
1343 Arch Street
Philadelphia, Pennsylvania
Tenn., N. C., S. C., Ala.,
Ga., Fla.
**HOLLINGSWORTH &
STILL**
Norris Bldg., Atlanta, Ga.

Minn., N. D., S. D., Wis.
KENNEDY SALES CO.
2362 University Avenue
St. Paul, Minnesota

Illinois, Wisconsin
R. O. LUND
1720 North Damen Avenue
Chicago, Illinois

Maine, N. H., Vt., Mass.,
Conn., R. I.
TRADE CONTACT CORP.
25 Huntington Avenue
Boston, Massachusetts

Calif., Nevada, Arizona
E. P. DEMAREST
1630 South Flower Street
Los Angeles, California

Texas, Okla., Ark., La.,
M. B. PATTERSON & CO.
434 Allen Bldg., Dallas, Tex.

Michigan—W. B. SWANK
610 Blaine Ave., Detroit, Mich.

New York City, New Jersey
D. R. BITTAN SALES CO.
53 Park Place INC.
New York City, New York

Export Agent:
C. LOHMAN-JANIK
241 East Illinois Street
Chicago, U. S. A.

HEINTZ & KAUFMAN
SOUTH SAN FRANCISCO, CALIF. LEE, CALIFORNIA, U. S. A.

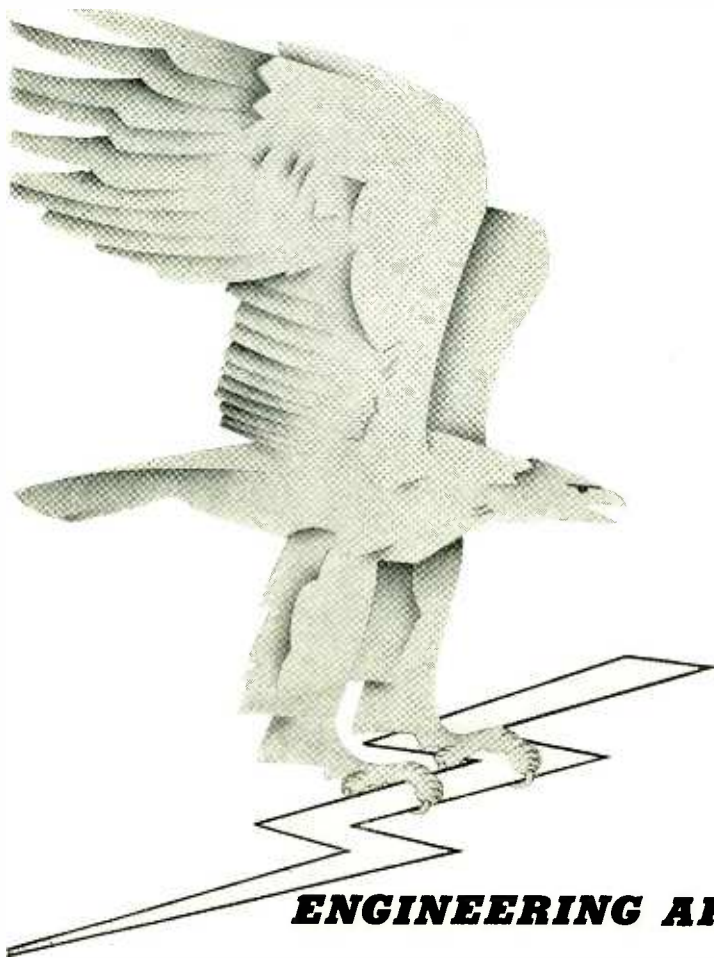

ENGINEERING AHEAD...

Never before have electronic engineers faced such a maze of complex problems.

With today's methods falling into obsolescence tomorrow, it has become Callite's job to "engineer ahead"—to *anticipate* the exacting demands of this industry, rather than to go about meeting them *after* they arise.

Consequently, you can depend on Callite for your requirements of electrical contacts of refractory and precious metals—bi-metals—lead-in wires, filaments and grids—materials and formed parts for all electronic applications.

Whatever tomorrow's needs may be, you'll find Callite in the front rank of service and supply. Meanwhile, when "metallurgent" problems arise, call on the knowledge and resourcefulness of Callite's technical staff. They'll serve you with efficiency and dispatch. Callite Tungsten Corporation, 544-39th St., Union City, N.J. Branches: Chicago, Cleveland.

CALLITE TUNGSTEN CORPORATION

in the plane indicated by B , halving the angle formed between them with the mirror M , Fig. 2. The scale may either be a transparency diffusely illuminated from the back, or opaque, and illuminated sideways from the front. Now if the mirror is made semitransparent then to any observer looking through the window W both the scale and the image will appear in the same plane B , without parallax if the distances between mirror and screen, and mirror and scale are made equal.

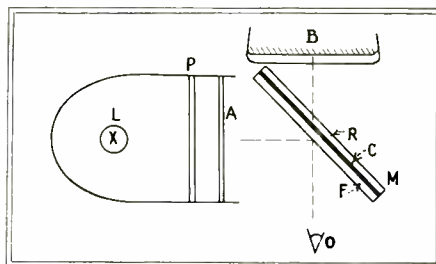

Fig. 3—Improved scale for cathode-ray tubes using color filter which acts as a semi-transparent interior

Although feasible, this scheme suffers from the fact that a semitransparent mirror is usually a very thin metal deposit on one side of a glass plate the other side of which also reflects; thus a double image of the scale is observed, unless either the glass is of negligible thickness or the semitransparent mirror is so dense that it reflects much more than the other side of the glass, and then absorbs much light from the cathode ray tube image. A better way of reducing the reflection from the other side of the glass plate to negligible proportions is to coat that side according to Cartwright so that its re-

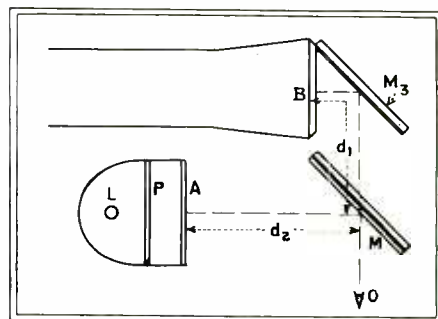

Fig. 4—A modification of the arrangement of Fig. 3 with cathode-ray tube mounted parallel to the front panel

flexion is eliminated by interference; if this is done, the reflecting surface may be a plain glass surface which for bundles of unpolarized light incident under an angle of about 45 deg. has a reflection coefficient of about 5 percent.

The most practical solution, however, applicable to monochrome images, is to use as a mirror a color filter of such color that it passes the spectral band

*Electrical
Outlets*

Everywhere

... thanks to

NATIONAL

VULCANIZED

FIBRE

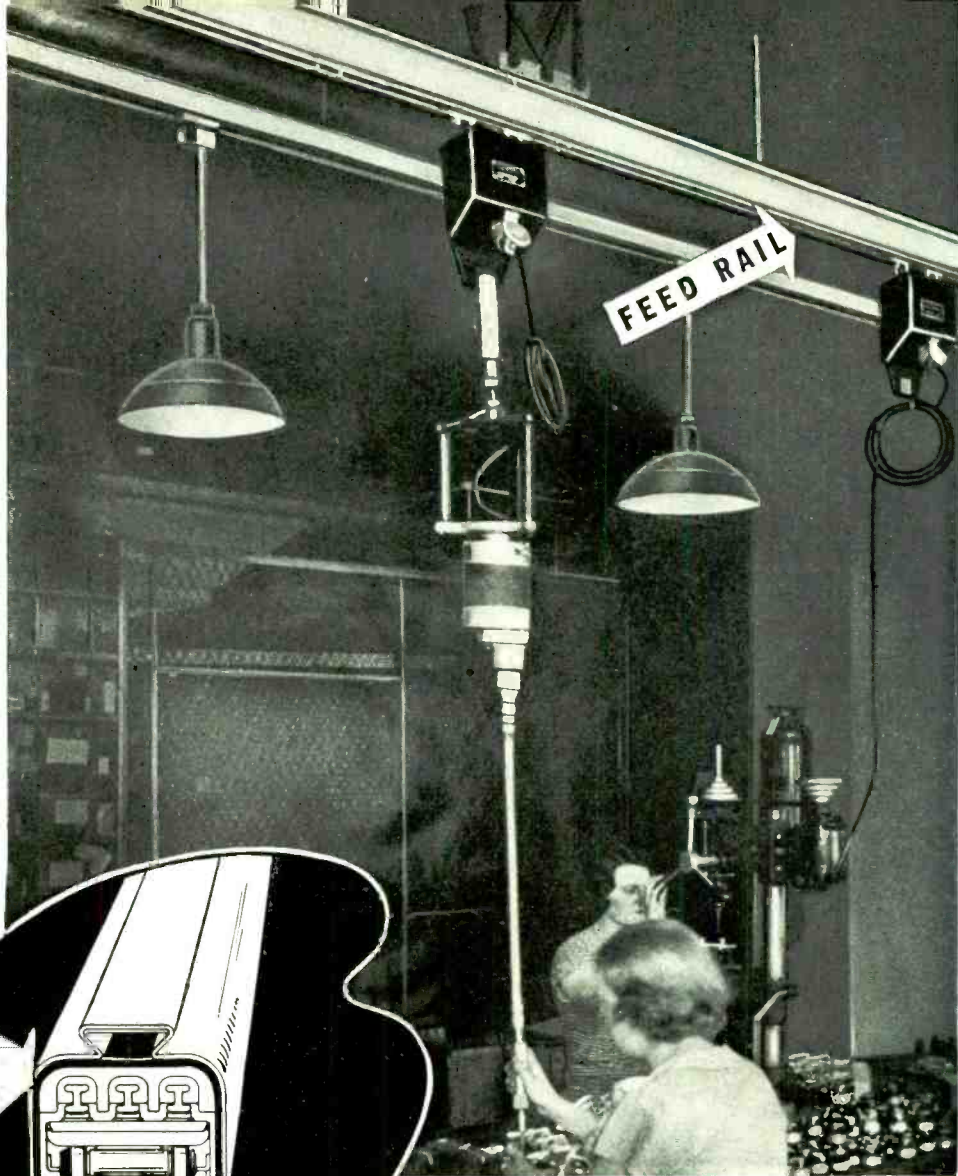
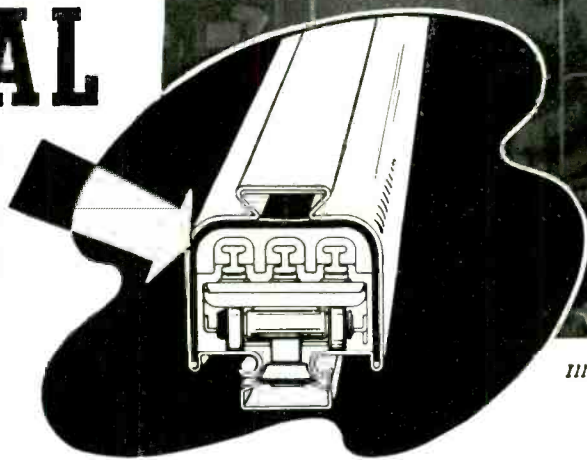

Illustration—Courtesy Feedrail Corporation, N. Y.

7

FEEDRAIL, an overhead trolley system, provides industrial plants with a practical method of supplying electrical current to portable lights and devices anywhere in the plant.

The Feedrail would not be possible without proper insulation for the copper rails. National Engineers developed a vulcanized fibre barrier to fit in the metal housing and protect the entire system electrically. Fibre is the ideal material for this application

because it can be formed and bent in the desired shape . . . and, it prevents any possibility of a short in the overhead system.

National technical men are helping manufacturers every day to improve products or production methods. Often a very small application of National Vulcanized Fibre can save hundreds of dollars in maintenance costs or increase a product's saleability many-fold. Write us for further interesting information about this remarkable material.

NATIONAL VULCANIZED FIBRE COMPANY

FOUNDED

1873

**NATIONAL
VULCANIZED
FIBRE**

WILMINGTON



DELAWARE

These NATIONAL Products have a Cost-Cutting Application in your field. We can make it easy for you to select the right product and grade.

PHENOLITE
Laminated BAKELITE

HIGH SPEED—LOW COST MEASUREMENTS



IMPORTANT NEW DEVELOPMENTS IN TEST EQUIPMENT SAVES YOU TIME AND MONEY

hp resistance tuned audio oscillators set a new standard of performance in laboratory and field testing. The saving of time, extreme accuracy and versatility of measurements coupled with low cost makes them the most profitable investment in the electronics field.

hp—instruments are the result of long research in a well equipped laboratory and have been thoroughly tested both in the laboratory and the field. You'll profit in many ways by investigating, at once, the advantages of these new instruments. Write today for data sheets. There's no obligation of course.

Laboratory
INSTRUMENTS
for speed and accuracy

HEWLETT-PACKARD CO.
481 Page Mill Rd., Palo Alto, Calif.

No. 205 AG Audio Signal Generator.
Combines a Resistance tuned oscillator having 5 watts output and less than 1% distortion, plus Output meter, Input meter, Attenuator and an impedance matching system... all in a single unit. Price \$340 Net.

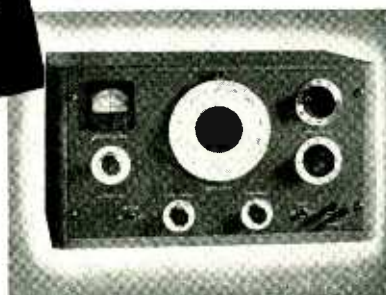

No. 205A Audio Signal Generator. Identical in every respect to the 205AG with the exception of the input gain set which is not included. Price \$290 Net.

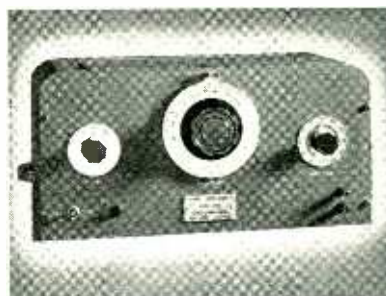

Series 200 Resistance Tuned Oscillators.
Consists of hp Resistance Tuned Oscillator only. Available in cabinet or for relay rack mounting in models A, B, C & D, covering frequency range from 7 cps. to 200 kc. Priced \$85.50 to \$130 Net.

Resistance Tuned Principle

A stabilized amplifier with regeneration supplied through a frequency selective resistance capacity network. The oscillation frequency is stable and the thermal drift extremely low. Furthermore, the thermal drift is not magnified as is the case with the beat frequency oscillator. A balancing circuit automatically selects the proper operating point for the oscillator. The result—a stable oscillator having constant output and very low distortion. Whether for low frequencies, geophysical work or high frequencies in the super-sonic region—resistance tuning is vastly superior. Send us your problems requiring audio frequency or super-sonic oscillators.

Write today... No obligation

of the cathode ray tube image and suppresses all other colors including that of the scale illumination. A color filter usually consists of a thin dyed gelatin foil *C* cemented between two glass plates. From Fig. 3 it is evident that the light from the image passes through the filter substantially unattenuated, apart from the 5 percent reflection losses on both external surfaces. The light from the scale will be reflected to the extent of 5 percent from the front surface *F* of the color filter; the color layer itself reflects it as little as would black ink in a bottle, and the rear surface *R* of the color filter is never reached by it since it is absorbed by the dyed gelatin layer *C*. Thus only a single reflected image of the scale appears to the eye, about 20 times weaker than the scale itself, but this is still adequately bright even if the weakest source *L* of illumination is used.

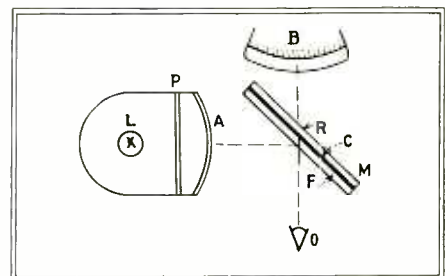

Fig. 5—Improvements can be made, to correct for curvature of the end of the cathode ray tube, by curving the scale at *A* thereby eliminating parallax at the edges of the image

It is evident from Fig. 3 that no other light but that from the image and that from the scale can reach the eye, since the color filter, used simultaneously as the dust protecting window, cannot, due to its tilt, reflect any external light, nor can the glass bulb and screen of the cathode ray tube since they are protected by the selective color filter. Nothing, of course, prevents application of this scheme to an arrangement in which the cathode ray tube is mounted with its axis parallel to the front of the apparatus and where its screen is viewed through a mirror (preferably a front-surface mirror). In this case the scale is also moved further away from the colored filter until again it appears in the same plane as the cathode ray tube screen, as shown in Fig. 4, that is $d_1 = d_2$.

There remains the difficulty that the screen of a cathode ray tube is not quite plane, so that an image of a plane scale which is free from parallax in the centre would appear to be wall in front of the screen near the edges. This defect can, if troublesome, be completely eliminated by printing the scale on a curved surface, formed to just match the shape of the screen of the cathode ray tube, Fig. 5.



LET'S GO!
U. S. A.
KEEP 'EM FLYING!



REA MAGNET WIRE

**Preferred in Peace,
Demanded for Defense!**

THE finest materials obtainable are not too good for America's Defense. Millions of miles of wire will be built into the electrical components of energizing, controlling and signaling equipment for the Army, the Navy, and the Air Forces. A quarter century of experience will go into every inch of Rea Magnet Wire produced for these defense uses.

And, because America's Defense Program must not be delayed, the Rea organization has been keyed to high-speed action . . . ready to ship Defense materials how, when, and exactly as wanted. If exacting applications call for special wire, Rea will "tailor-make" it to fit the job.

Superior spooling, longer continuous lengths, maximum uniformity both before and after enameling — these are REA quality characteristics which insure a speed-up of defense production.

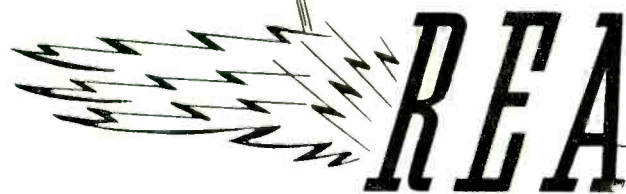

We invite you to submit your procurement, engineering, and production problems to us for quick attention!

REA MAGNET WIRE COMPANY, INCORPORATED
FORT WAYNE, INDIANA, U. S. A.

ON YOUR BUSINESS LETTERHEAD, WRITE FOR YOUR COPY OF THE REA WIRE DATA TABLE

SOLAR CAPACITORS

FOR RADIO • ELECTRICAL • INDUSTRIAL

SOLAR is proud of . . . and zealously guards . . . the reliability which its Capacitors add to radio and electrical control equipment for the Armed Service Branches of our Government. SOLAR reliability is built into all types of Capacitors for industrial applications.

SOLAR MFG. CORP. New Jersey
Bayonne

Quality . . . ABOVE ALL . . .

Midget Remote Amplifier

By VICTOR H. VOSS
Station WJJD

COMPACTNESS, LIGHT WEIGHT, low cost, and excellent electrical characteristics are combined in this battery operated remote amplifier. While designed primarily for emergency work and as a spare amplifier, its electrical characteristics make it satisfactory for any single channel service. Because of its light weight and small size it can be easily transported in a carrying case along with microphones and cables.

A 1N5GT and a dual purpose 1D8GT are employed in a three stage resistance-capacity coupled circuit. The 1N5GT is a pentode and has a short metal shield around the base. The 1D8GT contains a triode and a power pentode in the same envelope. These low drain, 1.4-volt filament tubes make it possible to use small batteries and yet obtain good battery life. Their ruggedness has been proved in shake-down tests on amplifiers, and they are used in many types of portable receivers with no shock mounting whatever. However, they do present a problem in the elimination of microphonics.

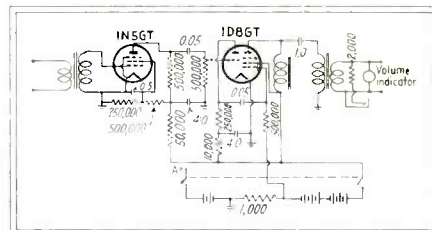

Circuit diagram of the midget remote amplifier

The 1N5GT input tube is pentode connected and is operated without bias other than that supplied by having the grid return and negative side of the filament battery at the same potential. The screen voltage of this tube seems quite critical, and the bleeder arrangement shown in the schematic diagram finally proved most satisfactory. It is important that a paper condenser be used as a screen by-pass. The triode section of the 1D8GT is also biased by the filament battery. Bias for the pentode section is obtained by operating the plate supply above ground through a resistance.

Decoupling is used on the first two stages to insure stability when the plate batteries become weak through usage. At low frequencies the plate choke in the output stage must have a high impedance with respect to the reflected load of the output transformer, and must have a low self-capacity to avoid loss of the high frequencies. Pentodes, when not driven beyond the flexion point on their dynamic curve, will supply ample power to feed a broadcast loop, and this at quite low distortion. Their efficiency and added gain over a triode are added incentives to their use.

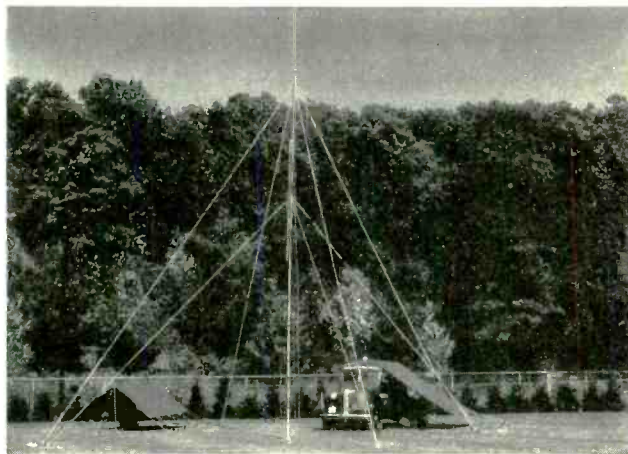

(Below) IN BROADCAST TRANSMITTERS, also, Western Electric makes extensive use of Isolantite's desirable properties. Photo shows rear view of the 50 KW transmitter at Station WJSV, Washington, D. C.

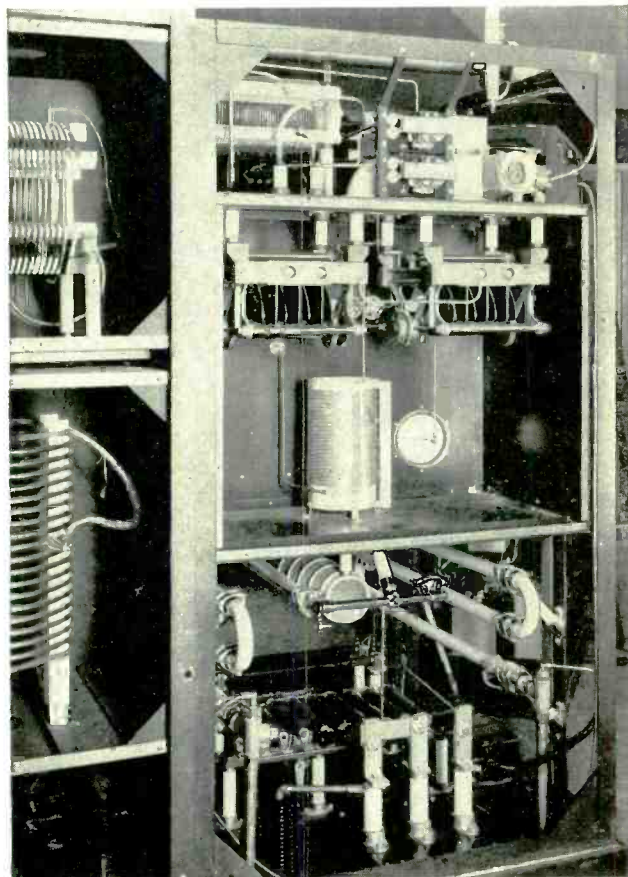

INSULATION HIGHLIGHTS

(Left) COLLAPSIBLE ANTENNA, designated type KS-10070 by the Western Electric Co., Inc., is designed for easy transportation by truck to scene of a field emergency. Photographs illustrate the individual sections in a specially built truck compartment and a completely erected antenna with support ready for use in the field. Isolantite* and Western Electric engineers collaborated in the design and development of this antenna using a special internal coupling which makes for speedy assembly and mechanical stability. The Radio Specialty Division of Isolantite, Inc. is equipped to assist in the development and manufacture of custom-built antenna equipment such as illustrated, in addition to offering a complete line of radio transmission line equipment.

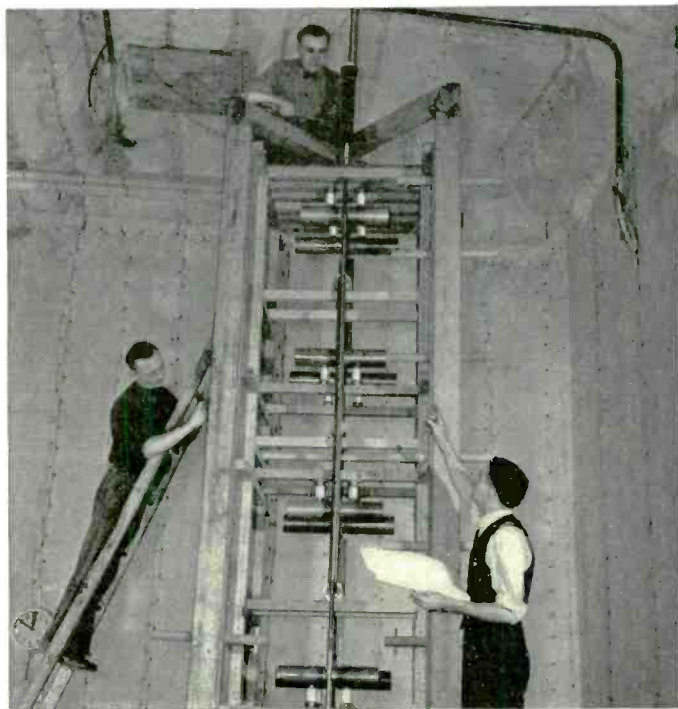

(Above) TELEVISION ANTENNA developed by the General Electric Co. at Schenectady for use with their studio-to-station transmitter. Main transmitting station is located in the Helderberg Mountains—12 miles away. Isolantite insulators of stand-off and lead, in variety and radio transmission line equipment are extensively used in connection with special television apparatus.

**Registered trade-name for the products of Isolantite, Inc.*

ISOLANTITE

CERAMIC INSULATORS

ISOLANTITE, INC. FACTORY: BELLEVILLE, NEW JERSEY
SALES OFFICE: 233 BROADWAY, NEW YORK, N. Y.

VERTICAL RADIATORS

For 44 years LINGO Vertical Tubular Steel Radiators have enjoyed an unequalled record of stability. Constructed of full-weight copper-bearing seamless steel tubing, Lingo "Tube" Radiators are not to be confused with other light-weight tubular or structural steel towers. This extra assurance of stability is only one of the many plus advantages that include a new peak of efficiency . . . and if you're "budget minded", that is only another reason why you should know just what Lingo can do to increase your performance standard.

*The ONE Name
for Every Antenna Need*

LINGO

"PROVEN BY SERVICE"

TURNSTILE RADIATORS

Lingo has set a new pace in the FM field! This new patented Turnstile Antenna is a distinct, new improvement over all previous designs. It is now offered with a background of experience and not experiment . . . it is the result of a basically sound process of development and its excellent performance has already been proven. This FM Antenna can be provided on your building roof or supporting tower.

**JOHN E. LINGO & SON
INC.**

Established 1897

**DEPT E-9
CAMDEN, NEW JERSEY**

WRITE FOR FACTS:
Our engineering staff is ready and glad to provide complete technical data concerning your particular station. Write today and state frequency, power and location. (For FM—give height of building or supporting tower.)

The amplifier is constructed on a chassis which is deep enough to accommodate the output choke and other components and yet give just enough room so the batteries fit snugly against the top of the case. The knock down metal case measures 5x6x9 inches, and the amplifier, complete with batteries weighs 10 pounds. Some details of the construction can be seen on the photograph. The midget input and output transformers are mounted on a shelf which has the edges turned down on the long side for strength. This shelf is rubber mounted on the chassis and the tube sockets are rubber mounted on the shelf. As a further precaution against microphonics the 1N5GT is provided with a heavy metal shield which fits snugly around the base. To the right on the photograph can be seen the input transformer and 1N5GT in its metal shield. Immediately behind the input transformer a set of spare tubes is held in

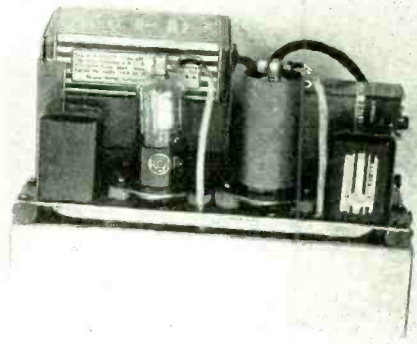

Interior arrangement of the parts of the amplifier

a clip, and behind them can be seen the flexible lead to the level indicator. The batteries are kept from sliding against the shelf by upright corner brackets. Input and output terminations are mounted in the ends of the chassis. Care must be taken to use very flexible wire in making connections to the tube sockets and transformers so as not to lose the value of the rubber mountings. Flexible shielded wire must be used in making the grid connections. A piece of sponge rubber glued to the inside of the front panel holds the smaller filament battery securely in place. To avoid having the amplifier accidentally turned on by coming in contact with other equipment in the carrying case, switching is done by means of two extra sets of contacts on the monitoring jack, rather than by an external switch. Three insulated tip jacks mounted on the chassis and extending through the front panel provide a means of measuring the filament and plate voltages. The level indicator, in conjunction with the proper shunts and resistors and a selector switch could also be used for this purpose.

The only items of appreciable cost

**TRY A NEW
PRESTO GLASS
RECORDING
DISC AT
OUR EXPENSE**



Every recording engineer who has used the new Presto glass disc says it's the finest disc he has seen. Seeing is believing. We want you to see for yourself. So we're asking you to fill out the coupon below and mail it to us. The distributor you name will send you, free of charge, a sample Presto 12" glass disc.

When you get your disc, examine it under a strong light. Note the perfect smoothness of the recording surface, the complete absence of blemishes, streaks or swirls. Note the extra thickness of the Presto disc, the added rigidity and durability that makes it easier to handle, safer to use. Of the first 25,000 Presto glass discs shipped, 3 arrived broken. No breakage was reported in use.

Notice also the 2 holes in the Presto disc, a center hole that fits snugly over the turntable shaft, centering the disc accurately on the table, and a hole for the drive pin essential for positive operation of your

cutting mechanism. Both holes are protected with brass eyelets to prevent chipping.

Record a frequency run on your Presto disc. You'll find it reproduces the entire range from 50 to 8,000 c.p.s. without a suggestion of surface noise. The famous "Q" compound, originated and perfected by Presto, is now triple-filtered to remove impurities that cause noise and needle wear. You'll be amazed at the long life of your cutting needles used exclusively on Presto discs.

Every detail of disc manufacture has been perfected in the new \$250,000 Presto disc plant to give you better recordings. Now is your chance to try this new Presto disc at no cost.

MAIL THIS COUPON TODAY

PRESTO RECORDING CORPORATION
242 West 55th St., New York, N. Y.

Send us the free sample Presto glass disc (E-941).

Name of firm.....

Street and Number.....

City and State.....

We regularly buy our discs from:.....

Name of distributor.....

Street and Number.....

City and State.....

IMPORTANT

If you are using Presto glass discs as well as the thinner metal discs, ask your distributor for a thin rubber turntable mat. It compensates exactly for the difference in the thickness of the two discs and keeps the adjustment of your cutting mechanism and needle angle correct for both types. Thin mats are sent without charge to users of Presto discs.

PRESTO
RECORDING CORP.
242 WEST 55th ST. N.Y.

In Other Cities, Phone . . . ATLANTA, Jack. 4372 • BOSTON, Bel. 4510
CHICAGO, Har. 4240 • CLEVELAND, Me. 1565 • DALLAS, 37093 • DENVER,
Ch. 4277 • DETROIT, Univ. 1-0180 • HOLLYWOOD, Hil. 9133 • KANSAS
CITY, Vic. 4631 • MINNEAPOLIS, Atlantic 4216 • MONTREAL, Wel. 4218
PHILADELPHIA, Penny. 0542 • ROCHESTER, Col. 5548 • SAN FRANCIS-
CO, Yu. 0231 • SEATTLE, Sen. 2560 • WASHINGTON, D. C., Shep. 4003

World's Largest Manufacturers of Instantaneous Sound Recording Equipment and Discs

New Books

Experimental Electrical Engineering—Vol. 2

BY VLADIMIR KARAPETOFF AND BOYD C. DENNISON, *Emeritus Professor of Electrical Engineering at Cornell University, and Professor of Electrical Engineering at Carnegie Institute of Technology respectively, John Wiley and Sons, Inc., New York, Fourth edition, 1941. Price \$7.50, 6 by 9, 930 illustrations, 814 pages.*

THE NEW EDITION of this well-known work has been completely revised and brought up to date. A knowledge of vectors, vector operators, and the subject matter of Volume 1 which is treated in a more advanced manner is assumed. The work includes material on a-c bridges, single-phase and polyphase commutator machines, mercury-arc rectifiers, transmission lines, magnetic contactor control, oscillographs, electronic devices, wave analysis, and high frequency measurements besides an extended development of the topics treated in Volume 1.

Of special interest to ELECTRONICS readers are the chapters on electronic devices and high frequency measurements which were written by Professor R. T. Gabler of Carnegie Institute of Technology. The former, entitled *Fundamentals of Electronic Devices*, covers electronic and photoelectric emission theory, motions of ions and electrons in electric and magnetic fields, and the characteristics and applications of vacuum tubes, phototubes, and gas-filled tubes. Twenty-two experiments are included. Some of the subjects covered in the latter chapter are: measurements of audio and ultra high frequencies, resistance, inductance, and capacitance at high frequencies, noise, and antenna parameters; calibration of a heterodyne frequency meter, an audio frequency oscillator, and an attenuator; and electromechanical systems. Twelve experiments are presented.

The form of the book makes it useful as a reference work as well as a good laboratory manual. The theoretical aspects of each topic are presented first; then follows a series of experiments illustrating the principles involved and showing methods of measuring the phenomenon discussed; and finally, a set of references which offer a more detailed treatment of the subject is listed. Though the entire field of electrical engineering is covered a good portion of the book (about 200 pages) is devoted to electronic and high frequency fields.—E.E.G.

Mathematical Tables

BY HERBERT B. DWIGHT,

Professor of Electrical Machinery, Massachusetts Institute of Technology. 231 pages. No illustrations. Price, \$2.50 McGraw-Hill Book Co.

THE MATHEMATICAL TABLES prepared by Prof. Dwight will provide in one convenient volume, data on practically all of the functions which the communications engineer or research worker is likely to require. There are eleven tables of the trigonometric functions and their logarithms, three tables of natural logarithms and exponentials, and six tables of hyperbolic functions. Other tables which are included are: binomial coefficients, $(a^2 + b^2)^{1/2}/a$, factorials, Gregory-Newton interpolation coefficients, Lagrangean interpolation coefficients, surface zonal harmonics with their first derivatives, complete elliptic integrals of the first and second kinds, Bernoulli's and Euler's numbers, gamma functions, probability integrals, Bessel functions, Reiman zeta functions, and a table of common logarithms. The Greek alphabet is also given. In most cases, differences are given so that interpolation for unlisted values of the argument may be quickly determined.

Like Prof. Dwight's companion volume, "Tables of Integrals and Other Mathematical Data", this book is to be regarded as a reference work rather than as a textbook of instruction, for there is no text explaining the procedure for using these tables. While this may be a disadvantage for the student in his early work, those who have need for a volume of this type would find textual explanations superfluous.—B. D.

Radio Engineer's Pocket Book

BY F. J. CAMM, *Chemical Publishing Co., Inc., Brooklyn, N. Y., 1941. Second edition. 150 pages. Price \$2.50.*

A SERIES OF DATA SHEETS originally published in *Practical Wireless* have been compiled into a pocket-sized volume which is designed to meet the needs of men engaged in the practical side of radio engineering. Though some of the tables embody British standards and units, enough universal material is contained to make the book a handy source of reference for American engineers.—E.E.G.

Elements of Electromagnetic Theory

BY A. WILMER DUFF AND SAMUEL J. PLIMPTON, *Worcester Polytechnic Institute. (173 pages. 86 illustrations. Price, \$2.75. The Blakiston Co.)*

THIS OUTLINE of the mathematical theory of electricity and magnetism was originally prepared for upper class students in general science, but is also suited to the needs of electrical engineering students. Because it is directed to the students of two different departments, certain topics with which electrical engineering students might be expected to be familiar with have been omitted.

Throughout, the book follows the historical development of electrical principles. A large portion of the book is devoted to electrostatics and to material on covered in intermediate physics texts dealing with electricity. The general impression is that the book is a science rather than engineering text, although the exercises at the end of each chapter bring forth the practical applications of the principles developed. A knowledge of calculus and vector analysis is necessary for complete understanding of all chapters. But the properly trained reader will find this little volume an excellent outline of the fundamentals of electricity.—B. D.

• • •

Handbook of Chemistry and Physics

CHARLES D. HODGMAN, *Associate Professor of Physics, Case School of Applied Science, Editor in Chief* and HARRY N. HOLMES, *Professor of Chemistry, Oberlin College, Associate Editor. Chemical Rubber Publishing Co., Cleveland, Ohio, 1940. 24th edition. 2581 pages. Price, \$3.50.*

THE 24TH REVISION of this familiar book contains 342 pages of new and revised data. An entirely new feature is a 65-page table which provides the trade names, formula, specific gravity and other facts regarding over 400 new and extensively used organic compounds. Recent advances in plastics has necessitated a complete revision of the tables regarding their properties. The physical constants of organic compounds are presented in tabular form rather than in paragraph form as was previously done. The scope of this table is best indicated by the fact that it consists of 520 pages. The entire table is cross referenced for convenience of use. A new table comprising six pages gives information on induced radioactivities is given and it should be of especial value for workers in this field. Also, many minor changes have been made to keep up with progress and to provide greater convenience of use.—C.W.

*For Uniform
Insulating Quality-*
FORMICA PARTS!

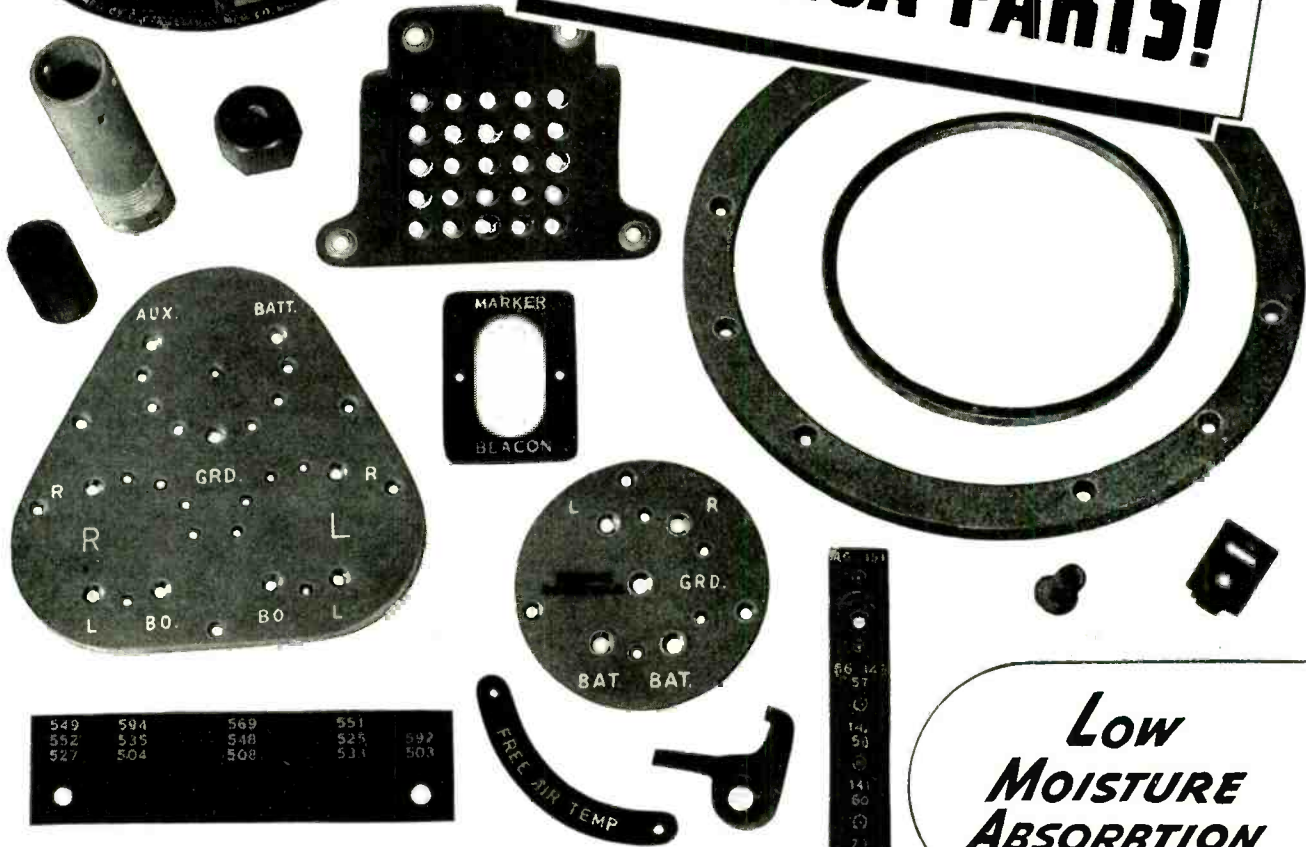
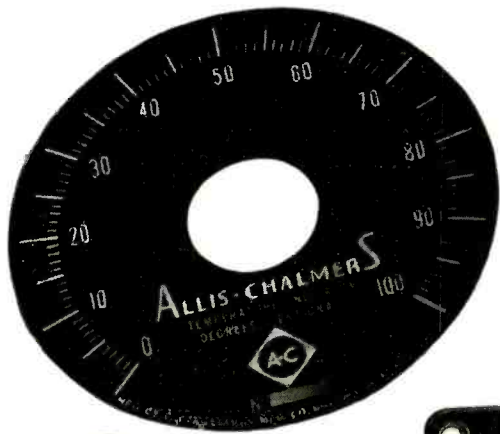

549	594	569	551
552	535	548	525
527	504	508	531
			503

*Low
MOISTURE
ABSORPTION*

*STABLE
DIMENSIONS*

*DECORATIVE
APPEARANCE*

INSULATING parts of Formica are the result of 28 years of concentration by a competent laboratory on the one problem of developing laminated phenolic insulating material. There are special types for special purposes. And all of them are produced under close control which assures quality and uniformity.

Formica's equipment for the production of sheets, tubes and rods is among the largest in the country, and fabricating departments for machining the material are also large and well equipped. Here is an excellent supply service for laminated parts — one that has no superior anywhere. Send your blue prints for quotations.

THE FORMICA INSULATION CO.
4661 SPRING GROVE AVENUE, CINCINNATI, OHIO





NEW!

Complete Insulating Varnish Manual

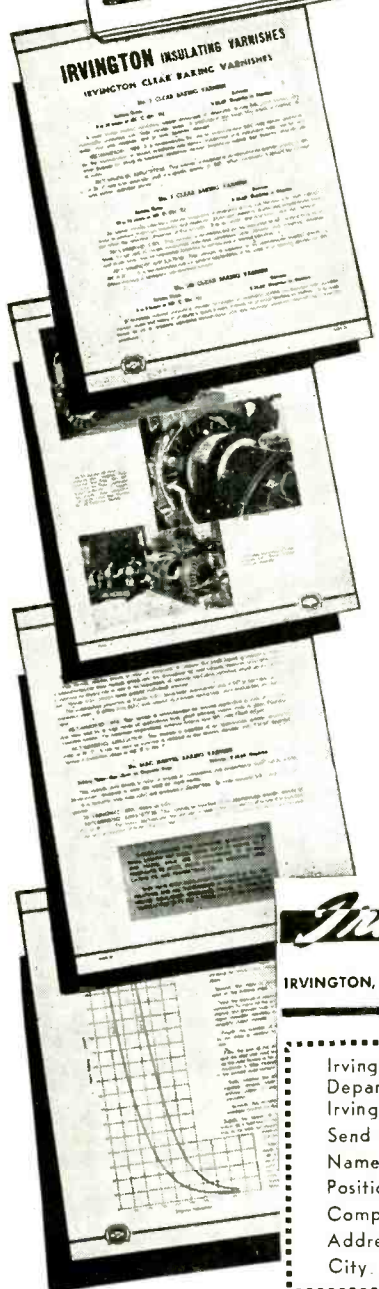

HERE it is! A new 34-page manual on Insulating Varnishes, printed in color and illustrated with 38 pictures and charts. It describes 31 different insulating varnishes, paints and enamels; explains characteristics, uses, applications and types; contains useful tables and information; and is fully cross-indexed for quick reference.

Pioneering in the development and manufacture of insulating varnishes since 1905, and continuous research in insulation applications, makes Irvington the logical source for information on insulating varnish practice.

Send for your copy at once—no obligation except to write Dept. 106, or fill in and return the coupon below.

Irvington VARNISH & INSULATOR CO.
 IRVINGTON, NEW JERSEY, U. S. A.  PLANTS AT IRVINGTON, N. J., and HAMILTON, ONT., CAN.
 Representatives in 20 Principal Cities

Irvington Varnish & Insulator Co.,
 Department 106,
 Irvington, N. J.
 Send me the new Insulation Varnish Manual.
 Name
 Position
 Company Name
 Address
 City

An Electronic Oscilloscope Marker

By ESTEN MOEN

THE VIEWING OF A CURVE on the screen of an oscilloscope is often more effective if means are provided to inject "identification marks" at known points upon the curve. The generator here described can inject sharp breaks in any sinusoidal wave of frequency from 60 to slightly under 1,000 cycles per second.

The circuit shown in Fig. 1 utilizes coupling between the plates of two amplifiers to generate the marking pulses.

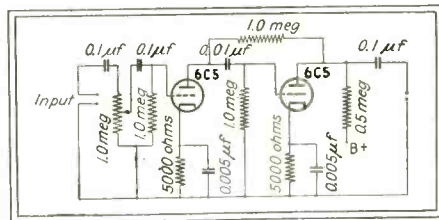
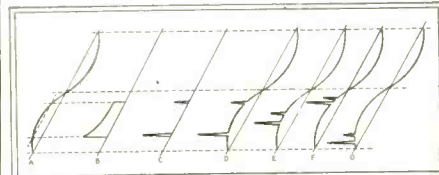

Fig. 1—Above. Circuit of the electronic "marker." Fig. 2—Below. Some of the "marks" made by the generator shown above



When the first plate tends to draw current, the current in the second plate which is in opposite phase is suddenly reduced by the reduction in plate voltage. The result is a sharp differential pulse at each change in input voltage.

Seven graphical examples (Fig. 2), illustrate the action of the circuit. The original or input wave, A, is assumed to be purely sinusoidal. From the bias-point at which the first grid may be held, we obtain the character-curve B, which is the plate-wave of the first tube (if it were not for the second

• • •

TERMITE DETECTOR

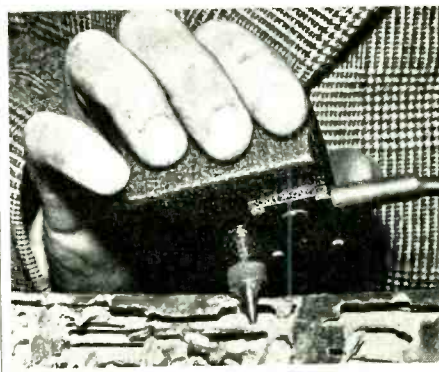

The pick-up microphone of a termite detector which amplifies the noise of the insects' boring, disclosing their presence. It is being held against wood infested with the pests

"LOCK-IN" PROTECTS PERFORMANCE

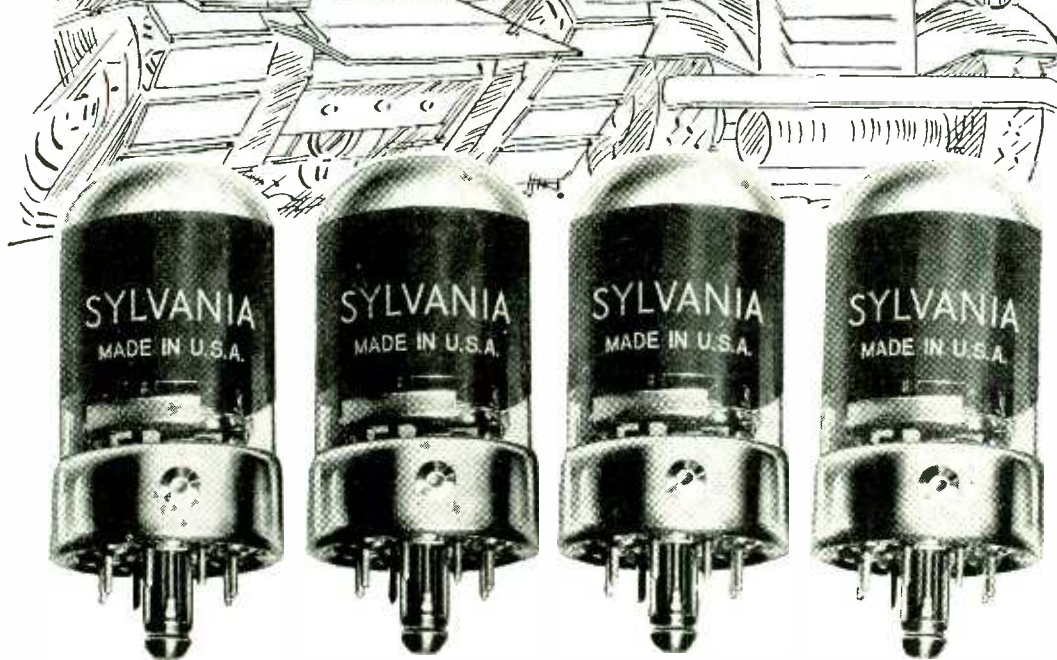

THE HIGH electrical performance quality built into every "Lock-In" tube is protected not only by superior internal mechanical strength but by the rugged "Lock-In" feature.

Sylvania "Lock-In" tubes are designed to stay put—the grooved center pin snaps into the spring clasp in the socket and the tube remains firmly seated whether it's mounted upside-down, sideways, or at an angle. In weapons of war where scores of lives may depend on steady and clear performance the Sylvania "Lock-In" tube is ideal.

In home and car sets, too, the "Lock-In"

tube gives unsurpassed performance.

While this is important to the defense program, there are three very significant radio tube qualities which are deciding engineers in favor of using Sylvania "Lock-In" for every application.

1. Resists physical punishment because of greater mechanical strength.
2. Performs with greater electrical efficiency.
3. Improves set operation resulting in higher consumer satisfaction.

Sylvania Radio Tube Division

HYGRADE
CORPORATION



SYLVANIA
EMPORIUM, PA.

500 FIFTH AVE., NEW YORK • SALEM, MASS. • ST. MARYS, PA. • IPSWICH, MASS. • TOWANDA, PA.

Also makers of Hygrade Lamp Bulbs, Hygrade Fluorescent Lamps and Miralume Fluorescent Light Fixtures

Corrosion-Proof Connections That LAST!



KESTER Rosin-Core Solder makes *permanent* electrical connections — virgin metal alloy withstands shocks, vibration, and temperature extremes. The pure, scientifically-compounded rosin flux will

not corrode wiring or injure insulation. Fire hazard is eliminated. Kester Rosin-Core Solder meets *every exacting electrical requirement*.

There are Kester Cored Solders for every industrial use, all aiding production and improving workmanship by their convenient form. Self-contained fluxes make them easier to use, results more satisfactory.

Kester engineers will gladly consult with you on any question of design or production, without obligation.



KESTER SOLDER COMPANY

4204 Wrightwood Avenue
Chicago, Illinois

Eastern Plant: Newark, N. J.
Canadian Plant: Brantford, Ont.

KESTER CORED SOLDERS

STANDARD FOR INDUSTRY

tube). Curve *C* is the pulse generated by *B* and is the wave fed out of the circuit at the output. Curve *D* is a recombination of *A* with *C* which appears when input and output are connected to the oscilloscope. Curve *E* differs from *D* because the first grid is held at higher negative potential. Curves *F* and *G* illustrate relative changes in phase relationship.

• • •

Television Beacon

BY PHILIP GRANT

A FOUR-MILLION CANDLEPOWER beacon which serves primarily as a warning to airplanes that swarm from Southern California's humming aircraft factories, has been installed on top of the 300-foot steel tower of the new Don Lee television station outside Hollywood, Calif.

The new beacon, a double-flashing type, and the top of the tower will be at an altitude of 2000 feet, the station itself located on a 1700-foot mountain.

At this height, the twelve-ton galvanized steel antenna on the grounds of the new W6XAO television studio has

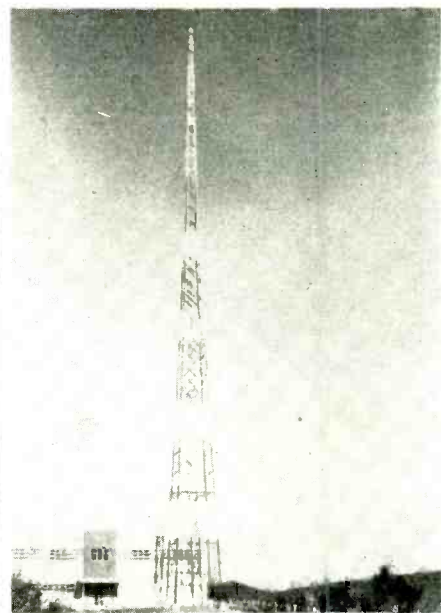

W6XAO's 300-foot television beacon

nearly a half-mile vertical clearance for transmission of synchronized images and sound to the 500 home television receivers in its vicinity. The tower measures 248 square feet at the base and 18 square feet at the top.

The \$100,000 studio, now nearing completion, is the first outlet of what eventually may result in a transcontinental chain of high-mountain television transmitting and relay towers. The Don Lee station, which will overlook Hollywood and the San Fernando Valley, will incorporate what is now the nation's highest television antenna. Harry R. Lubcke is supervising the installation of the equipment.

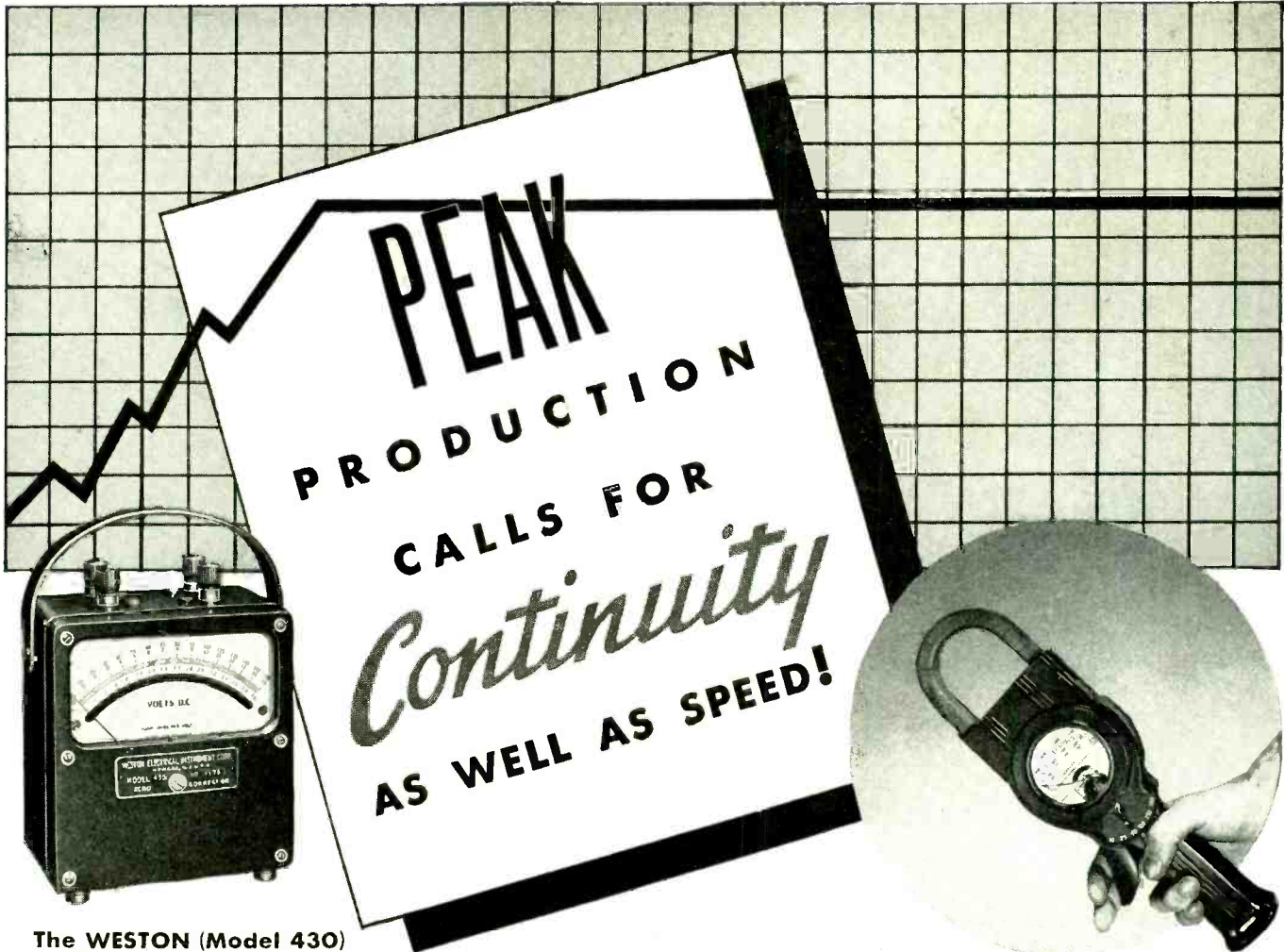

PEAK
PRODUCTION
 CALLS FOR
Continuity
AS WELL AS SPEED!

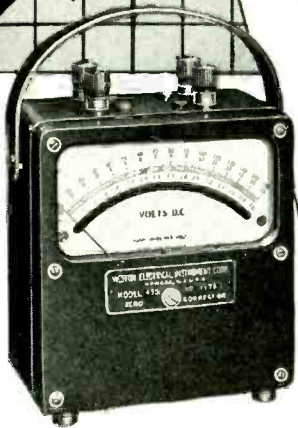

**The WESTON (Model 430)
 Maintenance Tester**

Built for active maintenance . . . extremely compact, rugged, and with *enduring* precision. Extra large openings with hand calibrated mirror scales insure quick, accurate readings. Available in AC and DC instruments and single phase wattmeters. Inexpensively priced.



**The WESTON (Model 633)
 AC Clamp-Ammeter**

Provides the quickest, simplest means for testing electrified equipment regularly . . . thus insuring efficient, uninterrupted operations. The clamping jaws are simply closed over the conductor or bus-bar, and current reading taken. Circuits are never disturbed . . . work never interrupted. Has 6 AC current ranges for maintenance needs.



**The WESTON (Model 703)
 Foot-Candle Meter**

Measures fluorescent, mercury-vapor, incandescent and all other types of lighting *direct* . . . without correction factors. Equipped with the WESTON VISCOR filter . . . a stable, all-glass filter which corrects for all types of lighting regardless of color composition. Saves time, eliminates errors in testing. Available in models for shop and laboratory requirements.

Here are the tools industry is using to help keep motors and machines constantly in fighting trim; forestalling costly break-downs and work interruptions, eliminating power losses . . . *and*, because of their simplicity, broad utility and dependable accuracy, cut precious hours from the usual testing routine. Weston Electrical Instrument Corporation, 618 Frelinghuysen Ave., Newark, New Jersey.

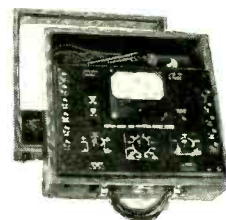

**The WESTON (Model 785)
 Industrial
 Circuit Tester**

With 27 carefully selected voltage, current and resistance ranges, Model 785 handles "trouble" in the most efficient, practical manner. With DC voltage sensitivity of 20,000 ohms per volt, it is ideal for testing sensitive relay circuits, signal and telegraphic systems, photocell circuits, alarm systems, etc. . . . also for testing small motors and controls, lighting circuits, etc. Can also be used with current transformers and voltage multipliers.

Laboratory Standards . . . Precision DC and AC Portables . . . Instrument Transformers . . . Sensitive Relays . . . DC, AC, and Thermo Switchboard and Panel Instruments.

WESTON

Specialized Test Equipment . . . Light Measurement and Control Devices . . . Exposure Meters . . . Aircraft Instruments . . . Electric Tachometers . . . Dial Thermometers.

FOR OVER 53 YEARS LEADERS IN ELECTRICAL MEASURING INSTRUMENTS

Organized for Defense

With These Sub-Contracting Facilities

- ✓ **Bakelite Molding Equipment**
for parts and sub-assemblies for equipment and instruments.
- ✓ **Complete Punch Pressing Department** operated by engineer craftsmen.
- ✓ **Complete Assembly Equipment** for production of small parts.
- ✓ **Design and Production Engineering** to solve your small parts and sub-assembly problems in connection with motors, instruments and other equipment for Government contracts.

Stackpole Engineers are ready to put to work for you their vast fund of knowledge and experience in the radio and the electrical fields. Technical data, covering switches, iron cores, resistors and other products in these fields, are yours for the asking. The Stackpole organization can provide the speed you require without the sacrifice of quality and reliability.

A consultation would not obligate you or your company.



STACKPOLE CARBON CO.
ST. MARYS, PENNA. U. S. A.

"Electric Eye" Breaker Boy

BY H. H. SLAWSON

THE COAL MINE BREAKER BOY, once the symbol of all that is horrible in child labor, has yielded his job to the "electric eye."

To remove slate, "boney" coal and other undesirable refuse material from the coal after it comes from the mines, progressive collieries today are making use of a mechanical device controlled by this modern "cyclops." In the coal washing and cleaning plant the coal, when raised from the underground galleries, is dumped into a trough of water which is agitated by the gentle, pulsating action of compressed air.

Because of its light specific gravity, clean coal floats on the surface and is easily collected and carried away. The refuse, meanwhile, sinks to the bottom of the trough where it makes contact with a sensitive, free-moving float, made of aluminum and weighted to conform to the specific gravity of the refuse material that is to be drawn off. This float rises or falls as the refuse bed varies in depth.

Attached to the float is an aluminum stem, moving between ball-bearing guide rollers within a box-like structure placed above the trough. On the upper tip of this stem is a vane which intercepts the beam of a photoelectric cell. As the refuse in the trough piles up, the float rises higher, until the vane no longer intercepts the light beam. This latter, falling on the photocell, actuates relays which set in motion a mechanism controlling a rotary gate.

Through this gate continuous and automatic discharge of refuse is thus maintained, without intermittent withdrawals to cause loss of good coal. Through a second photocell provision is made for increasing motor speed if the discharge gate cannot handle the accumulating refuse fast enough after it is opened. Decrease in depth of the refuse bed stops the motors and closes the discharge gate when the light beam is again intercepted by the beam.

• • •

Errata

"A SIMPLE 60-CYCLE Square Wave Generator", July, 1941 *ELECTRONICS* had an error in Fig. 1. The cathode resistor in the second section of the 6F8G should be 1,000 ohms instead of 100,000 ohms, as originally given.

Also, in Fig. 1 of the article on "Keyless Telegraphy", August 1941, *ELECTRONICS*, the word phototube should be omitted.

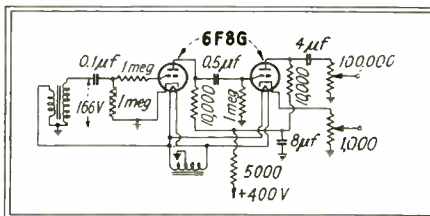

THE ELECTRON ART

A speed control, irradiation of living matter, a high speed oscillograph, induction heating, a high frequency sound generator, a carbon arc timer, and German aircraft radio, are reviewed

Ultracentrifuge Speed Control

AN AUTOMATIC optical speed control for the air-driven ultracentrifuge based on a stroboscopic principle is the subject of an article which appears in the July 1941 issue of *The Review of Scientific Instruments*. Alexandre Rothen of the Laboratories of The Rockefeller Institute for Medical Research in New York City, the author, points out that the accuracy with which the molecular weights of large molecules such as proteins can be obtained with the ultracentrifuge depends, among other factors, upon a precise knowledge of the speed of rotation, and upon maintaining that speed constant during the time necessary to make a determination. Since the speed of this device depends mainly on the pressure of the air driving the turbine, and the pressure of the residual air in the evacuated chamber, a good system of speed control would incorporate some

means of having the operation of the air valve which controls the air pressure, governed by the speed of the centrifuge.

The new control device is shown in block diagram form in Fig. 2. The knob *K* projects from the upper surface *T* of the air turbine that drives the rotor. One face of *K* is polished and acts as a mirror. The rest of the knob is blackened. A discontinuous light source of known and variable speed, such as a Strobolux unit, is placed at *L* and the rays are focused by the condensing lens *C* on the phototubes *E*₁ or *E*₂, depending on the position of the mirror *M*. The pulse generated by the light impinging on the phototubes is amplified by amplifiers *A*₁ or *A*₂, and actuates relays *R*₁ or *R*₂. *R*₁ starts *M*₁ which opens the valve *V* of the air line driving the centrifuge through the differential transmission *D*. Similarly *R*₂ starts *M*₂ which closes the valve *V*. If the number of revolu-

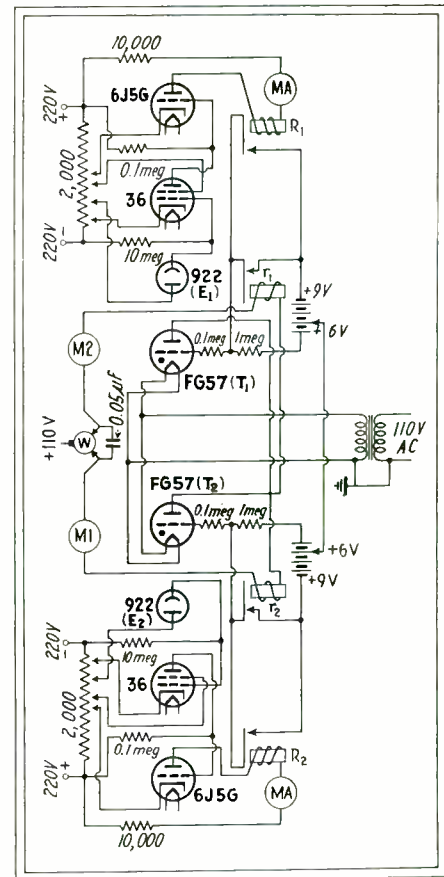

Fig. 1—Circuit diagram of the relay system which controls the speed of the ultracentrifuge. *M*₁ and *M*₂ are motors which regulate an air valve, and keep the speed constant

ATOM SMASHER MAGNET



The huge magnet which will be used in the University of California's 4900-ton cyclotron. Some idea of its magnitude can be gained from the relative size of the figures in the foreground

tions per second is identical with, or a multiple of the frequency of the flashes, then the turbine appears motionless. If the turbine rotates too fast then it will appear to rotate clockwise and the light will be reflected to *E*₂ first, starting motor *M*₂ which will tend to close the valve. A moment later the light will flash on *E*₁, so it is necessary to prevent the operation of *M*₁, and limit the period of operation of *M*₂.

The details of a relay system which accomplishes this is shown in Fig. 1. The effect of the current generated in *E*₂ is to decrease the plate current of the last tube (6J5G) of a two-tube amplifier thereby opening *R*₂ which increases the voltage of the grid of the thyatron *T*₂ (FG 57) which in turn causes current to flow through the plate circuit. The coils of the relay *r*₁ and the motor *M*₂ are connected in series in the plate circuit of *T*₂, and under the influence of the plate current, the motor starts slowly reducing the air pressure and thus the speed of the centrifuge. Simultaneously, *r*₁ closes the circuit of the control grid of *T*₁, thus preventing motor *M*₁ from operating. If the turbine is rotating too slowly then *E*₁ is struck first by the light and motor *M*₁ starts instead of *M*₂. Since the grid of the thyatron does not control the plate current once started, either motor would keep on running indefinitely if some means of

STRENGTH
 .. one of three extra values

The strength of Blaw-Knox towers shows up under severe conditions. It is revealed in low maintenance cost, and — ultimately — in much longer life. And what the structural engineer has done to make these towers sound and strong, the electrical engineer has done to give them the extra efficiency that means wider radio coverage. Add pleasing appearance due to correct designing — and you have the three extra values of Blaw-Knox towers. We'll gladly discuss your antenna problem with you. Write or wire.



BLAW-KNOX DIVISION
 OF BLAW-KNOX COMPANY
 FARMERS BANK BLDG. PITTSBURGH, PA.
 Offices in Principal Cities

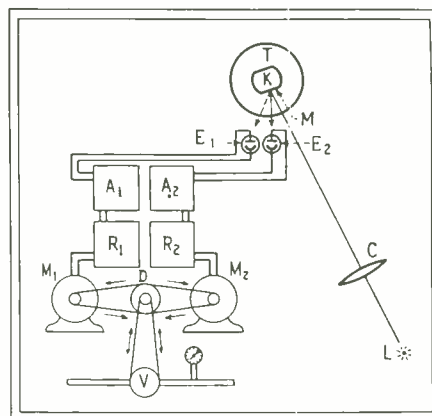

Fig. 2—Block diagram of the ultracentrifuge control system

interrupting were not included in the circuit. This means is the wheel *W*. The motors are geared down to a ratio of 1/595 and rotate a shaft through the differential transmission at a speed of 4 rpm. At the end of this shaft is the wheel *W*. The current, instead of going directly to the motors, first flows through a commutator on the wheel, and the circuit is broken about 0.1 second during each revolution of the wheel. Thus, every 15 seconds the motor which is operating stops, making the system once more subject to control.

It has been found that a variation of one pound at a time, in the operating pressure range of 20 to 25 pounds, is necessary for a satisfactory control between 20,000 to 40,000 rpm. At 60,000 rpm a variation of 1.5 pounds is more effective. With this control, the speed of the centrifuge can be maintained equal to the flashing speed or a multiple of it within less than one revolution per second.

• • •

PHOTOELECTRIC JUDGE FOR HIGH JUMPING



A new high-jump measuring device consists of four parallel beams of light, one inch apart, aimed at four phototubes. The bottom beam indicates the position of the cross bar, and compensates for its sag between the standards. The other beams give jumpers credit when they clear the bar by any distance up to three inches

2 New RCA Measuring Instruments TO SIMPLIFY STATION OPERATION!

RCA Model 322-A F-M MODULATION MONITOR

Precise indications of carrier-swing up to 90 kilocycles (equivalent to 120% modulation on standard 150 kc. channels) are secured directly with this new RCA Type 322-A monitor. The Neon warning indicator may be set to flash at any predetermined threshold of peak modulation.

Asymmetrical modulation—in which the carrier swings farther on one side of the resting frequency than on the other—presents no problem with the 322-A. Overswings are eliminated, because the 322-A will read *either* plus or minus swings at the touch of a switch. Wide band discriminator, low temperature-coefficient crystal control, and extremely stable amplifier design keep the 322-A highly accurate over the entire scale. Unique linear circuit creates less than 0.1% distortion in the discriminator—gives accurate overall distortion measurements in conjunction with standard RCA Model 69B Distortion Meter. The 322-A operates directly from your 110-volt line; requires only to be plugged in and connected to the R-F supply.

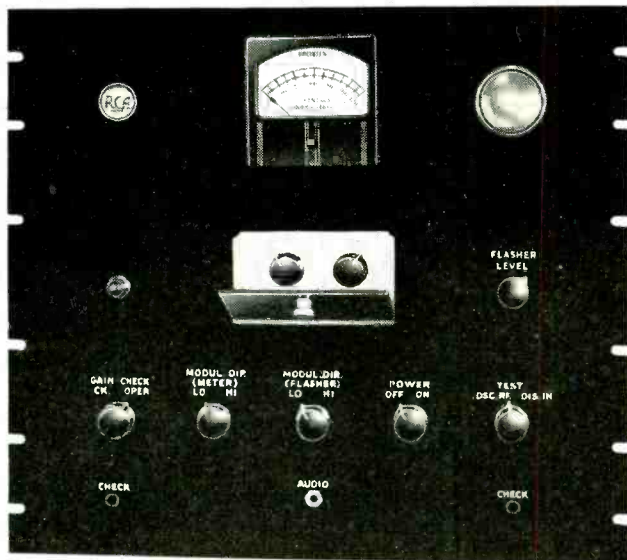

RCA Model 300-C PHASE MONITOR

Here is the simplest, most accurate phase monitor for directive-array systems that has yet been developed! With the 300-C, you can read the current in up to three lines *simultaneously* . . . without switching or complicated preliminary adjustments!

Balance can be read to within $\frac{1}{2}$ of 1° on the three-inch cathode-ray screen. Voltage division is *independent* of the total signal amplitude . . . and circuit-errors are balanced out by a unique *comparative* method of indication. Scale extends a full 8 inches.

Usable with any type of sampling coil, the 300-C comes equipped with sampling coil and meter of the parallel-tuned-circuit type for each element in your array. Because the sampling current is fed into a pure resistive load, coupling-variations introduce no more than negligible error. Write for complete data.

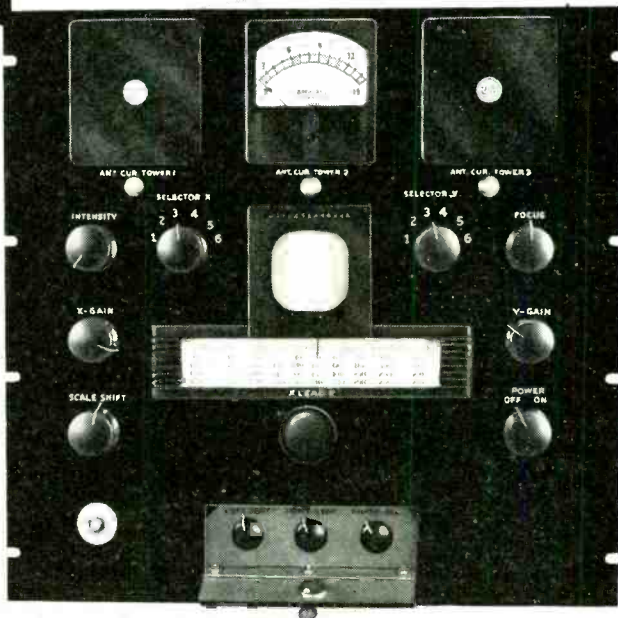

Use RCA Radio Tubes in your station for finer performance



Broadcast Equipment

RCA Manufacturing Company, Inc., Camden, N. J. • A Service of the Radio Corporation of America
In Canada: RCA Victor Co., Ltd., Montreal

New York: 411 Fifth Avenue • Chicago: 589 E. Illinois Street • Atlanta: 530 Citizens & Southern Bank Building • Dallas: Santa Fe Building
San Francisco: 170 Ninth Street • Hollywood: 1016 N. Sycamore Avenue



"WORTH ITS WEIGHT IN WAMPUM"

says Chief Engineer

"The Synchronizer — exclusive Western Electric feature — makes heap big contribution to FM," says the Chief. "Never lets carrier frequency stray from narrow trail. With Synchronizer on lookout, no need for all-the-time checking of transmitter circuits or readjusting of frequency controlling elements. Better send scout to Graybar's wigwam for whole story."

Graybar Electric Company, Graybar Building, New York, N. Y.

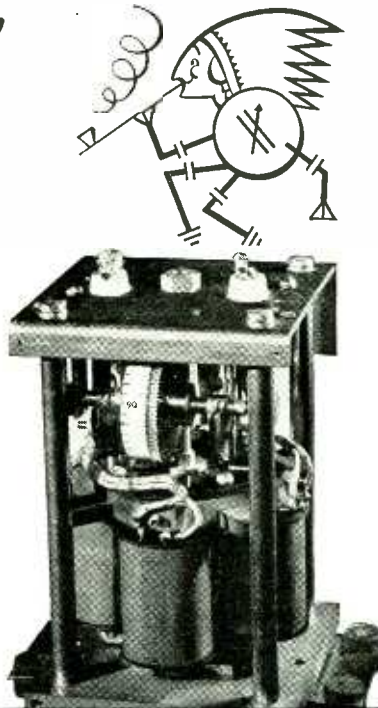

Western Electric

INSUROK

is NOT a Substitute

True, INSUROK has supplanted many materials . . . wood, porcelain, ferrous and non-ferrous metals, glass, leather, and others. But not as a substitute!

There's only one reason why manufacturers prefer INSUROK . . . its advantages make it the most desirable material to use.

Richardson Precision Plastics

The RICHARDSON COMPANY

MELROSE PARK, (CHICAGO) ILL. FOUNDED 1858 LOCKLAND, (CINCINNATI) OHIO
NEW BRUNSWICK, N. J. INDIANAPOLIS, IND.
DETROIT OFFICE: 4-262 G. M. BUILDING, PHONE MADISON 9386
NEW YORK OFFICE: 75 WEST STREET, PHONE WHITEHALL 4-4487

Irradiation of Living Matter

APPARATUS FOR THE irradiation of biological and chemical materials in vacuum with electron beam intensities varying from 10^{-6} to 10^{-20} coulomb per square cm and of energies ranging between 10 and 100 kilovolts is described by Messrs. O. Morningstar, R. D. Evans, and C. P. Haskins in the July 1941 issue of *The Review of Scientific Instruments*. The apparatus consists of an electron gun supplying electrons from a hot tungsten filament, a three-stage high voltage accelerator controlling the electron energies, and a raying chamber. The chamber houses a slit system for collimating the electron beam, a tray for supporting the target to be irradiated, and a Faraday cage assembly for collecting the beam whose intensity is to be measured. The control panel contains the ionization gauge for pressure measurements, the tray control for automatically indicating the settings within the chamber, the electrometer panel for amplifying and measuring the current to the Faraday cage, and the a-c power board. Also, a galvanometer suspension, attached to the ceiling and facing the apparatus, supports the galvanometer in the ion gauge circuit and the more sensitive galvanometer in the electrometer circuit. This support is located in such a way that the galvanometer light beams are reflected to the scales located on top of the apparatus.

The apparatus is evacuated by means of two independent pumping systems. Diffusion pumps backed by jet pumps and mechanical pumps are used. The system of approximately 28 liters can be pumped from atmospheric pressure to 5×10^{-6} mm of Hg in about two to three hours. Provisions are made for the continuous observation of the pres-

. . .

HOME CONSTRUCTED VIBRACHORD



Stanley De Wall, leader of the Sis Hopkins Orchestra built this addition to his orchestra, which he calls the electric vibrachord. Using a vibraharp, he added an electric resonator system and a set of electromagnets to strike the metal bars. Each magnet is operated by a separate key on the piano keyboard

sure by the McLeod gauge and the ionization gauge referred to above.

The tray allows for the irradiation of targets over an area of 36 sq. inches for a single loading. The exact position of the tray can be read at any time by means of the slide wire resistors located inside the chamber which are in series with batteries and external milliammeters. As a double check mechanical counters are geared to the tray shafts on the outside of the chamber. A series of stops on the outside gears quickly determine the settings for the proper positions of the targets for irradiation. A semi-automatic system of stops is used so that a minimum degree of attention is required during runs.

• • •

High Speed Oscillograph

A CATHODE-RAY oscillograph of extremely high writing speed which is used in the new high-voltage impulse laboratory of the National Bureau of Standards is described by Otto Ackermann in the July 1941 issue of *Instruments*. An analysis of the curve of a 22-Mc wave indicates that the writing speed is 66 inches per microsecond or 1000 miles per second. The cathode-ray tube is continuously evacuated with provision for the admission of very small amounts of air into the evacuated chamber to regulate the degree of vacuum. The electrons are radiated from a cathode of the "cold" type. The cathode is a small piece of aluminum exposed to high electric field stress and to the bombardment of ions which precipitate and concentrate the emission of electrons from a spot about the size of a needle point.

Photographic film can be inserted inside the tube for direct exposure to the cathode rays. A roll film may be used and the loading is very similar to loading an ordinary camera. The pumping equipment attains a working vacuum in about ten minutes and difficulties arising from poor vacuum have been practically eliminated.

Particularly important in the operation of this oscillograph is the method of regulating the internal pressure. As with all oscillographs of this type the vacuum is continuously maintained by a pump which reduces the internal pressure below that needed for satisfactory operation, while a tiny trickle of air is admitted from the surrounding atmosphere by an extremely small needle valve. These valves are quite erratic, making the exact control of the vacuum difficult. Slight changes in the atmospheric pressure upset their operation to an excessive degree. To stabilize the needle valve operation, a small air bellows, through which the needle valve draws air for admission to the evacuated chamber was attached. This bellows works so well that not only does it eliminate erratic action of the vacuum system, but it also provides a better air inlet control than by adjustment of the needle valve alone.

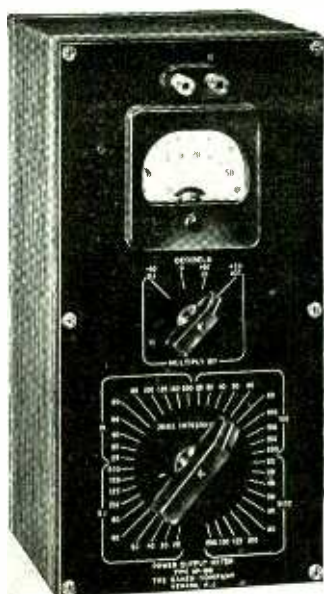

TYPE OP-182



TYPE OP-961

DAVEN OUTPUT POWER METERS

for Accurate Measurement of Power and Impedance

OP-182

Convenient meter reading is provided in this compact, space-saving OP-182 Output Power Meter. It is admirably suited for many power and impedance measurements, such as determining actual power delivered by an audio system to a given load, characteristic impedance or load variation effect on an A.C. source.

Terminal impedance remains essentially resistive over the audio frequency range of 30 to 10,000 cps. Impedances from 2.5 to 20,000 ohms in 40 convenient steps are available.

The indicating meter is calibrated from 0 to 50 mw., and from 0 to 17 db. Zero level at 1 mw. Four ranges of full scale readings from 5 mw. to 5 watts, and from -10 to +37 db. are provided by the meter multiplier. Accuracy within 5% at midscale.

The DAVEN catalog lists the most complete line of precision attenuators in the world; "Ladder", "T" type, "Balanced H" and Potentiometer networks—both variable and fixed types—employed extensively in control positions of high quality program distribution systems and as laboratory standards of attenuation.

Special heavy duty type switches, both for program switching and industrial applications are available.

Super DAVOHM resistors are precision type, wire-wound units from 1% to 0.1% accuracy. More than 80 laboratory test equipment models are incorporated in this catalog.

OP-961

A rugged, handy Output Power Meter for accurate measurements of audio signal systems having a maximum power output up to 50 watts. Highly recommended for measurements of characteristic impedance, load variation effects, transmission line equalization, insertion losses, filters, transformers, radio receiver outputs, and others.

Reliable readings of power and impedances from 2.5 to 20,000 ohms are guaranteed by a meter multiplier network of constant impedance, in combination with a carefully designed impedance changing network that remains essentially resistive throughout virtually the entire audio range.

Power ranges cover from 0.1 mw. to 50 watts in steps of 0.1 mw. Indicating meter is calibrated from 0 to 50 mw., and from 0 to 17 db., with a 1 mw. zero level. A 20-step multiplier extends the meter power reading from 0.1x to 1,000x scale value, and the db. reading in steps of 2 db., from -10 to +30 db., with full scale at +47 db. Accurate within 2% at midscale.

THE DAVEN COMPANY
158 SUMMIT STREET • NEWARK, NEW JERSEY

FRANKLIN

Patented U-shaped bow spring action contact has proven the best for tube pin tension.

Now serving a large number of the leading radio and electrical equipment manufacturers. Complete manufacturing facilities — experienced, skilled engineers — quality raw materials used — guaranteed workmanship.

May we discuss your design problems with you or quote from your blueprints? Your inquiry will receive prompt attention.

A. W. FRANKLIN MFG. CORP.

175 VARICK STREET NEW YORK, N. Y.

Sockets • Terminal Strips • Plugs • Switches • Metal Stampings

Induction Heating

A COMPARISON between various methods of generating high frequency power for induction heating are discussed in "Induction Heating With Electron Tubes" by Dudley B. Clark in the May 12th 1941 issue of *Steel*.

High frequency currents for induction heating are generally produced by means of motor-generator sets, spark-gap converters, and electron tubes. The electron tube method is divided into two classes, vacuum tube oscillators and gas-filled electron tubes. Disadvantages of the m-g sets are poor efficiency, high installation expense, large space needed, immobility, and most important of all, the frequency of the output can not be changed conveniently. The spark-gap converter, the oldest method of producing high frequency currents is strictly limited to small power applications, and is also not adapted to a controlled output frequency.

The vacuum tube oscillator is capable of accurate frequency control but is inefficient, requiring high voltages to produce relatively small amounts of power. However, in small sizes and for special purposes it furnishes a tool for metallurgical and chemical research which may be invaluable because of the high frequency possibilities. The gas-filled tube, usually water-cooled and of metal construction, offers the best means of obtaining high power high frequency waves.

After years of research the Clark

.

FINER THAN A HUMAN HAIR



Nickel-chromium wires only 0.0005 inch in diameter are being spot welded into a K shape at the G.E. Laboratories in the manufacture of thermocouples. The wires, about one-fourth the diameter of a human hair, are so fine, that the operators use microscopes to see them while carrying out the delicate welding operations.

Laboratory has developed a new converter which seems to meet the demands of the severest type of service. It does not draw a no-load current. This improves the power factor and cuts down the power bill. The full load efficiency is greater than that of a rotating machine since there are no friction losses. The output frequency can be tuned and maintained in spite of changes in load. The load can be maintained and the frequency changed over wide limits, a feature not previously attained with any type of rotating machinery.

The cost of building such units in sizes thus far designed has averaged less than half that of a rotating set. This covers units from 30 to 400 kva. The larger the unit, the greater is the difference in cost between the motor-generator set and the tube converter, the advantage being with the latter. The converters are not easily injured by overloads. The tubes themselves act as their own overload protection by opening the circuit in some part of 1/120th of a second should an overload occur.

• • •

A High Frequency Sound Generator

HIGH FREQUENCY SOUND WAVES can flocculate and remove suspended matter in smoke, fumes or fog. Ever since experiments showed this to be true some years ago, much research has been done to develop a suitable generator of these high frequency sound waves with the view of possible industrial application. An article called "An Electromagnetic Sound Generator for Producing Intense High Frequency Sound" by Hillary W. St. Clair, which appears in the May 1941 issue of *The Review of Scientific Instruments*, discusses a new development in this field.

A cross-section of the generator is shown in Fig. 1. A vibrator bar which is supported at its mid-section by an annular web, has one end machined into a driving ring. This ring projects into the radial gap of a magnet. An exciting coil is wound around the central pole of the magnet which is inside the driving ring. The coil acts as the primary of a step down transformer. A high frequency current flowing through it induces a much larger current in the driving ring which acts as a one-turn secondary. By inducing the current in the moving coil rather than by applying it directly, the friction caused by any mechanical connection or lead wires is eliminated, and since the single-turn secondary is part of the vibrator itself, it is better able to withstand the vigorous vibration to which it is subjected. In brief, the generator is a modification of the dynamic speaker with the cone or diaphragm replaced by a highly resonant bar, and the current induced rather than applied directly to the moving coil.

FRANKLIN

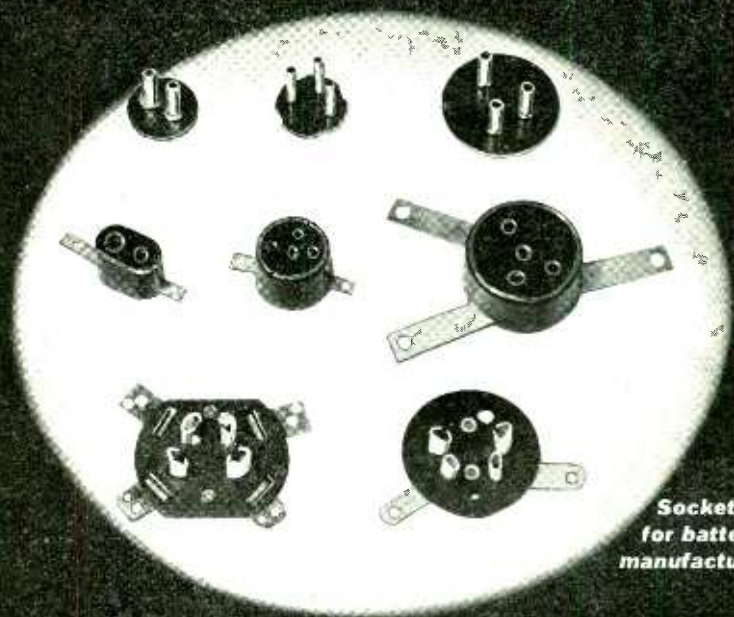

Sockets
for battery
manufacturers

As the leading supplier of laminated sockets and parts to radio and electrical equipment manufacturers, Franklin has enlarged its line to include MOLDED SOCKETS for aviation, battery, electrical, instrument, radio and allied apparatus. Plugs to match. Plugs for speaker and cable manufacturers.

Another Franklin first — developed through design collaboration between our engineers with the engineering department of a leading radio receiver manufacturer.

New terminal strips — with matching, positive-spring-contact male and female connections — for loop aeri- als, speakers, etc. Reduce assembly and manufacturing costs — replace bulky and more expensive plugs.

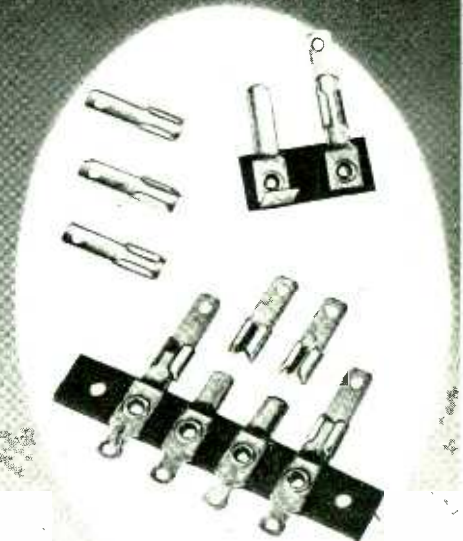

Manufacturing facilities for large quantity production on regular or special items — engineers to discuss your design problems — quotations made promptly from your blueprints.

A. W. FRANKLIN MFG. CORP.

175 VARICK STREET

NEW YORK, N. Y.

Sockets • Terminal Strips • Plugs • Switches • Metal Stampings

USE BRITISH 3-Core Solder



ERSIN MULTICORE

— the solder wire with 3 cores of non-corrosive Ersin Flux — now enables U.S.A. manufacturers to eliminate poor soldering and corrosive joints.



- Avoids dry joints.
- Speeds up production.
- Increases electrical efficiency of joints.
- Reduces overall soldering costs.
- Three flux cores guarantee flux continuity.
- Supplied in any alloy or gauge.



Used by manufacturers making electrical apparatus for R.A.F. Aircraft.

For technical information, samples and prices, apply:

U.S.A. Representative: M. H. Kelsey,
6604, Buckingham Place, CINCINNATI, OHIO.

Eastern Sales Agent & Warehouse—Ben Joseph, 258 Broadway, New York, N. Y.

MULTICORE SOLDERS LTD., BUSH HOUSE, LONDON W.C.2. ENGLAND.

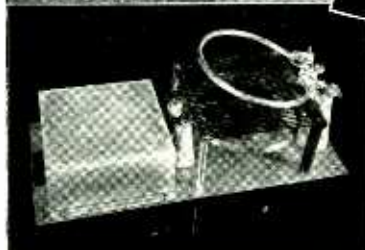
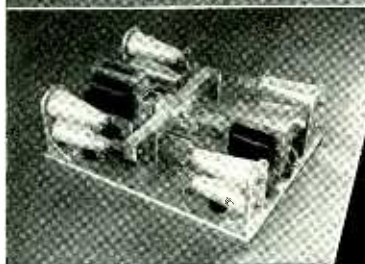
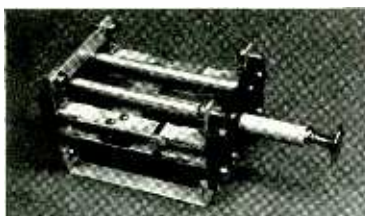

Hard to Get

COMPONENTS FOR BROADCASTING STATIONS

Illustrated are just a few of the many special items designed and built by Johnson. The R. F. Make-Before-Break switch permits the insertion or removal of a meter without breaking the circuit. The R. F. Contactor employs knife-type contacts and requires no holding current. Shown also is an Isolation Transformer for feeding a phase monitor or remote meter. The other illustration is

a terminal fitting for a 2 1/2" concentric line on which an adjustable safety gap is provided.

Johnson Engineers design and build many pieces of apparatus for specific applications. If you have a problem, write to them for suggestions and recommendations.

ASK FOR THE NEW CATALOG 967D



E. F. JOHNSON CO

WASECA, MINNESOTA

EXPORT: 25 WARREN ST., NEW YORK, N. Y.

"MANUFACTURERS OF RADIO TRANSMITTING EQUIPMENT"

Resonance is extremely sharp for the vibrator, a drift of a fraction of a cycle causing a marked decrease in amplitude. This necessitates the use of a very stable oscillator. However, by using the vibrator itself to control the oscillations which drive it this necessity is eliminated and the unit becomes self-exciting. A thin circular plate cemented to a thin disk of bakelite is fastened to the top of the central pole of the magnet. The plate serves as the fixed electrode of a condenser, the movable one being the end of the vibrator bar. The fixed electrode is insulated from the rest of the generator which is at ground potential, and is maintained at 300 volts through a two-megohm resistor. Any motion

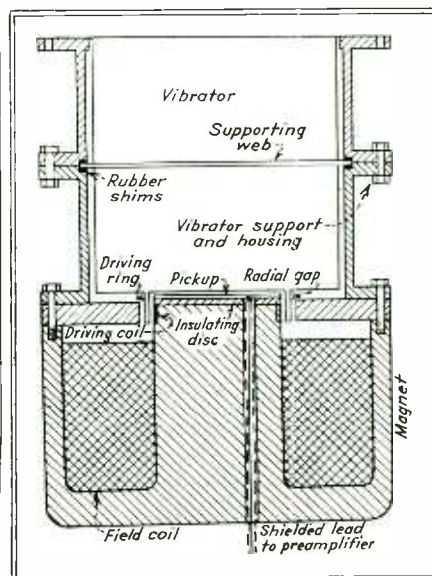

Fig. 1—Cross-section of the high frequency generator which is like a dynamic loudspeaker with the cone replaced by the resonant bar, and the current induced rather than fed directly to the moving coil

of the vibrator varies the capacity of this electrostatic pickup, and causes an alternating voltage proportional to the displacement of the vibrator to be set up across the resistance. This voltage is amplified, shifted to the proper phase, and then is fed back to the driving coil where it is transformed into an oscillatory mechanical force which drives the vibrator bar. Should the resonant frequency of the bar change slightly, the frequency of the electrical oscillations changes automatically keeping the vibrator operating at the optimum frequency. Enough instability exists in the system so that oscillations are started by merely increasing the gain of the amplifier. An automatic gain control permits the coupling of the vibrator to a resonating chamber without stopping oscillations or overloading the amplifier. Theory of operation including derived equations, a method of measuring the motional impedance and the logarithmic decrement of the vibrator are also discussed.

Intermittent Carbon Arc Timer

AN INTERESTING APPLICATION of electron tubes is presented in an article called "Characteristics of Intermittent Carbon Arcs", by F. T. Bowditch, R. B. Dull, and H. G. MacPherson which appears in the July 1941 *Journal of the Society of Motion Picture Engineers*. Intermittent timing circuits, similar to the ones used in arc welding work are applied to carbon arcs.

The carbon arc, usually considered a continuous source of light is used only intermittently in motion picture photography and projection. The intervals are determined by the camera or projection shutter. Since as much as one-half of the light generated is wasted in this way, worthwhile economies would result through the intermittent generation of light as needed. Then too, in a new system of motion picture photography known as the "increased range system" very short light pulses of one-eighth the duration of a single frame are required, separated by dark periods three times as long. Such a light-cycle, sup-

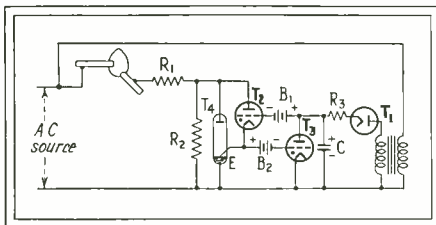
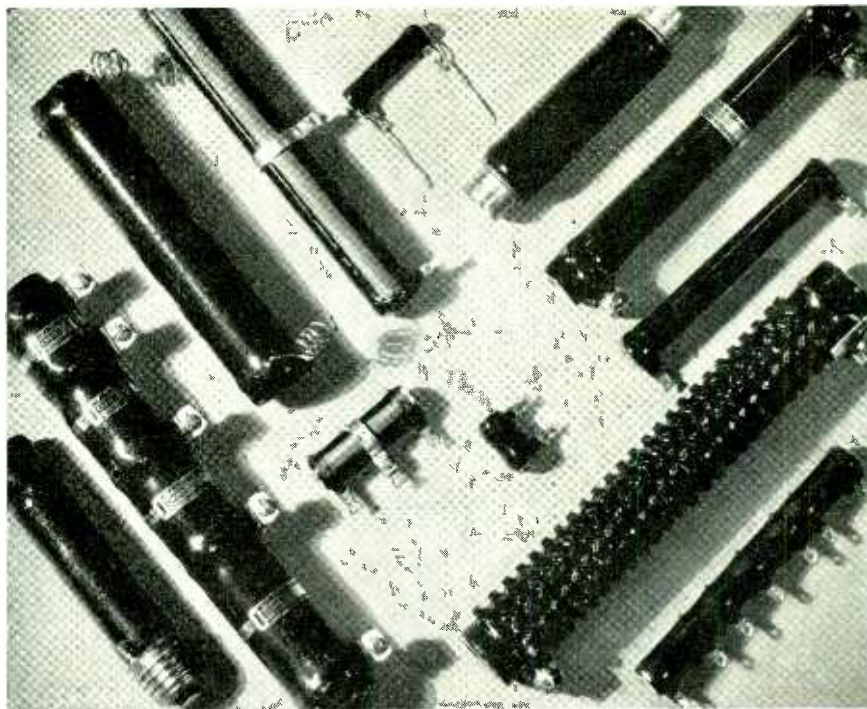

Fig. 1—Circuit of the apparatus which gives an intermittent carbon arc at the beginning of any half cycle of the a-c source

plied by a continuous source with a shutter would mean a waste of 75 per cent of the generated light.

The essential switching circuit consists of two resistors in series with the arc. One of these is shorted out at the desired intervals. A means of getting an intermittent carbon arc at the beginning of any half cycle of the a-c source is shown in Fig. 1. Here the alternating voltage of the source is used to charge a condenser through a transformer and a half-wave rectifier. The condenser is connected to the grid of a thyatron in such a way that its polarity opposes that of the bias battery. As the condenser charges, the negative grid potential of the mercury-vapor thyatron T_2 is reduced until the tube fires permitting current to flow into the ignitron-firing electrode E . The ignitron T_1 fires, shorts out the resistance R_2 and causes an increased current to flow into the arc circuit. As the ignitron fires, the voltage across it drops to a value below the excitation point of thyatron T_2 so that this tube is extinguished. In the meantime, the voltage developed between the electrode E and the mercury pool during firing overcomes the bias voltage B_2 , firing the small argon-filled thyatron T_3 so



RESISTORS you forget



When you install a resistor you have a right to forget it. You can, if the resistor is made right and conservatively rated. The differential in price between the most dependable resistor and the cheapest, is so slight, that it is not worth the annoyance and cost of a single failure. Ward Leonard Resistors have built their reputation upon this sound policy.

BULLETIN 11

Tells about Vitrohm Wire Wound Resistors, gives sizes, watt ratings.

BULLETIN 19

Describes Ward Leonard Rib-flex Resistors for unusually heavy duties.

BULLETIN 22

Is about plaque type non-inductive and non-capacitive resistors.

BULLETIN 25

Is a treatise of standard and special mountings and enclosures.

Electric control  devices since 1892.

WARD LEONARD

RELAYS • RESISTORS • RHEOSTATS

Ward Leonard Electric Company, 32 South Street, Mount Vernon, N. Y.

Please send me Bulletins No.
 Name
 Firm
 Address
 City State

AGASTAT



UNAFFECTED BY DUST
DIRT OR TEMPERATURE

SET SCREW ADJUSTMENT
FOR DELAY INCREASE

FOR USE WITH EITHER
AC OR DC CURRENT

DIVERSITY OF TIMING
EFFECTS POSSIBLE

POSITIVE SNAP-ACTION
TYPE CONTACTS

● This time delay relay offers the widest flexibility obtainable in a single precision instrument . . . without sacrificing accuracy and dependability. Multiple timing effects by various circuit combinations—a delay varying from a fraction of a second to several minutes is possible when circuit is either closed or opened.

Send for Bulletin N-40 describing this rugged compact unit. No obligation.

**AMERICAN
GAS ACCUMULATOR
COMPANY**
ELECTRICAL DIVISION
ELIZABETH, NEW JERSEY

that it may discharge condenser C . Finally, at the end of one half cycle when the voltage across the ignitron falls to zero, it also is extinguished so that all elements are returned to their original condition ready to set off the next surge. The timing of this circuit may be adjusted by varying the secondary voltage of the transformer, R_3 , or C independently to determine the number of half-cycle charging pulses needed to raise the condenser voltage to the firing value.

A circuit which offers more flexibility, allowing surge timing control at any time during any chosen half-cycle

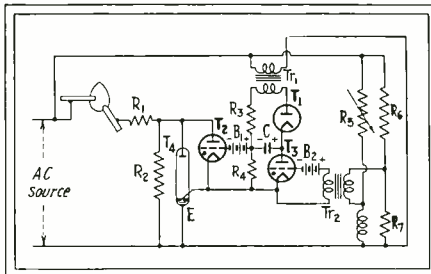

Fig. 2—A more flexible circuit which permits surge timing control at any time during any half cycle

is shown in Fig. 2. As before, the essential timing elements are transformer T_1 , the rectifier T_1 , condenser C , and resistor R_3 , but now they operate to raise the plate voltage of thyatron T_3 to its firing point so that the resulting discharge through R_4 may fire T_2 . The firing of T_3 also depends on the grid voltage pulse received each positive half-cycle through transformer T_2 . This transformer has a constricted iron magnetic path giving a very peaked waveform conducive to accurate timing of the voltage pulse. The primary is supplied through the phase-shifting network made up of the four elements arranged in a Wheatstone bridge manner. Thyatron T_3 receives a firing pulse once each positive half-cycle, in phase relationship with respect to the source as determined by the setting of the phase shifter circuit. If the voltage of the condenser has risen to a sufficiently high value the tube fires, firing thyatron T_2 and ignitron T_4 along with it. The act of firing discharges the condenser so that the circuit is cleared and ready for the next sequence. The article also discusses the choice of source frequency, and the increased brilliance obtained by using intermittent instead of continuous arcs.

• • •

German Aircraft Radio

THE DESCRIPTION OF a German military aircraft radio makes interesting reading in the August 1941 issue of *Aviation*. The article is called "The Messerschmitt Me 109 Radio" and is written by William P. Lear. The equipment, which was salvaged from a ship brought down in England, consists of

a low-power fixed-frequency transmitter, a companion receiver, and a dynamotor power unit operating from a 24-volt d-c power source. In general the equipment is obsolete when compared with modern designs, but it is pointed out that this is by no means the latest design in German aircraft radio. It is evident that the Germans had frozen this design several years ago and have concentrated on making a large number of these units available. In doing so, many production problems have been solved, but the penalty has been the necessity of adhering to obsolete designs.



The receiver (above) and the transmitter (below) which was taken from a German plane shot down in England



The receiver tunes from 250 to 3700 kc. It uses a five-tube superhetrodyne circuit which consists of an r-f, detector-oscillator, i-f, second detector, and an audio output stage. The same tube, a Telefunken RENS 1264, is used in each stage. It is equivalent to the now little-used 24 or 35. The maximum power output is about 70 milliwatts. The sensitivity is about 10 microvolts at the high frequency end, and varies up to 60 microvolts at the low end of the band.

The transmitter uses four tubes. A Telefunken REM-904 acts as a straight feed-back oscillator whose frequency is controlled by a tuning con-

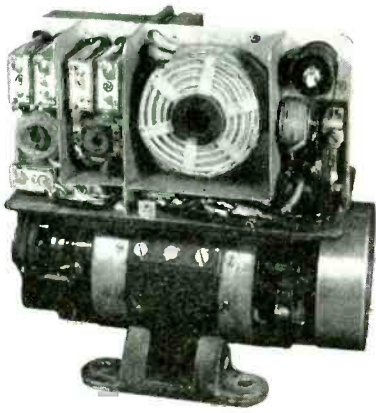

Motor-generator and filter unit which make up the power supply for the German aircraft radio

denser in the plate circuit. The output of the oscillator is fed to two Telefunken RES-1664D tubes in parallel which act as grid-modulated r-f amplifiers. One Telefunken REM-904 serves as the modulator. The power output is about 2 watts. Both receiver and transmitter are very ruggedly constructed. The chasses are light weight castings made of Electron, an aluminum alloy having a high percentage of magnesium.

The power supply consists of a motor-generator unit and filter combination for both the output and input voltages. The voltages supplied by this unit are 12 volts for lighting the filaments of the tubes, 400 volts for the plates and screens, and 275 volts at 90 cps which is rectified at the transmitter, to supply the bias voltages for the oscillator and speech amplifier tubes.

BLACKOUT LIGHT



One of the twelve specially designed 3½-candlepower argon lamps which were used in a demonstration of blackout lighting at Lynn, Mass. The lights are not visible from the air but are bright enough to permit the flow of traffic without the aid of headlights or street lamps

A
V
I
A
T
I
O
N

Bliley Crystals



Positive, dependable frequency control for radio transmitters in marine-craft (ship harbor service) and in itinerant aircraft (3105kc. and 6210kc.) is economically obtained with the type MC5 Crystal Unit. This unit, low in cost yet precision-built, is made possible by the application of quantity production methods to an essentially custom manufactured product. WRITE FOR CATALOG G-12

★
M
A
R
I
N
E
★

BLILEY ELECTRIC COMPANY

UNION STATION BUILDING

ERIE, PA.

**RELAY
QUALITY**

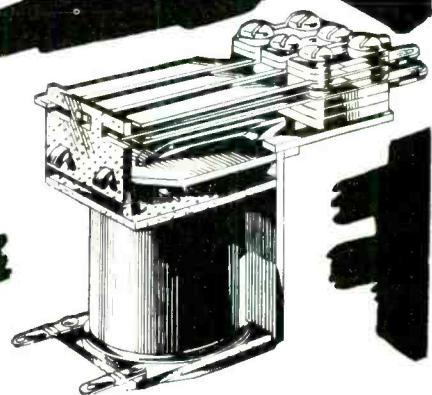

FOUNDED ON "KNOW-HOW"

The world-famous quality of Automatic Electric relays is backed by 50 years of manufacturing experience . . . constant daily use . . . endless laboratory tests. The resulting "know-how" takes tangible shape in superior performance and dependability, for which you pay no premium!

The Automatic Electric relay line is complete—includes units for every operating condition. All have Automatic Electric built-in quality, assuring positive action and long life.

Send for your free copy of our comprehensive relay catalog.

AMERICAN AUTOMATIC ELECTRIC SALES COMPANY
1033 W. Van Buren Street, Chicago

AUTOMATIC ELECTRIC
RELAY MAKERS SINCE 1898

New DECADE AMPLIFIER MODEL 220



A highly stable amplifier giving gains of exactly 10 and 100 times. Operated by self-contained batteries. Through the use of special circuits the gain is independent of battery voltage, circuit constants and tubes within 2% from 10 to 100,000 cycles. Particularly useful with our Model 300 Electronic Voltmeter to increase its sensitivity, permitting voltage measurements down to 30 microvolts. Send for Bulletin 7.

SENSITIVE ELECTRONIC AC VOLTMETER

MODEL 300



10 to 150,000 cycles.
1 millivolt to 100 volts in five ranges (to 1,000 and 10,000 volts with multipliers).
Logarithmic voltage scale.
AC operation, 115 volts, 60 cycles.
Accurate and stable calibration.

Ballantine Laboratories, Inc.

BOONTON

NEW JERSEY

TUBES

Characteristics of the type 6SL7GT, registered with the RMA Data Bureau in July, are given as well as the characteristics of a number of phototubes

Tube Registry

Tube Type registered by R.M.A.
Data Bureau During July 1941

Type 6SL7GT

DOUBLE triode amplifier, heater type, T-9 glass envelope, seated height 2 3/4 inches (max), intermediate shell 8-pin octal base.

RATINGS

$E_f = 6.3$ v
 $I_f = 0.30$ amp
 $E_b = 250$ v (max)
 $E_c = 0$ v (min)

TYPICAL OPERATION

(Each unit in Class A1)

$E_b = 250$ v
 $E_c = -2.0$ v
 $I_b = 2.3$ ma
 $\mu = 70$
 $t_m = 1600$ μ mbos
 $r_p = 44,000$ ohms
Basing 8BD-0-0

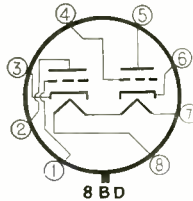

Phototubes

Farnsworth 6-Stage Photo-electronic Multiplier

HIGH-VACUUM multiplier phototube, caesium coated cathode, window area 0.75 square inch (1-inch diameter), seated height to center line of cathode 2 7/16 inches, overall length 4 3/4 inches, diameter of base 1 15/16 inch, 8-pin octal base. Numbers next to the pins refer to successive multiplying stages.

Maximum collector d-c supply voltage = 900 v
Maximum collector dissipation = 0.01 watt

Typical Operation

Voltage per stage = 100 v
Sensitivity = 10 ma/lumen
Interelectrode capacitances
Collector to electrode No. 6 = 2.6 μ f

Collector to all other electrodes = 4.2 μ f

Color sensitivity — Sensitive in the visible and infrared range up to 10,000 Å with maximum sensitivity in the visible portion of the range.

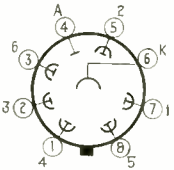

MOBILE ARMY X-RAY UNIT



A mobile x-ray unit, which consists of nine parts each weighing less than 200 pounds has been developed by the Army Medical Center in Washington. The unit is shown in a disassembled state

Farnsworth 11-Stage Photo-electronic Multiplier

HIGH-VACUUM multiplier phototube, caesium coated cathode, window area 1.75 square inch, (1½-inch diameter), sensitive part of cathode 0.5 square inch. Seated height to center line of cathode 3¾ inches, overall length 6 inches, glass envelope diameter 2½ inches, diameter of base 4 inches, special base. Numbers next to the pins refer to successive multiplying stages.

Maximum collector d-c supply voltage = 1500 v
Maximum collector dissipation = 0.1 watt

Typical Operation

Voltage per stage = 100 v
Sensitivity = 1 amp/lumen

Interelectrode capacitances

Collector to electrode No. 11 = 2 μμf

Collector to all other electrodes = 8 μμf

Color sensitivity — Sensitive in the visible and infrared range up to 10,000 Å with maximum sensitivity in the visible portion of the range.

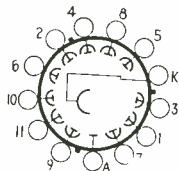

Type WL-770

Westinghouse

VACUUM phototube, aperture 1¾ inch diameter, seated height to center line of window 3½ inches, overall length 6½ inches (max), overall diameter 3 inches (max), 4-pin base with cathode cap.

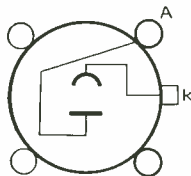
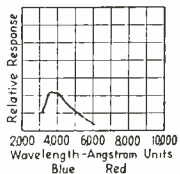

Sensitivity = 0.75 μa/lumen
Max Operating Voltage = 500 v
Max Current = 2.5 μa/sq inch

Type CE-7

Continental Electric Co.

PHOTOTUBE (vacuum or gas-filled), cathode area 1.73 sq inch, seated height to center line of cathode 2¾ inches, overall seated height 4 inches (max), diameter 1¾ inches (max), 4-pin base.

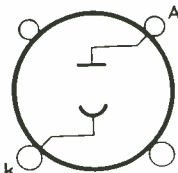
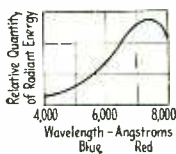

Sensitivity
Gas-filled phototubes are available with sensitivities ranging from 10 to 400 μa/lumen.

Vacuum phototubes are available with sensitivities ranging from 5 to 50 μa/lumen.

Operating voltage = 90 v
Ionization voltage (gas-filled tubes) = 115 v

HUNDREDS of leading firms who are Hunter customers will tell you: the easiest way to get the *right* spring for the job is the Hunter way. Long experience, exceptional laboratory facilities, suggestions based on tested facts, rigid standards for production—help guarantee the perfection of your product, and the continuing goodwill of your customers!



At right:

On precision devices such as this load testing machine for light springs, the performance of your springs is measured and their fitness assured.

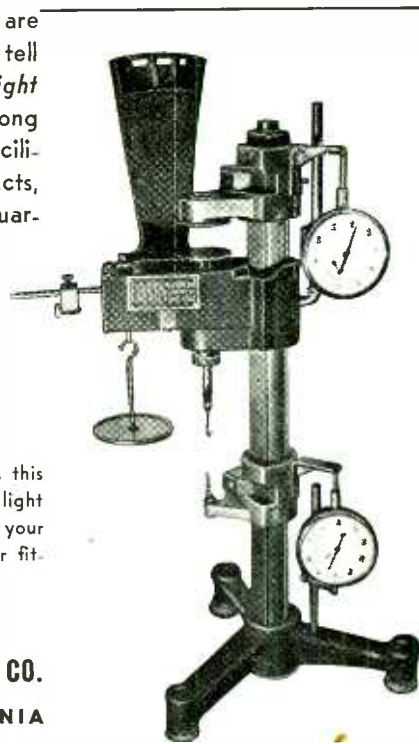

HUNTER PRESSED STEEL CO.
LANSDALE, PENNSYLVANIA

HUNTER

Springs



are **ENGINEERED** springs!

utah

PARTS FOR DEFENSE



Vitreous Enameled Resistors—Wirewound Controls—Plugs—Jacks—Switches—Mid-gut Motors A.C. and D.C.—Also Permanent Magnet Field Types.

NOW—in the emergency as in normal times—Utah Products are providing utmost satisfaction. Because dependable performance is assured at every Utah-point, the proper functioning of the entire unit is protected. All the experience, research and skill of the Utah laboratories are at your service—to aid you in your problems.

Many Utah Parts Meet Government Specifications. Let us know about your requirements.

UTAH RADIO PRODUCTS COMPANY, 837 Orleans St., Chicago, Illinois, Canadian Office: 560 King St., West, Toronto.

In Argentine: Ucoa Radio Products Co., SRL Buenos Aires. Cable Address: Utaradio, Chicago.

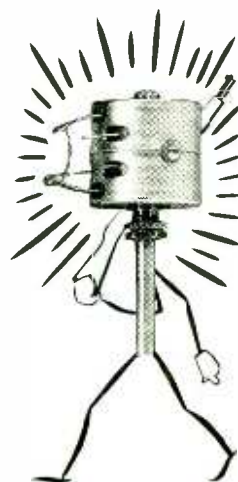

UTAH VITREOUS ENAMELED RESISTORS

Other Utah-Carter Products: Volume Controls
Potentiometers • Rheostats • Plugs • Jacks • Switches • Relays

STABILIZED A. C. VOLTAGE UP TO 25 KVA

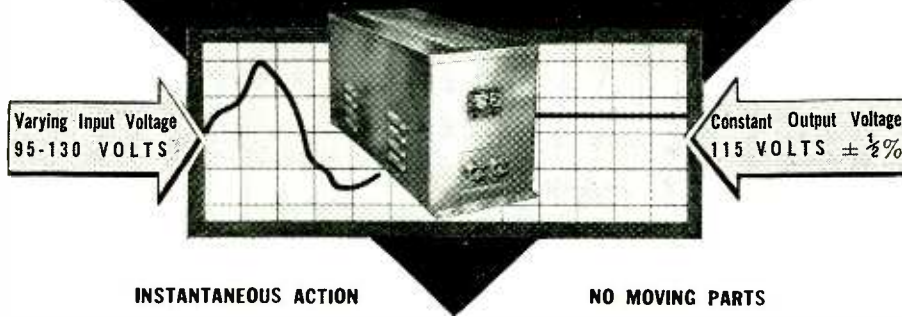

When a precision electrical device or a critical process is powered from an AC line, a Raytheon Voltage Stabilizer will permanently eliminate all of the detrimental effects caused by AC line voltage fluctuations. Made for all commercial voltages and frequencies, single or three phase.

Raytheon's twelve years of experience in successfully applying the Stabilizer to hundreds of perplexing voltage fluctuation problems is at your service. It will pay you to take advantage of our engineering skill.

Write for Bulletin DL48-71 JE describing Raytheon Stabilizers.

RAYTHEON MANUFACTURING CO.
100 Willow Street, WALTHAM, Massachusetts

MOLDED S. S. White RESISTORS *The All-Weather Resistors*

**RANGE OF VALUES
S. S. WHITE RESISTORS**

STANDARD RANGE—

1000 ohms to 10 megohms

HIGH VALUES—

15 to 1,000,000 megohms

**SEND FOR RESISTOR
BULLETIN 37**

It contains illustrations of the different types of S. S. White Molded Resistors and gives details about construction, dimensions, etc. A copy, with Price List, mailed on request. Write for it today.

NOISE TESTED

LOW NOISE LEVEL is a feature of all S. S. White Molded Resistors. But as an accommodation to manufacturers of equipment in which noiseless operation is of first importance, S. S. White will supply resistors in the Standard Range of 1000 ohms to 10 megohms, noise tested to the following standard:

"For the complete audio frequency range, resistors shall have less noise than corresponds to a change of resistance of 1 part in 1,000,000."

Each and every resistor on such orders is tested and guaranteed to meet these specifications and can therefore be used as received without further test. This is one reason why S. S. White Resistors are so widely used in quality radio, telephone, telegraph, sound picture, television and other commercial, industrial and scientific equipment.

S. S. WHITE

The S. S. White Dental Mfg. Co.

INDUSTRIAL DIVISION

Department R, 10 East 40th St., New York, N. Y.

Type 928

R.C.A.

GAS phototube, non-directional type, window area 0.7 square inch, seated height to center line of cathode 1 31/32 inch, overall length 2 15/32 inches.

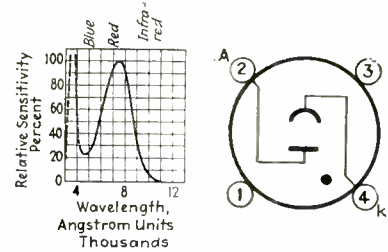

Gas Amplification Factor — Not over 10

Luminous Sensitivity

0 cps (dc) = 65 μ a lumen

1000 cps = less than 65

5000 cps = less than 65

C (cathode-anode) = 3.0 μ af

Max Ambient Temp = 100° C

Max Anode Supply Voltage

(dc or peak ac) = 90 v

Max Anode Current = 15 μ a

Sensitivity (E anode supply

= 90 v and R_L = 1 megohm)

0.0060 μ a / μ watt radiant flux

at 7500 A. See curve.

Type WL-767

Westinghouse

VACUUM phototube for ultraviolet light, titanium cathode, aperture 1 1/16 inch x 1 1/4 inch, seated height to center line of cathode 5 inches, overall length 8 inches (max), overall diameter 3 3/16 inches, 4-pin base with cathode cap.

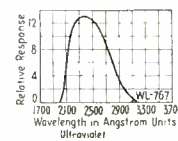

Max Anode Voltage = 500 v

Recommended Anode Voltage

= 90 v

Spectral Range 2000-3250 A.

Type WL-789

Westinghouse

VACUUM phototube for ultraviolet light, platinum cathode, aperture 1 1/8 inch diameter, seated height to center line of cathode 5 1/2 inches, overall length 8 inches (max), overall diameter 3 15/32 inches (max), 4-pin base with cathode cap.

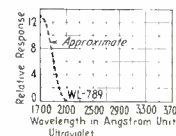

Max Anode Voltage = 500 v

Recommended Anode Voltage

= 90 v

Spectral Range — Below 2000 A.

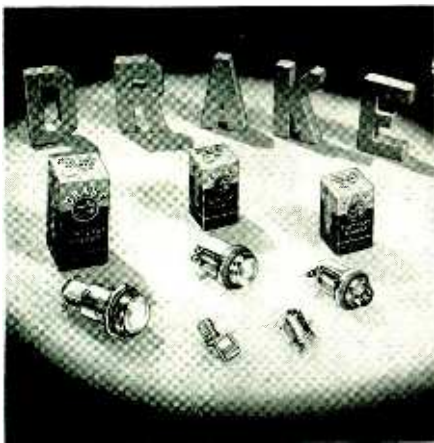

PILOT LIGHT ASSEMBLIES STANDARD TYPES IN LARGE VARIETY

Chances are you'll find it easy to get a standard type and size assembly from us to exactly suit your needs. For, we make stock units and parts in big variety. If a special design is required, our skillful engineers will gladly cooperate in creating a unit to exacting specifications.

Drake Assemblies are precision-built from finest materials. They are used by most leading electrical manufacturers. Will you write us about your needs?



SEND FOR CATALOG

DRAKE MANUFACTURING CO.
1713 W. HUBBARD ST. • CHICAGO, U. S. A.

New Carter AIRCRAFT TYPE GENEMOTORS

● **TRIPLE OUTPUT!!**—Think what this means—3 separate outputs from a single Dynamotor! The new Carter Triple Output Dynamotor shown below, is winning wide acclaim in the Aircraft Industry because of its high efficiency, small size, and extra light weight.



● Write today for descriptive literature on Carter Dynamotors—D.C. to A.C. Converters—Double and Triple Output Dynamotors—Magnomotors—Special Motors—High Frequency Converters—and Permanent Magnet Dynamotors.



1606 Milwaukee Ave. Cable: Genemotor
Carter, a well known name in Radio since 1922

Type CE-10

Continental Electric Co.

PHOTOTUBE (vacuum or gas-filled), circular cathode $1\frac{1}{8}$ inch in diameter facing end of bulb and split into four independent quadrants, common anode, overall seated height $2\frac{1}{4}$ inches, diameter $1\frac{1}{2}$ inch (max), 5-pin base.

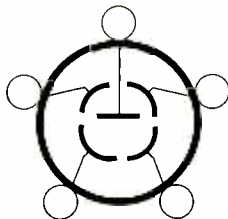
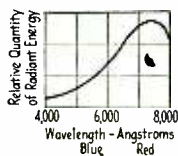

Sensitivity
Gas-filled phototubes are available with sensitivities ranging from 50 to 200 μ a/lumen.
Vacuum phototubes are available with sensitivities ranging from 10 to 30 μ a/lumen.
Operating voltage = 90 v
Ionization voltage (gas-filled tubes) = 115 v

Type CE-11

Continental Electric Co.

PHOTOTUBE (vacuum or gas-filled), cathode area 0.94 sq inch, seated height to center line of cathode 2 inches, overall seated height $3\frac{1}{8}$ inches (max), diameter 1 inch (max), 4-pin base, top cap for anode lead.

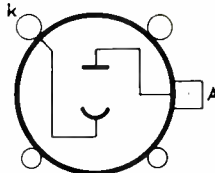
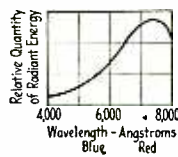

Sensitivity
Gas-filled phototubes are available with sensitivities ranging from 50 to 200 μ a/lumen.
Vacuum phototubes are available with sensitivities ranging from 10 to 30 μ a/lumen.
Operating voltage = 90 v

Type CE-14

Continental Electric Co.

PHOTOTUBE (vacuum or gas-filled), anode surrounded by a grid, seated height to center line of cathode $1\frac{1}{4}$ inch, overall seated height $3\frac{1}{2}$ inches (max), diameter $1\frac{1}{2}$ inch (max).

Sensitivity
Gas-filled phototubes are available with sensitivities ranging from 50 to 200 μ a/lumen.
Vacuum phototubes are available with sensitivities ranging from 10 to 30 μ a/lumen.
Operating voltage = 90 v
Ionization voltage (gas-filled tubes) = 115 v

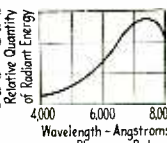

films

of

"AQUADAG"

Colloidal graphite in water

RESISTANCES: Colloidal graphite is a resistance material widely used in volume controls, tone controls, grid leaks, and similar types of fixed and variable resistors

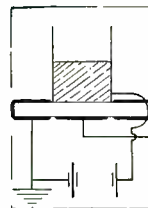
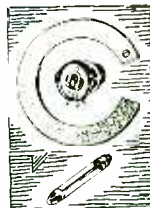

TEST SPECIMENS: This product also has many advantages over common foils for measuring constants of insulating substances.

VACUUM TUBES: Films formed with "dag" colloidal graphite discourage secondary and undesirable primary emission emanating from vacuum tube elements. Electrostatic shielding may also be accomplished.



THERMOPILES: Radiation collectors utilize the heat conducting and high "black-body" values of "dag" deposits.

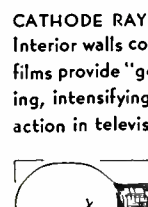

CATHODE RAY ENVELOPES: Interior walls coated with similar films provide "gettering", focusing, intensifying, and shielding action in television tubes.

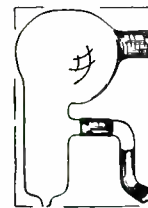

EVACUATED DEVICES: Shields, guard rings, "cat's whisker" contacts, conductive cements, and special electrodes or contacts are formed conveniently with "dag" dispersions.

PHOTOELECTRIC CELLS: Graphite surfaced electrodes absorb free alkalies and alkaline metals in photoelectric cells. No selenides result when the "dag" product is used in the selenium types.



The above is not a recommendation to use colloidal graphite in infringement of any patents.

ACHESON

COLLOIDS CORPORATION
PORT HURON, MICHIGAN

dag
COLLOIDAL PRODUCTS

"Aquadag" and "dag" are trade marks of the Acheson Colloids Corporation

"GLOBAR" OFFERS...



**MANY
SHAPES,
SIZES
AND TYPES
OF CERAMIC
RESISTORS**



**GLOBAR DIVISION
THE CARBORUNDUM COMPANY**
REG. U. S. PAT. OFF.
NIAGARA FALLS, N. Y.
(Carborundum and Globar are registered trade-marks of
and indicate manufacture by The Carborundum Company)

Globar CERAMIC RESISTORS
BRAND

BUD CONDENSERS

for all electronic applications



BUD Midget Condensers are made in a variety of stock sizes and to manufacturer's specifications. We will be glad to quote on your requirements.

BUD Condensers meet the rigid requirements of constant service in industrial, medical and laboratory equipment. They are used in diathermy equipment; police, aircraft and commercial transmitters; geo-physical apparatus and numerous similar applications.

NEUTRALIZING CONDENSERS

Their rugged construction insures dependable performance. Made in three capacity ranges.

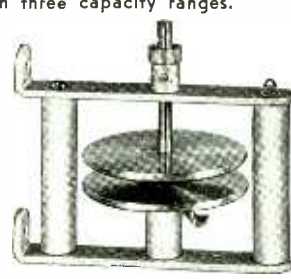

U. H. F. TRANSMITTING CONDENSERS

Center-of-rotor contact and insulated frame construction make them ideal for all U.H.F. requirements. Made in a variety of sizes.

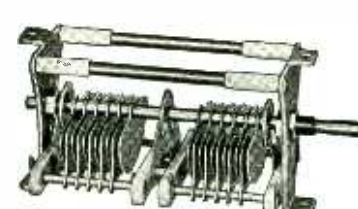

Write today for your copy of Catalog No. 241



BUD RADIO, INC.

CLEVELAND, OHIO

Type CE-13

Continental Electric Co.

PHOTOTUBE (vacuum or gas-filled), seated height to center line of cathode $1\frac{1}{2}$ inches, overall seated height $3\frac{1}{2}$ inches (max), diameter $1\frac{1}{2}$ inches (max), 4-pin base, anode lead brought out through cap.

Sensitivity
Gas-filled phototubes are available with sensitivities ranging from .50 to 200 $\mu\text{a}/\text{lumen}$.
Vacuum phototubes are available with sensitivities ranging from 10 to 30 $\mu\text{a}/\text{lumen}$.

Operating voltage = 90 v
Ionization voltage = 115 v

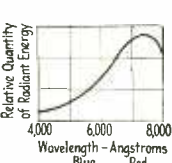

Type WL-775

Westinghouse

VACUUM phototube for ultraviolet light, tantalum cathode, aperture $1\frac{1}{16}$ inch x $1\frac{1}{4}$ inch, seated height to center line of cathode 5 inches, overall length 8 inches (max), overall diameter $3\frac{3}{16}$ inches (max), 4-pin base with cathode cap.

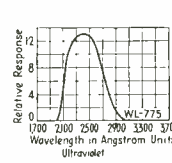
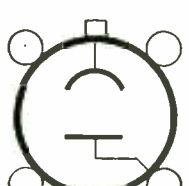



Max Anode Voltage = 500 v
Recommended Anode Voltage = 90 v
Spectral Range — 2000-3000 A.

Type 931

R.C.A.

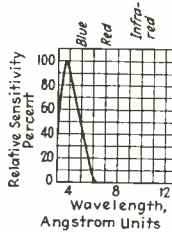
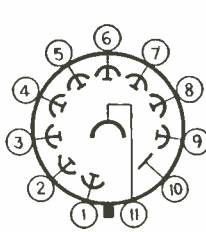
HIGH vacuum multiplier phototube, window area 0.25 square inch, seated height to center line of cathode $1\frac{15}{16}$ inch, overall length $3\frac{11}{16}$ inches (max), overall diameter 1.300 inch, small shell submagnal 11-pin base.

Surface — S4
Max Anode Supply Voltage (dc or peak ac) = 1250 v
Voltage between dynode No. 9 and Anode = 400 v (max)
Max Anode Current = 2.5 ma
Anode Dissipation = 0.5 watt
Max Ambient Temp = 50° C

Typical operation
Voltage per Stage = 100 to 125 v
Sensitivity = 0.6 to 2.3 amp/lumen
Interelectrode capacitances
Anode to Dynode No. 9 = 3.5 μf (approx)
Anode to all other Electrodes = 6.5 μf (approx)

Type CE-15

Continental Electric Co.

PHOTOTUBE (vacuum or gas-filled), rectangular anode, seated height to center line of cathode 4 inches, overall seated height 7 inches (max), diameter 1½ inch (max), 4-pin base.

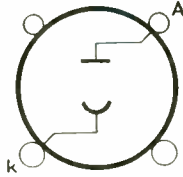
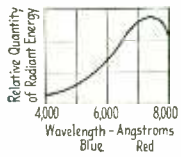

Sensitivity

Gas-filled phototubes are available with sensitivities ranging from 50 to 200 $\mu\text{a/lumen}$.

Vacuum phototubes are available with sensitivities ranging from 10 to 30 $\mu\text{a/lumen}$.

Operating voltage = 90 v

Ionization voltage (gas-filled tubes) = 115 v

Type CE-16

Continental Electric Co.

PHOTOTUBE (vacuum or gas-filled), cathode divided into independent halves, common anode, seated height to center line of cathode 2½ inches, overall seated height 3½ inches (max), diameter 1 inch (max).

Sensitivity

Gas-filled phototubes are available with sensitivities ranging from 50 to 200 $\mu\text{a/lumen}$.

Vacuum phototubes are available with sensitivities ranging from 10 to 30 $\mu\text{a/lumen}$.

Operating voltage = 90 v

Ionization voltage (gas-filled tubes) = 115 v

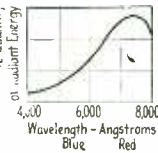

Type CE-22

Continental Electric Co.

PHOTOTUBE (vacuum or gas-filled), ⅝-inch circular cathode with ⅜-inch hole in center through which anode passes, seated height to center line of cathode 1½ inch, overall seated height 2 inches (max), diameter ⅜ inch (max), 3-pin base.

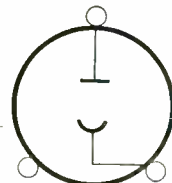
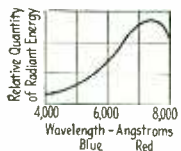

Sensitivity

Gas-filled tubes are available with sensitivities ranging from 10 to 400 $\mu\text{a/lumen}$.

Vacuum phototubes are available with sensitivities ranging from 5 to 50 $\mu\text{a/lumen}$.

Operating voltage = 90 v

Ionization voltage (gas-filled tubes) = 115 v

TERMINAL FILLS MY ORDERS!

NOW, MORE THAN EVER, I RELY ON TERMINAL. THEY'VE ALWAYS GOT THE RADIO PARTS I NEED IN STOCK—THAT MEANS PROMPT DELIVERIES FOR US—MAKES MY JOB SO MUCH EASIER! WHY DON'T YOU TRY TERMINAL?



For Example—

We carry a complete stock of **CANNON** sound plugs and receptacles. Broadcast stations, recording studios, etc., can now order direct from us instead of waiting for factory deliveries from Los Angeles, as heretofore.

TERMINAL RADIO CORP.

2 Stores in New York City

68 WEST 45th STREET • 80 CORTLANDT STREET

Phone • VAnDerbilt 6-5050

PROFESSIONAL MODEL LOW PRESSURE PICKUP



DESIGNED FOR
TRANSCRIPTIONS UP TO AND
INCLUDING 16" DIAMETERS

Incorporating all the advantages of low pressure pickup design, Astatic Model HP-16 insures greater tone fidelity of reproduction, reduces record wear to a negligible minimum and eliminates necessity for needle changing. This Pickup is made with ball bearing swivel base and accurately counterbalanced arm for one-ounce needle pressure. Genuine sapphire stylus is protected by an internal hold-down spring guard. Low friction pivots maintain constant needle pressure on uneven or warped recordings. Mounting center, 12". Finish, rich maroon. Complete with 2-ft. shielded cable and arm rest.

Model HP-16 (30 to 7,000 c.p.s.) List Price \$25.00

If desired, a high fidelity model, HP-36 (30 to 10,000 c.p.s.) is available at same list price.

ASTATIC

THE ASTATIC CORPORATION

YOUNGSTOWN, OHIO

Licensed Under Brush
Development Co. Patents

In Canada:
Canadian Astatic Ltd.
Toronto, Ontario

**To users of Thermostatic
Bi-Metals or Electrical Contacts**

THE H.A. WILSON COMPANY
REFINERS AND WORKERS OF PLATINUM GOLD AND SILVER
WILCO THERMOSTATIC METAL
BELAIS WHITE GOLD

105 CHESTNUT ST.
NEWARK, N. J.

To our manufacturing customers:

Thermostatic bi-metal and electrical contacts are playing a role of ever increasing importance in National Defense as well as everyday use.

We pledge ourselves to a continuation of our policy of excellence in material, skill in manufacture, and painstaking care in the inspection of our products.

To this end we guarantee personal attention to every order regardless of the size.

Harry A. Wilson
HARRY A. WILSON
President

personal attention counts!

THE H. A. WILSON CO.
105 CHESTNUT ST. • NEWARK, N. J.
Branches CHICAGO - DETROIT

Simultaneous

RADIO RANGE FILTER



This Simultaneous Radio Range Filter represents the highest achievement in precision engineering technique. It is one of Kenyon's great contributions to the aircraft industry for it is used extensively by all the major airlines throughout the world.

Each unit consists of combination Band Pass, Band Rejection Filter wholly enclosed in an aluminum case with black, egg-shell finish. Will hold their electrical characteristics from -40° to $+55^{\circ}$ Centigrade.

Kenyon S-6353 (BA-189) Radio Range Filter, Price upon request.

Complete technical and mechanical data available.

KENYON TRANSFORMER CO., Inc.
840 BARRY ST. NEW YORK, N. Y.

Type CE-17

Continental Electric Co.

PHOTOTUBE (vacuum or gas-filled), shadowless anode, seated height to center line of cathode, $1\frac{1}{8}$ inch, overall seated height $3\frac{3}{8}$ inches (max), diameter $1\frac{1}{2}$ inch (max), 4-pin base.

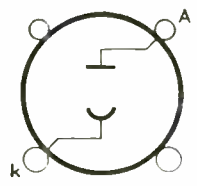
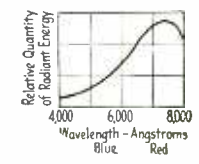

Sensitivity
Gas-filled phototubes are available with sensitivities ranging from 50 to 200 $\mu\text{a/lumen}$.
Vacuum phototubes are available with sensitivities ranging from 10 to 30 $\mu\text{a/lumen}$.
Operating voltage = 90 v
Ionization voltage (gas-filled tubes) = 115 v

Type CE-18

Continental Electric Co.

PHOTOTUBE (vacuum or gas-filled), seated height to center line of cathode $2\frac{1}{4}$ inches, overall seated height $3\frac{3}{8}$ inches (max), diameter $1\frac{1}{8}$ inch (max), 4-pin base.

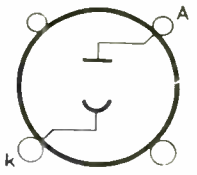
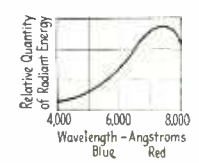

Sensitivity
Gas-filled phototubes are available with sensitivities ranging from 50 to 200 $\mu\text{a/lumen}$.
Vacuum phototubes are available with sensitivities ranging from 10 to 30 $\mu\text{a/lumen}$.
Operating voltage = 90 v
Ionization voltage (gas-filled tubes) = 115 v

Type CE-20

Continental Electric Co.

PHOTOTUBE (vacuum or gas-filled), seated height to center line of cathode $1\frac{1}{2}$ inches, overall seated height 2 inches (max), diameter $\frac{5}{8}$ inch (max), 3-pin base.

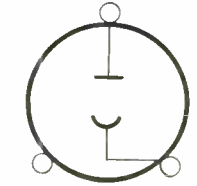
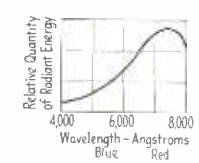

Sensitivity
Gas-filled phototubes are available with sensitivities ranging from 10 to 400 $\mu\text{a/lumen}$.
Vacuum phototubes are available with sensitivities ranging from 5 to 50 $\mu\text{a/lumen}$.
Operating voltage = 90 v
Ionization voltage (gas-filled tubes) = 115 v

T-PADS

For Speech Input Equipment



A complete line of speech input controls, Time tested—second to none—at Competitive prices.

Embodiment of years of engineering and production experience. Hundreds of satisfied customers. No exaggerated claims . . . but what we make will give you lasting and trouble-free service.

Also light and heavy duty tap switches—special control to your specs.

• Write for bulletin 411. Complete catalogue upon request.

TECH LABORATORIES
7 Lincoln Street Jersey City, N. J.

JERKIT

from the circuit with
JERKIT FUSE PULLER



3 1/8"

Made of 3/16" hard horn fibre. Wt. 4 1/2 gms. Pulls all fuses from 1/4" to 13/16" dia. with a jerk. Handiest gadget out for small fuses in vise-like grip of beryllium copper clips or on crowded panels. Saves wear and tear on fingers. Safer too! 15c each, postpaid anywhere in U. S. A.

NEW ANTI-VIBRATION LITTELFUSE

A 90° twist in element braces against severe vibration. Gooseneck spring prevents bending and crystallization — resulting in better service, longer life.

These two items talked about in *Littelfuse Catalog*. Write for your copy.

LITTELFUSE INC.
4755 RAVENSWOOD AVE. CHICAGO, ILL.

Type WL-773

Westinghouse

VACUUM phototube for ultraviolet light, thorium cathode, aperture 1 1/16 inch x 1 1/4 inch, seated height to center line of cathode 5 inches, overall length 8 inches (max), overall diameter 3 3/16 inches (max), 4-pin base with cathode cap.

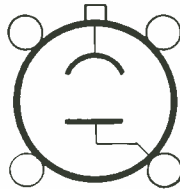
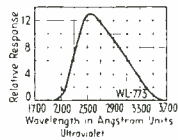

Max Anode Voltage = 500 v
Recommended Anode Voltage = 90 v
Spectral Range 2000-3750 A.

Type CE-21

Continental Electric Co.

TWIN phototube, two cathodes and two anodes, (vacuum or gas-filled), seated height to center line of cathodes 2 3/4 inches, overall seated height 3 3/4 inches (max), diameter 1 1/4 inch (max), 4-pin base.

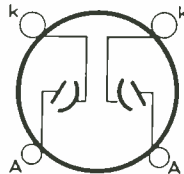
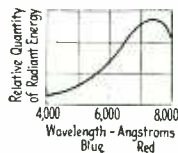

Sensitivity: Gas-filled phototubes are available with sensitivities ranging from 50 to 200 μ a/lumen. Vacuum phototubes are available with sensitivities ranging from 10 to 30 μ a/lumen. Operating voltage = 90 v. Ionization voltage (gas-filled tubes) = 115 v.

POTENTIAL R.A.F. MEN



A series of pre-entry university courses are now being given to young men who wish to become pilots and observers with the R.A.F. The students shown above are studying the wavelength of light



G.A.W. CARBONYL IRON POWDER

We are now supplying numerous iron core manufacturers with G.A.W. CARBONYL IRON POWDER. ★ This remarkable iron product, with each individual particle a true spheroid averaging four microns, yields performance warranting your early investigation.

FOR INFORMATION
ADDRESS
THE MANUFACTURER

GENERAL ANILINE WORKS

435 Hudson Street, N.Y.C.

OR THE DISTRIBUTOR

ADVANCE SOLVENTS & CHEMICAL CORPORATION

245 Fifth Avenue, N. Y. C.

New Shure Pickup Cartridges
Hi-Lo for Lightweight
 Crystal Pickups

VOLTAGE PRESSURE



Only 1 ounce needle pressure, with 1.4 volts output at 1000 cps (Audio-tone record)—over twice the output voltage of any other lightweight pickup cartridge! Very accurate production control of uniformity. Directly replaces other flat-type cartridges. Wide range response. Metal case. Bimorph Crystal. Available in 6 types with pressures from 1 ounce to 2 ounces, with outputs as high as 5½ volts. Low Cost.

SHURE

SHURE BROTHERS
 225 W. Huron St. Chicago, U.S.A.
 Shure Patents Pending Licensed under patents of the Brush Development Co.

Whatever Your Yardstick!
PRECISION INDUSTRIAL and LABORATORY TEST EQUIPMENT
 Will readily measure up to highest standards of accuracy, performance and value.

★ **SERIES 845** A NEW TYPE OF AC-DC MULTI-RANGE TESTER
 5000 and 1000 ohms per volt

41 RANGES to 6000 Volts AC-DC
 20 Megohms • 300 Microamps • 12 Amps • 70 DB

CONDENSED SPECIFICATIONS

- 6 DC Voltage Ranges (at 5000 Ohms per Volt) to 6000 Volts.
- 6 AC and 6 DC Voltage Ranges (at 1000 Ohms per Volt) to 6000 Volts.
- 7 DC Current Ranges to 12 Amps.
- 4 overlapping Resistance Ranges to 20 Megohms.
- 6 Decibel Ranges from -12 to +70 DB.
- 6 Output Ranges to 6000 Volts.
- Easy readings 4 7/8" rectangular 200 Microampere meter.
- 1% wire wound shunts and matched metallized multipliers.
- Telephone cabled, wax impregnated wiring plus highest quality insulating materials.

845-L (illustrated) In walnut finished, hardwood case with leather handle. Size 7 1/2 x 8 1/2 x 4". Less batteries and test leads. Net Price..... **\$28.95**

845-P In hardwood, walnut finished portable case with tool compartment and hinged removable cover. Size 9 x 10 x 6". Less batteries and test leads. Net Price..... **\$30.95**

WRITE FOR "PRECISION" CATALOG 42-E describing more than 40 radio and electrical test equipment models . . . Tube Testers, Combination Tube and Set Testers, AC-DC Multi-range Testers, Vacuum Tube Multi-range Testers, Signal Generators, Industrial Circuit Testers, etc.

PRECISION TEST EQUIPMENT
INDUSTRIAL · LABORATORY · RADIO · TELEVISION

PRECISION APPARATUS COMPANY • 647 KENT AVENUE • BROOKLYN, N. Y.
 Export Division: 458 Broadway, New York City, U.S.A. Cable Address: Morhanex

Electronics in Auditory Research

(Continued from page 41)

illustrated, couples this to the dynamic receiver used in this, as in the audiometric, test.

Two operators are required. One of these is located in the sound proof room (Fig. 3) with the subject. The other speaks into the microphone which with the amplifier is in the sound proof observing booth. The amplifier gain control is set at a constant level in all tests and strict attention to the volume indicator insures a reasonably constant output level. Sets of standard sentences, used for a similar purpose by the Bell Telephone Laboratories, are employed. The operator in the other room adjusts the attenuator until the threshold of hearing is reached and this level is noted. The level is now raised and through trial a point is found where approximately sixty percent of the sentences are correctly repeated. The question of using phonograph records for this test has been raised. This is largely a matter of convenience in that with the use of an announcer the flow of sentences may be started and stopped as desired. The question of record wear with resulting surface noise also plays a part. In our tests never less than fifty sentences are used

• • •

MODEL ANTENNA



CBS engineer adjusting u-h-f transmitter used to excite a small scale model directional antenna array. It was used to determine the radiation characteristics of a full size antenna of this type for use on a lower frequency

WE'RE READY

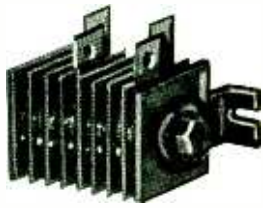

TO HELP!

Electrical rectifiers have been our "game" for more than twenty years. Our engineers have been, and are de-

signing and supplying copper oxide, copper sulphide, selenium and tube rectifiers and rectifying equipment for innumerable industrial applications—

Battery Chargers
Airplane Starters
Electroplating
Arc Welding
Magnetic Chucks

Cathodic Protection
Motion Picture Arc Supply
Battery Substitutes
Signal Systems
Elevator Controls

These are a few of the many ways our rectifiers are being used today.

Whatever your problem might be in changing alternating current to direct current, let Benwood Linze engineers be of assistance. Our long experience is at your command at all times during these critical days.



THE BENWOOD LINZE CO.
1805 LOCUST ST.
ST. LOUIS, MO.
MANUFACTURERS ENGINEERS

MR. ENGINEER...

Have you any needle problems? If so, let our engineers help you solve them. We specialize in playback and cutting needles for hill-and-dale, embossing on film, acetate instantaneous, wax recording. Permanent needles for record changers. The more "special" your needs, the better we can serve you. . .

No obligation . . . write today

The DUOTONE "Star" Sapphire has been acclaimed by leading engineers as the finest playback needle in its class. Reproduces without a trace of surface noise . . . excellent for dubbing work.

DUOTONE CO., Inc.
799 Broadway, New York City

and slight variations in volume level tend to average out. It is possible that an automatic compressor circuit would be helpful in equipment of this type, although quite consistent results have been obtained here without one. It is interesting to observe that the point of sixty percent accuracy is fairly critical and that a change of one or two decibels, although practically unnoticed in itself, usually makes a considerable and unmistakable variation in the percentage of correct repetitions. As in the calibration of the audiometer, standard hearing levels for this test were established through determinations of the average level of a representative sample of normal ears.

Other types of electronic equipment than those outlined above are also used in this laboratory, but space does not permit further description. However, the more important types have been indicated and an effort made to explain their uses. While no claims are advanced for any striking originality of circuit design, it is hoped that this brief survey of the application of familiar electronic devices to problems of hearing may prove of interest. Much of the equipment described in this paper was designed by Dr. E. G. Witting, formerly of this laboratory. This includes the sound proof rooms, the action potential amplifier, filters, and apparatus for loudness balance measurements.

• • •

SPOT BROADCASTING



Equipment such as this is used in "on the spot" broadcasts. The operator is covering a soap box derby

*To Serve Well the
Professional Radioman*

CREI Training Increases Technical Efficiency

Alert Engineers are encouraging CREI training for their employees . . . for it means:

- Step-up of individual efficiency
- Increased personal worth to company
- Additional technical ability

Yes, men who devote their own money and spare-time toward improving their technical ability through CREI training are an asset to any technical organization.

In our entire 14 years the CREI home study courses have been written and planned exclusively for the professional radioman to enable him to improve his technical ability and to be in a position to assume added technical duties.

The remarkable achievements made by CREI men throughout the commercial and manufacturing radio fields are convincing testimony that our efforts, properly confined to this one important course in Practical Radio Engineering, have been of real value to the industry in training better engineers.

Chief engineers fully recognize the need for men with modern technical training, and many welcome regular reports concerning students' progress. (Reports of students' enrollment and progress are made to employees only upon the direct request of the student.)

For example, a Chief Engineer of a large organization writes: "Thanks for the letter concerning the work which Mr. Fred Owens is doing with you. I shall be glad to have you keep me in touch with his progress as he seems to be very much interested and it is a very worthwhile undertaking."

We, at CREI, are proud to add our contribution to the radio industry by training men who are equipped to fulfill your demands. Perhaps a recommendation of our home-study courses to your associates might be as appreciated by them as it would be by us. May we send you our booklet and complete details?

"Since 1927"

CAPITOL RADIO

ENGINEERING INSTITUTE

E. H. Rietzke, President

Dept. E-9, 3224 16th St., N.W.
Washington, D. C.

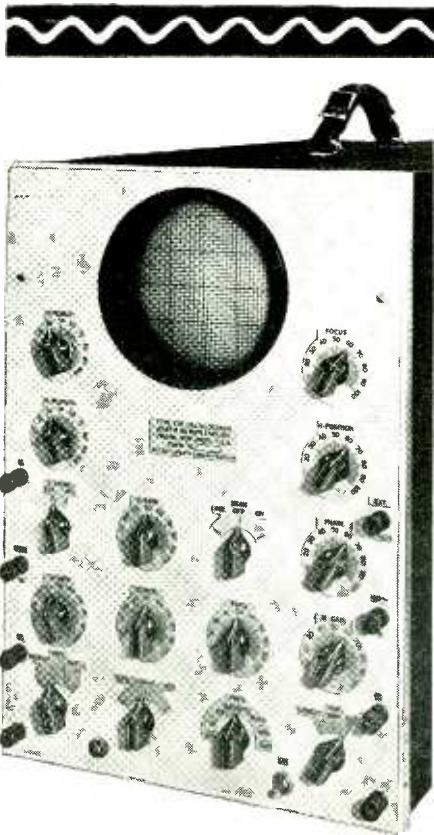

For the study of
**TRANSIENT
 PHENOMENA**

★ DuMont Type 175-A Cathode-Ray Oscillograph incorporates the many recent refinements, PLUS a single-sweep circuit designed for the study of transient phenomena. Such study imposes requirements not found in instruments designed for the investigation of recurrent waveforms. And to simplify photographic recording, a single-trace of intense brilliance is obtained because of the high accelerating potential at which the cathode-ray tube is operated. Therefore, if your work includes the study of transient phenomena, the Type 175-A DuMont Oscillograph is your logical choice.

Literature on request

DUMONT
 ALLEN B. DU MONT
 LABORATORIES, Inc.
 Passaic ★ New Jersey
 Cable Address: Wesplexin, New York

Gas Tetrodes

(Continued from page 37)

eration is intermittent, any small shift in the characteristics which might take place during the operating period, will be almost completely reversed during the inoperative period. Therefore, any permanent shift will be slight.

Another factor that must be considered in high-sensitivity control circuits is the change in the control characteristic with change in heater voltage. For the 2050 and 2051, a unipotential cathode was selected in order that the change in the characteristics with heater voltage should be a minimum. However, as the heater voltage is reduced, the temperature of the cathode is reduced, and the thermal velocity of emission of electrons from the cathode is lowered. This causes the control characteristic to shift toward a less negative value of grid voltage. In the normal operating range of the heater voltage, the shift in the control characteristic is approximately 0.35 volt per volt change in heater voltage.

It should be noted that the possible applications of these tube types are many and varied. To attempt to describe these is beyond the scope of this paper. In conclusion, however, I would like to call attention to an article in the January 1941 issue of *ELECTRONICS*, entitled, "Control Circuits for Industry," written by Gilbert Smiley. This paper gives circuits and operational data of a number of installations employing the RCA-2050 and RCA-2051.

• • •
X-RAY MOVIES



Motion picture x-rays of this soldier's heart are being taken to determine the value of supplementary vitamin feeding in army fare

WIRE & RIBBON

For Direct-Heated
ELECTRON EMITTERS
 in VACUUM TUBES

In a complete range of sizes and alloys for Transmitting, Receiving, Battery and Hearing-Aid Tubes . . .

Melted and worked under close supervision to assure maximum emissivity, uniformity and the highest tensile strength . . .

WIRES drawn to .0005" diam.
 RIBBON rolled to .0001" diam.

SPECIAL ALLOYS made to meet individual specifications . . .

Write for list of stock alloys

SIGMUND COHN

44 GOLD ST. NEW YORK
 SINCE 1901



"What do you
 require of a
DYNAMOTOR —
Long Life?"

It's an outstanding factor in Eicor design. Precision-built by specialists, Eicor Dynamotors take plenty of heavy continuous use every day in critical applications. All wearing parts — bearings, brushes, commutators — are designed to perform without fail.

Enlarged plant and personnel, while primarily for Defense purposes, makes possible continuing attention to our customers, large and small alike.



EICOR

EICOR, Inc., 1050 W. Adams St., Chicago, U.S.A.
 Export: Ad Auriama, 89 Broad St., New York

Preselection in Broadcast Receivers

(Continued from page 50)

not appear in the tuned r-f circuit as a result of the small amount of capacity coupling existing between these two sections of the gang.

The receiver designer will immediately appreciate the problem of providing enough tuning capacity and low enough minimum capacity in a three-section gang condenser of such small physical size. Table I shows the capacities of the three different sections.

Figure 2 is a circuit diagram of the \$14.95 receiver incorporating such a gang with a tuned r-f stage. It will be seen that the r-f secondary is tapped down so that the input capacity of the converter tube does not appear across the entire circuit, thus restricting the tuning range. In the interest of economy, a low impedance primary r-f coil is used. As is generally known, a low impedance primary r-f coil by itself gives four to six times more gain at the high frequency end of the broadcast band than at the low end. Hence, a resistor R_1 is placed in series with the primary to level off the gain at the high frequency end. This results in a fairly uniform gain across the broadcast band that varies from 6.3 to 9.6 times from the low end to the high end.

It may be of interest to note some of the other unusual economies employed in this receiver, such as a portion of the oscillator voltage being used as fixed bias for the r-f tubes, a capacity winding (coil with arrow) on the oscillator coil replacing the usual oscillator grid condenser, and the diode filter network

which is built in the trimmer base.

Table II shows the relative performance characteristics of four typical receivers introduced during the last 5 years in the same price bracket. An examination of the table discloses that receiver D with the tuned r-f stage is better in all respects when compared with the other receivers. Note that the image ratio of D is much better than that of the other receivers. Also note that the *ENSI* (Equivalent Noise Sideband Input) of C and D are essentially the same and are better than those of the other two receivers, showing the advantage that is gained through the use of an r-f stage; either tuned or untuned.

The term *ENSI* is the equivalent input magnitude of all random noise which is transferred to the output circuit, and therefore of all such noise within the frequency side bands passed by the receiver. The formula for computing this factor is:

$$ENSI = mE_s \sqrt{\frac{P_n}{P_s}}$$

where m = signal modulation factor

E_s = signal carrier input voltage

P_n = output power of noise only

P_s = output power of signal only

An examination of the formula shows that the lower the numerical figure of *ENSI* the better the characteristic.

TABLE II—Relative Performance of Four Receivers

	A	B	C	D
I-F sensitivity at 455 kc	38	31	57	31 μ v
Sensitivity at 1000 kc at loop	No loop	40	19	7.7 μ v/m
Sensitivity at 1000 kc at antenna or loop primary	8.9	6.7	1.9	1 μ v
Image ratio at 1000 kc	160	127	308	7000
I-F rejection ratio (set tuned to 600 kc)	33	33	52	1100
<i>ENSI</i> (Measured through loop)	No loop	4.7	3.1	3
<i>ENSI</i> (Measured through antenna or loop primary)	0.8	0.65	0.35	0.3

A — 5-tube ac-dc receiver appearing in 1936

B — 5-tube ac-dc loop-operated receiver appearing in 1939

C — 6-tube ac-dc loop-operated receiver with a stage of untuned radio frequency appearing in 1940

D — 6-tube ac-dc loop-operated receiver with a stage of tuned radio frequency, as described in this article

FM / AM

In one

General Coverage UHF RECEIVER



Incorporating both Frequency Modulation and Amplitude Modulation in one U.H.F. receiver. Covers three bands: 28 to 16 mc., 45 to 84 mc., 81 to 142 mc. Switch changing from FM to AM reception. Acorn tubes in RF and converter system. Beam power tubes in AF amplifier. Controls are: RF gain control, band switch, antenna trimmer, IF selectivity control and power switch, tone volume control, pitch control, tone control, "S" meter adjustment, AVC on-off switch, send-receive switch, phone jack, amplitude of frequency modulation switch. 15 tubes. Operates on 110 volt 50-60 cycle AC. Model S-27 complete with tubes. \$195.00.

the hallicrafters co.

CHICAGO, U. S. A.

USED BY 33 GOVERNMENTS
SOLD IN 89 COUNTRIES



S. S. WHITE FLEXIBLE SHAFTS

for "COUPLING"

The use of S. S. WHITE flexible shafting for connecting **driven** or **remote controlled** parts inside of instruments and other equipment—known as "coupling"—offers these important advantages.

SIMPLICITY—Because a single, easily applied length of shafting will couple any two parts regardless of their relative locations.

IMPROVED DESIGN—Because the use of flexible coupling shafts allows parts to be placed in whatever positions best satisfy requirements of electrical circuit efficiency, easy assembly, space saving and convenient servicing.

ECONOMY—Because Coupling with flexible shafts simplifies assembly by making accurate alignment of parts unnecessary.

A TYPICAL EXAMPLE

In this Radio Broadcasting Transmitter, coupling with S. S. WHITE Remote Control type shafts lets tuning elements be placed in the most favorable circuit and assembly positions while their controls are centralized.

GET DETAILS in Bulletins 1238 and 38. Copies mailed on request.

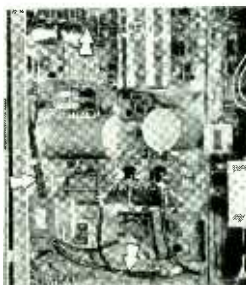

AT YOUR SERVICE
cooperation of our flexible
shaft experts for working
out actual applications.
Send details.

S. S. WHITE

The S. S. White Dental Mfg. Co.

INDUSTRIAL DIVISION

Department E, 10 East 40th St., New York, N. Y.

FREE!

Your **TEXTBOOK** on

RELAYS

by

GUARDIAN-

Design Engineers and Purchasing Agents:

★ Complete your files with this new free manual—"Relays by Guardian" showing the largest line serving American industry. Strictly informative . . . it points the way to apply the maximum degree of Electrical Control in a minimum amount of space . . . thereby eliminating costly priority materials, machine time, man-hours.

44 PAGES Devoted Entirely to RELAYS

Each illustration clearly depicts the compact design and easy mounting of controls by Guardian. Each carries complete data on contacts—coils—construction—mounting—specific applications.

*7,146 Standard Control Parts—Yes . . . more than *7,146 standard parts are available to make up any combination of controls shown in the Guardian Book. These represent thousands of design and tooling hours already spent . . . give you a big head-start unobtainable elsewhere.

NO COST—Get your new Guardian Book postpaid by return mail. Your copy is waiting. Send for it today. Write



Series BK—16 Relay. Built to minimum tolerances and the most exacting requirements in production quantities for the U. S. Signal Corps.

*Inventory Count Jan. 1, 1941

GUARDIAN



ELECTRIC

1625 West Walnut Street

Chicago, Illinois

LARGEST LINE OF RELAYS SERVING AMERICAN INDUSTRY

Radio Industry Meets Priorities Challenge

(Continued from page 29)

Miscellaneous radio components are affected by shortages of aluminum, copper, tin, plastics—with little possibility of substitutes, except with other scarce materials which offer no practical solution. Limited quantities will probably be available at higher prices with coming season probably marking decline of consumer purchases of low-priced "jalopy" type of radio merchandise.

Copper, rubber, synthetic rubber and silk affect supply of wire. One plant, normally supplying much to radio industry, is devoting 70 percent of its capacity to defense orders. Nylon and rayon may be possible satisfactory substitutes for silk. Satisfactory response has been obtained from one manufacturer's suggestion to use shorter connecting cords as means of conservation.

The Outlook

Coming into greater appreciation is the recognition that raw materials will become increasingly scarce. Indeed, OPM spokesmen have been careful to point out in recent weeks that there will soon not be sufficient aluminum, steel, copper, and other metals to meet even our defense needs. It is interesting to note that with regard to requirements for materials which are made by the Army, Navy, and the Maritime Commission, and other government defense agencies, OPM is not empowered to examine into the adequacy or extravagance of such requisitions. Consequently, Army and Navy have an excellent opportunity to enlist further co-operation and to show their own efficiency by setting at rest some doubts as to whether defense materials are put into actual use or are consigned to warehouses.

Manufacturers are turning their attention and productive facilities to the manufacture of radio and communication equipment for defense needs wherever possible. They are not only thus aiding the defense program, but are taking practically the only course open to them to stay in business. In such cases manufacturers have no difficulty in obtain-

—MICO— ENGRAVER



For lettering panels of steel, aluminum, brass, or bakelite, or for marking finished apparatus.

A sturdy machine for routine production as well as occasional engraving.

Attachments increase its versatility to include large work on flat or curved surfaces.

Excellent engraving can be produced by an inexperienced operator.

Catalogue on request.
Prompt Delivery

Priced from \$115 with type

Mico Instrument Co.

20 ARROW STREET
CAMBRIDGE, MASS.

Mathematics made plain —and easy-to-learn— and amusing!

That is the purpose, completely realized, of this new mathematics text. The authors begin (with a humorous story) right on the edge of the Unknown where arithmetic can no longer show the way. The style is light, the explanations are detailed and the book makes highly interesting reading.

LIVING MATHEMATICS

By R. S. Underwood and Fred W. Sparks, Texas, Technological College. 365 pages, 6 x 9, \$3.00.

Here is just the book for: Those who have met with initial failure in trying to master the intricacies of the subject, and those who took to it readily when first presented and now wish to pick up the threads and go on to higher mathematics—the calculus and number theory. In this book you will find drama, zest, humor, surprise, challenge and human interest.

EXAMINE IT FOR 10 DAYS

McGraw-Hill Book Co., 330 W. 42nd St., N. Y. C.
Send me Underwood and Spark's Living Mathematics for 10 days' examination on approval. In 10 days I will send \$3.00, plus few cents postage, or return book postpaid. (Postage paid on orders accompanied by remittance.)

Name
Address
City and State
Position
Company FL-9-41
(Books sent on approval in U. S. and Canada only.)

ing the raw materials essential for defense contracts and are sometimes able to obtain additional supplies for civilian needs or for replacement, maintenance, and servicing. Definitely, however, civilian radio equipment is getting the "left-overs". For those manufacturers and suppliers who have not turned to defense for one reason or another, the prospect of carrying on "business as usual" is, to say the least, extremely bleak. It is estimated that the radio business for 1942 will be about 30 per cent of the 1941 volume, although estimates vary from 50 percent to as little as 10 percent.

Summary

This situation can be summarized by saying that: (1) radio manufacturers and suppliers are turning to national defense not only as a matter of patriotism but as a matter of self preservation, (2) that civilian radio equipment for the coming year will be a small fraction of the production of previous years in spite of an available potential boom market, (3) design of new radio sets will differ from previous models not for style, advertising, or sales purposes but because of scarcity of essential materials such as aluminum, copper, steel, nickel, and, in fact, almost all materials entering into customary radio production; (4) the 1942 radio sets will be higher priced than present models, but there is a difference of opinion as to whether the quality will be seriously affected, (5) a few materials have been allotted for essential replacements, but greater allotments will certainly be required to maintain radio broadcasting service unimpaired, (6) a number of metals, particularly copper, iron, and nickel are so basically important to the industry that substitutes are impossible, and (7) extension of the increasing "plenty of nothing" philosophy will certainly impair essential radio services if in effect too long.

This survey indicates the present status with regard to the manner in which the radio industry is meeting the present emergency. Undoubtedly new circuits and devices will be developed, which will have permanent peace-time utility as well as war-time value. So far as possible, these developments will be reported in *ELECTRONICS*.

**NEW RCP 661
ELECTRONIC
MULTITESTER**
measures

- Oscillator amplifier grid voltages
- AVC, AFC
- Limiter and discriminator grid voltages

And does all this while signal is impressed without appreciably disturbing circuit constants! No other vacuum tube meter, in fact, is so comprehensive, or so valuable to the electronic engineer in laboratory or field. This compact Multitester actually is four complete, vital instruments in one.

DC VACUUM TUBE VOLTMETER —DIRECT READING

Sensitivity (constant) 160 megohms on high ranges, 16 megohms on low ranges.
Ranges: 0/6/30/150/600/1500/6000.
Invaluable for measuring oscillator and amplifier grid voltages, AVC, AFC, limiter and discriminator grid voltages—while signal is present and without disturbing circuit constants.

AC VACUUM TUBE VOLTMETER —DIRECT READING

Input capacity only .00005. Accurate over exceptionally wide range of frequencies. 16meg. input. Indispensable for gain measurements, output measurements, etc.
Ranges: 0/6/30/150/600/1500/6000.
Wide frequency range output meter.

VACUUM TUBE OHMMETER —DIRECT READING

Clear, accurate readings from .1 ohm to 1000meg.
Ranges: 0/1,000/10,000/100,000/1meg./10-meg./100meg/1000meg.
No test leads to short. No zero resetting when changing ranges. No danger of shock when testing high resistance values.

VACUUM TUBE CAPACITY METER —DIRECT READING

Wide range measurements from .03003 to 1000mfd.
Ranges: 0/.001/.01/.1/10/100/1070.
No danger of shock on low capacity ranges. No leads to short. No zero reset when changing ranges.

To make your work easier, safer and more profitable, you will want RCP's ELECTRONIC MULTITESTER 661. It's priced **\$36.95** reasonably at

FAMOUS DYNOPTIMUM TUBE TESTER 310 C-4

Dynoptimum test circuit, with plate voltages and loads specified by R.M.A., tests every type tube, including miniature and bantam, jr. All filament voltages up to full line voltages. Spare sockets for future base arrangements. Tests separate sections of multi-purpose tubes. Newest and finest mechanically operated ROLINDEX tube charts. Complete..... **\$24.50**

COMPLETE INFORMATION—Write for new catalog describing in detail the entire line of dependable Radio City Products. Whatever your requirements, there's an RCP test instrument designed to meet them with the greatest efficiency at the lowest cost. Send today for **FREE** catalog.

RCP
dependable
TEST
instruments

RADIO CITY

PRODUCTS COMPANY, INC.
88 PARK PLACE • NEW YORK, N. Y.

THE INDUSTRY IN REVIEW

News

◆ Simulating artillery fire, one of the most difficult problems in maneuvers has been solved through the use of two-way police type radios. Recent reports show that the marking of artificial artillery fire in war games has been improved from 40 to 92 percent by this method. The radio sets are of the frequency modulation type, and consequently can not be heard or interfered with by the other radio units in the field. They are used for communication between markers stationed in the front lines who report the effect of simulated artillery fire there, and umpires in each artillery battalion headquarters. A total of 240 sets have been purchased, with spare parts, at a cost of \$100,000. Their value, in terms of combat efficiency, has proved incalculable.

◆ L. McComas Young, Chief Engineer of KMOX, CBS station in St. Louis has been ordered to active duty for one year as a major in the United States Air Corps. Harry C. Harvey has been transferred from WBBM in Chicago to take his place . . . W. A. Coogan, Foreign Sales Manager of the Hygrade Sylvania Corp. has been re-appointed chairman of the R.M.A. export committee for the coming year . . . The Wheelco Instruments Co. has moved to larger quarters at Harrison and

Peoria Streets, Chicago, Ill. . . Webster-Rauland is moving to a one-story plant at 424 Knox Avenue, Chicago, Ill. . . Howard A. Holmes is now manager of the defense products division and acts as a representative of the Crosley Corporation in its dealings with the government on national defense projects . . . The Bell Telephone System is installing Dorex Adsorbers in the Brandywine Telephone Exchange at Braddock, Pa. in order to combat the adverse effect of common air-borne gases upon the proper functioning of automatic telephone equipment. After extensive research by the Bell Telephone Laboratories it was found that the most effective cure for the tarnishing of silver contactors of the automatic selectors was by extracting the gaseous impurities by means of solid adsorbents.

◆ NBC's research Division has just completed an analysis of the choice of media by the nation's 50 largest advertisers in 1940. The analysis indicates that the 50 leading advertisers spent 125 percent more for network time than they spent for newspaper space, and 27.3 percent more for network time than for magazine space . . . The Westinghouse Electric and Manufacturing Company, Bloomfield, N. J. has announced a price reduction on ignitron tubes. WL-655 and WL-658 are now \$250; WL-651 and WL-656 are now \$110; and WL-652 and WL-657 are now \$55.

◆ W8XXXN, a 250-watt f-m transmitter, and ten portable 25-watt two-way equipments are being installed in the Cleveland Railway Company's transit system by the General Electric Company of Schenectady . . . Borax and boric acid, of major importance in the manufacture of borosilicate glass which is used in radio tubes, X-ray tubes, and phototubes, are now under full priority control in order to meet a temporary shortage of the supply of these materials . . . R. V. Collins is director of the new export offices, at 36 Pearl Street in New York City, of the Amplifier Company of America. He replaces J. J. Sloane who now handles all special government defense contracts.

◆ The executive offices, laboratory, and factory of Temco, Transmitter Equipment Manufacturing Co., Inc., is now located at 3601-35th Avenue, Long Island City, N. Y. . . WAGA, NBC's Blue Network Atlanta station is changing its frequency from 1480 to 590 kc. and is increasing its power from 1 to 5 kw. The new plant is expected to be in operation by January 15th . . . F. G. Gardner, a veteran of 40 years experience in the communications industry has been selected Acting Chief Engineer of the Kellogg Switchboard and Supply Co., Chicago. George R. Eaton, vicepresident in charge of engineering is taking a much needed leave of absence because of ill health.

ALL WELDED CONSTRUCTION USED IN PRE-FABRICATED RADIO STATION

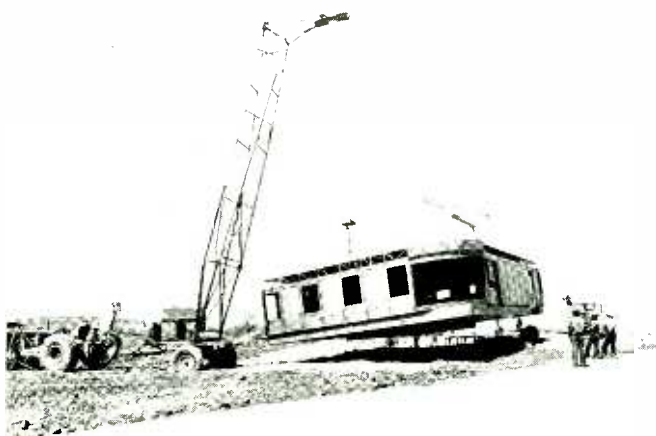

Arc welded steel was used exclusively in the construction of the new radio station WRLC of R. G. Le Tourneau, Inc. at Toccoa, Ga. The station, operating at 1450 kc with a power of 250 watts, was made of "building blocks" formed by pressure stamping of 12-gauge steel sheets, and arc welded together with interior

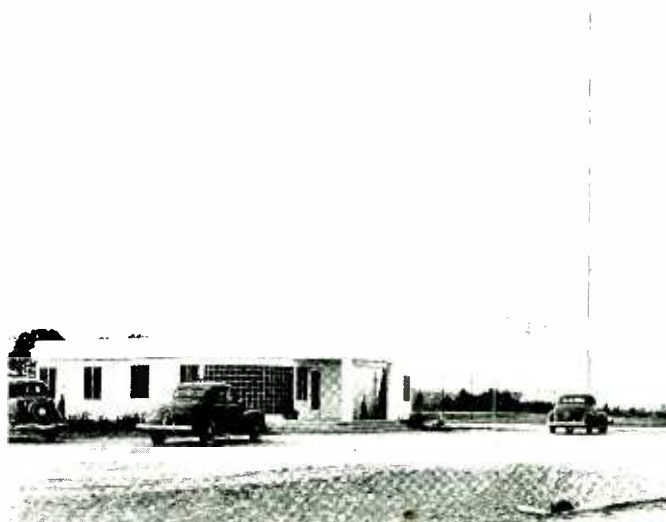

spacers set at intervals of 24 inches to form a strong structure. The picture on the left shows the welded building being lowered to its site, and the photo on the right shows the appearance of the completed station. Arc welded construction made possible the prefabrication of this building in two months

♦ Radio hams have been given more room for f-m transmission. This action was taken to encourage activity of amateurs in developing f-m equipment as well as to obtain data regarding the characteristics of this part of the radio spectrum for f-m use. Licensed radio amateurs will be permitted to make use of the 10 meter band (29.25 to 30.00 Mc) for experimentation with f-m transmission . . . The General Electric Co. has been granted a construction permit for a commercial television station, to operate on television channel No. 3 (66.0 to 72.0 Mc), by the Federal Communications Commission. The company will remodel its present experimental television station W2XB, in the Helderberg Hills, New Scotland, N. Y. for commercial purposes by September 1st. Incidental experimentation with color television is contemplated.

♦ Meade Brunet and Jay D. Cook have been elected vicepresidents of the RCA Manufacturing Company by the board of directors. Mr. Brunet will continue his duties as manager of the engineering products division, and Mr. Cook will remain in charge of the company's international division . . . The Western Electric Company is letting subcontracts at an average rate of 40 percent of its government orders to small manufacturers on such items as vacuum tubes, transformers, generators, meters, and radio parts. The company has farmed out more than \$16,000,000 in purchase orders out of a total of \$37,000,000 worth of government orders. This seems to be an efficient means of speeding delivery of vital communication apparatus, and at the same time relieving the pressure on the machine tool builders of the nation.

• • •
**RECRUITS LEARN
 RADIO OPERATION**



At Fort Dix, N. J., new selectees wishing to become radio telephone or telegraph operators for service in field maneuvers or in directing artillery fire are instructed in radio operation. Upon graduation they are taken into army units all over the country

**SILVER • PLATINUM
 PALLADIUM**

HARD ALLOYS FOR CONTACTS

PRECIOUS METAL IN ALL FORMS AND ALLOYS FOR
 RADIO, ELECTRICAL, AND CONTROL EQUIPMENT

Foil	Strip	Fine Wire
Discs	Gauze	Wollaston Wire
Contacts	Tubing	Thermocouple Wire

SILVER BRAZING ALLOYS—SOLDERS—FLUXES



The American Platinum Works

N. J. R. R. AVE. AT OLIVER ST.

Newark



New Jersey

EST. 1876

WRITE DEPT. "L"

FOR INFORMATION

"APIEZON"
 OILS, GREASES AND WAXES

*for high vacuum
 work*



have vapor pressures as low as 10⁻⁶ mm. of Hg, and even unmeasurable at room temperature.



The Apiezon products which we now carry in our Philadelphia stock, include special oils for oil-diffusion vacuum pumps, and a variety of oils, greases and waxes for sealing joints and stop-cocks in high vacuum systems. Bulletin 1565-E listing physical characteristics and prices will be forwarded upon request.

JAMES G. BIDDLE CO.
 ELECTRICAL AND
 SCIENTIFIC INSTRUMENTS
 1211-13 ARCH ST. PHILADELPHIA, PA.

**MORE THAN
 30 YEARS
 SPECIALIZING
 in
 RELAYS**

Your search for the "last word" in signaling and control devices and equipment ends with Autocall. Single units or complete systems are readily available under this well-known name which for over 30 years has set the standard in this highly specialized field.



TYPE R & RI

Positive indicating target type with contrasting white bars against dull black face when target is displayed and all flat black when target is not displayed. Large identification card, single low current coil, pivoted armature. Contacts returned to normal by contact spring tension and gravity. Core and armature are laminated.

The AUTOCALL Co.
 SHELBY, OHIO

Send for
**FREE
 Catalog**

AUTOCALL COMPANY
 Shelby, Ohio
 Without obligation, please send me a copy of your new No. R-5 catalog on signaling, control devices and equipment.

Name
 Address
 City State



SOLENOID POWER RELAYS-

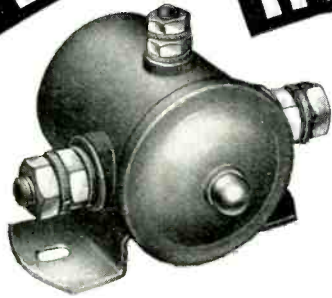

Type 70, direct current, R-B-M Solenoid Power Relays (illustrated) are for applications requiring, within a minimum of space, the control of heavy currents. They are finding ready acceptance for mobile radio transmitter and aircraft service.

The completely ironclad solenoid is dust-proof and water-tight. The stationary contact terminal studs and full-floating contacting discs are of high conductivity copper. A plunger return spring assures non-sticking contacts, and prevents closing of contacts due to vibration or sudden shock. For your particular problems our specialized engineering staff will adapt relays to your needs.

R-B-M MANUFACTURING Co.
Division of
ESSEX WIRE CORPORATION
 LOGANSPOUT, INDIANA



UNBRAKO

REG. U.S. PAT. OFFICE

SCREW PRODUCTS

STANDARD PRESSED STEEL CO.
 Box 596, JENKINTOWN, PENNA.

FAMOUS for years . . .

for their uniform accuracy and great strength . . . for the unique self-locking feature on the "Unbrako" Hollow Set Screw with the Knurled Points . . . for the Socket Head Cap Screw with the Knurled Head that gears right to the fingers and saves assembling time.

"Unbrako" Products are available in a complete range of sizes from number 4 up. For free samples and literature, write today. **KNURLING of Socket Screws originated with Standard PRESSED Steel Co. years ago.**

TAYLOR
LAMINATED PLASTICS
 Vulcanized Fibre • Phenol Fibre
 SHEETS, RODS, TUBES, FABRICATED PARTS
TAYLOR FIBRE COMPANY
 Norristown, Pennsylvania

♦The new 400 by 500 foot, windowless, supercharger factory which the General Electric Co. has built at Everett, Mass. is completely air-conditioned. Besides affording a desirable "blackout" feature in this defense plant, the air conditioning makes possible accurate machining processes on aluminum and magnesium alloys which require close temperature control throughout the year for successful results . . . The Crosley Corporation showed a net profit of \$798,634.58 for the first six months of 1941 after deducting \$300,000 for federal income taxes. This profit was based on total net sales of \$12,868,956.75 . . . The American Phenolic Corporation has acquired a new manufacturing plant to house their connector and socket factory. They have also erected an additional building which will be devoted to the production of polystyrene and other ultra-low-loss insulating materials. The firm's new address is 1830 S. 54th Avenue, Cicero Post Office, Chicago.

♦W65H, an f-m station in Hartford, Conn. recently gave its listeners a "bolt-by-bolt" description of a thunderstorm. The only way the audience could hear the storm was through the microphone since the reception was entirely static-free . . . FM Broadcasters Inc. reports that recently a listener in Tennessee heard f-m stations in Boston, New York, Rochester, Schenectady, and New Hampshire. Another listener says he heard f-m broadcasts in Jeanerette, Louisiana from Detroit, Chicago, New York, and Boston.

. . .

ELECTRON MICROSCOPE



An electron microscope was recently shown at California Institute of Technology's Annual Open House. A student is shown adjusting the unit which can magnify up to 10,000 times normal size

**HI-FIDELITY CUTTING
PERFECT REPRODUCTION**
... yours with **WALCO**
Genuine Sapphire Needles

Adopted as standard equipment by leading record player manufacturers, WALCO Sapphires have reached new heights of recording and playback excellence — prolonged needle life — minimum record wear.

Cutting life up to 25 hours before resharpening — more than 10,000 plays at 1 ounce pressure — such features reflect the ultra-modern design of WALCO Genuine Sapphires. Here are flawless jewels, ground to rigid specifications to meet your most exacting hi fidelity requirements.

High Grade Embossing, too

Many industries find WALCO Genuine Sapphires ideal for embossing on plastics. The extreme hardness and durability of WALCO Sapphire points may be the solution to your specific stylus problem. WALCO's engineering division will gladly make recommendations in accordance with your particular needs.

Investigate TODAY!

WALCO
ELECTROVOX COMPANY, INC.
356 Glenwood Avenue
EAST ORANGE, NEW JERSEY

COILS

Electrical  Windings

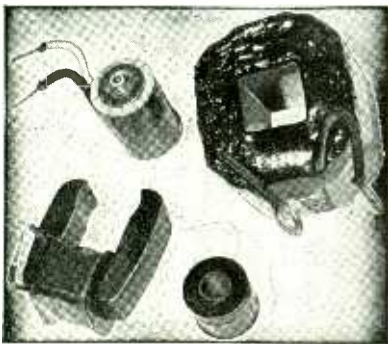

A COMPETENT and experienced organization devoted to the design and manufacture of coil windings. Paper interlayer sections—form wound and bobbin wound coils.

Equipped for prompt production on quantity or small orders.

REPRESENTATIVES

W. A. JORDAN 295 Madison Ave., New York, N. Y.	PARAGON SALES CO. (C. H. Fryburg) 402 Cherry St., Philadelphia, Pa.
GILBERT GISLASON 82 St. Paul St., Rochester, N. Y.	A. J. LOEB SALES CO. 1836 Euclid Ave., Cleveland, Ohio

MAGNETIC WINDINGS COMPANY
Sixteenth and Butler Streets EASTON, PENNA.

Literature

Relay Literature. A "Bibliography of Relay Literature, 1927-1939" has been published by the American Institute of Electrical Engineers. It is a 16-page pamphlet in which some 450 annotated reference items are divided into subject sections, and in each section entries are consecutively numbered and listed alphabetically by years. Some of the subjects covered are line, bus, apparatus, distribution, and network protection; service restoration, general and miscellaneous relaying; testing and analyzing; and methods of calculation. The pamphlet is available at the AIEE headquarters, 33 West 39th Street, New York City, at 25 cents per copy to members, 50 cents to non-members, and a 20 percent discount may be had for quantities of 10 or more to one address at one time.

Welding Data. The second edition of the Resistance Welding Data Book, devoted to the theory and practice of resistance welding has been issued by P. R. Mallory & Co., Inc., Indianapolis, Indiana. The new edition contains four sections: fundamentals of resistance welding, materials to be welded, alloys for resistance welding applications, and miscellaneous tables.

Transformers. "Open Type Transformers", and "Potted Transformers, Bulletin No. 2" published by Chicago Transformer Corp., 3501 Addison Street, Chicago, Ill. are two recent additions to the Chicago Transformer file. They list case dimensions, vertical frame, universal frames, and vertical and horizontal strap mountings.

Alnico Magnet. A booklet describing the manufacture of the new Alnico damping magnet for G-E Watthour Meters may be had by asking for GES-2764 from the General Electric Co. Schenectady, N. Y. Each step in the process is explained and illustrated, and pictures of meters incorporating the alnico magnet are shown.

F-M Transmitters. Five transmitters, comprising coordinated units and a new modulator, for 250 watts to 50 kw, making up the DL line of Radio Engineering Laboratories, Inc., Long Island City, N. Y. are covered in a 12-page reprint from *FM Magazine*. Brief specifications, including several illustrations are shown, but no circuit diagrams are given.

Spring Alloys. The performance of five metals, Z Nickel, K Monel, Monel, Inconel, and malleable nickel, in conditions involving corrosion and temperature extremes are presented in a booklet called "New Spring Alloys for Tough Jobs", published by the International Nickel Co., Inc., 67 Wall Street, New York City. Technical data and tables of strength, stiffness, endurance, resistance to corrosion and corrosion fatigue, effects of high temperatures, and magnetic and electrical properties are also included.



A Precision Crystal
Secondary
FREQUENCY STANDARD
THAT HAS BEEN
"Designed for Application"

A precision frequency standard capable of being adjusted to WWV or some other primary standard and putting out uniformly accurate calibrating signals with 10, 100, 1000 KC intervals. Uses the new GENERAL ELECTRIC No. 18A 1000 KC crystal having a frequency temperature coefficient of less than one cycle/Mo/C°. The crystal is sealed in Helium in a standard metal tube envelope.

The self-contained AC power supply has VR150-30 voltage regulator tube.

In addition to oscillator, multivibrators, and harmonic amplifier, a built-in mixer with phone jack and gain control on panel is incorporated.

JAMES MILLEN  MFG. CO. Inc.
150 EXCHANGE ST. MALDEN, MASS.

**YOUR ONE DEPENDABLE
SOURCE OF SUPPLY . .**



VAST
COMPLETE
STOCKS

★
Immediate
Delivery
★

Your ALLIED Catalog!

**EVERYTHING FOR THE
FIELD OF ELECTRONICS**

Today, more than ever, ALLIED is the name that means Everything in Radio. And more than ever, the new FREE 212 Page ALLIED Catalog is your Buying Guide to materials, parts, components and supplies for engineering, communications, laboratory and industrial applications of electronic equipment. You'll find —test equipment, communication sets, x-mitting gear—Everything in Radio—ready for delivery—all at the lowest prices. Reserve your copy of this Radio Buying Guide now!

Address Dept. 24-J-1 for FREE Copy

ALLIED RADIO
833 W. JACKSON • CHICAGO

**Save
trouble
time and
money**

**with the aid of this
practical radio
engineering
help**



1. 945 pages of carefully selected, accurate data—charts, tables, circuits, diagrams, formulas.
2. Covering all the most needed subjects for engineers, from fundamentals to specialized applications.
3. Every section prepared by one or more specialists, to assure you dependable, expert answers to your problems in design and practice.

Just Out

**Enlarged, Up-to-date, 3rd Edition
RADIO ENGINEERING
HANDBOOK**

HERE is a book that gives the radio engineering profession its own handbook, comparable to the standard handbooks available in other fields of engineering. It conveniently presents a great deal of constantly needed reference material covering all fields and aspects of radio engineering—concise, dependable, arranged in easy-to-get-at form. To meet the greatest and most lasting needs in such a rapidly developing field as radio, material has been chosen carefully for its importance to the practicing engineer. With the deletion of obsolete material and addition of material on important new developments, this new third edition brings you:—

- new data on crystal control circuits, ultra-high frequency apparatus, modulation systems, audio-frequency transformer design, vibrator power supply, long-line oscillators, etc.
- completely rewritten sections on aircraft radio, television, detection, loud speakers, facsimile, oscillators, etc.
- revision throughout to make the book as useful as possible in modern practice.

FOR 10 DAYS' FREE EXAMINATION

mail this coupon

McGRAW-HILL BOOK CO., INC.
330 W. 42nd St., N. Y. C.

Send me Henney's Radio Engineering Handbook for 10 days' examination on approval. In 10 days I will send you \$5.00 plus few cents postage or return book postpaid. (We pay postage on orders accompanied by remittance.)

Name

Address

City and State

Position

Company L. 9-41

(Books sent on approval in U. S. and Canada only.)

**Prepared by 23
radio specialists**

**KEITH HENNEY
Editor-in-Chief**

**945 pp., 836 illus.
over 100 tables
\$5.00**

House Organ. Two interesting articles appear in the *Aerovac Research Worker*, house organ of Aerovox Corp., New Bedford, Mass. "R-F Power Amplifier Operation" appears in the April 1941 issue, and "Fixed Condensers in Radio Transmitters" is in the March 1941 issue.

Bulletin. A description of the features of the rotary converters and dynamometers made by Janette Manufacturing Co., 556 West Monroe Street, Chicago, Ill. appears in Bulletin 13-25.

Relays. The new No. 641 catalogue listing seven new Staco relays may be had from Standard Electrical Products Co., 417 1st Ave. N., Minneapolis, Minn.

House Organ. Dynamic Balancing of small rotors by means of the cathode-ray oscillograph is discussed in the April-May issue of the *DuMont Oscillographer*, Vol. 5, No. 1, published by Allen B. DuMont Laboratories, Inc., 2 Main Ave., Passaic, N. J.

Vibration Control. This is a bulletin (No. 104) which outlines the basic engineering principles of vibration isolation. Two colored charts showing the relationship between static deflection and natural frequency, and isolation efficiency for any flexible mounting system are included as well as illustrations of applications of vibration control made by the Lord Manufacturing Co., Erie, Penna.

Leaflet. The specifications of Type S-5 Incandescent Searchlight are listed in bulletin GEA-3576 by the General Electric Co., Schenectady, N. Y.

Chart. Electrical and chemical engineers will find the engineering data and property chart No. 416 recently issued by American Lava Corp., Chattanooga, Tennessee useful. The physical properties of steatite, cordierite, and lava have been compiled in a convenient tabular form. Curves such as linear thermal expansion, volume resistivities with varying temperatures of AlSiMag ceramic compositions are also included in the chart which is available on request.

House Organ. The characteristics of vibration, and the Vibration Meter, a new electronic tool for industry are covered in the June issue, Vol. XVI, No. 1 of the *Experimenter*, house organ of the General Radio Co., 30 State St., Cambridge A, Mass.

Gear Materials. The principal properties of Synthane grades most used for gears, and the uses and advantages of Synthane are described in a new folder released by the Synthane Corporation, Oaks, Penna. The horsepower transmissible by Synthane gears is tabulated in six charts which cover gears of 2, 4, 6, 8, 12, and 18 pitch. Each chart shows the horsepower per inch of face at various pitch line velocities for gears of 12, 16, 25, 38, 50, and 60 teeth.

New Products

Vernier Dial

SPRING-LOADED GEARS drive a new vernier dial which is made by Bud Radio, Inc., Cleveland, Ohio. It is calibrated in 500 divisions over the 180-degree scale. The scale may be removed for calibration without remov-

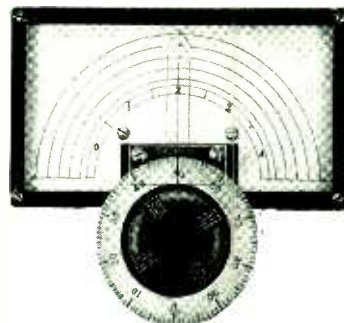

ing the dial drive. The mounting area is 5¼ by 5¼ inches. The gear ratio between the knob shaft and pointer shaft is 10 to 1. A friction clutch on the knob shaft prevents damage to the gears when maximum or minimum rotation is reached.

Mycalex

INJECTION MOULDING of Mycalex, a material useful in the radio and electronic fields because of its low dielectric power losses, has been announced by the plastics department of General Electric Co., Pittsfield, Mass. Mycalex,



consisting of ground mica and a specially developed glass has been compression-moulded and machined to required specifications for some time. The new injection process makes possible the production of more intricate shapes.

Microphone Control

A NEW "PUSHMIKE" adapter and stand has been introduced by RCA Manufacturing Co., Inc., Camden, N. J. The unit is equipped with a low capacity leaf switch which is actuated by a "push-to-talk" button that may be locked in the "talk" position if desired.

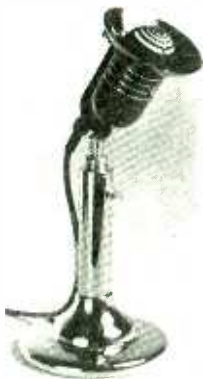

Crystal Controlled Receivers

MOST RADIO COMMUNICATION SERVICES depend upon a relatively small number of fixed channels for intercommunication. For this type of service, where only a few specific frequencies are to be received, Radio Manufacturing Engineers, Inc., Peoria, Ill., have introduced a new line of crystal controlled receivers. There are three types: the SPD-11, for six channel operation within an octave tuning range; the SPD-13, a single frequency receiver designed for low and medium frequency operation; and the SPD-15, for ultrahigh frequency single channel reception. These quartz plate controlled sets retain their frequency calibration regardless of climatic, electrical, or other physical disturbances. Accurate tuning is maintained day in and day out without adjustment. Since these receivers tune to one or a small number of channels, all circuits are peaked for maximum sensitivity, maximum signal-to-noise

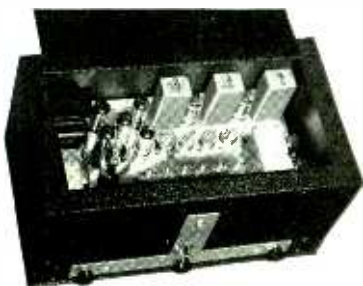

ratio, and the best image-to-signal ratio. The SPD-11 has a six channel tuning range. A selector switch is provided for rapid selection of frequency channels. The SPD-13 is designed for single channel operation. The SPD-15 is similar to the SPD-13 except that frequency doubler tubes and associated apparatus are incorporated for ultrahigh frequency operation.

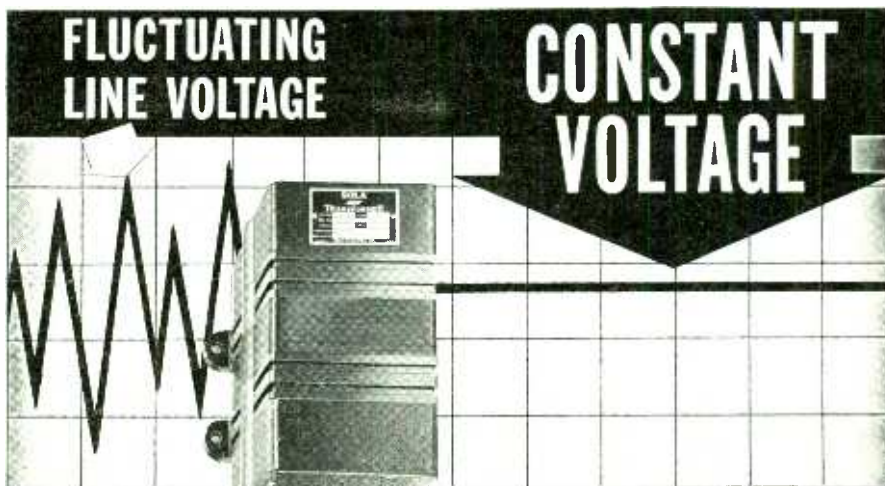

Ask For
BULLETIN
DCV-74

Whether it's 1 VA for an instrument or 10 KVA for a production line—here's constant, stable voltage for you at all times, even though the line voltage varies as much as thirty percent.

They are fully automatic and instantaneous in operation—have no moving parts—require no maintenance—and are self-protecting against short circuit.

You can build a SOLA CONSTANT VOLTAGE TRANSFORMER into your product, or incorporate it in your production line or laboratory and know that every test will be made under identical line conditions. Compact—economical. Standard designs are available, or units can be built to your special specifications.

SOLA ELECTRIC COMPANY, 2525 Clybourn Ave., Chicago, Ill.



SOLA

Constant Voltage TRANSFORMERS

JACKSON Resistance-Capacity Tuned ★ AUDIO OSCILLATOR



Model 652

★ Here is a tried, proven and accepted Audio Oscillator whose brilliant performance sets it apart from other makes. Audio Frequency voltage is developed at its Fundamental Frequency—by the Resistance-Capacity Tuned Principle. This is not a "beat frequency" oscillator and contains no R.F. circuits. Operation is vastly simplified. Characteristic faults of old style methods are eliminated. Glass enclosed direct reading dial is accurate to within 3% or one cycle. Many other outstanding features. Price \$74.50.

★ Write for descriptive literature

★ **THE JACKSON ELECTRICAL
INSTRUMENT COMPANY**

★ 123 Wayne Avenue Dayton, Ohio

JONES BARRIER STRIPS SOLVE MOST TERMINAL PROBLEMS



No. 151

A compact, sturdy terminal strip with Bakelite Barriers that provide maximum metal to metal spacing and prevent direct shorts from frayed wires at terminals.

6 SIZES

cover every requirement. From 3/4" wide and 13/32" high with 5-40 screws to 2 1/2" wide and 1 1/8" high with 1/4"-28 screws.

Jones Barrier Strips will improve as well as simplify your electrical intra-connecting problems. Write today for catalog and prices.

HOWARD B. JONES
2300 WABANSIA AVENUE,
CHICAGO ILLINOIS

Just use the RIGHT DISC...

Since the finest mechanical and electrical recording equipment is available to ALL sound engineers, there can be no "secrets" or so called "exclusive" techniques in producing good recordings.

Comparative results will justify your selection of GOULD-MOODY "Perfected" glass base recording blanks which are available either with center hole only, or with both center and drive pin holes. Aluminum discs may be re-coated at a nominal charge.

IMMEDIATE DELIVERIES

Recording Blank Div.

THE GOULD-MOODY CO.

395 BROADWAY

NEW YORK, N. Y.

★
DINAH
SHORE



Resistors

A LINE OF negative temperature coefficient resistors are being featured by the Keystone Carbon Co., 1935 State Street, Saint Marys, Pa. The resistor material is a hard, black, non-metallic substance whose chief characteristic is a decrease in electrical resistance with an increase in temperature. This change occurs in the region of ordinary

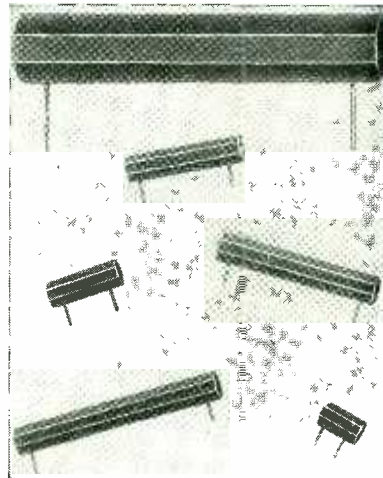

temperatures; 0 to 150 degrees Centigrade. This property makes the material useful where it is desired to reduce or eliminate initial current surges, and where temperature compensation in apparatus which exhibits rising resistance with increasing temperature is needed.

MEGABRIDGE Insulation Resistance TESTER



- This indispensable instrument pays for itself in a short while—out of actual savings in time, effort, trouble.

The Megabridge is the most rapid device for routine insulation measurements, which still retains the Wheatstone Bridge principle. Entirely self-contained and ready for operation. Requires no batteries or 'phones. Null point indicated on visual balance, quickly and accurately. Now employed in many radio and electronic labs. and shops.

• Write for DATA . . .

Bulletin MB-203 describing Megabridge, sent on request. Submit your checking or testing problems, since we also design and build special instruments.

Industrial Instruments, Inc.
156 Culver Ave., Jersey City, N. J.

McGraw-Hill DIRECT MAIL LISTS

As business paper publishers for over fifty years, McGraw-Hill is uniquely equipped to offer complete, authoritative direct mail coverage of industry's major markets. Extreme accuracy is maintained (guaranteed to 98%) and through careful analysis of markets, complete classification of companies and personnel, etc., the widest possible selections are available. Send for handy reference folder, "Hundreds of Thousands of Reasons Why" which describes how McGraw-Hill Lists are built and maintained.

What Fields Do You Want to Reach?

- Aviation
- Bus & Electric Railways
- Civil Engineering and Construction
- Coal Mining
- Electrical Construction
- Electrical Industry
- Food Industries
- Metal Mining
- Metal Working Industries
- Process Industries
- Textile Industries
- Administrative Executives
- Electrical Dealers & Wholesalers
- Mill Supply Houses
- Power Services
- Product Engineering & Design
- Production and Maintenance
- Radio Dealers & Wholesalers
- Radio Engineering and Design

For further details, selections from above basic classifications, counts, prices, etc., or estimates on special lists . . . ask any representative or write to

Complete Lists Covering Industry's Major Markets



Complete Lists Covering Industry's Major Markets

Salt-Shaker Microphone

A DYNAMIC SALT-SHAKER type microphone, No. 211, which uses a new type magnetic structure and acoustic network is a recent product of the Turner Co., Cedar Rapids, Iowa. The high frequency range has been extended, and the extreme lows have been raised 2 to 4 db to compensate for deficiencies



in loud speaker systems. Model 211 has a level of minus 56 db below 1 volt per bar for high impedance units. The 500 ohm model has an output of 2.5 millivolts for a 10 bar signal, the 200 ohm model has an output of 1.6 millivolts, and the 30 to 50 ohm unit has an output of 0.25 millivolts. The range is 30 to 10,000 cps.

Sound System

THE NEW HALLICRAFTERS Model RSC-2 includes an f-m and a-m tuner, a high fidelity 25-watt amplifier with microphone and phono inputs, and a monitor speaker. The tuner provides a-m reception from 540 to 1650 kc, and f-m reception in the range of 40 to 51 Mc. The frequency response of the amplifier alone is flat within plus or



minus 1.5 db from 30 to 20,000 cps. The response of the tuner alone for f-m reception varies less than 1.0 db from 30 to about 7,000 cps, drops 1.8 db at 10,000 and 4.0 db at 15,000 cps. The three units are all mounted on a table-mounting rack. The manufacturer is Hallicrafters, 2611 Indiana Ave., Chicago, Ill.

Relay

A RELAY WHICH IS AVAILABLE with 1, 2, 3, or 4 poles; either single or double throw to operate on alternating or direct current is the Type F, of the G-M Laboratories, Inc., Chicago, Ill. The unit is 2½ inches high, 2½ inches long, and 1½ inches wide. It is compact and capable of giving long, uninterrupted service.

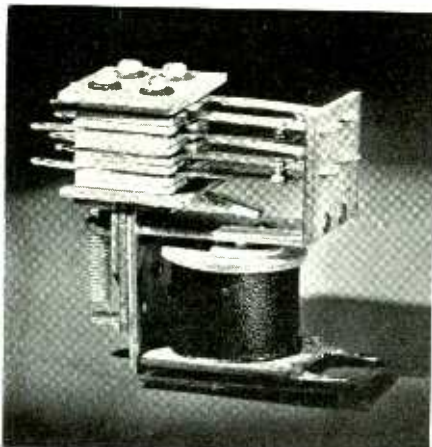

CLARE Type "G" Micro-Switch RELAY

Particularly adapted for aircraft, machine control, motor and lamp loads, photo electric and similar applications where space and weight are factors. The type "G" Relay is furnished to operate on d.c. only.* Contacts rated at 10 amperes, 110 V., a.c.—completely enclosed. Solder or screw type contact terminals optional.

Write for Clare
Data Book
and Catalog
TODAY!

C. P. CLARE & CO.
LAWRENCE & LAMON AVES. - CHICAGO
15 EAST 26TH STREET, NEW YORK CITY

* Other Clare Relays
are available for
a.c. operation.



"Sylvaloy"
FILAMENT
Dependability... Uniformity

WILBUR B. DRIVER CO.
NEWARK, NEW JERSEY



TEAMWORK

Instrument Resistors, Inc., offers you the close co-operation that your RESISTOR requirements demand.

Your production needs regulate our *delivery* schedules.

Our modern plant and skilled technicians produce Wire Wound Resistors when and as you want them.

Catalog upon request.



TYPE AL 4 Watts

Instrument Resistors, Inc., LITTLE FALLS, N. J.

ULTRA HIGH EFFICIENCY MICROVOLTER*

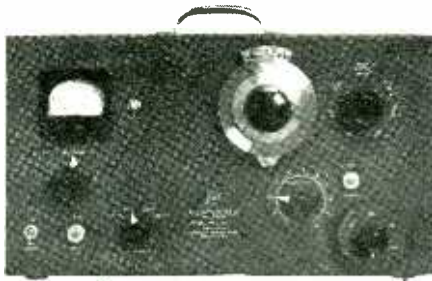

*Reg. U.S. Pat. Off.

MODEL 18-C

- Frequency range 5 to 175 mega-cycles
- Low Resistance Attenuator
- Terminated Transmission Line
- Output .2 to 100,000 microvolts
- Panel Jack for 2 volts output
- 400-1000 cycles and External Modulation

WRITE for new catalog E-4; illustrates and gives complete details and specifications for the complete line of Ferris Instruments.

FERRIS INSTRUMENT CORPORATION Boonton New Jersey



Cetron
6 amp. Rectifier

PERFORMANCE AND DEPENDABILITY

Electronic Tubes by Continental represent the accumulation of many years of experience in research, engineering, and production. They are definitely better both in performance and dependability.

That is why many of the country's foremost manufacturers have made Continental-built Electronic Tubes standard for their equipment. Your product, too, will perform better with them.

Write today for engineering data on photo cells, mercury rectifiers, ultra-violet lamp and other tubes produced by us.

CONTINENTAL ELECTRIC CO.

Merchandise Mart
Chicago, Illinois

Plant
Geneva, Illinois

BUT WHAT OF Tomorrow?

"All-out" production to meet today's pyramiding orders does not mean that Triplett has lost sight of the broader requirements of tomorrow. Instead, research and engineering programs actually have been "stepped-up" to assure constant improvements in products and processes; in addition to needed developments in new fields.

Today's demands are important, but the needs of tomorrow cannot be slighted—and are anticipated in never flagging engineering and research developments. You have assurance that in the months and years to come, new Triplett products will serve in expanded fields, where they will merit values and savings for every dollar spent in their purchase.

THE TRIPLETT ELECTRICAL INSTRUMENT CO.
Bluffton, Ohio

NO ENGINEER

whose work takes him into the field of sensitive electrical devices can say—today—that he is thoroughly grounded unless he "knows his electronics."

Because electronic circuits more and more are getting into industrial work as an automatic hand, an automatic eye, a new means of generating heat, etc., etc., they have become the background for a new cycle of industrial progress.

Are you trying to get along without **ELECTRONICS**? Better subscribe today!

Plug-in Relays

THESE RELAYS, known as Type SR, have a sensitivity of 12 milliwatts d.c., and will control 150 watts of non-inductive a-c load at 110 volts when the input power is 12 mw. They are equipped with a standard 5-prong plug which

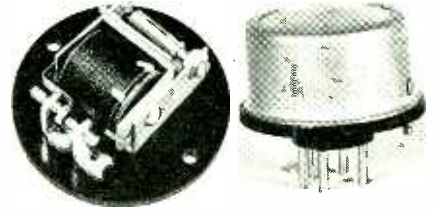

will fit a vacuum tube socket, and are especially designed for use in electronic and delicate control applications. The adjustable contacts are fine silver and the armature spring tension, control spacing, and armature gap are adjustable for specific pick-up and drop-out characteristics. The manufacturer is Standard Electrical Products Co., 417 First Ave. North, Minneapolis, Minn.

Portable Dynamic Balancer

A MACHINE WHICH CORRECTS the unbalance of turbines, generators, or both rotating elements is the new portable dynamic balancer recently developed by the General Electric Co., Schenectady, N. Y. The equipment consists of three parts; a sine-wave alternator, a vibration velocity unit, and an indicating unit with its associated circuits, all fitted in a handy carrying case. By permitting balancing under operating conditions in the rotor's own bearings, it eliminates the need for shipment of the rotor to a balancing machine. The quality of the results is improved since balancing under operating conditions corrects for changes such as those due to the effect of the load.

2½ Meter R-F Choke

A NEW R-F CHOKE especially applicable to transceivers, 2½ meter mobile transmitters, and therapeutic and diathermy equipment is a feature of the Ohmite Mfg. Co., 4835 Flournoy Street, Chicago, Ill. The unit is known as Type Z-O Plate Choke, and is 1½ inches long



and ½ inch in diameter. It is single layer wound on a low power factor steatite tube, and is covered with a moisture resisting insulating material which protects the wire. Other sizes are available for the 5, 10, 20, 40, 80, and 160 meter bands.

Helical Potentiometer

A LONG POTENTIOMETER SLIDE WIRE coiled helically into a small case, with a slider contact rotated in the usual manner make up the Helipot, a wide range potentiometer-rheostat sold by the National Technical Laboratories, 820 Mission Street, South Pasadena, Cal. At present the units are made in three and nine turn models, but units can be designed to accommodate almost any length of resistance wire desired.

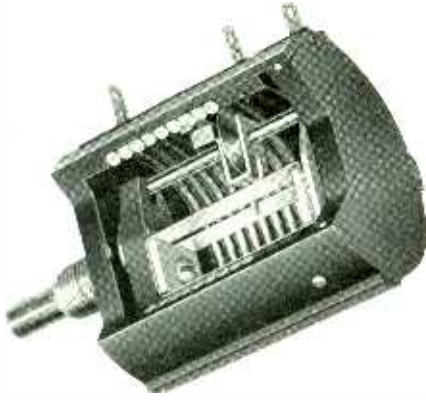

Volt-Ohm-Milliammeter

THE LATEST MEASURING INSTRUMENT to be added to the Hickok line, made by Hickok Electrical Instrument Co., 10307 Dupont Ave., Cleveland, Ohio is an a-c and d-c volt-ohm-milliammeter known as model 202. It can measure voltages in five ranges up to 1000 volts with an input impedance of about 2.5 megohms on alternating current. The d-c range runs up to 1000 volts in five

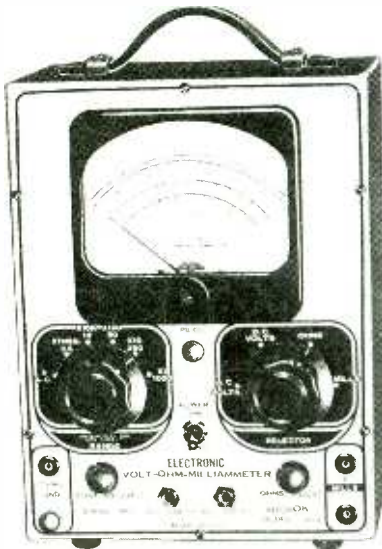

ranges with an input impedance of 14 megohms. There are five ohmmeter ranges up to 1000 megohms, and 5 milliammeter ranges up to 1000 milliamperes. The instrument operates from a 110 volt, 50 to 60 cps supply. It comes complete with a voltage regulator tube giving self contained regulation.

THE NEW G·M RELAY

TYPE "F"

Designed to Improve
Your Product
SAVE!

Space . . . Cost

IMPROVE!

*Efficiency, Performance,
Deliveries*

The new G-M Factory, with its enlarged facilities is at your service for a variety of relays. The new Type "F" relay is just one of many types available. Others will be announced shortly. Wire or write, telling us of your relay problems.

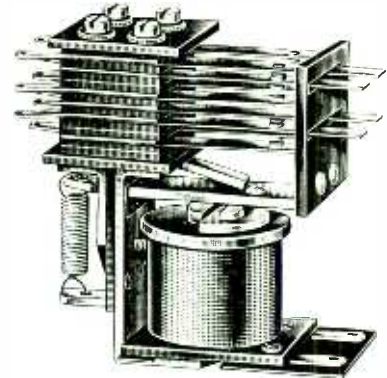

DIMENSIONS

2 1/4" High by 2 1/2" Long
1 1/8" Wide

1, 2, 3 or 4 poles; single throw or double throw, A.C. or D.C.; contacts have self-cleaning, wiping action with heavy contact pressure. Underwriters clearances can be supplied. Send for Bulletin No. 611 giving dimensions and characteristics.

G·M LABORATORIES INC.
4313 NORTH KNOX AVE. CHICAGO, U. S. A.



PERMANENT MAGNETS

ALL SHAPES — ALL SIZES
FOR ALL PURPOSES

Stamped, Formed, and Cast; Chrome, Tungsten Cobalt and **ALNICO**** (cast or sintered) under G. E. license.

THOMAS & SKINNER
STEEL PRODUCTS COMPANY
1116 E. 23rd STREET INDIANAPOLIS, INDIANA

Laminations for Radio Transformers — Tools
Dies — Heat Treating — Stampings

40 YEARS EXPERIENCE

CANNON ELECTRICAL CONNECTORS

Save Time and Money . . . Increase Efficiency



IN the transmission of electrical energy—electronic or otherwise—wherever cables are required, problems of efficient connection and quick disconnection are solved by CANNON Cable Connectors. Manufactured up to a standard and not down to a price, CANNON Multiple-Contact Electrical Connectors are the choice of the leading makers of fine equipment used in the fields of Sound, Aeronautics, Geophysical Research, Instrument Control on Ships and on Laboratory Panels.

Illustrated Bulletins contain valuable information on Plug Problems. Bulletin "P & O" devoted exclusively to Sound. Please specify your requirements when requesting bulletins.

CANNON ELECTRIC DEVELOPMENT CO.
3209 HUMBOLDT ST., LOS ANGELES, CALIFORNIA
Eastern Sales Office: 220 Fifth Ave., New York, N. Y.
Chicago: Kelburn Engineering Co., 600 W. Jackson Blvd.



CANNON PLUGS



For that
"PRO"
 touch...

- Your transmitter, power pack, sound-system amplifier or other assembly certainly takes on a decidedly professional aspect when you use these sturdy Aerovox Series-09 rectangular-can Hyvols. Mounted above or below chassis at any height, with adjustable mounting ring. Smaller units with mounting lugs. Larger units with mounting strap clamps placed on sides and gripping top or bottom bead. Voltages up to 5000 D.C.W.

ROUND CAN . . .

(Type —05)

Or you can have the —05 series in round aluminum cans with high-tension pillar terminals. Adjustable ring mounting. Voltages up to 3000 D.C.W. Series —12 up to 7500 v.

SCREW-MOUNTING . . .

(Type —10)

Similar to inverted-screw-mounting aluminum-can electrolytics. Ideal for power pack filters. Screw stud and lock nut for one-hole inverted mounting. Up to 1500 v. D.W.C.

Ask for DATA . . .

- Latest catalog sent on request. Write on business letterhead. Your capacitance problems are invited for engineering aid, recommendations, specifications, quotations.



Filament Transformer

A NEW TRANSFORMER, Type T-19F75, specially recommended for use with the RCA 816 rectifier tube has been added to the Thordarson line, made by Thor-



darson Electric Mfg. Co., 500 W. Huron Street, Chicago, Ill. This is an open frame unit with a 115-volt, 50-60 cps primary, and the secondary output is 2.5 volts at 5 amperes, center-tapped.

High-Frequency Iron

HIGH-FREQUENCY IRON is offsetting the aluminum shortage now troubling designers and manufacturers of radio sets. The Henry L. Crowley Co., 1 Central Avenue, West Orange, N. J. is eliminating aluminum shields through the use of iron-core coils and iron-core sleeves when necessary. These make i-f and r-f transformers more compact and efficient. High frequency iron is also used in permeability tuners which have a gang of coils and iron plungers, taking the place of aluminum condensers. A more compact assembly, and a higher efficiency is also claimed for this arrangement.

Switch

A SNAP-ACTION SWITCH with several modifications adapting it for a wide variety of uses is being made by Aero Electric Co., 3159 Fulton Rd., Cleveland, Ohio. It has a single pole, and is furnished with normally open, normally closed or double throw contact arrangements. The standard model



comes in the following ratings: 10 amps at 115 volts, 5 amps at 250 volts, and 3 amps at 450 volts. All these ratings are for alternating current. Further specifications include a low movement differential, 0.5 to 14-oz. pressure, less than one-ounce weight, and dimensions of 1 1/8 by 1 1/8 by 3/8 inches.

Universal Mounting Capacitors

A UNIVERSAL MOUNTING ARRANGEMENT is an integral part of the Type EZ dry electrolytic capacitors manufactured by Cornell-Dubilier, South Plainfield, N. J. They are equipped with a mounting strap around the center, and a pair

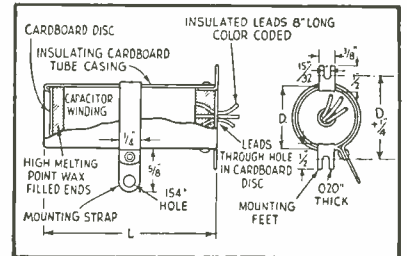

of slotted feet at one end, which permit mounting in a horizontal or vertical position. The units are available in single, dual, triple, and quadruple sections. Details of the mounting feature are shown in the diagram.

Drafting Machine

A NEW DRAFTING MACHINE, made by The Frederick Post Co., Hamlin and Avondale Avenues, Chicago, Ill., embodies a protractor, vernier, T-square, scales, and triangles. One simple control releases the scales for 15 degree automatic stops, or for intermediate stops. It also permits adjustment of the scale at any angle with a protractor and vernier reading of zero to zero. The protractor may be used at any angle in the complete circle so that the entire area of the board is made accessible.

Phono Amplifier

THIS UNIT specifically designed for phonograph record reproduction, incorporates such features as automatic volume expander up to 10 db, dual fader-phonograph unit permitting mixing and fading of two phonos, two separate tone controls which increase or decrease treble and bass respectively, and a master volume control with an a-c switch. The vertical panel is made within specified dimensions to permit rack mounting. The manufacturer is Webster-Rauland, 3825 W. Armitage Avenue, Chicago.

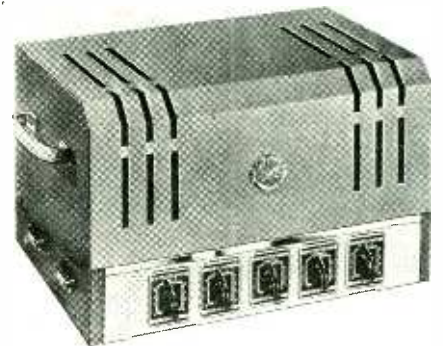

Rubber Micrometer

MEASUREMENT OF SOFT and compressible materials such as rubber can be made with the same degree of accuracy and precision obtained with precision measuring instruments on steel parts by means of the Carson Rubber Micrometer. The micrometer tip is brought in contact with a metallic rider resting upon the work, and the exact instant of contact is indicated by a green light before any pressure is exerted on the piece being measured. The instrument



may be had with a variety of special fittings and attachments for specific measuring problems on such materials as rubber, paper, plastics, cork, fibre, leather, felt, insulated wire, and textiles. Two standard dials are available; a 2½-inch diameter dial with divisions for every ten thousandth of an inch, and a 4¼-inch dial with divisions for half this distance. It is manufactured by Instrument Specialties Co., 246 Bergen Blvd., Little Falls, N. J.

Electronic Counter

A COUNTER WHOSE RANGE RUNS up to 2,000 counts per minute is being offered by the Shallcross Mfg. Co., Collingdale, Penna. This is a scale of 5 counter where each count is picked up by a gas triode and when the last tube is fired the register moves up one unit. The total count is obtained by multiplying the meter reading by 5 and adding the serial number of the last tube fired. The scale of 5 is standard, but a scale of 10 or 15 and other scales are available.



CONTACTS

For the Field of Electronics

SIGNICO
SIGNAL & INDICATOR PILOT LIGHTS
 for all electrical devices.

WRITE FOR CATALOGUE showing a complete line of assemblies for all purposes.

SIGNAL INDICATOR Corp.
 140 CEDAR ST. NEW YORK, N. Y.



Rex Rheostat Co.

We manufacture a complete line of equipment

SPOT WELDERS, electric, from ¼ to 500 KVA	AC ARC WELDERS
TRANSFORMERS, special and standard types	WELDERS
FLUORESCENT LAMP manufacturing equipment	From 100 to 400 Amps.
FLUORESCENT TUBE MAKING EQUIPMENT	400 Amps.
ELECTRONIC EQUIPMENT, vacuum pumps, etc.	
WET GLASS slicing and cutting machines for laboratory use	
GENERAL GLASS working machines and burners	
COLLEGE GLASS working units for students and laboratory	

EISLER ENGINEERING COMPANY, CHAS. EISLER, Pres.
 751 So. 13th St. (near Avon Ave.) Newark, New Jersey

ENGINEERS!

HERE'S YOUR COMPLETE
Source of Supply

ALL STANDARD RADIO PARTS and ELECTRONIC EQUIPMENT IN STOCK!
 There's NO WAITING—NO DELAY at SUN!
 Call BARCLAY 7-1840 for PROMPT Service!
 Have you a copy of our 416 page 1941 Catalog?

SUN RADIO CO.
 212 FULTON ST.
 NEW YORK, N. Y.

CRYSTALS by HIPOWER

The Hipower Crystal Company, one of America's oldest and largest manufacturers of precision crystal units, is able to offer the broadcaster and manufacturer attractive prices because of their large production and the exclusive Hipower grinding process. Whatever your crystal need may be, Hipower can supply it. Write today for full information.

HIPOWER CRYSTAL CO.
 Sales Division—205 W. Wacker Drive, Chicago
 Factory—2035 Charleston Street, Chicago, Ill.

LECTROHM
 Vitreous Enameled
RESISTORS

A complete range, from 1 to 200 W. wound with highest grade resistance wire. Tolerances plus or minus 5% (closer tolerances, if needed). Wound on low loss ceramic cores. Mounting legs furnished when requested.

SEND FOR SAMPLES
 Give complete data regarding resistance, maximum current, voltage drop required and mounting space available.

LECTROHM, INC.
 5131 WEST 25TH PLACE
 CHICAGO (CICERO P.O. ILL.)

HARVEY
has it
IN STOCK

Orders for national defense are slowing up deliveries from radio parts manufacturers. For your convenience, HARVEY is ordering "stock" supplies so that you may have the product you want—WHEN you want it! HAVE YOU A 1941 HARVEY CATALOG? Call BRYANT 7-1946 for SERVICE!

HARVEY RADIO CO.
 Conveniently located at Times Square
 103 W. 43 ST. • NEW YORK, N. Y.

MICROMETER

FREQUENCY METER for checking transmitters, from 1.5 to 56 mc., within 0.01 per cent.

LAMPKIN LABORATORIES
 —Bradenton, Fla., U. S. A.—

We welcome your inquiries for

LUMINESCENT MATERIALS

Fluorescent and Phosphorescent Chemicals for Lamp and Allied Industries

GENERAL LUMINESCENT CORP.
 732 S. Federal St. Chicago, Ill.

FINE RIBBONS
 of Tungsten and Molybdenum

Molybdenum in widths .006" to 1" in thickness to .0005"
 Tungsten Ribbon to specification

H. CROSS
 15 Beekman St. New York

Find what you are looking for?
 If this or other advertising in this issue does not supply the information of products wanted write

Departmental Staff
 Electronics
 330 West 42nd St., New York City

PROFESSIONAL SERVICES

(Rates on Application)

JOHN C. BATCHELOR

INDUSTRIAL PHYSICISTS-ENGINEERS

Specialists in industrial, technical and marketing investigations for manufacturers and bankers, on products being considered for production and financing.

100 E. 42nd Street New York City

DUDLEY B. CLARK

Consulting Engineer

Industrial Tube and Circuit Design.
Electronics as applied to Metal and Chemical Industries.

Research Laboratories and Shops
Palm Springs Calif.

ELECTRICAL TESTING LABORATORIES

Characteristics of Vacuum Tubes
Tests of photo cells, glow lamps, crater lamps.
Tests of electronics and optical devices.
East End Avenue and 79th Street
New York, N. Y.
Phone, Butterfield 8-2600

INTERNATIONAL ELECTRONICS, INC.

Special Instruments, Equipment and Methods to control gauging, welding, communications, signaling, safety, inspection, color and testing.

Quality control and cost reduction for mechanical, electrical, metallurgical and chemical industries.

Rockefeller Center New York City
Telephone: CIrcle 6-8494

HAROLD J. McCREARY

Mem. A.I.E.E. & W.S.E.

Consulting Engineer

Laboratory Facilities
Research Development Design Patent Studies
Electronics Television Radio Railroad Signaling Telephony
105 W. Adams St. Phone STate 4003 Chicago, Ill.

JOSEPH RAZEK, PH.D.

Consulting Physicist

Electrical and Mechanical Engineering Problems
Instruments and Control Devices Electronics
Specialist in Colorimetry, Spectrophotometry and Industrial Color Control

Laboratory and Shop Facilities
430 Greenview Lane Lanerch, Pa.

When time is short,

put the solution of some of your design or production problems up to some specialized Consultant whose advertisement appears on this page. His broad experience may save you months of costly experimentation.

Departmental Staff,

ELECTRONICS,

330 West 42nd St., New York City

15-Watt Sound System

THIS NEW ALL-PURPOSE sound system comes complete in one compact unit which includes a 15-watt amplifier, controls, and record player. It operates from 105-125 volts at 60 cps, or from a 6-volt storage battery with very



low drain. The unit measures 16.5 inches long, 12 inches deep, and 12 inches high. A turntable is mounted on top of the amplifier case in conjunction with a high quality crystal pickup. The manufacturer is RCA Commercial Sound Division, Camden, N. J.

Dynamotors

A COMPLETE LINE of dynamotors for aircraft, sound, and other power supply uses is being featured by Pioneer Gen-E-Motor, 5841 West Dickens Avenue, Chicago, Ill. These are single output units ranging from model DS which is rated up to 15 watts, to model



TS which is capable of 850 watts output. A new Pincor combination double input and double output dynamotor for both receiving and transmitting is also featured. It is designed to effect a saving in cost as well as to conserve space and weight to meet modern aircraft requirements.

Erratum

THE RADIAL INTERCOMMUNICATOR hooster speaker, Model IBR, which was incorrectly designated as being manufactured by the Turner Company of Cedar Rapids, Iowa last month, is actually made by the University Laboratories, 195 Chrystie Street, New York City. Also, in the description of the Jefferson-Travis PR-5 receiver, the dial was said to be marked for the control tower frequency of 287 kc. This should be 278 kc.

Terminal Strips

A LINE OF SERIES BARRIER terminal strips known as the 150 series are recent products of the Howard B. Jones Co., 2300 Wabansia Ave., Chicago, Ill. The series comprises three sizes: No. 150, which has 10-32 screws with 2-inch



metal-to-metal spacing; No. 151, which has 12-32 screws with 3/4-inch metal-to-metal spacing; and No. 152, having 1/4-28 screws with one-inch metal-to-metal spacing. The body is of heavy molded Bakelite.

Bond Tester

AN ELECTRIC BOND TESTER which is used to measure the effective electrical resistance of mechanical joints is being made by the Shallcross Mfg. Co., Collingdale, Penna. Essentially, it is an instrument which measures very low resistances. The Aero-Gun model, shaped like a revolver, weighs 5 1/2 lbs and comes in two ranges; 0.003 and 0.3 ohms at full scale, and 0.005 and 0.5 ohms at full scale. The accuracy is plus or minus 3 percent at full scale. The Milli-Ohm model comes in a rectangular box and weighs 8 lbs. Its ranges are: 0.5, 0.1, 0.05, 0.01, 0.005, and 0.001 ohm at full scale; 0.003 and 0.3 ohms at full scale; 0.04, 0.4, and 4.0 ohms at full scale; and 0.005 and 0.5 ohms at full scale. Both units are completely self contained, the batteries being mounted inside the units.

Power Relay

A NEW SENSITIVE POWER RELAY is being marketed by Kurman Electric Co., 241 Lafayette Street, New York City. Among some of the features of this device are: a moulded base of Navy approved material, 0.014 watt input, a balanced armature, silver contacts, and an output of 200 to 500 watts. It has a voltmeter accuracy of one per cent from minus 24 to plus 90 degrees Centigrade. The operating power is 0.0018 watts.



Backtalk

This department is operated as an open forum where our readers may discuss problems of the electronic industry or comment on articles which have been published in **ELECTRONICS**.

Spherical Tank Circuits

Editor's note. In cleaning house, recently, the following communication from H. E. Hollman, Berlin, came to light. In view of the present interest in uhf this letter is now published. Lest the authorities in Mr. Hollman's country take umbrage at the apparent leak in information, let us hasten to state that the communication is dated December 21, 1938.

The formulas given in the December number of **ELECTRONICS** for calculating the natural wavelength of spherical tank circuits (page 27) hold good only approximately. Further investigations, covering a wave range of 50-400 cm,

have given the following, considerably more accurate formula:

In general we can write for the natural wavelength of a spherical tank circuit:

$$\lambda^2 = 4\pi L C_f + \lambda_v^2$$

where

L = inductivity of axial tube,
 C_f = capacity of flanges and
 λ_v = residual wave at vanishing capacity C_f .

Furthermore, if we put

$f = D_f/D_k$ = ratio of flange to sphere,
 a = distance between the flanges and
 d = diameter of axial tube,

then we get:

$$C_f = \frac{1}{16} \frac{D_f^2 - D_k^2}{a} = \frac{1}{16} \frac{D_k^2}{a} (f^2 - 1).$$

Knowing that the magnetic flux around the axial tube is confined within the sphere it can be shown that:

$$L = \frac{\pi}{2} D_k \log \epsilon \frac{D_k}{d}$$

Finally, if the squares of their natural wavelengths measured on different circuits are marked over an abscissa divided into $1/a$, and the resulting straight lines are extended up to the value $1/a = 0$, then we get:

$$\lambda_v^2 = 4\pi D_k$$

Substituting these expressions in the above formula gives:

$$\lambda = 4\pi D_k \sqrt{\frac{2.45}{100} \frac{D_k}{a} (f^2 - 1) \log \epsilon \frac{D_k}{a} + 1}.$$

Thus if one enlarges a spherical circuit, keeping its geometrical proportions D_k/a , D_k/d and f constant, the quantity under the root remains constant and the natural frequency is proportional to D_k .

• • •

COSMIC RAY MICROSCOPE

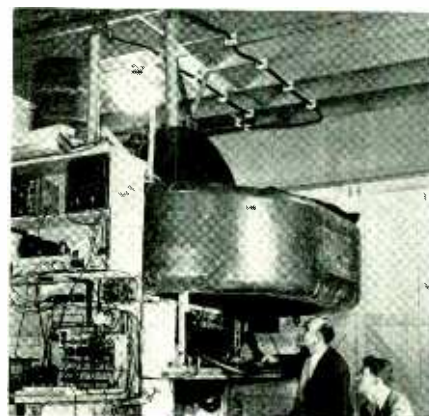

Dr. Carl Anderson, Nobel Prize winner, and student viewing the cloud chamber of the 25-ton cosmic ray microscope at California Institute of Technology

SEARCHLIGHT SECTION

EMPLOYMENT • BUSINESS • OPPORTUNITIES • EQUIPMENT—USED or RESALE

UNDISPLAYED RATE:

10 cents a word, minimum charge \$2.00.

(See ¶ on Box Numbers.)

POSITIONS WANTED (full or part-time salaried employment only), 1/2 above rates.

PROPOSALS, 50 cents a line an insertion.

INFORMATION:

BOX NUMBERS in care of any of our New York, Chicago or San Francisco offices count 10 words additional in undisplayed ads.

DISCOUNT of 10% if full payment is made in advance for four consecutive insertions of undisplayed ads (not including proposals).

DISPLAYED—RATE PER INCH:

The advertising rate is \$6.00 per inch for all advertising appearing on other than a contract basis. Contract rates quoted on request.

AN ADVERTISING INCH is measured 7/8 inch vertically on one column, 3 columns—30 inches—to a page.

NEW ADVERTISEMENTS received by 10 A. M. September 25th will appear in the October issue, subject to limitations of space available.

WANTED

HALF OR ONE KVA Transformer to deliver 15 KV from 115 volt input. Wave form must be within plus or minus 5% of sinusoidal. W-291, Electronics, 330 W. 42nd St., New York.

ANYTHING within reason, wanted in the field served by Electronics, can be quickly located through bringing it to the attention of thousands of men whose interest is assured because this is the business paper they read.

FOR IMMEDIATE SALE

The following surplus equipment, purchased in 1940 and used only a few months:

127 Clough-Bregle Oscillograph
 713 General Radio Beat Frequency Oscillator
 726-A General Radio Voltmeter
 663 Weston Volt Ohmmeter
 765 Weston Analyzer and Case
 787 Weston High Frequency Oscillator
 185 Dumont Electronic Switch
 CDA-5 Capacity Decade
 CDB-5 Capacity Decade
 B5CD Capacity Budke Condenser Tester

Write

Aviation Electric Corporation

460 E. Bacon St. Dayton, Ohio

DEPENDABLE

Used

ELECTRONIC TUBE EQUIPMENT

Complete line of used equipment for the manufacture of Radio Tubes, Neon Tubes, Incandescent Lamps, etc. Write for Bulletin showing 25 to 75% savings.

CALLITE TUNGSTEN CORPORATION
 formerly Eister Electric Corp.
 534 39th Street, Union City, N. J.

HIGH GRADE USED

ELECTRON TUBE MACHINERY

Huge Stock of Every Type and Variety

KAHLE ENGINEERING CORPORATION
 Specialists in Equipment for the manufacture of Neon Tubes, Radio Tubes, Incandescent Lamps, Photo Cells, X-ray Tubes, etc.

900 DeMott St., North Bergen, N. J.

SOLD!

"We sold—through an answer to the ad—the item advertised in the Searchlight Section of **ELECTRONICS**."

Can "Searchlight" help you?

What is YOUR Problem?

Do you need competent men for your staff?

Are you seeking employment?

Or, are you looking for—or offering—a business opportunity of special interest to men in the industry served by this publication?

The solution of any of these problems can logically be found first among other readers of **Electronics**. You can get their attention—at small cost—through an advertisement here.



AUDAX

"RELAYED-FLUX"

Microdyne

"The Standard by Which Others Are Judged and Valued"

Most important wide-range development since the advent of the pickup in 1926. The "RELAYED-FLUX" principle makes possible a moving system far beyond anything yet devised . . . capable of reproducing all the fine detail engraved at the original recording—MICRODYNE bears out the contention of scientists that high-fidelity is possible only with a Moving-Inductor system.

- Flat within $\pm 1\frac{1}{2}$ db to over 10,000 cycles
- Vibratory momentum extremely low
- Absence of distortion
- High stylus compliance
- Low Point-pressure
- Complete with special arm

With or without Jewel Point, the sharp, clean-cut *fac simile* reproduction of MICRODYNE—regardless of climatic conditions—is a marvel to all who have put it to the only test that really counts . . . the EAR test.

Pickup List Prices

\$11.50 to \$198.00

HIGH FIDELITY CUTTERS
List to \$125.00

WITH OUR COMPLIMENTS

A copy of "PICK-UP-FACTS" is yours for the asking. It answers many questions concerning record reproduction.

AUDAK COMPANY
500 Fifth Avenue New York City

"Creators of High Grade Electrical and Acoustical Apparatus Since 1915"

INDEX TO ADVERTISERS

A		K	
Acheson Colloids Corp.	87	Kenyon Transformer Co.	90
Advance Solvents & Chemical Corp.	91	Kester Solder Co.	70
Aerovox Corp.	108	Keuffel & Esser Co.	3
Allied Radio Corp.	101	L	
American Gas Accumulator Co.	82	Lampkin Laboratories	109
American Lava Corp.	13	Lapp Insulator Co.	15
American Platinum Works	99	Lectrohm Inc.	109
Astatic Corp.	89	Lingo & Son, Inc., John E.	62
Audak Co.	112	Littelfuse, Inc.	91
Autocall Co.	99	M	
Automatic Electric Co.	83	Magnetic Windings Co.	101
B		Mallory & Co., P. R.	22
Bakelite Corp.	Third Cover	McGraw-Hill Book Co.	102
Ballantine Laboratories, Inc.	84	Mico Instrument Co.	97
Benwood Linze Co.	93	Millen Mfg. Co., Inc., James	101
Biddle Co., James G.	99	Monsanto Chemical Co.	17
Blaw-Knox Co.	74	Multicore Solders, Ltd.	80
Biley Electric Co.	83	N	
Brand & Co., William	7	National Vulcanized Fibre Co.	57
Bud Radio, Inc.	88	O	
C		Ohmite Mfg. Co.	6
Callite Tungsten Corp.	56	P	
Cannon Electric Development Co.	107	Precision Apparatus Co.	92
Capitol Radio Engineering Institute	93	Presto Recording Corp.	63
Carborundum Co., Gload Div.	88	R	
Carter Motor Co.	87	Radio City Products Co.	97
Centralab Div. Globe Union, Inc.	2	Raytheon Mfg. Co.	86
Cinch Manufacturing Corp.	53	R-B-M Mfg. Co.	109
Clare & Co., C. P.	105	RCA Manufacturing Co.	75, Back Cover
Cohn, Sigmund	94	Rea Magnet Wire Co.	59
Collins Radio Co.	65	Rex Rheostat Co.	109
Continental Electric Co.	106	Richardson Co.	76
Cornell-Dubilier Electric Corp.	21	S	
Cross, H.	109	Shure Brothers	92
D		Signal Indicator Corp.	109
Daven Co.	77	Sola Electric Co.	103
Drake Mfg. Co.	87	Solar Manufacturing Corporation	60
Driver Co., Wilbur B.	105	Speer Carbon Co.	20
DuMont Laboratories Inc., Allen B.	94	Stackpole Carbon Co.	72
Dunn Inc., Struthers	11	Standard Pressed Steel Co.	100
Duotone Co., Inc.	93	Sum Radio Co.	109
E		Synthane Corp.	9, 10
Eicor, Inc.	94	T	
Eisler Engineering Co.	109	Taylor Fibre Co.	100
Eitel-McCullough, Inc.	19	Tech Laboratories	91
Electrovox Co.	101	Terminal Radio Corp.	89
Eric Resistor Corp.	16	Thomas & Skinner Steel Pds. Co.	107
F		Triplet Electrical Instrument Co.	106
Ferris Instrument Corp.	106	U	
Formica Insulation Co.	67	Union Carbide & Carbon Corp.	Third Cover
Franklin Mfg. Corp., A. W.	78, 79	United Transformer Corp.	Second Cover
G		Utah Radio Products Co.	85
General Electric Co.	5	W	
General Luminescent Corp.	109	Ward Leonard Electric Co.	81
General Radio Co.	12	Western Electric Co.	8, 76
G.M. Laboratories, Inc.	107	Weston Electrical Instrument Corp.	71
Gould-Moody Co.	104	White Dental Mfg. Co., S. S.	86, 96
Guardian Electric Mfg. Co.	96	Wilson Co., H. A.	90
H		Professional Services 110	
Hallicrafters, Inc.	95	SEARCHLIGHT SECTION	
Hammarlund Mfg. Co., Inc.	14	(Classified Advertising)	
Hardwick Hindle Inc.	64	EMPLOYMENT 111	
Harvey Radio Co.	109	USED EQUIPMENT FOR SALE	
Hewlett-Packard Co.	58	Aviation Electric Corp.	111
Heintz & Kaufman, Ltd.	55	Callite Tungsten Corp.	111
Hipower Crystal Co.	109	Kahle Engineering Corp.	111
Hunter Pressed Steel Co.	85	I	
Hygrade Sylvania Corp.	69	Industrial Instruments, Inc.	104
I		Instrument Resistors, Inc.	105
International Resistance Co.	4	Irvington Varnish & Insulator Co.	68
Isolantite, Inc.	61	J	
J		Jackson Electrical Instrument Co.	103
Jensen Radio Mfg. Co.	18	Jenson Co., E. F.	80
Jones, Howard B.	103	K	



Fabricator: Plax Corporation, Hartford, Conn.

Low-Loss "Bakelite" Polystyrene Plastics

NOW AVAILABLE IN SHEETS, RODS, TUBES, AND FILAMENTS

BAKELITE Polystyrene Plastics are now supplied in prefabricated forms, such as sheets, tubes, rods, and filaments. These new forms supplement the BAKELITE Polystyrene molding materials and insulating films which have already established their usefulness in high frequency circuits and other applications requiring superior electrical insulating properties.

Rods are furnished in varying lengths up to 72 in. with diameters ranging from 0.020 in. to 4½ in. Sheets are supplied in thicknesses from 0.003 in. to 2½ in., in varying widths and lengths. Tubes are made to special order with lengths and wall thicknesses furnished to specifications. The filaments, or fibers, are sold by the spool in 1000-ft. to 5000-ft. lengths with diameters ranging from 0.020 in. to ½ in.

Like BAKELITE Polystyrene molded

plastics, these new forms are dimensionally stable and exceptionally moisture-resistant. Their electrical properties remain constant over a wide frequency range. Because of these characteristics, BAKELITE Polystyrene Plastics, in their various forms, are especially suited for insulation on all types of communication equipment.

Enlist the services of our Engineering Advisory Staff to determine how BAKELITE Plastics may improve your electrical appliances and devices. Write Dept. 10.

BAKELITE CORPORATION
Unit of Union Carbide and Carbon Corporation



30 EAST 42ND STREET, NEW YORK

BAKELITE

The word "Bakelite" and the identifying products  Symbol are registered trade-marks of Bakelite Corporation.

PLASTICS HEADQUARTERS

Consider these advantages of "Bakelite" Polystyrene Plastics

HEAT DISTORTION
ASTM 170°F.

WATER ABSORPTION
(24 hr. immersion)
0.0002%

VOLUME RESISTIVITY
 10^{17} — 10^{19} ohm-cm.

DIELECTRIC STRENGTH
(short time)
0.005 in. thick = 3,500 volts/mil
0.015 in. thick = 2,200 volts/mil
0.125 in. thick = 500-700 volts/mil

DIELECTRIC CONSTANT
at 60 cycles = 2.5—2.6
at 10^3 cycles = 2.5—2.6
at 10^6 cycles = 2.5—2.6

POWER FACTOR
60 cycles = 0.0001—0.0002
 10^3 cycles = 0.0001—0.0002
 10^6 cycles = 0.0001—0.0004

Designed to Keep You Technically Up-to-the-Minute!

RCA TUBE PUBLICATIONS and ENGINEERING DATA

These RCA publications bring you the tube data and engineering help you need—when you need it—and in its most authentic and up-to-the-minute form. For years, RCA engineering has led the way, and these publications keep

you fully abreast of modern tube design and application. They are available through your RCA Tube and Equipment Distributor, or may be ordered direct from RCA, Commercial Engineering Section, Harrison, N. J.

RCA GUIDE FOR TRANSMITTING TUBES

Includes full details on RCA air-cooled transmitting tubes plus circuits and construction data on equipment of interest to experimenters, amateurs, and engineers. 50% larger. Fully illustrated. 72 pages. *Net price, 25c each.*

TT-100 TRANSMITTING TUBE BOOKLET

This attractively illustrated publication shows at a glance the maximum ratings and typical operation conditions of the entire line of RCA Transmitting and Special-Purpose Tubes. Contains 16 pages. *Single copies at no charge*

RCA HAM TIPS

RCA's newsy little publication devoted exclusively to the radio amateur. Jam-full of how-to-make-it articles, technical data, diagrams, transmitting tube advice, helpful hints. Fully illustrated. Issued seven or eight times a year. Your RCA Tube and Equipment distributor will be glad to supply you with it. *Available at no charge*

RCA PHOTOTUBE BOOKLET

Written by RCA engineers to give a clear understanding of phototube theory, construction, and operation. Complete with descriptive text, circuits, curves, and charted information. Booklet contains 16 pages. *Single copies at no charge*



HB-3 ALL TYPES TUBE HANDBOOK

Convenient, loose-leaf data, curves, etc., on all RCA transmitting, receiving, cathode ray, television and special-purpose tubes, complete with attractive, durable binders. Available on subscription basis. Write RCA Commercial Engineering Section, Harrison, N. J., for descriptive folder and order form.

RC-14 RECEIVING TUBE MANUAL

Now available with a 38-page supplement covering 99 additional receiving tube types and making the book a virtual encyclopedia, containing a total of 256 pages and covering 333 different receiving tube types. . . . *Net price, complete, 25c*

1275-B RECEIVING TUBE BOOKLET

A handy guide for quick, easy reference. Includes the salient characteristics, socket connections, and a special classification index of the complete line of RCA Receiving Tube types. 16 pages. *Single copies at no charge*

INSTRUCTION BOOKLETS

These booklets contain complete, authorized information on Radio's finest line of Transmitting and Special-Purpose Tubes. They are included in the cartons with RCA Tubes, but bulletins on any tube type are available upon request. *Single copies at no charge*



Radio Tubes

PROVED IN COMMUNICATION'S MOST EXACTING APPLICATIONS

RCA MANUFACTURING CO., Inc., Camden, N. J. • A Service of The Radio Corporation of America

For Canadian prices write to RCA Victor Company Limited, Montreal

