

electronics

radio, communication, industrial applications of electron tubes . . . engineering and manufacture

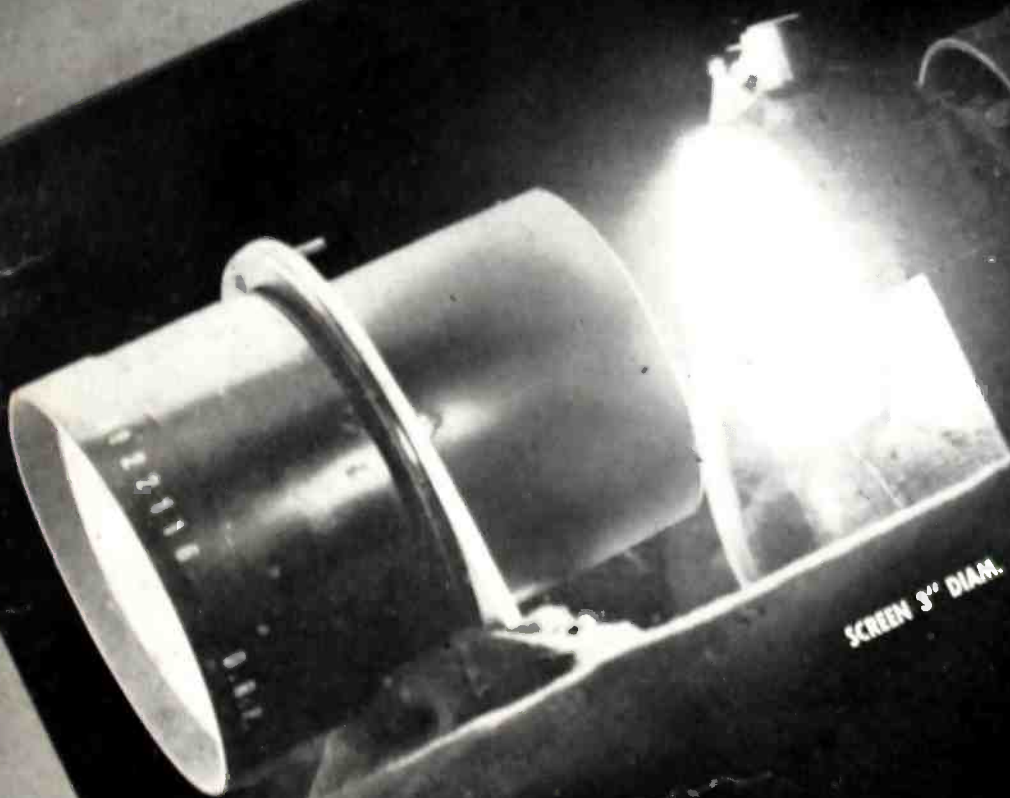

IMAGE ON SCREEN

DEFLECTION COIL



GUN



SCREEN 3" DIAM.

LENS

RCA EXPERIMENTAL
PROJECTION TELEVISION TUBE

MAY-1937
IRE 25th Anniversary

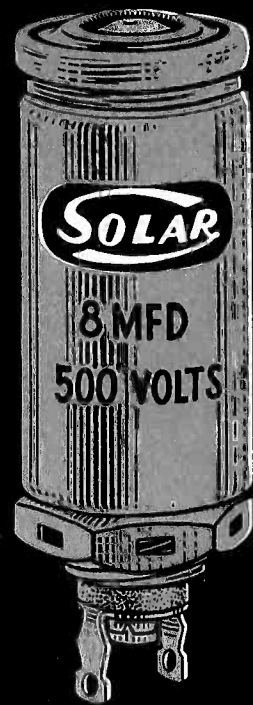
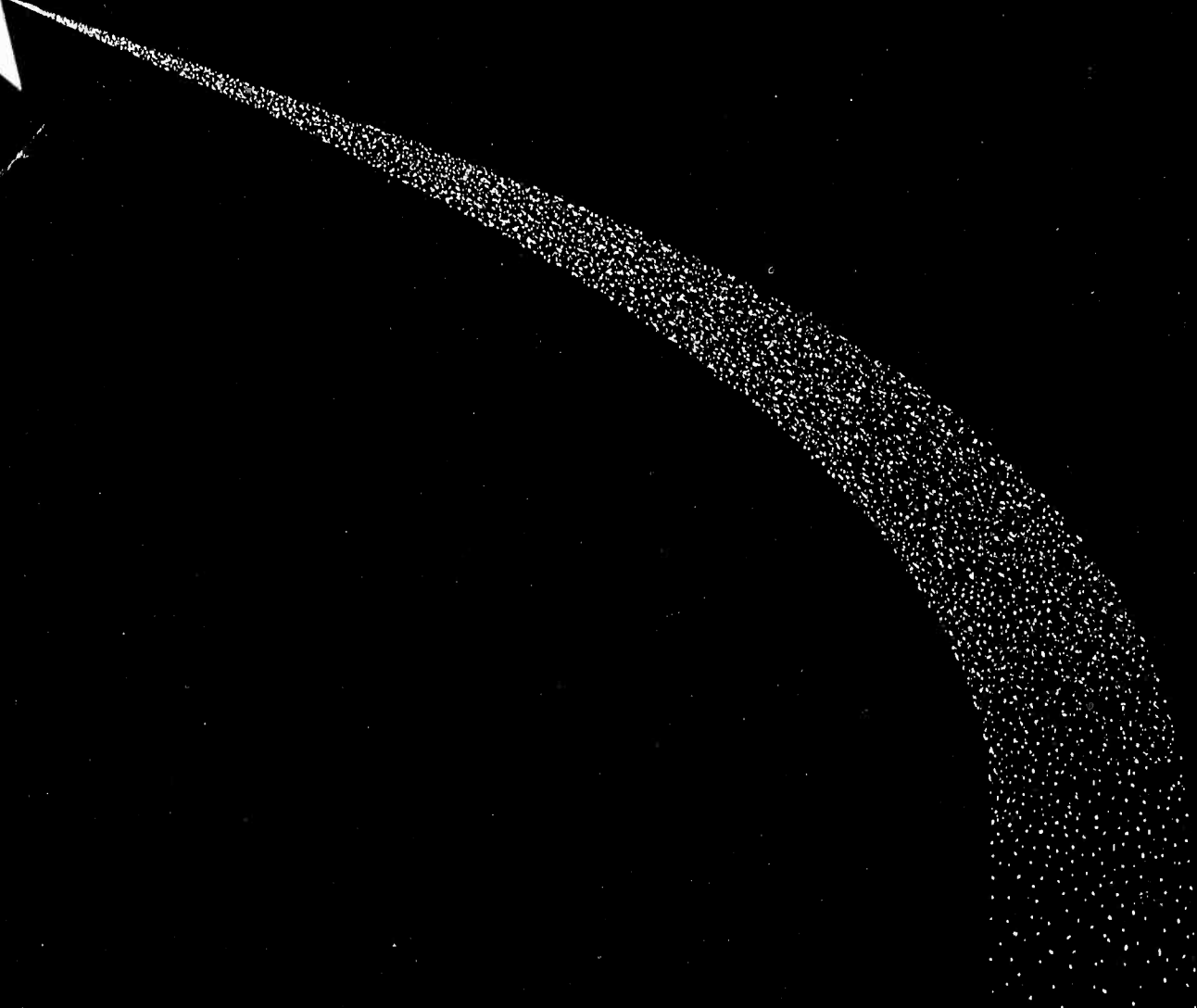
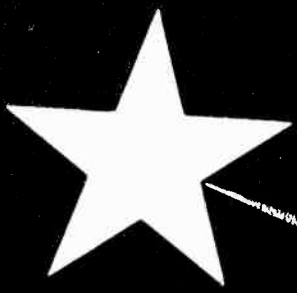

This new wet electrolytic capacitor is the Solar "MINICAP."
It is startling in size reduction (illustration exact size;
volume 85% less than previously). It is self-healing and
non-freezing. The "MINICAP" will be incorporated in
many future radio sets. Forward-looking engineers are
investigating now
SOLAR MFG. CORP., 599-601 BROADWAY, NEW YORK

ELECTRONICS

radio, communication and industrial applications of electron tubes . . . design, engineering, manufacture

HOWARD EHRLICH
Executive Vice-President

KEITH HENNEY
Editor

DONALD G. FINK
Associate Editor

H. W. MATEER
Manager

HARRY PHILIPS, Art Director

BEVERLY DUDLEY, Assistant Editor

Contents • May 1937

COVER:

Developmental Television projection tube demonstrated by RCA at I. R. E. Convention

Frontispiece 14

"The Transatlantic Times" first newspaper published at sea which obtained news by wireless

I. R. E. Silver Anniversary 15

In which we present the history and founding of an important engineering society

Frequency Modulation 22

BY HANS RODER

Analytical discussion of frequency modulation and its advantages in reducing noise in radio reception

Interoffice Communicating

Systems 26

BY JACOB ROSENBAUM

Review of audio, carrier, and wired carrier communication systems of current interest

Etched Foil Electrolytics 30

BY NATHAN SCHNOLL

Larger capacity, smaller space are advantages of electrolytic condensers with etched surfaces

Up in the Air 32

Pole raising activities at the Riverhead station of R.C.A.

Fidelity Control 34

BY ARTHUR G. MANKE

Switch for changing characteristics of high fidelity receivers to give better overall response

Radio Resistor Measurements . . . 37

BY EVERITT B. SCHWARTZ

Methods of measuring carbon composition resistors are described

The Padding Condenser 42

BY LOUIS B. SKLAR

Another solution is presented of the problem of getting the oscillator in superhets to track properly

I. R. E. Program 44

What the radio engineers are to discuss at their anniversary convention

DEPARTMENTS

Cross talk	13	Tubes at Work	42	Manufacturing Review	78
Reference Sheet	45	Electron Art	66	Index to Advertisers	112
		Book Reviews	51		

Volume 10 . . . Number 5

Contents Copyright, 1937, by McGraw-Hill Publishing Company, Inc.

ELECTRONICS, May 1937, Vol. 10, No. 5. Published monthly, price 50c a copy. Subscription rates—United States and possessions, Canada, Mexico and Central American countries, \$5.00 a year. All other countries, \$6.00 a year or 24 shillings. Entered as Second Class matter, August 29, 1936, at Post Office, Albany, N. Y., under the Act of March 3, 1879.

Branch Offices: 520 North Michigan Ave., Chicago; 883 Mission St., San Francisco; Aldwych House, Aldwych, London, W. C. 2; Washington; Philadelphia; Cleveland; Detroit; St. Louis; Boston; Atlanta, Ga.

James H. McGraw, Jr.
Chairman
Howard Ehrlich
Executive Vice President

Malcolm Muir
President
B. R. Putnam
Treasurer

James H. McGraw
Honorary Chairman
D. C. McGraw
Secretary

Cable Address: MCGRAWHILL, New York. Member A.B.P. Member A.B.C.

McGRAW-HILL PUBLISHING COMPANY, INC.

Publication Office
99-129 North Broadway, Albany, N. Y.
Editorial and Executive Offices
330 West 42nd Street, New York, N. Y.



PROGRESS IN TELEPHONY

aided by Bakelite Molded

FOR more than twenty years, Bakelite Molded has contributed to the advancement of telephone equipment by affording electric insulation with the combined merits of high resistivity, superior impact strength and ready adaptability of form. With the development of handset phones, its acoustical benefits also became apparent.

Now, these advantages of Bakelite Molded are aiding in the development of modern loud-speaking telephones. In the new Transducer

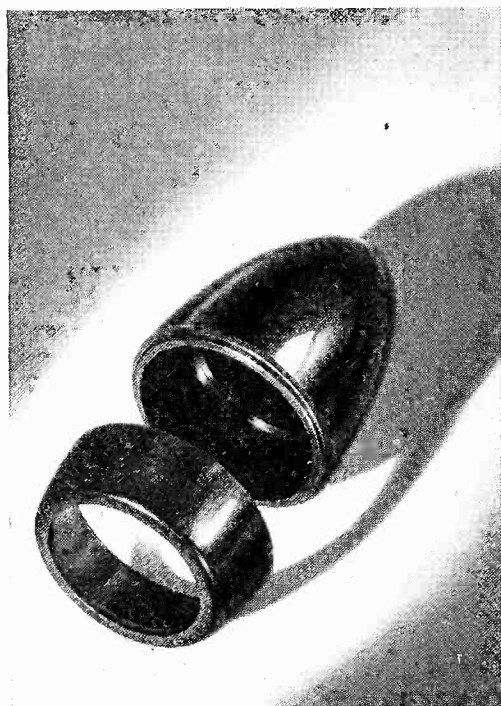

Accurate, two-piece Bakelite Molded housing of the "Bullet-Phone". Each part completely formed and finished in one molding operation.

"Bullet-Phone", pictured, Bakelite Molded was selected for the forming of the highly functional housing, after several other materials had been tested and rejected.

Three specific characteristics of Bakelite Molded which benefit the acoustics of this two-way phone are: its accuracy in reproducing difficult shapes and designs; its satisfactory acoustical qualities; and its freedom from expansion, contraction and distortion due to temperature change or moisture.

Other important characteristics of Bakelite Molded which provide improved design and performance in a wide variety of electrical products are its permanent lustre, self-con-

tained color, moisture-proofness and resistance to marring from constant handling, washing or long use. Because it permits the complete forming of intricate parts in a single molding operation, this material also offers production economies.

Electrical engineers and designers are invited to investigate the many useful applications of Bakelite Molded. Write for informative booklet 13M, "Bakelite Molded" which describes numerous uses and presents A. S. T. M. data.

(Above) "Bullet-Phone", housed in lustrous black Bakelite Molded, for two-way loud-speaking communication systems. Product of Transducer Corporation, New York, N.Y.

BAKELITE CORPORATION, 247 PARK AVENUE, NEW YORK, N.Y.
BAKELITE CORPORATION OF CANADA, LIMITED, 163 Dufferin Street, Toronto, Canada West Coast: Electrical Specialty Co., Inc., 316 Eleventh Street, San Francisco, Cal.

BAKELITE

REGISTERED U. S. PAT. OFF.

*The registered trade marks shown above distinguish materials manufactured by Bakelite Corporation. Under the capital "B" is the numerical sign for infinity, or unlimited quantity. It symbolizes the infinite number of present and future uses of Bakelite Corporation's products.

THE MATERIAL OF A THOUSAND USES

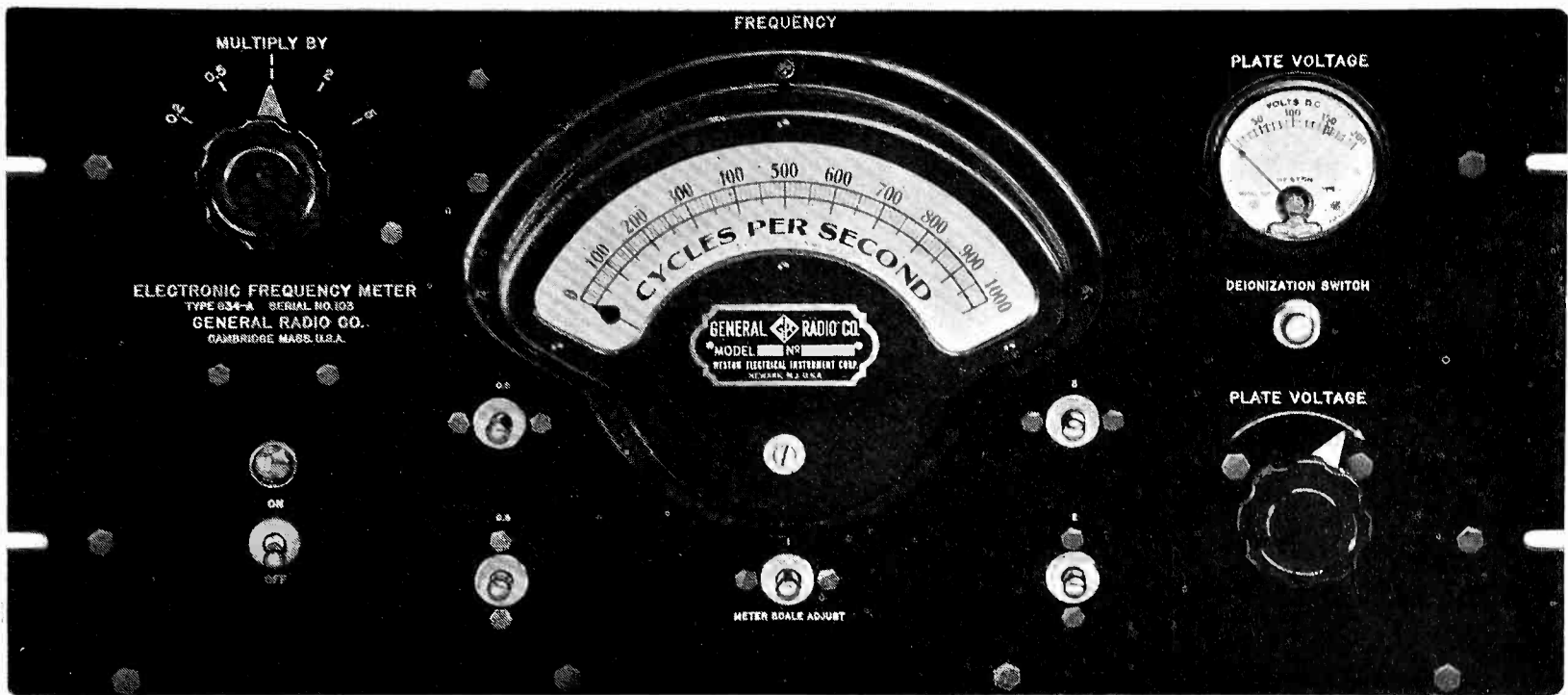

DIRECT READING—ZERO TO 5,000 CYCLES

BASED on a radically new design, the General Radio Type 834-A Electron Frequency Meter is direct-reading from zero to 5,000 cycles over five ranges each starting from zero and extending to 200, 500, 1,000, 2,000 and 5,000 cycles.

This instrument is especially useful in laboratory or production testing where routine measurements of frequency have to be made rapidly and accurately either on a large number of devices or continuously on a single instrument.

Some of its many applications are:

- Quartz Crystal Grinding
- Checking a Number of Radio Transmitters
- Noise Measurements and Analysis
- Analysis of Vibration in Machinery
- Tele-metering
- Industrial Measurements of Thickness, Capacitance and Quality
- Tuning Electrical Horns, Chimes and Organs
- Continuous Monitoring in any Frequency Measurement

The Type 834-A Electron Frequency Meter is entirely self-contained and operates from a 110-volt, 60-cycle a-c power source. Price, complete with vacuum tubes, fuses, spare pilot lamps, 115-volt cord and plug assembly and multipoint connector: \$250.00

Write for Bulletin 134-E for complete data

GENERAL RADIO COMPANY • CAMBRIDGE, MASS.

NEW YORK

SAN FRANCISCO

LOS ANGELES

**A
COMMAND**
to
Univex
Engineers

"PRODUCE A FINE PROJECTOR —ANYONE CAN AFFORD"

A REPORT
from a
Parker-Kalon
Assembly
Engineer

RESULT
Important
Assembly
Economies
—a low priced
Univex 8 mm
Projector!

"I was called in by Mr. Kende, Chief Engineer at Universal Camera Corp., to make recommendations on their new Projector. After studying their fastening problem I made the suggestions covered in this report."

FACED WITH the job of designing a fine movie projector, to sell at a price anyone could afford, Univex Engineers called in a Parker-Kalon Assembly Engineer at an early stage of the work. Not to learn about Parker-Kalon Hardened Self-tapping Screws, but to be certain of making the fullest possible use of them. Univex engineers knew from experience that every fastening made with a Self-tapping Screw meant a saving of time, labor and money. And greater security, too.

Eight different assembly jobs, involving 23 fastenings were made much simpler and better through this wise approach. The resulting assembly cost reduction is clearly reflected, with other examples of design initiative, in the low-price of the Univex machine.

Today, most design and production men "know" Parker-Kalon Hardened Self-tapping Screws and use them to some extent for making fastenings to metal and plastics. In

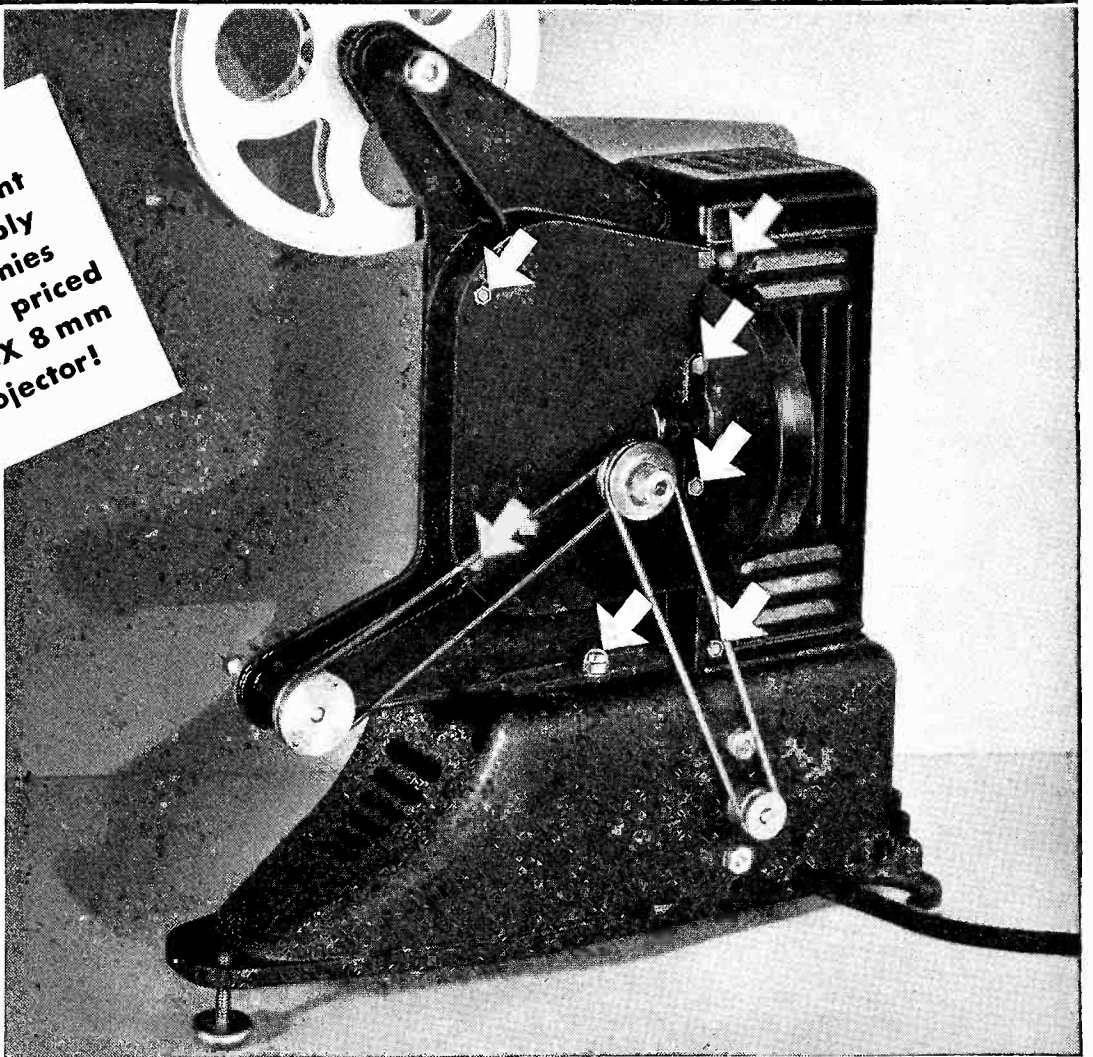

7 out of 10 cases, however, the specialized knowledge of a Parker-Kalon Assembly Engineer would help them effect greater savings. Any design or production head can have this help merely by asking us for it. It will pay you to get the recommendations of one of these practical assembly men for your present production, and whenever you face a new design job.

Univex Assemblies Made Better — at Lower Cost

Arrows indicate the following: Fastening a die cast plate, and a sheet metal lamp housing to the cast mounting unit. Fastening mounting unit to the base casting . . . using special Type "U" Parker-Kalon Self-tapping Screw as a stud, the end having a standard thread to take a Parker-Kalon Cold-forged Cap Nut. Other assemblies not visible are: Fastening a speed control switch unit, and a sheet metal base plate to the cast base. Fastening cadmium plated lamp base unit, and a brass shutter guide strip to the cast mounting unit. Also a combined attachment and bearing pin for a control lever.

PARKER-KALON CORPORATION
198 Varick Street New York, N. Y.

PARKER-KALON *Modern* FASTENING DEVICES

TYPE "Z" HEX CAP A HARDENED SELF-TAPPING SCREW FOR EVERY KIND OF ASSEMBLY TYPE "A" TYPE "U"

SOLD ONLY THROUGH RECOGNIZED DISTRIBUTORS

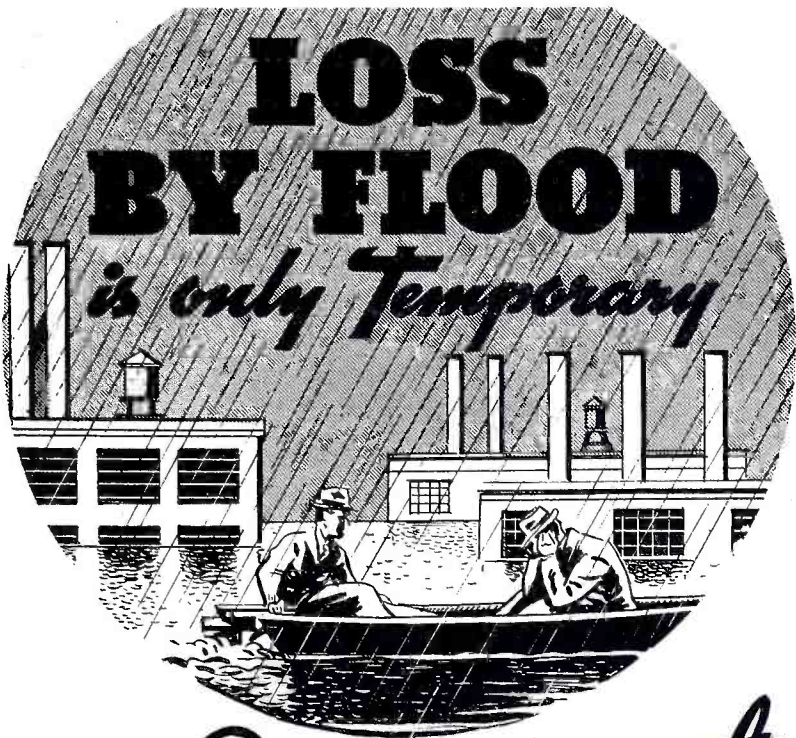

Instruments detect Losses
THAT MIGHT GO ON FOREVER

The losses suffered by industry in times of flood must be charged to the powerful and uncontrolled forces of nature. Unavoidable... the damage is only temporary... it is regretted, repaired and forgotten. Industry buckles down to work again.

But those unsuspected electrical losses that bore into profits like termites. They cannot be seen... they cannot be heard... they can only be detected by the use of electrical instruments. They might go on forever.

That motor drive which has grown such a familiar sight to you. Is it over-

loaded? Is it underloaded? Either way, it is a profit leak.

There is only one efficient and economical load for any electrical device, and that is its name-plate rating. And there is only one reliable means of determining load conditions... *the consistent use of electrical instruments.*

But even the intelligent use of electrical instruments is not enough unless the instruments have the quality that assures economy. Make sure your test data has the maintained accuracy assured by Westinghouse Portable Instruments. J 40080

Westinghouse Portable Instruments assure the accuracy, durability, and ease of reading which have marked Westinghouse instrument manufacturing since 1888. Available in every standard size and rating, these instruments are reasonably priced. No logical reason exists for accepting lower quality.

ASK for Booklet 2098, WESTINGHOUSE PORTABLE INSTRUMENTS

Westinghouse

PORTABLE INSTRUMENTS

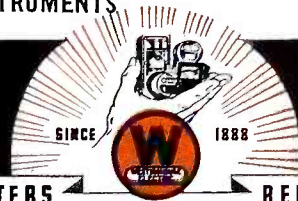

METERS INSTRUMENTS RELAYS

RADIO-FREQUENCY MILLIAMMETERS, AMMETERS ★ MICROAMMETERS ★ MILLIAMMETERS
 ★ AMMETERS ★ RECTOX MICRO- AND MILLIAMMETERS ★ MILLIVOLTMETERS ★ VOLTMETERS
 VOLT-AMMETERS ★ WATTMETERS ★ GALVANOMETERS

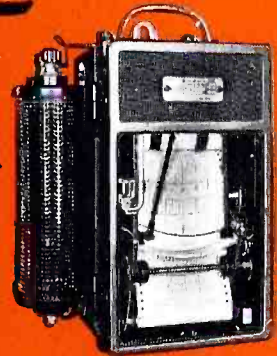

Type U Recording Voltmeter.

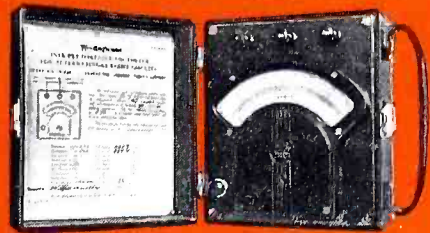

Type PY-5 Double-Range Voltmeter.



Type PY-4 Five-Range Voltmeter.



INDUSTRIAL ANALYZER—Self-contained for making complete a-c. tests up to 125 amperes, 600 volts on single, two, or three-phase circuits.



Photos through courtesy Quam Nichols Co., Radio Speakers, Inc., and Standard Transformer Co., Chicago, Ill.

IS IT A MATTER OF SPEEDING UP PRODUCTION?

... without sacrificing absolute sureness and accuracy in the insulation of radio and electrical parts? ...

TURBO has the answer. TURBO Oil Tubing—made by an exclusive process—is a tough, flexible material impervious to oils, moisture, acids, friction and IT BURNS EIGHT TIMES SLOWER than any sleeving of its kind.

TURBO Oil Tubing can be twisted, snarled or bent but it will never lose its tubular shape. Its glassy-smooth race way means quick, easy fishing of conductors and the fact that it comes in 12 standard colors—in some sizes—provides the answer to many production problems. Sizes .020 to 1-inch I. D.

TURBO Saturated Sleeving is another BRAND product that has met with approval for applications where extreme voltages are not encountered. It is a heavily varnished, woven cotton tubing of unusual toughness and resiliency. It is flame-proof and offers no mean savings in many types of apparatus.

Send for free full length strands of TURBO Oil Tubing and Saturated Sleeving and, keep this in mind—Brand ships all orders, regardless of quantities, on the day they are received.



TURBO

OIL TUBING AND
SATURATED SLEEVING

WILLIAM BRAND & CO. 268 4th AVE., NEW YORK
IN CHICAGO - 217 N. DESPLAINES ST.

GRATIS! AN ARC WELDING CIRCUIT ... THAT SLASHES COSTS ENGINEERED TO YOUR REQUIREMENTS

FEATURES OF THE CIRCUIT:

Requires Motor Generator set and A. C. transformer only where D. C. current of low voltage and varying amperage is required—gives pure D. C. current, free from pulsation—Deposits 25% more metal per ampere of current used than a Motor Generator set—No moving parts providing less maintenance cost—Initial cost approximately 75% less than Motor Generator set.

TYPICAL USES FOR THE CIRCUIT:

Any kind of arc welding for production, or repair.
Electro Plating
Steel Measuring
Flaw Detecting
Meter Calibrating
Solenoid Hammers
Electrolytic Oxygen and Hydrogen Gas making

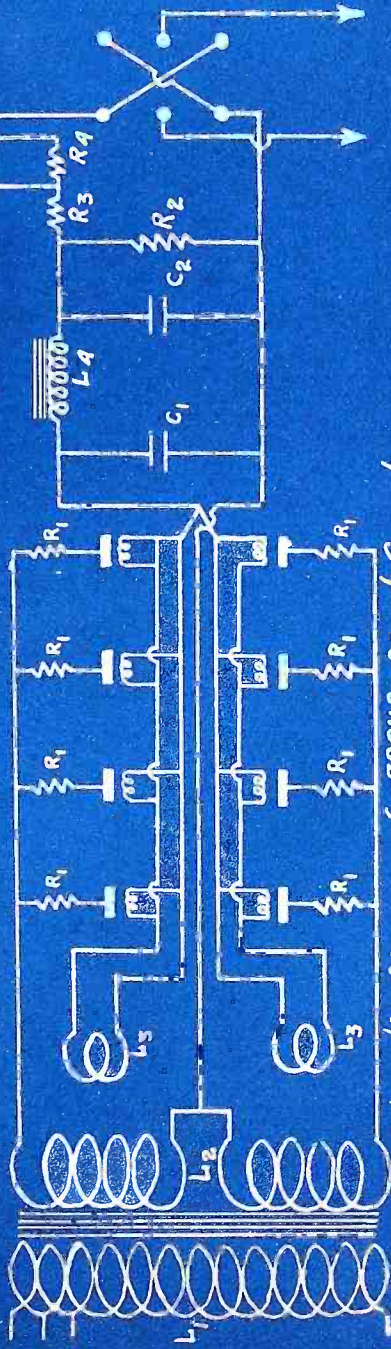

Schematic Diagram of ARGUS Direct Current Arc Welding Unit, 110-220 volt, Single Phase. Employing ARGUS Rectifying Bulbs - Full Wave.

Patent Applied For.

WHY WE OFFER YOU THIS OUTSTANDING WELDING CIRCUIT—GRATIS

Primarily—our business is the making of the ARGUS 1500 hour guaranteed Rectifier Bulb—our Engineers possessing 30 years' experience in Bulb making.

The outstanding (patent applied for) Arc Welding Circuit we offer herewith is a simple, but most practical circuit designed by ourselves. Its possibilities of use are many. Manufacturers of many kinds are asking for details. To these Manufacturers, and others who can use this outstanding circuit, we offer it use gratis, asking only that the ARGUS Rectifier Bulb be used with it. No additional obligations are involved. Stated simply—the Circuit helps us to sell the ARGUS Bulb.

We will gladly give you the further, complete details about the Circuit, and help engineer it to your particular specifications. Simply write to us stating briefly your requirements and we will respond promptly. Write today. The Argus Mfg. Corp., 1890 East 40th Street, Cleveland, Ohio.

SPECIAL NOTE:

We are prepared to engineer to specification any kind or type of Vacuum Tubes. Simply write us!

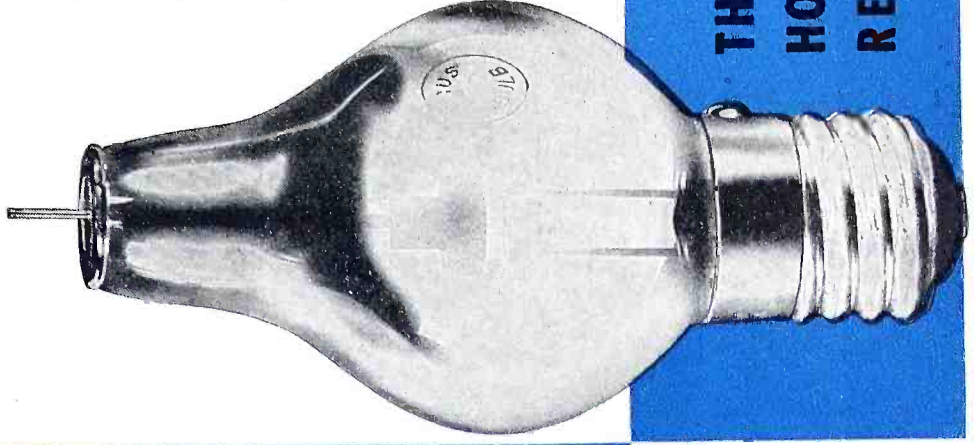

**THE ARGUS 1500
HOUR GUARANTEED
RECTIFIER BULB**

"ARGUS"

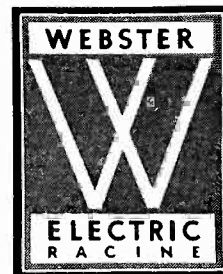
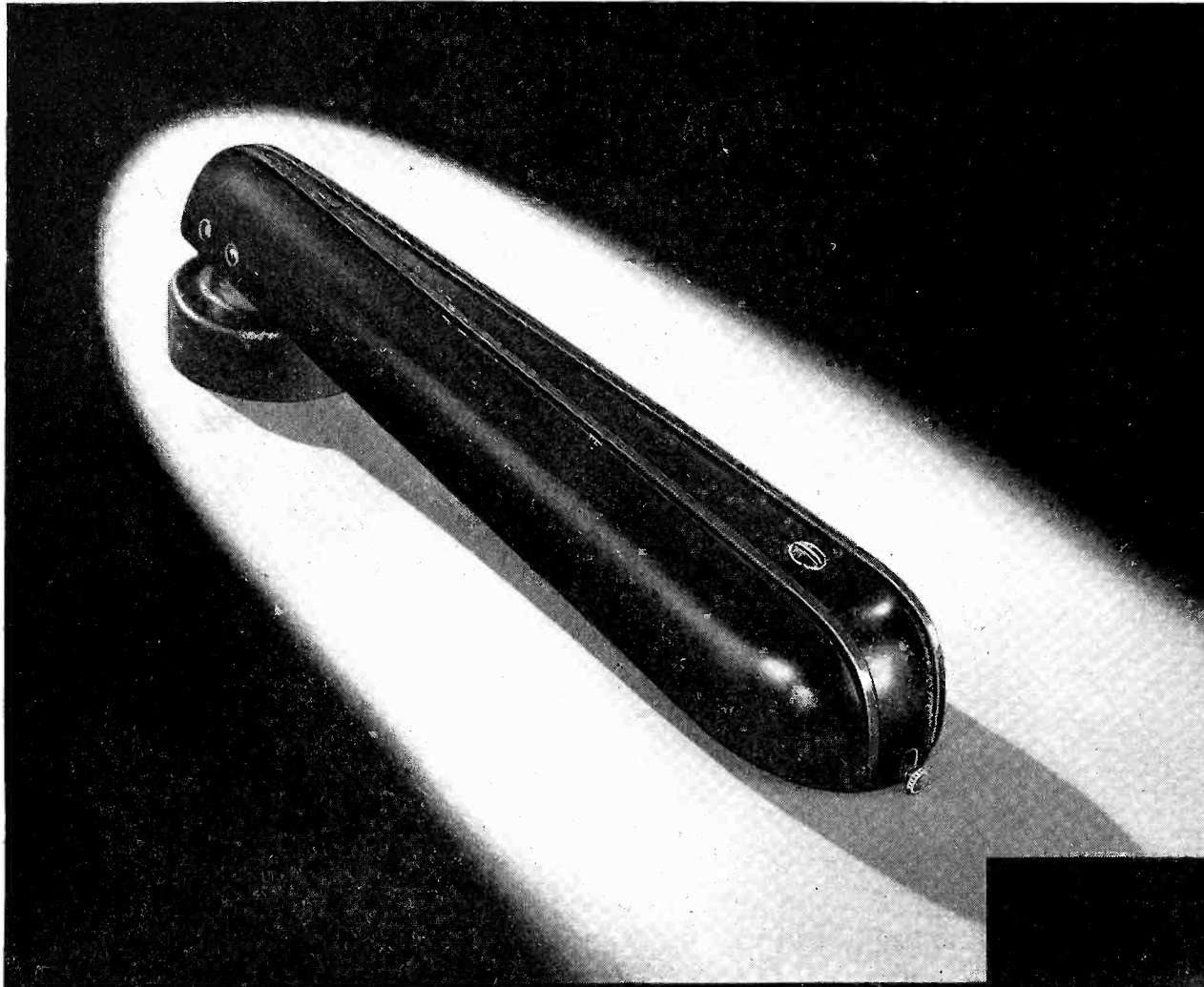

a New

WEBSTER ELECTRIC
Pick-up

**Modern in Appearance • Modern in Performance
Compact • • • Light • • • Low in Price**

Here—in this new model—Webster Electric introduces a new Pick-Up with all the modernity of beautiful, streamline design, plus the mechanical design and performance features which have made Webster Electric Pick-Ups outstanding in tone quality . . . This new Pick-Up is of the magnetic type. Its wide range of features are listed below. In addition to its typical Webster Electric high quality characteristics, it is low in price.



- | | |
|--|--|
| <ul style="list-style-type: none"> ① Critically damped armature, which completely eliminates resonance peaks and transient response ② Bearing and arm design coordinated so as to maintain compensated bass response and smooth tracking ③ Inherently light construction which eliminates need for counterbalancing and detrimental inertia effect ④ Vibration-free bearings | <ul style="list-style-type: none"> ⑤ Both vertical and lateral stops ⑥ 80 degree pivoting of vertical bearing makes needle changing easy ⑦ Mechanical designs and materials are time-proved ⑧ Modern in appearance |
|--|--|

WEBSTER ELECTRIC COMPANY

RACINE, WISCONSIN, U. S. A. • ESTABLISHED 1909 • EXPORT: 100 VARICK ST., NEW YORK CITY

RADIO PRODUCTS

by
Sylvania

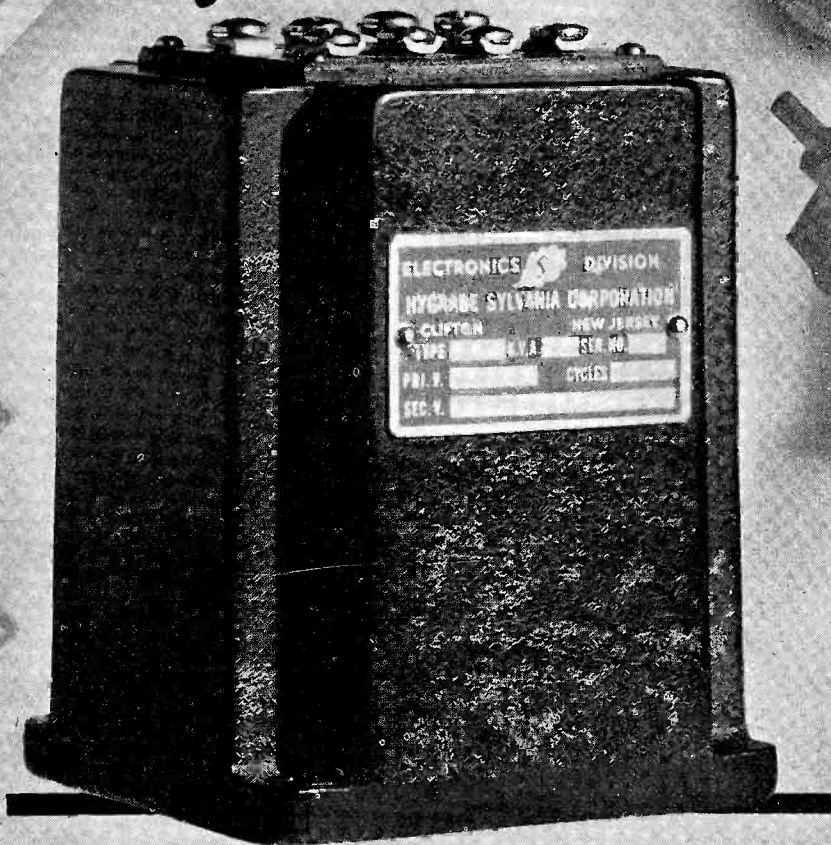

YOUR GUARANTEE of HIGH STANDARDS

Time-tested in airway, army, navy and communication services throughout the world, Sylvania Radio Products have proven their efficient performance and dependability under severe operating conditions. If you require *Transformers, Inductors, Chokes, Switches, Sockets, Precision Drive, Couplings, Equipment Racks, Cabinets and Accessories, Aviation Radio Parts, Custom-built Parts and Apparatus*, our recently enlarged engineering and manufacturing facilities assure prompt deliveries.

Address all correspondence to
ELECTRONICS DIVISION

Hygrade Sylvania

C O R P O R A T I O N

CLIFTON - - - - - NEW JERSEY

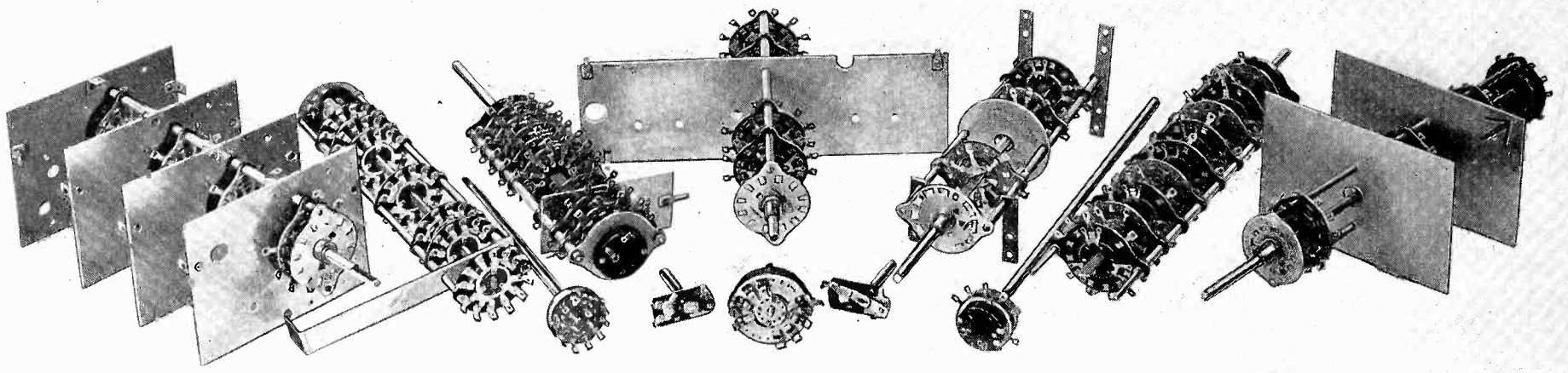

**Whatever Your
Switch Problem
YAXLEY
has the answer**



EACH Yaxley switch pictured at the top or bottom of this page answered a switching problem encountered by some radio engineer this season. They are all taken from standard production and serve to illustrate the flexibility of the Yaxley-Mallory line of wave change tone and tap switches.

Without a complete knowledge of the many possible combinations in the Yaxley-Mallory line, you may not be in a position to specify the most satisfactory or economical switch for your particular circuit.

Let Yaxley-Mallory engineers act as your consultants on switching problems. Your schematic circuit diagram and a sketch of space requirements

will enable us to furnish you promptly with samples and quotations.

Our inventory of materials and unlimited number of parts available from standard tools will result in economies if your problem is brought to the Yaxley Division of Mallory during the design of your chassis.

Specification sheets and descriptive literature to simplify your switch layout are available on request.



P. R. MALLORY & CO., Inc.
INDIANAPOLIS, INDIANA

Cable Address—PELMALLO

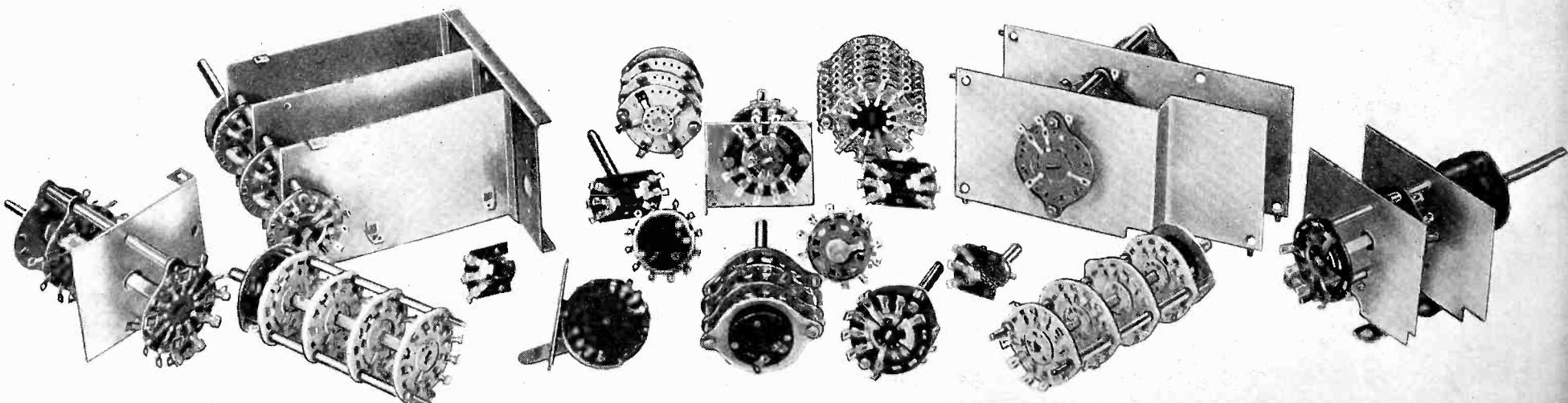

ELECTRONICS

MAY
1937

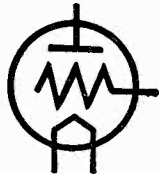

KEITH HENNEY
Editor

Crosstalk

► **25 YEARS . . .** The Editors, members of the Institute of Radio Engineers, take pleasure in presenting in this issue a short history of the I.R.E. The pages available for this first history are not enough to tell the whole story, for the life time of the Institute is also the life time of wireless and of radio. The men now at the helm of radio were once at the keys of wireless—and these men are not yet middle aged. For example, we have a copy of *The Wireless Age* Volume 1 Number 1 and in it is a story by one David Sarnoff called, "A Trip to the Ice Fields" with a photo of the author then a lad bearing in one corner of his mouth a very jaunty stogie. That was not long ago.

In preparing this history we have been aided materially by Arthur Van Dyck, J. V. L. Hogan, Harold Westman, Dr. Goldsmith, R. H. Marriott and especially by genial George Clark whose photo and memory files are very complete.

► **COVER CLUB . . .** *Technology Review* (M.I.T.) is one of the handsomest of collegiate alumni publications. Makers of its cover photos are inducted into a Cover Club with certain rites, including credit by name. Now *Electronics* also uses photos on its covers, and some of them are contributed by its readers. From now on we, too, shall have a cover club, and a frontispiece club to boot, and anyone having a swell shot is welcome to enter it. We give credit and pay ten dollars.

► **SPY GLASSES . . .** Speaking of photographs, we learn that 40 members of the General Radio staff have formed a camera club. This is bad. Photography is one of the worst of modern diseases. It keeps you up nights, and like cigarettes it burns holes in the carpets and linoleum and trousers, stains fingers, pollutes the air (with

hypo dust) and is a fire hazard. The ranks of camera widows grow daily. If, however, these GR boys can contribute a bit of engineering to the art of making pictures, the club will be worth while. The science of photography is beautifully worked out; the engineering is still in a sad state. For example a color photo for a magazine cover or ad will set you back about \$500 because the artist says he must often make 25 shots to get one good one.

The GR boys are also building a telescope. Another fine instrument maker, C. J. Franks of Ferris Instrument Company is a fiend on telescopes. He writes recently, that he has discovered "a great buy, a complete scope with a 60 mm. objective, inverting prisms, two oculars". Let GR and Franks set up their respective telescopes, and through them thumb their respective competitive noses in long distance safety.

► **RACKET . . .** Again speaking of photos—if you are approached in person or by telephone by a photographer purporting to be hired by McGraw-Hill to make a file photo, pay no attention. McGraw-Hill has no such arrangements, and it is only a gag to get you to buy prints.

► **SERVICE . . .** Readers who wish files of Reference Sheets, one of which appears in each issue of *Electronics*, but who deplore the necessity of tearing apart their monthly copies of the magazine, may subscribe on an annual basis to receive a complete yearly file by writing the Circulation Department. The cost is \$1 per year post free cash with order (otherwise the subscriber pays his own transportation charges.) No promises are made but Circulation hints that if a sufficient number of subscribers wish the service to lower the cost, an additional dividend of some sort may be available. Hint, send your dollar now.

► **HUNCH . . .** Under this title we suggested, a month or so ago, that degenerative feedback was used in the earlier days but in a not too scientific manner. Mr. L. C. F. Horle points out a patent issued to him on July 4, 1933, No. 1,917,204 on the use of feedback, and still further back, No. 1,582,470, April 1926. In true patent fashion it is difficult to understand the claims, but the diagrams look like pretty scientific stuff, even today. Thousands of receivers used them.

► **GOSSIP . . .** Columbia Broadcasting System orders a television transmitter from RCA at a reported price of \$330,000. This is good news. Rumor has it that CBS is a recent licensee of Farnsworth, that much Farnsworth equipment is already in New York, that the Chrysler building will be the scene of CBS transmissions, that within a year things are due to hum.

Readers of *Electronics* may be interested to know that in June will appear the first of a series of articles on television, a series which ought to get everyone acquainted with the art, its new technic, its new language. If anyone thinks an AVC, AFC, ASC radio receiver is complex, he will get a rude shock when he gets into a television chassis.

► **DISCORDS . . .** Hon. Harold L. Ickes, Secretary of the Interior, speaking at the First National Conference on Educational Broadcasting, Washington, not long ago said: "Often with a feeling of despair, not unmixed with disgust, do I snap off my radio, which I had turned on in the hope that I could pick from somewhere in the air something besides blaring discords, rough and tumble dialogue and ecstatic panegyrics of some commercial product. This same privilege of 'tuning out' is shared by all."

THE TRANSATLANTIC TIMES.

VOLUME I.

NUMBER I.

THE TRANSATLANTIC TIMES

Published on board the "ST PAUL," at Sea, en route for England, November 15th, 1899.

One Dollar per Copy in aid of the Seamen's Fund.

Mr. W W Bradfield, Editor in-Chief. Mr T Bowden, Assistant Editor. Miss J B Holman, Treasurer. Mr H H McClure, Managing Editor.

Through the courtesy of Mr G Marconi, the passengers on board the "St Paul," are accorded a rare privilege, that of receiving news several hours before landing. Mr Marconi and his assistants have arranged for work the apparatus used in reporting the Yacht Race in New York, and are now receiving dispatches from their station at the Needles. War news from South Africa and home messages from London and Paris are being received

The most important dispatches are published on the opposite page. As all know, this is the first time that such a venture as this has been undertaken. A Newspaper published at Sea with Wireless Telegraph messages received and printed on a ship going twenty knots an hour!

This is the 52nd voyage eastward of the "St Paul." There are 375 passengers on board, counting the distinguished and extinguished.

The days' runs have been as follows :-

Nov. 9th	435
" 10th	436
" 11th	425
" 12th	424
" 13th	431
" 14th	414
" 15th	412

97 miles to Needles at 12 o'clock, Nov. 15th.

BULLETINS

1.50 p.m. First Signal received, 66 miles from Needles

2-40 " Was that you "St. Paul"? 50 miles from Needles.

2-50 Hurrah! Welcome Home! Where are you?

3-30 40 miles, Ladysmith, Kimberley and Mafeking, holding out well. No big battle. 15,000 men recently landed.

3-40 " At Ladysmith no more killed. Bombardment at Kimberley effected the destruction of ONE TIN POT. It was auctioned for £200 It is felt that period of anxiety and strain is over, and that our turn has come."

4.00 Sorry to say the U. S. A. Cruiser "Charleston" is lost. All hands saved

The thanks of the Editors are given to Captain Jamison, who grants us the privilege of this issue

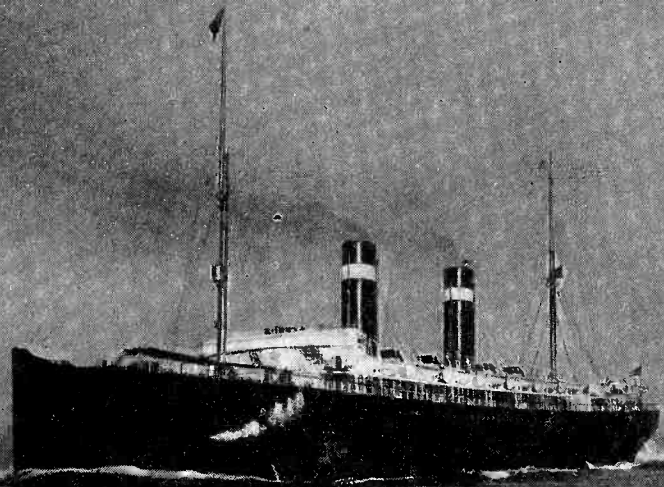

"S.S. ST. PAUL" AND FIRST RADIO NEWSPAPER PUBLISHED AT SEA

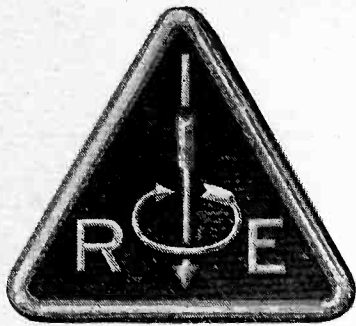

Silver Anniversary

The Institute of Radio Engineers

An easy going, generally self-satisfied World—not yet troubled by war clouds—was given a severe jolt on April 14, 1912 when the *S. S. Titanic* struck an iceberg on her maiden voyage across the Atlantic and sank with the loss of more than 1500 lives. True it is that Jack Phillips, wireless operator on the *Titanic*, had been able to send out the distress signal of that date—CQD—thereby summoning nearby vessels to aid, with the saving of more than 700 lives. But comparatively few vessels were equipped with transmitting and receiving apparatus, and what apparatus was available was not yet very effective nor highly developed. The need for reliable equipment, and a more thorough mastery of the physical principles underlying radio communication was plainly evident. Yet at the very time of the fateful *Titanic* disaster, efforts were already under way for the organization of an engineering society whose principal aim and purpose was the advancement of the science and art of radio communication—a society which within a month was to be known as the INSTITUTE OF RADIO ENGINEERS.

The small group of charter members of the I. R. E. had already had some years of experience in the management of technical and engineering societies devoted to wireless, for the Institute was formed by the combination of two societies devoted to progress in the radio field, the Society of Wireless Telegraph Engineers, formed in Boston during 1907, and the Wireless Institute, established in

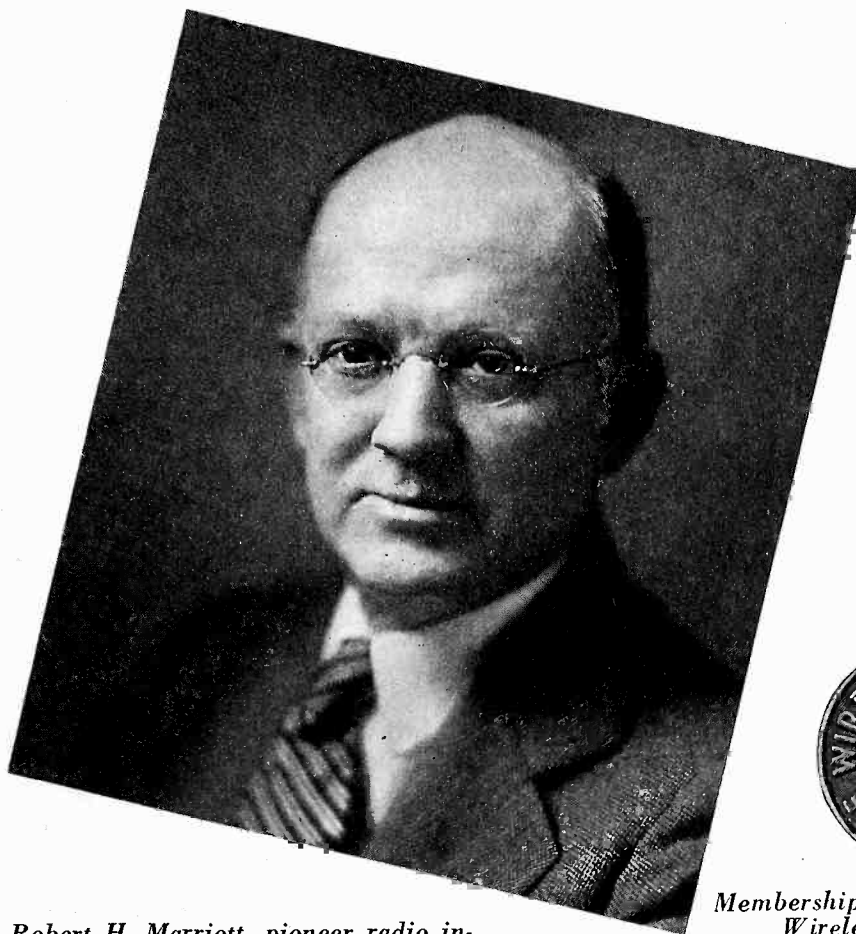

Robert H. Marriott, pioneer radio inspector, organizer of the Wireless Institute, and first president of the Institute of Radio Engineers

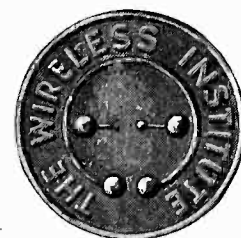

Membership badge of the Wireless Institute

New York two years later. This experience was extremely beneficial in launching the new enterprise, for the engineers were beset with difficulties from the start. They were without funds upon which they might depend in emergency. Their efforts were not taken too seriously by other engineering societies of the time. Worst of all, the attitude of the "radio industry" in 1912 was such that intellectual intercourse among professional men for engineering advancement was more likely to be discouraged than encouraged. But perhaps this state of affairs is not so startling when we realize the impetus given to research during the World War, and especially when we consider the development of the radio science up to the time of the establishment of the I. R. E.

By 1900 wireless communication was already recognized as an important adjunct to maritime communication. The Italian navy had adopted the Marconi system in 1897, and two years later communication tests were made on a large scale by the British Admiralty, which resulted in the installation of transmitting and receiving equipment on thirty-two warships and shore stations. During the same year tests were conducted on wireless communication by the United States Navy, and by the turn of the century, installations of radio stations by Belgian and German shipping companies were taking place.

Radio stations were installed at an early date on light ships, and wireless was used for life saving purposes as well as a means of trans-

mitting news. The international yacht races in 1899 were reported by wireless for the New York *Herald*, and newspapers (for which the news was obtained by radio) began to be published aboard ship. The first known of these ship-published newspapers was "The Transatlantic Times" printed aboard the *S. S. St. Paul* during the fall of 1899. Nor were the commercial aspects of the new communication medium overlooked, for the first paid radiogram was transmitted on June 3, 1898.

During 1902 the Marconi Wireless Telegraph Co. built its high power station at Glace Bay, Nova Scotia, and the Marconi Wireless Telegraph Company of America was organized. What is said to be the first complete transatlantic radio message was published in the London *Times* on March 30, 1903. Eight months later, on November 5, officers of the United States Signal Corps had established radio communication between Safety Harbor and St. Michaels, Alaska, a distance of 107 miles.

Soon came the application of the Edison effect to wireless rectifiers by Fleming, and, by 1906, the invention of the "audion" by DeForest. Arc transmitters, with microphones in the antenna circuit, were being used in early attempts at broadcasting—at least they were used until the individual granules in the microphones staged a sit down strike and

Year	Recipient	Field of Endeavor
1917	E. H. Armstrong	Pioneer work in development of regeneration
1919	E. F. W. Alexanderson	High frequency alternator, long wave systems
1920	Guglielmo Marconi	Pioneer development of practical radio systems
1921	R. A. Fessenden	CW telephony and heterodyne reception
1922	Lee DeForest	Invention of the three element vacuum tube
1923	John S. Stone	Pioneer engineering in the radio field
1924	M. I. Pupin	Theoretical investigations of value to radio
1926	G. W. Pickard	Crystal detector researches and studies of wave propagation
1927	L. W. Austin	Studies of long wave radio propagation
1928	Jonathon Zenneck	Researches on radio circuit performance
1929	G. W. Pierce	Applications of quartz crystals to oscillators
1930	P. O. Pedersen	Pioneer development on arc telegraphy
1931	G. A. Ferrie	Organization of radio communication systems in France
1932	A. E. Kennelly	Studies of wave propagation and a-c theory contributions
1933	J. A. Fleming	Introducing engineering principles into the radio art
1934	S. C. Hooper	Systematic organization of Navy communication
1935	Balth van der Pol	Studies of circuit theory and wave propagation
1936	G. A. Campbell	Contributions to the theory of electrical networks
1937	Melville Eastham	Pioneer work in field of radio measurements

made things hot for the management. By 1908, Fessenden reported successful radiophone communication between Brant Rock, Mass. and Washington, D. C., this distance of 600 miles being covered by using a 70 kc. alternator having an output of 2.5 kw.

A number of important and spectacular events took place during 1909. The most dramatic was the use to which wireless communication

was put when the *S. S. Republic* collided with the *S. S. Florida* off the American coast on January 23, 1909. By sending out distress signals, John R. Binns (who has deserted a berth at sea for the vice-presidency of the Hazeltine Corp.) was able to summon aid in time for all lives to be saved before the *Republic* sank. The effect of this rescue work on public imagination and emotion was tremendous. Here was a new and useful communication system; something which kept ships in touch with one another as well as with their home ports when at sea.

By 1912 the United States required by law that certain classes of ships leaving U. S. ports be equipped with radio transmitting and receiving apparatus, and a system of radio inspection service was established by the government. In 1913 the Lieben-Reisz soft tube had appeared and in 1913-14 Langmuir conclusively proved that the presence of gas in a tube was not only unnecessary, but undesirable in most cases. By 1914 the European nations had agreed to disagree, and early in 1915 the theory of regeneration had already been published.

This protean outline of events will serve to indicate the conditions existing at the time the Institute, as well as its parent societies, was



Sweet's Restaurant. The second floor of this palatial mansion at 2 Fulton St., New York, saw the birth of the Institute of Radio Engineers, and still lives (without much change, we understand) to talk about it

formed. The decade prior to the entrance of the United States into the World War seems to have been unusually propitious for the formation of radio societies. The American Radio Relay League and the Radio Club of America, both of which are still going strong, were formed during this period in addition to the I. R. E., the Society of Wireless Telegraph Engineers, and the Wireless Institute.

The Society of Wireless Telegraph Engineers

The Society of Wireless Telegraph Engineers had its origin in Boston and Cambridge among a small group of men who constituted the technical staff of the Stone Telegraph and Telephone Co. Reporting on the formation of the S. W. T. E. when he received the Institute's Medal of Honor, John Stone Stone said: "In 1907 it occurred to me that it would be a distinct advantage to each of us if we crystallized our ideas about our work into scientific papers and that it would be of great value to all of us to hear and discuss such papers. I therefore organized the Society of Wireless Telegraph Engineers within the staff of the Stone Telegraph and Telephone Company. We held regular meetings, usually at my house on Bay State Road, Boston. Many excellent papers were read and discussed, and after adjournment of the formal meetings, we had a light supper. The value of this Society to its members became so apparent that in 1908 it was decided to incorporate the Society and to extend the privilege of membership to radio engineers generally."

The life of the S. W. T. E. was about five years during which its membership rose steadily from 11 to 43.

The Wireless Institute

Following upon the heels, in point of time, but entirely independent of the Boston society, there was initiated a movement to form a radio engineering society among the employees of the United Wireless Telegraph Company in New York City. After discussing with prospective members their views on the subject, Robert H. Marriott, a U. W. T. Co. engineer, called a meeting at 42 Broadway, New York, on January 23,

1909 for the purpose of organizing the Wireless Institute.

The membership of the Wireless Institute included radio engineers and executives of that time but about half of the membership was composed of wireless telegraph operators and installation engineers. Important scientific and engineering papers were read, including one on "Radio Telephony" by Alfred N. Goldsmith, at that time an instructor in physics at the College of the City of New York.

For more than three years, the Wireless Institute held meetings either at the offices of the United Wireless Co. or later, at Columbia University. Starting with 14 in 1909, the Wireless Institute membership increased to 99 by 1911, but dropped to 27 the following year.

During 1911 two events which were to influence the activities of the S. W. T. E. and the W. I. occurred. The Fessenden company, whose members formed a substantial group of later S. W. T. E. members, moved their headquarters and laboratory from Brant Rock, Mass., to Brooklyn, N. Y. This split the membership of the Boston society, and increased the radio engineering activities in the New York area. But the influx of "Swatties" to the New York area was beneficial for the industry, for the officers of the United Wireless Telegraph Co. were about to be, or perhaps already had been, convicted of selling stock under false pretenses, and receiverships were ap-



"I therefore organized the Society of Wireless Telegraph Engineers within the staff of the Stone Telegraph and Telephone Company" — John Stone Stone



The Society of Wireless Telegraph Engineers used this form of spark oscillator to recognize brothers under the skin

PRESIDENTS OF THE I.R.E. AND ITS PARENT SOCIETIES

Society of Wireless Telegraph Engineers

- 1907 John Stone Stone
- 1908 John Stone Stone
- 1909 Lee DeForest
- 1910 Lee DeForest
- 1911 Fritz Lowenstein
- 1912 Fritz Lowenstein

The Wireless Institute

- 1909 Robert H. Marriott
- 1910 Robert H. Marriott
- 1911 Robert H. Marriott
- 1912 Robert H. Marriott

The Institute of Radio Engineers

- 1912 Robert H. Marriott
- 1913 Greenleaf W. Pickard
- 1914 Louis W. Austin
- 1915 John Stone Stone
- 1916 Arthur E. Kennelly
- 1917 Michael I. Pupin
- 1918 George W. Pierce
- 1919 George W. Pierce
- 1920 John V. L. Hogan
- 1921 E. F. W. Alexanderson
- 1922 Fulton Cutting
- 1923 Irving Langmuir
- 1924 John H. Morecroft

- 1925 John H. Dellinger
- 1926 Donald McNicol
- 1927 Ralph Bown
- 1928 Alfred N. Goldsmith
- 1929 A. Hoyt Taylor
- 1930 Lee DeForest
- 1931 Ray H. Manson
- 1932 Walter G. Cady
- 1933 Lewis M. Hull
- 1934 C. M. Jansky
- 1935 Stuart Ballantine
- 1936 L. A. Hazeltine
- 1937 H. H. Beverage

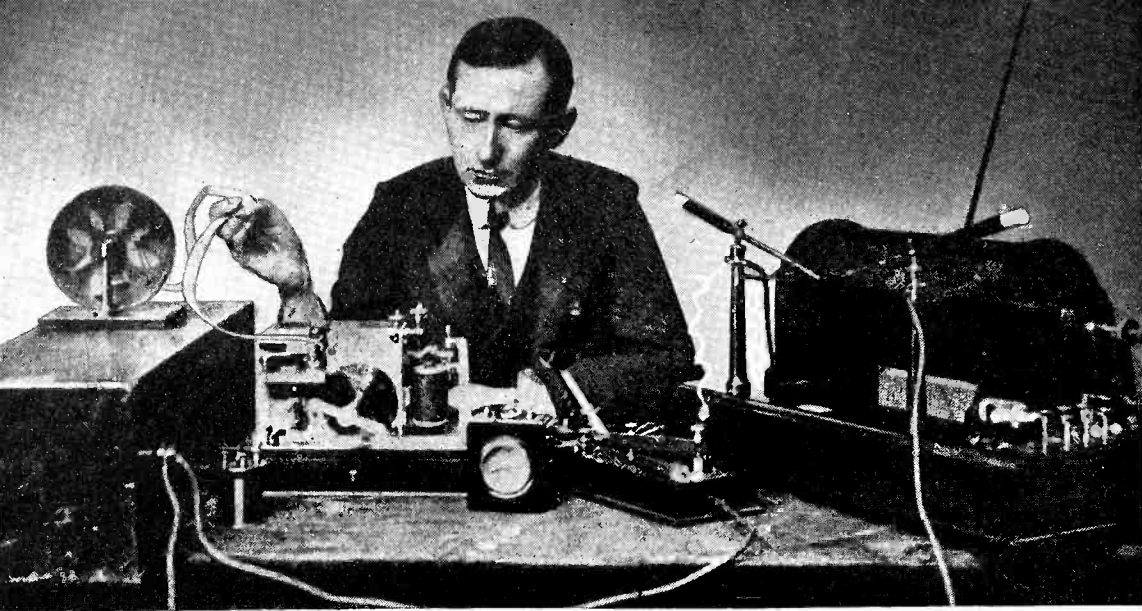

Marconi operating an early type of wireless outfit in 1901. This picture was taken in one of Marconi's stations (probably Boulogne) when the English channel was spanned by wireless

pointed for the company in four states. The effect of these legal proceedings on the newly formed Wireless Institute could not help but be disheartening.

Organization of the Institute of Radio Engineers

With the S. W. T. E. membership divided and the W. I. membership in a critical condition, it was decided early in 1912 that it would be advantageous if both organizations would combine to form a new society. A joint committee appointed to study this proposal met on March 9, 1912, acted favorably, and submitted their recommendations to the Boston and New York organizations for approval. Thus, at the time of the *Titanic* disaster, efforts at the consolidation of the two societies had progressed to such a point that the days of the original Stone and United Wireless clubs were numbered.

A joint meeting of the two societies—the last meeting at which they retained their separate identities—was held on May 6 and the articles of the constitution of the I. R. E. were discussed. The first meeting of the Institute of Radio Engineers was held on May 13, 1912 in Room 304, Fayerweather Hall, Columbia University. This business meeting was called for the election of officers to serve for the remainder of the year. Robert H. Marriott, president of the Wireless Institute since its inception, continued as first I. R. E. president. Fritz Lowenstein was elected vice-president, Emil J. Simon, secretary, and E. D. Forbes, treasurer. The Board of Direction included G. W. Pickard, Frank Fay, John L. Hogan, Jr., and Lloyd Espen-

schied in addition to the elected officers. The charter membership of the new Institute was composed of those who had been W. I. or S. W. T. E. members during 1912 and numbered less than fifty. Having been a member of both parent organizations, G. W. Pickard won the distinction of being the Institute's only double jointed charter member, and he is still active in Institute affairs.

With the formation of the Institute of Radio Engineers, a new emblem was adopted. The choice of the name, Institute of Radio Engineers, for the new society produced a fortuitous condition whereby its initials were associated with the symbols of a fundamental law of electricity. The emblem which was finally adopted aimed to express another fundamental electrical law, e.g., the relation between the electric and magnetic fields. The new emblem was therefore associated with unchanging fundamentals, rather than with apparatus which might become obsolete.

The I. R. E. had been organized less than a year when a meeting for incorporation was held on June 23, 1913. Sweet's Restaurant at 2 Fulton St., a stone's throw from the East River, was selected as the meeting place. There was plenty of atmosphere at this meeting. The lawyers, including Harold Zeamans, a member of the Institute, went through a few "whereases", and the papers of incorporation were issued on August 23. These state, in part, "that the particular purposes for which said corporation is formed are as follows: To advance the art and science of radio transmission, to publish works of literature, science, and art for such purpose, to do all and

every act necessary, suitable, and proper for the accomplishment of any of the purposes or the attainment of any of the objects or for the furtherance of any of the powers herein set forth, either alone or in association with other corporations, firms, or individuals, and to do every act or acts, thing or things, incidental or appurtenant to or growing out of or connected with the aforesaid science or art, or power or any parts thereof, provided the same be not inconsistent with the laws under which this corporation is organized, or prohibited by the State of New York." The Institute now had legal entity; it could be sued!

From the first the Institute held monthly meetings. Sometimes these would be held at Columbia University, at other times the College of the City of New York would be host to the communication engineers. The use of slides at the meetings was a much less frequent occurrence than now. Usually the speaker drew figures with crayon on large sheets of paper if it was necessary to illustrate his subject.

The Proceedings

Originally the *Proceedings* was published quarterly and had a brown cover. During 1913 the cover was changed to the oatmeal gray with semi-oiled finish which has been retained to this day. Beginning in 1916 the *Proceedings* appeared bi-monthly, and 1927 saw the initiation of monthly copies. The number of pages of the *Proceedings* remained between 250 and 650 per year up until 1923, when, largely due to the impetus given by the broadcasting era, the amount of published material increased tremendously.

Dr. Goldsmith was elected editor of the *Proceedings*, a position which he has held (with the exception of the year of his presidency) ever since. Of course, there was always an editorial office whenever Dr. Goldsmith, a blue pencil, and a submitted manuscript got together but otherwise editorial facilities were meager. Plenty of proof-reading and typographical and related editorial matters had to be taken care of, and it must have been a pretty strenuous one man show. The fact that the *Proceedings* is the recognized publication in the radio engineering field is in no small measure due to



G. W. Pickard wanted to be sure he would be an I.R.E. member so he signed up with both parent societies, became the Institute's second president, was awarded the Medal of Honor in 1926, and is still active in I.R.E. affairs

the interest and ability which Dr. Goldsmith has exhibited.

In November 1928 it became evident that it would be necessary to establish a board of editors to assist in the greatly increased technical editorial duties required in the publication of the *Proceedings*. The original board consisted of A. N. Goldsmith, chairman, Stuart Ballantine, Ralph R. Batcher, W. G. Cady, Carl Dreher, and G. W. Pickard. All extensive editing of the manuscripts published in the *Proceedings* is carried out by the editorial board. The Papers Committee aids the Board of Editors by reading the paper primarily for technical accuracy—the members of the Papers Committee are, as a group, more specialized than the members of the Board of Editors—and recommending that the paper be published or rejected.

Recognizing the need for standardization in the radio field, a Committee on Standards was appointed coincidentally with the formation of the Institute. This committee issued its first report, dealing with definitions, graphical symbols and tests and ratings, during 1913, the report being published with Vol. I,

CHARTER MEMBERS OF THE INSTITUTE OF RADIO ENGINEERS

and Their Affiliation with Parent Societies

Society of Wireless Telegraph Engineers

J. C. Armor	F. H. Knowlton
Sewall Cabot*	W. S. Kroeger*
W. E. Chadbourne	Fritz Lowenstein
E. R. Cram	Walter W. Massie
G. S. Davis	E. B. Moore
Lee DeForest*	G. W. Pickard*
E. D. Forbes	Samuel Reber
V. F. Greaves*	Oscar C. Roos
J. L. Hogan, Jr.*	J. S. Stone*
W. S. Hogg*	E. W. Sundberg
Guy Hill	A. F. Van Dyck*

The Wireless Institute

William F. Bissing	Frank Hinners*
P. B. Collison	James M. Hoffman
James Dages	Robert H. Marriott*
Lloyd Espenschied*	A. F. Parkhurst
Philip Farnsworth	G. W. Pickard*
Frank Fay	H. S. Price*
Edward Gage	A. Rau
Alfred N. Goldsmith*	Emil J. Simon*
Francis Hart*	C. H. Sphar
Robert L. Hatfield	Floyd Vanderpoel*
Arthur A. Hebert*	R. A. Weagent

* Member of the Institute at the present time

Part 4 of the *Proceedings*. Subsequent reports were issued in 1915, 1922, 1926, 1929, 1931 and 1933. The first really extensive report of the Committee on Standardization appeared in the 1929 Year Book and contained more than 100 pages of text. Much of this had to do with the standardization of tests on radio receivers as well as on vacuum tube measurements and technique. In this same report the term "transducer" was introduced and defined in such a manner, we are glad to note, as to be completely devoid of immoral implication.

The entry of the United States into the World War proved another difficult period for the Institute. Many, if not most, of the members were engaged in some type of communication work directly or indirectly connected with wartime activities. Many members were in one of the branches of service, and the membership which had been about 1300 during 1917 fell to something like 800 the following year. Cambridge, like most other cities, was a beehive of activity. The engineering school of Harvard had consolidated with the Massachusetts Institute of

Radio room on the S. S. St. Paul, where messages were received for publication in the first ship newspaper, "The Transatlantic Times", 1899

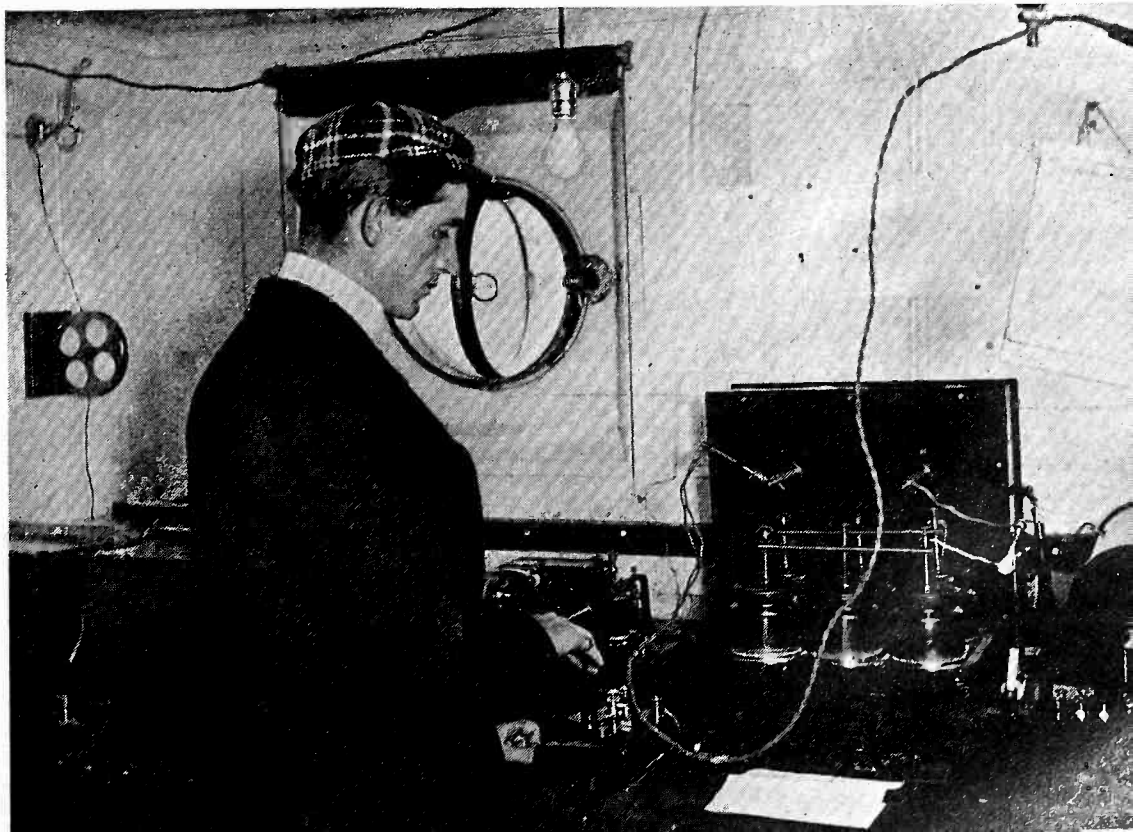

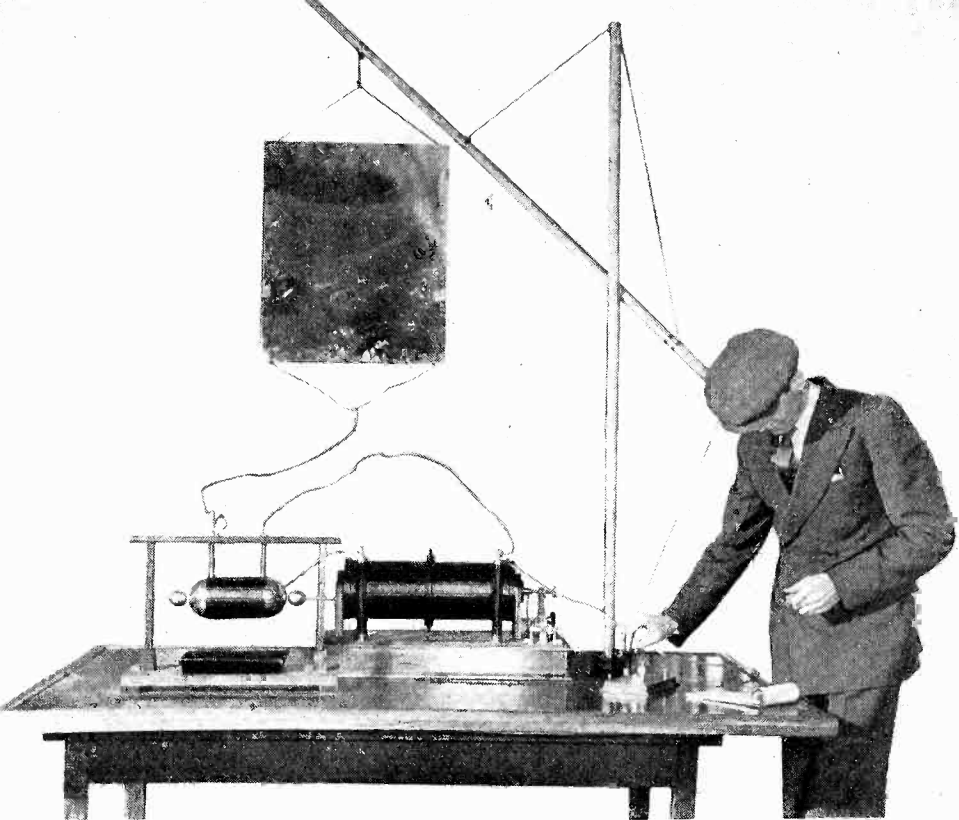

Replica of receiver (built by George Clark, radio old timer) used by Marconi to receive first signals across the Atlantic in 1901. The original equipment, from which the above was copied, was destroyed by fire

At first, broadcasting, like Topsy, "jest grew". But everyone wanted to operate on 360 meters, and so it wasn't long before all programs piped out into the still night air were as meaningless (although for another reason) as some of the programs of today. Something had to be done, so the Senators, who didn't know an Alexanderson alternator from a VT-1, began to talk kilocycles and legislation, and a temporary scheme of radio regulation was effected.

Technology—an affiliation which was later dissolved—and both schools worked overtime to produce properly trained men. G. W. Pierce had been elected president of the Institute for 1918, but served for two years, since it was impossible to get together enough members to hold an election.

After the War, of course, things resumed a somewhat more normal course. The membership rose steadily, overcoming the drop induced by the War activities. All things pointed to a reconstruction period of comparative peace and reasonable quiet.

But things were not to remain quiet for long. Out in Pittsburgh there was an engineer interested in clocks and other time keeping devices—a harmless enough hobby. He got interested in time signals from NAA, radio receivers, then radio transmitters, and before the country had quite got over its habit of saving peach pits to deposit in the red, white, and blue barrels down town, Frank Conrad had started up a radiophone station, 8XK, and was pumping out music and news to a handful of amateurs. KDKA followed in no time; the lid was off!

I. R. E. Broadcast Activities

That didn't last long. On several occasions during 1927 the Board of Direction of the Institute was consulted and asked to assist the Federal Radio Commission and the general public in the multiplicity of technical problems confronting the whole art. Up to this time the Federal Radio Commission had no engineering staff, and it naturally looked to the Institute for assistance in technical matters. This led to the formation of the I. R. E. Committee on Broadcasting, which worked in cooperation with the F. R. C. until the Commission obtained its own engineering staff. During April 1928 an invitation from the Federal Radio Commission, to send representatives to an informal conference to consider technical problems arising in connection with the allocation of broadcasting channels to zones and states, was received by the Institute. A special meeting of the Board of Direction was called to formulate suggestions and to appoint a committee to attend the conference. The allocation plan put into effect by the Commission on November 11, 1928 was closely related in its main engineering aspects to that recommended by the Board of Direction.

No outline of Institute history would be complete without making some mention of its various official "homes". We have already noted that some of the early meetings were held at Sweet's Restaurant, in the fish market area on Fulton St. Sometimes they were held at Whyte's Restaurant, also on Fulton St.

RECIPIENTS OF THE MORRIS LIEBMANN MEMORIAL PRIZE

Year	Recipient	Contributions
1919	L. F. Fuller	Development of the arc and early field strength measurements
1920	Roy A. Weagent	Pioneer work on static reducing systems
1921	R. A. Heising	Development of constant current system of modulation
1922	C. S. Franklin	Pioneer work in development of use of short waves
1923	H. H. Beverage	Invention of directive antenna system
1924	J. R. Carson	Theoretical work on vacuum tubes and electrical networks
1925	Frank Conrad	Pioneering work in short wave broadcasting
1926	Ralph Bown	Investigations of transmission phenomena
1927	A. Hoyt Taylor	Researches in short wave propagation
1928	W. G. Cady	Investigations of piezoelectric phenomena
1929	E. V. Appleton	Investigations in field of wave propagation phenomena
1930	A. W. Hull	Researches in fundamental electronic devices
1931	Stuart Ballantine	Investigations in numerous radio and acoustic devices
1932	Edmund Bruce	Investigations in domain of directional antennas
1933	H. Barkhausen	Researches on oscillation circuits
1934	V. K. Zworykin	Contributions of development of television
1935	F. B. Llewellyn	Mathematical theory of vacuum tubes at high frequencies
1936	B. J. Thompson	Contributions to vacuum tube art at very high frequencies
1937	W. H. Doherty	Improvement in efficiency of r-f power amplifiers

A 100 kw. arc transmitter installed at Tuckerton in 1915 and operated by the Navy. This installation contained a number of improvements in arc transmitters, of which the engineers of the time might be (and were) mighty, mighty proud

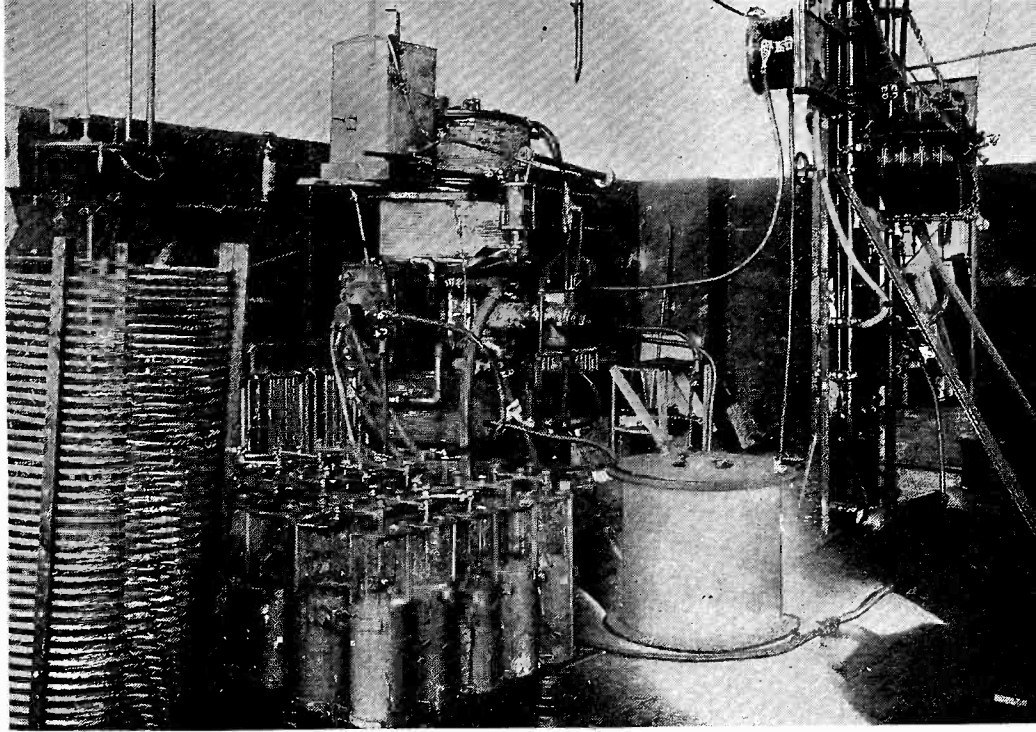

Monthly meetings at which papers were delivered were held at Columbia or C. C. N. Y.; the first meeting of the Institute was held at Columbia's Fayerweather Hall. The first "office" was at 71 Broadway, during 1914, where the use of a filing cabinet was generously loaned by John Hays Hammond, Jr., a member of the Institute. During 1915 to 1917 the Institute moved "uptown" to 111 Broadway, in the shadow of Trinity Church. Subsequently, the office was moved to C. C. N. Y. By 1924, the Institute could afford to rent an office and a full time employee, and established itself at 37 W. 39th St., across the alley from the home it began occupying in the Engineering Societies Building, 33 W. 39th St., in 1928. During the period between 1924 and 1928, the Institute's membership began to increase in earnest, and it was necessary to increase the office staff. By 1929 the staff had increased to fifteen persons. The offices were maintained at the Engineering Societies Building, where the monthly meetings were also held, until 1933 when the Institute moved to its present offices on the 26th floor of the McGraw-Hill Building, 330 W. 42nd St.

In recognition of distinguished service in radio communication, the Institute began the awarding of its

Medal of Honor early in its history (1917). In 1919 Emil J. Simon, a Fellow of the Institute and well known as a radio engineer, made a bequest of \$10,000, the income of which is awarded annually to a person who has made notable contributions in radio science. These awards are considered the highest honors which can be won in the field of the radio science, and a list of the recipients includes outstanding men in radio engineering, many of whom have been presidents of the Institute.

The Institute awards have been made for advances which often changed the entire course of radio development, but which in themselves were frequently simple, once the underlying physical principles were thoroughly appreciated. The Medal of Honor, for example, was awarded to Armstrong for putting a coil in the "wing" circuit of a vacuum tube and coupling this back to the grid coil; to Alexanderson for getting

more cycles per unit of time out of a Nipkow disc than any other man; to DeForest for not believing that "three is a crowd" and putting a kinked wire inside of next to nothing.

Likewise, the Morris Liebmann Memorial Prize has been awarded to Heising for being enough of a Scotchman to feed two different types of tubes from the same choke coil; to Beverage for short circuiting a telephone line through a resistance—when the telephone company wasn't looking—and getting directed signals out of the combination; to Cady—a Wesleyan prof., mind you—for discovering (and utilizing) the latent powers of the "shimmy"; to Ballantine who, among other things, made a virtue of necessity by capitalizing upon the fact the tube manufacturers couldn't produce constant μ tubes anyway; and to Thompson, for making little tubes out of big ones.

The Institute has done much more. During the depression it operated an emergency employment bureau; it dug into its surplus and kept things running on as normal a keel as any business. The true story of its relations with its membership during this trying time has never been fully disclosed publicly, but they were of such a nature as to be thoroughly beneficial to its loyal and substantial members. There are too many other facts and incidents which cannot be recalled in this short article.

But we're willing to crook an elbow in celebration of the silver anniversary of the Institute of Radio Engineers; may the next twenty-five years be as fruitful as the past have been.—B. D.

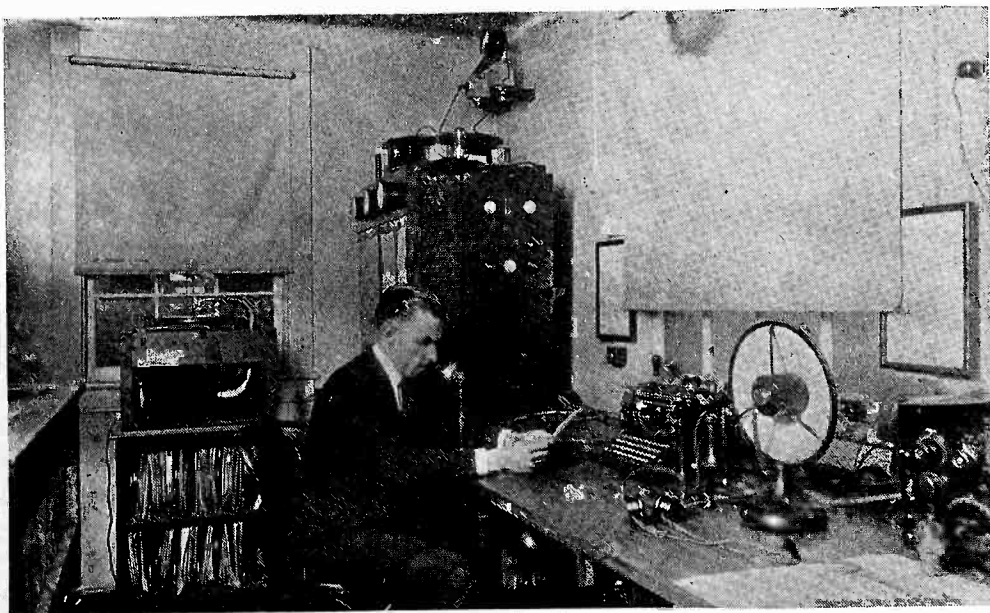

High fidelity a la 1920. The first installation at KDKA

Fig. 1—Side-band content of assumed noise voltage. Fig. 2—Noise voltage superimposed on amplitude modulated signal

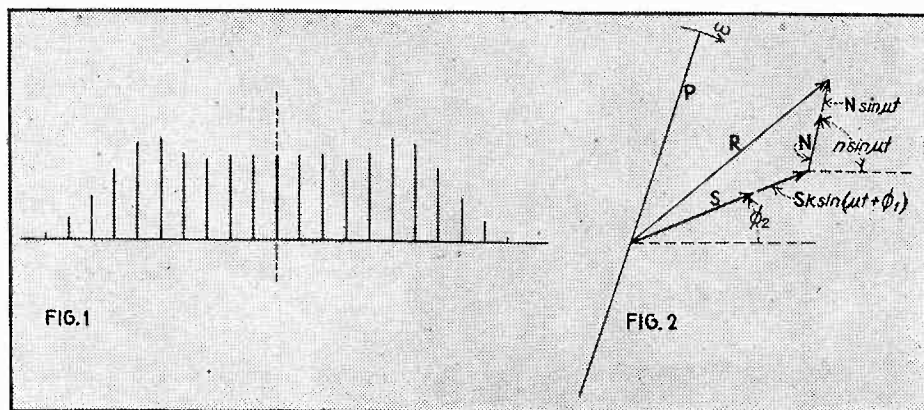

Noise in Frequency Modulation

The first published mathematical demonstration of the validity of the noise-suppression effect in wide-band frequency modulation, by one of the outstanding authorities on modulation theory, which shows the necessity of a wide band and of proper "limiter" action

EDITOR'S NOTE: The mathematical operations in Mr. Roder's paper are not so involved as they appear at first glance; for the most part only trigonometric operations and rotating vector-diagrams are employed. The interested reader is invited, therefore, to "dig in". As a preliminary, however, the following notes may be helpful:

Noise voltages encountered in radio frequency circuits are modulated both in amplitude and in frequency. When added to a conventional amplitude-modulated signal, such double-modulated noise produces disturbances in the *amplitude* of the modulated signal, and these disturbances appear in the output of the detector. To overcome the effect of these disturbances, the amplitude of the desired signal can be increased, relative to the noise, by increasing the power and/or the percentage modulation of the transmitter. The practical limit to this procedure is reached when the power can no longer be economically increased.

When the double-modulated noise is applied to a frequency-modulated signal of constant amplitude, however, the noise produces two effects. First it introduces an amplitude disturbance to the desired signal. By the use of an amplitude-limiter in the i-f circuit of the receiver, these amplitude disturbances are removed and hence do not affect the audio output of the

converter-detector, which is responsive both to frequency and amplitude variations. In the second place the noise, because of its frequency-modulated component, produces *disturbances in the frequency-swing* of the desired signal. These latter disturbances do affect the converter-detector and are present in the audio output. To overcome the effect of these disturbances, the frequency-swing of the desired signal must be increased with respect to the frequency-swing of the noise. The percentage modulation of the signal is thereby increased relative to the noise, and this can be done without increasing the power of the transmitter. Thus, the wider the frequency swing of the desired signal, the higher the signal-to-noise ratio. The degree of improvement depends on the amplitude of the noise relative to that of the signal. When the noise amplitude is not greater than one-half the signal amplitude, however, and when the frequency swing of the desired signal is 100,000 cycles compared with 7000 cycles for the noise, the interference factor is not greater than one percent throughout the audio signal range from 100 to 5000 cycles. The same noise, applied to an amplitude-modulated signal under the same conditions (noise amplitude one-half signal amplitude), would produce an interference factor of the order of 50 percent or higher.

By HANS RODER

General Electric Company, Bridgeport, Conn.

THE proposal to use frequency modulation in place of amplitude modulation was made early in radio development, but the hope of obtaining thereby greatly reduced band-

widths was shattered in 1922 when Carson¹ published his fundamental analysis. Despite his adverse criticism, much experimental research was done in the following years.

In 1936, Major E. H. Armstrong announced² and demonstrated the phenomenon of noise suppression with wide-band frequency modulation. This effect was made possible by the use of the ultra-high frequencies, which permitted the use of a bandwidth about 10 times greater than customary in amplitude modulation. The explanation of the noise-suppression effect has not, to the author's knowledge, been given a simple and satisfactory treatment. In view of the contrast between the predictions of earlier theories and the recent experimental results, it is desirable to extend the theory to the field of ultra-high frequencies and to greatly extended side-band coverage, as has been done in the practical attack on the problem.

This extension of theory is presented in the following paper. While the treatment refers to a simplified case, it will permit us to draw some interesting conclusions in regard to the system. The plan is as follows: We set up a convenient type of noise signal, which is both amplitude and frequency modulated, and we apply this noise signal first to a standard amplitude-modulated signal and second to a wide-band frequency modulated signal. We can then compare the effect of the noise on the two types of modulation.

The Form of the "Noise Signal"

The "noise signal" on which the analysis is based has the following

form: Its basic carrier frequency is $\omega/2\pi$. It is 100 per cent amplitude-modulated by a modulation frequency $\mu/2\pi$. It is frequency modulated by the same modulation frequency $\mu/2\pi$ and the maximum frequency shift involved in the frequency modulation is $\Delta\omega/2\pi$. Its mathematical form is:

$$e_n = N \left(1 + \sin \mu t \right) \sin \left(\omega t + \frac{\Delta\omega}{\mu} \sin \mu t \right) \quad (1)$$

The ratio $\frac{\Delta\omega}{\mu}$, which we shall give

the symbol n , is the maximum number of radians phase shift involved in the frequency modulation. As a convenient numerical example we can take a modulation frequency of 1000 cycles, and a maximum frequency shift of ± 7000 cycles, so that $n = 7$ radians or 402° . With this numerical value, Eq. (1) can be analyzed² to determine its side-band frequency content. It is found that there are about 12 sidebands on each side of the carrier, the spacing between each being 1000 cycles. The

strongest sidebands are between 2000 and 8000 cycles, and all the relative phases and amplitudes of adjoining sidebands are different. Because this signal covers a wide band (24,000 cycles total) and has many sideband components, all of different amplitudes and phases, it is a good representation of a "noise voltage." Its side-band content is represented graphically in Fig. 1.

"Noise" Superimposed on an Amplitude-Modulated Signal

Having set up a typical noise voltage, e_n , we apply it first to an amplitude modulated signal e_a , whose carrier frequency is $\omega/2\pi$, and whose modulation frequency $\mu/2\pi$, as in the case of the noise. The percentage modulation is $K \times 100$ per cent, and the phase angles of the modulation and carrier voltages are ϕ_1 and ϕ_2 respectively. The form of this amplitude-modulated signal is:

$$e_a = S \left(1 + K \sin (\mu t + \phi_1) \right) \sin (\omega t + \phi_2) \quad (2)$$

The resultant voltage at the receiver,

due to noise plus desired modulated signal, is found by adding Eqs. (1) and (2). If this resulting signal is detected by a perfectly linear rectifier, and if the electrical network preceding the detector is wide enough to pass all sidebands, then the output of the rectifier will be a perfect reproduction of the envelope of Eq. (1) plus Eq. (2). The form of this envelope is most conveniently found by graphical means, as shown in Fig. 2.

In Fig. 2, the projection axis P is rotating clockwise at an angular velocity of ω radians per second. The desired signal is given by the two vectors S and $S K \sin (\mu t + \phi_1)$. These two parts are at a fixed phase angle ϕ_2 . The vector expands and contracts $\mu/2\pi$ times per second between the limits $S - SK$ and $S + SK$.

The noise voltage is likewise in two parts, N and $N \sin \mu t$, but since it is both frequency and amplitude modulated, is performing a pendulum motion while contracting and expanding. The instantaneous phase angle, which measures the pendulum motion, is $n \sin \mu t$ radians, the phase changing from $+n$ to $-n$ radians $\mu/2\pi$ times per second. The length of the noise vector expands to $2N$ and contracts to zero, $\mu/2\pi$ times per second. During one audio cycle, the end of the noise vector $N (1 + \sin \mu t)$ describes a spiral. The vector addition of both the noise and desired signals yields the resultant signal R , which may be plotted versus time over one audio cycle, thus giving the desired envelope of Eqs. (1) + (2). Figure 3 shows the resulting envelopes for various values of the angles ϕ_1 and ϕ_2 , under the conditions that $N = S/2$ (noise amplitude one half of signal amplitude) $K = 1$ (100 per cent modulation of signal carrier) and $n = 7$ radians (as above). The heavy lines in Fig. 3 give the resultant envelope, the dotted lines the undisturbed signal envelope. It is evident that the harmonic content of the resultant envelope is excessive, that is, that the desired signal is badly damaged if not rendered completely useless by the superposition of the noise voltage.

Noise Superimposed on Wide-band Frequency-modulated Signal

We now apply the noise voltage e_n to a wide-band frequency-modulated signal e_r , as follows: The wide-band

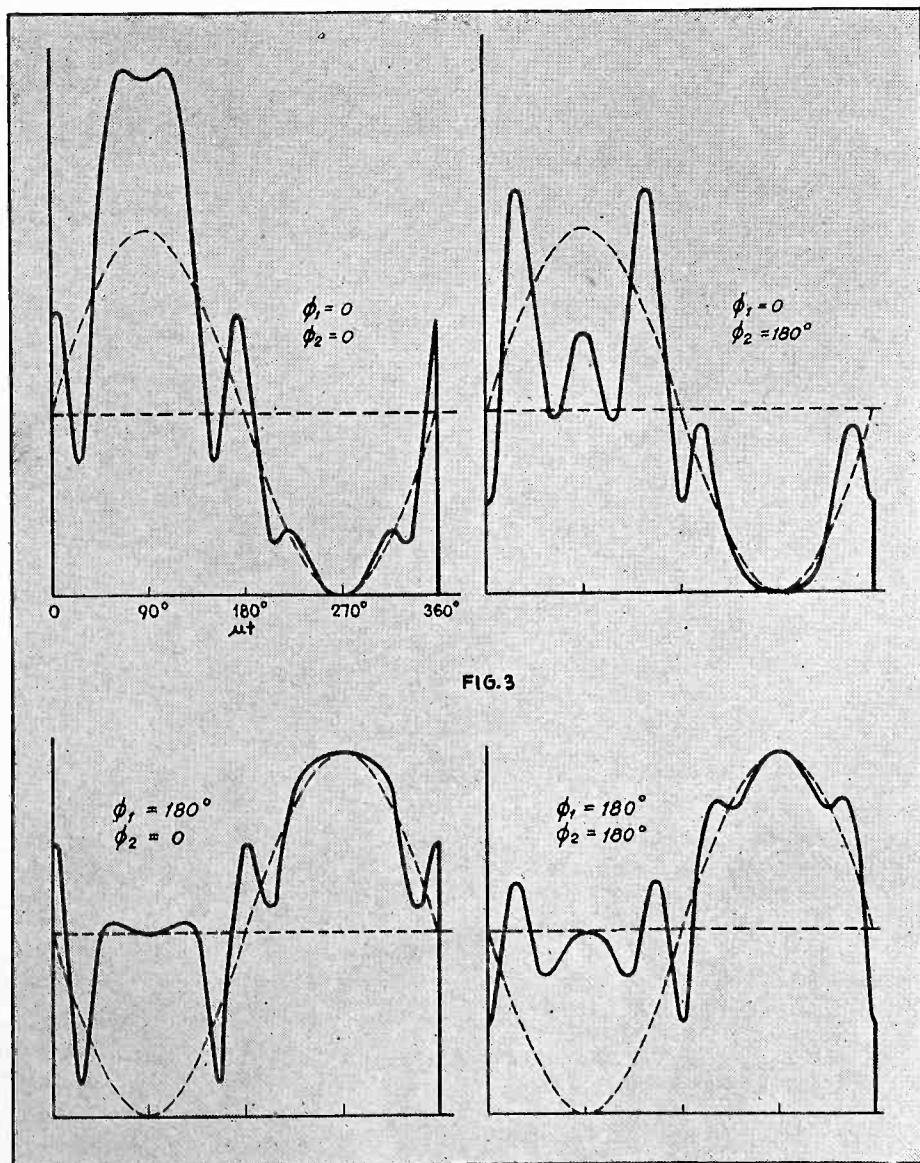

Fig. 3—Envelopes of amplitude modulated signal with (solid) and without (dotted) noise superimposed

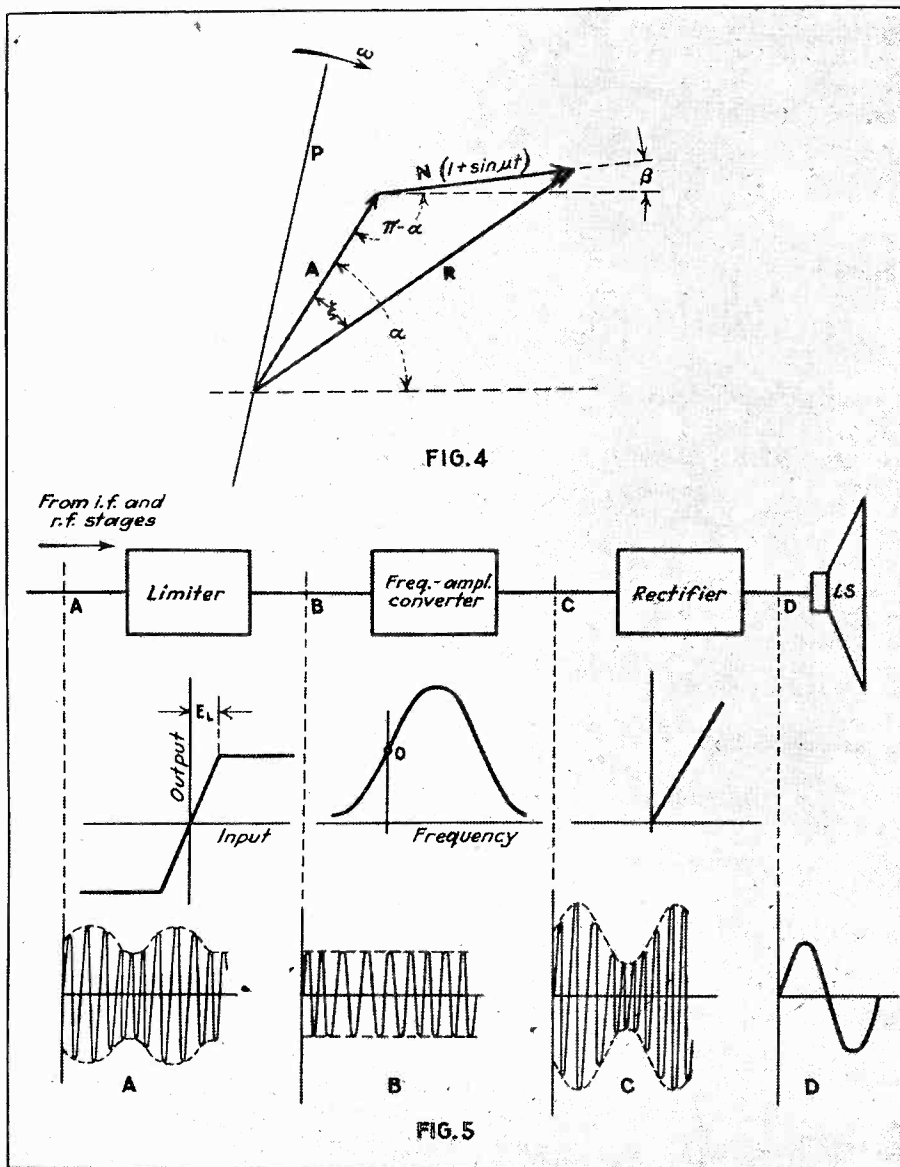

Fig. 4—Noise superimposed on frequency-modulated signal
Fig. 5—Elements of the frequency-modulated receiver

frequency-modulated signal has a constant carrier amplitude A , a central carrier frequency $\omega/2\pi$, a maximum frequency shift $\Delta\omega/\pi$, and a modulation frequency $\mu/2\pi$. The form of the frequency modulated signal is:

$$e_f = A \sin \left(\omega t + \frac{\Delta\omega}{\mu} \sin \mu t \right) \quad (3)$$

The ratio $\frac{\Delta\omega}{\mu}$, which in this case

is given the symbol m , is the maximum number of radians phase shift in the frequency-modulated signal. In the wide-band signal used by Major Armstrong, the frequency shift

$\frac{\Delta\omega}{2\pi}$ is of the order of $\pm 100,000$

cycles. For a modulation frequency of 1000 cycles, therefore, the value of m is 100 radians or 5729° .

We obtain the resultant voltage, as before, by adding the noise with the desired signal, that is, Eq. (1) plus Eq. (3), and determine its envelope by graphical construction, shown in Fig. 4. The projection

vector P rotates ω radians per second. The signal vector is of constant amplitude A but its phase $\alpha = m \sin \mu t$ changes from $+m$ to $-m$, $\mu/2\pi$ times per second. To this vector is added the noise vector, which is both amplitude- and frequency-modulated. The phase of the noise vector is $\beta = n \sin \mu t$. The noise and signal combine vectorially to give the resultant vector R , whose instantaneous phase is $\alpha - \xi$. The

angle ξ between A and R is determined by the instantaneous phase and amplitude of the noise voltage. In evaluating the effect of the noise on the desired signal, the resultant voltage vector R may be compared with the desired signal A itself. In so doing, it is necessary to consider the manner in which the frequency-modulation receiver operates in converting the frequency-modulated signals into audio signals.

The Frequency-modulated Receiver

In Fig. 5 are shown the essential elements of the frequency-modulated receiver. The r-f and i-f stages, which simply amplify all sideband frequencies proportionately, are not shown. The first essential element in the receiver is the limiter which removes any amplitude variations from the signal. These amplitude variations are introduced not only by the addition of the noise signal which is partially amplitude-modulated, but to some extent also by frequency discrimination in preceding tuned circuits. The signal leaving the limiter, containing only frequency variations, enters the frequency-amplitude converter (essentially a tuned circuit with the maximum slope of its resonant curve tuned to the signal carrier) which converts the frequency variations directly into amplitude variations. These are then detected in a linear rectifier which produces the audio signal. It is assumed that all conversion and detection is perfectly linear throughout the range of sideband frequencies involved.

After the signal leaves the limiter we are interested in its instantaneous frequency, since this instantaneous frequency is proportional to the instantaneous amplitude at the out-

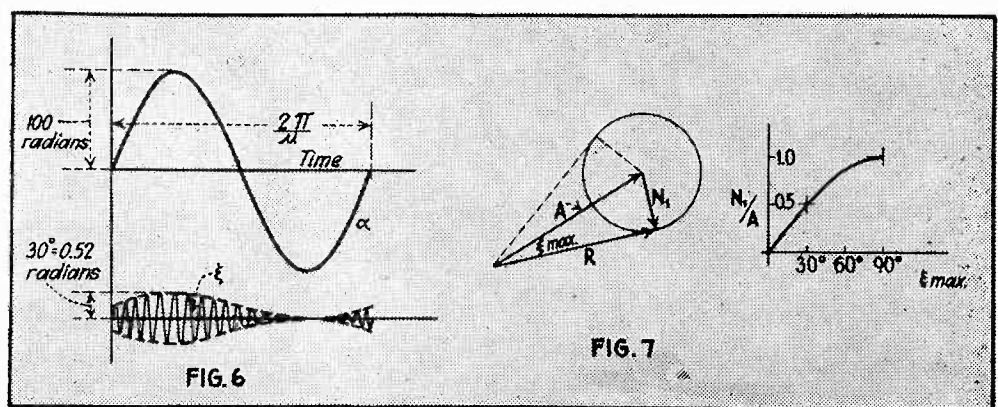

Fig. 6—Relative amplitudes of phase shift in signal and noise
Fig. 7—Maximum phase disturbance due to noise

put of the converter. The instantaneous angular frequency of any vector whose phase ϕ is variable is by definition $\omega = 2\pi f = d\phi/dt$, hence the frequency presented to the converter at any instant is:

$$f_{inst} = \frac{1}{2\pi} \frac{d(\alpha - \xi)}{dt} \quad (4)$$

since $\alpha - \xi$ is the instantaneous phase of the resultant voltage R (see Fig. 4). To solve Eq. 4, ξ must be found in terms of the desired-signal and noise-voltage parameters. The vector diagram in Fig. 4 reveals that:

$$\frac{\sin \xi}{\sin(\alpha - \beta - \xi)} = \frac{N(1 + \sin \mu t)}{A}$$

To facilitate the limiting process, the maximum noise amplitude $2N$ should not be greater than one-half the signal amplitude A . In other words the maximum value which the ratio $\sin \xi / \sin(\alpha - \beta - \xi)$ can have is $1/2$ and the maximum value of ξ is then 30° . We therefore make the approximations $\sin \xi = \xi$ and $\cos \xi = 1$, and write the expression for ξ :

$$\xi = \frac{k(1 + \sin \mu t) \sin(\alpha - \beta)}{1 + k(1 + \sin \mu t) \cos(\alpha - \beta)} \quad (5)$$

where $k = \frac{N}{A}$

Equation (5) may be made more convenient to use by substituting a change of variables and expanding in a series, as follows: Let $y = 1 + \sin \mu t$ and $\gamma = \alpha - \beta = m \sin \mu t - n \sin \mu t = (m-n) \sin \mu t$. Then:

$$\xi = ky \sin \gamma \frac{1}{1 + ky \cos \gamma} \quad (6)$$

This equation can be expanded in a converging power series, since $ky \cos \gamma$ is equal to or less than $1/2$. The

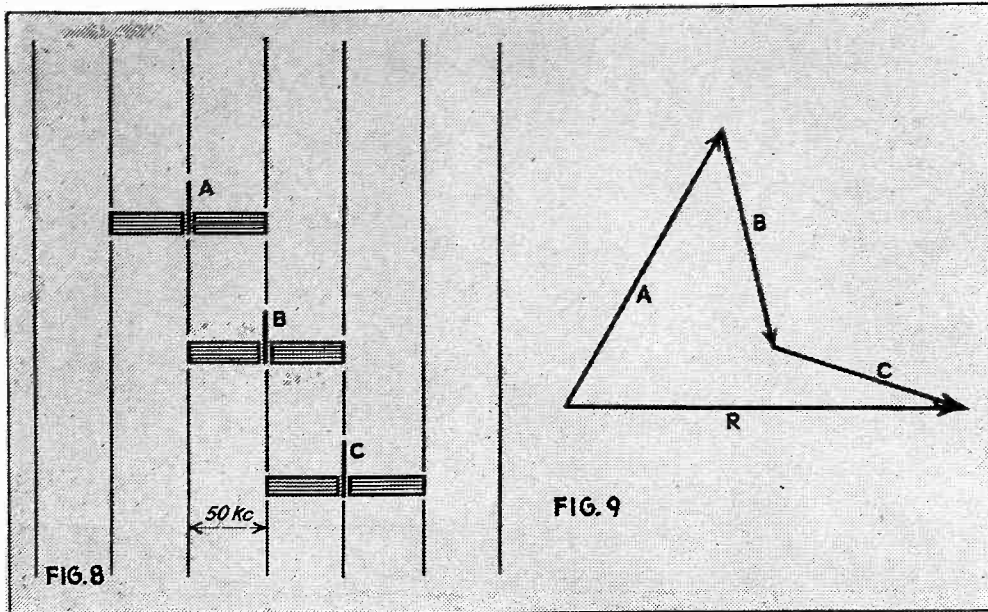

Fig. 8—Three over-lapping frequency-modulated stations assumed for purposes of interference analysis. Fig. 9—If R is larger than A , B , or C , no station is received

resulting series is given in Eq. (11) in the appendix. If as an approximation we neglect all terms containing k to the second or higher powers, this series expression for ξ becomes

$$\xi = 2 \sqrt{\frac{1}{\pi(m-n)}} (\sin \mu t - \sin 3 \mu t + \sin 5 \mu t - \dots) (\cos(m-n) - \sin(m-n) \cdot ky) \quad (7)$$

If we substitute this expression for ξ in Eq. (4), together with the expressions $\alpha = m \sin \mu t$, and $y = 1 + \sin \mu t$, and differentiate, we obtain the instantaneous frequency f_{inst} which is presented to the input of the frequency-amplitude converter, as follows:

$$f_{inst} = \frac{\mu}{2\pi} (m \cos \mu t - 2k \sqrt{\frac{1}{\pi(m-n)}} (\cos \mu t + 2 \sin 2 \mu t - 3 \cos 3 \mu t - 4 \sin 4 \mu t + 5 \cos 5 \mu t + 6 \sin 6 \mu t - 7 \cos 7 \mu t - 8 \sin 8 \mu t + \dots)) (\cos(m-n) - \sin(m-n)) \quad (8)$$

Since this instantaneous frequency is proportional to the rectifier's

audio output, the term $m \cos \mu t$ represents the desired audio frequency, while all the other terms are spurious frequencies introduced by the presence of the noise voltage. It will be seen that these spurious frequencies are multiples of the original audio frequency $\mu/2\pi$ and that their amplitude increases in direct proportion to their frequency. Fortunately only the lower frequency components in this interference spectrum are of practical importance because the audio system of the receiver (and the ear) will not respond to frequencies much higher than ten thousand cycles.

We set up the interference factor (which is the ratio of the amplitudes of the interference to that of the desired signal) directly from Eq. (8), and obtain

$$\text{Interference factor} = \frac{2k \sqrt{\frac{1}{\pi(m-n)}}}{m \sqrt{\frac{1}{\pi(m-n)}} \sqrt{1^2 + 2^2 + 3^2 + \dots Z^2}} \quad (9)$$

Now, remembering that $n = \Delta\omega/\mu$ for the noise signal, and $m = \Delta\omega/\mu$ for the frequency modulated signal, we can evaluate the interference factor for various combinations of audio frequencies and maximum frequency shifts. The greatest value which $(\cos(m-n) - \sin(m-n))$ can have is $\sqrt{2}$. The numerical value of the second root in (9) is computed from $1^2 + 2^2 + 3^2 + \dots Z^2 = \frac{1}{3} Z(Z+1)(2Z+1)$. Table 1 has been calculated for a value of $k = 1/2$ (noise amplitude half of signal amplitude), and on the assumption that all interference beat fre-

(Continued on page 60)

TABLE 1

Audio Freq.	Desired signal	Interference signal	No. of interference beats	Interference factor	Notes		
$\mu/2\pi$	$\Delta\omega$	m	n	Z			
100	100,000	1000	7000	70	930	0.760	Audio frequency variable. Per cent modulation of desired signal constant. Bandwidth of interfering signal constant.
500	100,000	200	7000	14	186	0.783	
1000 (A)	100,000	100	7000	7	93	0.810	
2000	100,000	50	7000	3.5	46.5	0.946	
5000	100,000	20	7000	1.4	18.6	1.03	
1000	100,000	100	10000	10	90	0.824	Audio frequency constant. Per cent modulation of desired signal constant. Interference signal bandwidth variable.
1000	100,000	100	20000	20	80	0.874	
1000	100,000	100	40000	40	60	1.01	
1000	100,000	100	80000	80	20	1.75	
1000	100,000	100	15,000	15	85	0.848	Audio frequency constant. Per cent modulation of desired signal variable. Interference signal bandwidth constant.
1000	50,000	50	15,000	15	35	3.65	
1000	20,000	20	15,000	15	5*	5.07*	
1000	10,000	10	15,000	15	-5*	10.14*	

*Formula (8) is correct only for large values of $m-n$. The above figures for $m-n = 5$ have been computed from a more accurate formula.

Interoffice Communication

Office communication equipment, right now, is one of the busiest corners in the electronic market. Herewith is a summary of the various systems, audio, carrier and wire-carrier, their capabilities and limitations

THE past year has seen an almost phenomenal growth of a relatively new branch of electronics industry, communication systems for office use. While intercommunicating systems have been manufactured by telephone equipment makers for a number of years, these units usually left much to be desired when viewed from the point of quality of sound output. They employed a horn type speaker and no tubes. With many types of units the user, when speaking over the telephone, had to use an additional handset to seek information by means of the intercommunicating system.

The earliest type of electronic intercommunicating system employing a tube amplifier, was the "paging" system. By this means a person could be called or information broadcast from a central amplifier to various floors and different locations on the same floor. Horn type loudspeakers and magnetic units were used and gave very satisfactory service. Considering the low output of the power amplifier tubes generally available a few years ago, the results were very satisfactory.

Small cone speakers of the magnetic and dynamic types soon replaced the air column speakers. It was easy to include a return wire from each speaker, and soon the loud speakers were switched into the circuit individually for "talk-back."

The outlying loudspeaker, when acting as a dynamic microphone, required no manipulation of switches on the part of the person at the outlying position since the switching was accomplished from the master unit. It was thus possible for the man in the stock-room to answer an inquiry as to the quantity of a certain item in stock even while he was perched on a ladder.

This system led to the development of the "desk" type of paging system. The amplifier, local speaker-

By JACOB ROSENBAUM

microphone and switching system, instead of being bulky and scattered in various parts of the building were scaled down and put into a small, neat, businesslike cabinet. The unit was no longer called a paging system. It had acquired the name of "intercommunicating system."

The master station arrangement, by means of which the master station could call any of the outlying stations individually, was satisfactory for some locations and business set-ups. However, occasionally there was need for intercommunication between all stations. The use of a single amplifier for intercommunication was out of the question as the entire system would be limited to only one conversation at a time. The answer was found in the use of an amplifier for each station as shown in Figs. 2 and 3. The usual troubles encountered in telephone circuits were found in these systems. Cross-talk was most annoying—to both designer and consumer. This cross-talk was encountered when attempts were made to run all the audio and signal lines for a complete multi-station system in one compact cable.

Another difficulty was r-f pick-up. The first tube in each amplifier, be-

cause of the biasing arrangements used, was often capable of detector action. If the lines connected to the amplifier were of the proper length, their resonant frequency lay in the broadcast band. The result was the "reception" of broadcast programs, even though the system was, in theory at least, purely an audio amplifier arrangement. Shielding of the connecting wires, and the use of r-f chokes and shunt condensers or wave-traps usually were effective in putting an end to this trouble.

The Inter-office Carrier Systems

The use of carrier current as the basis for transmission in intercommunicating systems was prompted not so much by the desire to obtain simultaneous transmission of several messages over the same pair of wires, as in telephone practice, as by the economy which would result from using the power lines themselves as the signal and voice circuits.

Two types of carrier current intercommunicating systems are commercially available, the major difference between them being in the means for conveying the carrier from one unit to the other. The most widely commercialized system uses the power lines, while another system employs a two-conductor transmission line.



In the audio systems a single permanent-magnet dynamic serves in each outlying station both as loudspeaker and microphone. Switching is accomplished at the headquarters station



The master station can be connected with any outlying station, each of which can talk back when the master is switched to "listen"

The following discussion concerns itself with the first type. The transmission line system is treated in subsequent paragraphs.

Figure 4 shows a typical circuit diagram of a carrier unit of the "power line" type. As can be seen, it is composed of three distinct units: 1. R-f oscillator (and detector). 2. A-f modulator and amplifier. 3. Filter.

Inductors L_1 and L_2 in conjunction with C_1 form the oscillatory cir-

cuit operating in the neighborhood of 100 kc. C_1 is a compression type of mica dielectric padder condenser. With the capacities employed in typical commercially available units, large frequency variations are not possible, but it is possible in some instances to vary the frequencies so that sufficient separation will exist between two sets of units to permit "private" (i.e. simultaneous, non-interfering) communication. Inductor L_3 in conjunction with capacitor C_2

forms a resonant circuit which feeds the signal energy into the power line through the high-pass filter.

In the receiving position the "oscillator" becomes a grid leak detector and R_1 (which had been out of the circuit on the transmitting position) becomes the plate load resistor. The IR drop in R_1 is sufficient to stop the circuit from oscillating.

The modulator and audio frequency amplifier, like the oscillator-detector, present no departures from standard practice. The loud speaker is used as a microphone and its output favors the low frequencies. Since frequencies below 300 cycles do not contribute materially to the intelligibility of speech it is advisable to design the audio amplifier so as to discriminate against these frequencies. Power-line hum will of course be greatly attenuated by these methods.

Perusal of the diagram may show what seems to be an anomalous situation. Small coupling condensers are used to attenuate the lower frequencies and then by-pass condensers are put across load resistors to accentuate (seemingly) the low frequencies. Since the unit must be built into a small space and the audio amplifier must have high gain (20 db), some of the r-f energy is bound to reach the audio circuit and produce results far from satisfactory or pleasant to the ear. The shunt condensers keep most of the r.f. out of the a-f amplifier. More effective and efficient means could undoubtedly have been employed, but they would have increased the cost of the unit and added very little to it in sales appeal. Since an audio system of sufficient power to modulate the oscillator plate is available, there is little reason for using any but the high level method of modulation.

The loud speakers employed by intercommunicating system manufacturers are usually of the small permanent-magnet dynamic type. In some instances electrodynamic speakers are used. The output transformer is designed to reflect the proper load impedance from the voice coil to the output tube plate. This same transformer is used as an input transformer in the transmitting position and the amplifier gain is sufficient to supply full output over the desired frequency range.

The filters employed to feed the r-f output into the power line may

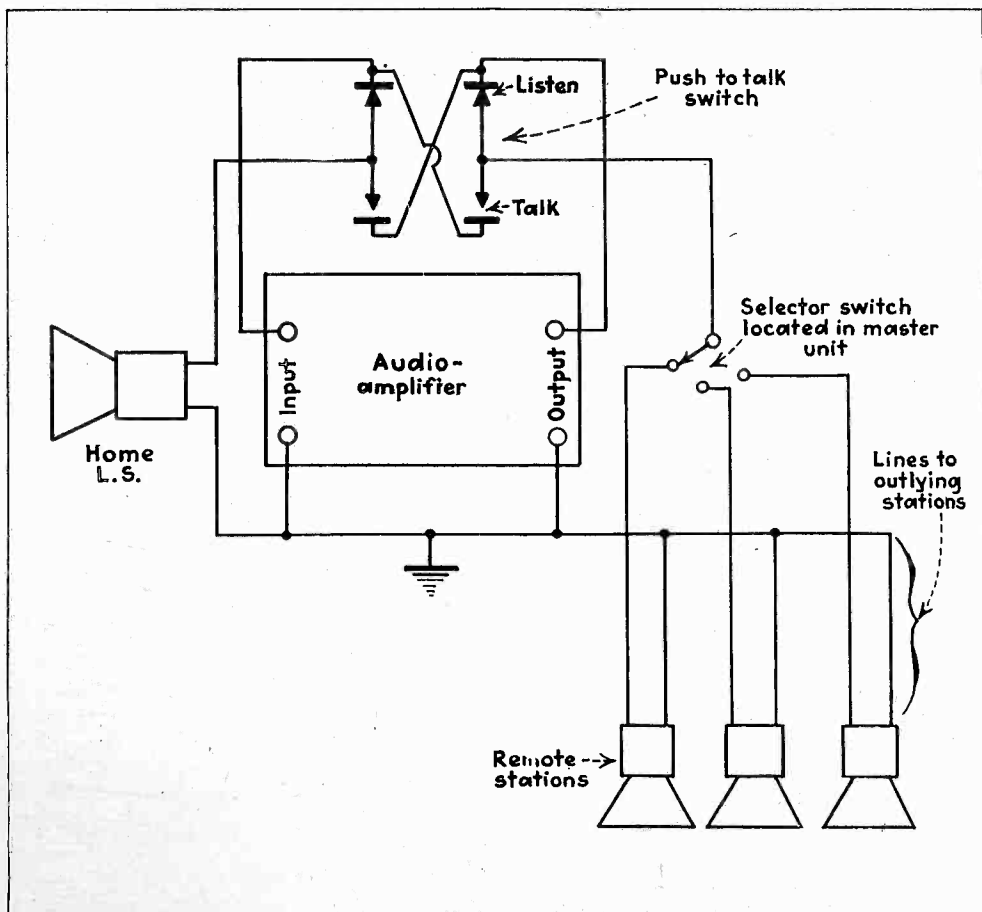

Fig. 1—A single amplifier and four loudspeakers with appropriate switching serve for master and three outlying stations

be either of the high-pass or band-pass type. Since the light line cannot be considered as a simple transmission line, but must be seen as a transmission line with mismatched spurs and one that is variously and variably loaded along its length, in considering terminal impedances of filters to be designed for this type of service one should assume a normal line condition and a highly shunted line condition and design for a midway impedance. For instance, assuming a radio receiver with a $0.1 \mu\text{f}$ line condenser (AC/DC midget) across the line, the reactance X_c at 100 kc. = approx. 16 ohms. A heater may reduce this to about half. The filters in this case should be designed for 10 ohm terminal impedance. In cases where the noise and variations in volume would become objectionable when the line becomes unloaded, preloading of the

line within the unit is entirely feasible. A $0.05 - 0.1 \mu\text{f}$ condenser does this very effectively, though not efficiently from the standpoint of r-f energy dissipated.

When operated on a.c. these units have some hum which is due to power line pickup by the detector. This hum, though of low intensity, is of a higher level than that present in even the lower priced radio sets. The better grade of intercommunicating system should include a high-pass filter to cut off below 300 cycles in addition to the precaution already discussed as applied to the a-f system. To the writer's knowledge no unit on the market employs a filter of this type.

As shown on the "typical" diagram the signaling system consists of an audio tone generated by feeding from the output tube plate to the input of the audio amplifier. In

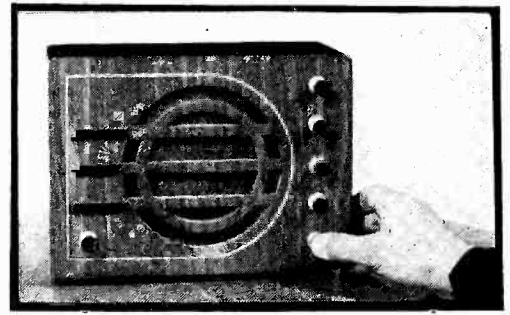

Push-buttons are used as station selectors in this neat-appearing unit

other units a neon tube oscillator is employed to generate the audio tone.

Design and service difficulties are encountered in the carrier system intercommunicating units of both the power line and transmission line type, but they cannot be considered as being inherent in any one make or type of unit.

In general, makers of these units claim good operation over line distances up to 2500 feet. With good units having comparatively high output and operation over a quiet and unloaded line, operation over such distances is possible. Since operation must be limited to the wiring on the consumer side of the meter, however, (the meter inductors act as r-f chokes) there is seldom the half mile or so of wiring available for such tests except of course in large office buildings, hospitals and institutions. A watt or two of r-f energy should prove sufficient to back the claims of any but the most visionary salesmen. Most of the units available use very much less power and avoid audio troubles due to stray r.f., but their range is extremely limited.

Most electrical wiring systems are of the 3-wire kind. They are usually 220 volts with a common wire having 110 volts from each leg to common. If a carrier unit is connected across one leg and another unit connected across the other there will of course be no communication between the units possible unless the two legs are connected together for r.f. A condenser ($1 \mu\text{f}$) of 600 volt or higher rating is usually sufficiently effective for such by-pass purposes. The condenser must be of a very good grade because it is continuously across the line. In some cases it will be found that shunting only one leg of the line with a $1 \mu\text{f}$ condenser will cause the signal to be heard in the other unit.

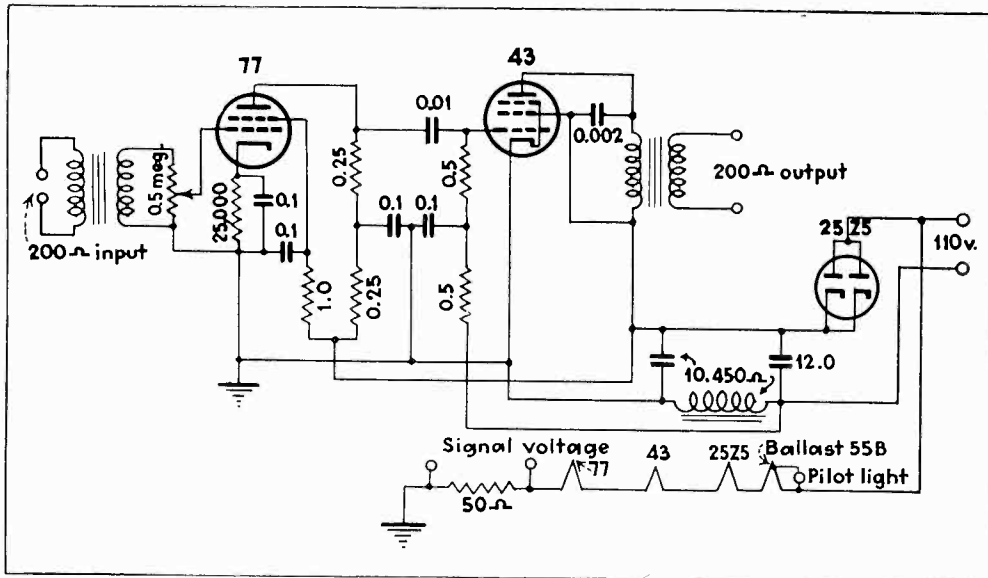

Fig. 2—Typical connections of a two-tube "straight audio" amplifier, such as is used in the system shown in Fig. 1

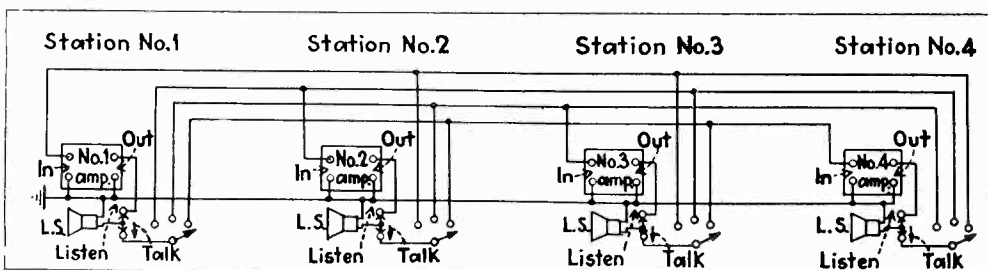

Fig. 3—An amplifier at each station permits any station to talk with any other. The arrangement of lines and selector switches is shown above

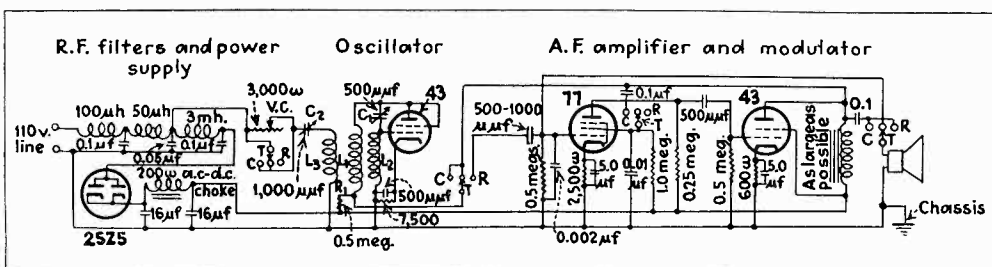
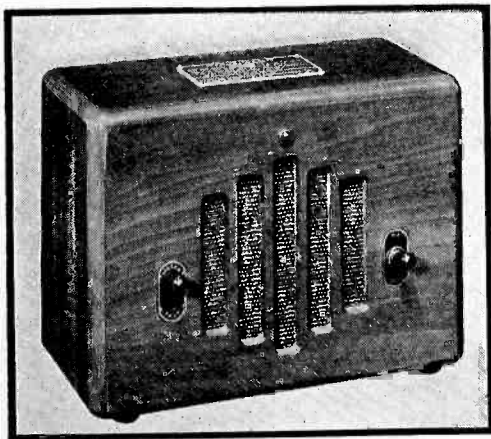

Fig. 4—Complete circuit diagram of a carrier unit which feeds modulated r-f over the lighting wires. The letters C, T, and R, stand for "call," "transmit" and "receive"

In the receiving position, the detector frequency (r-f input) is determined largely by the LC product. In the transmitting position however, the value of plate voltage is also a factor in the determination of frequency. The result is that a unit will transmit on one frequency and receive on another frequency. If the units are lined up in pairs or by using one unit as a standard it will be necessary to line the units up for optimum results midway between these two frequencies. Of course, a more logical method would be to employ an oscillator circuit arranged so that plate voltage variations will have a negligible effect upon the frequency. Circuits employing the new "beam" tetrodes lend themselves particularly well to use a simple oscillator which can be stabilized for frequency voltage variations. The power output from these tubes is also higher than other tubes used for the purpose.

The carrier system just described has many features to recommend it. Among these can be included those of portability and absence of special wiring. These units, however, are incapable of assuring privacy of communication. Unless special precautions are taken there is nothing to prevent a tenant in an office building from buying a set of units, which in all probability are tuned to the same frequency as another unit in an adjacent office or on another floor. The conversations over one set of units would be heard over the other. Some manufacturers have anticipated this condition and tune their units to about three or four different frequencies to avoid these difficulties. Since office buildings usually have one meter for the whole building (and electric service is included in



A typical audio unit. The switches control power and the talk-listen circuit.

the rental) the only way to avoid interference is by the use of r-f filters in series with the fuses in the line entering the office. This filter may often be placed in common fuse and switch box which has fuses for all offices on one floor. As a rule, the best time to make "corrections" to the incoming line is when one is positive that the building superintendent is nowhere near the fusebox.

"Wired Carrier" Systems

The *wired carrier* system has, except for its transmission line, all the advantages and few of the disadvantages of the "power line" carrier type of unit. The lack of privacy of conversations and inability to foretell the results to be obtained because of variations in line—(characteristics and noise pickup from line) have already been discussed.

Since the wired carrier system uses a two wire (or single wire) transmission line, results are uniform and unaffected by line variations. Line noises can easily be filtered out without also filtering out the desired signal, lower power is required since the line is lightly loaded, and, most important of all, absolute privacy is accorded all conversations over the system. The information relating to carrier systems given previously also applies to the "wired carrier systems" with the following exceptions:

1. Lower power (r-f and a-f) is required for results equivalent to those obtainable from power line carrier systems, resulting in savings in cost.
2. R-f filtering (if used) does not have to be as elaborate as in the other system.
3. Due to lower r-f power, less trouble will be experienced from stray r.f. finding its way into the audio system.

In this writer's opinion, this system combines the best qualities of the "carrier" and "audio" units. The only objection, the cost of the installation of a simple transmission line carrying no power (as concerns the Underwriters), is certainly small when the advantages of privacy and noiseless operation are considered.

Commercial Aspects

In the past year, over forty manufacturers with sufficient capital to

advertise have entered the field. It is safe to say that at least another twenty have entered the business on the proverbial shoestring and have offered intercommunicating units for sale. In most cases these have been copies of commercially acceptable units. It seems, however, that copying also requires a knack and some technical knowledge; neither of these qualities are reflected in many of the copies.

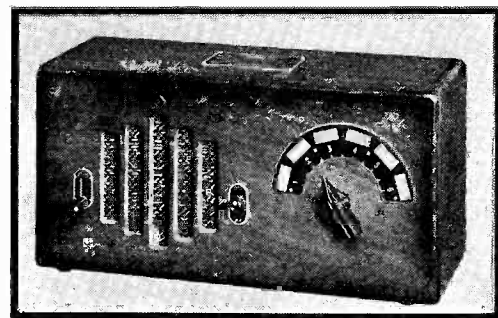

A selective unit, using a separate transmission line to each outlying station.

A recent list of intercommunication systems contains about forty systems made by twenty manufacturers. Four of these systems require no transmission lines and are therefore of the carrier type. Two of these carrier systems are listed for "master" operation, that is, communication is possible between the master station and any of the outlying stations. At least one carrier system employing a transmission line is being marketed. The manufacturer of this unit was one of the first to come on the market with an audio type of unit early last year.

The list prices for intercommunicating units are from about \$35.00 for a pair to \$170.00 for a pair. Additional stations may be had at list prices ranging from \$10 to \$52.50 each. Either three or four tubes are employed, with a few units using only two. The permissible distance separating units ranges from a maximum of 100 feet to one of 2,000 feet. In most cases the outside cabinet dimensions are smaller than the average 5 tube AC-DC Midget.

It is interesting to note that on the basis of an 8-hour day and 25-day month, tubes in units of this type give excellent service for over a year. Twenty-five volt rectifiers give more trouble than other tubes, but once these bad tubes are weeded out, very little trouble is experienced from tubes.

Etched Foil for Electrolytics

Increasing the anode area in electrolytic condensers by etching the aluminum foil has made possible larger capacity in smaller space without loss of useful life. Power factor increases which result are of small practical consequence

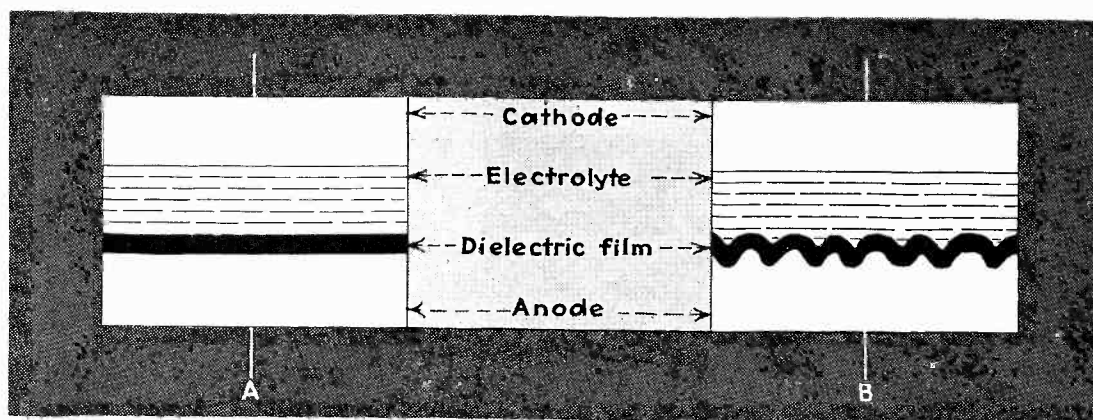

Fig. 1—Relationship between electrodes and dielectric in smooth and etched-foil condensers

ELECTROLYTIC condensers, in common with all other types, consist of two conductors separated by a dielectric. In electrolytic condensers, one of the conductors is the anode; the other conductor is the electrolyte. The dielectric separating the two conductors is a thin film of aluminum oxide on the anode. In order to clarify the effect of etching on the anode electrode, the elementary relationship of electrodes and dielectric is shown in Fig. 1. The cathode electrode as shown in this figure merely serves to make contact to the electrolyte. The effect of imperfect contact between cathode and electrolyte later is discussed later.

The capacity obtained between electrodes in the condenser shown in Fig. 1-A is proportionate to the anode electrode area facing the second conductor (the electrolyte) through the dielectric film. If the face of the anode is roughened, before formation of the insulating film on its surface, the structure shown in Figure 1-B results after assembly of the etched anode in the finished condenser. It will be readily appreciated that the capacity between the anode and electrolyte will be increased in proportion to the increase in surface area due to the roughening or etching operation.

It is interesting to note that

although the application of etched electrodes to electrolytic condensers is comparatively recent in commercial practice, the fundamental principle of roughening the surface of the anode electrode in electrolytic condensers was mentioned in a patent issued as far back as 1920.¹

In the past few years, intensive development work by manufacturers of electrolytic condensers has enabled economical production of etched foil having an effective area when used as anode material of three to

By **NATHAN SCHNOLL**

*Chief Engineer
Solar Manufacturing Corp.*

six times the normal surface. As a direct result of this, it is possible to produce electrolytic condensers of given capacity and voltage ratings in containers having a fraction of the volume previously required and at a considerable saving in cost due to reduction in material required. The advantages of etched foil anodes are not obtained without some sacrifice in other characteristics. But in general, it may be said, on the experience of producing condensers of this type for several years, that the

benefits overwhelmingly outweigh any disadvantages.

When the writer first considered the use of etched foil anodes in dry electrolytic condensers, it seemed reasonable to expect a considerable reduction in useful life as compared to similar units with plain foil. This belief was based on the decrease in volume of electrolyte when the etched anodes are used and when full advantage is taken of the possible reduction in volume. Field experience and life test records since then, however, have shown the expected decrease in life to be negligible. This is shown in Fig. 2, which gives typical life test results for etched foil dry electrolytic condensers. Two condenser units with similar construction, except for the use of etched foil anodes on one, plain foil on the other are very different in size. The reduction in volume made possible by the etching process is greater than 50 per cent.

The power factor of etched-foil dry condensers is higher than that of similar units with plain foil. This is due to the increased capacity per unit area of electrolyte with etched foil units as compared with plain foil. The effective series resistance, assuming the same electrolyte thickness, is therefore higher in the etched than in the plain foil unit. The effect of this increased electro-

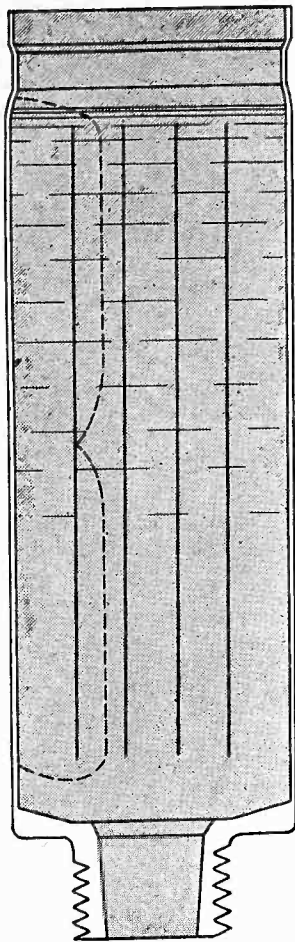

A-Etched foil

Fig. 3—The length and cross section of the current path through the electrolyte, for etched (A) and plain (B) foils

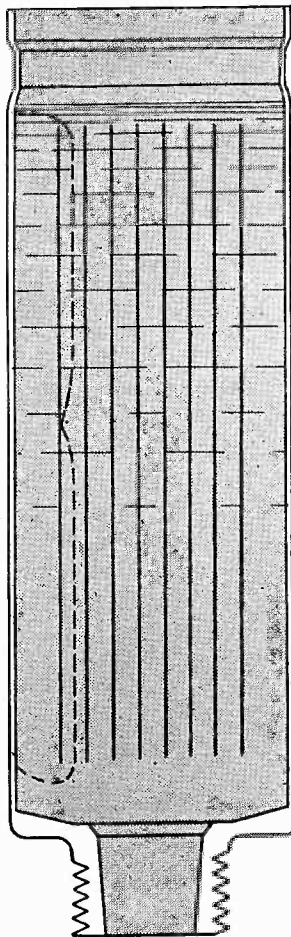

B-Plain foil

electrolytic condenser for r-f bypassing, this is done in some receivers. In such cases, and where the r-f bypass action is critical, etched foil units may not be suitable.

In wet electrolytics, as contrasted with the dry type, the use of etched foil anodes may, and generally does, improve the power factor of the con-

denser. The reason for this apparent anomaly is shown in Fig. 3. In wet electrolytic condensers, the effective cross section, as well as length, of the path from cathode electrode through the electrolyte to the anode is important in determining the power factor of the condenser.

The path through the electrolyte to a given point on the etched anode surface of a wet electrolytic condenser is shown in Fig. 3-A, the same path for a plain anode in 3-B. Due to the longer length of anode required for the plain foil unit, the cross section of the electrolyte path from cathode to anode is larger in the etched foil unit than in the plain foil. In many wet electrolytic condensers, this improvement in the constriction of the electrolyte path by use of etched foil more than offsets the effects of increased capacity per unit area of anode, and the power factor is therefore lowered. This is especially true in high-capacity, high-voltage condensers, where long anode foils are required.

Another important application of electrode etching, is etching of the cathode. This is of greatest importance in connection with aluminum can wet electrolytic condensers. In condensers of this type, where the can serves as cathode, it is found that the can-electrolyte contact is imperfect. As a matter of fact, it is well-nigh impossible to prevent the

(Continued on page 48)

lyte resistance is generally of no importance in determining the effectiveness as a filter at 60 or 120 cycles. It has been shown² that the relative efficiency of a condenser in the power pack filter does not differ more than 10 per cent from that of a perfect condenser until the power factor exceeds 43 per cent. Since the power factors of etched foil condensers are considerably better than this, the loss in efficiency is negligible; in practice, the capacities of etched foil condensers can be run higher so that even better filtering may be obtained in spite of the higher power factor.

There is one application, however, where etched foil dry condensers are at a disadvantage compared to plain foil. This is when bypass action at radio frequencies is required. At these high frequencies, the effective impedance of the condenser begins to approach the effective impedance of the electrolyte and since the effective electrolyte resistance of etched foil units is much higher than plain foil, the r-f impedances are in very nearly the same ratio. While present practice does not rely on the

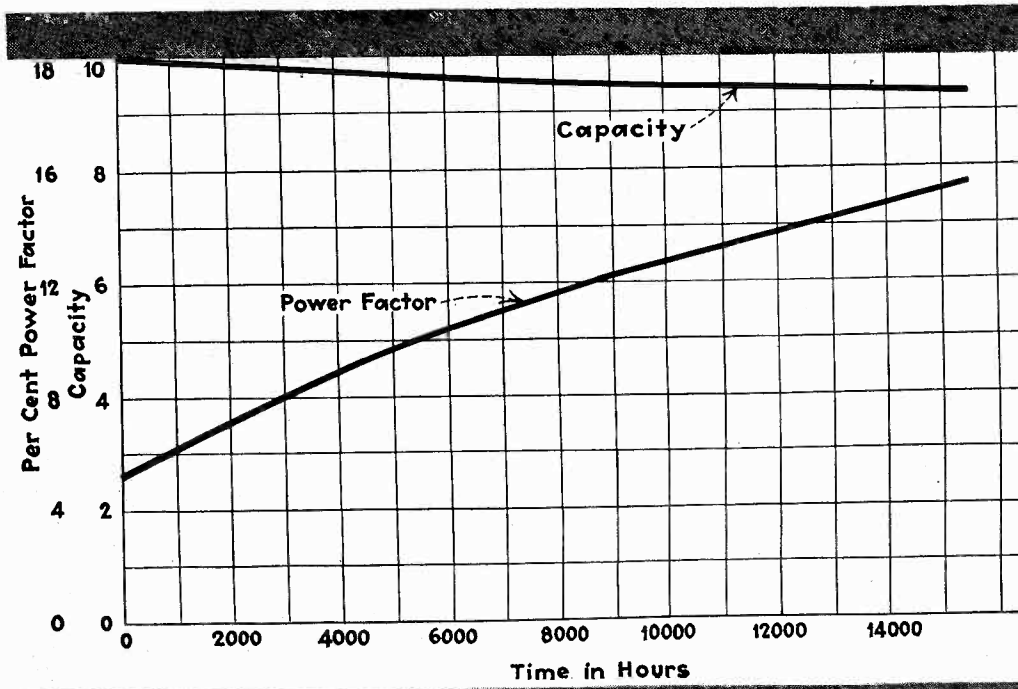
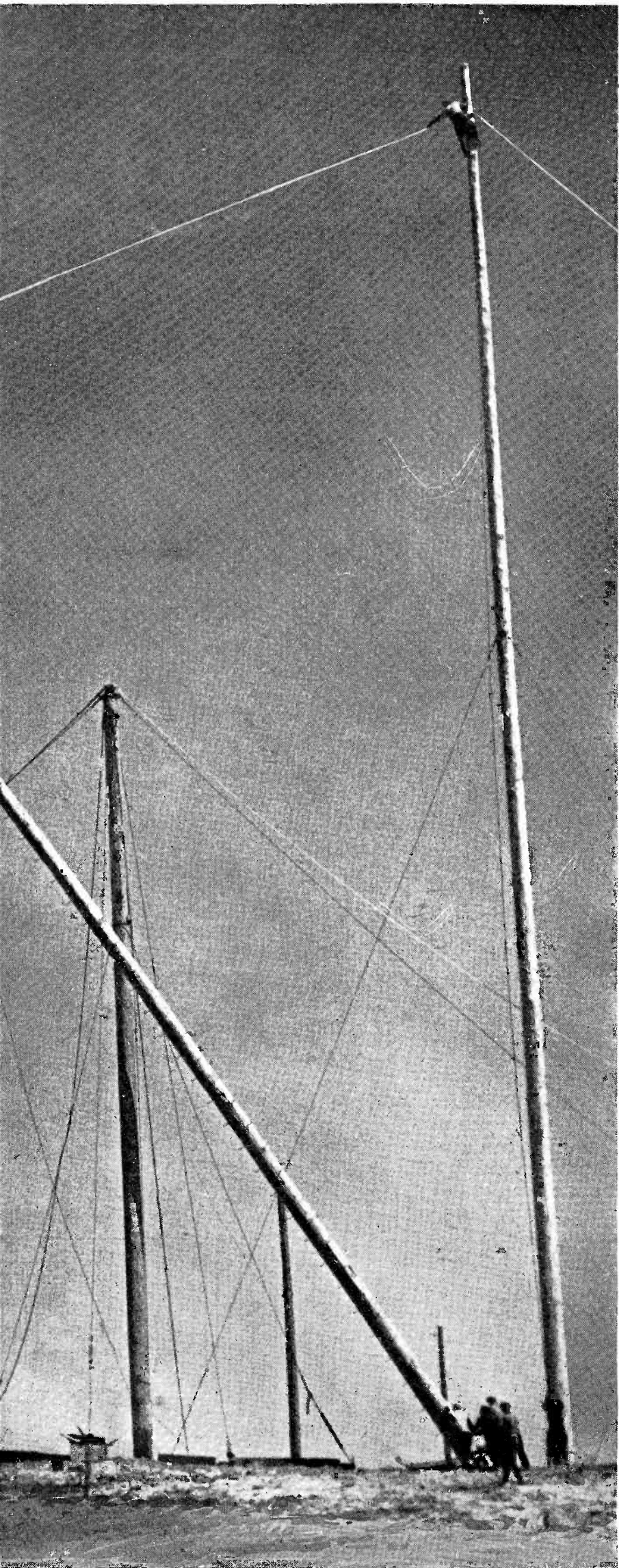
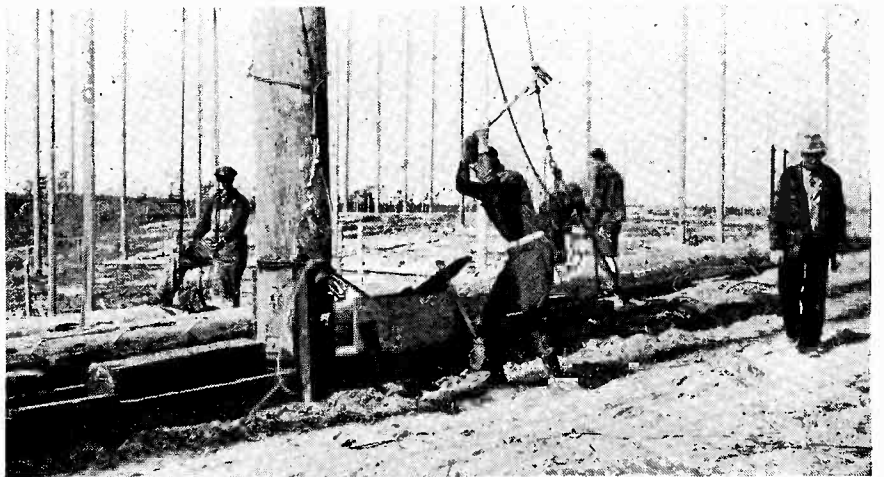
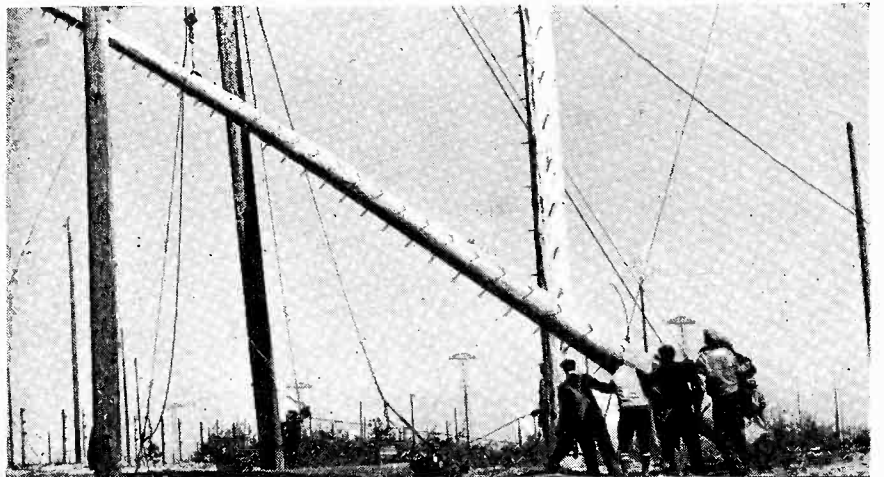
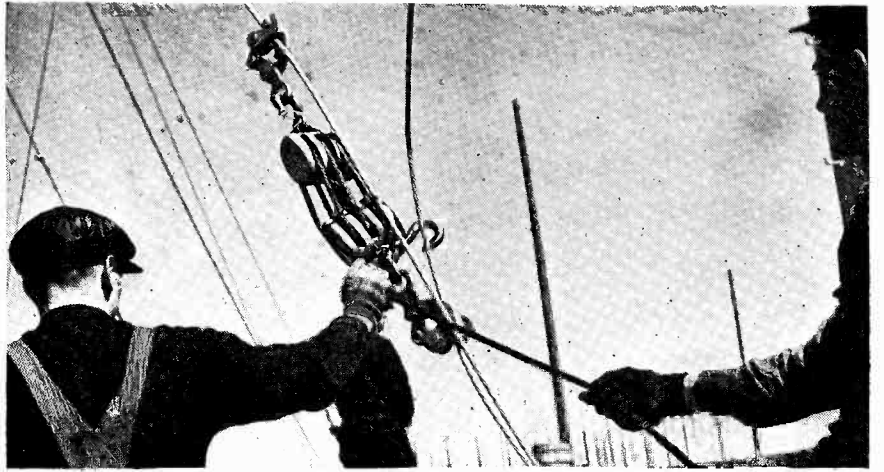

Fig. 2—Power factor and capacity variation during life of etched-foil unit. The power factor of the etched foil units is somewhat higher than that of plain-foil types



U P I N



EVERY day is Arbor day at RCA Communications, Riverhead, Long Island, but the trees have neither leaves nor roots. Spring, this year, sees a great new planting of 130-foot Douglas firs erected in about 3 minutes each by a trained crew.

The gin pole, 75 feet, is hauled about by a tractor, fixed in position by a stake. Men guide the bottom of the pole as a tractor hoists it. The base of the 4-ton mast is lowered into a concrete socket, a rigger frees the hoisting cable and guys, the pole is straightened and put in line with the others of the array which will have an effective height about 60 percent greater than existing antennas for the longer short waves for which it is adapted.

THE AIR

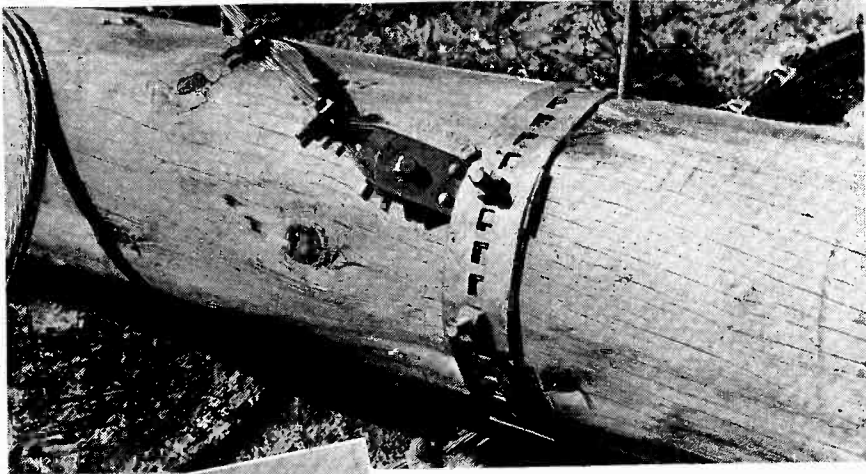
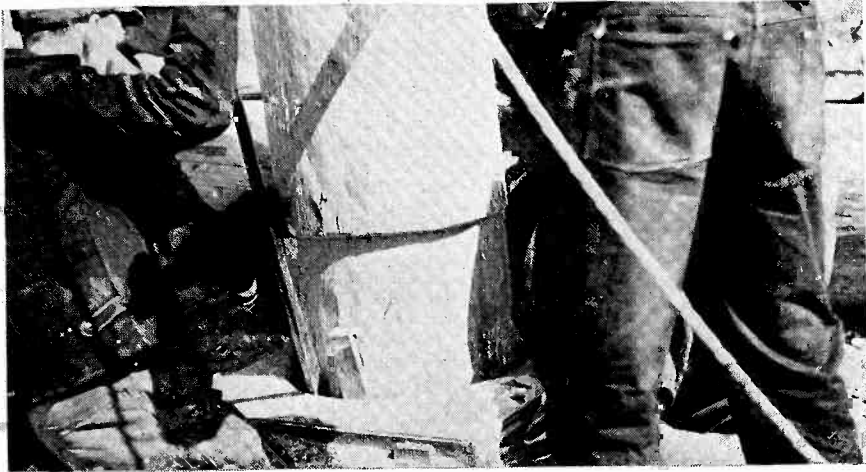

These antennas are called Beverage fishbones because they resemble in construction a piscatory vertebra

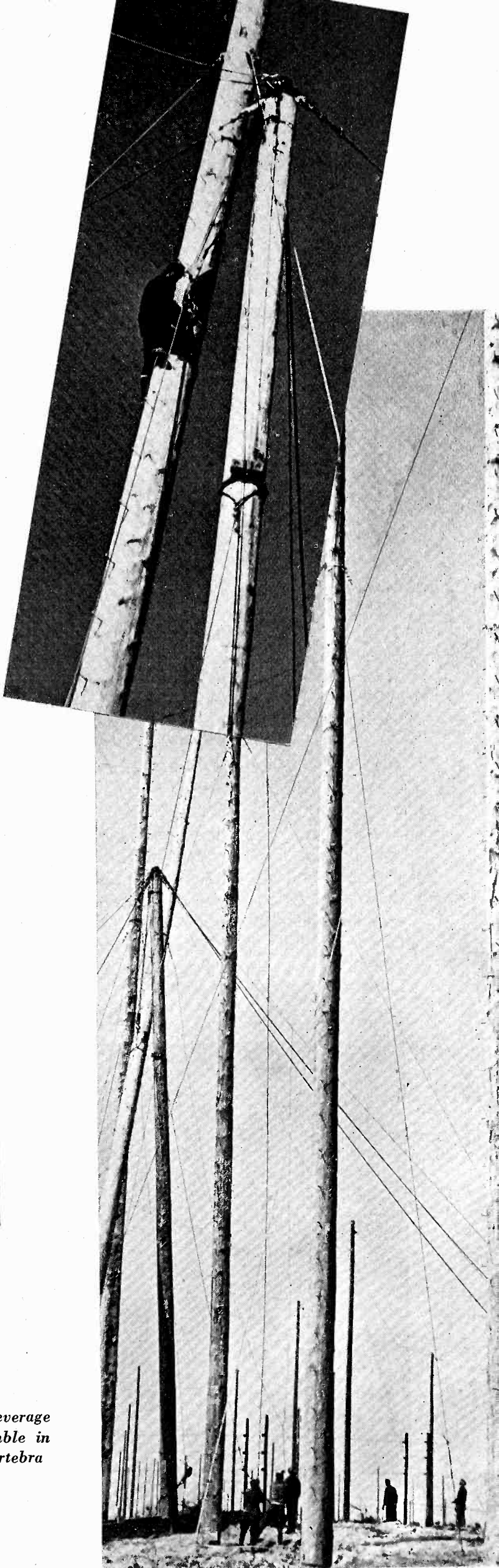

Tone Fidelity Switch

Radio receivers with extended audio bands need means by which user can control the response to suit conditions or his auditory taste. This system makes it possible to control both high and low frequencies

WITH the coming of higher fidelity receivers, the ordinary resistance type or capacity type tone control which performed a single function of reducing the high frequency response of the audio amplifier has now been replaced by a fidelity control switch. Externally the switch looks as simple as the tone control used on the average receiver. This switch, however, performs three distinct functions and therefore is complicated in construction. The fidelity control must accomplish either sharp or broad tuning in the r-f or i-f circuits, increase or decrease the low frequency response of the audio amplifier, and increase or decrease the high frequency response of the audio amplifier. The fidelity control is shown schematically in Fig. 1. There are six index positions and all of these are necessary when the receiver is equipped for shortwave and standard broadcast reception. The switch has definite indexing at each position and is marked for the operator's con-

By **ARTHUR G. MANKE**

*General Electric Co.
Bridgeport, Conn.*

venience or reference on Position 3 only. The reproduction rendered with the switch in Position 3 is like that obtained from the better grade console receiver not equipped with the higher fidelity feature. The principal components of the fidelity control, the method of accomplishing the various functions and the effects produced will be described below.

The principal parts of the fidelity control are: the six position electrical switch together with the associated resistors and condensers, and the connecting arms and their bearings for transmitting the desired rotation to the primary coils of the variable intermediate frequency transformers. This control differs from the ordinary tone control which affects only the a-f amplifier.

Figure 1 shows schematically how each of the electrical switches functions to control the high and low frequency response of the receiver.

Switch No. 2 controls the low frequency response of the audio amplifier and switch No. 1 controls the high frequency response of the audio amplifier and also the bandwidth of the r-f amplifier when operating on the broadcast band. The short wave r-f amplifier, at those frequencies where entertainment programs are broadcast, is broad enough so as not to impair the fidelity of reproduction. Since the fidelity control does not change the bandwidth of the r-f amplifier in the shortwave bands, Fig. 1 has been shown for the broadcast band only, and only those elements closely associated with the fidelity control switch are shown.

The bandwidth of the i-f amplifier is varied by a mechanism which is crudely indicated in Fig. 1. The coils are rotated to bring the axis of the plate and grid coils of the i-f transformers at right angles or into the same plane, in which case the coupling is maximum. The mechanical motion of the switch is arranged to bring about approximately

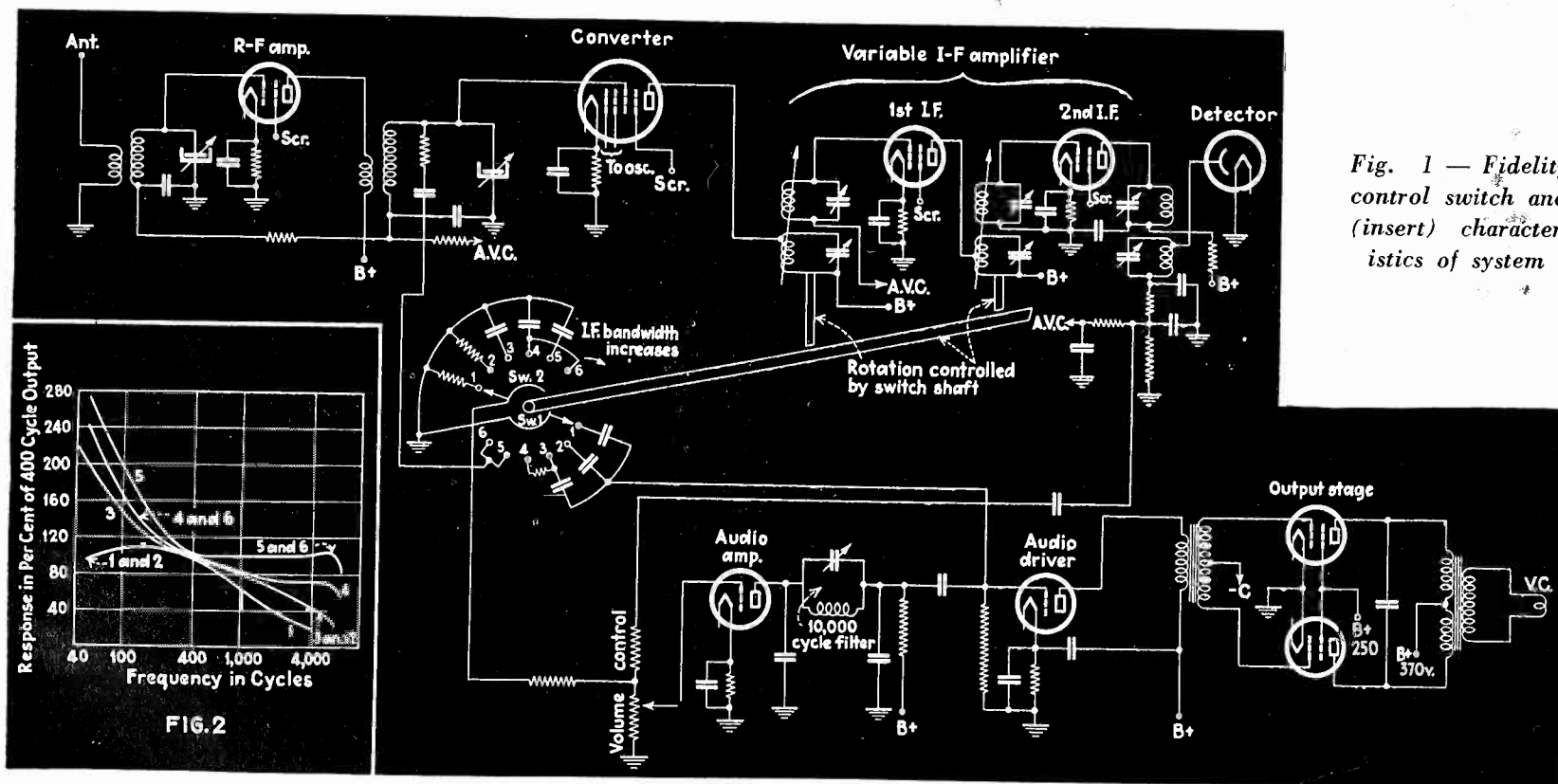

Fig. 1 — Fidelity control switch and (insert) characteristics of system

80% of the total bandwidth change from position No. 1 to 4. There is only a slight change in bandwidth of the i-f amplifier, when the control is moved from Position 5 to Position 6. The reason for this will be discussed later.

The function of the mechanical system used in the fidelity switch is to bring about the double peak effects or broad tuning in both of the sharp tuning i-f transformers. The third or diode transformer has fixed coupling and the bandwidth necessary in this transformer is dependent upon the degree of double peak effects produced in the preceding variable transformers. The mechanical arrangement used should be capable of varying the bandwidth of the i-f amplifier from approximately 4.0 to 18 kc. at two times. With the variable selectivity and the switching in the audio amplifier tied together, it is important that the mechanical system be free from back lash so that the same degree of selectivity can be obtained each time the switch is rotated to a given position. Curves showing what can be accomplished in bandwidth and also resonance curves for individual stages in a production receiver will not be given in this article, however, the reader is referred to the June 1935 issue of the *Proceedings of the Institute of Radio Engineers*, in which Messrs. Wheeler and Johnson give data on this subject and also to the June 1935 issue of *Electronics*.

Figure 2 shows the effects on the

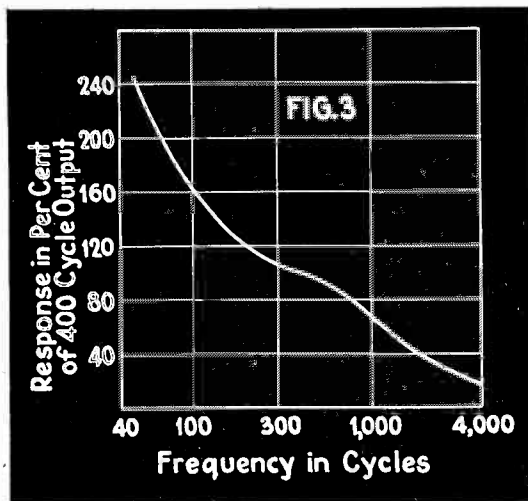

Fig. 3—Bass compensation characteristics

electrical output of a receiver as the fidelity control of Fig. 1 is turned to the various positions. These curves were taken with the volume control rotated to a position which brings the movable contact somewhere between the tap and the low potential end of the control. This position of the volume control is representative for average reception conditions as the tap is located at 50% of the total resistance of the control. By tracing the connections to Switch No. 1 and at the same time keeping in mind that the i-f amplifier increases in bandwidth as the switch is rotated from Position 1 to 6, the high frequency response characteristics shown in Fig. 2 can be readily understood. In Position 1 sufficient capacity is added across the input of the audio driver to reduce the high frequency response to a

value which will enable reception when the signal level is only slightly higher than the noise level. In this position and also in Positions 2, 3, and 4, the audio amplifier reduces the high frequency response in addition to that normally obtained due to the selectivity of the i-f and r-f amplifier. In Positions 5 and 6, the r-f and i-f amplifiers are limiting factors in the high frequency response, except for frequencies between 8,000 and 12,000 cycles which are attenuated principally by the 10,000 cycle filter in the audio amplifier. Frequencies higher than 12,000 cycles are sufficiently attenuated by the tweet filter associated with the diode output resistor and also by other fixed capacities used in the audio amplifier. Switch No. 1 performs another function besides that of controlling the high frequency response of the audio amplifier. The second function can be accomplished because the wiper arm of the switch is grounded. In Positions 5 and 6 the grounded wiper arm connects a resistance across the tuned circuit of the interstage r-f coil thereby materially increasing the overall high frequency response of the receiver. When the fidelity switch reaches Position 4, the i-f amplifier is expanded to the extent that the r-f interstage coil is the limiting factor as regards high frequency response. From Fig. 2 it will be observed that there is a considerable increase in high frequency response between curves 4 and 5.

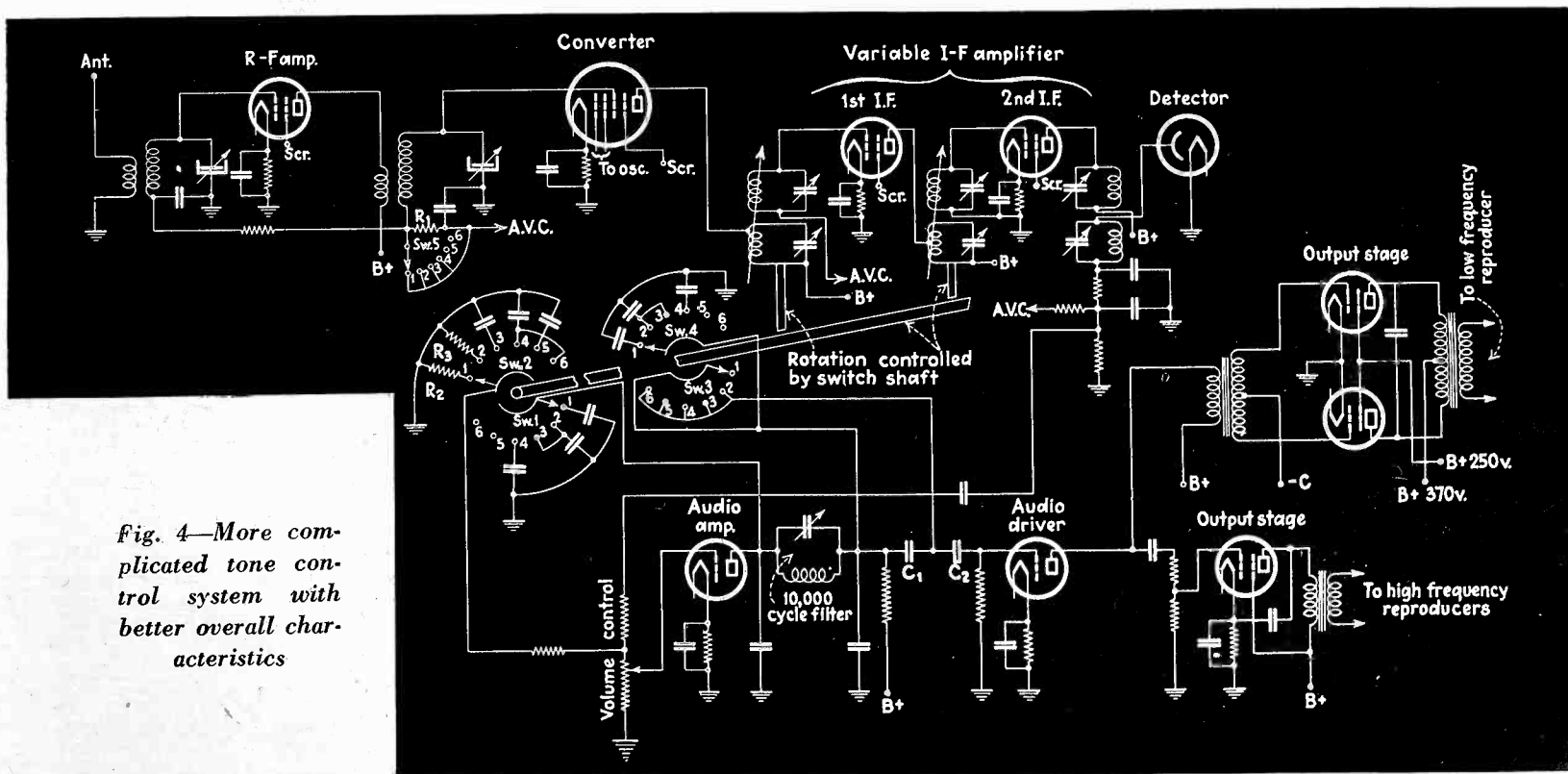

Fig. 4—More complicated tone control system with better overall characteristics

The difference in these two curves would not be appreciable if the r-f amplifier remained in its selective condition. It is desirable not to broaden the tuning of the r-f amplifier until maximum high frequency response has been obtained by other means, as a superheterodyne receiver is subject to numerous spurious responses when the selectivity of the r-f amplifier is impaired. It was not found necessary to reduce the selectivity of the antenna coil to obtain an overall fidelity of ± 2 db for a 7,000 cycle response. It is felt that this sequence of increasing the fidelity is most desirable where a manually controlled expander is used. Also this method does not reduce the gain of the antenna coil which is important in obtaining the best possible signal-to-noise ratio of the receiver at maximum expansion. The user must, of course, turn the fidelity control to Positions 1 or 2 to properly tune the receiver and then expand to suit his particular taste of proper reproduction, providing the expansion is not limited by atmospheric conditions or by interference of an adjacent station. There are numerous methods of tuning a high fidelity receiver of this type which do not require turning the fidelity control to its most selective position. Such systems have been described in recent issues of *Electronics* and other technical publications.

Bass Compensation

The control of the bass compensation is obtained by Switch No. 2. The circuit is conventional in that a capacity resistance shunt is used on a tapped volume control. Positions 1 and 2 allow no bass compensation, as the high frequency response is quite limited in these positions. Due to selective fading, hum modulation, electrical interference, and other limitations frequently present when receiving weak shortwave signals, the use of bass compensation would make the reproduction decidedly barrel-like in character unless the tap of the volume control is very close to the low potential end of the control, in which case the operating point is likely to be considerably above the tap for weak signals. This condition can also be avoided by appreciably reducing the sensitivity of the receiver which would bring the volume control near maximum in

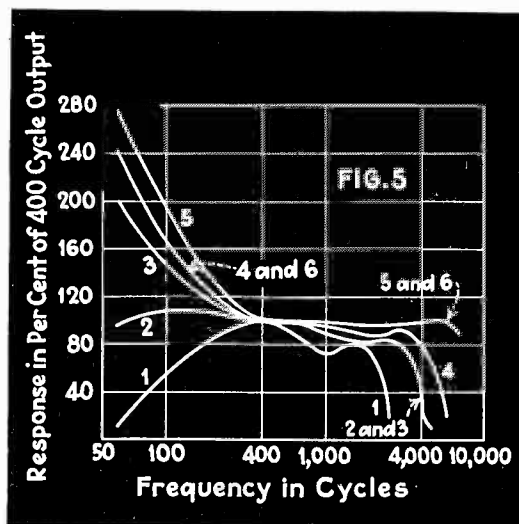

Fig. 5—Control characteristics of Fig. 4

which case the bass compensation would not be effective. Such a method of overcoming the difficulty would require a sensitivity control in the receiver and the user would also have to be familiar with its function.

The type of overall response characteristic obtained from a sensitive receiver which maintains full bass compensation, when the tone control is in a position for minimum high frequency response, is illustrated in Fig. 3. This is in general an undesirable frequency response characteristic and particularly so for voice reproduction. If arrangements are made to remove bass compensation it would seem most desirable to do so when the high frequencies are limited. With the fidelity control as outlined above, no arrangement is made for the removal of bass compensation, except in the positions having somewhat limited high frequency response. Should a reception condition be encountered which indicated the desirability of removing bass compensation when considerable high frequency response is present then Position 4 could be utilized for this purpose.

Positions 3 and 4 have bass compensation proportional to the high frequency response. These adjustments were made under conditions representative of average living rooms. Positions 5 and 6 have different bass compensation but have equal high frequency response. This allows the user a selection of bass compensation which is best suited to his particular taste or room conditions. With the explanation given above and with the curves of Fig. 2 it becomes evident that each posi-

tion of the fidelity control is aimed at making possible the best reception possible under a given set of circumstances. Position 1 is intended for the reception of signals which are essentially at the noise level of that particular location. For best reception of such signals, the circuits of both r-f and i-f amplifiers should have maximum selectivity, the audio amplifier should have a minimum of high frequency response and should, of course, have no bass compensation. Position 2 is intended for the reception of stronger signals and is also known as the "voice position" of the fidelity control as it passes sufficient high frequency for good voice definition and employs no base compensation. Position 3 is intended for those who desire a limited high frequency response with a liberal bass response. This position is most frequently used for the reproduction of dance music and might also be used for other purposes when local conditions do not permit a further expansion. Position 4 allows considerable more high frequency reproduction and would be used in preference to Position 3 when local conditions such as atmospheric and adjacent channel interference permit. Position 5 gives maximum high frequency response and maximum low frequency response. This position is best for the reproduction of the better types of music, such as symphonic music. Position 6 has the same high frequency response with less bass compensation. This was provided to give the user a choice of bass compensation at maximum fidelity. The choice of Positions 5 or 6 is often determined by the location of the receiver in a particular room. It is to be noted that with the above arrangement, the net effect of turning the fidelity control to the right is to increase the high frequency response relative to base response.

No doubt the best possible results might be obtained if all of the functions combined in the fidelity control switch were separated and brought out on external controls. This would allow the operator greater freedom of adjustment but would make a rather astounding and confusing array of control knobs.

Figure 4 shows a fidelity control switch which accomplishes more de-

(Continued on page 48)

Radio Resistor Measurement

Upward of 10 carbon composition resistors appear in every home and automobile radio. How to measure their important characteristics is a manufacturer and user problem

By EVERETT B. SCHWARTZ

Centralab Division
Globe-Union, Inc.

VOLTAGE and load characteristics of fixed composition resistors are of importance in determining the quality and suitability of such resistors for many types of industrial usage. Some applications demand characteristics varying widely from those required or suitable in other applications. Correct evaluation of these characteristics, and especially of that due to the effect of voltage alone, requires a thorough comprehension of the factors involved to enable the investigator to approach results not colored by individual methods.

In measuring these characteristics, two main effects are generally encountered. They include, (1) that which may be expressed as a "voltage coefficient"; and (2) that due purely to the heating effect of the applied load, expressed as a "heating coefficient". If the stable surface temperature of the resistor corresponding to the applied load is known, the heating effect may be described as a "temperature coefficient". Depending on the type of resistor and the amount of compensation introduced, these coefficients may be positive or negative in their effect on the resistance value. Usually, however, they are negative and take their sign from the characteristics of the main element, carbon. A third effect which is present sometimes and which must be considered is that due to permanent change of resistance with more or less prolonged application of any load. The permanent change during the test may also be either positive or negative in effect.

The voltage coefficient may be defined as, "an instantaneous change in the resistance value in ohms, per ohm, per volt, following a change in impressed voltage from one value to that of another—no time being

allowed for heating at either voltage". The actual voltage coefficient is seldom desired because it is not a real constant for any one type; varying not only with the resistance value, but also with the initial voltage and the voltage difference.

In commercial practice it is more desirable to know by what percentage a given resistance changes under different conditions. Therefore, a "voltage characteristic" is generally taken. This may be defined as, "a series of percent instantaneous overall changes in resistance for corresponding changes in applied 'cold load' from an initial load requiring a low voltage to others requiring successively higher voltages—with no time allowed for heating at any measurement". The results are conveniently plotted as a curve of "per cent overall change in re-

sistance" against "percent of rated load".

The word "instantaneous" above is very important. While the measurement of such instantaneous changes is difficult to achieve, it may be approached closely by any method which gives a very rapid indication of the resistance value *the moment that the voltage is applied*.

Probably one of the most accurate methods for obtaining the voltage characteristic of a resistor would be by means of a precision bridge circuit wherein the voltage could be applied for an exceedingly short interval of time by momentarily pressing a button in the supply circuit. The brief flick of the galvanometer needle in one direction or another would be a very rapid indication of whether the bridge decade was set too high or too low for balance. Difficulties are presented as follows:

(a) The voltage actually applied across the resistor is a function

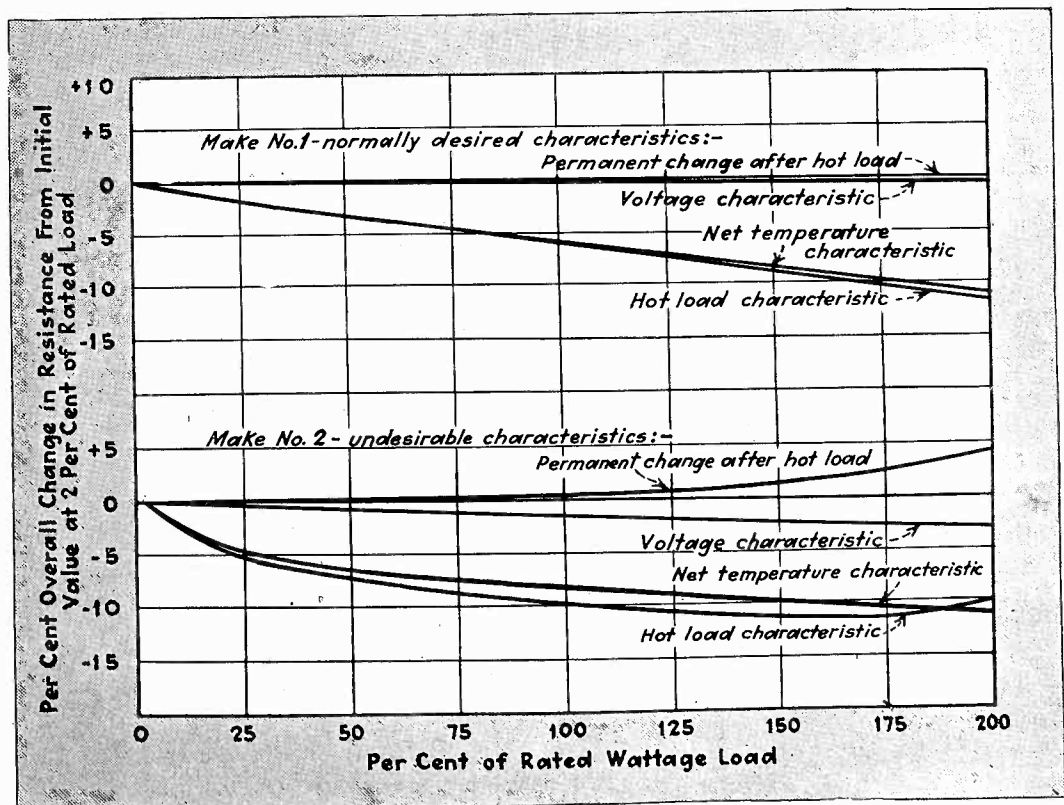

Desired and undesired composition resistor characteristics

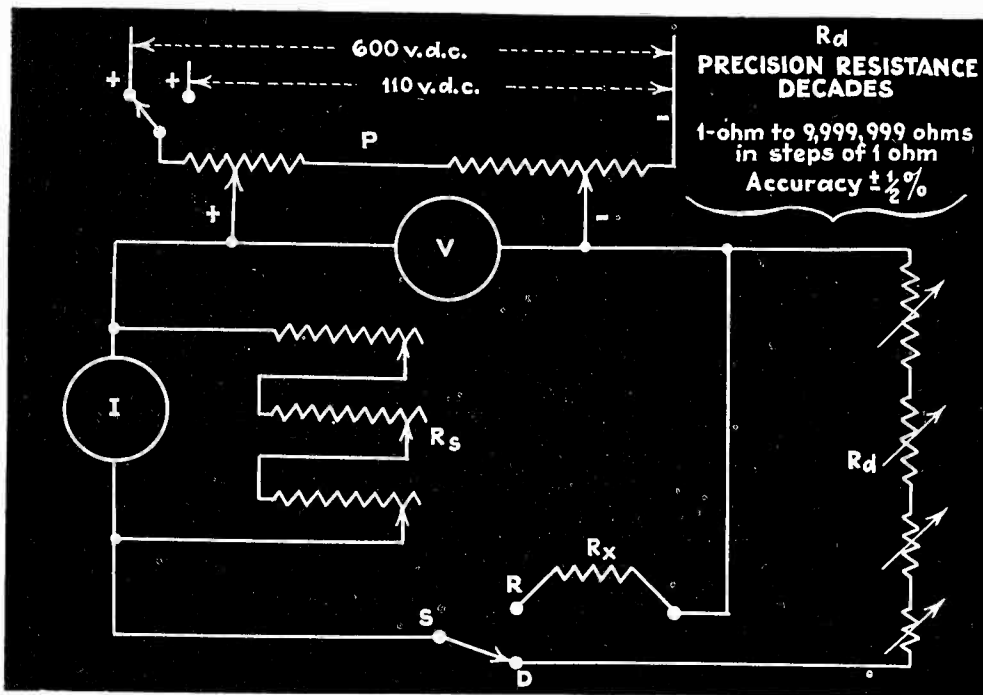

Fig. 1—Practical circuit for measuring voltage characteristic

of the ratio arms of the bridge and is not readily determinate except by calculation. After each readjustment of the bridge, the net voltage on the resistor would change;

- (b) Most resistance bridges are not constructed to withstand the high voltage necessary in running a complete voltage characteristic check on resistors of relatively high resistance values.

The conventional voltmeter-ammeter method of measuring resistance is outlawed mainly by the time element involved in obtaining a reading. By the time the current meter needle would start from rest and approach the correct point on the scale, enough heating effect may have occurred to falsify the indication. Indeed, for resistors having even a moderate temperature coefficient, no discernible hesitation of the needle could be noted to mark the reading corresponding to the true voltage coefficient. Instead, the needle would continue to shift slowly until the resistor had stabilized at the 'hot' value corresponding to the load. Another fault is that multi-range instruments are needed to cover a single complete test. It is difficult to obtain suitable instruments whose several ranges are exact multiples of each other. It is even more difficult to keep them so. Therefore, every time a new scale range must be introduced into the test, erratic results are possible.

The method used by the writer for obtaining the voltage characteristic, or, if desired, the voltage coefficient, combines the method of application of the voltage and the feature of a directly read voltmeter, as in the voltmeter-ammeter method, with the precision resistances and momentary flick of an indicating needle, as in the 'bridge' method.

The Voltage Characteristic

In Fig. 1 the current meter (0-200 microampere), is *not* used for a direct reading of any current value and need not be accurate. It is merely used as an indicating device. The plug type resistance box associated with it, as a shunt, is utilized only to adjust the indication to a convenient point of the scale.

With the resistance to be measured at R_x and with switch, S , at D , an estimation of the possible value of R_x at the desired load is made and this estimated value is then preset on the precision decade boxes, R_d . The voltage is adjusted by means of P , until the voltmeter reads the desired load voltage. Next, the shunt resistance across the current meter is increased until the needle is at a convenient point on the scale. Then the switch, S , (which is of the snap action type) is thrown from D , to R , and then back to D again.

The total time consumed in this operation should be less than about one-eighth of a second. If, during the above process, the current meter needle showed a "start" or tendency to move toward the upward part of the scale at the in-

stant contact to R was made, the decade boxes were set at too high a value and should be lowered for a new trial. An opposite flick of the indicating needle should be met by an increase of the pre-set resistance standards. After a few trials of this nature, a value of decade resistance will be found which results in no discernible movement of the needle during the switching operation. To avoid accumulative heating, a slight rest should be given R_x after several consecutive trials. The decade resistance setting then reads the exact value of R_x under the effect of the specific voltage employed, without at the same time including any effect due to heating.

The percentages overall change in resistance value for several percentages of rated load wattage should be plotted as per the definition for the "voltage characteristics".

The method outlined is more accurate than most because: 1. There is no heating; 2. The accuracy depends *only* on the precision of the decades which may be set to more places than one would be justified in deriving from the readings of voltage and current; 3. Greater accuracy may be obtained by observing and correcting for the movement of a needle than by trying to interpret the position of that needle on a calibrated scale.

To compare voltage characteristics of differently valued and rated composition resistors the following suggestions are given:

1. Regardless of the actual load resulting if there happens to be a considerable change in resistance with voltage change, the voltage set to give a certain percent of rated load should be computed on the basis of the original or nominal resistance value.
2. The initial or base reading of the resistance instead of being read at some low voltage universally employed for all resistances and ratings should be read at the voltage corresponding to the same proportionate part of the rated load—such as the voltage corresponding to an initial load of one or two percent of rated load watts.
3. An exception to the above is the case when the resistor to be measured is of such a high value that its rating is limited by the maximum voltage permitted instead of wattage. In this case an initial voltage of 10% of the maximum voltage should be employed for the base reading.
4. Subsequent voltages of measurement should be computed on the

basis of even division or multiples of the rated load wattage, or $E = \sqrt{KW R}$, where K is the factor of multiplication, W is the manufacturer's rating in watts, and R is the nominal resistance value in ohms.

5. As before the exception is for those resistors requiring the voltage limitation and for which even divisions of the maximum voltage should be used.
6. All differences in overall resistance should be recorded as percentage overall changes from the initial or base value.
7. The ambient temperature during the test should be kept constant and, if possible, of the same value for each test.

In taking up the second main effect mentioned as having a bearing on the performance characteristics of fixed composition resistors as exemplified by the voltage-load characteristics, it was stated that the effect was due purely to the heating caused by the load applied. The problem is then not to avoid the effect, as was done in the method described for obtaining the voltage characteristic, but to seek it.

Unfortunately, the heating effect of the load on the resistance value is not directly ascertainable because the effect of the voltage is present simultaneously, as is also any effect of permanent change. However, the combination may be determined as the total, or "hot load effect" by almost any of the conventional methods of measuring resistance in which the measurement can be made

while the load is applied, provided it has been applied a sufficient time for the resistor to attain stable radiation. The voltage effect is determinable, as has been explained, and so also is the effect due to permanent change, as will be explained presently. Therefore the temperature effect due to heating only may be calculated by algebraically subtracting the sum of the known quantities from the total for the same load. The overall change in resistance due purely to the temperature effect is, then, the difference between that value and the original initial (cold) value as found previously. The 'heating coefficient' for a particular range involved may be defined as, "the overall change in resistance in ohms, per ohm, per watt resulting purely from the change in resistor temperature occasioned by a change in load from one steady, hot value to another steady, hot value".

Sometimes writers refer to the total ohmic change in resistance occasioned by a change in load as a "temperature coefficient". This is erroneous because a true coefficient of temperature must be expressed not in simple units such as ohms, but in units per degree. Also, for all resistors other than wirewound, the total change in resistance due to varying the load is a complication of factors other than that due solely to heating.

Just as in the discussion on voltage coefficient it was stated that the

"voltage characteristic" of a resistor was of more practical interest, so also does the "load characteristic" more often give a better picture of its performance under steady, hot loads than do single values such as heating or temperature coefficients. The load characteristic of a resistor may be defined as, "a series of percent overall changes in resistance from an initial value taken for a load which requires a very low voltage and which is applied only for an instant, to other hot values corresponding to the respective steady-state loads requiring successively higher applied voltages". The results are conveniently plotted along with the voltage characteristic and to the same scale. Now if a voltage characteristic is run first, followed by a load characteristic, and if the amount of any permanent change is recorded simultaneously with the latter characteristic, all the data necessary are then at hand for computing any breakdown value desired.

While a hot load measurement can be made by any method in which the resistor is kept continually under load, the voltmeter-ammeter method is somewhat unsuitable for taking the whole characteristic for the same reason that a multi-range current indicating instrument may be inadvisable for taking the voltage characteristic. However, a modification of the circuit previously given will convert it from a method of taking instantaneous readings to one which permits an accurate ohmic measurement of the resistor under a steady, hot load.

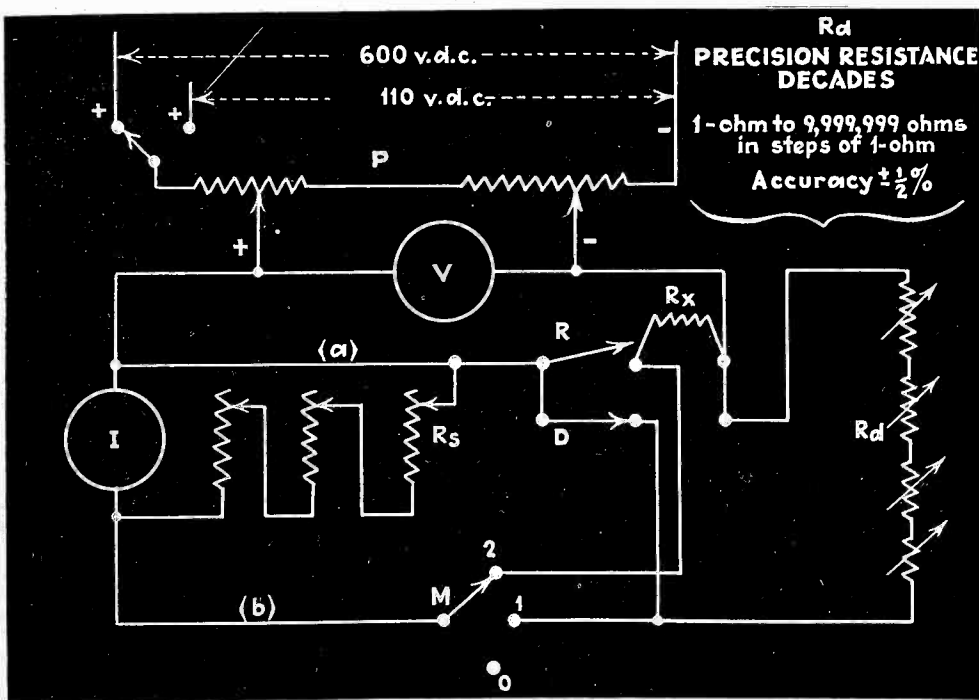

Fig. 2—Load characteristic set-up

In Fig. 2 I is a 0-200 micro-ampere meter and is not used for reading specific current values directly. It need not be accurate. The switches shown must be of the wiping contact type, having a low contact resistance.

With the resistance to be measured under hot load at R_x and with switches R and D closed, an estimation is made of the value of R_x and this value is preset on the decades, R_d . The voltage is brought up by adjusting P until the voltmeter reads the desired load voltage. This voltage is impressed through lead (a) on both R_x and R_d . It should remain on a sufficient length of time to insure that the resistor has reached temperature equilibrium.

After the resistor has reached

(Continued on page 106)

The Padding Condenser

Another solution to the perennial problem of mis-tracking in superheterodyne receivers. This one involves a slight mechanical change in the tuning condenser

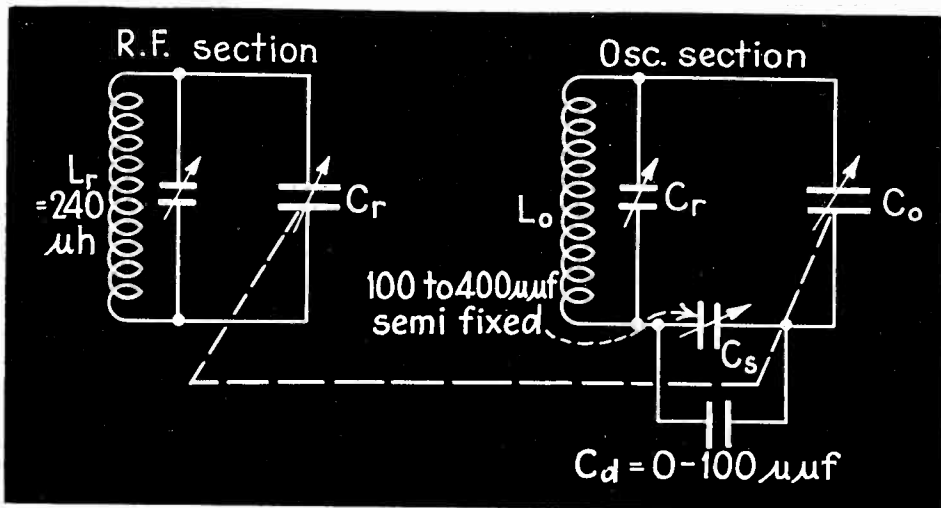

Fig. 1—Superheterodyne amplifier-oscillator section

By LOUIS B. SKLAR

PERFECT tracking in one-dial superheterodyne is, of course, a theoretical impossibility. It belongs to the same class as squaring the circle, trisecting the triangle, finding the exact value of π , and many others.

While it is true that a 100 per cent perfect solution is impossible, for all practical purposes, however, any solution within the limits of near-perfection is satisfactory. With this view in mind the writer derived a few simple equations which can be applied to find the various constants applicable to any type superheterodyne circuit.

Figure 1 shows a schematic diagram of a superheterodyne circuit. L_r and C_r are of such proportions that the circuit will tune from a maximum of 1600 kc. to a minimum of 540 kc. L_o and C_o are of such proportions that this circuit will tune from a maximum 2060 kc. down to 1000 kc. The i-f circuit is permanently tuned to resonate at 460 kc.

To obtain the greatest selectivity and efficiency in the i-f circuit the local oscillator must be so adjusted that it will always be exactly 460 kc. above the carrier frequency f_r .

Almost without exception, all modern one-dial superheterodyne receivers use variable condensers of equal capacity. The higher frequency in the oscillator circuit is obtained by using an oscillator coil of lower inductance than the r-f coil and by placing a fixed or semi-fixed, padding condenser C_s in series with the oscillator variable condenser, as shown in Fig. 1.

Let us take a specific problem: Suppose r. f. = 540 to 1600 kc., i. f. = 460 kc., and the variable condenser consists of two sections in tandem, each section having a maximum capacity of $370 \mu\mu f$. The r-f inductance coil is $240 \mu h$.

The problem is to find the value of the oscillator inductance coil L_o and the value of the padding condenser C_s . These values have to be of such proportions, that when the variable r-f and o-f condenser sections change from a maximum to a minimum, the frequency in the oscillator circuit has to be exactly 460 kc. higher than in the r-f circuit. This of course, is impossible, for this reason: a glance at Fig. 2, curve "A" shows the relation of frequency vs LC . Curve "B" is a similar curve

plotted in such a fashion that every point on "B" is exactly 460 kc. above "A". This would be the ideal condition. Such a thing, however, is a mathematical impossibility. The nearest to it would be a curve somewhat like "C".

In other words, if we use certain values of C_s and a certain fixed inductance L_o we will get a curve which will approach nearly the ideal curve "B". It will be observed that curve "C" being an hyperbola as well as curve "B", the two curves will meet at two points, and two points only.

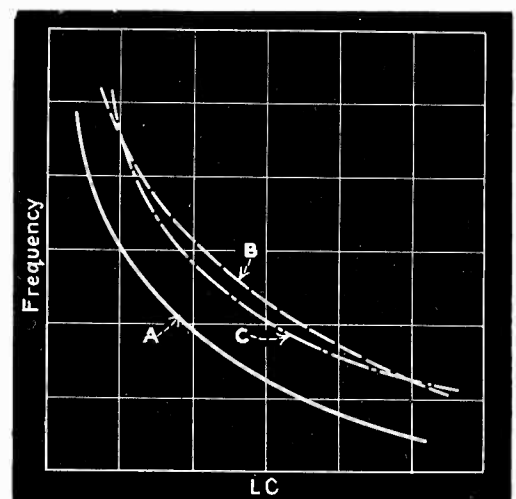

Fig. 2—Misalignment in frequency changing

With the view in mind that perfect tracking can only be accomplished at two points on the dial, the writer devised a new method whereby the values of L_o and C_s can be computed very quickly. The two points are the two extreme frequencies of the band; in our particular example, they are: 540 and 1600 kc., r-f or 1000 to 2060 kc., o-f.

The equation for finding C_s is as follows:

$$C_s = \frac{C_{r-max} \times C_{r-min} (K-1)}{C_{r-min} - K C_{r-max}} \quad (1)$$

C_s = the padding condenser.

C_{r-max} = r-f variable condenser at 1600 kc.

C_{r-min} = r-f variable condenser at 540 kc.

$$\text{and } K = \left(\frac{f_{max}}{f_{min}} \right)^2$$

After finding C_s , L_o can easily be computed by a single algebraic equation.

The equations used for finding the value of C_s as well as for all other computations in this paper are of logarithmic form. This was done, on account of the greater simplicity in using logarithms in the solution of problems of this nature.

The equation in logarithmic form is:

$$2 \log f + \log L_o + \log C_r - 10.40364 = 0 \quad (2)$$

f , = frequency in kc., $L_o = \mu h$ and $C_r = \mu \mu f$.

All computations are accurate to 5 and 6 decimal places.

Solving for $C_r - 540$, we get,
 $\log C_r - 540 = 2 \log f - 540 + \log L_o - 10.40364$

Substituting the values of f and L_o in the above equation, we get

$$\log C_r - 540 = 2.55865 \text{ and } C_r - 540 = 361.95$$

similarly

$$\log C_r - 1600 = 1.61519, \text{ and } C_r - 1600 = 41.228$$

We know, that in any circuit, the inductances remaining constant,

The above is boiled down to the following equation:

$$C_s = \frac{C_r - 1600 \times C_r - 540 (K-1)}{C_r - 540 - K C_r - 1600} = \frac{14922.5 \times 3.2436}{361.95 - 4.2436 \times 41.228} = 258.84 \mu \mu f$$

$$\text{and } C_o - 2060 = \frac{258.84 \times 41.228}{258.84 + 41.228} = 35.563 \mu \mu f$$

Substituting the value of C_o in equation (2) we can easily find L_o (oscillator inductance)

$$-L_o = 2 \log 2060 + \log 35.563 - 10.40364$$

and $L_o = 167.846 \mu h$

similarly,

$$C_o - 1000 = \frac{258.84 \times 361.95}{258.84 + 361.95} = 150.914 \mu \mu f$$

Substituting in equation (1), (as a check) we get:

$$(2 \log 1000 = 6) + (\log L_o = 2.22491) + (\log C_o - 1000 = 2.17873) = 10.40364$$

We now have L_o and C_s , and we also know that by using these values we will get perfect tracking at two frequencies on the two extreme ends of the band. The question is, how will this combination work out on all parts of the band? Column (6)

of table 1 shows the results. It shows that with $L_o = 167.846$ and $C_o = 258.84$, C_o will, at certain frequencies be exceeded by $5.7 \mu \mu f$. This excess capacity is undesirable if perfect tracking is to be obtained. To remedy this situation, a vernier variable condenser can be used in the oscillator section of the 2-gang condenser. This, however, would mean another control and would also complicate matters somewhat, especially if the set is handled by an inexperienced operator.

The writer, therefore devised the following scheme. With this scheme perfect tracking can be obtained, and at the same time will retain the single-dial feature.

Column (8) Table 1 shows the amount of capacity to be removed from C_s at various frequencies to produce a perfect C_o . These figures were calculated as follows:

$$C_o^1 = \frac{C_r C_s^1}{C_r + C_s^1}$$

$$C_r C_s^1 = C_o^1 C_r + C_s^1 C_o^1 \text{ and } C_s^1 (C_r - C_o^1) = C_o^1 C_r$$

$$C_s^1 = \frac{C_o^1 C_r}{C_r - C_o^1}$$

C_s^1 Column (7) is the padding condenser capacity required to produce the ideal oscillator capacity C_o^1 (column 5). Column (8) gives the various capacities C_d required to be removed from C_s .

Figure 3 which is the graph illustrating the relation of C_d vs f_o shows that the variations in C_d are the same on either side of the midpoint of the broadcast band.

Since the curve on Fig. 3 is almost a semicircle, a semicircular condenser, of $100 \mu \mu f$ was coupled to the shaft of the main 2-gang condenser and arranged as shown on Fig. 4. With this arrangement C_s will have the

(Continued on page 100)

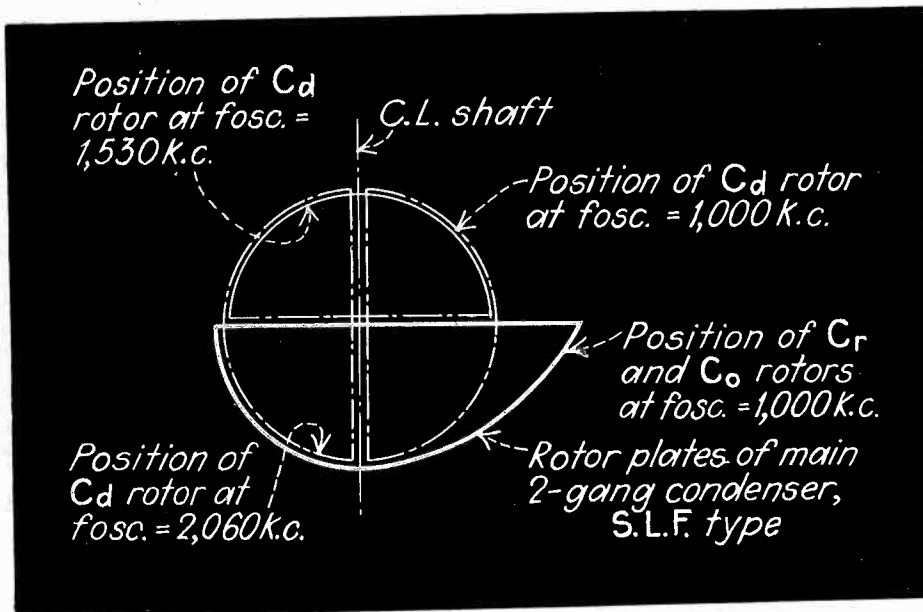

Fig. 4—An arrangement for better tracking

$$(f_1/f_2)^2 = C_2/C_1 = K$$

in our particular case

$$f^2_{2060}/f^2_{1000} = C_o - 1000/C_o - 2060$$

C_o = Oscillator condenser capacity required, which is equal to the combined capacity of C_r and padding condenser C_s , K is the proportionality factor, and is equal to $(2060)^2/(1000)^2 = 4.2436$

$$\text{Since } C_o - 1000 = \frac{C_r - 540 \times C_s}{C_r - 540 + C_s}$$

$$\text{and } C_o - 2060 = \frac{C_r - 1600 \times C_s}{C_r - 1600 + C_s}$$

$$\frac{C_r - 540 \times C_s / C_r - 540 + C_s}{C_r - 1600 \times C_s / C_r - 1600 + C_s} = K =$$

$$\frac{(C_r - 540 \times C_s) (C_r - 1600 + C_s)}{(C_r - 1600 \times C_s) (C_r - 540 + C_s)}$$

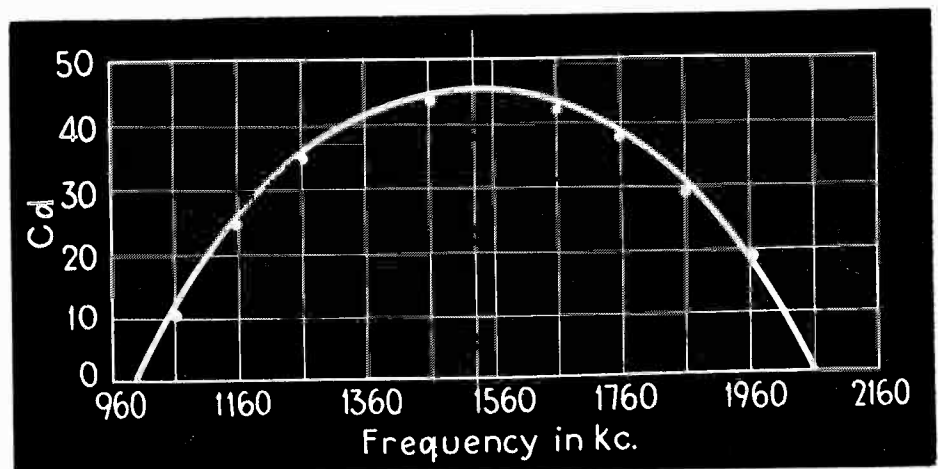

Fig. 3—Relation between excess capacity and frequency

Tubes At Work

The editors invite attention to the problem in flue-gas control, raised below. Solutions will be welcomed. Other tube applications presented this month are for welding control, burglar protection, and paint-thickness gauging

An Electronic Problem in Flue Gas Control

Mr. W. S. Wilder, technical assistant to the chief electrical engineer of the Milwaukee Electric Railway and Light Company, describes the existing installation of phototube equipment to a difficult situation. Having solved this problem, a still more complex one presents itself, that of projecting a ray of light across 40 feet of boiler breeching, filled with rapidly moving gases, onto the small area of a phototube.—The Editors

THE PHOTOTUBE APPLICATION that we now have under consideration is the logical sequence to our recent installation of what we believe to be the successful solution of the most difficult smoke indicating phototube application installed to date. The installation now in service successfully indicates flue gas conditions in the discharge breeching of a 690,000 pound-per-hour boiler, burning powdered coal applied to the furnace through twenty fire nozzles. Due to the boiler discharge breeching

leaving the boiler casing in two sections, it was necessary to resort to a rather unique mounting arrangement for the phototube equipment.

Due to the presence of smoke washers between the induced draft fans and the stack, the only suitable place where the phototube equipment could be mounted was on the induced draft fan casings. The two induced draft fans are mounted in their respective casings, parallel to each other in such a manner that by connecting a piece of 4" pipe 14½ ft. long between the casings, and mounting the phototube and light source on the two fan casings opposite this connecting pipe, the light beam was made to traverse the flue gas discharge area of the two fans, thus securing an indication of flue gas conditions across the discharge of the boiler. The wrought iron pipe, after some experimentation, was kept clear of smoke and ash by placing a glass partition across

it at middle distance from either end, and installing air vents adjacent to this partition so that the partial vacuum in the induced draft fan chamber would draw fresh air across the face of the glass partition and through the connecting 4" pipe. By thus keeping the interior of the pipe clear, the light beam from the phototube light source in its passage through the induced draft fan chambers and interconnecting pipe is intercepted only by flue gases in the induced draft fans.

Due to the use of powdered coal as a furnace fuel, the furnace flue gases are normally far from transparent, even under ideal combustion conditions. The problem in the phototube application was to detect changes in flue gas density, due to the presence of unconsumed combustibles (soot). The application, which has been made successfully, detects changes in flue gas density within 5 per cent. Experience has indicated that over a wide range of firing conditions, the density of the boiler flue gases under proper firing conditions varies but slightly, so that an alarm relay functioning in conjunction with the phototube detector can be set to sound a warning when combustion is not satisfactory. The application that has been made successfully detects changes in flue gas density, due to variation in the adjustment of one out of the twenty pulverized fuel firing burners. It is thus possible not only to detect the presence of smoke being emitted from the stacks, but to check upon combustion conditions in the furnace and the adjustment of individual burners on a large boiler. Even a slight improvement in efficiency by reduction in combustibles in the discharge gases will, in a year's time, result in savings far in excess of the cost of the phototube equipment.

The equipment which has been successfully installed is a General Electric type CR-7505-Y1 phototube and their type CR-7500-Y5 light source. A 50 c.p. automobile headlight-type lamp is used in the light source. The phototube is of the gas-filled type. In addition to the light source and phototube, a strip-chart type recording milliammeter provides a continuous record of flue gas condition.

The New Problem

The problem which now confronts us requires the projection of a beam across 40 feet of boiler breeching, or the

IGNITRON "GUN" PHOTOGRAPHS FAST-MOVING OBJECTS

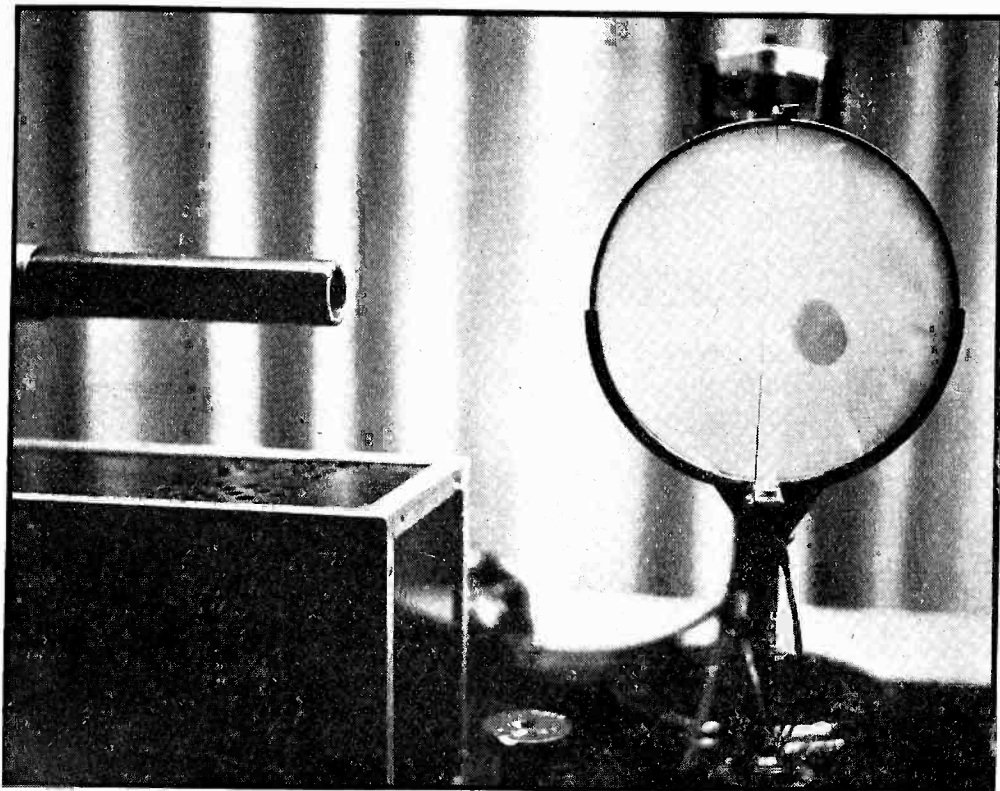

A small rubber "bullet", fired from a gas-operated gun, breaks a wire stretched across its path, thus interrupting the grid control circuit of an ignitron which fires within one-millionth of a second. The ignitron's light shows the "bullet", apparently stationary, in silhouette against a white screen. The device was shown by Dr. Phillips Thomas of Westinghouse

application of two phototubes in two discharge breechings in parallel. Two phototubes, since they must indicate conditions in the double discharge from one boiler, should be connected so as to operate one milliammeter. Obviously, the first approach to our problem suggests the procurement of a powerful light source which will penetrate 40 feet of flue gases with a concentrated beam so as to give a high intensity on a small surface of a phototube. A careful survey of the market indicates there is no commercially available light source with a concentrated beam which will project a high intensity light on the small area of a photocell 40 ft. away. Special lights, such as used in motion picture projectors, are available with suitable lenses for the application we have in mind, but when it is considered that the light source must be on continuously 24 hours a day, year in and year out, the high cost of these projection bulbs removes them from serious consideration. It is possible to build up a suitable reflector, using long-life, low-cost lights, but such a job would be special and run into more money than we care to invest in an experiment.

It has been suggested that a phototube device operating on a reflection principle might be more sensitive to color changes in boiler flue gases than a photocell operated by a penetrating beam. Naturally, the presence of even a small amount of soot in the light gray fly ash in the boiler discharge gases changes the color of the gases and their reflecting properties.

Surge Meter for Welding Measurement

IN MODERN WELDING operations, where large amounts of power are involved, it is highly desirable to measure the strength and duration of each welding cycle, not only to conserve power but to insure the excellence of the weld. To measure such current impulses, when they last only a few cycles, is not an easy matter, especially since the instrument must be simple, rugged, and capable of operation by an ordinary workman. The oscillograph, which is suitable for the purpose, is ruled out by practical considerations. However, it is possible to use a single rectifier tube to measure the current surges, as shown in the accompanying diagram which was developed by Dr. Paul G. Weillet, of the Welding Timer Manufacturing Company. The principle of operation is as follows: A winding which surrounds the primary lead of the welding transformer is connected through shunting resistors to a rectifier tube which charges a condenser. The condenser charge is proportional to the duration of the current flow and to its strength. The voltage indicated by the high resistance voltmeter across the condenser is a direct measure of the condenser charge and hence of the

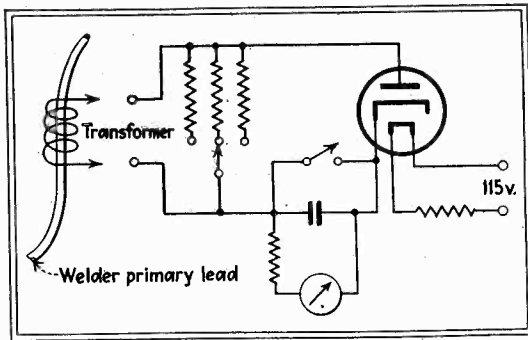

Welding surge-meter circuit

current surge. The accuracy of the instrument is about 5 per cent, which is sufficient for most purposes. Three ranges are obtained by shunting the transformer secondary by resistors of the proper value. In operation the indicating meter swings out when the welding current flows, returns quickly to a few divisions and then stops for a short time, thereafter gradually returning to zero. Readings are taken of the momentary stop. The meter is calibrated in r.m.s. units for readings taken either on long impulses (longer than 60 cycles duration) or short impulses, of the order of two cycles.

Infra-Red Photo-Alarm Protects 13,000 Sq.Ft.

AN IMPRESSIVE DEMONSTRATION of the use of infra-red light for protective purposes was given in New York recently by engineers of the Signaphone Corporation. The installation was made on the fourth floor of the General

Electric Building, a plan of which is shown in the diagram. The black lines indicate the path taken by the infra-red light from the light source to the phototube. A total of eleven mirrors (several of them serving double duty) was used to reflect the light back and forth over the enclosed area. The total length of the light beam was 1,800 ft. and the area protected 13,000 sq.ft.

The light source was a 32-candle-power automobile lamp in a projector fitted with a special filter which removed all of the light except the infra-red. Mirrors are placed inconspicuously on the walls of the room and are adjusted for the proper angle of reflec-

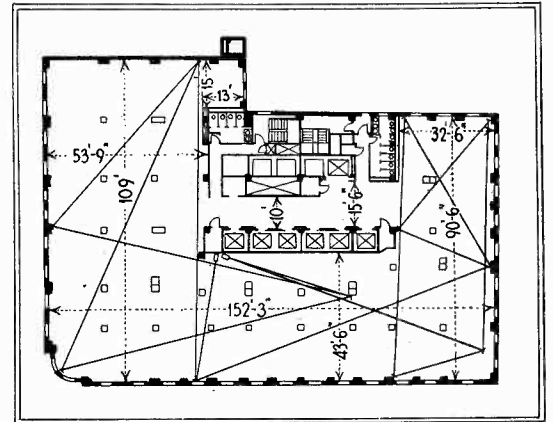

Plan of floor protected by criss-cross beams of infra-red light, at General Electric Building, New York

tion. The photo tube, which is of the infra-red sensitive caesium variety, feeds a sensitive amplifier which is responsive to very small changes of phototube current. This high sensi-

(Continued on page 52)

"EYE AND EAR" IN RADIO CIRCUIT ANALYSIS

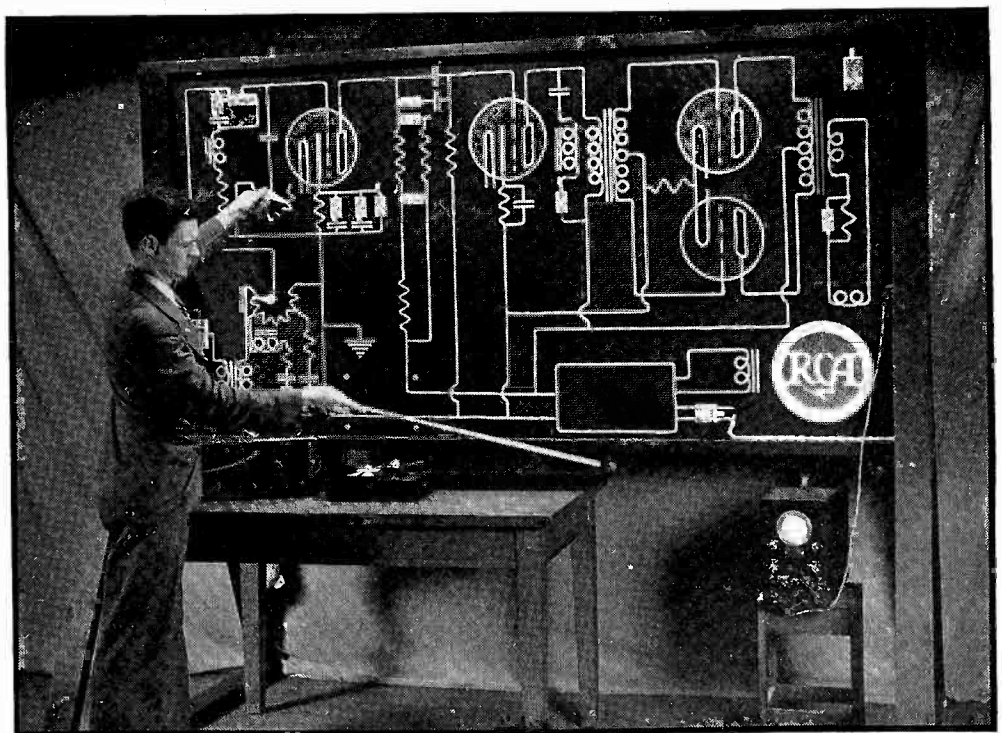

This unusual board has been used by RCA in service meetings to demonstrate both visually and audibly the effect of changing circuit connections on the audio response of an amplifier. Switches change the circuit, while the oscillograph shows the resulting response curve

INSTITUTE OF RADIO ENGINEERS

Silver Anniversary Convention

NEW YORK . . . MAY 10, 11, 12 . . . HOTEL PENNSYLVANIA

PROGRAM

MONDAY, MAY 10

9 a.m.

Registration and exhibition open

10:30 a.m.—12:30 p.m.

Official welcome by H. H. Beverage, President of the Institute. The last paper in this technical session is sponsored by the Radio Club of America and the speaker will be introduced by J. H. Miller, President of that organization.

Technical Session—Ballroom

"The Development of Radio Telephony" By Lloyd Espenschied, Bell Telephone Laboratories, Inc., New York, N. Y.

"Transoceanic Radio Telephone Developments" by Ralph Bown, Bell Telephone Laboratories, Inc., New York, N. Y.

"Ground Systems as a Factor in Antenna Efficiency" by G. H. Brown, R. F. Lewis, and J. Epstein, RCA Manufacturing Company, Inc., Camden, N. J.

"Simple Method for Observing Current Amplitude and Phase Relations in Antenna Arrays" by J. F. Morrison, Bell Telephone Laboratories, Inc., New York, N. Y.

"Ultra-High-Frequency Relay Broadcasting" by W. A. R. Brown and G. O. Milne, National Broadcasting Company, New York, N. Y.

2:30 p.m.—5 p.m.

Technical Session—Ballroom

"The Ultra-Short-Wave Beacon and Its Field of Application" by Walter Hahne-mann, C. Lorenz, A. G., Berlin, Germany.

"A Multiple Unit Steerable Antenna for Short Wave Reception" by H. T. Friis and C. B. Feldman, Bell Telephone Laboratories, Inc., New York, N. Y.

"Time Division Multiplex in Radio Telegraphic Practice" by J. L. Callahan, R. E. Mathes, and A. Kahn, RCA Communications, Inc., New York, N. Y.

"Automobile Receiver Design" by F. D. Schnoor and J. D. Smith, RCA Manufacturing Company, Inc., Camden, N. J.

"Radio Methods for the Investigation

of Upper Air Phenomena with Unmanned Balloons" by H. Diamond, W. S. Hinman, Jr., and F. W. Dunmore, National Bureau of Standards, Washington, D. C.

"Characteristics of the Ionosphere and Their Application to Radio Transmission" by T. R. Gilliland, S. S. Kirby, N. Smith, and S. E. Reymer, National Bureau of Standards, Washington, D. C.

"An Automatic Sound Pressure Recorder" by W. S. Bachman, General Electric Company, Bridgeport, Conn.

TUESDAY, MAY 11

9 a.m.

Registration and exhibition open

10 a.m.—12 noon.

Technical Session—Ballroom

"A Basis for Vacuum Tube Design" by M. A. Acheson, Hygrade Sylvania Corporation, Emporium, Pa.

"The Development Problems and Operating Characteristics of a New Ultra-High-Frequency Triode" by W. G. Wagner, RCA Manufacturing Company, Inc., Harrison, N. J.

"Effects of Space Charge in the Grid-Anode Region of Vacuum Tubes" by B. Salzberg and A. V. Haeff, RCA Manufacturing Company, Inc., Harrison, N. J.

"Study of Changes in Contact Potential" by E. A. Lederer, D. H. Walmsley, and E. G. Widell, RCA Manufacturing Company, Harrison, N. J.

"An Oscillograph for Television Development" by A. C. Stocker, RCA Manufacturing Company, Inc., Camden, N. J.

6 p.m.

Registration and exhibition close

WEDNESDAY, MAY 12

9 a.m.

Registration and exhibition open

10 a.m.—12:30 p.m.

Technical Session—Ballroom

"Relation Between Radio Transmission Path and Magnetic Storm Effects" by

G. W. Kenrick, University of Puerto Rico, Rio Piedras, P. R.; A. M. Braaten, RCA Communications, Inc., Riverhead, N. Y., and J. General, RCA Communications, Inc., San Juan, P. R.

"A New Antenna Kit Design" by W. L. Carlson and V. D. Landon, RCA Manufacturing Company, Inc., Camden, N. J.

"Concentric Narrow Band Elimination Filter" by L. M. Leeds, General Electric Company, Schenectady, N. Y.

"Higher Program Level Without Circuit Overloading" by O. M. Hovgaard, Bell Telephone Laboratories, Inc., New York, N. Y.

"A Wide Range Beat Frequency Oscillator" by J. W. Brumbaugh, RCA Manufacturing Company, Inc., Camden, N. J.

"Measurement of Condenser Characteristics at Low Frequencies" by W. D. Buckingham, Western Union Telegraph Company, Water Mill, N. Y.

"A New Method of Measurement of Ultra-High-Frequency Impedance" by S. W. Seeley and W. S. Barden, RCA License Laboratory, New York, N. Y.

2 p.m.—5 p.m.

Technical Session—Ballroom

The following papers on television problems are by members of the staff of RCA Manufacturing Company, RCA Radiotron Division, Harrison, N. J.

"Development of a Projection 'Kinescope'" by V. K. Zworykin and W. H. Painter.

"High Current Electron Gun for Projection 'Kinescopes'" by R. R. Law.

"A Circuit for Studying 'Kinescope' Resolution" by C. E. Burnett.

"The Brightness of Outdoor Scenes and Its Relation to Television Transmitters" by H. Iams, R. B. Janes, and W. H. Hickok.

"Television Pick-up Tubes with Cathode Ray Beam Scanning" by H. Iams and A. Rose.

"Theory and Performance of the 'Iconoscope'" by V. K. Zworykin, G. A. Norton and L. E. Flory.

3 p.m.

Close of registration and exhibition

7 p.m.

Silver Anniversary Banquet

Slide-rule Impedance Calculations

A simple method of obtaining the hypotenuse of an impedance triangle entirely from slide-rule settings, without the use of addition, mental or otherwise. Intermediate steps give reactance-resistance ratio and phase angle, from which power factor can be obtained. *An Electronics Reference Sheet*

IN MANY of the calculations required in electronic circuit analysis, particularly those involving impedance relationships in a-c circuits, it is necessary to perform the operation:

$$C = \sqrt{A^2 + B^2} \dots \dots \dots (1)$$

that is, to determine C when A and B are given. This is true for example when A is a series reactance and B a series resistance, and it is required to find the series impedance C , or when A and B are the r-m-s values of harmonic components of current or voltage and C is the r-m-s resultant.

The solution of Equation (1) on the slide rule is usually accomplished by squaring the quantities A and B , adding (either mentally or on paper since the slide rule cannot be used for addition) and extracting the square root. This method is cumbersome and its accuracy is limited if one of the three quantities is much smaller than the others. A simpler and more informative method, which performs all operations on the slide-rule and eliminates the necessity of addition, has been suggested by Mr. Verne O. Gunsolley of Minneapolis. The method is based on the geometrical interpretation of Equation (1), that is, that C is the hypotenuse of a right triangle whose other two sides are A and B , as shown on the reverse side of this reference sheet. For convenience the shortest side of the triangle is always labelled A , as shown.

The angles opposite the sides A , B , and C of the triangle are labelled α , β , and γ respectively, as shown. The law of sines then gives:

$$A/\sin \alpha = B/\sin \beta = C/\sin \gamma \dots \dots (2)$$

Since $\gamma = 90^\circ$ and $\sin \gamma = 1$:

$$C = A/\sin \alpha \dots \dots \dots (3)$$

Since A is the shortest side, α is always 45° or less. Any slide rule having trigometric scales contains angles up to 45° , so that α can always be found. When α is known C is determined by Equation (3). The angle α is most easily found by taking $A/B = \tan \alpha$.

When $\tan \alpha$ is known, $\sin \alpha$ can be determined directly from the slide rule scales. C is then given by dividing $\sin \alpha$ into A .

Example in the "3-4-5" triangle

To illustrate the method consider Equation (1) when $A=3$ and $B=4$.

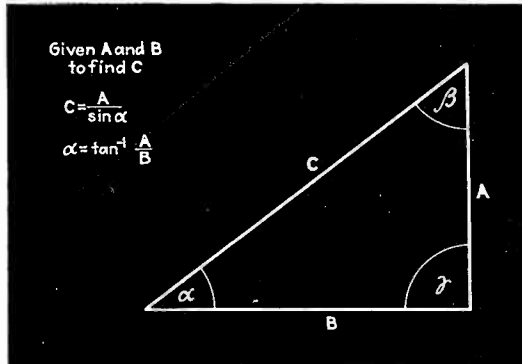

The basic triangle used in Mr. Gunsolley's method

Mental arithmetic reveals that C is then 5, and that the corresponding right triangle is the familiar "3-4-5" type. The method outlined above is applied as follows:

First: Form $\tan \alpha$, by dividing B into A , on the C and D scales of the rule.

$$A/B = 3/4 = 0.75$$

Second: Determine the angle α by reading on the T scale opposite 0.75.

$$\alpha = \tan^{-1} 0.75 = 36^\circ 52'$$

Third: Determine $\sin \alpha$, by setting the hairline on the S scale at $36^\circ 52'$ and reading on the B scale, $\sin \alpha = 0.60$.

Fourth: Divide A by $\sin \alpha$ using the A and B scales, thus determining C .

$$C = 3/0.60 = 5.0$$

The required value of C is 5.0. In this case mental computation gives the answer much more quickly than slide rule computation. In the general case, of course, the operations cannot be performed mentally. For example let $A = 4.7$ and $B = 9.1$. Then $\tan \alpha = A/B = 0.516$, and $\alpha = \tan^{-1} .516$ is $= 27^\circ 18'$. $\sin \alpha$ is then 0.46 and $C = A/\sin \alpha$ is $4.7/0.46 = 10.2$.

Reactance-resistance ratio and power factor

The above method introduces several ratios and angles which are of electrical significance. In the case where B is a resistance value, A a reactance value, and C an impedance value, then $\tan \alpha = A/B$ is the ratio of reactance to resistance. The angle α itself is the phase angle of the impedance. The power factor (ratio of power to volt-amperes) is $\cos \alpha$. To find $\cos \alpha$ on the slide rule the \sin of $90^\circ - \alpha$ is found. In the "3-4-5" triangle example the hairline is placed opposite $90^\circ - 36^\circ 52' = 53^\circ 8'$ and the power factor read off as 0.8.

The operations involved are not as complicated as might be supposed from reading the above directions; they can be performed quickly by anyone familiar with slide-rule manipulation. The photographs on the opposite page show the settings required for solving the "3-4-5" triangle. The first setting is that used for finding $\tan \alpha$, the second that for finding α , the third for finding $\sin \alpha$, and the fourth for finding $A/\sin \alpha = C$. The setting for finding $\cos \alpha =$ power factor is shown in the last illustration.

Slide-rule Impedance Calculations

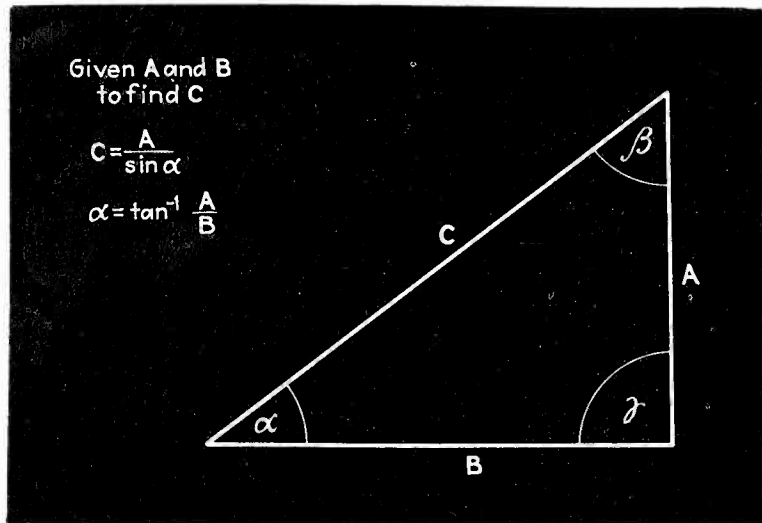

The basic triangle: If A is a series reactance and B a series resistance then C is the series impedance, α is the phase angle of the impedance and $\cos \alpha$ is the power factor of the impedance. The slide rule settings for the case where $A=3$ and $B=4$ are given below

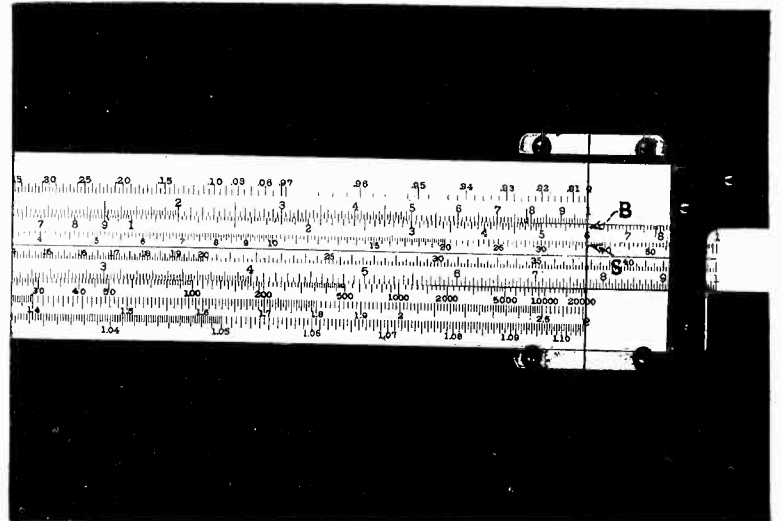

Third step: From the value of α determined above, find the value of $\sin \alpha$, as follows: Move the slide until the value $36^\circ 52'$ on the S scale is under the hair-line. On the B scale, under the hair-line, read the value 0.6 which is $\sin \alpha$

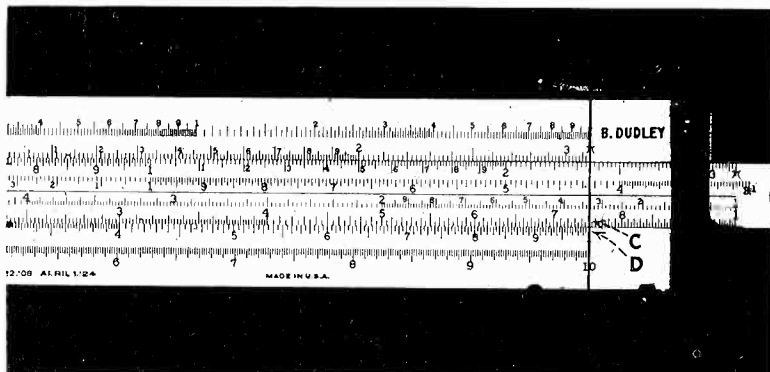

First step: From the given values of A and B, the value of $\tan \alpha = A/B$ is found as follows: Set 3 on the C scale opposite 4 on the D scale. Opposite the right-hand index (number 1) read the value of $\tan \alpha = 0.75$. Set the hair-line over this value as shown

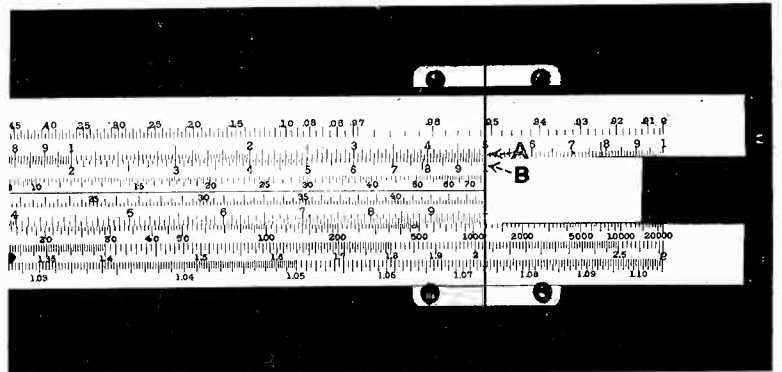

Fourth step: Divide the given value of A by the value of $\sin \alpha$ found above, to determine the value of $C = A/\sin \alpha$, as follows: Set the value of $A=3$ on the A scale, opposite the value of $\sin \alpha = 0.6$ on the B scale. Opposite the right-hand index read the required value of $C=5$

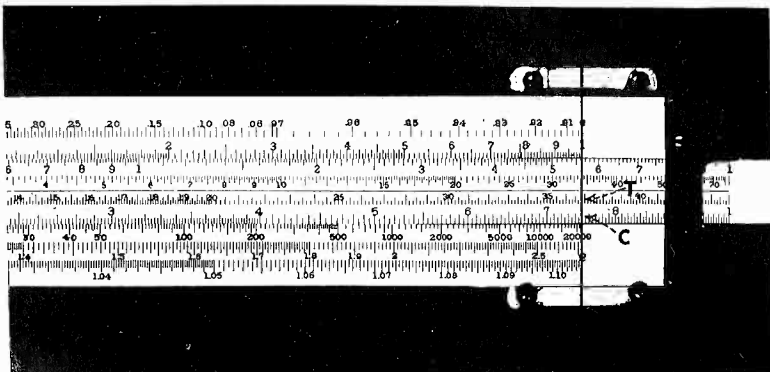

Second step: From the value of $\tan \alpha$ found above, determine the value of α on the T scale, as follows: Turn the rule over. Under the hair-line on the C scale is 0.75, as before. Under hair-line on the T scale is the value $36^\circ 52'$, which is the value of the angle α

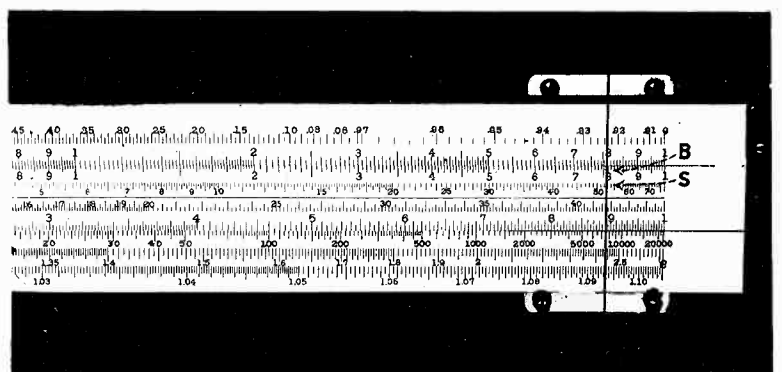

Power factor: If A is reactance and B resistance, the power factor is $\cos \alpha = \sin 90^\circ - \alpha$. In this case set the S scale at $90^\circ - 36^\circ 52' = 53^\circ 8'$ under the hair-line and read 0.8, the power factor, on the B scale. If A is a resistance and B reactance, the power factor is $\sin \alpha$



Unit Molded

INSULATED RESISTORS



TYPE BT INSULATED METALIZED RESISTORS



TYPE BW LOW RANGE INSULATED WIRE WOUNDS

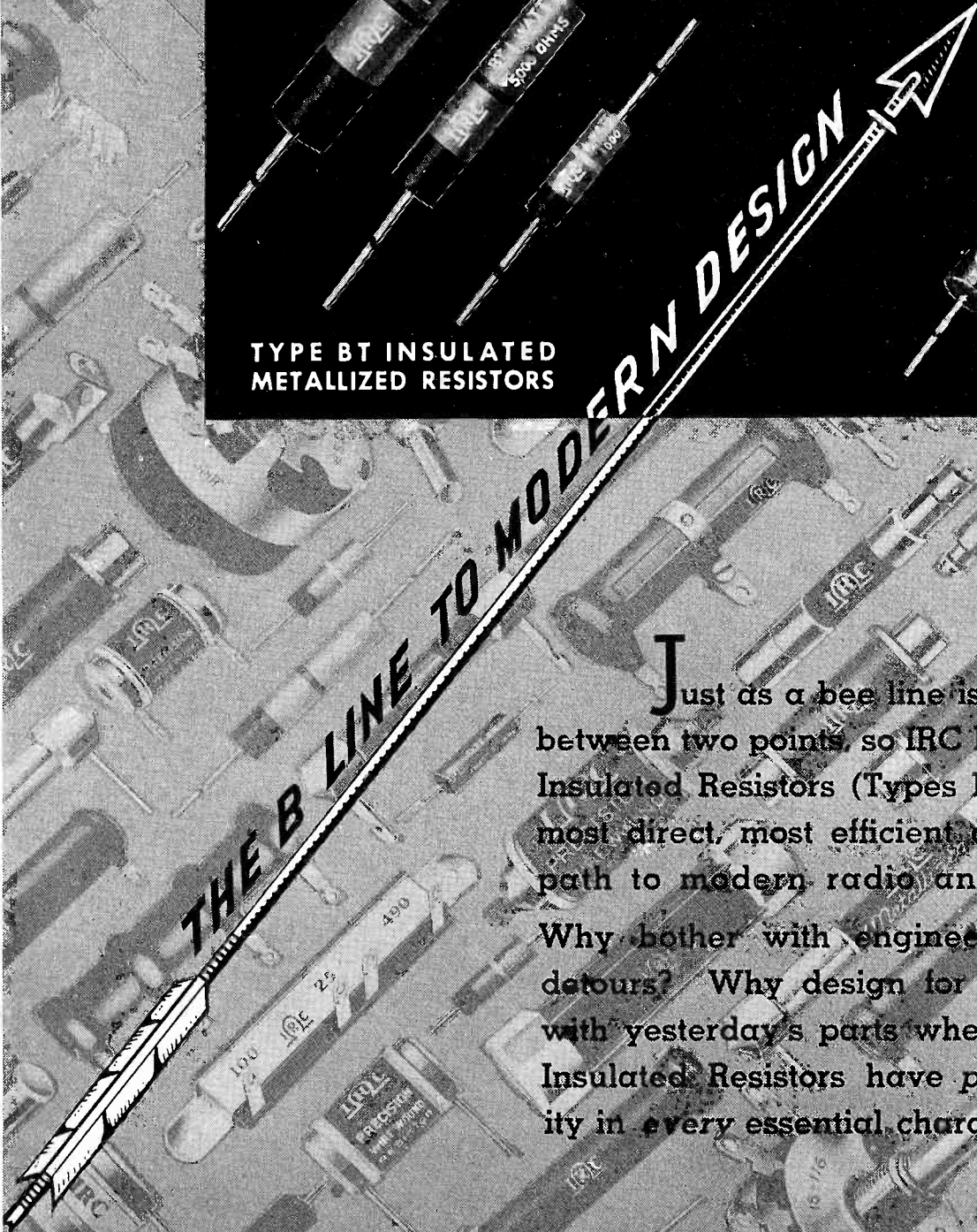

Just as a bee line is the shortest distance between two points, so IRC B type UNIT-MOLDED Insulated Resistors (Types BT and BW) offer the most direct, most efficient and most economical path to modern radio and electronic design. Why bother with engineering and production detours? Why design for today's requirements with yesterday's parts when IRC UNIT-MOLDED Insulated Resistors have proved their superiority in every essential characteristic?

INTERNATIONAL RESISTANCE COMPANY

401 NORTH BROAD STREET, PHILADELPHIA, PA.

Factories or Licensees in Canada, England, France, Germany, Italy, Denmark and Australia

MAKERS OF RESISTANCE UNITS OF MORE TYPES, IN MORE SHAPES, FOR MORE APPLICATIONS THAN ANY OTHER MANUFACTURER IN THE WORLD

Electrolytics

(Continued from page 31)

presence of a thin aluminum oxide film on the can since aluminum oxidizes in contact with air. Films of this type are generally much thinner than those formed on the anode electrolytically. In addition, there is a tendency during use to form an electrolytic film on the cathode, since the ripple current through the condenser during part of the voltage cycle is in such a direction as to permit film formation. The effect of both of these types of cathode films is to introduce a capacity between cathode and electrolyte. The capacity between can and electrolyte decreases the effective capacity of the condenser, since the two are in series. When the condenser is used in circuits with high ripple voltages applied, the decrease in capacity due to cathode film formation may be quite marked and the useful life of the condenser considerably reduced. If the cathode area is increased by etching the inner can surface, the effects of the cathode film are decreased in proportion to the increase in surface area. The cathode-electrolyte capacity is increased; and furthermore, the tendency towards electrolytic film formation is reduced. The improvement in the latter characteristic is due to reduction of ripple current density at the cathode surface. For all practical purposes, etching of the aluminum cans of wet electrolytics eliminates the necessity of plating the can with non-filming metals, as has sometimes been the practice in the past. In addition to the economic advantages of etching as compared to plating of the cathode, the etching method has an important advantage in that no metals other than aluminum need be present in contact with the electrolyte.

Experimental evidence of the effectiveness of the etched cathode container is indicated by the following measurements, which were made on a number of wet electrolytic condensers. Similar anodes were assembled in three different types of cans. Capacity and power factor measurements were made initially and then after sixty-six hours of operation with about twice normal

ripple current through the condensers.

Type of Can	Initial		After 66 Hours	
	Cap.	P.F. %	Cap.	P.F. %
Plain Aluminum	18.3	6.4	16.5	8.5
Etched Aluminum	19.4	6.3	19.8	7.0
Chromium Plated	19.4	6.25	19.7	7.0

The condensers with the plain aluminum cans initially are about 6 per cent lower in capacity than the other units. This is due to the film present on the aluminum cathode resulting from oxidization in air. After sixty-six hours, both the etched aluminum and chrome plated cans remain practically unchanged; the slight increase in capacity is due to change in the anode. During the same period, the plain aluminum can condenser has decreased about 10 per cent in capacity.

The performance characteristics of etched foil have proven so satisfactory in the past several years that it appears likely to displace plain foil completely in electrolytic condensers. In the case of wet electrolytics, etched foil is used almost exclusively, and a very large proportion of dry condensers are produced with etched foil as well.

REFERENCES

- 1—United States Patent No. 1,330,581—Coulson
- 2—"Radio Engineering"—January 1931—W. L. Dunn

Fidelity Control

(Continued from page 36)

sirable overall frequency characteristics than those shown in Fig. 2. Switch No. 1 and Switch No. 4 control the high frequency response of the audio amplifier. Switch No. 3 and No. 2 control the low frequency response and Switch No. 5 controls the bandwidth of the r-f amplifier. Since Switch No. 3 and Switch No. 4 have a common wiper, it is possible to put Switches 3, 4, and 5 on one wafer, thereby accomplishing all the switching with two wafers.

The difference in this circuit compared to Fig. 1 is that the inductance of the 10,000 cycle choke is used to obtain high frequency cut off in the audio amplifier at each switch position and also the introduction of an additional audio coupling condenser for Position 1. With this circuit arrangement a sharp cutoff of both high and low frequencies is obtained. A comparison of the response curves of Fig. 2 and Fig. 5

shows the effects of these circuit changes. The characteristic shape of response curves 1, 2, and 3 for frequencies above 400 cycles is due to the bandpass effects obtained. The sharp reduction in high frequencies is advantageous for reception in Positions 1, 2 and 3 when the noise level is high as much of the interference due to atmospheric and electrical disturbances is concentrated in the higher audio frequencies. Curve No. 1 shows the reduction obtained in the low frequency response between 70 and 400 cycles. Under this condition more high frequency response can be cut off without such noticeable muffled effects in the reproduction. This makes Position 1 considerably more noise reducing and gives better reception of signals which are at the noise level than is obtained with the control switch of Fig. 1. By tracing the connections to Switch No. 3 it will be observed that the reduction in bass response between 70 and 400 cycles is accomplished by placing C_1 in series with C_2 . C_1 is shorted for all positions except the number one position. A sharp reduction in bass response is desirable primarily when the high frequency response is very limited as in Position 1. Due to the change in the audio coupling condenser when changing from Position 1 to 2, R_2 is required to avoid an appreciable change in the level of the overall response of the receiver. R_3 is used for a similar purpose in Position 2 with bass compensation removed.

The reception conditions which the various positions of the fidelity control switch shown in Fig. 4 are intended to meet are the same as those explained in conjunction with Fig. 1 and will not be repeated here. In this case as in Fig. 1 the expansion in the bandwidth of the high frequency amplifier is such as to always supply the a-f amplifier with sufficient high frequencies so that the a-f amplifier can determine the reproduction for each position of the fidelity control. A switch of this type enables the user to obtain practically all useful combinations of selectivity, fidelity and bass response which are required for best reception of standard broadcast or short wave programs under the widely varying conditions which exist, such as variations in signal-to-noise ratio, separation between stations, different programs and room conditions.

A MILLION TIMES A SECOND



Actual physical motion so fast it can never be seen . . . yet, one million times a second is *not* unusual! Many Bendix Piezo Electric Crystals vibrate as rapidly as *fifteen million* times a second (15,000 KC) and their accuracy is controlled within unbelievably small limits . . . Because of this incredible exactness and precision under all temperature conditions, Bendix Crystals control frequencies throughout the world. The wonder of the Bendix Crystal as the ever-accurate controlling factor of thousands of transmitters is a tribute to the experience, knowledge and craftsmanship of Bendix engineers . . . and is typical of the advanced development and consistent performance of all Bendix Products.

From the raw product to the finished crystal. On the left are various formations of raw quartz as mined in Brazil. Next are shown marked inferior sections and the perfect cut blanks. On the right you see various sizes of finished ground crystals and types of holders.

Direct All Correspondence to
Bendix Radio Corporation, 9th and Kearny Streets, N. E., Washington, D. C.

BENDIX

RADIO CORPORATION

NEW YORK, WASHINGTON, DAYTON, CHICAGO, OAKLAND



Sawing the crystal blanks at the proper angle is the first important step.



Optical measurement equipment for determining flaws otherwise invisible to the naked eye.



Measuring the finished blanks on micrometer for final check-up on frequency.

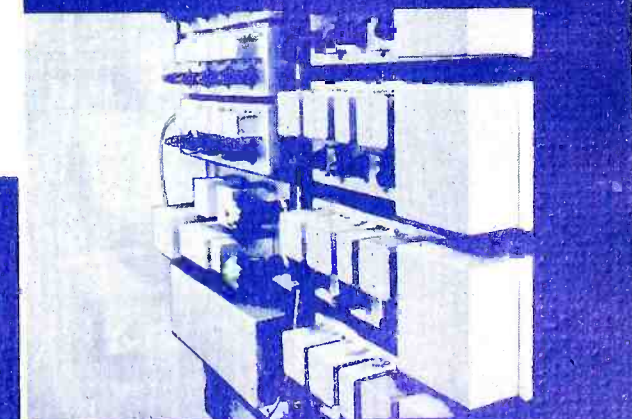

Rear view of exclusive Bendix frequency decade and standard, used for rapid setting and checking of crystal frequencies.

SUPPLANTING THE SOUTHERN CROSS



Ever since Schouten led the way through Southern Seas around perilous Cape Horn in 1616 the famous Southern Cross has given bearings and direction to anxious mariners. ★ Today Bendix engineers have conquered the uncertainty of the heavens with precise, unfailing instruments that keep "ships of the air" on a true and accurate course. Bendix has just equipped six different types of planes for the Air Force of the Argentine Navy with Bendix Direction Finders and other radio equipment. The instruments for each type plane were especially designed and constructed by Bendix engineers whose experience and knowledge defined the necessary requirements.

Bendix Aircraft Radio equipment is used not only in these planes for the Argentine government, but also for the U. S. Army; Navy and Coast Guard; Dept. of Commerce; Smithsonian Institution; United Airlines; American Airlines; TWA Airlines; Columbian Government, etc. That is because previous results have shown Bendix Aircraft Radio products superior in design, construction and performance.

Type of Bendix Equipment used in these planes now in Argentine Naval Service.

CONSOLIDATED

Transmitter, Receiver, Direction Finder, Interphone.

VOUGHT CORSAIR

Transmitter, Receiver.

GRUMMAN

Transmitter, Receiver, Direction Finder.

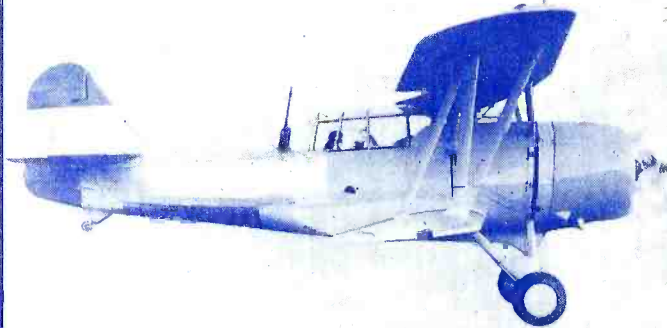
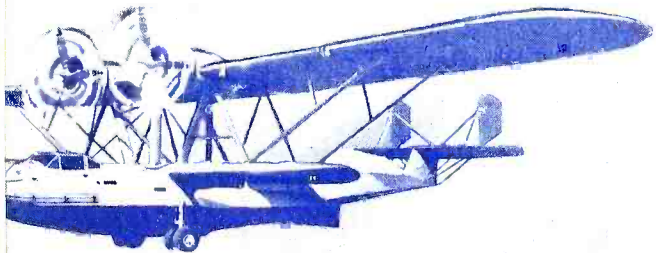

MARTIN

Transmitter, Receiver, Direction Finder, Interphone.



Direct All Correspondence to

Bendix Radio Corporation, 9th and Kearny Streets, N. E., Washington, D. C.

BENDIX

RADIO CORPORATION

NEW YORK, WASHINGTON, DAYTON, CHICAGO, OAKLAND

NEW BOOKS

Radio Service Encyclopedia

COMPILED AND PUBLISHED BY P. R. MALLORY & CO., INDIANAPOLIS, IND. *First edition, January 1937. (216 pp. Price \$2.50.)*

THE RADIO SERVICE ENCYCLOPEDIA is a single book designed to place essential service information on more than 12,000 models of radio receivers at the finger tips of the service man. Unlike the majority of service manuals, this is not accomplished by printing the circuit diagrams of the numerous radio receivers on the market but is made possible by listing for each receiver the essential component parts and component circuits used. Thus the service man has at his command not only information on receivers which have been built but is able to build up his own service experience as new circuits appear, even though a complete wiring diagram may not be immediately available to him. This material is presented in a table of approximately 100 pages, which lists the essential information on the resistance controls, condensers, and vibrators used in the circuit, indicates the type of tubes used, the i.f. employed, and gives the transformer circuit connection for the power supply. In addition to this table, three sections of the book are devoted to a technical description of various resistance controls, condensers, and vibrators. Several pages are devoted to the alignment of superheterodyne receivers, automatic frequency control, design of transformers, R.M.A. standard color coding, antenna design, various conversion tables and formulas, an extensive listing of tube characteristics, together with circuit connections, radio definitions and a section on the measurement of radio components.—B. D.

Wireless Engineering

BY L. S. PALMER, *D.Sc., Ph.D., Professor of Physics, University College of Hull. Longmans Green and Co., 1936. (544 pages, 307 illustrations, \$7.50.)*

MANY RADIO engineers, here and abroad, are familiar with Professor Palmer's "Wireless Principles and Practice" published nearly 10 years ago. It was a straightforward treatise of principles as they applied to the then existing art. In this decade much has changed, except those fundamental principles. The present volume is not a revised edition of his earlier work. It includes much of that matter, but shows evidence of the changing art in the additional material which includes

data on short wave systems, quartz oscillators, micro-wave oscillators, feeders, the ionosphere, etc.

This is a solid text designed for electrical engineers who wish to become conversant with radio transmission and for students in the universities. The treatment is essentially mathematical, with rigor and conventionality. The younger generation may wonder what spark gaps and damped waves are for but they provide excellent tests for one's knowledge of differential equations.—K. H.

• • •

Vibration and Sound

BY PHILIP M. MORSE, *Massachusetts Institute of Technology. McGraw-Hill Book Co., Inc., New York, 1936. (351 pp., illustrated. \$4.)*

THIS LATEST ADDITION to the "International Series in Physics" presents the theory of vibrating systems, especially those types applicable to acoustics, in a manner well adapted to the needs of communications engineering. In fact the book is a text intended for students in physics and communications. The treatment of the subject is clear, not too compact (the author is not loath to explain just what he means by various concepts and symbols), and modern in viewpoint.

CORONATION TELEVISION

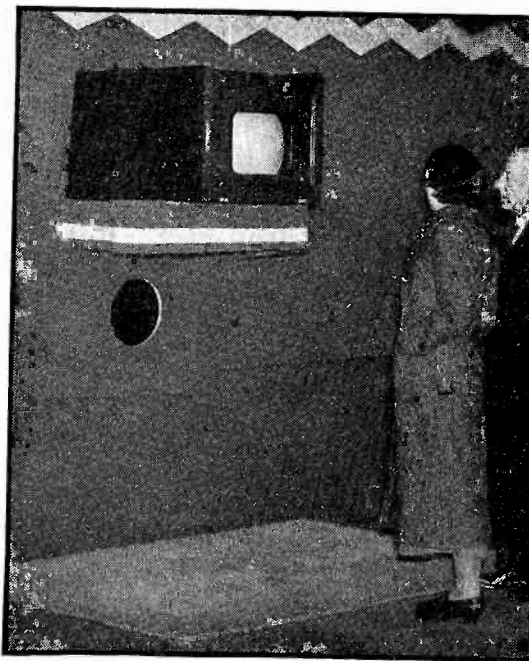

The first grand-stand completed for the Coronation Ceremonies was fitted with television facilities for viewing the Royal Pageant as it proceeds to Westminster Abbey

After a short introduction concerning power series solutions for differential equations, the general problems of free, forced, and damped oscillations are considered, together with oscillations in coupled systems. Following this discussion, the vibration of typical acoustic elements, such as a flexible string, the vibrating bar, and the stretched membrane are discussed at length. Finally, the problem of vibration in an extended medium, that is, of sound waves in air, is developed. For mathematical reasons the treatment of sound waves is restricted to the plane shape, but a complete treatment is given nevertheless. The radiation of sound, of particular importance in present-day loud speaker practice, is also given full attention.

In general, of course, the book is theoretical rather than practical. However, the author, being fully familiar with the practical aspects of the subject, has enlivened the discussion considerably by frequent references to practical applications. Also he has chosen to illustrate the physical reasoning behind each mathematical development, a feature which should add greatly to the student's "feeling" for the subject. A full knowledge of calculus is assumed, but not too heavily leaned upon, since each step in each derivation is clearly explained. The book is a thoroughly up-to-date review of theoretical acoustics into which has gone much thought and appreciation of the student's viewpoint.—D. G. F.

• • •

Telecommunications

BY J. M. HERRING, *University of Pennsylvania*, AND G. C. GROSS, *Federal Communications Commission. McGraw-Hill Book Co., Inc., New York, 1936. (544 pp., illustrated. \$5.)*

THIS BOOK deals with the economics and regulation of the various branches of the communications industry, wire, cable and radio. It deals with a subject with which engineers are not customarily concerned, but it should make interesting reading for those interested in the extra-technical aspects of the art. The book opens with chapters on the development of various forms of telegraphy and telephony, including radio, and then proceeds to discuss some of the economical aspects of each, particularly the matter of rate-making. The remainder of the book is concerned with regulation, both on the part of the Federal Government and international agreements between governments. Included in this material is a carefully written interpretation of the Communications Act of 1934. Nearly 100 pages are devoted to appendices, including the provisions of the Communications Act of 1934 in full. The book is recommended highly to those whose business demands a thorough understanding of the regulatory powers of government in relation to the economics of communication practice.

—D. G. F.

THE IDEAL POWER CURVE

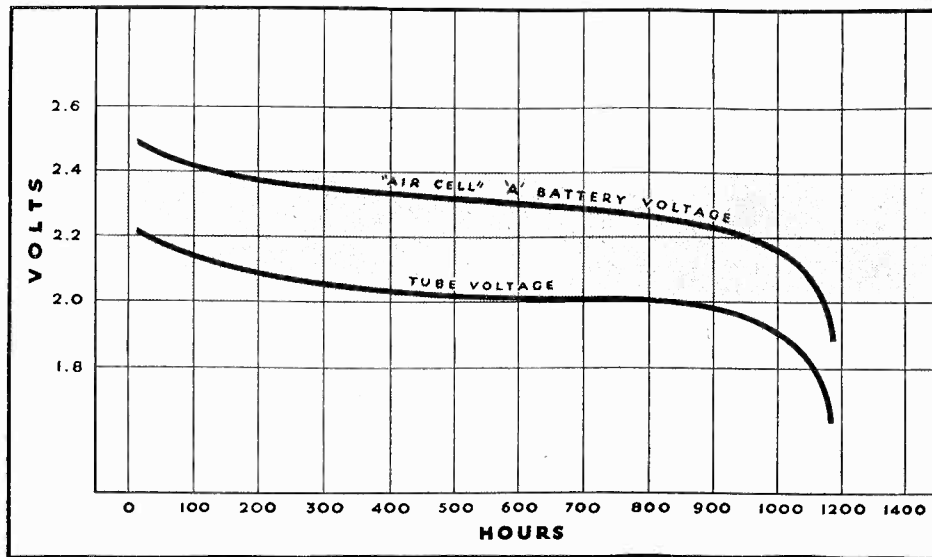

THE "EVEREADY" "AIR CELL" "A" BATTERY

is the only primary "A" battery with the ideal power curve—needing no ballast tube, tapped resistor or any other kind of voltage regulator. A simple fixed resistor sets the filament voltage right and the battery keeps it right.

These conditions obtain in a filament circuit drawing .60 amperes at 2.00 volts, which becomes .64 amperes at 2.20 volts with a new battery, and .56 amperes at 1.80 volts at end of the battery service life at least 1000 hours later.

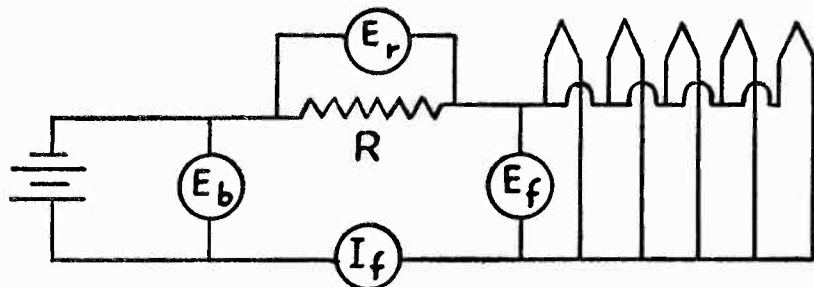

	START	TUBE CENTER	END
E_b	2.49 v.	2.27 v.	2.05 v.
E_f	2.20 v.	2.00 v.	1.80 v.
E_r	.29 v.	.27 v.	.25 v.
I_f	.64 a.	.60 a.	.56 a.
R	.45 ohms	.45 ohms	.45 ohms

R includes leads, wiring and series resistor

NATIONAL CARBON COMPANY, INC. specifically guarantees that the "Eveready" "Air Cell" "A" Battery No. A-600 will give a minimum of 1000 hours service.

NATIONAL CARBON COMPANY, INC.

General Offices: New York, N. Y.

Branches: Chicago, San Francisco

Unit of Union Carbide  and Carbon Corporation

The words "Eveready" and "Air Cell" are trade-marks of the National Carbon Co., Inc.

TUBES AT WORK

(Continued from page 43)

tivity makes possible the use of an extremely long beam (1,800 ft. in this case), and yet is achieved without loss of stability. The output of the amplifier controls a relay which can be used to actuate any alarm device required. In the demonstration the alarm device

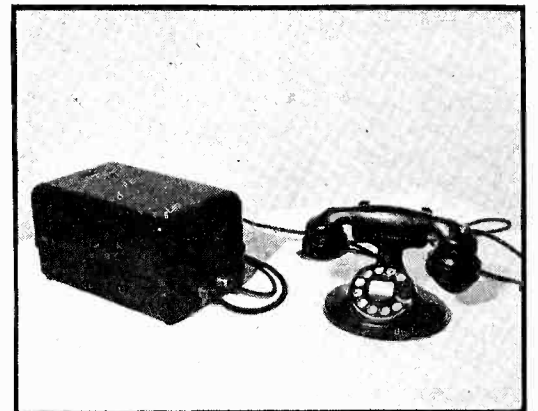

The automatic telephone alarm unit which dials the police, transmits a recorded alarm orally, hangs up, dials the telephone company, repeats the alarm, then releases the circuit

was a special telephone signalling instrument, shown in the photograph. This device contains a small phonograph turntable and pick-up, and relays for switching to telephone lines when an alarm is received. Whenever the beam is broken by the presence of some person, or even by the presence of smoke, the alarm circuit closes. The

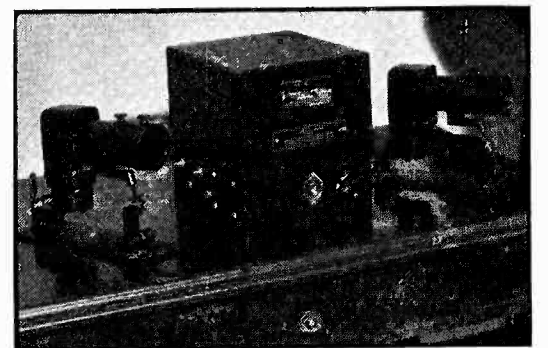

The projector, alarm amplifier and phototube housing of the Signaphone infra-red photo-alarm which will operate with a beam 1800 feet long

telephone unit thereupon connects to the telephone line, dials police headquarters and transmits an oral message from the record on the turntable, summoning aid. The message is repeated for a minute and a half. Thereafter the device disconnects from the line and then redials the telephone company, repeating the message as a check upon the first call. At the

SUPERIOR TUBE CO. 1934 - 37

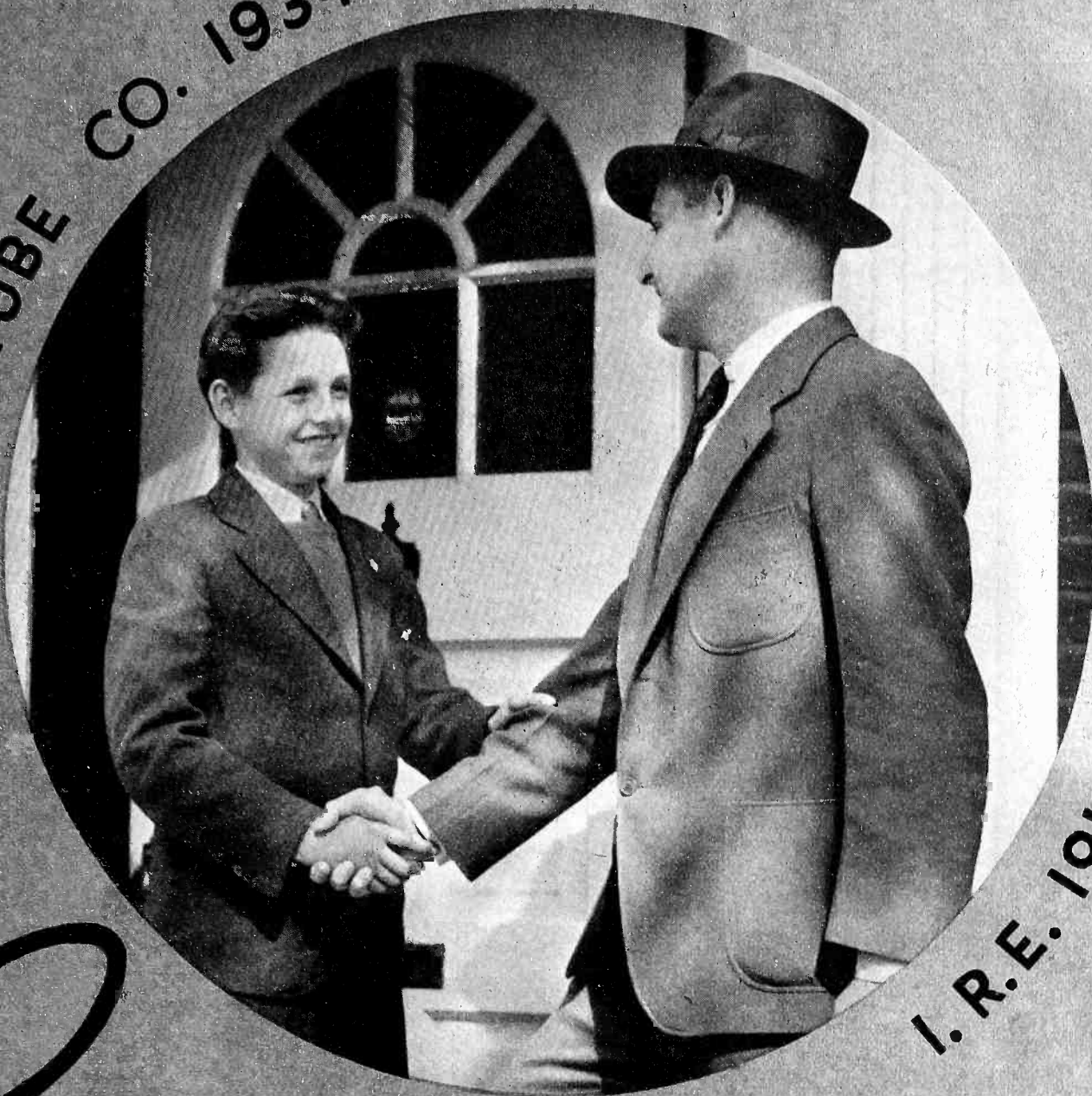

I. R. E. 1912 - 37

Congratulations-

FROM A YOUNGSTER

Young as our business may be, most of us here at Superior Tube are old enough to recall the very beginnings of radio. And with the rest of the world we are properly amazed at the technical strides its engineers have made during the 25 years of I.R.E.'s existence. We congratulate every one of you and look forward to many more years of pleasant associations within the industry and of maintaining the high regard you have always shown for our product.

TRY TO PAY US A VISIT AFTER THE CONVENTION

**SUPERIOR
TUBE COMPANY**
NORRISTOWN, PENNSYLVANIA

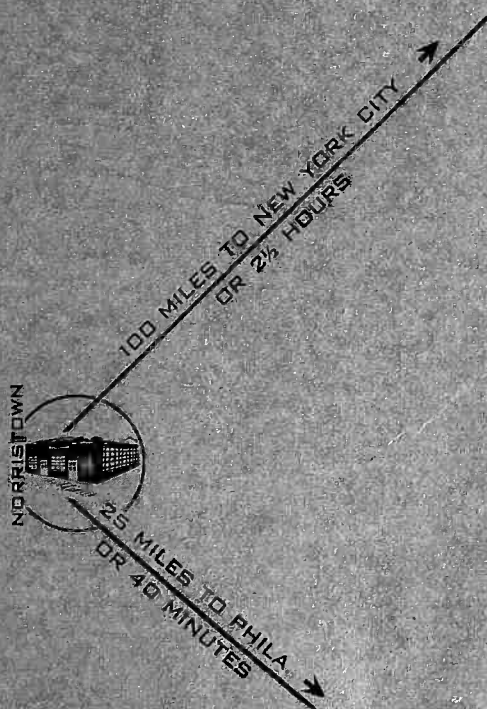

Manufacturers of Lockseam
and Seamless Cathodes and
Fine Seamless Tubing in
Various Metals and Alloys.

ANNOUNCING

A NEW

STANDARD SIGNAL GENERATOR

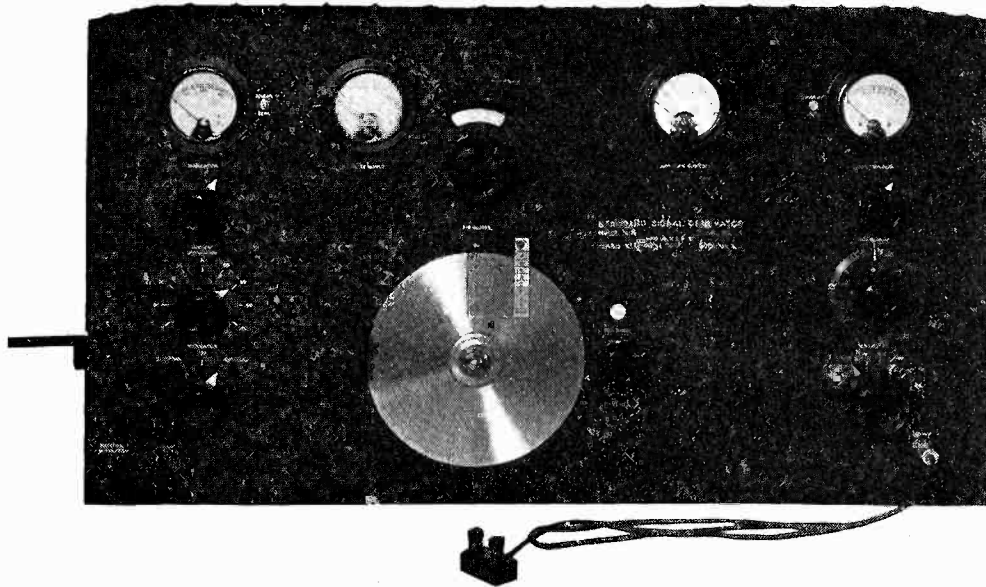

THE FERRIS MODEL 16-B.

ITS ADVANCED FEATURES FIT IT FOR USE IN
THE MOST CRITICAL ANALYSIS
THE MOST EXACTING DESIGN
THE WIDEST RANGE OF MEASUREMENT

Master oscillator-buffer — modulated final amplifier circuit covers 50 kilocycles to 25 megacycles in eight self-contained coil ranges.

Tuning condenser has thirty-foot scale spread for precise frequency setting, as well as a large direct-reading dial for convenience and speed in ordinary use.

Modulation system includes an amplifier giving 100% modulation with low input power. Internal 400 cycle oscillator filtered. Low envelope distortion permits use for receiver distortion measurements.

High-power output system includes Ferris transmission line for eliminating output lead resonances. Output voltage up to 2.5 volts; output resistance never over 15 ohms. Complete shielding and filtering for very low leakage.

Completely line operated from separate power supply unit provided with line voltage regulator.

For illustrated circular with complete details and prices write to

FERRIS INSTRUMENT CORPORATION
Boonton, New Jersey

conclusion of the second alarm, the device automatically disconnects itself from the telephone line which is then ready for usual service. The use of invisible infra-red light and the inconspicuous nature of the installation make the system particularly useful for burglar protection, since even an informed prowler will find it difficult if not impossible to evade breaking one of the beams.

• • •

An Electronic Paint-Thickness Gauge

*By Ralph A. Powers
 Electronic Control Corp., Detroit*

MEASURING THE THICKNESS of paint on a metal surface has always been a serious problem. Too thin a film of paint results in short life of the finished article, while too thick a coating is costly and unnecessary. Many various types of paint film thickness gauges have been presented—and many purchased. Magnetic and penetration types have received the widest acceptance. Of the two the penetration type is more universally accepted because it will operate on non-magnetic surfaces with the same degree of accuracy as on magnetic bases.

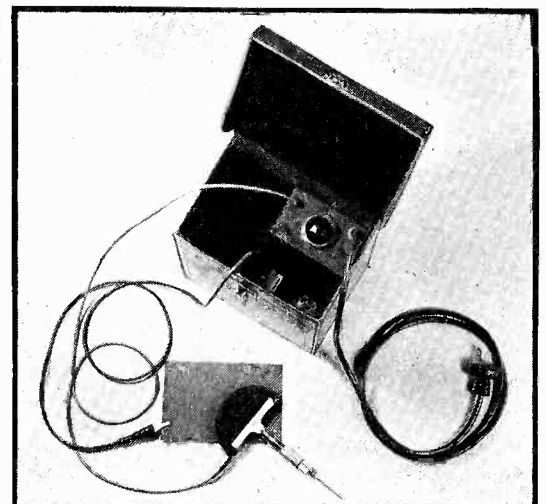

The electronic paint-film gauge, which operates on the penetration principle

The general principle underlying the operation of the penetration type of film thickness gauge is simple, and yet when properly applied, unusually accurate. A sharp stylus, such as a phonograph needle, is carefully driven through the non-conductive paint film to the metallic conductor below the surface. As this stylus makes electrical contact with the metallic base, a circuit is completed, which turns "on" an indicator lamp. As the stylus is usually driven through the paint film by a micrometer screw, an indication of the paint film thickness is readily noted. In some cases a dial indicator, reading directly in 0.0001", is used as a method of indicating the depth of paint film with a micrometer type of screw driving the stylus through the dial indicator.

In all of the penetration type gauges



Question

What is the AUTO RADIO Trade using for Remote Control?

Answer

S. S. WHITE
RADIO SHAFT No. 130R36
GALVANIZED CASING No. 147A2

This combination is used to such a predominant extent by the Auto Radio Trade that it might really be designated as STANDARD.

Question

Why is this particular S. S. WHITE combination so universally used?

Answer

Because both shaft and casing, designed expressly for Auto Radios, meet every installation and operating requirement with complete satisfaction.

Also because of the reliability of S. S. WHITE as a source of supply. The Company has the facilities, organization and resources to make scheduled deliveries without sacrifice of quality under pressure — a vital consideration at the season of peak demand.

GENERAL SPECIFICATIONS

RADIO SHAFT — — Diameter—.130" Length—As ordered.
No. 130R36

Ends— Shafting can be supplied with ends finished in any of the following ways:
(a) Square Swaged, (b) Octagonal Swaged, (c) Formed accurately square.

METALLIC CASING—Body O. D.—.233"—.238" Body I. D.—.147"—.152"
No. 147A2

Ends— Casing can be supplied with ends finished in any of the following ways:
(a) Plain, (b) Integral Enlarged End, (c) Integral Flanged End with Male or Female Coupling Nut. Ends (b) and (c) are shown in the illustration.

Finish— Galvanized—or Parkerized, if desired.

Samples of Shaft and Casing will be supplied on request. Engineering cooperation for working out specific applications is also offered without obligation.

The S. S. WHITE Dental Mfg. Co.
INDUSTRIAL DIVISION

10 East 40th St., Room 2310E, New York, N. Y.

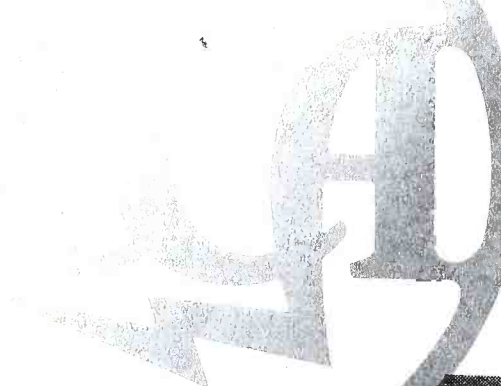

The Symbol

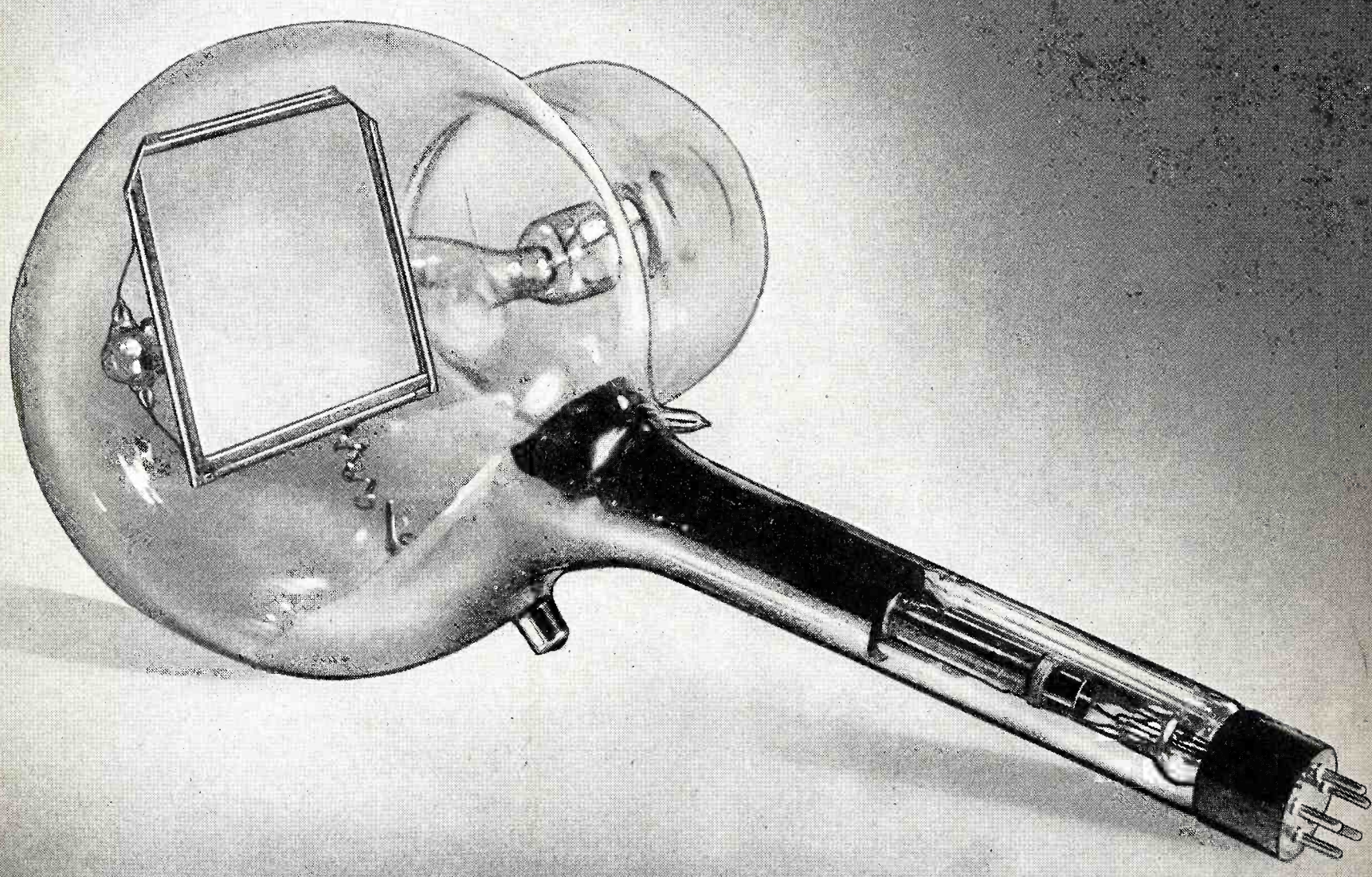

RADIO CORPO

of the Radio Age

THIS is the Radio Age. An era of rapid progress, which began only a few years ago, has been marked with engineering developments in the application of radio science, unparalleled in any other industry.

This program has been made possible by the achievements of the research worker and the radio technician. To these men RCA pays grateful tribute. Many men associated with RCA have devoted long years to careful, patient radio research in the laboratories—and some of the results of these years include the first power-operated dynamic-type loudspeaker for the home . . . the first practical superheterodyne receiver for home use . . . the first A. C. tubes and radio operated from the light socket.

On this 25th anniversary of the Institute of Radio Engineers it is well to look back on this period of radio advancement. It enables us to realize how important a place is filled by the technicians of the radio industry. Without these men, none of radio's far-reaching services would be possible today. Making earthly elements do mysterious things under the compulsion of electric currents, they have given us the many radio accomplishments which we now take for granted.

It is with great pleasure that RCA sends warm

greetings and good wishes to the members of the I. R. E. on this memorable anniversary. By providing a forum for the dissemination and discussion of technical advances, and by so ably collating and preserving rapidly expanding literature, I. R. E. has performed a work whose importance is inestimable.

Radio's age is still measured in terms of youth. It is a young industry—vibrant, aggressive—an industry that will continue to flourish in the future. An industry that may well create new businesses, new jobs, new wealth. In this future which holds so many possibilities for technical advance, I. R. E.'s splendid achievements in the past are the best assurance of brilliant performance in the years to come.

RCA REVIEW

A Quarterly of Radio Progress, and a source of news and reference material of value to engineers and laymen alike who wish to keep abreast of progress in radio and allied arts.

RCA Review now offers most attractive subscription terms of \$1.50 for one year or \$2.50 for two years, or \$3.50 for three years to U. S. and Canada; to other countries add 35 cents per year.

RCA INSTITUTES TECHNICAL PRESS
75 Varick Street, New York

RCA presents the "Magic Key" every Sunday, 2 to 3 p. m., E. D. T., on NBC Blue Network

RATION OF AMERICA

RADIO CITY • NEW YORK

SIMPLICITY, PREREQUISITE TO DEPENDABILITY *and* PERFORMANCE

● Simplicity is the theme of every Brush crystal sound cell microphone design, not only intentionally but inherently. Years of research have produced a homogeneous Rochelle Salt crystal. Years of development have made possible the bimorph element and sound cell microphone construction.

Brush microphones mean simplicity and dependability in that they do not require magnets, polarizing voltage, acoustic pads, acoustic screens, or moving parts in close mechanical limits.

Technical details on request

The BRUSH Development Company

3316 PERKINS AVENUE
CLEVELAND OHIO

AR26

AR43

BR2S

B1

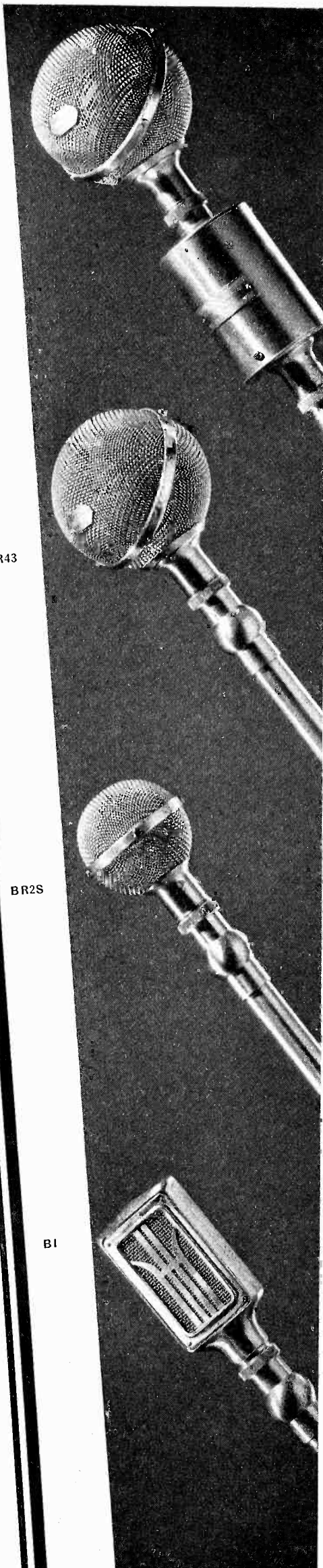

presented to the trade in the past, the contact of the spherical point of the stylus with the underlying metal has been the actual electrical contact to turn "on" the indicator lamp, at which time thickness readings are taken.

As all ordinary styli are ground to a so-called "point"—and such a point has a definite radius—at the time of actual mechanical contact of the point of the penetration stylus with the underlying metal—a section of sphere is coming in contact with a flat surface. At the actual time and depth of penetration of the stylus to this position when a thickness reading should be taken—there is an infinitesimal point contact. The electrical resistance of this point contact is so high, that actual indentation of the metal must take place before

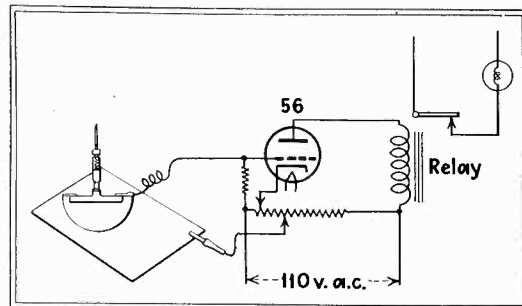

The low-current penetration circuit, showing method of making grid positive when stylus comes in contact with underlying metal

the resistance of this portion of the circuit is lowered sufficiently to cause current to flow to the indicator lamp.

Because of complete loss of accuracy with the conventional penetration type of paint film thickness gauge, because of the high currents through the stylus necessary to give pilot lamp indication—an electronic type of film thickness gauge was introduced.

From the circuit it can be easily appreciated that only a very small current is allowed to pass through the penetration stylus—making the grid of the Type 56 tube positive enough to allow plate current of about .003 amps. to energize the sensitive relay—the contacts of which initiate a circuit to the 110-volt, 1½ watt pilot lamp, shrouded by an easily-viewed jewel. The electronic circuit allows accuracy not possible before. 250,000 ohms of resistance between the bare metal and the penetration stylus is far lower than is needed to initiate energization of the sensitive relay. As a result, almost infinitesimal point contact between the spherical point of the stylus and the bare metal will provide a low enough resistance to turn "on" the pilot lamp and allow the operator to make an accurate reading of the depth of penetration of the stylus—and before the point of the stylus has to make an indentation in the bare metal.

The insulated foot of the micrometer depth gauge has been curved, so that thickness of paint may be easily measured on curved surfaces.

CINCH

MOUNTING STRIP

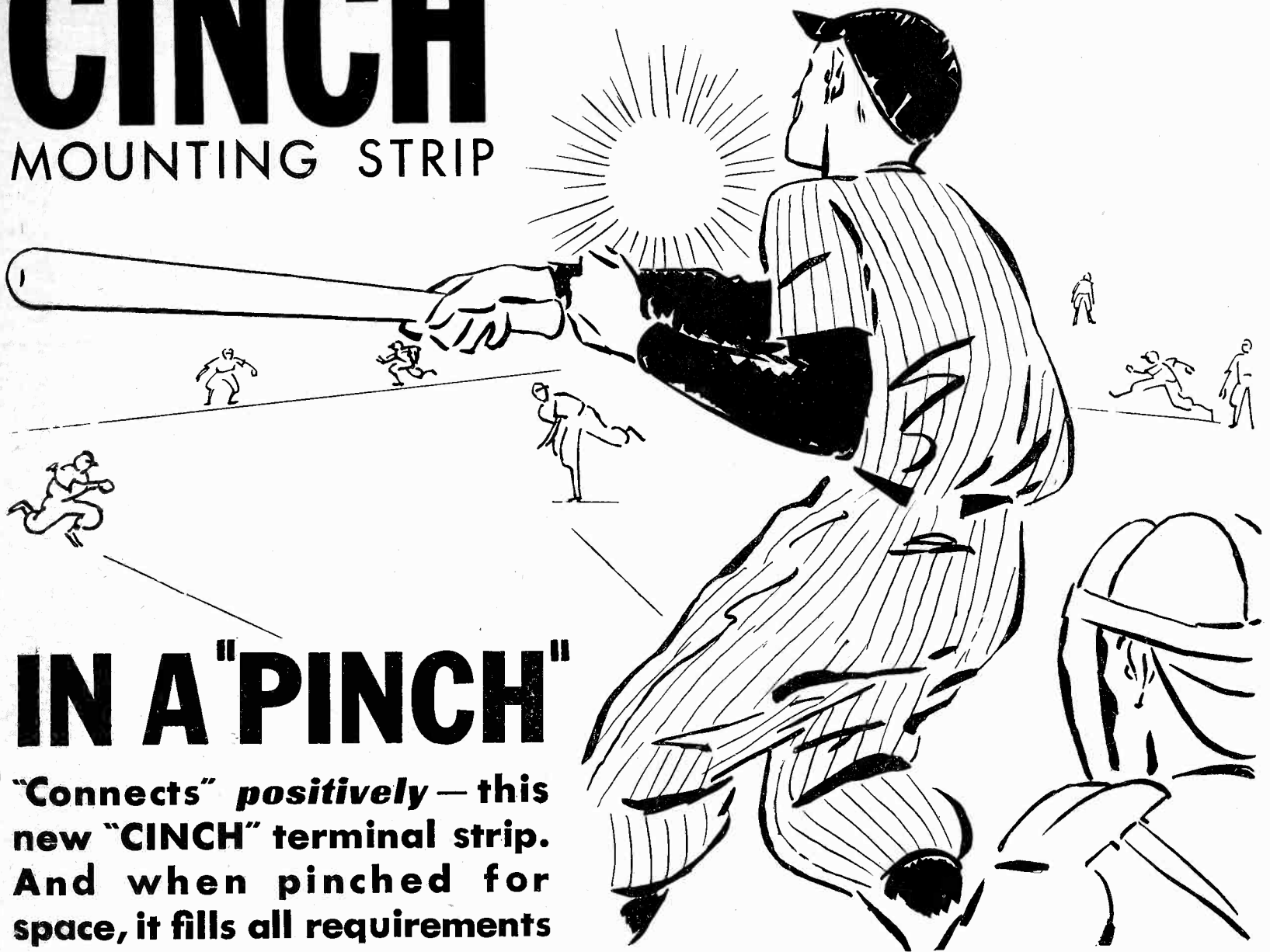

IN A "PINCH"

"Connects" positively — this new "CINCH" terminal strip. And when pinched for space, it fills all requirements

NEW CINCH MOUNTING STRIP

A most efficient speaker terminal strip, contacts made of highly resilient metal, treated by CINCH exclusive method — especially for easy soldering. Will not turn or distort under any continuous abuse; secured to dielectric strip end with three point support. Will not take a "set" — no tension loss. Strips may be had with from one to ten terminals with mounting centers of $\frac{1}{2}$ " spacing. For speakers or wherever space is limited . . . or anywhere for hook up of wires . . . this is the ideal terminal strip, strong, efficient — foolproof!

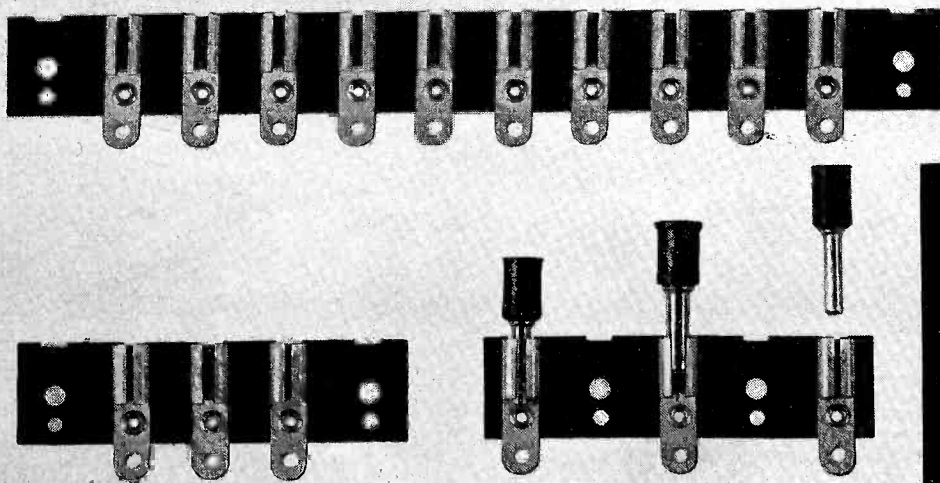

Remember it is *new!* It is just the terminal strip you need to save space and add to set efficiency. Write for samples and prices.

"Cinch" and Oak Radio Sockets are licensed under H. H. Eby socket patents.

CINCH

MANUFACTURING CORPORATION
2335 WEST VAN BUREN STREET
CHICAGO, ILLINOIS

SUBSIDIARY: UNITED-CARR FASTENER CORP., CAMBRIDGE, MASS.

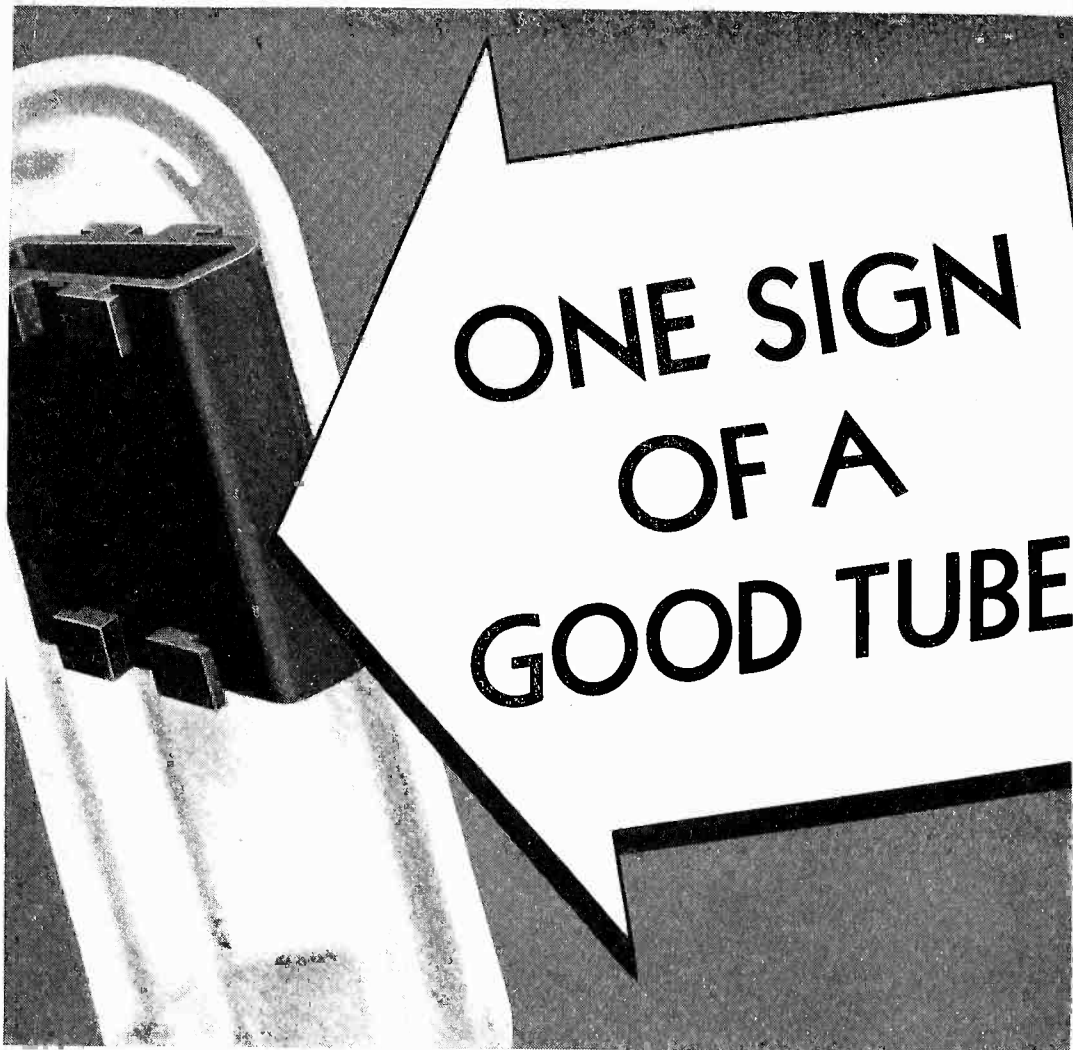

S P E E R

GRAPHITE ANODE

A special patented process makes the radiating area of Speer Graphite Anodes double the projected area. Will dissipate more than four times as much heat as metals. Cannot melt, warp or twist. Many other advantages add to tube life and usefulness. Regularly used by well-known tube manufacturers. List and booklet on request.



SPEER CARBON COMPANY

ST. MARYS, PA.

FREQUENCY MODULATION

(Continued from page 25)

quencies higher than 10,000 cps. are eliminated by the audio system (i.e. the value of Z in Eq. (9) does not go higher than $10,000/(\mu/2\pi)$). The table shows that the values of the interference factor are very small indeed, (below 1 per cent) particularly in case m is large compared with n . We may compare one case (marked (A) in the Table) directly with Fig. 3. The distortion in Fig. 3, in which the noise is added to an amplitude-modulated 1000-cycle signal, is excessive. When the same noise is added to a frequency-modulated 1000-cycle signal having a frequency shift of 100,000 cps., the interference factor is only 0.8 per cent. It will be noticed, however, that when the maximum frequency shift in the desired signal is not so great, the interference factor increases, being about ten per cent when the frequency shifts of noise and signal are approximately the same.

That the suppression of noise interference in frequency modulation thus depends on the use of a signal modulated over a wide frequency band can also be shown by considering equation (4), which states that the instantaneous frequency (proportional to audio output) is proportional to the derivative of $\alpha - \xi$. The phase shift of the desired signal $\alpha = m \sin \mu t$, can be made to have any desired maximum value; in the example a maximum value of 100 radians has been assumed. The angle ξ which is the phase disturbance produced by the noise, cannot have a maximum value higher than $30^\circ = 0.52$ radians, if the noise amplitude is kept lower than 1/2 the signal amplitude. The disturbing phase shift is thus never more than about 1/200 of the legitimate phase shift, as shown in Fig. 6, where α and ξ are plotted against time. This small disturbance cannot produce much interference. The secret of interference suppression thus depends on making α , the phase shift of the legitimate signal, large compared with ξ , the phase disturbance produced by the noise. If we decide that α should be ten times as great as ξ , which is 0.52 radians if the noise



**"I've USED
CENTRALAB
SINCE THE
PIONEER
DAYS"**

Says Mr. F. D. Wardner
Wardner Electric Co.
St. Paul, Minn.

Thanks, Mr. Wardner, and because we understand that you are one of the outstanding service men in the Northwest, we are doubly proud of your faith and confidence in Centralab.

Yes — since the very beginning Centralab has been building a *Quality control*.

The leading set manufacturers of the country depend upon Centralab controls for smooth, trouble-free performance. Centralab plays an important part in building public acceptance . . . so specify **CENTRALAB**.

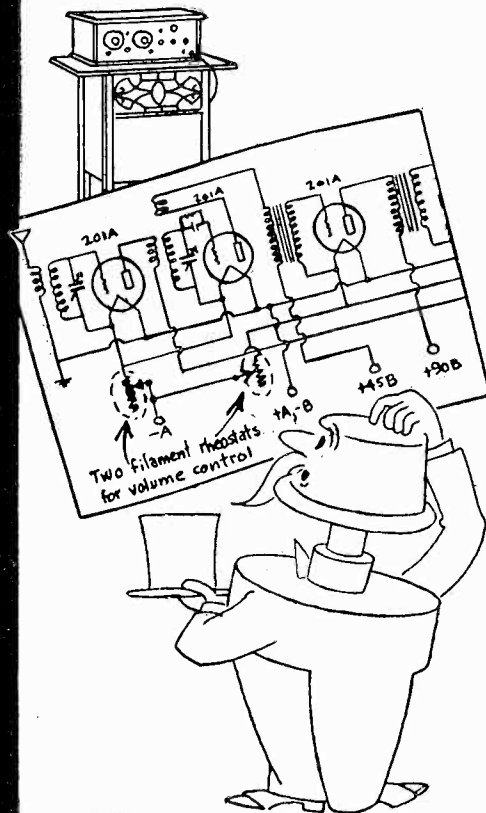
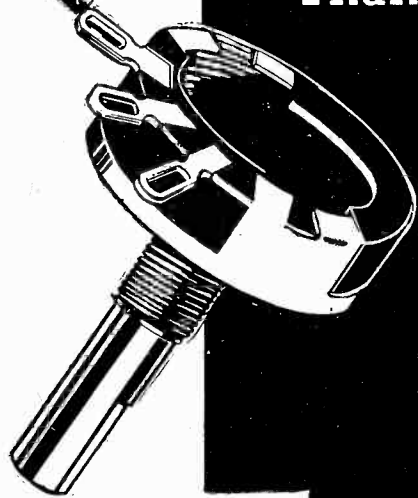

Remember-

when diagrams like these were all the vogue . . . and *Centralab Controls* were among the few "dependable" units?

Centralab
R A D I O H M

Milwaukee, Wisconsin
Division of Globe-Union Inc.
BRITISH CENTRALAB, Ltd.
Canterbury Road, Kilburn
London, N. W. 6, England
FRENCH CENTRALAB CO.
118 Avenue Ledru-Rollin
Paris XI, France

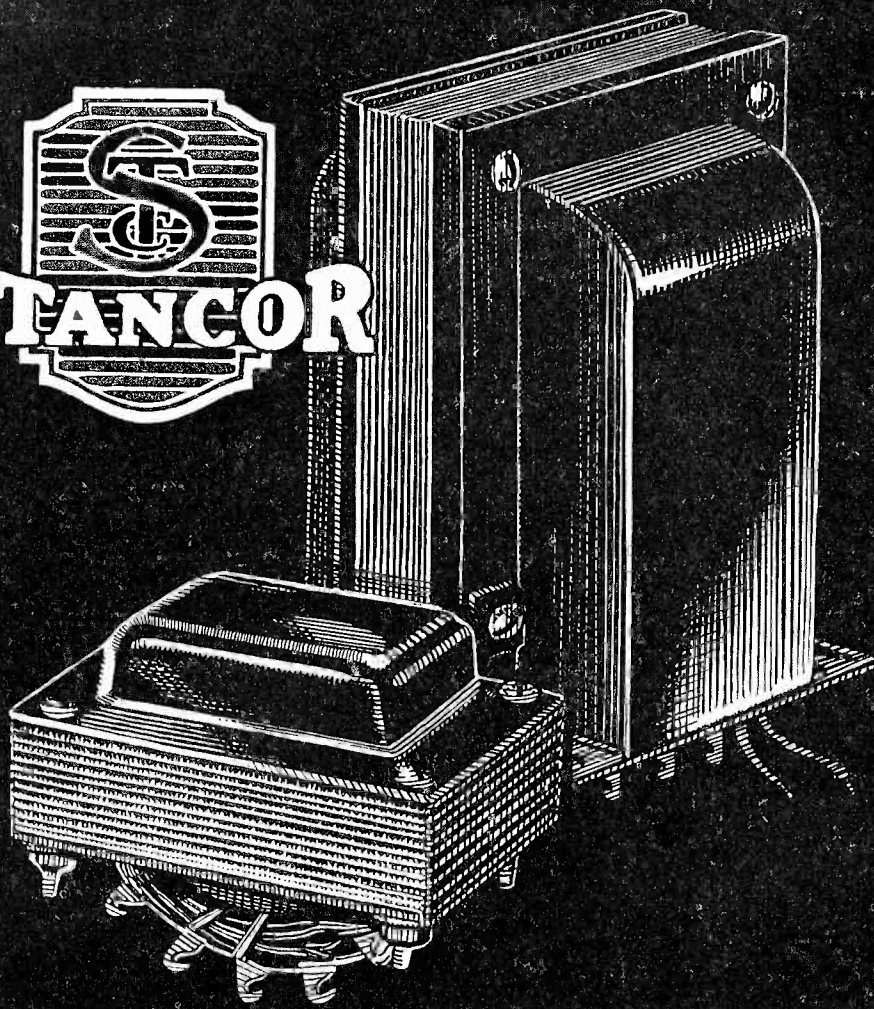

THE line of Stancor Transformers covers the whole scope of characteristics in common use. But the standard transformers of today were the laboratory transformers of yesterday . . . a large part of which were developed by Stancor engineers in cooperation with the engineering departments of manufacturers of electronic equipment of all descriptions.

YOUR TRANSFORMER PROBLEM IS OUR PROBLEM, and we will make it our business to apply our highly specialized experience and our carefully controlled manufacturing in arriving at an economical solution.

**STANDARD
TRANSFORMER
CORPORATION**
850 BLACKHAWK STREET, CHICAGO

amplitude is not more than $1/2$ the signal amplitude, then α must be $0.52 \times 10 = 5.2$ radians. Thus, if the highest audio frequency to be transmitted is 10,000 cycles, then the maximum frequency shift required is $\pm 52,000$ cycles.

Even when the maximum amplitude of the interfering noise is equal to that of the desired signal, the maximum value of ξ is comparatively small. This follows from the diagram in Fig. 7 which shows that $\sin \xi_{\max} = N_1/A$ where N_1 is the maximum noise amplitude and A the signal amplitude. For $N_1/A = 1$, therefore, $\xi_{\max} = 90^\circ = 1.57$ radians. If the desired signal phase shift is made 20 or more radians in this case, a very effective reduction of interference is obtainable.

The only additional requirement is that the difference $A - N_1$ must be large enough to permit operation of the limiter, i.e. it must be larger than E_L in Fig. 5. So long as this is true, the noise may be almost any kind of a signal. It may be wide-band or narrow-band, amplitude or frequency modulated, but its interference effect will always be small. *Thus to eliminate noise by frequency modulation, it is necessary to combine wide-band-frequency modulation with an effective limiting device at the receiver.*

The Effect of Interference Between Two or More Desired Signals

If two frequency-modulated transmitters are synchronized (carrier frequencies exactly the same) and are transmitting the same program simultaneously, the two signals will arrive at the receiver together. The question is what effect the two signals will have upon one another. By referring to Fig. 4, we see that $\alpha - \beta$ is constant, since both the radio and audio frequencies of the two signals are the same. Hence ξ is a constant also, and $d\xi/dt$ is zero. The two signals therefore do not produce any mutual interference, except in localities where they are of precisely the same amplitude and opposite phase, in which case they would cancel each other out. Thus in frequency modulation two synchronized signals will not interfere with one another so long as one signal is stronger than the other. This must not lead us to believe that transmitters may be set up, separated by 10 or 20 kc. in frequency, and operate

BEHIND THE VOICE

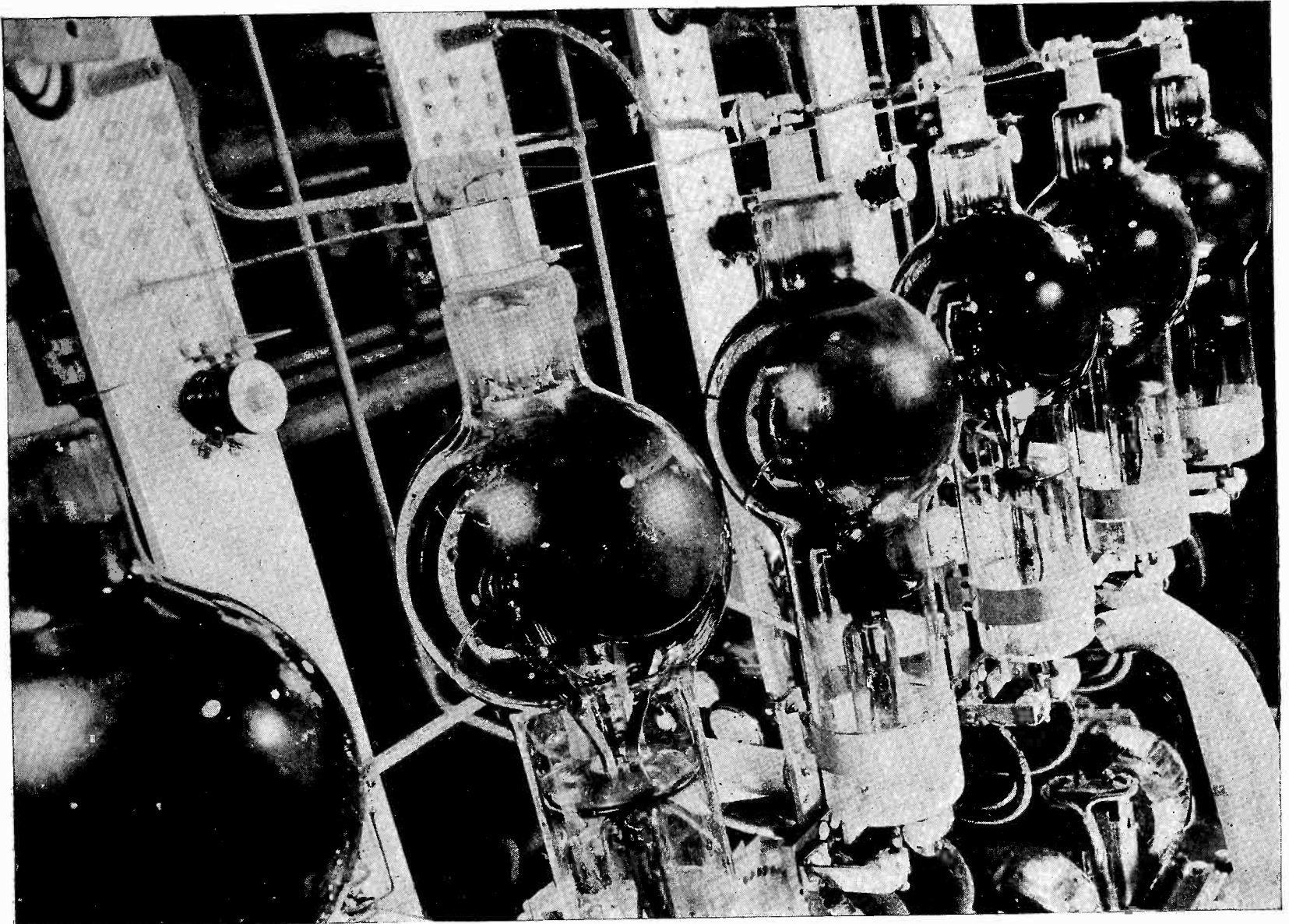

High-Voltage rectifiers at 50,000-watt broadcasting station of WJR, Detroit, Michigan. Built by Western Electric Company

● Supplying power to every broadcasting transmitter is a battery of high-voltage rectifier tubes. In the better engineered stations Isolantite is liberally used to harness the power behind the far-flung voice of radio. Isolantite's unusual mechanical properties and low electrical losses make it the ideal insulation not only for the high voltage, but also for the

radio frequency circuits of broadcast and other transmitting equipment. Broadcasting stations insulated throughout with Isolantite attain maximum operating efficiency. Isolantite engineers will aid in the design of suitable insulators.

ISOLANTITE INC.

CERAMIC INSULATORS

FACTORY: BELLEVILLE, N. J. • SALES OFFICE: 233 BROADWAY, NEW YORK, N. Y.

Speaking of ANNIVERSARIES

★ T H E N
O N E O F
O U R F I R S T
V A R I A B L E
C O N D E N S E R S

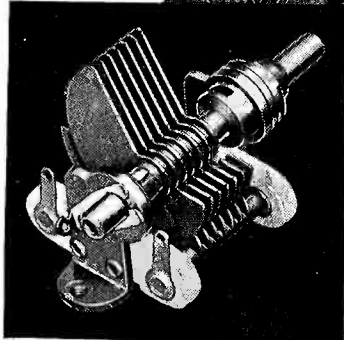

★ T O D A Y
O U R N E W -
E S T M I D -
G E T T Y P E
V A R I A B L E

OUR 25TH YEAR, TOO!

WE ARE deeply proud, too, to be celebrating our silver anniversary at the same time as that grand engineering organization—the I.R.E. The world knows how the I.R.E. gained international fame so rapidly because of their high ideals and purposes. Their distinctive efforts to build for the advancement of the science of radio has proven a stirring symbol throughout the profession. Hammarlund, who a quarter of a century ago, opened "shop" similarly achieved instant acclaim with their products also bearing the high ideals and skill of their designer and manufacturer. And over the span of years, Hammarlund's careful application of their conscientious and skillful talents has similarly made Hammarlund one of the foremost names in radio.

Hammarlund today manufactures over 400 radio products, among which are precision standard, midget and micro variable condensers; trimming and padding condensers; plug-in coils; coil forms; sockets; I. F. transformers; R. F. chokes; couplings; shields; "Comet-Pro" and "Super-Pro" professional receivers and special laboratory equipment for ultra-high frequency, high frequency and broadcast receiving and transmitting.

In celebration of its 25th year, Hammarlund has produced a special catalog with numerous mechanical drawings, curves, and illustrations. Mail the coupon below for your copy, free of charge.

MAIL THIS COUPON

.....

HAMMARLUND MFG. CO., Inc.
424-438 W. 33rd St., N.Y. City
 Please send me copy of new
"37" HAMMARLUND catalog.

Name

Address

City State E-5



HAMMARLUND'S 25TH YEAR

simultaneously with a bandwidth of $\pm 100,000$ cycles without interfering.

To show the fallacy in this case, assume three stations A, B and C each capable of 100 per cent modulation, producing a total bandwidth in each case of 200,000 cycles with carriers separated by 50,000 cycles, as shown in Fig. 8. If A operates 50 per cent modulated, the bandwidth is then 100,000 cycles. Now if station B comes on with a signal strength only 70 per cent of that of station A, station B cannot be tuned in because station A is stronger. This will occur even with the 50 kc. separation between carriers, since the receiver acceptance band must be 200,000 kc. to accept 100 per cent modulation. Now if station C joins in on the air, with a signal only 60 per cent as strong as A, in this case no station at all is received, because the sum of any two signal components is larger than the other, as shown in Fig. 9. To eliminate this effect, the carriers of the stations must be separated by a frequency interval equal to the pass-band of the receiver, namely 200,000 cycles in this case, which is the same requirement that exists in simple amplitude modulation. To bring in a weak signal adjacent to a strong one requires a certain amount of selectivity in the receiving set. The effect of this selectivity on reception is an interesting problem which yet remains to be investigated.

Appendix: Derivation of Series for ξ

If we substitute in Eq. (5) $y = 1 + \sin \mu t$, $y = \alpha - \beta = (m - n) \sin \mu t$ we obtain for ξ :

$$\xi = ky \sin \gamma \frac{1}{1 + ky \cos \gamma} \quad (6)$$

$$\xi = ky \sin \gamma (1 - ky \cos \gamma + (ky \cos \gamma)^2 - (ky \cos \gamma)^3 + \dots)$$

$$\xi = ky \sin \gamma - \frac{k^2 y^2}{2} \sin 2 \gamma + \frac{k^3 y^3}{4} (\sin 3 \gamma + \sin \gamma) - \frac{k^4 y^4}{8} (\sin 4 \gamma + 2 \sin 2 \gamma) + \frac{k^5 y^5}{16} (\sin 5 \gamma + 3 \sin 3 \gamma + 2 \sin \gamma) - \dots$$

By rearranging

$$\begin{aligned} \xi = & + ky \sin \gamma (1 + \frac{1}{4} k^2 y^2 + 2/16 k^4 y^4 + 5/64 k^6 y^6 + \dots) \\ & - \frac{1}{2} (ky)^2 \sin 2 \gamma (1 + 2/4 k^2 y^2 + 5/16 k^4 y^4 + 14/64 k^6 y^6 + \dots) \\ & + \frac{1}{4} (ky)^3 \sin 3 \gamma (1 + \frac{3}{4} k^2 y^2 + 9/16 k^4 y^4 + \dots) \\ & - 1/8 (ky)^4 \sin 4 \gamma (1 + 4/4 k^2 y^2 + 14/16 k^4 y^4 + \dots) \\ & + 1/16 (ky)^5 \sin 5 \gamma (1 + 5/4 k^2 y^2 + \dots) \end{aligned} \quad (10)$$

Using a well known expansion due

to Neumann, the terms $\sin \gamma = \sin ((m - n) \sin \mu t)$ can be developed into the following series:

$$\sin \gamma = 2 J_1 (m-n) \sin \mu t + 2 J_3 (m-n) \sin 3 \mu t + 2 J_5 (m-n) \sin 5 \mu t + \dots$$

The terms $J_p (m - n)$ are Bessel's functions of the first kind, order p, argument $(m - n)$. Now, the term $(m - n)$ is large for instance, $m = 100$ and $n = 7$ therefore the coefficients $J_p (m - n)$ can be expressed by trigonometric functions as is shown in the theory of Bessel's functions:

$$J_1 (m-n) = + \sqrt{\frac{1}{\pi (m-n)}} (\cos (m-n) - \sin (m-n))$$

$$J_3 (m-n) = - \sqrt{\frac{1}{\pi (m-n)}} (\cos (m-n) - \sin (m-n))$$

$$J_5 (m-n) = \sqrt{\frac{1}{\pi (m-n)}} (\cos (m-n) - \sin (m-n))$$

and so on. We then have

$$\sin \gamma = 2 \sqrt{\frac{1}{(m-n)\pi}} (\cos (m-n) - \sin (m-n)) (\sin \mu t - \sin 3 \mu t + \sin 5 \mu t \dots)$$

$$\sin 2 \gamma = 2 \sqrt{\frac{1}{2(m-n)\pi}} (\cos 2(m-n) - \sin 2(m-n)) (\sin \mu t - \sin 3 \mu t + \sin 5 \mu t)$$

$$\sin 3 \gamma = 2 \sqrt{\frac{1}{3(m-n)\pi}} (\cos 3(m-n) - \sin 3(m-n)) (\sin \mu t - \sin 3 \mu t + \sin 5 \mu t)$$

By substitution of these three expressions into (10) and by re-arranging, one obtains the following:

$$\begin{aligned} \xi = & 2 \sqrt{\frac{1}{\pi (m-n)}} (\sin \mu t - \sin 3 \mu t + \sin 5 \mu t - \sin 7 \mu t + \dots) \\ & \left[\frac{1}{\sqrt{1}} (\cos (m-n) - \sin (m-n)) ky (1 + \frac{1}{4} (ky)^2 + 2/16 (ky)^4 + 5/64 (ky)^6) \right. \\ & - \frac{1}{\sqrt{2}} (\cos 2(m-n) - \sin 2(m-n)) \frac{1}{2} k^2 y^2 (1 + 2/4 k^2 y^2 + 5/16 k^4 y^4 + 14/64 k^6 y^6) \\ & + \frac{1}{\sqrt{3}} (\cos 3(m-n) - \sin 3(m-n)) \frac{1}{4} k^3 y^3 (1 + \frac{3}{4} k^2 y^2 + 9/16 k^4 y^4 + \dots) \\ & - \frac{1}{\sqrt{4}} (\cos 4(m-n) - \sin 4(m-n)) \frac{1}{8} k^4 y^4 (1 + 4 k^2 y^2 + 14/16 k^4 y^4 + \dots) \\ & \left. + \frac{1}{\sqrt{5}} (\cos 5(m-n) - \sin 5(m-n)) \frac{1}{16} k^5 y^5 (1 + 5/4 k^2 y^2 + \dots) \dots \right] \quad (11) \end{aligned}$$

References:

1. Carson, J. R., Notes on the theory of modulation. Proc. I. R. E. Feb., 1922, page 57.
2. Armstrong, E. H., A Method of Reducing Disturbances in Radio Signalling by a System of Frequency Modulation. Proc. I. R. E. May 1936, page 689.
3. Roder, Hans. Amplitude, Phase, and Frequency Modulation. Proc. I. R. E. Dec. 1931, page 2145, Equation (22).

UNITED TRANSMITTING TUBES

*Used by
Leaders*

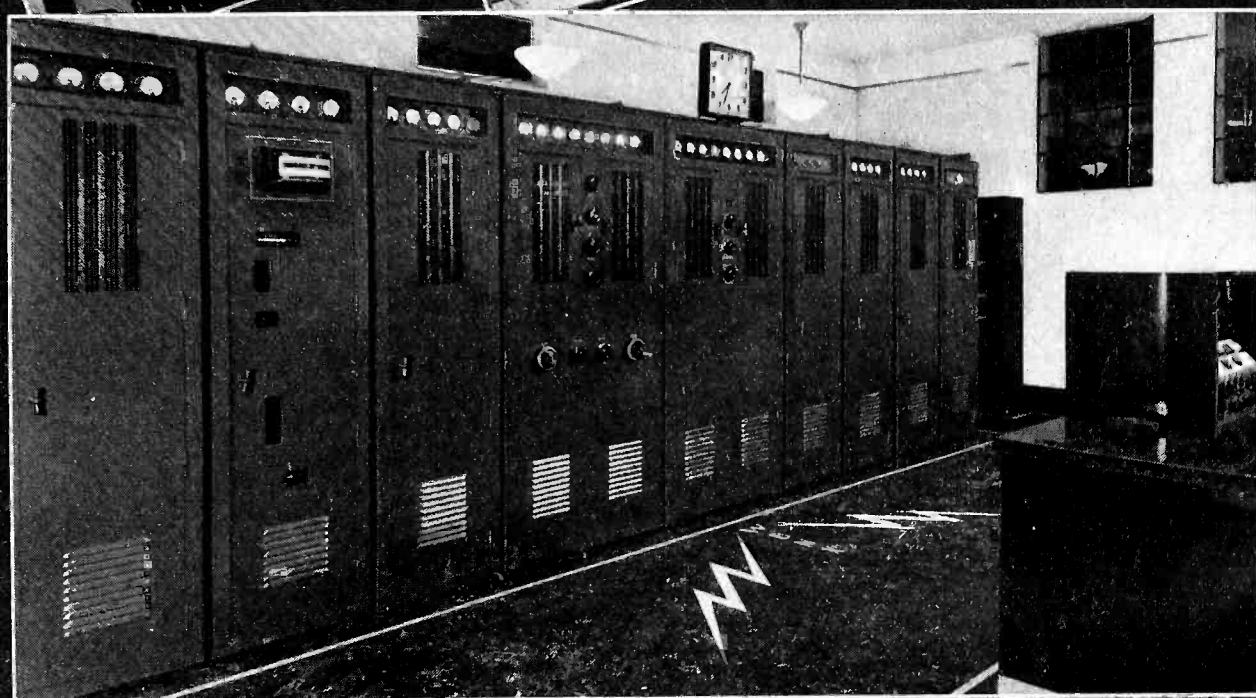
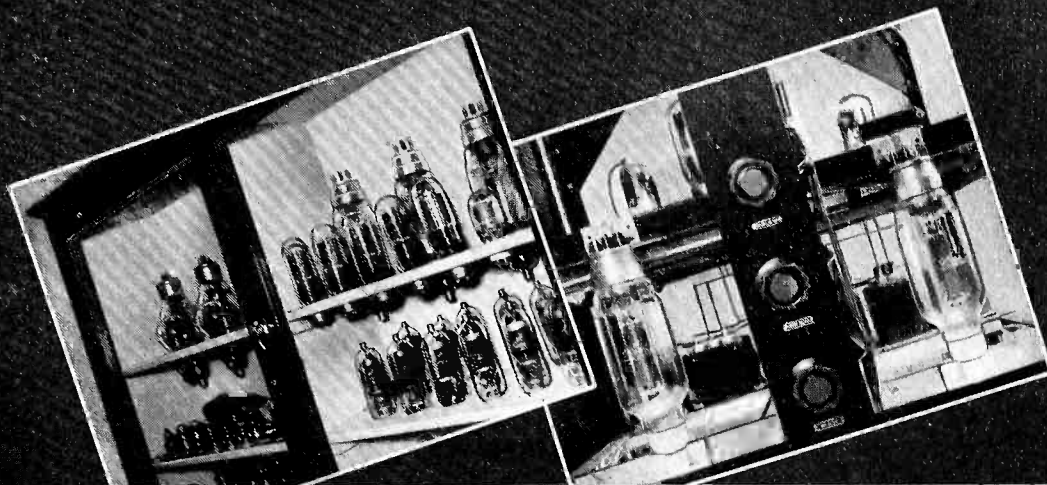

RADIO STATION WBNX

Designed and constructed by
Allied Research Laboratories
Herbert R. Wilson, Pres.

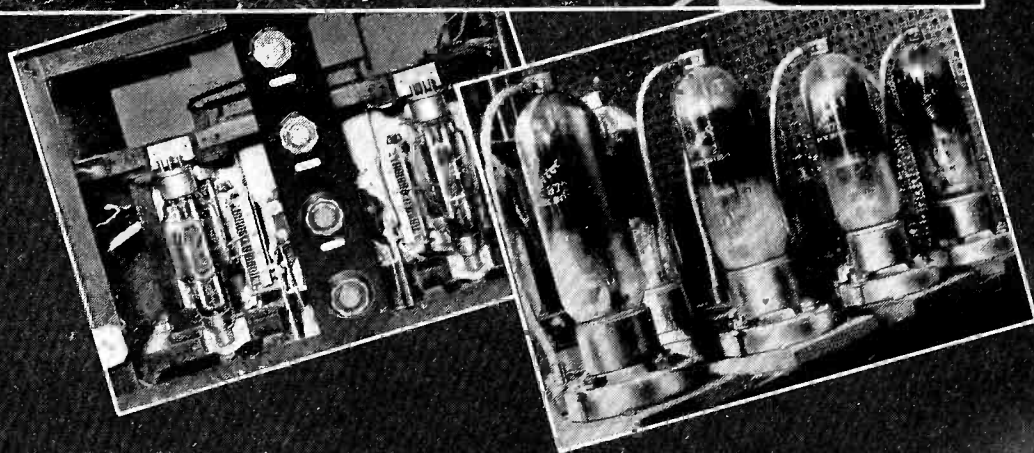

More and more UNITED tubes are seen in equipment of leading broadcast stations and in other important places. The WBNX transmitter pictured above is now 100% UNITED equipped, excepting small tubes we do not make. Their log reveals a splendid performance history for our products.

Write for complete new technical manual

UNITED ELECTRONICS COMPANY
42 SPRING STREET • NEWARK, NEW JERSEY

THE ELECTRON ART

EACH month the world's technical literature is scanned to see what physicists and engineers are doing with tubes, for presentation in tabloid form to Electronics' readers.

Strobotron Spot Welder Control

A METHOD in which the strobotron, recently described in *Electronics*, has been put to work in a spot welder operating for precisely controlled time periods is described by T. S. Gray and W. B. Nottingham in the February issue of the *Review of Scientific Instruments*. The schematic wiring diagram shows the circuit used by the authors in their article "Half-Cycle Spot Welder Control." The two elements of prime importance incorporated are the strobotron and a band-igniter mercury arc tube. The circuit is designed to operate from a center tap 230 volt, 60 cycle power line.

The essential welding circuit is shown in heavy lines, and the remainder of the circuit, for purposes of controlling the welding time, is shown in light lines. The strobotron circuit serves to deliver to the starting band on the mercury arc tube, a high voltage peak accurately timed with respect to the wave formed on the power line, normally impressed across the mercury arc tube. The strobotron controlled mercury arc tube becomes conducting for that fraction of the positive half cycle which remains after the starting impulse is delivered. The arc extinguishes itself at the end of the half cycle and the mercury arc tube remains non-conducting until another impulse is given to the starting band by the strobotron.

The type 80 rectifier tube is used to charge up a condenser which, when discharged through the strobotron and the primary of the spark coil, produces high voltage pulse to set up the arc in the mercury vapor tube.

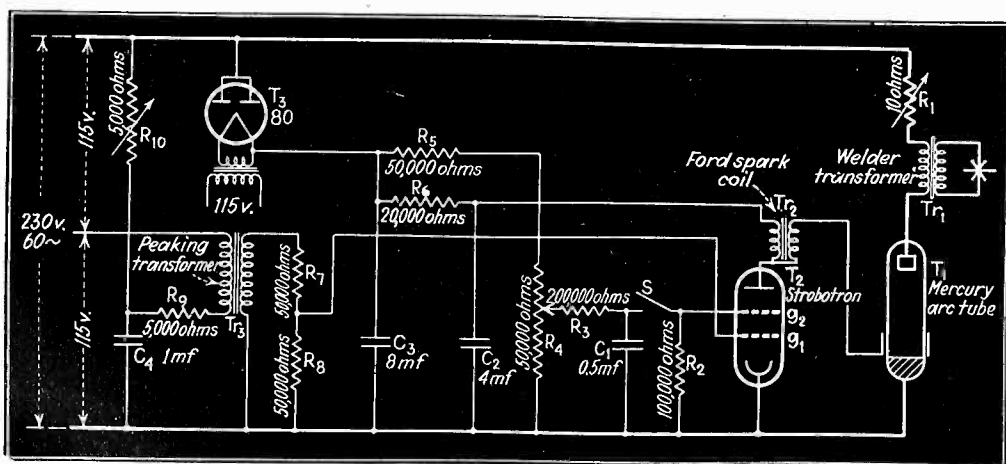

Schematic wiring diagram for strobotron controlled spot welder

Gas Filled Triodes

HIGH AMPLIFICATION and transconductance together with low internal plate resistance and an absence of pronounced noise are the essential features claimed for a gaseous discharge three-element tube, described in the December 1936 issue of the *Philips Technical Review* by H. G. Boumeester and M. K. Druyvesteyn under the title "Gas-Filled Triodes".

The construction of this new Philips tube is shown in the diagram. The indirectly heated cathode providing a source of electrons is shown at K. The essential control elements in the tubes are a cathanode, KA, a control grid G, and an anode A. These elements are inclosed in a glass bulb containing a drop of mercury so that an atmosphere of mercury vapor is present between the electrodes. The operation of this tube is described by the authors in part, as follows: "Between the cathode and the first gauze an arc discharge is produced for which this gauze (KA) acts as an anode. In the arc a large number of positive ions are formed which dilute the space charge of electrons so that the running voltage of the arc (i.e. the voltage between cathode and anode) is low, for example, 10 volts. Electrons pass through this gauzelike electrode and are attracted to the plate by the second gauze. The plate thus performs the same function as the anode in a vacuum valve, while the second gauze is fully comparable to the grid of a vacuum valve. The first gauze may be compared on the one hand to the cathode of a vacuum valve and since on the other hand it constitutes the anode of the arc dis-

charge, it is termed the 'cathanode.' "The properties of this valve may be explained by regarding the cathanode as a cathode, the action of the valve then being identical to that of a vacuum triode. Since the surface of the cathode is very large and the grid is located close to the cathode, the steep slope is readily accounted for. The number of positive ions formed between the grid and the anode is small and is not a measure of the slope. As on varying the grid voltage, the anode current is also altered but not the arc current, while at the same time the number of positive ions formed between the cathode and the cathanode remains constant, it would be expected that the slope is not related to the frequency, provided the latter does not assume such high values that the time of transit of the electrons has to be taken into consideration."

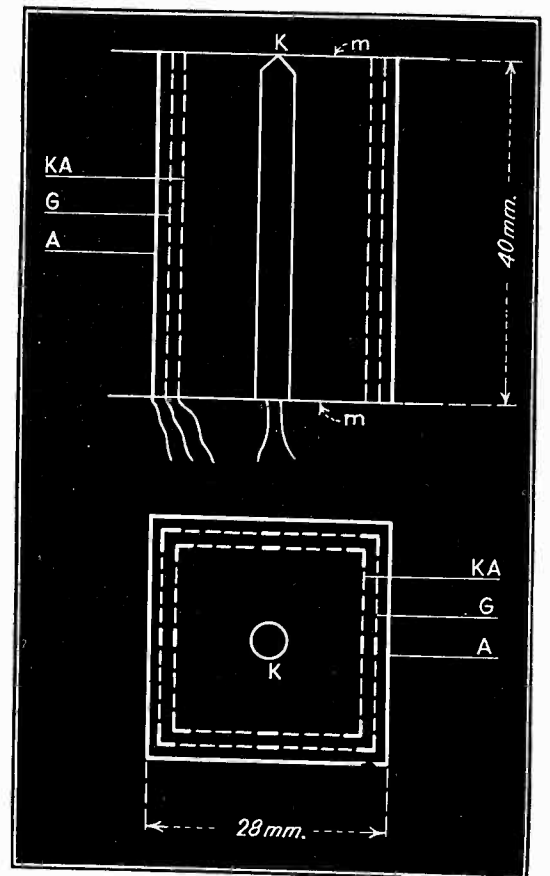

Structure of the Philips gas triode. Mica screens are shown at m

The ionized mercury vapor between the actual cathode K and the cathanode or virtual cathode, KA, fulfills the important purpose of neutralizing the space charge region surrounding the cathode and at the same time providing in the cathanode a copious source of electrons whose flow is controlled by the potential on the control grid. It may be inferred from the article that the absence of appreciable ionized mercury vapor between the cathanode and the anode results from spacing of the elements KA, G and A, less than the mean free path of ionization for mercury vapor. Important differences in operation between the Philips tube and the RK-100 triode described by Nelson and LeVan in the June, 1935, issue of *QST* are not brought out.



“PROGRAM AMPLIFIER” —latest development of Bell Telephone Laboratories—gives you better coverage

HAVE you heard about this latest Western Electric pace-setter—the 110A Program Amplifier? Advance news of what it does has gotten around—and orders have been pouring in. Briefly, here’s what it gives you:

1. An increase in average signal level of not less than 3db (equal to doubling the carrier power);
2. Limitation of excessive peaks of modulation;
3. Protection against over-modulation in case of accidental increase in program level;
4. Suppression of Extra Band Radiation (monkey chatter on adjacent channels) by prevention of over-modulation;
5. Continuous visual indication of magnitude and frequency of program peaks;
6. Program amplification of line output for feeding the transmitter at proper level.

The basis of this latest Bell Telephone Laboratories achievement is a variable loss network inserted in your program circuit. The loss introduced is con-

trolled directly by the instantaneous program level.

With such positive control, you can safely raise your average signal level at least 3db—increasing your effective coverage with no increase in carrier power. Better coverage means more dollars for you. Through Bell Telephone Laboratories research, Western Electric progressiveness, and Graybar service, you profit!

Delivery of the 110A will start in June. Write to Graybar for full details and get your order near the *top* of the pile.

3 Steps in 1 Direction

- | | |
|-------------|---|
| 1927 | Western Electric introduces 100% modulation (50% used formerly), effecting a 6db gain—giving 1KW transmitter the effective power of a 4KW. |
| 1931 | Western Electric introduces the halfwave radiator (.55 antenna), effecting a 3db gain. The 1KW transmitter now becomes an 8KW. |
| 1937 | Western Electric introduces the Program Amplifier with an effective gain of 3db. With all three features, the modern 1KW transmitter has the effective power of a 16 KW of the old style. |

Western Electric

BROADCASTING EQUIPMENT

Distributed by GRAYBAR Electric Co. In Canada: Northern Electric Co., Ltd.

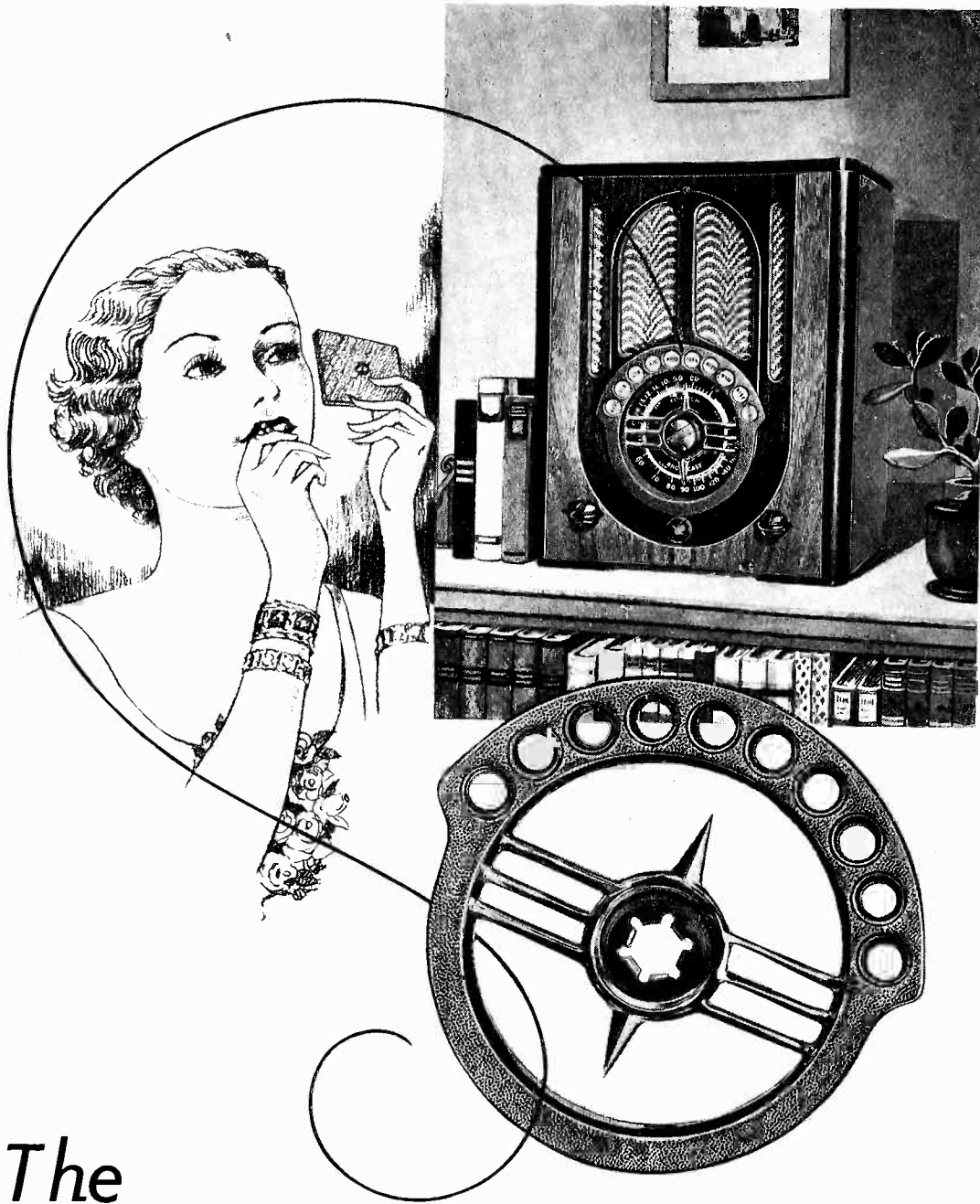

The FINISHING TOUCH

We extend you a cordial invitation to visit our show-rooms at: 500 Fifth Ave., New York, which is under the direction of our president, Mr. George B. Ogden. In Chicago, Mr. J. D. "Jack" Lindsay, a well known figure in the radio industry, is in charge of our office at 540 N. Michigan Boulevard, Room 323.

Escutcheons by American Emblem have the happy faculty of making any set look "expensive." They add that final touch of beauty so quickly recognized and appreciated by the buying public. The fine craftsmanship expressed in these escutcheons is the chief reason for American Emblem's selection by such concerns as Crosley, R C A-Victor, General Electric, International Radio, Wells-Gardiner, etc. Our mass production facilities enable us to quote attractive prices for quality escutcheons . . . For complete data write today for booklet "AE."

AMERICAN EMBLEM COMPANY, INC.
BOX 116L, UTICA, NEW YORK
Offices in Principal Cities

Recent Publications on the Electron Art

THE USE and application of electron tubes in the field of communications can usually be found without much difficulty in the various journals on communications. The fundamental physical principles of operation and the application of electron tubes to industrial applications are likely to be spread throughout the technical literature. We list here, a few recent articles on the electron art which may have escaped some of our readers.

"To Keep Electronic Devices Operating" by H. C. Jenks, *Factory*, March, 1937.

A concise article, written in non-technical language, outlining to the superintendent or maintenance electrician a rational approach and routine to follow in keeping electron tube controlled equipment in proper operating condition. With proper design and maintenance care, there is no reason why tube operated equipment cannot be made practically as foolproof and satisfactory in operation as any other piece of equipment.

"A Unique Application of Mercury Arc Rectifiers", by O. Keller. *Allis Chalmers Electrical Review*, March 1937.

A brief description is given of a 750-volt, 3-phase, 6-phase, or double 6-phase mercury arc rectifier capable of delivering 15,000 to 20,000 amperes for short time intervals. The characteristics of the rectifier fit particularly well for service in testing of high capacity d-c circuit breaker short circuit tests.

KEROSENE-LAMP RADIO



The batteries of this German radio set are charged by a small hot-air motor-generator, which derives its power from a kerosene lamp (lower left)

Let CLAROSTAT

Solve

YOUR RESISTANCE PROBLEM

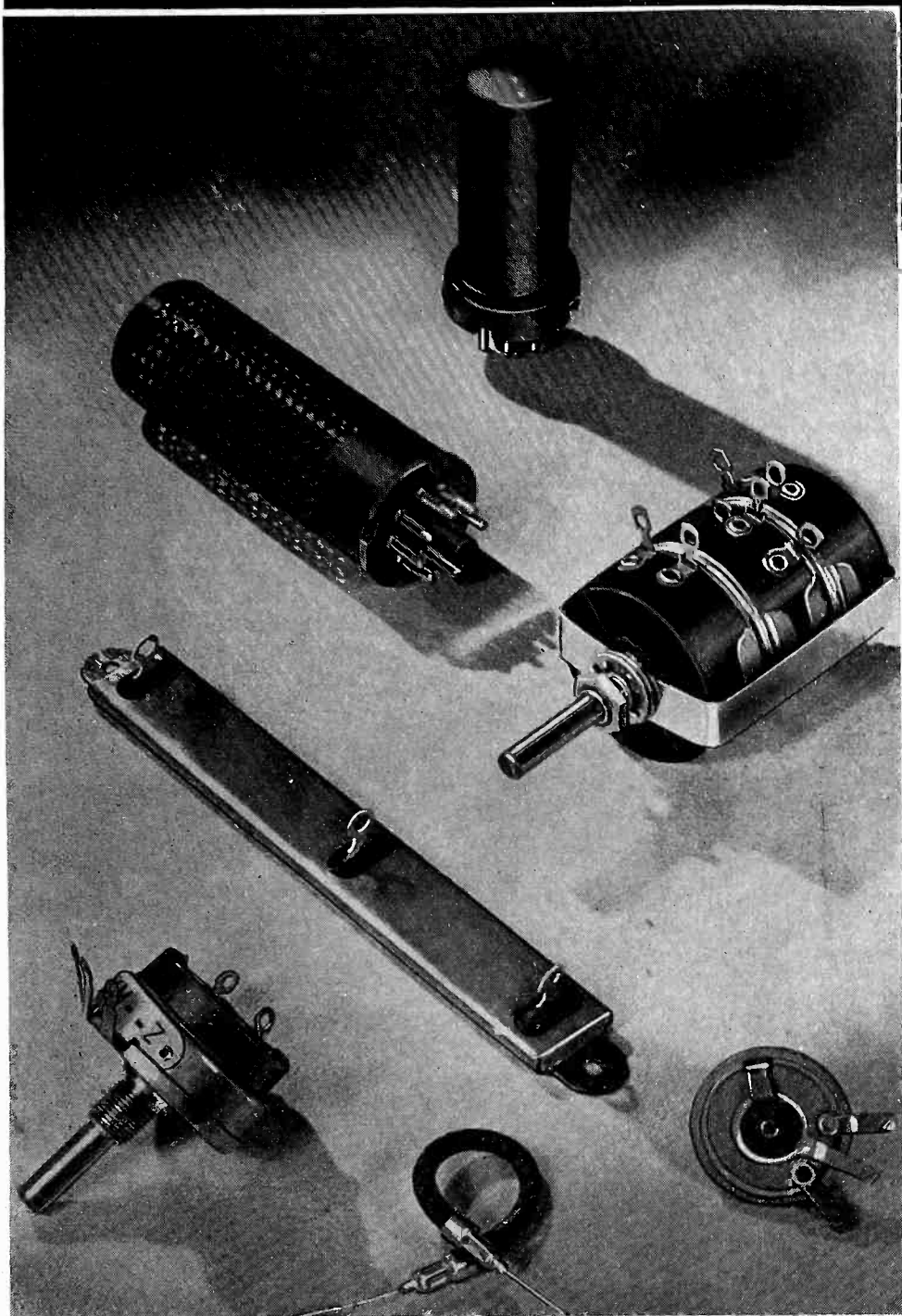

THE Clarostat organization does just one job: it makes resistors and resistance devices — nothing else. It plays no favorite type or types. That is why you can depend on getting precisely that type best suited to your particular assembly.

■ *Adjustable Resistors*

Potentiometers and rheostats. Wire-wound or composition-element. Dual and triple units for T-pad, L-pad and mixer constant-impedance controls, etc. With or without power switches. Any taper. Also constant impedance output (25 watt) attenuators for P-A systems. Handy hum controls. Etc. Etc.

■ *Fixed Resistors*

Inexpensive flexible resistors with braided covering. Wire-wound plug-in resistors for line-dropping and voltage-divider networks. Center-tapped strips. Metal-clad strip resistors, including NEW Molded-Seal Type.

■ *Ballast Resistors*

In perforated metal casings and in metal tube styles, for voltage regulation.

Loose-Leaf DATA covering every type of resistor in general use, available on request. Write on your business letterhead. Meanwhile, submit your resistance problems for engineering aid and quotations.

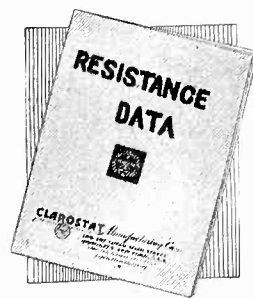

CLAROSTAT *Manufacturing Co. INC.*



285-287 NORTH SIXTH STREET
BROOKLYN, NEW YORK, U.S.A.

• OFFICES IN PRINCIPAL CITIES •

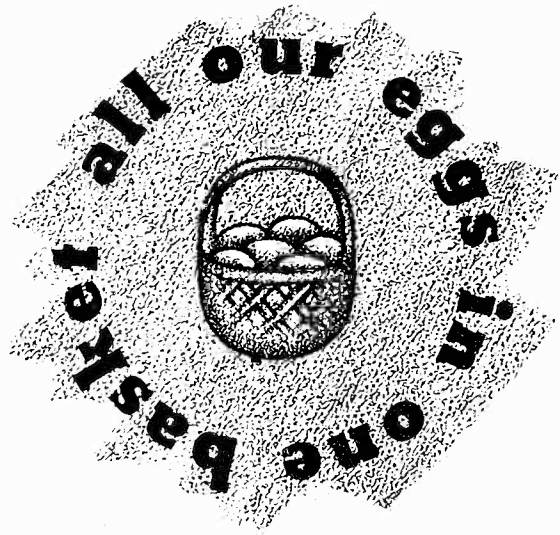

An old proverb advises against the wisdom of putting all your eggs in one basket. But we believe in doing only one job, and doing it well. That job is the rolling of metal strip lighter than .020 inches in thickness. In the last few years, we have specialized to an even greater degree... most of our efforts are devoted to the rolling of nickel and Monel strip for the manufacture of radio tubes and electrical parts. The result?... strip that is suited to your own operations, of uniform temper and exact size, prompt deliveries, and satisfactory prices.

"Somers Stands for Strip"

SOMERS BRASS CO. INC.

350 MADISON AVE.

NEW YORK, N. Y.

Mill at Waterbury, Conn.



BAREX

Embedded Getters

Our experience in specializing in the manufacture of just one product—the Embedded Getter—is illustrated by the fact that we produce more different sizes, shapes and compositions of getters than any other manufacturer in the world.

KING LABORATORIES, Inc.

205 Oneida St. Syracuse, N. Y.

"Electronic Switching in Mercury Arc Rectifiers" by O. Keller. *Allis Chalmers Electrical Review*, March 1937.

By applying suitable potentials to the grids of mercury arc power rectifiers it is possible to prevent the flow of arc currents between the mercury pool cathode and the various anodes of the tube, and thus effectively to open the circuit of the equipment. The control is effected by forcing the arc to flow through a grid in the form of a metal or graphite disc which is perforated with holes. The grids are connected through insulating bushings in the rectifier tank to the external control circuit and are, of course, placed between the cathode and anode. The grid takes control when the potential on the plate is reduced to zero, in much the same way that grid controlled thyratrons may be controlled. Thus is it possible to extinguish the arc in one complete cycle using electrical control methods.

"Modulation in the G-1 Carrier System" by E. C. Blessing. *Bell Laboratories Record*. March 1937.

This article describes a single channel carrier system for circuits of from five to twenty-five miles long in which modulation and demodulation is carried out through the use of the non-linear resistance characteristics of copper oxide rectifiers. Neon gaseous discharge tubes are connected across the line to protect the copper oxide rectifiers from breakdown. These neon tubes cause practically no loss to the transmitted current, but effectively short circuit the rectifiers when the voltage on the line rises above a value which is liable to harm the rectifiers.

"The 'Photoflux'" by J. A. M. Van Liempt and J. A. De Vriend. *Philips Technical Review*, October 1936.

The photoflux is a light source suitable for flashlight photography similar to the photoflash lamps on the American market. It consists of a glass bulb containing a filament which is ignited electrically, and a long wire of combustible material (instead of aluminum foil) in an atmosphere of oxygen. A spot of cobalt salt is painted on the glass bulb to assure against air leaks and shattering of an imperfect lamp in use. This spot is blue in a good bulb but turns rose color on exposure to the moisture of the air. The article deals with the method employed for measuring the quantity of light emitted and the luminous intensity as a function of time.

"Electron-Optical Observations of the Transition of Alpha to Gamma Iron" by W. G. Burgers, and J. J. A. Ploos Van Amstel. *Philips Technical Review*, November 1936.

To investigate the process of transformation or recrystallization in a metal by the standard etching method used in metallography etching must, in general, be performed during the transformation itself. In most instances this introduces difficulties, espe-

An institution of service to the radio industry

The radio industry...the American radio audience... and 119 foreign countries of the world now receiving increasingly large Sylvania shipments... all know Hygrade Sylvania as an organization whose amazing growth is the direct result of good and faithful service to the whole radio industry—from the manufacturer right down to the consumer.

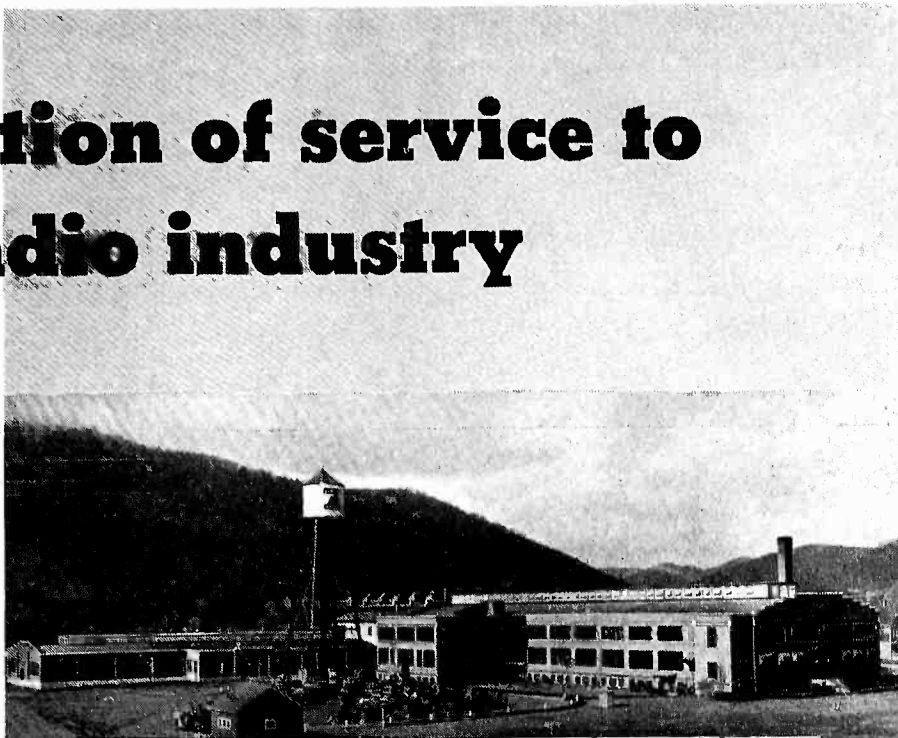

SYLVANIA RADIO TUBE FACTORY, EMPORIUM, PA.
Contains the most efficient equipment known to tube manufacturing. Daily capacity over 65,000 tubes.



SYLVANIA RADIO TUBE FACTORY, SALEM, MASS.
Another great up-to-the-minute tube plant. Daily capacity over 65,000 tubes.

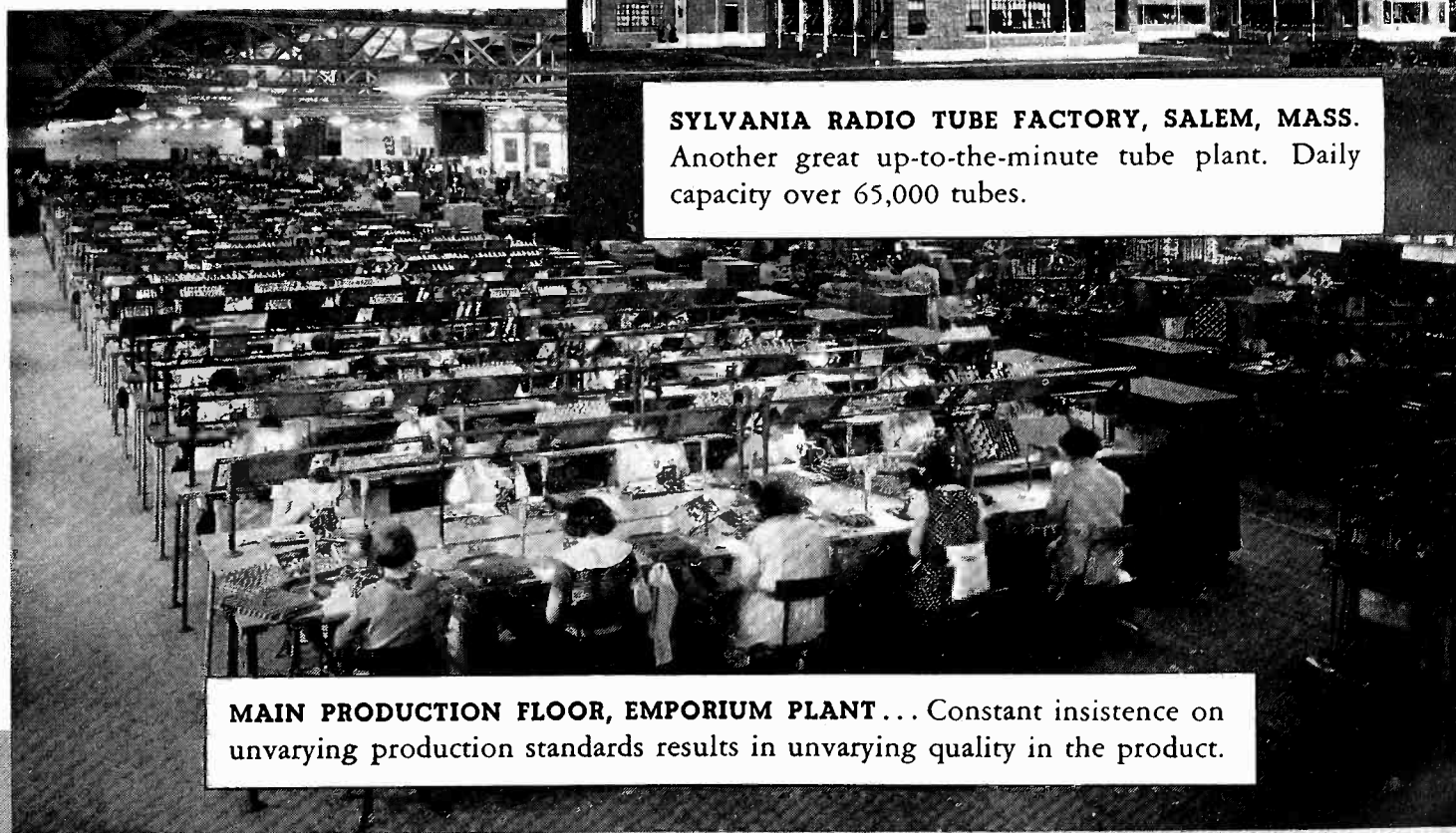

MAIN PRODUCTION FLOOR, EMPORIUM PLANT... Constant insistence on unvarying production standards results in unvarying quality in the product.

SYLVANIA SET-TESTED RADIO TUBES

A Superior Test Instrument

FOR ALL ELECTRICAL MEASUREMENTS NOT REQUIRING A NO CURRENT DRAW VACUUM TUBE VOLTMETER

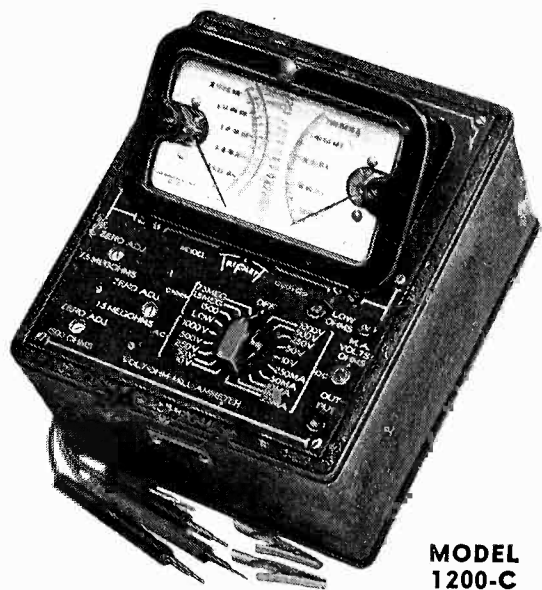

MODEL 1200-C

VOLT - OHM - MILLIAMMETER

- D. C. Resistance 5000 Ohms per Volt
- Resistance Readings to 7.5 Megohms

Model 1200-C has separate A.C. and D.C. instruments. Tilting case for accurate reading. Ohms scales separately adjusted. Low loss switch (contact error on Milliamperes less than 1/2%. No contact error on Voltage measurements.) Low Ohms scale requires but 6-2/3 Milliamperes. Accuracy both A.C. and D.C. guaranteed within 2%. All Metal Case.

Scale Reads: D.C. 10-50-250-500-1000 volts at 5,000 Ohms per volt; 250 Microamperes; 1-10-50-250 Milliamperes; 1/2 to 500 low ohms, 1500 ohms, 1.5 and 7.5 Megohms; A.C. 10-50-250-500-1000 Volts.

DEALER PRICE\$24.33

A TRIPLETT MASTER UNIT

One of a series of co-related single unit testers; made in standard sizes; the most economical method yet devised for completely equipping the all-around radio service shop with high quality instruments.

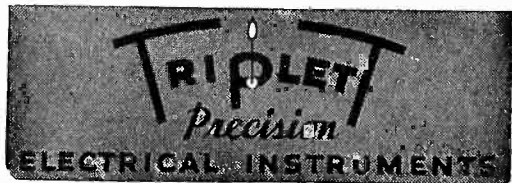

The Triplet Electrical Instrument Co.
235 Harmon Ave., Bluffton, Ohio

Without obligation please send me complete information on.....Model 1200-C:
.....I am also interested in.....

Name

Address

City..... State.....

cially at high temperature transformations. In such cases the electron-optical method of exhibiting the crystal structure of a metal at a high temperature can be used and the authors describe how this procedure may be applied to the investigation of the transformation of iron from the α phase below 900° C. to the γ phase. This is done by heating the iron strip under examination electrically and activating it by a volatilised coating of strontium or strontium oxide deposited from a tungsten coil coated with strontium carbonate.

"Television" by J. Van der Mark. *Philips Technical Review*, November 1936.

The television transmitter in the Philips laboratory has recently been revised for transmitting with a wide variety of line frequencies using sequential and interlaced scanning system. The transmitter may be used for any of ten different combinations from 50 pictures per second at 90 lines per picture or 25 pictures per second at 180 lines sequential scanning, to two interlaced pictures at the rate of 25 pictures per second (equivalent to 50 pictures per second) at 202.5 lines per picture. This last gives a definition of 405 lines per picture.

"Simplified Methods of Computing Performance of Transmitting Tubes" by W. C. Wagener. *Proc. I. R. E.*, January 1937.

Simplified methods are given for quickly computing, with reasonable accuracy, the performance of transmitting tubes in the usual radio frequency and audio frequency applications. These applications cover the cases

CLEARING SMOKE WITH SOUND WAVES

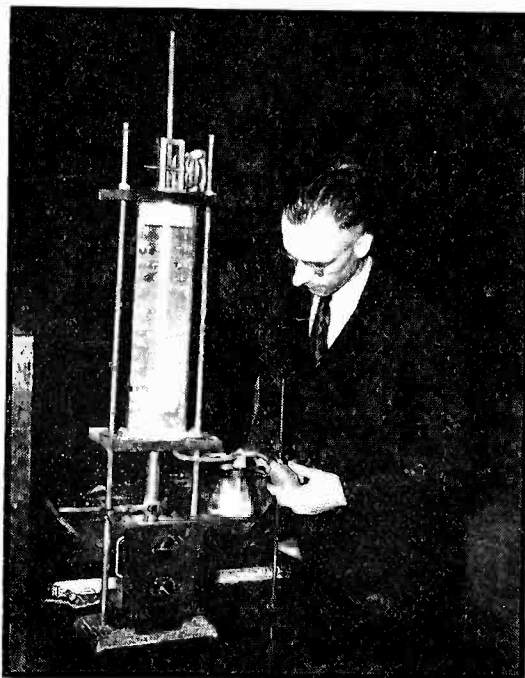

H. W. St. Clair of the Bureau of Mines with his smoke precipitator. A shrill electronically generated sound of high intensity is applied to the column of smoke, causing it to precipitate as snowlike flakes

THE EIMAC 450T SOLVES MANY TUBE PROBLEMS

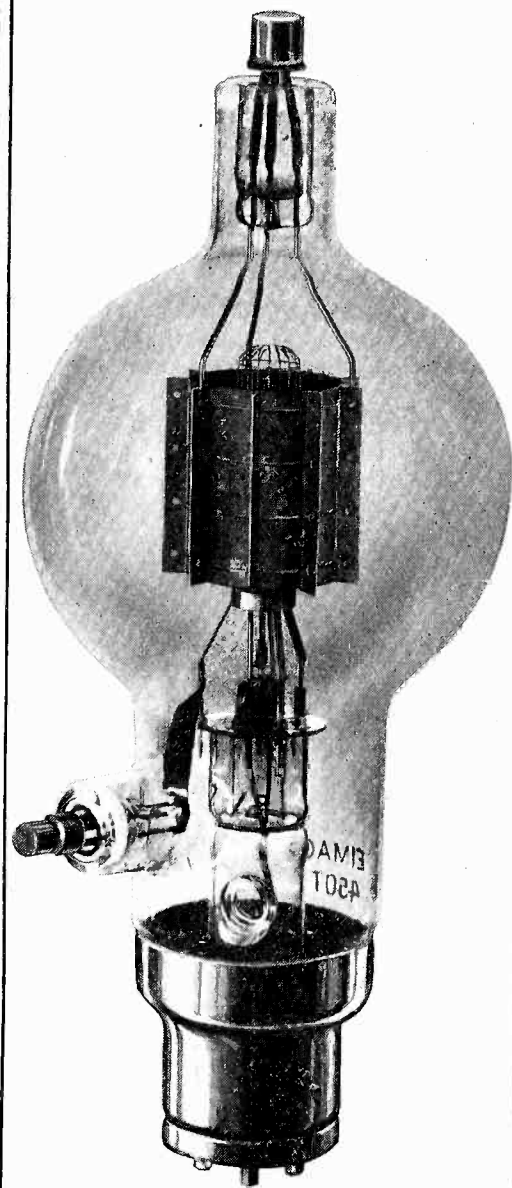

EIMAC 450T

Broadcasters—both low and high frequencies, will be interested in these characteristics.

450 TL Amplification Factor—16
450TH Amplification Factor—32

BOTH TYPES

FIL VOLT—7 1/2

FIL CUR.—12 Amps.

MAX. PLATE CUR.—500 milliamperes

NORMAL DISSIPATION—450 Watts

GRID-PLATE CAPACITY—4.5 mmfds.

NET PRICE \$75.00

EITEL-McCULLOUGH, INC.
San Bruno, California, U. S. A.



Capacitors for every circuit requirement

WE take pleasure, once more, in extending our sincere felicitations and expressing our gratitude to the Institute of Radio Engineers, upon the occasion of their Silver Anniversary. The whole-hearted acceptance of Cornell-Dubilier capacitors by the engineering fraternity has made possible, to a great extent, the phenomenal growth of our organization

Many new features in capacitor construction have been developed in the C-D Laboratories since the Cleveland Convention of last year. Unending research has made possible the design of such new capacitor types as the KR and JR etched foil dry electrolytics, TL Dykanol impregnated and filled high voltage filter condensers and many others.

There is no radio circuit or combination of circuits for which a Cornell-Dubilier fixed condenser has not already been developed.

**WORLD'S LARGEST EXCLUSIVE MANUFACTURERS OF CAPACITORS
MICA . . . DYKANOL . . . PAPER . . . WET AND DRY ELECTROLYTIC**

CORNELL - DUBILIER CORPORATION 1006 HAMILTON BOULEVARD
SO. PLAINFIELD, NEW JERSEY

CORNELL-DUBILIER

Above All . . . Reliability

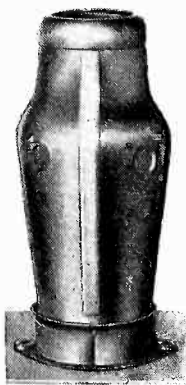
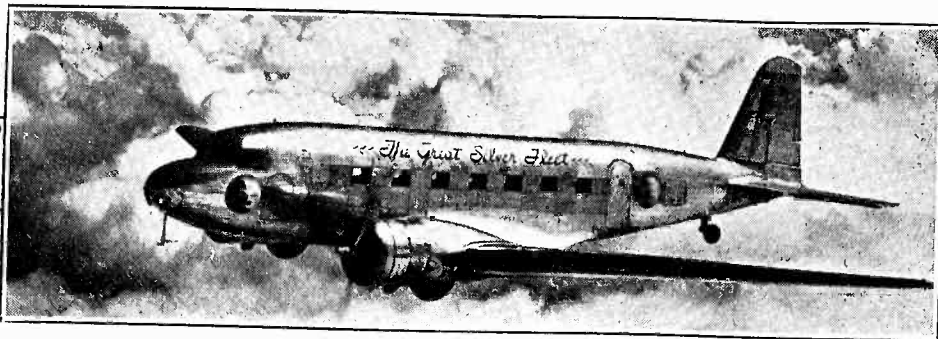

Radio sets of the
EASTERN AIR LINES
are equipped with

GOAT

Form-Fitting Tube Shields



GOAT RADIO TUBE PARTS, INC.

314 Dean Street, Brooklyn, N. Y.

(A Division of THE FRED GOAT CO., INC., Est. 1893)

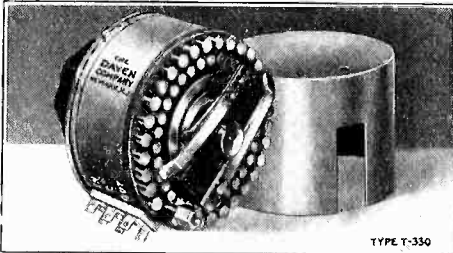

**The FIRST compact
30-Step "Tee" Network Attenuator
ever offered at a LOW COST . . .**

It is perfect as a mixer and a master gain control for low-level mixing. The new Attenuator has zero insertion loss, constant impedance both in and out of all settings and at all frequencies within the desired range, and the lowest attainable noise level.

30 Steps of Attenuation
Laminated positive wiping type switch
Low noise level. Below—130 Db.
Shielded from electrical disturbances
Rugged—light weight

Size only 2 3/4" diameter by 2 1/16" in depth
Zero insertion loss
Frequency error: None over the range of 30
to 17,000 Cps.
Resistors, unifilar wound. Price \$17.50

Write for Bulletin 534

The following impedances stocked for immediate shipment:

30/30	125/125	250/250	500/200	30/50
50/50	200/200	500/500	600/600	50/200

Special Impedances and Attenuation Upon Request.

THE DAVEN CO., 158 Summit St., Newark, N. J.

Manufacturers of:

Single & Dual
Potentiometers
Special Rotary Switches
Filament Rheostats
Mixer Panels

Variable & Fixed
Attenuators
Faders
Volume Indicators
Output Meters

Line Equalizers
Attenuation Boxes
Multipliers
Super Davohms
Laboratory Equipment

Speech Input Control
Apparatus
Decade Resistances
Resistances
Davohms

where the current wave shapes within the tubes are pulses of current which flow less than the full cycle. The factors controlling the shape of these pulses are discussed and a simplified analysis of the pulses is presented. The problem of choosing optimum conditions for a transmitting tube are discussed and the conditions for fully utilizing the tube's capabilities in the different classes of service are given. These methods are illustrated thoroughly by calculations for a standard transmitting tube.

"Electrical Communication in 1936", *Electrical Communication*, January 1937.

This unsigned article gives a summary of the developments of wire, carrier, and radio systems in use in several foreign countries during the past year.

"X-Rays in Vacuum Tube Manufacture" by W. T. Gibson and G. Rabuteau. *Electrical Communication*, January 1937.

A description is given of x-ray equipment for the examination of vacuum tubes as used in the Paris and London laboratories of Standard Telephones and Cables, Ltd. X-ray examinations are used as regular routine on all water cooled power tubes; for development work stereoscopic x-ray pictures are sometimes employed.

"An Experimental Television Transmitter" by S. Van Mierlo and P. Gloess.

"An Experimental Television Receiver" by S. Van Mierlo and C. A. Pullas. *Electrical Communication*, January 1937.

These two articles describe the transmitting and receiving equipment of Les Laboratoires Le Matériel Téléphonique, in Paris for the transmission and reception of television pictures having any of several definition values from 180 to 400 lines.

"Hot Cathode Mercury Vapor High Tension Supply Equipment for Broadcasting Stations" by G. Rabuteau. *Electrical Communication*, October 1936.

The respective characteristics and performances of the various types of high voltage d-c supplies for high power radio transmitters are briefly reviewed and compared with those of hot cathode mercury vapor rectifiers. Characteristics of a series of hot cathode mercury vapor tubes designed by the laboratories of Le Matériel Téléphonique, Paris, are given and the influence of the characteristics of the rectifier circuit on tube performance is also considered. Grid controlled hot cathode mercury vapor rectifiers are also reviewed and a description of a simple system for firing the tubes is given by the authors.

"Photoelectric Guiding of Astronomical Telescopes" by A. E. Whitford and G. E. Kron, *Review of Scientific Instruments*, March 1937.

A photoelectric system for maintaining the telescope definitely fixed at a given part of the sky is described. The system is especially useful in taking photographs. Essentially the system operates by taking the light from the

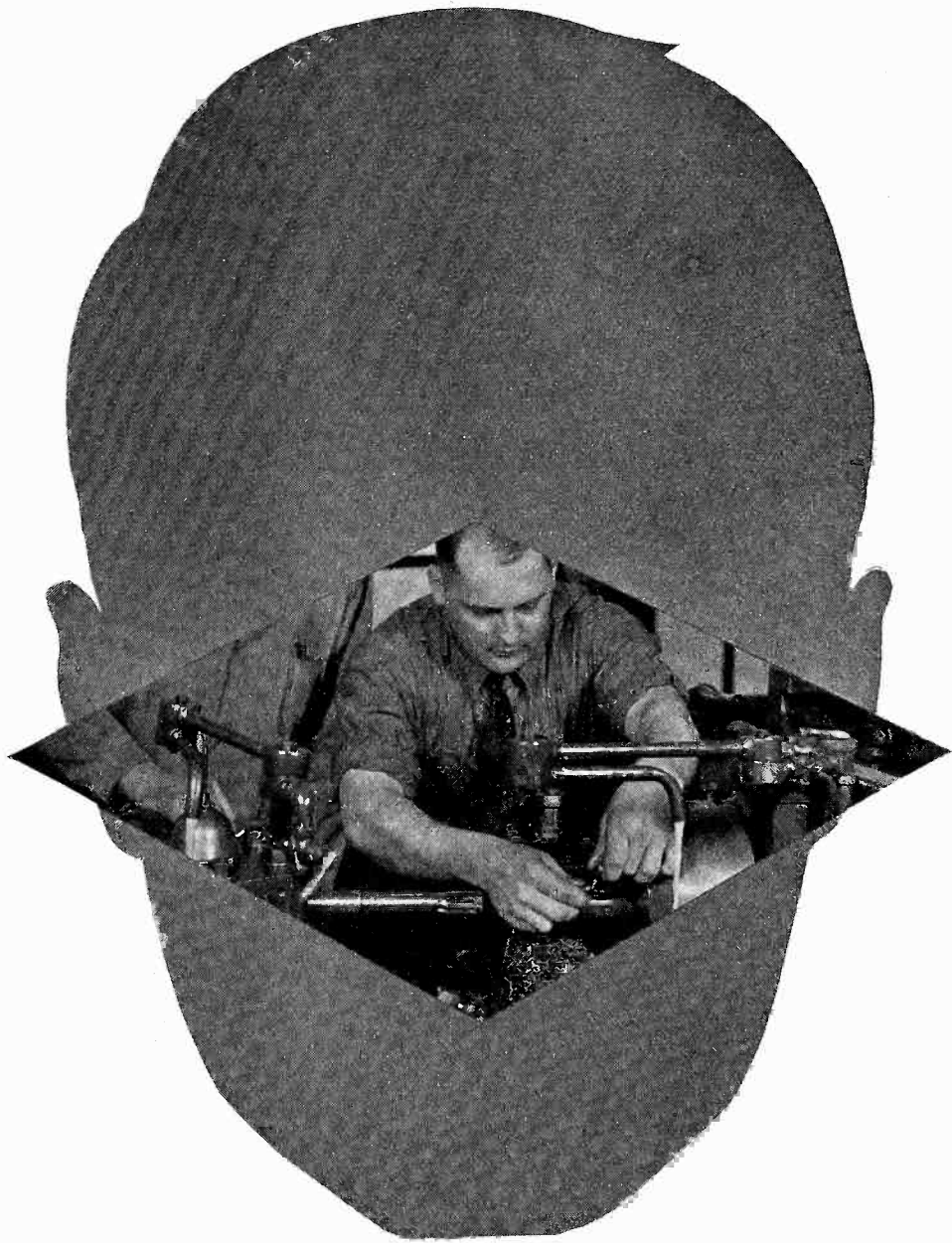

MECHANICAL SKILL *backed by* TECHNICAL KNOWLEDGE

FIXED RESISTORS

VARIABLE RESISTORS

SUPPRESSORS

VOLUME CONTROLS

TONE CONTROLS

No user of Stackpole Radio Specialities is ever required to try out an experiment. The "bugs" are located and corrected here by an organization that has both the brains and the determination to turn out products that are *right* all the way through. If you don't believe it can be done—you haven't tried Stackpole. Glad to quote on your requirements for any of the products listed at the left.

STACKPOLE CARBON COMPANY
ST. MARYS, PENNA., U.S.A.

These products are sold only to manufacturers of original equipment.

**if you haven't
used the
LATEST PRESTO
GREEN SEAL DISCS**

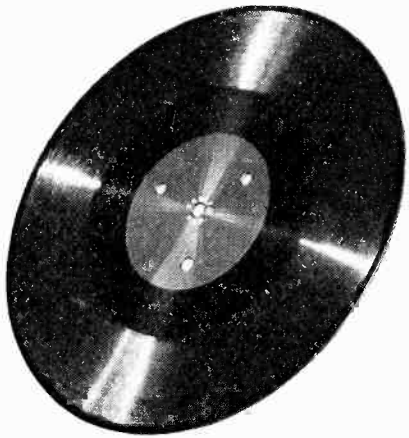

*Send for a
FREE SAMPLE TODAY*

See for yourself the radical improvements that have been made. Note the perfect smoothness of the surface . . . the uniform cutting quality throughout the record.

New air conditioning and purifying processes have made the Presto Green Seal disc absolutely free from grit and other hard particles which dull the cutting needle and produce surface noise. Users of Green Seal Discs now record from 20 to 30 hours with a single sapphire cutting needle.

TRY DISCLUBE

. . . the liquid hardener, sold exclusively with Presto Green Seal Discs. Disclube protects the delicate sound impressions in the record groove . . . makes it possible to play recordings 50 to 100 times without serious wear.

A blank Green Seal disc and a 2 oz. bottle of Disclube will be sent without charge to any person or firm equipped to make instantaneous recordings.

PRESTO
RECORDING CORPORATION

143 W. 19th St., New York, N. Y.

Export Division (Except Australia & Canada)
M. SIMONS & SON CO., INC.
25 Warren St., N. Y. Cable: Simontricc, N. Y.

Australia & New Zealand Agents & Stockists
A. M. CLUBB & CO., LTD.
76 Clarence St., Sydney, N. S. W., Australia

telescope objective, slitting this into two parts by means of a prism, each ray of which passes through a light chopper, the chopped or modulated rays being intercepted by a phototube which controls the movement of the telescope.

"A Laboratory Frequency Standard" by G. P. Harnell and J. B. H. Kuper, *Review of Scientific Instruments*, March 1937.

An inexpensive laboratory frequency standard is described consisting of a crystal controlled oscillator, with multi-vibrators and associated equipment, which operates a clock. A low temperature coefficient quartz crystal and simple thermostat control element using incandescent lamps serves as the frequency standard and is accurate to within one part in 10^6 or better, when standardized against WWV standard frequency signals.

"Prevention of Blocking in Resistance Coupled Amplifiers" by O. H. Schmitt, *Review of Scientific Instruments*, March 1937.

A method of reducing the time during which a resistance coupled amplifier becomes inoperative because of blocking by inserting a high resistance in series with the grid of the second tube is described.

"Leaky Condensers in Resistance Coupled Amplifiers" by O. H. Schmitt, *Review of Scientific Instruments*, March 1937.

A method is described in which instability caused by leaky condensers in resistance coupled amplifiers may be

overcome by using two blocking condensers and two grid bias resistors. Results obtained with this circuit and commercial condensers compare favorably with the usual circuit using the highest quality mica condensers.

"The Interaction of Radio Waves" by V. A. Bailey. *Wireless World*, February 26, 1937.

The Telegren or Luxembourg effect, in which the modulated radiations from one powerful station are heard when listening to another station, is discussed. The effect can be accounted for by assuming non-linear processes to take place in the ionosphere so that the modulation of one wave is impressed on the other wave. If this is true, the modulation of the undesired station onto that of the desired station is proportional to the power of the undesired station; likewise the depth of modulation impressed on the wanted station is proportional to that of the unwanted station. The interaction is most easily observed when the wanted wave is reflected within a circle concentric with the unwanted wave and of radius of 200 to 300 kilometers. The interaction in European latitudes has also been most readily observed at the higher broadcast frequencies than at the lower. The depth of modulation under favorable conditions exceeds 0.3% and thereby provides a perceptible background. There is a noticeable distortion of the impressed modulation which tends to favor the low audio tones.

"MANY YEARS AGO"

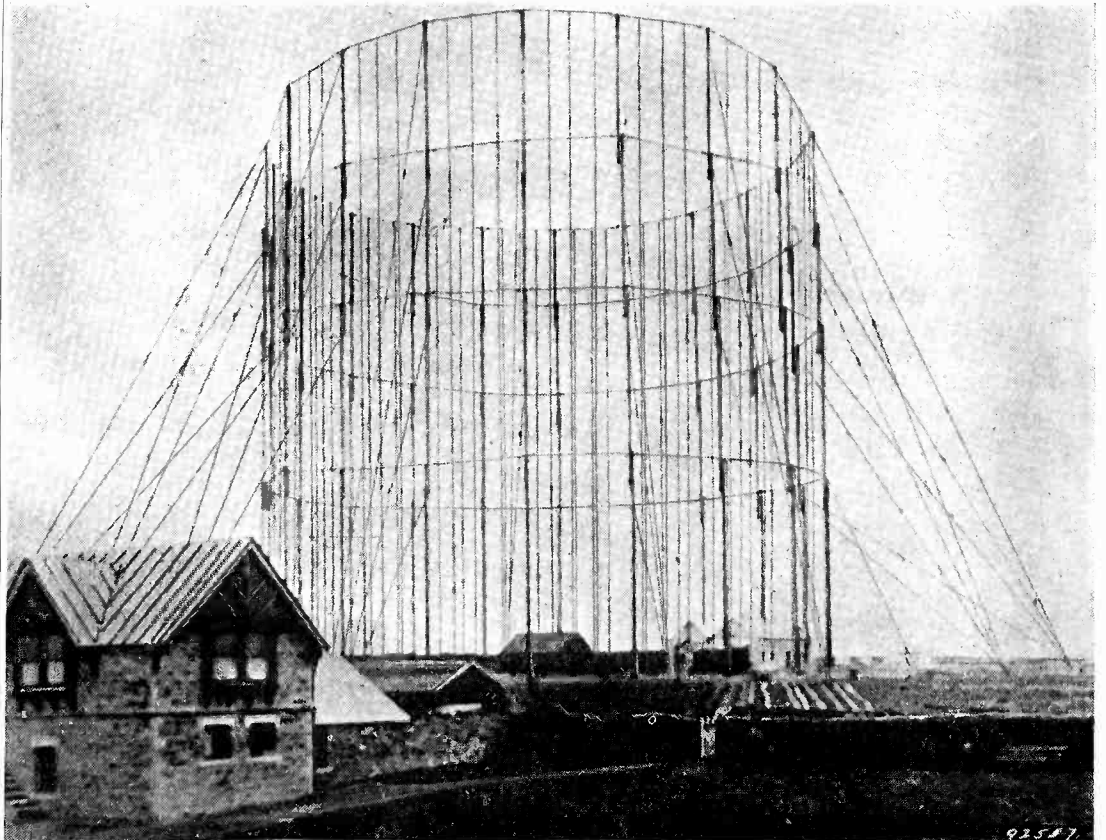

Original antenna erected at Poldhu, England, for tests across the Atlantic in 1901. A short time before the tests the masts blew down, but a smaller number was hastily set up and the tests went off on schedule

STAMP IT

PUNCH IT

DRILL IT

MACHINE IT

For HIGH FIDELITY

In both transmission and reception High Fidelity is the order of the day. Your aim at perfection is our opportunity to demonstrate the electrical and mechanical excellence of Dilecto—the standard laminated phenol fibre for radio insulation. It's as versatile as it is practical, and can be furnished to meet the most exacting requirements. Let us quote on your specifications.

CONTINENTAL-DIAMOND FIBRE CO.
NEWARK, DELAWARE

DILECTO

MANUFACTURING REVIEW

Dividends

♦ Orders received by the General Electric Company for the first quarter of 1937 amounted to \$105,747,030, compared with \$59,569,879 for the corresponding quarter of 1936, an increase of 78 per cent; the largest first quarter in the history of the company.

♦ At the meeting of the directors of the Western Electric Co., held on March 9, a dividend of 50 cents per share on its common stock was declared. The improvement in general business during 1936 is reflected in the sales of the Western Electric Company which were \$146,421,000, an increase of 38.9 per cent over 1935, according to the annual report to its stockholders. At the close of the year the company's plants were operating on a five-day, 40-hour week, at about 53 per cent of capacity, as compared with 27 per cent at the beginning of 1936. Net earnings were

\$18,698,049 in 1936 as compared with \$2,620,279 in the previous year.

♦ The annual report of the Westinghouse Electric & Mfg. Co., shows a net income of \$15,099,291 in 1936 compared with \$11,983,380 in 1935. Orders received amounted to \$182,521,304, an increase of 48 per cent over 1935. Sales billed totalled \$154,469,031, representing an increase over 1935 of 26 per cent.

♦ At a meeting of the board of directors of the General Electric Co. on March 6, the preliminary results for 1936 showing the amount of sales billed amounting to \$268,545,000, compared with \$208,733,000 in 1935, an increase of 29 per cent. Orders received for 1936 amounted to \$296,748,000, compared with \$217,362,000 for 1935, an increase of 37 per cent.

Net income for the year amounted to \$43,947,000, equivalent to \$1.52 per share of common stock, compared with \$27,844,000 or 97¢ a share for 1935. Dividends totalling \$1.50 a share were declared in 1936, compared with 70¢ a share in 1935 and \$1.60 a share in 1930. According to announcement made by Gerard Swope, orders received during the first two months of 1937 amounted to \$64,000,000, an increase of 79 per cent over the corresponding period of last year. A dividend of 40¢ a share for the first quarter, has been declared by the directors.

♦ The annual report of the Stewart-Warner Corp. shows sales amounting to \$27,074,509 in 1936 as compared with \$20,479,164 in 1935, and a net profit during 1936 of \$2,113,234 as compared with a profit of \$1,724,313 a year ago.

News

♦ Control of the former Polymiet Delta Co., of Hamilton, Ont., Canada, has been taken over by the Aerovox Corp., Brooklyn, N. Y. The Canadian plant will operate as Aerovox Canada, Ltd., and will produce a line of dry and wet electrolytic condensers as well as mica and paper condensers for the Canadian trade. Howard E. Rhodes is vice-president and chief engineer of the Brooklyn and Canadian companies.

♦ The appointment of Aubrey R. Goodwin as manufacturing engineer of the Radio Division, General Electric Co., Bridgeport, Conn., has been announced by W. R. G. Baker, chairman of the Radio Management Committee. Mr. Goodwin will be in charge of all receivers and allied radio manufacturing operations. Since 1925, when he was assistant superintendent of the Radio Department of the Schenectady Works of the General Electric Company, Mr. Goodwin has been affiliated with problems in the manufacture of radio equipment. He has spent several years in charge of manufacturing assignments in South America.

♦ On April 1 the Brush Development Company, moved to its own new building at 3311 Perkins Avenue, Cleveland. It has enlarged its facilities from 1,000 sq. ft. in 1932 to its present four-story building, and has increased the number of its employees accordingly.

♦ The Bendix Aviation Corp. has secured manufacturing rights to produce the Pan American Airways direction finder on a plan whereby this aid to air navigation will be made available to all American aviation interests. Eventually this work will be done at the new plant of Teterboro, N. J., although initial construction will be started at the Washington plant of the Bendix Corp.



Robert L. Barr, Clough-Brengle Company, 2815 West 19th St., Chicago, has been appointed general sales manager for that company.

♦ The Port-O-Matic Corp., 1013 Madison Avenue, New York City, has been formed for the purpose of manufacturing and distributing portable radio and automatic radio-phonograph combinations. Mr. M. Lehman is president and general manager.

♦ At the annual meeting of the directors of the Electrical Research Products, Inc., held on April 13, Whitford Drake, executive vice-president was elected president to succeed Edgar F. Bloom, who is president of the Western Electric Company. Mr. Drake became associated with Western Electric in 1924 and has been connected with ERPI since its formation in 1927.

♦ The factory of the Arcturus Radio Tube Company, at Newark, N. J., is hiring many additional operators in all departments to take care of the great increase in tube sales which the company is experiencing. Prospects for this year are bright.

♦ Mr. Otto Paschkes, president of the Solar Manufacturing Corp., 599 Broadway, N. Y. C., has announced lease of an additional factory at the foot of West 23rd Street, Bayonne, N. J. This expansion has been made necessary because of greatly increased business offered the company for the coming season, and will be devoted to the manufacture of condensers.

WESTON

low energy consuming

Relays

FOR PROBLEMS OF CONTROL



MODEL 30

Sensitive Relay . . . Permanent Magnet Moving Coil Type . . . platinum iridium contacts . . . flexible contact arm . . . for regulating current and voltages within definite, narrow limits . . . also for use in vacuum tube and photoelectric cell circuits. Surface mounting.

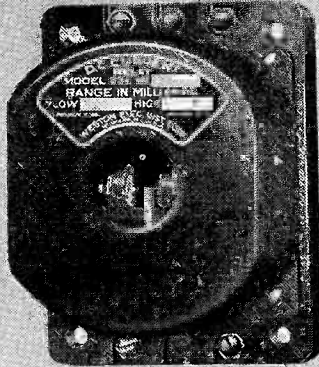

MODEL 534

A Sensitive Relay similar to Model 30 . . . for commercial uses where a smaller and lower price relay is required and where extreme accuracy is not of prime importance. Surface or flush mounting.

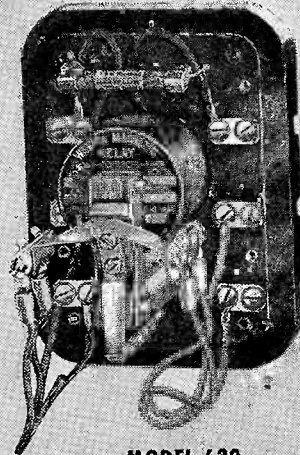

MODEL 630

Power Relay . . . Electro-magnetic Type with mercury or mechanical contacts . . . multi-circuit . . . will control circuits up to 3 thousand watts with less than one watt input . . . may be supplied with interlocking contacts . . . operates on 6 volts DC . . . surface mounting.

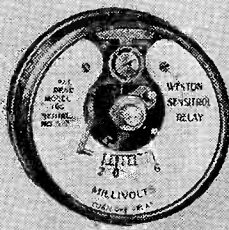

MODEL 705

Sensitrol Indicating Relays . . . operate on values down to 2 microamperes or 1/2 millivolt . . . handle up to 5 watts non-inductive load at 110 volts in output circuit . . . new magnetic contact principle . . . manual or electrical reset . . . scales calibrated in units determined by application. Surface mounting.

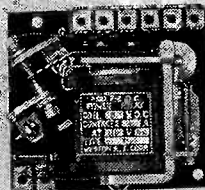

MODEL 712

Power Relay . . . Electro-magnetic Auxiliary Type . . . silver contacts capable of handling 5 amps at 110 volts AC non-inductive . . . operates on 6 volts DC . . . single or double circuit.

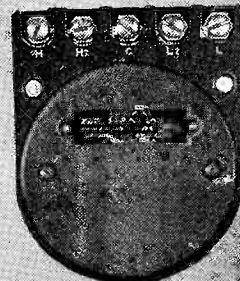

MODEL 613

Thermal time-delay relay of compensated type - single or double circuit - low energy input.

WESTON Relays operate on DC current and will function on changes in—

- Microamperes
- Milliamperes
- Amperes
- Millivolts
- Volts
- Temperature
- Etc.

From the broad WESTON line you can obtain sensitive relays and contact-making indicators which are capable of selecting or controlling on minute changes in current or voltage, down to 2 microamperes or 1/2 millivolt . . . as well as time-delay and power relays of various types designed to operate from the sensitive relay contacts. Thus WESTON

Relays make it possible to combine the various circuit functions into a complete control sequence for a wide variety of applications. Information on the complete WESTON line, as well as engineering cooperation on any relay problem, is freely offered . . . Weston Electrical Instrument Corporation, 618 Frelinghuysen Avenue, Newark, New Jersey.

WESTON Instruments

TANTALUM

The Ultimate Metal for Power Tubes

Every power tube engineer who has investigated tantalum has stated without qualification that tantalum is superior to all other anode or grid materials.

The rapidly growing use of this unique metal by an increasing number of tube manufacturers is visible testimony, not only to the inherent quality of tantalum but to its sales benefit and profit.

FANSTEEL
METALLURGICAL CORPORATION
NORTH CHICAGO, ILLINOIS

TANTALUM COLUMBIUM
TUNGSTEN MOLYBDENUM
ELECTRICAL CONTACTS

Vari-Volt Transformers

The Halldorson Company announce a new transformer which the serviceman can use at his bench for adjusting his line voltage for any requirement. The Halldorson Vari-Volt transformer will supply voltages from 0 to 256 volts in

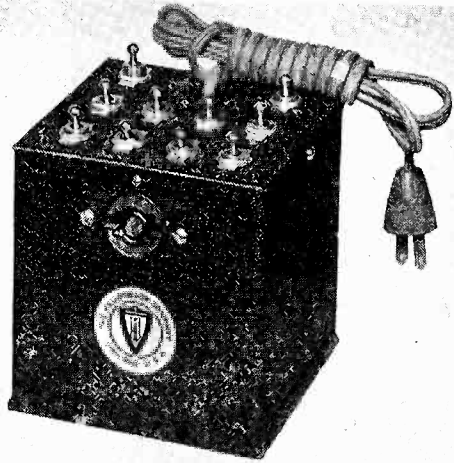

two-volt steps or from 0 to 128 volts in one-volt steps. Power output 250 watts maximum. Obtainable from the Halldorson Company, 4500 Ravenswood Avenue, Chicago, Ill.

Counting Devices

A NEW SOLENOID TYPE of counter available either as reset or non-reset, enables the manufacturer to offer remote control of production, either as original

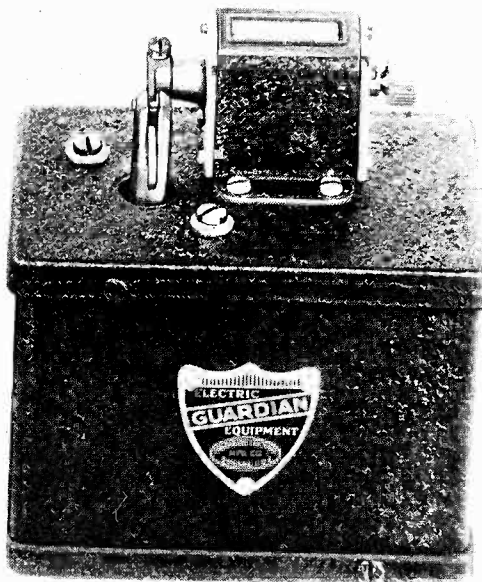

equipment, or as an extra feature. Counters are available up to and including five digits from the Guardian Electric Manufacturing Co., 1621 West Walnut Street, Chicago.

Permug Speakers

A COMPLETE LINE of permanent magnet speakers is announced by the Oxford Radio Corp., 950 West Van Buren Street, Chicago, Ill. This line is outstanding in completeness, comprising speakers ranging in size from 3 in. in diameter to 14 in. No external field excitation is required. These speakers are useful for automotive and portable installations.

NEUMANN ELECTRO-DYNAMIC REPRODUCER

This new designed reproducer makes use of the Electro-dynamic principle. The superiority is characterized by the constancy of impedance and freedom of distortion. Its impedance is of an essentially pure resistance of 200 ohms, therefore sharp cut off band controlling filters can be used without any effect on their filter characteristics. The response curve is flat from 40 to 8,000 cycles per second. Figure 1 shows a filter system used for this Dynamic Pick-up. Figure 2 shows the principle of the Electro-dynamic Reproducer.

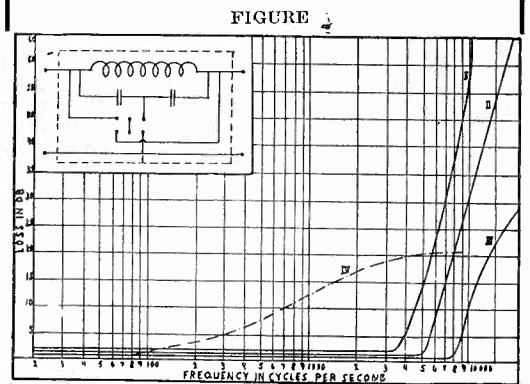
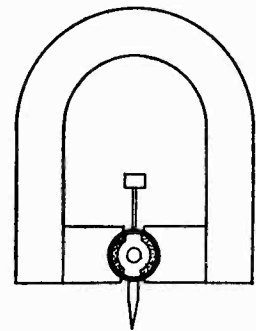

FIGURE SHOWS:
CURVE 1—Loss with 3 sections in series
CURVE 2—Loss with 2 sections in series
CURVE 3—Loss of last section alone
CURVE 4—Loss of typical "Tone Control" setting

FIGURE 2



SOUND APPARATUS COMPANY
are also Distributors of

NEUMANN CUTTING HEADS
Neumann High Speed Automatic Power Level Recorders
Saja Synchronous Recording motors
Duralotone discs
HEROLD cutting and playback needles

Write for Literature

SOUND APPARATUS COMPANY
150 W. 46th St. New York, N. Y.

T

here is a reason for the
great popularity of . . .

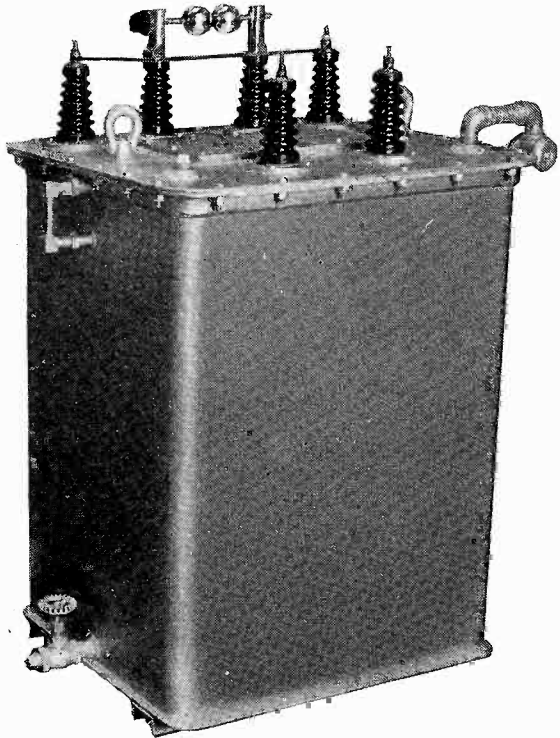

AmerTran oil-immersed class "B" modulation transformer for operation at +65 dB. used in a 25-kilowatt transmitter.

Modulation,
Audio-Frequency
and
Power-Supply
Transformers
by
AmerTran

AmerTran Products

Transformers:
Audio frequency
Modulation
Filament supply
Plate supply
Special Purpose

Transformers:
Power (5000 Kva.)
Distribution
Instrument
Air Cooled
Testing

Voltage Regulators
Testing Sets
Rectifiers
Spot Welders
Tap-changers
Electronic Devices

AmerTran Sales Offices

Boston, Mass.—Electrical Apparatus Co., 10 High St.
Chicago, Ill.—Kelburn Engineering Co., 600 W. Jackson Blvd.
Cleveland, O.—A. D. Fishel Co., Engineers Bldg.
Council Bluffs, Iowa—Theo. W. Keller, 303 Harrison St.
Dallas, Texas—Edward F. Aymond, 3750 Urban Ave.
Hartford, Conn.—Electrical Apparatus Co., 650 Main St.
Ithaca, N. Y.—Arthur C. Stallman, 218 Waite Ave.
Los Angeles, Cal.—C. R. Lynch, I. N. Van Nuys Bldg.

Montreal, Que.—W. O. Taylor & Co., Canada Cement Bldg.
New York, N. Y.—American Transformer Co., 30 Rockefeller Plaza
Newark, N. J.—American Transformer Co., 178 Emmet St.
Philadelphia, Pa.—L. D. Joralemon, 112 So. 16th St.
Pittsburgh, Pa.—Edgar M. Moore & Co., Farmers Bank Bldg.
St. Louis, Mo.—J. W. Jones, 660 So. 18th St.
Seattle, Wash.—James J. Backer Co., 109 Bell St.
San Francisco, Cal.—James H. Southard, 420 Market St.
Export Agent—Ad. Auriema, Inc., 116 Broad St., N. Y. C.

WITHOUT fear of contradiction, AmerTran is proud to claim that it has furnished a large majority of all class "B" modulation sets used in the larger American broadcast stations. Many of these stations have also standardized on AmerTran transformer equipment for all amplifier and power-supply requirements.

The successful results obtained with AmerTran equipment explain its great popularity. Actual tests on modulation transformers show an insertion loss of less than 1 dB and frequency characteristics uniform within ± 1 dB from 30 to 16,000 cycles. Such equipment has been supplied for all sizes of transmitters from 100 watts to 500 kilowatts.

AmerTran transformers are available for every broadcast station requirement. May we send engineering details on equipment to meet your needs?



TRANSFORMERS

Manufactured Since 1901 by—

AMERICAN TRANSFORMER COMPANY
172 Emmet St. Newark, N. J.

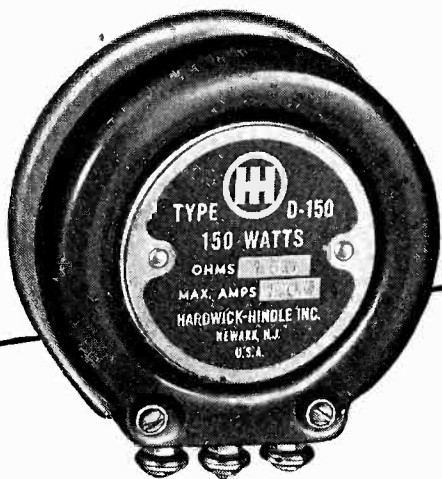

IT'S NEW

The New D-150

THIS new rheostat is the last word in porcelain-vitreous enamel construction. A newly patented contact system gives exceptionally smooth control. All moving parts are enclosed; great strength and ease of mounting are provided by new metal mounting plates. Two popular sizes—50 and 150 watts in a wide range of resistance values—are available now, larger sizes will be ready soon. Write for further information...and remember the mark  means reliable rheostats and resistors.

HARDWICK, HINDLE • INC.
136 Pennington Street, Newark, N. J.



EFFICIENCY

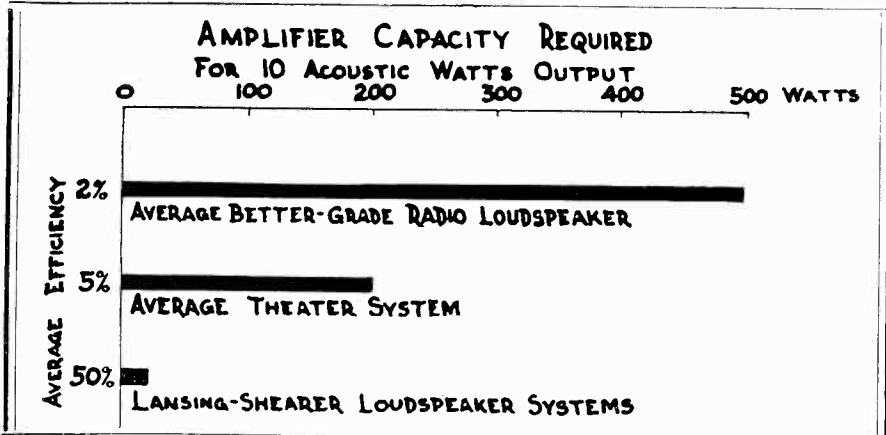

**Ten Times the Usual Efficiencies over the Entire Frequency Range*

Efficiency becomes vitally important when you begin paying for amplifier capacity.

On new installations a given output can be secured most economically with a Lansing-Shearer Loudspeaker System. Also, the same System will give you the best results with your present amplifier.

Complete information will be furnished to all inquirers giving detailed information regarding their requirements.

**Fourth of a series of Advertisements beginning with February issue.*

LANSING MANUFACTURING CO.

6900 McKinley Ave., Los Angeles, Calif.

Super-Pro

A new model of the Super-Pro receiver has been announced by the Hammarlund Company, 424 West 33rd Street, New York, and is described in a six-

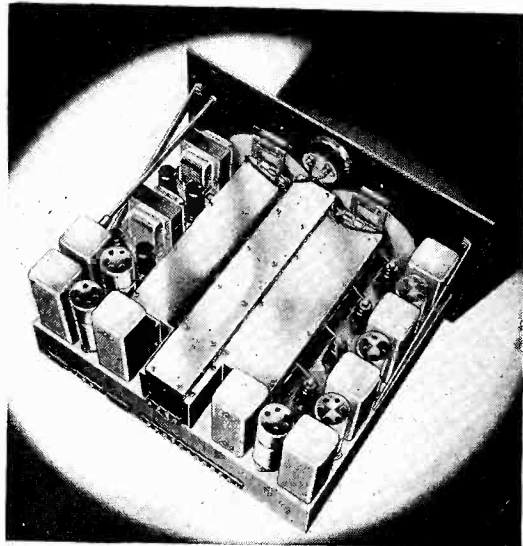

page bulletin. Variable bandwidth control as well as a beat frequency control calibrated in kilocycles are two of the many features which characterize this already popular radio receiver. All controls are mounted on the front panel. The selectivity is variable between three to sixteen kc.

Fixed Audio Oscillator

A FIXED FREQUENCY audio oscillator operating from the 60-cycle, 110 or 220 volt supply line and supplying an output of 35 milliwatts has been an-

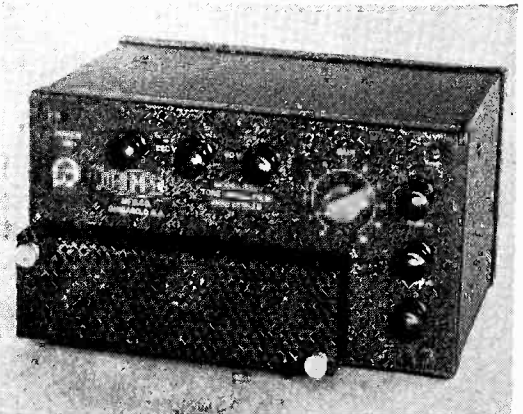

nounced by the Triumph Manufacturing Co., 4017 West Lake St., Chicago. Output terminals of 500 ohms and 5000 ohms impedance are provided.

Wire Stripper

A WIRE STRIPPER that strips either from left to right or right to left, and takes care of twisted pairs of all varieties by clockwise or counter-clockwise rotation, has recently been put on the market by the Ideal Commutator Dresser Co., 1631 Park Ave., Sycamore, Ill. When the wire is inserted into the stripper, the insulation is cut clean, the wire is properly twisted and polished and made ready for soldering. The length of stripped insulation may be varied up to two inches. A flexible metal tube carries the waste strippings to a disposal container.

RADIO

reaches out with

TRUSCON VERTICAL RADIATORS

Greater coverage of primary service area with no increased power input... low shunt capacity... absence of night fading... these are among the many technical advantages of Truscon Vertical Radiators. Structurally, the Truscon self-supporting, vertical antenna system is a tower of strength and beauty, economically designed, mechanically sound and exceptionally resistant to wind pressure. This partial list of Truscon Vertical Radiator installations indicates their wide acceptance:

STATION	LOCATION	TOWER HEIGHT
WDOD	Chattanooga, Tenn.	320'
WADC	Akron, Ohio	350'
WLW	Cincinnati, Ohio	(2) 322'
WDGY	Minneapolis, Minn.	184'
KGHL	Billings, Mont.	558'
WSVA	Harrisonburg, Va.	182'
WTMV	E. St. Louis, Ill.	154'
WMFE	New Britain, Conn.	185'
KTRH	Houston, Texas	375'
WBNX	Cliffside, N. J.	(2) 235'
WIS	Columbia, S. C.	352'
WIS	Columbia, S. C.	260'
WOKO	Albany, N. Y.	180'
WGAR	Cleveland, Ohio	374'
WCOP	Boston, Mass.	227'
WELI	New Haven, Conn.	281'
WJAX	Jacksonville, Fla.	281'
WEMP	Milwaukee, Wisc.	173'
WJJD	Mooseheart, Wisc.	281'
WREC	Memphis, Tenn.	(2) 410'
KOMO	Seattle, Wash.	570'
KFBK	Sacramento, Calif.	334'
WDRC	Hartford, Conn.	308'
WFBC	Greenville, S. C.	375'
KBTM	Jonesboro, Ark.	189'
WIBA	Madison, Wisc.	430'
WIBA	Madison, Wisc.	(2) 195'
WTAQ	Greenbay, Wisc.	(4) 196'
WDAE	Tampa, Florida	238'
WFMD	Frederick, Md.	257'
WSAI	Cincinnati, Ohio	225'
WHBL	Sheboygan, Wisc.	285'
	Canton, China	622'
WSPR	Springfield, Mass.	222'
KFEL	Denver, Colo.	285'
WROK	Rockford, Ill.	238'
WAAF	Chicago, Ill.	231'
WCLO	Janesville, Wisc.	259'
WSIX	Nashville, Tenn.	195'
KFPY	Spokane, Wash.	466'
WSBC	Chicago, Ill.	195'
WTRC	Elkhart, Ind.	174'
	Tallin, Esthonia	645'
WKY	Oklahoma City, Okla.	285'
KMA	Shenandoah, Iowa	488'
KWYO	Sheridan, Wyo.	187'
KRSC	Seattle, Wash.	218'
WNBF	Binghamton, N. Y.	227'
WORL	Boston, Mass.	308'
WCBM	Baltimore, Md.	231'
KLRA	Little Rock, Ark.	300'
KVI	Tacoma, Wash.	444'
KID	Idaho Falls, Idaho	330'
WGRC	New Albany, Ind.	231'
WIRE	Indianapolis, Ind.	(2) 330'
WTAD	Quincy, Ill.	280'
WDWS	Champaign, Ill.	152'
KOBH	Rapid City, S. D.	174'
WILL	Urbana, Ill.	(2) 333'
WEEI	Boston, Mass.	(2) 364'

POLICE TOWERS

WMP	Framingham, Mass. State Police	220'
WQPS	Springfield, Ill. State Police	338'
WQPC	Chicago, Ill. State Police	338'
WQPP	Pontiac, Ill. State Police	338'
WQPG	Sterling, Ill. State Police	338'
WQPM	Macomb, Ill. State Police	338'
WQPD	Duquoin, Ill. State Police	338'
WQPF	Effingham, Ill. State Police	338'
KACD	Atlantic, Iowa State Police	227'
KACC	Fairfield, Iowa State Police	227'
	Terre Haute, Ind. City Police Dept.	154'
	Boston, Mass. City Police	(4) 132'
	Oregon State Police Dept.	(8) 120'
	Dept. of Commerce Lighthouse Service, New York	125'
	Montgomery, Ala. Police Dept.	95'

"Check up" on Truscon Vertical Radiators. Then call Truscon engineers to assist you in a thorough analysis of your requirements.

TRUSCON STEEL COMPANY

YOUNGSTOWN • OHIO

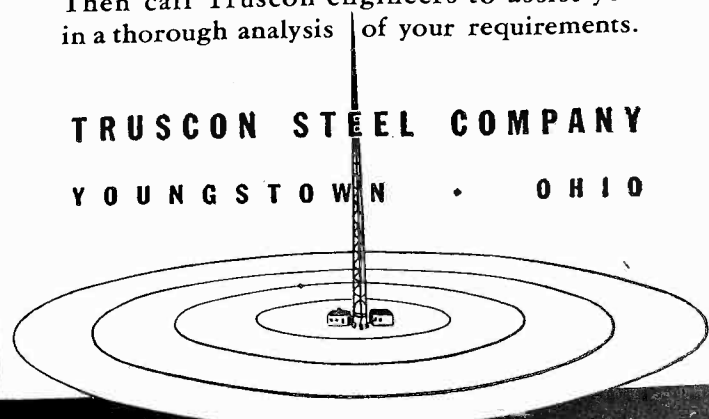

Learadio

AVIATION COMMUNICATION EQUIPMENT

The answer to economical air-craft radio communication

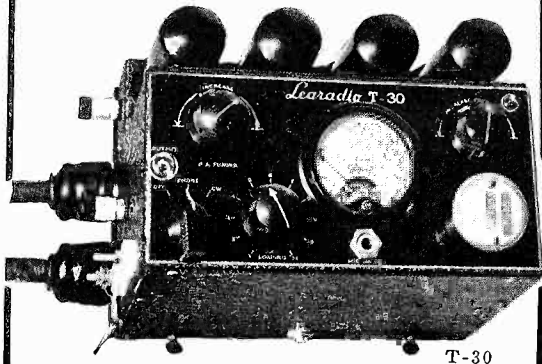

T-30

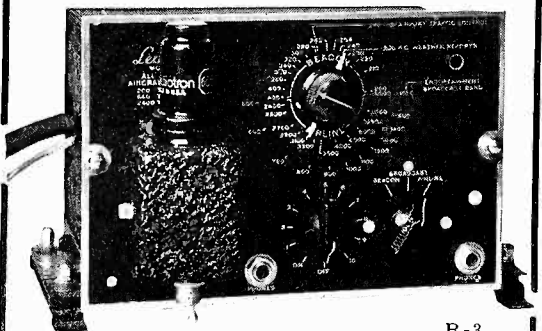

R-3

A COMPLETE TWO-WAY OUTFIT

30 Watt Transmitter—3 Band Receiver. Weight 24 lbs. complete installed. 300 to 500 mile range regularly reported. (Code: Tuway) \$498.00.

A BEACON RECEIVER

For Light Planes and Auxiliary Use. With Dry Batteries. Weight complete 10 lbs. Set of Batteries Operates 250 hours. (Code: Arone) \$69.50.

A NEW LEAR-O-SCOPE

(Something entirely new and different). Aircraft Radio Compass and Direction Finder with anti-rain static loop—with all the safety features demanded by airlines. Weight 30 lbs. (Code: Kakum).

A NEW LEARADIO MOTOREEL

Fully Automatic Weighted Trailing Wire Antenna. It thinks for itself, reels in and out automatically after take-off and before landing. Greatly improves transmitting range. Weight 11 lbs. (Code: Morel) \$198.00.

A NEW LEARADIO UNIFLEX

For Marine, Portable, Police and Amateur Purposes. 30 Watt Transmitter—5 Band Receiver—200 KC to 40 Mc. range—Crystal Controlled—Beat Frequency Oscillator, etc. \$598.00.

Write for detailed information.

LEAR DEVELOPMENTS, INC.

121 West 17th Street, New York, N. Y.

Export Division: 17 State St., N. Y. C.

Cable Address: Learvelop

Electronic Oscilloscope

TWO MODELS of cathode ray oscilloscopes using a tube with a two-inch screen are available from the Supreme Instrument Corp., Greenwood, Miss. Model 535, the larger of the two can be used as a complete visual servicing device in connection with the frequency modulator signal generator. Spot centering adjustments, as well as amplifiers for vertical and horizontal deflection are provided. A linear time base oscillator from 15 to over 30,000 cycles is also provided. The model 530 is useful for visual alignment with frequency modulated signal generator. It is particularly adapted for use by amateurs for transmitter adjustment. The price of this unit will be \$29.95 complete, whereas the larger unit (model 535) will sell complete for \$49.95.

Transcription Turntables

IN THE NEW Remler model PT-192 transcription turntable, designed for the continuous service requirements of broadcast stations, the condenser split phase synchronous motor, mounted on rubber, drives a 16-in. turntable. Speeds of 33 $\frac{1}{3}$ r.p.m. and 78 r.p.m. may be obtained at will, the slower speed being obtained by a roller bearing planetary mechanism with a speed change lever mounted on the top of the turntable. This transcription unit is furnished with an electromagnetic lateral pick-up with double section equalizer network to compensate for deficient bass response. A response curve which is uniform to within 3 db. from 45 to 6600 cycles per second is claimed. Available from the Remler Co., Ltd., 2101 Bryant St., San Francisco, Calif.

Velocity Microphone Connector

A new and improved cable connector is now supplied as standard equipment with Amperite velocity microphone model RBMn, and RBHn. The cable connector is of the positive three pin type.

Ceramic Sealed Resistors

Erie Resistor Corp., Erie, Pa., announces a new line of insulator resistors in $\frac{1}{4}$ and $\frac{1}{2}$ watt sizes. These units are known as "ceramic sealed" insulator resistors since they are completely covered with a preformed ceramic case and sealed at the ends. These resistors will withstand as high as 3,000 volts a.c. without insulation breakdown. Both types of resistors are obtainable in all resistance values from a few ohms to several megohms.

WORLD'S SMALLEST PERMAG SPEAKER

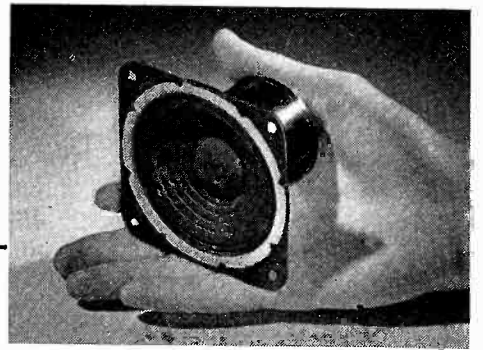

THE 3" Oxford "Permag"—a high quality permanent magnet dynamic speaker with remarkable sensitivity for a speaker of this size. Ideal for many small AC-DC sets and inter-office communication systems.

This is just one of the outstanding units in the new COMPLETE line of OXFORD PERMAG speakers now available from 3" to 14". There is also a new Oxford trumpet-type permanent magnet speaker with a 6" cone for use with an exponential horn.

Write for complete data—or see us at Booth 48, Radio Parts Manufacturers National Trade Show, Chicago, Stevens Hotel, June 10-13.

OXFORD-TARTAK
RADIO CORPORATION
915 W. VAN BUREN ST. • CHICAGO, U. S. A.

no matter **WHAT** you are building—
(if radio or electrical)
it has to be connected with **WIRES**

HAVE you considered the advantages of the new ALDEN detachable connectors in place of terminal strips, binding posts, or continuous wires?

These new connectors—

Provide complete insulation between each individual lead. Are small compact connectors which can be modified to accommodate from one to fifty-eight wires.

The connector moldings do not need to be much larger than the cable on which it is used.

They meet the Underwriters' requirements of protected live contacts.

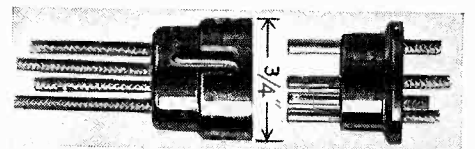

Typical 4-wire ALDEN connector and plug. Can be made any multiple desired.

Each contact completely insulated from the other.

ALDEN PRODUCTS COMPANY
Dept. ELM Brockton, Mass.



AUDI-O-GRAPH



A FULLY AUTOMATIC RECORDER FOR AUDIO FREQUENCY MEASUREMENTS

A complete, accurate, automatic instrument that has already proved its utility as a practical, time-saving tool for the radio and acoustical engineering profession.

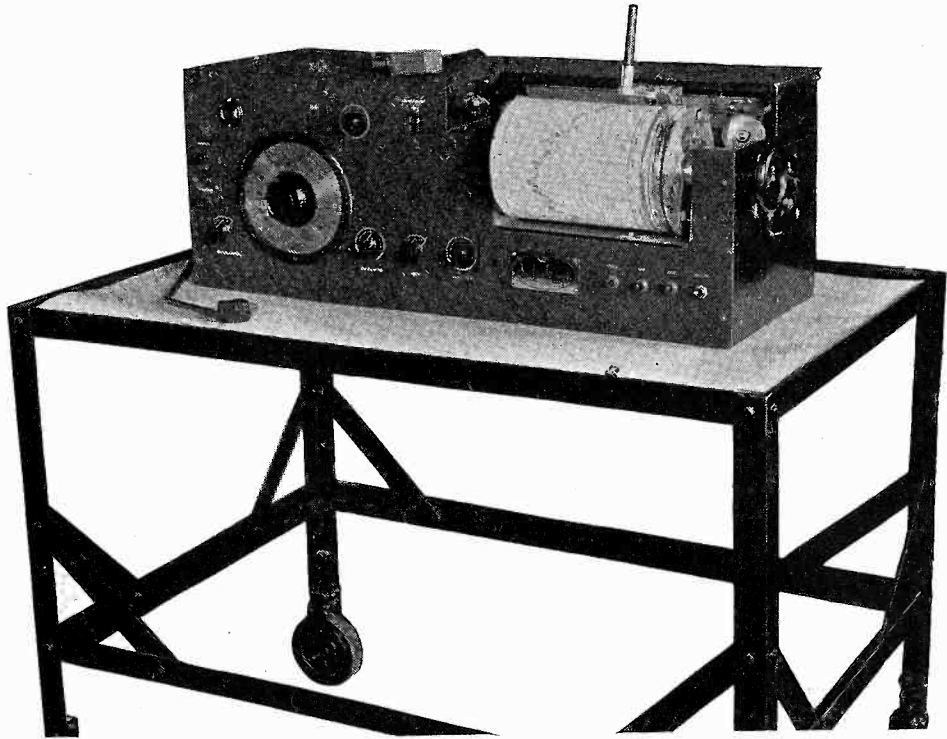

1. FULLY AUTOMATIC OPERATION

Beat frequency oscillator control direct connected to cylindrical chart carrier driven by variable speed motor. Recording pen driven by high speed reversing motor. No adjustment required while curves are being traced.

2. PERMANENT RECORD

Produced on heavy paper charts by pen having large ink reservoir.

3. INTERCHANGEABLE PENS

Allow use of various color inks for easy comparison of graphs superimposed on a single chart.

4. LARGE RECORD CHARTS

Decibel scale zero to 40— $7\frac{1}{4}$ inches
Frequency scale 30 to 12,000 cycles approximately logarithmic— $17\frac{3}{8}$ inches.

5. INSTANT GRAPH CHECK

Any point or portion of the graph automatically checked by turning chart carrier back without removing chart.

6. STABLE OSCILLATOR

Stable frequency available without warm-up period. Oscilloscope tube (913) for zero beat check.

7. SOUND PRESSURE AND VOLTAGE RECORDING

Adjustable transformers, for oscillator output and recording amplifier input, match instrument to impedances of 50-200-500-5000 ohms out and 50-200-500-10,000,000 ohms in; also allow use of dynamic, velocity, and crystal microphones. Connection of oscillator output to recorder input allows check of instrument response characteristics.

8. CALIBRATED GAIN CONTROL

20—2 DB steps
Allows calibration of Microphone Amplifier.

9. OVER-ALL RECEIVER RESPONSE TEST

By means of self-contained 1000 K.C. oscillator 30% modulated by the audio oscillator.

10. INDEPENDENT MANUAL CONTROL

Allows use of oscillator as separate instrument with high fidelity range of zero to 23,000 cycles.

11. PORTABILITY

Easily moved from place to place. Contained in steel case 39" x 12" x 15". Weight 240 lbs. Rolling stand available.

SEE THE AUDI-O-GRAPH AT THE I.R.E. SHOW

Don't fail to see this instrument in operation at the I.R.E. Show, Hotel Pennsylvania, New York City. Our engineer in charge will gladly demonstrate its performance and arrange for further test in your own laboratory.

*Skillful manufacturers of
Electrostatic and Electro-
lytic Condensers, Electrical
Measuring Instruments, In-
terference Locators, Filter-
ettes, etc.*

TOBE DEUTSCHMANN

CORPORATION

CANTON

MASSACHUSETTS

SPEER *Insulated Resistors* NOTED FOR UNIFORMITY

Used by the millions in the nation's leading sets. Special facilities and unmatched experience insure full control of quality specifications, delivery schedules and safeguarding the customers' interests at every step.

SPEER CARBON COMPANY
ST. MARY'S, PA.



FOR VIBRATION MEASUREMENTS

in

- Physical Research
- Engineering Design
- Production Inspection
- Field Surveys

To find unwanted noise at the source . . . to locate destructive vibration . . . to inspect production for quietness . . . to analyze complex motions . . . to measure sound transmission through solids . . . to check "smoothness"—these and many similar problems are easily solved with Shure Piezo-electric Vibration Instruments. They are specially designed, carefully engineered, and accurately constructed to give you practical, dependable results.

Model 61A. Inertia-operated vibration pickup. Indicates amplitude, frequency components and direction of vibration. The

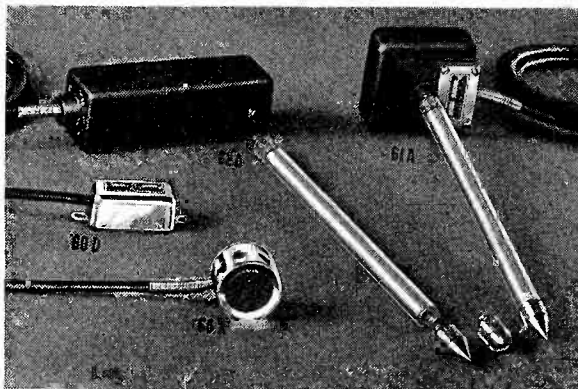

unit has a rising response characteristic. May be attached to the object for extended observation or used with exploring prod for quick tests and comparisons.

Model 62A. An inertia-type instrument similar to 61A except that it provides better response to low frequency vibrations.

Model 60D. A small inertia-operated pickup for general applications. Ideal for reproduction of stringed instruments and pickup of sound through walls.

Model 66A. An improved non-acoustic Stethophone for pickup of heart beats and body sounds for reproduction and recording. Special design practically eliminates acoustic feedback and room noise pickup.

For Price and Complete Details, Write Today!

SHURE

M  **SHURE BROTHERS**
225 W. HURON ST., CHICAGO, U.S.A.
CABLE ADDRESS: SHUREMICRO
MICROPHONES & ACOUSTIC DEVICES

Licensed under patents of the Brush Development Company. Shure patents pending.

Police Radio Equipment

A 50-WATT ultra high-frequency transmitter especially suitable for police radio communication systems is now available from the General Electric Co., Schenectady, N. Y. The extensive use of low-voltage metal tubes results in low tube maintenance costs. A low temperature coefficient crystal, operating at one-sixth of the station frequency, is employed so that temperature control devices are unnecessary.

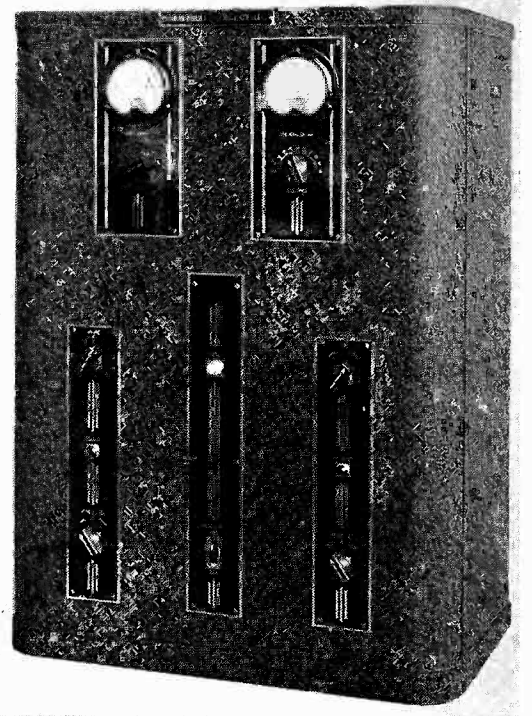

Frequency stability is given as 0.02 per cent. The audio response is flat to within 1 db. from 100 to 10,000 cycles per second. The carrier noise level is reported to be more than 45 db. down, at 100 per cent modulation. Full 100 per cent modulation may be employed and the distortion is given as less than 10 per cent (r.m.s. values) at all levels below 100 per cent, measured at 400 cycles. The carrier frequency range of the equipment is adjustable between 30 and 42 megacycles. The entire transmitter operates from the 116-volt, 50 or 60 cycle lines.

Audio Oscillator

A new portable audio oscillator, model 1260, manufactured by the Triplet Electrical Instrument Company and having a frequency range from 100 to

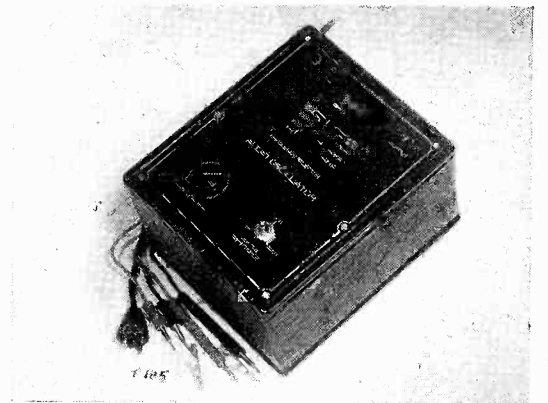

10,000 cycles in ten steps is now available for the serviceman. The signal developed is sufficiently strong to be used in checking low-gain amplifiers.

Cathode Ray Screen Material

ANNOUNCEMENT of a black and white material for coating the screens of cathode ray tubes has been announced by the Allen B. Du Mont Laboratories, Upper Montclair, N. J. These new screens may be obtained on the Du Mont 3 in., 5 in., or 9 in. cathode ray tubes type 34-XH, 54-HH or 94-HH respectively. Tests have been made on various tubes for television reception and modifications have been made so that they can be used equally well in cathode ray oscillography or television reception.

Signal Recorder

AUTOMATIC RECORDING DEVICES for producing a visible record on tapes of radio telegraph transmissions up to

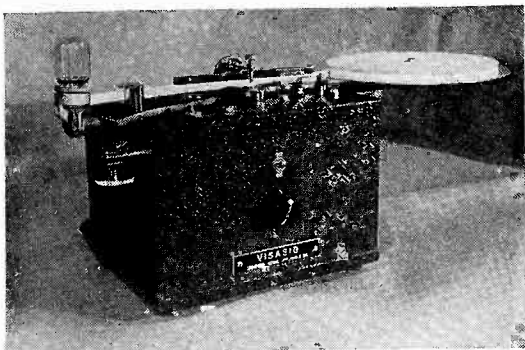

and including 200 words per minute are announced by the Universal Signal Appliances, 64 West 22nd Street, New York City.

Constant Impedance Control

A CONSTANT IMPEDANCE control at little more than the cost of a good potentiometer has been recently announced by Centralab, 900 E. Keefe Ave., Milwaukee, Wis., and is known as the "delta-T" pad. These units are intended to be

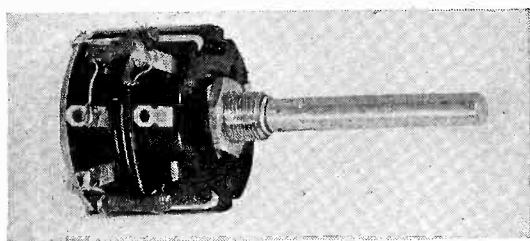

used in all conventional low impedance attenuator circuits. Two variable units connected together on the same shaft and using the bridged-T network as a basis provide the fundamental idea underlying the new delta-T pad.

Low Loss Plastics

A new phenolic molding compound with low power factor has recently been developed by General Plastics, Inc., Tonawanda, N. Y. Known as Durez 1601, this new material is suited for high frequency electrical and radio equipment since it has a power factor of 0.34%. It has excellent molding qualities.

**CONTACT
CALLITE**

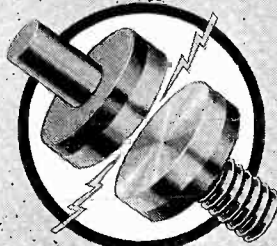

**FOR
CONTACTS**

**FOR VIBRATORS
RELAYS AND
OTHER
Electronics
Devices**

TUNGSTEN

and

MOLYBDENUM

Rivets and Screws

- SILVER & PLATINUM
- SPECIAL ALLOYS
- PRECIOUS METAL LAMINATED

Silver and Platinum on Base Metals

**...AND CONTACT
CALLITE FOR...**

TUNGSTEN

- Rod, Sheets, Wire & Special Shapes
- For Hard Glass Welds

MOLYBDENUM

- Rod, Sheet, Wire & Special Shapes
- For Grids, Round or Flat
- For Grids, Supports, Heating Elements
- For Hard Glass Welds

KULGRID

- Kulgrid KK—A New Special Alloy Grid Wire
- High Tensile Strength —Reduces Grid Emission & Elongation

Write for Samples

- Kulgrid "C" Tungsten Welds—For Hard Glass Leads

CAL-LUX Fluorescent Materials

with
Measured Characteristics
for all applications

CALLITE PRODUCTS DIVISION

EISLER ELECTRIC CORPORATION

544-39th STREET

UNION CITY, N. J.

Evaluating existing
regulatory legislation and
machinery in telecommunication

Are they adequate? Are they sound?

Just published

Telecommunications

Economics and Regulation

By James M. Herring and Gerald C. Gross

544 pages, 6 x 9, \$5.00

THIS book gives you an adequate picture of the communication services of the United States, their relation to the normal conduct of business and social intercourse, and to national security; the costs which must be covered by the rates charged, and the way in which these costs are distributed among the various classes of consumers; the inadequacy and inefficiency of Federal regulation of communications prior to 1934, and the main features and defects of the Communications Act of 1934; and finally the requirements of regulation designed to promote the establishment of the best possible national and international communication services for the citizens of the United States at the lowest cost commensurate with the well-being of the services.

SEE IT 10 DAYS—SEND THIS MCGRAW-HILL COUPON
MCGRAW-HILL BOOK CO., Inc., 330 W. 42nd St., New York City

Send me Herring and Gross's Telecommunications for 10 days' examination, on approval. In 10 days I will pay \$5.00 plus few cents postage, or return the book postpaid. (We pay postage on orders accompanied by remittance.)

Name

Address Position

City and State..... CompanyL. 5-37

(Books sent on approval in U. S. and Canada only.)

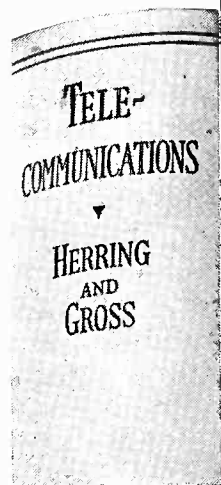

Read this list of chapters

- Growth and Development of the Telegraph Industry
- Growth and Development of Submarine Telegraphy
- Growth and Development of the Telephone Industry
- Development and History of Radio Communication and Broadcasting
- Revenues and Expenditures
- Rate-Making in the Communication Utilities
- Competition, Combination and Coordination
- Federal Regulation of Communications Prior to 1934
- Federal Regulation of Radio Communication
- State Regulation of Communications
- The International Regulation of Telecommunication Services
- The Communications Act of 1934

Fitted
TO YOUR JOB

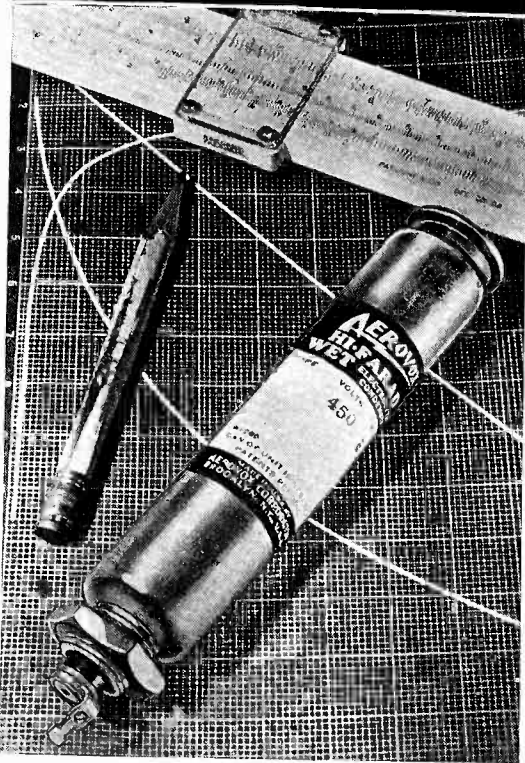

AEROVOX believes in the closest cooperation with users of its condensers. Only after a critical study of your circuits, voltages and needs, is a condenser recommended for your use.



And our engineers work with you in effecting unexpected economies while safeguarding the performance standards you have set. A decade and a half of such exceptional experience is at your disposal.



Call on Us

Submit your condenser problems for our engineering aid and quotations. Samples submitted to responsible parties. And if you are in the neighborhood at any time, visit our plant.



Capacitance Bridge

AN AUDIO FREQUENCY Schering bridge, known as their type 716-A capacitance bridge has been recently developed and is available from stock from the General Radio Co., 30 State St., Cambridge, Mass. The bridge is direct reading in capacitance up to $1 \mu\text{mf.}$ as well as in power factors up to 0.06, including most of the ranges ordinarily encountered in communication engineering practice. The accuracy over the direct reading range is, for capacitance, $\pm 2 \mu\text{mf.}$ for the air capacitance range (100 to 1100 $\mu\text{mf.}$) and $\pm 2 \mu\text{mf.}$ multiplied by the multiplier setting for higher values of capacitance. The accuracy in power factor measurement is ± 0.0005 or $\pm 2\%$ of the dial read-



ing. The power factor dial is calibrated in power factor at 1 kilocycle although measurements of other frequencies between 60 and 10,000 cycles per second may be made. In this case, power factor may be obtained directly by multiplying the dial reading by the frequency in kilocycles. Where greater precision is desired, the substitution method can be used in place of the direct reading calibration of the bridge itself. Using the substitution method, capacitance standards in both air and mica units may be intercompared with an accuracy of 0.02%.

By adding external resistors and precision condensers to this bridge, other types of capacitance bridge circuits can be used with the type 716-A, so that the bridge becomes suitable for a wide field of applications. The type 716-A capacitance bridge is available in either relay-rack or cabinet mounting.

Bias Cell Mounting

AN IMPROVED single bias cell holder (No. 1803) is announced by Cinch Manufacturing Corp., 2335 West Van Buren Street, Chicago, manufacturers of bias cell mountings for the P. R. Mallory & Company. This new, sturdy and compact unit is easily attached in a very limited space and soldering connections are freely accessible. An improved design of a highly resilient spring will permit rough handling without impairing efficiency, thereby assuring a constant vibration proof connection. Other types for multiple number of cell's are also available.

DYNAMOTORS

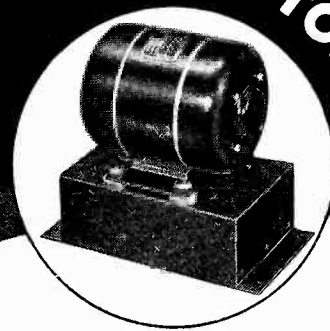

A DEPENDABLE POWER SUPPLY

Dynamotors, gen-e-motors and converters produced by this pioneer manufacturer of power supply units afford the last word in this type of equipment for air craft, police, marine and auto radios, public address systems, etc. Compact and light weight. Sturdily constructed to assure long, dependable service. For complete information address

PIONEER GEN-E-MOTOR CORPORATION

Dept. No. R-4E, 466 WEST SUPERIOR STREET
CHICAGO, ILL.



GEN-E-MOTORS

Coil Parts • Radio
Cabinets • Litzendraht and Textile
Covered Wire • Trimmer and Padder
Condensers • CoilWinding Machinery.

GUTHMAN Coils

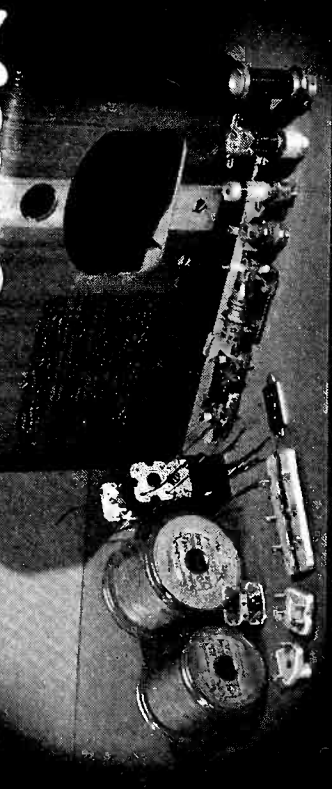

EDWIN I. GUTHMAN AND CO., INC., 400 So. Peoria Street, CHICAGO
PLANTS IN CHICAGO AND GRAND RAPIDS

New Tubes Announced

Raytheon Production Corp. announces three new tubes. The first is an improved type tuning indicator which is interchangeable with the old 6G5 and has been given the number 6G5-6H5. The most noticeable improvement in this tube is that it maintains constant current throughout its normal life and has no tendency to run away. The second tube is the 6W5G rectifier designed primarily for service in automobile sets. The third tube is the 6B8G which is a twin triode amplifier designed primarily for use in phase inverter circuits. Both triodes have been designed to match each other closely, making it possible to build an inexpensive, high quality push-pull audio output system.

Resistor

CENTRALAB is introducing the type 710 resistor; a completely insulated end-lead type, conservatively rated at $\frac{1}{2}$ watt. Contact is made to the active resistor element at the extreme end, so that the entire length of the resistor is utilized. The radiation area is increased. An inert ceramic jacket surrounds the conducting core to provide a seal against humidity. Available from Centralab, 900 East Keefe Ave., Milwaukee, Wis.

Record Players

To help radio dealers capitalize more fully on the revival of interest in recording music RCA Manufacturing Co., has recently announced two improved record playing instruments in the low price range. One of these, the R-93-A record player includes an efficient motor, an improved pick-up arm and is characterized by more quiet operation and marked improvement in the bass response through the use of bass compensation. To replace another popular record player, model R-93-2, RCA Victor introduces the latest in de luxe record players, model R-94, having a mechanism which is completely new and a vast improvement over its predecessor. Both 10-inch and 12-inch records may be played on it with the lid closed.

Replacement Vibrators

THE AMERICAN TELEVISION AND RADIO Co. of St. Paul, Minn., announces a complete line of replacement vibrators for automobile and farm radio receiving sets. Features claimed for these replacement units are long life, improved performance, accurate construction, and moderate prices.

Here it is! THE NEW MUTER RELAY



Here is a new relay you will want to know about! It's built by MUTER, so you know it's not "just another relay." In addition to characteristic MUTER dependability at low cost, these new relays are *easily* adapted to a *wide* range of electrical uses.

Send your specifications to MUTER for quotations and samples. Do it today!

See our display at the National Radio Parts Trade Show, Booth 129

YOU'LL DO BETTER WITH MUTER PARTS

RELAYS	SWITCHES
CANDOHMS	BALLAST TUBES
ZIPOHMS	RESISTANCE BRIDGES
JACK SPRINGS	PAPER CONDENSERS
DECADE BOXES	SPIRASHIELDS

THE MUTER COMPANY

1255 S. Michigan Ave.

Chicago, Illinois

A TRIAL WILL CONVINCCE YOU

35 Years' Experience
Insures Dependability

We Manufacture

PERMANENT MAGNETS	TOOLS and DIES
METAL STAMPINGS	LAMINATIONS

Suppliers of

ALNICO MAGNETS

THOMAS & SKINNER STEEL PRODUCTS CO

23d St. at Alvord

Indianapolis, In



The SIGMA RELAY

MODEL 2-A

A 12 milliwatt semi-sensitive instrument for general electronic and industrial uses.

It embodies the following features:

Input 12 milliwatts, D.C.
Hair-spring adjustment.
Single-pole-double-throw.
Operable in any position at rated input.
Fine silver contacts control non-inductive loads up to $1\frac{1}{2}$ amperes at 110 volts A.C.
Neatly housed in glass-topped dust cover.
Mounted on 5-pronged plug-in base fitting standard V.T. socket.

	List Price
With coil resistances up to 2,000 ohms.....	\$5.00
With higher coil resistances up to 8,000 ohms...	5.50

SIGMA INSTRUMENTS, INC.

388 Trapelo Road

Belmont, Mass.

USED BY LEADING BROADCAST STATIONS

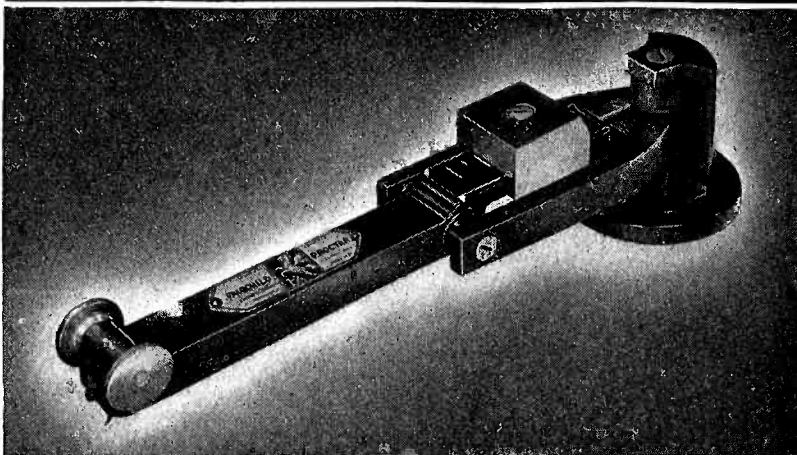

FAIRCHILD-PROCTOR
Crystal PICKUP



Electrically and *mechanically* engineered to produce the finest and most uniform response throughout the entire audio range—with minimum record wear—Fairchild-Proctor Pickups are becoming standard equipment in the foremost broadcast stations throughout the world.

Light Weight - Scientific Balance by Adjustable Counterweight; Calibrated Needle Pressure Scale - Ball-bearing throughout - Minimum Record Wear - Extended Frequency Range, High and Low - Uniform Response - Non-Resonant - Non-Magnetic - Freely Damped - Selected Crystal - Precision Manufacture.

Write for Complete Catalog

FAIRCHILD AERIAL CAMERA CORPORATION
SOUND EQUIPMENT DIVISION
62-10 WOODSIDE AVENUE • WOODSIDE, NEW YORK CITY

**RECOGNITION—the
REWARD FOR ACCOMPLISHMENT**

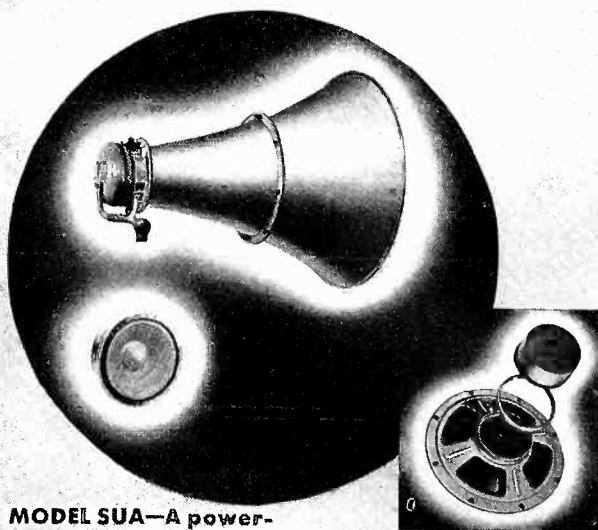

MODEL SUA—A powerful exponential unit with 3½" voice coil—the ultimate in air column sound projectors.

COUPLING RING UNIT ASSEMBLY Assures Permanent Voice Coil Alignment and Simplifies Cone Replacement.

CINAUDAGRAPH CORPORATION, with its extensive background of engineering experience and modern manufacturing facilities, has earned leadership recognition for the industry. This is because its line of speakers is outstanding in performance, quality of materials and workmanship. CINAUDAGRAPH Speakers are styled and built to meet today's requirements—they are sold on a competitive price basis.

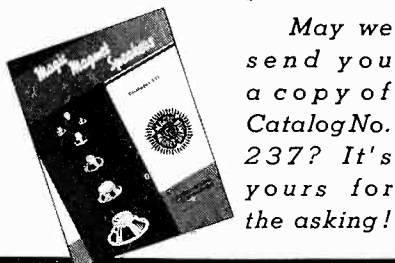

May we send you a copy of Catalog No. 237? It's yours for the asking!



CINAUDAGRAPH CORPORATION
Speaker Division • Stamford, Conn.

A complete line of Magic Magnet Speakers ranging in size from 5 to 18 in.

High Fidelity Speakers

To FULFILL the most exacting requirements in sound reproduction, the RCA Manufacturing Co., of Camden, N. J. has introduced a new console cabinet speaker with uniform frequency response from 60 to 10,000 cycles. The cabinet is of modern design, finished in black with aluminum trimming. Com-

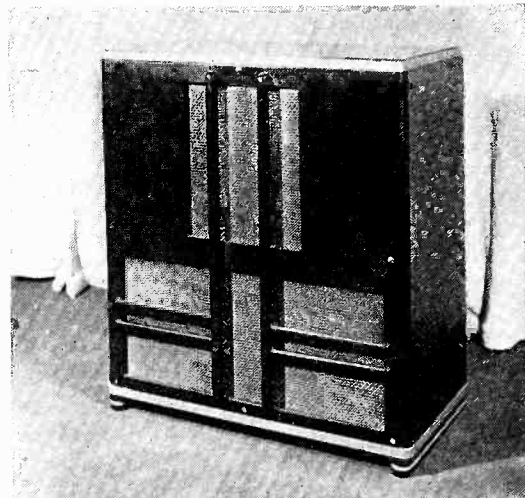

pletely enclosed it measures 33 1/3 inches high, 28 1/4 inches wide and 16 1/2 inches deep. The speaker has a voice coil impedance of 15 ohms and a power handling capacity of 10 watts. Receptacles are provided for supplying either a.c. or field current supply to the unit, and also for audio input. The list price is \$133.20.

P. A. System

The high quality, high gain, resistance coupled speech recording amplifier introduced by Universal Microphone, Inglewood, Calif., becomes a public address system with the entire outfit

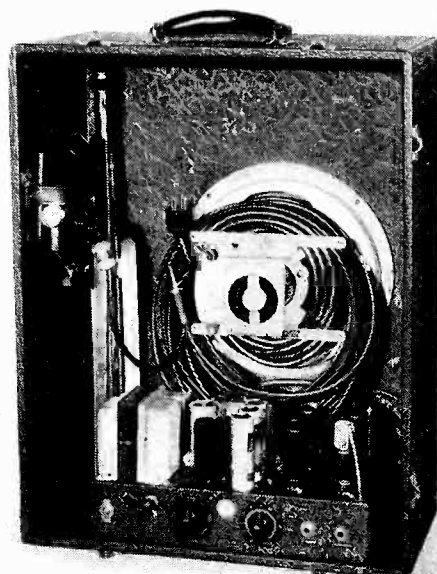

which includes a carrying case, cables and connectors, amplifiers and tubes, the option of one 10-in. or two 8-in. dynamic speakers, a high impedance velocity microphone and collapsible orchestra microphone stand, cord and plug.

High Capacity Primary Cell

The LeCarbone Company of Boonton, N. J. announces the perfection of a high capacity primary power carbon cell. These new cells are built into attractive bakelite molded boxes and are completely and effectively sealed. Provision is made for the introduction of water at the location where the cells are installed. Until this water is added, the electrolyte is solid, thus



reducing weight and shipping and handling costs. The cells must be used within their current ratings. The cells are not designed for heavy intermittent work but for railroad lamp lighting and signalling, telegraph and telephone work, control circuits, radio tubes, instruments, and all such applications where there are no heavy peak load requirements. The 618 and 619 cells have an open circuit voltage of 1.4 volts which is practically constant throughout life.

Low Loss Radio Parts

In keeping with the desire for improvements in component parts, especially on the part of laboratory technicians, instrument builders and advanced amateurs interested in high frequencies, Boonton Radio Corp., has brought out a line of high Q component parts.

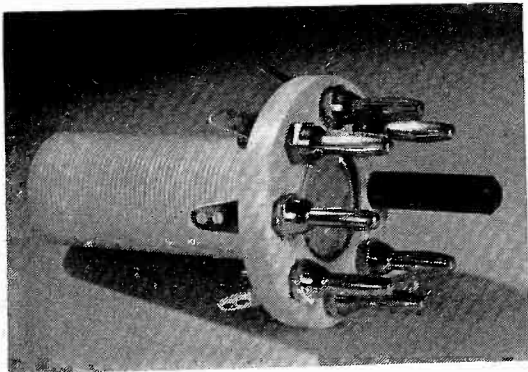

The main items of the line are the threaded and grooved low-loss Isolantite form for high frequency coupled coils, as well as complete inductors and aluminum shields. Special block sockets are available to take the prongs of the inductors and the coils. There is also a line of special low-loss mica-insulated binding posts, jacks and terminals, and miscellaneous parts.



HOOK-UP WIRES

Made by Engineers...for Engineers

The Radio industry demands specialization. We specialize in designing and producing wire products. For many years we have supplied to your industry a large percentage of the wire required. Our intimate knowledge of your problems make us an ideal source. Let us work together

"COR-LAC" "NU-COR"
"SUPER-COR" "BRAIDITE"

Waxed . . . Lacquered . . . Shielded

Mr. Engineer—Our wires are scientifically made, with due regard to insulation resistance and voltage breakdown.

Mr. Production Manager—These wires have the essential qualities which permit easy pushback or mechanical stripping.

Mr. Purchasing Agent—Wires bearing our trade mark will give you the all-important service that spells true economy.

Send for Information and Samples

CORNISH WIRE CO., Inc.

30 Church Street

New York, N. Y.

VARIABLE PURE RESISTANCES'

NON-INDUCTIVE

For Use in Laboratory

Measuring Circuits

\$10.00

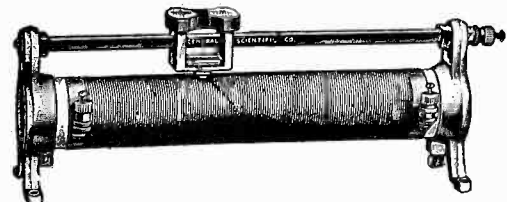

No. 82925	F	G	H	J	K	L	M	N	P	R
Resistance, ohms	1400	720	360	180	90	44	22	11	5.6	2.8
Max. Current, amps.55	.78	1.1	1.6	2.2	3.1	4.4	6.2	8.7	12

CENTRAL SCIENTIFIC COMPANY

1700 Irving Park Blvd., Chicago, Ill.

HI-POWER FOR PORTABLE SOUND EQUIPMENT

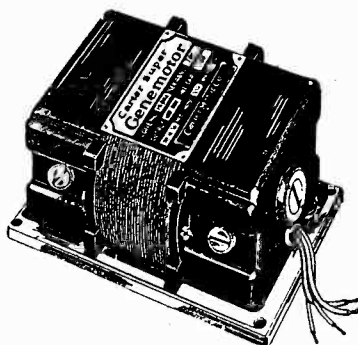

The Carter GENEMOTOR supplies the most reliable and economical "B" Power for Class A or B amplifiers from a 6 or 12 volt battery. Output up to 500 volts. Sturdy—Compact—Quiet in operation—Requires no oiling—Guaranteed. Also can be supplied for A.C. output.

Write for Circular

CARTER MOTOR CO.

365 W. Superior St.

Chicago

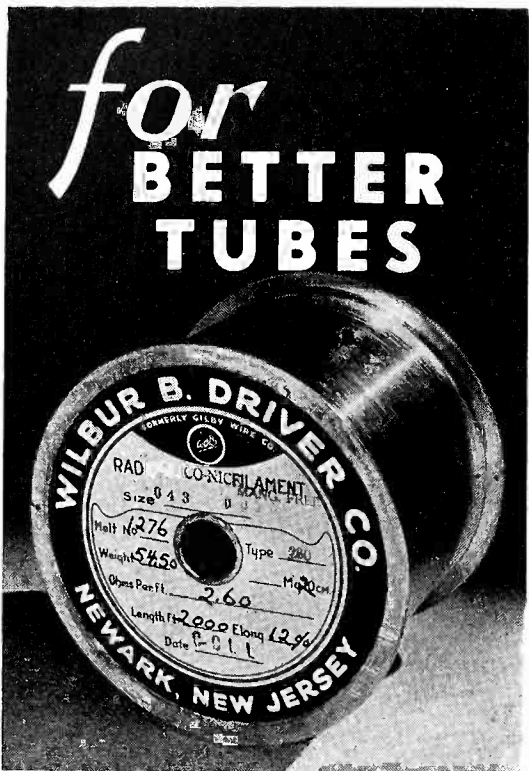

As likely as not we already have just the filament wire or tube material you require. But if not, we can develop an alloy for your particular requirements. For instance:

FILAMENT WIRES

In keeping with the demand for longer life and improved characteristics, several alloy filaments are available such as Hilo, Modified Hilo, Cobanic and Tensite. Held to most exacting limits on size, milligram weight, resistance, elongation.

CARBONIZED NICKELS

RadioCarb A or carbonized nickel ribbon in widths up to 6" and in thicknesses from .002" to .015". Also bare strip in widths up to 6" and in thickness as fine as .001".

GRIDS AND SUPPORTS

Precisely tempered wire for grids fabricated in "Tophet A", "Tophet C", Pure Nickel, Manganese-Nickel, and "Molimet". For supports, pure nickel wire specially treated for uniform elongation.

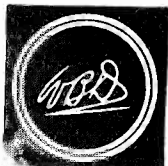

Submit your tube requirements for our collaboration.

WILBUR B. DRIVER CO.
formerly GILBY WIRE COMPANY
NEWARK, NEW JERSEY



Relays

Two new relays have been announced by the Kurman Electric Company, 243 Lafayette Street, New York City. The magnetic circuit is of nickel alloy, of

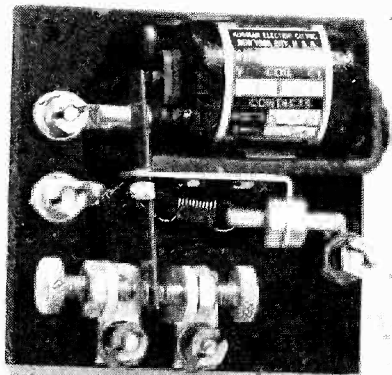

exceptionally high permeability and the contacts are of silver, rated to carry 1½ amp. and are available in single throw, double throw arrangements.

Handset

A new handset is announced by the Turner Company, Cedar Rapids, Iowa. A crystal microphone and a sensitive magnetic receiver are combined in an attractive molded one-piece unit. The device is particularly adaptable to portable transceiver work.

Photoelastic Polariscopes

OVERCOMING THE HIGH COST of small aperture polarizing prisms through the use of Polaroid, the Polarizing Instrument Co., 8 West 40th St., New York City has made available a portable photoelastic polariscopes for the determination of stress analysis. The photoelastic method of analysis is based upon the temporary double refraction in-



duced in a beam of polarized light when passing through a stressed isotropic transparent medium. In use the material to be analyzed is placed in the U-shaped slot of the polariscopes and is viewed from the eyepiece. A parallel beam light source is suitable for most applications where qualitative results only are desired. For quantitative results, however, a monochromatic light source is essential.

GOING • COMING
remember this about
needles...

THEY'VE got to be GOOD to do justice to the new high fidelity electrical records. ACTONE 100% Shadowgraphed Needles, product of a lifetime's rich experience, are preferred by the world's leading broadcast stations because they deliver the SERVICE expected of needles under today's stern demands. Use ACTONE Needles to get the BEST out of any modern recording.

ALSO Specify ACTONE steel cutting needles for acetate recording; the finest Science has yet produced.

Products of W. H. BAGSHAW CO.
Sole Distributor

H. W. ACTON CO., Inc.
370 Seventh Ave., N. Y. City

WRITE FOR DATA ON NEW UNITS
A NEW KIRKLAND BULL-I-UNIT
AN IDEAL SMALL PILOT-LIGHT

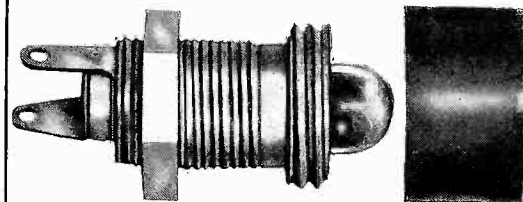

TYPE #400 UNIT FOR T3 LAMP (Actual Size)

THE PREMIER 110 V. UNIT

TYPE #600 UNIT



BAYONET OR SCREW BASE

For single hole mounting, (1 3/8" dia.)
Used by a host of well known electrical manufacturers as an indicating light and to build lamp annunciators.

ANNUNCIATORS WITH ECONOMY

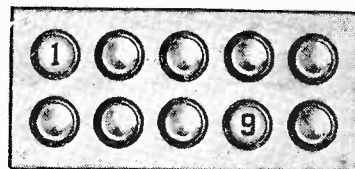

TYPICAL ANNUNCIATOR MOUNTING

Distributed by

THE GRAYBAR ELECTRIC CO., INC.
Mfgd. by
The H. R. Kirkland Co., 75 West St., N. Y.

PROFESSIONAL SERVICES

BLILEY ELECTRIC CO.

Designers—Manufacturers

Quartz Crystals for standard or special radio frequency applications.

Inquiries Invited.

240 Union Station Bldg.
Erie, Penna.

CHARLES EISLER

EISLER ENGINEERING CO.

Consulting and Designing Engineer

Electric Welding Machines for Metal Tubes
Electric Welding Problems, High Vacuum
Compound Pumps, Soft and Hard
Glass Working Equipment, Radio and
Electronic Tube Machinery

753 So. 13th St.

Newark, N. J.

ELECTRICAL TESTING LABORATORIES

Characteristics and

Life Tests of Vacuum Tubes

Tests of photo cells, glow lamps, crater lamps.

Tests of electronic and optical devices.

30th Street and East End Avenue

New York, N. Y.

Phone: Butterfield 8-2600

THAD R. GOLDSBOROUGH

REGISTERED PATENT ATTORNEY

Patent and Trademark Soliciting

Consulting Service

Patent Sale and License Negotiations

201-205 McLachlen Building

Washington, D. C.

INTERNATIONAL ELECTRONICS, INC.

CONSULTING ENGINEERS

offer designs, specifications and manufacturing instructions concerning all the new American developments in electrolytic condensers, tubes, resistors, coils and receivers. Clients all countries. No royalties. Profitable results guaranteed. Write for further information without obligation.

RESEARCH LABORATORIES

145 W. 45th Street

New York, N. Y.

The Solution of Your Problem

in the field of Electronic devices may be found through enlisting the services of the Consultants whose cards appear on this page.

This is a highly specialized field and specialists are therefore better able to undertake the rapid developments necessary to keep in step with modern manufacturing progress.

Modulation Transformers

A NEW LINE of modulation transformers having as a special feature a plug-in set of connectors in order that the transformer impedance may be matched to the plate impedance of the tube with which it is operating, has been announced by the Thordarsen

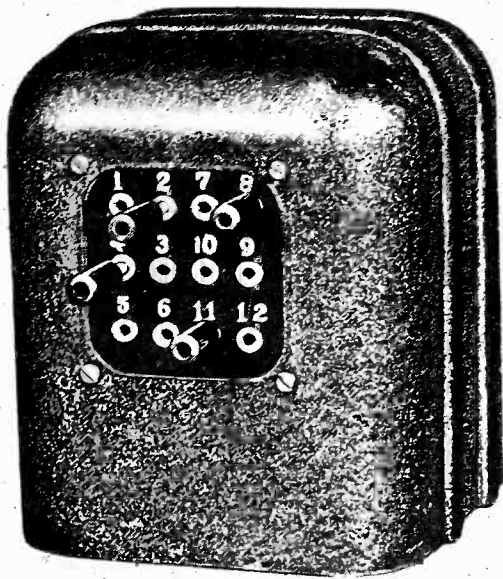

Electric Mfg. Co., of Chicago, Ill. The plug-in feature is especially useful in that connections may be made for any tube or set of tubes (within the power rating of the transformer) and connection may be made instantly without soldering. Four of these "multi-match" transformers have been announced, having ratings of 50, 125, 250 and 500 watts.

Dynamic Microphone

A NEW DYNAMIC microphone has recently been announced by the RCA Mfg. Co., Camden, N. J. This is a pressure-operated device having an im-



pedance of 250 ohms, and operating at a level of -68 db. The frequency range is given as from 100 to 6000 cycles per second. The net weight of the microphone is 1½ lb.

Insulator FOR TYPE 824 COAXIAL TRANSMISSION LINE

A product unique in construction, superior in performance. Write for prices and technical data.
* Shown 3 times actual size.

HEINTZ AND KAUFMAN
SOUTH SAN FRANCISCO CALIFORNIA U.S.A.

REPRESENTS A FULLY CHARGED BATTERY THAT NEVER RUNS DOWN



EPCO STORAGE BATTERY ELIMINATOR

Provides 6 volt-10 amps. filtered, adjustable D.C. from 110 volt A.C. Specially designed for

laboratory tests and for demonstrating 6 volt automobile radios, small D.C. motors, magnets, solenoids, signals, relays and similar apparatus. Also used as an efficient battery charger.

As Illustrated Variable Voltage List Price **19.75** | Model B 6 volts—5 amps. Fixed Voltage **15.75**

ELECTROPAK

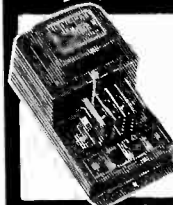

Supplies rectified D.C. for operating relays, solenoids and remote controls. Voltage ranges from 6 to 24 volts, rated at 2 to 15 amps. Operates on 110 volt A.C.

ADAPTOPAK

Operates A.C. radios in D.C. districts and 110 volt A.C. radios in autos and trailers. Write for further descriptive literature.

ELECTRICAL PRODUCTS CO.

6531 Russell Avenue • Detroit, Michigan

DU MONT CATHODE RAY RESONOSCOPE

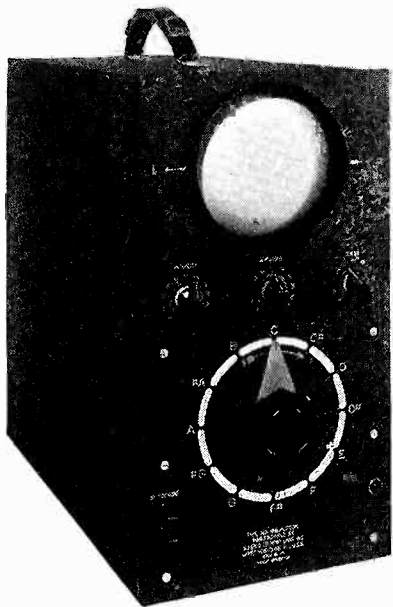

*for Tuning
Musical
Instruments*

The need for a device to be used as a standard for tuning musical instruments has long been felt by broadcasting and sound recording studios. The RESONOSCOPE is the answer. It accomplishes accurately, efficiently and simply all the functions of musical analysis that heretofore were not possible. Any of the twelve standard frequencies in the instrument may be selected one at a time by the turn of the control knob. These twelve frequencies represent the twelve notes of the scale. (International Pitch) and each setting will accommodate all octaves of that particular note. Now you can see when the pitch is perfect.

For complete technical data on the RESONOSCOPE and other DU MONT products write to:

ALLEN B. DU MONT LABORATORIES, INC.
UPPER MONTCLAIR, N. J. Cable Address: NEW YORK, WESPEXLIN

SOUND RECORDING EQUIPMENT

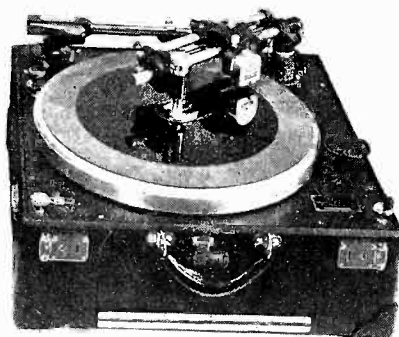
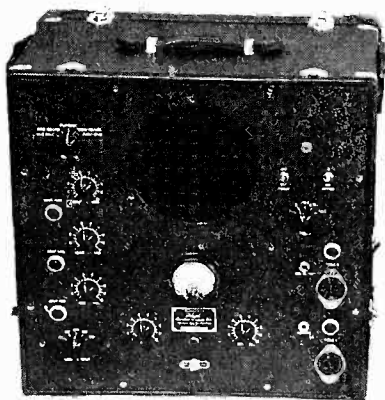

Designed, engineered and manufactured with laboratory precision by men with long recording experience who understand recording problems—these instruments will meet the most exacting professional requirements—yet they are priced within the range of every potential user.

Sturdy in construction—simple in operation—with many NEW and EXCLUSIVE mechanical and electrical features.

Before you invest in ANY recording equipment, we urge you to investigate Allied Equipment. Let us demonstrate to your satisfaction that you can obtain the same outstanding results as our present enthusiastic users.

We invite you to consult us freely concerning your recording problems. Write for photos, including complete descriptive literature, data and prices.

Also manufacturers of the famous ALLIED blanks for instantaneous recording. Literature and price list sent upon request.

ALLIED RECORDING PRODUCTS CO.
126 West 46th Street, New York, N. Y.
Cable Address: Allrecord

Electronic Oscillograph

A COMPACT cathode ray oscillograph having a built in frequency modulator has been recently put on the market by the Hickok Electrical Instrument Co., Cleveland, Ohio. The range of the sweep circuit oscillator is variable between from 1 cycle per second to more than 150,000 cycles per second. Controls have been simplified and reduced to the minimum for simple and flexible operation. The entire oscillograph is enclosed in a case 11 in. wide by 9 in. high by 7 in. deep.

Battery Power

DEVELOPMENT OF a battery container with which dealers or servicemen may make a plate and grid supply power pack for almost any battery radio receiver by using regular standard "B" and "C" batteries has been announced by the National Carbon Co. This new Eveready "B-C" battery package holds



three large size, heavy duty "B" batteries and up to three 4½-volt "C" batteries. All the plug-in connections to the battery cable are made inside the package, the cable passing through a round hole at one end. Although shipped flat in one piece, the battery containers can be easily set up and locked together to form a sturdy power supply unit.

Stethophone

An improved piezoelectric stethophones, model 66 A is announced by Shure Bros., 225 West Huron Street, Chicago. This new device is designed for pick-up of heart beats and for reproduction and recording. Extremely faint noises can be heard clearly and fully which would be difficult or impossible to detect with the ordinary stethoscope. A feature of this new model is the anti-feedback design which permits the stethophone to be used near loud speakers without the usual acoustic feedback. A suitable high gain amplifier and reproducer are required in connection with this new stethophone which bears a list price of \$35.

electronics

Catalog & Literature Service

Manufacturers' literature constitutes a useful source of information. To make it easy to keep up to date, "Electronics" will request manufacturers to send readers literature in which they are interested. Merely fill in the card—we do the rest.

- 1 † **Speakers.** A 16-page, two-color catalog, describing their new line of magnetic speakers, in which complete description of each speaker is included, has been announced by the Cinaudagraph Corp. of Stamford, Conn. This catalog is known as No. 237.
- 2 † **Escutcheons.** A loose-leaf folder describing a wide variety of metal products including special radio dial escutcheons and name plates, has just been released by the American Emblem Co., Utica, N. Y.
- 3 † **Control.** Bulletins describing indicating and control instruments for industrial purposes have been received from C. J. Tagliabue Manufacturing Co., Park & Nostrand Avenues, Brooklyn, N. Y. Catalog 1101-C describes high speed pyrometers, utilizing a phototube and mirror galvanometer to effect the controlling or recording of temperature variation. Industrial thermometers are covered in Bulletin 1125. Catalog No. 699-B gives information on oil testing instruments for petroleum products, including thermometers and hydrometers. Non-indicating temperature and pressure control devices are described in Catalog No. 900-C, while laboratory thermometers and hydrometers are covered fully in Catalog No. 1100-A.
- 4 † **Mike.** The new model BT-73 crystal microphone is described in bulletin 28 of the Turner Co., Cedar Rapids, Iowa.
- 5 † **Relays.** Several new bulletins describing Ward Leonard products have recently been issued. Bulletin 81 describes a series of intermediate duty relays for operation on either a.c. or d.c. and available in all combinations up to and including four-pole double throw contacts. Bulletin 131 describes heavy duty relays for a.c. or d.c. and insulated for 2500 volts. Motor driven time delay relays are described in Bulletin 362, a-c automatic motor starters in Bulletin 4001, a-c combination starters in Bulletin 4021, and a-c automatic motor reversing starters are given in Bulletin 4201.
- 6 † **Wire Guide.** A 32-page publication designed to clarify present-day practice involving the selection and application of wire and cable is the "Industrial Guide" published by the Anaconda Wire & Cable Company, 25 Broadway, New York.
- 7 † **Sockets.** An editorial entitled "The Chisel Is Worn Out" is contained in a four-page Eby Radio Bulletin which also lists Eby ceramic and molded vacuum tube sockets. Copies are available from Hugh H. Eby, 2066 Hunting Park Avenue, Philadelphia.
- 8 † **Transmitters.** New bulletins describing transmitting equipment made by Transmitter Equipment Manufacturing Co., 130 Cedar Street, New York have recently been published.
- 9 † **Relays.** Bulletin 131 listing more than 100 relays for a.c. and d.c. circuits where currents of from 1 to 25 amperes must be carried has recently been issued by the Ward Leonard Electric Co., Mount Vernon, N. Y. This bulletin supersedes the publication of June 1934. Bulletin 81 lists relays for intermediate currents (10 to 15 amperes) for a.c. or d.c. circuits.

- 10 † **Cable and Wire.** A comprehensive, catalog bulletin giving information on the various types of insulated wire and cables, has just been published by the Crescent Insulated Wire & Cable Company, Trenton, N. J.
- 11 † **Tubes.** Technical Data Sheets have been issued by the Raytheon Production Corp., Newton, Mass., covering the type 6W5G rectifier, the 5U4G, an equivalent of the 5Z3, the 6A8, 6A8G, 6L7 and 6L7G.
- 12 † **Tubes.** A revised edition of the Sylvania characteristic sheet, containing complete operating characteristics, condensed technical information and base diagrams for all Sylvania tubes announced up to April 1 is available from the Hygrade Sylvania Corp., 500 Fifth Avenue, New York.
- 13 † **Transmitter.** A description of a 500-watt radiophone transmitter suitable for operation between 1500 and 30,000 kc. is described in a four-page bulletin issued by the U. S. Transmitter Corp., 100 Varick Street, New York. A single descriptive sheet is also available describing the type UST-103 remote speech amplifier.
- 14 † **Switch.** A stationary vapor-proof switch which operates in any position and is capable of carrying a load of more than 1 kw., is described in a folder issued by the Heineken Machinery Corp., 95 Liberty Street, New York, N. Y.
- 15 † **Filter.** *Filter Line Chokes* is the name of a technical data sheet describing chokes and filters manufactured by the J. W. Miller Co., 5917 South Main St., Los Angeles, Calif.
- 16 † **Tube Charts.** The Arcturus Radio Tube Co., 720 Frelinghuysen Ave., Newark, N. J. has just issued a new wall chart of tube characteristics.
- 17 † **Iron Core Inductors.** A technical bulletin from the Aladdin Radio Industries, Inc., 466 West Superior St., Chicago, Ill. describes a wide variety of intermediate frequency transformers and coupling coils for use in modern radio receivers.
- 18 † **Dynamic Microphones.** A 12-page bulletin describing the type 633 A dynamic microphone (sometimes known as the "salt-shaker" microphone) is available from the Western Electric Co., 195 Broadway, New York.
- 19 † **Automobile Radio.** A broadside describing a series of automobile radio receivers is available from the Philco Radio & Television Co., Camden, N. J.
- 20 † **House Organ.** *The Radio Engineer* published by the Commercial Radio Equipment Co., Kansas City, Mo. made its appearance as Vol. I, No. 1 in March. The aim is to make *The Radio Engineer* a technical medium for commercial radio engineers and operators.

Postage
Will Be Paid
by
Addressee

No
Postage Stamp
Necessary
If Mailed in the
United States

BUSINESS REPLY CARD
FIRST CLASS PERMIT NO. 64, SEC. 510 P. L. & R. NEW YORK, N. Y.

ELECTRONICS

330 WEST 42nd STREET

30th Floor

NEW YORK, N. Y.

- 21 † **Noise Measurements.** *Industrial Noise* is the title of a 4-page folder describing the type 759-K sound level meter, manufactured by the General Radio Co., of Cambridge, Mass. The noise meter consists essentially of a piezo-electric microphone, a resistance coupled amplifier, attenuators, weighting networks, and an output meter.
- 22 † **Laboratory Equipment.** Several technical bulletins have been received from the G-M Laboratories, Inc., 1731 Belmont Ave., Chicago, in which G-M galvanometers, relays, rheostats and other electrical and laboratory equipment are featured. Circular No. 590 gives specifications for a number of high sensitivity relays. Galvanometers are described in bulletin 586-A. Bulletin 559-A discusses electro-magnetic relays for d.c. circuits.
- 23 † **Oscilloscope.** A small size but versatile oscilloscope, using the new 913 cathode ray tube, which may be constructed by the engineer or service-man is described in Bulletin SD-356, issued by the Thordarson Electric Manufacturing Co., 500 West Huron St., Chicago, Ill.
- 24 † **Dynamic Microphone.** A technical bulletin on dynamic microphones giving the directional characteristics as well as the frequency response of "Bullet" microphones has been issued by the Transducer Corp., 30 Rockefeller Plaza, New York City.
- 25 † **DuMont House Organ.** Vol. I, No. 1 of the *DuMont Oscillographer* made its appearance in March, and will be published monthly for the purpose of supplying information to engineers, scientists, servicemen, and others interested in the application of cathode ray tubes.
- 26 † **Condenser Catalog.** Catalogs 8-S and 1-R describe, respectively, various types of general purpose condensers for radio purposes as well as replacement condensers manufactured by the Solar Manufacturing Corp., 599 Broadway, New York.
- 27 † **Colloidal Graphite.** *Colloidal Graphite as an Impregnating Material* is the name borne by two technical bulletins issued by the Acheson Colloids Corp., Port Huron, Mich.
- 28 † **Generator.** An oscillograph-wobbulator using the recently developed 1¼-in. cathode ray tube is available in a four-page folder from the Triumph Manufacturing Co., 4017 West Lake Street, Chicago. This bulletin also describes a signal generator, giving an output of 50,000 microvolts.
- 29 † **Sound Effects.** Bulletin SE-1 describes sound effect reproducers suitable for use in broadcasting stations. These Remco type 95 reproducers are manufactured by the Radio Engineering & Manufacturing Co., 26 Journal Square, Jersey City, N. J.
- 30 † **Broadcast Equipment.** The Collins type 12H speech input assembly which will handle four microphone inputs, two turntables and six incoming lines, is described in a bulletin of the Collins Radio Co., Cedar Rapids, Iowa.
- 31 † **Iron.** General properties, characteristics, and advantages of high permeability electrical iron are covered thoroughly in a twelve-page technical publication issued by the Swedish Iron & Steel Corp., 17 Battery Place, New York City.
- 32 † **Scientific Apparatus.** Catalog D-185 describes a complete line of laboratory microscopes, condensers, mechanical stages, microscope lenses, and other accessories manufactured and sold by Bausch & Lomb, Rochester, N. Y. Another bulletin describes Polaroid equipment.
- 33 † **Switch.** The new Clark TCR-1 indoor oil-type circuit breaker, having a rating of 75,000 kva. is described in Catalog 6, section 9, of the Roller-Smith Co., 233 Broadway, New York.
- 34 † **Corrosion Reprint.** A technical paper entitled "Some Consequences of Graphitic Corrosion of Cast Iron," reprinted from the November 1936 issue of *Metals and Alloys* deals with the mechanism of a type of corrosion of cast iron resulting from the surface layer of residual graphite. Copies are available from the International Nickel Company, New York City.
- 35 † **Furnaces.** A wide variety of high frequency induction furnaces for laboratory or industrial melting operations are described in Bulletin No. 11 of the Ajax Electrothermic Corp., Trenton, N. J.
- 36 † **Temperature Control.** Several interesting subjects in connection with thermostat and temperature controls are discussed in the February and March 1937 issues of "Temperature Controls" issued by the Electrical Controls Division of Thomas A. Edison, Inc., West Orange, N. J.
- 37 † **Tube Developments.** Information Bulletin No. 9, issued by the Westinghouse Lamp Division of the Westinghouse Electric & Mfg. Co., Bloomfield, N. J. gives the technical characteristics on Westinghouse thyatron and grid glow tubes.
- 38 † **Amperex Tubes.** Characteristics of twelve new types of water-cooled tubes which have been added to the line of products manufactured by Amperex Electronics Products, Inc., 79 Washington St., Brooklyn, N. Y., are given in a folder recently issued by Amperex.
- 39 † **Input Capacity of Tubes.** The Hygrade Sylvania Corp., 500 Fifth Ave., New York City, offers an engineering news letter No. 30 on *Input Capacitance of Tubes at Audio Frequency*. A brief discussion of the effective input capacitance is given in addition to the input capacitance of 21 popular receiving tubes. A revised technical data sheet covering the type 6A5G has been released, covering a change in heater current from 1.0 amp. to 1.25 for the new rating.
- 40 † **Parts.** Among products featured in the new RCA parts catalog are the various types of cathode ray oscillographs, oscillators, calibrating and modulator devices, service engineering tools, phonograph modernization and hard-of-hearing equipment, transformers, antenna kits, and other parts. Copies may be obtained from RCA Manufacturing Co., Camden, N. J.
- 41 † **Microphones.** Bruno Laboratories, Inc., 30 West 15th Street, New York have published a six-page folder describing their velocity microphones and accessories.
- 42 † **Resistors.** A heavy cardboard resistor chart, suitable for hanging on the wall, is available from the Carborundum Co., Global Division, Niagara Falls, N. Y.
- 43 † **Molding.** A new catalog "The Story of Plastic Molding," which is a 48-page, 6"x9" booklet, is now available from the Chicago Molded Products Corp., 2145 Walnut Street, Chicago.
- 44 † **Vector Addition.** Engineering news letter No. 37 gives a nomograph for determining absolute values in vector addition. The charts may be employed to evaluate the magnitude of impedance when the resistive and reactive components are known or may be used to determine the per cent of total distortion in terms of the percentages of individual harmonics. Available from Hygrade Sylvania, Emporium, Pa., or 500 Fifth Ave., N. Y. C.
- 45 † **Electrostatic Voltmeters.** A line of flush, projected and portable types of electrostatic voltmeters is described in a 4-page folder issued by Ferranti Electric, Inc., 30 Rockefeller Plaza, New York City.

ELECTRONICS

May

Please have sent me, without obligation, manufacturers' literature herein described and identified by numbers circled below.

- | | | | | | | | | | | | | | |
|----|----|----|----|----|----|----|----|----|----|----|----|----|----|
| 1 | 2 | 3 | 4 | 5 | 6 | 7 | 8 | 9 | 10 | 11 | 12 | 13 | 14 |
| 15 | 16 | 17 | 18 | 19 | 20 | 21 | 22 | 23 | 24 | 25 | 26 | 27 | 28 |
| 29 | 30 | 31 | 32 | 33 | 34 | 35 | 36 | 37 | 38 | 39 | 40 | 41 | 42 |
| 43 | 44 | 45 | | | | | | | | | | | |

NAME..... TITLE.....

COMPANY.....

ADDRESS.....

CITY..... STATE.....

Electric Counters

A NEW LINE of electrical counters has recently been made available by Struthers Dunn, Inc., 139 N. Juniper St., Philadelphia, Pa. These counters are available with five digits in either the reset or non-reset types. The construction of the counters is such that the load on the operating mechanism is constant regardless of the number being counted or the number of discs which must be moved. This is accomplished by gearing the indicating wheels together in the manner used in the construction of watt-hour meters, so that any tendency for the counter to skip when only one or two wheels should be turning, or miss when all wheels are operating, is eliminated. Only one number appears on the dials at a time.

Midget Trimmer Condensers

THE ALLEN D. CARDWELL MFG. CORP., 81 Prospect St., Brooklyn, N. Y. have made available a new complete line of ten standard double section air dielectric trimmer condensers. These low cost units are available with either circular or square shields removable from the nickel tie rods. Four convenient methods of mounting may be employed and several units may be ganged together by means of a $\frac{1}{4}$ inch extended shaft. Isolantite insulation is employed.

Speaker Floor Stand

MAXIMUM PORTABILITY is offered in a light weight floor stand for loud speakers recently introduced by the Atlas Sound Corp., 1451 39th St., Brooklyn, N. Y. Two telescopic tubes of stainless steel are easily adjusted to a height of 8 ft. and may be securely locked in position. The stand is provided with three rubber tipped feet and weighs 11 lb. A special saddle for mounting a baffle is included as part of the stand. The list price of model AS-10 is \$12.50.

Radio Set Tester

A NEW SET TESTER for radio receivers is one of the recent products developed by the Simpson Electric Co., 5216 West Kinzie St., Chicago. The meter which forms the essential unit has voltage scales of $2\frac{1}{2}$, 10, 50, 250 and 1000 volts d.c. or a.c. For the d.c. ranges the resistance is 20,000 ohms per volt, whereas for the a.c. ranges the resistance is 1,000 ohms per volt. The meter may also be used to read current from 1 microampere to 500 milliamperes in addition to a 25 ampere range for checking the current drains in automobile receivers. Resistances from $\frac{1}{2}$ ohm to 40 megohms may be measured with this tester.

For Higher Fidelity



LINEAR STANDARD TRANSFORMERS

UTC MODEL 3A EQUALIZER

The UTC 3A equalizer is an ideal universal equalizer for broadcast and recording service. It combines tap switches and pad controls permitting accurately controlled equalization up to 25 DB at both low and high frequencies. This unit will equalize telephone lines, pickups, cutting heads, sound on film, and other applications of similar nature. Net price to broadcast stations \$85

UTC Linear[®] standard transformers are available in sizes from minus 130 DB operating level to 50 kw. All standard units are guaranteed to be ± 1 DB from 30 to 20000 cycles. The UTC LS-10 input transformer illustrated below incorporates trialloy magnetic filtering, which, combined with the UTC hum balanced coil structure, assures lowest hum pickup ever attained in an input transformer.

MODEL 3D UNIVERSAL ATTENUATOR

The UTC model 3D attenuator is similar to the 3A equalizer, but is designed to ATTENUATE the low or high frequencies. The low frequency control consists of a switch for adjusting the point at which cutoff starts to 100, 175 or 250 cycles, and a calibrated pad control to adjust the slope of the attenuation curve. The high frequency portion is tapped at 4000, 6000, 8000 and 10000 cycles with a similar attenuation control. This type of equalizer finds many applications in recording, dialogue equalization, and P. A.—theatre applications. Net price to broadcast stations \$75



MODEL 4B SOUND EFFECTS FILTER

The UTC model 4B filter is an improved design based on the sound effects filter developed by UTC for the Columbia Broadcasting System. The low pass control has cutoff frequencies of 500, 1000, 2000, and 3000 cycles and incorporates a pad control to govern the rapidity of attenuation. The high pass section has a switch for cutoff frequencies of 500, 1000, 2000 and 4000 cycles, with a calibrated attenuator. Net price to broadcast stations \$70

In addition to originally developing the hum bucking and hum balanced audio designs now copied extensively by contemporary manufacturers, UTC has been supplying hum-balanced power supply equipment to Western Electric, Electrical Research Products, and other organizations for over three years. The use of hum-balanced construction plus the UTC high permeability cast shield reduces external flux to extremely small values. All UTC Linear Standard power supply components can be obtained in this form of construction at a 30% increase above normal list prices.

UNITED TRANSFORMER CORP.

72 SPRING STREET

NEW YORK, N. Y.

EXPORT DIVISION: 100 VARICK STREET NEW YORK, N. Y. CABLES: "ARLAB"

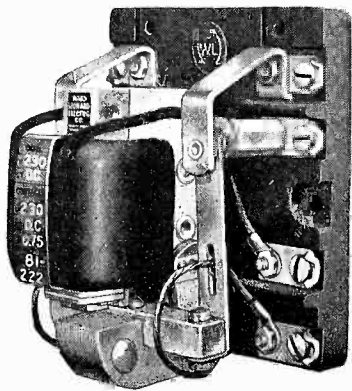

THIS IS THE
BASIC RELAY
 for Automatic
 and Remote Control

There are many different arrangements built around this Ward Leonard Intermediate Duty Relay. Various pole combinations, contact arrangements and auxiliary equipment make it possible to use this basic design for practically every purpose within its current limitations. Thus an efficient relay for special requirements can be produced without undue delay and expense. It is described in *Bulletin No. 81*.

OTHER RELAY BULLETINS

- | | |
|--|--|
| <i>Bulletin No. 106</i>
Midget Magnetic Relay | <i>Bulletin No. 251</i>
Sensitive Relay |
| <i>Bulletin No. 131</i>
Heavy Duty Relay | <i>Bulletin No. 362</i>
Time Delay Relays |

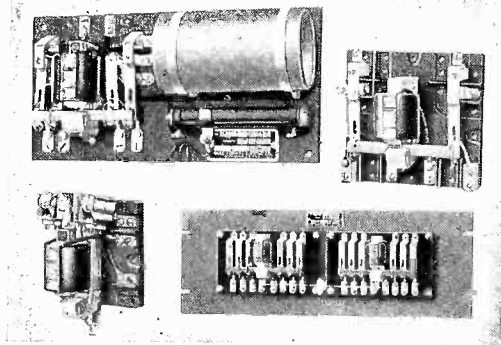

Here are a few of the possible relays built up from type No. 81.

WARD LEONARD RELAYS

WARD LEONARD ELECTRIC CO.
 32 South Street
 Mount Vernon, N. Y.

Please send me Relay Bulletins No.
 Name
 Firm
 Address
 City State

Adjustable Frequency Amplifier

To overcome the inherent acoustic effects which are met once a public address system is installed in architectural surroundings not acoustically treated, the Webster Company, Chicago, have designed a new amplifier,

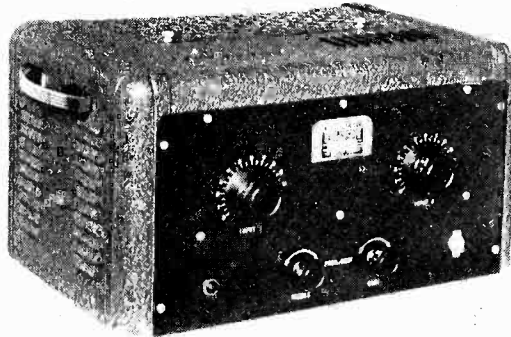

type 2A-30 which has an adjustable frequency characteristic. Either the low or the high frequency end can be accentuated or attenuated at will, with the result that the amplifier can be adjusted to most suitably fit the acoustic characteristics of the location in which it is installed.

New Microphones

THE BRUNO LABORATORIES announce two new microphones; one designed to fill the demands for a small, light and inexpensive microphone, and the other to introduce a wide angle pick-up. The model FP, with an output of -55 db. measures 2 in. by 2 1/4 in. by 1/2 in. and

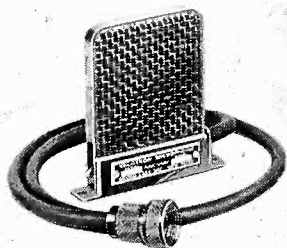

weighs 5 oz. complete with 3 ft. cable. Supplied in gun metal finish with 3 ft. of single conductor shielded cable. This model lists at \$15.30. The model WF is a directional microphone. It is possible to increase considerably the response from the front while at the same time reducing the response from the rear. The model WF supplied in gun metal finish with standard connector, is listed at \$31.00.

Mercury Switches

A NEW LINE OF mercury switches housed in a metallic envelope, hydrogen filled and equipped with a seal which prevents gas leakage has been announced by the Electric Switch Corp., of Columbus, Ind. The switch operates by tilting it to an angle of approximately 10 degrees from the horizontal. The switches have low contact resistance, reliability of operation, long life, and are free from vapors.

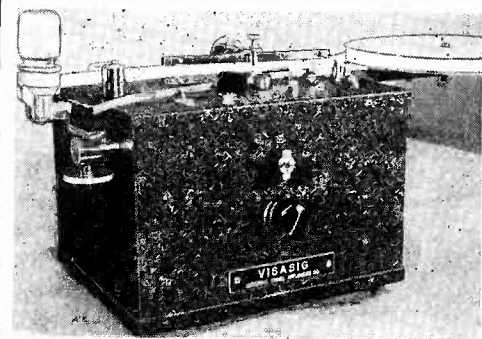

VISASIG
 Full Automatic Siphon
 Tape Recorder

For Commercial and Amateur Use
 Let Visasig solve your code reception problems

Model VI-B—records code signals from a radio receiver up to and in excess of 100 WPM. Complete as pictured above

\$69.00

Model V-4—records up to and in excess of 200 WPM. Complete

\$150.00

—Write for full particulars—

Prices FOB New York City

Universal Signal Appliances

64 West 22nd St., New York City
 Department E

Model C-4, the 5 K.V.A. Converter

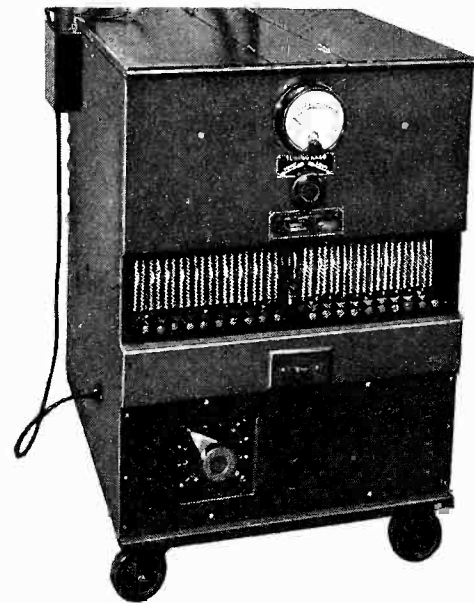

SPARK-GAP CONVERTERS
 FOR BOMBARDING

PHOTO-ELECTRIC CELLS

COATED ELECTRODES

CATHODE RAY TUBES, ETC.

AT LOWEST COST

LEPEL

HIGH FREQUENCY LABORATORIES
 39 W. 60th St., New York, N. Y.

Hearing Aid

A 15-WATT AMPLIFIER, designed to feed any number of headsets up to 60 as well as one or two dynamic loud speakers has been announced by the Radolek Co., 601 West Randolph St., Chicago. The system is intended especially for meeting places such as churches and theatres where certain members of the audience may be hard of hearing. Head-

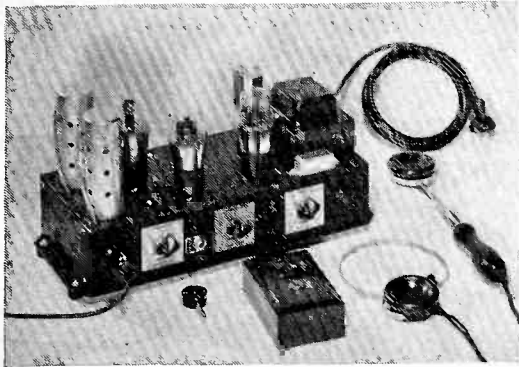

phone connections are made to a control box designed to be mounted on the arms of the seats that are to serve the hard of hearing. Light weight headsets are supplied with the complete system which may be easily installed.

Resistor Replacement Kit

TO TAKE CARE of the demand for metal tube resistor replacements in radio receivers using such line voltage dropping resistors, the Clarostat Mfg. Co., 285 N. Sixth St., Brooklyn, N. Y., is offering a general utility kit of a dozen of the most representative units. These units have been selected to take care of the largest variety of sets with a minimum inventory investment. A cross reference list packed with each kit indicates the interchangeability of Clarostat types with resistors of other manufacture.

U. S. Patent Suits

1,970,287, Early & Harrington, Sound and moving picture reproducing machine; 2,022,108, J. W. Early, same, filed Oct. 30, 1936, D. C., S. D. Calif., C. Div., Doc. E 1046-S, *J. W. Curtiss v. R. C. A. et al.*

1,403,932, R. H. Wilson; 1,465,332, H. D. Arnold; 1,507,016, L. de Forest; 1,507,017, same; 1,936,162, R. A. Heising, D. C., S. D. Calif. (Los Angeles), Doc. E 1075-C, *R. C. A. et al. v. Pacific Trading Co.* Decree for plaintiff, injunction Dec. 30, 1936.

1,251,377, A. W. Hull; 1,297,188, I. Langmuir; 1,573,374, P. A. Chamberlain; 1,728,879, Rice & Kellogg, D. C., S. D. Calif. (Los Angeles), Doc. E 257-C, *R. C. A. et al. v. C. F. Sexton (Radio Products Sales Co.)*. Decree for plaintiff for injunction Feb. 4, 1936).

F
E
R
R
A
N
T
I

25th
Anniversary
I. R. E.

55th
Anniversary
Ferranti

*Embodying the newer applications
and more recent viewpoints
in acoustics*

Just Published

Vibration and Sound

By PHILIP M. MORSE

Associate Professor of Physics, Massachusetts Institute of Technology

351 pages, 6 x 9, illustrated, \$4.00

INTERNATIONAL SERIES IN PHYSICS

Because the rapid growth of atomic physics in the past ten years has induced a complete reorganization of the science of acoustics, this book on the theory of vibrations and sound will be of particular interest to workers in the field of acoustics and to communications engineers.

The book aims to give a general introduction to the theory of vibration and sound, emphasizing newer applications and the more recent points of view and to give a series of examples in the method of theoretical physics—how a theoretical physicist attacks a problem and how he finds its solution.

Some special topics discussed

- propagation of sound in tubes;
- propagation of sound in horns;
- radiation from cylinders;
- radiation from spheres;
- loud-speakers and microphones;
- speech, music and hearing.

SEND THIS ON-APPROVAL EXAMINATION COUPON

McGRAW-HILL BOOK COMPANY, INC.
330 West 42d Street, New York, N. Y.

Send me Morse—Vibration and Sound for 10 days examination, on approval. In 10 days I agree to pay \$4.00 plus a few cents postage and delivery, or return book postpaid. (We pay postage on orders accompanied by remittance.)

Name

Address

City and State

Position

Company

(Books sent on approval in U. S. and Canada only.)

FL-5-37

Padding Condenser

[Continued from page 41]

full capacity at 1000 and 2060 kc. As the main condenser moves either clockwise or counter clockwise, capacity will be added or subtracted proportional to the increase or decrease of the oscillator frequency.

In an experimental model the 100 $\mu\mu\text{f}$ condenser was of a semi-circular type with split end-plates. After a slight adjustment of the end-plates, the set tracked perfectly, resulting in a highly efficient output and exceptionally good selectivity.

TABLE 1

(1) <i>R-F</i> Carrier in kc.	(2) <i>O-F</i> in kc.	(3) C_r in $\mu\mu\text{f}$	(4) $C_o = \frac{C_r C_s}{C_r + C_s}$ in $\mu\mu\text{f}$	(5) C_o^1 required for perfect tracking	(6) (4) - (5) in $\mu\mu\text{f}$	(7) C_s^1 in $\mu\mu\text{f}$	(8) $C_d = C_s - C_s^1$ in $\mu\mu\text{f}$
540	1000	361.95	150.914	150.914	0	258.8	0
600	1060	293.18	137.47	134.31	3.16	247.7	11
700	1160	215.41	117.57	112.15	5.42	234	25
800	1260	164.91	100.73	95.06	5.67	224	35
900	1360	130.32	86.666	81.589	5.077	218	41
1000	1460	105.54	74.976	70.80	4.176	215	44
1100	1560	87.227	65.241	62.014	3.227	214	45
1200	1660	73.294	57.120	54.766	2.354	217	41
1300	1760	62.452	50.313	48.720	1.593	221	38
1400	1860	53.848	44.575	43.622	.953	230	29
1500	1960	46.908	39.712	39.283	.430	240	19
1600	2060	41.228	35.563	35.563	0	258.8	0

sign necessary to control the relaxation oscillators. Lorenz. No. 457,417.

Electron multiplier. An electron image may be projected upon a target emitting secondary electrons under bombardment by the primary electrons and a second screen upon which the secondary electrons are focused to give

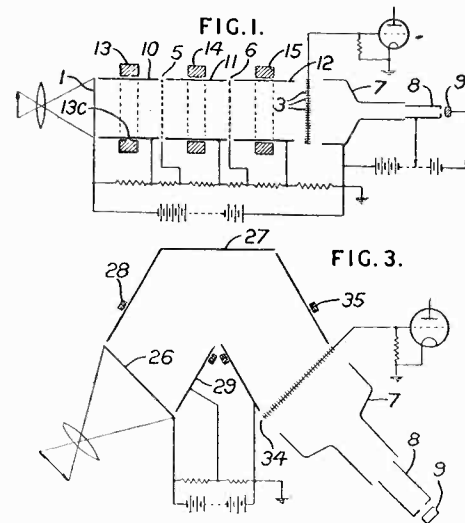

an electrostatic, electron, photographic or fluorescent image. H. G. Lubszynski and J. E. Keyston. No. 457,493.

Camera tube. A method of generating picture signals employs a cathode ray tube comprising a mosaic screen and a signal plate, the mosaic screen being provided with a border of conducting material having a capacity to the signal plate greater than the capacity of any mosaic element, and consists in scanning both the mosaic and the border with a beam of electrons. Preferably means are provided for biasing the border relatively to the signal plate. The border is preferably not photoelectric and may be a coating of metallic paint such as "liquid silver." Alternatively, the border may be an extension of the silver mosaic layer which is either screened during the subsequent oxidation and treatment with caesium, or, if unscreened, is subsequently treated with an intense beam of radiation or electrons to destroy the photo-electric coating. J. D. McGee. No. 457,531.

Intensity control. The intensity of a cathode-ray beam is prevented from exceeding a desired maximum, irrespective of the potentials which control the intensity. When the modulating potentials exceed a required maximum the primary of a transformer in series with a diode and a biasing potential induces in the secondary a current which sets up a potential across a resistance to reduce the effective magnification of an amplifying tube. Baird Television, Ltd. No. 457,800.

Screen treatment. After receiving a coating of luminescent material, of which the main components may be zinc and cadmium sulphides, a screen is covered with a mask and the uncovered portion is subjected to intense illumination or strong sunlight or to X-rays. When the screen so treated is in use, the parts previously exposed will appear dark, while the remainder luminesces. G. E. Co. No. 457,951.

British Patents

Television

Synchronizing circuits. To prevent the short line-synchronizing impulses from influencing the framing scanning oscillator, the long framing impulses are separated from the short line-synchronizing impulses by causing the impulses to control the charging of a condenser or inductance, the amplitude of the derived pulse increasing during the impulse to a value depending on its duration. The charge on the condenser or inductance due to the short line-synchronizing impulses falls to a fixed minimum during the interval between successive impulses; building-up of a charge which might simulate the effect of a framing impulse is thus avoided. E. C. Cork, No. 455,375.

Cathode ray tubes. The arrangement relates to tubes in which a large dispersion is tolerated for the sake of increased sensitivity. It is concerned with the electron optics of a tube for the prevention of undue spreading of the beam. Philips, No. 455,736.

Cathode ray tubes. Construction of a special type of receiving tube. V. K. Zworykin, Marconi Co., No. 455,927.

Kerr cell. Interleaved gold or silver plated metal plates separated by ruby mica washers, etc. J. Bell, London. No. 455,983.

Scanning system. Interlaced system in which synchronizing signals of substantially constant frequency and waveform and frame synchronizing signals having initial portions of the same shape and which are arranged to occur

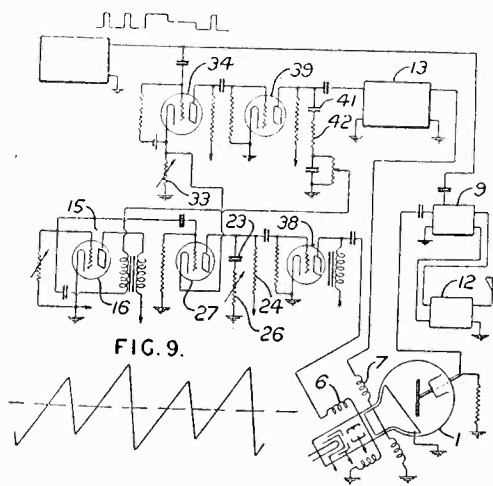

in the same phase with respect to the line synchronizing impulses, each frame signal has a wave form different from that of the frame signal preceding it and succeeding it and from that of the line synchronizing signals. Marconi Co. No. 456,564.

Synchronizing signal. "Blacker than black" synchronizing signals isolated by an amplitude filter tube are reversed in phase to render them to the right

Frequency multiplier. Means for producing scanning and/or deflecting impulses from a source of a.c. of predetermined frequency by frequency multiplication, particularly for interlaced

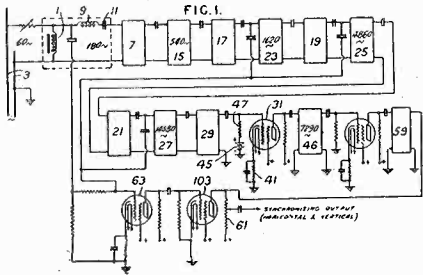

scanning to avoid "pairing" of adjacent lines. A. W. Vance, Marconi Co. No. 457,135.

Scanning. Intercalated system in which line-synchronizing and field-traversal signals are transmitted in the same phase in intervals between trains of picture signals, and a receiver generates oscillations for field traversal with a duration equal to the time occupied by scanning a whole number of lines plus a fraction of a line. M. Bowman-Manifold. No. 456,651, No. 456,709.

Screens. Screens are prepared by distributing fine non-aggregate particles of fluorescent material in a liquid and allowing them to settle on a base member under gravity, the particles being small enough to pass through a 400-mesh screen and the liquid being a solution of an electrolyte having an ionic dissociation constant greater than 10^{-10} . Suitable electrolytes are ammonium carbonate, ammonium carbamate, and carbonic acid. In one example, .01 gm./ml. of Willemite ($Zn_2SO_4 \cdot Ba \cdot Mn$) is added to a solution containing .125 gm./ml. of ammonium carbamate and allowed to settle therefrom onto the end wall of a glass blank for a cathode-ray tube, which may be provided with a silver coating, the supernatant liquid being then decanted by rotating the blank about a horizontal axis. H. W. Leverenz, Marconi Co. No. 456,755.

Electron multiplier. Source of primary electrons, two opposed plate-like secondary emitting electrodes and an output electrode, and means for applying an alternating potential across the plate-like electrodes having a half-period equal to the time of flight of

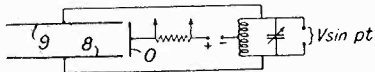

electrons between the two plates, and further means for applying a magnetic field having a component perpendicular to the electric field and inclined so that electrons travelling from one plate to the other move also towards the output electrode. E. W. B. Gill, Marconi Co. No. 456,991.

Scanning system. Means are provided whereby a part only of an electron image obtained on a mosaic screen from a projected optical image may be transmitted by varying the area scanned by the cathode ray. Marconi Co.; H. Iams. No. 458,750.

CONCENTRIC TRANSMISSION LINE

For Conducting Radio Frequency Power

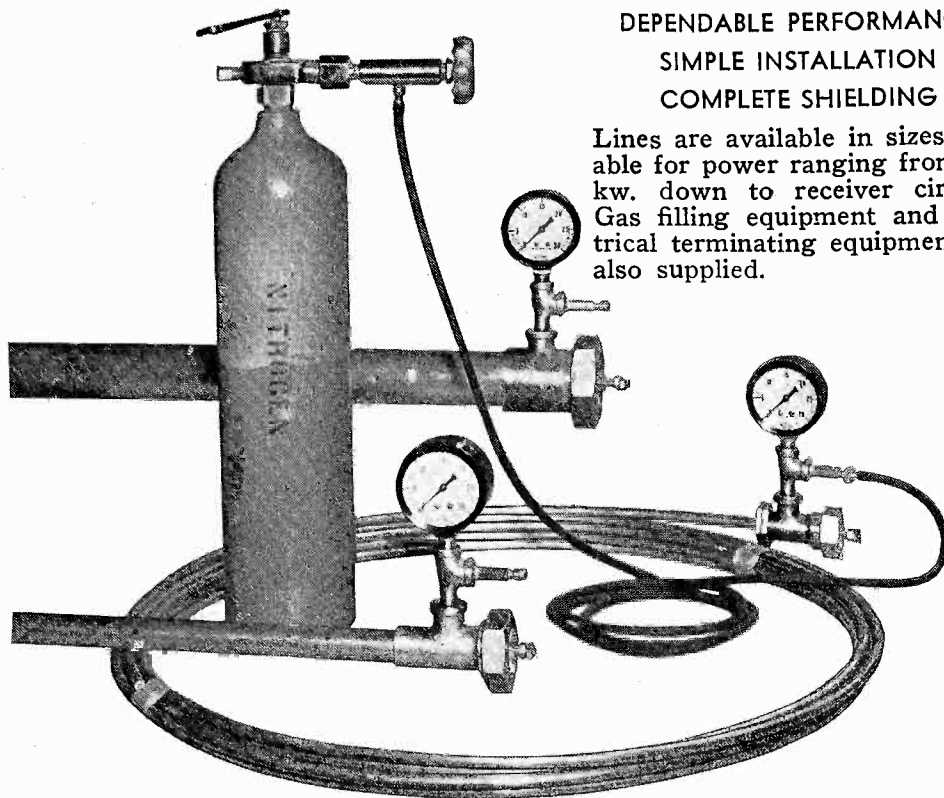

DEPENDABLE PERFORMANCE
SIMPLE INSTALLATION
COMPLETE SHIELDING

Lines are available in sizes suitable for power ranging from 500 kw. down to receiver circuits. Gas filling equipment and electrical terminating equipment are also supplied.

Supplied in rigid or semi-flexible lengths.

DOOLITTLE & FALKNOR, Inc.

7421-23 S. LOOMIS BOULEVARD
CHICAGO, ILLINOIS



Signal maintenance and service men know the value of Relays by Guardian. Relays that insure steady unfailing control of railroad signals. Relays for stop—change—and—go lights. Relays that take up the shock of animated "spectaculars" and control landing field flood lights. Uniformly reliable, Relays by Guardian are the answer to your circuit control problems. Send us your specifications and we'll gladly design a sample relay to show how we meet your specific needs.

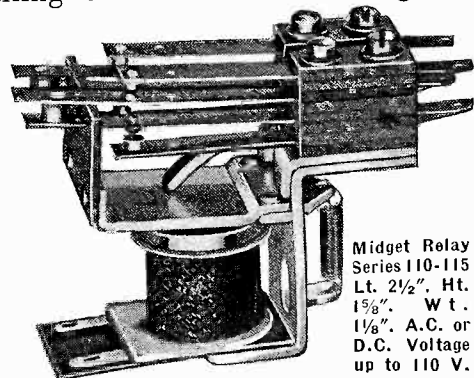

Midget Relay
Series 110-115
Lt. 2 1/2". Ht.
1 5/8". Wt.
1 1/8". A.C. or
D.C. Voltage
up to 110 V.

Write today for fully illustrated catalog
"RELAYS BY GUARDIAN."

GUARDIAN  **ELECTRIC**
1625 W. WALNUT ST. CHICAGO, ILLINOIS

if

you are an

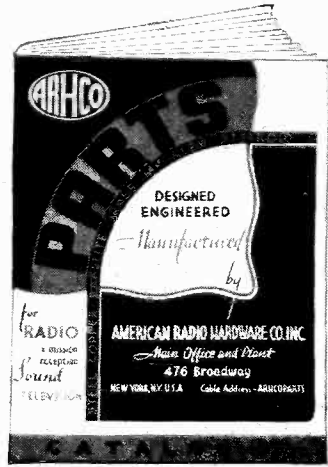

ENGINEER
EXPERIMENTER
DESIGNER

this is **YOUR** catalogue -

Over 2,000 parts, designed and engineered to completion in our own plant . . . embodying the latest scientific principles of design and construction! A catalogue which furnishes at last **ONE SOURCE** for all those miscellaneous hardware accessories, so essential to Radio, Sound and Television. We are not jobbers but **MANUFACTURERS**. Special stamping assignments in metal and compositions are our specialty. Consult us freely without obligation.



AMERICAN RADIO HARDWARE CO., Inc.
476 Broadway New York City



Frequency Measuring Service



Many stations find this exact measuring service of great value for routine observation of transmitter performance and for accurately calibrating their own monitors.

MEASUREMENTS WHEN YOU NEED THEM MOST
at any hour every day in the year

R.C.A. COMMUNICATIONS, Inc.

Commercial Dept.

A RADIO CORPORATION OF AMERICA SERVICE

66 BROAD STREET

NEW YORK, N. Y.

WAXES • COMPOUNDS • VARNISHES for ELECTRICAL INSULATION

Zophar offers prompt service on Insulating Compounds for a wide variety of electrical applications, including:

. . . insulation for CONDENSERS, TRANSFORMERS, COILS, power packs, pot heads, sockets, wiring devices, wet and dry batteries, etc. Also WAX SATURATORS for braided wire and tape. WAXES for radio parts.

Special compounds made to your order.

ZOPHAR MILLS INC.

130-26th St.

Brooklyn, N. Y.

FOUNDED 1846

Electron lenses. Patent relating to various types of electron optical structures. British Thomson-Houston Co., Ltd. No. 458,015.

Electron optics. Patent Nos. 457,846 and 457,848 to Loewe on electron optics. See also No. 457,853 to Loewe on separating synchronizing signals from picture signals, and No. 457,879 to Loewe on the use of a limiting device so that image potentials of such sign and magnitude as are likely to interfere with the synchronizing signals are subjected to limiting.

Receiving system. The line and frame frequency oscillations are derived from a common oscillator which is controlled by the phase relationship between the frame oscillation and an a-c supply so as to maintain a predetermined fre-

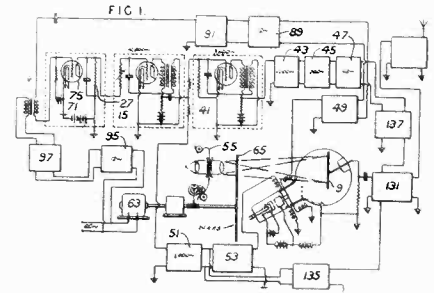

quency and phase relationship with the supply. A-c supply also drives the film so that the scanning is correlated with the movement of the film. A. V. Bedford, Marconi Co. No. 458,161.

Scene shifting. When the scene being transmitted is changed, the bright parts of the old scene tend to persist on the fluorescent screen of the receiving tube due to after-glow, and so interfere with the new scene. Methods of preventing this are provided in this patent. Scophony, Ltd. No. 458,382.

Correction circuits. Picture signals and synchronizing signals are applied to an "observing" tube normally biased to cut-off, but which is rendered conducting by an impulse derived from the synchronizing signals, so that correcting signals appear in its output. These correcting signals are then utilized for the insertion of lost a-c components in the original signals or to compensate for varying attenuation. The invention is applicable to any transmission having recurrent check signals. A. D. Blumlein, London. No. 458,585.

Focusing system. This patent relates to arrangements for keeping the electron beam of a cathode-ray tube or image-dissector accurately focused

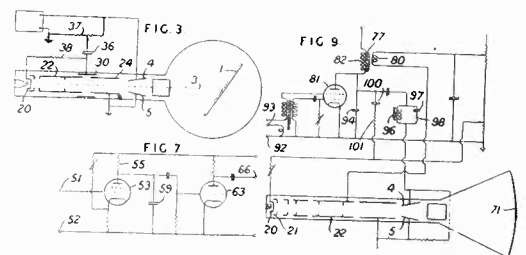

during its deflection. Arrangements are given for compensating for the shape of the screen, or for compensating for distorting effect of deflecting plates and gives data on image dissectors. J. E. Keyston, etc. No. 458,746.

Scanning system. Means are provided whereby a part only of an electron image obtained on a mosaic screen from a projected optical image may be transmitted by varying the area scanned by the cathode ray. Marconi Co.; H. Iams. No. 458,750.

Color television. A system adapted for reproduction in color or of stereoscopic effects which employs at the

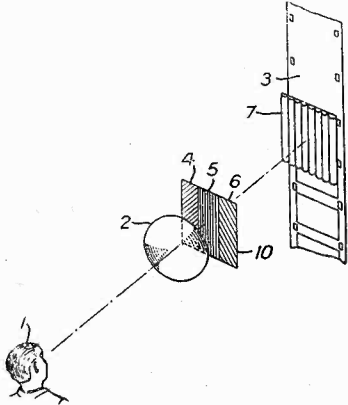

transmitter and receiver a lenticular grating. Baird. No. 458,791.

Radio Circuits

Frequency control. A superhet in which the local oscillator frequency is automatically adjusted to give exact tuning following approximate manual adjustment by means of a tube the impedance slope of which is controlled in function of departure from exact tune and presenting a reactive or resistive impedance in its output circuit which is associated with the frequency determining circuit of the local oscillator. Murphy Radio, Ltd. No. 443,423.

High frequency tube. In a regenerative type circuit wherein the frequency determining circuit is such that the periodicity of the generated oscillations is of the same order as the electron transit time from cathode to anode in the associated tube, the spacing of the grid from the cathode is less than one quarter of the space

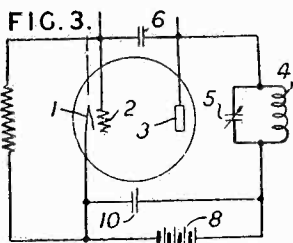

from cathode to anode, so that the electrons early in their transit pass out of control of the grid. The patent states that the preferred ratio is less than one-eighth. R. A. Heising, Standard Telephones & Cables, Ltd. No. 454,902.

Telephone system. Telephone subscribers are provided with an apparatus whereby they can, when away from their substations, communicate with any other subscriber through the exchange network with the aid of portable wireless apparatus. D. Mastini, Rome. No. 454,564.

NEW

ASTATIC

MODEL K-2

Reduced PRICE

NOW
Only
\$27.50

The famous Astatic Non-Directional Dual Diaphragm Dual Unit Studio Model K-2 is now within the purse range of every microphone user. Never before has a crystal microphone of this quality been offered at so low a price.

Featuring THE NEW ASTATIC PLUG AND SOCKET AND CABLE PROTECTOR

Furnished equipped with the exclusive Astatic plug and socket connector, permitting instant interchange with Astatic D-2 or D-104. Plus the new Astatic Spring Cable Protector which prevents cable breakage at mounting.

Licensed under Brush Development Co. Patents

ASTATIC MICROPHONE LABORATORY, INC.
DEPT. E, YOUNGSTOWN, OHIO, U. S. A.
Pioneer Manufacturers of Quality Crystal Devices

**WRITE
FOR
LITERATURE**

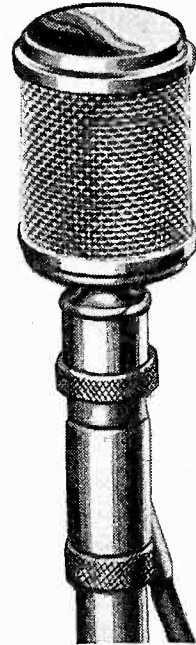

The dependable, clear-toned crystal microphone that broadcasting and P. A. engineers are installing to replace now outdated, bulkier, more erratic devices.

NEOBEAM OSCILLOSCOPE

Makes HIGH FIDELITY easy—
helps modernize old equipment

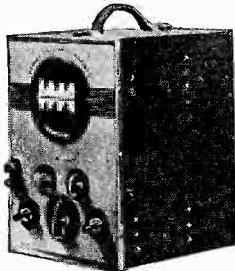
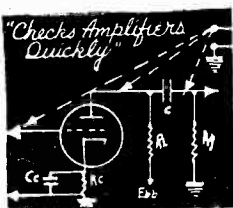

Self-contained power supply, sweep system, high gain amplifier, and calibrated input.

By attaching just one test prod, as illustrated above, you are ready to check every part of your audio system.

Before your eyes—as plain as daylight—is an image of sound—a true story of the fidelity of your amplifier, so simple even the less technical layman understands.

Now it is easy to adjust the plate and grid loads of the amplifier until each stage can portray a clear HIGH FIDELITY tone on the full 4" calibrated screen of the NEOBEAM.

The image has contrast—orange against black—you see every detail of hum and distortion.

The NEOBEAM OSCILLOSCOPE comes complete with tubes and ready to operate. Full satisfaction guaranteed or money back. \$40.00 net.

**SUNDT ENGINEERING
COMPANY**

Affiliate of Littelfuse Laboratories
4248 Lincoln Avenue, Chicago, Ill.

ECCO THE MOST MODERN High Frequency Converters for BOMBARDING



Incorporate
Straight line power output control •
High conversion efficiency • Balanced
low loss circuits • Simplicity of operation,
safety, rugged construction and many
other New and Exclusive features.

Units from 1/4 to 25 KVA Available

ECCO High Frequency Corp.
120 W. 20th Street, New York, N. Y.

DUMONT WORLD'S FINEST CONDENSERS

OIL IMPREGNATED
AND SEALED

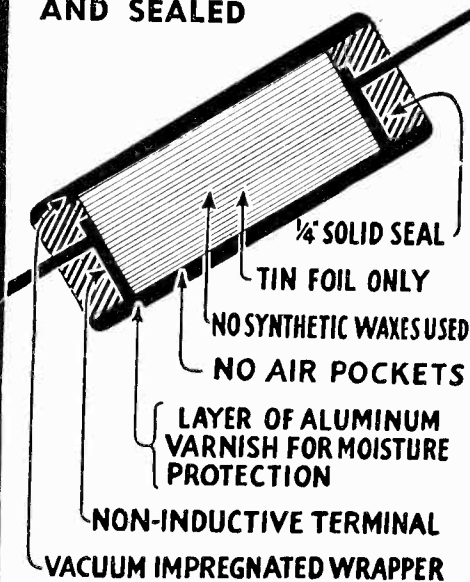

Check these Features:

1. No aluminum foil. (We use tin foil only, for permanent, soldered connection.)
2. A layer of aluminum varnish. (This keeps the condenser moisture-proof.)
3. Impregnated wrapper. (No air pockets, with this type of construction, to cause leakage.)
4. 1/4-inch wax sealed on the edge. (This makes a rigid terminal.)
5. Vacuum impregnated and sealed.
6. Double tube construction—(one inner—one outer).
7. Small in size.
8. We do not use Chlorinated Wa.es.
9. Quality at all costs.
10. High Breakdown Test.
Used by U. S. Government

The Life of DUCO Condensers is remarkably long, due to the process of manufacture, and the thorough testing of all raw materials entering into their manufacture.

Manufactured by

DUMONT ELECTRIC CO., Inc.

514-516 BROADWAY
60-62-64-66 CROSBY ST.
NEW YORK, N. Y.
WRITE FOR FREE CATALOG, DEPT E.

Mosaic. In subdividing a metal layer on an insulating base into minute, insulated particles as in forming the mosaic screen, the metal layer is so thin that it is transparent and breaks up into the particles on heating to about 400-450 deg. C. in a suitable gas, preferably in the presence of oxygen. Mica bases are not damaged by such heating, but polished glass or ceramic bases may also be used. The layer is of silver or copper produced by cathode atomization, condensation in vacuo or chemically and is .1-.01, preferably .03-.05 μ thick. The layer is heated subsequently to, or simultaneously with, its deposition. The layer 2 on a mica base three may be heated for 15-20 minutes by radiation from a plate

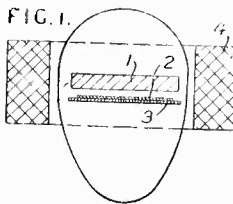

1 heated by eddy currents by a high-frequency coil 4. The final metal particles are about 1 μ in size. The effect of the thickness of the metal layer on the temperature at which it subdivides is discussed. Methods of subdividing the layer by engraving or chemically or by heating to 800-1000 deg. C. in vacuo or indifferent gas or by alternate oxidation and reduction are referred to; in the last method, the silver layer is heated alternately in oxygen and vacuo or subjected to glow discharges alternately in oxygen and hydrogen at a pressure of 1 mm., the silver layer forming the cathode or being arranged behind a grid-shaped cathode. D. S. Loewe, No. 459,231.

Miscellaneous Circuits

D-c amplifier. In a circuit which can be used for amplifying intermittent signals such as television picture signals separated by other signals such as synchronizing signals, the latter are employed to control the bias on the amplifier in such a manner as to prevent slow drifting of the output current. A. W. Vance, Marconi Co. No. 454,511.

Regenerative receiver. In a circuit in which a tube amplifies at both high and low frequency and is provided with a reactive coupling, a direct voltage depending on the detector output is applied to the tube so as to decrease the mutual conductance as the reaction is increased. Philips. No. 443,191.

Control circuit. The change in the mean value of a direct current caused by the tuning of a radio set controls a device which tends to maintain the change until the receiver is in tune with the signal from the carrier of which the direct current is derived. E. K. Cole. No. 443,363.

At Last . . .

ONE Instrument For Measuring ANY Resistances

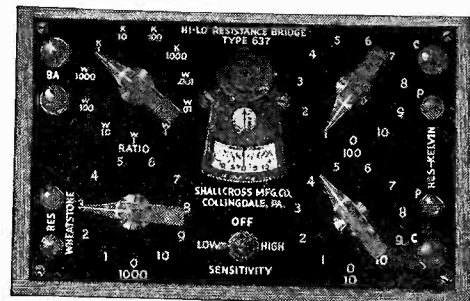

A convenient compact little instrument, completely self-contained, for measuring any resistance from .00001 ohm to 11.1 megohms. Especially practicable for measuring the resistance of relay contacts, coils, armature windings, and other uses.

This one unit includes both a standard Kelvin Bridge and a standard Wheatstone Bridge. Send for Bulletin 637-KC for complete description.

SHALLCROSS MFG. CO.
COLLINGDALE, PA.

"JAGABI" Rheostats

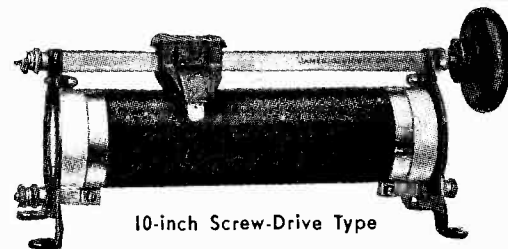

For Fine Adjustment and Control of Electric Current

For many years Jagabi Sliding Contact Porcelain Tube Rheostats have been first choice of engineers and research workers in many fields. They are quality rheostats, carefully engineered, built to serve well and last long.

For list of stock sizes, ratings, prices and complete information, send for Catalog 1370-E.

JAMES G. BIDDLE CO.
ELECTRICAL AND
SCIENTIFIC INSTRUMENTS
1211-13 ARCH ST. PHILADELPHIA, PA.

PATENT SUITS

1,354,939, H. D. Arnold, Vacuum tube device; 1,459,412, H. M. Nicolson, Thermionic translating device; 1,479,778, H. J. Vander Bijl, Vacuum tube device; 1,893,466, R. F. Gowen, Audion construction, D. C., S. D. Calif. (Los Angeles), Doc. E 1077-J, *R. C. A. et al. v. Pacific Trading Co.* Consent decree for plaintiffs holding infringement; injunction Dec. 30, 1936.

1,403,475, H. D. Arnold; 1,403,932, R. H. Wilson; 1,618,017, F. Lowenstein; 1,702,833, W. S. Lemmon; 1,811,095, H. J. Round; 1,936,162, R. A. Heising; Re. 18,579, Ballantine & Hull, D. C., N. D. Ill., E. Div., Doc. 15,090, *R. C. A. et al. v. B. Olshansky et al.* Consent decree holding patents valid and infringed; injunction Apr. 13, 1936.

1,755,114, L. A. Hazeltine, Uni-control signaling system; 1,755,115, same, Variable condenser, D. C., N. D. Ill., E. Div., Doc. 14,285, *Hazeltine Corp. v. Stewart-Warner Corp.* Counterclaim, praying for declaratory decree, adjudging patents invalid filed Feb. 1, 1935. Bill and counterclaim dismissed without prejudice Sept. 25, 1936.

1,623,996, P. S. Carter, Radio transmission system; 1,909,610, same, Electric circuit; 1,884,006, N. E. Lindenblad, Antennae; 1,927,522, same, Antennae for radio communications, D. C., E. D. N. Y., Doc. E 7234, *R. C. A. v. Mackay Radio & Telegraph Co., Inc.* Decree for defendant dismissing complaint Dec. 30, 1936.

1,403,475, H. D. Arnold; 1,403,932, R. H. Wilson; 1,507,016, L. de Forest; 1,507,017, same; 1,936,162, R. A. Heising; Re. 18,579, Ballantine & Hull; 1,618,017, F. Lowenstein, D. C., E. D. N. Y., Doc. E 8182, *R. C. A., et al. v. Universal Tube Mfg. Corp. et al.* Consent decree for plaintiff Jan. 13, 1937.

1,573,374, P. A. Chamberlain; 1,707,617, 1,795,214, E. W. Kellogg; 1,894,197, Rice & Kellogg; 1,728,879, same, filed Dec. 17, 1936, D. C., S. D. Calif. (Los Angeles), Doc. E 1079, *R. C. A. et al. v. J. Forbes.* Doc. 1081-Y, *R. C. A. et al. v. O. J. Bates.* Doc. E 1083-C, *R. C. A. et al. v. F. Sage.*

1,789,949, A. Georgiev, Electrolytic cell; 1,815,768, same, Electrolyte, D. C., S. D. N. Y., Doc. E 76/187, *Aerovox Corp. v. S. Klepper (American Sales Co.)*. Dismissed without prejudice (notice Jan. 26, 1937).

1,800,719, S. S. Cramer, Electrical condenser; 1,932,328, E. H. Tompkins, Condenser frame construction, appeal filed Jan. 11, 1937, C. C. A., 2d Cir., Doc. —, *Condenser Development Corp. v. Montgomery Ward & Co.*

Re. 17,245, Re. 17,247, W. G. Cady, Method of maintaining electric currents of constant frequency; Re. 17,355, same, Piezo-electric resonator, D. C., S. D. N. Y., Doc. E 52/389, *R. C. A. v. R. C. Powell & Co., Inc.* Interlocutory decree made final, sustaining patents and granting injunction (notice Jan. 25, 1937).

Announcing a new

REMLER

HI-FIDELITY TRANSCRIPTION UNIT



Famous Remler quality . . . sturdily constructed with precision accuracy to stand up under the grueling test of continuous service. Improved mechanical-filter drive system provides constant speed and freedom from wow at either 33 $\frac{1}{3}$ or 78 R.P.M. FEATURES: True synchronous motor, condenser starting, mounted on rubber. Exclusive roller-bearing planetary speed reduces drive for 33 $\frac{1}{3}$ R.P.M. Speed change by simple lever. Oil-damped mechanical filter in drive shaft. Heavy 16" "flywheel" platter. High fidelity lateral pickup and equalizer gives response within 3 db. from 45 to 6600 C.P.S. Ball-bearing mounted long radius pickup arm, with adjustable needle pressure— $\frac{1}{2}$ oz. to 6 oz. Available in cabinet or as a unit for mounting in control table. All parts mounted in heavy cast iron framework assuring permanent alignment and simple installation. The price is unusually low. Send for complete information.

REMLER COMPANY, LTD., 19th at Bryant, San Francisco

REMLER—THE RADIO FIRM AS OLD AS RADIO

WHEN YOU NEED A TIMING DEVICE—

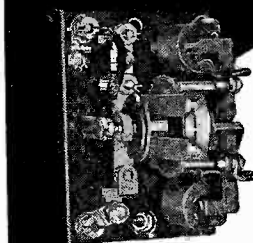

MOTOR
DRIVEN

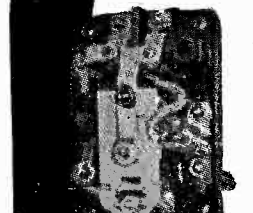

THERMAL

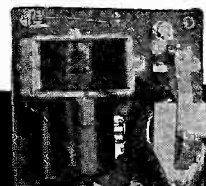

AIR DASH POT



ALSO CAPACITOR,
INERTIA AND
ELECTRONIC
TYPES

DUNCO Dependable
Accurate **TIMERS**

a DUNCO timer designed to meet your specific needs will add greatly to the performance, dependability and saleability of your product.

What are your requirements or timing problems?

STRUTHERS DUNN, INC.

148 N. Juniper Street
Philadelphia, Penna.

**AUTOMATIC
ELECTRIC**

RELAYS

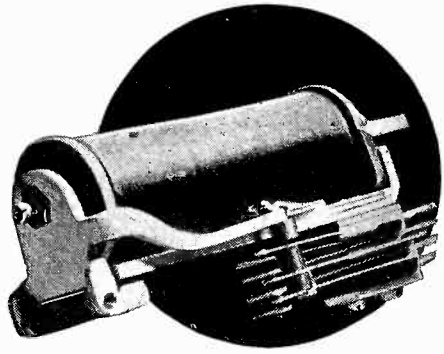

A WIDE VARIETY OF TYPES FOR EVERY INDUSTRIAL USE

The Automatic Electric line of relays includes quick and delayed action types, sensitive and heavy duty types, mechanical locking types, polarized relays, etc., etc. Available for operation on D.C. or A.C. circuits, any voltage, any contact combination.

Also stepping switches, electric counters, solenoids, keys and other electric control accessories. Write for complete illustrated catalogs.

AMERICAN AUTOMATIC ELECTRIC SALES COMPANY
1019 WEST VAN BUREN STREET CHICAGO

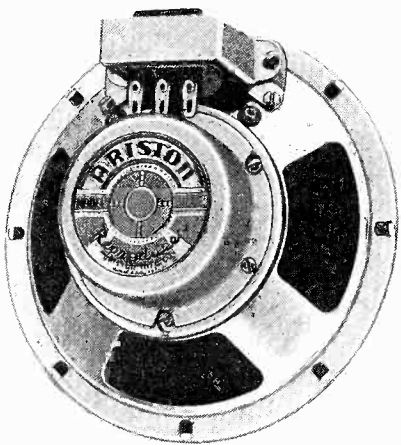

A NEW PERMANENT MAGNET Dynamic Speaker

A new development in a permanent magnet dynamic speaker which permits the removal of the magnet assembly from the basket, voice coil and cone assembly, without disturbing the magnet assembly, the center location of the magnet piece or the strength of the magnet. Engineers and service men will readily appreciate this desirable feature in repairing and servicing this type of speaker. Present production in 5", 6 1/2" and 8" models.

ARISTON MANUFACTURING CORPORATION
4049-59 Diversey Avenue Chicago, Illinois

LEACH LR RELAYS

you can depend upon their
OPERATING RELIABILITY

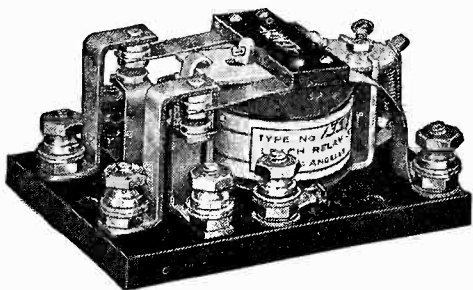

TYPE
NO.
1357

Leach small size circuit control relay, type No. 1357 is a compact, rugged and reliable control relay ideal for your control circuit. These relays have solid cores, positive contact and low current consumption—built so that you can depend upon them!

LEACH RELAY COMPANY
5915 Avalon Boulevard, LOS ANGELES, CALIF.
15 E. 26th St., New York City

LEACH RELAY COMPANY; 5915 Avalon Boulevard, Los Angeles, Calif.

Please send your catalog. I am interested in.....type relay.

Name
Company
Address City

Resistor Measurements

(Continued from page 39)

equilibrium conditions, switch *M* should be thrown to position (2) and *R* should be opened. The switches should be thrown consecutively in the order given. These operations throw the current indicator into the resistor circuit and follow by removing the shorting effect of *R* on the indicator. The shunt resistance across the microammeter should be adjusted so that the needle exactly registers over some convenient line on the scale and this reading should be remembered.

Now close *R*, throw *M* to (1), and, finally open *D*. These operations transfer the microammeter to the decade circuit without breaking the current in the resistor branch. The decades should be adjusted until the needle again reads the same as before. If the difference from the value estimated is appreciable, the voltage may have to be reset due to a change in the voltage drop through the potentiometer. In any event the above operations should be repeated until a perfect balance is attained. The resistance value read off the decades under balanced conditions is equivalent then to the actual value of the resistor at the particular hot load. It is the resultant of the voltage, the temperature, and the permanent change effects. This value expressed as a "percentage overall change in resistance" should be plotted as per the definition for the load characteristic.

To know what part of the total hot load effect may be ascribed to a permanent change in resistance value, the latter may be ascertained after allowing the resistor to cool down to the original body temperature, by measuring the instantaneous value again at the original initial (cold) load using the method discussed under "voltage characteristic". Any difference between this recheck value and the initial base reading is due to the fact that the resistor suffered somewhat during the heating period. Such difference should be computed also as a 'percentage overall change in resistance value' and plotted against 'percent of rated load wattage' to give a point on the "permanent change characteristic". The load voltage *must* be removed from the resistor immediately after the hot reading has been obtained, in order to arrest the drift at the value in effect at the hot reading.

So that the load characteristics and the permanent change characteristic of different types, values, and ratings of commercial composition resistors may be comparable, it is recommended that the sugges-

THE ONLY SOURCE FOR INFORMATION YOU NEED

Electronics — Every Month

Electronics is the only publication devoted to all the news of electronic tube research, engineering, manufacturing and industrial application that you need.

Since ELECTRONICS was originated, seven years ago, it has grown and kept pace with the remarkable growth of the industry. ELECTRONICS is now better able to keep you informed than ever before.

Each issue is a handbook of current progress giving a wealth of data on factors relating to design, manufacture and use of all equipment using the electronic tube.

All important news of the industry—how tubes are put to work, new books, new patents, reference sheets, etc., are brought to you by departments each month.

If you are to keep abreast of the great strides this remarkable field is making, you need additional help. You can rely on ELECTRONICS to give you this help. A personal subscription will supplement your own knowledge and will keep you up to date.

For Your Convenience.

The coupon below will enable you to subscribe to this service with the current issue. Fill it in and mail it today.

Enter my subscription to Electronics for
 1 yr. @ \$5 2 yrs. @ \$8
 3 yrs. @ \$10

Name.....

Address.....

City and State.....

Company and Position.....

ELECTRONICS
 330 W. 42nd St., New York City

tions given for deriving the voltage characteristics be adopted for these additional curves. The heating time at each load should be standardized at a uniform value. This is of particular importance relative to the permanent change characteristic, wherein the amount of the change is liable to be a function of the time on load. The writer uses a heating period of ten minutes per load, and keeps the number of load increments the same for each test.

The above tests comprise a complete criterion of the probable reaction to load of any composition resistor. The methods used are both accurate and rapid. At first reading, they may seem to be somewhat cumbersome. Actually they are not. For instance, an experienced operator can take all the data necessary for a complete voltage characteristic on several similar resistors in less than one-half hour. The time necessary to run the corresponding load characteristic is very little longer than would be required using the 'voltmeter-ammeter' method.

While some of the suggestions given may be rather arbitrary, all attempts at standardization necessarily result in arbitrary decisions regulating procedures.

To illustrate characteristics which may be obtained by the above test methods, the values for two different sets of resistors were plotted and their respective curves are given. These sets of curves were not selected primarily as representing the best and the worst obtainable, because often that varies with the application, but on the basis of showing to best advantage the effects that temperature coefficient, voltage coefficient, and permanent change may have on the resultant performance under stable, hot loads. They also were selected to indicate the manner of deriving the net temperature characteristic from the latter three by graphical methods.

The design engineer faced with the necessity of selecting a type of resistor most suitable for his purpose should obtain as many samples of different makes as he can and apply these tests. Solely on their performance on these tests, which take but a comparatively short time, he can often eliminate many of them. The long time tests such as load-life and humidity-life may then be performed on the remainder.

Compressed Gas Condenser TYPE 174

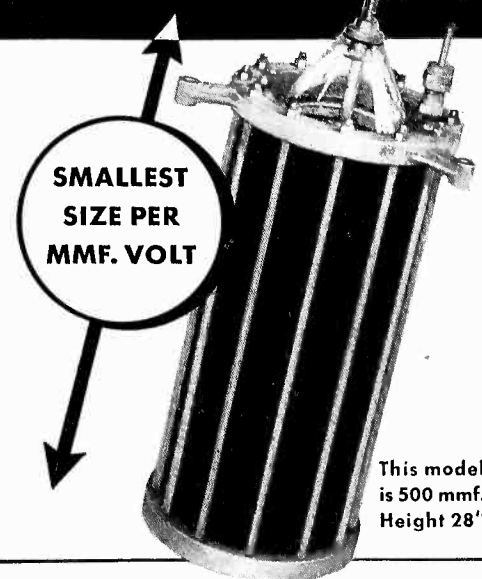

INVESTIGATE these UNIQUE compressed gas condenser ADVANTAGES

FOUR CAPACITIES: 250, 500, 1000 and 1500 mmf.
 TWO RATINGS . . . 40,000 and 32,000 rms working volts.

CONTROL External, continuously variable.

LOSSES Lower than equivalent air condensers.

ALSO Lower distributed inductance, complete shielding.

HEINTZ AND KAUFMAN
 LTD
 SOUTH SAN FRANCISCO CALIFORNIA U. S. A.

FERROCART

Manufactured in our own United States Plant and Laboratories at Hastings-on-Hudson, N. Y.

The Dependable IRON CORE

DESIGN: Our engineers, with years of actual iron coil production experience, are part of our important service. American and European research laboratories are constantly designing new Ferrocart shapes and sizes.

DELIVERY AND QUALITY: Our plant is equipped with new type of machinery which insures our ability to deliver any quantity required, on reasonably short notice. **GUARANTEED UNIFORMITY WITHIN CLOSE TOLERANCES**—immune to temperature, humidity and age.

PATENT PROTECTION: We have **PROVEN** our ability to defend any customer against any infringement suits. We also give the protection of our own patent rights: U. S. Patent Nos. 2,064,771, 2,064,772, 2,064,773, 2,038,251, 2,011,697 and 2,011,698 and numerous other U. S. and Foreign patents pending.

**FERROCART CORPORATION
 OF AMERICA**
 12 EAST 41 STREET
 NEW YORK CITY

SYNTHANE

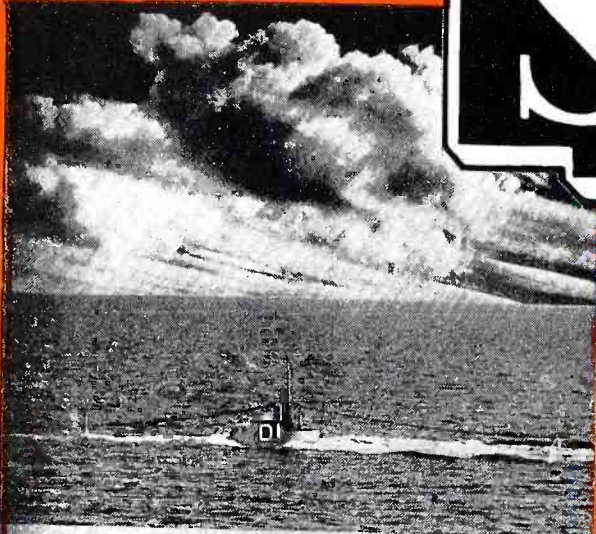

DECKS AWASH...

Men go below, staking their lives on the best equipment known to marine engineering... The use of SYNTHANE laminated bakelite in apparatus for the operation and control of submarines may acquire its applicability to your products where dependable insulation is required.

SYNTHANE LAMINATED BAKELITE SHEETS - RODS - TUBES FABRICATED PARTS Send for Sample Book

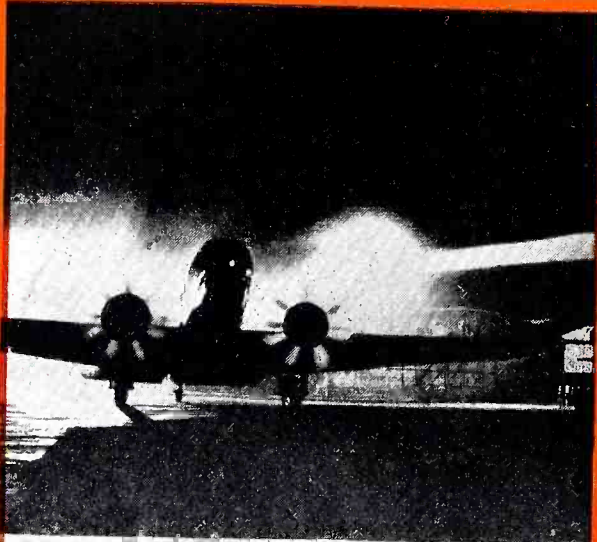

A PERFECT LANDING

Through its reliability in radio and electrical equipment, Synthane contributes a vital part to the safety of night flying. You can secure this same reliable performance in your products if you use the same dependable insulation - Synthane laminated bakelite.

SYNTHANE LAMINATED BAKELITE SHEETS - RODS - TUBES FABRICATED PARTS Send for Sample Book

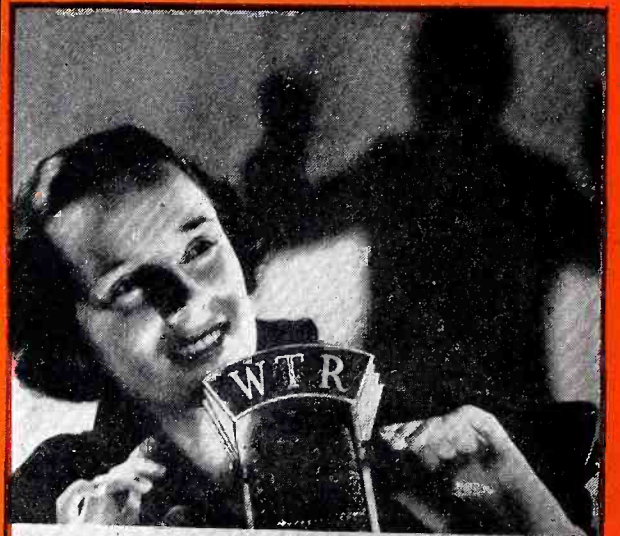

THE SHOW GOES ON

Radio broadcasting stations, where an interruption is fatal, depend upon SYNTHANE laminated bakelite. While on the receiving end, radio sets in millions of homes function better, more dependably through its use. SYNTHANE, the same dependable insulation that makes uninterrupted transmission and reception possible, can contribute the same reliability to your product.

SYNTHANE LAMINATED BAKELITE SHEETS - RODS - TUBES FABRICATED PARTS Send for Sample Book



It Pays to Advertise in . . .

SYNTHANE CORPORATION

MANUFACTURERS OF LAMINATED BAKELITE PRODUCTS

OAKS - PENNSYLVANIA

Mr. Harry M. Grinton, General Manager
Eastern Division,
McGraw-Hill Publishing Company,
16 South Broad Street,
Philadelphia, Pa.

March 23, 1937

Dear Mr. Grinton:

We are pleased to write you regarding our advertising in Electrical World, Electronics and Product Engineering.

Synthane Corporation started in business during 1929. We have consistently advertised since that time, and believe that advertising has been helpful in gaining recognition for our company and its products. We use advertising to help establish and maintain the name of our company and products among buyers and prospective buyers whom we desire to reach. Your papers have been an integral and valuable part of our plan over the past eight years.

Very truly yours,

SYNTHANE CORPORATION

R. R. Titus
R. R. Titus, President.

RRT:MK

SYNTHANE

Advertising is prepared by --

John Falkner Arndt & Co. Advertising Agency

McGRAW-HILL PUBLICATIONS

MICROHM WIRE WOUND RESISTORS

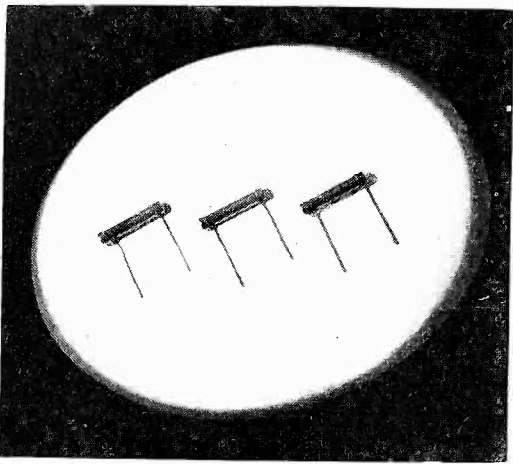

NEW Quality
Low Price
One watt wire wound Resistors
GUARANTEED to 1% Accuracy

10 - 10,000 ohms.
Replacing Composition Resistors
Because of extreme accuracy and low temperature coefficient—these resistors are desirable for use in analyzer and meter circuits and other precision electrical circuits. Position of leads made to suit your specifications.

Also manufacturers of: tubular potentiometers, multipliers, shunts, high wattage resistors, mica sheet resistors, bakelite strip resistors, low wattage replacement units, decade boxes and other special equipment. Custom-built wire wound resistors.

Write for Catalog and Prices
PRECISION RESISTOR CO.
332 BADGER AVE., NEWARK, N. J.

Addenda

New products are news to the editors who hope they are news to the readers too. Each month items arrive too late to be "written up" in regular Electronics style. Often items other than those describing products appear in the mail, items for which there seems to be no regular manner of handling at the present time. Until a better method is found, all such material will be found under the above title.

♦ **Remote Control.** Switches to be mounted on the rear of a panel, using mercury contacts handling 15 amps. at 125 volts a.c., useful for motor control, safety and limit switches. Jefferson Electric, Bellwood, Illinois.

♦ **Pickup.** Critically damped armature, coordinated bearing and arm design to maintain bass compensation and smooth tracking, light construction, vibration-free bearings, vertical and lateral stops, 80 degree pivoting of vertical bearing for ease of needle replacement. Model 40A-5, \$8.00, Webster Electric Co., Racine, Wisc.

♦ **Tone Switch.** Step-type controls for radio receivers, 1 amp. at 6 volts, 3 models—1 pole 2 positions, 1 pole 3 positions, 2 pole 2 positions. Also useful for sensitivity control, channel selector, meter reverser, intercommunicator talk-back etc. Centralab, Milwaukee.

♦ **Transmitting Condensers.** New line of popular priced units for high and ultra-high frequencies, aluminum, stainless steel shaft, bronze bearing on beryllium cushion, isolantite insulation. MTC Series. Hammarlund Mfg. Co., New York.

♦ **Microphone.** Dynamic, high and low impedance, 2½" by 3½", level approx. minus 55 db. D-5-T, 10,000 ohms, \$32.50; D-5, 50 ohms, \$27.50, cable, etc. American Microphone Co., Los Angeles.

♦ **News Letter.** Hygrade Sylvania—"Tube data for 90-volt battery receivers." Data on 1G5G, 1H4G, 1J6G, 1H6G. News Letter No. 38.

NEW ULTRA-HIGH TUBE

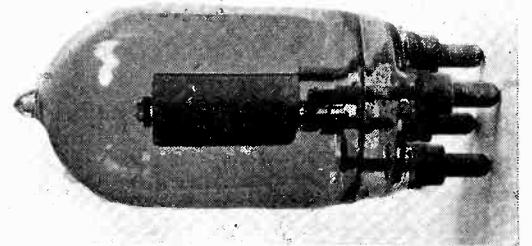

Westinghouse E&M Company announce a new tube for low wavelengths. Known as the WL-461 this tube delivers 400 watts at 50 Mc., plate dissipation of 160 watts, 2000 volts on plate

♦ **Aerovox Research Worker.** "Use of oil condensers in amateur transmitters." March 1937.

♦ **Coil Winder.** Winding 28 coils at once the Universal Winding Company "Duo-Matic" No. 105 Winder proves revelation to large user of neon transformer coils. Produced 480 coils per 8-hour day, 19,000 turns of No. 37 wire, spaced turns on first two and last two layers, four layers of paper between each of first three and last three layers. 1000 sections per day of tapped radio power amplifying transformer, 1,850 turns, No. 34 enameled wire.

♦ **Components.** Electronics Division, Hygrade Sylvania, Clifton, New Jersey, which has specialized in design and manufacture of radio equipment for naval, marine, and commercial service, announces commercial production of transformers, reactors, flexible insulated couplings, special r-f transformers, inductors, chokes, switches, tube sockets, precision drives and dials, relay racks, panels and accessories, metal cabinets, aviation radio parts and custom built apparatus. A. H. Hotopp is manager and chief engineer. W. E. Taylor is sales manager.

♦ **Flourescent Materials.** A sixteen page illustrated technical bulletin with colored data chart giving important information on flourescent and phosphorescent materials—received last minute from Callite Products Division of the Eisler Electric Corp., Union City, N. J.

Specify

CETRON

PHOTO CELLS

for dependable, efficient performance

These fine photo cells are available in thirty-five different types. Also made to your specifications. We are equipped to manufacture vacuum or gas filled devices of all types. Your inquiry is invited.

Write for bulletin today.

CONTINENTAL ELECTRIC CO.
St. Charles, 7, Illinois



McGraw-Hill DIRECT MAIL LISTS

As business paper publishers for over fifty years, McGraw-Hill is uniquely equipped to offer complete, authoritative direct mail coverage of industry's major markets. Extreme accuracy is maintained (guaranteed to 98%) and thorough careful analysis of markets, complete classification of companies and personnel, etc., the widest possible selections are available. Send for handy reference folder "Hundreds of Thousands of Reasons Why" which describes how McGraw-Hill Lists are built and maintained.

What Fields Do You Want to Reach?

Aviation
Bus & Electric Railways
Civil Engineering and Construction



Complete Lists Covering Industry's Major Markets

Administrative Executives
Electrical Dealers & Wholesalers
Mill Supply Houses
Power Services
Product Engineering & Design
Production and Maintenance
Radio Dealers & Wholesalers
Radio Engineering & Design

For further details, selections from above basic classifications, counts, prices, etc., or estimates on special lists . . . ask any representative or write to

SEARCHLIGHT SECTION

EMPLOYMENT : BUSINESS : OPPORTUNITIES : EQUIPMENT—USED or RESALE
 RATES: See page 81, April Issue
 COPY: Accepted until May 27th for the June Issue

EMPLOYMENT AGENCY

DRAFTSMEN, Designers, Engineers, and many other technical positions now open in New York. Consult employment columns of the New York Herald Tribune, mornings and Sundays. Write for free booklet "Classes of Employment" handled by the better New York employment agencies. Address New York Herald Tribune, Dept. 23C, 230 West 41st St., New York City.

POSITION WANTED

RADIO TELEPHONE OPERATOR — First class, age 27; experienced in construction, maintenance and operation of control room and transmitting equipment; R.C.A. graduate; Service record "Very Satisfactory." Desires work in manufacturing or broadcasting company. Warren Bell, 1815 19th St., N. W., Washington, D. C.

WANTED TO BUY

Miniature Electrical Instruments

D.C. and A.C., Model 301 and others. State price and quantity.

W-101, Electronics
 520 No. Michigan Ave. Chicago, Ill.

CASH WAITING

We pay highest prices for your surplus laboratory equipment as meters, rheostats, bridges, decade boxes, etc. Submit your lists of what you have to offer.

AMERICAN ELECTRICAL SALES CO.
 65-67 E. 8th St. New York, N. Y.

DEPENDABLE

New and Used

ELECTRONIC TUBE EQUIPMENT

A complete line of equipment for the manufacture of Radio Tubes, New Tubes, Incandescent Lamps, etc.

Write for Bulletin showing savings from 25 to 75%
EISLER ELECTRIC CORP.
 534 39th Street, Union City, N. J.

HIGH GRADE NEW AND USED ELECTRON TUBE EQUIPMENT

Huge Stock of Equipment of Every Type and Variety

KAHLE ENGINEERING CORPORATION
 Specialists in Equipment and Methods for the Manufacture of Neon Tubes, Radio Tubes, Incandescent Lamps, Photo Cells, X-ray Tubes, etc.
 941 DeMott St., North Bergen, N. J.

COMPLETE EQUIPMENT

New and Used for

ELECTRONIC TUBE MAKING, LABORATORY, and SCHOOL UNITS

Glass Cutters, Spot Welders, Annealers, Flare, Stem, Sealing, and Basing Machines, Vacuum Pumps, Burners

ELECTRONICS MACHINE CO.

751 13th Street, Newark, N. J.

+ EXPERIENCE +

Eleven years of it—is our assurance that we can recondition your transmitting tubes properly and build in Long Life and Proper Characteristics.

Aircooled Tubes 100 to 1000 watts

Watercooled 5 to 35 KW

Satisfaction Guaranteed

National Radio Tube Co., Inc.
 3420 18th St. San Francisco, Calif.

Meters repaired, made more serviceable. Conversion to higher sensitivity as high as 10 microamperes for Weston type I or 24-57.

Sensitive vacuum thermo couples For Sale used Weston panel meters, Rawson microammeters, Brown pyrometers.

Reasonable Prices
Precision Electrical Instrument Co.
 561 Broadway, N. Y. C.

Now—A high-powered RADIO ENGINEERING LIBRARY

—especially selected by radio specialists of McGraw-Hill publications

—to give most complete, dependable coverage of facts needed by all whose fields are grounded on radio fundamentals

—available at a special price and terms.

THESE books cover circuit phenomena, tube theory, networks, measurements, and other subjects—give specialized treatment of all fields of practical design and application. They are books of recognized position in the literature—books you will refer to and be referred to often. If you are a researcher or experimenter—if your interest in radio is deep-set and based on a real desire to go further in this field—you want these books for the help they give in hundreds of problems throughout the whole field of radio engineering.

5 volumes, 3064 pages, 2000 illustrations

1. Glasgow's PRINCIPLES OF RADIO ENGINEERING
2. Terman's MEASUREMENTS IN RADIO ENGINEERING
3. Chaffee's THEORY OF THERMONIC VACUUM TUBES
4. Hund's PHENOMENA IN HIGH-FREQUENCY MEASUREMENTS
5. Henney's RADIO ENGINEERING HANDBOOK



Special Low Price Easy Terms

Bought singly, the five volumes comprising this library would cost you \$26.00. Under this offer you save \$2.50 and, in addition have the privilege of paying in easy installments beginning with \$2.50, 10 days after receipt of the books, and \$3.00 monthly thereafter. Already these books are recognized as standard works that you are bound to require sooner or later. Take advantage of these convenient terms to add them to your library now.

New
 The Library now comprises a revised selection of books culled from latest McGraw-Hill publications in the radio field.

McGRAW-HILL ON-APPROVAL COUPON

SEND THIS ON-APPROVAL COUPON
McGRAW-HILL BOOK COMPANY, INC.
 330 West 42d Street, New York, N. Y.

Send me Radio Engineering Library 5 vols., for 10 days' examination on approval. In 10 days I will send \$2.50, plus few cents postage, and \$3.00 monthly till \$23.50 is paid, or return books postpaid. (We pay postage on orders accompanied by remittance of first installment.)

Name

Address

City and State.....

Position

Company FL 5-37
 (Books sent on approval in U. S. and Canada only.)

COLLOIDAL GRAPHITE

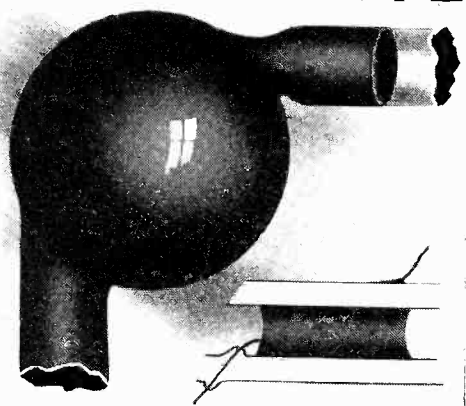

..for Useful Films

Aqueous suspensions of "dag" colloidal graphite yield highly tenacious films to a variety of substances.

These films

- Retard corrosion;
- Dry with sharp boundaries;
- Possess a high "black-body" factor;
- Are homogeneous;
- Possess a matt-like finish;
- Absorb radiation;
- Promote radiation;
- Are electrically conductive;
- Resist electron bombardment;
- Are photo-electrically poor;
- Are radio-inactive;
- Are chemically inert.

Two useful applications of such films in vacuum techniques are the formation of guard rings and the coating of complicated glass forms for shielding, "gettering" and opacity.

Ask for Bulletins B12, 171, 191,
230, A260, B260.



INDEX TO ADVERTISERS

	Page
Aerovox Corp.	88
Acheson Colloids Corp.	112
Acton Co., Inc., H. W.	92
Alden Products Co.	84
Allied Recording Products Co.	94
American Automatic Electric Co.	106
American Emblem Co.	68
American Radio Hardware Co., Inc.	102
American Transformer Co.	81
Ariston Manufacturing Corp.	106
Argus Manufacturing Co.	9
Astatic Microphone Laboratory, Inc.	103
Audak Company	7
Bakelite Corporation	2
Bendix Radio Corporation	49, 50
Biddle Co., James G.	104
Brand & Co., Wm.	8
Brush Development Co.	58
Callite Products Division	87
Carter Motor Co.	91
Centralab Div., Globe Union, Inc.	61
Cinaudagraph Corp., Speaker Div.	90
Cinch Manufacturing Co.	59
Clarostat Mfg. Co., Inc.	69
Continental-Diamond Fibre Co.	77
Continental Electric Co.	110
Cornell-Dubilier Corp.	73
Cornish Wire Co., Inc.	91
Daven Co.	74
Deutschmann Corp., Tobe	85
Doolittle & Falkner Co.	101
Driver, Wilbur B., Co.	92
Dumont Electric Co., Inc.	104
Dumont Laboratories, Inc., Allen B.	94
Dunn, Inc., Struthers	105
Ecco High Frequency Labs.	103
Eitel-McCullough, Inc.	72
Electrical Products Co.	93
Erie Resistor Corp.	6
Fairchild Aerial Camera Corp.	90
Fansteel Metallurgical Corp.	80
Ferranti Electric, Inc.	99
Ferris Instrument Corp.	54
Ferrocort Corporation of America	107
General Radio Co.	3
General Scientific Co.	91
Goat Radio Tube Parts, Inc.	74
Guardian Electric Manufacturing Co.	101
Guthman Co., Inc., Edwin I.	88
Hammarlund Mfg. Co., Inc.	64
Hardwick, Hindle, Inc.	82
Heintz & Kaufman, Ltd.	93, 107
Hygrade Sylvania Co., Electronics Div.	11
Hygrade Sylvania Corp., Tube Div.	71
International Resistance Co.	47
Isolantite, Inc.	63
King Laboratories, Inc.	70
Kirkland Co., H. R.	92
Lansing Manufacturing Co.	82
Lear Development Co.	84
Leach Relay Co.	106
Lepel High Frequency Labs., Inc.	98
Mallory & Co., Inc., P. R.	12
McGraw-Hill Book Co.	87, 99, 111
McGraw-Hill Publishing Co.	108, 109
Muter Co.	89
National Carbon Co.	52
Oxford-Tartak Radio Corp.	84
Parker-Kalon Corp.	4
Pioneer Gen-E-Motor Corp.	88
Precision Resistor Co.	110
Presto Recording Corporation	76
Radio Corporation of America	56, 57
RCA Communications, Inc.	102
RCA Manufacturing Co.	Back Cover
Remler Co., Ltd.	105
Shallcross Mfg. Co.	104
Shure Brothers	86
Sigma Instruments, Inc.	89
Solar Manufacturing Corp.	Inside Front Cover
Somers Brass Co., Inc.	70
Sound Apparatus Co.	80
Speer Carbon Company	60, 86
Stackpole Carbon Co.	75
Standard Transformer Corp.	62
Sundt Engineering Co.	103
Superior Tube Co.	53
Thomas & Skinner Steel Prod. Co.	89
Triplett Electrical Instrument Co.	72
Truscon Steel Co.	83
United Electronics Co.	65
United Transformer Corp.	97
Universal Signal Appliances	98
Utah Radio Products Co.	112
Ward Leonard Electric Co.	98
Webster Electric Co.	10
Western Electric Co.	67
Westinghouse Elec. & Mfg. Co.	5
Westinghouse Elec. & Mfg. Co., Lamp Div.	Inside Back Cover
Weston Electric Instrument Corp.	79
White Dental Mfg. Co., S. S.	55
Zophar Mills, Inc.	102

NOW! A Complete LINE OF UTAH

P.M. DYNAMIC SPEAKERS

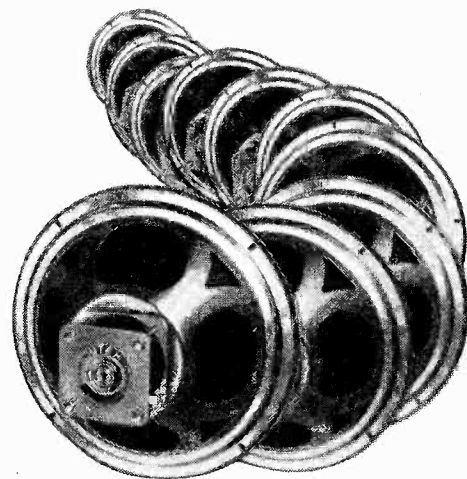

For EVERY Radio and Sound System Requirement

They're ready for you! Thirty-four models—all utilizing UTAH'S recent advancement in P.M. Dynamic speaker efficiency. Cone diameters range from five to fourteen inches, with output capacities as high as thirty watts. The new UTAH "Perpetual Magnets" range in weight from five to forty-six ounces.

Select your P.M. Dynamic speakers from the UTAH line. It's complete! It's more efficient! It includes the speaker that exactly suits your needs. Write Dept. E-5 for details.



Remember!

UTAH VIBRATORS have EXCLUSIVE features that mean LONGER life and HIGHER EFFICIENCY!

Use the vibrator that can really take it! Recent tests prove UTAH vibrators are the finest and toughest ever made. Test them yourself. You'll find they work better, last longer, but cost no more. Write Dept. E-5 for details.

See the UTAH exhibit at the National Radio Parts Trade Show. Booths 69-70.

UTAH RADIO PRODUCTS CO.
CHICAGO, U. S. A.

TORONTO ONTARIO, CANADA BUENOS AIRES UCOA RADIO PRODUCTS CO.

"15 YEARS OF LEADERSHIP"

NEW

HIGH FREQUENCY TUBE

WL 461

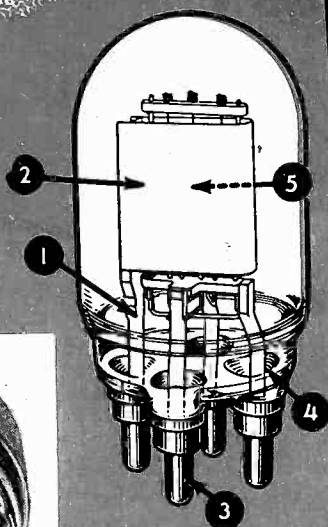

1. Large high conductivity internal connectors (low impedance paths for high frequency).
2. Tantalum plate.
3. Large high conductivity external connecting thimbles.
4. Pyrex Glass, hard, heat resisting; low dielectric loss.
5. Large filament, generous filament emission.

Short transit time resulting in small phase angle between grid and plate voltage at high frequencies.

The new base construction eliminates soldered connections and high loss insulation. The convenient arrangement of the pins permits efficient high frequency circuit design.

Westinghouse, through new design features marks another milestone in ultra high frequency tube construction.

The WL 461, because of its superiority in design is the modern power tube for therapy, radio and other high frequency purposes.

Bases, stems presses and lead-in wires are eliminated in this modern power tube. The grid, filament and plate are supported by short heavy rods which terminate in rugged metal thimbles.

This type of design is the result of development work on high wattage airport flood lamps. Clamping your circuit directly to these terminals provides a very low inductance path to the tube electrodes. This construction together with low inter-electrode capacities and high mutual conductance gives 5 megacycle performance at 50 megacycles and useful output up to 150 megacycles.

Special Products Sales Dept., Westinghouse Lamp Division
Westinghouse Electric & Manufacturing Co.
Bloomfield, N. J.

PRELIMINARY TECHNICAL INFORMATION

General Design

Filament—5.0 volts . . . 11.5 amperes
 Mu—28 G_m —4800 micromhos @ 80 ma.
 Dimensions—7½ in. long, 3¾ in. diameter

Unmodulated Class 'C' Maximum Ratings for Fifty MC—(6 Meter) Operation

Plate Voltage DC (Filtered or Pulsating) . . . 2000 volts
 Plate Voltage AC (RMS) . . . 2500 volts
 Plate Current 250 milliamps
 Plate Dissipation 160 watts
 Plate Power Output (approx.) . . . 460 watts

Westinghouse

Electronic Tubes

New RCA Cathode Ray Tube

A Sensational Success!



Write us for complete technical information on the RCA-913 which sells for only

\$ 5.00

Orders for RCA-913 pour in from radio engineers...service men... amateurs ... school laboratories

IN six short months RCA's newest Cathode Ray Tube—the RCA-913—has become an amazing success! This exceptional tube, which is only $4\frac{3}{4}$ inches long, is proving of outstanding value not only to radio engineers and service men but amateurs and school laboratories as well.

The RCA-913 is a high-vacuum, low-voltage electrostatic type of cathode-ray tube with all-metal construction and a fluorescent screen nearly one inch in diameter. It is particularly suited to compact, portable oscillograph equipment. Moreover, this tube can be built right into transmitters as an integral part to be used for checking circuit operation and measuring modulation percentage.

The RCA-913 operates at a maximum of 500 volts besides giving excellent results at 250 volts. It has two sets of electrostatic deflecting plates, fits into standard applications.



Radiotrons

RCA MANUFACTURING CO., INC., Camden, N. J. • A Service of the Radio Corporation of America