

# electronics

radio, sound, communications and industrial applications  
of electron tubes • • • design, engineering, manufacture

Radio industry  
attacks  
interference

Costs of  
police  
radio

Broadcast  
transmitter  
characteristics

Detector  
distortion

Direct-reading  
tube meters

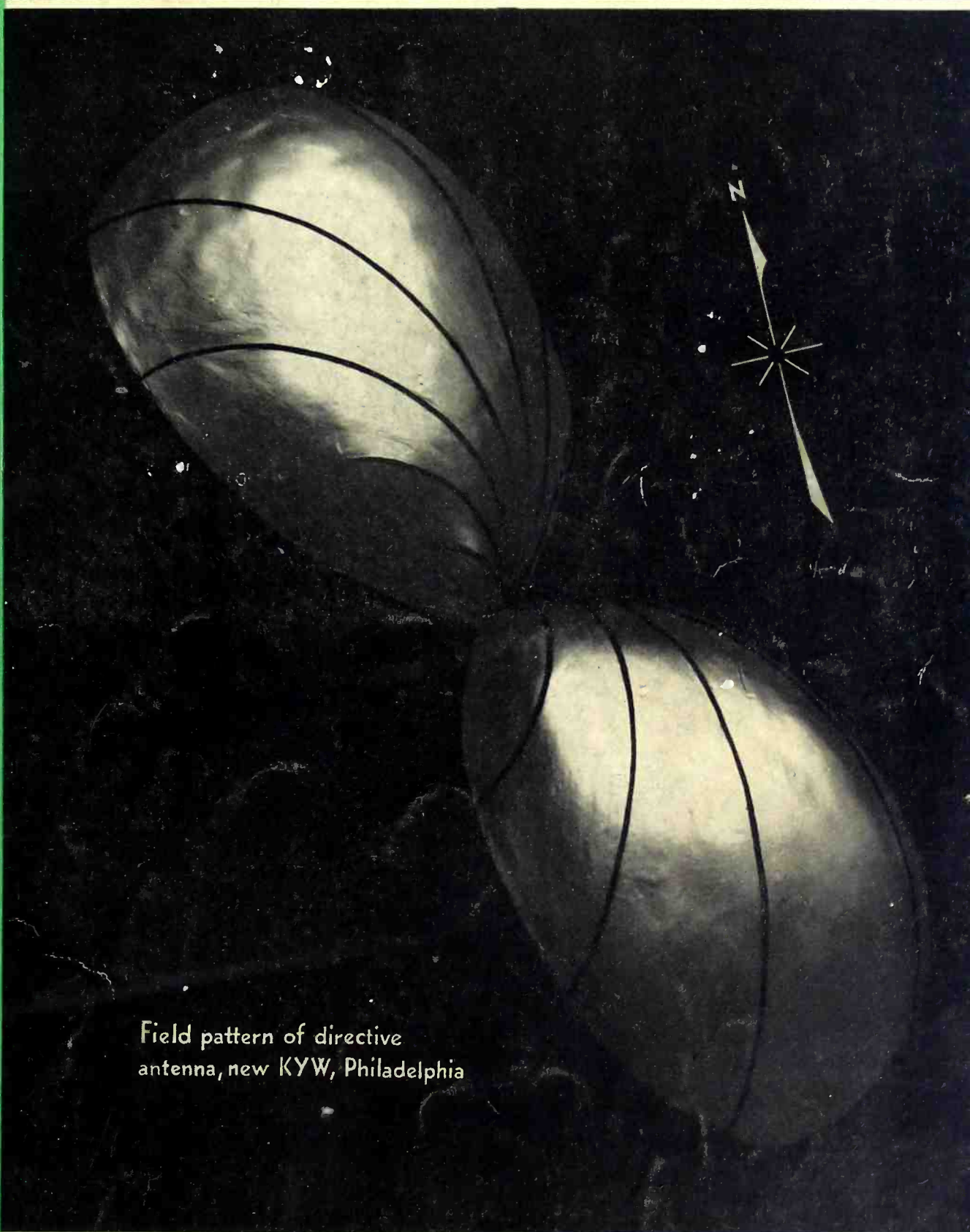

Field pattern of directive  
antenna, new KYW, Philadelphia



McGRAW-HILL PUBLISHING COMPANY, INC.

Price 35 Cents

DECEMBER, 1934

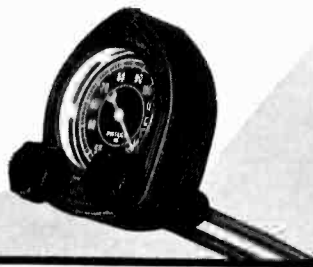

## A better way to connect remote control flexible shafts to radio receivers

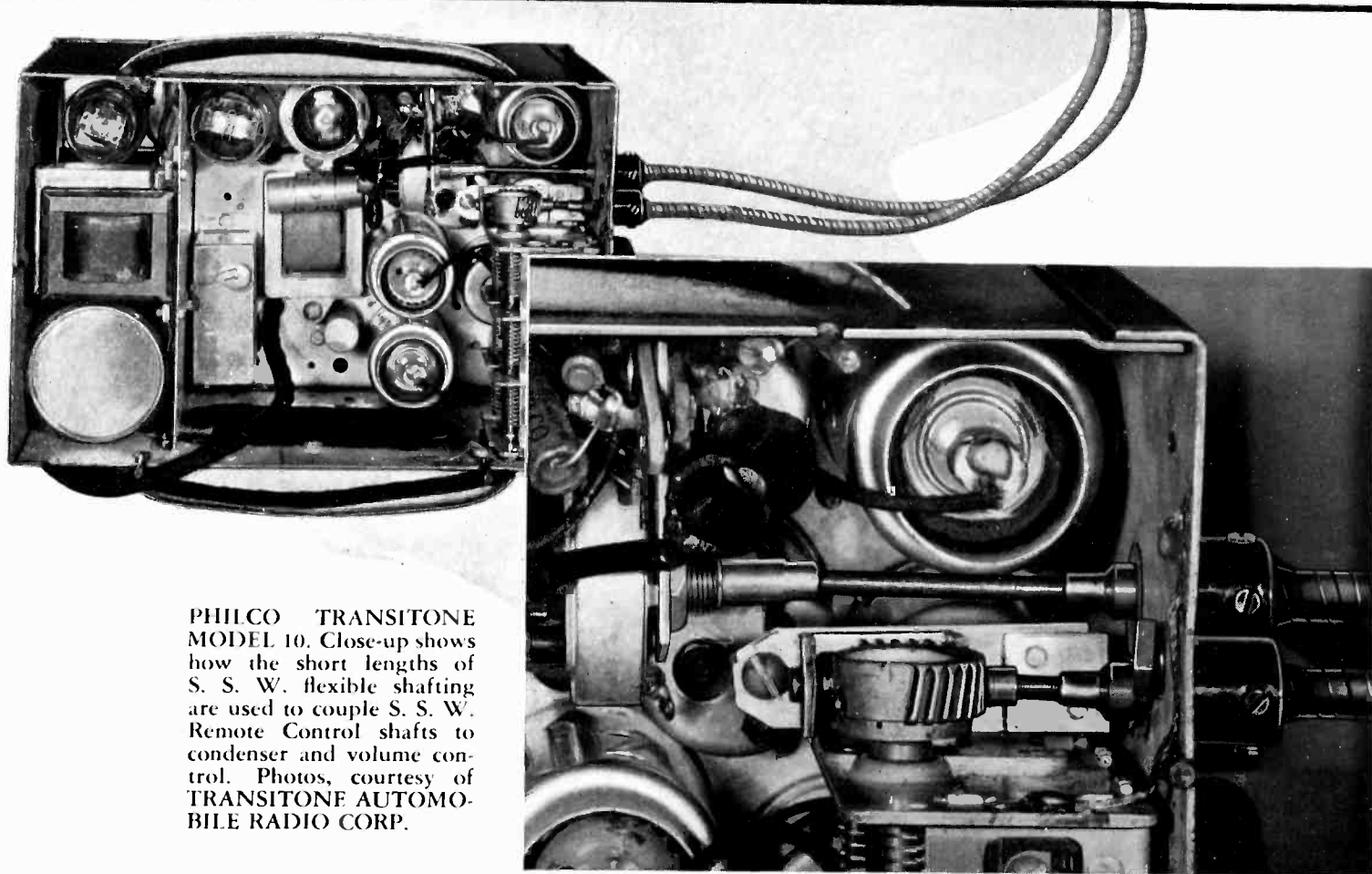

PHILCO TRANSITONE MODEL 10. Close-up shows how the short lengths of S. S. W. flexible shafting are used to couple S. S. W. Remote Control shafts to condenser and volume control. Photos, courtesy of TRANSITONE AUTOMOBILE RADIO CORP.

The method illustrated, was developed by PHILCO with S. S. WHITE cooperating. Instead of connecting the S. S. WHITE remote control flexible shafts direct to the solid shafts of the condenser and volume control, short lengths of S. S. WHITE flexible shafting with end fittings attached, are used inside the receiver as couplings.

*These flexible coupling shafts provide automatic alignment of the shafts of the condenser and the volume control with their respective holes in the receiver case, thus facilitating the assembly of these units in the receiver.*

They also have the advantage of preventing any noise which may be caused by vibration of

the outside shafts, from being communicated to the sensitive parts of the receiver circuit.

*In the case of auto radios, the smaller the size of the receiver the better. It is possible that the use of flexible coupling shafts may permit of a rearrangement of receiver parts and a reduction in overall dimensions.*

Since these coupling shafts can be made up in any length and can be equipped with end fittings of varied design, they are practicable for all receivers.

Call on us freely for further information about the use of flexible coupling shafts or for assistance in working out specific applications. No obligation is involved.



**The S. S. WHITE Dental Mfg. Co., INDUSTRIAL DIVISION**  
Knickerbocker Building . . . . . New York, N. Y.

# electronics

O. H. CALDWELL  
*Editor*  
KEITH HENNEY  
*Managing Editor*  
DONALD FINK

McGRAW-HILL PUBLISHING COMPANY, INC.

New York, December, 1934



radio  
sound  
pictures  
telephony  
broadcasting  
telegraphy  
counting  
grading  
carrier  
systems  
beam  
transmission  
photo  
cells  
facsimile  
electric  
recording  
amplifiers  
phonographs  
measurements  
receivers  
therapeutics  
traffic  
control  
musical  
instruments  
machine  
control  
television  
metering  
analysis  
aviation  
metallurgy  
beacons  
compasses  
automatic  
processing  
crime  
detection  
geophysics

## Brighter skies for radio

**T**HE year 1934 draws to a close with bright prospects before the radio industry. Current production of sets and tubes is at a peak for the depression, and retail sales are running 40 per cent ahead of a year ago. Official figures for the third quarter show an encouraging upturn in manufacturing, indicating that the year's output will reach 4,500,000 sets.

The radio audience now numbers at least 76,000,000 persons, in 19,000,000 homes equipped with radios (30 per cent of these homes having two, three or more sets). In addition 2,000,000 automobile radios are roaming the highways.

**O**PTIMISM also marks the future, as new developments manifest themselves. Higher tone fidelity and better eye-value design will characterize next season's sets. Noise and interference are to be cleared away by united industry effort. Facsimile is a prospect of the immediate future, as broadcasters explore the business possibilities of new visual advertising. Television also becomes a nearer reality as the German and British invoke government aid in financing transmitters, an expedient which may have to be resorted to here.

**P**OLICE radio is finding an important place in city and state organizations, as analyzed on following pages of this issue. The new acorn tubes open up new possibilities for short-wave reception, and also for "pocket radios" operating in the broadcast band. Portable transceivers for laymen—handy sets working around five meters—may create another volume-merchandise market, reminiscent of radio's gold rush days.

Thus, all around the radio horizon, the sky is brightening, and one discovers cheering new prospects of big things ahead.

# PLAN TO ELIMINATE

## RMA Engineering Division launches educational campaign directed at interference sources

By DR. ALFRED N. GOLDSMITH

Chairman Committee on Radio Interference  
Radio Manufacturers Association  
444 Madison Avenue, New York City

**T**HE Radio Manufacturers Association, working through the Committee on Interference of its Engineering Division, has launched one of the most important forward movements and campaigns in the history of radio broadcasting—a campaign which should greatly increase the pleasure of the radio listeners in future years. It is the purpose of the campaign to reduce, in all parts of the United States, electrical noises heard in radio reception and due to man-made devices. In this way the campaign aims to enhance the musical and tonal quality of the programs which the listeners receive. The Committee on Interference will work in cooperation with other interested electrical and radio organizations, and will:

1. Systematically study and classify the various general sources of such interference. Most of this information is already available.

2. Methodically list the general methods which may be used and the instruments which are required for locating and measuring the seriousness of various sources of interference, and for determining the extent to which individual receivers are shielded against various sorts of interference.

3. Classify the known methods of reducing or avoiding such interference.

4. Endeavor to enlist the help of all concerned in eliminating such sources of interference.

### French and German policies

How can this help be secured? Let us first contrast the German, French and proposed American methods of attacking this problem. Recently the German Government decided to eliminate all such interference in the city of Baden. A positive order was issued by the Government; practically every source of interference was located; and the necessary equipment to eliminate the interference was installed by peremptory order. This was done without discussion or debate.

In France a ministerial decree (that is, a law) promulgated at the end of March, 1934, precisely defined radio interference, listed the sources of such interference, and made it obligatory for the owner of the interfering equipment to eliminate the interference under penalty of the law.

What we propose to do is simply to convince all makers or users of interfering equipment that it is in their own interest as well as in that of the radio listeners to make their equipment non-interfering. Among the electrical products which will be considered are household devices, automobile ignition systems, advertising signs, traction power lines, and high tension transmission lines. In every instance it can be shown to be just as much in the interest of the owner of the device to clear up the interference as it is to the advantage of the otherwise disturbed listeners.

So far as antenna construction is concerned, history is repeating itself. Originally an efficient and interference-sheltered antenna was needed because of the *lack* of receiver sensitivity and the low prevailing signal strengths. Such high-grade antennas are now needed because of an *excess* of receiver sensitivity which is required for distance and short-wave reception, and they are also required because the signal strengths on high-fidelity and short-wave reception are sometimes inadequate.

Some interesting statistics were given recently by the German Post Office relative to sources of interference. They cleared 140,000 cases of interference between January, 1930, and June, 1934. It was found that the causes were as follows:

|   |     |
|---|-----|
| Small motors, etc., in homes, farms,<br>or commerce | 30% |
| Faults in receiving installations                   | 24% |
| Atmospheric and untraceable sources                 | 18% |

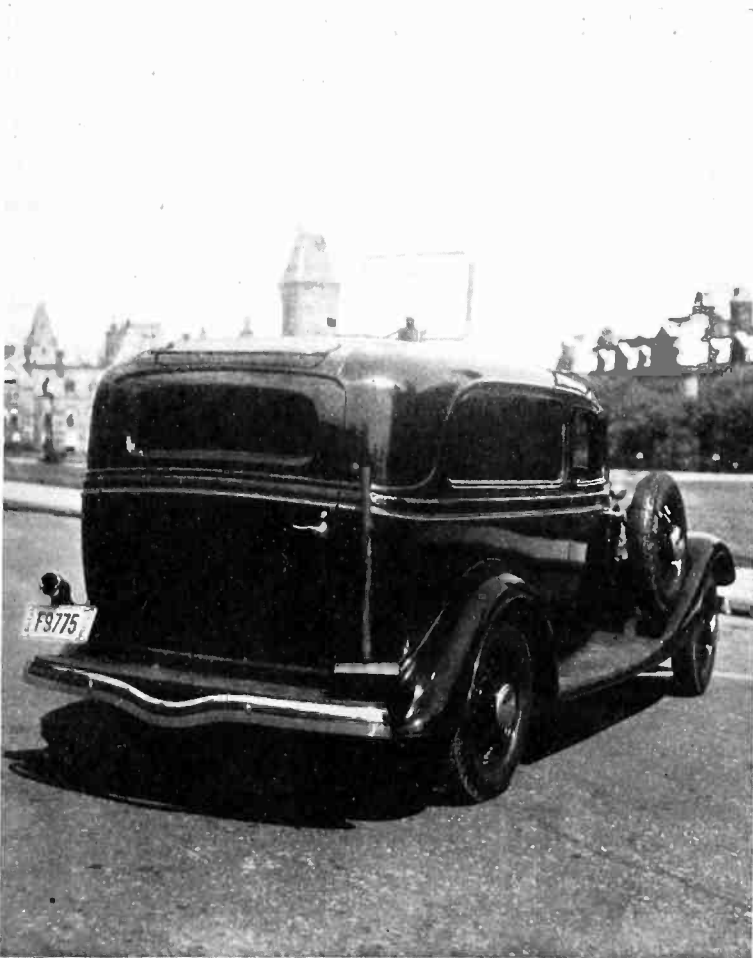

Car for interference location used by Canadian Department of Marine, Ottawa. Note loop antenna, also rear door opening to operating instruments. Grab-handles on roof permit riding running-boards during inspections

# RADIO INTERFERENCE

## Electrical home appliances, power lines, and automobile ignition causes to be studied

As regards the cures of interference:

|                                       |     |
|---------------------------------------|-----|
| Dealt with at the source .....        | 48% |
| Dealt with at the receiving end ..... | 31% |

The method of determining the magnitude of electrical interference is quite different in the various countries. In Germany, the radio-frequency voltage produced at the source of interference, either on the power lines or on a standard antenna at a standard distance, is measured.

In England, there is measured the equivalent field strength of the interference, by adding up or integrating the radiation over a standard frequency band.

In France, it is held that reception is disturbed if:

(1) The interference level is not at least 3 nepers (about 25 decibels) below a signal of one millivolt per meter with 30% modulation at 800 cycles per second, and if the disturbances continue for more than 3 seconds.

(2) If, for more powerful disturbances than mentioned under (1) above, the disturbances last less than 3 seconds but recur within 10 minutes.

### Canadian definition of radio noise

In Canada, close attention is paid to the susceptibility to interference of receivers. This is measured as the ratio of the interference voltage (measured in an output voltmeter) to a standard output voltage (corresponding, for example, to 0.05 watts output). The interference, which is artificially produced, consists of a series of d.c. impulses, between 100 and 2500 per second, and delivered between 10 microvolts and 100 millivolts. The susceptibility of the receiver is measured with relation to the power supply and also with relation to the set wiring. The total susceptibility is greater than either but generally considerably less than the sum of the separate components.

The American and French methods resemble each other in that they both consider the field strength of a radio-frequency signal, with standard modulation at a standard frequency note. The measurement of interference is made by comparison of the audio effect of this artificially-produced signal and of the interference. The City of Los Angeles has seen fit to enact an interference-elimination ordinance. The statute first defines "thorough and effectively shielded receivers" as those which deliver less than 50 milliwatts output when placed, without antenna or ground, in a field of 10 millivolts per meter, the receiver having full sensitivity. It then states that a receiver "must be suitably installed," which is stated to require an antenna of No. 14 wire at least 40 feet long and more than 20 feet above the ground. No interference is permissible under this law if the signal to be received has a strength of at least 500 microvolts per meter within 50 feet of the receiver location. However, the enactment of local statutes of this sort is unde-

sirable since the matter is obviously suitable for nationwide regulation.

The only tentatively proposed international standard is that of the International Electrotechnical Commission. This requires that the noise field shall not be greater than 2 microvolts per meter, measured in accordance with the British method. It is believed that this standard is probably more rigorous than is required or justifiable in some instances, for example, in certain areas, and at certain distances from powerful broadcasting stations.

It is clear from the foregoing that methods of measuring interference, of specifying receiver susceptibility, and of defining the permissible upper limits of interference (at least so far as the United States is concerned) require further study and due consideration of the methods and problems originating in other countries. It is also clear that whatever methods and standards are to be adopted in the United States as the result of the work of the Committee on Interference and its collaborators, should result from experience in the United States and should be particularly suitable and adapted to conditions in this country.



Interior of radio-interference car, showing control panels, battery cabinets, loudspeaker, etc. The heavy mallet at right is used to jar pole-line structures, and thus show up interference sources

# What are the costs for POLICE RADIO SYSTEMS?

By DONALD FINK

Editorial Staff  
Electronics

—the facts and figures

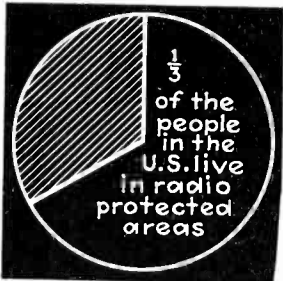

**W**HY is police radio hard to sell? The manufacturers have good equipment and they want to sell it. The municipal authorities want to buy it. But the situation isn't as ideal as might appear. For one thing, city finances have been in such condition that funds for so

nical training, they are faced with two alternatives: they can hire a consultant to decide the technical questions, or they can call in the salesmen and believe what they are told. Neither alternative is pleasant. The consulting engineer is expensive. The salesmen are prejudiced.

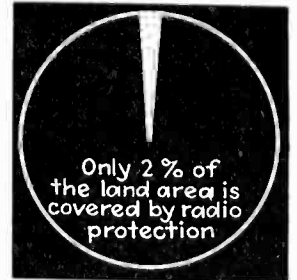

useful a service as police radio have not been available, generally. This situation is improving, as city financial affairs have improved, and as Federal funds, released through municipal channels for expenditure on public works, become available. But the availability of funds is not the only problem.

City fathers, seeing the possibility of obtaining funds for police radio, must attack a tough technical problem before they can decide what sort of system they need and how much they must pay for it. Having no tech-

Often as a compromise the police chief's nephew, who owns a ham station, is called in. He builds and installs a home-made transmitter, known as "composite" among the elite. Thereby the industry loses a contract; and thereby, often, the police department gets poorly engineered equipment which cannot give good continuous service. This condition is not rare. Twenty-three out of seventy-nine cities reporting to a recent questionnaire, nearly one out of every three, were using composite equipment.

Fig. 1—Charts for determining the power required for police radio service, explained in the text. The circle diagrams are based on a report in the I. R. E. Proceedings, October, 1933. The bar diagram is based on the FCC regulations

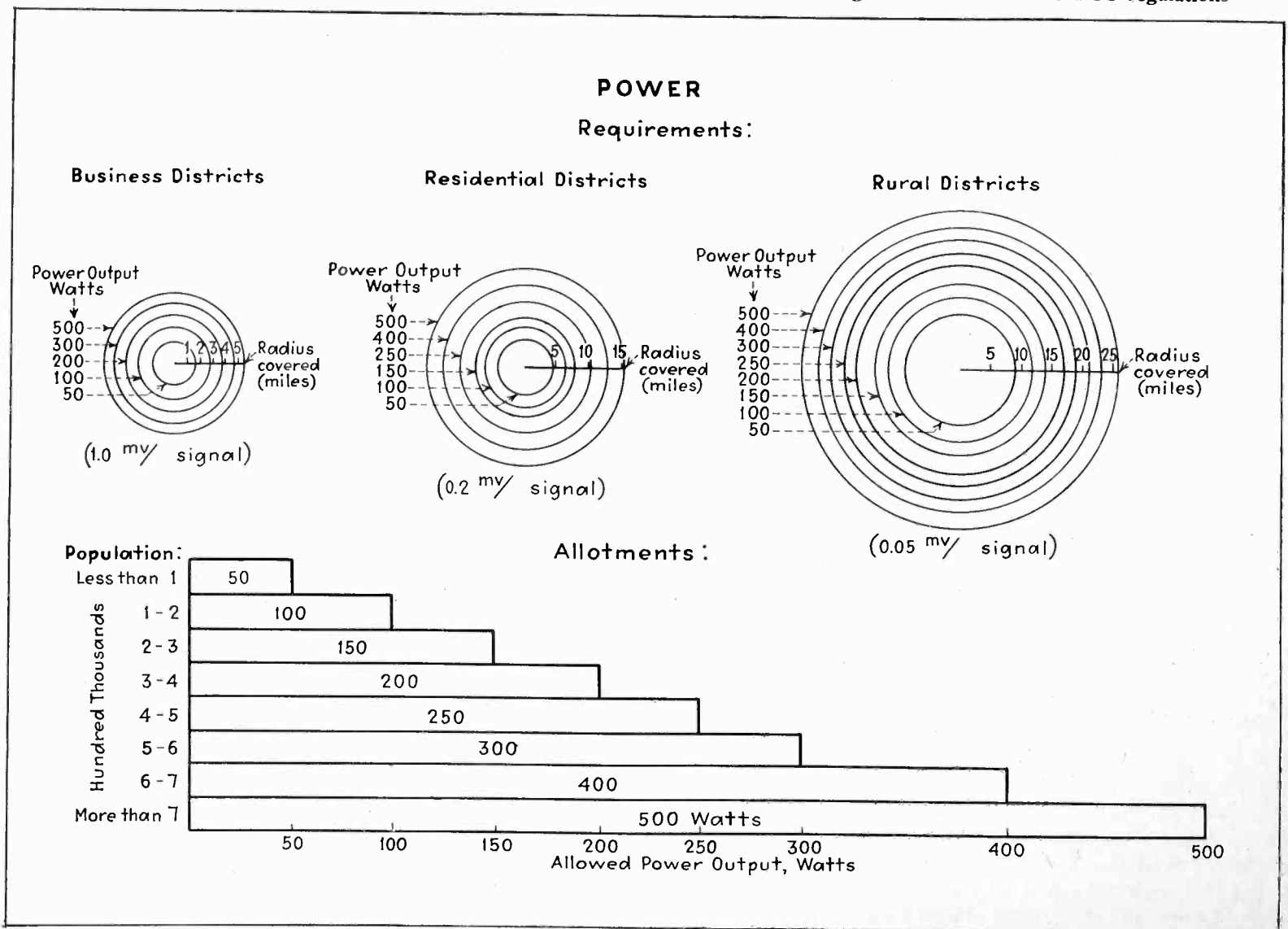

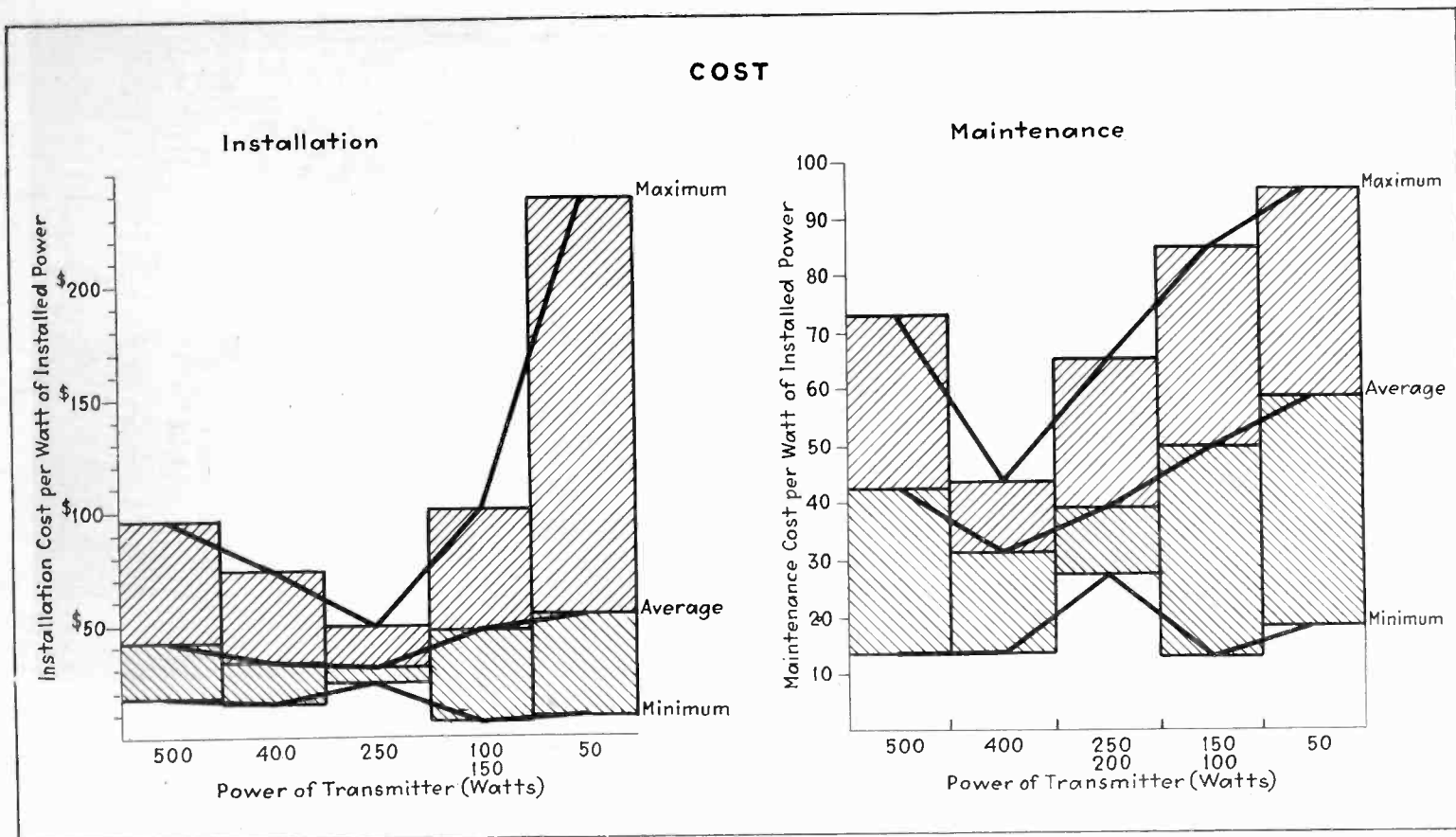

Fig. 2—Police radio costs. Data for these charts were obtained from the report "Municipal Police Radio Systems," issued by the American Municipal Association

Much of the lack of success with such home-made equipment, or apparatus bought at too low a price has been lack of data on the power requirements, the service upkeep, the number of cars required and other reliable information based on actual experience. There has been no source of information the consultant, or the salesman, or the police departments, could use which can be considered as reliable or unprejudiced.

Recently the report of the American Municipal Association of Chicago on municipal police radio systems has appeared; other data have been accumulated and together with facts in the above mentioned report have been put into easily assimilable form for those who wish concrete information on the general subject of "what cost, police radio?"

#### How many watts?

The question of the power required to cover adequately the particular city one has in mind can be settled with accuracy only by an actual survey of field strengths in the various parts of the city. But for purposes of obtaining a rough estimate, Fig. 1 may be used.

To get at the power required by the size and population distribution of the city, the circle diagrams should be used. The transmitting antenna location must be assumed, usually at or very near the police headquarters. Then, measuring out from this central point, the business, residential and rural sections of the city should be mapped out. The point within the business section that lies furthest from headquarters should be marked. The furthest residential section should be marked, and the furthest rural point to be reached should be determined. The circle diagrams will then give the power required to reach each of these three points. The highest

of these three is the value of power required. Unless very unusual conditions of noise, or of topography interfere, this value of power should be satisfactory.\*

Having decided the power, the cost of installation and of maintenance can be estimated. Of course, the salesman can quote at once his company's price for a trans-

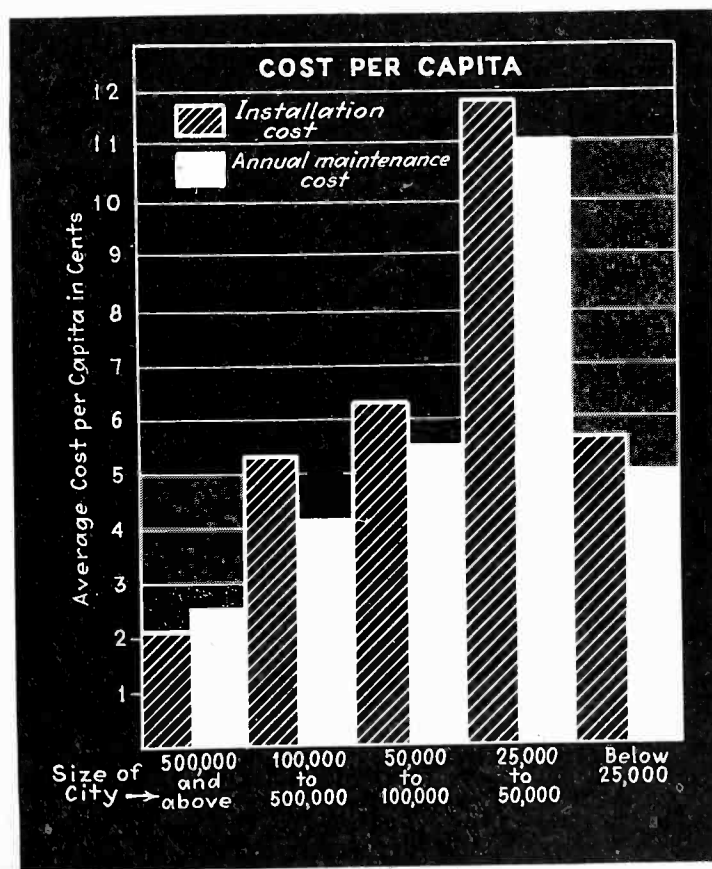

Fig. 3—Per capita costs of police radio, based on the A. M. A. report and the 1930 census figures

\*If two-way or one-way ultra-high frequency equipment is desired, this estimate is probably too high, but as yet no reliable survey has been published to cover these ranges.

mitter of that power, but the police commissioner may think it too high or too low. Figure 2 tells the story without reference to any manufacturer's price list. It is averaged from the *actual prices paid* by over 70 of the 174 departments owning transmitters, arranged according to the different power brackets of the FCC, and showing the minimum, the maximum and the average price paid, per watt of installed power. This chart may prove embarrassing to the salesman because it shows such a wide range of prices for substantially equivalent equipment. This wide range arises from several causes: the more expensive installations were installed in the early days; the less expensive are often poorly engineered "composite" jobs. There is a wide range in the refinements provided, necessary and desirable in some cases, superfluous in others.

But the average price shown in the chart can be taken as a reliable index of what the commissioner can expect to have to pay for his equipment. In this connection, Fig. 3 is also interesting. It shows the average cost for the installation of a police radio system per person protected by it; the cost is measured in cents.

### How many dollars to maintain?

The maintenance and operation cost of the various installations, presented in Fig. 2, has been computed in exactly the same fashion as the installation costs, from the same sources. The figures include salaries, and all expenses which can be directly attributed to the radio installation. Comparison of this chart with that showing the installation costs shows the interesting fact that installation costs average as much as maintenance for a single year. This fact is accounted for largely by the salaries chargeable to radio maintenance, but at least part of this annual maintenance expenditure goes to the radio industry, showing that police radio, once sold, is not definitely off the books. Replacements, except tubes, are not numerous, however, and repair bills on the well-engineered installations are small.

### What is the market?

The effort expended upon selling police radio will depend largely upon the attractiveness of the unsold mar-

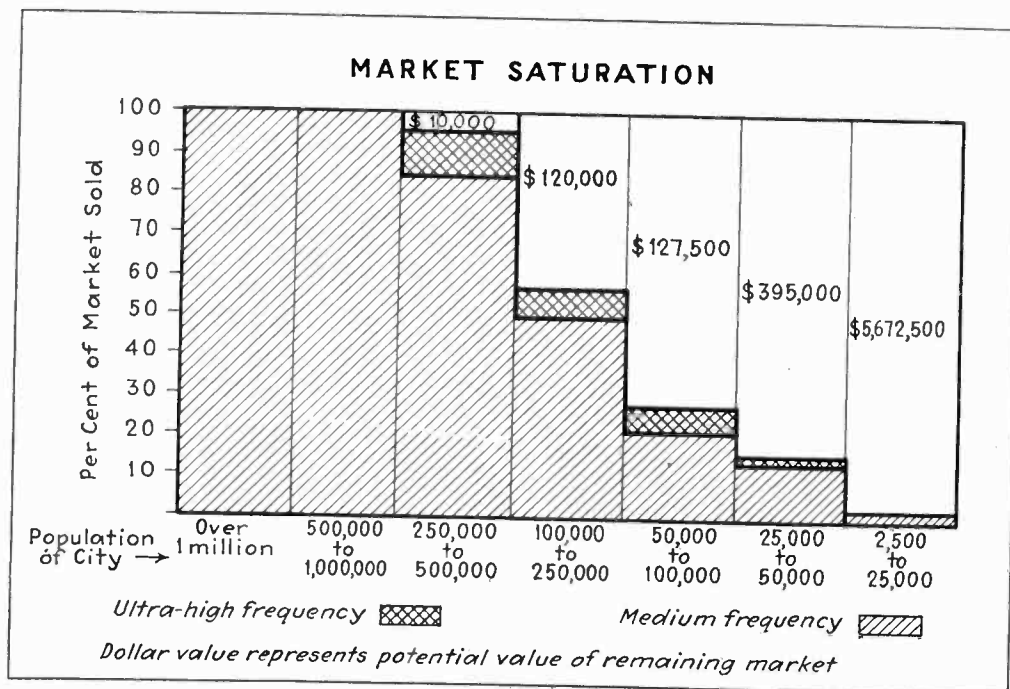

Fig. 5—Market analysis based on FCC reports, census lists, power allotments, and average costs. Dollar values probably high, as explained in text

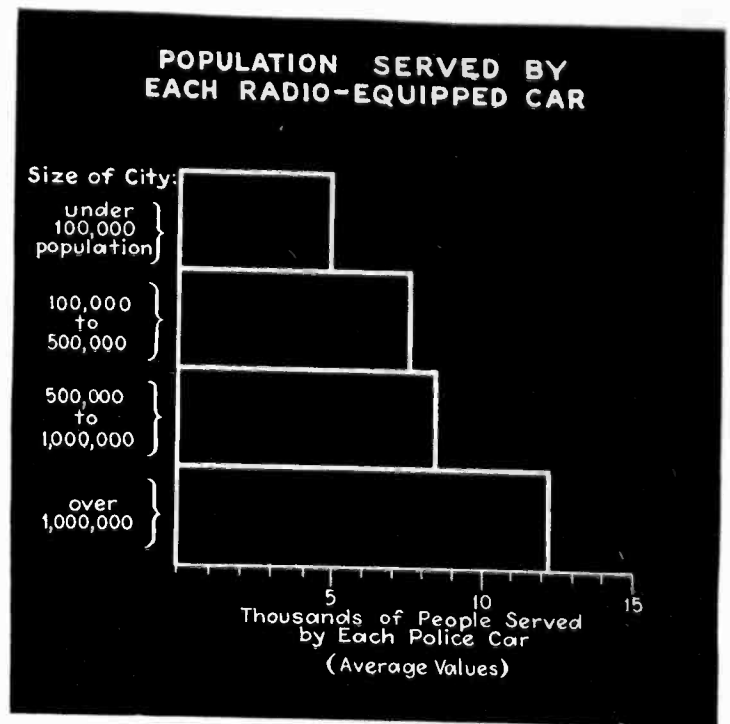

Fig. 4—Chart for determining number of police cars required. Based on A. M. A. report

ket. Fig. 5 has been compiled to give an idea of the market saturation, and to evaluate the unsold remainder. This chart is necessarily approximate, since really complete data are not yet available, but the general outline can be depended upon. The figures were arrived at in this way: The number of cities in the country in each population bracket were obtained from the census figures. The number of cities having police radio installations in each bracket was found, and the percentage taken, as indicated. Figures for the medium wave installations were fairly complete, but only 19 of the 50-odd ultra-high frequency installations are included. The portions shown for ultra-high frequency equipment are thus highly conservative.

In figuring the value of the unsold portions, the number of unsold cities in each population class was multiplied by the number of watts allowed to that class of city by the Commission, and by the installation cost per watt.

Therefore, these figures are optimistic, particularly for the smaller cities. Not more than 1/4 of the smaller cities, which represent the 5 million dollar market could probably be sold, even if the interference problem were solved by the use of ultra-high frequencies. And it is probable that even that many installations would be uneconomical.

But in the cities of higher population, which have already been sold to the extent of 30 percent or more, the market is very real and readily available. Moreover it is extremely likely that these larger cities will be signed on the dotted line before another year is up. The market, therefore, while measured only in hundreds of thousands, is immediate and not too highly competitive.

In the smaller cities particularly, the market for ultra-high frequency equipment is expanding.



# Engineers discuss new developments

## at Rochester IRE

### Fall Meeting



**P**APERS on a wide variety of subjects held the attention of a record attendance at the recent Fall Meeting of the Institute of Radio Engineers. Always a happy assembly, this year's group gave clear evidence of enthusiasm for the future of the art as well as for the immediate business prospects. The three-day session was made the occasion for meetings of the various technical committees of the RMA and for a joint technical session with the RMA Engineering Division on the general subject of radio interference. These meetings will be found discussed below and elsewhere in this issue of *Electronics*.

Several forward-looking papers on fundamental problems were given, among them the results of research on "automatic reactance control systems" by Dr. Travis of the RCA License Laboratory. Other papers were of immediate practical value and still others demonstrated advances in ultra-high frequency and high fidelity technique.

#### Automatic frequency control

The paper by Dr. Travis has most interesting possibilities. He described methods of controlling the frequency of a tuned circuit by means of a vacuum tube. Stating that the variation of plate impedance of a vacuum tube with grid voltage had been used in many other applications, Mr. Travis showed how this action might be used to control the resonant frequency of a tuned circuit.

The frequency at which a tuned circuit will resonate depends primarily upon the capacity and inductance of the circuit, but also to a smaller degree upon the resistance in the circuit. Thus, if the cathode-plate resistance path of a vacuum tube be placed

in series or parallel with the inductance, the resonant frequency of the tank circuit can be varied over a limited range by changing the grid-cathode voltage of the tube.

The action can be made entirely automatic by taking this grid-cathode voltage from a part of the circuit which is directly or indirectly controlled by the frequency of the tuned circuit.

As an example, Mr. Travis pointed out how the method was used to control a superheterodyne oscillator circuit. As the oscillator drifted, the AVC voltage changed, the tube resistance changed, and the oscillator frequency was brought back to its original value. The necessity of knowing which way the oscillator had drifted, so that the compensation would be in the opposite direction, required circuits somewhat more complicated than the brief description above would indicate, but of essentially the same principle.

Mr. Travis stated that automatic

frequency control, or AFC, was only a refinement, perhaps, for superheterodynes used in the broadcast band, but might prove to be a definite necessity in short and ultra-short wave receivers, in which oscillator drift is a definite limitation to sensitivity.

The application of these reactance or frequency control circuits to modern superheterodynes is of importance from the standpoint of high fidelity as well as gain. K. W. Jarvis in a paper on detector distortion (reviewed in this issue of *Electronics*) gave data showing the distortion resulting from inaccurate tuning in high-Q circuits.

#### High fidelity receivers—and standards

Benjamin Olney of Stromberg Carlson described, and demonstrated, the result of his recent work on high fidelity receivers. One of the problems to which he directed his engineering was that of providing suffi-



(Above) Virgil Graham (left) and Kelly Johnson, Wells Gardner, deciding which (if any) of the technical papers they will attend

(Left) A. A. Leonard and Leslie Woods (right) congratulating each other on Philco success. Mr. Woods made the Leica camera studies shown here



Dr. C. M. Jansky, Jr., retiring president IRE, and Stuart Ballantine, RFL, president of the Institute for 1935

broadcast system to put to work idle studio capacity and personnel during evening hours when broadcast stations are handling chain programs was made by L. C. F. Horle. These programs, originating locally and transmitted to a local audience should go on the wave lengths below 10 meters, according to Mr. Horle. A comparison of the plant and antenna investment for these high frequency emissions and the standard broadcast band equipment showed that for equivalent local coverage the economics were all in favor of higher frequencies.

It has been found that a typical city, now covered by a 1-kw. transmitter, with antenna located some distance from the center of the audience could be covered quite as well with a 30-watt transmitter on 7-8 meters. In this case the highest field strength would be secured at points where the inherent noise was highest and that the signal-to-noise ratio would be more or less constant, both radiations falling off as the distance from the transmitter increased. At present the noise is highest where the signal is weakest, and the signal highest where there is no one to listen.

Mr. Horle believed that such a secondary station for local programs could be made to contribute appreciably to the income of the station,

cient loading for the loud speakers at low frequencies. Dr. Olney handled the problem in the following manner: A tube or pipe whose natural frequency is somewhat below the lower response of the receiver is open at one end and the other end is coupled to the back of the loud speaker.

Thus the system acts like a source and a load coupled by a line of the proper terminating impedances. Even in cabinets of large size, however, it is not possible to provide a length sufficient for the pipe or tube desired. Therefore a labyrinth or cabinet composed of many semi-partitions with inner walls coated with absorbent material (rock wool) is used. The air vibrations to reach open air must traverse through this multi-sectioned path with a length equivalent to the open ended pipe of the proper size.

A most remarkable discussion of high fidelity receivers took place at the meeting of the RMA receiving set committee. For months this committee has been endeavoring to decide upon standards of performance of high fidelity receivers. Thus the committee wished to define, according to the desire of the industry, the frequency response, volume range, freedom from harmonics power output, etc., of high-fidelity receivers.

At the Rochester meeting the definition, or standard, was up for suggested changes. The argument was advanced that no such standard was needed or desirable at this time. The reasons offered were that the industry had no policing power; that regardless of such standards certain manufacturers would label inferior apparatus as "high fidelity" and that such

standards of performance could be settled after the public had decided what it believed a high-fidelity receiver should be!

The suggestion was made that for sets of this type a new term be invented which could be copyrighted and protected; a good suggestion without a doubt. It is generally felt that high-fidelity possibilities should not be allowed to simmer away to nothing merely because the industry has no ability (or desire?) to police its own ranks. High fidelity, it is felt, represents something more than merely a new item to sell; its social possibilities and its probable effect for the betterment of all types of receiver are too great to be lost through an unwillingness to participate in a cooperative effort.

The suggestion that a secondary

Leslie F. Muter, (right) president RMA, John Scanlon (center) and R. C. Stinson, Chrysler Corp., not worrying about automobile radio



(Above) John Dreyer (left), Radiotron, and Malcolm Ferris (right), signal generators de luxe, listen to Jim Millen try to get a little publicity for a new National condenser from Keith Henney. (He got it.)



Dr. Weeks (right), Raytheon, E. W. Wilby (left), A. F. Van Dyck, RCA License Lab., and E. T. Dickey (next to Wilby), RCA Victor discussing dynamic symmetry

as well as put to use electrical and personnel equipment idle now during the most productive period of the day.

At the termination of this paper a most illuminating demonstration of the possibilities of ultra-short waves was given by C. J. Franks. Actual conversations were carried on between the auditorium in which the meetings were held and a cruising automobile by means of amateur 5-meter radio.

At the joint meeting with the Radio Club of America, Dr. I. Wolff of RCA Victor demonstrated the transmission and reception of centimeter waves. A convincing illustration of what causes selective fading as well as ordinary interference fading was carried out.

The input losses at high frequencies experienced in using vacuum tubes of various designs were discussed by B. J. Thompson and W. R. Ferris. Evidence points to the fact that the input losses vary as the square of the frequency. Thus with the tubes of the 57 or 58 type the input resistance is of the order of 20,000 ohms at 48 Mc. and 30,000 ohms at 30 Mc. under given conditions. The best method of reducing

Dr. Travis (center), RCA License Lab., inspects a low-loss tube of B. J. Thompson (left) and W. R. Ferris, both of RCA Radiotron



the input losses and to attain higher amplification seems to be to reduce the size of the tubes. Thus the 955 Acorn tubes (see *Electronics*, August, 1933, and September, 1934), have a resistance of about 55,000 ohms at 60 Mc. ten times better than the 58 or the 57.

Further data on high frequencies were disclosed by W. A. Harris of RCA Radiotron in his paper on converter tubes at high frequencies. Since this paper has been printed for distribution it will not be reviewed.

Further progress toward utilizing the higher Q circuits obtained by proper use of Polydoroff iron cores to radio and intermediate frequencies

was disclosed by Alfred Crossley. Typical coils now for sale for use at 456 kc., having an inductance of 1.67 millihenries, wound with 7-strand No. 41 Litz and having about the same over-all dimensions of approximately one inch had Q's of 184 for iron and 90.2 for air. Multiple-section coils, representing the best the coils makers can do today in getting high Q's in small size were compared by Mr. Crossley, who showed that the air coils of 1.5 mh. for use at 370 kc. had a Q of 130, while the iron-core coil had a Q of 216.

The virtues of iron-core coils in the antenna stage, especially of automobile receivers, were pointed out. The results of substituting iron for air coils in a typical 4-tube tuned r.f. set showed that the sensitivity at 1,000 kc. was increased from 660 microvolts to 135 and that the band width at 10 times at the same frequency decreased from 43 kc. to 22 kc. An 8-tube super designed for use abroad (450 kc. intermediate) had double the sensitivity (1.6 microvolts) and half the band width at 10 times all at 1,000 kc. In this case the band width at 10 times became only 8.2 kc.

Two other papers of considerable interest were given, one by J. R. Nelson of Raytheon on diode coupling considerations and the other by H. W. Parker and F. J. Fox of Rogers Radio Tubes and Rogers Majestic, respectively. The latter paper dealt with a visual method of measuring distortion in receivers. Mr. Parker's cathode-ray apparatus showed plenty of distortion in modern receivers.



Norman Wunderlich (right) explains why Lear-equipped Pangborn plane did not win the Australia race. Meade Brunet, Radiotron, and W. E. Davison, Radio Valve Co., do not seem much impressed



(Above) John Miller (left), Weston, Henry Freyling (large foot), Erie Resistor, and L. F. Curtis (right), Bosch, still worrying Al Crossley about lines of force in iron-core coils

Harold Westman (right), Dr. Cook, RCA Victor, J. R. Nelson, Raytheon, and J. H. Thompson, chief engineer Canadian Marconi, wondering what to do next



# Broadcast transmitter characteristics

## A survey of 36 stations

By A. S. CLARKE and  
L. A. SCHUTTIG

Radio Research Co., Washington, D. C.

THE data presented herein were obtained during the past year in the course of a detailed analysis of the operating characteristics of thirty-six broadcast stations. The carrier power ratings of these stations varied from 100 watts to 5 kilowatts. Eleven of these stations were of standard manufacture, while the balance were of composite design. The installations varied in age from a few months to several years. Sixteen of the total used systems in which the final stage was modulated while the remainder employed low-level modulation with one or two stages of class B linear amplification. Eight of the high-level stations operated their modulating equipment as class B modulators.

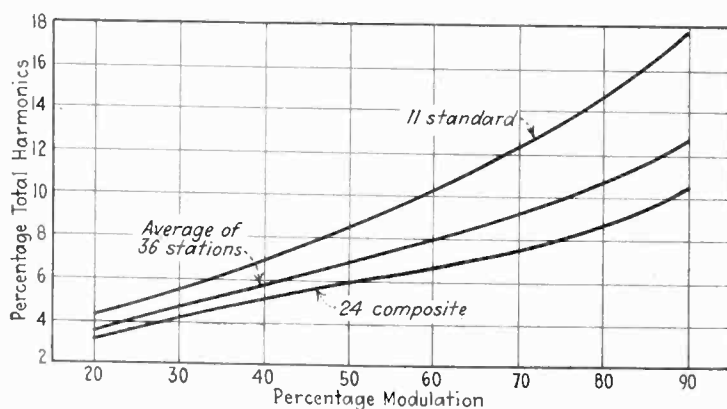

Fig. 1—Distortion data on standard and composite stations compared to the average distortion of 36 stations

The total number of stations checked, the length of service, and the number of each of the several accepted types of modulation and amplification are considered sufficient:

(A) To permit an analysis of the service performance of the several classes of transmitting equipment.

(B) To determine the average characteristics of broadcast transmitters as now installed and operated.

(C) To determine whether, by the use of adequate testing equipment, the average station can improve its performance to meet present-day standards for high fidelity transmission.

From the very beginning broadcasters have taken the attitude that receivers were far behind the development of their transmitting systems. As a result of this attitude, the standards of fidelity have merely been maintained high enough to surpass the average receiver. It is recognized that these standards have been strongly influenced by operating costs. The cost of high-quality telephone lines is an important factor in this connection. In many cases, however, the use of low-quality lines is due to the consideration that they are sufficient and often the continued use of inferior or poorly adjusted transmitting equipment is due to the same attitude.

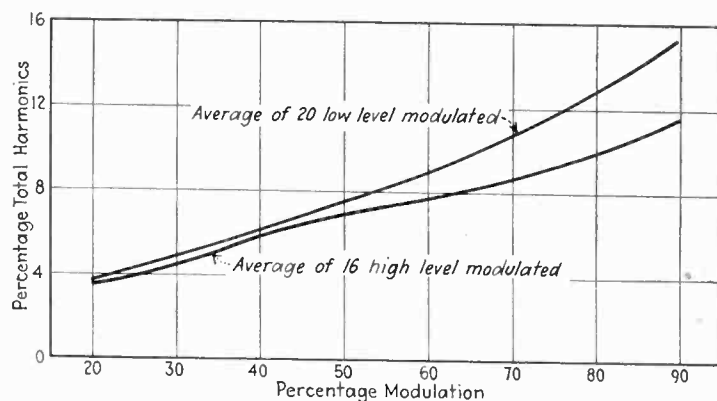

Fig. 2—Comparison of low-level versus high-level modulation stations

Some station engineering staffs maintain a complete check on the performance of their installations from microphone to antenna. They have invested in maintenance equipment and by its intelligent use are able to attain the highest possible performance within the limits determined by the fundamental design of their equipment. Such installations are usually among the leaders in quality performance. Unfortunately, too many stations are operated over long periods of time with no dependable checks on their performance.

A large number of broadcasters assume that the overall characteristics of their equipment are the same as those originally set forth by the manufacturers' specifications. The fallacy of such an assumption is well illustrated by the case of a certain popular 1-kw. transmitter which is very widely used. Under laboratory conditions, this transmitter is capable of approximately 80 per cent modulation without objectionable distortion. In

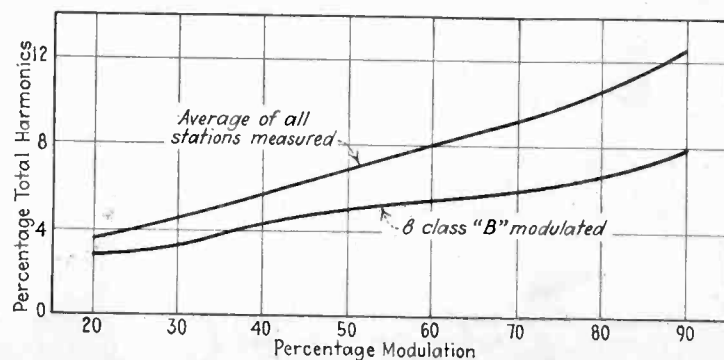

Fig. 3—Class B modulated transmitters are shown to be freer from distortion

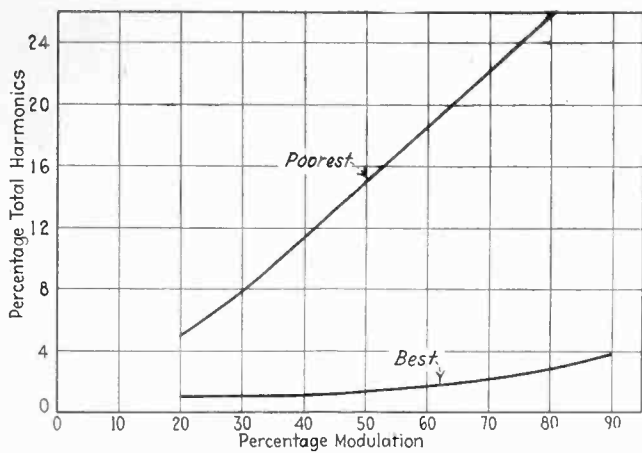

Fig. 4—Poorest and best stations encountered from standpoint of harmonic distortion

the field we have found almost invariably that this transmitter begins to show a severe carrier shift at 50 to 70 per cent modulation. Another illustration is found in the case of a new 250-watt transmitter of standard manufacture which had only been operating three months when checked. The audio harmonic content was found to be over 20 per cent at 75 per cent modulation, the highest distortion figure found on the entire survey. Poor field performance, however, is not always due to poor fundamental design but may often be blamed on the cut-and-try adjustment methods employed.

We wish to emphasize at this point, that the purpose of this article is not to compare transmitters with receivers nor is it intended to bring out the relative merits of different makes of transmitters. The data and analysis which follow are presented for what interest they may hold.

In all cases the performance characteristics were taken under ordinary operating conditions before any corrective measures had been applied. All input measurements were made at the input to the mixer system and all output measurements were performed on the rectified carrier voltage. A linear diode circuit was used to demodulate the carrier.

### Methods of measurement

The harmonic distortion measurements were made at a test frequency of 400 cycles. The method used was that in which the effective value of the combined harmonic voltages and the effective value of the fundamental voltage are measured separately, the harmonic distortion being expressed as a percentage in terms of the

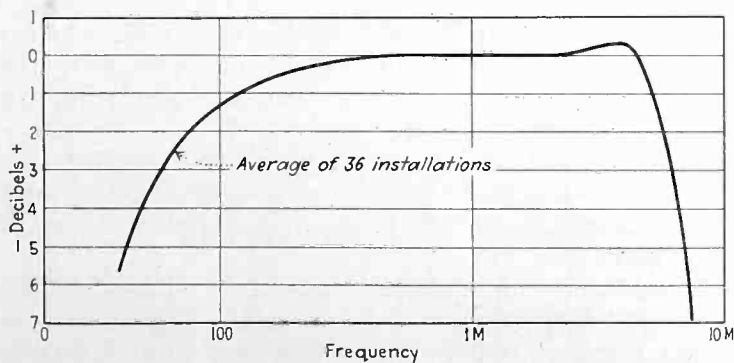

Fig. 5—Average frequency range of 36 transmitters

ratio of these two quantities. Expressed mathematically,

Per cent total harmonics =

$$\frac{\sqrt{E_2^2 + E_3^2 + E_4^2 + E_5^2 + \dots + E_N^2}}{E_1} \times 100$$

where  $E_1$  is the effective value of the fundamental and  $E_2, E_3, E_4$ , etc., are the effective values of the various harmonics.

Distortion was measured as a function of percentage modulation. The modulation meter and distortion meter were both of reputable standard manufacture and were considered to have an accuracy of 5 per cent or better. In order to insure a good test frequency waveform, the output of the audio frequency source was purified by means of a band pass filter which attenuated all harmonics and hum to a level at least 60 db. below that of the fundamental.

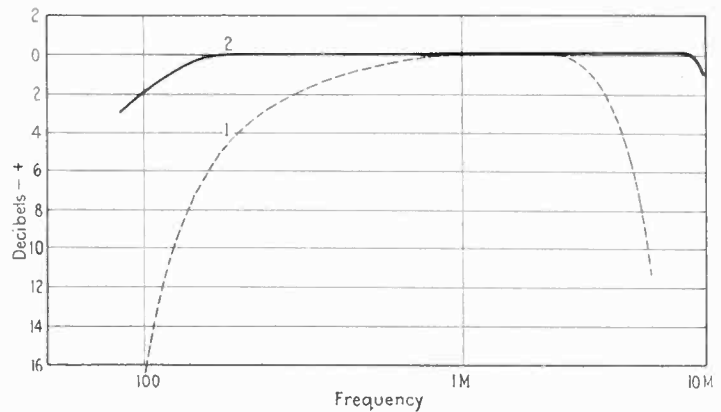

Fig. 6—Extremes of frequency response met in survey of 36 stations

In making the measurements, the pure sine wave input of 400 cycles was adjusted to obtain the desired percentage modulation. The modulation meter and distortion meter were coupled through their respective linear rectifiers to the output circuit of the transmitter.

Figure 1 shows three distortion curves. Curve No. 1 is the average characteristic of thirty-six installations included in the survey. Curves 2 and 3 are the averages of eleven standard and twenty-four composite installations respectively.

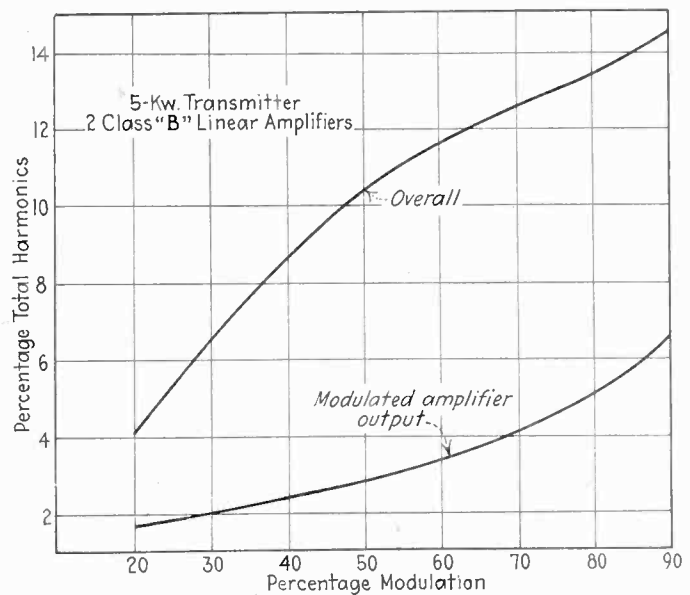

Fig. 7—Increase in distortion attributable to the linear amplifiers following a modulated stage in a 5-kw. transmitter

Curve No. 1 is interesting in view of the fact that it is practically linear up to 60 per cent modulation, beyond this point becoming exponential. Our measurements would seem to indicate that the average system begins to depart from linearity at approximately 60 per cent modulation. In other words, carrier shift usually becomes noticeable at this level. In view of this we may consider the characteristic in two sections. The section below 60 per cent modulation is dependent mainly upon the inherent non-linearity of tube and circuit characteristics. This type of distortion usually does not affect the symmetry of the waveform and the average value remains substantially the same. Beyond 60 per cent modulation, however, another type of distortion becomes important, namely, that due to non-linearity which affects the upper and lower halves of the wave unequally. Such distortion is indicated by a shift in average peak voltage during modulation, a condition commonly designated as carrier shift.

The distortion due to inherent non-linearity can be reduced only by improving impedance conditions and increasing the power and voltage capabilities of tubes and iron core equipment. Such changes usually involve considerable revamping with resultant expense. Distortion of the second type is dependent to a great extent upon the adjustment of the transmitter, particularly adjustment of modulators and class B linear radio frequency amplifiers. It is entirely within the power of a capable engineer to improve the operation under such circumstances by the readjustment of voltages and circuit parameters. The use of proper measuring equipment will facilitate this work and should be available for a constant check on operating characteristics. Relatively inexpensive modulation meters are now available. Likewise, equipment for measuring distortion has been developed to a point where it is thoroughly practical for regular use by the broadcast station.

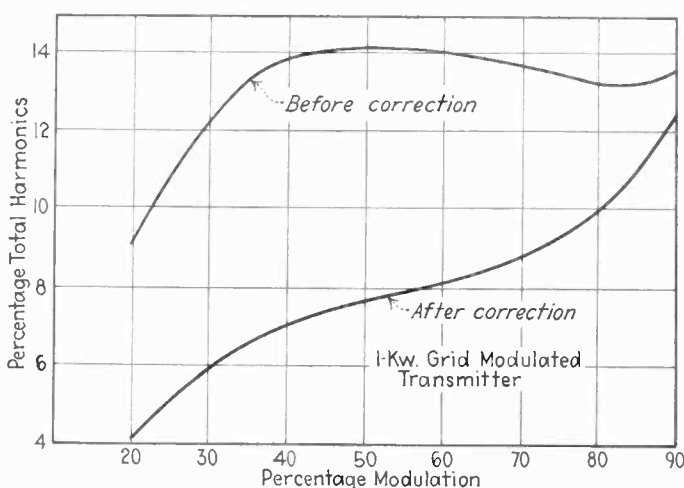

Fig. 8—Improvement affected by proper transmitter adjustment

In continuing the analysis of the average distortion characteristics shown in Curve No. 1, Fig. 1, we find that if more than 10 per cent distortion is to be avoided, the modulation must be held below 75 per cent. If our hypothetical average broadcaster has higher standards of quality and wishes to avoid more than 5 per cent distortion, the modulation must be held below approximately 35 per cent. Now let us consider the following trend of thought. Suppose the operator in the first case is able by proper adjustment to improve this characteristic so that it indicated 10 per cent distortion at 95 per cent

modulation. He could then permit higher audio levels and still maintain his standard of quality. An increase in level to 95 per cent modulation would be equivalent to a carrier power increase of 60 per cent. In the second case similar reasoning leads to the conclusion that an in-

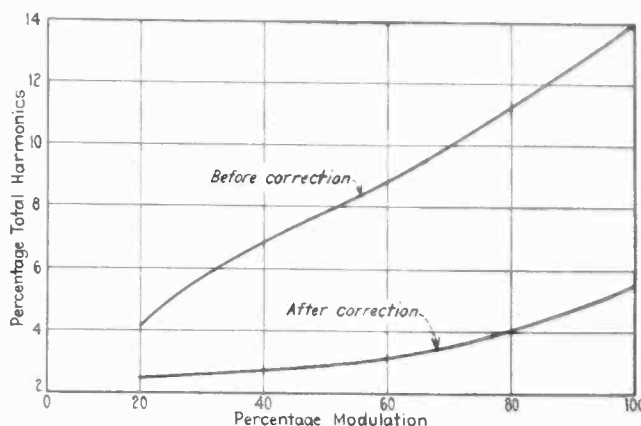

Fig. 9—Improvement produced by adjusting bias and load condition of the modulator

crease in level equivalent to 830 per cent increase in carrier power would be effected.

Considering curves No. 2 and 3 in Fig. 1, we find that the composite installations have much less distortion than those of standard manufacture. This may be difficult to believe until one considers that composite installations usually employ high level modulation while those of standard manufacture that were tested generally modulate at low level and amplify beyond this point with class B linear amplifiers. A comparison of high- and low-level transmitters is shown in Fig. 2. The curves on Fig. 7 are interesting inasmuch as they show an actual example of the increase in distortion attributable to the two linear amplifiers following the modulated stage in a standard 5-kw transmitter. Another factor is to be considered in comparing standard with composite transmitters. Operators are usually reluctant to attempt to improve the performance of factory built sets. This attitude is probably due to the fact that they consider them to be at optimum adjustment and are inclined to let what they consider well enough alone.

A comparison of eight class B modulated transmitters with the total average is shown in Fig. 3. The comparison is strongly in favor of this type of modulation. In view of the small number of these transmitters tested, definite conclusions should not be formed. The slope of this curve is interesting. The rate of increase in distortion with percentage modulation is definitely less than that shown in Curve 1, Fig. 1. Between 40 and 80 per cent modulation the distortion increases only 2 per cent.

Figures 8 and 9 are given to illustrate what can be done in the way of reducing distortion by proper adjustment of the transmitter with the aid of adequate instruments. In both cases, only one night was spent on the work and it is probable that even the "after correction" curves could be improved upon. The case of Fig. 9 is particularly interesting because the improvement indicated was effected almost entirely through the readjustment of bias and load conditions on the modulator.

Frequency response characteristics were taken at a constant modulation degree of 50 per cent. The input to the mixer system from the audio frequency source was adjusted to maintain this percentage modulation. Input

[Continued on page 392]

# Direct-reading meters for tube measurements

By W. P. KOECHEL

ALMOST all technical users of radio tubes are interested in the characteristics of the tubes dealt with, but comparatively few have the necessary equipment to determine simply the transconductance, amplification factor, and impedance. Large laboratories, as a rule, utilize balancing bridges or other complicated methods. But these are slow, costly, require the use of a trained operator, and often take up valuable space. Accordingly they are not suited for the smaller laboratory.

Recently, however, compact meters have been designed which are simple to use, and which give accurate indications of both transconductance and impedance. With these two characteristics known, it is a simple matter to determine the amplification factor. The meter is a dynamometer type instrument, equipped with various multi-range direct reading scales. The transconductance scales are calibrated in micromhos, and the impedance scales in ohms. This meter can be obtained as a self-contained unit completely wired, with pre-set range and check switches, or can be constructed by the user from a suitable dynamometer meter.

## Dynamometer characteristics

A dynamometer type meter has no permanent magnet, but utilizes instead a stationary coil element (sometimes composed of two coils). It also has the customary moving coil equipped with restoring springs, as used in d-c meters. Any current which flows through both the moving and stationary coils, will cause the meter to indicate in proportion to the respective field strengths of the two coils. However as these coils both have air cores, the resultant field is too weak to give readable meter indications for small currents. Therefore it becomes necessary to apply a comparatively high voltage to one of the coils (the field coil) and then pass the current to be measured through the other coil. Actual field voltage ratings vary from twenty to eighty volts depending upon the design.

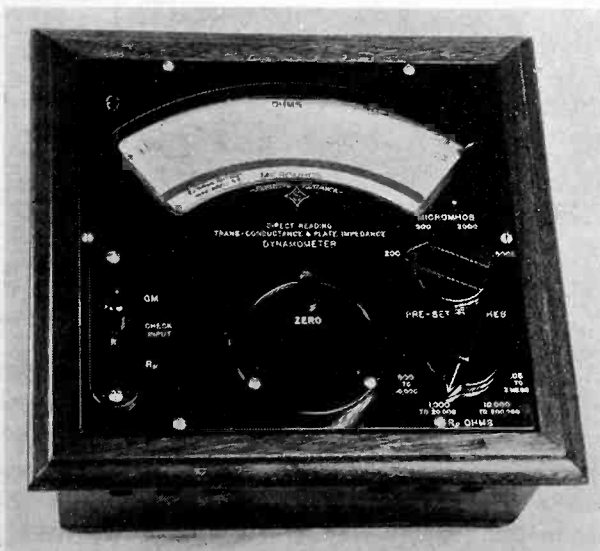

Fig. 1—Commercial tube measuring dynamometer

When a-c currents are measured on a dynamometer meter it is essential that the phase and frequency of the applied field voltage should correspond to that of the current being measured, otherwise serious errors may result.

If a complex current composed of both d-c and a-c components is passed through the moving coil, as is often the case in tube measurements, there will result a d-c field around this coil, which will be acted upon by the earth's field (or other stray d-c fields), and cause a fictitious in-

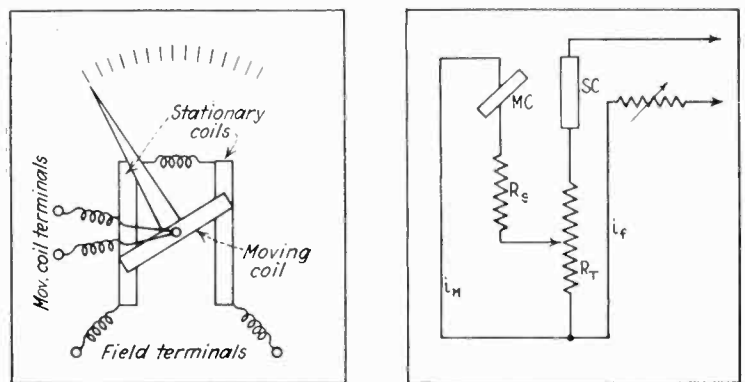

Fig. 2—Elements of dynamometer and checking circuit

dication. To overcome this it is necessary to cancel out the d-c component of the a-c current being measured, by means of a bucking circuit.

If a dynamometer type meter is connected in a circuit in such a way that a difference of potential exists between the two coil elements, there will be caused electrostatic stresses, which will tend to change the position of the moving coil. The only remedy for this condition is to utilize a meter which is equipped with an efficient electrostatic shield.

Before going on to the description of the actual measuring circuits, a few brief definitions will be given: if the voltage applied to an electrode "j" of a radio tube, is changed by a small amount, there will be a resultant change of current in the circuit of electrode "k." The relation of this resulting current change, to the voltage causing it, is known as and designated by  $s_{jk}$ . Subscripts refer to the electrodes involved in measurement.

If the voltage applied to an electrode "k" of a radio tube is changed by a small amount, there will be a resulting change of current in the circuit of the same electrode. The relation of the resulting current change to the voltage causing it, is known as and designated by  $r_k$ . The subscript again indicates the electrode referred to.

If an a-c voltage, or signal, is applied to the grid of a tube, there will be a resultant a-c current component in the plate circuit. The value of this current will be in direct proportion to the product of  $e_p s_m$ . Therefore if the signal voltage  $e_p$  is maintained at a known fixed value, the measured a-c component of plate current will be in direct proportion to the transconductance of the tube. Accord-

ingly if a dynamometer meter is employed to measure this a-c current, it becomes possible to calibrate the meter directly in micromhos, instead of milliamperes.

Figure 3-A shows the fundamental circuit used in measuring  $s_m$ . It will be noted that the signal voltage  $e_g$  is obtained from a divider resistor in series with the field coil. This insures that the phase of the signal voltage will correspond with the phase of the field voltage. As the tube itself causes a phase shift of  $180^\circ$  the current through the coil element will also be in proper phase relation, if the proper polarity of coil connections is observed. The calibration in micromhos on the meter scale will be equal to  $10^3 i_c / e_g$  (1) where  $e_g$  equals the value of signal voltage employed, and  $i_c$  equals the meter calibration in milliamperes.

The battery  $E_a$  and resistors  $R_R$  and  $R_x$  constitute the "bucking" circuit, described in detail in a later paragraph.

The value of signal voltage  $e_g$  is calculated from  $e_g = 10^3 i_m / s_m$  (2) where  $i_m$  equals the full scale range of the meter utilized, in milliamperes, and  $s_m$  equals the required full scale range in micromhos. For example, if we are using a meter having a full scale range of one milliamperes and wish to obtain a full scale range of 2000 micromhos, then we would have  $e_g = 10^3 \times 1 / 2000 = 0.5$  volt, for required signal voltage.

Two "rule of thumb" methods will serve as a rough guide for the upper values of  $e_g$ . First,  $e_g$  should not

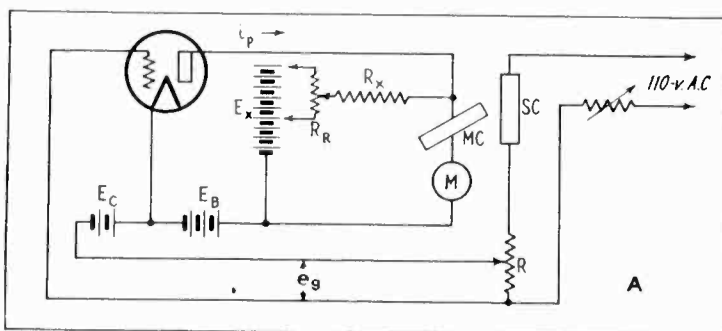

Fig. 3A—Transconductance measurement circuit

exceed  $\frac{1}{3}$  the value of d-c bias applied to the tube, while being measured; second, a value of  $e_g$  should be used which will cause the d-c plate current to change by not more than 10 per cent when  $e_g$  is applied. Any  $e_g$  values which exceed these conditions are apt to cause serious errors in indicating  $s_m$ .

As shown, a divider resistor is connected in series with the field coil, and  $e_g$  values are then obtained from properly tapped points. The resistance values of these tapped points are obtained from  $R_t = e_{gt} / i_f$  (3) where  $e_{gt}$  equals the required signal voltage, for any given range, and  $i_f$  equals the rated field current of the particular meter being used. Where several ranges of transconductance scales are to be used, there will of course be an  $e_g$  tap for each range.

As the current measuring element of the meter has both resistance and impedance, its effect in the plate circuit of the tube being measured should not be neglected. However, if the bucking circuit is utilized, as later described, this IR drop will automatically be cancelled out.

Another possible source of error is the impedance of the current coil. It is important to use a meter which has the lowest possible current-coil resistance. The combination meter the author uses has a coil impedance of approximately 50 ohms, and so causes negligible error.

If an a-c voltage or signal is applied in series with the plate circuit of a radio tube, there will be a resultant a-c

current component, in this same circuit. The value of this current  $i_p$  is equal to  $e_p / r_p$ . Therefore if the signal voltage  $e_p$  is maintained at a fixed known value, the measured a-c current  $i_p$  will bear a fixed relation to the plate impedance of the tube.

Figure 3-B shows the fundamental circuit, for measuring  $r_p$ . It will be noted that the signal voltage  $e_p$  is obtained in the same way as grid signal voltage  $e_g$ , thus insuring proper phase relations between  $i_p$  and field voltage. The calibration in ohms on the meter scale will be  $r_p = e_p / i_c$  (4) where  $e_p$  is the applied signal voltage, and  $i_c$  is the indicated a-c current reading.

As the  $r_p$  scale is obtained from a reciprocal relation, the maximum current range of the meter will represent the lowest portion of the  $r_p$  scale. Therefore to determine the required signal voltage, we must decide on a minimum scale range value of ohms, somewhat below the lowest value we expect to measure. The required signal voltage will then be  $e_p = i_m r_{min}$  (5) where  $r_{min}$  equals the minimum impedance in ohms and  $i_m$  equals the full scale range of the meter in ma. If, for example, a 0-1 ma is used and a minimum scale range of 5000 ohms is required, then the signal would be  $e_p = 5000 \times .001$  or 5 volts rms.

As the maximum range of  $r_p$  in ohms, corresponds to the lower range of the meter in milliamperes, the upper range of  $r_p$  will be dependent upon the lowest value of current which can be accurately read. For example, assume that the lowest value of current that can be read on a 0-1 ma, is .05 ma. The maximum value of  $r_p$  which could be read would be  $r_{max} = e_p / i_{min}$  or  $5 / .00005$  which equals 100,000 ohms.

Signal voltage values for measuring  $r_p$  should be kept as small as possible, consistent with the range of meter used. For triodes this value should never exceed 5 volts, but with pentodes and screen grid tubes it is permissible to go higher. The peak voltage of the signal, should never be of such a value that it embraces any serious curvature on the  $e_p - i_p$  curve of the tube being measured. Any noticeable displacement of dc plate current due to the applied a-c signal values, indicates that the signal is too high.

It will be noted from Fig. 3-B that a portion of the divider resistor is in series with the plate. Therefore the resistance of this resistor should be kept as low as pos-

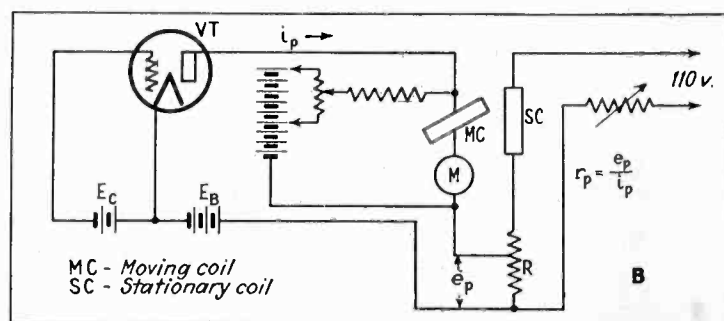

Fig. 3B—Circuit for measuring resistance

sible, to eliminate IR drop error, due to the d-c plate current passing through it.

### Combination $s_m - r_p$ circuit

It is entirely practical to combine the functions of  $s_m$  and  $r_p$  measurement, in one meter. Figure 1 shows such an instrument. This meter is equipped with separate  $s_m$  and  $r_p$  range switches, which makes it possible to pre-set for the required scale ranges. This is a rather im-



portant feature for production testing. Without such a pre-set scheme, it becomes necessary to operate a single scale range switch, every time a tube is tested, and this also offers the possibility of accidentally turning the switch too far, while the tube is in its test socket. Thus, if the range switch were set for two megohms ( $e_p = 50V$ ), and

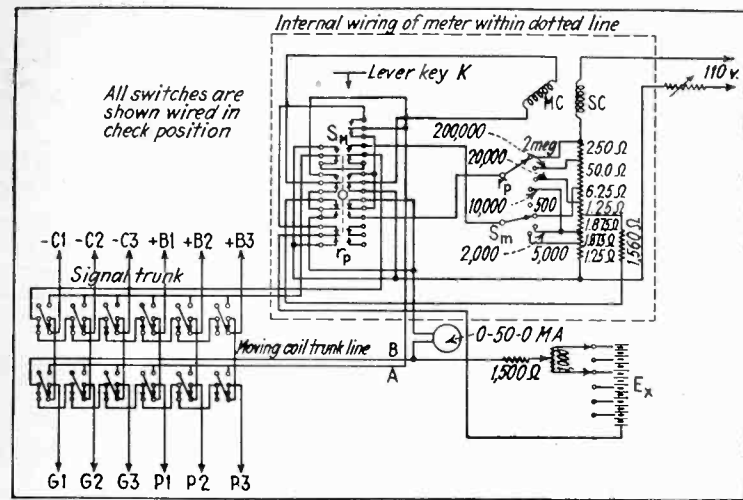

Fig. 4—Wiring diagram of tube testing meter

the check key were on  $s_m$ , there would be a peak signal voltage of 70 volts applied to the grid.

Figure 4 shows the complete wiring diagram of the meter, together with other associated circuits. The circuit constants shown will apply when used with a meter having characteristics similar to the one described. However constants for other meters can easily be found, from the various equations given.

The telephone lever key "k" utilized, is wired up in such a way, that it is in effect a three-way key. The center position is for check reading, and the others for  $s_m$  and  $r_p$ .

### Auxiliary circuits

The calibration of any separately excited dynamometer instrument is entirely dependent upon the voltage applied to the field. The calibration will remain constant only if the field voltage is held at a constant and predetermined value. To do this in operation, a check circuit is utilized as shown in Fig. 2.

A voltage tap is taken from any convenient point on the divider resistor, and fed directly to the moving coil through a series resistor. The value of this series resistor is

$$R_s = \frac{i_f R_{ct}}{i_m} - R_c \quad (6)$$

where  $i_f$  equals the rated field current,  $R_{ct}$  equals the value of the resistance tap,  $R_s$  equals the value of the series resistor, and  $i_m$  equals the maximum range of the meter. The voltage to the field is then varied until the meter indicates at exactly  $i_m$ . The check resistor  $R_s$  is so wired with the check switch, that it can be connected in the circuit, in this way, at any subsequent time by operation of the check switch.  $R_c$  is the moving coil resistance.

Therefore, when in use, the meter is checked, first, by setting the check switch in its proper position, and then by varying the field control rheostat, until the meter indicates the proper value. This proper value is usually marked as a red line inscribed on the meter scale.

As mentioned earlier, there will be a d-c component in

the moving coil, due to the plate current of the tube being measured. This will cause a d-c field, which may cause a fictitious reading of the meter. For example, with no voltage of any sort applied to the field, and only ten milliamperes passed through the moving coil of a 0-1 ma movement, there may be caused a lineal scale deflection of half an inch, due to the action of the earth's field. Other stray d-c fields may cause even larger deflections.

### Use of bucking circuit

This error can be overcome by the use of a bucking circuit as shown in Fig. 3. When rheostat  $R_r$  is properly adjusted, for any given plate current, meter  $M$  should indicate zero current, and there will also be zero voltage across the moving coil. Meter  $M$ , is a small auxiliary zero-center millimeter. When it indicates zero current, the "bucking" current is equal to, and cancels out the d-c plate current, through moving the coil. It is important that the resistance of this bucking circuit should be as high as possible, and even then should be taken into consideration where extreme accuracy is involved.

### Flexible transconductance switching scheme

Until multi-grid-and-plate tubes showed up, the technical user of radio tubes was interested only in mutual conductance and plate impedance. However with the advent of pentodes and multi-purpose tubes it was found desirable and necessary to measure transconductance relations between various combinations of electrodes. For example if an a-c signal is applied in series with the screen of a pentode there will be a resultant a-c current in the plate. This relation is known as screen-to-plate transconductance, and can be designated by  $s_{sp}$ . Or if the signal is applied in the plate, and the current measured in the screen circuit, then it becomes plate to screen transconductance and designated by  $s_{ps}$ .

By a suitable switching scheme used in connection with a direct reading  $s_m - r_p$  meter, it becomes possible to read directly any combination of transconductances by merely operating switches corresponding to the electrode circuits.

Referring to Fig. 4 it will be noted that there are two rows of DPDT toggle switches, connected to two trunk lines. The upper row is connected to the signal trunk line, and permits selecting any electrode circuit, to which to apply the signal voltage. Thus if  $G_1$  switch is thrown to the up position, there will be an  $e_g$  signal fed to grid No. 1.

The lower row of switches is connected to the moving coil trunk line, and permits connecting the moving coil in series with any electrode circuit. Thus if switch  $P_2$  is thrown upward, then the moving coil is connected in series with plate-2 circuit. With switch  $G_1$  and  $P_2$  operated we would be in a position to read transconductance between circuits  $G_1$  and  $P_2$ . If these were connected respectively to control grid No. 1 and screen of a pentode, then we would read grid to screen transconductance. Tubes such as the 6F7 and 2A7, require the determination of many combinations of transconductance and can, therefore, be very readily read in a flexible circuit such as described.

Thanks is hereby extended to the Sensitive Research Inst. Corp. of New York City for their co-operation in furnishing photographs, scales and diagram of the internal wiring of their meter. All associated external circuits represent the personal design of the writer.

# HIGH LIGHTS ON ELECTRONIC

## Metropolitan Opera installs electron-tube lighting control

WHEN THE OPERA season in New York opens on December 24, occupants of the "Diamond Horseshoe" will observe for the first time the results of the thorough remodeling and modernizing program which, carried out during the past summer and early fall, has effected sweeping improvements from the stage to the marquees of the historic Metropolitan Opera House. Most notable of the changes will be the installation of the most modern type of electron-tube control for both the stage and house lights.

This new lighting equipment will place the control of all lighting effects, including proportional dimming and scene-to-scene fading, at the finger tips of a lighting technician who will manipulate the numerous small levers and toggle switches of the master-pilot and presetting controllers located on the first level below stage. While so doing, he will be able to observe the lighting effects produced by looking through a hooded opening in the stage floor near the footlights. From this "lighting pit" each of the 156 circuits for the stage may be independently preset for three

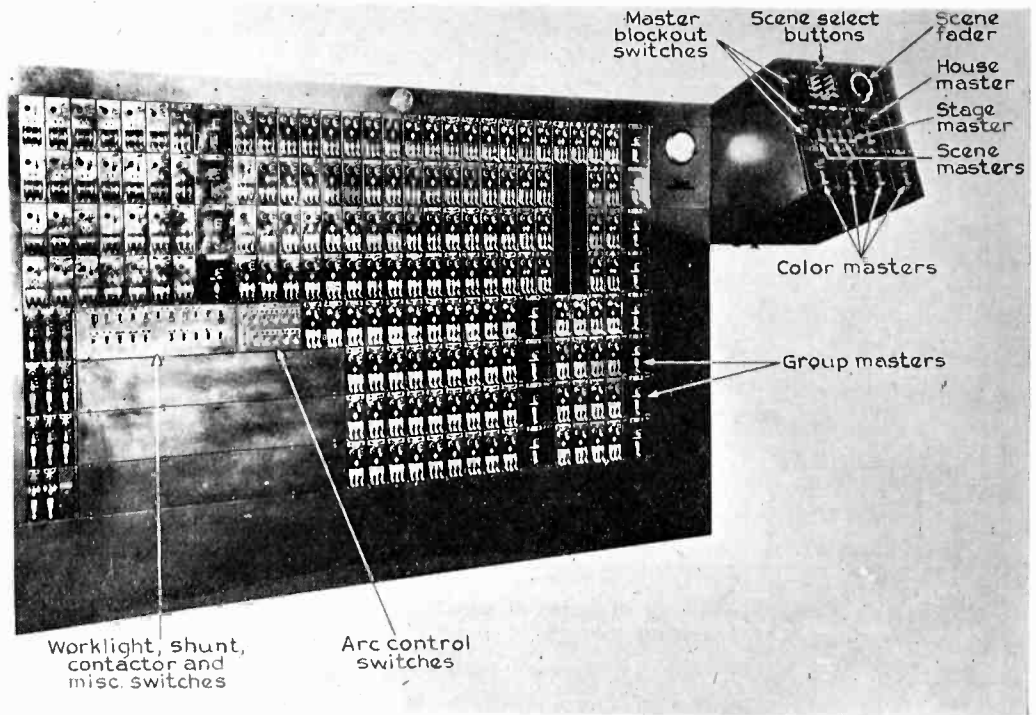

Control switch board for electron-tube circuits,  
Metropolitan Opera House

complete lighting scenes, so that the touch of a button will accomplish the scene-to-scene change of circuits. In addition, the 11 house circuits may be controlled from this point.

The presetting controller, located in

the lighting pit, provides for the individual control of each circuit. The master controller is designed to simplify the work of the operator and is mounted at the end of this presetting controller at a convenient angle to facilitate manipulation while observing the effects from his raised platform. It enables him to govern all circuits simultaneously—either for dimming or for blackout—and to split the control into major divisions of color. The circuits are arranged to provide one color for the house and four colors for the stage, except for the footlights where five colors are to be used.

### Reduces resistance losses

This type of theater lighting equipment, known as the Thyatron-reactor dimming control, is a development of the General Electric Company. The system, through the use of electron tubes, reduces the electricity consumption in the dimming equipment and eliminates the bulky backstage switchboards required by the resistance type of control. The master or pilot controllers of the new system are relatively compact and may, therefore, be placed beneath the front of the stage, enabling the lighting technician to see all details of the effects which he produces. The rest of the Thyatron-reactor equipment, including electron-tube panels, distribution panels, and reactors, is mounted on "remote racks" located in the sub-basement of the Metropolitan Opera House building.

## PHOTO-CELL AIDS SEWAGE ANALYSIS



With the aid of this Westinghouse photoelectric apparatus for measuring transparency, G. W. Holmes studies sewage turbidity for the city of Syracuse, N. Y. The method can also be applied for sewage treatment operations involving automatic control

# DEVICES IN INDUSTRY + +

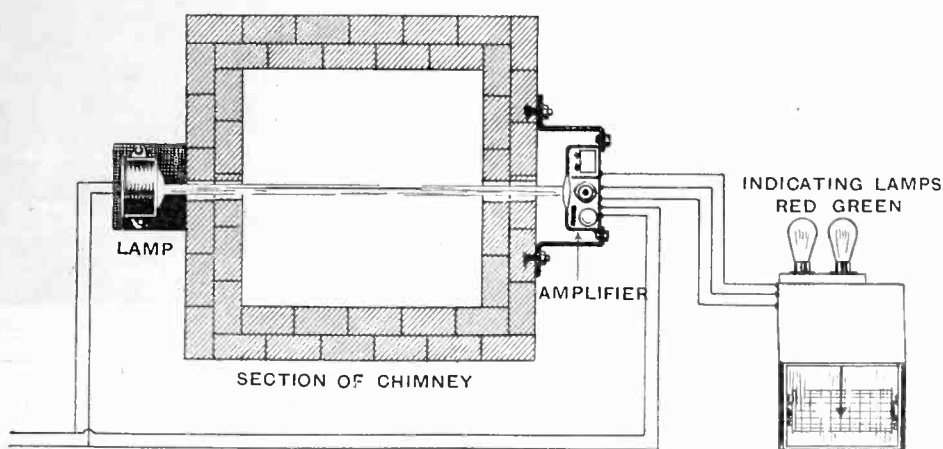

Horizontal section through chimney, showing photo-cell beam, amplifier and recorder

## Installation of photo-cell smoke indicator

A NUMBER OF British manufacturing plants have installed smoke-detector units of the GEC type, as shown in the accompanying sketch.

Two small holes are made in the wall at the base of the chimney, at diametrically opposite points. The two units are mounted on iron brackets, one on each side of the chimney, so that light from the lamp is projected across to the photo-cell in the amplifier. Such an arrangement dispenses with troublesome accessories like glass windows in a chimney, which become fouled very quickly and are difficult to keep clean.

Many ingenious devices, such as spraying glass windows with water, or using mechanically operated windscreen wipers, have been suggested and tried, but all such expedients have disadvantages since they require constant service and attention.

As soon as smoke impedes the passage of the light from the lamp to the photo-cell, the relay in the amplifier closes and brings into operation an alarm, which may consist of one of several forms. The cover of the amplifier is fitted with an adjustable iris diaphragm to enable the engineer in charge to set the point at which the alarm comes into operation, after he has decided exactly what may be considered as objectionable smoke—a decision which may be influenced to some extent by local conditions.

The alarm could, for example, consist of a bell wired to ring continuously as long as excessive smoke passes. It would, in most cases, be supplemented by a red and green lamp, the green lamp being alight when the shaft is clear, and the red as soon as the alarm rings. In the case of an installation on several boilers there would be one bell, with a pair of lamps on each boiler.

## Loudspeaker for giving orders at sea

A NEWLY DEVELOPED loudspeaker, so powerful that it can magnify the human voice 1,000,000 times, was in operation for the first time at the International Yacht Races where it was used aboard the Coast Guard cutter Tampa to warn shipping off the course and issue instructions to spectator craft.

While the Tampa used the new sound-projecting device at less than its full power, the speaker has been designed by

engineers of the Western Electric Company so that it can be made 500 times more powerful than the ordinary loudspeaker. At full power it hurls sound into the air with the force of a 50-pound hammer blow. Over flat terrain, in still air, it can project intelligible speech a distance of several miles.

The volume produced exceeds the classically loud sounds of nature. The voice can be made louder than a clap of thunder. Measured at the horn's mouth, sound is about 1,000 times louder than the roar at the foot of Niagara Falls. Clarity is obtained in spite of the tremendous power, owing to the fact that the design deliberately sacrifices naturalness by focusing on those frequencies which make speech most readily intelligible and filtering out the other frequencies.

Use is foreseen for the new speaker in directing throngs of people either too vast or in the presence of too much noise for the ordinary loudspeaker to be heard. Fire fighters within burning buildings, deafened by the crackle of flames, could be directed by the giant voice. A rescuing vessel at sea could bellow instructions to a distressed crew or to persons in life-boats. In place of the fog horn's simple warning the loudspeaker could give spoken directions.

See illustration, page 391.

## HOTEL NEW YORKER'S "MAGIC DOORS"



Like many other progressive hotels and restaurants, the Hotel New Yorker, New York City, has installed photo-cell self-opening doors between dining rooms and kitchens. As the waiter walks through a light-beam, the door jumps open

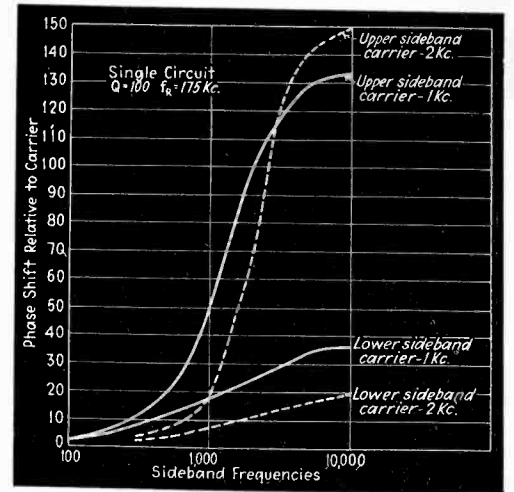
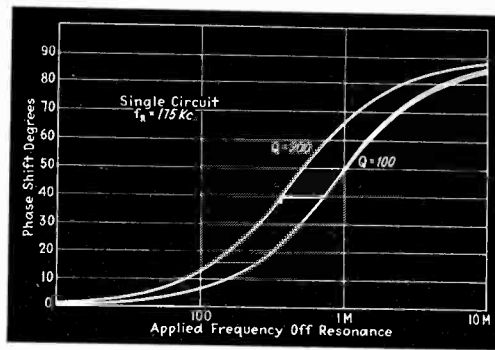
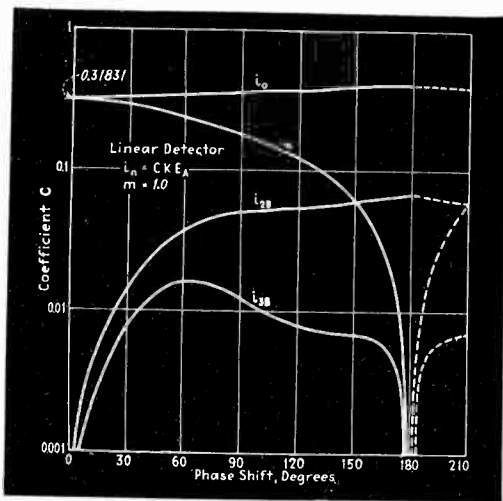

Fig. 1—Phase shift distortion

Fig. 2—Phase shift vs. frequency

Fig. 3—Result of slight detuning

# Linear detector distortion

By K. W. JARVIS

IT is generally held among radio and communication engineers that the linear detector is quite fine. Of all the devices capable of detecting, that characteristic consisting of two linear regions joined at one point of discontinuity seems to be best. It can be shown that when operating at this point of discontinuity, a normal signal, modulated less than 100 per cent will produce only those modulation frequencies originally in the modulation, and will not add any spurious harmonic or cross modulation components. Unfortunately, such a correct situation is seldom actually the case.

Several other forms of distortion are common although not so generally considered. One of these occurs when a signal having more than 100 per cent modulation is impressed on a detector. It has been shown that in the case of a square law detector the percentage of second harmonic (referred to the fundamental) is  $m/4$  regardless of the value of  $m$ , the percentage of modulation. In a linear detector this ratio does not hold, for with percentages of modulation less than 100 per cent no distortion is produced, while with greater percentages of modulation much distortion is produced.

Other distortion results from having the sidebands unsymmetrical in phase with respect to the carrier. When such phase shift occurs, we no longer have the ideal type of signal to apply to a linear detector, and distortion results.

For example, Fig. 1 shows the d.c. ( $i_o$ ), fundamental ( $i_b$ ), second harmonic ( $i_{2b}$ ) and third harmonic ( $i_{3b}$ ) produced in a linear detector with 100 per cent modulation as the phase of a sideband is shifted. A number of interesting observations may be made. At zero degrees phase shift, the ideal condition, no distortion occurs. The peak current (all relative values given are peak values)  $i_H$  is  $0.31831 KE_A$  where  $K$  represents the slope of the detector (or difference in slope of the two linear portions) under operating conditions.  $E_A$  is the peak value of the unmodulated carrier. As the phase shift is increased to 180 degrees the d.c. increases, the fundamental falls to zero, the second and third harmonics increase. The second harmonic reaches a maximum at 180 degree phase shift while the third harmonic returns to zero. Beyond 180 degrees the curves back track. At about 150 degrees we have 100 per cent second harmonic distortion. All other even harmonics follow the same

law as that of the second harmonic, increasing to 180 degrees. The odd harmonics increase to a maximum (the exact point depending on the percentage of modulation) and then decrease to zero at 180 degrees.

The next point to determine is where and when such phase shifts can be obtained in practice. When an a-c energy carrier is impressed through an impedance on a tuned circuit the amplitude of the voltage across the circuit varies as the applied frequency is shifted through resonance, and the phase of the resulting voltage across the tuned circuit shifts. The phase shift in which we are here most interested is zero at resonance, positive for frequencies above resonance, and negative for frequencies below resonance.

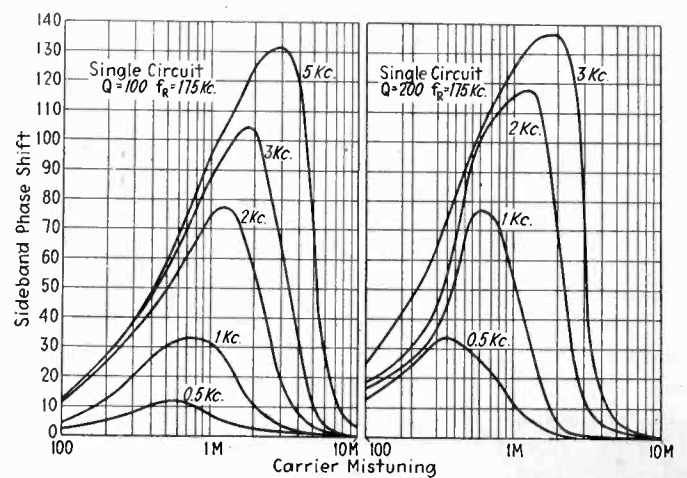

Fig. 4—Detuning effect at several frequencies

Figure 2 shows the value of this phase shift with respect to frequencies off resonance. For  $Q = 100$  the higher curve represents the phase shift for the frequencies below resonance, while the lower curve shows the phase shift for frequencies above resonance. The maximum difference is approximately 1 degree. This shows that when tuned to resonance the phase shift of the two side bands is about equal and so they remain symmetrical in phase and no distortion such as shown in Fig. 1 results. The difference between positive and negative phase shift for  $Q = 100$  is very small. However, if detuning is encountered, the phase shifts will be unequal. Figure 3 shows the phase shift with re-

spect to sideband frequency for two degrees of detuning, namely one and two kc. off resonance. As one phase shift is positive and the other negative, the difference between these two curves represents the relative phase shift of the sidebands.

A demonstration is given in Fig. 4 for circuits of different  $Q$ . Here the relative phase shift is plotted against amount of detuning for several sideband frequencies. It may be observed that the phase shift for any given frequency is a maximum for some particular degree of detuning, and that for any amount of detuning the phase shift increases with increase in frequency. The only surprising thing about these curves is the large phase shifts possible in a single tuned circuit.

Now to return to some more distortion data before combining these effects. Figure 5 shows the per cent second and third harmonic in a linear detector with various values of modulation. As before noted, the second harmonic for  $m = 1$  is 100 per cent at 150 degrees phase shift. Other modulations gave more or less distortion as shown. With  $m$  less than 1, the distortion is zero for zero phase shift, while for  $m$  greater than 1, an initial distortion is present.

As has been shown, distortion even with large phase shifts, decreases with  $m$ . This is more clearly shown in Fig. 6, where the per cent second harmonic is plotted against the factor  $m$  for several phase shifts. This shows the great advantage which results when  $m$  is low.

Figure 7 shows a comparison of the distortion of linear and square-law detectors. While at low phase shifts the linear detector is superior, as soon as appreciable phase shift is present the difference is not so marked. Considering the amount of third harmonic which the linear detector produces, the advantages of this detector are minimized.

While the phase shift resulting when tuning near resonance is small, the overall phase shift in a radio receiver may be considerable as the total phase shift is the sum of the phase shift of each circuit. We may therefore find phase shifts of 180, 360, 540 degrees and even higher, each of the noted shifts giving nodal points. Figure 8 shows such a result in a fairly selective superheterodyne detuned 1 kc. from resonance. The first nodal point comes at 830 cycles, where the fundamental frequency drops to zero while the second harmonic increases to infinity. Another nodal point (corresponding to 360 degrees) occurs at 1120 cycles. Here the fundamental is back to normal while the distortion is zero. Still another nodal point occurs at 1660 cycles (540 degrees)

where the fundamental frequency component is again zero and the second harmonic is correspondingly infinite. At still higher modulation frequencies the phase further increases and the distortion falls, but does not pass through another nodal point. Still further detuning of the receiver would produce more nodal points, four or five being easily possible.

The important point about Fig. 8 is that with the exception of a very narrow band about 1,100 cycles, more than 10 per cent second harmonic is present at all frequencies above about 450 cycles. This receiver, which might be quite good when tuned properly, would hardly

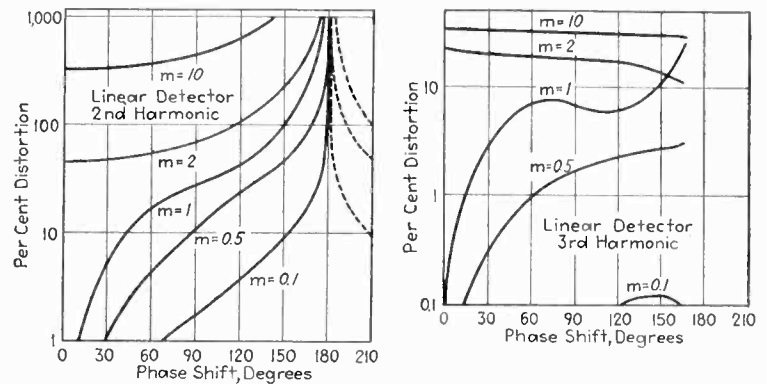

Fig. 5—Production of second and third harmonics

sound acceptable operating in such a condition. In some measure at least, this effect has prevented using high frequency audio systems for high fidelity receivers, as the high percentage of distortion due to causes as shown in Fig. 8 is thus made many times worse.

Detuning, causing the phase shifts and distortion noted, often results in unequal sideband amplitudes. Such unequal sidebands cause distortion but as this effect has been discussed elsewhere, no stress is placed upon it here. The unequal sideband amplitude distortion which occurs in such detuning in general adds to the distortion produced by phase shift. Under conditions where the distortions indicated above are present, cross modulation is also present. This also adds to the distortions already given. Reducing the percentage of modulation reduces this cross modulation as rapidly as the harmonic distortion is reduced as shown in Fig. 6.

One or both, of two solutions to this distortion problem are under way. The first is an automatic tuning system for insuring that the receiver is always tuned correctly. The second method is to artificially reduce the effective percentage of modulation.

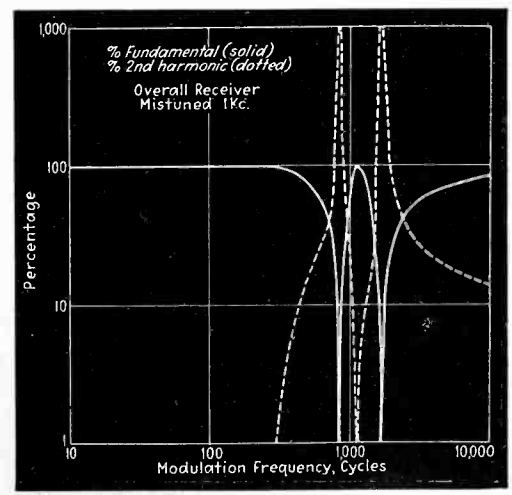
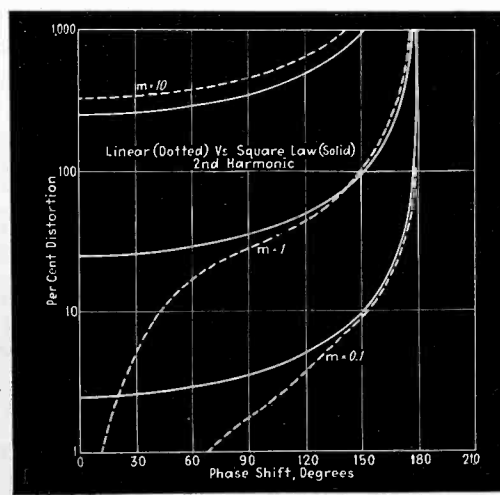
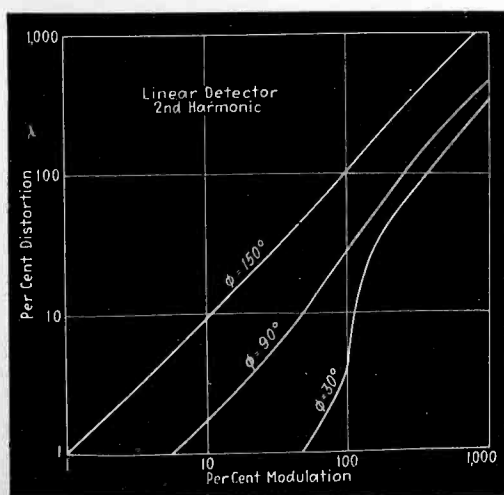

Fig. 6—Second harmonic vs. modulation. Fig. 7 (center)—Linear vs. square-law detectors  
Fig. 8—Typical super distortion

# ++ NOTES ON ELECTRON

## D. C. voltage stabilization

By H. W. KOHLER,  
Cruft Laboratory, Harvard University

IF IT IS DESIRED to have a d-c source of highly constant voltage supplying a constant load over an extended period of time a gaseous tube rectifier with filter and an apparently little known stabilizing circuit described below is recommended. The stabilizing circuit keeps the d-c load voltage practically constant and independent of the fluctuations of the output d-c voltage of the rectifier. These fluctuations are caused by the usual voltage variations in the commercial 60 cycle network to which the rectifier is connected.

Load voltage stabilization is brought about by drawing a current  $I_p + \Delta I_p$  through resistance  $R$  in series with the rectifier, as shown below.\*  $R$  is but a fraction of the load resistance  $R_o$ . Current  $\Delta I_p$  is caused to be of such magnitude that the voltage drop produced by it in  $R$  equals the deviation  $\Delta E_1$  from the average output voltage  $E_1$  of the rectifier, viz.:

$$(1) \quad \Delta I_p R = \Delta E_1$$

The proper stabilizing current for each output voltage  $E_1 + \Delta E_1$  is obtained by having a variable resistance  $R_1$  in parallel with the load. Best suited for an inertia-free variable resistance is a triode. The grid of the triode is con-

nected to a potentiometer across the output terminals of the rectifier and biased negatively by the battery  $E'_1$ .

The quiescent point  $Q$  for the triode is then determined by a steady plate voltage  $E_o$  and steady grid voltage  $cE_1 - E'_1 = E_g$  where  $c$  is a fraction determined by the potentiometer contact  $C$ . According to the equivalent, plate-circuit theorem, remembering the  $e_p = E_o = \text{constant}$

$$(2) \quad \Delta I_p = \frac{\mu_p \Delta E_o}{r_p} = \frac{\mu_p c \Delta E_1}{r_p}$$

where  $\mu_p$  = amplification factor of tube  
 $r_p$  = variational plate resistance.  
Combining equations (1) and (2)

$$(3) \quad cR = \frac{r_p}{\mu_p} = \frac{de_o}{di_p}$$

The choice of stabilizing tube, average

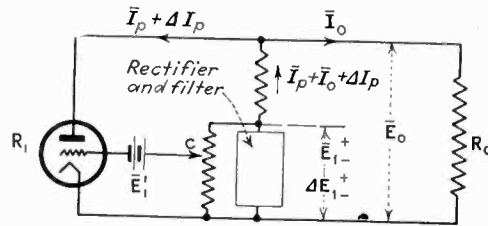

operating point  $Q$  and resistance  $R$  may be made by considering the  $e_g - i_p$  static characteristic curve as illustrated below. The geometrical tangent to

the characteristic curve at the  $Q$ -point makes an angle with the ordinates whose anti-tangent equals  $cR$ .

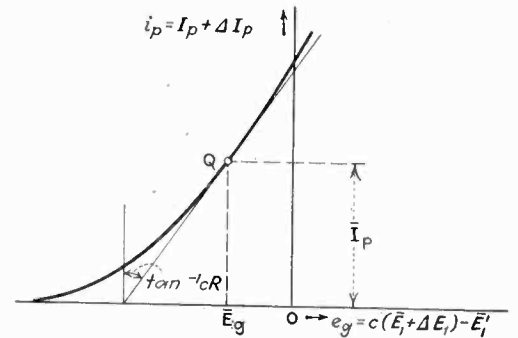

Test results showing the load voltage  $E_o$  for the stabilized and not stabilized rectifier versus the input alternating voltage  $E$  are given in the table below. In order to obtain comparable data for the two cases the curves were made to intersect at the average alternating input voltage. By a switch a fixed resistance could be substituted for the tube  $R_1$ . The sloping down of the stabilized voltage curve on both sides is due to the curvature of the static characteristic curve of the tube which makes the current  $I_p + \Delta I_p$  too large for large changes  $\Delta E_1$ .

Data relating to the results in the table are:

|                           |                             |
|---------------------------|-----------------------------|
| Tube 112-A                | $E_f = 4.0 \text{ V}$       |
| $E_o = 150 \text{ Volts}$ | $I_p = 14.8 \text{ mA}$     |
| $R = 445 \Omega$          | $c = 93.8 \text{ per cent}$ |

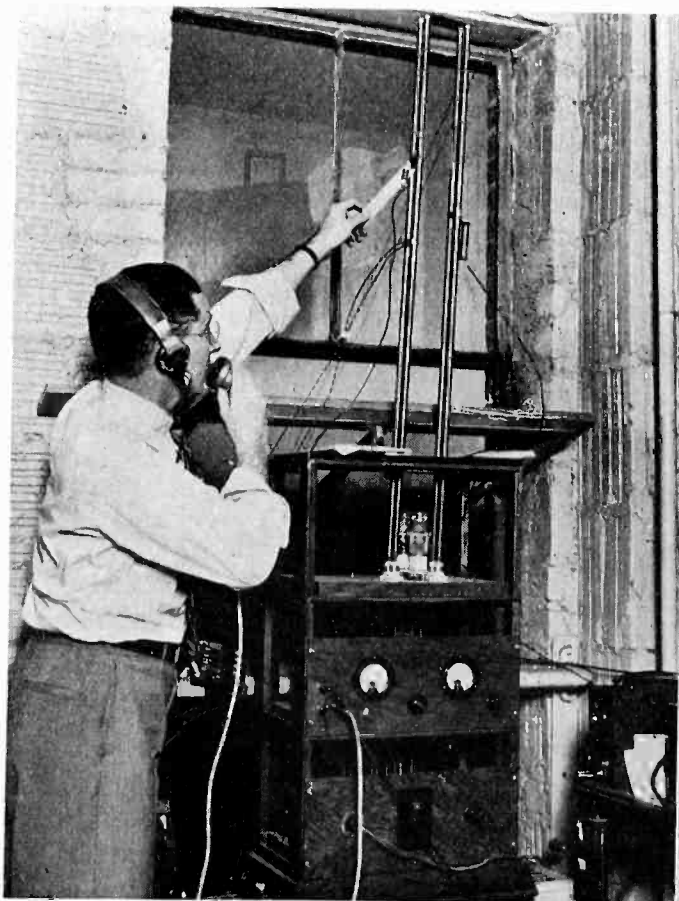

## 5-METER BEAM ANTENNA

Located on the roof of the Hotel New Yorker, 45 stories above ground, this directive structure has been erected by Arthur Lynch in an attempt to beat 5-meter dx records. It works from the "long line" oscillator shown at the left

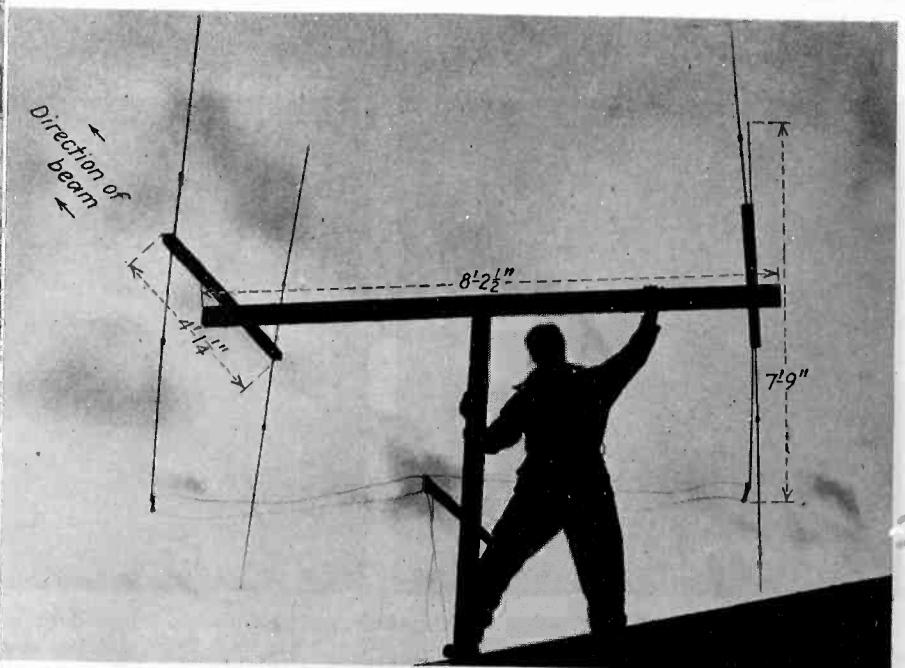

# TUBES AND CIRCUITS + +

TABLE

| $E$ (rms V) | Stabilized $E_0$ (V) | $I_p + \Delta I_p$ (mA) | Not Stabilized $E_0$ (V) |
|-------------|----------------------|-------------------------|--------------------------|
| 90          | 149.5                | 6.0                     | 142.7                    |
| 91          | 149.7                | 7.8                     |                          |
| 92          | 149.9                | 9.7                     |                          |
| 93          | 150.0                | 11.0                    | 147.0                    |
| 94          | 150.0                | 13.0                    |                          |
| 95          | 150.0                | 14.8                    | 150.0                    |
| 96          | 150.0                | 16.5                    |                          |
| 97          | 150.0                | 18.3                    | 153                      |
| 98          | 150.1                |                         |                          |
| 99          | 150.1                | 21.4                    |                          |
| 100         | 150.1                | 23.5                    |                          |
| 101         | 150.0                | 25.0                    |                          |
| 102         | 149.9                | 27.7                    |                          |
| 103         | 149.7                |                         |                          |

The stabilizing circuit was used in connection with the operation of a time standard and gave very satisfactory performance.

\*The notation employed here is that used in the "Theory of Thermionic Vacuum Tubes" by Professor Chaffee.  $I_p$  denotes the steady part of the plate current,  $\Delta I_p$  denotes a small but finite increment of the plate current.

## Vacuum tube handbooks

FOR SEVERAL years the loose-leaf handbooks of information on receiving tubes furnished by RCA Radiotron have been of great value to all users of tubes for design or other purposes. These books are made up of characteristic curves, tables of tube constants, circuits, base connections and other data pertinent to the employment of the many types of tubes now on the market.

Recently a second handbook has been

added, taking care of similar data on transmitting tubes. Now RCA Radiotron announces that a third handbook will be made available, this one combining information in the receiving and transmitting handbooks. In addition to this data there will be included, soon, information on cathode ray and other special purpose tubes.

The price of the receiving and transmitting handbooks is \$2.50 for the first year and an annual charge of \$1.00 thereafter; for the combined book the charge is \$4.00 and an annual charge of \$1.50 thereafter.

Loose-leaf books of tube data may also be obtained from the Westinghouse company, notably the July, 1934, catalog of tubes issued by the Westinghouse Lamp company at Bloomfield, N. J. This book contains data on all the tubes made by this company including high vacuum amplifiers, grid-glow tubes, light sensitive tubes, rectifiers, etc.

## Quality vs. cut-off frequency in music reproduction

AS EVIDENCE OF the desirable width of sideband required for high-fidelity broadcast transmission, the United States submitted to the C.C.I.R. at Lisbon the data contained in the accompanying figure, which shows the quality of orchestral music, as judged by ten ex-

pert observers, which can be transmitted by various bands. The "quality" appraisal depends largely upon the psychology of the listener, but since the points on the curve represent average values the results may be taken as a reliable indication of what the trained musical ear demands of radio reproduction. It will be seen that with a cut-off at 7,500 cycles per second, the value

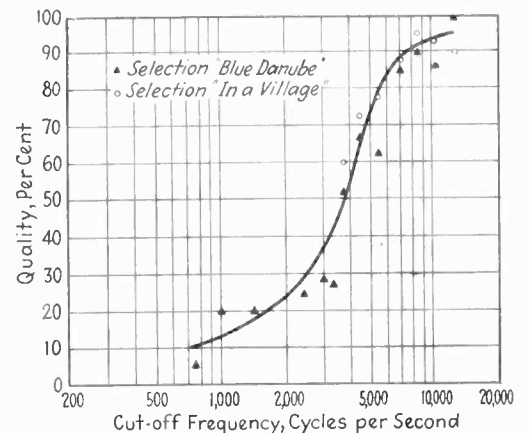

used on commercial high-fidelity receivers today, the quality was judged at 90% and that above that frequency the quality does not improve markedly as the cut-off is increased to 10,000 cycles and above. It is interesting to note that in the opinion of the listeners, the quality of the selection "In a Village" decreased as the cut-off increased from 8,500 to 15,000 cycles, showing that too faithful reproduction is sometimes a detriment to music enjoyment.

## 56-MEGACYCLE TRANSCEIVER

The simplicity of 5-meter apparatus (and antenna!) may be seen from this transceiver outfit operated on the roof of the McGraw-Hill building by Donald G. Fink of the editorial staff of *Electronics*

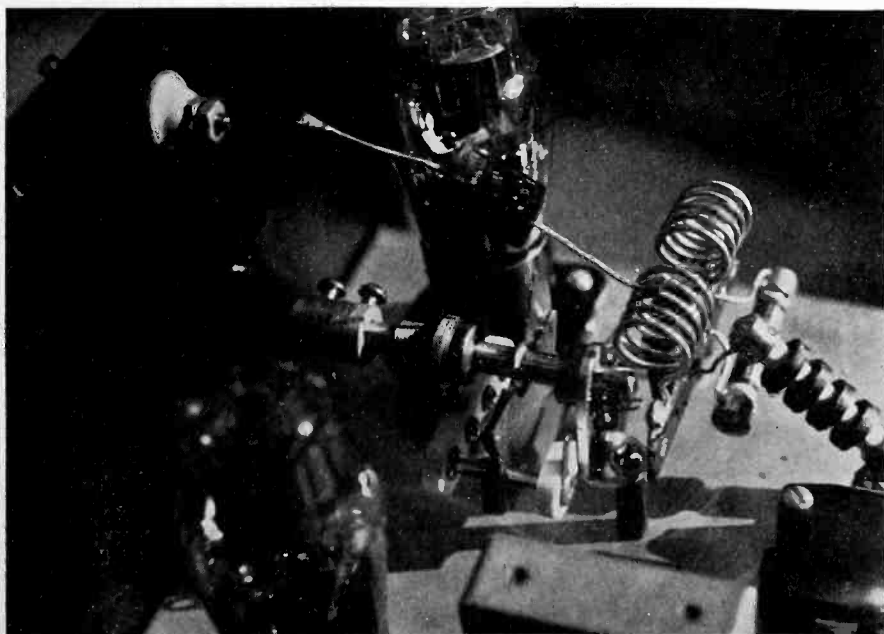

# electronics

McGraw-Hill Publishing Company, Inc.  
330 West 42d Street  
New York City

O. H. CALDWELL, *Editor*

Vol. VII —DECEMBER, 1934— Number 12

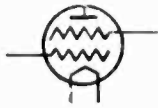

## The New Deal helps radio research

**N**EWs trickling out of Washington indicates that there is considerable Government money being spent on radio research, both in the Federal departments on the banks of the Potomac, and also in the laboratories of radio manufacturers located throughout the country.

The judicious expenditure of U. S. Government funds for the development of radio equipment for the Army and Navy, it appears, is rapidly advancing fundamentals of the radio art. While the nature of the problems being solved is subject to secrecy at the present time, the information gained as a result of the research will in general be of considerable aid to the entire radio industry. The Government is also replacing much of its obsolete equipment, a procedure which is definitely in line with the New Deal policy. The Administration is certainly to be applauded for its foresight.



## But where are the broadcasters?

**I**T IS time indeed an industry move got under way to reduce if not eliminate radio interference. The new campaign sponsored by the Radio Manufacturers Association under the supervision of its Engineering Division, can render valuable service supplementing the conference work that has already been done by the Joint Co-ordination Committee on Radio Reception of

the Edison Electrical Institute, the National Electrical Manufacturers Association, and the RMA.

But the surprising thing about all this radio-interference prevention work is that leadership has not been taken by the radio broadcasters, the group which have most at stake in money value! When million-dollar broadcast programs are shot through with noise and interference, losing listeners and good-will, the broadcasters have lost markets worth a lot of money. Values here are more direct by far, than any relationship of interference to the power companies, the appliance makers, or even the radio-set manufacturers and distributors. It is amazing that the broadcasters have not taken the lead in all this work of clearing up the channels over which go their wares, instead of leaving the task to the casual good offices of other groups with far less immediate interest in interference elimination.



## Take relay broadcasting out of "experimental"

**B**BROADCASTING on the short waves has now reached a point of importance which certainly merits such short-wave broadcasting being taken out of the experimental classification and put into regular commercial service.

As long as international broadcast programs have to be sent out on a non-commercial basis, it is evident that only casual program matter can be transmitted. At the present time, such short-wave transmissions are usually picked up from current programs on the broadcast band.

If special programs appropriate for foreign listeners are to be sent out by short-wave, it is evident that commercial support must be obtained.



## Loans for manufacturers

**J**ESSE H. JONES, chairman of the Reconstruction Finance Corporation, points out that many solvent industrial plants which are in need of funds for the payment of labor or for the purchase of materials incidental to normal business operations, are not yet making full use of the facilities offered



by the RFC. Such loans, adequately secured, and not to exceed five years, will be handled by the Corporation when it can be shown that money so borrowed will speed permanent business recovery.

"We suggest to industrial concerns—", explains Chairman Jones, "concerns to which credit at prevailing bank rates for loans of such character is not available, but which can offer adequate security (even though such security may be frozen and therefore not generally acceptable to banks) and which can profitably use additional funds for labor and materials, that they communicate with the local loan agency of this Corporation."



## Steel auto tops bring new radio problems

**A**LL-STEEL tops are to be used on a large scale in the automobile production of 1935, according to reports reaching us from Detroit.

This will mean that radio antennas will have to be of the underslung type. Already the space is scant under the chassis, and in these few inches between ground and car body, the antenna will have to be hung, as far from the car and as close to the ground as possible. Under these conditions, average radio pickup may be as little as one-fifth of that provided by an antenna in the car roof.

Widespread stealing of cars of the fabric-roof type is given as a principal reason for the change to steel roofs. With the present type of roof thieves easily make a small hole in the roof with a pen-knife, put a stick through, unlatch one of the doors, enter and drive away. With the new construction, nothing will be able to get into the car interior—not even a radio wave!



## A move for noise abatement

**I**N England an active campaign has long been under way to put an end to unnecessary noises, street-traffic roar, railroad racket, industrial noises have all been made to yield place.

Now the American League for Noise Abate-

ment has been organized to perform a similar service on this side of the Atlantic. "Noise," declares the League's spokesman, "is an absurd and useless appendage to modern civilization. Industrially speaking, noise is a badge of inefficiency. When you hear a machine making noise, you hear a machine operating at low efficiency. Science and industry are able today to reduce or eliminate every discordant sound."

The new League is establishing sections to study noises in industry, noises in public, and noises in the home.

This movement is one bound to spread to cities and towns throughout the nation carrying with it wide opportunities for electronic sound-measuring apparatus, acoustic materials, and acoustic treatment.



## TAMPA'S 500-WATT LOUDSPEAKER

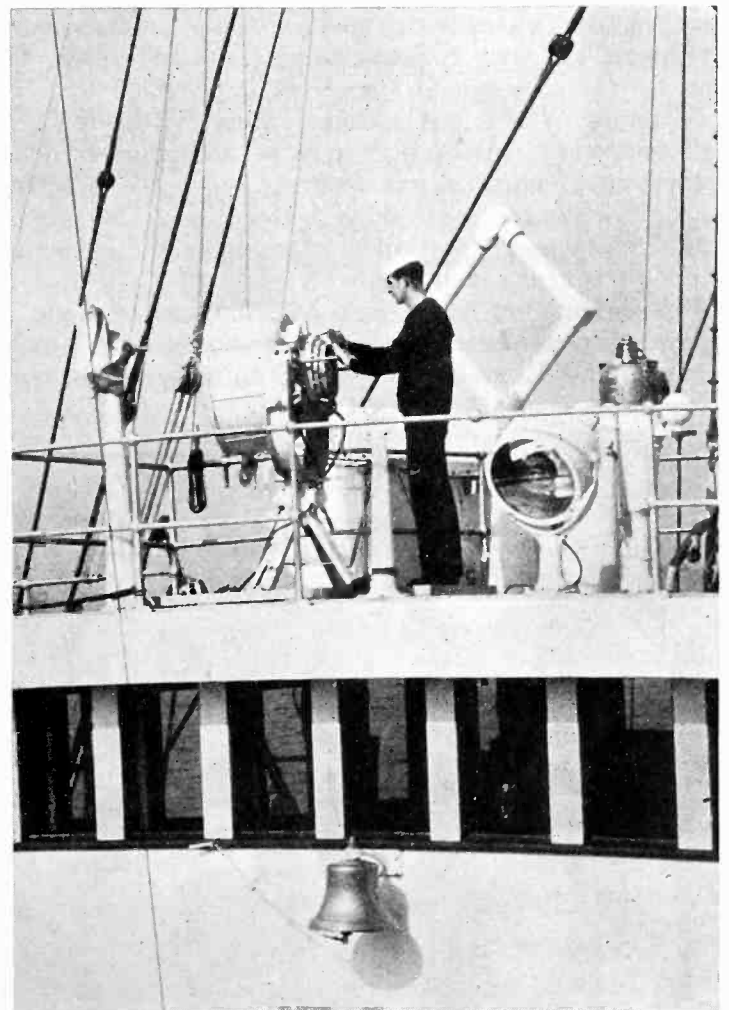

The Coast Guard Cutter "Tampa" is equipped with this "bull-horn" speaker, developed by Bell Laboratories. The duralumin diaphragm moves only one-fortieth inch but develops sound pressures of one pound per square inch. Speaker and horn measure 30 inches across and 30 inches deep

# Broadcast transmitter characteristics

[Continued from page 380]

measurements were precise to 0.25 db. and the input meter was corrected for frequency response. The modulation meter had a negligible frequency response deviation within the range of frequencies used.

Figure 5 shows average frequency response characteristics. In considering this, the fact should be borne in mind that it is representative of complete installations from mixer to antenna. Frequency response deviations present in individual component parts of a system are all additive. This curve shows the average frequency response of 36 installations to be uniform within plus or minus 1 db from approximately 100 cycles to 5500 cycles. It is down 6 db from the reference level at approximately 40 and 7000 cycles. The slight peak at the upper end is probably due to the influence of equalizers.

Figure 6 shows the extremes in frequency response encountered. Curve No. 1 requires no comment. Curve No. 2 shows what can be done and may be considered to be near the peak of modern attainment. As pointed out above, the uniformity of frequency response is dependent upon the sum total effect of the many components of an entire system. The audio frequency "bottle neck" in many cases is the telephone line and associated equipment. If such is the case, proper equalization will improve performance to some extent provided that the line characteristic is not extremely poor. Both low and high frequency equalization may be necessary in some instances. If equalization does not solve the problem, the only recourse is to hire better lines. Reflection losses due to poor impedance matching is another cause of poor frequency response.

Figure 10 is an actual case of what can be done in improving the over-all frequency response of a broadcast station. It was accomplished in two nights work

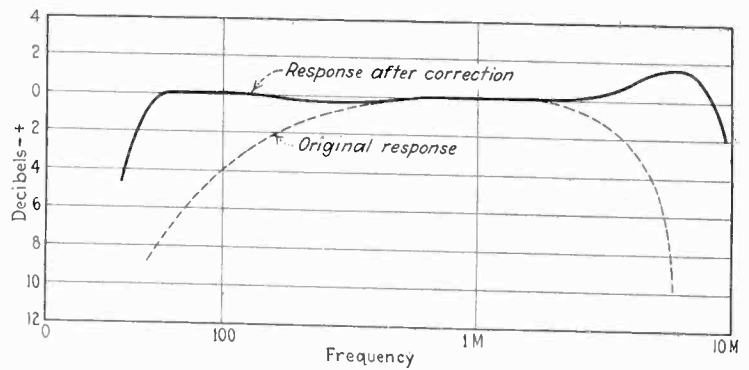

Fig. 10—Improved frequency response by use of measuring equipment and odd parts about the station

with the use of adequate measuring equipment and such odd parts as were available around the station. While not perfect, the improvement in audio quality was apparent even to the most casual listener.

In reviewing this survey of 36 stations, we think the following conclusions are justifiable.

(A) The performance of the average broadcast station as at present operated is inferior to the advertised characteristics of high fidelity receivers now appearing on the market.

(B) The majority of stations can, through the use of measuring equipment to check and correct operating characteristics, improve their performance to meet the requirements of the immediate future.

(C) Without regular checks on performance made with proper measuring equipment, a station cannot be kept properly adjusted.

(D) Not over 2 per cent of the stations possess adequate maintenance equipment.

(E) High level modulated transmitters, as checked in the field, almost invariably showed lower distortion than those employing linear r-f amplifiers after the modulated stage.

(F) At the test frequency employed Class B modulated transmitters showed lower distortion than the average.

## BRITISH TELEVISION COMMISSION

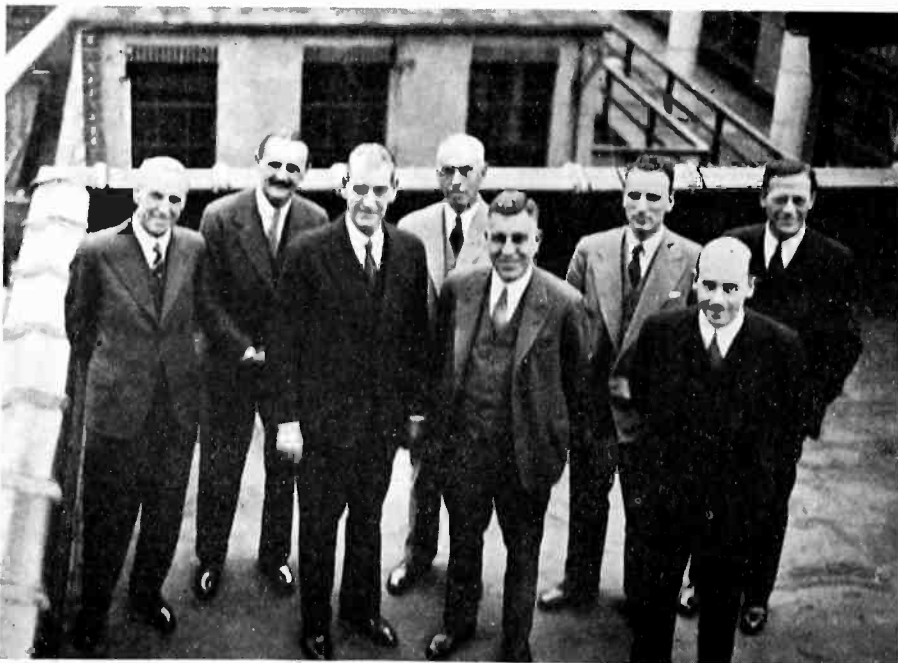

In its study of the possibilities of television, the British Government sent a commission to investigate the systems in the United States. From left to right the members of this body, with officials of the Philco Radio and Television Corporation, whom they were visiting, are:

- F. W. Phillips, Under-secretary of the British Postoffice.
- Col. A.S. Angwin, British General Postoffice, Wireless department.
- Lord Selsdon, Head of the Government Television Committee.
- W. E. Holland, Vice-president in charge of engineering, Philco.
- J. M. Skinner, President, Philco.
- W. Grimditch, Chief engineer, Philco.
- Noel Ashbridge, Asst. Chief engineer, British Broadcasting Company.
- L. A. Good, Works Manager, Philco.

# A REVIEW OF THE ELECTRONIC ART

## HERE AND ABROAD

### Features of the new mixing tubes

[K. STEIMEL, Telefunken Laboratory.]  
The use of screen grid tubes as combined oscillator and mixer has proved feasible in the circuit placing the feedback coil in the cathode lead with an *R* and *C* combination between the feedback coil and the cathode proper to provide for the proper bias. The screen prevents direct capacitive coupling between the signal and the local oscillator.

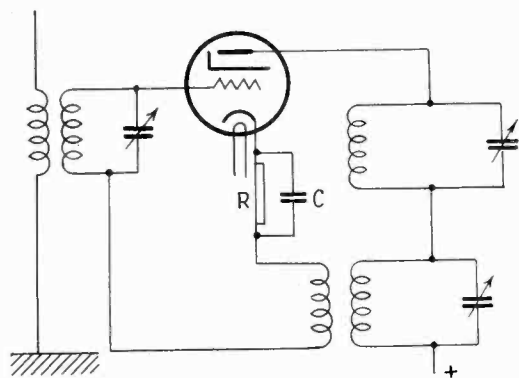

Feed-back in cathode lead of screen-grid mixer-oscillator

The circuit gives good amplification, and the influence of secondary electrons which might change the ratio of screen to plate current and thereby the amplitude of the oscillation, may be reduced by adding a suppressor grid, but since the local r-f voltage is applied between filament and cathode, noises are likely to be produced unless the insulation be-

tween the two elements is extremely constant and uniform.

Whether the circuit will maintain its place beside the new hexode principle remains to be seen. It is true that at the moment the new fading-mixing hexode presents a certain number of practical problems which only experience can solve. One of these questions is whether it is more important to have high amplification or freedom from harmonics; another whether the signal and the local wave shall be applied to the same grid or to separate grids. When on the same grid, amplification is easier, but grid current may flow when both frequencies are in series; tubes are difficult to replace and the oscillator voltage difficult to control. When two separate grids are used, it is possible so to adjust the bias of the mixing grid that changes in oscillator voltage produced by the incoming signal are without effect.

There remains the coupling between signal and oscillator wave produced by the tube current itself. It would seem that this influence can best be reduced by employing a separate plate for the oscillator, a feature which distinguishes the hexode from other mixing tubes in which one of the series of grids between cathode and plate serves as oscillator plate (penta-grid, octode, tube).

Finally, with the application of the superhet principle to three or four tube sets, a.v.c. is applied to the combined oscillating and mixing tube.

Changes in grid voltage should not affect the frequency of the local oscillator by more than about 1/50,000.

The solution proposed for these problems is the present form of the fading-mixing hexode ACHL and, mainly developed by Philips, the octode or six-grid tube.

The first grid of the fading-mixing hexode receives signal and automatic volume bias, grid 2 and 4 are connected and act as screens, grid 3, joined to the oscillator grid, produces the modulation. The feedback coil is placed in the grid rather than in the plate lead as this practice insures more constant frequency.

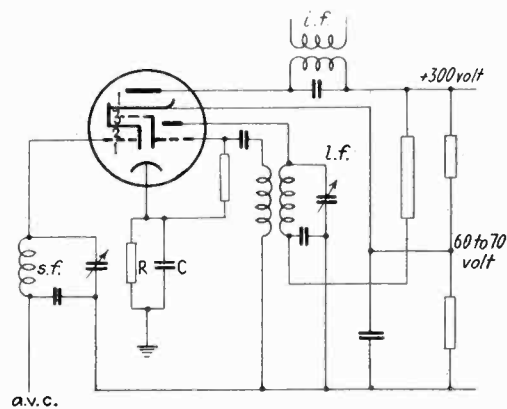

Circuit for new German "fading-mixing" hexode

The first grid of the octode is an oscillator grid, the second electrode consists of two small rods acting as plates, grid 3 and 5 are permanently connected screens, grid 4 is given the signal and a.v.c., while grid 6 is a suppressor grid connected to the cathode.—*Telef. Röhre*, No. 2: 45-57. 1934.

### — THE NEW KYW — (see front cover)

Reproduced from a three-dimensional model, the front cover shows the field pattern radiated from KYW's four-tower antenna array. The ratio of maximum signal (directed at Philadelphia) to minimum (directed at New York) is 100 to 1, possible interference with New York stations being thus minimized. At left is the aluminum panel construction of the 50 KW transmitter, only 10 KW of which are now being used

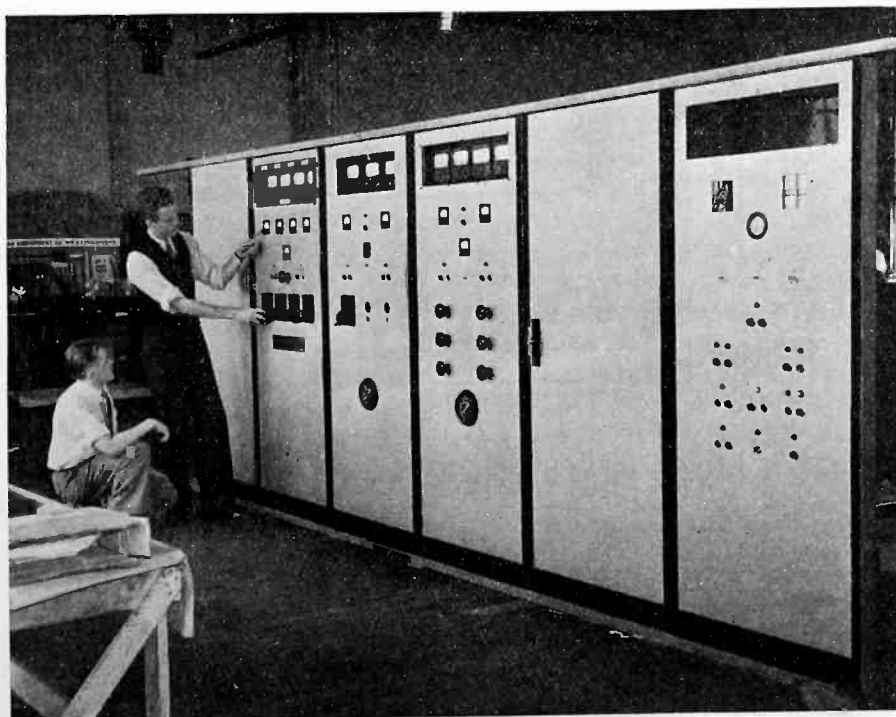

## Changes announced in "Onde Electrique"

"ONDE ELECTRIQUE," the monthly journal of the French Society of Radio Engineers and published by E. Chiron, rue de Seine, Paris, announces interesting changes in its contents. In the past the magazine has been devoted to important articles and reviews covering wide fields. It has brought some of the most thorough theoretical investigations on filter and oscillating circuits. Beginning with the October, 1934, issue, each number is now introduced by an editorial written by a prominent engineer or physicist on a topic of general or personal interest. Articles in the form of proceedings and reviews follow with a section on principles and errors in practical radio engineering. The October issue contains an article on detectors by P. Davis, Chief Engineer of the National Radio Laboratories, who has taken an active part in recent international conferences. The second part of the magazine is now devoted to details of construction and of receivers. As a first example, P. Besson, General Secretary of the Society, contributes a description of an American receiver sold in France and consisting of two stages of amplification with pentodes preceding the frequency changer (pentagrid) a single pentode intermediate frequency amplifier, a double diode pentode 2 B7 in the detector stage, and an a-f triode amplifier driving a double triode output tube for B operation.

A new section brings a list of French patents and details on important patents. As in the past a selection of abstracts completes each number, which is now to be accompanied by notices relating to foreign societies, journals, etc.

The Society of Radio Engineers hopes to cover the expenses resulting from this expansion by winning an additional 300 or 400 members. The steady development of the "Onde" under the care of an independent society is an important achievement.

### Bridge for testing parts

[J. M. UNK, N. V. Philips, Eindhoven, Holland.] The following tests are currently required on parts or finished receivers: matching of condensers in various positions, mounted and unmounted, and measuring their r-f losses, measuring inductances and their losses and the losses in tuned circuits. Only an instrument lending itself to all of these tests is really practical and an r-f bridge has been developed by means of which the components can be tested at the frequency for which they are intended, before or after mounting.

In the simplest case two arms of the bridge consist of adjustable condensers  $C_1$  and  $C_2$ , the two other arms of the

two parts  $Z_1$  and  $Z_2$  to be measured or compared, the bridge with amplifier and meter going from the point  $D$  between the two condensers to the point  $E$  between the two impedances and from here directly to ground. An r-f oscillator built on the dynatron principle, supplies the testing wave at the remaining two points  $A$  and  $B$  of the bridge. Such a simple bridge suffers from stray capacities and inductances which may exceed the desired accuracy ( $1/100 \mu\mu\text{f}$ . for comparing condensers). For general work in the factory it is indeed desirable to work the oscillator from the commercial supply. This method introduces capacitive bypasses between the input terminals  $A$ ,  $B$  to the bridge and the ground by way of the power transformer, bypasses which are in parallel with the components  $Z_1$  and  $Z_2$  and involve high dielectric losses. Remedies proposed and used are the insertion of an r-f transformer between r-f oscillator and bridge and a grounded screen between primary and secondary of the transformer. The considerable spacing between primary and secondary leads, however, to high r-f losses which, moreover, depend on the values of  $Z_1$  and  $Z_2$  and make it necessary to tune the bridge for each value of  $Z$ . Tight or direct coupling is preferable. For certain purposes it is also desirable to have  $C_1$  and  $C_2$  very accurately interchangeable and to be able to check this condition in the course of the tests. The bridge is therefore separated in two halves at the points  $A$  and  $B$  and a switch  $s$  inserted which in one position establishes the previous connections  $AP$  and  $BQ$  and in the other interchanges  $C_2$  with  $C_1$  by making the connection  $AQ$  and  $BP$ .

Capacitive bypasses exist, for instance between  $A$  and  $E$  and  $B$  and  $E$  which, since they remain the same when the

switch is moved from one position to the other, introduce errors. The same applies to the symmetrical points  $P$  and  $D$  and  $Q$  and  $D$  parallel to  $C_1$  and  $C_2$ . The connecting wires are kept short.

To get rid of stray capacitance, screens are placed between oscillator and ground, between  $AB$  and ground and between  $P$ ,  $Q$  and  $D$  in the following way. The oscillator is set inside two half boxes of metal insulated and slightly separated from one another and forming the terminals  $A$  and  $B$  of the oscillator. When in operation the screens  $A$  and  $B$  are completely enclosed in the case  $D$  acting as terminal  $D$ . A closed solid iron frame  $I$  traverses one side of the double box formed by  $A$ ,  $B$  and  $D$ ; the portion outside  $A$ ,  $B$  and  $D$  carries the primary coil  $N$  of the power transformer fed from the commercial supply, while the secondary coil sits on the inside screened from the core by  $B$  and  $D$ . The condensers formed by the surfaces  $D$  and  $A$  on one side, and  $B$  and  $A$  on the other, form the bridge condensers  $C_1$  and  $C_2$ , their relative position can be accurately adjusted.

The container  $D$  is placed inside an earthed screen  $E$ . The bridge containing the amplifier and the meter goes from  $D$  to  $E$  and is placed inside of  $E$ . The screening of points  $A$  and  $B$ , of the oscillator and the power transformer is complete so that the oscillator can be directly connected to the bridge. It becomes merely necessary that two leads from  $P$  and  $A$  issue from the cage; they form the condensers  $C_1$  and  $C_2$  with  $D$ . When the bridge is balanced for both positions of the switch  $s$ , the error in per cent produced by these condensers is equal to  $100 (C_p - C_q) C_1$ ; it can be diminished by using thin wires placed close together and surrounded by a grounded screen from the point on where they leave the cage. The leads

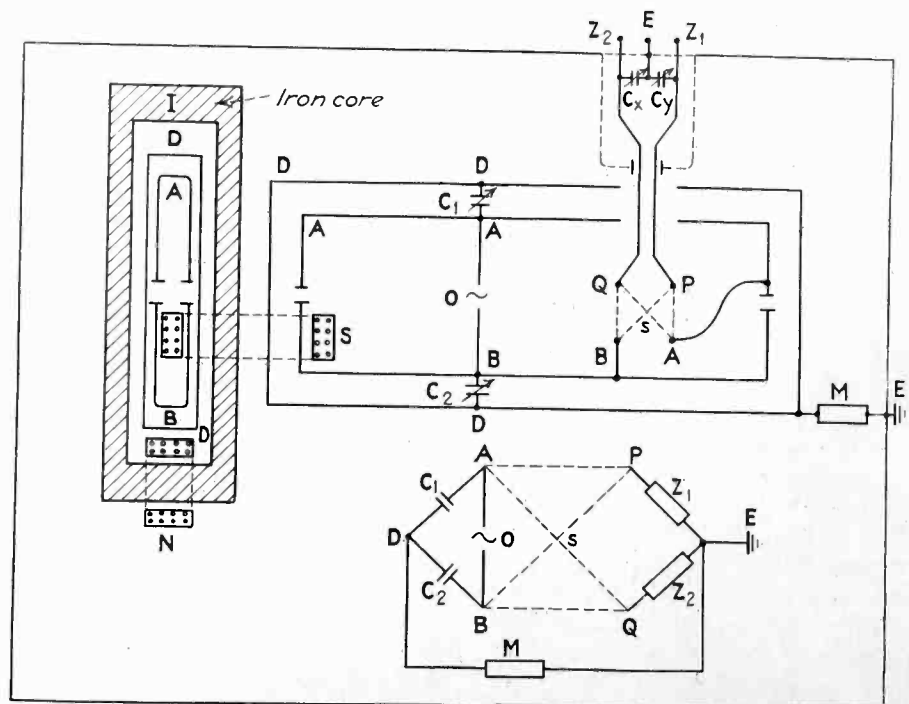

Component parts bridge measurement circuit

go to two binding posts  $Z_1$  and  $Z_2$ , which form  $C_x$  and  $C_y$  with  $E$ ; their effect on the balance can be compensated by means of two small condensers. Capacities parallel to the oscillator and to the bridge  $M$  are less important if losses are kept small. The oscillator is modulated with the supply frequency. The position of the switch is changed from the outside. The container  $E$  houses moreover a voltage regulator. A mercury switch in  $B$  allows various frequencies to be chosen.

When now two coils are placed in the positions  $Z_1$  and  $Z_2$ , the bridge oscillates at a frequency determined by the coil and by  $C_1$  (about 300  $\mu\mu\text{f.}$ ) A difference of 3  $\mu\mu\text{f.}$  in the capacity of the coils produces the same effect as a discrepancy of 1% in the inductances, and when the latter only are of importance it is advisable to measure with a lower frequency by inserting a condenser in parallel with the oscillator. The influence of losses in the coils can be eliminated by means of an adjustable resistance in series with the standard coil and a fixed resistance in series with the coil to be tested. On adjusting the resistances a position of minimum deflection is observed which, provided the losses are small, is entirely due to differences in  $L$ . The influence of the unavoidable harmonics is eliminated by tuning the bridge  $M$  to the fundamental frequency. When comparing variable condensers the sensitivity depends on the capacity to be measured; it is small for small  $C$ , but can be greatly increased by placing coils  $L$  in parallel with each condenser and a coil  $L_0$  and condenser  $C_0$  in parallel with the oscillator (for instance  $C_1 = C_2 = 250 \mu\mu\text{f.}$ ,  $C_0 = 150 \mu\mu\text{f.}$ ,  $Z_{10}$  to 500  $\mu\mu\text{f.}$ ,  $C_m$  the capacity of measuring branch 200  $\mu\mu\text{f.}$ ) When  $L_0/L$  is equal to the sum  $(2C_0 + C_1)/C_m + C_0/C_2$ , then the sensitivity is independent of  $Z$ ; when the sum becomes negative then the sensitivity increases with a decrease in  $Z$ ; it becomes infinite when  $L_0/L = -1$ .—*Assoc. Swiss Elect. Bull.* 25 (No. 21): 561-568. 1934.

### Saturation in heater-type tubes

[F. HEHLGANS, General Electric Co., Berlin.] For many uses of electronic tubes it is essential that the saturation current be obtained and a-c heated tubes with an oxide-coated cathode are at a disadvantage. It is found, however, that when tubes with two grids are used, nearly perfect saturation is obtained when the second grid is directly connected to the plate of the tube and the first grid made slightly positive, in practice the cathode potential. Screen-grid tubes possessing a high amplification factor, but not necessarily all the tubes of the same batch, are suitable for the purpose.—*H. f. Tech. El. Ak.* 44: 132-137. 1934.

### New photoelectric counters

[E. BUSSE and P. GÖRLICH, Dresden.] In these simple counting devices, see figure, the photoelectric current flows through the coupling resistor placed across the grid-filament space; light

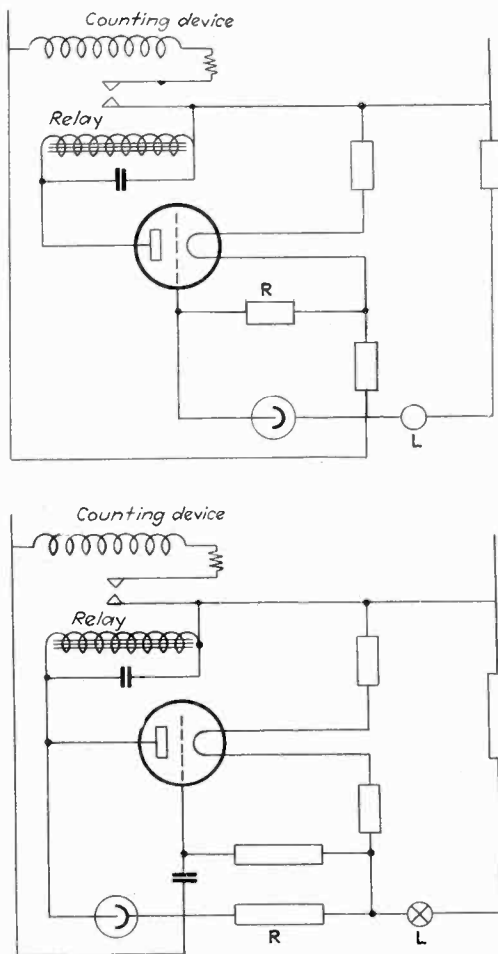

source  $L$ , plate and relay all take their voltage from the main a.c. or d.c. supply. When the cell is placed between grid and plate of the vacuum tube, the resistor, separated from the grid by a condenser, is put in place of the cell and the place of the coupling resistance is given to a grid load, a definite time constant is introduced into the circuit, which now responds only to rapid changes, not to slow fluctuations of the daylight, for instance. If required, a rotating sector may be placed in front of the source. The output of barrier film cells still is too small to operate relays, unless an external voltage of two volts is applied in a direction opposite to that which is suitable when the cell is used as a rectifier.—*Zeits. f. Instr.* 54 No. 7: 233-236. 1934.

### Internal combustion engine interference

[A. NEUBAUER, Institute for Applied Physics, Jena.] It is found that in agreement with other investigators the strongest radiation by which the internal combustion engine causes interference has a wave-length of less than 40 or 30 m. When a machine is

started the interference as measured by a super-regenerative receiver is often particularly annoying, but in the course of time the spark establishes a preference for passing between the same spots. For studying the character of the radiation, horizontal antennas three meters long are attached to the two spark plugs of a series of motors and their length gradually reduced. With the receiver tuned to a definite wave-length  $\lambda$  between 3 and 8 m., a maximum effect is obtained when the antenna has a length of  $\lambda/4$  or  $3\lambda/4$  and a minimum at  $\lambda/2$ , as to be expected, since the spark goes to the metallic mass of the engine. Lines between the high voltage source and the spark plug oscillate most strongly as half-wave dipoles, that is when 30 cm. long they send out a wave-length of 60 cm. Stray capacities and inductances cause deviations from the simple rule. Choke coils consisting of 5 to 20 turns on a 2-cm. form are of little help and attempts to tune the coils by placing condensers in parallel result in stronger interference. Wire-wound resistors in series with the spark gap, 5,000 ohms for the smaller and 15,000 ohms for the more powerful engines reduce the interference to 10 or 20%. Screening the entire engine and introducing resistance is an ideal remedy, but imperfect screening may make matters worse. Measurements on six engines of different type give about 10 microvolts for the radiated energy which increases, of course, with the length of the high tension wires. (See also *Electronics*, March 1934, p. 70).—*H. f. Techn. El. Ak.* 44 (No. 4): 109-118. 1934.

### CELL ENERGY MONITOR

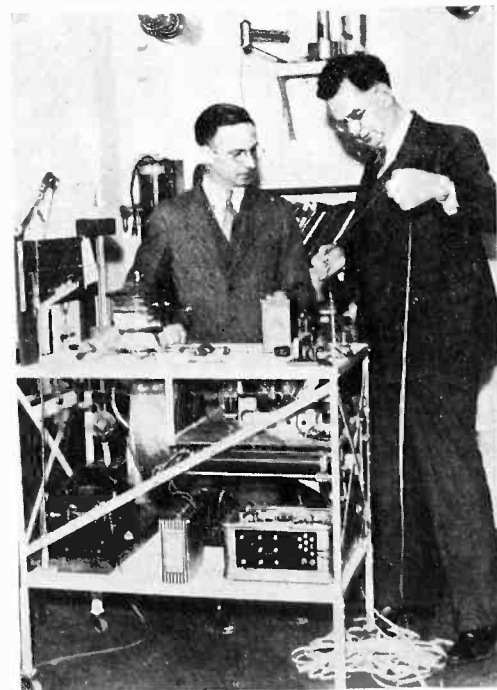

Dr. Otto Glasser and I. E. Beasley, Cleveland, measure emissions from living cells on moving tape

# + NEW PRODUCTS

## THE MANUFACTURERS OFFER

### Automatic repeat weld timer

FOR USE in connection with resistance welding machines in which the electrodes of the welder are air or motor-operated, The Electric Controller & Mfg. Company, 2702 E. 79th St., Cleveland, Ohio, announce the EC&M Automatic Repeat Weld Timer.

This Repeat Timer is the same as the standard EC&M Automatic Weld Timer except that it has an additional timing circuit for governing the length of time the electrodes of the welding machine are separated to allow the work to be moved to the position of the next weld.

The timer uses a rectifier tube which charges a fixed condenser (located in the top of the cabinet) in proportion to the rate of current flowing in the weld-

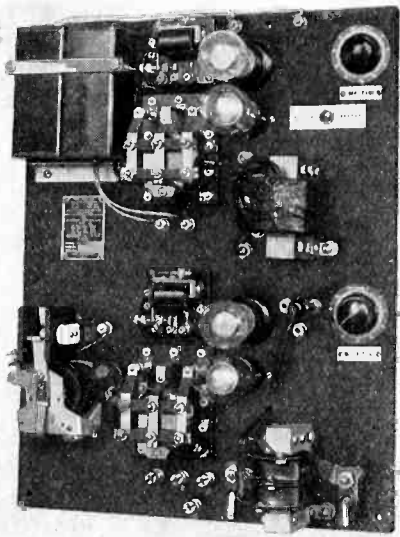

ing circuit. When the charge reaches an amount sufficient to pass current thru the Neon gas filled tube, a small relay is operated which in turn opens the relay controlling the main line contactor. These tubes are in the circuit only when the welding circuit is on so that as soon as the main welding current is opened, the Weld Timer is ready for the next operation.—*Electronics*.

### The new velocity microphone

A NEW Velocity Microphone Model RAE which is especially designed for small studio work is announced by Amperite Corp., 561 Broadway, New York. The open construction obtained

with the perforated case is used to prevent high or low frequency cut off. A nickel alloy (permalloy) core transformer preserves the flat characteristic of the hand hammered duraluminum (.00015") ribbon.

The microphone is of a rugged construction, not affected by temperature, humidity, or age. Service is, therefore, practically negligible. It can be used for both speech or music. One microphone is sufficient to "pick up" an entire orchestra.—*Electronics*.

### "Megger" circuit testing ohmmeter

"MEGGER" CIRCUIT testing ohmmeters are direct-reading electrical instruments for quick measurements of resistance, from as low as a fraction of an ohm to as high as 200,000 ohms. In addition to being suitable for checking coils, rheostats, fixed resistances, etc., they provide a ready means for testing continuity of circuits, and—within their range—insulation resistance.

A 4½-volt dry cell, of standard size available anywhere, provides the necessary testing current. The indicating part of the instrument is a true ohmmeter having a "crossed coil" winding on the moving system. It is not just a voltmeter calibrated in ohms. Consequently, the readings are independent of variations in battery voltage, and no "zero" or other adjustments are necessary,—one simply makes connections, completes the circuit (a push-button is provided), and reads the scale.—Sold by James G. Biddle Co., 1211-13 Arch Street, Philadelphia.—*Electronics*.

### Meter accessories

STANDARD PARTS, used in conjunction the Weston meters and tube checkers, are offered for sale by the Weston Electrical Instrument Corporation, Newark, N. J. Switches of the rotary, uni-polar, and bi-polar type, panel operated for various radio and measurement purposes can be obtained at prices ranging from \$3.00 for a 12 position uni-polar switch to \$26.00 for a 6 deck, 36 point rotary switch. In addition resistors, shunts, and other meter accessories may be obtained either in standard ranges or to specifications.—*Electronics*.

### Relays for various purposes

A SERIES of quick-acting, time delay, heavy duty, light duty, d-c. and a-c. type relays, manufactured by the Ward Leonard Electric Company, Mount Vernon, New York, is designed to fill the needs of the engineer regardless of the particular relay application he must fill. These relays are described in a series of bulletins issued by the Company, and available upon request. The sensitive relays will close on as little as .65 milliamperes coil current, and will handle as much as 1.5 amperes at 220 a-c. The heavy duty series will handle a contact current up to 25 amperes and a-c. voltages up to 250, with a coil wattage rating of 7 watts. Magnetic contactors of a capacity up to 150 amperes, 2 or 3 poles, 550 volts a-c. are built for extremely heavy duty work. Motor driven time-delay relays are available for use with mercury type rectifiers whose filaments must be lighted before the plate voltage is applied. A line of midget magnetic relays, of small size but capable of handling as much as 6 amperes is also available.—*Electronics*.

### Short wave condenser

A NEW SHORT wave condenser using Victron AA as the insulating material is offered by the Alden Products Co., 715 Center Street, Brockton, Mass. Known as the C-140 Na-Ald Victron AA Short Wave Condenser, the unit is intended for use in short- and all-wave receivers where a condenser of very small power factor is required. The insulating material used has a power



factor of 0.0002 at 877 k.c. compared with 0.0002 at 100 k.c. for pure transparent fused quartz. Victron AA is supplied by the Dielectric Products Corporation, 63 Park Row, New York.—*Electronics*.

## Insulation testing equipment

A TEST SET for testing the dielectric strength of various insulation materials over a voltage range from 200 to 30,000 volts has been developed by the Sound Engineering Corporation, 416 North Leavitt Street, Chicago, Ill. Model 2 Dielectric Strength Test Set operates from 110 volt a-c power supply, weighs 65 pounds, is mounted in a case 19 in. by 18½ in. by 10½ in., and provides a voltage range from 200 to 15,000 volts. The measurement is made with a-c voltages, using vane-type a-c meters. The list price is \$225. Model 3 is similar in operation, but larger in size, and provides a potential range from 500 to 30,000 volts. Its list price is \$350.—*Electronics*.

## Magnetic telephone system

A NEW telephone operating on the magnetic principle first used by Alexander Graham Bell in his original telephone has been developed by the Automatic Electric Company, of Chicago. The telephone consists of two similar units, one for transmission and one for reception, both embodied in a regulation handset. No batteries or external source



of power are used. The diaphragm of the transmitter reacts with a highly powerful permanent magnetic field, and as a result voice currents are set up in the winding about the magnet. These currents, after traveling along the connecting line, actuate a similar unit used as a receiver.

With two such handset units and a connecting line, commercial conversation has been possible over 20 miles of standard cable, and it is claimed that over a good copper open-wire circuit

transmission is possible over distances up to 300 miles. The unit is known as the Magnetic Monophone, and is available for use in industrial and private applications.—*Electronics*.

## Crystal microphone

A NEW CRYSTAL microphone which costs no more than a good carbon microphone has just been placed on the market by the Turner Company of Cedar Rapids, Iowa, licensed under Brush Development patents. Known as the type "G," this piezo-electric device is "flat" from 50 to 10,000 cycles, comparing favorably with expensive condenser types. Because of its minus 55 DB output rating, however, the unit will deliver carbon-type level when equipped with



one stage of high-gain pre-amplification.

The Turner microphone requires no energizing current, eliminating the necessity for batteries or other field supply. Due, also, to its 80,000-ohm impedance rating (at 60 cycles), the type "G" works directly into an amplifier tube without a matching transformer. Equipped with a 6-ft. shielded cable and four removable hooks around the frame, the microphone may be obtained without a mounting, or with a spring-and-ring or small cast base.—*Electronics*.

## Auto-radio vibrator replacement condenser

TO TAKE care of condenser replacements in auto-radio vibrators, a line of tiny units specifically designed for the purpose is announced by the Aerovox Corporation, Brooklyn, N. Y. These replacement units comprise oil-impregnated, oil-filled, pure linen paper sections in hermetically sealed metal containers, with mounting lug and pigtail lead. The units are designed to withstand heat, vibration, moisture and climatic conditions, as well as exceptional peak loads, without breakdown. They are available in several standard capacities.—*Electronics*.

## New hand-sets for portable radio transmitters

TWO NEW hand-sets, especially designed for portable and mobile radio transmitters, have been announced by Shure Brothers Company, "Microphone Headquarters," 215 West Huron Street, Chicago. Each hand-set unit consists of a high-output microphone transmitter and



a sensitive telephone receiver conveniently combined in a special hand mounting.

The Model 6A Transceiver Hand-Set has a 70-ohm receiver unit and is furnished with a three-lead cord, one side of microphone and receiver using a common conductor. This unit is suitable for use with equipment designed to work with ordinary telephone hand-sets, and lists at \$12.00.

The Model 6B Transceiver Hand-Set is similar to the 6A, but has a 2,000 ohm receiver and is supplied with a four-lead cord so that entirely isolated microphone and receiver circuits may be employed if desired. The Model 6B is recommended where the receiver is to be connected directly in the plate circuit of a vacuum tube. The list price is \$12.50.—*Electronics*.

## Standard air condenser

A NEW AIR condenser which is a continuously adjustable standard of low capacitance, readable directly in micro-microfarads without the use of vernier or micrometer reading devices is offered by Leeds & Northrup Company, 4911 Stenton Avenue, Philadelphia, Pa. It is the only high-precision variable Air Condenser of its range with this feature.

Accelerated life tests of this condenser show that both its calibration and reproducibility of setting are practically unaffected by wear. Its zero capacitance is 50  $\mu\mu\text{f}$ , and its range is 50-1,300  $\mu\mu\text{f}$ . The use of this condenser makes it possible to increase substantially the precision and speed of measuring small capacitances.

It can be furnished either with isolantite insulation or, at slight extra cost, with quartz insulation. A complete statement of limit of error, other performance data, and prices will be sent upon request.—*Electronics*.

## Sound projection controls

CENTRAL RADIO LABORATORIES, 900 E. Keefe Ave., Milwaukee, Wisconsin, has announced a new series of sound projection controls, covering a line of constant impedance *T* pad attenuators, *T* pad faders, *L* pad attenuators, gain

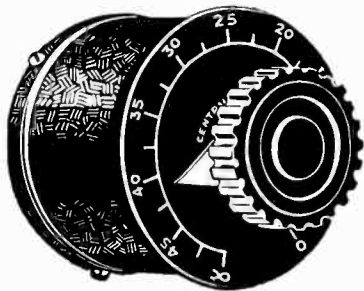

controls, and straight faders. Outstanding characteristics claimed by the manufacturer for these units are: straight-line attenuation, constant impedance over entire rotation range, permanent noiselessness, and long life. The list prices range from \$4.00 for a straight double potentiometer type gain control to \$15.00 for the *T* pad fader.—*Electronics*.



## Cathode ray resonance indicator

A SINGLE instrument which fulfills the functions of a visual resonance indicator, cathode ray oscillograph, and all-wave signal generator is being manufactured by Egert Engineering, Inc., 179 Varick Street, New York, N. Y. A frequency range of 100 to 22,000 k.c. and a frequency sweep of 22 k.c. makes possible the testing of over-all receiver performance, audio fidelity from 60 to 11,000 cps, oscillator and detector alignment, sensitivity, selectivity, and general resonance curve. Absolute values can be determined for each of these factors. A standard 3-inch cathode-ray tube is used, with its power supply and all auxiliary circuits contained in the same metal cabinet. Beside the cathode-ray tube, 5 other tubes are used. The unit is entirely a-c. operated and sells for \$99.67.—*Electronics*.



## Translucent radio dials

TRANSLUCENT Synthane laminated bakelite makes a highly desirable radio-dial material, according to the Synthane Corporation, Oaks, Pa. It will not shrink or deteriorate with age. It is unaffected by variations of temperature and humid-

ity. On the other hand the translucent dial materials heretofore in use have shown serious changes in shape; and size changes have distorted dial calibrations to a corresponding degree.

Illuminated Synthane gives off a soft amber light, which, by controlling the color of the resinoid, can be varied to harmonize with the finish of the cabinet or mounting panel.

In spite of these many advantages, the use of laminated bakelite for radio dials was, until recently, handicapped by the lack of a successful, economical means of applying the calibrations to the hard, impervious bakelite surface.

The Synthane Corporation has overcome this problem by adapting its new Synthographic Process for durable printing on bakelite to the exacting fineness of dial markings. The calibrations and designs are clear-cut and can be applied in a variety of colors or color combinations, including gold, silver, bronze, black, red, green and blue.—*Electronics*.



## Regulated power supply unit

THE RCA PARTS DIVISION, Camden, N. J. announces a regulated power unit which will provide a constant source of B voltage for use in laboratory testing and design, for production testing, school laboratories, and wherever a supply of voltage substantially free from variation with load is desired. The unit uses 5 tubes, a rectifier, a voltage regulator, a d-c.-a-c. amplifier, a voltage standard tube, and a special regulator. The unit will deliver voltages from 135 to 180 volts d-c. constant within 2% when the line voltage varies 10% and the current drain changes from 10 to 80 ma. Performance data may be obtained in a circular which describes this unit, Model TMV-118-B. The list price with tubes is \$39.50.—*Electronics*.



## Getter cups

GETTER CUPS made of Svea metal produced by the Swedish Iron and Steel Corp., 17 Battery Place, New York, N. Y., are now offered to tube manufacturers. Since this metal melts at a temperature 100° C. higher than that of nickel, it is possible to flash the getter pellet at a higher temperature with this metal. Welding to the cup support is positive and strong. The metal will react with oxygen freed from the getter-oxide, thus preventing oxygen contamination of the emitter coating in the tube.—*Electronics*.

## Vacuum-tube voltmeter

CLOUGH-BREngle engineers, 1134 W. Austin Ave., Chicago, have developed a new portable, accurately calibrated vacuum-tube voltmeter expressly designed for radio service work. The new Model UC will read potentials as low as 0.2 volt without drawing any current from the circuit under measurement.

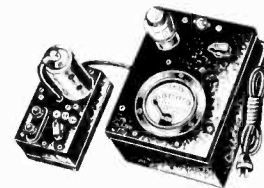

Where the ordinary voltmeter has a resistance of 1,000 or 2,000 ohms per volt, this model has practically infinite resistance, well over 10 megohms on the lowest voltage range.

The Model UC likewise is designed for measurement of voltage at both radio and audio frequencies. These properties give it wide application for uses, such as the measurement of audio and r.f. gain, hum level, noise level, locating shorted r.f. and a.f. coils, and impedance of transformers and speaker voice coils.—*Electronics*.



## All-metal vacuum switch

A NEW SMALL vacuum switch, made almost entirely of steel and designed to take advantage of the absence of an arc when breaking a circuit in a high vacuum, has been announced by the General Electric Company. Although this new vacuum switch is only about  $\frac{1}{4}$  of an inch in diameter and  $1\frac{1}{2}$  inches long, and can be operated by a fraction of an ounce of pressure, it is capable of interrupting as much as five horsepower as fast as thirty times a second. Designated as the Type FA-6 vacuum switch, this new device is rated at 10 amperes, 250 volts d-c. or 440 volts a-c.—or 5 amperes at 500 volts d-c.

The G-E Type FA-6 vacuum switch is made of steel, hydrogen-copper-brazed and exhausted to a high vacuum through a hollow steel operating stem. This operating stem passes into the vacuum contact chamber through a thin steel end-wall whose flexibility permits the slight motion necessary for operation of the contact. The leading-in wires to the contacts are sealed in tiny glass beads inside small Fernico alloy thimbles which are inserted through the heavier opposite end-wall of the chamber. The Fernico-glass seal is a development of the General Electric Research Laboratory, and provides a sturdy and reliable gas-tight joint.—*Electronics*.

December, 1934 — ELECTRONICS





# BOOKS



## FOR ENGINEERS USING ELECTRON TUBES

### Thermionic Emission

By Arnold L. Reimann, of the Research Staff of the General Electric Co., Ltd., Wembley, England. John Wiley and Sons, Inc., New York. (324 pages. Price \$5.50.)

DR. REIMANN has accomplished the very difficult task of producing a book of great value both to the engineer and the physicist. The theory of emission is developed using Fermi-Dirac statistics in terms of which is expressed an acceptable theory of electrons in metals. The thermodynamical aspects of electron emission are also presented in a clear and simplified exposition. Around this framework of theory is built with care and insight an exhaustive treatment of most of the important experimental knowledge available at the time of writing. The interpretations of the experiments are critically and yet simply presented. Although experts in the field will not be in entire agreement with every conclusion reached, such a criticism cannot possibly be avoided in a field which has such vast unexplored regions being so actively investigated in research laboratories. Practically one third of the book is devoted to the theory and experiments on composite surfaces including an entire chapter on Oxide Cathodes. The reviewer is aware of no other book in English which makes a really serious attempt to summarize and evaluate this literature.

The bibliography included at the end of each chapter is extensive and arranged alphabetically with respect to the authors. This together with a well arranged index gives the book exceptional merit for reference work.

W. B. NOTTINGHAM.



### Electrical Communication

By Arthur L. Albert, Associate Professor of Communication Engineering, Oregon State College. John Wiley and Sons, Inc., New York. (448 pages, price \$5.00, 1934).

INTENDED PRIMARILY for use as a college textbook, *Electrical Communication* provides a thoroughgoing and comprehensive view of the communications field which should be of use to everyone interested in the subject. The various

ramifications of the arts of telephony, telegraphy, and radio all well treated in other volumes, but this book provides the service of bringing all the branches together, describing their history, underlying principles, and methods of practical application in a readable, but nevertheless highly accurate form.

Faced with the problem of covering so broad a field in a single book, the author has had to pay particular care to the selection of material and to its arrangement. Use has been made of a large group of authoritative reference sources.

A short history of electrical communication opens the book, followed by a discussion of the fundamentals of electric circuits, sound, speech, and hearing which underlie the practices described in the rest of the book. Chapters on the various forms of transmitters (microphones), receivers and loudspeakers are followed by general descriptions of modern telephone and telegraph systems. Transmission theory, network and filter theory, inductive loading, and problems of inductive interference are discussed in separate chapters.

The description of radio which closes the book is short, but it borrows from the preceding chapters much of the practice which is common to both wire telephony and radio. A good chapter on the electron tube and another on its applications in wire communication are included. The author has accomplished much in covering an enormous range of information, theory, and practice; the book is a thoroughly up-to-date guide to electrical communication.

### Television, theory and practice

By J. H. Reyner. Chapman and Hall, London. (196 pages, 88 illustrations, 1934. Price 12/6.)

IN THE international race for the honors of first putting television into the ether on the grand scale, it is interesting to note that most of the writers on the subject reside abroad. In this most recent treatise from England the reader will find a good outline of the methods, the apparatus, the personalities involved in the art of sending moving pictures over the ether or wire path. The book is not too technical; and if it does not contain all the data one would desire on present systems it is because the author could not get these data from the sources which have them.

The chapter headings give a good account of the art: optical systems, the part played by the eye, cathode ray tubes, film and color television, contrasts of the American and European systems. Scanning by discs, by rotating mirrors, by off-set reflectors, by moving beams of electrons all are described.

The author comments on the fact that America does not seem to be much ahead of the workers abroad, probably because those who have been successful in developing something new have been so reticent about publication. One cannot help but wonder what the state of the art would be if all workers had exchanged information.

### AIRCRAFT SPIDERS

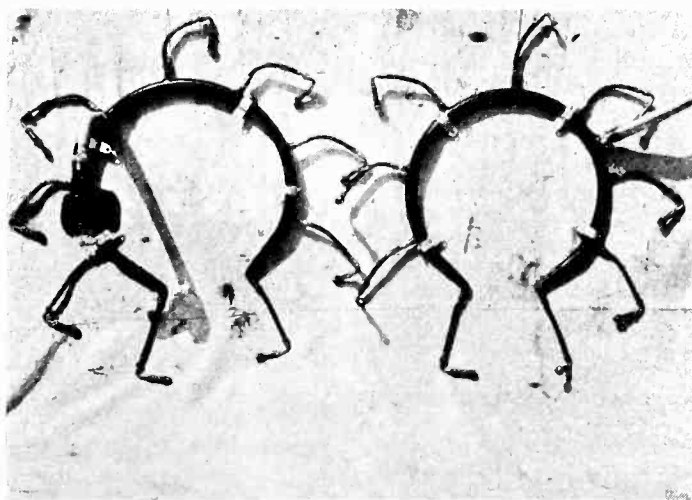

These odd-looking structures are the metallic shielding units installed on airplane motors to prevent interference with radio reception

# U. S. PATENTS

## IN THE FIELD OF ELECTRONICS

### Radio receiver circuits

**Resistance cord.** Use of a conductor external to the radio having high resistance and low resistance conducting elements, as a means of getting the proper voltage in a series-operated receiver. C. T. Mason and B. B. Minnium, Stewart-Warner Corp. No. 1,978,053.

**Multi-band receiver.** In a super-heterodyne separate sets of coils for the short and long wave length ranges for the r-f and oscillator circuits. Means for selectively connecting the coils in the circuit and a local oscillator whereby for the reception of short wave signals a harmonic component of the oscillator is used as a beating oscillation to produce a frequency different from the beat frequency produced by the long wave signals and the fundamental component of

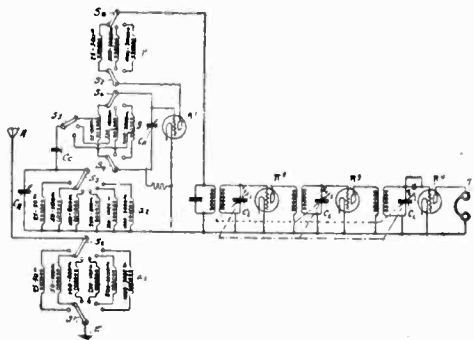

the local oscillator. E. Falkenthal, Radio Patents Corp., filed in Germany, June 22, 1930, 15 claims. No. 1,976,574.

**Circuit tester.** Portable radio set tester using an indicating meter, a socket to receive the terminals of at least one of the tubes of the set, and a plug by which the various voltages on the receiver may be easily tested. Herman Hollerith, R.C.A. No. 1,976,021.

**Multi-antenna system.** A receiver using two antennas of different lengths, coils selectively arranged to connect with one or the other of the antennas. J. W. Alexander, Philips, Holland. No. 1,978,661.

**Intermediate frequency amplifier.** Interstage network comprising tuned circuits in the plate circuit of the first and grid circuit of the second tube, and an intermediate circuit comprising inductances coupled respectively to the two tuned circuits, these inductances connected together by two condensers. Across this intermediate circuit is a third condenser connected between the low potential end of the two inductances in series, its high potential end connected between the two fixed coupling condensers. K. Posthumus and T. J. Weyers, R.C.A. No. 1,978,475.

### Amplification, modulation, etc.

**Demodulation system.** A method of producing a carrier current of constant amplitude from a signal-modulated current having carrier and side-band com-

ponents. R. S. Ohl, B.T.L., Inc. No. 1,976,457.

**Push-pull amplifier.** Method of using high-impedance constant-current tubes in which the input transformer has high primary impedance and high leakage re-

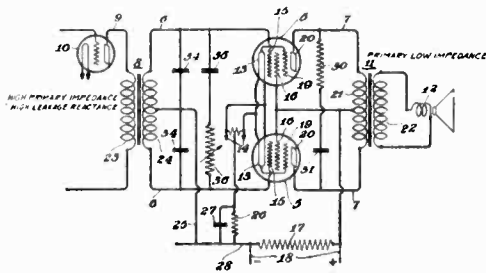

actance, and the output transformer has a low impedance primary. P. F. G. Holst, R.C.A. No. 1,978,578.

**Anti-hum system.** In an a-c system the cathodes are heated by alternating current. The negative terminal of the B battery is connected through a winding on the filament heating transformer to the filament and in such a direction that the effect of a-c ripple in the output of the tube is eliminated. Application dated Oct. 20, 1923. R. D. Duncan, Wired Radio, Inc. No. 1,975,834.

**Volume control.** Method of reducing the volume of strong signals without adverse effect upon the signal-noise ratio by changing the direct current difference of potential between the cathode and an electrode of an r-f tube, while the cathode continues at an elevated temperature suitable for electron emission so that the anode current is reduced to eliminate amplification of signal and noise currents, transferring signal-representing energy beyond said tube, and translating the energy so transferred into observable signals. Sarkes Tarzian, Atwater Kent Co. No. 1,978,514.

**Side-band reversal.** A transmitting system involving dividing the carrier frequency into at least two portions and shifting the phase of one of the portions

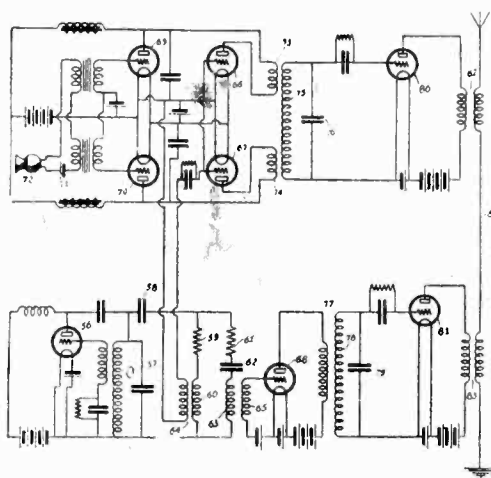

with respect to the other by 90 degrees. J. H. Hammond, Gloucester, Mass. No. 1,976,393.

**Noise suppressor.** In an a-v-c system, method of suppressing noise resulting from the increase in amplification when the signal fades by causing opposition between the effect of the detected current and the effect of a direct current varying in proportion to the r-f amplification. R. Villem, Paris, France. No. 1,978,482.

**Preselector.** Two tuned circuits magnetically coupled in such a manner as to reduce the coupling between the first inductance and a later resonant circuit. H. J. Loftis, R.C.A. No. 1,978,466.

**Protective circuit.** Use in a bridge of two elements having highly positive temperature coefficients so that sufficient time delay occurs for cathode of tube to get to normal temperature before tube fires. M. M. Morack, G.E. Co. No. 1,954,680.

**Current regulating means.** In a gas tube circuit effective current flow is controlled by stopping tube periodically by gradually storing energy to provide a potential increasing with successive discharges and impressing on the grid the progressive values of this potential. C. Stansbury, Cutler-Hammer. No. 1,954,028.

**Electric hammer.** Use of gas triodes for operating a reciprocating hammer. C. Stansbury, Cutler-Hammer. No. 1,954,029.

**Regulating system.** A speed-regulating system for rotating machine, involving changing the phase of a tube grid with respect to its voltage to adjust its conductivity. S. A. Staeger, WE&M Co. No. 1,968,575.

### Radio circuits

**Anti-distortion transmitter.** Generation of a current of a predetermined frequency and having a distinctive wave form followed by an amplifier. A compensator comprising an inductance and capacity for parallel resonance at the frequency of the signaling current, and a copper-oxide rectifier inserted in one of the branches for eliminating distortion of the wave form. This compensator is connected across the input of the amplifier. W. P. Place, Union Switch & Signal Co. No. 1,975,371.

**Image frequency suppression.** In series with the antenna coil of a receiver is a condenser. To the high side of this condenser is a series circuit tuned to the image frequency. The other end of this circuit is connected to the plate of the first tube so that a voltage equal and opposite to the image frequency voltage produced in this first tube is introduced into the circuit. Garrard Mountjoy, RCA. No. 1,976,958.

**Hum balance.** Method of introducing into a dynamic loud speaker circuit a hum voltage equal and opposite to that naturally there by virtue of the use of rectified current. The method involves a condenser shunted across a portion of the field coil to resonate it to the offending hum frequency. E. J. H. Bussard, Crosley Radio Corp. No. 1,977,469.

**Automatic tuning system.** Station setting dialing elements with conducting surfaces separated by non-conducting segments and means for rotating. J. E. Weckler, Jr., Blue Island, Ill. No. 1,977,330.

**A-c D-c system.** A series filament system including a five-prong socket connecting to the filaments of all tubes.

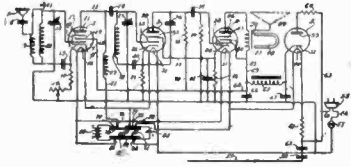

the anodes, and to the positive terminal of the high voltage battery. R. P. Wuerfel, International Research Corp. No. 1,975,441.

**Super-regenerator.** A transmitter-receiver system including an electrical bridge for preventing transmitter sig-

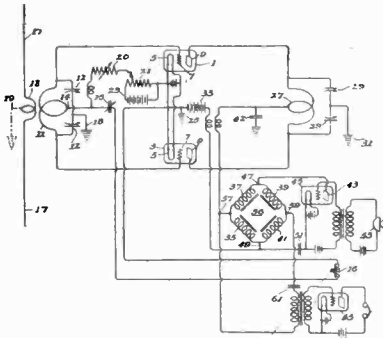

nals from interfering with the reception of signals from a distant station. A super-regenerator circuit is used. C. D. Haigis, RCA. No. 1,974,184.

**Pre-selector system.** Selecting in geometric progression electrical oscillations of a given frequency from oscillations differing therefrom in frequency comprising at least three circuits of low decrement. The several circuits are interposed between the antenna and the first amplifier of the receiver. L. L. Jones. No. 1,970,315.

**Automatic tuning device.** Method for controlling a radio receiver comprising several control circuits, a continuously rotating clock-driven arm, etc. R. J. Dodds, Chicago, Ill. No. 1,972,921.

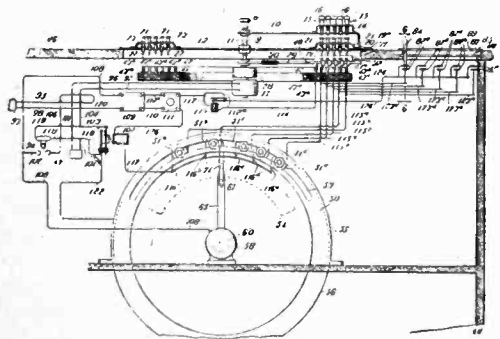

**Stabilizing system.** In tuned amplifiers utilizing several transformers, method of stabilization using inherent capacity and reversal of transformer windings to effect stability, and varying the voltage transformation ratio of a transformer as the amplifier is tuned to different frequencies to compensate for variation in effectiveness of stabilization. J. M. Miller and Sarkes Tarzian, Atwater Kent Mfg. Co. No. 1,973,293.

**Band-pass circuit alignment.** Method of lining up band-pass circuits having essentially flat tops composed of two tuned circuits with capacity coupling. On

the circuit is impressed a voltage of the desired carrier frequency, adjusting the variable tuning condensers to bring the circuit into resonance at the carrier frequency; shorting the coupling impedance and adjusting the trimmers to bring maximum transmission at the lower limit of the band-pass region. P. O. Farnham, RCA. No. 1,977,435.

**Antenna circuit.** In series with an anti-resonant circuit is a condenser connected to the antenna. To the high potential end of this condenser is an inductance coupled to the coil of the anti-resonant circuit, the lower end of this accessory coil being unconnected. The receiver is connected to the point where the series condenser and the anti-resonant circuit join. P. K. Giddens, Kansas City, Mo. No. 1,977,271.

### Anti-static systems

**Static reduction.** Separating desired from undesired oscillations by operating a pair of coils in opposed relation to each other so that one presents finite constant impedance to energy therein while the other presents finite varying impedance to energy therein. D. G. McCaa, Philadelphia, Pa. No. 1,969,657. See also No. 1,959,275 to McCaa on a method of using diode tubes, and also No. 1,956,689 to McCaa, both on the subject of reducing the effects of electrical disturbances.

**Static reducing.** Shunted across the antenna-ground system is a device comprising a number of plates formed from sheet iron each coated with tin on the surfaces, the plates being placed in a stack and insulated one from another and arranged in alternate connections, one set connected to the antenna and the other to the ground. Frank Ecker, Walton, N. Y. No. 1,969,599.

**Static reducer.** A dielectric container, mercury, water and a means of increasing the conductivity of water, and two terminals, one of which is in contact with the mercury in the water and the other in contact with the water only. This is shunted across the antenna and ground. James A. McGovern, New York, N. Y. No. 1,974,189.

### Patent Suits

1,828,654, A. Galbarini, Acoustic instrument; 1,838,081, J. M. Aufiero, Horn, filed July 31, 1934, D. C., E. D. N. Y., Doc. E 7336, E. A. Laboratories, Inc., v. Montgomery, Ward & Co., Inc.

1,470,696, A. M. Nicolson, Television, filed July 11, 1934, D. C., S. D. N. Y., Doc. E 78-269, Communication Patents, Inc. (Delaware) v. Bell Telephone Laboratories, Inc.

1,537,708, W. Schottky, Thermionic vacuum tube; 1,672,233, W. J. Skinner, Radio grid and filament spacer; 1,811,095, H. J. Round, Thermionic amplifier and detector; 1,374,679, J. B. Pratt, Degasifying process; 1,558,437, I. Langmuir, Electrical discharge apparatus; 1,855,885, A. W. Hull, Electron discharge device, D. C. Mass., Doc. E 3810, Radio Corp. of America et al. v. Hytron Corp. Dismissed pursuant to stipulation July 12, 1933.

1,736,815, W. J. Albersheim, Audion tube; 1,850,981, H. P. Donle, Rectifier; 1,432,867, M. J. Kelly, Electron discharge

device and method of making same; 1,738,269, H. J. Vander Bijl, same, D. C. Mass., Doc. E 3820, Radio Corp. of America et al. v. Munder Electric Co. Consent decree for plaintiff for an injunction Oct. 25, 1933.

1,785,392, Sawford & Sawford, Device for indicating and recording the quality of smoke, D. C. Mass., Doc. E 3900, F. Sawford et al. v. Westinghouse Electric & Mfg. Co. Dismissed without prejudice June 9, 1934.

1,962,104, D. E. Harnett, Radioreceiver, filed Aug. 22, 1934, D. C., S. D. N. Y., Doc. E 78/376, Hazeltine Corp v. Emerson Television Radio, Inc., et al.

1,680,370, P. E. Edelman, Radio power supplying suit, D. C., W. D. Mich., S. Div., Doc. E. 2606, E. Banning v. Sears, Roebuck & Co. Dismissed Aug. 29, 1934.

1,696,263, C. E. Bonine, Radio apparatus; 1,673,287, L. L. Jones, Electron discharge tube amplifier system; 1,713,130, same, Method of and means for controlling energy feed back in electron discharge devices; Re. 17,915 (of 1,713,132), same, Radio frequency amplifying system; 1,732,937, same, Transformer and coil system; 1,770,525, same, Radio receiving apparatus; 1,779,881, same, Amplifier; 1,788,197, same, Radio frequency circuits; 1,791,030, same, Radio receiving system, appeal filed Nov. 29, 1933, C. C. A., 2d Cir. Doc. —, Technidyne Corp. et al. v. McPhilben-Keator, Inc.

1,710,035, R. E. Thompson, Sound reproducing instrument, filed Aug. 15, 1934, D. C., S. D. N. Y., Doc. E 78/355, Hazeltine Corp v. Emerson Television Radio, Inc., et al.

1,710,073, 1,714,191, S. Ruben, Electrical condenser, filed Aug. 3, 1934, D. C., S. D. N. Y., Doc. E 78/321, Ruben Condenser Co. et al. v. Stuyvesant Electric Co., Inc. Same filed Aug. 6, 1934, D. C., N. D. Ohio, E. Div., Doc. E 5002, Ruben Condenser Co. et al. v. Curtis Condenser Corp.

### Adjudicated Patents

(C. C. A. N. Y.) Jones patent, No. 1,620,661, for radio-frequency amplifying system, claims 5, 6, and 7, Held not infringed. Technidyne Corporation v. McPhilben-Keator, Inc., 72 F.(2d) 242.

(C. C. A. N. Y.) Jones patent, No. 1,673,287, for electron-discharge-tube amplifier system, Held invalid. Id.

(C. C. A. N. Y.) Bonine patent, No. 1,696,263, for radio apparatus. Held invalid. Id.

(C. C. A. N. Y.) Jones patent, No. 1,770,525, for radio receiving apparatus, Held invalid. Technidyne Corporation v. McPhilben-Keator, Inc., 72 F.(2d) 242.

(C. C. A. N. Y.) Jones patent, No. 1,779,881, for amplifier, claims 1, 10, 17, and 19, Held invalid. Id.

(C. C. A. N. Y.) Jones patent, No. 1,788,197, for radiofrequency circuits, claims 1, 5, 8, 18, 21 and 26, Held invalid. Technidyne Corporation v. McPhilben-Keator, Inc., 72 F. (2d) 242.

(C. C. A. N. Y.) Jones patent, No. 1,791,030, for radio receiving system, Held invalid. Id.

(C. C. A. N. Y.) Jones reissue patent, No. 17,915, for radiofrequency amplifying system, Held invalid. Technidyne Corporation v. McPhilben-Keator, Inc., 72 F.(2d) 242.

# BRITISH PATENTS IN THE FIELD OF ELECTRONICS

## Amplification, detection, etc.

**Detection circuit.** The detector is so arranged that the grid circuit rectification is smaller in value than the anode rectification as the input signal is increased to a considerable magnitude so that the ratio of input high-frequency voltage to output audio-frequency voltage varies at a uniform rate. This invention obtains adequate voltages for automatic gain control without produc-

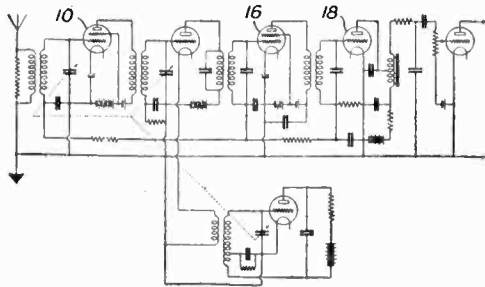

ing distortion due to overloading. The detector is a variable-mu tube and may comprise a tetrode with anode and screen-grid connected. The figure shows a superheterodyne receiver with the control voltage derived from the second detector 18 and applied to the high frequency amplifier 10 and the intermediate frequency amplifier 16. J. K. Johnson, Hazeltine Corp. No. 402,773.

**Push-pull circuit.** Combination of a push-pull amplifier with a diode rectifier so that as the input signal voltage increases the applied grid-bias is auto-

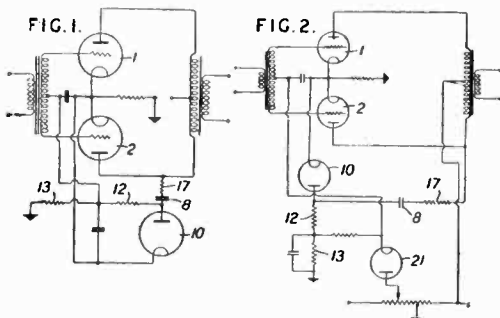

matically brought nearer the lower bend of the characteristic curve, so that as the input rises the combination automatically changes from class A to class B amplification. A. H. Cooper, Electrical & Musical Industries. No. 408,269.

## Radio circuits

**Two-band receiver.** A condenser is connected across one or more sections of an inductance by a switch. L/C ratio is high for the tuning circuit but low for the remainder of the the coil connected through a condenser to ground. A preliminary stage acts as an aperiodic amplifier. S. Becker, British Thomson-Houston Co. No. 412,152.

**Image suppressor.** Method of eliminating image frequencies by using two tuned circuits primarily coupled by inductance and secondarily by capacity in such a way that the two couplings

neutralize one another for the unwanted frequency. This neutralization varies, however, with tuning, and the secondary coupling is therefore supplemented with compensating means such as a further magnetic coupling, the first coupling being more effective at the higher-frequency settings while the compensating coupling is more effective at the low-frequency settings. Both wanted and unwanted frequencies are attenuated by the opposition between the couplings, but since the unwanted frequencies lie near the limits of the pass band, the additional attenuation is sufficient to extinguish them, while it permits a substantial amount of the wanted energy to be transmitted. Electric & Musical Industries. No. 412,253.

**Directive antenna.** To produce a horizontally-polarized field of substantially-uniform intensity in that plane, a number of horizontal half-wave radiators are arranged at equal angles about a common vertical axis, and are fed from a common source through lines of different lengths designed to supply symmetrically-dephased currents. H. O. Peterson. No. 411,724.

**A-c d-c.** A guard resistance protects electrolytic condensers in the event of the d-c supply being poled incorrectly to the terminals. A small lamp is preferably connected in series with the smoothing condensers and lights on incorrect poling as the result of the larger leakage current through the condensers. D. S. Loewe, Berlin. No. 412,054.

**Telegraph keying.** Signals are applied to the screen-grid of a tube and the same signals integrated in respect to time and reversed in phase are applied to the control grid. This makes the marking time constant despite variations in amplitude of the incoming signals due to fading or other causes. R. E. Mathes, Marconi Co. No. 411,710.

**Radio phonograph.** In a receiver using diode detection, the load resistance 5 serves as volume control for radio or for phonograph connected to terminals 11 and a transformer 7 common to the two circuits feeds the signals across the

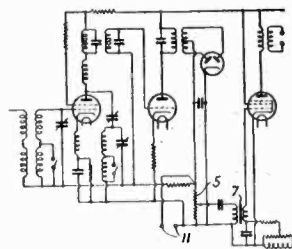

resistance to a common amplifier. The unidirectional voltage across 5 may be used for a-v-c. E. K. Cole, E. J. Wyborn and A. W. Martin. No. 410,567.

**Detection.** A diode rectifier is prevented from rectifying until the peak rises to a value substantially greater than the d-c potential applied between its electrodes, thus providing delayed a-v-c. P. O. Farnham, R.F.L. No. 410,674.

**Superheterodyne.** The frequency-changing tube is coupled to the aerial through a selective input comprising two low-decrement rejector circuits, one tuned 9 kc. above and the other 9 kc. below the received carrier-wave. The frequency-correcting networks, shown in Figs. 2 and 3, are inserted in the input

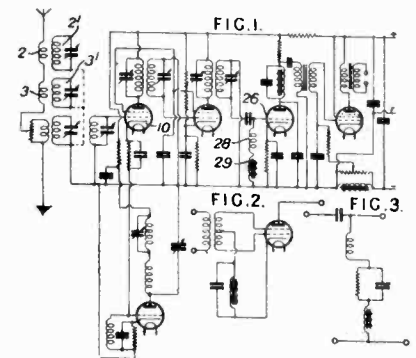

circuit of the second detector to compensate for high frequency losses in the tuned circuits. E. K. Cole, E. J. Wyborn, etc. No. 410,791.

**A-c d-c receiver.** A switching arrangement for supplying current for the tube heaters obtained from either a-c or d-c. On d-c the rectifier is cut out of the circuit. L. A. Nordfalk. No. 410,806.

**Superheterodyne.** A filament type tube used as the first-detector-oscillator has its plate circuit inductively coupled to an inductance in the filament lead while a choke in the other filament lead is not coupled to the-plate circuit. Mullard Radio Valve Co. and R. G. Clark, London. No. 411,208.

**A-V-C.** A circuit in which a noise suppressor tube is controlled by the direct current variations in a gain control tube and in turn controls the operation of an audio-frequency amplifier. J. S. Starrett, Marconi Co. No. 411,351.

**Regenerative circuit.** Across the tuned input circuit is a condenser of about 10 to 12 centimeters and a resistance in series with a value to 10 to 43 thousand ohms, which may be additional to the usual grid condenser and grid leak. The object is to provide constant regeneration. Philips. No. 411,416.

**Modulation system.** A short-wave dynatron oscillator is modulated in frequency or phase by applying the modulating voltage or current to a grid within the tube, or to a coil surrounding the tube. The modulating voltage may be distorted by a circuit designed to emphasize the components of higher frequency. The use of such distortion network is stated to render the modulation effectively a phase modulation rather than a frequency modulation. M. G. Crosby, Marconi Co. No. 411,644.

**Coupling circuit.** To avoid the use of a visual tuning meter in a receiver embodying a-v-c, a double-humped characteristic is given to the coupling between a carrier amplifier and gain control detector. By such a circuit more intermediate-frequency energy is passed through, if its frequency is displaced either above or below the required value by inaccurate tuning of the oscillator and high-frequency stages, to produce a reduction of amplification in the receiver proper, the maximum amplification for small changes of the tuning dial occurring when the incoming signals are correctly tuned. C. Travis, Marconi Co. No. 408,531.

# Index to electronics—Volume VII

January to December issues, inclusive, 1934

McGraw-Hill Publishing Company

330 West 42nd Street, New York City

## Pages by Issues

|           |         |
|-----------|---------|
| January   | 1-32    |
| February  | 33-64   |
| March     | 65-100  |
| April     | 101-134 |
| May       | 135-170 |
| June      | 171-202 |
| July      | 203-234 |
| August    | 235-266 |
| September | 267-298 |
| October   | 299-334 |
| November  | 335-368 |
| December  | 369-404 |

(ed) Editorial \* Illustrated

## Acoustics:

|   |     |
|---|-----|
| Emergency acoustic treatment for armory | *40 |
| Soundings from a plane by acoustic echo | 49  |

## Aeronautics:

|  |      |
|--|------|
| Aircraft radio service improved              | *270 |
| Aviation beacon receiver                     | *248 |
| Soundings from a plane by acoustic echo      | 49   |
| Teaching pilots "blind flying" in radio beam | *216 |

## Amplifiers:

|  |      |
|--|------|
| A-C operated high gain amplifiers. D. E. Noble               | *210 |
| Applying neutralization to a.f. amplifiers. P. W. Klipsch    | *252 |
| AVC applied to audio frequency amplifier tubes. J. R. Nelson | *50  |
| Diversified uses of amplifiers                               | *34  |
| Dynamic microphone amplifier. A. J. Sanial                   | *52  |
| High-gain amplifier  | *54  |
| Improved single tube balanced d-c amplifier                  | *159 |
| Simplifying dynamic tube curves. R. C. Hitchcock             | *220 |
| Study of super-regeneration                                  | *42  |
| Used to study currents produced by thoughts                  | 48   |

Book reviews. 53, 91, 129, 224, 263, 292, 320, 357, 399

## Broadcasting:

|   |      |
|---|------|
| Annual tube replacement cost for broadcast stations                                   | 113  |
| Automatic line-measuring equipment of the German broadcast system. R. W. P. Leonhardt | *347 |
| Automatic recording of field strength. C. M. Jansky, Jr.                              | *148 |
| Broadcast transmitter characteristics. Clark & Schuttig                               | *378 |
| Do radio listeners want high fidelity? (ed)   | 33   |
| High fidelity broadcast transmitter performance. E. A. Laport                         | *144 |
| High fidelity—economics and technique   | *108 |
| High fidelity program circuits. J. B. Epperson  | *341 |
| Improving the broadcast of recorded programs. G. H. Miller                            | *178 |
| Keep faith with "high fidelity" (ed)  | 135  |
| Measuring resistance of broadcast antennas. Scott Helt                                | *45  |
| Metal-clad grid-controlled mercury rectifiers for radio stations. S. R. Durand        | *4   |
| Microphone switching systems for broadcast stations. L. W. Barnett                    | *152 |
| 100 watt broadcast station costs  | 308  |
| Present costs of broadcast stations   | 254  |
| Prospects of high fidelity transmission   | *206 |
| Registering broadcast listeners' opinions   | 118  |
| Revise transmitter sales practices  | *204 |
| Studio characteristics (table)  | 327  |
| Ten meters and below  | *273 |
| Time switch starts station WLW  | 154  |
| Tower antennas. E. A. Laport  | *238 |

|   |      |
|---|------|
| Trans-Atlantic phone uses "Com-pandor" to overcome static | 317  |
| Transmission progress at CBS. A. B. Chamberlain           | *138 |
| Visual indicator for orchestral levels                    | *82  |
| WBBM and KFAB to be synchronized                          | *54  |

## Cathode Rays:

|   |      |
|---|------|
| Advance in cathode-ray system                           | 272  |
| Problems of cathode ray television. I. G. Maloff        | *10  |
| Photography of transients with cathode ray oscillograph | *125 |

## Electron Tubes:

|  |      |
|--|------|
| "Acorn" tubes for ultra-high frequencies. Bernard Slazberg | *282 |
| All-metal vacuum tubes. Pike & Metcalf                     | *312 |
| Characteristics of 1934 tubes (chart)                      | 151  |
| Electron multiplier  | *242 |
| Evolution of the thermionic tube                           | *147 |
| Linear modulation by a 55-tube. Bagno & Egert              | *16  |
| Processes in vacuum tube manufacture. E. R. Wagner         | *213 |
| Raw materials in vacuum tube manufacture. E. R. Wagner     | *104 |
| Recent developments set pace for progress in 1934          | *1   |
| Relations in the receiving tube family (chart)             | 343  |
| Tube classification chart                                  | 158  |
| Voltage doubler tube—new light relay                       | *124 |

## Electron Tubes—Application:

|  |      |
|--|------|
| Electron control for high speed motion pictures. D. G. Fink          | *250 |
| Electron-tube voltage control for photometry. Kilpatrick & Bernhardt | *352 |
| Electronic voltage control of d-c generators. W. P. Koehler          | 86   |
| Electronic voltage regulators in power plants                        | 354  |
| Electronic voltage relay. J. W. Graff                                | *80  |
| Frequency control with thermionic tubes                              | *284 |
| Motor control by electron tubes. F. H. Gulliksen                     | *179 |
| Speedomax—electron tube recording potentiometer                      | *21  |
| Telemetering system using vacuum tube detectors                      | *322 |
| Temperature control by electron tubes. Keith Henney                  | *183 |

## Electrons:

|   |      |
|---|------|
| How cosmic rays smash atoms, penetrate steel and concrete | *117 |
|---|------|

## Facsimile:

|                             |      |
|-----------------------------|------|
| Facsimile apparatus         | *71  |
| Facsimile newspapers        | 2    |
| "Home radio printing press" | *336 |
| Now in the commercial stage | *269 |

Geophysical prospecting consultants. 216

## High Frequencies:

|   |      |
|---|------|
| "Acorn" tubes for ultra high frequencies. Bernard Salzberg  | *282 |
| Coil design for short wave receivers                        | *174 |
| Electric wave filters for high frequencies. C. L. Frederick | *84  |

Inductance-coil calculations (chart). 315

## Institute of Radio Engineers:

|  |      |
|--|------|
| Fall meeting at Rochester discusses new developments | 375  |
| Fall meeting of Rochester Section—program            | 314  |
| Program for convention                               | *136 |

## Lights and Lighting:

|   |      |
|---|------|
| Electronic units control theatre lighting. J. W. Dawson | *323 |
|---|------|

## Measurements:

|  |     |
|--|-----|
| Analysis of efficient modulation. E. N. Dingley, Jr. | *78 |
|--|-----|

|   |      |
|---|------|
| All wave signal generator for production tests. R. F. Shea                                | *244 |
| Chart for simple attenuator design. W. W. Waltz   | 247  |
| D-C voltage stabilization. H. W. Kohler   | *388 |
| Diode-triode peak voltmeter. A. W. Barber   | *322 |
| Dynamic tube measurements. W. P. Koehler  | *381 |
| Electronic multiplier for high speed counting. Lord & Livingston                          | *7   |
| Electronic photometer   | 221  |
| Fineness of cement measured   | *15  |
| Linear rectification. Ray Lambert   | *21  |
| Logarithmic voltmeter   | *87  |
| Making a-c and d-c scales correspond on a universal voltmeter. C. F. Mathieson            | *55  |
| Measuring resistance of broadcast antennas. Scott Helt                                    | *45  |
| Oscillator detector   | 83   |
| Photography of transients with cathode-ray oscillograph                                   | *125 |
| Power supply and linear time axis for cathode ray oscillographs. Meier & Richards         | *110 |
| Precise light measurement. D. G. Fink   | 190  |
| Precision condenser calibration at radio frequencies. Hall & George                       | *318 |
| Reactance values of capacitances and inductances for the middle radio frequencies (chart) | 219  |
| Regenerative null indicator. D. E. Noble  | *190 |
| Single-tube beat-frequency oscillator. Podolsky & McBride                                 | *356 |

## Music:

|   |      |
|---|------|
| Electronic music from vibrating reeds. R. G. Silbar | *226 |
| WCAU'S photocell organ                              | *157 |

## National Electrical Mfgs. Assn.:

|   |      |
|---|------|
| Industrial Electronic-Tube section meeting                            | *350 |
| New products. 28, 60, 95, 130, 164, 197, 230, 260, 294, 329, 365, 396 |      |

## Noise:

|  |    |
|--|----|
| Survey of Buffalo and New York City noises | 14 |
| Transportation noise intensities           | 48 |

## Patents:

|  |     |
|--|-----|
| British patents. 64, 100, 202, 266, 334, 402                           |     |
| Vibrator power supply patents  | 296 |
| U. S. patents. 30, 62, 97, 133, 167, 200, 232, 264, 296, 332, 368, 400 |     |

## Photo-Electric Cell:

|  |      |
|--|------|
| Analog between dry-disc phototube and chemical cell            | 20   |
| Photocell static discharger at WLW                             | *316 |
| Photoelectric density comparator for analyzing spectrograms    | *358 |
| Vacuum type phototube with sensitivity of the better gas cells | *86  |
| Weather Bureau uses photocells. E. B. Lyford                   | 316  |

## Photo-Electric Cell—Industrial Applications:

|   |      |
|---|------|
| Cable stretch compensated by photocells                               | 49   |
| Car painting controlled by photocell                                  | 284  |
| Cement bags registered by photocells                                  | 49   |
| Color analyzer  | *285 |
| Cuts cloth labels of ribbon width automatically                       | *14  |
| Daylight intensity controlled by phototubes                           | *186 |
| Deep sea fishing levels studied by photocells                         | 15   |
| Elevators, automatic, protected by photocell                          | 15   |
| High speed electronic resistor sorter                                 | *249 |
| Machine designer looks at electronic industrial control. R. W. Carson | 156  |
| Measuring luster of textiles  | *187 |
| Possibilities in electronic exhibits                                  | 119  |
| Rubber sheeting protected by photocell                                | 285  |
| Tube control of rubber extruder                                       | 118  |
| WCAU'S photocell organ  | *157 |

**Radio:**

- All-wave signal generator for production tests. R. F. Shea .....\*244
- Aircraft radio service improved in many directions .....\*270
- "All-wave" receivers .....\*276
- Assignments in the radio spectrum (chart) ..... 274
- Auto radio forges ahead .....\*37
- Aviation beacon receiver .....\*248
- Cabinet design. John Vassos .....\*146
- Catechism on iron for radio tubes... 124
- Characteristics of German radio receivers. W. E. Schrage .....\*306
- Characteristics of insulated wires used in radio set production. R. G. Zender .....\*18
- Coil design for short wave receivers...\*174
- Detector distortion. K. W. Jarvis...\*386
- Eleven years of radio receiver manufacture .....\*72
- Federal Communications Commission (ed) ..... 65
- High fidelity—economics and technique .....\*108
- I.R.E. discusses new developments at Rochester meeting ..... 375
- Increased efficiency from tower antennas. E. A. Laport .....\*238
- Legislation before Congress regarding radio ..... 102
- Mechanical features of the season's radio set .....\*344
- Mobile printer for police and aircraft radio .....\*218
- Plan to eliminate radio interference. A. N. Goldsmith .....\*370
- Police radio adopts two-way system on ultra high frequencies .....\*271
- Police radio communication. H. E. Thomas .....\*74
- Power transformers for automobile radio vibrators. V. C. MacNabb...\*149
- Program for Radio Engineers' convention .....\*136
- Relations in the receiving tube family (chart) ..... 343
- Statistics and markets for 1933 .....\*68
- Study of r-f choke coils. Reuben Lee...\*120
- Sun's effects on radio. J. L. Richey...\*188
- Suppressor resistors and their effects on automobile operation ..... 70
- Teaching pilots "blind" flying in radio beam .....\*216
- Testing capacitors and resistors. C. G. Seright .....\*279
- Vibrator power supply from dry cells. Walter van B. Roberts .....\*214
- What are the costs of police radio? D. G. Fink .....\*372

**Radio Manufacturers Assn.:**

- "Self government" and new code....\*236
- Rectification, linear. K. C. DeWalt.....\*252

**Relays:**

- Electronic voltage relay. J. W. Graff \*80
- Review of electronic literature.... 25, 58, 92, 126, 162, 194, 227, 258, 290, 326, 362, 393

**Sound Pictures:**

- Home-recording on 16-mm film.....\*176
- March toward high fidelity in sound (charts) ..... 185
- Noiseless recording with double triangle slit. Dimmick & Belar.....\*142

**Superheterodyne:**

- Superheterodyne tuning condenser design. Burnell & Schwartzmann...\*180

- Telephone and telegraph arts find many electronic applications .....\*268

**Television:**

- Electron multiplier .....\*242
- Nears technical solution.....\*172
- Problems of cathode ray television. I. G. Maloff .....\*10
- Representative television systems... 305
- Survey of present-day systems.....\*300
- Television progress .....\*272

**Thyratrons:**

- Shield grid thyratrons. Livingston & Maser .....\*114

**Traffic Control:**

- Counting traffic at Cairo, Ill. bridge.\*275
- Traffic volume analyzed by photocells 354

**Transformers:**

- Design for radio set transformers. C. A. Hultberg .....\*286, \*310
- Ferrocarril and its applications. J. V. Fill .....\*358
- Iron-core coils for use at r.f. or i.f. W. J. Polydoroff ..... 13
- Power transformers for automobile radio vibrators. V. C. MacNabb...\*149

**X-Rays:**

- Gigantic welded pipe tested with X-ray .....\*154
- Television scanning technique applied to X-ray diagnosis ..... 253

**AUTHORS' INDEX**

- BAGNO, S., and S. S. EGERT.** Linear modulation by a 55-tube.....\*16
- Barber, A. W.** Diode-triode peak voltmeter.\*322
- Barnett, Louis W.** Microphone switching systems for broadcast stations...\*152
- Belar, H., and G. L. Dimmick.** Noiseless recording with double-triangle slit.\*142
- Bernhardt, Carl P., and F. E. Kilpatrick.** Electron-tube voltage control for photometry .....\*352
- Burnell, L. G., and H. Schwartzmann.** Superheterodyne tuning condenser design .....\*180
- CARSON, ROBERT W.** Machine designer looks at electronic industrial control ..... 156
- Chamberlain, A. B.** Broadcast transmission progress at CBS .....\*138
- Clark, A. S., and L. A. Schuttig.** Broadcast transmitter characteristics...\*378
- DAWSON, J. W.** Electronic units control theatre lighting .....\*323
- DeWalt, K. C.** Linear rectification.....\*252
- Dimmick, G. L., and H. Belar.** Noiseless recording with double triangle slit .....\*142
- Dingley, E. N. Jr.** Analysis of efficient modulation .....\*78
- Durand, Samuel R.** Metal-clad grid-controlled mercury rectifiers for radio stations .....\*4
- EGERT, S. S., and S. Bagno.** Linear modulation by a 55-tube .....\*16
- Epperson, J. B.** High fidelity program circuits .....\*341
- FILL, J. V.** Ferrocarril and its applications .....\*358
- Fink, Donald G.** Electron control for high speed motion pictures...\*250
- Precise light measurement ..... 190
- What are the costs of police radio? \*372
- Frederick, Carl L.** Electric wave filters for high frequencies .....\*84
- GEORGE, W. D., and E. L. HALL.** Precision condenser calibration at radio frequencies .....\*318
- Goldsmith, Alfred N.** Plan to eliminate radio interference .....\*370
- Graff, J. W.** Electronic voltage relay..\*80
- Gulliksen, F. H.** Electron tube motor control .....\*179
- HALL, E. L., and W. D. GEORGE.** Precision condenser calibration at radio frequencies .....\*318
- Helt, Scott.** Measuring resistance of broadcast antennas .....\*45
- Henney, Keith.** Temperature control by electron tubes .....\*183
- Hitchcock, R. C.** Simplifying dynamic tube curves .....\*220
- Hultberg, C. A.** Economical design for radio set transformers .....\*286, \*310
- JANSKY, C. M., JR.** Automatic recording of field strength .....\*148
- Jarvis, K. W.** Detector distortion.....\*386
- KILPATRICK, F. E., and C. P. BERNHARDT.** Electron-tube voltage control for photometry .....\*352
- Klipsch, Paul W.** Applying neutralization to a.f. amplifiers .....\*252
- Koehler, W. P.** Dynamic tube measurements .....\*381
- Kohler, H. W.** D-C voltage stabilization.\*388
- LAMBERT, RAY.** Linear rectification..\*21
- Electronic voltage control of d-c generators ..... 86
- Laport, Edmund A.** High fidelity broadcast transmitter performance...\*144
- Increased efficiency from tower antennas .....\*238
- Lee, Reuben.** Study of r-f choke coils...\*120

- Leonhardt, R. W. P.** Automatic line measuring equipment of the German broadcast system .....\*347
- Livingston, O. W., and H. W. Lord.** Electronic multiplier for high speed counting .....\*7
- Livingston, O. W., and H. T. Maser.** Shield grid thyratrons .....\*114
- Lord, H. W., and O. W. Livingston.** Electronic multiplier for high speed counting .....\*7
- Lyford, Elmore B.** Photocells in Weather Bureau observations... 316

- MacNABB, V. C.** Power transformers for automobile radio vibrators...\*149
- Maloff, I. G.** Problems of cathode ray television .....\*10
- Maser, H. T., and O. W. Livingston.** Shield grid thyratrons .....\*114
- Mathieson, Carl F.** Making a-c and d-c scales correspond on a universal voltmeter .....\*55
- McBride, Eugene, and Leon Podolsky.** Single tube beat-frequency oscillator .....\*356
- Meier, W. L., and P. A. Richards.** Power supply and linear time axis for cathode ray oscillographs.....\*110
- Metcalfe, G. F., and O. W. Pike.** All-metal vacuum tubes .....\*312
- Miller, George H.** Improving the broadcast of recorded programs .....\*178
- NELSON, J. R.** AVC applied to audio frequency amplifier tubes .....\*50
- Noble, Daniel E.** A-C operated high gain amplifiers .....\*210
- Regenerative null indicator .....\*190

- PIKE, O. W., and G. F. METCALF.** All-metal vacuum tubes .....\*312
- Podolsky, Leon, and Eugene McBride.** Single tube beat-frequency oscillator .....\*356
- Polydoroff, W. J.** Further notes on iron-core coils for use at r.f. or i.f... 13
- RICHARDS, P. A., and W. L. MEIER.** Power supply and linear time axis for cathode ray oscillographs...\*110
- Richey, J. L.** Sun's effects on radio...\*188
- Roberts, Walter van B.** Vibrator power supply from dry cells .....\*214

- SALZBERG, BERNARD.** Design and use of "acorn" tubes for ultra-high frequencies .....\*282
- Santal, Arthur J.** Dynamic microphone amplifier .....\*52
- Schrage, W. E.** Characteristics of German radio receivers .....\*306
- Schuttig, L. A., and A. S. Clark.** Broadcast transmitter characteristics...\*378
- Schwartzmann, H., and L. G. Burnell.** Superheterodyne tuning condenser design .....\*180
- Seright, C. G.** Testing capacitors and resistors .....\*279
- Shea, Richard F.** All-wave signal generator for production tests .....\*244
- Silbar, Robert G.** Electronic music from vibrating reeds .....\*226
- Sundt, E. V.** Cathode ray tube used to test fuses ..... 316

- THOMAS, HARRY E.** Police radio communication .....\*74
- VASSOS, JOHN.** Selecting the right radio cabinet design .....\*146

- WAGNER, E. R.** Processes in vacuum tube manufacture .....\*213
- Raw materials in vacuum tube manufacture .....\*104
- Waltz, W. W.** Chart for simple attenuator design ..... 247

- ZENDER, RAYMOND G.** Characteristics of insulated wires used in radio set production .....\*18