

# electronics

radio, sound, communications and industrial applications  
of electron tubes . . . design, engineering, manufacture

Expanding  
ultra-short  
wave radio

Photocells  
in industry  
Lists of uses

A gas tube  
amplifier

Public address  
at A Century  
of Progress

Cathodes for  
gaseous tubes

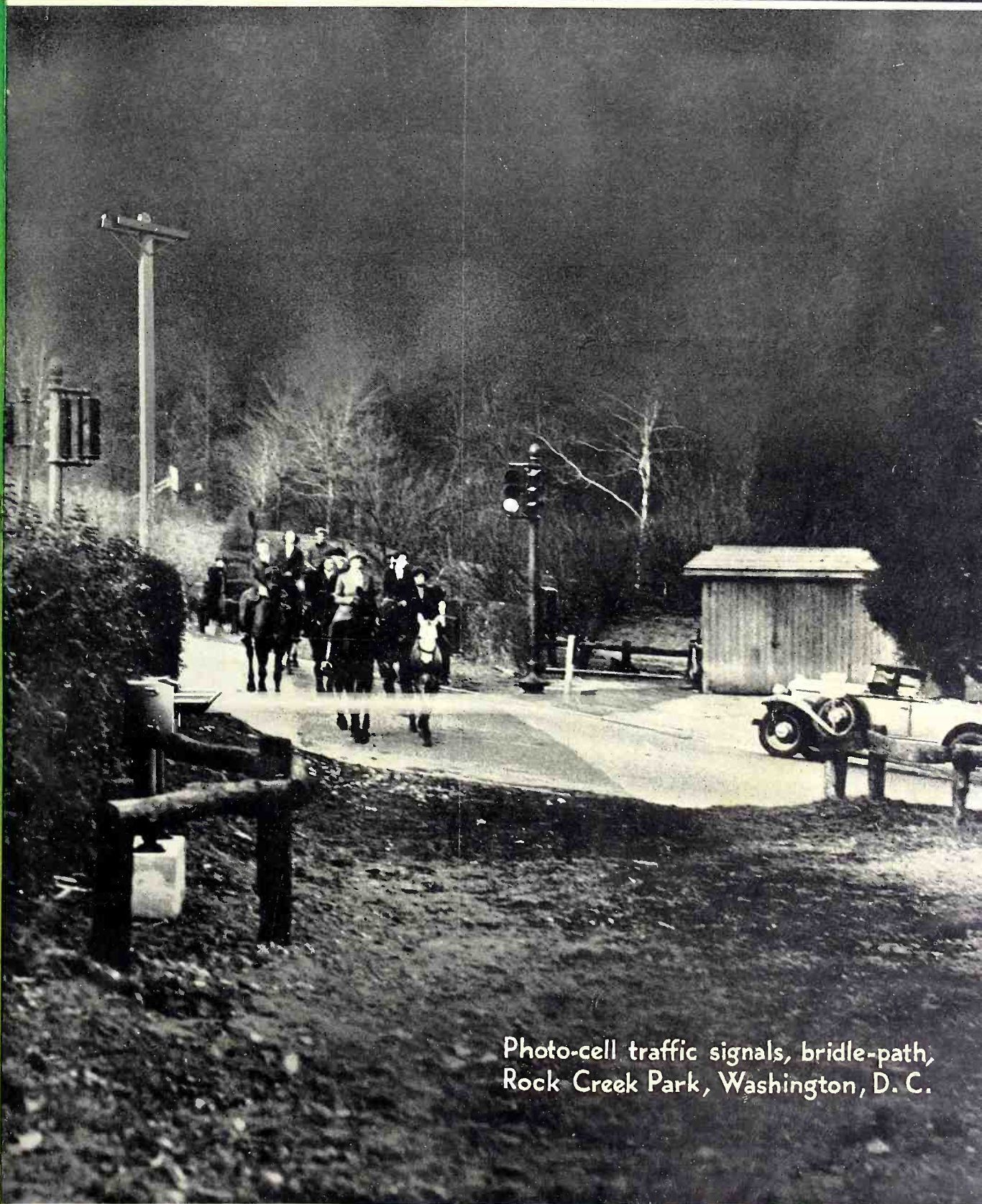

Photo-cell traffic signals, bridle-path,  
Rock Creek Park, Washington, D. C.



McGRAW-HILL PUBLISHING COMPANY, INC.

Price 35 Cents

OCTOBER, 1933



# TRY ★ PHOTRONIC (PHOTO-ELECTRIC) CONTROL

— *Right in Your Own Plant!*

## WESTON PHOTRONIC EQUIPMENT



MODEL 594  
Photronic Cell in  
metal housing  
and visor



MODEL 594  
Photronic Cell in  
Bakelite case

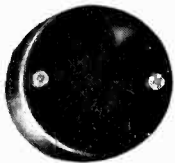

D68690  
100 Watt Auxiliary  
Relay



MODEL 613  
Time Delay  
Relay



MODEL 30  
Sensitive Relay

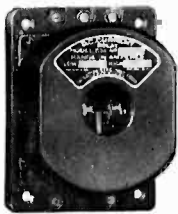

MODEL 534  
Sensitive Relay



MODEL 630  
1000 Watt Auxiliary  
Relay

FOR those manufacturers who prefer to do their own experimenting, Weston now supplies an inexpensive and practical means for them to determine the applications of PHOTRONIC Control for mechanical equipment, mechanical operations, and processes of various kinds.

A complete and inexpensive Weston PHOTRONIC Control Kit now is available—containing all equipment and diagrams necessary to start immediate experiments with this efficient and economical method of control.

The equipment included in this kit can be used as a smoke detector, burglar alarm, turbidity detector, door opener, counter for all classes of service, safety device on machines, etc., etc. These are but a few of the present industrial applications for the Weston PHOTRONIC Cell, which has the peculiar faculty of transforming light energy directly into useful electrical energy.

There is hardly a plant or a process but what can be benefitted by the use of PHOTRONIC Control. It undoubtedly has some application in your plant. Investigate its possibilities today. This new kit simplifies the job. Write for bulletin C2 which gives complete data . . . Weston Electrical Instrument Corporation, 618 Frelinghuysen Avenue, Newark, New Jersey.



★ PHOTRONIC — a registered trademark designating the photoelectric cells and photoelectric devices manufactured exclusively by the Weston Electrical Instrument Corporation.

# WESTON *Instruments*

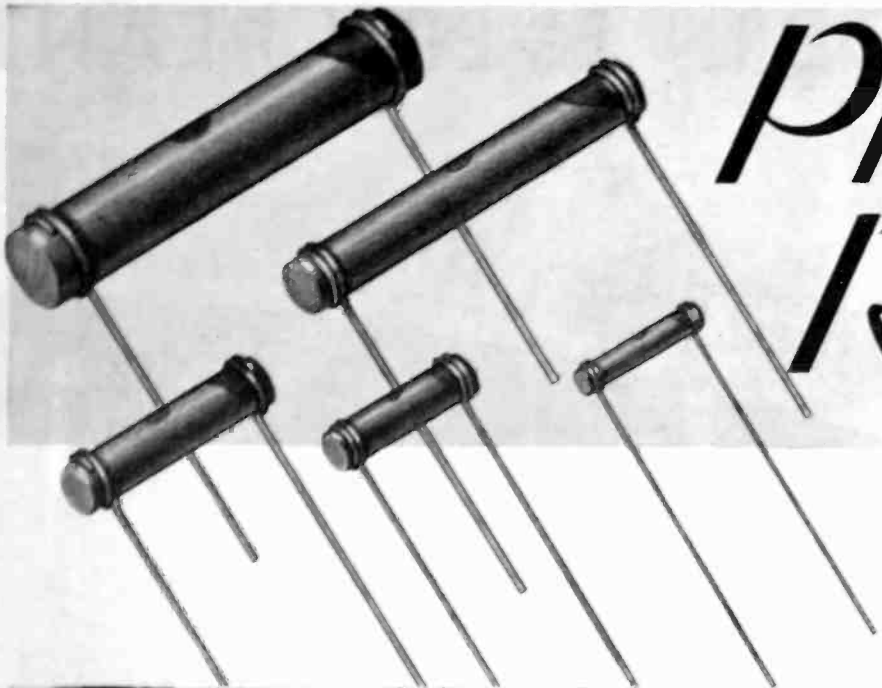

# PRECISION RATINGS

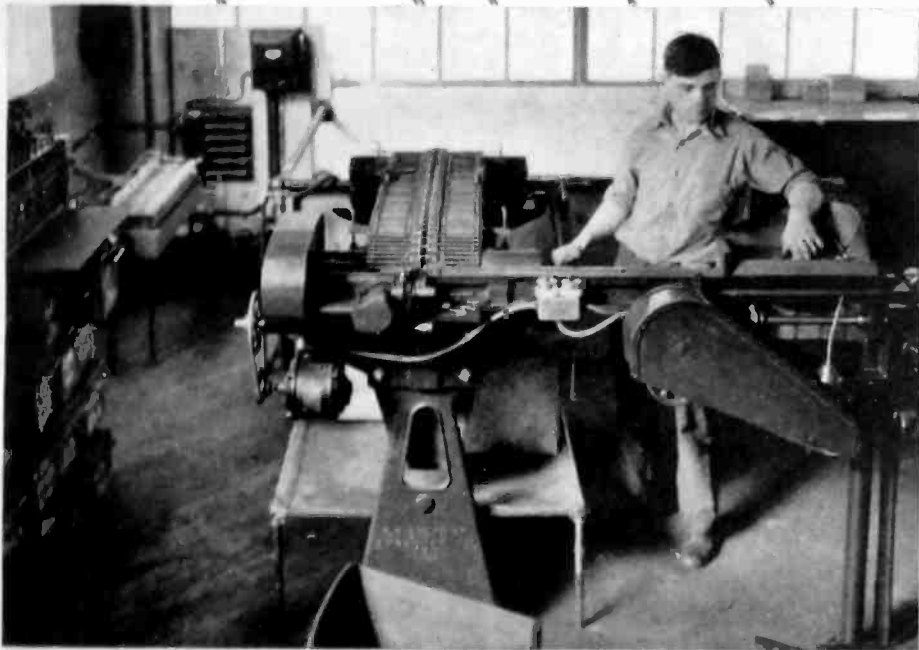

*Left. The electrically controlled and operated machine which automatically sorts values within predetermined percentages of tolerance limits.*

*Below. Trained operators complete the final stage in manufacture by a check test.*

Throughout the various stages involved in the manufacture of ERIE RESISTORS every possible precaution is taken to insure precision ratings.

Automatic machinery designed especially for our use, is employed throughout each of the many steps necessary to produce a dependable resistor. After completion, the work of the various machines is given a final check test by trained operators.

The thoroughness which characterizes ERIE RESISTOR manufacturing methods is reflected in a finished product which measures up to the most rigid requirements.

When you specify ERIE RESISTORS for your production you may be certain that you are giving your eventual customer the very best the market affords.

May we send you samples, prices and additional data?

Erie Resistor Corporation  
Erie, Pa.—Toronto, Canada—London, Eng.

# ERIE RESISTORS



# THERE IS A JOB IN EVERY PLANT



## COUNTING... SORTING... GRADING...



G-E photoelectric equipment acts as "dispatcher" on this conveyor line, switching preselected "cargoes" in the boxes from the continuous stream on the main line to the spur line. The application provides positive automatic control

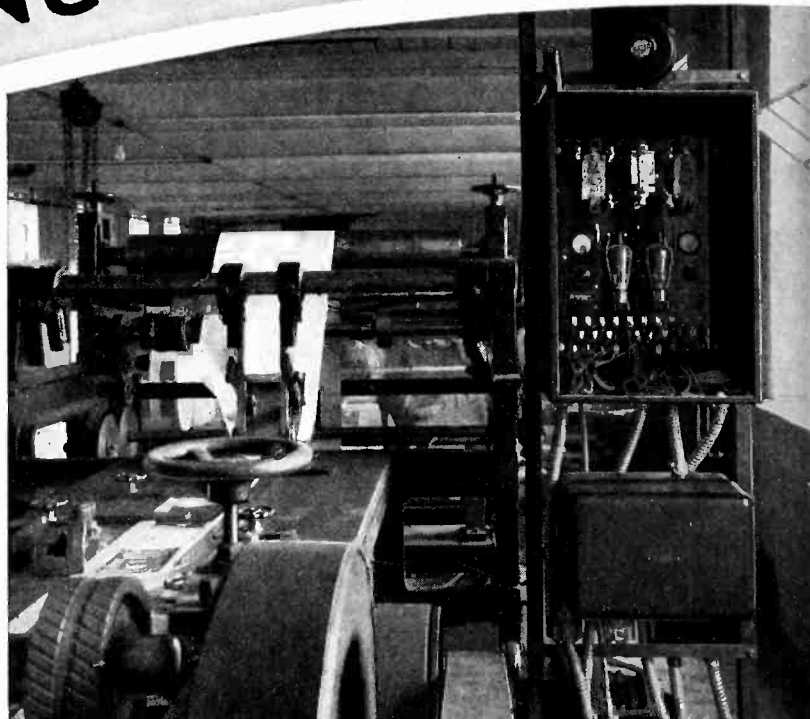

G-E electron-tube control that includes both "electric eyes" and Thyatron tubes, is used on this bag-making machine for maintaining register when cutting the printed paper. Cumulative errors are avoided

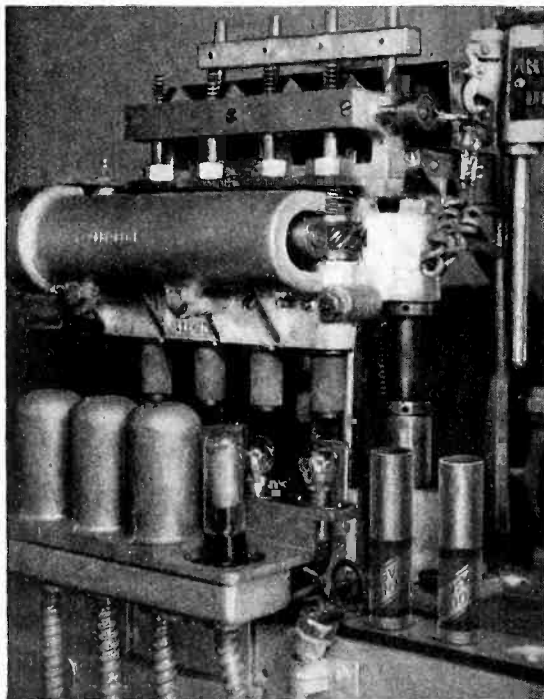

In this tooth-paste-tube filling machine, G-E photoelectric relays stand guard to see that the tubes are rotated into position for crimping, thus reducing spoilage of material and containers, as well as increasing production

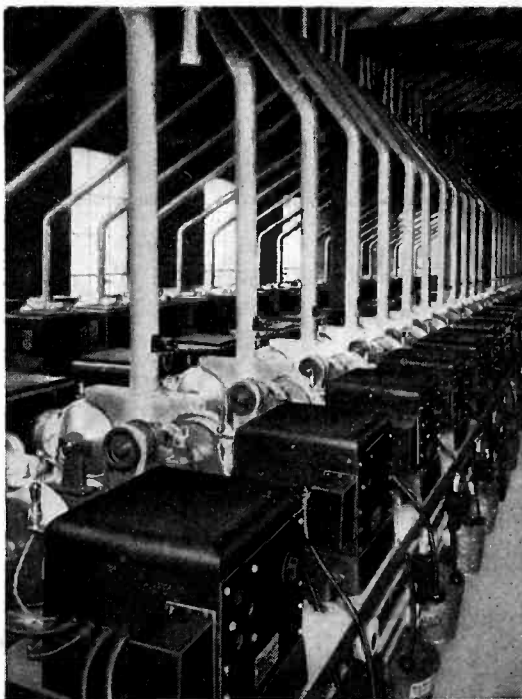

Here a battery of "electric eyes" in G-E photoelectric relays inspects beans. Only perfect beans will pass this critical inspection. Installations like this improve products and reduce costs



A G-E photoelectric relay was put to work counting sheets of mica passing through this machine, and registering an exact count before the eyes of the operator. The saving in time and material more than justified the cost of the installation

# GENERAL ELECTRIC

# THAT "ELECTRIC EYES" CAN DO BETTER

**REGULATING...INSPECTING...INDICATING...CONTROLLING**



ILLUSTRATED here are just a few of the many difficult jobs perfectly handled by "electric eyes" in G-E photoelectric control. Products are improved, production costs are lowered—50% in one case and many times the cost of the equipment in another—spoilage is decreased, and accuracy assured, all by the addition of simple equipment that is easily installed.

Ask a General Electric representative to show you a sample of our photoelectric control, and to explain how a simple unit can reduce waste motion. The coupon is for your convenience; clipped and mailed, it is an investment in efficiency information.



The CR7505-K1 is the latest addition to the family of G-E photoelectric relays, all of which have been carefully designed to meet your needs. The CR7505-K1 is compact, inexpensive, and easily installed.

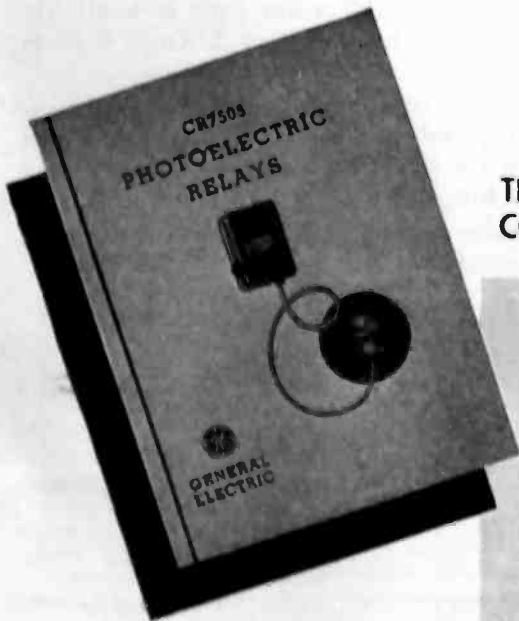

**TEAR OUT AND MAIL FOR COMPLETE INFORMATION**

Address the nearest G-E Office, or General Electric, Dept. 6-201, Schenectady, New York.

Please send me a free copy of your new bulletin, GEA-1654A, which describes and illustrates your complete line of photoelectric control.

Name.....

Company.....

Address.....

301-147



# MALLORY ELKON DRY DISC RECTIFIERS

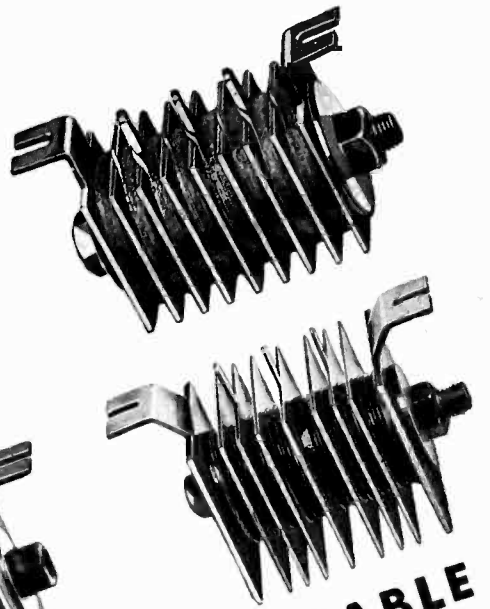
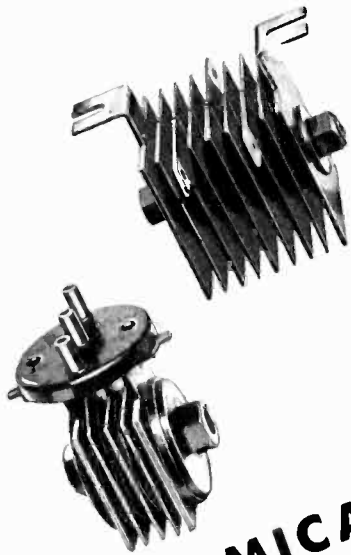

ECONOMICAL . . . COMPACT . . . DEPENDABLE . . . DURABLE

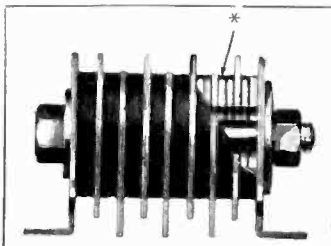

\*Fabric impregnated with compound which is unaffected by moisture and does not harden after being subjected to temperature encountered on surface of rectifier.

Mallory-Elkon Dry Disc Rectifiers are designed for battery chargers, and applications in which high currents and small sizes are essential requirements. They are right in principle and you'll find them unusually efficient for relays, magnetic devices such as clutches, brakes, chucks and separators. Their standard of performance on solenoids, motors, signaling devices and electroplating units is equally outstanding.

### Mallory-Elkon Battery Charger

Available in standard capacities from 2 Amp. 6 volts to 12 Amp. 12 volts. Other capacities available upon request.

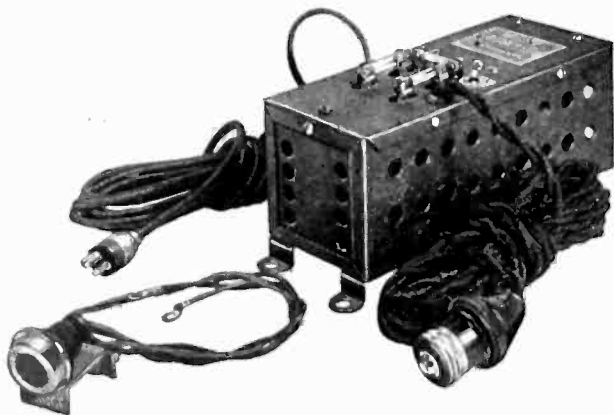

In connection with Mallory-Elkon high capacity dry electrolytic Condensers, the Mallory-Elkon Rectifier unit is available as an A Power in capacities of the order of 2 Amp. 6 volts to 6 Amp. 6 volts.

Checked on a basis of size or cost—you'll find that Mallory-Elkon Dry Disc Rectifiers lead the field for efficiency and economy. They are sealed for protection against atmospheric conditions—and noted for longer life.

Let Mallory-Elkon engineers assist you in the solution of problems involving the use of rectifiers.

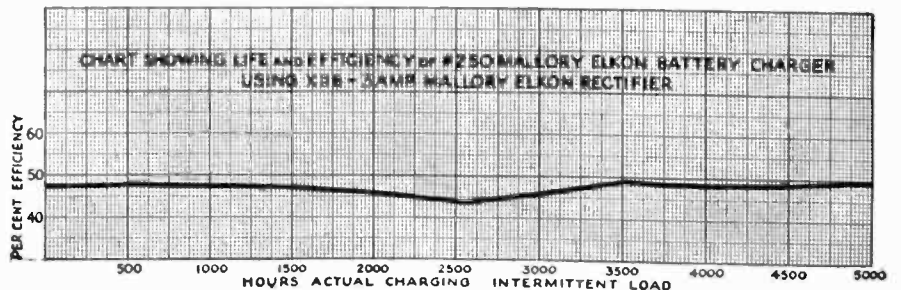

This is service equivalent to approximately three years, three nights per week, ten hours per night.



P. R. MALLORY & CO., Incorporated  
Indianapolis Indiana



in RADIO, ELECTRICAL,  
AUTOMOTIVE AND  
INDUSTRIAL FIELD

# electronics

O. H. CALDWELL  
*Editor*  
KEITH HENNEY  
*Associate Editor*

McGRAW-HILL PUBLISHING COMPANY, INC.

New York, October, 1933



radio  
sound  
pictures  
telephony  
broadcasting  
telegraphy  
counting  
grading  
carrier  
systems  
beam  
transmission  
photo  
cells  
facsimile  
electric  
recording  
amplifiers  
phonographs  
measurements  
receivers  
therapeutics  
traffic  
control  
musical  
instruments  
machine  
control  
television  
metering  
analysis  
aviation  
metallurgy  
beacons  
compasses  
automatic  
processing  
crime  
detection  
geophysics

## The plight of the radio engineer

**N**O CONDITION facing the radio industry is more important to the present and future prosperity of the art, than the unemployment situation in which the average radio engineer finds himself.

If he has a job at all, the technical radio man is likely to have imposed on him low wages, long hours, Saturday and Sunday overtime, and insecurity of employment. In certain plants, good men are temporarily taken on at bare subsistence wages, drained of their ideas, and then in a few weeks turned out on the street again—the process to be repeated with a new batch of “laboratory fodder.”

**I**T IS clear that such a policy cannot build for stability or real progress of the art. New products and services which the public buys, come from engineering minds. It is poor economy to kill off the producers of the golden eggs.

The Institute of Radio Engineers has recognized this unsound employment condition by the appointment of a special committee to study the problem, with no less a chairman than the president of the Institute, Dr. L. M. Hull himself. This committee can set out the facts and propose solutions. It early developed that the NRA Codes had no place to take up the radio engineers' problems, but there is still hope that out of the improved business conditions resulting from NRA, the radio engineer may benefit.

Meanwhile there is much talk about organizing the engineers for self-protection.

**W**E WOULD be slow in advising intellectual laborers like radio engineers to attempt to organize on an out-and-out labor-union basis. Yet there are those who feel this is the only way to amelioration of the radio engineers' present plight.

# ULTRA SHORT WAVES—

Between 10 meters and 5 meters there are 1000 channels three times as wide as existing broadcast channels. These bands are ideal for local services

**T**HE visit of Senatore Marconi to this country, and his optimistic reports of his successes in transmitting intelligence beyond the theoretical horizon, on very short waves, have focussed attention again on this vast region below 10 meters, perhaps even below one meter, which is being rapidly explored and exploited. From all appearances history is to be repeated; wavelengths once thought useless are suddenly found to be of great importance; soon the scramble to stake claims in this new goldfield will be on.

Tubes and circuits for generating power below 10 meters have not been available generally until recently. Receivers did not function as well there as on the longer waves; but the introduction of new forms of oscillators, the dome-shaped amplifiers and still more recently the brilliant work of B. J. Thompson (*Electronics*, August, 1933, p. 214) seem to have overcome these difficulties. Transmitters and receivers of conventional circuits now operate at wavelengths of one meter and lower.

In the region between 10 meters and 1 meter, services are already being found. For several years the broad-

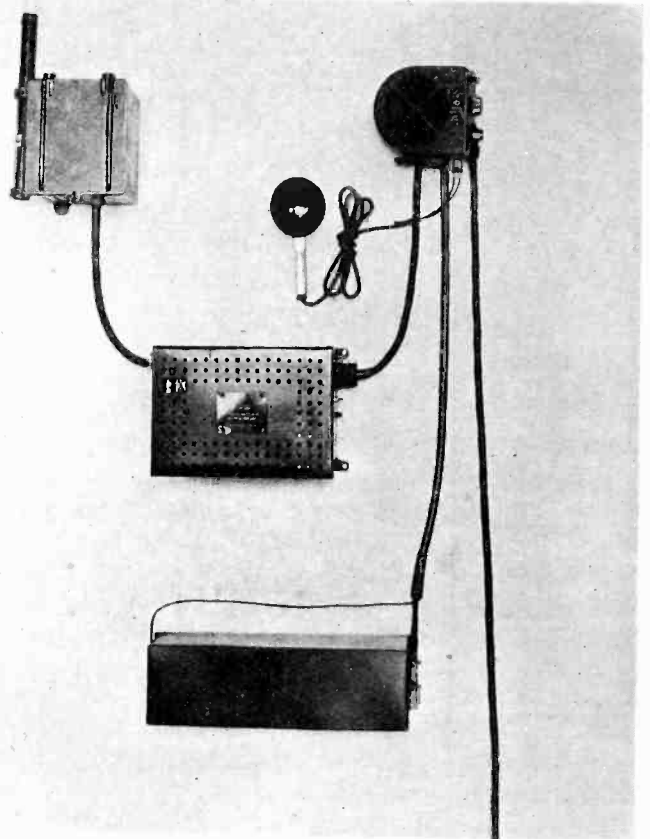

Police car transmitter and receiver as used in Bayonne, N. J., operated on 34.6 Mc. and affording two-way communication with headquarters and other cruisers



Compact one-pound transmitter built by Sergeant Milton A. Sewell of the Signal Corps for sending dots and dashes from meteorological balloon to give air conditions aloft

casting chains have used portable equipment for remote pick-ups, using wavelengths of the order of 5 meters. Several installations of two-way police communication systems have been put in operation using waves much below 10 meters. So simple are these equipments that they cost much less to install and keep up than similar, or even less useful, systems on frequencies now assigned to police use. There are ten channels now available for police networks; but eighty odd stations already are on the air. And there are more than 250 cities with population greater than 25,000—and each has a right to ask for a wavelength and permission to protect itself with police radio communication. From any one of these cities a dozen other police systems can be heard after nightfall—so great is the interference that what was once “interesting listening” to the novice now becomes an uncomfortable babel of bells, whistles, gongs, buzzes and “that is all.”

Just as in pre-200-meter days there are technical bugaboos. One is the horizon beyond which very short, optical-like, waves are not supposed to go. There are two answers—one is that there are many conceivable uses for radio where the communication need not go beyond the horizon. And secondly, Marconi and others



# AND NEW MARKETS

An additional 8000 channels exist between 5 meters and 1 meter—each 30 kc wide, free from static, fading and interference by distant stations

have demonstrated that horizon or no horizon, messages put into a transmitter get to the receiver far beyond the theoretical limit.

"It is dangerous to put limits on wireless," said Mr. Marconi, recalling the famous case of thirty years ago when all scientific opinion agreed that radio waves could not go beyond the horizon. In his most recently reported work he has outdistanced the horizon by a mere nine times! It is indeed dangerous to put limits to wireless.

At a press conference with Marconi on the day he landed at New York, Mr. Sarnoff raised the question if the day might not come when personal communicating systems would be developed so that any two persons in a given locality could communicate with each other at will by means of their own portable apparatus. Mr. Marconi refused to be drawn into a discussion of this dream—but he did not refute the fact that there are sufficient channels in this part of the spectrum for the many millions of the population of a city like New York to have individual calling waves for personal communication.

At the present time frequencies above 30 megacycles are not assigned by the Federal Radio Commission for services other than "experimental." In February of this year the Commission publicly stated that "the very high frequencies offer a possible solution of the shortage of frequencies (for police systems) but these bands are still in the developmental stage and will not be opened for any commercial use until more specific information with regard to the possibilities has been obtained."

But in Bayonne, N. J., a system is in operation by which police cars may not only communicate with headquarters and get orders from the man on the desk, but can converse with each other as they may be hurrying to a given location. Much time is saved by this two-way system. Tests have been made in Boston on a similar system; equipment of the same nature has been placed in a plane owned by the Conservation Department of the State of New York. At an altitude of 6000 feet it was possible to carry on successful communication at a distance of 110 miles.

These tests are not on the so-called ultra high frequencies, that is, waves below one meter in length. But the intermediate region will probably become congested before the frontier is pushed vigorously into the nether regions. In the meantime the researchers are working on tubes and circuits which will enable use to be made of centimeter waves when the use is found.

Such wavelengths will permit the design of extremely small receivers and transmitters. The trend is in this direction even on the much longer waves used by broadcasters, as proponents of high tone fidelity have noted. One of the features of the Fall models is the "vest pocket" set illustrated here. The same elements of design which made such a compact receiver possible are being employed to make receivers for policemen to wear



*"There is a great vista opening up in the micro-ray region. The tiny waves are not limited to optical distances and I stake my reputation on it—micro waves are not affected by static"*  
—Guglielmo Marconi

under their coats, extremely compact and light compared with the older art.

Manufacturers already actively pushing investigation and practical application into these lower wavelength regions are Westinghouse (Chicopee Falls), Hygrade Sylvania (Clifton Electronics Division), Radio Corporation, Radio Engineering laboratories, and the Bell Telephone Laboratories. Of course, the Army Signal Corps and Navy engineers are busy investigating the possibilities of the frequencies above 30 megacycles for their own special needs.

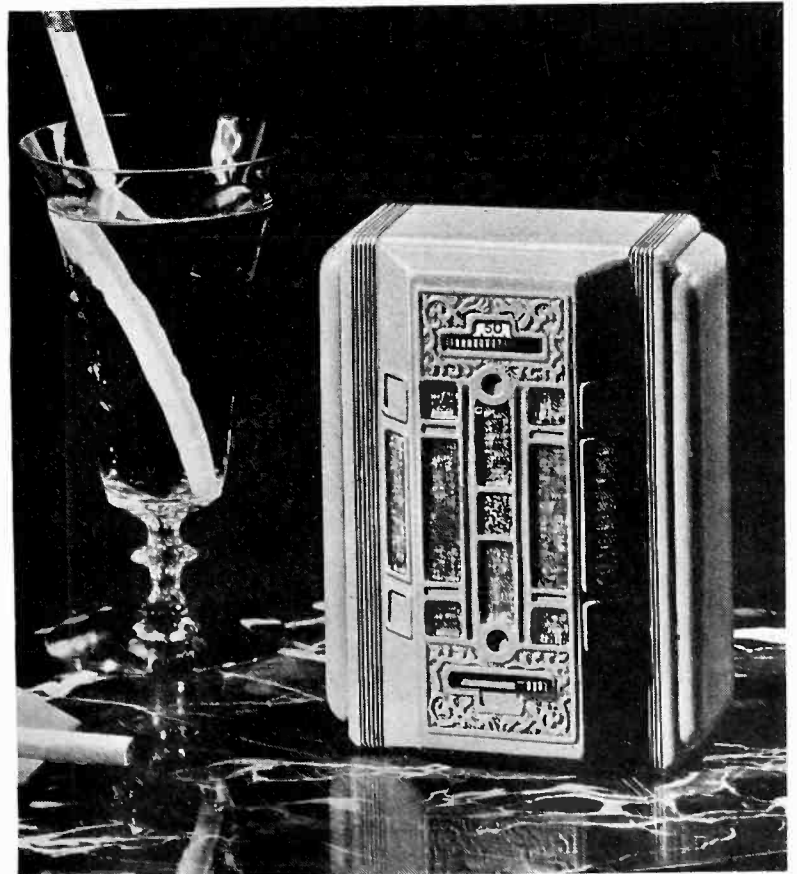

Extremely small receivers are available even on broadcast waves where a large band must be tuned over. This new Kadette is 2 in. by 4 in. by 6 in. in size and has two tubes

# PHOTOELECTRIC CONTROL

Applications expand rapidly in number and in diversity of use

## ILLUMINATION CONTROL IN OFFICES



When daylight fades, the photocell switch on the wall at the left automatically turns on the lights. And it never forgets to turn them off again, if they are not needed

## AUTOMATIC BATCHING OF CEMENT

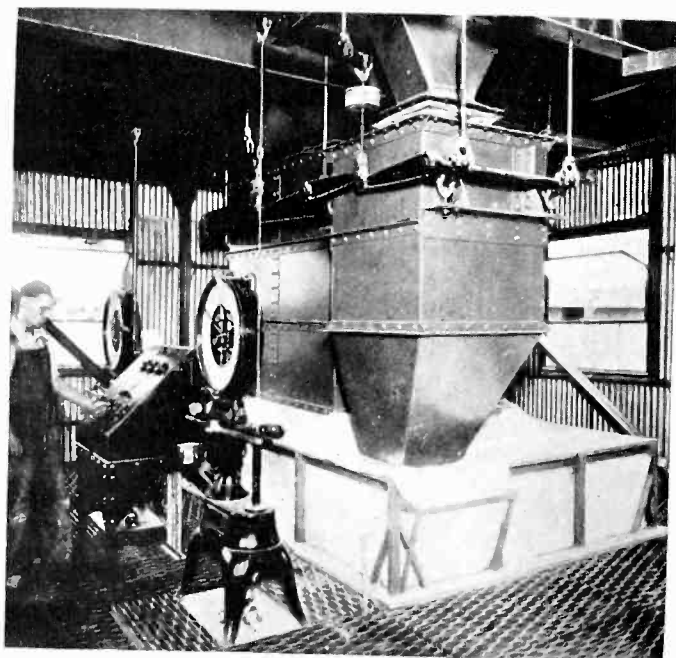

In the Brooklyn "ready-mix concrete" plant the constituents are weighed, and proper amounts automatically delivered, as scale pointer intercepts photocell

IT seems to be the history of all new inventions and innovations, that after the basic idea or method is completed, there is still a long period of lag or delay before the application of the new principle gets underway in any volume. This was the history of the steamboat, telegraph, telephone, airplane and radio,—where in each case, years elapsed between the original application, and large-scale commercial development.

The photoelectric cell has been going through an intermediate period of this kind, during recent years, when its slow development has been a matter of keen disappointment to its enthusiastic promoters. The photo-sensitive element and its relay have been ready a long time, but probably because few persons knew of the possibilities it offered in the solution of their own particular problems, the numbers of uses have been relatively limited.

But now there is evidence on every hand that photocell applications are increasing rapidly, both in diversity and in number. Installations are reaching out into new fields, and in industrial plants, power houses, machine shops, scientific laboratories, stores, offices and homes, use is being made of this electronic robot control.

On following pages the long list of uses of photo-cell units, bears witness to the rapid progress that has been made since a similar list was compiled by *Electronics* two years ago. Naturally this list, long as it is, is necessarily incomplete, for there undoubtedly are scores of other uses that have not come to light. Plant managers who find some new adaptation of the photoelectric cell too often shroud their discovery and use in great secrecy, and one of the principal difficulties the *Electronics* staff has had is in getting photocell users and enthusiasts to let the outside world know what they are doing. The suppliers of the photocell equipment often do not learn what use is being made of the apparatus, and if they do learn, they are obligated to keep the confidence of the customer. This attitude of secrecy, and effort to secure some advantage of exclusive use, holds back the wider extension of photocell apparatus. Eventually, of course, this will be overcome, and uses of photocells will become universal, and universally known.

An important extension of the application of photocells made during the past year or two, has been the incorporation of photoelectric units into the apparatus and machines made by other manufacturers. Builders of mechanical conveyors now supply built-in photocell units for counting and for dispatching of conveyor loads according to pre-set schedules. Makers of dyeing equipment make use of photocells to control the handling and processing of the materials going through their machines. The automatic-scale people have been quick to see the advantages of photoelectric linkage between the beam pointer and any mechanical operation to be performed, since the intercepting of a ray of light imposes no load whatever on the accurate reading of the scale. The makers of automatic door-openers, now find the photocell the best possible means of control. Elevator makers have found the safety value of photocell protec-

# WIDENS IN INDUSTRY

Manufacturers of machines now provide photoelectric features

tion of their elevator thresholds, against improper starting of their cars, and now build photocells into their elevator equipment as integral parts, for safety-doors and for car-leveling. Meanwhile a host of scientific instruments have had their usefulness or sensitiveness or accuracy extended, by utilizing photocells which now become a part of the apparatus.

The only shadow that lingers over photoelectric installations is that of proper and adequate individual design and construction, where single or initial jobs are concerned. The engineer who installs a photocell unit is not finished with his job if he merely makes it work. He must make sure that its performance fits in with all the everyday requirements and conditions surrounding its use. The installing engineer must approach the problem from the standpoint of the ultimate user, and find out what is going to happen under practical conditions.

Take the installation of such a simple job as a photocell drinking fountain, to enable a valve to be controlled and the water turned on when one lowers his head over the spout. In one case, we know about, the photocell man came and arranged the circuit all right. But in this job, as he left it, any failure of the lamp or photocell circuit left the valve irrevocably closed and a hundred office workers without water. Next it was discovered that the tubes were mounted on a swinging door, which the cleaning women could bang closed, wrecking the tubes. The automobile-lamp socket also softened in the continuous heat, letting the lamp contacts slide open. The lamp and photocell supports of light metal, proved too weak; people leaned against them, twisted them, got them out of line. For all these failures and annoyances the *photocell* had to *take the blame*, although never in months of operation did the photoelectric apparatus itself ever give any trouble. Now a pushbutton contact has been put onto the relay so that the valve can be operated at all times, a main switch has been installed controlling both lamp and amplifier panel, and the installation gives no more trouble. It is now a workaday installation, that fits the everyday office routine. Yet as the photocell man left it, because he did not look beyond his photoelectric circuits, it was a failure and a nuisance.

The lesson here, is, that the man who installs photocell or electronic equipment must, before leaving it, see that it meets the everyday conditions to which it will be exposed.

But now photocell applications are going ahead on a constantly wider front. New cells are being developed, and new facilities are being provided for special uses. The characteristics of cells are better understood, and engineers are learning that there is a cell for each purpose, and that the right unit can be depended upon to bring results. The production of photocells is climbing rapidly, while the number of concerns allied in one way or other with photoelectric control continues to expand. A new industry is developing which will bring new facilities of control to machines, replacing the routine action of the human eye and brain, and freeing human faculties for more constructive effort.

## DIRECTS REGISTER OF CUTTING KNIFE

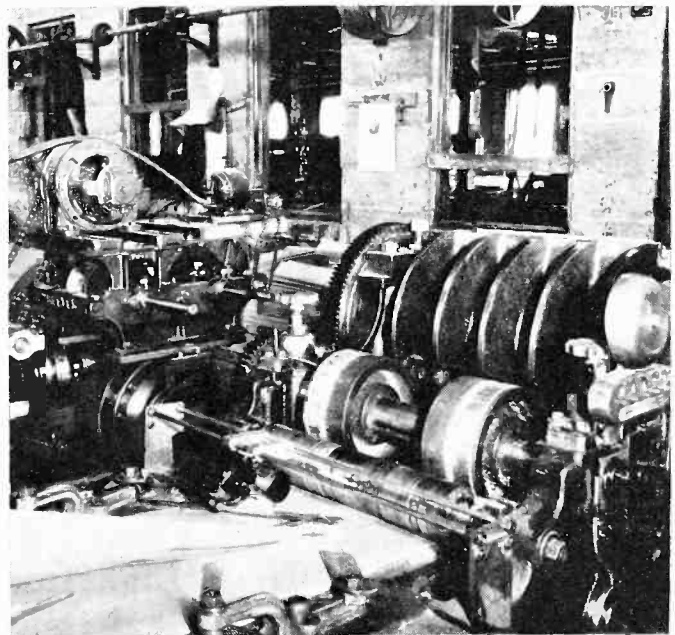

In this cement-bag-making machine at Jaite, Ohio, a photocell controls the register of the cutting knife, so as to line up with the printing

## SAFETY-RAY ELEVATORS AT RADIO CITY

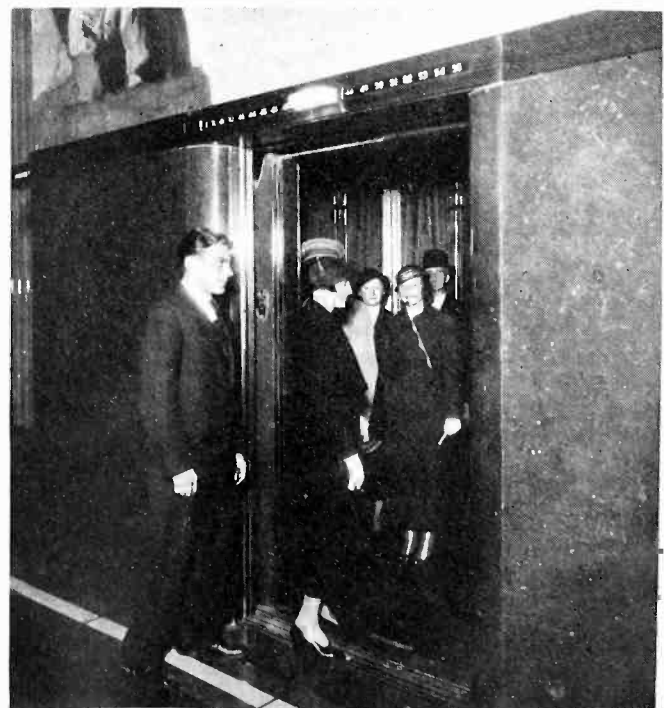

If a belated passenger steps across the threshold of this elevator, two safety-ray beams are intercepted and reopen the door. There are 58 elevators so equipped at Radio City, New York



# A LIST OF PHOTO-

► This list of uses of photoelectric-control applications has been collected and compiled by *Electronics* from a large number of sources. Most of the uses named are actual operating installations. In a few cases, ap-

plications listed are potential or experimental. They are included here, however, since the chief value of a listing of this kind, lies in its stimulation of invention and the application of photo-cells to other problems.

★ ★ ★

## Industrial

Reversing rolls in steel mill  
Removal of soaking-pit covers  
Control of cut-off saws  
Furnace temperature control  
Operating limit switches for motor travel  
Controlling thickness of sinter beds  
Smoke indicators in smoke stacks  
Combustion indicators (showing "haze-point")  
Detecting fine cracks in polished surfaces  
Opening doors for hand trucks, motor trucks, etc.  
Automatic operation of mine ventilating doors  
Operating valves, switches  
Warning signals on rolls in tire factory  
Remote control of machines  
Safety protection of machines  
Detection of flaws in products  
Alarm for water-hardness  
Analysis of card records  
Turning threads on pipe and conduit  
Fire-alarms, smoke alarms  
Paper-making machine—paper break detection  
Piling bags by conveyor  
Conveyors in heat-treating furnaces  
Operation of rod shears, merchant-mill shears  
Pressure application in chain welding  
Feed to rubber-cutter table  
Pre-selective conveyor dispatching system  
Automatic weighing of batches  
Registering printing, folding, cut-offs, etc.  
Synchronizing conveyors  
Chemical process control  
Leveling elevators  
Inspect storage-battery caps for vent holes  
Sorting electrical resistances  
Flagging tote pans on conveyor at selected station  
Control of pulp in beater in paper mill  
Controlling thickness of enamel on wires  
Rejection of non-sharp razor blades

## Food and Chemical Processes

Controlling levels of contents of tanks and bins  
Drinking fountain control  
Turbidity control in water supply  
Cold-room door operation  
Control of motors from indicating meters

Automatic control of heat-treating  
Opening doors for animals (dairy, stables, etc.)  
Tooth-paste filling machine  
Bottle fillers  
Metal-tube inspection  
Control of coffee roasters  
Candling eggs  
Moth control in orchards  
Synchronizing of two conveyors  
Sorting raisins at 1,000 per minute  
Sorting lemons, beans, etc.  
Eliminating green peaches from cannery stock  
Sorting cigars  
Testing oil  
Control of acidity, alkalinity  
Sludge level indicator for sewage-disposal plant

## Light Control

School-room lighting  
Shop and factory lighting  
Electric signs

★

## A PHOTOCELL LUMBER PAINTER

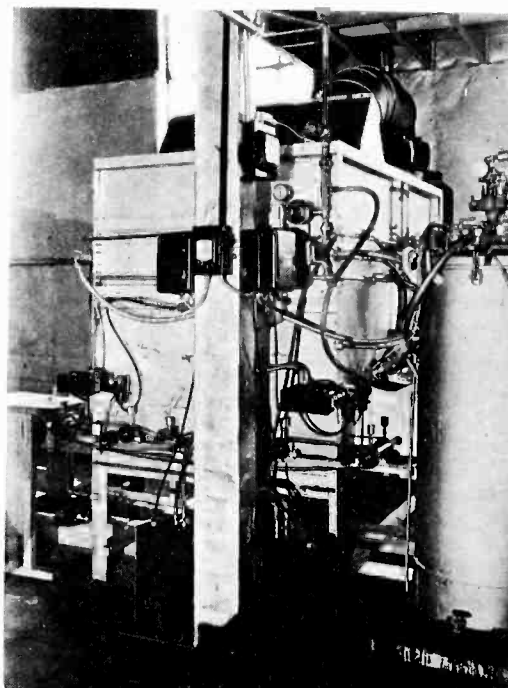

This machine sprays paint as lumber passes through its spray chamber. But photocells control the spray valves, so that only when a piece of lumber is in the machine does the paint-spray operate

Flood lighting and decorative effects  
Store lighting  
Office lighting  
Street lighting circuits  
Air ports, aviation beacons  
Light-houses, range lights, markers, etc.  
Store and window lights, turned on at approach of passers-by or patrolman  
Parking lights on autos, automatically lighted at dusk  
Riding lights on moored vessels, automatically lighted  
Signs along roadway, lighted on approach of car headlights  
Photographic printing and enlarging

## Counting, Measuring

Production lines (motors, automobiles, radios, refrigerators, etc.)  
Traffic in tunnels, on bridges, etc.  
People passing, or entering (theaters, etc.)  
Animals, livestock, etc. in stock-yard pens  
Recording beats of master clock  
Printing and engraving  
Tabulating statistics, quantities  
Measuring lamp candlepower  
Timing races  
Integrating irregular areas by measuring light transmitted  
Astronomical measurements  
Color measurement  
Turbidity measurement  
Projectile velocities  
Calipering steel balls  
Control of sprays in lumber painting machine  
Boiler-gauge level alarms  
Automatic sheet-catchers in rolling mills  
Counting of printed items on cards, totaling and analyzing  
Life tests of floor material in public places  
Automatic inspection of razor blades  
Counting ingress and egress of honey-bees from hive  
Weighing machines

## Visual Reproduction

"Facsimile" transmission of photographs, maps, newspapers, etc.  
Television transmission  
Half-tone and line-cut production  
Three-color plate engravings  
Enabling blind to read ordinary print  
Automatic curtains framing movie screen  
Photography of wild-animal life  
Automatic photographing of sneak-thieves, burglars, etc.

# CELL APPLICATIONS

## BEAN-SORTING MACHINES

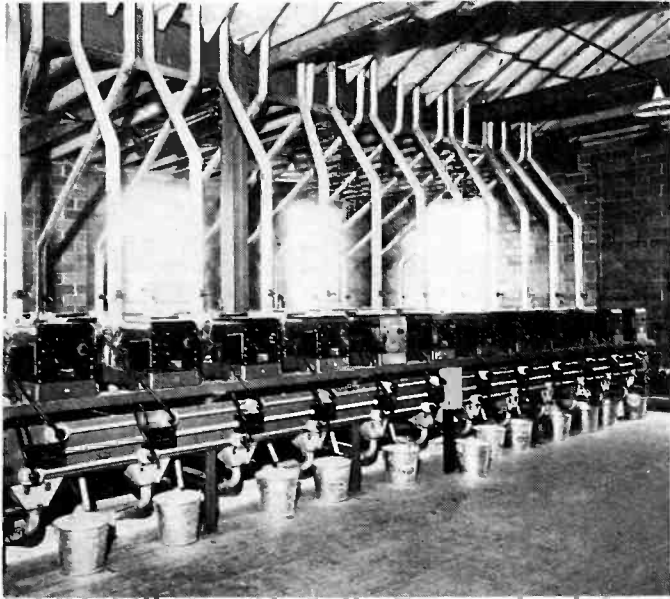

Beans by the carload can be sorted rapidly and cheaply by these twenty-four photoelectric thyatron sorting machines at Lowell, Mich.

## SEES FLASHOVER BEFORE IT HAPPENS

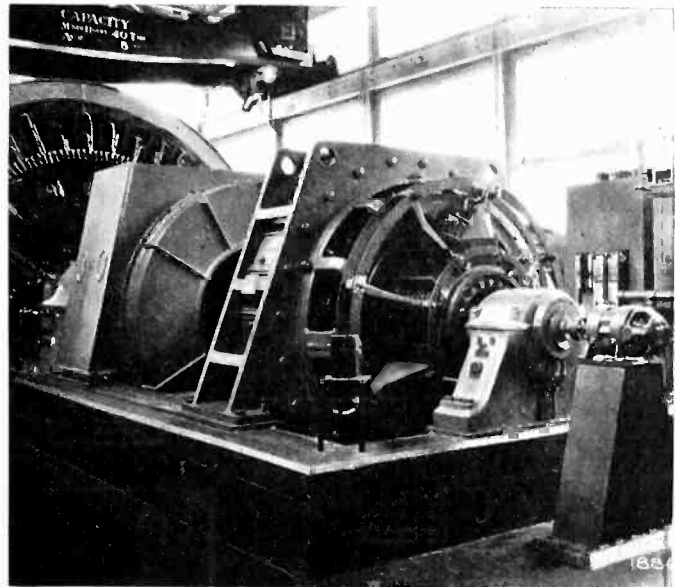

If a flashover starts on this railway motor-generator commutator, the photocell trips the circuit-breaker before damage can be done



## Safety Uses

- Protection of punch-presses and other dangerous machines
- Protection of elevator doors, preventing car from starting unless all passengers are clear of threshold
- Transmission of weather maps to ships at sea
- Detection of ice-bergs, ships, etc. through fog
- Safety doors in mines
- Remote control of dangerous processes
- Protection of jails, penitentiaries, etc.
- Protection of electrical machinery
- Traffic-signal operation
- Auto speeding detectors
- Street-lighting control
- Burglar and kidnapping alarms
- Talking "rogues' gallery" (sound pictures)
- Detection of dangerous gases in tunnels
- Hold-up protection, banks, etc. (closing of safety steel shutters)
- Fire alarms, smoke alarms
- Safety protection of oil-burners
- Airway beacons
- Lighthouses and marker lamps
- Sewage treatment control
- Gunfire control

## Sports

- Timing horse races
- Timing athletic contests
- Foul-line for bowling alleys
- Timing of golf-club swings
- The photo-electric shooting gallery (Light-beam gun; photocell as target)

## Grading

- Cigars
- Tile
- Beans, vegetables
- Detecting missing labels
- Inspecting tin-plate
- Calipering small parts
- Color comparison
- Adjusting auto headlights
- Detecting flaws in products
- Sorting checks and bills
- Matching false teeth

## Traffic Applications

- Railroad signals (European)
- Street traffic lights
- Elevator leveling
- Elevator-door safety control
- Elevator safety stops
- Routing mail-bags and letters
- Counting street traffic
- Checking up bridge toll collections
- Speeding subway traffic
- Checking up theater patronage
- Detecting dangerous gas in tunnels
- Lighting air-beacons and air-fields
- Controlling wind indicators from pilot-vanes
- Detecting automobile speeding, by two photocells in roadway
- Horse-operated signals for bridle-paths (See front cover)
- Parking lights on automobiles lighted at dusk
- Head lamps dimmed at approach of another car
- Head-room alarms for tunnel and bridge approaches
- Adjoining street signs and displays controlled by traffic lights

- Swing-bridge pin-lock safety indicator
- Identifying and recording freight-car numbers
- Checking auto crank-case oil at service stations
- Adjusting illumination in vehicular tunnels
- Calling gas-station attendant when car stops
- Speedometer, using two cells focussed on terrain, getting variation from first one then second cell
- Sextant for locating sun's position obscured by clouds

## Printing, Publishing, Etc.

- Automatic machine setting of type, from typewritten copy
- Half-tones made by photo-electric scanning
- Automatic control of register on web presses
- Automatic control of accurate trimming
- Accurate cutoffs for labels, bags, etc.
- Automatic stops for presses, preventing paper breaks
- Adjusting density of printing
- Counting of sheets and forms in binderies
- Control of paper thickness and moisture during manufacture
- Matching the colors of inks and papers
- Controlling uniformity of color during printing runs
- Providing permanent unfading color records
- Measuring glare and opacity of paper
- Transmitting photos by wire direct to engravings
- Safety-first devices around presses

Detecting and correcting press vibrations  
 Automatic door-openers for binderies, shipping rooms, etc.  
 Automatic mailing list analysers and sorters  
 Automatic light-intensity control in printing and engraving plants  
 Control of paraffine-vapor spray for preventing offset  
 Grading of photographic negatives in gravure process  
 Bleaching-process control  
 Reclaiming of "white water," control of digester, etc.

## Sound Production

Phonograph recording  
 Sound-picture recording  
 Sound-picture reproduction  
 Light-beam transmission  
 Light siren  
 Photo-electric organ  
 Modulation of broadcast transmission  
 The "talking book"  
 Talking wills  
 Talking "rogue's gallery"  
 Automatic merchandiser says "thank you" when purchase is made

## Scientific Instruments

Titration of chemicals  
 Measuring viscosity  
 Measuring density of photographic films  
 Temperature control  
 Testing oils  
 Measuring total light flux  
 Indicating wind velocity  
 Color analyzers  
 Color matchers  
 Light-intensity meters  
 Exposure meters  
 Turbidity meters  
 Combustion indicator  
 Master-clock control of secondary clocks  
 Control of circuits from indicating meters  
 Indicating shaft rotation  
 Meridian passage of stars  
 Recording variable stars  
 Guiding telescope on star  
 Detecting faint spectral lines  
 Measure instant of eclipse  
 Measure width of eclipse path  
 Measuring high rotational speeds by light producing tones  
 Sighting guns for automatic firing  
 Current detectors and amplifiers. Light beam reflected from galvanometer mirror falls on photo-cell

## Home Possibilities

Controlling uniform illumination in work rooms  
 Monitoring oil-burner pilot flame, to operate safety valve  
 Garage-door openers  
 Alarms against burglars and trespassers  
 Flood-lighting control  
 Night-lights around house automatically turned on and off  
 Automatic operation of door between dining room and kitchen  
 Automatic opening of refrigerator door  
 Motor shaking of furnace grates automatically cut off when bright coals pass into ash-box

Photographic exposure meter  
 Turn off radio set during objectionable programs  
 Photo-cell musical instruments  
 Window raising and closing mechanism  
 Aids for invalids, the crippled, etc.  
 Kidnapping alarms for nurseries

## Electric Power Systems

Synchronizing power circuits  
 Controlling alternator frequency  
 Detecting flash-overs on rotary converters  
 Reporting circuit-breaker operation  
 Controlling street-lighting circuits  
 Safeguarding high-tension buses  
 Bus flash-over protection  
 Controlling isolated plant operation from predrawn chart

## COLOR CONTROL OF CHEMICAL PROCESSES

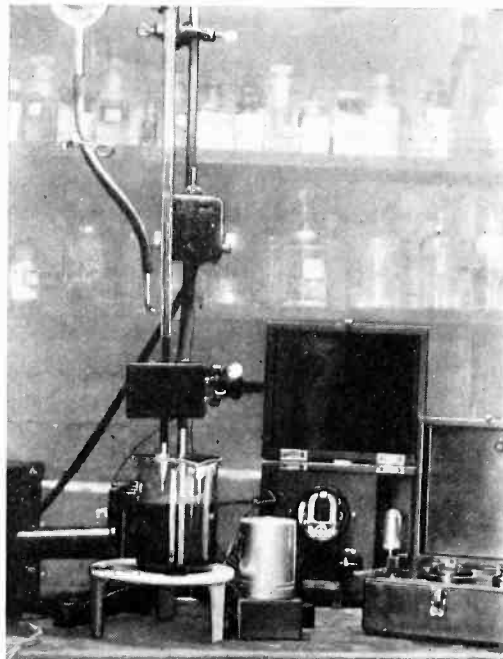

When the mixture in the beaker changes color, indicating the end point of the reaction, the photo-cell relay closes the valve admitting the standard solution

## Manufacturers of light-sensitive cells

Acousto-lite Corporation,  
 2908 S. Vermont Ave., Los Angeles, Calif.  
 Selenium and self-generating cells

Burgess Battery Company,  
 Freeport, Ill.  
 Selenium cells

Burt, R. C. Laboratories,  
 890 E. California St., Pasadena, Calif.  
 Photoelectric and selenium cells

Clark Instrument Company,  
 119 N. Fourth St., Camden, N. J.  
 Selenium cells

Central Scientific Company,  
 460 E. Ohio St., Chicago, Ill.  
 Photoelectric cells

Continental Electric Company,  
 St. Charles, Ill.  
 Photoelectric cells

DeVry, H. A. Company,  
 55 E. Wacker Drive, Chicago, Ill.  
 Photoelectric cells

Electronic Inspection Laboratories,  
 624 Hayden Ave., Cleveland, Ohio.  
 Liquid self-generating cells

General Electric Company,  
 Schenectady, N. Y.  
 Photoelectric and selenium cells

G-M Laboratories  
 1731 Belmont Ave., Chicago, Ill.  
 Photoelectric cells

Hygrade-Sylvania Corporation  
 Clifton, N. J.  
 Photoelectric cells

Intellect-a-Ray Corporation,  
 Singer Building, Pasadena, Calif.  
 Selenium cells

OST Laboratories,  
 6921 Natural Bridge Road, St. Louis, Mo.  
 Selenium cells

Pacific Research Laboratories  
 489 W. Washington St., Los Angeles, Calif.  
 Selenium cells

RCA-Radiotron Company,  
 Harrison, N. J.  
 Photoelectric cells

Rhamstine, J. T.,  
 500 E. Woodbridge St., Detroit, Mich.  
 Selenium cells

Raytheon Manufacturing Company,  
 Cambridge, Mass.  
 Photoelectric cells

Telephoto & Television Corporation,  
 133 W. 19th St., New York City.  
 Photoelectric cells

Western Electric Company,  
 (Graybar Electric Company, sales agents)  
 420 Lexington Ave., New York City.  
 Photoelectric cells

Westinghouse Lamp Company  
 Bloomfield, N. J.  
 Photoelectric and self-generating cells  
 (Photox)

Weston Electrical Inst. Corp.,  
 Newark, N. J.  
 Self-generating cells (Photronic)

## Light-sensitive relay units

Allen-Bradley Company,  
 Milwaukee, Wis.

American Instrument Company,  
 Washington, D. C.

Burgess Battery Company,  
 Freeport, Ill.

Burt, R. C. Laboratories,  
 890 East California St., Pasadena, Calif.

H. A. DeVry Company,  
 55 E. Wacker Drive, Chicago, Ill.

General Electric Company,  
 Schenectady, N. Y.

G-M Laboratories,  
 1731 Belmont Ave., Chicago, Ill.

Intellect-a-Ray Corporation,  
 Singer Building, Pasadena, Calif.

Western Electric Company,  
 (Graybar Electric Company, sales agents)  
 420 Lexington Ave., New York City.

Westinghouse Electric & Mfg. Co.,  
 Newark, N. J.; East Pittsburgh, Pa.

Weston Electrical Inst. Corp.,  
 Newark, N. J.

J. T. Rhamstine,  
 500 E. Woodbridge St., Detroit, Mich.

Struthers Dunn, Inc.,  
 139 N. Juniper St., Philadelphia, Pa.



# Suppression of auto radio noise

By GLENN H. BROWNING  
and RUPERT HASKINS

*Tobe Deutschmann Corporation,  
Canton, Mass.*

**T**O INVESTIGATE the various factors governing the noise received in auto radio sets due to the disturbance set up by the electrical system of the gas engine is all very well, but to start such an investigation with the expectancy of obtaining data which might help solve the noise problem takes a great deal of optimism. In fact, when the writers were asked about the possibilities of uncovering useful facts along that line, they were anything but encouraging. However, measurements proved conclusively that a great deal of noise emitted from the engine could be kept from getting into the radio receiver.

In any interference problem the first task is to locate and isolate the mechanisms causing the disturbance. In many cases this is the most difficult part of the task, for once the offender is located the cure is relatively simple. Not so with auto interference. It is almost self-evident that the spark plugs are the source of most of the noise, and though commutator brushes, and other equipment may contribute a small amount, this noise is quite readily taken care of. The direct method of attacking spark plug interference yielded very mediocre results. Various designs of spark plug suppressors were made up and tried as well as elaborate shielding systems. The net results were that the interference could be reduced but not eliminated by any system that was deemed practical to install.

In running a number of such tests, curves were taken showing the noise picked up on a receiving antenna as its distance was varied from the spark plugs. It would be expected that the magnitude of this radiation would fall off rapidly, but it was difficult to predict that it would fall to about 1/70 of its value in a distance of 8 feet.

The way this radiation diminished as the distance from the source to the radio pick-up is increased is shown in Fig. 1. It will be noted that the interference is practically the same on 1,400 kc. as it is on 600 kc. Thus it would appear that all the noise sent out was a "shock" in the radio receiver at the frequency it is tuned. The set used for these measurements tuned slightly broader at 1,400 kc. than it did at 600 kc. Therefore, shock excitation was less effective on the higher frequency.

The curve indicates that if the radio antenna were

[Please turn to page 283]

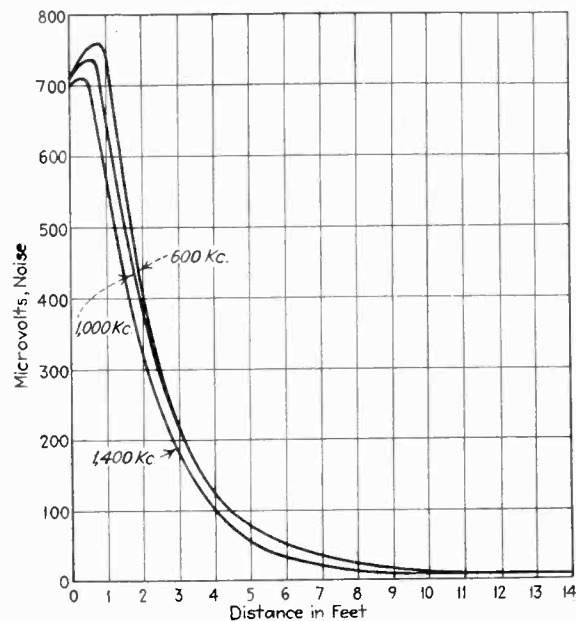

Fig. 1—Relation between radiated noise and distance from spark plugs

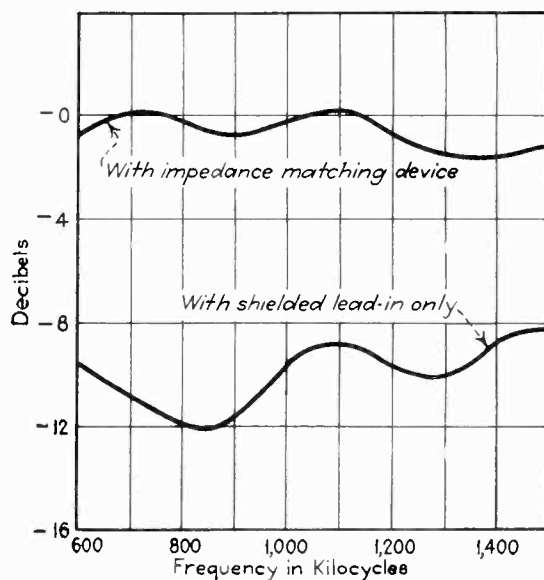

Fig. 2—Loss or gain of signal strength with or without matching transformer

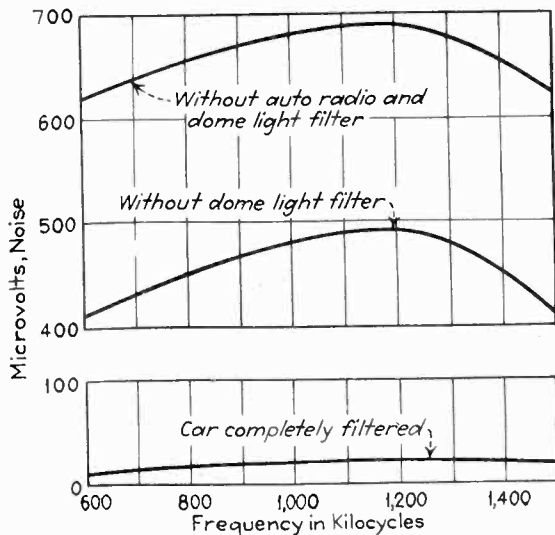

Fig. 3—Reduction of radio noises by proper filtering

# Public address at The Century of Progress

**A**MONG the many outstanding engineering feats at the A Century of Progress Exposition in Chicago, sound reproduction holds a very prominent position. More sound equipment is in use at this exposition than has ever been concentrated in one locality before. The main sound distribution system alone is the largest ever assembled anywhere in the world.

The unusual demand for coverage of an area three miles long with as many as 350,000 people in attendance has presented several very interesting engineering problem aspects of which are presented below as outlined by the Electro-Acoustic Products Company of Fort Wayne, Indiana, which developed the system.

The system is used not only for distributing information pertaining to various activities on the Exposition grounds, urgent messages to locate individuals, instructions to the Exposition Police force, which are delivered in code, but also for reproducing musical programs.

Each loudspeaker station consists of an amplifier and two loudspeakers. The construction of the towers in



One of the many outdoor loudspeaker sound outlets

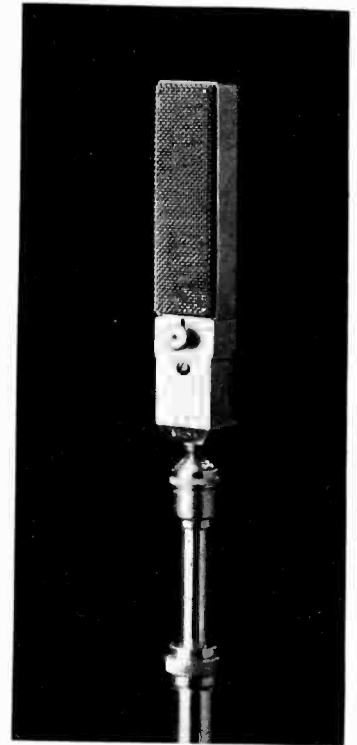

Crystal microphone — efficient input of the vast P.A. system

which this equipment is mounted is unique from both architectural and acoustical standpoints. Two heavy duty electro-dynamic sound reproducers are mounted in a box baffle on top of a 30-foot steel pole. The amplifier is located under a circular seat at the base of the pole, where it is easily accessible for tube replacements. The baffle box at the top of the tower is divided into four sections so that radiation of sound is accomplished from the back as well as the front of the cone diaphragm, thus effecting a distribution of sound over an area of 360 degrees. The top and bottom of the baffle box are sloped

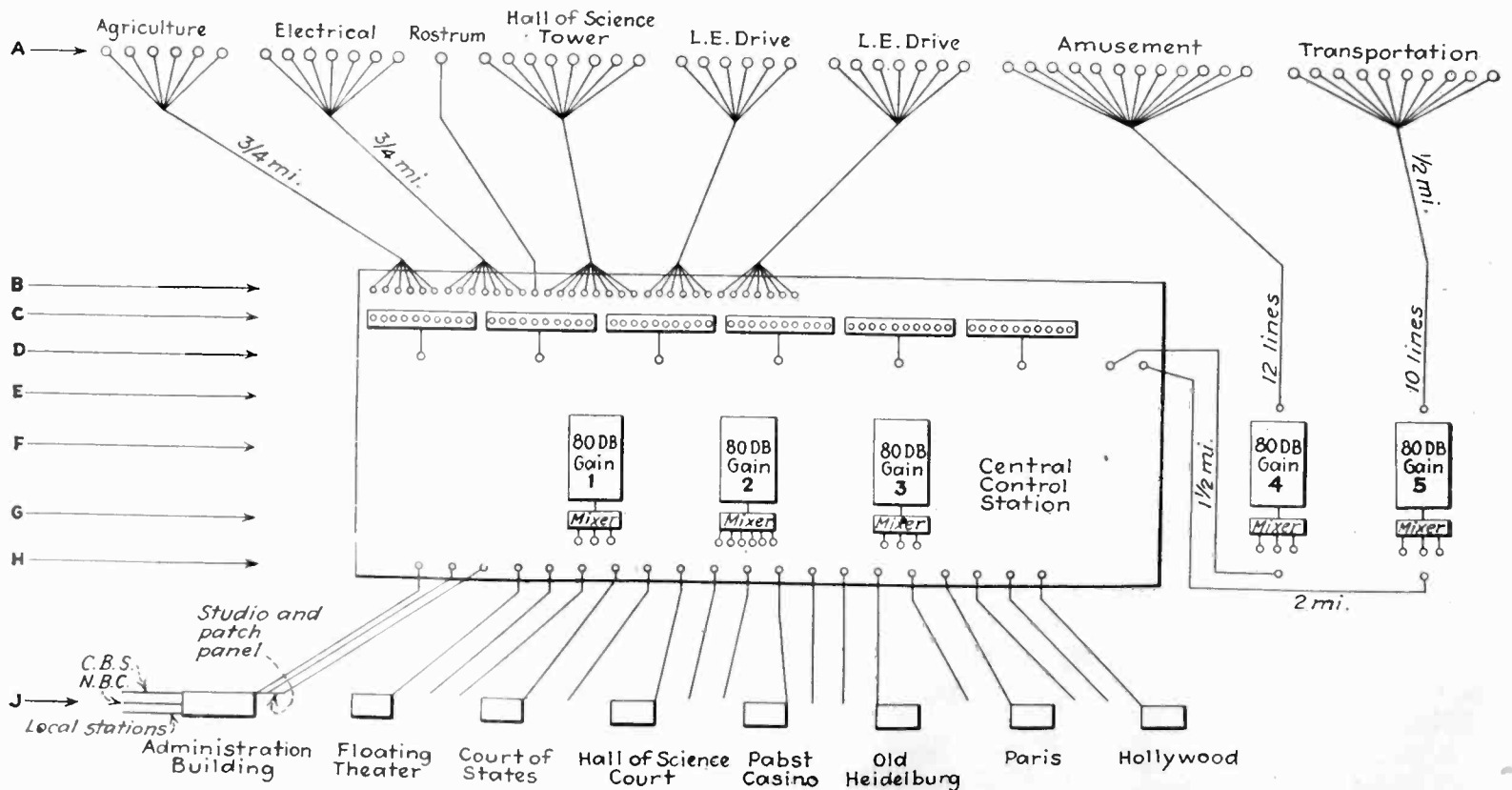

Layout showing the input stations and the central control station from whence radiates sound to 57 speaker stations situated in all parts of the Century of Progress grounds. Local music, from records, is augmented by programs from pickups from five exposition points and both large national broadcasting systems

downwards at an angle of 20 degrees to project the sound into the crowd.

Naturally a uniform radiation over an area of 360 degrees is not obtained at all frequencies: however, the tower is designed so that the baffle may be turned in the direction where the best coverage is desired. Sufficient radiation of extreme highs is obtained over the entire 360 degrees to transmit satisfactory quality over this area. Ten of these baffles are mounted on decorative flagpoles along the Avenue of Flags and a number of them on structures mounted on concession buildings.

Sixteen loudspeakers and eight amplifiers are installed in the Hall of Science tower, using the wall of the tower as a baffle. The speakers are mounted at a 15 degree angle to project the sound down and effect satisfactory distribution of the higher frequencies. The amplifier associated with each pair of loudspeakers is a three stage resistance and transformer coupled unit using a type 56, 59, and four 250 tubes. Two 866 rectifier tubes supply the amplifier and 30 watts to each speaker field. A gain of 75db. is available with a response flat within 3 db. from 50 to 8000 cycles. Each amplifier has a relay across the power switch and is operated through a 12 volt d-c circuit from the Central Control Station.

The gain control on each amplifier is adjusted so that the maximum level of sound desired in its area is obtained when a level of plus 2 is received from the Central Control Station.

### Central control station equipment

At the South end of the Hall of Science is the Central Control Station with a room provided for announcers. The operating room is provided with a glass front through which visitors may view the amplifier racks, the patching panels and the three sets of dual turntables.

There are three input amplifier racks here with a spare amplifier used as a "standby" to be cut in immediately in case of a failure. Each rack consists of a three stage amplifier having a gain of 80 db., a main gain control, volume indicator, a three position mixer and a monitor speaker fed by its own output tube bridged across the output of the amplifier. One rack has a six position mixer.

The frequency transmission characteristics of these amplifiers are not flat, the amplifiers being equalized to give plus 3 db. at 60 cycles and plus 9 db. at 7500 cycles. This equalizes the loss in the lines to the loudspeaker stations and the deficiencies of the loudspeaker above 5000 cycles, resulting in a uniform response from 60 to 7000 cycles over the entire system.

On the schematic layout of the system, the 57 loudspeaker stations are represented as circles "A" and are shown grouped as normally used. Each station has two lines to a jack "B" at the Central Control Station. When a plug is inserted in one of these jacks, the relay at the loudspeaker station is energized and the amplifier turned on. By means of the jack panels "C" any ten stations may be connected together as a group. Provision is made for six groups with as many as ten stations in a group. By patching from "D" to "E" any number of groups may be connected to any one of the three input amplifier channels "F" in the Central Control Station. The mixers "G" may be fed from any of the lines terminating at the jacks "H."

Pickup channels are provided for programs originating in five local stations as well as from the studios of the National Broadcasting Company and the Columbia Broadcasting System. Facilities are also provided for a

[Please turn to page 283]



One of the many distinctive types of loudspeaker stations which effectively cover the principal thoroughfares, concessions, and important buildings. By these outlets visitors—or police—can be reached in any part of the out-of-doors

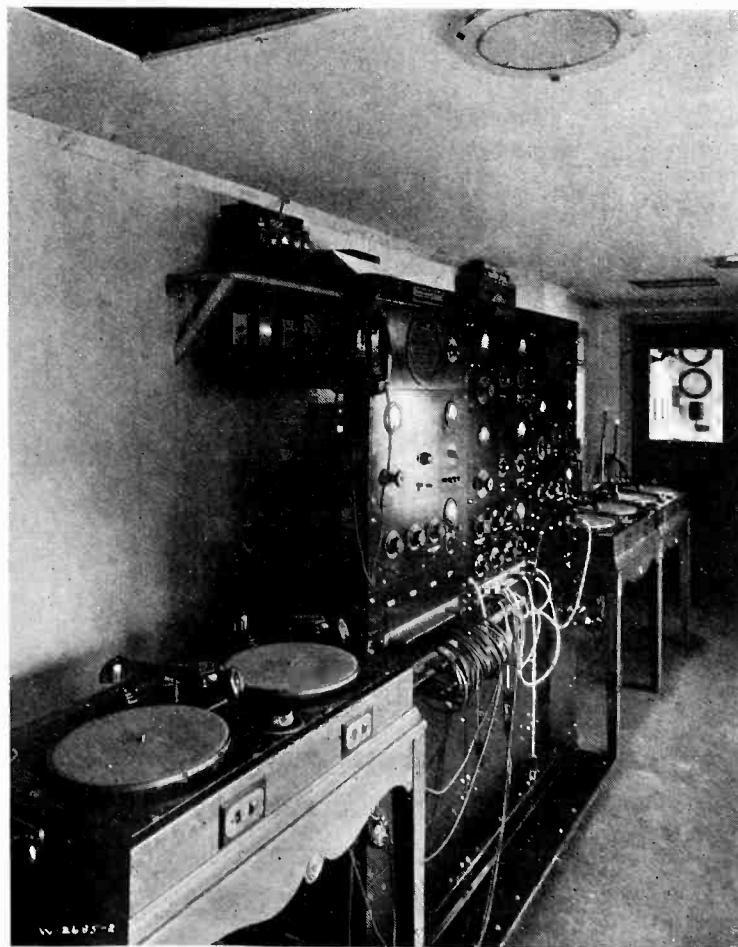

Interior of the central control booth housing the input lines from all parts of the grounds, broadcasting stations and other sources of pickup, plus the record turntables and three 80-db. amplifiers



# Installing photocell control

in manufacturing plants.  
Practical advice from  
an experienced consultant

By REX D. McDILL

*Industrial electronic engineer,  
Cleveland, Ohio*

---

**T**HERE is now a very wide field for the application of photocell and electronic devices locally in industry, a field that at present is not over-supplied with talent. It is the most interesting of all forms of engineering because every problem calls for invention.

▼

## JOBS FOR THE INDUSTRIAL ENGINEER TO UNDERTAKE

- Automatic sorting machines
  - Automatic inspection machines
  - Automatic wire gauging
  - Automatic dimension gauging
  - Automatic color sorting
  - Automatic thickness gauging
  - Automatic hardness testing
  - Automatic machine control
  - Automatic production machines
  - Automatic sorting of electrical units
  - Automatic control mechanisms
- ▲

---

### *Creative thinking needed*

The electronic engineer who is taking up photocell control work must have inventive ability. Every job will require creative thinking,—and the visualization of a complete working mechanical and electronic device, with every element co-ordinating to do the work planned for it.

---

As the art develops the need for invention will be less because there will then be precedents and standards to go by. But at the present time there are no such standards, and every new principle has to be worked out on the job.

The industrial electronics engineer who is taking up such work of photocell and electronic equipment must have inventive ability. Every job will require creative thinking, and unless he can completely visualize a working mechanical and electronic device in operation, functioning in every part—with each mechanical, electrical and electronic element coordinating in doing the work he has planned for it to do, he had better “steer clear” of it. He will find few references to help him out on his problem unless it is a simple one, and if it is simple he will find that in many cases one of the large manufacturers of electronic equipment is already working on his prospect. There is not much money in installing door-openers or counting machines for products. There is good money in building production machines if you know how.

### **A minor tool on a major tool**

Mechanical machines will always be the primary tools in manufacturing. Electronic devices as integral parts of those machines perform functions that cannot be done by mechanical methods. In the photocell and other electronic devices we therefore have developed a minor tool to use on a major tool. Unless you know how the major tool is constructed and can build one, your electronic device is of no value as such. This is the principal thing that the industrial electronic engineer must bear in mind before he tries to convince any manufacturer that he can save him money by building a machine.

The special measuring instrument field is one which does not require a great amount of mechanical knowledge. Meters can be purchased and the engineer can build his own amplifiers. This work requires lots of ingenuity and specialization, but there is a growing demand for instruments to measure everything from hair to steel billets. The only drawback to the work is that it requires lots of thinking to turn out something new, and unless there is a repeat demand the pay is small. It is a good way to get started, but don't figure on making a living off of it the first year.

Functions of electronic devices in industry are limited to instrumentation, inspection and control, and when narrowed down their only function is really *inspection*. The instrument itself is an *inspection tool*, and electronic control devices really inspect before their control functions start. Many factories turn out products that cost more to inspect than the actual cost of material and machine labor. If these products are made in large

quantities and require 100 per cent inspection there is an excellent opportunity to devise a machine to do the trick and save money.

Analysis of factory production costs in many instances indicate that inspection costs are often in excess of labor production costs. In one instance where inspection on a product cost \$1.17 per thousand pieces, an electronic sorting machine did the job for \$.08.

Savings may be indicated by investigation of this service when tooling for the manufacture of a new product.

These are the kind of electronic jobs that pay, but they require special ability.

### Study the manufacturer's product

The engineer will find that he will have some difficulty in getting into the average plant. If the plant has its own development department it is an even bet that he won't get in at all! Most manufacturers consider that they have certain ways to do things that are better than the other fellow's and don't want their ways known outside their shop. Therefore examine your manufacturer's product before you go to his plant and try to figure out how he makes it and then find out if you can suggest to him a way to do it better or faster. I don't mean that you have to go into details on how you would build the machine. If you do that you are giving your intellectual merchandise away. Ask for a problem like an inspection job that is giving trouble and you will awaken his interest and get something to think about.

One of the first things a manufacturer wants to know is the "patent situation" as he calls it. The only way an engineer can get along is to guarantee nothing in the way of patentability or freedom from infringement and to claim exclusive rights on everything new that he has developed while working on the machine. If he gives anything else with the machine than the working machine and instructions for its operation and maintenance, he is giving his property away. Sometimes it is necessary to assign a license to the manufacturer for his exclusive use in his industry on a device that is special and developed at a great expense. In that event the engineer should retain exclusive rights for the idea in all other industries and the manufacturer should pay for the cost of obtaining the patent through your attorney. This writer advances no socialistic doctrine when he says that the engineers in the last decade in this country have sold their work for a mess of pottage, and that most of them can learn better business methods from the corner newsboy. Hang on to your intellectual property that is rightfully yours and which will be your main stock in trade if you continue in the profession.

### Pricing the finished job

Last, but not least, sell the machine or the idea for *what it does* and *not* what it costs to make. A good way to work is to figure the machine on the basis of what it saves in the course of a year's time when setting the price. And don't forget to include the three-shift periods that will eventually be coming along, the improved quality of the product and other factors that enter into the savings. Then charge for the machine what those savings would be in a year's time. If you can't do it for that, pass up the job, because it is an even bet that there will not be a sale anyway. But if the savings run, say, \$6,000 for the year, ask that much for the machine even if it costs only \$200 to build. You will not only get the money with greater grace than if you asked \$250, but you will get more respect.

---

*"There is no depression*

*in this business of electronic installation, if you can deliver the goods,"*  
says Mr. McDill.

*"The hard-boiled factory owner can always dig down for anything that will save him money, no matter how loud he yells for more business and about hard times."*

---

Always get a down payment, guarantee the job, and give the client his deposit back if not satisfied. The biggest credited concern in the country will do that if it believes in you.

A thinker can get more fun out of this work than any other kind of work under the sun. Every day there is something new to play with and think about. There is no depression in this business of electronic installation if you can deliver the goods. The hard-boiled factory-owner or industrialist can always dig down for anything that will save him money, no matter how loud he yells for more business and about hard times.

The "modernization" and "rehabilitation" propaganda that has recently been put out will be a great help. Industry will have fewer machines, smaller and funnier-looking perhaps than those in the past, and the days of mass production haven't even a good start. There is no such thing as modernization in any plant if the industrial electronics engineer is left out of the picture. The six-day week is gone never to return, and the present depression will be forgotten even in the leisure time to come from the thirty-hour week. All progress comes from new ideas and new things to use, and I firmly believe that the new cycle in progress that we are entering will be known as the electronic age.

---

### PHOTO-CELL BAG FILLER



When the pointer on this Toledo scale reads proper quantity, the photo-cell cuts off supply of powder

# HIGH LIGHTS ON ELECTRONIC

## Minedoors photocell controlled

TWO DOORS IN THE MINE OF THE Buck-eye Coal Co. at Nemaocolin, Pa., are being operated by photocells. As the locomotive and cars pass along the heading, they intercept a ray of light which is directed toward a photoelectric cell. The interference of another light path sets another train of sequences in operation, by which the door motor is reversed and the door is closed.

At Nemaocolin two entirely separate systems of ventilation are employed, receiving their air from different sources and being set in operation by separate fans. Where the cars pass from one system to another, a dead section is provided long enough for the retention of a single group of cars, with some space to spare. The first door is opened, and the cars pass into the neutral or dead section and the door is closed. Immediately thereafter the second door is opened and the cars pass through it, and the second door is then shut.

In order to save time and to avoid the stopping of the cars, and at the same time to provide an unquestioned sequence in the operation of the doors, the photocell method of operation was introduced.

Among the difficulties to be avoided were the discontinuity of the mine train, the cars and locomotive not forming a continuous barrier to a ray of light, and the danger that men passing along the roadway would intercept the light and disrupt the operation of the door, which would begin to open when the man passed the light and be closed long before he reached it.

To obviate the first difficulty the light was thrown at such an angle that the line of the beam when projected on a horizontal plane would be at an angle of 45 deg. to the direction of the heading; thus the light could not fail to be intercepted by the rear end of one car or the front of another when the coupling between the cars was actually abreast of the light. To avoid the operation of the electric eye by the passage of men, the lights were set near the roof and in the center of the roadway, and the electric eye was placed in the lower corner of the heading on the road side, so that a man 6 ft. tall walking on the clearance side of the track, or even on that half of the track thereto adjacent, would not intercept the light with any part of his body, and to make sure that no one would attempt to travel on the light side of the heading, or on that half of the track toward the light side, a guard such as is used to keep cattle off the railroad track was installed immediately beneath the light on both sides of

the rail on the light side of the heading.

Three signal lights are provided—red, green and white. Red shows that door is closed, green that it is open, red and white that the door is closing and green and white that it is opening.

★

## TESTING AUTO ENGINE

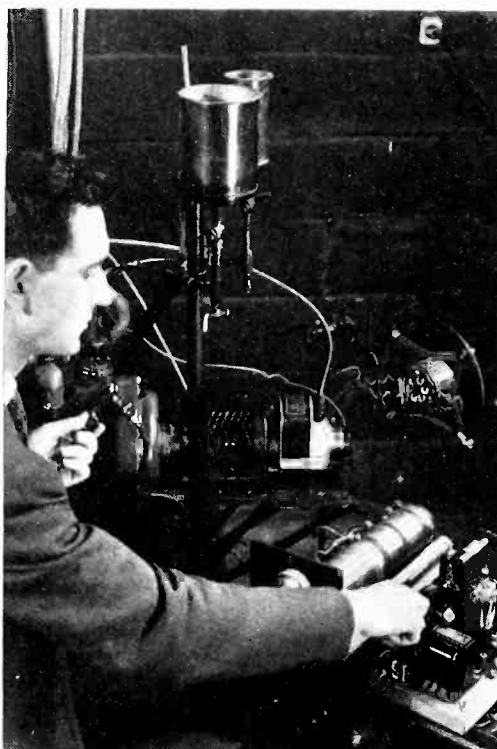

Performance of gasoline engines is being studied by means of microphones and amplifier circuits which filter out unwanted sound, enabling tester to concentrate attention on particular mechanical cycle under scrutiny

★

## Air-field wind-vane controlled by photocells

TO AVOID THE DIFFICULTIES with the troublesome standard "wind-sock," which is usually too small to be seen at a distance, and requires that considerable wind be blowing before it will indicate, a large remote-controlled "wind-T" has been experimented with at the Cleveland air-port.

This wind-T is operated from photocell controls on a small and highly-accurate pilot wind-vane. As the pilot vane freely turns about, it covers and uncovers photo-cells governing the movement of the large indicator. In this way difficulties with friction and contacts on the pilot vane have been eliminated.

## Photocell traffic signals on bridle path

THE PHOTO-CELL TRAFFIC SIGNALS IN Rock Creek Park, Washington, D. C., shown on the front cover of this issue of *Electronics*, have now been in service for a number of months, and have solved an otherwise difficult problem of providing at a dangerous intersection signal lights operated by horseback riders. Regular timed signals could not be set up, since the horseback riders come along at rare and irregular intervals. Contact-mats or treadles for the horses to step on would also have been out of the question. So the photoelectric method was the only one that contained the elements of complete satisfactory service. Two beams are used on each approach, affording one-way operation only, so that the signals work only when horses approach the auto roadway.

The story locally is that at the first installation the photo-cells were placed too low, so that a large dog passing by would operate the signals. This was corrected.

Then, after the system had been in use several months, trouble began to develop in mid-summer from the signals operating in reverse every time a white horse went by. This was finally traced to a patch of sunlight which illuminated the horse's coat, and so signaled the photo-cell. When this sunlight was shaded, the signals resumed their orderly operation, much to the relief of the traffic policemen on the park assignment.

Photo-cell controls have also been used with success to operate gates on bridle-paths. Ordinarily it is a difficult operation to open a gate from on horseback, let the animal through, and close the gate again. But with a photo-cell-operated gate, the rider merely approaches the gate, which swings open and closes behind him.

★

## Radio phones connect up big San Francisco construction job

RADIO TELEPHONES OPERATING ON 4 to 6 meters, and using 6-ft. vertical aluminum rods as antennas, are being used to connect up the various isolated bridge pilings, boats and shore works, preceding the construction of the great bridge and causeway which will connect San Francisco with Oakland, 4 miles away. By means of this system of 22 radio telephone stations, the superintendents can talk to their men at work on any of the piles scattered across the bay, or



# DEVICES IN INDUSTRY + +

on the boats carrying materials as they ply back and forth across the bay.

C. H. Purcell, chief engineer, declares that the communication thus afforded to inaccessible points, will greatly reduce expensive trips by messengers and save large amounts of money during the years of bridge construction.

D. R. Tibbetts, an engineering student at the University of California, installed the short-wave telephone system. He also made the first Pacific Coast police radio installation for Chief Vollmer of Berkeley, Calif., in 1927, when he was 16 years old.

+

## Bedroom windows controlled by photocell

COMBINATION OF AN electric window-closer and a photocell concealed in a small bedside table, make it possible for the bedroom occupant to open his windows by a wave of the hand after he has gotten into bed, and to have them closed automatically next morning by the first flushes of rosy dawn.

One of the first installations of such a photocell window opener is in the lighting exhibit of the Electrical Association of Philadelphia, in the Architects Building in that city. Windows can be opened or closed to any position, by the duration of the illumination of the photocell. This Cyco window-control unit was also recently shown in the "wonderhouse" rooms at Strawbridge and Clothier's store in Philadelphia.

## Photocell titration shown in British Museum

A LONDON READER OF ELECTRONICS wrote to the editorial offices in New York for information on photo-cell methods of controlling large-scale chemical processes handling several hundred tons of solutions daily, and operating continuously. Such information as could be located was assembled and forwarded to him by the next boat.

His next letter explains: "All the data sent are most helpful. A week after I had written, however, I paid a visit to the Science Museum at South Kensington, where I found a model set-up for a parallel operation—for the photo-electric control of chemical titration."

+

## Photocell door opener for household refrigerators?

A PHOTOCCELL DOOR-OPENER for the household electric refrigerator, by which the housewife can open the door with both hands fully laden, by intercepting a light-beam, is suggested by G. W. Alder, engineer for Good House-keeping Institute, New York City. The need for such door-opening aids is already being recognized by refrigerator manufacturers in supplying foot pedals, knee levers, and thigh pressure-plates, Mr. Alder points out.

But each of these devices requires

that the housewife or maid go through some unnatural action—even to the extent of balancing on one foot, with both hands full, while she operates the pedal-opener. On the other hand, a photocell opener would require merely that the woman approach the refrigerator and—presto—the ice-box door would open, without any effort.

+

## Sheet-catcher with photocell control

TODAY'S CHEAP AUTOMOBILES and corrugated iron sheds and roofs typify the influences which, by tremendous increase in demand, have revolutionized the making of sheet steel. Formerly, as sheets were being rolled, at every pass men caught them and thrust them back into the rolls again, a slow, expensive performance.

Then came the continuous wide-strip mill, which poured out rolls of wide steel strip as a paper mill pours out paper. To this the sheet mill now makes response: to catch and return the sheets there is a motor-driven sheet catcher controlled by an electric eye. It is quick work—its 2-hp. alternating-current motor can reverse 40 times a minute.

The electric sheet-catchers, with photo-electric control, shown in the accompanying pictures, are installed at the plant of the Newton Steel Company, Monroe, Mich. Ray Fenton is electrical superintendent in charge.

+ + +

## PHOTOCCELL TRIGGER CONTROLS HOT-SHEET CATCHER

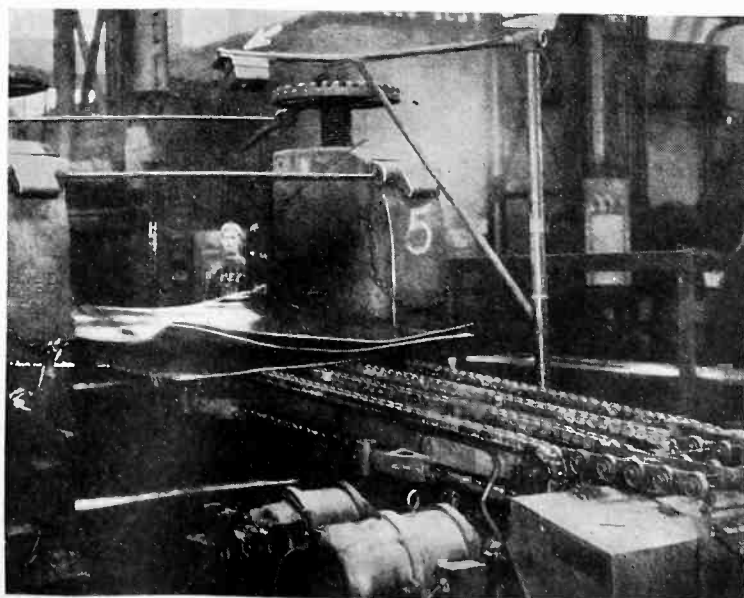
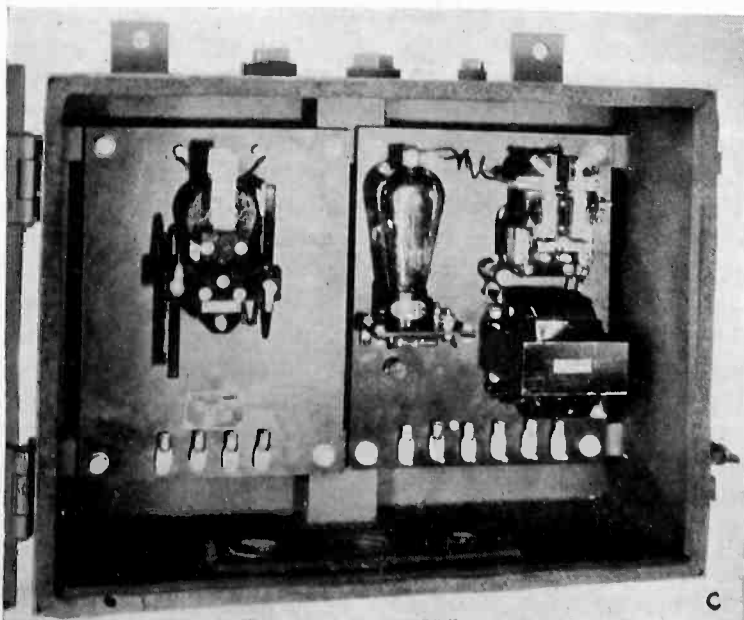

In place of the mechanical trigger actuated by the impact of the hot sheets in rolling mills, a photocell control has been applied. The light-source is above the table at right, the photo-cell below. The control-panel is pictured at the left

# Thermionic cathodes

## for gas-filled tubes

By E. F. LOWRY

*Westinghouse Elec. & Mfg. Company,  
East Pittsburgh, Pa.*

**I**N THE high vacuum type of thermionic device only the simplest forms of cathode structure may be used. This limitation of design is imposed by the negative space charge which builds up in the region immediately surrounding the cathode. If the cathode surface contains any cavities or recesses, the space charge in these depressions may reach such high values that no electrons can escape except under the influence of abnormally high positive potentials. As a result, the only practical way of increasing the efficiency of cathodes for use in high vacuum is by using a thermionically active material which has a lower work of emission for electrons.

In gas or vapor filled tubes this space charge limitation is not so important a factor in design, for the reason that positive ions are constantly falling into the negative space charge region. One positive ion has the capacity of neutralizing the space charge of a fairly large number of electrons. As a result electrons may readily be drawn from deep slots or corrugations in the cathode surface

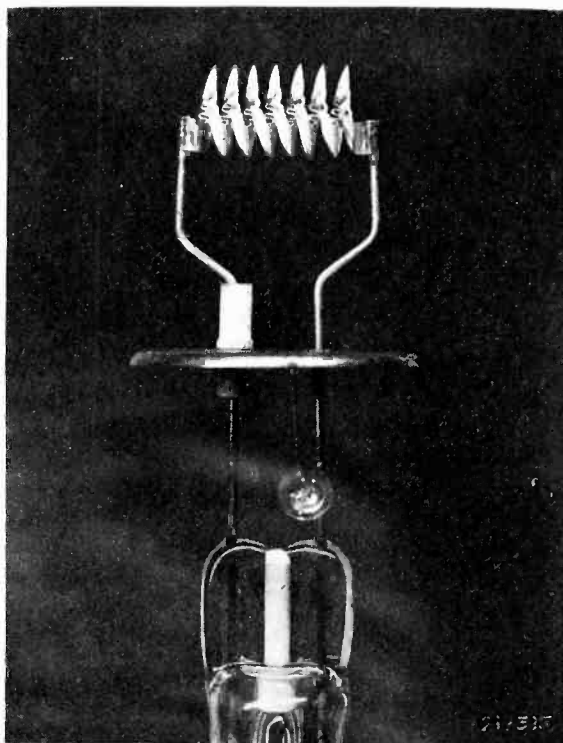

**Fig. 1—Helical cathode made from ribbon 14.5 inches long but crimped and compressed into one inch length**

by potentials only slightly greater than the ionization potential of the gas filling the tube, the number of electrons so drawn being limited chiefly by the thermionic emission from the walls of the slot and to a lesser degree by the geometry of the slot.

Conversely, the walls of such cavities are very poor heat radiators indeed. We come then at once to the

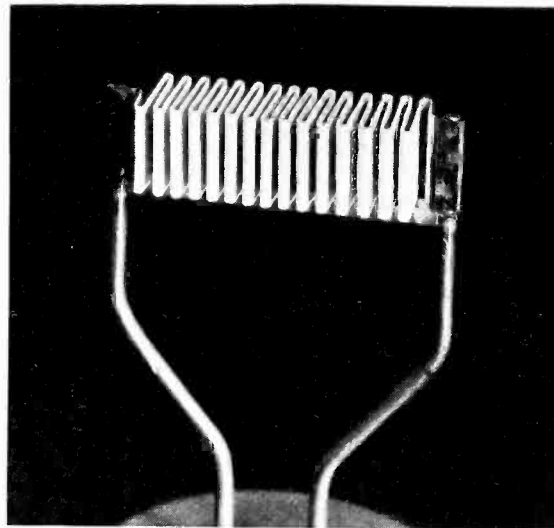

**Fig. 2—Filament requiring 200 watts heating energy with a heating time of two minutes and a peak plate current rating of 65 amperes**

proposition that if we fold or crimp a filament ribbon in such a way that it forms a series of parallel surfaces whose separation is small compared to the ribbon width, we will materially reduce the heating energy necessary to maintain our cathode at the desired temperature without impairing the electron emission which it can furnish. Furthermore, such a cathode may be surrounded by one or more suitably designed radiation shields which will still further reduce the necessary heating energy. It is obvious that this method of construction will give large gains in efficiency as figured in terms of amperes of space current per watt of heating energy supplied to the cathode. It is well to bear in mind, however, that this high efficiency is gained at the expense of rapid heating. An increased length of time for the cathode to come to operating temperature is a necessary consequence of the reduced heating energy and, where radiation shields are used, of the increased heat capacity. One must, therefore, choose between high efficiency and short heating time. It is impossible to combine both properties in a high degree in the same cathode. At present the major emphasis seems to be on getting maximum efficiency.

Another angle to the design of cathodes for this type of service is the problem of mechanical rigidity. We no longer have a simple ribbon stretched between a series of hooks, but a complicated structure made from such a ribbon and which is supported, usually in a horizontal position, only at its two ends. No sagging of this structure is permissible over a lifetime of something like 10,000 hours at an operating temperature in the neighborhood of 900 degrees C. To this end the strongest possible material must be chosen as well as the most rigid type of structure that can be built.

A type of cathode recently developed in this laboratory which fills these requirements reasonably well is shown in Fig. 1. It presents a radical departure in appearance from the conventional filament of the radio or vacuum tube art. The ribbon of which this cathode is formed is 14.5 inches long, yet when crimped and wound into its

helical form, a structure is obtained which has a length of only one inch. The reduction in radiating area obtained results in an increase of efficiency of nearly 250 per cent. This filament in the size illustrated, operates at 5 volts 20 amperes, yet has a peak plate current rating of 22.5 amperes, an efficiency of 225 milliamperes per watt. Since it is self-shielding, its heating time is relatively short, 45 seconds. If radiation shields were used to increase the efficiency still further, the heating time would be considerably increased. By a close inspection of the figure it will be evident that the corrugations of the ribbon are not disposed radially, but make a considerable angle with the helix radius. This detail of the design improves the rigidity of the structure.

The material used for the core of this cathode is a nickel alloy called Konel, which has been in use for several years in the vacuum tube field as a core material for oxide filaments. Its mechanical and electrical properties are such at 900 degrees C. that the cathode illustrated has at least five times the mechanical stability it would have had if nickel, for example, were used as a core. Another type of cathode design particularly advantageous when the filament width is at least  $\frac{1}{2}$  inch is shown in Fig. 2. This filament, as shown, has an emitting area of 22.5 square inches, yet requires only 200 watts heating energy, or about 9 watts per square inch. If it were stretched to full length, nearly 700 watts would be required to bring it to the same temperature. It has a peak plate current rating of 65 amperes and requires only two minutes heating time.

The peak ratings given for the two filaments mentioned are by no means the maximum electron emission of which they are capable, but represent all it is felt they should be called upon to furnish if they are to meet operating life requirements of 5,000-10,000 hours. It is quite possible to draw emissions as high as 10 amperes per square inch from these filaments without ill effects. It must be understood that other considerations than the maximum emission limit the currents which may be drawn from these filaments. It is not the purpose of this article to discuss these factors, but one at least must be mentioned, and that is the heating effect imparted by the plate current. True, the work done in liberating electrons from the coating has a distinct cooling effect on the filament, but this is far outweighed by the heat developed, at the negative end of the filament at least, by the plate current flowing back into the filament core. This becomes a serious factor when it becomes equal or greater in amount than the size of the filament heating current itself, as it might very well do if the plate current approached the saturation emission value. This then is one of the chief reasons why peak plate current values must be limited to the order of magnitude of the filament current with the average considerably below this figure.

Further gains in efficiency have been attained in the cathode illustrated in section in Fig. 3. Here a filament of the same surface area as that of Fig. 1 has been surrounded by three concentric bright nickel cylinders, which cuts the power required to heat the filament about in half. The inner of these cylinders, having nearly the same surface as that of the filament itself, reaches a temperature of 800 degrees C. or over. It is a simple matter to coat the inside surface of this cylinder with a highly active mixture of barium and strontium oxides. Thus, in one stroke we have cut our heating energy in two and doubled our emitting surface, a gain in efficiency over the filament of Fig. 1 of nearly 400 per cent. That

this is not 400 per cent is due solely to the fact that the inner shield cannot of necessity come to quite the same temperature as the filament itself. However, efficiencies as high as one ampere per watt are readily obtainable, which, by the way, represents only 10 per cent of the total energy loss in the tube, so that further gains in efficiency are of minor importance, except in applications where the filament must be operated continuously, though plate currents are drawn only at irregular intervals. This cathode which partakes at once of the nature of directly heated and indirectly heated cathode portions we have called, for want of a better term, a "compound cathode."

A second type of compound cathode is shown in Fig. 3. In this type the greater portion of the cathode is indirectly heated and is enclosed by the filament. This arrangement is the ideal one from the standpoint of uniform temperature. In both the compound cathodes shown it is essential that the indirectly heated portion be negative with respect to the directly heated portion of the cathode during the half cycle that anode current is flowing. This requirement is for the reason mentioned above; viz., that portion of the plate current contributed by the indirectly heated part of the cathode must not be allowed to flow through the heater ribbon before reaching the emitting surface, since it may be several times the size of the heating current used to bring the cathode

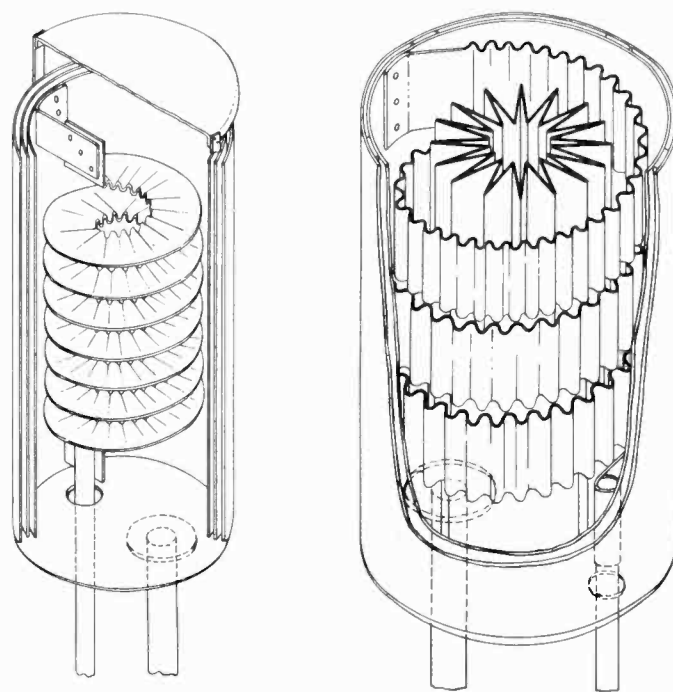

Fig. 3—Left—Filament four times as efficient as that in Fig. 1. Right—Cathode surrounded by the filament and indirectly heated by it

to full operating temperature. By the simple expedient just described, this difficulty is completely eliminated and only the heating current  $I_f$  plus that portion of the plate current emitted from the filament surface itself ever enters the core of the heater ribbon.

There has been no attempt in this article to give a complete discussion of the problems met in the design of cathodes for gas-filled tubes for the industrial field. We have simply endeavored to show how the demand for cathodes of from a few amperes to several hundred amperes capacity has been met with cathodes of the oxide-coated type which have the required mechanical ruggedness, thermionic efficiency and, for some of the designs mentioned, a proven useful life of over 10,000 hours.



# A cold-cathode amplifier tube

By HERBERT J. REICH and  
WILFRED M. HESSELBERTH

THE recent development of several types of cold-cathode amplifier tubes has focussed attention upon this interesting branch of the field of electronics. Such a grid, properly designed and placed, can control the breakdown of the tube but has practically no subsequent effect upon the anode current except in diverting the anode current to itself if the total current is constant. The "grid-glow tube" and the "thyatron" are examples of tubes which employ grids to control the breakdown. Any difference of potential between the grid and the ionized gas which surrounds it results in the

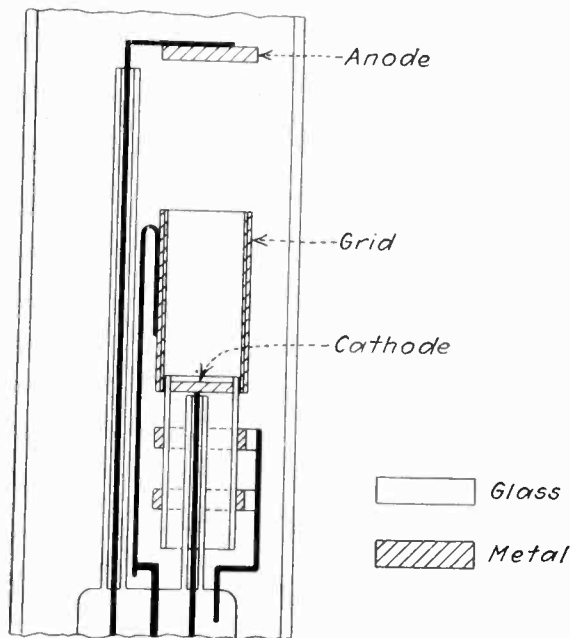

Fig. 1—Cross-section of grid-controlled glow-discharge tube.

formation around the grid of a space charge of opposite polarity to the grid. This space charge or "sheath" shields the main part of the discharge from the grid, so that the only effects of variation of grid potential are a variation of the magnitude and direction of the grid current, and a corresponding variation in the thickness of the sheath.

Perhaps the most natural method of attacking the problem lies in the introduction of a grid between the anode and cathode of a glow or arc discharge tube. If the total cathode current is fixed by means of a ballast resistance, the grid current does, of course, decrease or increase the anode current, but no amplification is obtained. Under certain conditions it is possible to

increase the thickness of the sheaths surrounding individual grid wires to a point at which they become continuous and result in extinction of the discharge.<sup>1</sup>

Preliminary research by one of the writers<sup>2</sup> at Cornell University on the use of a special type of grid in a gas-filled discharge tube indicated that it might be possible to design a three-element gas-filled tube in which the current is at all times under complete control of the grid. More recent work at the University of Illinois has resulted in the development of a tube which, although its characteristics are far from ideal at the present time, nevertheless gives promise of the desired end.

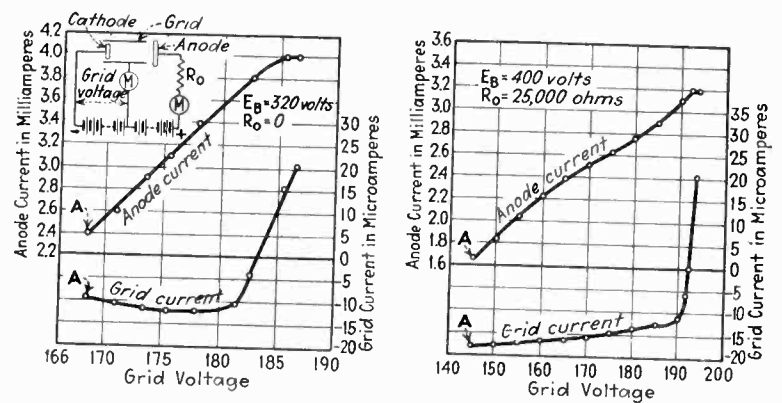

Fig. 2—Mutual and grid characteristics of helium-filled tube. Static at left; dynamic at right

Figure 1 shows the cross-section of one form of this type of tube. Glass insulation of the leads forces the discharge between anode and cathode to pass inside of the cylindrical grid. The tube is filled with an inert gas at a pressure of about 3 to 4 centimeters of mercury.

In the circuit used in obtaining characteristic curves, it should be noted that the potential of the grid is intermediate between that of the cathode and anode and that it is measured with respect to the cathode. The characteristics of individual tubes vary with structure and gas pressure. The static and dynamic mutual and grid characteristics of a typical helium-filled tube are shown in Fig. 2. The anode current is at all times under control of the grid and may be completely extinguished if the grid is made sufficiently negative (points A in Fig. 2). The grid current is small over the operating range; by proper design and choice of gas pressure it may be limited to 5 microamperes. The anode voltage in more recent tubes has been reduced considerably.

This tube differs from the ordinary glow-discharge tube in that with dimensions and gas pressures which are usually used in this tube no ballast resistance is required in the anode circuit. Its function is the same as that of the load or coupling resistance in a high-vacuum amplified tube, and it may be replaced by an inductance.

To date the best mutual conductance that has been obtained is slightly more than 100 micromhos, and the best amplification factor about 4. The tube is quiet in operation and has been successfully used both as an a-f amplifier and as a control tube operated by photocells. The dependence of operation upon positive ion current obviously makes the tube in its present form unsuitable for r-f amplification. The attainment of complete grid control in a simple three-element gas-filled tube appears to be a step forward, and it is hoped that further research now in progress will result in the development of a tube available for commercial use.

1. Lübecke; Zeit. für Tech. Phys., 8, 445-449, 1927.  
2. H. J. Reich.

## Public address at The Century of Progress

[Continued from page 275]

remote control microphone pickup of programs originating in such locations as the studio in the Administration Building, or any one of 25 other locations such as the Floating Theater, the Court of States, Hall of Science, and a number of such concessions as Pabst Casino, Paris, and Old Heidelberg.

The system is a-c operated and consists of five input amplifier channels which supply the 57 loudspeaker stations scattered over the grounds. Five different programs can be broadcast simultaneously from the 57 stations, or these stations may be grouped together in any desired number or location. When occasion demands, all five input amplifiers may be fed from the same source thus sending out programs over the entire system.

Three of the five input channels are located in the Central Control Station at the Hall of Science, one in the Transportation Building and one at Fort Dearborn. The input channels located in the Transportation Building and Fort Dearborn are entirely self sustaining and programs picked up at those locations may be sent to the loudspeaker stations in the territory immediately adjacent. When desired these programs may also be picked up at the will of the operator in the Central Control Station and patched through the main input equipment for redistribution to other parts of the grounds.

Because of the large area covered and the amount of audio power involved, a departure was made from the usual practice of concentrating both the input and power output equipment in one location and radiating therefrom to the output channels to the loudspeakers.

Situations arise in which five separate programs are going through the five channels and it is desired to make a general announcement over the entire system and then resume with the five separate programs. To accomplish this with a minimum of effort and loss of time, a break-in arrangement is provided.

The six position mixer of channel "2" is used for the general announcement. Channels "1" and "3" are cut from their mixers and connected to the mixer of channel "2." Channels "4" and "5" are cut from their mixers and connected to the output of channel "2" by means of relays. The complete operation requires the changing of four switches and the operation of the mixer on channel "2." The four switches could be replaced by relays operated by one switch, but greater flexibility is realized with a separate switch for each channel "1", "3", "4", and "5".

The main gain controls of channels "4" and "5" are always set at one position and a pad is in the line coming from the central control station. This means that the operators of these two channels need not touch their controls when their channels are switched in for a general announcement. At the end of the announcement the four switches are thrown back to their normal positions and the original programs continue.

For microphone pick-ups sent to the central control station over short lines, only the microphone and its associated three stage amplifier are used, which gives a level of minus 20 db. For pick-ups sent over longer lines, the microphone and its amplifier are supplemented by a portable amplifier with a three position mixer which supplies the Central Station with a zero level.

The microphone used for this work is a special twelve cell crystal unit. These microphones give excellent reproduction due to their smooth frequency response characteristic and the absence of the strident character of response caused by cavity resonance which is quite noticeable from microphones of the condenser and carbon types. The sensitivity and frequency response are the same in all directions which makes the microphone especially suited for the pick-up of large organizations out of doors.

The entire system is an outstanding example of flexibility, power and quality in a public address system. The quality of sound delivered has been adjudged excellent—even though the steamboat whistle at the Streets of Paris once interrupted a pick-up that sounded like an audio feedback to some alert NBC operator, who promptly cut the circuit.



## Suppression of auto radio noise

[Continued from page 273]

located even a short distance away from the spark plug the noise received would be greatly reduced. Working on this theory a receiver capable of measuring the magnitude of interference was connected to a standard car roof antenna by a lead off the rear of the antenna and, consequently, as much out of the field of interference as the antenna itself. It was estimated that with this set-up the maximum noise would be about 15  $\mu$ v/m. The actual noise measured was over 400  $\mu$ v. until the wire running to the dome light was disconnected at the dash, and grounded. Under these conditions, the interference was reduced to approximately 20  $\mu$ v.

The tests indicated the necessity of filtering all wires not directly grounded to the chassis which were in any way associated with the engine's ignition system, and which run close to the receiving antenna. It also indicated that the lead-in wire to the radio set should be thoroughly shielded, as well as the receiver, itself.

At first it was thought that the short lead-in could be shielded without appreciable transmission loss. However, measurements on 10 feet of shielded lead-in showed transmission losses of from 8 to 10 db. As a consequence an impedance matching transformer was designed, with the result that the shielded lead could be used with practically no loss in signal strength.

Having thus uncovered a few facts concerning auto radio interference it remained to make up and try out a few of these systems on various autos. The devices used on these trials were filterettes for the dome or tail light, depending whether a roof or under car antenna was used, and shielded lead-in from the antenna connected to an impedance matching transformer. Care was taken that this lead-in was completely shielded into the set itself. The ordinary spark plug suppressors were also used. Under these conditions measurements showed that the noise was reduced to less than 20  $\mu$ v.

Thus, much relief can be obtained from ignition noise in practically all auto radio installations by filtering some of the wiring of the car together with stopping all pick-up from the antenna lead.

# electronics

McGraw-Hill Publishing Company, Inc.  
330 West 42d Street  
New York City

O. H. CALDWELL, *Editor*

Volume VI —OCTOBER, 1933— Number 10

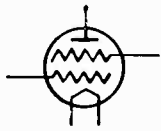

## New tube types in industry

THERE has been much talk against the introduction of new tube types for radio. This is sound, for simplification of radio tube numbers will best serve the public and the distributing trade that supplies it.

But when it comes to industrial types of tubes, used for a wide variety of functions, and supervised by competent electrical men, the situation is quite different. Tube types for industry are bound to become multitudinous, as tube applications spread in many different directions. Operating conditions will vary, and so special tubes will have to be developed to meet them. Price is less a factor here, because the tube's importance to its surrounding machinery or service is always out of all proportion to the tube's intrinsic cost, even produced in small numbers. In industry specialized service is the watchword, and it will be hopeless to keep tube types down.



## Nine times the horizon distance

USING his micro-short-waves, whose "optical" maximum distance of reception should be only about 20 miles measured by any ordinary "horizon," Senator Marconi has been getting distinct reception as far as 180 miles, or nine times the optical maximum, he said during his American visit. Signals at these frequencies (500,000 kc) he finds *wholly free from static*, even nearby lightning flashes being without audible effect. Fading, however, is severe, and unaccountable in its vagaries, but seems quite

independent of daylight or seasons. Still further work is to be done in these very short waves, and the limit of the new micro-waves domain is only the infra-red. Already 3-millimeter waves have been produced, but without actual transmission as yet. Their characteristics are unknown, and may be wholly different from anything we now have. Properties change quickly, even as one goes from, say, 60 cm. to 30 cm., the range of the Marconi micro-waves.

"And, remember—some new discovery tomorrow may upset everything we have today," commented the Marchese as his parting observation.



## Something else than "wired radio" —

CONSIDERABLE misunderstanding has resulted from newspaper headlines declaring "Wired radio held illegal in U. S. test case at Bridgeport, Conn."

The facts are that the principle of carrier-current broadcasting, as developed by Wired Radio, Inc., and the telephone companies, using carrier frequencies in the range from 15 to 60 kilocycles, had nothing to do with the Bridgeport case.

There, without a broadcast-station license, the Bridgeport man had operated a regular space-radio broadcast transmitter on 1510 to 1525 kilocycles, except that his antenna was tied into the local lighting circuit. His claim was that he thus produced only impulses in the lighting company's wires, and that this "wired radio" actuated his listeners' sets. At such frequencies of course there was large radiation, and the Government witnesses were able to pick up his programs on Long Island, twenty miles away. Radio sets in Bridgeport also responded to these illicit oscillations, some only at the bottom of the dial, others at four or five critical points on their dials, and still others all along the dial, depending on the principle of operation.

Judge Hincks, of the Federal Court, fined Norman Cohen, station owner, \$25 and costs, for producing radio radiation and emanations without a Federal license. The question of non-interfering distribution of programs over wire lines, as contemplated by wired-radio adherents, was not involved in the Bridgeport case.



## Photocell life and deterioration

**E**XPERIMENTERS new to the use of photocells, ask about the expected *life* of these light-sensitive units.

Photocells of the vacuum type which are constructed to show only the normal photoelectric effect, should show no deterioration with life. If the sensitivity of the cell drops down, this can be traced to some impurity, or to some misuse of the cell, such as getting the cell too hot, or liberating some impurity inside the cell, from some cause or other.

Cells of the ordinary commercial types, however, are a little more subject to temperature effects than cells showing the normal photoelectric effect from the metal itself. All alkali metal cells are more or less subject to this, and the caesium cell is particularly affected, inasmuch as the vaporization of caesium takes place at a much lower temperature than is the case with any of the other metals used in the construction of photocells.



## A new instrument for the creative musician

**V**LADIMIR KARAPETOFF of Cornell has just had constructed for himself a novel electronic musical instrument which has possibilities for large expansion among those who delight to play creatively. In fact, with it, a versatile musical genius like Professor Karapetoff can play duets with himself, or might successively build himself into a whole orchestra or brass band, himself playing every instrument that is heard.

The elaborate new Karapetoff device has recording cutting heads for both aluminum and celluloid. The playback is provided with sensitive and prompt volume and speed controls, by pedals, so that the phrasing is under close control. Thus the musician listening to a record on this machine can put his own emphasis on music however recorded. And Professor Karapetoff can record his own masterly piano rendition, and then play this back under new phrasing control, while he accompanies his recorded music with the manual bowing of his violin

## NEWS NOTES

**Rochester Fall Meeting, I.R.E., Nov. 13, 14, 15,**—Papers to be delivered at the Rochester Fall meeting of the I.R.E. are as follows: Development of cathode ray tubes for oscillograph purposes—by H. B. Headrick, R. T. Orth, and C. W. Taylor, RCA Radiotron Company.

Dynamic detection—by Kenneth W. Jarvis, Zenith Radio Corporation.

Some television problems and their solutions—by I. G. Maloff, RCA Victor Company.

Super-regeneration as applied to ultra high frequency reception—by David Grimes and Wm. S. Barden, RCA License Laboratory.

Losses in Electrolytic Capacitors—P. Robinson, Sprague Specialties Company.

Speaker problems in high fidelity receivers—Hugh S. Knowles, Jensen Radio Mfg. Company.

Conditions necessary for an increase in usable receiver fidelity—by Dr. Alfred N. Goldsmith, Consulting Engineer.

Problems in ignition interference suppression—by L. F. Curtis, United American Bosch Corporation.

Current Tube design problems—by Roger M. Wise, Hygrade-Sylvania Corporation.

Vibrating rectifiers for "B" power supplies—by C. T. Wallis, Delco Appliance Corporation.

**Receivers controlled from stations**—Synchronous radio receiving sets, the operation of which is controlled from the broadcasting stations, are being introduced for use in retail stores, especially chains, by Point-O'-Purchase Broadcasting System, Inc., Union Guardian Building, Detroit, Mich. George B. Storer is chairman and treasurer, and Joseph H. Neebe is president.

**Mexico authorizes 500-kw. broadcaster**—The Secretary of Communications at Mexico City has granted permission to Senor Gumaro Lazarraga, of Matamoros, to construct a 500-kw. radio broadcasting station in Matamoros, according to a report from Vice Consul Henry G. Krause.

**"Edison-effect" lamp as broadcast detector**—During ceremonies marking the fiftieth anniversary of Edison's discovery of thermionic emission, conducted by the New York Electrical Society Sept. 28, during the New York Radio Show, this exact replica of the Edison lamp of 1883 was arranged by engineers of the Electrical Testing Laboratories, New York, to pick up local broadcasting. Dr. Clayton H. Sharp, of White Plains, N. Y., former vice-president of the laboratories, and now consultant in electricity and light, recounted Edison's several contributions to the art we now call radio.

### MR. EDISON'S DIODE OF 1883

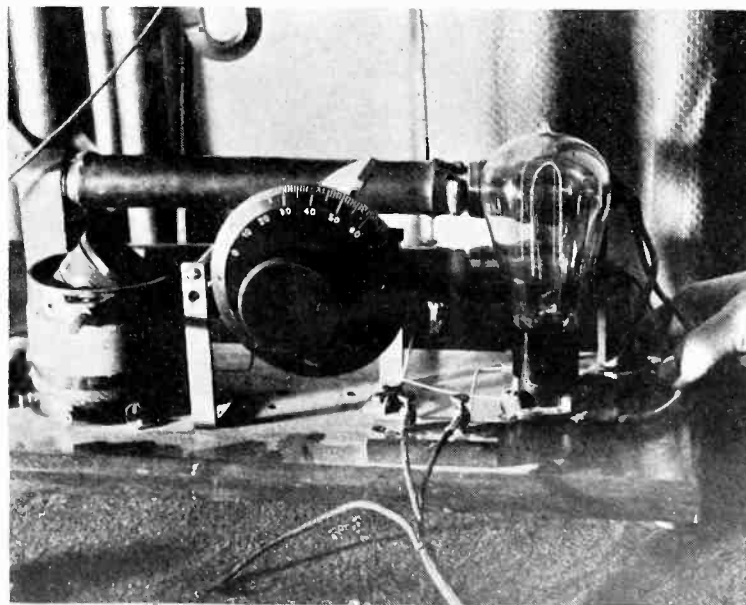

This working replica of Mr. Edison's diode of 1883 picked up modern broadcasting during the N. Y. Radio Show. Its tone quality proved excellent

### Electrical properties of the two-wire telephone relay

[A. BYK, Cable Laboratory, German General Electric Company.] The properties of the ordinary symmetrical two-wire amplifying relay are deduced as a

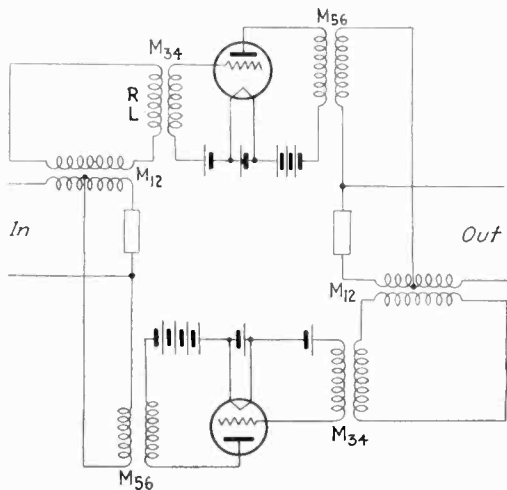

function of its surge impedance and velocity of propagation constant, and the conditions for highest amplification are obtained. The formulas arrived at are found to be in good agreement with the experimental results as measured at 800 cycles per sec.—*El. Nachr. Techn.* 10: 333-344. 1933.

### Multiple modulation

[GEORGES FAYARD, University of Grenoble.] The principle of multiple modulation is to apply the modulated high

frequency current to the grid of the first stage of the amplifier, and the amplified modulated high frequency together with a potential proportional to that of the modulating wave and in phase with it to the grids of all the later stages. The result claimed is doubled output for each stage and linear amplification with complete modulation the operating point being chosen in the middle of the straight line portion of the amplifier. Simultaneous modulation of several stages with small percentages of modulation gives a completely modulated and undistorted output.—*Onde cl.* 12: 295-325. 1933.

### The screen-grid tube as a detector tube

[J. KAMMERLOHER, Telefunken Laboratory.] When the operating point is chosen near the lower bend of the plate current-grid voltage curve, in such a way that the more positive half of the modulated r-f wave falls upon the nearly straight portion of the curve, whereas the more negative half is practically suppressed the rectified current is proportional at any amount to  $\sin^2$  pt. These r-f pulses flow through the by-pass condenser which shunts the plate resistance, the average charging current being equal to  $I/4$  per cycle and the voltage drop across the load to  $IR/4$  where  $I$  is the peak of the plate current. The no-load characteristic curve of the tube is valid for the r-f

components, so that  $I = \mu E_g$ , and the a-f current is amplified in the ratio  $\mu R/4$ . It is necessary to prevent saturation, which occurs when the plate voltage falls and becomes equal to the screen voltage—that is,  $E_p - IR/4$  must be larger than the screen voltage  $E_s$ . To be safe  $R$  may be taken equal to  $4(E_p - E_s)/I_0$  is the current at zero grid bias. The capacity of the condenser shall not exceed the value  $1/\omega R$ , when  $\omega$ , the highest audio frequency, multiplied by 6.28, is to be reproduced with 70 per cent of its strength.—*El. Nachr. T.* 10: 345-352. 1933.

### Electrical properties of rubber at radio frequencies

[A. H. SCOTT, A. T. MCPHERSON AND HARVEY L. CURTIS.] At one frequency the power factor of purified and then vulcanized rubber passes through a sharp maximum at a certain temperature which is higher the higher the frequency. For a sulphur content of less than 1 per cent the maximum occurs below  $0^\circ$  C. for the entire range of

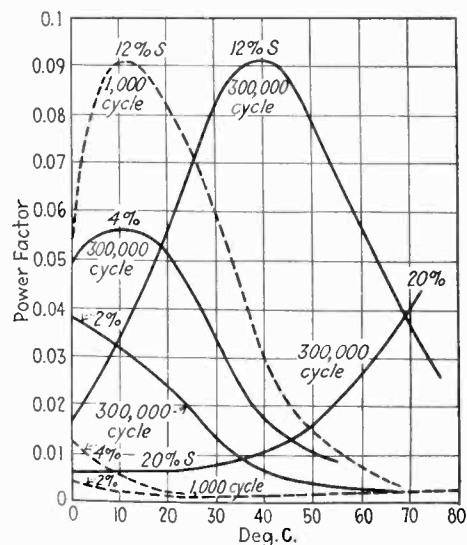

frequencies between 0 and 300,000 cycles; the maximum value (0.06) for the 100,000 cycle frequency lies near  $0^\circ$  C. at 4 per cent sulphur; it is of the order of 0.08 for both audio and radio waves when the sulphur content is around 10 per cent. Above 20 per cent sulphur (hard rubber) the power factor remains below 0.01 as long as the temperature remains below  $50^\circ$  C. The dielectric constant has values higher than 2.8 between 0 and  $100^\circ$  C. except when the sulphur content falls below 4 per cent. It reaches the value 4 at  $25^\circ$  C. and 12 per cent sulphur.—*Bureau Stand. J. Research* 11: 173-211. 1933.

### HERR HITLER IS TELEVISIONED

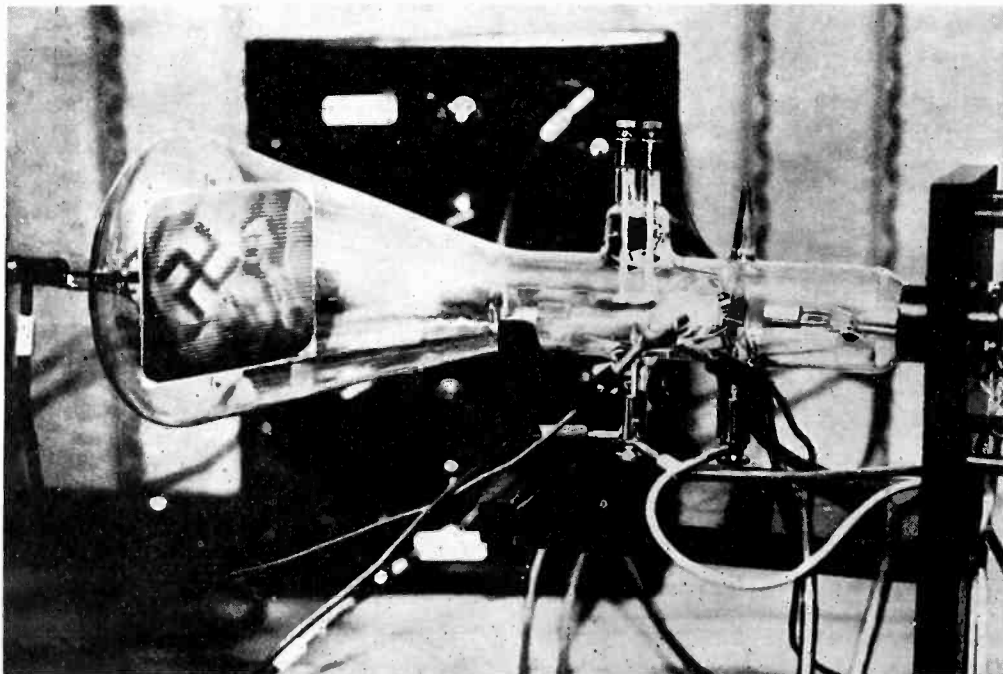

Photograph of picture seen in cathode ray tube of Von Ardenne television apparatus



# BOOKS



## FOR ENGINEERS USING ELECTRON TUBES

### Conduction of electricity in gases

By Joseph Slepian, Ph.D. Published by the Educational Department, Westinghouse Elec. & Mfg. Company, East Pittsburgh. 188 pages, 180 sketches. Price \$4.

AN AUTHORITATIVE TEXTBOOK dealing with the theory of the passage of electricity through gases and stressing the applications in electrical engineering. The text represents notes taken by students in Dr. Slepian's course in the subject given to a specially selected group of physicists and engineers.

The first part of the book, naturally, deals with the fundamentals of electrical conduction in gases. The remainder of the book, the larger part, deals then with the discharges occurring in the form of arcs, glows, sparks and corona. The atomic theory of matter, kinetic theory of gases are developed; ideas of classical mechanics and electromagnetism prevail throughout. Such matters as back-fire in mercury arc rectifiers, a-c switching, glow discharge in the vacuum switch are well handled.

Dr. Slepian is known not only as a consulting engineer for the Westinghouse Electric & Manufacturing Company, but even more widely through his publications in the proceedings of learned societies and in the technical press.



### High frequency measurements

By August Hund. 1933, McGraw-Hill Book Company. 490 pages, 373 illustrations. Price, \$5.

THE REVIEWER'S TASK on facing a book of this nature is second only to that of the author who wrote it; the volume is so large in scope so minute in treatment and so extensive in the subjects handled. But even a cursory appraisal is sufficient to reveal the value of this book not only to laboratory workers but all designers and even manufacturing engineers of high frequency equipment. Some of the chapter headings will be found in other books, chiefly on radio engineering, but there are others which seem to be unique. For example the author has packed nearly 500 pages with details

on the measurements of the electrical quantities of voltage, frequency, current, inductance, capacity, effective resistance, power, losses, and has included data on ferromagnetic measurements, descriptions of laboratory oscillators and other equipment, details on the measurement of minute and ionization currents, vacuum and gaseous tubes, modulation, antennas and lines, field strength, piezo-electric apparatus. The volume ends with some 20 pages of tables of various sorts.

Throughout the book will be found typical examples for the measurement under consideration to give the reader a sense of values. There are nearly 400 illustrations, and while it would be unsafe to state that every known method of measuring high frequency phenomena or apparatus is included, the methods omitted must be confined to the unimportant.

Dr. Hund's standing as an engineer and scientist, his authorship of a well known German book on high frequency technique make certain the accuracy, the pertinence, the practical nature of the contents.



### Die Kathoden strahl rohre (The cathode ray tube)

By M. von Ardenne. (Verlag von Julius Springer, Berlin, 1933, 398 pages, 432 figures.) Price, bound, 36 marks.

THE FIRST HUNDRED PAGES are devoted to the description of the cathode ray tube, the methods of transforming the very diffuse stream of electrons, obtained with 30 to 3,000 volts on the plate, into a sharp pencil, either by means of a magnetic field produced by an outside coil or by means of the radial electric field formed by the ions (Van der Bijl and Johnson), and the methods of controlling the strength and the direction of the ray. The positive ions create peculiar conditions with regard to the control of the current strength, but as recognized by Ardenne, when a negatively charged cylinder is surrounding the cathode, a close approach to the behavior of the current in the three electrode tube is obtained, a feature which is of value in television work. A similar, but more sensitive control is obtained by applying the control voltage to a separate grid or ring

electrode inside the metal cylinder. Origin distortion of the beam deflected by a pair of plates and loss of definition at very high frequencies, are fully discussed; owing to the presence of positive ions between the plates an amount of energy of about 1/100 watt is absorbed for complete deflection. American products dealt with in the section on commercial tubes are the Western Electric tube suitable for voltages below 500 and the tube described by Zworykin in *Electronics* for November, 1931. The sensitivity of present day tubes is given as lying between 0.2 and 2 mm. deflection per volt so that 50 to 500 volts are required for complete deflection.

The deflections obtained are spread out into a curve with the aid of rotating or vibrating mirrors, or more often, with an additional pair of deflecting plates giving either a linear or a sinusoidal time axis, and the entire second third of the book is taken up by a description of the many time-sweep and locking circuits. The use of a gas-filled glow lamp with external grid, in place of discharge tubes and thyratrons, is new and seems to be promising.

The reader not interested in the details of the tube and its circuits may start with the last third of the book which shows the tube at work in various fields, but mainly as a measuring instrument in the study of radio receivers and their circuits and component parts and finally as a tool in picture transmission and television sets. It is to be regretted that in this part of the book a large number of oscillograms have not been provided with suitable scales.

The American literature on cathode ray tubes and circuits is not very extensive and could have been considered and presented more fully the more as the author does not limit himself to German periodicals of recognized standing. Articles by the way, are not always cited with the care usual in books of this kind.

In their book on the same subject officers of the laboratory of the British Radio Research Board state (page 4) that such advances as they have been able to make in recent years by application of the cathode ray tube owe much to the ingenuity resource and unfailing friendliness of Baron M. v. Ardenne. We are indebted to the author whose name is often found in *Electronics* for a book which places his rich knowledge and experience at the service of a much wider circle.



# + NEW PRODUCTS

## THE MANUFACTURERS OFFER

### Relay for self-generating photocell

A NEW PHOTOELECTRIC RELAY using the new Visitron F2 photoelectric cell which operates without external source of voltage and without amplification, is announced by G-M Laboratories, Inc., 1735 Belmont Ave., Chicago. The complete unit, designated as the FSE photoelectric relay, incorporates a Visitron F2 cell, a sensitive relay and an auxiliary electromagnetic relay housed in a small, compact cast aluminum case, 6¼ in. by 5⅞ in. by 4 in. The cell can be mounted behind a glass window in the front of the case or externally at any point within hundreds of feet of the



sensitive relay. The unit can be completely weatherproofed.

Because the Visitron F2 photoelectric cell requires no external voltage and no amplification, the unit can be used in locations not served by electric power lines, and since there are no tubes to necessitate replacements, it will operate for long periods without attention. It is consequently of great importance in controlling lighthouse beacons, night lights on boats at anchor, obstruction lights, airway beacons, highway traffic warning lights, electric signs (both battery and power operated), suburban station lights, railway signal lights and street lighting systems.—*Electronics*.

### Felt-coated metal sheets

THE D. R. BITTAN SALES COMPANY, Inc., 27 Park Place, New York City, is marketing "R-B-M Robertson bonded metal," ("R-B-M"), a development of the Mellon Institute of Industrial Research, and manufactured by the H. H. Robertson Company of Pittsburgh, Pa. R-B-M is produced by

coating ordinary sheet iron with a layer of low-melting-point metal which acts as an adhesive for a coating with suitable fibrous material by a hot pressing operation.

While developed principally for the building industries, R-B-M is of interest to radio and electrical manufacturers as it permits construction of radio cabinets, horns, etc., with the desirable qualities of metal but without the characteristic "metallic ring."

R-B-M may be coated with cotton, wool or hair felts, cork, paper, cloth, asbestos, etc. It may be bent and drawn to the extent permitted by the bare metal and the character of the coating. This material is proposed for the construction of cabinets, baffles, horns, sound-proof and fireproof studios, loud-speaker back-boxes, and (using asbestos coatings) heat-resistant metal housings.—*Electronics*.

### Noise-reducing antennas for auto radios

THE LYNCH MANUFACTURING COMPANY of 51 Vesey St., New York City, has developed a new line of noise-reducing antennas which diminish motor interference and simplify auto-radio installations. These antennas of various types, including running-board antennas, are equipped with noise-reducing leads, making it possible to locate the antenna so as to reduce engine interference greatly.

The Lynch company has also applied its broadcast antenna system to automobile installations. There are two impedance-matching transformers and a noise-reducing lead-wire which may be attached between the existing aerial and the receiver in a radio-equipped car. The new coupling system is said also to increase the pick-up.—*Electronics*.

### Neon-tube transformers

THE CANATSEY ELECTRIC MANUFACTURING COMPANY, 512-16 Wyandotte St., Kansas City, Mo., has brought out a line of neon-tube transformers, of improved design and long life. The coils are wound on automatic machines and assembled on high-silicon steel cores. Tests include operation of each transformer on open circuit eight hours at 125 per cent of rated voltage. Secondary voltages run from 3,500 to 15,000 volts. A 12,000-volt 30-milliamper transformer, featured by the company, is priced at \$4.90.—*Electronics*.

### Door-operating motor mechanisms

ELECTRIC MOTOR-DRIVEN door-openers for a wide variety of applications, including control by photocell, sound or radio mechanisms, are built by the Cyco organization, 9 South 36th St.,

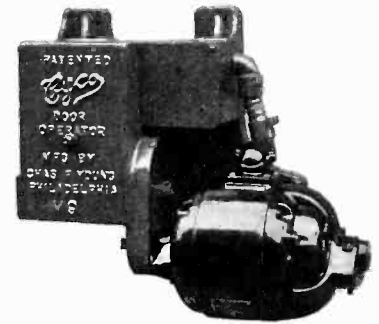

Philadelphia, Pa., headed by Charles F. Young.

In place of having separate photocell channels for opening and closing, this is now provided with a single photocell, operating in conjunction with the Cyco master-switch which keeps the cycles of operation in order. A limit switch is also built into the operator unit. With this equipment any number of photocells or other control contacts can be used in multiple or series.

Use of these door-opening mechanisms has been made in industrial plants and on large estates for operating gates. In one private dairy the doors are automatically opened and closed for each cow as she leaves the milking stable.—*Electronics*.

### Wide-area horn

A NEW HORN DESIGNED to give wide-area coverage has just been developed by the Macy Engineering Company, 1451-39th St., Brooklyn, N. Y. While this horn has been designed especially for sound truck use it is also applicable for airport and stadium purposes. The bell of the horn measures 23 in. in height and 50 in. in width. The horn is exponentially shaped and is 54 inches in length. With this horn an area may be served that would require two horns of the narrow-mouth type. A detachable aluminum throat is provided for attachment of the unit. The horn proper is made of tough weatherproof material which has brass-bound riveted seams and mitered wood trim. The horn composition is a wood-base substance. The standard finish is aluminum. List price, horn only, \$50. *Electronics*.

## Photocells with tip anodes

THE CONTINENTAL ELECTRIC COMPANY, St. Charles, Ill., has two new photocells with tip connections. The CE-13 photoelectric cell is either filled with argon or is a vacuum cell having the anode rod coming out the top instead of through the stem press. Due to the very high resistance leakage path resulting therefrom the light from a distant star or other very weak lights may be measured. The cell cathode has the usual Cetron caesium-coated silver cathode, which is an extremely sensitive coating. There is an additional support wire brought up through the stem press which can be used to control the current somewhat.

The CE-14 type of photocell also has the anode brought out through the top, and has the anode rod surrounded by a shield grid. This permits the cell to respond to even higher frequencies than the usual Cetron cell. This cell is usually supplied in the vacuum type. The grid may also be used as a control member.—*Electronics*.

+

## Thumb screws

A NEW CONSTRUCTION OF thumb screw, adaptable for photo-cell adjustment, has been announced by the Parker-Kalon Corporation, 200 Varick St., New York City. The screw is made in one piece by a new process and is free of burrs

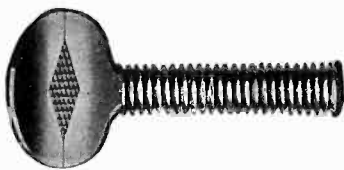

and roughness and will take an excellent plated finish. The heads are well shaped and well proportioned. The screws are roll-threaded, come in sizes from  $\frac{1}{8}$ -24,  $\frac{1}{2}$ -in. long to  $\frac{3}{8}$ -16, 3-in. long.

The stock is finished in plain steel, but other standard finishes are available. Special threads, special points, or special metal or alloy screws are available too.—*Electronics*.

+

## Piezoelectric loudspeaker unit

TO IMPROVE HIGH-FIDELITY sound reproduction, the Electrophone Corporation, 2019 Rittenhouse Square, Philadelphia, Pa., has announced a piezoelectric loudspeaker unit designed for the distortionless reproduction of the higher audio frequencies. This unit is known as the Mode 4 high-frequency electrophone and comprises a self-actuating piezoelectric diaphragm made of Rochelle salt crystals, a small exponential horn and a self-contained coupling device.

It is to be used with an ordinary low-frequency loudspeaker and can be directly connected in parallel with such a

unit without extra networks or filters affording an economical solution of the problem of wide range reproduction. No field excitation or polarizing voltages are necessary,

The low price of this unit will make it attractive to engineers, manufacturers, experimenters, and service men for use in new receivers, to improve existing receivers, public address systems, sound-picture systems, monitors for broadcast



studios and electrical phonographs. In theaters the addition of the unit to each sound projector furnishes high-fidelity reproduction from existing equipment, taking full advantage of the recent advances made in high-fidelity recording. This unit is a product of research work of the Boonton (N.J.) Research Corporation. Manufacture is licensed under patents and applications of this corporation and of the Brush Development Company.—*Electronics*.

+

## Adjustable-voltage transformer

THE "VARIAC," PRONOUNCED "VARY-ACK," is the name of a novel power transformer that gives a-c voltage control with the smoothness of a rheostat and the efficiency of a transformer, and more than any rheostat, it gives a continuous voltage adjustment between 0 and 130 volts when operated from a 115-volt, 60-cycle line.

The Variac has applications in both the laboratory and the industrial fields. A few of its uses include:

1. Brilliancy control on theater and sign-lighting installations,
2. Laboratory source of adjustable voltage,
3. Speed control on small motors,
4. Over-voltage and under-voltage testing on electrical household appliances of all kinds.

The novelty of the Variac is due to the design of a contact mechanism which eliminates the bogey of short-circuited turns which has heretofore made a continuously adjustable tapped transformer an impractical device. In the Variac the turning of a single knob covers the entire range from 0 to 130 volts.

The Variac is made in two models: Type 200-CM has a protecting case, an attachment cord, and an outlet receptacle and is intended for laboratory and experimental use; another model, without the case, is available for those who wish to build the Variac into other equipment. The maximum current rating of this Variac is 5 amperes. Models for larger and for smaller currents are under de-

velopment. This device is manufactured by the General Radio Company of Cambridge, Mass. Price, \$16.50.—*Electronics*.

+

## Photo-electric relay kit

THE ARGUS PHOTO-ELECTRIC RELAY in kit form is being supplied by the electronic division of the A. M. I. Distributing Company, 1500 Union Ave., S. E., Grand Rapids, Mich. When assembled this unit can be used for all photo-sensitive controls, including door-openers, signs, lighting, counting, alarms, etc. The unit measures  $4\frac{1}{2}$  in. by  $5\frac{1}{2}$  in. by  $5\frac{1}{4}$  in. high, and weighs 4 lb. The Argus photo-relay kit sells at a list price of \$30.

Other accessory apparatus includes a

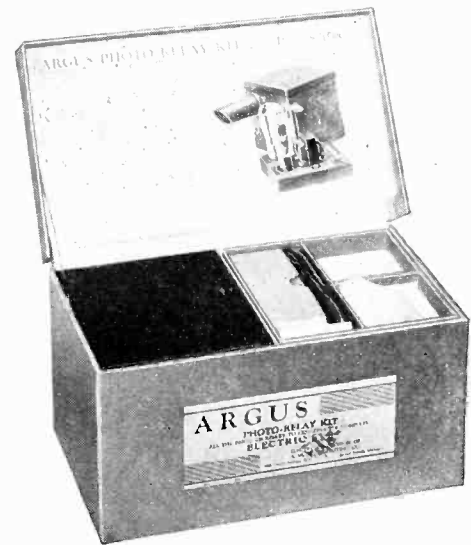

light source (110 v., a.c.) with focussing lens, priced at \$10, and the Argus infrared filter of imported Jena solid-color filter glass, one blue, one red, assembled in barrel-type holder, list price \$7.50.—*Electronics*.

+

## Photo-electric road switch

A NOVEL ROAD-SWITCH for operation by passing motor cars, which employs a photoelectric principle, has been put on the market by the Tiffin Electro-Mechanical Company, Tiffin, Ohio. This "Hayes treadless road switch" comprises a heavy metal box which is placed in the roadway. It contains a compass magnet which is so positioned that when at rest, the mirror carried by the magnet reflects a beam of light onto a photocell. But if an automobile comes along, the change in the magnetic lines of force produced by the steel car chassis, causes the needle to swing, interrupting the light beam and sending out an operating impulse, the same as if the car had actually passed through an exposed light beam. In this case, however, all parts are enclosed in the road-bed housing. The device is especially designed to respond to slow-moving vehicles, such as cars approaching a garage door or toll-collector's gate.—*Electronics*.

## Photoelectric cells

"LUMOTRONS" ARE THE photoelectric cells manufactured and distributed by the Central Scientific Corporation, 4829 South Kedzie Ave., Chicago. Unexcelled performance is warranted by the high output gain and low variation, which insure uniform, perfect performance. Lumotrons are guaranteed for a year, but are expected to last two years. Being non-microphonic these cells are without background noise. Sharp, concise tones and overtones are faithfully and brilliantly reproduced. Large volume is assured, even when operating at voltages lower than normal rating, thus insuring longer life. Lumotrons will operate for long periods without attention, according to the makers, and, owing to their rugged construction, do not require exceptional care. Each cell is scientifically tested before it leaves the laboratories, assuring both efficiency and uniformity.—*Electronics*.

## Paper condensers to replace electrolytics

THE IGRAD CONDENSER & MANUFACTURING COMPANY, Rochester, N. Y., has been purchased by Continental Carbon, Inc., 13900 Lorain Ave., Cleveland, Ohio. The Rochester plant is being moved to Cleveland, and a complete line of paper condensers will be offered by the same organization that is now distributing Continental resistors and auto-radio suppressors.

Carl Grams, Igrad factory superintendent, has had twenty years' experience in the manufacture and design of paper condensers with Stromberg-Carlson, and will have charge of the production of Continental-Igrad condensers.

The new Continental-Igrad line will include all paper condenser types now in use. An exclusive new development of the Continental-Igrad engineers is a line of paper condensers to replace electrolytic condensers. These are housed in containers of the same size as the electrolytics they replace and will withstand exceptionally high potentials and temperatures.—*Electronics*.

## Control of lighting

A RELIABLE AND ACCURATE device that operates to turn electric lights on or off when daylight decreases or increases in intensity to a predetermined value has been developed by the Westinghouse Electric & Manufacturing Company.

The applications for this unit, called the Photolux, are many and vary from insuring adequate office and factory lighting to lending a maximum of advertising value to illuminated signs and

show windows that no manual operation ever succeeded in reaching.

Some of the places where the Photolux is applied to turn artificial light on and off, without any supervision are as follows: Offices, industrial plants, show windows, schools, signs, floodlighting installations, street lighting, navigation lights, and airway and airport lighting.

The indoor models of Photolux are housed in attractive panel board cabinets for either flush or projection mounting equipped with locks. Adequate knockouts are provided on all sides of the case and there is ample room for wiring inside the cabinet.

Mounted in the cabinet, in compact arrangement, is a vacuum phototube, a one-tube amplifier, and the necessary auxiliary apparatus.—*Electronics*.

## New cement for radio use

A PRACTICAL LIQUID PORCELAIN CEMENT, developed by Henry L. Crowley & Company, ceramic engineers and manufacturers, West Orange, N. J., is available in three consistencies: a cement paste for application with trowel or similar tool; a dipping cement suitable for dipping, spraying or brushing; and a dry powder ready to be mixed with water to the desired consistency. The cement paste is widely employed in radio production assembly for holding small parts in place, doing away with the usual nuts, screws and metal solder; and for filling holes and cracks as a sealing compound. The dipping cement is employed for coating electrical resistors and radio coil forms, as well as for general adhesive purposes.

Setting in a short time without the application of heat, this liquid porcelain is proof against oil, acids, gases, and heat up to 2,000 deg. F. It can be made waterproof and is an excellent electrical insulator.

It is available in small cans for experimenter and repair-shop use, and in large cans and steel drums for bulk users.—*Electronics*.

## Self-generating photocell

A NEW SELF-GENERATING photo-electric cell is the outcome of one and one-half years of original research by Edward Praetorius, in the laboratories of the Acousto-Lite Corp., Ltd., 2908 South Vermont Ave., Los Angeles, Calif.

The new cell is of a very convenient form of construction so as to be very easily adaptable to any type of experiment or use. It is hermetically sealed in a gas-filled glass tube of the approximate size and form of the new 230 type radio tubes, and equipped with a neat UX type base measuring  $1\frac{1}{8}$  inches outside diameter.

The light sensitive element is in the

form of a special sensitized plate having an active area of 0.8 sq.in. and the internal d-c resistance of the cell is approximately 100 ohms. Exposed to direct sunlight the cell will generate approximately one milliamperere without the aid of batteries or any other source of emf. Thus the cell will directly operate some kinds of electrical apparatus without the aid of amplification, which is usually necessary with other types of photo-electric cells.

The photo-emf. generated by the Acoustolite Cell is a straight line function of the intensity of illumination, and it is instantaneous in action. It will readily pick up sound on film, and can be coupled to various forms of amplifiers by simple transformer coupling, no batteries in the circuit of the Acoustolite Cell and transformer primary. The Acoustolite Cell clearly responds to the full range of audio frequencies. While tests are not yet complete with respect to radio frequencies, there is reason to believe that the cell will readily respond to this higher order of frequencies—Price \$10.—*Electronics*.

## Transposition insulator

A GLAZED PORCELAIN TRANSPPOSITION insulator of novel design for use in the feeder lines of anti-noise receiving aeriels and transmitting antennas, is announced by the E. F. Johnson Company of Waseca, Minnesota.

Unlike previous devices for this service, the Johnson transposition insulator keeps the feeder wires in a continuous line throughout their length which eliminates the usual tendency for the feeder system to twist and get out of shape. There are no sharp bends at the point of transposition thus imposing a minimum of strain on both the conductors and the insulator and extending the probable life of the line.—*Electronics*.

## Recording feed screw

THE UNIVERSAL MICROPHONE COMPANY, Inglewood, Calif., has a universal recording feed-screw device which moves any recording cutting head across the face of the recording disk and thereby grooves the record at the time of making the recording.

This method of making the groove at the actual time of recording is said to have proven far superior to the use of pregrooved records. The device is so constructed that the recording head may be lifted from the record without disturbing the feed screw.

There are no critical adjustments required in the operation of the device, and the instrument will fit any phonograph turntable. Records up to 12 inches in diameter can be accommodated and the thread is cut at the rate of 80 grooves an inch.—*Electronics*.

# U. S. PATENTS

## IN THE FIELD OF ELECTRONICS

### Electron Tubes

**Co-planer grid tube.** H. A. Pidgeon and J. O. McNally, assigned to B.T.L. No. 1,923,686, filed June 5, 1929.

**Discharge tube.** Use of a hollow metallic anode with relatively low mechanical strength and small heating radiating surface sealed to form an evacuated chamber in which is a cathode and a hollow outer vessel of relatively high mechanical strength and large radiating surface enclosing the anode, but insulated from it. Carl J. R. H. von Wedel, Berlin. Assigned to Electrons, Inc. No. 1,923,521.

**Discharge tubes.** Gaseous tube of the controlled discharge type in which is a temperature responsive means for rendering the control element inoperative to prevent the flow of current when the temperature rises above a predetermined point. P. L. Spencer, assigned to Raytheon, Inc. No. 1,923,335.

**Photoelectric cells.** Patents by R. C. Rentschler, assigned to Westinghouse Lamp Co. No. 1,923,844 and 1,923,845 on photocells responsive to wavelengths less than 3000 angstroms.

### Electronic Applications

**Pantographic scanning.** Method of associating a light-sensitive tracing media and a cutting tool by means of an amplifier. Walter Howey, New York City, N. Y. No. 1,923,208.

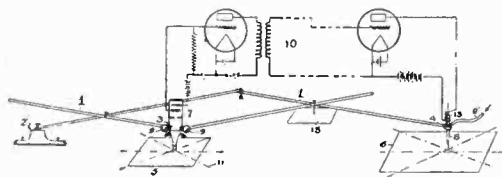

**Height indicator.** Determining the height of an all-metal aircraft by electrical means symmetrically placed with respect to the metal surface, and positioned to be inductively coupled to the surface to induce oscillatory current therein. R. A. Fessenden, Bermuda. No. 1,924,032.

### Power Apparatus

**Power conversion apparatus.** Including a d-c and a-c circuit using three electrode tubes of the gaseous type. C. H. Willis, assigned to the G. E. Co. No. 1,923,696.

**Phase device.** Method of deflecting a cathode ray beam by means of a phase shifting network. A. H. Brolly, assigned to Television Laboratory, Inc. No. 1,923,252.

**Keying system.** Method of removing by means of a key the positive potential on space charge grid. J. D. Wallace, Washington, D. C. No. 1,923,345.

**A.c.-d.c. system.** A vibrating system for producing a.c. from a d.c. source. E. L. Barrett, assigned to Utah Radio Products Co. No. 1,924,082.

**Hum elimination.** Method of eliminating ripples in cascade amplifiers. E. O. Löfgren, assigned to Ericsson. No. 1,923,222.

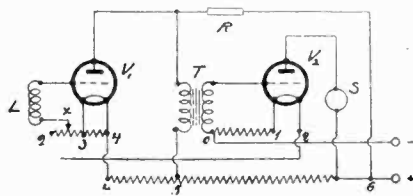

### Radio Circuits

**Course shift indicator.** Method of shifting the course indicator on a double modulation radio beacon. H. Diamond and F. W. Dunmore, assigned to the Government of the United States. No. 1,923,920.

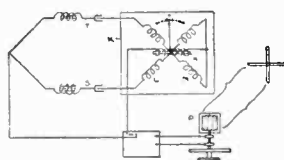

**Selective system.** Combined electric and electro-mechanical frequency selecting devices. P. R. Coursey, assigned to Radio Patents Corp. No. 1,923,354.

**Course shifting system.** A method of shifting two radio beacon courses from their normal 180 degree displacement to align them with two airways intersecting at a radio beacon at an angle other than 180 degrees which consists of introducing circular radiation into the normal figure of a radiation from the beacon. F. G. Kear, assigned to the Government of the United States. No. 1,923,934.

**Navigation aid.** Method of making a receiver sensitive or not sensitive to distress signals, or to conventional telegraphic signals. W. N. Flanning, Alameda, Calif. No. 1,923,430.

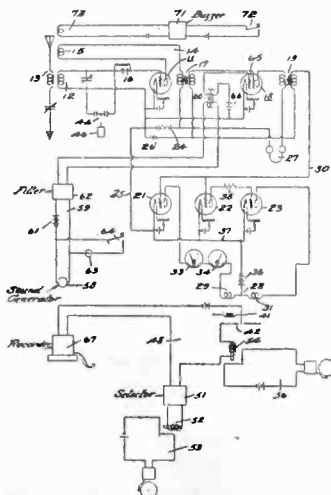

**Electro optical register.** Use of a piezo-electric axis, coupled with a recording circuit, and optical means adapted to cooperate with the crystal. Alexis Guerbilsky, Paris, France. No. 1,923,619.

**Interstate system.** Method of resonating part of an inductance for rejecting energy of a wavelength on one side of a selected wavelength. W. T. Lewis and A. R. Woolfolk. No. 1,923,155.

### Patent Suits

1,173,079, E. F. Alexanderson, Selective tuning system; 1,195,632, W. C. White, Circuit connections of electron discharge apparatus; 1,251,377, A. W. Hull, Method of and means for obtaining constant direct current potentials; 1,728,879, Rice & Kellogg, Amplifying system; 1,573,374, P. A. Chamberlain, Radio condenser, D. C., E. D. N. Y., Doc. E 6721, Radio Corp. of America v. Vim Electric Co., Inc. Constant decree for plaintiff, June 29, 1933.

1,195,632, W. C. White, Circuit connections of electron discharge apparatus; 1,251,377, A. W. Hull, Method of and means for obtaining constant direct current potentials; 1,297,188, I. Langmuir, System for amplifying variable currents; 1,728,879, Rice & Kellogg, Amplifying system; 1,811,095, H. J. Round, Thermionic amplifier and detector; Re. 18,579, Ballantine & Hull, Demodulator and method of demodulation, filed June 23, 1933, D. C., S. D. Calif. (Los Angeles), Doc. E 12-J, Radio Corp. of America et al. v. D. W. Rogers (Los Angeles Radio Mfg. Co.) et al.

1,231,764, F. Lowenstein, Telephone relay; 1,618,017, same, Wireless telegraph apparatus; 1,403,475, H. D. Arnold, Vacuum tube circuit, D. C., E. D. N. Y., Doc. E-6720, Radio Corp. of America v. Vim Electric Co., Inc. Consent decree for plaintiff June 29, 1933.

1,105,924, Pridham & Jensen, Telephone; 1,266,988, same, Amplifying receiver; 1,448,279, 1,579,392, same, Electrodynamical receiver, D. C. Minn. (St. Paul), Doc. E 1562, The Magnavox Co. v. Wright-De Coster, Inc. Dismissed April 4, 1933.

1,455,141, Lowell & Dunmore, Radio receiving apparatus, D. C. Del., Doc. E 664, Dubilier Condenser Corp. et al. v. Radio Corp. of America. Decree upon mandate of Circuit Court of Appeals, dismissing bill June 29, 1933.

1,635,117, F. W. Dunmore, Signal-receiving system, D. C. Del., Doc. E 663, Dubilier Condenser Corp. v. Radio Corp. of America. Decree upon mandate dismissing bill June 29, 1933.

1,231,764, F. Lowenstein, Telephone relay; 1,618,017, same, Wireless telegraph apparatus; 1,403,475, H. D. Arnold, Vacuum tube circuit; 1,465,332, same, Vacuum tube amplifier; 1,573,374, P. A. Chamberlain, Radio condenser, filed June 23, 1933, D. C., S. D. Calif. (Los Angeles), Doc. E 11-C, Radio Corp. of America et al. v. D. W. Rogers (Los Angeles Radio Mfg. Co.) et al. Same, D. C., S. D. N. Y., Doc. E 76/56, Radio Corp. of America, Inc., et al. v. Insuline Corp. of America. Consent decree for plaintiff (notice July 13, 1933).



## Power, Amplification, Etc., Circuits

**Sub-harmonic producer.** Crystal-controlled oscillator and method of using a charged condenser for producing a wave having a frequency with a sub-multiple of the typical frequency. W. A. Morrison, assigned to B. T. L. No. 1,919,795.

**Hum prevention.** Method of diminishing a-c noise in vacuum tube circuits. Walter Schaffer, assigned to Telefunken. No. 1,919,598.

**Amplifier-rectifier system.** Combination of circuit with tubes having grid and plate electrodes and two emitters in which rectification and amplification take place within the same tube. M. E. Mack-soud, assigned to the Electron Corp., July 3, 1926. No. 1,920,576.

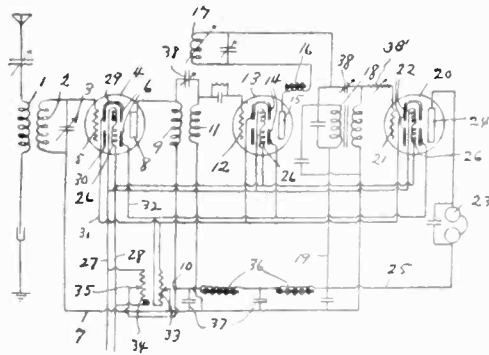

**Interstage system.** An r-f coupling system comprising a transformer with a tuned secondary and primary which is resonant lower than the lowest frequency within the tunable range. E. A. Beane and E. F. Andrews, assigned to RCA, filed June 17, 1924. No. 1,920,342.

**Inverter system.** Method of operating a synchronous machine from a non-synchronous supply source by rectification and inversion. C. W. Stone, Feb. 17, 1931, assigned to G. E. Co. No. 1,920,814.

**Signaling systems.** Patents Nos. 1,921,087 and 1,921,088 to W. A. Macdonald, assigned to Hazeltine Corp., on multi-stage amplifier systems of a super-heterodyne nature.

**Relaxation oscillator.** Use of a three-grid tube, the inner grid biased to prevent the tube from operating at the point of saturation. R. M. Paige, Washington, D. C., July 13, 1929. No. 1,921,476.

**Translation circuit.** The method of using grid-controlled vapor electric tubes for inversion. August Schmidt, Jr., assigned to G. E. Co., May 24, 1932. No. 1,921,704.

**Receiving system.** A receiver for an oscillation whose frequency is constant and whose phase assumes alternatively two values in opposition. H. J. Bellestive, France, Feb. 24, 1932. No. 1,922,282.

**Amplifier voltage control.** Method of using two-element valves for regulating a-c generators and for amplifying. F. H. deJong, assigned to Philips, May 19, 1930. No. 1,922,794.

**Super-regenerative receiver.** Regenerative detector, oscillatory circuit having a steep wave-front and means for coupling

these two circuits together. C. A. Gunther, assigned to G. E. Co. No. 1,917,113, filed April 28, 1932.

**Direct-current voltage transformer.** Method by which direct current is interrupted by a vibrator sent through a transformer to step up the voltage and it is then rectified by other contacts on the vibrator. R. J. Rockwell, Crosley Radio Corp. No. 1,920,150, filed Dec. 7, 1932.

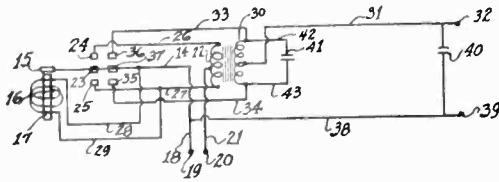

## Electron tubes

**Glow lamps.** Several electrodes within a bulb one of which comprises a coating of nitrided alkaline earth material and a gas within the bulb comprising a high percentage of helium and a comparatively low percentage of nitrogen. T. W. Case, assigned to Case Research Laboratories, July 27, 1929. No. 1,923,051.

**Tube tester.** Process of determining the mutual conductance of a vacuum tube consisting in impressing upon the grid an alternating current rectifying the alternating component in the plate circuit and measuring the rectified current. October 31, 1930. No. 1,920,906. W. N. Goodwin, assigned to Weston.

**Co-planar grid.** A two-grid tube, one of which applies a positive biasing potential of as much as 25 volts. H. A. Pidgeon and J. O. McNally, assigned to B. T. L., June 5, 1931. No. 1,920,274.

**Tube construction.** Cathode surrounded by a heating element and heated by direct radiation, a shield electrode between the heater and the grid of the tube and the plate being positioned on the opposite side of the shield from the heating element. C. J. Kay, assigned to Spark-Withington, No. 1,921,619. See also No. 1,921,620 to Kay on a glow tube.

## Short-wave apparatus

**Shielding system.** Device for preventing external electrostatic capacity from disturbing radio signaling apparatus comprising a shield and a ground connection of such length as would produce a voltage node on the shield at the frequency of the signaling wave. J. O. Watson, assigned to International Communications Laboratories, September 16, 1930. No. 1,920,223.

**Wave meter.** A micro-ray wave meter, comprising two sections of transmission line of fixed length and a section of transmission line of variable lengths intermediate two sections wherein for the range of frequency to be measured the characteristic impedance of the variable length sections is large as compared to that of either fixed length sections. R. H. Darbord, assigned to International Communications Laboratories, July 10, 1931. No. 1,921,117.

**Short wave oscillation generator.** A telescopic inductance in the form of a circle comprising two sections, one

movable with respect to the other. R. Baranowski, Berlin, assigned to Telefunken, September 5, 1930. No. 1,921,448.

**Ultra short wave receiver.** A two-tube receiver, the first having a positive grid and free anode to produce ultra high frequency oscillation directly coupled to the second amplifying tube. H. E. Hollman, A. T. & T. Co., October 22, 1931. No. 1,921,187.

**Transmitting tube.** An ultra short wave circuit for transmitting oscillations of the order of one meter and less in length comprising a tube with a high positive potential to the control electrode and a lower potential to the anode the surface of the control electrode being treated for aiding thermal radiation and the anode being perforated whereby there is obtained a reduction in the capacity between anode and control electrode. Fritz Schroeder, assigned to Telefunken, March 9, 1933. No. 1,921,640.

**Super regenerative receiver.** W. J. Brown, assigned to Associated Electric Industries, Ltd. No. 1,922,195, July 11, 1928.

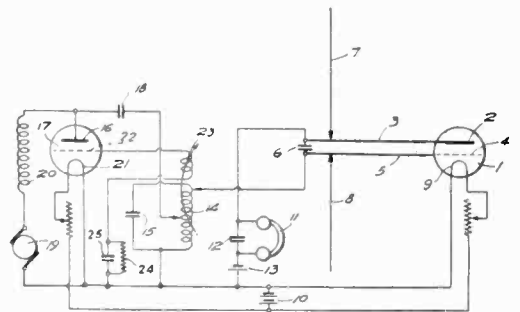

## Patent Suits

1,195,632, W. C. White, Circuit connections of electron-discharge apparatus; 1,251,377, A. W. Hull, Method of and means for obtaining constant direct current potentials; 1,728,879, Rice & Kellogg, Amplifying system; Re. 18,579, Ballantine & Hull, Demodulator and method of demodulation; 1,811,095, H. J. Round, Thermionic amplifier and detector, D. C., S. D. N. Y., Doc. E 75/346, Radio Corp. of America et al. v. Radio Syndicate Co., Inc. Consent decree for plaintiff (notice May 27, 1933).

1,231,764, F. Lowenstein, Telephone relay; 1,465,332, H. D. Arnold, Vacuum-tube amplifier; 1,573,374, P. A. Chamberlain, Radio condenser; 1,618,017, F. Lowenstein, Wireless telegraph apparatus, D. C., S. D. N. Y., Doc. E 75/345, Radio Corp. of America et al. v. Radio Syndicate, Inc. Consent decree for plaintiff (notice May 27, 1933).

## Adjudicated Patents

(C. C. A. N. Y.) Cohen patent No. 1,563,893, for multiple variable condenser, Held invalid. Id.

(C. C. A. N. Y.) Georgiev patent, No. 1,789,949, for electrolytic cell, claims 11, 12, 19, and 20 Held valid and infringed. Aerovox Corporation v. Concourse Electric Co., 65 F.(2d) 386.

(C. C. A. N. Y.) Georgiev patent, No. 1,815,768, for electrolyte, claims 8, 9, 10, and 14 Held valid and infringed. Id.

# A typical *Sylvania* development (Reg. U. S. Pat. Off.)

## GRAPHITE ANODE TUBES!

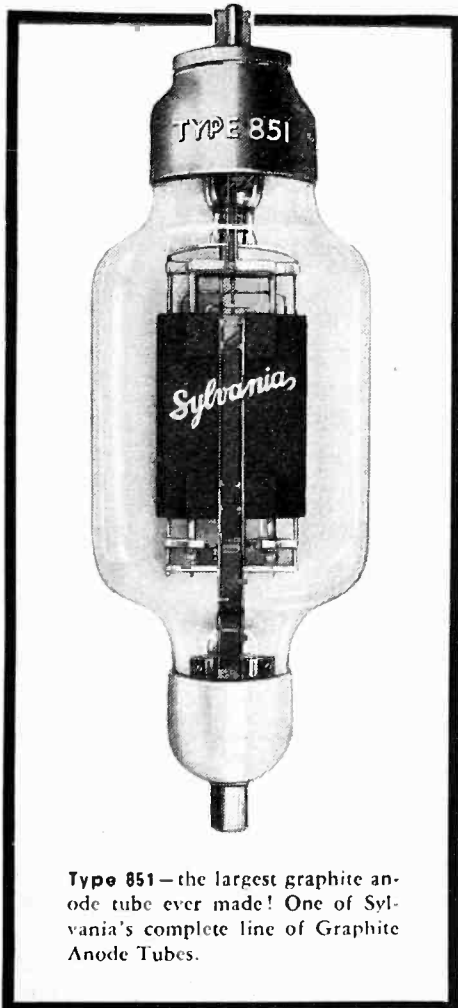

Type 851—the largest graphite anode tube ever made! One of Sylvania's complete line of Graphite Anode Tubes.

● A new process developed in the Electronics Laboratory of Hygrade Sylvania Corporation enables us to treat carbon in such a manner that it is reduced to pure graphite with all amorphous carbon and other impurities removed. This revolutionary contribution of Sylvania engineers now gives radio science a complete new line of transmitting tubes with the following major advantages:

- 1 High plate dissipation without over-heating . . . a direct result of graphite's high thermal emissivity.
- 2 Lower operating temperature at anode and, consequently, at other electrodes. Prevents secondary and primary emission from the grid.
- 3 Uniformity of characteristics. Physical properties of graphite permit exact processing and obviate distortion. Relation between tube elements remains constant. Normal electrical characteristics preserved.
- 4 Long life. Graphite's comparative freedom from gas permits high vacuum . . . gives longer tube life.

It was for the purpose of just such development work in all fields of electronics that Hygrade Sylvania instituted a special Electronics Department.

Early this year, a separate plant in Clifton, N. J., was established for the design and production of radio transmitters, transmitting tubes, industrial power tubes, and custom-built electronic devices.

We invite inquiries concerning special electronic problems or equipment. Eminent Sylvania engineers will cooperate with you.



## HYGRADE SYLVANIA CORPORATION

*Hygrade Lamps*

**ELECTRONICS DEPARTMENT**

*Sylvania Tubes*

**CLIFTON, NEW JERSEY**

**FACTORIES**

SALEM, MASS.

EMPORIUM, PA.

ST. MARYS, PA.

CLIFTON, N. J.

WAREHOUSE FACILITIES IN

PORTLAND, ORE.

CHICAGO, ILL.

PHILADELPHIA, PA.

LOS ANGELES, CAL.

ATLANTA, GA.

SALEM, MASS.

NEW YORK, N. Y.

# BRITISH PATENTS IN THE FIELD OF ELECTRONICS

## Radio and Television Circuits

**Superheterodyne.** The local oscillator is provided with mixed magnetic and capacity back coupling whereby its output frequency characteristic over the tuning range may be arranged to compensate for or be otherwise correlated with the amplification frequency characteristic of the RF amplifier. W. A. MacDonald, Hazeltine Corp., No. 391,521.

**Automatic volume control.** A full-wave attenuator connected across a line for compressing or expanding volume to enable the signal to comply with the limitations of the apparatus in the system which may be a transcontinental, short-wave broadcasting, or cable circuit. A. Pfister, Marconi Co. No. 391,681.

**Detector-amplifier.** A tube with high frequency potentials applied to cathode and anode to rectify voltages applied to one grid and amplify low frequency energy is taken from the second grid. Marconi Co. No. 391,979.

**Screen-grid circuits.** Degree of damping in an amplifier employing screen-grid tubes is reduced by coupling the screen-grid circuit of one tube to the same circuit of the succeeding stage. Ideal Werke Akt. No. 392,045.

**Modulation measurements.** Direct currents are established proportional respectively to the crest and average voltages of the modulated wave and the degree of modulation is deduced from a comparison of the values of the two currents. The high-frequency currents are impressed on grids on two tubes across an inductance. The grid leak and condenser of one detector has a time constant so large that the peak voltage is maintained on the second tube. C. F. Elwell and F. E. Terman. No. 392,053.

**Crystal oscillator.** To obtain stable operation the anode of the tube is coupled to the tuned grid circuit in reverse in such a manner that oscillations could not occur without the inclusion of the piezo-electric crystal. British Thomson-Houston Co. No. 392,436.

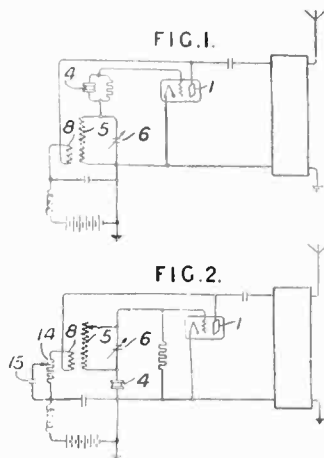

**Television system.** Television and sound signals are transmitted on neighboring carrier frequencies, for example, 50,000 and 51,000 kilocycles and both carrier frequencies are received by damped circuits in a superheterodyne. All the television signals are passed by a detector to control the emission in a cathode ray tube but other detectors are biased to respond only to the peak of the horizontal and vertical scanning frequencies. Marconi Co. No. 392,456.

**Cathode ray tubes.** A tube with an internal wall which divides the tube into two air-tight compartments and formed of a number of transverse conductors so that it has a higher conductivity transversely than in other directions, the cathode ray being diverted against one side of the wall and an auxiliary anode being arranged in the gas-filled compartment remote from that in which the ray is produced, the intensity of the glow varying with the intensity of the impinging ray. British Thomson-Houston Co. No. 392,583.

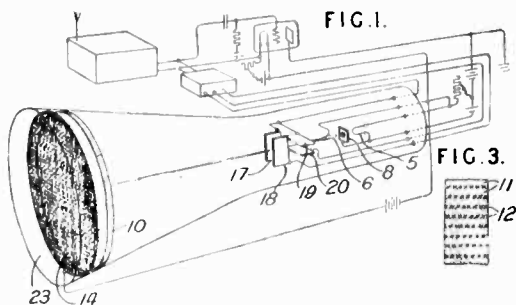

**Short wave circuit.** An ultra short-wave circuit comprising a pair of Barkhausen-Kurz oscillators the grids of which are connected through a tuned Lecher-wire circuit to points on each side of the center point of the dipole aerial so as to match the surge impedance. The anodes of the valves are interconnected through a Lecher-wire circuit while the filaments are similarly interconnected. When used for reception, the dipole aerial is connected to the anode instead of to the grid. Marconi Co. No. 392,210.

**Modulating system.** The low-frequency modulation current applied to a carrier is maintained approximately constant by the use of variable- $\mu$  tubes whereby the modulation level is maintained at a deep value and overloading of the transmitter when the signal intensity is high is prevented. Marconi Co. No. 392,230.

**Television amplifier.** Frequency response characteristic peaks at or about the line scanning frequency and its harmonics. The major peak occurs at the line scanning frequency and the other peaks decrease in size as the order of the corresponding harmonics increases. The amplifier incorporates one or more tuned coupling circuits of high decrement and resonant at the line scanning frequency. Marconi Co. No. 392,229.

**Superheterodyne.** An oscillator-modulator comprising a feedback coupling so proportioned that oscillations of constant amplitude are produced and are insufficient to render the grid positive. Hazeltine Corp. No. 392,841.

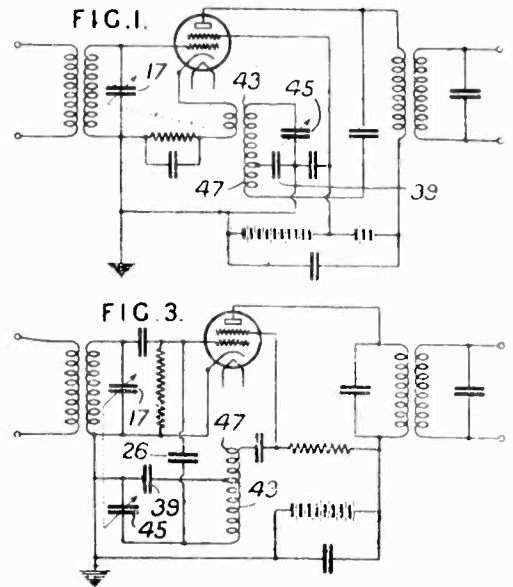

**Hum prevention.** Cathode of a heater type tube is made two or more volts negative with respect to the filament, sufficient to saturate the space charge between them. No. 392,866. Telefunken.

**Automatic volume control.** The a.v.c. voltage is produced by a resistance whose magnitude varies in accordance with the received signal strength. Marconi Co. No. 393,318.

**Distance finder.** The distance between a transmitter and receiver is determined by comparing the signal strength at the receiver of two signals of the same frequency but of different attenuations from the transmitter or of one of the signals and the radiation from a local oscillator. E. G. Gage, Brooklyn, N. Y. No. 393,344.

**Modulation system.** Plate current at a transmitter tube is fed from a triode which has both its grid and plate excited at a supersonic frequency. The microphone being arranged to vary the phase relation between the grid and plate excitation. G. E. Co. No. 393,379.

**Short-wave systems.** Various systems for handling the wavelengths of the orders of decimeters down to the infrared. Standard Telephones. No. 392,962.

**Apparatus control.** Use of light rays for switching on lamps as daylight fades maintaining liquids at a definite transparency or dyeing materials to a uniform color by means of light sensitive cells. A. W. Isenthal. No. 393,248.

**Television system.** In a cathode ray television receiver the visible return traced by the cathode ray are eliminated. Marconi Co. No. 392,383.

**Superheterodyne circuits.** An intermediate frequency amplifier has one inter-valve transformer coupling designed to give a double resonance and one or more succeeding transformer couplings designed for single resonance the over-all response being substantially uniform over the side-band range. W. A. MacDonald, Hazeltine Corp. No. 392,411.

# NO DANGER OF ARCING

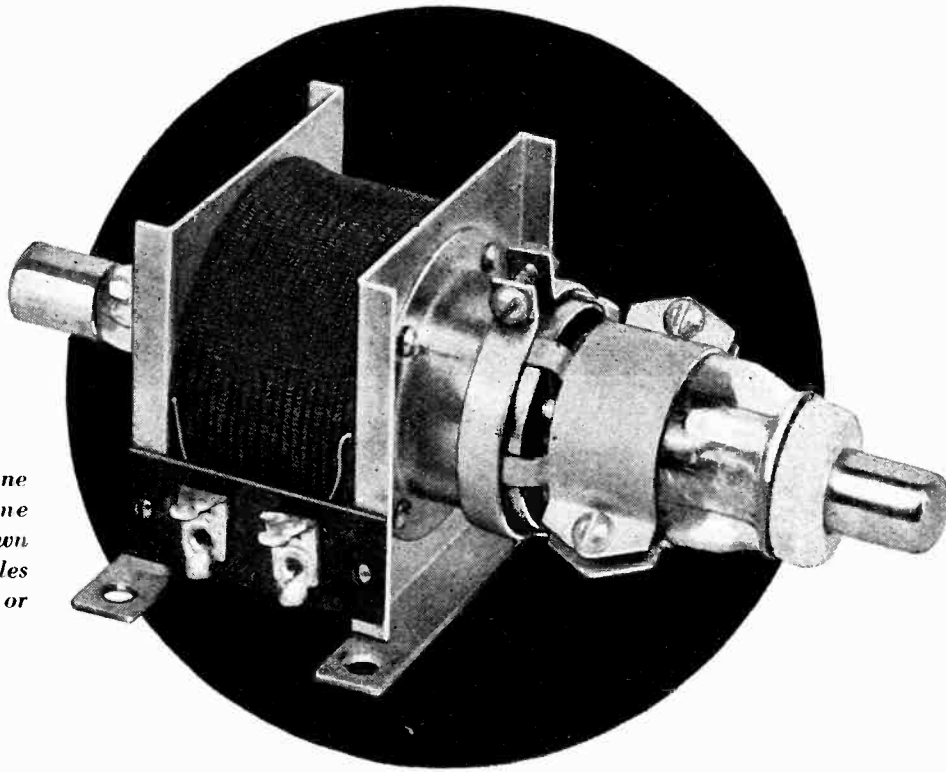

*Developed by Bell Telephone Laboratories for airplane radio, 244A Relays have flown many hundred thousand miles without record of arcing or failure of any kind.*

... with this *fast, dependable* relay

The Western Electric 244A Relay rapidly opens any high voltage, low current circuit—contacts moving only 1/16 inch. All moving parts are enclosed in a highly evacuated tube, which assures long life, prevents arcing, gives a clean make and break. This is especially important where circuits must be opened in explosive or rarified atmosphere.

The 244A Relay consists of a 706A Vacuum Switch mounted in a solenoid, wound for operation on 12 volts D.C. Switch closes by means of the magnetic field. Coil resistance is approximately 26.5 ohms.

Connections for the high voltage load circuit are made directly by means of standard grid clips on the ends of the vacuum switch.

Small (4-1/2"x2-3/8"x1-13/16"), light (18 oz.) the 244A may be mounted in any position. Being controlled remotely, it safeguards the operator against high voltages. Although used in the 13A Aircraft Transmitter to break 1250 Volts at 1/2 ampere, it can be conservatively rated for interrupting peak voltages as high as 2500 Volts.

Send the coupon for further details.

## *Western Electric*

**ELECTRONIC EQUIPMENT**

*Distributed by GRAYBAR Electric Company*

GRAYBAR ELECTRIC CO.  
Graybar Building, New York, N. Y.

E. 10-33

Gentlemen: Please send me full information on the Western Electric 244A Relay.

NAME .....

ADDRESS .....

CITY .....

STATE .....



# *Electronics Readers*

*are cordially invited to investigate*  
*the Research and Development Laboratory facilities of the*  
*RCA Radiotron Company, Incorporated*

A radio tube is no better than the laboratory facilities behind it. RCA Radiotron Co., Inc., believes that the excellent reputation of its product is due to its superb technical talent and equipment—its unsurpassed laboratory facilities. We invite you to investigate them through the medium of these pages.

## **Systematic Development and Application of Radio Tubes**

The Research and Development Laboratory of RCA Radiotron Company, Inc., at Harrison, N. J., is necessarily organized on a broad basis. While the primary functions of such a laboratory are to develop new types of tubes for broadcast and amateur use, and to perfect existing types, a conscientious and vigorous application of this program leads into almost limitless paths of research and engineering endeavor. Exploration of these paths, many of them long and difficult, has no attraction for a manufacturer who is concerned solely with immediate sales. Yet it is through research, backed up by a capable and sympathetic development and application engineering organization, that the real advances are made.

The aim of the RCA Radiotron Laboratory staff is to cover the broad field of electronics in so far as this is humanly possible; to concern themselves equally with research on the fundamentals of tube characteristics and designs, the development of new tubes and the application of existing tubes; to look not only at the immediate present but the near and distant future as well.

The pursuit of this objective involves a division of laboratory activity into three parts:—research, development and application. While at times, due to the closely related nature of the work, the activities of one section may merge with those of another, the general field of each section remains clearly defined.

## **The Research Sections**

The Research Sections are concerned with new ideas in radio tube characteristics, principles of design, basic materials and processes. Seldom do they occupy themselves with existing tubes, or even the introduction of new tubes of conventional design. Their research activities extend into the field of physical and chemical science. An example of physical research is the recent work on the fundamental principles of tubes for ultra-short waves. The work of the chemical division includes such things as new "getter" substances, ceramics for insulation, alloys for various tube parts, chemical processes and studies of primary and secondary electron emission.

## **The Development Section**

The introduction of RCA Radiotrons and Cunningham Radio Tubes for which there is an immediate practical market, or for

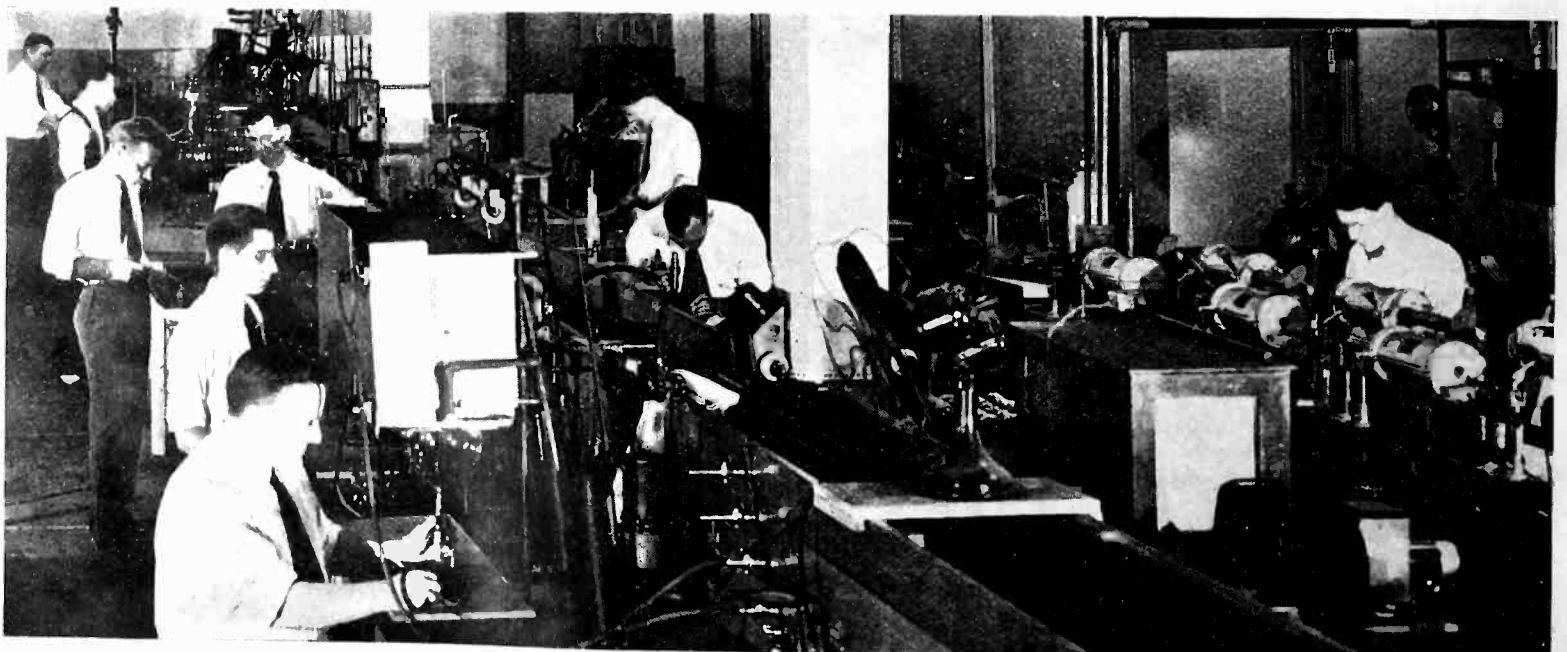

A SECTION OF THE RCA RADIOTRON RESEARCH AND DEVELOPMENT LABORATORY

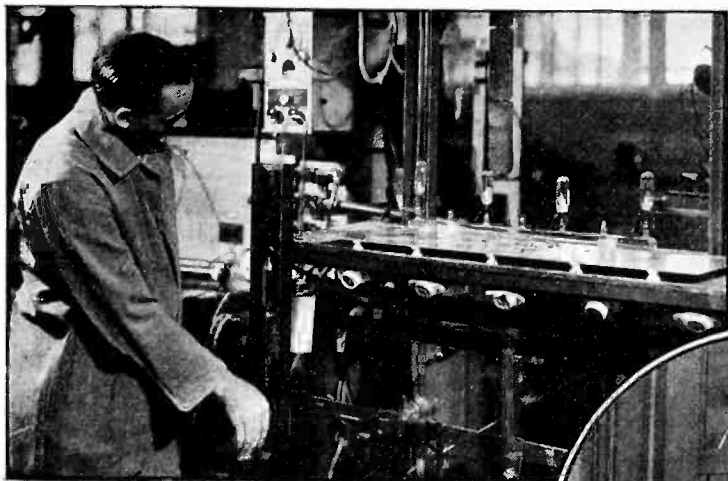

*Exhausting experimental tube types*

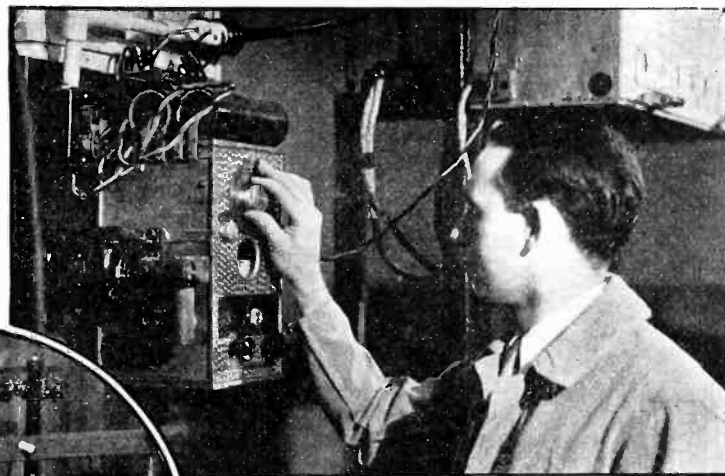

*Precision apparatus reduces errors to a minimum*



*Extreme care is exercised in all measurements*

which there will be such a market in the future, and the constant improvement of existing types, fall in the province of the Development Section. It is the designing engineering group of the company and is the largest section of the RCA Radiotron Laboratory. It is continually incorporating into actual tube designs the new ideas obtained from the Research Sections, as well as from its own personnel. In this section a new design is carefully worked out before it goes on to the factory for regular production. Developmental tubes are made in a special factory where the combined experience of engineers and expert factory personnel is applied.

## The Application Engineering Section

RCA Radiotron Company, Inc., has long prided itself on its Application Engineering Section. Working closely with "Development," this section acts as a "proving ground" for tubes in process of development.

No automobile under development is put through more thorough performance tests on the proving ground than these tubes under actual performance tests in circuits.

Before any new tube is introduced it should be proven that it offers the equipment-design engineers at least two possibilities as compared with tubes already available. These are, to produce a receiver which will give better performance for the same cost, or equal performance for less cost. The two-fold function of this section is, therefore, to find out (1) what can be done with both old and new

tube designs, and (2) the manner of obtaining best results from them. The coordination between tube and set manufacturer is facilitated by the Field Division of the Application Engineering Section, whose members are constantly calling on set manufacturers, discussing their problems, answering their questions and receiving their recommendations.

## Commercial Engineering Section

Another highly important work of the RCA Radiotron Laboratory is the collection, correlation and dissemination of technical data in concise and usable form. This work is performed by the Commercial Engineering Section. The staff of this section, through handling much technical correspondence with users of the product, are fully informed as to the type of data which will be helpful to the technical man. As a result, they are always mindful of his needs and viewpoint when preparing information for distribution.

## Testing

The activities of the RCA Radiotron Research and Development Laboratory have been outlined in brief. Numerous essential engineering functions that belong to the laboratory as a whole have not been discussed. Probably the most important of these is the thorough and extensive testing program which is carried on to insure a product of uniformly high quality. The development of the test equipment for measuring both the common and more obscure tube characteristics, careful test procedure, rigid test limits and a consistent lifetesting program are activities which have been developed to a high degree because of the leading role which testing plays in RCA Radiotron engineering, as it does in RCA Radiotron manufacture.

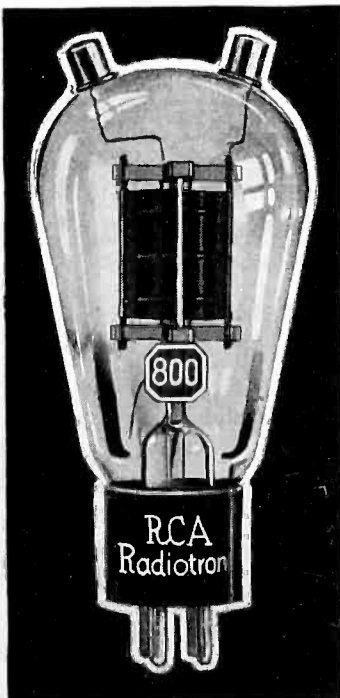

*RCA-800—an example of RCA Radiotron Engineering development. The new 800 is designed particularly for short wave transmitting.*

*The broad scope of RCA Radiotron research and engineering, plus a manufacturing organization that works hand in hand with it, is responsible for the technical leadership of RCA Radiotrons and Cunningham Radio Tubes.*

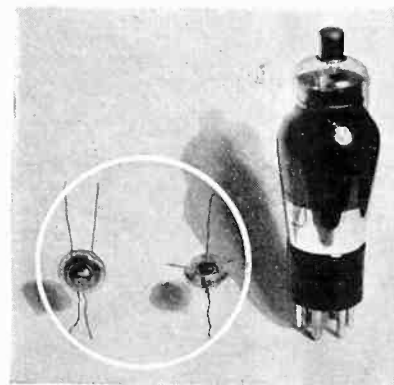

*An example of RCA Radiotron research—a miniature laboratory tube used in research on ultra-short waves.*

# RCA RADIOTRON CO., INC.



HARRISON . . . . . NEW JERSEY  
A Radio Corporation of America Subsidiary





# GOAT Inside the Tube

# SERVICE Outside the Tube



SHIELD



PLATE



COLLAR

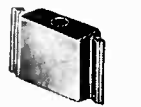

DIODE  
SHIELD



DIODE  
PLATE

Goat quality parts improve tube performance.

In addition to furnishing a complete range of parts for standard receiving tubes such as these used in 2B7 and 6B7 types, Goat manufactures these parts in unlimited quantities.

All parts are of Goat high standard, and include nickel strip, plain and carbonized, mesh, wire, iron, molybdenum and tantalum.

Facilities are also available for producing special parts for Cathode Ray Rectifiers, Power Tubes, X-Ray Tubes, etc.



*Write for further information, samples and engineering data, pertaining to Goat Parts and Service.*

Goat form-fitting Tube-shields are revolutionizing tube shielding. They save time and space in chassis design, as well as material and labor.

When Goat Shields are used in place of the old-style "can" shields, tubes can be much closer spaced and still be accessible. The designer is given a free hand in arranging components to suit his requirements and at the same time achieve compactness and simplicity.

Goat Tube-Shields improve appearance and performance. They are available in five types, including new models to fit practically all existing standard receiving tubes.



### Cost Sheet savings with GOAT TUBE-SHIELDS

Shields . . . 10% to 25%  
Chassis . . . . . up to 10%  
Cabinet . . . . . up to 10%  
Mounting  
Shields . . 10% to 50%

**Goat Radio Tube Parts, Inc.**  
314 DEAN STREET, BROOKLYN, N. Y.

# TONE PERFECTION for Radios and Sound Equipment



1/8th actual size

High fidelity reproduction over the full audio range is economically obtained with the new Model 4A High-Frequency Electrophone. By connecting the Electrophone directly in parallel with your present speaker, projector or reproducer, absolute tone perfection is secured. Simple to install. No additional filters, special networks, field supply or polarizing voltage necessary. Acoustical engineering service available to manufacturers.

*Write for free Bulletin 1E.*

## ELECTROPHONE CORPORATION

2019E Rittenhouse Square

Licensed under patents and applications of The Boonton Research Corporation and Brush Development Company.

Philadelphia, Penna.

# ELMET MOLYBDENUM GRID WIRE

## IT MEANS BETTER TUBES!

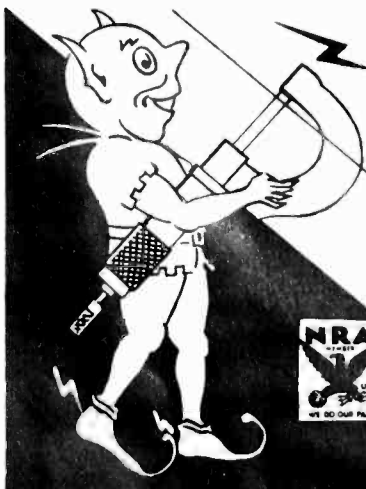

SMALLER  
TOLERANCES



*Because* - ELMET is truly accurate throughout the extra long lengths in which it is available—we guarantee it.

*Because* - Due to its unmatched purity and our special methods of manufacture, ELMET discourages Grid Emission.

We control the production of ELMET GRID WIRE from the ore to the finished product and know that it will give you satisfaction.

*If you want the best, order ELMET. Send for prices.*

**AMERICAN ELECTRO METAL CORP.**  
**LEWISTON, MAINE**



# MOLDED CARBON VOLUME CONTROL

by  
**STACKPOLE**  
*Keeps pace with  
Radio Progress*

# 9

**FEATURES**  
*of design which  
promote performance*

## 1 Protection offered in fully insulated bushing and shaft

A bakelite hub carries the spring arm and the contact for the moving element. The shaft is molded into the other end of this bakelite hub. Mounting bushing and shaft are thus fully insulated from entire Control Resistor.

## 2 Accurate switch operation

The cam dog which operates the A.C. switch on switch type variable resistors, is assembled as a composite part of the moving arm member. Accurate switch operation in respect to the resistance curve or hop-off value is assured.

## 3 Stable and solid assembly

Rugged stop pins are accurately located through the resistor element and the bakelite frame and hold the entire assembly into one solid form.

## 4 Easy assembly

The lugs of the resistor as well as those on the AC Switch are tin dipped to facilitate the soldering of connecting wires.

## 5 Smooth action and noiseless operation

A one-piece special tempered spring arm maintains constant spring tension against a nickel chrome, highly polished, non-corrosive sliding shoe. Smooth and easy rotation of the variable resistor arm is assured.

## 7 Simple mounting

A standard brass bushing for one-hole mounting is fully insulated from the arm and resistor element.

## 8 Quiet, easy operation

The shaft is of non-rusting cadmium plated steel, perfectly fitted in the bore of the brass bushing to provide smooth and quiet operation.

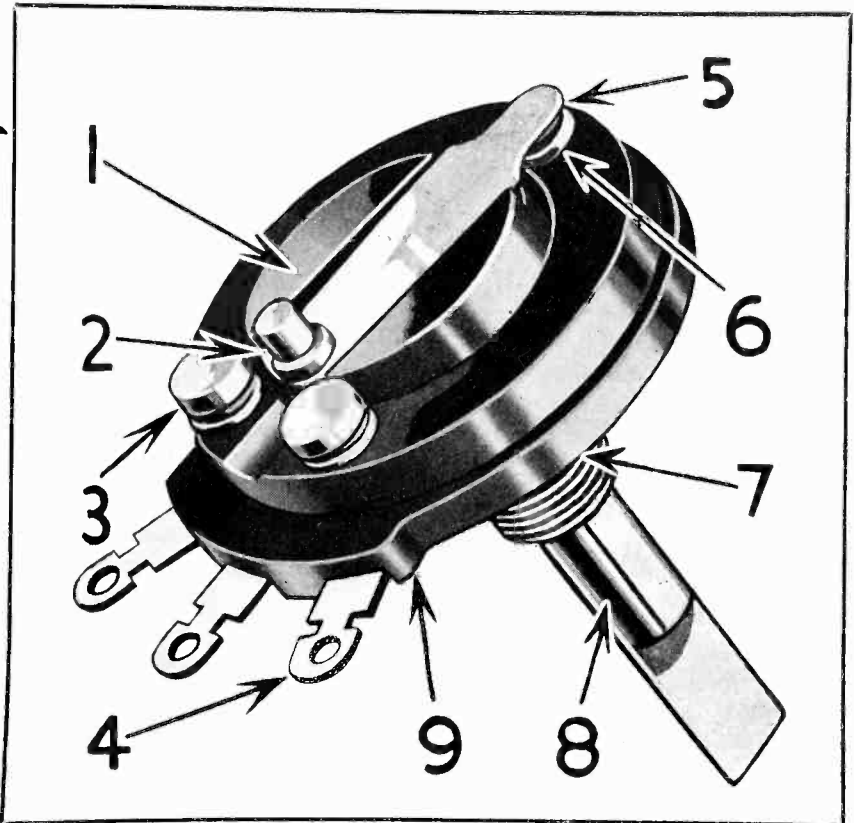

## And A New, Permanent, Molded Carbon RESISTOR ELEMENT

Stackpole offers the first control of its type and the first compact variable resistor which is permanent and unaffected by humidity.

The thick molded carbon resistor element, mounted on bakelite frame, is made in much the same way as permanent carbon resistors. Its hard glass-like surface is the result of firing at high temperatures and assures imperviousness to humidity—hard usage and

varying temperatures. Stackpole Molded Carbon Volume Controls will carry considerable current, are free from capacity effect, and have low heat and voltage coefficient. They are smooth and quiet in any circuit.

Made in any value from a few hundred ohms to a couple of megohms with any desired resistance taper and any hop off or fixed value of resistance at either or both ends.

**Manufacturers of  
Quality Resistors  
and Suppressors**

**STACKPOLE CARBON CO.**  
ST. MARYS, PA.



# Announcing merTran De Luxe Audio Transformers

in  
New Mountings  
New Designs



All types are available with terminals at top, and those who mount transformers behind a panel will find this arrangement the most convenient.



Where transformers are installed on a chassis and concealed wiring is desirable, base-mounted transformers are necessary. All types can be supplied in this form.

Effective Nov. 1, 1933 AmerTran De Luxe Audio Transformers will be available in new mountings of more attractive appearance, in new designs of greater flexibility. The same high quality which has been maintained for more than 10 years will be built into each unit.

Black crackle finished mountings of similar appearance but varying in size will be used to house all units in our De Luxe Line, including audio, plate, filament, and power transformers, also audio and filter reactors. Terminals are located either at the top or base as specified by the customer.

Electrical designs have been revised so as to provide greater flexibility wherever possible without reducing the efficiency. New types are also available for use with new tubes and in latest circuits.

*Write for bulletin giving complete information and latest list prices.*

**American Transformer Company**  
*Transformer builders for over 31 years*

178 Emmet St.

Newark, N. J.



**AMERTRAN  
TRANSFORMERS**



## A NEW GEN-RAL (REGISTERED) COIL

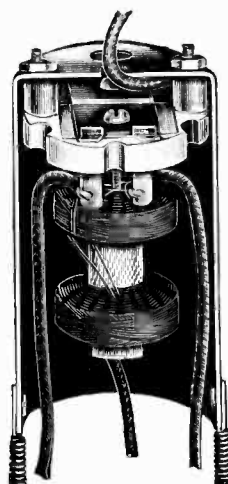

A double tuned unit for extremely small AC and DC receivers; peaked at an average of 456 K.C. or 175 K.C., and housed in a shield  $1\frac{1}{2} \times 3$  in.

The 1933 GEN-RAL Loose Leaf Catalogue is now ready. Be sure to have a copy in your files.

MCX200 D.V.M.  
I.F. UNIT

**GENERAL MFG. COMPANY**  
8066 South Chicago Avenue  
CHICAGO, ILL.

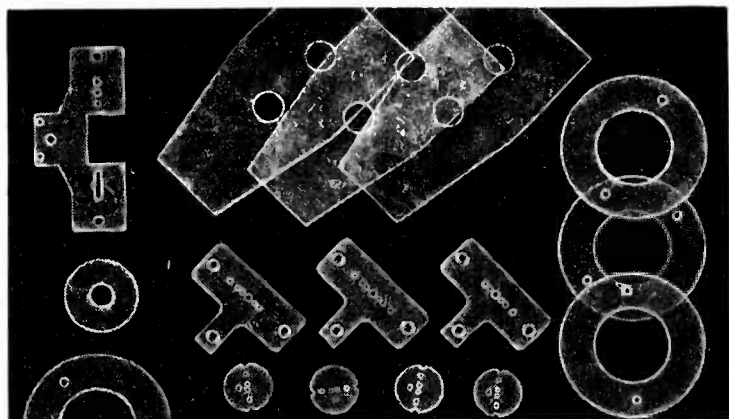

## These MICA SHAPES are noted for accuracy

Tube and condenser manufacturers are most enthusiastic about the accurate machining of our mica shapes. They are made of the finest mica obtainable . . . Munsell's India Ruby Mica.

Further details, prices, and samples gladly furnished.

**Other Electrical Insulations:** more than 120, including "Empire" Varnished Cloths and Tapes, "Lamicoid" Bakelite Laminated and Micanite are described in our new Price Lists. Write for copies.

## MICA INSULATOR COMPANY

200 Varick Street, New York, N. Y.; 542 So. Dearborn Street, Chicago, Ill.; 1330 Schofield Building, Cleveland. Branches at Birmingham, Boston, Cincinnati, Los Angeles, San Francisco, Seattle. Canada: Montreal, Toronto.

# GIANTS

in carrying capacity

# MIDGETS

in Size

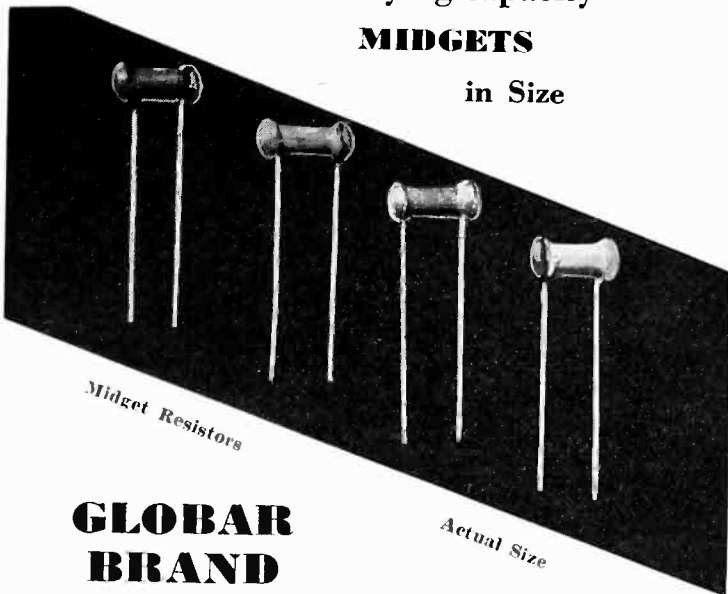

## GLOBAL BRAND

### Giant-Midget Resistors

Now available, a new series of Global Resistors—Tom Thumbs in size—Goliaths as carriers.

*Glad to send samples and complete information as to sizes, wattages, etc.*

### GLOBAL CORPORATION

A Subsidiary of The Carborundum Company  
Niagara Falls, N. Y.

# REMLER

## NEW LADDER TYPE ATTENUATOR

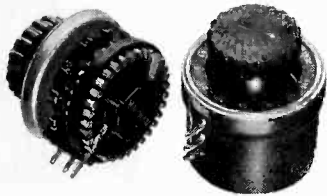

Designed to meet exacting voice-circuit requirements. Attenuation increased in 53 steps of  $\frac{3}{4}$  d.b. to 45 decibels. A rising attenuation serves to completely fade the program from 45 d.b. to infinity. Flat characteristic over range of 20 to 20,000 c.p.s. Extremely low noise level. Dimensions  $2\frac{1}{4}$  in. deep by  $2\frac{3}{8}$  in. wide. Standard impedances, 50, 200

and 500 ohms. Special values on order. LA-5 Ladder Type Attenuator, List Price ..... \$18.00

## NEW A.C. REMOTE CONTROL BROADCAST AMPLIFIERS

The rapidly increasing demand for these new amplifiers is a tribute to their efficiency. Full A.C. operated including condenser microphone supply. Equipped with level indicator, ladder attenuators, phonograph input, lock type connectors. Adaptable for carbon microphone operation, also for both A.C. and battery operation at slight additional cost. List prices: 1 microphone channel, \$245.00; 2 microphone channels, \$285.00; three, \$325.00; four \$365.00. Combination Remote and Public Address Unit, \$495.00 List.



Send for illustrated literature.

### REMLER COMPANY, Ltd.

2101 Bryant St., San Francisco, Calif.

**REMLER—THE RADIO FIRM AS OLD AS RADIO**

# SHAKEPROOF

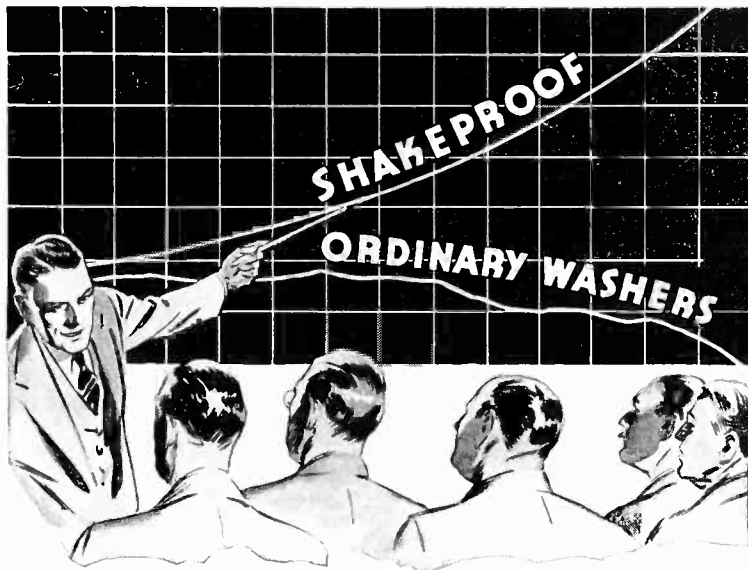

## Vibration Control

### ASSURES SMOOTH

### ECONOMICAL PERFORMANCE

THERE'S nothing that destroys efficient performance as quickly as vibration. It strikes at vital connections and, if any nut or screw is unprotected, serious trouble is certain. No product can escape Vibration—but every metal manufacturer can use the Shakeproof principle of "Vibration Control" to keep connections tight. The twisted teeth of Shakeproof Lock Washers bite into both work and nut surfaces—and

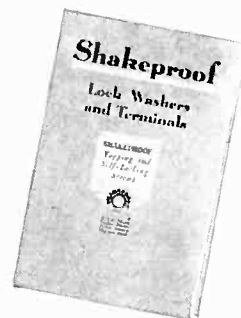

Send today for your free copy of this complete Shakeproof Catalog. Explains thoroughly the many advantages that Shakeproof offers—also shows new patented Shakeproof products.



"It's the Twisted Teeth that LOCK!"

the greater the vibration the tighter they hold. Let Shakeproof show you how to improve your product and build into it extra years of satisfying, money-saving performance. Write for free testing samples today!

# SHAKEPROOF Lock Washer Company

{Division of Illinois Tool Works}

2539 N. Keeler Ave.

Chicago, Ill.

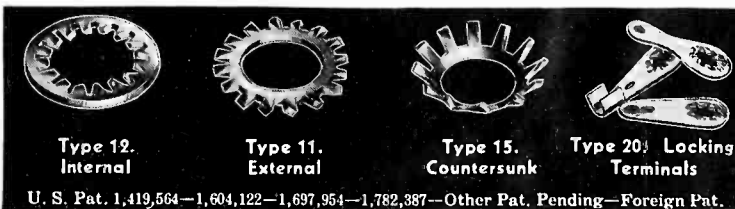

Type 12. Internal

Type 11. External

Type 15. Countersunk

Type 20. Locking Terminals

U. S. Pat. 1,419,564—1,604,122—1,697,954—1,782,387—Other Pat. Pending—Foreign Pat.

Our part of the job

Every step in the manufacture of Resinox is toward one goal: to produce a molding material whose quality and uniformity are unexcelled. You can expect consistently good work with material like this.

KEEP IN TOUCH WITH RESINOX DEVELOPMENTS

Specify

**RESINOX**

Molding Resins

Molding Compounds

Laminating Varnishes

**RESINOX CORPORATION**

Subsidiary of Commercial Solvents Corporation and Corn Products Refining Company  
230 Park Avenue, New York City

## CANNON PLUGS

Keep Good Company

MICROPHONES are known by the company they keep. And so is other electrical equipment. The larger manufacturers have found that CANNON Plugs support and make certain the performance of the "built-in" quality of their products. When a manufacturer supplies a "boot-leg" or cheap plug with his equipment, can you trust his equipment?

It will pay you to insist, if necessary, on CANNON Plugs. But almost without exception, you will find that leading manufacturers supply them without insistence.

[ There Is a CANNON Plug for Every Cable Connector Need ]

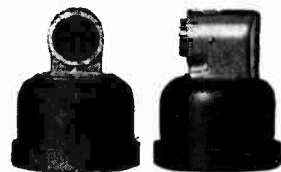

Write for fully illustrated Catalog.

CANNON ELECTRIC DEVELOPMENT CO.  
MANUFACTURING ENGINEERS

Main Office: 420 West Avenue 33, Los Angeles, Calif.

Eastern Sales Office: 245 Fifth Ave.,  
New York, N. Y.



Representatives:  
Chicago: Jenkins & Adair, Inc., 3333 Belmont Ave.  
Bombay, India: Eastern Electric & Engineering Co.,  
175 Hornby Road, Fort, Bombay, India

## SHALLCROSS



## WIRE WOUND



## RESISTORS

To build accurate testing equipment you must have precision resistors.

Shallcross Wire Wound Resistors are normally calibrated with precision to 1%; they can be furnished to a precision of 1/10 of 1%, if required. Use them wherever precision and permanent accuracy of the resistance is a factor. Bulletin 85 contains electrical and mechanical specifications—send for it.

Shallcross Mfg. Company  
Collingdale, Pa.



## Bombarder Capacitors

Cornell-Dubilier announces a new line of Bombarder Capacitors for use with radio-frequency induction heaters and designed for severe service.

THESE CAPACITORS FEATURE:



Rugged mechanical and electrical construction in standard units offered in capacities of .004 to .05 mfd.

Better cooling and improved internal design, with even distribution of currents, permitting greater KVA capacity in smaller space.

High-voltage-insulated terminal with massive threaded stud and nuts, and mounting feet now placed at base to facilitate mounting and wiring.

Write for technical data on these new  
C-D Bombarder Capacitors

CORNELL-DUBILIER CORPORATION  
4377 Bronx Boulevard - New York City



# AGASTAT . . . . The Time Delay Relay with Wide Application

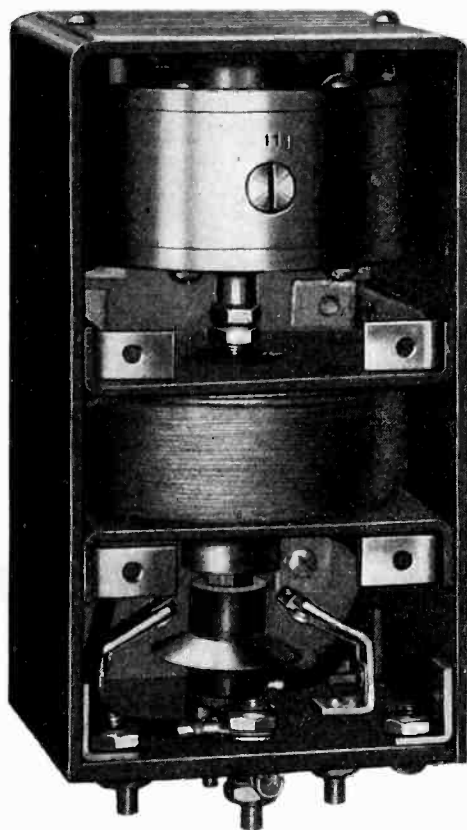

Size 5 1/4 in. high x 2 5/8 in. sq.

Wide Range . . . Adjustable . . . Compact . . .  
Immediate Recycling . . . Temperature Compensated  
. . . Pressure Compensated . . . Time Interval Re-  
mains Constant . . . Snap Acting Contacts . . .  
Timing Independent of Voltage Fluctuations.

### Types Available

- NA-11 Delayed Make After Coil is Energised
- NA-12 Delayed Break After Coil is Energised
- NA-21 Immediate Make When Coil is Energised  
Delayed Break After Coil is De-Energised
- NA-22 Immediate Break When Coil is Energised  
Delayed Make After Coil is De-Energised

Infinite variations of timing effects possible by circuit combinations of above types.

Write for Bulletin with Technical  
Details, Application and  
Design Information



AMERICAN GAS ACCUMULATOR COMPANY  
ELIZABETH NEW JERSEY

## ENAMELITZ

Reduce manufacturing costs on I.F. and R.F. coils through the use of Enamelitz—"Litz" wire without a fabric covering.

Three Fold Savings—

1. Cost of wire
2. More coils per pound of wire
3. Less space—Greater safety

Sample and Technical Bulletin on Request.

### Other Acme Wire Co. Products

Magnet Wire (all insulations)

Coils, Magnet Wire Wound

Varnished Insulations

(Cambric, paper, silk, tape)

Parvolt Condensers

(Filter, By-pass, Power Factor Correction)

Aerial Wire

(Stranded and Solid—Bare or Enameled)

For over 25 Years, suppliers to the largest radio and electrical manufacturers.

**THE ACME WIRE CO.**

New Haven, Conn.

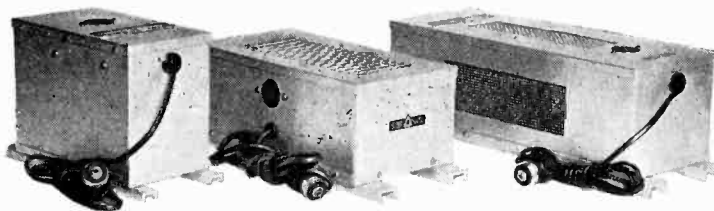

60 Watt

120 Watt  
Stock Sizes

250 Watt

## CONSTANT VOLTAGE for Photo-Cell Operation

LINE VOLTAGE 90 to 130, OUTPUT 115 ± 1%

A constant voltage is absolutely essential to the effective operation of many photo-cell and other devices. Delta Voltage Regulators will maintain output voltage regulation within ± 1% with any load and line voltage within their operating range. Embodying the latest developments of our laboratory under the direction of F. S. Dellenbaugh, Jr., they are compact, efficient and contain no moving parts whatever. Users include: General Electric Co., Bell Laboratories, Federal Telegraph Co., Eastman Kodak Co., Western Union, and many others. Write us for specifications, stating your problem in detail.

## DELTA VOLTAGE REGULATORS

Entirely Automatic . . . Negligible Time-Constant



DELTA MANUFACTURING CO.  
39 OSBORNE ST.,  
CAMBRIDGE, MASS.

F. S. Dellenbaugh, Jr., Pres.  
and Chief Engineer.

Gentlemen: Please send me full particulars on the Delta Voltage Regulators.

Name .....

Address .....

EL 10-33



# NOW ≡ a high-powered radio engineering library

—especially selected by radio specialists of the McGraw-Hill Publications

—to give the most comprehensive, useful, authoritative coverage of radio engineering

—available at a special price and on easy terms

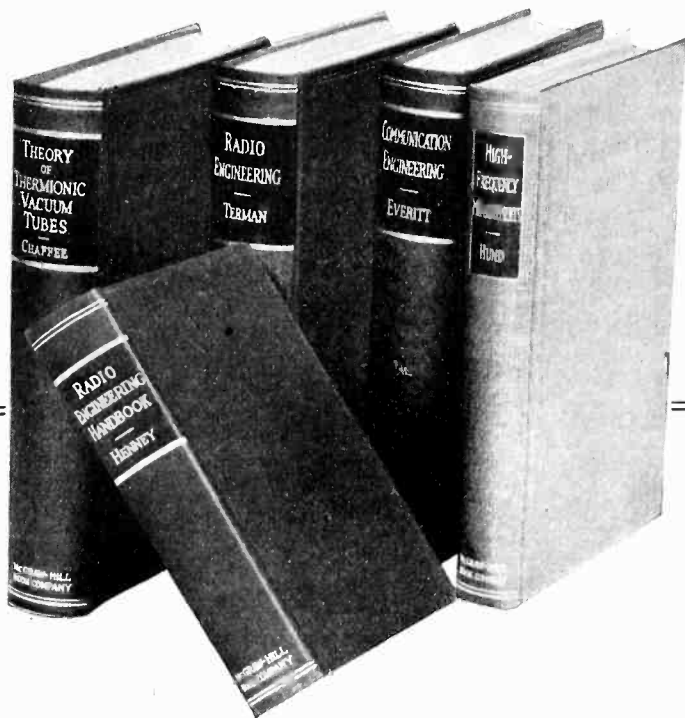

## Radio Engineering Library

5 volumes—2981 pages—nearly 2000 illustrations, \$23.50, payable \$2.50 in 10 days and \$3.00 monthly.

### What the library contains:

#### Communication Engineering

By Professor W. L. Everitt of The Ohio State University. Expository treatment of fundamentals of communication. Stresses broad principles. Covers classification of impedance elements, networks using linear bilateral impedances, networks using unilateral impedances, networks using non-linear impedances, negative resistance effects, coupling between electrical and mechanical circuits, coupling between electrical circuits and free space.

#### Radio Engineering

By Professor Frederick E. Terman of Stanford University. Comprehensive engineering treatment of important vacuum-tube and radio phenomena. Analyzes circuits and tubes and reduces them to quantitative relations predicting performance of tubes and radio apparatus with accuracy and certainty. Includes material on radio aids to navigation.

#### Theory of Thermionic Vacuum Tubes

By Professor E. Leon Chaffee of Harvard University. Comprehensive treatment of fundamentals of thermionic emission and the vacuum tube. Covers use of tube as amplifier and detector as well as its general properties. New, original material on large-signal regeneration, regeneration in coupled circuits, detection, all types of amplifiers, non-linear elements, etc.

#### High-Frequency Measurements

By August Hund. Complete, thorough reference work on measurements of high frequency. For research workers, practical designers and engineers. Presents theory and practice of measuring all manner of electrical quantities as well as present-day radio apparatus. Methods presented in a manner practical enough to meet needs of anyone interested in the increasingly important high frequency art.

#### Radio Engineering Handbook

Editor-in-chief, Keith Henney, Associate Editor of *Electronics*, assisted by staff of specialists. Handbook of radio comparable to standard handbooks in other fields of engineering. Emphasizes design area, covers everything from fundamentals to latest practical applications. Covers new tubes and circuits, Class B amplifiers, transmitters, receivers, short-wave, television, sound pictures, aircraft radio, etc.

**H**ERE is an announcement of importance to every radio engineer. These outstanding radio books, comprising a complete library of radio engineering essentials, now conveniently grouped and offered at terms that enable all to start using this library at once.

This is a real engineering library. Radio specialists of the McGraw-Hill publications selected the books for this library as those giving the most complete, dependable coverage of those facts needed by all engineers whose special fields are grounded on radio fundamentals. Covers circuit phenomena, tube theory, networks, measurements, and other subjects—gives specialized treatment of all fields of practical design and application.

These are books of recognized position in the literature—books that you will refer to and be referred to often. If you are a practical designer, researcher or engineer in any field that is based on radio, you want these books at hand for the help they can give you on hundreds of occasions, in scores of problems throughout the whole branch of radio engineering.

Space doesn't permit more than to suggest the value this library can have for you. Therefore we offer to send the entire set on approval, for your personal inspection and appraisal. If after examination you don't think these books will pay for themselves over and over as a needed and dependable reference tool in your work, return them without question. Take advantage of this offer.

### Special low price and easy terms

Bought singly, the five volumes comprising this library would cost you \$26.00. Under this offer you save \$2.50 and in addition have the privilege of paying in easy installments beginning with \$2.50, 10 days after receipt of the books, and \$3.00 monthly thereafter. Already these books are recognized as standard works that you are bound to require sooner or later. Take advantage of these convenient terms to add them to your library now.

### Examine this library 10 days—Send this coupon McGRAW-HILL ON-APPROVAL COUPON

McGraw-Hill Book Company, Inc., 330 West 42nd St., New York City  
Send me the Radio Engineers' Library, 5 volumes, for 10 days' examination on approval. Within 10 days of receipt I will send \$2.50, plus a few cents for postage and delivery, and \$3.00 monthly thereafter till \$23.50 is paid, or return the books postpaid. (We pay postage on orders accompanied by remittance of first installment.)

Name .....  
Address ..... Position .....  
City and State ..... Company .....  
(Books sent on approval in U. S. and Canada only) L. 10-33

# BRUSH

## GRILLE-TYPE MICROPHONES

adopted as standard at A Century of Progress and the Canadian National Exhibition for their fidelity of sound reproduction; adopted for the Byrd Antarctic Expedition for their ruggedness and reliability.

*Write for the new circular and technical information*

**THE BRUSH DEVELOPMENT COMPANY**  
3715 Euclid Avenue, Cleveland, Ohio

## Another BRUSH PRODUCT

# BERYLLIUM OXIDE

For Vacuum Tube Refractories, etc.

**BRUSH BERYLLIUM COMPANY**  
3715 EUCLID AVENUE, CLEVELAND, OHIO

# COILS . . .

**RADIO FREQUENCY COILS:** R.F. coils for radio manufacturers. Coils manufactured with the utmost precision. Our special designed testing equipment guarantees complete accuracy.

**INTERMEDIATE FREQUENCY COILS:** I.F. coils for radio manufacturers. Our experience in supplying some of the leading manufacturers in the industry, puts us in a position to successfully serve additional clients.

**LITZ WIRE:** Special Litz wire of all sizes made to order. We have served a number of representative manufacturers with Litz wire for over four years.

**WIRE INSULATING:** We are fully equipped to handle your requirements for wire insulating on all sizes down to .0005.

*Let us submit samples and quote on your requirements.*

## SCIENTIFIC COIL & WIRE CO.

4348 Broadway  
Chicago, Ill.

Telephone: Lakeview 1006

## Hear room conversations, music, etc., by using UNIVERSAL'S NEW HEARING AID DEVICES

For table and desk use—2 stages of amplification—Special highly sensitive microphone and Featherweight ear phone with head band.

Model HA-1 has volume to operate up to 10 ear phones at one time. List price with one ear phone (less batteries and tubes) \$48.00.

Sold by Radio dealers and jobbers everywhere. (Standard Discounts)



**UNIVERSAL  
MICROPHONE  
CO., Ltd.**

424 Warren Lane,  
Inglewood, Calif., U. S. A.

KENYON

PRODUCTS

# Specify

# KENYON

## TRANSFORMERS!

Because KENYON ranks among pioneer transformer specialists. All parts manufactured in KENYON plant, including coil winding. Electrical and mechanical characteristics of both raw materials and finished units constantly checked by completely equipped research laboratory. From start to finish, nothing is overlooked, skimmed, forgotten. That's why KENYON means transformer quality at the right price for lasting satisfaction. Thus . . .

### • for Laboratory Standards

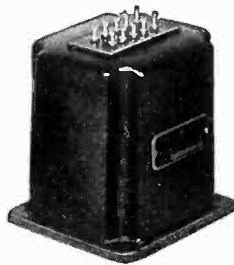

KENYON Laboratory Standard Audio Components meet highest standards. Really flat curve in components and assemblies. High efficiency attained through proper and liberal proportioning of materials. Housed in high-permeability cast-iron cases. Cross-talk proof. No A.C. hum pickup. Electrostatic shielded coil structure. Thoroughly vacuum-impregnated and sealed against moisture and climate. Complete line for all needs.

### • for Dependable Power Packs

Compact but husky power transformer supplying combined filament and plate voltages. Also filament transformers, center-tapped secondaries. Conservatively rated for continuous, troubleproof operation. Likewise reactors or choke coils. Complete KENYON rectifier assemblies made to order, as well as voltage regulators.

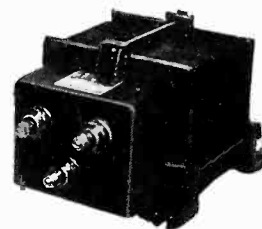

### • for Long-Life Transmitters

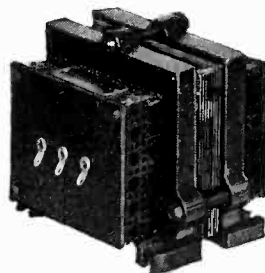

Conservatively rated components manufactured for many years for broadcast and amateur transmission. Any voltage and any current output can be met. Filter and plate transformers, also filter and modulation reactors. Highest quality both in performance and in handsome appearance. KENYON components are used in many transmitters the world over.

### • And for Any Special Purpose

In addition to the complete line of standard radio transformers and chokes, the KENYON engineering and production departments are ready to design and make special equipment for any radio, laboratory, electrical or industrial need. No job is too large; none is too small. Just try KENYON!

Send for Catalog covering the standard line of KENYON radio transformers and chokes. And do not hesitate to place your transformer problems before our engineers, or to send along your specifications for our quotations.



**KENYON TRANSFORMER CO., Inc.**

122-124 Cypress Ave. - - - - - New York

# Help!

---

## FOR THE ROBINSON CRUSOES

**T**HOUGH your business be in the center of things or far off the beaten track, if you aren't in constant touch with the news and developments of your industry you are as isolated as was Robinson Crusoe . . . Yes, isolated!

Isolated from the changing economic picture that will certainly affect you whether you realize it or not!

Isolated from the new production ideas, new machinery, new materials that mean competitive advantage to the first to use them!

Isolated from the new distribution methods, new outlets, new price policies, new style or packaging ideas that may put your product out of the running if you don't keep up with them!

How can you avoid this business isolation? How can you keep alert to ever-changing conditions? The answer is simple. Follow the news regularly in your business paper, the industry's clearing house for new ideas.

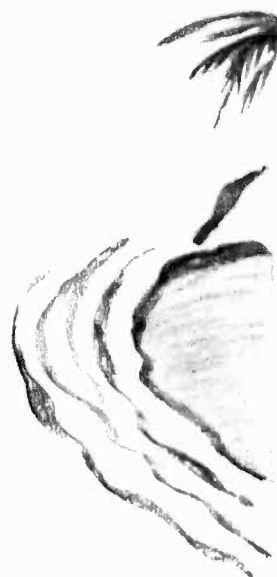

### Put Your Company on a "Keep Alert" Program

Here is an easy and practical program suggesting a few simple steps to get the maximum benefit from business journals for your own organization.

1. Keep up with your own industry by reading regularly its leading business paper:—

#### ELECTRONICS

2. See that your department heads read regularly publications pertaining to their own jobs, whether in management or operation, production or maintenance. (See list of Publications opposite.)
3. Ask to have a McGraw-Hill representative explain the various editorial features and services of the publications.

4. Keep in touch with the McGraw-Hill Book Company for the latest treatises on business and technical subjects.

Today, more than ever, you must keep alert, must be posted on what's going on. So must your subordinates and responsible heads of departments. Thousands of McGraw-Hill readers are finding this suggested program just what they need.

McGraw-Hill wants you too, to become better acquainted with their publications, books and services. Without obligating yourself in any way, sign and send in the coupon on the opposite page, check the items you would like to have and ask for sample copies of the publications in which you are interested.



McGRAW-HILL PUBLISHING COMPANY, Inc.

# OF BUSINESS

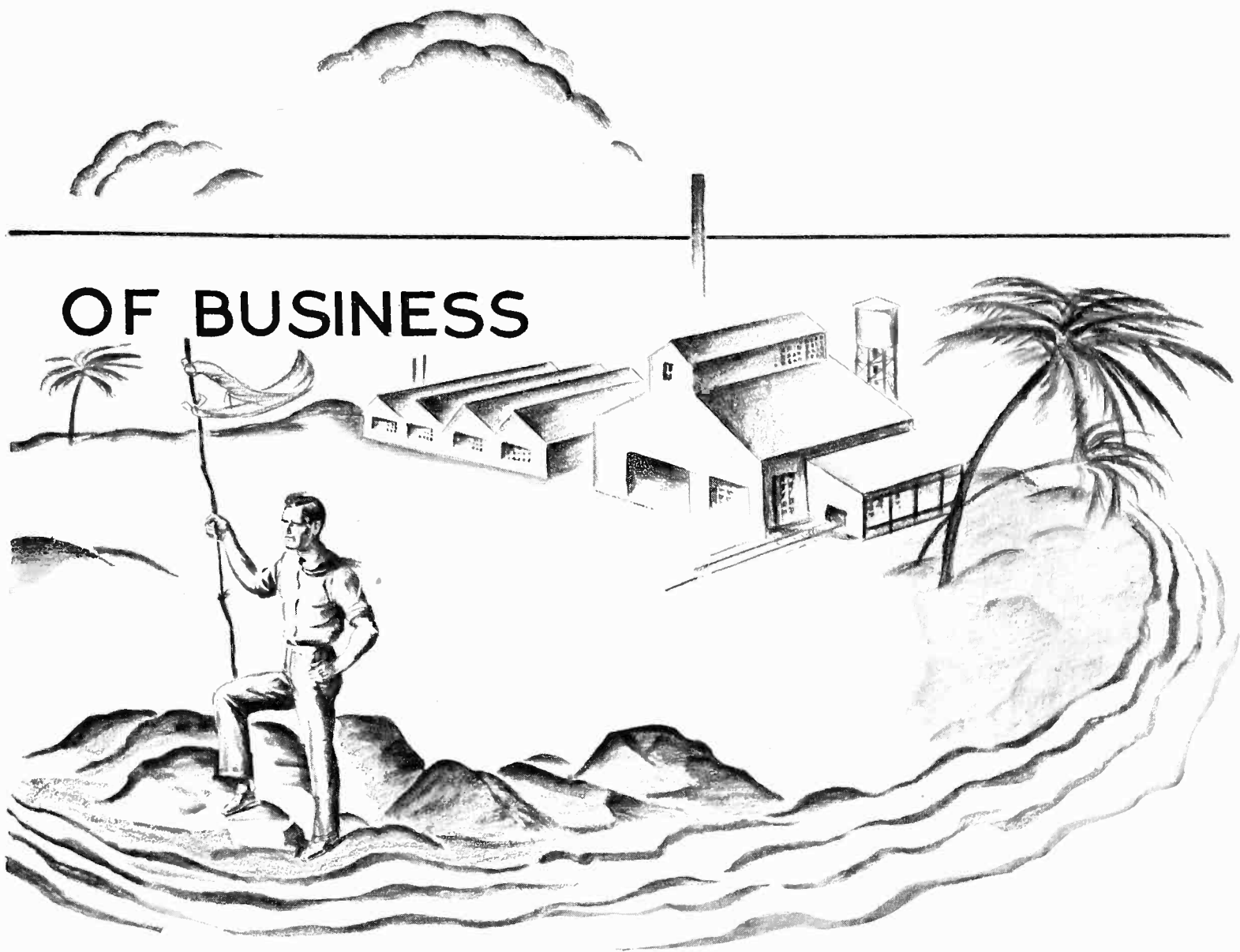

**American Machinist** . . . for machinery and metal product manufacturers . . . business and technical magazine of the metal-working industries.

**Aviation** . . . covers all business and technical developments in private and industrial flying, including production, operating and maintenance.

**Bus Transportation** . . . for executives of transportation companies operating and maintaining buses in common carrier service.

**Business Week** . . . gives the busy executive all important and significant business news in one publication . . . quickly . . . accurately . . . tersely.

**Chemical and Metallurgical Engineering** . . . covers production, technology, marketing, finance, economics, and management of these two industries.

**Coal Age** . . . devoted to the operating, technical and business problems of mining and marketing coal.

**Construction Methods** . . . an illustrated review of current field practice and equipment used in all general and special construction activities.

**Electrical Merchandising** . . . serves the electrical appliance trade . . . electrical retailers and wholesalers . . . helps them become better merchants.

**Electrical West** . . . serves the specific interests both of engineering and of selling in the electrical industry of the eleven Western States.

**Electrical World** . . . weekly business and technical coverage of central station activities, including all phases of generation, distribution and utilization of electricity.

**Electronics** . . . industrial design, engineering and manufacture of radio, sound, and communication equipment. Features new applications of electronic tubes.

**Engineering and Mining Journal** . . . complete and authoritative technical and market publication of mining, milling, smelting and metal refining industries.

**Engineering News-Record** . . . leading weekly publication of civil engineering and construction, covering news and technical performance.

**Factory Management and Maintenance** . . . all phases of plant operation . . . management, production and services including maintenance of electrical and mechanical equipment.

**Food Industries** . . . production, operation, engineering and distribution in food manufacturing and processing plants of all kinds.

**Power** . . . every phase in the production and transmission of power in any form, including all prime movers, and auxiliary equipment.

**Product Engineering** . . . for engineers and executives who create, de-

sign, and develop machinery and "engineered" metal products.

**Radio Retailing** . . . home entertainment merchandising . . . for retailers and wholesalers of radios and allied products, and their service men.

**Textile World** . . . business and technical, edited generally for the textile industries, and specifically for each large division.

**Transit Journal** . . . engineering and business magazine of local transportation, electric cars, rapid transit, buses, trolley buses and taxicabs.

McGRAW-HILL PUBLISHING COMPANY, Inc.,  
330 West 42nd Street, New York, N. Y.

Please send me, without obligation, the material checked below.

Sample copies of the following publications

Descriptive folder of all McGraw-Hill Publications

Catalog of McGraw-Hill Books

NAME.....

TITLE.....

COMPANY.....

ADDRESS.....

NEW YORK • BOSTON • PHILADELPHIA • WASHINGTON • GREENVILLE  
CLEVELAND • DETROIT • CHICAGO • ST. LOUIS • SAN FRANCISCO • LONDON



## Rugged • Sensitive Relays for Every Purpose

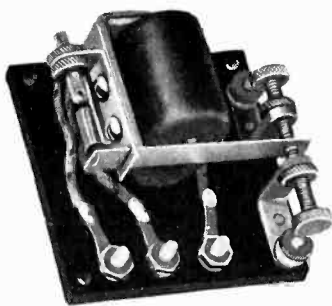

Economical in operation, economical in first cost. K-1 Adjustable Relay; .03 Watts for positive operation; coin silver contacts rated to carry 1 amp. non-inductive load. Especially suitable for photoelectric applications. The K-1 Relay has a sharp drop out at approximately 60% of the operating current value. Can be supplied to operate from .001 amps at 19 volts to .23 amps at .083 volts.

Send for engineering data. Special relays built to meet your special applications.

**KURMAN ELECTRIC CO.**  
241 Lafayette St., New York, N. Y.

## CANDOHMS

ARMoured WIRE WOUND RESISTORS

**WILL LOWER YOUR COSTS**

OVER SEVEN MILLION IN USE  
MAY WE SAMPLE AND QUOTE

**THE MUTER COMPANY**

1255 So. Michigan Ave., Chicago

A TRIAL WILL CONVINCe YOU

30 Years' Experience  
Insures Dependability

We Manufacture

PERMANENT MAGNETS TOOLS and DIES  
METAL STAMPINGS LAMINATIONS

**THOMAS & SKINNER  
STEEL PRODUCTS CO.**

23d St. at Alford

Indianapolis, Ind.

Only Reliable  
Products Can Be  
Continuously Advertised

# Competing Under the Codes

THESE codes that Uncle Sam has approved to govern manufacturers are great levelers. They put competitors under standardized labor hours and wage scales. They make competition more difficult. But competitive advantages will not be destroyed under the codes. To be sure, many of the old advantages will be lost but new advantages will arise in their place. The only trouble is that the manufacturers who once had the advantages may not have the new ones.

Competition under the codes will call for increased operating efficiency. Manufacturers, for example, will be forced to buy more shrewdly than ever before. They will have to check every available source of supply on raw materials, parts and accessories to be sure that the best suited product is bought.

MANUFACTURERS and other organizations who have products to sell to the industries that have a common interest—electron tubes—may be sure that their sales messages will receive even greater attention from the 7,000 executives and engineers who read *Electronics*, now that we're under the codes.



## electronics

a McGraw-Hill publication

—devoted to radio, sound, communications and industrial applications of electron tubes — design, engineering and manufacture

# CONTINENTAL A Dependable SOURCE OF SUPPLY

SUPPRESSORS



New Flexo-Terminal Spark Plug Suppressor fits all cars and eliminates the need for numerous separate types.

Continental Suppressors are available in all standard types and may be quickly supplied to meet any special specification.

Isolantite housings, which have proven superior to any other substance under the severe heat, moisture and vibration of automobile installations, are used exclusively.

Complete kits including spark plug and distributor suppressors and filter condensers are supplied for 4, 6, 8 and 12 cylinder cars.



RESISTORS

Continental has specialized in the manufacture of molded resistors since the beginning of broadcasting. Today Continental design, manufacturing processes and automatic machinery are leaders in the industry.

Thus Continental resistors are maintained at a standard of quality which would otherwise be prohibitive at their moderate cost. This superior quality costs you nothing extra—yet it has cut production costs for many well-known radio manufacturers.

Prove these facts yourself. Get a supply of Continentals for test today!

WRITE OR WIRE FOR SAMPLES AND PRICES

**CONTINENTAL CARBON Inc.**

13906 LORAIN AVE. CLEVELAND, OHIO  
Canadian factory Toronto, Ontario

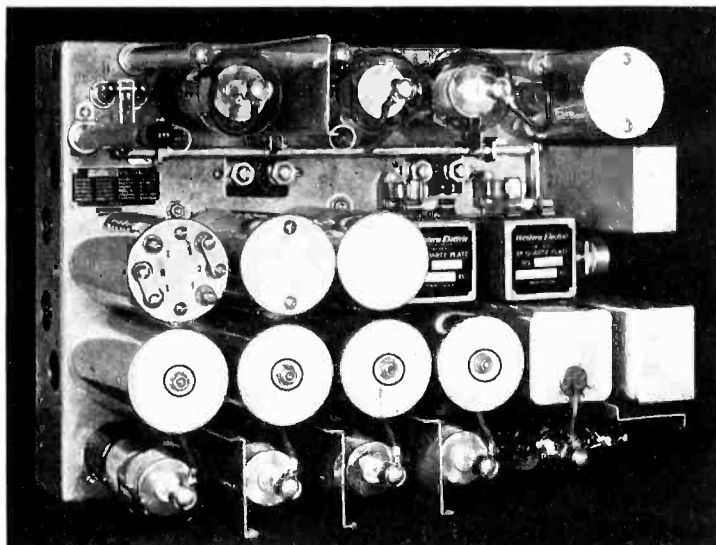

Western Electric 12-A two frequency superheterodyne aircraft receiver showing Elastic Stop Nuts used as standard throughout.

THERE is more dependable performance when radio apparatus is Elastic Stop Nut equipped.

Electrical terminal connections held with Elastic Stop Nuts are permanent and have low contact resistance. This lock nut will maintain balancing condenser adjustments for keeping the sensitivity and selectivity of high grade apparatus. Microphonic noises are eliminated on chassis mechanical connections held with Elastic Stop Nuts. Speaker rubber mountings fastened with Elastic Stop Nuts do not work loose.

Elastic Stop Nuts eliminate "loose nut" troubles on any equipment subject to vibration. Users in the electronic field include manufacturers of broadcast receivers, aircraft apparatus, automobile sets, and contractors to the government signal services, etc. Write for technical details.

**ELASTIC STOP NUT DIVISION**

A.G.A. CO.

ELIZABETH, N. J.



# PROFESSIONAL SERVICES

Consulting—Design—Research—Testing  
Measurement—Development—Acoustics—Patents

## ELECTRICAL TESTING LABORATORIES

Characteristics and  
Life Tests of Vacuum Tubes  
Tests of photocells, glow lamps, crater lamps.  
Tests of electronic and optical devices.  
80th Street and East End Avenue  
New York, N. Y.  
Phone: Butterfield 8-2600

## The Solution of Your Problem

found through enlisting the services of the  
in the field of Electronic devices may be  
Consultants whose cards appear on this  
page.

## ELECTRONICS MUSIC LABS.

Portable Electronic Organs  
for professional and broadcasting use. Equal to  
largest pipe organs. Qualities based on Eremeeff-  
Helmholtz simultaneous and Eremeeff multi-step-  
by-step synthesis. Mechanical and photoelectric in-  
struments and sound on film devices.  
WCAU Building, 1622 Chestnut Street.  
Philadelphia, Pa.

## RALPH H. LANGLEY, E. E.

Licensed Professional Engineer Fellow I.R.E.  
Twenty years' experience in the Development  
Design, Production of Radio Transmitters and  
Receivers and in Radio Patents and Inventions.  
Barclay 7-0398  
165 Broadway, New York

## JENKINS & ADAIR, INC.

Engineers  
Designers, developers, and manufacturers  
of accessories and essentials for recording,  
broadcasting and testing at sound fre-  
quencies.

3333 Belmont Avenue, Chicago, U. S. A.  
Cable Address: Jenkadair Telephone: Keystone 2130

## Thos. U. White & Associates, Inc.

Electrical development work of all kinds under-  
taken. Patents arranged and all necessary work  
preparatory to manufacturing. Electrical and  
mechanical inventions completed for market. Ex-  
cellent laboratory facilities and model shop.

128 N. Wells St., Chicago, Ill.

## SEARCHLIGHT SECTION

### AGENTS WANTED

EARN from \$1 to \$5 an hour extra without  
interfering with your present employment.  
Whether office man, salesman, technical man,  
foreman or worker you can make ready cash  
quickly and easily each week showing our lists  
of business and technical books to fellow em-  
ployees and others. You recommend them, we  
do the rest. No experience required. Complete  
equipment free. Write Tom Crawford, Dept.  
Elect., McGraw-Hill Book Co., 330 West 42d  
New York City.

## HIGH GRADE NEW AND USED ELECTRON TUBE EQUIPMENT

Write for Bulletin Showing Savings  
From 20% to 80%

**KAHLE ENGINEERING CORPORATION**  
Specialists in Equipment and Methods for the  
Manufacture of Neon Tubes, Radio Tubes, Incan-  
descent Lamps, Photo Cells, X-ray Tubes, etc.  
350 Manhattan Ave., Union City, N. J.

## electron tube equipment

### New—Reconditioned and "As Is"

Used equipment available—Stem, Sealing,  
Exhaust, Flare, Basing, and Bead Machines,  
Also Air Blowers, Gas Boosters, Spot Weld-  
ers, Aspirators, Vacuum Pumps and etc.  
Buy Direct from the Manufacturer—Be  
Assured of Full Value—Advise Us of Your  
Requirements.

## EISLER ELECTRIC CORPORATION

Manufacturers of Electron Tube, Neon  
Sign and Incandescent Lamp Equipment  
756 So. 13th St., Newark, N. J.

# Leading Auto Radio Manufacturers are using this Effortless, Accurate, Safe control

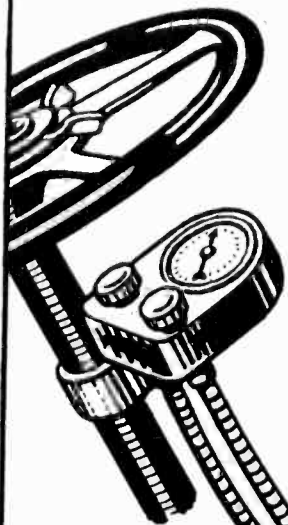

They favor it because it simplifies design, improves performance, makes any set easy to install in any car, never gives trouble, and assures owner satisfaction.

It's the S. S. WHITE Shaft described below that makes this control a complete success. It provides tuning that is as effortless and accurate as a direct connection.

## CONTROL

of tuning, volume and switch, right under the driver's hand, permits operation without shifting position or taking eyes off the road.

**S. S. WHITE**  
FLEXIBLE SHAFT No. 150 L 53  
with METALLIC CASING  
No. 170 A1

Expressly developed for remote control of radio, this shaft has minimum torsional deflection, and deflection is equal for either direction of rotation. When properly applied, deflection is virtually eliminated. A feature of the casing is its small size, .255" O.D.

## RECEIVER

can be mounted in the most favorable position in the car with respect to avoiding electrical, structural and physical interference.

WRITE FOR full details of this shaft and casing. Samples furnished to responsible manufacturers.

The S. S. WHITE Dental Mfg. Co. INDUSTRIAL DIVISION

Knickerbocker Bldg.  
New York, N. Y.

YOU WILL GET  
BETTER RESULTS WITH  
THESE DEPENDABLE

## CETRON

PHOTO ELECTRIC CELLS



Continental CETRONS are made by an organization whose knowledge and experience in the manufacture of electronic devices is one of the most comprehensive in the industry.

In addition, they are built to the highest standards of performance, of the best materials available. As a result, CETRON Photo Cells have five major points of superiority:

- Greater current output
- Better frequency response
- A much higher ionization point
- Rugged mechanical construction
- Longer life

Write today for complete information

### CONTINENTAL ELECTRIC COMPANY

Manufacturers of ELECTRONIC DEVICES  
and  
TRU-VAC VACUUM GAUGES  
ST. CHARLES, ILLINOIS

FOR  
ELECTRON-  
TUBE  
CONTROL  
PURPOSES

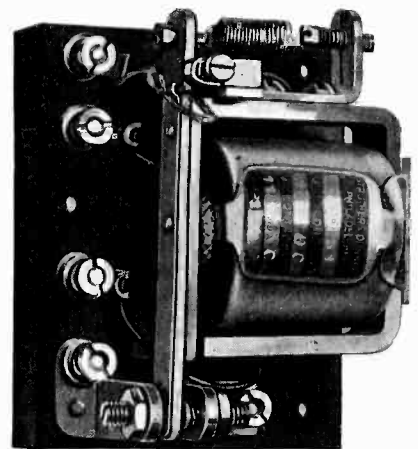

## Use this DUNCO SENSITIVE RELAY

Primarily designed for use in electronic tube circuits, such as radio or light sensitive cell units. Has many applications where low current is essential. Send for Bulletin Form P-27.

If it is a relay problem we shall be happy to handle it. We invite your inquiries.

**STRUTHERS & DUNNING**  
148 N. JUNIPER ST. **DUNCO** PHILADELPHIA, PA.

# 2 NEW CATHODE-RAY OSCILLOGRAPHS

IT'S the size of the tube screen that marks the principal difference between these two complete oscillographs. Both operate on commercial a.c.; both are pumped hard; and both have excellent photographic and visual brilliance. Each is a fine job of coordination between the engineering departments of the tube manufacturers and our own

staff. The tubes are uniform in performance with a guaranteed long life. The power-supply equipment is designed to fit them.

Glance over the specifications and write for Bulletin EX-3306. It gives complete details. Address General Radio Company, Cambridge, Massachusetts.

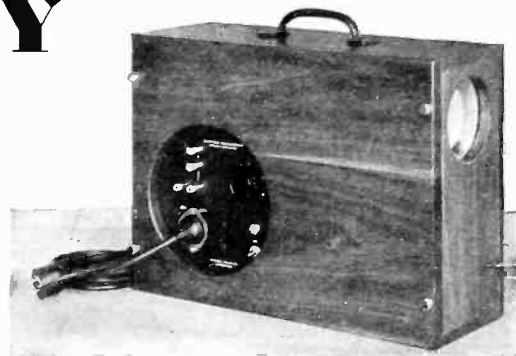

**TYPE 635 (Above)**

Power supply and tube mounting in one portable assembly. 3-inch screen. 1000-volt electrons. Guaranteed for 300 hours or 6 months. Price, \$90.00, complete.

## GENERAL RADIO

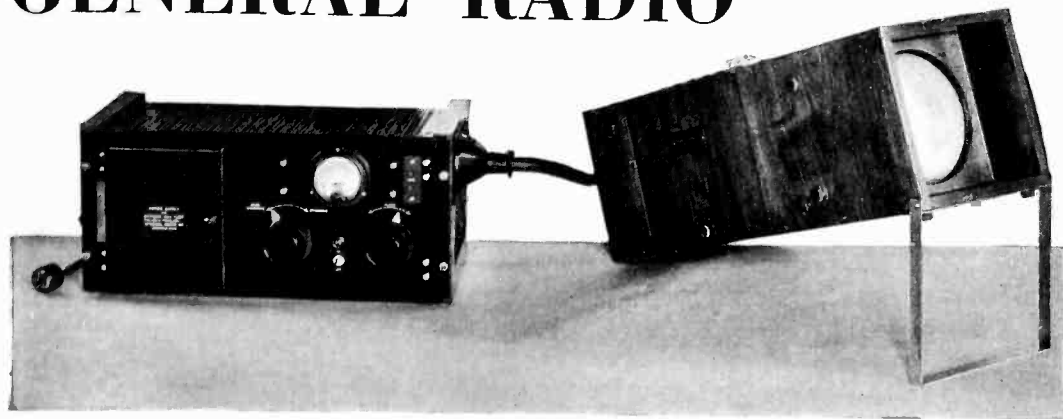

**TYPE 528 (Left)**

A larger, more versatile oscillograph. 6 1/4-inch screen. 3000-volt electrons. Guaranteed for 500 hours or 12 months. Price, \$330.00, complete.

### INDEX TO ADVERTISERS

This index is published as a convenience to the reader. Every care is taken to make it accurate but *Electronics* assumes no responsibility for errors or omissions.

Acme Wire Co. ....	15	McGraw-Hill Book Co. ....	16
American Gas Accumulator Co. ....	15-21	Mica Insulator Co. ....	12
American Electro Metal Corp. ....	10	Muter Co. ....	20
American Transformer Co. ....	12	Remler Co., Ltd. ....	13
Bakelite Corp. ....		Resinox Corp. ....	14
Inside Back Cover		RCA Radiotron Co. ....	8-9
Brush Beryllium Co. ....	17	RCA Victor Co., Inc. ....	
Brush Dev. Co. ....	17	Back Cover	
Cannon Elec. Dev. Co. ....	14	Scientific Coil & Wire Co. ....	17
Central Radio Lab. ....	24	Shakeproof Lock Washer Company ....	13
Continental Carbon, Inc. ....	21	Shalleross Mfg. Co. ....	14
Continental Elec. Co. ....	22	Stackpole Carbon Co. ....	11
Cornell-Dubilier Corp. ....	14	Thomas & Skinner Steel Prod. Co. ....	20
Delta Mfg. Co. ....	15	Universal Microphone Co. ....	17
Dunn, Inc., Struthers ....	22	Western Elec. Co. ....	7
Electrophone Corp. ....	10	Weston Elec. Instr. Corp. ....	
Erie Resistor Corp. ....	1	Inside Front Cover	
General Elec. Co. ....	2-3	White, S.S., Dental Mfg. Co. ....	22
General Mfg. Co. ....	12	Professional Services ....	21
General Radio Co. ....	23	SEARCHLIGHT SECTION	
Global Corp. ....	13	Classified Advertising	
Goat Radio Tube Parts, Inc. ....	10	EMPLOYMENT ....	21
Hygrade-Sylvania Corp. ....	5	EQUIPMENT FOR SALE ....	21
Kenyon Transformer Co. ....	17	Eisler Electric Corp. ....	21
Kurman Elec. Co. ....	20	Kahle Engineering Co. ....	21
Mallory & Co., Inc., P. R. ....	4		

### CONTENTS for OCTOBER, 1933

The plight of the radio engineer .....	265
Ultra short waves and new markets .....	266
Photoelectric control widens in industry .....	268
A list of photocell applications .....	270
A list of manufacturers of light sensitive cells and light sensitive relay units .....	272
Suppression of auto radio noise .....	273
BY GLENN H. BROWNING and RUPERT HASKINS	
Public address at The Century of Progress .....	274
Installing photocell control .....	276
BY REX D. McDILL	
Highlights on electronic devices in industry .....	278
Thermionic cathodes for gas-filled tubes .....	280
BY E. F. LOWRY	
A cold-cathode amplifier tube .....	282
BY HERBERT J. REICH and WILFRED M. HESSELBERTH	
Editorials .....	284
News Notes .....	285
Review of electronic literature here and abroad .....	286
Books for engineers using electron tubes .....	287
New products .....	288
U. S. patents .....	291
British patents .....	294

McGraw-Hill Publishing Company, Inc., 330 West 42d Street, New York, N. Y.

Branch offices: 520 North Michigan Ave., Chicago; 883 Mission St., San Francisco; Aldwych House, Aldwych, London, W. C. 2; Washington; Philadelphia; Cleveland; Detroit; St. Louis; Boston; Greenville, S. C.; James H. McGraw, Chairman of the Board; Malcolm Muir, President; James H. McGraw, Jr., Vice-President and Treasurer; Mason Britton, Vice-President; Edgar Kobak, Vice-President; H. C. Parmelee, Vice-President; Harold W. McGraw, Vice-President; B. R. Putnam, Secretary.



# "Carrying ON"

Day and night, nimble fingers and almost-human machines turn out thousands of Radiohms, each an exact duplicate of the other, each as near perfect as human ingenuity and super-sensitive instruments can make them. Centralab is CARRYING ON under the new deal, bringing a new light into the homes of hundreds of our co-workers, and continuing our standard of quality in the industry.

**Central Radio Laboratory**  
Milwaukee, Wis.

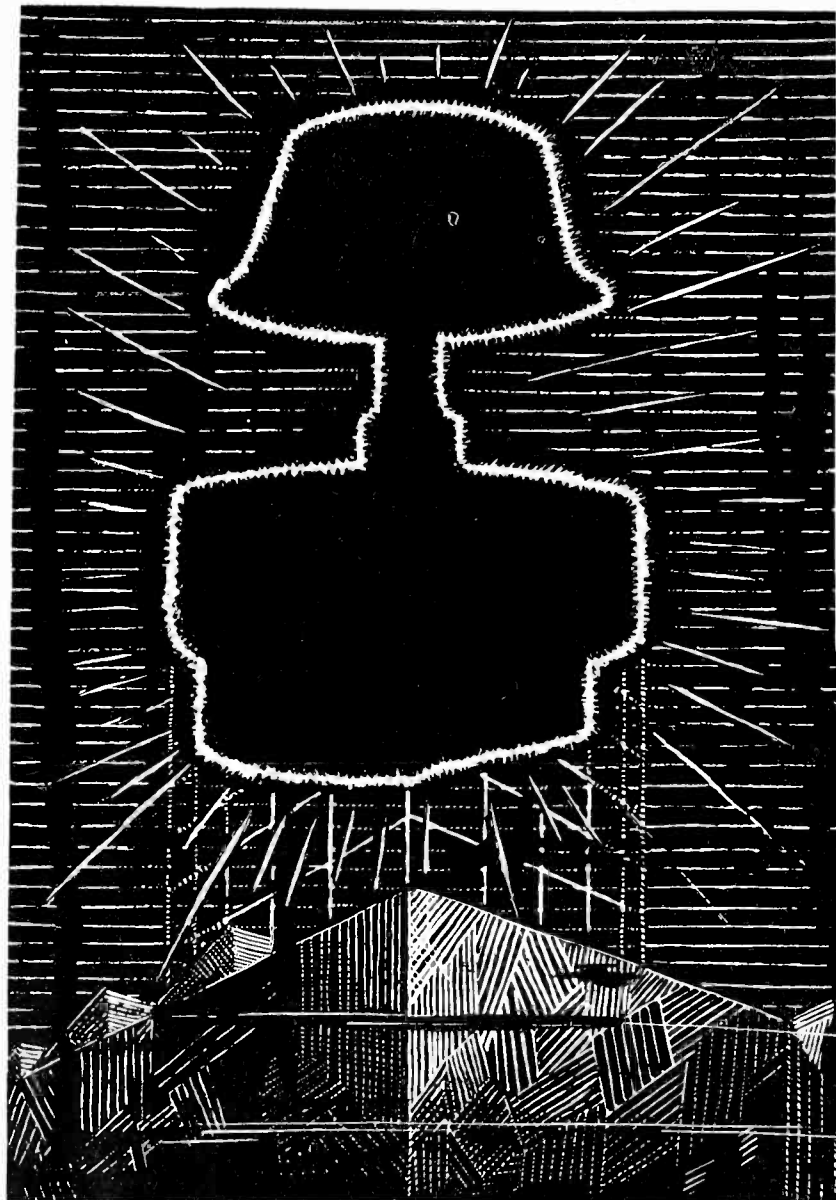

**Centralab**  
CENTRAL RADIO  LABORATORIES  
**RADIOHM**



# Simplified Assembly

## *through using Bakelite Molded*

### *for this remote control housing*

**C**OMpletely formed to close dimensions in one press operation, so that each part slips into place with ease, this Bakelite Molded housing for the Falck Remote Control makes the assembly operation simple, quick, and inexpensive. In addition to these practical advantages the use of Bakelite Molded provides lasting beauty of

color and finish, light weight combined with strength to resist the vibrations and shocks of automobile service.

This is but one of the manifold uses of Bakelite Molded for radio. Others include cases for midget receivers and various types of instruments, dialing knobs, terminals, tube bases, condensers, and dozens

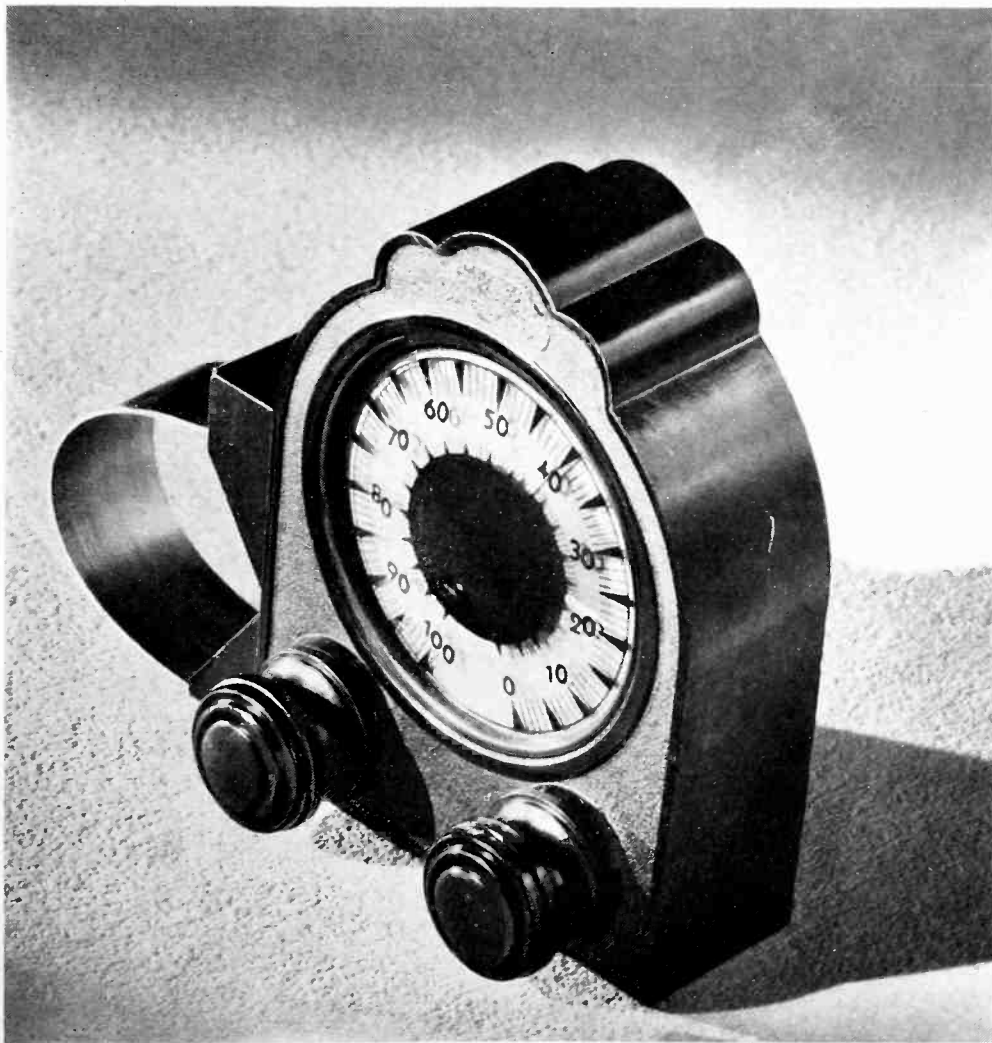
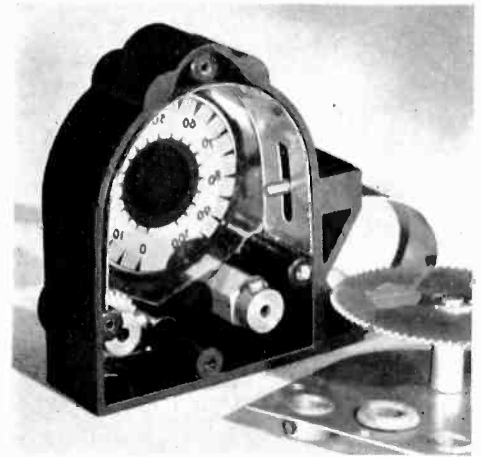

of other parts. Bakelite Molded possesses a combination of properties which make it especially valuable in the construction of radio receivers and parts. It has high insulation value, is unaffected by temperature and atmospheric variations, is resistant to most chemicals and to mild alkalis, and retains its molded form, dimensions, and finish indefinitely.

We invite radio engineers and manufacturers to enlist our cooperation in the economical solution of production problems involving the use of Bakelite Materials. We also would be glad to mail on request a copy of illustrated descriptive booklet 13M, "Bakelite Molded".

*Don't miss the Bakelite Exhibit when you visit the Century of Progress Exposition.*

*Photos show Falck Remote Control with Bakelite Molded housing & knobs. Product of Advance Electric Co., Los Angeles, Cal.*

BAKELITE CORPORATION, 247 Park Avenue, New York, N.Y. . . . . 43 East Ohio Street, Chicago, Ill.  
BAKELITE CORPORATION OF CANADA, LIMITED, 163 Dufferin Street, Toronto, Ontario, Canada

# BAKELITE

REGISTERED U.S. PAT. OFF.

The registered trade marks shown above distinguish materials manufactured by Bakelite Corporation. Under the copied "B" is the numerical sign for infinity, or unlimited quantity. It symbolizes the infinite number of present and future uses of Bakelite Corporation's products.

## THE MATERIAL OF A THOUSAND USES

ELECTRONICS — October, 1933

# BIG FEATURES IN BIG BROADCASTS

An important event —  
The public expectantly waiting

*Will the TUBES  
perform?*

OF COURSE *they will*

*They're RCA*

TRANSMITTING

## RADIOTRONS

For economy in maintenance, — for a maximum of satisfactory operating life, — for dependability under all conditions, — for freedom from interruptions in service — use

### RCA TRANSMITTING RADIOTRONS

The engineering genius which pioneered the high powered tubes, — which has had the utmost in experience in their development and production — is today providing you with the most advanced designs known to the art.

From the smallest to the largest — amplifiers, modulators, oscillators, rectifiers, — the standard

### RCA TRANSMITTING RADIOTRONS

will reduce your operating expenses and end your tube worries.



ENGINEERING PRODUCTS DIVISION

RCA VICTOR COMPANY, Inc.

CAMDEN, N. J.

### “RADIO HEADQUARTERS”

New York: 153 E. 24th St.      San Francisco: 235 Montgomery St.  
Chicago: 111 N. Canal St.      Dallas: Santa Fe Bldg.  
Atlanta: 150 Walton St., N.W.

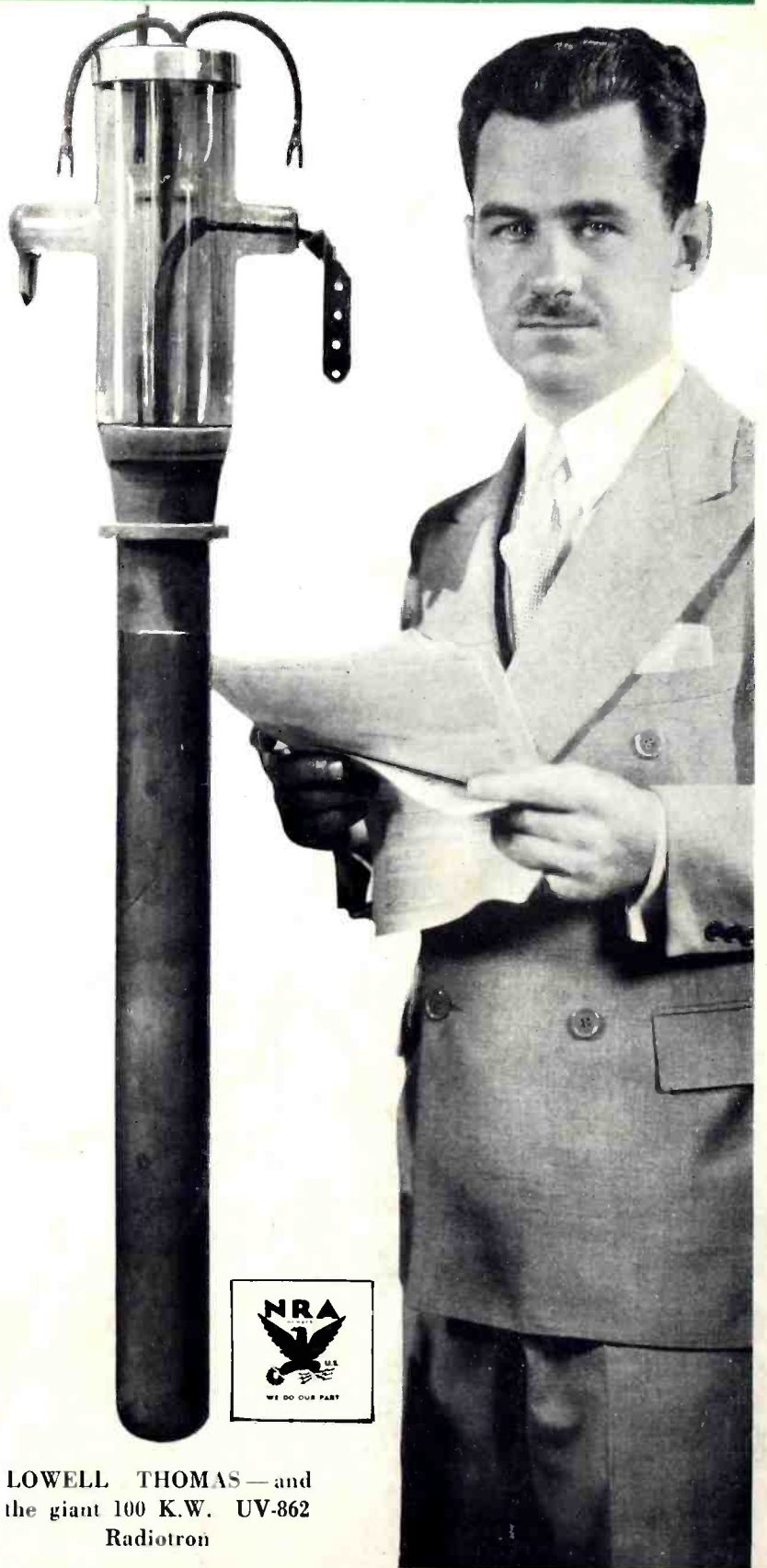

LOWELL THOMAS — and  
the giant 100 K.W. UV-862  
Radiotron