

Electronics World

MARCH, 1969
60 CENTS

THERMOLUMINESCENCE—*Light from Heat*
BANDWIDTH COMPRESSION FOR DIGITAL COMMUNICATIONS
A 50-MHz DIGITAL COUNTER
USE CONTROLS TO TROUBLESHOOT TV

**TESTING
LOUDSPEAKERS**

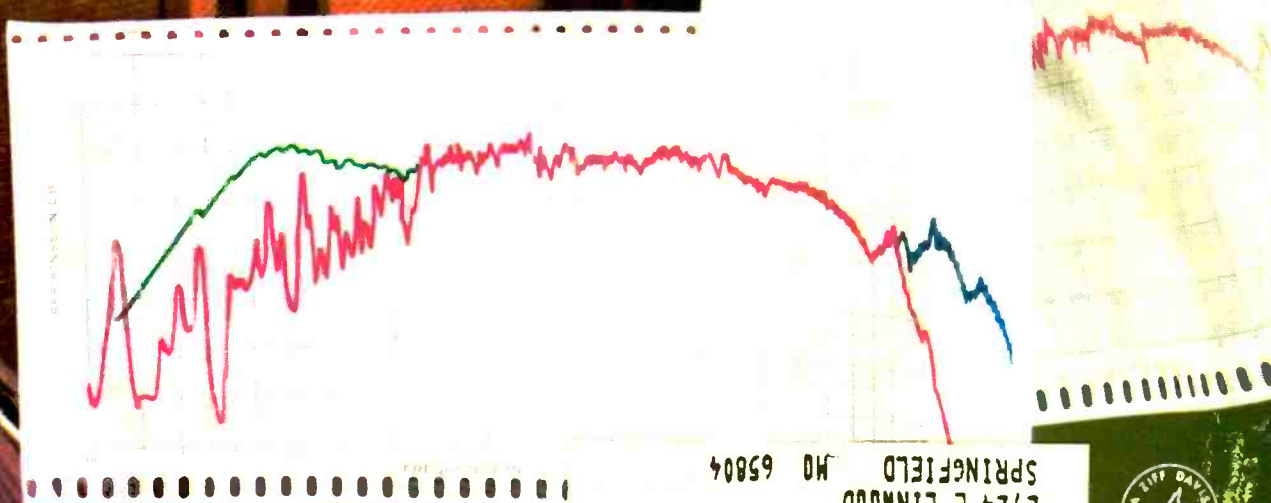

514700 HND 2724L097 OCT76 1 M
M J HINDMAN
2724 E LINWOOD
SPRINGFIELD MO 65804
4
03



Talk about electronic supermarkets

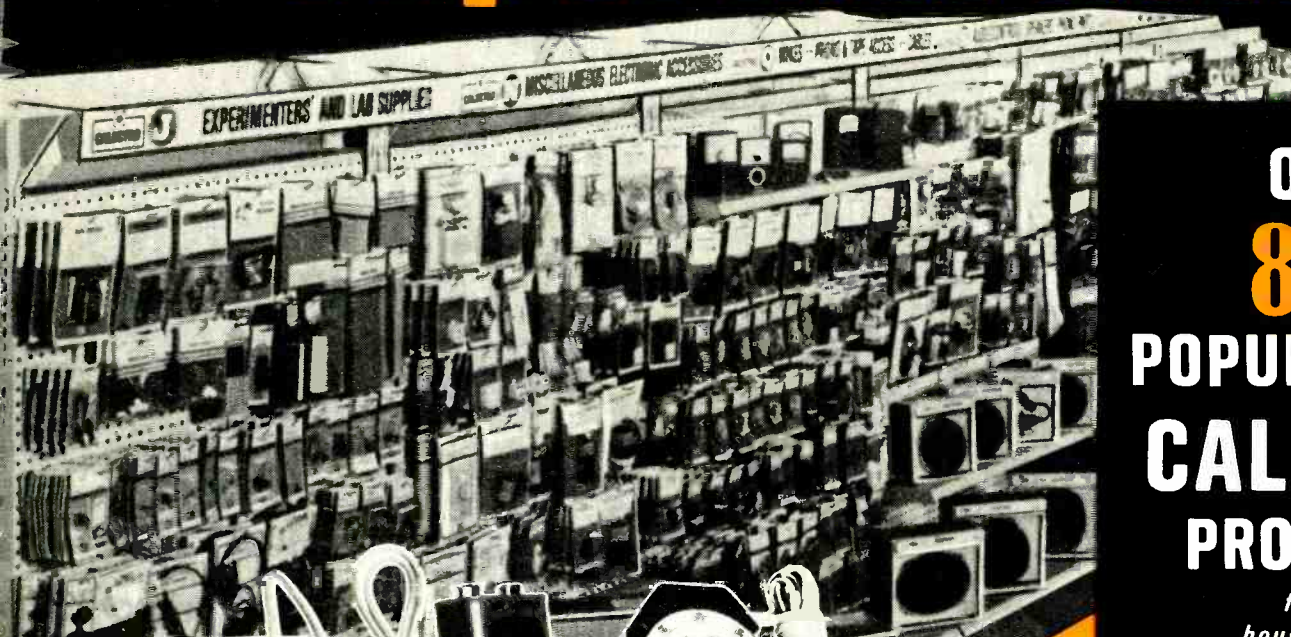

**OVER
800
POPULAR, NEW
CALECTRO
PRODUCTS**

*for every
household use!*

- TEST EQUIPMENT — TOOLS
- EXPERIMENTERS & LAB SUPPLIES
- ELECTRONIC ACCESSORIES
- MIKES — PHONO & TAPE ACCESSORIES
- SPEAKERS & AUDIO ACCESSORIES
- RESISTORS & CONTROLS ■ CAPACITORS
- METERS — COILS — RELAYS — TRANSFORMERS
- SWITCHES — LAMPS ■ WIRE — CABLES
- ANTENNA HARDWARE
- PLUGS — JACKS — BATTERY HOLDERS

Now at each location, hundreds and hundreds of items for everyone . . . hobbyist, enthusiast, amateur, executive, home-owner, executive, do-it-yourselfer. See the SELF-SERVICE G-C CALECTRO display at your CALECTRO ELECTRONIC SUPERMARKET TODAY!



Telephone Amplifier for Group Listing

Perfect for family calls at home, conference calls at the office, or "hands-free" operation when taking orders or instructions by phone. Suction cup pickup attaches to outside of phone, brings in conversations loud and clear. Built-in volume control governs loudness. Battery in kit. Ask for Catalog No. N4-103

\$995



Automatic Timer On-Off Switch

Convenient remote control unit for any appliance, timer control sets for any interval up to 60 minutes. Beautiful green and white case, extra-long 12 foot cord. Installed in seconds, plugs into any wall outlet.

Ask for Catalog No. N4-005

\$695

Dynamic Microphone with switch

For high fidelity recording of words and music. Built-in on-off switch. Folding desk top stand. Dual plug for most tape recorder inputs.

Ask for Catalog No. Q4-186

\$395

Frequency Response: 80-8000 cps
Impedance: 200 ohm. Sensitivity: -56DB

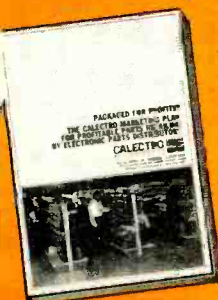

This "G-C CALECTRO HOBBYIST HANDBOOK" is available at G-C CALECTRO ELECTRONIC SUPERMARKETS. WRITE TODAY and we'll give you the name of your nearest



CALECTRO

GC ELECTRONICS
Division of Hydrometals, Inc.
400 SO. WYMAN ST.
ROCKFORD, ILLINOIS 61101

700 Locations

*all over the country
and Canada*

See your electronic parts distributor and SAVE!

LOOK

In the Yellow Pages under "Electronics" and call your Calectro source.

Special introductory offer to new members of the ELECTRONICS AND CONTROL ENGINEERS' BOOK CLUB



For trial membership take
ANY ONE
for only \$ **1.00**
Values up to \$12.50
Choose bonus from Library Group A

For trial membership take
ANY ONE
for only \$ **2.00**
Values up to \$16.50
Choose bonus from Library Group B

For trial membership take
ANY ONE
for only \$ **3.00**
Values up to \$37.50
Choose bonus from Library Group C

- #A850 MATHEMATICS FOR ELECTRONICS WITH APPLICATIONS by H. M. Nodelman and F. W. Smith. Pub. price, \$8.00. Club price, \$6.80
- #A896 BASIC PULSE CIRCUITS by R. Blitzer. Pub. price, \$8.50. Club price, \$7.25
- #A530 PROJECT ENGINEERING by V. Hajek. Pub. price, \$9.75. Club price, \$8.30
- #A355 FIELD-EFFECT TRANSISTORS by L. J. Sevin. Pub. price, \$10.00. Club price, \$8.50
- #A475 MOSFET IN CIRCUIT DESIGN by R. H. Crawford. Pub. price, \$10.00. Club price, \$8.50
- #A142 TUNNEL-DIODE AND SEMI-CONDUCTOR CIRCUITS by J. M. Carroll. Pub. price, \$11.00. Club price, \$9.35
- #A509 MATHEMATICS MANUAL by F. S. Merritt. Pub. price, \$11.95. Club price, \$10.15
- #A955 ELECTRONIC TESTING by L. L. Farkas. Pub. price, \$12.00. Club price, \$10.25
- #A144 DESIGN MANUAL FOR TRANSISTOR CIRCUITS by J. M. Carroll. Pub. price, \$12.50. Club price, \$10.65

- #B978 TRANSFORMERS FOR ELECTRONIC CIRCUITS by N. R. Grossner. Pub. price, \$14.00. Club price, \$11.90
- #B905 INTRODUCTION TO RADAR SYSTEMS by M. I. Skolnik. Pub. price, \$14.50. Club price \$12.35
- #B677 DATA TRANSMISSION by W. R. Bennett. Pub. price, \$14.50. Club price \$12.35
- #B270 MICROWAVE MEASUREMENTS by E. L. Ginzton. Pub. price, \$15.50. Club price \$13.25
- #B310 AUTOMATIC FEEDBACK CONTROL SYSTEMS by J. G. Truxal. Pub. price, \$15.50. Club price, \$13.25
- #B690 MODERN OPTICAL ENGINEERING by W. J. Smith. Pub. price, \$16.00. Club price, \$13.60
- #737 TRANSISTOR CIRCUIT DESIGN by Texas Instruments, Inc. Staff. Pub. price, \$16.50. Club price, \$14.05
- #B981 DIGITAL COMPUTER AND CONTROL ENGINEERING by R. S. Ledley. Pub. price, \$16.50. Club price, \$14.05

- #C509 ELECTRONIC AND RADIO ENGINEERING by F. E. Terman. Publisher's price, \$17.50. Club price, \$14.95
- #C861 FLUID AMPLIFIERS by J. M. Kirshner. Pub. price, \$17.75. Club price \$15.10
- #C381 PULSE, DIGITAL, AND SWITCHING WAVEFORMS by J. Millman and H. Taub. Pub. price, \$18.00. Club price, \$15.30
- #C360 ELECTRONIC ANALOG AND HYBRID COMPUTERS by G. A. Korn and T. M. Korn. Pub. price, \$18.75. Club price, \$15.95
- #C085 DIGITAL AND SAMPLED-DATA CONTROL SYSTEMS by J. T. Tou. Pub. price, \$19.75. Club price, \$16.75
- #C304 HANDBOOK OF SEMICONDUCTOR ELECTRONICS 2/e by L. P. Hunter. Pub. price, \$22.50. Club price, \$19.10
- #C290 ANTENNA ENGINEERING HANDBOOK by H. Jasik. Pub. price, \$27.75. Club price, \$23.60
- #C371 SYSTEM ENGINEERING HANDBOOK edited by R. E. Machol. Pub. price, \$29.50. Club price, \$25.00
- #C503 AMPLIFIER HANDBOOK by R. F. Shea. Pub. price, \$37.50. Club price, \$29.50

YOUR BONUS BOOK comes with your first selection

YOUR FIRST CLUB SELECTION available from any Library Group above

HERE is a professional book club designed to meet day-to-day engineering needs by providing practical books in your field on a regular basis at below publisher prices.

How the club operates: Basic to the Club's service is its publication, the *Electronics and Control Engineers' Book Club Bulletin*, which brings you news of books in your field. Sent to members without cost, it presents in detail the featured book of the month as well as many alternate selections also available at special members' prices.

When you want to examine the Club's featured book, you do nothing. It will be mailed as a regular part of your Club service. If you prefer one of the alternate selections—or if you want no book at all for that month—you let us know by returning the convenient card enclosed with each Bulletin.

As a member, you agree only to take four books in two years. Considering the many essential books published in your field, there will surely be at least four that you would want to own anyway. By joining the Club, you save both money and the trouble of searching for the best books.

You can save time and money by using this coupon to join today

NEVER A MEMBERSHIP FEE

ELECTRONICS AND CONTROL ENGINEERS' BOOK CLUB
582 Princeton Road, Hightstown, N.J. 08520

Please enroll me as a member of the Electronics and Control Engineers' Book Club and send me the two books indicated below. I am to receive the bonus book at the special Library Group price and my first selection at the special Club price. These books are to be shipped on approval, and I may return them both without cost or further obligation. If I decide to keep the books, I agree to purchase as few as four additional books during the next two years at special Club prices guaranteed to be about 15% under publisher prices.

Write Code No. of bonus book here	Write Code No. of first selection here
<input style="width: 100%;" type="text"/>	<input style="width: 100%;" type="text"/>
Name _____	
Address _____	
City _____	
State _____ Zip _____	
(Offer good in U.S. and Canada only.)	
(E33077)	

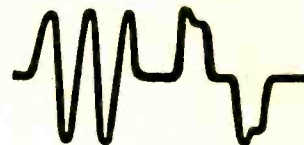

Versatile Sonalert® Signal makes a great ingenuity tester

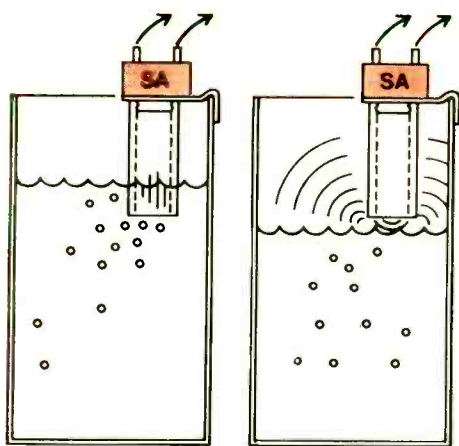

Fig. 1—Trapped Sound System



Fig. 2—Mechanical System

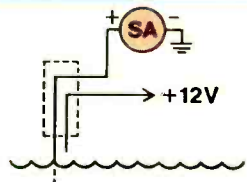

Fig. 3—Simple Electronic System

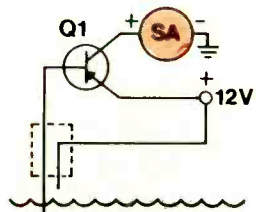

Fig. 4—High Output Electronic System

Crank up your inventive powers and put them to work with Sonalert®, the low-drain, solid-state tone signal that gives a big sound with just a few milliamp drive. More than likely you can come up with some great ideas for your shop, home or car. Ideas for fun, safety—and, perhaps, profit.

Just to give you a few clues, let's take a look at the way would-be Edisons turned Sonalerts into interesting ideas. We've picked four ways in which others have used this new signaller for one application: liquid level alarm.

One of the simplest is a compact system that requires no trigger circuits or complex mechanical devices. All you have to do is install a glass or plastic tube on the unit's nose cone, and hook the Sonalert to a power source. (See figure 1.) Insert the tube into the liquid to the level required for alarm. Since the tube is immersed, no sound can escape. Once the fluid falls below the critical level, out comes a loud, clear, unmistakable signal. Here's an ideal system for use in explosive atmospheres; Sonalert produces no arcs or sparks.

Figure 2 shows a mechanically actuated system—float and switch. It's made up by mounting a float ball on a lever arm that actuates a plunger switch in series with the Sonalert and power source. Reliability might be a problem because of mechanical failures.

For greater reliability, the simple electronic system (figure 3) is hard to beat. Fluid acts as the switch to close the circuit between Sonalert and the source. Just one problem presents itself. The sound level from Sonalert is proportional to current flow. If the liquid is not a good conductor, current flow may be too low.

To overcome this limitation, a high output electronic signal system was developed (refer to figure 4). Here transistor Q1 acts as a low resistance switch; and current flow to the Sonalert is maximum as long as there is enough base current flowing through the fluid to hold Q1 ON.

Here are four variations on one theme. Bet you can come up with some great ideas on your own. Try. If you can't, we've got more tips for you in booklet No. 9-406 that's yours for the asking at your Mallory Distributor's. It's chock-full of information: how Sonalert works, ratings, specs, mounting instructions and more tips. You can write for a copy, if you prefer. Mallory Distributor Products Company, a division of P. R. Mallory & Co. Inc., Indianapolis, Indiana 46206.

DON'T FORGET TO ASK 'EM— *“What else needs fixing?”*

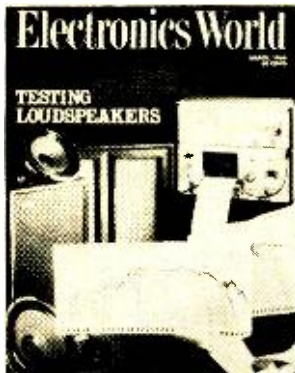

THIS MONTH'S COVER is related to our lead story "Loudspeakers—Can We Measure What We Hear?" The response measurement in the foreground shows (lower curve) the performance of a developmental speaker system as measured in a reverberation chamber. The top curve at the left shows improvement in bass response when the speaker is measured in a living room, while the top curve at the right shows the effect of substituting an on-axis capacitor pickup microphone. The larger speaker system at the center is a Scott S-12, while the Scott S-15 is at the left. The three unmounted loudspeakers are components used in the company's speaker systems. The test equipment at the right is a General Radio 1350-A assembly comprising a beat-frequency audio generator connected to a graphic-level recorder, which draws the speaker-response curves. Photo by Dirone-Denner.



Publisher
PHILLIP T. HEFFERNAN

Editor
WM. A. STOCKLIN

Technical Editor
MILTON S. SNITZER

Associate Editors
W. J. EVANZIA
P. B. HOEFER

Contributing Editors
WALTER H. BUCHSBAUM
Prof. ARTHUR H. SEIDMAN
FOREST H. BELT

Art Editor
EUGENE F. LANDINO

Art and Drafting
J. A. GOLANEK

Advertising Manager
JOSEPH E. HALLORAN

Advertising Service Manager
ARDYS C. MORAN

Associate Publisher
LARRY SPORN

March, 1969

Electronics World

MARCH 1969 VOL. 81, No. 3

CONTENTS

- 25 Loudspeakers—Can We Measure What We Hear?** *Victor Brociner*
 Speaker designers measure their products in completely dead as well as in reverberant rooms. Here is how the measurements are made and how they are used to predict how the speaker will sound in your living room.
- 30 Recent Developments in Electronics**
- 32 Using Controls to Troubleshoot TV** *Don Motsuda*
 Many color and black-and-white TV troubles can be diagnosed quickly by noting the effect of the various controls on the picture-tube pattern.
- 35 Strain Gages Come of Age** *Joseph Tusinski*
- 38 Low-Noise Receiver Performance Measurements** *Lee R. Bishop*
- 40 A 50-MHz Digital Counter** *Frank E. Cody*
 Precision digital counters have been very expensive, costing \$2000 or more and many are limited in frequency, sensitivity, and accuracy. Here's an inexpensive unit that compares quite favorably with the higher priced designs.
- 43 Thermoluminescence—Theory & Applications** *Donald E. Lancaster*
 When certain irradiated materials are heated, they produce light that depends on the amount of their radiation. This provides a powerful tool for solid-state research, nuclear safety, medical dosimetry, and in archeological dating.
- 47 Stop-Action Photos** *A. J. Lowe*
- 48 Series-Pass Regulators** *G. V. Fay*
- 49 Bandwidth Compression for Efficient Digital Communications**
J. W. Stumpe
- 80 Low-Cost Precision Scope & V. T. V. M. Calibrator** *Gary H. Lehmann*
- 84 Metal Boxes Built to Size** *Robert E. Brock*

- 22 EW Lab Tested**
 Kenwood KA-6000 Stereo Amplifier
 Ampex AG-600-2 Tape Deck
- 54 The Spirit of Leonardo** *John Frye*
- 68 Test Equipment Product Report**
 RCA Model WP-700A, 702A Power Supplies
 Delta Products Model 3000 FET V.O.M.
 Jackson Model CRO-4 Oscilloscope

MONTHLY FEATURES

- 4** Coming Next Month
- 5** Radio & Television News
- 13** Reflections on the News
- 16** Letters From Our Readers
- 60** Book Reviews
- 85** New Products & Literature

Electronics World: Published monthly by Ziff-Davis Publishing Company at 307 North Michigan Ave., Chicago, Illinois 60601. One year subscription \$6.00. Second Class Postage paid at Chicago, Illinois and at additional mailing offices. Subscription service and Forms 3579: Portland Place, Boulder, Colorado 80302. Copyright © 1969 by Ziff-Davis Publishing Company. All rights reserved.

Earn Your DEGREE in Electronics!

The Grantham Electronics Degree Program (available mostly by correspondence) is divided into two main courses—(1) *Electronics Engineering Technology*, which leads to the Associate Degree, and (2) *Electronics Engineering*, which leads to the Bachelor Degree. The second course is an extension of (or addition to) the first course, both courses together making up the entire degree curriculum.

The Associate Degree Course

The course in Electronics Engineering Technology, leading to the Associate Degree, consists of *six semesters* (or sections) and a final two-week class of review and examination. All sections of this curriculum except for #3 are offered *by correspondence*. Section #3 may be taken in residence, or credit for it may be given for at least one year of fulltime experience as an electronics technician. Thus, if you are an electronics technician, you may earn your Associate Degree in Electronics without any resident attendance except for a final two-week period of review and examination.

The Bachelor Degree Course

The curriculum in Electronics Engineering (leading to the Bachelor of Science Degree) includes all of the Associate Degree course and, in addition to that, includes 210 lessons in advanced mathematics and advanced engineering—and also includes credits in English, Business, etc., which are to be earned in other colleges and transferred to Grantham.

The Grantham educational program in electronics places heavy stress on fundamental concepts of logic and mathematics rather than on superficial manipulative skills. Since these fundamental ideas are largely unfamiliar to many electronics technicians, it is necessary to develop them in a systematic manner, before real advancement is possible.

Accreditation and G.I. Bill Approval

Grantham School of Electronics is *accredited* by the Accrediting Commission of the National Home Study Council, is *approved* under the G.I. Bill, and is *authorized* under the laws of the State of California to grant academic degrees.

Grantham School of Electronics

• Established in 1951 •

1505 N. Western Ave. or 818 18th Street, N.W.
Hollywood, Calif. 90027 or Washington, D.C. 20006

Telephone:
(213) 469-7878

Telephone:
(202) 298-7460

Mail the coupon below for our free Bulletin.

Grantham School of Electronics EW-3-69 1505 N. Western Ave., Hollywood, Calif. 90027	
Please mail me your free Bulletin, which explains how the Grantham educational program can prepare me for my Associate in Science Degree, and my Bachelor of Science Degree in Electronics Engineering.	
Name _____	Age _____
Address _____	
City _____	State _____ Zip _____

COMING NEXT MONTH

SPECIAL ISSUE: FILTERS



Take a random signal and pass it through a special network to restore some of its original shape. Then hand it to a feedthrough device which removes more noise. Finally, give it to a special circuit which combs out the frequencies of interest. Filters do all of these things and more. In next month's Special Section experts from Microlab/FXR, Collins Radio, ESC Electronics, Damon Engineering, Cleveite, and Sprague give us a succinct explanation of the operation, characteristics, and applications of various types of filter units. In addition, we will find out what makes a mechanical unit a good filter for sophisticated communications sets and why crystal filters are best for certain applications. We will also be shown how transistors and RC elements can provide filtering without the need for inductors, and how to eliminate RFI/EMI problems.

IONOSPHERIC-PROPAGATION PREDICTIONS

Frequency, temperature, radiation angle, and solar activity such as sunspots or flares can improve the ability of the ionosphere to bend and reflect radio waves back to earth. High solar activity can also make long-distance communications noisy and unreliable.

All these and many more interesting and informative articles will be yours in the April issue of ELECTRONICS WORLD . . . on sale March 18th.

STEREO VERSUS THE CONCERT HALL

Stereo, like any other high-fidelity reproduction process, has its limitations. But, by knowing what these are, an astute listener can make his home music system sound almost like a 56-piece orchestra in a concert hall. Stereo balance and phasing are also covered.

ZIFF-DAVIS PUBLISHING COMPANY

William Ziff
President

W. Bradford Briggs
Executive Vice President

Hershel B. Sarbin
Senior Vice President

Philip Sine
Financial Vice President

Walter S. Mills, Jr.
Vice President, Circulation

Stanley R. Greenfield
Vice President, Marketing

Phillip T. Heffernan
Vice President, Electronics Division

Frank Pomerantz
Vice President, Creative Services

Arthur W. Butzow
Vice President, Production

Edward D. Muhlfeld
Vice President, Aviation Division

Irwin Robinson
Vice President, Travel Division

Furman Hebb
Administrative Vice President

George Morrissey
Vice President

Sydney H. Rogers
Vice President

Editorial and Executive Offices
One Park Avenue
New York, New York 10016 212 679-7200

NEW YORK OFFICE 212 679-7200
Joseph E. Halloran

MIDWESTERN OFFICE
307 North Michigan Avenue
Chicago, Illinois 60601 312 726-0892
Midwestern Advertising Manager, Robert J. Ur

WESTERN OFFICE
9025 Wilshire Boulevard
Beverly Hills, California 90211
213 CRestview 4-0265; BRAdshaw 2-1161
Western Advertising Manager, Bud Dean

JAPAN: James Yagi Ishikawa Mansion,
#4, Sakuragaoka Shibuya-ku, Tokyo 462-2911-3

CIRCULATION OFFICE
Portland Place, Boulder, Colorado 80302



Member
Audit Bureau of
Circulations

Radio & TV News • Radio News • Radio-Electronic Engineering Trademarks Reg. U.S. Pat. Off.
SUBSCRIPTION SERVICE: Forms 3579 and all subscription correspondence should be addressed to Electronics World, Circulation Department, Portland Place, Boulder, Colorado 80302. Please allow at least six weeks for change of address. Include your old address, as well as new—enclosing if possible an address label from a recent issue.
EDITORIAL CONTRIBUTIONS must be accompanied by return postage and will be handled with reasonable care; however publisher assumes no responsibility for return or safety of art work, photographs, or manuscripts.
ELECTRONICS WORLD (March, 1969, Vol. 81, No. 3). Published monthly at 307 North Michigan Avenue, Chicago, Illinois 60601, by Ziff-Davis Publishing Company—also the publishers of Airline Management and Marketing, Boating, Business & Commercial Aviation, Car and Driver, Cycle, Flying, Stereo Review, Modern Bride, Popular Electronics, Popular Photography, Skiing, Skiing Area News, and Skiing Trade News. (Travel Weekly is published by Robinson Publications, Inc., a subsidiary of Ziff-Davis Publishing Company.) One year subscription rate for U.S., U.S. Possessions, and Canada, \$6.00; all other countries, \$7.00. Second Class postage paid at Chicago, Illinois and at additional mailing offices. Authorized as second class mail by the Post Office Department, Ottawa, Canada and for payment of postage in cash.

Pay-TV Makes It

By its Fourth Report and Order, the Federal Communications Commission authorized nationwide subscription television, known best as pay-TV or STV. The plan is for on-air telecasting, but wired-TV pay systems aren't prohibited.

Home-electronics leader in STV is *Zenith*, who supplied its "Phonevision" equipment for the lengthy Hartford, Conn. experiment. STV wasn't notably successful in Hartford by most standards; only a few hundred subscribers bought. But when compared with the mere hundreds it takes to make a CATV system profitable, Hartford may have proved STV has a market. *Zenith* thinks so, and is pushing to have encoding and decoding equipment ready by June 12, when the Order goes into effect. The new equipment can handle color.

One expressed hope is that STV will save u.h.f. stations. It might. But it looks better for wired-TV operators, although they have disavowed any intent to scramble some of their programs and charge the extra fee for unscrambling. If they don't, they'll be ignoring a lucrative source of extra income.

The expressed purpose of STV is to provide "much improved" cultural and entertainment television, uninterrupted by commercials. If the public pays for STV directly, STV operators should be held to their promises; no commercials should be permitted.

Picking on Servicemen

"See you in the funny papers" may be a fair greeting for service technicians. Within three days awhile back, three different comic strips—all from the same syndicate—lampooned service people. Two of them suggested improper charges. In the third, a TV technician was cast as a sweat-shirted, sleepy-eyed, and slouchy individual, with cigarette dangling, who talked the housewife out of getting her set fixed.

If that's what the public thinks of service people, then the image is badly in need of repair. If that comic strip comes even close to describing any service technician, then that technician should seriously examine his own pride, his ability, and his reasons for being in this business. There are lots of other jobs where appearance doesn't count for much and where ability and willingness to fix things aren't needed.

Two CB's in Every Garage

We reported last month that Citizens Band sales might be picking up. Since that was written, a spokesman for the Electronic Industries Association has added another note. EIA would like to get CB radios into the majority of cars in the U. S. Talk is, the Automobile Manufacturers Association may revive its proposal to the FCC that two CB channels be set aside for automobile use exclusively. The FCC hasn't said whether it will act this time or not. With industry effort to convince "CB-playboys" that the band is a useful tool for convenience and safety, rather than a toy to annoy legitimate users with, EIA's goal could be reached (if FCC doesn't wipe out the idea). Many accounts of CB's usefulness to highway safety have been reported; collected and publicized, they might persuade an uninterested FCC or Congress.

Field-Effect Transistors Boom

In case you hadn't noticed, the FET is making a mark now on home-entertainment electronics. They're still outnumbered by tubes and bipolar transistors, but they vie with integrated circuits for top billing in new consumer gear. More than twice as many FET's are being sold than at this time last year, and volume soon may triple. Prices keep coming down, which helps penetrate the OEM market.

FET's are great for test equipment, for hi-fi preamps, and in any spot that needs a high-impedance, efficient amplifier. They've been introduced into TV tuners, and are popular in FM tuners. Their r.f. performance is greatly improved over earlier versions. Biggest drawbacks now are power (they can't handle much) and delicacy (they can't be handled much).

Keep Buyers Happy?

A true story: December 11th, Mrs. Brown (not her true name) bought a stereo record player—a well-known and widely advertised make. With guests coming Christmas Day, she wanted music. The player was

delivered the 20th, with a stack of new Christmas records. It didn't play at all, so it was taken back for repair. Brought back again that afternoon, it played with some wow, but the dealer talked her into accepting it that way until after the holiday. Next morning, it wouldn't play at all. The dealer came on Monday, the 23rd, and again took it in. Brought it back, and the turntable wouldn't turn. He fiddled with it awhile, then took it away, promising to have it back by noon on the 24th. Christmas morning dawned—no player, no music. Guests and family were disappointed.

New Year's Day, still no music. Repeated calls to the store January 2nd drew—eventually—a curt answer: she could “take it like it is or leave it until (dealer) gets time to work on it.” Phone calls to the distributor and finally the manufacturer merely disclosed that it was “the dealer's responsibility.”

After two more weeks, it was delivered. Still had wow, sounded bad, and dealer said that's all he could do with it. He told Mrs. Brown it was “her baby,” that she couldn't expect much else from under-\$100 models, they were just made that way. Better Business Bureau suggested it was too bad she'd paid cash.

It took a good technician barely 40 minutes to find and fix four troubles in the player. Only one of them was original; the others were caused by inept servicing. The moral? Manufacturers should examine the servicing ability of dealers. Dealers who can't sell are cancelled; why not those who can't service?

Another Color-TV IC

Zenith has a new integrated-circuit color demodulator in its spring line of color-TV sets. The new IC comprises 19 transistors, 2 diodes, and 24 resistors on a ceramic base, all sealed in epoxy. Best news to servicers is that it plugs into a socket instead of being soldered to a circuit board. And, to our surprise, it's an ordinary 9-pin tube socket. Other IC's for consumer products have 11 closely spaced leads of thin wire; soldering is about the only way to use them.

Toward Better Hi-Fi Listening

As we predicted, expect more emphasis on music this year. One contribution is a course called “Enjoy Music More,” planned and offered to students by *H. H. Scott*. The goal of the course is to deepen perception of the basic elements of music. It has instruction material and four long-play records. Students learn about all kinds of music, from earliest musical sounds through modern electronic music.

Distribution of the complete course, including material for 30 students, is being handled by *Project Publications, Inc.*, New York, N. Y.

Quality in Tape Machines

Cassette players have held the news limelight lately, but there's no abandonment of reel-to-reel types. Serious listeners still seem to prefer the quality of reel machines. In fact, the medium- and upper-priced reel units appear with more features to attract buyers. As an example, a number of models offer four playing speeds (from 15/16 to 7½ in/s); two- and four-track modes; echo and reverberation built in; sound-on-sound recording on a single track; edit facilities; and amplifiers which can be used alone for p.a. sound reinforcement. All these features are “extras” that push cost up but are available only on reel-to-reel machines. Add to that the fidelity advantage of reel players and they compete very successfully with less expensive and less versatile cassette players.

Stereo cassettes are offering more competition than ordinary cassettes. Some well-known names in hi-fi now supply cassette equipment. *Ampex*, *Fisher*, *Harman-Kardon*, and *H. H. Scott* are examples. In some of these, special narrow-gap heads are said to extend frequency response beyond 12 kHz—that's pretty good for such slow tape speed.

Flashes in the Big Picture

A dozen Japanese companies have divided up chore of designing FM-stereo receiver on single IC chip; thick-film hybrid technique will be used, with several chips on one substrate. . . . National Commission on Product Safety had funds cut; hearings go on anyway, though curtailed; consumer electronics can still expect close look. . . . *Neilsen* (TV ratings firm) says people with color sets watch more than 10 extra hours of TV each week. . . . National Electronics Associations is alerting set owners that Certified Electronic Technicians are identified by small triangular lapel pin and ID card; expects program will assure public of technically competent services. . . . Multiplex sound being considered for Japanese TV; not for stereo, but for language dubbing (listen to language you prefer). . . . Watch shortly for announcement of cartridge-type tape player that accepts all three types of cartridges (not cassettes). . . . *McGraw-Hill* acquired *National Radio Institutes*, well-known electronics correspondence school. ▲

The Alarmists.

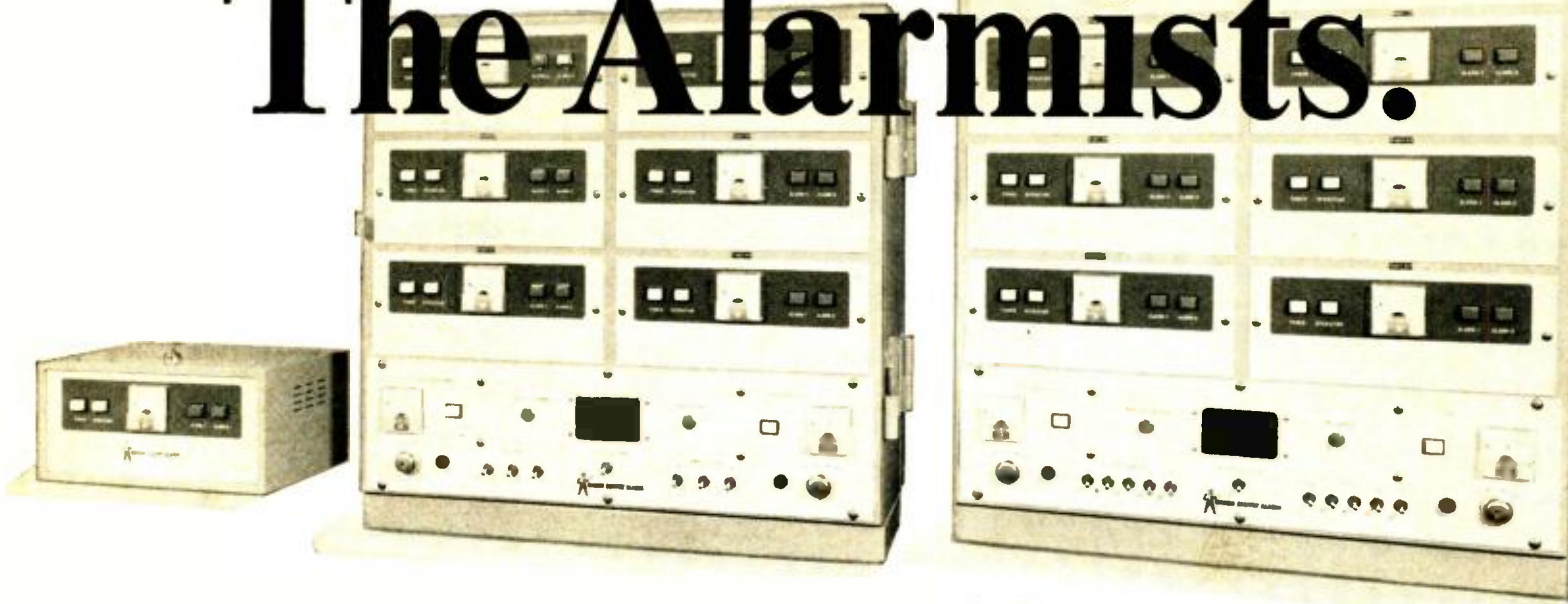

Radar Sentry Alarm supervises security from every angle.

Radar Sentry Alarm covers every angle. It works on the same principle used by the U.S. government to protect our borders. Microwaves beamed by an installation of modular units are foolproof.

Any human movement, even the slightest gesture, sets off the alarm. And what an alarm! An ear-splitting blast that would frighten anything. You can't beat it.

And there's no way to escape detection...whether the intruder comes in from the wall, window, door or ceiling. Even if he shuts off the power, the alarm sounds.

This is the newest and completely proven system that everyone's talking about.

Take any of the set-ups pictured here.

The smallest is our model 301: its remote detector unit covers up to 5,000 square feet. Can set off an alarm that's heard half a mile away. Add up to 3 antennas for a coverage of up to 15,000 square feet. Model 5006 modular unit is 6 units in one. It will cover up to 90,000 square feet. The big one on the right, 5010, will give customized coverage of up to 150,000 square feet.

Take any of these solid state numbers, add Dialtronic automatic telephone dialer, programmed to phone the police or direct-hook-up or, in case of fire, the fire department. Or add the special Radar Sentry Alarm holdup and prowler alarm. It can be used in combination with any of these set-ups, plus the telephone alarm, without the thief's knowledge.

There's no hiding place. These units are considered the best burglar traps in the world. Solid state circuitry gives effective performance, means a minimum of false alarms and reliable operation. And the heart of the electronic system is printed on one single printed circuit module. To replace, just pull out the old one, plug in the new one, no lapse in security.

Design your own inviolable customized system with Radar Sentry Alarm and accessories. You won't be able to find a more versatile, more adaptable system...nor one that is more tamper-proof against burglars.

Get the full story on Radar Sentry Alarms. Write now for our new booklet covering all the facts.

RADAR DEVICES MFG. CORP.
22003 Harper Avenue
St. Clair Shores, Michigan 48080

EW-39

- Send me the alarming details.
 Also send me booklet outlining available dealerships.

Name

Address

CityStateZip

CIRCLE NO. 81 ON READER SERVICE CARD

**NRI “hands-on” training
in communications
can give you as much as
2 years of on-the-job
experience.**



EARN YOUR FCC LICENSE – OR YOUR MONEY BACK

NRI Communications training programs will qualify you for a First Class Commercial Radiotelephone License issued by the FCC. If you fail to pass the FCC examinations for this license after successfully completing an NRI Communications course we will, on request, refund in full the tuition you have paid. This agreement is valid for the period of your active student membership and *for six months* after completion of your training. No school offers a more liberal FCC License agreement.

Experience is still your best teacher

...here's how you get it with unique NRI training at home

Ask any teacher, job counselor, engineer, technician or prospective employer about the need for practical application of theory in Electronics. He'll tell you Electronics is as much a "hands-on" profession as dentistry or chemistry. That's how you learn at home with NRI. You prove the theory you read in "bite-size" texts, by actual experimentation with the type of solid-state, transistor and tube circuits you'll find on the job today — *not* hardware or hobby kits. You introduce circuit defects, analyze results, discover quickly the kind of trouble-shooting and design techniques that will make you employable in Electronics.

Train with the leader—NRI

NRI lab equipment is designed from chassis up for effective, fascinating training — not for entertainment. The fact that end results are usable, quality products is a bonus. In Communications, for example, you build and analyze, stage by stage, your own 25-watt phone/cw transmitter. It's suitable for use on the 80-meter amateur band, if you have an interest in ham radio. In TV-Radio Servicing your practical training gives you your choice of monochrome or color TV sets. All training equipment is included in the low tuition — you pay nothing extra. Discover for yourself the ease, excitement and *value* of NRI training. Mail postage-free card today for new NRI Catalog . . . or use the coupon below. No obligation. No salesman will call on you. NATIONAL RADIO INSTITUTE, Washington, D.C. 20016.



NRI Achievement Kit is educator-acclaimed and the original "starter" kit in home study training. Imitated but never duplicated, this kit is designed and personalized for you and your training objective. It has one purpose — to get you started quickly and easily.



"Bite-Size" Texts average an easily-digested 40 pages of well-illustrated, scientifically prepared subject matter in the course of your choice. Questions in each book are carefully hand-graded and returned to you with helpful instructional notes. You get unlimited personal help from the day you enroll.



Designed-For-Learning Equipment

Like this phone-cw transmitter (Kit #7 in the Communications course) is engineered from chassis up to demonstrate principles you must know. NRI does not use modified hobby kits for training, but the finest parts money can buy, professionally and educationally applied.

APPROVED UNDER NEW GI BILL

If you have served since January 31, 1955, or are in service now, check GI line on postage-free card or in coupon.

MAIL THIS COUPON IF CARD IS GONE

	NATIONAL RADIO INSTITUTE 2-039 Washington, D.C. 20016
	Please send me your new NRI Catalog. I understand no salesman will call and there is no obligation.
Name _____	Age _____
Address _____	
City _____	State _____ Zip _____
<input type="checkbox"/> Check for facts on new GI Bill	
ACCREDITED MEMBER NATIONAL HOME STUDY COUNCIL	

A message from the heads of Ampex.

Listen.

The message is about stereo sound. Listen to Ampex tell it like it is.



The heads are unquestionably the most important part of any stereo tape recorder.

As you know, in order to obtain outstanding frequency response from tape heads, it's necessary to maintain an extremely narrow gap between their poles. Most quality tape heads look like the one pictured here.



But as the head begins to wear down, the pole gap widens, causing frequency response to decline. To maintain original frequency response, heads may need replacement after as little as 500 to 1000 hours of normal playing.

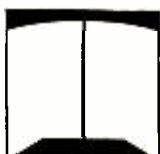

Ampex exclusive deep-gap heads consist of two *parallel* poles. Thus the gap remains constant after years of use.

And so does your frequency response. Ampex heads have been known to last well over 12 years, based on an average of two hours use per night, every night.

We invite you to listen to four of the Ampex stereo tape recorders featured during the "Ampex Stereo Hear-In" at participating Ampex dealers now.



Listen to the Ampex 755 Stereo Tape Deck. It adds professional tape capabilities to your existing system, and gives you sound-with-sound, sound-on-sound and echo. Plus direct tape

monitoring, three Ampex heads and pause control. It mounts in your present cabinet or in its own handsome walnut base (optional).



Listen to the 2161, the Ultra-Automatic Portable Stereo Tape System featuring two-second automatic threading, silent electronic signal automatic reverse, new bi-directional recording and a two speaker system with a 6" woofer and 3 1/2" tweeter in each. Plus built-in mixer and two omnidirectional dynamic microphones.

Listen to the Ampex 1455 Automatic Reverse Stereo Tape Deck. Get professional features like sound-with-sound, tape monitor and pause control. Plus two-second automatic threading, silent electronic automatic reverse, and four deep-gap heads.



Listen to the Ampex 761 Portable Stereo Tape System. It has sound-on-sound, sound-with-sound, echo, direct tape monitoring, three exclusive Ampex deep-gap heads, dual capstan drive, two dynamic stereo microphones and acoustic suspension cube speakers. (You must hear these speakers to believe the sound.)



AMPEX

Hear them all during the "Ampex Stereo Hear-In" at participating Ampex dealers. Learn how you can save over 50% on an Ampex Stereo Tape Library. Pick up your free 36 page booklet, "Head Start to Better Tape Recording," just for listening.

Electronic Devices . . .

continue to make it more and more difficult for certain elements to escape the law. On the other hand, however, crime is making some electronics manufacturers prosperous. According to Solomon R. Baker, Chairman and President of *Baker Industries*, of whom the *Wells-Fargo Protective Agency* is a division:

“Criminals are knowledgeable. They’re sophisticated, and they work and plan their operations in great detail. The scary thing is that they’re well aware of the progress that is being made in electronic detection and surveillance devices and techniques.”

This means that old methods are out; and that heavier reliance will be put on super-sophisticated electronic protection equipment. In fact, some industry analysts expect that the private security market will reach \$2 billion in sales by next year.

Low-cost home protection alarm systems should really get moving this year. Accordingly, a spokesman for *Walter Kidde Inc.*, a company which makes a variety of industrial protection devices, says his company will market a residential protective device that costs under \$100. Supposedly, the system uses magnetic contacts on all doors and windows and sounds an alarm and, if desired, it can contact the local police precinct. It is estimated that there are about 5000 companies in the United States which sell some sort of burglar or fire alarm equipment. All, no matter how big or small, are utilizing new electronics, especially integrated circuits, to develop new protective devices.

Leasing Lasers . . .

has become such a big business for the industrial equipment division of *Westinghouse Electric Corp.* that they’ve opened a new laboratory in Sykesville, Md. According to John Barnyak, Manager of Laser Products at the Maryland lab, many industrial operations can be performed cheaper with a laser, and some operations can only be done with this device. The net result is many manufacturers have found laser leasing to be a practical way of determining the usefulness of laser systems (for their purposes) without the bother of a big purchase.

The cost will, of course, depend on the time involved but, typically, it costs about \$350 to lease a laser. For this, the manufacturer gets the use of the laser—complete with engineering staff. He also gets a complete engineering report on the operation, including a material analysis by a metallurgist and an economic report which shows how industrial laser techniques compare in cost and ease of operation with other processing methods.

Three systems are available for lease: A neodymium-glass solid-state pulsed laser (about 100 joules energy) for microwelding and drilling of metallic material. A CO₂ system with a 100-watt and a 200+-watt laser. This c.w. or pulsed system can be used for slitting, cutting, or perforating non-metallic materials. The third system is a continuous-output solid-state YAG (yttrium-garnet) device which can be used for trimming resistors, punching holes in light metallic material, or welding. This system can also be used in a c.w. or pulsed mode. If a manufacturer were to install any of these three systems in his plant, it would cost him from \$12,000 to \$23,000.

Pulses Move Faster . . .

all the time. Now there is a subpicosecond pulse, or so it’s claimed. The ultra-fast optical pulse was discovered by scientists at the *United Aircraft Research Laboratories* in East Hartford, Conn. They used a mode-locked neodymium-doped glass laser oscillating at 1.06 microns wavelength to generate the ultra-short pulses which were compressed to the theoretical limit of 4×10^{-13} second.

It seems that scientists knew that a neodymium-doped glass laser had sufficient bandwidth to generate pulses about $\frac{1}{3}$ of a picosecond in length, but there was always a discrepancy between the measured—4 to 10 picoseconds—and theoretical length. Some at the research lab thought this was caused by the presence of an amplitude or carrier wave modulation in the picosecond pulses. They therefore assumed that the pulses could be compressed to a length approaching the reciprocal of the bandwidth by passing them through a dispersive system which had a linear relationship between time delay and length. The system they used consisted of a pair of glazed diffraction gratings (1200 lines per millimeter) arranged with their

faces and rulings running parallel. Light diffracting between the two gratings is an increasing function of wavelength and, it turns out, the output beam is almost as well collimated as the input.

Anyway, this is how they get these short, short pulses. What has all this to do with living? The scientists say this helps in the understanding of the reaction of laser light with matter.

An Underwater Mapping System . . .

developed by *CBS Laboratories* combines holography and sonar techniques to produce images of objects or underwater terrain. The experimental sonography system was developed for the Office of Naval Research (ONR).

Apparently, system operation is based upon a special laser tube. Complete details of the tube were not available at press time, but it is known that the tube consists of an electron gun and a thermoplastic film. Basically, the system works like this. An array of up to 1000 barium titanate (BaTiO_3) hydrophones in a three-square-foot bank monitors acoustic waves (interference pattern) reflected from the underwater object. The electron gun scans the sonic information and a stereophonic image pair is projected by the laser on the thermoplastic film at the rate of one or two times per second.

Semiconductor Selection . . .

has become as much a thorn in the side of equipment designers, purchasing men, and technicians as tubes. Over the past few years the number of so-called standard devices reached over 65,000. Not only has "choice" become difficult, but wrong selections meant higher equipment costs and resulted in the availability problems typical of specialized devices. *Texas Instruments* claims to have done something about this problem in its new approach to discrete semiconductor selection.

What they have done is use a computer to analyze demand-analysis curves and specifications and to select, out of 15,000 standard and special discrete devices, the components which satisfy the majority of semiconductor requirements. To fall within the "preferred" group, the product had to be in wide use and known by the majority of design engineers; it had to be in volume production; it must be readily available from distributors and factory; and the device must be recommended by engineers for either present or future designs.

A special catalogue listing the preferred semiconductors—germanium and silicon small-signal and power transistors, diodes, thyristors, rectifiers, regulators, light sensors, and resistors—is now available from TI when requested on company letterhead. Each preferred component is stocked in depth.

Airport Congestion . . .

has been one of the top topics for months among concerned individuals. And many alternatives have been proposed as a solution to the problem. Chief among the many solutions offered are electronics systems and how they can aid in relieving some of the difficulties.

Many people are unaware of the scope of electronics in the modern aircraft industry. On military aircraft, electronics may account for almost one-third the total cost of the plane. On commercial planes, electronics can represent as high as 20% of the cost. Future aircraft, such as the supersonic transport, the Boeing 747, and other airbus types, could conceivably raise the price of aircraft electronics systems even higher.

When one considers the needs of a rapidly growing aircraft industry for electronics, the results can be overwhelming. Some manufacturers are already finding it hard to keep up with orders for communications systems, distance measuring equipment, or instrument landing systems, etc. Add to this the possibilities for new airborne navigation devices and ground-control systems which could help the airport congestion problem and the possibilities are tremendous.

Some Thoughts . . .

about things going on. The two U.S. destroyers which cruised the Black Sea last December were packed full of electronic gear. They made some important anti-submarine warfare measurements as well as snoop on Russian coastal radar and radio stations. The frequencies and operating characteristics of these stations could prove invaluable in the event of difficulty between the U. S. and Russia. . . . Russians are now trying to close the space gap and may decide to land a man on the moon instead of merely orbiting our natural satellite. Apollo's success may mean some space spending cuts may be held off. . . . Jet Propulsion Lab did so well on the recent space shots that NASA has given Cal Tech "all systems are go" for the next three years. . . . Electronic Industries Association wants to help the FCC write the rules for interconnecting to *AT&T* lines. Is this self protection? ▲

Solve 95% of all your solid state replacement problems with this little box.



Take 24 of the most likely to be replaced solid state parts. Diodes, transistors, color focus rectifier, boost rectifier and the like.

Put them in a box. A little box. (That will fit easily into your big box.)

Add a cross reference guide that shows the Sylvania equivalent of a non-Sylvania component.

Put them all together and what do you have? Sylvania's Solid State Replacement Kit. It can replace more than 10,000 JEDEC types and set manufacturers' part numbers.

And it's a lot neater.

SYLVANIA
A DIVISION OF
GENERAL TELEPHONE & ELECTRONICS

For more information about the ECG-303 contact your Sylvania distributor or write Sylvania, CADD, 1100 Main Street, Buffalo, New York 14209.

CIRCLE NO. 88 ON READER SERVICE CARD

FIRST AND ONLY compact Scrulox® screwdriver sets

Increasing use of Scrulox square recess screws in appliances, radios, TV sets, electronic instruments... even the control tower at Cape Kennedy... has created a need. A need for compact, versatile driver sets. Small enough to tuck in a pocket. Complete enough to be practical on shop bench or assembly line.

Now, here they are... from Xcelite, of course.



PS44
COMPACT
CONVERTIBLE SET

Five color coded midget Scrulox drivers—#00 thru #3

One midget nutdriver—1/4" hex

"Piggyback" torque amplifier handle increases reach and driving power

See-thru plastic case doubles as bench stand



99SL
INTERCHANGEABLE
BLADE KIT

Five Sculox blades—#00 thru #3

Shockproof, breakproof, Service Master handle
Durable, see-thru plastic case



CIRCLE NO. 83 ON READER SERVICE CARD
16

LETTERS FROM OUR READERS

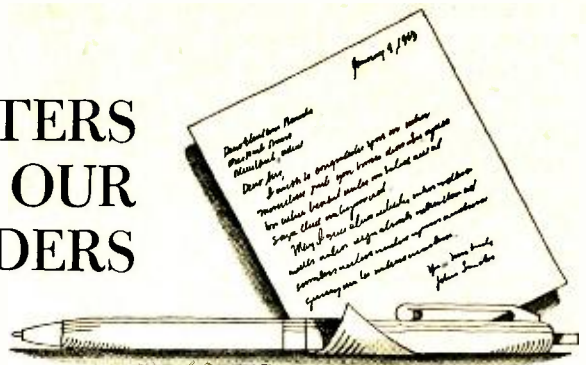

RFI DUE TO C-D IGNITION

To the Editors:

In the December, 1968 "Letters" column, Tom Lamb asks about RFI from C-D ignition systems.

I have a 1964 *Rambler* V-8 with a *Sydmar* Compac C-D system. Since the coil is at the back of the engine and the C-D unit is mounted ahead of the radiator for sufficient cooling, the leads are very long. No shielding is used and the high-tension wiring is stainless steel—not resistance wire. The broadcast-band receiver picks up ignition noise when the radio is receiving no signal or when the car is in a steel building. However, when tuned to a station, the interference is completely drowned out and is no problem.

I also had a company-owned *Plymouth* V-8 with a broadcast-band receiver and a two-way business radio operating on approximately 46 MHz. A transistor ignition system was installed and the standard-resistance high-tension ignition wiring retained. With no additional shielding or filtering there was absolutely no ignition noise in either radio.

I have heard that the ignition coil metal case, if not properly grounded, can cause RFI since it is floating in the magnetic field. However, I have always checked to be sure a good ground was established and have had no trouble.

R. N. SELFRIDGE
Glendive, Mont.

To the Editors:

A *Sydmar* C-D ignition was assembled and installed in a 1967 *Jeep* Wagoneer. The RFI to amateur, citizen, and FM services was intolerable. However, it should be noted that the *Jeep* is very noisy, electrically, even without the C-D ignition. Incidentally, the gain from the ignition was noticed in the improved gas mileage.

Coaxial cable was installed between the ignition system and the coil and distributor, and a ground strap was added to the metal enclosure of the coil. This reduced the noise by one-half. The remainder was silenced with a *Hallett* shielding system.

WILLARD L. GRAVES, JR.
Computation Consulting Service
Baltimore, Md.

To the Editors:

I'm using a capacitive-discharge type circuit and have noticed no added ignition noise in either AM or FM auto radios. I have found, however, that the high-pitched sing of the inverter circuit in the ignition system feeds through the FM radio. Operation of the AM radio remains unaffected.

P. KALTENBORN
Dunellen, N. J.

* * *

MAINTAINING TAPE RECORDERS

To the Editors:

I read with interest the article in October's *ELECTRONICS WORLD* by Mr. Leonard Kubiak, telling all about maintaining tape equipment (page 67).

To me, it read as though Mr. Kubiak had just discovered an *Ampex* standard alignment tape and wanted to tell the world about it. In the "Tests and Adjustments" paragraphs on page 68 we are told to adjust the playback level on the 700-Hz tone "to any convenient level." Additionally we are told to adjust the record level so as to play back at the same level ("since all of the tones are recorded at the same level"). We are told, also, to adjust the bias level for a maximum output reading on the meter. I assume that he is talking about the playback output.

To set this thing straight so that a lot of persons don't end up ruining the fidelity of their tape equipment: First, there is a normal maximum level recorded on the alignment tape. The playback gain must be set for a "0-vu" indication on the meter. The playback gain must not be adjusted for the rest of the tests. The other tones will play back at between -12 to -20 vu with -15 vu being the originally recorded level.

After the playback-equalization controls are adjusted for the best compromise, the record adjustments can be set. First, the amplitude of the oscillator signal (at 700 Hz) is set so that, with the gain control in the center of its range, the playback level is "0 vu."

The bias control is then adjusted for very slightly less than maximum playback level—this being on the side of the peak requiring the least bias. Peak-recording bias will result in partial erasure of high frequencies if the head is even slightly worn.

The amplitude of the audio oscillator signal is then reduced until the playback level is -15 on the vu meter. This is very important. If equalization is attempted at a higher level, the tape will go into saturation at high frequencies and the meter indications will be erroneous.

Additionally, the author's insistence upon intensive demagnetization is food for thought. Head demags cause more damage than the trouble they are supposed to correct.

I have never seen a tape head that required demagnetization. Every machine that I ever maintained was so designed that no large d.c. signals ever got to the head. Also the materials used in the construction of the heads are carefully selected so as not to retain magnetization. If this were not the case, it would be impossible to record anything but the very low frequencies.

And I have never seen a tape-guide made of magnetic material. What I have seen is a lot of scratched heads, resulting from misuse of a head demagnetizing device.

Now it is true that head demagnetization can lower the apparent noise by several dB, but I kind of doubt that the increase in listenability is worth the chance of ruining a head. After all, the ear cannot hear the difference between a -50 dB and a -52 dB S/N ratio, no matter how loud you play the equipment. The major cause of noise on tapes (that is, noise that you can hear) is an improperly made recording. The major cause of noise on pre-recorded tapes is the foul way in which most are duplicated.

RICHARD B. JOHNSON
Chief Engineer, WERI
Westerly, R. I.

Perhaps Author Kubiak should have gone into a little more detail on the techniques described. We thank Reader Johnson for this additional information. On the matter of head demagnetization, engineers at many professional recording studios and tape-duplicating plants make it a practice to do this every morning as a matter of routine. It is done carefully, however, and as one engineer told us recently, "it may not have too much effect, but we want to squeeze everything we can out of our tapes."—Editors

HEATH COLOR-TV & SCOTT RECEIVER

There was an omission in the Heath listing of 1969 color-TV chassis on page 26 of our January issue. The company still sells the GR-295; it's the same as the GR-681 listed but without a.f.t. and powered channel selection.

On p. 32 of our Feb. issue, reference to a new Scott Model 33 receiver in the photo caption is incorrect. Our printer failed to delete "Model 33."—Editors ▲

March, 1969

NEW DELTA DESIGN!

MODEL 3000 FET VOM



*A unique
and efficient
instrument
bridging the gap
between a
multimeter and a
digital voltmeter!*

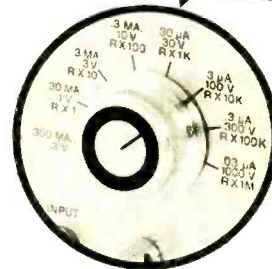

Delta, pioneer of the famous Mark Ten® CD System, now offers a compact, versatile, and extremely sensitive VOM which combines FETs and ICs for extreme accuracy. Compact (6½" W x 8" H x 3½" D), portable, wt. 3¾ lbs. In full production at only

\$74.95
ppd.

Would you believe:

1. Mirror scale 200μ A D'Arsonval meter
2. Integrated circuit (IC) operational amplifier for extreme accuracy
3. FET input stage with current regulator
4. Two stage transistor current regulator and Zener diode on OHMS for absolute stability and accuracy
5. Voltage clippers for protection of input stage
6. Fully temperature compensated for low low zero drift
7. Ten turns ZERO and OHMS adjust potentiometers
8. Epoxy glass circuit boards and metal case
9. Enclosed switches
10. Uses readily available type AA cells
11. Uses standard test leads for maximum flexibility and ease of measurement
12. 10 Megohms input impedance

Available in Kit form:
Feedback network with pre-selected components to eliminate all final calibration. Ready to use when assembled!

Kit:
Only **\$59.95** ppd.



DELTA PRODUCTS, INC.

P. O. Box 1147, Grand Junction, Colorado 81501

I enclose \$ _____ . Please send postpaid:
_____ Model 3000 FET VOMs @ \$74.95 assembled
_____ Model 3000 FET VOMs @ \$59.95 kit form

Name _____

Address _____

City/State _____ Zip _____

D.P. 8-7

CIRCLE NO. 116 ON READER SERVICE CARD

Two more examples of how RCA Institutes provides up-to-the-minute Home Training in all phases of electronics:

NEW CATV LESSONS

The demand is heavy for technicians in the booming field of CATV (Community Antenna Television Systems).

CATV was initially used to make it possible for large numbers of television receiver users to get good reception in remote areas through the use of a common antenna. It now brings to more people more programs than are available from local stations. It also improves reception where multipath signal transmission exists.

RCA Institutes includes two comprehensive lessons, covering the practical phases of CATV systems and servicing in Television Servicing and Communications courses and programs at no additional total tuition cost. Get in on the ground floor of this rewarding and expanding field. Send for full information today!

Prepare yourself for a career in the expanding field of CATV.

NEW COLOR TV KIT

To make courses even more practical and to better prepare you for a more rewarding future, RCA Institutes now includes an exciting Color TV Kit in both the beginner's program and the advanced course in color TV servicing. The cost of the kit is included in the tuition—nothing extra to pay. You also get five construction/experiment manuals plus a comprehensive service manual.

You'll receive all the materials and components to perform over 50 information-packed experiments. When you finish you'll have constructed an 18" (measured diagonally) high quality, color TV set, complete with rich cabinet in wood grain design.

Get all the details on RCA Institutes' valuable new Color TV Kit!

SEND THE ATTACHED CARD TODAY!

This is the high quality color TV set you'll construct, complete with rich cabinet wood grain design.

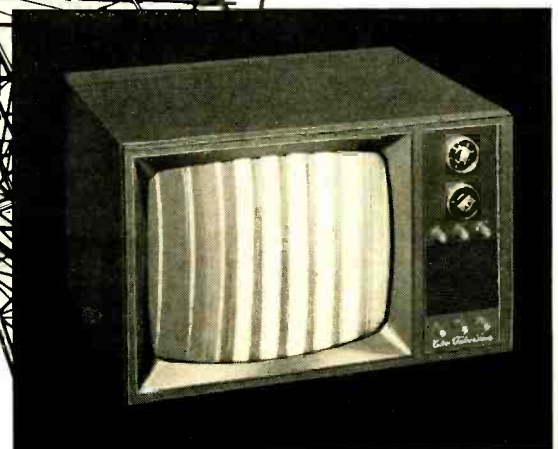

Learn electronics at home faster, easier, almost automatically—with RCA AUTOTEXT

Are you just a beginner with an interest in the exciting field of electronics? Or, are you already earning a living in electronics and want to brush-up or expand your knowledge in a more rewarding field of electronics? In either case, AUTOTEXT, RCA Institutes' own method of Home Training will help you learn electronics more quickly and with less effort, even if you've had trouble with conventional learning methods in the past.

THOUSANDS OF WELL PAID JOBS ARE OPEN NOW TO MEN SKILLED IN ELECTRONICS!

Thousands of well paid jobs in electronics go unfilled every year because not enough men have taken the opportunity to train themselves for these openings. RCA Institutes has done something positive to help men with an aptitude and interest in electronics to qualify for these jobs.

HOME STUDY CAN TRAIN YOU FOR REWARDING CAREER OPPORTUNITIES

To help fill the "manpower gap" in the electronics field, RCA Institutes has developed a broad scope of Home Training courses, all designed to lead to a well paying career in electronics in the least possible time. You also have the opportunity to enroll in an RCA "Career Program" exclusively created to train you quickly for the job you want! Each "Career Program" starts with the amazing AUTOTEXT Programmed Instruction Method. And, all along the way, your program is supervised by RCA Institutes experts who become personally involved in your training and help you over any "rough spots" that may develop.

VARIETY OF KITS ARE YOURS TO KEEP

To give practical application to your studies, a variety of valuable RCA Institutes engineered kits are included in your program. Each kit is complete in itself, and yours to keep at no extra cost. You get the new Programmed Electronics Breadboard for limitless experiments, including building a working signal generator, multimeter, and a fully transistorized superheterodyne AM receiver.

ONLY FROM RCA INSTITUTES— TRANSISTORIZED TV KIT— VALUABLE OSCILLOSCOPE

All students receive a valuable oscilloscope. Those enrolled in the Television program receive the all-new transistorized TV Kit. Both at no extra cost and only from RCA Institutes.

CHOOSE THE "CAREER PROGRAM" THAT APPEALS MOST TO YOU

Start today on the electronics career of your choice. Pick the one that suits you best and mark it off on the attached card.

- Television Servicing
- Telecommunications
- FCC License Preparation
- Automation Electronics
- Automatic Controls
- Digital Techniques
- Industrial Electronics
- Nuclear Instrumentation
- Solid State Electronics
- Electronics Drafting

ADVANCED TRAINING

For those already working in electronics, RCA Institutes offers advanced courses. You can start on a higher level without wasting time on work you already know.

2 CONVENIENT PAYMENT PLANS

RCA Institutes offers a unique tuition plan that lets you progress at your own pace. You only pay for lessons as you order them. You don't sign a contract obligating you to continue the course.

There's no large down-payment to lose if you decide not to continue.

However, if you desire, RCA Institutes also offers a convenient monthly payment plan.

CLASSROOM TRAINING ALSO AVAILABLE

If you prefer, you can attend classes at RCA Institutes Resident School, one of the largest of its kind in New York City. Coeducational classroom and laboratory training, day and evening sessions, start four times a year. Simply check "Classroom Training" on the attached card for full information.

JOB PLACEMENT SERVICE, TOO!

Companies like IBM, Bell Telephone Labs, GE, RCA, Xerox, Honeywell, Grumman, Westinghouse, and major Radio and TV Networks have regularly employed graduates through RCA Institutes' own placement service.

SEND ATTACHED POSTAGE PAID CARD TODAY. FREE DESCRIPTIVE BOOK YOURS WITHOUT OBLIGATION. NO SALESMAN WILL CALL.

All RCA Institutes courses and programs are approved for veterans under the new G.I. Bill.

Accredited Member
National Home Study Council

IF REPLY CARD IS DETACHED—SEND THIS COUPON TODAY

RCA INSTITUTES, Inc., Dept. EW-39
320 West 31st Street, N.Y., N.Y. 10001

Please rush me FREE illustrated catalog. I understand that I am under no obligation, and that no salesman will call.

Name _____ Age _____
(please print)

Address _____

City _____

State _____ Zip _____

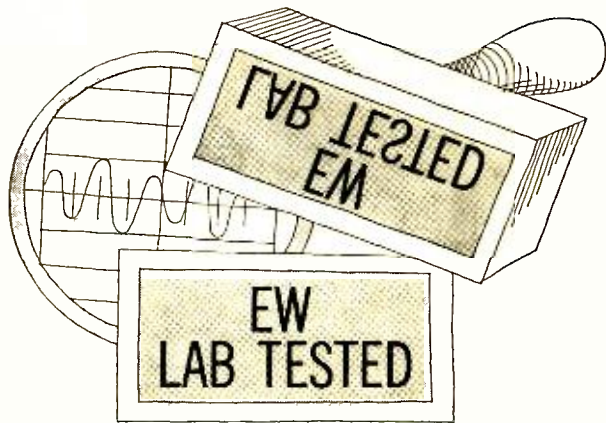

HI-FI PRODUCT REPORT

TESTED BY HIRSCH-HOUCK LABS

Kenwood KA-6000 Stereo Amplifier
Ampex AG-600-2 Tape Deck

Kenwood KA-6000 Stereo Amplifier

For copy of manufacturer's brochure, circle No. 23 on Reader Service Card.



To supplement its line of stereo receivers, Kenwood has introduced a pair of deluxe components—an FM-stereo tuner and an integrated amplifier. The Model KA-6000 amplifier, which we tested for this report, features high power (very conservatively rated at 45 watts per channel) with low distortion, considerable control flexibility, and handsome styling.

The dominant feature of the KA-6000 front panel is the large volume-control knob, with a concentric outer ring for channel balancing. The switch-type bass and treble tone controls provide five 2-dB steps of cut or boost at 100 and 10,000 Hz, respectively. A "Tone Mode" switch can bypass both tone controls or activate either bass or treble controls alone.

The input selector offers a choice of high-level auxiliary and tuner inputs, two magnetic phono-cartridge inputs, a

tape-head input, and unequalized microphone inputs. The selected program source is shown by one of a row of six blue indicator lights on the panel. A single control selects operating mode or tape-monitoring functions. In three of its positions, it provides normal stereo, reversed-channel stereo, or mixed (mono) operation. It has three more positions, for monitoring from a three-head tape recorder (or simply playing back previously recorded tapes from any tape recorder) and for playing back either channel through both speakers. These last two positions are particularly useful with four-track mono recordings.

The speaker-output selector, which also controls the a.c. power to the amplifier, connects either or both of two pairs of speakers, or silences all speakers for headphone listening via the front-panel headphone jack. The remaining front-panel controls are a row of

five "piano-key" switches. One reduces the volume by about 20 dB, a convenience when one's listening is interrupted by a phone call or a visitor. Another switch is the loudness compensation, which affects both low and high frequencies and is sufficiently mild in effect to be quite listenable. Two low-frequency filter switches introduce cut-offs below 40 or 80 Hz, and a high-cut filter operates above 8000 Hz. All filters are rated for 12-dB-per-octave slopes.

At the rear of the KA-6000, in addition to all the inputs and outputs, is a center-channel mixed output suitable for driving a separate mono power amplifier and speaker. The tape-recorder input and output jacks are duplicated in a DIN (European type) five-pin connector, simplifying direct connection to tape recorders that are similarly equipped.

The signal path is interrupted between the preamplifier outputs and the power-amplifier inputs, with jumper plugs normally installed across the jacks in the rear. This feature permits electronic crossovers, reverberation units, and similar signal-processing accessories to be connected into the system.

One of the two phono inputs has adjustable sensitivity, accomplished by means of a three-position switch located near the input connectors. Nominal sensitivity is 2 millivolts for full output with a 100,000-ohm input impedance. The other sensitivities are 0.5 and 0.05
(Continued on page 65)

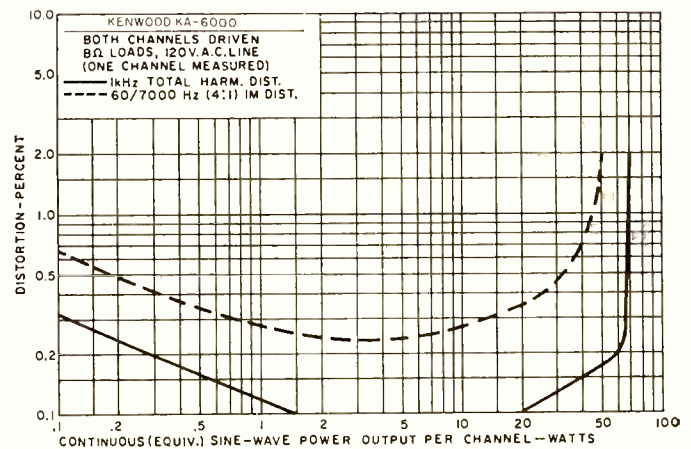
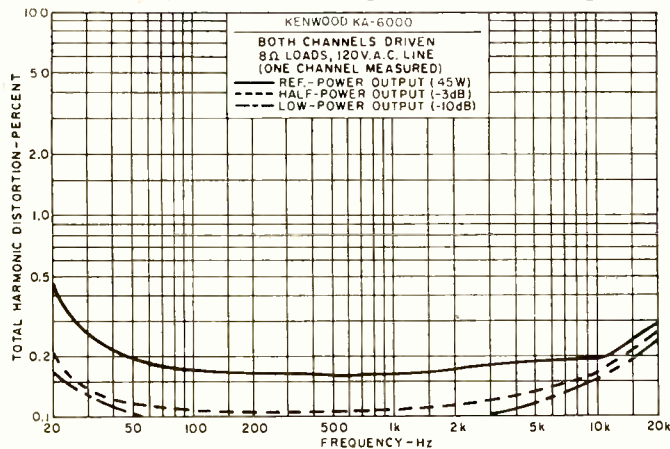



HAAAAH PROOF

THE SHURE UNIDYNE IV is the newest and premier member of the famed Unidyne family of true cardioid dynamic microphones which have pickup symmetrical about microphone axis at all frequencies . . . in all planes. The Unidyne IV is so rugged that it can withstand a Karate chop. Reinforced, cushioned cartridge withstands severe impacts and vibrations . . . the diaphragm can take the full force of a leather-lunged Karate yell! Trouble-free Cannon-type connector. Exceptionally easy to service in the field. The strongest, most durable Unidyne yet! Send for all the facts: Shure Brothers, Inc., 222 Hartrey Ave., Evanston, Ill. 60204.

Available in two models: Model 543 (hand-held), at \$100.00 list; Model 548S (with On-Off switch and swivel connector for stand use), at \$105.00 list.

CIRCLE NO. 93 ON READER SERVICE CARD

© 1968 SHURE BROTHERS, INC.

**BEST FOR YOU—
IT'S MOST VERSATILE**



MODEL 850 ELECTRONIC VOLT-OHMMETER

USES UNLIMITED:

Field Engineers • Application Engineers • Electrical, Radio, TV, and Appliance Servicemen • Electrical Contractors • Factory Maintenance Men • Industrial Electronic Maintenance Technicians • Home Owners, Hobbyists

MODEL 850 \$93.00

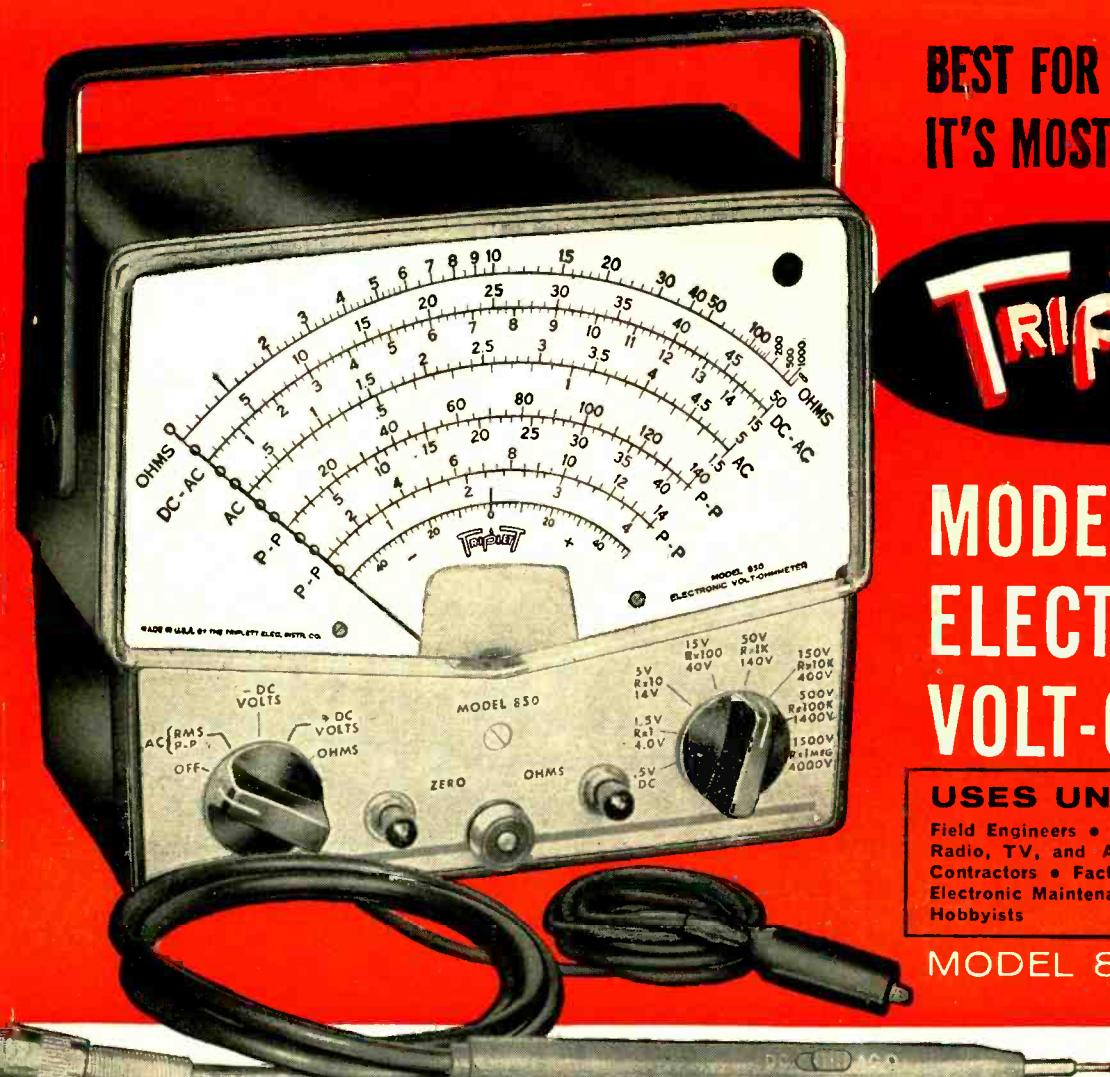

FACTS MAKE FEATURES:

- 1** Long 7" easy-to-read scale.
- 2** .5 D.C. volt range for transistor circuits.
- 3** HIGH STABILITY. Meter connected in cathode circuit of 12 AU7.

High Input Impedance (11 MEGOHMS) and wide Frequency Ranges give this extremely versatile Electronic Volt-Ohmmeter considerable advantage in the measurement of DC voltages, AC RMS and Peak-to-Peak voltages. It measures directly the Peak-to-Peak values of high-frequency complex wave forms and RMS values of sine waves on separate scales. Exclusive Triplet BAR-RING instrument is fully self-shielded; high flux magnet and spring-backed jewels for ruggedness. Wired circuit.

ADDED PROTECTION. Meter is shorted out in OFF position for greater damping, meter safety during transit, electrically protected against accidental overload. ZERO CENTER mark for FM discriminator alignment, plus other galvanometer measurements.

New pencil thin test probe used for all functions: DC, AC, and ohms. No need to change cables. Beautifully styled case for professional appearance and functional utility, 7 1/4" x 6 1/16" x 3 3/4".

Carrying handle can be used as a tester stand to place the tester at 25° angle for ease in reading.

Frequencies to 250 mHz may be measured with auxiliary Diode. Probe \$9.00 extra. DC voltages to 50KV may be measured with auxiliary High Voltage Probe, \$25.20 extra.

TRIPLET ELECTRICAL INSTRUMENT COMPANY, BLUFFTON, OHIO

CARRYING CASE

Case 859—OP—Black leather
Padded Carrying Case. \$23.10 Net.



RANGES

8 DC VOLTS RANGES	0-.5-1.5-5-15-50-150-500-1500
7 AC RMS VOLTS RANGES	0-1.5-5-15-50-150-500-1500
7 PEAK-TO-PEAK VOLTS RANGES	0-4-14-40-140-400-1400-4000
7 RESISTANCE RANGES	0-1000-10,000-100,000 OHMS: 1-10-100-1000 MEGOHMS.

FREQUENCY RANGE 15 CPS to 3MC; (Up to 250 MC with accessory diode probe available extra.)

INPUT IMPEDANCE DC Volts 11 Megohms;
AC Volts minimum of .83 Megohms.

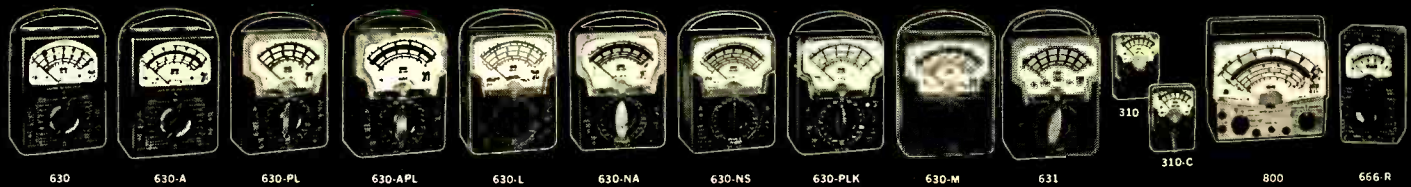

THE WORLD'S MOST COMPLETE LINE OF V-Q-M'S. AVAILABLE FROM YOUR TRIPLET DISTRIBUTOR'S STOCK.

LOUDSPEAKERS— Can we measure what we hear?

By VICTOR BROCIER /Assistant to the President, H. H. Scott, Inc.

Is it really possible to make meaningful speaker measurements? Here's a reverberant-room technique that gives valid, objective measurements that are useful in predicting how a loudspeaker will sound in the home.

TO the novice, measurement of the frequency response of a loudspeaker system appears to present no more problems than the measurement of an amplifier. Considerable irritation is sometimes expressed at the aura of mystery and the atmosphere of controversy which surround loudspeaker measurements. There is often a feeling that the "experts" are going out of their way to make matters unnecessarily complicated. Is this criticism justified? Is the subject really so complicated? Or is it possible to make relatively straightforward measurements that convey meaningful information? This article will attempt to shed some light on these questions.

Let us begin by sidestepping temporarily the question of the relationship between the measurement and what a speaker sounds like. All we want to know at this point is the frequency response of the loudspeaker. We immediately encounter the difficulty that the loudspeaker, unlike an amplifier, has no output terminals to which we can conveniently attach a measuring instrument, because the output that we want to measure is not electrical in nature, but acoustical. Consequently, we have to use a microphone to make the measurements. This in itself presents no particular problem; there are microphones available that have extremely wide range, flat response, and can be obtained accurately calibrated. When such a microphone is connected to a suitable amplifier and indicating voltmeter or recording instrument, we have a suitable system for measuring the acoustic output of the loudspeaker.

The difficulties begin when we attempt to use this measuring system. In what kind of environment shall we operate the loudspeaker and where shall we place the microphone? Taking up the second question first, we know of course that the output from a loudspeaker varies with the distance, so we have to decide upon a distance at which to make our measurement. At first glance this presents no particular problem because, remembering our elementary physics, we know from the inverse square law of sound propagation that it is always possible to relate the sound intensity at any given point to that at any other distance from the source. We are not quite so likely to remember that this applies only to a point source, but if we do, we conclude that it is merely necessary to make the measurement at a location sufficiently far from the loudspeaker to insure that it behaves like a point source.

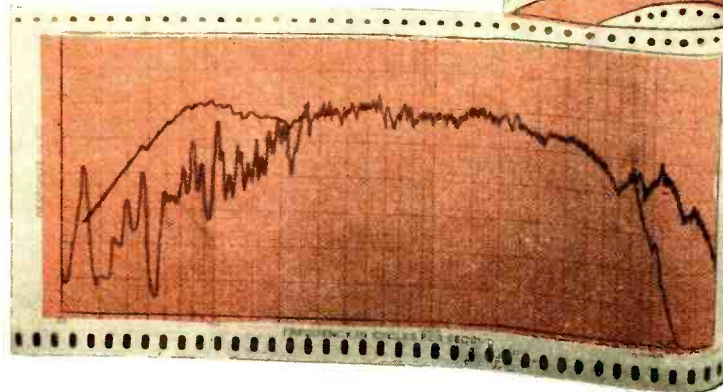
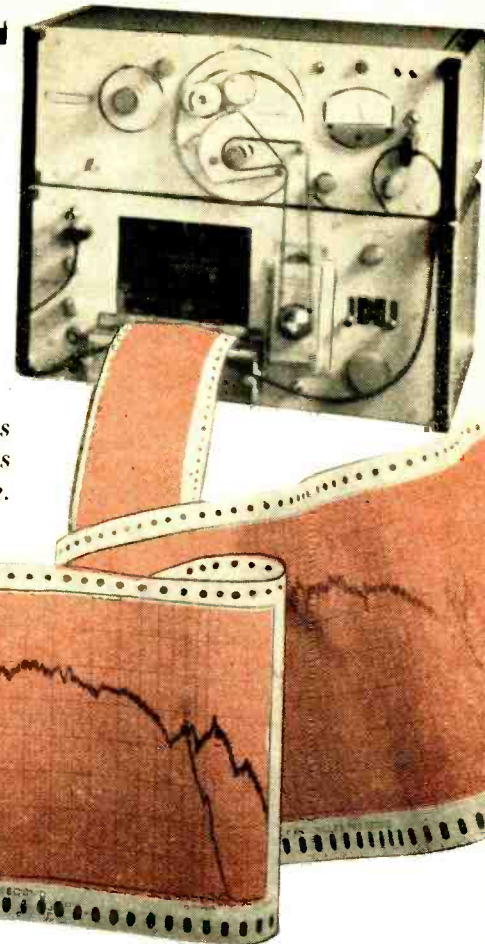

If loudspeakers radiated sound equally well in all directions at all frequencies, there would be no problem involved in deciding whether to place the measuring microphone on-axis or at some point off the axis of the loudspeaker. But practical loudspeakers do depart from perfect omnidirectionality to a considerable extent; consequently, some kind of a decision has to be made. In the days of monophonic sound reproduction it was often argued that practically all listening was done on or near the axis of the loudspeaker, and that consequently the most significant measurement was the one made on the axis. There may have been a little difficulty in defining the axis exactly (except for a perfectly symmetrical loudspeaker) as for example in the case of a two-way system, but the problem could be minimized by making the measurement at a sufficiently great distance from the loudspeaker so that it did not make very much difference. This line of reasoning does not apply to today's use of loudspeakers for stereophonic reproduction. Obviously, if the listener is positioned midway between the left and right speakers, he is not on the axis of either one of them.

Although we started out with the assumption that we would not allow subjective considerations to influence our

Fig. 1. Response measurements taken in an anechoic room on loudspeaker axis (0°) and at various angles off the axis.

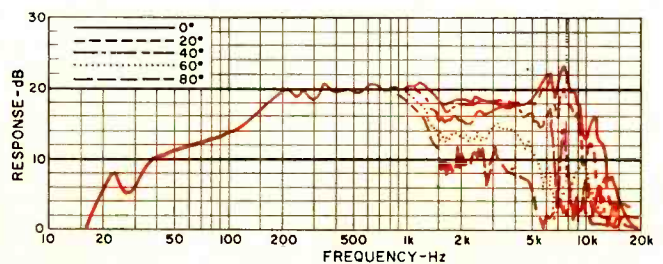

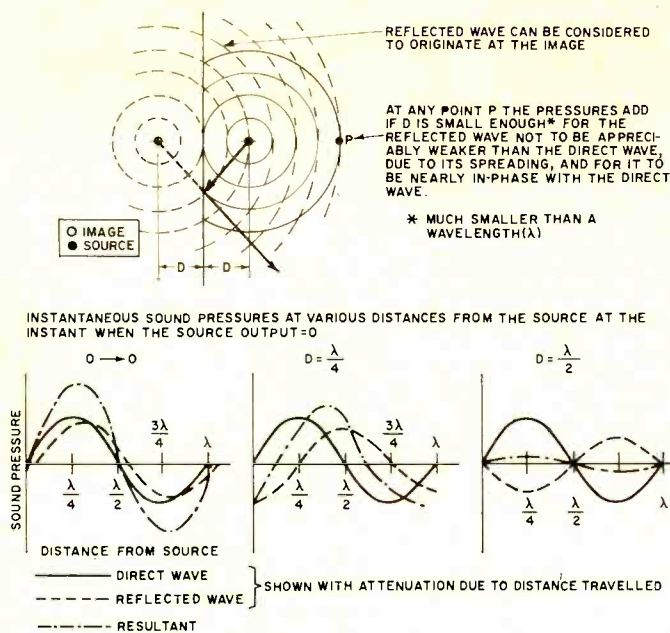

Fig. 2. With reflecting surface placed immediately behind the speaker, the results are as shown in this illustration.

judgment, we suddenly find ourselves entangled in a discussion of where the listener is positioned with respect to the loudspeakers. The listener sneaked in while we were not looking and there does not seem to be any way of getting rid of him.

The Acoustic Environment

Perhaps it would be the better part of valor to retreat to a consideration of the other topic that we started with—the acoustic environment. The previous discussion has assumed that all the sound received by the measuring microphone comes directly from the loudspeaker. This would hold true in a space free of reflecting surfaces, such as a wide-open space well removed from the ground or, more practically, an anechoic chamber. It must be obvious to the reader that we are now heading towards a repetition of the old statement, “but a loudspeaker is not listened to in open space, nor in an anechoic chamber.” This is inconsistent with our starting premise that the subjective aspect was going to be disregarded. We had stated that we were interested only in the frequency response of the loudspeaker. Why don't we decide that the measurement is going to be made in an anechoic chamber, or its equivalent, and let it go at that? Matters become considerably simplified if this decision is made, except for the fact that we are then driven to a reconsideration of the question of where to place the measuring microphone.

The entire problem can be solved by means of a bold step: measurements will be made at many points, both on-axis and off-axis, and the results presented as a series of curves showing frequency response on-axis and at vari-

Fig. 3. When reflecting surface is much less than half a wavelength behind speaker, pressure of the sound at distant point approaches twice that of the loudspeaker alone.

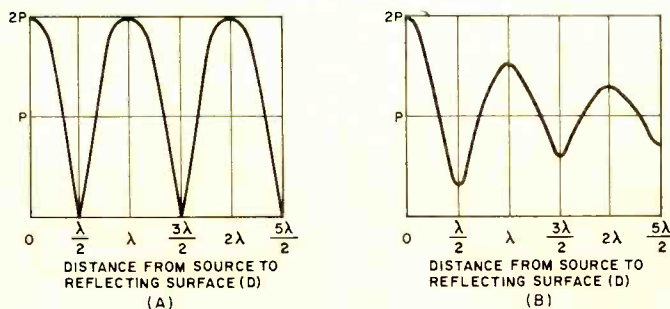

ous angles off-axis (Fig. 1). This is a perfectly logical scheme and there is no question but that it completely defines the frequency response of a loudspeaker in an anechoic environment. The question is: of what use is this information to the user of the loudspeaker and to the loudspeaker designer?

The response curves obtained in the manner outlined provide full information regarding the smoothness of response of the loudspeaker and are useful in comparing one loudspeaker with another. This is strictly true only in the case of single loudspeaker units. With multi-speaker systems it is usually not practicable to make measurements at a distance sufficiently great to avoid errors caused by the measuring microphone's being on the axis of one loudspeaker and off the axis of another, or somewhere in between. In the regions of crossover between speakers, such as between the woofer and a midrange speaker, there is considerable interference between the two speakers in the frequency range where their outputs overlap. This can result in peaks or valleys in the response curve. This may occur on-axis and not at some angles off the axis, or *vice versa*. The designer is often confronted with the dilemma that while he can design for smooth response on-axis at the expense of rough response off-axis, or the reverse, he has no way of telling which is the preferred condition. In multi-speaker systems the off-axis responses tend to become quite irregular because of the finite size and spacing of the radiating elements, which cause interference effects. These are also extremely difficult for the designer to evaluate.

When the user examines these curves he is apt to be rather surprised to find that all loudspeaker systems, even the very best, show a progressive decrease in response as the frequency goes down below several hundred hertz. Is it really true that all loudspeakers are deficient in bass response? Yes, it is—in an anechoic environment; however, when operated in rooms, as they are in practice, the bass response is considerably better. It is possible, but not particularly easy, to determine the bass response of a loudspeaker when operated in a room by calculation, starting with the frequency response curves made in an anechoic chamber. This is certainly beyond the scope of the average hi-fi fan. It would be useful to have a method of measurement which would provide this information directly.

Effect of Reflecting Surfaces on Bass

Since it appears to be impossible to avoid considering the effects of the listening room, an outline of the way it affects the performance of a loudspeaker might lead to some conclusions regarding a suitable method of measurement. Consider what happens when making a measurement in free space, if a large, perfectly reflecting surface is placed immediately behind the loudspeaker. To simplify the discussion, assume that the loudspeaker is perfectly omnidirectional.

The sound from the rear of the loudspeaker is reflected by the surface so that the sound direction is reversed and it reaches the measuring microphone in addition to the sound arriving directly from the loudspeaker. Instead of one sound wave reaching the microphone, two identical waves fall upon it. The sound pressure at the microphone is doubled, or increased by 6 dB. Since intensity, or acoustic power per unit area, is proportional to the square of the sound pressure, the intensity is multiplied by four.

Note that the area into which the speaker radiates has been reduced by a factor of two by the surface that has been introduced. The power output of the speaker itself is equal to the intensity (power per unit area) times the area; this must be doubled when a reflecting surface is immediately behind the speaker. This can be visualized by considering that the diaphragm must move twice as fast in a smaller volume, *i.e.*, in a half-sphere rather than a full sphere.

It is necessary to define what is meant by “immediately behind the speaker.” If the reflecting surface is spaced from

the radiating element by a very small fraction of a wavelength, the reflected sound travels from the radiating element to the surface and then back out again so that it is only slightly delayed with respect to the direct sound. It is convenient to think of the reflected sound as originating from an image, spaced behind the reflecting surface as shown in Fig. 2.

If the source and image are very close together, their outputs add up to only slightly less than double their original values. As the distance from source to surface is increased, one wave becomes displaced in space with respect to the other, and they reinforce each other to a lesser and lesser extent until finally, when the displacement is equal to one-half wavelength, they cancel each other, so that their sum is equal to zero. (See Fig. 3A.) When the distance is still further increased, the waves begin to reinforce each other again, with the sum reaching a maximum when the distance is one wavelength, and again decreasing to zero when it is one and a half wavelengths. The pattern is repeated endlessly. By the way, it is assumed that the distance to the observation point is so much greater than the distance from the source to the wall that the direct and reflected waves have essentially equal amplitudes. If the reflected wave has less amplitude than the direct wave, the resultant is as shown in Fig. 3B.

Fig. 3A shows that for a distance less than half a wavelength from source to reflecting surface, the sound pressure at a given point is always increased, but that for greater distances it varies from double its original value to zero. Consequently, the term "immediately behind the speaker" means that the distance must be a small fraction of a wavelength. This is generally the case at low frequencies.

For a given distance from source to reflector, the frequency response at a point on axis looks like Fig. 4. Responses off-axis look similar. The directivity patterns are shown in Fig. 5, in which the horizontal line at the bottom of the illustration represents the axis through the source and its image. The total power is obtained by integrating the values for all the lobes. For frequencies equal to and above those corresponding to Distance = (between source and image) = $\lambda/2$, the directivity index (D.I.) for the axis of any lobe is 3 dB. (The directivity index is equal to 10 times the logarithm of the ratio of the intensity to the intensity that would exist if the source were omnidirectional and radiating the same total power as the directional source.) Since all the lobes have maxima that are equal in strength to the response obtained under omnidirectional conditions (distance equal to a small fraction of a wavelength), it follows from the value of the directivity index that their total power must be 3 dB below the power obtained when the wavelength is large.

We have already pointed out that at low frequencies the sound intensity increases by 6 dB. At higher frequencies it is 3 dB less. The net result is a boost of 3 dB at low frequencies.

A second reflecting surface at right angles to the first provides a net gain in intensity of 6 dB. If a third reflecting surface is added, the intensity is increased by 9 dB. In Fig. 6 these conditions correspond to a loudspeaker in free space, a loudspeaker on the floor in the center of a room, one placed on the floor against the wall, and finally a loudspeaker in the corner of a room.

Fig. 7 shows the results of measurements on a mid-range loudspeaker in the different positions indicated. The increase in sound pressure level at the lower frequencies accords with the theory, and the curves illustrate how the effect decreases as the frequency is increased. It is also apparent, when the shapes of these curves are compared to anechoic-chamber measurements of the same speaker, the latter do not correctly depict the low-frequency performance of loudspeakers when they are used in rooms.

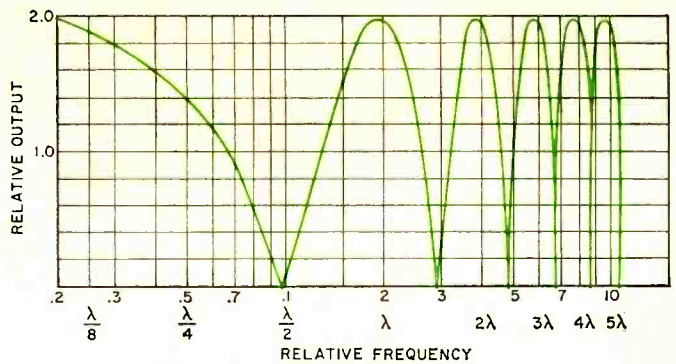

Fig. 4. Relative frequency response at a point on the loudspeaker axis for a given distance from source to reflector.

Multiple Reflections

Let us now consider the effect on loudspeaker performance of multiple reflections in rooms. Fig. 8 shows a plan view of a room containing a loudspeaker at S, and a listener at O. The sound traveling directly from the speaker to the listener is shown by the double line marked D, for direct sound. Sound also reaches the listener after one or more reflections from the walls.

The diagrams at the right show how the energy reaching the listener is built up following the direct sound, by successive reflections. Curve A shows the effect of several rays of sound that reach the listener after one reflection from the walls of the room. The intensity of this reflected sound is somewhat lower than that of the direct sound because there is some loss upon reflection, and also due to the longer paths traversed. At B, the build-up of sound is shown for two reflections from the walls. The reflections become progressively weaker; consequently the curve showing the build-up begins to bend over as shown.

It should be kept in mind that the situation is depicted in two dimensions only for the sake of simplicity. Actually, sound is reflected from the floor and ceiling as well. As time goes on, the various sound paths fill the room, crisscrossing in a rather random manner, and the curve levels off to a steady-state condition when all of the sound emitted by the source is absorbed at the walls and through transmission losses in the air. The total reflected sound is referred to as *reverberation*.

Just as the reverberation of a room causes a gradual build-up of a given sound, it also causes a gradual decay when the sound stops. The rate of build-up and decay is determined by the volume and the total absorption of the room. The length of time required for the sound to decrease from

Fig. 5. Directivity patterns for speaker near wall. Vertical axes in polar charts (response in ratios) correspond to on-axis line below.

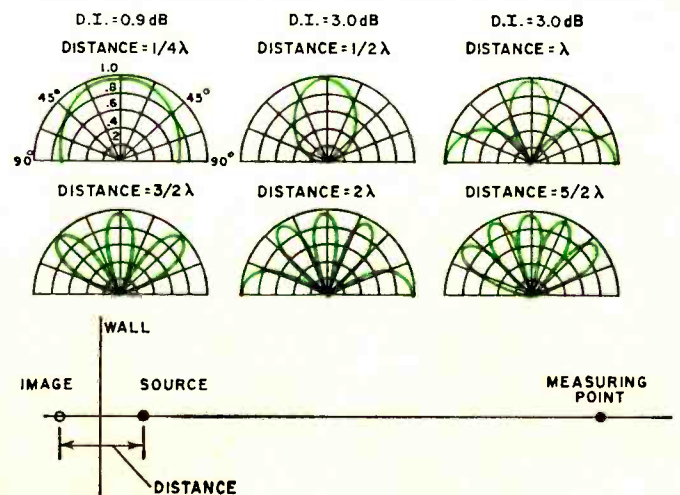

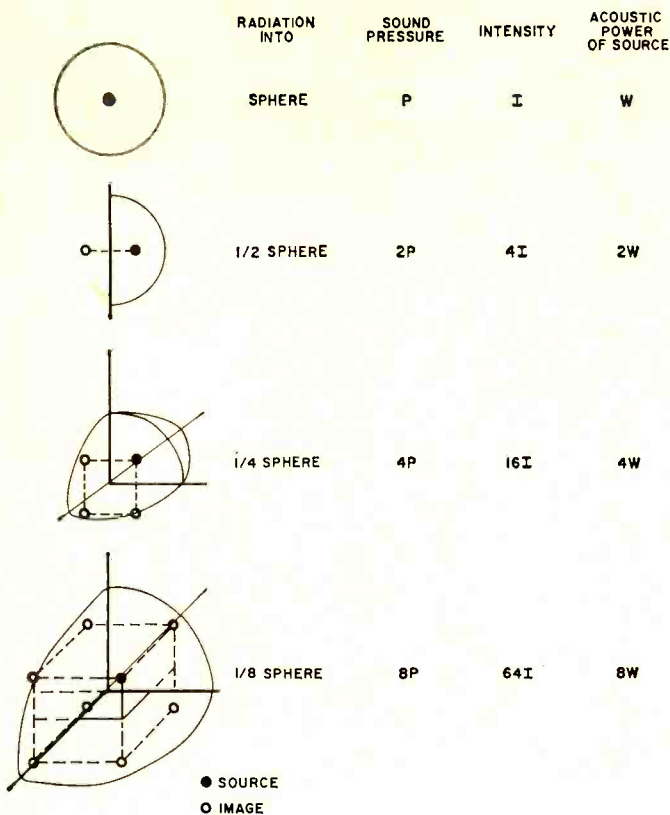

Fig. 6. As the speaker is moved from free space, to a floor in the center of a room (one reflecting surface), to the floor and against a wall (two reflecting surfaces), and finally to the corner of a room (three reflecting surfaces), the sound intensity produced increases proportionally as shown here.

its steady-state value, after the source has been turned off, to a level 60 dB below this value, is called the *reverberation time* of the room. The relationship among the reverberation time, the room volume, and the total absorption, is expressed by the following approximate formula:

$$T = .049 V/S\alpha \text{ seconds}$$

where V = room volume in cubic feet, S = total surface area in square feet, and α = sound-absorption coefficient.

Some interesting conclusions can be obtained by calculating the intensity of the reverberant sound in a typical living room under normal listening conditions, and comparing it to the direct sound. The intensity of the reverberant sound is:

$$I_R = 800 WT/V \text{ watts per square meter, where } W = \text{acoustic power produced by the source.}$$

The direct sound is spread over the surface of a sphere with radius equal to the distance from the measuring point to the source. Assuming this to be d in meters, then $I_D = W / 4\pi d^2$.

Comparing the values for I_R and I_D for a typical living room, one obtains the rather surprising result that at a distance of approximately two feet from an omnidirectional

source, the reverberant sound has an intensity approximately equal to that of the direct sound. At greater distances, the direct sound decreases, but the reverberant intensity remains constant. *The greater part of what one hears at normal listening distances is the reverberant sound.*

When a source is directional, more of the sound is concentrated in the direction of the listener and less of it reaches the room surfaces to become reverberant sound. With practical loudspeakers located as they normally are in living rooms, the speaker is made more directional by its usual position at the junction of a wall and floor, and of course at the higher frequencies, practical loudspeakers tend to become more directional anyway. As a result, the critical distance (at which the direct and reverberant sound intensities are equal) is more likely to be something over five feet.

What We Hear

While the mathematics of the previous section is convincing, one tends to reject the conclusion. If the reverberant sound predominates—and, of course, this comes from all directions—how is it that we can tell where the sound is coming from? We can do this because of loudness differences and the *precedence effect*. If one listens to monophonic program material on a stereo reproducing system while sitting on the axis of one of the loudspeakers, all of the sound seems to be coming from that loudspeaker. In fact, it is necessary to move near the axis of the other loudspeaker to convince oneself that it is operating at all. What distinguishes the sound of the on-axis loudspeaker is that it arrives earlier and is somewhat louder than the sound from the other loudspeaker. If one sits on the axis between the two loudspeakers, as one would when listening to stereo, the sound appears to come from a point midway between the speakers. Adjusting the balance control moves the virtual sound source nearer one of the speakers, as the level of one speaker is raised with respect to the other. If the difference in level is made great enough, all of the sound appears to come from one loudspeaker. From these experiments, one can conclude that if one is equidistant from two loudspeakers and varies their relative loudness, then beyond a certain point all of the sound appears to come from the louder one.

An interesting experiment is to introduce time delays. Suppose we delay the sound coming from one loudspeaker, either by using a tape loop or some similar delay device or by placing the speaker farther away so that the time taken for the sound to arrive at the listening point is increased. An effect analogous to the results obtained with varying intensities is obtained. For very small time delays the sound source appears to move away from the delayed speaker toward the undelayed speaker. The time differences involved for this effect are somewhere between 0.6 and 1.0 millisecond (or about the time required for sound to travel 1 foot). For longer time delays, all of the sound seems to come from the undelayed speaker.

A fascinating aspect of this precedence effect is that it is possible to use increased loudness to compensate for delay. If we listen to sounds of equal intensity from two loudspeakers, one of which is delayed by a few milliseconds, and we increase the output of the delayed loudspeaker, there is a point beyond which the sound no longer appears to come from the undelayed loudspeaker. More delay requires more level difference for compensation. Strangely enough, this only holds true up to a maximum, in the neighborhood of 15 milliseconds, where it takes something less than 11 dB to make up for the difference. Beyond this point, that is for longer delays, it takes less level increase to make up the difference. As the delay is increased beyond 50 milliseconds or so, the delayed speaker begins to be heard as an echo.

The precedence effect greatly influences what one hears

Fig. 7. Measured response of mid-range speaker in various locations in room. Note 9-dB rise in low-frequency output.

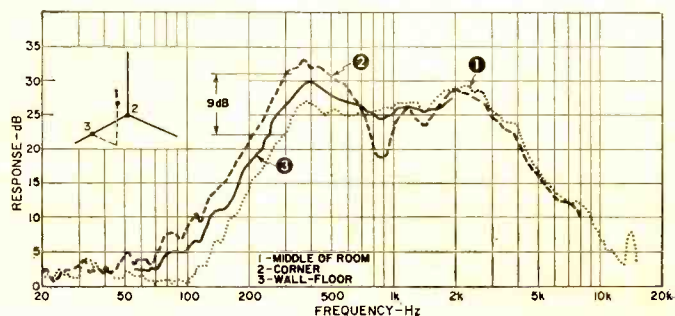

in the presence of both direct and reverberant sound. In general, the reverberant sound is somewhat attenuated in level and is delayed with respect to the source of direct sound as the apparent source. The reverberant sound contributes to the loudness and to our sense of ambience or sensation of being immersed in sound, but it does not confuse us as to where the original sound is coming from.

One might well conclude that the reverberant sound has no significance after all. However, this is not really the case. The reverberant sound contributes to a sense of ambience (which is definitely present in a concert hall) and also to the loudness. Does it also affect one's conclusions about the tonal balance, that is, the frequency response of the loudspeaker? This is a rather ticklish question. Some people maintain that the direct sound is the determining factor, others that the total energy represented by the direct plus reverberant sound is the criterion, and there are views in between. But before attempting to come to our own conclusions, it would be well to decide for ourselves whether the tonal character of the reverberant sound is different from that of the direct sound. If it is not, there is nothing to argue about.

With an omnidirectional source operating in a room whose surfaces reflect sounds without frequency discrimination, the reflected sound reaching the listener has exactly the same tonal balance as the direct sound. For example, if the reflecting surfaces discriminate against the higher frequencies, the reverberant sound lacks high frequencies and the tonal balance is different from that of the direct sound. In rooms that are good acoustically, this is not a very serious consideration. If a source is directional and its directionality increases as the frequency goes up, the reverberant sound contains less and less of the high-frequency range as the frequency increases, so that the tonal balance of the reverberant sound is quite different from that of the direct sound. If one thinks of the sum of the direct and reverberant sound as the acoustical output of the system comprising the loudspeaker and the room, the system response can be considerably different from the on-axis speaker response alone. Consequently we do have to be concerned whether the ear takes the reverberant sound into account when judging tonal balance.

It is probable that in making this judgment the ear sums the direct sound and that part of the reverberant sound produced by the early reflections. This is based partly on the precedence effect and on the fact that the ear tends to listen to varying sounds as if it were a detector with an integrating time of the order of 1/20 second. The sound path corresponding to 1/20 second is approximately 55 feet, which gives some idea of the number of reflections included in the "early sound" in an average living room.

To sum up, the ear follows the precedence effect in establishing the apparent source of a sound and tends to judge its intensity during its integrating time so that the system frequency response referred to above involves summing the direct sound and the early part of the reverberant sound.

When one considers that for stereo listening the direct sound referred to above is not the on-axis sound produced by the speaker and that the degree to which the listener is off-axis is apt to vary considerably from one listening setup to another, it is difficult to conceive of a measuring system for frequency response that would take all these factors into account. It does seem quite clear, however, that the on-axis frequency response is not the sole determining factor and that some method of summing the output of the speaker in all directions would be more meaningful.

Reverberation Chamber

A reverberation chamber is essentially a large room with highly reflecting surfaces in which the level of the reverberant sound is so great that a measuring micro-

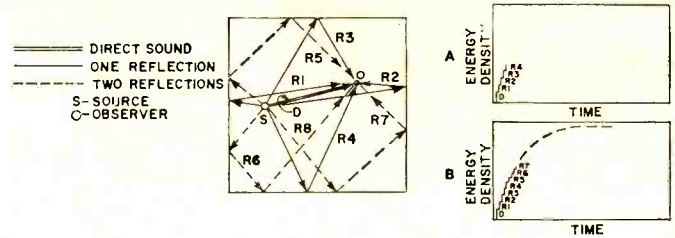

Fig. 8. What we hear in a normal listening room is largely made up of sound that has been reflected one or more times.

phone, if not placed too close to the loudspeaker, measures the reverberant sound alone. Since the latter is composed of reflections originating as the sound emitted by the speaker in all directions, it is proportional to the total acoustic power output of the loudspeaker. This is essentially what we wish to measure. Originally reverberant chambers were used primarily to measure the total power output of loudspeakers in order to relate it to the electrical input and thereby determine the efficiency. What we are interested in, however, is finding out how the total power output of the loudspeaker varies with frequency. For this purpose, a frequency-swept signal is applied to the loudspeaker and the amplified output of the measuring microphone is fed to a sound level recorder which plots the power frequency response of the loudspeaker automatically. The instrumentation is essentially similar to that used for frequency-response measurements in an anechoic chamber. However, the problems involved in obtaining a meaningful measurement are quite different.

The description previously given of the manner in which a sound field is built up in a room due to multiple reflections assumed a more or less random set of paths for the reflected waves. In actual rooms, however, which possess a certain degree of regularity and symmetry in shape, it frequently happens that the paths of a pair of outgoing and incoming waves are identical. The result is the formation of a standing wave similar to that formed in an organ pipe. In the simplest type of standing wave the pressure is maximum at two opposite parallel walls of the room and zero at the center. If this is plotted in terms of pressure vs. distance, the shape of the curve is half a sine wave.

Again, as in an organ pipe, there are multiples of the frequency of the lowest mode just described. Since this occurs between each pair of parallel surfaces, there are three sets of these axial modes (or room resonances) in a rectangular room. Standing waves can also be formed along diagonals of a room parallel to the plane of each bounding surface and to diagonals between opposite corners not in the same bounding surface. The standing waves in a room are comparatively sparse in a given bandwidth at low frequencies and become more closely spaced as the frequency increases. Fig. 9 shows a typical distribution.

Suppose the source is emitting sound of a frequency corresponding to the lowest mode (*Continued on page 74*)

Fig. 9. Characteristic frequencies below 100 Hz for a rectangular listening room measuring 15 by 20 by 10 feet high.

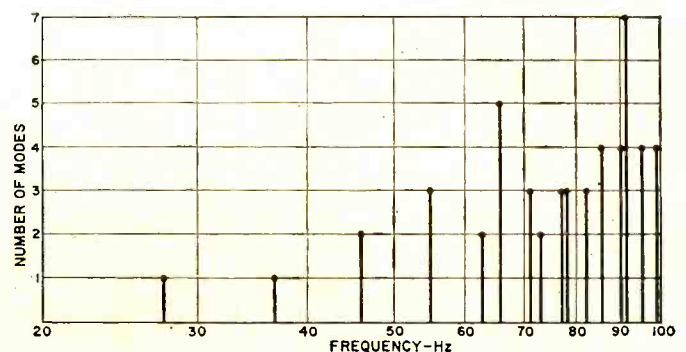



RECENT DEVELOPMENTS IN ELECTRONICS



Rechargeable Heart Pacer. (Top left) A heart pacer is a surgically implanted pulse generator whose output leads are connected directly to the heart muscle in order to keep the heart beating regularly. Most such pacers use five or six mercury batteries as power source. When these batteries run down, surgery is required to temporarily remove the pacer to replace the batteries. The new heart pacer shown here uses a miniature rechargeable nickel-cadmium battery which is not only lighter than the group of mercury batteries but can be recharged without removing it from the patient's body. An induction coil, along with related microelectronic circuitry, make up the charging circuit. The arrangement is fairly similar to the induction charger used in some electric toothbrushes. The external charger coil can be installed in a vest worn by the patient. Transmission of the signal to the pacer's receiving coil recharges the battery overnight. The pacer is then ready for another month's operation. The new pacer weighs only 60 grams rather than 100 to 150 grams for other pacers. It has not yet been implanted in humans but it has been tested in animals. Manufacturer is ESB (formerly Electric Storage Battery).

Gated-Laser Viewer Sees in Fog, Darkness. (Center) This new viewer permits the user to see 300 feet in fog, heavy rain, blizzards, sandstorms, or in complete darkness. The device uses pulsed gallium arsenide lasers as its infrared light source along with an image-converter tube that makes the invisible light visible to the viewer. The lasers are pulsed to produce brief bursts of infrared light that travel to a distant object. The converter tube is kept off until the leading edge of the reflected pulse occurs. As a result, all backscatter is eliminated so that there is an improvement in contrast when the device is used in adverse atmospheric conditions. The new viewer has been designed by Laser Diode Laboratories for use in ground vehicles, boats, helicopters, or on foot. The gated-laser unit weighs 15 lbs and costs in the neighborhood of \$3000.



1000 Holograms in One Crystal. (Bottom left) A lithium niobate crystal, smaller than a sugar lump, can store as many as 1000 different laser holograms. In a Bell Labs experiment the crystal was used to record the complex interference patterns of laser light forming the hologram. The laser beam produces changes in the refractive index of the crystal due to the internal electric field that is set up by the intense light. The crystal can then be rotated just a fraction of a degree, and another hologram can be stored in the same manner. The interference pattern that is recorded can be removed simply by heating the crystal to a temperature of 170 degrees C. In this way, the same crystal can be used again and again for storing new holograms. Such a device can be used as an optional memory from which desired information could be retrieved or erased.

Thick-Film IC Voltage Regulator. (Top right) This new solid-state regulator at the right takes the place of the conventional relay regulator used to keep the output voltage of an auto alternator constant. Using thick-film microcircuitry, the new regulator is built right into the alternator and replaces the conventional external unit at the left. Advantages of the new device are absence of moving parts, greater reliability and accuracy, and elimination of servicing. Developed by Delco, the new regulator is standard on Oldsmobile 442, Pontiac Firebird, Chevrolet Corvette, and on certain Chevrolet trucks.

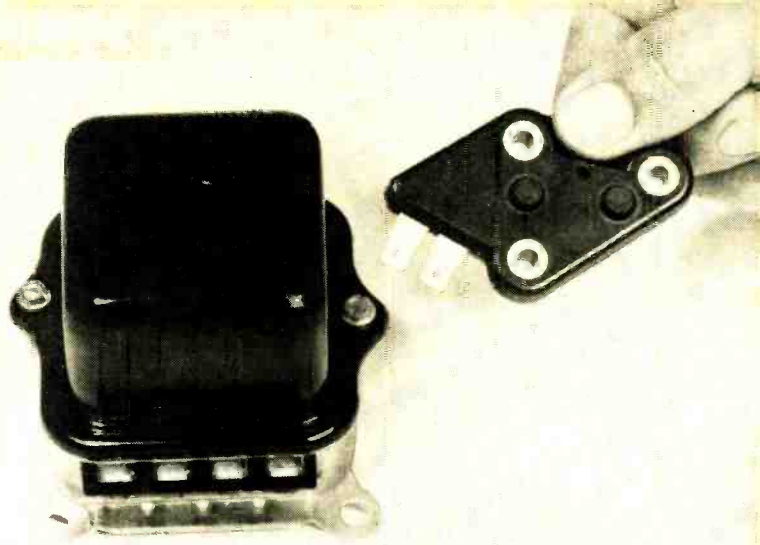

Laser Color-TV Display. (Center) The picture on the screen in the background is in bright color and measures 48-in wide by 31-in high. It was produced by a new laboratory laser-display system which works off a standard home color-TV set. An argon laser produces blue and green beams while a krypton laser produces a red beam which are all combined to make up the display. The beams are made to scan by means of rotating and vibrating mirrors to generate the TV-like raster. Long before the experimental GT&E Laboratories system will find use in the home, it will probably find applications in the areas of military, industrial, commercial, and educational-type displays.



Computer-Predicted Ramp-Jump. (Below left) The upper drawing is part of an animated cartoon made by a high-speed computer at Cornell Aeronautical Lab. It predicts the motions of a catapulting car as it jumped 70 feet from one ramp to another at high speed as shown in the photo. This computer-simulation technique is being used in a program aimed to provide a greater understanding of auto crashes. The computer creates a series of line drawings on a CRT. The tube is then exposed to a motion-picture film and by advancing the film between drawings, the cartoon is produced, frame by frame. The Lab has recently been awarded a \$113,000 contract extension by the U.S. Bureau of Public Roads to continue this program.

Electronic-Hydraulic Artificial Arm. (Below right) The armless 15-year old youngster shown here learned to write her name with ease using a new artificial arm with less than an hour's practice. The arm uses combined electric and mechanical controls to operate four separate power functions. Myoelectric (muscle-generated voltages) or manual devices can also be used. A nickel-cadmium battery supplies 12 volts to operate the arm for one day; the battery can be recharged overnight. The arm weighs but 2½ lbs and is capable of lifting up to 20 lbs. The prosthetic arm was developed by Northern Electric Company Limited (Canada) which is making complete details and drawings available to any recognized organization in the field.

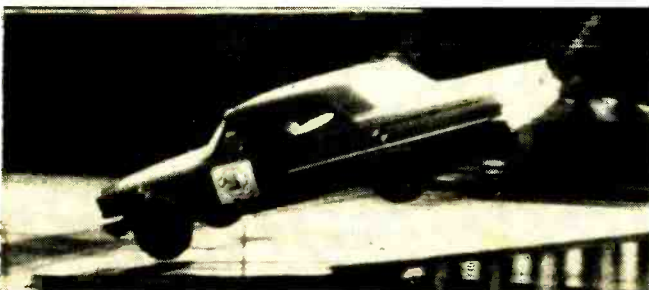
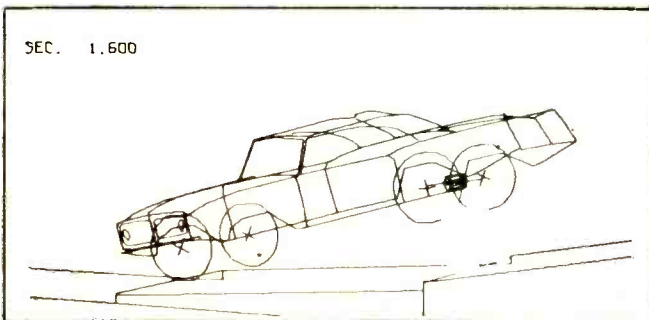

Using Controls To TROUBLESHOOT TV

By DON MATSUDA

A quick preliminary diagnosis of TV troubles can often be made just by observing what effect the various controls have on the television picture. Here is what to look for.

Editor's Note: Our author, who is currently living and working in Honolulu, has been in the servicing field for 18 years. About half of this time was spent as an independent, and five years were spent with G-E in Los Angeles. During these five years he received a top award for excellent performance in TV servicing.

A WELL-organized test bench with all tools, parts, and probes within easy reach is essential for rapid and profitable TV servicing. These are times, however, when quick, preliminary diagnoses will have to be made. For example, an accurate estimate is required in the home or over the phone. Or a customer walks in with a portable TV and wants to know immediately whether the set can be fixed right away.

For extracting preliminary information, the experienced TV technician uses various controls on the set itself. Just about every circuit in the set modifies or generates a sig-

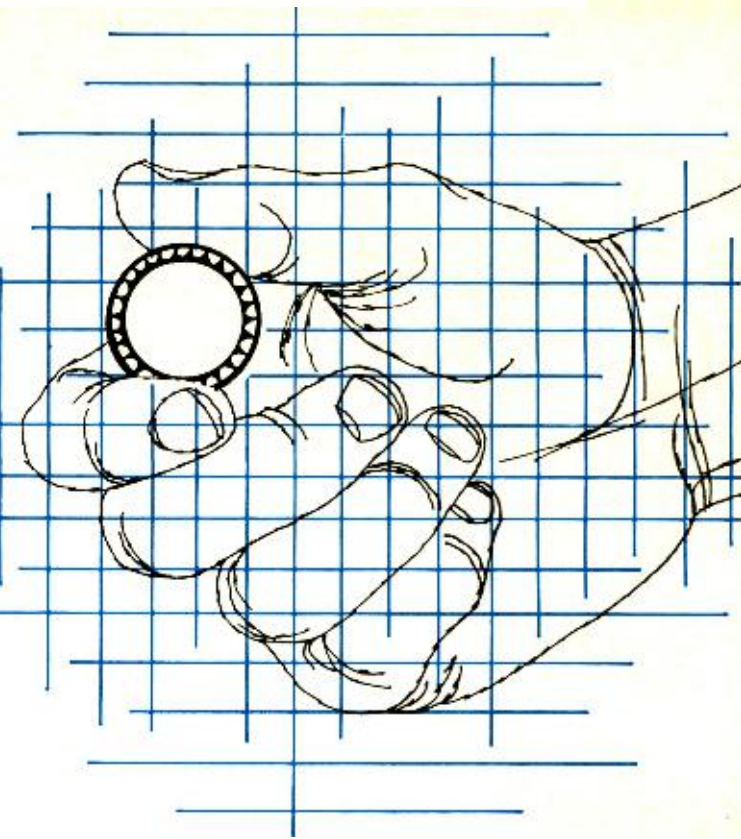

nal that can be regulated by these controls. The effect of these controls can often be observed on the picture-tube screen and sometimes even heard in the speaker. It's almost like having a scope and signal tracer built right into the television set.

On/Off Switch

Let's start with first things first: turn the set on. If it's dead, check the switch. Listen and feel for the click. A spongy feel indicates a defective push-pull type switch. We assume that you have made the other simple checks, such as wiggling the a.c. plug, line and interlock, and looking in back to see if the tubes are lighted.

Watch for abnormal warm-up symptoms. A lot of things happen during warm-up that happen at no other time, not until you have cooled off the set thoroughly, perhaps even for a day or two.

The sound should come on first. If you get noise only, but

Fig. 1. The dashed curves represent the heterodyne output of the TV set converter stage. The heavy solid curves represent the set's i.f. bandpass response. (A) shows conditions with the fine-tuning control set at the proper position. Note that the video carrier is halfway down the slope of the i.f. response as required for proper equalization of the vestigial sideband transmission. In many cases, the color subcarrier is positioned halfway down the other side of the i.f. curve, rather as shown. In such a case, equalization is accomplished in the chroma section of the receiver. As the

converter output is shifted to the left (B) by adjusting the fine-tuning control, the sound, color, and higher video frequencies are all lost, while the lower frequencies and sync are accentuated. When the fine-tuning control is adjusted to shift the output of the converter stage to the right (C), the low video frequencies and sync are greatly attenuated so that sync is unstable or lost altogether. Color becomes saturated and sound enters the picture in the form of a beat pattern. Correct fine tuning is achieved by adjusting for this condition, and then backing off a bit to condition (A).

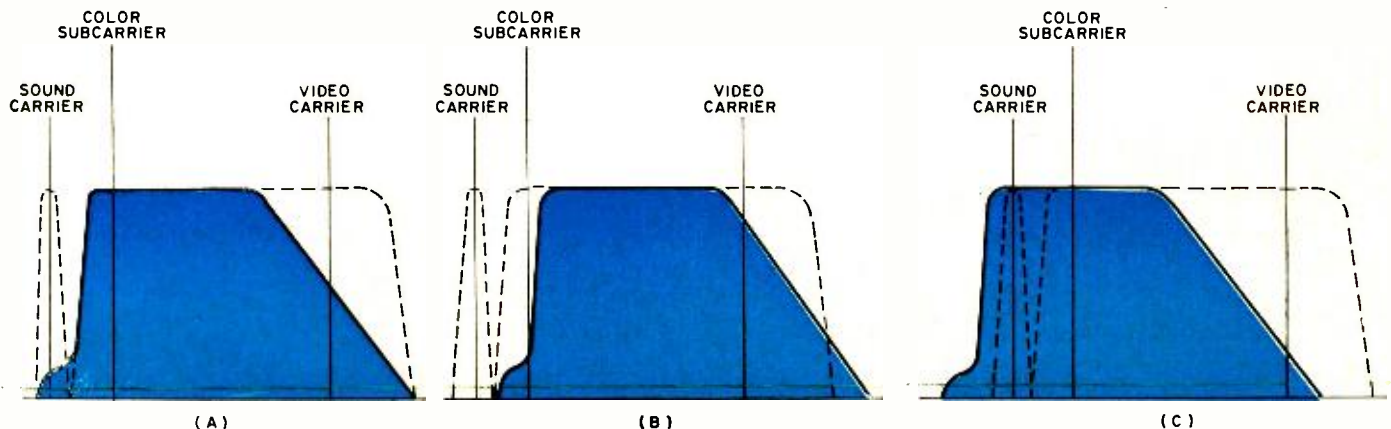

you can vary it with the volume control, the audio is probably okay. If you can't—the trouble is in the audio section. If you get buzz during warm-up, suspect slow-warming a.g.c. components or intermittent filter capacitors. Vertical buzz will vary in tone if you adjust the vertical hold control.

The picture should come in locked. If it doesn't, notice whether it is rolling up or down. Note whether the sync bars are slanting uphill or downhill from left to right. These symptoms will be discussed later. As for now, remember that troubles due to open parts and connections are more likely to occur when the set is cold—before expansion closes contacts or breaks down oxidized coating; and that troubles due to leaky capacitors and increased resistances are more likely to occur when the set is hot. Also remember that the customer adjusted the controls when the set was hot, so look for the opposite trouble when you first turn the set on.

There are several checks you can make by quickly turning the set off and on. If the picture recovers immediately, the over-all stability is good. If you leave the set off for more than a few seconds, the horizontal frequency may take a while longer to recover; this may be normal. If you have no raster, you may catch a glimpse of one by turning the set off and on. You might also hear the horizontal frequency taking off, providing you have good ears. In color sets you might hear high voltage make its presence known by the characteristic crackling sounds.

Volume Control

If you have no sound, rock the volume control back and forth. A scratchy noise in the output indicates a dirty control—and good audio as well.

We have already mentioned that no change in hum or noise level as you turn the volume control indicates trouble in the audio section. Distortion at high level also indicates trouble in the audio section, possibly a leaky coupling capacitor or high resistance in the grid circuit. Distortion or loss of sound at low level could be caused by a sticking voice coil in the loudspeaker. Sudden changes of volume as you operate the control could be caused by a defect in the control itself.

Channel Selector

By simply turning the channel-selector knob, you can unlock a treasure chest of information. First of all, there should be no play in the shaft. If there is, check the detent or the shaft fitting itself. If you can get the station by turning it in one direction only, check for a loose contact or rotor fitting in the oscillator section of wafer tuners.

A dirty tuner will show the same symptoms, but it will also produce characteristic streaks in the picture. Incidentally, these streaks can serve as a test for i.f. and video amplification. No tuner contact is perfectly clean. A dirty tuner is also a very common cause of intermittent color.

Check for reception on all channels. In a turret tuner, loss of a single channel is due to a defect in the corresponding channel strip. It can also be caused by a.g.c. overload. Confirm this by turning to a weaker station and checking for other a.g.c. symptoms, such as high contrast, unstable and negative picture.

Loss of reception on the higher channels can result from oscillator failure. The higher channels are also more susceptible to regeneration—streaks in the picture accompanied by loud screeches in the sound.

The low channels will be lost if the oscillator coils in wafer tuners have been spread out too far. They have a natural tendency to unwind. Also remember that in wafer tuners, if one channel fails, all lower channels will be affected.

You can check picture stability by changing channels; the picture should recover immediately. Changing channels will also show up mechanical intermittents elsewhere in the set. Also, remember that indiscriminate banging might clean off the oxidized coating of an intermittent contact. A better

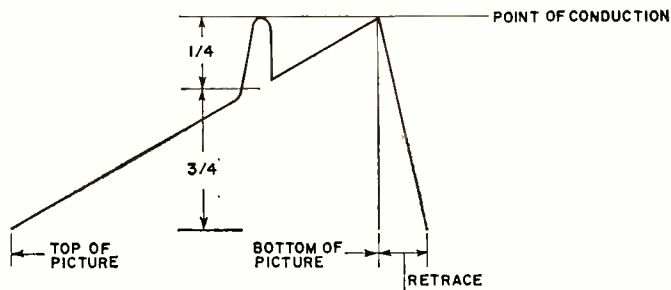

Fig. 2. Vertical oscillator grid waveform showing sync pulse.

method of finding an intermittent is by careful wiggling of individual parts and wires in the section causing the trouble.

Fine-Tuning Control

By observing the various parts of the picture and tuning the fine-tuning control, the experienced technician can almost visualize the shape of the over-all response of the set. This control shifts the entire heterodyned signal from one side of the i.f. passband to the other (Fig. 1).

As you tune from the low frequency to the high, the wide areas in the picture (including the sync bars) should gradually lose contrast until only the edges and fine detail remain at the point where the picture loses sync and breaks up. At the same time, the edges and fine details should come in gradually and reach a peak at break up. The sound should clear up in the same way and enter the picture at break up. You will see streaks across the picture that will move around with the sound. Color should come in smoothly, although not as broadly as the sound.

Any unevenness and sharp changes in the output as you turn the fine-tuning control would indicate a defect in the over-all response. Remember that in color sets there are chroma bandpass circuits besides r.f. and i.f. circuits.

Sound responds well to this test because of its narrow bandwidth. Sound should be clearest near the picture break-up point. If sound peaks at more than one point, check the alignment.

The sync bars, which lie in the low-frequency vestigial sideband also respond well to this test. If the vestigial sideband is not attenuated properly, the effect on the bars would be greatly exaggerated as you shift the signal. If sync is weakest at the point of lowest contrast in the wide areas or sync bars, the bandpass is at fault. If it is weakest at the point of greatest contrast, check for overloading.

If poor frequency response is evident in the picture, as shown by smears and ringing, and if this is not affected by turning the fine-tuning control, the fault is in the video section. Look for trouble in the peaking coils first.

Fig. 3. Appearance of normal vertical blanking bar that has been rolled down into view by means of vertical hold control.

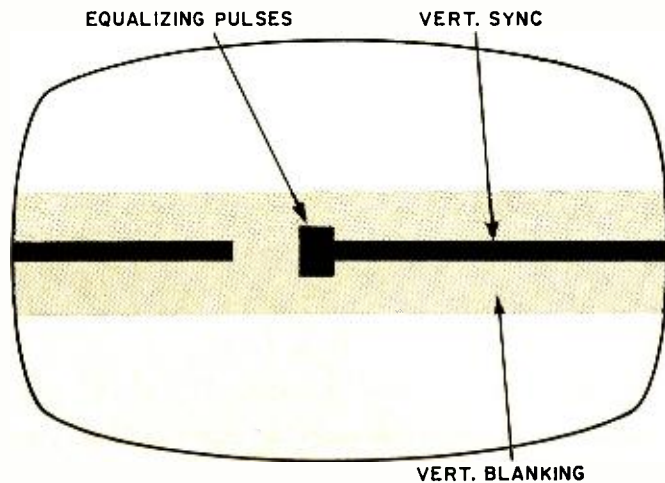

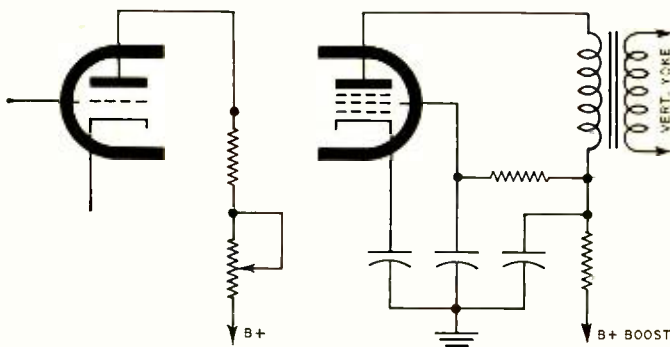

Fig. 4. Components to check in locating height problems.

Contrast Control

If you have no picture, rock or wiggle the contrast control. If streaks appear, your video is probably okay—but you have a dirty or defective control. Few controls are perfectly clean. If you have a picture and the contrast control has no effect on it, suspect the control itself or the associated network; there is possibly a shorted bypass capacitor. If the brightness changes as you turn the contrast control, check for a shorted coupling capacitor to the grid of the video stage. If you have poor sync at high contrast levels, check for defective filters which permit video to enter the sync circuits. On some older sets that take their sync after the video, overload could cause the same trouble. In color sets, proper setup procedure may be all that is needed for good contrast and stability.

Brightness Control

The brightness control is useful in testing the over-all performance of the set. Blooming (loss of focus and increased picture size) as you turn up the brightness indicates trouble in the high-voltage circuit.

If you have no raster, you might see one by shading the picture-tube face and rapidly varying the brightness control. Observe whether the picture is in sync, folded, narrow, or blooming. If it is far off horizontal frequency, check the horizontal oscillator and a.f.c. If it is folded, check the damper circuit. If it is narrow, but can be synchronized, check the horizontal-output circuit. If it blooms, check the high-voltage circuit. If it shows no other trouble but darkness, check the picture tube and its bias voltages.

Turn down the brightness part way if you suspect hum or filtering troubles. A single dark bar across the screen indicates 60 Hz in the video; two such bars indicate 120-Hz power-supply hum; vertical shading on the side of the raster indicates 15,750-Hz horizontal voltage in the video.

In color sets, the picture should remain stable at all brightness levels. Focus should be maintained, except possibly at the extremes. Although picture tubes vary greatly in performance, proper setup should take care of most troubles related to brightness.

Vertical Hold Control

Let's consider vertical roll problems next. The picture rolls down when the vertical oscillator runs fast and the pic-

Fig. 5. If the out-of-sync lines slant downhill, as shown at the left, then the horizontal oscillator is running fast. If lines slant uphill, as at right, oscillator is running slow.



ture rolls up when the oscillator runs slow. Remember: downhill fast; uphill, slow.

The most likely reason for a fast-running vertical oscillator would be a leaky capacitor feeding positive voltage to the oscillator grid. This shortens the time it takes for the negative voltage to discharge to the point where the tube begins to conduct for the next cycle. An increased resistance in the cathode circuit would cause the same thing. In both cases the linearity would be affected, and the height would decrease. Occasionally the grid resistor decreases in value, thus reducing the time constant and the discharge time.

Sometimes the picture rolls so fast, it is not easy to determine whether it's rolling down or up. If the height decreases as you turn the control, the picture is rolling down.

The most likely reason for a slow-running oscillator would be an increased value of grid resistor.

The vertical sync can be checked by rolling the picture up with the vertical hold control. The picture should lock in so solidly you will not be able to roll it up slowly. Only by advancing it to a point where it rolls fast should you be able to break sync.

Another method of checking sync is to roll the picture down slowly with the vertical hold control. The picture should roll down smoothly, without hesitations, and flip out of sight at a point that is about one-fourth of the way from the bottom. This is the point where the sync pulse, which is riding on the grid voltage, kicks the tube into conduction. It shows the actual height of the pulse in relation to the grid voltage—usually about one fourth (Fig. 2). If the bar flips out of sight at a point lower than that, the sync is weaker than normal.

If the picture does not roll down smoothly at the top portion of the picture, or if it can be made to lock in with the blanking bar showing, the integrated vertical sync pulse is distorted or extraneous signal is entering the vertical circuit.

The condition of the sync pulse at the take-off point can be seen by looking at the vertical sync bar. The outer bar, indicating the blanking level, should be darker or just as dark as the darkest part of the video. The inner bar, the vertical sync and equalizing pulses, should be much darker than the blanking level (Fig. 3). If not, vertical sync is being compressed before the take-off point. If this display looks okay and there is vertical trouble, there may be problems in the sync circuits or the integrator.

Vertical Height and Linearity Controls

Vertical sync, linearity, and height are interdependent, and it is difficult to isolate a fault within the receiver section affecting these characteristics. If you can obtain good linearity with the hold control well within range, the height control circuit itself may be defective. Loss of height is often caused by an increased value resistor in series with the height control. In general, look for trouble that would not have significant effect on linearity or frequency. Check for defects in the vertical-output circuit, screen supply, or for an open cathode bypass capacitor (Fig. 4).

If linearity is off, but the frequency is okay, the wave-shaping network is defective.

Poor linearity, which is usually accompanied by a change in frequency, can be analyzed by checking for the frequency defect, by noting first whether the pattern is rolling up or down.

Another method is to see whether both the top and the bottom can be stretched and compressed by operating the linearity control and whether the picture as a whole can be shifted up or down. If only the top can be compressed, look for defects that would put excess negative bias on the grid, and just the opposite if only the bottom can be compressed. A word of caution: part values in these circuits are critical and interdependent. Don't try to compensate for defects by changing part values. (Continued on page 83)

STRAIN GAGES COME OF AGE

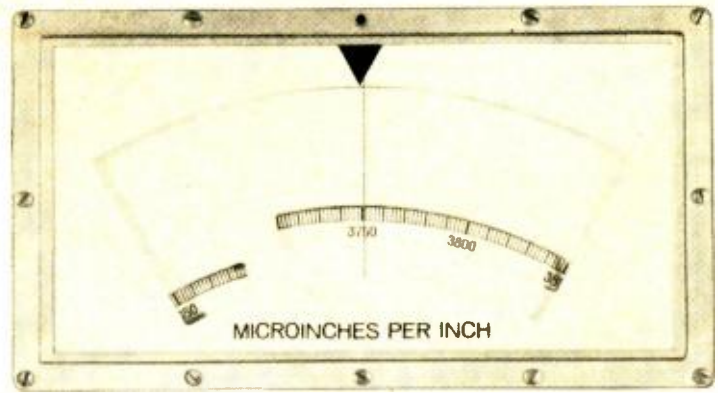

By JOSEPH TUSINSKI/Chief Technical Instructor, Old Dominion College

It appears little is known about what constitutes a strain gage and how it works. This article discusses some heretofore hidden characteristics of the device and tells technical men how they can get the most out of it.

IF you should see a group of technicians hovering around a giant *Boeing 707* cargo carrier checking instrument dials and flicking switches, chances are they're using strain gages to find the aircraft's center of gravity or to measure stress caused by cargo loading. The strain gage has been available for more than two decades, but only now are technical men beginning to use them effectively. The motivation?—technological advances in electronics.

What is a strain gage? An electrical strain gage is an instrument that measures the change in resistance of a conductor as it is stretched or compressed. This principle is utilized in a number of devices where displacement takes place as the result of force.

Linear Stress

Linear deformation or strain occurs when an external force (stress) is applied to the body of a material, that is, it changes its dimensions. Hooke's Law, which relates small deformations of elastic bodies to the applied stress, does not recognize limits or the point where elongation is not proportional to applied force. However, this important non-conformity, which is called the proportional limit, makes deformation or strain a dependent variable and related to the amount of force exerted. The force, which is normally referred to as stress, is measured in pounds per square inch. A typical stress-strain curve of a metal is shown in Fig. 1. Unfortunately, strain which is graphed as the independent variable, can lead to some misconceptions.

Note that a new term, Young's modulus, has been injected in Fig. 1. This is defined as the ratio of stress to strain. Strain is deformation and hence it has units of length. However, it can also be defined as the ratio of a change in length to the original length, that is, inches-per-inch (at times called a unit strain as opposed to total strain). Thus $\epsilon = \Delta L/L$ (inches/inch). Since strain measuring instruments are calibrated in microinches/inch, it is becoming popular to use the term "microstrain" in lieu of microinches/inch. Thus, one microstrain equals one-millionth of an inch per inch of material. This, of course, shortens the description of the unit, but it loses meaning.

There is another important physical concept in strain measurement analysis. The resistance of a wire varies according to the type of material (specific resistivity) and its length, and is inversely proportional to the cross-sectional area. Thus, if a piece of wire is stretched, it will get longer and R will increase. However, its cross-sectional area also decreases, so R increases further. What is important is that R does not increase proportionally. A little known fact is responsible for this relationship, *i.e.*, the volume of an elastic body decreases as opposed to a plastic (putty-like material) body, whose volume remains the same when

stretched. Wire is an elastic body when it is stretched below its proportional limit.

If the ratio of the change in diameter to the change in length is considered for metals, this ratio will vary between 0.25 to 0.35 but will be 0.5 for plastic materials. The ratio of a change in diameter to a change in length is called Poisson's ratio. What does all this mean? Well, the most significant fact is that the specific resistivity of the wire changes. Thus the change in resistance cannot be predicted simply by physical relationships alone.

The above relationship is accounted for by a unit called the gage-factor (*G.F.*), and is used in the equation: $\Delta R/R = G.F. (\Delta L/L)$.

Thus the gage factor is defined as: $G.F. = (\Delta R/R) (\Delta L/L)$ or $\Delta R/R\epsilon$, where $\epsilon = \Delta L/L = \text{strain}$.

Gage-factors vary considerably, depending on the type of material used for the gage. For example, nichrome has a factor of 2, platinum 4.8, and nickel -12.1, and some of the semiconductor gages have factors of several hundred. However, most wire and etched-foil gages have identical characteristics when compressed as compared to elongation (tension). The resistance of the gage decreases in most cases when under compression and increases under tension. Some gages, like nickel, work in reverse.

Suppose that we apply some of these mechanical concepts and then consider the electrical side of a problem.

Let us determine the strain exerted on a 10-inch piece of a *hypothetical* metal which has a cross-sectional area of two square inches. Under stress, the 10-in bar becomes

Fig. 1. Typical stress curve for metal. E is Young's modulus of elasticity, σ is stress, and $\Delta \epsilon$ is the change in the strain.

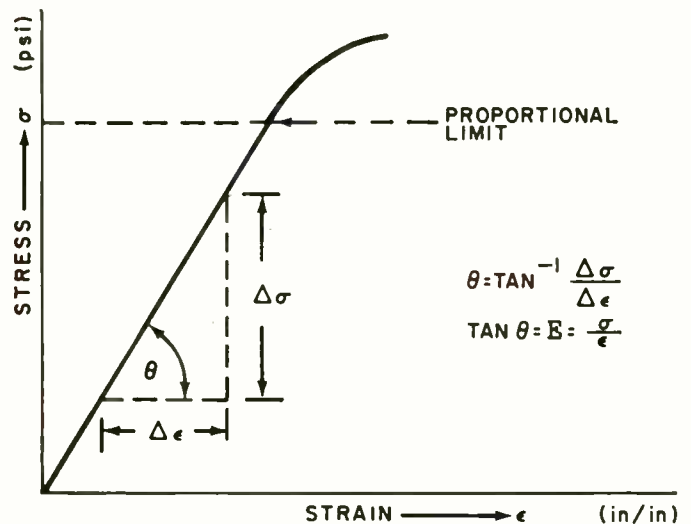

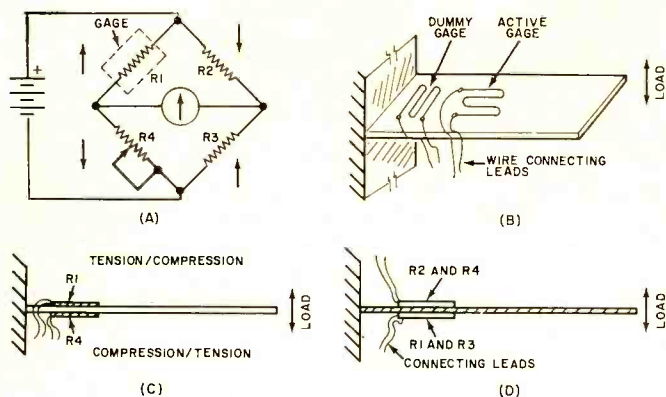

Fig. 2. (A) Wheatstone bridges are used to measure resistance changes. (B) Temperature compensation using dummy gage. (C) Temperature sensitivity is enhanced by using two active gages. (D) If a load on a cantilevered beam is down, then R2 and R4 (A) are under tension, and R1 and R3 are under compression.

10.01 inches long. $\Delta L = 10.1 - 10.0 = 0.1$ inch. That is, the bar changed 0.1 inch for the entire 10-inch length. The strain is then, $\epsilon = \Delta L/L = 0.1''/10'' = 0.01$ in/in.

Suppose further, to achieve this strain, a total load of 10,000 pounds was used. The stress is then:

$$\sigma = \frac{\text{Force (lbs)}}{\text{Area (in}^2\text{)}} = \frac{10,000 \text{ lbs}}{2 \text{ in}^2} = 5000 \text{ lbs/in}^2$$

The modulus of elasticity can then be computed as:

$$\frac{\sigma}{\epsilon} = E = \frac{5000 \text{ lbs/in}^2}{0.01 \text{ in/in}} = 500,000 \text{ (psi)}$$

Analyzing this relationship another way, suppose what we want to know is how much a $\frac{1}{2}$ " rod will elongate if it has a total length of two feet and is subjected to a 10,000-lb load. From a table of physical constants of materials, this grade of metal has a modulus of elasticity of 30×10^6 lbs/in² (psi).

The stress in lbs/in² is computed first. Thus, $\sigma = F/A$, $\text{lbs/in}^2 = 10,000 \text{ lbs}/0.1964 \text{ in}^2 = 50,916 \text{ lbs/in}^2$; where $\text{area} = \pi r^2 = 3.1416 (0.25)^2 = 0.1964 \text{ in}^2$.

The amount of strain is then:

$$\epsilon = \frac{\sigma}{E} = \frac{50,916 \text{ lbs/in}^2}{30 \times 10^6 \text{ psi}} = 1.697 \times 10^{-3} \text{ in/in}$$

or 1697 microstrains.

Then, from $\epsilon = \Delta L/L$, $L\epsilon = \Delta L$ and $\Delta L = 24'' \times 1.697 \times 10^{-3} = 0.04$ inch or 40 mils. From these equations we can see the measurement of strain can be incorporated into load-cells which are capable of measuring hundreds or even thousands of pounds of load.

Fig. 3. These are examples of etched-foil and wire strain gages.

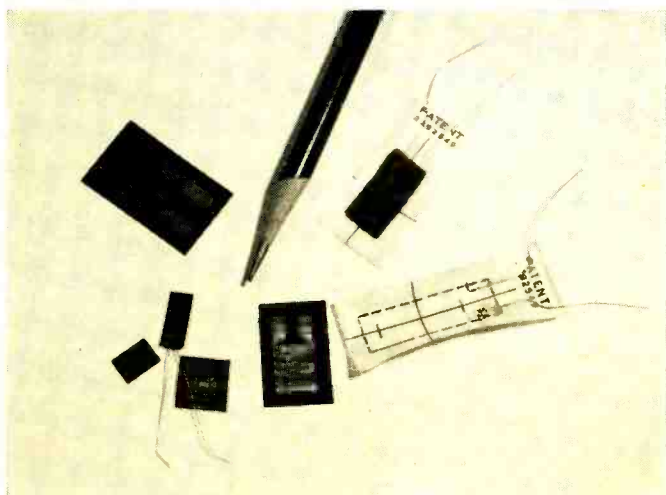

Now let us attach a wire strain gage to a $\frac{1}{2}$ " rod. Let us further use a gage that has a length of one inch and a resistance of 120 ohms (120 ohms is a popular value for a strain gage). The gage manufacturer has specified a *G.F.* of 2. Calculate the change of resistance that would take place when the 10,000-pound load is impressed. Since $\epsilon = (\Delta R/R)/G.F. = (G.F.) \epsilon R = \Delta R$, where $\epsilon = 1.697 \times 10^{-3}$ (from the previous example), $R = 120$ ohms, and $G.F. = 2$, then, $\Delta R = 2 \times 1.697 \times 10^{-3} \times 120 = 0.4073$ ohm.

To measure a change of 0.4073 ohm in a total resistance of 120.4073 ohms, an instrument such as a Wheatstone bridge must be used.

One of the advantages of a resistance gage is that it is a bilateral device, hence a bridge may be excited with a.c. or d.c. As shown in Fig. 2A, the gage is represented by R1, thus R4 may be made variable to restore balance to the bridge. This method has advantages for measuring certain static types of loading. It is also possible to calibrate R4 directly in microinches/in (or units of strain).

Temperature Effects

Temperature affects the resistance of a gage; and temperature changes (ambient or self-heating) cause false indications of strain. Thus, most strain gage applications employ a minimum of two gages. For example, if R4 is made a compensating gage and is positioned so that a 90° angle is formed with respect to the axis of stress, then the bridge will be self-compensating (Fig. 2B). Then sensitivity may be enhanced by making both gages active, as shown in Fig. 2C. Note that even though both gages are active, temperature effects will still cancel. This same procedure may be extended to make all of the bridge arms active, increasing sensitivity and improving temperature compensation. An arrangement showing all gages in an active mode is shown in Fig. 2D.

Bonded versus Unbonded Gages

The bonded gage was developed simultaneously on both coasts of the United States. Simmons of California Institute of Technology and Ruge of MIT developed the principles in 1938. These gages were given the designation of SR-4 (using the initials of the co-inventors), a trademark of the *Baldwin-Lima-Hamilton Corp.*

Extremely fine wires, supported by various materials, were used to fabricate the gages. The materials dictate where and how the gage is used. Paper is used extensively and Bakelite is also used to a large degree.

Etched-foil gages further improved gage instrumentation. For it was this development that resulted in an almost ideal gage. That is, they could be made so that the effective gage length was infinitesimal (individual conductors could not be seen with the unaided eye). Another characteristic was that the conductors could be made large at the loop ends so that transverse response was reduced to a minimum. Still another ideal characteristic was that the gage wire was flat, hence it had a more intimate physical contact than round wire and could conduct self-generated (I^2Rt) heat away more efficiently. Finally, the gage could attain virtually any configuration, and was only limited by the capabilities of the draftsman. Some of the configurations are shown in Fig. 3.

Plastic, thermosetting plastic, epoxies for high-temperature work, and special ceramic cements are used to bond the gage to a test member. Again, the type of adhesive is determined by the type of measurement, environment (temperature, humidity, etc.), and the type of stressed member.

Unbonded gages, as the name implies, are not supported by an adhesive, but the wire is self-supported by insulated posts or other structure. One type of patented fixture uses ruby support posts, as shown in Fig. 4.

Note that a force moving support #1 to the right causes

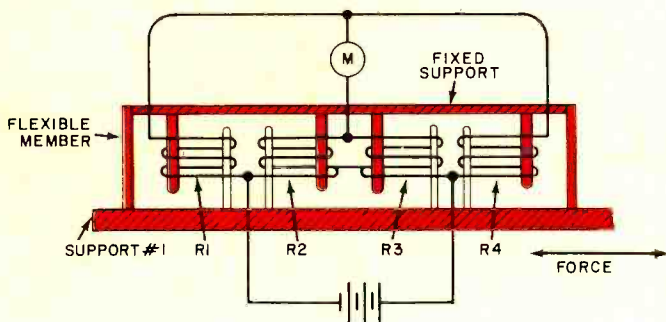

Fig. 4. Unbonded gages are supported by insulated posts.

$R1$ and $R3$ to increase, whereas $R2$ and $R4$ decrease. As can be seen in the diagram, this will cause four times the unbalance of a single gage (refer to Fig. 1). Secondly, any change in temperature-influenced resistance will affect all gages equally, thus the bridge will be temperature-compensated. Initially the wire is placed on the posts in a stressed condition, so stress may be increased further or decreased to measure plus or minus forces.

Semiconductor Gages

Semiconductor strain gages are characterized by extremely high gage factors, which can be positive or negative. Early gages were plagued by high temperature coefficients. Thus, users were wary of their measurements.

A significant achievement was attained when it was discovered that high radiation fields could reduce the temperature coefficient to almost zero. This hardening process opened up new vistas for the high-sensitivity semiconductor gage. The author experimented with some of the radiated gages and found that resistance would not change even when the gage was subjected to a match flame.

Recently, a new type of semiconductor strain gage, manufactured by the *Kulite Semiconductor Products Corporation*, has made inroads in the field of miniature instrumentation. The manufacturer is using integrated-circuit techniques to some extent. One of these gages is shown in Fig. 5A. These gages have nominal gage factors of about 50. This is considerably greater than the wire or foil gage; however, it does not surpass the bulk semiconductor gage. These devices may be used in temperatures ranging from -400°F to $+1200^{\circ}\text{F}$. Gage lengths are measured in thousandths of an inch, hence they are approaching the ideal gage.

Recently, another type of transistor gage, manufactured by *Stow Laboratories*, has been marketed. This gage has been designated "Pitran" and is an *n-p-n* planar transistor with provisions for a mechanical pressure coupling. Therefore, it can be operated as a standard transistor, with the mechanical coupling modulating the collector current. The device is capable of measuring displacement; however the author feels that it is difficult to use to measure strain. The point is that a strain gage must be capable of measuring a change in length in the given length of the material. Thus all displacement gages cannot truly be classed as strain gages. This gage, however, is capable of measuring extremely low pressures and, if coupled to a stiff diaphragm, may be calibrated to measure high pressures.

Thin-film technology cannot be left out of the strain-gage picture. *Statham Instruments, Inc.* of Los Angeles has produced a thin-film gage having factors comparable to conventional gages. The advantages of attaching a deposited gage to a diaphragm is that no organic material is used as the adhesive, that is, adhesion is the result of semi-molecular adhesion. Thus creep and long-time stability are enhanced.

Some Applications

A typical commercial arrangement may utilize an ampli-

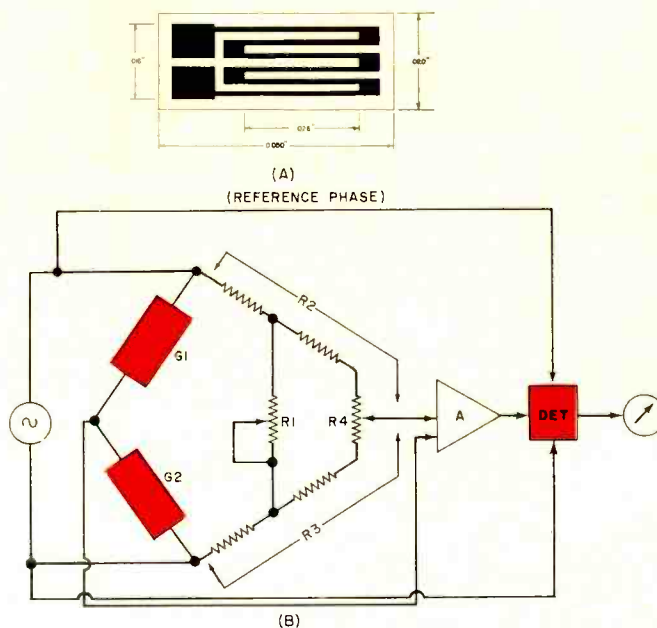

Fig. 5. Miniature diffused semiconductor gages have gage factors of 50. Commercial gage (B) uses amplifier to raise sensitivity of system. A is the amplifier; DET, the phase-sensitive detector; $R1$, gage-factor correction; $R4$, slide-wire balancer; and $G1$ and $G2$, active gages. The bridge network is a.c.-excited.

fier to enhance the sensitivity of the system, as shown in Fig. 5B. Other arrangements use self-balancing bridges. For example, a four-arm bridge gage can be used to measure the force exerted on a $\frac{1}{8}$ -inch test beam when a coin is placed on one end and the other end is fixed.

Care must be exercised in analyzing the effects of gage placement. For example, if tension is to be measured on a round rod, then some unpredictable results may be obtained. Suppose that bending or twisting takes place when it was assumed only tension existed. Fig. 6 demonstrates the problem.

This problem is rectified by placing gages in series. Thus the average change in R will indicate true tension and the bending result is cancelled.

It is possible to dwell on a great number of problems and applications. However, it is the intent of this article only to acquaint the reader with an important innovation in the field of instrumentation. This is, of course, the strain gage and the vast number of jobs it is being called upon to perform. Secondly, more needs to be known about the device because only then can the technician and engineer start to use the strain gage knowledgeably in existing or future techniques. ▲

Fig. 6. If the test member is not loaded correctly (through its geometrical center), a bending moment can cause errors.

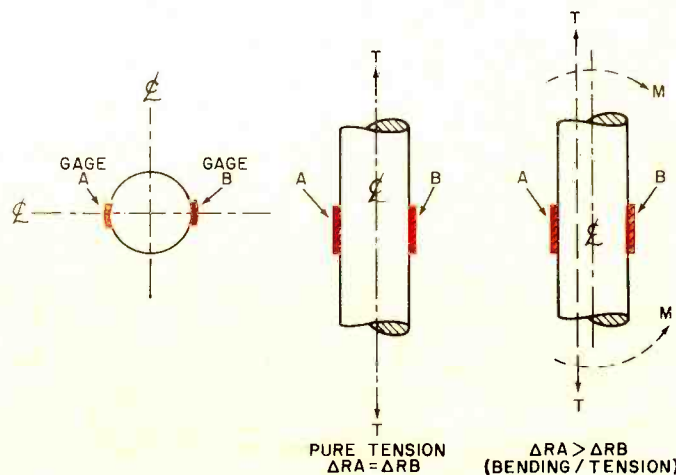

Low-noise RECEIVER PERFORMANCE MEASUREMENTS

By LEE R. BISHOP/U. S. Air Force

Noise-figure measurements are easy to make; it's an efficient, simple, and accurate method of determining receiver performance.

DURING the past decade, low-noise receivers have become practical devices and are widely used in commercial and military communications systems. However, the literature which describes their performance continues to confuse many engineers and technicians. In this article, two of the most meaningful receiver sensitivity terms—"noise figure" and "effective noise temperature" (ENT)—have been related and the problems involved in gauging the actual sensitivity of a receiver rated with a "negative" noise figure shown. The hot/cold body standard technique, a testing procedure specifically designed to measure the noise figure or ENT of low-noise receivers, is also discussed.

Both noise figure and ENT are currently used by engineers to indicate the performance of low-noise radio-frequency amplifiers. Most engineers prefer to use ENT for the extremely low noise devices and noise figure for conventional receivers (for example, those with noise figures greater than 6 decibels).

Noise Figure

The noise figure of a receiver represents a comparison between an actual receiver and its theoretically perfect counterpart. The term "noise figure" was first used in 1940 by radar engineers making receiver sensitivity measurements. They found that a receiver's bandwidth had a disturbing effect on sensitivity readings: the narrower the bandwidth, the better the reading. But when sensitivity was measured using gas or thermal noise generators, the bandwidth did not affect the readings; low receiver gain showed up as an abnormal noise figure.

The noise figure of a network is defined by the IEEE as the ratio of the total noise power available at the output port when the input termination is at 290° Kelvin to that portion of the total available noise power produced by the

input termination and delivered to the output by the primary signal channel. It will become apparent from the discussion clarifying this definition that noise figures below zero decibels are automatically excluded. Therefore, the "perfect" amplifier has a noise figure of 0 dB.

Fig. 1 illustrates the case of the perfect receiver with its input network at a temperature of 290° K (63° F). The resistance (R), which represents the impedance of the feed, generates a noise voltage called Johnson noise. This noise results from the random motion of thermally agitated free electrons. Although this noise voltage has an infinitely wide bandwidth, we are only interested in the signals which fall within the receiver's bandwidth because only these noise voltage signals pass through the amplifier and register on the power meter. It is only this noise with which the incoming signals have to compete.

When a perfect receiver is matched to an input network, the input noise power (in watts) can be expressed as:

$$\text{noise power input} = kBT \quad (1)$$

where k is Boltzmann's constant (1.38×10^{-23} joule/degree Kelvin), B is noise bandwidth of the amplifier in Hz, and T is 290° K.

The noise bandwidth of the network is not the same as the half-power bandwidth normally given in performance specifications; rather, it is somewhat wider and normalized at the network's center frequency. In some cases, it is quite close to the 3-dB bandwidth, but sometimes it is as much as 1.57 times the half-power figure. However, as long as the receiver is tested with very wide thermal or gas noise sources, this difference is of no great concern.

A power meter hooked to the output of a perfect receiver as shown in Fig. 1 would read a power N_1 equal to $kBTG$, where G is the power gain of the receiver. However, a receiver contributes noise of its own (ΔN) so that an actual receiver's output (N_2) is $kBTG + \Delta N$. Specifically, the term noise figure (F) is a ratio that compares a receiver with its ideal counterpart and is equal to the noise power output from an actual receiver with its input network at 290° K, divided by the noise power output from an ideal receiver with its input network at 290° K. Or,

$$F = \frac{N_2}{N_1} = \frac{(kBTG + \Delta N)}{kBTG} \quad (2)$$

Expressed in decibels, the noise figure is:

$$f = 10 \log_{10} F \quad (3)$$

If the device under test were perfect, ΔN would be zero

Fig. 1. Thermally agitated electrons cause noise in receiver input circuits. Johnson noise reduces signal intelligibility.

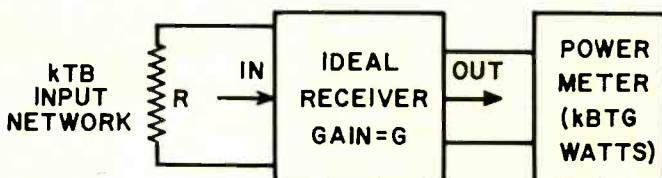

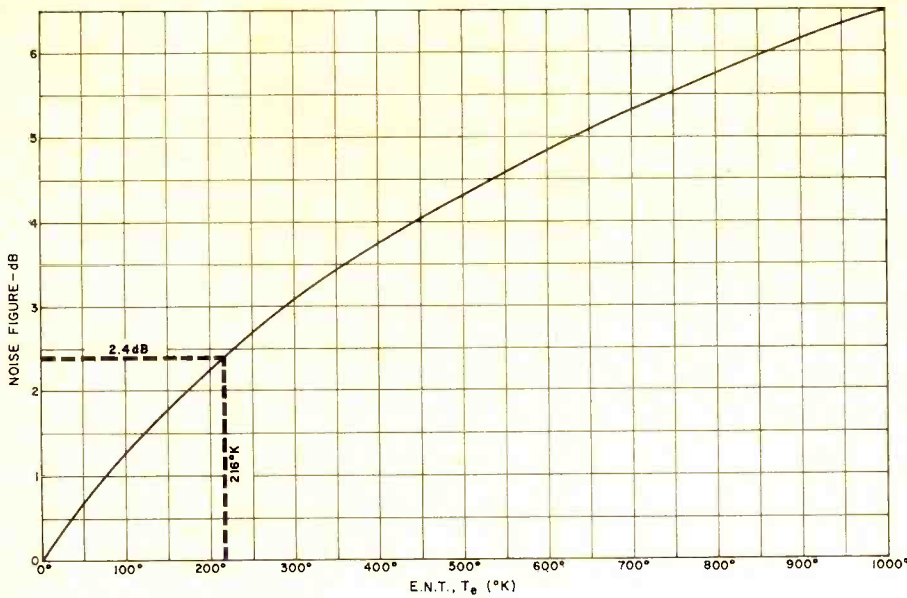

Fig. 2. This graph can be used to convert effective noise temperature measurements to their true noise figure value.

and the receiver's noise figure would reach the limit of unity or 0 dB.

Effective Noise Temperature

The effective noise temperature is more difficult to determine. When a receiver's input-network temperature is raised above 290° K, the random noise generated by the network increases and the output noise power rises to a new value of N_2 . The ENT is the number of degrees that the input network's temperature had to be raised before the receiver's output reached the new value of N_2 .

When the expression for N_2 in equation (2) is resolved into thermal components, the equation has the following form:

$$F = \frac{kBG(T + T_e)}{kBTG} \quad (4)$$

Component T is the noise from the receiver's input network (at 290° K) and T_e is the internally generated amplifier noise or ENT.

If the receiver contributed no noise of its own, T_e would be zero and F would again be unity or 0 dB. When the kBG terms of equation (4) are cancelled, we are left with a simple expression for noise figure in terms of ENT:

$$F = \frac{T + T_e}{T} = 1 + \frac{T_e}{T} \quad (5)$$

ENT is an absolute quantity in degrees Kelvin defined by the relationship $T_e = (F - 1)T$. It is emphasized at this point that ENT is not the physical temperature of the receiver's input network; it is an apparent temperature that is representative of an amplifier's internally generated noise. Fig. 2 is a graph for converting ENT ratings to noise figure and *vice versa*.

Measuring Errors

We have excluded negative values from our definition of noise figure and have, until now, assumed that all networks behave as though they were at 290° K. Quite frequently, however, a network acts as though it were at a lower temperature. The result is an abnormal noise figure which, by conventional measuring techniques, is difficult to distinguish from an acceptable noise figure measurement. If, for example, the input circuit behaved as though it were at a temperature lower than 290° K and the amplifier itself contributed little noise, the quantity of noise proportional to $kBTG + \Delta N$, which conventional techniques measure, is small. On the other hand, the quantity $kBTG$, which conventional techniques calculate, will be considerably greater

than its true value. If the amplifier's true noise figure is low enough and the network's temperature deviation from the assumed 290° K is large enough, the calculated value almost equals the measured values.

The magnitude of the measurement error depends upon the true noise figure. Measurement errors increase rapidly as lower noise figure values are reached. Fig. 3 is a graph of the equation used to correct the values of noise figures. In the example shown on the graph, the 5-dB noise figure measurement was made while the input network behaved as though it were operating at 100° K. The correction is +1 dB so that the true noise figure, referenced to 290° K, is 6 dB.

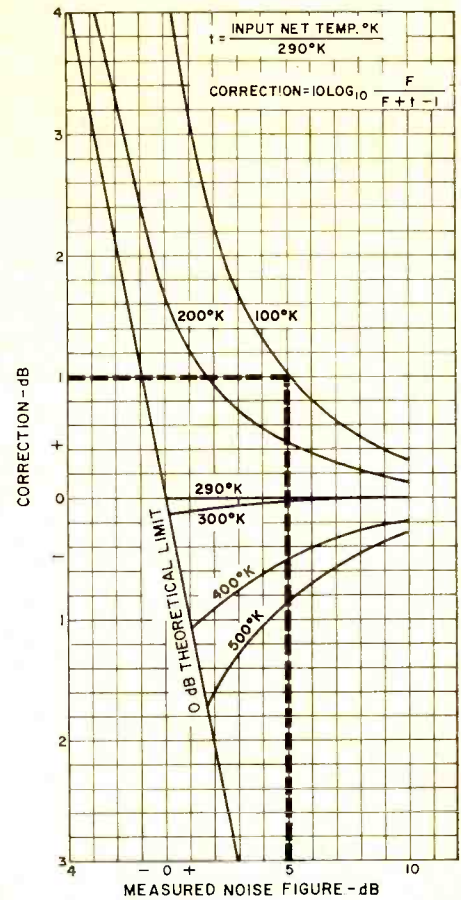

Fig. 3. Measurement errors are greater at the lower noise figure values. This graph is used when the input network behaves as though it were operating at other than 290° Kelvin. In the example, a 5-dB measurement is corrected to read 6 dB.

Hot/Cold Body Standards

Hot/cold body standards enable the previously described measurement difficulties to be overcome. While not suitable for the amateur or small shop owner, they enable the manufacturer to test his products and assign them a proper noise figure or ENT.

Hot/cold body standards use two resistive elements, one immersed in liquid nitrogen at 77.3° K and the other in a temperature-controlled oven at (Continued on page 64)

Fig. 4. Accurate noise figure measurements can be obtained by switching a receiver between an input network immersed in liquid nitrogen and a network in a temperature-controlled oven.

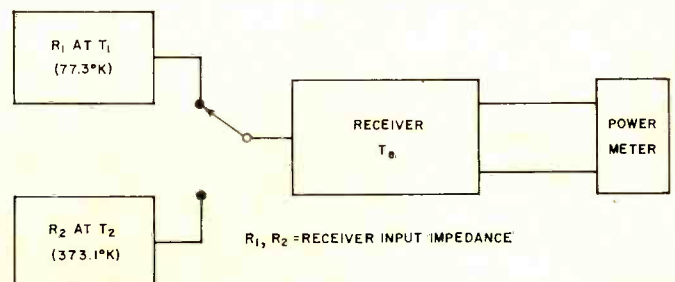



A 50-MHz Digital Counter

By FRANK E. CODY

Precise high-frequency digital counters cost \$2000 or more. Here is a design more accurate than most at less than one-fifth the price.

DIGITAL frequency counters with sufficient sensitivity and accuracy to measure Citizens Band frequencies to the FCC requirement of $\pm .005\%$ usually cost \$2000 to \$5000. This article discusses the design of a unit which pushes the price down under \$400.

Obviously this new low price in precision counter design is possible because of advances in integrated circuit logic and display components. These two developments also help make a smaller, more reliable package.

As Fig. 1 shows, the counter contains few individual components. The IC's are mounted on printed-circuit boards to reduce wiring errors and, since the decade counters are straightforward, adjustment potentiometers are not necessary as they would be with a "staircase" counter.

An instrument of this kind has many uses. It can aid in tuning transmitters, aligning receivers, calibrating dials on audio and r.f. generators, checking crystals and other test instruments; and, with a voltage-to-frequency converter, be made to read a.c., d.c., and resistance.

Circuit Operation

The complete logic diagram of a 50-megahertz counter is shown in Fig. 2. Functionally, the counter is divided into five major sections: the frequency-counting decades (Fig. 3); the time base oscillator and countdown decades (Fig. 4); the signal conditioning, main gate, and control circuits (Fig. 5); and power supplies (Fig. 6).

As shown in Fig. 2, signals entering the input jack are biased by the sensitivity control to a point just below the firing level of the Schmitt trigger. (By adjusting the bias to this point, signals as low as 20 mV r.m.s. will fire the trigger.) From here, the signal passes through the Schmitt trigger, which consists of an *or/nor* gate and a bias driver. At the output of the Schmitt trigger, the signal being measured is converted to a series of pulses with extremely fast rise time—one pulse for each cycle of the input frequency. This pulse train is fed to one input of the main gate (an MC1004P); the other input is enabled by a precise 1-second pulse from the 1-megahertz crystal oscillator and count-

down chain. As the main gate is enabled, the Schmitt trigger pulses pass through the gate (for precisely one second) to the decade counters which totalize the count. Binary information is decoded to decimal form in the Nixie driver IC. At the end of the one second count period, the main gate is disabled and the 170 V "B+" supply for the Nixies is switched on, lighting the proper numbers.

The one-second time base is derived from a 1-MHz oscillator and seven-decade counters which provide count periods of 1 μ s to 10 seconds. These timing periods are selected by a ganged switch which also lights a decimal point so that the display always reads MHz. The time base square wave is passed on to a differentiating network (Fig. 5), amplified, and applied to the trigger input of a JK flip-flop. In the auto mode, the J and K inputs are floating

Fig. 1. Components categorized by function, mount on individual printed-circuit boards which plug into a mother board assembly.

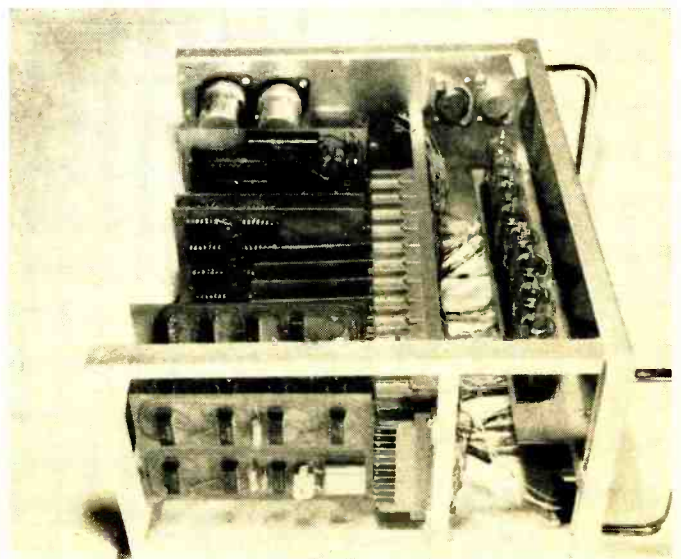

and the flip-flop will toggle at the time base rate—in this case, every second. When the “count” side of the flip-flop is high, the reset gate is inhibited. Coincidentally, the “display” side is low. This enables the main gate and allows the decades to count. At the end of 1 second, the control F-F toggles, disabling the main gate to stop the count and enabling the reset gate. The control F-F also turns on the 170-V switch which lights the Nixies. This switch is turned off during the count mode to eliminate false counts due to high-voltage switching transients. In the display mode, the counter reads out the count until the next timing pulse arrives at the control F-F. This pulse resets the decades to 0 just before the main gate is opened and the cycle repeated.

The first two decades in the counting chain (Fig. 3) are *Motorola* emitter coupled logic MC1013 P, which have a maximum counting frequency of 85 MHz. MECL II logic is non-saturated logic and permits tremendous toggling speeds. (Selected units in *Motorola* laboratories have toggled at 270 MHz.) However, MECL logic levels are approximately -1.5 V for “Q” (0) and -7 V for “Q̄” (1), and this is not compatible with diode transistor logic (DTL) levels which are 0 V for “Q” and $+1.5$ V for “Q̄”. Therefore, level translators are required wherever MECL and DTL logic interface.

By the time the input signal has passed through the first two decades, it has been divided by 10 twice, so that an input frequency of 50 MHz has now been divided down to 0.5 MHz. That is, for every 10 pulses into the first decade, one pulse will appear at its output, and so on, down the chain of decades. This lower frequency is within the maximum count rate of DTL logic and, from this point on, the logic levels are those of the DTL. The final six stages of decade counters are *Fairchild* C μ L 9958. This integrated circuit is a complete decade counter in one dual-inline package, including four F-F's and all the gating necessary to provide binary coded decimal outputs. The Nixie drivers are *Fairchild* C μ L9960. These C μ L devices were designed specifically to be used in counters and greatly simplify circuit interconnections.

The remainder of the logic is *Motorola* MRTL. This line is the most economical per logic function on the market. For example, the MC790P is a dual JK flip-flop priced at \$2.00 or \$1.00 per flip-flop, which is (as far as the author has been able to determine) the least expensive IC flip-flop available.

On many counting instruments, a buffered test output is provided on the front panel. This is the selected time base signal. By connecting a short lead to the panel jack and setting the time base switch to 1 μ s, the counter will radiate a signal. This signal can be picked up by any communications receiver for zero beating with WWV on 10 MHz. By adjusting the trimmer in the 1-MHz oscillator circuit, it is possible to beat with WWV to within 1 Hz. For example, if the receiver has an “S” meter, you can observe the needle dip at a 1-Hz rate. The oscillator is now set to $1 \text{ MHz} \pm 0.1 \text{ Hz}$, or .00001%. Measuring a frequency in the Citizens Band to an accuracy of .00001% will give a reading of $27,000,000 \text{ Hz} \pm 2.7 \text{ Hz}$ \pm the one count that is inherent in all digital counters. The FCC $\pm .005\%$ tolerance allows approximately 1355-Hz error at midband.

In the “Auto” mode, the counter will count and display for equal periods of time. With the time base switch set to 1 s, the readout will be extinguished for 1 second while

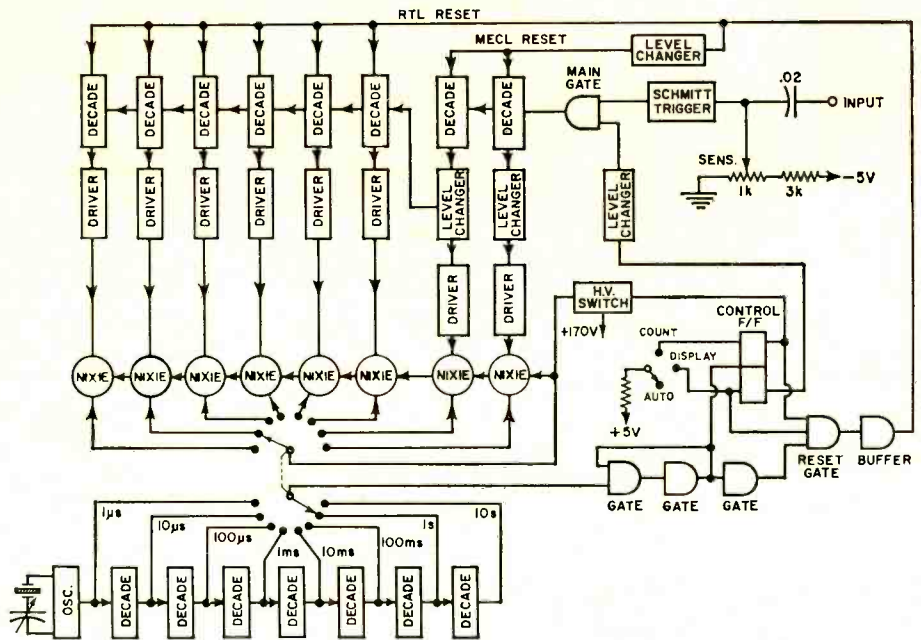
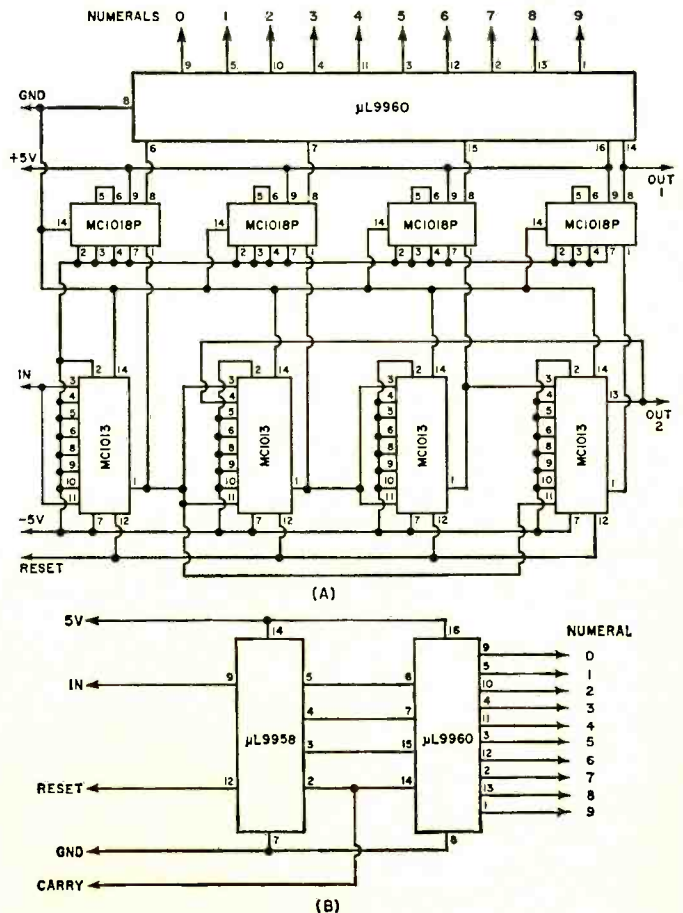

Fig. 2. Functional diagram of a 50-MHz digital counter.

counting; then light for 1 second with the totalized count. With the time base switch in the 0.1-second position, the display will blink off and on 5 times per second. In the 0.01-second and subsequent positions, blinking is at a rate faster than the eye can detect and the reading will appear continuous. Changes in frequency are immediately noticeable. A 10-second position is available where an average count over a 10-second period is desirable, or readings to an accuracy of 0.1 Hz.

With the mode switch in the “Count” position, the counter

Fig. 3. (A) MECL and (B) DTL frequency counting decades.



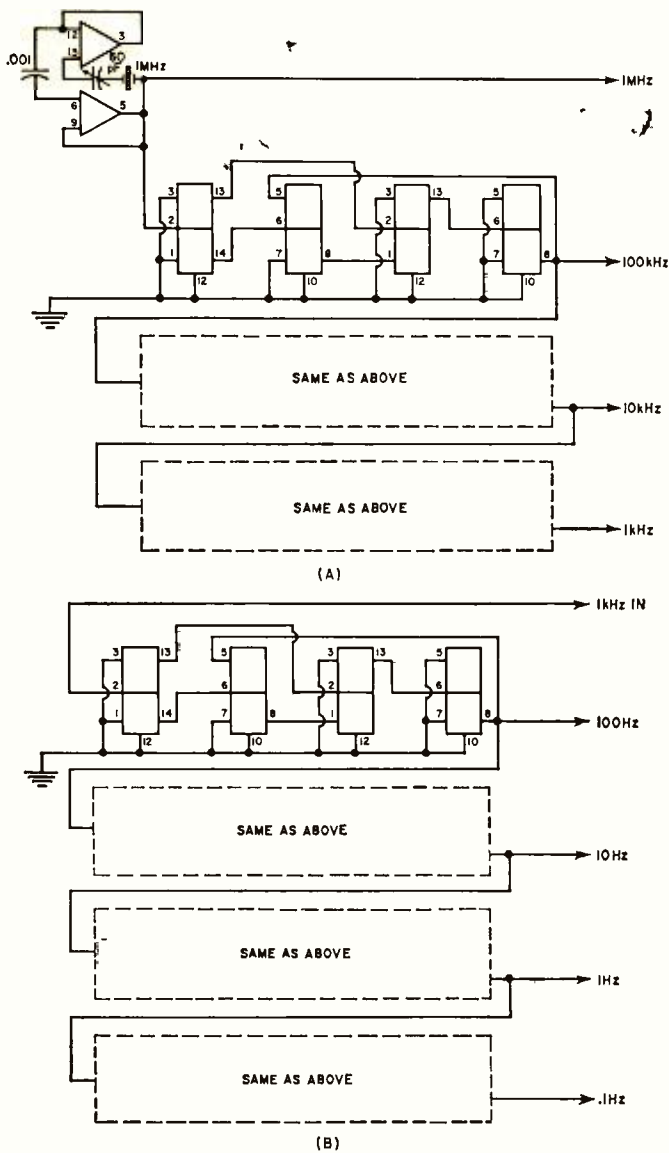

Fig. 4. Count periods of 1 μ s to 10 seconds are provided by the time-base oscillator (A) and countdown decades (A and B).

will be extinguished and counting for as long as the switch is in that position. This position is particularly useful for counting widely spaced events, such as one event per hour, per day, or per week. At the end of the desired count, the mode switch may be switched to "Display" for readout of the accumulated count. The readout will remain as long as the switch is in the "Display" position. When measuring transmitter frequencies, the transmitter is keyed with the mode switch in the "Auto" position. As soon as the readout appears the mode switch is set to the "Display" position and the transmitter turned off; the readout remains displayed.

Construction

Of course, anyone constructing a counter such as this will want to use printed-circuit cards, and there are a few things which should be kept in mind. Cards vary in size, but the largest card needed is $3\frac{1}{4} \times 5$ " so that it is possible to make a very compact unit. Mounting the cards is a matter of individual taste but, in general, Nixie tubes should be mounted on a separate phenolic board and placed near the decade card outputs, so that interconnecting leads are kept short. Separate 10,000-ohm resistors should be used to connect the Nixie anodes to the ± 170 V transistor switch. Signal lines should be routed away from power lines and Nixie wiring, and shielded if possible. The time-base oscillator board should be placed next to one side of

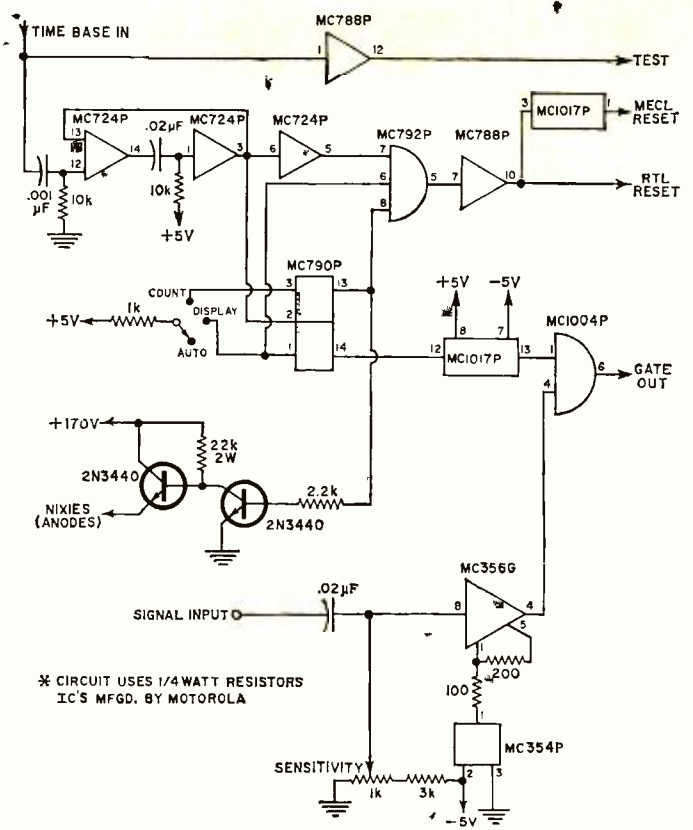
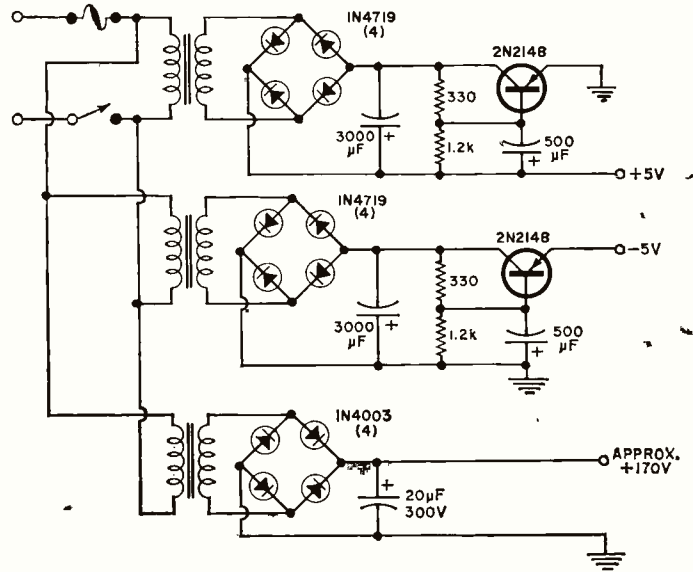

Fig. 5. Control circuits, signal conditioning, and main gate. The Schmitt trigger is used to change the input signal to a pulse train, one pulse for every cycle of the input frequency.

the case so that the trimmer capacitor can be adjusted through a hole in the case. The time-base decade card, the control card, the RTL decade cards, MECL decade cards, and the power-supply card should be mounted one next to the other, in that order. The transformers and power transistors can be mounted on the right-hand frame next to the power-supply card.

The MECL counter board will have two "carry" outputs labeled "carry first and second decades" or "Out 1 and 2." The output of the first decade, i.e., the one immediately after the Schmitt trigger—should be obtained from the "Out 2 decade" terminal. This, then, is fed to the input of the second MECL decade. Therefore, the output of this decade is taken from "Out 1." This (Continued on page 61)

Fig. 6. Two 6.3-V, 3-A filament transformers and an isolation transformer are used for the counter's three power supplies.



THERMOLUMINESCENCE

THEORY & APPLICATIONS

By DONALD E. LANCASTER

Certain materials, when heated, release light proportional to previous radiation dosage. This provides a powerful, versatile tool for solid-state research, nuclear safety, medical dosimetry, geological age determination, and for archeological dating.

TAKE a chunk of limestone and crush it. Now heat it at a constant rate to kitchen-stove temperatures under laboratory conditions. It will probably emit light, but only while the temperature is *increasing*. Cool it back down again and repeat the process. Nothing happens. This strange behavior is an example of *thermoluminescence*, a new and valuable tool of use to the solid-state researcher, the nuclear scientist, the medical doctor, the geologist, and the archeologist.

Thermoluminescence is the release of light in a crystalline material as it is heated at a constant rate. The light is proportional to the previous nuclear radiation dosage the material has received. Once the light is produced, the previous radiation history of the material is "erased" as the thermal cycling performs a destructive readout of the sample's past history.

Had we measured the output light produced by the limestone sample and made a few other measurements and assumptions, we could find out either *how old* the limestone is or else *how long* it has been since it had last been heated. Conversely, we could heat-cycle our piece of limestone to erase all the old radiation history. Any measurement made in the future on this sample would tell us how much new radiation the limestone had been exposed to since we last heat-cycled it.

Thermoluminescence is then a two-way street; it can either tell us how long it has been since a substance was last heated, if we make some assumptions about dosage rate; or it can tell us how much radiation has been picked up in a given time. The "how long?" is of value to geologists and archeologists; the "how much?" is important to doctors using radioactive treatment and to nuclear scientists and other personnel exposed to possibly dangerous radiation levels.

Before looking further at this new field and its exciting applications, we must note that thermoluminescence is a very specific effect. It should not be confused with *incandescence* or *luminescence*, the ordinary light you get when you heat something up red hot or hotter. The temperatures involved in thermoluminescence are far lower. While the maximum temperature involved is around 600°F, most of the light is obtained at much lower temperatures. In fact, ice can be made to thermoluminesce.

The Basic Mechanism

Crystals can suffer radiation damage just like people can, and the damage is a cumulative effect that can be picked up in a single big blast of radiation, or over a very long time at very low radiation levels. Consider a crystalline substance that is also an insulator or a semiconductor. Table salt will do. Assume that it is initially a perfect crystal,

without any impurities or mechanical problems. If we looked down into the crystal, we'd see a *crystal lattice*, a nice orderly arrangement of sodium and chlorine ions, one after the other, alternating in all three directions. Strong forces, called *valence bonds*, will try to hold all the ions in perfect alignment. Should we heat the crystal, thermal agitation will excite the individual ions. The higher the temperature, the greater the ion energy level, and the more likely the valence bonds will be broken. If we provide too much heat, the bonds all break and the crystal melts.

Table 1. A listing of various thermoluminescent materials.

MATERIALS	MINERALS	CHEMICALS
Ancient pottery	Alumina	Barium titanate Barium fluoride
Bone	Anhydrite	
Boiling stones (prehistoric cookers)	Anthracene	Calcium carbonate Calcium oxide Calcium fluoride* Calcium sulfate* Calcium sulfide
Ceramics	Borate glass	
Firepits	Calcite	
Fossil shells	Clays	Cesium bromide (AH) Cesium iodide (AH)
Glass	Diamond	
Ice	Dolomite	Lithium borate* Lithium bromide (AH) Lithium chloride (AH) Lithium fluoride (AH)* Lithium phosphate
Meteors	Fluorite	
Moon	Limestone	
Polyethylene	Magnasite	Magnesium oxide Magnesium sulfide
Pottery kilns	Obsidian	
Roof tiles	Quartz	Potassium bromide (AH) Potassium chloride (AH) Potassium fluoride (AH) Potassium iodide (AH) Potassium sulfate*
Salt	Sandstone	
Sand	Sapphire	
Volcanoes	Silica	Rhodium bromide (AH) Rhodium chloride (AH) Rhodium iodide (AH)
	Talc	
		Silicon dioxide
		Sodium bromide (AH) Sodium chloride (AH) Sodium fluoride (AH) Sodium iodide (AH)
		Thorium dioxide
		Zinc oxide Zinc sulfide

(AH) = alkali halide; * = popular dosimetry material.

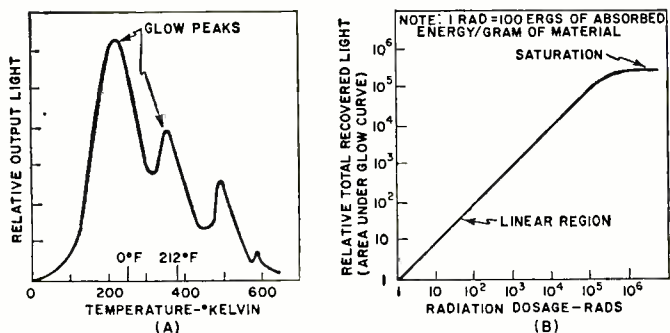

Fig. 1. (A) Typical glow curve. (B) Typical dosage curve.

Things are fine with our crystal until some high-energy particle comes along—the familiar *alpha*, *beta*, or *gamma* particles we'd get in any nuclear reaction, or perhaps a particle from an ultraviolet laser. One of these particles can “blast” one of the ions and literally knock an electron into orbit. In the process, the electron gets its own energy level raised so high that it cannot be recaptured by its own ion, and thus is free to wander throughout the crystal lattice. If more and more particles strike the crystal, more electrons get knocked loose and are free to roam around the crystal; they all have too much energy to get recaptured, and an electron cloud forms. The greater the radiation, or the longer the radiation dosage lasts, the bigger the electron cloud.

Electron clouds cannot thermoluminesce by themselves. If crystals were perfect, there would be no thermoluminescence. But crystals have imperfections. They can have impurities locked in their lattice structures, just like the *n* and *p* impurity doping in semiconductors. They can have mechanical structure defects. At higher temperatures, they can have “statistical” defects, caused by thermal agitation. Some of these defects can capture a loose electron. These are called *traps*, and once an electron gets trapped, it is stuck there, at least for the time being.

A trap that has caught an electron is called a *filled trap*. The greater the radiation dosage, the more electrons get knocked loose, and the greater the number of filled traps.

Each trap can only supply so much holding energy to an electron. If we heat the material, the electrons can achieve enough additional thermal energy so that the trap releases the electron. Certain types of traps will also cause the electron to release its own excess energy in the form of light when the release temperature is reached. These traps produce thermoluminescence; they are also closely related to the mechanisms that determine the color of the substance.

Once the electron has released its excess energy, it is free to once again get captured by an ion with a missing electron, removing the effect of the radiation dosage.

To summarize, energy from external radiation increases the energy of some internal electrons and breaks them loose, forming an electron cloud. Some of the electrons get trapped by crystal imperfections. Heating the crystal at a later time releases the extra kinetic energy stored in the trapped electrons and, for certain traps, the excess energy is liber-

ated as light, thereby producing thermoluminescence.

Some traps can very tenaciously hold onto an electron, while others can only retain one weakly. These are called high-energy and low-energy traps. There are usually many more low-energy traps. A slight temperature increase can empty a low-energy trap, while a large temperature increase is needed to empty a high-energy trap. When long, uniform dosage rates are being used, the *equilibrium temperature* is defined as that temperature at which thermal agitation is emptying the traps just as fast as incident radiation is filling them.

Glow Curves

If we take some crystalline substance with imperfections and blast it at a fairly low temperature with nuclear radiation, and then crush the sample and heat it at a constant rate, we would get a light-vs-temperature curve called a *glow curve*. One such curve appears in Fig. 1A. The glow curve has glow peaks that correspond to different energy-level traps that get progressively released as the increasing sample temperature provides more and more thermal energy.

The shape of the glow curve depends upon the material selected, as does the position of the glow peaks and their number. The total area under the glow curve, or the total light produced, is proportional only to the received radiation dosage and nothing else. While the heating rate will affect the height of the glow peaks, it does not affect the total amount of light produced.

If we ran the glow curve over and over again for increasing dosage rates, we would generate a *dosage curve*, such as that shown in Fig. 1B. Dosage is normally expressed in rads. One rad is equal to 100 ergs of absorbed energy per gram of sample. As the figure shows, the total recovered light is proportional to the radiation dosage. With suitable calibration, we can find what the dosage was—simply by measuring the total light produced when the glow curve was generated.

An extreme dosage could fill up all the traps and saturate the material. However, this is usually such an extreme amount of radiation that almost all thermoluminescent measurements are made well down on the dosage curve, retaining a linear relation between dosage and light level.

The output light is shown in relative units. The actual output depends upon how the material is prepared, the number of traps, the optics and photomultiplier in use, and the electronic amplification. Calibration is necessary when a substance is undergoing measurement. By exposing the material to a known radiation dosage, an output light level will be obtained. This level can be compared to a measured output to determine an unknown dosage by simple proportion.

How much light is produced depends upon the material and the dosage. Some materials put out enough thermoluminescence to read a newspaper by for several minutes; others emit light so feebly that elaborate precautions are needed to get meaningful results. Some materials do not thermoluminesce at all.

Table 1 lists some of the more interesting materials, min-

Fig. 2. Glow curves produced (A) when material is irradiated at low temperature and thermoluminescent measurement made immediately. (B) When material remains at “room” temperature for long time, and (C) when material is annealed at high temperature.

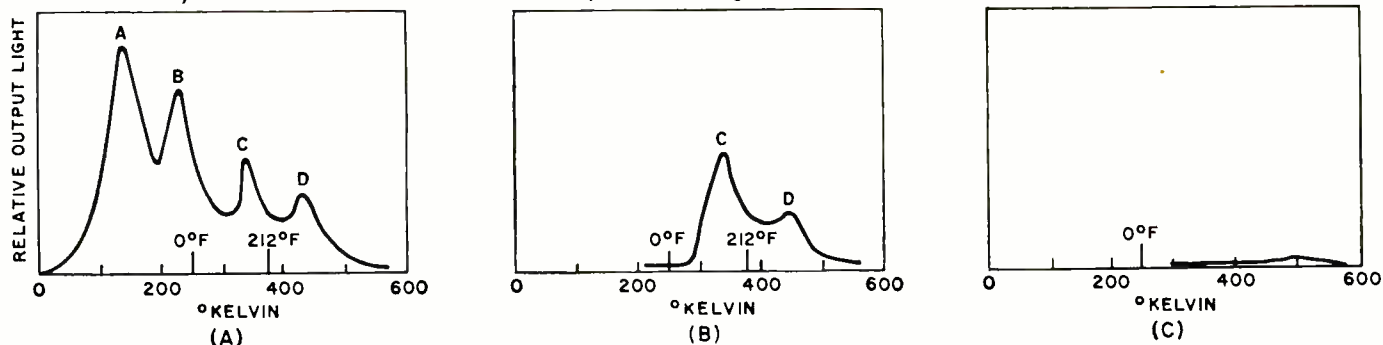

erals, and chemicals that exhibit thermoluminescence. All we require is that a material have an ordered crystalline structure, or at least a semi-ordered, glass-like structure. It can be either an insulator or a semiconductor, but must not be a conductor. It has to have light-producing traps, so the material requires either impurities or imperfections in its structure. As the table shows, there are many materials that meet these requirements.

One group of chemical compounds that produces useful thermoluminescence are the *alkali halides*, of which ordinary table salt is a typical member. These have been widely studied. Several alkali halides are used as dosimetry materials in quantitative applications of thermoluminescence.

One popular alkali halide is lithium fluoride. It thermoluminesces brightly, is chemically stable, reasonably non-toxic, and easy to form into bar, rod, disc, or powder. It, along with other dosimetry materials and instruments, is available from companies such as *Controls for Radiation, Inc.*, 130 Aiewife Brook Parkway, Cambridge, Mass. 02140 or *Harshaw Chemical Company*, 1945 East 97th St., Cleveland, Ohio 44106. The cost runs \$8-\$20 per gram, but since only a fraction of a gram is needed per measurement, and since many materials are reusable, the price per measurement is quite low.

Actually, very pure lithium fluoride does not thermoluminesce very well because there are not enough traps to produce a useful light output. To get around this problem, impurities are introduced purposely to increase substantially the number of traps. These impurities are called *activators*, and are often trace quantities of magnesium, terbium, europium, or other rare-earth elements. By close control of the amount and type of activator, sensitive, stable, and reproducible dosimetry materials are obtained. Further refinements, particularly in controlling which lithium isotopes get into the final material, allow the material to discriminate between different types of atomic radiation. Neutrons are particularly easy to identify with one commercial dosimetry powder.

Important Side Effects

Before we look at how to make a useful thermoluminescence measurement, we have to consider several important side effects. How long the material has remained at what temperature is very important. If we are researching materials, we would purposely irradiate the substance at a low temperature and then run the entire glow curve, possibly getting a glow curve such as the one shown in Fig. 2A. If we are dealing with an archeological ceramic or a Pre-Cambrian rock, it has remained at "room" temperature for many centuries. This, combined with a low and constant dose rate, will cause all the low-energy traps to be emptied eventually, and a glow curve such as the one in Fig. 2B will usually result. Note that all traps lower than "room" temperature have been emptied. There is even a slight chance that traps above this temperature have been slightly emptied. This problem is avoided in geological and archeological dating by using only the highest temperature glow peaks; these are far above the equilibrium temperature and most likely have not been disturbed.

To empty a material of all its previous radiation history, we anneal it by heating. For effective annealing, the material is first heated to a very high temperature for a relatively short time, and then to a moderate temperature for a relatively long time. The two-step process favors emptying both low- and high-energy traps, and a no-light curve of Fig. 2C results. We anneal a material whenever we want to erase its entire dosage history up to the present time.

A second side effect is called *spurious luminescence*. Other factors can make a material emit light. These factors include how it was ground, the pressures it has been subjected to, organic combustion, and chemical activity. Spurious luminescence is a particularly acute problem in archeological

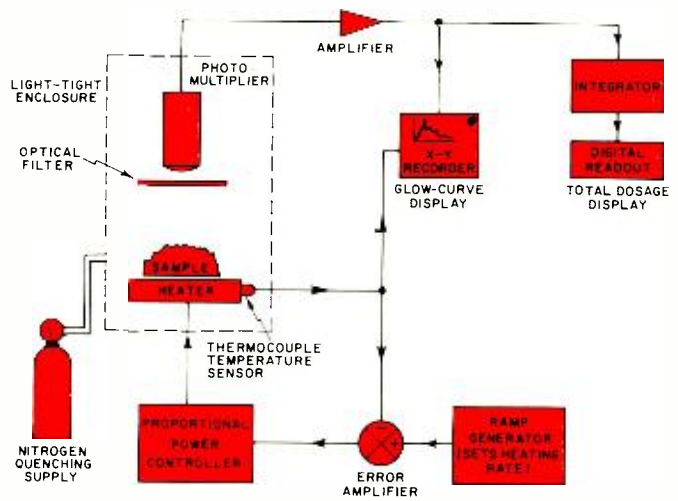

Fig. 3. Instrumentation used in thermoluminescent measurement. Servo-controlled heater assures constant heating.

dating. This is because low dose rates for a relatively short time on a relatively poorly thermoluminescing material result in very low light levels that are easily masked by the spurious effects.

Most of the spurious luminescence is caused by oxygen in the air. We can get rid of most of it by making the measurements in a nitrogen atmosphere. This is called *nitrogen quenching*, and works only if the nitrogen is very pure. Spurious luminescence may be further reduced by a reducing paint near the sample. The reducing paint chemically "grabs" any oxygen remaining on the surface of the material under test.

There are other side effects. Pressure—either from grinding or, in cons gone by, in geological activity—can affect the glow curves. The sample size and its preparation are critical for optimum results. The heating rate is also critical, for heating too slowly does not produce enough instantaneous light, and heating too fast skews the glow peaks and makes them hard to interpret. Rates of 1° C/second to 25° C, second are often used in routine dosimetry measurements.

Instrumentation Employed

To make a thermoluminescence measurement, we have to heat a sample at a constant rate and observe the light produced. A system for doing this is shown in Fig. 3. The sample typically weighs around 30 milligrams and is sometimes processed to form a thin disc-shaped spot, perhaps half an inch across. To get precise temperature control and a constant rate of rise of temperature, servo feedback is used. We start with a ramp generator that controls a proportional power controller, usually using an SCR or a triac. This drives the sample heater. A temperature sensor on the heater produces a feedback voltage that is compared against the ramp generator's output; any differences alter the heating power applied to linearize the results.

Fig. 4. Details of sample holder in commercial instrument.

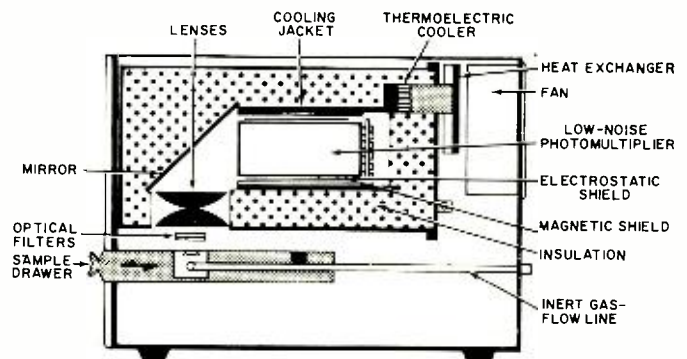

A photomultiplier observes the sample and produces an output proportional to the thermoluminescence. The enclosure surrounding the sample, heater, and photomultiplier must be light-tight, and is normally flushed with nitrogen from a tank supply to eliminate any spurious luminescence.

The photomultiplier output is amplified and, together with a signal from the temperature sensor, is fed to an X-Y recorder that generates the glow curve in graphic form. The photomultiplier output also goes to a charge integrator that calculates the total light produced, digitizes it, and presents the total dosage on a digital readout.

A heater and photomultiplier assembly are shown in Fig. 4. It has several refinements over the basic measuring process just described. The light path is bent to put the photomultiplier outside of any direct infrared radiation from the sample heater. Lenses and a mirror bend the light suitably but are largely opaque to the infrared radiation. An optical filter also enhances the thermoluminescence signal at the expense of spurious and infrared background. The photomultiplier is a very-low-noise type. It is shielded both magnetically and electrostatically to prevent internal light and noise from being generated. The photomultiplier is cooled with a thermoelectric cooler which keeps the background noise low and uniform, regardless of whether the measurement is at the high end or the low end of the glow curve; the entire assembly is suitably insulated.

A complete instrument is shown in the photo. This is the *Harshaw Chemical Model 2000* thermoluminescence analyzer. The left unit contains the sample drawer, heater, and photomultiplier, while the right one contains the integrator and dosage readout. Other features include a calibration light source, a sample vibrator and dispenser, and direct-temperature readout. An additional X-Y plotter is needed if a glow curve is to be obtained. If quenching is desired, an external connection must be made to a nitrogen tank.

Nuclear & Medical Applications

One application of thermoluminescence is in basic solid-state research. Crystals with slight impurities are the keystone of today's solid-state materials. Basic thermoluminescence studies can add new knowledge to this all-important field.

Thermoluminescence can be a much more sensitive radiation indicator than either a Geiger or a scintillation counter, as it responds to the total dosage through time instead of making an instantaneous or short-term measurement.

For nuclear prospecting and for radioactive deposit mapping, thermoluminescence can be a highly sensitive radiation indicator. Rock samples near a suspected radioactive source have dosage measurements made on them; results of the dosage measurements plot extent and value of the deposit.

To protect people working around a nuclear reactor or other dangerous radioactive source, badges using lithium fluoride are often worn. Special finger rings are also used where people might expose only their hands to radiation hazards. These badges and rings are annealed before being issued; the resultant thermoluminescence as a result of use indicates the dosage the person wearing the badge has absorbed. Personal dosage histories are kept easily and accurately this way. Compared to the film-badge technique, thermoluminescence is more accurate and less dose-dependent at low dosage rates.

A similar measurement was recently applied to roof tiles recovered from Hiroshima, plotting the extent and strength of the atomic-bomb radiation.

Much of today's cancer and tumor research is centered around radioactive treatment. Thermoluminescence provides an attractive method of measuring the actual dosage absorbed. To do this, annealed lithium fluoride or another one of the dosimetry materials is encased in inert Teflon in either a pill or a probe shape. The dosimeter built this way is either implanted or swallowed and later recovered after ir-



A complete thermoluminescence analyzer. Unit at left contains sample drawer, heater, and photomultiplier; the unit at the right contains the integrator and the digital readout.

radiation or other radioactive treatment. The thermoluminescence gives an accurate account of the total dosage.

Uses in Geology & Archeology

There are many geological uses for thermoluminescence. By comparing the total thermoluminescence to date of two different rocks, the relative age of one with respect to the other can often be determined. By making certain assumptions as to what the dose rate was, an absolute dating scale may also be obtained. To do this, the sources of radioactivity affecting the sample must be known, as must the sample's susceptibility to thermoluminescent activity. Given these two factors, the absolute age is readily determined.

Subtle changes in equilibrium temperature of a material can give profound clues of past climatic activity. Thermoluminescence tests run in Antarctica have placed a bound upon how long the area was cold.

The moon is one big thermoluminescence machine. For fourteen days, the hot surface temperature anneals all the surface materials. For fourteen more days, when the surface is around on the dark side, high-energy particles from the solar wind fill the traps on surface thermoluminescent materials. As the surface comes around to the sunny side again, it is heated at a fairly constant rate and provides thermoluminescence for a few hours. Astrogeologists are able to draw certain conclusions about meteors and surface materials on the basis of this evidence.

The newest application of thermoluminescence is in archeology. It can provide absolute calendric dating of ancient pottery. When a pot is fired, it is also conveniently annealed, and its past radiation history is erased. From the firing on, the slight thorium and uranium impurities in the clay emit high-energy particles which fill the traps with electrons. To find the age of the pot, a sample is crushed, separated into optimum size particles, and its thermoluminescence is measured. The amount of new dosage is found which produces the same amount of thermoluminescence by annealing and the reradiating with a known dose. Finally, the particle emanation caused by the uranium and thorium impurities is measured. Knowing the dose rate and total dosage, a simple division gives the age of the ceramic.

Today, this technique is just beginning to be put to use. There are important advantages of thermoluminescence over the popular carbon-14 dating technique in that the dating is applied to the artifact itself, the pottery is widely available for testing, and sample contamination and dosage uniformity are not as significant. Other archeological applications include the evaluation of pre-pottery stone boilers, cave temperatures, firepits, and kiln temperatures. The technique is also a powerful tool for identifying fake "ancient" pottery. ▲

STOP-ACTION PHOTOS

By A. J. LOWE

Startling and interesting action pictures can be taken with any strobe light. All that's required is the change of one inexpensive component.

JUST one low-cost capacitor can open up a whole new field of photography—if you are already a strobe-light owner. It's easy to capture fast-action events. For example, the photographs of balloons bursting (Fig. 1) demonstrates what can be done.

Modern strobe units have a flash duration of about 1/1000 second or longer. However, this is much too long for "freezing" some motions. But if you were to disconnect the main high-voltage capacitor of the strobe and replace it with one of much smaller capacitance, you could produce startling and interesting frozen-action pictures. It's as simple as that! Of course, the smaller capacitor must have the same, or higher, voltage rating as the original, and must be connected so that its polarity is correct. If either of these is disregarded, then the capacitor will be destroyed.

A number of capacitor values can be used depending upon the flash duration desired. The photos of the balloons were taken with an ordinary radio-type 16-microfarad electrolytic capacitor, inserted into a 500-volt flash gun. This gave a rating of only 2 watt-seconds and a flash duration of about 1/5000 second.

The flash duration may be calculated from an empirical equation proposed by Carlton and Pritchard and noted in an authoritative text "*Electronic Flash Photography*" by Aspden. The equation states that the effective flash duration (i.e., until the light intensity is down to 1/3 of its peak value) is:

$$20 \times \frac{C^{0.69}}{V^{0.625}}$$

where C is the capacitance in farads, and V the operating voltage. Using this formula and the standard equation which states that watt-seconds = 1/2 CV², the power ratings and approximate flash durations for different capacitor values can be derived.

Although the power rating is reduced by using a smaller capacitor (down to 2 watt-seconds in this example), this is adequate. Most "stop-action" pictures are of relatively small subjects and the flash can be worked in pretty close, and a reflector used, as well. With a 2 watt-second flash and Tri-X film in the camera, a guide number of 25 is used. Up to 50% extra development time is needed because the extremely short flash time causes a significant loss of film speed.

The balloon pictures were taken in a dark room with the camera shutter open. An electronic sound-triggering device fired the flash and took the picture. Circuits for this purpose have been described in the past.

The progressive sequence effect with the balloons was achieved by bursting a number of balloons, one at a time. A microphone located at increased distances from the balloon as the series progressed, picked up the bang. This introduced a delay in the flash firing so that the action is seen at a number of different stages. If a sound-triggering device is not readily available, then the flash may be synchronized with the action by other means, such as light contacts, photocell devices, threads, and so on. It's up to the reader to work out a suitable trigger for his own particular photographic subject matter.

Some motions last sufficiently long so that no special triggering is required and photos may be taken in the normal way by pressing the shutter release of the camera with the flash connected. However, it's important that room lights be off, otherwise the ambient light would cause a blurred image.

There are an infinite number of subjects available. The experimenter might try splashes of milk, breaking crockery, balls being kicked, or perhaps, bursting electric bulbs and a cascade of coins falling into a tray. Any way, it adds up to fun for the photographer and electronic innovator. ▲

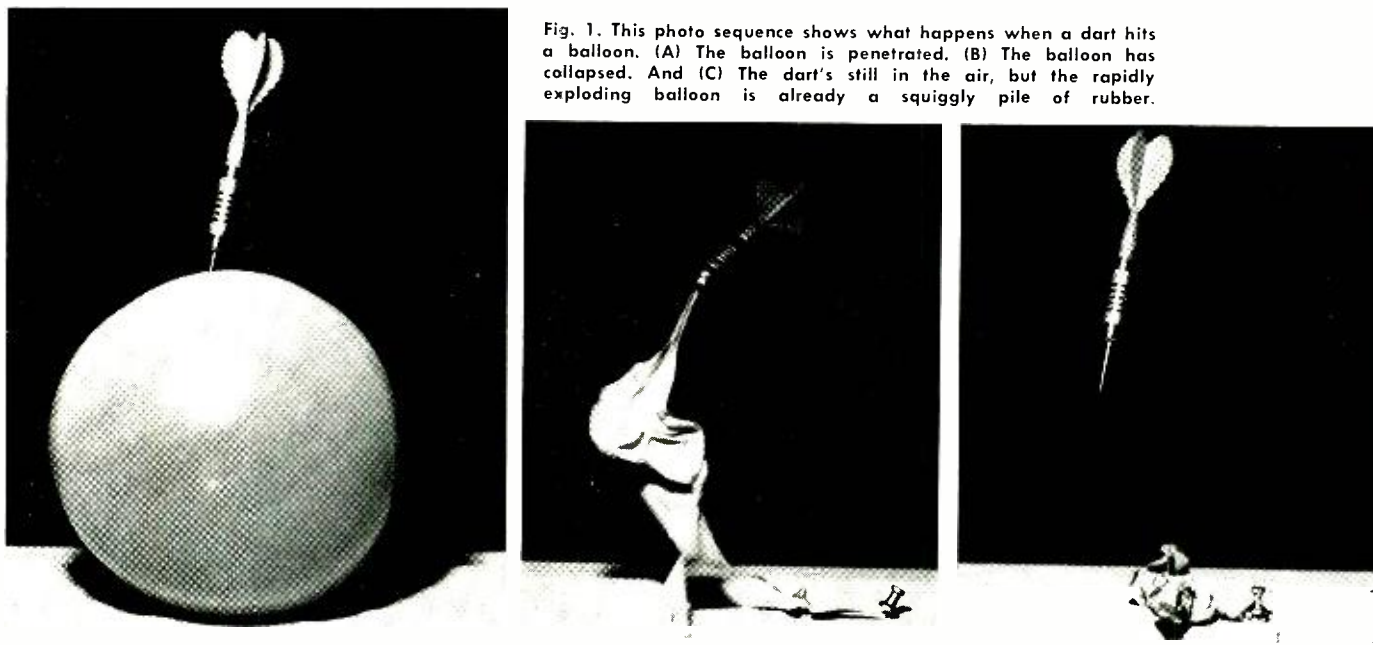

Fig. 1. This photo sequence shows what happens when a dart hits a balloon. (A) The balloon is penetrated. (B) The balloon has collapsed. And (C) The dart's still in the air, but the rapidly exploding balloon is already a squiggly pile of rubber.

Series-Pass Regulators

By G. V. FAY/Applications Engineering, Motorola Semiconductor Products Inc.

Design of a 11- to 32-volt, 700-mA power supply which has good regulation and built-in overcurrent protection.

AN ideal voltage-regulated power supply has zero output impedance so that the output voltage remains constant for any load current requirements. But, zero output impedances cannot be achieved, although supplies with impedance levels of a milliohm can be constructed. And, too, semiconductor device characteristics place a limit on the current and voltage that can be supplied to a load.

Two simple series-pass voltage regulators are shown in Figs. 1 and 2. Transistor Q1 in each of these circuits controls the output voltage; thus the collector-emitter voltage rating of Q1 determines the maximum input-to-output voltage. All the current delivered to the load passes through Q1. Therefore, the power dissipated in Q1 is $(V_{in}-V_{out})$ times I_{Load} . If high input voltages and low output voltages and/or large load currents are necessary, it is possible that Q1 will have to dissipate large amounts of power. Obviously, under these conditions the regulator efficiency is low and the power rating (for the particular heat sinking) limits regulating capacity. For limited load variations, Q1 can be shunted by a resistor, thus shifting some power from Q1 to the resistor. The output voltage of the circuit (Fig. 1) is the zener voltage minus the base-emitter voltage of Q1. R1 must provide enough current to the base of Q1 and to D1 to keep the voltage of D1 above its knee at all times. If the temperature characteristic of D1 is equal and opposite that of the base-emitter junction of Q1, the output voltage will remain constant with temperature.

When variable output voltages are required, a circuit similar to that of Fig. 2 can be used. Here, the lowest possible output voltage is the breakdown voltage of D1 plus the base-emitter voltage of Q2.

Maximum output voltage is limited by the changes in the unregulated input plus the drive requirements of Q1. R1 provides the bias current for D1 whose voltage is compared to that at the potentiometer arm. If the load increases and causes the output voltage to drop, Q2 conducts less and Q1 conducts more, restoring the voltage to the original level.

Basically, series-pass regulators are current, voltage, and power limited; and the circuit's control transistor must always be run in the safe operating area—the region where there is no danger of secondary breakdown. However, series-pass regulators do provide extremely good regulation, fast response time, low output impedance, and low ripple. Their performance is almost independent of input frequency fluctuations and they have excellent dynamic response. They also provide variable output voltages and are readily adaptable to remote voltage sensing, remote programming, and current limiting applications. The circuit output is virtually transient free.

Overcurrent Protection

The circuit shown in Fig. 3 is a regulated power supply with overcurrent protection and an output of 11 to 32 volts d.c. The diode bridge consisting of D1 through D4 provides full-wave rectification of the 25-volt secondary of T1. Capacitor C1 is used to filter the rectified current and keep a positive voltage on the collectors of Q1 and Q2. Resistor R1 and capacitor C2 further reduce the ripple to maintain a stable d.c. voltage as a collector supply for Q3 and Q4, and for driving the base of Q1. Transistor Q2 is the series-pass device which regulates the output voltage. The resistor divider, R4-R5-R6, forms a sensing network. The voltage at the arm of potentiometer R5 is applied to the base of Q4, which compares the voltage to that of zener diode D5. (Continued on page 78)

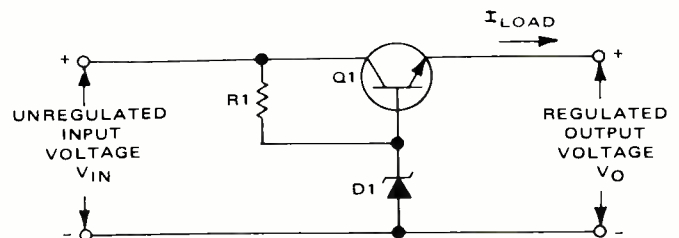

Fig. 1. In this simple series-pass fixed-voltage regulator transistor Q1 controls the regulated output voltage, V_{O} .

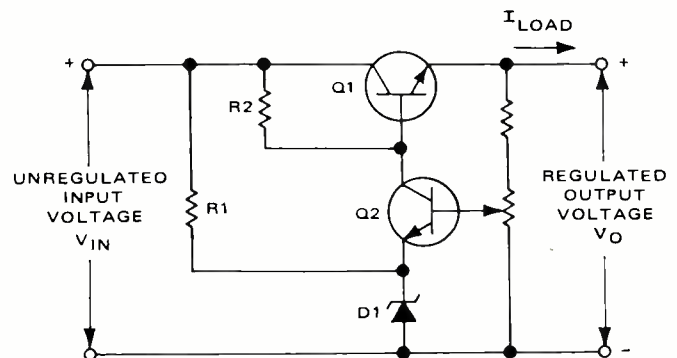

Fig. 2. In this variable-voltage series-pass regulator, transistor Q2 and a potentiometer are used to set voltage level.

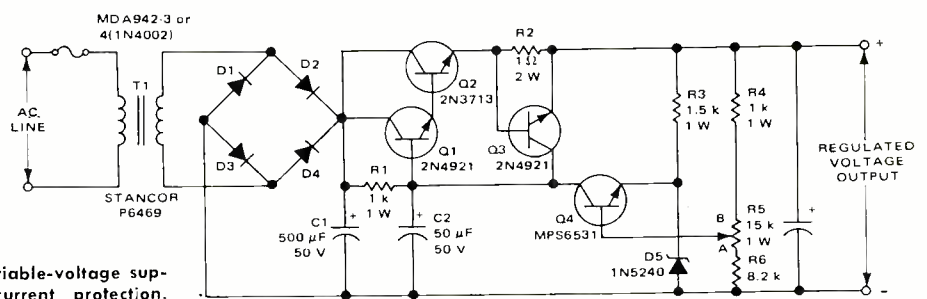

Fig. 3. This variable-voltage supply has overcurrent protection.

BANDWIDTH COMPRESSION *for efficient* DIGITAL COMMUNICATIONS

By JOHN W. STUMPE / Associate Principal Engineer, Radiation Inc.

Voice communication is not as reliable as digital and also lacks security. Digital transmissions, however, require wider bandwidth but new compression techniques make such systems more efficient, thus cutting the cost of transmission lines.

IN the past five years, digital communications techniques and facilities have doubled and tripled, and current indications are that this growth will continue at the same rapid rate for years to come. This article discusses some of the reasons for this maturation, investigates some of the advantages and disadvantages of digital transmission, and discusses various bandwidth compression techniques that can be used to overcome a great number of the problems.

Solid-state circuitry and digital computer development have contributed greatly to the current boom in digital communications. Now it's possible to build complex high-speed communications systems that operate automatically or under program control to speed the flow of message traffic from user to user.

Actually, digital communications techniques have been in use for hundreds of years. The drums of the African natives and smoke signals used by the Indians can be classified as crude forms of digital communications. And of course, pioneers in the West depended upon the telegraph to provide a rapid means of message transmission. With the advent of radio transmission, however, Morse code became the standard means of long-distance communication, until the teletypewriter replaced the telegrapher, and now it's being used in almost every country of the world. Today, vast networks such as *Western Union* use digital techniques to move huge volumes of messages.

The techniques described in the preceding paragraph are all characterized by the fact that the transmission is in message form. For voice transmission as well as facsimile and similar types of continuous data, analog techniques have been used. The analog processes generally are simpler, require less complicated hardware, and use less bandwidth for transmission. In fact, the digital transmission process is relatively inefficient. For example, consider a single telephone channel using a nominal bandwidth of 4 kHz which we want to convert to digital format. An analog-to-digital converter will be required to represent the voice signal as a synchronous pulse-code-modulated (PCM) bit stream. Six-bit quantizing at an 8-kHz rate, which is typically used to provide reasonable quality, results in a 48 kilobit/second bit stream. At the receiver, synchronization circuitry and a digital-to-analog converter with appropriate filtering are required to reproduce the voice waveform.

Why, then, use digital transmission if it requires more complex equipment and more bandwidth? There are two

reasons. The first and most important to the commercial user is graphically illustrated in Fig. 1. The original waveform to be transmitted is shown in A. The waveform will suffer some degradation during transmission due to the characteristics of the transmission medium, as shown in B. If transmission must be accomplished over significant distances, the waveform must normally be amplified at periodic intervals. When using analog transmission, linear amplification is required in order to preserve the waveshape. Therefore, any noise or distortion that falls within

Fig. 1. During transmission, waveforms are degraded due to characteristics of the transmission media, but in a digital system, it's relatively easy to restore the original waveshape.

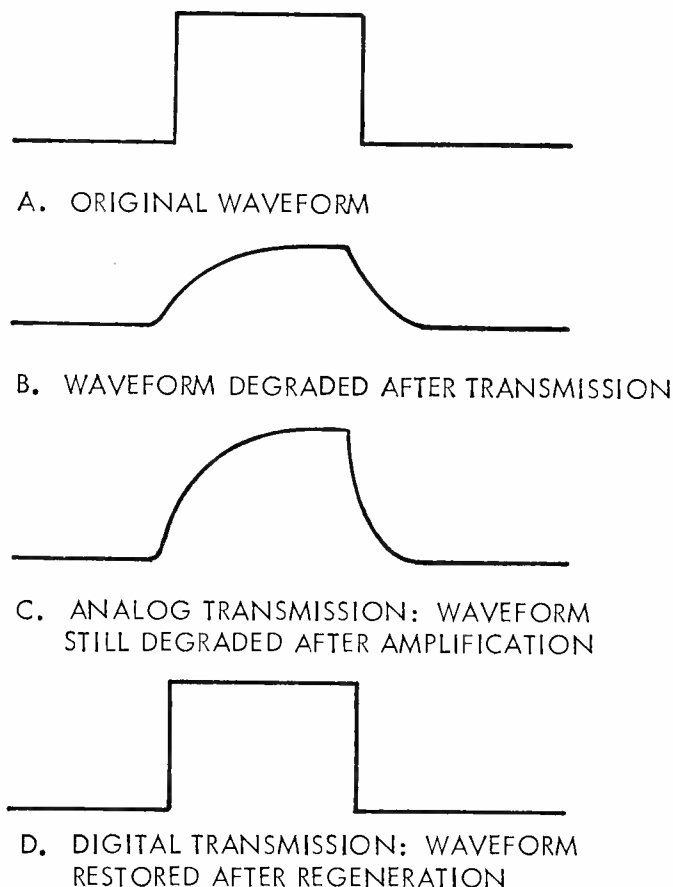
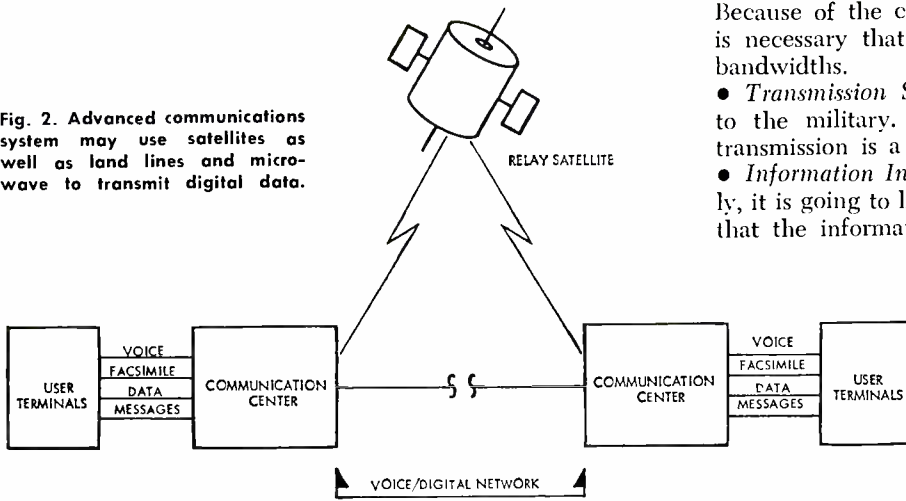

Fig. 2. Advanced communications system may use satellites as well as land lines and microwave to transmit digital data.



the passband of the signal is amplified right along with it, as shown in C. The end result is a noisy signal that may vary considerably in amplitude if fading is present in the transmission channel.

When using digital transmission, however, the waveform can be regenerated and retimed by simple repeater amplifiers as shown in D. As long as amplitude variations and noise are not sufficient to cause erroneous receiver bit decisions, the digital signals will provide noise-free communications of proper amplitude. The major trade-off here is transmitted signal quality *vs* bandwidth and equipment cost.

The second important reason for employing digital transmission is to allow the use of digital devices for secure transmission. This condition is, of course, a military requirement where the need for security is paramount.

Fig. 2 shows an advanced communications system. This system is representative of digital systems processing voice, facsimile, data, and message information through communications centers and digital transmission links or satellite relays to other communications centers. Common factors that must be considered in the design and operation of these systems are as follows:

- **Bandwidth Utilization.** This is of primary importance.

Fig. 3. Evolution of digital data transmission systems.

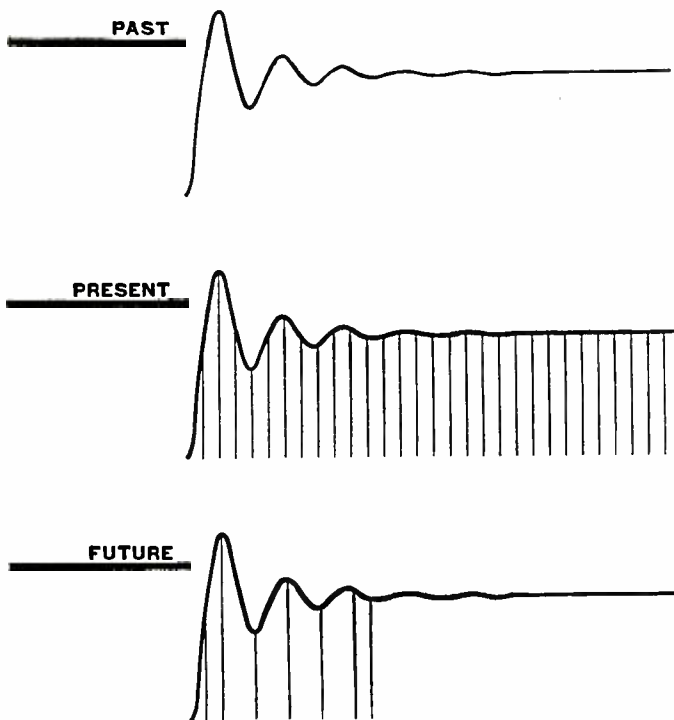

Because of the crowded spectrum and limited facilities, it is necessary that we make maximum use of all available bandwidths.

- **Transmission Security.** Security is of prime importance to the military. To meet security requirements, digital transmission is a must.

- **Information Integrity.** Unless data is transmitted properly, it is going to be of no value to the user. We must insure that the information gets to the user on time and in the proper form. If there are errors in the transmission, the data becomes meaningless. Delays are caused because the information must be retransmitted or some alternate means found for passing the data along.

- **Vulnerability.** This is also important, not only to the military from the standpoint of anti-jam capabilities, but to the commercial user as well, when one considers the problem of insensitivity to noise, interference on telephone channels, and other similar effects.

Adaptive Systems

Adaptive data systems have characteristics which lend themselves to solving the previously mentioned problems. An adaptive data system is basically classified as a data transmission system which selects and transmits only those points in a data waveform which cannot be predicted (within a given accuracy) at the receiver. This is the *basis* for redundancy reduction techniques for bandwidth compression which this article discusses. Data which does not add significant value to the received information is considered to be redundant. Therefore, it is not necessary to transmit this data if the values can be predicted at the receiver. Consequently, redundancy reduction techniques involve looking at the information as it is being processed to determine which data points must be transmitted; then only significant data points are put into the transmission link. This is the *means* by which the bandwidth compression is accomplished.

Fig. 3 illustrates the application of these techniques. The top figure shows an analog waveform which would normally be transmitted (if it were voice) on a standard telephone channel. If PCM techniques are to be used for digital transmission, this waveform would be sampled at a synchronous rate high enough to reproduce the frequencies present in the waveform, converted to digital format. If typical voice PCM requirements are met, the sampling rate of a 3-kHz voice signal would be fixed at approximately 8 kHz. To maintain adequate quality, each of these samples would be converted to a minimum of 6 bits of digital information. With 6-bit sampling at the 8-kHz rate, a 48 kilobit/second stream must be transmitted. This system now requires the equivalent bandwidth of 12 telephone channels in order to transmit the information. But, through the application of reduction techniques, only significant samples that provide specific information are selected for

Fig. 4. In the first-order redundancy reduction method, waveform is reproduced by using straight-line approximations.

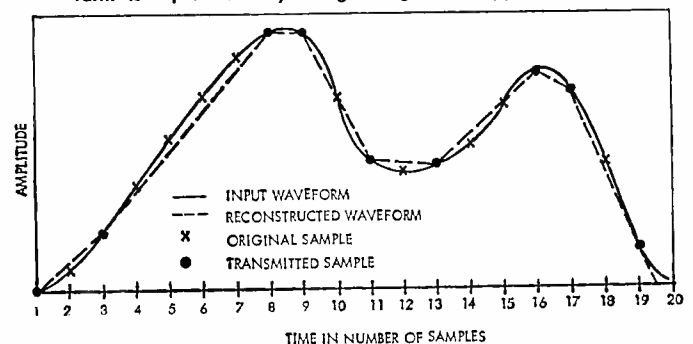

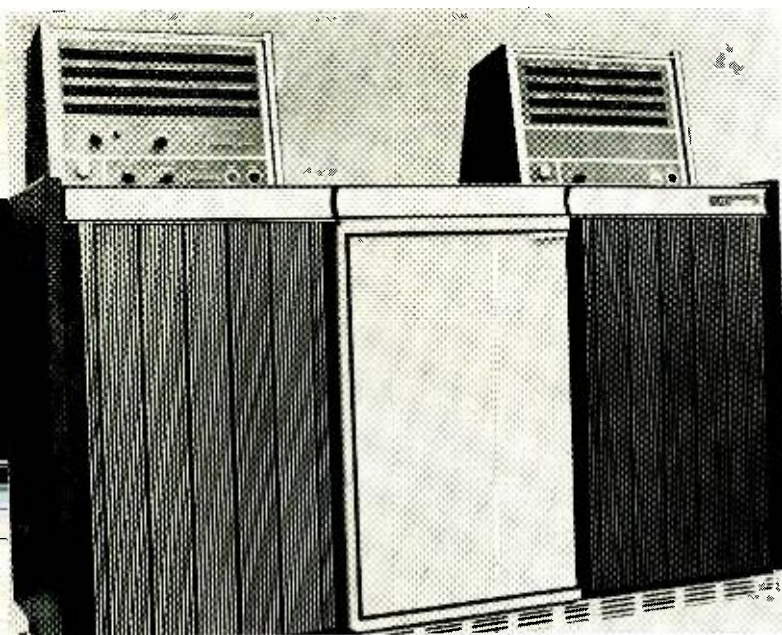

Fig. 5. A data analyzer used to evaluate reduction techniques.

transmission, thereby accomplishing the required compression.

Fig. 4 illustrates actual compression operations. The signal is effectively represented at the receiver as a straight-line approximation of the input waveform (shown by the solid line). The dotted lines show the interconnected straight-line segments that are generated at the receiver to represent the original input waveform. The points which cannot be predicted at the receiver are represented by the solid dots at the segment intersections. Note that the 20 original samples required for PCM transmission have now been reduced to only nine samples, thereby providing significant savings in the over-all operation.

To enable the receiver to reconstruct the transmitted waveform, some additional data is sent with each non-redundant sample value. This data consists of the number of sample intervals which have occurred between the present sample and the last transmitted sample, and is called the "time tag." In Fig. 4, the value transmitted at sample time 8 would carry a time tag of 5. With the amplitude values occurring at sample times 3 and 8 and the proper number of sample intervals between the two values, the receiver circuitry can now compute values for the intermediate samples that were not transmitted, thus reconstructing an approximation of the input waveform.

To use the results of the redundancy reduction for bandwidth compression, it is necessary to place the non-redundant samples that are occurring at non-synchronous intervals into a storage buffer. Then the data points can be clocked at the lower synchronous rate which is equal to the average rate-of-occurrence of the non-redundant samples.

The system shown in Fig. 5 is called a Data Management Analyzer. This is a laboratory tool which was designed specifically for the purpose of evaluating effects of various redundancy reduction techniques on actual data. General-purpose computers could have been used for evaluation purposes; however, two high-speed units would have been needed to accomplish the operations performed by this equipment. In addition, the computers would require extensive programming support for the

various processing operations. The DMA processes volumes of data in a very short period of time, at low cost, and provides the flexibility which the operator needs to change parameters and quickly evaluate different processing techniques. This system has been used to evaluate telemetry data, biomedical data, and facsimile data, and was the system used to perform the feasibility studies for the digital voice compression program described here.

Some of the studies of data compression techniques involved various classes of pulse-code-modulated (PCM) telemetry data. For example, three channels of rocket booster data were studied to determine how much bandwidth reduction was possible using adaptive techniques. The three channels included a flow measurement, a temperature measurement, and an ignition pressure measurement. The measurement period studied was 220 seconds and included first-stage cut-off. Using the Fan method (this will be explained in greater detail later), a reduction of 161 to 1 is possible without any loss of data. Originally, the total PCM system was made up of 216 ten-bit channels, each sampled 12 times per second. This required a transmission bandwidth of approximately 13 kHz. If all the channels could be reduced like the three studied, the total bandwidth could be reduced to approximately 80 Hz.

Weather pictures (facsimile) like those taken by a camera in the Nimbus satellite are usually reproduced on the ground by analog techniques. But if the picture is reproduced by converting the analog signal to synchronous PCM at a high enough sample rate, a good quality picture is obtained. Through adaptive techniques, bandwidth compression of more than 9 to 1 over synchronous PCM is possible and essential details in the picture are still apparent and usable. Now here is the important result of all this. If a system such as this is applied to a spacecraft requirement, thousands of dollars can be saved, because by reducing the bandwidth, the power required for transmission in the vehicle is reduced and a reduction in vehicle power means a reduction in weight. A reduction of the payload's weight is multiplied many fold in the total booster weight and the power requirements for the booster. The net effect is a significant cost saving in the total vehicle system.

NASA's Marshall Space Flight Center, Huntsville, Alabama used a system called the Telemetry Redundancy Analyzer System to study telemetry data. This particular system was capable of handling up to 32 channels of input information and implemented five different compression algorithms.

Document Transmission Bandwidth Compression studies have also been made. These programs were aimed at reducing bandwidth requirements for high-speed document transmission systems. Today, typical systems require transmission bandwidths of about 240 kHz for a document transmission rate of six pages per minute. These circuits are of limited availability and very expensive. If a compression ratio of 5 to 1 can be obtained, the documents can be transmitted at the same page rate, with no degradation in quality, over a 48-kHz channel. The cost saving in transmission lines alone is 7 to 1. When line lengths are long, this saving can amount to millions of dollars within a year's time. The study proved conclusively that an average com-

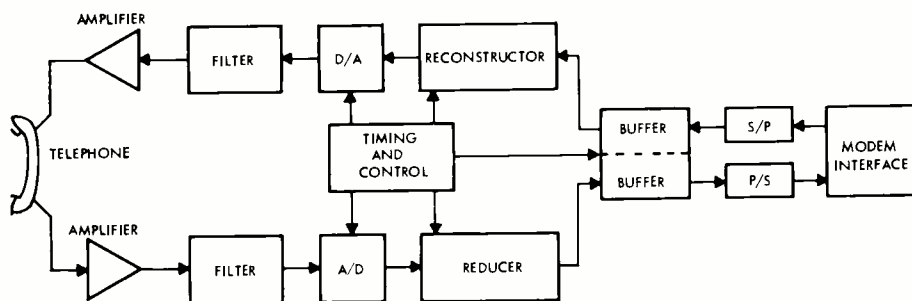

Fig. 6. Block diagram of RACE adaptive compression system.

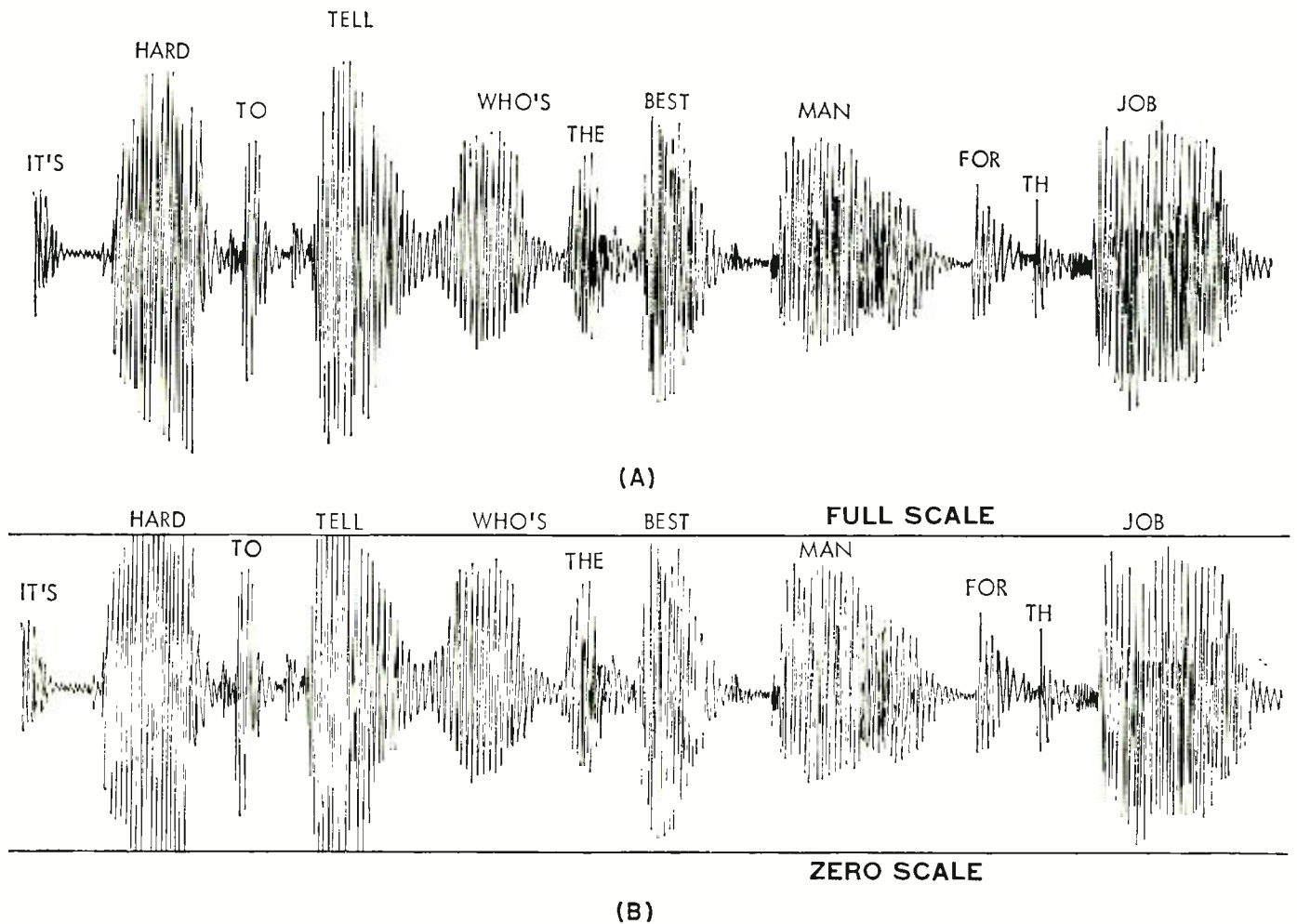

Fig. 7. (A) Typical voice pattern. (B) An a.g.c. circuit limits the input signal swing and assures maximum signal level.

pression ratio of 5.8 to 1 can be obtained on the type of documents which were processed. These programs are now continuing with the evaluation of other compression techniques to determine whether it's possible to attain higher compression ratios with additional cost savings.

More recently, studies have been conducted in digital voice-compression techniques. The Vocoder is probably the most widely known device for reducing voice bandwidth requirements. Vocoder systems provide significant improvements in transmission efficiency with typical transmission rates of 2400 to 9600 bits/second. However, they produce a voice commensurate with their bit rates, *i.e.*, the lower the rate, the lower the quality. Even at 9600 bits per second, the quality is still not as good as a 48-kilobit PCM signal because the voice is produced by a frequency synthesis process rather than by waveform reproduction. While intelligibility may be excellent when using such devices, the "natural" quality of the voice is destroyed.

In an effort to improve digital voice transmission, the Defense Communications Agency (DCA) has sponsored several research and development study programs in digital voice transmission. The goal of one of the study programs was to determine the feasibility of providing high-quality digital voice communications at bit rates of 9600 bits per second or less through the use of selected redundancy reduction techniques. Again, the DMA was used to process the input voice after digitizing, to simulate the transmission of the compressed digital data, and to reconstruct the original waveform at the receiving end. To provide data for quality evaluation, tape recordings of both the input and the reconstructed output waveforms were made simultaneously on a dual-track recorder. Although quality evaluations were made by listening to the test tapes, numerical

data was also recorded to indicate the compression ratio attainable on each test sample. These tests were performed using two redundancy reduction algorithms known as the Extended Step Method and the Fan Method. The Extended Step Method is a zero-order process whose usefulness lies chiefly in the simplicity of the hardware required for implementation. The Fan Method, which is a first-order process, requires additional hardware, but provides better over-all quality and compression performance.

Listening comparison tests indicated that quality equivalent to that produced by a 48-kilobit PCM system was feasible using the redundancy reduction techniques described in the previous paragraphs. Based on these test results, a prototype system was built.

The prototype system is called Radiation Adaptive Compression Equipment (RACE). A detailed block diagram of a single full-duplex RACE terminal is shown in Fig. 6. Input signals from a standard desk telephone are applied to an a.g.c. amplifier to provide gain adjustment for various speaker levels. After filtering to (Continued on page 76)

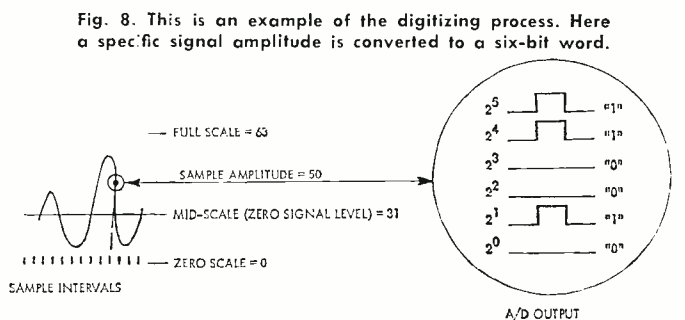
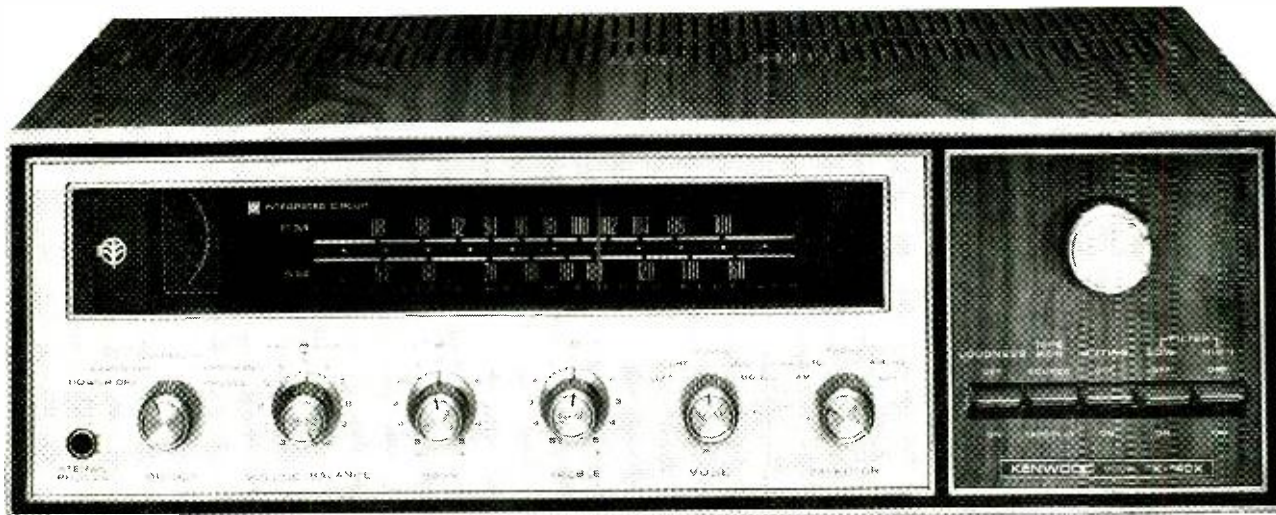
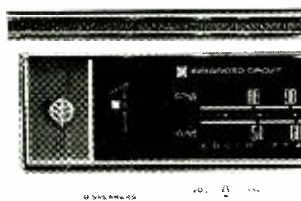

Fig. 8. This is an example of the digitizing process. Here a specific signal amplitude is converted to a six-bit word.



KENWOOD TK-140x Triple Threat Receiver

● NEW FEATURES...



Brilliant "Luminous Dial" that glows blue when set is "on"...disappears to an opaque panel when set is "off". Also, new Tuning Meter with FM Stereo Light Indicator



200 watts (4 ohms) music power plus special circuits and heavy-duty silicon transistors both in driver and main amplifier



"Feather-Touch Control" to regulate Muting, Loudness (bass, treble boost at low listening levels), Tape Recorder Modes and Low and High Filters

● NEW PERFORMANCE...

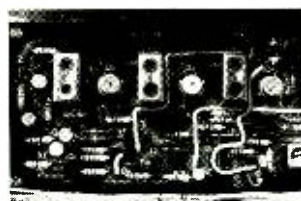

High-gain Integrated Circuits (IC) in all four IF Amplifiers to provide a mere 1 dB difference to capture one station and reject another on the same frequency



4-gang Tuning Condenser super-sensitive FM Front End with 3 FETs provides an exceptionally outstanding 1.7 μ V sensitivity.



Exclusive Electronic Protection Circuit (U. S. Pat.) guards against blow-up of power transistor. Another example of KENWOOD's quality and dependability.

● NEW VALUES...

Visit your nearest KENWOOD dealer and compare the TK-140x point for point with more expensive receivers. Check the features. Listen critically to the sound. Then compare the price. Hard to believe, but it is true. It's only \$349.95 and even includes the cabinet!

the sound approach to quality



3700 S. Broadway Pl., Los Angeles, Calif. 90007
69-41 Calamus Ave., Woodside, N. Y. 11377
Exclusive Canadian Distr. — Perfect Mfg. & Supplies Corp. Ltd.



J OHN FRYE

A widening gulf between men of science and men of literature poses a threat to the future of mankind.

THE SPIRIT OF LEONARDO

IT was coffee-break time at Mac's Service Shop. Matilda, the office girl, was sharing a leisurely cup of coffee in the service department with her employer and with Barney, the technician. "Say," she said, cradling her cup in both her hands, "I'd like the opinion of you two self-admitted geniuses on something I was reading last night."

"I dunno, Mac," Barney said cautiously. "Do you think she can afford us?"

"Aw, why not?" Mac replied. "She does make a good cup of coffee, and we both have brains we haven't even used yet. Let's give her our opinion."

"That's what I like: modest men!" Matilda said. "Anyway I took home a copy of *Western Electric's* house organ 'The Engineer' to read the editorial—which is about the only thing in that magazine I can understand. The editor, Timothy C. N. Mann, was discussing a 'Lecture on Two Cultures' delivered by C. P. Snow in 1959."

"I remember that," Mac said.

"So do I," Barney chimed in.

"Good! Then you'll both remember Mr. Snow said modern culture has become polarized into two separate cultures, the literary and the scientific, and that these two cultures have less and less to do with one another. Do you think this is true?"

"I'm afraid it is," Mac replied thoughtfully. "Non-scientific people all too often stubbornly refuse to become interested in modern scientific achievement. They retreat into their ivory towers and sneer at people with 'slide rules for souls.' They are blind to the effect such achievement has on the grave problems afflicting mankind."

"And the other side of the coin," Barney broke in, "is that members of the growing scientific community defend their deep ignorance of things literary by saying that literature has nothing to contribute to the problems they are solving. They even suggest an interest in literary matters is a waste of brain power and that literary culture is actually dying."

"Mr. Mann believes this separation results more from what he calls 'intellectual fear' than from any rational conviction on either side," Matilda said. "The literary person who ordinarily deals with subjective concepts and interprets them in the light of his convictions and personal experience has little interest in impersonal ideas. To him, only the living world of men rather than the dead world of things is worthy of deep thought. To him technology threatens the loss of his precious selfhood. He wants to be a man, not a number."

"By the same token the scientist who deals only with clearly defined objective concepts, which he discusses in rigorous terms of logic, instinctively distrusts all subjective ideas. He considers these, at best, a waste of time and, at worst, a serious danger to his precise and well-ordered world. To him the 'human factor' is something to be guarded against, not courted; and he fears the vagaries of his own nature."

"Editor Mann believes that, because fear can be surmounted, an explanation of the dichotomy between the two

cultures in terms of fear provides a basis for hope they can be united—at least for a significant number of individuals. For this to happen, though, the members of each culture must be shown why they should admit alien ideas into their ordered world.

"For members of the literary culture, the question is simply one of relevance. They must understand the technology that frees man from toil also shapes society. They must be aware of the growing interaction between men and the machines they invent. The telephone, television, airplane, automobile, and atomic bomb all have profound effect on our lives; and now our space travel machines are swinging open the door to the universe. Modern man cannot, like Thoreau, retreat to Walden Pond and grow in wisdom by ignoring the rest of the world. The world of today is a technological world, and you cannot understand it or the people in it without making some sort of peace with technology.

"For scientists and engineers, the question is one of coming of age. When scientists were eccentrics and engineers were artisans, it was perhaps just as well that they pursued their lonely and misunderstood interests apart from the ignorant judgments of mankind. Science revealed its own inner logic, and when knowledge was pursued in the light of this logic, undiluted by prevailing superstition, understanding resulted. The new scientists never doubted this understanding would prove beneficial to mankind. They reasoned: knowledge is power; power means progress; progress results in the perfection of mankind.

"Science today is having second thoughts. Internal contradictions, such as contained in the duality of the nature of light, prove complete understanding is not yet and may never be possible. Social inventions such as mass propaganda and the totalitarian state have made possible more nearly perfect dictatorships. Machines have become fantastically efficient—including, unfortunately, the death-dealing ones. Finally, better living through technology has shown that perhaps the affluent society is a disintegrating society.

"But at the same time scientists and engineers have been raised to positions of greater freedom and power within modern society. Since only they understand and are able to control the Machine that feeds and protects and provides comforts for the modern man, money, social status, and attention are showered on them, and vast amounts of public funds and private investment are placed at their disposal.

"Mann thinks these twin developments—gathering doubt as to man's inevitable improvement through technology and the rise of scientists and engineers to power—have forced members of the scientific culture to take another look at their accomplishments and goals in the light of *human* reality. Power carries with it responsibility, and as technology 'comes of age' members of the scientific culture must accept that responsibility and examine themselves and their roles in society with the same objectivity they use on their technical problems. To accomplish this unaccustomed task,

they must get help from the literary culture, which has largely concerned itself with man's continuing attempt to cope with his own nature."

"Whew!" Barney exclaimed. "That's pretty heavy stuff to be throwing at a couple of lowly solder-slingers. What you seem to be saying is that we need more men who are at home in both the scientific and the literary cultures. Do you honestly think there ever will be such a critter?"

"There have been in the past," Mac offered. "How about Leonardo da Vinci? He not only painted the *Mona Lisa* and *The Last Supper*, but he was also a sculptor, an architect, a military engineer, and an inventor. We know from his sketches that if he had only had a fuel such as gasoline at his disposal, he very likely would have been the first man to fly."

"Well, how about our own Thomas Jefferson?" Matilda asked. "He wrote the *Declaration of Independence* and was an excellent musician, but he was also an inventor, an agrarian scientist, and a fine mathematician. Certainly he understood both people and machines."

"Yeah, and come to think of it Ben Franklin was no slouch in either culture," Barney added thoughtfully. "When he wasn't writing some of the clearest prose in the English language or helping lay the foundations of this country, he was experimenting with electricity, inventing the lightning rod, or explaining *The Cause and Cure of Smoky Chimneys*. Both literary people and men of science mourned his passing."

"This whole discussion reminds me of something I read the other evening," Mac said. "It was written by John William Gardner in his essay *Excellence: Can We Be Equal and Excellent, Too?* He said: 'The society which scorns excellence in plumbing because plumbing is a humble activity and tolerates shoddiness in philosophy because it is an exalted activity will have neither good plumbing nor good philosophy. Neither its pipes nor its theories will hold water.'"

"I like that," Matilda said with a smile. "It hits the nail precisely on the head. Maybe it will take a while for each culture to *understand* the other; but if they will only *respect* one another, that will be a good beginning."

"I believe a beginning is actually being made," Mac offered. "The other day I read an advertisement from one of our great technological companies in which it was stated that every ten to fifteen years our store of technical knowledge doubles. At the same time acknowledgment was made of some of the pressing human problems. The advertisement went on to say, 'The real solution is putting this knowledge to

work at the right time, in the right direction, against the right problem.' That sounds to me like a mature and responsible scientific culture talking."

"Probably the reason this subject is so interesting to me right now is because of the discussions I am constantly hearing about our space endeavors," Matilda explained. "While everyone was thrilled by the brilliant success of Apollo VIII, there is by no means a consensus regarding the real value of this feat. Over and over I hear people say, 'It was a wonderful scientific accomplishment and a source of tremendous satisfaction to the men who planned and executed it, but actually how much better off is mankind as a result of this round-trip to the moon? What if those three-hundred million dollars and all that brain power had been focussed on conquering cancer or strokes, on the growing twin threat of over-population and famine, on water pollution, or on the smoldering unrest in the ghettos? Would not the solution of any one of these problems be of infinitely more benefit to mankind than the exploration of the moon?'"

"Is that the way you feel?" Mac asked curiously.

"I really don't know," Matilda answered. "Sometimes I think one way and sometimes the other. But the important thing is that many people are becoming less and less enchanted with technology for its own sake. We Americans have been accused of worshipping our machines. If so, we are beginning to see our gods have feet of clay and that they are not omnipotent—at least when it comes to solving our social problems. If the scientific culture wishes to continue to bask in public favor, it must establish a rapport with the literary culture and convince the people it is a friend, not a Frankenstein. It should really think big and infuse itself with the warm human spirit of Leonardo da Vinci!" ▲

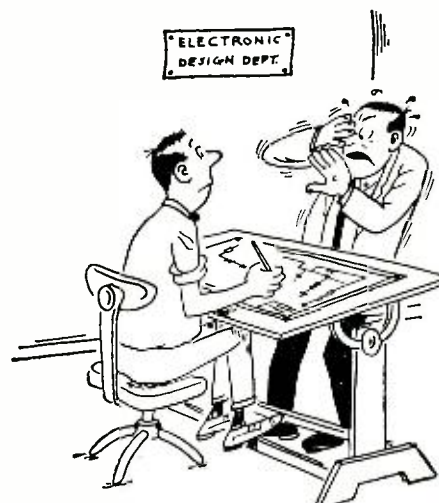

"Hurry up—erase that connection before you start a fire!"

Electronics Technicians COMSAT LABORATORIES

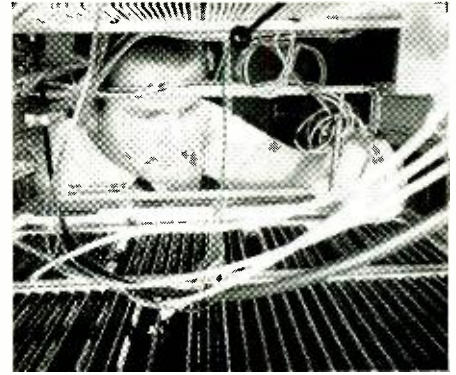

COMMUNICATIONS SATELLITE CORPORATION, the unique privately owned company that provides communications satellite services, has immediate openings for electronic technicians in its rapidly expanding COMSAT laboratories.

Presently located in downtown Washington, D.C., the laboratories will move soon to their new facility now under construction in nearby Maryland.

Immediate openings are now available for candidates experienced in construction and testing:

- SATELLITE COMMAND AND TELEMETRY SYSTEMS
- HIGH SPEED DIGITAL SUBSYSTEMS AND CIRCUITS
- RF RECEIVERS AND TRANSMITTERS
- MODULATOR AND DEMODULATORS
- MICROWAVE COMPONENTS, ANTENNAS AND FILTERS
- SPACE BORN MICROWAVE AMPLIFIERS AND OSCILLATORS

COMSAT Laboratories offers excellent salaries, outstanding education, insurance, retirement and hospitalization benefits.

RELOCATION TO THE WASHINGTON AREA WILL BE PAID

If you are interested please direct your resume and salary requirements to:

J. K. Milligan

COMSAT

COMMUNICATIONS
SATELLITE CORPORATION

1835 K Street, N.W.
Washington, D.C. 20006

An Equal Opportunity Employer

Hunting for a better job?

**Here's the
license
you need
to go after
the big ones**

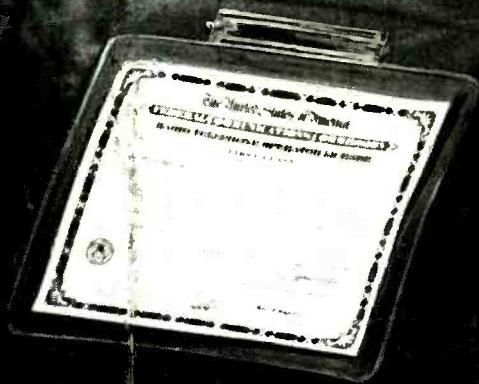

A Government FCC License can help you bring home up to \$10,000, \$12,000, and more a year. Read how you can prepare for the license exam at home in your spare time—with a passing grade assured or your money back.

IF YOU'RE OUT TO BAG A BETTER JOB in Electronics, you'd better have a Government FCC License. For you'll need it to track down the choicest, best-paying jobs that this booming field has to offer.

Right now there are 80,000 new openings every year for electronics specialists—jobs paying up to \$5, \$6, even \$7 an hour... \$200, \$225, \$250, a week... \$10,000, \$12,000, and up a year! You don't need a college education to make this kind of money in Electronics, or even a high school diploma.

But you *do* need knowledge, knowledge of electronics fundamentals. And there is only one nationally accepted method of measuring this knowledge... the licensing program of the FCC (Federal Communications Commission).

Why a license is important

An FCC License is a legal requirement if you want to become a Broadcast Engineer, or get into servicing any other kind of transmitting equipment—two-way mobile radios, microwave relay links, radar, etc. And even when it's not legally required, a license proves to the world that you understand the principles involved in *any* electronic device. Thus, an FCC "ticket" can open the doors to thousands of exciting, high-paying jobs in communications, radio and broadcasting, the aerospace program, industrial automation, and many other areas.

So why doesn't everyone who wants a good job in Electronics get an FCC License and start cleaning up?

The answer: it's not that simple. The government's licensing exam is tough. In fact, an average of two out of every three men who take the FCC exam fail.

There is one way, however, of being pretty certain that you will pass the FCC exam. And that is to take one of the FCC home study courses offered by Cleveland Institute of Electronics.

CIE courses are so effective that better than 9 out of 10 CIE graduates who take the exam pass it. That's why we can back our courses with this iron-clad Warranty: Upon completing one of our FCC courses, you must be able to pass the FCC exam and get your license—or you'll get your money back!

They got their licenses and went on to better jobs

The value of CIE training has been demonstrated time and again by the achievements of our thousands of successful students and graduates.

2 NEW CIE CAREER COURSES

1. BROADCAST (Radio and TV) ENGINEERING... now includes Video Systems, Monitors, FM Stereo Multiplex, Color Transmitter Operation and CATV.

2. ELECTRONICS ENGINEERING... covers steady-state and transient network theory, solid state physics and circuitry, pulse techniques, computer logic and mathematics through calculus. A college-level course for men already working in Electronics.

Ed Dulaney, Scottsbluff, Nebraska, for example, passed his 1st Class FCC License exam soon after completing his CIE training...and today is the proud owner of his own mobile radio sales and service business. "Now I manufacture my own two-way equipment," he writes, "with dealers who sell it in seven different states, and have seven full-time employees on my payroll."

Daniel J. Smithwick started his CIE training while in the service, and passed his 2nd Class exam soon after his discharge. Four months later, he reports, "I was promoted to manager of Bell Telephone at La Moure, N.D. This was a very fast promotion and a great deal of the credit goes to CIE."

Eugene Frost, Columbus, Ohio, was stuck in low-paying TV repair work before enrolling with CIE and earning his FCC License. Today, he's an inspector of major electronics systems for North American Aviation. "I'm working 8 hours a week less," says Mr. Frost, "and earning \$228 a month more."

Send for FREE book

If you'd like to succeed like these men, send for our FREE 24-page book "How To Get A Commercial FCC License." It tells you all about the FCC License... requirements for getting one... types of licenses available... how the exams are organized and what kinds of questions are asked... where and when the exams are held, and more.

With it you will also receive a second FREE book, "How To Succeed In Electronics," To get both books without cost or obligation, just mail the attached postpaid card. Or, if the card is missing, just mail the coupon below.

ENROLL UNDER NEW G.I. BILL. All CIE courses are available under the new G.I. Bill. If you served on active duty since Jan. 31, 1955, or are in service now, check box on reply card for complete details.

CIE Cleveland Institute of Electronics

1776 E.17th St., Cleveland, Ohio 44114

Accredited Member National Home Study Council
A Leader in Electronics Training... Since 1934



Cleveland Institute of Electronics
1776 East 17th Street, Cleveland, Ohio 44114

Please send me without cost or obligation:
Your 44 page book "How to Succeed In Electronics" describing job opportunities in Electronics today, and how your courses can prepare me for them.
Your book on "How To Get A Commercial FCC License."

I am especially interested in:

<input type="checkbox"/> Electronics Technology	<input type="checkbox"/> Electronic Communications
<input type="checkbox"/> Broadcast Engineering	<input type="checkbox"/> Industrial Electronics
<input type="checkbox"/> First Class FCC License	<input type="checkbox"/> Electronics Engineering

Name _____ (PLEASE PRINT)
Address _____
City _____
State _____ Zip _____ Age _____

Check here for G.I. Bill information EW-39

CIRCLE NO. 118 ON READER SERVICE CARD

BOOK REVIEWS

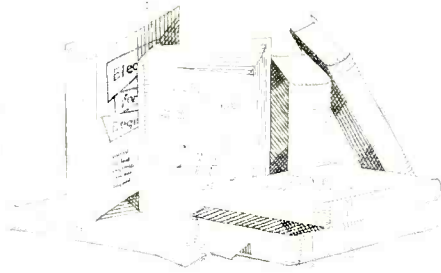

"ON THE COLOR TV SERVICE BENCH" by Jay F. Shane. Published by *Tab Books*, Blue Ridge Summit, Pa. 17214. 190 pages. Price \$6.95; \$4.95 soft cover.

This is a guidebook for the professional service technician—one who is familiar with black-and-white television servicing and just needs a little help in tracking down circuit faults in color sets.

The book details specific problems and then tells how to handle them easily, swiftly, and profitably. There are step-by-step alignment instructions and useful information on alignment equipment and other test gear.

The text is divided into 14 clearly segregated chapters, each dealing with a specific section of the receiver and its troubles. The book is illustrated by partial schematics, scope traces, performance graphs, and other pertinent material.

"REFERENCE DATA FOR RADIO ENGINEERS". Published by *Howard W. Sams & Co., Inc.*, Indianapolis, Ind. 46268. 1150 pages. Price \$20.00.

This is the Fifth Edition of the handbook that engineers have been consulting since 1942. It represents five years' revision and compilation work by groups of practicing engineers, professors, and industry and government experts under the direction of H.P. Westman, editor, and the *ITT* staff.

In 45 chapters the contributors have not only presented data on all of the basic phases of radio and electronics but new material on microminiature electronics, space communications, navigation aids, reliability and life testing, international telecommunications, switching networks and traffic concepts, and quantum electronics. Over half of the material presented is new. There are hundreds of charts, nomograms, diagrams, curves, tables, and illustrations which add further to the storehouse of useful information that is contained in this reference manual.

To make it easy for the engineer to find exactly the data he is seeking, there is a comprehensive 40-page index for fingertip reference.

Any engineer who has ever used "Reference Data" in the past will welcome this new edition with enthusiasm. For those not familiar with this "bible", this is a chance to acquire a complete reference "library" between two covers.

"WORLD WHO'S WHO IN SCIENCE" compiled and published by *Marquis-Who's Who*, 200 East Ohio Street, Chicago, Illinois 60611. 1855 pages.

This is the First Edition of the familiar "Who's Who" but devoted to scientists from antiquity to the present time. Under the editorship of Allen G. Debus of the University of Chicago, this volume retains the familiar "Who's Who" format with persons listed in alphabetical order and their achievements detailed in telegraphic form.

Company libraries, general and technical libraries, colleges and universities, as well as writers and editors dealing with scientific material will find this volume an authoritative reference source.

"TRANSISTOR AUDIO AMPLIFIERS" by Dwight V. Jones & Richard F. Shea. Published by *John Wiley & Sons, Inc.*, New York. 259 pages. Price \$9.95.

This is a completely revised and updated version of Mr. Shea's 1955 book. The emphasis has been shifted from theory

NOW YOU CAN
UNSOLDER...

NEW LOW PRICE*



FOR SOLDERING AND DESOLDERING

uniline mark VII

SOLDER AND DESOLDER WITH ONE TOOL!

The Uniline Mark VII is a dual purpose pencil soldering-desoldering tool. This truly revolutionary system allows you to solder and desolder any joint with finger tip ease and control. Simply press the button to desolder. How about that!

The tool is composed of three basic components that give it unprecedented versatility. You can select what you need from: **FOUR DIFFERENT COLORS OF HANDLES, FOUR INTERCHANGEABLE HEAT CARTRIDGES (20-30-40 & 50 WATTS), DOZENS OF DIFFERENT TIPS IN MANY DIFFERENT STYLES AND SHAPES.**

How's that for a combination tool? Exciting, isn't it! If you are interested in saving time and money you need one right now. See your local distributor today, and tomorrow start enjoying cost reduction you never thought possible.

Vanguard
ELECTRONIC TOOLS INC. UNILINE DIVISION
NEWTON, KANSAS

SEE YOUR LOCAL DISTRIBUTOR TODAY!

AS LOW AS *
\$9.95

CIRCLE NO. 85 ON READER SERVICE CARD

to practical circuits and their application and thus the book should be more useful to engineers and designers.

The text is divided into thirteen chapters covering transistor fundamentals, small-signal characteristics, large-signal characteristics and biasing, the terminated equivalent circuit, coupled stages, feedback in transistor amplifiers, pre-amplifiers, class-A power amplifiers, class-B and -AB push-pull amplifiers, power supplies, stereo systems, tape record and playback systems, and monolithic integrated audio amplifiers.

The treatment is mathematical and the text is lavishly illustrated with graphs, line drawings, tables, and schematics. For those with the requisite background in transistor engineering, this little volume should be of immediate and practical assistance.

* * *

"FREQUENCY MODULATION RECEIVERS" By A. B. Cook & A. A. Liff. Published by *Prentice-Hall, Inc.*, Englewood Cliffs, N. J. 519 pages. Price \$15.00.

This is the most comprehensive treatment of FM receivers we have seen and one that should be welcomed by r.f. engineers, broadcast and communications engineers, and especially by service technicians. With only a background in basic electronic theory, fundamental algebra, and basic trigonometry, the student should have no trouble grasping the material.

An introductory chapter provides pertinent information on various items regarding AM and FM transmission and reception. The balance of the book deals with specifics: interference, noise, v.h.f. effects, r.f. amplifiers, frequency changers, i.f. amplifiers, limiters, slope-type FM detectors, phase-shift detectors, quadrature-type detectors for TV sound, FM tuning indicators, stereo broadcasting, and miscellaneous circuitry. Each chapter carries a summary, a list of references, and an appendix. The text is lavishly illustrated, the writing is clear and concise, and the presentation is logical and progressive. ▲

A 50-MHz Digital Counter

(Continued from page 42)

output is at DTL levels and used to feed the next decade in line. Table 1 provides wiring information for those who desire to build the instrument. It shows the proper correlation among the display numerals, the Nixie tube-pin numbers, and two popular integrated-circuit Nixie drivers—the DTL and $C_{\mu}L$ 9960. ▲

Table 1. Nixie/IC driver wiring data and bottom views.

NUMERAL	NIXIE PINS	DRIVER PINS
0	12	9
1	1	5
2	2	10
3	3	4
4	4	11
5	5	3
6	6	12
7	8	2
8	9	13
9	11	1
Decimal Point	13	
Anode	7	

Connect to decimal wafer sw. Through 10k res. to hi-volt sw.

DTL

NIXIE

$C_{\mu}L$ 9960 ONLY

Should you be using a reed switch?

Are you switching with a costly solid-state device or lumbering mechanical device, instead of with a reed switch that could do the job better at less cost? Unless you know about the types of reed switches available and how to select the best switch for your application, you may be guilty.

Find out if you are by sending for your **FREE** 22-page booklet *Reed Switch Application Notes*. In addition to such selection criteria as reed size, gap location, power factors, operate and release points and contact materials; information is given on lead cutting and bending, encapsulation, bounce, dynamic noise, temperature effects, and insulation resistance.

Free.

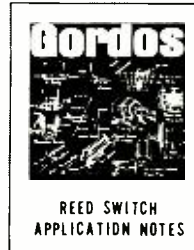

Everyone interested in reed switches should own this booklet. Send for your free copy NOW.

GORDOS CORPORATION 201-743-6800
250 Glenwood Ave. Bloomfield, N.J. 07003

CIRCLE NO. 109 ON READER SERVICE CARD

FREE



GIANT 1969 RADIO-TV ELECTRONICS CATALOG

228 GIANT VALUE-PACKED PAGES

YOUR BUYING GUIDE FOR . . . TV's, Radios, Recorders, Phonos, Amateur and CB equipment, electronic parts, tubes and test equipment . . . plus featuring B-A's famous bargain packed section!

WRITE FOR YOUR FREE CATALOG TODAY!

BURSTEIN-APPLEBEE CO., DEPT. EW-C
3199 MERCIER ST., KANSAS CITY, MO. 64111

Name _____
Address _____
City _____
State _____ Zip Code _____

CIRCLE NO. 120 ON READER SERVICE CARD

"Performance-Plus" Kits For Shop And

NEW
kit IG-18
\$67⁵⁰
wired IGW-18
\$99⁵⁰

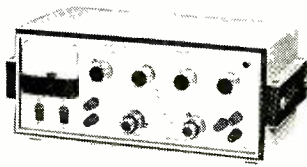

HEATHKIT IG-18 Solid-State Sine-Square Wave Generator

A precision source of sine or square waves at a low kit price . . . that's the new solid-state IG-18 from Heath. Delivers 5% accuracy thru the wide range of 1 Hz to 100 kHz. The sine wave section features less than 0.1% distortion thru the audio range, 8 output voltage ranges from 0.003 to 10V, switch-selected internal 600 ohm load or external load and metered output of both voltage & dB. The square wave section has a 50 nS rise time and three output voltage ranges from 0.1 to 10 V P-P. Both sine & square waves are available simultaneously and the frequency is switch-selected for constant repeatability and fast operation. Circuit board construction makes the new IG-18 easy to build . . . new Heathkit styling and engineering excellence make it easy to use. Put the new IG-18 on your bench now. 10 lbs.



kit IM-18
\$28⁵⁰
wired IMW-18
\$47⁹⁵

HEATHKIT IM-18 VTVM

The new Heathkit IM-18 continues the features that made the IM-11 famous . . . 7 AC and 7 DC voltage ranges that measure from 0-1500 volts full scale . . . 7 ohms ranges for measurements from 0.1 ohm to 1000 megohms . . . the convenience of a single probe . . . 11 megohm input impedance . . . ± 1 dB 25 Hz to 1 MHz response . . . precision 1% resistors . . . DC polarity reversing position on the function switch . . . RMS & P-P AC voltage and dB measurement capability . . . precision $4\frac{1}{2}$ " 200 uA meter for extra sensitivity. In addition, the new IM-18 has 120 V. or 240 V. AC wiring options, new Heathkit styling and a 3-wire line cord for safety. 5 lbs.

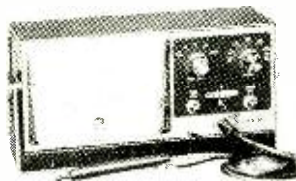

kit IM-13
\$36⁵⁰
wired IMW-28
\$56⁹⁵

HEATHKIT IM-13 "Service Bench" VTVM

The Heathkit IM-13 has the same performance specifications as the new IM-18 above, but it also incorporates other features that put it in a class by itself, such as a large, easy-to-read 6" meter . . . extra 1.5 and 5 volt AC ranges for additional accuracy . . . convenient gimbal mounting that allows attachment to your most convenient surface . . . "Set and Forget" calibration — all controls are adjustable from the front panel with a screwdriver . . . smooth ten-turn vernier control of Zero and Ohms adjust for greater accuracy and easier setting . . . clean, open parts layout and a readily accessible "ohms" battery. Assembly is easy, thanks to the famous Heathkit manual, and operating convenience and versatility are tops. For maximum value in a general service VTVM, you just can't beat the Heathkit IM-13. 7 lbs.



kit IM-38
\$39⁵⁰
wired IMW-38
\$54⁹⁵

HEATHKIT IM-38 Laboratory AC VTVM

For all around general service work, audio design or laboratory analysis, there isn't a better value than the new Heathkit IM-38 AC VTVM. Here's why — 10 voltage ranges measure from 0.01 to 300 volts RMS full scale . . . extended frequency response of 10 Hz to 500 kHz at ± 1 dB . . . 10 megohm input on all ranges for higher accuracy . . . wide -52 to $+52$ dB range . . . VU-type ballistic meter damping . . . very low AC noise . . . 120 or 240 VAC wiring options and new Heathkit styling in sharp beige & brown with an easy-to-grasp, easy-to-read knob. 5 lbs.



kit IP-18
\$19⁹⁵

HEATHKIT IP-18 1-15 VDC Power Supply

If you work with transistors, this is the power supply for you. All solid-state circuitry provides 1-15 VDC at up to 500 mA continuous. Features adjustable current limiting, voltage regulation, floating output for either + or - ground, AC or DC programming, circuit board construction, and small, compact size. 110 or 220 VAC. 5 lbs.



kit IT-18
\$24⁹⁵

HEATHKIT IT-18 In-Circuit Transistor Tester

In-Circuit transistor testers don't have to be expensive, and the IT-18 is proof of that . . . tests DC Beta 2-1000, in or out-of-circuit . . . leakage I_{cbo} and I_{ceo} current 0-5000 uA out-of-circuit . . . identifies NPN or PNP devices . . . tests diodes in or out-of-circuit for opens & shorts . . . identifies unknown diode leads . . . matches PNP & NPN transistors. The IT-18 is completely portable — runs on just one "D" cell. Easy to use too . . . rugged polypropylene case, attached 3' test leads, big $4\frac{1}{2}$ " 200 uA meter, all front panel controls, 10-turn calibrate control. 4 lbs.



kit IM-17
\$21⁹⁵

HEATHKIT IM-17 Solid-State Volt-Ohm Meter

Another very popular volt-ohmmeter from Heathkit engineering and it's easy to see why — all solid-state circuitry . . . high impedance FET input, 11 megohms on DC, 1 megohm on AC . . . 4 AC voltage ranges . . . 4 DC voltage ranges . . . 4 ohm ranges . . . $4\frac{1}{2}$ " 200 uA meter . . . 3 built-in test leads . . . DC polarity reversing switch . . . zero-adjust & ohms-adjust controls . . . continuous 12-position function switch. And that's not all — the IM-17 is battery powered for complete portability and comes in a rugged polypropylene case with built-in handle. Simple circuit board assembly. 4 lbs.

kit IG-57
\$135⁰⁰
wired IGW-57
\$199⁰⁰

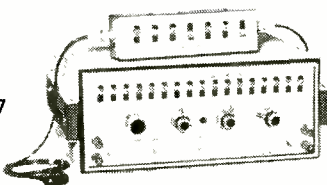

HEATHKIT IG-57 Solid-State Post Marker/Sweep Generator

The new IG-57 plus a 'scope is all you need . . . no external sweep generator required. Switch selection of any of 15 crystal-controlled marker frequencies (you can view up to six different frequencies on one 'scope trace). Select the sweep range and you are ready to instantly see the results of any changes you make. Four markers for setting color bandpass, one for TV sound, eight at 1F frequencies between 39.75 & 47.25 MHz plus picture and sound carrier markers for channels 4 & 10. Three sweep oscillators produce the 5 most-used ranges . . . color bandpass, FM 1F, color & B&W 1F and VHF channels 4 & 10. Save hundreds of dollars and put full alignment facilities in your shop too — order your IG-57 now. 14 lbs. Kit IG-14, same as IG-57 w/o the sweep, 11 lbs. \$99.95.

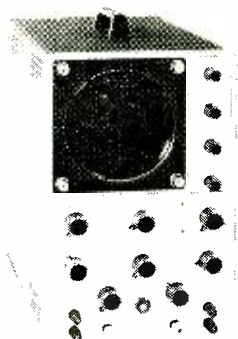

kit IO-18
\$84⁹⁵
wired IOW-18
\$139⁹⁵

HEATHKIT IO-18 Wide-Band 5" 'Scope

The New Heathkit IO-18 is destined to be the world's most popular 'scope, just as its predecessor, the IO-12 was. Features 5 MHz bandwidth, the famous Heath patented sweep circuit — 10 Hz to 500 kHz in 5 ranges, two extra sweep positions which can be preset to often-used rates, frequency compensated vertical attenuation, built-in P-P calibration reference, Z-axis input, retrace blanking, wiring options for 120 or 240 VAC operation and new Heathkit styling in beige and brown. 24 lbs.

Home... From The Leader



Now There are 4 Heathkit Color TV's ...
All With 2-Year Picture Tube Warranty

NEW Deluxe "681" Color TV With Automatic Fine Tuning

The new Heathkit GR-681 is the most advanced color TV on the market. A strong claim, but easy to prove. Compare the "681" against every other TV — there isn't one available for any price that has all these features. Automatic Fine Tuning on all 83 channels ... just push a button and the factory assembled solid-state circuit takes over to automatically tune the best color picture in the industry. Push another front-panel button and the VHF channel selector rotates until you reach the desired station, automatically. Built-in cable-type remote control that allows you to turn the "681" on and off and change VHF channels without moving from your chair. Or add the optional GRA-681-6 Wireless Remote Control described below. A bridge-type low voltage power supply for superior regulation; high & low AC taps are provided to insure that the picture transmitted exactly fits the "681" screen. Automatic degaussing, 2-speed transistor UHF tuner, hi-fi sound output, two VHF antenna inputs ... plus the built-in self-servicing aids that are standard on all Heathkit color TV's but can't be bought on any other set for any price ... plus all the features of the famous "295" below. Compare the "681" against the others ... and be convinced.

GRA-295-4, Mediterranean cabinet shown..... \$119.50
Other cabinets from \$62.95

Deluxe "295" Color TV... Model GR-295

Big, Bold, Beautiful ... and packed with features. Top quality American brand color tube with 295 sq. in. viewing area ... new improved phosphors and low voltage supply with boosted B + for brighter, livelier color ... automatic degaussing ... exclusive Heath Magna-Shield ... Automatic Color Control & Automatic Gain Control for color purity, and flutter-free pictures under all conditions ... preassembled IF strip with 3 stages instead of the usual two ... deluxe VHF tuner with "memory" fine tuning ... three-way installation — wall, custom or any of the beautiful Heath factory assembled cabinets. Add to that the unique Heathkit self-servicing features like the built-in dot generator and full color photos in the comprehensive manual that let you set-up, converge and maintain the best color picture at all times, and can save you up to \$200 over the life of your set in service calls. For the best color picture around, order your "295" now.

GRA-295-1, Walnut cabinet shown..... \$62.95
Other cabinets from \$99.95

Deluxe "227" Color TV... Model GR-227

Has same high performance features and built-in servicing facilities as the GR-295, except for 227 sq. inch viewing area. The vertical swing-out chassis makes for fast, easy servicing and installation. The dynamic convergence control board can be placed so that it is easily accessible anytime you wish to "touch-up" the picture.

GRA-227-1, Walnut cabinet shown..... \$59.95
Mediterranean style also available at \$99.50

Deluxe "180" Color TV... Model GR-180

Same high performance features and exclusive self-servicing facilities as the GR-295 except for 180 sq. inch viewing area. Feature for feature the Heathkit "180" is your best buy in deluxe color TV viewing ... tubes alone list for over \$245. For extra savings, extra beauty and convenience, add the table model cabinet and mobile cart.

GRS-180-5, table model cabinet and cart..... \$39.95
Other cabinets from \$24.95

Now, Wireless Remote Control For Heathkit Color TV's

Control your Heathkit Color TV from your easy chair, turn it on and off, change VHF channels, volume, color and tint, all by sonic remote control. No cables cluttering the room ... the handheld transmitter is all electronic, powered by a small 9 v. battery, housed in a small, smartly styled beige plastic case. The receiver contains an integrated circuit and a meter for adjustment ease. Installation is easy even in older Heathkit color TV's thanks to circuit board wiring harness construction. For greater TV enjoyment, order yours now.

kit GRA-681-6, 7 lbs., for Heathkit GR-681 Color TV's..... \$59.95
kit GRA-295-6, 9 lbs., for Heathkit GR-295 & GR-25 TV's..... \$69.95
kit GRA-227-6, 9 lbs., for Heathkit GR-227 & GR-180 TV's..... \$69.95

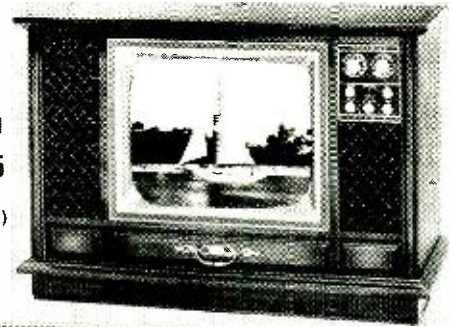

kit GR-681
\$499⁹⁵
(less cabinet)



kit GR-295
now only
\$449⁹⁵
(less cabinet)



kit GR-227
now only
\$399⁹⁵
(less cabinet)



kit GR-180
now only
\$349⁹⁵
(less cabinet)



New Wireless
TV Remote Control
For GR-295, GR-227
& GR-180
\$69⁹⁵
New Wireless
TV Remote Control
For GR-681
\$59⁹⁵



NEW
FREE 1969 CATALOG!
Now with more kits, more color. Fully describes these along with over 300 kits for stereo/hi-fi, color TV, electronic organs, electric guitar & amplifier, amateur radio, marine, educational, CB, home & hobby. Mail coupon or write Heath Company, Benton Harbor, Michigan 49022.

HEATH COMPANY, Dept. 15-3
Benton Harbor, Michigan 49022
In Canada, Daystrom Ltd.
 Enclosed is \$ _____, plus shipping.
Please send model (s) _____
 Please send FREE Heathkit Catalog.
 Please send Credit Application.
Name _____
Address _____
City _____ State _____ Zip _____
Prices & specifications subject to change without notice. CL-353

SONARCOM

FOR FIRE, POLICE, SECURITY, BUSINESS
AND INDUSTRIAL APPLICATIONS
SONAR VHF-FM TRANSCEIVER

(132-174 MHz)

YOU ALWAYS GET THROUGH... OPERATES ANYWHERE!
INDOORS, OUTDOORS, IN STEEL BUILDINGS

More performance and features than much higher priced units. Engineered with space age techniques and military type components for high reliability.

- Provides instant voice contact with base stations, mobile units and other portable transceivers
- Compatible with all VHF narrow band systems
- Full frequency range for all public safety, industrial and land transportation services
- Exclusive "Push-to-Talk" microphone for easy to use action
- Electronic mode switching, no relays
- Receiver and transmitter can be operated on independent frequencies
- External connections for antenna, earphone and battery charger
- Sensitive, noise immune squelch
- Single or split channel operation
- 1.6 watt output

\$375.00
with 1 pair of crystals
and penlite batteries

Sonar Radio Corporation
73 Wortman Avenue, Brooklyn, N.Y. 11207

Please send information on Model 2301—the SONARCOM.
Dept. 929

Firm Name _____ Title _____
Address _____ Phone _____
City _____ State _____ Zip _____

CIRCLE NO. 91 ON READER SERVICE CARD



FCC TYPE
ACCEPTED

for parts 89,91,93
and part 21
telephone use



ABOUT YOUR SUBSCRIPTION

Your subscription to **ELECTRONICS WORLD** is maintained on one of the world's most modern, efficient computer systems, and if you're like 99% of our subscribers, you'll never have any reason to complain about your subscription service.

We have found that when complaints do arise, the majority of them occur because people have written their names or addresses differently at different times. For example, if your subscription were listed under "William Jones, Cedar Lane, Middletown, Arizona," and you were to renew it as "Bill Jones, Cedar Lane, Middletown, Arizona," our computer would think that two separate subscriptions were involved, and it would start sending

you two copies of **ELECTRONICS WORLD** each month. Other examples of combinations of names that would confuse the computer would include: John Henry Smith and Henry Smith; and Mrs. Joseph Jones and Mary Jones. Minor differences in addresses can also lead to difficulties. For example, to the computer, 100 Second St. is not the same as 100 2nd St.

So, please, when you write us about your subscription, be sure to enclose the mailing label from the cover of the magazine—or else copy your name and address exactly as they appear on the mailing label. This will greatly reduce any chance of error, and we will be able to service your request much more quickly.

FOREDOM MINIATURE POWER TOOLS

for the Professional Technician

Drill, grind, debur, polish, sand, cut, drive screws and nuts. No other tools can perform the range of intricate, precision operations you can do with **FOREDOM**.



SEND FOR
COMPLETE
MINIATURE
POWER TOOL
CATALOG 3W250.



THE FOREDOM ELECTRIC COMPANY
Bethel, Connecticut 06801

CIRCLE NO. 110 ON READER SERVICE CARD

Noise Measurements (Continued from page 39)

373.1° K. The noise power (in watts) from either resistor equals kBT , where T is the temperature of the particular resistor in degrees Kelvin and k and B are the quantities described in equation (1). The testing procedure is illustrated in Fig. 4.

$$F = \frac{(T_2/T_0 - 1) - Y(T_1/T_0 - 1)}{(Y - 1)} \quad (6)$$

where T_0 is 290° K, T_1 is 77.3° K, T_2 is 373.1° K, and Y is N_2/N_1 . By measuring N_1 when the receiver's input network is at a known temperature (T_1) and measuring N_2 when it is terminated at T_2 , the corrected noise figure can be calculated directly by equation (6).

Other Errors

Although hot/cold body standards were specifically developed to clear up the problems that arose when low-noise amplifiers were tested by conventional methods, they have, unfortunately, also been used as a means to further improve noise figure specifications. In examining the literature, one can find examples of noise figures specified as the ratio of ENT to the nitrogen bath temperature. Such ratings are usually presented as *negative* noise figures. Another practice, even more misleading because it yields a positive noise figure, is that of specifying noise figure as the ratio of the nitrogen bath temperature plus ENT to the bath temperature.

A further difficulty, not necessarily associated with the hot/cold body standards, is the tendency of some experimenters to specify noise figures based on reference temperatures other than 290° K.

Noise figure and ENT are equivalent ways of describing low-noise receiver performance. For absolute comparisons to be made between devices, however, both terms must be referenced to the standard temperature of 290° K. ▲



"Nothing like keeping in shape for when
TV quits at the GoGo Club."

EW Lab Tested

(Continued from page 22)

millivolt, with a 200-ohm input impedance. These permit the use of low-output moving-coil cartridges, such as the *Ortofon SL-15T* or *Grado Model A*, without the step-up transformers usually required with these cartridges. Incidentally, the phono-sensitivity, switch tends to pick up hum so it is necessary to keep the a.c. line cord well away from it during use. In keeping with current good practice, output transistors are electronically protected against damage from speaker-line short circuits or from overdriving. Additional protection is provided by a 5-ampere fuse in each speaker line.

Our lab measurements showed the amplifier to be most conservatively rated. At 1000 Hz, it delivered more than 60 watts per channel, with both channels driven into 8-ohm loads. Into 4-ohm loads, its output was about 72 watts per channel, and into 16 ohms it was about 37 watts. The 1000-Hz harmonic distortion was under 0.1 percent from 1.5 to 20 watts output, increasing to a mere 0.2 percent at 0.3 watt and 60 watts. IM distortion was under 0.5 percent from 0.2 watt to 33 watts, increasing to 1 percent at about 45 watts.

At the rated 45-watts-per-channel output, the harmonic distortion was about 0.16 percent over most of the

audible frequency range, rising to 0.3 percent at 25 and 20,000 Hz. At half power or less, the distortion was under 0.2 percent from 20 to 13,000 Hz, and under 0.1 percent over most of that range. Hum and noise were extremely low, 64 dB below 10 watts on phono inputs and 80 dB below 10 watts on high-level inputs. At the "normal" phono sensitivity, only 0.83 millivolt was needed to develop a 10-watt output, yet overload did not occur until the signal reached 64 millivolts. The KA-6000 obviously offers a remarkable combination of extremely high gain, low noise, and wide dynamic range on its phono inputs.

The filters and tone controls were highly effective in performing their intended functions. The RIAA equalization error was within +2, -0 dB and the NAB tape-head equalization was within +3.5, -2 dB over its frequency range.

The controls operate with a smoothness and positive "feel" that testify to their careful construction. Amplifier sound is as good as the test results imply which is to say that it has no sound of its own at all. This is, after all, the characteristic of an ideal amplifier.

The *Kenwood KA-6000* is supplied complete in a metal cabinet with walnut end panels. It is a handsomely styled, conservatively rated, and highly flexible unit, and an altogether excellent value at its price of \$249.95. ▲

Ampex AG-600-2 Tape Deck

For copy of manufacturer's brochure, circle No. 24 on Reader Service Card.

THE *Ampex AG-600-2* is a portable two-track (half-track) stereo tape deck (transport plus preamps) which is directly descended from the company's popular 600-series of a few years ago. The original unit was often used by audiophiles who wanted the best performance then obtainable from a light, portable machine while broadcasters adopted it for remote recording applications for the same reasons.

The AG-600 series is frankly intended for professional users, although superficially the units resemble many home recorders. Output of the unit is for 600-ohm loads. The tape transport uses a single synchronous motor, with belt drive to the capstan flywheel and reel turntables. Friction brakes on the latter supply the necessary tape tension and braking action. The AG-600 is a two speed ($3\frac{3}{4}$ and $7\frac{1}{2}$ in/s) deck, capable of handling reels up to 7 inches in diameter.

In this latest version, the prior 600-series transport mechanism has been modified to include a three-digit push-button reset index counter, improved cooling, and a redesigned clutch assembly. Speed change is by moving a knob in or out, which shifts the capstan drive



belt on a stepped pulley. All transport operations are controlled mechanically, unlike the solenoid-operated AG-500 recorder (see *ELECTRONICS WORLD*, June 1968), so that remote control of the AG-600 is not possible. One knob selects either fast-forward or rewind operation. Another has "Off", "Play", or "Rec" positions, with a push-button safety which must be pressed to engage the record mode. The two transport controls are mechanically interlocked so that improper operation is impossible.

Tape threading is very easy and could even be done in total darkness—a decided advantage in a recorder which

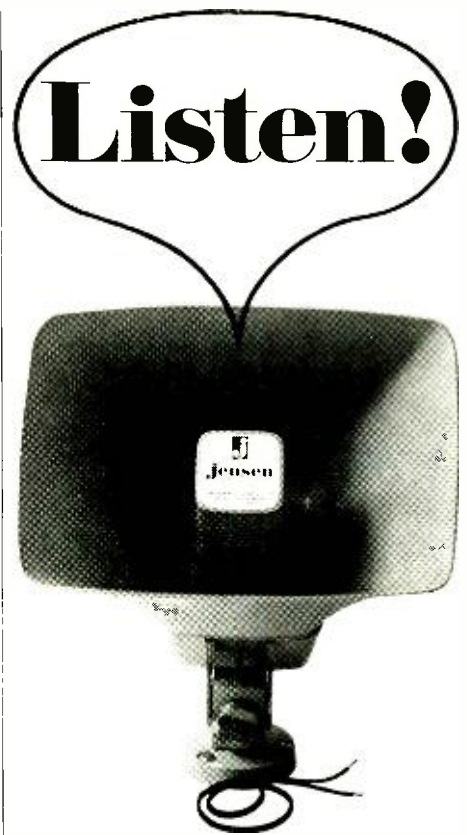

Hang it fast and easy then forget it!

The new Jensen VH-100 Series horn speakers were designed for fast installation and a lower installed cost. Their new and exclusive features let you install three VH-100's for the labor penalty previously charged for two.

KWIKON® connectors, an easily detached base, universal angle adjustment, accessible power control and an optional pre-integrated transformer are but a few of the many advantages of these rugged new weatherproof 32 watt speakers.

Our new brochure tells all.

Write Jensen Manufacturing Division, The Muter Company, 5655 West 73rd Street, Chicago, Illinois. 60638.

jensen

CIRCLE NO. 105 ON READER SERVICE CARD

For
**RELIABLE
PERFORMANCE**

the
LONG
and
SHORT
of **CRYSTEK**
is

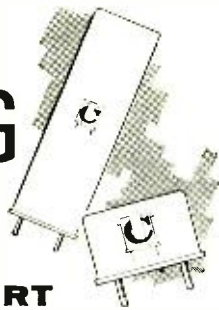

QUALITY



Our control of quality throughout precision manufacturing gives you crystals produced for your operating requirements that assure exact frequency control.

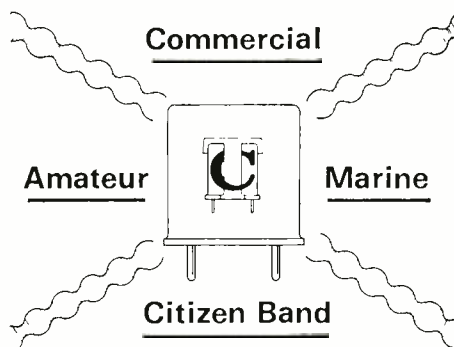

Whatever Your Application
Tell Us Your Needs



TEXAS CRYSTALS DIVISION
of Whitehall Electronics Corp.
1000 Crystal Drive
Fort Myers, Florida 33901
Telephone Area 813 - WE 6-2100
Plants in Fort Myers and Los Angeles

CIRCLE NO. 200 ON READER SERVICE CARD
66

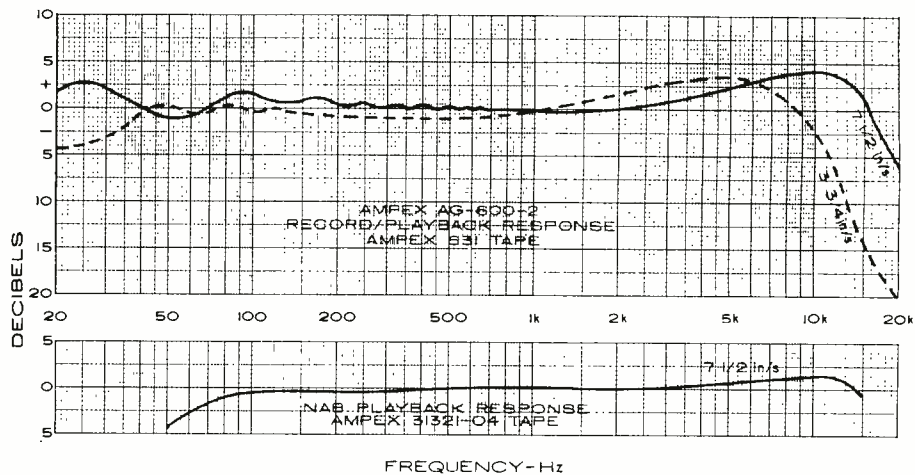

may be used in the field under less-than-ideal conditions. As a matter of fact, we are quite certain that this machine could be loaded easily and operated successfully by a blind person, which can be said for few tape recorders we have seen.

The AG-600 lacks a couple of minor conveniences found on its more expensive relative, the AG-500, and on many of the better home recorders. It has no automatic shut-off in case of tape breakage or run out. However, since the supply reel stops turning under this condition, the only effect is a rapidly spinning take-up reel. Second, there are no tape lifters and the tape contacts the heads in high-speed operation. This requires the user to turn down the volume controls on the playback amplifier, to prevent annoying noises.

Several head configurations are available, including full-track or half-track mono and half-track or quarter-track stereo. On domestic models (117 volts at 60 Hz) equalization is provided for the 120- μ s (3 $\frac{3}{4}$ in/s) characteristic and for the standard NAB 7 $\frac{1}{2}$ in/s characteristic. Export models can also operate on 230 volts and are available with 50-Hz motors. In these, the 7 $\frac{1}{2}$ in/s equalization can be had with the European CCIR characteristic.

The electronics of the *Ampex* AG-600-2 are completely separate from the tape transport, except for the interlocking of the recording function with the "Rec" mode selector. The AG-600-2 has two identical preamplifier/oscillator units installed below the transport. Each is an all solid-state unit, with its own power supply, recording and playback preamps, bias oscillator, and illuminated vu meter. In the stereo version, the power switch on the upper amplifier serves as a master switch for the entire recorder.

Each recording preamplifier has two inputs, with individual mixing-type level controls. In its basic form, the AG-600-2 has dummy plugs installed in its input accessory sockets (accessible through removable covers at the rear of the case), providing a 100,000-ohm

unbalanced input. Optional plug-in transformers can be installed for a 20,000-ohm balanced bridging input, or a 600-ohm balanced line input. Plug-in transistorized amplifiers permit operation from low-impedance microphones or magnetic phono cartridges, with RIAA equalization. The inputs are through professional three-pin locking type connectors.

The playback preamplifiers may be switched to reproduce either the input signal or the signal from the playback heads. The vu meters, at the output of the playback preamplifiers, always read the selected signal source. No playback level control is provided, but a 0-vu recording level (about 18 millivolts at maximum gain) results in a playback output of approximately 1 to 1.3 volts, across the floating 600-ohm output. A bridging headphone jack for 600-ohm phones, across the line output, permits monitoring the output of each channel individually. The line-output connector is a standard three-circuit phone jack.

The bias oscillators operate at 100 kHz. Each electronic unit has a "Safe/Ready" switch which must be in "Ready" to energize the bias oscillator (the transport must also be in "Rec"). A red light for each channel indicates that it is recording. Each preamp also has its own "Slow/Fast" equalization switch.

In our laboratory measurements, the *Ampex* AG-600-2 delivered an impressive performance. For all practical purposes it behaved just like its higher-priced relative, the AG-500. The 7 $\frac{1}{2}$ in/s record/playback frequency response was ± 4 dB from 20 to 19,000 Hz. At 3 $\frac{3}{4}$ in/s, the response was ± 4 dB from 25 to 10,500 Hz. The 7 $\frac{1}{2}$ in/s playback response from the *Ampex* 31321-04 test tape was +1.5, -4 dB from 50 to 15,000 Hz. The signal-to-noise ratio, referred to 0-vu recording level, was 45.7 dB at 3 $\frac{3}{4}$ in/s and 48 dB at 7 $\frac{1}{2}$ in/s. However, the distortion was only about 1% at that level and an input of +12 vu was needed to generate 2 to 3% distortion. Referred to that level, the signal-to-noise ratio was

56.5 dB at 3¼ in/s and 58.5 dB at 7½ in/s. All measurements were made using Ampex 631 tape.

Wow and flutter were, respectively, 0.02% and 0.07% at 7½ in/s and 0.03% and 0.10% at 3¼ in/s. These excellent figures were comparable to those we measured on the AG-500 recorder. Tape speeds appeared to be exact and at fast speeds 1200 feet of tape was handled in 95 seconds.

When recording FM programs off the air, virtually no difference could be heard between incoming and outgoing signals at 7½ in/s, and only a very slight loss of extreme highs at 3¼ in/s. Tape hiss was not audible at normal listening levels. In its sound quality and ease of use, the AG-600-2 left nothing to be desired. Some users might criticize the lack of interlocking between the tape-speed selector and the equalization switches, but we did not find that this presented any problems. With its rugged construction, proven reliability, and freedom from troublesome gadgetry, it is easy to understand the appeal of the AG-600-2 to broadcast engineers. Its compact dimensions and reasonable weight (42 lbs) add further to its overall utility.

The Ampex AG-600-2, in its portable case, sells for \$1010. The quarter-track version, the AG-600-4, is the same price, while unmounted units are somewhat less expensive. The lowest-priced full- or half-track mono version, intended for rack mounting, is \$660. Separate single-channel 20-watt portable amplifier-speaker systems, Model AA-620, are available at \$239. ▲

LOW-RATE PULSE GENERATOR

By FRANK H. TOOKER

THIS pulse generator has a repetition rate of one cycle every 4 seconds, yet it uses no electrolytic capacitors and no unusually large value timing components. Timing resistor R1 is 20 megohms, timing capacitor C1 is only 0.22 µF.

UJT Q1 operates as a relaxation oscillator with a repetition rate of one cycle every 2 seconds. The positive-going pulse, which appears at base-1 of Q1 each time the UJT fires, is fed via capacitors C2 and C3 to the silicon controlled switch Q2. The SCS in this circuit is operated in the manner of a bistable multivibrator. Thus, one positive pulse from Q1 turns the SCS on at its cathode gate; the next one turns it off at the anode gate. The signal across load resistor R6 is, therefore, of rectangular waveform and has a repetition rate of one cycle every 4 seconds. ▲

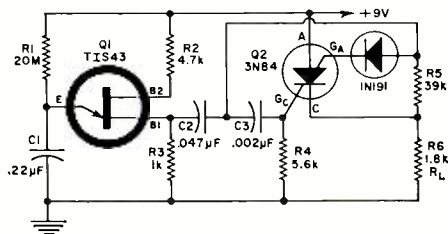

March, 1969

BESTSELLING SAMS BOOKS

for every electronics interest

NEWLY PUBLISHED AND IMPORTANT!

NEW 12TH EDITION OF THE FAMOUS TUBE SUBSTITUTION HANDBOOK

Lists over 12,000 direct substitutions. A complete guide to substitutions for receiving, picture tube, miniature, industrial, and communications types; includes foreign tubes. Tells how and when to make proper substitutions.

Order 20701, Twin-Pak (regular size for bench use; pocket-size for caddy) both for only...\$2.25
Order 20700, shop edition, only...\$1.75

Color-TV Servicing Guide

Shows how to apply fast troubleshooting procedures, based on analysis of trouble symptoms. Includes full-color picture tube photos showing various operating troubles; clearly explains how to diagnose trouble causes; gives repair procedures. Order 20358, only...\$4.25

Transistor-TV Servicing Guide, 2nd Ed.

Updated to provide full information on latest circuitry and many additional new test procedures. Covers general transistor circuitry and servicing techniques; then proceeds through the receiver, section by section, describing various picture and/or sound trouble symptoms.

Order 20696, only...\$3.95

Closed Circuit TV for Engineers & Technicians

An invaluable textbook and reference for anyone who designs, operates, and maintains cctv systems. Data is also useful to those involved in the technical aspects of television broadcasting and educational TV. This volume presents a practical discussion of circuits and applications, as opposed to a book on theory.

Order 20606, only...\$8.50

Ham Antenna Construction Projects, 2nd Ed.

All antennas covered are either homemade or represent major modifications of manufactured antennas. All the designs presented are practical and proved, including new improved versions of Marconi, Yagi, and 8JK antennas, primarily for 10-500 watt PEP class rigs.

Order 20654, only...\$3.95

49 Easy Entertainment & Science Projects 2 Vols.

Shows how to build unusual and instructive electronic circuits. Some are for practical use around the house; others are for science fair projects, toys, weird effects, and general entertainment. With full parts lists, diagrams, and instructions for each project.

Vol. 1, Order 20703, only...\$2.50

Vol. 2, Order 20704, only...\$2.50

RECENT AND TIMELY BESTSELLERS

Amateur Radio SSB Guide

Essential for anyone owning or planning to build or buy ssb equipment. Covers basic principles, purpose of ssb transmission; detailed analysis of the balanced modulator circuit and its application in a typical transmitter. Includes schematic diagrams for those interested in building or troubleshooting ssb transmitters and receivers, along with circuit analysis.

Order 20629, only...\$3.95

101 Questions & Answers About CATV and MATV

Describes the growing applications of catv (community antenna television) and matv (master antenna television) in the fields of home entertainment, schools, public safety, and industry. Fully covers equipment and system designs and installations, and the future for this field.

Order 20655, only...\$2.50

101 Questions & Answers About Fixed Radiocommunications

A valuable reference for all who work with microwave and other fixed radio systems. Covers long distance, high-frequency voice and teletype communications, short range vhf and uhf links, low-density and high-density microwave multi-channel transmission of telephone, telegraph, data, tv, and other intelligence. Essential for anyone who designs, operates, or maintains fixed radio communications systems. Includes examples of specifications of microwave and other types of fixed radio systems.

Order 20584, only...\$3.95

Short-Wave Listener's Guide—3rd Ed.

Lists all short-wave stations by country, call letters, frequency, power, and transmission time. Includes Voice of America and Radio Free Europe stations and a listing of stations operating behind the Iron Curtain. With conversion chart and handy log. Order 20695, only...\$2.25

Semiconductor Handbook

Here, in one comprehensive heavily illustrated volume, is the most complete, modern sourcebook for industrial semiconductor data. Covers latest circuitry in a wide variety of applications; provides full data on industrial semiconductors, including grown-junction, alloyed-junction, drift, MDT, mesa, planar, and epitaxial mesa types.

Order 20620, only...\$5.75

NEW 5TH EDITION OF THE WORLD-FAMOUS Reference Data for Radio Engineers

Now contains 50% more data to cover the developments of the past 12 years. Prepared by outstanding engineers, professors, and experts, under the direction of the International Telephone and Telegraph Corporation staff. Provides comprehensive data on all basic phases of electronics, including tables, formulas, standards, and circuit information—PLUS—all-new data on micro-miniature electronics, navigation aids, reliability and life testing, international telecommunication recommendations, switching networks and traffic concepts, and quantum electronics. Over 1350 illustrations 1138 pages. Order 20678, only...\$20.00

Using & Understanding Miniature Neon Lamps

Describes the neon lamp in detail: electrode size, gases used, firing, extinction voltages, aging characteristics, and maintenance. Explains its uses as an indicator, voltage regulator and voltage reference, oscillator, pulse generator, flasher, and applications in computers. Includes fascinating, easy-to-build circuits for the experimenter. Also includes the characteristics of most available neon lamps.

Order 20698, only...\$2.95

HOWARD W. SAMS & CO., INC.

Order from any Electronic Parts Distributor, or mail to Howard W. Sams & Co., Inc., Dept. EW-3 4300 W. 62nd St., Indianapolis, Ind. 46268

Send books checked at right. \$_____enclosed.

Send FREE 1969 Sams Book Catalog

Name _____
PLEASE PRINT

Address _____

City _____ State _____ Zip _____

- | | |
|--------------------------------|--------------------------------|
| <input type="checkbox"/> 20701 | <input type="checkbox"/> 20629 |
| <input type="checkbox"/> 20700 | <input type="checkbox"/> 20655 |
| <input type="checkbox"/> 20358 | <input type="checkbox"/> 20584 |
| <input type="checkbox"/> 20696 | <input type="checkbox"/> 20695 |
| <input type="checkbox"/> 20606 | <input type="checkbox"/> 20620 |
| <input type="checkbox"/> 20654 | <input type="checkbox"/> 20678 |
| <input type="checkbox"/> 20703 | <input type="checkbox"/> 20698 |
| <input type="checkbox"/> 20704 | |

CIRCLE NO. 95 ON READER SERVICE CARD

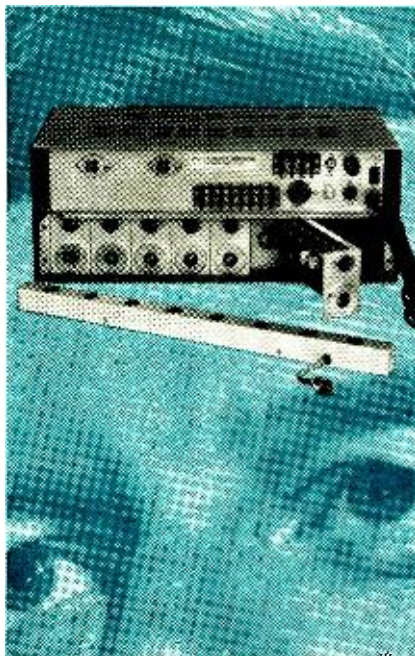

TEST EQUIPMENT

PRODUCT REPORT

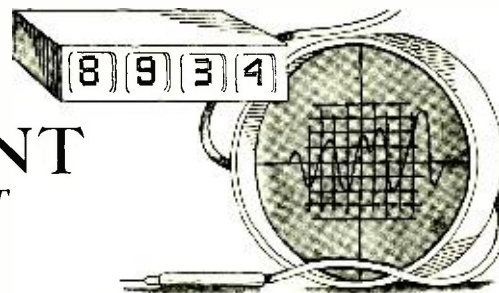

RCA Models WP-700A, WP-702A Power Supplies

For copy of manufacturer's brochure, circle 25 on Reader Service Card.

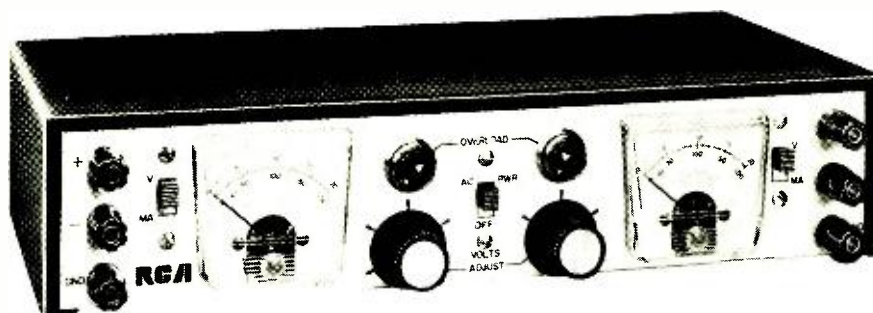

dream factory!

"Invent" a whole new sound system ... fast 'n easy ... with new BELL P/A MODULAR AMPS

Bell P/A's "stacking" principle gives you *unusual design flexibility*. Place up to 8 input modules in different positions ... get thousands of possible input configurations.

FET's are located up front for true Hi Z input (or bal. lo Z with trans.). Units have 20, 45, 90 or 200-watt output (RMS ratings)! All silicon solid state design.

Exclusive, fully automatic output circuit protection (with signal light) saves time, labor, components ... eliminates guesswork. See your local electronics distributor, or send for full specs.

BELL p/a
professional appeal

BELL P/A PRODUCTS CORPORATION
1209 North Fifth St., Columbus, Ohio 43201

A PAIR of versatile, bench-type, regulated d.c. power supplies has recently been introduced by RCA. The supplies are solid-state, constant-voltage devices which are suitable for use in solid-state circuit design, servicing, and in industrial and educational applications.

Both supplies furnish continuously adjustable outputs from 0 to 20 volts at currents up to 200 mA. The Model WP-700A has a single output, while the Model WP-702A (shown in photo) consists essentially of two 700A's in the same housing but with a common power transformer. All other components are duplicated and the two outputs are completely isolated from one another.

The circuit automatically limits the overload current to prevent damage to the power supply. Even if the load is

completely shorted, no damage will result. Overload-indicator lamps on the front panel begin to glow when the output currents approach 200 mA, and glow brightly if the current exceeds this value. Dual-function (current and voltage) meters are used to monitor the outputs of the supply.

All transistors and diodes used in the units are silicon types. A negative-feedback regulator circuit maintains constant output voltage with low ripple regardless of varying line voltage or load resistance (see circuit diagram). There will be less than 30-mV change in output voltage with a power-line variation of 105 to 135 V a.c., and less than a 50-mV voltage change for a 200-mA load change. Ripple is under 500 microvolts r.m.s.

Both units are compact and light-

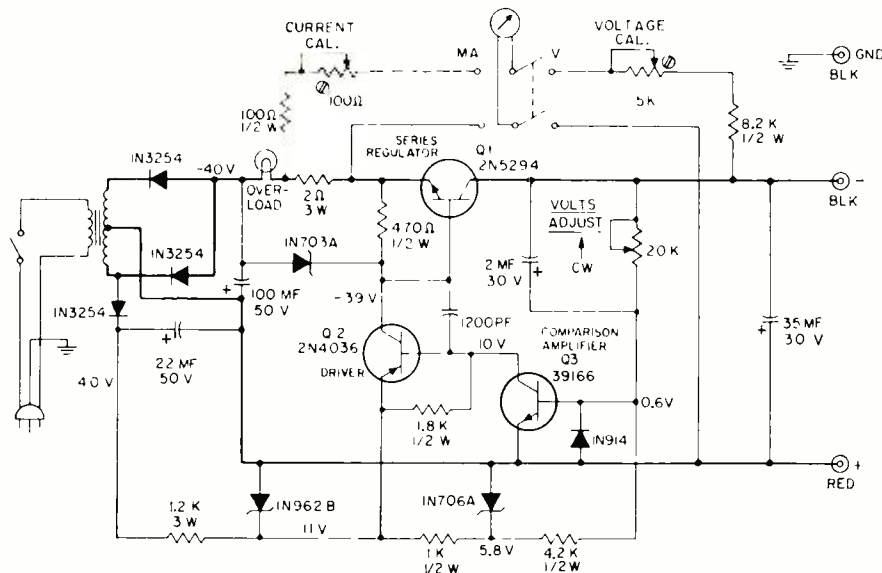

weight, with attractively designed functional front panels. The WP-700A measures 4" x 6½" x 3" and weighs only 3 lbs; the WP-702A measures 6" x 12" x 3" and weighs 3 lb. 10 oz. Both sup-

plies have rugged metal cases, finished in blue-gray hammertone enamel. The single-output unit is priced at \$48 while the dual-output supply is priced at \$87. ▲

Delta Products Model 3000 FET V.O.M.

For copy of manufacturer's brochure, circle No. 26 on Reader Service Card.

DELTA Products, long known as a manufacturer of C-D ignition systems, as well as dwell meters and tachometers for autos, has come out with its first general-purpose instrument for servicing and laboratory use. The Model 3000 FET v.o.m. is not just another meter with a field-effect transistor front-end to give it high impedance. The instrument has a number of interesting and unique features.

The first difference one sees is right at the front panel. The zero and ohms-adjustment pots use a vernier planetary drive, similar to those on some FM tuners, to permit a very fine adjustment to be made. Also, in addition to the usual a.c. and d.c. voltage ranges (down to as low as 0.3 V full-scale and up to 1000 V) and resistance scales, there are eight d.c. current ranges all the way down from a mere 0.03 μ A full-scale up to 300 mA.

It's when you get inside the unit that you note some other differences. For example, an integrated-circuit operational amplifier forms a part of the metering circuit. This should avoid errors on a.c. due to non-linearity of the signal rectifiers. Another unique feature is the use of a current regulator for resistance measurements. This regulator provides a maximum voltage of 0.3 V

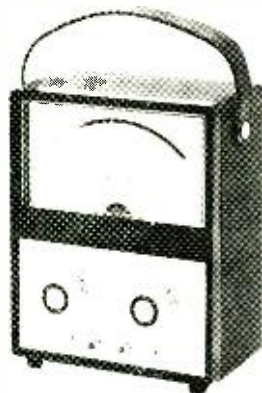

and a maximum current of 30 mA to the external circuit so that sensitive semiconductor will not be damaged while they are being checked. Two FET's are used in the input circuitry (one serves as the constant-current source for the other) in order to produce the high 10-megohm input impedance which is then converted down to a low impedance for the metering circuit. Other transistors, operated as back-to-back diodes, serve to protect the circuitry against damage due to overload.

The meter is powered by standard penlight cells and has a 2% full-scale accuracy on d.c. It is available in kit form at \$59.95 or factory-assembled at \$74.95. ▲

Jackson Model CRO-4 Oscilloscope

For copy of manufacturer's brochure, circle No. 27 on Reader Service Card.



THIS new, strikingly styled 5-in scope from Jackson Electrical Instrument Co. has been designed to make it as simple as possible for the technician to take voltage readings as well as to observe waveforms. By using a readily removable graticule with two sets of calibrations just like a meter

scale, the user can read off peak-to-peak voltage values just as easily as on a v.o.m. This special scale is used in conjunction with the calibrated, direct-reading vertical input attenuator which is used just like a meter range switch.

The Model CRO-4 has a vertical amplifier with response out to 5.8 MHz so that color-burst signals can be readily observed. Sensitivity is 5.8 mV (r.m.s.)/cm and rise time is 0.06 microsecond. Horizontal sweep-frequency range is from 5 Hz to 500 kHz.

When the vertical-attenuator switch is placed in its last position, the scope is ready for use as a vectorscope for color-TV servicing. In this function, the receiver's (R-Y) signal is applied directly to the vertical-deflection plates of the scope's CRT, while the (B-Y) signal is plugged into the scope via a front-panel jack to the horizontal-deflection plates. With a color-bar generator connected to the receiver, the result is the circular flower-petal vector display pattern on the scope screen.

Model CRO-4 is priced at \$249.95. ▲

MAKE YOUR OWN TUNER TEST!

If you're like most professional TV technicians, you clean the tuner of every chassis you service.

But how careful are you in choosing your tuner spray? The wrong spray can cost you a lot in aggravation and callbacks.

That's why we ask you to

MAKE THIS TEST YOURSELF

1. Tune in a good color picture on any color set.
2. Spray the tuner with anything but a Chemtronics Spray.
3. You will see the color fade and disappear almost immediately, due to the changes of capacitance in tuned circuits caused by the spray.

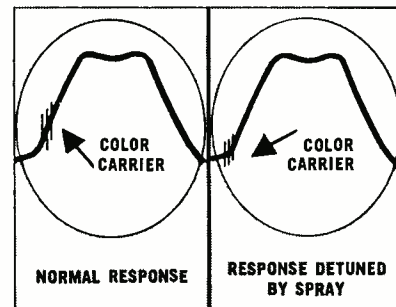

4. Wait about 10 minutes for the spray to dry. Unfortunately, the color will not come back.
5. Spray the tuner with Chemtronics TUN-O-WASH.
6. Wait about two minutes and color will be restored.

WHAT THIS TEST MEANS TO YOU

Most tuner sprays leave a residue of slow drying, petroleum base lubricant. This saturates the coils and other components causing a shift in response as shown in illustration.

To compensate for this shift, you often adjust oscillator slugs. Then, when the set has played in your customer's house for a week or two, the residue dries out, shifting the oscillator back toward its original frequency. If the customer can't compensate for this drift with the fine tuner, you have a **callback** on your hands. Even if the drift is not too severe, the remaining residue picks up dirt and eventually "gunks up" the tuner.

TUN-O-WASH IS LIKE NO OTHER SPRAY ON THE MARKET

TUN-O-WASH is a powerful, high pressure spray designed to do just one job superlatively well. It melts away grease, oil, dirt and corrosion quickly and completely. It leaves absolutely no residue behind. Tests show that TUN-O-WASH is at least 10 times as effective as any other tuner spray in degreasing gunked up tuners.

Use TUN-O-WASH as your first step in repairing any tuner. It gives you a clean start in much the same way as the ultrasonic bath used by tuner specialists — but without harmful vibration. You'll be surprised at how many tuners you can repair the TUN-O-WASH way.

Then, once the tuner is restored to good working condition, you can lubricate it with a light spray of Chemtronics famous COLOR-LUBE, guaranteed not to detune, attack plastic parts or "gunk up." COLOR LUBE uses a unique synthetic lubricating formula developed specifically for color TV tuners.



Giant 24 oz. can only \$3.25 dealer net.

1260 RALPH AVENUE • BROOKLYN, N.Y. 11236

CIRCLE NO. 119 ON READER SERVICE CARD

**“He’s a good worker.
I’d promote him
right now if he had
more education
in electronics.”**



Could they be talking about you?

You'll miss a lot of opportunities if you try to get along in the electronics industry without an advanced education. Many doors will be closed to you, and no amount of hard work will open them.

But you can build a rewarding career if you supplement your experience with specialized knowledge of one of the key areas of electronics. As a specialist, you will enjoy security, excellent pay, and the kind of future you want for yourself and your family.

Going back to school isn't easy for a man with a

full-time job and family obligations. But CREI Home Study Programs make it possible for you to get the additional education you need without attending classes. You study at home, at your own pace, on your own schedule. You study with the assurance that what you learn can be applied to the job immediately.

CREI Programs cover all important areas of electronics including communications, radar and sonar, even missile and spacecraft guidance. You're sure to find a program that fits your career objectives.



NEW!
 Expanded coverage of solid state electronics including integrated circuits!

You're eligible for a CREI Program if you work in electronics and have a high school education. Our FREE book gives complete information. Mail postpaid card for your copy. If card is detached, use coupon at right or write: CREI, Dept. 1103H, 3224 16th St., N.W., Washington, D.C. 20010.

**CREI, Home Study Division
 McGraw-Hill Book Company
 Dept. 1103H, 3224 Sixteenth Street, N.W.
 Washington, D.C. 20010**

Please send me FREE book describing CREI Programs. I am employed in electronics and have a high school education.

NAME _____ AGE _____

ADDRESS _____

CITY _____ STATE _____ ZIP CODE _____

EMPLOYED BY _____

TYPE OF PRESENT WORK _____ G.I. BILL

- I am interested in Electronic Engineering Technology
 Space Electronics Nuclear Engineering Technology
 NEW! Digital Communications

APPROVED FOR TRAINING UNDER NEW G.I. BILL

Founded 1927



Accredited Member of the National Home Study Council



One of a series of brief discussions
by Electro-Voice engineers



Much has recently been written about the sonic problems of typical auditoriums and the effect of poor room acoustics on sound system design. In an effort to better understand the extent of this problem, a series of laboratory tests of room response was conducted in a variety of community and university auditoriums.

Using a "pink noise" generator and a 1/10-octave band pass filter, plus calibrated transducers, each auditorium was curved from 20 to 20,000 Hz (obtaining usable information from 60 to 18,000 Hz). Composite or average curves were computed from 30 separate locations in each room. These curves were remarkably similar and distinguished by a lack of sharp peaks and dips. In short, the rooms studied were relatively flat, with no pronounced deviations in response.

Techniques for narrow-band filtering to compensate for both room and sound system response variations have gained prominence lately, and for good reason. In many installations such methods provide markedly higher gain before feedback, permitting installation of a successful system in environments that would otherwise be notably deficient.

But such elaborations are expensive and complex, demanding considerable experience and knowledge to install correctly. Our studies have convinced us that the use of truly flat transducers can achieve virtually equal results in the majority of auditoriums at greatly reduced cost while retaining simplicity and reliability.

Unfortunately, many highly-regarded sound reinforcement transducers are far from flat, and may themselves introduce serious flaws in system response. Faulty placement of speakers can also create response problems and hinder good coverage. The addition of narrow-band filtering to such a system may achieve the desired final result, but at the expense of greatly increased cost compared to flat, unfiltered, peak-free components.

In any event, if flat response is the desired goal, it seems logical to begin with flat transducers, adding filtering only as needed to complement the characteristics of the room. Experimental results so far confirm the value of this approach in terms of both audible performance and ultimate cost.

For reprints of other discussions in this series,
or technical data on any E-V product, write:
ELECTRO-VOICE, INC., Dept. 393N
629 Cecil St., Buchanan, Michigan 49107



CIRCLE NO. 112 ON READER SERVICE CARD
74

Loudspeaker Measurements

(Continued from page 29)

for a given pair of opposite parallel surfaces of the room. If a measuring microphone is moved from one wall across the room to the opposite wall, the sound level at the microphone will vary from a maximum, through nearly zero, and then back to a maximum. At double this frequency the pressure will go through two minima and one maximum, the maximum being at the center of the room. At higher frequencies the number of maxima and minima will increase correspondingly. Finally a point will be reached beyond which the spacing between maxima and minima is of the order of magnitude of the dimensions of the microphone, which will consequently average these, and show a more uniform output as it traverses the room.

In this discussion, the effect of other types of modes has been neglected so that in fact the variations in intensity measured by the microphone as its position is changed from one wall to the opposite wall will be extremely irregular. It is rather easy to see that much the same thing will happen if the microphone position is fixed and the frequency is varied. In place of the extreme variations in recorded sound pressure occurring as the microphone is moved across the room, similar extreme variations will be found as the frequency is varied.

Since this irregularity is predicated on a completely uniform output from the sound source, any variations in frequency response of an actual loudspeaker will tend to be obliterated by the extremely irregular response of the room. A frequency response curve obtained in this manner turns out to be a frequency response curve of the room rather than the loudspeaker, except for very broad variations in the speaker frequency response. For example, if the speaker response decreases with increasing frequency, the average of the recorded response curve will reveal this. However, sharp variations in speaker frequency response, in which we are definitely interested, will not be discernible.

The reference to averaging in the previous paragraph gives a hint of the approach which makes speaker frequen-

cy response measurements feasible. A warbled frequency might be used so that at any given point in its sweep the recorded trace registers the average of a narrow band of frequencies. Similarly, a narrow band of noise could be swept from one end of the spectrum to the other. The bandwidth must be sufficiently great to obtain a reasonably good average of the room response without making it so broad as to obscure minor variations in the speaker response.

Additional improvement is obtained by *space averaging* as well as frequency averaging. The microphone or the loudspeaker, or both, can be moved continuously while recording the frequency response. If the speaker is moved, this changes the pattern of the standing waves. If the microphone is moved, it rapidly samples the sound pressure along its path and averages it. Each element may be swung back and forth or rotated. Still further smoothing can be obtained by rotating or swinging large reflecting surfaces within the room. These procedures are effective but rather clumsy mechanically. An alternative is to use a number of microphones placed in random positions in the room and sum their output. This is the system that was adopted for use in the reverberation chamber at H. H. Scott, Inc. (It is also the procedure used by Hirsch-Houck Labs for checking speaker response, but in a normal listening room.—Editors)

When the outputs of a reasonable number of microphones, say six, are added, some smoothing takes place, but the system is less effective than might be expected. The reason is that the sound pressures at the different microphones vary not only in amplitude but in phase as well. At a given point, the sound pressure might be identical at two microphones but opposite in phase, as a result of which their output sum would be zero. The effect of phase can be eliminated by rectifying the output of each microphone and adding the resulting d.c. outputs. This was tried experimentally, but difficulties were encountered due to nonlinearities of the rectifiers. Incidentally, the ideal system would be to add the power outputs of the microphones. This could be done by squaring the voltage and then adding; however, squaring circuits having wide dynamic and frequency range are not simple.

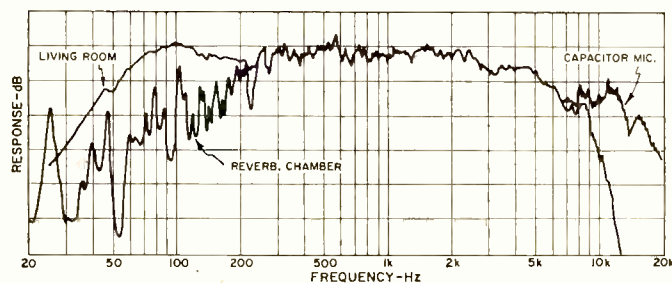

Fig. 10. Speaker frequency response in reverberation chamber. Upper curve at bass end is close-up pressure measurement in typical living room with speaker on floor against wall.

It was finally decided to sample the microphone outputs one at a time in order to obtain an effective average. This can be done by means of a commutator but again it was felt desirable to stay away from mechanical devices and to use an electronic commutator. This consists of twelve field-effect transistors used as switches. The gates of the FET's are driven by 60-Hz sine-wave signals shifted in phase by multiples of 60° for successive FET's. The commutated signal for each channel has a rectangular envelope, being on for $1/360$ second and off for $5/360$ second. The choice of six microphones was rather arbitrary. Since smoothness is improved in proportion to the square root of the number of microphones, the law of diminishing returns is involved. For example, the use of twelve microphones would have resulted in 30% better smoothness, but only at high frequencies because of residual room irregularities at lower frequencies.

The *H. H. Scott, Inc.* reverberation chamber was constructed with a height:width:length ratio of 1:1.6:2.5, which is a set of proportions traditionally recommended for the best distribution of modes. Inside dimensions are approximately 23 x 15 x 9 feet. The walls and floor at two diagonally opposite corners are perpendicular to each other to permit testing of corner speaker systems. Three of the surfaces were made non-parallel, with a slope of approximately 5% to improve the diffusion. The room is substantially constructed, the walls being of eight-inch cement block filled with dry sand. The construction provides very stiff walls and ceiling; the sound transmitted through the walls is reduced by approximately 40 dB. Background noise in the room, measured on the C-scale of a sound-level meter is below 40 dB at all times. The reverberation time varies from 4 seconds near 100 Hz to 1.5 seconds near 10 kHz. The frequency response of the room decreases at the higher frequencies due to decreased reflectivity of the room surfaces and losses through transmission in the air itself. The frequency characteristic was measured and corrected for large-scale variations in frequency response by means of an equalizing network. The room is not usable at low frequencies but this is no problem because, due to the omnidirectionality of loudspeakers in this range, an on-axis frequency response measurement is adequate.

The measuring system produces a graph which is a composite of the irregularities of the loudspeaker response and irregularities of the room response. Over the frequency range involved, the speaker response will, in general, be smoother than the room response because of the large number of room modes in a given band of frequencies

and because the sharpness of resonance of these modes is considerably greater than that of the speaker resonances. For recorder pen and chart speeds of values that permit accurate tracing of the irregularities in speaker response, the modes of the room, some of which are increasing, some at maximum, and some decaying at a given instant, do not have a chance to build up to very high intensities.

Fig. 10 shows measured curves on a developmental speaker system. Below 300 Hz or so, the room irregularities are extremely great; consequently the low-frequency response of this speaker system is shown as a pressure measurement taken with the microphone close to the speaker in a partially absorbing room. The rather sharp drop at 9 kHz is due to the response of the microphones used in the reverberation chamber. A single microphone measurement on-axis, using a *Bruhl* and *Kjaer* 4133 capacitor microphone, is superimposed on the graph. Since this microphone is flat to 20 kHz, the curve represents the response of the speaker system at high frequencies more accurately. In this range the room modes are so closely spaced that the use of only one microphone is acceptable. The high-frequency response of the speaker system has a downward slope, which is to be expected for anything but a perfectly omnidirectional speaker. In other words, the power response drops much faster than the on-axis frequency response.

The reverberation chamber has been found to be particularly useful in the measurement of the frequency response of speaker systems employing several speakers and crossover networks, and radio-phonograph consoles. Because of the short time required for measurement as opposed to taking a complete set of on-axis and off-axis curves in an anechoic chamber, it is practical to make numerous measurements to determine the influences of baffle sizes and shapes, locations of speakers on the baffle, effect of grille cloth, metallic, wood and molded grilles, frames, and other decorative treatment. As an example of the sensitivity of such tests, it is possible to distinguish the effect of a shift in tweeter location relative to the mid-frequency speaker of only $1/4$ inch.

Experience with the reverberation chamber has shown that it is an excellent means of detecting lack of smoothness in the frequency response of a speaker system. Listening tests have indicated that irregularities in the curve obtained in the reverberation room are heard as annoying resonances and roughness. While it cannot be claimed that a speaker system having a smooth response in a reverberation room will necessarily sound good, the technique is extremely useful in detecting design defects. ▲

The TRUE electronic solution to a major problem of engine operation!

DELTA'S FABULOUS MARK TEN[®]



Only \$44.95 ppd.
In easy-to-build Deltakit[®]
Only \$29.95 ppd.

CAPACITIVE DISCHARGE IGNITION SYSTEM

You've read about The Mark Ten in *Mechanix Illustrated*, *Popular Mechanics*, *Electronics* and other publications!

Now discover for yourself the dramatic improvement in performance of your car, camper, jeep, truck, boat—any vehicle! Delta's remarkable electronic achievement saves on gas, promotes better acceleration, gives your car that zip you've always wanted. Find out why even Detroit has finally come around. In four years of proven reliability, Delta's Mark Ten has set new records of ignition benefits. No re-wiring! Works on literally any type of gasoline engine.

Why settle for less when you can buy the original DELTA Mark Ten, never excelled and so unique that a U.S. Patent has been granted.

READY FOR THESE BENEFITS?

- ▲ Dramatic Increase in Performance and in Fast Acceleration
- ▲ Promotes more Complete Combustion
- ▲ Points and Plugs last 3 to 10 Times Longer
- ▲ Up to 20% Mileage Increase (saves gas)

LITERATURE SENT BY RETURN MAIL
BETTER YET — ORDER TODAY!



DELTA PRODUCTS, INC. DP 7-17

P.O. Box 1147 EW • Grand Junction, Colo. 81501

Enclosed is \$_____ Ship ppd. Ship C.O.D.

Please send:

- Mark Tens (Deltakit[®]) @ \$29.95
(12 VOLT POSITIVE OR NEGATIVE GROUND ONLY)
- Mark Tens (Assembled) @ \$44.95
- 6 Volt: Negative Ground only. Positive Ground
- 12 Volt: Specify Negative Ground

Car Year: _____ Make: _____
Name: _____
Address: _____
City/State: _____ Zip: _____

CIRCLE NO. 115 ON READER SERVICE CARD

NEW CONAR
All-Channel
COLOR TV KIT
\$366.00
Model 600UK

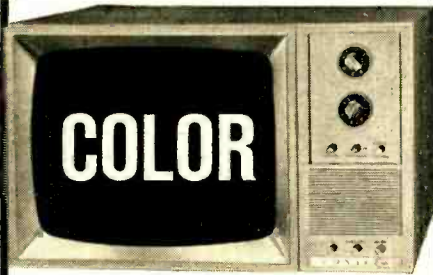

- Easier to build because it's designed for learning
- Complete with cabinet—nothing else to buy!

Tops for quality, simplicity of design, ease of building, the new CONAR 600 gives you the latest advances in the art of color TV receiver construction. In addition to 21 tubes, this all-channel receiver incorporates a transistor UHF tuner, transistor noise cancellation circuit and 16 solid-state diodes. Separate gun killer switches and a cross hatch generator are built in. All hardware is engineered for accessibility. Attractive bronze-tone steel cabinet with durable wood-grained vinyl covering.

For information write Dept. CB9C

CONAR instruments

DIVISION OF NATIONAL RADIO INSTITUTE
3939 Wisconsin Ave., Washington, D.C. 20016

WRITE FOR FREE
CONAR CATALOG



Bandwidth Compression
(Continued from page 52)

eliminate extraneous noise, the signals are converted to a digital format and fed into the bandwidth compression circuitry and the storage buffer. From the buffer, parallel words are converted to a serial bit stream and fed to a data modem for transmission. On the receive side, the serial bit stream is converted back to parallel format and placed in the buffer. Data flows from the buffer into a reconstructor where the original waveform is regenerated in digital form. The signal then passes through a digital-to-analog converter and output filter to smooth the waveform, and through the amplifier to the receiver.

Fig. 7A shows what a typical input voice signal looks like. This is one of the test sentences from a test tape used in the feasibility study. Notice that there are very large variations from word to word. This is typical of individual speakers. In addition, there are significant differences in the dynamic range of various speakers. Thus, to attain the most efficient performance with the compression processes, the input must be normalized. This is accomplished by the a.g.c. circuit which limits the swing of the input signal, as shown in Fig. 7B. Note that in some instances small portions of the waveform peaks have been clipped. This can be done without significantly affecting the quality of the voice signal and insures that the system will operate at a reasonably constant amplitude level, no matter who is using it.

The input information is sampled

in the analog-to-digital converter. At each of the sample points, the actual amplitude value (in this example, the value is 50) is converted to a six-bit digital word as shown in Fig. 8.

After the compression process is complete, the information will have a standard digital format that looks just like typical computer data as far as the transmission facilities are concerned. The standard data format shown in Fig. 9 has sync words to establish frame synchronization and data words containing specific information on each data point transmitted. Therefore, the system can interface with a common digital data net for transmission. As far as the transmission facilities are concerned, they couldn't care less whether the information is voice, data, or teletypewriter traffic. They all share a common format which permits the use of a single common, inexpensive system operating in a narrow-band mode.

At the receiver, information is converted back to the straight-line approximation through the process shown in Fig. 10. Two transmitted points are shown. In order to reconstruct this straight-line segment, it is only necessary to know the respective amplitudes of the two end points and the time duration between the two points. By calculating the slope of this line, the value of each of the intermediate points can be computed by the reconstructor. Note that this computational process is accomplished at a rate which is twice the original sample rate. This provides additional gains in quality by making the output filters much more effective during the smoothing process and giving a pleasing output waveform. ▲

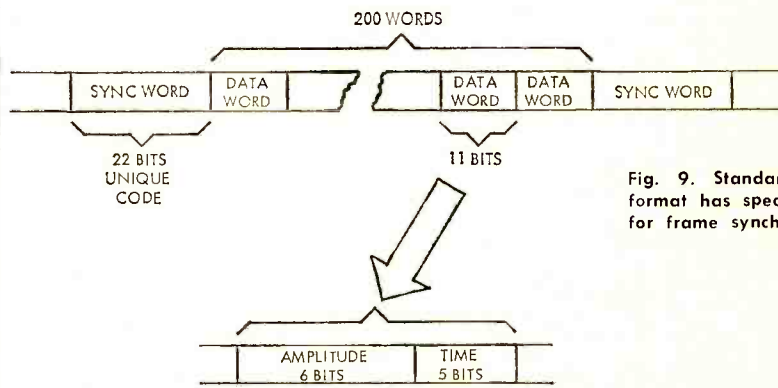

Fig. 9. Standard digital format has special words for frame synchronization

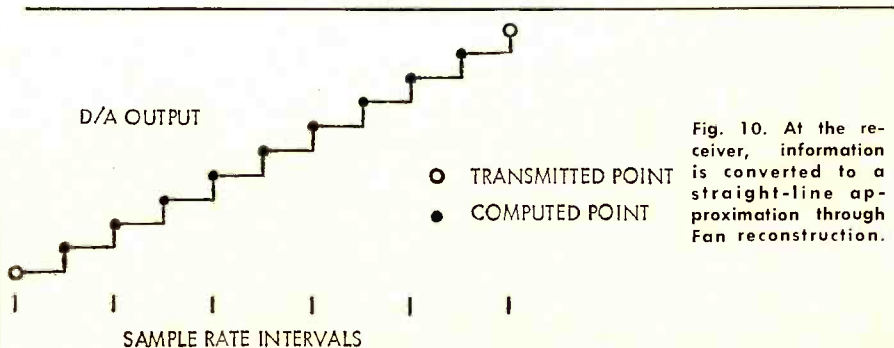

Fig. 10. At the receiver, information is converted to a straight-line approximation through fan reconstruction.

GET INTO **ELECTRONICS**



V.T.I. training leads to success as technicians, field engineers, specialists in communications, guided missiles, computers, radar and automation. Basic & advanced courses in theory & laboratory. Electronic Engineering Technology and Electronic Technology curricula both available. Assoc. degree in 29 mos. B. S. also obtainable. G.I. approved. Graduates in all branches of electronics with major companies. Start February, September. Dorms, campus. High school graduate or equivalent. Write for catalog.

VALPARAISO TECHNICAL INSTITUTE
Dept. RD, Valparaiso, Indiana 46383

Announcing the **NEW STANDARD** in Stereo Testing!

Get the All-New Model SR12 STEREO TEST RECORD

The most complete...most sophisticated...most versatile
Test Disc available today... **For Just \$4.98!**

Who Needs the New Model SR12?

If you've read this far, you do. Whether you're an avid audiophile who'll settle for nothing but peak performance from his stereo components... a casual listener who'd like more insight into the challenging world of stereo reproduction... or a professional technician who needs precise standards for lab testing... the new MODEL SR12 will be the most important disc in your entire collection.

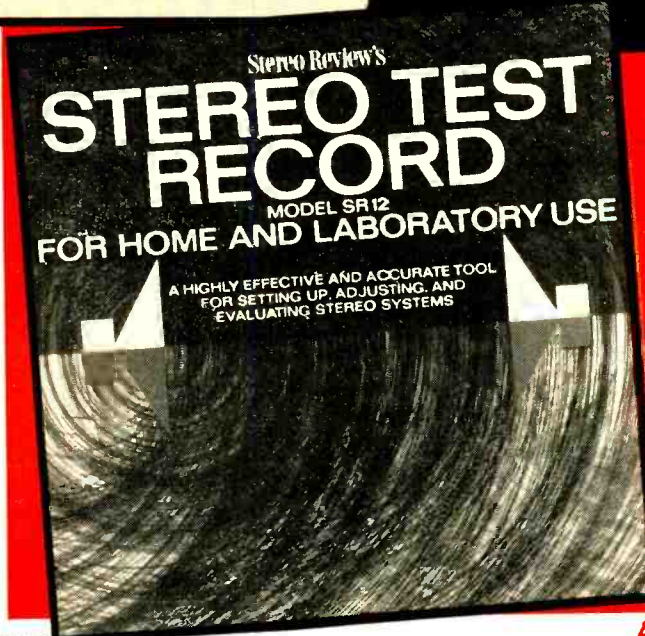

Like its predecessor Model 211, MODEL SR12 has been produced by Stereo Review Magazine (formerly HiFi/Stereo Review) as a labor of love — by music lovers... for music lovers who want immediate answers to questions about the performance of their stereo systems and how to get the best possible sound reproduction.

Now greatly expanded and updated with the most modern engineering techniques, MODEL SR12 is the most complete test record of its kind — containing the widest range of checks ever included on one test disc. An ear-opener for every serious listener!

AND, for the ultimate in stereo testing, 7 critical TEST EQUIPMENT checks...

You'll make these important stereo checks BY EAR... (no test instruments of any kind required)

- ▶ Frequency response—a direct warble-tone check of nineteen sections of the frequency spectrum, from 20 to 20,840 Hz, which will pinpoint any frequency response defects in your system.
- ▶ Separation—an ingenious test which indicates whether you have adequate separation for good stereo.
- ▶ Cartridge tracking—the most sophisticated tests ever devised for checking the performance of your cartridge, stylus and tone arm.
- ▶ Channel balance—two broad-band, random-noise signals which permit you to eliminate any imbalances originating in cartridge, amplifier, speakers or room acoustics.
- ▶ Hum and rumble—foolproof tests that help you evaluate the actual audible levels of rumble and hum in your system.
- ▶ Flutter—a sensitive "musical" test to check whether your turntable's flutter is low, moderate, or high.

PLUS! ● Cartridge and Speaker Phasing ● Anti-Skating Adjustment ● "Gun Shot Test" for Stereo Spread ● Multi-purpose Musician's "A" ● Equal-tempered Chromatic Octave ● Guitar-tuning Tones.

Don't waste another minute on less-than-perfect stereo—Order Your Model SR12 Stereo Test Record NOW!

Consider the hundreds—even thousands—you've spent on your set-up and you'll agree \$4.98 is a small price to pay for the most valuable performance tool ever made. So to be sure your order is promptly filled from the supply available, mail the coupon at right with your remittance... today!

Attention professionals: Stereo Review's new Model SR12 Stereo Test Record is also designed to be used as a highly efficient design and measurement tool. In the following tests, recorded levels, frequencies, etc. have been controlled to laboratory tolerances—affording accurate numerical evaluation when used with oscilloscope, chart recorder, output meter, intermodulation-distortion meter and flutter meter.

- 1,000-Hz square waves to test transient and high-frequency response of phono pickups.
- 500 to 20,000 Hz frequency-response sweep.
- Sine-wave tone-bursts to test transient response of pickup.
- Intermodulation test using simultaneous 400-Hz and 4,000-Hz signals.
- Intermodulation sweep to show distortion caused by excessive resonances in tone arm and cartridge.
- 1,000-Hz reference tones to determine groove velocity.
- 3,000-Hz tone for flutter and speed tests.

Sample waveforms—illustrating both accurate and faulty responses are provided in the Instruction Manual for comparison with the patterns appearing on your own oscilloscope screen.

FREE Instruction Manual Includes Detailed Instructions, Charts, Tables and Diagrams.

Nothing is left to chance... or misinterpretation. Every segment of every band is fully, clearly, graphically explained. You'll know exactly what responses to listen for in each test. Which sounds and patterns indicate accurate performance... which ones spell trouble... as well as the cause of trouble and precise corrective measures to follow and help you pinpoint, analyze and cure your stereo headaches!

Stereo Test Record • P. O. Box 3110
Church St. Station, New York, N.Y. 10008

EW-39

Please send _____ test records at \$4.98 each, **postpaid**.

My check (or money order) for \$ _____ is enclosed.
(Outside U.S.A. please send \$7.00 per record ordered.) N. Y. State residents please add local sales tax.

Print Name _____

Address _____

City _____

State _____

Zip _____

PAYMENT MUST BE ENCLOSED WITH ORDER

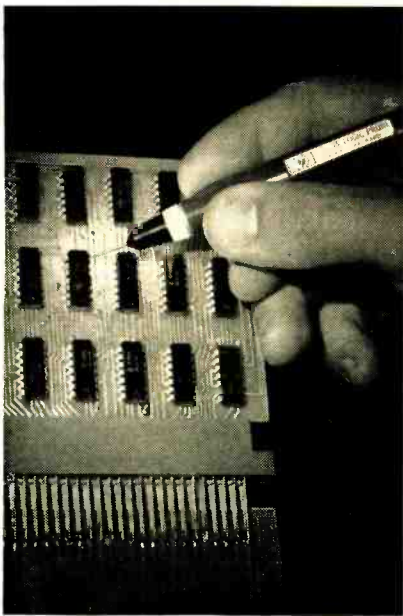

This probe lights up when a pulse goes by.

Even a pulse as short as 30 ns—positive or negative—will cause this logic indicator to flash a signal. You can trace pulses, or test the logic state of TTL or DTL integrated circuits, without taking your eyes off your work. In effect, the probes act like a second oscilloscope at your fingertips.

No adjustments of trigger level, slope or polarity are needed. A lamp in the tip will flash on 0.1 second for a positive pulse, momentarily extinguish for a negative pulse, come on low for a pulse train, burn brightly for a high logic state, and turn off for a low logic state.

The logic probe—with all circuits built into the handpiece—is rugged. Overload protection: -50 to +200 V continuous; 120 V ac for 10 s. Input impedance: 10 k Ω . Price of HP 10525A Logic Probe: \$95, quantity discounts available.

Ask your HP field engineer how you could put this new tool to work in logic circuit design or troubleshooting. Or write Hewlett-Packard, Palo Alto, Calif. 94304; Europe: 54 Route des Acacias, Geneva.

02825A

HEWLETT  PACKARD

CIRCLE NO. 106 ON READER SERVICE CARD
78

Series-Pass Regulators

(Continued from page 48)

The difference between the two voltages determines how much Q_4 conducts. If the output voltage increases, the base voltage of Q_4 increases and pushes it farther into the conduction region. This reduces the base current of Q_1 , which in turn reduces the current through Q_2 , lowering the output voltage. If the output voltage drops, Q_4 moves toward cut off and Q_1 and Q_2 turn on. This increases the output voltage. In essence, the circuit is a feedback amplifier which tries to maintain the output voltage at a constant level independent of load condition.

The output voltage is determined by the potentiometer setting according to the following equation:

$$V_{out} = \frac{(V_{D5} + V_{BEQ4})(R4 + R5 + R6)}{R6 + R5 \text{ (setting)}}$$

If $R5$ is set at the low end (A), the output is maximum and is given by:

$$V_{out(max)} = \frac{(10.7)(24.2 \text{ kohms})}{8.2 \text{ kohms}} \\ = 31.7V$$

The minimum output voltage (11.2 V) occurs when the arm of $R5$ is set to the high side (B).

The regulation is a function of the potentiometer setting since this determines the amount of feedback. The closer the base of Q_4 is to the positive output the greater the feedback.

Overcurrent protection is provided by R_2 and Q_3 . Since R_2 is in series with the output, the voltage across it is proportional to the output current. This voltage is used to drive Q_3 so that the larger the output current becomes, the

more Q_3 conducts. When Q_3 is turned on, the base drive is removed from Q_1 and this turns off power regulator Q_2 , thus limiting the output current. In this example, component values were chosen to limit the maximum current to approximately 700 mA. Fig. 4 shows the effectiveness of the current limiter.

Load regulation at several output voltage levels is shown in Fig. 5. The overcurrent actually degrades the performance of the regulator circuit, particularly at the higher current levels, since it decreases the base drive of Q_1 .

The power stage transistors, Q_1 and Q_2 , were selected for high gain at -55°C . This maximizes the voltage and current regulator's control. At maximum output voltage and at low temperatures, Q_1 requires a base current of about 1 mA. R_1 was selected to deliver approximately 2.5 mA. This sets the minimum voltage regulator current in Q_4 (MPS6531) at 1.5 mA, when the current regulator is not working. When the current regulator Q_3 (2N4921) comes on, it must handle this current. For the opposite condition at high temperatures and low output voltages, R_1 provides about 25 mA maximum current. The drive requirement for the power stage is not critical here, but Q_3 and Q_4 must be able to handle this current for effective control.

The maximum temperature at which the circuit will operate is set by the heat sinking of Q_1 and Q_2 . If these transistors are mounted directly to a heat sink and a good silicone grease is used, then the worst-case temperature rise above the temperature of the heat sink for Q_2 is 25°C , while that for Q_1 is about 20°C . Since the maximum operating temperature of Q_1 is 150°C , this means the heat-sink temperature must be kept less than 130°C . ▲

Fig. 4. Voltage output versus load current for the circuit of Fig. 3.

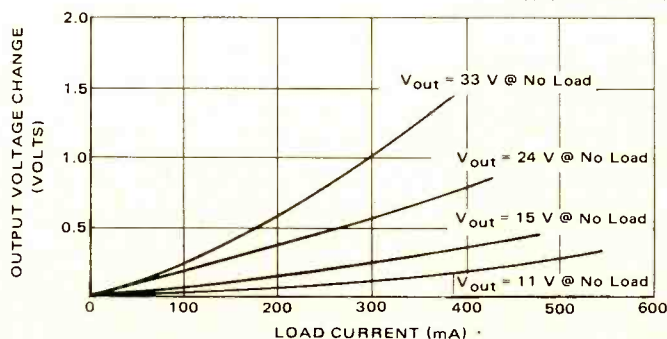
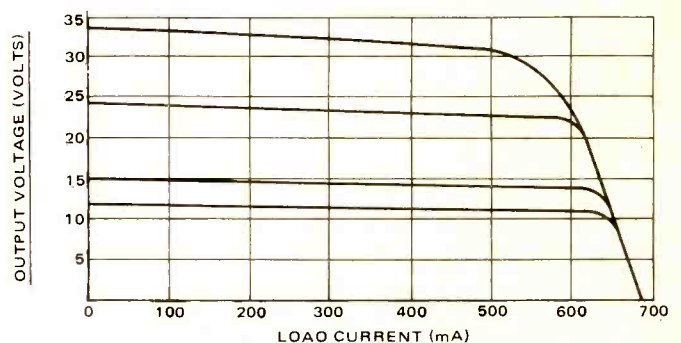

Fig. 5. Regulation versus load current for the circuit shown in Fig. 3.

*For the
Serviceman
who is also a
Businessman...*

**ELECTRONICS
INSTALLATION & SERVICING
HANDBOOK 1969**

SPECIAL BUYER'S GUIDE FOR
1969 COLOR-TV RECEIVERS • TV-CB ANTENNAS
ELECTRONIC IGNITION SYSTEMS • TEST EQUIPMENT • CB EQUIPMENT

COMPLETE REPORT ON
NEW COLOR-TV SETS

HOW TO ADD
MORE SPEAKERS TO YOUR
HI-FI SYSTEM

CIRCUIT DIAGRAMS OF
1000 COLOR-TV RECEIVERS

WHAT ABOUT
AUTOMOTIVE ELECTRONIC
IGNITION SYSTEMS?

HOW TO GET BEST COLOR
ON YOUR TV SET

How To Adjust
Purity & Convergence

TUNE UP YOUR CAR
WITH ELECTRONIC TESTERS

Pinpoint Service Troubles
Via Picture Tube

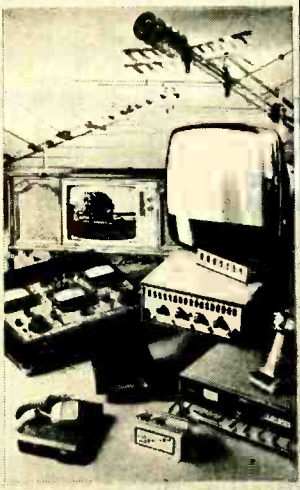

Now, all 8 areas of consumer electronics servicing—all the tricks of the trade—in one complete, up-to-date guide!

Whether you are an established electronics serviceman, just learning the business, or an avid do-it-yourselfer, the

1969 ELECTRONICS INSTALLATION AND SERVICING HANDBOOK

is one guide you'll want to keep within arm's reach.

COVERS ALL EIGHT AREAS

This is the industry's "how-to" book for installing and servicing consumer electronics equipment. From the basic tools and test equipment to the not-so-basic techniques. Color and B&W TV—am/fm radio—TV/fm antennas—stereo/hifi and tape—CB—automotive gear—intercoms and P.A. systems. All in clear, concise and comprehensive detail.

GIVES YOU VITAL TIPS

With the 1969 ELECTRONICS INSTALLATION AND SERVICING HANDBOOK, you'll learn how to recognize the causes of malfunctions. You'll learn how to select exactly the right piece of test equipment. How to save valuable time on a job. The shortcuts. How to avoid common problems.

BENEFIT FROM THE EXPERIENCE OF OTHERS

You'll be advised on what you can—and cannot—handle based on the experience of experts. You'll have hundreds of charts, circuit diagrams and tables at your fingertips—all designed to help you do a better job in the least amount of time. You'll become both a better serviceman and a better businessman.

So don't delay. Start doing more, earning more—use the coupon below to order your copy of the 1969 ELECTRONICS INSTALLATION AND SERVICING HANDBOOK today. Just \$1.35.

*...the
Hobbyist
who is also a
Perfectionist*

GET THE EXQUISITE
LEATHERFLEX-BOUND
EDITION

for just \$3.50 POSTPAID!

The 1969 ELECTRONICS INSTALLATION & SERVICING HANDBOOK is also available in an attractive, gold-embossed, Leatherflex-bound edition—a superb addition to your library of permanent reference books. This deluxe volume will be mailed to your home, **postpaid**, for just \$3.50, when you check the appropriate box on the order form.



FILL IN, CLIP & MAIL THIS FORM TODAY!

ZIFF-DAVIS SERVICE DIVISION • DEPT. IS
589 BROADWAY • NEW YORK, N.Y. 10012

YES! Send me a copy of the 1969 ELECTRONICS INSTALLATION & SERVICING HANDBOOK, as checked below:

- \$1.35 enclosed, plus 25¢ for shipping and handling. Send me the regular edition. (\$2.00 for orders outside the U.S.A.)
- \$3.50 enclosed. Send me the DeLuxe Leatherflex-bound edition, postpaid. (\$4.50 for orders outside the U.S.A.) Allow three additional weeks for delivery.

Name _____ please print

Address _____ EW-39

City _____ State _____ Zip Code _____

PAYMENT MUST BE ENCLOSED WITH ORDER

LOW-COST PRECISION SCOPE & V.T.V.M. CALIBRATOR

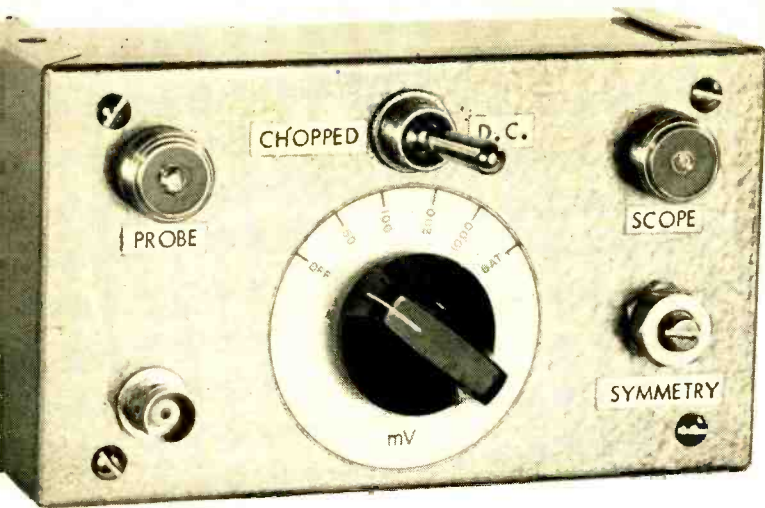

Front-panel view of the scope and meter calibrator.

By GARY H. LEHMANN/Sylvania Electronic Systems

Measuring voltage amplitudes, especially at low levels, is becoming more important with transistor equipment. This calibrator checks scope and meter by use of four switch-selected voltages, accurate to within 2%.

ANYBODY seriously involved in the service business or who does design work will agree that properly maintained and calibrated test equipment is a "must." The progressive technician knows that measuring amplitudes can often provide him with more important hints for the proper diagnosis of a malfunction than observation of the waveform alone. The much-neglected lowest range of the v.t.v.m. has gained new importance when servicing transistorized equipment and here, as well as when using the oscilloscope, the technician wants to be sure that the readings obtained are reasonably accurate. The calibrator described here provides four switch-selected voltages which are accurate to within $\pm 2\%$ and maintain this accuracy for a reasonable time.

Electrical Design

The basic calibrator circuit, shown in Fig. 1, consists of a series-string voltage divider using 1% precision resistors. A

Fig. 1. Basic calibrator consists of 1% precision divider.

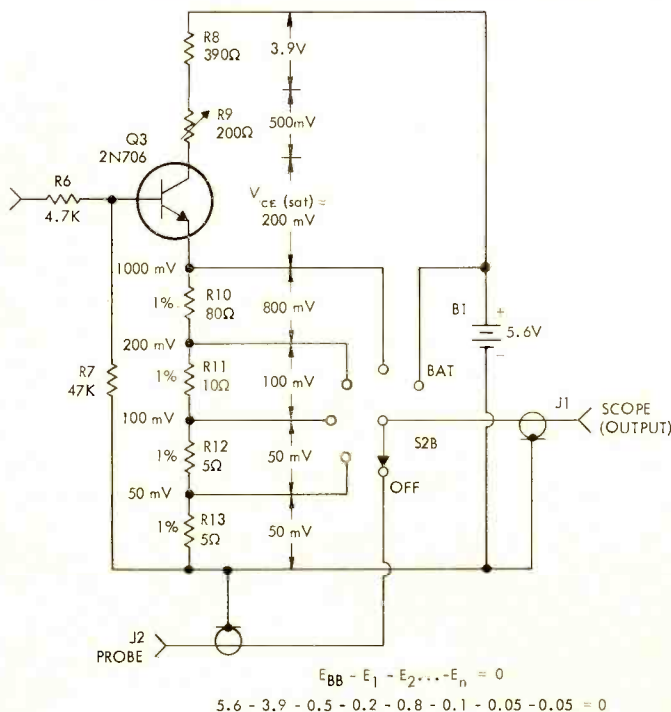

mercury battery (B1), consisting of four individual 1.4-volt cells, provides 10 mA of bleeder current for the voltage divider. A switching transistor (Q3) serves to convert the d.c. voltages to a pulse train that may be observed on an oscilloscope. The source impedance of the divider is 100 ohms (resistive) at the 1-volt tap and calibrator accuracy is $\pm 1\%$, provided that the external load (a scope or v.t.v.m.) is no less than 20,000 ohms.

Articles published on the chemical and electrical performance of mercury cells attest to their long shelf life (measured in years) and to the stability of their terminal voltage, especially with low discharge rates. The cells recommended for this application have a current capacity of over 2000 mA/hr. A calibrator is not likely to be used for any extended period of time and the current drain is quite low for this type of cell. Therefore, terminal voltage is considered adequately stable for the intended purpose.

The voltage divider shown in Fig. 1 provides outputs of 50, 100, 200, and 1000 mV. If other calibrating voltages are desired, the required resistor values can be calculated easily. For the given bleeder current of 10 mA, the voltage drop across one ohm is 10 mV. The difference between the battery terminal voltage and the calibrator voltage is dropped by the collector resistor of Q3 (R8) and by the trimmer R9, which is used to adjust the output voltage to exactly 1000 mV, with S2 in the corresponding position.

Switch S2B serves to switch the various taps of the voltage divider to the "Scope" connector. In the "Off" position, S2B bypasses the calibrator altogether and provides a direct connection to the scope probe. In this manner, the calibrator can be left permanently connected between the vertical input terminals of the scope and the scope probe. The scope can even be calibrated with the probe applied to a circuit under test. In the "Bat" position, S2B bypasses the switching transistor and makes the terminal voltage of B1 available for checking the condition of the battery.

One of the major problems in designing solid-state circuits is their inherent sensitivity to variations in temperature. This difficulty has been largely circumvented in the calibrator circuit by the use of silicon transistors working in the saturated mode. With Q3 heavily forward-biased by a positive-going square wave, the saturated collector-to-emitter voltage ($V_{CE(sat)}$) is approximately 200 mV. This voltage has a positive temperature characteristic increasing at a rate of 0.086 mV/°C. For a normal temperature range in the electronics shop ranging from about 60°F (15°C) to 90°F (32°C) or

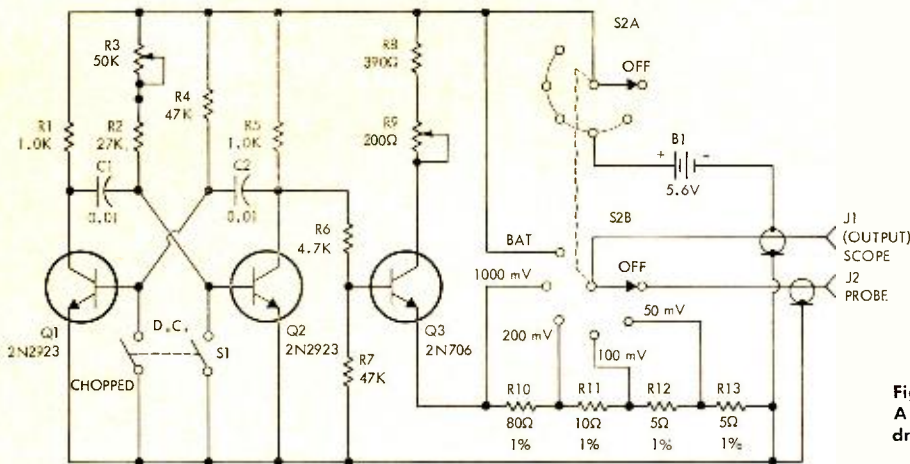

- R1, R5—1000 ohm, 1/2 W res.
- R2—27,000 ohm, 1/2 W res.
- R3—50,000 ohm, 1/2 W linear-taper pot
- R4, R7—47,000 ohm 1/2 W res.
- R6—4700 ohm, 1/2 W res.
- R8—390 ohm, 1/2 W res.
- R9—200 ohm, 1/2 W linear-taper pot
- R10—80 ohm res. $\pm 1\%$
- R11—10 ohm res. $\pm 1\%$
- R12, R13—5 ohm res. $\pm 1\%$
- C1, C2—0.01 μ F ceramic disc capacitor
- S1—D.p.d.t. switch
- S2—D.p. 6-pos. rotary switch
- B1—Four 1.4-V mercury cells (Mallory ZM9)
- J1, J2—Connectors (Amphenol 75PCM1)
- Q1, Q2—2N2923 transistor
- Q3—2N706 transistor
- 1—Chassis box 5 1/4" x 3" x 2 1/8".

Fig. 2. Complete schematic and parts list. A free-running multivibrator (Q1 and Q2) drives the voltage-divider stage of unit.

ΔT of 17° C, $V_{CE(sat)}$ would change $17 \times 0.086 = 1.46$ mV. This is less than 1% of the total saturation voltage. Even at a range of 60 to 170 degrees F (ΔT of 60° C), to which the circuit might be exposed if built into an existing tube-operated scope, $V_{CE(sat)}$ would change only 5.16 mV or less than 3%. If we consider that $V_{CE(sat)}$ represents only 3.6% of the total battery voltage across the circuit, it can be seen that changes in $V_{CE(sat)}$ due to temperature (3% of 3.6%) may be neglected.

It is interesting to note that the semiconductors present no serious problem while the temperature coefficient of the resistors in the voltage divider comes into play if a temperature rise of 60° C is to be tolerated without sacrificing accuracy.

Fig. 2 is the complete circuit of the calibrator. Transistors Q1 and Q2 form a saturating, free-running multivibrator designed to run at approximately 1500 Hz.

Resistors R1 and R5 were selected for a reasonably fast rise time of the output waveform and to provide a source impedance suitable to furnish sufficient drive current to Q3. Resistor R3 is used to adjust for a symmetrical waveform. When Q2 is turned off, the voltage at its collector rises toward the battery voltage. Resistor R6 limits the amount of base drive for Q3 while offering some isolation between the multivibrator and the switching transistor. As mentioned before, the base current for Q3 is selected to drive Q3 into deep saturation, which largely eliminates the effects of temperature variations on the accuracy of the calibrator. When Q2 is turned on, its collector voltage falls to $V_{CE(sat)}$ or approximately 200 millivolts, which is insufficient to keep Q3 in conduction. Since a minimum of 600 mV is required at the base of Q3 to cause this transistor to conduct, $V_{CE(sat)}$ of Q2 may vary as much as 100% without affecting the switching action of Q3.

If the calibrator is to be used with a d.c. oscilloscope or to calibrate a v.t.v.m., it might be desirable to have calibrated d.c. levels available at the output terminal. This capability is provided by S1. When this switch is closed, Q1 and Q2 are cut off and Q3 goes into full saturation. To keep the terminal voltage of B1 as nearly constant as possible without changing from the square-wave output to the d.c. level output, the average d.c. load to the battery should remain the same. With a symmetrical square wave, the voltage divider runs at a 50% duty factor or 5 mA average d.c. current. When in the d.c. mode, this load increases to 10 mA. The multivibrator is designed for an average current consumption of approximately 5 mA. With S1 closed, the multivibrator is turned off except for the negligible bleeder current through R2, R3, and R4. It can be seen that the total load for B1 remains at 10 mA which was the original design objective.

Mechanical Construction

The lead photo shows the finished calibrator and identifies

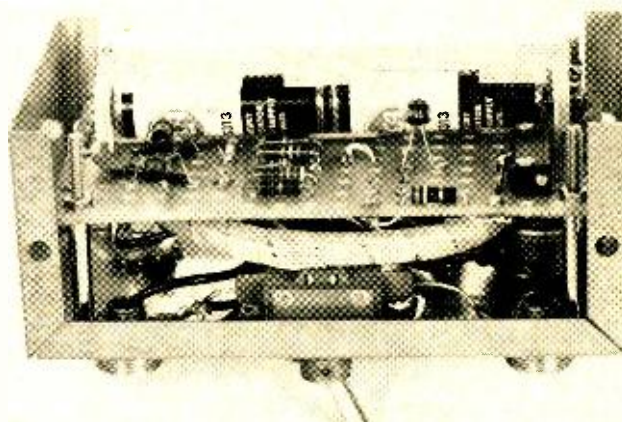

Back cover has been removed to show construction.

the location of controls and the input and output connectors. The second probe connector (not shown on the schematic diagram) was provided to accommodate a commercial oscilloscope probe which requires a BNC-type plug. Both connectors are electrically in parallel. The above photo shows the calibrator with the back cover removed. The subassembly carries most of the transistor circuits and the battery and is mounted on one half of the enclosure, using 2-inch-long, 6-32 machine screws.

The various components are wired together on the perforated phenolic board using brass eyelets for solder junctions. Lead dressing is uncritical with the exception of the wire between the "Scope" connector, S2B, and the "Probe" connector, which should be as short as possible and as far away from the metal case to keep capacitance to ground at a minimum. The front panel carries S1, S2, R9, and the connectors. The voltage divider resistors R10-R13 are wired directly to the terminals of S2. To facilitate access to the switches and connectors, all leads from the perforated board to the front panel are combined into a cable tree about four inches long. The battery holder is tied to the board by two loops of wire.

Adjustments and Calibration

Thoroughly check all wiring against Fig. 2 before inserting the batteries. Watch for proper polarity. Connect a scope to the "Scope" connector, set S1 to "Chopped", and S2 to "1000 mV". Adjust the scope for a stable display about two inches high. If necessary, adjust the "Symmetry" (R3) control to obtain a waveform of equally spaced negative and positive portions. Set S1 to "D.C." and verify that the square wave changes to a horizontal line.

The calibration procedure depends on what other test equipment or standards are available. The following procedure will give results that are usually accurate to $\pm 1\%$

Delta Launches the
COMPUTACH*

The
Great
One!



*An exclusive computer-tachometer for precise RPM measurement in easy-to-build Kit form!



ONLY
\$29.95
ppd.

Delta, pioneers in CD ignition who produced the fabulous MARK TEN®, now offer a precise computer-tachometer which obsoletes any type tachometer on the market today! You achieve unbelievable accuracy in RPM readings due to the advanced, solid-state electronic matched components used in the computer, coupled with the finest precision meter in the world. Works on all 2, 3, 4, and 6 cylinder 2 cycle and with 4-6-8 cylinder—4 cycle 12 volt engines.

- ▲ 0-8000 RPM range
- ▲ Perfect linearity—zero parallax
- ▲ Adjustable set pointer
- ▲ Wide angle needle sweep
- ▲ Translucent illuminated dial
- ▲ Chrome plated die-cast housing
- ▲ All-angle ball & socket mounting
- ▲ Use it with ANY ignition system
- ▲ Meter: 3 1/8" dia. X 3 3/8" deep
- ▲ Calibration kit included, no test eqpt. needed.

Orders shipped promptly.
Satisfaction guaranteed.



DELTA PRODUCTS, INC.
Send check today!

P.O. Box 1147 EW / Grand Junction, Colo. 81501
Enclosed is \$ _____ Ship ppd. Ship C.O.D.
Please send:

COMPUTACH® Kits @ \$29.95 ppd
Sold in Kit Form ONLY!

Name _____
Address _____
City/State _____ Zip _____

CIRCLE NO. 114 ON READER SERVICE CARD
82

using a v.t.v.m. or v.o.m. and a fresh flashlight or mercury cell.

To provide an even temperature, carry the cell in your pocket for a few hours. Then measure the terminal voltage with a voltmeter of at least $\pm 1\%$ accuracy and at least 20,000 ohms/volt input impedance. The terminal voltage will be between 1.3 and 1.6 volts. Record the voltage to the nearest hundredth of a volt. Carry your "standard" cell in your pocket while returning to your shop and calibrate the 1.5-volt range of your v.t.v.m. or v.o.m. using this cell. You now have one point on the v.t.v.m. scale that corresponds to the cell voltage which is fairly close to a value of 1.0 volt.

On your calibrator set S1 to "D.C." and S2 to "1000 mV". Connect the v.t.v.m. to the "Scope" connector and adjust R9 until the v.t.v.m. reads exactly 1.00 volt (taking into account the previous calibration point). Gentle tapping of the v.t.v.m. meter movement is often useful in overcoming the small amount of friction in the meter bearings.

Using Calibrator

Application of the calibrator is self-evident. Connect the "Scope" jack to the vertical input of your oscilloscope using a short piece of low-capacitance coax with suitable plugs. Square waves of 50, 100, 200, and 1000 mV peak-to-peak may be switched to the "Scope" jack and displayed on your oscilloscope.

It is not necessary to set the scope time base to obtain a square-wave display. At higher sweep rates, two lines will be visible on the scope screen; the distance between them will represent the peak-to-peak amplitude of the square wave. If you own a d.c. oscilloscope, you can calibrate its d.c. ranges with S1 set to "D.C.". With S2 set to "Off", the calibrator is turned off and bypassed and the probe is connected to the oscilloscope.

Parts Substitutions

Fig. 2 lists the parts used in the construction of the calibrator. A word of caution to those who would like to use parts already on hand: Don't try to use inexpensive germanium transistors in this circuit, especially for Q3. The two 2N2923's and the 2N706 cost less than \$2.00 total. The precision resistors (R10-R13) are needed to obtain the specified calibrator accuracy. If the calibrator is to be built into an existing scope, R8 must also be a precision, low-temperature-coefficient resistor and R9 a high-quality trimmer if the specified accuracy of the calibrator is to be maintained. This requirement and the need to replace B1 by a temperature-compensated, electronically regulated power supply will increase the parts cost considerably. ▲

LIKE MUSIC WITHOUT COMMERCIALS?

The SCA-2B Sub-Carrier Adapter makes it possible for you to enjoy the background music transmitted on a 67KHz sub-carrier on many FM stations. (These programs cannot be heard on a FM set without an adapter) In the US there are approximately 400 FM stations authorized by the FCC to transmit the 67KHz programs. If you are within 50 miles of a city of 100,000 or more, it is probable that you are within the satisfactory reception range of one or more of these stations. If in doubt write for a list of such stations in your area.



Patent Pending
Sub-Carrier Adapter, Model SCA-2B with two 3" shielded cables. Price \$39.95.
117 Volt AC Operated Power Supply, PS-9, Price \$4.95.

SCA-2B FEATURES

SIZE: 4" x 2 7/8" x 1 1/8". • Simple plug-in connections to your FM tuner/amplifier. (If your FM tuner does not have a multiplex output jack, we supply hook-up information). • No installation adjustments • All silicon transistors • Operates from our PS-9 Power Supply or 6 to 12 volts D.C. One Year Factory Guarantee

For Custom Installations: Completely Wired SCA-2 PC card (size: 2 1/2" x 3" x 3/4") with installation instructions for \$34.95. Also available SCA-2 installed in AC operated Panasonic 7-Transistor AM-FM Radio Model R-E6137 \$61.95.

Write for Dealer Quantity Discounts.
Commercial use of these units is not advised, unless the consent of the originating station is obtained.

Send order to **KENZAC CO.**
P.O. Box 177, Stamford, Conn. 06904
or **KENZAC Co.**
P.O. Box 66251, Houston, Tex. 77006

CIRCLE NO. 103 ON READER SERVICE CARD

Electronics World SUBSCRIBER SERVICE

Please include an address label when writing about your subscription to help us serve you promptly. Write to: Portland Place, Boulder, Colo. 80302

CHANGE OF ADDRESS:

Please let us know you are moving at least four to six weeks in advance. Affix magazine address label in space to the right and print new address below. If you have a question about your subscription, attach address label to your letter.

TO SUBSCRIBE:

Check boxes below.

- New Renewal
 5 years \$21
 3 years \$15
 1 year \$6

SPECIFY:

- Payment enclosed—
You get 1 extra issue
per year as a **BONUS!**
 Bill me later.

AFFIX LABEL

state	city	address	name	please print	If you have no label handy, print OLD address here.
zip code					

[Add'l postage: \$1 per year outside U.S., its possessions & Canada.]

name _____ please print _____ 0284

address _____

city _____

state _____ zip-code _____

ELECTRONICS WORLD

Using Controls

(Continued from page 34)

Check the picture and the range of all the controls if you do, and you will find that at least one of the controls is off.

The vertical stability in color sets can often be improved by proper adjustment of the height and linearity. The dynamic convergence can also be improved by this adjustment. In many cases, this is all that is needed to put a set into better convergence.

Horizontal Hold Control

The picture should hold through nearly the entire range of the horizontal hold control. In some models, the picture will hold throughout the range. If you cannot sync the picture at the center of the control range, note which way the lines are slanting. If they slant downhill from left to right, the oscillator is running fast. If they slant uphill from left to right, the oscillator is running slow (Fig. 5).

If the oscillator is running fast, look for decreased resistances or capacitance in the time-constant networks, or an unbalanced condition in the a.f.c. circuit that would feed a positive voltage to the oscillator grid. If the oscillator is running slow, look for the opposite trouble in the same circuits.

Phasing trouble, as evidenced by a filmy foldover of the picture (not to be confused with raster foldover), can be caused by the same defects.

Bending at the top of the picture should straighten out over a wide range of the control. If bending persists, look for sync trouble. Check the vertical sync bar and the vertical sync too. Make sure the stabilizing coil is aligned. The oscillator should be on frequency with the coil and the a.f.c. shorted out.

We have dealt here primarily with preliminary diagnoses, in most cases with the back cover still on the set. The technician will undoubtedly find a good many more uses for the controls in conjunction with tube substitution and with the indispensable test equipment on his bench. ▲

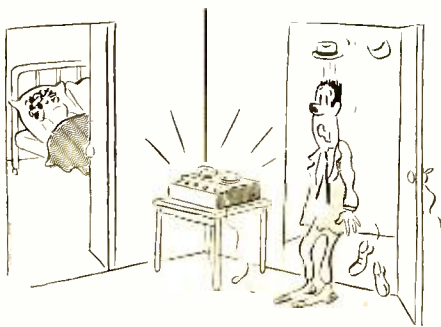

"Harvey! How dare you come in at this hour and in that condition! My mother warned me against marrying you."

March, 1969

LOOK! A NEW ELECTRONICS SLIDE RULE with complete instruction program



Here's a great new way to solve electronic problems accurately, easily... a useful tool for technicians, engineers, students, radio-TV servicemen and hobbyists. The Cleveland Institute Electronics Slide Rule is the only rule designed specifically for the exacting requirements of electronics computation. It comes complete with an illustrated Instruction Course. You get four AUTO-PROGRAMMED lessons... each with a short quiz you can send in for grading and consultation by CIE's expert instructors.

See for yourself. Learn how to whip through

all kinds of reactance, resonance, inductance, AC and DC circuitry problems in seconds... become a whiz at conventional computations too!

This all-metal 10" rule is made to our rigid specs by Pickett, Inc... comes complete with top grain leather carrying case and Instruction Course. A \$50 value for less than \$25. Send coupon for FREE illustrated booklet and FREE Pocket Electronics Data Guide, without obligation. Cleveland Institute of Electronics, 1776 E. 17th St., Dept. EW-161, Cleveland, Ohio 44114. *TRADEMARK

GET BOTH FREE!

ELECTRONICS SLIDE RULE

Send coupon today →

Cleveland Institute of Electronics

1776 E. 17th St., Dept. EW-161, Cleveland, Ohio 44114

Send FREE Electronics Slide Rule Booklet. Special Bonus: Mail promptly and get FREE Pocket Electronics Data Guide too!

NAME _____ (Please Print)

ADDRESS _____ COUNTY _____

CITY _____ STATE _____ ZIP _____

A leader in Electronics Training... since 1934

CIRCLE NO. 117 ON READER SERVICE CARD

Olson

FREE

Fill in coupon for a FREE One Year Subscription to OLSON ELECTRONICS' Fantastic Value Packed Catalog—Unheard of LOW, LOW PRICES on Brand Name Speakers, Changers, Tubes, Tools, Stereo Amps, Tuners, CB, Hi-Fi's, and thousands of other Electronic Values. Credit plan available.

NAME _____

ADDRESS _____

CITY _____ STATE _____

GIVE ZIP CODE _____

If you have a friend interested in electronics send his name and address for a FREE subscription also.

OLSON ELECTRONICS

341 S. Forge Street Akron, Ohio 44308

CIRCLE NO. 97 ON READER SERVICE CARD

WORLD'S FINEST

5-CORE SOLDER

ERSIN MULTICORE

NEW EASY DISPENSER PAK ONLY 69¢

BUY IT AT RADIO-TV PARTS STORES
MULTICORE SALES CORP., WESTBURY, N.Y. 11590

CIRCLE NO. 99 ON READER SERVICE CARD

ABOUT YOUR SUBSCRIPTION

Your subscription to **ELECTRONICS WORLD** is maintained on one of the world's most modern, efficient computer systems, and if you're like 99% of our subscribers, you'll never have any reason to complain about your subscription service.

We have found that when complaints do arise, the majority of them occur because people have written their names or addresses differently at different times. For example, if your subscription were listed under "William Jones, Cedar Lane, Middletown, Arizona," and you were to renew it as "Bill Jones, Cedar Lane, Middletown, Arizona," our computer would think that two separate subscriptions were involved, and it would start sending you two copies of **ELECTRONICS WORLD** each month. Other examples of combinations of names that would confuse the computer would include: John Henry Smith and Henry Smith; and Mrs. Joseph Jones and Mary Jones. Minor differences in addresses can also lead to difficulties. For example, to the computer, 100 Second St. is not the same as 100 2nd St.

So, please, when you write us about your subscription, be sure to enclose the mailing label from the cover of the magazine—or else copy your name and address exactly as they appear on the mailing label. This will greatly reduce any chance of error, and we will be able to service your request much more quickly.

Multi-Band Coverage will MAKE YOU MONEY!



LOW BAND
BUSINESS
AIRCRAFT
MARINE
CITIZENS
BAND
NO EXTRA CRYSTALS

Lampkin Frequency Meter Type 105-B
GUARANTEED ACCURACY .001%

Range: 100 KHz-175 MHz. **\$295.00**

You can buy separate frequency meters for mobile-radio transmitters in the separate bands — BUT — when you need just ONE channel outside that band, you are money ahead with the LAMPKIN.

Dial readings for virtually EVERY mobile-radio channel (printed by computer) now available at less than 3¢ per channel.

For complete specifications — MAIL COUPON TODAY!

Use this coupon for FREE booklet "How To Make Money in Mobile-Radio Maintenance" and information on Lampkin meters.

Name _____

Address _____

City _____ State _____ Zip _____

LAMPKIN LABORATORIES, INC.
MFM Div., Bradenton, Fla. 33505

METAL BOXES BUILT TO SIZE

By ROBERT E. BROCK/Ampex Corp.

Often an experimenter finds he cannot get component boxes in the size he needs. Here's how he can design his own.

SOONER or later, everyone who builds electronic equipment finds that a ready-made box of the size or proportions needed is not available. His alternatives are to use an oversize box or build one himself. If he tries the latter, he may encounter serious difficulties in bending the pieces for lack of box forming facilities.

The situation just described led to the design of an equal-halves box which may be tailored to needed dimensions and formed in any workshop equipped with a vise. As its name implies, the equal-halves box is composed of two identical halves except that each is the mirror image of the other.

To make the box, it is necessary to lay out only one of the halves to the required inside dimensions. For construction purposes, the basic pattern for box half I may be drawn full size on vellum or any "see through" paper. A word of caution, remember that the sheet-metal thickness must be included in the dimensions.

After the pattern of box-half I is drawn on the vellum, a metal scribe or awl and a piece of carbon paper can be used to transcribe the design onto the sheet metal. Next, the pattern is turned over (for box half II) and traced again through carbon paper onto another area of the sheet metal. Saw out the areas just traced in solid lines. Now notch the junction formed by the cutouts in the aluminum sheet (this makes the bending process easier); then label the

sheet as follows: A long side, B main box cover, C short side, and X flap. Next draw a series of dashed lines between A and B; B and C; and C and X. These lines are used as a forming guide. Form the box halves by bending A, X, and C (in that order) upward exactly 90 degrees. Fit and clamp the box halves.

Either self-tapping sheet metal screws or regular machine screws can be used to hold the box together. If machine screws are desired, select a tap drill for the screw size to be used in holding the box halves together. For example, for 6-32 screws use a 0.106-inch diameter tap drill. Drill through surface X (of one box half) and B (of the opposite half) at the center of their overlap. Then tap through both drilled holes to produce a 6-32 female thread.

Remove the clamp and separate the box halves. Using a clearance size drill (5/32-inch diameter in our previous example), enlarge the tapped hole through surface X (the flap) on both box halves. Re-assemble the box, and fit the screws in place to check on the closure and final fit of the box.

Either box half provides three surfaces that may be used for inputs, outputs, and controls. Many times all of the electronics can be installed in one of the box halves, leaving the mating half to serve only as a closure.

Incidentally, sheet aluminum 0.036-inch thick is best for forming these boxes. You'll find it inexpensive and simple to make boxes of any size. ▲

Examples of typical boxes made to the exact size required by equipment.

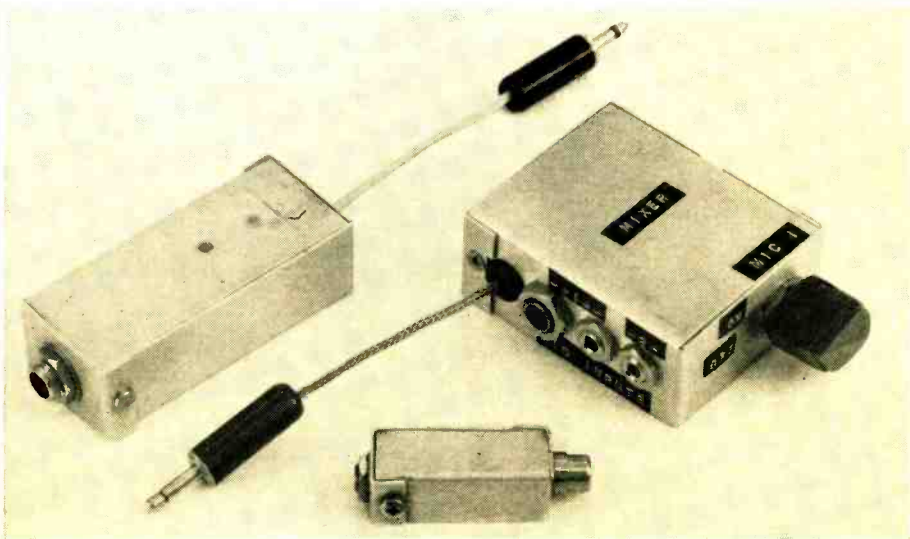

NEW PRODUCTS & LITERATURE

Additional information on the items covered in this section is available from the manufacturers. Each item is identified by a code number. To obtain further details, fill in coupon on the Reader Service Card.

COMPONENTS • TOOLS • TEST EQUIPMENT • HI-FI • AUDIO • CB • HAM • COMMUNICATIONS

PC-TYPE CHASSIS CONNECTORS

A line of four miniature unshielded chassis sockets, designed specifically for printed-circuit board and solderless wrap terminations, is now

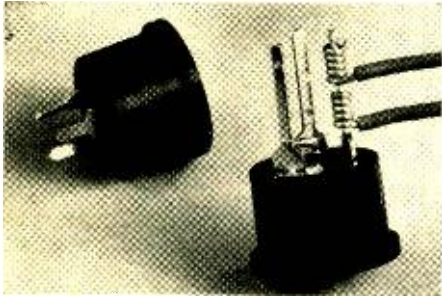

available. Included are a three-contact miniature unit with solderless wrap or PC contacts, a four-contact with solderless wrap or PC contacts, a five-contact with PC contacts, and a six-contact with PC contacts. All sockets mount easily without screws or rivets in 0.6250-in diameter round or "D"-shaped holes. Standard dielectric material is black phenolic, but mica-filled phenolic or other thermosetting plastics can also be specified. Amphenol Industrial

Circle No. 126 on Reader Service Card

HIGH-FREQUENCY INDUCTORS

A new line of hermetically sealed, continuously variable high-frequency inductors has been introduced. Reduced in size, the new inductors have very high "Q" with a large inductance variation range. They are said to be free from any residual d.c. effect. Variable "Hi-Q" tapped reactors and two-winding transformers can be supplied in the same size (package). Available for PC-mounting, these components are $\frac{21}{32}$ " diameter by $\frac{9}{16}$ " high. Weight is $\frac{1}{2}$ ounce.

The line features a "Q" of 500. Types VHI-1 through 10 have an inductance range of 1 mH to 50 mH and a frequency range of 50,000 to 500,000 Hz. Types VHI-11 through 22 have an inductance range of 9 μ H to 600 μ H and a frequency range of 100,000 Hz to 10 MHz. Freed Transformer

Circle No. 127 on Reader Service Card

DIPPED MICA CAPACITOR

Capacitance up to 1500 pF and dimensions as small as 0.310" wide x 0.230" high are being offered in a miniature dipped mica capacitor, the D-7.

This highly stable unit features high performance in a space-saving design, according to the

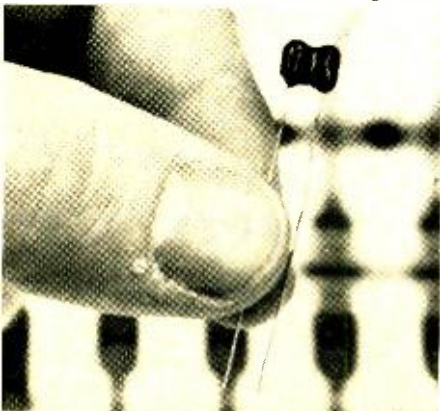

March, 1969

company. It is possible to place up to 40,000 pF in one square inch of board space. Complete details are available on request. Sangamo

Circle No. 128 on Reader Service Card

RANDOM-ACCESS MEMORY

A 64-bit random-access read/write memory is now being offered as an off-the-shelf item, the TT μ L 9035. The new high-speed unit has a 285-gate complexity organized in a 16-word by 4-bit format.

The 9035 features a read access time of 35 ns and a 25 ns write time. It is designed primarily for scratch pad memories and other applications where rapid access temporary storage is required. Additional uses for this circuit can be found in operational storage, main memory relocation control, "look ahead" programming, memory protection, and input/output data transfer buffering. Fairchild Semiconductor

Circle No. 129 on Reader Service Card

V.H.F. CRYSTAL OSCILLATOR

The CO-233 crystal oscillator provides a stable fixed-frequency output in the 25-125 MHz frequency range at a level exceeding 0.5 V r.m.s. into 50 ohms. This $1\frac{1}{2}$ " x $1\frac{1}{2}$ " x $\frac{3}{8}$ " module is designed for printed-circuit board mounting. It operates from any specified voltage in the 15-30 V d.c. range, with a current drain of less than 15 mA.

Stability is better than $\pm 0.0003\%$ over the

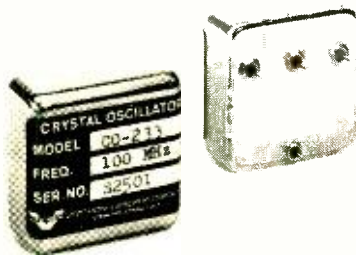

range of 20 to 30° C and $\pm 0.0025\%$ over the range 0 to 70° C. While the oscillator is factory set to within 0.001% of the specified frequency, a frequency adjustment for setting to within 0.0001% is optionally available. Vectron

Circle No. 130 on Reader Service Card

LINEAR IC DESIGN KIT

A new "all-in-one" linear integrated-circuit design kit is now available. The kit offers designers two each of twelve different circuit types, covering nearly all linear applications. In addition, the kit also provides a complete technical library on everything in the firm's linear IC line.

The twenty-four linear devices included in the kit are contained in safe-keeping trays for easy accessibility. The carrying case is of sturdy leatherette. The design library includes all data sheets, application notes, selection information, and detailed specs on 70 standard linear types. Motorola Semiconductor

Circle No. 131 on Reader Service Card

DIGITAL DISPLAY HEADS

A new generation of microminiature digital display heads has been introduced as the "Midgi-Lite" M series. The new units permit direct viewing of seven incandescent filaments as light bars. Use of filaments allows voltage controlla-

bility for varying brightness according to ambient light conditions. The range of readability spans aircraft cockpit displays from night carrier operations to direct sunlight at high altitudes.

The package measures only $\frac{3}{16}$ " from front to back. Six of the medium-size display heads can be stacked in less than one square inch. Two standard character heights are currently available, with alphanumeric and decimal points due shortly. Pintlites

Circle No. 132 on Reader Service Card

MINIATURE TRANSFORMERS

A new series of input, output, interstage transformers, and audio chokes is now available in tiny 0.31" x 0.41" x 0.465" package sizes for PC board applications.

These new units can be used as incoming

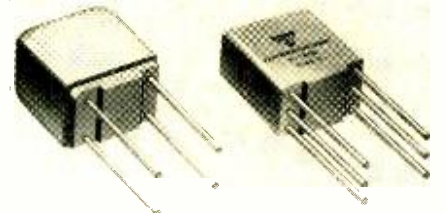

signal transformers, i.f. transformers, and output transformers with a wide variety of input impedances to match circuit requirements. Most of the series have both center-tapped input and output windings. Included in the convenient size are several audio chokes with inductances from 0.1 H to 6 H. A Mu-Metal shield case is offered as an optional slip-on cover for protecting the transformer from stray magnetic fields.

For PC board applications the leads are on 0.1" grid layout with 0.020" gold-plated leads $\frac{3}{4}$ " long as standard. The transformers are encapsulated in epoxy cases for environmental protection. Useful operating range is 100 to 100,000 Hz.

For complete information on available units, including electrical and mechanical characteristics, a free data sheet is available. Nytronics

Circle No. 133 on Reader Service Card

FULL-WAVE BRIDGES

Two new silicon-rectifier full-wave bridges (Series F903-standard and FS903-fast switching) are now available. These molded assemblies are designed for PC board insertion. The standard type has a normal switching speed of approximately 2 microseconds and the fast-switching model has a speed of approximately 75 nanoseconds. The bridges are available in 1, 2, and 4 amp versions. The p.i.v. ratings range from 50 to 1200.

Three case styles are available: Standard measuring $\frac{3}{4}$ x $\frac{3}{4}$ x $\frac{7}{16}$ inch with terminals in corners of square; Style A measuring $\frac{3}{4}$ x 0.300 x

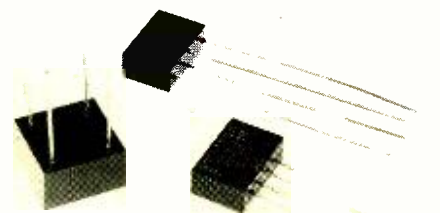

**LAFAYETTE
RADIO ELECTRONICS**

FREE!

**1969 CATALOG No. 690
JUST OFF THE PRESS!!
SEND FOR YOUR EXCITING COPY NOW!**



**BIGGER
& BETTER
THAN EVER**
OVER 500 PAGES!

**YOUR 1st GUIDE TO
EVERYTHING IN
ELECTRONICS**

- * CITIZENS BAND 2-WAY RADIO
- * STEREO/HI-FI COMPONENTS
- * MUSICAL INSTRUMENTS AND AMPLIFIERS
- * PUBLIC ADDRESS
- * AMATEUR RADIO
- * TEST EQUIPMENT
- * PARTS
- * PORTABLE AND TABLE RADIOS
- * PHOTO EQUIPMENT
- * TOOLS BOOKS
- * AUTO ACCESSORIES
- * EDUCATIONAL AND OPTICAL
- * TV AND ANTENNAS

Mail This Coupon Today For Your 1969 Catalog No. 690

LAFAYETTE Radio ELECTRONICS
Dept. 01039, P.O. Box 10
Syosset, L.I., N.Y. 11791

Please send the FREE 1969 LAFAYETTE Catalog 690 01039

Name _____

Address _____

City _____ State _____

Zip _____ (please include your Zip Code No.)

CIRCLE NO. 102 ON READER SERVICE CARD

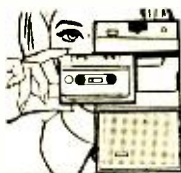

Norelco
Cassette Recorder

If our price for **NORELCO** is not the **LOWEST** we will refund difference within 10 days of purchase.

*** CASSETTES**

- * INDIVIDUAL PAPER MAILER BOX
- * NORELCO-TYPE PLASTIC BOX 15c EXTRA.
- C-30 1/2 Hr. .55
- C-60 1 Hr. .69
- C-90 1 1/2 Hr. 1.19
- C-120 2 Hr. 1.39
- Discount Music Catalogs
- 4 track open reel;
- 8 track OR cassettes.
- Free blank tape or Recorder discount catalog.

POSTAGE 8% of Total Purchase (over \$20 we pay)
1776 Columbia Rd., N.W.
Washington, D. C. 20009

SAXITONE

1/2 inch with terminals in a diamond configuration; and Style B measuring 3/4 x 0.300 x 1/2 inch with all terminals in line. Solitron Devices
Circle No. 134 on Reader Service Card

"CUSTOM" PRECISION RESISTORS

An inexpensive and simple-to-use installation, for manufacturing high-stability, precision resistors for prototype and production use, is now available. The package permits users to "custom" make resistors for prototype and short production run needs.

The package needs only seventeen basic resistor elements to cover the entire range from 10 ohms to 30,000 ohms. When the actual resistor value is determined, the proper element (chip) is adjusted simply, using a null detector, 1:1 bridge, decade box, binocular microscope, jig, and scribe. The adjusted resistor is then coated and encapsulated and ready for use in less than two days. Many companies already own most of the equipment required, thus reducing the initial cost of the package.

Resistors can be made with tolerance to 0.005%, shelf stability to 25 ppm/yr, response of 1 ns, and non-measurable noise. Vishay
Circle No. 135 on Reader Service Card

SET-POINT CONTROLLER

The Model 1050 digital set-point controller, designed to be used with the company's DMS digital measuring system, can start and/or stop the operation of any peripheral function at predetermined measurement values, as selected by the operator. According to the company, set-points are absolute, assuring start or stop functions at specific values with zero set-point error.

Although specifically designed as a companion unit to the DMS 3200 system, it can be used with



any device which provides ten-line decimal data outputs at the proper logic levels, along with appropriate read commands.

When used with the DMS main frame and suitable plug-in, digital measurements of voltage, frequency, period, resistance, capacity, and events can be used to activate external mechanical feeds, drives, print-outs, reject hoppers, feed motors, fuel adjustments, blowers, tabulation recorders, etc. Two controllers may be used in tandem for six-digit control. Hickok
Circle No. 136 on Reader Service Card

LIGHTED ROCKER SWITCHES

Three new series of lighted rocker switches designed to add color and a modern touch to appliances, musical instruments, amplifiers, test equipment, and computers are now available. The lighted switches save mounting space by eliminating separate indicator lights.

The a.c. switch mechanism is completely enclosed in a molded phenolic housing. The nylon rocker has self-lubricating pivots for longer life. A variety of rocker colors, lens colors, and color combinations can be supplied. High or low mounting brackets are supplied as required.

The switches can be provided with solder lugs, screw terminals, quick connect terminals, or wire leads to any specifications. Full details on all three series are included in Bulletin No. 206 which will be forwarded on request. Leviton
Circle No. 137 on Reader Service Card

WIDE-BAND SERVICE SCOPE

A wide-band, high-sensitivity, 5-MHz oscilloscope/vectorscope specifically designed to meet the requirements of waveform observation in TV servicing has been introduced as the Model 3000. The vertical amplifier has a sensitivity of 4.6



mV r.m.s./cm while the horizontal amplifier has a frequency response of 5 to 500,000 Hz ±3 dB. The scope measures 11" high x 9" wide x 16" deep and weighs 22 pounds. It is available in either kit or factory wired versions. Mercury
Circle No. 1 on Reader Service Card

SUBMINIATURE COIL

To meet the demand for space-conserving encapsulated coils, three new series of coils, all suited for use with integrated circuitry, have been introduced.

The smallest of these new coils is the Series 1054. This series is especially designed for use in hybrid circuitry and measures only 0.075" diameter x 0.170" long. There is a choice of 55 individual fixed r.f. inductors in the series, ranging from 0.10 μH through 3300 μH.

The Series 1050 subminiature series features flexible leads to permit soldering to PC lands or thick or thin films, and "flocked" tuning elements for inductance tuning. Inductance ranges are 0.06 μH to 2000 μH and dimensions are 0.80" diameter x 0.188" long. The Series 1051 covers a range of 0.10 μH to 10,000 μH and measures 0.100" x 0.160" x 0.260".

Detailed engineering data on these new coils will be forwarded on request. Cambridge Thermionic
Circle No. 138 on Reader Service Card

LOW-COST TV CAMERA

A small, low-cost television camera which can be used as an unseen detective, classroom aide, or industrial watchman has been introduced as the PK-501.

The unit weighs only 8 pounds and is in a compact tubular shaped housing especially designed for use by law enforcement agencies, educational institutions, and manufacturing firms. This closed-circuit monochrome unit has a one-inch vidicon. For longer distance observations, a zoom-type lens can be attached to the camera. The unit features automatic light compensation over a brightness range of 4000 with only an insignificant change in picture output level. Horizontal resolution in the picture measures 600 lines. Many of the camera's functions are automated, leaving only a minimum of controls to be adjusted for reliable and unattended camera operation over extended periods. RCA Commercial Electronic
Circle No. 2 on Reader Service Card

HI-FI—AUDIO PRODUCTS

STEREO CASSETTE DECK

The Model CAD4 is a professional stereo cassette tape deck which incorporates new electronics and a narrow gap head to extend the high-frequency response to beyond 12,000 Hz. According to the company, the deck has extremely low noise and distortion and clean bass response without hangover.

The deck features two large, illuminated vu



meters located on the sloped front panel; a recording overload indicator light keyed to the vu's and triggered at +2 vu to show when a tape recording is being overmodulated; automatic shut-off at the end of the tape; push-button operation; stereo microphone inputs; dual recording level controls; tape-footage counter; and motor and recording indicator lights. Harman-Kardon

Circle No. 3 on Reader Service Card

BOOKSHELF SPEAKER SYSTEM

A new deluxe bookshelf speaker system has just been introduced as the AS-48. The new damped reflex, tube-ported 8-ohm system uses a 14" woofer with an 11½-pound magnet assembly and a 4" edgewound copper ribbon voice coil in conjunction with a 2" piston-type direct radiator to handle up to 50 watts of program material. Both speakers are made by JBL.

Simplified construction is accomplished by building the 2000-Hz LC crossover network and wiring the high-frequency level control prior to installation. Both speakers, crossover, and level control are mounted from the front of the one-piece cabinet to insure cabinet sealing. The cabinet is finished in Mediterranean pecan and features a removable front grille. Full specifications on this new speaker kit will be supplied on request. Heath

Circle No. 4 on Reader Service Card

RHYTHM-INSTRUMENT KIT

The "Portable Dynabeat" is a complete rhythm-instrument section in a small carrying case. When connected to any amplifier-speaker system, such as a guitar amplifier or hi-fi stereo system, tapping its 10 buttons produces authentic

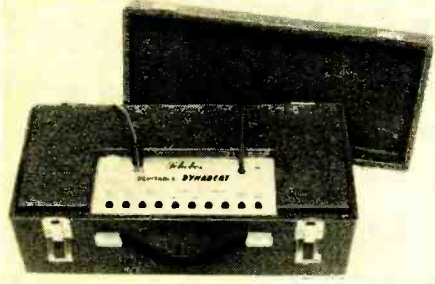

replicas of the ten most wanted rhythm sounds. These are: bass drum, snare drum, brush and crash cymbals, hi and lo bongos, hi and lo wood blocks, tom-tom, and castanets.

The unit weighs just six pounds and all sounds are produced by solid-state electronic circuitry, with no moving parts. The "Dynabeat" is being offered in both kit and assembled versions. Schober Organ

Circle No. 5 on Reader Service Card

AM-FM-STEREO RECEIVER

A new AM-FM-stereo receiver, rated at 100 watts, has just been introduced as the Model S-7600a.

The receiver features an integrated-circuit FM i.f. and limiters and uses FET's for the r.f. and mixer stages. Front-panel controls include rocker switches for loudness compensation, main and/or remote speaker switching, and tape monitor. Other controls are loudness and AM-FM tuning as well as bass, treble, balance, and variable FM interchannel hush. A three-position switch on the rear panel adjusts the phono-input level to equalize the magnetic phono cartridge level to the tuner signal level.

Over-all size is 16½" x 4½" x 12" deep which makes this receiver suitable for bookshelf installations. Either a walnut-grained leatherette metal case or an oiled-walnut wood cabinet is available as an optional accessory. Sherwood

Circle No. 6 on Reader Service Card

PLASTIC SPEAKERS

Two models of the "Poly-Planar" plastic speaker are now available. The 20-watt speaker is said to provide the same reproduction as a standard 20-watt woofer-tweeter combination and

covers the frequencies from 40 to 20,000 Hz. The speaker is 1½" thick and weighs 19 ounces. It is 14½" high x 11¾" wide.

The 5-watt version covers the range from 60 to 20,000 Hz. It measures 1½" thick x 8½" high x 4½" wide and weighs 10 ounces.

Both speakers will operate over the temperature range -20° F to +175° F and are resistant to extremes of humidity, shock, and vibration. They may be used un baffled or incorporated into acoustic enclosures, either conventional or unconventional. ERA Acoustics

Circle No. 7 on Reader Service Card

SERVO TURNTABLE SYSTEM

The PS-1800 is a new turntable which uses a slow-speed, servo-controlled d.c. motor to drive the turntable. According to the company, this

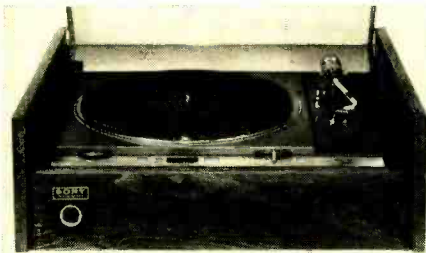

eliminates much of the noise that originates in mechanical speed-reducing systems.

The system compares motor speed with a very stable frequency reference. Any error in motor speed results in a correction in the current supplied to the motor. The speed reference is entirely independent of outside influence.

In addition, the PS-1800 features a new sensing device to lift the tonearm, return it to its rest position, and turn off the unit after the record is finished. The sensing device, called an SMD, adds no mechanical load to the tonearm. A convenient pause system permits interruption of a record during playing. This is done without damage to the record or stylus.

The PS-1800 is supplied with tonearm but without cartridge. Any standard cartridge of good quality can be used with this turntable. Sony Corp.

Circle No. 8 on Reader Service Card

MONITOR/PLAYBACK SPEAKER

The new Model 9845 Senior monitor/playback speaker system is a deluxe, larger version of the company's Model 844A compact monitor used by the professional recording industry. The Model 9845 uses a Model 416 15-inch low-frequency speaker which has a heavy Alnico V magnet in an efficient magnetic return structure.

The high-frequency compression driver is coupled to a cast aluminum sectoral horn and reproduces from the 500-Hz crossover frequency up to 22,000 Hz.

The enclosure has been strengthened by using cross braces in the 13-ply hardwood cabinet. The new system is 9 inches wider, 4 inches higher, and 8½ inches deeper than the Model 844A.

Data sheet AL-1756, giving complete details on the Model 9845, is available on request. Altec Lansing

Circle No. 9 on Reader Service Card

4-SPEED STEREO TURNTABLE

The Model 929 4-speed turntable and record changer permits fully automatic, semi-automatic, or manual playing of stereo and mono records. It may be set for continuous repeat-play or automatic shut-off. The British-built turntable will operate at 16⅔, 33⅓, 45, and 78 r/min.

A unique feature is the pause and cueing control. The tonearm may be lifted off a record in play and then lowered into the same groove. A low-mass tubular tonearm is counterbalanced on nearly frictionless ball bearings for accurate tracking.

The turntable also features a stylus pressure adjustment (0-6 grams), automatic lock to se-

Build this exciting Schober Console Organ for only \$925!*



*Includes finished walnut console. (Only \$716 if you build your own console.) Amplifier, speaker system, optional accessories extra.

You couldn't touch an organ like this in a store for less than \$1800—and there never has been an organ of the Console II's graceful small size with 22 such pipe-like, versatile voices, five-octave big-organ keyboards, and 17 pedals! It sings and schmaltzes for standards, pops, old-time favorites, speaks with authority for hymns and the lighter classics, all with a range of variety and satisfying authenticity you've never found before in an instrument under church or theatre size. If you've dreamed of an organ of your own, to make **your own** beautiful music, even if your home or budget is limited, you'll get more joy from a Schober Console II than any other "home size" organ—kit or no kit.

You can learn to play it. And **you** can build it, from Schober Kits, world famous for ease of assembly without the slightest knowledge of electronics or music, for design and parts quality from the ground up, and—above all—for the highest praise from musicians everywhere.

Send **right now** for the full-color Schober catalog, containing specifications of all five Schober Organ models, beginning at \$599.50. No charge, no obligation. If you like music, you owe yourself a Schober Organ!

The Schober Organ Corp., Dept. RN-63
43 West 61st Street, New York, N.Y. 10023

Please send me Schober Organ Catalog and free 7-inch "sample" record.

Enclosed please find \$1.00 for 12-inch L.P. record of Schober Organ music.

NAME _____

ADDRESS _____

CITY _____ STATE _____ ZIP _____

CIRCLE NO. 94 ON READER SERVICE CARD

FREE!

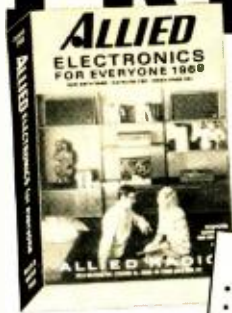

**NEW 1969
ALLIED
CATALOG
536
PAGES**

SAVE ON:

- Electronic & Hobby Kits
- Stereo Hi-Fi
- Tape Recorders, Tape
- CB 2-Way Radios
- Walkie-Talkies
- FM-AM & AM Radios
- Shortwave Receivers
- Portable TV
- Phonographs
- Amateur Gear
- Intercoms & PA
- Automotive Electronics
- Test Instruments
- TV Antennas & Tubes
- Power Tools, Hardware
- Tubes, Transistors
- Parts, Batteries, Books

**TOP SAVINGS ON
THE BEST IN
ELECTRONICS
FOR EVERYONE**

Shop by mail and save at Allied, world's largest electronics headquarters. Hundreds of money-saving values. NO MONEY DOWN. Up to 2 years to pay!

**MAIL COUPON
BELOW**

ALLIED RADIO, Dept. 031 | Please Print
P.O. Box 4398, Chicago, Ill. 60680

NAME First Middle Last

ADDRESS

CITY

STATE ZIP

CIRCLE NO. 124 ON READER SERVICE CARD

ENJOY THE "MUSIC ONLY" FM PROGRAMS

M. A. D.

MUSIC ASSOCIATED'S DETECTOR
NO COMMERCIALS—NO INTERRUPTIONS



It's easy! Just plug Music Associated's Sub Carrier Detector into multiplex jack of your FM tuner or easily wire into discriminator. Tune through your FM dial and hear programs of continuous commercial-free music you are now missing. The Detector, self-powered and with electronic mute for quieting between selections, permits reception of popular background music programs no longer sent by wire but transmitted as hidden programs on the FM broadcast band from coast to coast. Use with any FM tuner. Size: 5 1/2" x 9". Shipping weight approx. 7 lbs.

KIT \$49.50
(with pre-tuned coils, no alignment necessary)

WIRED \$75.00

COVER \$4.95 EXTRA

Current List of FM Broadcast Stations with SCA authorization \$1.00

MUSIC ASSOCIATED

65 Glenwood Road, Upper Montclair, N.J. 07043
Phone: (201)-744-3387

CIRCLE NO. 98 ON READER SERVICE CARD

cure arm in "off" position, adjustable anti-skate control, dynamically balanced 4-pole motor, pop filter and muting switch, shock-proof suspension of the 11-inch turntable, and clip-in cartridge holder for quick cartridge changing. The turntable measures 13 1/8 x 11 1/4 inches. A wood base and dust cover are optional extras. Allied Radio
Circle No. 10 on Reader Service Card

PORTABLE TAPE RECORDER

The TRQ-310 mono tape recorder/player is a true portable unit which operates either from its 9-volt battery pack or from standard house current. Weighing just 5 pounds and less than 12 inches high, the recorder operates at 3 3/4 and 1 7/8 in/s speeds. The amplifier has special jacks for "line" recording from a radio, phono, or other sound source; a microphone jack accepts the electronically matched dynamic mike supplied with the unit or any other high-level, high-impedance microphone. The amplifier is fully transistorized and uses a low-noise thermistor



and SCR as well. Amplifier output is 700 mW, sufficient to drive either the built-in 4-inch oval speaker or a high-efficiency external speaker through the speaker jack.

Frequency response is 150-7000 Hz at 3 3/4 in/s. Maximum reel capacity is 3". Hitachi
Circle No. 11 on Reader Service Card

CB-HAM-COMMUNICATIONS

ELECTRIC WAVE FILTER

A new signal line filter with a wide range of applications in communications equipment has been introduced as the INW-2. The new unit is a 600-ohm dual-section filter for line-to-line service. It operates between -55° C and +85° C and is rated to carry 150 mA of current at either 250 volts a.c. or 600 volts d.c.

The filter is intended for applications in telephone, teletypewriter, audio, and digital transmission lines and high-speed data circuits. It can be provided in a wide choice of passbands to suit specific requirements. Aerovox

Circle No. 139 on Reader Service Card

MARINE RADAR

The "Seafarer" (Model LN66) transistorized marine radar is designed to provide high-definition visual indication of buoys, markers, other craft, and the shoreline.



88

The radar display has six range scales from 1/2 to 24 nautical miles (statute miles optional), heading and stern markers, and a variable range marker. Minimum range is 20 yards or less. Bearing accuracy is ±1°.

The system consists of three basic units: a 4-foot antenna and rotator, a compact transmitter-receiver unit, and a 10-inch display unit which can be mounted on the deckhead, bulkhead, or on a pedestal.

Solid-state circuitry is used wherever latest state-of-the-art permits. Plug-in printed-circuit boards, fold-out trays, and swing panel assemblies simplify maintenance and adjustment.

The unit is available for operation from a 12, 24, or 32-volt d.c. electrical source or a 115 or 230-volt a.c. power source. Kaar

Circle No. 12 on Reader Service Card

CB "WALKIE-TALKIE"

The "Dyna-Com 12" features twelve switchable crystal-controlled transmit and receive positions; 5 watts input power; removable battery pack; 117-volt, 60-Hz a.c. operation with battery eliminator/charger; or 12-volt d.c. mobile operation with auto cigarette lighter cable assembly.

The circuit incorporates 14 transistors, 6 diodes, and one posistor. The superheterodyne receiver, plus an r.f. stage, has a sensitivity of 0.7 µV. There is an automatic compressor/range boost for high talk power and a jack which permits an external speaker to be connected for p.a. applications. Lafayette

Circle No. 13 on Reader Service Card

MARINE RADIOPHONE

The Model 130-A marine radiotelephone is designed for use in congested areas but with a reliable range in excess of 100 miles. The unit operates on six marine channels and will receive standard broadcasts. Crystals for all six channels are included.

Features of the radio include "Posi-dent" chan-



nel identification markers, low-drain receiver, gate squelch, universal mounting cradle, automatic noise limiter, transmitter standby switch, power plug, and front-mounted speaker.

The aluminum cabinet is finished in vinyl. It measures 10" wide x 6" high x 15" deep and weighs 18 pounds. Operation is from a 12-volt d.c. supply. Simpson Electric

Circle No. 14 on Reader Service Card

CB TRANSCEIVER

A new 23-channel CB transceiver, with special features which are designed to provide maximum selectivity combined with rejection of outside noise and interference, is now available as the "Royale".

The unit features a new exclusive full-time range-expand and speech compressor and an exclusive "Modulation Sampler" which electronically converts a weak voice and makes it strong and reduces a too-strong voice to the proper audio level. It also has a new Clevite hybrid ceramic filter for selectivity and high stopband rejection.

The "Royale" comes complete with crystals for all 23 channels. Courier

Circle No. 15 on Reader Service Card

SOLID-STATE CB RADIO

The "Panther" is a 3-pound, 5-channel, all solid-state CB radio which is capable of providing an output of 4 watts.

ELECTRONICS WORLD



The unit features an illuminated channel selector and power-on indicator light, low current drain (0.3 A on receive), LC filter, superhet receiver, class-B push-pull audio, electronic switching, and preset automatic noise limiter and squelch control. The noise limiting circuit virtually eliminates ignition and alternator noise, according to the company.

This mobile, 12-volt unit comes complete with channel-9 crystals, power cord, and mounting cradle with locking, adjustable bracket. It measures 7 3/4" x 2 1/4" high x 6" deep. Pearce-Simpson

Circle No. 16 on Reader Service Card

MANUFACTURERS' LITERATURE

MINIATURE POWER TOOLS

Catalogue #241 provides complete details on the Series 85 miniature power screwdriver and nut runner which is designed to handle a variety of production jobs in the electronics and related industries.

The 4-page booklet illustrates various applications and provides complete specifications on the three models available in the series as well as accessories designed to be used with the driver/runner. Foredom

Circle No. 17 on Reader Service Card

NICKEL-CADMIUM BATTERIES

Complete specifications on a line of long-rate

nickel-cadmium pocket plate storage batteries are covered in a new bulletin, AG-424.

Designed specifically for standby and emergency power applications, the 4-page brochure lists performance data on 31 different capacity cell types, ranging from 10 to 1245 ampere-hours, dimensional data including weights, and typical discharge curves. Also featured is a listing of long duration discharges—indicating the availability of capacity over 100% of nominal rate capacity and final cell voltages for discharge periods longer than 10 hours. NIFE

Circle No. 18 on Reader Service Card

AIR-MOVING DEVICES

A new "quick reference catalogue" which lists an extensive line of propeller fans, tubaxial fans, vaneaxial fans, squirrel-cage blowers, radial wheel and centraxial blowers, high-pressure/vacuum low-speed blowers and spiral blowers, and cooler panels, is now available for distribution. Rotron

Circle No. 19 on Reader Service Card

STRIP-CHART RECORDERS

A 20-page catalogue describing the new "200" series of miniature strip-chart recorders is now available for distribution. The publication describes the complete line of more than 30 models for recording current, voltage, power, events, pressure, temperature, or almost any parameter which can be converted to voltage or current.

The catalogue also includes detailed information on chart paper, drive motor specifications, accessories, optional features, dimensions, weights, and complete ordering instructions. Rustrak

Circle No. 140 on Reader Service Card

PHONO-CARTRIDGE DATA

The new high-trackability "Easy-Mount" phono cartridge as well as other hi-fi stereo cartridges, tonearms, styli, and headphone amplifiers

are highlighted in a new, illustrated 8-page catalogue now available.

The publication covers the company's complete cartridge line and provides specifications and performance information as well as charts and definitions of trackability. Application data and prices are given for all products shown. Shure

Circle No. 20 on Reader Service Card

PRINTED-CIRCUIT CONNECTORS

A comprehensive line of printed-circuit connectors is described in a new 24-page catalogue, PC-5.

The catalogue features complete data on all four popular PC connector families: bifurcated bellows contacts, tuning fork contacts, preloaded cantilever contacts, and modular plate assemblies. Included are photographs, line drawings, electrical characteristics, and mechanical specifications on over 100,000 different PC connector combinations. A selection guide provides information necessary for finding the right connector for any printed-circuit board application. Amphenol

Circle No. 141 on Reader Service Card

TIME-DELAY RELAYS

A six-page brochure which gives complete descriptions and specifications on six different lines of electronic time-delay relays is now available. The information is presented in a form which makes it easy to compare various characteristics of the different time delays. This side-by-side listing of information is designed to help the engineer select the correct relay to fit his application. A general description is also given for each series, outlining the outstanding features. Universal Technology

Circle No. 142 on Reader Service Card

RELAY BUYING GUIDE

A 12-page brochure covering the selection of relays is now available for distribution. The

DON'T MAKE A SOUND

WITHOUT THE POWERLINE FROM UNIVERSITY

The industry's first and only solid state, transistorized, computerized public address amplifiers with high fidelity performance.

Built from the ground up to take full advantage of space-age circuitry, with features you won't find in any other line at any price.

Dependable? Any amp in the Power-Line series can go from no load to full load, even a complete short circuit, without blowing an output transistor! (Or anything else, including your stack.) Why? Because of University's exclusive automatic computer logic cir-

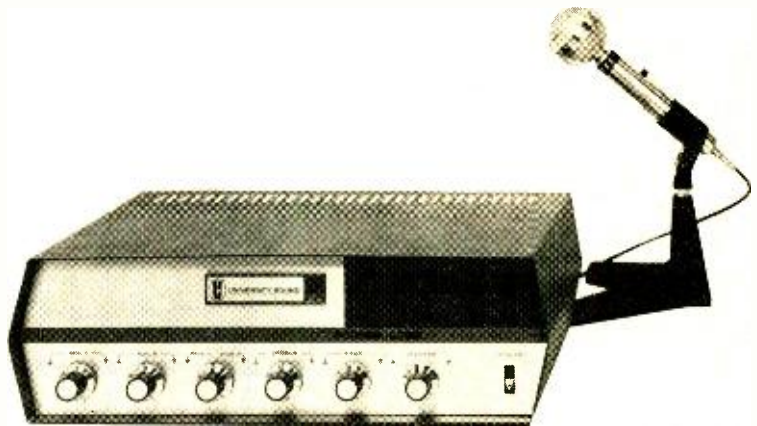

cuit. Direct coupling for cleanest sound, greatest efficiency, lowest distortion.

High fidelity performance? You bet! You can use the Power-Line not only for public address applications but it's also great for quality background music reproduction.

16 Models to choose from: eight deluxe and eight standard with or WITHOUT OUTPUT TRANSFORMERS (and if your system's size will let you use the transformerless models, University just saved you a bundle of time and money), with 20, 35, 60, or 100 watts of clean, proven performance.

For more details, write for our new catalogue and the name of your nearest University dealer.



UNIVERSITY[®] SOUND

A DIVISION OF LTV LING ALTEC, INC.
P. O. Box 26105 Oklahoma City, Okla. 73126

CIRCLE NO. 86 ON READER SERVICE CARD

DEALERS! HOBBYISTS!

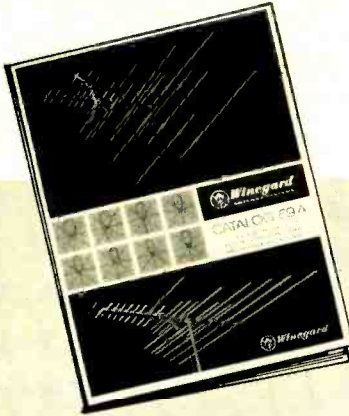

NEW AND FREE FROM WINEGARD

Our giant catalog of TV and FM antennas, mounts, wire, couplers, amplifiers, wall plates and antenna systems equipment!

Now, for the first time ever, you can have Winegard's sensational 52-page Catalog illustrating and describing the world's most complete line of high quality antennas and MATV equipment for homes and commercial buildings. That's right! Even if you're not in the electronics business, you can use this Catalog to select Winegard products. Send for your FREE copy today, plus the name of your nearest Winegard distributor.



WINEGARD COMPANY, 3003-1 Kirkwood Street
Burlington, Iowa 52601

Gentlemen: Please send me your FREE Catalog.
 Electronics is my business. Electronics is my hobby.

NAME (please print) _____

ADDRESS _____

CITY _____

STATE _____ ZIP _____

CIRCLE NO. 84 ON READER SERVICE CARD

A Treasury of
HARD-TO-FIND TOOLS

NEW CATALOG

Unique collection of hard-to-find versatile hand tools and small power tools rarely found in stores or other catalogs. Large selection of unusual knives, precision tweezers, jewelers' and electronics pliers, flexible shaft machines, endless hacksaw, diamond glass cutter, soldering jigs, carbide hacksaw blades, silver solder, micro-miniature tools and scores of other fascinating items to make projects easier, more fun. All are top quality tools. Used extensively by electronic technicians, researchers, model makers. Money-back guarantee. Write to:

BROOKSTONE CO.

3965 River Road, Worthington, Mass. 01098

booklet includes information on trade-offs in relay selection, showing many cost-saving practices. Also included is a relay ordering checklist designed to answer most of the basic questions asked in fitting a relay to a particular application.

All of the units listed in the brochure are standard stock items with immediate availability. Cornell-Dubilier

Circle No. 143 on Reader Service Card

ANTENNAS FOR COLOR-TV

A booklet entitled "Yes! You Need a Color Antenna!", developed for sales presentations at the point of TV set sales, has just been published.

Geared to the idea that a color-TV antenna is actually a necessity for good color reception and should, therefore, be sold as a package with the set, the text is presented in a simple, logical, direct, and easy-to-understand format. Finney Company

Circle No. 21 on Reader Service Card

READOUTS & LAMP DATA

A new 12-page, 1969 product catalogue detailing a line of microminiature digital display heads, microminiature display packages, micro decoder/driver modules, and incandescent lamps is now available.

Included in the catalogue are technical data, graphs and diagrams showing light/life voltage relationships, life expectancy data, response times, compatible connectors, and mounting designs. Pinlites

Circle No. 144 on Reader Service Card

VIDEOTAPE PLAYBACK UNIT

A four-page brochure which contains a description and specifications on the VP-5900 dial-access videotape playback unit is now available. The unit is designed for use in education, industry, medicine, and governmental closed-circuit television applications. Ampex

Circle No. 22 on Reader Service Card

DAYLIGHT-ACTIVATED PHOSPHORS

Technical information bulletins on four new daylight-activated phosphors are now available. The phosphors described include: Type 911-green; Type 920-blue; Type 930-red; and Type 940-yellow orange. The bulletins provide general information, optical and physical properties, graphs of persistence curves, and excitation and emission spectrums. Sylvania

Circle No. 145 on Reader Service Card

MICROWAVE IC's

A complete microwave component catalogue, which features microwave integrated circuits for the first time, is now ready for distribution. The 24-page publication also carries details on solid-state signal sources, isolators, circulators, duplexers, phase shifters, and equalizers. Sperry Microwave

Circle No. 146 on Reader Service Card

INSTRUMENT MODULES

A 12-page booklet which gives complete details on a fourth-generation system-compatible instrument module, Series 100, is now ready for distribution.

Concise descriptions of units in the Series 100 are presented, along with a photo of the unit and system peripherals, and interface accessories designed to be used with them.

Various system applications are discussed, along with block diagrams indicating interconnections. Monsanto

Circle No. 147 on Reader Service Card

POWER-SUPPLY DATA

More than 300 power supplies, including modular, high-voltage, and frequency converters are detailed in a new three-ring catalogue just issued. Page references and convenient charts for cross-indexing aid in selecting the appropriate power supply for specific needs such as voltage and current range, regulation, ripple, and proper size model.

A new section in the catalogue features the LVC mini-bench or 1/4-rack series-regulated unit. This particular power supply is designed to provide a well-regulated, stable source of d.c. power. NJE Corporation

Circle No. 148 on Reader Service Card

DISCRETE DEVICES

A complete listing of the company's discrete devices—from diodes to FET's to power transistors—is provided in a new 64-page catalogue, "Transistor & Diode Condensed Catalogue 1969". A nine-page index section which lists products by 1N, 2N, EN, non-registered type numbers, and military approved transistors and diodes, makes it easy to locate specific products.

Included in the listing are diodes, small-signal transistors, dual transistors, FET's, power transistors, communications devices, SCR's, specialty diode product, and electro-optical devices. Package outline dimensions are included in a special 3-page section. Fairchild Semiconductor

Circle No. 149 on Reader Service Card

MICROMINIATURE TRIMMERS

Comprehensive data on a series of microminiature trimmer pots is now available in a new publication, Bulletin No. P-66.

Detailed electrical, mechanical, and environmental specifications are listed along with dimensioned drawings and actual size photographs of the pots. The fold-out brochure can be used as a wall chart if desired. The line includes single-turn, wire-wound pots which meet all applicable MIL-Specs. Minelco

Circle No. 150 on Reader Service Card

PUSH-BUTTON SWITCHES

A 6-page, 4-color catalogue describing five lighted and unlighted push-button switches is now available as Catalogue M300.

Illustrations and specifications describe the application flexibility for two models of lighted push-button switches with a range of colors for buttons and bezels, a combination switch and receptacle, a push-button receptacle with switch, and a special record-changer switch. The switches are designed for snap mounting and, depending on type and use, are obtainable in ratings from 2 to 9 amps for up to 250-volt applications. Molex

Circle No. 151 on Reader Service Card

INTEGRATED CIRCUITS

A compatible line of 29 ECL functions is described in a new 30-page brochure which provides complete technical specifications on the ECL2500 Series, featuring typical propagation delays of 2 to 3 ns per gate. The line consists of 18 basic logic configurations, 3 complex logic functions, 4 interface circuits, and 3 storage functions. Also included is a 4-word by 2-bit MSI active-element memory. All of these circuits are available in plastic-encapsulated, dual in-line packages. Texas Instruments

Circle No. 152 on Reader Service Card

PHOTO CREDITS

Page	Credit
22	Kenwood Electronics, Inc.
25	H. H. Scott, Inc.
30 (top)	ESB
30 (center)	Laser Diode Laboratories
30 (bottom)	Bell Telephone Laboratories
31 (top)	Delco
31 (center)	GT&E Laboratories
31 (bottom left)	Cornell Aeronautical Lab
31 (bottom right)	Northern Electric Co. Ltd. (Canada)
37 (Fig. 5A)	Kulite Semiconductor Products Corp.
46	Harshaw Chemical Co.
51	Radiation Inc.
65	Ampex Corp.
68	Radio Corporation of America
69 (top)	Delta Products
69 (bottom)	Jackson Electrical Instrument Co.

ELECTRONICS MARKET PLACE

COMMERCIAL RATE: For firms or individuals offering commercial products or services. 85¢ per word (including name and address). Minimum order \$8.50. Payment must accompany copy except when ads are placed by accredited advertising agencies. Frequency discount: 5% for 6 months; 10% for 12 months paid in advance.

READER RATE: For individuals with a personal item to buy or sell. 50¢ per word (including name and address). No minimum! Payment must accompany copy.

GENERAL INFORMATION: First word in all ads set in bold caps at no extra charge. Additional words may be set in bold caps at 10¢ extra per word. All copy subject to publisher's approval. **Closing Date:** 1st of the 2nd preceding month (for example, March issue closes January 1st). Send order and remittance to: Hal Cymes, **ELECTRONICS WORLD**, One Park Avenue, New York, New York 10016.

FOR SALE

JUST starting in TV service? Write for free 32 page catalog of service order books, invoices, job tickets, phone message books, statements and file systems. Oelrich Publications, 6556 W. Higgins Rd., Chicago, Ill. 60656.

GOVERNMENT Surplus Receivers, Transmitters, Sniperscopes, Radios, Parts, Picture Catalog 25¢. Meshna, Nahant, Mass. 01908.

METERS Surplus, new, used, panel or portable. Send for list. Hanchett, Box 5577, Riverside, Calif. 92507.

CONVERT any television to sensitive big-screen oscilloscope. Only minor changes required. No electronic experience necessary. Illustrated plans, \$2.00. Relco-A22, Box 10563, Houston, Texas 77018.

MUSIC LOVERS, CONTINUOUS, UNINTERRUPTED BACKGROUND MUSIC FROM YOUR FM RADIO, USING NEW INEXPENSIVE ADAPTER. FREE LITERATURE, ELECTRONICS, 11500-Z NW 7TH AVE., MIAMI, FLORIDA 33168.

TREASURE HUNTERS! Prospectors! Relco's new instruments detect buried gold, silver, coins. Kits, assembled models. Transistorized. Weighs 3 pounds. \$19.95 up. Free catalog. Relco-A22, Box 10839, Houston, Texas 77018.

WHOLESALE components: Manufacturers and distributors only. Request free catalog on business letterhead. **WESCOM**, Box 2536, El Cajon, California 92021.

ELECTRONIC ignition, various types. Free literature. Anderson Engineering, Epsom, N.H. 03239. **GARRARD** Record Changers, Hi-Fi Components, Cartridges, Needles, Tape, TV Parts, Schematics. Write for Unbelievable Prices. Gregg Electronics, P.O. Box 184, Glen Head, N.Y. 11545.

WRITE now for free 1969 catalog McGee Radio Company. 1001 bargains. Speakers — Parts — Tubes — High Fidelity Components — Record Changers—Tape Recorders—Kits. Everything in Electronics. 1901 McGee Street, Kansas City (GE), Missouri 64108.

SEND ONLY 25¢ for TWO new & unique catalogs of unusual items for home & auto. You'll also receive certificate for \$1.00 refund on your first order. Great ideas! Send now! J. Ross, 80-34 Kent St., Jamaica, N.Y. 11432. Dept. EW.

INVESTIGATORS, LATEST ELECTRONIC AIDS, FREE LITERATURE. CLIFTON, 11500-J NW 7th AVE., MIAMI, FLORIDA 33168.

LABORATORY chemicals supplies. 1969 catalog has over 400 listings many scientific publications, catalogues \$25. Casco, Dept. X, P.O. Box 77, Riverdale, New Jersey 07457.

FREE ELECTRONICS PARTS FLYER. Large catalog \$1.00 deposit. **BIGELOW ELECTRONICS, BLUFFTON, OHIO 45817.**

FIND BURIED TREASURE with the most popular transistorized metal detector in the country. Treasure Probe available as kit (\$14.88), assembled (\$18.88), with powerful builtin speaker (\$24.88). Schematic, parts list, and step by step instructions \$1.00. Ten day money back guarantee. Free catalog available. Treasure Probe Dept. EGG, P.O. Box 64, Lakewood, New Jersey 08701.

AMAZING Performance! Newest Models—Treasure Detectors. Sensational low prices! Complete models and kits from \$14.95 to \$129.50. Let us prove it. Free catalog. Jetco Electronics, Box 132-EW, Huntsville, Texas 77340.

NOW Motors, Tubes, Chassis, Gear Units, Components, Government and Industrial Surplus. Catalog 20¢. Mechtronics, Dept. 5EW, 25260 Gratiot, Roseville, Mich. 48066.

SCHEMATICS, airmailed, \$2. Make, model. Brown, 321 East Price, Philadelphia 19144.

COMPUTER experimenters! Twelve place transistor lamp driver with neon lamps, \$15.00! P.C. board alone, \$5.00! **ADD**, Box 5226, Huntsville, Alabama 35805.

ONE YEAR GUARANTEE!

33¢

PER TUBE

TUBES!

100 OR MORE TUBES

30¢

ea.

Special!
With Every \$10 Order

25¢

PER TUBE

Your Choice Of These Sizes

6AG5 6SN7
6W4 6A6 6B6 6A7



Prestige & Success as an

ELECTRONICS EXPERT!



HOME STUDY COURSES

TV SERVICING \$3.50

RADIO SERVICING \$3.00

BOTH COURSES \$6.00

2 STATION INTERCOM

12⁹⁵

A.C. 110 VOLT TRANSISTORIZED INTERCOM!

ONE YEAR GUARANTEE!

DUMONT TUBES!



Brand New Except Glass!

TUBE TYPE	DUD DEP.	TUBE PRICE
19XP4	3.00	21.95
21AMP4	1.00	14.95
21CBP4	1.00	14.95
21CEP4	1.00	14.95
23FP4	3.00	18.95
21FJP22	5.00	24.95
23EGP22	20.00	79.95
25AP22	35.00	119.95
23AHP4	27.50	99.95
24AEP4	5.00	24.95
	1.00	22.95

Please remit full tube price plus dud deposit with order. Dud deposit will be returned immediately upon postpaid return of dud. No C.O.D.'s on picture tubes. All duds returned for refund must be under full vacuum.

FREE! CORNELL'S NEW CATALOG! WRITE FOR YOUR COPY TODAY!

RED & BLACK TUBE CARTONS
High Gloss, Clay Coated, Built in Diag. Partitions

SIZE	TUBE SIZE	10 CARTONS	100 CARTONS
MIN.	6AU6	.29	2.59
GT.	6SN7	.39	3.49
LG.GT	5U4GB	.59	5.29
G.	5U4G	.89	7.99

NO SUBSTITUTIONS WITHOUT YOUR PERMISSION!
YOUR ORDER FREE IF NOT SHIPPED WITHIN 24 HRS.

Terms: Orders over \$5.00: Add 3¢ per tube shipping. Prepay in full and avoid C.O.D. charges. Send \$3.00 deposit on C.O.D. orders. Orders under \$5.00: Add 3¢ per tube plus 50¢ handling. Canadian and Foreign Orders: add approx. postage. No C.O.D. orders. Combine varied orders to bring order over \$5.00.

DEPT. EW-3 4217 UNIVERSITY
SAN DIEGO, CALIFORNIA 92105

NEW G&G CATALOG!

MILITARY ELECTRONICS



24 PAGES crammed with Gov't Surplus Electronic Gear—the Biggest Bargain Buys in America! It will pay you to

SEND 25¢ for your copy—Refunded with your First Order!

BC-645 TRANSCEIVER. 15 tubes. 435 to 500 Mc. Easily adapts for 2 way voice or code on Ham, Mobile, Television Experimental and Citizens' Bands. With tubes, less than supply in factory carton. **\$16.95**



SPECIAL PACKAGE OFFER: BC-645 Transceiver, Lyttomotor and all accessories, including mounts, CBF Antenna Assembly, control box, complete. **BRAND NEW \$26.95**

AN/APR-4Y FM & AM RECEIVER "FB" FOR SATELLITE TRACKING!

High precision lab instrument, for monitoring and measuring frequency and relative signal strength. 38 to 4000 Mc. in 5 tuning ranges. For 110 V 60 cycle AC. Built-in power supply. Original circuit diagram included. Checked out, perfect. **\$88.50**

LIKE NEW
All Tuning Units Available for Above

SCR-274-N, ARC-5 COMMAND SET HQ!

Freq. Range	Type	Exc. Used	Like New	BRAND NEW
190-550 Kc.	DC-453	\$18.95	\$23.50
3-6 Mc.	BC-454	\$18.95	\$21.50
6-9.1 Mc.	BC-454	\$14.95	\$19.95
1.5-3 Mc.	R-25	\$21.50
TRANSMITTERS. Complete with Tubes				
4-5.3 Mc.	BC-457	\$ 6.95	\$11.95
5-3.7 Mc.	BC-458	\$ 6.95	\$12.95
7-9.1 Mc.	BC-459	\$17.95	\$22.50
2-1.3 Mc.	T-18	\$10.95
3-4 Mc.	T-19	\$10.50	\$14.95

BC-906 FREQ. METER—SPECIAL

Cavity type 1.45 to 235Mc. Complete with antenna. Manual and original calibration charts included. **LIKE NEW. OUR LOW PRICE \$14.50**

TERMS: Either 25% Deposit with order, balance, once C.O.D. OR—Remittance in Full. Minimum Order \$5.00. All shipments F.O.B. our warehouse. NYC. All merchandise subject to prior sale and price change.

G & G RADIO SUPPLY COMPANY
Telephone: (212) CO 7-4605
75-77 Leonard St., New York, N.Y. 10013

ELECTRONIC bargain catalog on unusual kits, parts, do-it-yourself, stereo, intercoms, Alcon, P.O. Box 1348 W, Lawrence, Mass. 01843.

TEST equipment. Immediate delivery. Most Models, Sencore, B & K. Ship anywhere. Catalog free. Signal Electronics, 555 New Park Ave., West Hartford, Conn. 06110.

IGNITION COIL, transistor, new 45,000 volts, epoxy, \$10.50. Raybin, 9 Bertlee Drive, Huntington Station, New York 11746.

EUROPEAN wholesale new products catalog. \$1.00 refundable. Deecow, 10639 Riverside, North Hollywood, Calif. 91602.

JAPAN HONG KONG DIRECTORY. Electronics, all merchandise. World trade information. \$1.00 today. Ippano Kaisha Ltd., Box 6266, Spokane, Washington 99207.

RECTIFIERS, transistors, other components. Free Catalog. Lowest Prices. Electronic Components Co., Box 2902E, Baton Rouge, La. 70821.

ELECTRONICS WORLD COLOR ORGAN P.C. BOARD (Jan. 1969) four active filter sections on board \$3.00 ppd. C. Andrew, 312 South Pugh, State College, Pa. 16801.

PLANS AND KITS

BUILD-IT-YOURSELF. Save big dollars. Transistor stereo amplifiers. Color organs. Speakers. Write Workshop, Box 393, Bethpage, NY. 11714.

INTEGRATED CIRCUIT KITS: COMPUTER, AUDIO, Others. New catalog free. KAYE ENGINEERING, Box 3932-B, Long Beach, California 90893.

ELECTRONICS ENGINEERING AND INSTRUCTION

ASSOCIATE Degree in Electronics Engineering earned through combination correspondence-classroom educational program. Free brochure. Grantham Technical Institute, 1505 N. Western Ave., Hollywood, Calif. 90027.

LEARN ELECTRONIC ORGAN SERVICING at home. All Makes including transistors. Experimental kit—troubleshooting. Accredited NHSC. Free Booklet. NILES BRYANT SCHOOL, 3631 Stockton, Dept. A, Sacramento, Calif. 95820.

FCC First Class License in six weeks—nation's highest success rate—approved for Veterans Training. Write Elkins Institute, 2603C Inwood Road, Dallas, Texas 75235.

R.E.I.'s famous (5) week course for the First Class Radio Telephone License is the shortest, most effective course in the nation. Over 98% of R.E.I. graduates pass F.C.C. exams for 1st class license. Total tuition \$360.00. Job placement free. Write for brochure Radio Engineering Incorporated Schools, 1336 Main Street, Sarasota, Florida 33577—or 3123 Gillham Road, Kansas City, Missouri 64109—or 809 Caroline Street, Fredericksburg, Virginia 22401—or 625 E. Colorado Street, Glendale, California 91205.

SHIP RADIO OFFICER TRAINING—SHIPS have been held up awaiting needed personnel. Train now at Long Beach the home of the Queen Mary. Radio officers earn to \$1800.00 monthly. Write for free information. Western Technical School, 5459 Atlantic Avenue, Long Beach, Calif. 90805, Desk B. Approved for veterans.

ELECTRONICS! Associate degree—29 months. Technicians, field engineers, specialists in communications, missiles, computers, radar, automation. Start September, February. Valparaiso Technical Institute, Dept. N, Valparaiso, Indiana 46383.

TUBES

TUBES—33¢ each. Year guarantee. Tuner Cleaner \$1.09. Free catalog. Cornell, 4213-W University, San Diego, Calif. 92105.

TUBES, SEMICONDUCTORS, ELECTRONIC EQUIPMENT & COMPONENTS. Quality merchandise only! Servicing engineers. Purchasing Agents, TV/HiFi Servicemen and Hams for 20 years. Write for Catalog or call 212-WA 5-7000. **BARRY ELECTRONICS**, 512 Broadway, New York, N.Y. 10012.

RECEIVING & INDUSTRIAL TUBES, TRANSISTORS, All Brands—Biggest Discounts. Technicians, Hobbyists, Experimenters—Request FREE Giant Catalog and SAVE! ZALYTRON, 469 Jericho Turnpike, Mineola, N.Y. 11501.

TUBES—lowest prices in the world. Hard to get British, German, foreign and American obsolete and present day special purpose transmitting tubes. Send for giant tube and parts catalog. United Radio Co., Dept. W-56 Ferry St., Newark, N.J. 07105.

WANTED

QUICKSILVER, Platinum, Silver, Gold. Ores Analyzed. Free Circular. Mercury Terminal, Norwood, Mass. 02062.

QUICK CASH . . . for Electronic Tubes, Semiconductors, Equipment (Receivers, Transmitters, Scopes, Vacuum Variables, etc.) Send lists now! Write: **BARRY ELECTRONICS**, 512 Broadway, New York, N.Y. 10012 (212-WA 5-7000).

DO-IT-YOURSELF

PROFESSIONAL ELECTRONICS PROJECTS—\$1.00 up. Catalog 25¢. PARKS, Box 25655A, Seattle, Wash. 98125.

TAPE AND RECORDERS

BEFORE renting Stereo Tapes, try us. Postpaid both ways — no deposit — immediate delivery. Quality—Dependability—Service—Satisfaction—prevail here. If you've been dissatisfied in the past, your initial order will prove this is no idle boast. Free Catalog. Gold Coast Tape Library, Box 2262, Palm Village Station, Hialeah, Fla. 33012.

TAPEMATES make available to you ALL 4-TRACK STEREO TAPES—ALL LABELS—postpaid to your door—at tremendous savings. For free brochure write: **TAPEMATES**, 5727 W. Jefferson Blvd., Los Angeles, California 90016.

RENT 4-track open reel tapes—all major labels—3,000 different—free brochure. Stereo-Parti. 55 St. James Drive, Santa Rosa, Calif. 95401.

TAPE RECORDER SALE. Brand new nationally advertised brands, \$10.00 above cost. Amazing discounts on stereo components. Arkay Electronics, 1028-B Commonwealth Ave., Boston, Mass. 02215.

HI-FI Components, Tape Recorders at guaranteed "We Will Not Be Undersold" prices. 15-day money-back guarantee. Two-year warranty. No Catalog. Quotations Free. Hi-Fidelity Center, 239 (LT) East 149th Street, New York 10451.

INTEGRATED CIRCUITS / RECTIFIERS SEMICONDUCTORS / TRIACS

TRIACS

**TO-66
5 AMP**

PRV	100	.90
200	1.40	
300	1.75	
400	2.25	
500	2.60	

ER900 TRIGGER DIODES. These bidirectional trigger diodes are one of the best and cheapest methods to trigger SCR's and triacs3/\$1.00

UNIUNCTIONS!

Similar to 2N2419. RBB of 5-7 stand off ratio of .6 and Ip of 12, with data sheet.....\$1.50

ZENERS 1 Watt 7-68V \$.40
10 Watt 7-200V \$.75

MOUNTING

HARDWARE KITS.

These kits are used to mount our SCR's Zeners and Rectifiers etc.
6x32 stud (3+12 amp rectifiers, 7A SCR's) 6 sets/\$1.00
¼x28 stud (20+40 amp rectifiers, 20 amps SCR's.) 4 sets/\$1.00

Send for our latest catalog featuring Transistors and Rectifiers; 325 Elm St., Cambridge, Mass.

SIM to 2N3429 (NPN). SI ¼" stud, min HFE of 30, 7.5 Amps. 175 watts, VCe of 75\$1.75

N-CHANNEL FET'S TO-18 plastic units, low noise, low leakage, 25 volts source to gate, 50 ma gate current Gain to 9000 µmho's.\$1.00

NEON LIGHT OR NIXIE TUBE DRIVERS. An NPN, TO-18, SI Transistor. With a VCBO of 120 3/\$1.00

IN2326 voltage and temperature compensating diodes 4/\$1.00

Silicon Power Rectifiers

PRV	3A	12A	40A
100	.09	.30	.75
200	.16	.50	1.25
400	.20	.70	1.50
600	.30	1.00	1.80
800	.40	1.25	
1000	.55	1.50	

Terms: FOB Cambridge, Mass.
Send check or Money Order. Include Postage, Average Wt. per package ½ lb. No C.O.D.'s. Minimum Order \$3.00

Rated companies 30 days net

9030 8 bit memories \$5.95
LINEAR CIRCUITS

FM IF AMPLIFIERS \$.90
702C WIDE BAND DC AMPL.\$2.75
709C OPERATIONAL AMPL.\$2.75
710C HI SPEED DIFF. AMP.\$2.75
711C DUAL COMPARATOR\$2.75

DIGITAL RTL CIRCUITS

2-914 QUAD 2 input gates.....\$1.25
900 Buffer\$1.25
925 Dual 2 input gate expander.....\$1.25

923 JK flip flop\$1.25
2-923 Dual JK flip flops\$1.50

Controlled Avalanche or Epoxy Rectifiers 1 AMP.

PRV	100	.07
200	.09	
400	.12	
600	.18	
800	.22	
1000	.35	

PRV	3A	7A	20A	70A
50	.35	.45	.70	
100	.50	.65	1.00	4.00
200	.70	.95	1.30	8.00
300	.90	1.25	1.70	
400	1.20	1.60	2.10	12.00
500	1.50	2.00	2.50	
600	1.80	2.40	3.00	16.00
700	2.20	2.80		
1000			5.00	24.00

SOLID STATE SALES

Post Office Box 74B

Somerville, Mass. 02143

Tel. (617) 547-4005

CIRCLE NO. 92 ON READER SERVICE CARD

STEREO TAPE CLUB; AVERAGE COST \$3.78—\$4.20 Cartridges, Cassettes, Reels. No minimum monthly purchases. Mail—10¢—catalog. Star Recordings, Box 1055, El Paso, Tex. 79946.

STEREO Tapes, Save 30% and up; no membership or fees required; postpaid anywhere U.S.A. Free 70-page catalog. We discount batteries, recorders, tape/accessories. Beware of slogans, "not undersold," as the discount information you supply our competitor is invariably reported to the factory. **SAXITONE**, 1776 Columbia Road, N. W., Washington, D. C. 20009.

RECORDS

SPECIAL INTEREST RECORDS AVAILABLE, PRODUCED BY THE EDITORS OF THE WORLD'S LEADING SPECIAL INTEREST MAGAZINES. SEND FOR FREE CATALOG. RECORD CATALOG- EW, ZIFF-DAVIS PUBLISHING COMPANY, ONE PARK AVENUE, NEW YORK, N.Y. 10016.

19¢ RECORDS from your tapes. Write Concert Recording, Lynwood, California 90262.

HIGH FIDELITY

FREE! Send for money saving stereo catalog #E3W and lowest quotations on your individual component, tape recorder or system requirements. Electronic Values Inc., 200 West 20th Street, N.Y., N.Y. 10011.

HI-FI Components, Tape Recorders at guaranteed "We Will Not Be Undersold" prices. 15-day money-back guarantee. Two-year warranty. No Catalog. Quotations Free. Hi-Fidelity Center, 239 (L) East 149th Street, New York 10451.

HI-FI EQUIPMENT—GET Our "ROCK BOTTOM" prices on NAME BRAND amplifiers—tuners—tape-recorders — speakers FRANCHISED — 60 YEARS IN BUSINESS. Write for this month's specials—NOW! Rabson's 57th St., Inc., Dept. 569, 119 W. 57th St., New York, New York 10019. **DON'T THROW YOUR OLD CARTRIDGE AWAY.** Send us \$50.00 and any old used cartridge and we will ship you via air Prepaid anywhere the following Top Stereo Cartridges: Shure V-15 Type II, Empire 999VE, ADC 10EMK II, Stanton 681EE. Write for lowest quotations all stereo components. **DEFA ELECTRONICS**, 2207 Broadway, New York, N.Y. 10024.

"ARCTURUS SALE"

- 1700 transistor types at 39¢ each.
- 40 watt germanium power transistor, same as Delco 501, 2N278 (etc), cat. #349, 59¢ each.
- Color TV cartridge focus rectifier 6.5 kv. Used in every color TV. Cat. #CFR-20, 79¢ each.
- Motorola 2500 ma. at 1000 ppi, high voltage/current epoxy silicon rectifier, axial leads. Cat. #HEP-170, 49¢ each.
- 2 Printed circuit I.F. transformers, 4 lug. 455 kc input and output, cat. #1909P4, 99¢ each.
- RCA UHF transistor type TV tuners, KRK-120 (long-shaft) cat. #UHF-20; KRK-120 (short-shaft), cat. #UHF-21, each \$4.98.
- RCA VHF transistor type TV tuners, KRK-146, cat. #VHF-74, \$9.99 each.
- Transistorized U.H.F. tuners used in 1965 to 1967 TV sets made by Admiral, RCA, Motorola, etc. Removable gearing may vary from one make to another. Need only 12 volts d.c. to function. No filament voltage needed. Easy replacement units. Cat. #UHF-567, \$4.95.
- U.H.F. Tuner-original units as used in TV sets such as RCA, Admiral, etc. covering channels 14 through 82, as part #94D173-2. Complete with tube. Drive gearing is removable. Can be used in most sets. Cat. #UHF-3, \$4.95.
- Color yokes. 70° for all round color CRT's. Cat. #XRC-70, \$12.95. 90° for all rectangular 19 to 25" color CRT's. Cat. #XRC-90, \$12.95.
- Kit of 30 tested germanium diodes. Cat. #100, 99¢.
- Silicon rectifier, octal based replacement for 5U4, 5Y3, 5AS4, 5AW4, 5T4, 5V4, 5Z4. With diagram. Cat. #Rect-1, 99¢ each.
- 7", 90° TV bench test picture tube with adapter. No ion trap needed. Cat. #7BP7, \$7.99.
- Tube cartons 6AU6 etc. size, \$2.15 per 100. 6SN7 etc. size, \$2.55 per 100. 5U4GB size, \$2.95 per 100. 5U4 G size, 3¢ each.

Send for complete free catalog. Include 4% of dollar value of order for postage. \$5 MINIMUM ORDER. Canadian check, 8% dollar differential.

ARCTURUS ELECTRONICS CORP.

502-22nd. St., Union City, N.J. 07087 Dept. MEW
Phone: 201-864-5568

CIRCLE NO. 122 ON READER SERVICE CARD
March, 1969

LOW, LOW quotes: all components and recorders. Hi-Fi, Roslyn, Penn. 19001.

HI-FI components, tape recorders, sleep learn equipment, tapes. Unusual Values. Free catalog. Dressner, 1523 R Jericho Turnpike, New Hyde Park, N.Y. 11040.

DON'T THROW YOUR OLD CARTRIDGE AWAY. Send us \$19.95 and any old cartridge. We will ship **PREPAID** any one of the following top rated elliptical diamond stereo cartridges **NEW:** Shure M75E, M91E, M92E, Empire 888E, Pickering V15AME3, XV15 ATE, ADC 660E, 550E. Write for lowest quotations all stereo components. **DEFA ELECTRONICS**, 2207 Broadway, New York, N.Y. 10024.

ACOUSTIC RESEARCH products now available to overseas personnel, diplomats, and citizens of foreign countries. Write for full product and dealer information. AR International, Dept. EW, 24 Thorndike St., Cambridge, Mass. 02141.

NEW record changers. BSR—\$13; V.M.—\$16; Garrard—\$22; Radio-Phono stereo—\$15. "CHANGERS," E.W., 2737 Third Ave., Bronx, N.Y. 10451.

ASSEMBLE and repair kits any manufacturer. Build custom equipment your design or mine. DNS Electronics, 4023 Myerwood Lane, Dallas, Texas 75234.

GOVERNMENT SURPLUS

JEEPS Typically From \$53.90 . . . Trucks From \$78.40 . . . Boats, Typewriters, Airplanes, Multimeters, Oscilloscopes, Transceivers, Electronics Equipment. Wide Variety, Condition, 100,000 Bid Bargains Direct From Government Nationwide. Complete Sales Directory and Surplus Catalog \$1.00 (Deductible First \$10.00 Order). Surplus Service, Box 820-K, Holland, Michigan 49423.

AUTHORS' SERVICES

AUTHORS! Learn how to have your book published, promoted, distributed. **FREE** booklet "ZD," Vantage, 120 West 31 St., New York 10001.

PERSONALS

MAKE FRIENDS WORLDWIDE through international correspondence. Illustrated brochure free. Hermes, Berlin 11, Germany.

LEMURIAN VIEWPOINT—Meaningful discussions of Cosmic Truth: the purpose of human life, reincarnation, man's place in a Higher Plan, and subjects from the Lemurian Philosophy. Send for **FREE** copy. Lemurian Fellowship, Dept. 910, Box 397, Ramona, Calif. 92065.

HYPNOTISM

FREE Hypnotism, Self-Hypnosis, Sleep Learning. Catalog! Drawer H400, Ruidoso, N.M. 88345.

HYPNOTIC Sleep Learning recordings produce fabulous results. Catalogue free. ASR Foundation, Box 7021eg Henry Clay Station, Lexington, Kentucky 40502.

AMAZING HYPNOTIC record kit releases fantastic mental power! Free offer expires soon. Write: Forum, Studio AA3, 333 North Michigan, Chicago 60601.

PHOTOGRAPHY—FILM, EQUIPMENT, SERVICES

MEDICAL FILM—Adults only—"Childbirth" one reel, 8mm \$7.50; 16mm \$14.95. International W. Greenvale, Long Island, New York 11548.

SCIENCE Bargains—Request Free Giant Catalog "CJ"—148 pages—Astronomical Telescopes, Microscopes, Lenses, Binoculars, Kits, Parts, War Surplus bargains. Edmund Scientific Co., Barrington, New Jersey 08007.

EDUCATIONAL OPPORTUNITIES

LEARN While Asleep, hypnotize with your recorder, phonograph. Astonishing details, sensational catalog free! Sleep-Learning Association, Box 24-ZD, Olympia, Washington 98501.

USED Correspondence Courses and Books sold and rented. Money back guarantee. Catalog free (Courses Bought). Lee Mcuntain, Pisgah, Alabama 35765.

GREGORY ELECTRONICS

NINIC FM POCKET RECEIVER

\$59⁹⁵



WITH DRY BATTERY

Add \$7.50 for nickel-cadmium battery. Add \$20 for crystals and tuning to your frequency.

30-50 MHz or 150-170 MHz. All units new. Solid state, modular-assembly construction. Adjustable squelch. Sensitivity 0.3 microvolts to break squelch. Dual conversion crystal controlled. With conventional dry cell or rechargeable nic-cad battery. Weight: less than 1 lb. Size: 6 1/8" x 2 1/2" x 1 1/4".

450-470 MHz General-Electric Progress Line Accents

10 watts, 12 volts/transistor power supply; front or rear mount. Complete accessories.
Model No. EG48S
Wide Band \$178.
Narrow Band \$198.
Same model with channel guard \$233.
EG 48CT (Trunk) EG 48CF (Front)

50-Watt 450-470 MHz

Meets latest FCC narrow banding specifications. DumontM-430 RTN, with transistorized power supply. New! In sealed factory cartons.
with tone added \$445., minus reeds.

\$395.

New! FM 100-Watt Mobile Linear Amplifier

High Band—146-174 MHz
RF output 90-120 watts into 50 ohms.
Gonsset Comtron Series—Model 972-A
In factory-sealed cartons.
Installation Kit, if needed, Model 3459 \$25

\$150.

Motorola Motrac 30-50 MHz

U41HHT, 12 v, 30 w transistorized receiver & power supply. Complete with accessories

\$325.

Reconditioned & Used FM 2-Way Radio Equipment

most enlarged inventory now on hand for practically everything you need—at savings!

We Buy Late Model Equipment for Cash
Send For '69 Catalog—



GREGORY ELECTRONICS CORPORATION

249 Rt. 46, Saddle Brook, N.J. 07662
Phone: (201) 489-9000

CIRCLE NO. 108 ON READER SERVICE CARD

STAMPS

SURPRISE COLLECTION! Exotic mint British Colonials, absolutely free with approvals **VIKING**, Great Neck 50, N.Y. 11021

MAGNETS

MAGNETS. All types. Specials—20 disc magnets, or 2 stick magnets, or 10 small bar magnets, or 8 assorted magnets, \$1.00. Maryland Magnet Company, 5412-E Gist, Baltimore, Maryland 21215

PRINTING

WPE—HAM—CB QSL'S samples 25¢. Dick, W8VXK. Gladwin. Mich. 48624.

BOOKS

FREE CATALOG. BOOKS FOR ADULTS. CATALOG. 2217 LACKLAND, ST. LOUIS, MISSOURI 63114.

BUSINESS OPPORTUNITIES

INVESTIGATE ACCIDENTS: Earn to \$1000 monthly. Men urgently needed. Car furnished. Business expenses paid. No selling. No college education necessary. Pick own job location. Investigate full time or earn to \$8 hour spare time. Write for **FREE** information. No obligation. Universal Schools, CZ-3, 6801 Hillcrest, Dallas, Texas 75205.

FREE CATALOGS. Repair air conditioning, refrigeration. Tools, supplies, full instructions. Doolin, 2016 Canton, Dallas, Texas 75201.

I MADE \$40,000.00 YEAR by mailorder! Helped others make money! Start with \$10.00—Free proof. Torrey, Box 318-N, Ypsilanti, Mich. 48197.

JAPANESE Electronics New Products Monthly! Specimen copy \$1, deductible. Dee, 10639-W Riverside, North Hollywood, Calif. 91602.

FREE BOOK "990 Successful Little-Known Businesses." Work home! Plymouth 345-W, Brooklyn, New York 11218.

MAILORDER . . . Positively No Investment in products! Details: Methods, 1412-FD Lafayette Hill, Pennsylvania 19444.

MAGAZINES

BACK DATE MAGAZINES! Send needs. Midtown, Box 917-EW, Maywood, N.J. 07607.

MISCELLANEOUS

WINEMAKERS: Free illustrated catalog of yeasts, equipment. Semplex, Box 7208, Minneapolis, Minn. 55412.

EMPLOYMENT Resumes. Get a better job & earn more! Send only \$2.00 for expert, complete Resume Writing Instructions. J. Ross, 80-34 Kent St., Jamaica, N.Y. 11432 Dept. EW.

STOP BURGLARS THE EASY WAY!! Affix authentic "Protected by Electronic Sentry Alarm" Decals to auto windows, doors & windows of home, retail stores; vending machines, etc. Whether you have an alarm or not—thieves stay away! Only \$1.00 for each set of two. J. Ross, 80-34 Kent St., Jamaica, N.Y. 11432. Dept. EW.

EVERYTHING UNCONDITIONALLY GUARANTEED!

BRITISH SIGNAL GENERATOR SIMILAR TO HEWLETT-PACKARD NO. 608-D

Marconi TF-801D/1: 10 to 470 MHz. CW & AM up to 100%. Crystal-calibrated each 2 and 5 MHz and movable cursor (dialing indicator) that dial at each zero beat. Rated freq. accuracy 0.01%. Standard 50 ohm output impedance from standard Type N plug. Calibrated output 0.1 us to 1.0 us has Automatic Level Stabilization ckt to stay where you set it. 100% of down time is eliminated because the turret band-switching is contactless; capacity coupled, no parts touch. Similar to the PTO system in Collins K-2000 rev. Marconi is noted for low leakage and extremely low incidental EM. U.S. price \$4600.00. Avron, radio shops which are forced to the 2608D because of the crystal calib. and movable cursor can now get both in this unit. Imported from an RCA Base subunit, in exceptionally clean condition and tested for good operation. With the book, but calibration un-certified. Calibrated and with NBS-traceable Cert. of Calib. & dated sticker **\$495.00** or **\$595.00**

Other SIGNAL GENERATORS: Ask for our Cat. 39. OSCILLOSCOPE BARGAINS: Feb. ad, or Cat. 24. FREQUENCY COUNTERS: Ask for our Cat. 114. FREQ. METERS, STANDARDS: Ask for Cat. 118. AMPLIFIERS, ATTENUATORS: Ask for Cat. 2. FREQ. CHANGERS & PWR SPLIES: Cat. 28. AUDIO TEST EQUIPMENT: Ask for Cat. 1. BRIDGES, POTENTIOMETERS: Ask for Cat. 5. PRECIS. METERS (Transfer Standards): Cat. 18rd. VTM's AC & DC: Ask for Cat. 18rd. METER CALIBRATORS: Ask for our Cat. 29. RF/NOISE FIELD STRENGTH: Ask for Cat. 22. PULSE GENERATORS: Ask for our Cat. 30. GRAPHIC & TAPE RECORDERS: Ask for Cat. 32. LINE-VOLTAGE REGULATORS: Ask for Cat. 37. SEMICOND. & TUBE TESTERS: Ask for Cat. 37. TUNING-FORK OSCILLATORS: Ask for Cat. 50. RF WATTMETERS: Ask for Cat. 52. COMMUNIC. RCVRs, XMTRS: Ask for Cat. 7.

Samplers from our Meter Calib. Cat. 29, which also includes digital-set pwr splies for both voltage & current; everything with NBS-traceable calib. certifi. from a Standards Lab.: Holt Instrument Co. Model TVI is a state-of-the-art thermal AC Transfer Standard, priced at less than 1/2 of current catalog. Engelhard type at \$895. Fluke 805 AC/DC diff. VM. Cals. digital current & voltage source catalogued at \$2995. from us \$895. Two other Comu pwr splies: Fluke 801C, 301A, 110A. A 20 pwr divider sply, and a North Hills current sply for semiconductor testing.

A.R.C. R-11A modern Q-5'er 100-550 kc 12.95
SILIC. RECTIF. 8000 PIV 400 MA. pair. . . . 5.30
R-23 ARC-5 Command rear 100-550 kc. . . . 14.95
A.R.C. 12 22 Command rear 550-1000 kc. . . . 17.95
LM-14 freq. meter, .01% 125 kc-20 mc. . . . 57.90
SP-600-JX ultra-clean, in cabinet, aligned, ready to use, 0.34-34 mc, w/xtl filter & provisions for a remote station to be xtl selected. . . . 325.00
Only

TEKTRONIX = 531 SCOPE with a plugin, overhauled and with NBS. Traceable certificate and dated calibration sticker **\$515.00**

WE PROBABLY HAVE THE BEST INVENTORY OF GOOD LAB TEST EQUIPMENT IN THE COUNTRY. BUT PLEASE DO NOT ASK FOR CATALOG! ASK FOR SPECIFIC ITEMS OR KINDS OF ITEMS YOU NEED! WE ALSO BUY! WHAT DO YOU HAVE?

R. E. GOODHEART CO. INC.

Box 1220-A, Beverly Hills, Calif. 90213

Phones: Area 213, office 272-5707, messages 275-5342

\$100,000 "EYE SEE" BONANZA BY POLY PAK INTEGRATED CIRCUITS!



PENNY SALE!

By far the biggest Integrated Circuit Sale in our history. NOBODY! That's right NOBODY under-sells Poly Paks. Imagine—buy 1 Integrated Circuit at our bargain price and get the 2nd one for ONLY 1c . . . that's right ONE CENT! NO LIMIT PER ITEM! Every item guaranteed as advertised. All include data on Integrated Circuits, schematics, and/or hookups, and as much as 40 circuits. THIS OFFER IS LIMITED!

Fairchild No.	EACH	1c MORE
900	Buffer	1 for 1.49 2 for 1.50
902	R-S Flip Flop	1 for 1.49 2 for 1.50
903	3 In. Gate Nand/Nor	1 for 1.49 2 for 1.50
903-903*	3 Input gate Nand/Nor	1 for 1.49 2 for 1.50
904-904*	Half adder	1 for 1.49 2 for 1.50
910	Dual Two Input Gate	1 for 1.29 2 for 1.30
914-914*	Dual Two Input Gate	1 for 1.49 2 for 1.50
915	Dual 3 Input Gate Nand/Nor	1 for 1.49 2 for 1.50
923	JK-Flip Flop	1 for 1.49 2 for 1.50
923-923*	JK Flip Flop	1 for 1.69 2 for 1.70
925	Dual 2 Input Gate. Expander	1 for 1.49 2 for 1.50
927	Quad Inverter	1 for 1.49 2 for 1.50
930	Dual 4 Input Gate Nand/Nor	1 for 1.49 2 for 1.50
933	Dual Input Gate. Expander	1 for 1.49 2 for 1.50
944	Dual 4 Input Power Gate	1 for 1.49 2 for 1.50
945	Clocked Flip Flop	1 for 1.69 2 for 1.70
946	Quad 2 Input Gate Nand/Nor	1 for 1.49 2 for 1.50
948	Clocked Flip Flop	1 for 1.69 2 for 1.70
950	AC Binary	1 for 1.98 2 for 1.99
952	Dual 2 Pininput Inverter Gate	1 for 1.29 2 for 1.30
954	Dual 4 Input and Gate	1 for 1.29 2 for 1.30
955	8 Input and Gate w 2 output	1 for 1.29 2 for 1.30
956	Dual 2 Input Buffer	1 for 1.29 2 for 1.30
957	Dual Rank (hold) Flip Flop	1 for 1.98 2 for 1.99
961	Dual 4 Input Gate w/expander	1 for 1.49 2 for 1.50
962	Triple Gate	1 for 1.49 2 for 1.50
963	Triple Gate	1 for 1.49 2 for 1.50

* Two identical IC's in one package

1 AMP TOP HAT AND EPOXIES

PIV	Sale	PIV	Sale	PIV	Sale
50	5¢	800	19¢	1800	82¢
100	7¢	1000	29¢	2000	1.25
200	8¢	1200	42¢	3000	1.50
400	10¢	1400	55¢	4000	1.95
600	15¢	1600	69¢		

Actual Size

1 AMP MICROMINIATURE SILICON RECTIFIERS

PIV	Sale	PIV	Sale
50	5¢	600	15¢
100	7¢	800	19¢
200	8¢	1000	29¢
400	10¢		

'GLASS AMP' SILICON RECTIFIERS

ONE AMP

PIV	Sale	PIV	Sale
50	5¢	600	19¢
100	7¢	800	21¢
200	9¢	1000	32¢
400	12¢	1200	45¢

PRV may be exceeded without the rectifier breaking down.

NE-2 NEON BULBS 20 for \$1

Terms: add postage. Rated: net 30, cod's 25%
Phone Orders: Wakefield, Mass. (617) 245-3829
Retail: 211 Albion, St., Wakefield, Mass.

GIANT 1969 CATALOG ON: Parts, Rectifiers 10¢

Transistors, SCRs, I.C.'s, Equipment, Etc.

POLY PAKS P.O. BOX 942W LYNNFIELD, MASS 01940

Buy 10 PAKS & CHOOSE 1 FREE

- 50 COILS AND CHOKES, if. rf. ant. osc. peaking, etc. \$1
- 65 HALF WATTERS, to 1 meg, 5% popular values to \$1
- 60 HI-QUALITY RESISTORS, 1/2, 1, 2W asst values \$1
- 10 RCA PHONO PLUGS & JACK SETS, tuners, etc. \$1
- \$25 SURPRISE PAK: transistors, rect. diodes, etc. \$1
- 2-PC INFRARED DETECTOR & FILTER Sciense prof \$1
- 2 FIELD EFFECT TRANSISTORS, n channel, hobby \$1
- 50 TERMINAL STRIPS, 1 to 8 lug types \$1
- 3 PHOTO ELECTRIC CELLS, hi. imp., schematic \$1
- 3 TRANSISTOR AMPLIFIER, WIRED, 3x2x3/4 " schematic \$1
- 10 PRINTED CIRCUIT BOARDS, copper clad, 100 use \$1
- 10 TRANSISTOR SOCKETS, for pnp & npn types \$1
- 10 PANEL SWITCHES, toggle, slide, micro, rotary \$1
- 40 CORNING "LOW NOISE" resistors, popular 5% \$1
- 40 "MICRO" RESISTORS, 1/10W, 5% Hobby mus \$1
- 50 GERMANIUM GLASS DIODES, 1N34, 1N48 no tes \$1
- 40 TOP HAT SILICON RECTIFIERS, no testast value \$1
- 25 EPOXY RECTIFIERS, silicon asst, no test \$1
- 40 PRECISION RESISTORS, 1/2-2W, 1% asst values \$1
- 30 TRANSISTORS, rf. if. audio, osc, no test \$1
- 60 TUBULAR CONDENSERS, to .5mf to 1KV, asst \$1
- 50 DISC CONDENSERS, to .05mf npo, temp coef, asst \$1
- 60 TUBE SOCKETS, receptacles, plugs, audio, etc. \$1
- 30 POWER RESISTORS, to 25 watts, to 24K ohms \$1
- 6 "IBM" COMPUTER BOARDS, many trans, diodes \$1
- 3 2N3563 TRANSISTORS, npn, 600mc, 100hf, epox \$1
- 10 VOLUME CONTROLS, to 1 meg, switch too! \$1
- 10 ELECTROLYTICS, to 100mf, tubulars too, asst \$1
- 50 RADIO & TV KNOBS, asstcd colors & styles \$1
- 10 TRANSISTOR ELECTROLYTICS to 100mf, asst values \$1
- 40 "MICRO" CONDENSERS, for transistor circuits \$1

CIRCLE NO. 96 ON READER SERVICE CARD

FREE Catalog of The WORLD'S FINEST GOV'T SURPLUS ELECTRONIC BARGAINS

Now BIGGER and BETTER Than Ever!

MAIL COUPON TODAY

NAME: _____
ADDRESS: _____
CITY: _____ STATE: _____ ZIP NO.: _____

FAIR RADIO SALES Dept. EW • BOX 1105 LIMA, OHIO 45802

CIRCLE NO. 111 ON READER SERVICE CARD

U.S. GOV'T ELECTRONIC SURPLUS

* Nationally Known - World Famous SURPLUS CENTER offers finest, most extensive, Government Surplus electronic units and components at a fraction of their original acquisition cost.

ORDER DIRECT FROM AD or WRITE FOR CATALOGS

(IBM) SILICON DIODE RECTIFIERS

* "Great Buys" in top quality, surplus, silicon diode rectifier units, (IBM Computer Units)

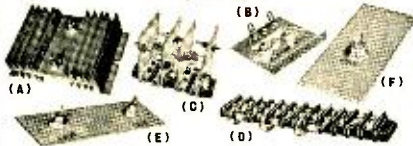

- * (#REC-4) -- Top 12-amp., 50-V. silicon diodes on finest aluminum sinks. (1 lb.) **\$2.69**
- * (#22-925) -- Twin 12-amp., 150-V. silicon diodes on finest aluminum sinks. (1 lb.) **\$1.31**
- * (#11-949) -- Eight 12-amp., 100-V. silicon diodes on heavy copper heat sinks. (1 lb.) **\$3.97**
- * (#11-900) -- Six 1-amp., 100-V. silicon diodes on Kulkra strip. Very versatile. (1 lb.) **\$1.71**
- * (#22-926) -- Two 25-amp., 50-V. silicon diodes on heavy copper heat sink. (1 lb.) **\$2.69**
- * (#22-914) -- One 25-amp., 50-V. silicon diodes on heavy copper heat sink. (1 lb.) **\$1.81**

COMPUTER TRANSISTORS ON HEAT SINKS

IBM Computer Quality Units

* (#22-928) -- Unit consists of one 150-watt power transistor on heavy ribbed aluminum heat sink. Many experimental uses. (1 lb.)
List Gov't Over \$10.00 **\$1.99**



* (#22-915) -- Unit consists of two 150-watt power transistors, 4 pots, several diodes, capacitors, resistors, etc. on heavy ribbed aluminum heat sinks. Ideal for use as motor speed control. (4 lbs.)
List Gov't Over \$35.00 **\$4.91**



COMPUTER GRADE FILTER CAPACITORS

* Latest design, high MFD units. Different sizes for electrolytic, paper, and mica. (1 lb.)
List Gov't Over \$2.50

- (#C-14-1) -- 15,500-MF @ 10-Volts **.99**
- (#C-14-2) -- 1500-MF @ 150-Volts **.98**
- (#C-14-3) -- 5000-MF @ 55-Volts **.97**
- (#C-14-7) -- 12,500-MF @ 10-Volts **\$1.19**
- (#C-14-12) -- 750-MF @ 25-Volts **.98**



RUNNING TIME METER

* (#DX-104) -- Use to record number of operating hours of electric lights and electrical devices, such as refrigerators, furnaces, etc. Records total hours, tenths and hundredths up to 9999.99 hours. For 115-volt, 60-cycles. Size 4 1/2" x 3" x 2 1/2". Shipping weight 2 lbs.



\$5.69 List Over \$29.00

12 and 24-VOLT TRANSFORMER

* (#15-920) -- General Electric 115-volt, tapcode to 12 and 24-volts. 750-watts, output @ 42-amps., 24-volts, 63-amps. at 12-volts. 1-welding battery charger, running lights, etc. 7 1/2" x 5 1/2" x 5 1/2". (18 lbs.)
List Gov't Over \$35.00 **\$16.72**



EXPANDED SCALE 0 - 15 DCVM

* (#21-900) -- Brand new, expensive voltmeter reads 0.5 to 15-volts DC and 5 to 8-volts AC. Very useful for automotive and aircraft battery charge indicator, etc. 100-megohm input, black plastic case. 7 1/2" x 5 1/2" x 2 1/2". (3 lbs.)
List \$32.50



SILICON DIODES

* (#REC-3) -- New, per-rect. Westinghouse #770-A, 275-amp., 50-volt. #18-914. 1-amp. hi-current rectifier. (1 lb.)
List Over \$15.00 **\$5.90**



DIGITAL READ-OUT UNIT

* (#EE-17) -- Sophisticated electronic unit contains solid state, electric motor, gear train, relays, etc. 5 1/2" x 6 1/2" x 7 1/2". (10 lbs.)
List Gov't \$191.00 **\$3.97**



TYPICAL BUYS FROM OUR 1969 CATALOGS

- * Our new 1969 Catalogs (Vol. #1 and #2) contain hundreds of tremendous buys in electronic equipment, power plants, welding generators, battery chargers, buxits, electric golf carts, hydraulic gear, walk-behind, tape recorders, binoculars, surviving instruments, all types 12-volt power motors, blowers, relays, etc.
- * \$100.00 Automatic Telephone Step Switches **\$9.95**
- * \$275.00 Geared Battery Motors For Electric Cars **\$26.95**
- * \$ 30.00 Standard Dial Handset Telephones **\$7.50**
- * \$ 4.50 Power Transformer 115V to 25V **\$1.21**
- * \$ 37.50 750-Watt Transformers 115V. to 24V **\$19.81**
- * \$650.00 Power Plant 5000-Watts 115-Volts **\$135.00**
- * \$ 30.00 115-Volt AC Watt-hour Meters **\$5.95**
- * \$ 42.50 115-Volt, 35-Amp. Clock Timer Switch **\$8.91**
- * 15-Vol. Discontinued Correspondence Course in Electrical Engineering **\$8.79**

SEND 25¢ COIN OR STAMPS FOR CATALOGS
All Items FOB Money Back Guarantee

SURPLUS CENTER
DEPT. EW-039 LINCOLN, NEBR. 68501

CIRCLE NO. 89 ON READER SERVICE CARD 96

ELECTRONICS WORLD MARCH 1969

ADVERTISERS INDEX

READER			READER		
SERVICE NO.	ADVERTISER	PAGE NO.	SERVICE NO.	ADVERTISER	PAGE NO.
124	Allied Radio	88	103	Kenzac	82
123	Ampex Corporation	12	102	Lafayette Radio Electronics	86
122	Arcturus Electronics Corp.	93		Lampkin Laboratories, Inc.	84
121	Bell P. A.	68	101	Liberty Electronics, Inc.	94
	Brookstone Co.	90	100	P. R. Mallory & Co., Inc.	2
120	Burnstein-Applebee Co.	61	99	Multicore Sales Corp.	83
	CREI, Home Study Division, McGraw-Hill Book Company	70, 71, 72, 73	98	Music Associated	88
119	Chemtronics, Inc.	69		McGraw-Hill Book Co.	1
118	Cleveland Institute of Electronics	56, 57, 58, 59		National Radio Institute	8, 9, 10, 11
117	Cleveland Institute of Electronics	83	97	Olson Electronics, Inc.	83
	Comsat Corp.	55	96	Poly Paks	95
	Connor	76		RCA Electronic Components & Devices	FOURTH COVER
82	Cornell Electronics Co.	91	90	RCA Electronic Components & Devices	THIRD COVER
116	Delta Products, Inc.	17		RCA Institutes, Inc.	18, 19, 20, 21
115	Delta Products, Inc.	75	81	Radar Devices Mfg. Co.	7
114	Delta Products, Inc.	82	95	Howard W. SAMS & CO., Inc.	67
113	Edmund Scientific Co.	94		Saxitone Tape Sales	86
112	Electro-Voice, Inc.	74	94	Schober Organ Corporation	87
111	Fair Radio Sales	95	93	Shure Brothers	23
110	Freedom Electric Co.	64	92	Solid State Sales	92
125	G. C. Calctro	SECOND COVER	91	Sonar Radio Corporation	64
	G & G Radio Supply Company	92	89	Surplus Center	96
	R. E. Goodheart Co., Inc.	95	88	Sylvania Electric	15
109	Gordos Corp.	61	200	Texas Crystals	66
	Grantham School of Electronics	4	87	Triplett Electrical Instrument Co.	24
108	Gregory Electronics Corporation	93	86	University Sound	89
107	Heath Company	62, 63		Valparaiso Technical Institute	76
106	Hewlett-Packard	78	85	Vanguard Electronics	60
105	Jensen Manufacturing Co.	65	84	Winegard Company	90
104	Kenwood Electronics	53	83	Xcelite, Inc.	16

CLASSIFIED ADVERTISING 91, 92, 93, 94, 95

Printed in U.S.A.

ELECTRONICS WORLD

FREE INFORMATION SERVICE



a/ Here's an easy and convenient way for you to get additional information about products advertised or mentioned editorially in this issue. Just follow the directions below...and the material will be sent to you promptly and free of charge.

b/ Tear out one of the perforated postage-free cards. Please print or type your name and address where indicated.

c/ Circle the number on the card that corresponds to the key number at the bottom of the advertisement or editorial mention that interests you. (Key numbers for advertised products also appear in the Advertisers' Index.)

d/ Simply mail the card. No postage is required.

e/ Inquiries for information other than "Free Information Service" are to be directed to Electronics World, One Park Avenue, New York, N.Y. 10016.

f/ The "Free Information Service" is available to all readers of Electronics World. If your copy is passed along, the next reader can also take advantage of this service. All he has to do is tear out the remaining card and follow the same directions.

g/ Electronics World's Free Information Service lets you "shop by mail".



Important: BLACK numbers are of general interest and you do not have to include your company name and address to receive the information requested.

BLUE numbers correspond to an ad or editorial mention of professional interest. Manufacturers will honor your request **only** if it is to be mailed direct to your company—so be sure to include your company's name and address.

I AM EMPLOYED IN: INDUSTRY -1 COMMERCIAL -2
COMMUNICATIONS -3 MILITARY/GOVERNMENT -4 OTHER -5

NAME (Print Clearly) _____ TITLE _____

ADDRESS _____

CITY _____ STATE _____ ZIP CODE _____

(Fill in the following only if you circle any BLUE numbers below)

NAME (Print Clearly) _____ TITLE _____

COMPANY NAME _____

COMPANY ADDRESS _____

CITY _____ STATE _____ ZIP CODE _____

(Zip Code must be included to insure delivery.) (Void 60 days after date of issue.)

Please send me additional information on products I have circled.
(Key numbers for advertised products also appear in Advertisers Index.)

SB 369

1 2 3 4 5 6 7 8 9 10 11 12 13 14 15 16 17 18 19 20 21 22 23 24 25
26 27 28 29 30 31 32 33 34 35 36 37 38 39 40 41 42 43 44 45 46 47 48 49 50
51 52 53 54 55 56 57 58 59 60 61 62 63 64 65 66 67 68 69 70 71 72 73 74 75
76 77 78 79 80 81 82 83 84 85 86 87 88 89 90 91 92 93 94 95 96 97 98 99 100
101 102 103 104 105 106 107 108 109 110 111 112 113 114 115 116 117 118 119 120 121 122 123 124 125
126 127 128 129 130 131 132 133 134 135 136 137 138 139 140 141 142 143 144 145 146 147 148 149 150
151 152 153 154 155 156 157 158 159 160 161 162 163 164 165 166 167 168 169 170 171 172 173 174 175
176 177 178 179 180 181 182 183 184 185 186 187 188 189 190 191 192 193 194 195 196 197 198 199 200

I AM EMPLOYED IN: INDUSTRY -1 COMMERCIAL -2
COMMUNICATIONS -3 MILITARY/GOVERNMENT -4 OTHER -5

NAME (Print Clearly) _____ TITLE _____

ADDRESS _____

CITY _____ STATE _____ ZIP CODE _____

(Fill in the following only if you circle any BLUE numbers below)

NAME (Print Clearly) _____ TITLE _____

COMPANY NAME _____

COMPANY ADDRESS _____

CITY _____ STATE _____ ZIP CODE _____

(Zip Code must be included to insure delivery.) (Void 60 days after date of issue.)

Please send me additional information on products I have circled.
(Key numbers for advertised products also appear in Advertisers Index.)

SA 369

1 2 3 4 5 6 7 8 9 10 11 12 13 14 15 16 17 18 19 20 21 22 23 24 25
26 27 28 29 30 31 32 33 34 35 36 37 38 39 40 41 42 43 44 45 46 47 48 49 50
51 52 53 54 55 56 57 58 59 60 61 62 63 64 65 66 67 68 69 70 71 72 73 74 75
76 77 78 79 80 81 82 83 84 85 86 87 88 89 90 91 92 93 94 95 96 97 98 99 100
101 102 103 104 105 106 107 108 109 110 111 112 113 114 115 116 117 118 119 120 121 122 123 124 125
126 127 128 129 130 131 132 133 134 135 136 137 138 139 140 141 142 143 144 145 146 147 148 149 150
151 152 153 154 155 156 157 158 159 160 161 162 163 164 165 166 167 168 169 170 171 172 173 174 175
176 177 178 179 180 181 182 183 184 185 186 187 188 189 190 191 192 193 194 195 196 197 198 199 200

FREE
INFORMATION
SERVICE



FIRST CLASS
PERMIT NO. 25682
PHILADELPHIA, PA.

BUSINESS REPLY MAIL
NO POSTAGE NECESSARY IF MAILED IN U. S. A.

POSTAGE WILL BE PAID BY

Electronics World

P.O. BOX 7842

PHILADELPHIA, PA. 19101

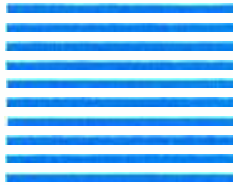

FIRST CLASS
PERMIT NO. 25682
PHILADELPHIA, PA.

BUSINESS REPLY MAIL
NO POSTAGE NECESSARY IF MAILED IN U. S. A.

POSTAGE WILL BE PAID BY

Electronics World

P.O. BOX 7842

PHILADELPHIA, PA. 19101

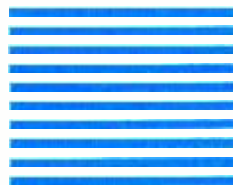

**Read
each
month
by the
world's
largest
audience
of
electronics
professionals**

VIEW

The RCA WO-33A Super-Portable 3-Inch Oscilloscope helps solve virtually any electronics servicing problem, inside or outside the shop. Its combination of exceptionally low cost and high performance have already made it popular as a monitoring and trouble shooting 'scope in black and white and color TV broadcasting studios, and in professional service. And why not? Here's a 3-inch 'scope that meets your requirements for gain, bandwidth, transient response, accuracy, versatility, and portability. **AND IT'S ONLY \$139.00.*** Also available in an easy to assemble kit, WO-33A (K).

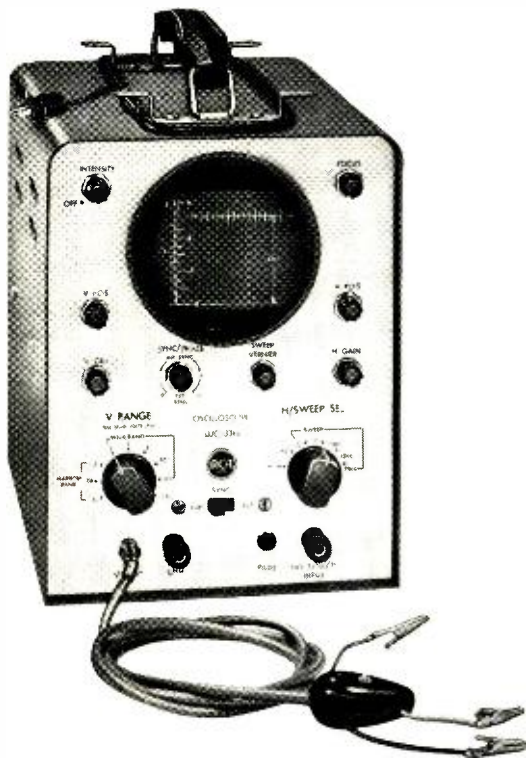

The RCA WO-91C 5-inch Dual Band Oscilloscope is a reliable, heavy-duty, precision 'scope in use in thousands of installations from classrooms to TV distribution systems...from service benches to broadcast stations. You probably can't find a better value. Applications include waveform analysis, peak-to-peak voltage measurement, square-wave testing, and observation of circuit characteristics. A front-panel switch gives you an easy choice of wide-band or narrow-band (high sensitivity) operation. It's easily portable, **AND IT'S ONLY \$269.00.*** The WO-91C-V1 is available for 240V operation, no increase in price.



*Optional Distributor resale price. Prices may be slightly higher in Alaska, Hawaii, and the West.

Write for a catalog with complete descriptions and specifications for all RCA test equipment: RCA Electronic Components, Commercial Engineering, Department No. C41W, Harrison, N. J. 07029

**LOOK TO RCA FOR INSTRUMENTS TO TEST/MEASURE/VIEW/MONITOR/GENERATE
CIRCLE NO. 90 ON READER SERVICE CARD**

The RCA logo, consisting of the letters 'RCA' in a stylized, outlined font.

All new from every angle ...RCA HI-LITE

You end all doubts and confusion when you specify RCA HI-LITE. Then you can be certain that there is the all-new replacement picture tube from the leader in Color TV. All-new glass...gun...the works.

OEM QUALITY from every angle: the same tubes that go into original equipment sets, incorporating the latest technology of the world's most experienced color picture tube manufacturer. Everything about them exudes know-how, confidence, leadership.

If you've set your sights on quality, then look to RCA HI-LITE for your replacement tube needs. Available in the broadest line of types in the industry from your Authorized RCA Distributor.

RCA Electronic Components,
Harrison, N. J.



RCA